

SECTION BR

MODIFICATION NOTICE:

- Wiring Diagrams have been changed.
- Service data and specifications (SDS) has been changed.

CONTENTS

TROUBLE DIAGNOSES	2002	Diagnostic Procedure 3 (Motor relay o	
Component Parts and Harness Connector		rmotor).....	2023
Location.....	2002	Diagnostic Procedure 4 (Low voltage)	2025
Schematic/2WD Models.....	2003	Diagnostic Procedure 5 (G sensor)	2026
Wiring Diagram - ABS -/2WD LHD Models.....	2004	Diagnostic Procedure 6 (Control unit)	2027
Wiring Diagram - ABS -/2WD RHD Models	2007	TROUBLE DIAGNOSES FOR SYMPTOMS	2028
Schematic/4WD Models.....	2010	Diagnostic Procedure 12 (Warning lamp does	
Wiring Diagram - ABS -/4WD LHD Models.....	2011	not come on when ignition switch is turned	
Wiring Diagram - ABS -/4WD RHD Models	2015	ON.).....	2028
TROUBLE DIAGNOSES FOR		Diagnostic Procedure 13 (Warning lamp stays	
SELF-DIAGNOSTIC ITEMS	2019	on when ignition switch is turned ON.).....	2030
Diagnostic Procedure 1 (Wheel sensor or		SERVICE DATA AND SPECIFICATIONS	
rotor).....	2019	(SDS)	2031
Diagnostic Procedure 2 (ABS actuator		General Specifications	2031
solenoid valve and solenoid valve relay).....	2021		

TROUBLE DIAGNOSES

Component Parts and Harness Connector Location

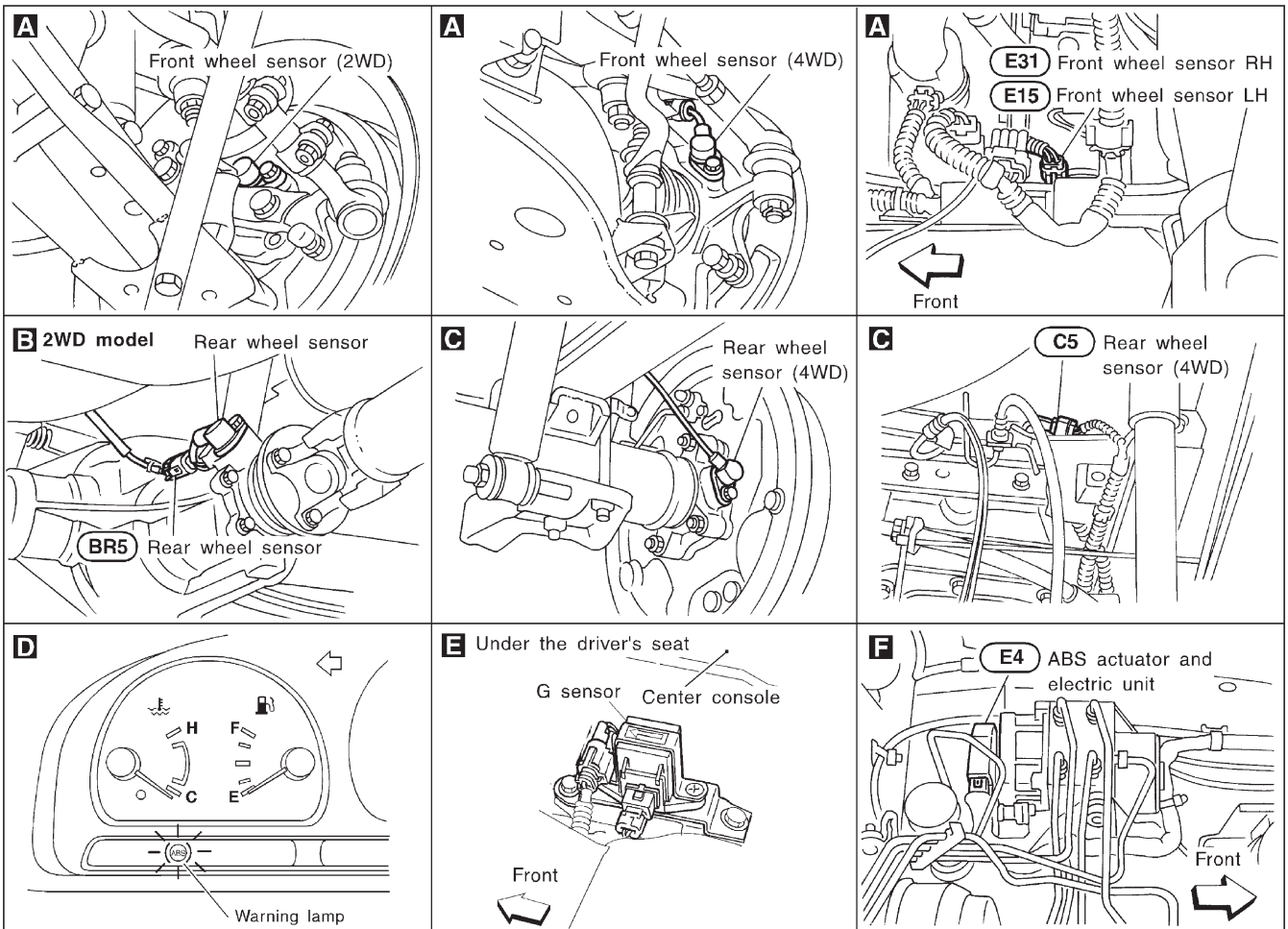
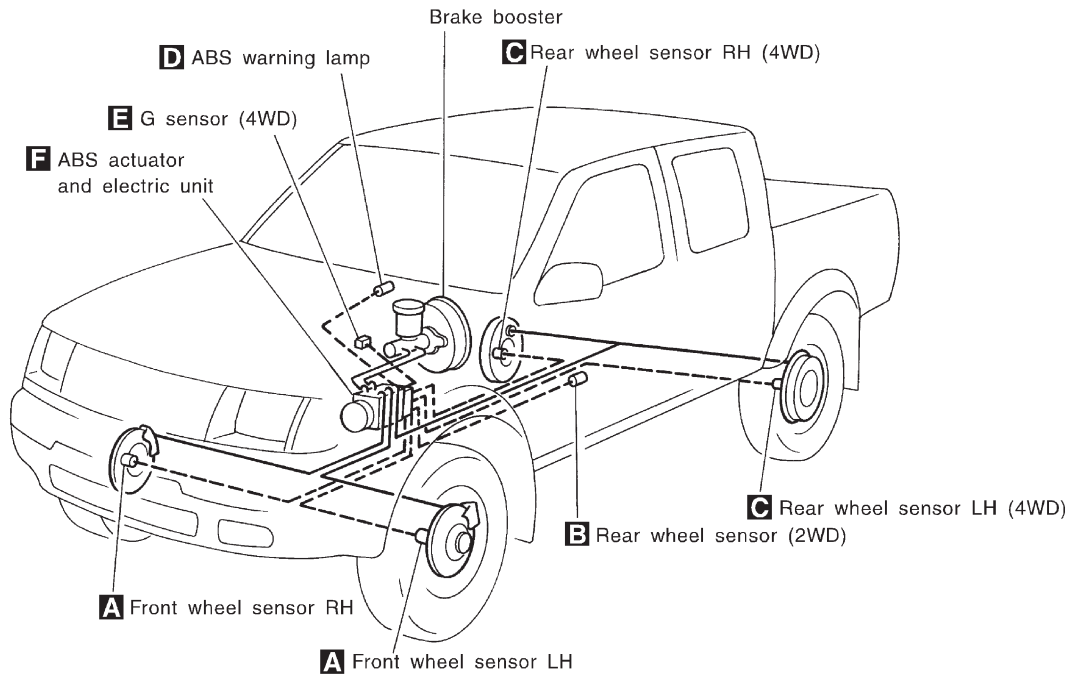

SBR076EA

TROUBLE DIAGNOSES

Schematic/2WD Models

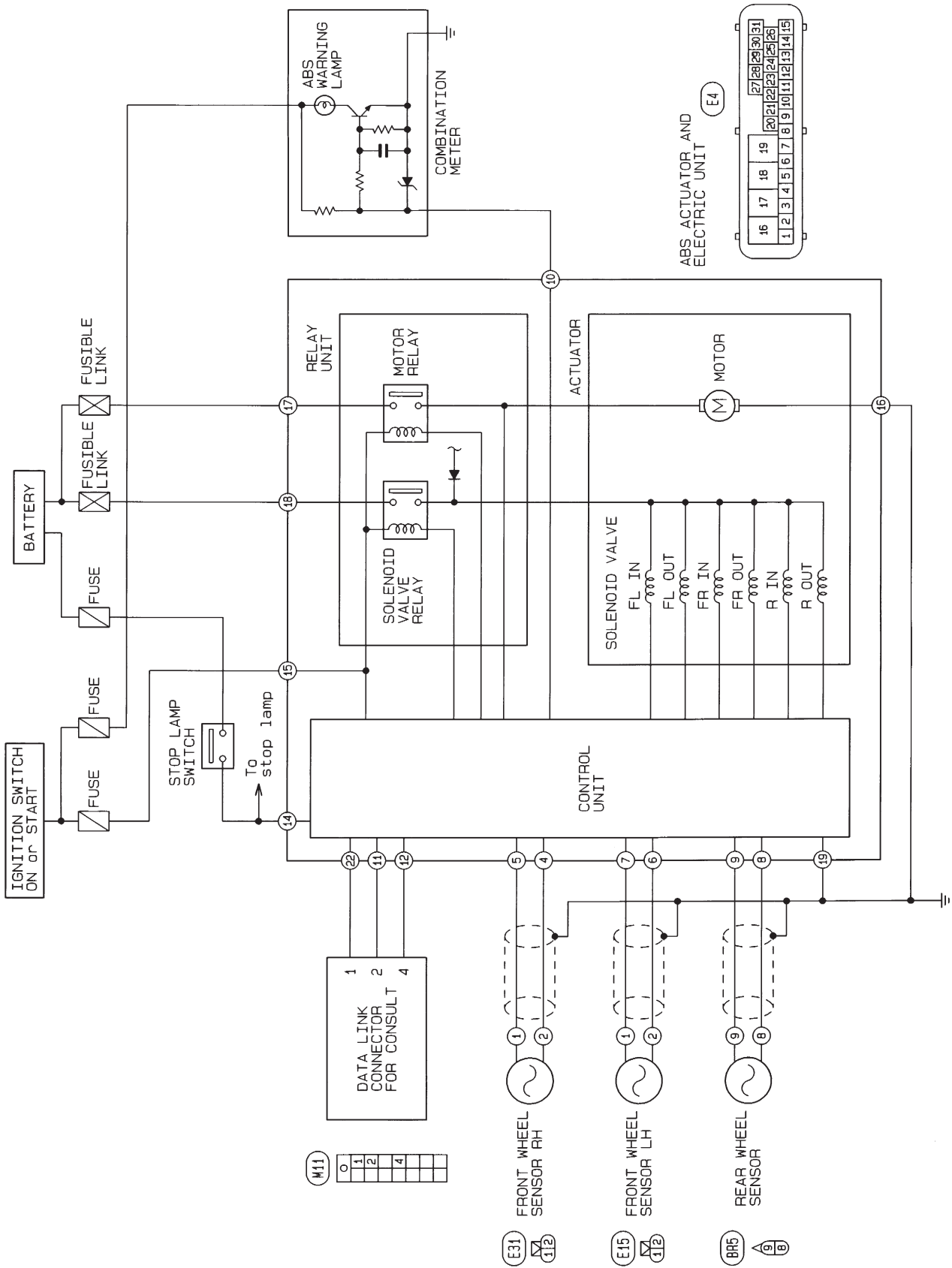

TROUBLE DIAGNOSES

Wiring Diagram — ABS —/2WD LHD Models

BR-ABS-01

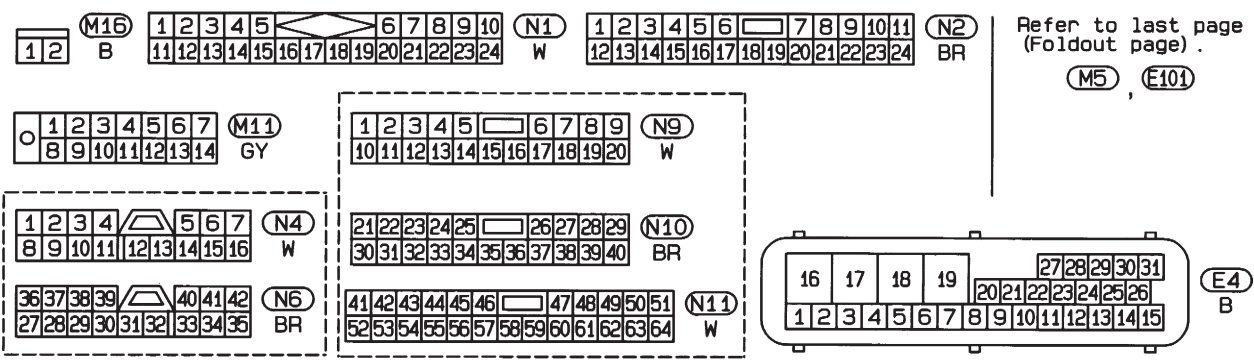
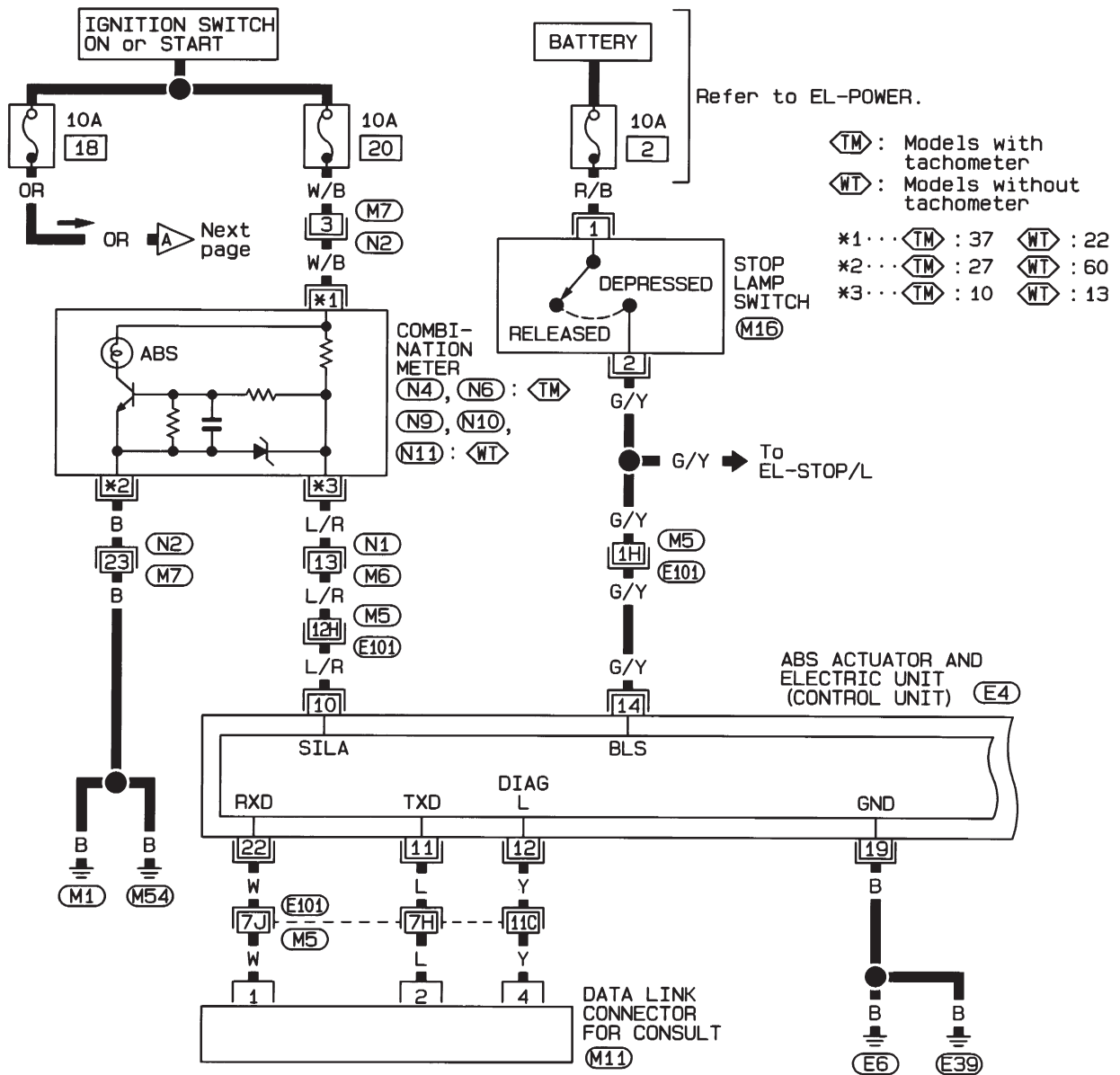

TROUBLE DIAGNOSES

Wiring Diagram — ABS —/2WD LHD Models (Cont'd)

BR-ABS-02

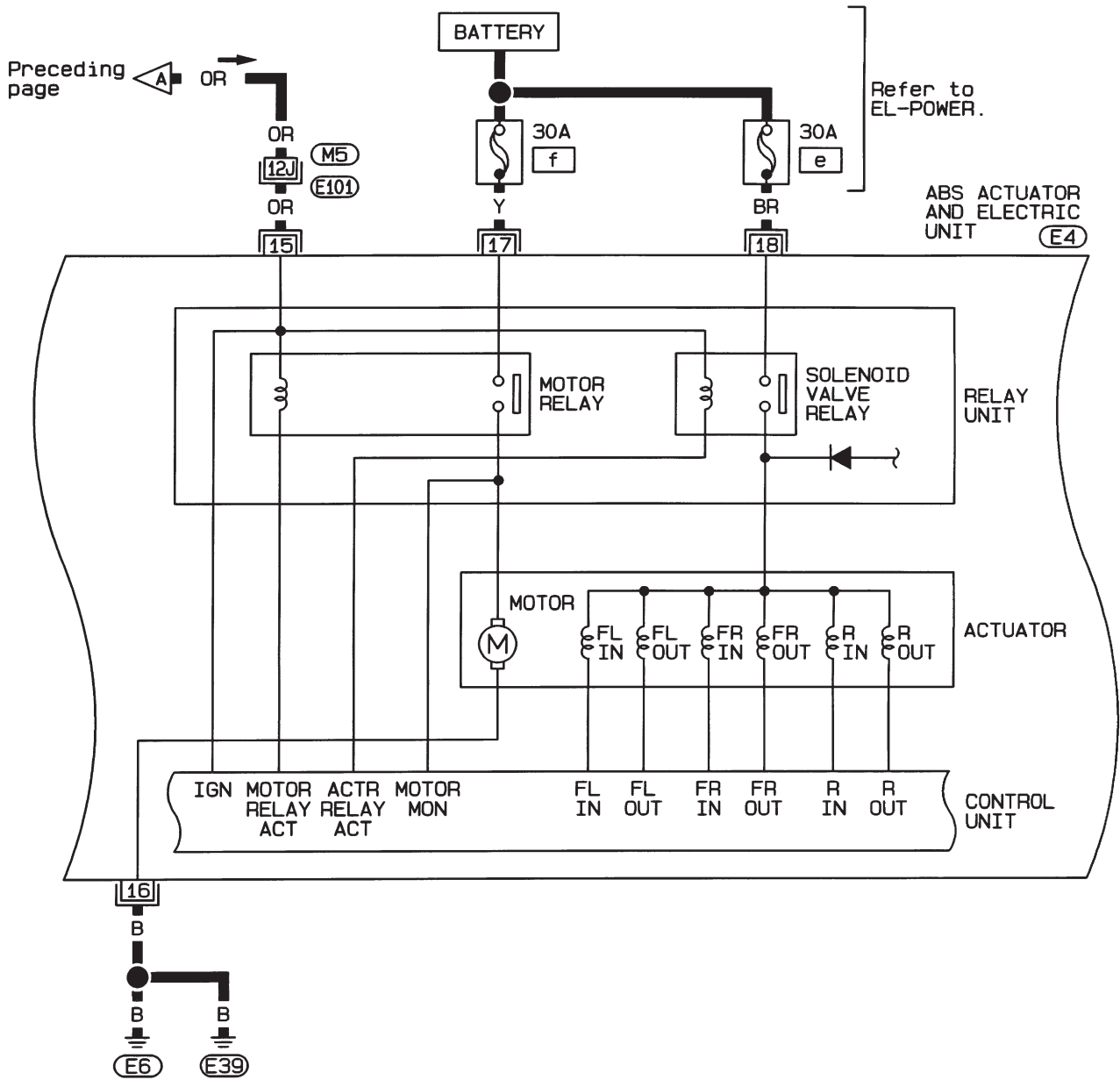

Refer to EL-POWER.

ABS ACTUATOR AND ELECTRIC UNIT (E4)

RELAY UNIT

ACTUATOR

CONTROL UNIT

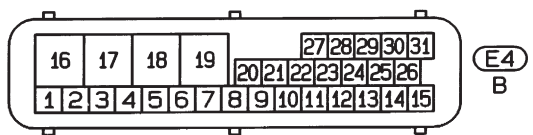

Refer to last page (Foldout page).

(M5), (E101)

TROUBLE DIAGNOSES

Wiring Diagram — ABS —/2WD LHD Models (Cont'd)

BR-ABS-03

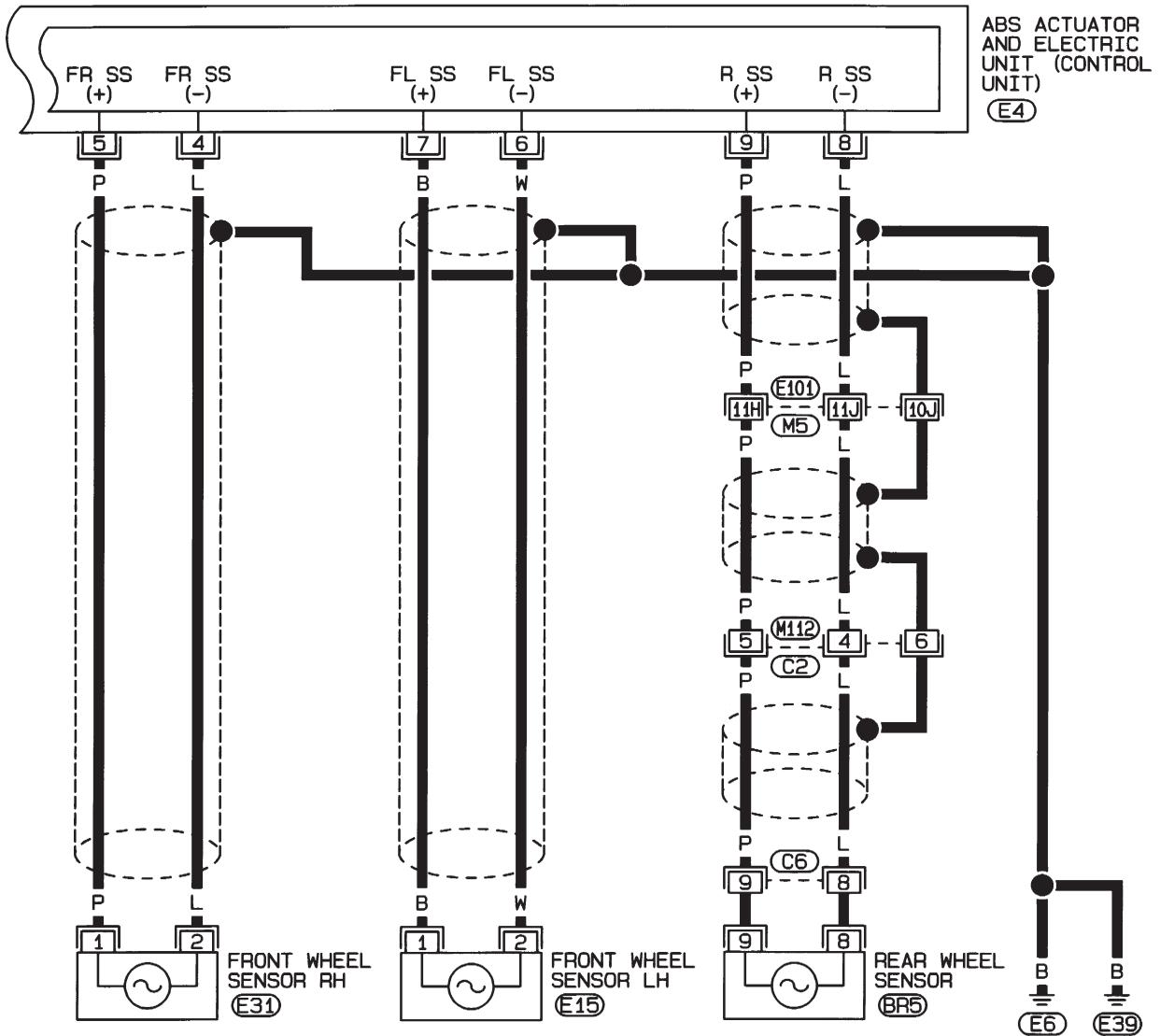

Refer to last page (Foldout page).

M5, E101

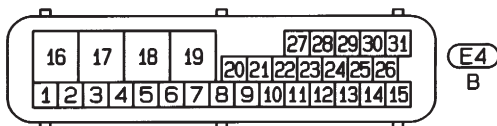

* : This connector is not shown in "HARNES LAYOUT", EL section.

TROUBLE DIAGNOSES

Wiring Diagram — ABS —/2WD RHD Models

BR-ABS-04

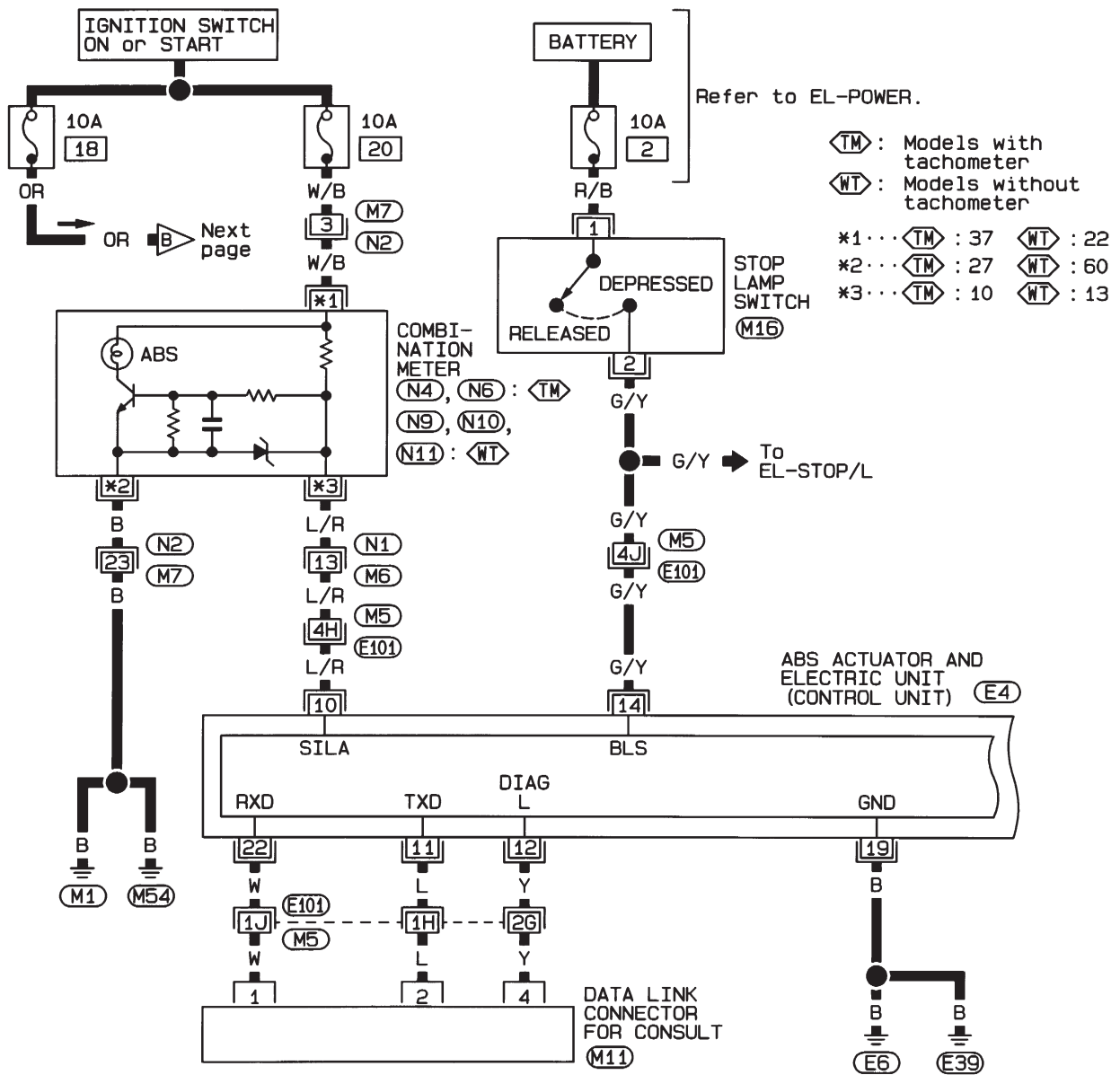

- ◁TM : Models with tachometer
- ◁WT : Models without tachometer
- *1... ◁TM : 37 ◁WT : 22
- *2... ◁TM : 27 ◁WT : 60
- *3... ◁TM : 10 ◁WT : 13

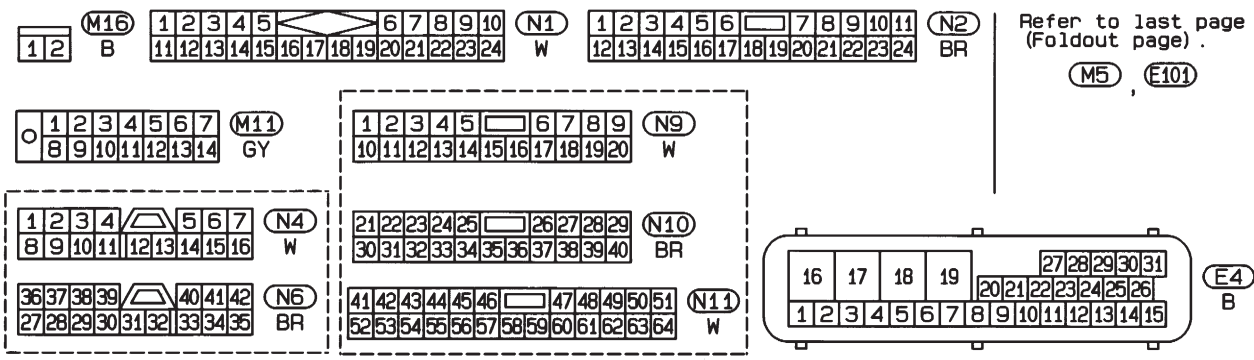

TROUBLE DIAGNOSES

Wiring Diagram — ABS —/2WD RHD Models (Cont'd)

BR-ABS-05

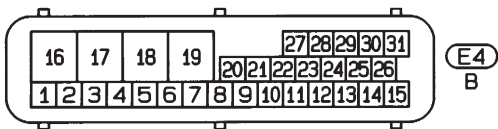
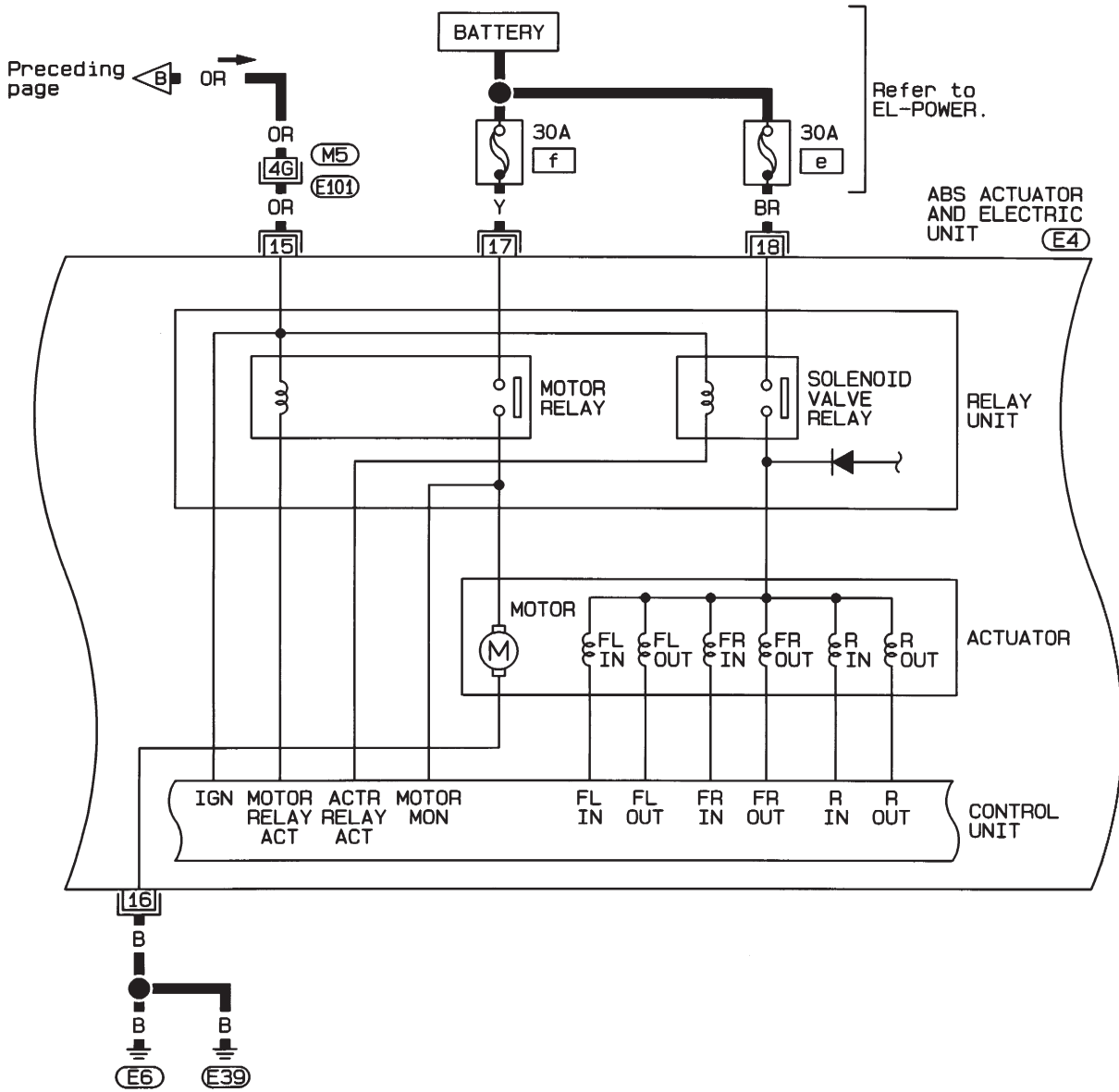

Refer to last page
(Foldout page).

(M5), (E101)

TROUBLE DIAGNOSES

Wiring Diagram — ABS —/2WD RHD Models (Cont'd)

BR-ABS-06

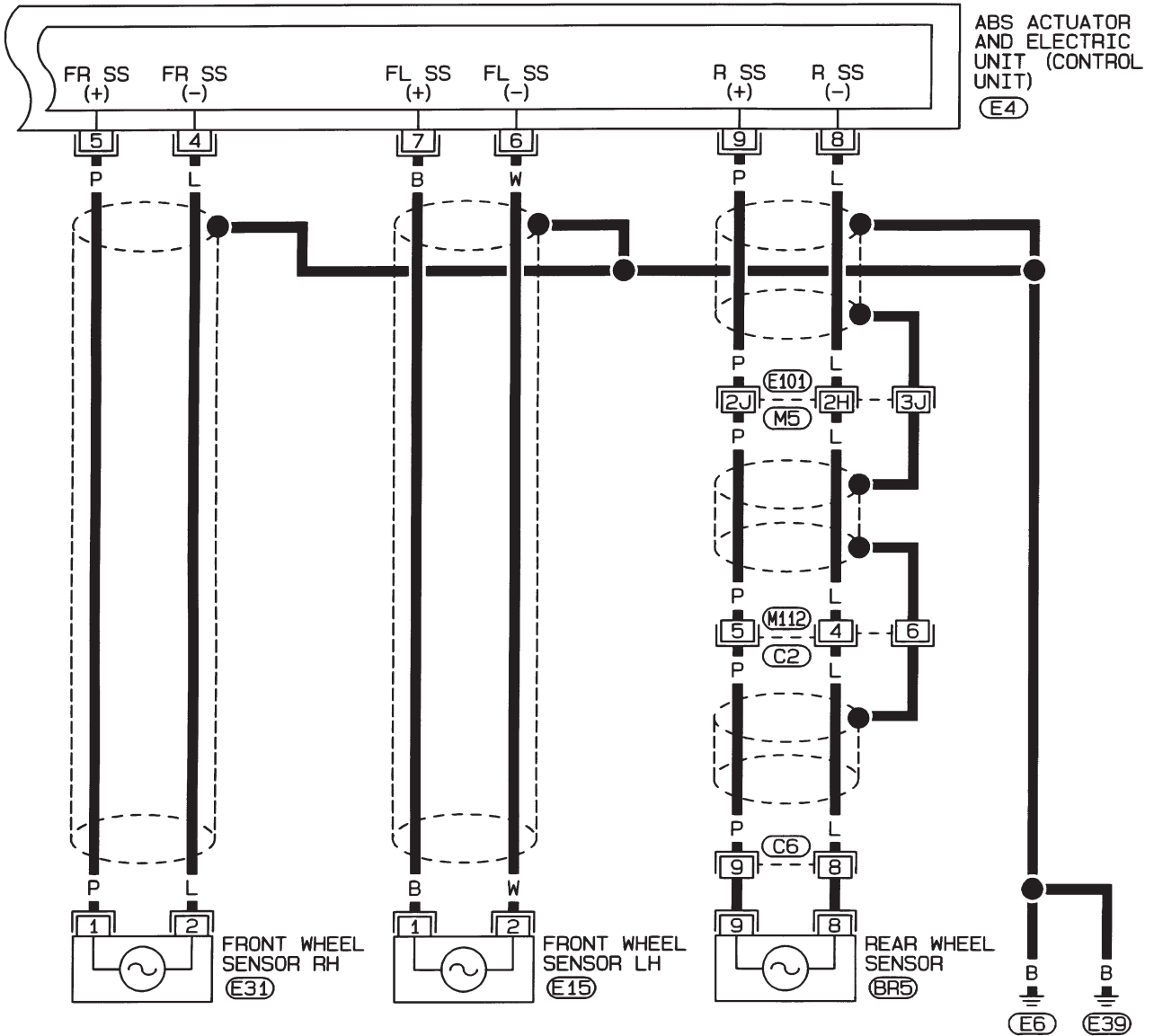

Refer to last page (Foldout page).

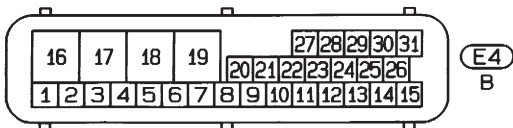

* : This connector is not shown in "HARNES LAYOUT", EL section.

TROUBLE DIAGNOSES

Schematic/4WD Models

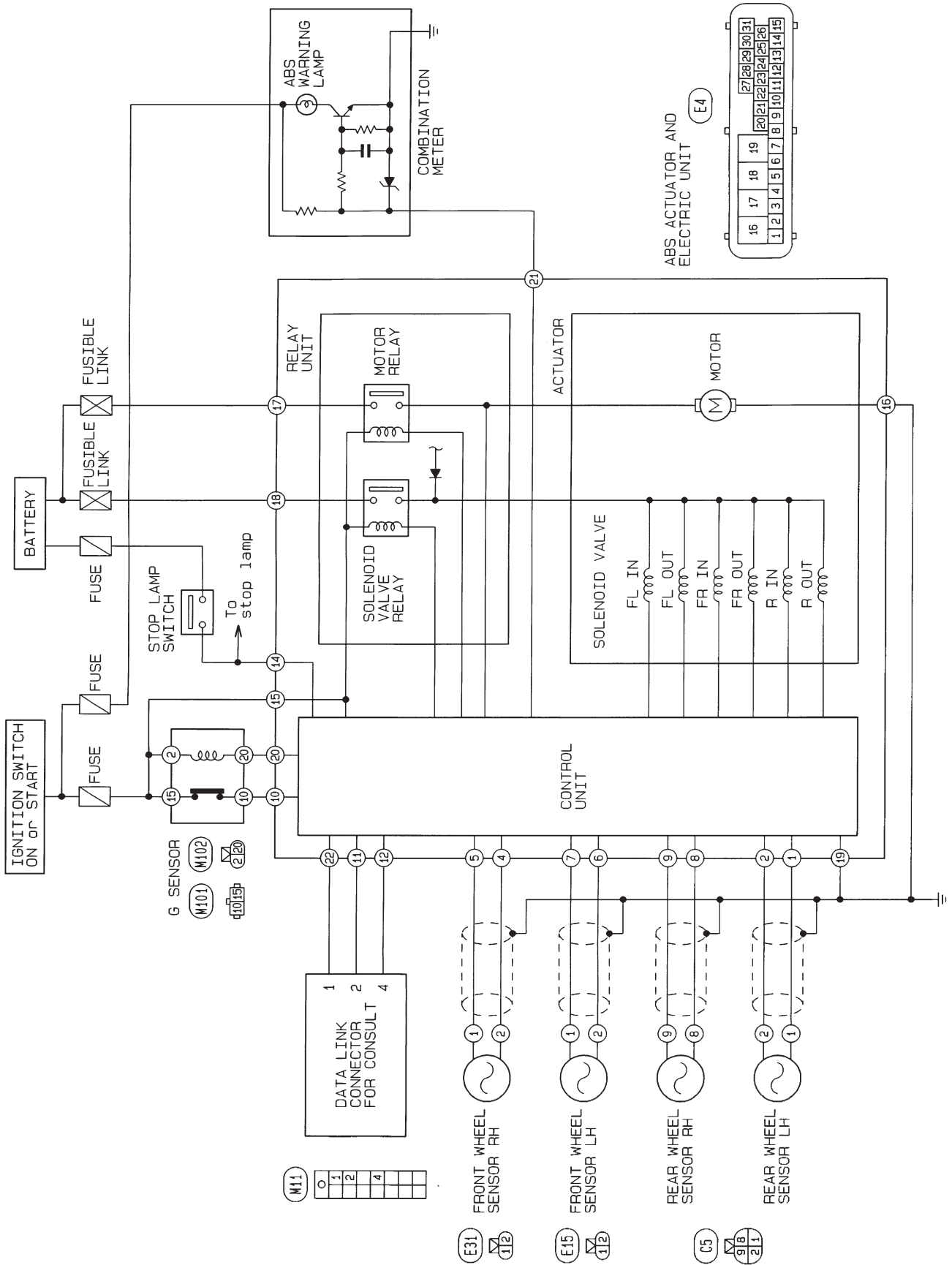

TROUBLE DIAGNOSES

Wiring Diagram — ABS —/4WD LHD Models

BR-ABS-07

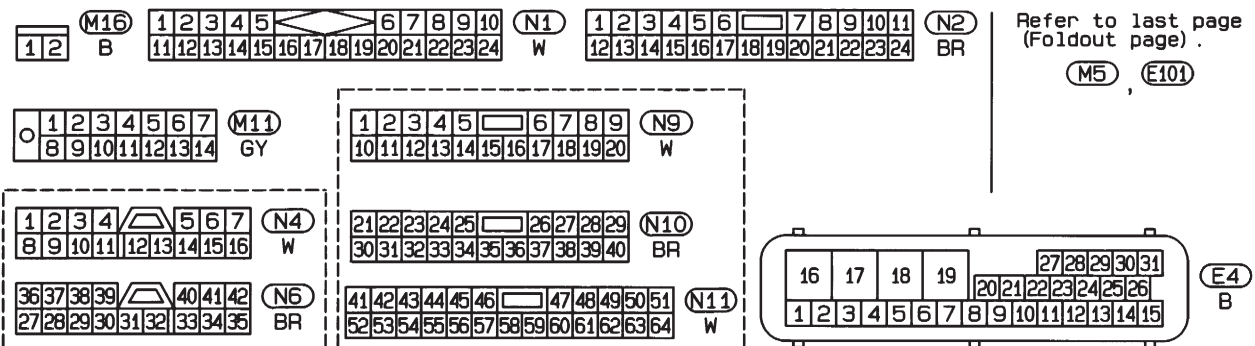
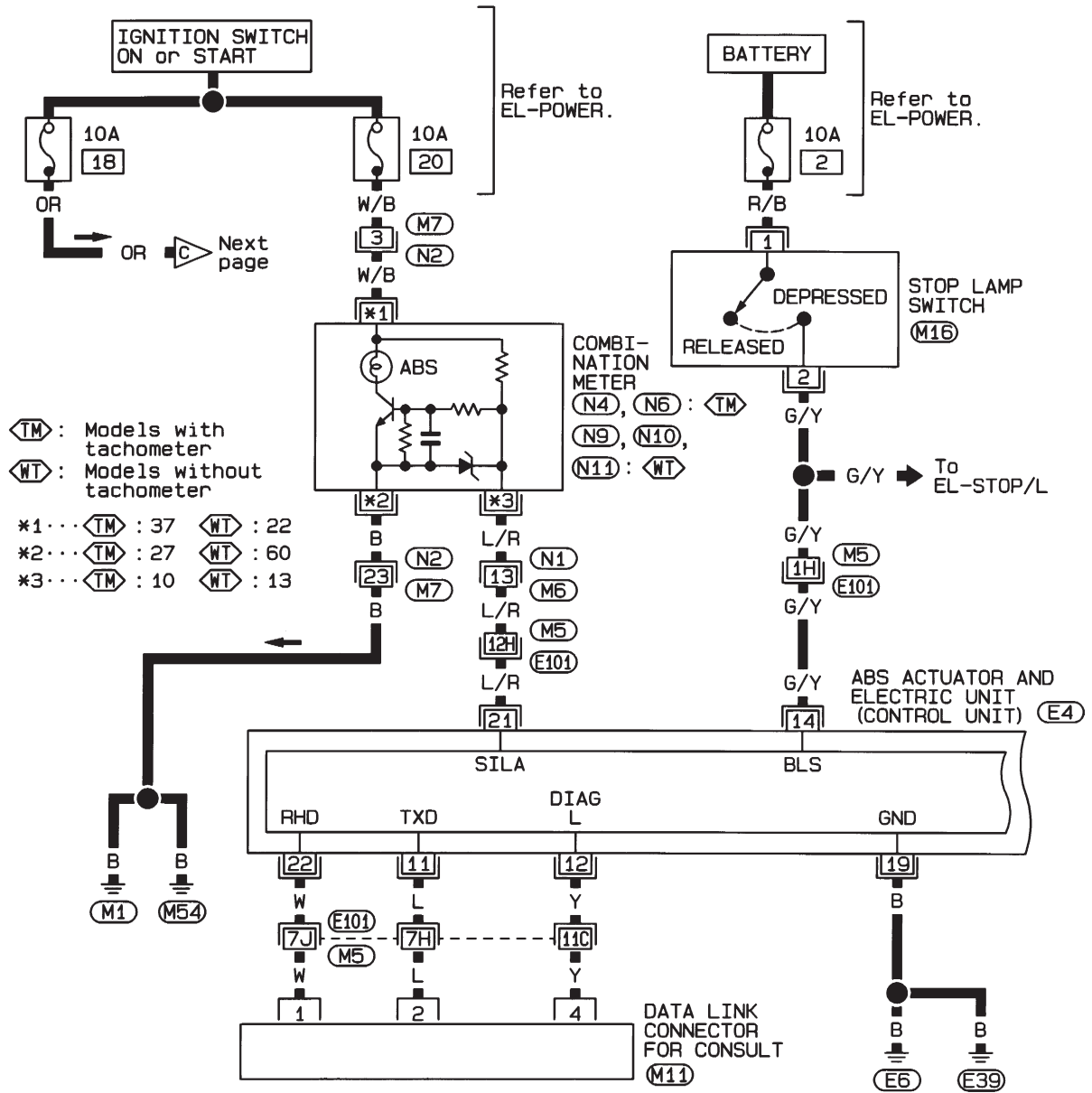

TROUBLE DIAGNOSES

Wiring Diagram — ABS —/4WD LHD Models (Cont'd)

BR-ABS-08

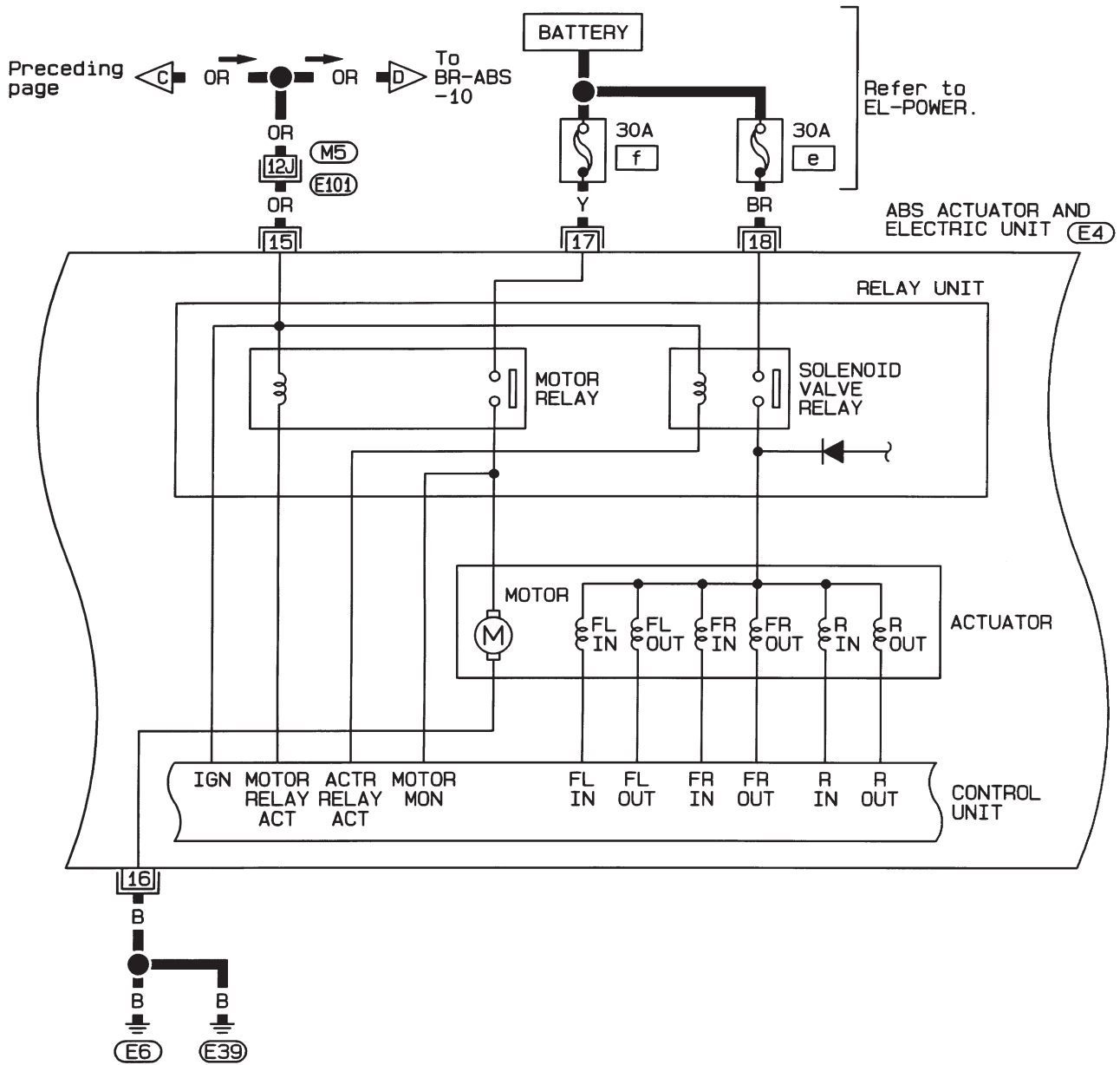

Refer to EL-POWER.

ABS ACTUATOR AND ELECTRIC UNIT (E4)

Refer to last page (Foldout page).

(M5), (E101)

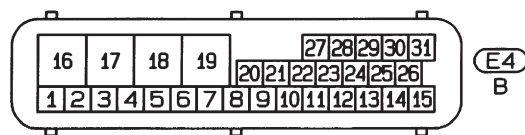

TROUBLE DIAGNOSES

Wiring Diagram — ABS —/4WD LHD Models (Cont'd)

BR-ABS-09

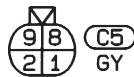
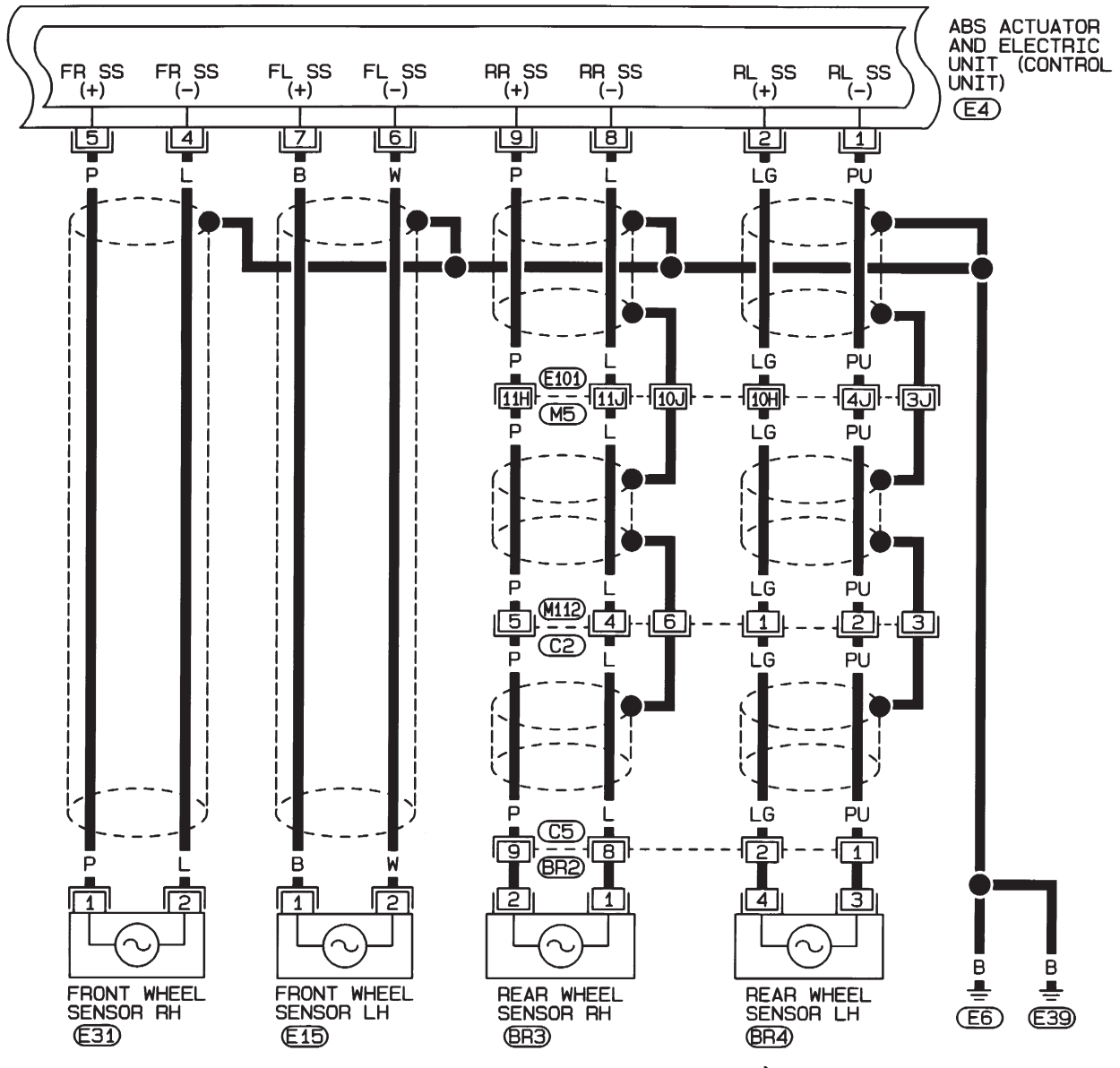

Refer to last page (Foldout page).

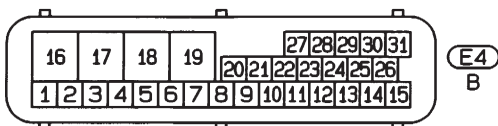

* : This connector is not shown in "HARNES LAYOUT", EL section.

HBR091

TROUBLE DIAGNOSES

Wiring Diagram — ABS —/4WD LHD Models (Cont'd)

BR-ABS-10

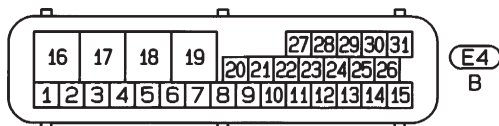
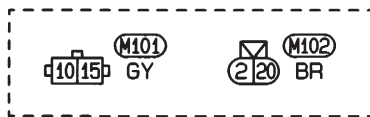
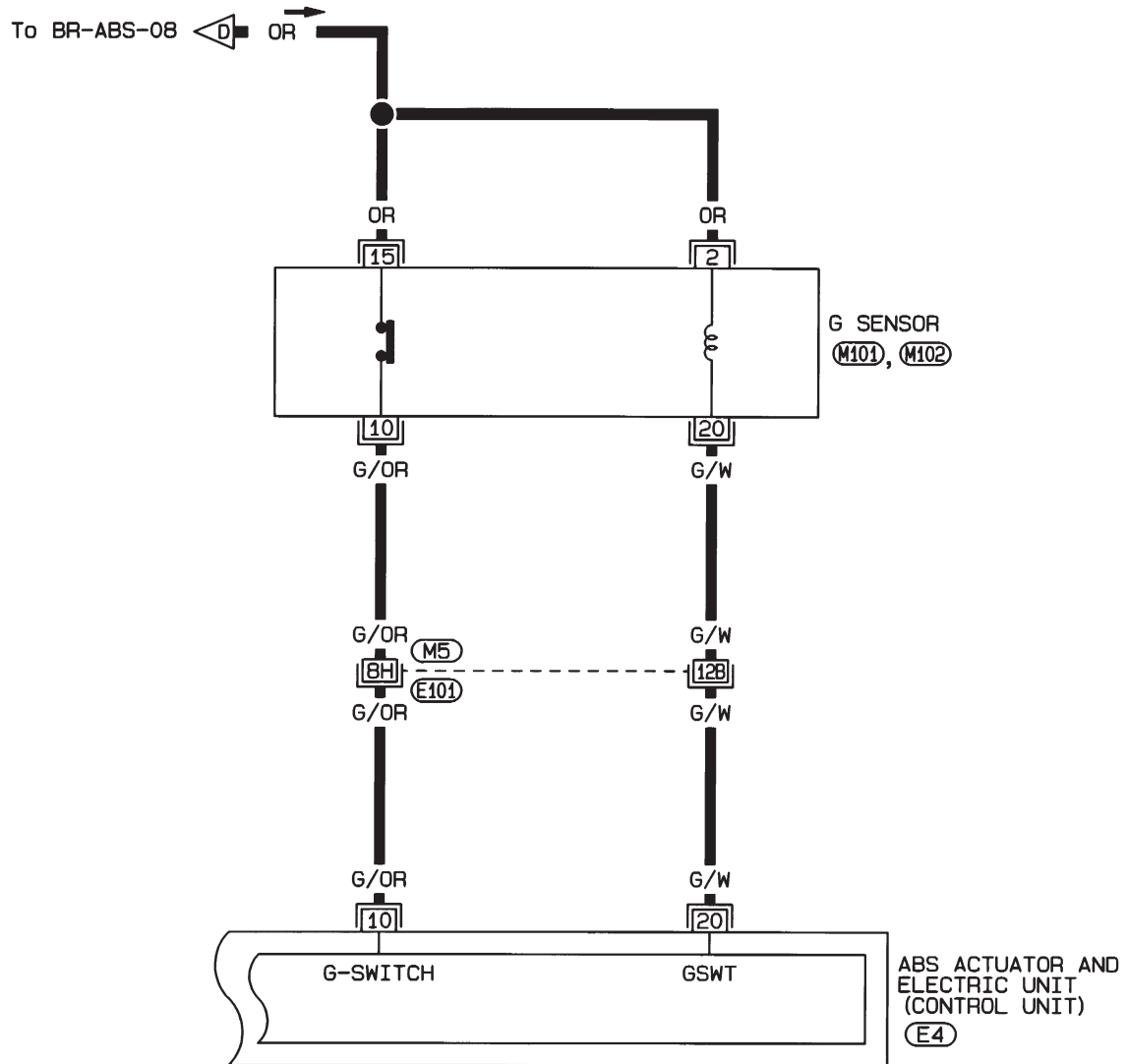

Refer to last page (Foldout page).

(M5), (E101)

TROUBLE DIAGNOSES

Wiring Diagram — ABS —/4WD RHD Models

BR-ABS-11

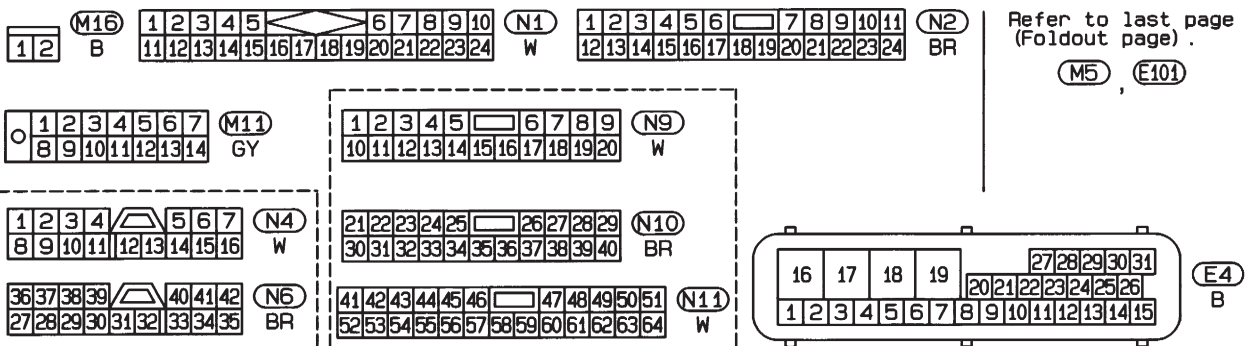
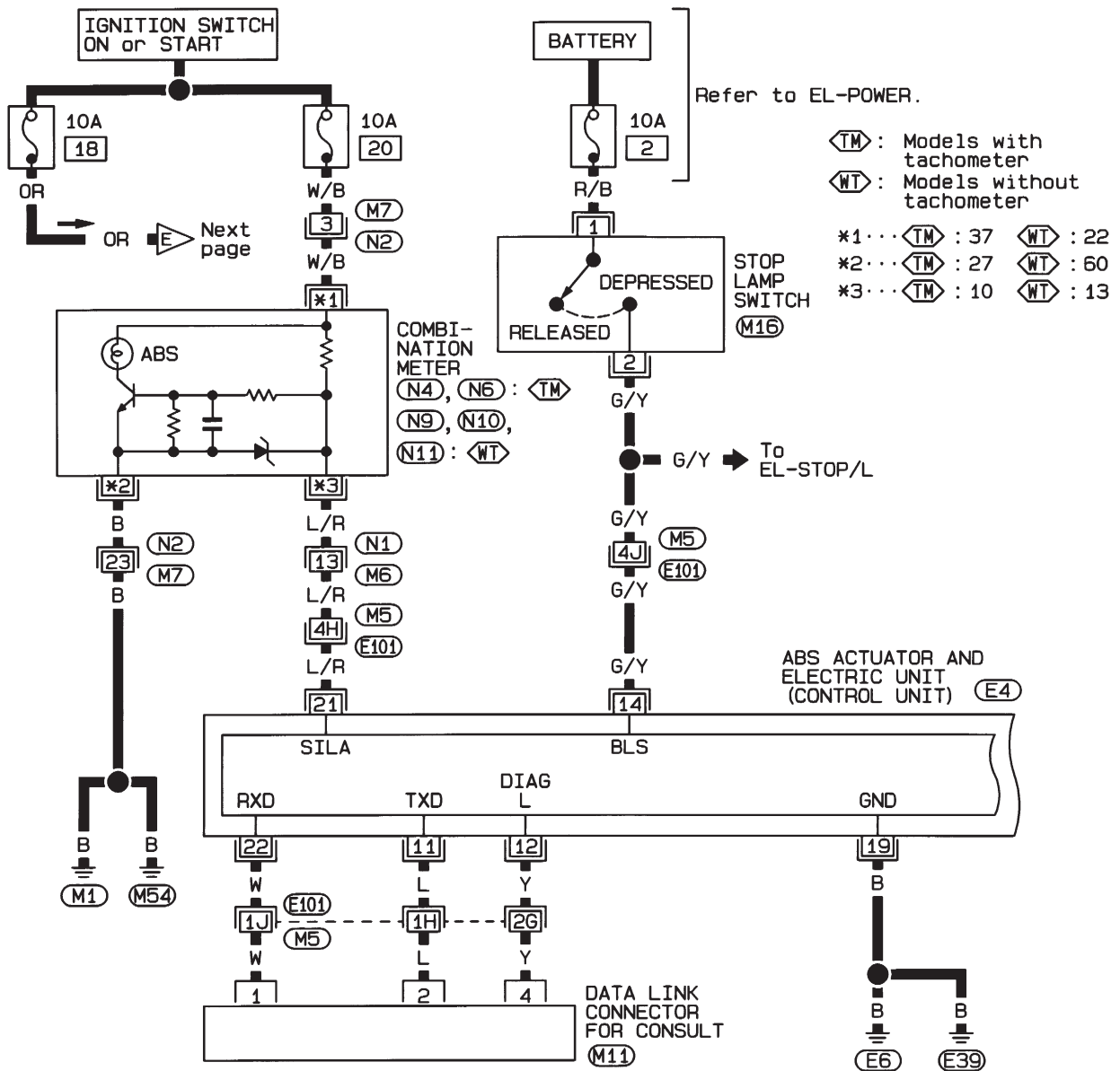

TROUBLE DIAGNOSES

Wiring Diagram — ABS —/4WD RHD Models (Cont'd)

BR-ABS-12

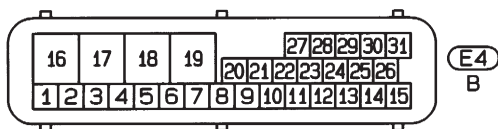
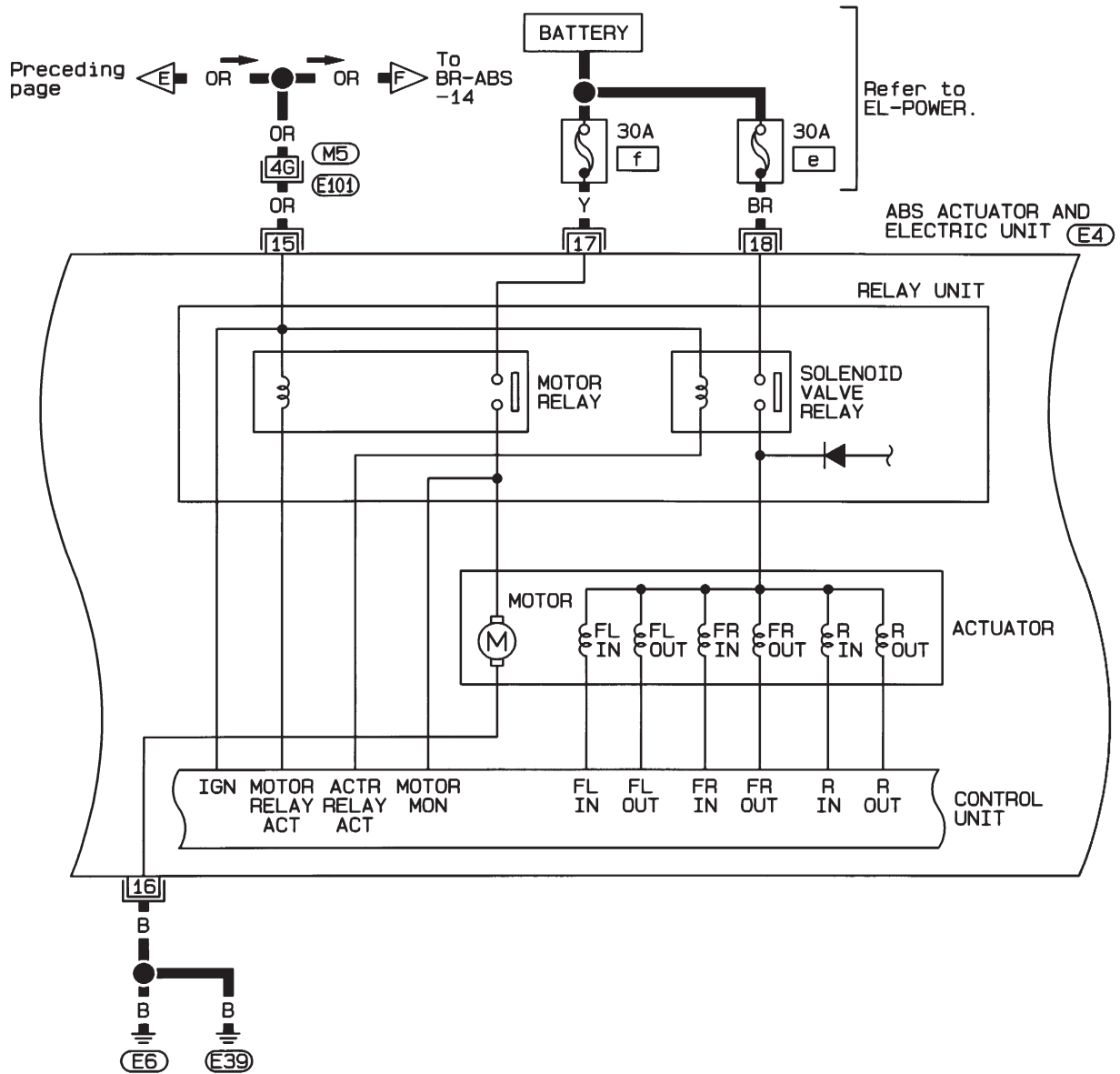

Refer to last page
(Foldout page).

(M5), (E101)

TROUBLE DIAGNOSES

Wiring Diagram — ABS —/4WD RHD Models (Cont'd)

BR-ABS-13

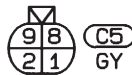
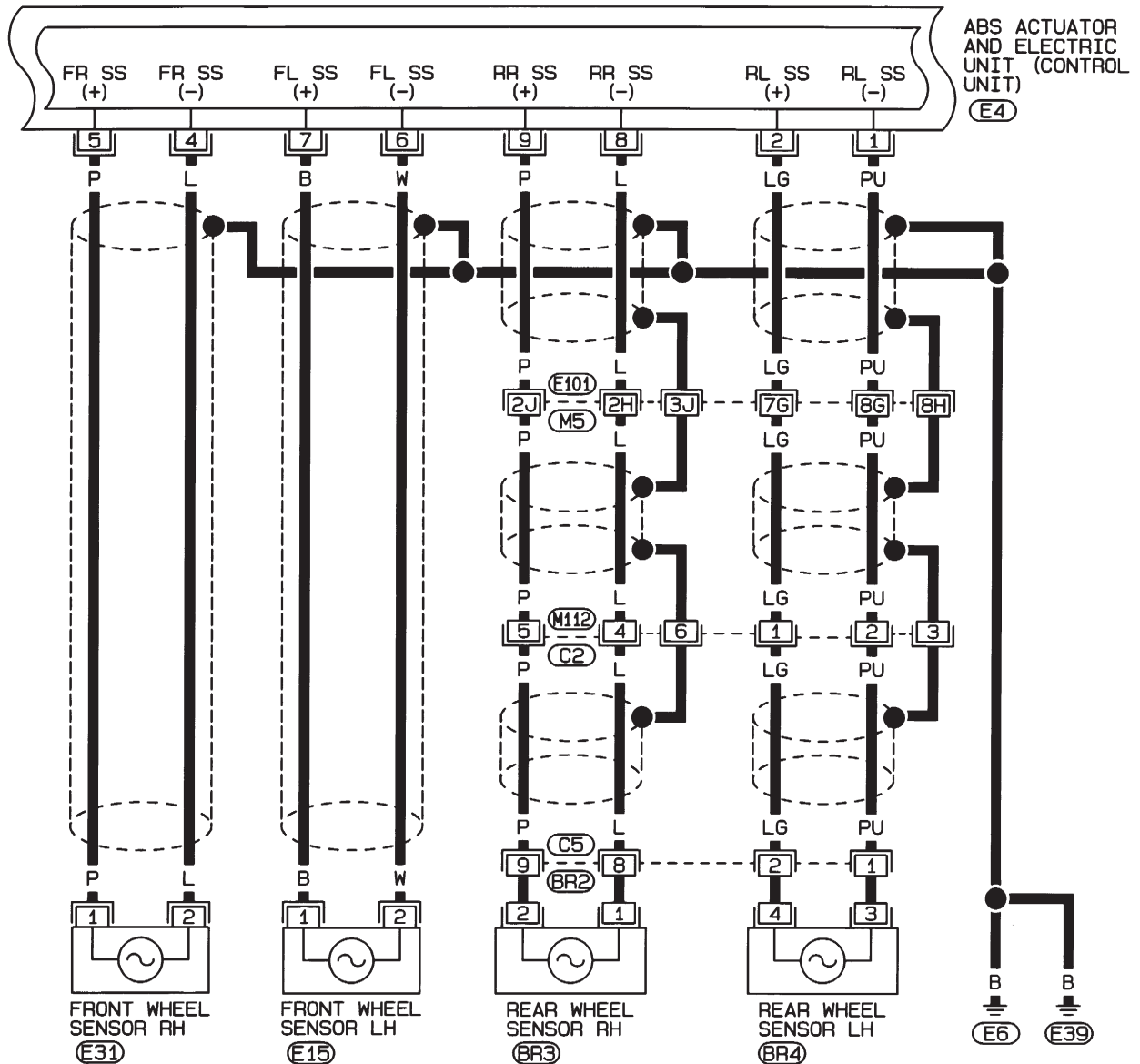

Refer to last page (Foldout page).

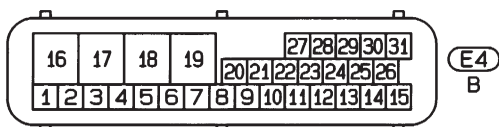

* : This connector is not shown in "HARNES LAYOUT", EL section.

TROUBLE DIAGNOSES

Wiring Diagram — ABS —/4WD RHD Models (Cont'd)

BR-ABS-14

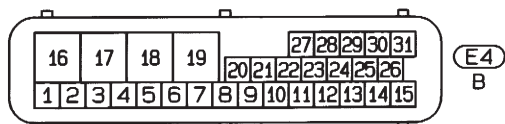
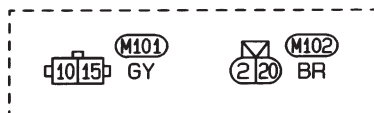
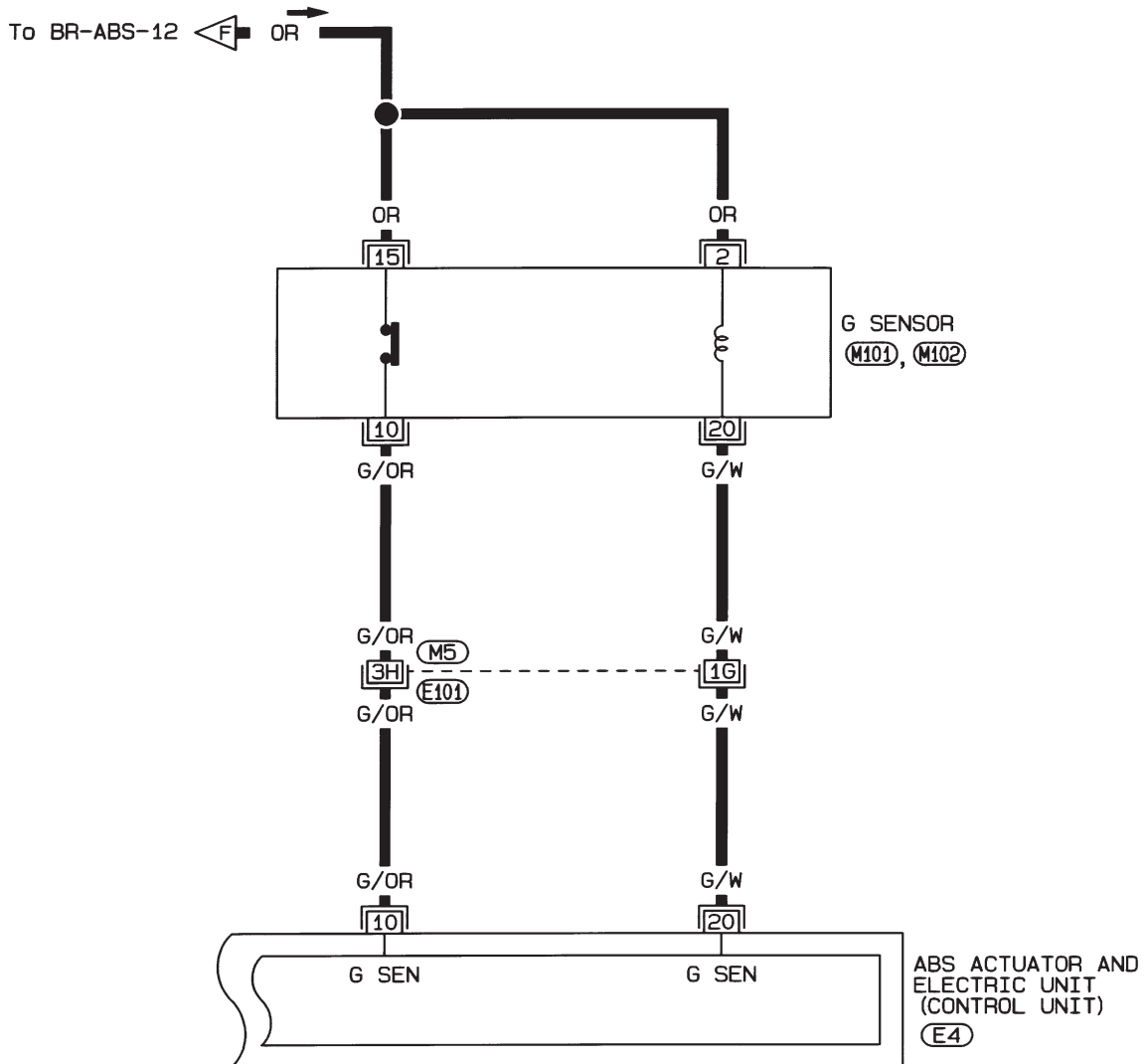

Refer to last page
(Foldout page).

M5, E101

TROUBLE DIAGNOSES FOR SELF-DIAGNOSTIC ITEMS

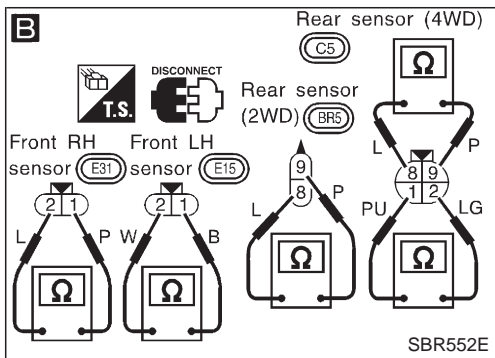
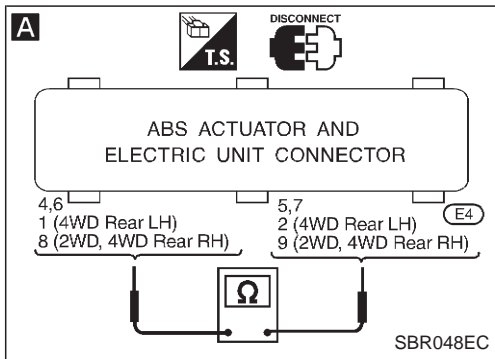
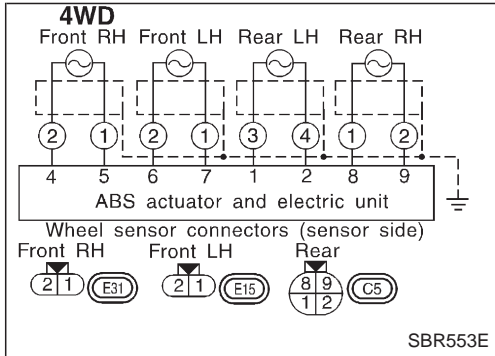
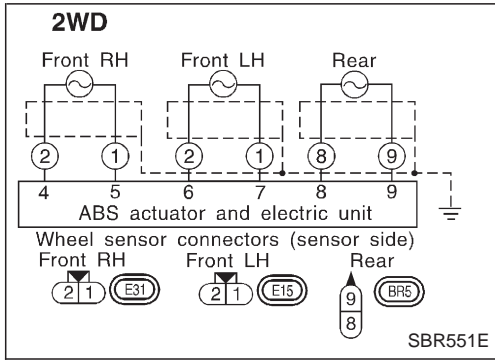

Diagnostic Procedure 1 (Wheel sensor or rotor)

Malfunction code No. 21, 22, 25, 26, 31, 32, 35, 36 or 18

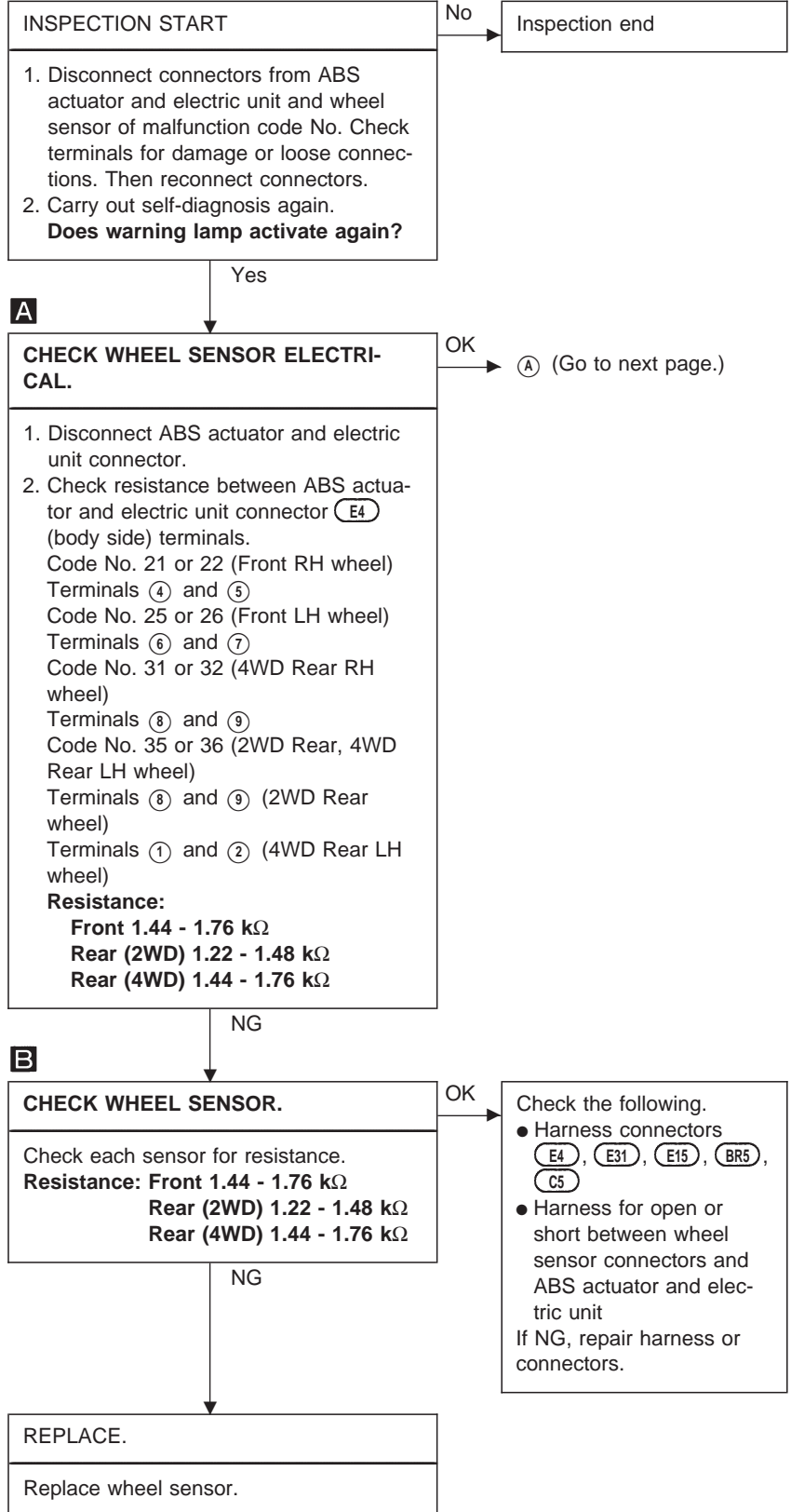

TROUBLE DIAGNOSES FOR SELF-DIAGNOSTIC ITEMS

Diagnostic Procedure 1 (Wheel sensor or rotor) (Cont'd)

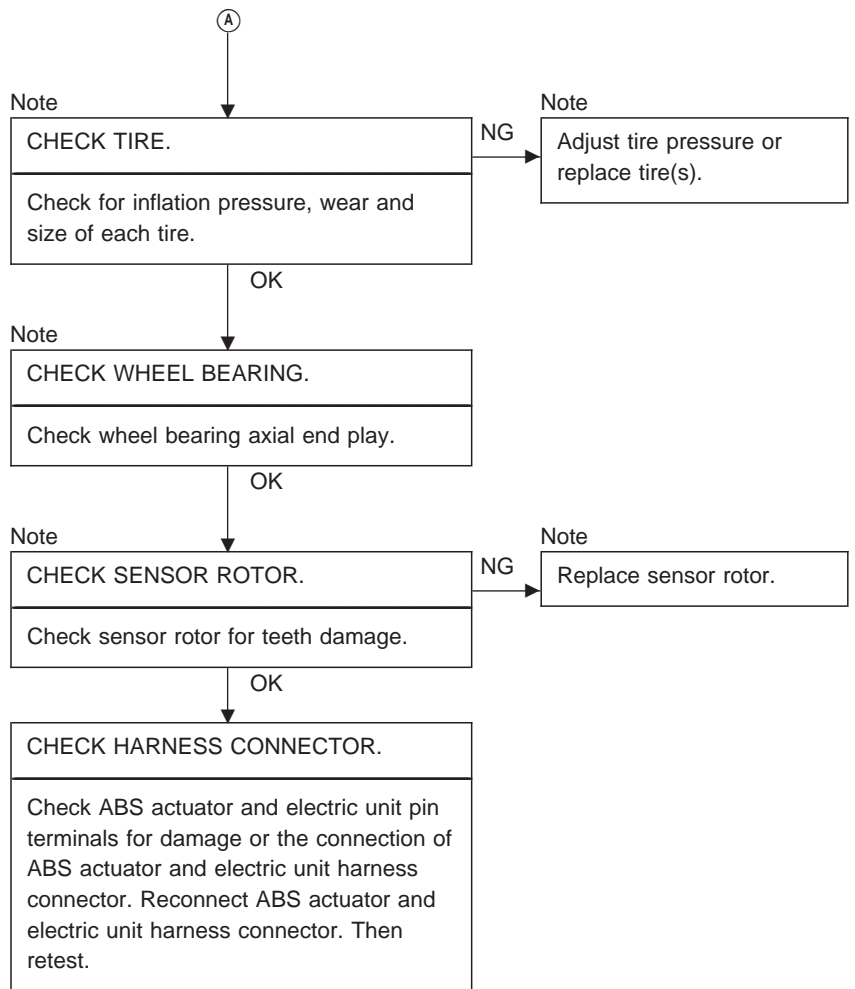

Note: Wheel position should be distinguished by code numbers except code No. 18 (sensor rotor).

TROUBLE DIAGNOSES FOR SELF-DIAGNOSTIC ITEMS

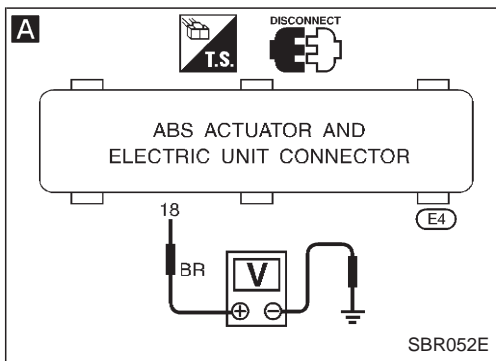
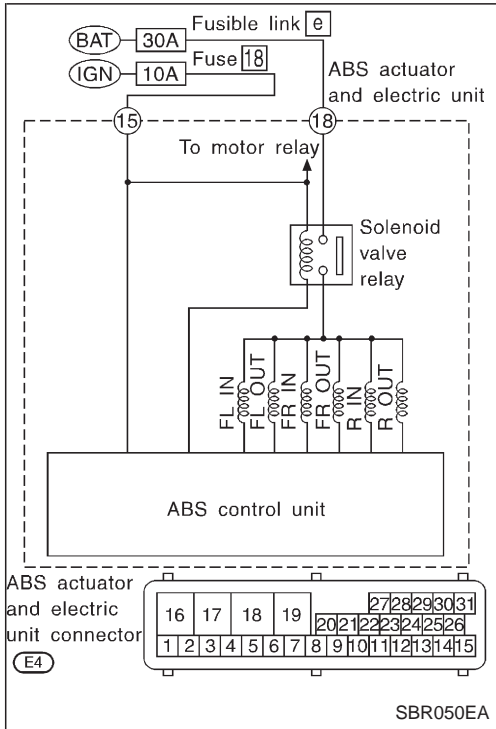

Diagnostic Procedure 2 (ABS actuator solenoid valve and solenoid valve relay) Malfunction code No. 41, 45, 55, 42, 46, 56, 63

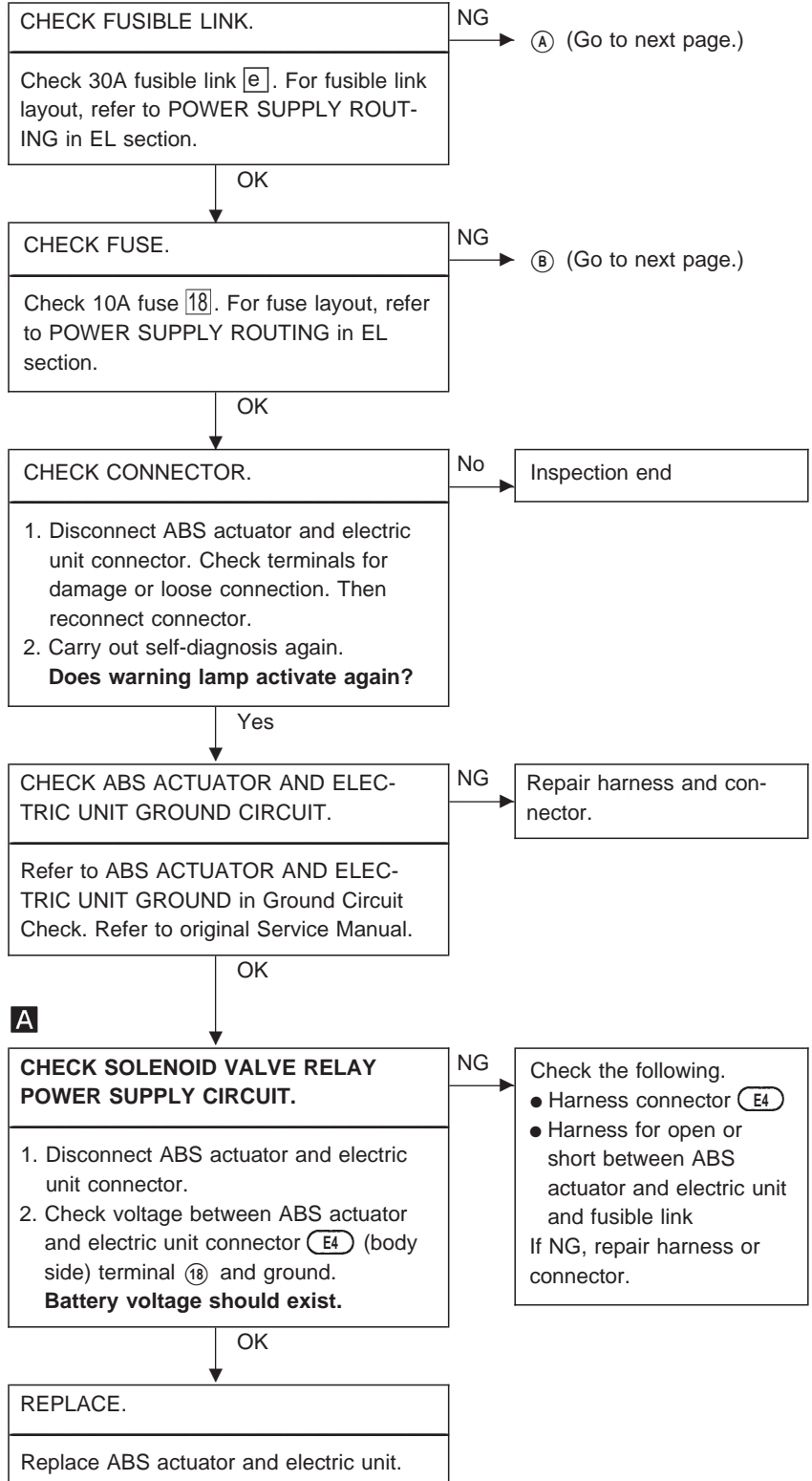

TROUBLE DIAGNOSES FOR SELF-DIAGNOSTIC ITEMS

Diagnostic Procedure 2 (ABS actuator solenoid valve and solenoid valve relay) (Cont'd)

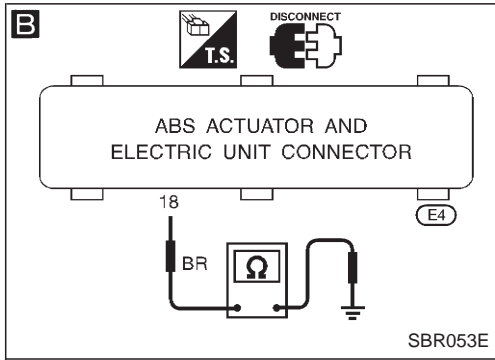

REPLACE.

Replace fusible link.
Does the fusible link blow out when ignition switch is turned "ON"?

No → Inspection end

Yes

CHECK SOLENOID VALVE RELAY POWER SUPPLY CIRCUIT.

1. Disconnect ABS actuator and electric unit connector.
2. Check continuity between ABS actuator and electric unit connector (E4) (body side) terminal 18 and ground.
Continuity should not exit.

NG → Check the following.

- Harness connector (E4)
- Harness for open or short between ABS actuator and electric unit and fusible link

If NG, repair harness or connector.

OK

REPLACE.

Replace ABS actuator and electric unit.

B

REPLACE.

Replace fuse.
Does the fuse blow out when ignition switch is turned "ON"?

Yes → Check the following.

- Harness connector (E4)
- Harness for open or short between ABS actuator and electric unit and fuse

If NG, repair harness or connector.

No

END

INSPECTION END

TROUBLE DIAGNOSES FOR SELF-DIAGNOSTIC ITEMS

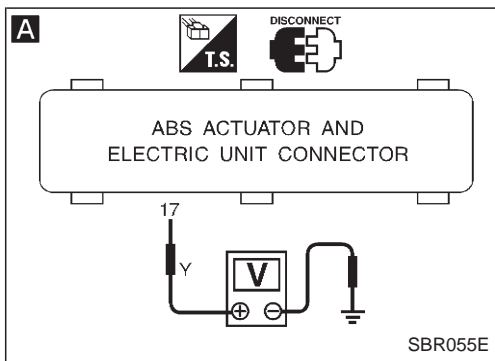
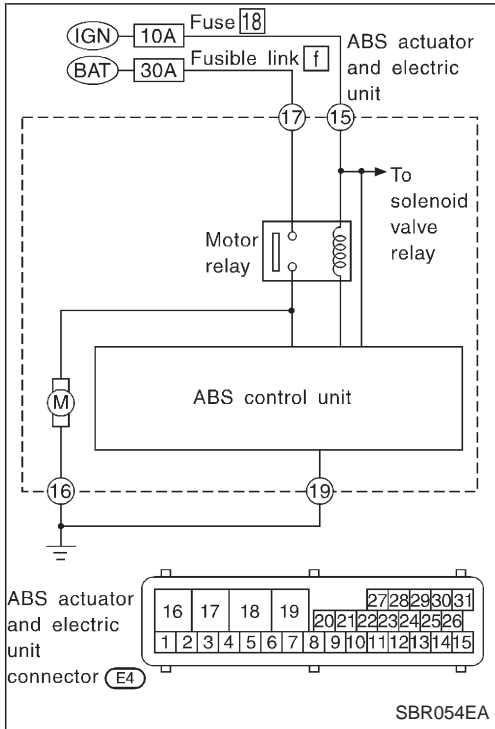

Diagnostic Procedure 3 (Motor relay or motor)

Malfunction code No. 61

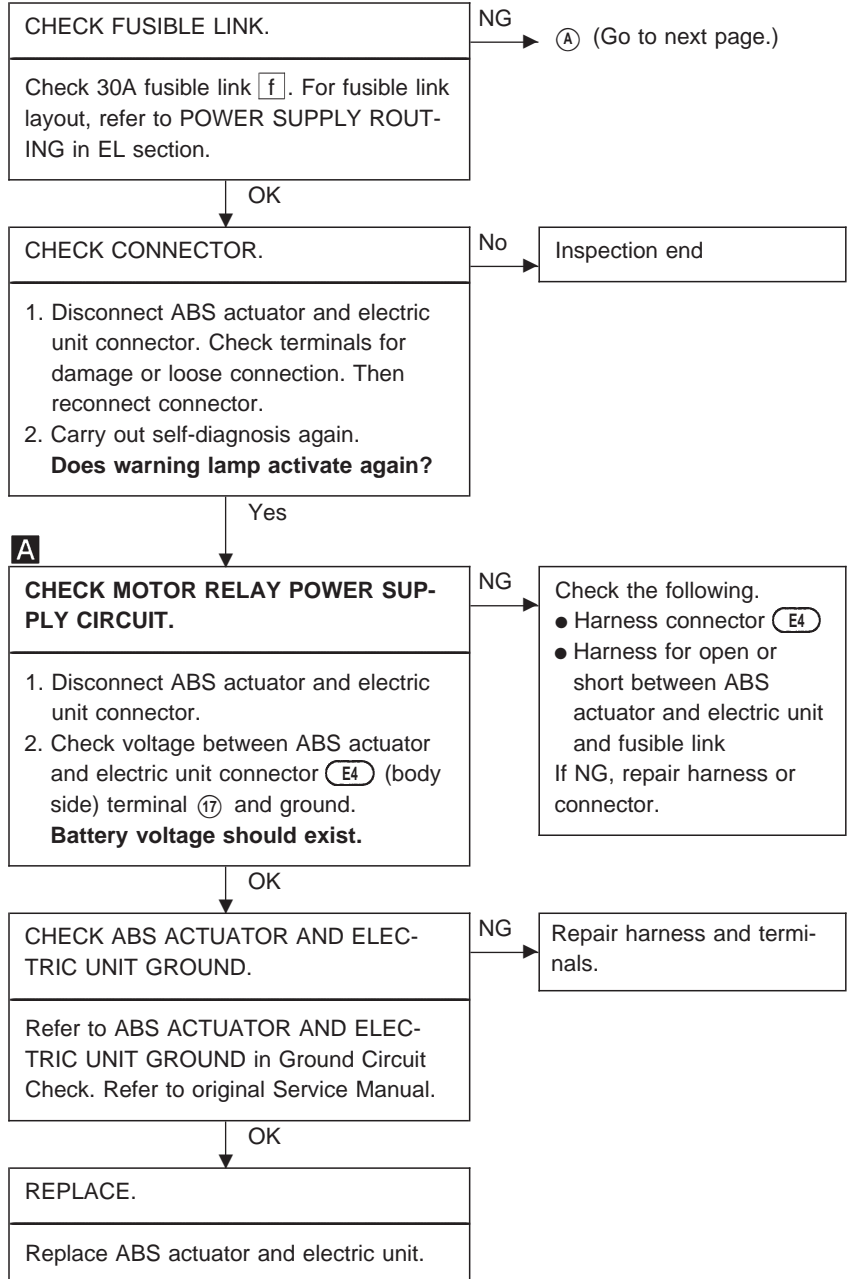

TROUBLE DIAGNOSES FOR SELF-DIAGNOSTIC ITEMS

Diagnostic Procedure 3 (Motor relay or motor) (Cont'd)

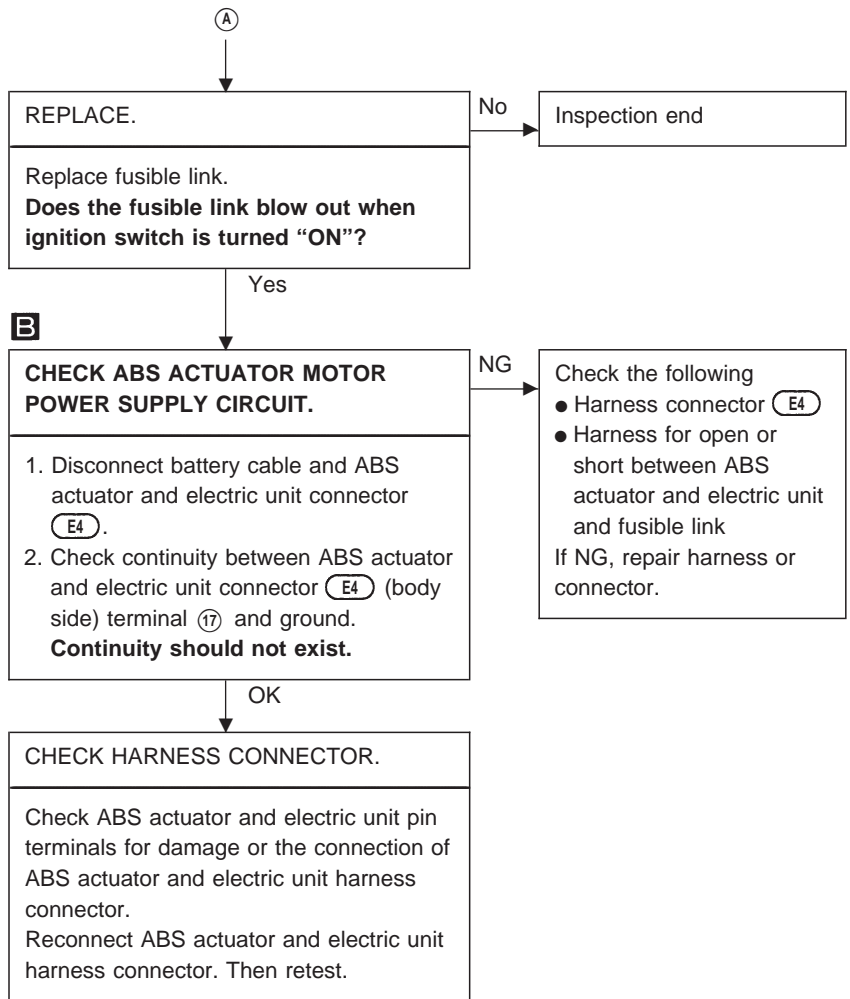
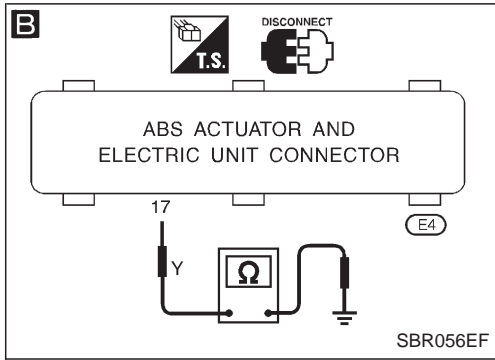

TROUBLE DIAGNOSES FOR SELF-DIAGNOSTIC ITEMS

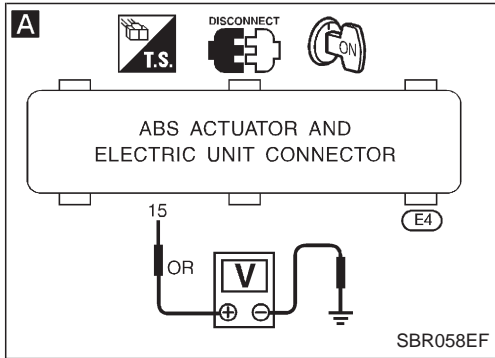
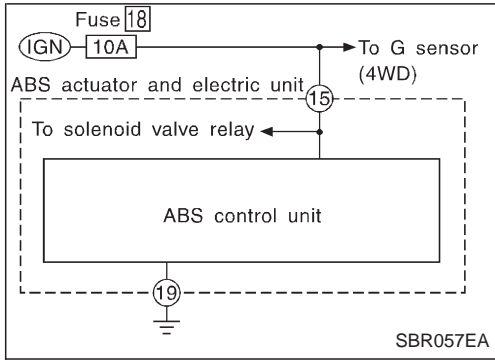

Diagnostic Procedure 4 (Low voltage)

Malfunction code No. 57

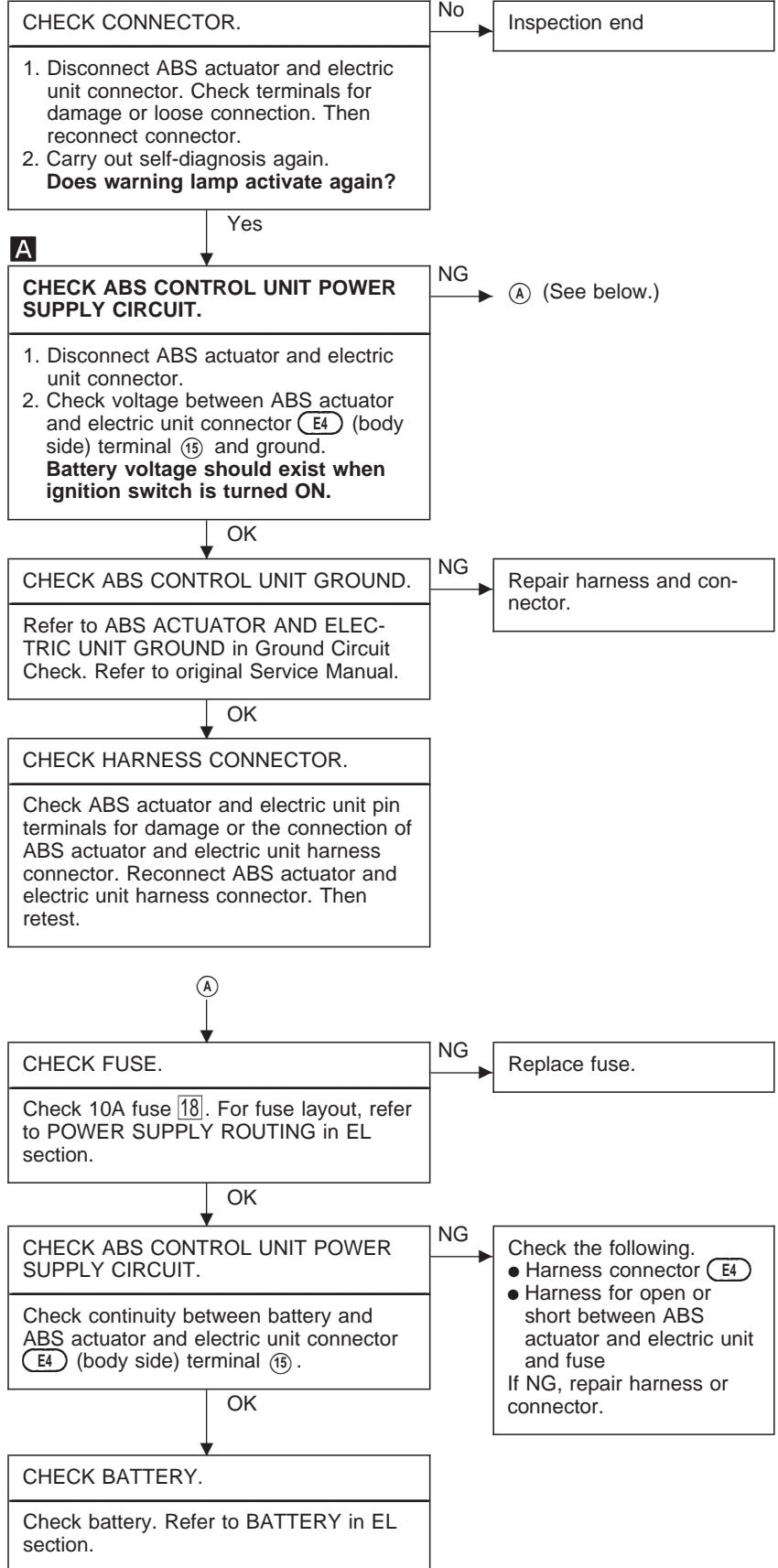

TROUBLE DIAGNOSES FOR SELF-DIAGNOSTIC ITEMS

Diagnostic Procedure 5 (G sensor)

Malfunction code No. 17

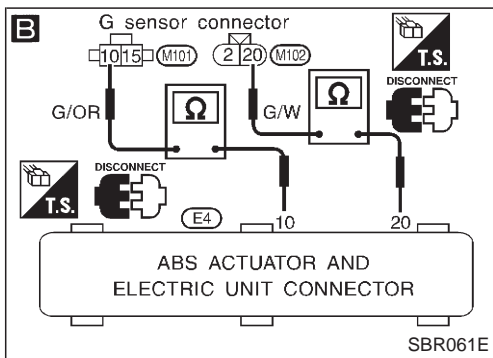
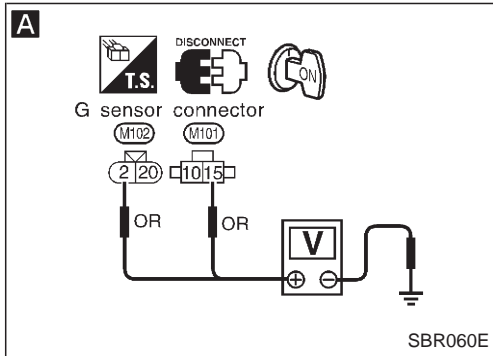
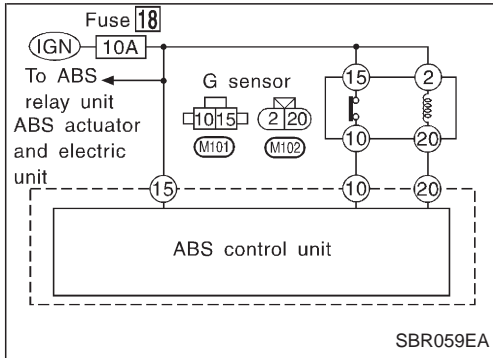

CHECK G SENSOR POWER SUPPLY CIRCUIT.

NG → Replace fuse.

Check 10A fuse 18. For fuse layout, refer to POWER SUPPLY ROUTING in EL section.

OK

CHECK CONNECTOR.

No → Inspection end

1. Disconnect ABS actuator and electric unit connector. Check terminals for damage or loose connection. Then reconnect connector.

2. Carry out self-diagnosis again.

Does warning lamp activate again?

Yes

CHECK G SENSOR.

NG → Replace G sensor.

Refer to G SENSOR in Electrical Components Inspection, BR-2027.

OK

A

CHECK G SENSOR POWER SUPPLY CIRCUIT.

NG → Check the following.

- Harness connectors (M101), (M102), (E4)
- Harness for open or short between G sensor and ABS actuator and electric unit

If NG, repair harness or connectors.

1. Disconnect G sensor connector.

2. Check voltage between G sensor connector (M101), (M102) (body side) terminal 2, 15 and ground.

Battery voltage should exist.

OK

B

CHECK G SENSOR GROUND.

NG → Check the following.

- Harness connectors (M101), (M102), (E4)
- Harness for open or short between G sensor and ABS actuator and electric unit

If NG, repair harness or connectors.

1. Disconnect ABS actuator and electric unit connector and G sensor connectors.

2. Check continuity between ABS actuator and electric unit connector (E4) (body side) terminals 10, 20 and G sensor connectors (M101), (M102) (body side) terminals 10, 20.

Continuity should exist.

OK

CHECK HARNESS CONNECTOR.

Check ABS actuator and electric unit pin terminals for damage or the connection of ABS actuator and electric unit harness connector. Reconnect ABS actuator and electric unit harness connector. Then retest.

TROUBLE DIAGNOSES FOR SELF-DIAGNOSTIC ITEMS

Diagnostic Procedure 5 (G sensor) (Cont'd) ELECTRICAL COMPONENTS INSPECTION

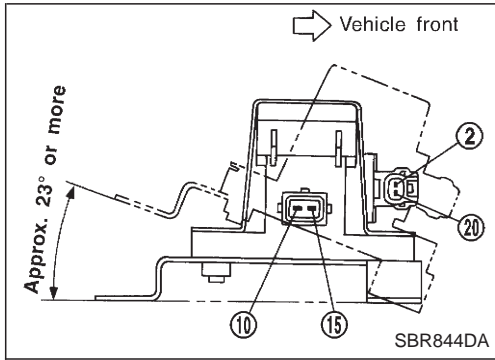

G sensor

CAUTION:

The G sensor is easily damaged if it sustains an impact. Be careful not to drop or bump it.

1. Measure resistance between terminals ⑩ and ⑮ of G sensor unit connector.

G sensor condition	Resistance between terminals ⑩ and ⑮	G sensor switch condition
Installed in vehicle	1.4 - 1.6 kΩ	"ON"
Tilted as shown in figure	4.7 - 5.5 kΩ	"OFF"

2. Measure resistance between terminals ② and ⑳ of the G sensor unit connector.

Resistance:	70 - 124 Ω
-------------	------------

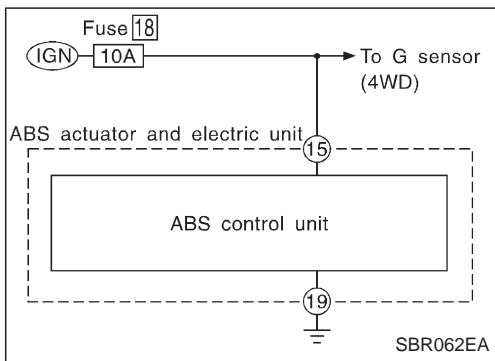

Diagnostic Procedure 6 (Control unit)

Malfunction code No. 71

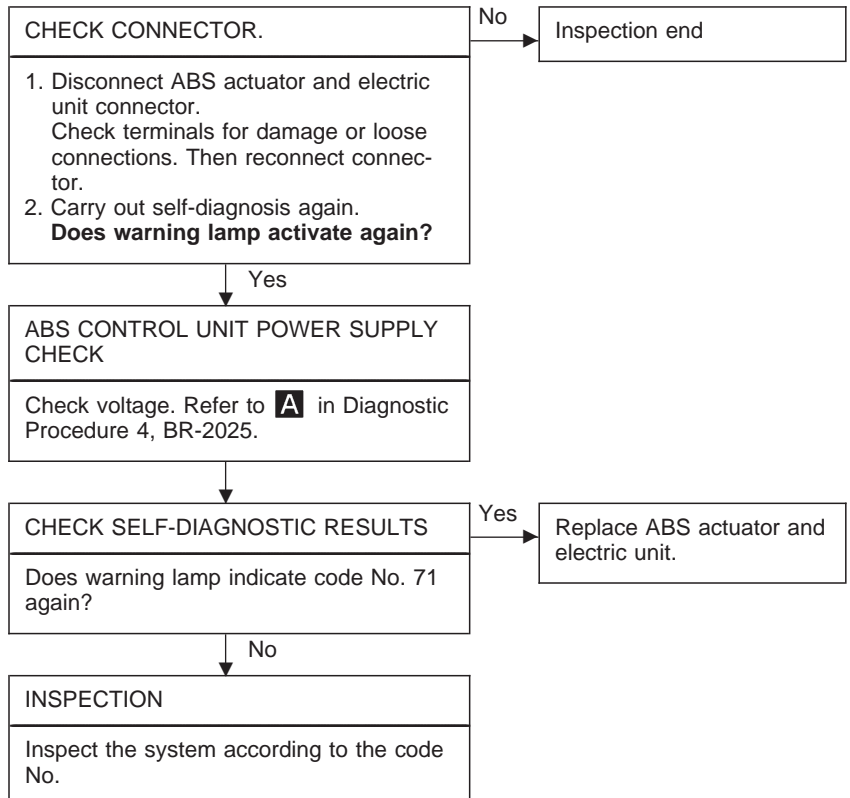

TROUBLE DIAGNOSES FOR SYMPTOMS

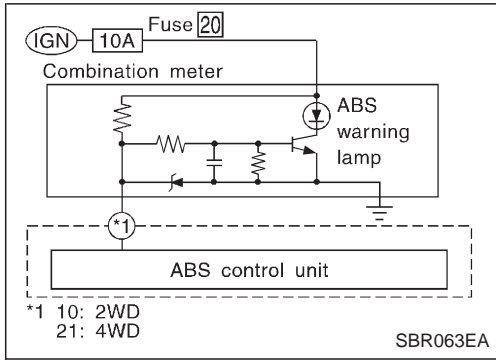

Diagnostic Procedure 12 (Warning lamp does not come on when ignition switch is turned ON.)

CHECK FUSE.

Check 10A fuse **20**. For fuse layout, refer to POWER SUPPLY ROUTING in EL section.

NG → Replace fuse.

OK ↓

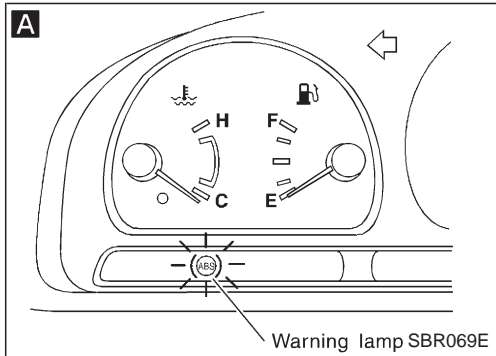

A

CHECK WARNING LAMP ACTIVATE.

Disconnect ABS actuator and electric unit connector.
Does the warning lamp activate?

Yes → **A** (Go to next page.)

No ↓

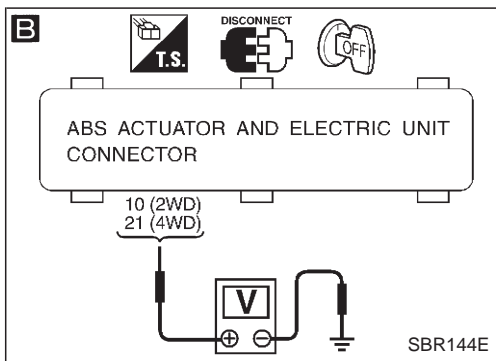

B

CHECK HARNESS FOR SHORT.

1. Disconnect ABS actuator and electric unit connector.
2. Check voltage between ABS actuator and electric unit connector **E4** (body side) terminal **10** (2WD) or **21** (4WD) and ground.
Battery voltage should not exist.

NG → Repair harness or connector.

OK ↓

CHECK COMBINATION METER.

Check combination meter. Refer to WARNING LAMPS in EL section.

TROUBLE DIAGNOSES FOR SYMPTOMS

Diagnostic Procedure 12 (Warning lamp does not come on when ignition switch is turned ON.) (Cont'd)

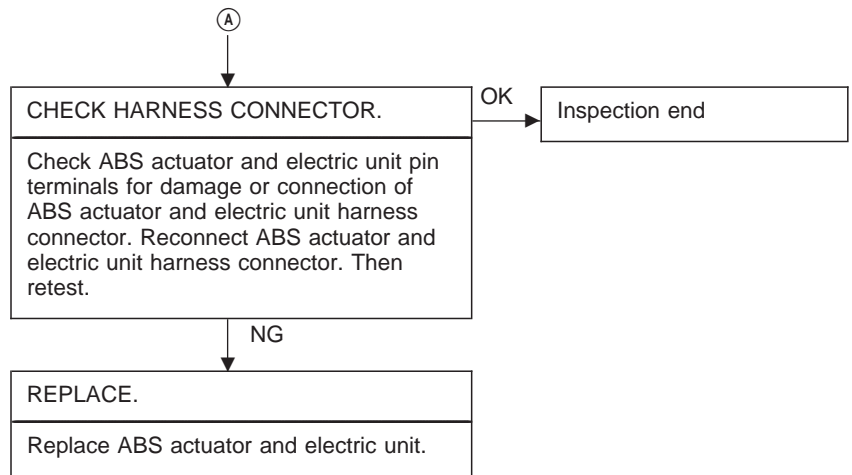

TROUBLE DIAGNOSES FOR SYMPTOMS

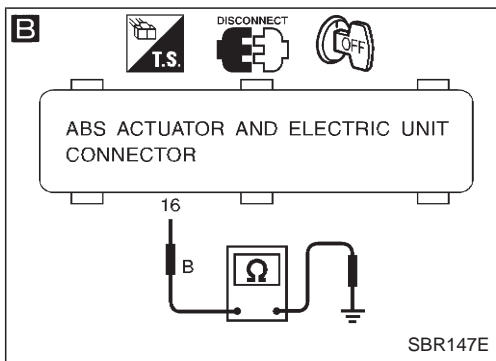
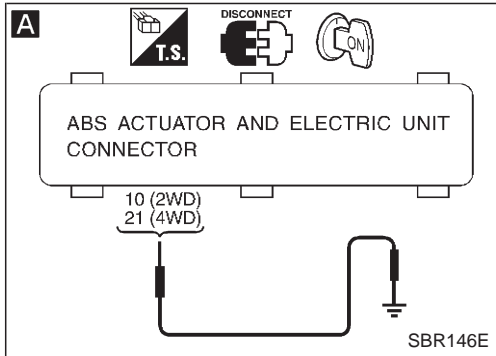
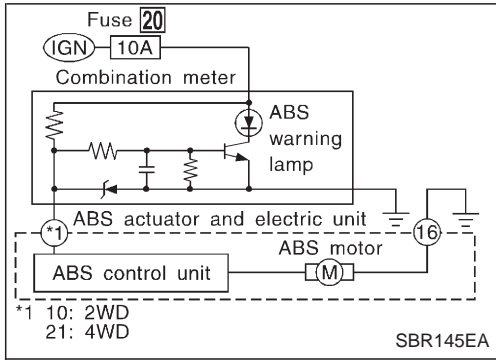

Diagnostic Procedure 13 (Warning lamp stays on when ignition switch is turned ON.)

A

CHECK WARNING LAMP.

1. Disconnect ABS actuator and electric unit connector.
2. Connect suitable wire between ABS actuator and electric unit connector (E4) (body side) terminal ⑩ (2WD) or ⑳ (4WD) and ground.

Warning lamp should not activate.

NG

Repair combination meter. Check the following.

- Harness connector (E4)
 - Harness for open or short between ABS actuator and electric unit and fuse
- If NG, repair harness or connector.

OK

CHECK HARNESS CONNECTOR.

OK

Inspection end

Check ABS actuator and electric unit pin terminals for damage or the connection of ABS actuator and electric unit harness connector. Reconnect ABS actuator and electric unit harness connector. Then retest.

NG

B

CHECK ABS MOTOR GROUND.

1. Turn ignition switch "OFF".
2. Disconnect ABS actuator and electric unit connector.
3. Check continuity between ABS actuator and electric unit connector (E4) (body side) ⑯ and ground.

Continuity should exist.

NG

Check the following.

- Harness connector (E4)
- Harness for open or short between ABS actuator and electric unit and ground

If NG, repair harness or connector.

OK

REPLACE.

Replace ABS actuator and electric unit.

SERVICE DATA AND SPECIFICATIONS (SDS)

General Specifications

2WD MODELS

Destination	Europe	
	With ABS	Without ABS
Applied model		
Front brake	CL28VD disc brake	
Type	CL28VD disc brake	
Cylinder bore diameter mm (in)	42.8 (1.685) x 2	
Pad dimension Length x width x thickness mm (in)	146.6 x 48.5 x 10.0 (5.77 x 1.909 x 0.394)	
Rotor outer diameter x thickness mm (in)	260 x 26 (10.24 x 1.02)	
Rear brake	LT26B drum brake	
Type	LT26B drum brake	
Wheel cylinder bore diameter mm (in)	23.81 (15/16)	
Lining dimension Length x width x thickness mm (in)	249.6 x 50 x 5.5 (9.83 x 1.97 x 0.217)	
Drum inner diameter mm (in)	260 (10.24)	
Master cylinder bore diameter mm (in)	25.4 (1)	23.81 (15/16)
Control valve	LSV	
Type	LSV	
Split point x reducing ratio kPa (bar, kg/cm ² , psi)	(Variable) x 0.15	
Brake booster	M195T	
Model	M195T	
Diaphragm diameter mm (in)	Primary: 205 (8.07) Secondary: 180 (7.09)	
Recommended brake fluid	DOT 4*	

* Never mix DOT 3 and DOT 4 (DOT 3 is filled at factory).

4WD MODELS

Destination	Europe	
	All	
Applied model		
Front brake	CL28VD disc brake	
Type	CL28VD disc brake	
Cylinder bore diameter mm (in)	42.8 (1.685) x 2	
Pad dimension Length x width x thickness mm (in)	146.6 x 48.5 x 10 (5.77 x 1.909 x 0.39)	
Rotor outer diameter x thickness mm (in)	277 x 26 (10.91 x 1.02)	
Rear brake	LT30A drum brake	
Type	LT30A drum brake	
Wheel cylinder bore diameter mm (in)	22.22 (7/8)	
Lining dimension Length x width x thickness mm (in)	296.0 x 50.0 x 6.1 (11.65 x 1.969 x 0.240)	
Drum inner diameter mm (in)	295 (11.61)	
Master cylinder bore diameter mm (in)	23.81 (15/16)	
Control valve	LSV	
Type	LSV	
Split point x reducing ratio kPa (bar, kg/cm ² , psi)	(Variable) x 0.15	
Brake booster	M215T	
Model	M215T	
Diaphragm diameter mm (in)	Primary: 230 (9.06) Secondary: 205 (8.07)	
Recommended brake fluid	DOT 4*	

* Never mix DOT 3 and DOT 4 (DOT 3 is filled at factory).