

SECTION BT

MODIFICATION NOTICE:

- The instrument panel has been changed.
- The body side trim has been changed.
- The headlining has been changed.
- A jump seat has been added.
- An auto reverse function has been added to the driver's door window.

CONTENTS

PRECAUTIONS	2002	INSTRUMENT PANEL	2004
Supplemental Restraint System (SRS) "AIR		INTERIOR TRIM	2007
BAG" and "SEAT BELT PRE-TENSIONER" ..	2002	Side and Floor Trim	2007
DOOR	2003	Roof Trim	2010
Front Door Limit Switch Reset (Driver side		SEAT	2012
only)	2003	Jump Seat - King Cab Model	2012

PRECAUTIONS

Supplemental Restraint System (SRS) “AIR BAG” and “SEAT BELT PRE-TENSIONER”

The Supplemental Restraint System such as “AIR BAG” and “SEAT BELT PRE-TENSIONER” used along with a seat belt, helps to reduce the risk or severity of injury to the driver and front passenger in a frontal collision. The SRS system composition which is available to NISSAN MODEL D22 is as follows (The composition varies according to the destination and optional equipment.):

Driver air bag module (located in the center of the steering wheel), front passenger air bag module (located on the instrument panel on passenger side), seat belt pre-tensioner, a diagnosis sensor unit, warning lamp, wiring harness and spiral cable.

Information necessary to service the system safely is included in the **RS section** of this Service Manual.

WARNING:

- **To avoid rendering the SRS inoperative, which could increase the risk of personal injury or death in the event of a collision which would result in air bag inflation, all maintenance must be performed by an authorized NISSAN dealer.**
- **Improper maintenance, including incorrect removal and installation of the SRS, can lead to personal injury caused by unintentional activation of the system. For removal of Spiral Cable and Air Bag Module, see the RS section.**
- **Do not use electrical test equipment on any circuit related to the SRS unless instructed to in this Service Manual. Spiral Cable and wiring harnesses (except “SEAT BELT PRE-TENSIONER”) covered with yellow insulation either just before the harness connectors or for the complete harness are related to the SRS.**

DOOR

Front Door Limit Switch Reset (Driver side only)

RESET CONDITIONS

After each of the following operations are performed, reset the limit switch (with built-in motor).

- Regulator removal and installation
- Removal of motor from regulator
- Operation of regulator as a single unit
- Door glass removal and installation
- Glass run removal and installation

RESET PROCEDURES

After installing parts, proceed as follows:

1. Close the door window completely.
2. Press the reset switch and open the door window completely.
3. Release the reset switch. After making sure the reset switch has returned to the original position, close the door window completely.
4. The limit switch is now reset.

CAUTION:

Be sure to manually open or close the door window. (Do not use the automatic open-close procedures.)

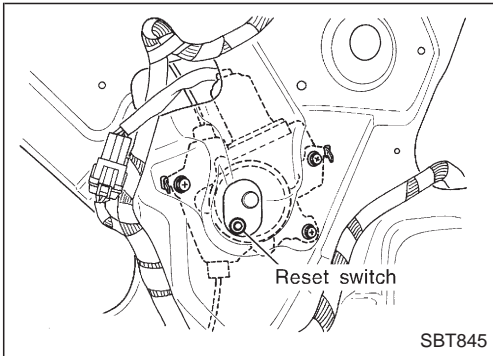

INSTRUMENT PANEL

CAUTION:

- Disconnect both terminals from battery in advance.
- Disconnect air bag module connector in advance.
- Be careful not to scratch finishers and other parts.
- Never tamper with or force air bag lid open, as this may adversely affect air bag performance.

REMOVAL — Instrument panel assembly

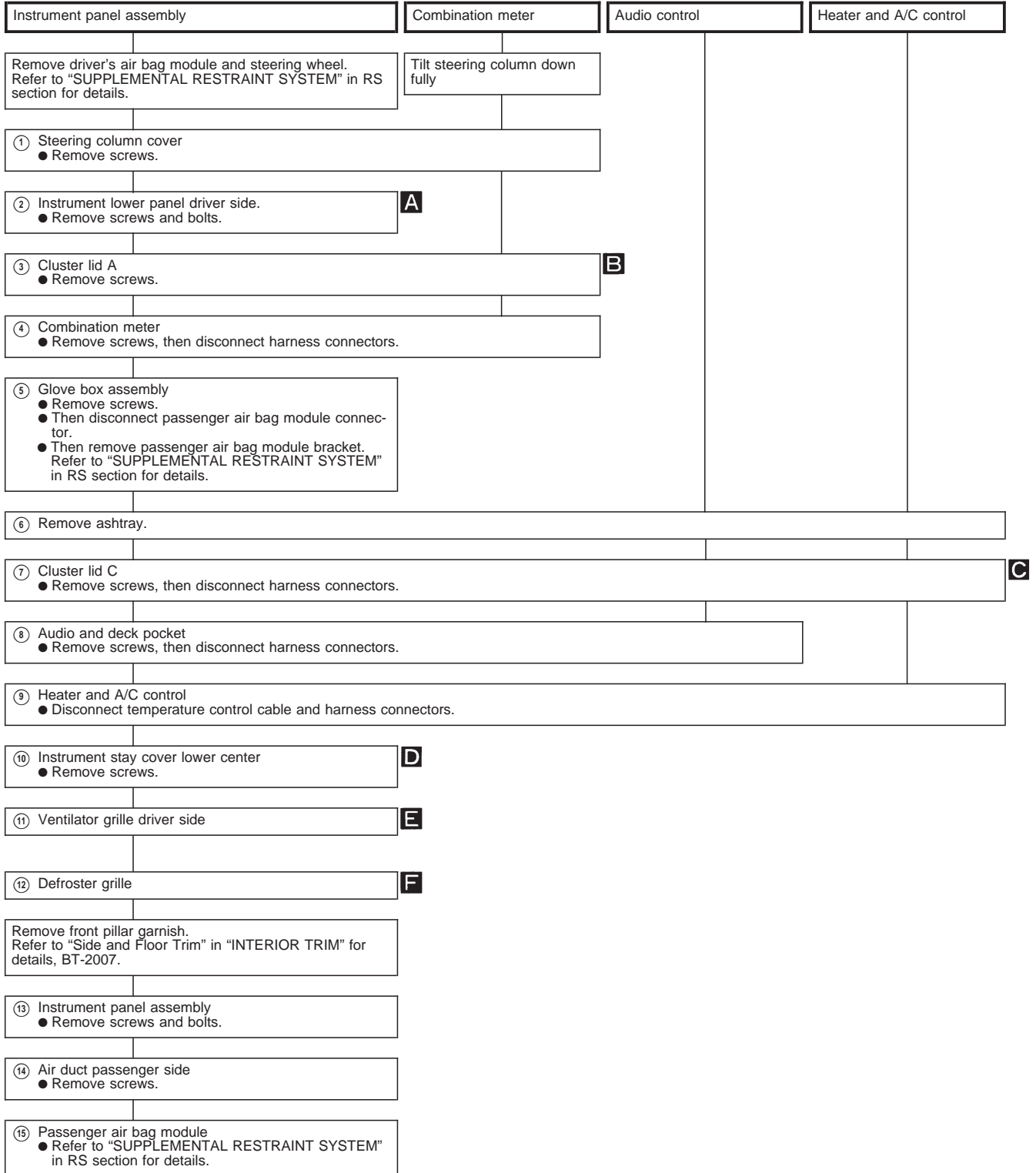

INSTRUMENT PANEL

SEC. 272•280•680•685

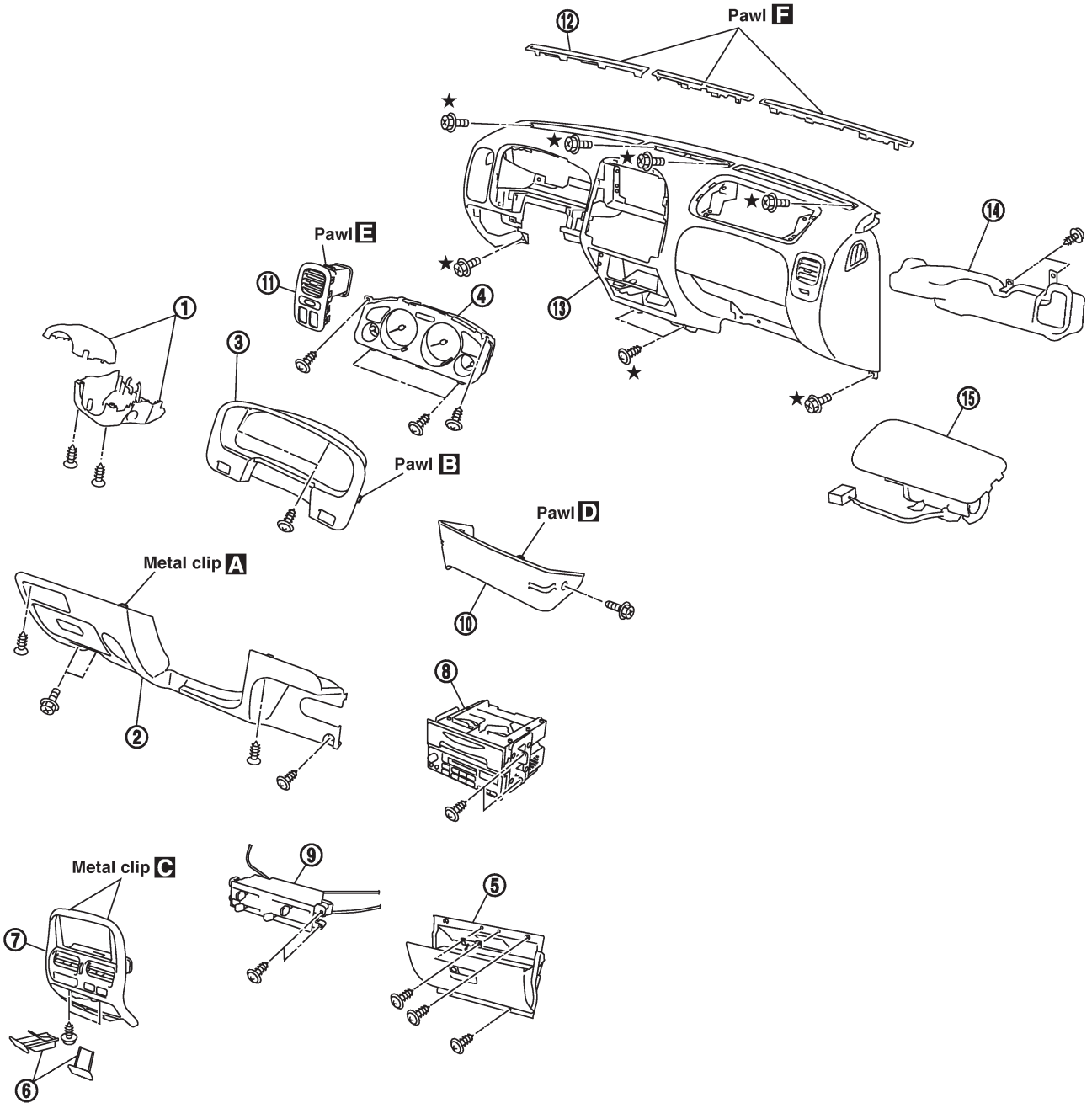

★: Instrument panel assembly mounting bolts and screws

SBT830

BT-2005

INSTRUMENT PANEL

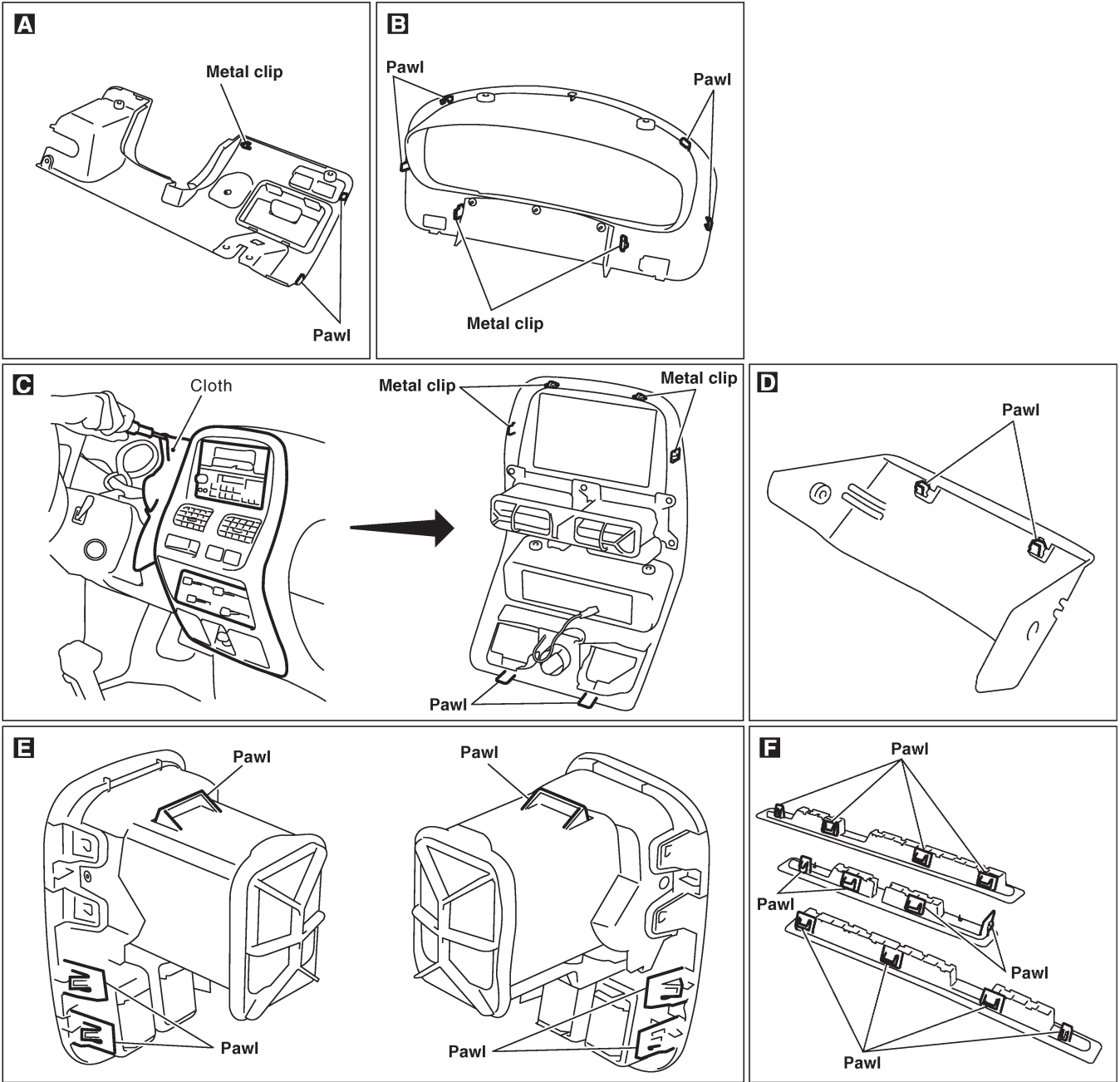

INTERIOR TRIM

Side and Floor Trim

CAUTION:

Wrap the tip of flat-bladed screwdriver with a cloth when removing metal clips from garnishes.

REMOVAL — Body side trim

- ① Remove front and rear seats. Refer to "SEAT" for details, in BT section of Service Manual Pub. No. SM8E-0D22E0E.
- ② Remove front and rear seat belts. Refer to "SEAT BELTS" in RS section details.
- ③ Remove front and rear kicking plate.
- ④ Remove dash side lower finishers. **B**
- ⑤ Remove front and rear body side welts.
- ⑥ Remove front pillar garnishes. **C**
- ⑦ Remove center pillar lower garnishes. **D**
- ⑧ Remove center pillar upper garnishes. **E**
- ⑨ Remove lock pillar garnishes. **F**

INTERIOR TRIM

Side and Floor Trim (Cont'd)

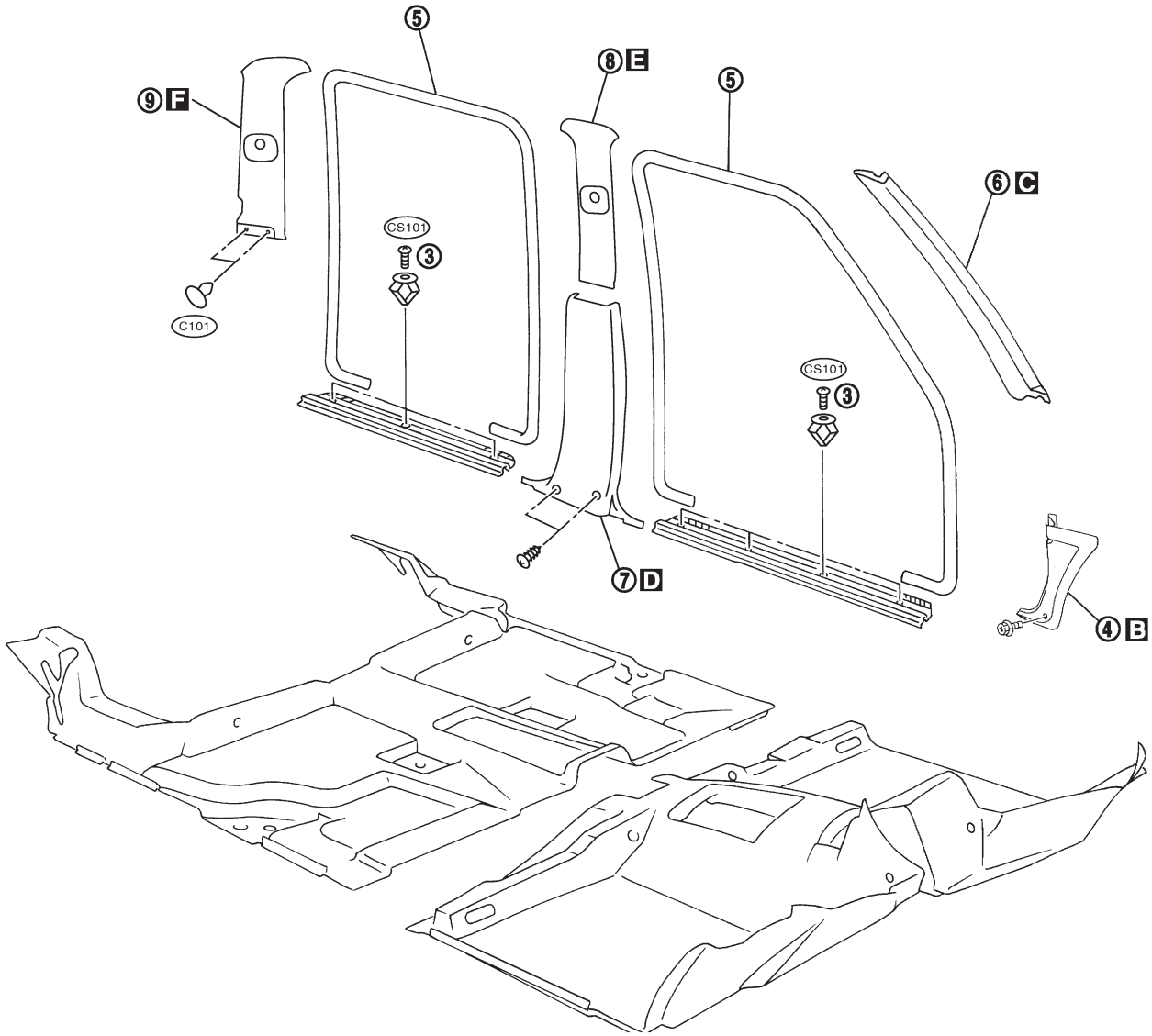

INTERIOR TRIM

Side and Floor Trim (Cont'd)

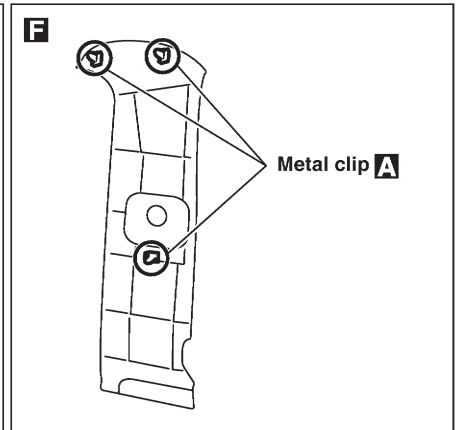
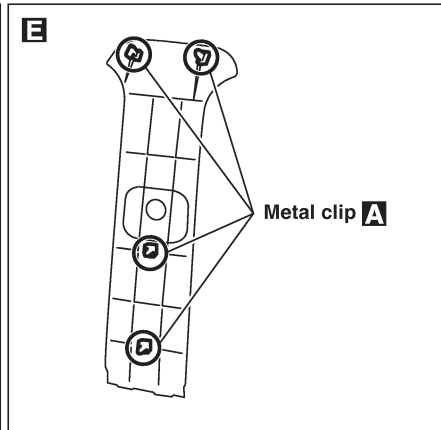
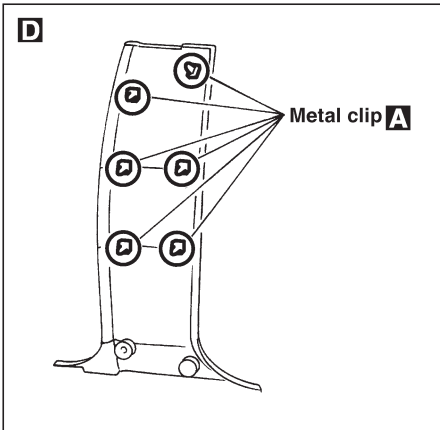
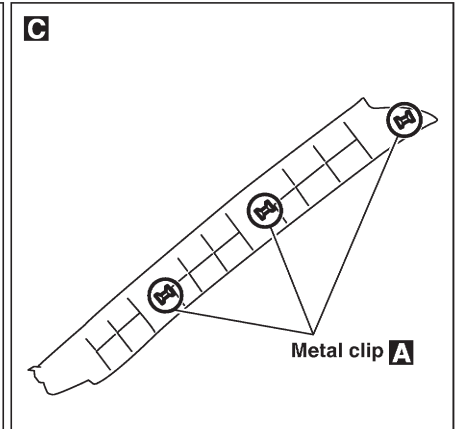
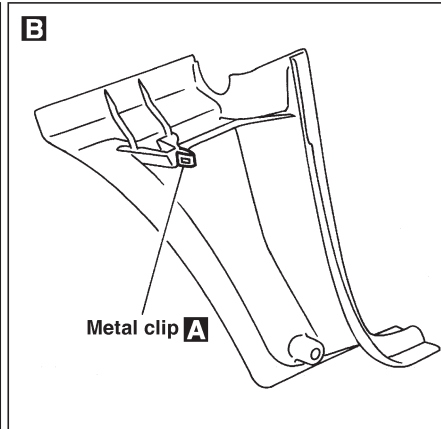
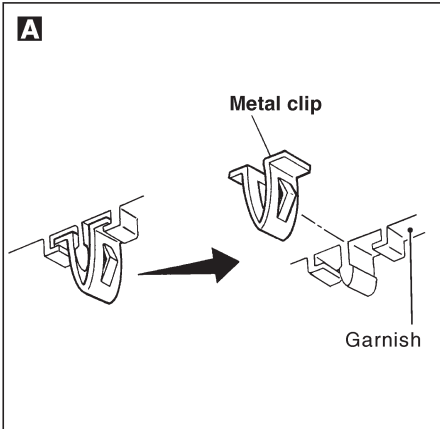

INTERIOR TRIM

Roof Trim

REMOVAL — Headlining

- ① Remove front and rear seats. Refer to "SEAT" for details, in BT section of Service Manual Pub. No. SM8E-0D22E0E.
- ② Remove front and rear seat belts. Refer to "SEAT BELTS" in RS section for details.
- ③ Remove body side trim. Refer to "Side and Floor Trim" for details, BT-2007.
- ④ Remove sun visors.
- ⑤ Remove spot lamp assembly.
- ⑥ Remove inside mirror assembly.
- ⑦ Remove interior lamp assembly. **A**
- ⑧ Remove assist grips.
- ⑨ Remove rear window weatherstrip and remove rear window glass. **B**
- ⑩ Remove clips, then remove headlining.

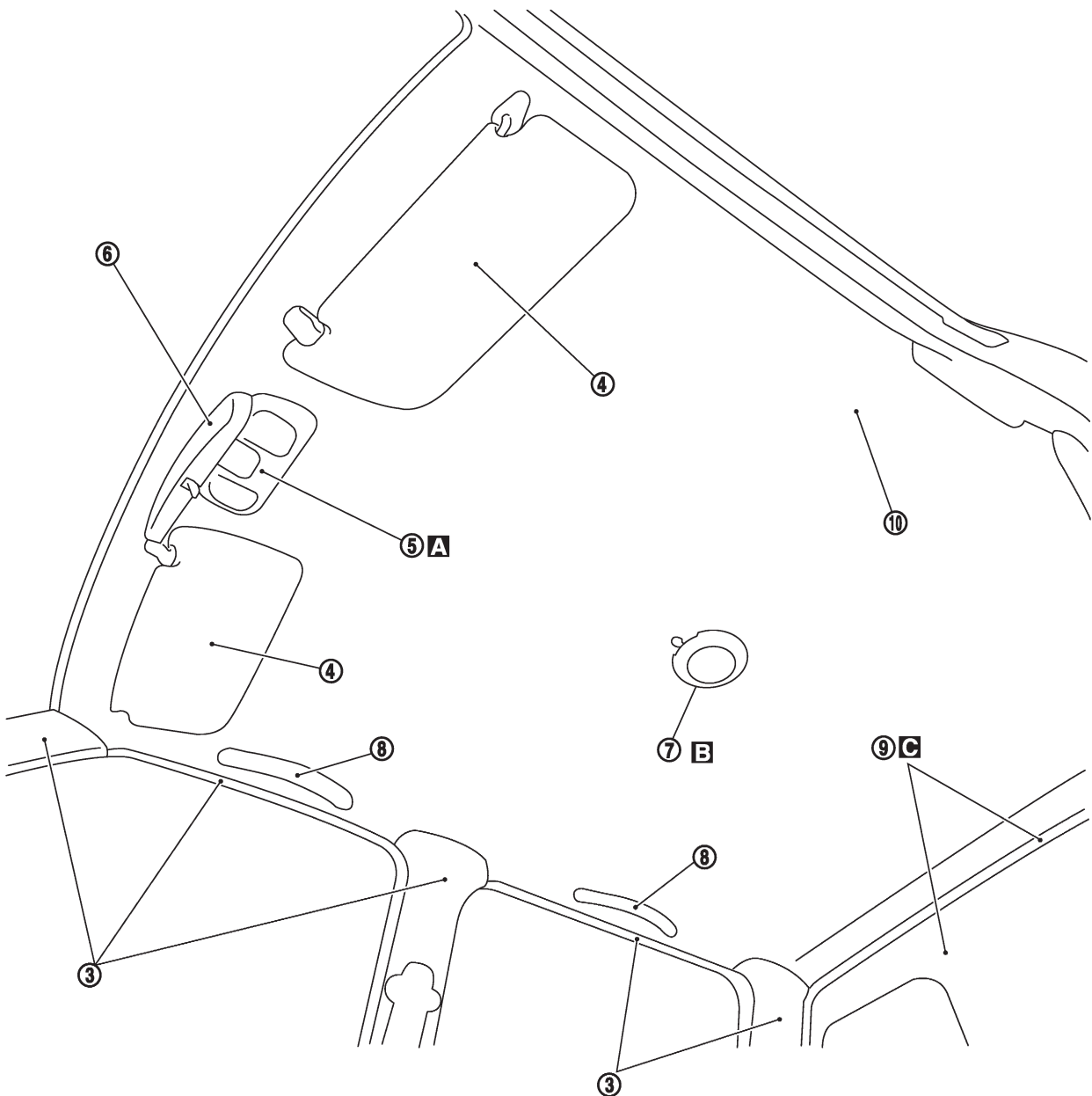

SBT834

INTERIOR TRIM

Roof Trim (Cont'd)

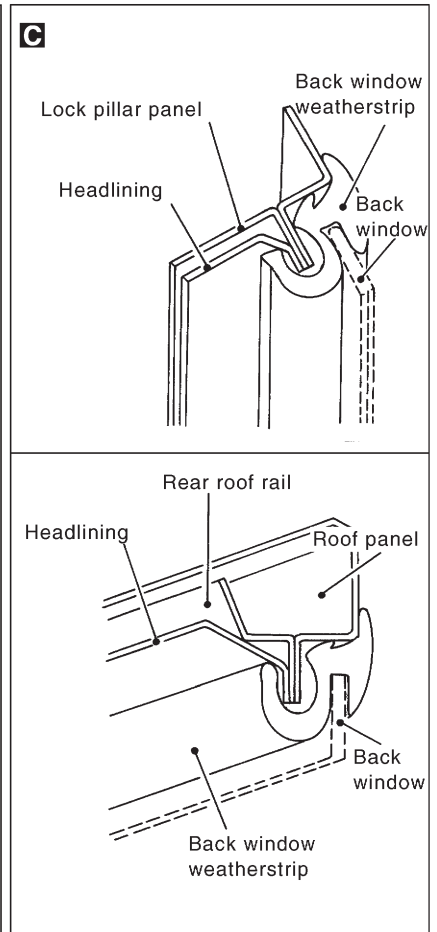
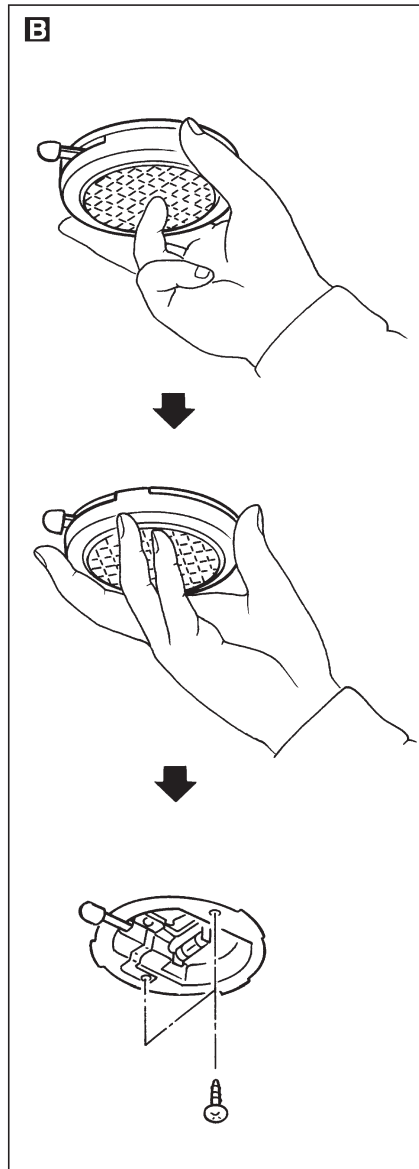
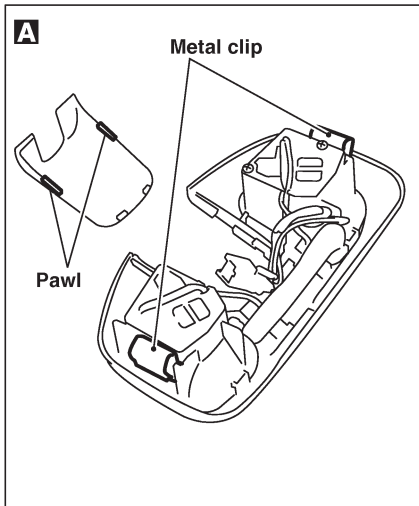



SEAT

Jump Seat — King Cab Model

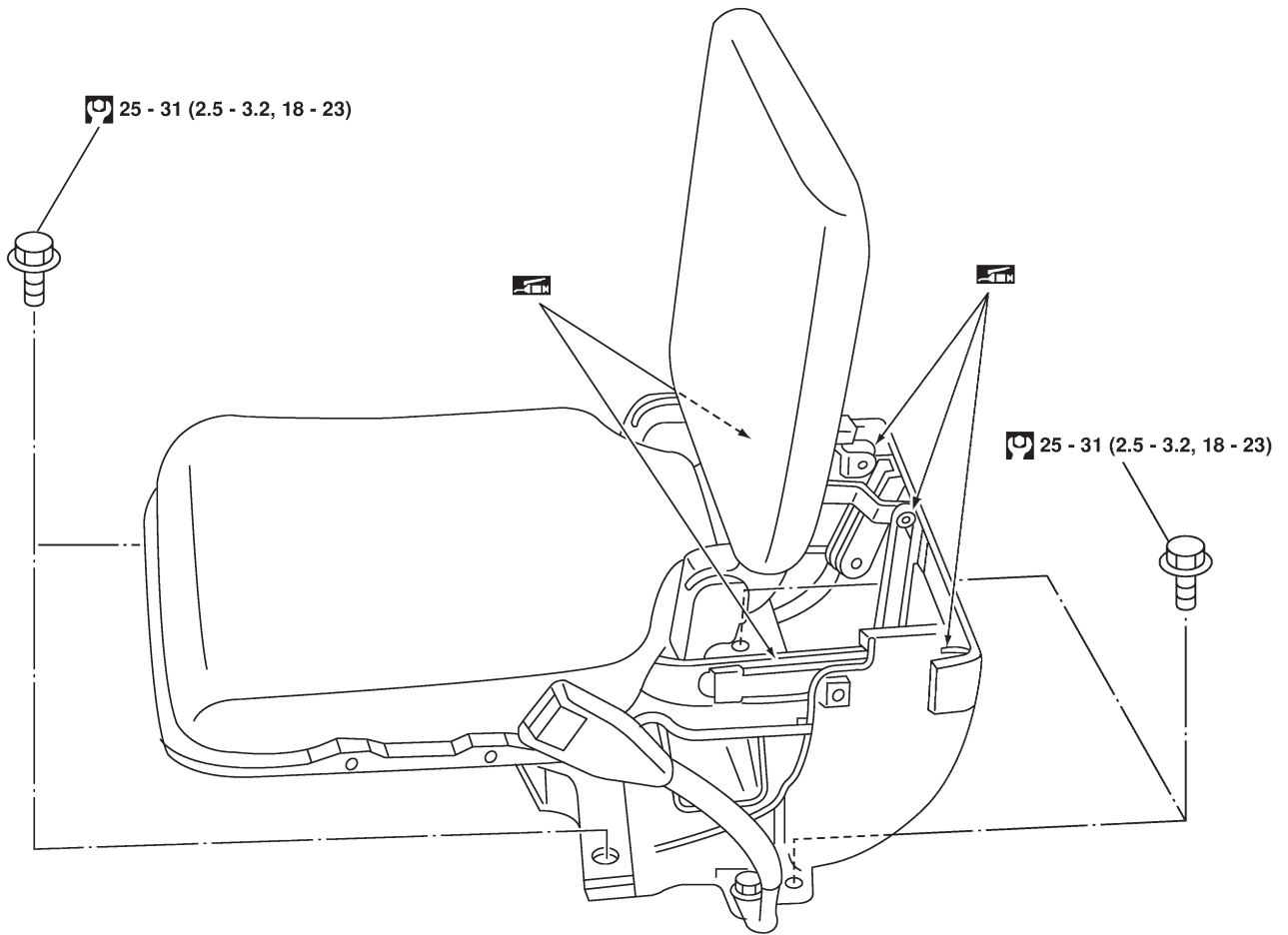
SEC. 880



-  : N•m (kg-m, ft-lb)
-  : Grease-up points
(Do not apply too much as it will drip.)