

## SECTION HA

### MODIFICATION NOTICE:

- Wiring Diagrams for manual A/C have been changed.
- Auto A/C has been added to RHD models for Europe.
- Auto A/C of LHD models for Europe have been changed.

## CONTENTS

### MANUAL AND AUTO

<b>PRECAUTIONS AND PREPARATION</b> .....	2002
Supplemental Restraint System (SRS) "AIR BAG" and "SEAT BELT PRE-TENSIONER" ..	2002

### MANUAL

<b>TROUBLE DIAGNOSES</b> .....	2003
Wiring Diagram - HEATER -.....	2003
Circuit Diagram - Air Conditioner.....	2004
Wiring Diagram - A/C, M -/Except for KA Engine Models .....	2005
Wiring Diagram - A/C, M -/KA Engine LHD Models.....	2008
Wiring Diagram - A/C, M -/KA Engine RHD Models.....	2011
Magnet Clutch.....	2014

### AUTO

<b>DESCRIPTION</b> .....	2023
Introduction .....	2023
Features .....	2023
Overview of Control System .....	2024
Control Operation.....	2024
<b>TROUBLE DIAGNOSES</b> .....	2026

Component Location.....	2026
Circuit Diagram .....	2027
Wiring Diagram - A/C, A -.....	2028
Auto Amp. Terminals and Reference Value....	2032
Self-diagnosis.....	2034
How to Perform Trouble Diagnoses for Quick and Accurate Repair .....	2040
Operational Check .....	2041
A/C System .....	2045
Mode Door Motor.....	2047
Air Mix Door Motor.....	2052
Intake Door Motor .....	2058
Blower Motor.....	2062
Magnet Clutch.....	2068
Insufficient Cooling.....	2075
Insufficient Heating .....	2076
Noise .....	2077
Self-diagnosis.....	2078
Memory Function .....	2079
Ambient Sensor .....	2080
In-vehicle Sensor .....	2082
Aspirator Motor .....	2084
Sunload Sensor .....	2084
Intake Sensor.....	2087

#### When you read wiring diagrams:

- Read GI section, "HOW TO READ WIRING DIAGRAMS".
- See EL section, "POWER SUPPLY ROUTING" for power distribution circuit.

When you perform trouble diagnoses, read GI section, "HOW TO FOLLOW FLOW CHART IN TROUBLE DIAGNOSES" and "HOW TO PERFORM EFFICIENT DIAGNOSIS FOR AN ELECTRICAL INCIDENT".

## **Supplemental Restraint System (SRS) “AIR BAG” and “SEAT BELT PRE-TENSIONER”**

The Supplemental Restraint System such as “AIR BAG” and “SEAT BELT PRE-TENSIONER” used along with a seat belt, helps to reduce the risk or severity of injury to the driver and front passenger in a frontal collision. The SRS system composition which is available to NISSAN MODEL D22 is as follows (The composition varies according to the destination and optional equipment.):

Driver air bag module (located in the center of the steering wheel), front passenger air bag module (located on the instrument panel on passenger side), seat belt pre-tensioner, a diagnosis sensor unit, warning lamp, wiring harness and spiral cable.

Information necessary to service the system safely is included in the **RS section** of this Service Manual.

### **WARNING:**

- **To avoid rendering the SRS inoperative, which could increase the risk of personal injury or death in the event of a collision which would result in air bag inflation, all maintenance must be performed by an authorized NISSAN dealer.**
- **Improper maintenance, including incorrect removal and installation of the SRS, can lead to personal injury caused by unintentional activation of the system. For removal of Spiral Cable and Air Bag Module, see the RS section.**
- **Do not use electrical test equipment on any circuit related to the SRS unless instructed to in this Service Manual. Spiral Cable and wiring harnesses (except “SEAT BELT PRE-TENSIONER”) covered with yellow insulation either just before the harness connectors or for the complete harness are related to the SRS.**

Wiring Diagram — HEATER —

EXCEPT FOR AUSTRALIA

HA-HEATER-01

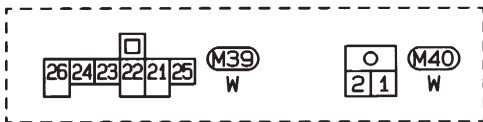
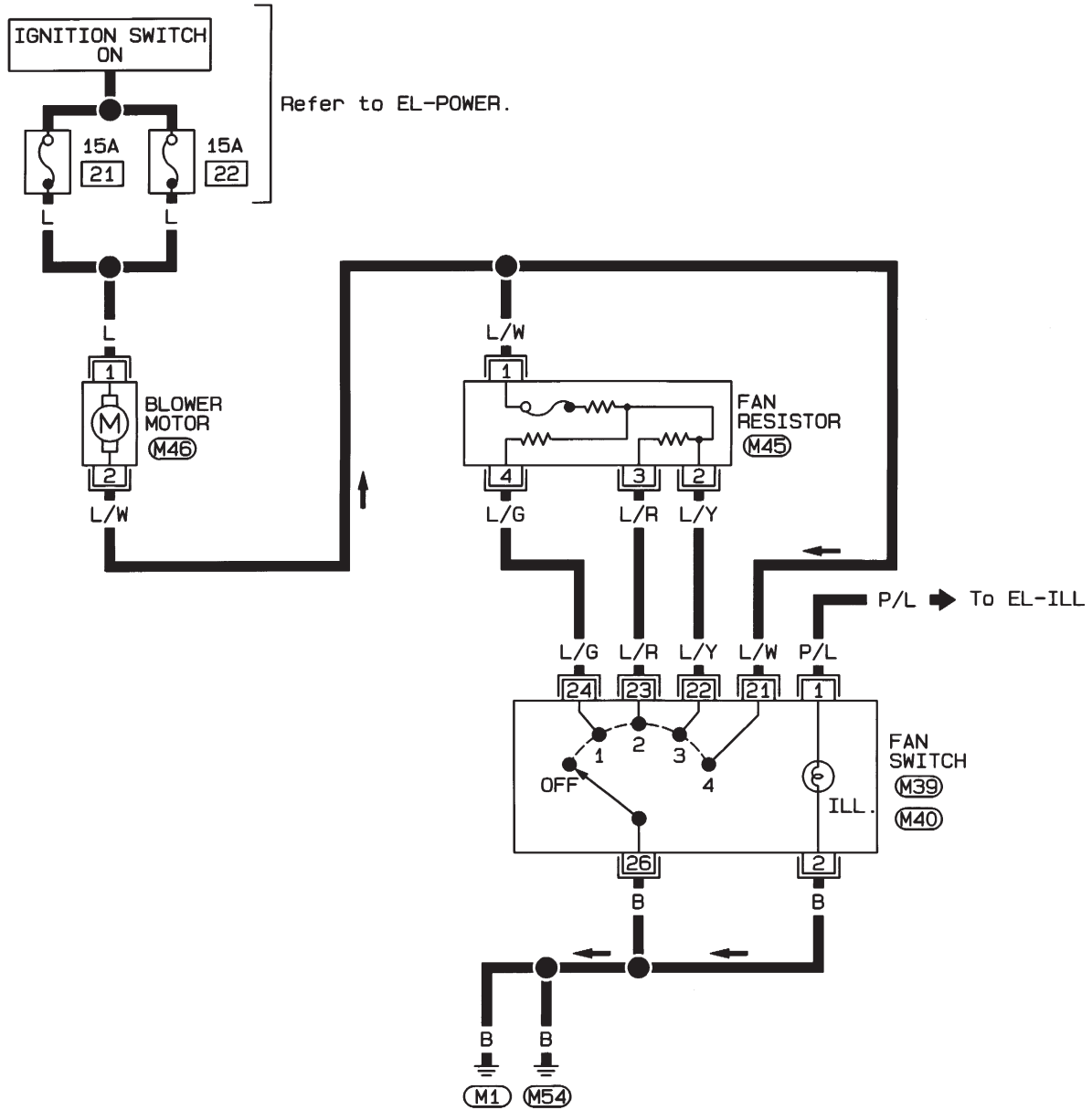

Circuit Diagram — Air Conditioner

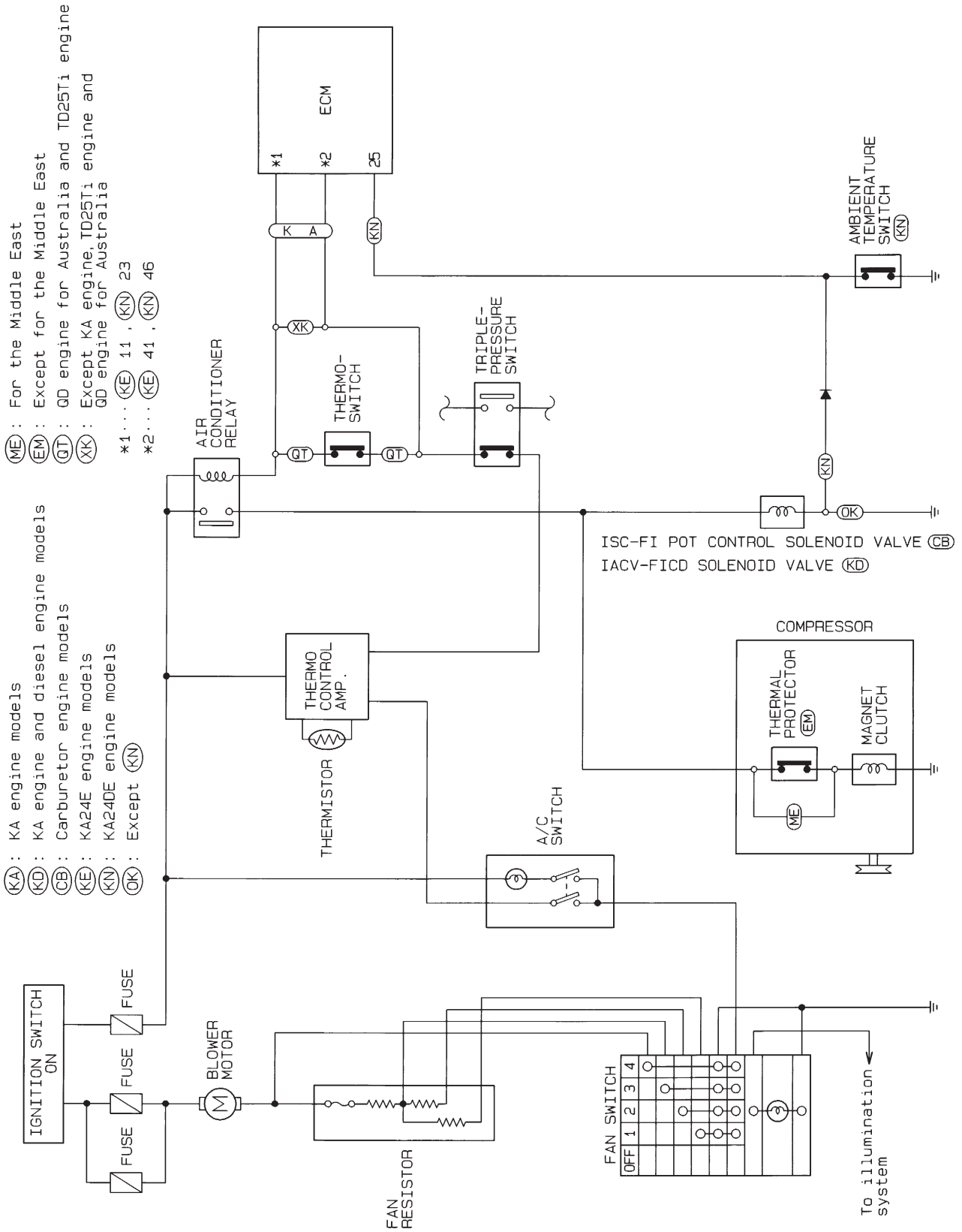

Wiring Diagram — A/C, M —/Except for KA Engine Models

HA-A/C, M-01

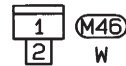
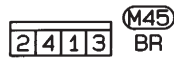
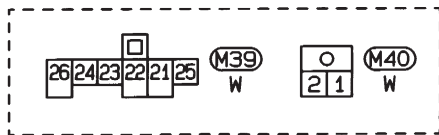
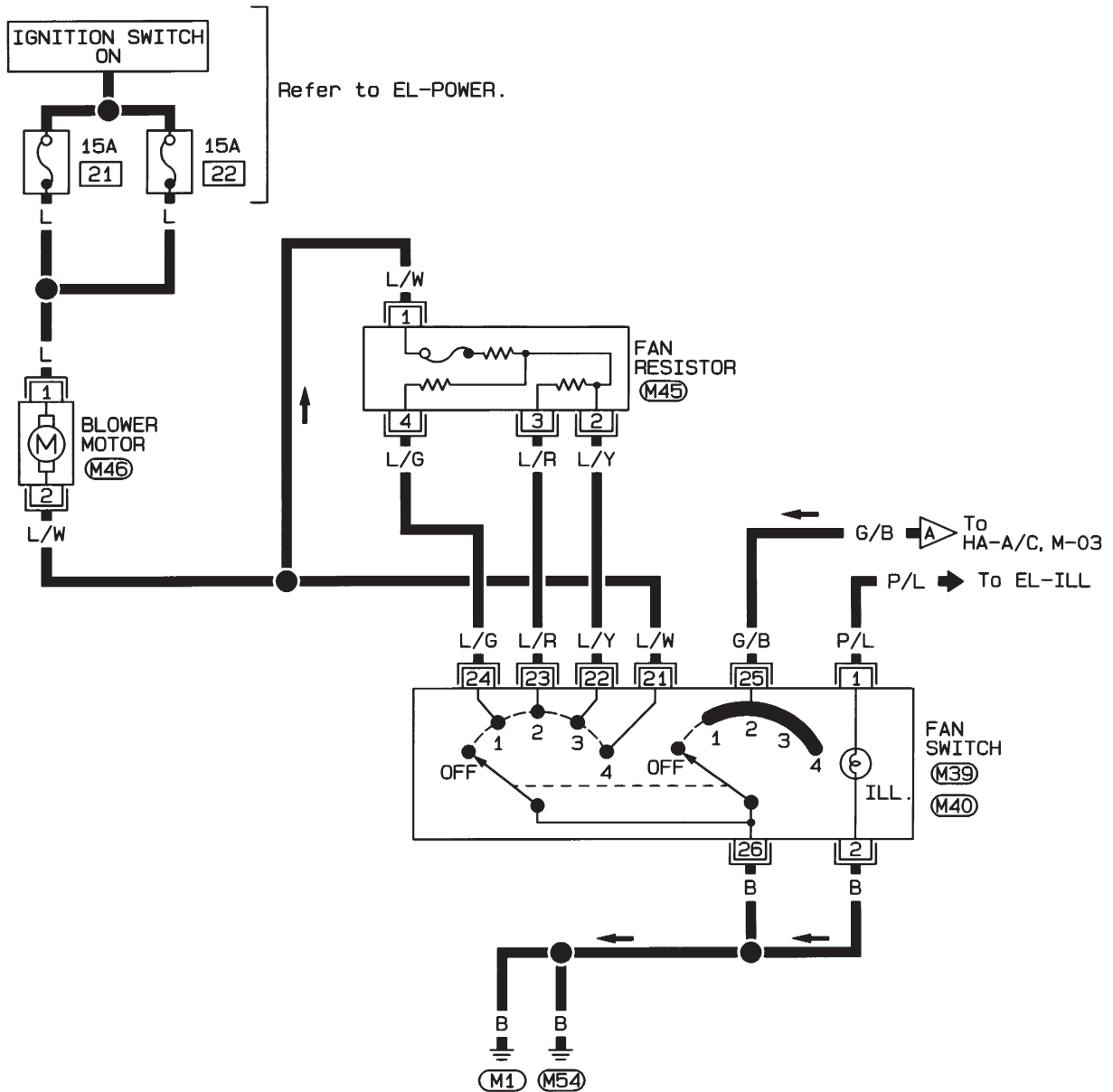

Wiring Diagram — A/C, M —/Except for KA Engine Models (Cont'd)

HA-A/C, M-02

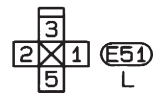
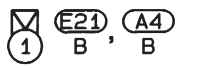
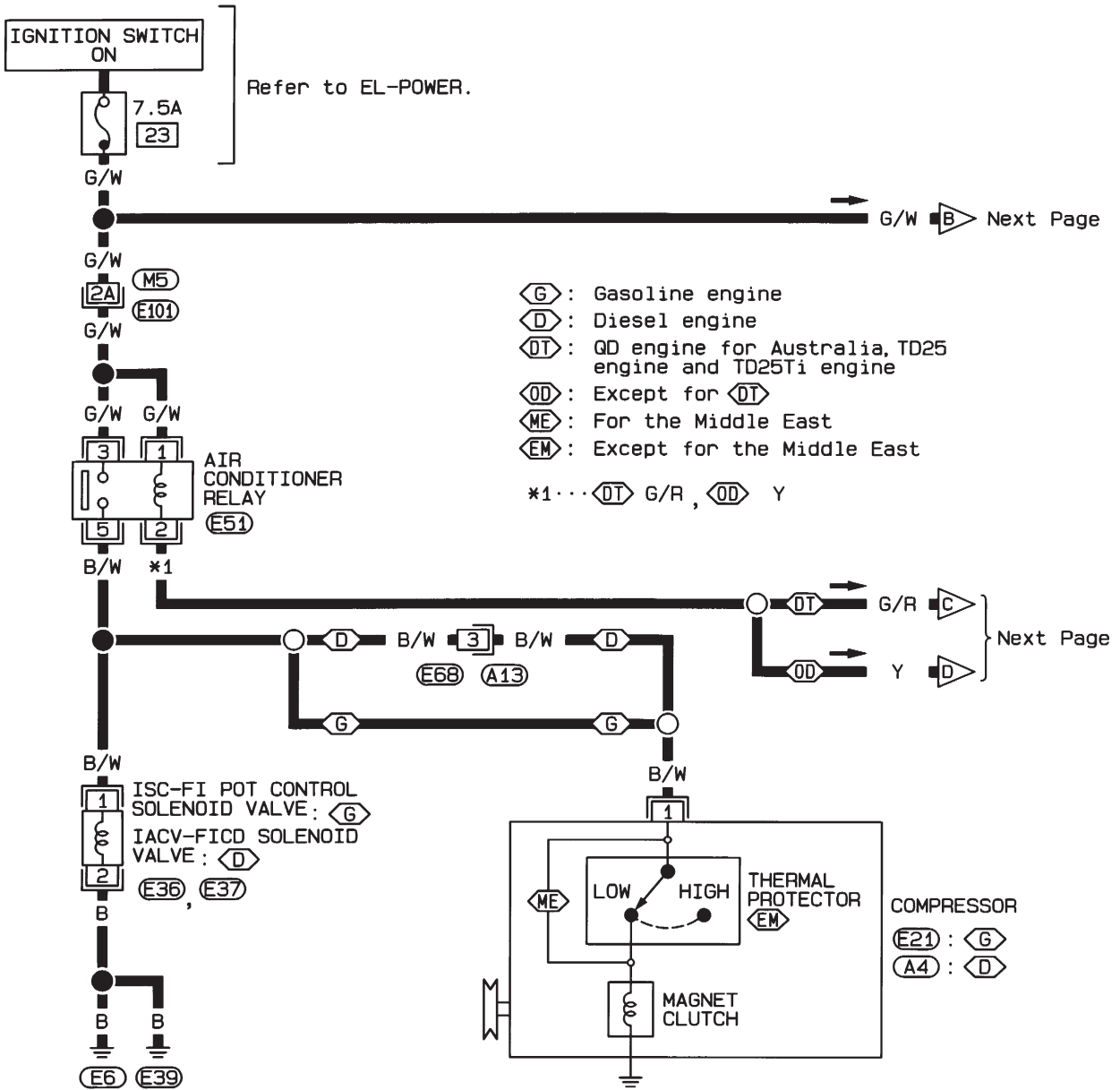

Refer to last page (Foldout page).

M5, E101

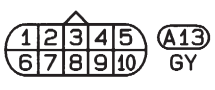

Wiring Diagram — A/C, M —/Except for KA Engine Models (Cont'd)

HA-A/C, M-03

- ⓪T: QD engine for Australia, TD25 engine and TD25Ti engine
- ⓪D: Except for ⓪T
- ⓪T: QD engine for Australia and TD25Ti engine
- ⓪5: TD25 engine

\*1... ⓪T Y, ⓪5 G/R

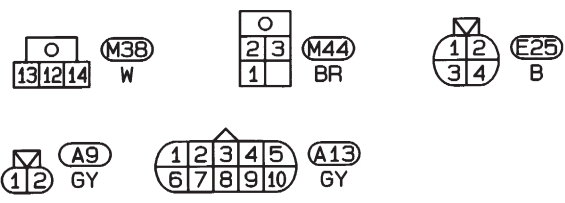
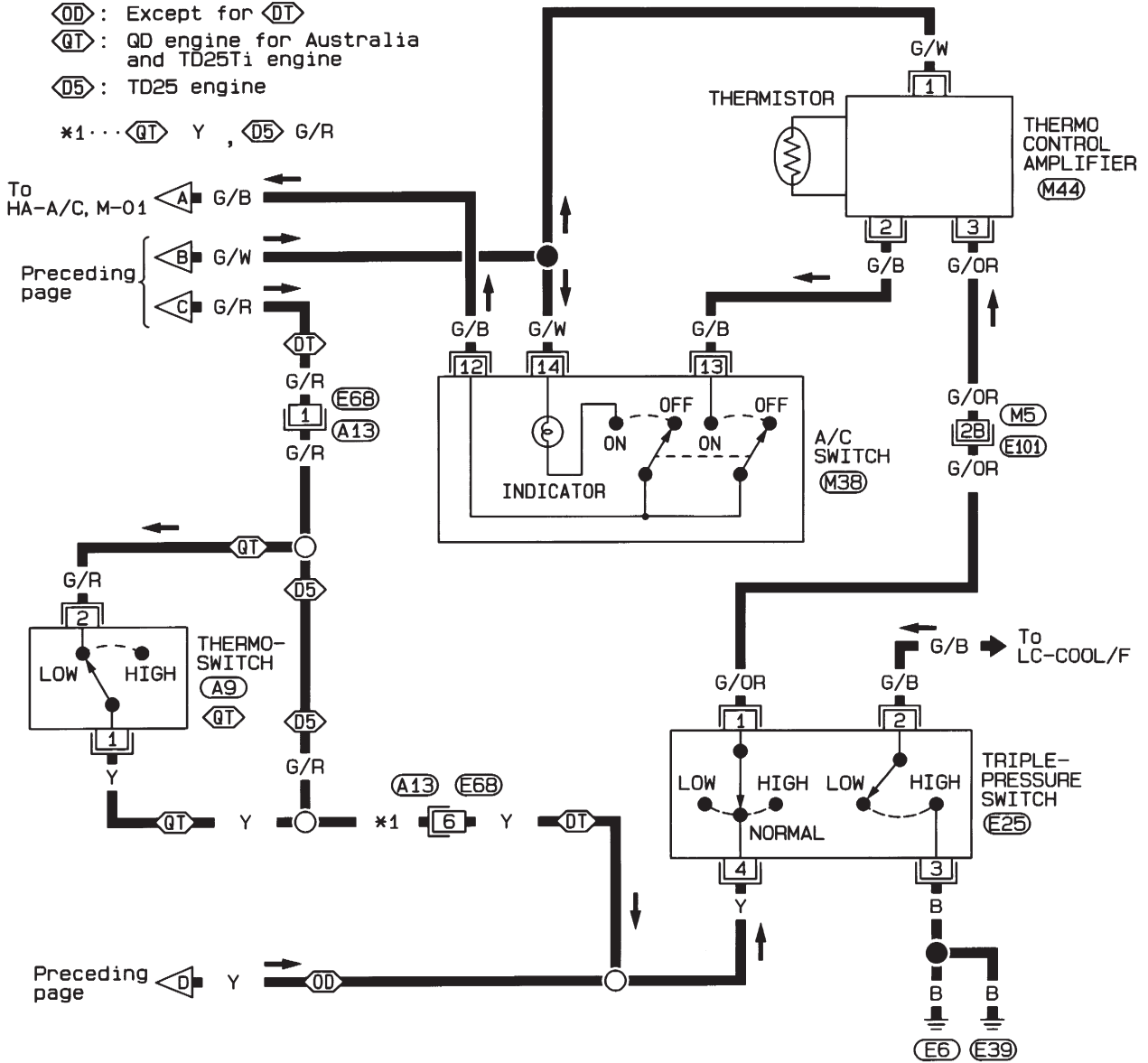

Refer to last page (Foldout page).

⓪5, ⓪101

Wiring Diagram — A/C, M —/KA Engine LHD Models

HA-A/C, M-04

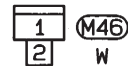
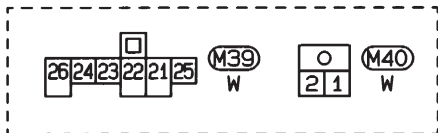
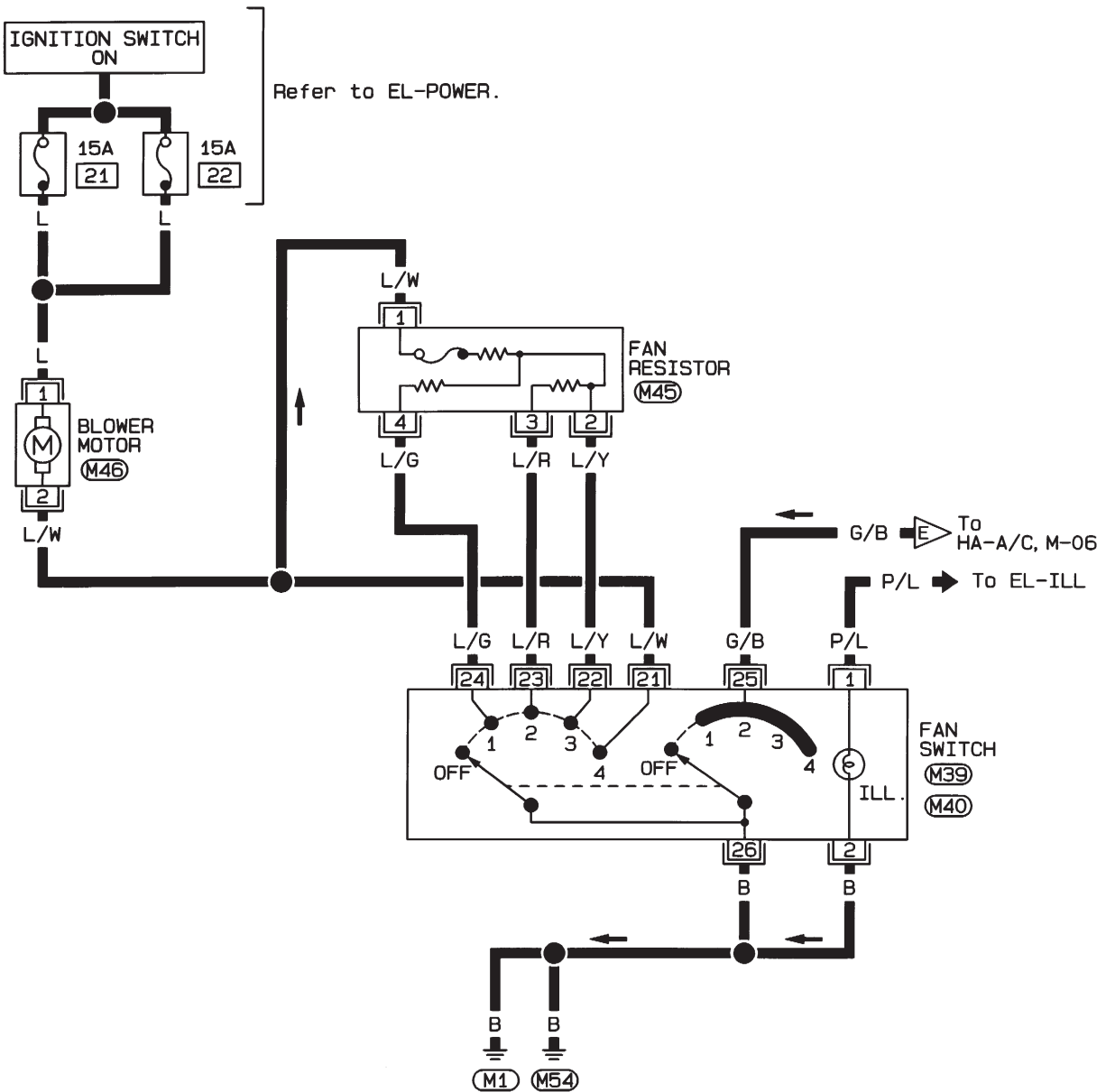



Wiring Diagram — A/C, M —/KA Engine LHD Models (Cont'd)

HA-A/C, M-05

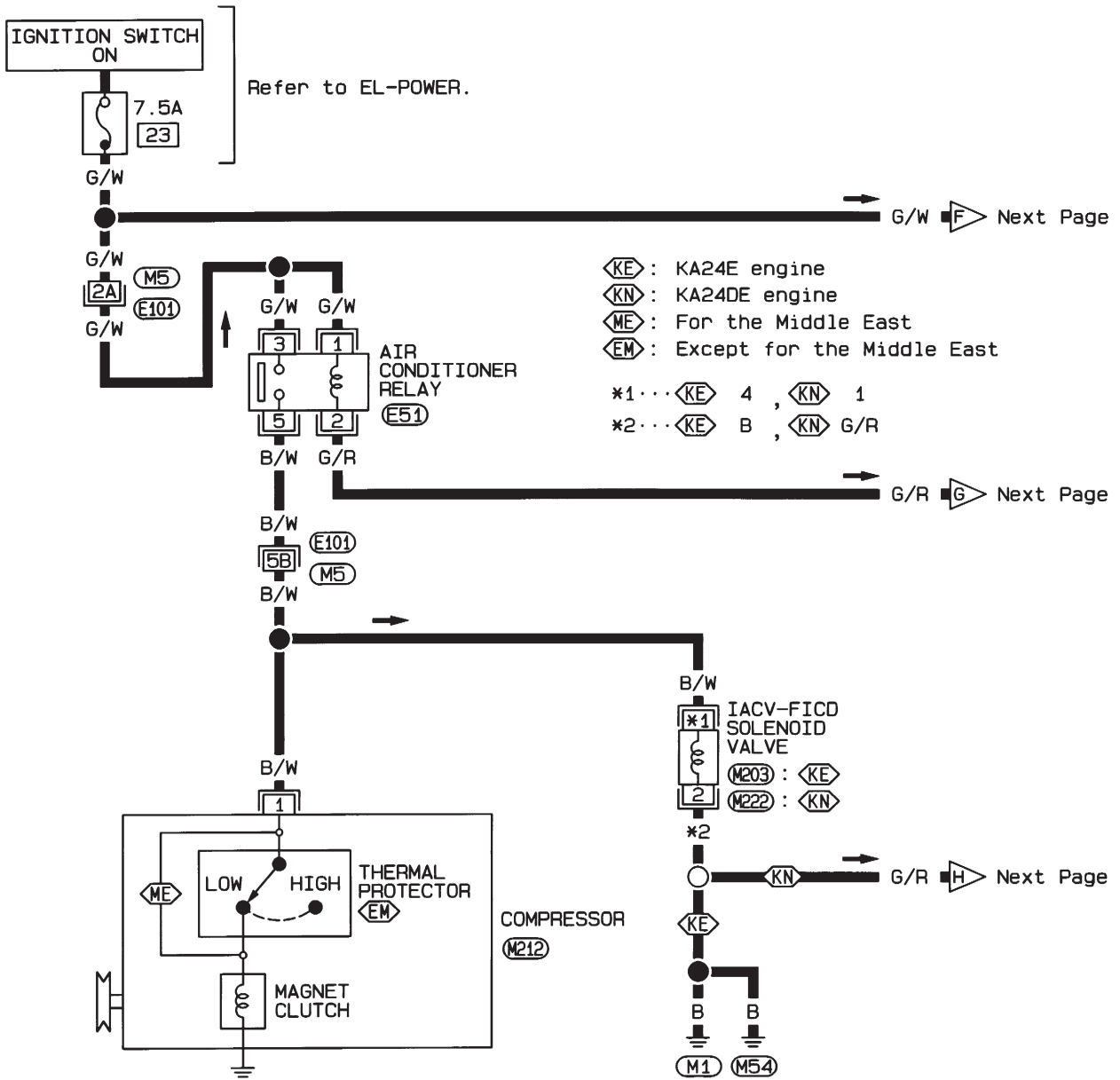

<KE> : KA24E engine  
 <KN> : KA24DE engine  
 <ME> : For the Middle East  
 <EM> : Except for the Middle East  
 \*1... <KE> 4 , <KN> 1  
 \*2... <KE> B , <KN> G/R



Refer to last page (Foldout page).

M5, E101

Wiring Diagram — A/C, M —/KA Engine LHD Models (Cont'd)

HA-A/C, M-06

ⓀE: KA24E engine  
 ⓀN: KA24DE engine

\*1...ⓀE 11, ⓀN 23  
 \*2...ⓀE 41, ⓀN 46

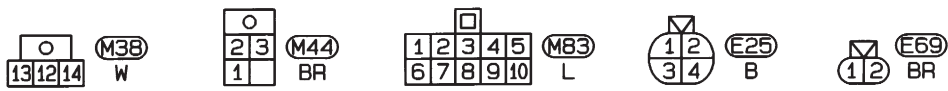
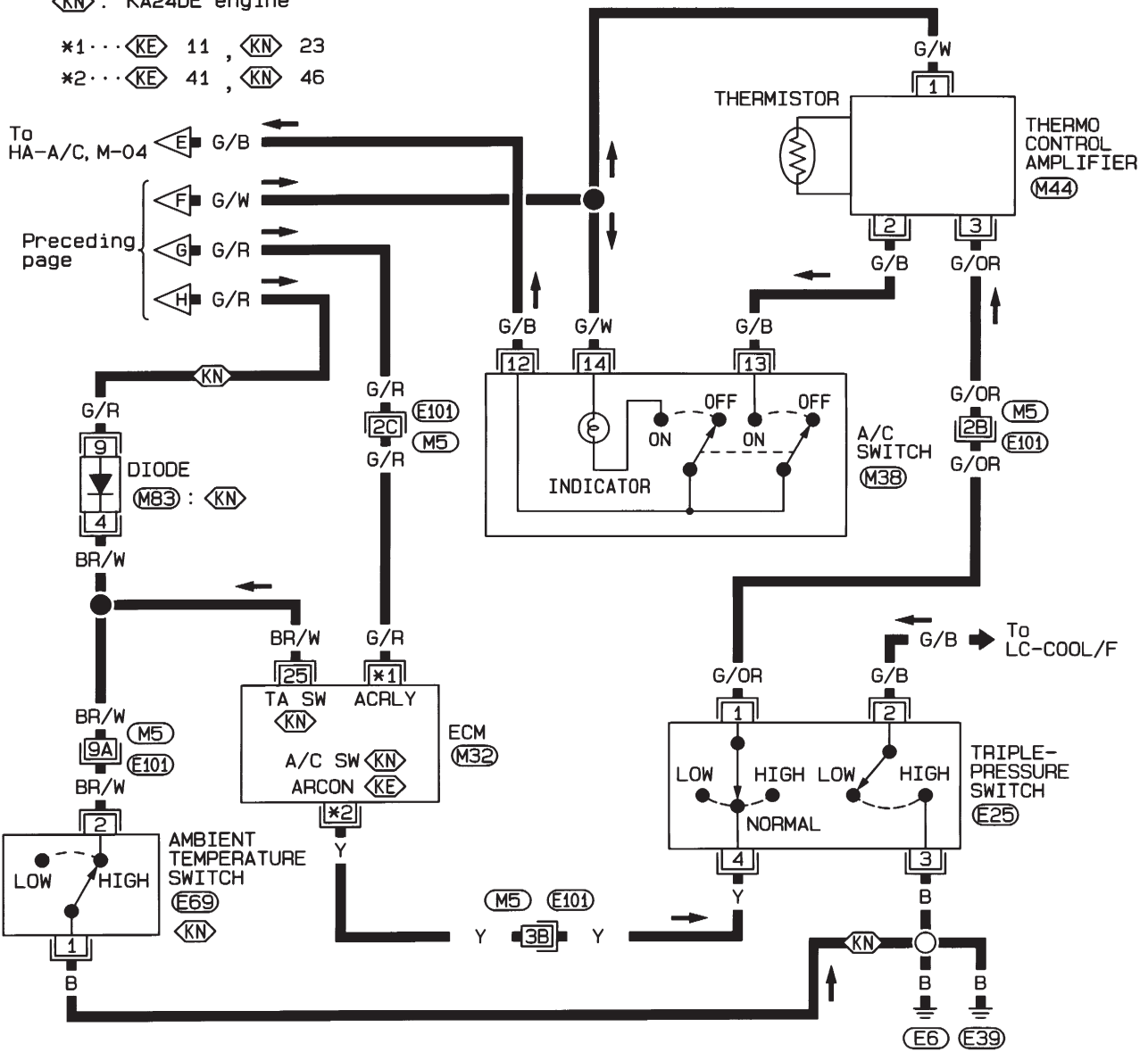

Refer to last page (Foldout page).  
 ⓀM5, ⓀE101  
 ⓀM32

Wiring Diagram — A/C, M —/KA Engine RHD Models

HA-A/C, M-07

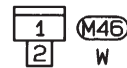
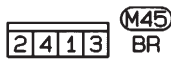
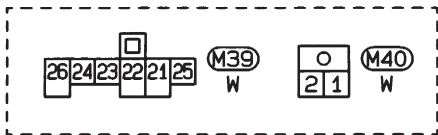
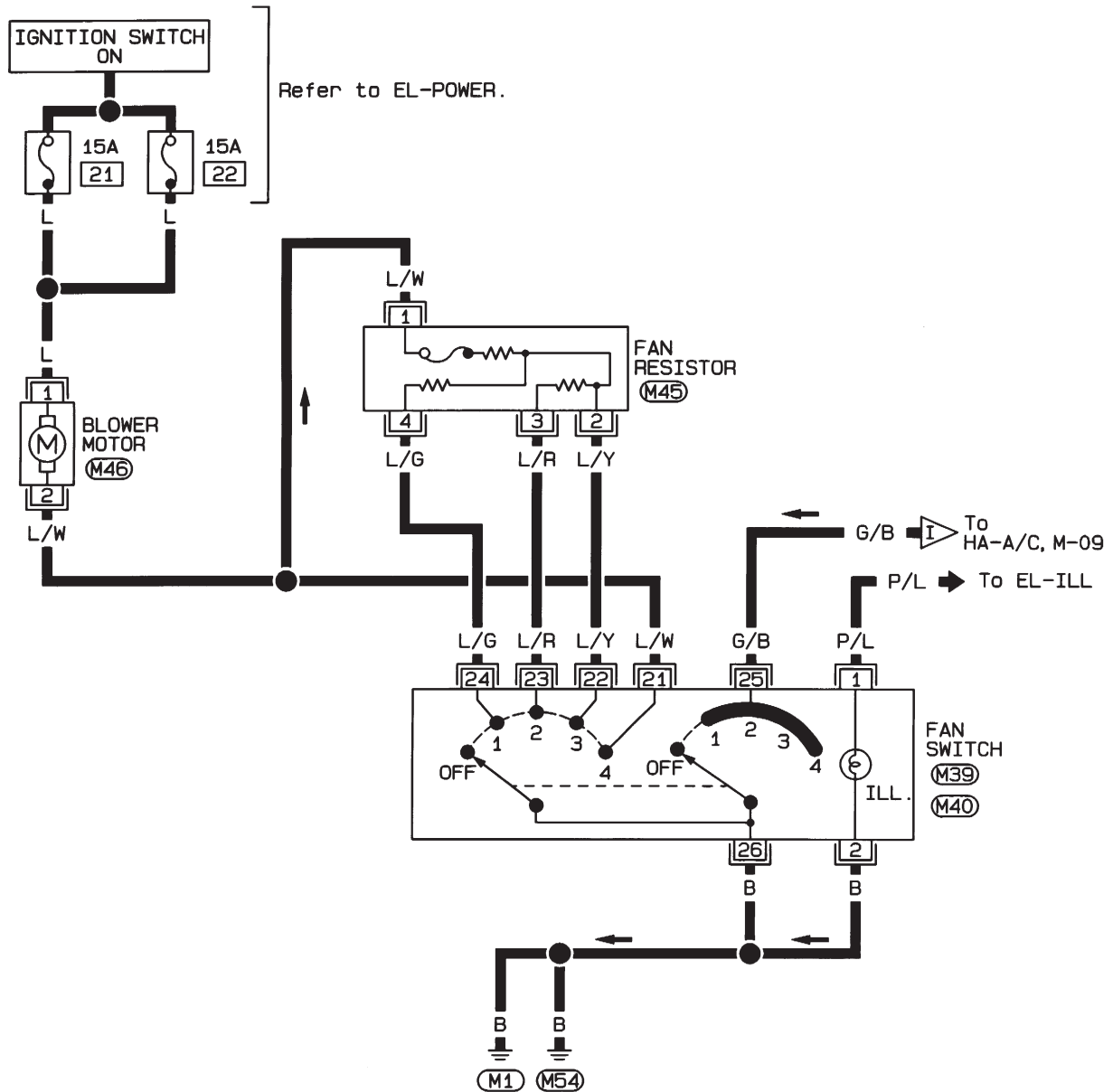

Wiring Diagram — A/C, M —/KA Engine RHD Models (Cont'd)

HA-A/C, M-08

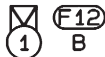
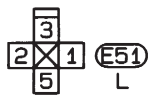
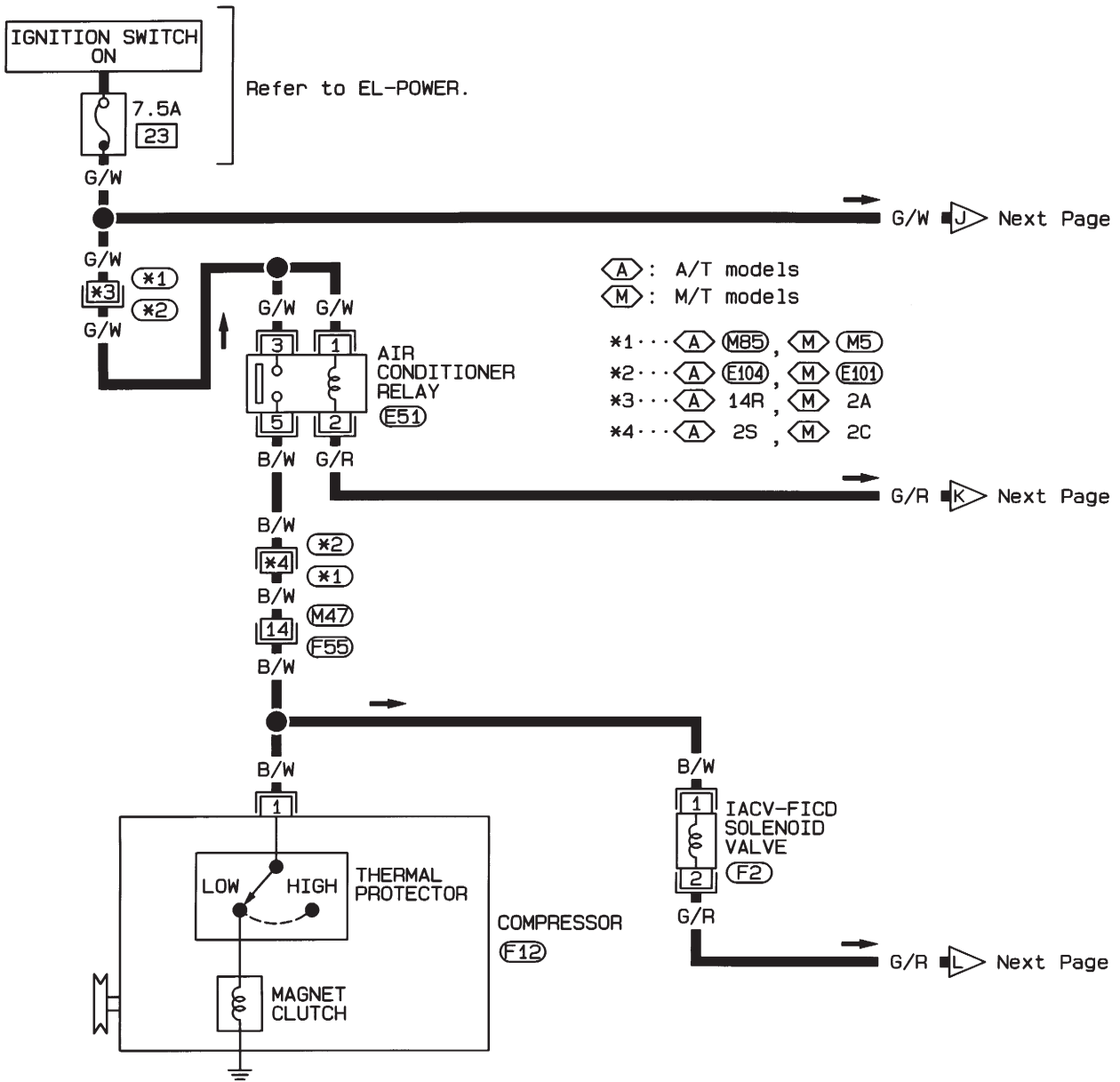

Refer to last page (Foldout page).

- (M5), (E101)
- (M85), (E104)

Wiring Diagram — A/C, M —/KA Engine RHD Models (Cont'd)

HA-A/C, M-09

(A) : A/T models  
(M) : M/T models

- \*1... (A) (M85), (M) (M5)    \*4... (A) 5R, (M) 12H
- \*2... (A) (E104), (M) (E101)    \*5... (A) 13S, (M) 1A
- \*3... (A) 9S, (M) 1B    \*6... (A) 6R, (M) 2B

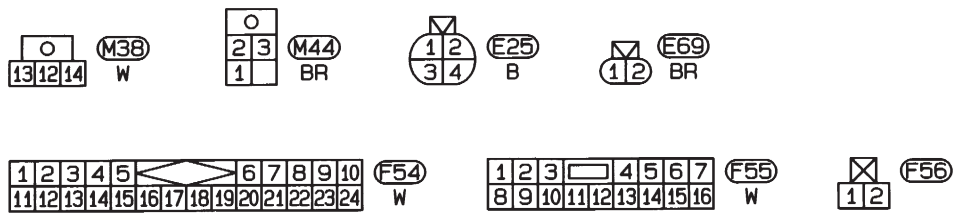
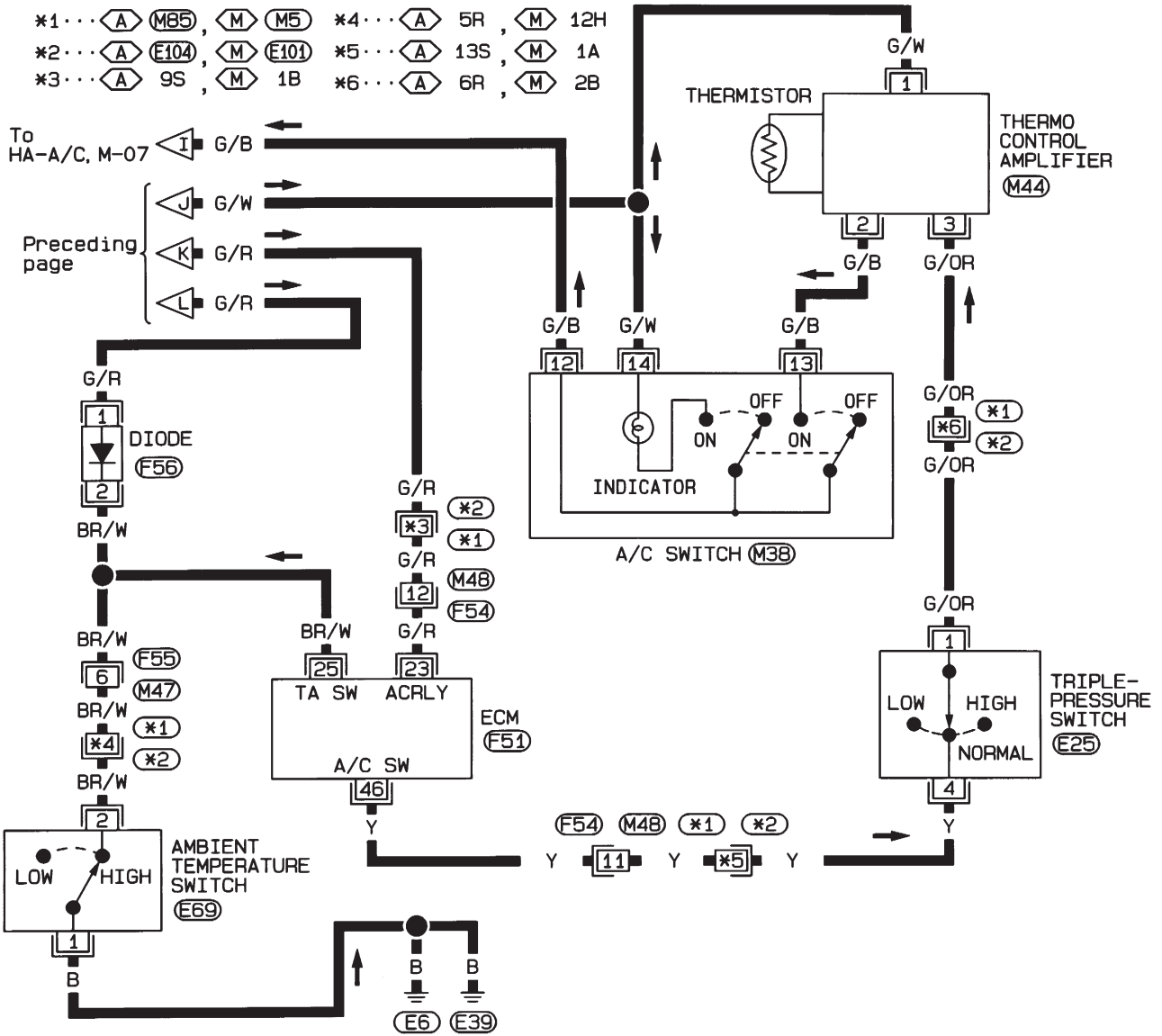

Refer to last page (Foldout page).

- (M5), (E101)
- (M85), (E104)
- (F51)

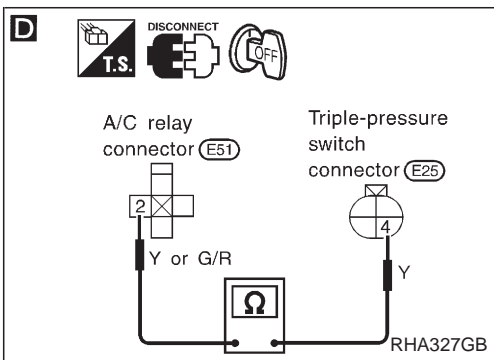
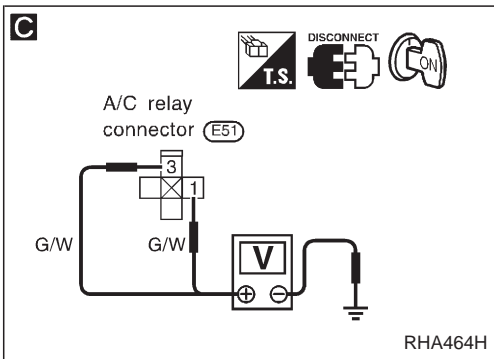
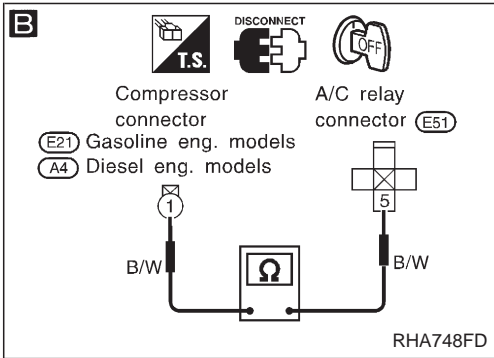
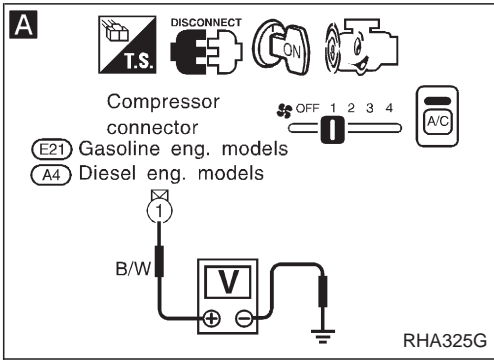

### Magnet Clutch

#### DIAGNOSTIC PROCEDURE Except for KA engine models

**SYMPTOM: Magnet clutch does not engage when A/C switch and fan switch are ON.**

**A**

**CHECK POWER SUPPLY FOR COMPRESSOR.**  
Disconnect compressor harness connector.  
Do approx. 12 volts exist between compressor harness terminal No. ① and body ground?

Yes → Check the following.  
● Magnet clutch coil  
● Thermal protector (Except for the Middle East)

NG → Replace magnet clutch. Refer to HA-69 in D22 SERVICE MANUAL, Publication No. SM7E-0D22G1.

No

**B** Note

Check circuit continuity between A/C relay harness terminal No. ⑤ and compressor harness terminal No. ①.  
**Continuity should exist.**  
If OK, check harness for short.

OK

**C**

**CHECK POWER SUPPLY FOR A/C RELAY.**  
Do approx. 12 volts exist between A/C relay harness terminal Nos. ①, ③ and body ground?

No → Check power supply circuit and 7.5A fuse (No. 23, located in the fuse block). (Refer to "POWER SUPPLY ROUTING" in EL section and Wiring Diagram.)

Yes

**CHECK A/C RELAY AFTER DISCONNECTING IT.**  
Refer to HA-2021.

NG → Replace A/C relay.

OK

Reconnect A/C relay. → (A) (Go to next page.)

Except for, TD25 and TD25Ti engines

**D** Note

Check circuit continuity between A/C relay harness terminal No. ② and triple-pressure switch harness terminal No. ④.  
**Continuity should exist.**  
If OK, check harness for short.

OK

(Go to next page.)

**Note:**  
If the result is NG or No after checking circuit continuity, repair harness or connector.

Magnet Clutch (Cont'd)

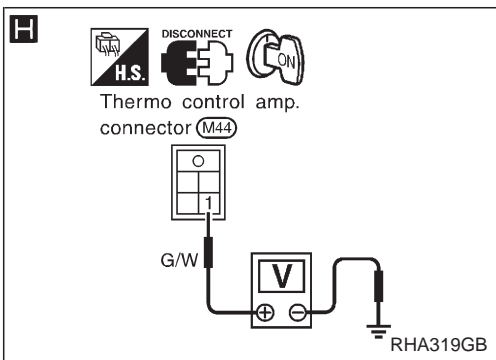
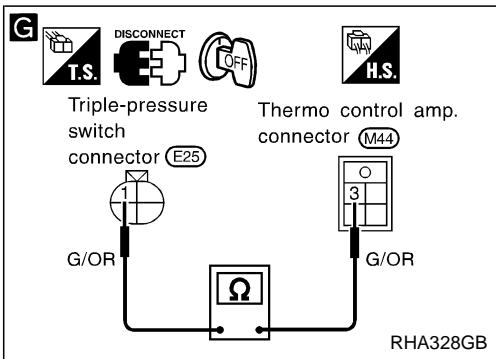
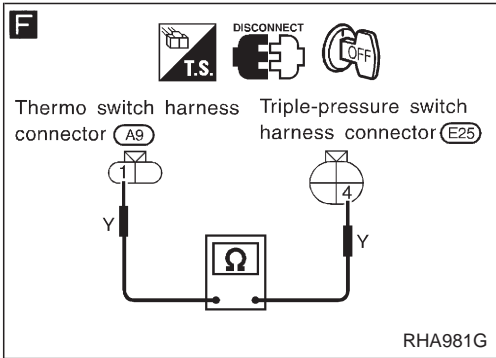
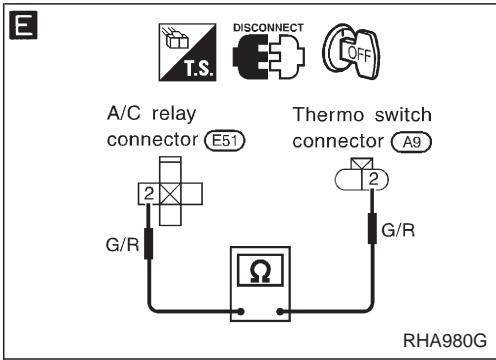

A

**E** Note

Check circuit continuity between A/C relay harness terminal No. ② and thermo switch harness terminal No. ②.  
**Continuity should exist.**  
 If OK, check harness for short.

OK

CHECK THERMO SWITCH. Refer to HA-2022.

NG → Replace thermo switch.

OK

B

**F** Note

Check circuit continuity between thermo switch harness terminal No. ① and triple-pressure switch harness terminal No. ④.  
**Continuity should exist.**  
 If OK, check harness for short.

OK

CHECK TRIPLE-PRESSURE SWITCH. Refer to HA-2022.

NG → Check refrigerant change amount.

OK

OK → Replace triple-pressure switch.

C

**G** Note

Check circuit continuity between triple-pressure switch harness terminal No. ① and thermo control amp. harness terminal No. ③.  
**Continuity should exist.**  
 If OK, check harness for short.

OK

**H**

**CHECK POWER SUPPLY FOR THERMO CONTROL AMP.**  
 Do approx. 12 volts exist between thermo control amp. harness terminal No. ① and body ground?

No → Check power supply circuit and 7.5A fuse (No. 23) located in the fuse block.  
 (Refer to "POWER SUPPLY ROUTING" in EL selection and Wiring Diagram.)

Yes

C

(Go to next page.)

**Note:**  
 If the result is NG or No after checking circuit continuity, repair harness or connector.

Magnet Clutch (Cont'd)

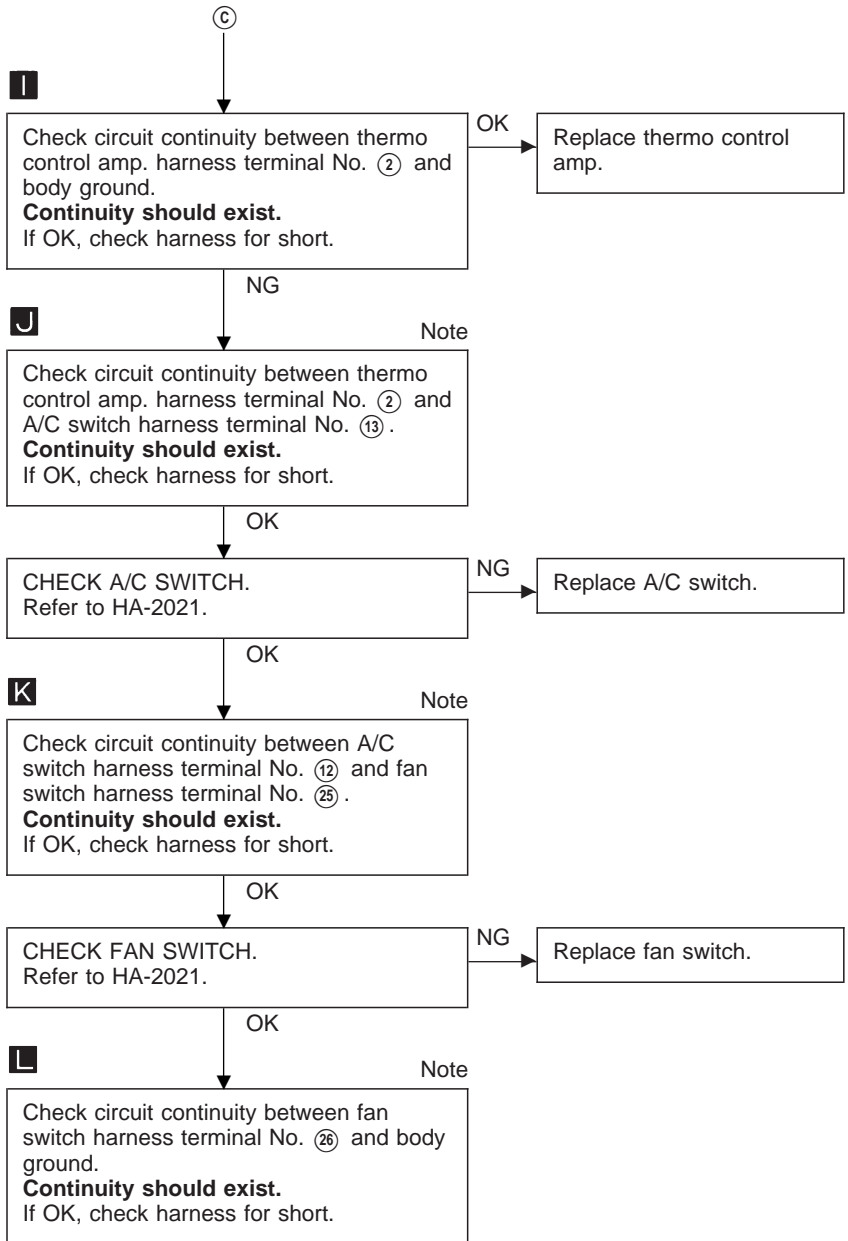
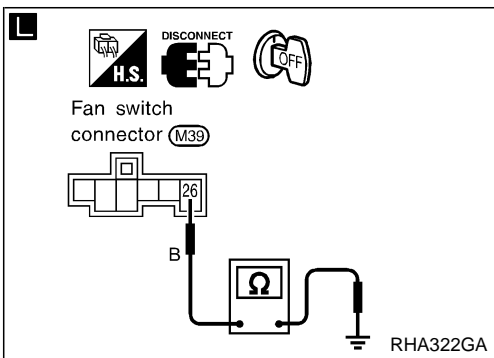
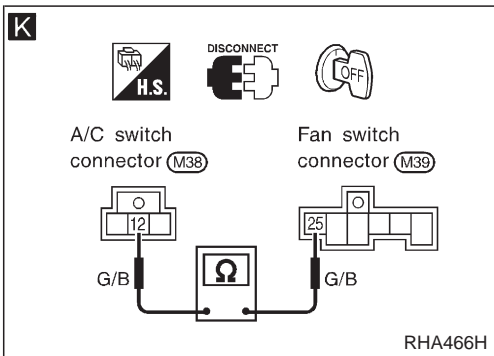
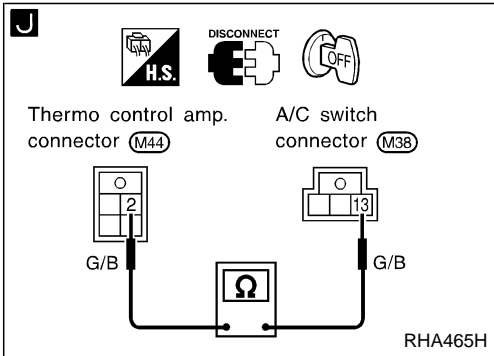
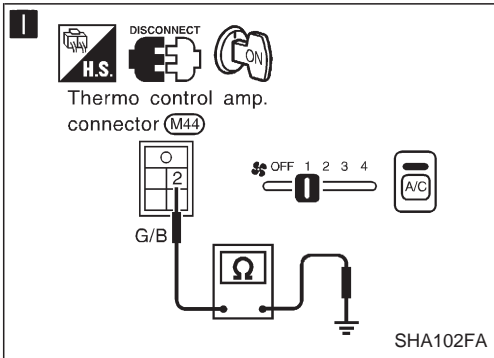

**Note:**  
 If the result is NG or No after checking circuit continuity, repair harness or connector.



Magnet Clutch (Cont'd)

For KA engine models

**SYMPTOM: Magnet clutch does not engage when A/C switch and fan switch are ON.**

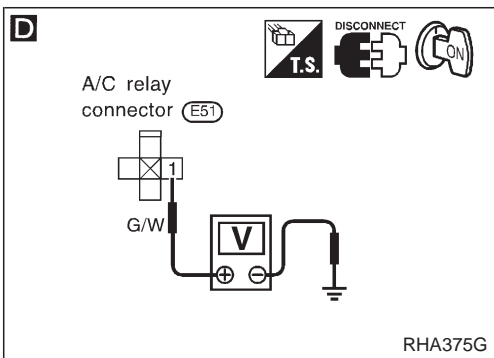
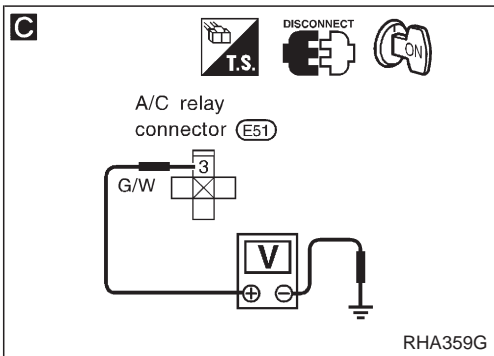
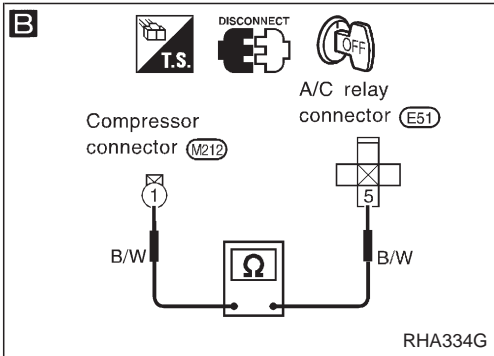
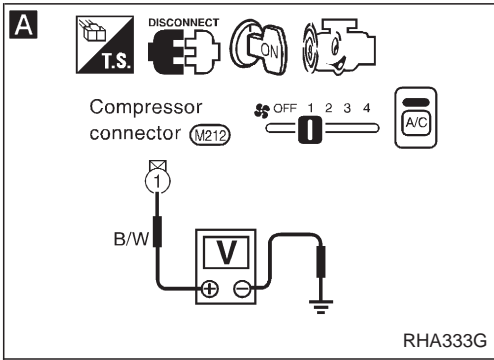

**A**

**CHECK POWER SUPPLY FOR COMPRESSOR.**  
Disconnect compressor harness connector.  
Do approx. 12 volts exist between compressor harness terminal No. ① and body ground?

Yes → Check the following.  
●Magnet clutch coil  
●Thermal protector  
Refer to HA-2021.  
NG → Replace magnet clutch. Refer to HA-69 in D22 Service Manual, Publication No. SM7E-0D22G1.

No →

**B**

**Note**  
Check circuit continuity between A/C relay harness terminal No. ⑤ and compressor harness terminal No. ①.  
**Continuity should exist.**  
If OK, check harness for short.

OK →

**C**

**CHECK POWER SUPPLY FOR A/C RELAY.**  
Do approx. 12 volts exist between A/C relay harness terminal No. ③ and body ground?

No → Check power supply circuit and 7.5A fuse (No. 23, located in the fuse block). (Refer to "POWER SUPPLY ROUTING" in EL section and Wiring Diagram.)

Yes →

**D**

**CHECK POWER SUPPLY FOR A/C RELAY.**  
Do approx. 12 volts exist between A/C relay harness terminal No. ① and body ground?

No → Check power supply circuit and 7.5A fuse (No. 23, located in the fuse block). (Refer to "POWER SUPPLY ROUTING" in EL section and Wiring Diagram.)

Yes →

**CHECK A/C RELAY AFTER DISCONNECTING IT.**  
Refer to HA-2021.

NG → Replace A/C relay.

OK → Reconnect A/C relay.

Ⓐ

(Go to next page.)

**Note:**  
If the result is NG or No after checking circuit continuity, repair harness or connector.

Magnet Clutch (Cont'd)

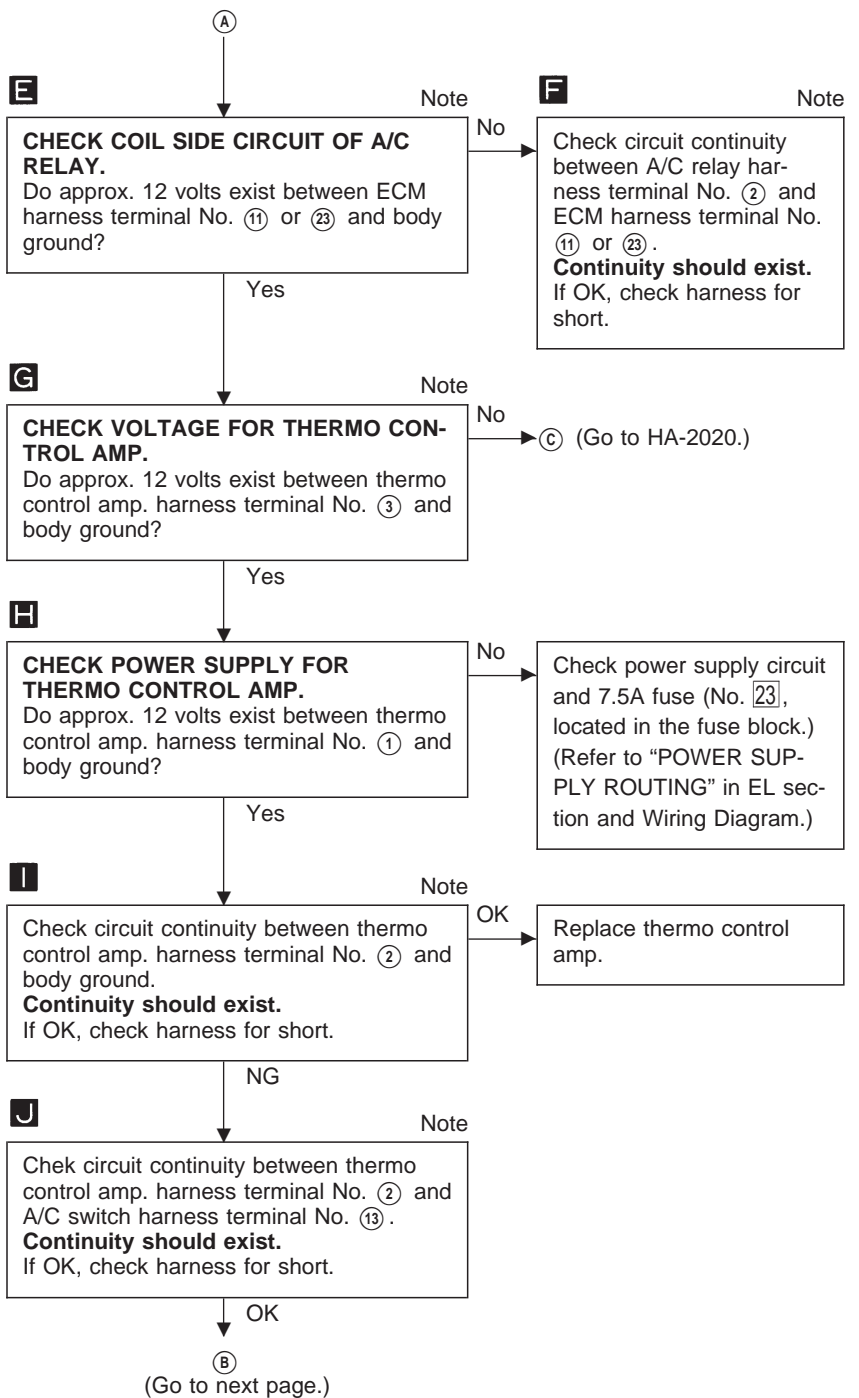
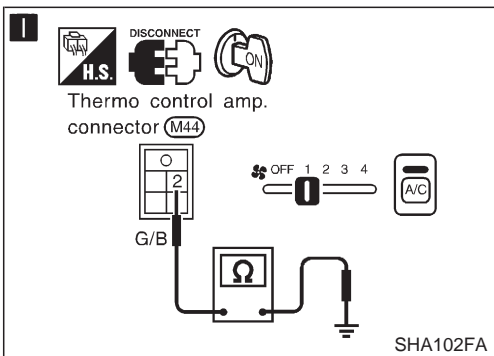
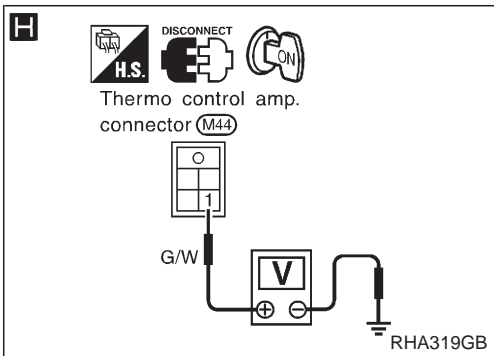
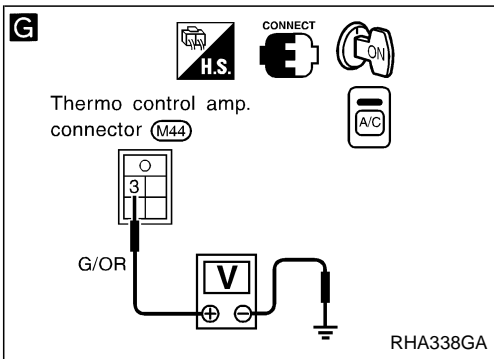
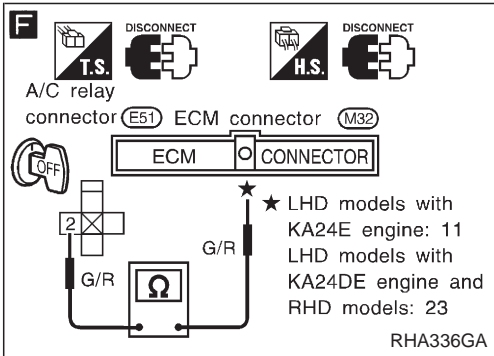
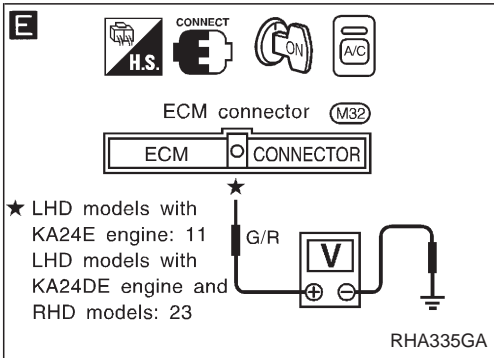

Magnet Clutch (Cont'd)

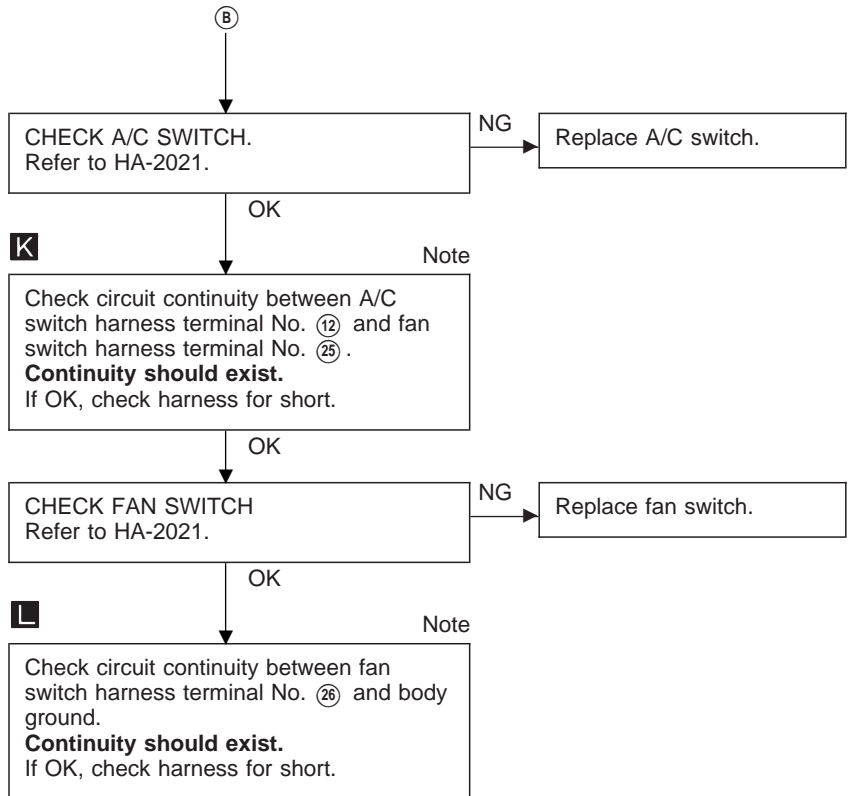
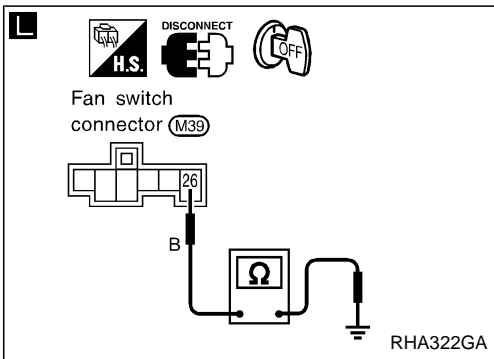
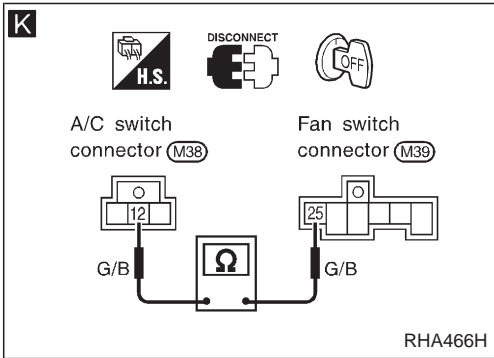
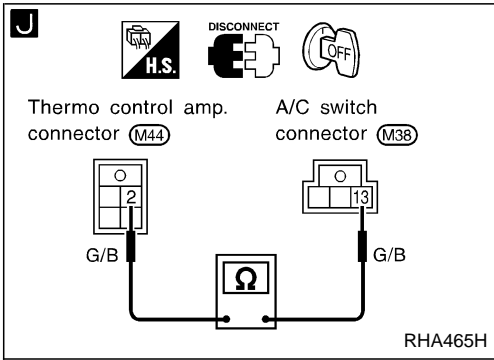

**Note:**

If the result is NG or No after checking circuit continuity, repair harness or connector.

Magnet Clutch (Cont'd)

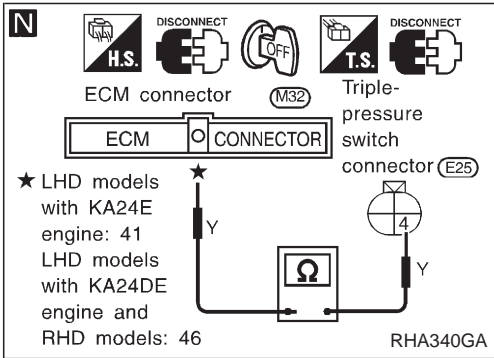
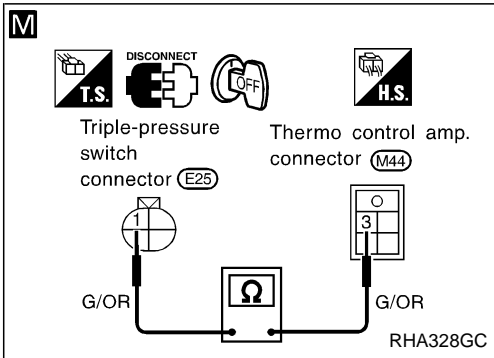

③

**M** Note

Check circuit continuity between thermo control amp. harness terminal No. ③ and triple-pressure switch harness terminal No. ①.  
**Continuity should exist.**  
 If OK, check harness for short.

OK

**CHECK TRIPLE-PRESSURE SWITCH.** Refer to HA-2022.

NG → Replace triple-pressure switch.

OK

**N** Note

Check circuit continuity between triple-pressure switch harness terminal No. ④ and ECM harness terminal No. ④① or ④⑥.  
**Continuity should exist.**  
 If OK, check harness for short.

OK

Replace ECM.

**Note:**  
 If the result is NG or No after checking circuit continuity, repair harness or connector.

**Magnet Clutch (Cont'd)**  
**ELECTRICAL COMPONENTS INSPECTION**

**Fan switch**

Check continuity between terminals at each switch position.

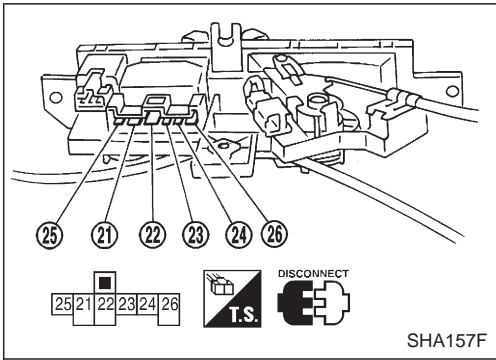

Knob position	Continuity between terminals
OFF	
1	②④ — ②⑥ — ②⑤
2	②③ — ②⑥ — ②⑤
3	②② — ②⑥ — ②⑤
4	②① — ②⑥ — ②⑤

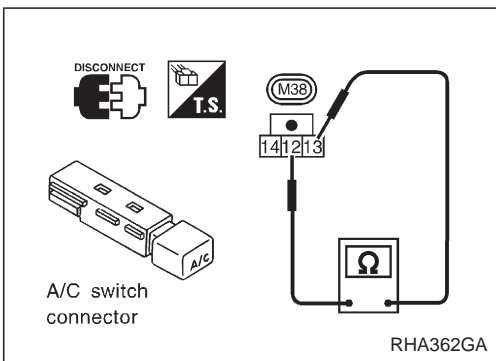

**A/C switch**

Check continuity between terminals at each switch position.

Switch condition	Terminal No.		Continuity
A/C	⊕	⊖	Yes
ON	⑬	⑫	
OFF			No

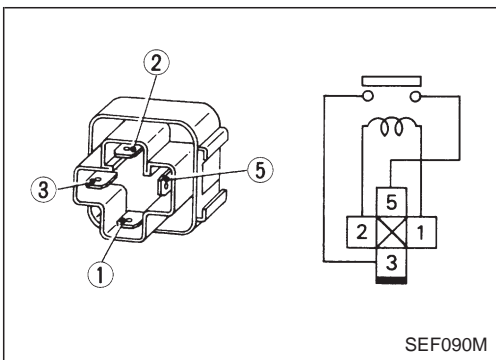

**A/C relay**

Check continuity between terminal Nos. ③ and ⑤.

Conditions	Continuity
12V direct current supply between terminal Nos. ① and ②	Yes
No current supply	No

If NG, replace relay.

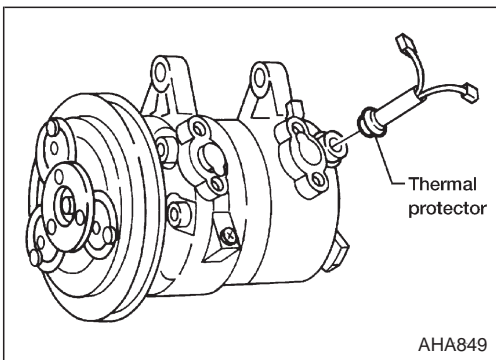

**Thermal protector (For DKV-14C)**

Temperature of compressor °C (°F)	Operation
Increasing to approx. 145 - 155 (293 - 311)	Turn OFF
Decreasing to approx. 130 - 140 (266 - 284)	Turn ON

Magnet Clutch (Cont'd)

Triple-pressure switch

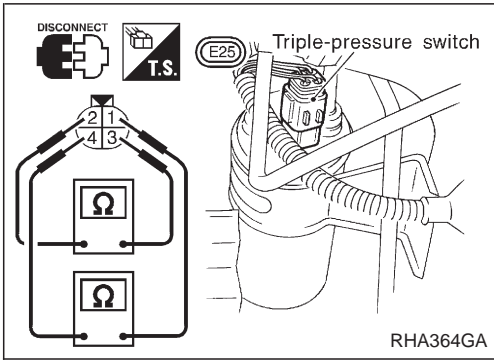

	Terminals	High-pressure side line pressure kPa (bar, kg/cm <sup>2</sup> , psi)	Operation	Continuity
Low-pres- sure side	① - ④	Increasing to 152.0 - 201.0 (1.520 - 2.010, 1.55 - 2.05, 22.0 - 29.2)	ON	Exists.
		Decreasing to 152.0 - 201.0 (1.520 - 2.010, 1.55 - 2.05, 22.0 - 29.2)	OFF	Does not exist.
Medium- pressure side*	② - ③	Increasing to 1,422 - 1,618 (14.22 - 16.18, 14.5 - 16.5, 206 - 235)	ON	Exists.
		Decreasing to 1,128 - 1,422 (11.28 - 14.22, 11.5 - 14.5, 164 - 206)	OFF	Does not exist.
High-pres- sure side	① - ④	Decreasing to 2,059 - 2,256 (20.6 - 22.6, 21 - 23, 299 - 327)	ON	Exists.
		Increasing to 2,648 - 2,844 (26.5 - 28.4, 27 - 29, 384 - 412)	OFF	Does not exist.

\*: For cooling fan motor operation

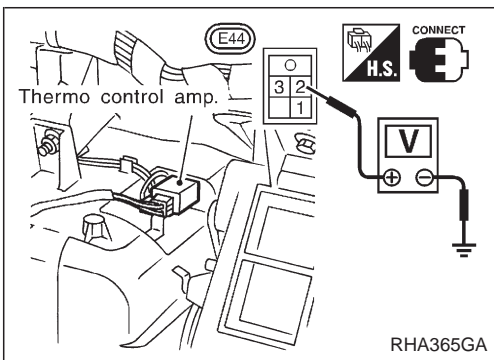

Thermo control amp.

Evaporator outlet air temperature °C (°F)	Thermo amp. operation	Tester
Decreasing to 0.1 - 0.9 (32 - 34)	Turn OFF	Approx. 12V
Increasing to 2.5 - 3.5 (37 - 38)	Turn ON	Approx. 0V

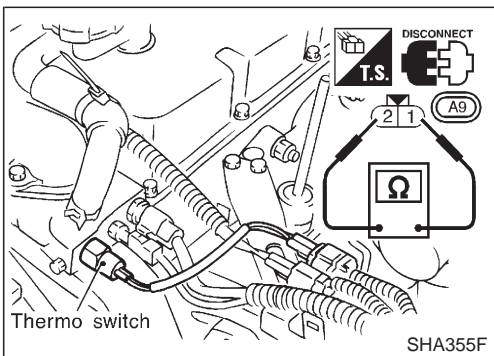

Thermo switch

Water tempera- ture °C (°F)	Terminal No.		Continuity
	⊕	⊖	
Over 105 (221)			No
Less than 100 (212)	①	②	Yes

## Introduction

The Automatic Temperature Control (ATC) system provides automatic regulation of the vehicles interior temperature. The operator selects "set temperature", on which the regulation is based, regardless of the outside temperature changes. This is done by utilizing a microcomputer, also referred to as the automatic amplifier, which receives input signals from several sensors. The automatic amplifier uses these input signals (including the set temperature) to automatically control the ATC system's outlet air volume, air temperature and air distribution.

## Features

### Air mix door control

The air mix door is automatically controlled so that in-vehicle temperature will reach, and be maintained at the operator selected "set temperature". For a given set temperature, the air mix door position will depend on: Ambient temperature, in-vehicle temperature, amount of sunload, and intake air temperature.

### Fan speed control

Blower speed is automatically controlled based on temperature setting, ambient temperature, in-vehicle temperature, intake air temperature, amount of sunload and air mix door position.

With FAN switch set to "AUTO", the blower motor starts to gradually increase air flow volume.

When engine coolant temperature is low, the blower motor operation is delayed to prevent cool air from flowing.

### Intake door control

The intake door position will be determined by: Ambient temperature, in-vehicle temperature, and whether the compressor is on or off.

### Outlet door control

The outlet door position will be determined by: Ambient temperature, in-vehicle temperature, intake air temperature, and amount of sunload.

### Magnet clutch control

The compressor operation (ON-OFF) is automatically controlled by the ambient sensor to prevent compressor damage in very cold ambient temperatures.

### Self-diagnostic system

The self-diagnostic system consists of five steps. Each step can be accessed by pushing the switches on the automatic amplifier.

### Memory function

With ignition switch turned OFF, the auto amplifier stores in memory the set temperature and inputs of various switches. When the ignition switch is turned ON, the system begins operation with the information stored in memory. The system, then immediately compensates for the actual operating conditions.

### Overview of Control System

The control system consists of input sensors, switches, the automatic amplifier (microcomputer) and outputs. The relationship of these components is shown in the diagram below:

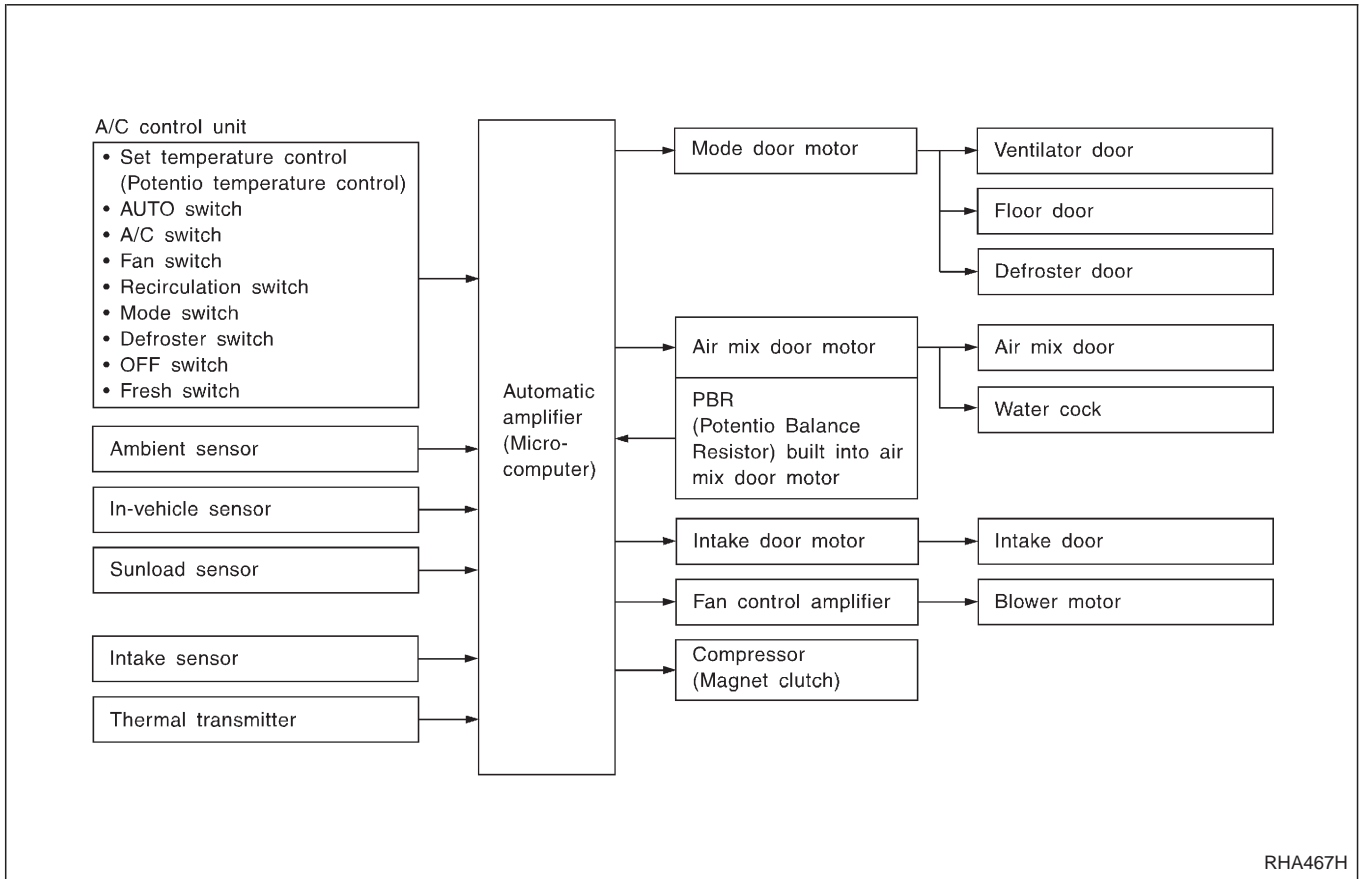

### Control Operation

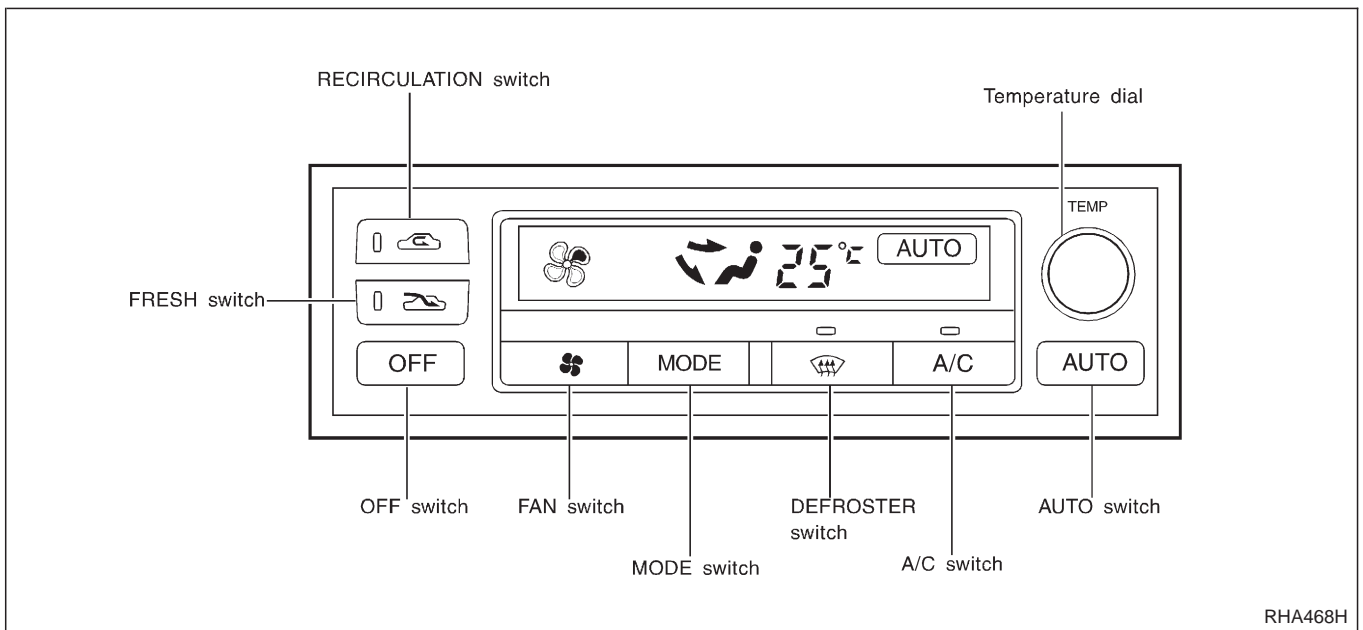



---

**Control Operation (Cont'd)****Display screen**

Displays the operational status of the system.

**AUTO switch**

The compressor, intake doors, air mix door, outlet doors, and blower speed are automatically controlled so that the in-vehicle temperature will reach, and be maintained at the set temperature selected by the operator.

**Temperature dial (Potentio Temperature Control)**



Increases or decreases the set temperature.

**OFF switch**

The compressor and blower are OFF, the intake doors are set to the outside air position, and the air outlet doors are set to the foot (80% foot and 20% defrost) position.

**FAN switch**

Manual control of the blower speed. Four speeds are available for manual control (as shown on the display screen):

low  , medium low  , medium high  , high 

**RECIRCULATION switch**

OFF position: Automatic control resumes.

ON position: Interior air is recirculated inside the vehicle.

**DEFROSTER switch**

Positions the air outlet doors to the defrost position. Also positions the intake doors to the outside air position.

**MODE switch**

Control the air discharge outlets.

**FRESH switch**

OFF position: Automatic control resumes.

ON position: Outside air is drawn into the passenger compartment.

**A/C switch**

Manual control of the compressor operation. When the A/C switch indicator illuminates, compressor operation is being carried out.

Component Location

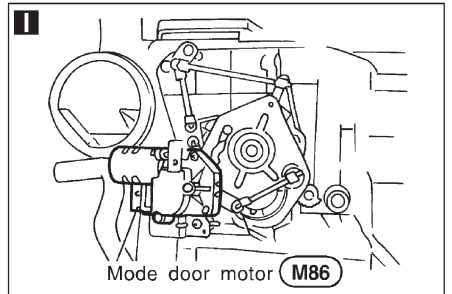
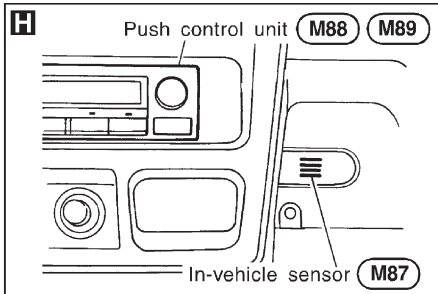
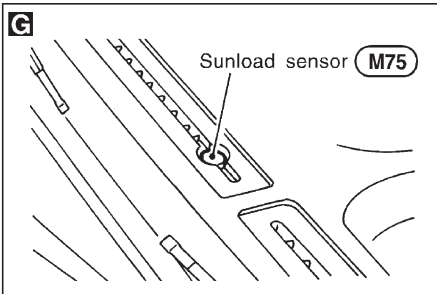
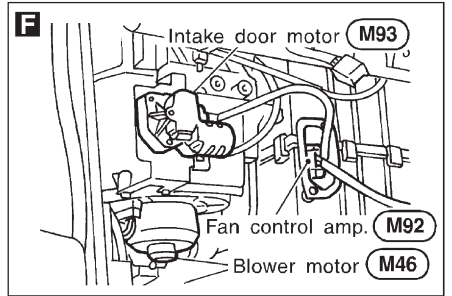
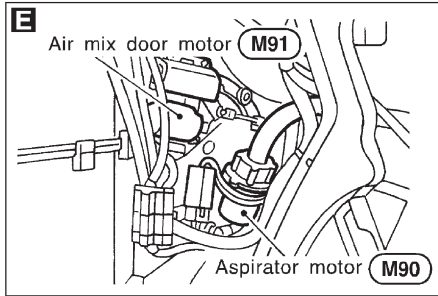
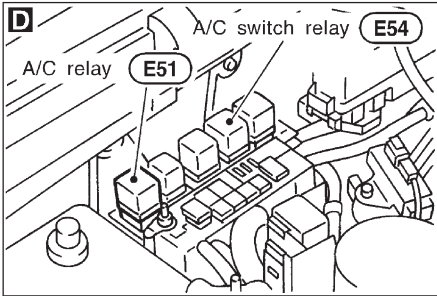
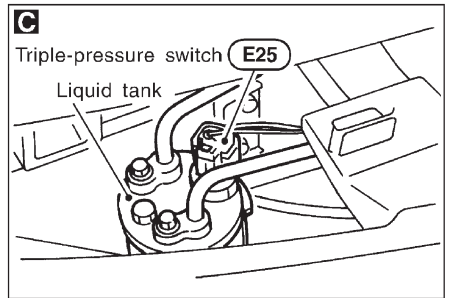
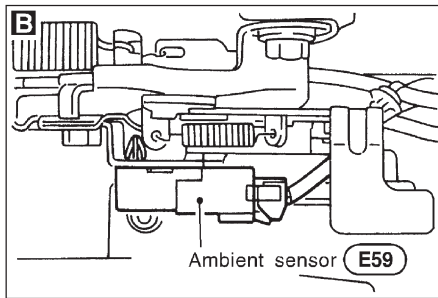
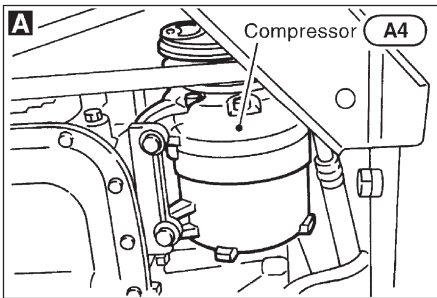
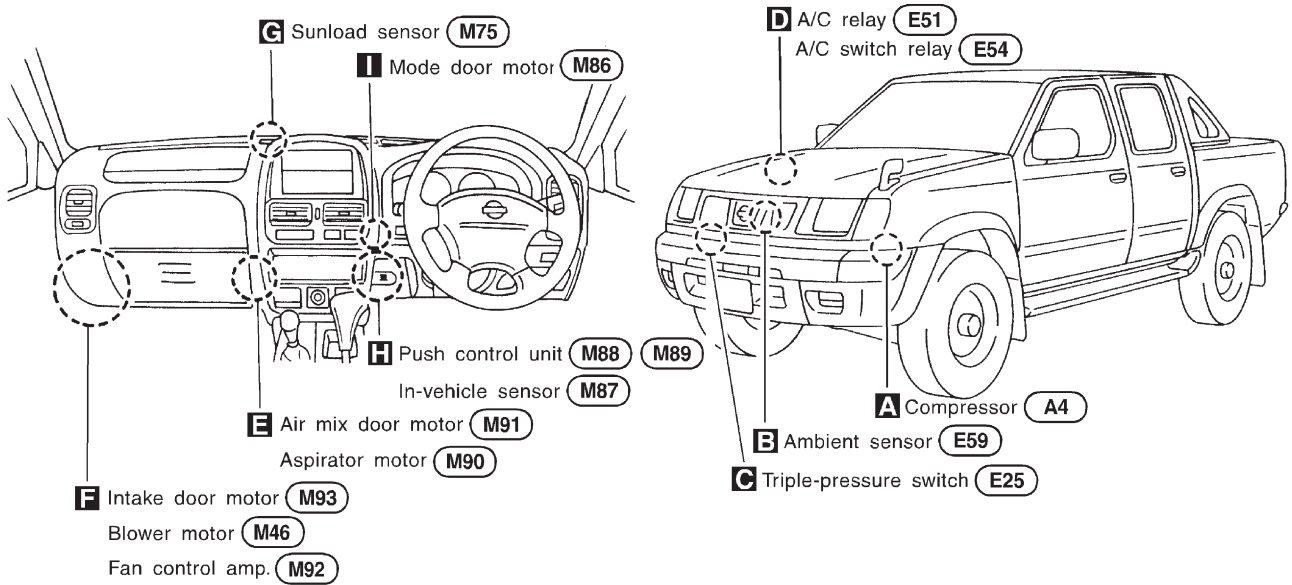

Circuit Diagram

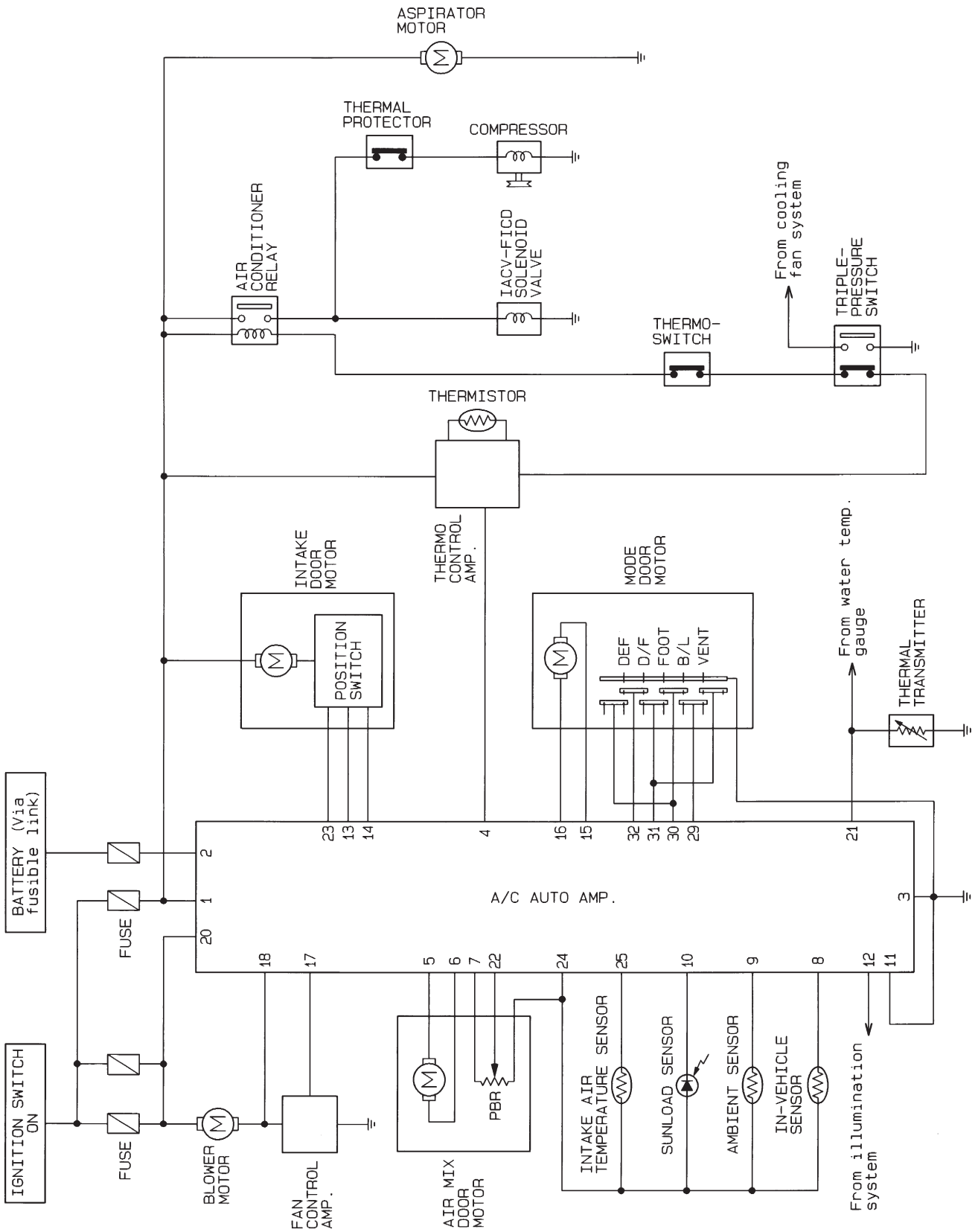

Wiring Diagram — A/C, A —

HA-A/C, A-01

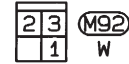
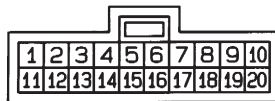
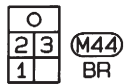
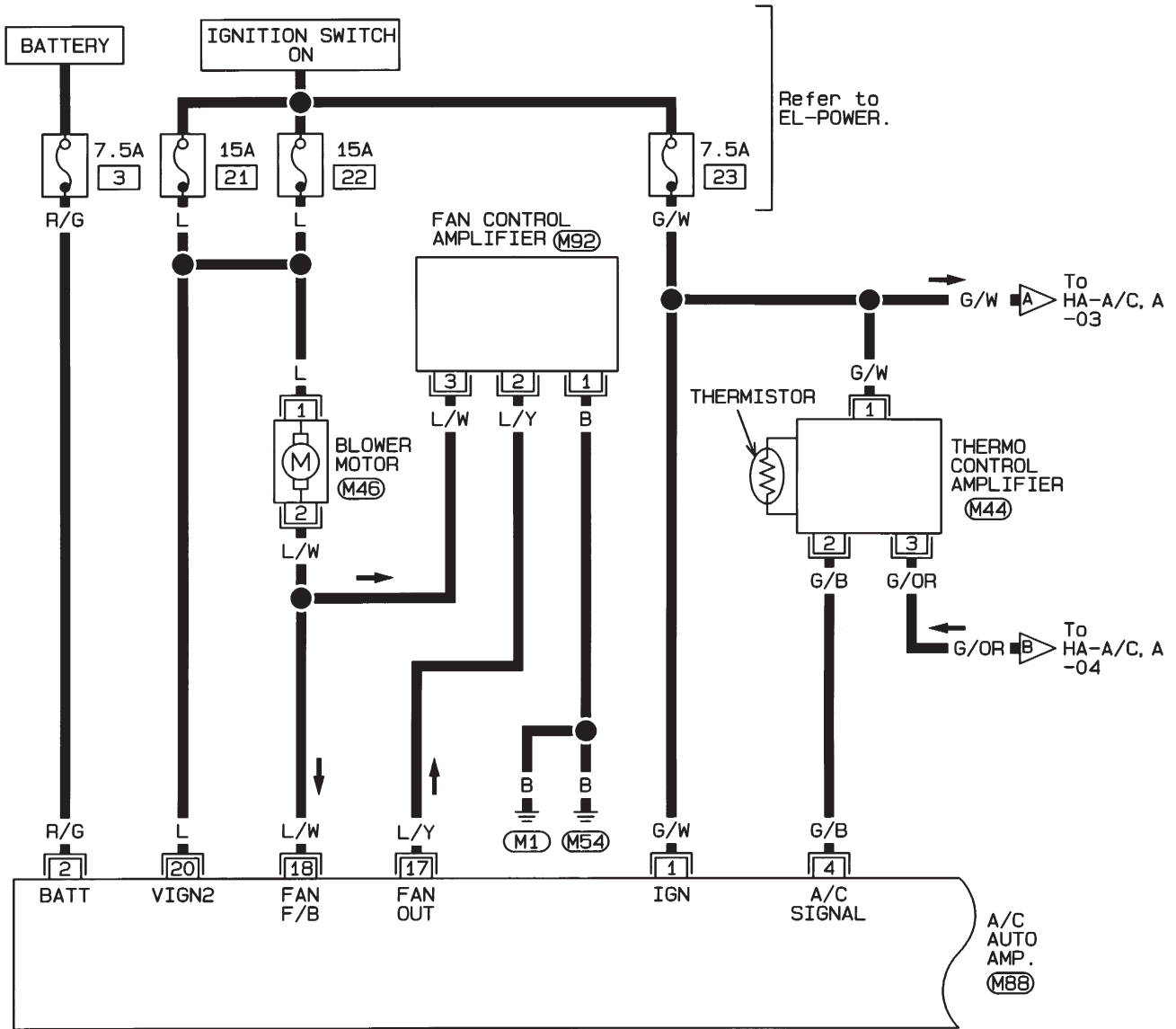

# TROUBLE DIAGNOSES

AUTO

## Wiring Diagram — A/C, A — (Cont'd)

HA-A/C, A-02

⬅ : LHD models \*1... ⬅ 8J, ➡ 3B  
 ➡ : RHD models \*2... ⬅ 12C, ➡ 3C

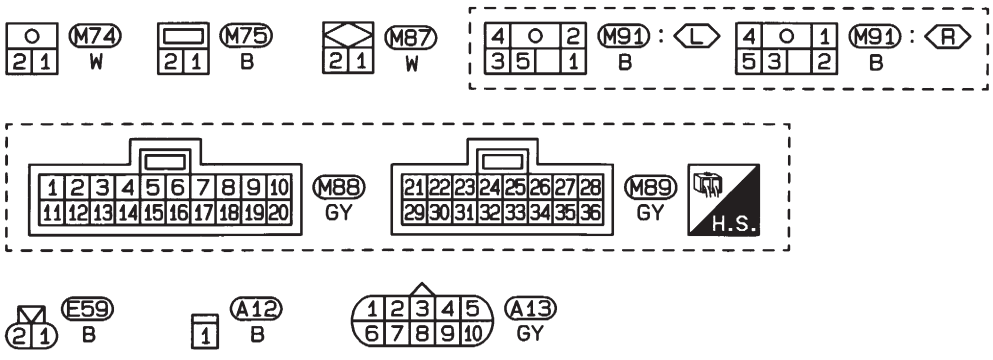
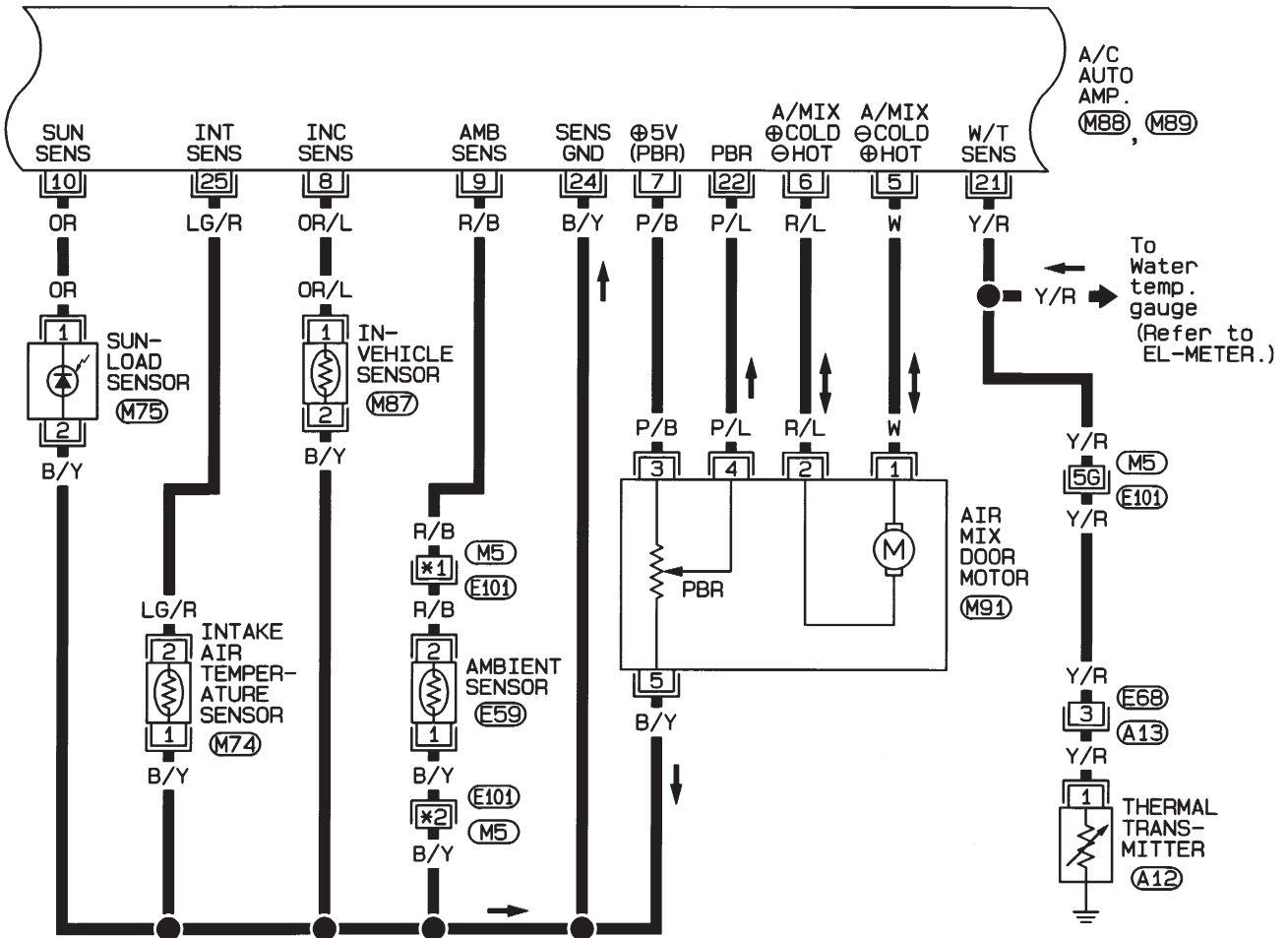

Refer to last page (Foldout page).

(M5), (E101)

# TROUBLE DIAGNOSES

**AUTO**

## Wiring Diagram — A/C, A — (Cont'd)

HA-A/C, A-03

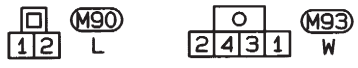
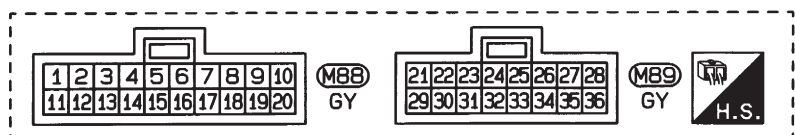
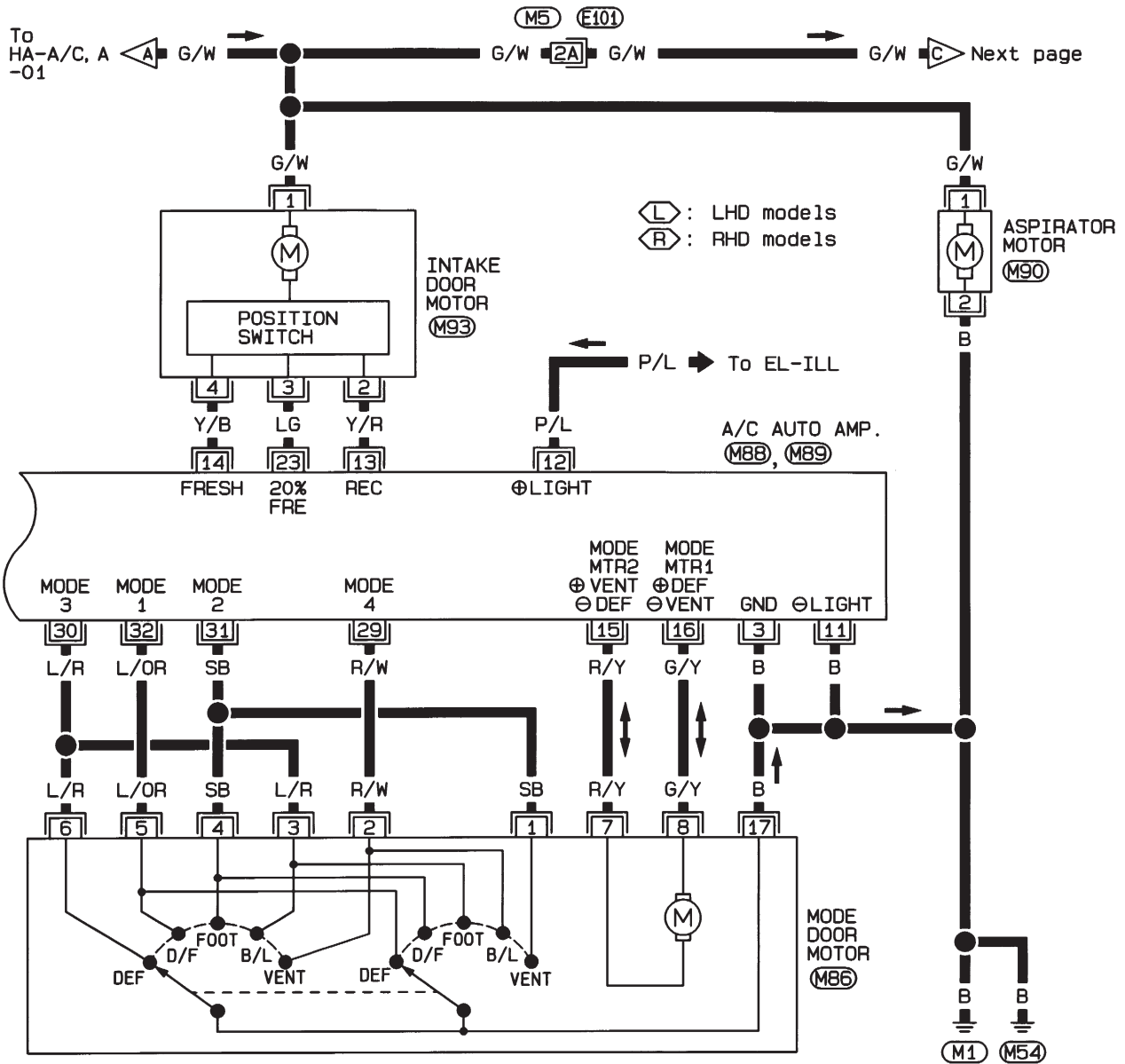

Refer to last page (Foldout page).

(M5), (E101)

Wiring Diagram — A/C, A — (Cont'd)

HA-A/C, A-04

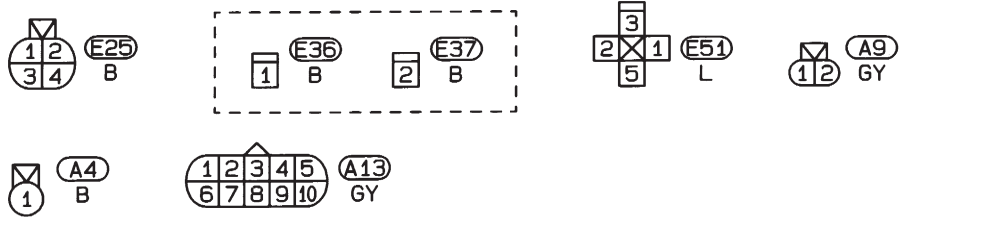
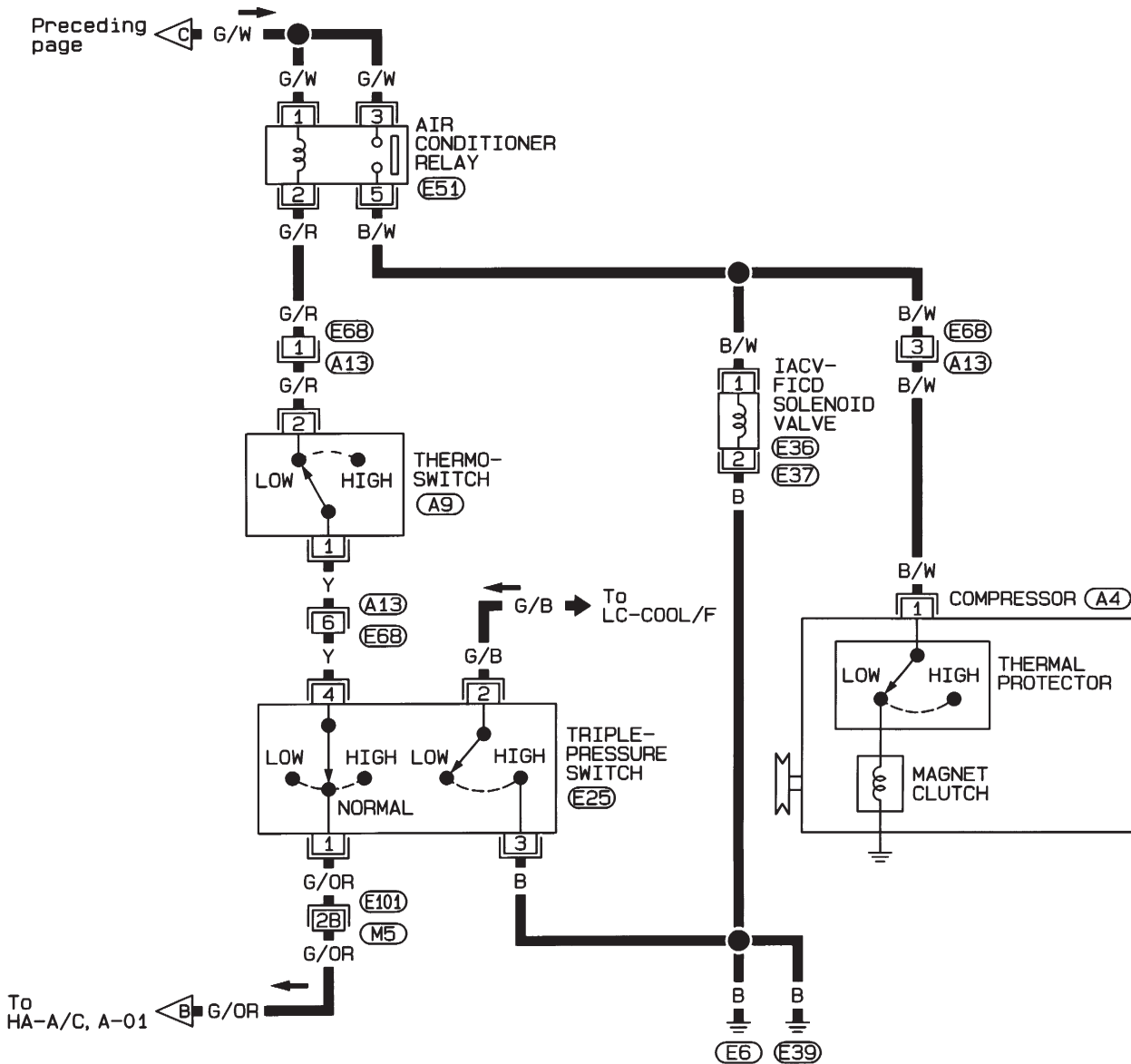

Refer to last page (Foldout page).  
 M5, E101

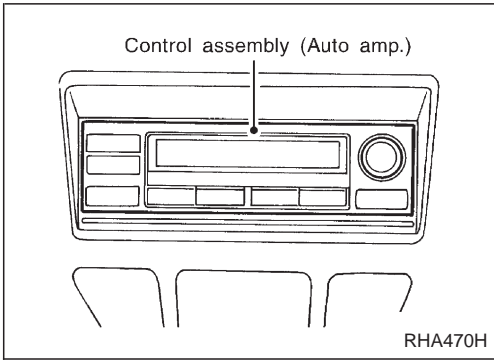

**Auto Amp. Terminals and Reference Value**

**INSPECTION OF AUTO AMP.**

- Measure voltage between each terminal and body ground by following "AUTO AMP. INSPECTION TABLE".

- Pin connector terminal layout

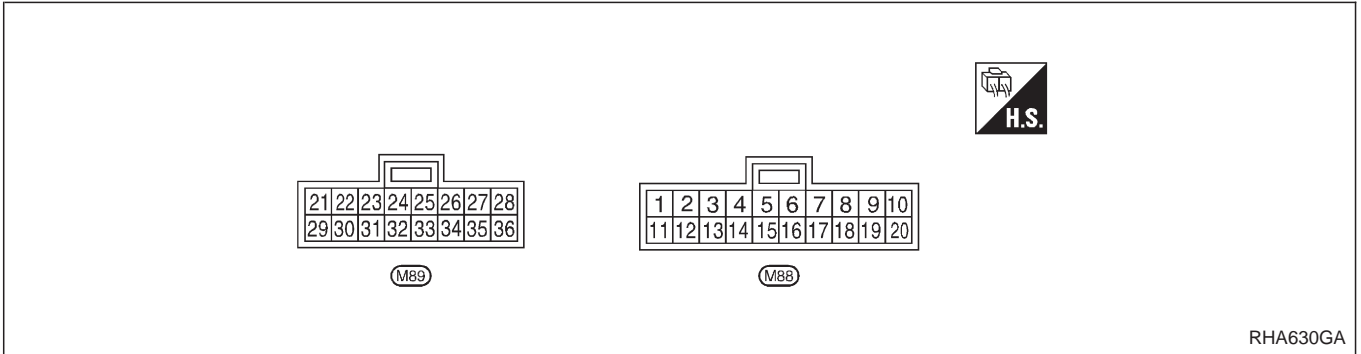







# TROUBLE DIAGNOSES

AUTO

## Auto Amp. Terminals and Reference Value (Cont'd)



### AUTO AMP. INSPECTION TABLE

TERMINAL NO.	ITEM	CONDITION		Voltage V	
1	Power supply for IGN		—	Approximately 12	
2	Power supply for BAT		—	Approximately 12	
3	Ground	—		—	
4	Compressor ON signal		Compressor ON	Approximately 0	
5	Power supply for air mix door motor		Set temperature	32°C	Approximately 12
				18°C	Approximately 0
6	Power supply for air mix door motor		Set temperature	32°C	Approximately 0
				18°C	Approximately 12
7	Power supply for PBR		—		Approximately 5
8	In-vehicle sensor	—		—	
9	Ambient sensor	—		—	
10	Sunload sensor	—		—	
11	Ground	—		—	
12	Power supply for illumination		Illumination switch ON	Approximately 12	
13	Intake door position switch		Recirculation	Approximately 0	
			Fresh or 20% Fresh	*	
14	Intake door position switch		Fresh	Approximately 0	
			Recirculation or 20% Fresh	*	
15	Power supply for mode motor		DEF → VENT	Approximately 12	
			VENT → DEF	Approximately 0	
16	Power supply for mode motor		DEF → VENT	Approximately 0	
			VENT → DEF	Approximately 12	
17	Fan control amp. control signal		Fan speed	Low, Middle Low, Middle high	Approximately 2.5 - 3.0
				High	Approximately 9.0
18	Blower motor feed back		Fan speed	Low	Approximately 8
19	Blower fan motor ON signal		Blower fan: ON		Approximately 0
			Blower fan: OFF		Approximately 5
20	Power supply for IGN		—		Approximately 12
21	Thermal transmitter		—		—
22	Air mix door motor PBR signal			Set temperature 32°C	Approximately 4.5
				18°C	Approximately 0.5
23	Intake door motor position switch		20% Fresh		Approximately 0
		Recirculation or Fresh		*	
24	Ground	—		—	
25	Intake sensor	—		—	
27	FICD ON signal		Compressor ON	Ambient temperature: 20.5°C (69°F) or less	Approximately 0
				Ambient temperature: 23.5°C (74°F) or more	Approximately 12
29	Mode door motor position signal	VENT, B/L		Approximately 0	
30	Mode door motor position signal	FOOT, D/F, DEF		Approximately 5	
		B/L, FOOT		Approximately 0	
31	Mode door motor position signal	VENT, D/F, DEF		Approximately 5	
		VENT, FOOT, D/F		Approximately 0	
32	Mode door motor position signal	B/L, DEF		Approximately 5	
		D/F, DEF		Approximately 0	
		VENT, B/L, FOOT		Approximately 5	

\*: When the motor is working approx. 0V will be indicated. When the motor is stopped, approx. 12V will exist.

### Self-diagnosis

#### INTRODUCTION AND GENERAL DESCRIPTION

The self-diagnostic system diagnoses sensors, door motors, blower motor, etc. by system line. Refer to applicable sections (items) for details. Shifting from normal control to the self-diagnostic system is accomplished by starting the engine (turning the ignition switch from "OFF" to "ON") and pressing "OFF" switch for at least 5 seconds. The "OFF" switch must be pressed within 5 seconds after starting the engine (ignition switch is turned "ON"). This system will be canceled by either pressing  (AUTO) switch or turning the ignition switch "OFF". Shifting from one step to another is accomplished by means of turning temperature dial clockwise or counterclockwise, as required. Additionally shifting from STEP 4 to AUXILIARY MECHANISM is accomplished by means of pushing  (fan) switch.

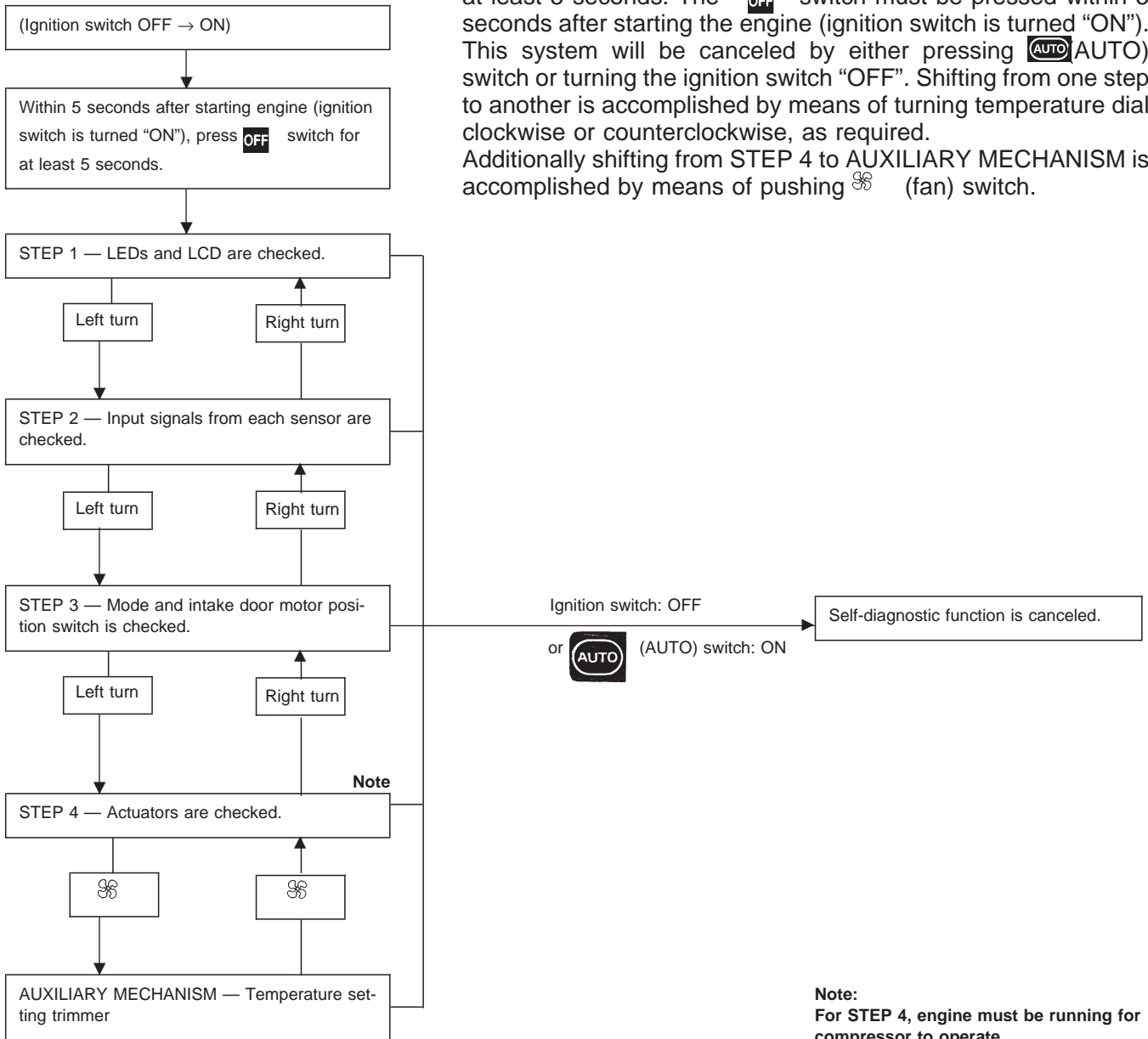

## Self-diagnosis (Cont'd)

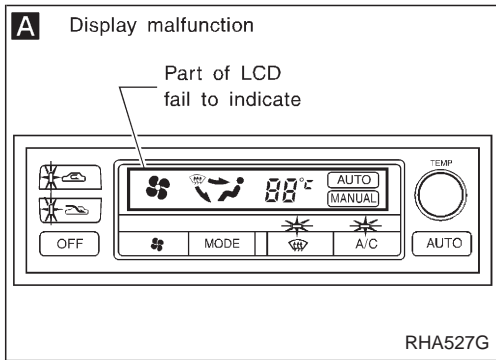
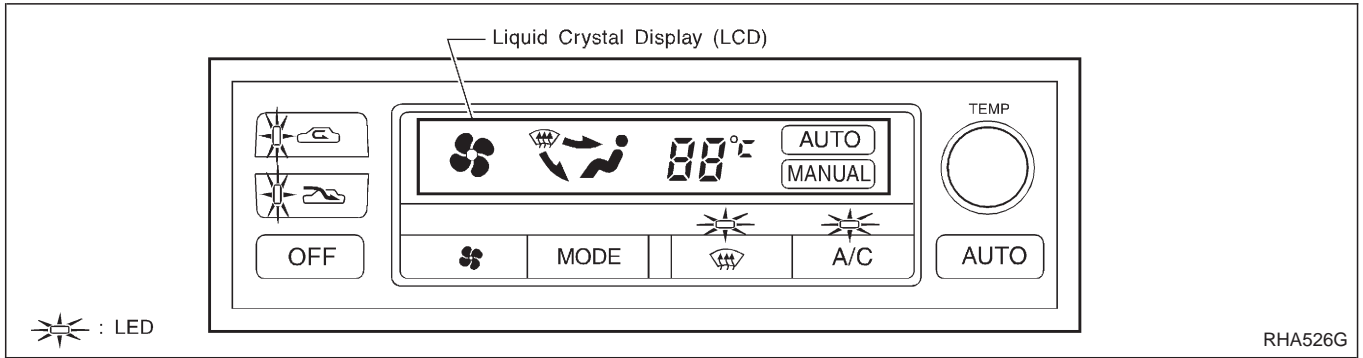

### STEP-BY-STEP PROCEDURE

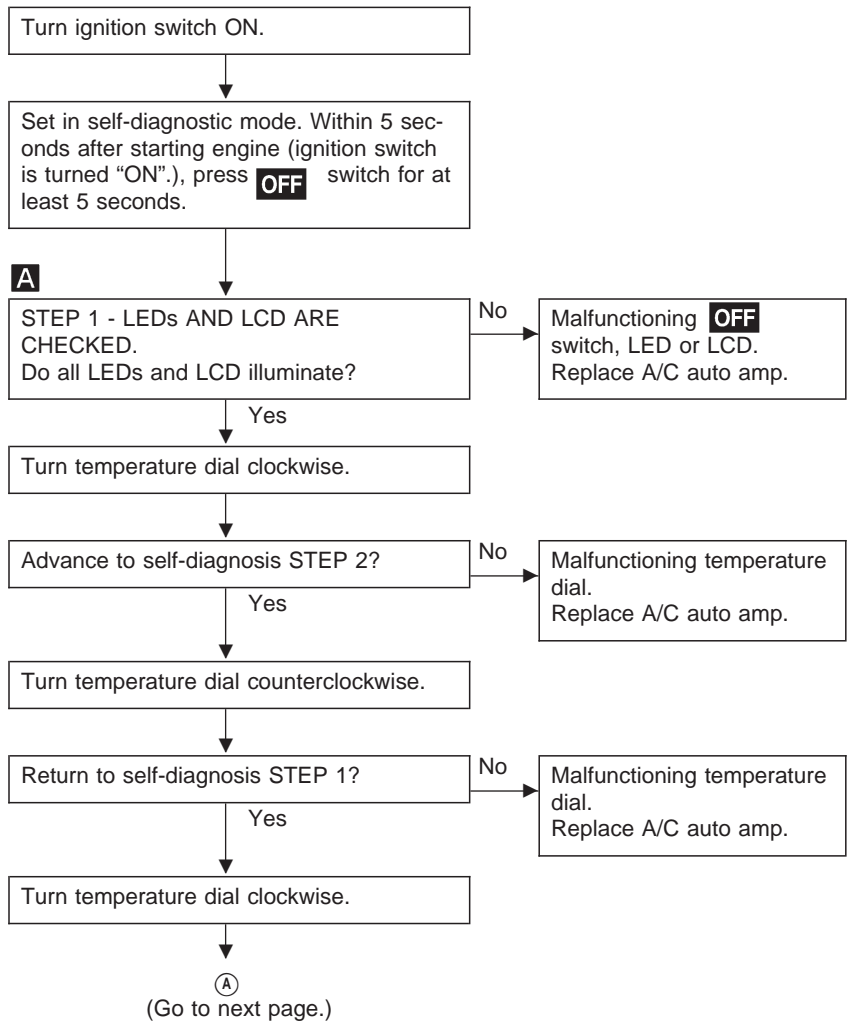

Self-diagnosis (Cont'd)

**B** Display (when all sensors are in good order)

Illuminates 4 seconds after "2" is illuminated.

RHA970DA

Display (when sensor malfunctions)

Code No. (blinks)

Illuminates

Indicating a short circuit

A/C

RHA528G

**C**

Each code No. blinks two times.

RHA501A

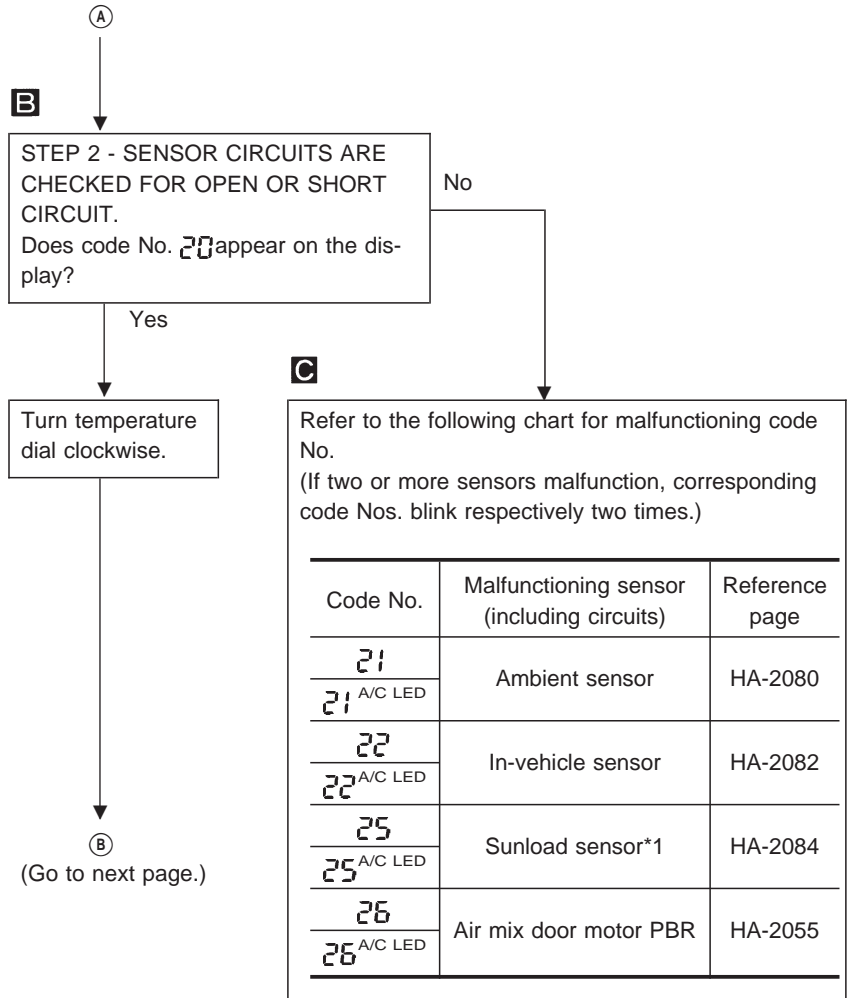

**\*1: Conduct self-diagnosis STEP 2 under sunshine.**  
When conducting indoors, aim a light (more than 60W) at sunload sensor, otherwise Code No. 25 will indicate despite that sunload sensor is functioning properly.

**Self-diagnosis (Cont'd)**

**D** Display (when all doors are in good order)

Illuminates 50 seconds after "3" is shown on display.

Illuminates

RHA869DC

**E** Display (when a door is out of order)

Code No. (blinks)

Illuminates

RHA168DA

**E**

Each code No. blinks two times.

RHA498A

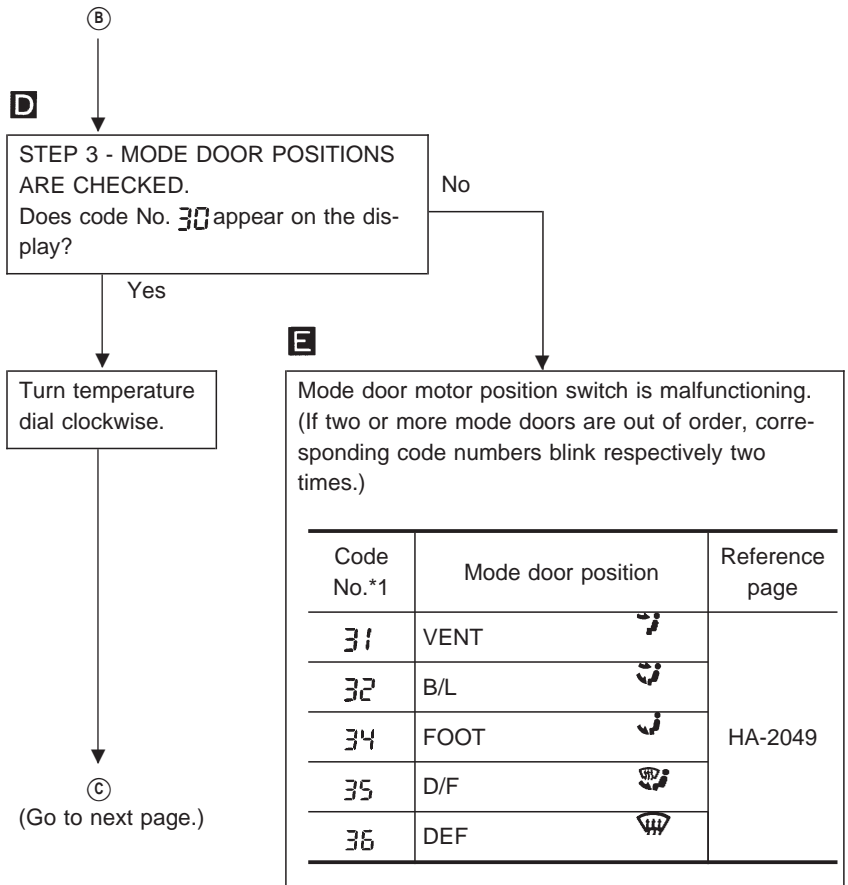

\*1: If mode door motor harness connector is disconnected, the following display pattern will appear.

→ 31 → 32 → 34 → 35 → 36

## Self-diagnosis (Cont'd)

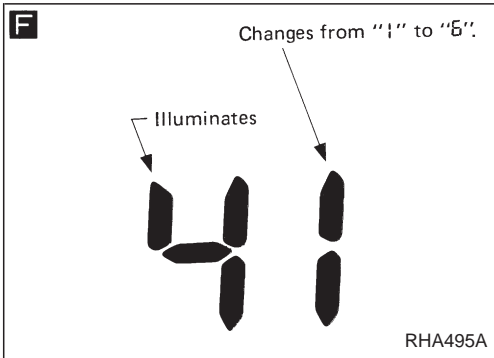

**G**

**Discharge air flow**

Mode door position	Air outlet/distribution		
	Face	Foot	Defroster
	100% (100%)	-	-
	60% (55%)	40% (45%)	-
	-	80% (100%)	20% (-)
	-	60% (65%)	40% (35%)
	-	-	100% (100%)

( ): For RHD models

RHA654FG

Ⓒ

**F**

STEP 4 - OPERATION OF EACH ACTUATOR IS CHECKED.  
Engine running.  
Press DEF switch, code No. of each actuator test is indicated on the display.

**G**

Refer to the following chart and confirm discharge air flow, air temperature, blower motor voltage and compressor operation.  
**Checks must be made visually, by listening to any noise, or by touching air outlets with your hand, etc. for improper operation.**

Code No.	Actuator test pattern					
	Mode door	Intake door	Air mix door	Blower motor	Compressor	FICD
41	VENT 	REC	Full Cold	4 - 5V	ON	ON
42	B/L 	REC	Full Cold	9 - 11V	ON	ON
43	B/L 	20% FRE	Full Hot	7 - 9V	ON	OFF
44	FOOT 	FRE	Full Hot	7 - 9V	OFF	OFF
45	D/F 	FRE	Full Hot	7 - 9V	OFF	OFF
46	DEF 	FRE	Full Hot	10 - 12V	ON	OFF

- NG
- Air outlet does not change.  
Go to HA-2047.
  - Intake door does not change.  
Go to HA-2058.
  - Discharge air temperature does not change.  
Go to HA-2052.
  - Magnet clutch does not engage.  
Go to HA-2068.
  - Blower motor operation is malfunctioning.  
Go to HA-2062.

OK

Turn ignition switch OFF or AUTO switch ON.

END

**Self-diagnosis (Cont'd)****AUXILIARY MECHANISM: Temperature setting trimmer**

The trimmer compensates for differences in range of  $\pm 3^{\circ}\text{C}$  between temperature setting (displayed digitally) and temperature felt by driver.

Operating procedures for this trimmer are as follows:

- Begin Self-diagnosis STEP 4 mode.
- Press  (fan) switch to set system in auxiliary mode.
- Turn temperature dial clockwise or counterclockwise as desired. Temperature will change at a rate of  $1^{\circ}\text{C}$  each time a switch is pressed.

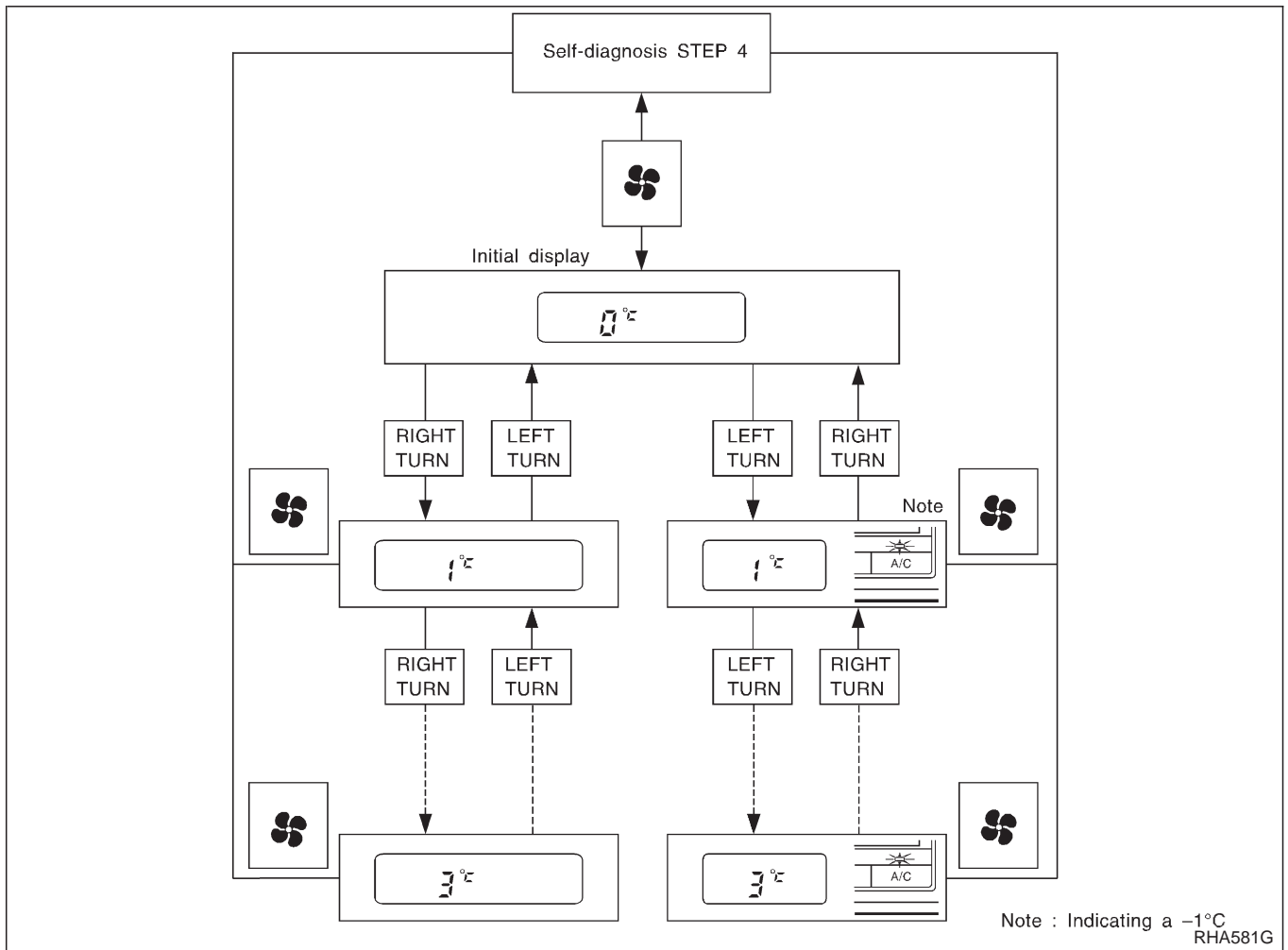

When battery cable is disconnected, trimmer operation is canceled. Temperature set becomes that of initial condition, i.e.  $0^{\circ}\text{C}$ .

How to Perform Trouble Diagnoses for Quick and Accurate Repair

WORK FLOW

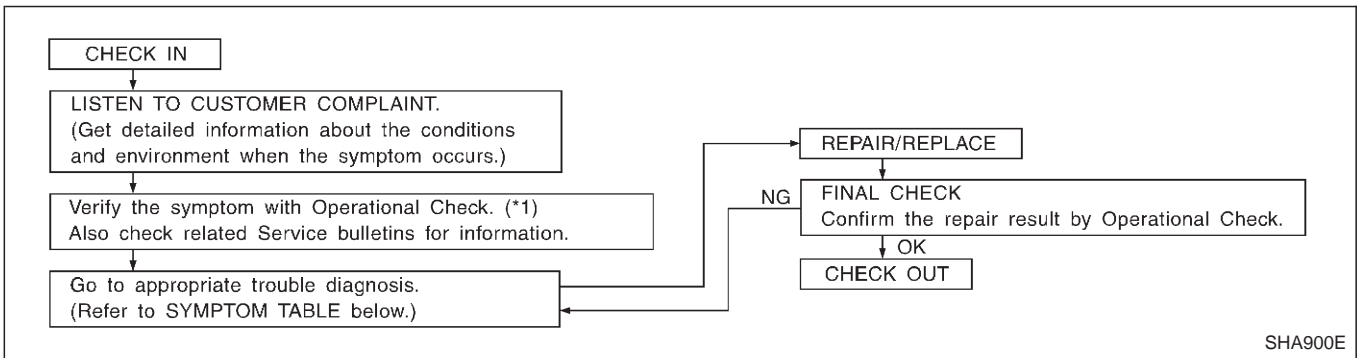

\*1: Operational Check (HA-2041)

SYMPTOM TABLE

Symptom	Reference page
●A/C system does not come on.	●Go to Trouble Diagnosis Procedure for A/C system. HA-2045
●Air outlet does not change.	●Go to Trouble Diagnosis Procedure for Mode Door Motor. HA-2049
●Mode door motor does not operate normally.	
Discharge air temperature does not change.	●Go to Trouble Diagnosis Procedure for Air Mix Door Motor. HA-2055
●Air mix door motor does not operate normally.	
●Intake door does not change.	●Go to Trouble Diagnosis Procedure for Intake Door Motor. HA-2060
●Intake door motor does not operate normally.	
●Blower motor operation is malfunctioning.	●Go to Trouble Diagnosis Procedure for Blower Motor. HA-2065
●Blower motor operation is malfunctioning under out of starting fan speed control.	
●Magnet clutch does not engage.	●Go to Trouble Diagnosis Procedure for Magnet Clutch. HA-2070
●Insufficient cooling.	●Go to Trouble Diagnosis Procedure for Insufficient Cooling. HA-2075
●Insufficient heating.	●Go to Trouble Diagnosis Procedure for Insufficient Heating. HA-2076
●Noise.	●Go to Trouble Diagnosis Procedure for Noise. HA-2077
●Self-diagnosis cannot be performed.	●Go to Trouble Diagnosis Procedure for Self-diagnosis. HA-2078
●Memory function does not operate.	●Go to Trouble Diagnosis Procedure for Memory Function. HA-2079



## Operational Check

The purpose of the operational check is to confirm that the system operates properly.

### CONDITIONS

- Engine running and at normal operating temperature.

### PROCEDURE

#### 1. Check memory function



- Set the temperature 25°C.
- Press OFF switch.
- Turn the ignition OFF.
- Turn the ignition ON.
- Press the AUTO switch.
- Confirm that the set temperature remains at previous temperature.
- Press OFF switch.

If NG, go to trouble diagnosis procedure for memory function (HA-2079).

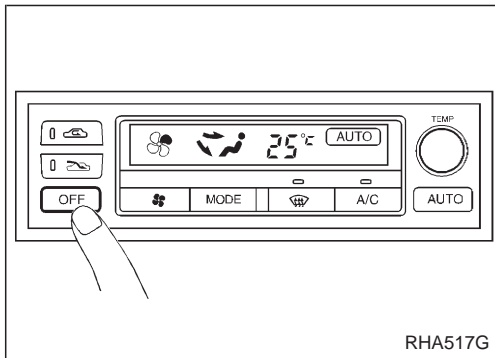
If OK, continue with next check.



#### 2. Check blower

- Press fan switch one time.  
Blower should operate on low speed.  
The fan symbol should have one blade lit .
- Press fan switch one more time, and continue checking blower speed and fan symbol until all speeds are checked.
- Leave blower on MAX speed .

If NG, go to trouble diagnosis procedure for blower motor (HA-2065).

If OK, continue with next check.

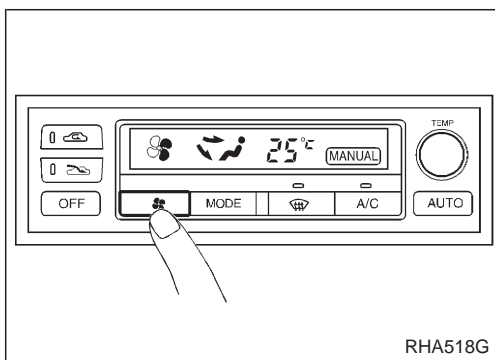

#### 3. Check discharge air

- Press mode switch four times and DEF button.

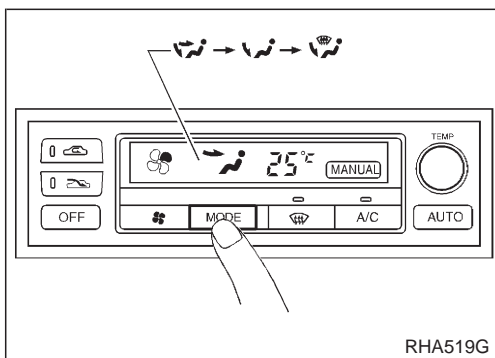

Operational Check (Cont'd)

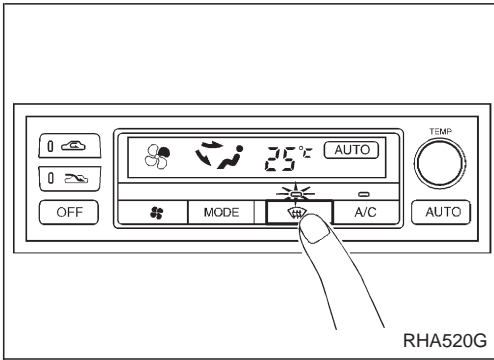

**Discharge air flow**

Mode switch	Air outlet/distribution		
	Face	Foot	Defroster
	100% (100%)	-	-
	60% (55%)	40% (45%)	-
	-	80% (100%)	20% (-)
	-	60% (65%)	40% (35%)
	-	-	100% (100%)

( ): For RHD models

b. Confirm that discharge air comes out according to the air distribution table at left.

Refer to “Discharge Air Flow” (HA-15 in D22 Service Manual, Publication No. SM8E-0D22E0E).

**NOTE:**

**Confirm that the compressor clutch is engaged (visual inspection) and intake door position is at FRESH when the DEF is selected.**

**Intake door position is checked in the next step.**

If NG, go to trouble diagnosis procedure for mode door motor (HA-2049).

If OK, continue with next check.

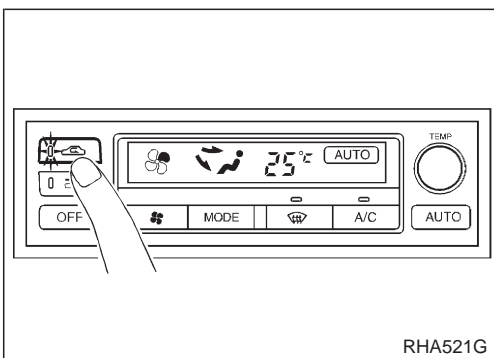

**4. Check recirculation**

a. Press REC switch.

Recirculation indicator should illuminate.

b. Listen for intake door position change (you should hear blower sound change slightly).

If NG, go to trouble diagnosis procedure for intake door motor (HA-2060).

If OK, continue with next check.

**Operational Check (Cont'd)****5. Check temperature dial**

a. Turn temperature dial counterclockwise until 18°C is displayed.

b. Check for cold air at discharge air outlets.

If NG, go to trouble diagnosis procedure for insufficient cooling (HA-2075).

If OK, continue with next check.

c. Turn temperature dial clockwise until 32°C is displayed.

d. Check for hot air at discharge air outlets.

If NG, go to trouble diagnosis procedure for insufficient heating (HA-2076).

If OK, continue with next check.

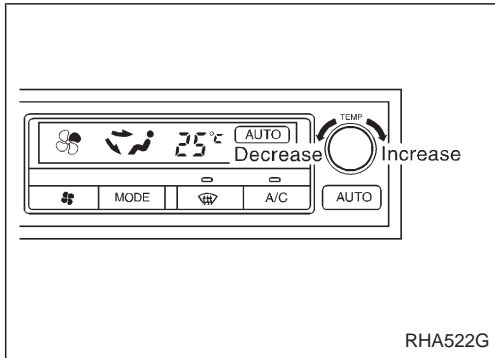

## Operational Check (Cont'd)

### 6. Check AUTO mode

- a. Press AUTO switch.
- b. Display should indicate AUTO.  
 Confirm that the compressor clutch engages (audio or visual inspection).  
 (Discharge air and blower speed will depend on ambient, in-vehicle, and set temperatures.)

If NG, go to trouble diagnosis procedure for A/C system (HA-2045).

If OK, continue with next check.

Then if necessary, go to trouble diagnosis procedure for magnet clutch (HA-2068).

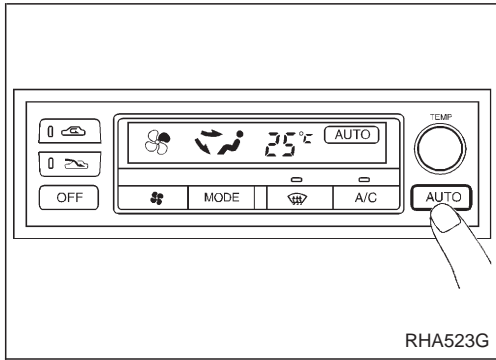

### 7. Check FRESH switch

- a. Press FRE switch.  
 FRESH indicator should illuminate.
- b. Listen for intake door position change. (You should hear a slight change in blower sound.)

If NG, go to trouble diagnosis procedure for intake door motor (HA-2060).

If OK, continue with next check.

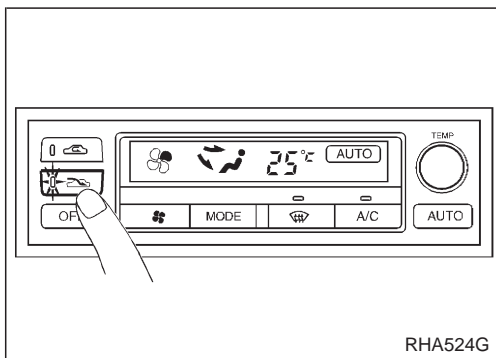

### 8. Check A/C switch

- a. Press A/C switch.  
 A/C indicator should illuminate.
- b. Confirm that the compressor clutch is engaged.

If NG, go to trouble diagnosis procedure for A/C system (HA-2045).

If OK, continue with next check.

If all operational check are OK (symptom cannot be duplicated), go to "Incident Simulation Test" (GI section) and perform test as outlined to simulated driving conditions environment. If symptom appear, refer to "SYMPTOM TABLE" (HA-2040) and perform applicable trouble diagnosis procedures.

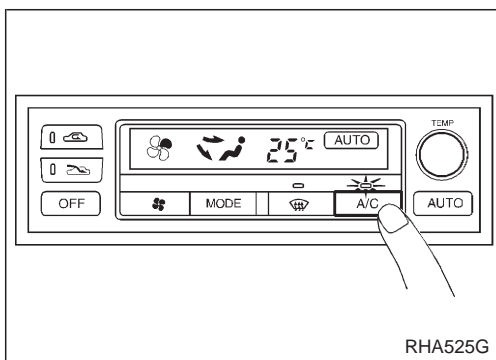

## A/C System

## TROUBLE DIAGNOSIS PROCEDURE FOR A/C SYSTEM

## SYMPTOM:

- A/C system does not come on.

## Inspection flow

1. Confirm symptom by performing the following operational check.

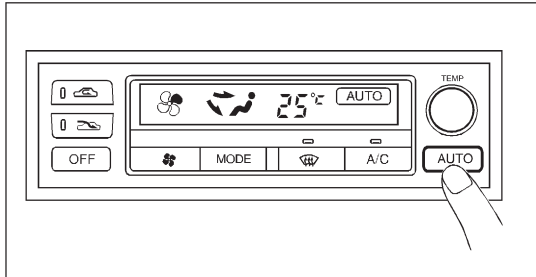
**OPERATIONAL CHECK – AUTO mode**

- Press AUTO switch.
- Display should indicate AUTO.  
Confirm that the compressor clutch engages (audio or visual inspection).  
(Discharge air and blower speed will depend on ambient, in-vehicle, and temperatures dial.)

If OK (symptom cannot be duplicated), perform complete operational check (\*2).  
If NG (symptom is confirmed), continue with STEP-2 following.

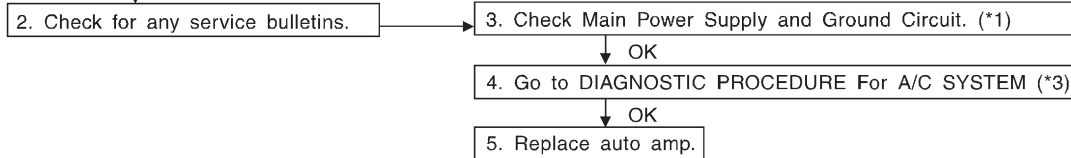

SHA354F

\*1: HA-2046

\*2: HA-2041

\*3: HA-2046

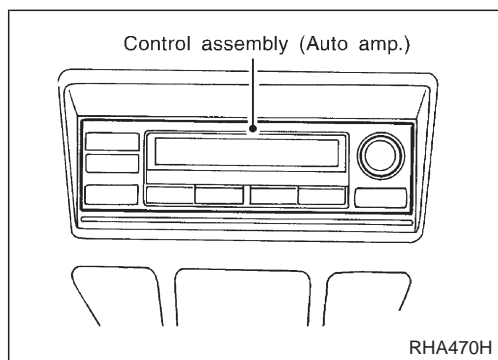
**COMPONENT DESCRIPTION****Automatic amplifier (Auto amp.)**

The auto amplifier has a built-in microcomputer which processes information sent from various sensors needed for air conditioner operation. The air mix door motor, mode door motor, intake door motor, blower motor and compressor are then controlled.

The auto amplifier is unitized with control mechanisms. Signals from various switches and Potentio Temperature Control (PTC) are directly entered into auto amplifier.

Self-diagnostic functions are also built into auto amplifier to provide quick check of malfunctions in the auto air conditioner system.

**Potentio temperature control (PTC)**

The PTC is built into the A/C auto amp. It can be set at an interval of 1°C in the 18°C to 32°C temperature range by turning the temperature dial. The set temperature is digitally displayed.

**A/C System (Cont'd)**

**MAIN POWER SUPPLY AND GROUND CIRCUIT CHECK**

**Power Supply Circuit Check**

Check power supply circuit for air conditioner system.

Refer to EL section (“Wiring Diagram”, “POWER SUPPLY ROUTING”).

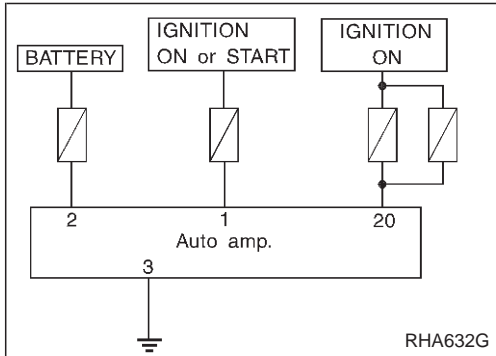

**DIAGNOSTIC PROCEDURE**

**SYMPTOM: A/C system does not come on.**

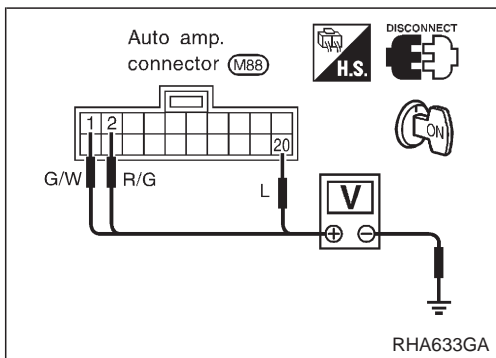

**Auto amp. check**

Check power supply circuit for auto amp. with ignition switch ON. Measure voltage across terminal Nos. ①, ②, ⑳ and body ground.

Voltmeter terminal		Voltage
⊕	⊖	
①	Body ground	Approx. 12V
②		
⑳		

## Mode Door Motor

### TROUBLE DIAGNOSIS PROCEDURE FOR MODE DOOR MOTOR

#### SYMPTOM:

- Air outlet does not change.
- Mode door motor does not operate normally.

#### Inspection flow

1. Confirm symptom by performing the following operational check.

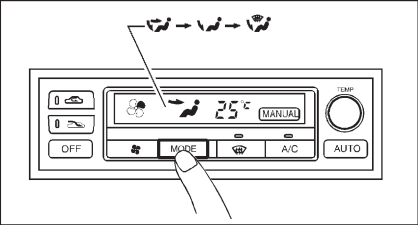

**Discharge air flow**

Mode switch	Air outlet/distribution		
	Face	Foot	Defroster
	100% (100%)	-	-
	60% (55%)	40% (45%)	-
	-	80% (100%)	20% (-)
	-	60% (65%)	40% (35%)
	-	-	100% (100%)

**OPERATIONAL CHECK – Discharge air**

a. Press mode switch four times and DEF button.  
b. Each position indicator should change shape.

c. Confirm that discharge air comes out according to the air distribution table at left.  
Refer to “Discharge Air Flow” (\*1).

**NOTE:**

- If OK (symptom cannot be duplicated), perform complete operational check (\*2).
- If NG (symptom is confirmed), continue with STEP-2 following.
- Confirm that the compressor clutch is engaged (visual inspection) and intake door position is at FRESH when DEF is selected.

( ): For RHD models

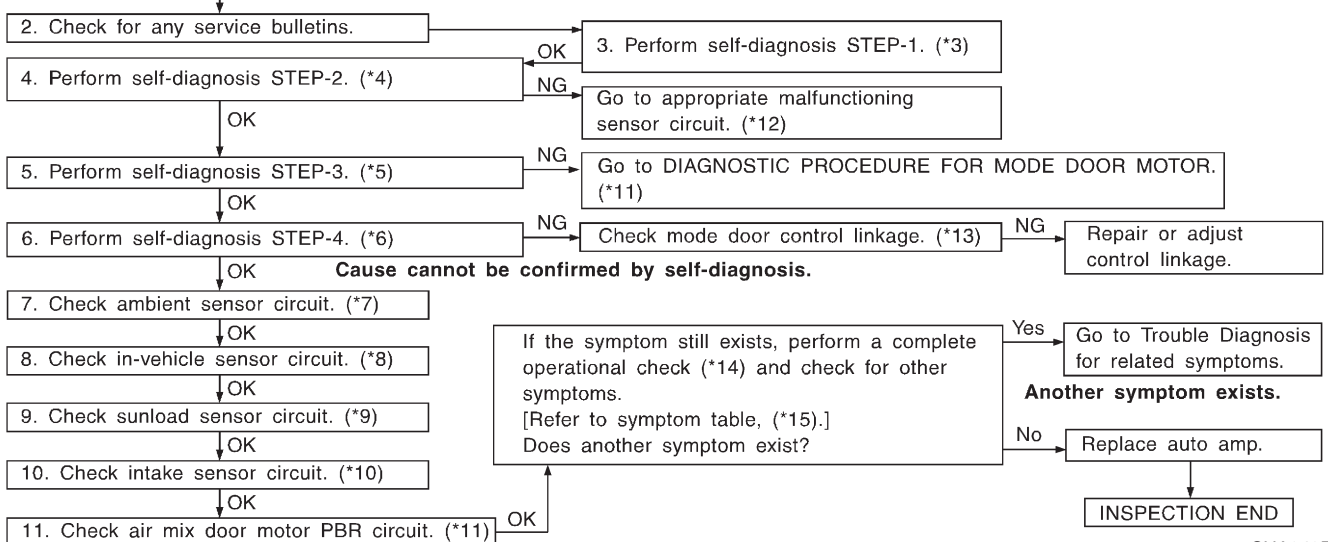

SHA343F

\*1: HA-15 in D22 Service Manual, Publication No. SM7E-0D22G1

\*2: HA-2041

\*3: HA-2035

\*4: HA-2036

\*5: HA-2037

\*6: HA-2038

\*7: HA-2081

\*8: HA-2083

\*9: HA-2085

\*10: HA-2087

\*11: HA-2049

\*12: HA-2036

\*13: HA-2051

\*14: HA-2041

\*15: HA-2040

**Mode Door Motor (Cont'd)**

**SYSTEM DESCRIPTION**

**Component parts**

Mode door control system components are:

- |                      |                   |
|----------------------|-------------------|
| 1) Auto amplifier    | 4) Ambient sensor |
| 2) Mode door motor   | 5) Sunload sensor |
| 3) In-vehicle sensor | 6) Intake sensor  |

**System operation**

The auto amplifier computes the air outlet conditions according to the ambient temperature and the in-vehicle temperature. The computed outlet conditions are then corrected for sunload to determine air outlet through which air is discharged into the passenger compartment.

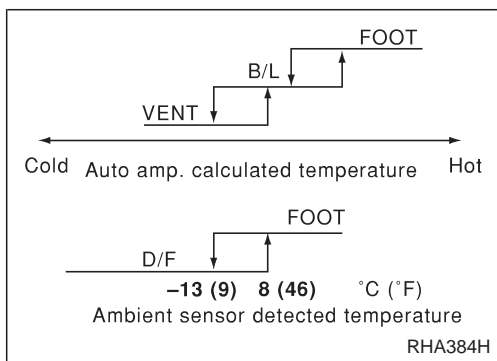
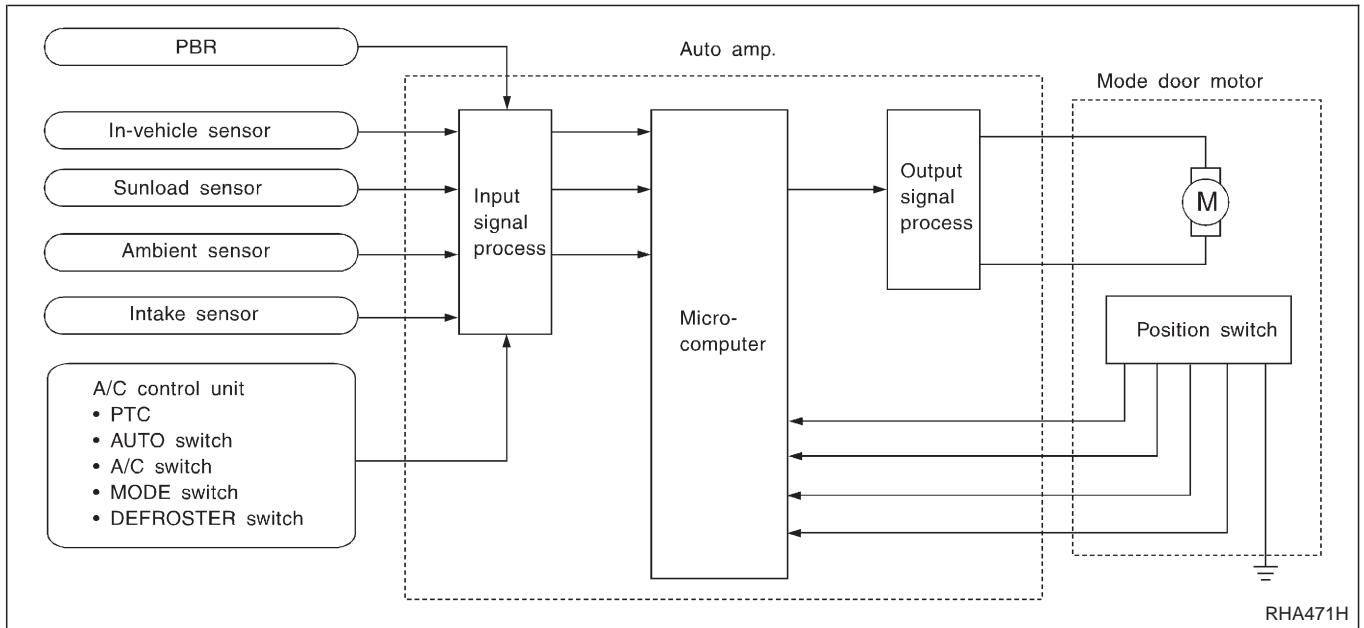

**Mode door control specification**

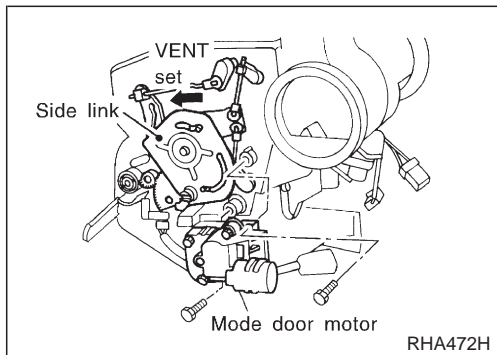

**COMPONENT DESCRIPTION**

The mode door motor is attached to the heater unit. It rotates so that air is discharged from the outlet set by the auto amplifier. Motor rotation is conveyed to a link which activates the mode door.



## Mode Door Motor (Cont'd)

### DIAGNOSTIC PROCEDURE

**SYMPTOM:** Mode door motor does not operate normally.

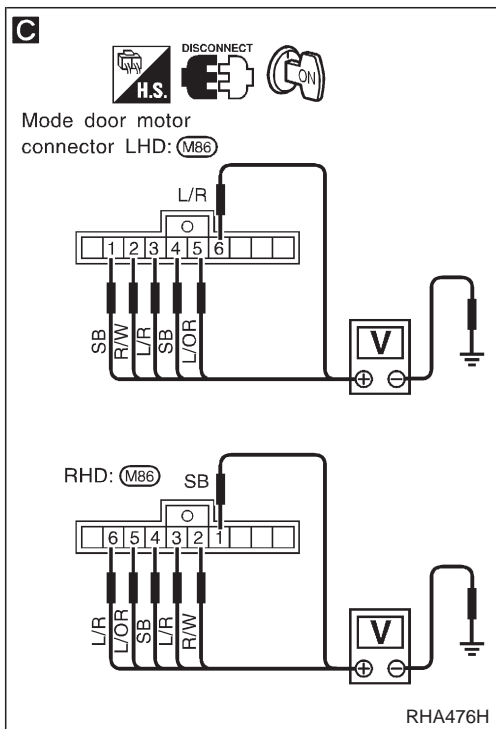
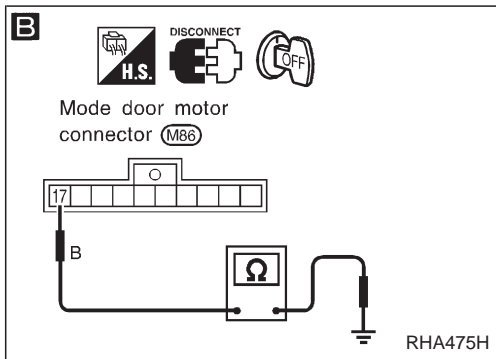
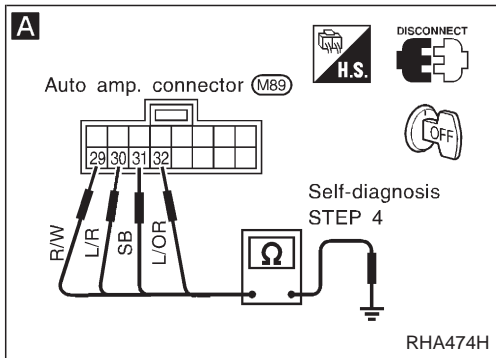
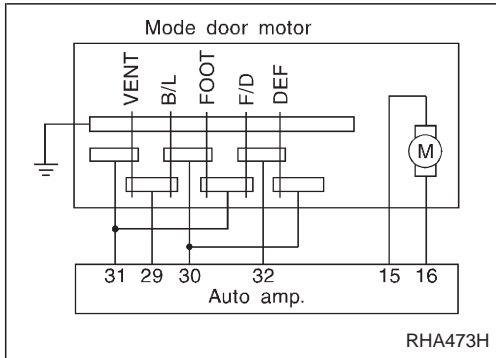

**A**

CHECK MODE DOOR MOTOR POSITION SWITCH.

1. Set up code No. 41 in Self-diagnosis STEP 4.
2. Disconnect auto amp. harness connector after turning ignition switch OFF.
3. Check if continuity exists between terminal Nos. (29), (31) of auto amp. harness connector and body ground.
4. Using above procedure, check for continuity in other modes, as indicated in chart.

Code No.	Condition	Terminal No.		Continuity
		⊕	⊖	
41	VENT	(29) or (31)	Body ground	Yes
42 or 43	B/L	(29) or (30)		
44	FOOT	(30) or (31)		
45	D/F	(31) or (32)		
46	DEF	(30) or (32)		

OK

INSPECTION END

NG

Disconnect mode door motor harness connector.

**B**

Note

CHECK BODY GROUND CIRCUIT FOR MODE DOOR MOTOR.

Does continuity exist between mode door motor harness terminal No. (17) and body ground?

Yes

Reconnect auto amp. harness connector.

**C**

CHECK POWER SUPPLY FOR MODE DOOR MOTOR CONTROL CIRCUIT.

Do approx. 5 volts exist between mode door motor harness terminals and body ground?

Terminal No.		Voltage
⊕	⊖	
(1)	Body ground	Approx. 5V
(2)		
(3)		
(4)		
(5)		
(6)		

Yes

No

Reconnect mode door motor harness connector.

(A)

(B)

(Go to next page.)

**Note:**

If the result is NG or No after checking circuit continuity, repair harness or connector.

## Mode Door Motor (Cont'd)

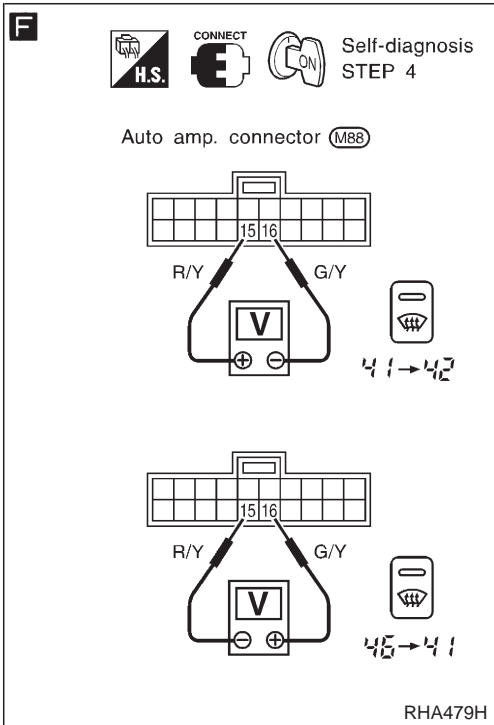
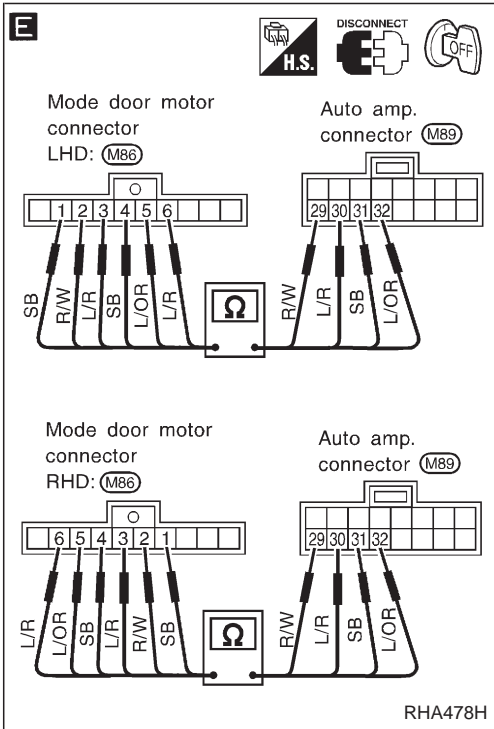
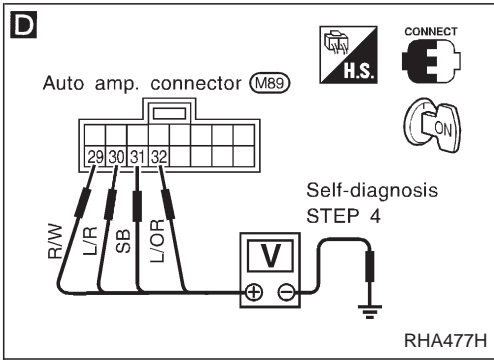

**D**

(A)

**CHECK MODE DOOR MOTOR POSITION SWITCH.**  
Set up Self-diagnosis STEP 4.  
Measure voltage across auto amp. harness terminals and body ground.

Code No.	Condition	Terminal No.				Body ground	
		⊕					⊖
		29	30	31	32		
41	VENT	0V	5V	0V	5V	Body ground	
43 or 42	B/L	0V	0V	5V	5V		
44	FOOT	5V	0V	0V	5V		
45	D/F	5V	5V	0V	0V		
46	DEF	5V	0V	5V	0V		
		0V	5V	0V	5V		

0V: Approx. 0V  
5V: Approx. 5V

**E**

(B)

**Note**

Check circuit continuity between each terminal on auto amp. and on mode door motor.

Terminal No.		Continuity
⊕	⊖	
Auto amp. 29	Mode door motor 2	Yes
30	3 or 6	
31	1 or 4	
32	5	

If OK, check harness for short.

OK

Replace auto amp.

OK

NG

Replace mode door motor.

**F**

**CHECK FOR OUTPUT OF AUTO AMP.**  
Do approx. 10.5 volts exist between auto amp. harness terminals No. 15 and 16 when code No. is switched from "41" to "42" or when code No. is switched from "46" to "41"?

Code No.	Mode door motor operation	Terminal No.		Voltage V
		15	16	
41 → 42	VENT → B/L	⊕	⊖	Approx. 10.5
46 → 41	DEF → VENT	⊖	⊕	
-	Stop	-	-	0

Yes

Replace mode door motor.

No

Replace auto amp.

**Note:**  
If the result is NG or No after checking circuit continuity, repair harness or connector.

## Mode Door Motor (Cont'd)

### COMPONENT INSPECTION

#### Mode door motor

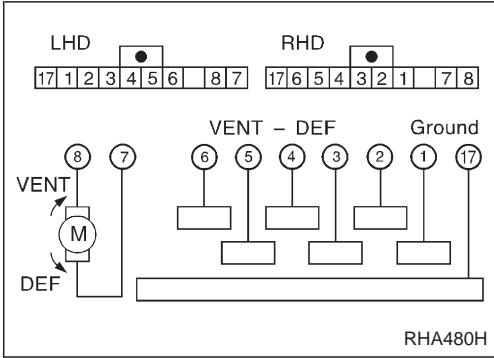

Terminal No.		Mode door operation	Direction of side link rotation
⑧	⑦		
⊕	⊖	VENT → DEF	Counterclockwise
-	-	STOP	STOP
⊖	⊕	DEF → VENT	Clockwise

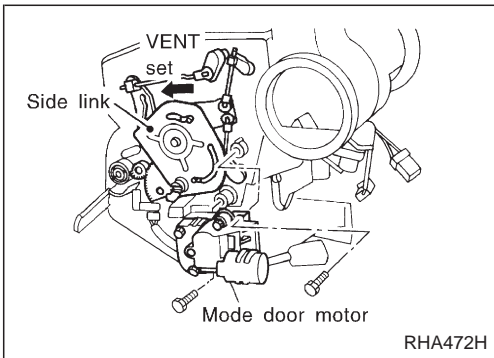
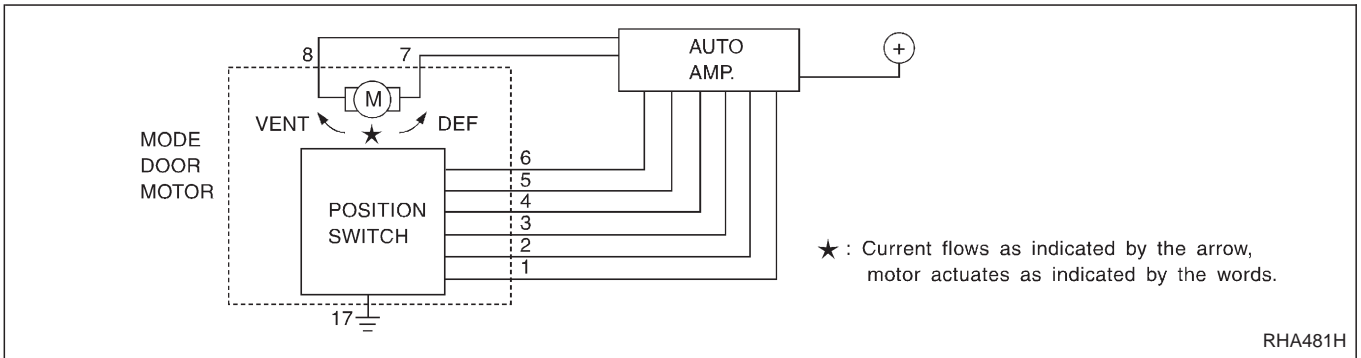

### CONTROL LINKAGE ADJUSTMENT

#### Mode door

1. Install mode door motor on heater unit and connect it to main harness.
2. Set up code No. 45 in Self-diagnosis STEP 4. Refer to HA-2038.
3. Move side link by hand and hold mode door in DEF mode.
4. Make sure mode door operates properly when changing from code No. 41 to 45 by pushing DEF switch.

41	42	43	44	45	46
VENT	B/L	B/L	FOOT	D/F	DEF

## Air Mix Door Motor

### TROUBLE DIAGNOSIS PROCEDURE FOR AIR MIX DOOR

**SYMPTOM:**

- Discharge air temperature does not change.
- Air mix door motor does not operate.

**Inspection flow**

1. Confirm symptom by performing the following operational check.

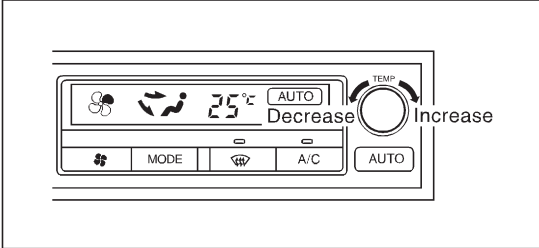

**OPERATIONAL CHECK**

**Temperature increase**

a. Turn the temperature dial increase until 32°C is displayed.

b. Check for hot air at discharge air outlets.

**Temperature decrease**

a. Turn the temperature dial decrease button until 18°C is displayed.

b. Check for cold air at discharge air outlets.

**If OK (symptom cannot be duplicated), perform complete operational check (\*12).  
If NG (symptom is confirmed), continue with STEP-2 following.**

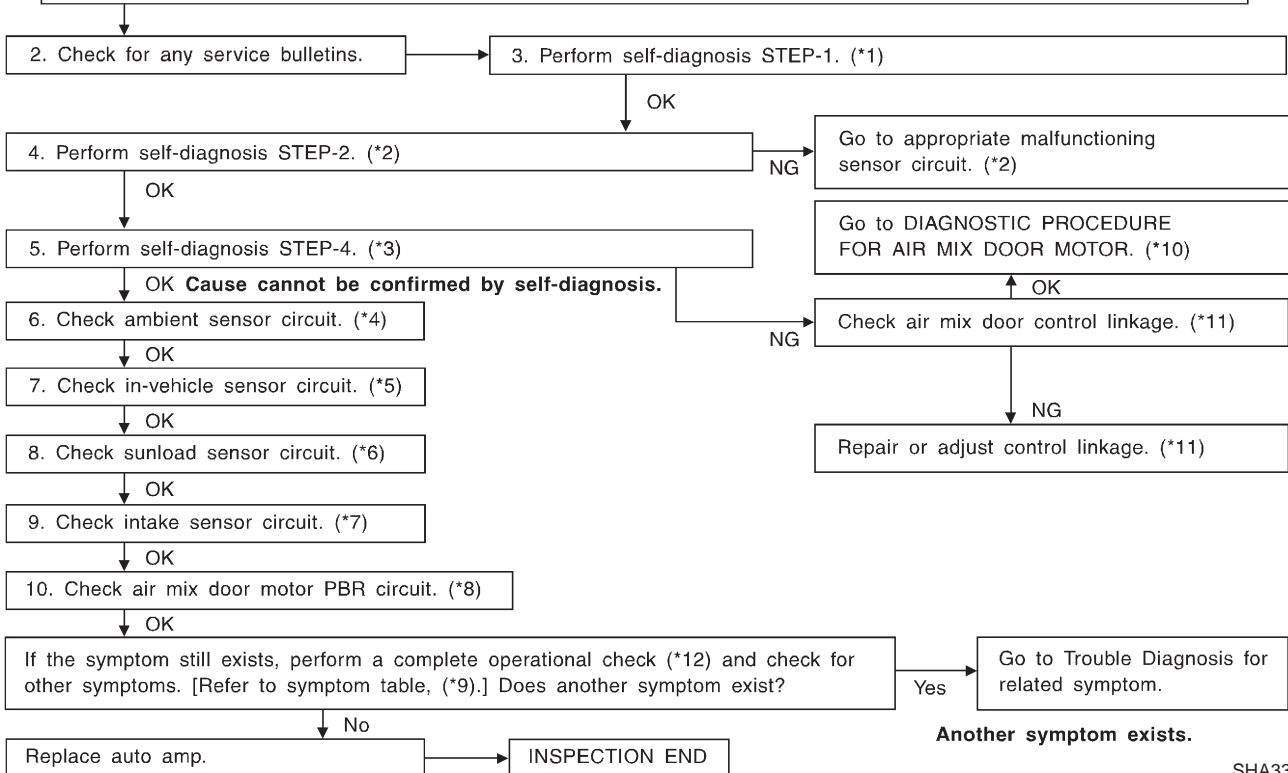

SHA338F

- \*1: HA-2035
- \*2: HA-2036
- \*3: HA-2038
- \*4: HA-2081

- \*5: HA-2083
- \*6: HA-2085
- \*7: HA-2087
- \*8: HA-2055

- \*9: HA-2040
- \*10: HA-2055
- \*11: HA-2057
- \*12: HA-2041

**Air Mix Door Motor (Cont'd)**

**SYSTEM DESCRIPTION**

**Component parts**

- Air mix door control system components are:
- |                             |                   |
|-----------------------------|-------------------|
| 1) Auto amplifier           | 4) Ambient sensor |
| 2) Air mix door motor (PBR) | 5) Sunload sensor |
| 3) In-vehicle sensor        | 6) Intake sensor  |

**System operation**

Temperature set by Potentio Temperature Control (PTC) is compensated through setting temperature correction circuit to determine target temperature.

Auto amplifier will operate air mix door motor to set air conditioning system in HOT or COLD position, depending upon relationship between conditions (target temperature, sunload, in-vehicle temperature and ambient temperature) and conditions (air mix door position and intake air temperature).

When target temperature is set at 18°C (65°F) or 32°C (85°F), air mix door opening position is fixed in full cold position or full hot position.

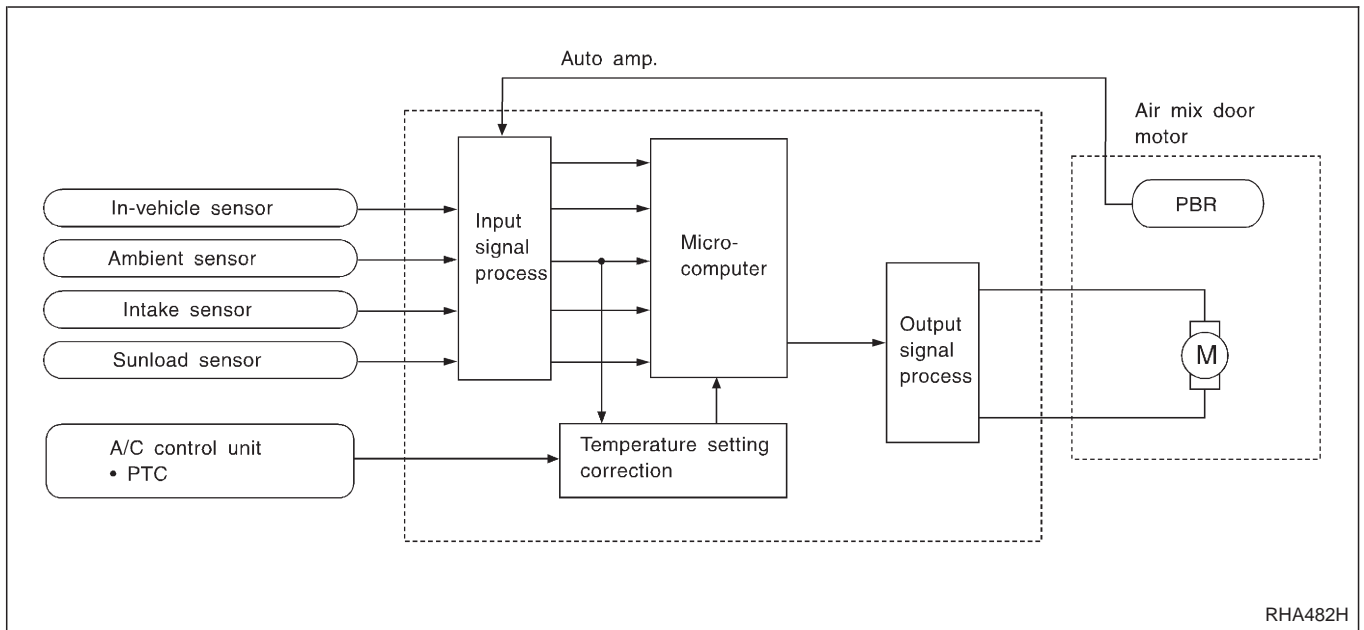

RHA482H

**Air mix door control specification**

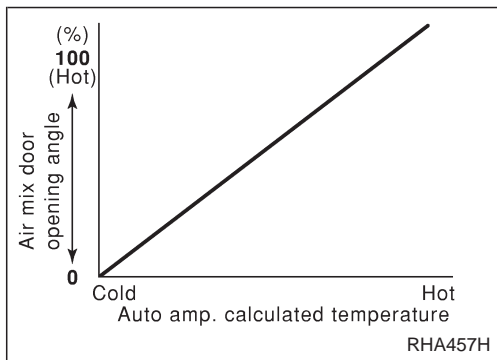

RHA457H

**Air Mix Door Motor (Cont'd)****COMPONENT DESCRIPTION**

The air mix door motor is attached to the heater unit. It rotates so that the air mix door is opened or closed to a position set by the auto amplifier. Motor rotation is then conveyed through a shaft and the air mix door position is then fed back to the auto amplifier by PBR built-in air mix door motor.

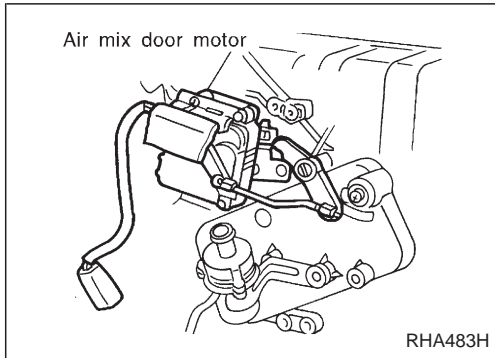

## Air Mix Door Motor (Cont'd)

### DIAGNOSTIC PROCEDURE

**SYMPTOM: Air mix door motor does not operate normally.**

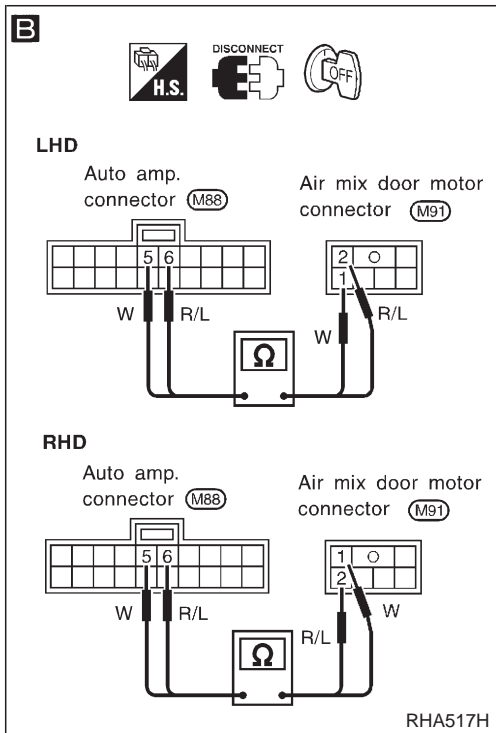
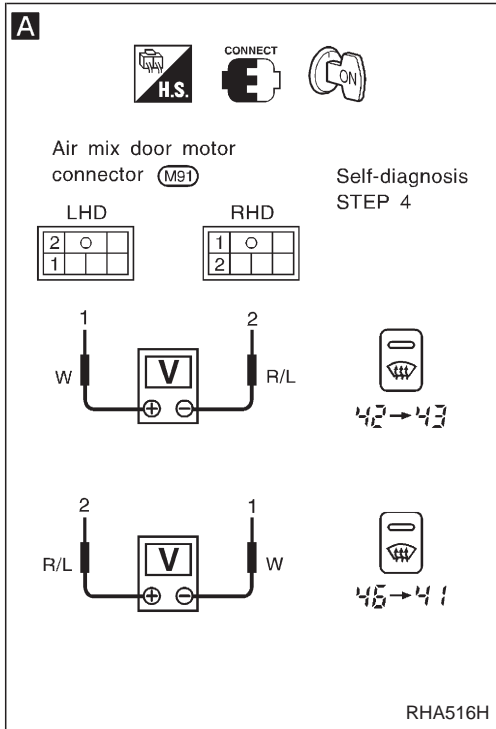
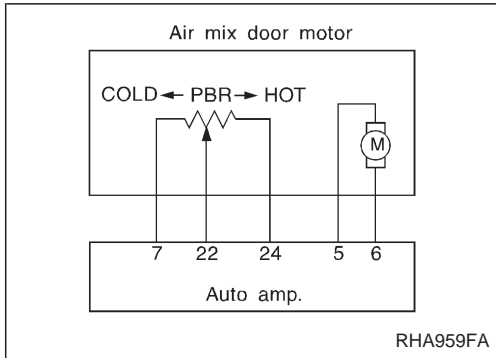

IS PBR OPERATING NORMALLY?  
Refer to Self-diagnoses STEP 2.

No → **A** (Go to next page.)

Yes

**A**

CHECK FOR OUTPUT OF AUTO AMP.  
Set up Self-diagnosis STEP 4.  
Do approx. 10.5 volt exist between air mix door motor harness terminals No. ① and ② when code No. is switched from "43" to "44" or when code No. is switched from "48" to "41"?

No → Disconnect auto amp. and air mix door motor harness connectors.

Code No.	Air mix door operation	Terminal No.		Voltage V
		①	②	
42 →	Cold →	⊕	⊖	Approx. 10.5
43	Hot	⊖	⊕	
46 →	Hot →	⊖	⊕	0
41	Cold	⊕	⊖	
-	Stop	-	-	

**B**

Note

Check circuit continuity between auto amp. harness terminal No. ⑤ (⑥) and air mix door motor harness terminal No. ① (②).  
**Continuity should exist.**  
If OK, check harness for short.

Yes

OK

Replace air mix door motor.

Replace auto amp.

**Note:**

If the result is NG or No after checking circuit continuity, repair harness or connector.

## Air Mix Door Motor (Cont'd)

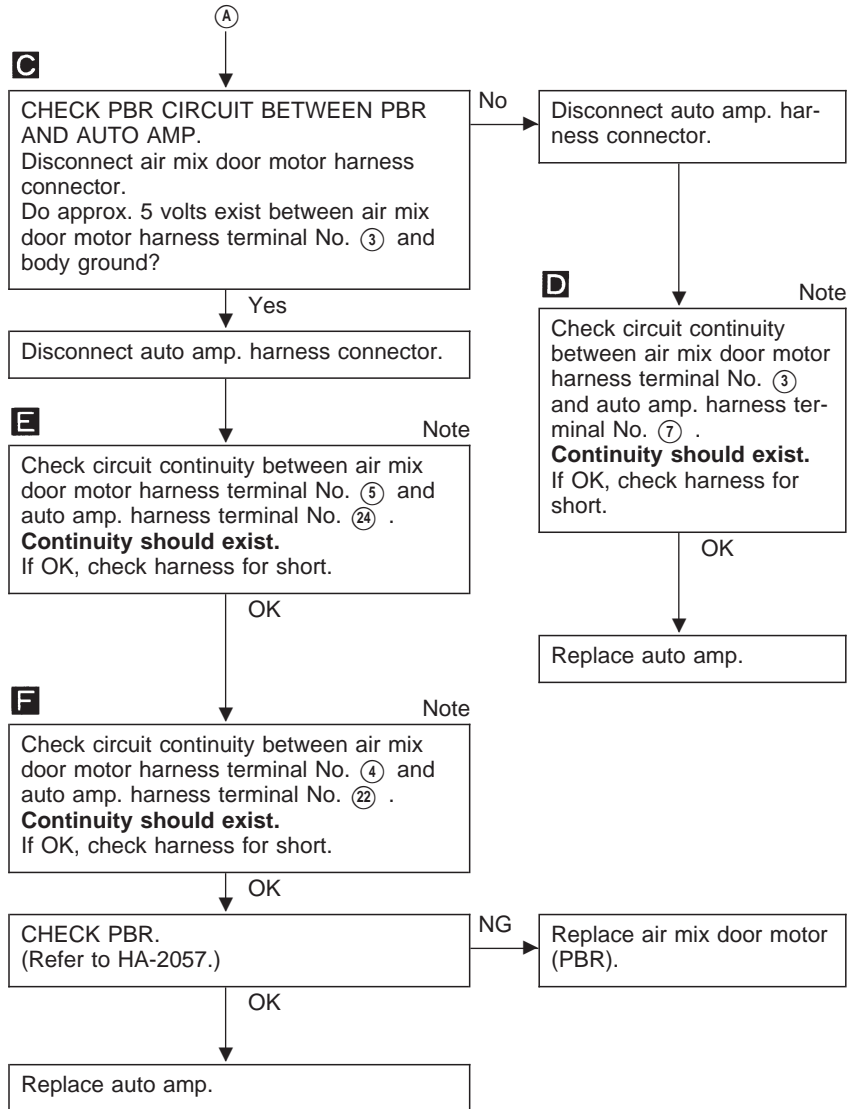
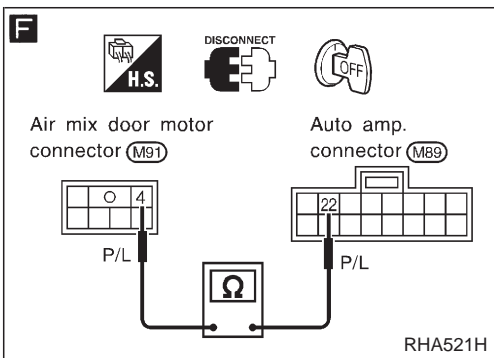
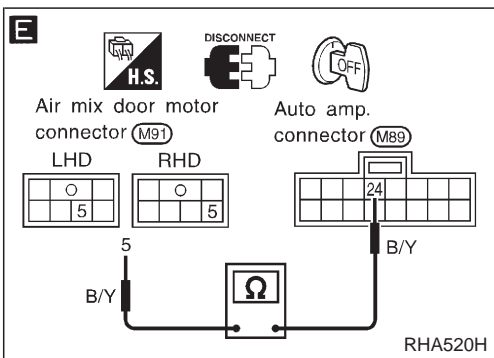
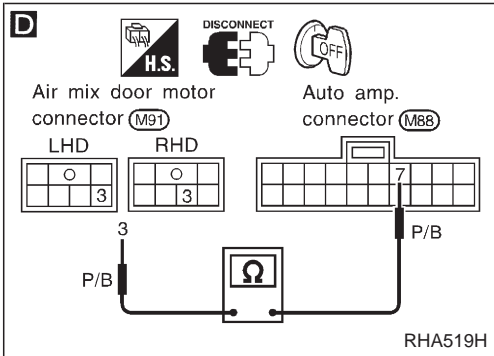
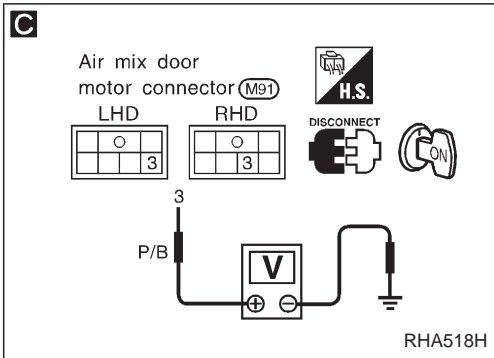

**Note:**  
If the result is NG or No after checking circuit continuity, repair harness or connector.



**Air Mix Door Motor (Cont'd)**

**COMPONENT INSPECTION**

**PBR**

Measure voltage between terminals ③ and ④ at vehicle harness side.

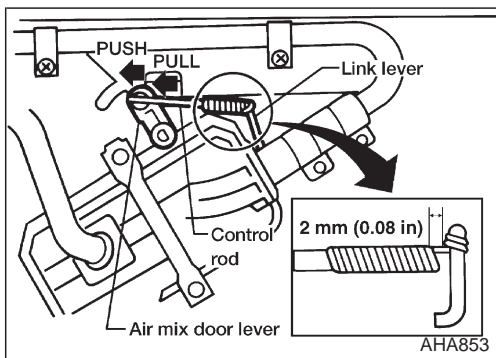
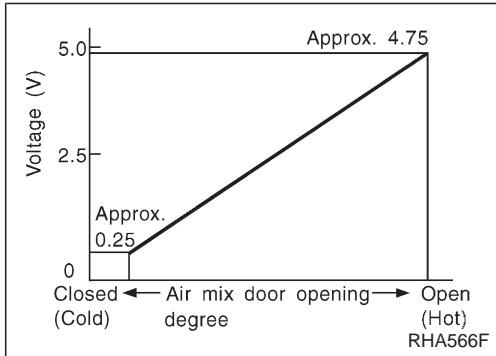
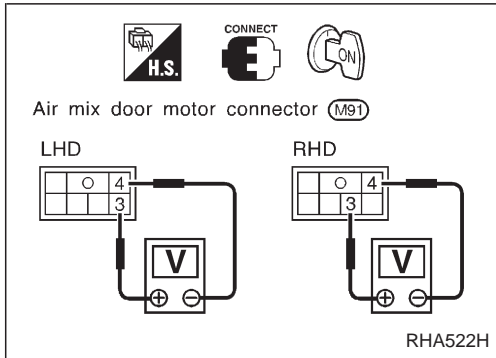

**CONTROL LINKAGE ADJUSTMENT**

**Air mix door (Water cock)**

1. Install air mix door motor on heater unit and connect it to main harness.
2. Set up code No. 41 in Self-diagnosis STEP 4. Refer to HA-2038.
3. Move air mix door lever by hand and hold it in full cold position.
4. Attach air mix door lever to rod holder.
5. Make sure air mix door operates properly when changing from code No. 41 to 46 by pushing DEF switch.

41	42	43	44	45	46
Full cold			Full hot		

6. Set up code No. 41 in Self-diagnosis STEP 4.
7. Attach water cock cable to air mix door linkage and secure with clip.
8. Rotate and hold water cock lever AND plate in the full cold position (CLOCKWISE completely).
9. Attach water cock cable to plate and secure with clip (white mark on cable housing should be centered under the retaining clip).
10. Check that water cock operates properly when changing from code No. 41 to 46 by pushing DEF switch. (After several cycles, water cock lever should be midpoint of plate opening when code No. 41 is set.)

## Intake Door Motor

### TROUBLE DIAGNOSIS PROCEDURE FOR INTAKE DOOR

**SYMPTOM:**

- Intake door does not change.
- Intake door motor does not operate normally.

**Inspection flow**

1. Confirm symptom by performing the following operational check.

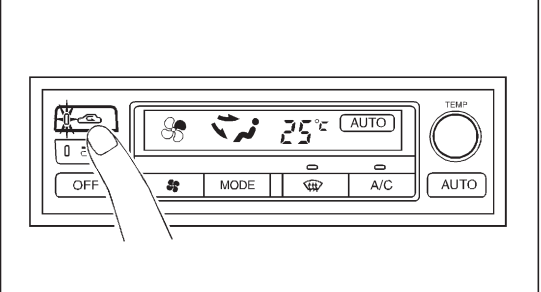

**OPERATIONAL CHECK – Recirculation**

a. Press REC switch. Recirculation indicator should illuminate.

b. Press FRE switch. Fresh indicator should illuminate.

c. Listen for intake door position change (you should hear blower sound change slightly).

**If OK (symptom cannot be duplicated), perform complete operational check (\*11).**

**If NG (symptom is confirmed), continue with STEP-2 following.**

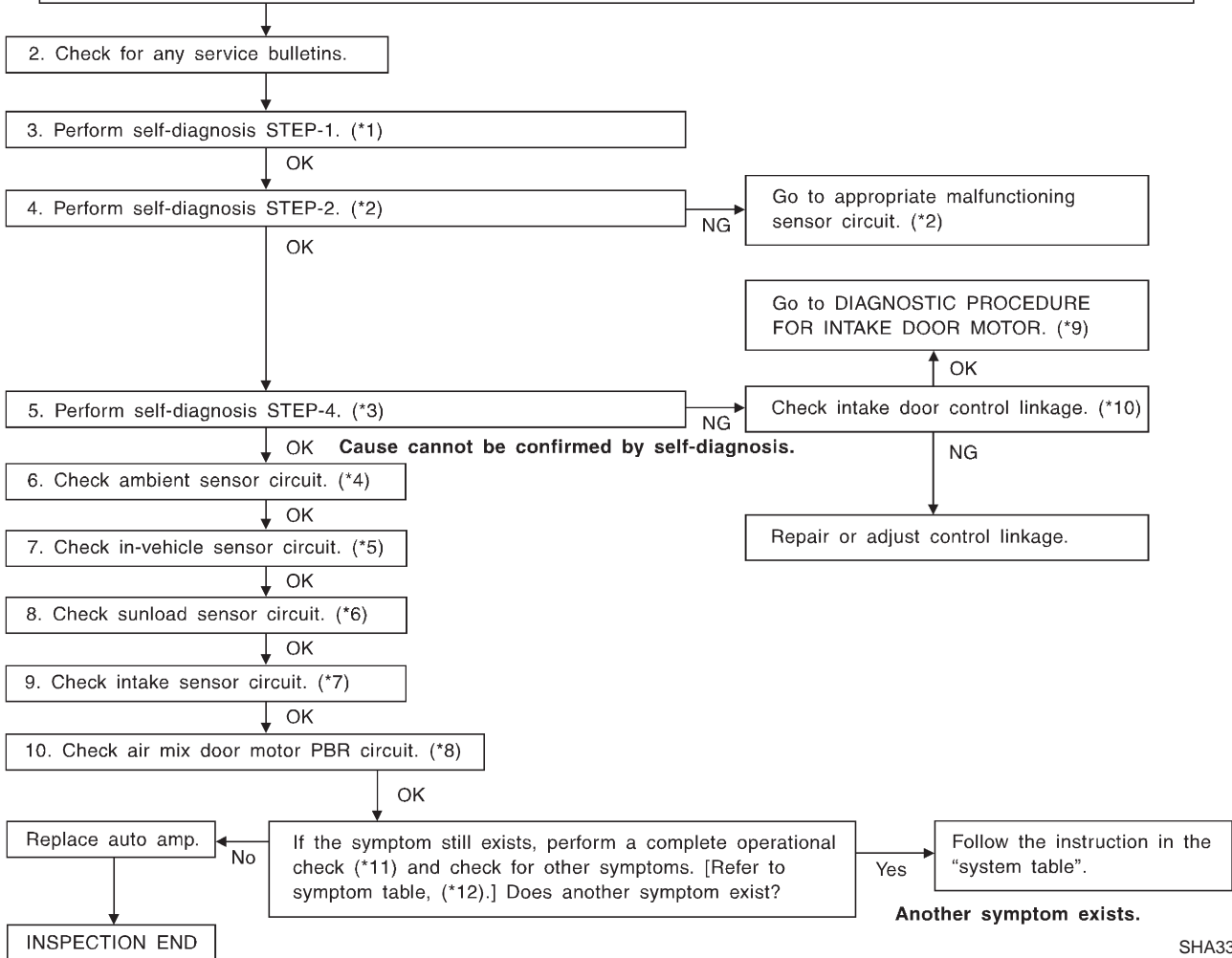

- \*1: HA-2035
- \*2: HA-2036
- \*3: HA-2038
- \*4: HA-2081

- \*5: HA-2083
- \*6: HA-2085
- \*7: HA-2087
- \*8: HA-2055

- \*9: HA-2060
- \*10: HA-2061
- \*11: HA-2041
- \*12: HA-2040

SHA339F

**Intake Door Motor (Cont'd)**

**SYSTEM DESCRIPTION**

**Component parts**

Intake door control system components are:

- 1) Auto amp.
- 2) Intake door motor
- 3) Mode door motor
- 4) In-vehicle sensor
- 5) Ambient sensor
- 6) Sunload sensor
- 7) Intake sensor

**System operation**

The intake door control determines intake door position based on the ambient temperature, the intake air temperature and the in-vehicle temperature. When the A/C, DEFROSTER, or OFF switches are pushed, the auto amplifier sets the intake door at the "Fresh" position.

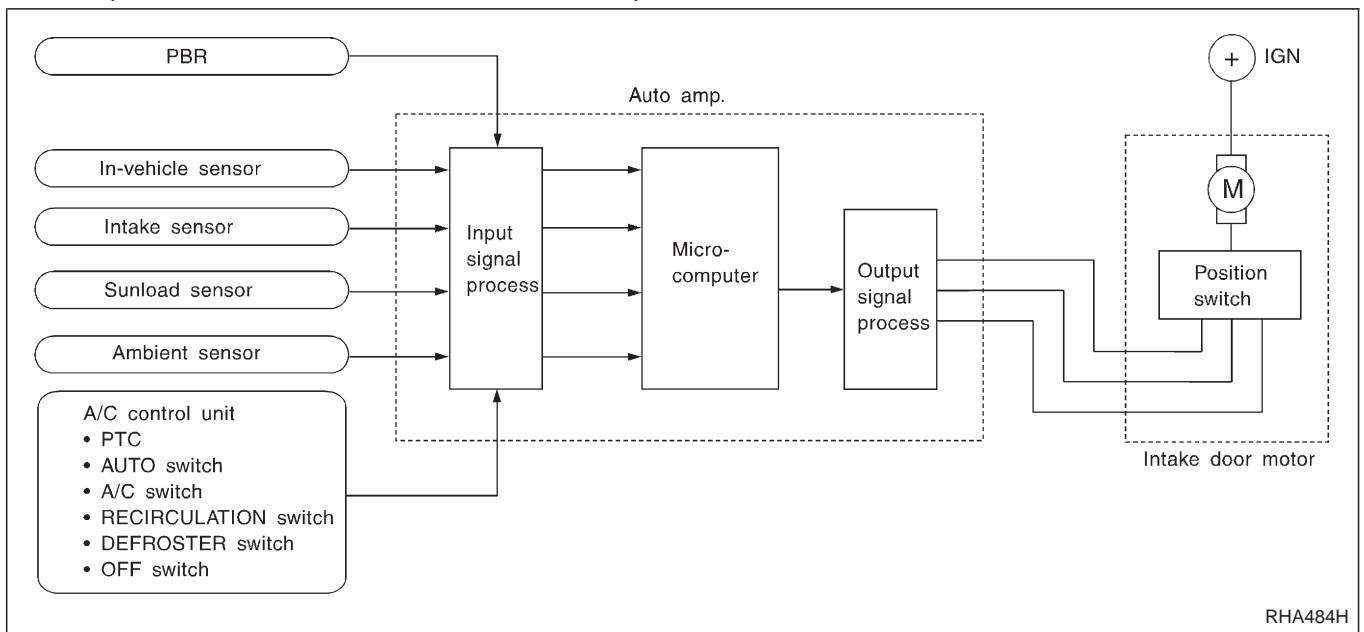

RHA484H

**Intake door control specification**

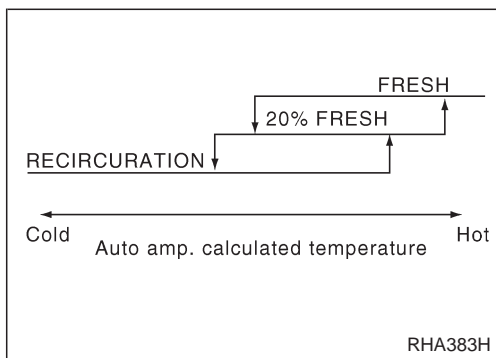

RHA383H

**COMPONENT DESCRIPTION**

The intake door motor is attached to the intake unit. It rotates so that air is drawn from inlets set by the auto amplifier. Motor rotation is conveyed to a lever which activates the intake door.

## Intake Door Motor (Cont'd) DIAGNOSTIC PROCEDURE

**SYMPTOM:** Intake door motor does not operate normally.

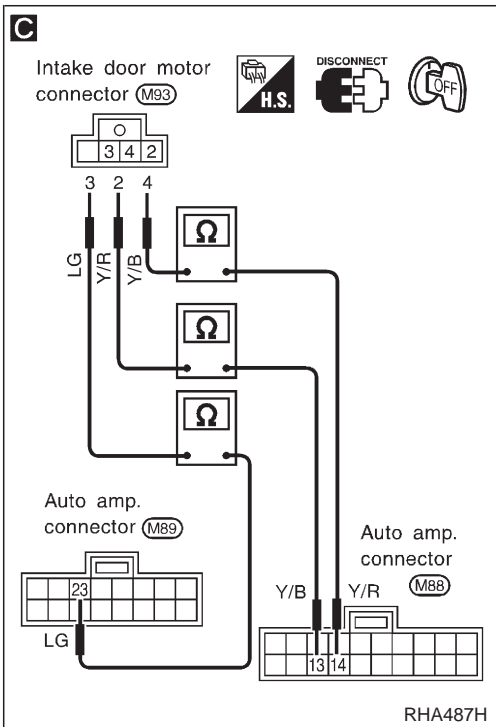
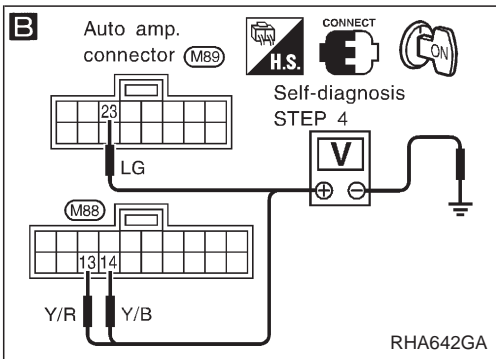
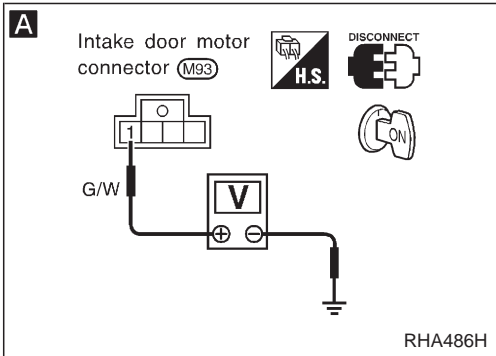
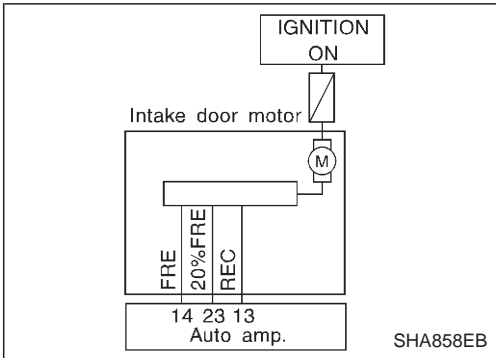

**A**

**CHECK POWER SUPPLY FOR INTAKE DOOR MOTOR.**  
Disconnect intake door motor harness connector.  
Do approx. 12 volts exist between intake door motor harness terminal No. ① and body ground?

No

Check power supply circuit and 7.5A fuse (No. 23, located in the fuse block).

Yes

**B**

**CHECK FOR AUTO AMP. OUTPUT.**  
Set up Self-diagnosis STEP 4.  
Measure voltage across auto amp. harness terminals and body ground.

Code No.	Terminal No.		Condition	Voltage V
	⊕	⊖		
41 42	(13)	Body ground	REC	0
	(23)			12
	(14)			12
43	(13)	Body ground	20% FRE	12
	(23)			0
	(14)			12
44 45 46	(13)	Body ground	FRE	12
	(23)			12
	(14)			0

0V: Approx. 0V  
12V: Approx. 12V

NG

**C**

Note

Check circuit continuity between each terminal on auto amp. and on intake door motor.

Terminal No.		Continuity
⊕	⊖	
Auto amp. (13)	Intake door motor (2)	Yes
(23)	(3)	
(14)	(4)	

OK

Replace auto amp.

OK

Replace intake door motor.

**Note:**

If the result is NG or No after checking circuit continuity, repair harness or connector.

**Intake Door Motor (Cont'd)  
CONTROL LINKAGE ADJUSTMENT**

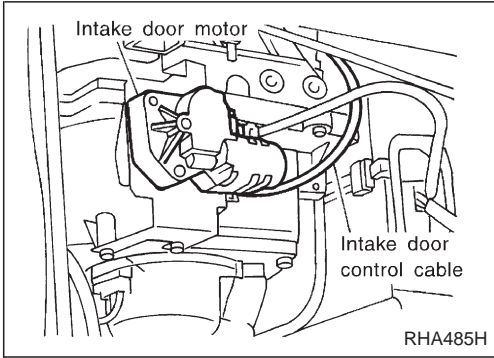

**Intake door**

1. Install intake door motor on intake unit and connect it to main harness.
2. Set up code No. 41 in Self-diagnosis STEP 4. Refer to HA-2038.
3. Move intake door link by hand and hold it in REC position.
4. Clamp intake door control cable. Refer to HA-54 in D22 Service Manual, Publication No. SM8E-0D22E0E.
5. Make sure intake door operates properly when changing from code No. 41 to 46 by pushing DEF switch.

41	42	43	44	45	46
REC		20% FRE	FRE		

Blower Motor

TROUBLE DIAGNOSIS PROCEDURE FOR BLOWER MOTOR



SYMPTOM:

- Blower motor operation is malfunctioning.
- Blower motor operation is malfunctioning under out of starting fan speed control.

Inspection flow

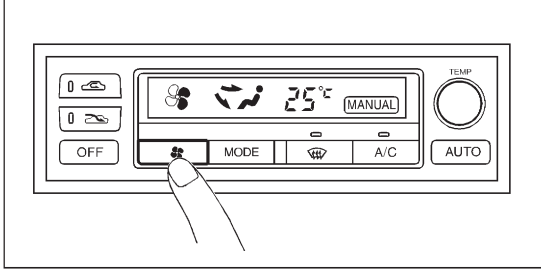
1. Confirm symptom by performing the following operational check.



**OPERATIONAL CHECK – Blower**  
 a. Press fan switch one time.  
 Blower should operate on low speed.  
 The fan symbol should have one blade lit .  
 b. Press fan switch one more time,  
 and continue checking blower speed and fan symbol until all speeds are checked.  
 c. Leave blower on MAX speed .

**If OK (symptom cannot be duplicated), perform complete operational check (\*10).**  
**If NG (symptom is confirmed), continue with STEP-2 following.**

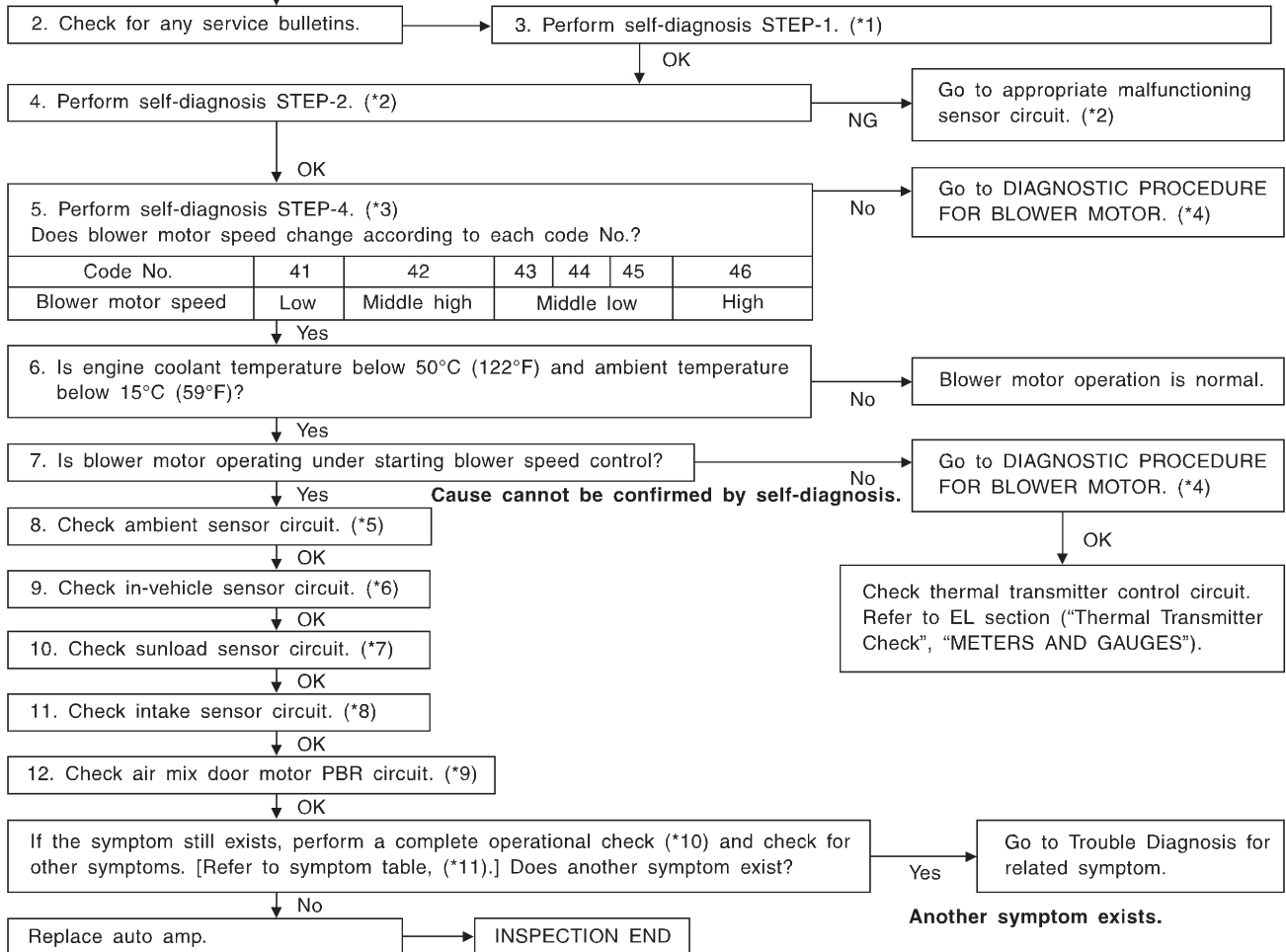

- \*1: HA-2035
- \*2: HA-2036
- \*3: HA-2038
- \*4: HA-2065

- \*5: HA-2081
- \*6: HA-2083
- \*7: HA-2085
- \*8: HA-2087

- \*9: HA-2055
- \*10: HA-2041
- \*11: HA-2040

SHA340F

## Blower Motor (Cont'd)

## SYSTEM DESCRIPTION

## Component parts

Fan speed control system components are:

- 1) Auto amp.
- 2) Fan control amp.
- 3) PBR
- 4) In-vehicle sensor
- 5) Ambient sensor
- 6) Sunload sensor
- 7) Intake sensor

## System operation

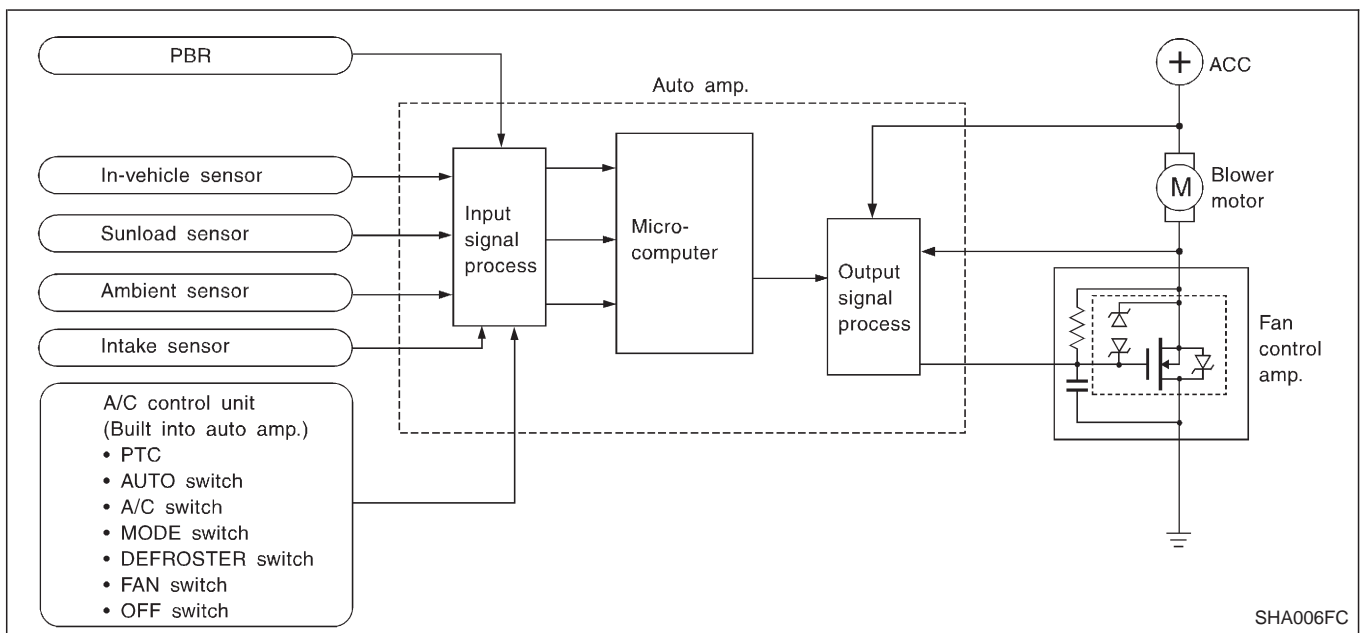

## Automatic mode

In the automatic mode, the blower motor speed is calculated by the automatic amplifier based on inputs from the PBR, in-vehicle sensor, sunload sensor, intake sensor and ambient sensor. The blower motor applied voltage ranges from approximately 5 volts (lowest speed) to 12 volts (highest speed).

The control blower speed (in the range of 5 to 12V), the automatic amplifier supplies a gate voltage to the fan control amplifier. Based on this voltage, the fan control amplifier controls the voltage supplied to the blower motor.

## Starting fan speed control

## Start up from "COLD SOAK" condition (Automatic mode)

In a cold start up condition where the engine coolant temperature is below 50°C, the blower will not operate for a short period of time (up to 150 seconds). The exact start delay time varies depending on the ambient and engine coolant temperature.

In the most extreme case (very low ambient) the blower starting delay will be 150 seconds as described above. After this delay, the blower will operate at low speed until the engine coolant temperature rises above 55°C, at which time the blower speed will increase to the objective speed.

## Start up from normal or "HOT SOAK" condition (Automatic mode)

The blower will begin operation momentarily after the AUTO button is pushed. The blower speed will gradually rise to the objective speed over a time period of 3 seconds or less (actual time depends on the objective blower speed).

**Blower Motor (Cont'd)**

**Blower speed compensation**

**Sunload**

When the in-vehicle temperature and the set temperature are very close, the blower will be operating at low speed. The low speed will vary depending on the sunload. During conditions of high sunload, the blower low speed is "normal" low speed (approx. 6V). During low or no sunload conditions, the low speed will drop to "low" low speed (approx. 5V).

**Ambient**

When the ambient temperature is in the "moderate" range [10 - 15°C], the computed blower voltage will be compensated (reduced) by up to 3.5V (depending on the blower speed). In the "extreme" ambient ranges [below 0°C and above 20°C] the computed objective blower voltage is not compensated at all. In the ambient temperature ranges between "moderate" and "extreme" [0 - 10°C and 15 - 20°C], the amount of compensation (for a given blower speed) varies depending on the ambient temperature.

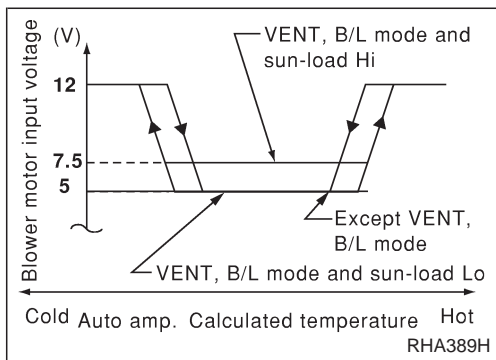

**Fan speed control specification**

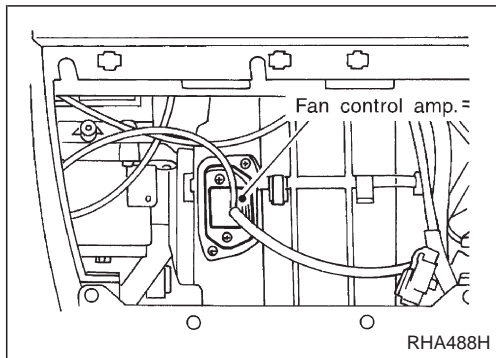

**COMPONENT DESCRIPTION**

**Fan control amplifier**

The fan control amplifier is located on the cooling unit. The fan control amp. receives a gate voltage from the auto amp. to steplessly maintain the blower fan motor voltage in the 5 to 12 volt range (approx.).



## Blower Motor (Cont'd) DIAGNOSTIC PROCEDURE

**SYMPTOM: Blower motor operation is malfunctioning under Starting Fan Speed Control.**

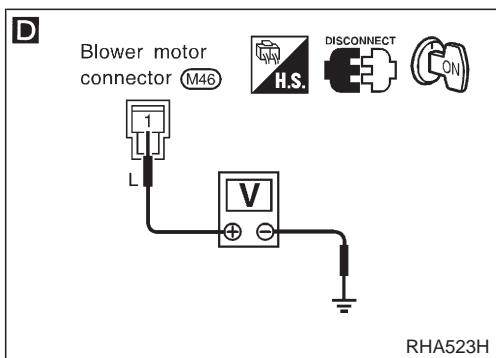
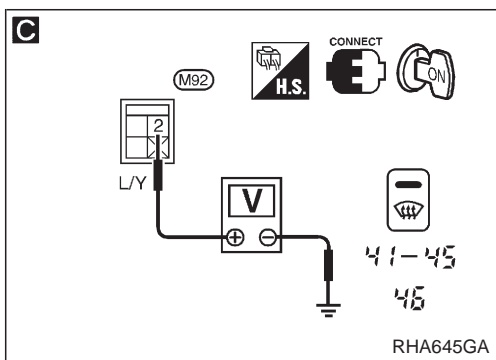
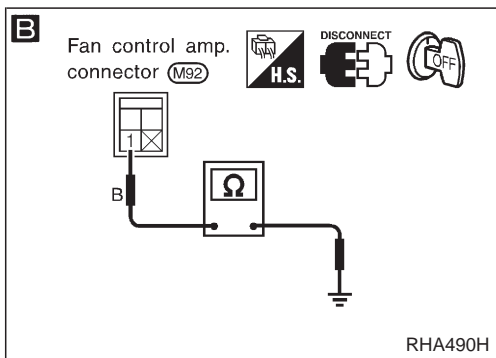
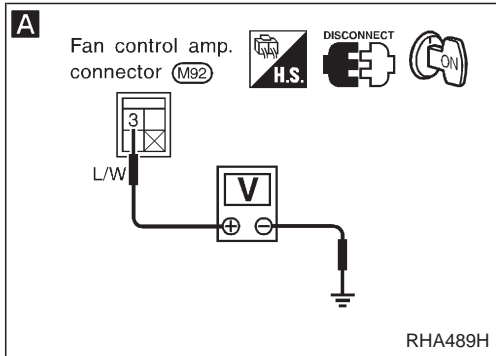
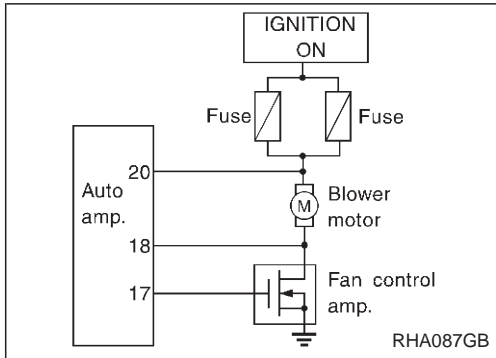

**A** CHECK POWER SUPPLY FOR FAN CONTROL AMP.  
Disconnect fan control amp. harness connector.  
Do approx. 12 volts exist between fan control amp. harness terminal No. ③ and body ground?

**B** Note  
CHECK BODY GROUND CIRCUIT FOR FAN CONTROL AMP.  
Does continuity exist between fan control amp. harness terminal No. ① and body ground?

Reconnect fan control amp. harness connector.

**C** CHECK FOR AUTO AMP. OUTPUT.  
Set up Self-diagnosis STEP 4.  
Measure voltage across fan control amp. harness terminal No. ② and body ground.

Code No.	Terminal No.		Voltage
	⊕	⊖	
41 - 45		Body ground	Approx. 2.5 - 3V
46	②	Body ground	Approx. 9 - 10V

Replace fan control amp.

**D** CHECK POWER SUPPLY FOR BLOWER MOTOR.  
Disconnect blower motor harness connector.  
Do approx. 12 volts exist between blower motor harness terminal No. ① and body ground?

Check power supply circuit and 15A fuses (No. 21 and 22, located in the fuse block).

**E** Note  
Check circuit continuity between blower motor harness terminal No. ② and fan control amp. harness terminal No. ③.

CHECK BLOWER MOTOR.  
(Refer to HA-2067.)

Replace blower motor.

**Note:**  
If the result is NG or No after checking circuit continuity, repair harness or connector.

Blower Motor (Cont'd)

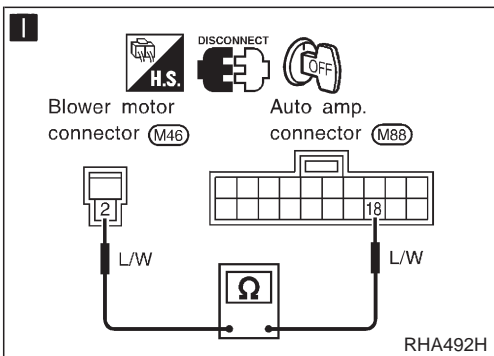
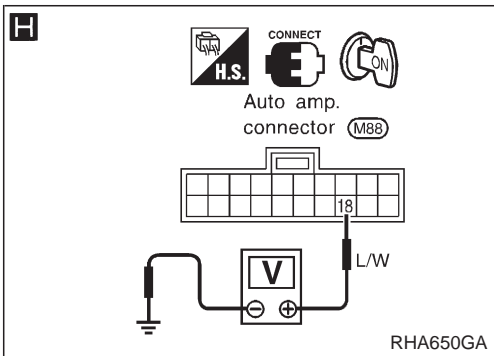
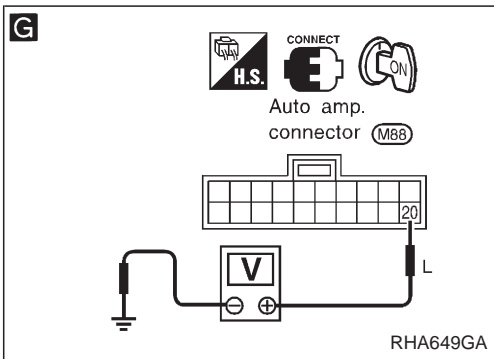
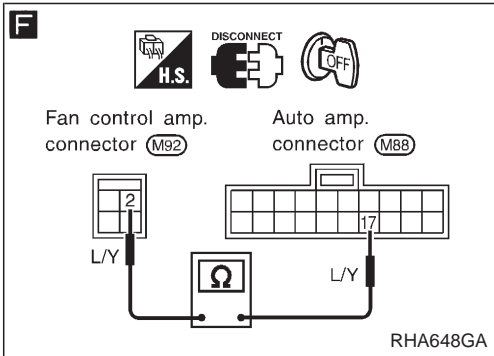
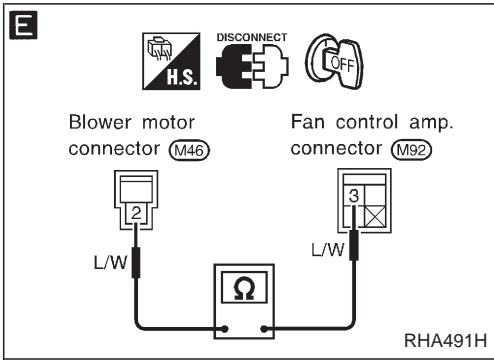

**A**

Disconnect auto amp. and fan control amp. harness connector.

**F**      Note

Does continuity exist between auto amp. harness terminal No. (17) and fan control amp. harness terminal No. (2) ?

**Continuity should exist.**  
If OK, check harness for short.

**G**

CHECK FAN FEED BACK CIRCUIT.  
Do approx. 12 volts exist between auto amp. harness terminal No. (20) and body ground?

No

Check power supply circuit and 15A fuses (No. 21 and 22, located in the fuse block). Refer to EL section ("Wiring Diagram", "POWER SUPPLY ROUTING").

**H**

Do approx. 12 volts exist between auto amp. harness terminal No. (18) and body ground?

**I**      Note

No

Check circuit continuity between blower motor harness terminal No. (2) and auto amp. harness terminal No. (18).  
**Continuity should exist.**  
If OK, check harness for short.

Yes

Replace auto amp.

**Note:**  
If the result is NG or No after checking circuit continuity, repair harness or connector.

**Blower Motor (Cont'd)  
COMPONENT INSPECTION****Blower motor**

Confirm smooth rotation of the blower motor.

- Ensure that there are no foreign particles inside the intake unit.

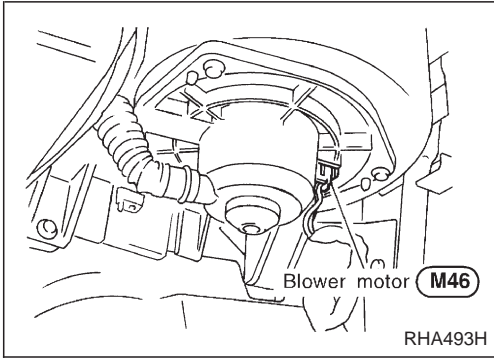

## Magnet Clutch

### TROUBLE DIAGNOSIS PROCEDURE FOR MAGNET CLUTCH

**SYMPTOM:**

- Magnet clutch does not engage.

**Inspection flow**

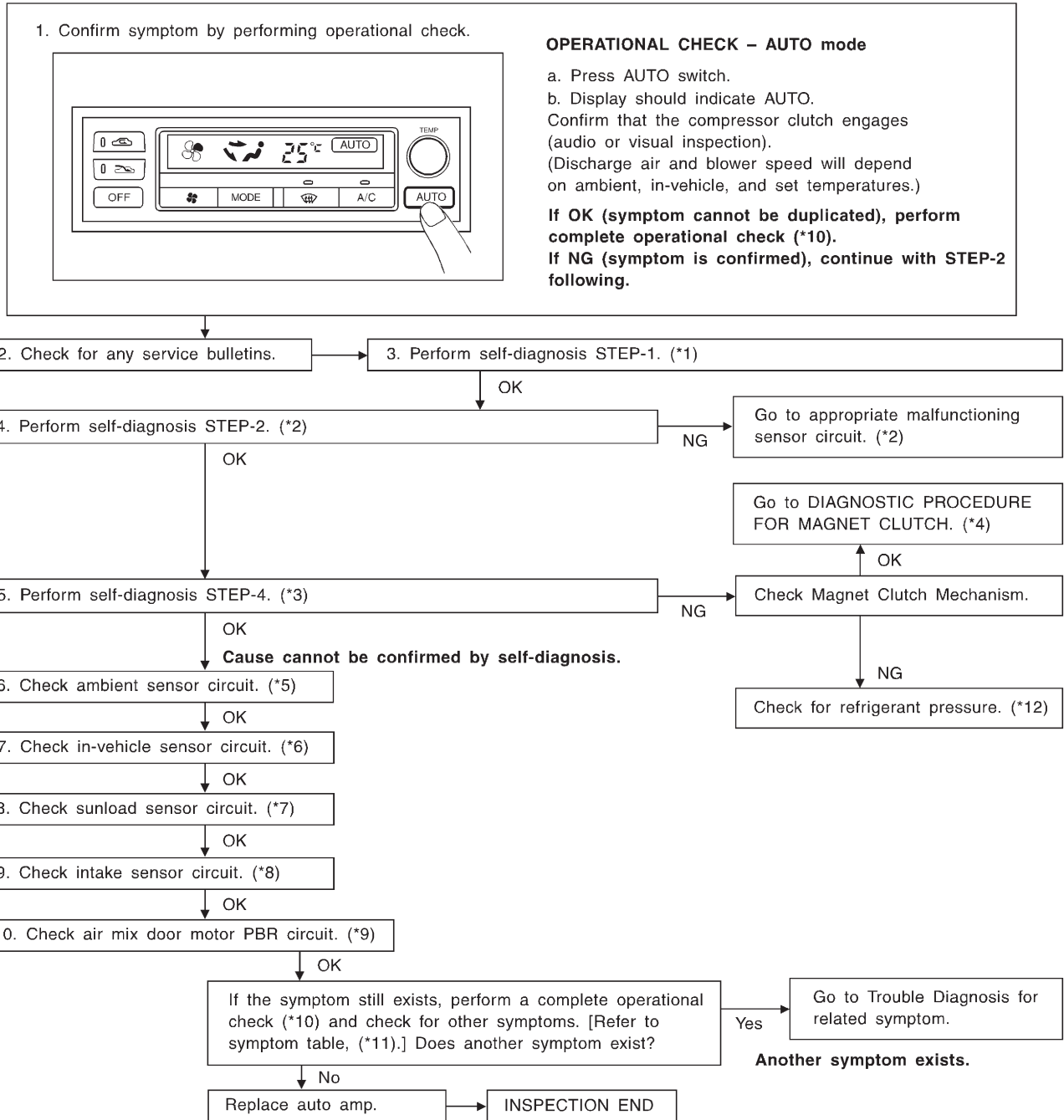

- \*1: HA-2035
- \*2: HA-2036
- \*3: HA-2038
- \*4: HA-2070
- \*5: HA-2081

- \*6: HA-2083
- \*7: HA-2085
- \*8: HA-2087
- \*9: HA-2055
- \*10: HA-2041

- \*11: HA-2040
- \*12: HA-28 in D22 Service Manual, Publication No. SM8E-0D22E0E

SHA341F

**Magnet Clutch (Cont'd)****SYSTEM DESCRIPTION**

Auto amplifier controls compressor operation by ambient temperature and signal from ECM.

**Low temperature protection control**

Auto amplifier will turn the compressor "ON" or "OFF" as determined by a signal detected by ambient sensor.

When ambient temperatures are greater than 1°C, the compressor turns "ON". The compressor turns "OFF" when ambient temperatures are less than -2°C.

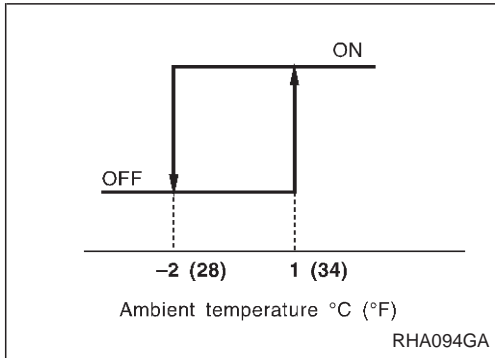

**Magnet Clutch (Cont'd)  
DIAGNOSTIC PROCEDURE**

**SYMPTOM:** Magnet clutch does not engage when A/C switch and fan switch are ON.

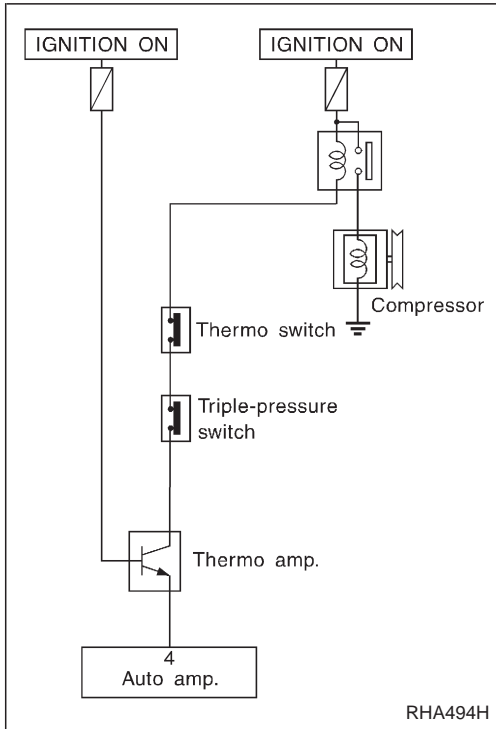

**A**  
CHECK POWER SUPPLY FOR COMPRESSOR.  
Disconnect compressor harness connector. Do approx. 12 volts exist between compressor harness terminal No. ① and body ground?

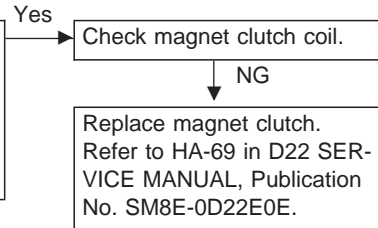

Disconnect A/C relay.

**B** Note  
CHECK CIRCUIT CONTINUITY BETWEEN A/C RELAY HARNESS TERMINAL NO. ⑤ AND COMPRESSOR HARNESS TERMINAL NO. ①.  
**Continuity should exist.**  
If OK, check harness for short.

**C**  
CHECK POWER SUPPLY FOR A/C RELAY.  
Disconnect A/C relay. Do approx. 12 volts exist between A/C relay harness terminal Nos. ①, ③ and body ground?

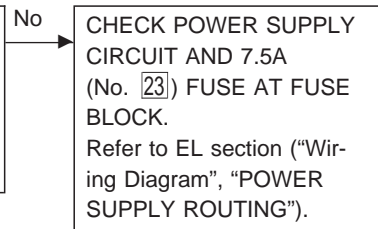

Replace A/C relay.

OK  
Ⓐ  
(Go to next page.)

**Note:**  
If the result is NG or No after checking circuit continuity, repair harness or connector.

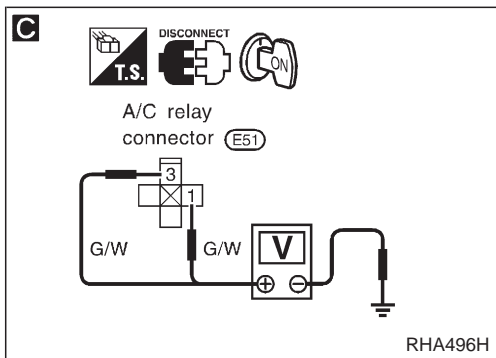
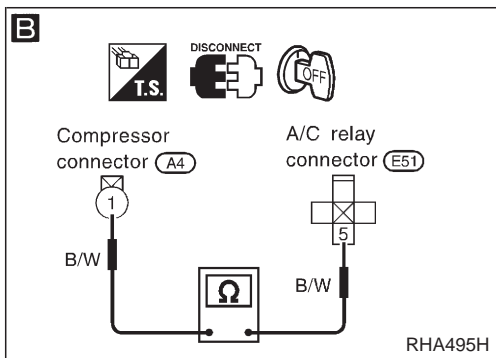
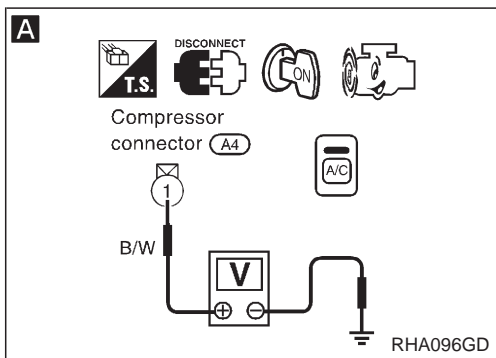

Magnet Clutch (Cont'd)

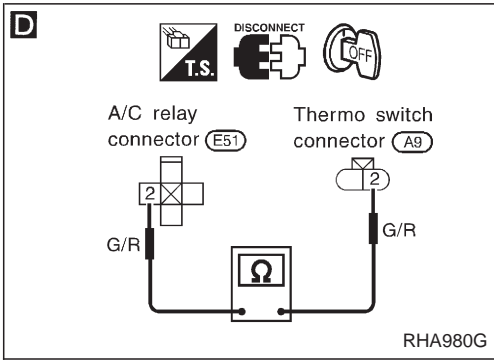

**D** Note

Check circuit continuity between A/C relay harness terminal No. ② and thermo switch harness terminal No. ②.  
**Continuity should exist.**  
 If OK, check harness for short.

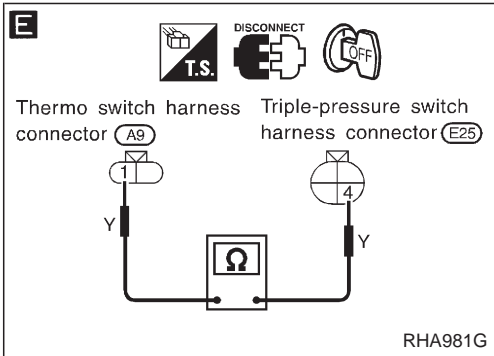

**E** Note

Check circuit continuity between thermo switch harness terminal No. ① and triple-pressure switch harness terminal No. ④.  
**Continuity should exist.**  
 If OK, check harness for short.

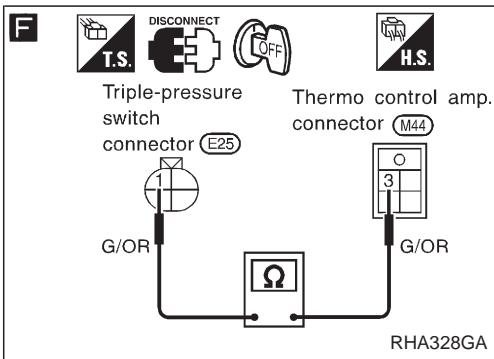

**F** Note

Check circuit continuity between triple-pressure switch harness terminal No. ① and thermo control amp. harness terminal No. ③.  
**Continuity should exist.**  
 If OK, check harness for short.

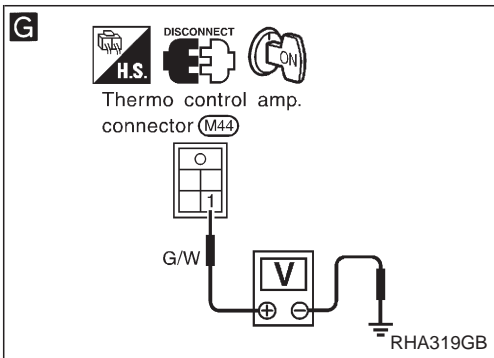

**G** Note

Check power supply for THERMO CONTROL AMP.  
 Do approx. 12 volts exist between thermo control amp. harness terminal No. ① and body ground?

(Go to next page.)

**Note:**  
 If the result is NG or No after checking circuit continuity, repair harness or connector.

Magnet Clutch (Cont'd)

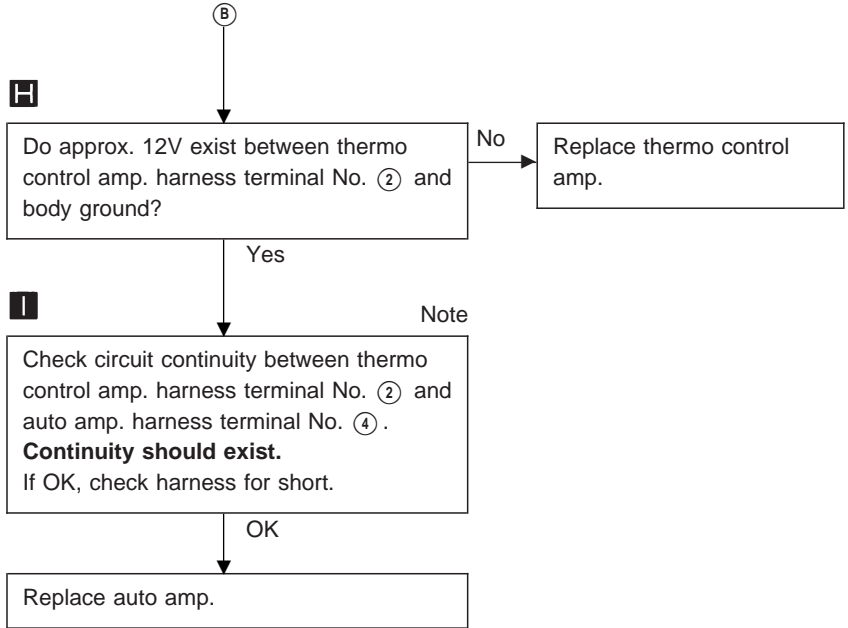
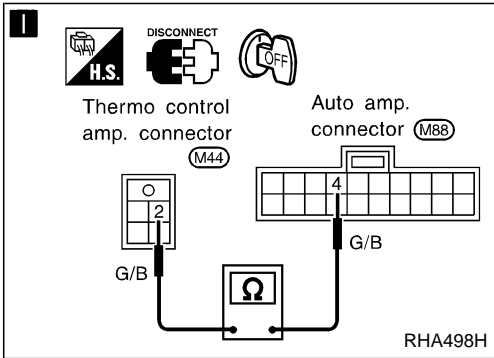
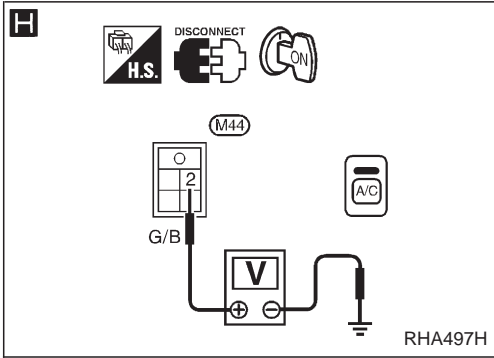

**Note:**  
If the result is NG or No after checking circuit continuity, repair harness or connector.



**Magnet Clutch (Cont'd)**

**COMPONENT INSPECTION**

**A/C relay**

Check continuity between terminal Nos. ③ and ⑤.

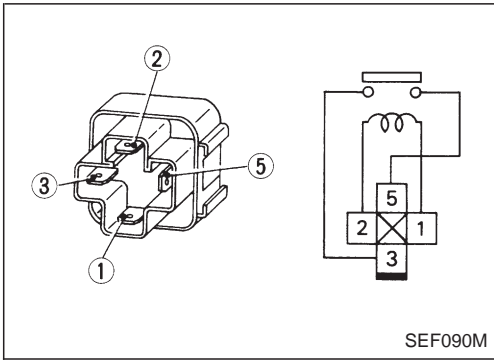

Conditions	Continuity
12V direct current supply between terminal Nos. ① and ②	Yes
No current supply	No

If NG, replace relay.

**Triple-pressure switch**

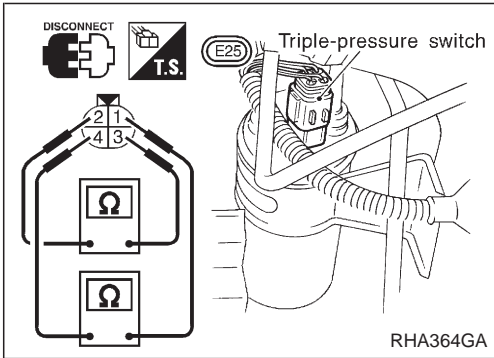

	Terminals	High-pressure side line pressure kPa (bar, kg/cm <sup>2</sup> , psi)	Operation	Continuity
Low-pressure side	① - ④	Increasing to 152.0 - 201.0 (1.520 - 2.010, 1.55 - 2.05, 22.0 - 29.2)	ON	Exists.
		Decreasing to 152.0 - 201.0 (1.520 - 2.010, 1.55 - 2.05, 22.0 - 29.2)	OFF	Does not exist.
Medium-pressure side*	② - ③	Increasing to 1,422 - 1,618 (14.22 - 16.18, 14.5 - 16.5, 206 - 235)	ON	Exists.
		Decreasing to 1,128 - 1,422 (11.28 - 14.22, 11.5 - 14.5, 164 - 206)	OFF	Does not exist.
High-pressure side	① - ④	Decreasing to 2,059 - 2,256 (20.6 - 22.6, 21 - 23, 299 - 327)	ON	Exists.
		Increasing to 2,648 - 2,844 (26.5 - 28.4, 27 - 29, 384 - 412)	OFF	Does not exist.

\*: For cooling fan motor operation

**Thermo control amp.**

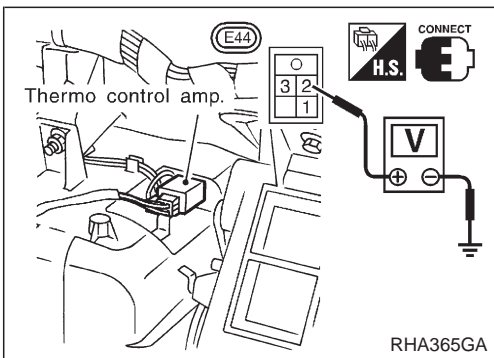

Evaporator outlet air temperature °C (°F)	Thermo amp. operation	Tester
Decreasing to 0.1 - 0.9 (32 - 34)	Turn OFF	Approx. 12V
Increasing to 2.5 - 3.5 (37 - 38)	Turn ON	Approx. 0V

**Magnet Clutch (Cont'd)**

**Thermo switch**

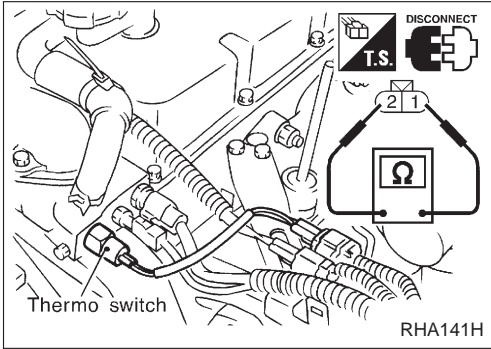

Water temperature °C (°F)	Terminal No.		Continuity
	⊕	⊖	
Over 105 (221)			No
Less than 100 (212)	①	②	Yes

## Insufficient Cooling

### TROUBLE DIAGNOSIS PROCEDURE FOR INSUFFICIENT COOLING

**SYMPTOM:**

- Insufficient cooling.

**Inspection flow**

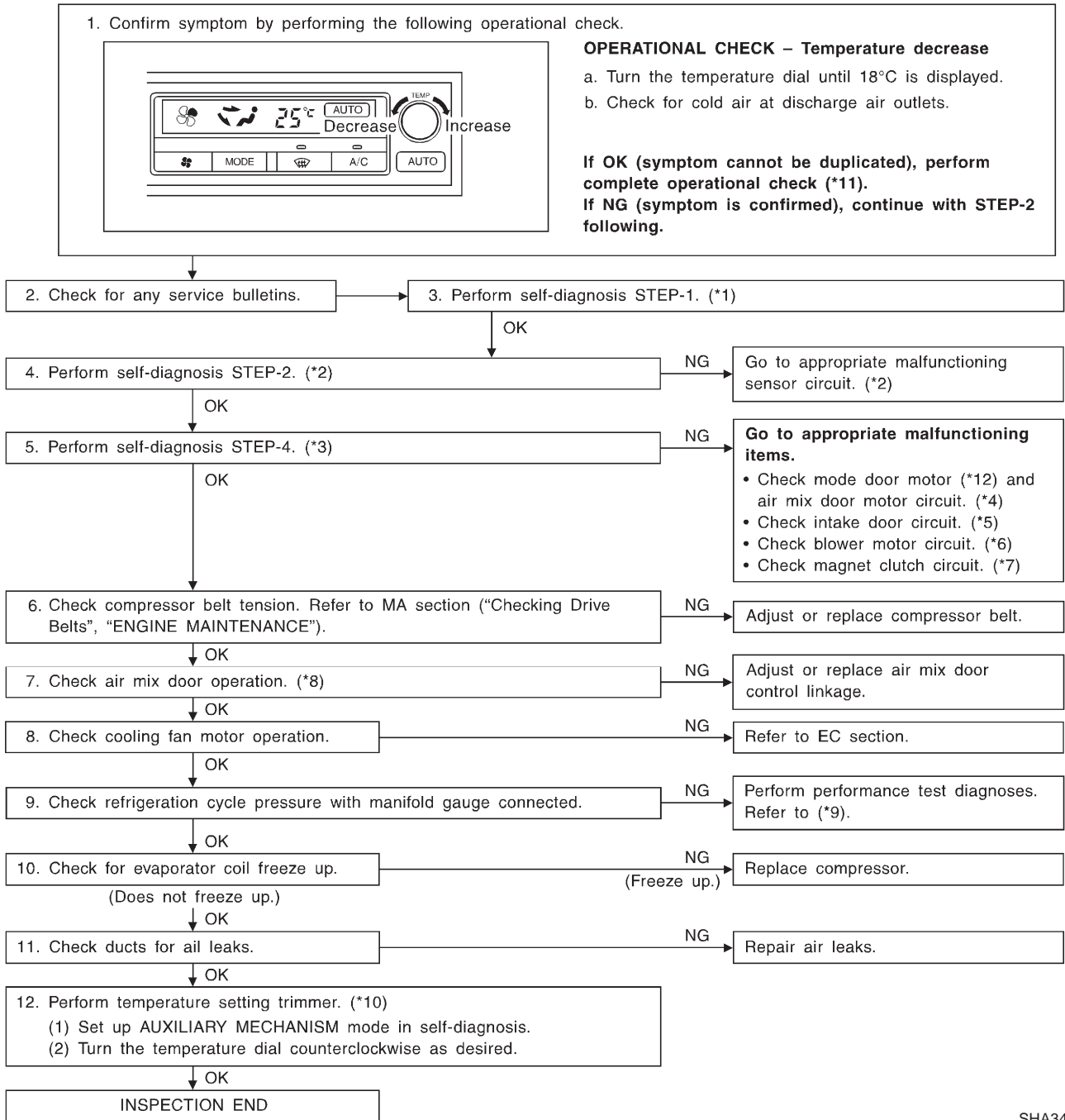

SHA347F

- \*1: HA-2035
- \*2: HA-2036
- \*3: HA-2038
- \*4: HA-2055
- \*5: HA-2060
- \*6: HA-2065

- \*7: HA-2070
- \*8: HA-2052
- \*9: Refer to HA-27, D22 Service Manual, Publication No. SM8E-0D22E0E.

- \*10: HA-2039
- \*11: HA-2041
- \*12: HA-2049

## Insufficient Heating

### TROUBLE DIAGNOSIS PROCEDURE FOR INSUFFICIENT HEATING

**SYMPTOM:**

- Insufficient heating.

**Inspection flow**

1. Confirm symptom by performing the following operational check.

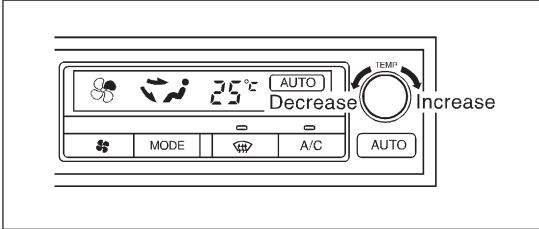

**OPERATIONAL CHECK – Temperature decrease**

a. Turn the temperature dial until 18°C is displayed.

b. Check for cold air at discharge air outlets.

**If OK (symptom cannot be duplicated), perform complete operational check (\*1).**

**If NG (symptom is confirmed), continue with STEP-2 following.**

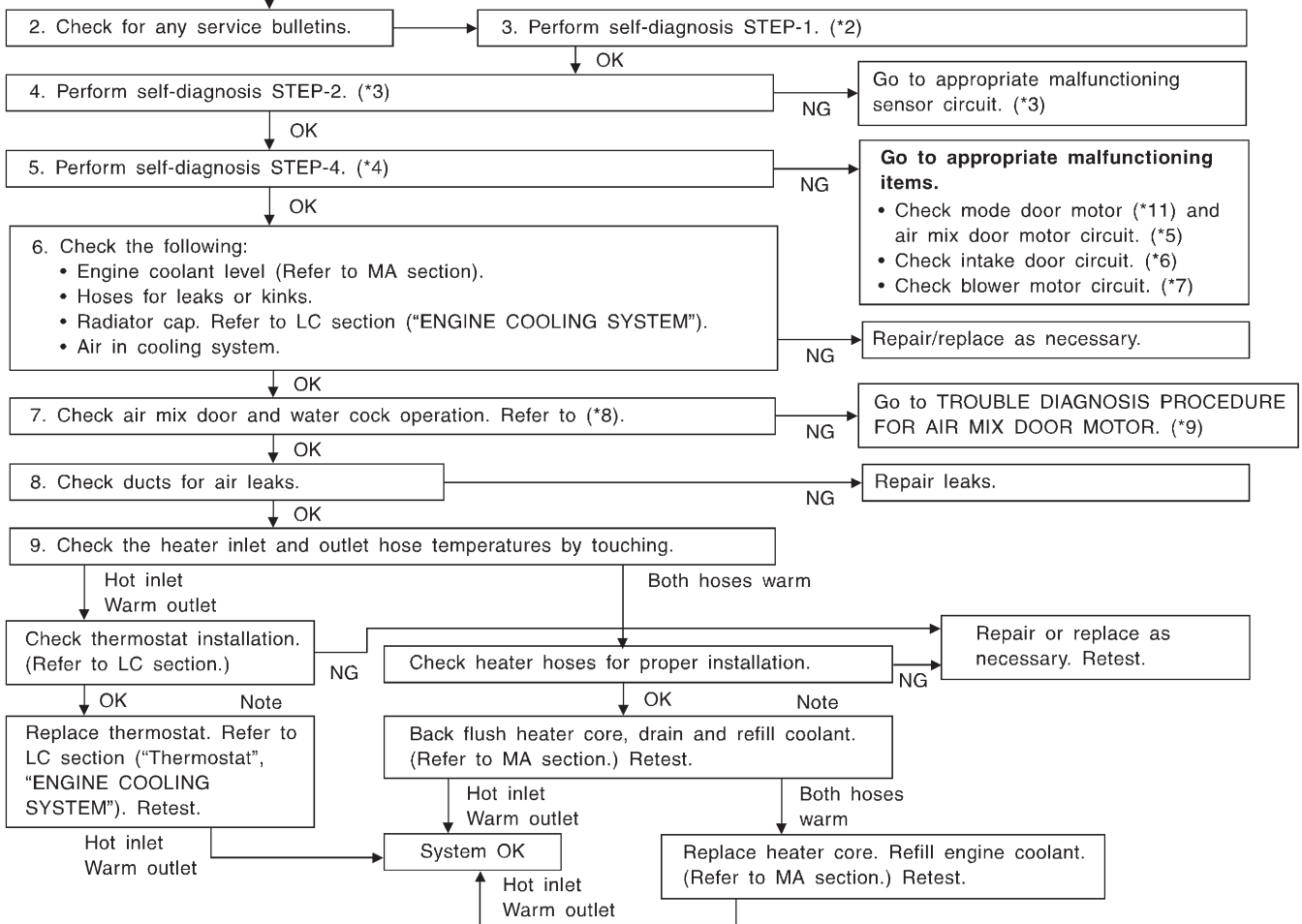

Note: To avoid unnecessary service of heating system, first perform TEMPERATURE SETTING TRIMMING. Refer to "AUXILIARY MECHANISM", "Self-diagnosis". (\*10)

SHA346F

- \*1: HA-2041
- \*2: HA-2035
- \*3: HA-2036
- \*4: HA-2038

- \*5: HA-2055
- \*6: HA-2060
- \*7: HA-2065
- \*8: HA-2057

- \*9: HA-2055
- \*10: HA-2039
- \*11: HA-2049

## Noise

### TROUBLE DIAGNOSIS PROCEDURE FOR NOISE

**SYMPTOM:**

- Noise

**Inspection flow**

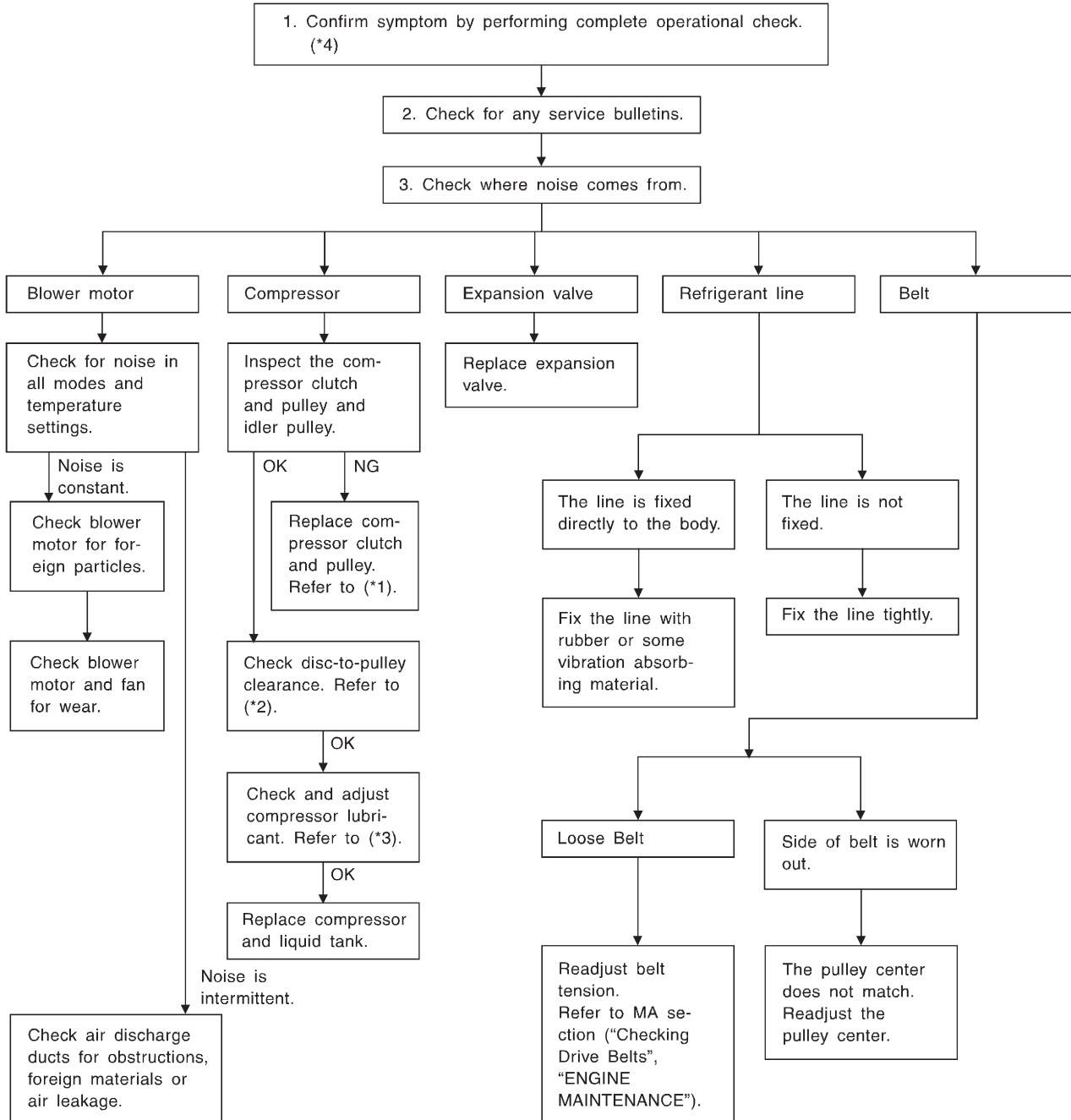

RHA539H

\*1: HA-69 in D22 Service Manual, Publication No. SM8E-0D22E0E

\*2: HA-71 in D22 Service Manual, Publication No. SM8E-0D22E0E

\*3: HA-57 in D22 Service Manual, Publication No. SM8E-0D22E0E

\*4: HA-2041

## Self-diagnosis

### TROUBLE DIAGNOSIS PROCEDURE FOR SELF-DIAGNOSIS

**SYMPTOM:**

- Self-diagnosis cannot be performed.

**Inspection flow**

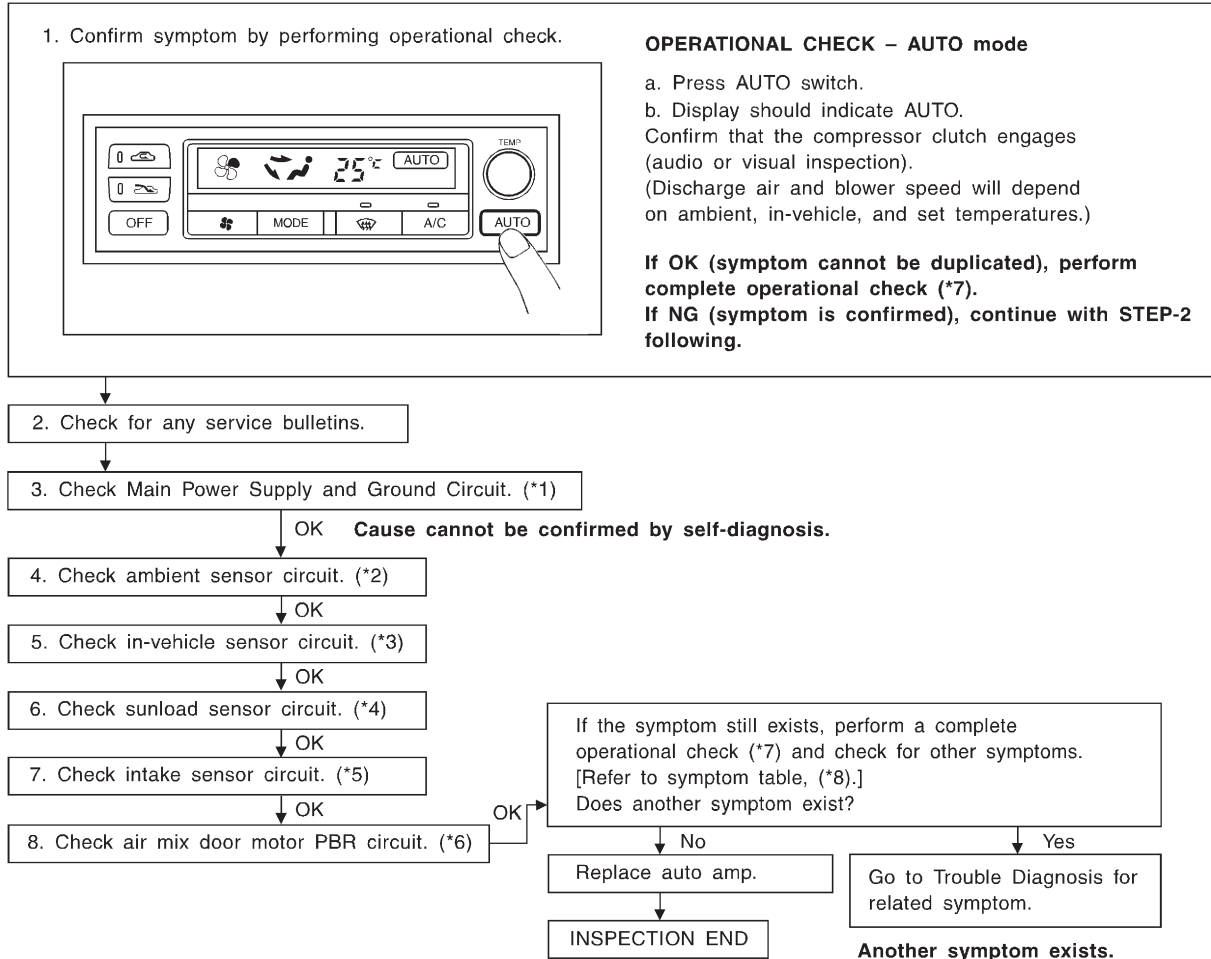

\*1: HA-2046  
\*2: HA-2081  
\*3: HA-2083

\*4: HA-2085  
\*5: HA-2087  
\*6: HA-2055

\*7: HA-2041  
\*8: HA-2040

Memory Function

TROUBLE DIAGNOSIS PROCEDURE FOR MEMORY FUNCTION

SYMPTOM:

- Memory function does not operate.

Inspection flow

1. Confirm symptom by performing the following operational check.

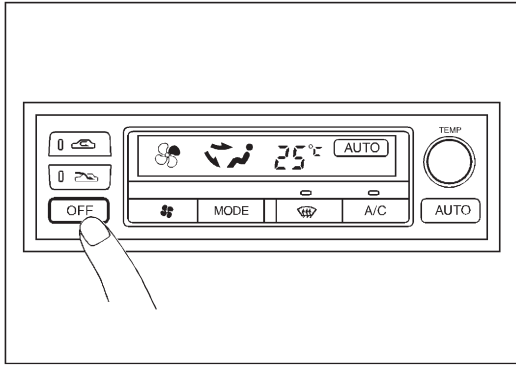

OPERATIONAL CHECK – Memory function

- Set the temperature 25°C.
- Press OFF switch.
- Turn the ignition off.
- Turn the ignition on.
- Press the AUTO switch.
- Confirm that the set temperature remains at previous temperature.
- Press OFF switch.

If OK (symptom cannot be duplicated), perform complete operational check (\*2).

If NG (symptom is confirmed), continue with STEP-2 following.

2. Check for any service bulletins.

3. Check Main Power Supply and Ground Circuit. (\*1)

OK

4. Replace auto amp.

5. FINAL CHECK

Go to self-diagnosis step-by-step procedure (\*3) and perform self-diagnosis STEP-2.  
Confirm that code No. 20 is displayed.

SHA027F

\*1: HA-2046

\*2: HA-2041

\*3: HA-2035

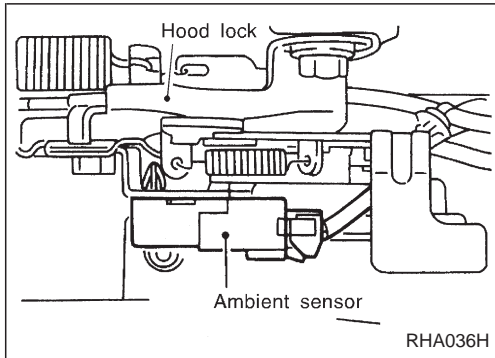

## Ambient Sensor

### COMPONENT DESCRIPTION

The ambient sensor is attached in front of the driver's side condenser. It detects ambient temperature and converts it into a resistance value which is then input into the auto amplifier.

### AMBIENT TEMPERATURE INPUT PROCESS

The automatic amplifier includes a "processing circuit" for the ambient sensor input. However, when the temperature detected by the ambient sensor increases quickly, the processing circuit retards the auto amp. function. It only allows the auto amp. to recognize an ambient temperature increase of 0.33°C per 100 seconds.

As an example, consider stopping for a cup of coffee after high speed driving. Although the actual ambient temperature has not changed, the temperature detected by the ambient sensor will increase. This is because the heat from the engine compartment can radiate to the front grille area, location of the ambient sensor.



## Ambient Sensor (Cont'd)

### DIAGNOSTIC PROCEDURE

**SYMPTOM:** Ambient sensor circuit is open or shorted. (21 or 21<sup>A/C</sup> LED is indicated on auto amp. as a result of conducting Self-diagnosis STEP 2.)

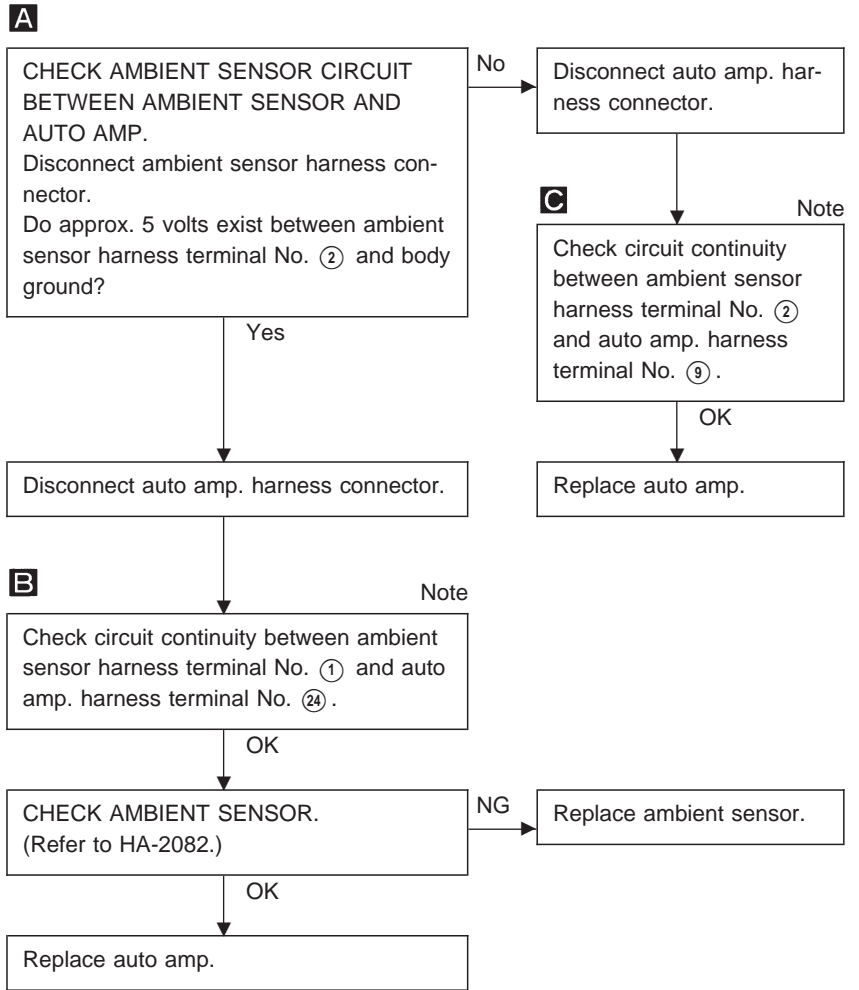
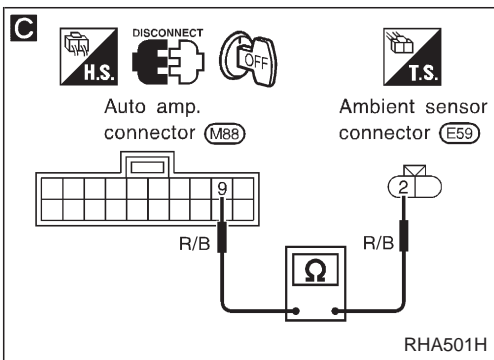
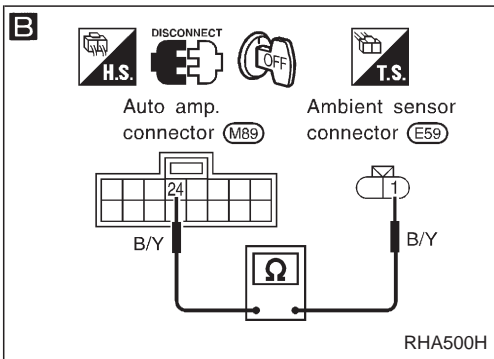
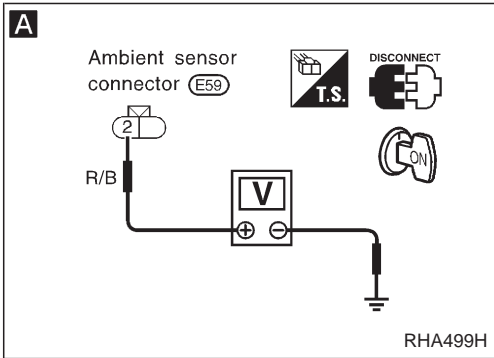
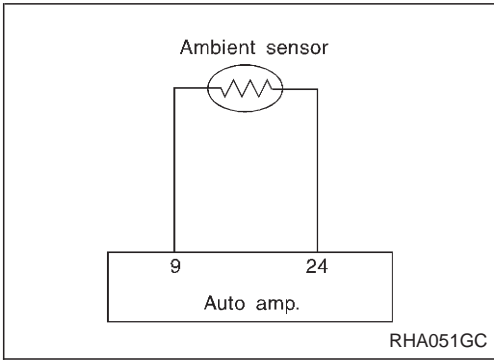

**Note:** If the result is NG or No after checking circuit continuity, repair harness or connector.

**Ambient Sensor (Cont'd)**

**COMPONENT INSPECTION**

**Ambient sensor**

After disconnecting ambient sensor harness connector, measure resistance between terminals ① and ② at sensor harness side, using the table below.

Temperature °C (°F)	Resistance kΩ
-20 (-4)	9.98
-10 (14)	5.57
0 (32)	3.26
10 (50)	1.98
20 (68)	1.25
25 (77)	1.00
30 (86)	0.81
40 (104)	0.54

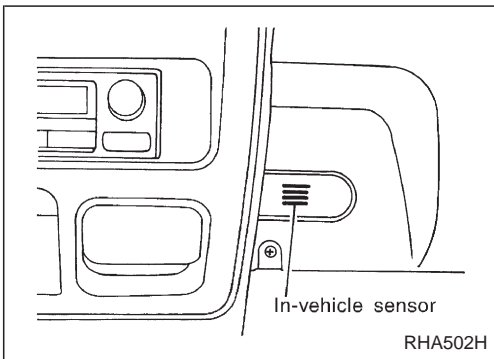
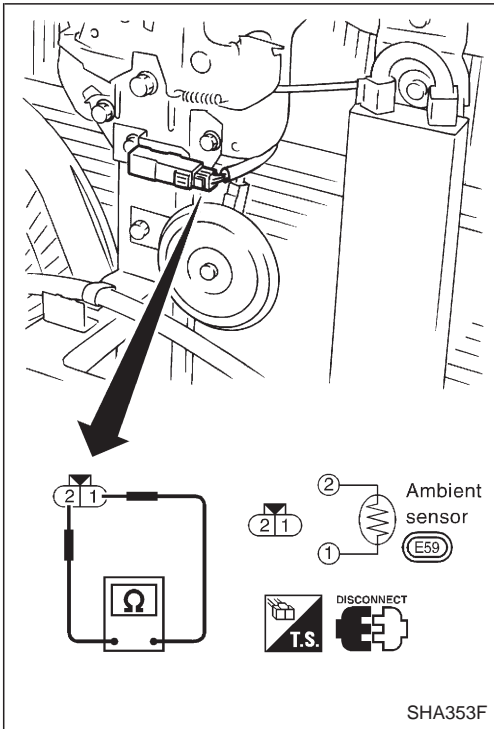

**In-vehicle Sensor**

**COMPONENT DESCRIPTION**

The in-vehicle sensor is located on instrument lower panel. It converts variations in temperature of compartment air drawn from the aspirator. It is then input into the auto amplifier.

In-vehicle Sensor (Cont'd)

DIAGNOSTIC PROCEDURE

**SYMPTOM:** In-vehicle sensor circuit is open or shorted. (  $\overline{22}$  or  $\overline{22}^{A/C}$  LED is indicated on auto amp. as a result of conducting Self-diagnosis STEP 2.)

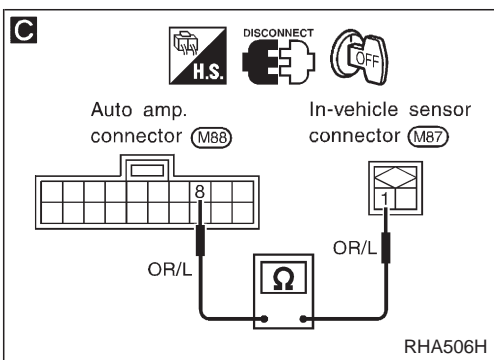
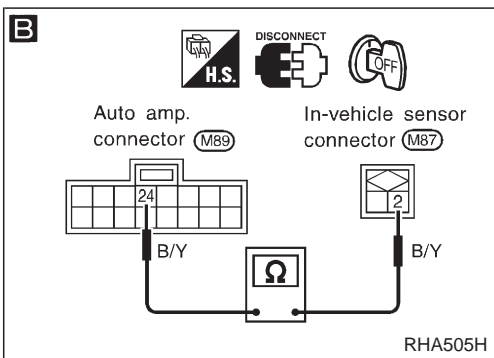
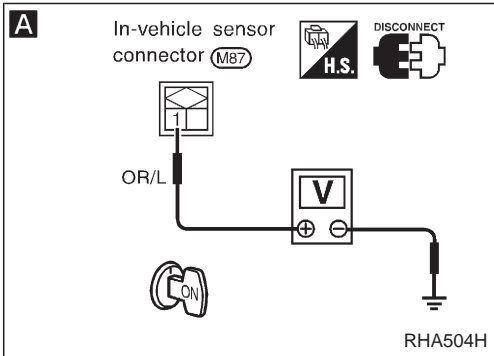
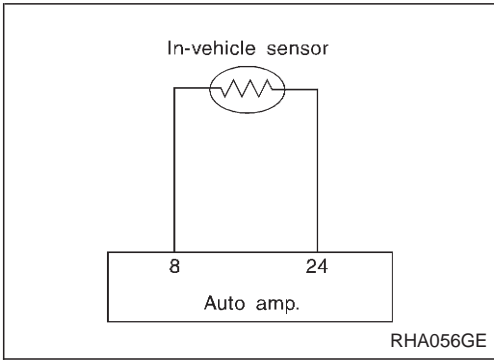

**A**

CHECK IN-VEHICLE SENSOR CIRCUIT BETWEEN IN-VEHICLE SENSOR AND AUTO AMP.

Disconnect in-vehicle sensor harness connector.

Do approx. 5 volts exist between in-vehicle sensor harness terminal No. ① and body ground?

No

Disconnect auto amp. harness connector.

**C**

Note

Check circuit continuity between in-vehicle sensor harness terminal No. ① and auto amp. harness terminal No. ⑧.

OK

Replace auto amp.

Yes

Disconnect auto amp. harness connector.

**B**

Note

Check circuit continuity between in-vehicle sensor harness terminal No. ② and auto amp. harness terminal No. ②④.

OK

CHECK IN-VEHICLE SENSOR. (Refer to HA-2084.)

NG

Replace in-vehicle sensor.

OK

Replace auto amp.

**Note:**

If the result is NG or No after checking circuit continuity, repair harness or connector.

**In-vehicle Sensor (Cont'd)**

**COMPONENT INSPECTION**

**In-vehicle sensor**

After disconnecting in-vehicle sensor harness connector, measure resistance between terminals ① and ② at sensor harness side, using the table below.

Temperature °C (°F)	Resistance kΩ
0 (32)	6.0
5 (41)	4.95
10 (50)	3.99
15 (59)	3.24
20 (68)	2.65
25 (77)	2.19
30 (86)	1.81
35 (95)	1.51
40 (104)	1.27

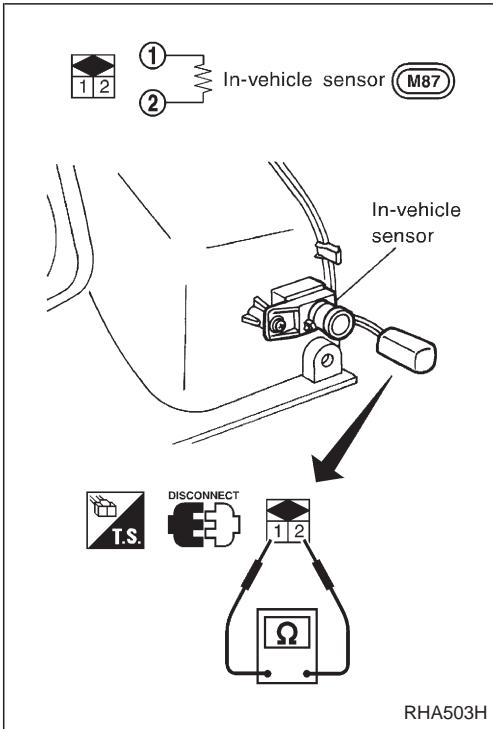

RHA503H

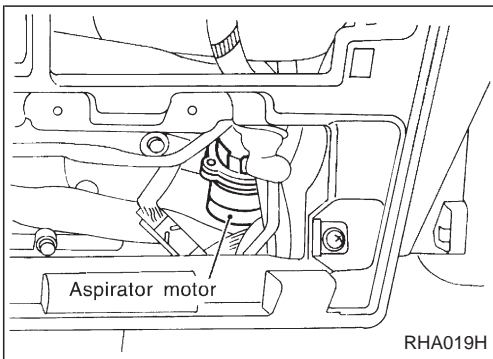

RHA019H

**Aspirator Motor**

**COMPONENT DESCRIPTION**

The aspirator motor is located in front of the heater unit. The aspirator motor continuously draws compartment air into the in-vehicle sensor while the ignition switch is ON.

Check that smoke is properly sucked into in-vehicle sensor when a lighted cigarette is moved close to the sensor.

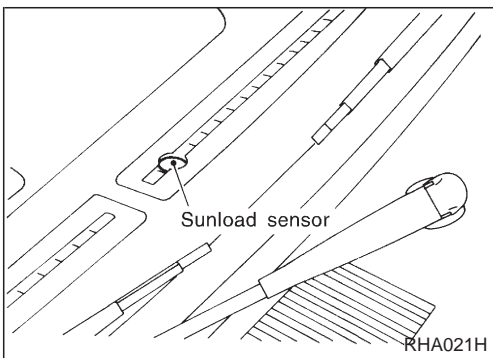

RHA021H

**Sunload Sensor**

**COMPONENT DESCRIPTION**

The sunload sensor is located on the center defroster grille. It detects sunload entering through the windshield by means of a photo diode and converts it into a current value which is then input to the auto amplifier.

Sunload Sensor (Cont'd)

DIAGNOSTIC PROCEDURE

**SYMPTOM:** Sunload sensor circuit is open or shorted. ( 25 or 25<sup>A/C</sup> LED is indicated on auto amp. as a result of conducting Self-diagnosis STEP 2.)

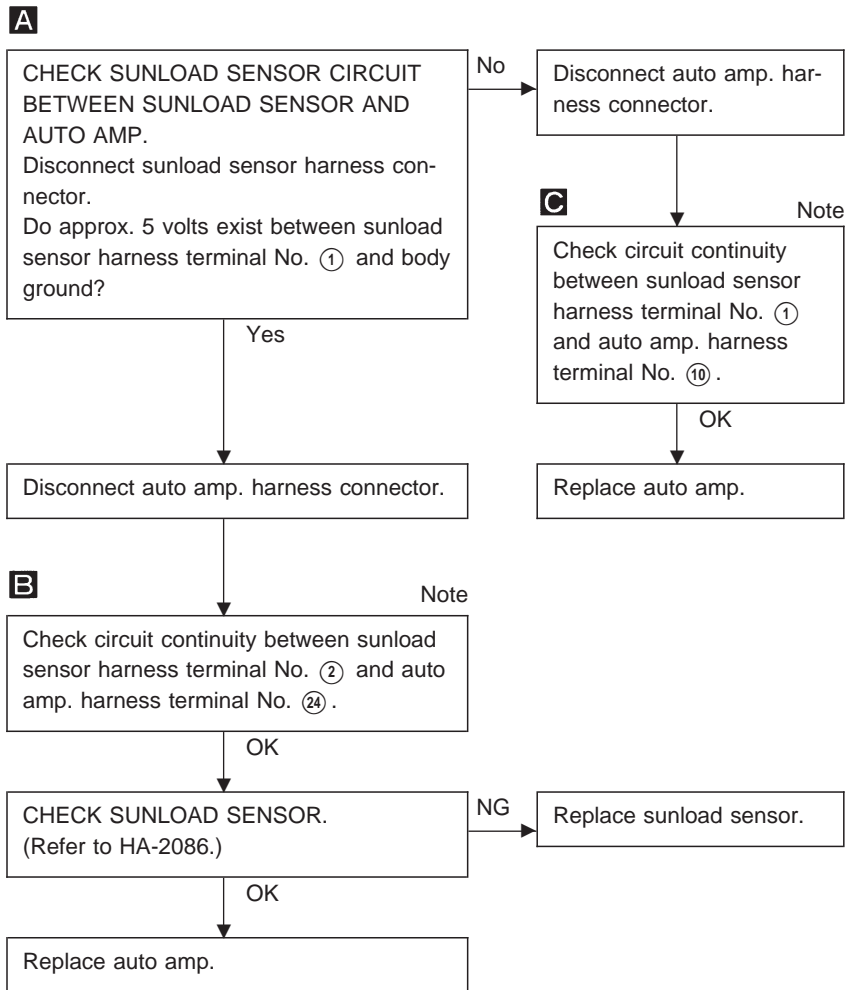
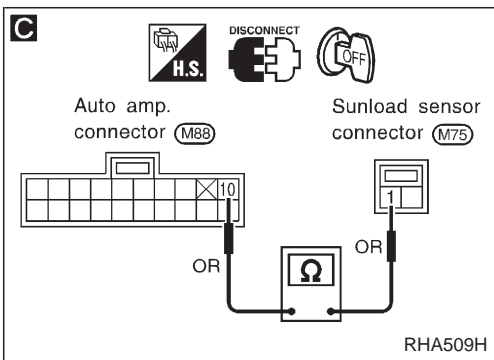
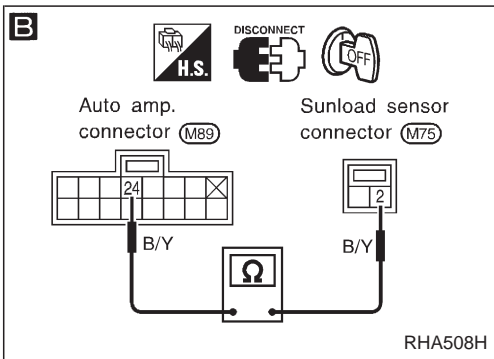
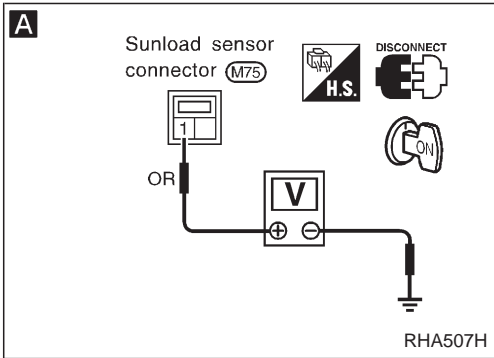
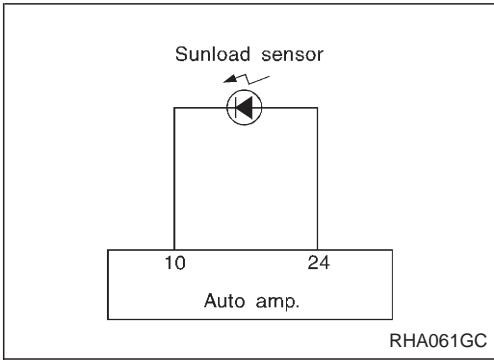

**Note:**  
If the result is NG or No after checking circuit continuity, repair harness or connector.

## Sunload Sensor (Cont'd)

## COMPONENT INSPECTION

## Sunload sensor

Measure voltage between auto amp. terminal ⑩ and body ground.

- When checking sunload sensor, select a place where sun shines directly on it.

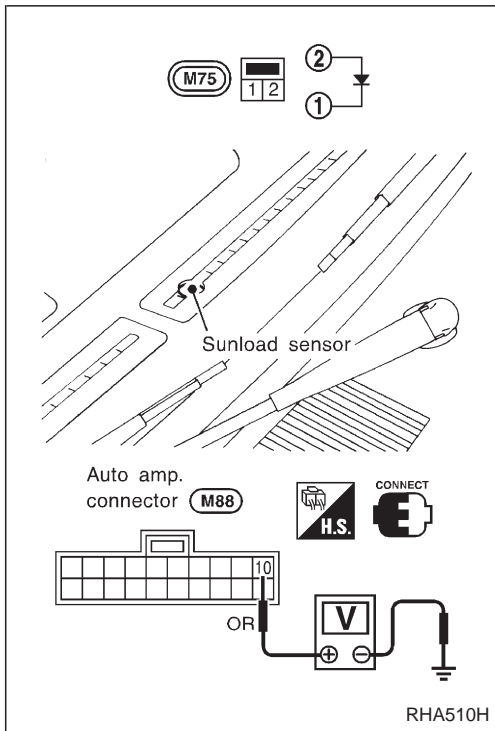

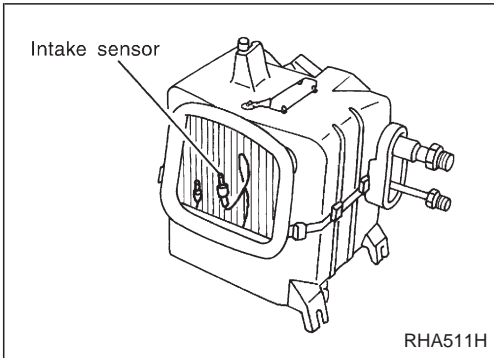

## Intake Sensor

### COMPONENT DESCRIPTION

The intake sensor is located on the cooling unit. It converts temperature of air after it passes through the evaporator into a resistance value. The value is then input to the auto amplifier.

### DIAGNOSTIC PROCEDURE

**SYMPTOM:** Intake sensor circuit is open or shorted.

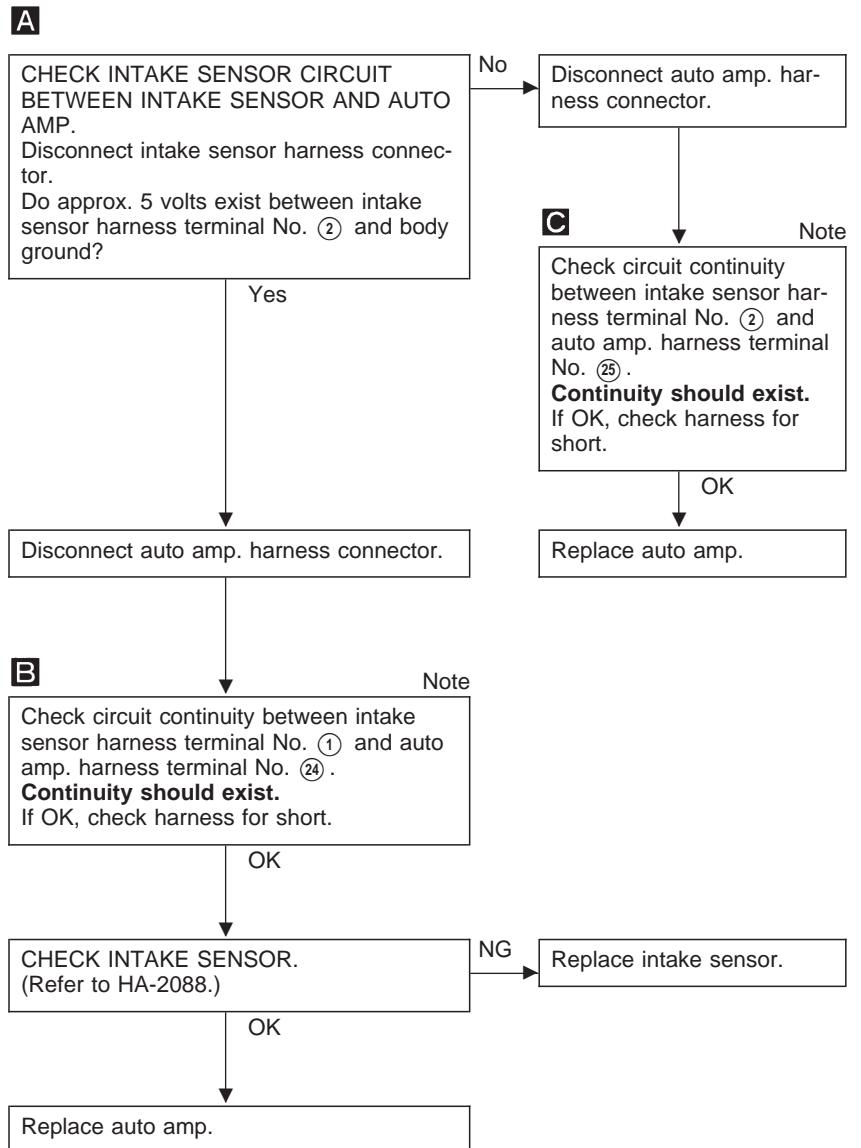
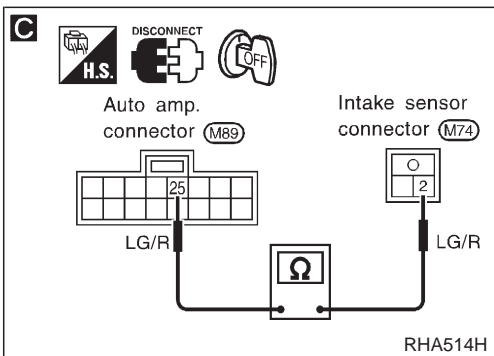
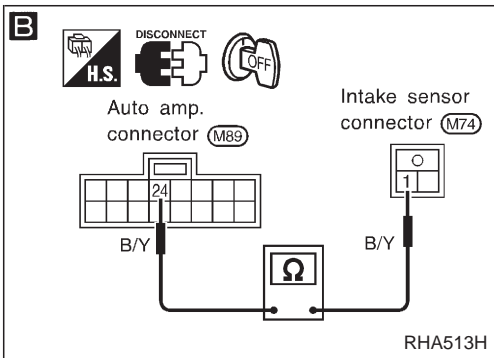
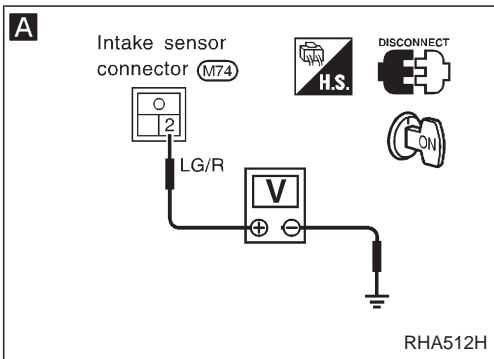
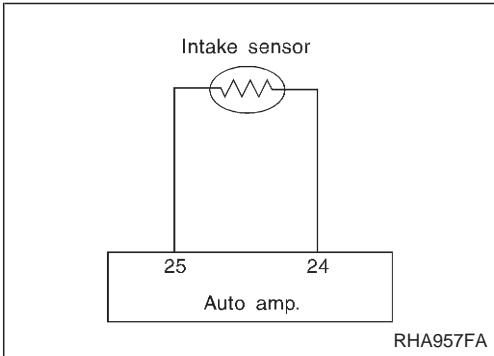

**Note:**  
If the result is NG or No after checking circuit continuity, repair harness or connector.

**Intake Sensor (Cont'd)**  
**COMPONENT INSPECTION**

**Intake sensor**

After disconnecting intake sensor harness connector, measure resistance between terminals ②⑤ and ②④ at sensor harness side, using the table below.

