

<SUPPLEMENT-II>

ENGINE LUBRICATION & COOLING SYSTEMS

SECTION **LC**

LC

MODIFICATION NOTICE:

Diesel engine:

Oil pump inspection data have been changed.

CONTENTS

<input type="checkbox"/>	TD	<input type="checkbox"/>
ENGINE ROOM FAN MOTOR ELECTRICAL CIRCUIT		2002
Wiring Diagram		2002

SERVICE DATA AND SPECIFICATIONS (SDS)	2003
Engine Lubrication System (TD).....	2003

Wiring Diagram

LC-COOL/F-01

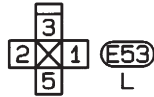
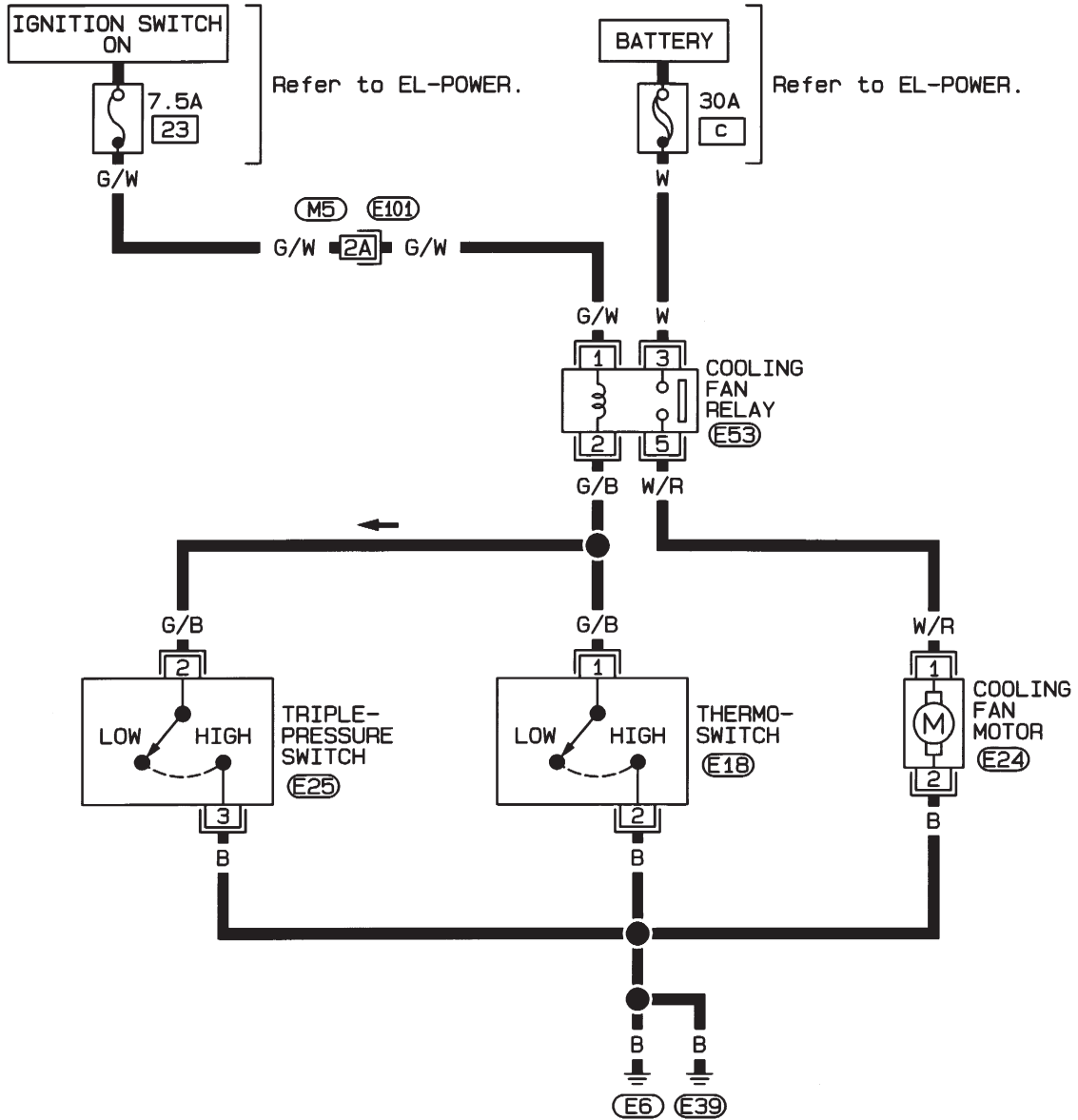

Refer to last page (Foldout page).

M5, E101

Engine Lubrication System (TD)

Oil pump inspection

Unit: mm (in)

Gear side clearance	Less than 0.16 (0.0063)
Gear backlash	Less than 0.43 (0.0169)
Oil pump bushing clearance	Less than 0.15 (0.0059)
Oil pump bushing inside diameter	13.012 - 13.106 (0.5123 - 0.5160)
Drive gear shaft outside diameter	12.981 - 12.992 (0.5111 - 0.5115)