

<SUPPLEMENT-II>

REAR AXLE & REAR SUSPENSION

SECTION **RA**

MODIFICATION NOTICE:

Tightening torque of rear spring front pin mounting bolts has been changed.

CONTENTS

REAR SUSPENSION.....2002

REAR SUSPENSION

2WD

SEC. 431

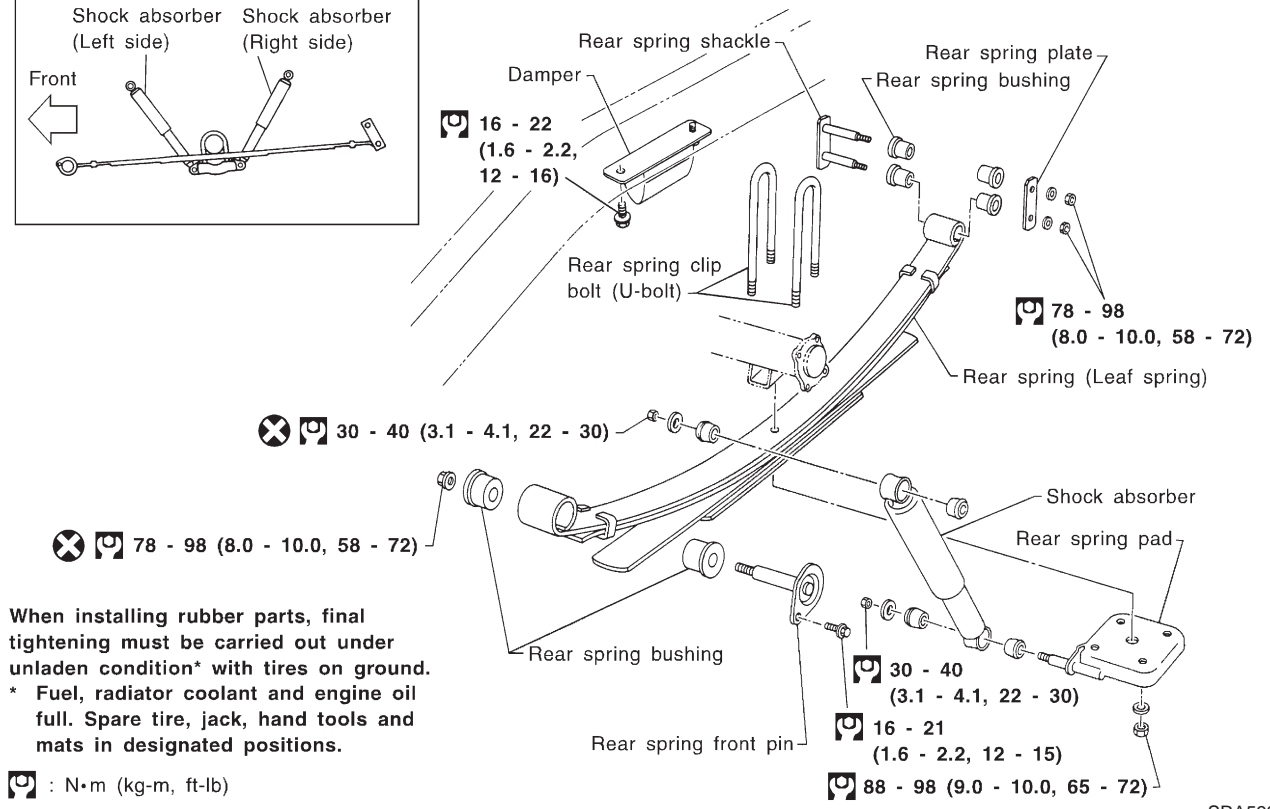
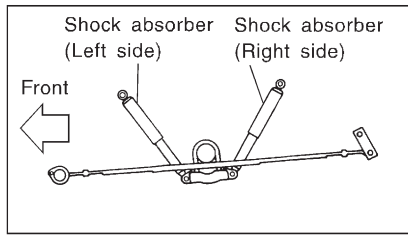

When installing rubber parts, final tightening must be carried out under unladen condition* with tires on ground.
 * Fuel, radiator coolant and engine oil full. Spare tire, jack, hand tools and mats in designated positions.

: N·m (kg-m, ft-lb)

SRA593CB