

RESTRAINT SYSTEM

SECTION **RS**

MODIFICATION NOTICE:

- Passenger air bag has been adopted as optional equipment.
- Diagnosis sensor unit has been changed.
- The air bag system with a diagnosis sensor unit located in the steering wheel has been deleted.

CONTENTS

PRECAUTION	2002	Installation - Driver Air Bag Module and Spiral Cable.....	2009
Supplemental Restraint System (SRS) “AIR BAG”	2002	Removal - Front Passenger Air Bag Module ..	2011
SEAT BELTS	2003	Installation - Front Passenger Air Bag Module	2011
Precaution for Seat Belt Service	2003	Disposal of Air Bag Module	2012
SUPPLEMENTAL RESTRAINT SYSTEM (SRS)	2004	TROUBLE DIAGNOSES - Supplemental Restraint System (SRS)	2015
Precautions for SRS “AIR BAG” and “SEAT BELT PRE-TENSIONER” Service.....	2004	Trouble Diagnoses Introduction.....	2015
Special Service Tools	2004	How to Perform Trouble Diagnoses for Quick and Accurate Repair	2017
Commercial Service Tool.....	2005	Schematic	2019
Description	2005	Wiring Diagram - SRS -/LHD Models.....	2020
SRS Component Parts Location.....	2006	Wiring Diagram - SRS -/RHD Models	2023
Maintenance Items.....	2006	Self-diagnosis.....	2025
Removal and Installation - Diagnosis Sensor Unit.....	2007	Trouble Diagnoses for Air Bag Warning Lamp	2037
Removal - Driver Air Bag Module and Spiral Cable.....	2008	COLLISION DIAGNOSIS	2039

PRECAUTION

Supplemental Restraint System (SRS) “AIR BAG”

The Supplemental Restraint System “AIR BAG” used along with a seat belt, helps to reduce the risk or severity of injury to the driver and front passenger in a frontal collision. The SRS composition which is available to NISSAN MODEL D22 is as follows (The composition varies according to the destination and optional equipment.):

Driver air bag module (located in the center of the steering wheel), front passenger air bag module (located on the instrument panel on passenger side), a diagnosis sensor unit, warning lamp, wiring harness and spiral cable.

WARNING:

- **To avoid rendering the SRS inoperative, which could increase the risk of personal injury or death in the event of a collision which would result in air bag inflation, all maintenance must be performed by an authorized NISSAN dealer.**
- **Improper maintenance, including incorrect removal and installation of the SRS, can lead to personal injury caused by unintentional activation of the system.**
- **Do not use electrical test equipment on any circuit related to the SRS unless instructed to in this Service Manual. Spiral cable and wiring harnesses covered with yellow insulation either just before the harness connectors or for the complete harness are related to the SRS.**

SEAT BELTS

Precaution for Seat Belt Service

CAUTION:

- Do not disassemble buckle or seat belt assembly.
- Replace anchor bolts if they are deformed or worn out.
- Never oil tongue and buckle.
- If any component of seat belt assembly is questionable, do not repair. Replace the whole seat belt assembly.
- If webbing is cut, frayed, or damaged, replace seat belt assembly.
- When replacing seat belt assembly, use a genuine seat belt assembly.

AFTER A COLLISION

WARNING:

Inspect all seat belt assemblies including retractors and attaching hardware after any collision. NISSAN recommends that all seat belt assemblies in use during a collision be replaced unless the collision was minor and the belts show no damage and continue to operate properly. Failure to do so could result in serious personal injury in an accident. Seat belt assemblies not in use during a collision should also be replaced if either damage or improper operation is noted.

Replace any seat belt assembly if:

- The seat belt was in use at the time of a collision (except for minor collisions and the belts, retractors and buckles show no damage and continue to operate properly).
- The seat belt was damaged in an accident. (i.e. torn webbing, bent retractor or guide, etc.)
- The seat belt attaching point was damaged in an accident. Inspect the seat belt attaching area for damage or distortion and repair as necessary before installing a new seat belt assembly.
- Anchor bolts are deformed or worn out.

SUPPLEMENTAL RESTRAINT SYSTEM (SRS)

Precautions for SRS “AIR BAG” and “SEAT BELT PRE-TENSIONER” Service

- Do not use electrical test equipment to check SRS circuits unless instructed to in this Service Manual.
- Before servicing the SRS, turn ignition switch “OFF”, disconnect both battery cables and wait at least 3 minutes.
For approximately 3 minutes after the cables are removed, it is still possible for the air bag to deploy. Therefore, do not work on any SRS connectors or wires until at least 3 minutes have passed.
- Diagnosis sensor unit must always be installed with their arrow marks “↖” pointing towards the front of the vehicle for proper operation. Also check diagnosis sensor unit for cracks, deformities or rust before installation and replace as required.
- The spiral cable must be aligned with the neutral position since its rotations are limited. Do not attempt to turn steering wheel or column after removal of steering gear.
- Handle air bag module carefully. Always place driver and passenger air bag modules with the pad side facing upward.
- Conduct self-diagnosis to check entire SRS for proper function after replacing any components.
- After air bag inflates, the front instrument panel assembly should be replaced if damaged.

Special Service Tools

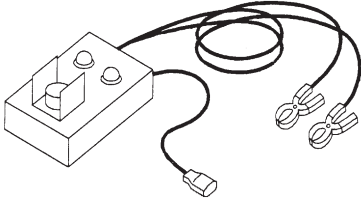
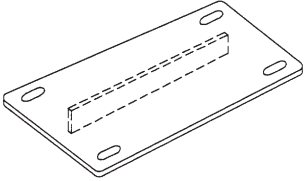
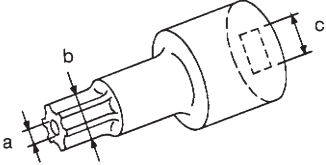
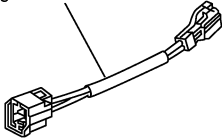
Tool number Tool name	Description
KV99106400 Deployment tool	 <p>Disposing of air bag module</p> <p>NT357</p>
KV99105300 Air bag module bracket	 <p>Anchoring air bag module</p> <p>NT354</p>
HT61961000 and HT62152000 combined *Special torx bit	 <p>Use for special bolts [TAMPER RESISTANT TORX (Size T50)]</p> <p>a: 3.5 (0.138) dia. b: 8.5 - 8.6 (0.335 - 0.339) dia. c: approx. 10 (0.39) sq. Unit: mm (in)</p> <p>NT361</p>
KV99108300 Deployment tool adapters for passenger air bag	 <p>For passenger air bag module</p> <p>NT776</p>

*: Special tool or commercial equivalent

SUPPLEMENTAL RESTRAINT SYSTEM (SRS)

Commercial Service Tool

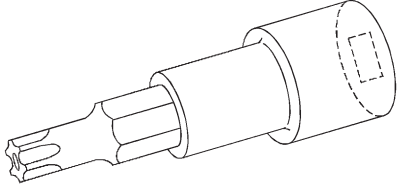
Tool name	Description	Specification
Tamper resistant torx socket		Size: T30

Description

The air bag deploys if the diagnosis sensor unit activates while the ignition switch is in the "ON" or "START" position.

SRS configurations vary with vehicle depending on optional equipment and destination.

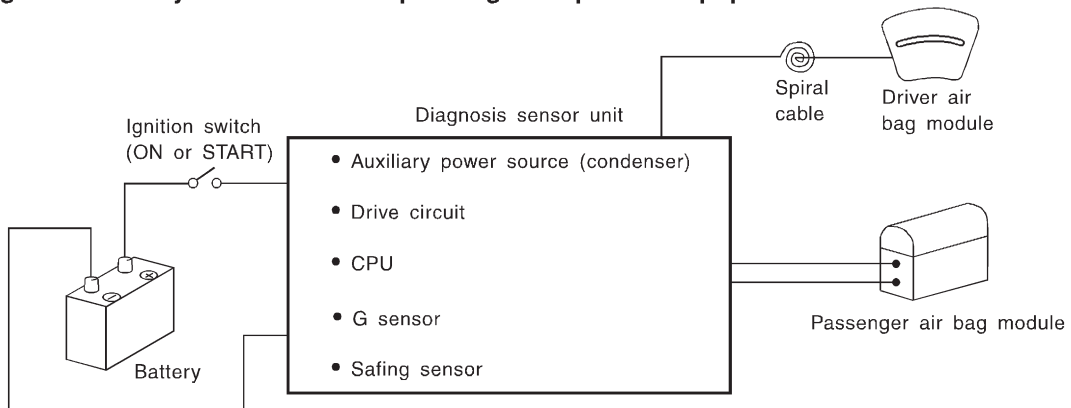

NRS087

SUPPLEMENTAL RESTRAINT SYSTEM (SRS)

SRS Component Parts Location

SEC. 240•251•253•484•680

SRS configurations vary with vehicle depending on optional equipment and destination.

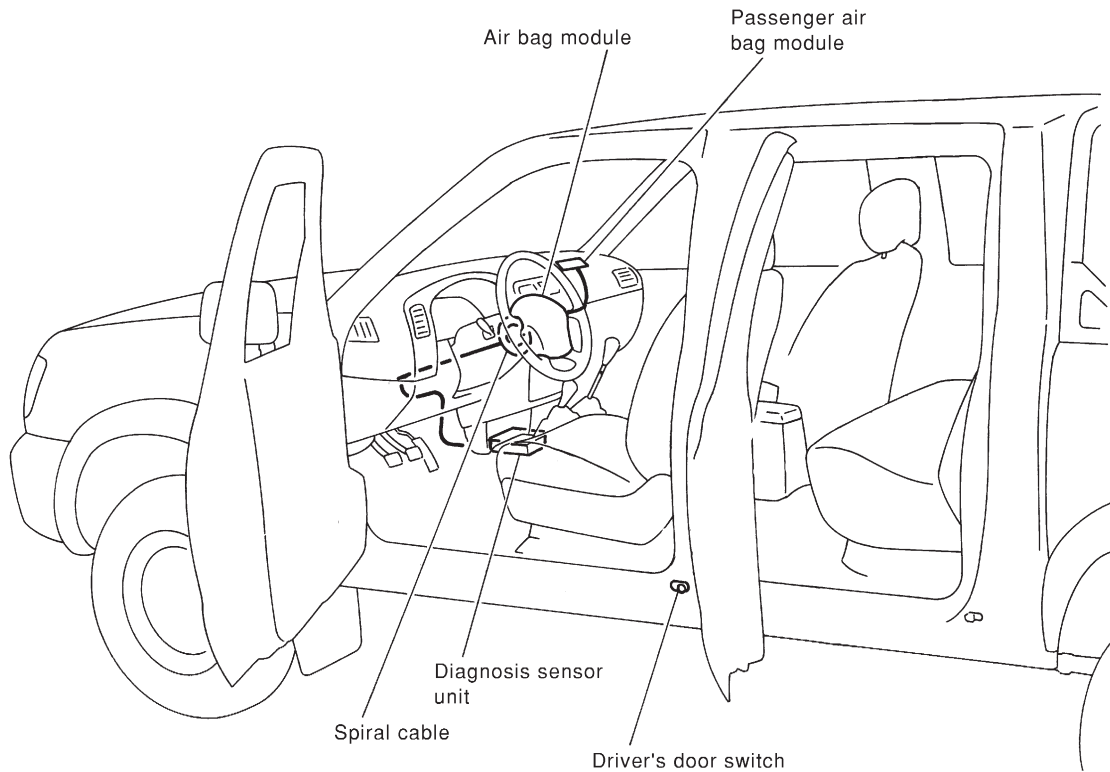

NRS088

**AIR
BAG**

SRS296

Maintenance Items

CAUTION:

Do not use electrical test equipment to check SRS circuit.

1. Check operation of "AIR BAG" warning lamp.
After turning ignition key to "ON" position, the warning lamp illuminates. The "AIR BAG" warning lamp will go off after about 7 seconds if no malfunction is detected. If any of the following warning lamp conditions occur, immediately check the air bag system. Refer to RS-2025 for details.
 - The "AIR BAG" warning lamp does not illuminate when the ignition switch is turned "ON".
 - The "AIR BAG" warning lamp does not go off about 7 seconds after the ignition switch is turned "ON".
 - The "AIR BAG" warning lamp blinks after about 7 seconds after the ignition switch is turned "ON".
2. Visually check SRS components
 - (1) Diagnosis sensor unit
 - Check diagnosis sensor unit and bracket for dents, cracks or deformities.
 - Check connectors for damage, and terminals for deformities.
 - (2) Air bag module and steering wheel

RS-2006

SUPPLEMENTAL RESTRAINT SYSTEM (SRS)

Maintenance Items (Cont'd)

- Remove air bag module from steering wheel, instrument panel or seat back. Check harness cover and connectors for damage, terminals for deformities, and harness for binding.
 - Install driver air bag module to steering wheel to check fit or alignment with the wheel.
 - Check steering wheel for excessive free play.
 - Install passenger air bag module to instrument panel to check fit or alignment with the instrument panel.
- (3) Spiral cable
- Check spiral cable for dents, cracks, or deformities.
 - Check connectors and protective tape for damage.
 - Check steering wheel for noise, binding or heavy operation.
- (4) Main harness and air bag harness
- Check connectors for poor connections, damage, and terminals for deformities.
 - Check harnesses for binding, chafing or cut.

CAUTION:

Replace previously used special bolts and ground bolt with new ones.

Removal and Installation — Diagnosis Sensor Unit

CAUTION:

- Before servicing SRS, turn the ignition switch off, disconnect both battery cables and wait at least 3 minutes.
- Do not use old special bolts and nuts coated with bonding agent after removal; replace with new ones.
- Check diagnosis sensor unit for proper installation.
- Check diagnosis sensor unit to ensure it is free of deformities, dents, cracks or rust. If it shows any visible signs of damage, replace it with a new one.
- Check diagnosis sensor unit brackets to ensure they are free of deformities and rust.
- After replacement of diagnosis sensor unit, check SRS function and perform self-diagnosis for SRS. Refer to “Self-diagnosis” for details. (RS-2025)
- Do not attempt to disassemble diagnosis sensor unit.
- Replace diagnosis sensor unit and if it has been dropped or sustained an impact.

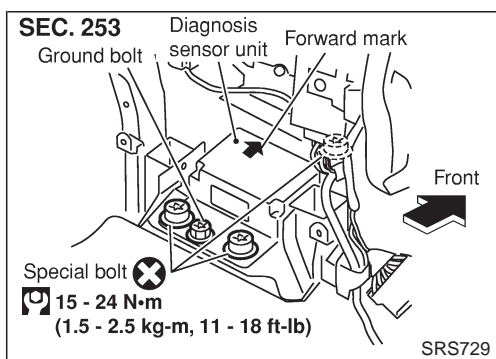

REMOVAL OF DIAGNOSIS SENSOR UNIT

1. Disconnect driver and passenger air bag module connectors.
2. Remove instrument panel. Refer to “INSTRUMENT PANEL” in BT section.
3. Remove air duct.
4. Disconnect diagnosis sensor unit connector.
5. Remove ground bolt and also remove special bolts using the TAMPER RESISTANT TORX (Size T50), from diagnosis sensor unit.
Then remove the diagnosis sensor unit.

NOTE:

- To install, reverse the removal procedure sequence.
- After replacement, perform self-diagnosis for SRS. Refer to “Self-diagnosis” for details (RS-2025).

CAUTION:

- Do not use old special bolts and ground bolt coated with bonding agent; replace with new coated special bolts and ground bolt.

RS-2007

SUPPLEMENTAL RESTRAINT SYSTEM (SRS)

Removal — Driver Air Bag Module and Spiral Cable

SEC. 253•484

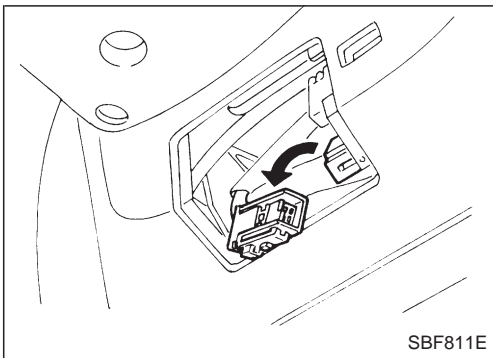
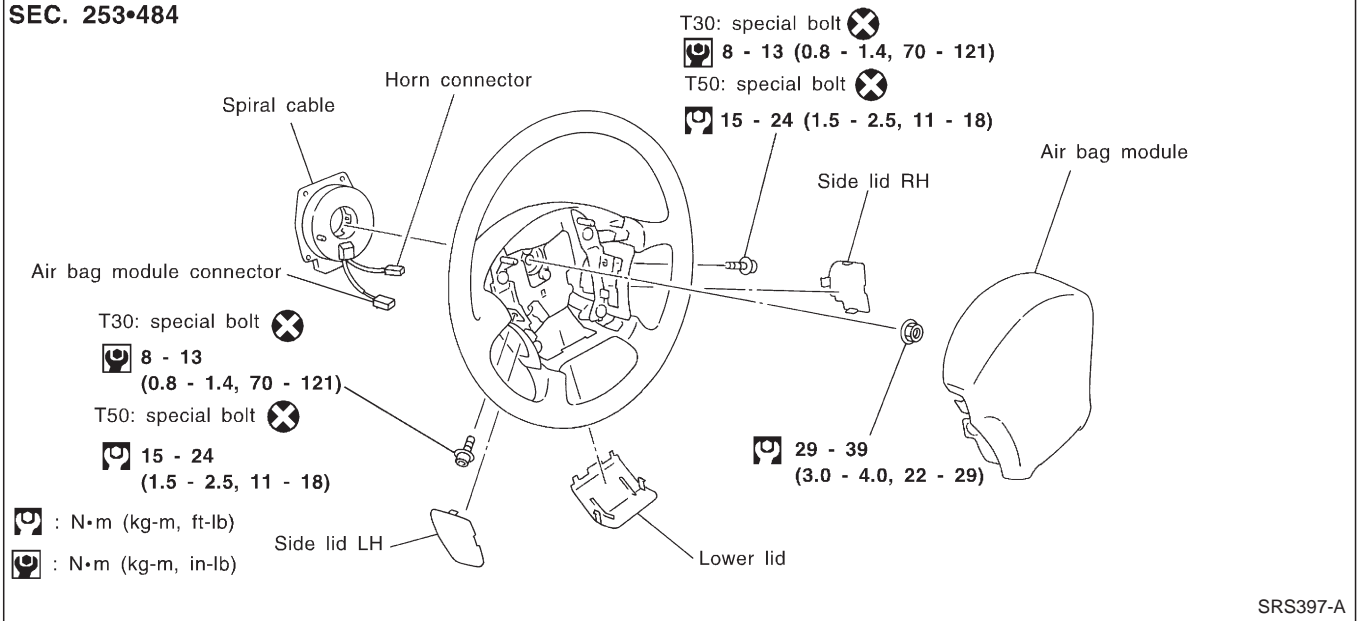

CAUTION:

- Before servicing SRS, turn the ignition switch OFF, disconnect both battery cables and wait at least 3 minutes.
- Always work from the side of air bag module.

1. Remove lower lid from steering wheel, and disconnect air bag module connector.

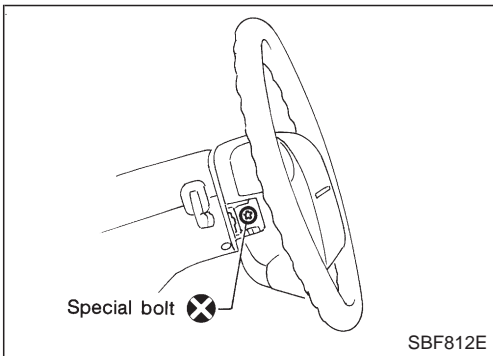

2. Remove side lid. Using the TAMPER RESISTANT TORX (Size T50) or TAMPER RESISTANT TORX SOCKET (T30), remove left and right special bolts. Air bag module can then be removed.

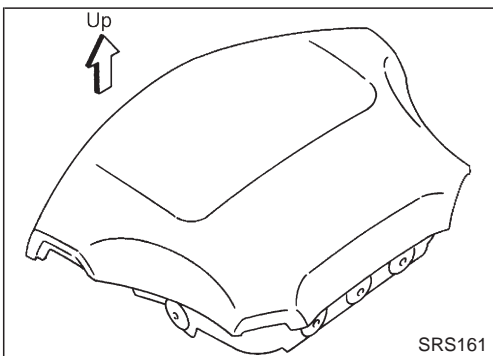

CAUTION:

- Always place air bag module with pad side facing upward.
- Do not attempt to disassemble air bag module.
- The special bolts are coated with bonding agent. Do not use old bolts after removal; replace with new ones.
- Do not insert any foreign objects (screwdriver, etc.) into air bag module connector.

RS-2008

SUPPLEMENTAL RESTRAINT SYSTEM (SRS)

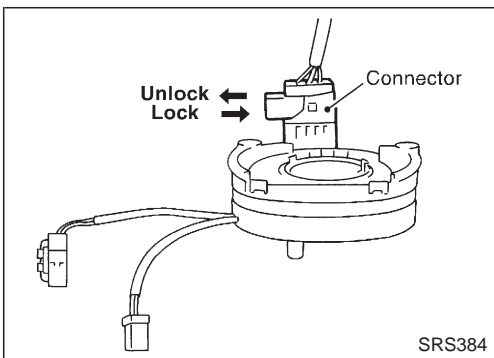
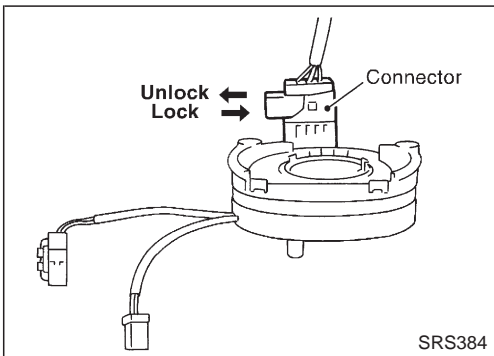
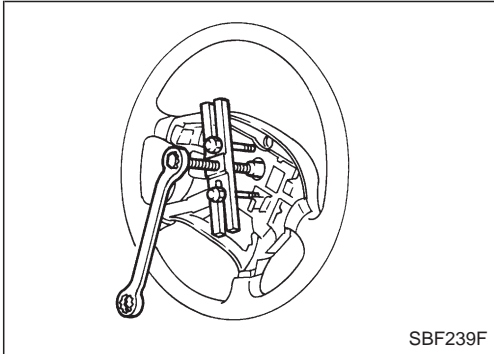
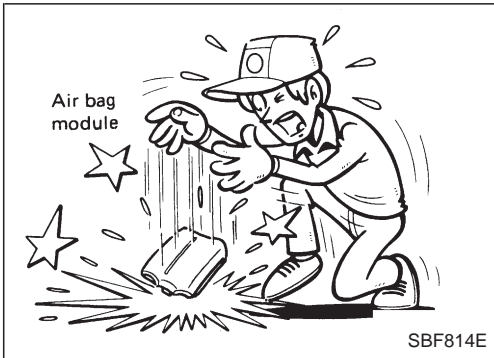

Removal — Driver Air Bag Module and Spiral Cable (Cont'd)

- Replace air bag module if it has been dropped or sustained an impact.
- Do not expose the air bag module to temperatures exceeding 90°C (194°F).
- Do not allow oil, grease or water to come in contact with the air bag module.

3. Set steering wheel in the neutral position.
4. Disconnect horn connector and remove nuts.
5. Using steering wheel puller, remove steering wheel. Be careful not to over-tighten puller bolt on steering wheel.

CAUTION:

- Do not tap or bump the steering wheel.
6. Remove steering column cover.

7. Remove the four screws. Then unlock the spiral cable connector and disconnect connector. The spiral cable can then be removed.

CAUTION:

- Do not attempt to disassemble spiral cable.
- Do not apply lubricant to the spiral cable.

Installation — Driver Air Bag Module and Spiral Cable

1. Set the front wheels in the straight-ahead position.
2. Connect spiral cable connector. Then, lock the connector and tighten with screws. Install steering column cover.

SUPPLEMENTAL RESTRAINT SYSTEM (SRS)

Installation — Driver Air Bag Module and Spiral Cable (Cont'd)

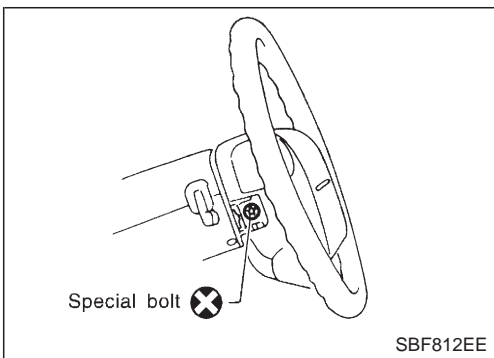
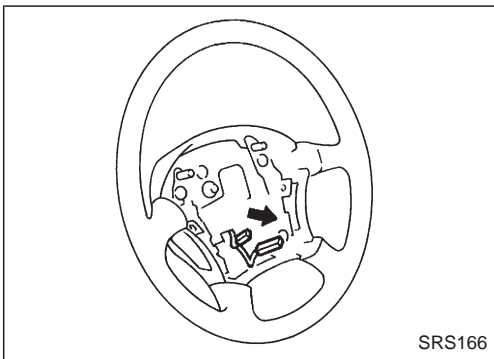
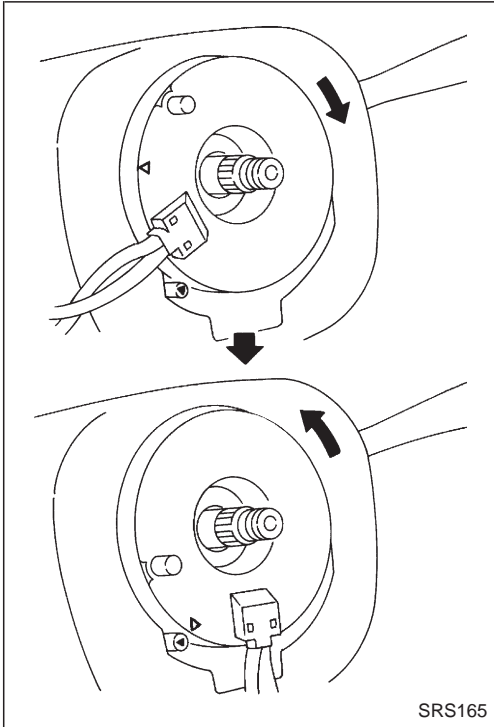

3. Make sure that the spiral cable is in the neutral position. The neutral position is detected by turning left about 2.5 revolutions from the right end position. Align the two marks (X).

CAUTION:

- The spiral cable may snap due to steering operation if the cable is installed in an improper position. Also, with the steering linkage disconnected, the cable may snap by turning the steering wheel beyond the limited number of turns.

The spiral cable can be turned up to about 2.5 turns from the neutral position to both the right and left.

4. Connect spiral cable connector and tighten with screws. Install steering column cover.

5. Install steering, wheel setting spiral cable pin guide, and pull spiral cable through.
6. Connect horn connector and engage spiral cable with pawls in steering wheel. Move air bag module connector away from steering wheel lower lid opening.
7. Tighten nut.
: 29 - 39 (3.0 - 4.0 kg-m, 22 - 29 ft-lb)

8. Position air bag module and tighten with new special bolts.
 - **Always service the air bag module from the side.**
9. Connect air bag module connector.
10. Install all lids.
11. Perform self-diagnosis to ensure entire SRS operates properly. (Use CONSULT or warning lamp check.) Refer to RS-2025.
Before performing self-diagnosis, connect both battery cables.
12. Turn steering wheel to the left end and then to the right end fully to make sure that spiral cable is set in the neutral position.
If air bag warning lamp blinks or stays ON (at the User mode), it shows the spiral cable may be snapped due to its improper position. Perform self-diagnosis again (use CONSULT or warning lamp). If a malfunction is detected, replace the spiral cable with a new one.
13. Perform self-diagnosis again to check that no malfunction is detected.

SUPPLEMENTAL RESTRAINT SYSTEM (SRS)

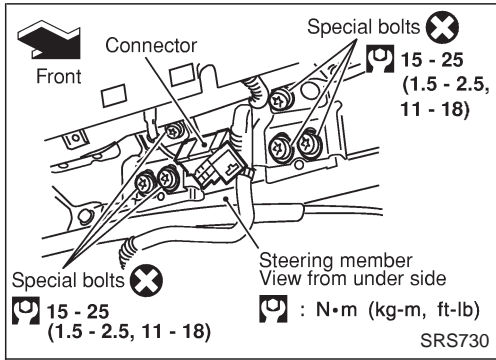

Removal — Front Passenger Air Bag Module

CAUTION:

- Before servicing SRS, turn the ignition switch off, disconnect both battery cables and wait for at least 3 minutes.
- Always work from the side of or under air bag module.
 1. Remove glove box assembly. Refer to “INSTRUMENT PANEL” in BT section for details.
 2. Disconnect passenger air bag module connector.
 3. Remove bolts and special bolts using the TAMPER RESISTANT TORX (Size T50) from front passenger air bag module.
 4. Remove instrument panel assembly. Refer to “INSTRUMENT PANEL” in BT section for details.
 5. Remove air duct from instrument panel.
 6. Remove the bolts from left and right sides of front passenger air bag module. Then remove the air bag module from the instrument panel assembly.
- The air bag module is heavy and should be supported using both hands during removal.

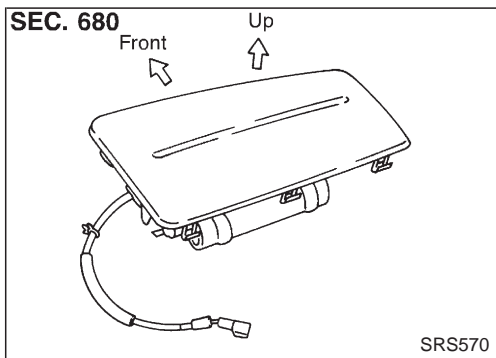

CAUTION:

- Always place air bag module with pad side facing upward.
 - Do not attempt to disassemble air bag module.
 - The special bolts are coated with bonding agent. Do not use old bolts after removal; replace with new coated bolts.
 - Do not insert any foreign objects (screwdriver, etc.) into air bag module connector.
-
- Replace air bag module if it has been dropped or sustained an impact.
 - Do not expose the air bag module to temperatures exceeding 90°C (194°F).
 - Do not allow oil, grease or water to come in contact with the air bag module.

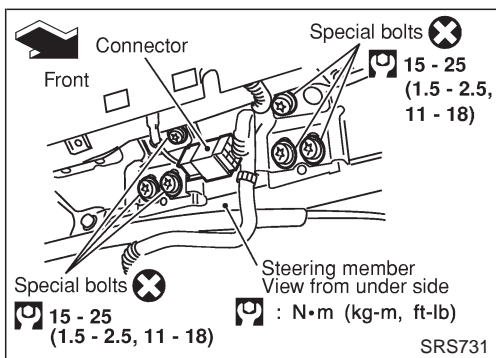

Installation — Front Passenger Air Bag Module

- Always work from the side of or under air bag module.
 1. Install front passenger air bag module to instrument panel assembly.
 2. Install air duct to instrument panel.
 3. Install instrument panel.
 - Ensure harness is not caught between rear of air bag module and steering member.
 4. Install front passenger air bag module to steering member.
 5. Connect air bag module connector.
 6. Install glove box assembly.

RS-2011

SUPPLEMENTAL RESTRAINT SYSTEM (SRS)

Disposal of Air Bag Module

- Before disposing of air bag module, or vehicles equipped with such a system, deploy the system. If such a system has already been deployed due to an accident, dispose of them as indicated in "DISPOSING OF AIR BAG MODULE" (RS-2014).
- When deploying the air bag module, always use the Special Service Tool; Deployment tool KV99106400.
- When deploying the air bag module, stand at least 5 m (16 ft) away from the deployment component.
- When deploying air bag module, a fairly loud noise is made, followed by smoke being released. The smoke is not poisonous, however, be careful not to inhale smoke since it irritates the throat and can cause choking.
- Always activate one air bag module at a time.
- Due to heat, leave air bag module unattended for more than 30 minutes after deployment.
- Be sure to wear gloves when handling a deployed air bag module.
- Never apply water to the deployed air bag module.
- Wash your hands clean after finishing work.
- Place the vehicle outdoors with an open space of at least 6 m (20 ft) on all sides when deploying air bag module while mounted in vehicle.
- Use a voltmeter to make sure the vehicle battery is fully charged.
- Do not dispose of the air bag module un-deployed.

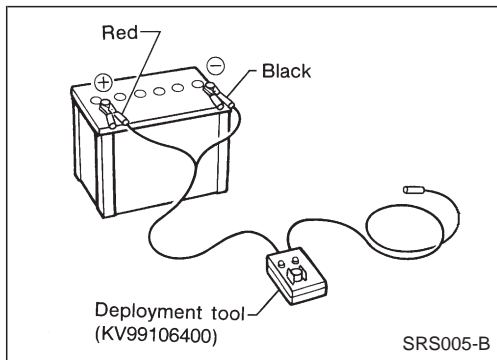

CHECKING DEPLOYMENT TOOL

Connecting to battery

CAUTION:

The battery must show voltage of 9.6V or more.

Remove the battery from the vehicle and place it on dry wood blocks approximately 5 m (16 ft) away from the vehicle.

- Wait 3 minutes after the vehicle battery is disconnected before proceeding.
- Connect red clip of deployment tool to battery positive terminal and black clip to negative terminal.

Make sure the polarity is correct. The right side lamp in the tool, marked "deployment tool power", should glow with a green light. If the right side lamp glows red, reverse the connections to the battery.

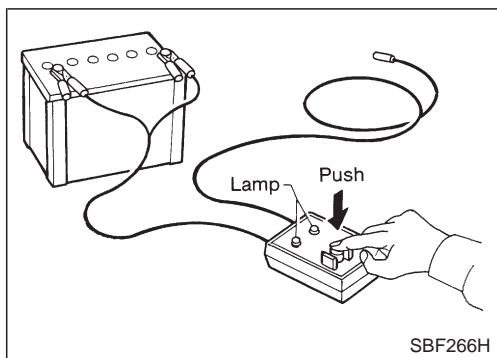

Deployment tool check

Press the deployment tool switch to the "ON" position. The left side lamp in the tool, marked "air bag connector voltage" should illuminate. If it does not illuminate, replace the tool.

Air bag deployment tool lamp illumination chart (Battery connected)

Switch operation	Left side lamp, green* "AIR BAG CONNECTOR VOLTAGE"	Right side lamp, green* "DEPLOYMENT TOOL POWER"
OFF	OFF	ON
ON	ON	ON

*: If this lamp glows red, the tool is connected to the battery incorrectly. Reverse the connections and make sure the lamp glows green.

RS-2012

SUPPLEMENTAL RESTRAINT SYSTEM (SRS)

Disposal of Air Bag Module (Cont'd)

Deployment of passenger air bag module (outside of vehicle)

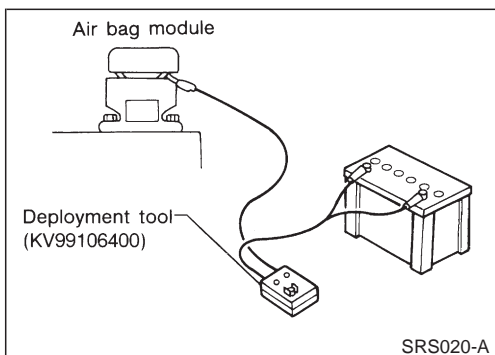
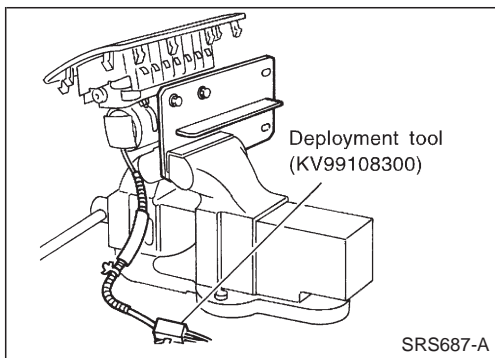
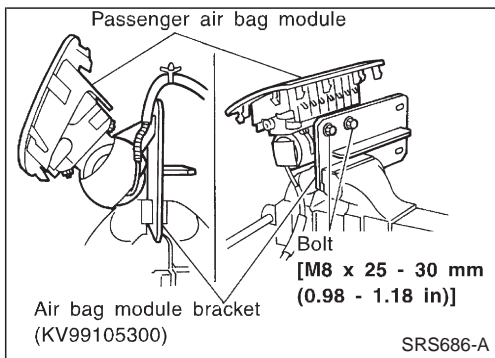
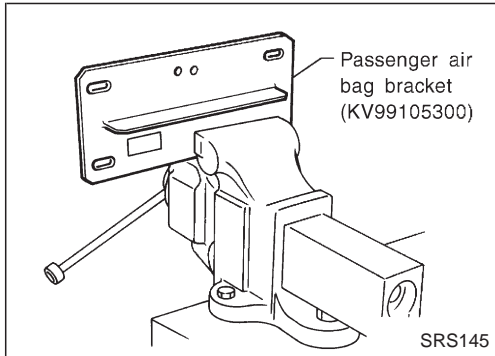
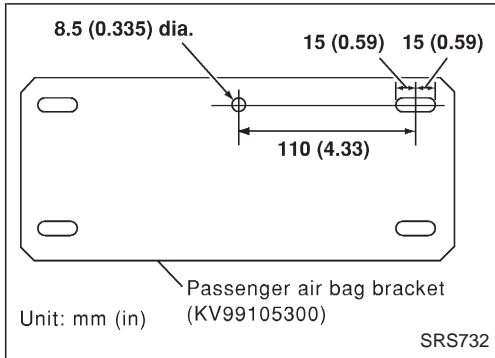

1. Make an 8.5 mm (0.335 in) diameter hole in passenger air bag bracket (SST: KV99105300) at the position shown in figure at left.

2. Firmly secure passenger air bag bracket (SST: KV99105300) in a vise.

3. Match the two holes in passenger air bag bracket (held in vise) and passenger air bag module and fix them with two bolts [M8 x 25 - 30 mm (0.98 - 1.18 in)].

CAUTION:

If a gap exists between passenger air bag module and passenger air bag bracket, use a piece of wood inserted in the gap to stabilize the air bag module.

4. Connect deployment tool adapter (SST: KV99108300) to deployment tool (SST: KV99106400) connector and connector on either side of air bag module.
5. Connect red clip of deployment tool to battery positive terminal and black clip to negative terminal.
6. The lamp on the right side of the tool, marked "deployment tool power", should glow green, not red.
7. Press the button on the deployment tool. The left side lamp on the tool, marked "air bag connector voltage", will illuminate and the air bag module will deploy.

CAUTION:

- When deploying the air bag module, do not stand on the deploying side.
- Stand at least 5 m (16 ft) away from the air bag module.

SUPPLEMENTAL RESTRAINT SYSTEM (SRS)

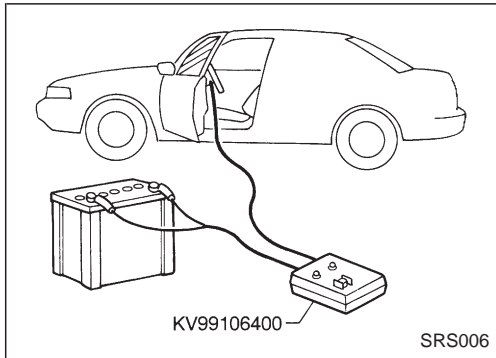

Disposal of Air Bag Module (Cont'd) DEPLOYMENT OF AIR BAG MODULE WHILE MOUNTED IN VEHICLE

When disposing of a vehicle, deploy air bag modules while they are mounted in vehicle.

CAUTION:

When deploying air bag module, ensure vehicle is empty.

1. Disconnect both the vehicle battery cables and wait 3 minutes.
2. Disconnect air bag modules connector.
3. Connect deployment tool [SST: KV99106400] to air bag module.
For front passenger air bag module, attach deployment tool adapter [SST: KV99108300] to the tool connector.
4. Connect red clip of deployment tool to battery positive terminal and black clip to negative terminal.
5. The lamp on the right side of the tool, marked "deployment tool power", should glow green, not red.
6. Press the button on the deployment tool. The left side lamp on the tool, marked "air bag connector voltage", will illuminate and the air bag module will deploy.

CAUTION:

Activate only one air bag module or seat belt pre-tensioner at a time.

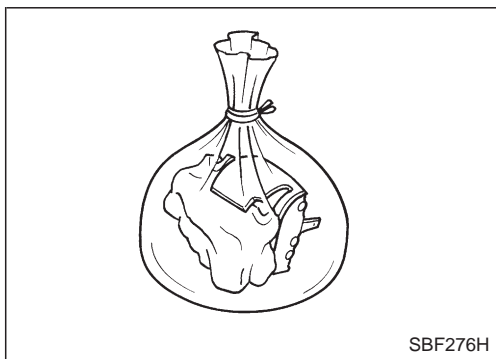

DISPOSING OF AIR BAG MODULE

Deployed air bag modules are very hot. Before disposing of air bag module, wait at least 30 minutes. Seal them in a plastic bag before disposal.

CAUTION:

- Never apply water to a deployed air bag module.
- Be sure to wear gloves when handling a deployed air bag module.
- No poisonous gas is produced upon air bag module deployment. However, be careful not to inhale gas since it irritates throat and can cause choking.
- Do not attempt to disassemble air bag module.
- Air bag module can not be re-used.
- Wash your hands clean after finishing work.

TROUBLE DIAGNOSES — Supplemental Restraint System (SRS)

Trouble Diagnoses Introduction

CAUTION:

- Do not use electrical test equipment to check SRS harness connectors unless instructed to in this Service Manual. SRS wiring harnesses can be identified by yellow harness protector or yellow insulation tape before the harness connectors.
- Do not attempt to repair, splice or modify the SRS wiring harness. If the harness is damaged, replace it with a new one.
- Keep ground portion clean.

DIAGNOSIS FUNCTION

The SRS self-diagnosis results can be read by using “AIR BAG” warning lamp and/or CONSULT. The reading of these results is accomplished using one of two modes — “User mode” and “Diagnosis mode”. The User mode is exclusively prepared for the customer (driver). This mode warns the driver of a system malfunction through the operation of the “AIR BAG” warning lamp.

The Diagnosis mode allows the technician to locate and inspect the malfunctioning part.

The mode applications for the “AIR BAG” warning lamp and CONSULT are as follows:

	User mode	Diagnosis mode	Display type
“AIR BAG” warning lamp	X	X	ON-OFF operation

DIAGNOSIS MODE FOR CONSULT

● “SELF-DIAG [CURRENT]”

A current Self-diagnosis result (also indicated by the warning lamp flashes in the Diagnosis mode) is displayed on the CONSULT screen in real time. This refers to a malfunctioning part requiring repairs.

● “SELF-DIAG [PAST]”

Diagnosis results previously stored in the memory are displayed on the CONSULT screen. The stored results are not erased until memory erasing is executed.

● “TROUBLE DIAG RECORD”

With TROUBLE DIAG RECORD, diagnosis results previously erased by a reset operation can be displayed on the CONSULT screen.

● “ECU DISCRIMINATED NO.”

The diagnosis sensor unit for each vehicle model is assigned with its own, individual classification number. This number will be displayed on the CONSULT screen, as shown at left. When replacing the diagnosis sensor unit, refer to the part number for the compatibility. After installation, replacement with a correct unit can be checked by confirming this classification number on the CONSULT screen. The diagnosis sensor unit classification number varies depending on SRS configuration.

For NISSAN MODEL D22, the diagnosis sensor unit classification numbers assigned are as follows.

MODEL	ECU DISCRIMINATED NO.
Single air bag	5A0B
Dual air bag	5A0A

TROUBLE DIAGNOSES — Supplemental Restraint System (SRS)

Trouble Diagnoses Introduction (Cont'd)

HOW TO CHANGE SELF-DIAGNOSIS MODE

With CONSULT

From User mode to Diagnosis mode

After selecting AIR BAG on the “SELECT SYSTEM” screen, User mode automatically changes to Diagnosis mode.

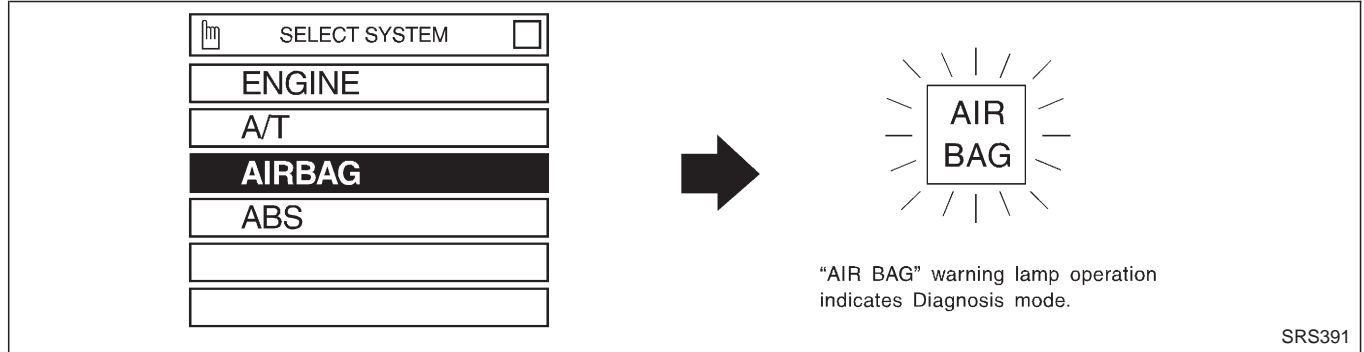

From Diagnosis mode to User mode

To return to User mode from Diagnosis mode, touch “BACK” key of CONSULT until “SELECT SYSTEM” appears, Diagnosis mode automatically changes to User mode.

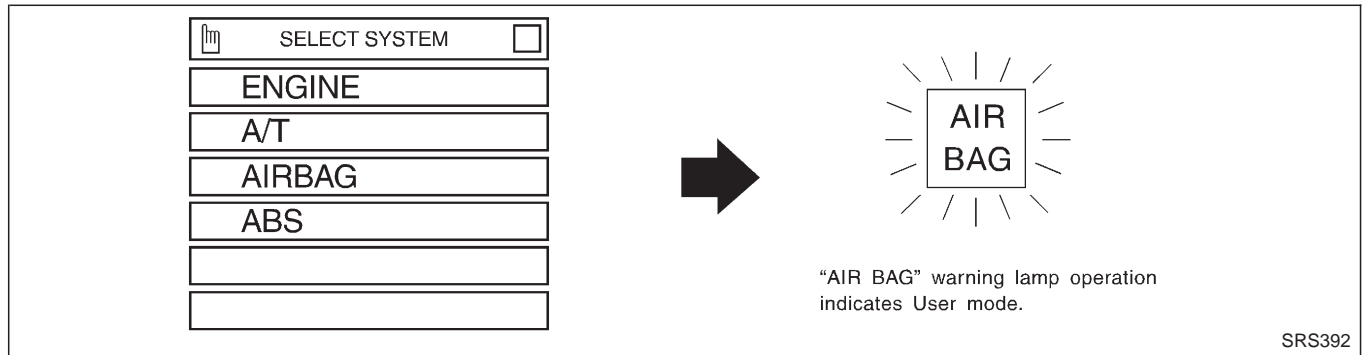

Without CONSULT

From User mode to Diagnosis mode

Diagnosis mode activates only when a malfunction is detected, by pressing the driver's door switch at least 5 times within 7 seconds after turning the ignition “ON”. SRS will not enter Diagnosis mode if no malfunction is detected.

From Diagnosis mode to User mode

After a malfunction is repaired, switch the ignition “OFF” for at least 1 second, then back “ON”. Diagnosis mode returns to User mode. If switching from Diagnosis mode to User mode is required while malfunction is being detected, switch the ignition “OFF”, then back “ON” and press the driver's door switch at least 5 times within 7 seconds.

TROUBLE DIAGNOSES — Supplemental Restraint System (SRS)

Trouble Diagnoses Introduction (Cont'd)

HOW TO ERASE SELF-DIAGNOSIS RESULTS

With CONSULT

- “SELF-DIAG [CURRENT]”
A current Self-diagnosis result is displayed on the CONSULT screen in real time. After the malfunction is repaired completely, no malfunction is detected on “SELF-DIAG [CURRENT]”.

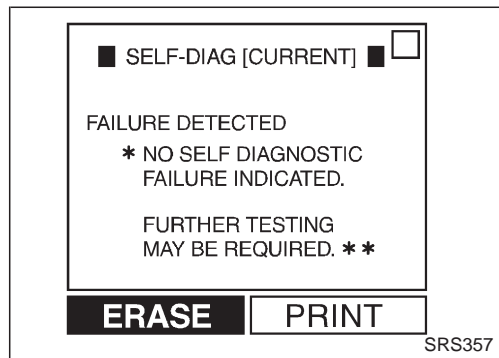

- “SELF-DIAG [PAST]”
Return to the “SELF-DIAG [CURRENT]” CONSULT screen by pushing “BACK” key of CONSULT and select “SELF-DIAG [CURRENT]” in “SELECT DIAG MODE”. Touch “ERASE” in “SELF-DIAG [CURRENT]” mode.

NOTE:

If the memory of the malfunction in “SELF-DIAG [PAST]” is not erased, the User mode shows the system malfunction by the operation of the warning lamp even if the malfunction is repaired completely.

- “TROUBLE DIAG RECORD”
The memory of “TROUBLE DIAG RECORD” cannot be erased.

Without CONSULT

After a malfunction is repaired, return Diagnosis mode to User mode by switching the ignition “OFF” for at least 1 second, then back “ON”. At that time, the self-diagnostic result is cleared.

How to Perform Trouble Diagnoses for Quick and Accurate Repair

A good understanding of the malfunction conditions can make troubleshooting faster and more accurate. In general, each customer feels differently about a malfunction. It is important to fully understand the symptoms or conditions for a customer complaint.

INFORMATION FROM CUSTOMER

WHAT	Vehicle model
WHEN	Date, Frequencies
WHERE	Road conditions
HOW	Operating conditions, Symptoms

PRELIMINARY CHECK

Check that the following parts are in good order.

- Battery [Refer to EL section (“BATTERY”) of Service Manual.]
- Fuse [Refer to EL section (“Fuse”, “POWER SUPPLY ROUTING”) of Service Manual.]
- System component-to-harness connections

TROUBLE DIAGNOSES — Supplemental Restraint System (SRS)

How to Perform Trouble Diagnoses for Quick and Accurate Repair (Cont'd)

WORK FLOW

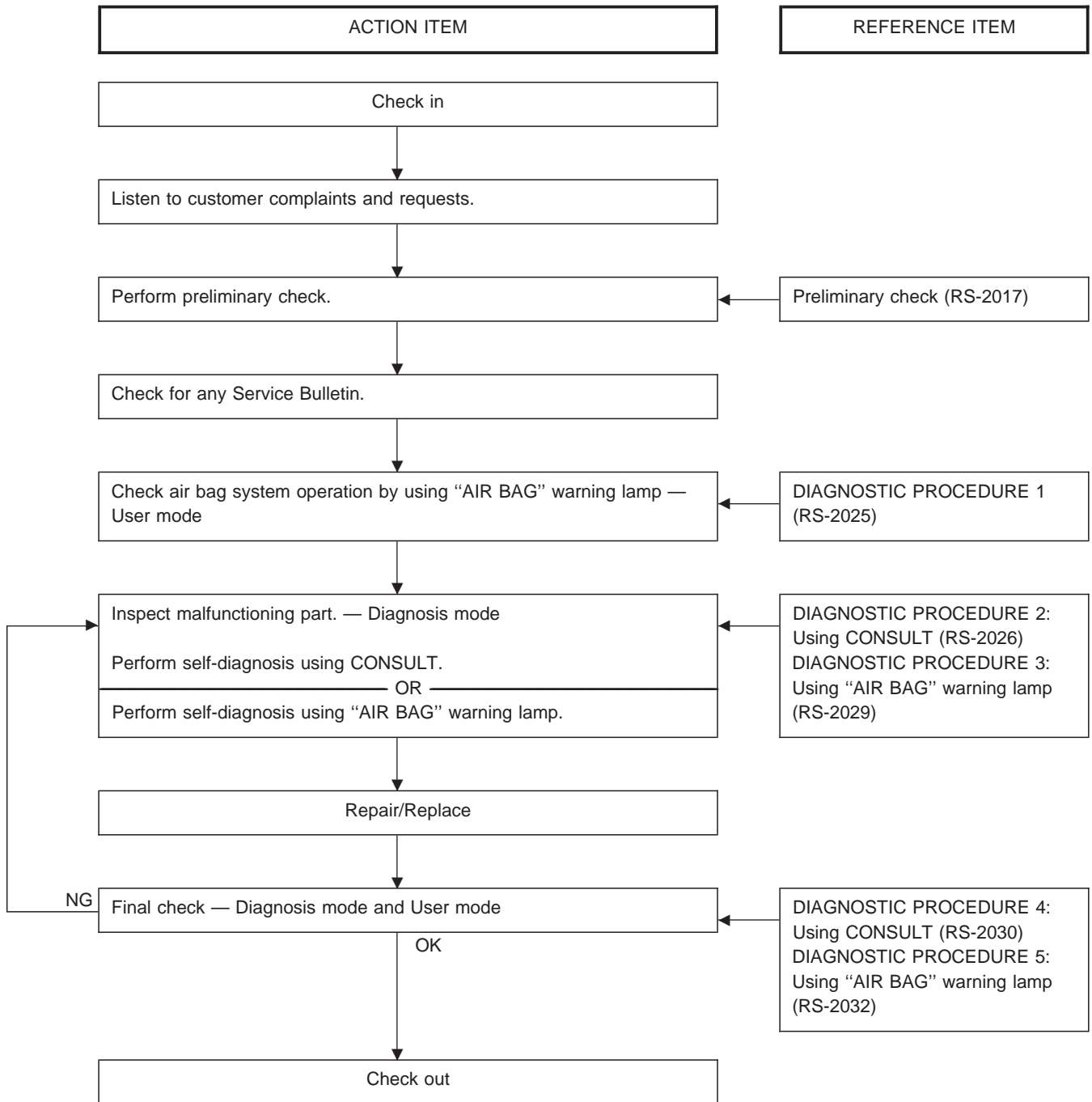

TROUBLE DIAGNOSES — Supplemental Restraint System (SRS)

Schematic

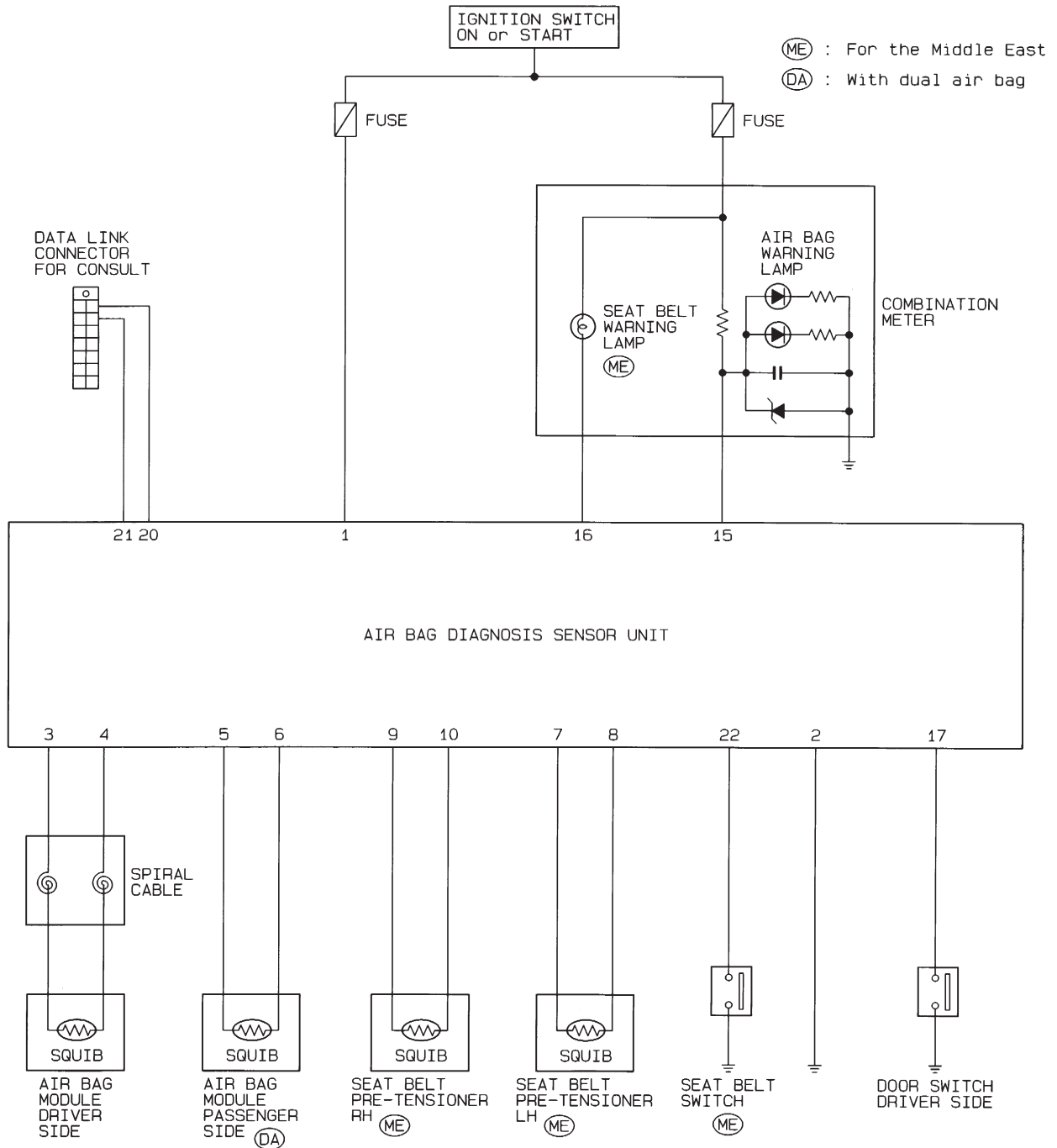

TROUBLE DIAGNOSES — Supplemental Restraint System (SRS)

Wiring Diagram — SRS —/LHD Models

RS-SRS-01

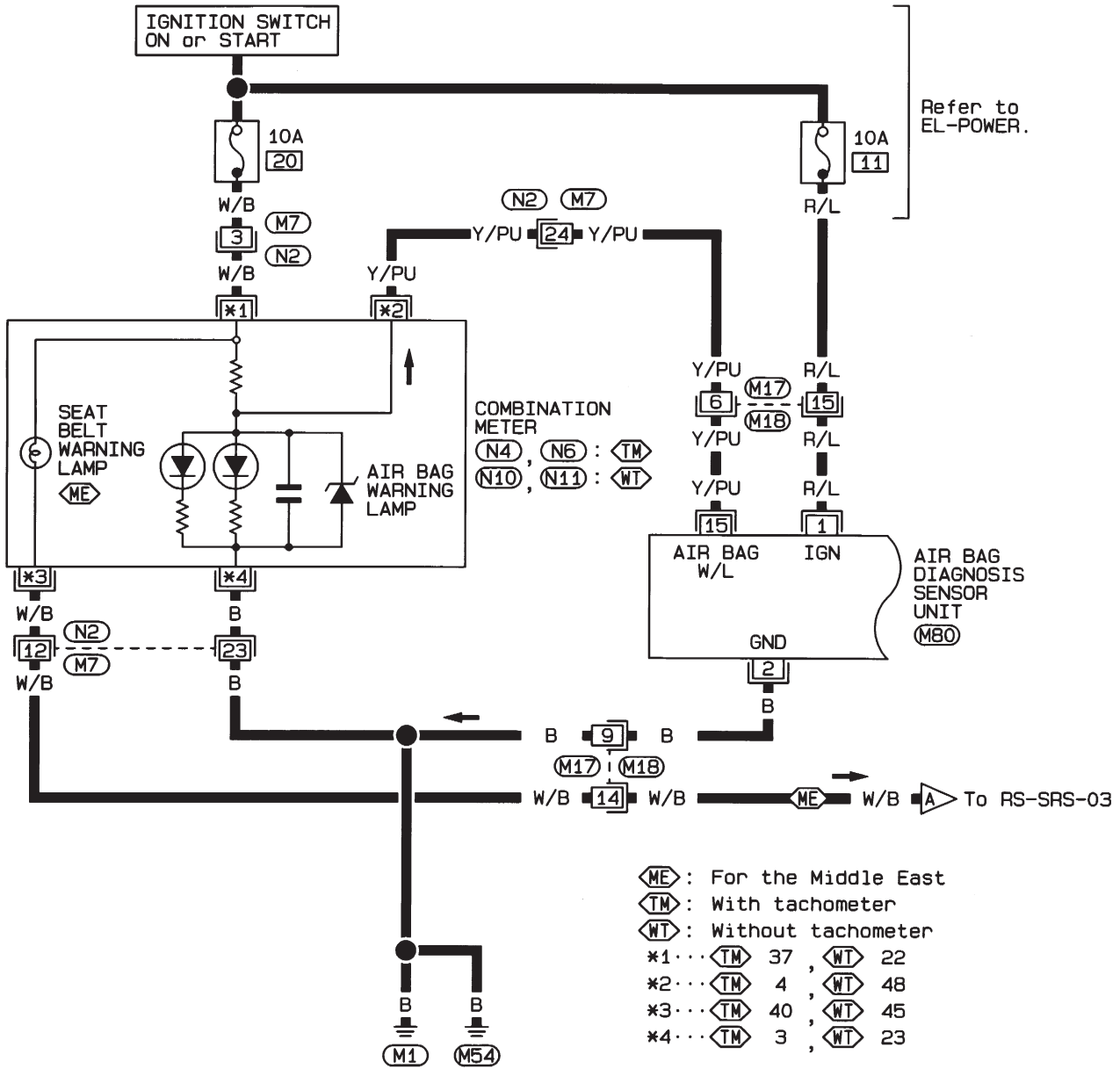

1	2	3	4	5	6	7	(M18)		
8	9	10	11	12	13	14	15	16	W

24	23	17	18	(M80)			
3	4	12	11	6	5	Y	
21	22	20	15	19	1	16	2

1	2	3	4	5	6	7	8	9	10	11	(N2)		
12	13	14	15	16	17	18	19	20	21	22	23	24	BR

1	2	3	4	5	6	7	(N4)		
8	9	10	11	12	13	14	15	16	W

36	37	38	39	40	41	42	(N5)		
27	28	29	30	31	32	33	34	35	BR

21	22	23	24	25	26	27	28	29	(N10)		
30	31	32	33	34	35	36	37	38	39	40	BR

41	42	43	44	45	46	47	48	49	50	51	(N11)		
52	53	54	55	56	57	58	59	60	61	62	63	64	W

TROUBLE DIAGNOSES — Supplemental Restraint System (SRS)

Wiring Diagram — SRS —/LHD Models (Cont'd)

RS-SRS-02

⊠ER: For Europe and with multi-remote control system
⊠OR: Except ⊠ER

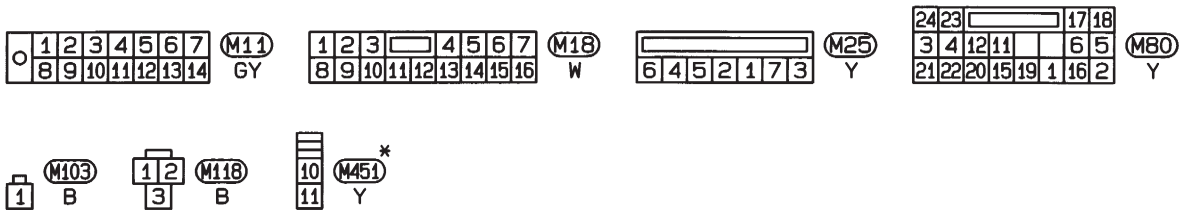
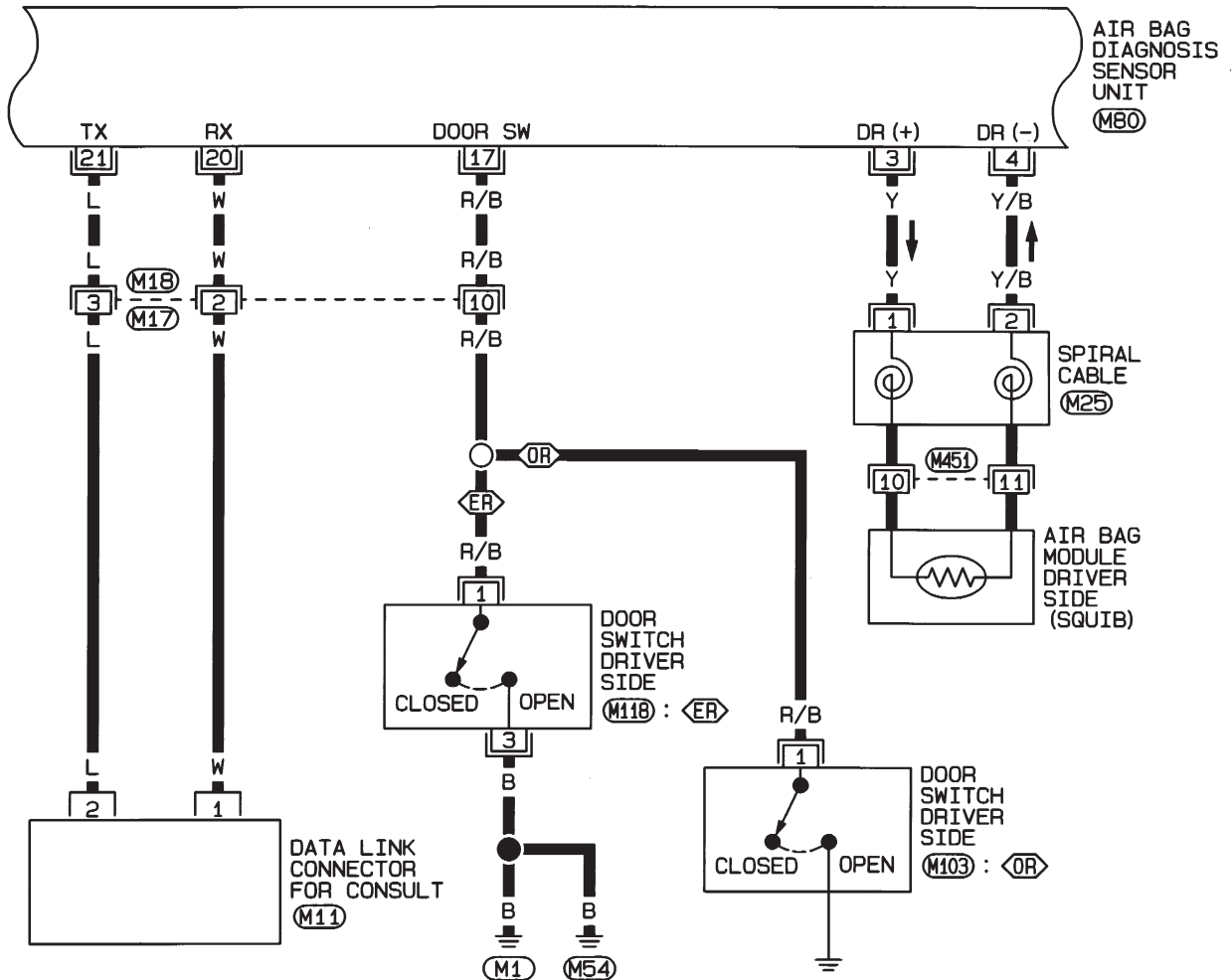

* : This connector is not shown in "HARNESS LAYOUT", EL section.

TROUBLE DIAGNOSES — Supplemental Restraint System (SRS)

Wiring Diagram — SRS —/LHD Models (Cont'd)

RS-SRS-03

ME : For the Middle East
DA : With dual air bag

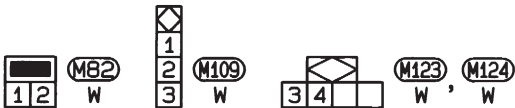
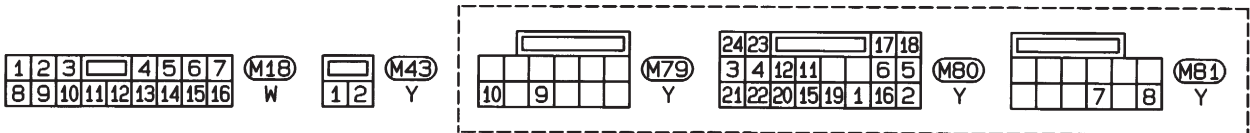
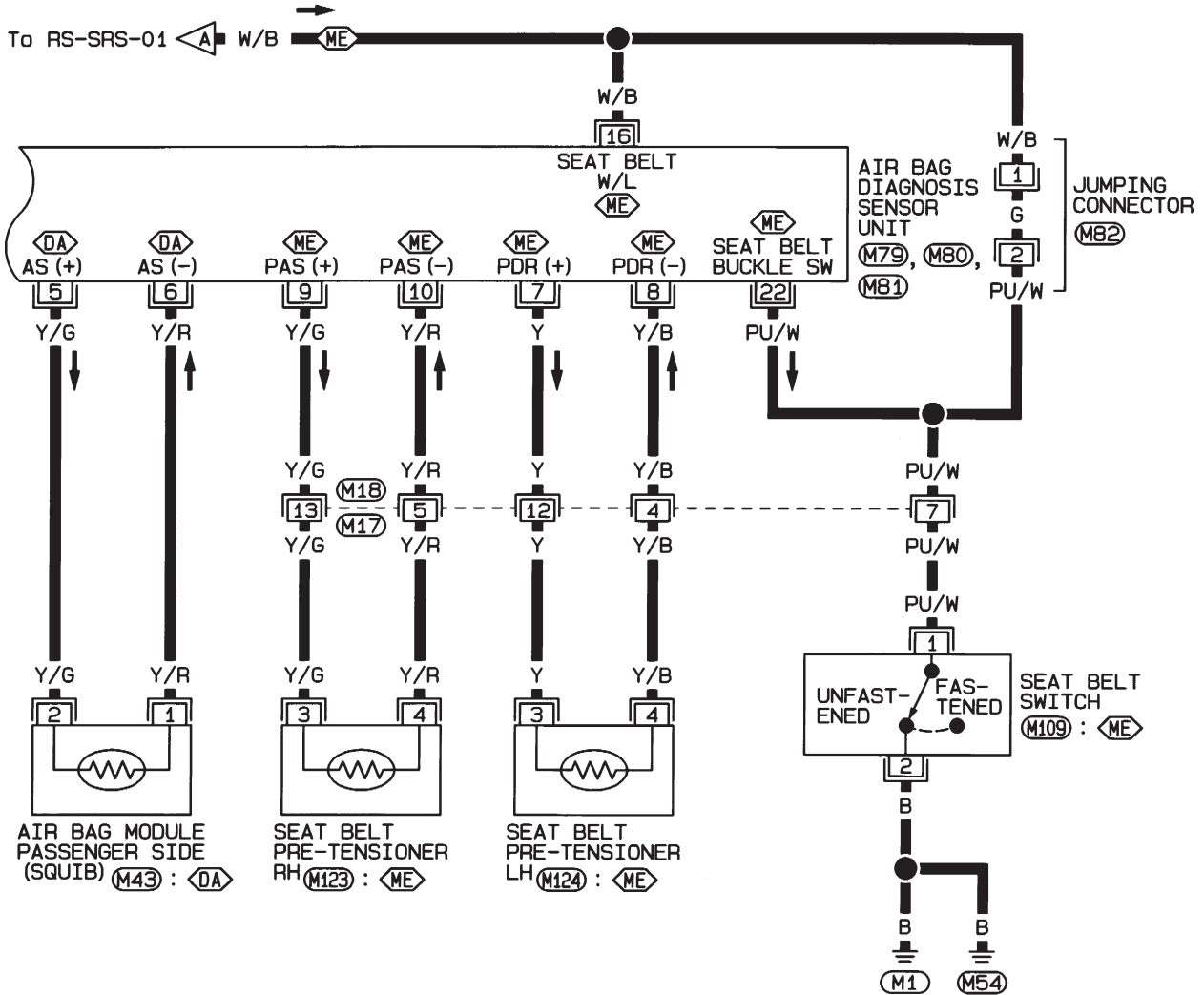

TROUBLE DIAGNOSES — Supplemental Restraint System (SRS)

Wiring Diagram — SRS —/RHD Models

RS-SRS-04

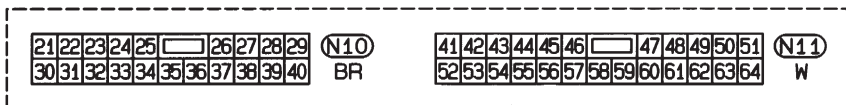
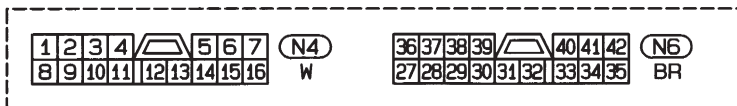
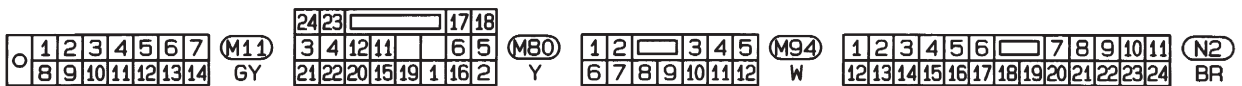
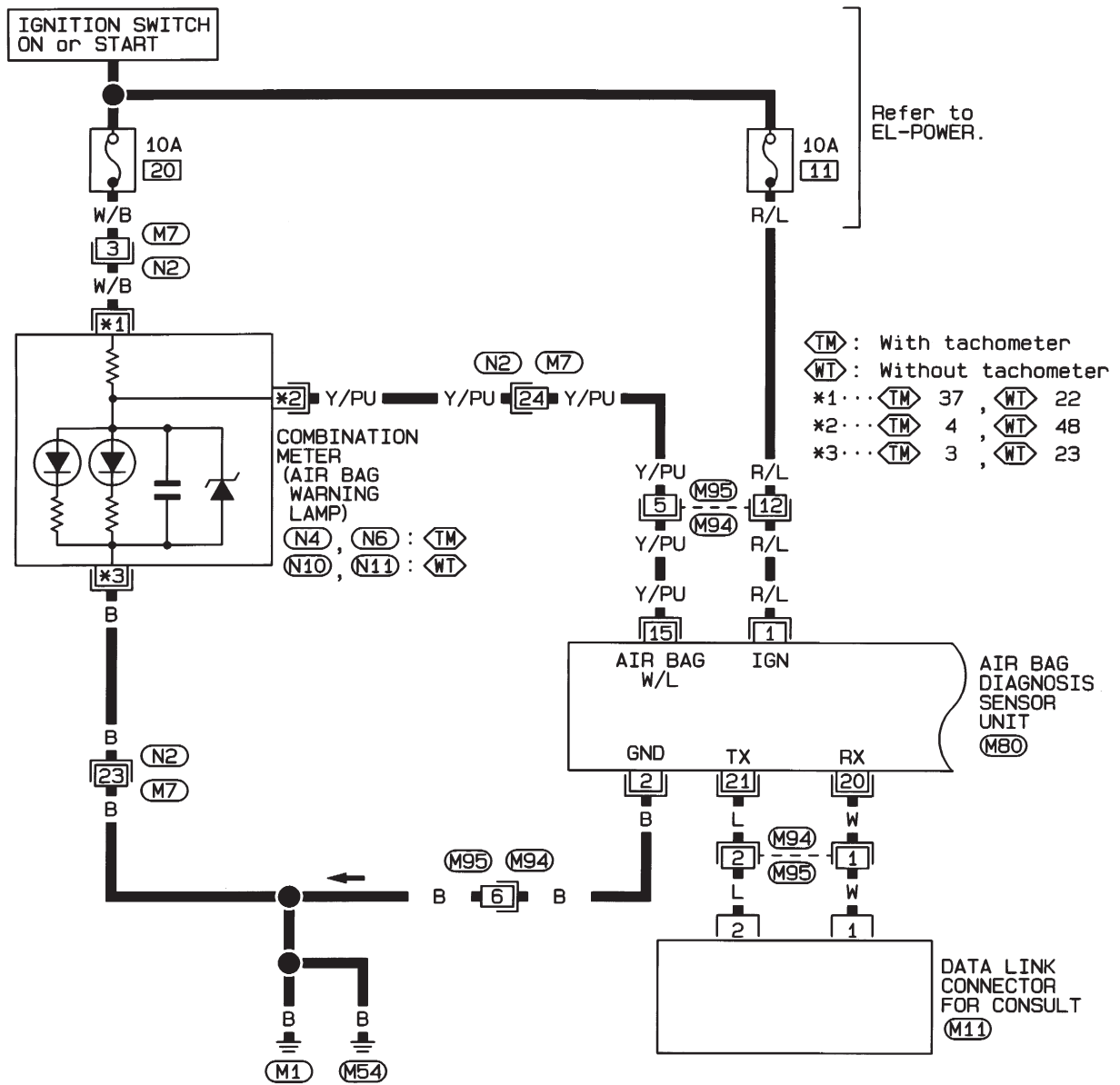

TROUBLE DIAGNOSES — Supplemental Restraint System (SRS)

Wiring Diagram — SRS —/RHD Models (Cont'd)

RS-SRS-05

- ⬡EU : For Europe
- ⬡NE : Except for Europe
- ⬡DA : With dual air bag system

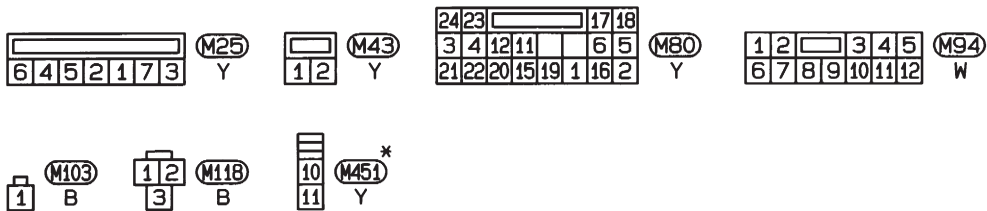
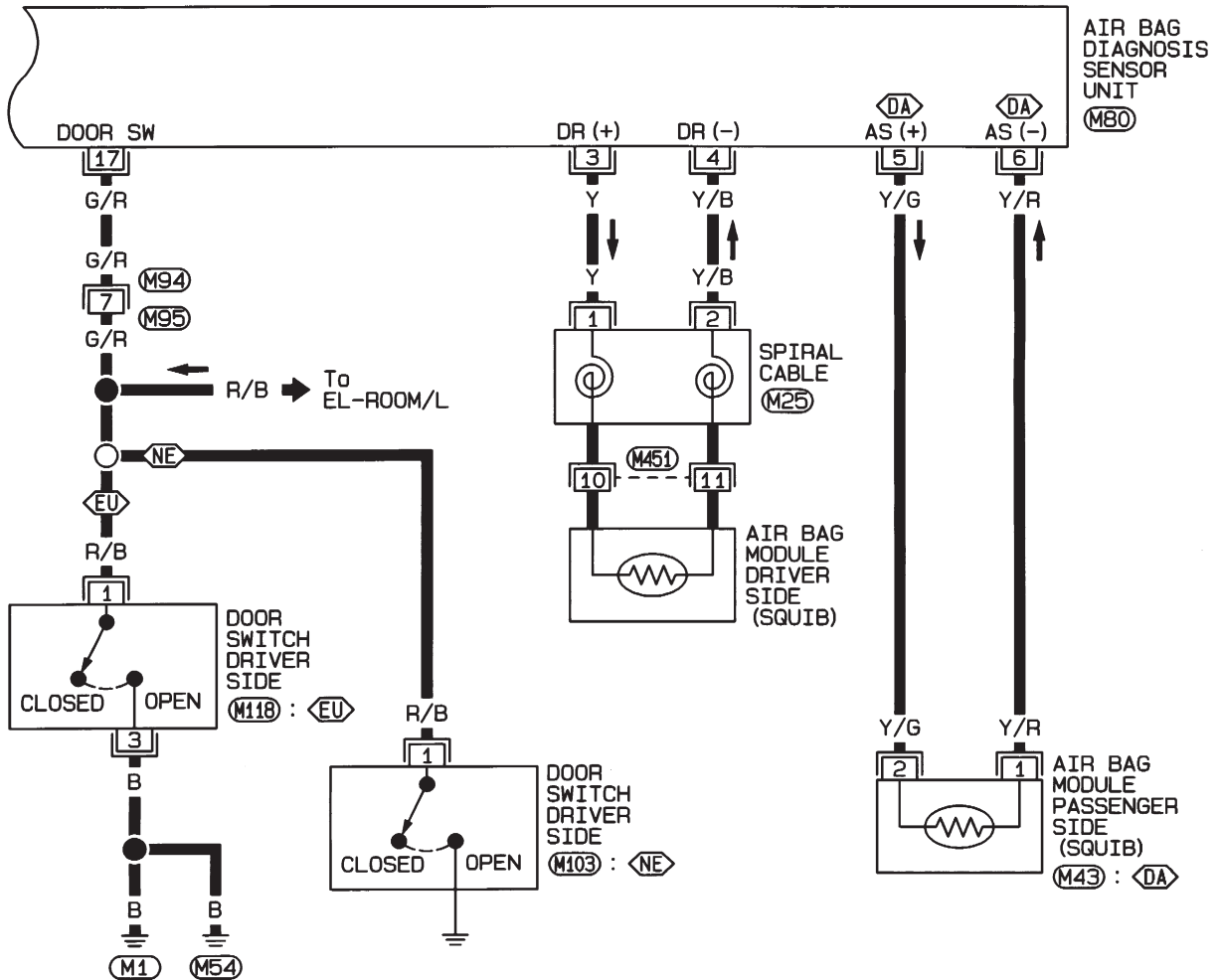

* : This connector is not shown in "HARNES LAYOUT", EL section.

TROUBLE DIAGNOSES — Supplemental Restraint System (SRS)

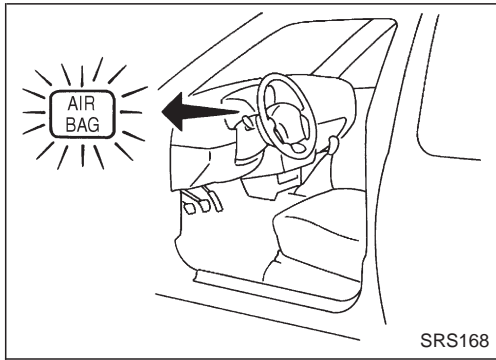

Self-diagnosis

DIAGNOSTIC PROCEDURE 1 (without CONSULT) Checking SRS operation by using "AIR BAG" warning lamp — User mode

1. After turning ignition switch from "OFF" to "ON", "AIR BAG" warning lamp operates.
2. Compare "AIR BAG" warning lamp operation to the chart below.

"AIR BAG" warning lamp operation — User mode —	SRS condition	Reference item
<p>MRS095A</p>	No malfunction is detected. No further action is necessary.	—
<p>MRS096A</p>	The system is malfunctioning and needs to be repaired as indicated.	Go to DIAGNOSTIC PROCEDURE 2, or 3 (RS-2026 or 2029).
<p>MRS097A</p>	Air bag is deployed.	Go to COLLISION DIAGNOSIS (RS-2039).
<p>MRS098A</p>	Air bag fuse, diagnosis sensor unit or harness is malfunctioning and needs to be repaired.	Go to DIAGNOSTIC PROCEDURE 9 (RS-2037).
<p>MRS098A</p>	One of the following has occurred and needs to be repaired. <ul style="list-style-type: none"> ● Meter fuse is blown. ● "AIR BAG" warning lamp circuit has open or short. ● Diagnosis sensor unit is malfunctioning. 	Go to DIAGNOSTIC PROCEDURE 10 (RS-2037).

NOTE:

If "AIR BAG" warning lamp operates differently from the operations shown above, refer to "AIR BAG" warning lamp operation — Diagnosis mode —, DIAGNOSTIC PROCEDURE 3 (step 4), RS-2029.

TROUBLE DIAGNOSES — Supplemental Restraint System (SRS)

Self-diagnosis (Cont'd)

DIAGNOSTIC PROCEDURE 2 (CONSULT with CONSULT)

Inspecting SRS malfunctioning parts by using CONSULT — Diagnosis mode

1. Turn ignition switch "OFF".
2. Connect "CONSULT" to Data link connector.

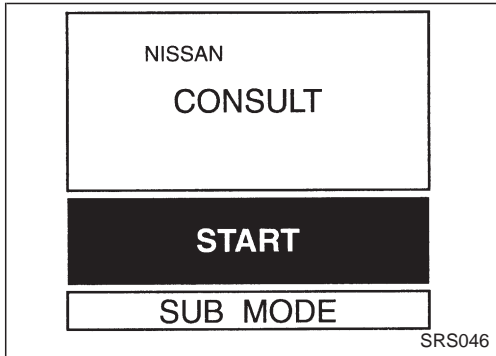
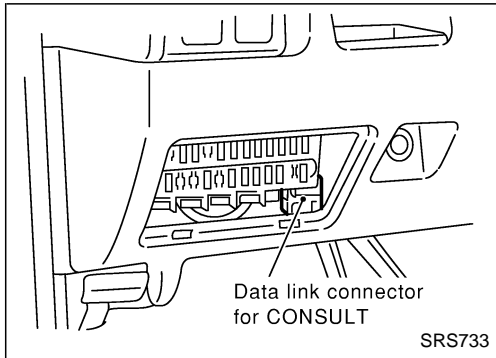

3. Turn ignition switch "ON".
4. Touch "START".

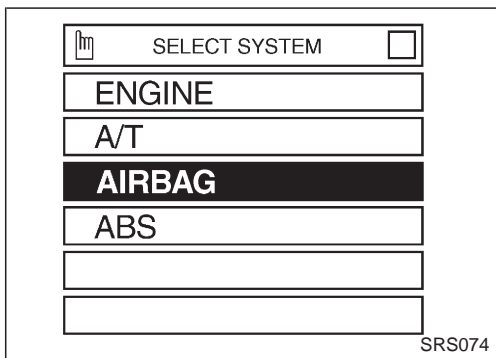

5. Touch "AIRBAG".

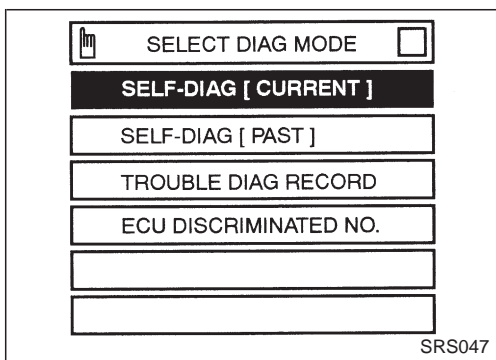

6. Touch "SELF-DIAG [CURRENT]".

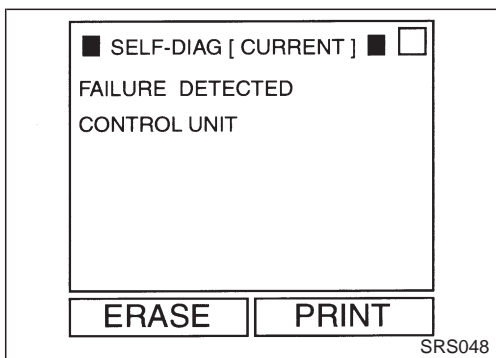

7. Diagnostic codes are displayed on "SELF-DIAG [CURRENT]".

TROUBLE DIAGNOSES — Supplemental Restraint System (SRS)

Self-diagnosis (Cont'd)

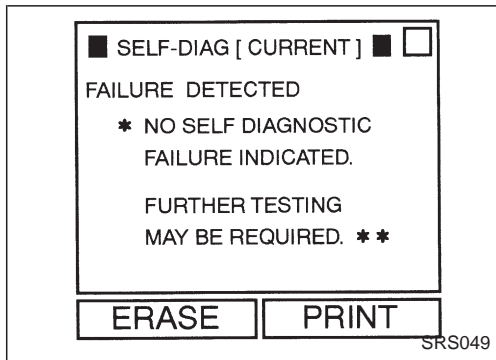

If no malfunction is detected on “SELF-DIAG [CURRENT]” even though malfunction is detected by the “AIR BAG” warning lamp, check the battery voltage.

If the battery voltage is less than 9V, charge the battery. Then go to DIAGNOSTIC PROCEDURE 4 for final checking, page RS-2030.

If the battery voltage is OK, go to DIAGNOSTIC PROCEDURE 6, page RS-2034, to diagnose the following situations:

- Self-diagnostic result (previously stored in the memory) might not be erased after repair.
- The SRS system malfunctions intermittently.

8. Touch “PRINT”.
9. Compare diagnostic codes to the CONSULT DIAGNOSTIC CODE CHART, page RS-2028.
10. Touch “BACK” key of CONSULT until “SELECT SYSTEM” appears in order to return to User mode from Diagnosis mode, then turn off CONSULT.
11. Turn ignition switch “OFF”, then disconnect CONSULT and both battery cables.
12. Repair the system as outlined by the “Repair order” in CONSULT DIAGNOSTIC CODE CHART, that corresponds to the self-diagnostic result. For replacement procedure of component parts, refer to RS-2007.
13. After repairing the system, go to DIAGNOSTIC PROCEDURE 4 for final checking, page RS-2030.

TROUBLE DIAGNOSES — Supplemental Restraint System (SRS)

Self-diagnosis (Cont'd)

CONSULT DIAGNOSTIC CODE CHART (“SELF-DIAG [CURRENT]”)

Diagnostic item	Explanation		Repair order Recheck SRS at each replacement.
NO SELF DIAGNOSTIC FAILURE INDICATED	When malfunction is indicated by the “AIR BAG” warning lamp in User mode	<ul style="list-style-type: none"> ● Low battery voltage (Less than 9V) 	<ul style="list-style-type: none"> ● Go to DIAGNOSTIC PROCEDURE 4 (RS-2030) after charging battery.
		<ul style="list-style-type: none"> ● Self-diagnostic result “SELF-DIAG [PAST]” (previously stored in the memory) might not be erased after repair. ● Intermittent malfunction has been detected in the past. 	<ul style="list-style-type: none"> ● Go to DIAGNOSTIC PROCEDURE 6 (RS-2034).
	<ul style="list-style-type: none"> ● No malfunction is detected. 		<ul style="list-style-type: none"> ● Go to DIAGNOSTIC PROCEDURE 4 (RS-2030).
AIRBAG MODULE [OPEN]	<ul style="list-style-type: none"> ● Driver’s air bag module circuit is open. (including the spiral cable) 		<ol style="list-style-type: none"> 1. Visually check the wiring harness connection. 2. Replace the harness if it has visible damage. 3. Replace the spiral cable. 4. Replace driver’s air bag module. (Before disposal of it, it must be deployed.) 5. Replace the diagnosis sensor unit. 6. Replace the related harness.
AIRBAG MODULE [VB-SHORT]	<ul style="list-style-type: none"> ● Driver’s air bag module circuit is shorted to some power supply circuit. (including the spiral cable) 		
AIRBAG MODULE [GND-SHORT]	<ul style="list-style-type: none"> ● Driver’s air bag module circuit is shorted to ground. (including the spiral cable) 		
AIRBAG MODULE [SHORT]	<ul style="list-style-type: none"> ● Driver’s air bag module circuits are shorted to each other. 		
ASSIST A/B MODULE [VB-SHORT]	<ul style="list-style-type: none"> ● Front passenger air bag module circuit is shorted to some power supply circuit. 		
ASSIST A/B MODULE [OPEN]	<ul style="list-style-type: none"> ● Front passenger air bag module circuit is open. 		<ol style="list-style-type: none"> 3. Replace front passenger air bag module. (Before disposal of it, it must be deployed.) 4. Replace the diagnosis sensor unit. 5. Replace the related harness.
ASSIST A/B MODULE [GND-SHORT]	<ul style="list-style-type: none"> ● Front passenger air bag module circuit is shorted to ground. 		
ASSIST A/B MODULE [SHORT]	<ul style="list-style-type: none"> ● Front passenger air bag module circuits are shorted to each other. 		
CONTROL UNIT	<ul style="list-style-type: none"> ● Diagnosis sensor unit is malfunctioning. 		<ol style="list-style-type: none"> 1. Visually check the wiring harness connections. 2. Replace the harness if it has visible damage. 3. Replace the diagnosis sensor unit. 4. Replace the related harness.

* Follow the procedures in numerical order when repairing malfunctioning parts. Confirm whether malfunction is eliminated using the air bag warning lamp or CONSULT each time repair is finished. If malfunction is still observed, proceed to the next step. When malfunction is eliminated, further repair work is not required.

TROUBLE DIAGNOSES — Supplemental Restraint System (SRS)

Self-diagnosis (Cont'd)

DIAGNOSTIC PROCEDURE 3 (ⓧ without CONSULT) Inspecting SRS malfunctioning parts by using "AIR BAG" warning lamp — Diagnosis mode

NOTE:

SRS will not enter Diagnosis mode if no malfunction is detected in User mode.

1. Open driver's door.
2. Turn ignition switch from "OFF" to "ON".
3. Press driver's door switch at least 5 times within 7 seconds after turning ignition switch "ON".
SRS is now in Diagnosis mode.
4. "AIR BAG" warning lamp operates in Diagnosis mode as follows:

NOTE:

If SRS does not enter Diagnosis mode even though malfunction is detected in User mode, go to DIAGNOSTIC PROCEDURE 11, page RS-2038.

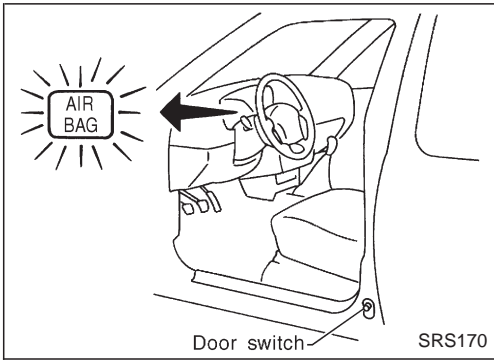

No.	"AIR BAG" warning lamp flash pattern — Diagnosis mode —	SRS condition
1	<p style="text-align: right;">ⓐ through ⓑ are repeated.</p> <p style="text-align: right;">SRS333</p>	<ul style="list-style-type: none"> ● Diagnosis results (previously stored in the memory) might not be erased after repair. ● Intermittent malfunction has been detected in the past. Go to DIAGNOSTIC PROCEDURE 7 (RS-2034).
2	<p style="text-align: right;">ⓐ through ⓓ are repeated.</p> <p style="text-align: right;">ⓑ — Driver and passenger air bag marker (For identifying driver and/or passenger air bag malfunctioning)</p> <p style="text-align: right;">ⓔ — Indicates malfunctioning part. The number of flash varies with malfunctioning part (0.5 sec. ON and 0.5 sec. OFF is counted as one flash.)</p> <p style="text-align: right;">SRS341</p>	<p>The system is malfunctioning and needs to be repaired.</p>

5. Malfunctioning part is indicated by the number of flashes (part ⓔ). Compare the number of flashes to AIR BAG WARNING LAMP FLASH CODE CHART, page RS-2030, and locate malfunctioning part.
6. Turn ignition switch "OFF", and disconnect both battery cables.
7. Repair the system as outlined by the "Repair order" in AIR BAG WARNING LAMP FLASH CODE CHART that corresponds to the flash code. For replacement procedure of component parts, refer to RS-2007.
8. After repairing the system, go to DIAGNOSTIC PROCEDURE 5, page RS-2032.

TROUBLE DIAGNOSES — Supplemental Restraint System (SRS)

Self-diagnosis (Cont'd)

AIR BAG WARNING LAMP FLASH CODE CHART (DIAGNOSIS MODE)

Warning lamp	Flash code (⑩) (# of flashes)	Explanation	Repair order "Recheck SRS at each replacement."
"AIR BAG" warning lamp	0	<ul style="list-style-type: none"> ● Diagnosis results (previously stored in the memory) might not be erased after repair. ● Intermittent malfunction has been detected in the past. 	Go to DIAGNOSTIC PROCEDURE 7 (RS-2034).
	2	The driver's air bag module circuit is malfunctioning.	<ol style="list-style-type: none"> 1. Visually check the wiring harness connections. 2. Replace the harness if it has visible damage. 3. Replace the spiral cable. 4. Replace the driver's air bag module. (Before disposing of it, it must be deployed.) 5. Replace the diagnosis sensor unit. 6. Replace the related harness.
	7	The diagnosis sensor unit is malfunctioning.	<ol style="list-style-type: none"> 1. Visually check the wiring harness connections. 2. Replace the harness if it has visible damage. 3. Replace the diagnosis sensor unit. 4. Replace the related harness.
	8	The front passenger air bag module circuit is malfunctioning.	<ol style="list-style-type: none"> 1. Visually check the wiring harness connections. 2. Replace the harness if it has visible damage. 3. Replace the front passenger air bag module. (Before disposing of it, it must be deployed.) 4. Replace the diagnosis sensor unit. 5. Replace the related harness.

* Follow the procedures in numerical order when repairing malfunctioning parts. Confirm whether malfunction is eliminated using the air bag warning lamp or CONSULT each time repair is finished. If malfunction is still observed, proceed to the next step. When malfunction is eliminated, further repair work is not required.

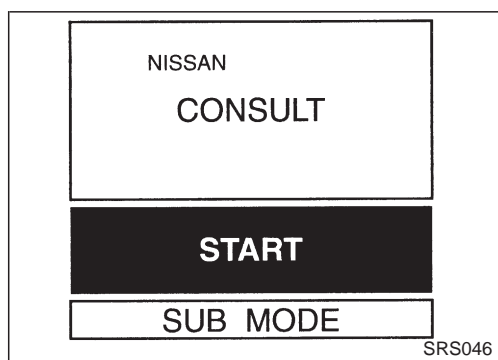
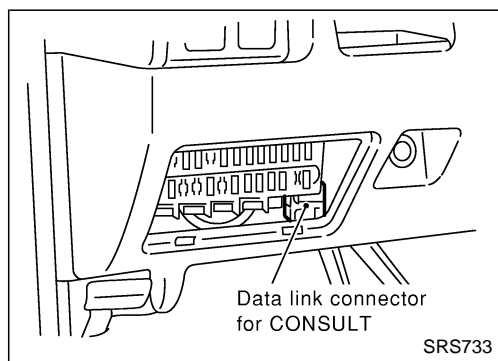

DIAGNOSTIC PROCEDURE 4 (⑩ with CONSULT)

Final checking after repairing SRS by using CONSULT — Diagnosis mode

1. After repairing SRS, connect both battery cables.
2. Connect CONSULT to Data link connector.
3. Turn ignition switch from "OFF" to "ON".

4. Touch "START".

TROUBLE DIAGNOSES — Supplemental Restraint System (SRS)

Self-diagnosis (Cont'd)

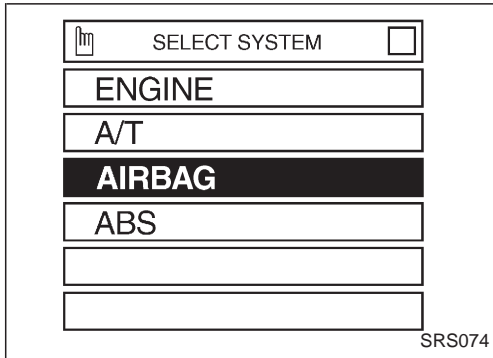

5. Touch "AIRBAG".

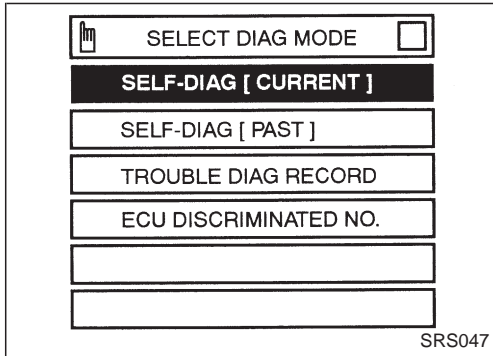

6. Touch "SELF-DIAG [CURRENT]".

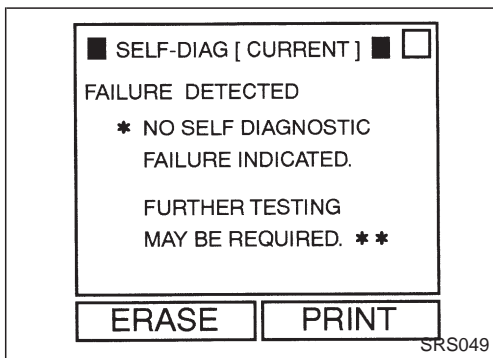

7. If no malfunction is detected on "SELF-DIAG [CURRENT]", repair of SRS is completed. Go to step 8.
(When the malfunction was only in seat belt pre-tensioner system, go to step 11.)

If any malfunction is detected on "SELF-DIAG [CURRENT]", the malfunctioning part is not repaired completely or another malfunctioning part is detected. Go to DIAGNOSTIC PROCEDURE 2, page RS-2026, and repair malfunctioning part completely.

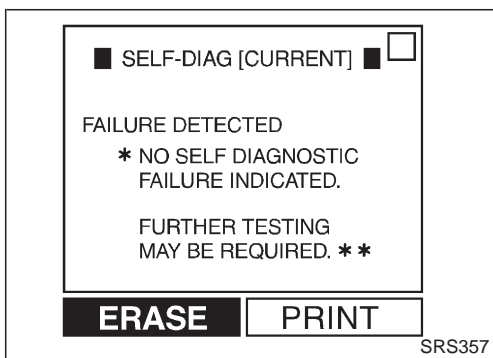

8. Touch "ERASE".

NOTE:

Touch "ERASE" to clear the memory of the malfunction ("SELF-DIAG [PAST]").

If the memory of the malfunction is "SELF-DIAG [PAST]" is not erased, the User mode shows the system malfunction by the operation of the warning lamp even if the malfunction is repaired completely.

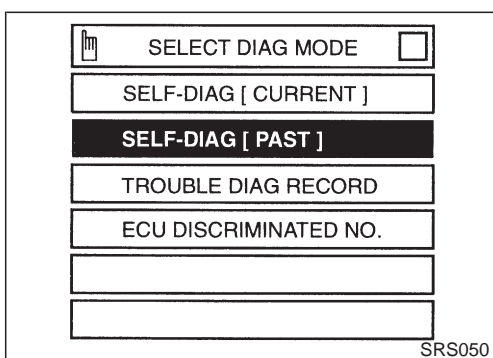

9. Touch "BACK" key of CONSULT to select "SELF-DIAG [PAST]" in the "SELECT DIAG MODE" screen. Touch "SELF-DIAG [PAST]".

TROUBLE DIAGNOSES — Supplemental Restraint System (SRS)

Self-diagnosis (Cont'd)

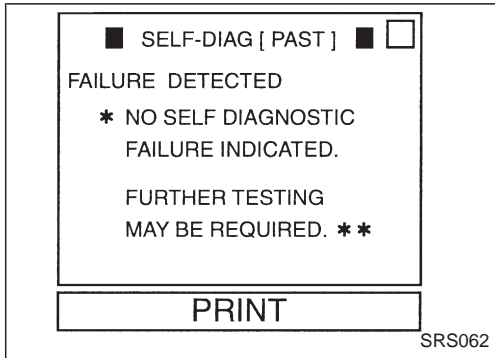

10. Check that no malfunction is detected on "SELF-DIAG [PAST]".

11. Touch "BACK" key of CONSULT until SELECT SYSTEM appears, turn off CONSULT, then disconnect CONSULT.

12. Turn ignition switch "OFF".

13. Go to DIAGNOSTIC PROCEDURE 1, page RS-2025 to check SRS operation by using "AIR BAG" warning lamp with User mode.

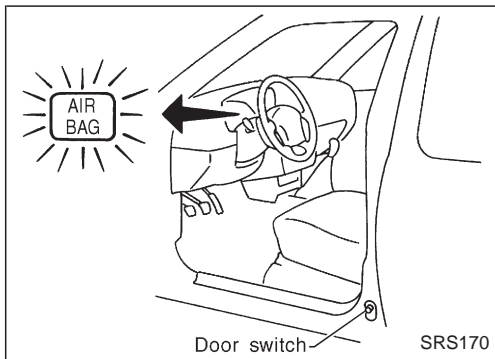

DIAGNOSTIC PROCEDURE 5 (without CONSULT) Final checking after repairing SRS by using "AIR BAG" warning lamp — Diagnosis mode and User mode

1. After repairing SRS connect both battery cables.
2. Open driver's door.
3. Turn ignition switch from "OFF" to "ON".
4. "AIR BAG" warning lamp operates in Diagnosis mode as follows:

No.	"AIR BAG" warning lamp flash pattern — Diagnosis mode —	SRS condition
1	<p style="text-align: right;">SRS333</p>	<p>①a through ①b are repeated.</p> <p>No malfunction is detected or repair is completed. No further action is necessary.</p>
2	<p style="text-align: right;">SRS341</p>	<p>②a through ②d are repeated.</p> <p>②b — Driver and passenger air bag marker (For identifying driver and/or passenger air bag malfunctioning)</p> <p>②d — Indicates malfunctioning part. The number of flashes varies with malfunctioning part (0.5 sec. ON and 0.5 sec. OFF is counted as one flash.)</p> <p>The system is malfunctioning and needs to be repaired.</p>

TROUBLE DIAGNOSES — Supplemental Restraint System (SRS)

Self-diagnosis (Cont'd)

NOTE:

When diagnosis sensor unit is replaced with new one, "AIR BAG" warning lamp will operate in User mode. Checking "AIR BAG" warning lamp operation in Diagnosis mode is not required. Go to step 6.

- If "AIR BAG" warning lamp operates as shown in No. 1 in chart above, turn ignition switch "OFF" to reset from Diagnosis mode to User mode and to erase the memory of the malfunction. Then go to step 6.

If "AIR BAG" warning lamp operates as shown in No. 2 in chart above, the malfunctioning part is not repaired completely, or another malfunctioning part is detected. Go to DIAGNOSTIC PROCEDURE 3, page RS-2029, and repair malfunctioning part completely.

- Turn ignition switch "ON". "AIR BAG" warning lamp operates in User mode. Compare "AIR BAG" warning lamp operation to the chart below.

NOTE:

If switching Diagnosis mode to User mode is required while malfunction is being detected, turn ignition switch from "OFF" to "ON". Then press driver's door switch at least 5 times within 7 seconds after turning ignition switch "ON". SRS is now in User mode.

"AIR BAG" warning lamp operation — User mode —	SRS condition	Reference item
<p>MRS095A</p>	No malfunction is detected. No further action is necessary.	—
<p>MRS096A</p>	The system is malfunctioning and needs to be repaired as indicated.	Go to DIAGNOSTIC PROCEDURE 2 or 3 (RS-2026 or 2029).
<p>MRS097A</p>	Air bag is deployed. Air bag fuse diagnosis sensor unit or harness is malfunctioning and needs to be repaired.	Go to COLLISION DIAGNOSIS (RS-2039). Go to DIAGNOSTIC PROCEDURE 9 (RS-2037).
<p>MRS098A</p>	One of the following has occurred and needs to be repaired. <ul style="list-style-type: none"> ● Meter fuse is blown. ● "AIR BAG" warning lamp circuit has open or short. ● Diagnosis sensor unit is malfunctioning. 	Go to DIAGNOSTIC PROCEDURE 10 (RS-2037).

TROUBLE DIAGNOSES — Supplemental Restraint System (SRS)

Self-diagnosis (Cont'd)

DIAGNOSTIC PROCEDURE 6 (Continued from DIAGNOSTIC PROCEDURE 2)

Inspecting SRS malfunctioning record

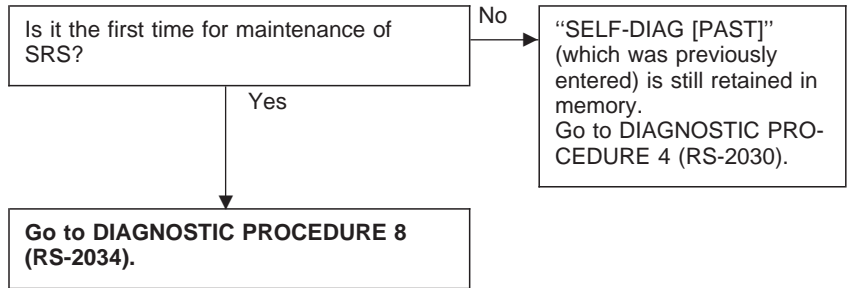

DIAGNOSTIC PROCEDURE 7 (Continued from DIAGNOSTIC PROCEDURE 3) (⌚ without CONSULT)

Inspecting SRS malfunctioning record

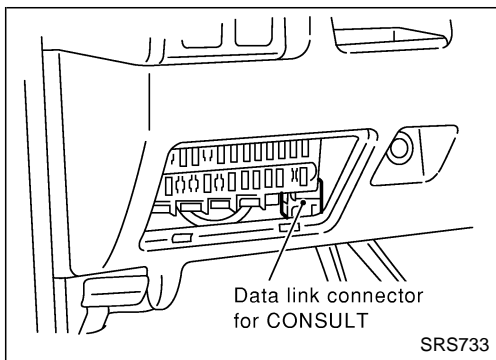
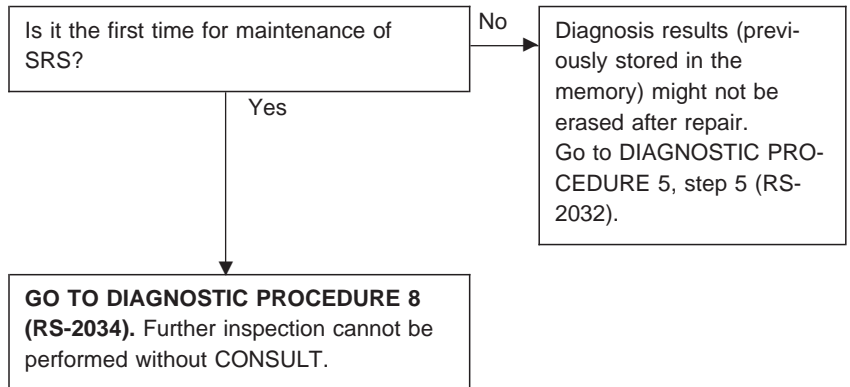

DIAGNOSTIC PROCEDURE 8 (📱 with CONSULT)

Inspecting SRS intermittent malfunction by using CONSULT — Diagnosis mode

1. Turn ignition switch "OFF".
2. Connect "CONSULT" to Data link connector.
3. Turn ignition switch "ON".
4. Touch "START".

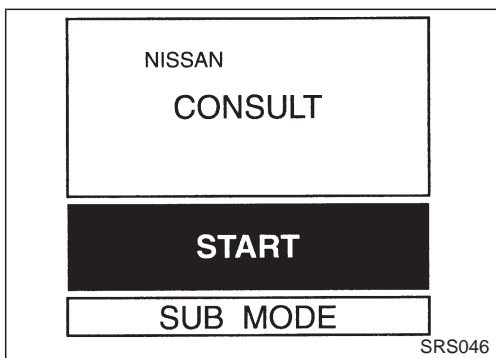

TROUBLE DIAGNOSES — Supplemental Restraint System (SRS)

Self-diagnosis (Cont'd)

SELECT SYSTEM

ENGINE

A/T

AIRBAG

ABS

SRS074

5. Touch "AIRBAG".

SELECT DIAG MODE

SELF-DIAG [CURRENT]

SELF-DIAG [PAST]

TROUBLE DIAG RECORD

ECU DISCRIMINATED NO.

SRS050

6. Touch "SELF-DIAG [PAST]".

■ SELF-DIAG [PAST] ■

FAILURE DETECTED
CONTROL UNIT

PRINT

SRS054

7. If diagnostic codes are displayed on "SELF-DIAG [PAST]", go to step 10.

■ SELF-DIAG [PAST] ■

FAILURE DETECTED

* NO SELF DIAGNOSTIC
FAILURE INDICATED.

FURTHER TESTING
MAY BE REQUIRED. **

PRINT

SRS062

If no malfunction is detected on "SELF-DIAG [PAST]", touch "BACK" and go back to "SELECT DIAG MODE".

SELECT DIAG MODE

SELF-DIAG [CURRENT]

SELF-DIAG [PAST]

TROUBLE DIAG RECORD

ECU DISCRIMINATED NO.

SRS055

8. Touch "TROUBLE DIAG RECORD".

NOTE:

With "TROUBLE DIAG RECORD", diagnosis results previously erased by a reset operation can be displayed.

TROUBLE DIAGNOSES — Supplemental Restraint System (SRS)

Self-diagnosis (Cont'd)

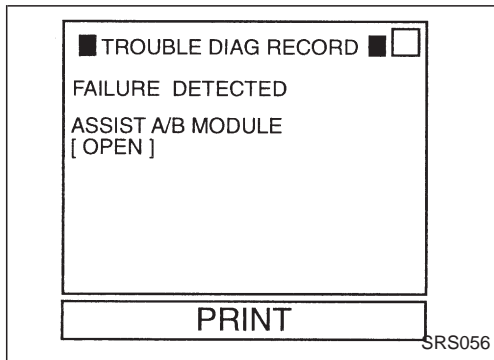

9. Diagnostic code is displayed on “TROUBLE DIAG RECORD”.

10. Touch “PRINT”.
11. Compare diagnostic codes to the INTERMITTENT MALFUNCTION DIAGNOSTIC CODE CHART, page RS-2036.
12. Touch “BACK” key of CONSULT until SELECT SYSTEM appears, then turn off CONSULT.
13. Turn ignition switch “OFF”, then disconnect CONSULT and both battery cables.
14. Repair the system as outlined by the “Repair order” in INTERMITTENT MALFUNCTION DIAGNOSTIC CODE CHART, that corresponds to the self-diagnosis result. For replacement procedure of component parts, refer to RS-2007.
15. Go to DIAGNOSTIC PROCEDURE 4, page RS-2030.

INTERMITTENT MALFUNCTION DIAGNOSTIC CODE CHART (“SELF-DIAG [PAST]” or “TROUBLE DIAG RECORD”)

Diagnostic item	Explanation	Repair order
NO SELF DIAGNOSTIC FAILURE INDICATED.	When malfunction is indicated by the “AIR BAG” warning lamp in User mode	● Low battery voltage (Less than 9V)
	● No malfunction is detected.	● Go to DIAGNOSTIC PROCEDURE 4 (RS-2030) after charging battery.
AIRBAG MODULE [OPEN]	● Driver’s air bag module circuit is open. (including the spiral cable)	1. Visually check the wiring harness connection. 2. Replace the harness if it has visible damage. 3. If the harness check is OK, replace the spiral cable, diagnosis sensor unit and driver air bag module. (Before disposing the driver air bag module, it must be deployed.)
AIRBAG MODULE [VB-SHORT]	● Driver’s air bag module circuit is shorted to some power supply circuit. (including the spiral cable)	
AIRBAG MODULE [GND-SHORT]	● Driver’s air bag module circuit is shorted to ground. (including the spiral cable)	
AIRBAG MODULE [SHORT]	● Driver’s air bag module circuits are shorted to each other.	
ASSIST A/B MODULE [VB-SHORT]	● Front passenger air bag module circuit is shorted to some power supply circuit.	1. Visually check the wiring harness connection. 2. Replace the harness if it has visible damage. 3. If the harness check is OK, replace the diagnosis sensor unit and passenger air bag module. (Before disposing the passenger air bag module, it must be deployed.)
ASSIST A/B MODULE [OPEN]	● Front passenger air bag module circuit is open.	
ASSIST A/B MODULE [GND-SHORT]	● Front passenger air bag module circuit is shorted to ground.	
ASSIST A/B MODULE [SHORT]	● Front passenger air bag module circuits are shorted to each other.	
CONTROL UNIT	● Diagnosis sensor unit is malfunctioning.	1. Visually check the wiring harness connection. 2. Replace the harness if it has visible damage. 3. If the harness check is OK, replace the diagnosis sensor unit.

* Follow the procedures in numerical order when repairing malfunctioning parts, then make the final system check.

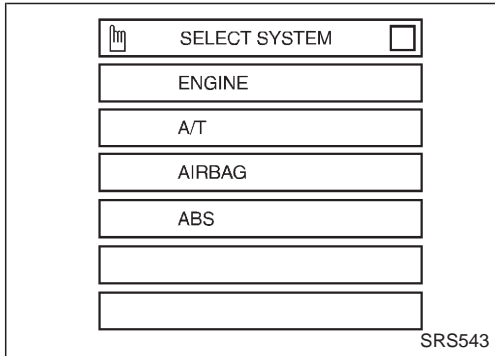
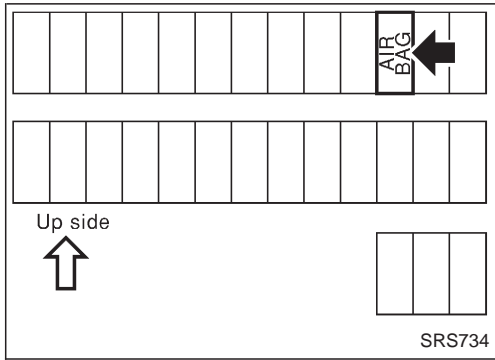

Trouble Diagnoses for Air Bag Warning Lamp

DIAGNOSTIC PROCEDURE 9

SYMPTOM: "AIR BAG" warning lamp does not turn off.

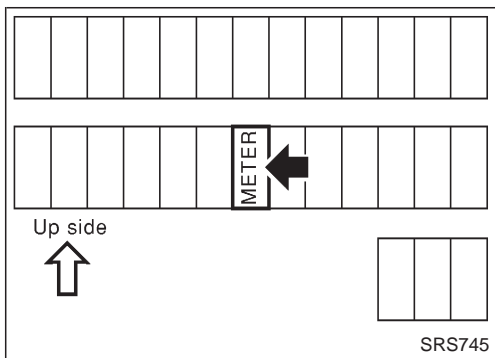
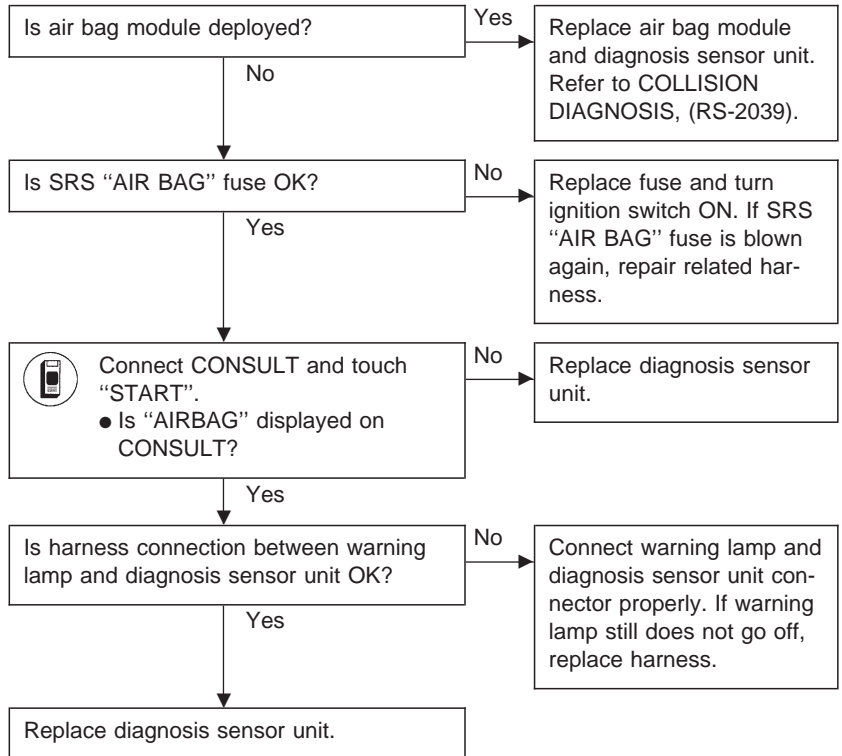

DIAGNOSTIC PROCEDURE 10

SYMPTOM: "AIR BAG" warning lamp does not turn on.

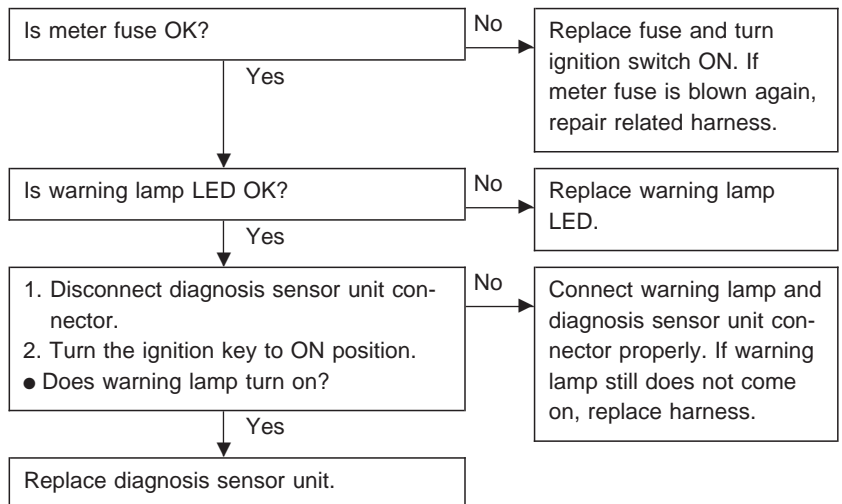

TROUBLE DIAGNOSES — Supplemental Restraint System (SRS)

Trouble Diagnoses for Air Bag Warning Lamp (Cont'd)

DIAGNOSTIC PROCEDURE 11 (Models for Europe and with multi-remote control system)

SYMPTOM: SRS does not enter Diagnostic mode.

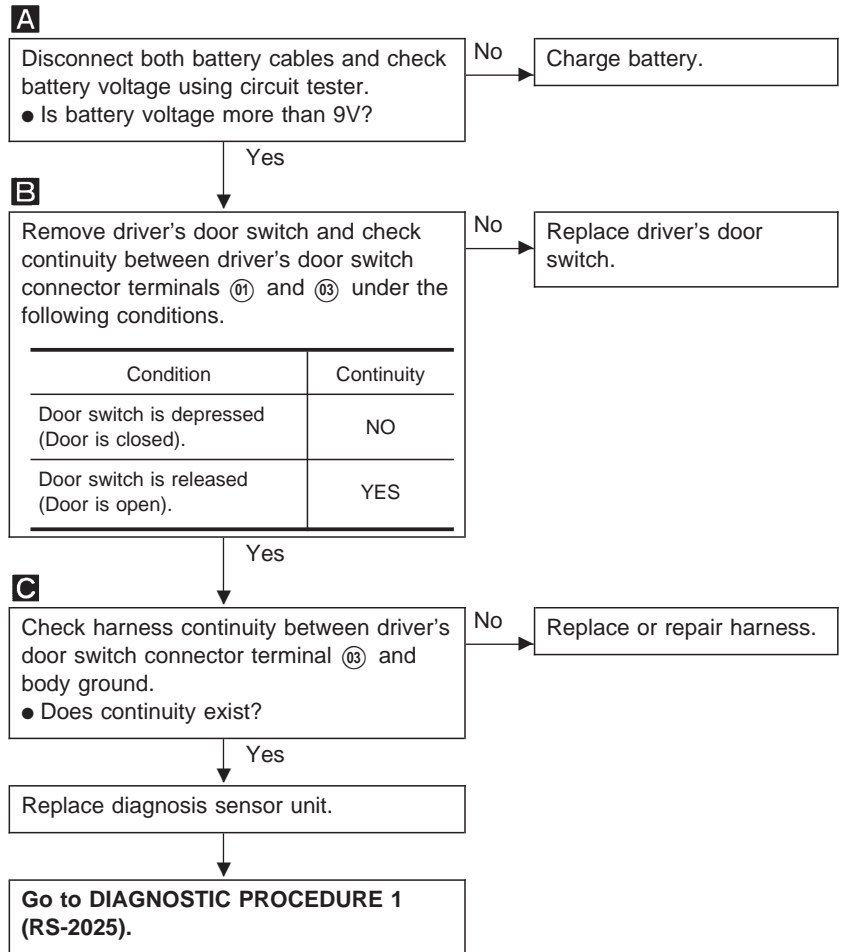
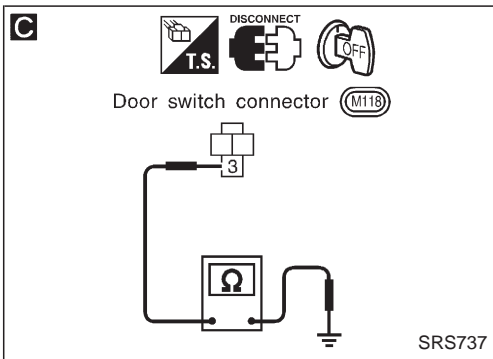
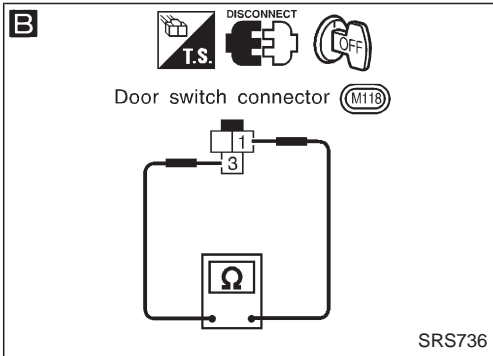
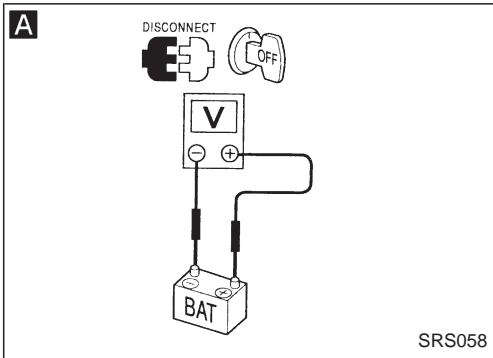

COLLISION DIAGNOSIS

FOR FRONTAL COLLISION

To repair the SRS for a frontal collision, perform the following steps.

When SRS is activated in a collision:

- ① Replace the diagnosis sensor unit.
- ② Remove the air bag modules.
- ③ Check the SRS components using the table shown below:
 - Replace any SRS components showing visible signs of damage (dents, cracks, deformation).
- ④ Install new air bag modules.
- ⑤ Conduct self-diagnosis using CONSULT, and “AIR BAG” warning lamp. Refer to “Self-diagnosis” for details (RS-2025). Ensure entire SRS operates properly.







When SRS is not activated in a collision:

- ① Check the SRS components using the table shown below:
 - Replace any SRS components showing visible signs of damage (dents, cracks, deformation).
- ② Conduct self-diagnosis using CONSULT, and “AIR BAG” warning lamp. Refer to “Self-diagnosis” for details (RS-2025). Ensure entire SRS operates properly.

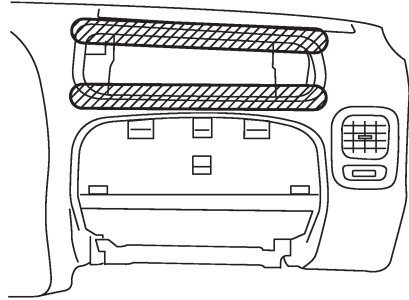
SRS inspection

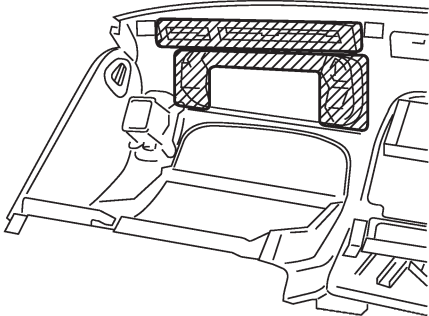
Part	SRS is activated	SRS is NOT activated
Air bag module (driver and passenger side)	REPLACE Install air bag module with new bolts.	1. Remove air bag module. Check harness cover and connectors for damage, terminals for deformities, and harness for binding. 2-1. Install driver air bag module into the steering wheel to check fit and alignment with the wheel. 2-2. Install passenger air bag module into the instrument panel to check fit with the instrument panel. 3. No damage found, reinstall with new bolts coated with bonding agent. 4. If damaged—REPLACE. Air bag must be deployed before discarding.
Diagnosis sensor unit	REPLACE Install diagnosis sensor unit with new bolts.	1. Check case and bracket for dents, cracks or deformities. 2. Check connectors for damage, and terminals for deformities. 3. If no damage is found, reinstall with new bolts. 4. If damaged—REPLACE. Install diagnosis sensor unit with new bolts coated with bonding agent.
Steering wheel		1. Visually check steering wheel for deformities. 2. Check harness (built into steering wheel) and connectors for damage, and terminals for deformities. 3. Install air bag module to check fit or alignment with steering wheel. 4. Check steering wheel for excessive free play. 5. If no damage is found, reinstall the steering wheel. 6. If damaged—REPLACE.
Spiral cable		1. Visually check spiral cable and combination switch for damage. 2. Check connectors, flat cable and protective tape for damage. 3. Check steering wheel for noise, binding or heavy operation. 4. If no damage is found, reinstall the spiral cable. 5. If damaged—REPLACE.
Harness and Connectors		1. Check connectors for poor connection, damage, and terminals for deformities. 2. Check harness for binding, chafing, cuts, or deformities. 3. If no damage is found, reinstall harness and connectors. 4. Damaged—REPLACE damaged section of harness. Do not attempt to repair, splice or modify any SRS harness.
Instrument panel		Refer to the table on the next page.

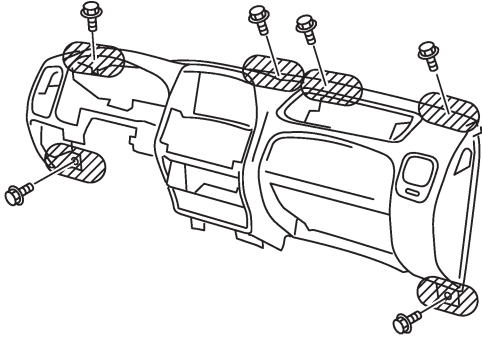
COLLISION DIAGNOSIS

Part	Side is activated	SRS is NOT activated
Instrument panel		<p>1. When passenger air bag inflates, check the following points for bending, deformities or cracks.</p> <ul style="list-style-type: none"> ● Opening portion for passenger air bag
		 <p>  : Check points </p> <p style="text-align: right;">SRS738</p>
		<ul style="list-style-type: none"> ● Passenger air bag module brackets <p>Back face of instrument panel</p>
		 <p>  : Check points </p> <p style="text-align: right;">SRS739</p>
		<ul style="list-style-type: none"> ● The portions securing the instrument panel
		 <p>  : Check points </p> <p style="text-align: right;">SRS740</p>
		<p>2. If no damage is found, reinstall the instrument panel.</p> <p>3. If damaged—REPLACE the instrument panel with bolts.</p>