

ELECTRICAL SYSTEM

SECTION **EL**

MODIFICATION NOTICE:

- Wiring diagrams have been changed.
- Combination meter has been changed.
- Headlamp has been changed.
- Headlamp aiming control has been added.
- Headlamp washer has been added.
- A hazard reminder feature has been added to the multi-remote control system.
- NATS (Nissan Anti-Theft System) has been changed.

CONTENTS

PRECAUTIONS	3004	Wiring Diagram - DIMDIP -	3033
Supplemental Restraint System (SRS) "AIR BAG" and "SEAT BELT PRE-TENSIONER" ..	3004	Bulb Replacement.....	3036
POWER SUPPLY ROUTING	3005	Aiming Adjustment	3036
Schematic	3005	HEADLAMP - Headlamp Aiming Control -	3037
Wiring Diagram - POWER -	3006	Wiring Diagram - H/AIM -	3037
BATTERY	3013	PARKING, LICENSE AND TAIL LAMPS	3039
Service Data and Specifications (SDS).....	3013	Wiring Diagram - TAIL/L -/Except LHD Models for Europe	3039
STARTING SYSTEM	3014	Wiring Diagram - TAIL/L -/LHD Models for Europe.....	3041
Wiring Diagram - START -/M/T Models	3014	STOP LAMP	3043
Construction	3015	Wiring Diagram - STOP/L -	3043
Service Data and Specifications (SDS).....	3017	BACK-UP LAMP	3044
CHARGING SYSTEM	3018	Wiring Diagram - BACK/L -/M/T Models	3044
Wiring Diagram - CHARGE -/Diesel Engine ...	3018	REAR FOG LAMP	3045
Wiring Diagram - CHARGE - (KA engine)	3019	Wiring Diagram - R/FOG -/LHD Models	3045
Construction	3020	Wiring Diagram - R/FOG -/RHD Models	3046
Service Data and Specifications (SDS).....	3022	TURN SIGNAL AND HAZARD WARNING LAMPS	3047
HEADLAMP - Conventional Type -	3023	Wiring Diagram - TURN -	3047
Wiring Diagram - H/LAMP -/LHD Models.....	3023	Trouble Diagnoses.....	3049
Wiring Diagram - H/LAMP -/RHD Models	3025	ILLUMINATION	3050
Bulb Replacement.....	3027	Wiring Diagram - ILL -/LHD Models	3050
Aiming Adjustment	3027	Wiring Diagram - ILL -/RHD Models.....	3052
Low Beam	3028	INTERIOR ROOM LAMP	3054
HEADLAMP - Daytime Light System -	3029	Wiring Diagram - ROOM/L -	3054
Wiring Diagram - DTRL -	3029	SPOT LAMP	3055
Bulb Replacement.....	3032	Wiring Diagram - INT/L -	3055
Aiming Adjustment	3032		
HEADLAMP - Dim-dip Lamp System -	3033		

METER AND GAUGES	3056	Wiring Diagram - AUDIO -/RHD Models	3114
System Description	3056	AUDIO ANTENNA	3115
Combination Meter/With Tachometer	3057	Power Antenna/Wiring Diagram - P/ANT -	3115
Combination Meter/Without Tachometer	3058	POWER DOOR MIRROR	3116
Schematic/With Tachometer	3059	Wiring Diagram - MIRROR -/LHD Models.....	3116
Schematic/Without Tachometer	3060	Wiring Diagram - MIRROR -/RHD Models	3117
Construction	3061	HEATED SEAT	3118
Wiring Diagram - METER -/Gasoline Engine		Wiring Diagram - H/SEAT -	3118
with Tachometer	3062	POWER WINDOW	3120
Wiring Diagram - METER -/Gasoline Engine		Schematic/Without Interruption Detection	
without Tachometer	3064	Function	3120
Wiring Diagram - METER -/LHD Diesel Engine		Schematic/With Interruption Detection	
Models with Tachometer.....	3065	Function	3121
Wiring Diagram - METER -/RHD Diesel		Wiring Diagram - WINDOW -/Without	
Engine Models with Tachometer	3067	Interruption Detection Function.....	3122
Wiring Diagram - METER -/Diesel Engine		Wiring Diagram - WINDOW -/With Interruption	
without Tachometer	3069	Detection Function	3126
Meter/Gauge Operation and Odo/Trip Meter		Trouble Diagnoses/Without Interruption	
Segment Check in Diagnosis Mode	3070	Detection Function	3130
Trouble Diagnoses/With Tachometer	3071	Trouble Diagnoses/With Interruption Detection	
Trouble Diagnoses/Without Tachometer	3076	Function	3131
WARNING LAMPS	3081	POWER DOOR LOCK	3133
Schematic/With Tachometer.....	3081	Wiring Diagram - D/LOCK -	3133
Schematic/Without Tachometer	3082	MULTI-REMOTE CONTROL SYSTEM	3135
Wiring Diagram - WARN -/Gasoline Engine		System Description	3135
with Tachometer	3083	MULTI-REMOTE CONTROL SYSTEM	3136
Wiring Diagram - WARN -/Gasoline Engine		Wiring Diagram - MULTI -	3136
without Tachometer	3087	Trouble Diagnoses.....	3137
Wiring Diagram - WARN -/Diesel Engine with		ID Code Entry Procedure	3139
Tachometer.....	3091	Remote Controller Battery Replacement.....	3140
Wiring Diagram - WARN -/Diesel Engine		THEFT WARNING SYSTEM	3141
without Tachometer	3095	Wiring Diagram - PRWIRE -	3141
A/T INDICATOR	3100	NATS (Nissan Anti-Theft System)	3142
Wiring Diagram - AT/IND -/RHD Models.....	3100	Component Parts and Harness Connector	
Wiring Diagram - CHIME -/LHD Models.....	3101	Location.....	3142
Wiring Diagram - CHIME -/RHD Models	3102	System Description	3143
FRONT WIPER AND WASHER	3103	System Composition	3144
Wiring Diagram - WIPER -/Without Intermittent		Wiring Diagram - NATS -/LHD Models.....	3145
for Floor-shift.....	3103	Wiring Diagram - NATS -/RHD Diesel Engine	
Wiring Diagram - WIPER -/Without Intermittent		Models.....	3146
for RHD Column-shift Models.....	3106	CONSULT-II.....	3147
HEADLAMP WASHER	3108	Trouble Diagnoses.....	3149
Wiring Diagram - HLC -	3108	How to Replace NATS IMMU.....	3160
HORN	3109	LOCATION OF ELECTRICAL UNITS	3161
Wiring Diagram - HORN -	3109	Engine Compartment.....	3161
CIGARETTE LIGHTER	3110	Passenger Compartment.....	3162
Wiring Diagram - CIGAR -	3110	HARNESS LAYOUT	3164
CLOCK	3111	Main Harness.....	3164
Wiring Diagram - CLOCK -	3111	Engine Room Harness.....	3174
REAR WINDOW DEFOGGER AND MIRROR		Engine Control Harness/KA engine.....	3182
DEFOGGER	3112	Engine Control Harness.....	3184
Wiring Diagram - DEF -	3112	Engine Harness	3185
AUDIO	3113	Alternator Harness	3187
Wiring Diagram - AUDIO -/LHD Models.....	3113	Instrument Harness.....	3189

Chassis Harness and Tail Harness 3190
Front Door Harness (LH side) 3191
Front Door Harness (RH side)..... 3192

Rear Door Harness 3193
WIRING DIAGRAM CODES (CELL CODES)..... 3194

PRECAUTIONS

Supplemental Restraint System (SRS) “AIR BAG” and “SEAT BELT PRE-TENSIONER”

The Supplemental Restraint System such as “AIR BAG” and “SEAT BELT PRE-TENSIONER” used along with a seat belt, helps to reduce the risk or severity of injury to the driver and front passenger in a frontal collision. The SRS system composition which is available to NISSAN MODEL D22 is as follows (The composition varies according to the destination and optional equipment.):

Driver air bag module (located in the center of the steering wheel), front passenger air bag module (located on the instrument panel on passenger side), seat belt pre-tensioner, a diagnosis sensor unit, warning lamp, wiring harness and spiral cable.

Information necessary to service the system safely is included in the **RS section** of this Service Manual.

WARNING:

- **To avoid rendering the SRS inoperative, which could increase the risk of personal injury or death in the event of a collision which would result in air bag inflation, all maintenance must be performed by an authorized NISSAN dealer.**
- **Improper maintenance, including incorrect removal and installation of the SRS, can lead to personal injury caused by unintentional activation of the system. For removal of Spiral Cable and Air Bag Module, see the RS section.**
- **Do not use electrical test equipment on any circuit related to the SRS unless instructed to in this Service Manual. SRS wiring harnesses can be identified by yellow harness connector.**

POWER SUPPLY ROUTING

Schematic

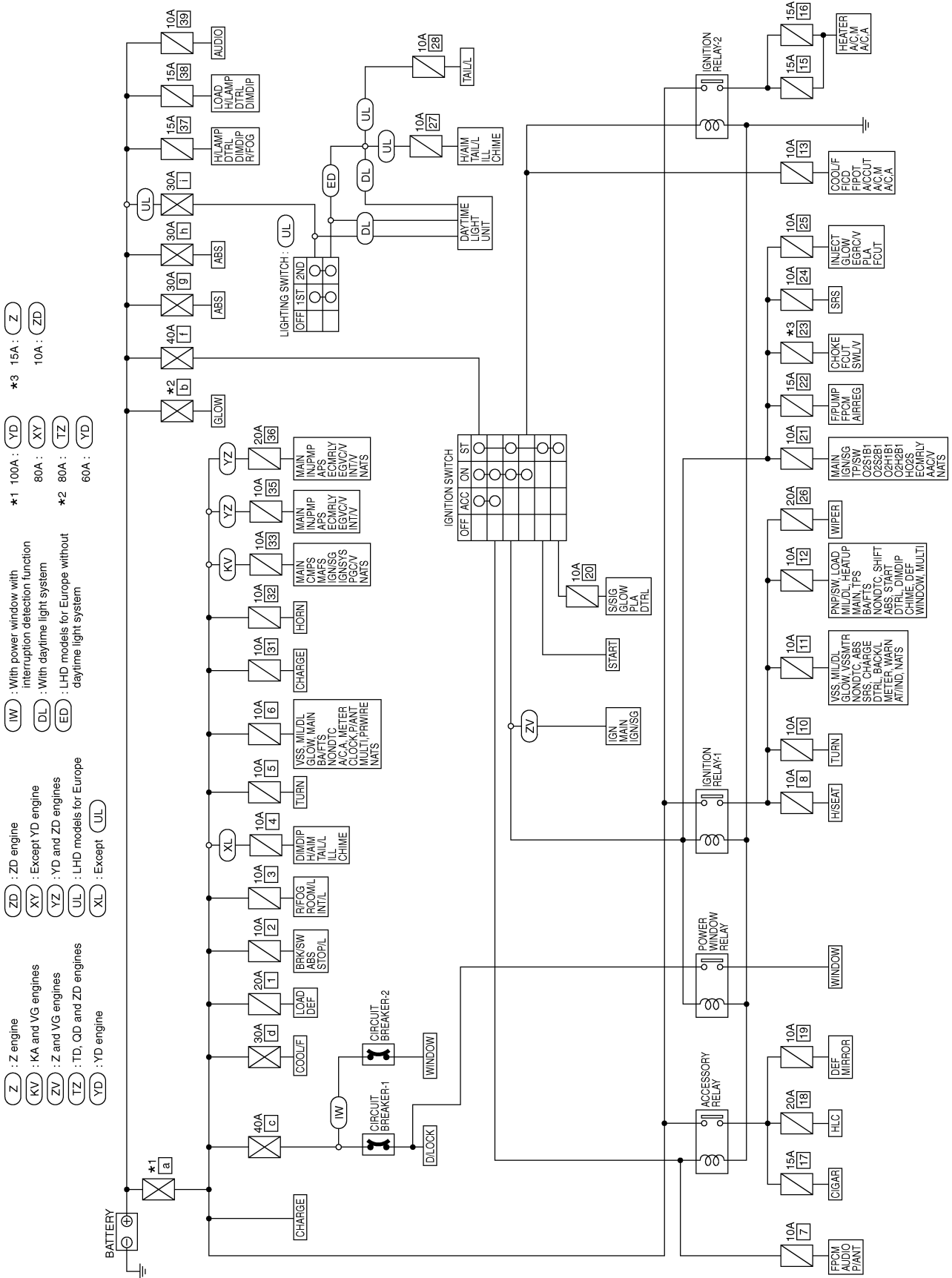

POWER SUPPLY ROUTING

Wiring Diagram — POWER —

BATTERY POWER SUPPLY — IGNITION SWITCH IN ANY POSITION

EL-POWER-01

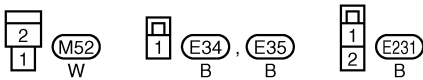
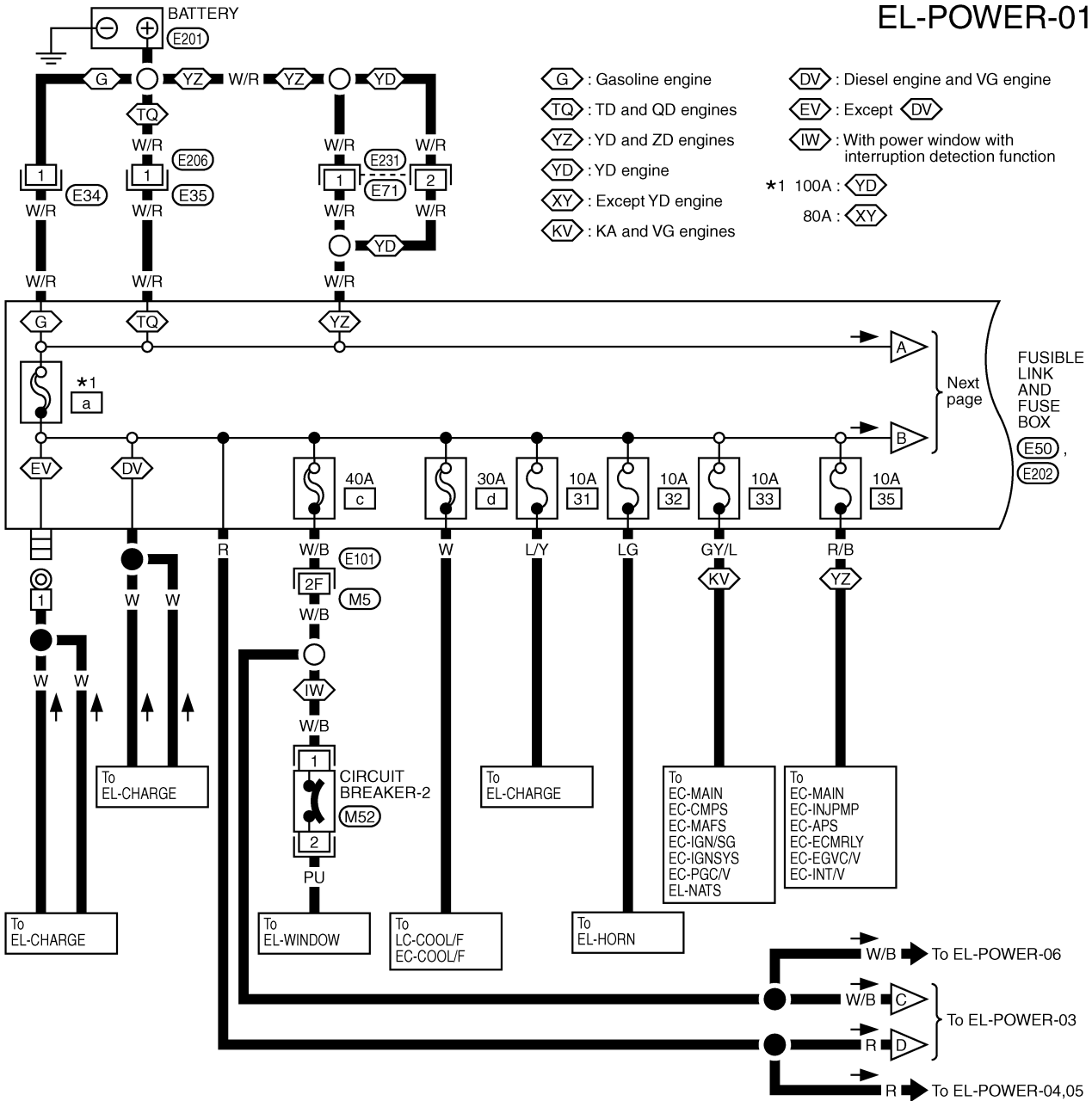

Refer to last page (Foldout page).
M5 E101

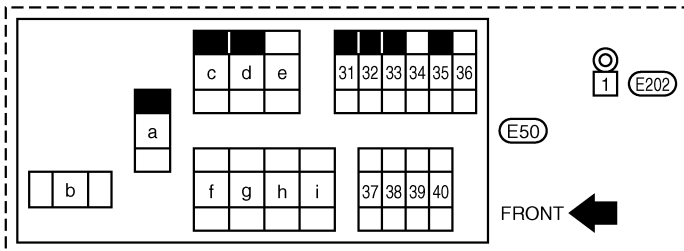

POWER SUPPLY ROUTING

Wiring Diagram — POWER — (Cont'd)

EL-POWER-02

- : YD and ZD engines
- : LHD models for Europe
- : YD engine
- : TD, QD and ZD engines
- *1 80A :
- 60A :

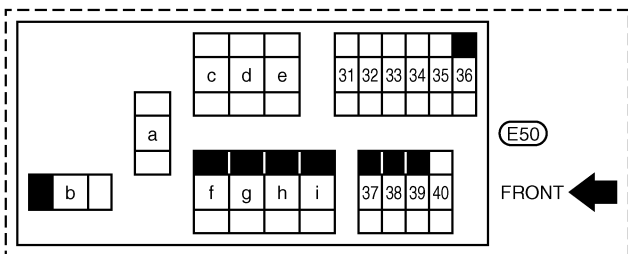
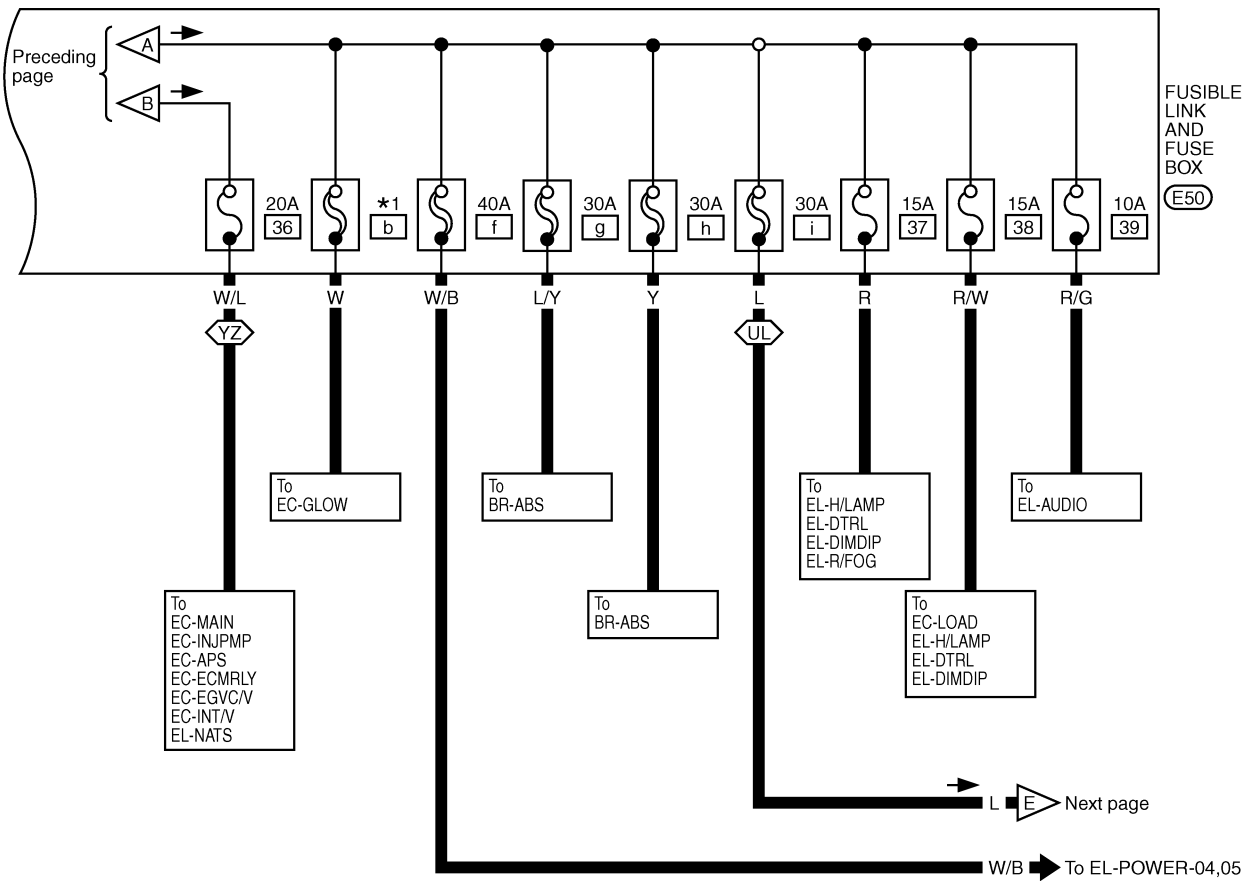

POWER SUPPLY ROUTING

Wiring Diagram — POWER — (Cont'd)

EL-POWER-03

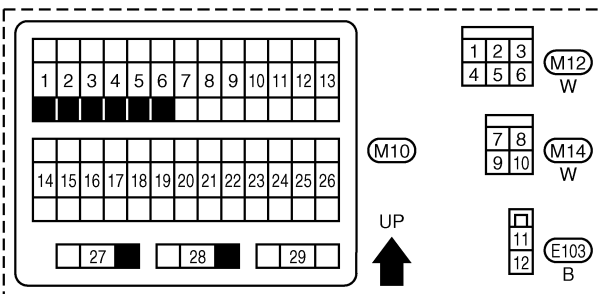
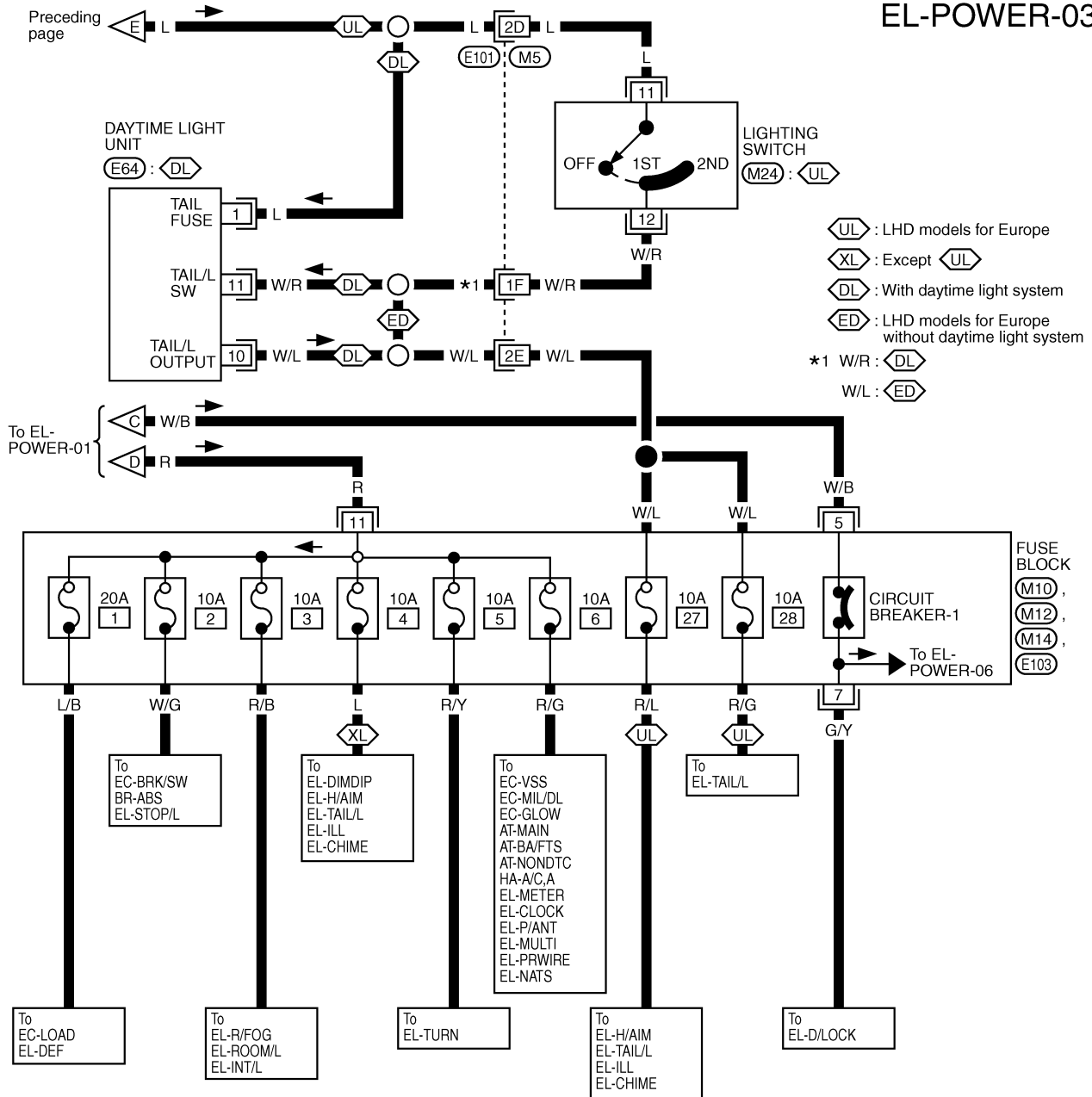

Refer to last page (Foldout page).

M5, E101

POWER SUPPLY ROUTING

Wiring Diagram — POWER — (Cont'd)

ACCESSORY POWER SUPPLY — IGNITION SW. IN "ACC" OR "ON"

EL-POWER-04

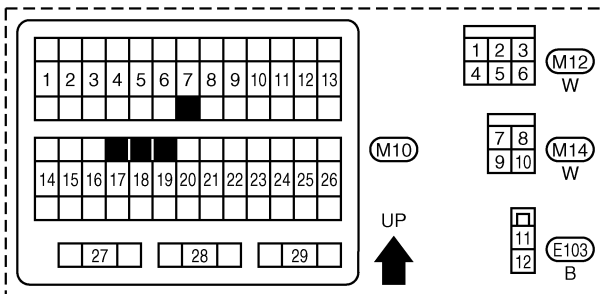
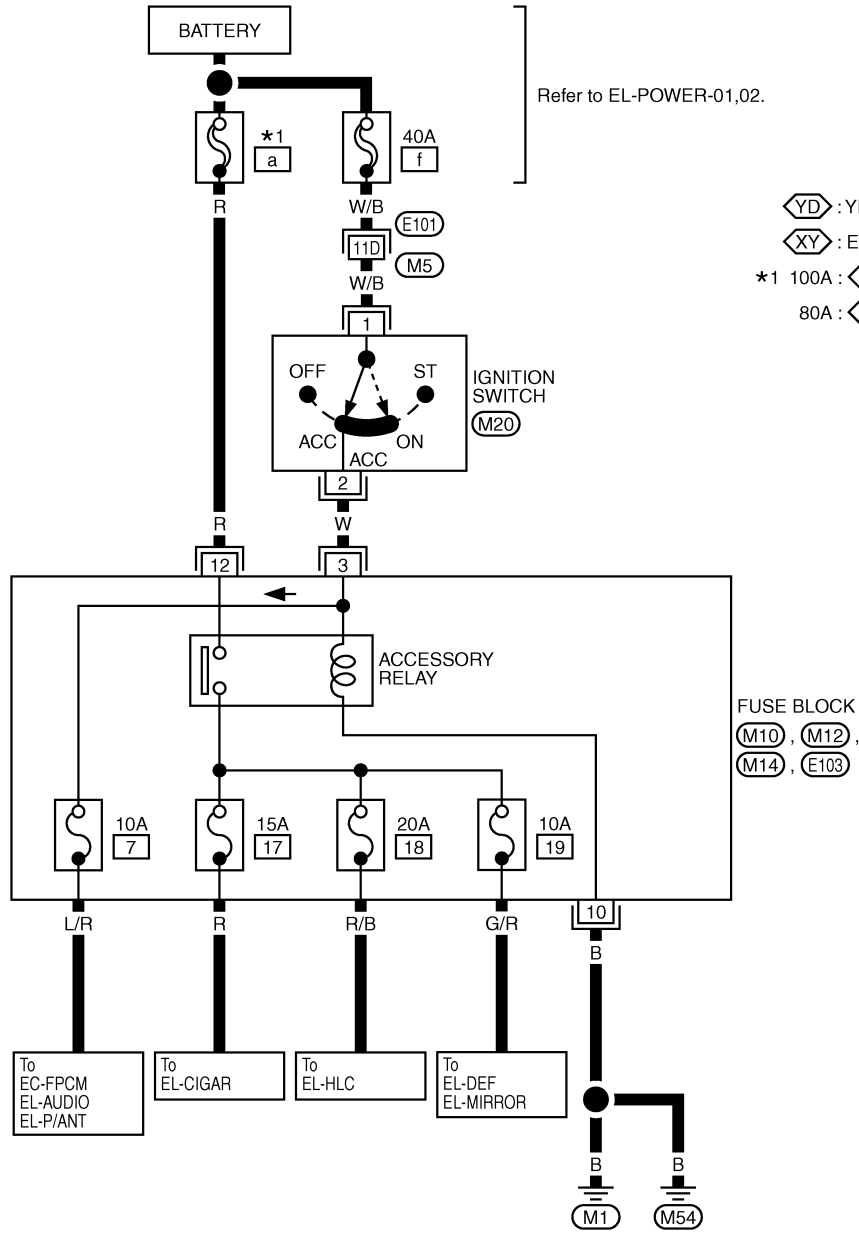

Refer to last page (Foldout page).
 M5, E101

POWER SUPPLY ROUTING

Wiring Diagram — POWER — (Cont'd)

IGNITION POWER SUPPLY — IGNITION SW. IN "ON" AND/OR "START"

EL-POWER-05

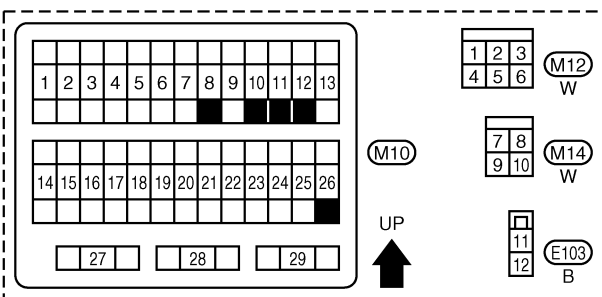
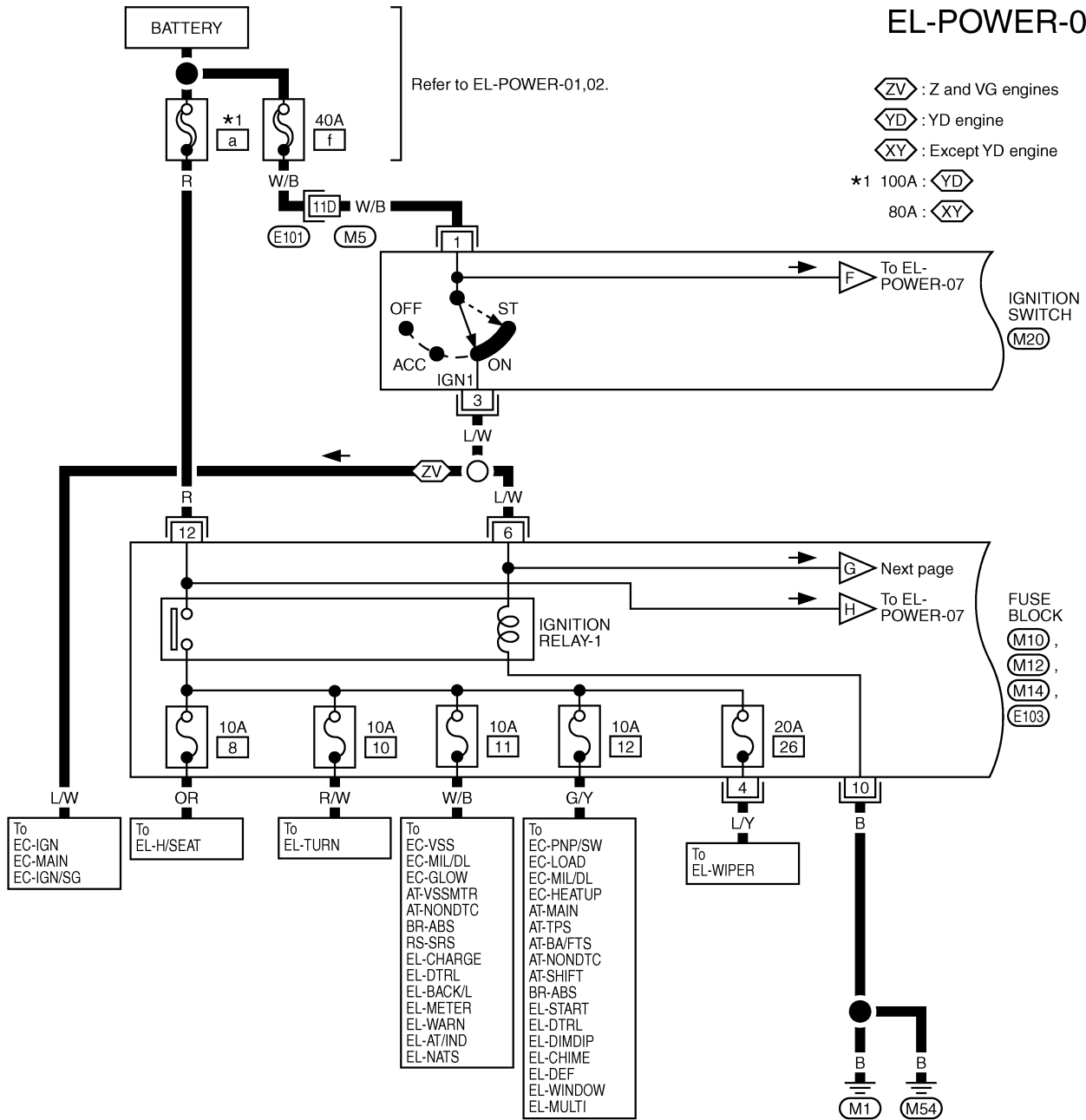





Refer to last page (Foldout page).
 M5, E101

POWER SUPPLY ROUTING

Wiring Diagram — POWER — (Cont'd)

EL-POWER-06

-  : Z engine
-  : ZD engine
-  : KA engine for Europe
-  : With ECM control engine except KA engine for Europe

- *1 W/L : 
- W/R : 
- *2 15A : 
- 10A : 
- *3 W/L : 
- BR/Y : 

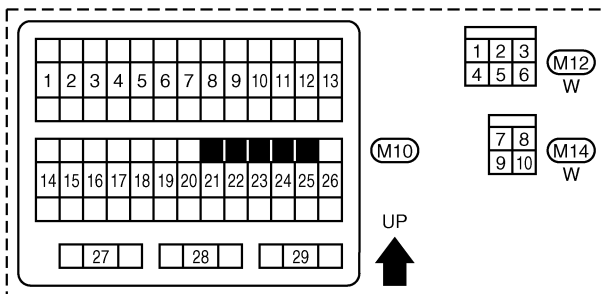
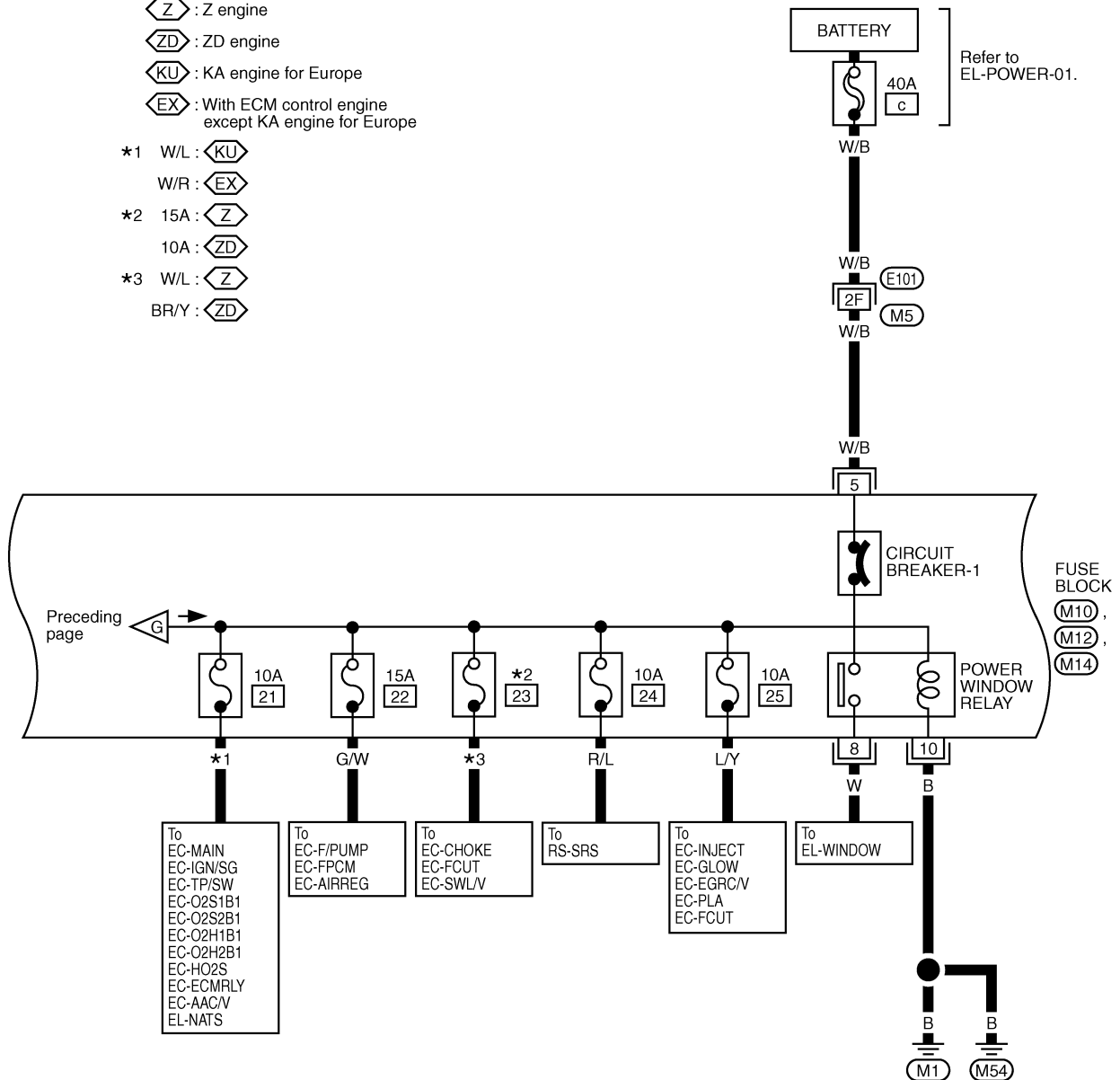

Refer to last page (Foldout page).

(M5), (E101)

POWER SUPPLY ROUTING

Wiring Diagram — POWER — (Cont'd)

EL-POWER-07

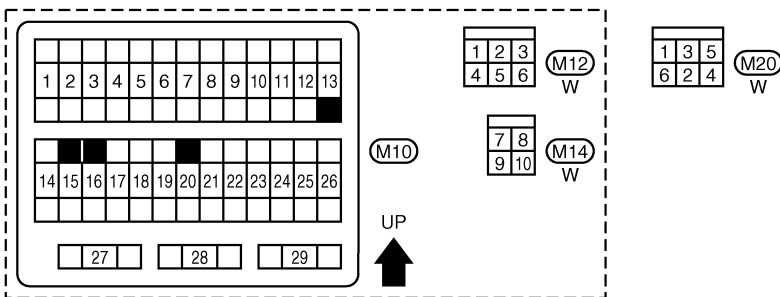
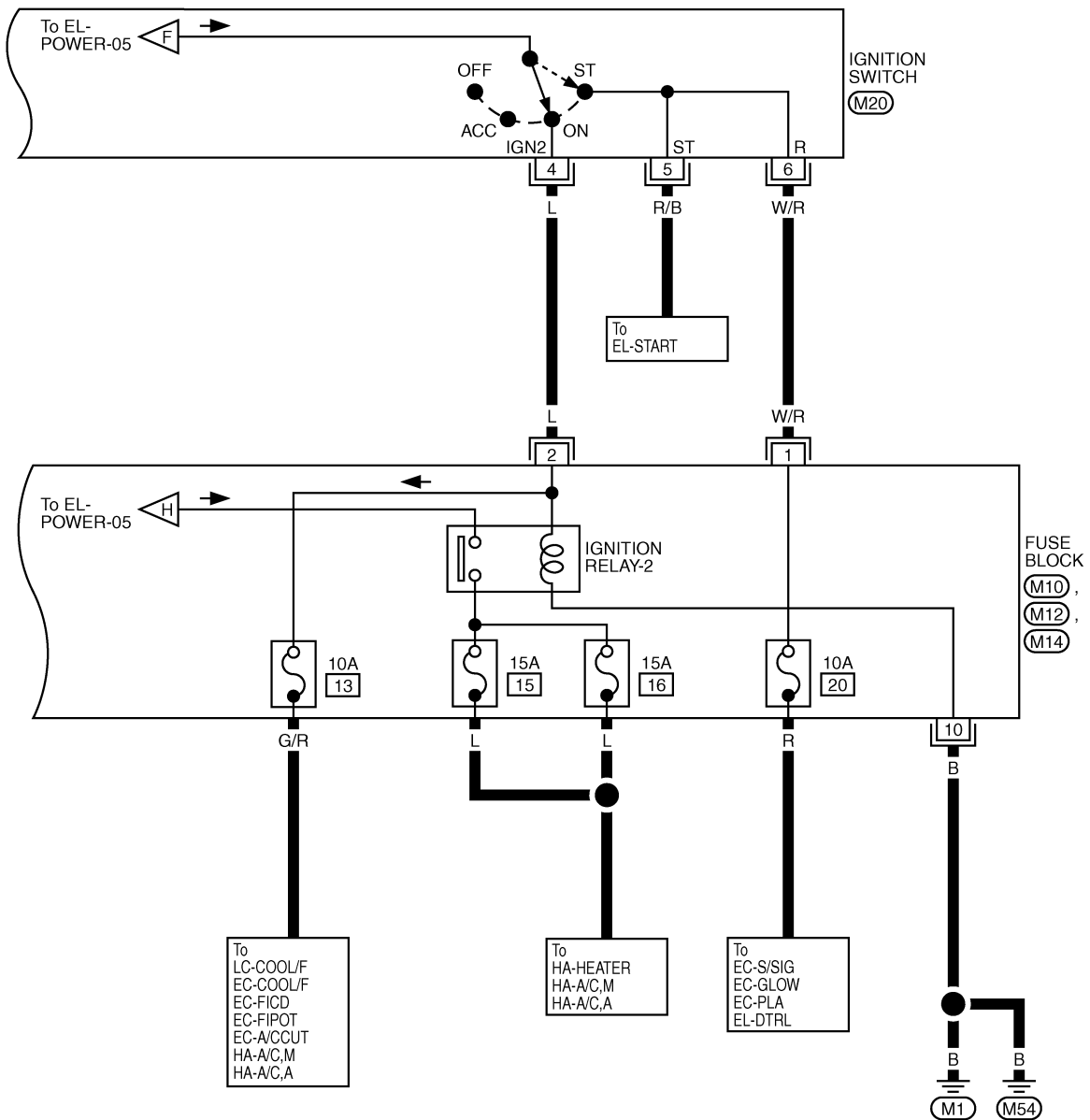

BATTERY

Service Data and Specifications (SDS)

Applied model		Europe
		YD25
		Standard
Type		110D26R
Capacity	V-AH	12-64

STARTING SYSTEM

Wiring Diagram — START —/M/T Models

EL-START-01

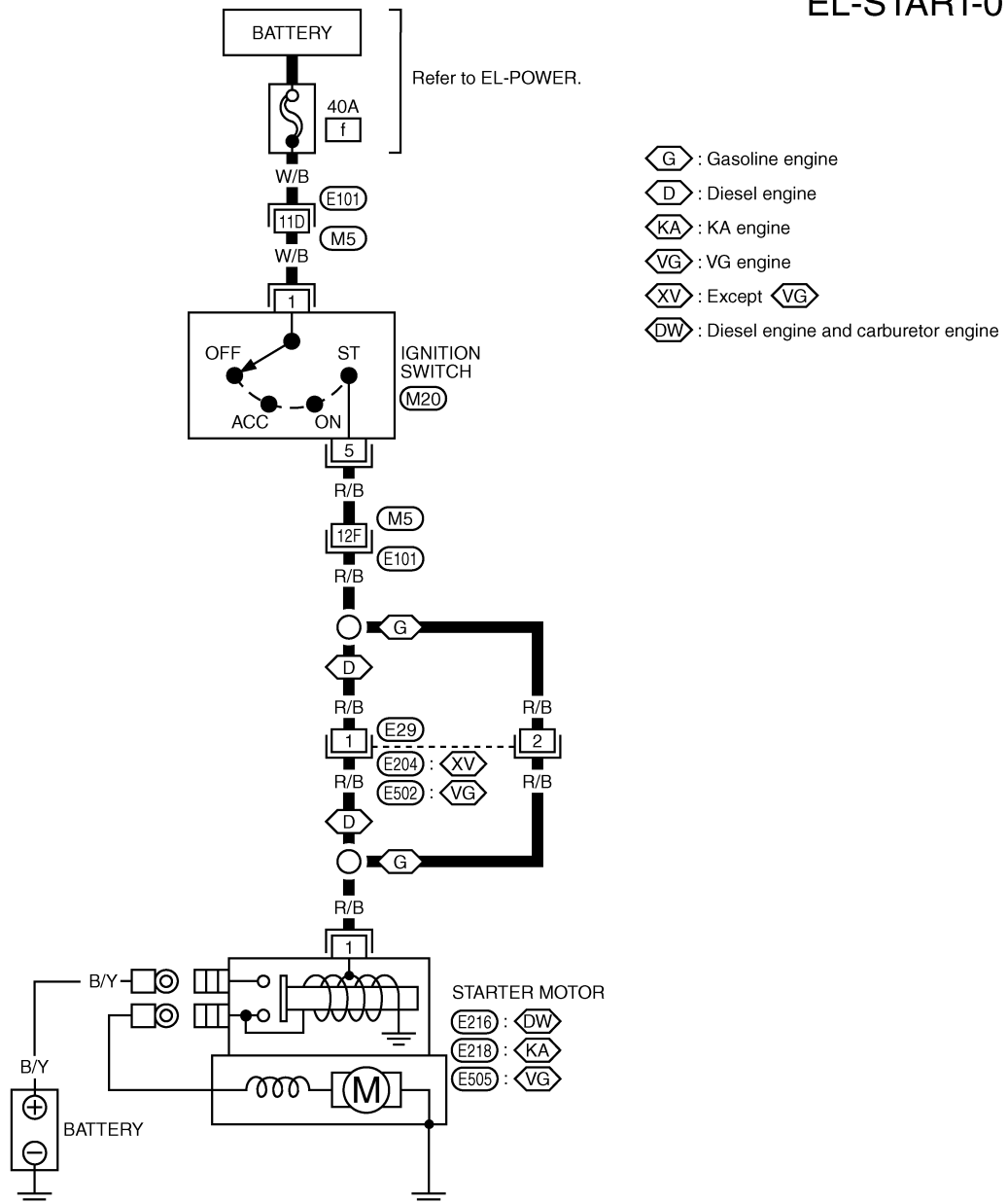

Refer to last page (Foldout page).

M5, E101

STARTING SYSTEM

Construction

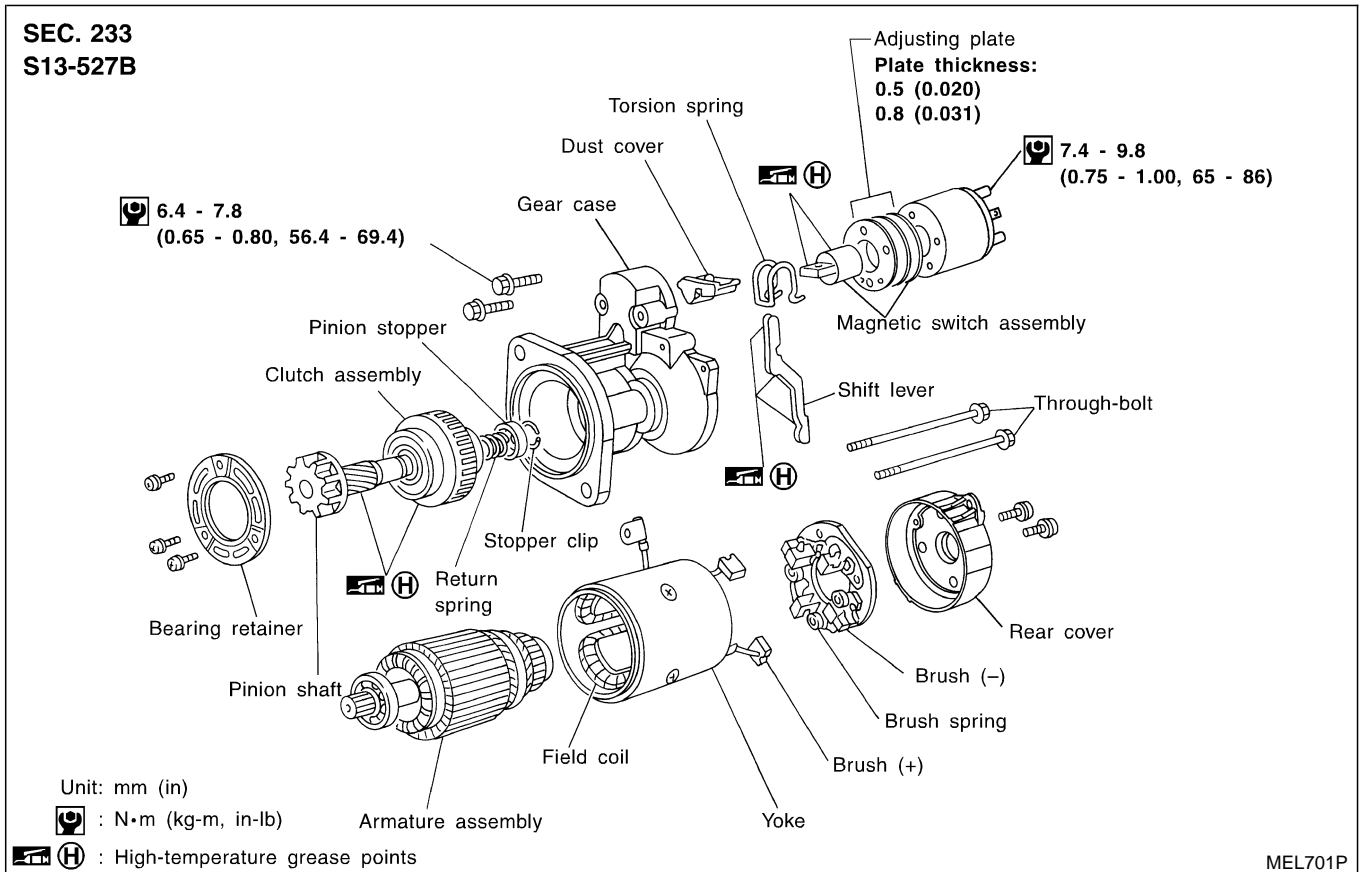
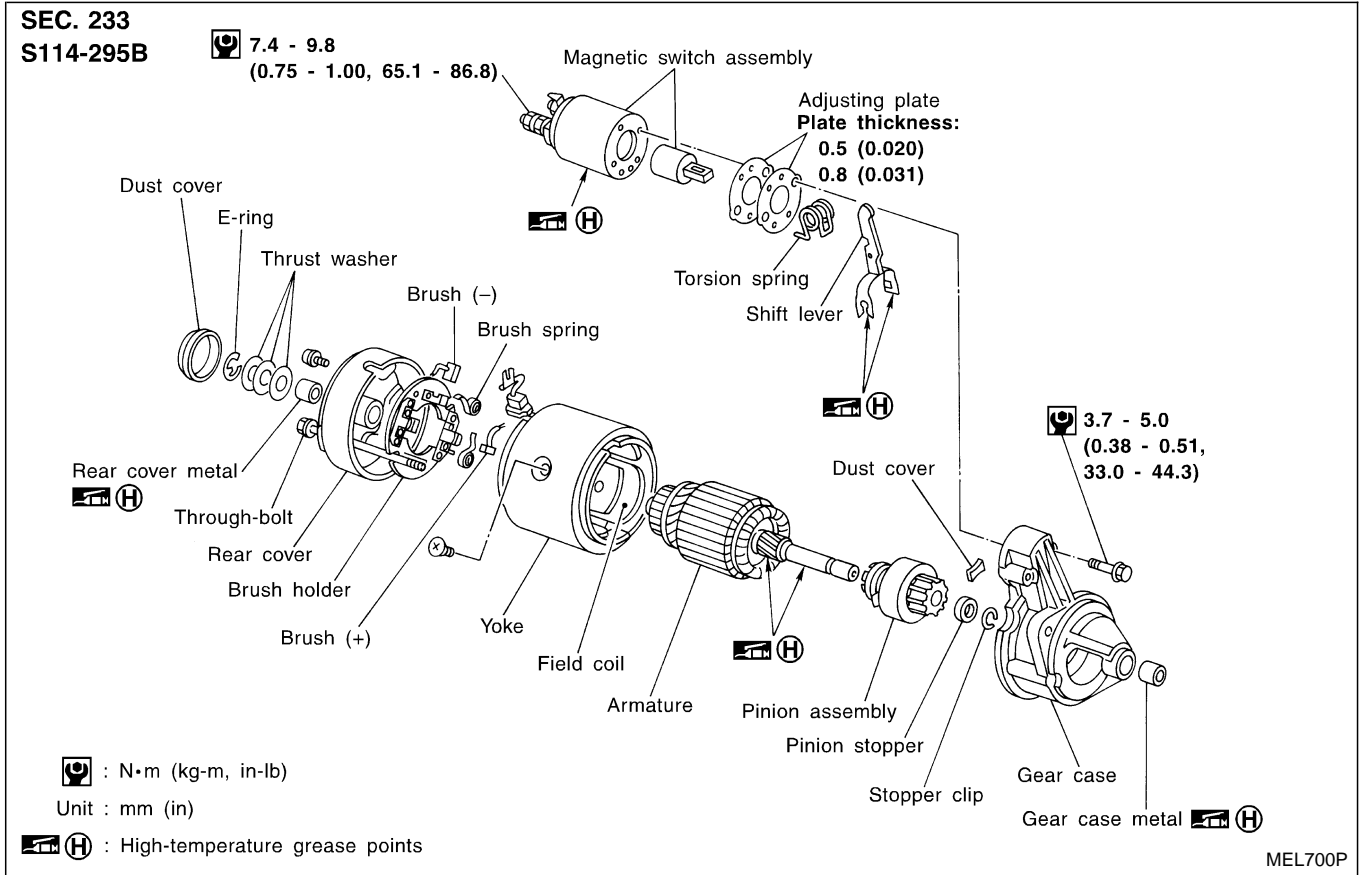

STARTING SYSTEM

Construction (Cont'd)

SEC. 233
M2TSO571

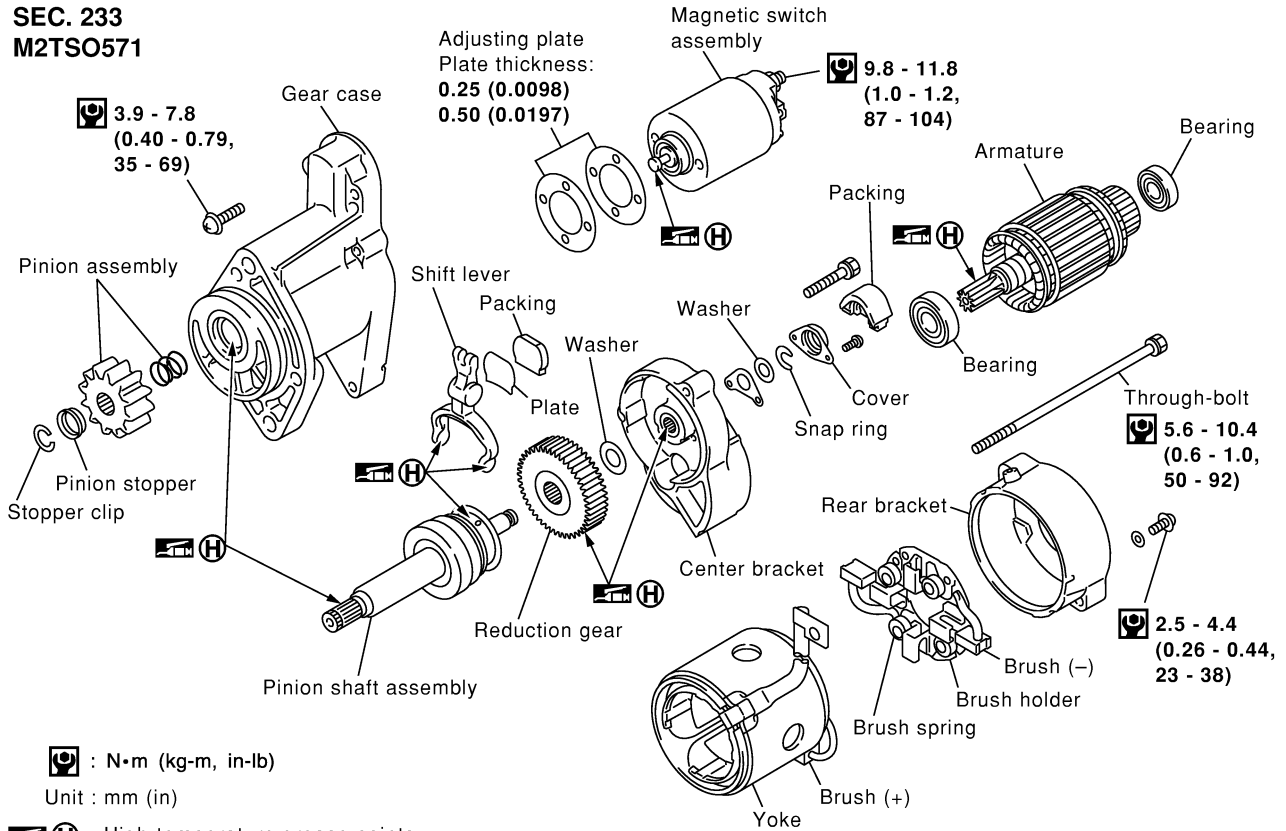

: N•m (kg-m, in-lb)

Unit : mm (in)

: High-temperature grease points

MEL702P

STARTING SYSTEM

Service Data and Specifications (SDS)

STARTER

Type		M2TS0571	M3T29482D	S114-348A	S114-295B	S13-527B	
		MITSUBISHI		HITACHI			
Applied model		Reduction		Non-reduction		Reduction	
		2WD	4WD	2WD		4WD	
		YD25		Z24		ZD30	
System voltage		V		12			
No-load							
Terminal voltage	V	11.0		11.5		11.0	
Current	A	Less than 145		Less than 60		Less than 160*	
Revolution	rpm	More than 3,200		More than 6,500	More than 7,000	More than 6,000	
Minimum diameter of commutator	mm (in)	31.4 (1.236)		39.0 (1.535)		35.5 (1.398)	
Minimum length of brush	mm (in)	11.0 (0.433)		11.5 (0.453)	12.0 (0.472)	11.0 (0.433)	
Brush spring tension	N (kg, lb)	26.7 - 36.1 (2.7 - 3.7, 6.0 - 8.2)		13.7 - 25.5 (1.4 - 2.6, 3.1 - 5.7)	17.7 - 21.6 (1.8 - 2.2, 4.0 - 4.9)	17.6 - 21.6 (1.8 - 2.2, 4.0 - 4.9)	
Clearance between bearing metal and armature shaft	mm (in)	Less than 0.2 (0.008)				—	
Clearance "ℓ" between pinion front edge and pinion stopper	mm (in)	—		0.5 - 2.0 (0.020 - 0.079)	0.3 - 2.5 (0.012 - 0.098)	—	
Movement "ℓ" in height of pinion assembly	mm (in)	0.5 - 2.0 (0.020 - 0.079)		—		0.3 - 2.0 (0.01 - 0.079)	

*: Includes magnet switch current.

CHARGING SYSTEM

Wiring Diagram — CHARGE —/Diesel Engine

EL-CHARGE-01

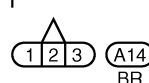
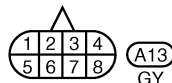
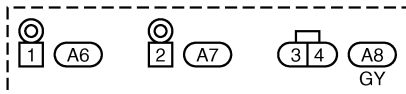
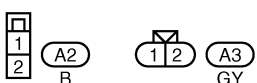
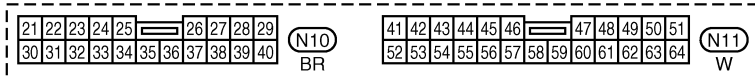
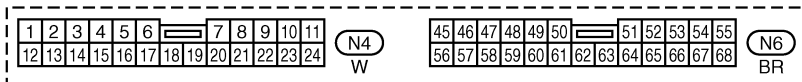
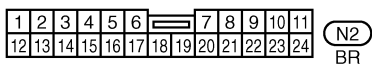
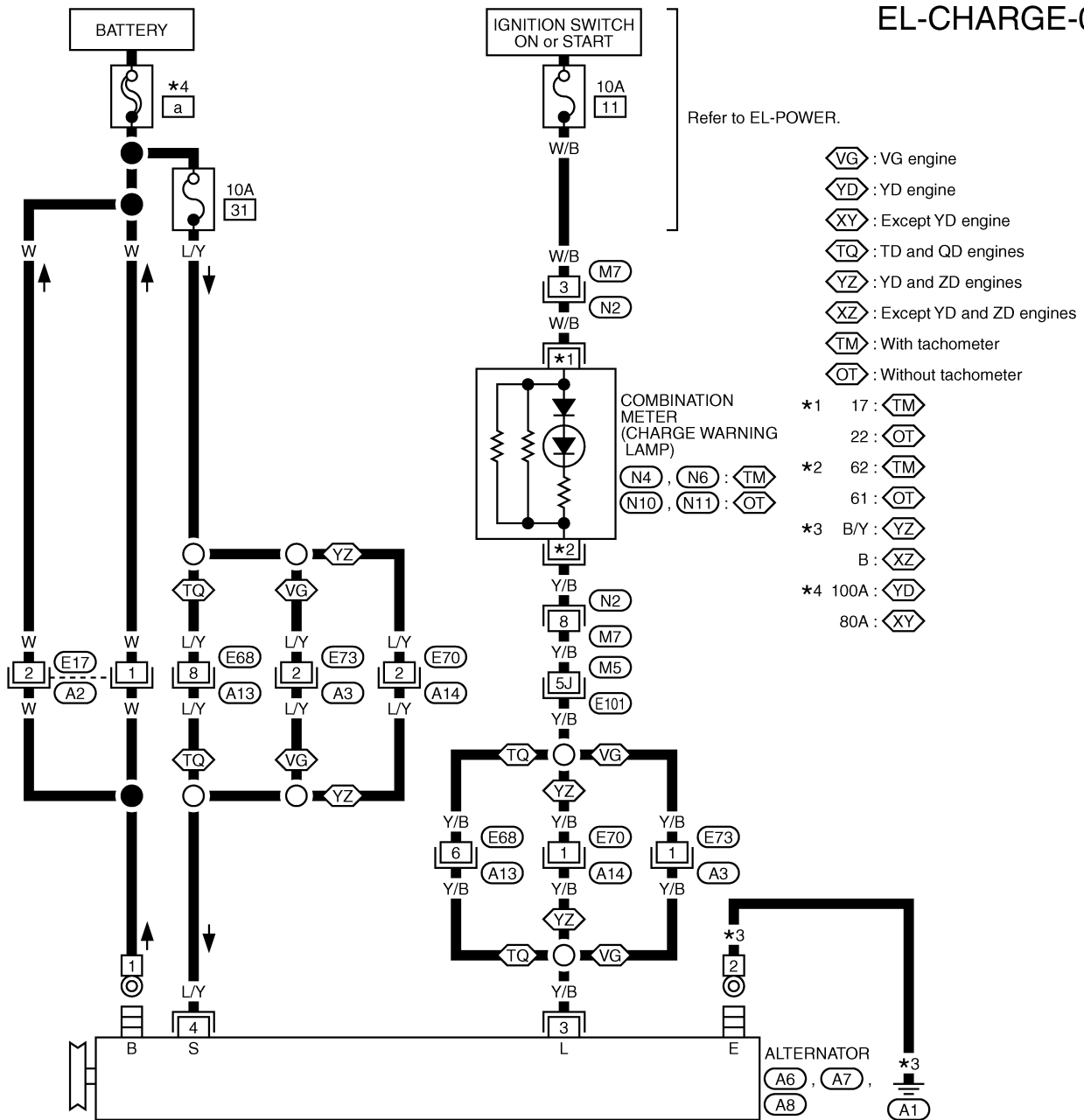

Refer to last page (Foldout page).

(M5), (E101)

CHARGING SYSTEM

Wiring Diagram — CHARGE — (KA engine)

EL-CHARGE-02

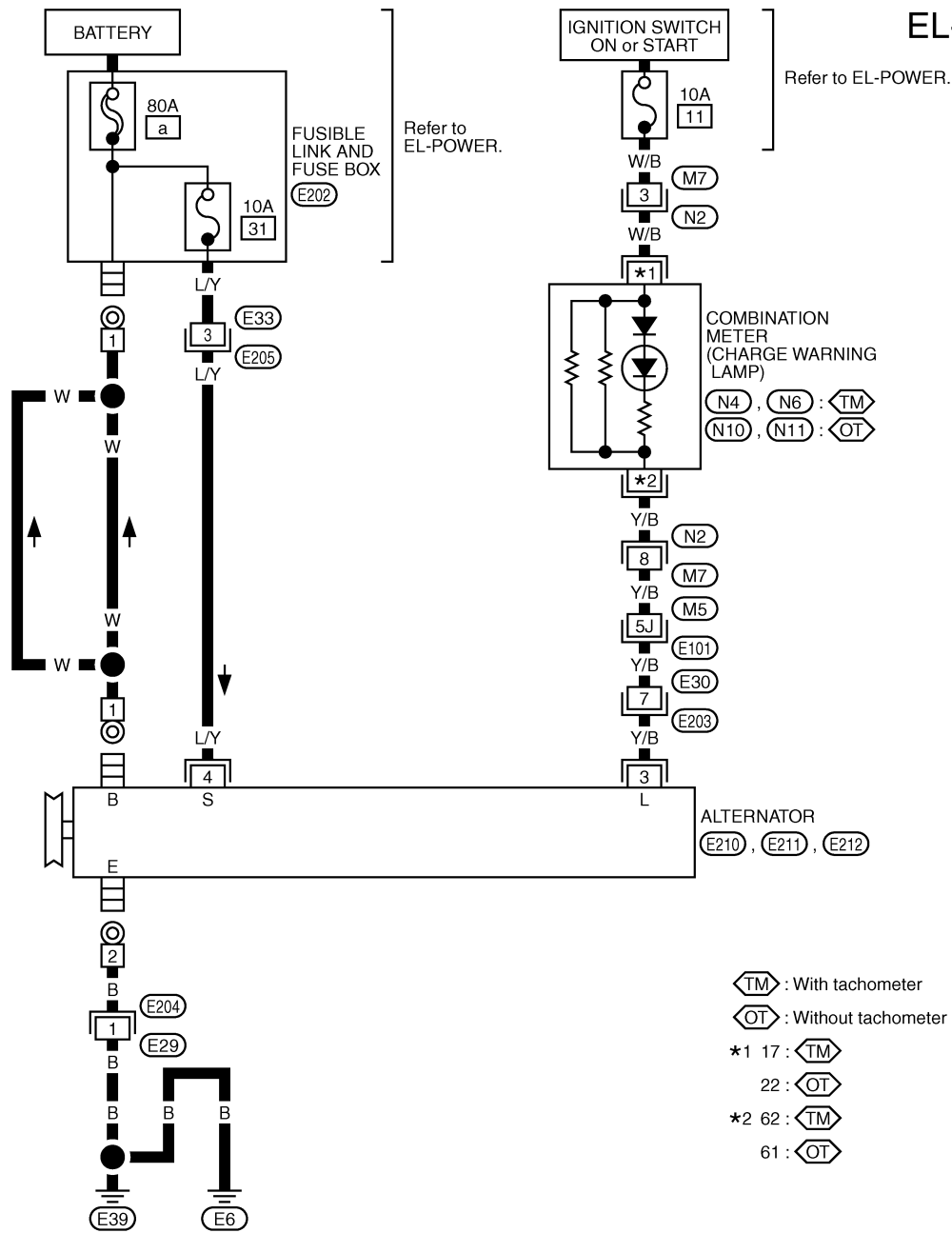

- TM : With tachometer
- OT : Without tachometer
- *1 17 : TM
- 22 : OT
- *2 62 : TM
- 61 : OT

1	2	3	4	5	6	7	8	9	10	11		
12	13	14	15	16	17	18	19	20	21	22	23	24

(N2) BR

1	2	3	4	5	6	7	8	9	10	11		
12	13	14	15	16	17	18	19	20	21	22	23	24

(N4) W

45	46	47	48	49	50	51	52	53	54	55		
56	57	58	59	60	61	62	63	64	65	66	67	68

(N6) BR

21	22	23	24	25	26	27	28	29		
30	31	32	33	34	35	36	37	38	39	40

(N10) BR

41	42	43	44	45	46	47	48	49	50	51		
52	53	54	55	56	57	58	59	60	61	62	63	64

(N11) W

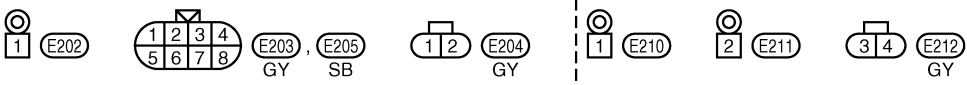

Refer to last page (Foldout page).

(M5), (E101)

CHARGING SYSTEM

Construction

SEC. 231
LR160-728E

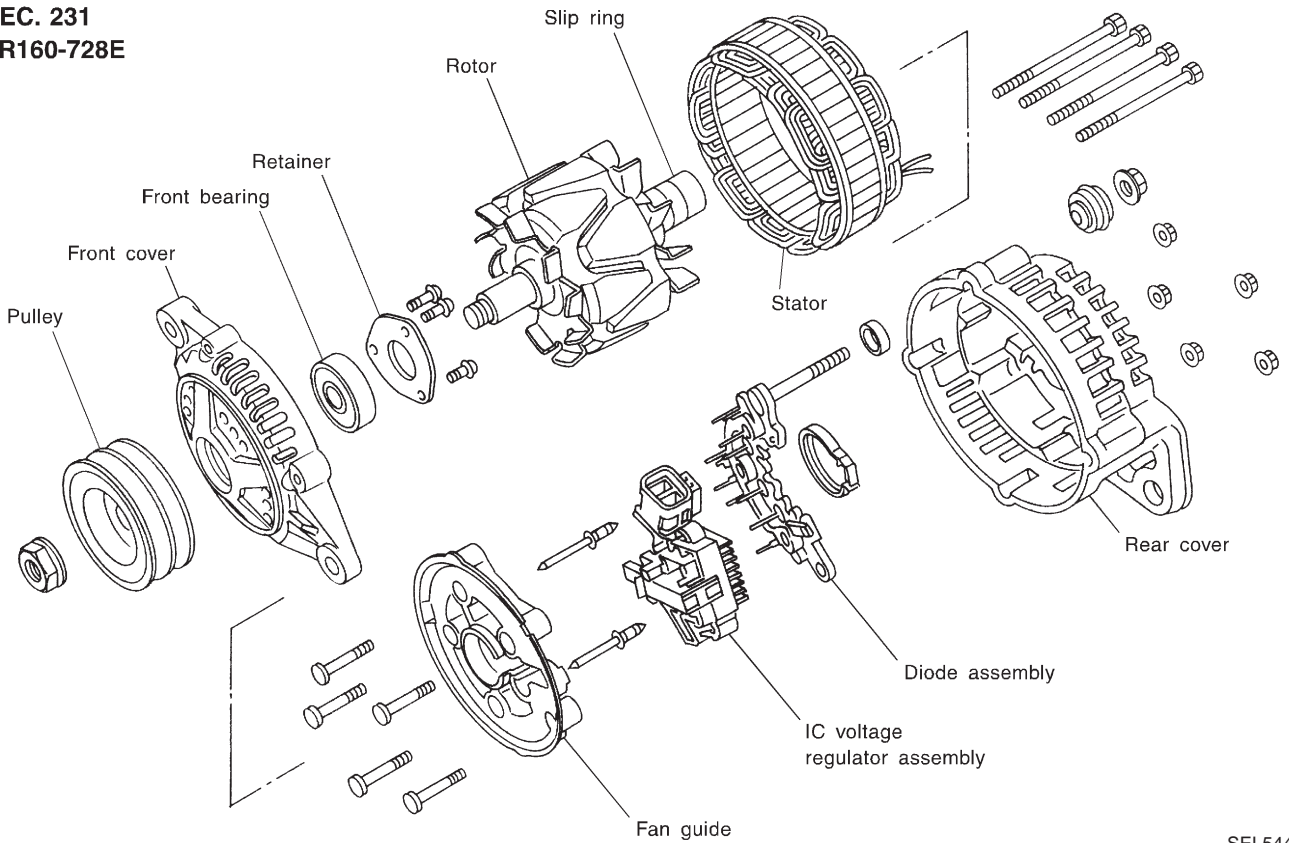

SEL544V

SEC. 231
A3TB0699

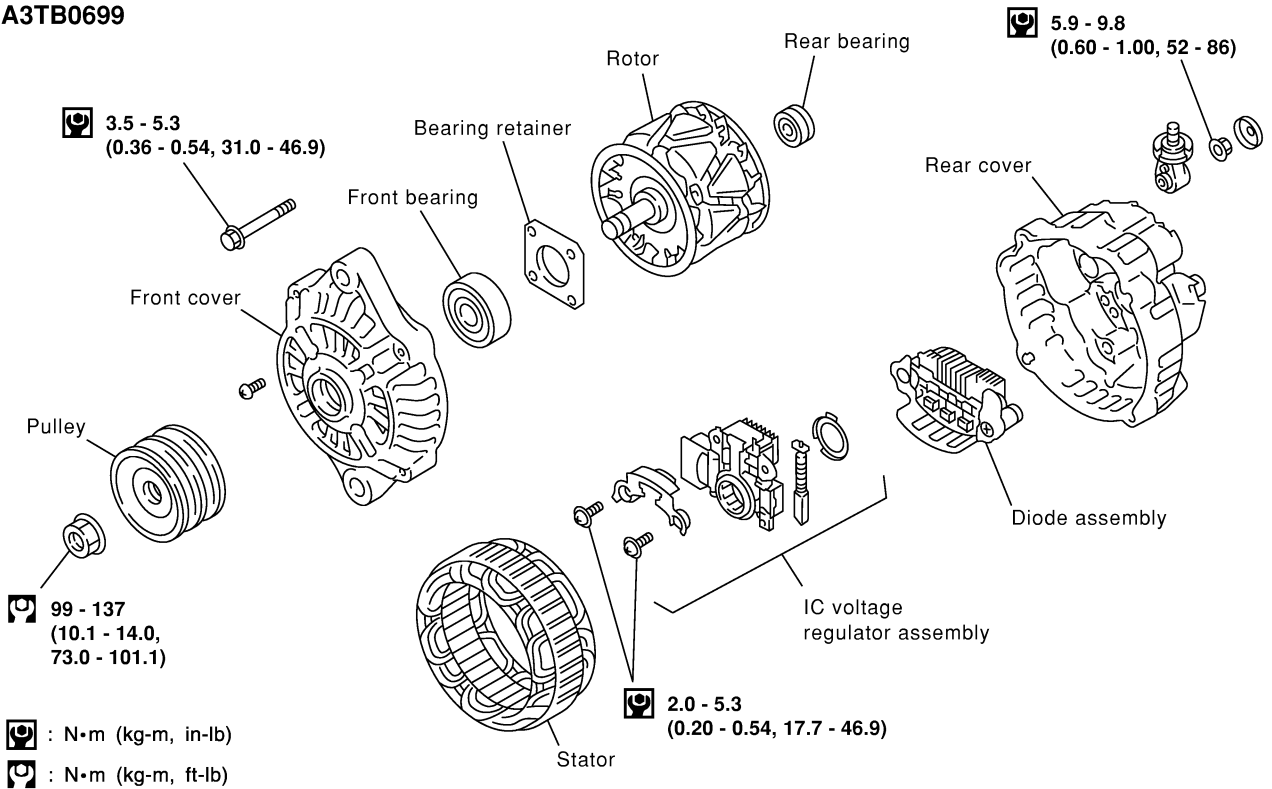

: N·m (kg-m, in-lb)

: N·m (kg-m, ft-lb)

MEL704P

EL-3020

CHARGING SYSTEM

Construction (Cont'd)

SEC. 231
LR160-745

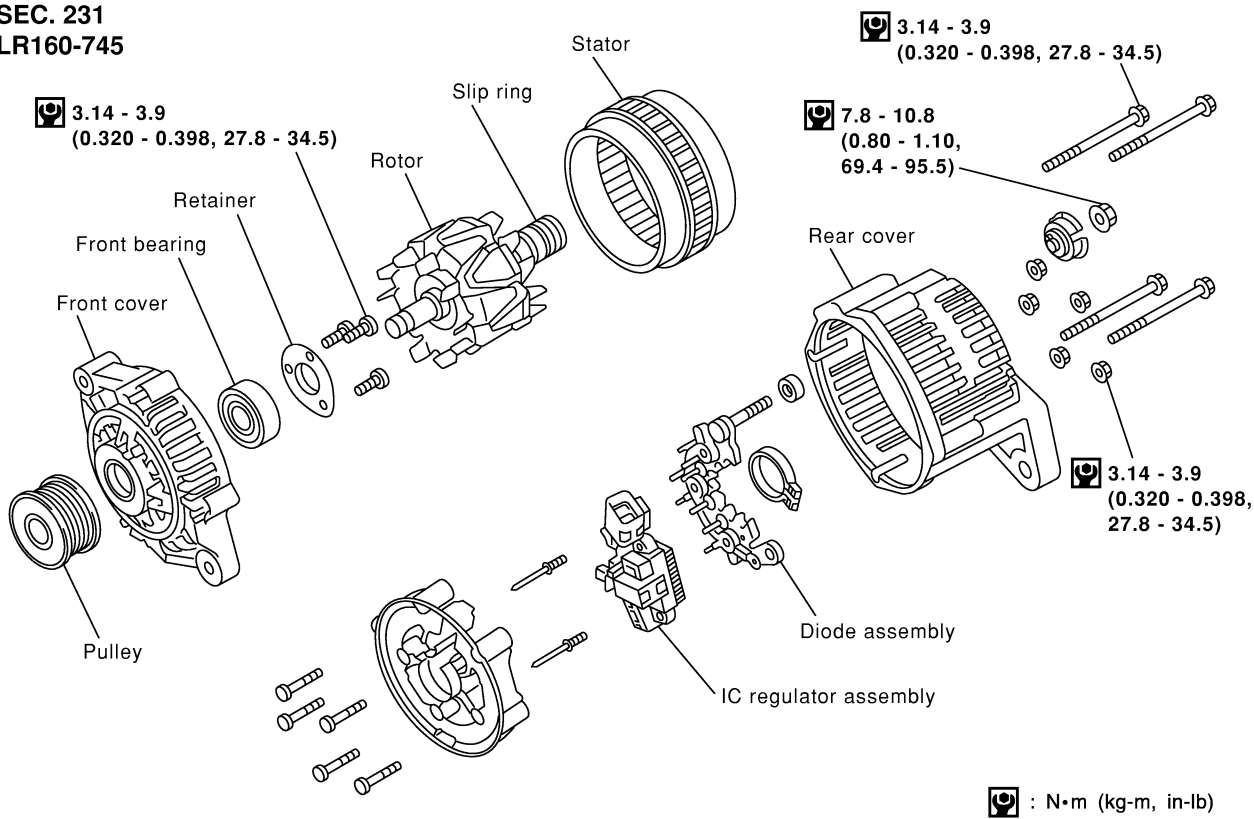

MEL703P

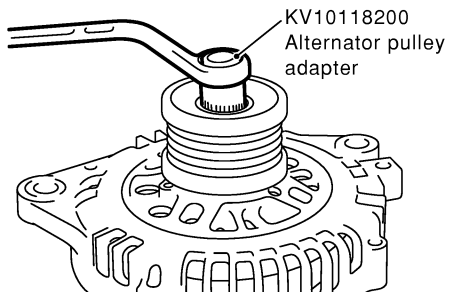

PKIA1240E

Disassembly (For LR160-745)

- When removing alternator pulley, use special service tool (KV10118200).

CHARGING SYSTEM

Service Data and Specifications (SDS)

ALTERNATOR

Type	A5TA5271	A7TA8471	A5TA5372	A3TB0699	LR160-745	LR160-728E
	MITSUBISHI				HITACHI	
Applied model	KA24DE	Z24		YD25	ZD30	TD27, QD32
		Standard	Option*			
Nominal rating V-A	12-70	12-35	12-70	12-90	12-60	
Ground polarity	Negative					
Minimum revolution under no-load (When 13.5V is applied) rpm	Less than 1,300				Less than 1,000	
Hot output current (When 13.5V is applied) A/rpm	More than 14/1,300 More than 54/2,500	More than 27/2,500	More than 18/1,300 More than 51/2,500	More than 29/1,300 More than 76/2,500 More than 88/5,000	More than 17/1,300 More than 48/2,500 More than 57/5,000	
Regulated output voltage V	14.1 - 14.7					
Minimum length of brush mm (in)	5.0 (0.20)				6.0 (0.236)	
Brush spring pressure N (g, oz)	4.8 - 6.0 (487 - 612, 17.25 - 21.59)				1.0 - 3.43 (102 - 350, 3.60 - 12.34)	
Slip ring minimum outer diameter mm (in)	22.1 (0.870)				26.0 (1.024)	
Rotor (Field coil) resistance Ω	2.5 - 2.9	2.7 - 3.2	2.5 - 2.9	2.1 - 2.5	2.6	2.58

*: Models with power steering and air conditioner

HEADLAMP — Conventional Type —

Wiring Diagram — H/LAMP —/LHD Models

EL-H/LAMP-01

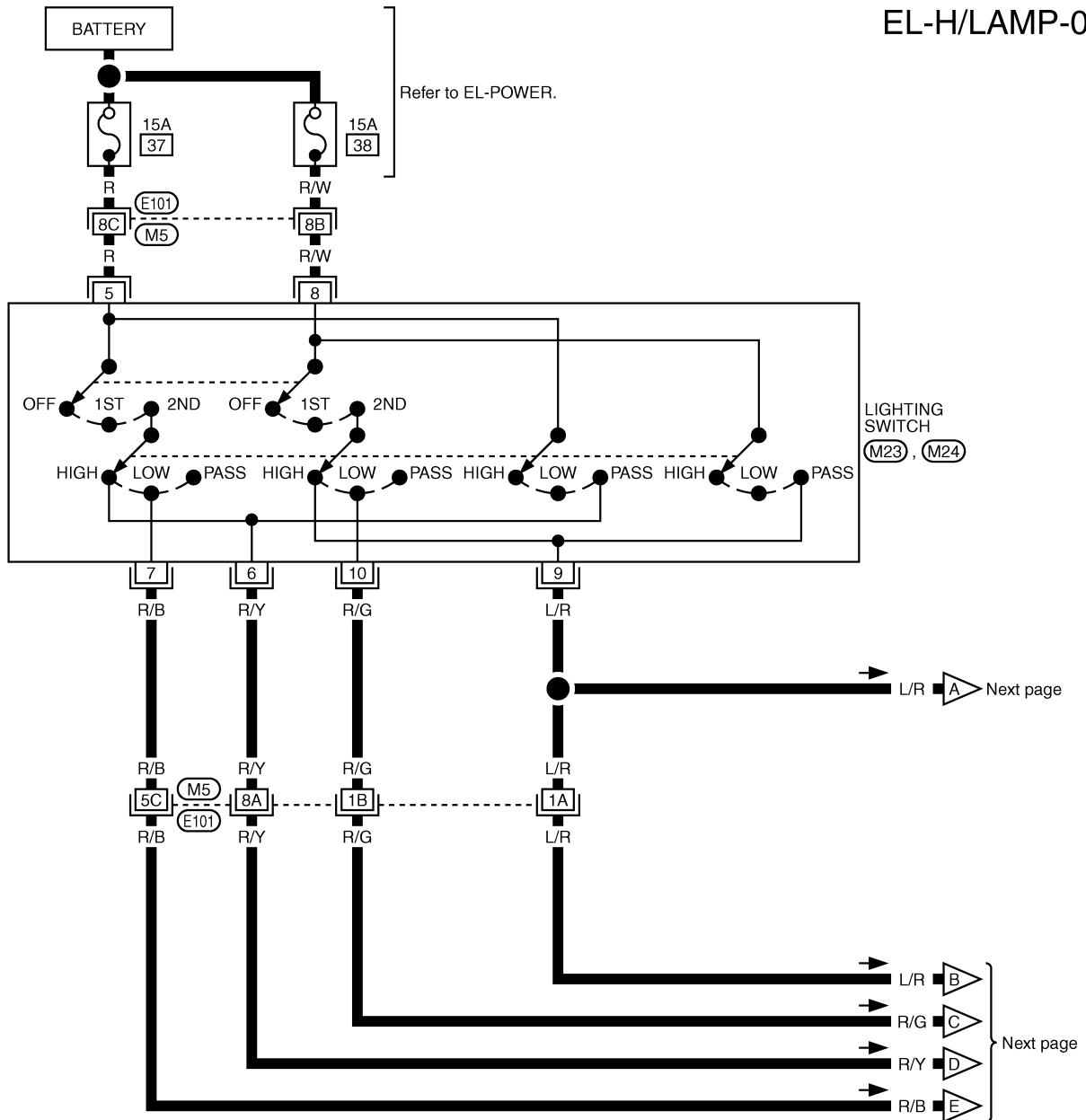

Refer to last page (Foldout page).

(M5), (E101)

HEADLAMP — Conventional Type —

Wiring Diagram — H/LAMP —/LHD Models (Cont'd)

EL-H/LAMP-02

⊡ : With tachometer
⊡ : Without tachometer

*1 46 : ⊡
51 : ⊡
*2 47 : ⊡
50 : ⊡

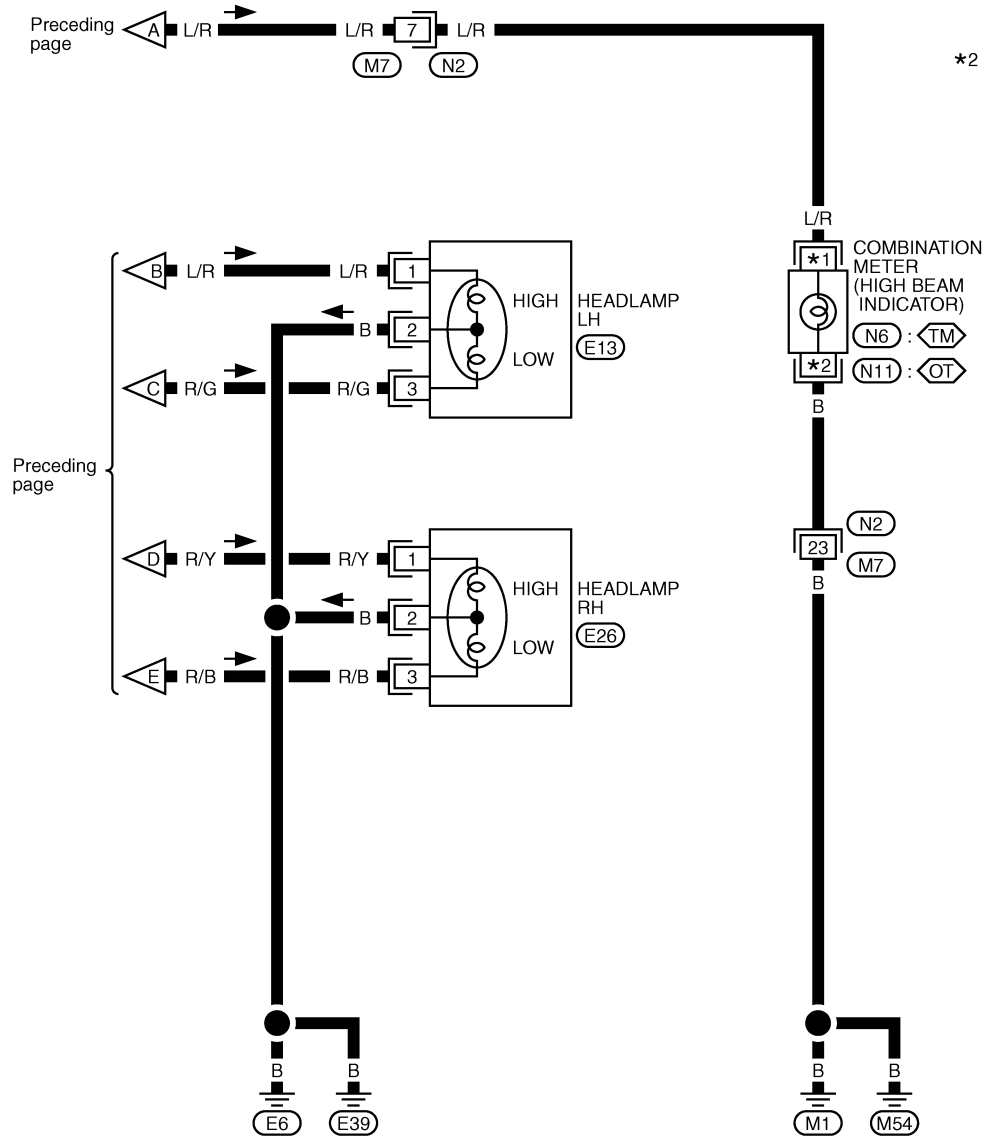

1	2	3	4	5	6	7	8	9	10	11		
12	13	14	15	16	17	18	19	20	21	22	23	24

N2
BR

45	46	47	48	49	50	51	52	53	54	55		
56	57	58	59	60	61	62	63	64	65	66	67	68

N6
BR

41	42	43	44	45	46	47	48	49	50	51		
52	53	54	55	56	57	58	59	60	61	62	63	64

N11
W

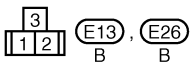

HEADLAMP — Conventional Type —

Wiring Diagram — H/LAMP —/RHD Models

EL-H/LAMP-03

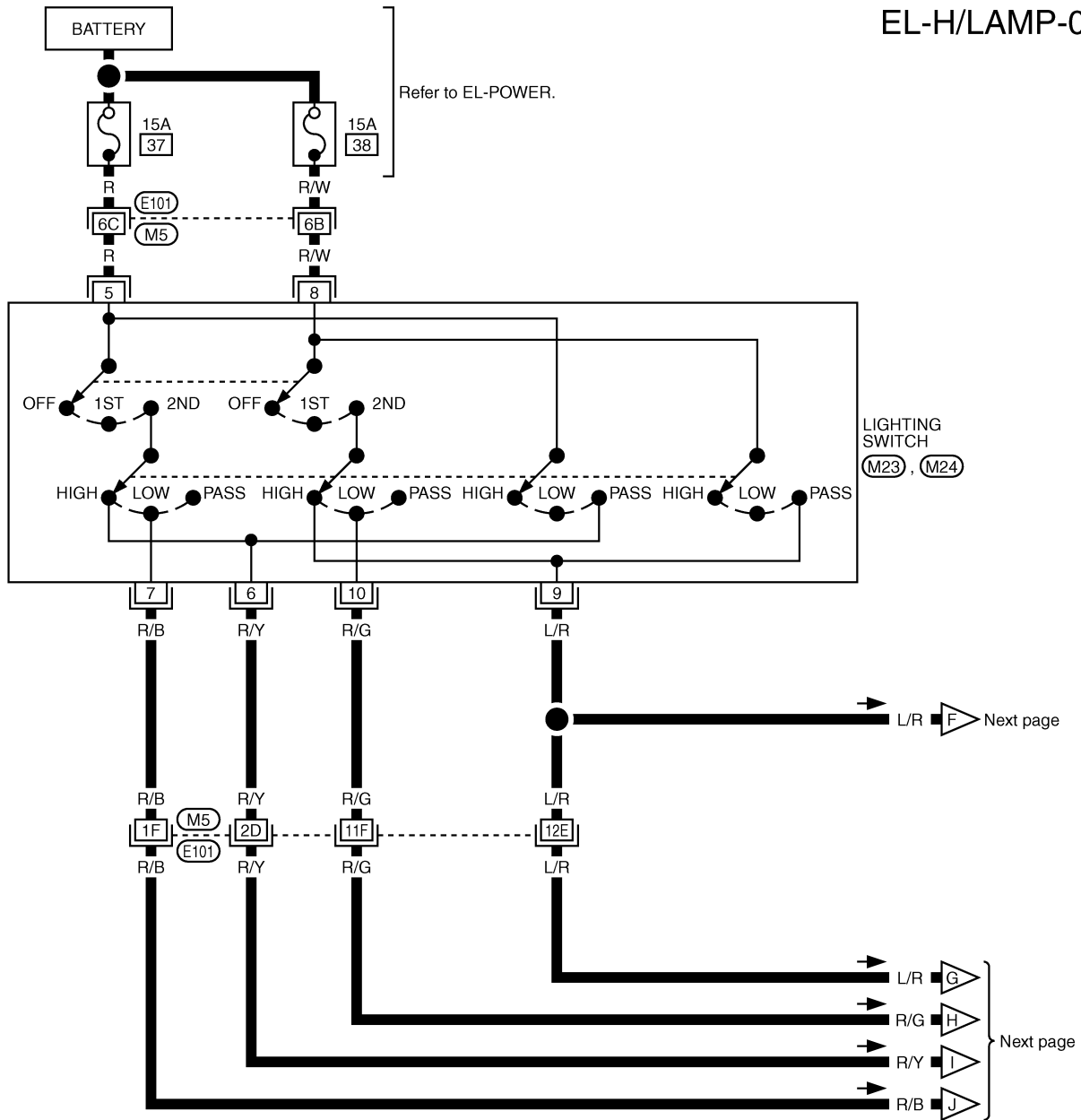

Refer to last page (Foldout page).

(M5), (E101)

HEADLAMP — Conventional Type —

Wiring Diagram — H/LAMP —/RHD Models (Cont'd)

EL-H/LAMP-04

- ⊡ : With tachometer
- ⊡ : Without tachometer
- *1 46 : ⊡
- 47 : ⊡
- *2 51 : ⊡
- 50 : ⊡

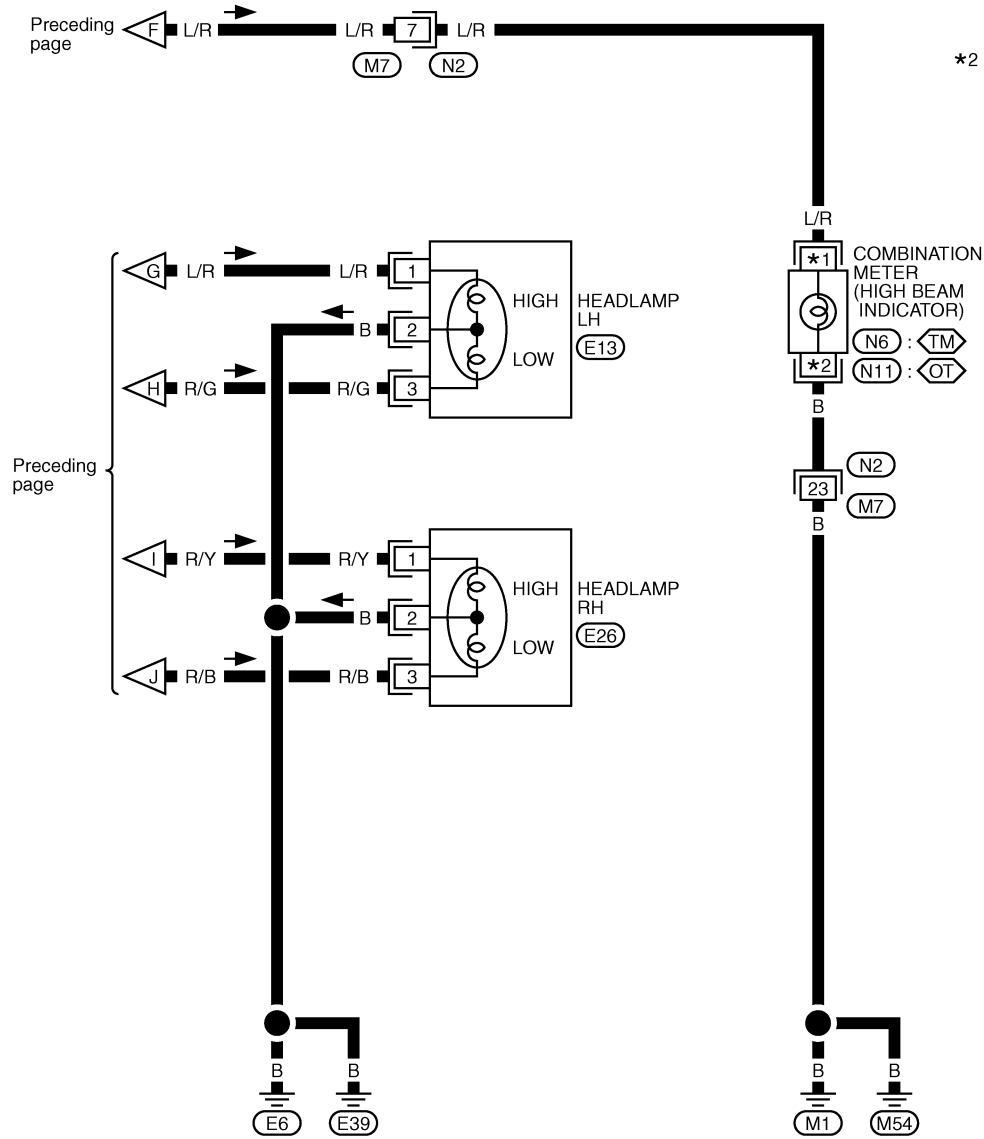

1	2	3	4	5	6	7	8	9	10	11		
12	13	14	15	16	17	18	19	20	21	22	23	24

(N2)
BR

45	46	47	48	49	50	51	52	53	54	55		
56	57	58	59	60	61	62	63	64	65	66	67	68

(N6)
BR

41	42	43	44	45	46	47	48	49	50	51		
52	53	54	55	56	57	58	59	60	61	62	63	64

(N11)
W

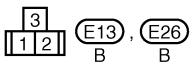

HEADLAMP — Conventional Type —

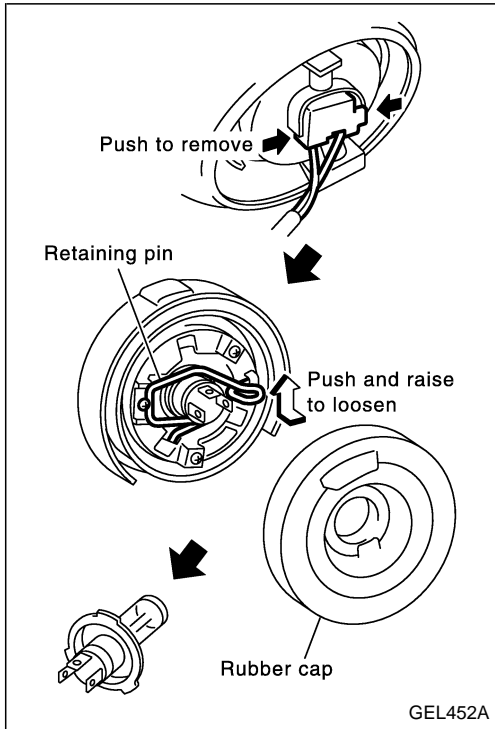

Bulb Replacement

The headlamp is a semi-sealed beam type which uses a replaceable halogen bulb. The bulb can be replaced from the engine compartment side without removing the headlamp body.

- **Grasp only the plastic base when handling the bulb. Never touch the glass envelope.**
1. Disconnect the battery cable.
 2. Disconnect the harness connector from the back side of the bulb.
 3. Pull off the rubber cap.
 4. Push and raise retaining pin to loosen it.
 5. Remove the headlamp bulb carefully. Do not shake or rotate the bulb when removing it.
 6. Install in the reverse order of removal.

CAUTION:

Do not leave headlamp reflector without bulb for a long period of time. Dust, moisture, smoke, etc. entering headlamp body may affect the performance of the headlamp. Remove headlamp bulb from the headlamp reflector just before a replacement bulb is installed.

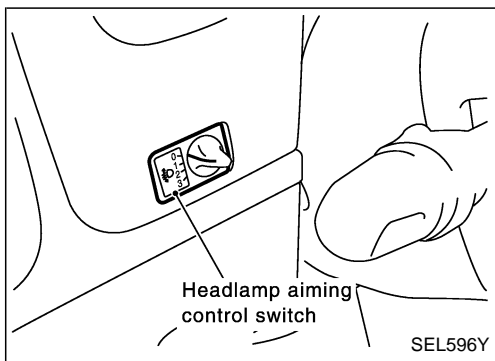

Aiming Adjustment

When performing headlamp aiming adjustment, use an aiming machine, aiming wall screen or headlamp tester. Aimers should be in good repair, calibrated and operated in accordance with respective operation manuals.

If any aimer is not available, aiming adjustment can be done as follows:

For details, refer to the regulations in your own country.

- a. **Keep all tires inflated to correct pressures.**
- b. **Place vehicle and tester on one and same flat surface.**
- c. **See that there is no-load in vehicle (coolant, engine oil filled up to correct level and full fuel tank) other than the driver (or equivalent weight placed in driver's position).**

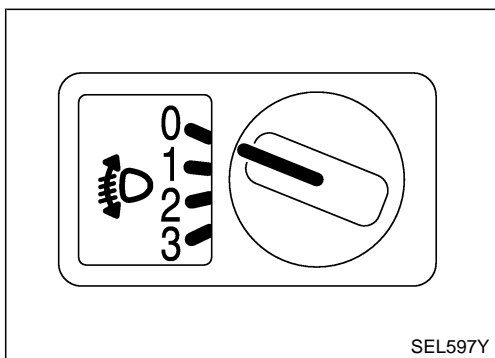

CAUTION:

Be sure aiming switch is set to "0" when performing aiming adjustment on vehicles equipped with headlamp aiming control.

HEADLAMP — Conventional Type —

Multi-beam type headlamp

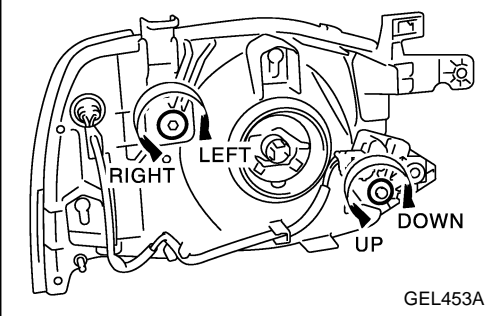

Non-multi-beam type headlamp

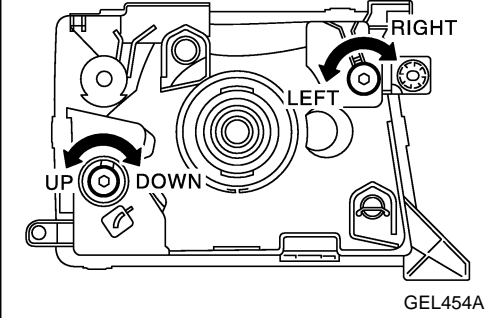

Low Beam

1. Turn headlamp low beam on.
2. Use adjusting screws to perform aiming adjustment.
 - First tighten the adjusting screw all the way and then make adjustment by loosening the screw.

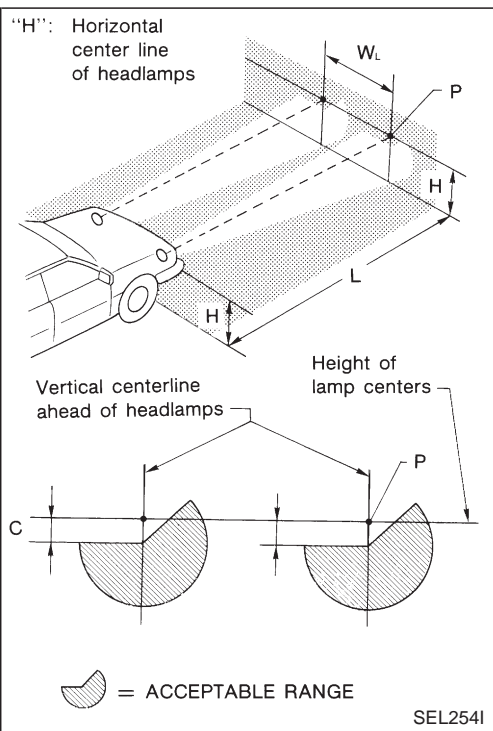

- Adjust headlamps so that main axis of light is parallel to center line of body and is aligned with point P shown in illustration.
 - Figure to the left shows headlamp aiming pattern for driving on right side of road; for driving on left side of road, aiming pattern is reversed.
 - Dotted lines in illustration show center of headlamp.
- "H": Horizontal center line of headlamps
 " W_L ": Distance between each headlamp center
 "L": 5,000 mm (196.85 in)
 "C": 65 mm (2.56 in)

HEADLAMP — Daytime Light System —

Wiring Diagram — DTRL —

EL-DTRL-01

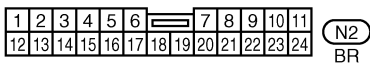
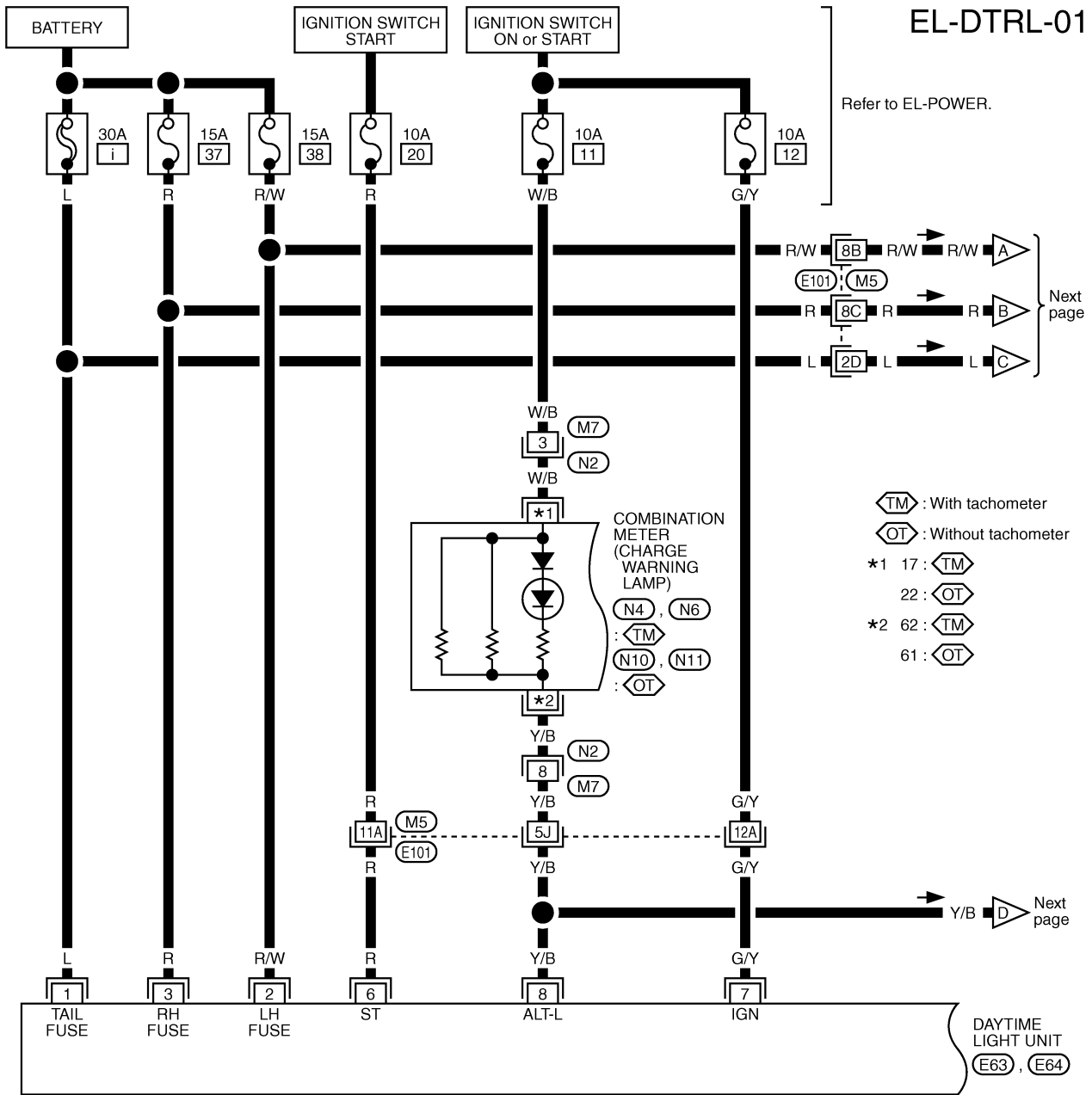

Refer to last page (Foldout page).

(M5), (E101)

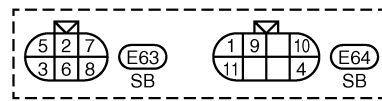
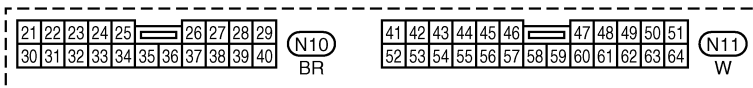
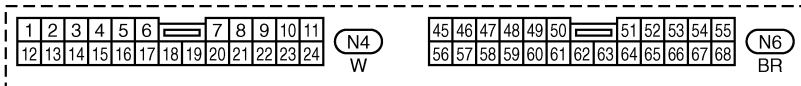

HEADLAMP — Daytime Light System —

Wiring Diagram — DTRL — (Cont'd)

EL-DTRL-02

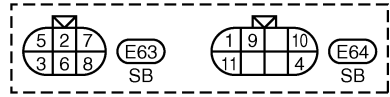
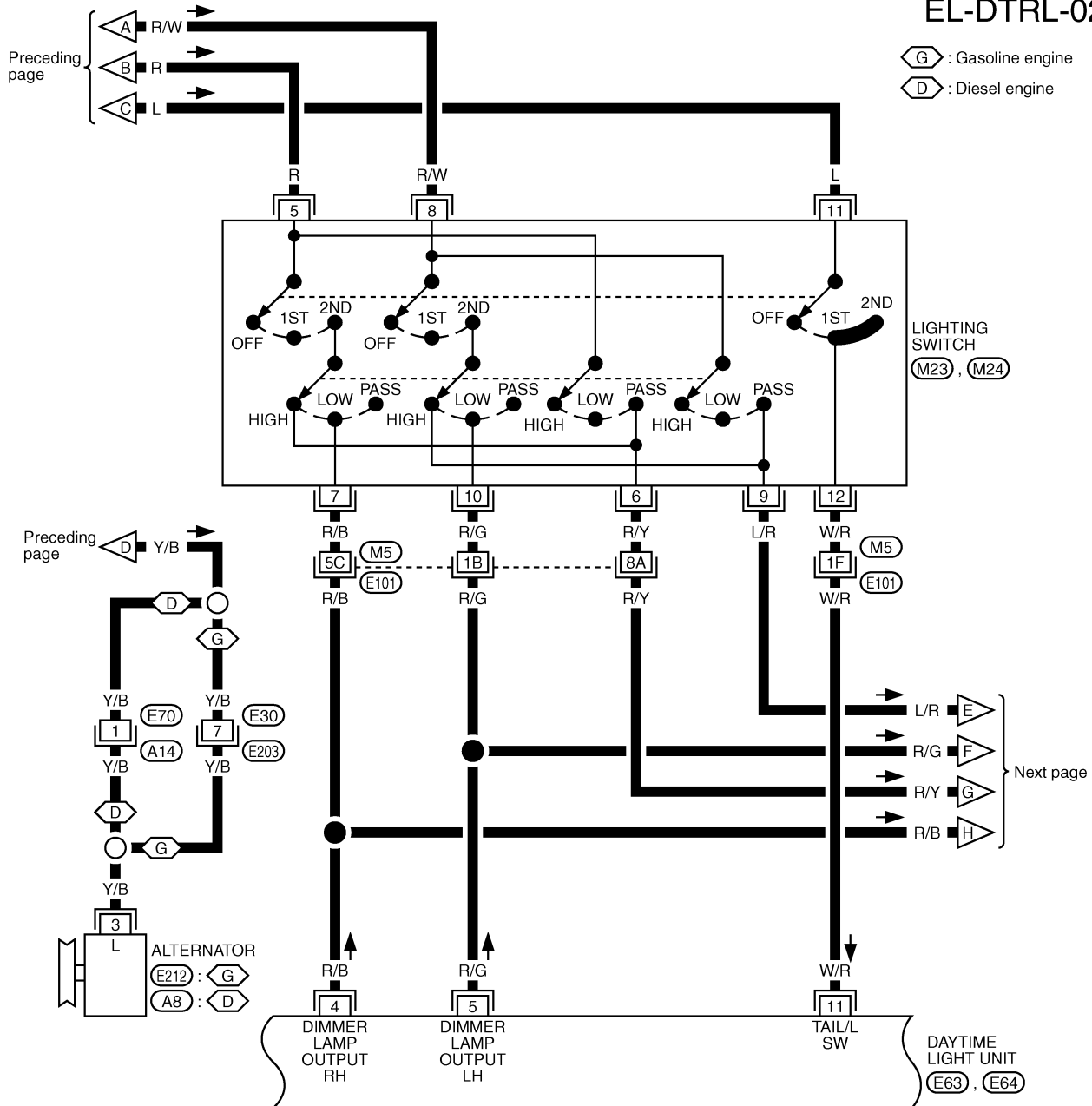

Refer to last page (Foldout page).

M5, E101

HEADLAMP — Daytime Light System —

Wiring Diagram — DTRL — (Cont'd)

EL-DTRL-03

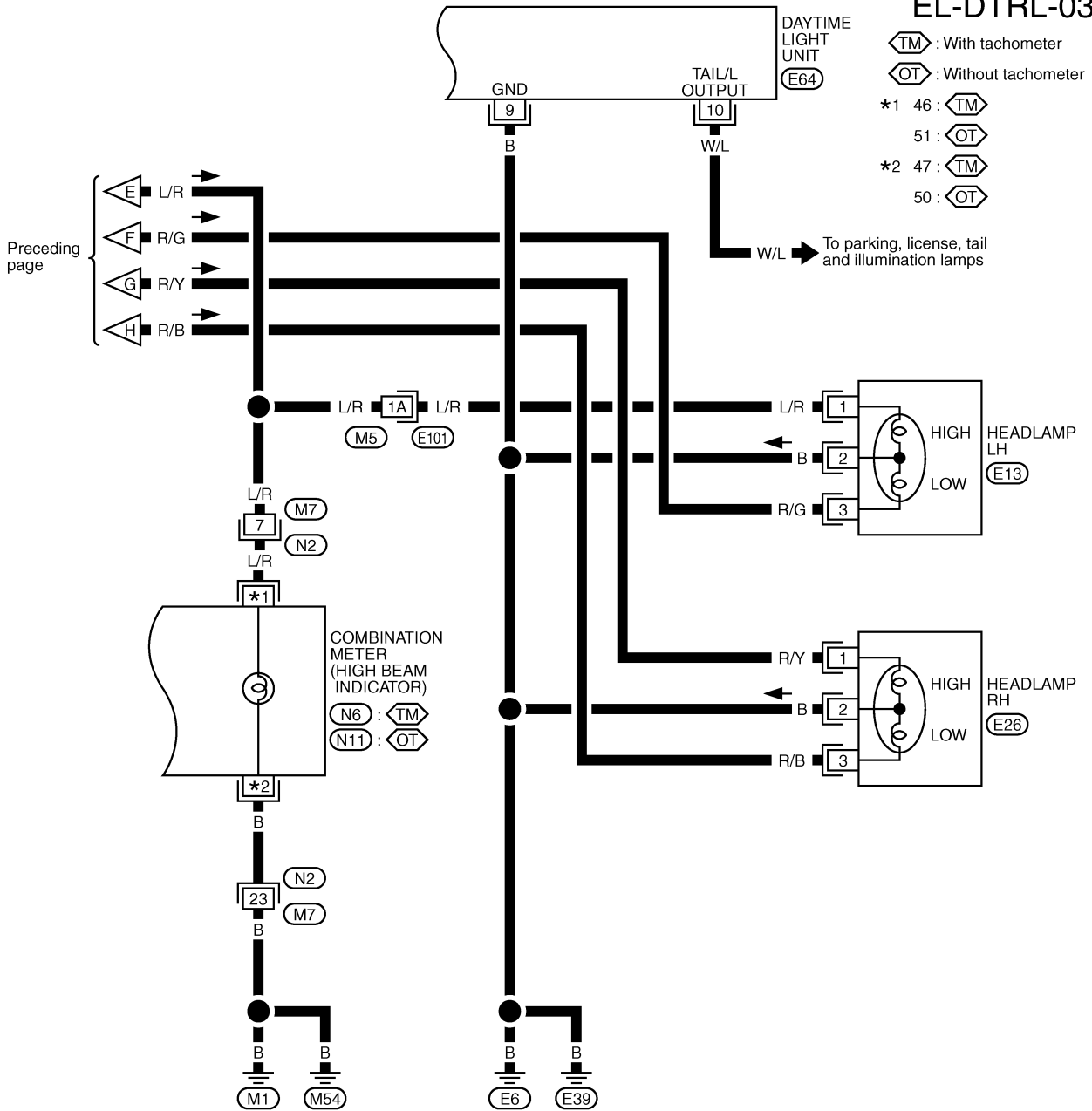

- Ⓜ : With tachometer
- Ⓞ : Without tachometer
- *1 46 : Ⓜ
- 51 : Ⓞ
- *2 47 : Ⓜ
- 50 : Ⓞ

1	2	3	4	5	6	7	8	9	10	11		
12	13	14	15	16	17	18	19	20	21	22	23	24

(N2) BR

45	46	47	48	49	50	51	52	53	54	55		
56	57	58	59	60	61	62	63	64	65	66	67	68

(N6) BR

41	42	43	44	45	46	47	48	49	50	51		
52	53	54	55	56	57	58	59	60	61	62	63	64

(N11) W

3	
1	2

(E13) B, (E26) B

1	9	10
11		4

(E64) SB

Refer to last page (Foldout page).

(M5), (E101)

HEADLAMP — Daytime Light System —

Bulb Replacement

For bulb replacement, refer to “HEADLAMP — Conventional Type —” EL-3027.

Aiming Adjustment

For aiming adjustment, refer to “HEADLAMP — Conventional Type —” EL-3027.

HEADLAMP — Dim-dip Lamp System —

Wiring Diagram — DIMDIP —

EL-DIMDIP-01

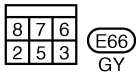
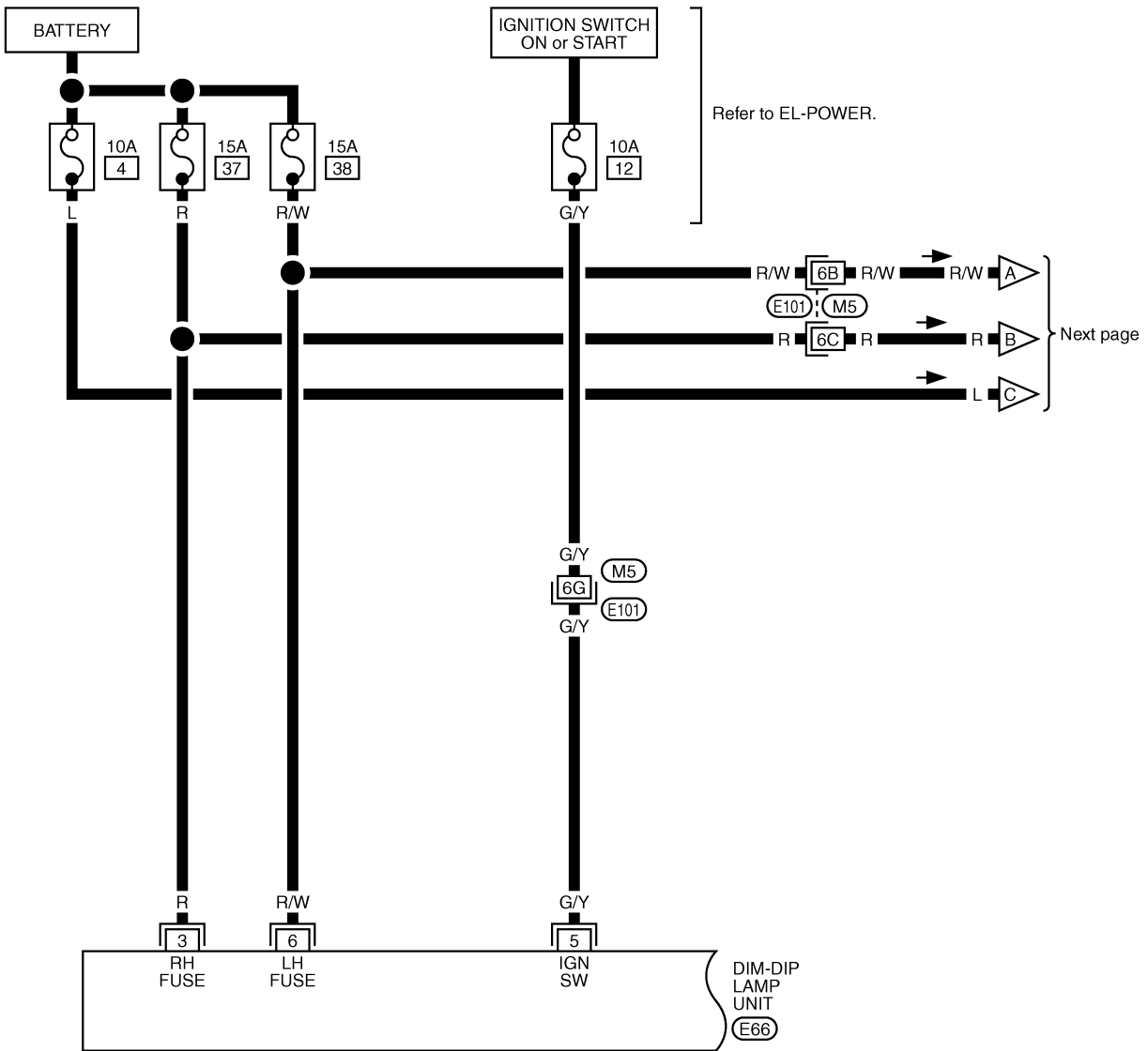

Refer to last page (Foldout page).

(M5), (E101)

HEADLAMP — Dim-dip Lamp System —

Wiring Diagram — DIMDIP — (Cont'd)

EL-DIMDIP-02

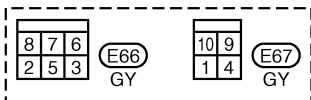
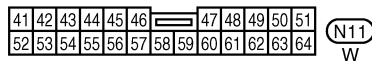
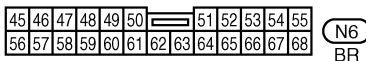
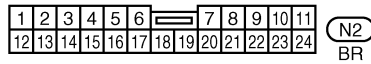
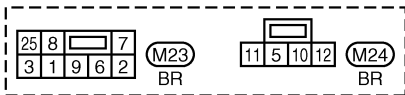
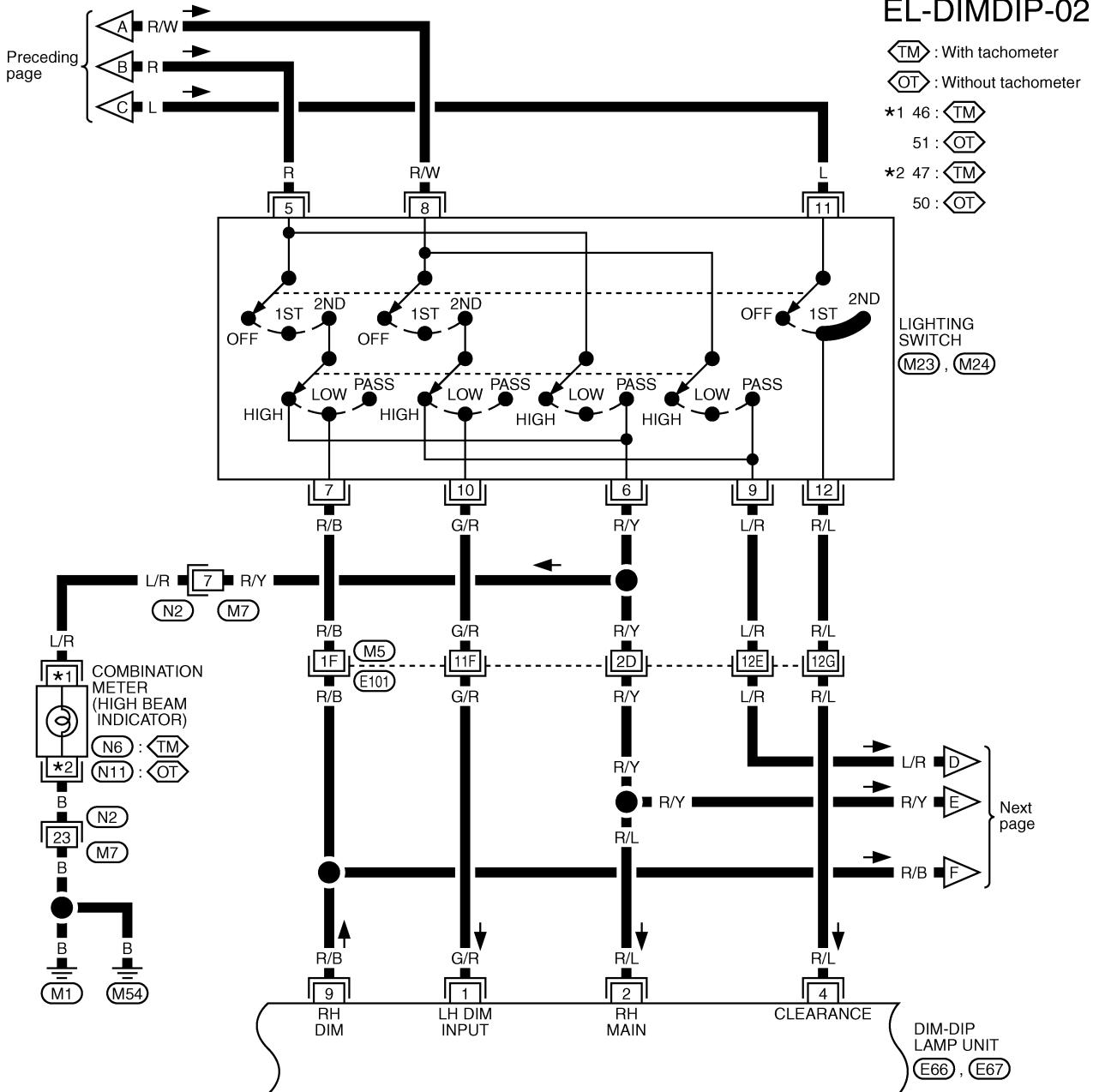

Refer to last page (Foldout page).

M5, E101

HEADLAMP — Dim-dip Lamp System —

Wiring Diagram — DIMDIP — (Cont'd)

EL-DIMDIP-03

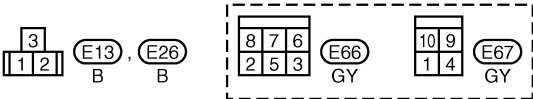
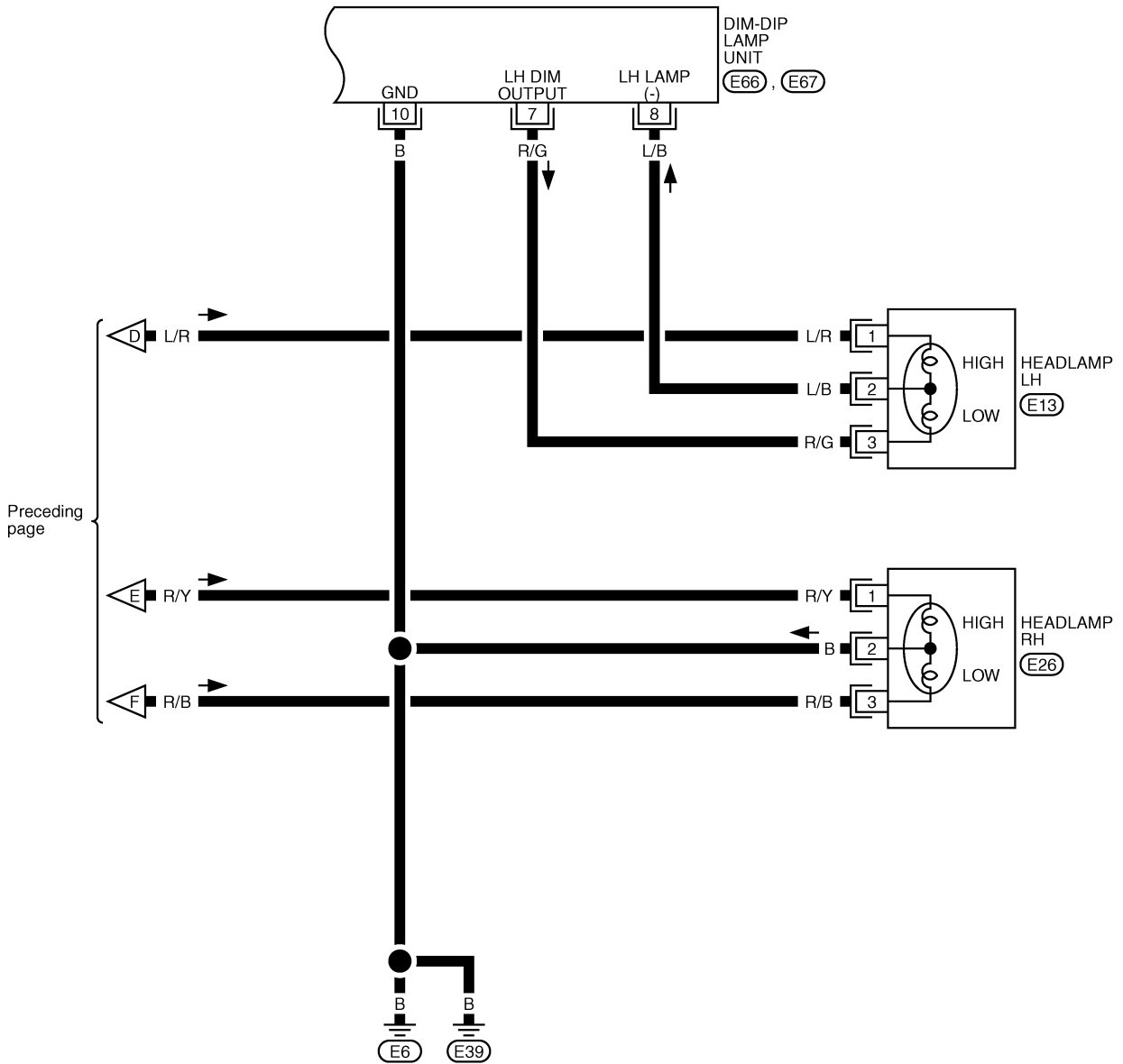

Bulb Replacement

For bulb replacement, refer to EL-3027.

Aiming Adjustment

For aiming adjustment, refer to EL-3027.

HEADLAMP — Headlamp Aiming Control —

Wiring Diagram — H/AIM —

EL-H/AIM-01

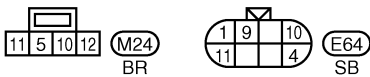
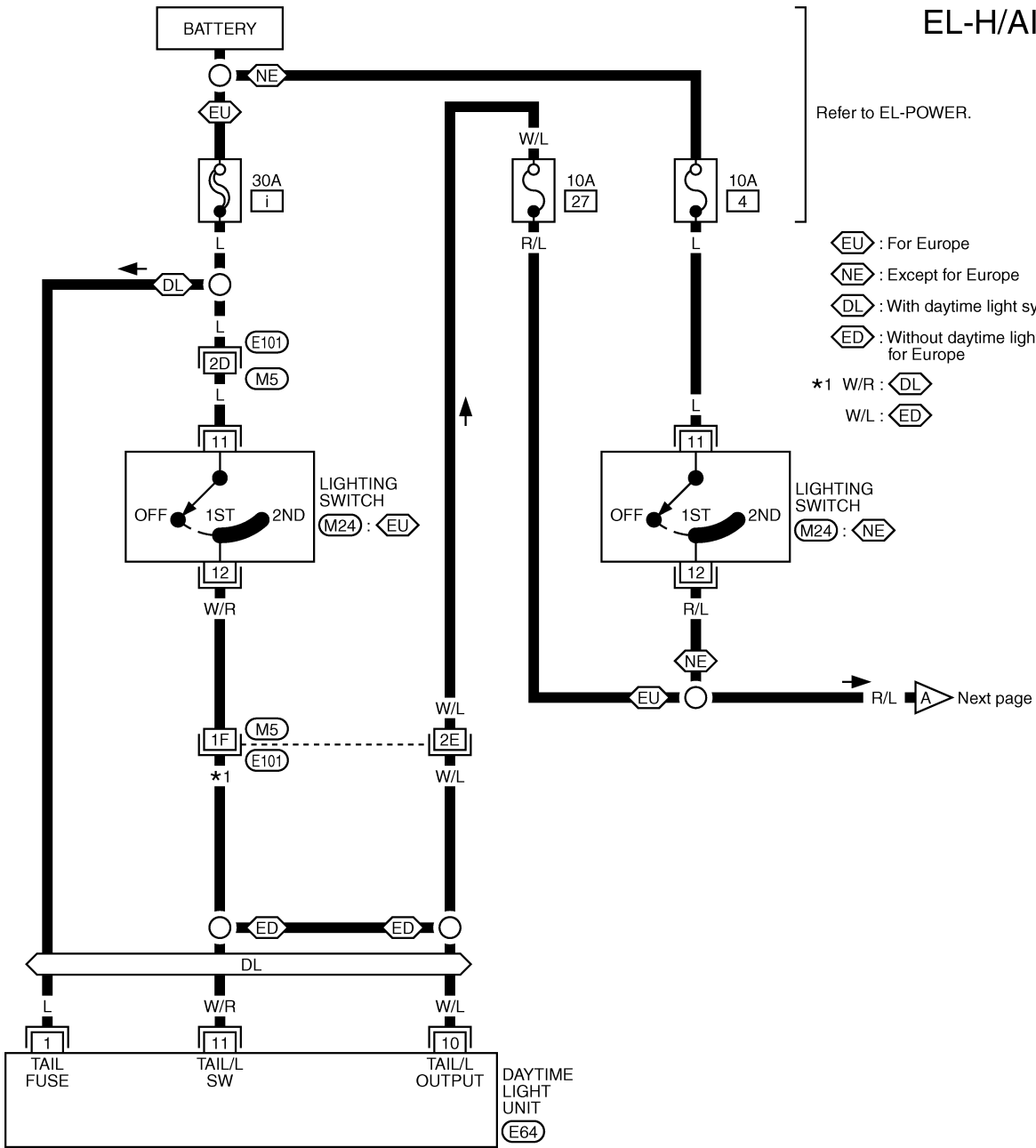

Refer to last page (Foldout page).

(M5), (E101)

HEADLAMP — Headlamp Aiming Control —

Wiring Diagram — H/AIM — (Cont'd)

EL-H/AIM-02

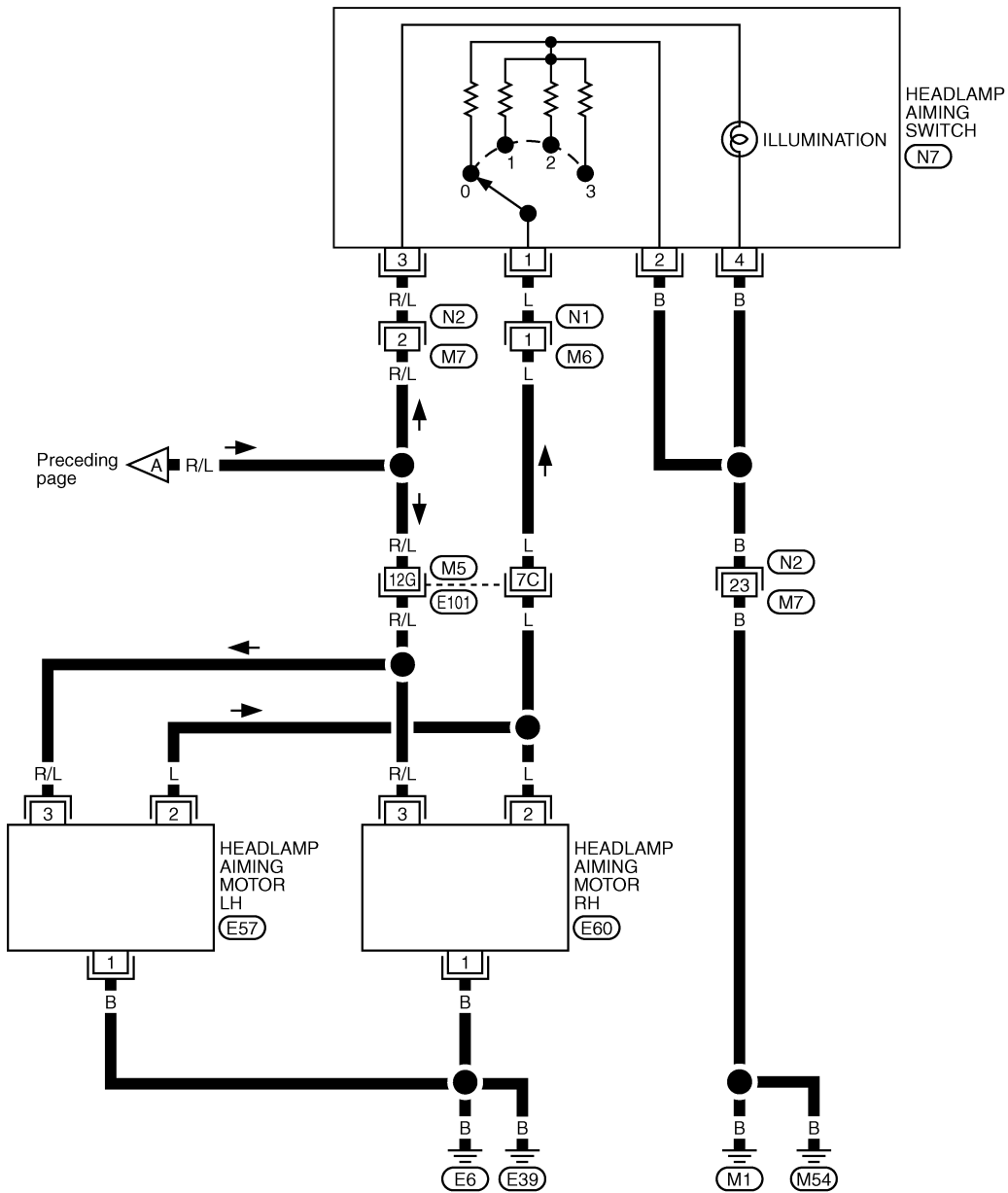

1	2	3	4	5	6	7	8	9	10	11		
12	13	14	15	16	17	18	19	20	21	22	23	24

(N1) : (N2)
W BR



(N7)
W



(E57), (E60)

Refer to last page (Foldout page).

(M5), (E101)

PARKING, LICENSE AND TAIL LAMPS

Wiring Diagram — TAIL/L —/Except LHD Models for Europe

EL-TAIL/L-01

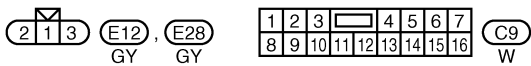
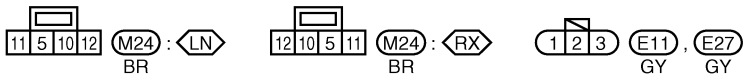
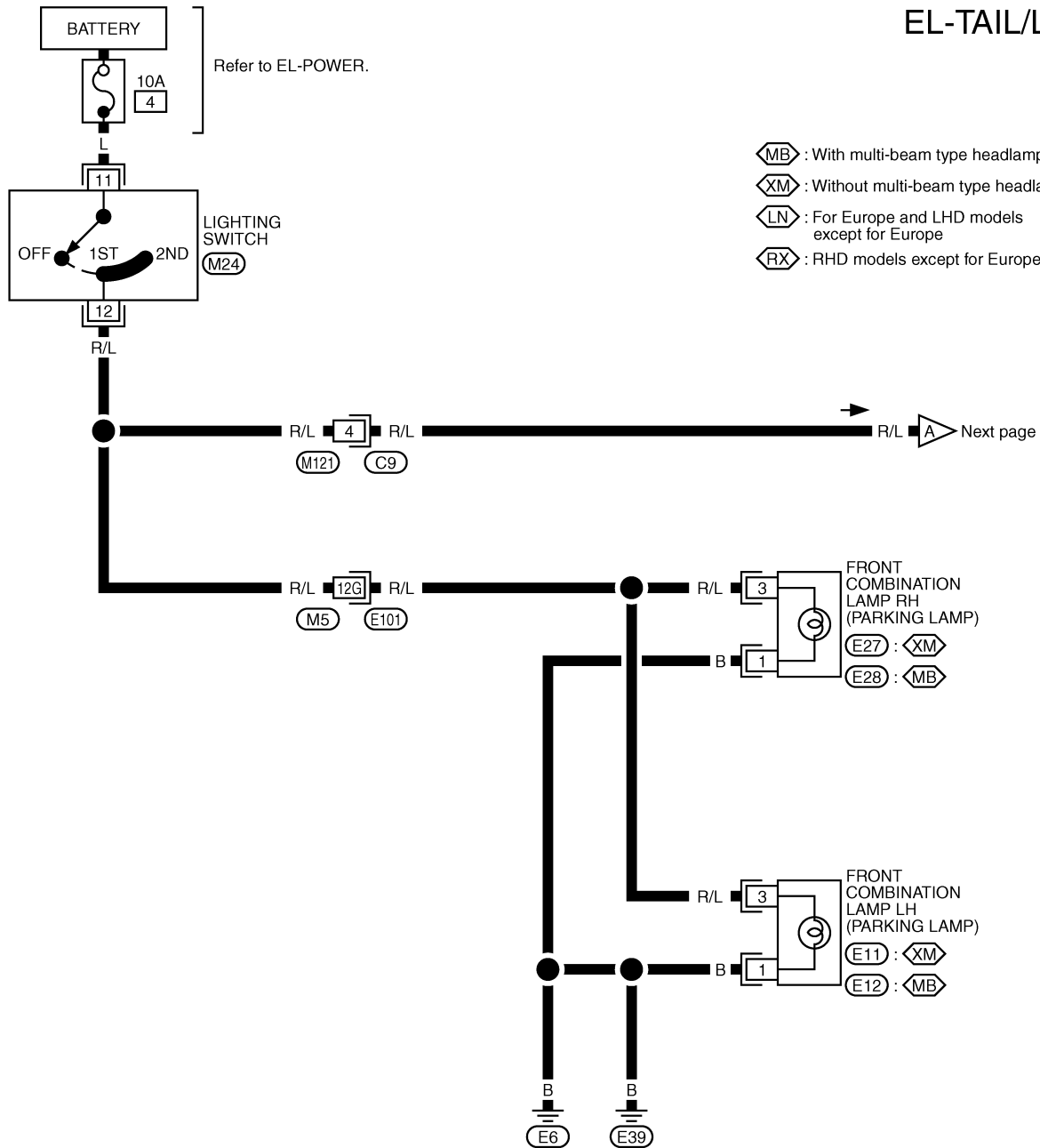

Refer to last page (Foldout page).

(M5) (E101)

PARKING, LICENSE AND TAIL LAMPS

Wiring Diagram — TAIL/L —/Except LHD Models for Europe (Cont'd)

EL-TAIL/L-02

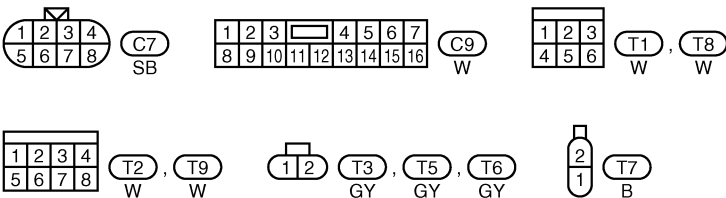
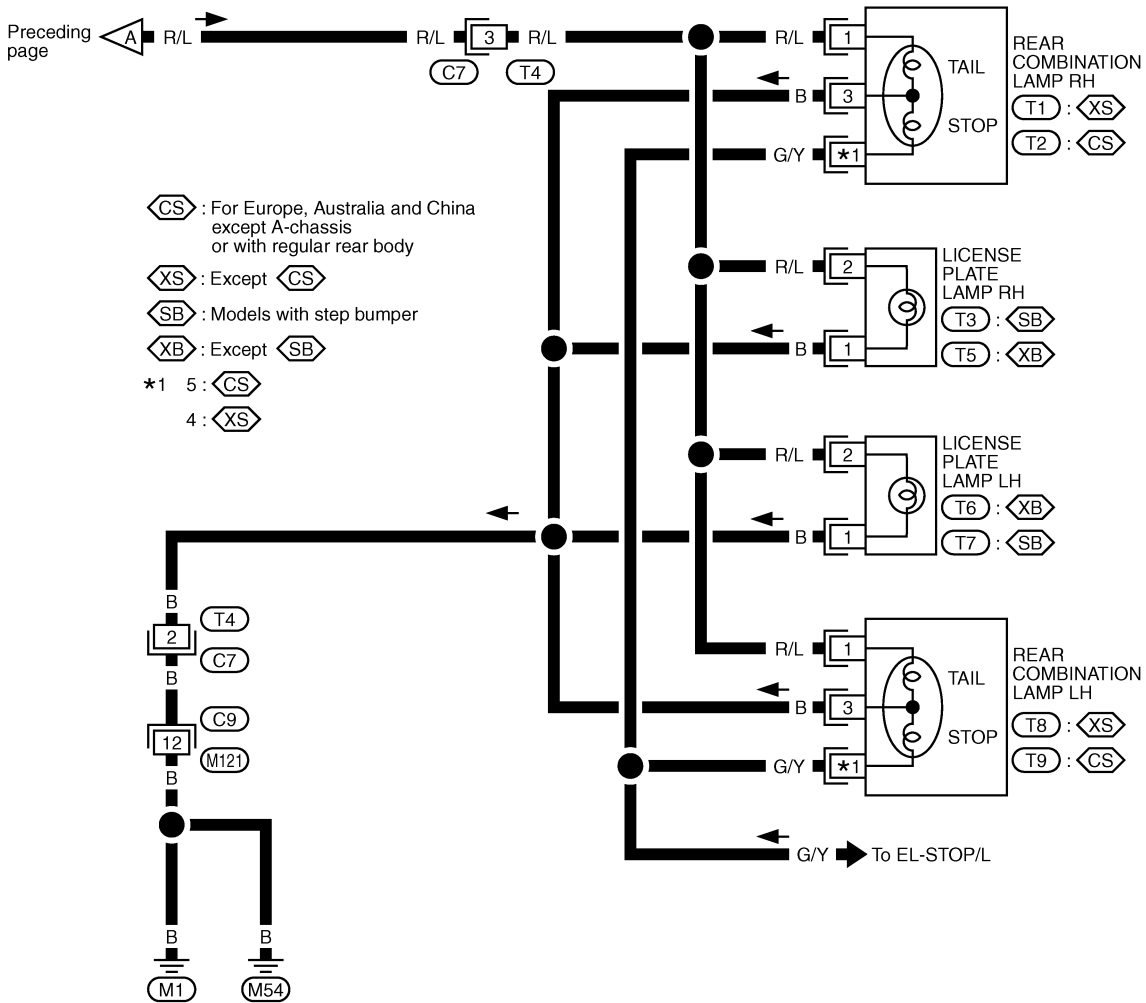

PARKING, LICENSE AND TAIL LAMPS

Wiring Diagram — TAIL/L —/LHD Models for Europe

EL-TAIL/L-03

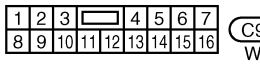
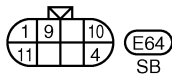
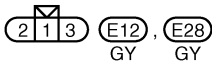
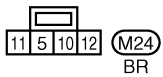
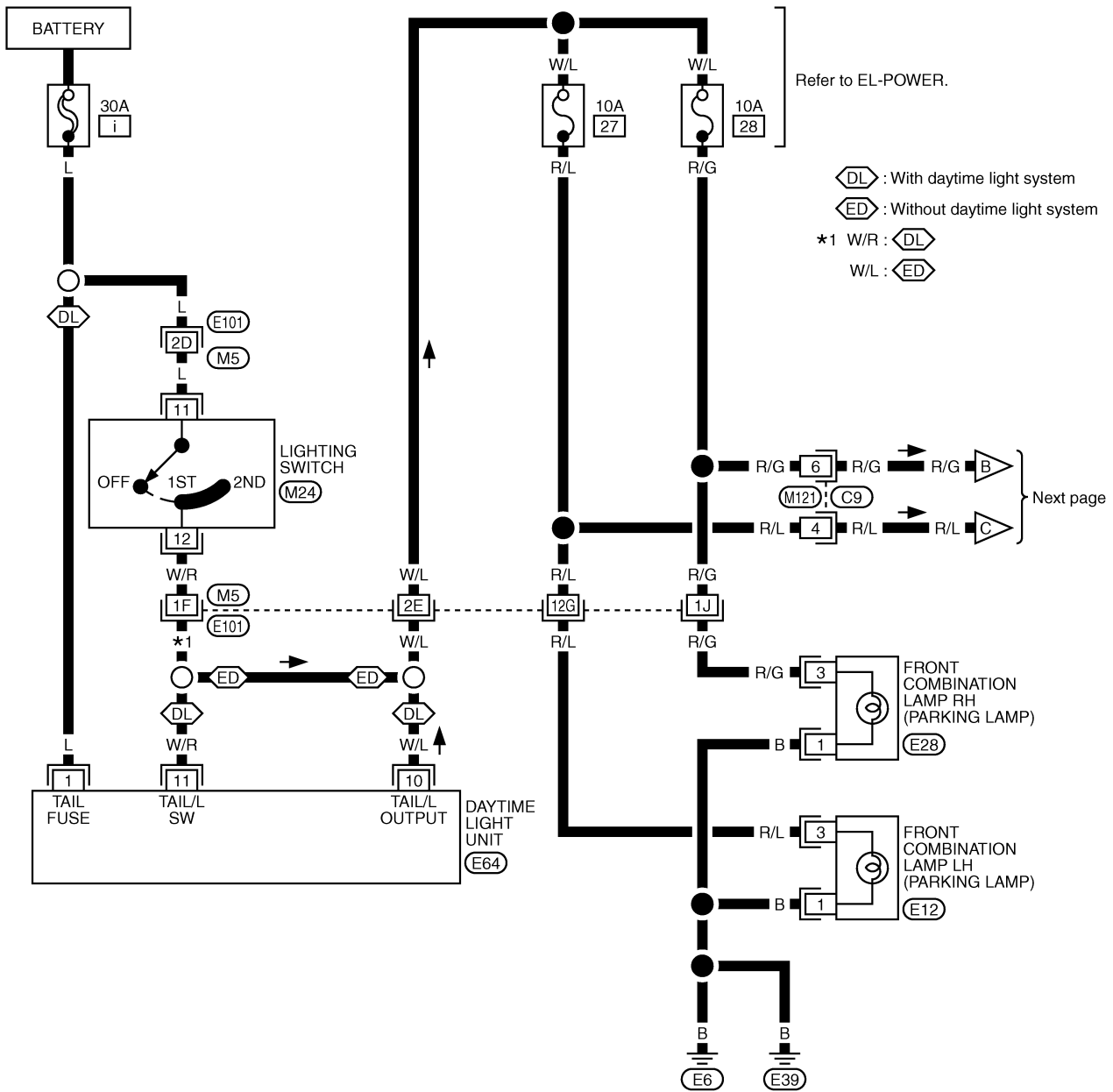

Refer to last page (Foldout page).



PARKING, LICENSE AND TAIL LAMPS

Wiring Diagram — TAIL/L —/LHD Models for Europe (Cont'd)

EL-TAIL/L-04

- ⬡CH⬡ : A-chassis models
- ⬡XH⬡ : Except A-chassis models
- ⬡SB⬡ : Models with step bumper
- ⬡XB⬡ : Except ⬡SB⬡
- *1 4 : ⬡CH⬡
- 5 : ⬡XH⬡

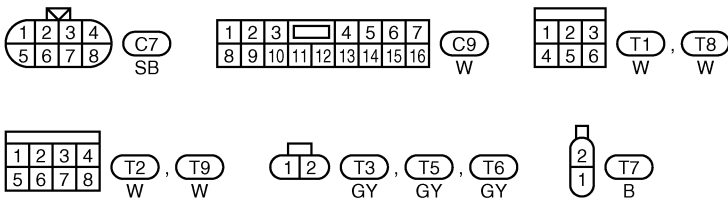
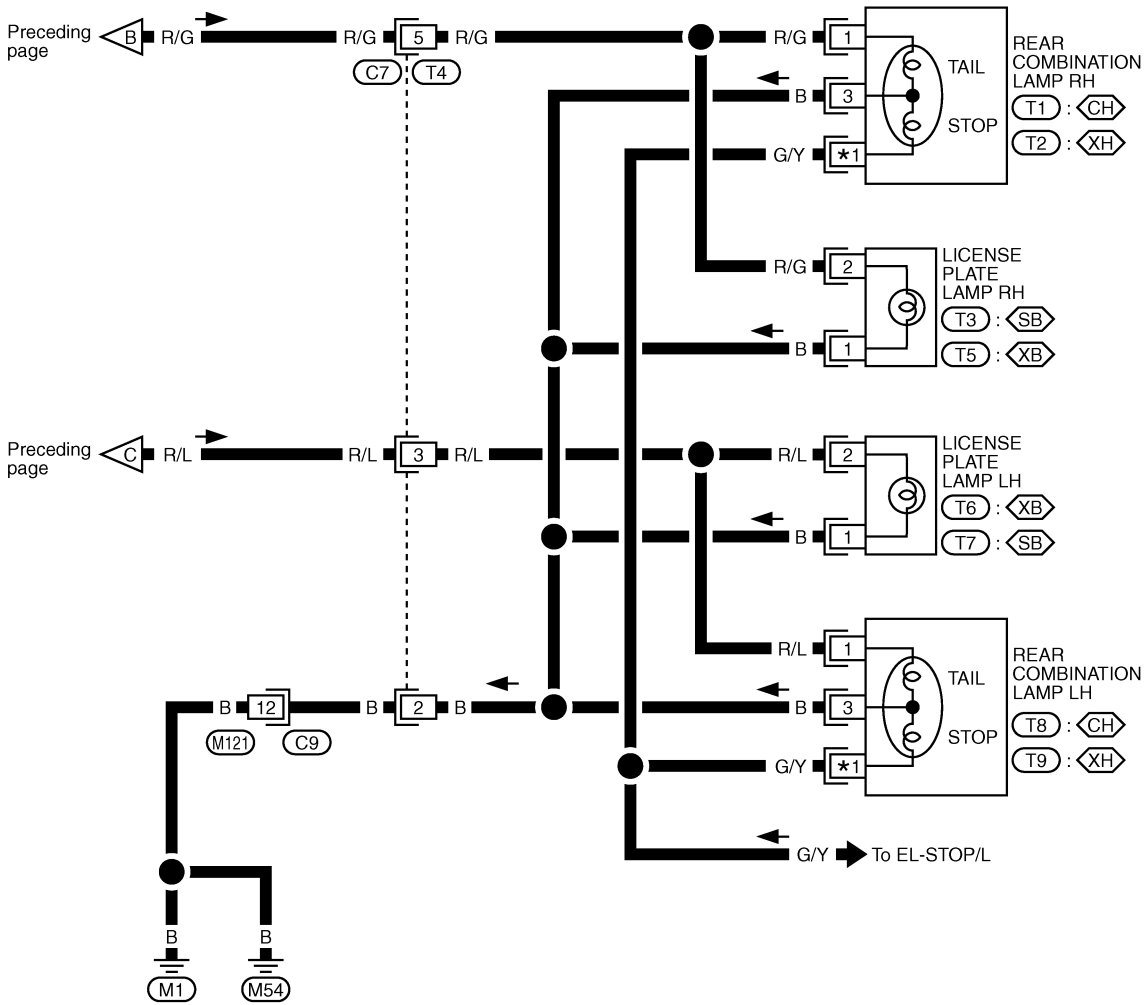

STOP LAMP

Wiring Diagram — STOP/L —

EL-STOP/L-01

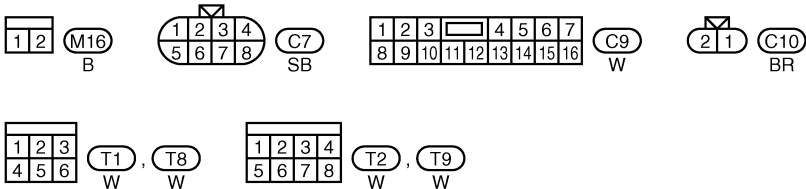
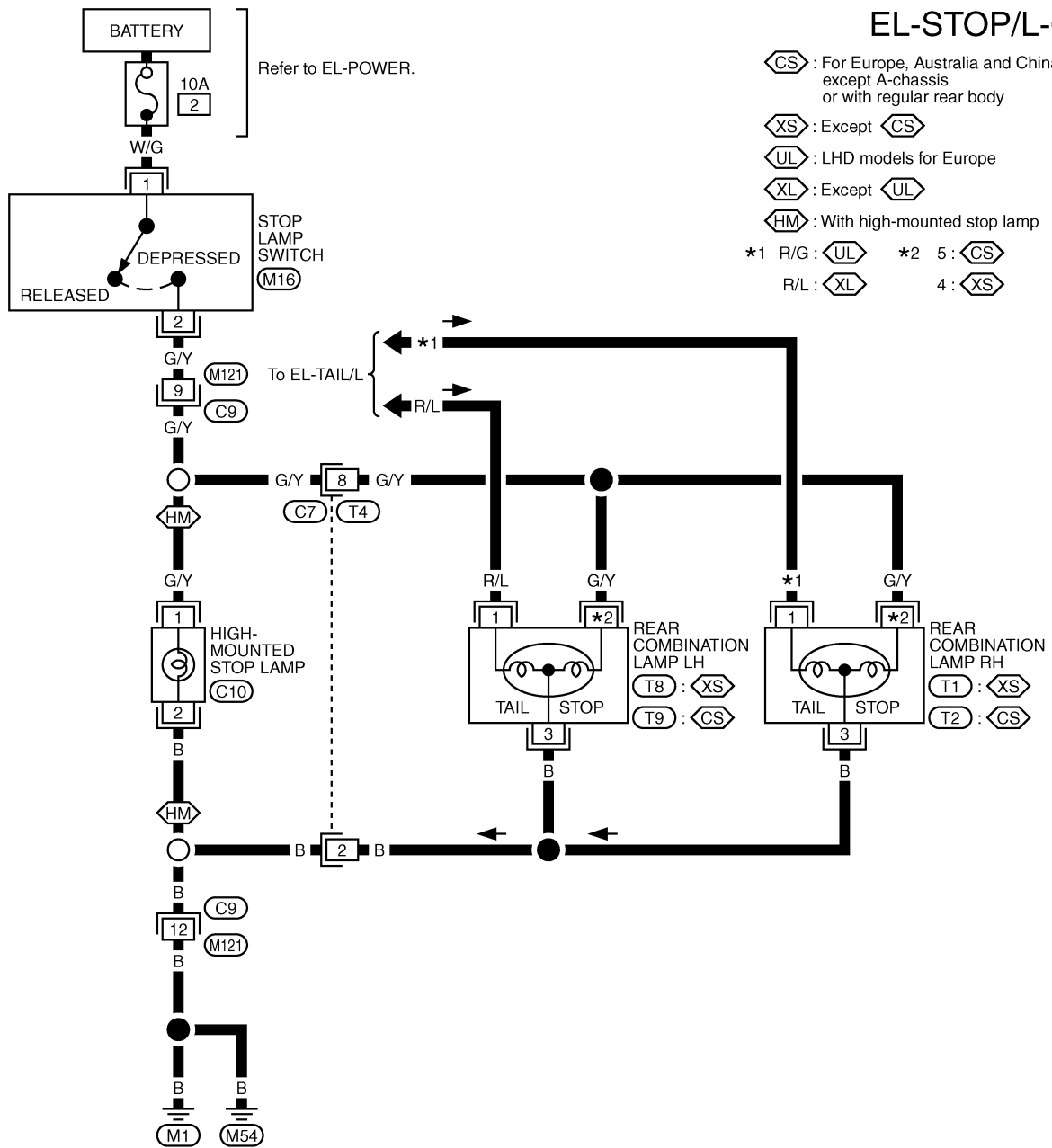

BACK-UP LAMP

Wiring Diagram — BACK/L —/M/T Models

EL-BACK/L-01

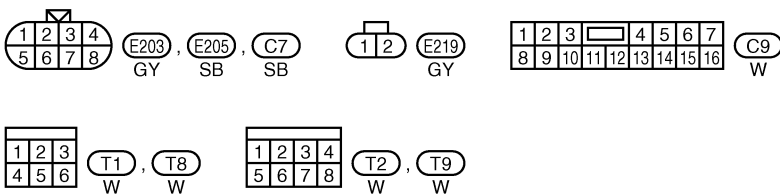
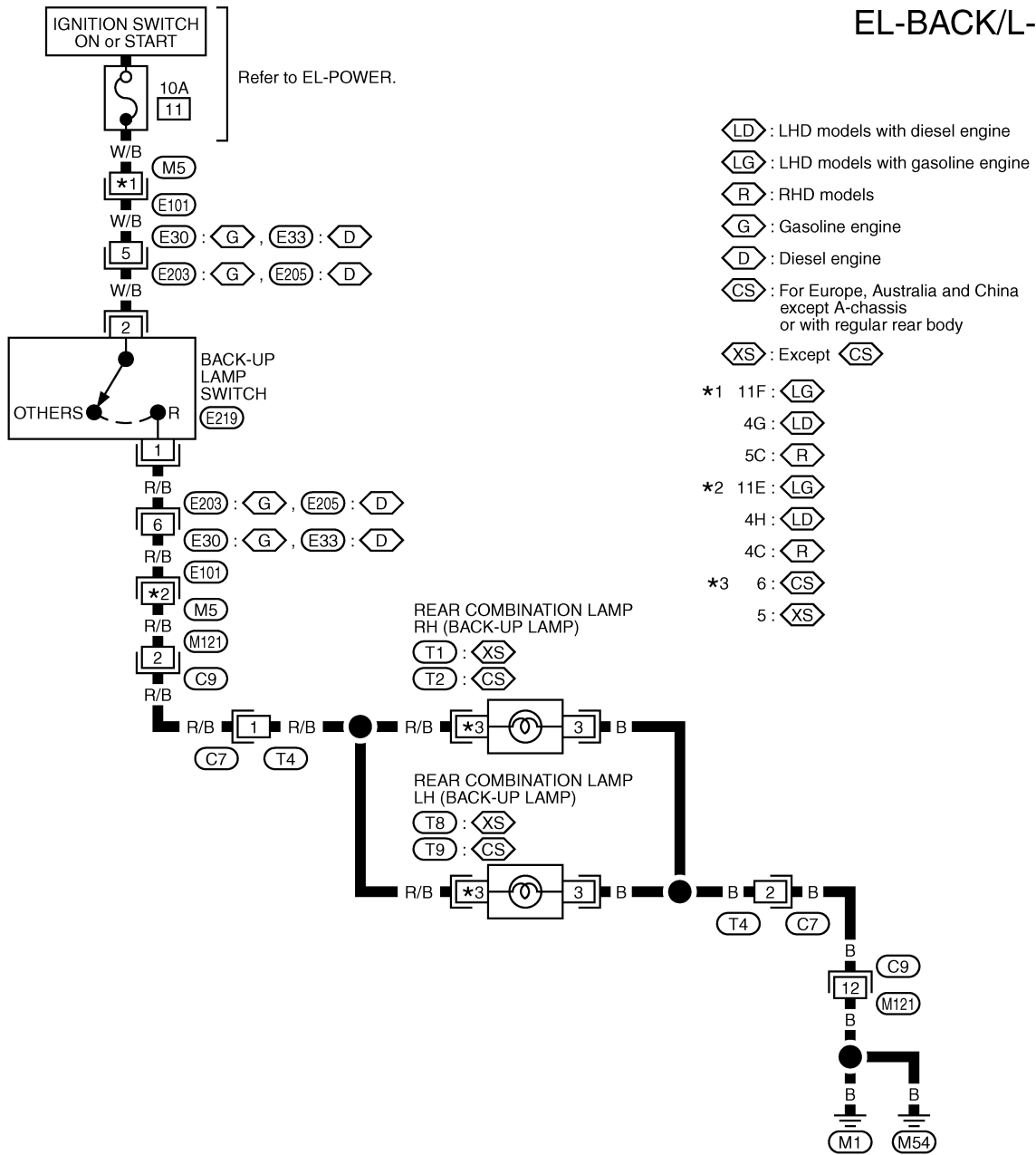

Refer to last page (Foldout page).

<M5> , <E101>

REAR FOG LAMP

Wiring Diagram — R/FOG —/LHD Models

EL-R/FOG-01

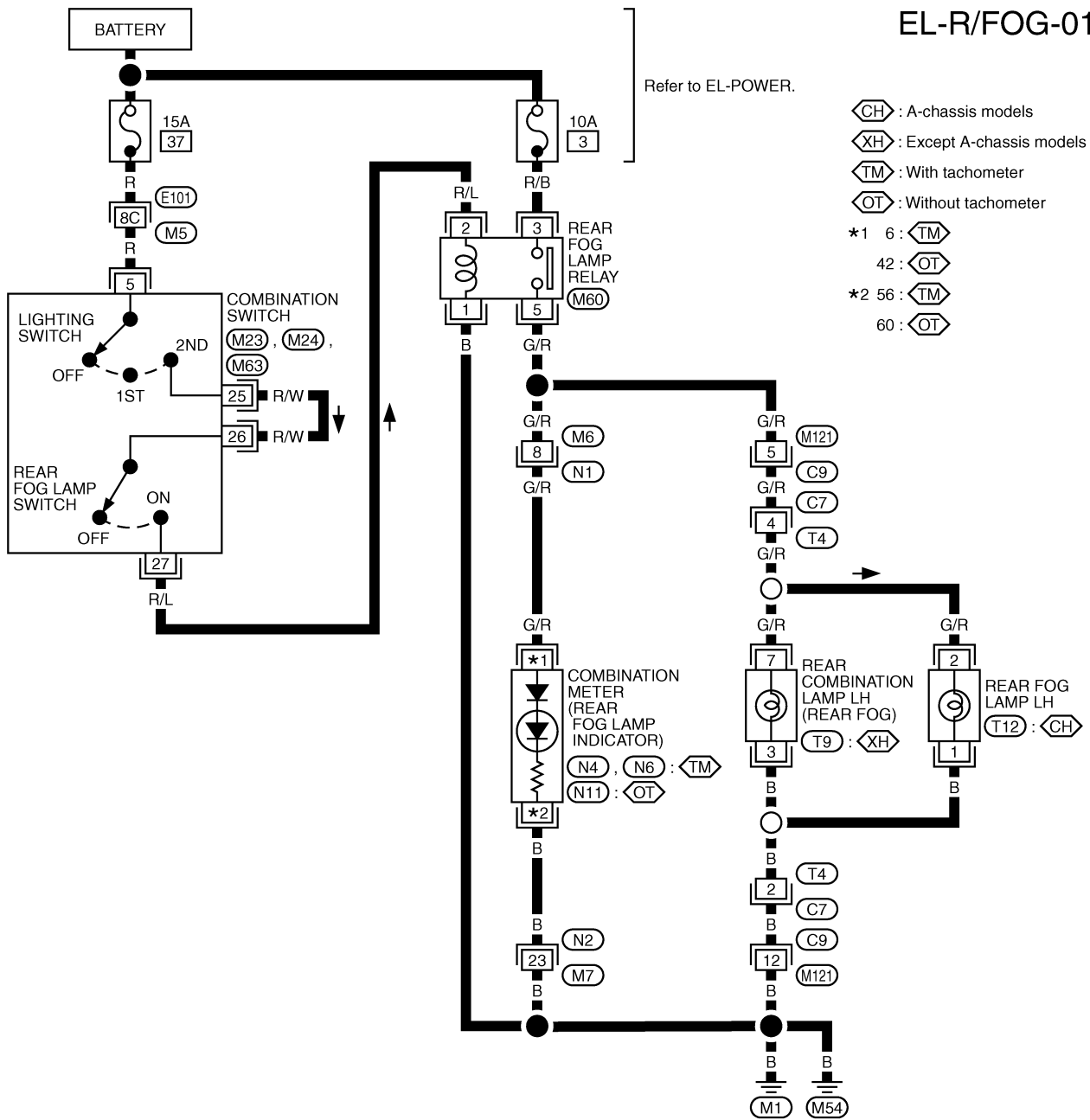

Refer to EL-POWER.

- ◊CH : A-chassis models
- ◊XH : Except A-chassis models
- ◊TM : With tachometer
- ◊OT : Without tachometer
- *1 6 : ◊TM
- 42 : ◊OT
- *2 56 : ◊TM
- 60 : ◊OT

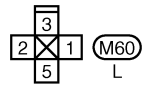
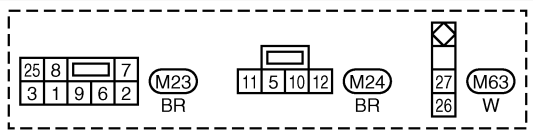

Refer to last page (Foldout page).
◊M5, ◊E101

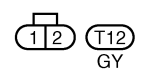
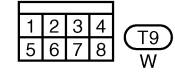
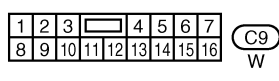
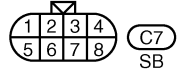
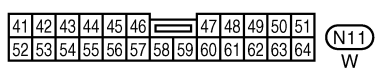
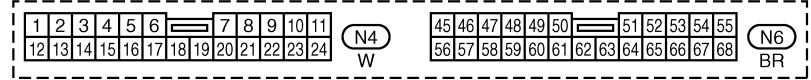
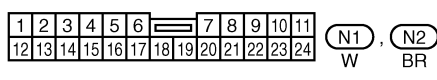

REAR FOG LAMP

Wiring Diagram — R/FOG —/RHD Models

EL-R/FOG-02

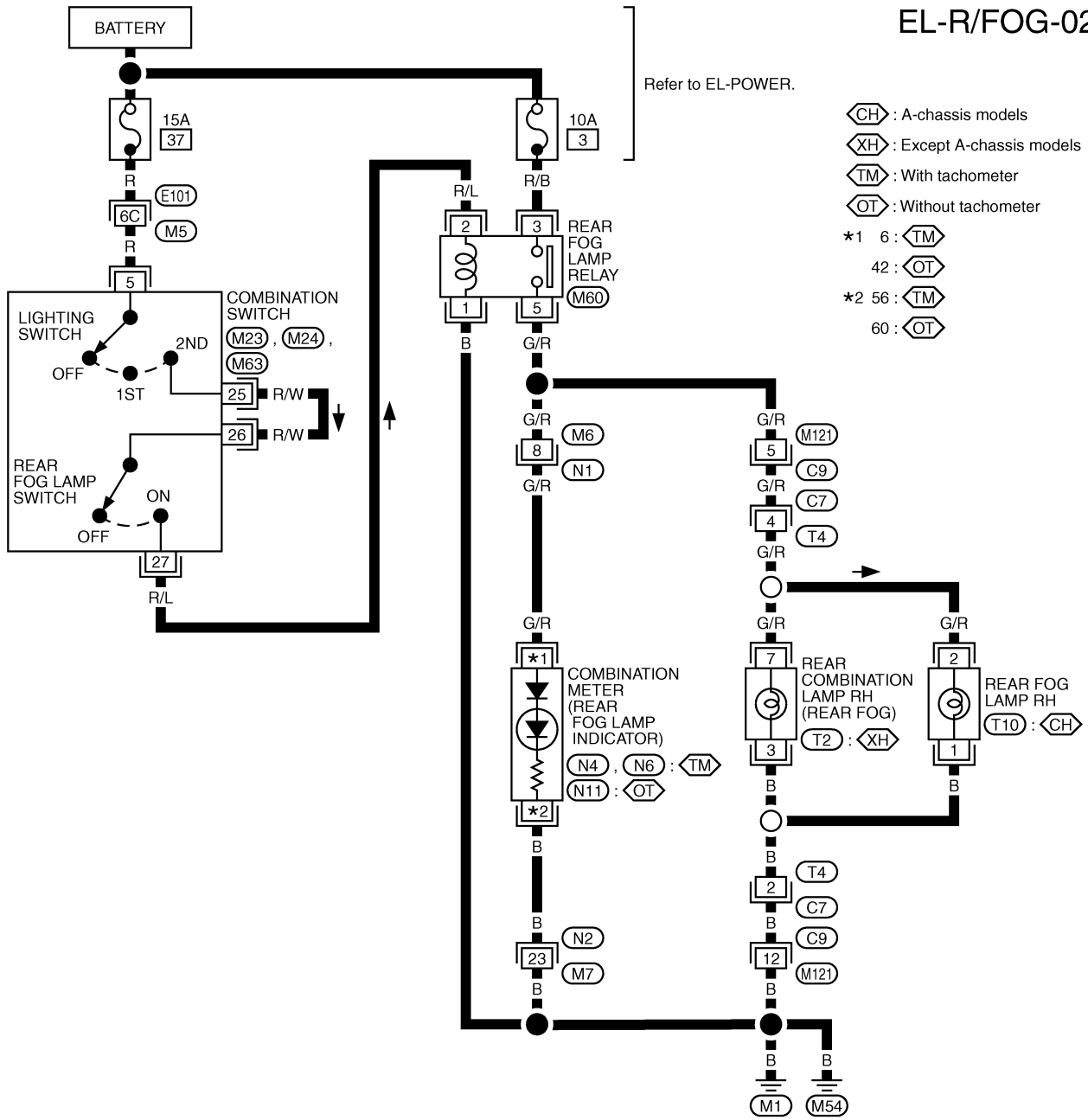

Refer to EL-POWER.

- ⬡CH⬢ : A-chassis models
- ⬡XH⬢ : Except A-chassis models
- ⬡TM⬢ : With tachometer
- ⬡OT⬢ : Without tachometer
- *1 6 : ⬡TM⬢
- 42 : ⬡OT⬢
- *2 56 : ⬡TM⬢
- 60 : ⬡OT⬢

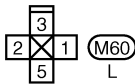
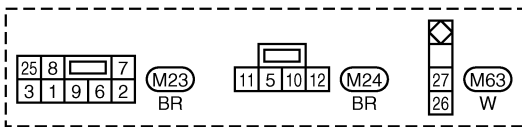

Refer to last page (Foldout page).

⬡M5⬢, ⬡E101⬢

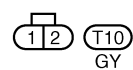
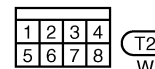
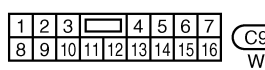
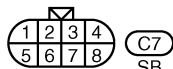
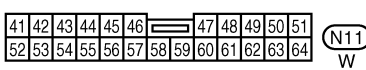
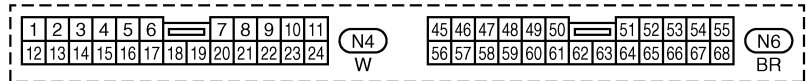
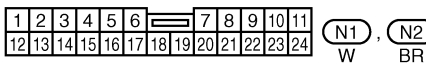

TURN SIGNAL AND HAZARD WARNING LAMPS

Wiring Diagram — TURN —

EL-TURN-01

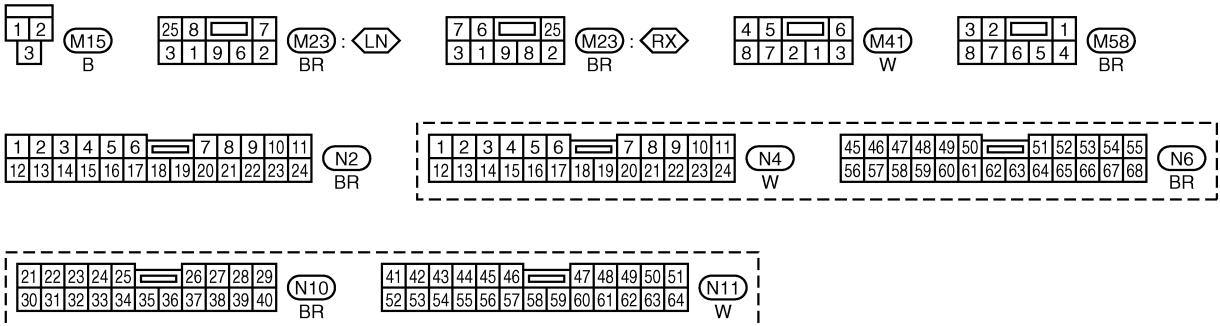
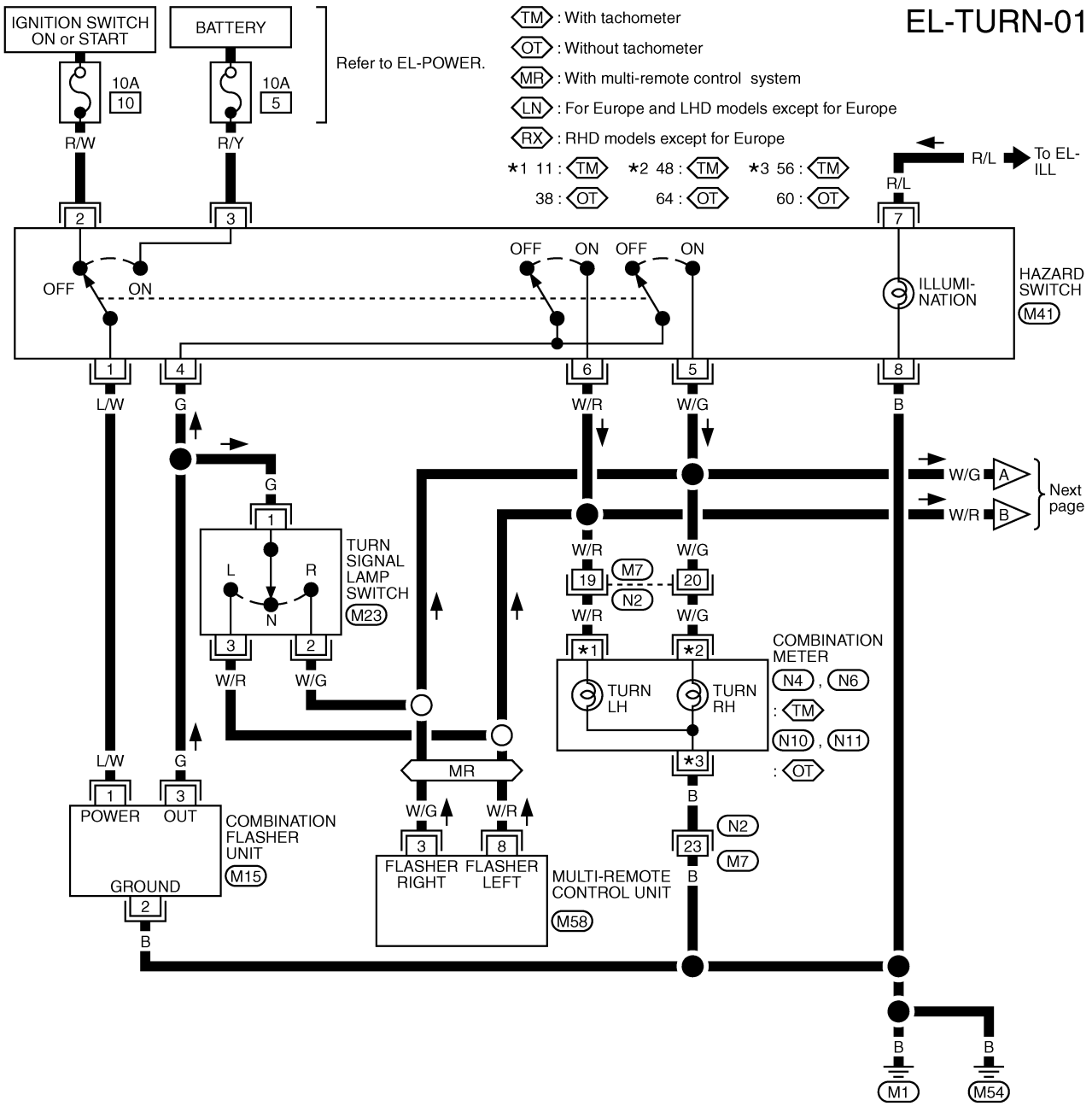

TURN SIGNAL AND HAZARD WARNING LAMPS

Wiring Diagram — TURN — (Cont'd)

EL-TURN-02

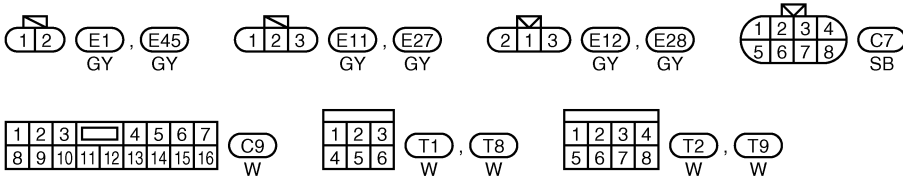
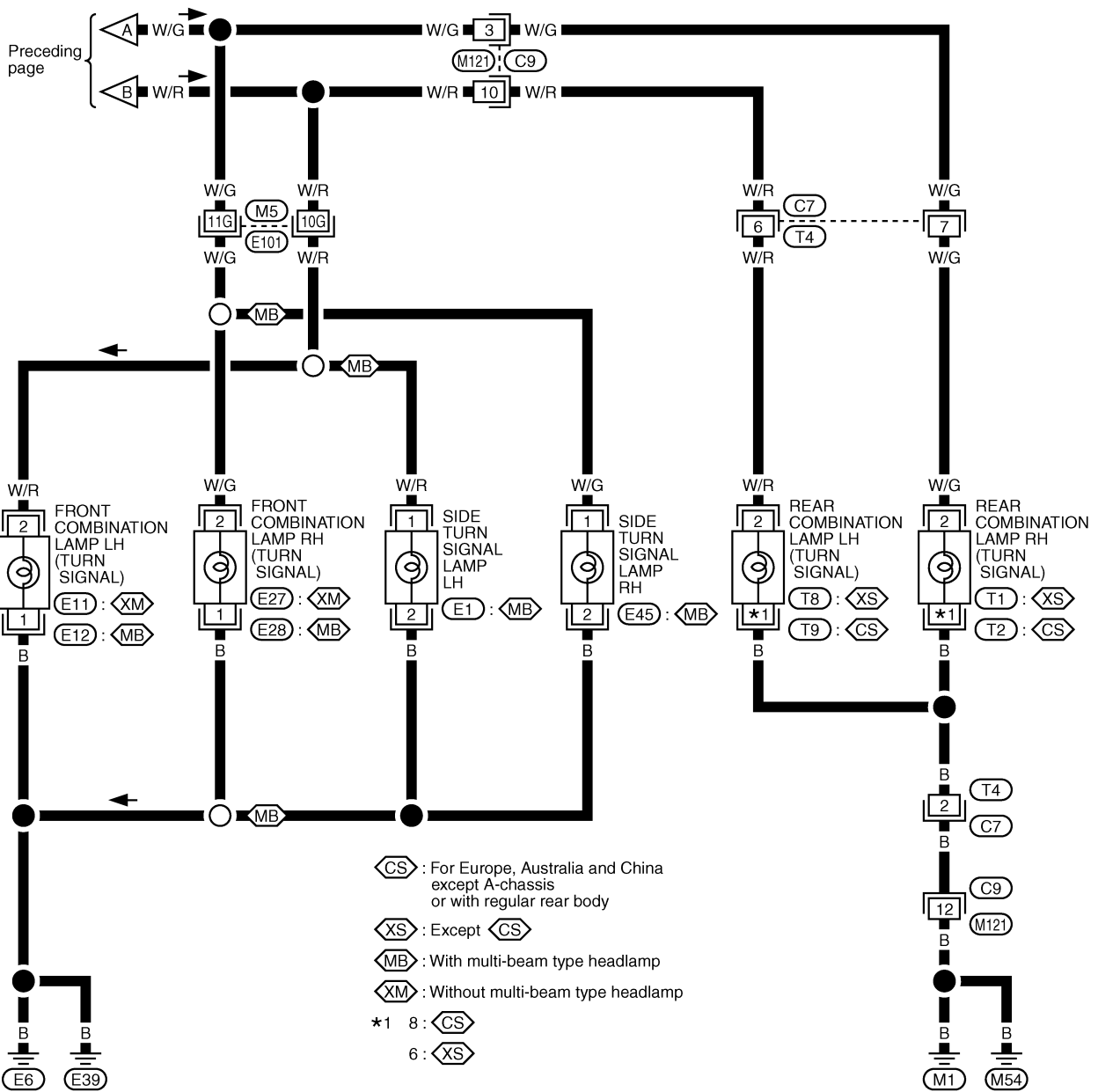

Refer to last page (Foldout page).

M5, E101

TURN SIGNAL AND HAZARD WARNING LAMPS

Trouble Diagnoses

Symptom	Possible cause	Repair order
Turn signal and hazard warning lamps do not operate.	<ol style="list-style-type: none"> 1. Hazard switch 2. Combination flasher unit 3. Open in combination flasher unit circuit 	<ol style="list-style-type: none"> 1. Check hazard switch. 2. Refer to combination flasher unit check. 3. Check wiring to combination flasher unit for open circuit.
Turn signal lamps do not operate but hazard warning lamps operate.	<ol style="list-style-type: none"> 1. 10A fuse 2. Hazard switch 3. Turn signal switch 4. Open in turn signal switch circuit 	<ol style="list-style-type: none"> 1. Check 10A fuse (No. 10), located in fuse block). Turn ignition switch ON and verify battery positive voltage is present at terminal 2 (R/W) of hazard switch. 2. Check hazard switch. 3. Check turn signal switch. 4. Check G wire between combination flasher unit and turn signal switch for open circuit.
Hazard warning lamps do not operate but turn signal lamps operate.	<ol style="list-style-type: none"> 1. 10A fuse 2. Hazard switch 3. Open in hazard switch circuit 	<ol style="list-style-type: none"> 1. Check 10A fuse (No. 5), located in fuse block). Verify battery positive voltage is present at terminal 3 (R/Y) of hazard switch. 2. Check hazard switch. 3. Check G wire between combination flasher unit and hazard switch for open circuit.
Front or side turn signal lamp LH or RH does not operate.	<ol style="list-style-type: none"> 1. Bulb 2. Grounds E6 and E39 	<ol style="list-style-type: none"> 1. Check bulb. 2. Check grounds E6 and E39.
Rear turn signal lamp LH or RH does not operate.	<ol style="list-style-type: none"> 1. Bulb 2. Grounds M1 and M54 	<ol style="list-style-type: none"> 1. Check bulb. 2. Check grounds M1 and M54.
LH and RH turn indicators do not operate.	<ol style="list-style-type: none"> 1. Ground 	<ol style="list-style-type: none"> 1. Check grounds M1 and M54.
LH or RH turn indicator does not operate.	<ol style="list-style-type: none"> 1. Bulb 	<ol style="list-style-type: none"> 1. Check bulb in combination meter.

ILLUMINATION

Wiring Diagram — ILL —/LHD Models

EL-ILL-01

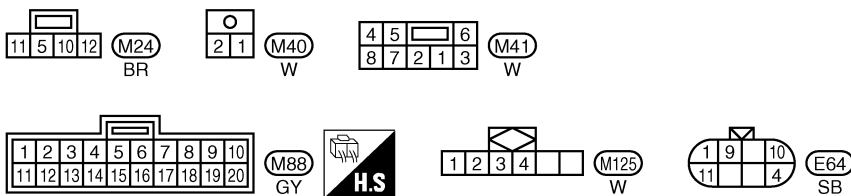
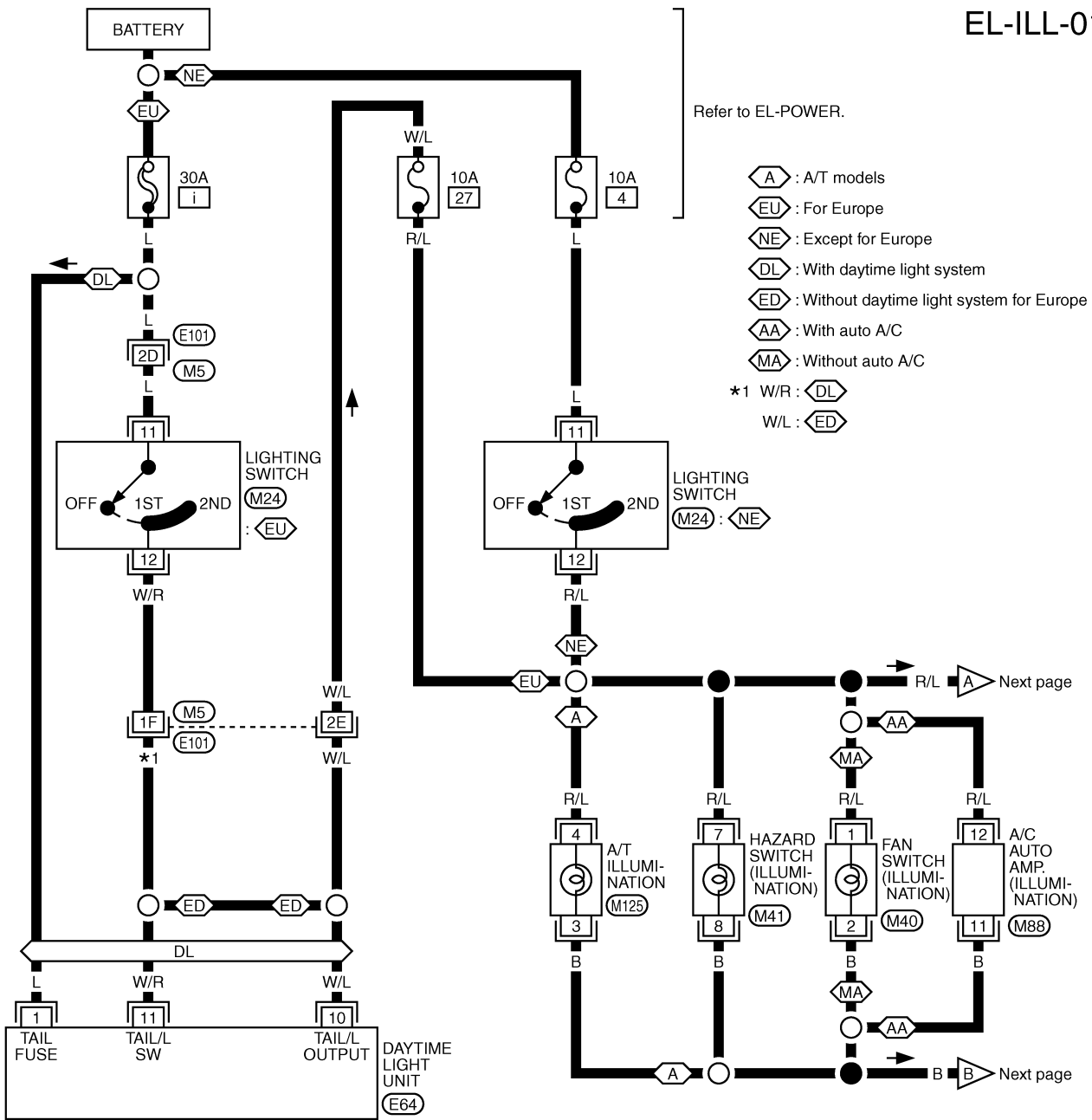

Refer to last page (Foldout page).

(M5), (E101)

ILLUMINATION

Wiring Diagram — ILL —/LHD Models (Cont'd)

EL-ILL-02

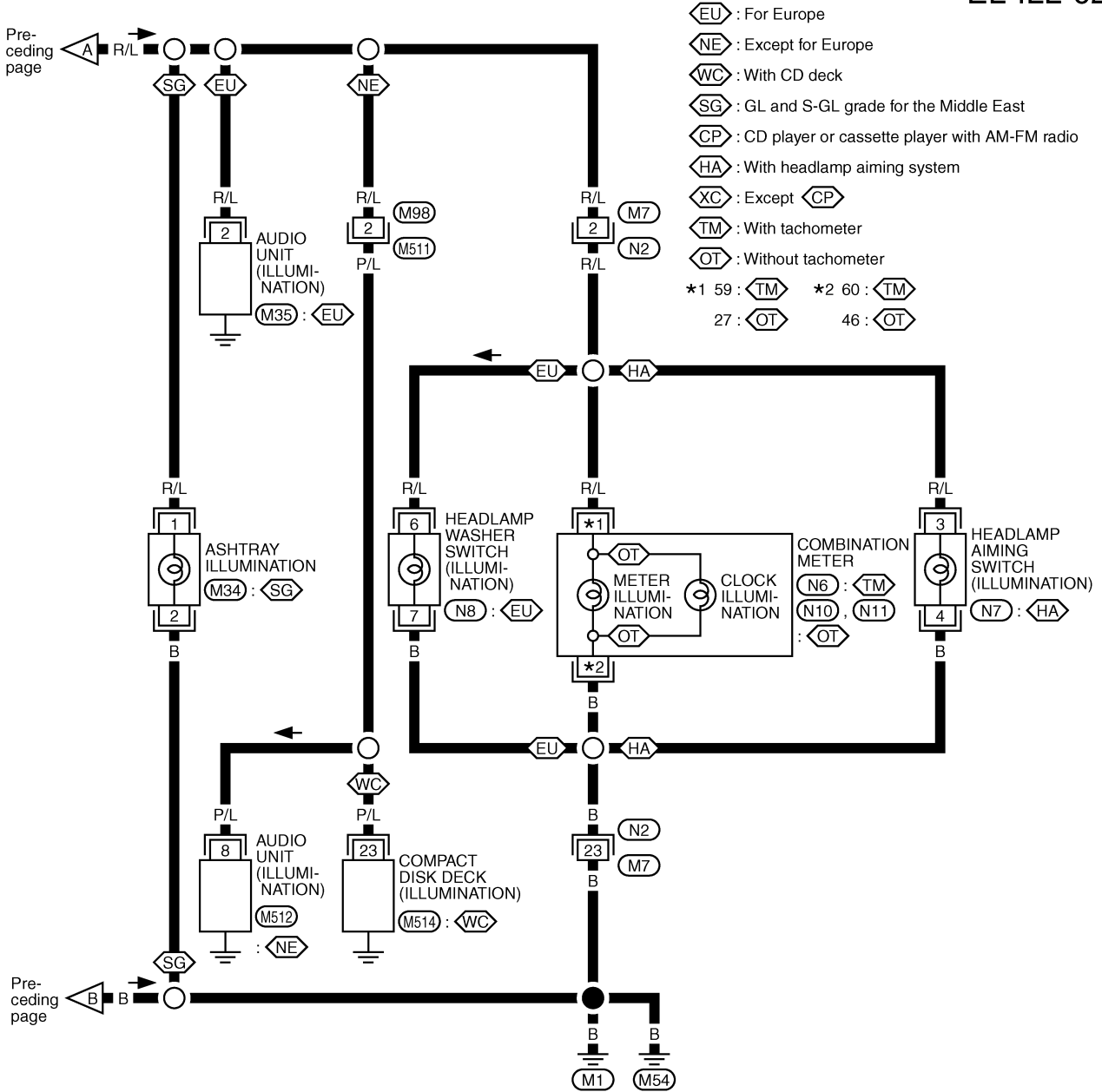

- ⬡ : For Europe
- ⬢ : Except for Europe
- ⬤ : With CD deck
- ⬢ : GL and S-GL grade for the Middle East
- ⬢ : CD player or cassette player with AM-FM radio
- ⬢ : With headlamp aiming system
- ⬢ : Except ⬢
- ⬢ : With tachometer
- ⬢ : Without tachometer
- *1 59 : ⬢ *2 60 : ⬢
- 27 : ⬢ 46 : ⬢

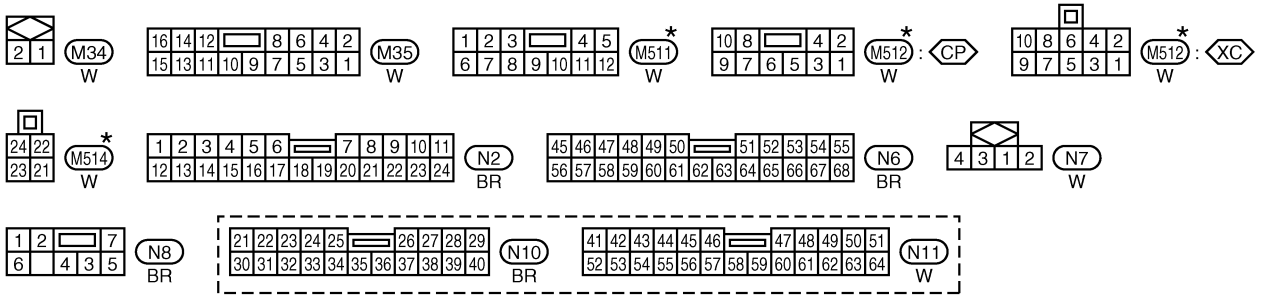

*: This connector is not shown in "HARNESS LAYOUT".

ILLUMINATION

Wiring Diagram — ILL —/RHD Models

EL-ILL-03

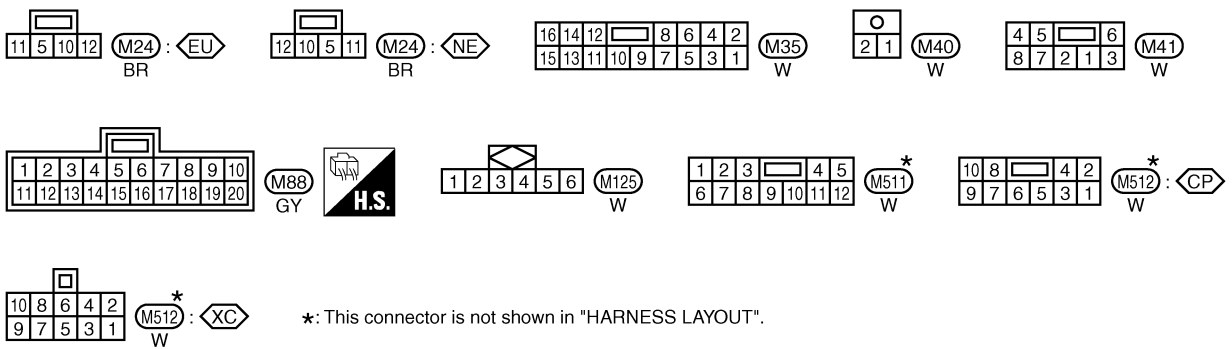
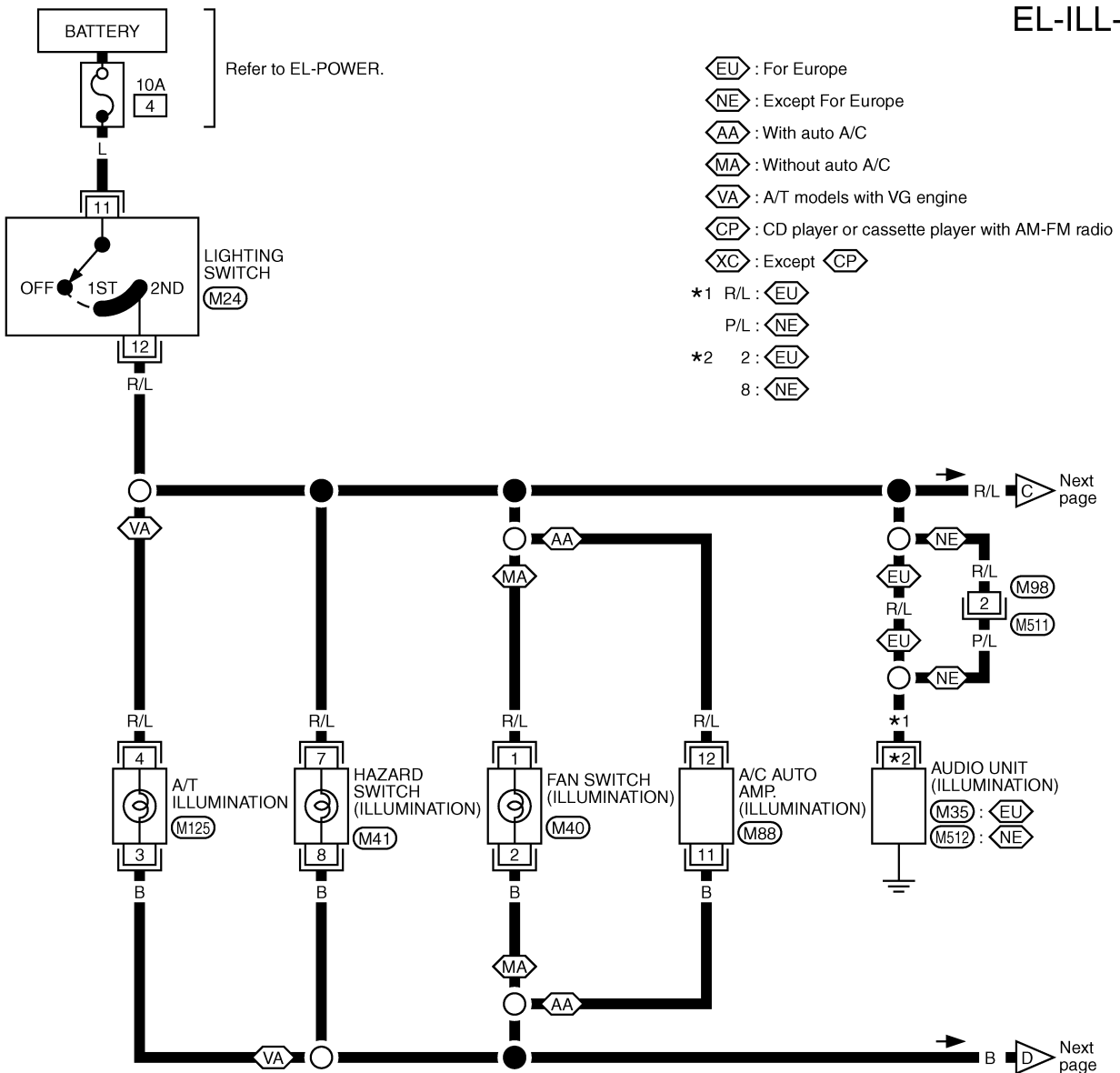

ILLUMINATION

Wiring Diagram — ILL —/RHD Models (Cont'd)

EL-ILL-04

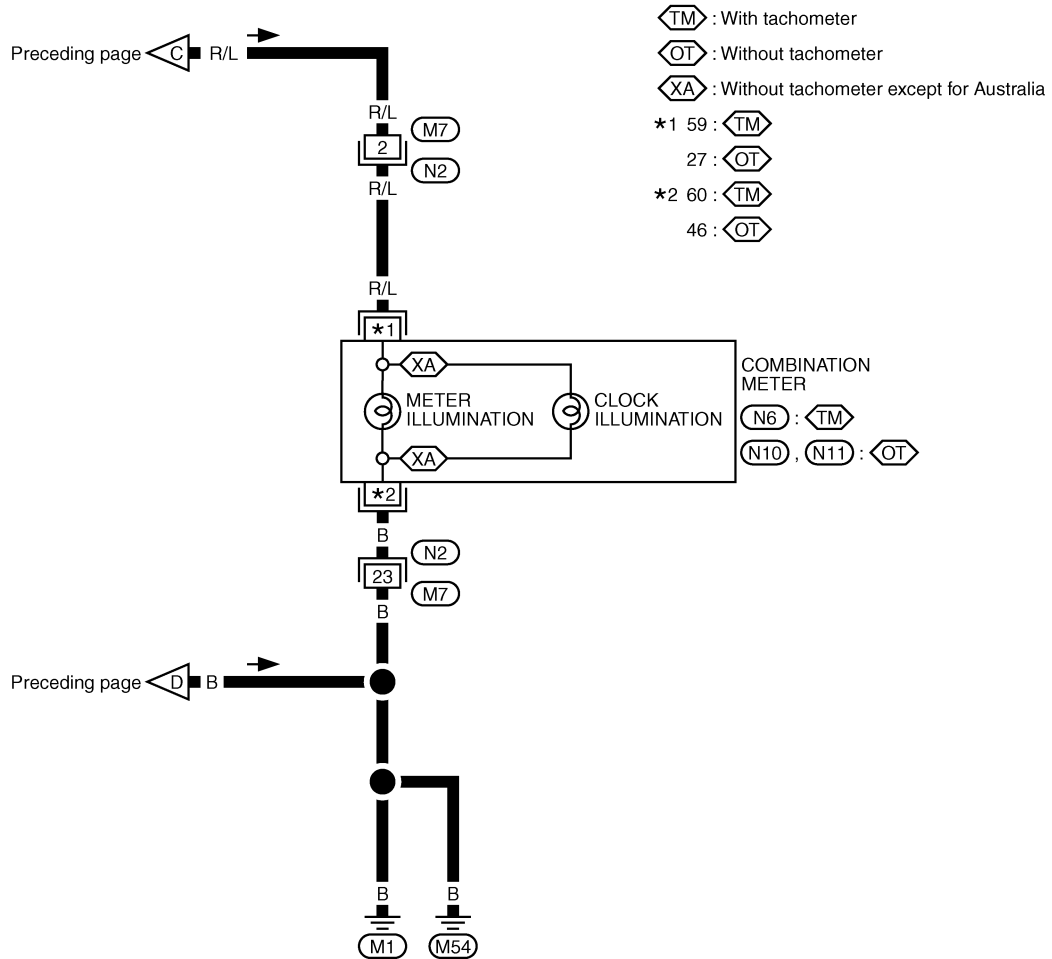

1	2	3	4	5	6	7	8	9	10	11	N2 BR	45	46	47	48	49	50	51	52	53	54	55	N6 BR		
12	13	14	15	16	17	18	19	20	21	22		23	24	56	57	58	59	60	61	62	63	64		65	66

21	22	23	24	25	26	27	28	29	N10 BR	41	42	43	44	45	46	47	48	49	50	51	N11 W		
30	31	32	33	34	35	36	37	38		39	40	52	53	54	55	56	57	58	59	60		61	62

INTERIOR ROOM LAMP

Wiring Diagram — ROOM/L —

EL-ROOM/L-01

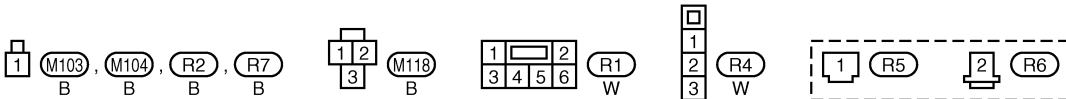
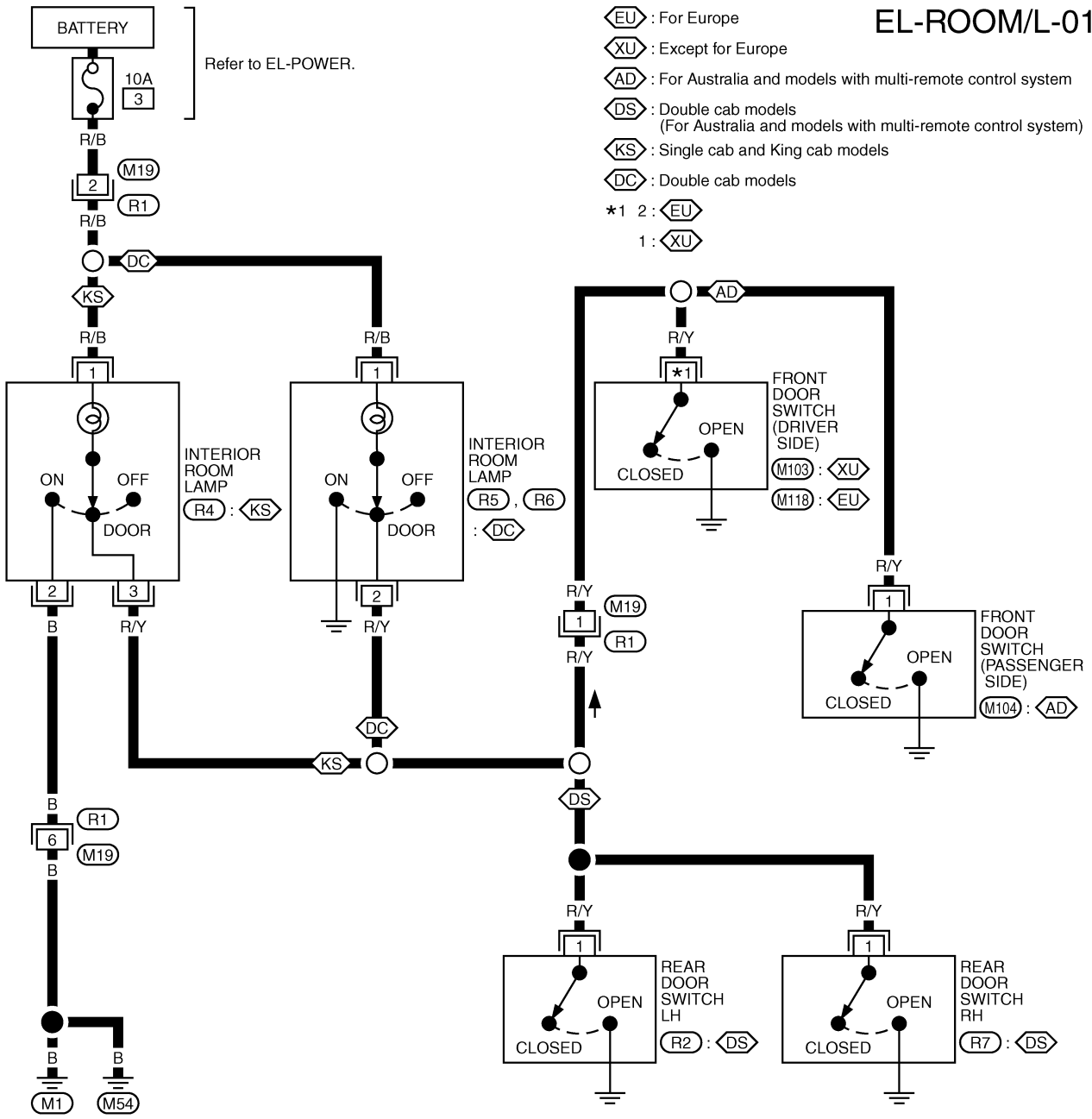

SPOT LAMP

Wiring Diagram — INT/L —

EL-INT/L-01

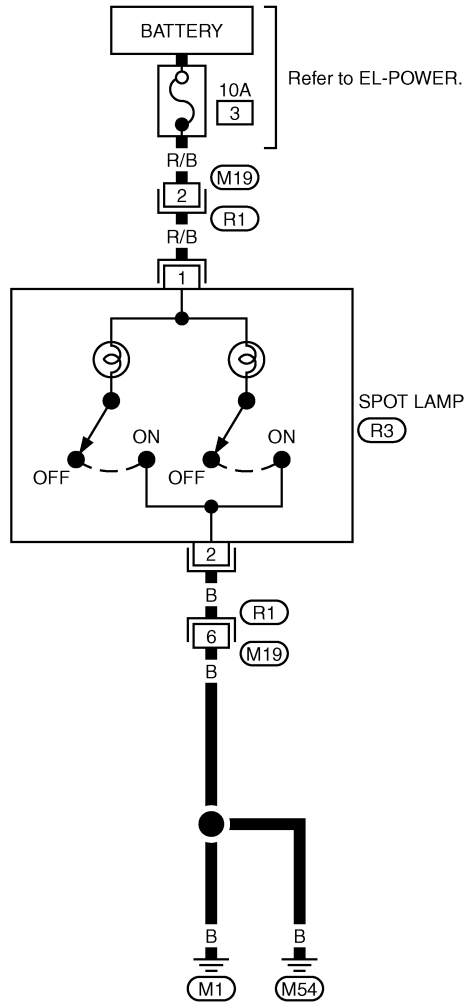

METER AND GAUGES

System Description

UNIFIED CONTROL METER

- Speedometer, odo/trip meter, tachometer, fuel gauge and water temperature gauge are controlled totally by control unit.
- Digital meter is adopted for odo/trip meter.*
 - *The record of the odo meter is kept even if the battery cable is disconnected. The record of the trip meter is erased when the battery cable is disconnected.
- Odo/trip meter segment can be checked in diagnosis mode.
- Meter/gauge can be checked in diagnosis mode.

HOW TO CHANGE THE DISPLAY FOR ODO/TRIP METER

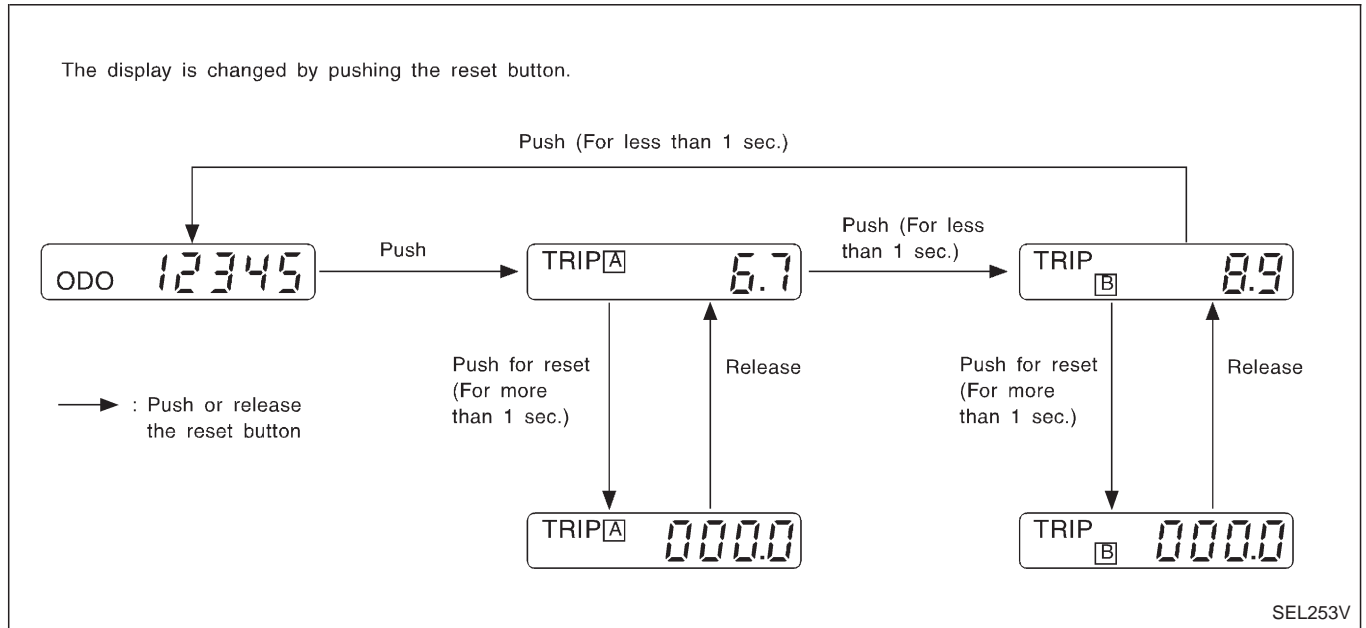

Note:

Turn ignition switch to the "ON" position to operate odo/trip meter.

METER AND GAUGES

Combination Meter/With Tachometer

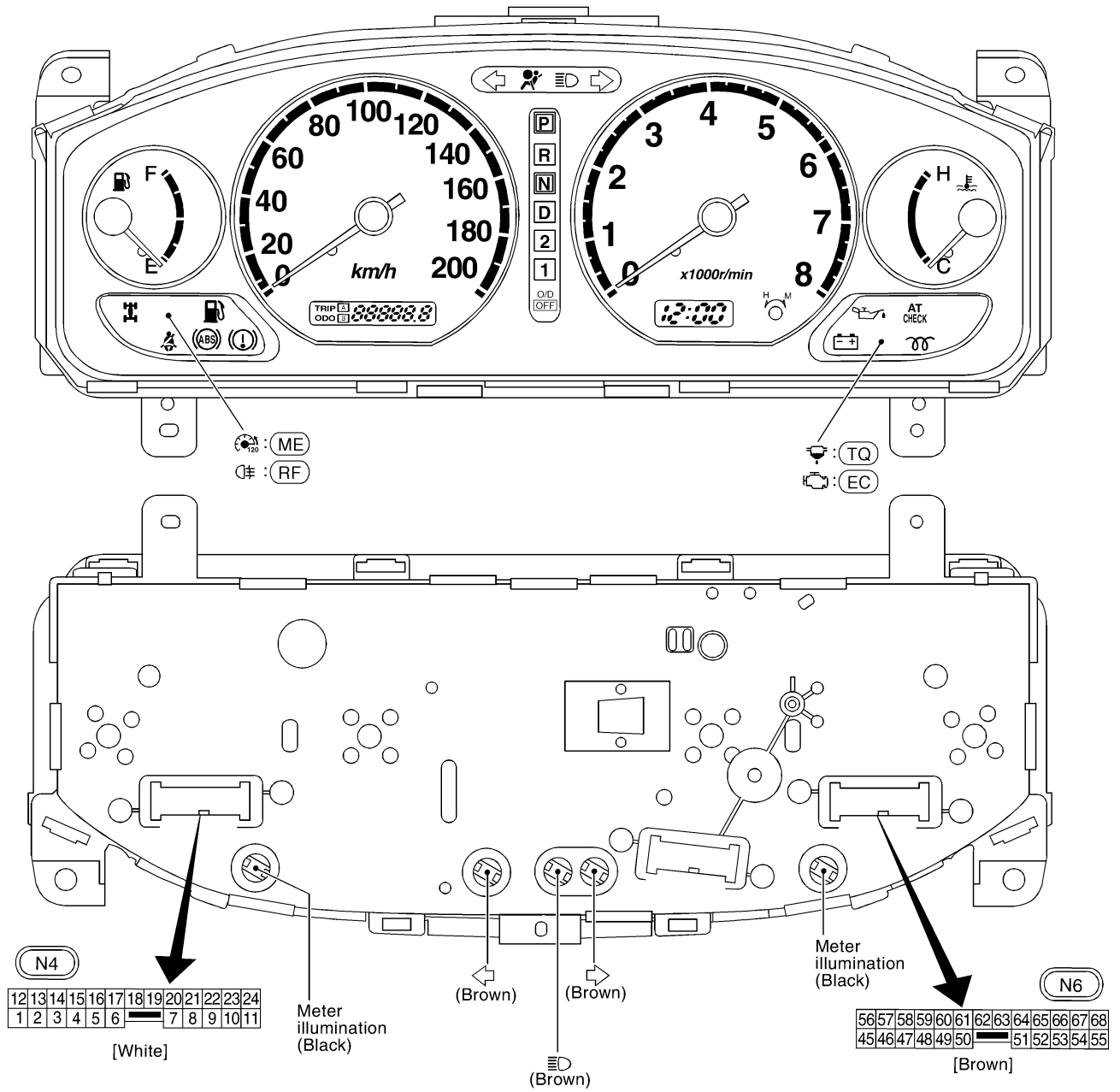

Bulb socket color	Bulb wattage
Brown	1.4W
Black	3.0W

() : Bulb socket color

- (ME) : For the Middle East
- (RF) : With rear fog lamp
- (TQ) : TD and QD engines
- (EC) : With ECM control engine

METER AND GAUGES

Combination Meter/Without Tachometer

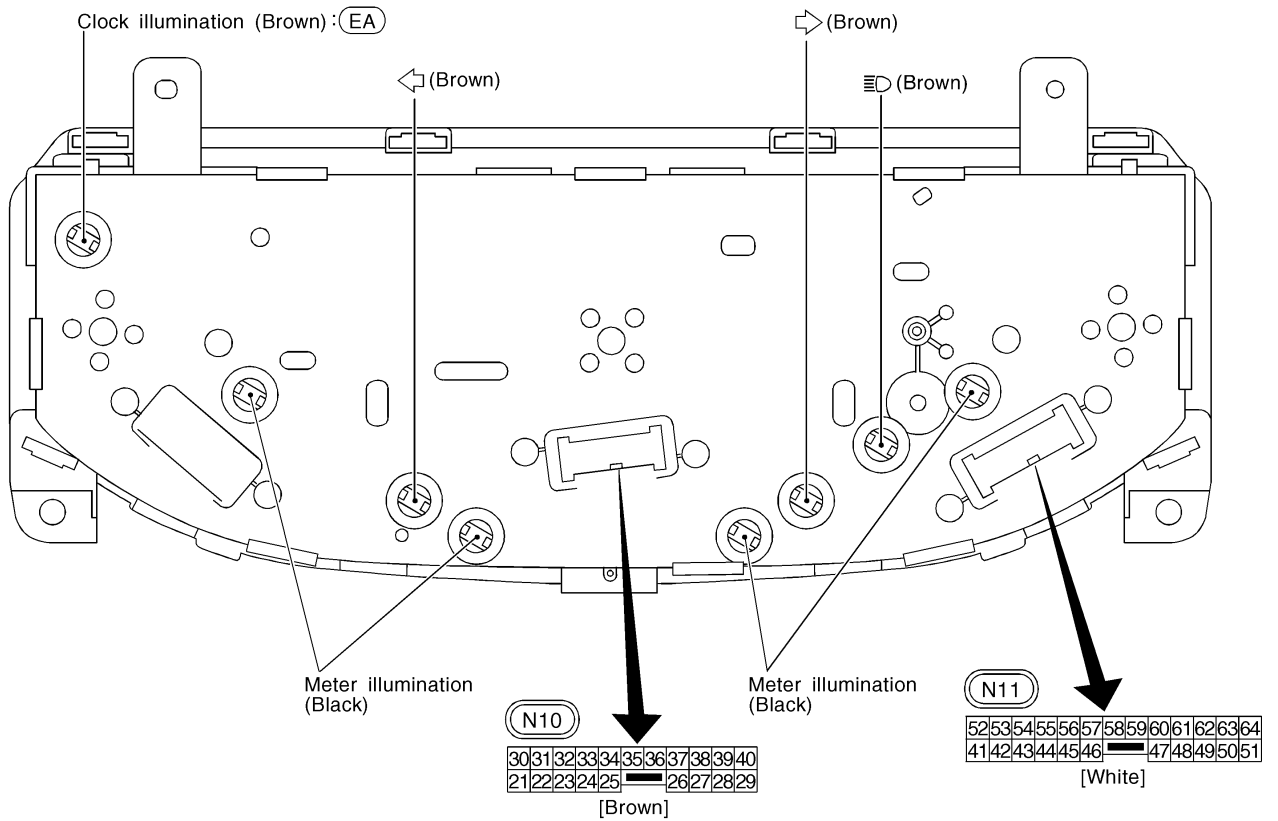
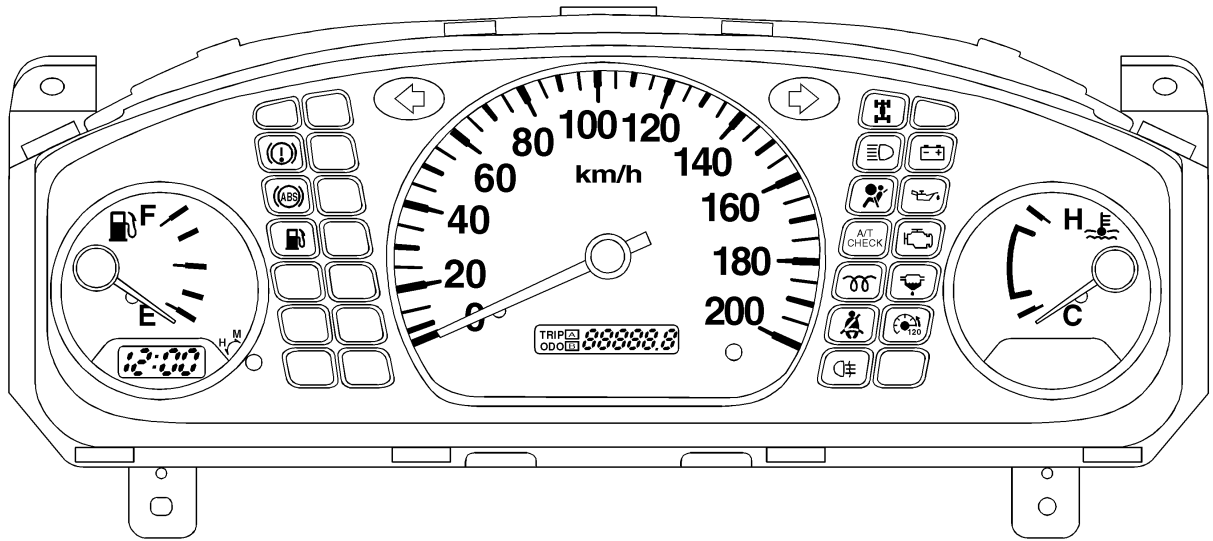

(EA) : Except for Australia

Bulb socket color	Bulb wattage
Brown	1.4W
Black	3.0W

() : Bulb socket color

METER AND GAUGES

Schematic/With Tachometer

- (LA) : LHD models with A/T
- (RA) : RHD models with A/T
- (D) : With diesel engine
- (AB) : With air bag
- (AS) : With ABS
- (RF) : With rear fog lamp
- (EC) : With ECM control engine (Except TD27)

- (EA) : With ECM control engine (Except TD27) or for Australia
- (TQ) : TD and QD engines
- (4W) : 4-wheel drive models
- (ME) : For the Middle East
- (SW) : For Europe, Australia and the Middle East

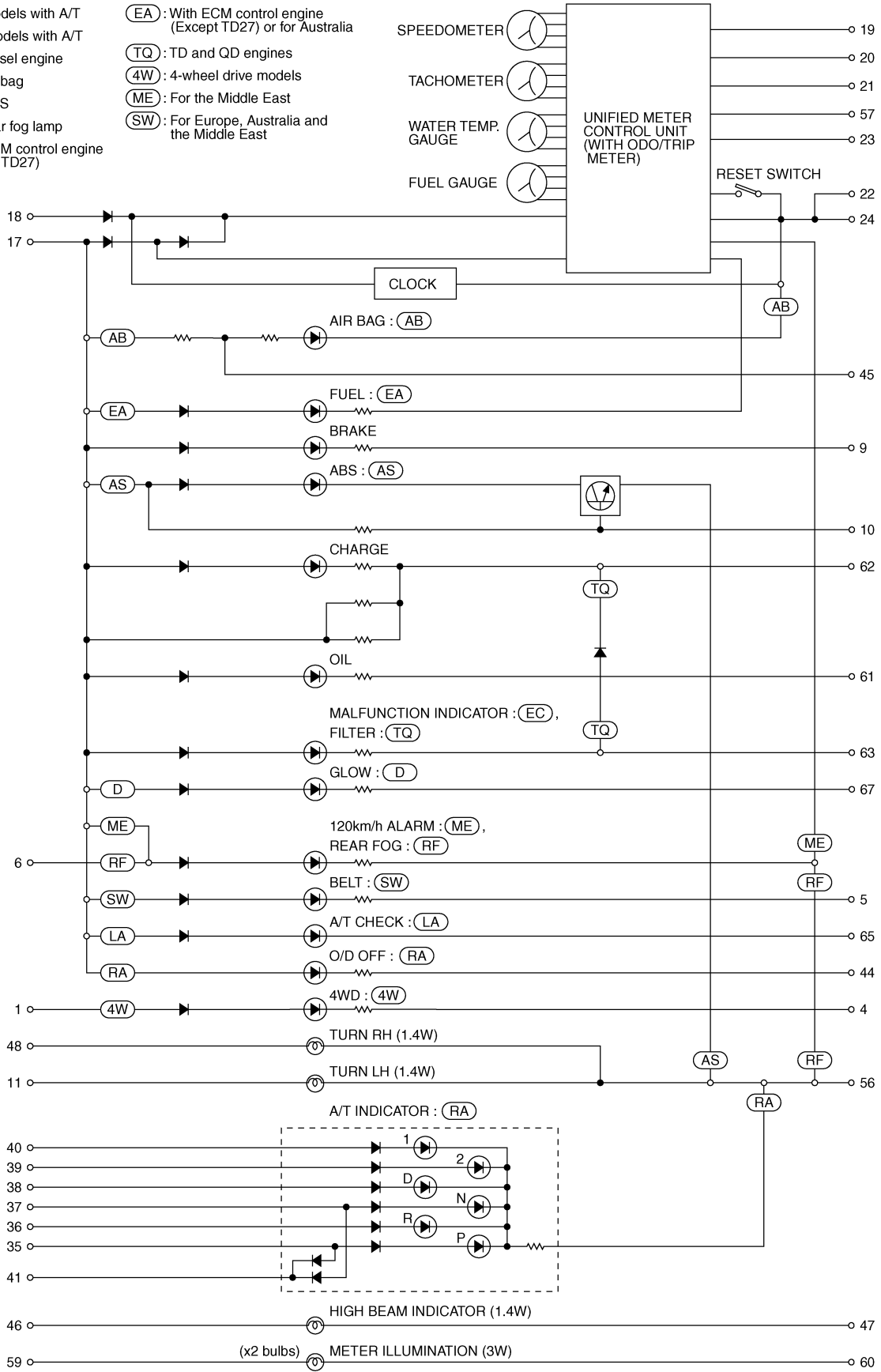

METER AND GAUGES

Schematic/Without Tachometer

- (A) : A/T models
- (D) : With diesel engine
- (AB) : With air bag
- (AS) : With ABS
- (RF) : With rear fog lamp
- (EC) : With ECM control engine (Except TD27)
- (TQ) : TD and QD engines
- (4W) : 4-wheel drive models
- (ME) : For the Middle East
- (SW) : For Europe, Australia and the Middle East
- (XA) : Except for Australia

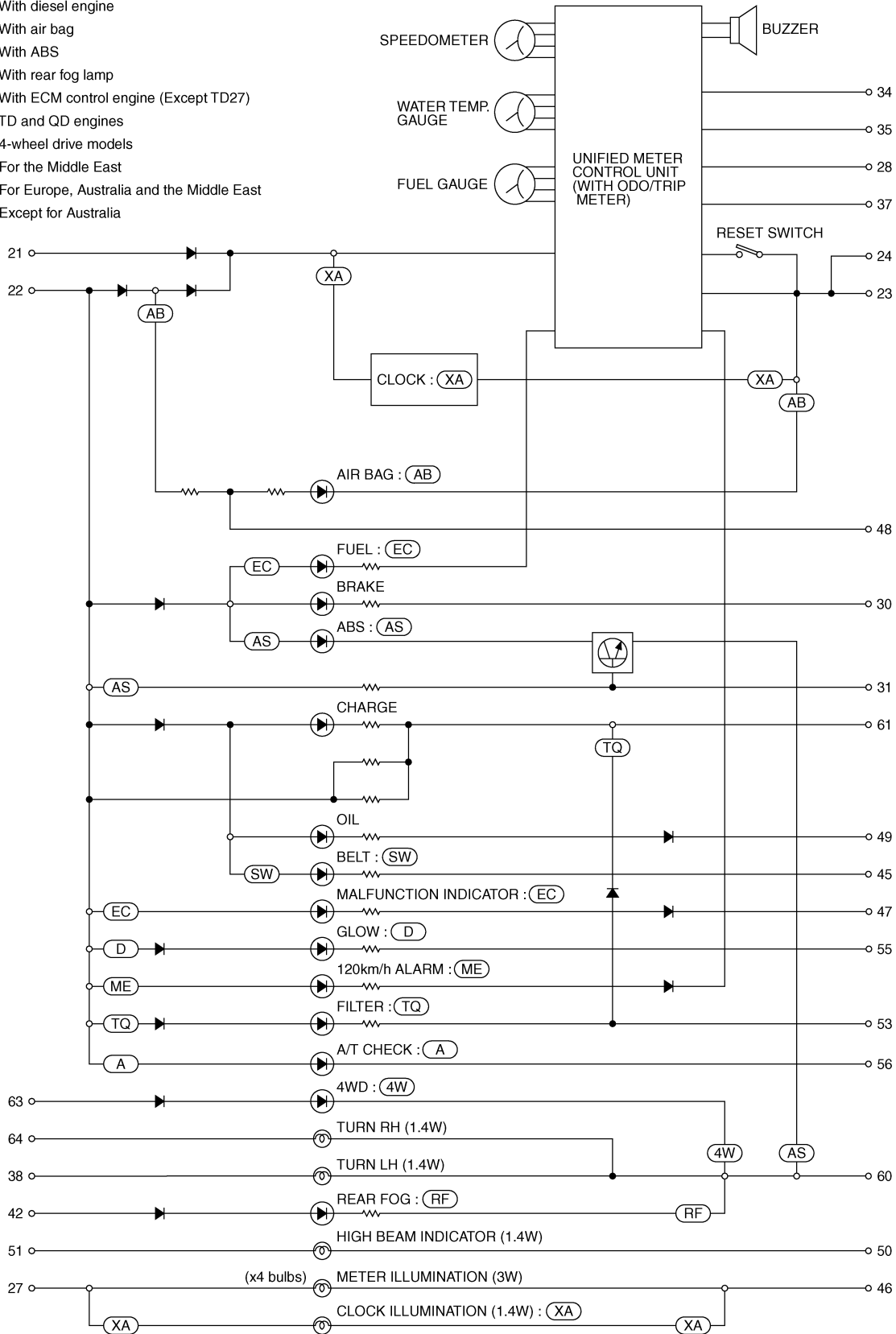

METER AND GAUGES

Construction

WITH TACHOMETER

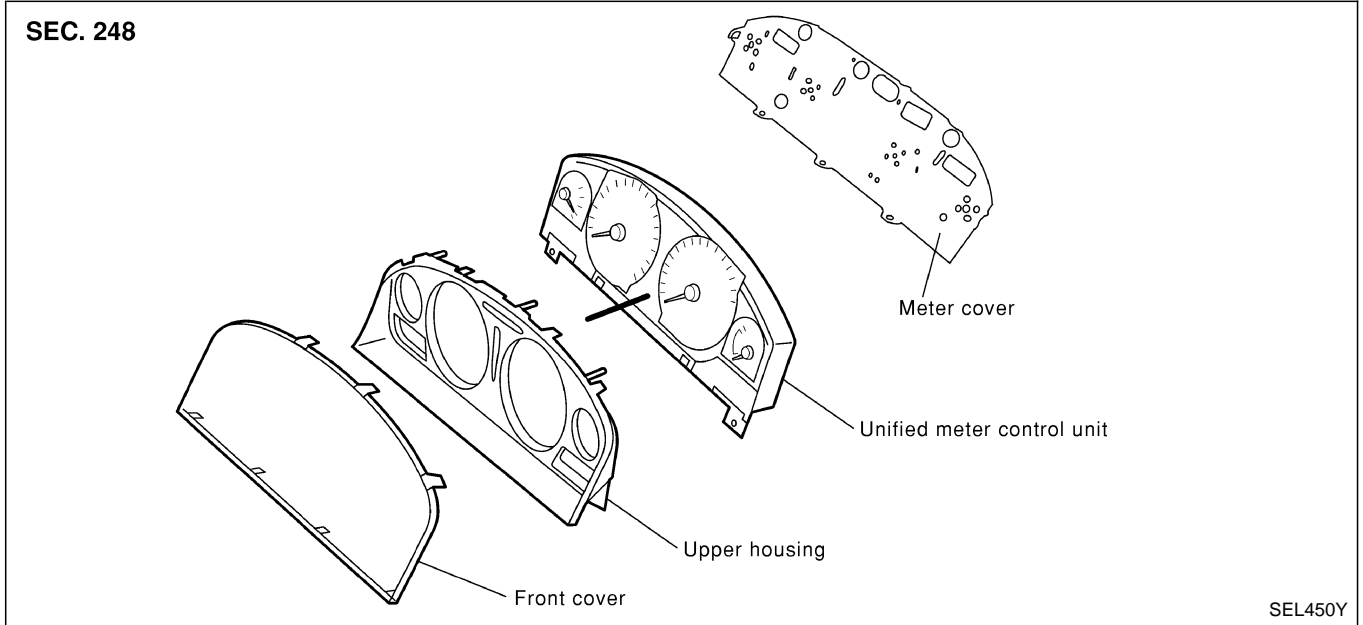

WITHOUT TACHOMETER

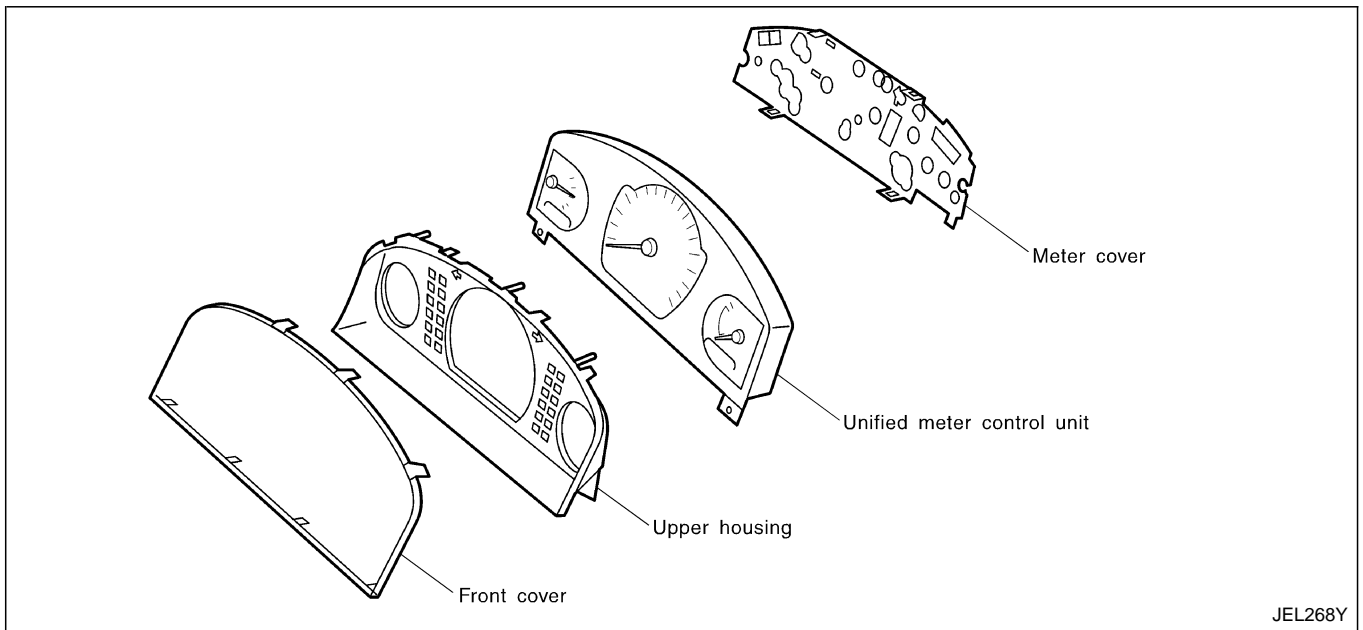

METER AND GAUGES

Wiring Diagram — METER —/Gasoline Engine with Tachometer

EL-METER-01

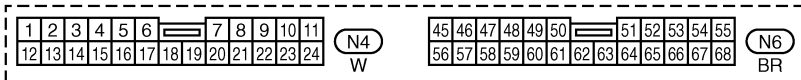
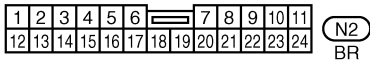
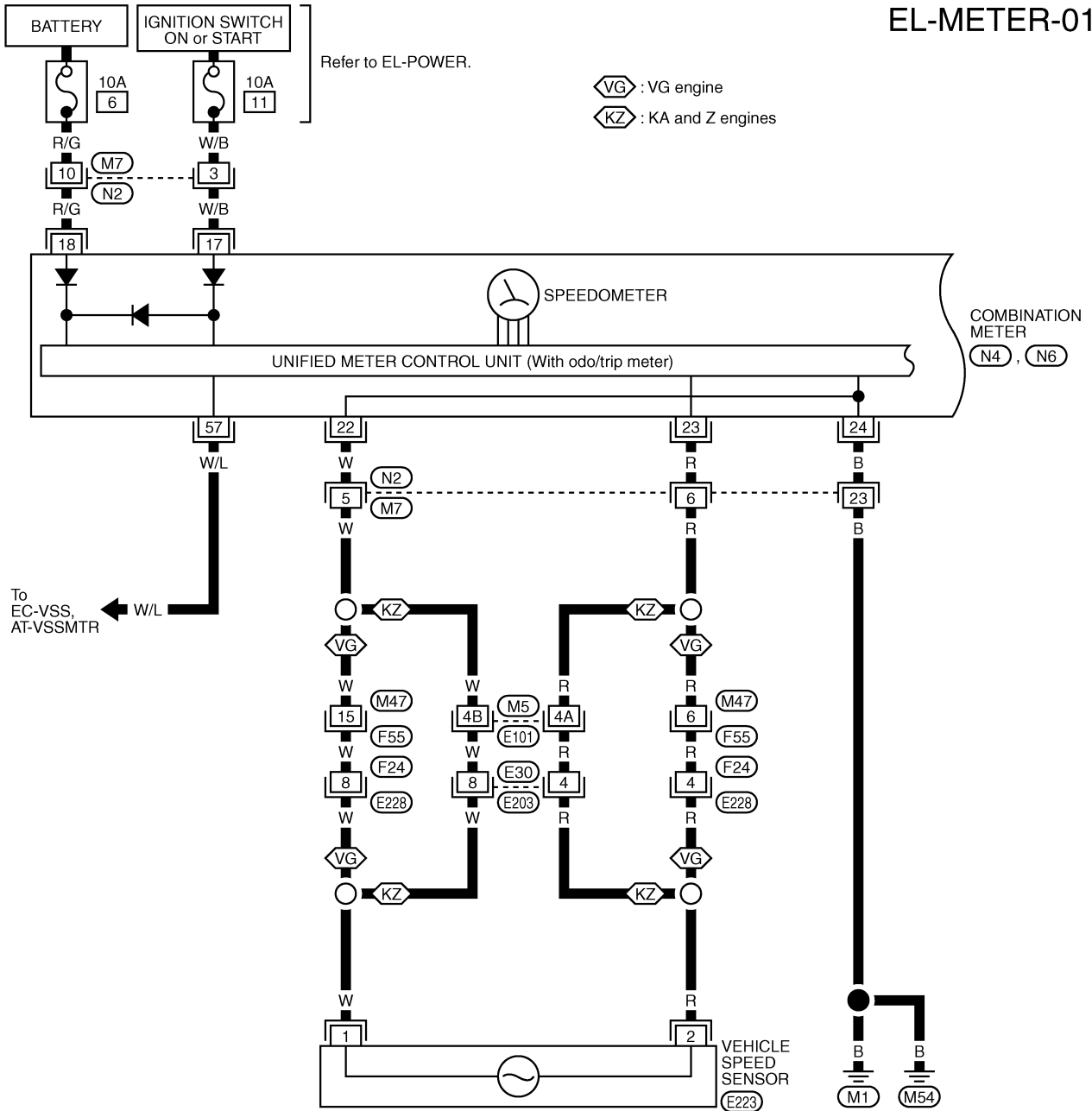

Refer to last page (Foldout page).

(M5), (E101)

METER AND GAUGES

Wiring Diagram — METER —/Gasoline Engine with Tachometer (Cont'd)

EL-METER-02

- L : LHD models
- R : RHD models
- EU : For Europe
- NE : Except for Europe
- CB : Carburetor engine
- VG : VG engine
- LK : LHD models with KA engine
- RK : RHD models with KA engine
- RV : RHD models with KA engine and VG engine
- *1 3C: L *2 3: EU *3 18: RK
- 6A: R 18: NE 7: VG

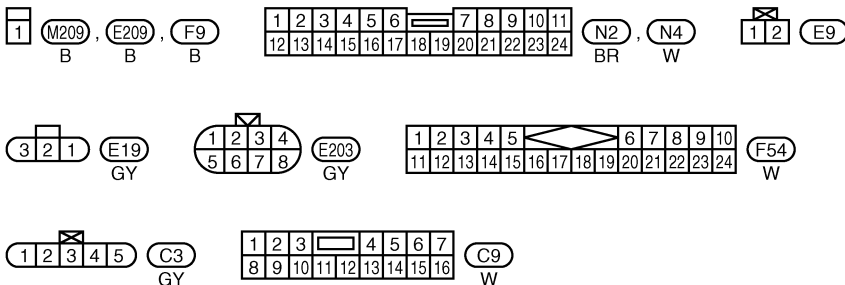
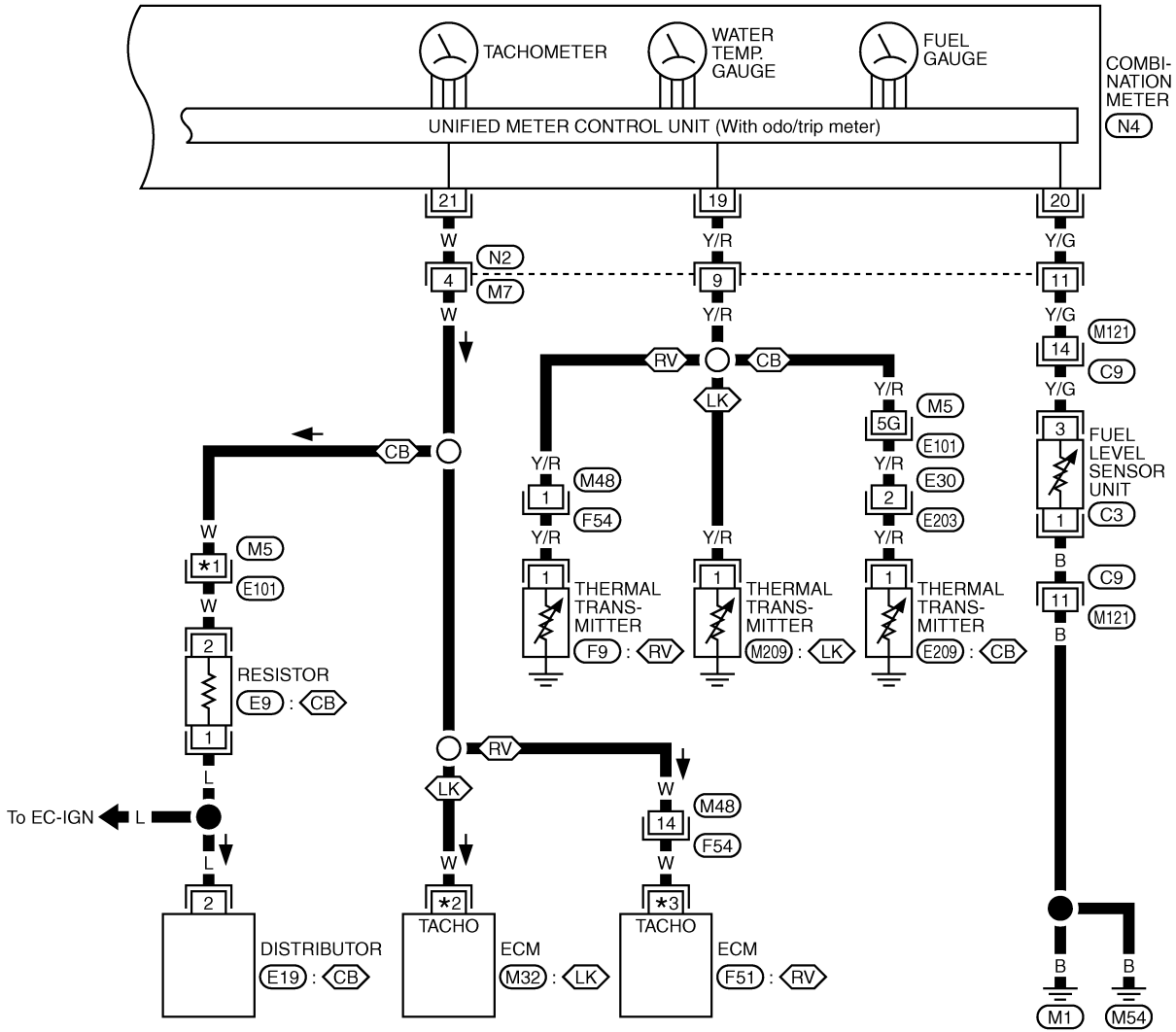

Refer to last page (Foldout page).

- M5 , E101
- M32
- F51

METER AND GAUGES

Wiring Diagram — METER —/Gasoline Engine without Tachometer

EL-METER-03

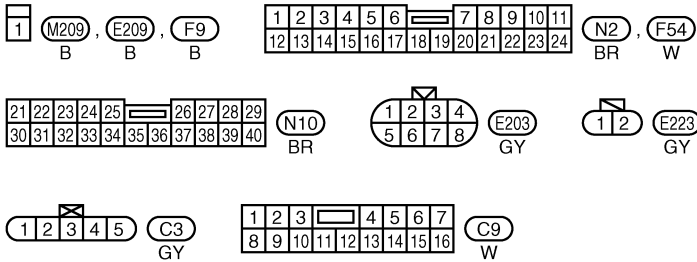
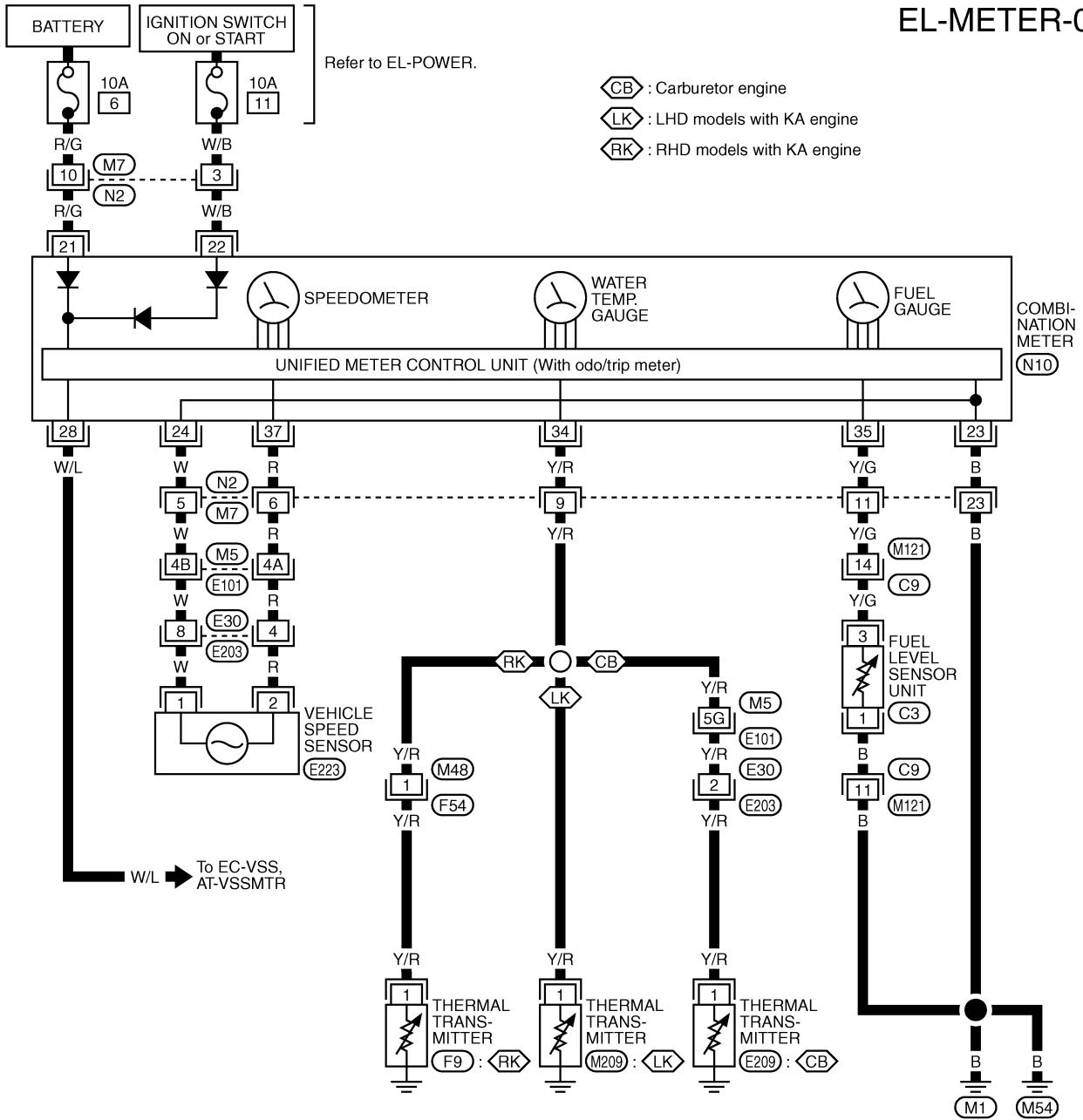

Refer to last page (Foldout page).

(M5), (E101)

METER AND GAUGES

Wiring Diagram — METER —/LHD Diesel Engine Models with Tachometer

EL-METER-04

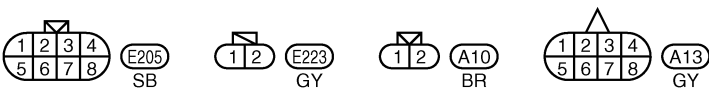
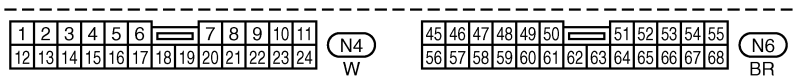
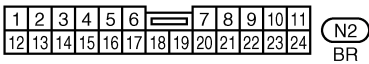
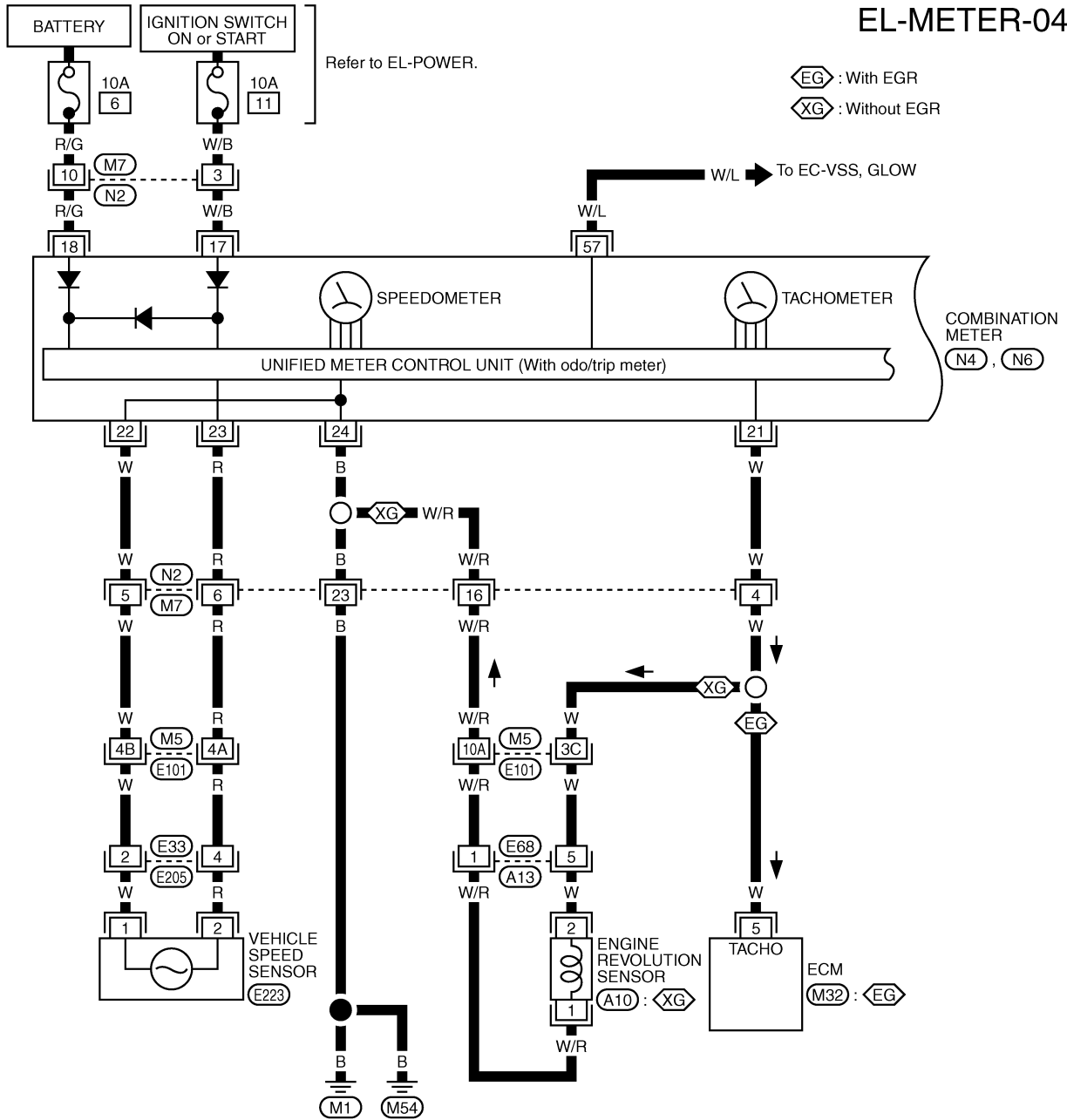

Refer to last page (Foldout page).

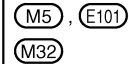

METER AND GAUGES

Wiring Diagram — METER —/LHD Diesel Engine Models with Tachometer (Cont'd)

EL-METER-05

- : YD engine
- : ZD engine
- : YD and ZD engines
- : TD and QD engines

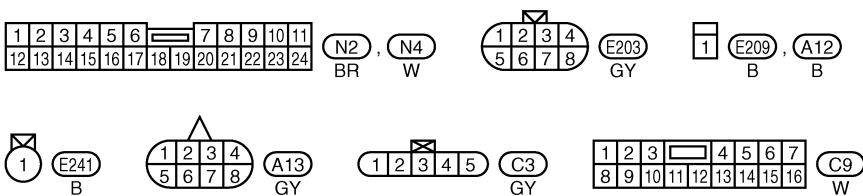
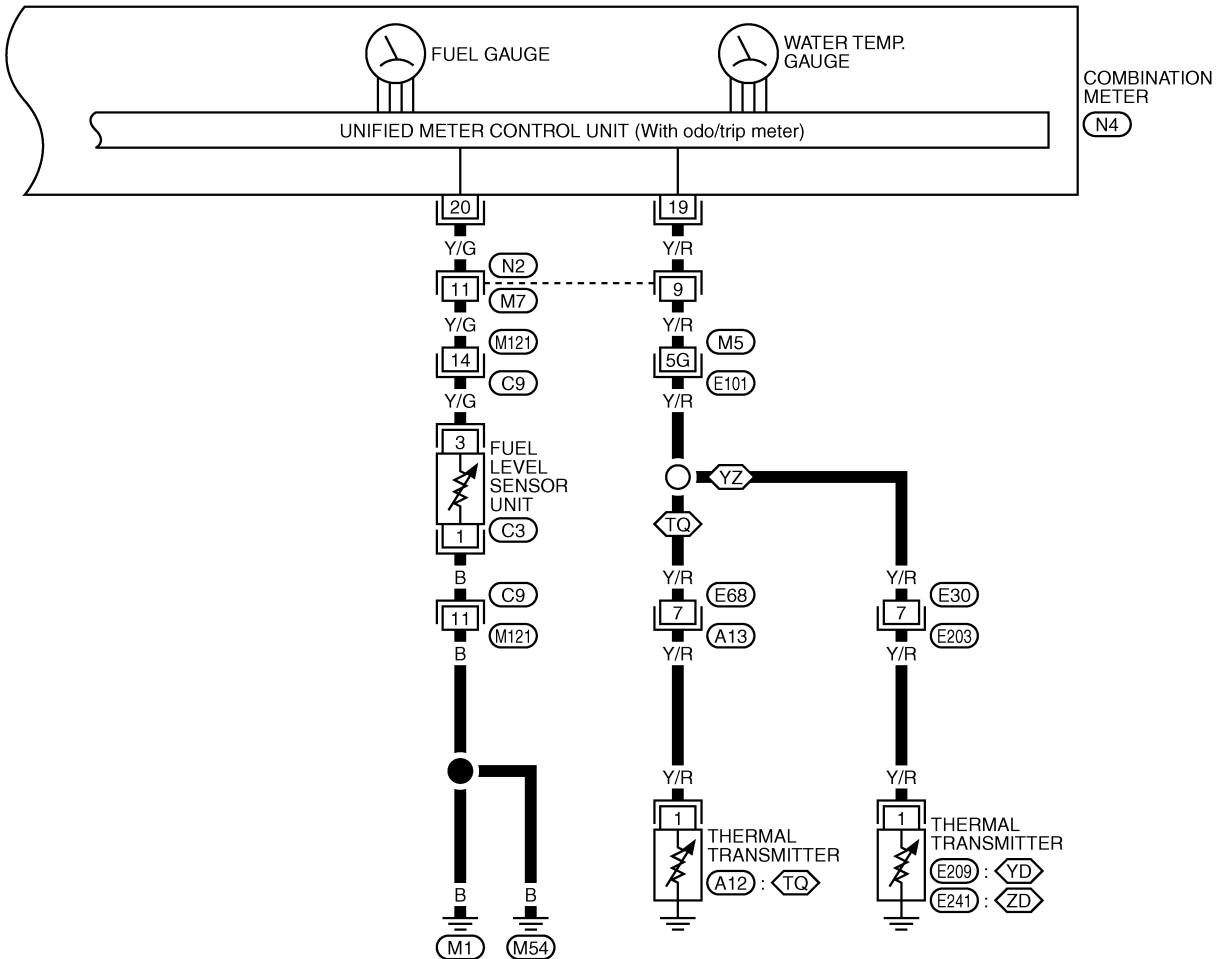

Refer to last page (Foldout page).

M5, E101

METER AND GAUGES

Wiring Diagram — METER —/RHD Diesel Engine Models with Tachometer

EL-METER-06

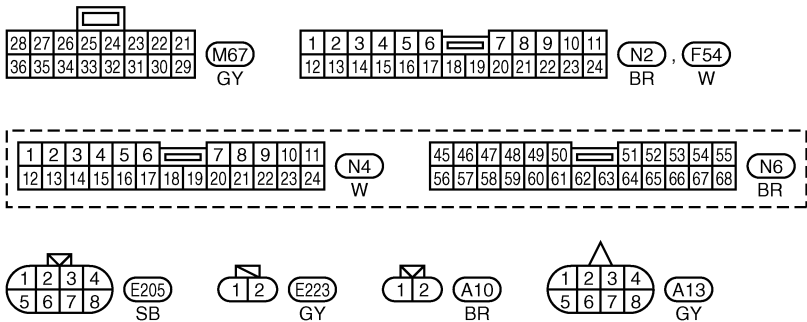
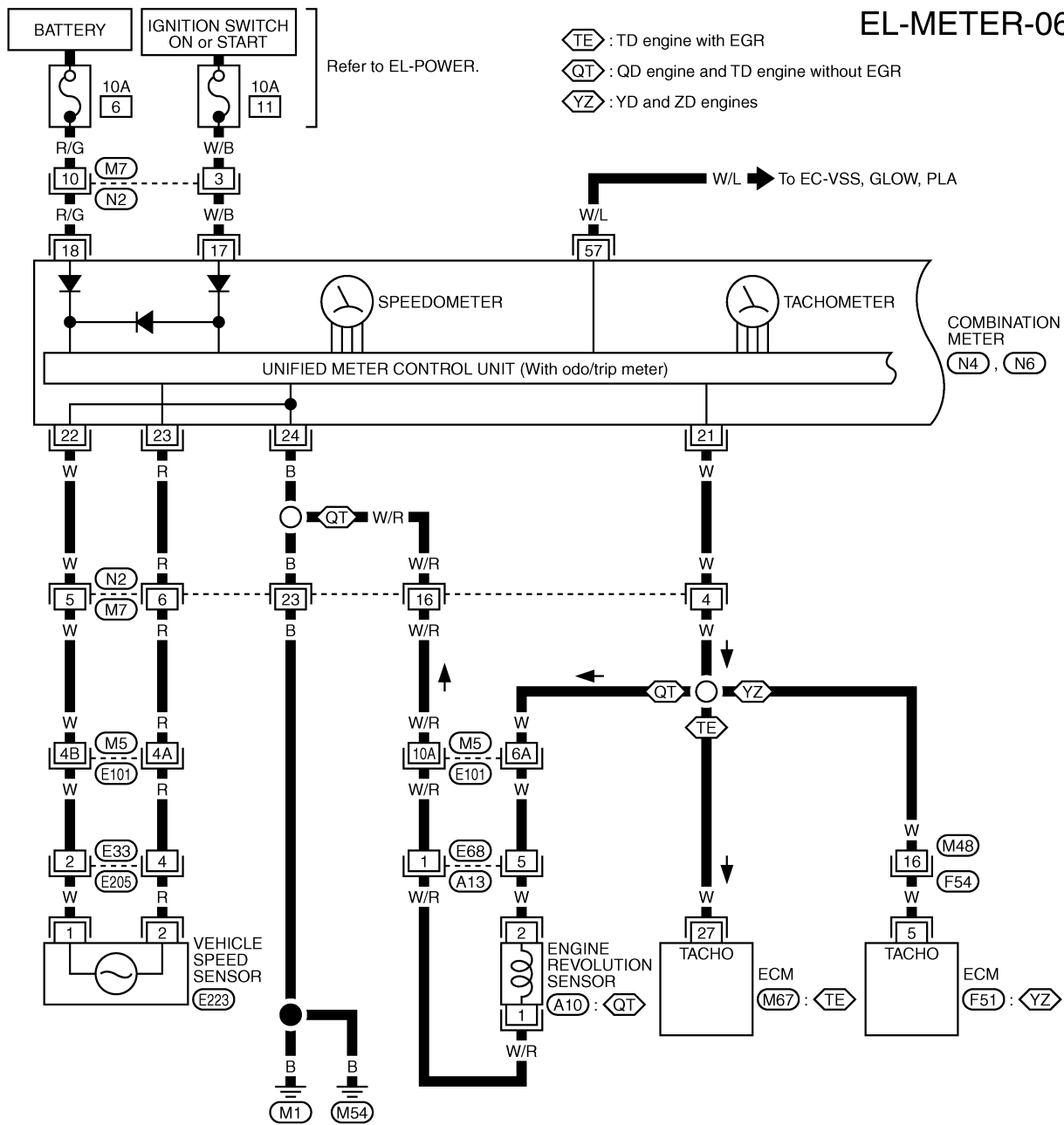

Refer to last page (Foldout page).

(M5), (E101)
(F51)

METER AND GAUGES

Wiring Diagram — METER —/RHD Diesel Engine Models with Tachometer (Cont'd)

EL-METER-07

- : YD engine
- : ZD engine
- : YD and ZD engines
- : TD and QD engines

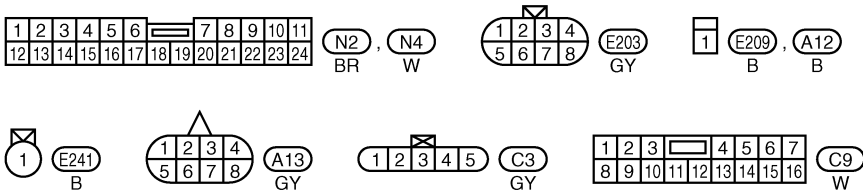
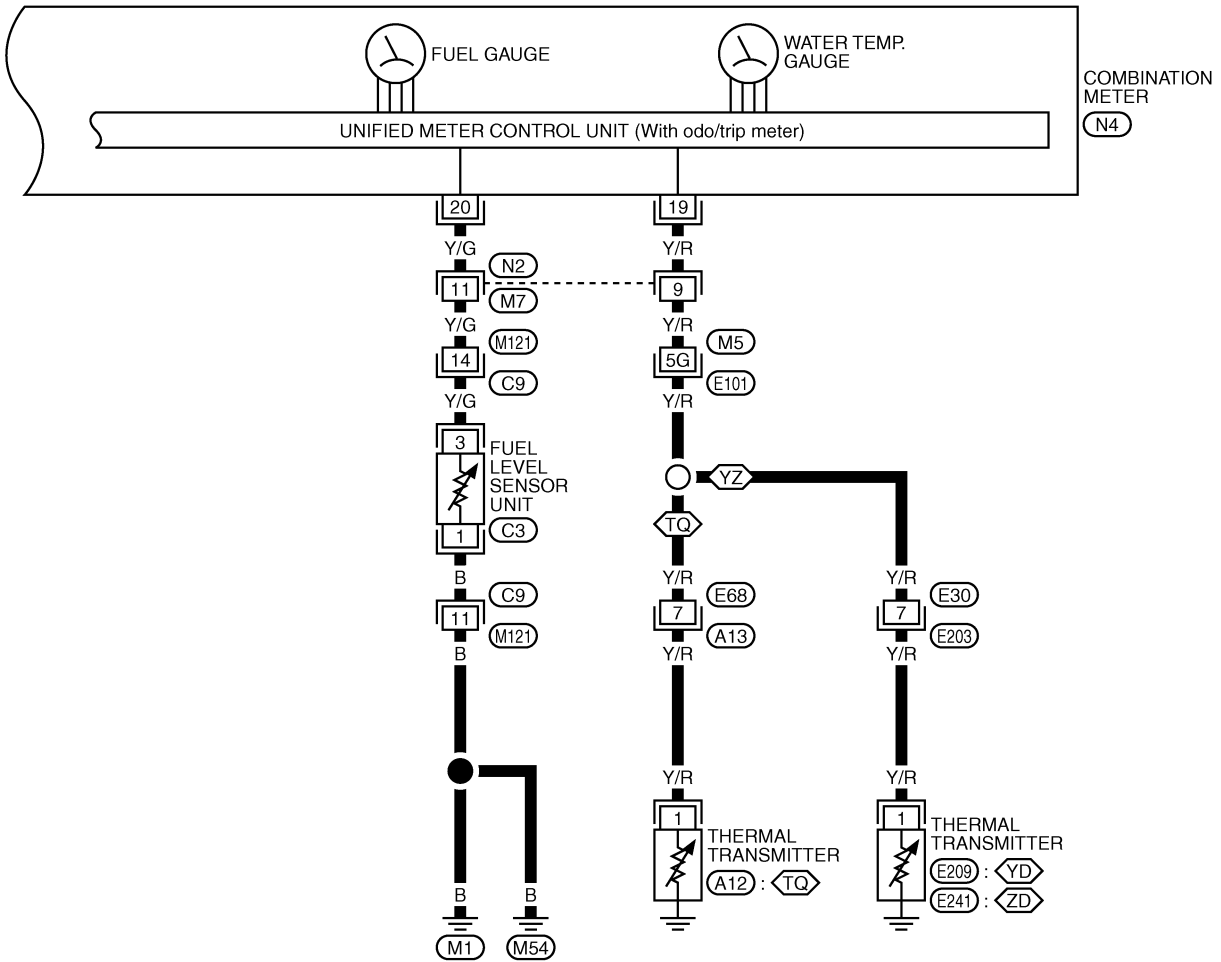

Refer to last page (Foldout page).

M5, E101

METER AND GAUGES

Wiring Diagram — METER —/Diesel Engine without Tachometer

EL-METER-08

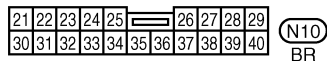
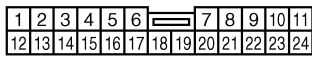
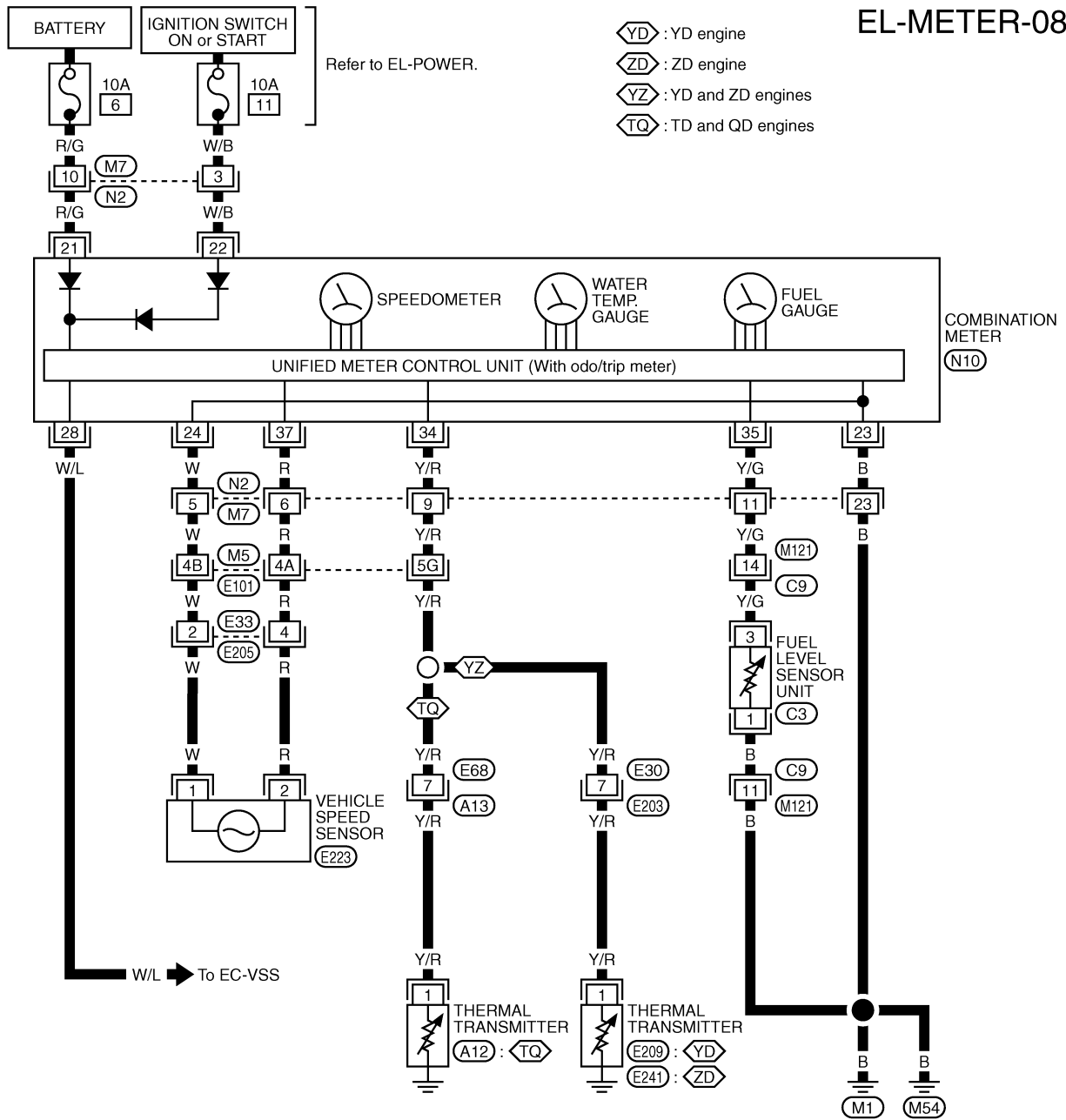

Refer to last page (Foldout page).

M5, E101

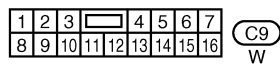
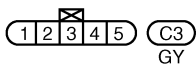
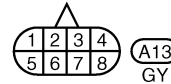
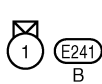
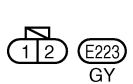
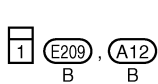
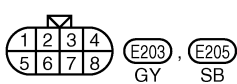

METER AND GAUGES

Meter/Gauge Operation and Odo/Trip Meter Segment Check in Diagnosis Mode

DIAGNOSIS FUNCTION

- Odo/trip meter segment can be checked in diagnosis mode.
- Meters/gauges can be checked in diagnosis mode.

HOW TO ALTERNATE DIAGNOSIS MODE

1. Turn ignition switch to ON and change odo/trip meter to "TRIP A" or "TRIP B".
2. Turn ignition switch to OFF.
3. Turn ignition switch to ON when pushing odo/trip meter switch.
4. Confirm that trip meter indicates "000.0".
5. Push odo/trip meter switch more than three times within 5 seconds.

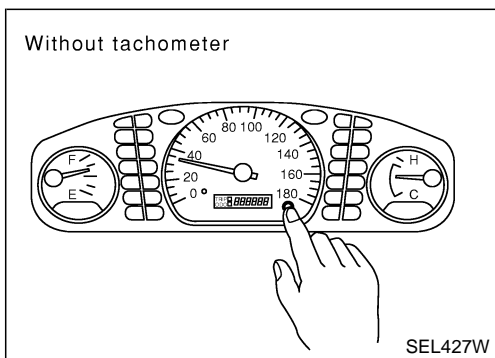
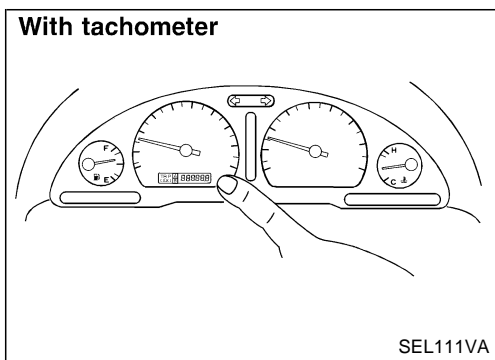
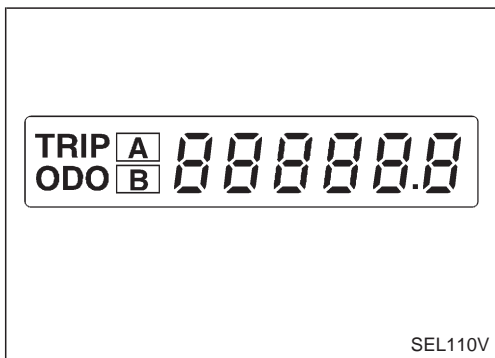

6. All odo/trip meter segments should be turned on.

NOTE: If some segments are not turned on, unified meter control unit with odo/trip meter should be replaced.

At this point, the unified control meter is turned to diagnosis mode.

7. Push odo/trip meter switch. Indication of each meter/gauge should be as shown left during pushing odo/trip meter switch if it is no malfunctioning.

NOTE: It takes about a few seconds for indication of fuel gauge to become stable.

METER AND GAUGES

Trouble Diagnoses/With Tachometer PRELIMINARY CHECK

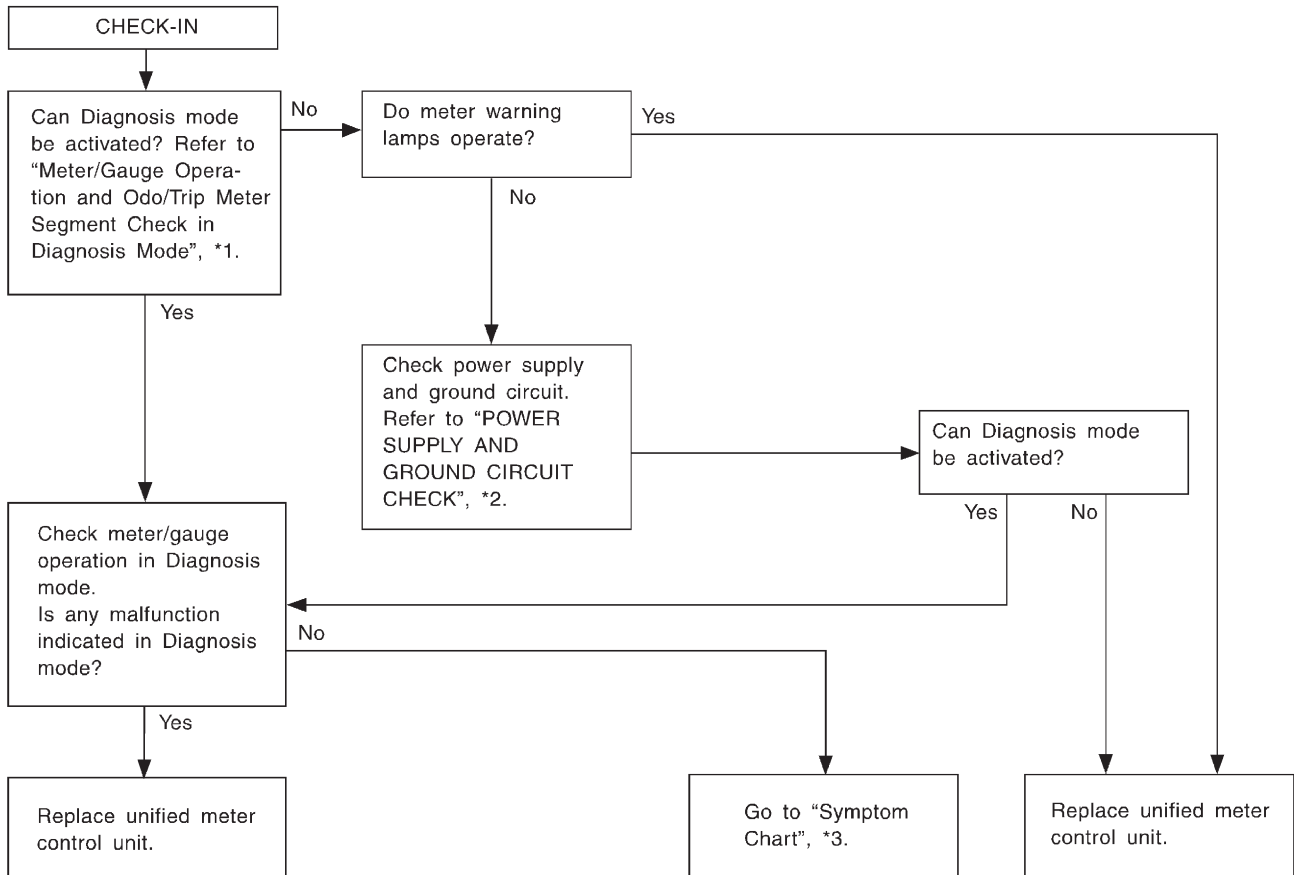

SEL269Y

*1: Meter/Gauge Operation and Odo/Trip Meter Segment Check in Diagnosis Mode (EL-3070)

*2: POWER SUPPLY AND GROUND CIRCUIT CHECK (EL-3072)

*3: Symptom Chart (EL-3071)

SYMPTOM CHART

Symptom	Possible causes	Repair order
One of speedometer/fuel gauge/water temp. gauge is malfunctioning.	1. Sensor signal - Vehicle speed signal - Fuel gauge - Water temp. gauge 2. Unified meter control unit	1. Check the sensor for malfunctioning meter/gauge. INSPECTION/VEHICLE SPEED SIGNAL (Refer to EL section "Vehicle speed signal" in original Service Manual.) INSPECTION/FUEL LEVEL SENSOR UNIT INSPECTION/THERMAL TRANSMITTER 2. Replace unified meter control unit.
Multiple meter/gauge are malfunctioning. (except odo/trip meter)		

Before starting trouble diagnoses below, perform PRELIMINARY CHECK, EL-3071.

METER AND GAUGES

Trouble Diagnoses/With Tachometer (Cont'd)

POWER SUPPLY AND GROUND CIRCUIT CHECK

Power supply circuit check

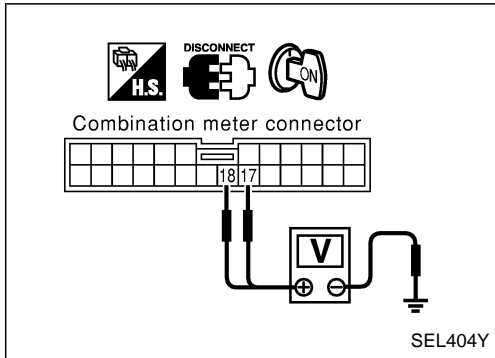

Terminals		Ignition switch position		
⊕	⊖	OFF	ACC	ON
⑱ (R/G)	Ground	Battery voltage	Battery voltage	Battery voltage
⑰ (W/B)	Ground	0V	0V	Battery voltage

If NG, check the following.

- 10A fuse [No. 11], located in fuse block (J/B)]
- 10A fuse [No. 6], located in fuse block (J/B)]
- Harness for open or short between fuse and combination meter

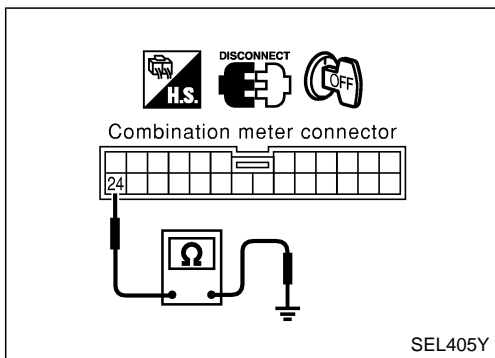

Ground circuit check

Terminals	Continuity
⑳ - Ground (B)	Yes

METER AND GAUGES

Trouble Diagnoses/With Tachometer (Cont'd) INSPECTION/VEHICLE SPEED SENSOR

Without ABS for the Middle East and Except for the Middle East

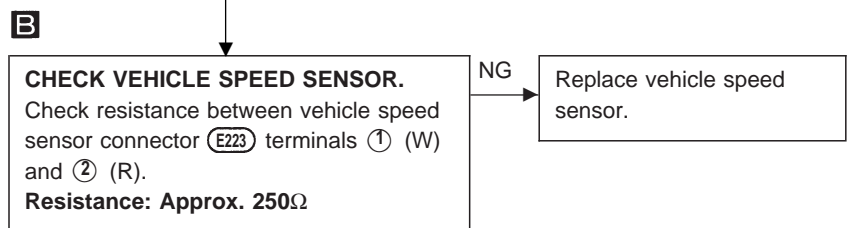
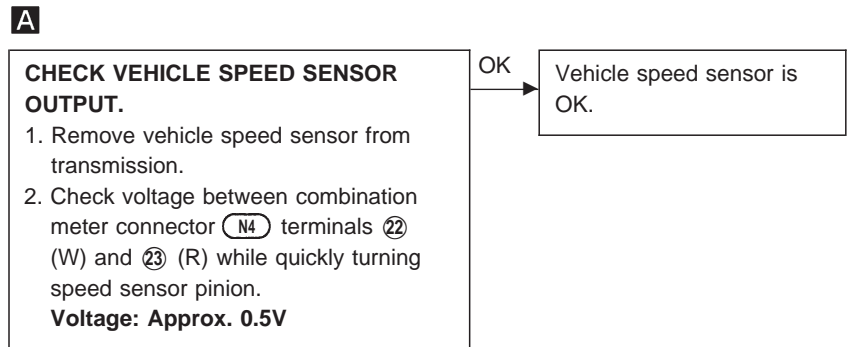
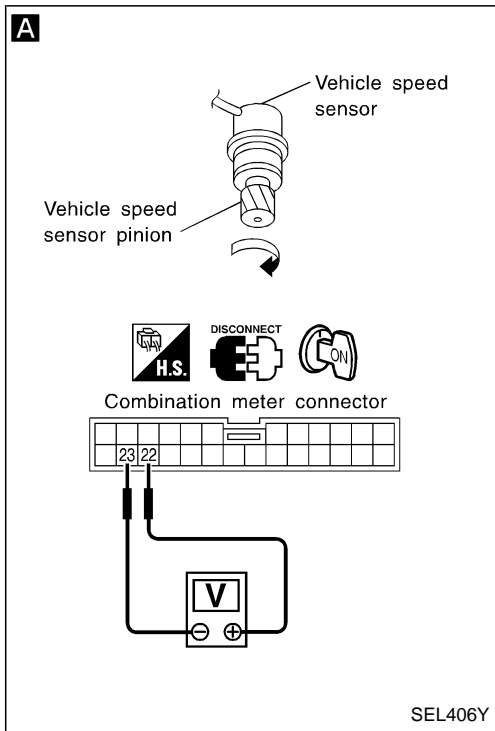

Check harness for open or short between combination meter and vehicle speed sensor.

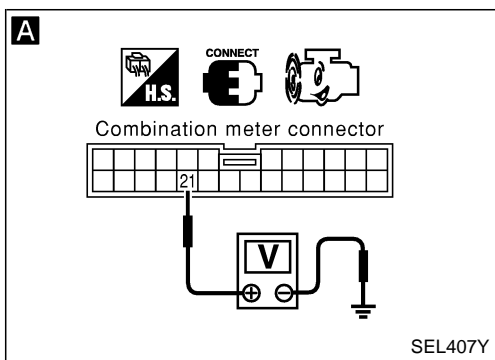
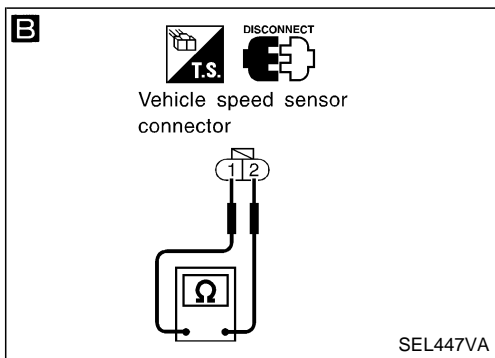

INSPECTION/ENGINE REVOLUTION SIGNAL

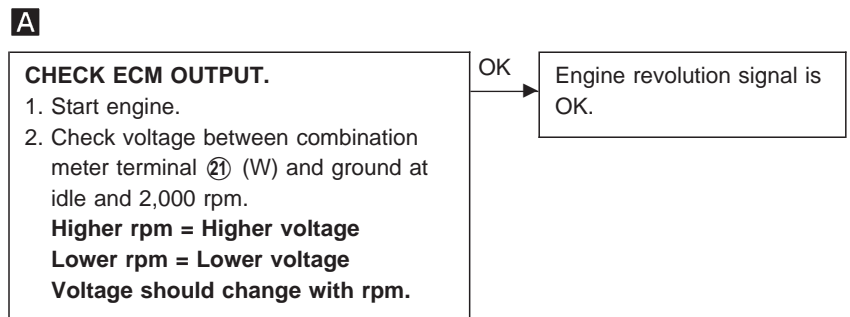

Check the following.

- Harness for open or short between ECM and combination meter

METER AND GAUGES

Trouble Diagnoses/With Tachometer (Cont'd) INSPECTION/FUEL LEVEL SENSOR UNIT

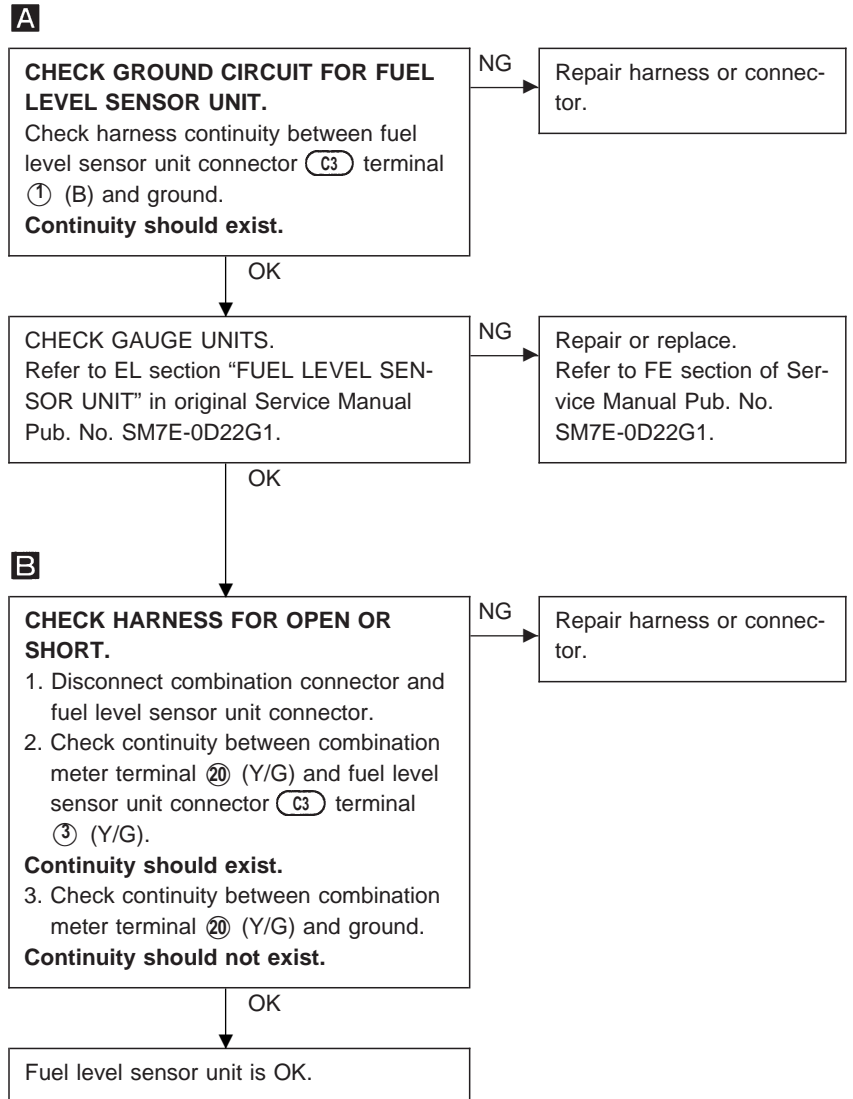
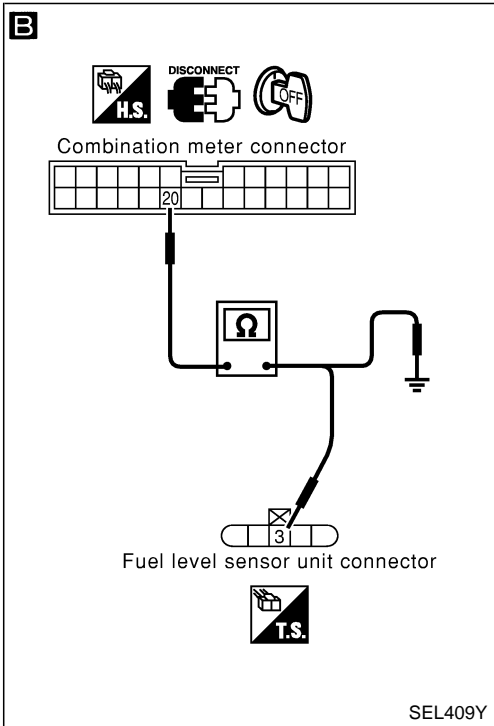
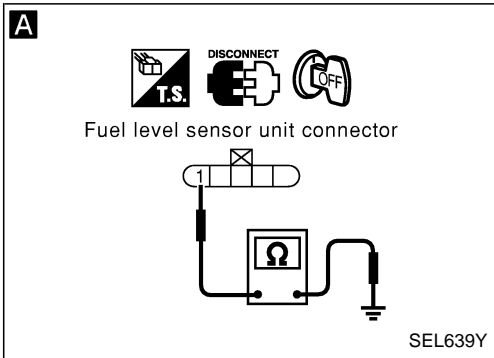

METER AND GAUGES

Trouble Diagnoses/With Tachometer (Cont'd) INSPECTION/THERMAL TRANSMITTER

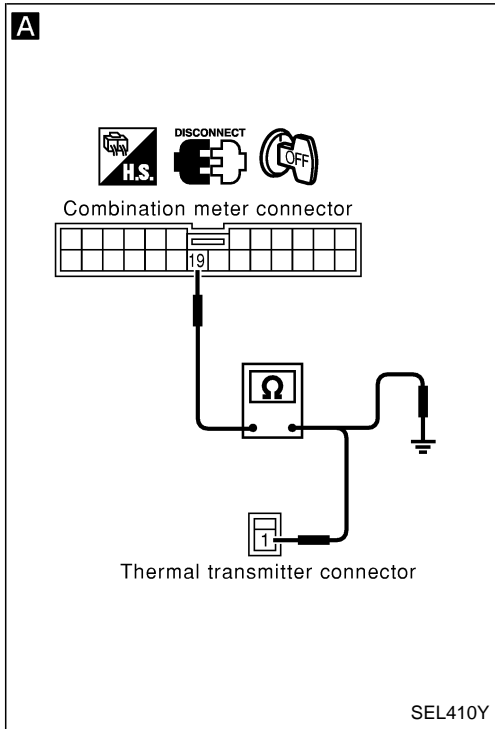

CHECK THERMAL TRANSMITTER.
Refer to EL section "THERMAL TRANSMITTER" in original Service Manual Pub. No. SM7E-0D22G1.

NG

Repair or replace.

OK

A

CHECK HARNESS FOR OPEN OR SHORT.

1. Disconnect combination connector and thermal transmitter connector.
2. Check continuity between combination meter terminal ① (Y/R) and thermal transmitter connector (E9), (M209), (E209) terminal ①.

Continuity should exist.

3. Check continuity between combination meter terminal ① (Y/R) and ground.

Continuity should not exist.

NG

Repair harness or connector.

OK

Thermal transmitter is OK.

METER AND GAUGES

Trouble Diagnoses/Without Tachometer

PRELIMINARY CHECK

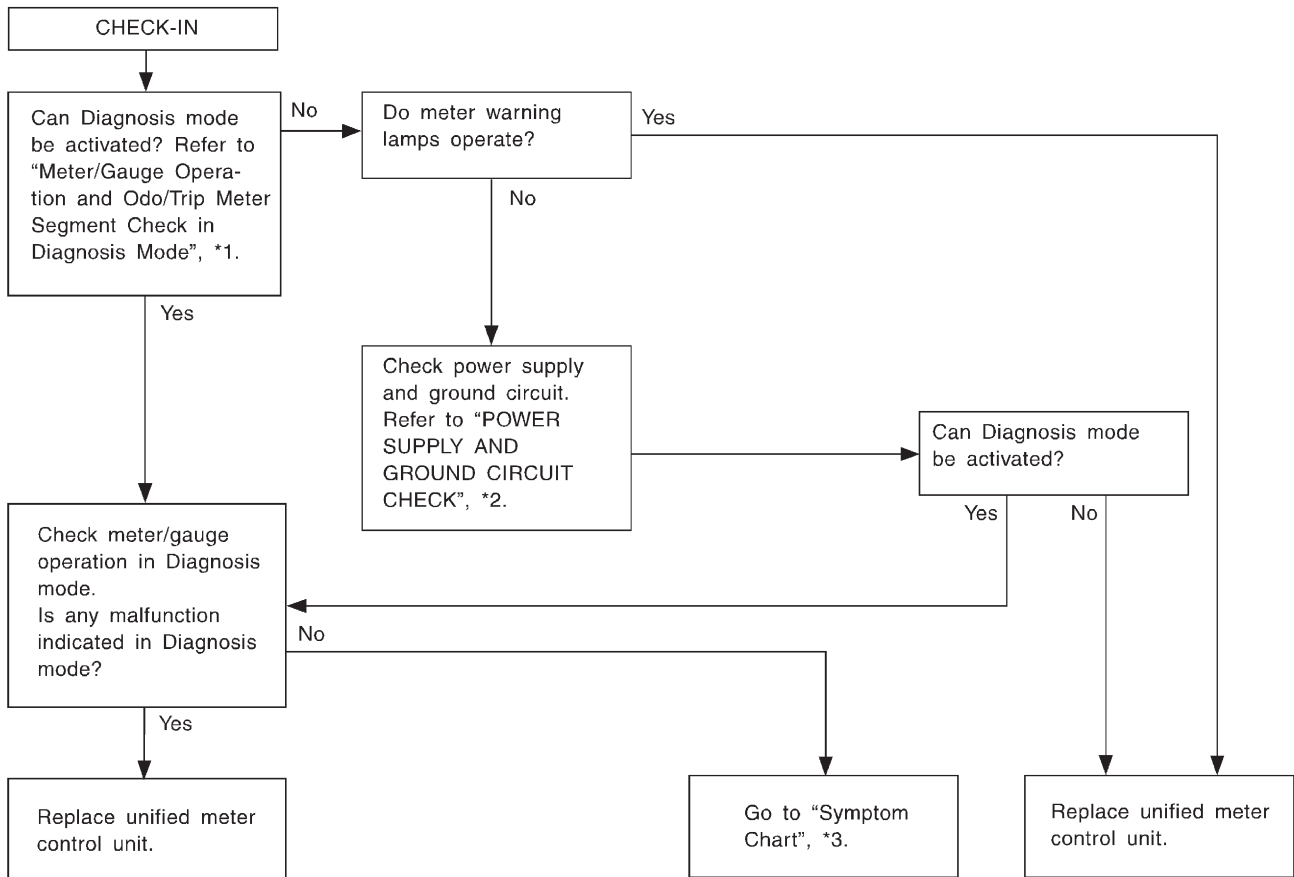

SEL269Y

*1: Meter/Gauge Operation and Odo/Trip Meter Segment Check in Diagnosis Mode (EL-3070)

*2: POWER SUPPLY AND GROUND CIRCUIT CHECK (EL-3077)

*3: Symptom Chart (EL-3076)

SYMPTOM CHART

Symptom	Possible causes	Repair order
One of speedometer/fuel gauge/water temp. gauge is malfunctioning.	1. Sensor signal - Vehicle speed signal - Fuel gauge - Water temp. gauge 2. Unified meter control unit	1. Check the sensor for malfunctioning meter/gauge. INSPECTION/VEHICLE SPEED SIGNAL (Refer to EL section "Vehicle speed signal" in original Service Manual.) INSPECTION/FUEL LEVEL SENSOR UNIT INSPECTION/THERMAL TRANSMITTER 2. Replace unified meter control unit.
Multiple meter/gauge are malfunctioning. (except odo/trip meter)		

Before starting trouble diagnoses below, perform PRELIMINARY CHECK, EL-3076.

METER AND GAUGES

Trouble Diagnoses/Without Tachometer (Cont'd)

POWER SUPPLY AND GROUND CIRCUIT CHECK

Power supply circuit check

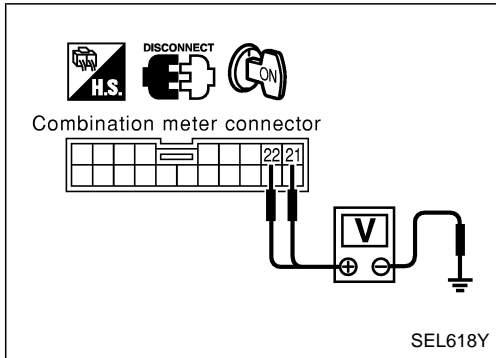

Terminals		Ignition switch position		
⊕	⊖	OFF	ACC	ON
⑰ (R/G)	Ground	Battery voltage	Battery voltage	Battery voltage
⑳ (W/B)	Ground	0V	0V	Battery voltage

If NG, check the following.

- 10A fuse [No. ⑥], located in fuse block (J/B)]
- 10A fuse [No. ⑪], located in fuse block (J/B)]
- Harness for open or short between fuse and combination meter

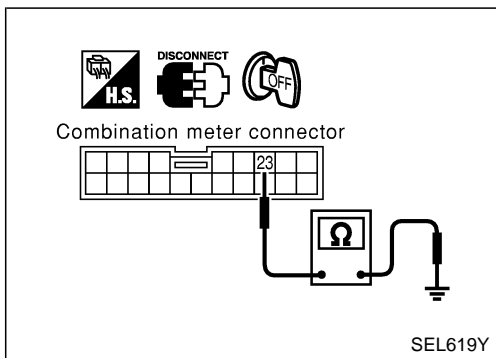

Ground circuit check

Terminals	Continuity
⑳ - Ground (B)	Yes

METER AND GAUGES

Trouble Diagnoses/Without Tachometer (Cont'd)

INSPECTION/VEHICLE SPEED SENSOR

Without ABS for the Middle East and Except for the Middle East

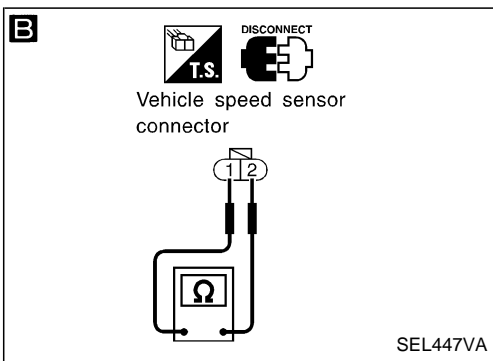
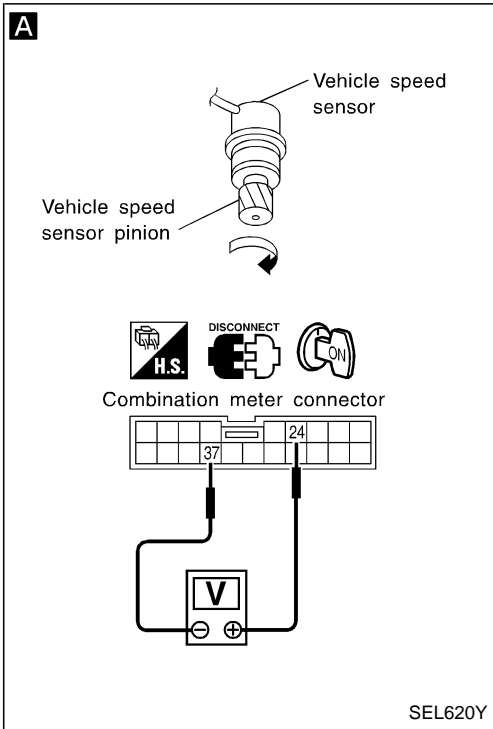

A

CHECK VEHICLE SPEED SENSOR OUTPUT.

1. Remove vehicle speed sensor from transmission.
2. Check voltage between combination meter connector (N10) terminals ② (W) and ③ (R) while quickly turning speed sensor pinion.

Voltage: Approx. 0.5V

OK

Vehicle speed sensor is OK.

NG

B

CHECK VEHICLE SPEED SENSOR.

- Check resistance between vehicle speed sensor connector (E223) terminals ① (W) and ② (R).

Resistance: Approx. 250Ω

NG

Replace vehicle speed sensor.

OK

Check harness for open or short between combination meter and vehicle speed sensor.

METER AND GAUGES

Trouble Diagnoses/Without Tachometer (Cont'd) INSPECTION/FUEL LEVEL SENSOR UNIT

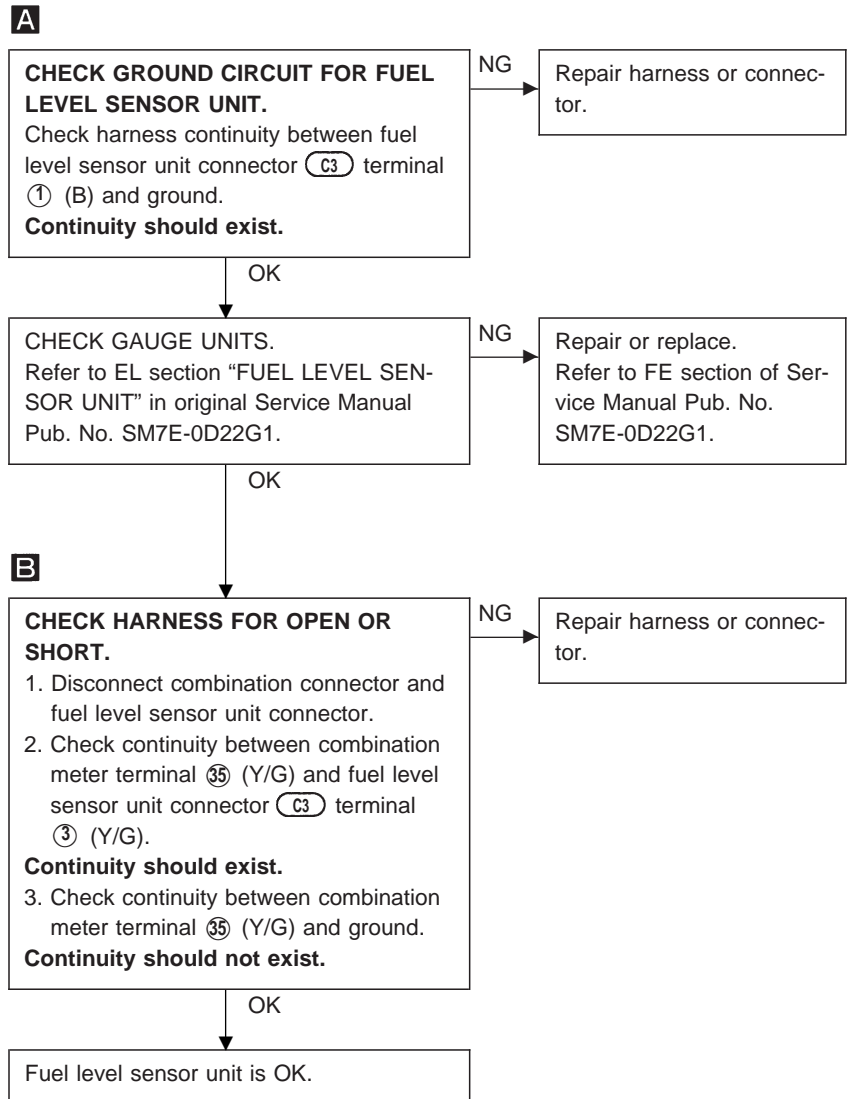
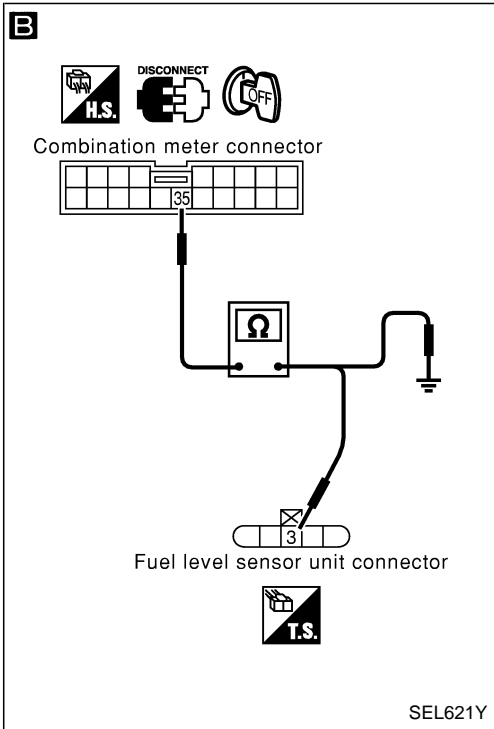
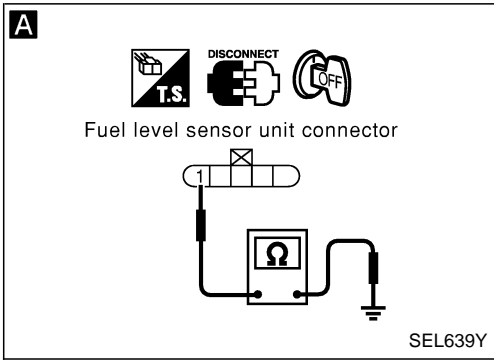

METER AND GAUGES

Trouble Diagnoses/Without Tachometer (Cont'd)

INSPECTION/THERMAL TRANSMITTER

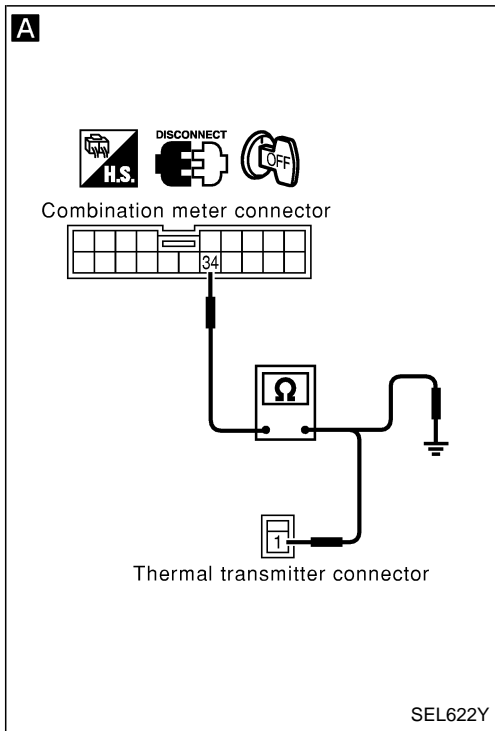

CHECK THERMAL TRANSMITTER.
Refer to EL section "THERMAL TRANSMITTER" in original Service Manual Pub. No. SM7E-0D22G1.

NG

Repair or replace.

OK

A

CHECK HARNESS FOR OPEN OR SHORT.

1. Disconnect combination connector and thermal transmitter connector.
2. Check continuity between combination meter terminal ③④ (Y/R) and thermal transmitter connector ① (E9, M209, E209).

Continuity should exist.

3. Check continuity between combination meter terminal ③④ (Y/R) and ground.

Continuity should not exist.

NG

Repair harness or connector.

OK

Thermal transmitter is OK.

WARNING LAMPS

Schematic/With Tachometer

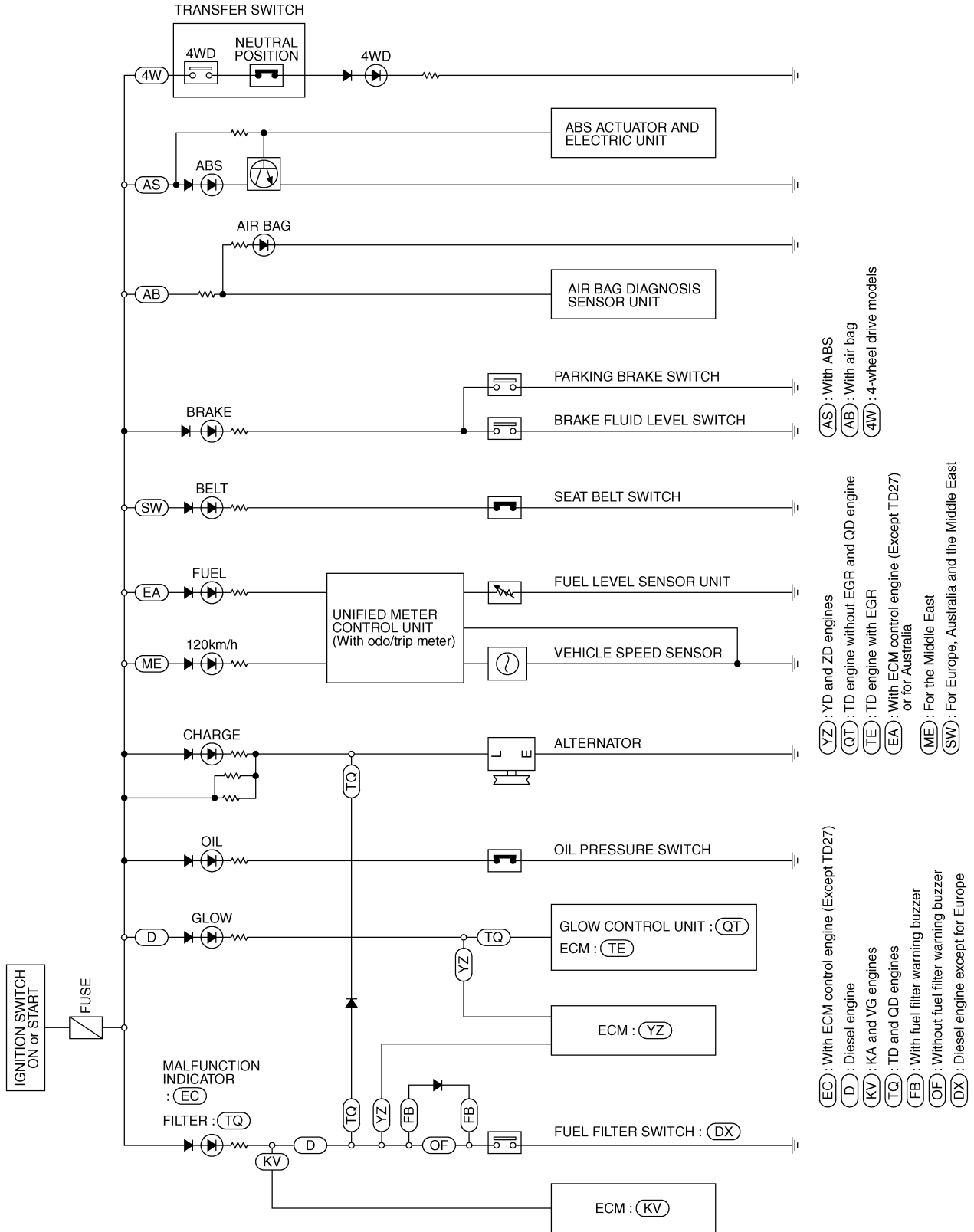

WARNING LAMPS

Schematic/Without Tachometer

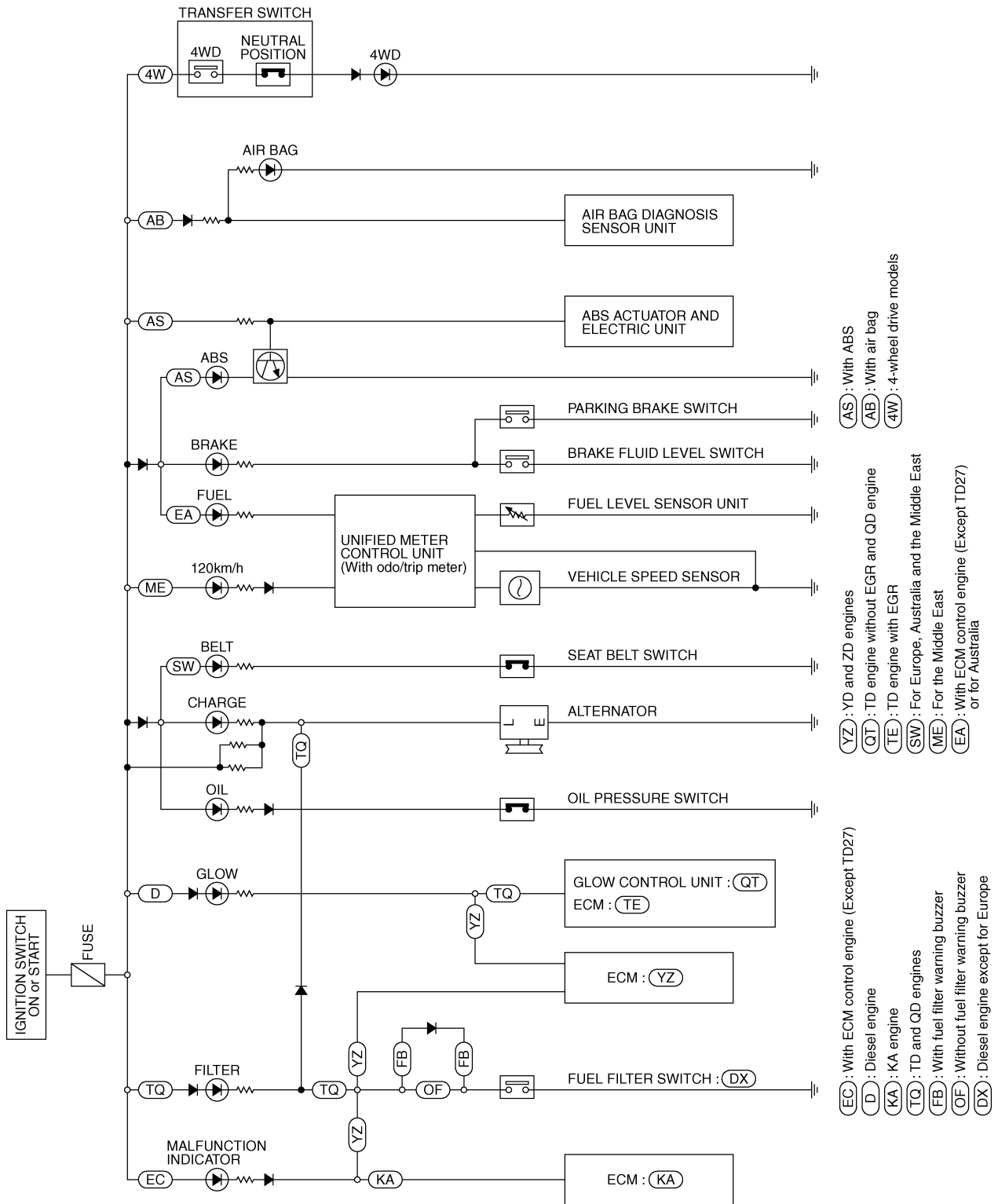

WARNING LAMPS

Wiring Diagram — WARN —/Gasoline Engine with Tachometer (Cont'd)

EL-WARN-02

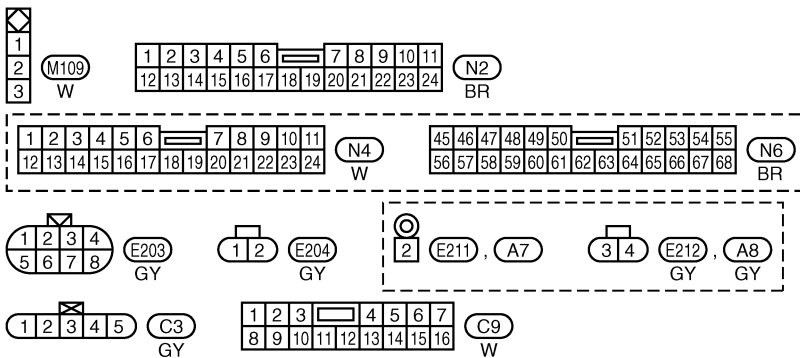
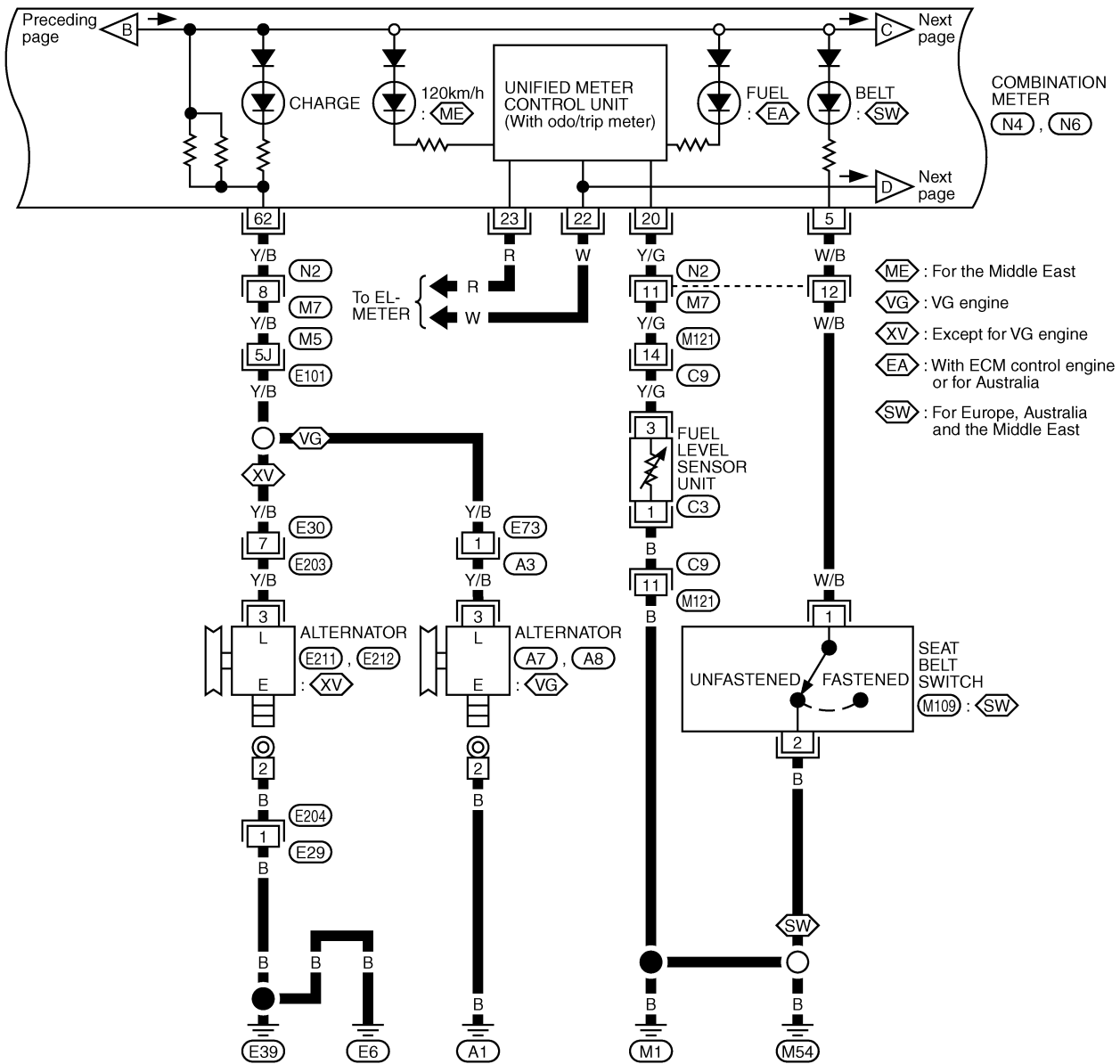

Refer to last page (Foldout page).

M5, E101

WARNING LAMPS

Wiring Diagram — WARN —/Gasoline Engine with Tachometer (Cont'd)

EL-WARN-03

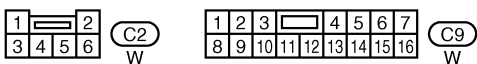
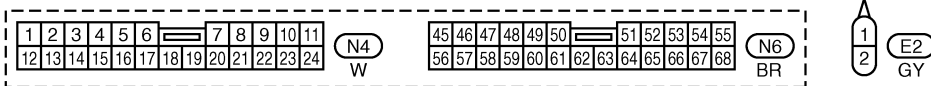
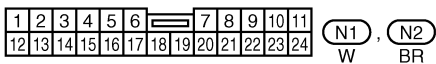
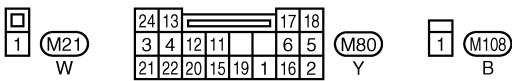
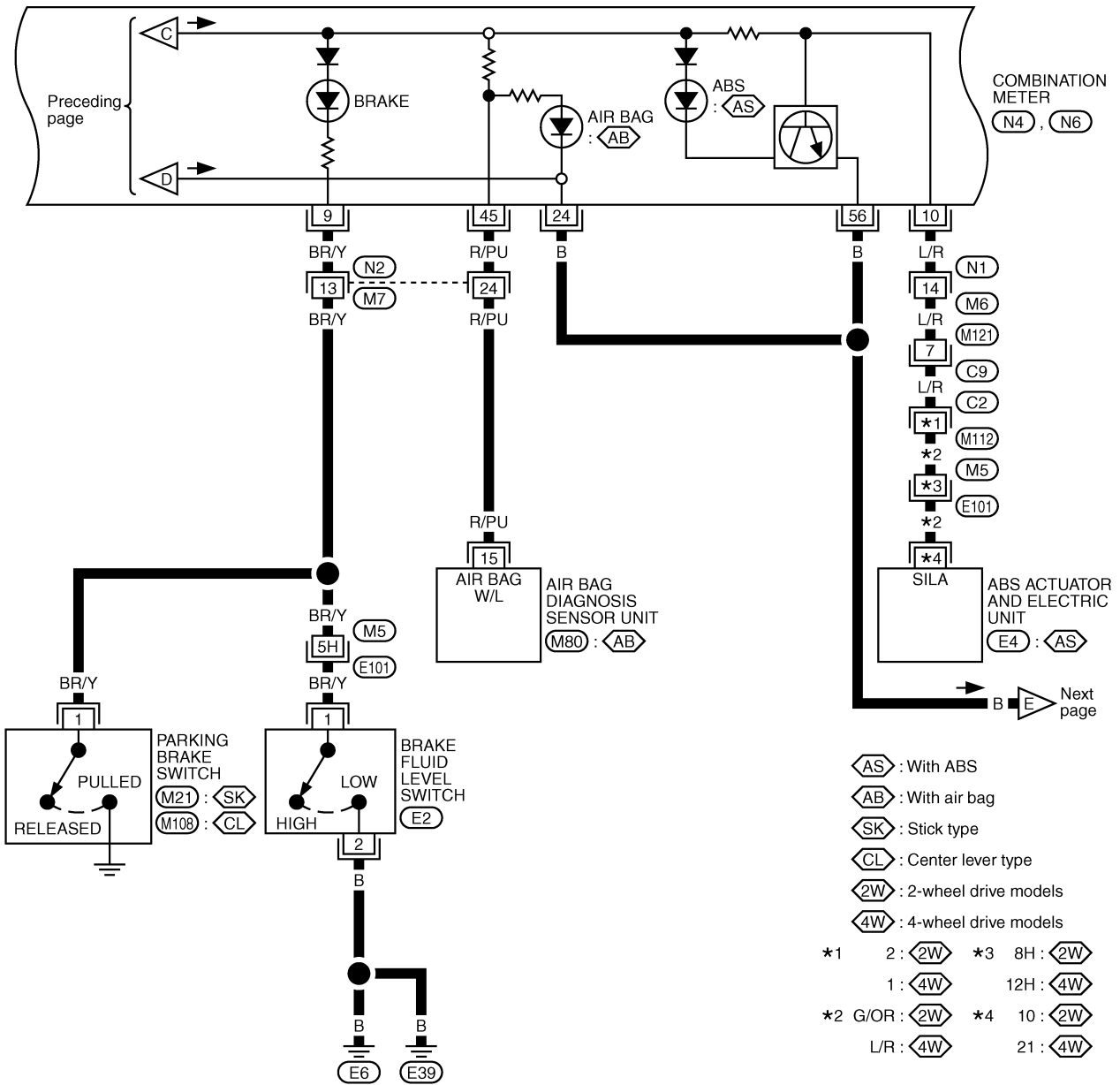

Refer to last page (Foldout page).

M5, E101
E4

WARNING LAMPS

Wiring Diagram — WARN —/Gasoline Engine with Tachometer (Cont'd)

EL-WARN-04

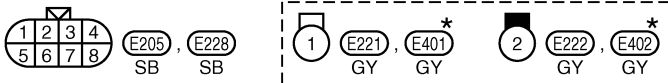
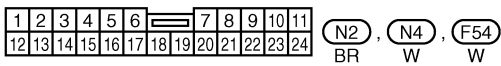
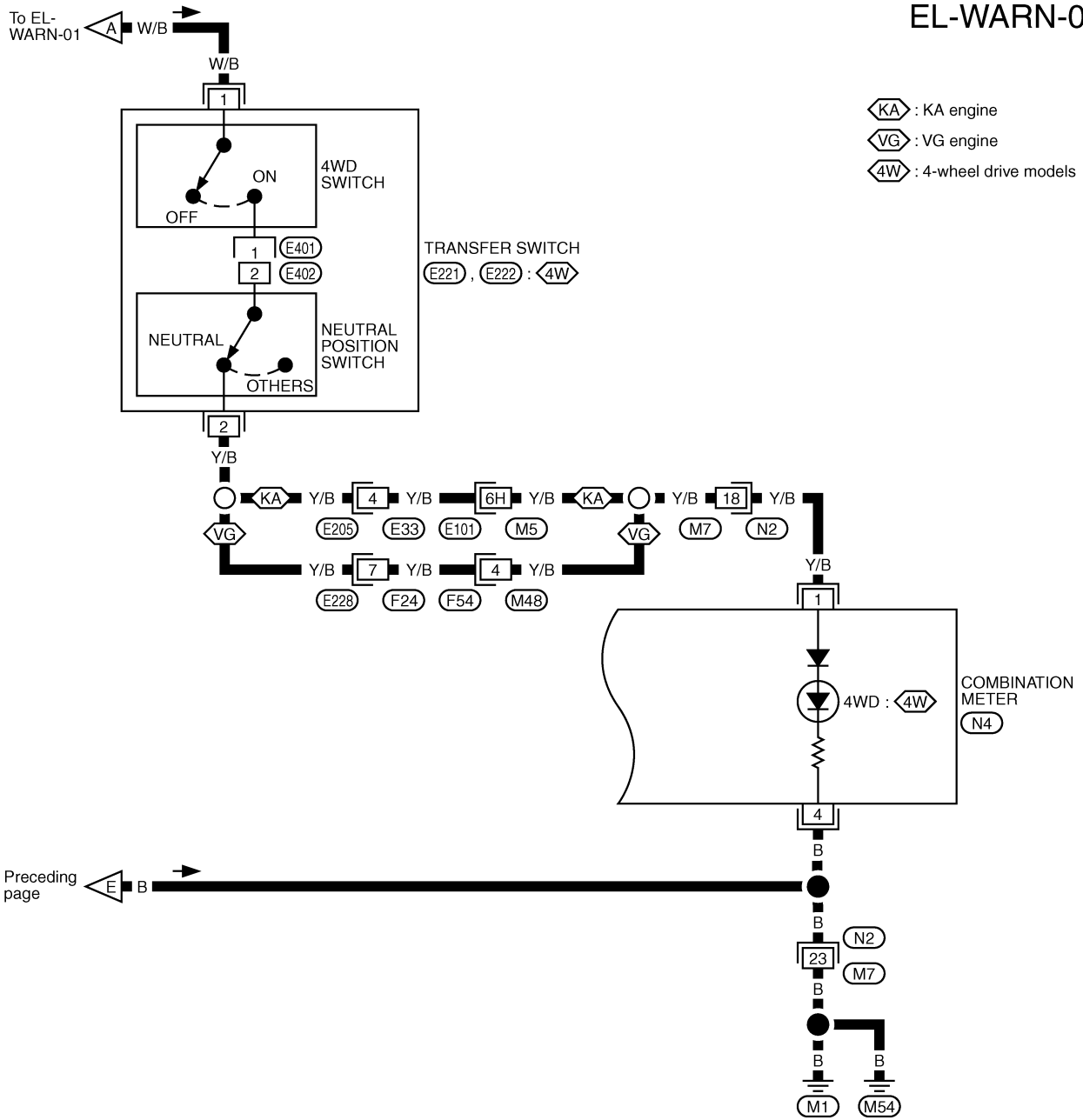

*: This connector is not shown in "HARNES LAYOUT".

Refer to last page (Foldout page).
(M5), (E101)

WARNING LAMPS

Wiring Diagram — WARN —/Gasoline Engine without Tachometer

EL-WARN-05

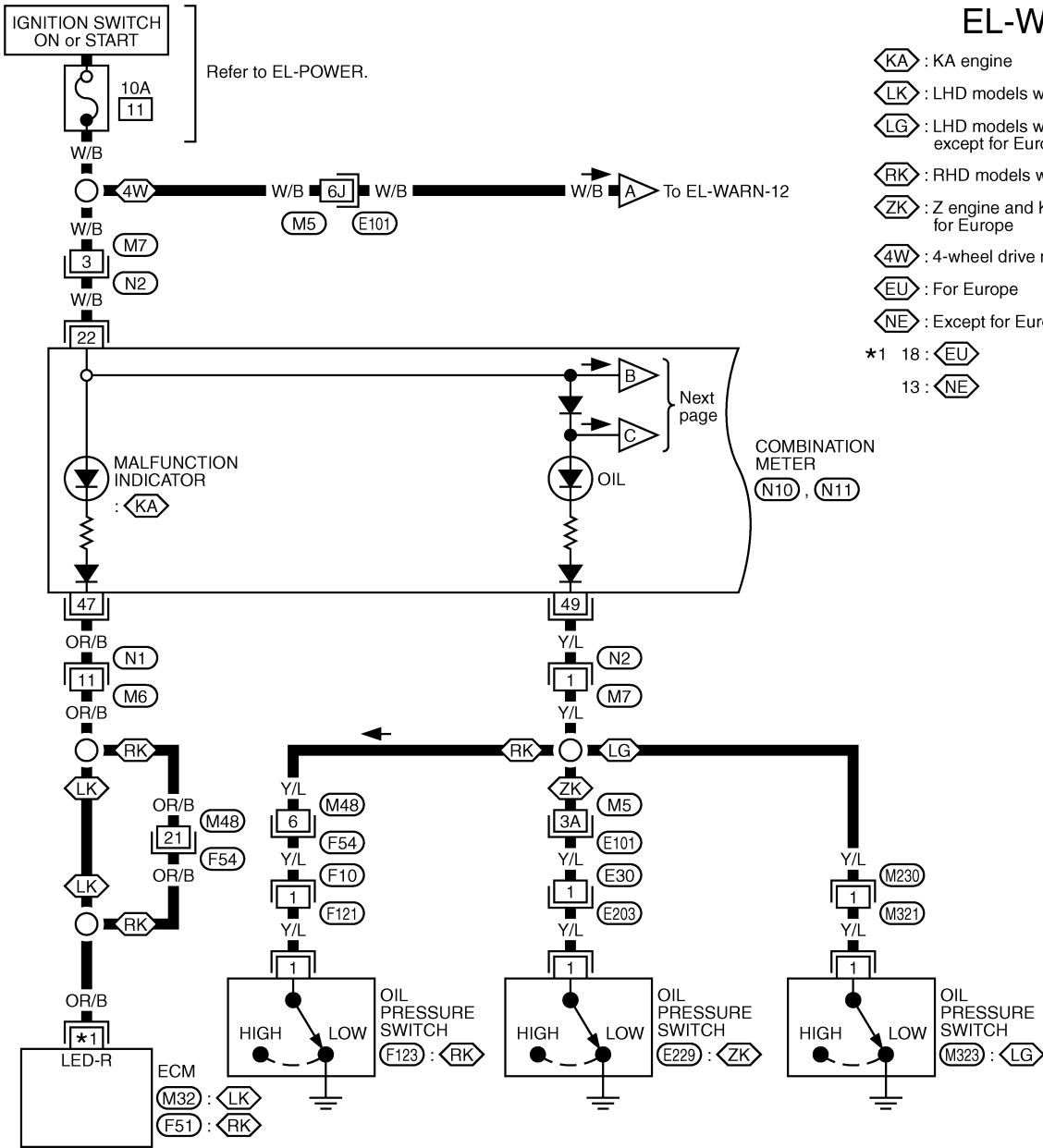

- <KA> : KA engine
- <LK> : LHD models with KA engine
- <LG> : LHD models with KA engine except for Europe
- <RK> : RHD models with KA engine
- <ZK> : Z engine and KA engine for Europe
- 4W : 4-wheel drive models
- EU : For Europe
- NE : Except for Europe
- *1 18 : EU
- 13 : NE

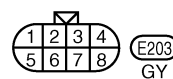
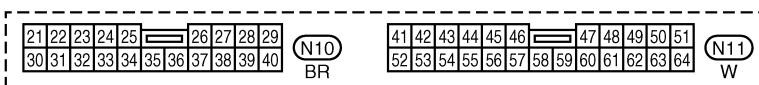
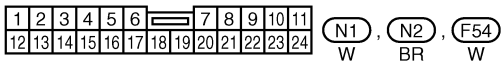
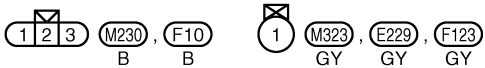

Refer to last page (Foldout page).

- M5, E101
- M32
- F51

WARNING LAMPS

Wiring Diagram — WARN —/Gasoline Engine without Tachometer (Cont'd)

EL-WARN-06

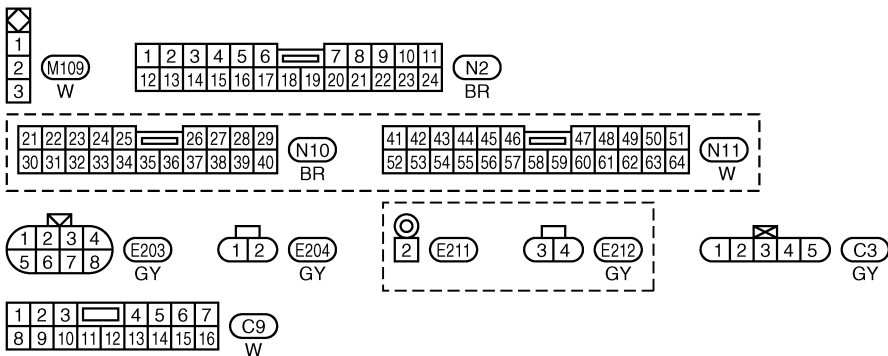
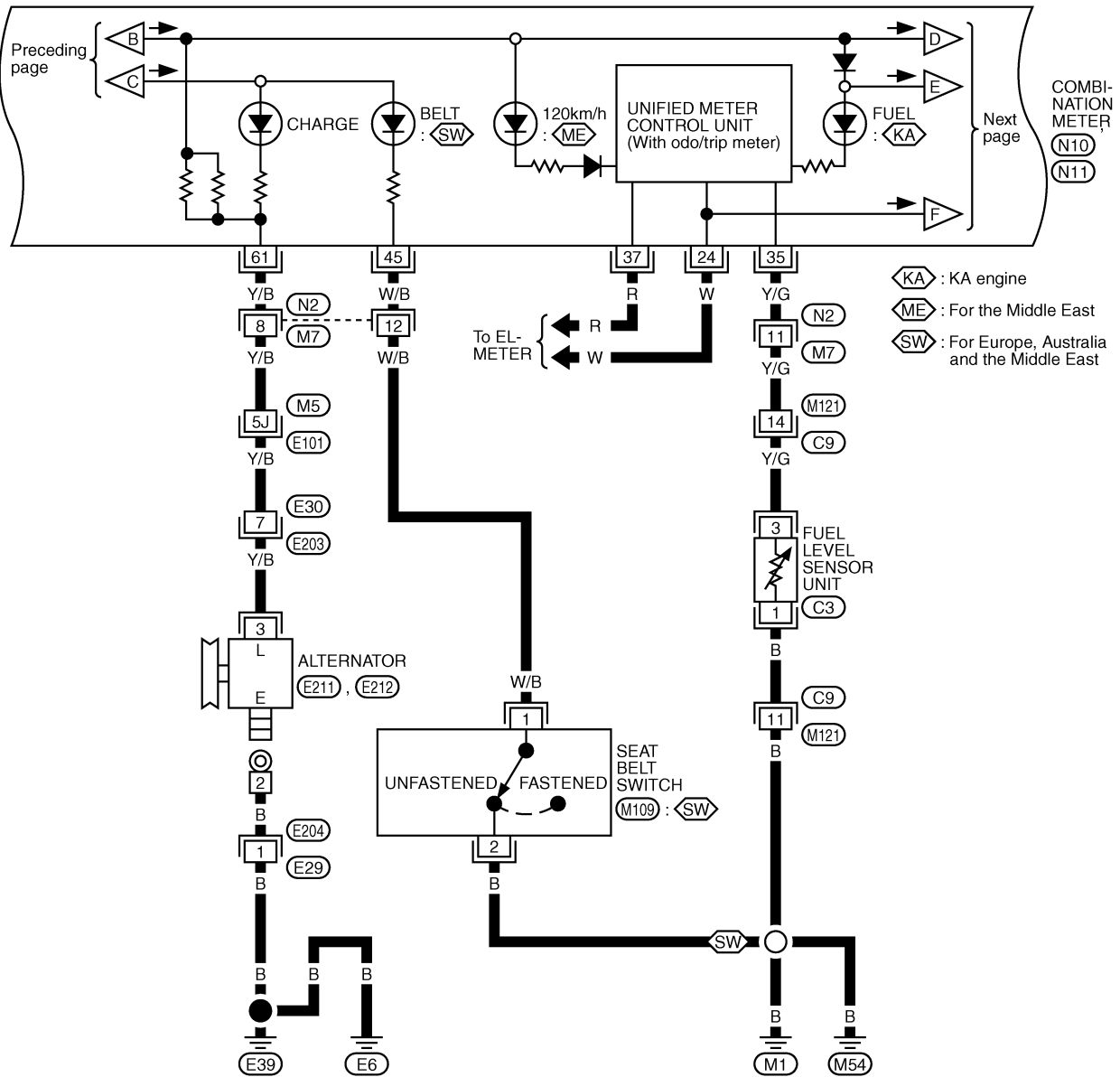

Refer to last page (Foldout page).

M5, E101

WARNING LAMPS

Wiring Diagram — WARN —/Gasoline Engine without Tachometer (Cont'd)

EL-WARN-07

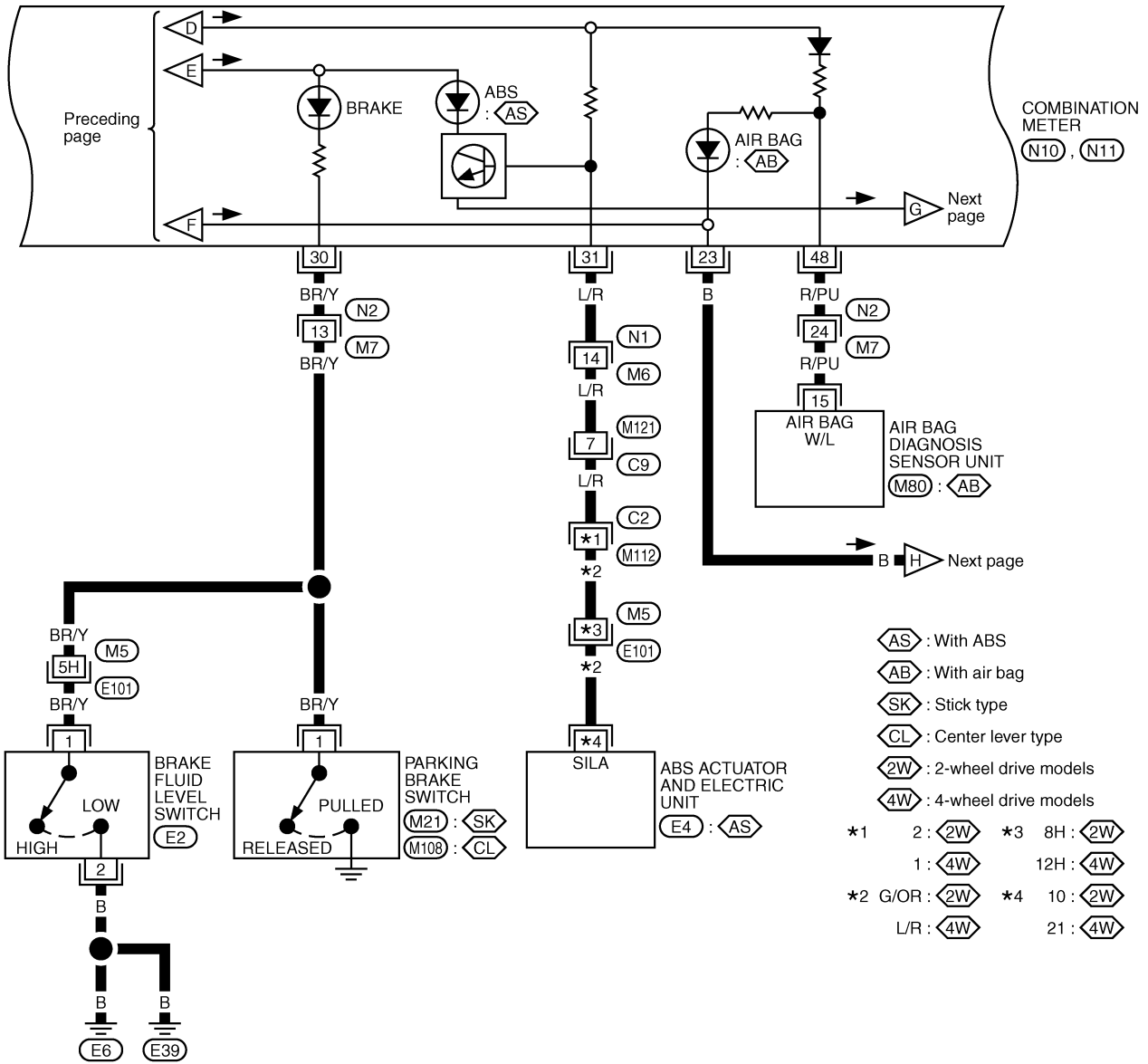

- AS : With ABS
- AB : With air bag
- SK : Stick type
- CL : Center lever type
- 2W : 2-wheel drive models
- 4W : 4-wheel drive models
- *1 2: 2W *3 8H: 2W
- 1: 4W 12H: 4W
- *2 G/OR: 2W *4 10: 2W
- L/R: 4W 21: 4W

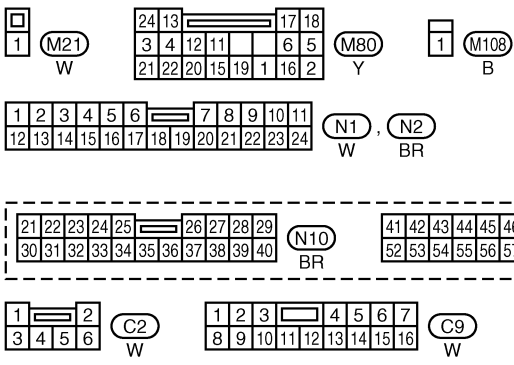

Refer to last page (Foldout page).
M5, E101
E4

WARNING LAMPS

Wiring Diagram — WARN —/Gasoline Engine without Tachometer (Cont'd)

EL-WARN-08

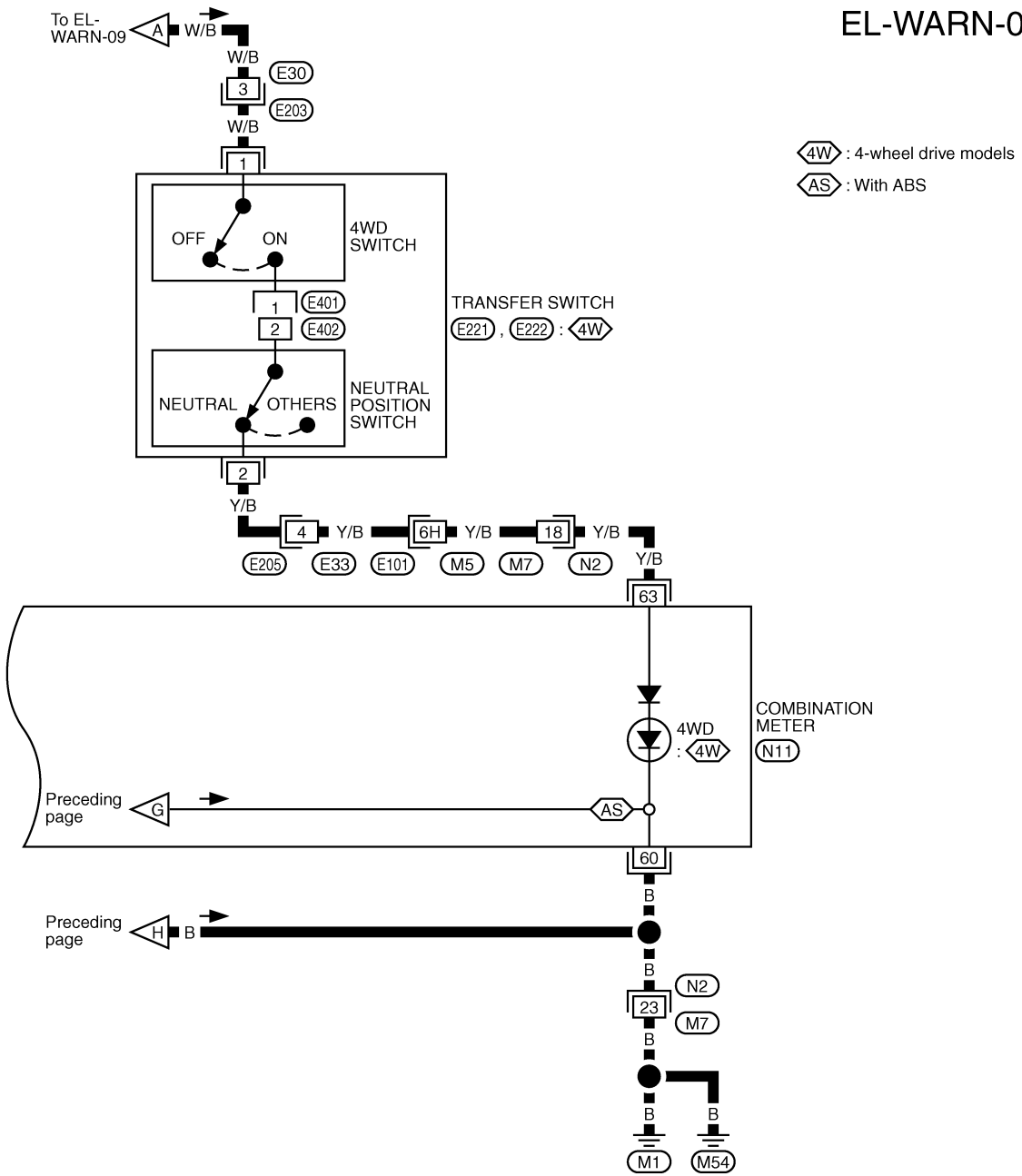

1	2	3	4	5	6	7	8	9	10	11		
12	13	14	15	16	17	18	19	20	21	22	23	24

41	42	43	44	45	46	47	48	49	50	51		
52	53	54	55	56	57	58	59	60	61	62	63	64

(N2)
BR

(N11)
W

1	2	3	4
5	6	7	8

1	2
3	4

(E203)
GY

(E205)
SB

(E221)
GY

(E401)
GY*

(E222)
GY

(E402)
GY*

Refer to last page (Foldout page).

(M5), (E101)

*: This connector is not shown in "HARNES LAYOUT".

WARNING LAMPS

Wiring Diagram — WARN —/Diesel Engine with Tachometer

EL-WARN-09

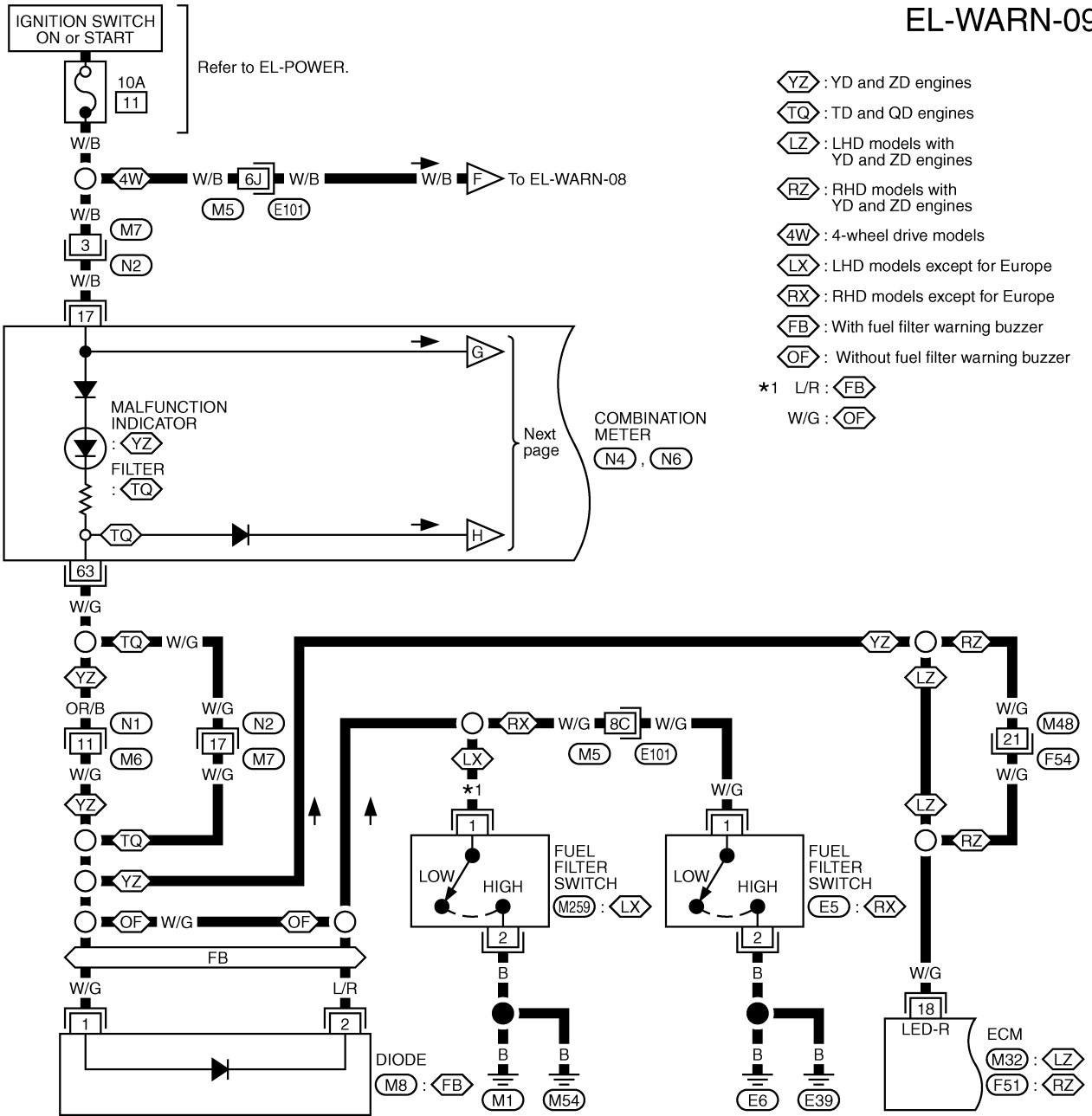

- YZ : YD and ZD engines
 - TQ : TD and QD engines
 - LZ : LHD models with YD and ZD engines
 - RZ : RHD models with YD and ZD engines
 - 4W : 4-wheel drive models
 - LX : LHD models except for Europe
 - RX : RHD models except for Europe
 - FB : With fuel filter warning buzzer
 - OF : Without fuel filter warning buzzer
- *1 L/R : FB
- W/G : OF

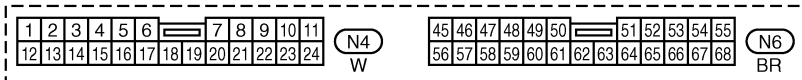
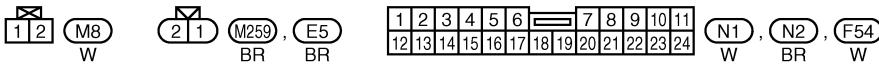

Refer to last page (Foldout page).

- M5, E101
- M32
- F51

WARNING LAMPS

Wiring Diagram — WARN —/Diesel Engine with Tachometer (Cont'd)

EL-WARN-10

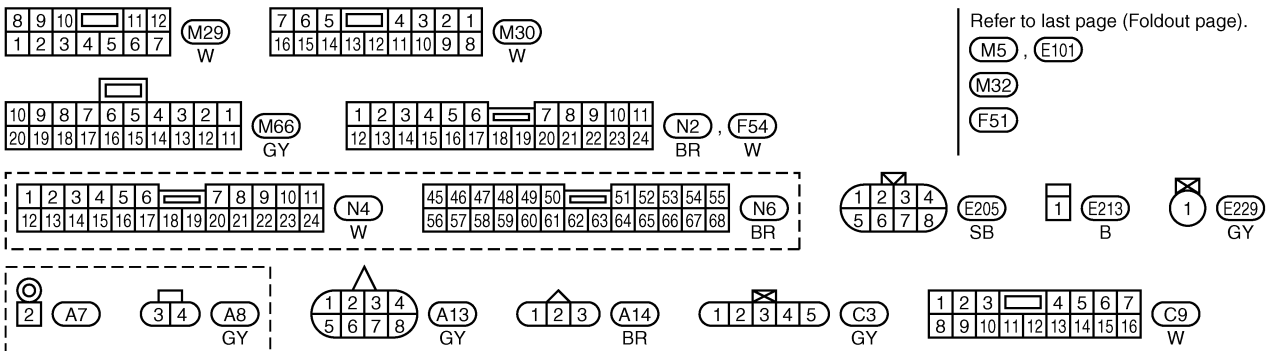
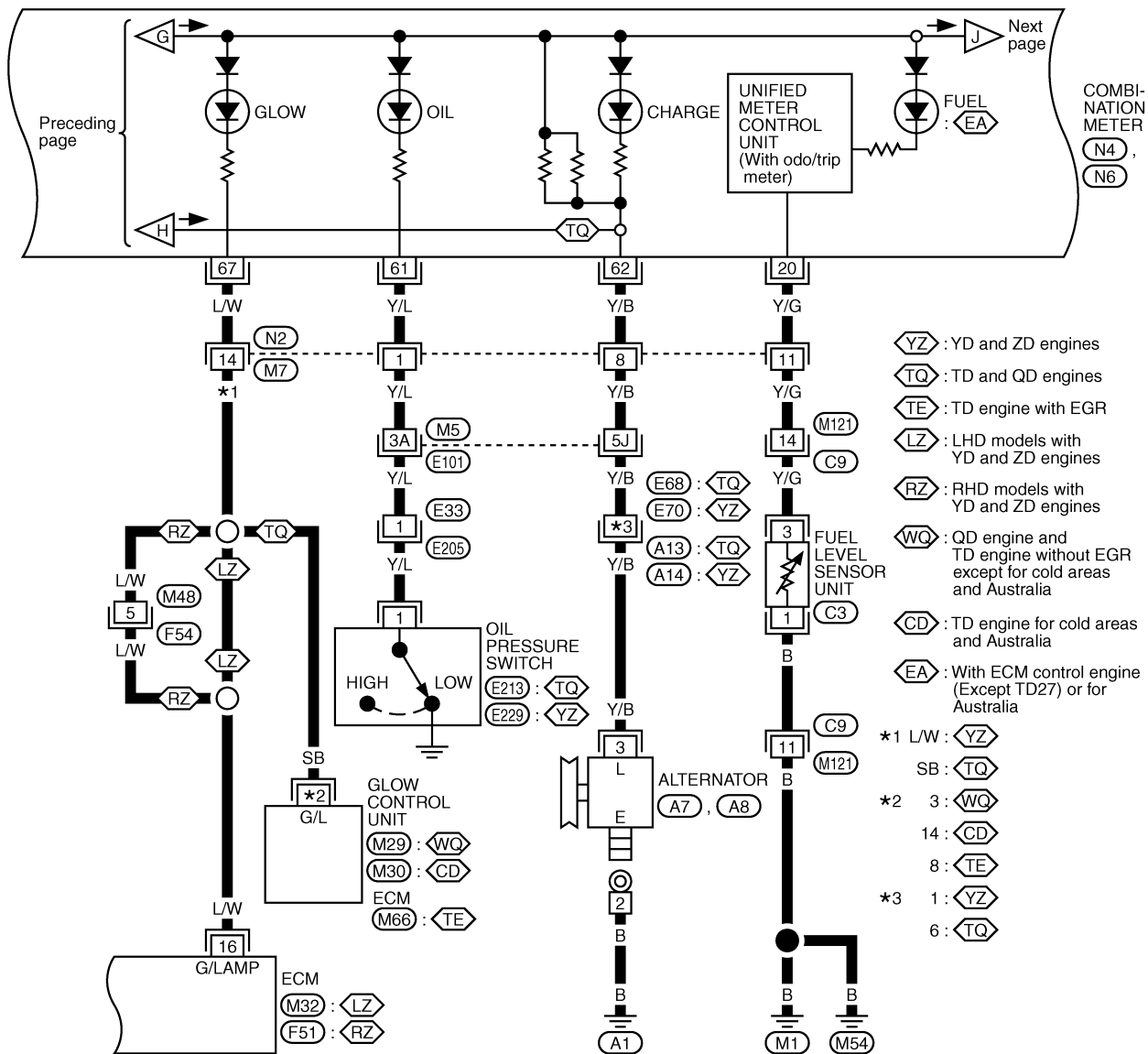

WARNING LAMPS

Wiring Diagram — WARN —/Diesel Engine with Tachometer (Cont'd)

EL-WARN-11

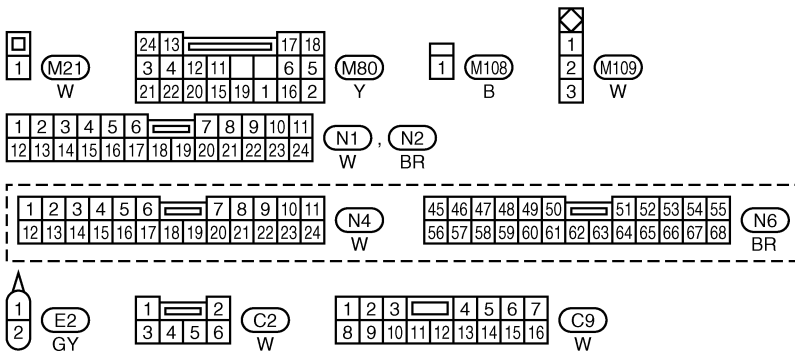
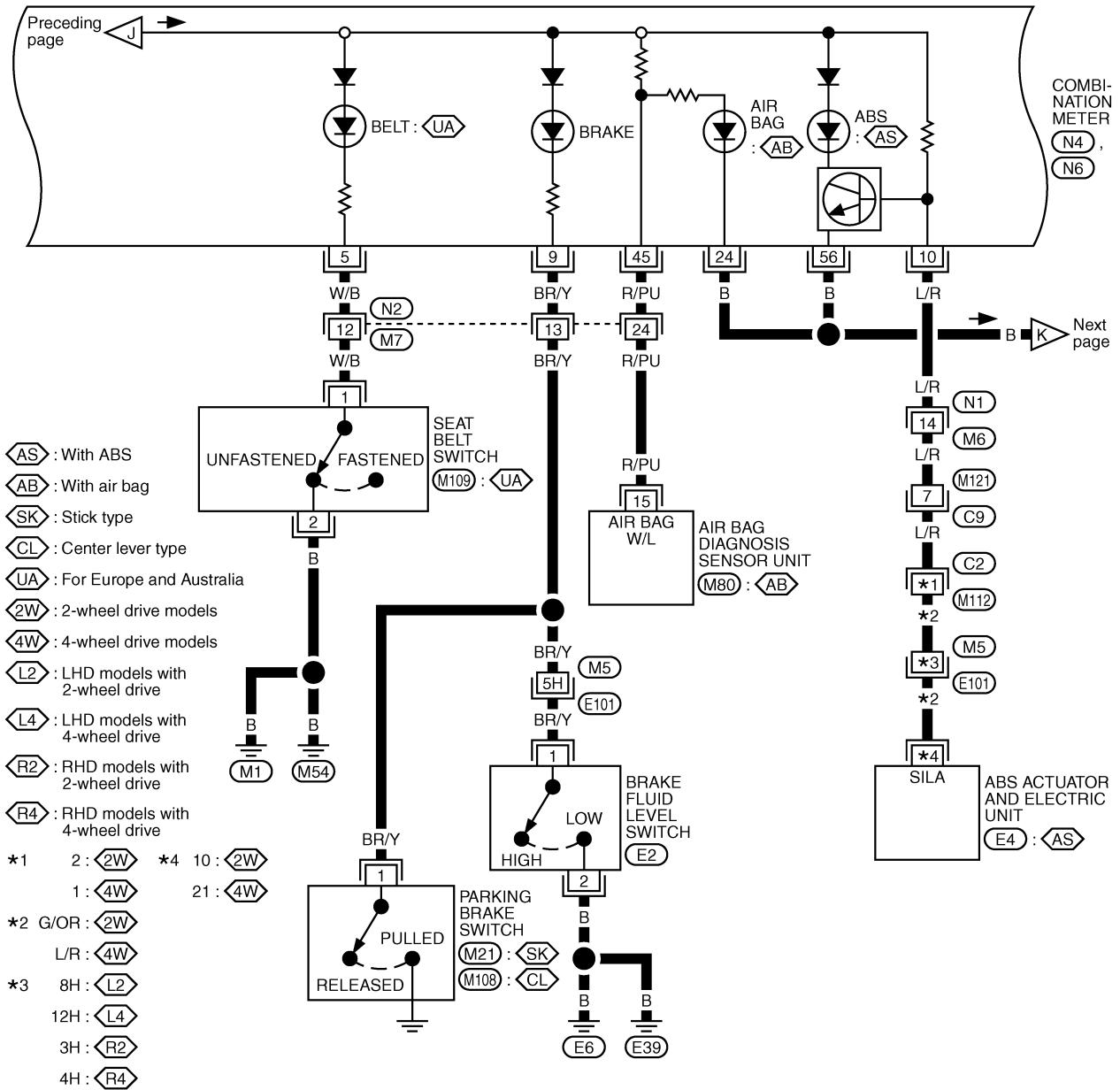

Refer to last page (Foldout page).

M5, E101
E4

WARNING LAMPS

Wiring Diagram — WARN —/Diesel Engine with Tachometer (Cont'd)

EL-WARN-12

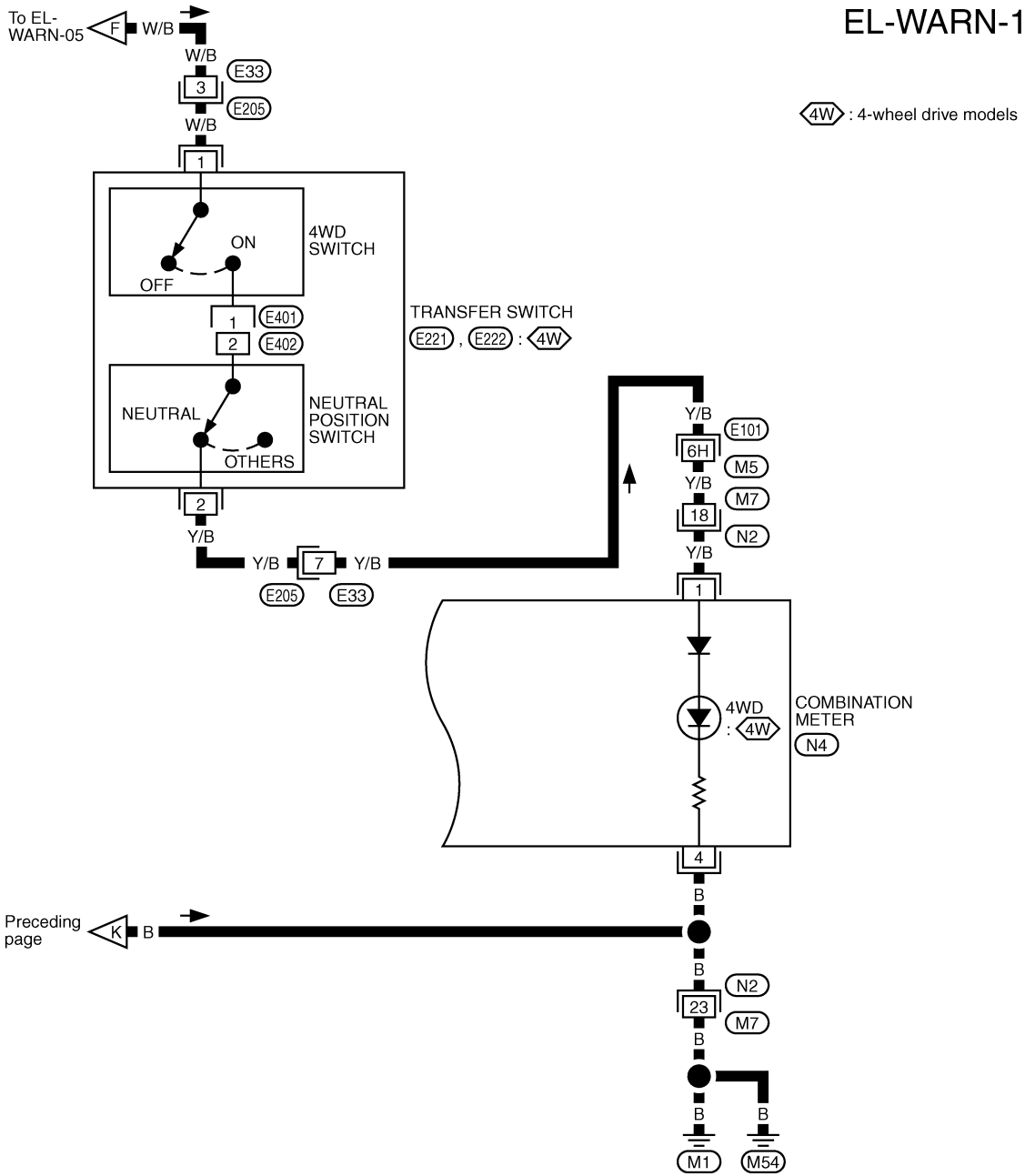

1	2	3	4	5	6	7	8	9	10	11		
12	13	14	15	16	17	18	19	20	21	22	23	24

(N2) BR, (N4) W

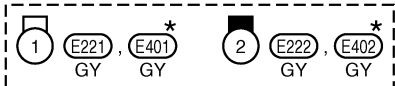
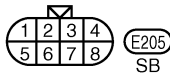

*: This connector is not shown in "HARNES LAYOUT".

Refer to last page (Foldout page).

(M5), (E101)

WARNING LAMPS

Wiring Diagram — WARN —/Diesel Engine without Tachometer

EL-WARN-13

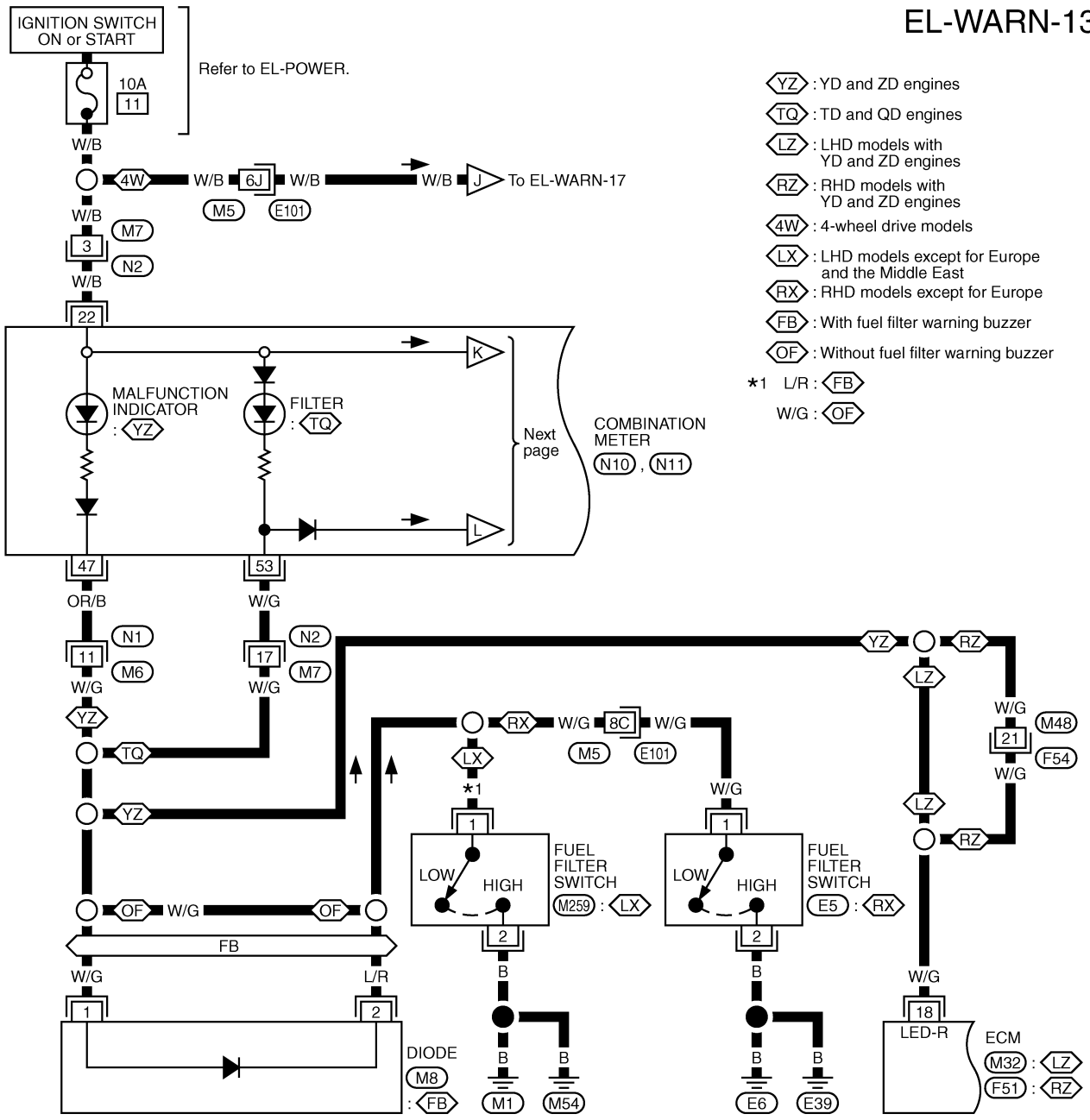

- YZ : YD and ZD engines
- TQ : TD and QD engines
- LZ : LHD models with YD and ZD engines
- RZ : RHD models with YD and ZD engines
- 4W : 4-wheel drive models
- LX : LHD models except for Europe and the Middle East
- RX : RHD models except for Europe
- FB : With fuel filter warning buzzer
- OF : Without fuel filter warning buzzer
- *1 L/R : FB
- W/G : OF

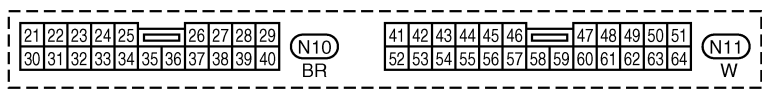
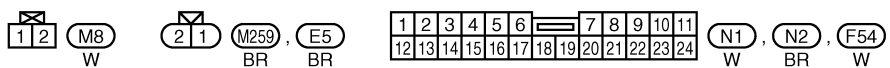

Refer to last page (Foldout page).
(M5), (E101)
(M32)
(F51)

WARNING LAMPS

Wiring Diagram — WARN —/Diesel Engine without Tachometer (Cont'd)

EL-WARN-14

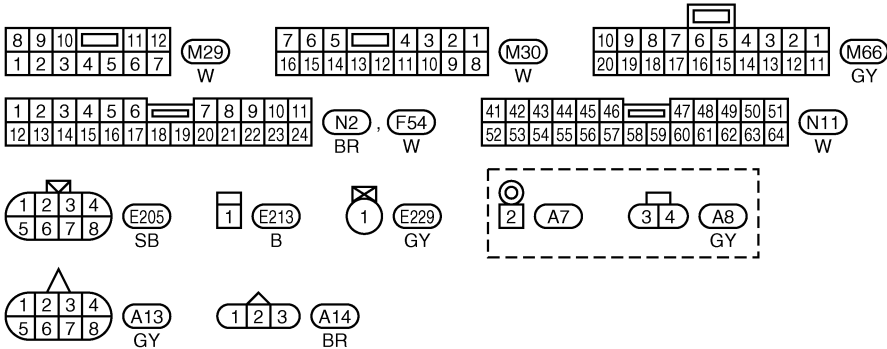
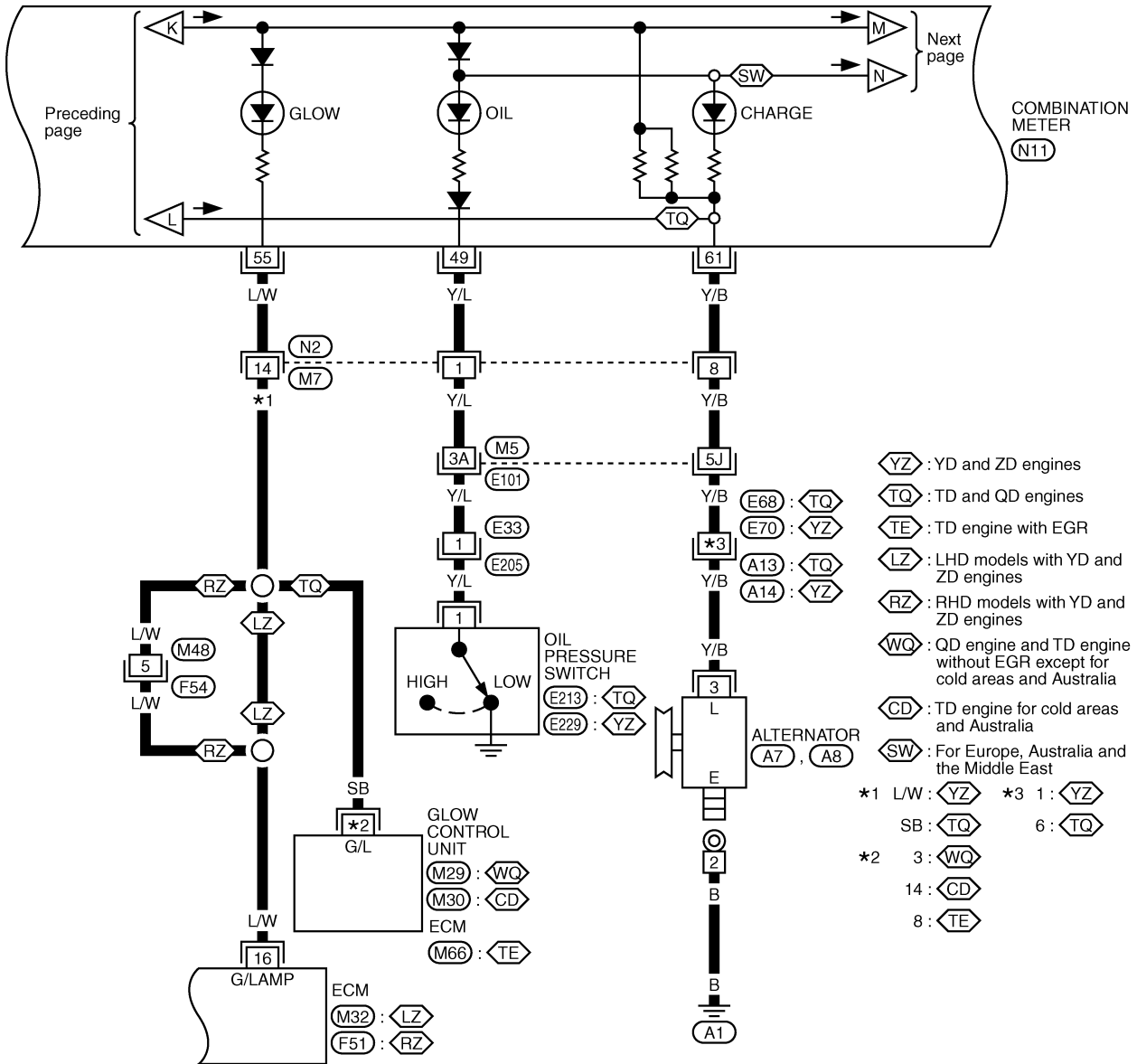

Refer to last page (Foldout page).

M5, E101
M32
F51

WARNING LAMPS

Wiring Diagram — WARN —/Diesel Engine without Tachometer (Cont'd)

EL-WARN-15

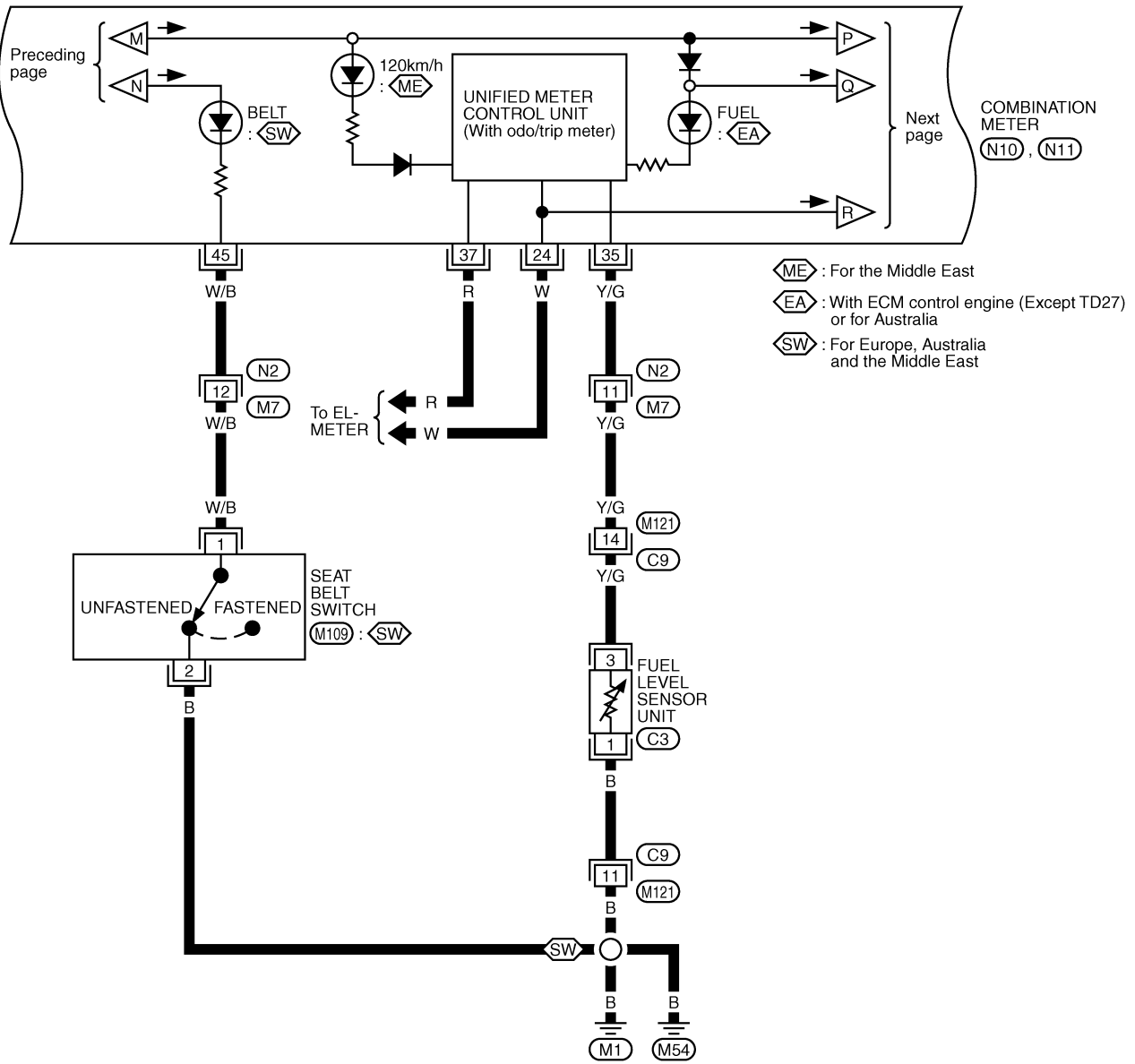

WARNING LAMPS

Wiring Diagram — WARN —/Diesel Engine without Tachometer (Cont'd)

EL-WARN-16

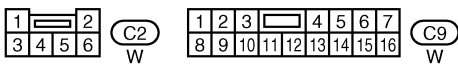
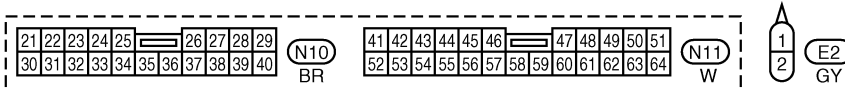
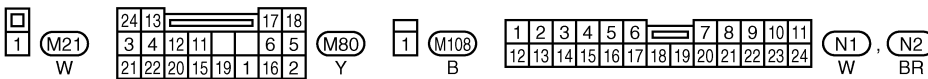
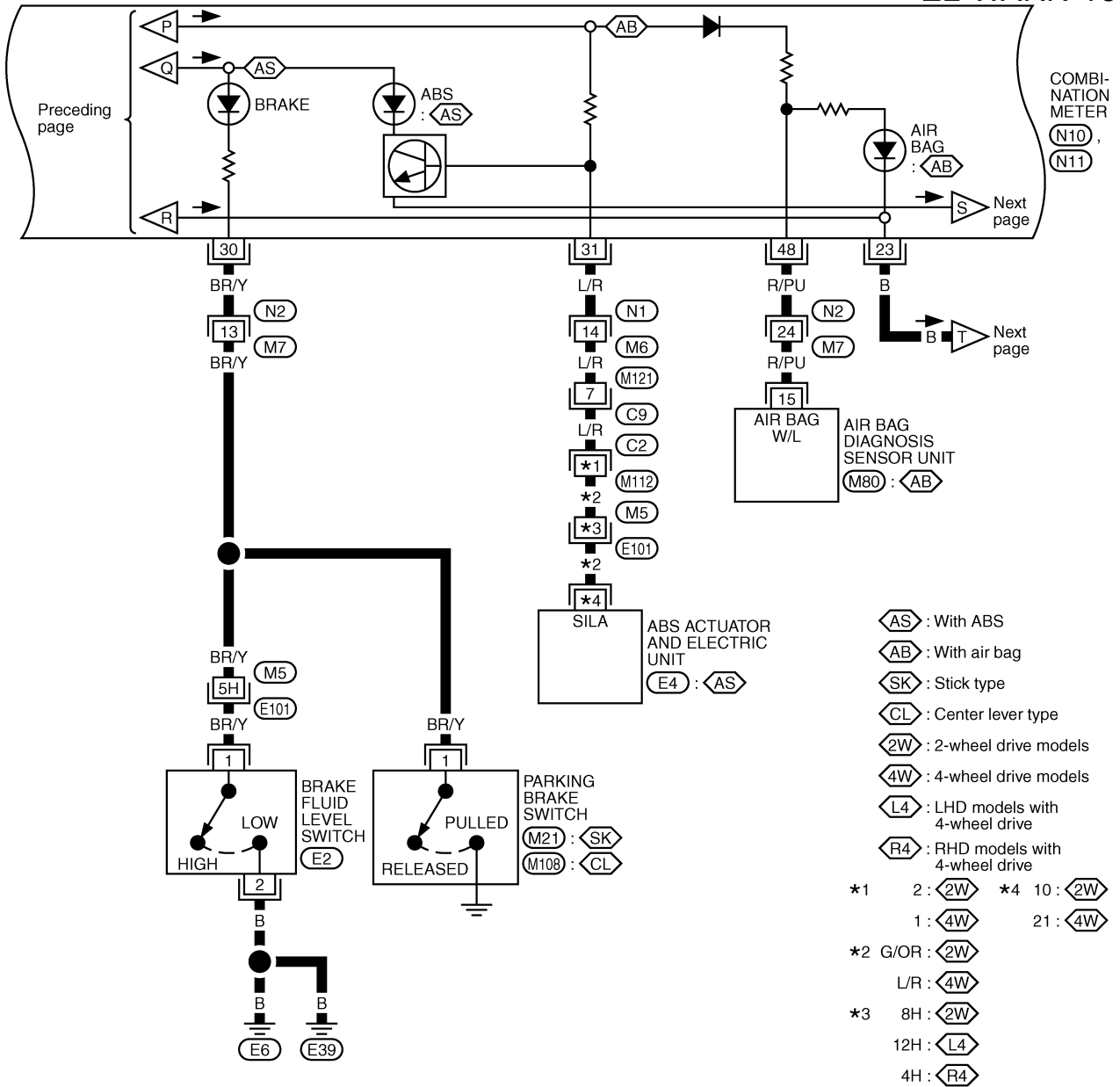

Refer to last page (Foldout page).

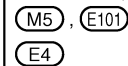

WARNING LAMPS

Wiring Diagram — WARN —/Diesel Engine without Tachometer (Cont'd)

EL-WARN-17

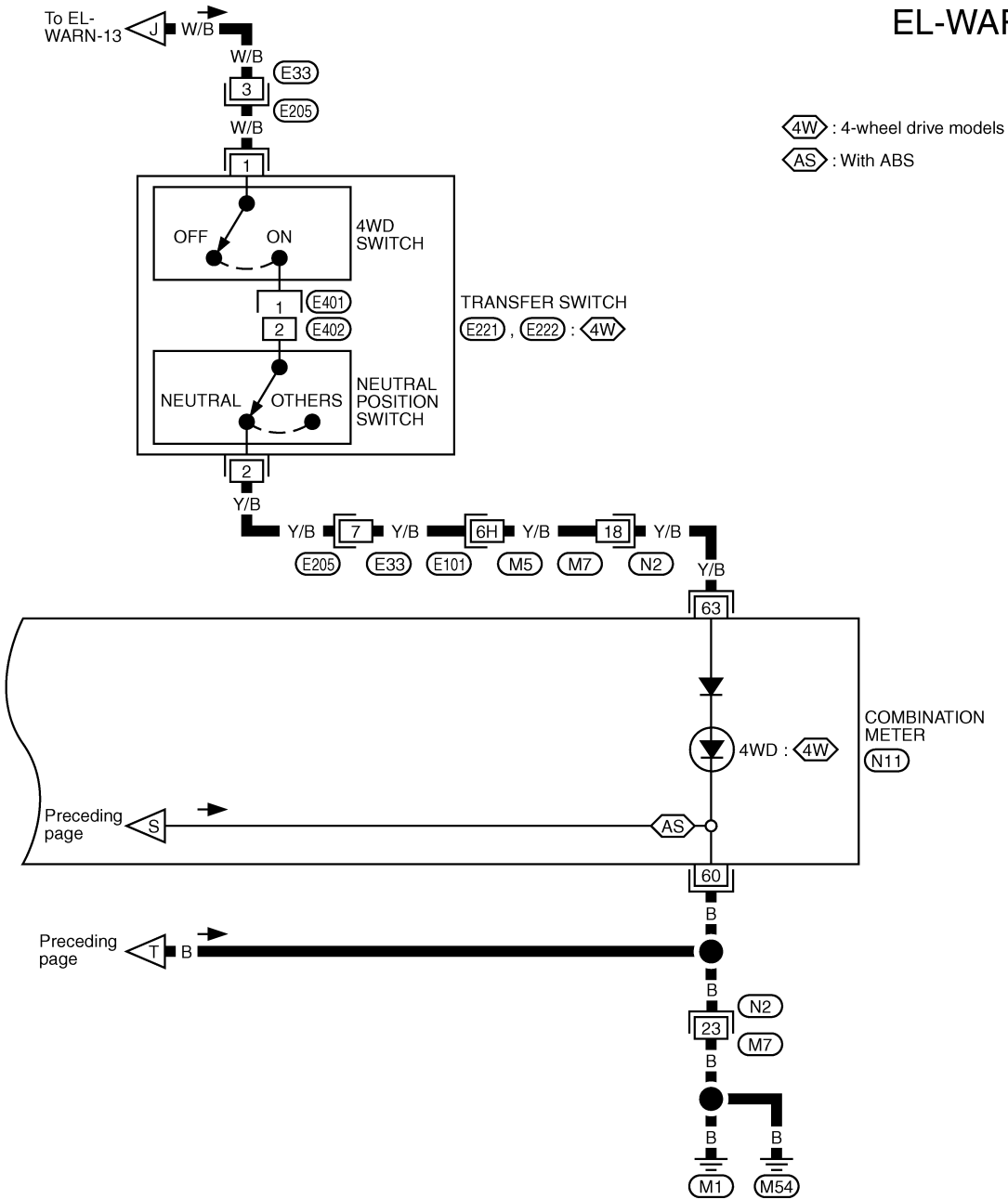

4W : 4-wheel drive models
AS : With ABS

1	2	3	4	5	6	7	8	9	10	11	N2	41	42	43	44	45	46	47	48	49	50	51	N11				
12	13	14	15	16	17	18	19	20	21	22	23	24	BR	52	53	54	55	56	57	58	59	60	61	62	63	64	W



*: This connector is not shown in "HARNESS LAYOUT".

Refer to last page (Foldout page).
M5, E101

A/T INDICATOR

Wiring Diagram — CHIME —/LHD Models

LIGHT WARNING BUZZER

EL-CHIME-02

Refer to EL-POWER.

- DL : With daytime light system
- ED : Without daytime light system
- *1 W/R : DL
- W/L : ED

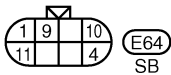
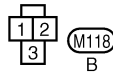
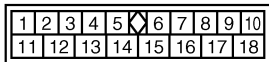
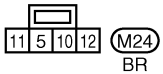
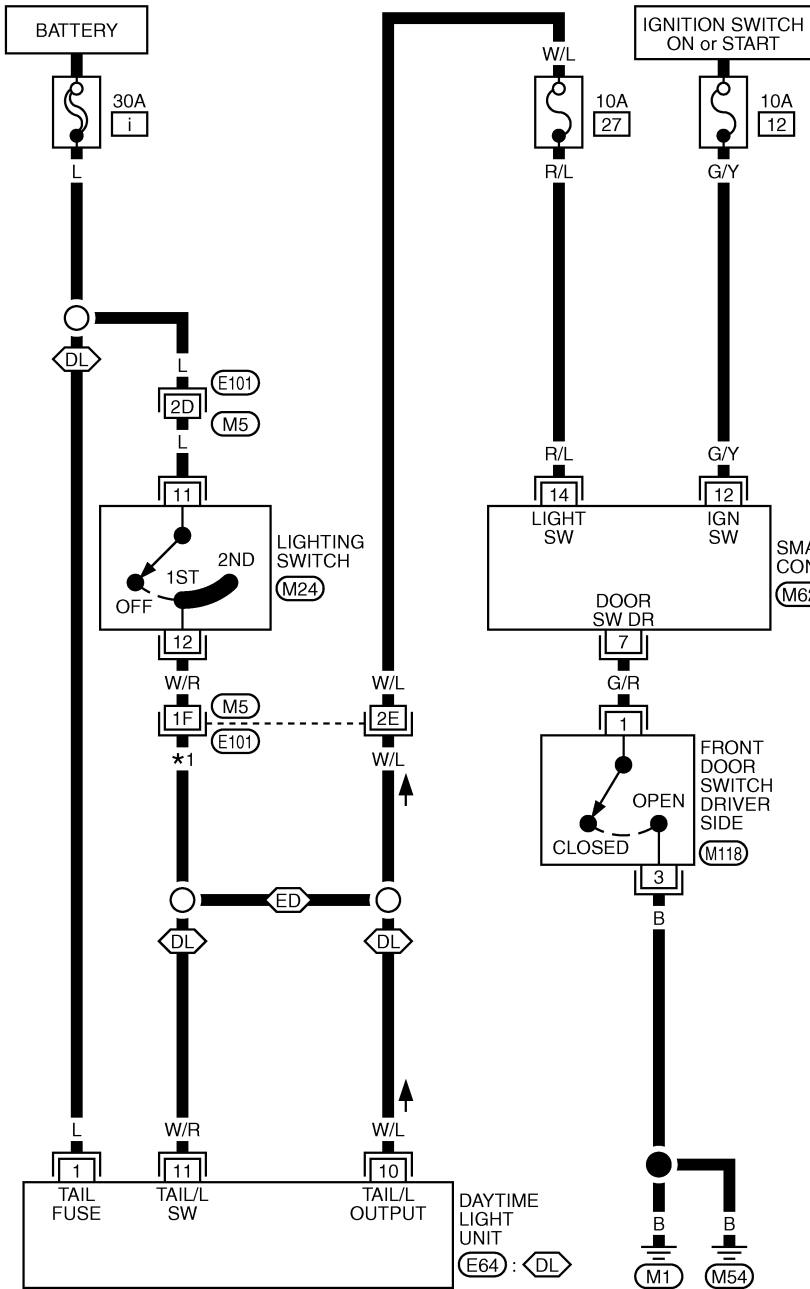

Refer to last page (Foldout page).

M5, E101

A/T INDICATOR

Wiring Diagram — CHIME —/RHD Models

LIGHT WARNING BUZZER

EL-CHIME-03

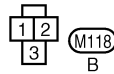
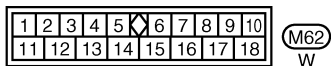
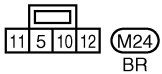
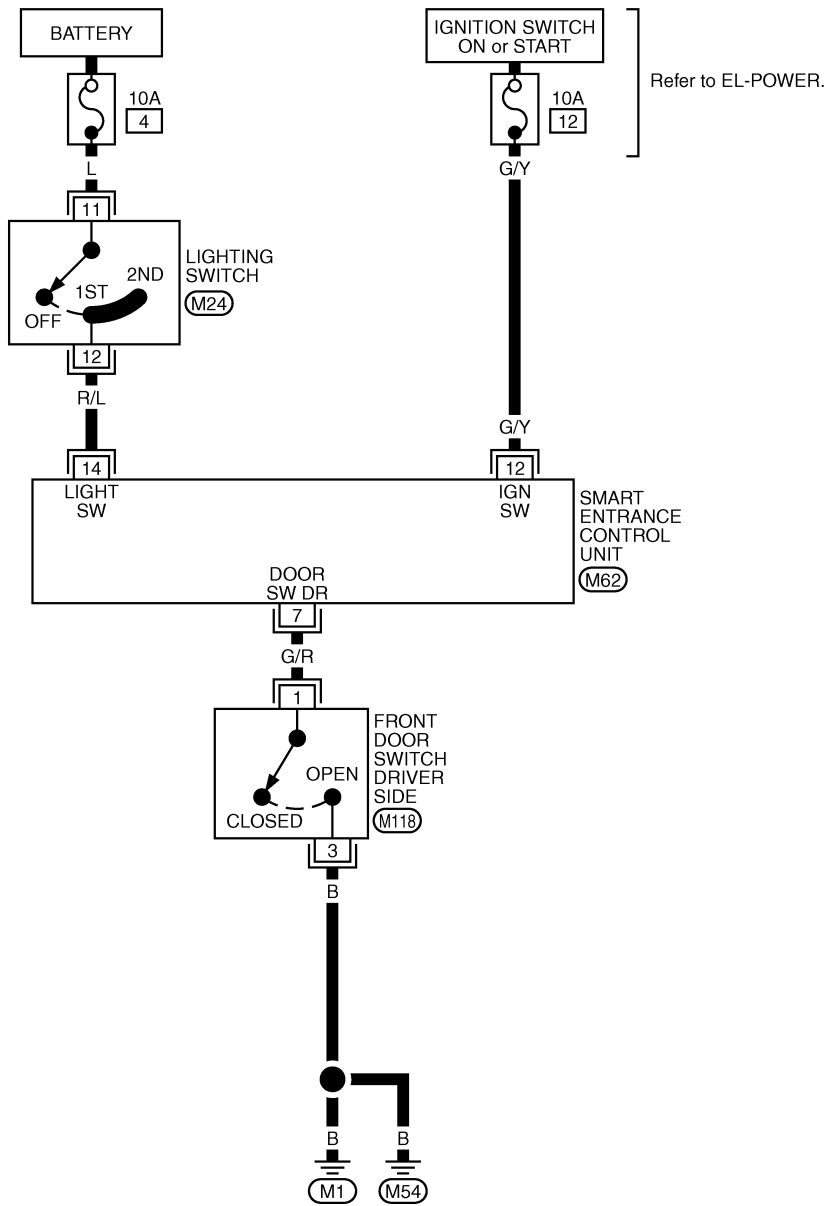

FRONT WIPER AND WASHER

Wiring Diagram — WIPER —/Without Intermittent for Floor-shift

RHD MODELS KA ENGINE

EL-WIPER-03

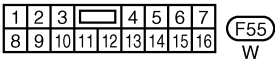
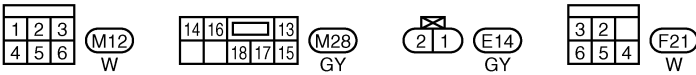
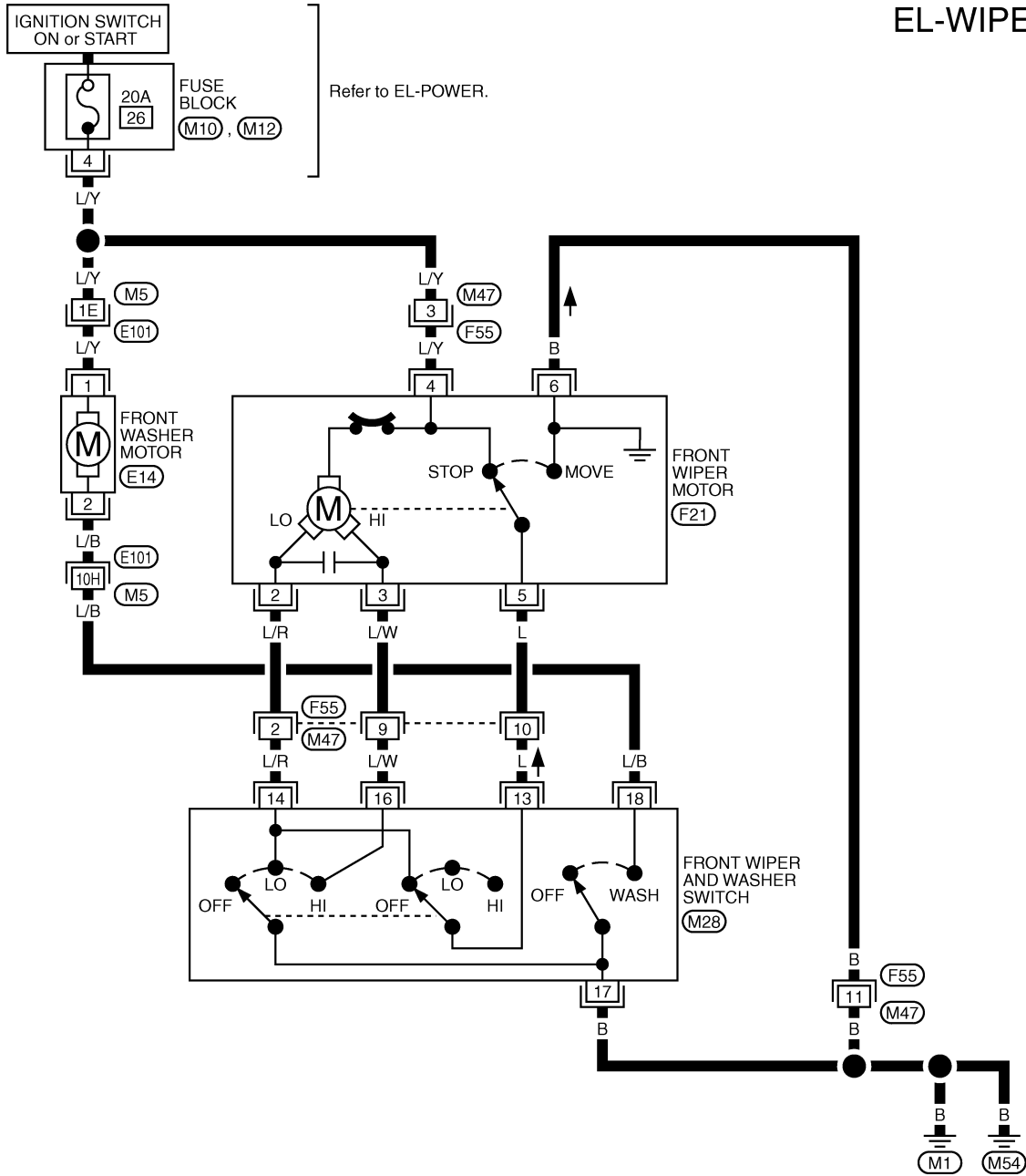

Refer to last page (Foldout page).

(M5), (E101)
(M10)

FRONT WIPER AND WASHER

Wiring Diagram — WIPER —/Without Intermittent for Floor-shift (Cont'd)

RHD MODELS

EL-WIPER-04

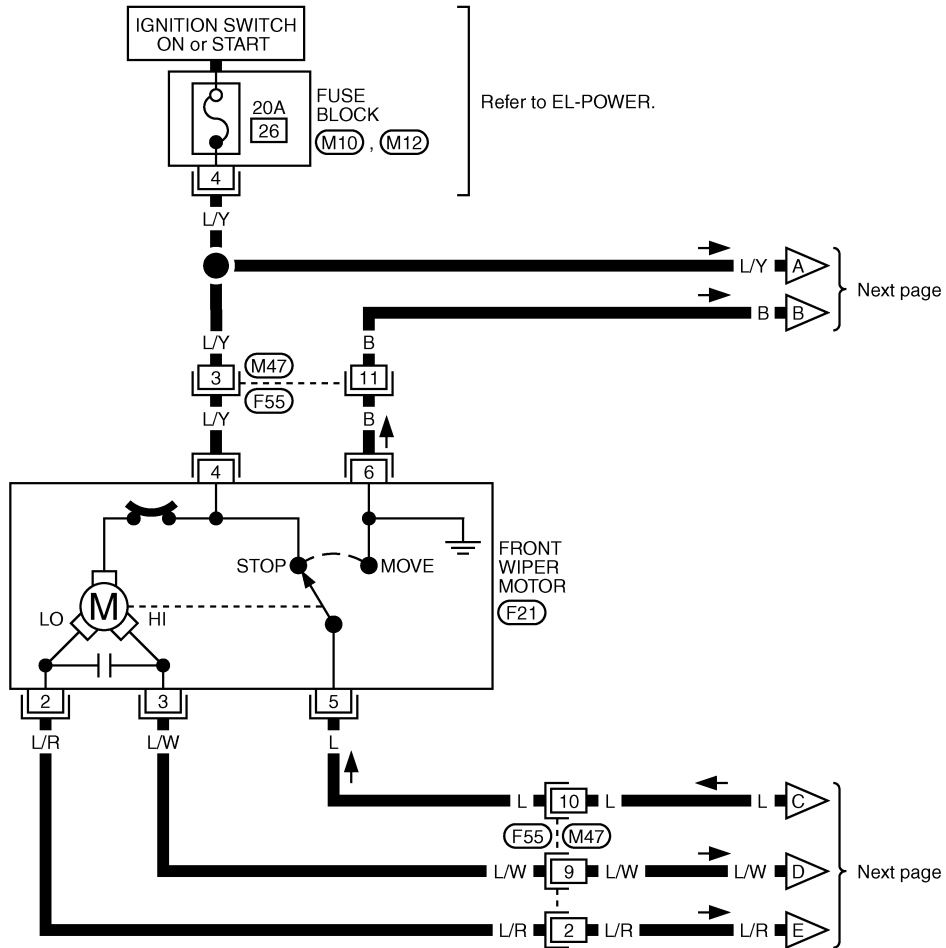

1	2	3
4	5	6

(M12)
W

3	2
6	5

(F21)
W

1	2	3	4	5	6	7		
8	9	10	11	12	13	14	15	16

(F55)
W

Refer to last page (Foldout page).
(M10)

FRONT WIPER AND WASHER

Wiring Diagram — WIPER —/Without Intermittent for Floor-shift (Cont'd)

EL-WIPER-05

⬠EU⬠ : For Europe

⬠NE⬠ : Except for Europe

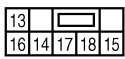
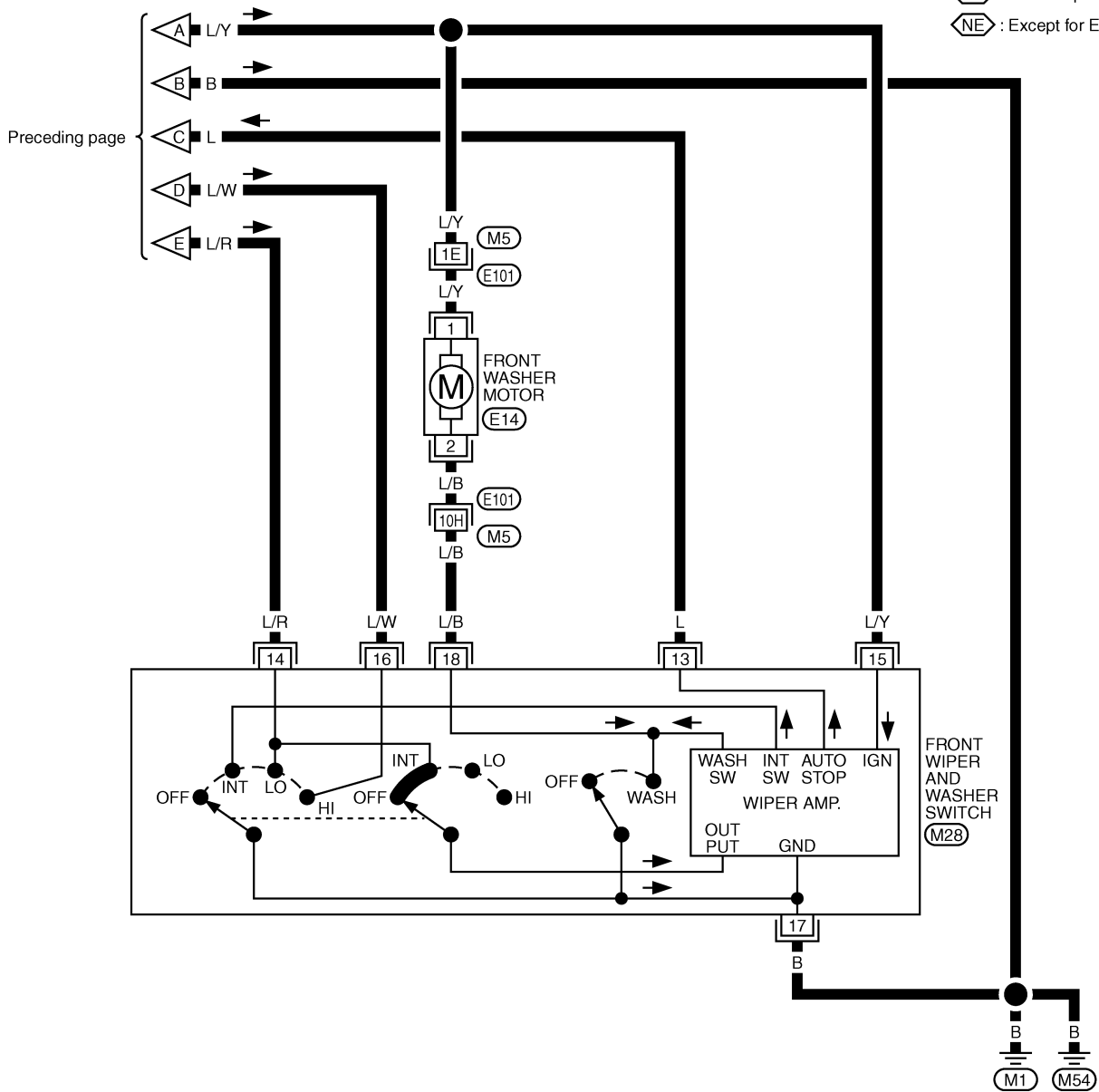

(M28) : ⬠EU⬠
GY

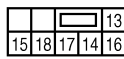

(M28) : ⬠NE⬠
GY

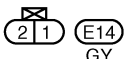

(E14) : GY

Refer to last page (Foldout page).

(M5) , (E101)

FRONT WIPER AND WASHER

Wiring Diagram — WIPER —/Without Intermittent for RHD Column-shift Models

EL-WIPER-06

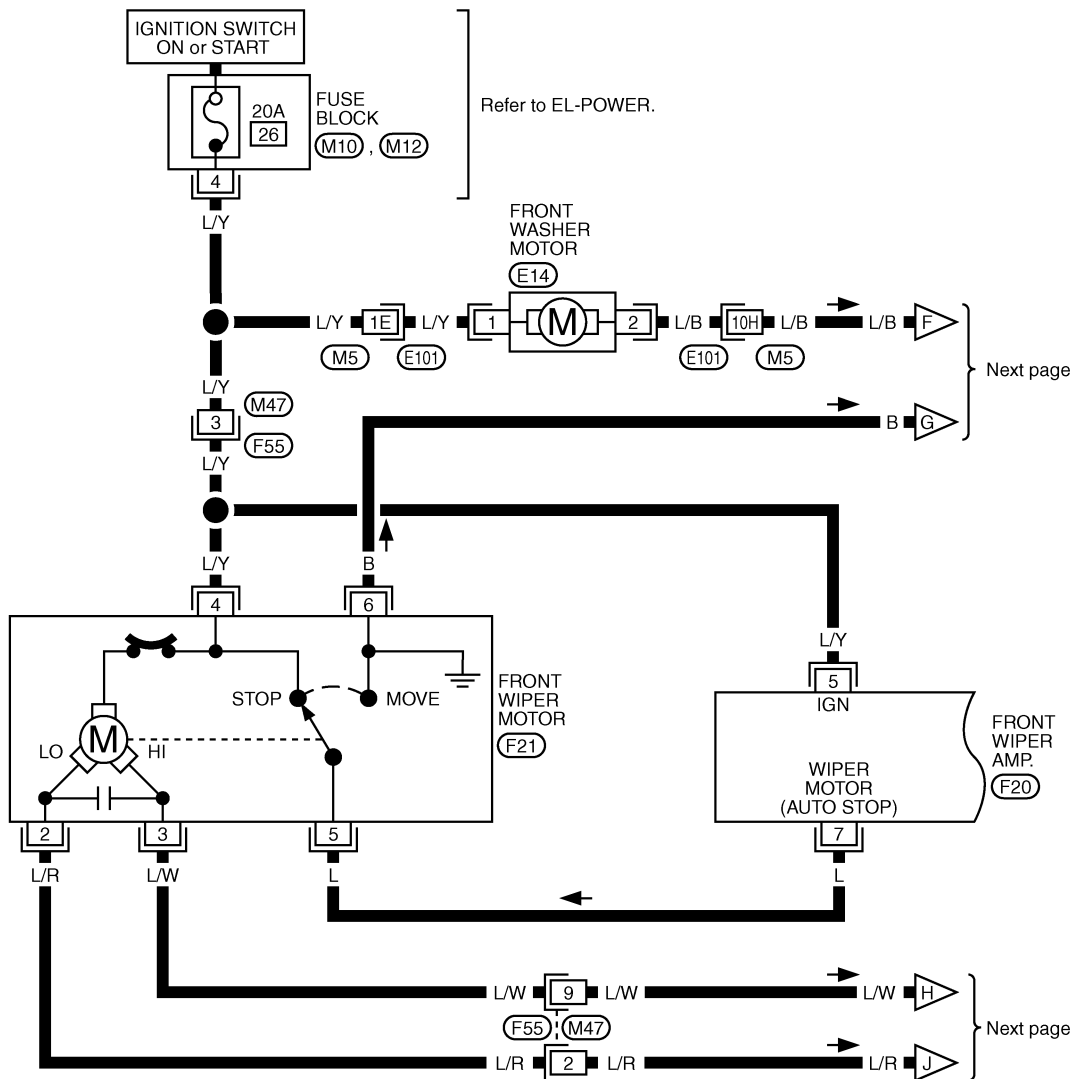

1	2	3
4	5	6

(M12)
W



(E14)
GY

3	2	1
7	6	5

(F20)
GY

3	2
6	5

(F21)
W

1	2	3	4	5	6	7		
8	9	10	11	12	13	14	15	16

(F55)
W

Refer to last page (Foldout page).

(M5), (E101)

(M10)

FRONT WIPER AND WASHER

Wiring Diagram — WIPER —/Without Intermittent for RHD Column-shift Models (Cont'd)

EL-WIPER-07

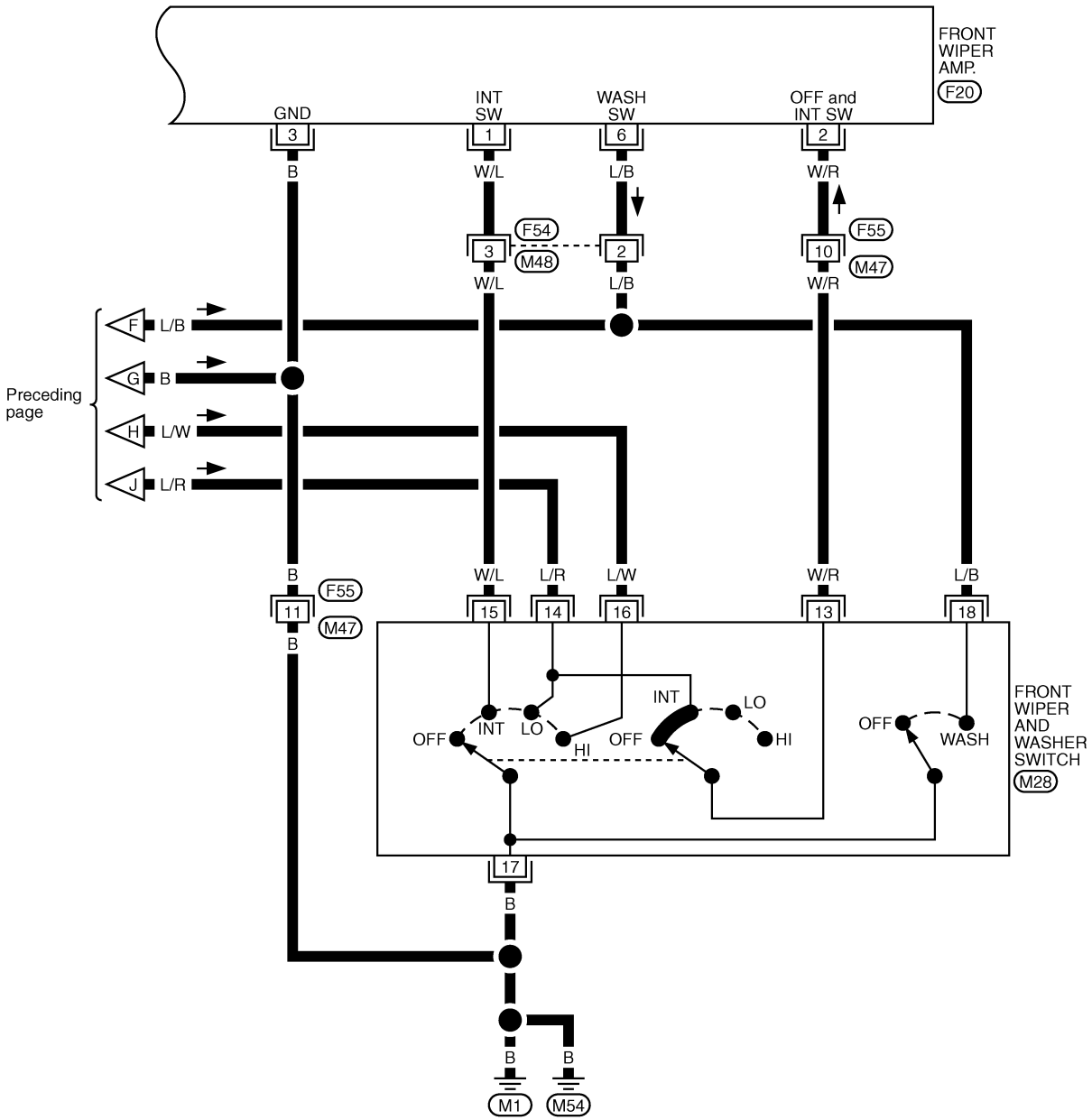

14	16	13
18	17	15

(M28)
GY

3	2	1
7	6	5

(F20)
GY

1	2	3	4	5	6	7	8	9	10	11		
12	13	14	15	16	17	18	19	20	21	22	23	24

(F54)
W

1	2	3	4	5	6	7		
8	9	10	11	12	13	14	15	16

(F55)
W

HEADLAMP WASHER

Wiring Diagram — HLC —

EL-HLC-01

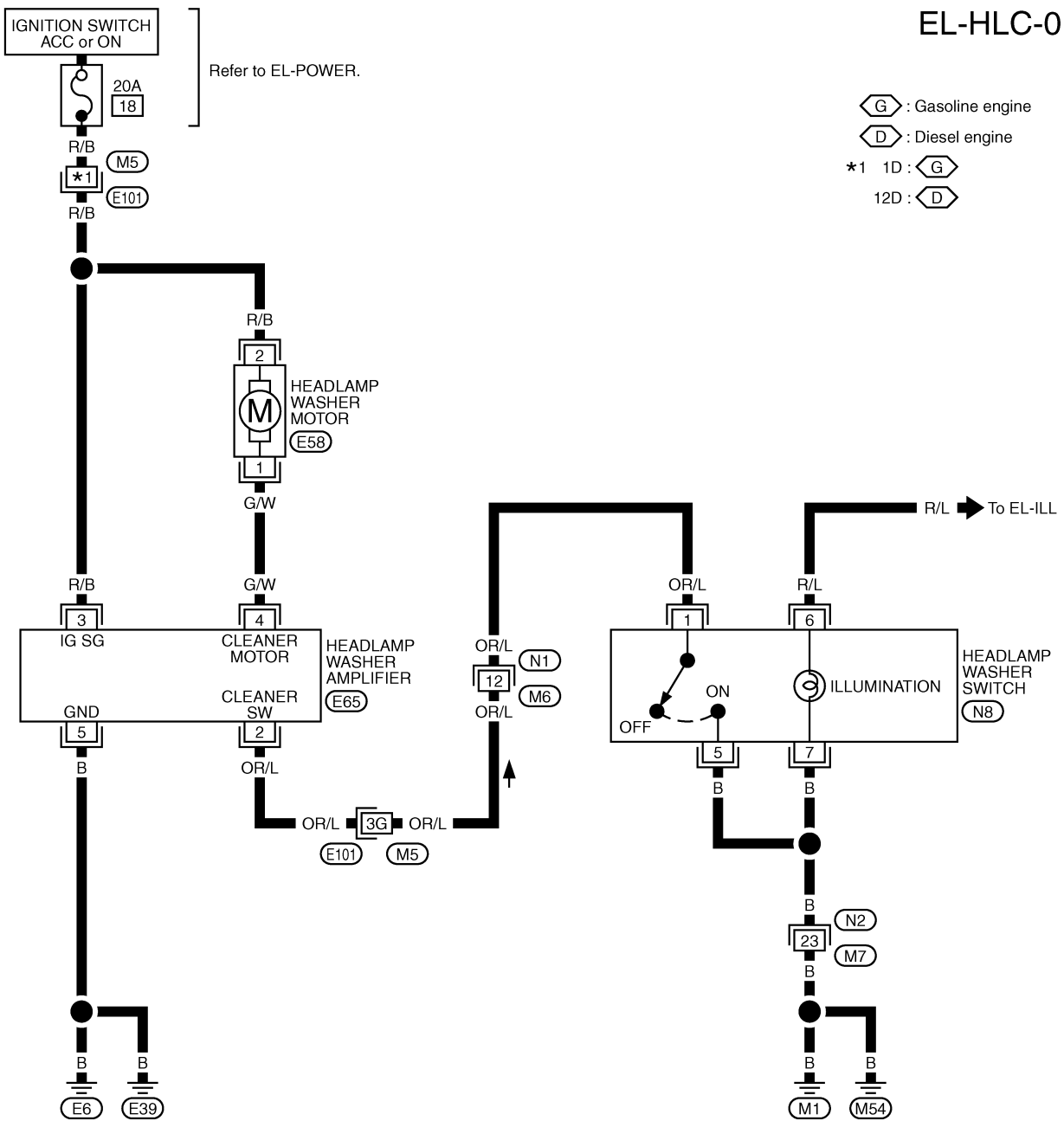

⬡ G : Gasoline engine
⬡ D : Diesel engine
*1 1D : ⬡ G
12D : ⬡ D

1	2	3	4	5	6	7	8	9	10	11		
12	13	14	15	16	17	18	19	20	21	22	23	24

N1
W

N2
BR

1	2	7	
6	4	3	5

N8
BR

1 2
E58
GY

1	2	3
4	5	

E65
W

Refer to last page (Foldout page).

M5, E101

HORN

Wiring Diagram — HORN —

EL-HORN-01

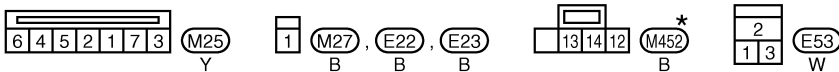
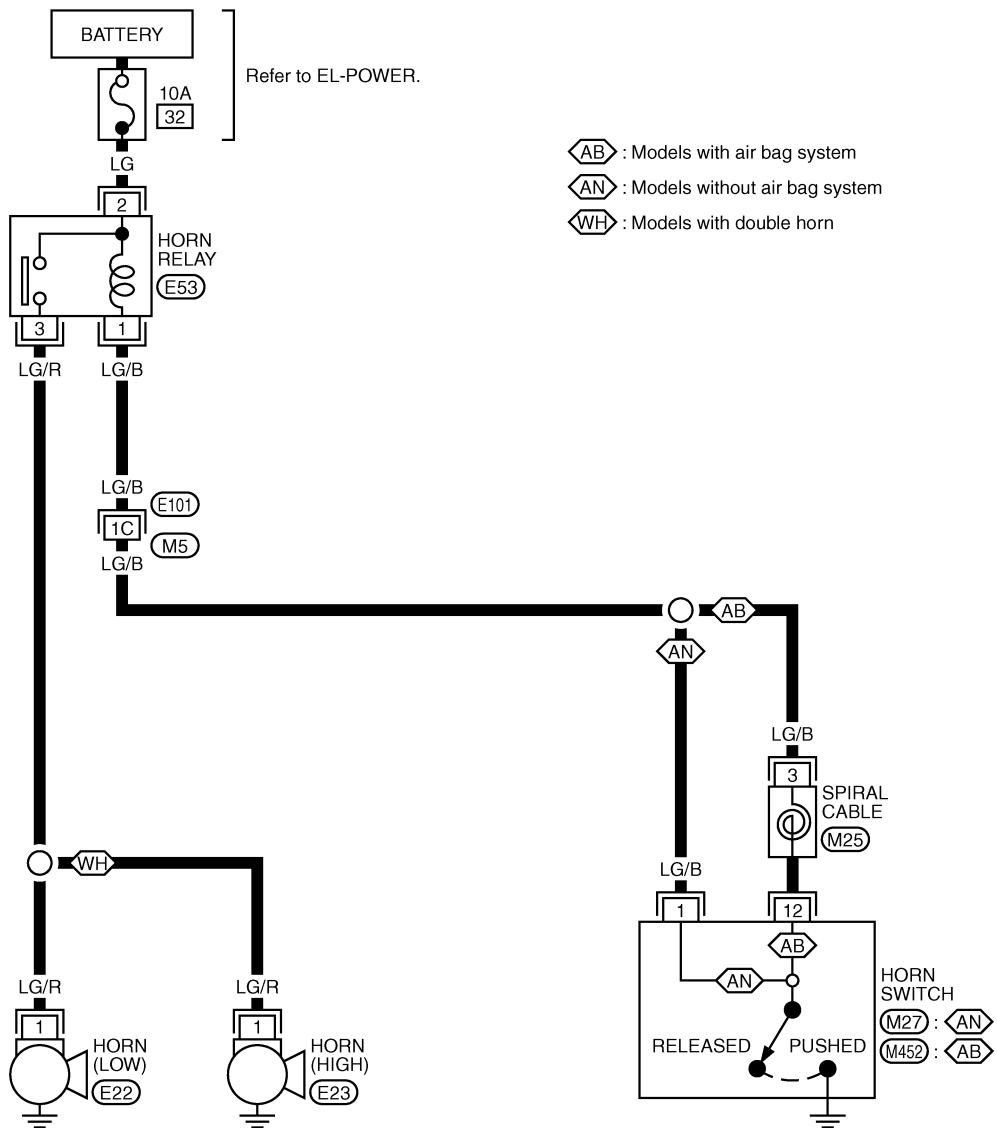

Refer to last page (Foldout page).

(M5), (E101)

*: This connector is not shown in "HARNESS LAYOUT".

CIGARETTE LIGHTER

Wiring Diagram — CIGAR —

EL-CIGAR-01

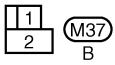
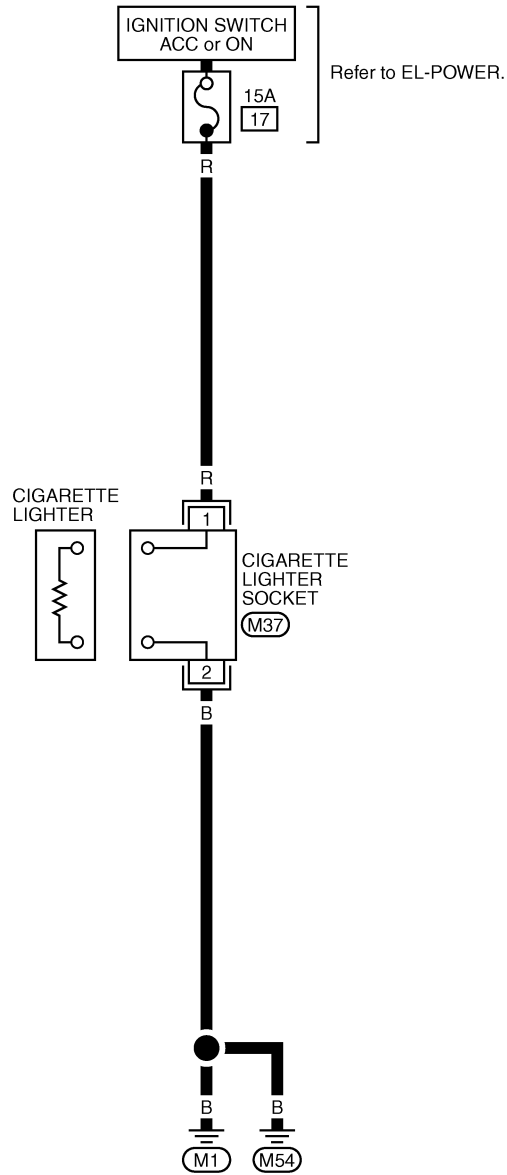

CLOCK

Wiring Diagram — CLOCK —

EL-CLOCK-01

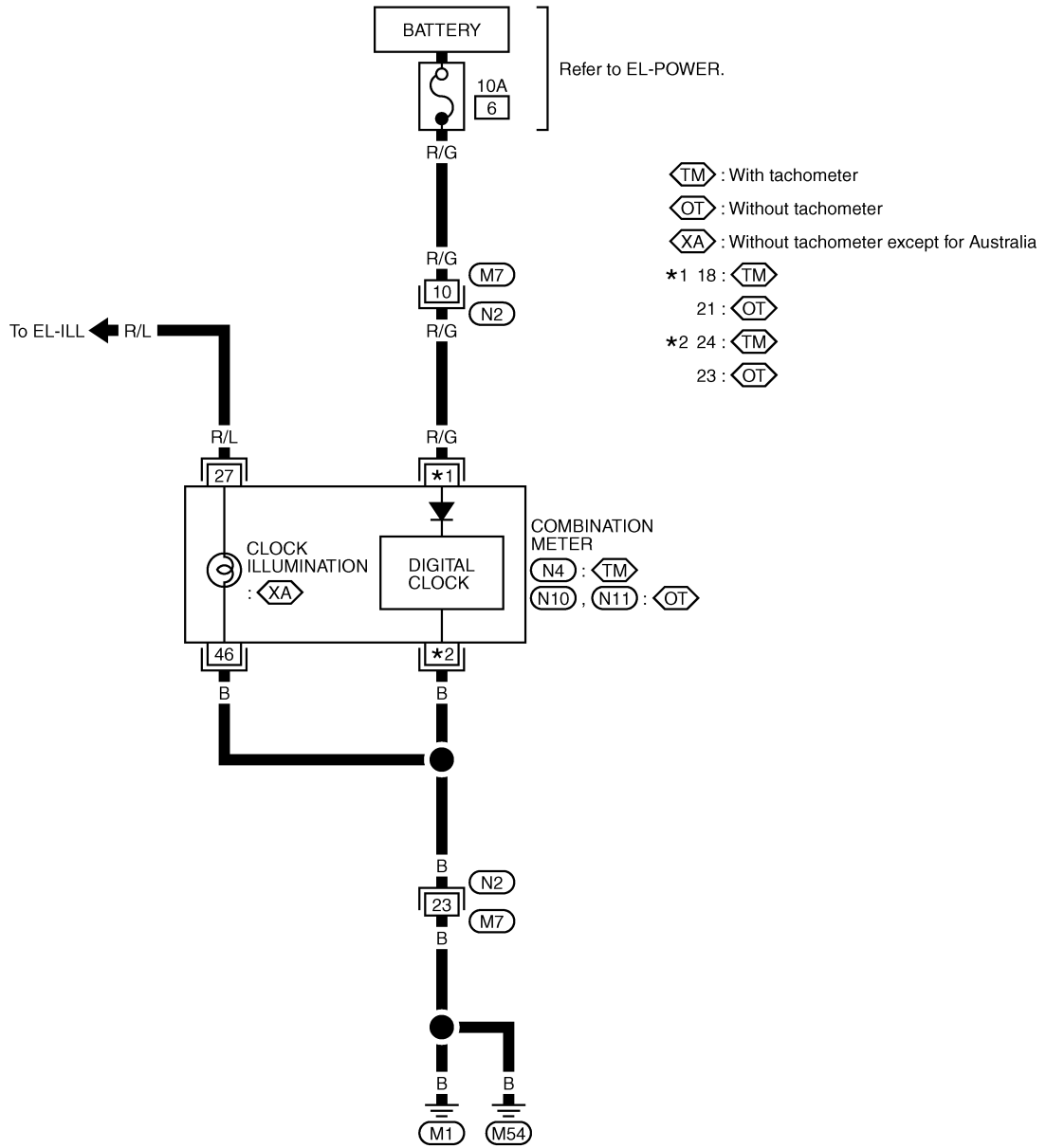

1	2	3	4	5	6	7	8	9	10	11		
12	13	14	15	16	17	18	19	20	21	22	23	24

(N2) BR (N4) W

21	22	23	24	25	26	27	28	29		
30	31	32	33	34	35	36	37	38	39	40

(N10) BR

41	42	43	44	45	46	47	48	49	50	51		
52	53	54	55	56	57	58	59	60	61	62	63	64

(N11) W

REAR WINDOW DEFOGGER AND MIRROR DEFOGGER

Wiring Diagram — DEF —

EL-DEF-01

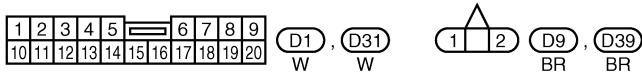
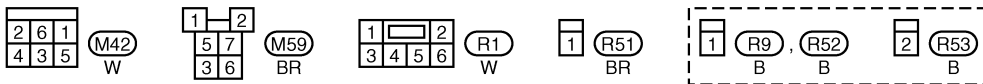
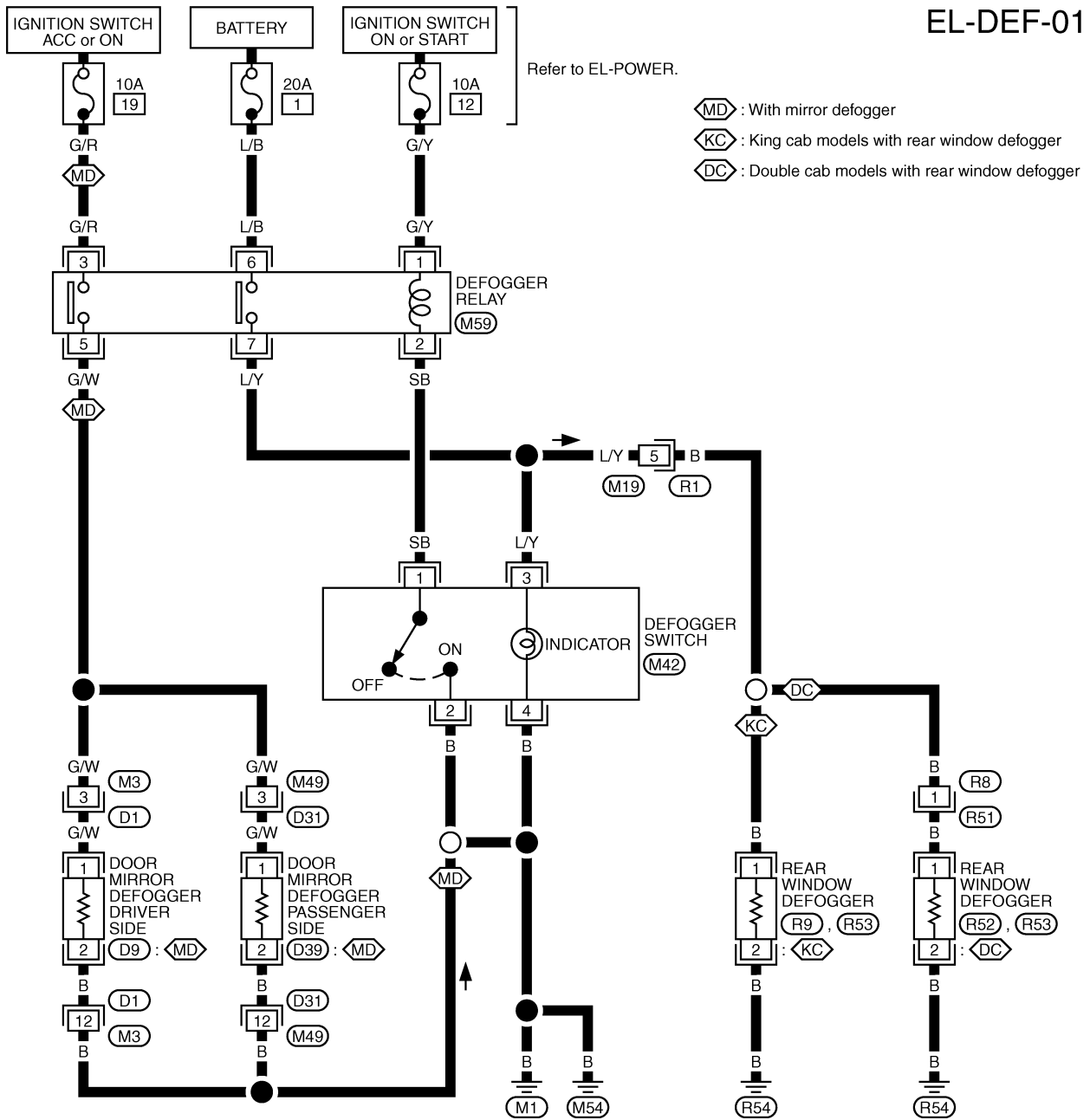

AUDIO

Wiring Diagram — AUDIO —/LHD Models

EL-AUDIO-04

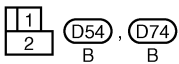
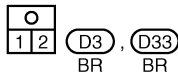
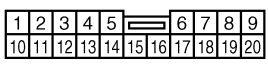
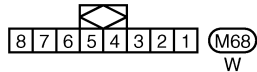
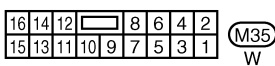
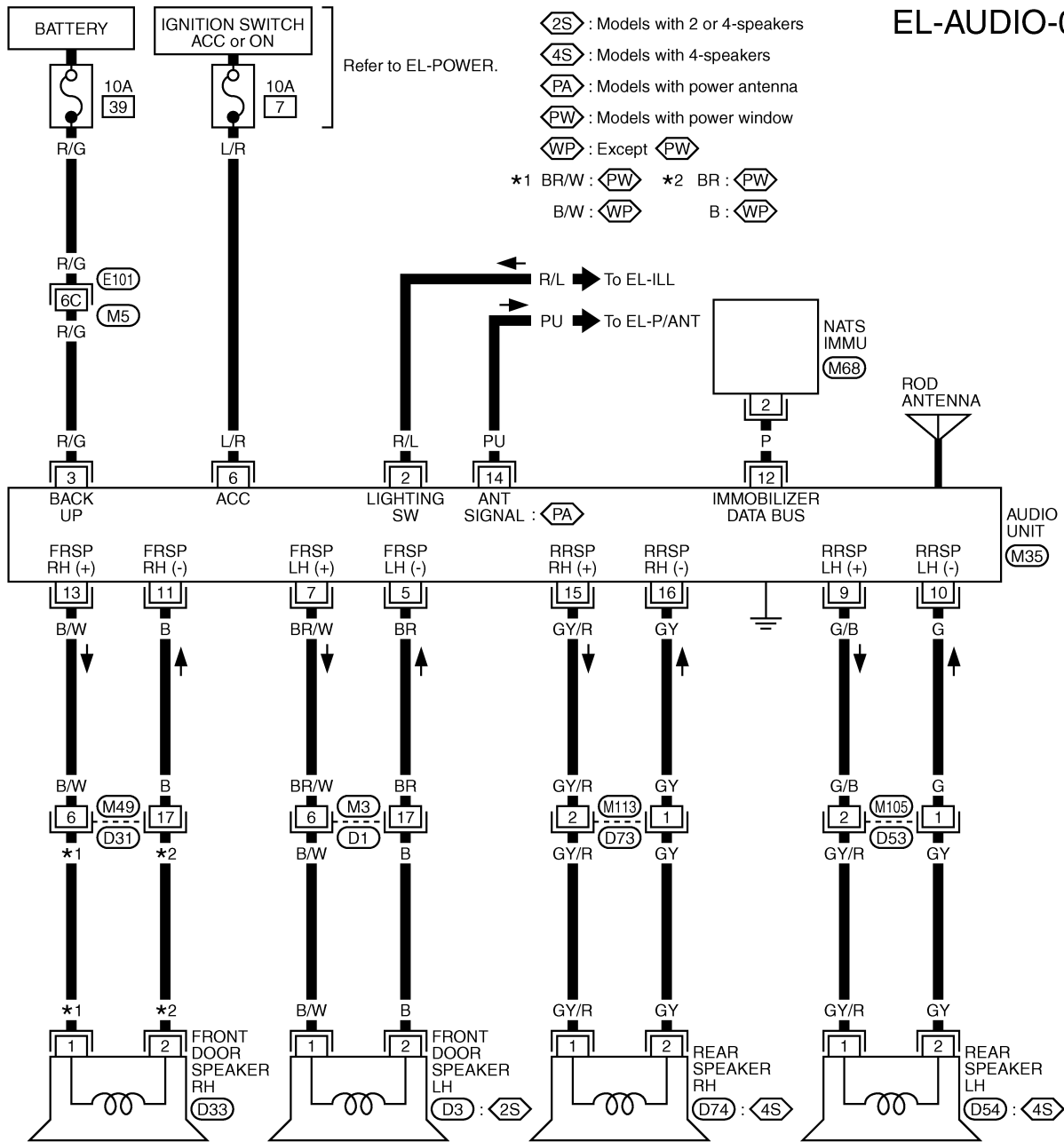

Refer to last page (Foldout page).

(M5), (E101)

AUDIO

Wiring Diagram — AUDIO —/RHD Models

EL-AUDIO-06

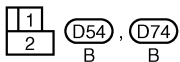
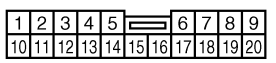
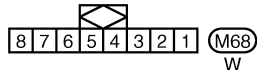
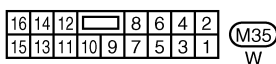
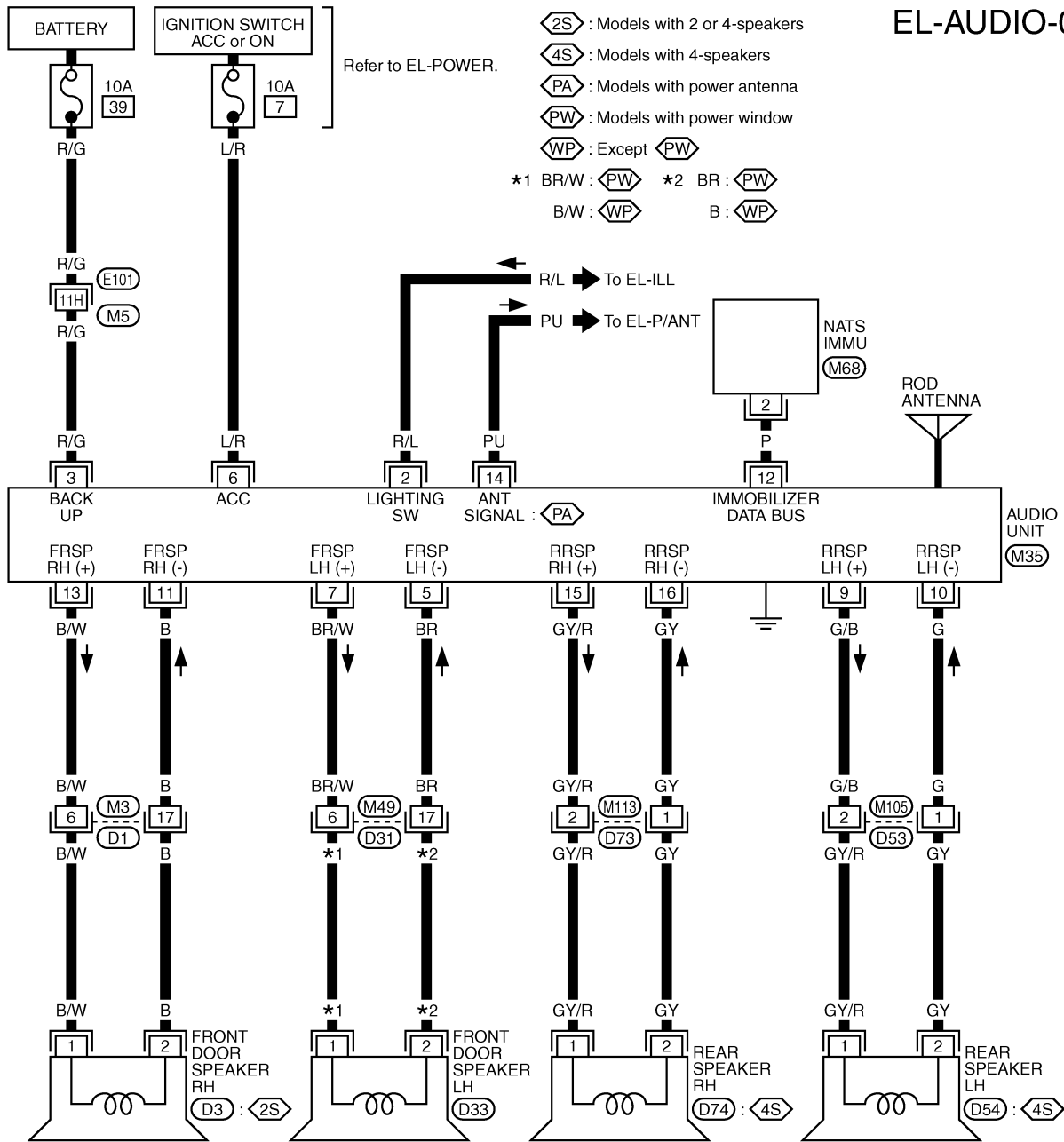

Refer to last page (Foldout page).

(M5), (E101)

AUDIO ANTENNA

Power Antenna/Wiring Diagram — P/ANT —

EL-P/ANT-01

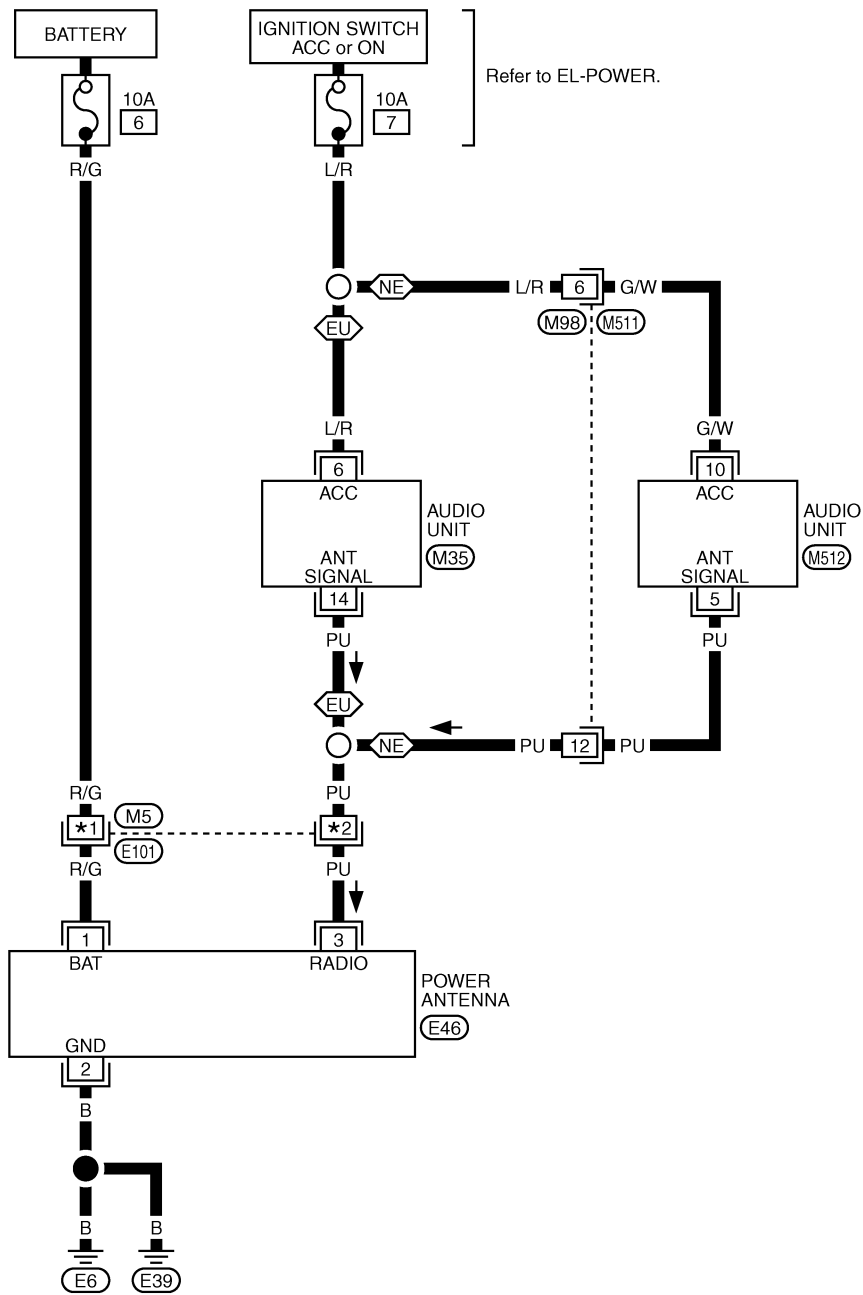

- ⬡ : LHD models
- ⬡ : RHD models
- ⬡ : For Europe
- ⬡ : Except for Europe
- ⬡ : Cassette player with AM-FM radio
- ⬡ : Except ⬡
- *1 6A: ⬡
- 12J: ⬡
- *2 6B: ⬡
- 11J: ⬡

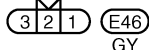
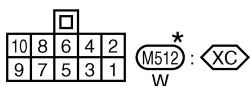
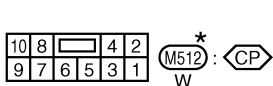
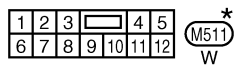
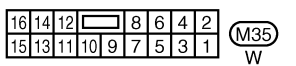

Refer to last page (Foldout page).

M5, E101

*: This connector is not shown in "HARNESS LAYOUT".

POWER DOOR MIRROR

Wiring Diagram — MIRROR —/LHD Models

EL-MIRROR-01

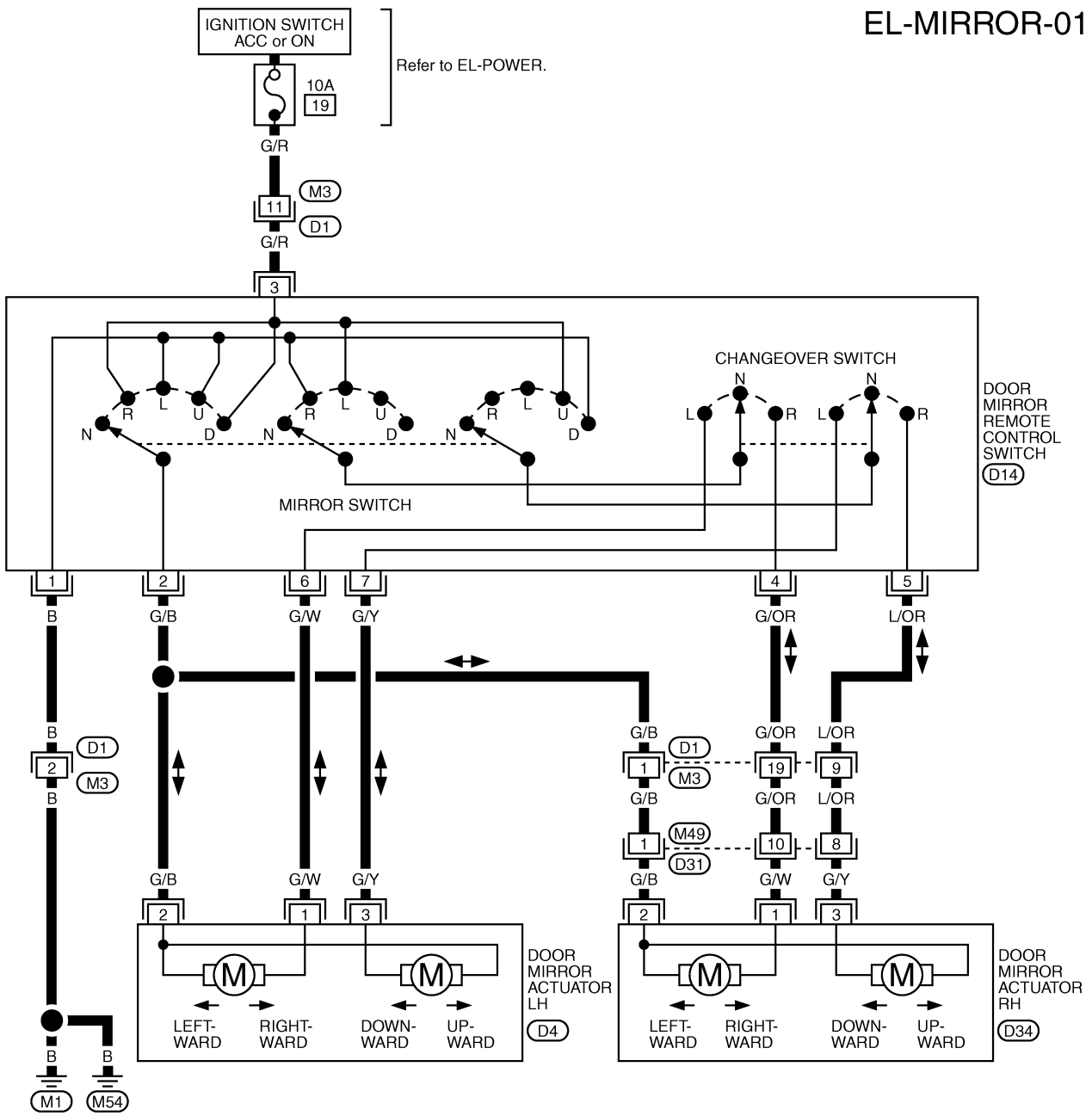

1	2	3	4	5	6	7	8	9		
10	11	12	13	14	15	16	17	18	19	20

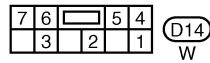
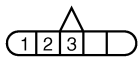
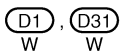

POWER DOOR MIRROR

Wiring Diagram — MIRROR —/RHD Models

EL-MIRROR-03

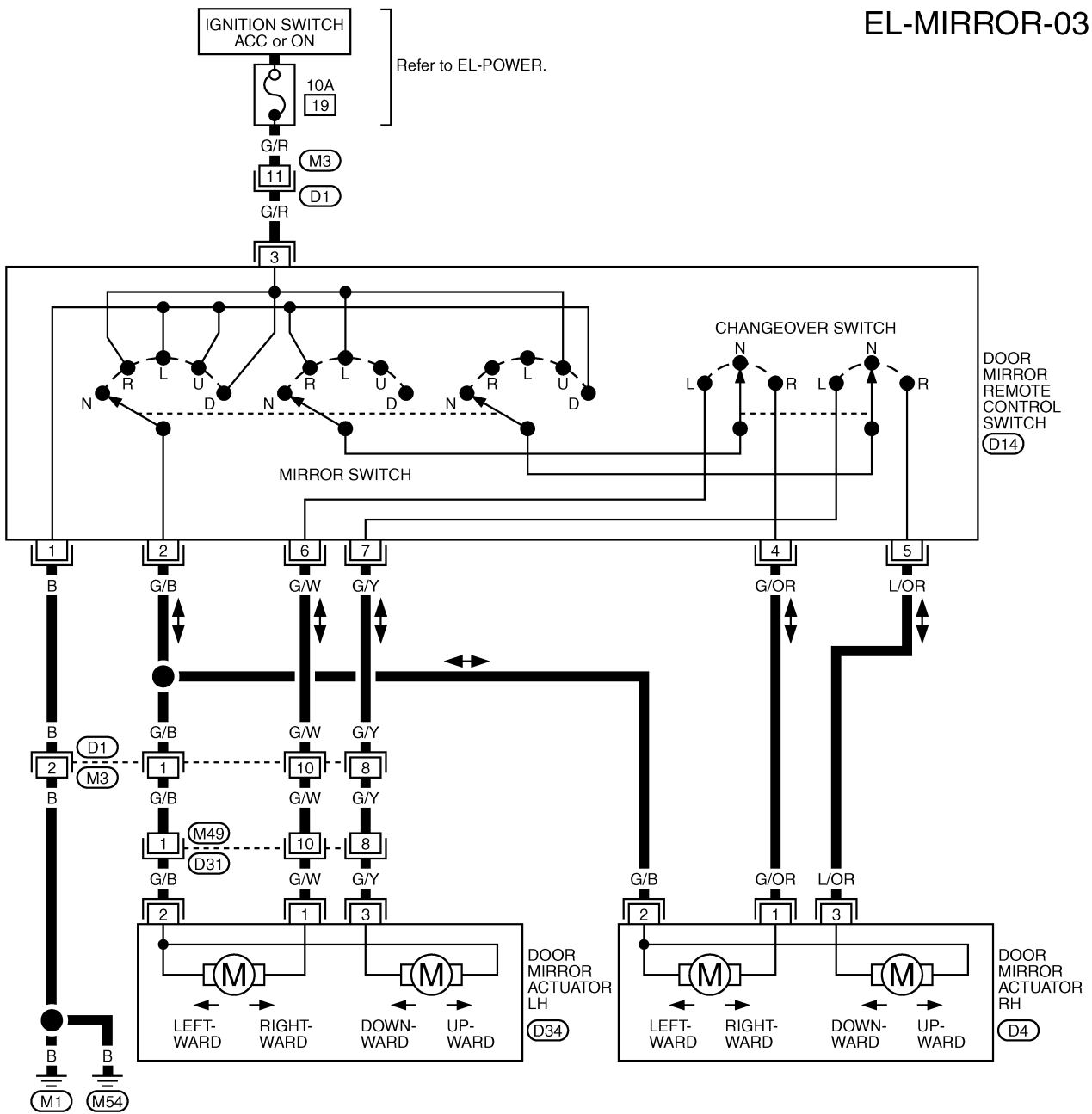

1	2	3	4	5	6	7	8	9		
10	11	12	13	14	15	16	17	18	19	20

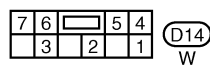
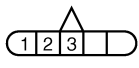
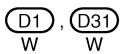

HEATED SEAT

Wiring Diagram — H/SEAT —

EL-H/SEAT-01

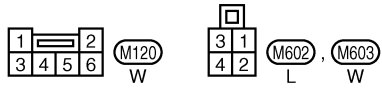
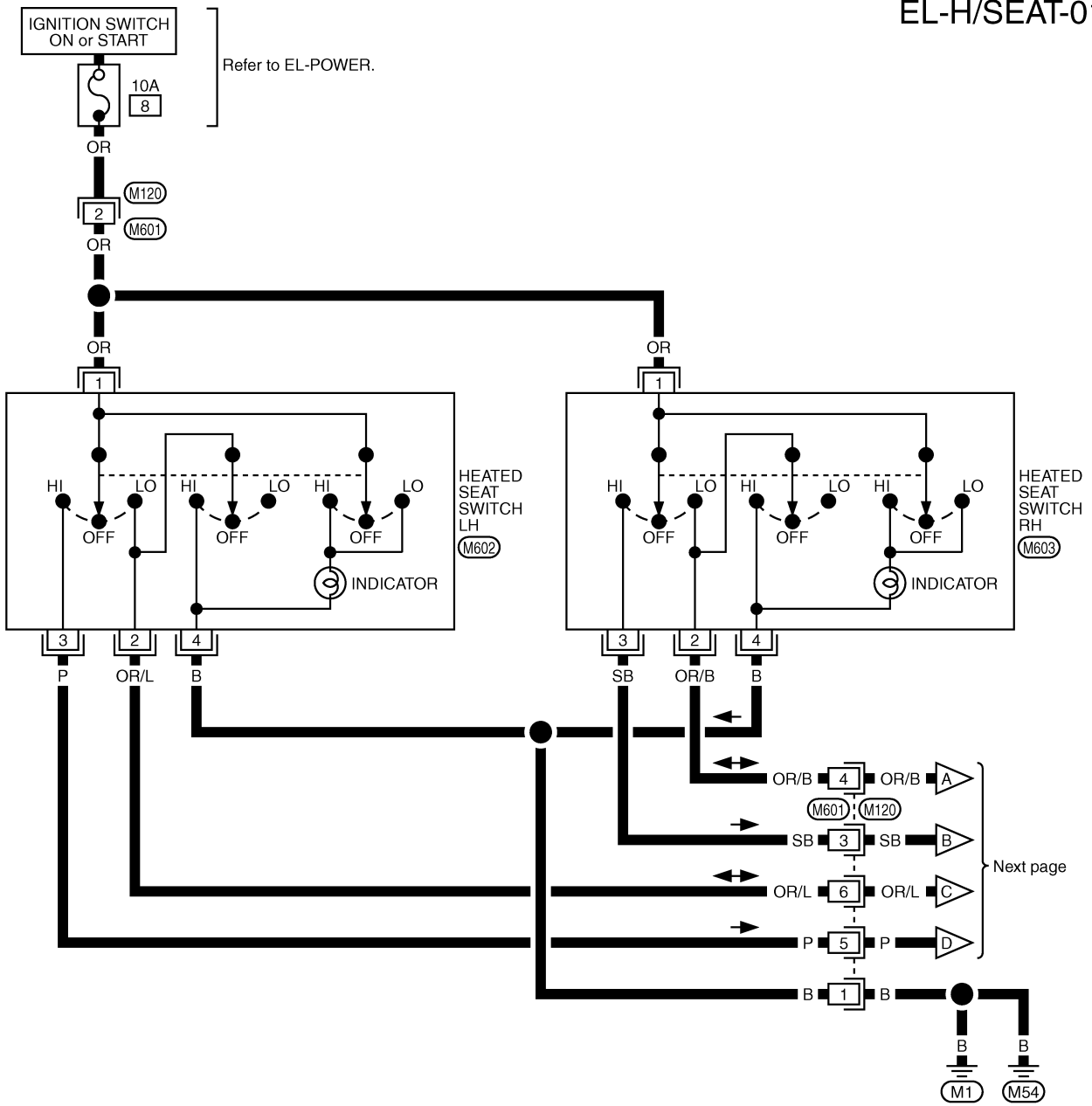

Next page

HEATED SEAT

Wiring Diagram — H/SEAT — (Cont'd)

EL-H/SEAT-02

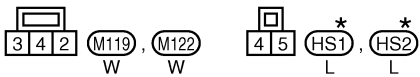
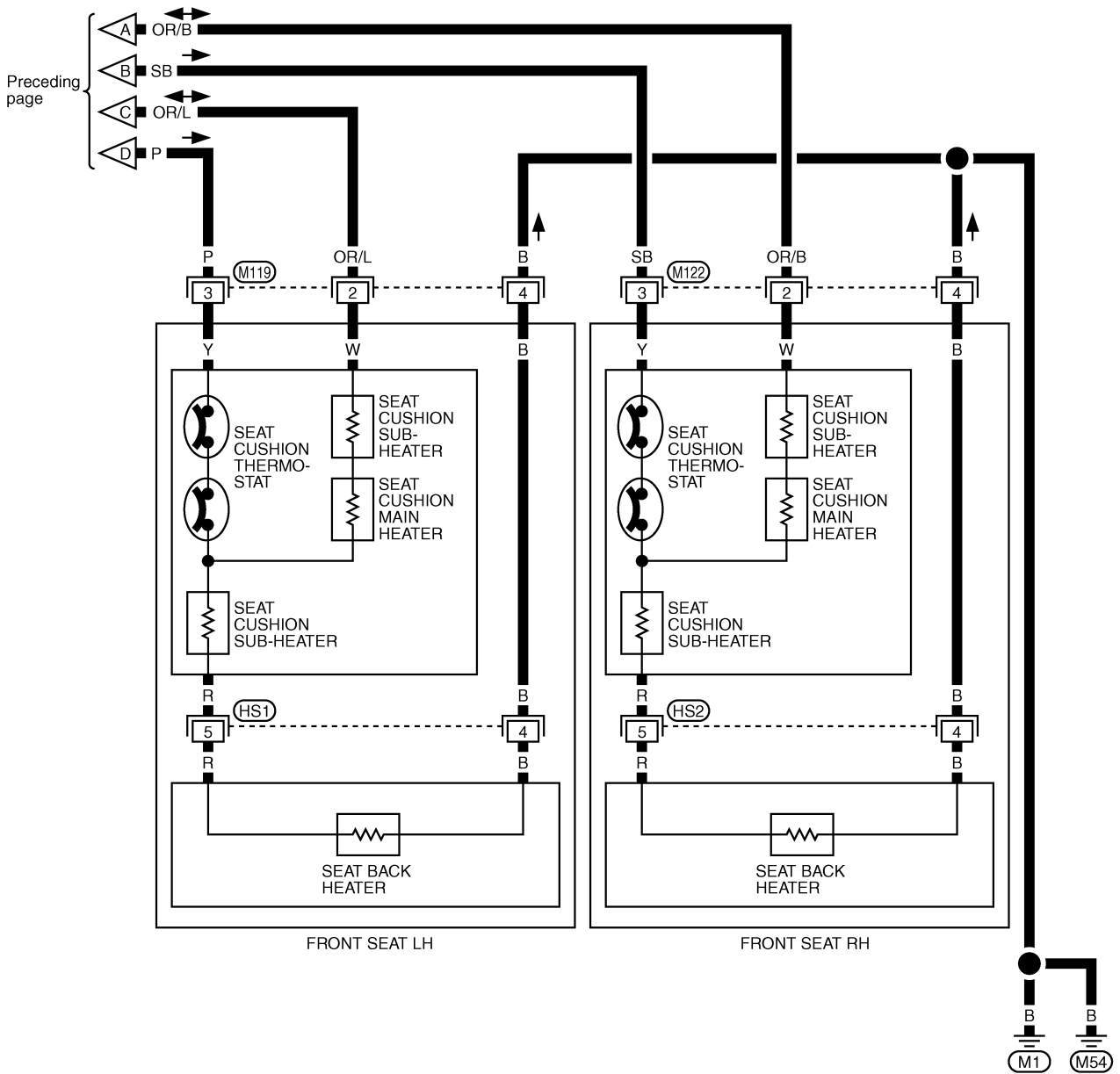

*: This connector is not shown in "HARNES LAYOUT"

POWER WINDOW

Schematic/Without Interruption Detection Function

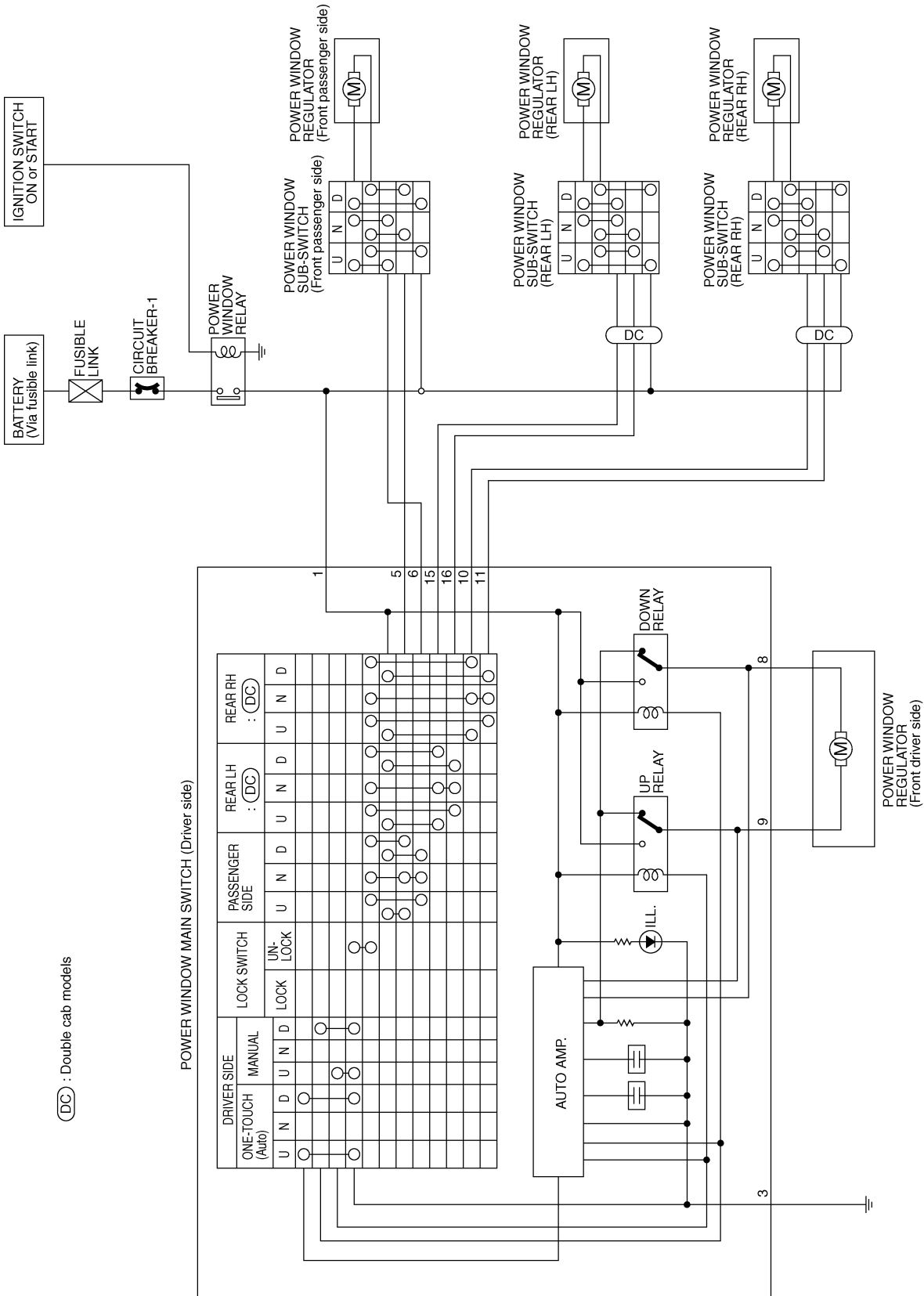

POWER WINDOW

Schematic/With Interruption Detection Function

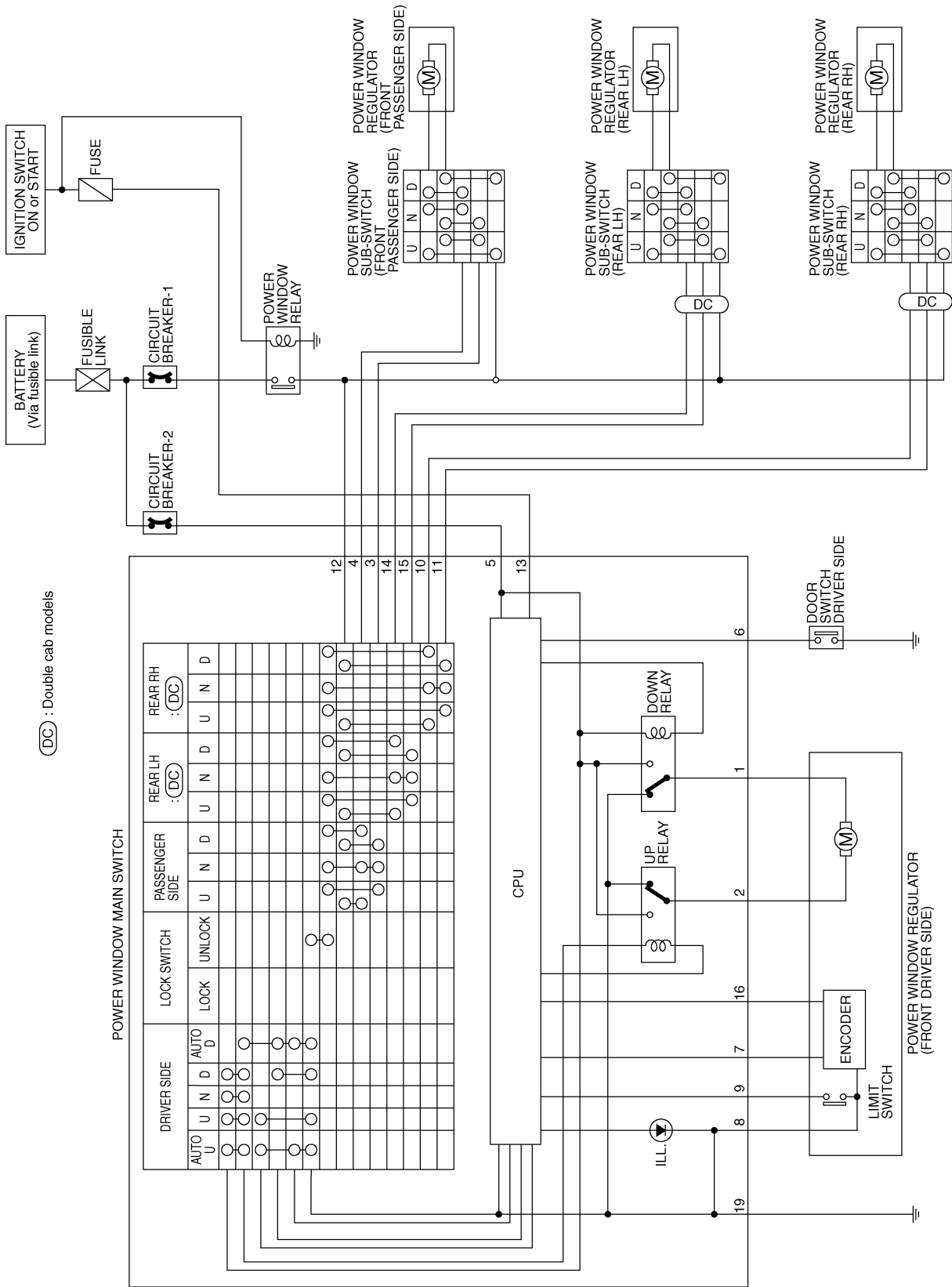

POWER WINDOW

Wiring Diagram — WINDOW —/Without Interruption Detection Function

EL-WINDOW-01

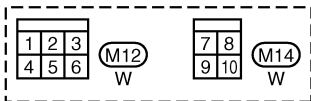
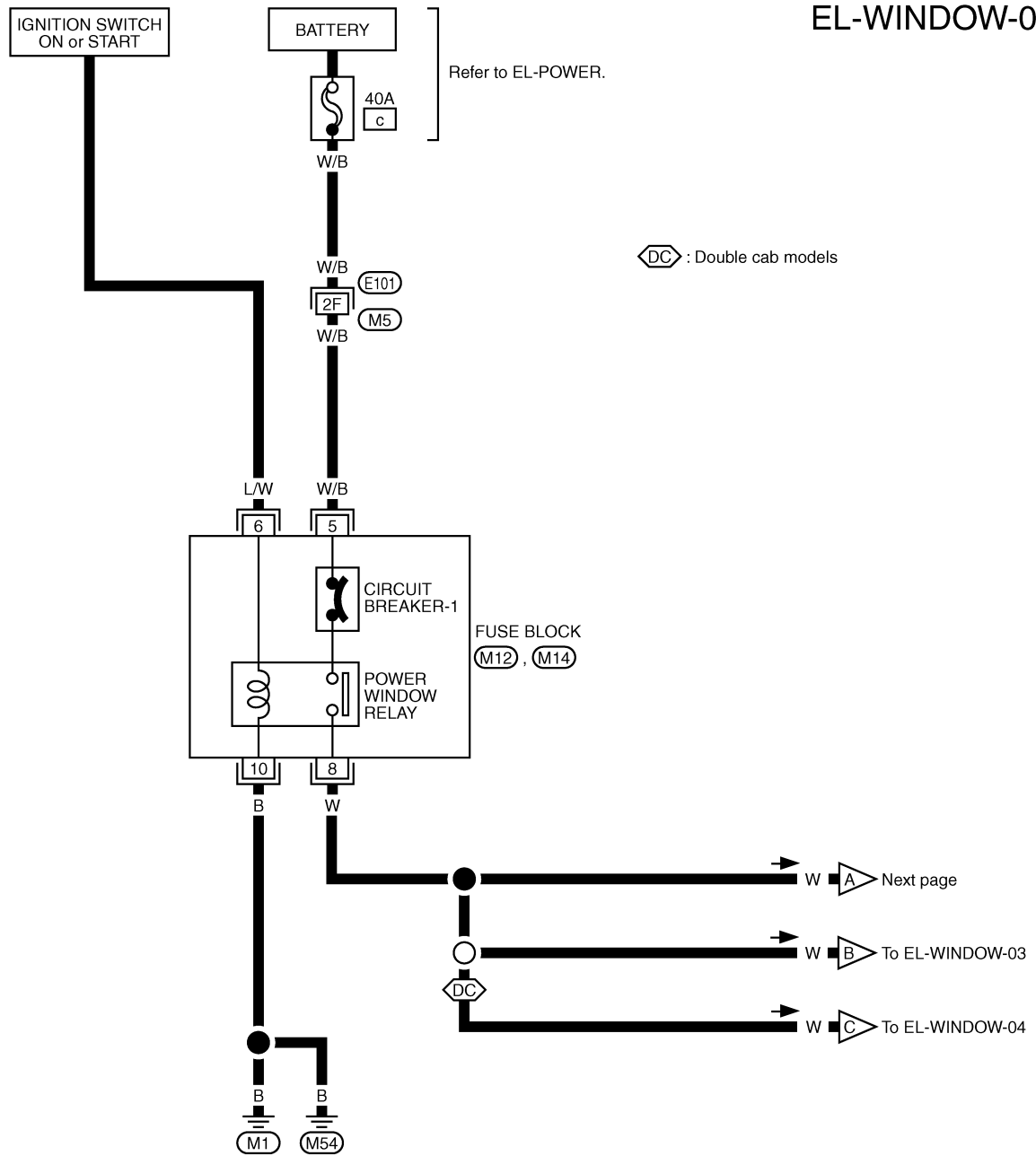

Refer to last page (Foldout page).

(M5), (E101)

POWER WINDOW

Wiring Diagram — WINDOW —/Without Interruption Detection Function (Cont'd)

EL-WINDOW-02

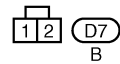
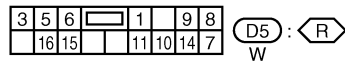
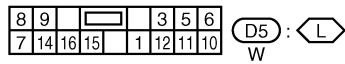
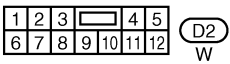
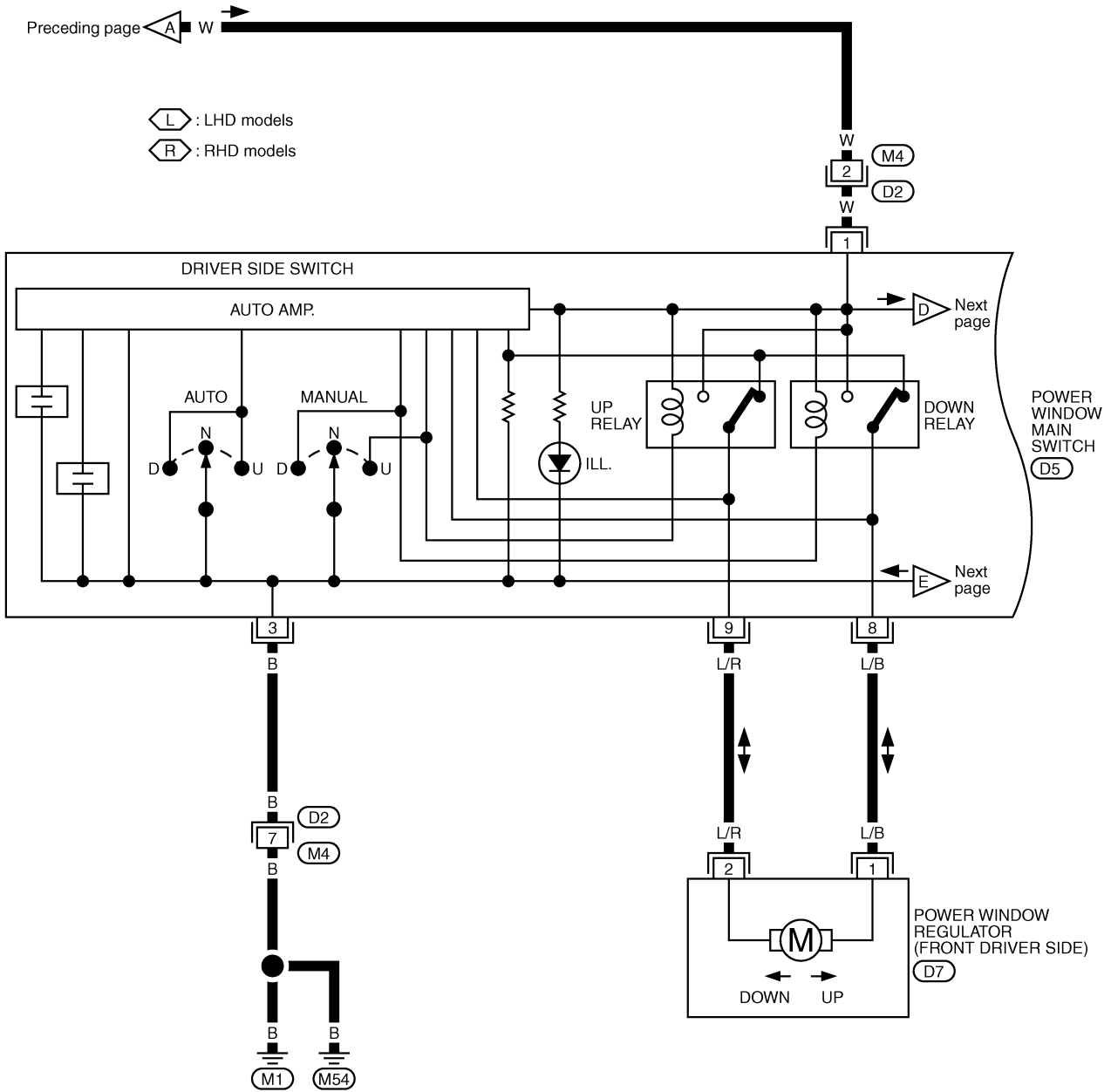

POWER WINDOW

Wiring Diagram — WINDOW —/Without Interruption Detection Function (Cont'd)

EL-WINDOW-03

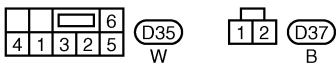
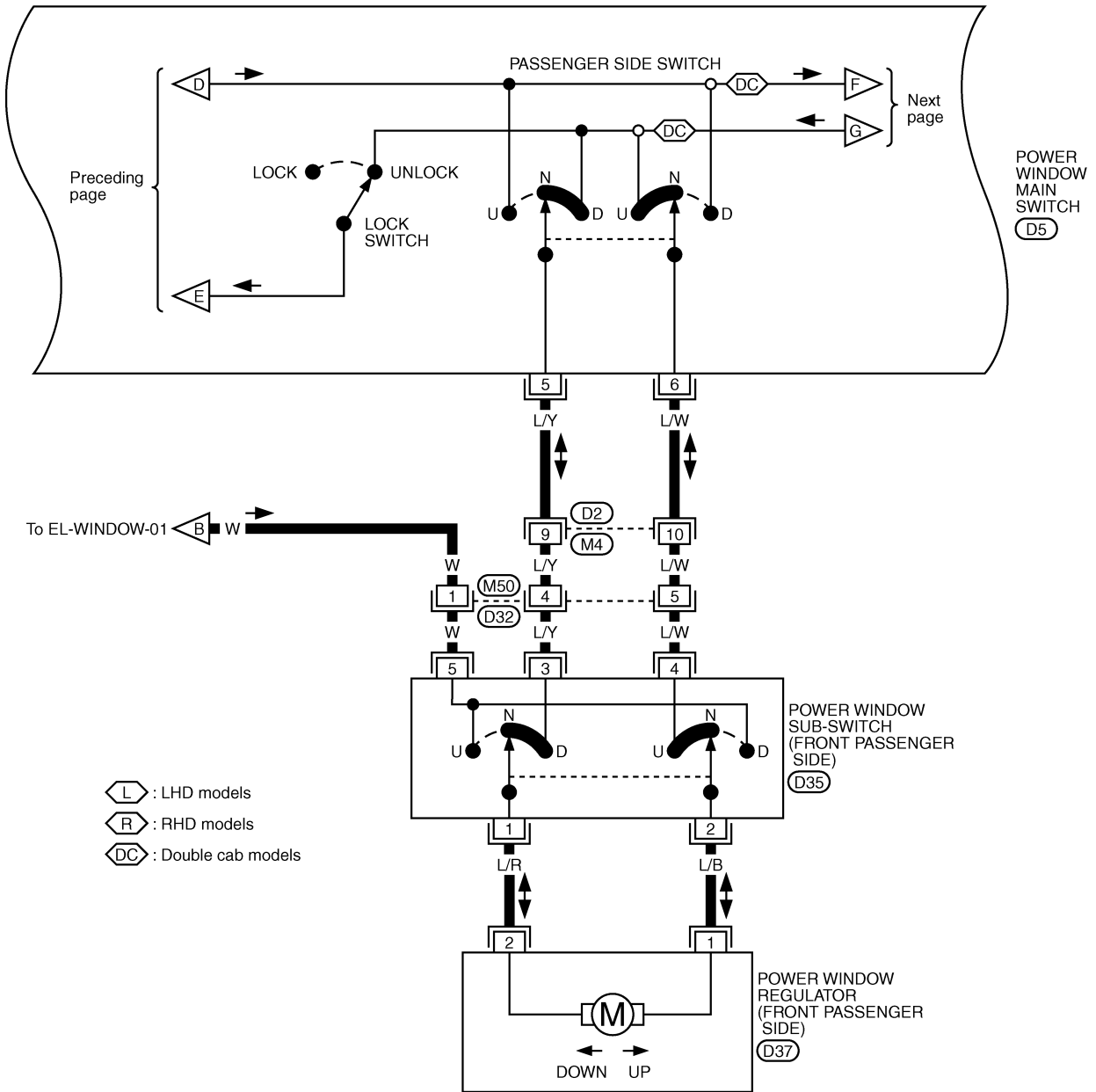

POWER WINDOW

Wiring Diagram — WINDOW —/Without Interruption Detection Function (Cont'd)

EL-WINDOW-04

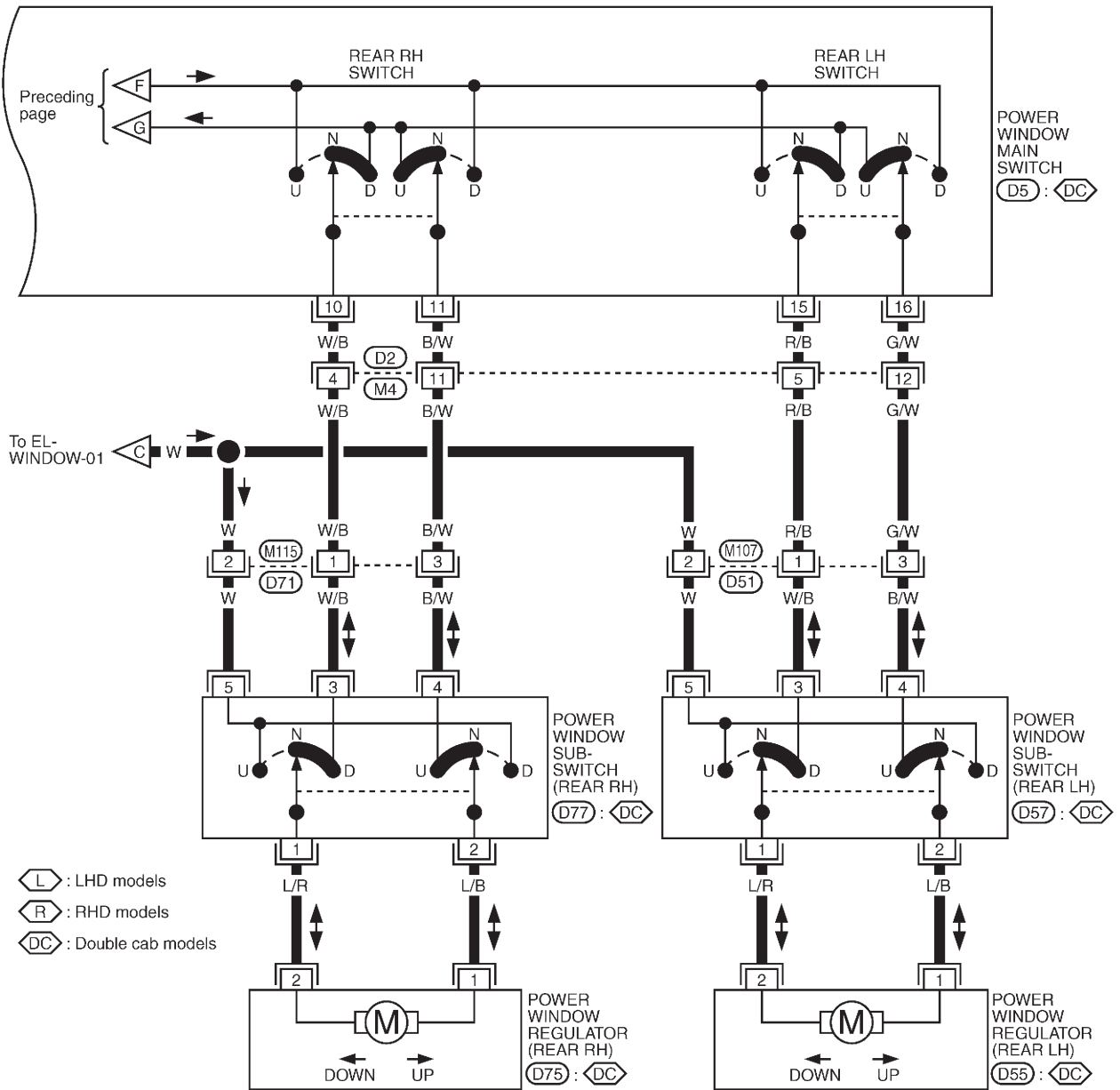

- : LHD models
- : RHD models
- : Double cab models

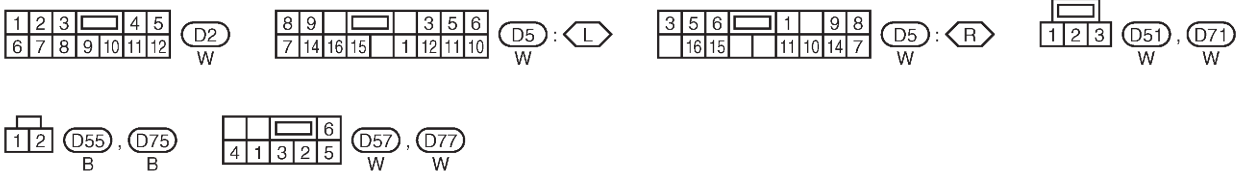

POWER WINDOW

Wiring Diagram — WINDOW —/With Interruption Detection Function

EL-WINDOW-05

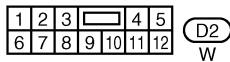
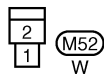
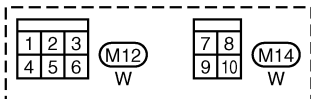
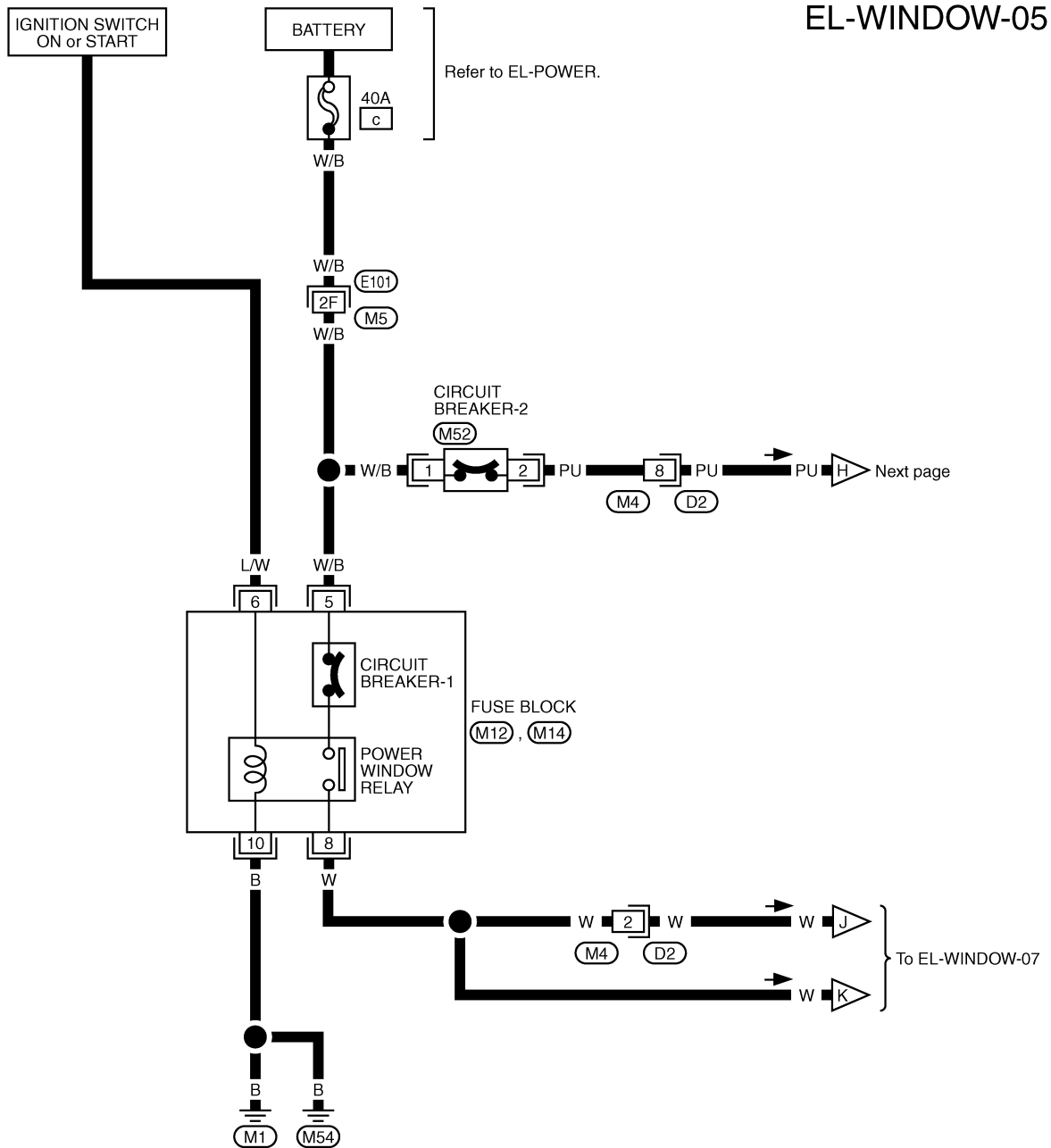

Refer to last page (Foldout page).

M5, E101

POWER WINDOW

Wiring Diagram — WINDOW —/With Interruption Detection Function (Cont'd)

EL-WINDOW-06

Refer to EL-POWER.

Preceding page PU

- : LHD models
- : RHD models
- : For Europe
- : For the Middle East
- *1 G/R :
- R/Y :

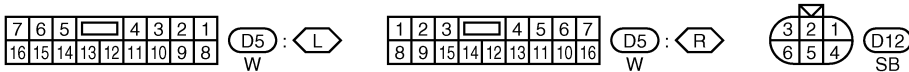
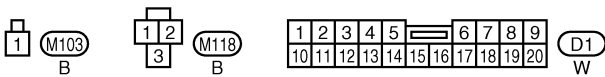
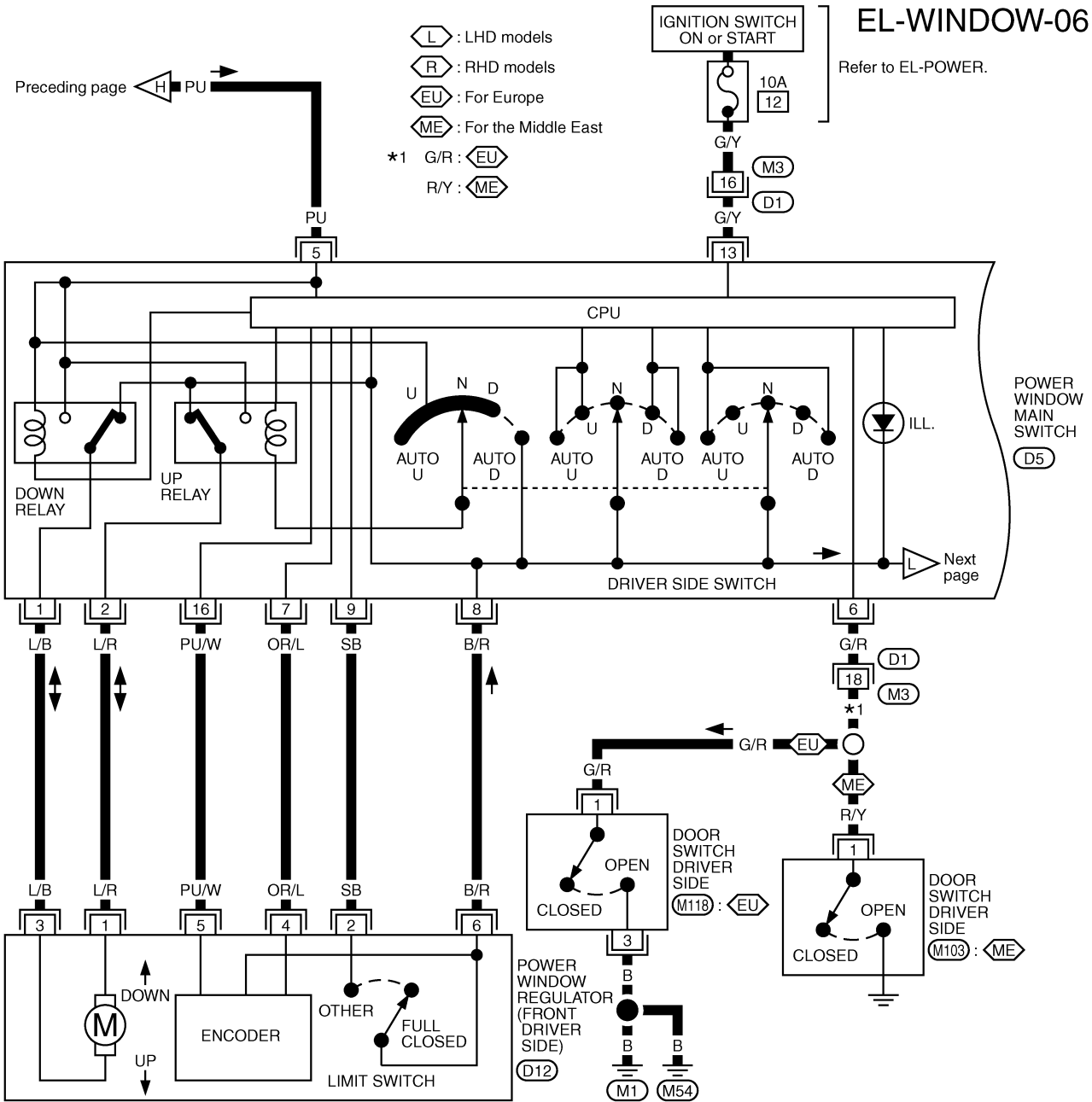

POWER WINDOW

Wiring Diagram — WINDOW —/With Interruption Detection Function (Cont'd)

EL-WINDOW-07

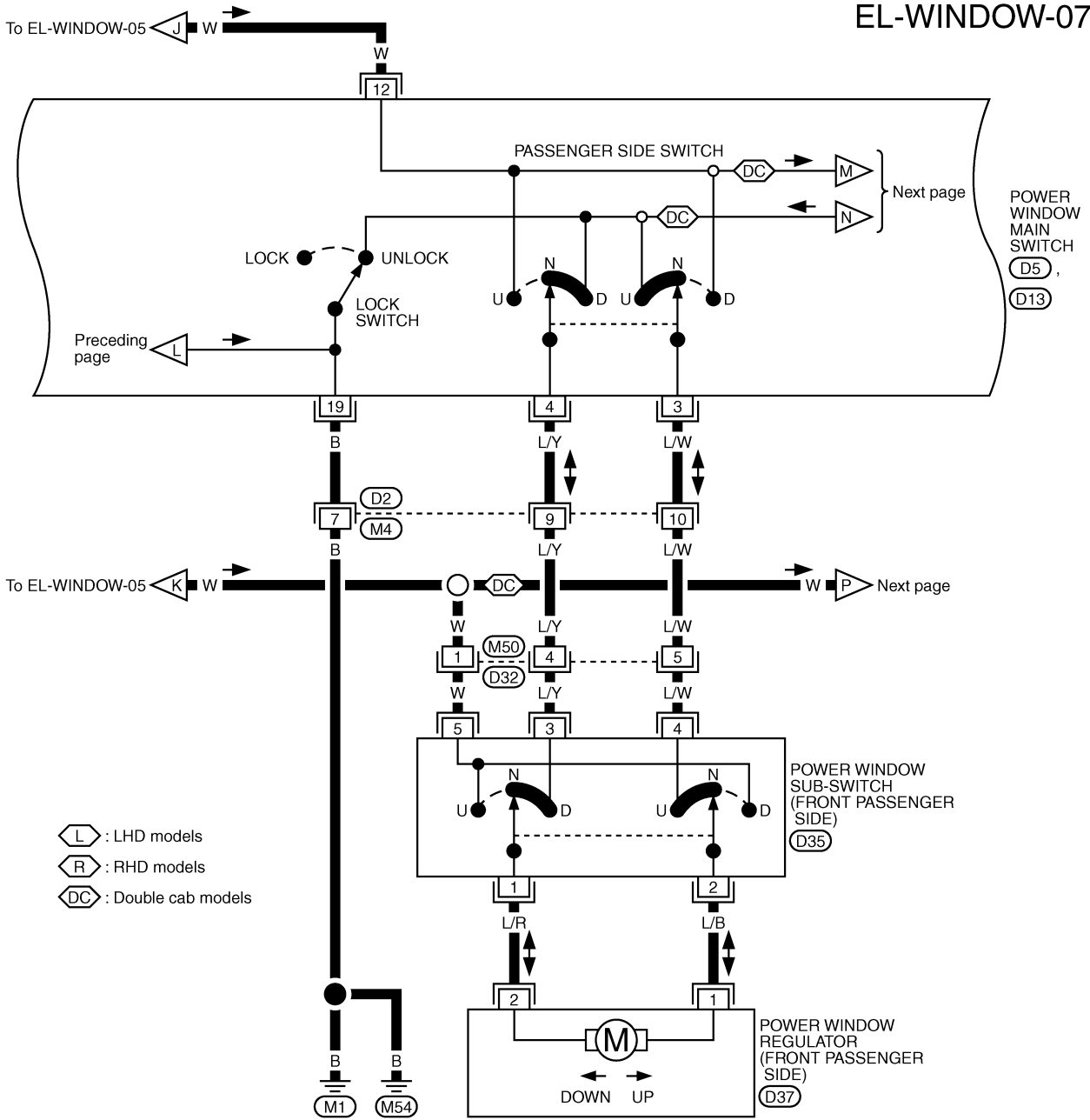

- : LHD models
- : RHD models
- : Double cab models

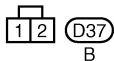
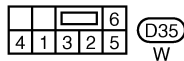
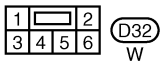
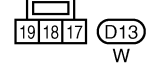
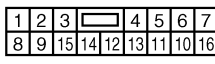
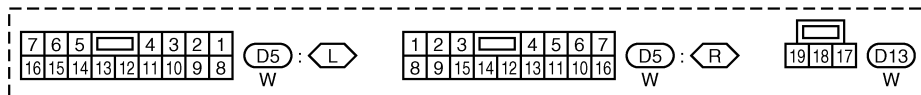
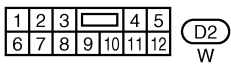

POWER WINDOW

Wiring Diagram — WINDOW —/With Interruption Detection Function (Cont'd)

EL-WINDOW-08

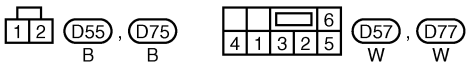
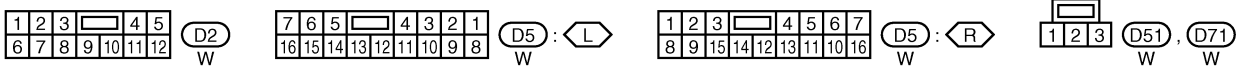
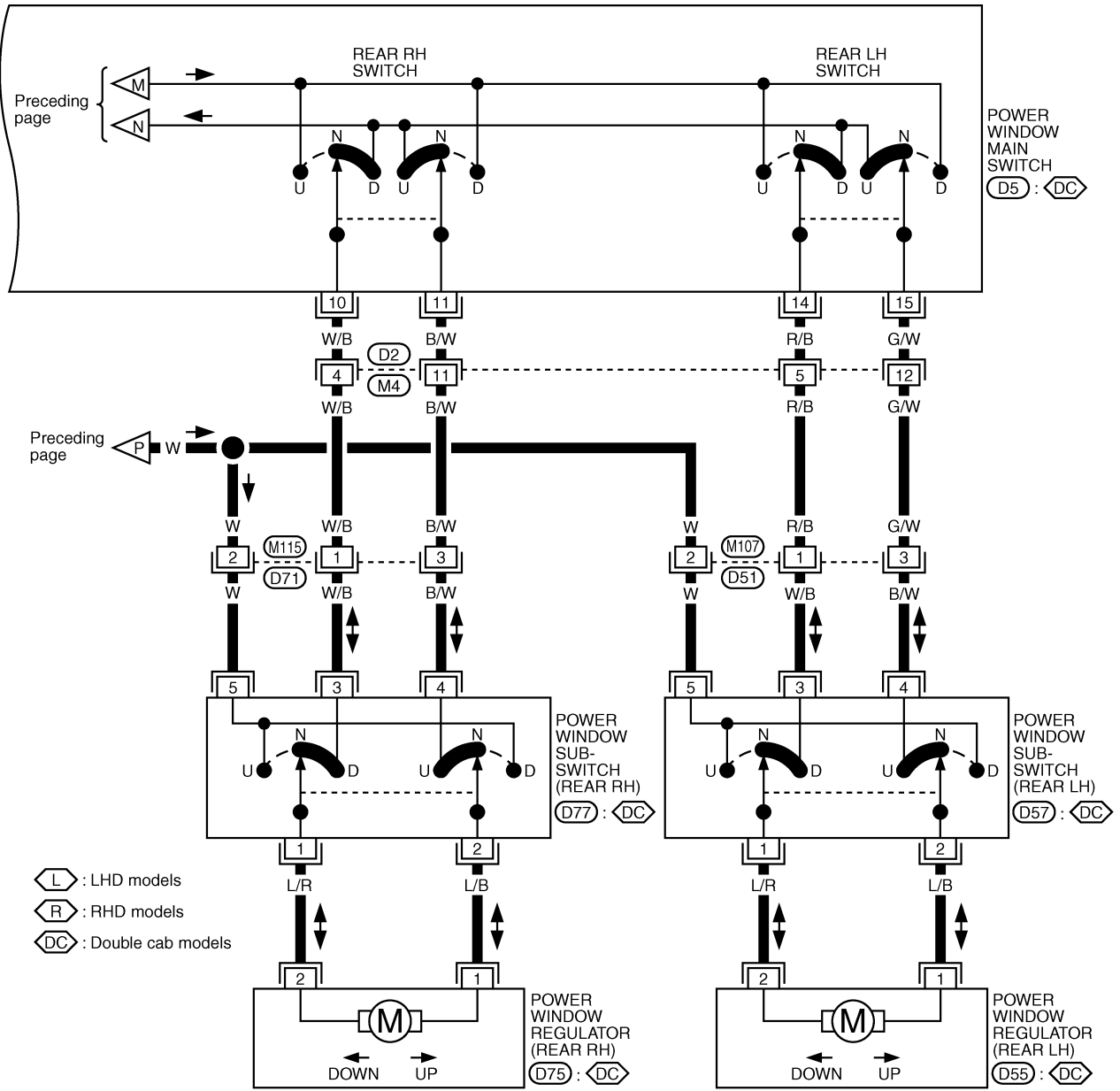

POWER WINDOW

Trouble Diagnoses/Without Interruption Detection Function

Symptom	Possible cause	Repair order
None of the power windows can be operated using any switch.	<ol style="list-style-type: none"> 1. 40A fusible link and circuit breaker-1 2. Grounds (M1) and (M54) 3. Power window relay 4. Open/short in power window main switch circuit 	<ol style="list-style-type: none"> 1. Check 40A fusible link (letter C), located in fusible link and fuse box) and circuit breaker-1, located in fuse block. Turn ignition switch "ON" and verify battery positive voltage is present at terminal ① of power window main switch and terminal ⑤ of sub-switch. 2. Check grounds (M1) and (M54). 3. Check power window relay. 4. Check harness between power window relay and power window main switch for open/short circuit.
Driver side power window cannot be operated but other windows can be operated.	<ol style="list-style-type: none"> 1. Driver side power window regulator circuit 2. Driver side power window regulator 	<ol style="list-style-type: none"> 1. Check harness between power window main switch and power window regulator for open or short circuit. 2. Check driver side power window regulator.
One or some of power window except driver side power window cannot be operated.	<ol style="list-style-type: none"> 1. Power window sub-switch 2. Passenger side power window regulator 3. Power window main switch 4. Power window circuit 	<ol style="list-style-type: none"> 1. Check power window sub-switch. 2. Check power window regulator of malfunctioning power window. 3. Check power window main switch. 4-1. Check harnesses between power window main switch and power window sub-switch for open/short circuit. 4-2. Check harnesses between power window sub-switch and power window regulator for open/short circuit.
Passenger power window cannot be operated using power window main switch but can be operated by power window sub-switch.	<ol style="list-style-type: none"> 1. Power window main switch 	<ol style="list-style-type: none"> 1. Check power window main switch.
Driver side power window auto function cannot be operated using power window main switch.	<ol style="list-style-type: none"> 1. Power window main switch 	<ol style="list-style-type: none"> 1. Check power window main switch.

POWER WINDOW

Trouble Diagnoses/With Interruption Detection Function

Symptom	Possible cause	Repair order
None of the power windows can be operated using any switch.	<ol style="list-style-type: none"> 1. 10A fuse, 40A fusible link 2. Ground circuit 3. Power window main switch 	<ol style="list-style-type: none"> 1. Check 10A fuse [No. 12], located in fuse block (J/B)], 40A fusible link (letter C), located in fuse and fusible link box). 2. Check ground circuit of power window main switch terminal 19. 3. Check power window main switch.
Driver side power window cannot be operated but other windows can be operated.	<ol style="list-style-type: none"> 1. Driver side power window regulator circuit 2. Driver side power window regulator 3. M52 circuit breaker-2 4. M52 circuit breaker-2 circuit 5. Power window main switch circuit 	<ol style="list-style-type: none"> 1. Check harness between power window main switch and driver side power window regulator for open or short circuit. 2. Check driver side power window regulator. 3. Check M52 circuit breaker-2. 4. Check harness between M52 circuit breaker-2 and 40A fusible link (letter C), located in fuse and fusible link box). 5-1. Check harness between power window main switch terminal 13 and 10A fuse [No. 12], located in fuse block (J/B)]. 5-2. Check harness between power window main switch terminal 5 and M52 circuit breaker.
One or more power windows except driver's side window cannot be operated.	<ol style="list-style-type: none"> 1. Power window sub-switches 2. Power window regulators 3. Power window main switch 4. Power window circuit 	<ol style="list-style-type: none"> 1. Check power window sub-switch. 2. Check power window regulator. 3. Check power window main switch. 4-1. Check harnesses between power window main switch and power window sub-switch for open/short circuit. 4-2. Check harnesses between power window sub-switch and power window regulator for open/short circuit.
Power windows except driver's side window cannot be operated using power window main switch but can be operated by power window sub-switch.	<ol style="list-style-type: none"> 1. Power window main switch 	<ol style="list-style-type: none"> 1. Check power window main switch.
Driver side power window automatic operation does not function properly.	<ol style="list-style-type: none"> 1. Power window main switch 2. Encoder and limit switch 	<ol style="list-style-type: none"> 1. Check power window main switch. 2. Check encoder and limit switch. (EL-3132)
Timer control for supplying power after turning ignition switch to "OFF" does not operate properly. (Except models for Europe)	<ol style="list-style-type: none"> 1. Driver side door switch circuit 2. Driver side door switch 3. Ignition switch ON signal circuit 4. Power window main switch 	<ol style="list-style-type: none"> 1. Check harness between driver side door switch and power window main switch. 2. Check driver side door switch. 3. Check ignition switch ON signal circuit to power window main switch. 4. Check power window main switch.

POWER WINDOW

Trouble Diagnoses/With Interruption Detection Function (Cont'd)

ENCODER AND LIMIT SWITCH CHECK

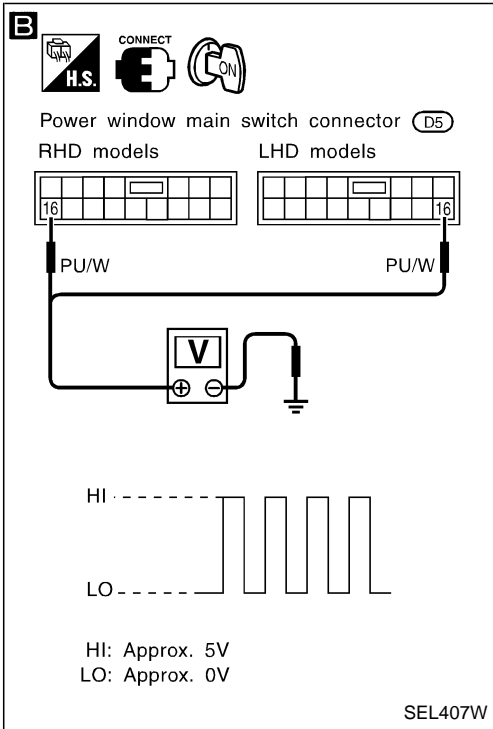
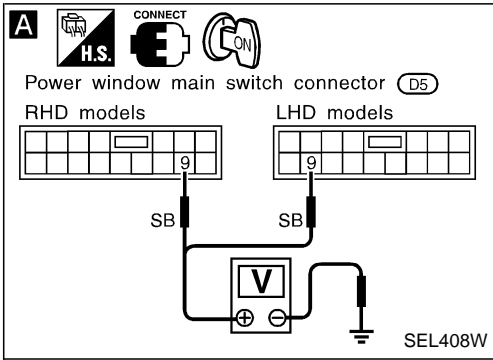

CHECK DOOR WINDOW SLIDE MECHANISM
Check the following.

- Obstacles in window, glass molding, etc.
- Worn or deformed glass molding
- Door sash tilted too far inward or outward
- Door window regulator

NG → Remove obstacles or repair door window slide mechanism.

A **CHECK POWER SUPPLY TO LIMIT SWITCH**

1. Disconnect driver side power window regulator connector.
2. Turn ignition switch ON.
3. Check voltage between power window main switch terminal ⑨ and ground. **Approx. 5V should exist.**

NG → Replace power window main switch.

CHECK LIMIT SWITCH OPERATION

1. Turn ignition switch OFF.
2. Connect driver side power window regulator connector.
3. Turn ignition switch ON.
4. Check voltage between power window main switch terminal ⑨ and ground during power window closing operation.

B **CHECK ENCODER**
Measure voltage between power window main switch terminal ⑯ and ground with oscilloscope when power window is in automatic closing operation. If check result is NG, replace power window regulator motor (front driver side). If check result is OK, replace power window main switch.

Terminal No.	Condition	Voltage (DCV)
⑨	Approx. 15 mm (0.59 in) below the full closed position to full closed position	Approx. 5
	Other positions	Approx. 0

RESET LIMIT SWITCH
Reset limit switch. Refer to BT section. Then check voltage between power window main switch terminal ⑨ and ground during power window closing operation at least ten times.

NG → Replace power window regulator motor (front driver side).

Terminal No.	Condition	Voltage (DCV)
⑨	Approx. 15 mm (0.59 in) below the full closed position to full closed position	Approx. 5
	Other positions	Approx. 0

B **CHECK ENCODER**
Measure voltage between power window main switch terminal ⑯ and ground with oscilloscope when power window is in automatic closing operation.

NG → Replace power window regulator motor (front driver side).

Replace power window main switch.

POWER DOOR LOCK

Wiring Diagram — D/LOCK —

EL-D/LOCK-03

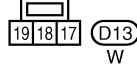
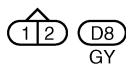
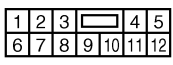
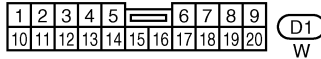
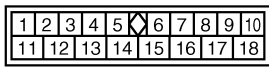
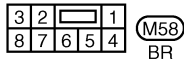
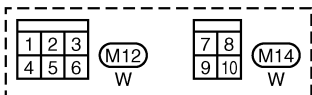
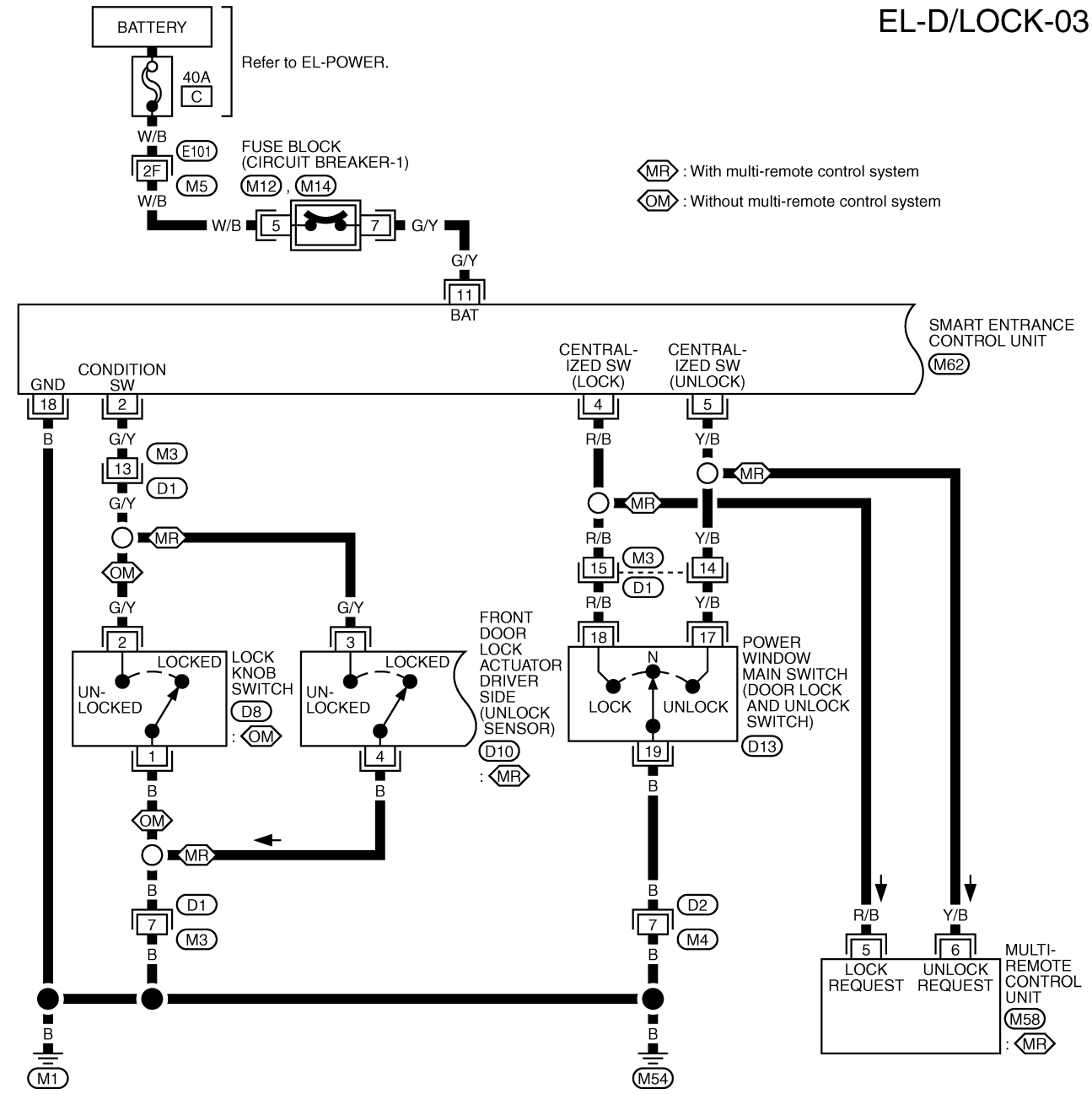

Refer to last page (Foldout page).

(M5), (E101)

POWER DOOR LOCK

Wiring Diagram — D/LOCK — (Cont'd)

EL-D/LOCK-04

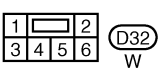
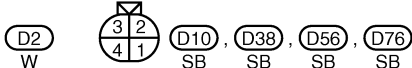
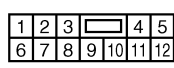
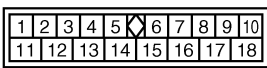
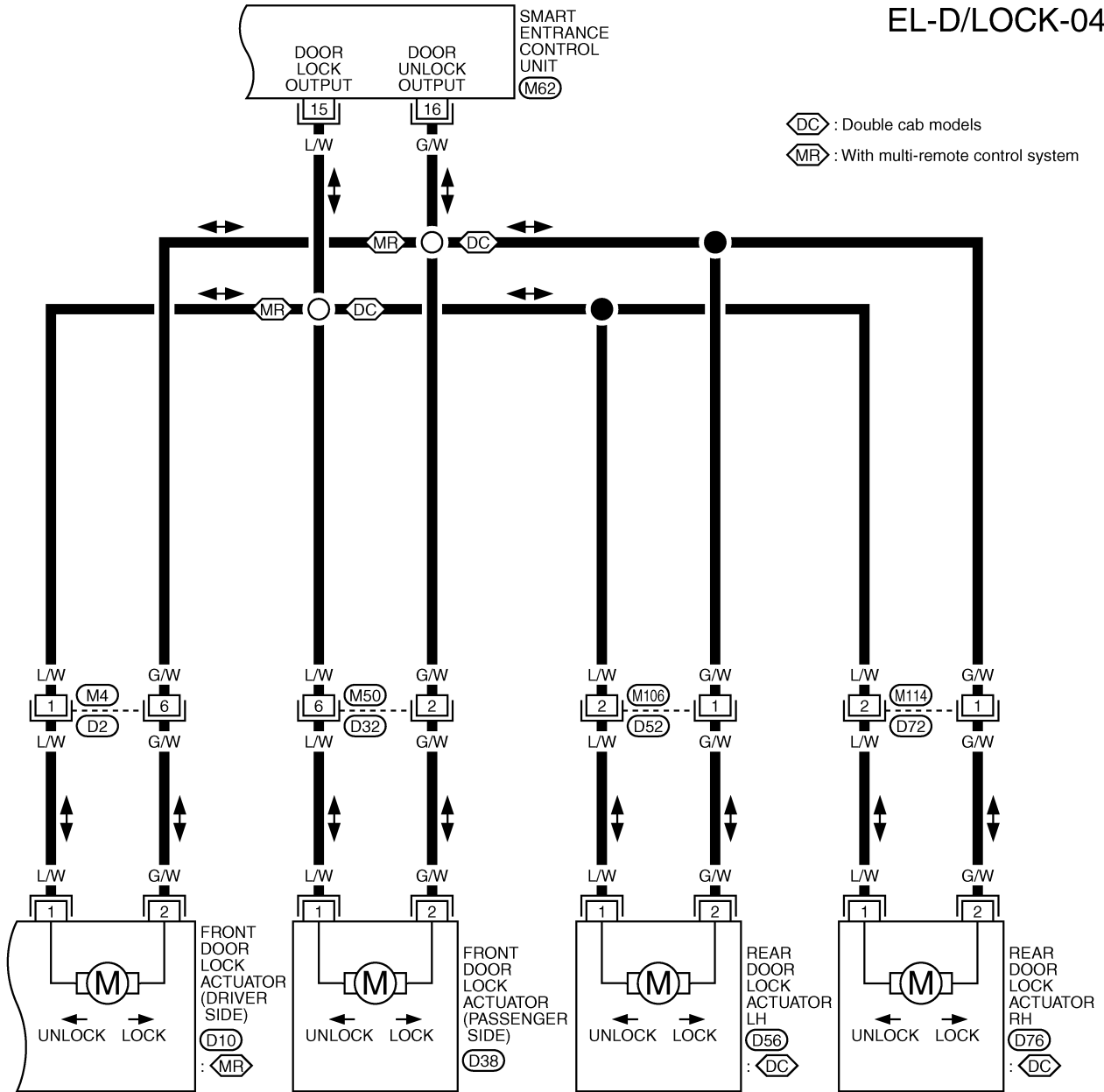

MULTI-REMOTE CONTROL SYSTEM

System Description

FUNCTION

Multi-remote control system has the following function.

- Door lock
- Door unlock
- Hazard reminder

LOCK OPERATION

When the LOCK signal is input to multi-remote control unit (the antenna of the system is combined with multi-remote control unit), ground is supplied

- through multi-remote control unit terminal ⑤
- to smart entrance control unit terminal ④.

Then smart entrance control unit supplies power and ground to each door lock actuator.

UNLOCK OPERATION

When the UNLOCK signal is input to multi-remote control unit (the antenna of the system is combined with multi-remote control unit), ground is supplied

- through multi-remote control unit terminal ⑥
- to smart entrance control unit terminal ⑤.

Then smart entrance control unit supplies power and ground to each door lock actuator.

HAZARD REMINDER

When the doors are locked or unlocked (signal from driver's door unlock sensor) by multi-remote controller, power is supplied

- through multi-remote control unit terminals ③ and ⑧
- to the hazard warning lamps

Then hazard warning lamp flash as follows.

- Lock operation: Flash once
- Unlock operation: Flash twice

MULTI-REMOTE CONTROLLER ID CODE ENTRY

A maximum of four remote controllers can be entered. Any attempt to enter a remote controller will erase all ID codes previously entered. Therefore, be sure to receive all remote controllers from the vehicle owner when any ID code entry is performed.

To enter ID code entry, the following signals must be input to the multi-remote control unit.

- Ignition switch ON signal
- Battery power supply
- Signal from remote controller

For detailed procedure, refer to "ID Code Entry Procedure" in EL-3139.

MULTI-REMOTE CONTROL SYSTEM

Wiring Diagram — MULTI —

EL-MULTI-01

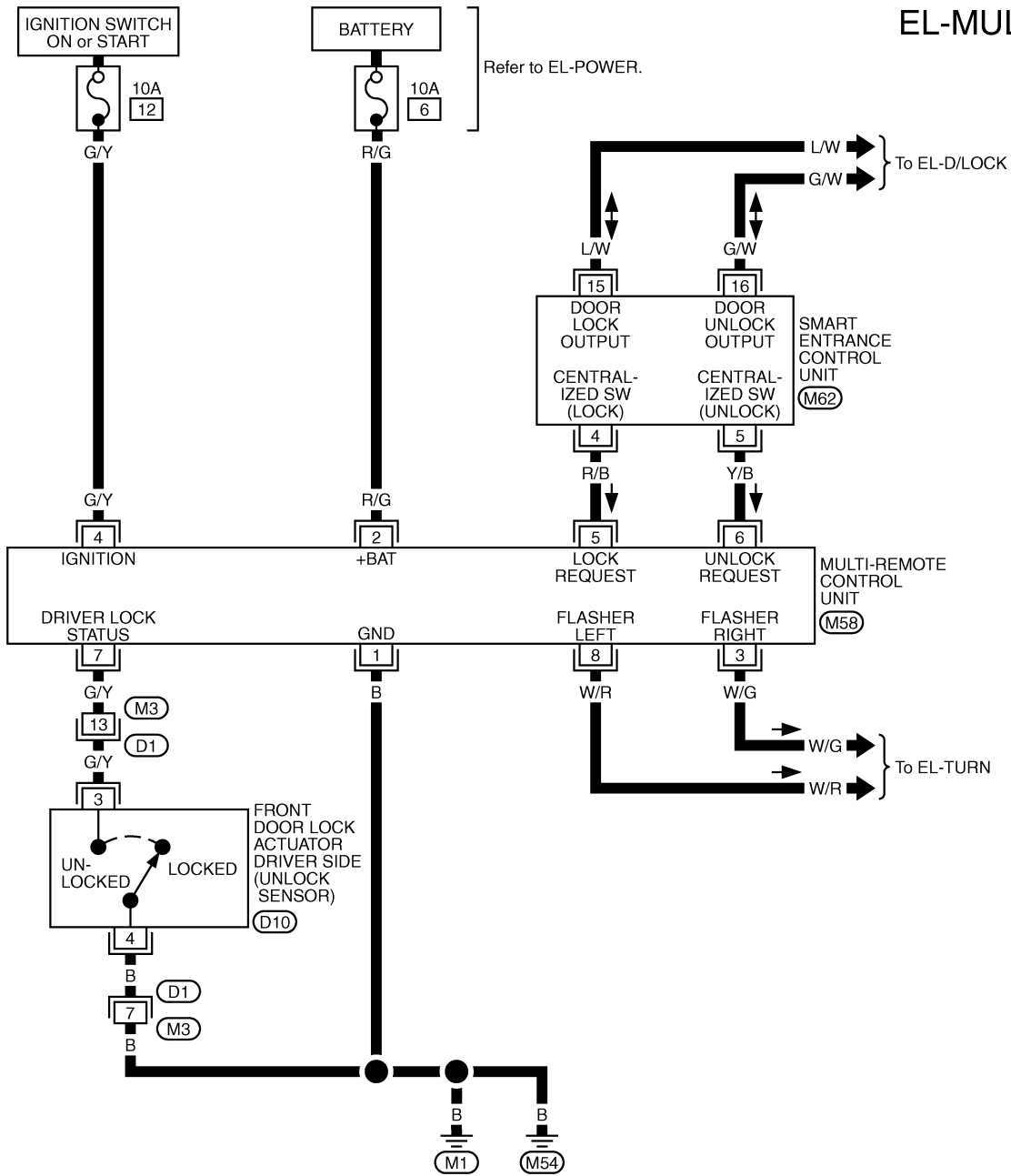

3	2	1
8	7	6

(M58)
BR

1	2	3	4	5	6	7	8	9	10
11	12	13	14	15	16	17	18		

(M62)
W



1	2	3	4	5	6	7	8	9
10	11	12	13	14	15	16	17	18

(D1)
W

3	2
4	1

(D10)
SB

MULTI-REMOTE CONTROL SYSTEM

Trouble Diagnoses

SYMPTOM CHART

Symptom	Possible cause	Diagnoses/service order
No doors can be locked or unlocked by remote control operation. (See NOTE.)	<ol style="list-style-type: none"> 1. Power door lock system 2. Remote controller battery 3. Door lock/unlock circuit 4. Ignition power supply circuit for multi-remote control unit 5. Power supply circuit for multi-remote control unit 6. Ground circuit for multi-remote control unit 7. Remote controller 	<ol style="list-style-type: none"> 1. Check power door lock operation. 2. Check remote controller battery. Refer to EL-3140. 3. Check harness for open or short between multi-remote control unit and smart entrance control unit. 4. Make sure battery voltage is present at terminal ④ of multi-remote control unit while ignition switch is in IGN position. 5. Make sure battery voltage is present at terminal ② of multi-remote control unit. 6. Check continuity between terminal ① of multi-remote control unit and ground. 7. Replace remote controller. Refer to EL-3139.
Hazard reminder does not operate properly.	<ol style="list-style-type: none"> 1. Hazard reminder output to hazard warning lamps 2. Hazard reminder circuit 3. Driver's door unlock sensor 	<ol style="list-style-type: none"> 1. Check hazard reminder output to hazard warning lamps at terminals ③ and ⑧ of multi-remote control unit. 2. Check the harness for open or short between hazard warning lamps and multi-remote control unit. 3. Check driver's door unlock sensor signal at terminal ⑦ of multi-remote control unit.
The new ID of remote controller cannot be entered.	<ol style="list-style-type: none"> 1. Remote controller battery 2. Ignition power supply circuit for multi-remote control unit 3. Driver's door unlock sensor 4. Remote controller 	<ol style="list-style-type: none"> 1. Check remote controller battery. Refer to EL-3140. 2. Make sure battery voltage is present at terminal ④ of multi-remote control unit while ignition switch is in IGN position. 3. Check driver's door unlock sensor signal at terminal ⑦ of multi-remote control unit. 4. Replace remote controller. Refer to EL-3139.

Refer to "MULTI-REMOTE CONTROL UNIT INSPECTION TABLE" on next page to check the control unit signals.

NOTE:

- The lock operation of multi-remote control system does not activate with the ignition key ON position.

MULTI-REMOTE CONTROL SYSTEM

Trouble Diagnoses (Cont'd)

MULTI-REMOTE CONTROL UNIT INSPECTION TABLE

Terminal No.	Connections	Condition	Voltage (V) (approximate values)
1	Ground	—	—
2	Power source (BAT)	—	12
3	Hazard warning lamp RH	Remote controller LOCK/UNLOCK button is pushed (All doors are closed and key is not in ignition key cylinder.)	12
		Other than above condition	0
4	Ignition power supply	Ignition switch	OFF 0
			ON or START 12
5	Lock signal	Remote controller LOCK button is pushed (All doors are closed and key is not in ignition key cylinder.)	0
		Other than above condition	5
6	Unlock signal	Remote controller UNLOCK button is pushed (Key is not in ignition key cylinder.)	0
		Other than above condition	5
7	Driver side door unlock sensor	Driver side door	Locked 5
			Unlocked 0
8	Hazard warning lamp LH	Remote controller LOCK/UNLOCK button is pushed (All doors are closed and key is not in ignition key cylinder.)	12
		Other than above condition	0



Multi-remote control
unit connector

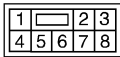

SEL147X

MULTI-REMOTE CONTROL SYSTEM

ID Code Entry Procedure

Activation of the registration mode:

The vehicle must have been unlocked by either the multi-remote controller or a transponder OK signal (TPOK) from the vehicle's immobilizer.

Preparation: - Make sure all doors unlock.

- Make sure all multi-remote controllers to be registered are available.
- Make sure the batteries of all multi-remote controllers are in a good condition.
- Make sure all transmitting sources are out of the neighbourhood of the vehicle.
- Make sure the battery of the vehicle is in a good condition.

Switch ignition-switch exactly six times from the "LOCK" to the "ON" position within 10 seconds and return the ignition switch to the "LOCK" position (leaving the key in the ignition switch).

After 2 seconds the registration mode is activated. The turn signal lamps will flash twice.

NG

OK

Proceed with the registration mode.

NOTE

The registration mode is operated when:

- The ignition-switch is turned to the "ON" position.
- 4 multi remote controllers have been learned.
- No multi-remote controller or ignition switch input is received within 120 seconds.

Registration mode

Press and hold the "UNLOCK" button of the multi-remote controller.

Press the "LOCK" button 3 times.

Release the "UNLOCK" button.

Do you want to register another multi-remote controller? (max. 4)

No

Yes

After registration of the requested No. of multi-remote controller(s), confirm the ID-code(s) by switching the ignition switch to the "ON" position.

If the multi-remote controller registration is performed correctly, the turn signal lamp will flash twice.

Take the ignition key out of the ignition switch and confirm the functioning of all multi-remote controllers by locking and unlocking the vehicle with each of the multi-remote controllers.

OK

NG

End

MULTI-REMOTE CONTROL SYSTEM

Remote Controller Battery Replacement

NOTE:

- Be careful not to touch the circuit board or battery terminal.
- The remote controller is water-resistant. However, if it does get wet, immediately wipe it dry.
- Push the remote controller button two or three times to check its operation after replacing battery.

STEP 1

STEP 2

STEP 3

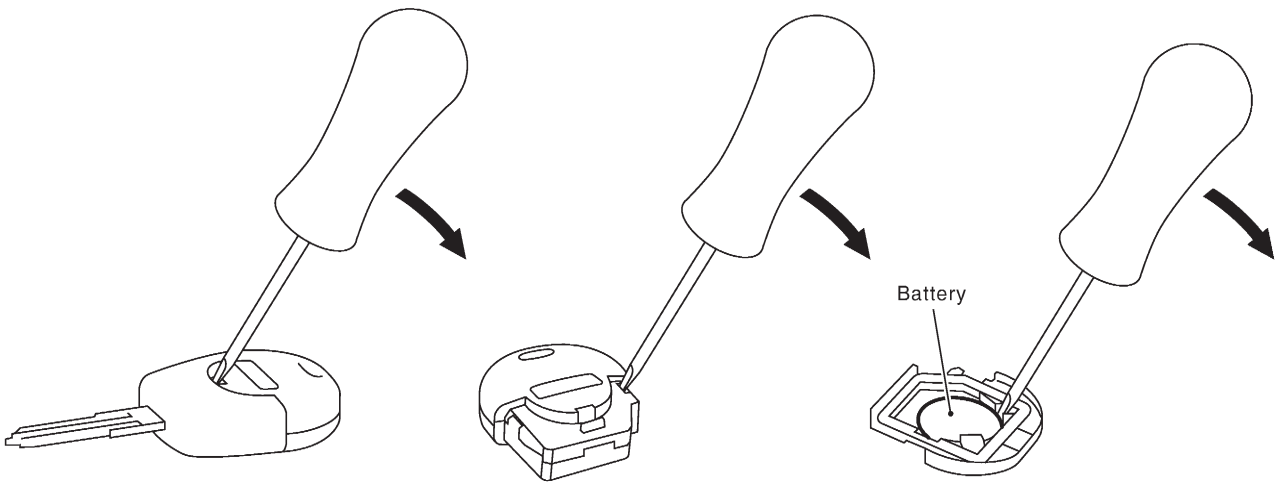

SEL241X

THEFT WARNING SYSTEM

Wiring Diagram — PRWIRE —

EL-PRWIRE-01

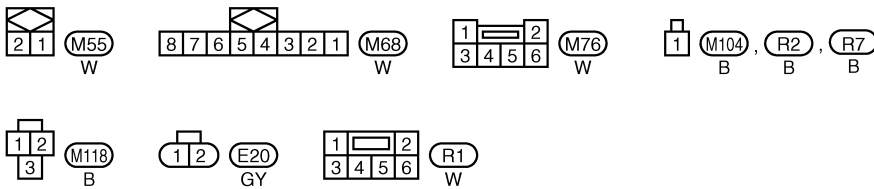
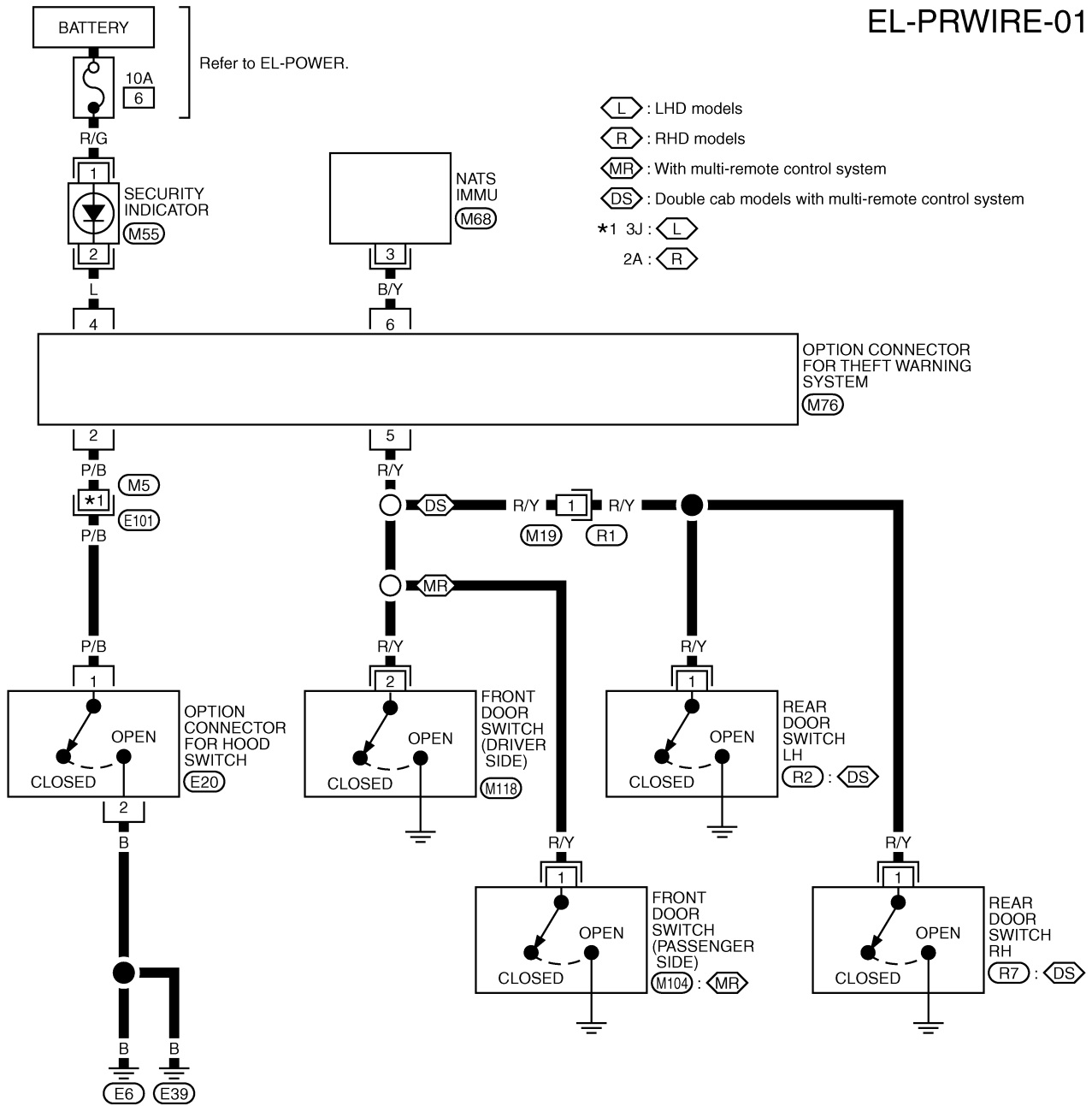

Refer to last page (Foldout page).

(M5), (E101)

NATS (Nissan Anti-Theft System)

Component Parts and Harness Connector Location

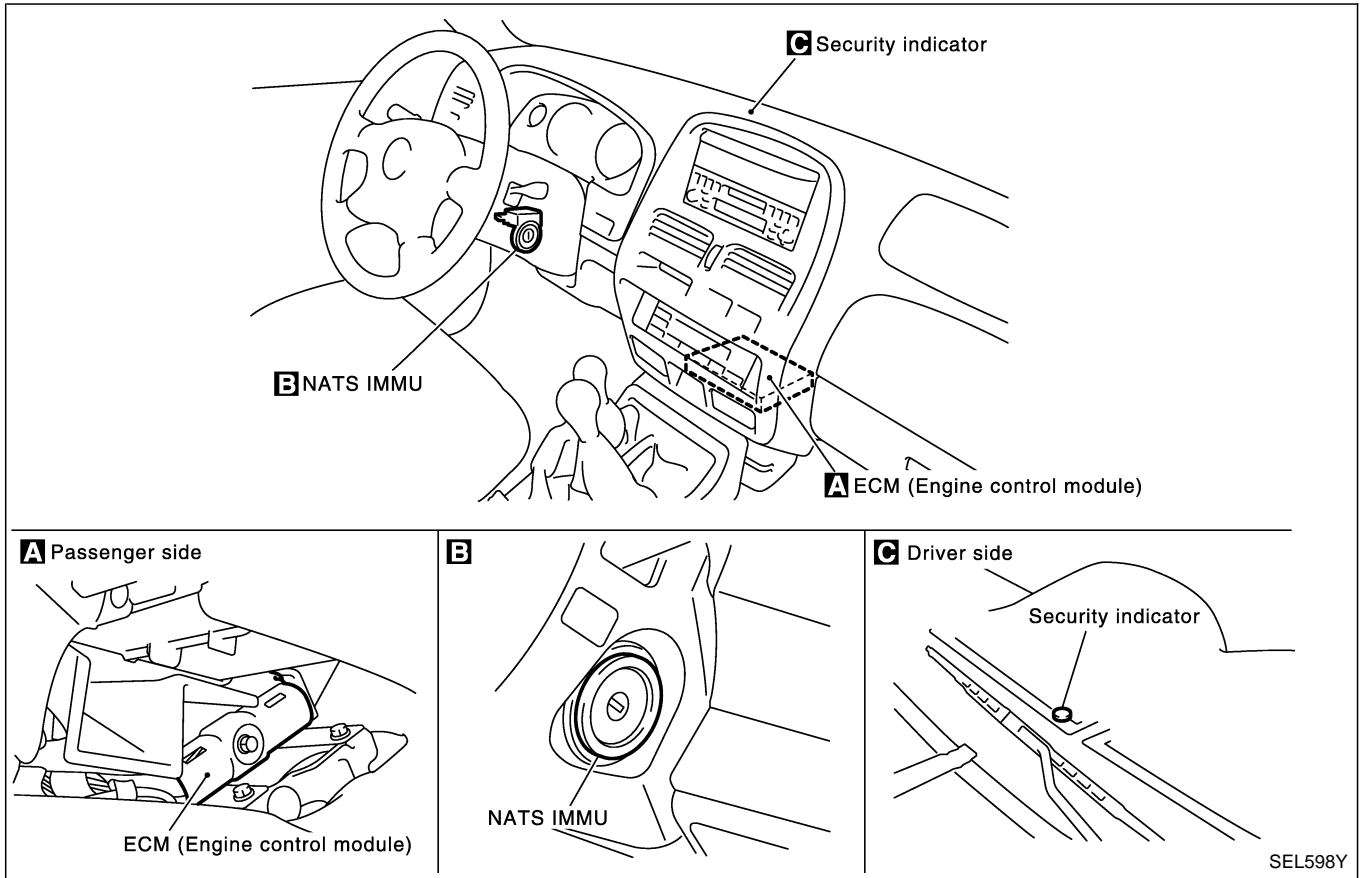

NOTE:

If customer reports a "No Start" condition, request ALL KEYS to be brought to the Dealer in case of a NATS malfunction.

NATS (Nissan Anti-Theft System)

System Description

NATS has the following immobilizer functions:

- Since only NATS ignition keys, whose ID nos. have been registered into the ECM and IMMU of NATS, allow the engine to run, operation of a stolen vehicle without a NATS registered key is prevented by NATS.
That is to say, NATS will immobilize the engine if someone tries to start it without the registered key of NATS.
- This version of NATS has dongle unit to improve its anti-theft performance (RHD models for Europe). Dongle unit has its own ID which is registered into NATS IMMU. So it dongle unit is replaced, initialization must be carried out.
- When malfunction of dongle unit is detected:
 - The security indicator lamp illuminates for about 15 minutes after ignition switch is turned to ON.
 - When dongle unit has a malfunction and the indicator lamp is illuminated, engine can not be started. However, engine can be started only one time when security indicator turns off in about 15 minutes after ignition switch is turned to ON.
- Both of the originally supplied ignition key IDs have been NATS registered.
If requested by the vehicle owner, a maximum of five key IDs can be registered into the NATS components.
- The NATS security indicator (NATS security ind.) blinks when the ignition switch is in “OFF” or “ACC” position. Therefore, NATS warns outsiders that the vehicle is equipped with the anti-theft system.
- When NATS detects trouble, the security indicator lamp lights up as follows.

Condition IGN ON and	With Dongle	Without Dongle
	Security Indicator	Security Indicator
NATS malfunction (except dongle unit) is detected	1. 6 times blinking 2. Staying ON after ignition switch is turned ON	Staying ON
Only malfunction of dongle unit is detected.	Staying ON for about 15 minutes after ignition switch is turned ON.	—
Malfunction of NATS and engine related parts are detected	1. 6 times blinking 2. Staying ON after ignition switch is turned ON	Staying ON
Just after initialization of NATS	6 times blinking	—

- NATS trouble diagnoses, system initialization and additional registration of other NATS ignition key IDs must be carried out using CONSULT-II hardware and CONSULT-II NATS software.
Regarding the procedures of NATS initialization and NATS ignition key ID registration, refer to CONSULT-II operation manual, NATS.
- **When servicing a malfunction of the NATS (indicated by lighting up of security Indicator Lamp) or registering another NATS ignition key ID no., it is necessary to re-register original key identification. Therefore, be sure to receive ALL KEYS from vehicle owner.**

NATS (Nissan Anti-Theft System)

System Composition

The immobilizer function of the NATS consists of the following:

- NATS ignition key
- NATS immobilizer control unit (NATS IMMU), located in the ignition key cylinder
- Engine control module (ECM)
- Dongle unit (RHD models for Europe)
- NATS security indicator

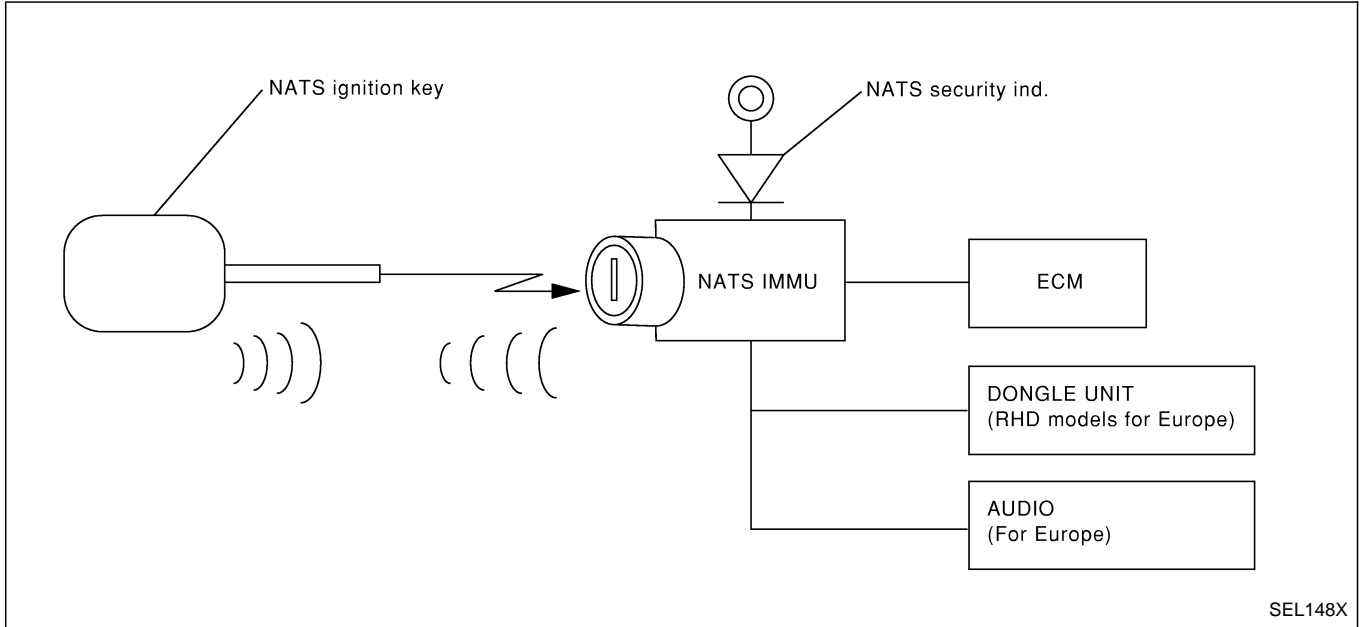

NATS (Nissan Anti-Theft System)

Wiring Diagram — NATS —/LHD Models

EL-NATS-01

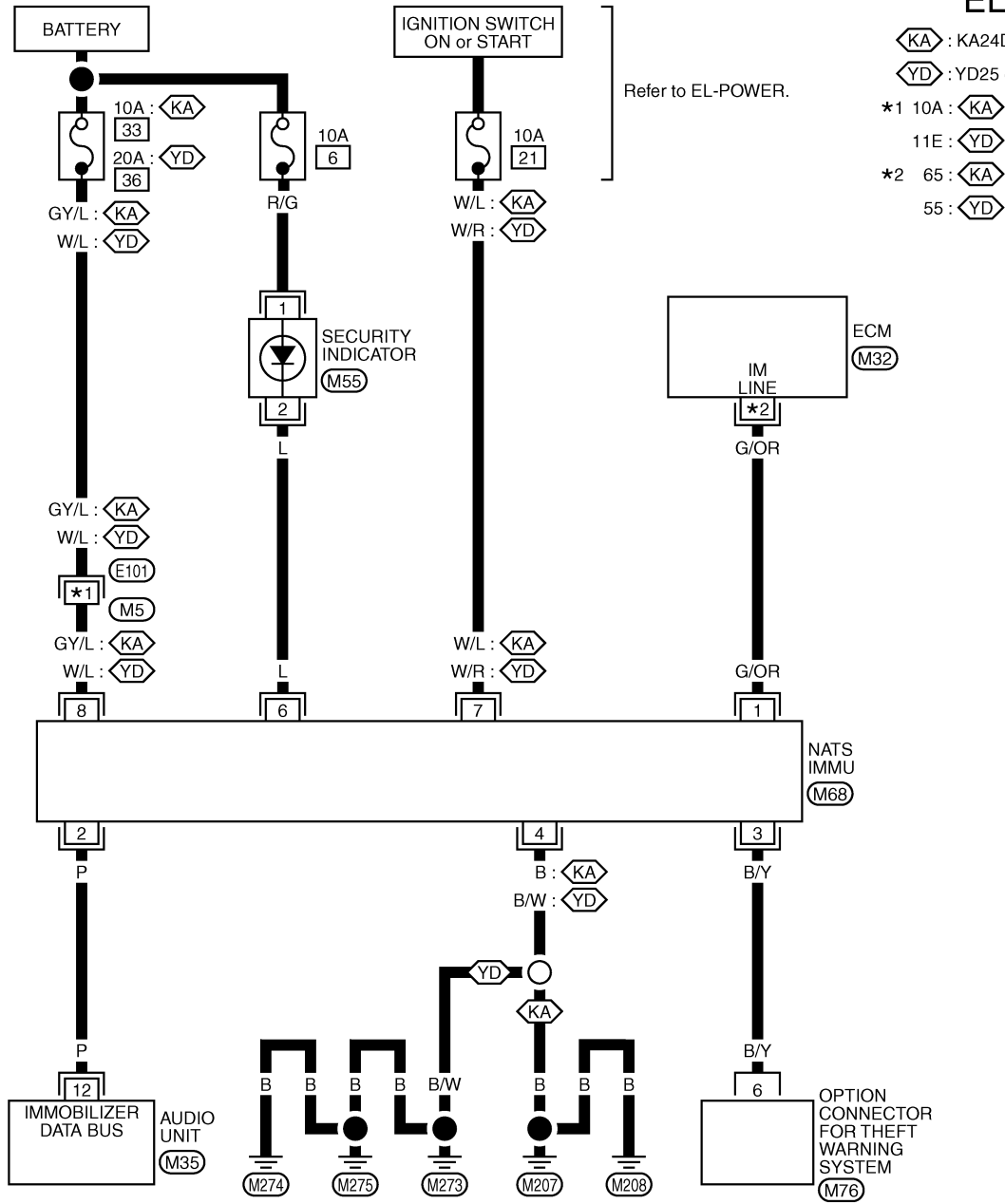

Refer to EL-POWER.

- ⬡ KA : KA24DE engine models
- ⬡ YD : YD25 engine models
- *1 10A : ⬡ KA
- 11E : ⬡ YD
- *2 65 : ⬡ KA
- 55 : ⬡ YD

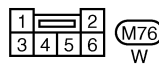
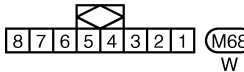
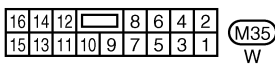

Refer to last page (Foldout page).

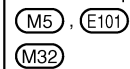

NATS (Nissan Anti-Theft System)

Wiring Diagram — NATS —/RHD Diesel Engine Models

EL-NATS-02

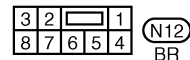
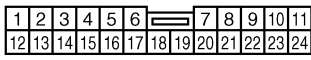
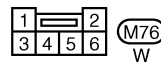
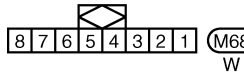
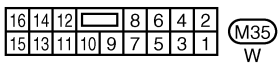
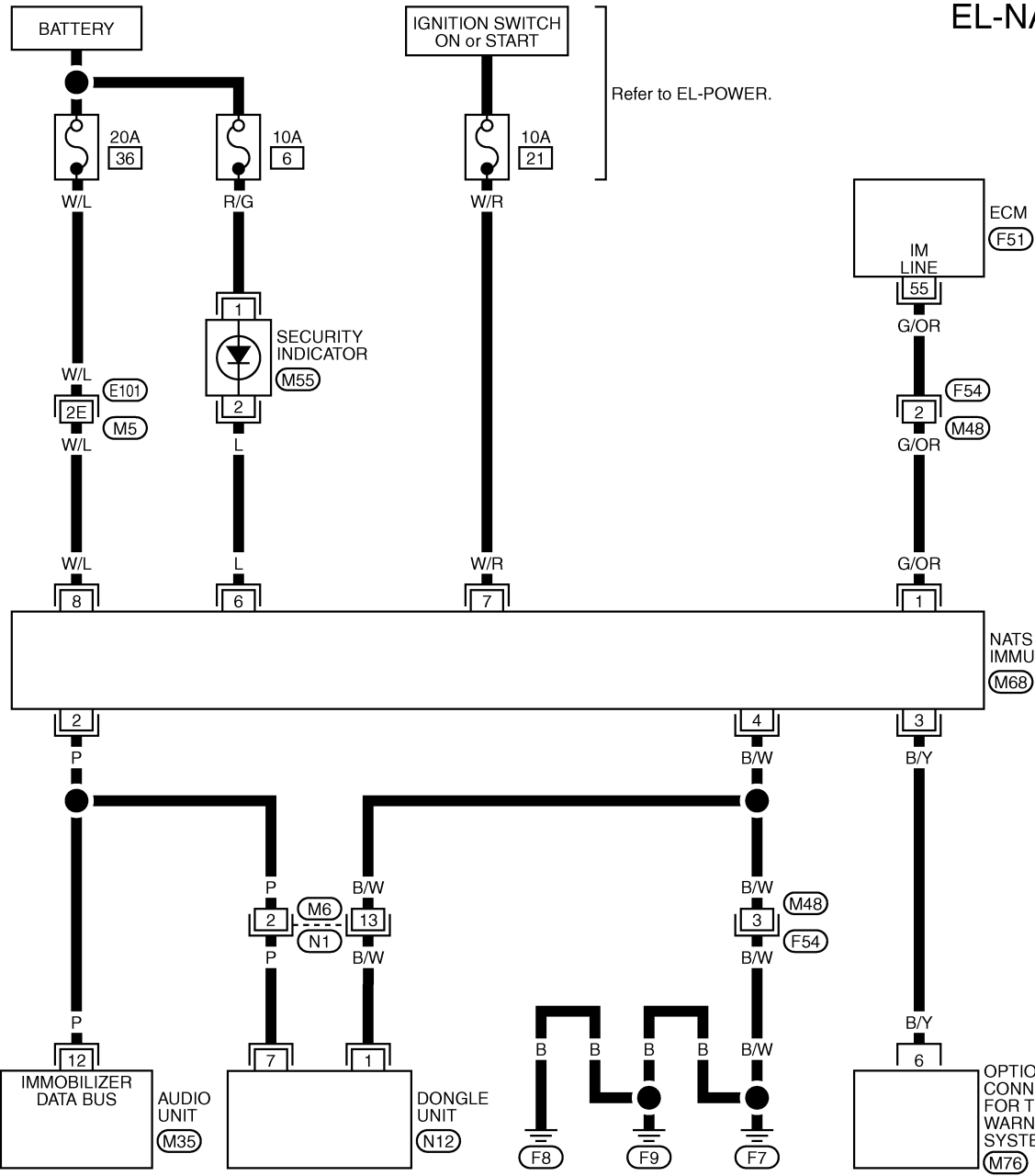

Refer to last page (Foldout page).

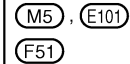

NATS (Nissan Anti-Theft System)

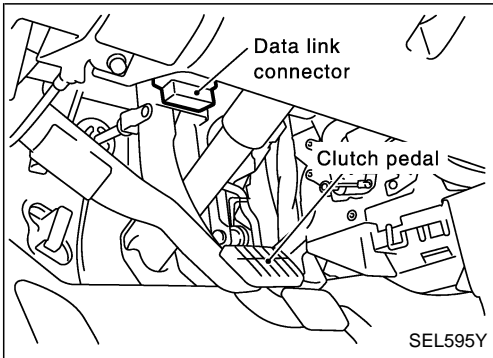

CONSULT-II

CONSULT-II INSPECTION PROCEDURE

1. Turn ignition switch OFF.
2. Insert NATS program card into CONSULT-II.

Program card

AEN00A/B

3. Connect CONSULT-II to Data link connector which is located behind the fuse box cover.

4. Turn ignition switch ON.
5. Touch "START".

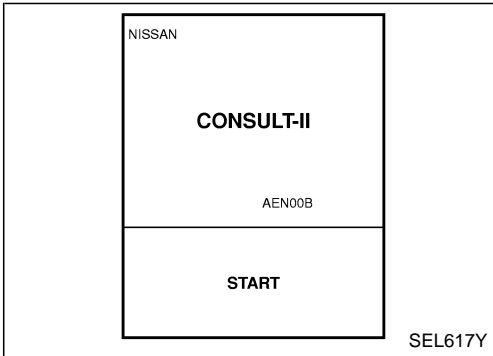

6. Perform each diagnostic test mode according to each service procedure.

For further information, see the CONSULT-II Operation Manual, NATS.

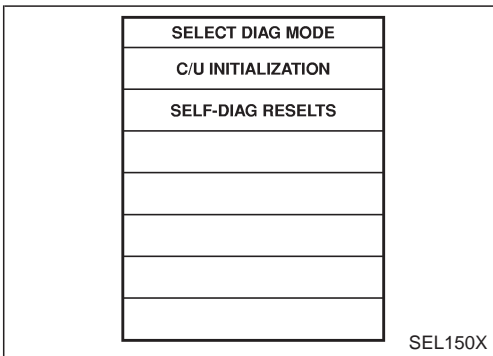

NATS (Nissan Anti-Theft System)

CONSULT-II (Cont'd)

CONSULT-II DIAGNOSTIC TEST MODE FUNCTION

CONSULT-II DIAGNOSTIC TEST MODE	Description
C/U INITIALIZATION	When replacing any of the following components, C/U initialization is necessary. [NATS ignition key/IMMU/ECM/Dongle unit]
SELF-DIAG RESULTS	Detected items (screen terms) are as shown in the chart below.

NOTE:

When any initialization is performed, all ID previously registered will be erased. So all NATS ignition keys must be registered again.

The engine cannot be started with an unregistered key. In this case, the system may show "DIFFERENCE OF KEY" or "LOCK MODE" as a self-diagnostic result on the CONSULT-II screen.

When initialization is performed (for RHD models), security indicator will flash six times to demonstrate recognition of dongle unit ID.

HOW TO READ SELF-DIAGNOSTIC RESULTS

Result display screen (When no malfunction is detected)

SELF-DIAG RESULTS	
DTC RESULTS	TIME
NO DTC IS DETECTED. FURTHER TESTING MAY BE REQUIRED.	
PRINT	

Result display screen (When malfunction is detected)

SELF-DIAG RESULTS	
DTC RESULTS	TIME
CHAIN OF ECM-IMMU	0
DIFFERENCE OF KEY	1
Scroll down	
ERASE	PRINT

Detected items →

If "Scroll Down" is indicated, there are four or more defected items.

When touched, the results stored in the engine control module (ECM) are erased.

Time data
This indicates how many times the vehicle was driven after the last detection of a malfunction. If the malfunction is detected currently, the time data will be "0".

When touched, the results are printed out.

SEL151X

SELF-DIAGNOSTIC RESULTS ITEM CHART

Detected items (Screen terms)	Description	Reference page
ECM INT CIRC-IMMU	The malfunction of ECM internal circuit of IMMU communication line is detected.	EL-3152
CHAIN OF ECM-IMMU	Communication impossible between ECM and IMMU. (In rare case, "CHAIN OF ECM-IMMU" might be stored during key registration procedure, even if the system is not malfunctioning.)	EL-3153
DIFFERENCE OF KEY	IMMU can receive the key ID signal but the result of ID verification between key ID and IMMU is NG.	EL-3155
CHAIN OF IMMU-KEY	IMMU cannot receive the key ID signal. Otherwise, the registered ID signal from dongle unit cannot be received when the IMMU requests the ID.	EL-3156
ID DISCORD, IMM-ECM	The result of ID verification between IMMU and ECM is NG. System initialization is required.	EL-3157
DON'T ERASE BEFORE CHECKING ENG DIAG	Engine trouble data and NATS trouble data have been detected in ECM.	EL-3149
LOCK MODE	When the starting operation is carried out 5 or more times consecutively under the following conditions, NATS will shift the mode to one which prevents the engine from being started. <ul style="list-style-type: none"> ● unregistered ignition key is used ● IMMU or ECM malfunctioning 	EL-3158

NATS (Nissan Anti-Theft System)

Trouble Diagnoses

WORK FLOW

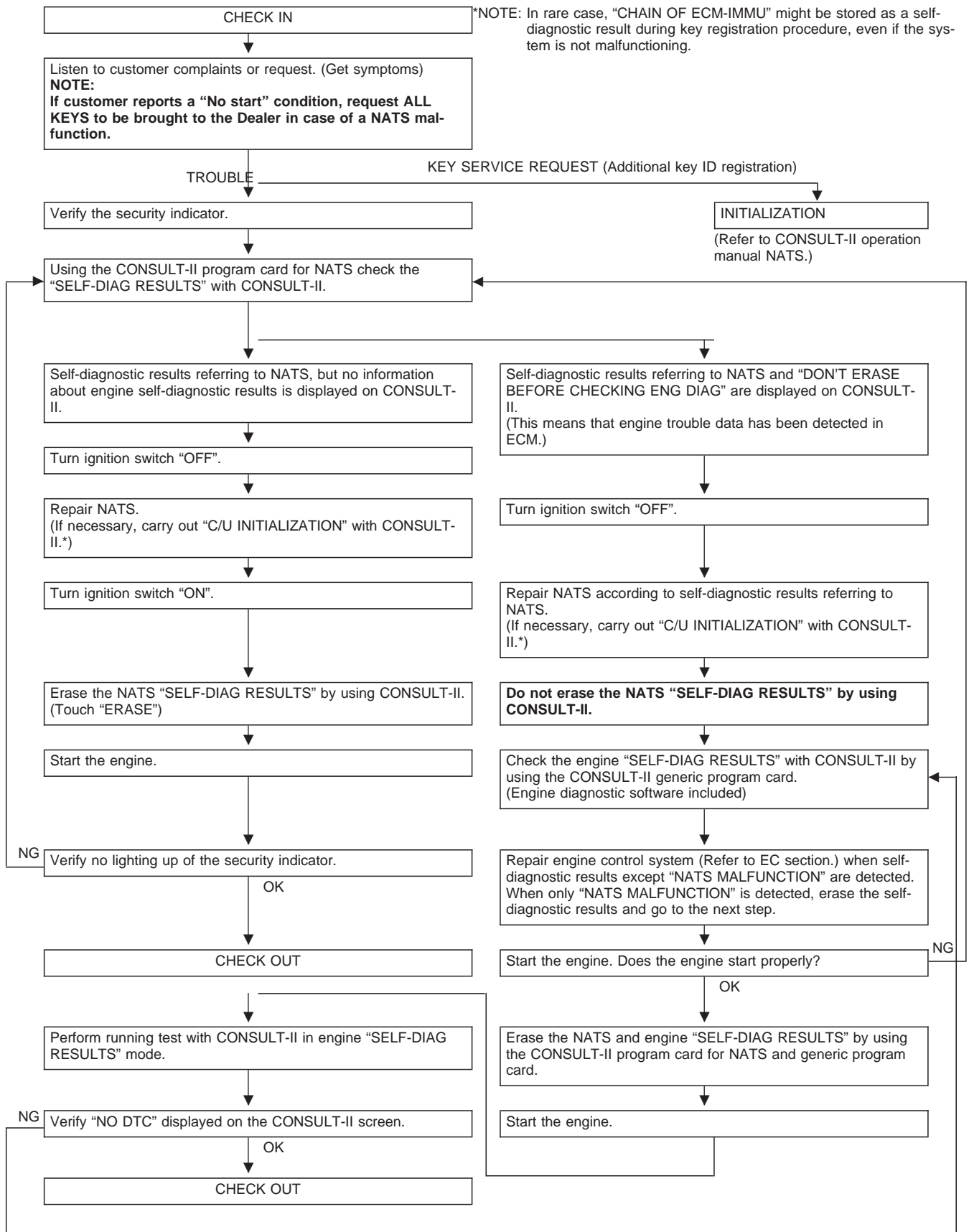

NATS (Nissan Anti-Theft System)

Trouble Diagnoses (Cont'd)

SYMPTOM MATRIX CHART 1 (Self-diagnosis related item)

SYMPTOM	Displayed "SELF-DIAG RESULTS" on CONSULT-II screen.	DIAGNOSTIC PROCEDURE (Reference page)	SYSTEM (Malfunctioning part or mode)	REFERENCE PART NO. OF ILLUSTRATION ON DIAGNOSTIC SYSTEM DIAGRAM
<ul style="list-style-type: none"> ● Security indicator lighting up* ● Engine does not start 	ECM INT CIRC-IMMU	PROCEDURE 1 (EL-3152)	ECM	B
	CHAIN OF ECM-IMMU	PROCEDURE 2 (EL-3153)	In rare case, "CHAIN OF ECM-IMMU might be stored during key registration procedure, even if the system is not malfunctioning.	—
			Open circuit in battery voltage line of IMMU circuit	C1
			Open circuit in ignition line of IMMU circuit	C2
			Open circuit in ground line of IMMU circuit	C3
			Open circuit in communication line between IMMU and ECM	C4
			Short circuit between IMMU and ECM communication line and battery voltage line	C4
			Short circuit between IMMU and ECM communication line and ground line	C4
			ECM	B
	IMMU	A		
	DIFFERENCE OF KEY	PROCEDURE 3 (EL-3155)	Unregistered key	D
			IMMU	A
	CHAIN OF IMMU-KEY	PROCEDURE 4 (EL-3156)	Malfunction of key ID chip	E
			IMMU	A
			Open circuit in ground line of dongle unit circuit	C6
Open or short circuit in communication line between IMMU and dongle unit			C5	
Dongle unit			G	
<ul style="list-style-type: none"> ● Security indicator lighting up* ● Engine hard to start 	ID DISCORD, IMM-ECM	PROCEDURE 5 (EL-3157)	System initialization has not yet been completed.	F
			ECM	B
	LOCK MODE	PROCEDURE 6 (EL-3158)	LOCK MODE	D

*: When NATS detects trouble, the security indicator lights up while ignition key is in the "ON" position.

*: When the vehicle is equipped with dongle unit, the security indicator blinks 6 times just after ignition switch is turned to ON. Then the security indicator will light up while ignition key is in the ON position.

NATS (Nissan Anti-Theft System)

Trouble Diagnoses (Cont'd)

SYMPTOM MATRIX CHART 2 (Non self-diagnosis related item)

SYMPTOM	DIAGNOSTIC PROCEDURE (Reference page)	SYSTEM (Malfunctioning part or mode)	REFERENCE PART NO. OF ILLUSTRATION ON DIAG- NOSTIC SYSTEM DIAGRAM
Security ind. does not light up.	PROCEDURE 7 (EL-3159)	Security ind.	—
		Open circuit between Fuse and NATS IMMU	—
		Continuation of initialization mode	—
		NATS IMMU	A
Security ind. does not blink just after initialization even if the vehicle is equipped with dongle unit.	PROCEDURE 8 (EL-3160)	NATS might be initialized without connecting dongle unit properly.	—
		Open circuit in ground line of dongle unit circuit	C6
Security ind. does not blink just after ignition switch is turned to ON when some mal- function related to NATS is detected even if the vehicle is equipped with dongle unit.	PROCEDURE 8 (EL-3160)	Open or short circuit in communication line between IMMU and dongle unit	C5
		Dongle unit	G

DIAGNOSTIC SYSTEM DIAGRAM

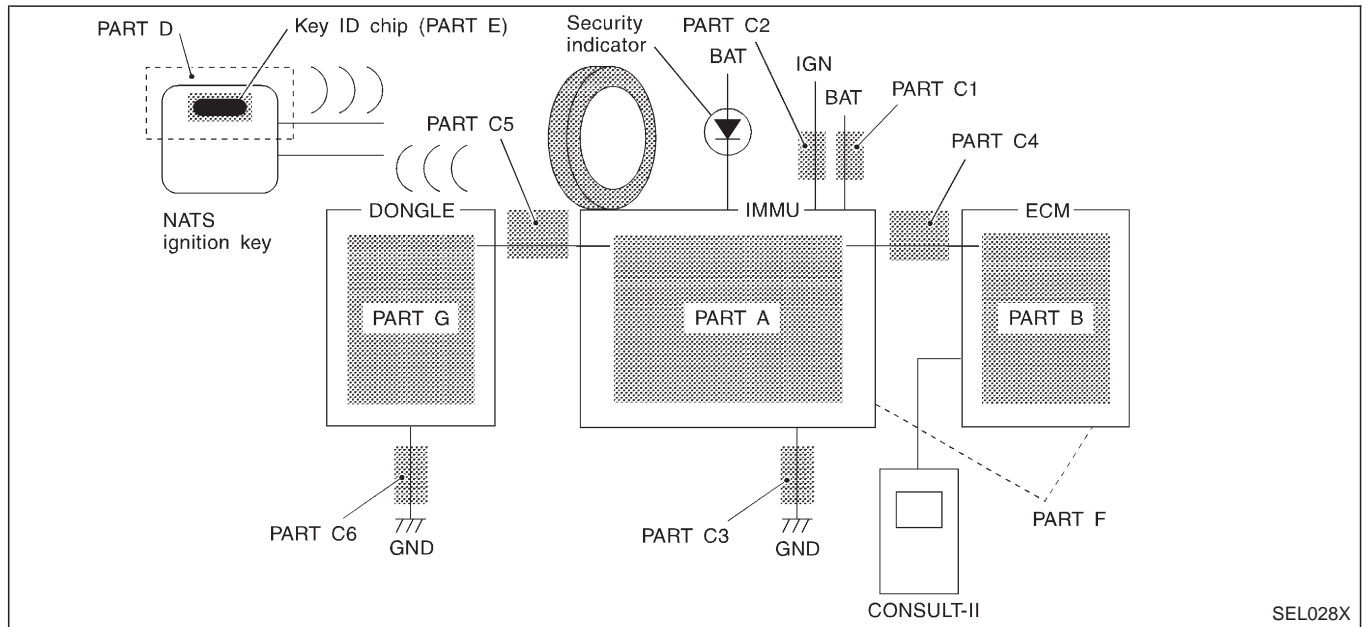

NATS (Nissan Anti-Theft System)

Trouble Diagnoses (Cont'd)

DIAGNOSTIC PROCEDURE 1

Self-diagnostic results:

“ECM INT CIRC-IMMU” displayed on CONSULT-II screen

A

SELF-DIAG RESULTS	
DTC RESULTS	TIME
ECM INT CIRC-IMMU	0

SEL152X

A



Confirm SELF-DIAGNOSTIC RESULTS “ECM INT CIRC-IMMU” displayed on CONSULT-II screen.
Ref. part No. B.



Replace ECM.



Perform initialization with CONSULT-II.
For the operation of initialization, refer to “CONSULT-II operation manual NATS”.

NATS (Nissan Anti-Theft System)

Trouble Diagnoses (Cont'd)

DIAGNOSTIC PROCEDURE 2

Self-diagnostic results:

“CHAIN OF ECM-IMMU” displayed on CONSULT-II screen

A

SELF-DIAG RESULTS	
DTC RESULTS	TIME
ECM INT CIRC-IMMU	0

SEL153X

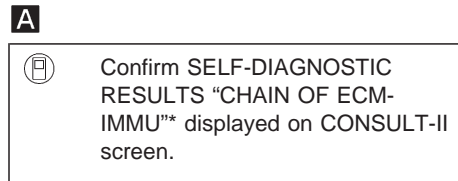
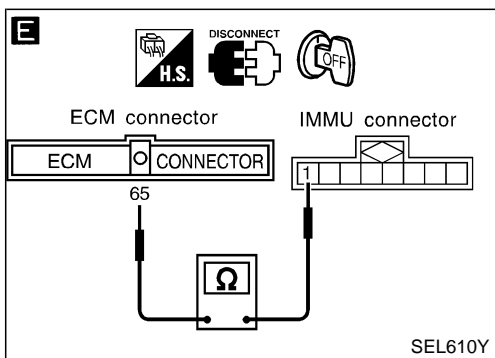
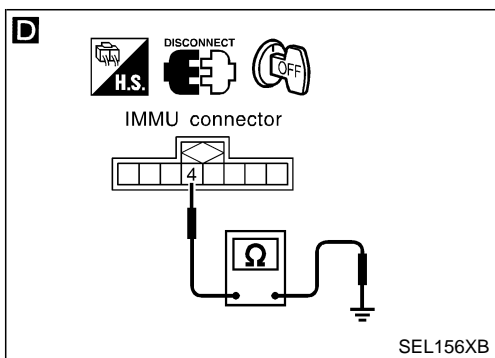
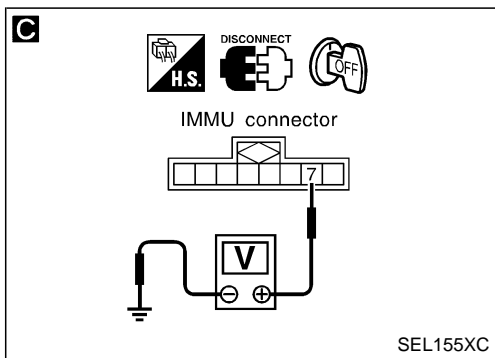
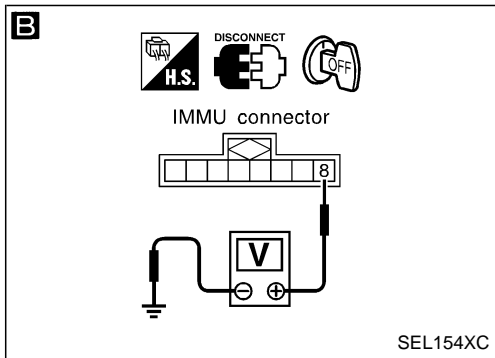

*: In rare case, “CHAIN OF ECM-IMMU” might be stored during key registration procedure, even if the system is not malfunctioning.

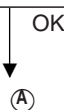
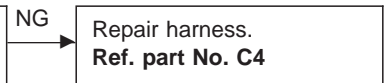
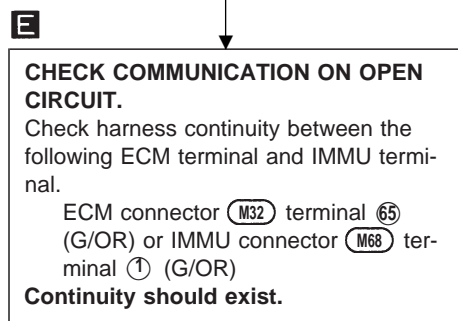
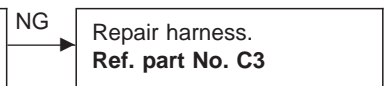
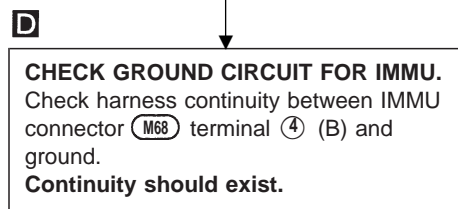
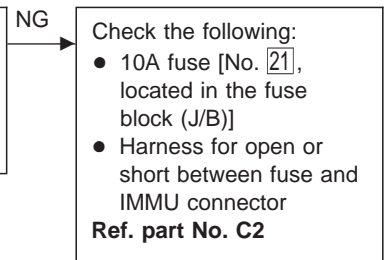
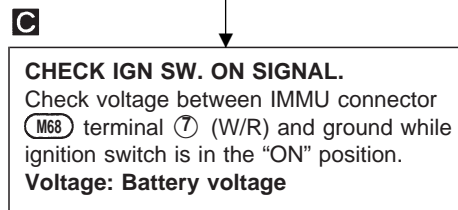
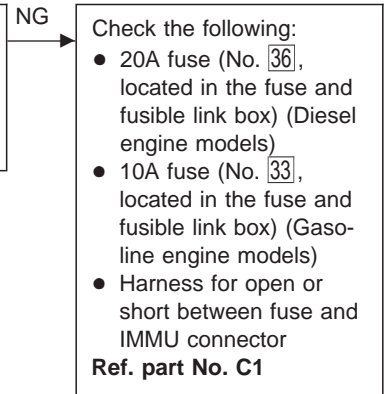
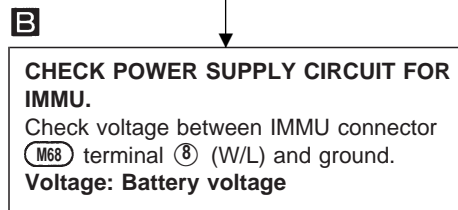

NATS (Nissan Anti-Theft System)

Trouble Diagnoses (Cont'd)

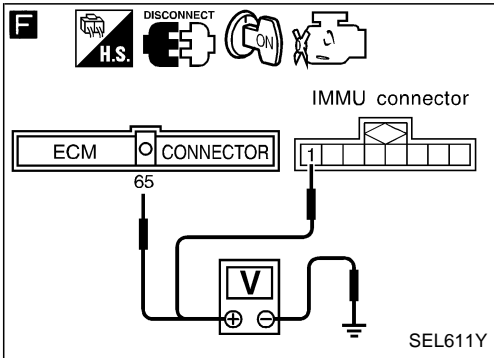

F

CHECK COMMUNICATION LINE BATTERY SHORT CIRCUIT.

1. Disconnect ECM connector and IMMU connector.
2. Turn ignition switch to ON.
3. Check voltage between ECM connector (M32) terminal 65 (G/OR) or IMMU connector (M68) terminal ① (G/OR) and ground.

No voltage should exist.

NG → Repair harness. Ref. part No. C4

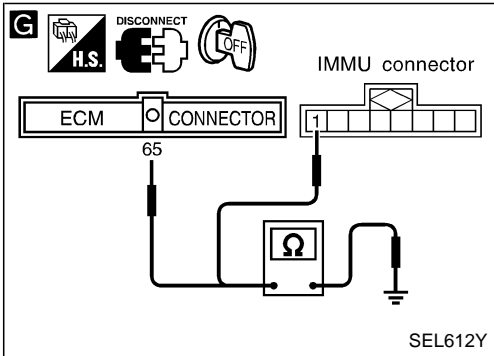

G

CHECK COMMUNICATION LINE GROUND SHORT CIRCUIT.

1. Disconnect ECM connector and IMMU connector.
2. Turn ignition switch OFF.
3. Check continuity between ECM connector (M32) terminal 65 (G/OR) or IMMU connector (M68) terminal ① (G/OR) and ground.

Continuity should not exist.

NG → Repair harness. Ref. part No. C4

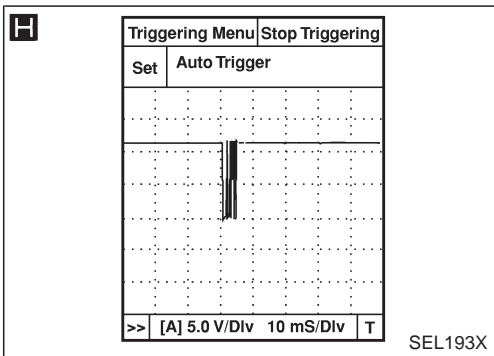

H

SIGNAL FROM ECM TO IMMU CHECK

1. Check the signal between ECM connector (M32) terminal 65 (G/OR) and ground with CONSULT-II or oscilloscope when ignition switch is turned "ON".
2. Make sure signals which are shown in the figure below can be detected during 750 msec. just after ignition switch is turned "ON".

NG →

- ECM is malfunctioning.
 1. Replace ECM. Ref. part No. B
 2. Perform initialization with CONSULT-II. For the initialization procedure, refer to "CONSULT-II operation manual NATS".

OK

- IMMU is malfunctioning.
 1. Replace IMMU. Ref. part No. A
 2. Perform initialization with CONSULT-II. For the initialization procedure, refer to "CONSULT-II operation manual NATS".

NATS (Nissan Anti-Theft System)

Trouble Diagnoses (Cont'd)

DIAGNOSTIC PROCEDURE 3

Self-diagnostic results:

“DIFFERENCE OF KEY” displayed on CONSULT-II screen

A

SELF DIAG RESULTS	
DTC RESULTS	TIME
DIFFERENCE OF KEY	0

SEL163X

B

IMMU INITIALIZATION
INITIALIZATION FAIL
THEN IGN KEY SW 'OFF' AND 'ON', AFTER CONFIRMING SELF-DIAG AND PASSWORD, PERFORM C/U INITIALIZATION AGAIN.

SEL566W

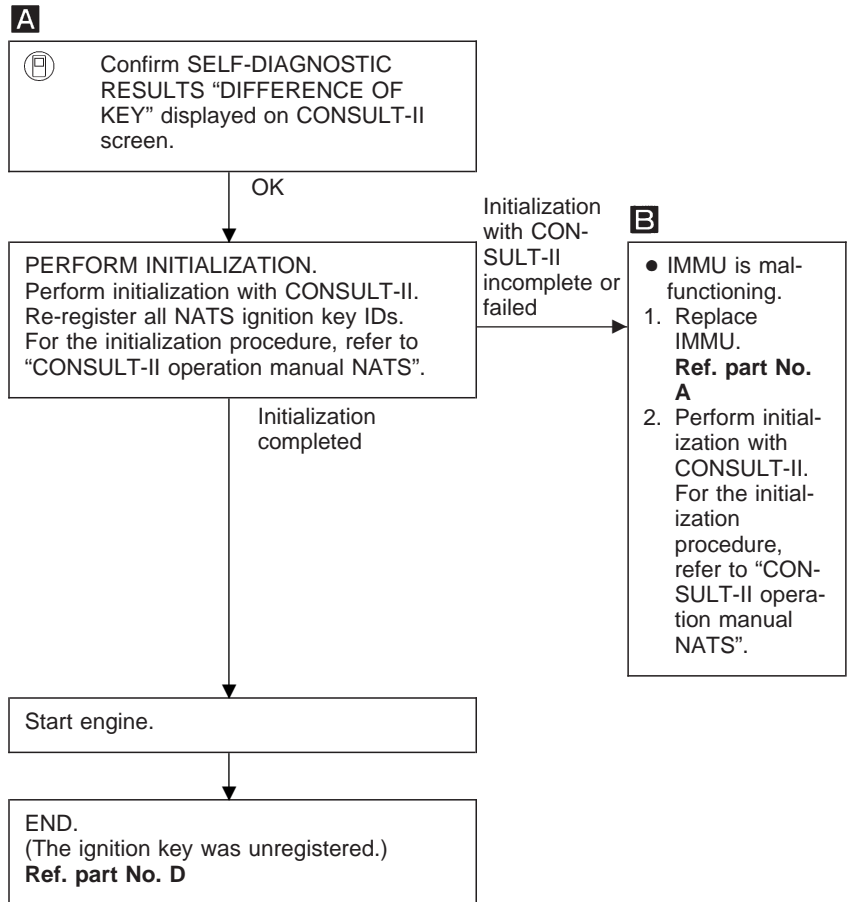

NATS (Nissan Anti-Theft System)

Trouble Diagnoses (Cont'd)

DIAGNOSTIC PROCEDURE 4

Self-diagnostic results:

“CHAIN OF IMMU-KEY” displayed on CONSULT-II screen

A

SELF DIAG RESULTS	
DTC RESULTS	TIME
CHAIN OF IMMU-KEY	0

SEL165X

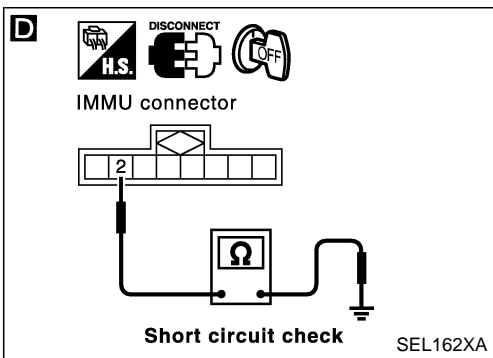
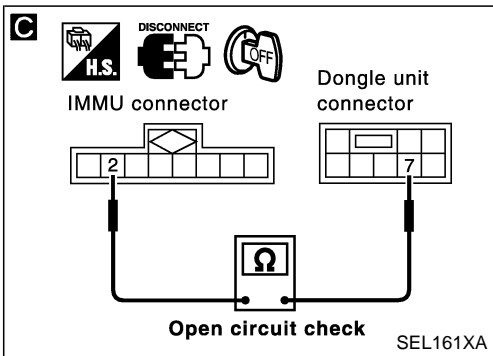
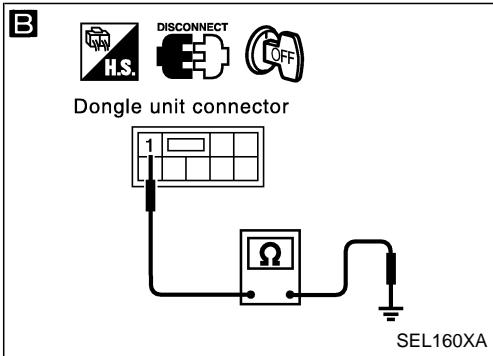

A

Confirm SELF-DIAGNOSTIC RESULTS “CHAIN OF IMMU-KEY” displayed on CONSULT-II screen.

OK

CHECK NATS IGNITION KEY ID CHIP. Start engine with another registered NATS ignition key.
Does the engine start?

Yes

- Ignition key ID chip is malfunctioning.

- Replace the ignition key.

Ref. part No. E

- Perform initialization with CONSULT-II. For the initialization procedure, refer to “CONSULT-II operation manual NATS”.

No

Is this vehicle equipped with dongle unit (RHD models for Europe)?

No

- IMMU is malfunctioning.

- Replace IMMU.

Ref. part No. A

- Perform initialization with CONSULT-II. For the initialization procedure, refer to “CONSULT-II operation manual NATS”.

Yes

CHECK HARNESS CONNECTOR CONNECTION. Check the following harness connector connection: (M68), (N12)
Does the engine start?

Yes

System is OK. (The malfunction is caused by improper connector connection.)

No

B

CHECK GROUND CIRCUIT FOR DONGLE UNIT. Check continuity between dongle unit terminal ① (B/W) and ground.
Continuity should exist.

No

Repair harness.
Ref. part No. C6

Yes

C D

CHECK INTERFACE CIRCUIT.

- Check continuity between IMMU connector (M68) terminal ② (P) and dongle unit terminal ① (P) (Open circuit check)
Continuity should exist.
- Check continuity between IMMU connector (M68) terminal ② (P) and ground. (Short circuit check)
Continuity should not exist.

No

Repair harness.
Ref. part No. C5

Yes

Dongle unit is malfunctioning.

- Replace dongle unit. **Ref. part No. G**
- Perform initialization with CONSULT-II. For the initialization procedure, refer to “CONSULT-II operation manual NATS”.

NATS (Nissan Anti-Theft System)

Trouble Diagnoses (Cont'd)

DIAGNOSTIC PROCEDURE 5

Self-diagnostic results:

"ID DISCORD, IMM-ECM" displayed on CONSULT-II screen

A

SELF-DIAG RESULTS	
DTC RESULTS	TIME
ID DISCORD, IMM-ECM	0

SEL166X

B

IMMU INITIALIZATION
INITIALIZATION FAIL
THEN IGN KEY SW 'OFF' AND 'ON', AFTER CONFIRMING SELF-DIAG AND PASSWORD, PERFORM C/U INITIALIZATION AGAIN.

SEL566W

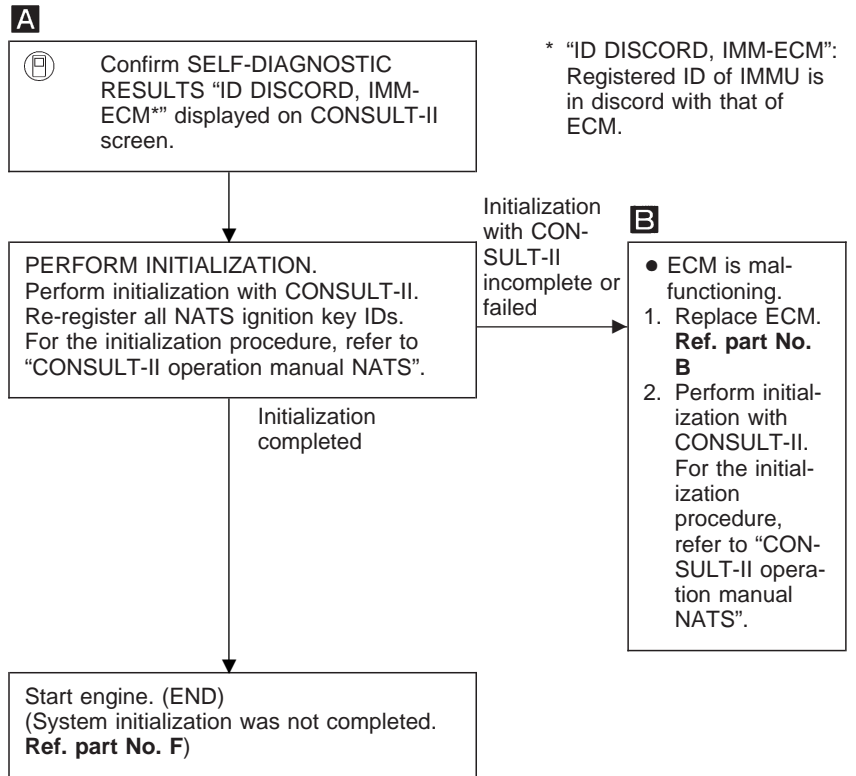

NATS (Nissan Anti-Theft System)

Trouble Diagnoses (Cont'd)

DIAGNOSTIC PROCEDURE 6

Self-diagnostic results:

“LOCK MODE” displayed on CONSULT-II screen

A

SELF DIAG RESULTS	
DTC RESULTS	TIME
LOCK MODE	0

SEL167X

B

IMMU INITIALIZATION
INITIALIZATION FAIL
THEN IGN KEY SW 'OFF' AND 'ON', AFTER CONFIRMING SELF-DIAG AND PASSWORD, PERFORM C/U INITIALIZATION AGAIN.

SEL566W

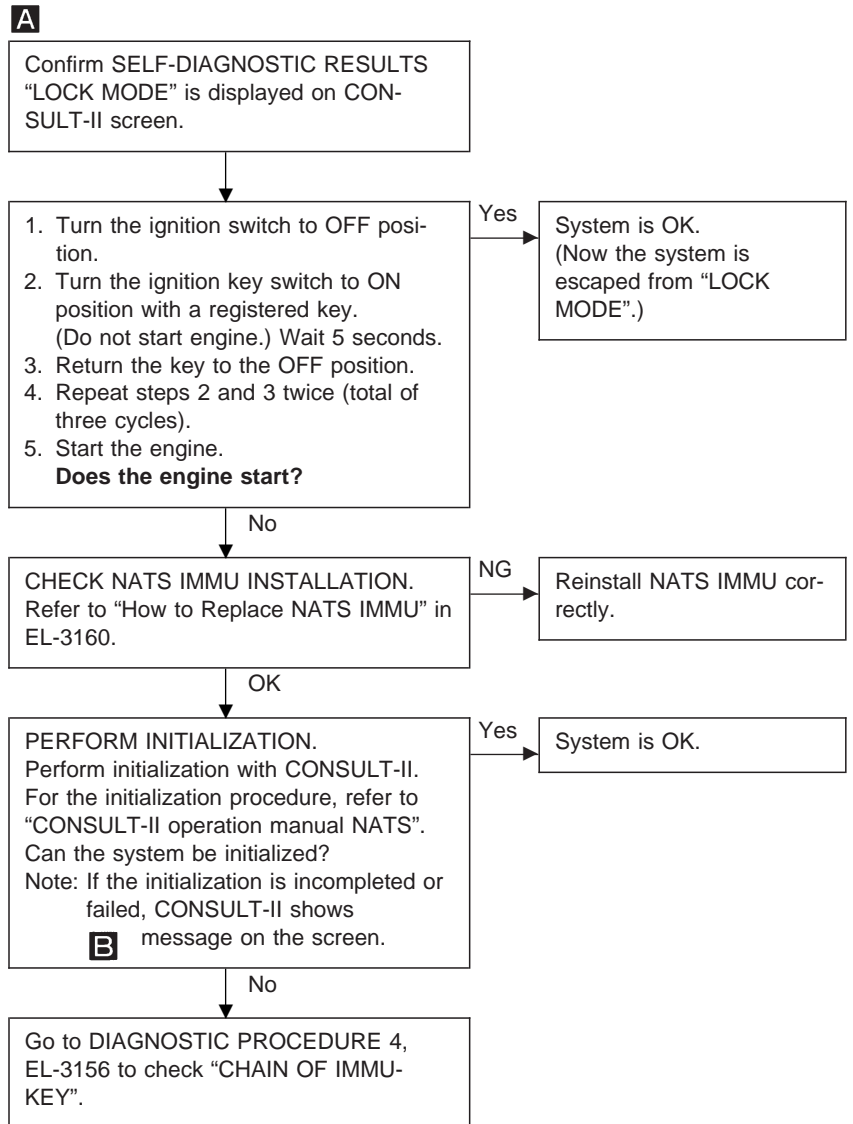

NATS (Nissan Anti-Theft System)

Trouble Diagnoses (Cont'd)

DIAGNOSTIC PROCEDURE 7

“SECURITY IND. DOES NOT LIGHT UP”

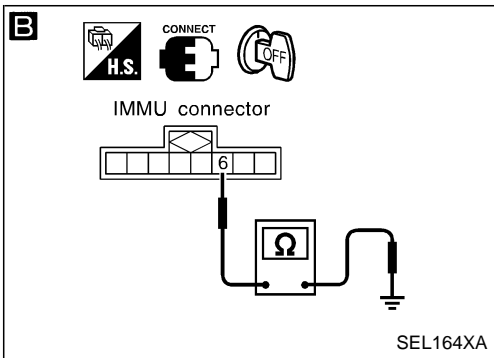
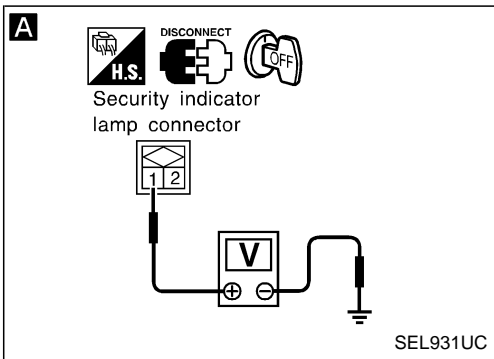
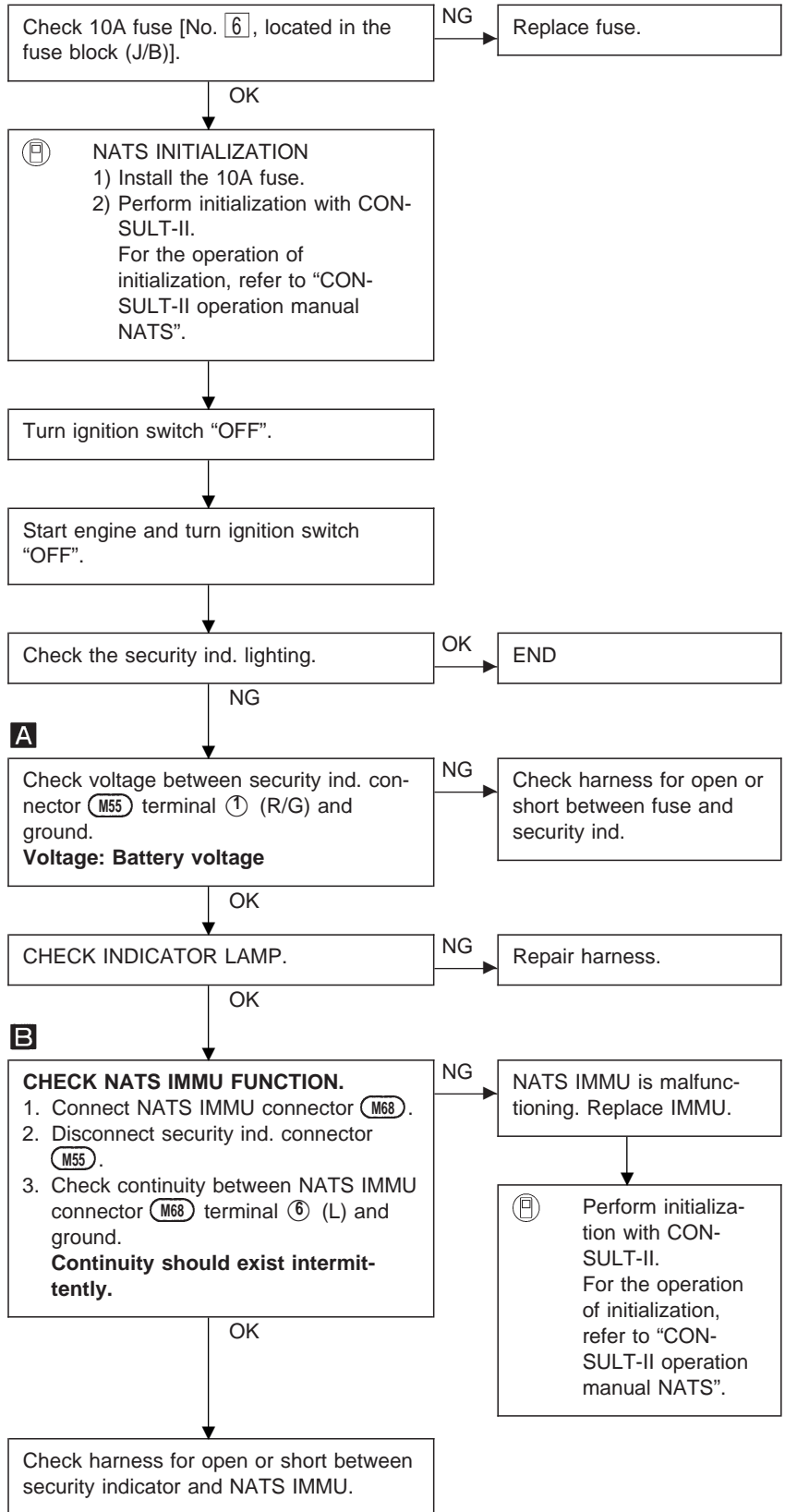

NATS (Nissan Anti-Theft System)

Trouble Diagnoses (Cont'd)

DIAGNOSTIC PROCEDURE 8

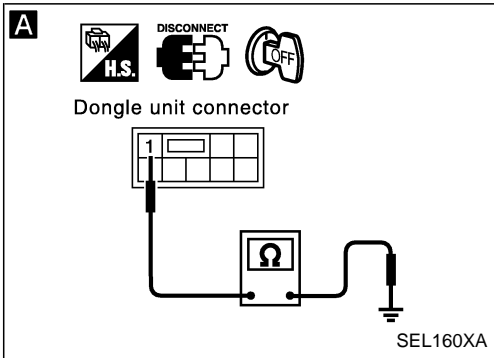

A

CHECK GROUND CIRCUIT FOR DONGLE UNIT.
Check continuity between dongle unit connector (N12) terminal ① (B/W) and ground.
Continuity should exist.

No → Repair harness.
Ref. part No. C6

Yes

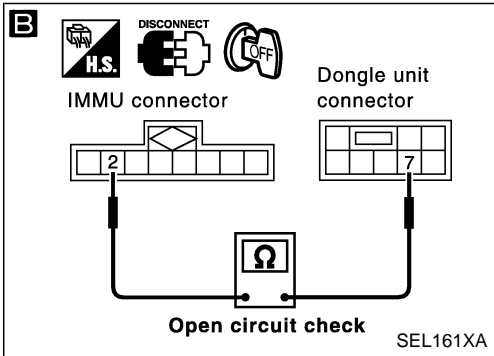

B

CHECK INTERFACE CIRCUIT.
1. Check continuity between IMMU connector (M68) terminal ② (P) and dongle unit connector (N12) terminal ⑦ (P). (Open circuit check)
Continuity should exist.
2. Check continuity between IMMU connector (M68) terminal ② (P) and ground. (Short circuit check)
Continuity should exist.

No → Repair harness.
Ref. part No. C5

Yes

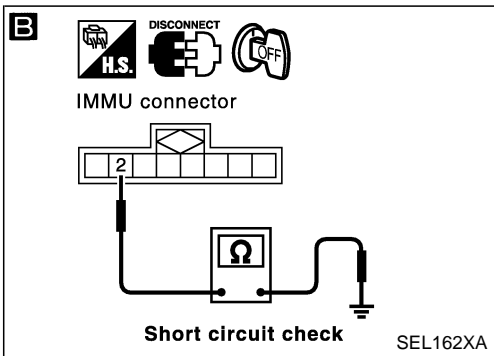

Dongle unit is malfunctioning.
1. Replace dongle unit.
Ref. part No. G
2. Perform initialization with CONSULT-II.
For the initialization procedure, refer to "CONSULT-II operation manual NATS".

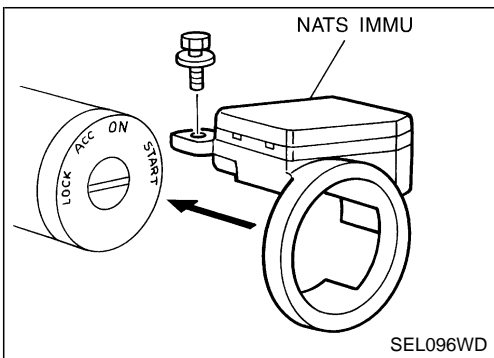

How to Replace NATS IMMU

NOTE:

- If NATS IMMU is not installed correctly, NATS system will not operate properly and SELF-DIAG RESULTS on CONSULT-II screen will show "LOCK MODE".

LOCATION OF ELECTRICAL UNITS

Engine Compartment

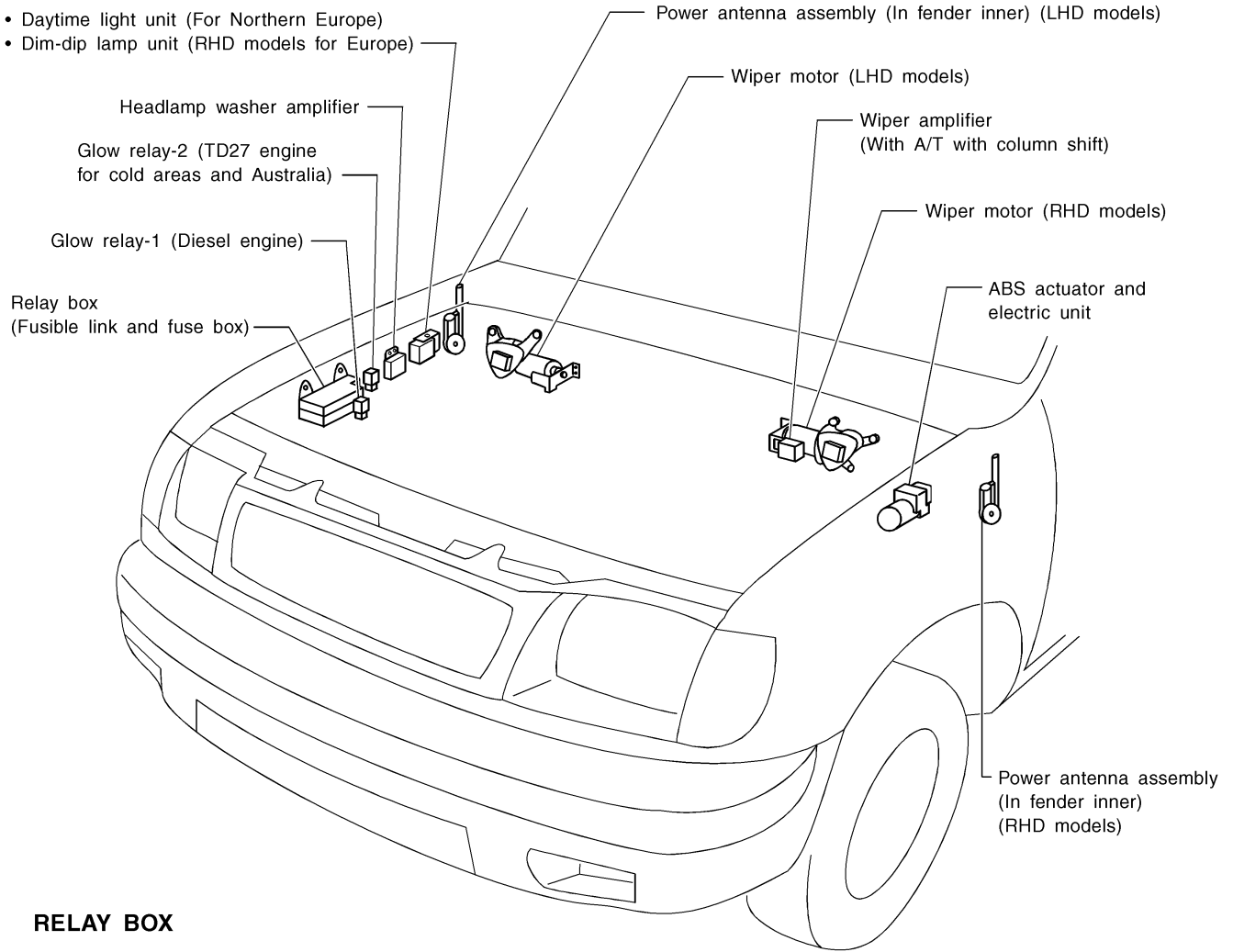

RELAY BOX

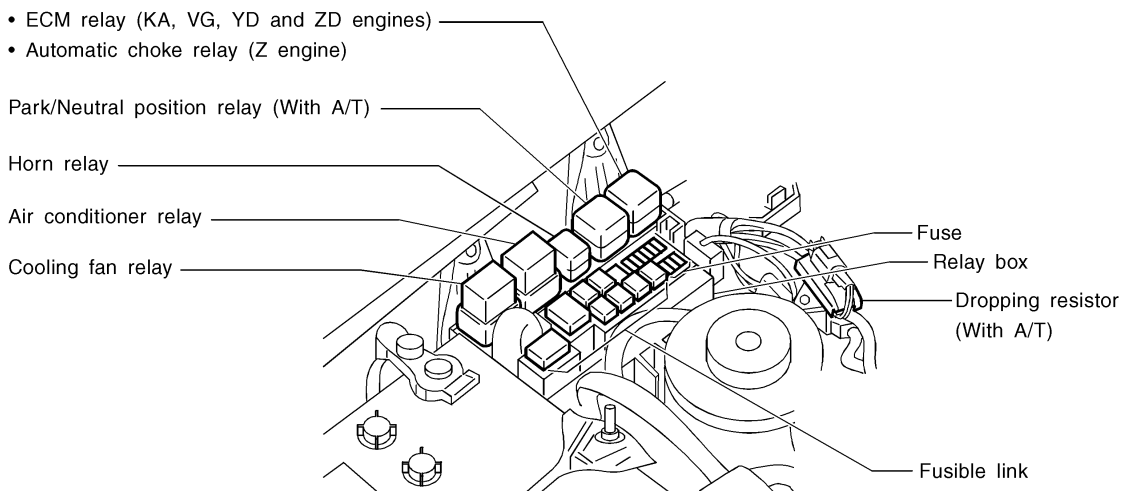

LOCATION OF ELECTRICAL UNITS

Passenger Compartment

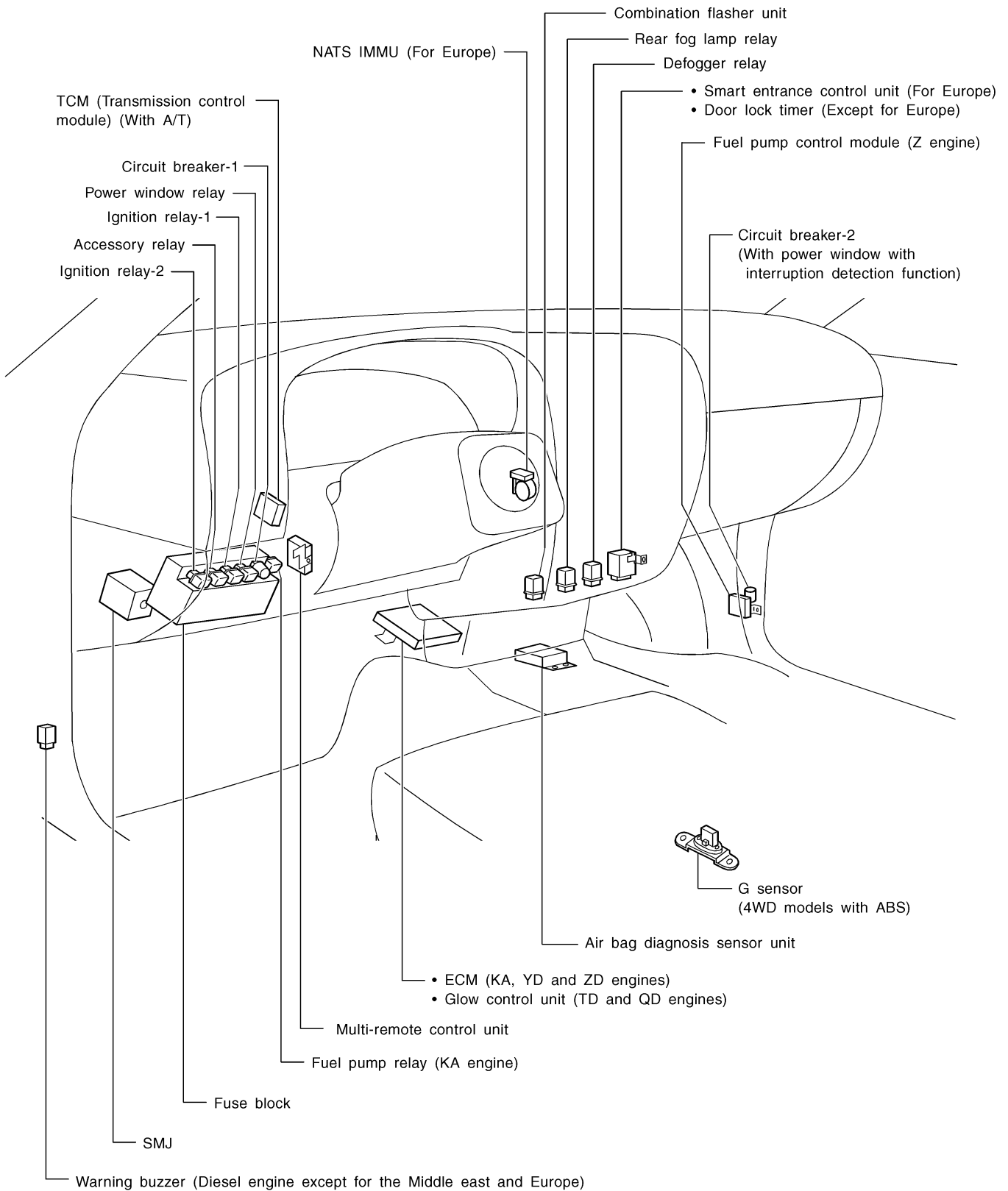

LOCATION OF ELECTRICAL UNITS

Passenger Compartment (Cont'd)

RHD MODELS

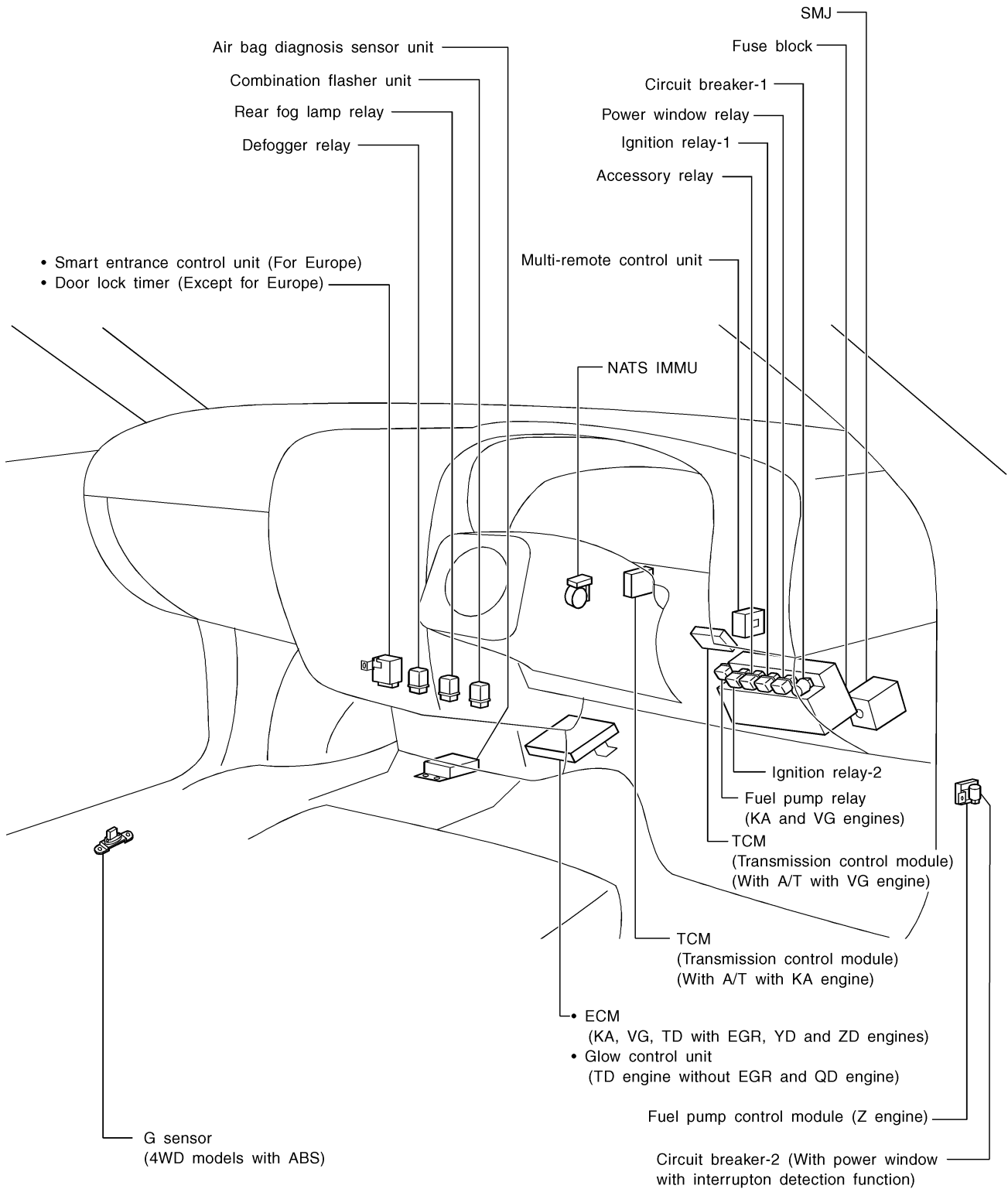

HEL850B

HARNESS LAYOUT

Main Harness

INSTRUMENT PANEL — LHD MODELS

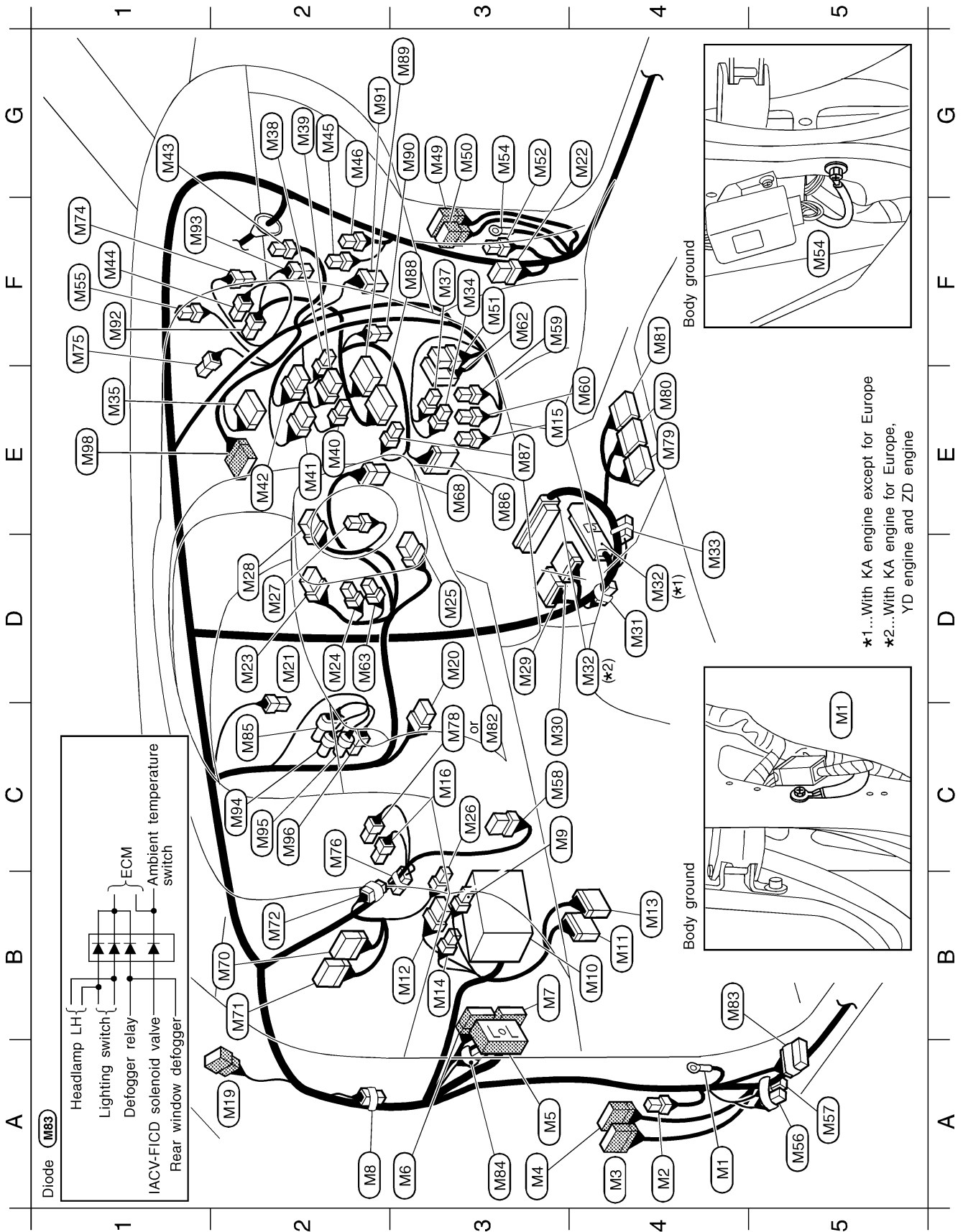

HARNESS LAYOUT

Main Harness (Cont'd)

A4 (M1)	—	: Body ground	F3 (M37)	B/2	: Cigarette lighter	F1 (M74)	W/2	: Intake air temperature sensor (With auto A/C)
A4 (M2)	W/2	: Warning buzzer (Diesel engine except for Europe and the Middle East)	G2 (M38)	W/3	: A/C switch (Without auto A/C)	F1 (M75)	B/2	: Sunload sensor (With auto A/C)
A4 (M3)	W/20	: To (D1)	G2 (M39)	W/6	: Fan switch (Without auto A/C)	C2 (M76)	W/6	: Option connector (For Europe) (For theft warning system)
A3 (M4)	W/12	: To (D2) (With power window)	E2 (M40)	W/2	: Fan switch illumination (Without auto A/C)	C3 (M78)	L/2	: Shift lock brake switch (With A/T)
A3 (M5)	SMJ	: To (E101)	E2 (M41)	W/8	: Hazard switch	E4 (M79)	Y/12	: Air bag diagnosis sensor unit (For pre-tensioner seat belt)
A3 (M6)	W/24	: To (N1)	E2 (M42)	W/6	: Defogger switch (Except for the Middle East except Single cab with TD engine)	E4 (M80)	Y/20	: Air bag diagnosis sensor unit
B3 (M7)	BR/24	: To (N2)	G1 (M43)	Y/2	: Front passenger air bag module	F4 (M81)	Y/12	: Air bag diagnosis sensor unit (For pre-tensioner seat belt)
A2 (M8)	-/2	: Diode (Diesel engine except for Europe and the Middle East)	F1 (M44)	BR/4	: Thermo control amplifier	C3 (M82)	B/2	: Brake pedal position switch (YD25)
C3 (M9)	L/4	: Fuel pump relay (KA engine)	G2 (M45)	BR/4	: Fan resistor (Without auto A/C)	B4 (M83)	L/10	: Diode (KA24DE)
B4 (M10)	—	: Fuse block	G2 (M46)	W/2	: Blower motor	A3 (M84)	BR/2	: Resistor (With A/T)
B4 (M11)	W/16	: Data link connector	G3 (M49)	W/20	: To (D31)	C2 (M85)	GY/6	: Accelerator work unit (YD25)
B3 (M12)	W/6	: Fuse block	G3 (M50)	W/6	: To (D32) (With power window)	E3 (M86)	BR/10	: Mode door motor (With auto A/C)
B4 (M13)	B/10	: Check connector (Z24S)	F3 (M51)	W/8	: Door lock timer (With power window except for Europe)	E3 (M87)	W/2	: In-vehicle sensor (With auto A/C)
B3 (M14)	W/4	: Fuse block	G3 (M52)	W/2	: Circuit breaker-2 (For Europe and with gasoline engine for the Middle East)	F3 (M88)	GY/20	: A/C auto amp. (With auto A/C)
E3 (M15)	B/3	: Combination flasher unit	G3 (M54)	—	: Body ground	G3 (M89)	GY/16	: A/C auto amp. (With auto A/C)
C3 (M16)	B/2	: Stop lamp switch	F1 (M55)	W/2	: Security indicator (With NATS)	G3 (M90)	L/2	: Aspirator motor (With auto A/C)
A2 (M19)	W/6	: To (R1)	G3 (M56)	-/2	: Diode (Z24S)	G2 (M91)	B/6	: Air mix door motor (With auto A/C)
D3 (M20)	W/6	: Ignition switch	A5 (M57)	-/2	: Diode (Z24S)	F1 (M92)	W/4	: Fan control amp. (With auto A/C)
D2 (M21)	W/1	: Parking brake switch (Stick type)	C3 (M58)	BR/8	: Multi-remote control unit (For Europe)	F1 (M93)	W/4	: Intake door motor (With auto A/C)
G4 (M22)	W/6	: Fuel pump control module (Z24S)	F3 (M59)	BR/6	: Defogger relay (Except for the Middle East)	C2 (M94)	BR/3	: Accelerator position sensor (ZD30)
D2 (M23)	BR/8	: Lighting switch • Turn signal lamp switch	E4 (M60)	L/4	: Rear fog lamp relay (For Europe and with KA engine except for the Middle East)	C2 (M95)	GY/3	: Accelerator position switch (ZD30)
D2 (M24)	BR/4	: Lighting switch	F3 (M62)	W/18	: Smart entrance control unit (For Europe)	E1 (M98)	W/12	: Audio unit (Via sub-harness) (Except for Europe)
D3 (M25)	Y/7	: Spiral cable (With air bag)	D2 (M63)	W/3	: Rear fog lamp switch (For Europe and with KA engine except for the Middle East)	Diode (M8)		
C3 (M26)	L/2	: A/T check switch (With A/T)	E3 (M68)	W/8	: NATS IMMU (For Europe)	Diode (M56, M57)		
D2 (M27)	B/1	: Horn switch (Without air bag)	B2 (M70)	W/24	: TCM (Transmission control module) (With A/T)	Diode (M56, M57)		
D2 (M28)	GY/8	: Wiper and washer switch	B2 (M71)	GY/24	: TCM (Transmission control module) (With A/T)	Fuel pump control module		
D3 (M29)	W/12	: Glow control unit (TD engine except for cold areas and QD engine)	B2 (M72)	-/6	: Joint connector-2 (With A/T)	CHARGE warning lamp		
C3 (M30)	W/16	: Glow control unit (TD engine for cold areas)				Alternator (L)		
D4 (M31)	GY/6	: Joint connector-1 (KA engine)				OIL warning lamp		
D4 (M32)	SMJ	: ECM (KA, YD and ZD engines)				OIL pressure switch		
D4 (M33)	—	: Joint connector-3 (KA engine for Europe)						
F3 (M34)	W/2	: Ashtray illumination (With gasoline engine for the Middle East)						
E1 (M35)	W/10	: Audio unit (For Europe)						

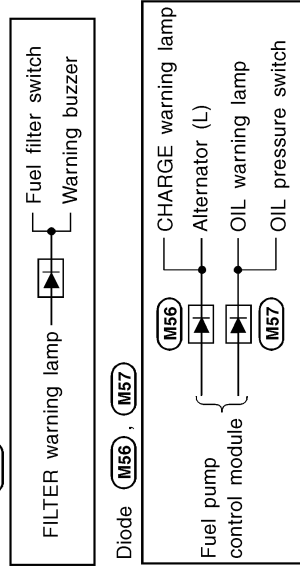

HARNESS LAYOUT

Main Harness (Cont'd)

INSTRUMENT PANEL — RHD MODELS

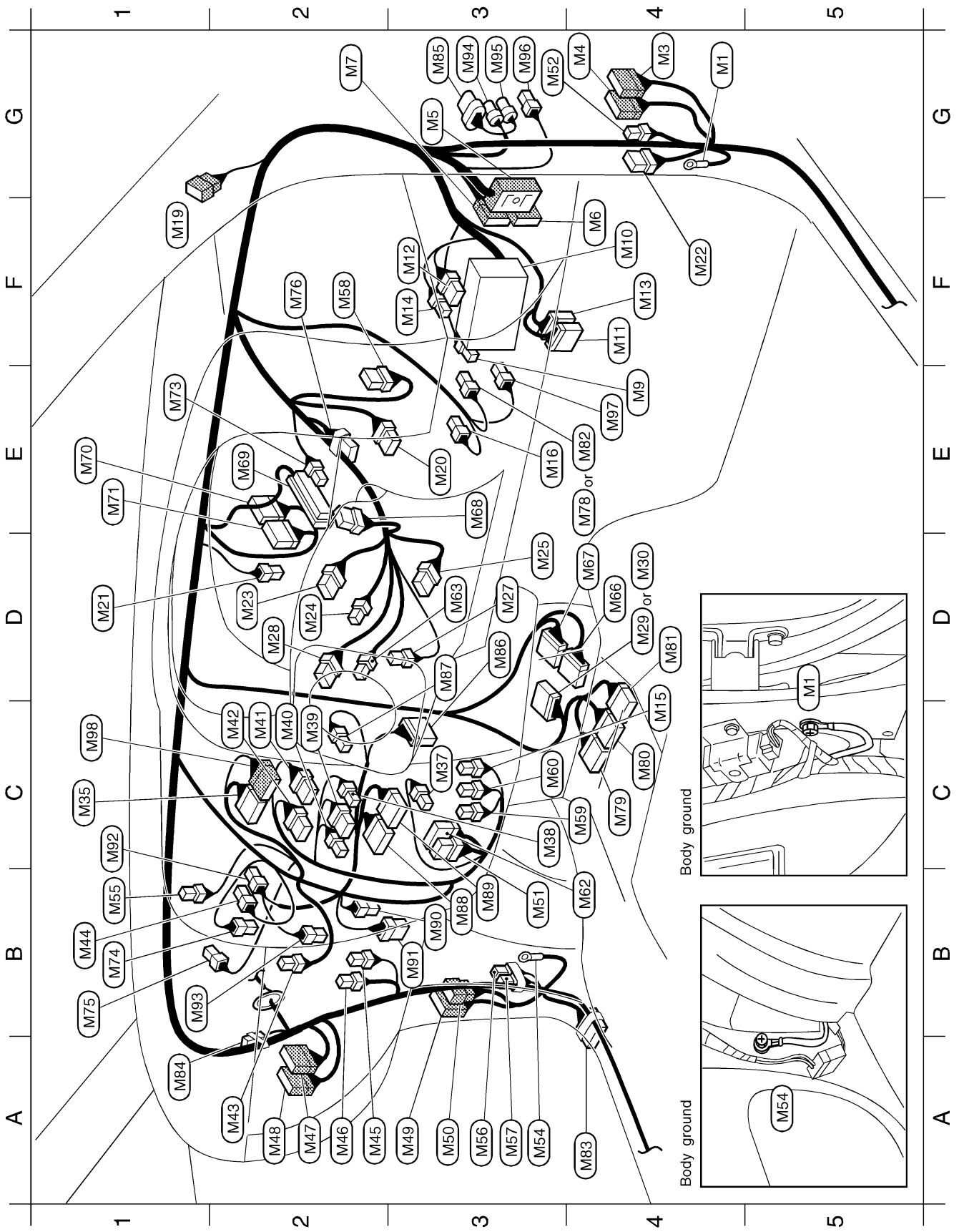

HARNESS LAYOUT

Main Harness (Cont'd)

G4	(M1)	—	: Body ground	A2	(M46)	W/2	: Blower motor	G3	(M85)	GY/6	: Accelerator work unit (YD engine)
G4	(M3)	W/20	: To (D1)	A2	(M47)	W/16	: To (F55) (KA, VG, YD and ZD engines)	D3	(M86)	BR/10	: Mode door motor (With auto A/C)
G4	(M4)	W/12	: To (D2)	A2	(M48)	W/24	: To (F54) (KA, VG, YD and ZD engines)	D3	(M87)	W/2	: In-vehicle sensor (With auto A/C)
G3	(M5)	SMJ	: To (E101)	A3	(M49)	W/20	: To (D31)	B3	(M88)	GY/20	: A/C auto amp. (With auto A/C)
F4	(M6)	W/24	: To (N1)	A3	(M50)	W/6	: To (D32) (With power window)	B3	(M89)	GY/16	: A/C auto amp. (With auto A/C)
G2	(M7)	BR/24	: To (N2)	B3	(M51)	W/8	: Door lock timer (With power window except for Europe)	B3	(M90)	L/2	: Aspirator motor (With auto A/C)
E4	(M9)	L/4	: Fuel pump relay (KA and VG engines)	G3	(M52)	W/2	: Circuit breaker-2 (For Europe)	B3	(M91)	B/6	: Air mix door motor (With auto A/C)
F4	(M10)	—	: Fuse block	A3	(M54)	—	: Body ground	C1	(M92)	W/4	: Fan control amp. (With auto A/C)
F4	(M11)	W/16	: Data link connector	B1	(M55)	W/2	: Security indicator (For Europe)	B1	(M93)	W/4	: Intake door motor (With auto A/C)
F3	(M12)	W/6	: Fuse block	A3	(M56)	-/2	: Diode (Z engine)	G3	(M94)	BR/3	: Accelerator position sensor (ZD engine)
F4	(M13)	B/10	: Check connector (Z engine)	A3	(M57)	-/2	: Diode (Z engine)	G3	(M95)	GY/3	: Accelerator position switch (ZD engine)
F3	(M14)	W/4	: Fuse block	F2	(M58)	BR/8	: Multi-remote control unit (For Europe)	G3	(M96)	W/3	: Accelerator switch (F/C) (ZD engine)
C4	(M15)	B/3	: Combination flasher unit	C4	(M59)	BR/6	: Defogger relay (Except models without intermittent wiper for Australia)	E4	(M97)	W/2	: Kickdown switch (With A/T with VG engine)
E3	(M16)	B/2	: Stop lamp switch	C3	(M60)	L/4	: Rear fog lamp relay (For Europe)	C1	(M98)	W/12	: Audio unit (Via sub-harness) (Except for Europe)
F1	(M19)	W/6	: To (R1)	B4	(M62)	W/18	: Smart entrance control unit (For Europe)				
E3	(M20)	W/6	: Ignition switch	D3	(M63)	W/3	: Rear fog lamp switch (For Europe)				
D1	(M21)	W/1	: Parking brake switch (Stick type)	D4	(M66)	GY/20	: ECM (Diesel engine with EGR)				
F4	(M22)	W/6	: Fuel pump control module (Z engine)	D4	(M67)	GY/16	: ECM (Diesel engine with EGR)				
D2	(M23)	BR/8	: Lighting switch	E3	(M68)	W/8	: NATS IMMU (For Europe)				
D2	(M24)	BR/4	: Turn signal lamp switch	E2	(M69)	W/48	: TCM (Transmission control module) (With A/T with VG engine)				
D3	(M25)	Y/7	: Lighting switch	E1	(M70)	W/24	: TCM (Transmission control module) (With A/T with KA engine)				
D3	(M27)	B/1	: Horn switch (Without air bag)	E1	(M71)	GY/24	: TCM (Transmission control module) (With A/T with KA engine)				
D2	(M28)	GY/8	: Wiper and washer switch	E1	(M73)	W/4	: A/T device (With A/T with column shift)				
D4	(M29)	W/12	: Glow control unit (TD27 engine without EGR except for Australia and QD engine)	B1	(M74)	W/2	: Intake air temperature sensor (With auto A/C)				
D4	(M30)	W/16	: Glow control unit (TD27 engine for Australia)	B1	(M75)	B/2	: Sunload sensor (With auto A/C)				
C1	(M35)	W/16	: Audio unit (For Europe)	F2	(M76)	W/6	: Option connector for theft warning system (For Europe)				
C3	(M37)	B/2	: Cigarette lighter	E4	(M78)	L/2	: Shift lock brake switch (With A/T)				
C3	(M38)	W/3	: A/C switch (Without auto A/C)	C4	(M79)	Y/12	: Air bag diagnosis sensor unit (With air bag for Europe and Australia)				
C2	(M39)	W/6	: Fan switch (Without auto A/C)	C4	(M80)	Y/20	: Air bag diagnosis sensor unit (With air bag)				
C2	(M40)	W/2	: Fan switch illumination (Without auto A/C)	D4	(M81)	Y/12	: Air bag diagnosis sensor unit (With air bag for Europe and Australia)				
C2	(M41)	W/8	: Hazard switch	E4	(M82)	B/2	: Brake pedal position switch (YD engine)				
C2	(M42)	W/6	: Defogger switch (Except models without intermittent wiper for Australia)	A4	(M83)	L/10	: Diode (KA engine)				
A2	(M43)	Y/2	: Air bag module passenger side	A1	(M84)	BR/2	: Resistor (With A/T)				
B1	(M44)	BR/4	: Thermo control amplifier								
A2	(M45)	BR/4	: Fan resistor (Without auto A/C)								

Engine compartment



(M221) W/6 : Wiper motor (Z, TD and QD engines)

Diode (M56, M57)

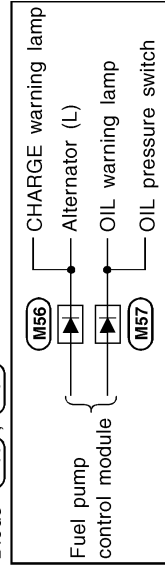

Diode (M83)

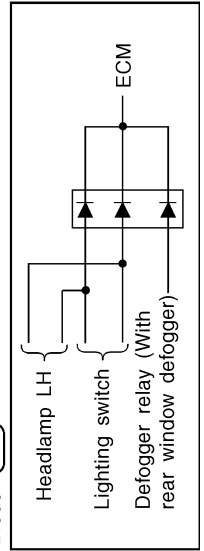

HARNESS LAYOUT

Main Harness (Cont'd)

BODY SIDE — LHD MODELS

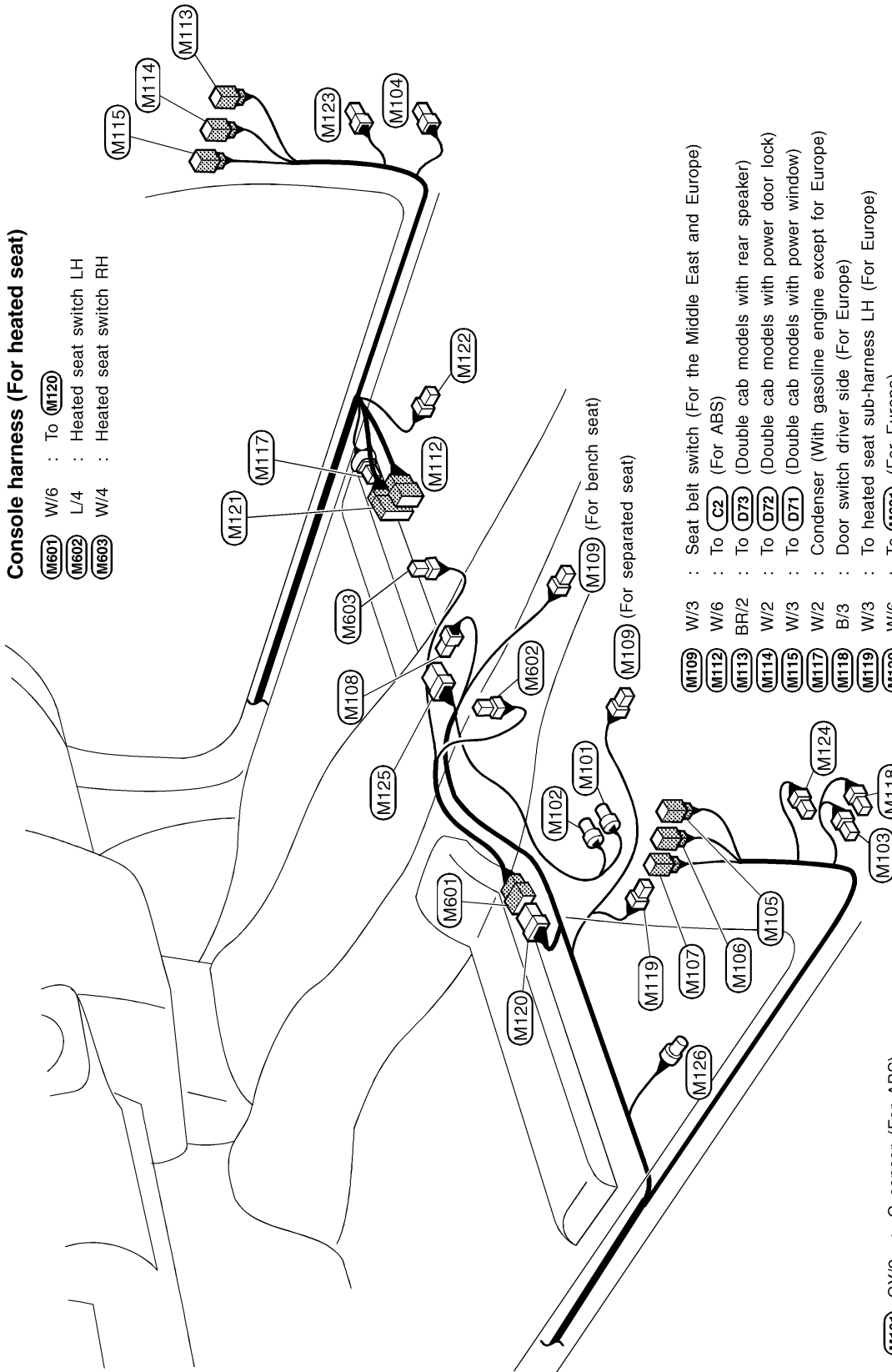

Console harness (For heated seat)

M601 W/6 : To M120

M602 L/4 : Heated seat switch LH

M603 W/4 : Heated seat switch RH

M101 GY/2 : G sensor (For ABS)

M102 BR/2 : G sensor (For ABS) (For Europe)

M103 B/1 : Door switch driver side (Except for Europe)

M104 B/1 : Door switch passenger side (For Europe)

M105 BR/2 : To D53 (Double cab models with rear speaker)

M106 W/2 : To D52 (Double cab models with power door lock)

M107 W/3 : To D51 (Double cab models with power window)

M108 B/1 : Parking brake switch (Center lever type)

M109 W/3 : Seat belt switch (For the Middle East and Europe)

M112 W/6 : To C2 (For ABS)

M113 BR/2 : To D73 (Double cab models with rear speaker)

M114 W/2 : To D72 (Double cab models with power door lock)

M115 W/3 : To D71 (Double cab models with power window)

M117 W/2 : Condenser (With gasoline engine except for Europe)

M118 B/3 : Door switch driver side (For Europe)

M119 W/3 : To heated seat sub-harness LH (For Europe)

M120 W/6 : To M601 (For Europe)

M121 W/16 : To C9

M122 W/3 : To heated seat sub-harness RH (For Europe)

M123 W/4 : Front RH seat belt pre-tensioner (With air bag for Europe and the Middle East or with air bag with KA engine)

M124 W/4 : Front LH seat belt pre-tensioner (With air bag for Europe and the Middle East or with air bag with KA engine)

M125 W/6 : A/T device (With A/T)

M126 G/4 : Heated oxygen sensor-2 (With KA engine for Europe)

HARNESS LAYOUT

Main Harness (Cont'd)

BODY SIDE — RHD MODELS

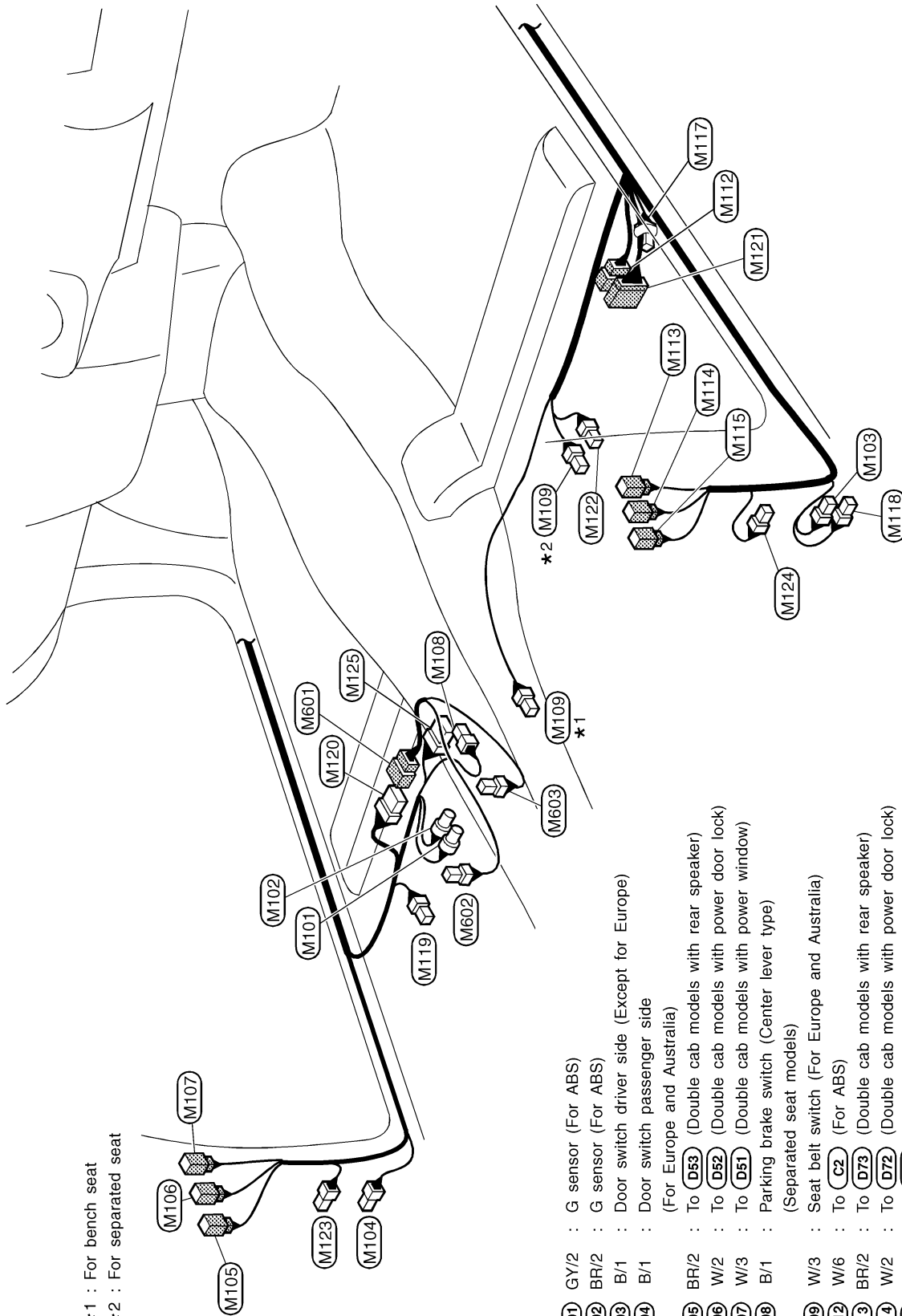

*1 : For bench seat
*2 : For separated seat

- (M101) GY/2 : G sensor (For ABS)
- (M102) BR/2 : G sensor (For ABS)
- (M103) B/1 : Door switch driver side (Except for Europe)
- (M104) B/1 : Door switch passenger side (For Europe and Australia)
- (M105) BR/2 : To D53 (Double cab models with rear speaker)
- (M106) W/2 : To D52 (Double cab models with power door lock)
- (M107) W/3 : To D51 (Double cab models with power window)
- (M108) B/1 : Parking brake switch (Center lever type) (Separated seat models)
- (M109) W/3 : Seat belt switch (For Europe and Australia)
- (M110) W/6 : To C2 (For ABS)
- (M111) BR/2 : To D73 (Double cab models with rear speaker)
- (M112) W/2 : To D72 (Double cab models with power door lock)
- (M113) W/3 : To D71 (Double cab models with power window)
- (M114) W/2 : Condenser (Z and KA engines)
- (M115) W/2 : Door switch driver side (For Europe)
- (M116) W/3 : To heated seat sub-harness LH (For Europe)
- (M117) W/6 : To M601 (For Europe)
- (M118) W/16 : To C9
- (M119) W/3 : To heated seat sub-harness RH (For Europe)

Console harness

- (M601) W/6 : To (M120)
- (M602) L/4 : Heated seat switch LH
- (M603) W/4 : Heated seat switch RH
- (M123) W/4 : Front LH seat belt pre-tensioner (With air bag for Europe and Australia)
- (M124) W/4 : Front RH seat belt pre-tensioner (With air bag for Europe and Australia)
- (M125) W/6 : A/T device (A/T models with floor shift)

HARNESS LAYOUT

Main Harness (Cont'd)

ENGINE COMPARTMENT — LHD models

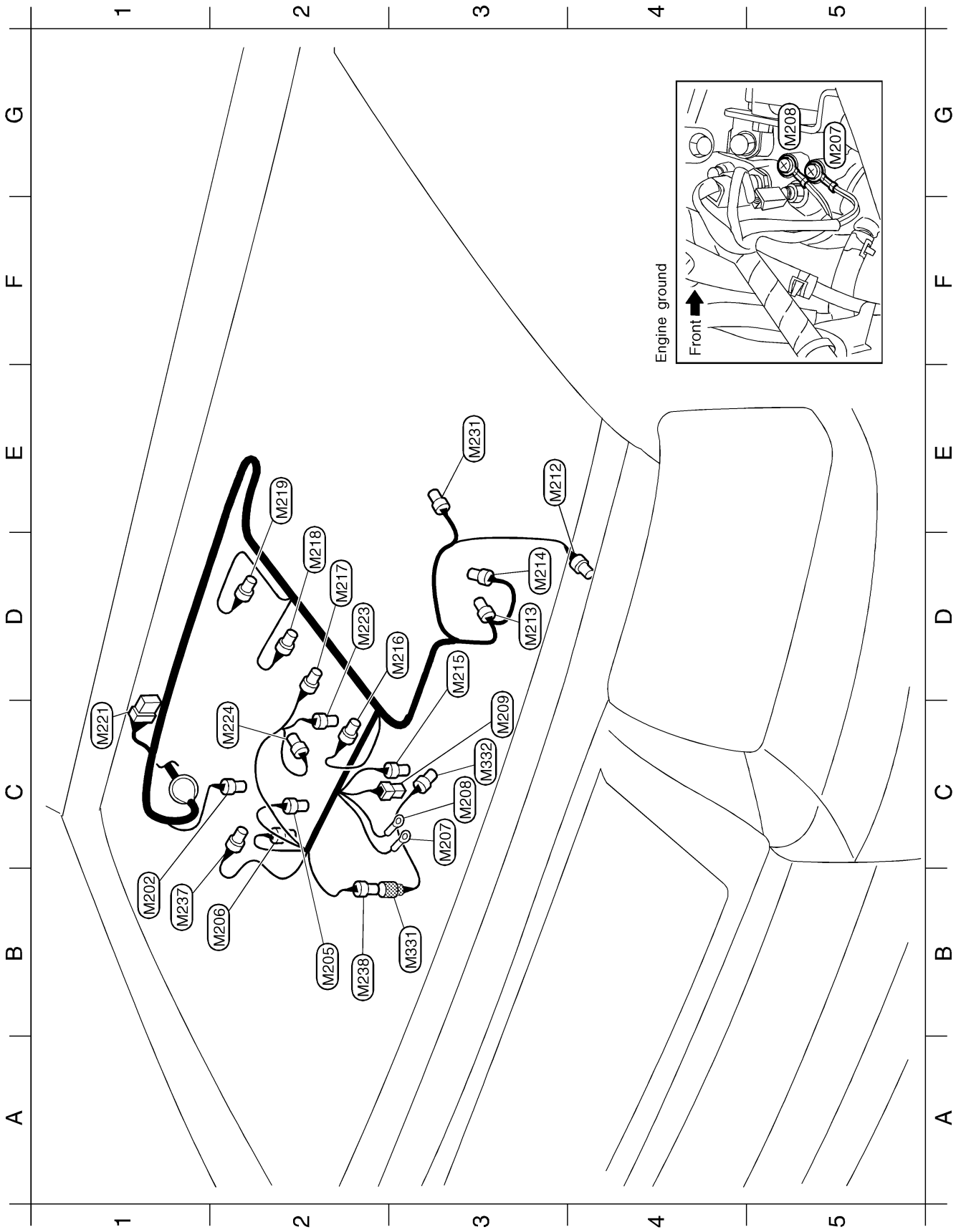

HEL857B

HARNES LAYOUT

Main Harness (Cont'd)

Sub-harness

B1 (M202)	L/2	:	EVAP canister purge control solenoid valve
B2 (M205)	BR/3	:	Throttle position sensor
B2 (M206)	GY/3	:	Throttle position switch
C3 (M207)	—	:	Engine ground
C3 (M208)	—	:	Engine ground
C3 (M209)	B/1	:	Thermal transmitter
E3 (M212)	B/1	:	Compressor
D3 (M213)	GY/2	:	Distributor
D3 (M214)	GY/6	:	Distributor
D3 (M215)	GY/2	:	Engine coolant temperature sensor
D3 (M216)	B/2	:	Injector No.1
D2 (M217)	B/2	:	Injector No.2
D2 (M218)	B/2	:	Injector No.3
E2 (M219)	B/2	:	Injector No.4
C1 (M221)	W/6	:	Wiper motor
D2 (M223)	BR/2	:	IACV-AAC valve
C2 (M224)	PU/2	:	IACV-FICD solenoid valve
E3 (M231)	SB/3	:	Heated oxygen sensor 1
B1 (M237)	BR/4	:	Mass air flow sensor
B2 (M238)	GY/2	:	To (M331)

B3 (M331) GY/2 : To (M238)
 C3 (M332) GY/2 : Knock sensor

HARNES LAYOUT

Main Harness (Cont'd)

ENGINE COMPARTMENT — YD ENGINE (LHD models)

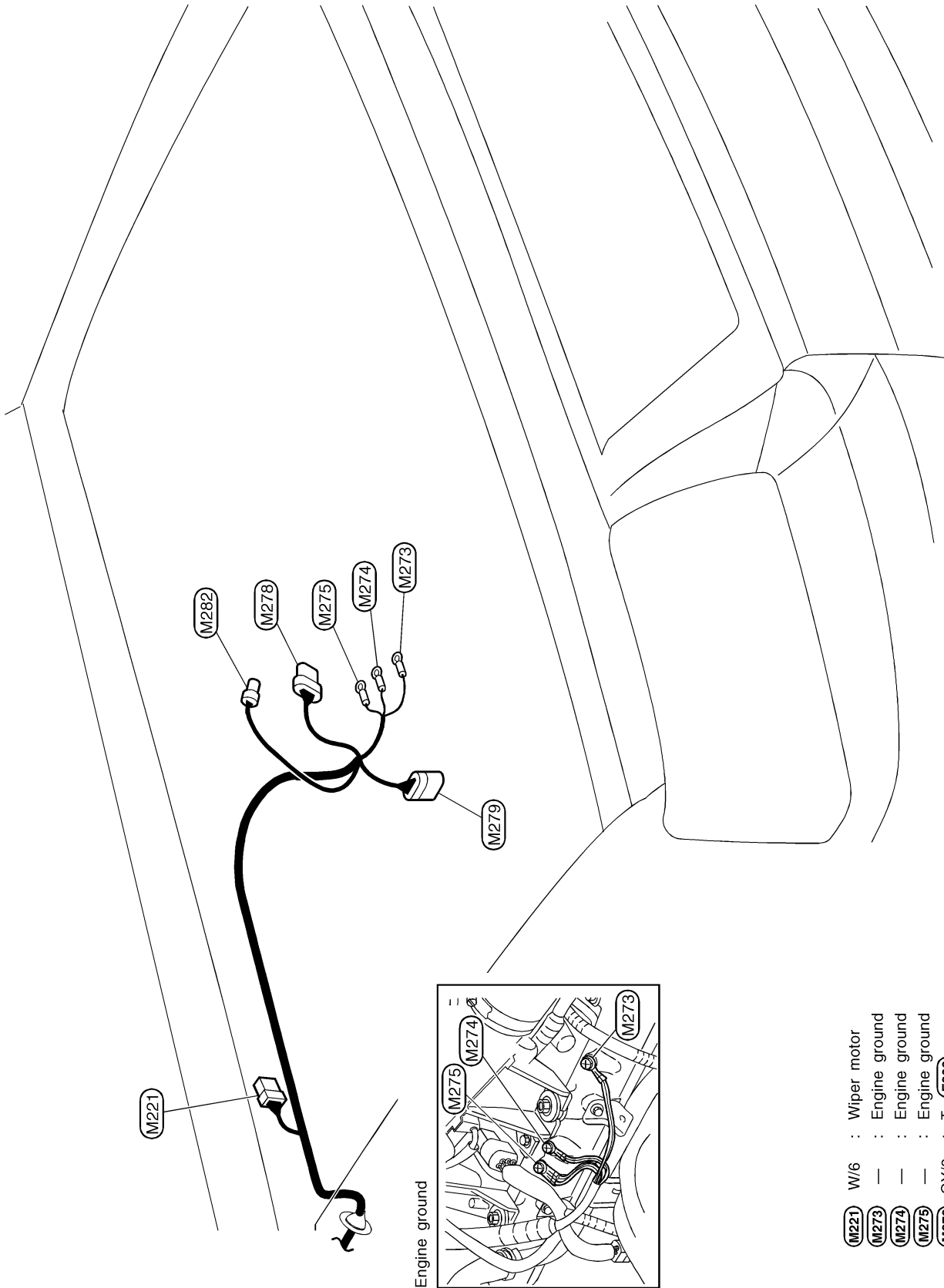

- (M221) W/6 : Wiper motor
- (M273) — : Engine ground
- (M274) — : Engine ground
- (M275) — : Engine ground
- (M278) GY/8 : To (E236)
- (M279) GY/10 : To (E237)
- (M282) GY/3 : Charge air pressure sensor

HARNESS LAYOUT

NOTE

HARNESS LAYOUT

Engine Room Harness

LHD MODELS — GASOLINE ENGINE

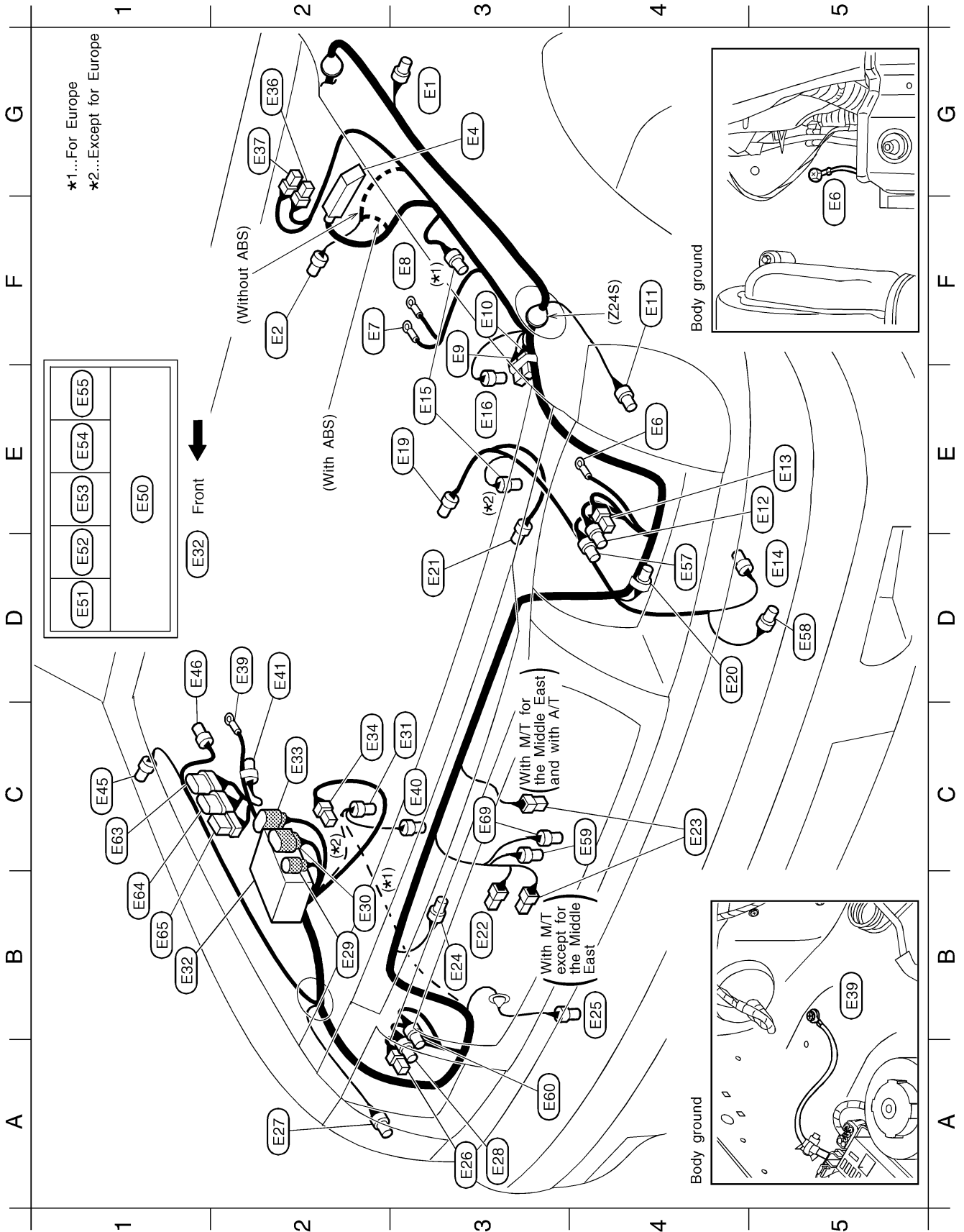

HARNESS LAYOUT

Engine Room Harness (Cont'd)

- D1 (E52) L/4 : Air conditioner relay
- E1 (E53) W/3 : Horn relay
- E1 (E54) BR/6 : Park/neutral position relay (With A/T)
- E1 (E55) B/5 : Automatic choke relay (Z engine)
- BR/6 : ECM relay (KA engine)
- D4 (E57) -/3 : Headlamp aiming motor LH (For the Middle East and Europe)
- D5 (E58) GY/2 : Headlamp washer motor (For Europe)
- C4 (E59) B/2 : Ambient sensor (For Europe)
- A3 (E60) -/3 : Headlamp aiming motor RH (For the Middle East and Europe)
- C1 (E63) SB/6 : Daytime light unit (With daytime light system)
- B1 (E64) SB/8 : Daytime light unit (With daytime light system)
- B1 (E65) W/6 : Headlamp washer amplifier (For Europe)
- C3 (E69) BR/2 : Ambient temperature switch (KA engine)

PASSENGER COMPARTMENT

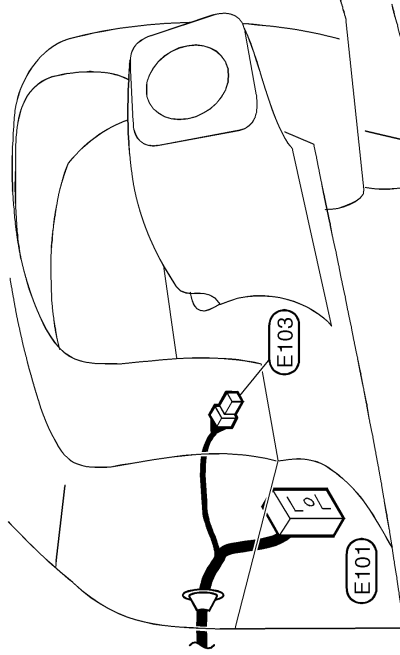

- (E101) SMJ : To (M5)
- (E103) B/2 : Fuse block

Resistor (E9)

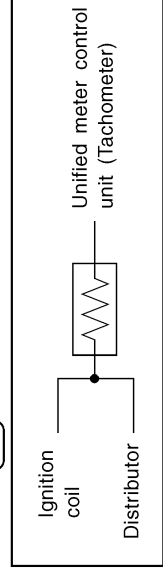

- G3 (E1) GY/2 : Side turn signal lamp LH (With multi-beam type headlamp)
- F2 (E2) GY/2 : Brake fluid level switch
- G3 (E4) B/31 : ABS actuator and electric unit (For ABS)
- E4 (E6) — : Body ground
- F2 (E7) — : Ignition coil (Z engine)
- F3 (E8) — : Ignition coil (Z engine)
- F3 (E9) -/2 : Resistor (Z engine)
- F3 (E10) W/2 : Condenser (Z engine)
- F4 (E11) GY/3 : Front combination lamp LH (Without multi-beam type headlamp)
- E5 (E12) GY/3 : Front combination lamp LH (With multi-beam type headlamp)
- E5 (E13) B/3 : Headlamp LH
- D5 (E14) GY/2 : Washer motor
- E3 (E15) BR/2 : Front wheel sensor LH (For ABS)
- E3 (E16) BR/2 : Intake air temperature sensor (KA engine for Europe)
- E3 (E19) GY/3 : Distributor (Z engine)
- D4 (E20) GY/2 : Option connector (For hood switch) (For Europe)
- D3 (E21) B/1 : Compressor (Z engine)
- B3 (E22) B/1 : Horn low
- C4 (E23) B/1 : Horn high
- B3 (E24) GY/2 : Cooling fan motor (KA engine for the Middle East and Europe)
- B4 (E25) GY/4 : Triple-pressure switch
- A3 (E26) B/3 : Headlamp RH
- A2 (E27) GY/3 : Front combination lamp RH (Without multi-beam type headlamp)
- A3 (E28) GY/3 : Front combination lamp RH (With multi-beam type headlamp)
- B2 (E29) GY/2 : To (E204)
- B2 (E30) GY/8 : To (E203)
- C3 (E31) GY/2 : Front wheel sensor RH (For ABS)
- B1 (E32) — : Relay box (Fusible link and fuse box)
- C2 (E33) SB/8 : To (E205)
- C2 (E34) B/1 : Battery
- G2 (E36) B/1 : ISC-FI pot control solenoid valve (Z engine)
- G2 (E37) B/1 : ISC-FI pot control solenoid valve (Z engine)
- D2 (E39) — : Body ground
- C3 (E40) B/2 : Power steering oil pressure switch (For Europe)
- D2 (E41) B/1 : Option connector (For front fog lamp) (For Europe)
- C1 (E45) GY/2 : Side turn signal lamp RH (With multi-beam type headlamp)
- D1 (E46) GY/3 : Power antenna (For the Middle East and Europe)
- E1 (E50) — : Fusible link and fuse box
- D1 (E51) L/4 : Cooling fan relay (KA engine for the Middle East and Europe)

HARNESS LAYOUT

Engine Room Harness (Cont'd)

LHD MODELS — DIESEL ENGINE

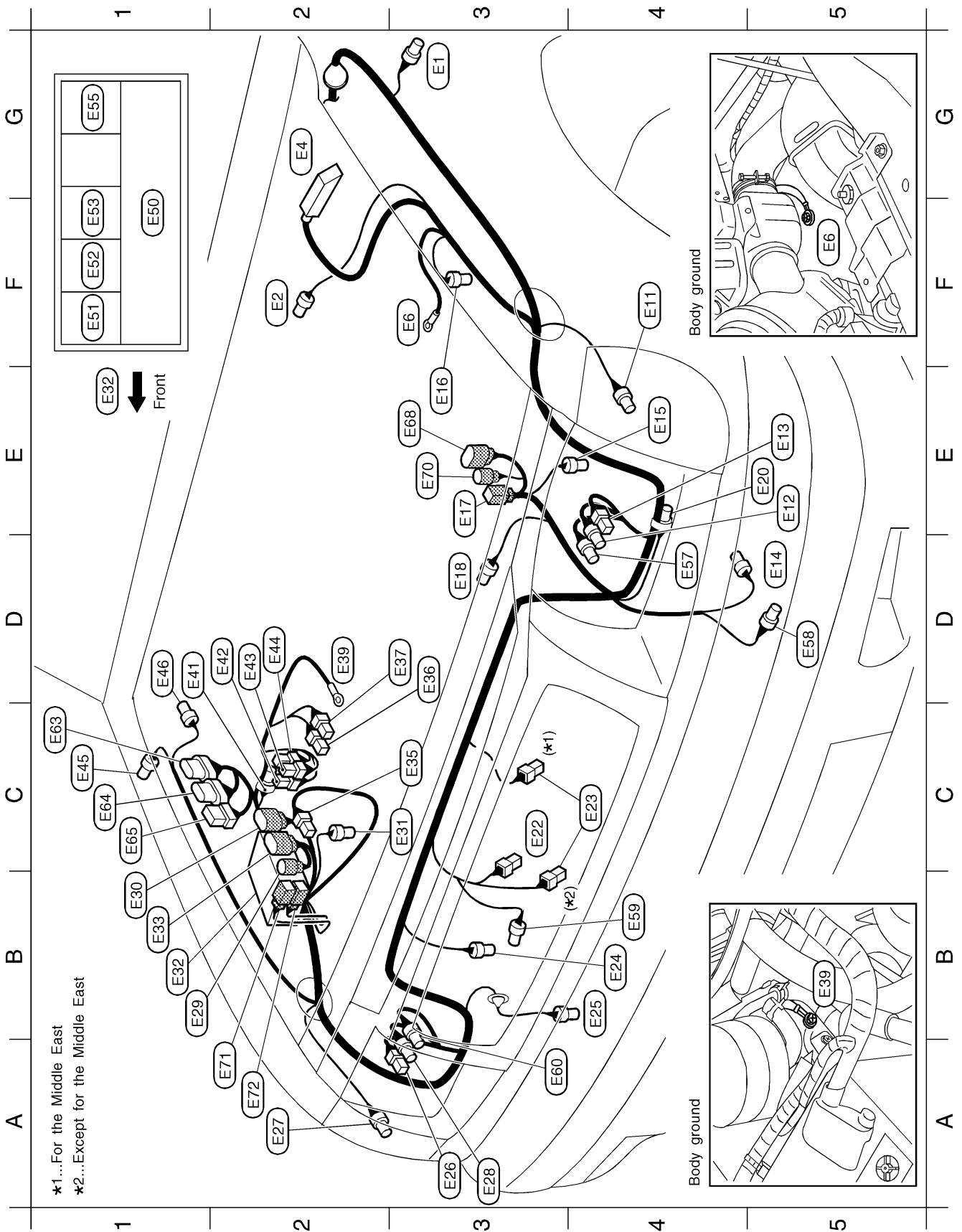

HARNESS LAYOUT

Engine Room Harness (Cont'd)

- D4 **E57** -/3 : Headlamp aiming motor LH (For the Middle East and Europe)
- D5 **E58** GY/2 : Headlamp washer motor (For Europe)
- B4 **E59** B/2 : Ambient sensor (For auto A/C) (YD and ZD engines)
- A3 **E60** -/3 : Headlamp aiming motor RH (For the Middle East and Europe)
- C1 **E63** SB/6 : Daytime light unit (With daytime light system)
- C1 **E64** SB/8 : Daytime light unit (With daytime light system)
- C1 **E65** W/6 : Headlamp washer amplifier (For Europe)
- E3 **E68** GY/8 : To **A13** (TD and QD engines)
- E3 **E70** BR/3 : To **A14** (YD and ZD engines)
- A2 **E71** B/2 : To **E231** (YD and ZD engines)
- A2 **E72** B/1 : To **E232** (YD and ZD engines)

PASSENGER COMPARTMENT

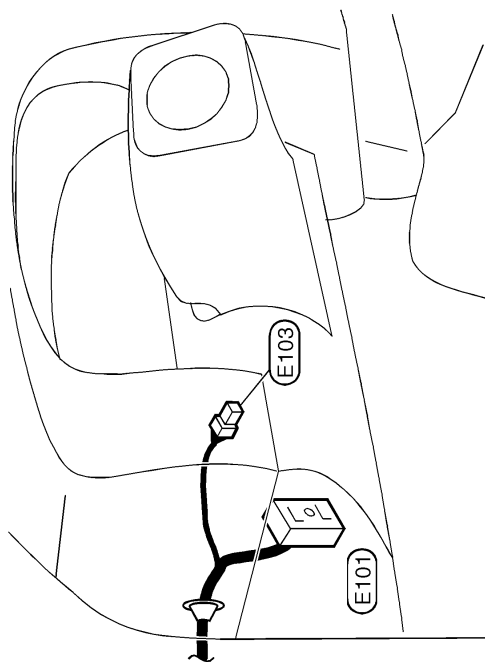

- E101** SM/J : To **M5**
- E103** B/2 : Fuse block

- G3 **E1** GY/2 : Side turn signal lamp LH (Except for the Middle East)
- F2 **E2** GY/2 : Brake fluid level switch
- G2 **E4** B/31 : ABS actuator and electric unit (For ABS)
- F3 **E6** — : Body ground
- F4 **E11** GY/3 : Front combination lamp LH (For the Middle East)
- E5 **E12** GY/3 : Front combination lamp LH (Except for the Middle East)
- E5 **E13** B/3 : Headlamp LH
- D5 **E14** GY/2 : Washer motor
- E4 **E15** BR/2 : Front wheel sensor LH (For ABS)
- E3 **E16** GY/2 : Intake air temperature sensor (YD and ZD engines)
- E3 **E17** B/2 : To **A2**
- D3 **E18** GY/2 : Thermostat (TD engine for the Middle East and QD engines)
- E5 **E20** GY/2 : Option connector (For hood switch) (For Europe)
- C3 **E22** B/1 : Horn low
- C4 **E23** B/1 : Horn high
- B4 **E24** GY/2 : Cooling fan motor (TD engine for the Middle East, QD, YD and ZD engines)
- B4 **E25** GY/4 : Triple-pressure switch
- A3 **E26** B/3 : Headlamp RH
- A2 **E27** GY/3 : Front combination lamp RH (For the Middle East)
- A3 **E28** GY/3 : Front combination lamp RH (Except for the Middle East)
- B1 **E29** GY/2 : To **E204**
- B1 **E30** GY/8 : To **E203** (YD and ZD engines)
- C3 **E31** GY/2 : Front wheel sensor RH (For ABS)
- B1 **E32** — : Relay box (Fusible link and fuse box)
- B1 **E33** SB/8 : To **E205**
- C3 **E35** B/1 : To **E206** (TD and QD engines)
- D3 **E36** B/1 : IACV-FICD solenoid valve (TD and QD engines)
- D3 **E37** B/1 : IACV-FICD solenoid valve (TD and QD engines)
- D2 **E39** — : Body ground
- D1 **E41** B/1 : Option connector (For front fog lamp) (For Europe)
- D2 **E42** W/1 : Gloe relay-1 (YD and ZD engines)
- D2 **E43** W/1 : Gloe relay-1 (YD and ZD engines)
- D2 **E44** G/2 : Gloe relay-1 (YD and ZD engines)
- C1 **E45** GY/2 : Side turn signal lamp RH (Except for the Middle East)
- D1 **E46** GY/3 : Power antenna (For Europe)
- F1 **E50** — : Fusible link and fuse box
- F1 **E51** L/4 : Cooling fan relay (TD engine for the Middle East, QD, YD and ZD engines)
- F1 **E52** L/4 : Air conditioner relay
- F1 **E53** W/3 : Horn relay
- G1 **E55** BR/6 : ECM relay (YD and ZD engines)

HARNESS LAYOUT

Engine Room Harness (Cont'd)

RHD MODELS — GASOLINE ENGINE

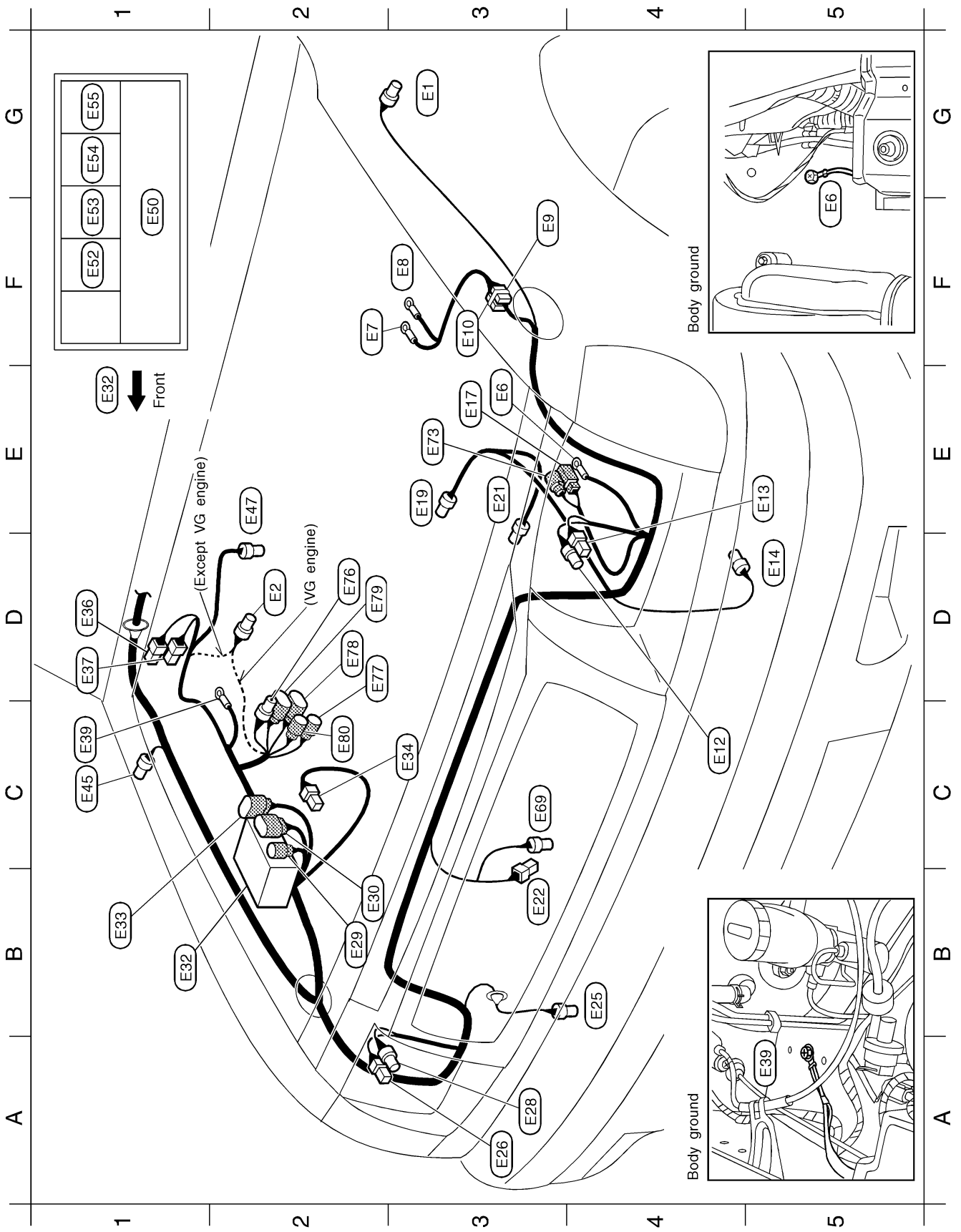

HARNESS LAYOUT

Engine Room Harness (Cont'd)

- E3 (E73) GY/2 : To (A3) (VG engine)
- D2 (E76) GY/2 : Dropping resistor (With A/T)
- D2 (E77) GY/2 : Park/Neutral position switch (With A/T)
- D2 (E78) GY/8 : Park/Neutral position switch (With A/T)
- D2 (E79) BR/8 : To terminal cord assembly (With A/T)
- C2 (E80) GY/3 : Revolution sensor (With A/T)

PASSENGER COMPARTMENT

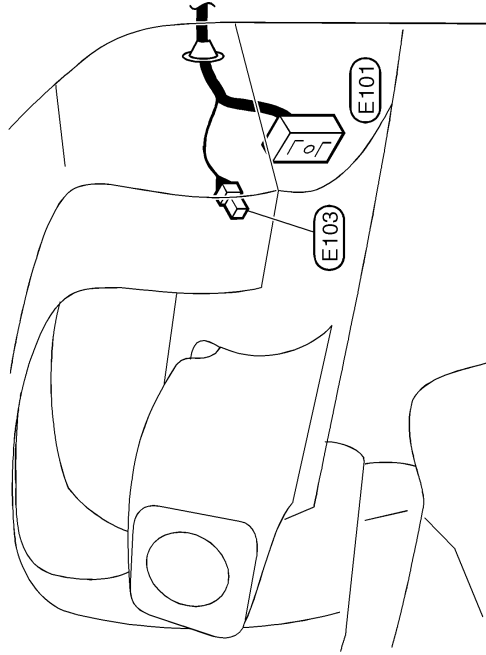

- (E101) SMJ : To (M5)
- (E103) B/2 : Fuse block

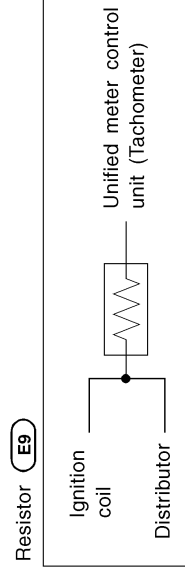

- G3 (E1) GY/2 : Side turn signal lamp LH
- D2 (E2) GY/2 : Brake fluid level switch
- E3 (E6) — : Body ground
- F2 (E7) — : Ignition coil (Z engine)
- F3 (E8) — : Ignition coil (Z engine)
- F3 (E9) -/2 : Resistor (Z engine)
- F3 (E10) W/2 : Condenser (Z engine)
- C4 (E12) GY/3 : Front combination lamp LH
- E5 (E13) B/3 : Headlamp LH
- D5 (E14) GY/2 : Washer motor
- E3 (E17) B/2 : To (A2) (VG engine)
- E3 (E19) GY/3 : Distributor (Z engine)
- E3 (E21) B/1 : Compressor (Z engine)
- B3 (E22) B/1 : Horn low
- B4 (E25) GY/4 : Triple-pressure switch
- A3 (E26) B/3 : Headlamp RH
- A3 (E28) GY/3 : Front combination lamp RH (For Australia)
- B2 (E29) GY/2 : To (E204) (Except VG engine)
- B2 (E30) GY/8 : To (E502) (VG engine)
- B1 (E32) — : To (E203) (Except VG engine)
- B1 (E33) SB/8 : Relay box (Fusible link and fuse box)
- C3 (E34) B/1 : To (E205) (Except VG engine)
- D1 (E36) B/1 : Battery
- D1 (E37) B/1 : ISC-FI pot control solenoid valve (Z engine)
- C1 (E39) — : ISC-FI pot control solenoid valve (Z engine)
- C1 (E45) GY/2 : Body ground
- E2 (E47) GY/3 : Side turn signal lamp RH
- F1 (E50) — : Carburetor (Z engine)
- F1 (E52) L/4 : Fusible link and fuse box
- F1 (E53) W/3 : Air conditioner relay
- G1 (E54) BR/6 : Horn relay
- G1 (E55) BR/6 : Park/Neutral position relay (With A/T)
- B/5 : ECM relay (KA engine)
- B/5 : ECM relay (VG engine)
- B/5 : Automatic choke relay (Z engine)
- C3 (E69) BR/2 : Ambient temperature switch (KA engine)

HARNESS LAYOUT

Engine Room Harness (Cont'd)

RHD MODELS — DIESEL ENGINE

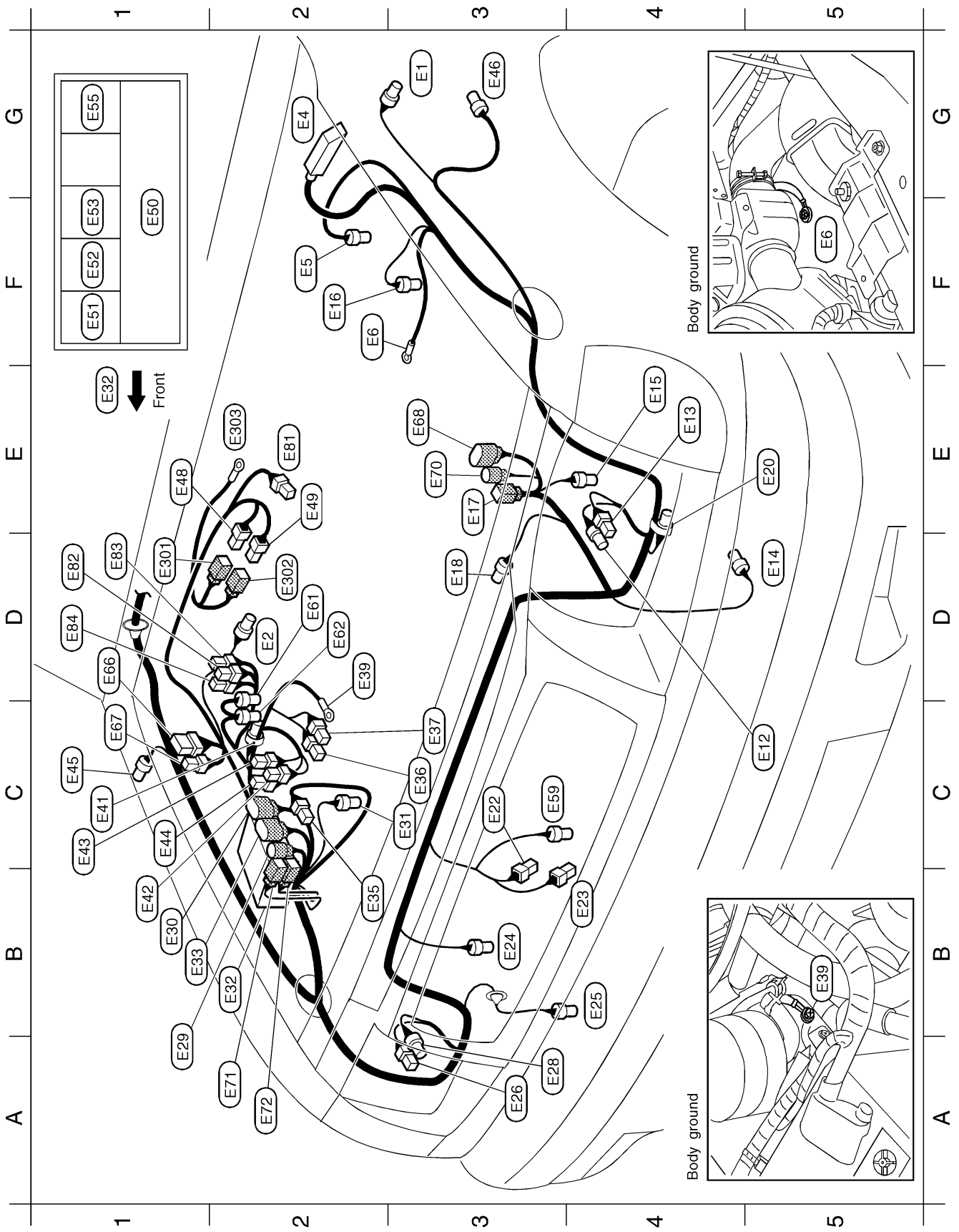

HARNESS LAYOUT

Engine Room Harness (Cont'd)

D2 E61	B/2	: EGRC-solenoid valve (Throttle chamber) (TD engine with EGR)
D2 E62	BR/2	: EGRC-solenoid valve (EGR valve) (TD engine with EGR)
D1 E66	GY/6	: Dim-dip lamp unit (For Europe)
C1 E67	GY/4	: Dim-dip lamp unit (For Europe)
E3 E68	GY/8	: To A13 (TD and QD engines)
E3 E70	BR/3	: To A14 (YD and ZD engines)
A2 E71	B/2	: To E231 (YD and ZD engines)
A2 E72	B/1	: To E232 (YD and ZD engines)
E2 E81	B/2	: Dropping resistor (TD engine for Australia)
D1 E82	W/1	: Glow relay-2 (TD engine for Australia)
D1 E83	W/1	: Glow relay-2 (TD engine for Australia)
D1 E84	G/2	: Glow relay-2 (TD engine for Australia)

PASSENGER COMPARTMENT

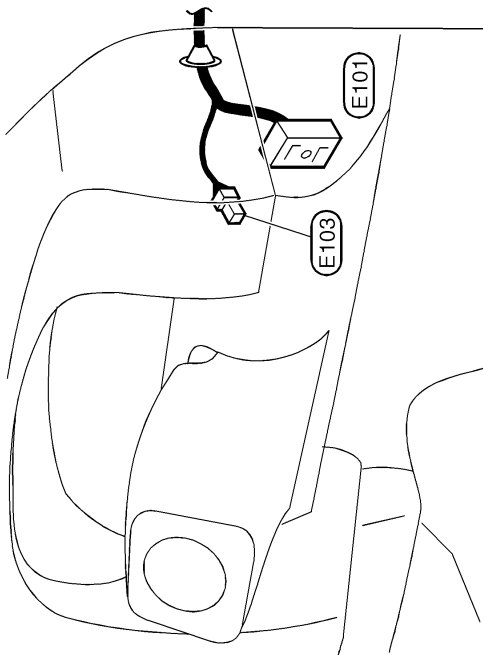

E101 SMJ : To **M5**
E103 B/2 : Fuse block

Sub-harness

D1 E301	B/1	: To E48 (QD engine)
D2 E302	L/2	: To E49 (TD engine)
E2 E303	—	: Glow plug (TD and QD engines)

G3 E1	GY/2	: Side turn signal lamp LH
D2 E2	GY/2	: Brake fluid level switch
G2 E4	B/31	: ABS actuator and electric unit (For ABS)
F2 E5	BR/2	: Fuel filter switch (Except for Europe)
F2 E6	—	: Body ground
C5 E12	GY/3	: Front combination lamp LH
E4 E13	B/3	: Headlamp LH
D5 E14	GY/2	: Washer motor
E4 E15	BR/2	: Front wheel sensor LH (For ABS)
F2 E16	GY/2	: Intake air temperature sensor (YD and ZD engines)
E3 E17	B/2	: To A2
D3 E18	GY/2	: Thermostat (QD engine)
E5 E20	GY/2	: Option connector (For hood switch) (For Europe)
C3 E22	B/1	: Horn low
B4 E23	B/1	: Horn high (ZD engine except for Australia, YD and QD engines)
B4 E24	GY/2	: Cooling fan motor (Except TD engine)
B4 E25	GY/4	: Triple-pressure switch
A3 E26	B/3	: Headlamp RH
A3 E28	BR/3	: Front combination lamp RH
A1 E29	GY/2	: To E204
B1 E30	GY/8	: To E203 (With ECM control engine)
C3 E31	GY/2	: Front wheel sensor RH (For ABS)
B2 E32	—	: Relay box (Fusible link and fuse box)
B1 E33	SB/8	: To E205
B2 E35	B/1	: To E206 (TD and QD engines)
C3 E36	B/1	: IACV-FICD solenoid valve (TD and QD engines)
C3 E37	B/1	: IACV-FICD solenoid valve (TD and QD engines)
D2 E39	—	: Body ground
C1 E41	B/1	: Option connector (For front fog lamp) (For Europe)
B1 E42	W/1	: Glow relay-1
C1 E43	W/1	: Glow relay-1
C1 E44	G/2	: Glow relay-1
C1 E45	GY/2	: Side turn signal lamp RH
G3 E46	GY/3	: Power antenna (For Europe)
E1 E48	B/1	: To E301 (QD engine)
E2 E49	L/2	: To E302 (TD engine)
F1 E50	—	: Fusible link and fuse box
F1 E51	L/4	: Cooling fan relay (Except TD engine)
F1 E52	L/4	: Air conditioner relay
F1 E53	W/3	: Horn relay
G1 E55	BR/6	: ECM relay (YD and ZD engines)
C3 E59	B/2	: Ambient sensor (YD and ZD engines)

HARNESS LAYOUT

Engine Control Harness/KA engine

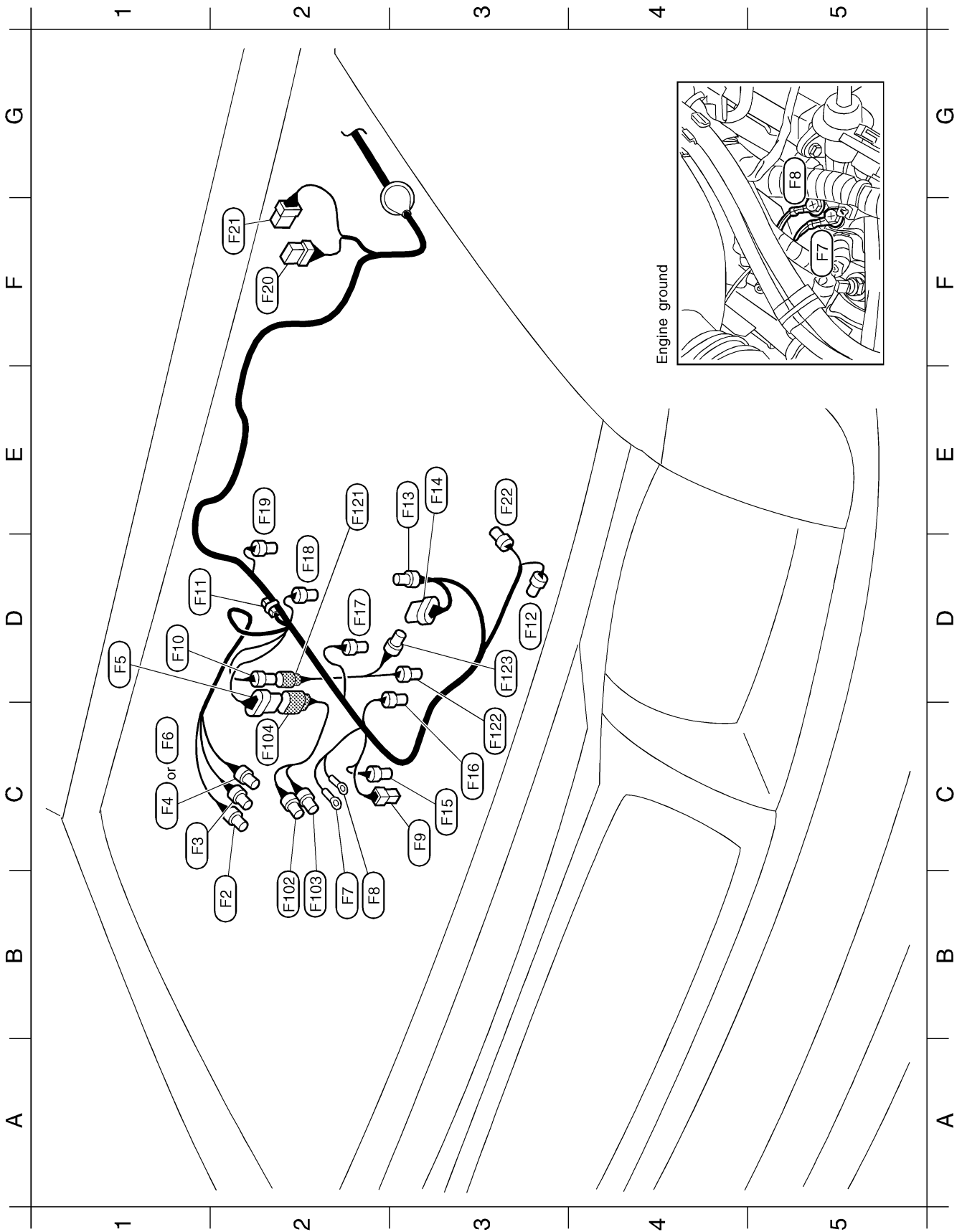

HARNESS LAYOUT

Engine Control Harness/KA engine (Cont'd)

PASSENGER COMPARTMENT

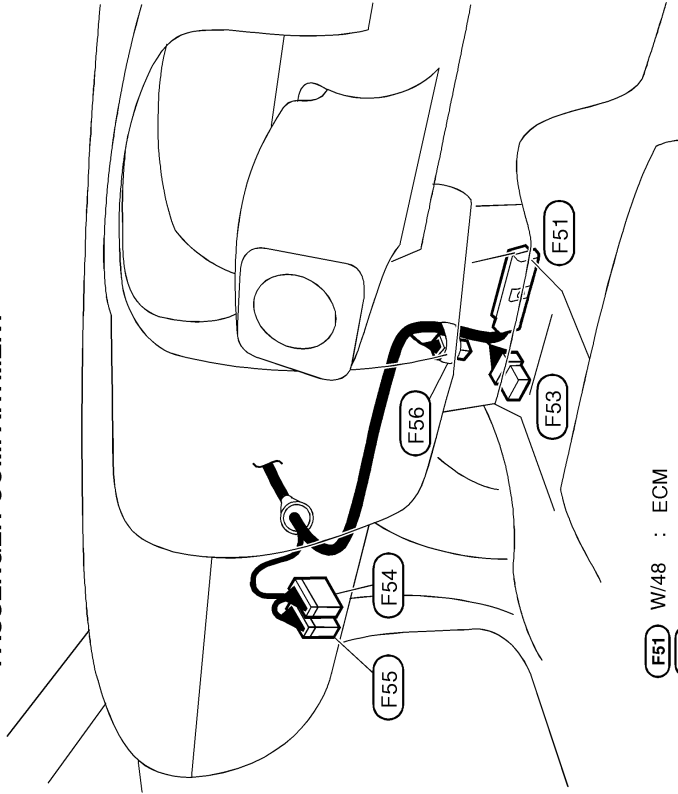

- (F51) W/48 : ECM
- (F53) GY/6 : Joint connector-1
- (F54) W/24 : To (M48)
- (F55) W/16 : To (M47)
- (F56) -/2 : Diode

Resistor (F11)

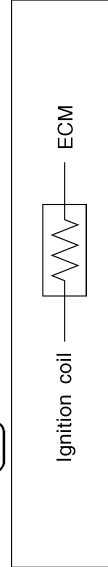

Diode (F56)

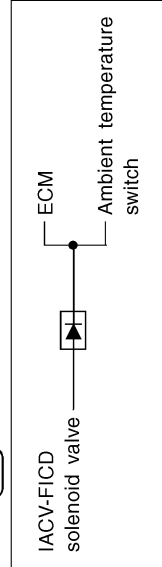

- B2 (F2) B/2 : IACV-FICD solenoid valve
- C1 (F3) BR/2 : IACV-AAC valve
- C1 (F4) GY/3 : Mass air flow sensor (With three way catalyst)
- D1 (F5) GY/6 : To (F104)
- C1 (F6) BR/4 : Mass air flow sensor (Without three way catalyst)
- B2 (F7) — : Engine ground
- B2 (F8) — : Engine ground
- C3 (F9) B/1 : Thermal transmitter
- D1 (F10) B/3 : To (F121)
- D1 (F11) -/2 : Resistor
- D3 (F12) B/1 : Compressor
- E3 (F13) GY/2 : Distributor
- E3 (F14) GY/6 : Distributor
- C3 (F15) GY/2 : Engine coolant temperature sensor
- C3 (F16) GY/2 : Injector No.1
- D2 (F17) GY/2 : Injector No.2
- D2 (F18) GY/2 : Injector No.3
- E2 (F19) GY/2 : Injector No.4
- F2 (F20) GY/8 : Wiper amplifier (A/T models)
- F2 (F21) W/6 : Wiper motor
- E2 (F22) B/3 : Heated oxygen sensor 1 (With three way catalyst)

Sub-harness

- B2 (F102) BR/3 : Throttle position sensor
- B2 (F103) GY/3 : Throttle position sensor
- C2 (F104) B/6 : To (F5)
- E2 (F121) B/3 : To (F10)
- C3 (F122) -/2 : Knock sensor
- D3 (F123) GY/1 : Oil pressure switch

HARNESS LAYOUT

Engine Control Harness

ENGINE COMPARTMENT — YD ENGINE (RHD models)

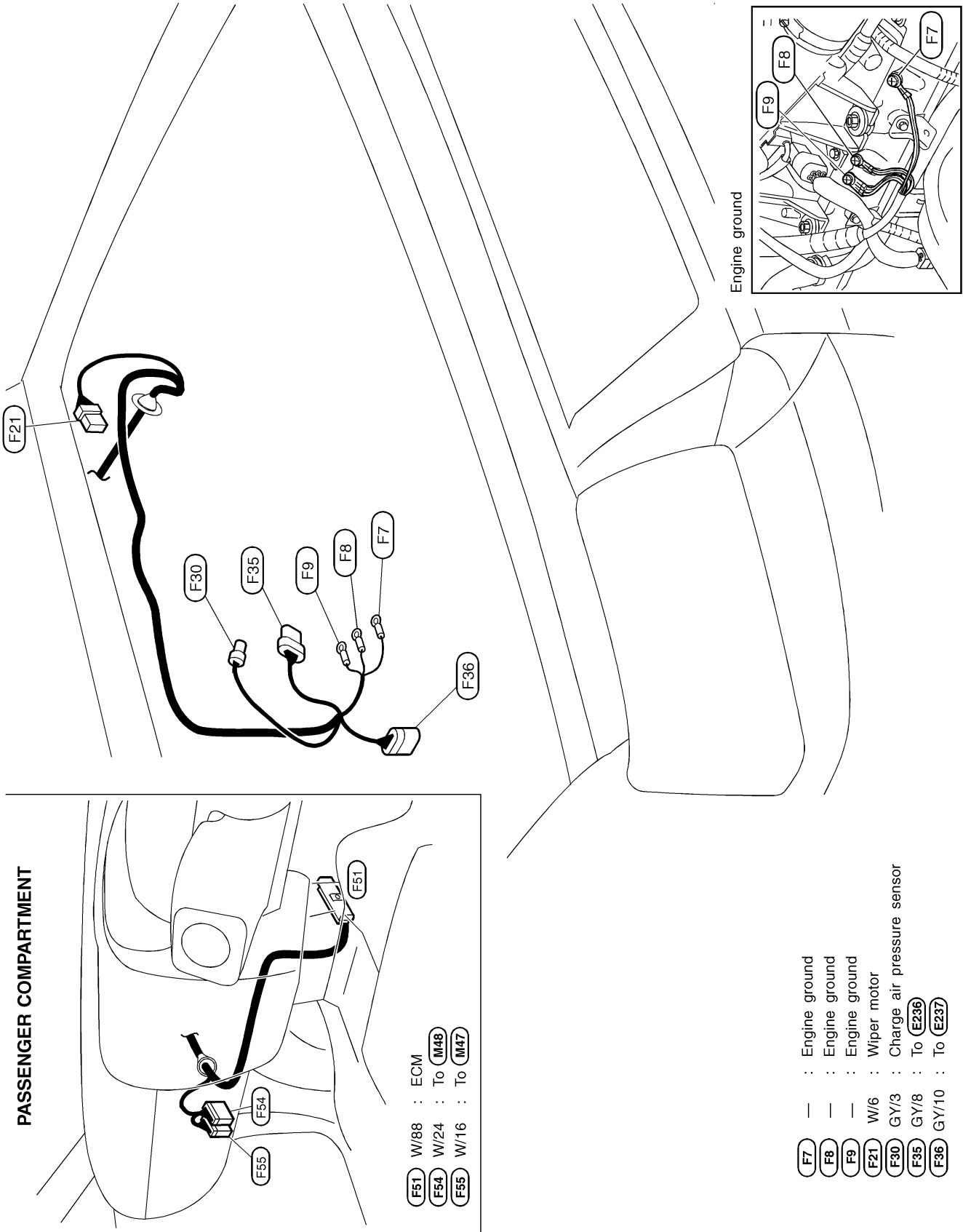

HEL875B

HARNESS LAYOUT

Engine Harness

KA ENGINE

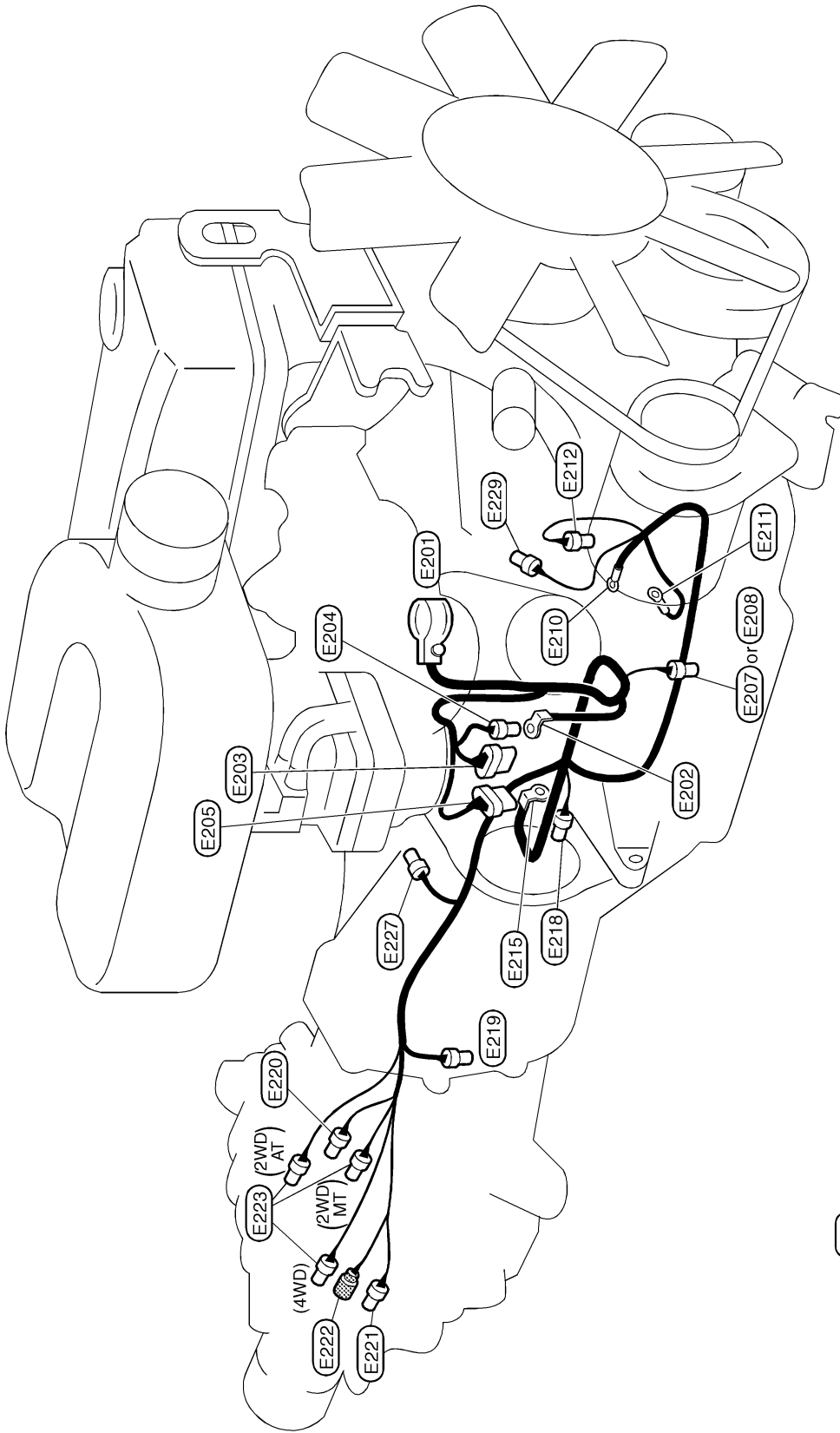

- (E201) — : Battery
- (E202) — : Fusible link and fuse box
- (E203) GY/8 : To (E30)
- (E204) GY/2 : To (E29)
- (E205) SB/8 : To (E33)
- (E207) GY/2 : Power steering oil pressure switch
(RHD 4WD models except for Europe)
- (E208) B/2 : Power steering oil pressure switch
(Except RHD 4WD models except for Europe)
- (E210) — : Alternator (B)
- (E211) — : Alternator (E)
- (E212) GY/2 : Alternator (S,L)

- (E215) — : Starter motor
- (E218) GY/1 : Starter motor
- (E219) GY/2 : Back-up lamp switch (With M/T)
- (E220) B/2 : Park/Neutral position switch (With M/T)
- (E221) GY/1 : Transfer switch (4WD models)
- (E222) GY/1 : Transfer switch (4WD models)
- (E223) GY/2 : Vehicle speed sensor
- (E227) GY/2 : Crankshaft position sensor (OBD) (For Europe)
- (E229) GY/1 : Oil pressure switch (For Europe)

HARNESS LAYOUT

Engine Harness (Cont'd)

YD ENGINE

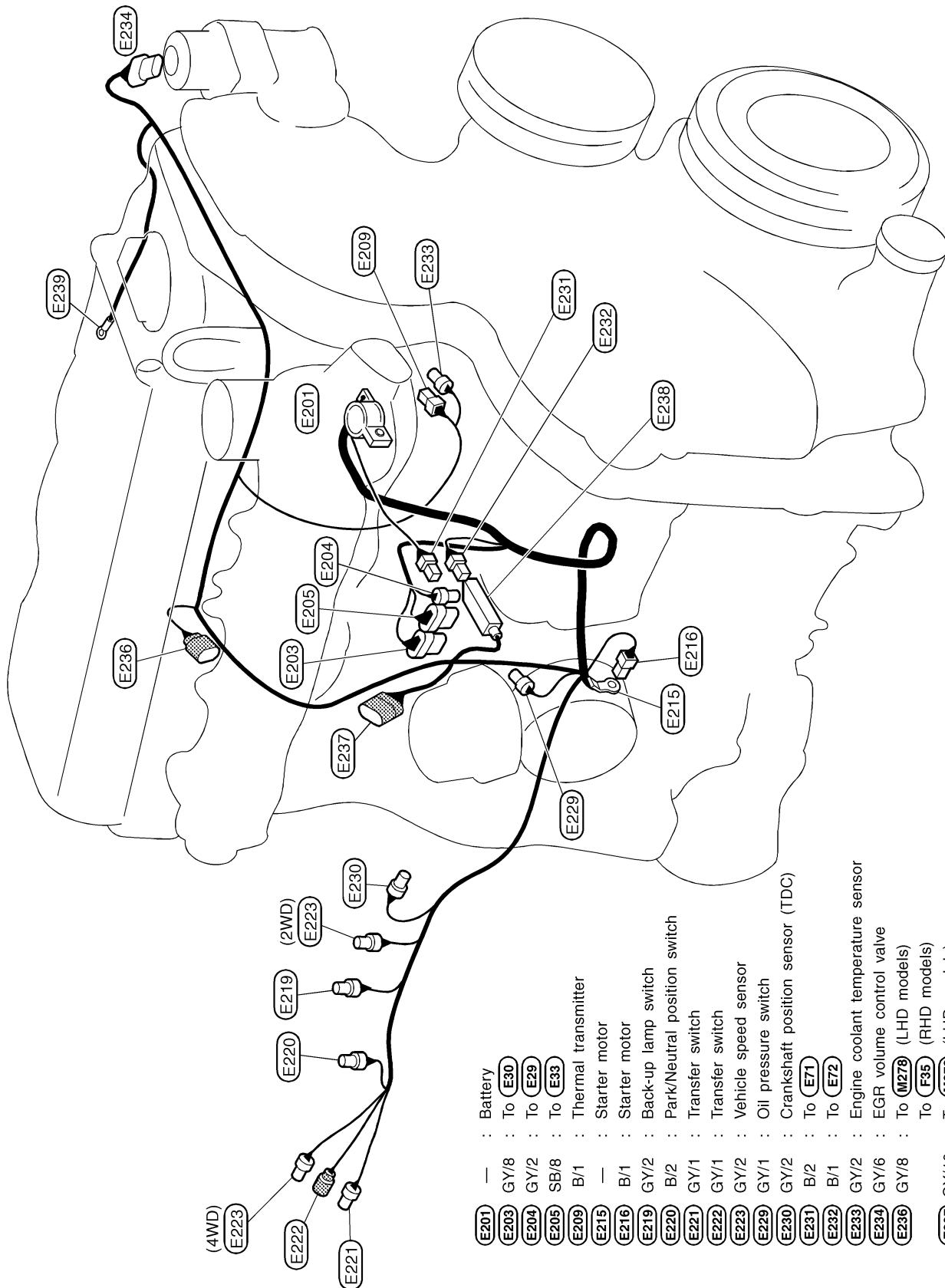

- | | | | | | | | | | | | | | | | |
|------------------------|-----------------------|------------------------|-----------------------|--|---------------|---------------------|------------------------------|-----------------|-----------------|----------------------|---------------------|----------------------------------|----------|----------|-----------------------------------|
| (4WD) | E223 | E219 | E220 | E221 | E222 | E223 | E230 | E231 | E232 | E233 | E234 | E236 | E237 | E238 | E239 |
| (2WD) | E223 | E219 | E220 | E221 | E222 | E223 | E230 | E231 | E232 | E233 | E234 | E236 | E237 | E238 | E239 |
| — | GY/8 | GY/2 | SB/8 | B/1 | — | B/1 | GY/2 | B/2 | GY/1 | GY/1 | GY/2 | GY/1 | GY/2 | B/2 | B/1 |
| To (E30) | To (E29) | To (E33) | Thermal transmitter | Starter motor | Starter motor | Back-up lamp switch | Park/Neutral position switch | Transfer switch | Transfer switch | Vehicle speed sensor | Oil pressure sensor | Crankshaft position sensor (TDC) | To (E71) | To (E72) | Engine coolant temperature sensor |
| To (M278) (LHD models) | To (F35) (RHD models) | To (M279) (LHD models) | To (F36) (RHD models) | Electronic control fuel injection pump | — | Glow plug | | | | | | | | | |

HARNESS LAYOUT

Alternator Harness

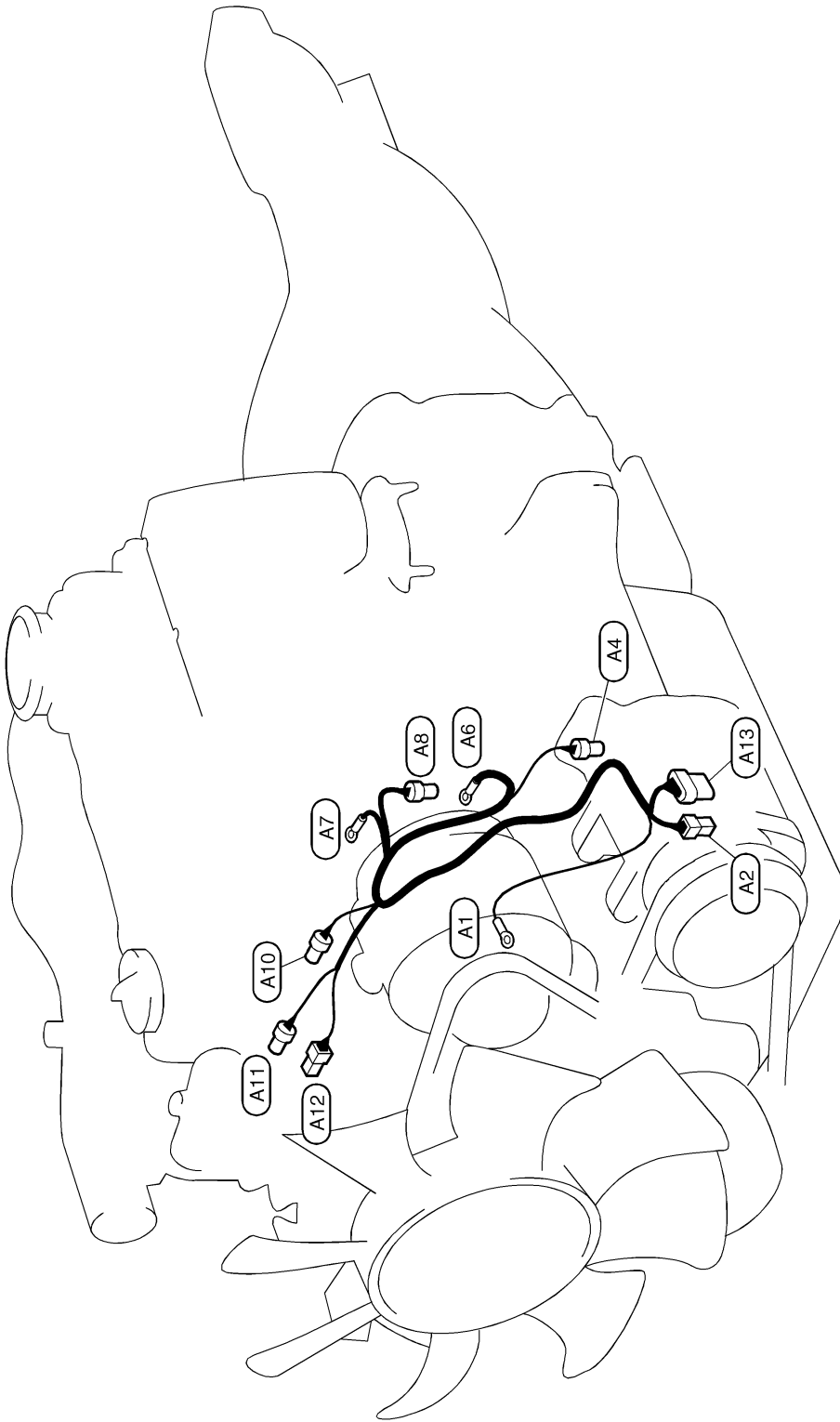

A1	—	: Body ground
A2	B/2	: To (E17)
A4	B/1	: Compressor
A6	—	: Alternator (B)
A7	—	: Alternator (E)
A8	GY/2	: Alternator (S.L)
A10	BR/2	: Revolution sensor
A11	GY/2	: Engine coolant temperature sensor
A12	B/1	: Thermal transmitter
A13	GY/8	: To (E68)

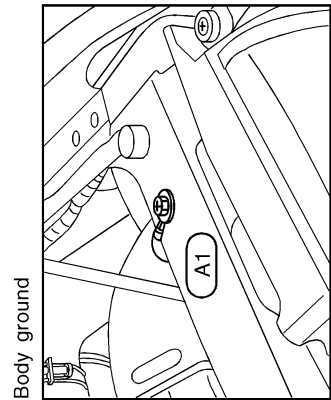

HARNESS LAYOUT

Alternator Harness (Cont'd)

YD ENGINE

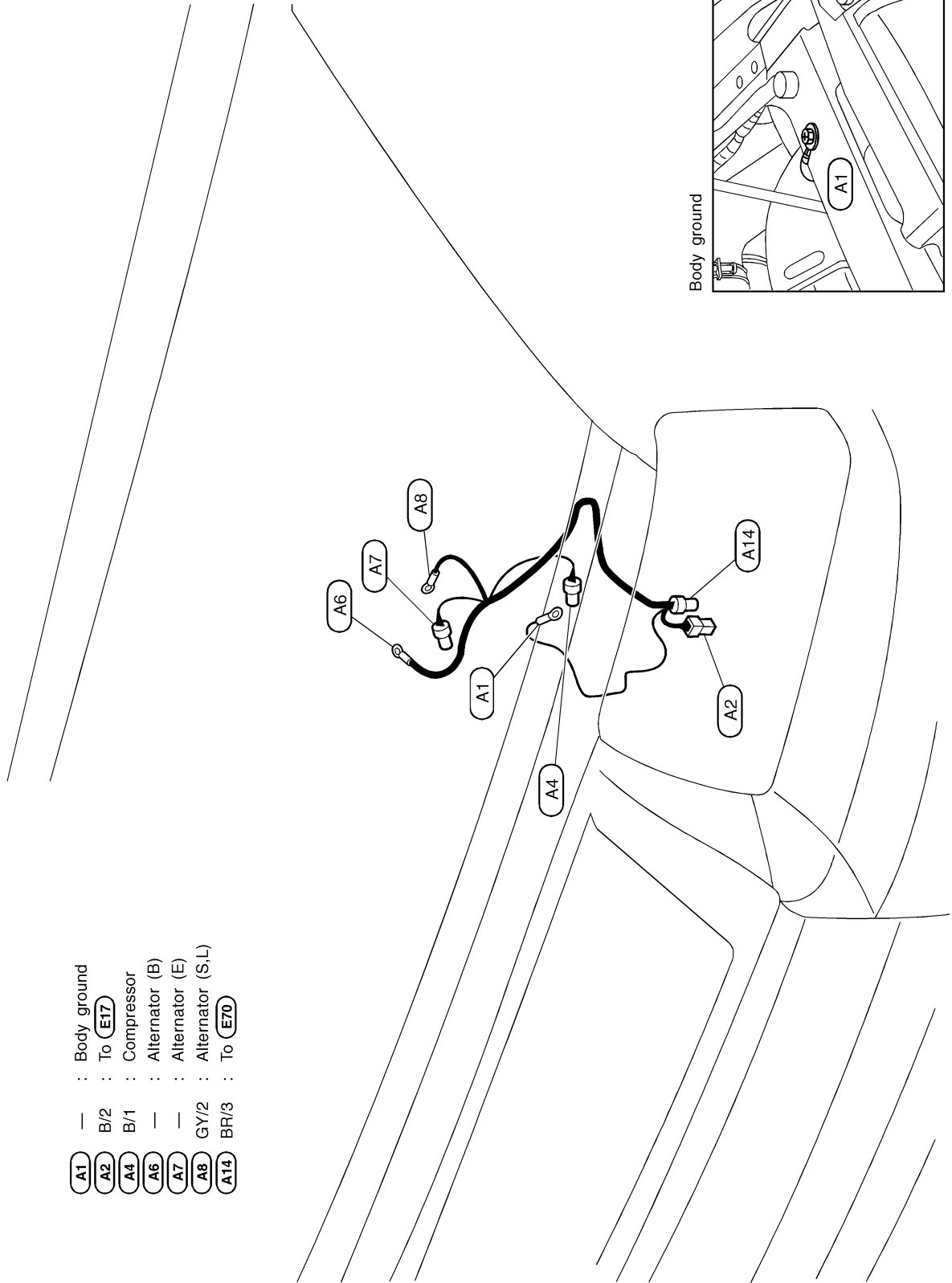

HARNESS LAYOUT

LHD MODELS

Instrument Harness

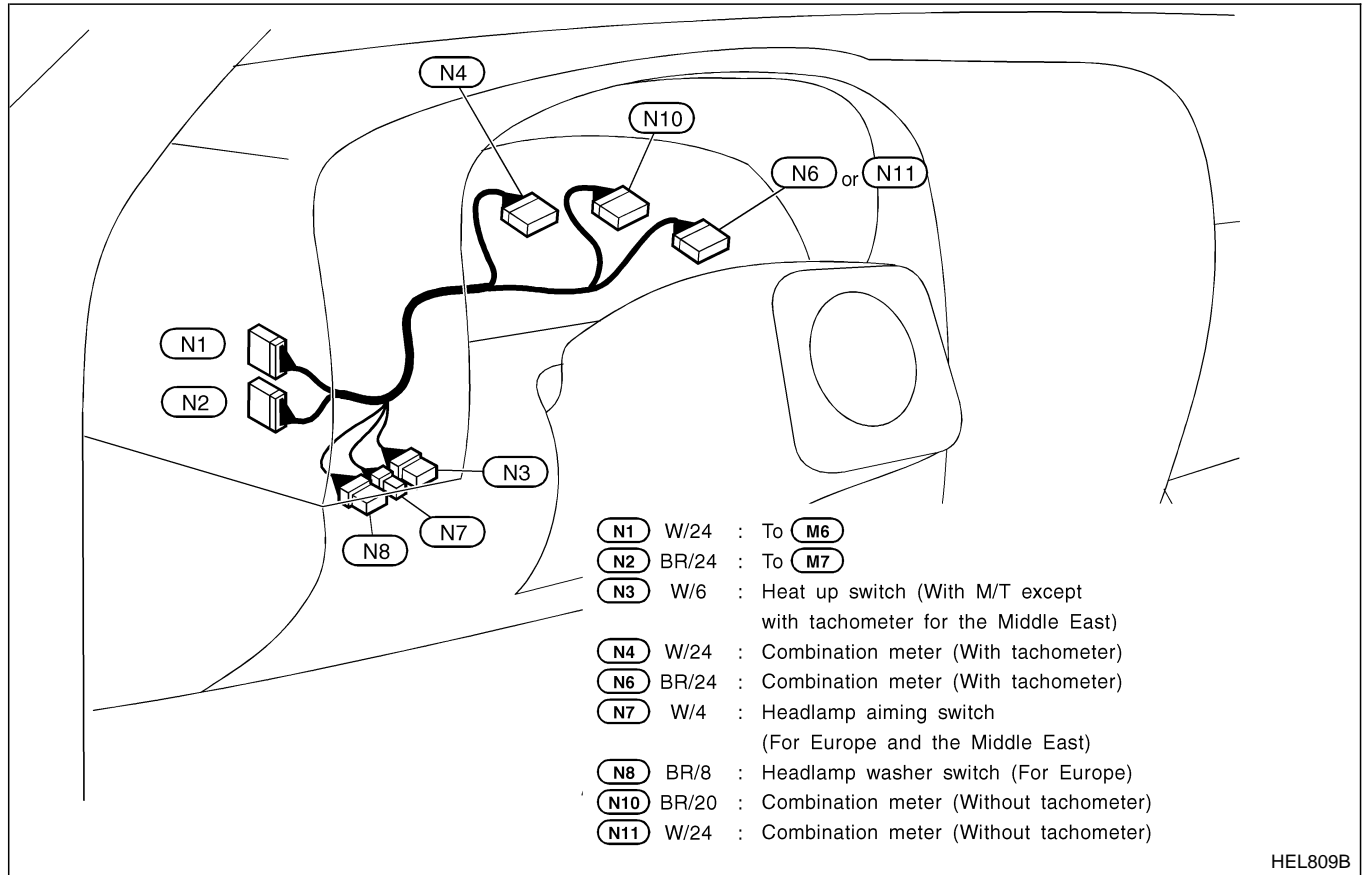

RHD MODELS

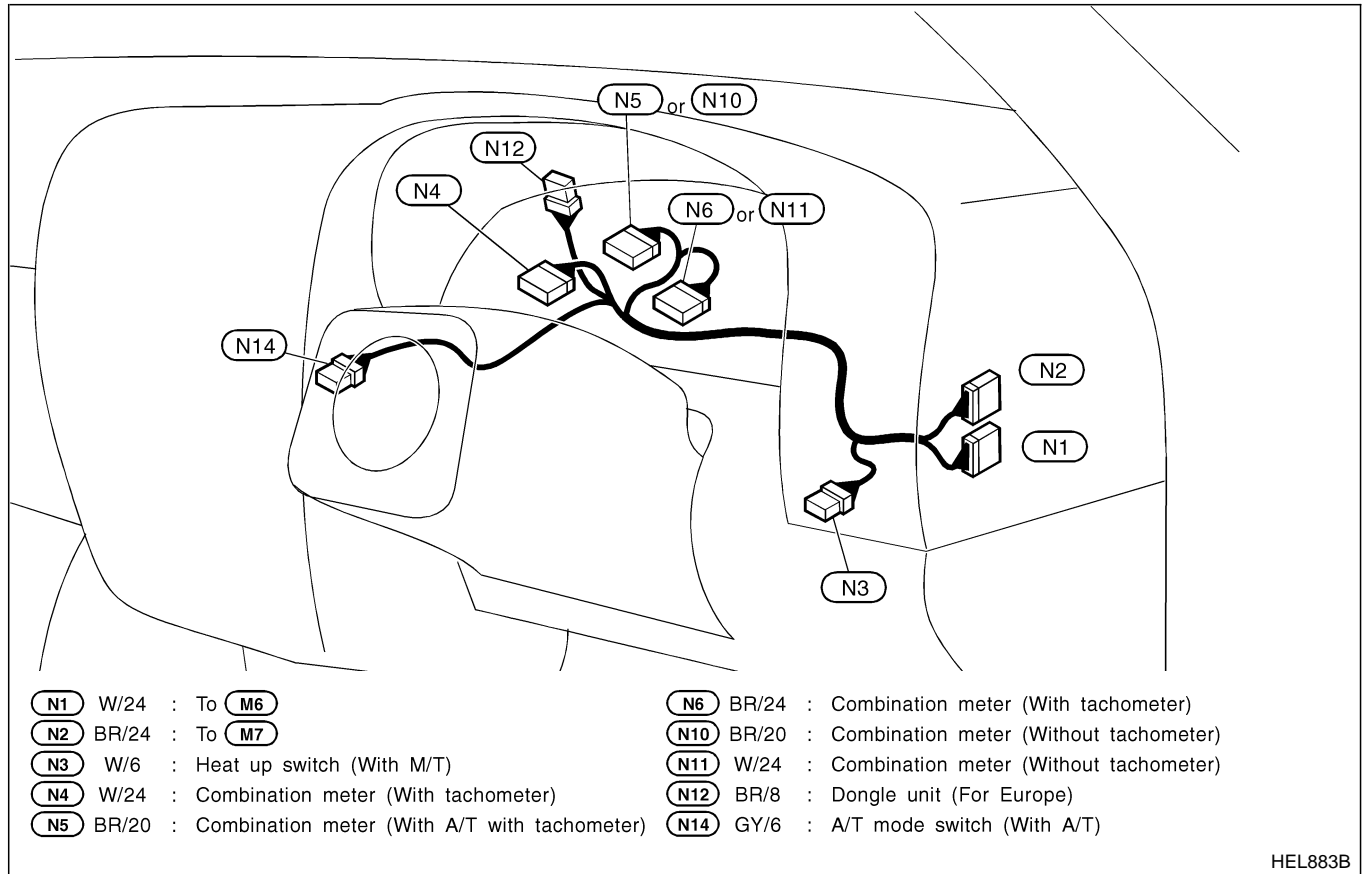

HARNESS LAYOUT

Chassis Harness and Tail Harness

Tail harness

- (T1)** W/6 : Rear combination lamp RH
(A-chassis models or with smooth rear body except for Europe, Australia and China)
- (T2)** W/8 : Rear combination lamp RH (For Europe, Australia and China except A-chassis models or with regular rear body)
- (T3)** GY/2 : License plate lamp RH (With step bumper)
- (T4)** SB/8 : To **(C7)**
- (T5)** GY/2 : License plate lamp RH (Without step bumper)
- (T6)** GY/2 : License plate lamp LH (Without step bumper)
- (T7)** B/2 : License plate lamp LH (With step bumper)
- (T8)** W/6 : Rear combination lamp LH
(A-chassis models or with smooth rear body except for Europe, Australia and China)
- (T9)** W/8 : Rear combination lamp LH (For Europe, Australia and China except A-chassis models or with regular rear body)
- (T10)** GY/2 : Rear fog lamp (RHD A-chassis models for Europe)
- (T12)** GY/2 : Rear fog lamp (LHD A-chassis models for Europe)

Chassis harness

- (C2)** W/6 : To **(M112)** (With ABS)
- (C3)** GY/5 : Fuel level sensor unit and fuel pump
- (C5)** SB/4 : To rear wheel sensor sub-harness (For ABS) (4WD models and 2WD models with LT30 rear brake)
- (C6)** GY/2 : Rear wheel sensor (For ABS) (2WD models with LT26B rear brake)
- (C7)** SB/8 : To **(T4)**
- (C9)** W/16 : To **(M121)**
- (C10)** BR/2 : High-mounted stop lamp (With guard bar for the Middle East)

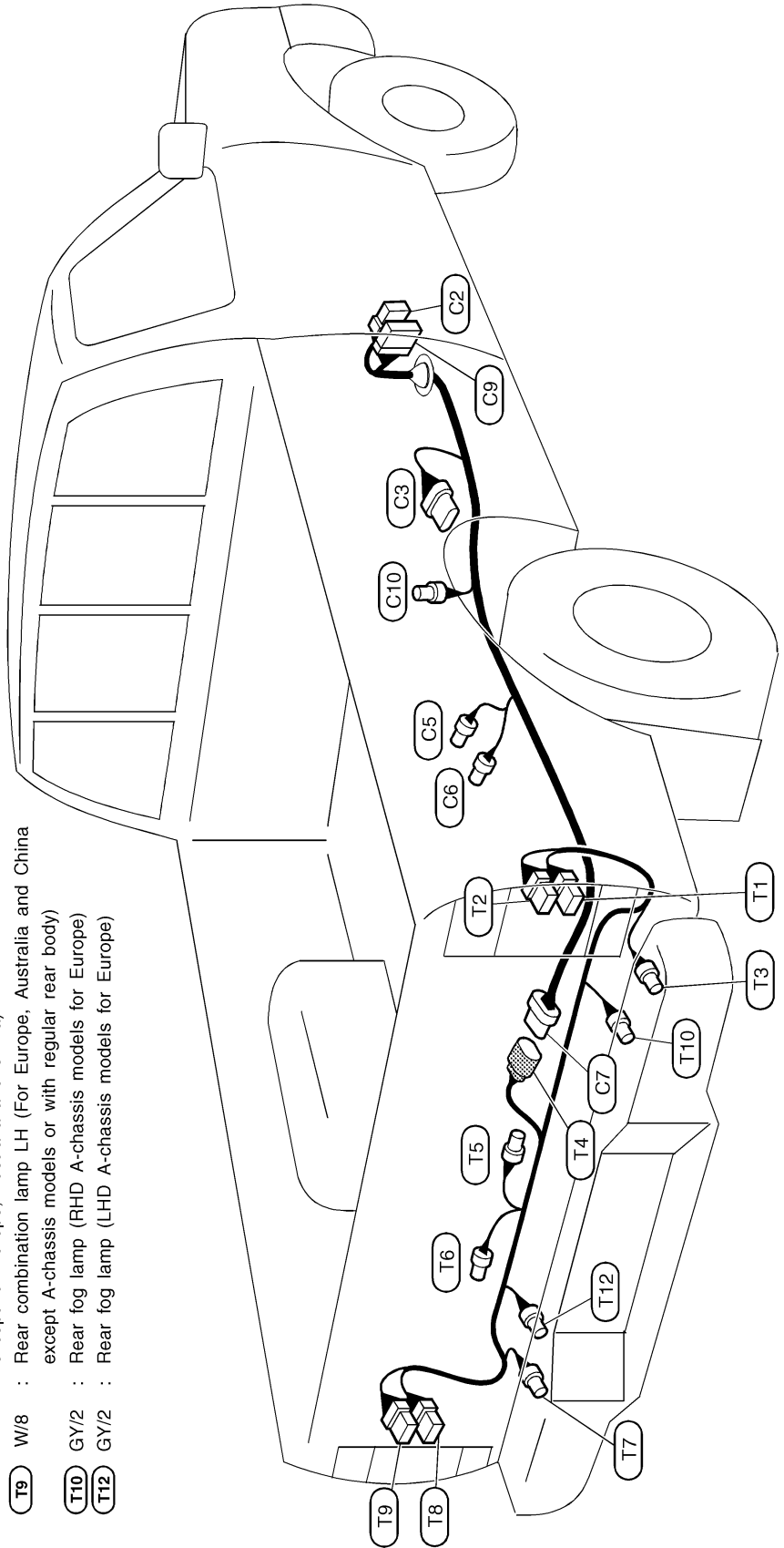

HARNESS LAYOUT

LHD MODELS

Front Door Harness (LH side)

- | | |
|--|--|
| D1 W/20 : To M3 | D9 BR/3 : Door mirror defogger (With power window for Europe) |
| D2 W/12 : To M4 (With power window) | D10 SB/4 : Door lock actuator (With multi-remote control system) |
| D3 BR/2 : Front speaker | D11 GY/3 : Door mirror actuator (With power door mirror for the Middle East) |
| D4 GY/5 : Door mirror actuator (With power door mirror except for the Middle East) | D12 SB/6 : Power window regulator (With power window with interruption detection function) |
| D5 W/16 : Power window main switch | D13 W/3 : Power window main switch (With power window with interruption detection function) |
| D7 B/2 : Power window regulator (With power window without interruption detection function) | D14 W/10 : Door mirror remote control switch |
| D8 GY/2 : Lock knob switch (With power door lock without multi-remote control system) | |

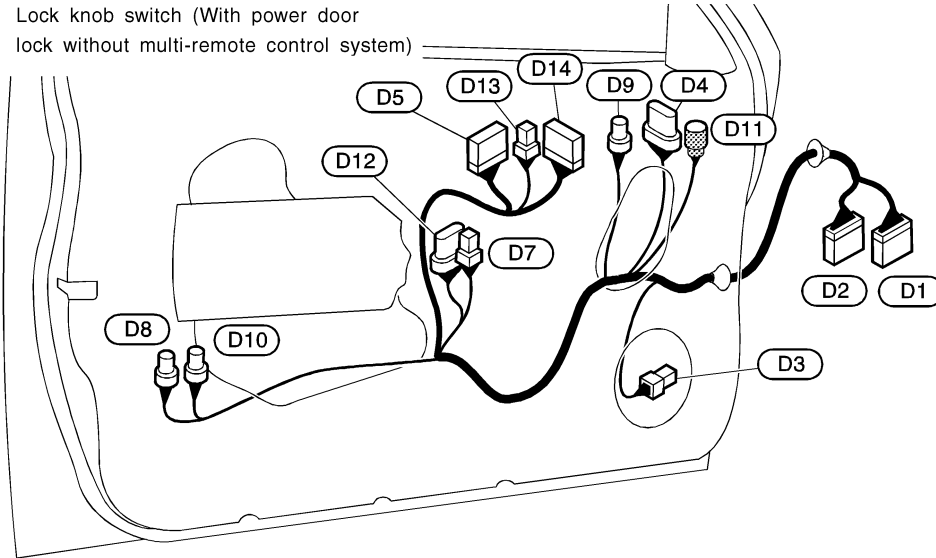

HEL811B

RHD MODELS

- | |
|---|
| D31 W/20 : To M49 |
| D32 W/6 : To M50 (With power window) |
| D33 BR/2 : Front speaker |
| D34 GY/5 : Door mirror actuator (With power door mirror) |
| D35 W/8 : Power window sub-switch (With power window) |
| D37 B/2 : Power window regulator (With power window) |
| D38 SB/4 : Door lock actuator (With power door lock) |
| D39 BR/3 : Door mirror defogger (With power door mirror) |

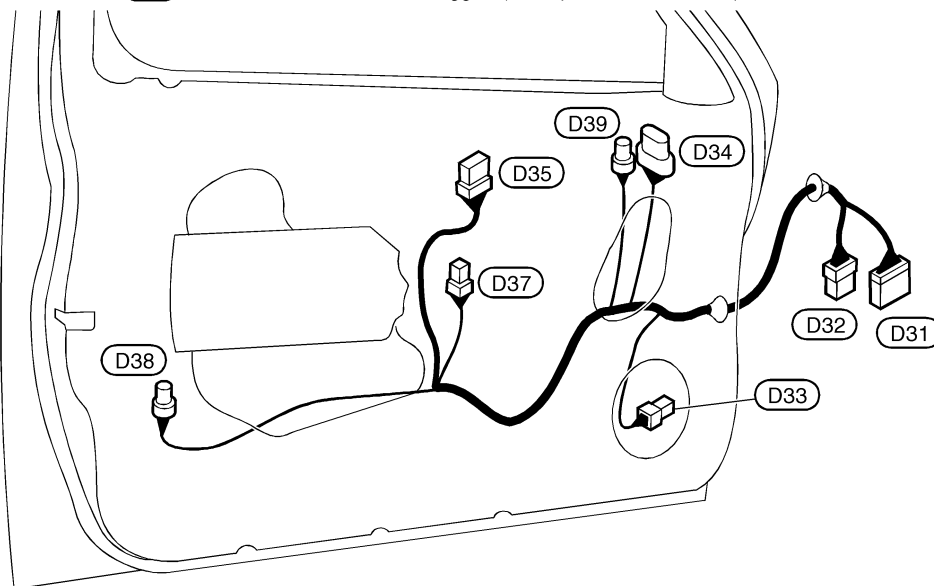

HEL885B

HARNESS LAYOUT

Front Door Harness (RH side)

LHD MODELS

- (D31) W/20 : To (M49)
- (D32) W/6 : To (M50) (With power window)
- (D33) BR/2 : Front speaker
- (D34) GY/5 : Door mirror actuator (With power door mirror except for the Middle East)
- (D35) W/8 : Power window sub-switch (With power window)
- (D37) B/2 : Power window regulator (With power window)
- (D38) SB/4 : Door lock actuator (With power door lock)
- (D39) BR/3 : Door mirror defogger (With power door mirror except for the Middle East)
- (D41) BR/3 : Door mirror actuator (With power door mirror for the Middle East)

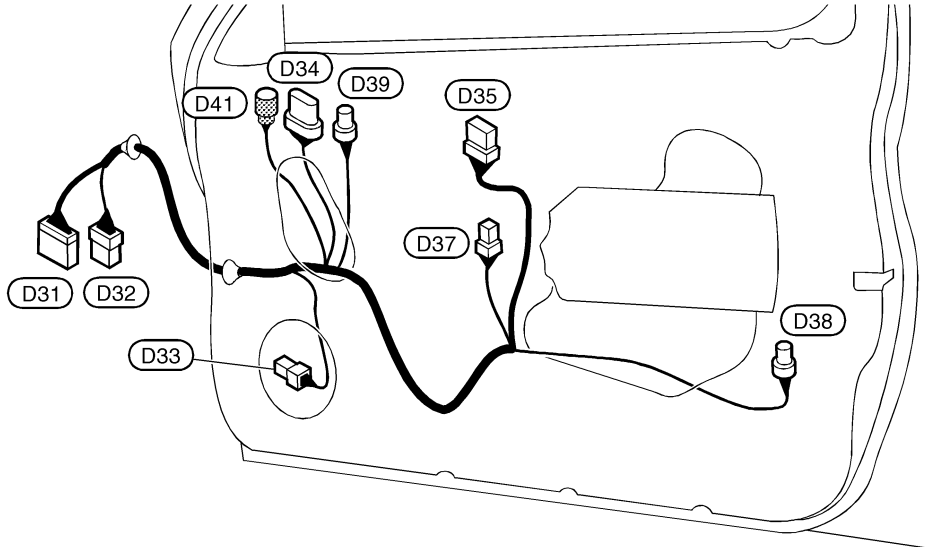

HEL812B

RHD MODELS

- (D1) W/20 : To (M3)
- (D2) W/12 : To (M4) (With power window)
- (D3) BR/2 : Front speaker
- (D4) GY/5 : Door mirror actuator (With power window)
- (D5) W/16 : Power window main switch
- (D7) B/2 : Power window regulator (With power window except for Europe)
- (D8) GY/2 : Lock knob switch (With power door lock without multi-remote control system)
- (D9) BR/3 : Door mirror defogger (With power window for Europe)
- (D10) SB/4 : Door lock actuator (With multi-remote control system)
- (D12) SB/6 : Power window regulator (With power window for Europe)
- (D13) W/3 : Power window main switch (With power window for Europe)
- (D14) W/10 : Door mirror remote control switch (With power window)

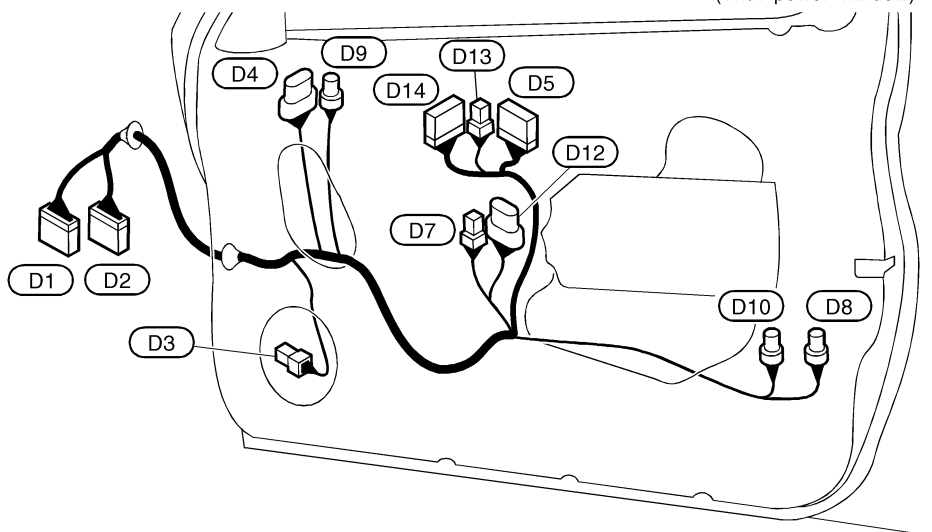

HEL884B

HARNESS LAYOUT

LH SIDE

Rear Door Harness

- (D51) W/3 : To (M107)
- (D52) W/2 : To (M106)
- (D53) BR/2 : To (M105)
- (D54) B/2 : Rear speaker
- (D55) B/2 : Power window regulator
- (D56) SB/4 : Door lock actuator
- (D57) W/8 : Power window sub-switch

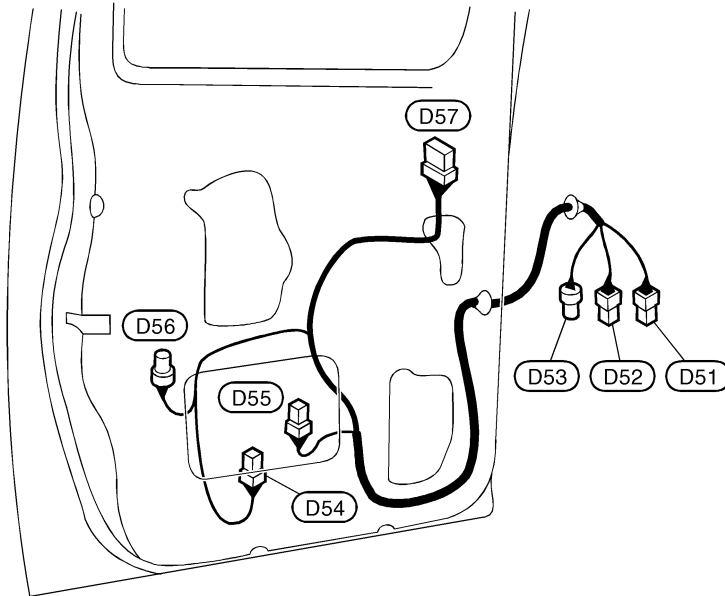

HEL886B

RH SIDE

- (D71) W/3 : To (M115)
- (D72) W/2 : To (M114)
- (D73) BR/2 : To (M113)
- (D74) B/2 : Rear speaker
- (D75) B/2 : Power window regulator
- (D76) SB/4 : Door lock actuator
- (D77) W/8 : Power window sub-switch

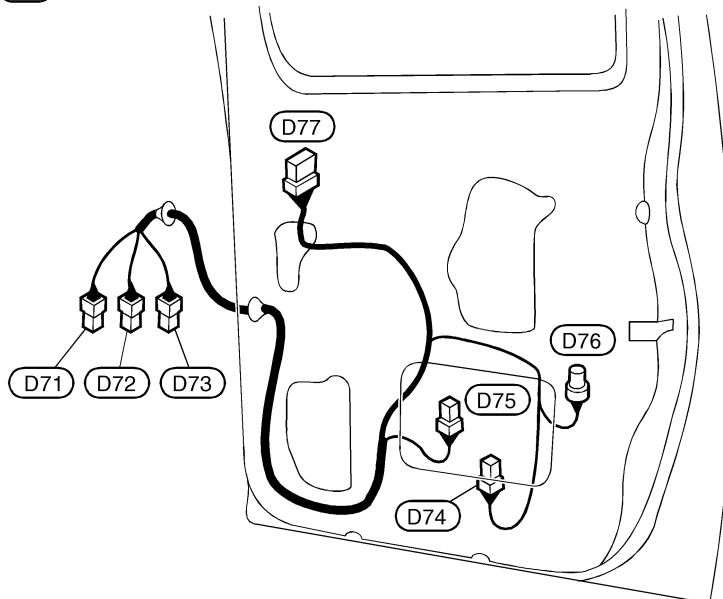

HEL887B

WIRING DIAGRAM CODES (CELL CODES)

Use the chart below to find out what each wiring diagram code stands for.

Refer to the wiring diagram code in the alphabetical index to find the location (page number) of each wiring diagram.

Code	Section	Wiring Diagram Name
AAC/V	EC	IACV-AAC Valve
ABS	BR	Anti-lock Brake System
A/C, A	HA	Auto Air Conditioner
A/C, M	HA	Manual Air Conditioner
ACC/SW	EC	Accelerator Switch
A/CCOT	EC	Air Conditioner Control
AIRREG	EC	IACV-Air Regulator
APS	EC	Accelerator Position Sensor
AT/IND	EL	A/T Indicator
AUDIO	EL	Audio
BACK/L	EL	Back-up Lamp
BA/FTS	AT	BATT/A/T Fluid Temperature Sensor and TCM Power Supply
BOOST	EC	Turbocharger Boost Sensor
BRK/SW	EC	Brake Switch Signal
CHARGE	EL	Charging System
CHIME	EL	Warning Chime
CHOKE	EC	Automatic Choke
CIGAR	EL	Cigarette Lighter
CKPS	EC	Crankshaft Position Sensor
CLOCK	EL	Clock
CMPS	EC	Camshaft Position Sensor
COOL/F	LC, EC	Cooling Fan Control
DEF	EL	Rear Window Defogger and Mirror Defogger
DIMDIP	EL	Headlamp — With Dim-dip Lamp System
D/LOCK	EL	Power Door Lock
DTRL	EL	Headlamp — With Daytime Light System
ECMRLY	EC	ECM Relay
ECTS	EC	Engine Coolant Temperature Sensor
EGRC/V	EC	EGRC — Solenoid Valve
EGVC/V	EC	EGR Volume Control Valve
ENGSS	AT	Engine Speed Signal
FCUT	EC	Fuel Cut Solenoid Valve
FICD	EC	IACV-FICD Solenoid Valve
FIPO	EC	ISC-FI Pot
FPCM	EC	Fuel Pump Control Module
F/PUMP	EC	Fuel Pump

Code	Section	Wiring Diagram Name
GLOW	EC	Quick-glow System
H/AIM	EL	Headlamp Aiming Control
HEATER	HA	Heater
HEATUP	EC	Heat up Switch
H/LAMP	EL	Headlamp
HLC	EL	Headlamp Washer
HO2S	EC	Heated Oxygen Sensor
HORN	EL	Horn
H/SEAT	EL	Heated Seat
IATS	EC	Intake Air Temperature Sensor
IGN	EC	Ignition System
IGN/SG	EC	Ignition Signal
ILL	EL	Illumination
INJECT	EC	Injector
INJPMP	EC	Electronic Control Fuel Injection Pump
INT/L	EL	Spot Lamp
INT/V	EC	Intake Air Control Valve Control Solenoid Valve
KS	EC	Knock Sensor
LOAD	EC	Electric Load Signal
LPSV	AT	Line Pressure Solenoid Valve
MAFS	EC	Mass Air Flow Sensor
MAIN	EC, AT	Main Power Supply and Ground Circuit
METER	EL	Speedometer, Tachometer, Temp. and Fuel Gauges
MIL/DL	EC	MIL and Data Link Connectors
MIRROR	EL	Power Door Mirror
MULTI	EL	Multi-remote Control System
NATS	EL	Nissan Anti-theft System
NONDTC	AT	Non-detectable Items
O2H1B1	EC	Heated Oxygen Sensor 1 Heater
O2H2B1	EC	Heated Oxygen Sensor 2 Heater
O2S1B1	EC	Heated Oxygen Sensor 1
O2S2B1	EC	Heated Oxygen Sensor 2
OVRCSV	AT	Overrun Clutch Solenoid Valve
P/ANT	EL	Power Antenna
PGC/V	EC	EVAP Canister Purge Control Solenoid Valve
PLA	EC	Partial Load Advance Control

WIRING DIAGRAM CODES (CELL CODES)

Code	Section	Wiring Diagram Name
PNP/SW	EC	Park/Neutral Position Switch
POWER	EL	Power Supply Routing
PRWIRE	EL	Theft Warning System Pre-wire
PST/SW	EC	Power Steering Oil Pressure Switch
R/FOG	EL	Rear Fog Lamp
ROOM/L	EL	Interior Room Lamp
SHIFT	AT	Shift Lock System
SSV/A	AT	Shift Solenoid Valve A
SSV/B	AT	Shift Solenoid Valve B
SRS	RS	Supplemental Restraint System
S/SIG	EC	Start Signal
START	EL	Starting System
STOP/L	EL	Stop Lamp
SWL/V	EC	Swirl Control Valve Control Solenoid Valve

Code	Section	Wiring Diagram Name
TAIL/L	EL	Parking, License and Tail Lamps
TCV	AT	Torque Converter Clutch Solenoid Valve
TPS	EC, AT	Throttle Position Sensor
TP/SW	EC	Throttle Position Sensor
TURN	EL	Turn Signal and Hazard Warning Lamps
VSS	EC	Vehicle Speed Sensor
VSSA/T	AT	Vehicle Speed Sensor A/T (Revolution Sensor)
VSSMTR	AT	Vehicle Speed Sensor Meter
WARN	EL	Warning Lamps
WINDOW	EL	Power Window
WIPER	EL	Front Wiper and Washer