

<SUPPLEMENT-III>

MANUAL TRANSAXLE

SECTION **MT**

MODIFICATION NOTICE:

- YD25DDTi engine model information has been added.

CONTENTS

<input type="text"/>	FS5R30A	<input type="text"/>
REMOVAL AND INSTALLATION		3002
Installation		3002

SERVICE DATA AND SPECIFICATIONS	
(SDS)	3004
General Specifications	3004

MT

Installation

YD25DDTi engine models only (with FS5R30A)

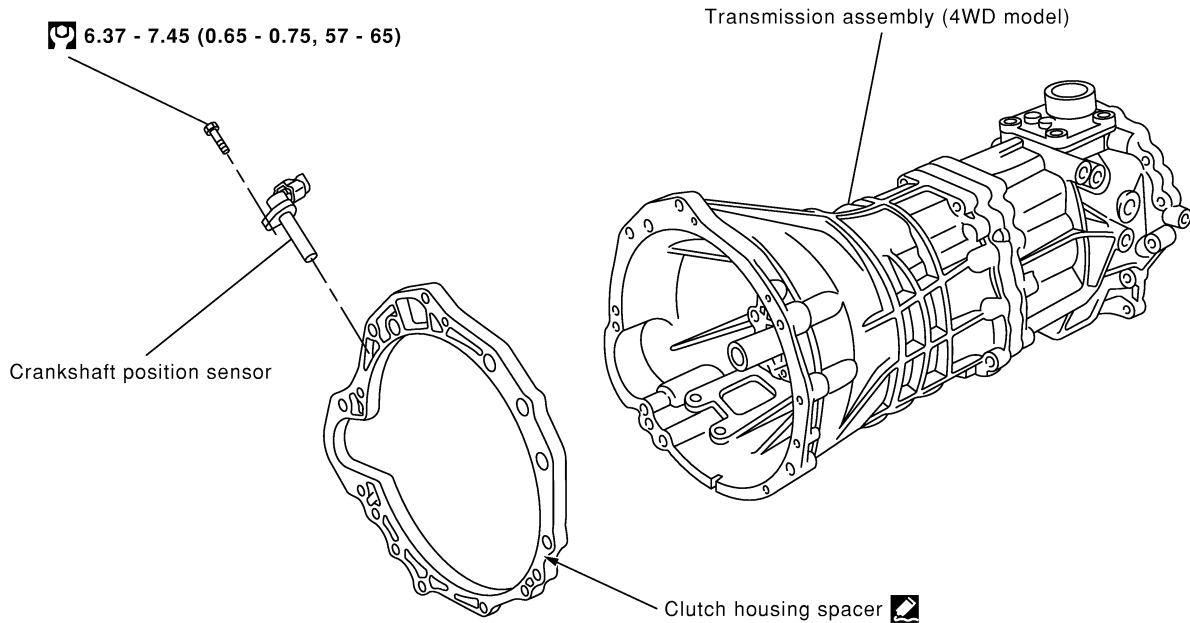

: N·m (kg-m, ft-lb)

: Apply genuine anaerobic liquid gasket, Three Bond TB1215, Loctite Part No. 51813 or equivalent.

SMT141E

● Apply sealant as below.

YD25DDTi engine with FS5R30A

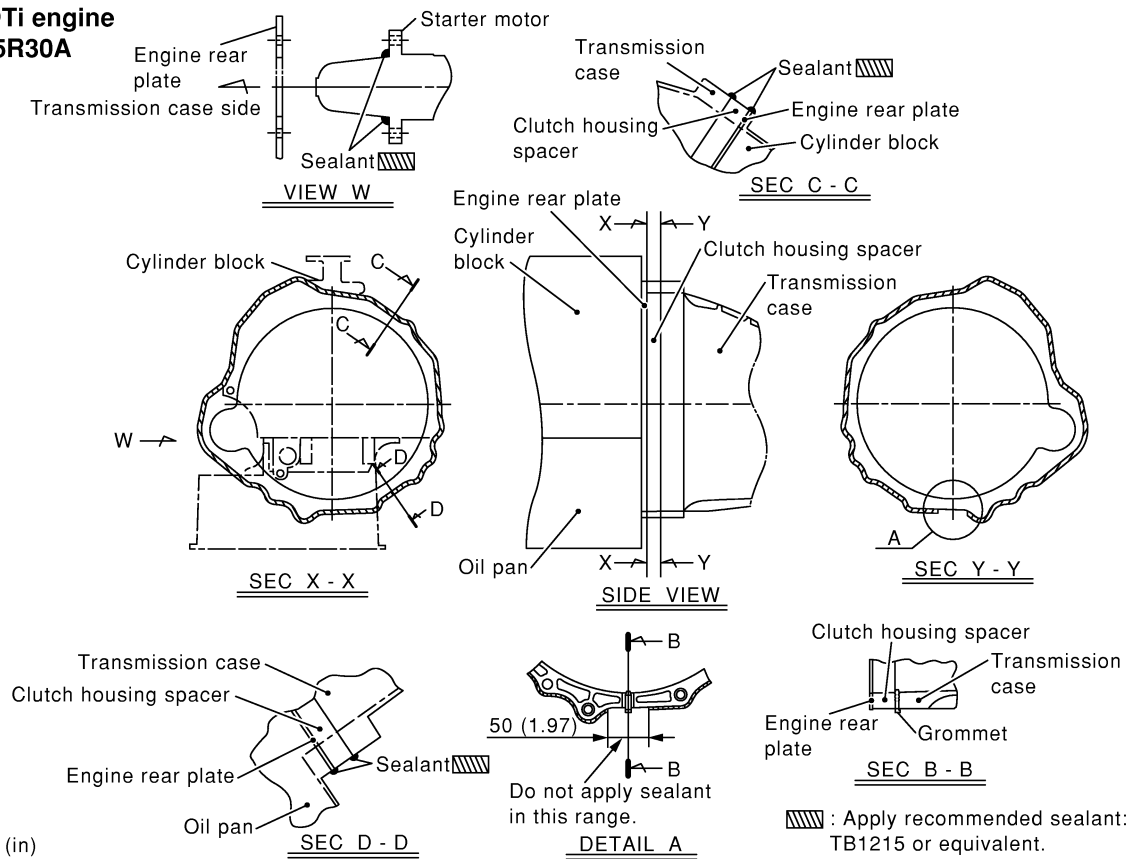

Unit: mm (in)

SMT142E

Installation (Cont'd)

- Tighten bolt securing transmission.
YD25DDTi engine model

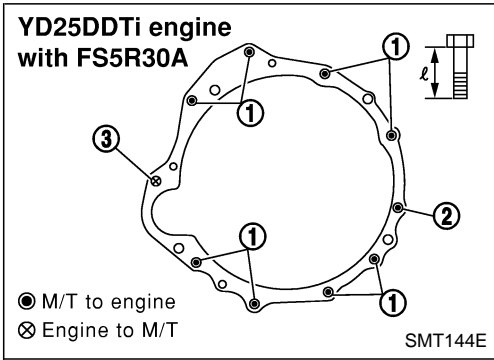

Bolt No.	Tightening torque N·m (kg·m, ft·lb)	ℓ mm (in)
①	39 - 49 (4.0 - 5.0, 29 - 36)	90 (3.54)
②	39 - 49 (4.0 - 5.0, 29 - 36)	95 (3.74)
③	39 - 49 (4.0 - 5.0, 29 - 36)	75 (2.95)

General Specifications

Applied model	2WD		
	YD25DDTi		
Transmission	FS5R30A		
Number of speed	5		
Shift pattern			
Synchromesh type	Warner		
Gear ratio			
1st	3.580		
2nd	2.077		
3rd	1.360		
4th	1.000		
OD	0.760		
Reverse	3.636		
Number of teeth			
Mainshaft			
Drive	22		
1st	32		
2nd	30		
3rd	29		
OD	23		
Reverse	30		
Countershaft			
Drive	32		
1st	13		
2nd	21		
3rd	31		
OD	44		
Reverse	12		
Reverse idler gear	22		
Oil capacity	ℓ (Imp pt)	2.8 (4-7/8)	
Remarks	Sub-gear	Counter drive gear	Installed
		Reverse idler gear	Not installed
	Double baulk ring type synchronizer		Not installed
	Reverse synchronizer		Installed