

# RESTRAINT SYSTEM

## SECTION **RS**

### MODIFICATION NOTICE:

- Diagnosis sensor unit fixing bolt has been changed.
- Front passenger fixing bolt has been changed.
- Driver air bag module has been changed.
- Trouble diagnosis has been changed.
- Deployment procedure of driver air bag module has been changed.

## CONTENTS

<b>PRECAUTION</b> .....	3002	Removal - Front Passenger Air Bag Module ..	3009
Supplemental Restraint System (SRS) “AIR BAG” and “SEAT BELT PRE-TENSIONER” ..	3002	Installation - Front Passenger Air Bag Module .....	3010
<b>SUPPLEMENTAL RESTRAINT SYSTEM (SRS)</b> .....	3003	Disposal of Air Bag Module and Seat Belt Pre-tensioner.....	3011
Precautions for SRS “AIR BAG” and “SEAT BELT PRE-TENSIONER” Service.....	3003	<b>TROUBLE DIAGNOSES - Supplemental Restraint System (SRS)</b> .....	3014
Special Service Tools .....	3003	Trouble Diagnoses Introduction.....	3014
Commercial Service Tool.....	3004	How to Perform Trouble Diagnoses for Quick and Accurate Repair .....	3016
Removal and Installation - Diagnosis Sensor Unit.....	3005	Wiring Diagram - SRS -/LHD.....	3018
Removal - Driver Air Bag Module and Spiral Cable.....	3006	Self-diagnosis.....	3020
Installation - Driver Air Bag Module and Spiral Cable.....	3007	Trouble Diagnoses for Air Bag Warning Lamp .....	3036
		<b>COLLISION DIAGNOSIS</b> .....	3037

## PRECAUTION

---

### **Supplemental Restraint System (SRS) “AIR BAG” and “SEAT BELT PRE-TENSIONER”**

The Supplemental Restraint System such as “AIR BAG” and “SEAT BELT PRE-TENSIONER” used along with a seat belt, helps to reduce the risk or severity of injury to the driver and front passenger in a frontal collision. The SRS composition which is available to NISSAN MODEL D22 is as follows (The composition varies according to the destination and optional equipment.):

Driver air bag module (located in the center of the steering wheel), front passenger air bag module (located on the instrument panel on passenger side), seat belt pre-tensioner, a diagnosis sensor unit, warning lamp, wiring harness and spiral cable.

**WARNING:**

- **To avoid rendering the SRS inoperative, which could increase the risk of personal injury or death in the event of a collision which would result in air bag inflation, all maintenance must be performed by an authorized NISSAN dealer.**
- **Improper maintenance, including incorrect removal and installation of the SRS, can lead to personal injury caused by unintentional activation of the system.**
- **Do not use electrical test equipment on any circuit related to the SRS unless instructed to in this Service Manual. SRS wiring harnesses can be identified by yellow harness connector.**

## SUPPLEMENTAL RESTRAINT SYSTEM (SRS)

### Precautions for SRS “AIR BAG” and “SEAT BELT PRE-TENSIONER” Service

- Do not use electrical test equipment to check SRS circuits unless instructed to in this Service Manual.
- Before servicing the SRS, turn ignition switch “OFF”, disconnect battery ground cable and wait at least 3 minutes.

For approximately 3 minutes after the cables are removed, it is still possible for the air bag and seat belt pre-tensioner to deploy. Therefore, do not work on any SRS connectors or wires until at least 3 minutes have passed.

- Diagnosis sensor unit must always be installed with their arrow marks “↖” pointing towards the front of the vehicle for proper operation. Also check diagnosis sensor unit for cracks, deformities or rust before installation and replace as required.
- The spiral cable must be aligned with the neutral position since its rotations are limited. Do not attempt to turn steering wheel or column after removal of steering gear.
- Handle air bag module carefully. Always place driver and passenger air bag modules with the pad side facing upward.
- Conduct self-diagnosis to check entire SRS for proper function after replacing any components.
- After air bag inflates, the front instrument panel assembly should be replaced if damaged.

### Special Service Tools

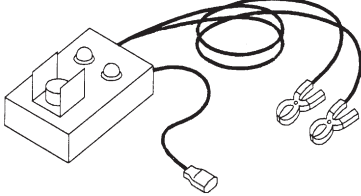
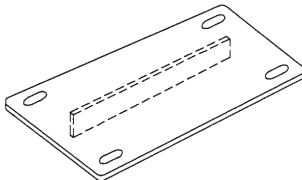
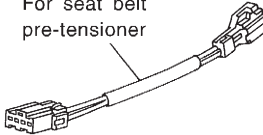
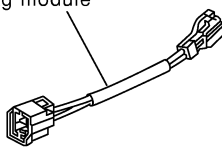
Tool number Tool name	Description
KV99106400 Deployment tool	<div style="text-align: right;">Disposing of air bag module</div>  <p style="text-align: center;">NT357</p>
KV99105300 Air bag module bracket	<div style="text-align: right;">Anchoring air bag module</div>  <p style="text-align: center;">NT354</p>
KV99108200 Deployment tool adapters for seat belt pre-tensioner	<div style="text-align: right;">For seat belt pre-tensioner</div>  <p style="text-align: center;">NT721</p>
KV99108300 Deployment tool adapters for passenger air bag	<div style="text-align: right;">For passenger air bag module</div>  <p style="text-align: center;">NT776</p>

# SUPPLEMENTAL RESTRAINT SYSTEM (SRS)

## Special Service Tools (Cont'd)

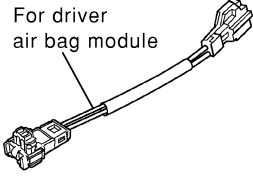
Tool number Tool name	Description
KV99109700 Deployment tool adapter for driver air bag	<p data-bbox="571 309 721 362">For driver air bag module</p>  <p data-bbox="453 506 520 524">JRS995</p>

## Commercial Service Tool

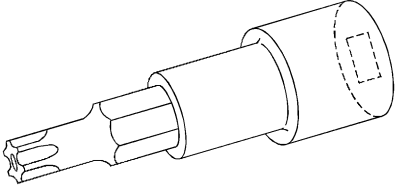
Tool name	Description	Specification
Tamper resistant torx socket	 <p data-bbox="427 976 488 994">NT757</p>	Size: T30

# SUPPLEMENTAL RESTRAINT SYSTEM (SRS)

## Removal and Installation — Diagnosis Sensor Unit

### CAUTION:

- Before servicing SRS, turn the ignition switch off, disconnect battery ground cable and wait at least 3 minutes.
- Do not use old bolts and nuts after removal; replace with new ones.
- Check diagnosis sensor unit for proper installation.
- Check diagnosis sensor unit to ensure it is free of deformities, dents, cracks or rust. If it shows any visible signs of damage, replace it with a new one.
- Check diagnosis sensor unit brackets to ensure they are free of deformities and rust.
- After replacement of diagnosis sensor unit, check SRS function and perform self-diagnosis for SRS. Refer to “Self-diagnosis” for details. (RS-3020)
- Do not attempt to disassemble diagnosis sensor unit.
- Replace diagnosis sensor unit if it has been dropped or sustained an impact.

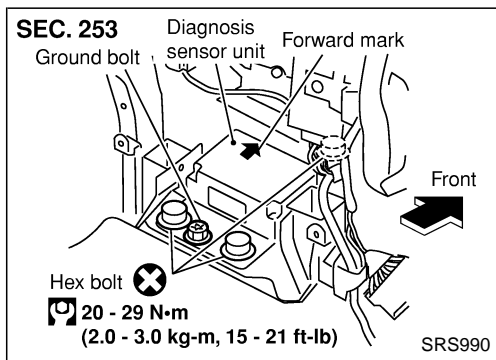

### REMOVAL OF DIAGNOSIS SENSOR UNIT

1. Disconnect driver and passenger air bag module connectors. Also, disconnect seat belt pre-tensioner connector (Models for the Middle East).
2. Remove instrument panel. Refer to Service Manual (Pub. No. SM9E-D22BE0E), “INSTRUMENT PANEL” in BT section.
3. Remove air duct.
4. Disconnect diagnosis sensor unit connector.
5. Remove ground bolt and also remove special bolts using the TAMPER RESISTANT TORX (Size T50), from diagnosis sensor unit.

Then remove the diagnosis sensor unit.

### NOTE:

- To install, reverse the removal procedure sequence.
- After replacement, perform self-diagnosis for SRS. Refer to “Self-diagnosis” for details (RS-3020).

### CAUTION:

- Do not use old hex bolts and ground bolt; replace with new bolts and ground bolt.

# SUPPLEMENTAL RESTRAINT SYSTEM (SRS)

## Removal — Driver Air Bag Module and Spiral Cable

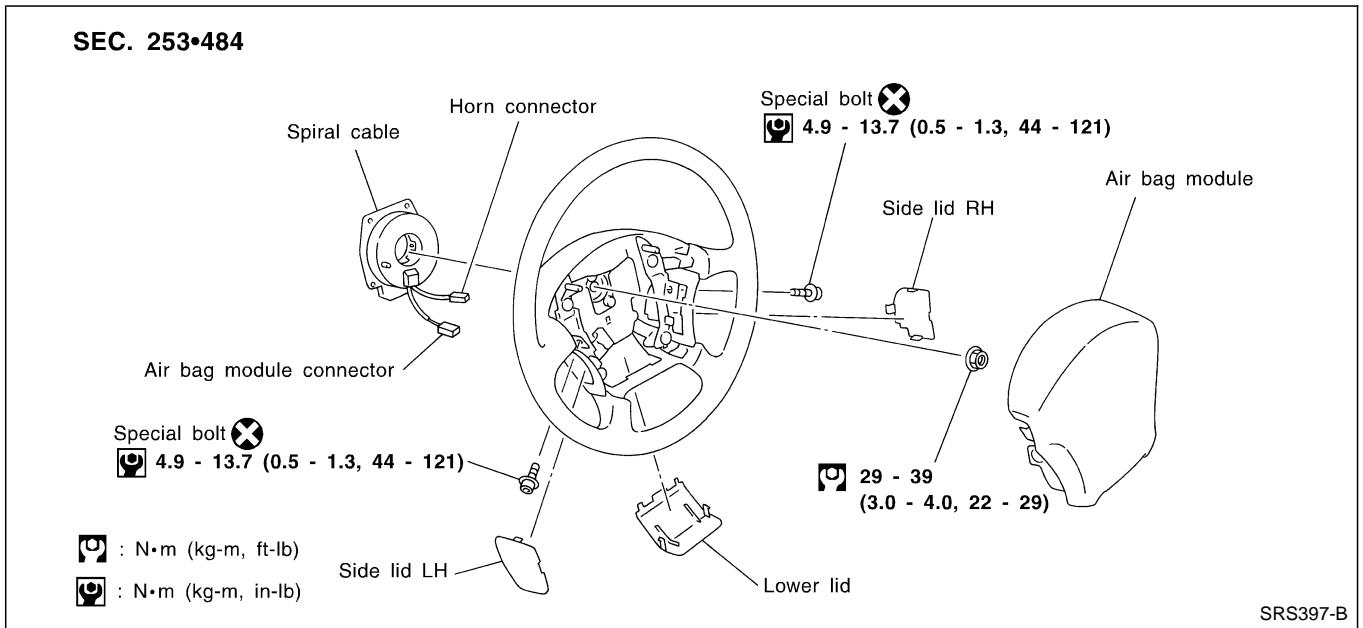

### CAUTION:

- Before servicing SRS, turn the ignition switch OFF, disconnect battery ground cable and wait at least 3 minutes.
- Always work from the side of air bag module.

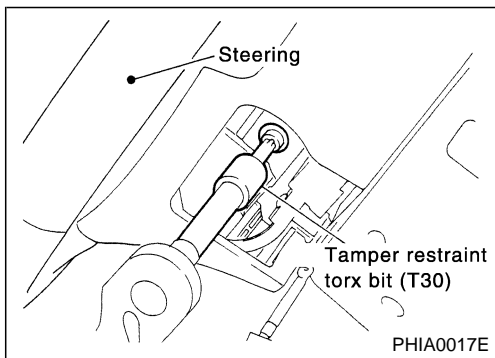

1. Remove side lid. Using the TAMPER RESISTANT TORX SOCKET (T30), remove left and right special bolts. Air bag module can then be removed.
2. Remove the lower lid.

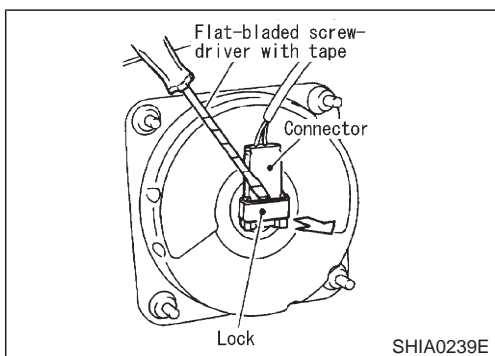

3. Disconnect the air bag harness connector. Then remove driver air bag module.

### CAUTION:

When removal of driver air bag module connector, insert the lock using flat-blade driver with tape. Then push up the lock.

## SUPPLEMENTAL RESTRAINT SYSTEM (SRS)

### Removal — Driver Air Bag Module and Spiral Cable (Cont'd)

#### CAUTION:

- Always place air bag module with pad side facing upward.
- Do not attempt to disassemble air bag module.
- Do not use old bolts after removal; replace with new ones.
- Do not insert any foreign objects (screwdriver, etc.) into air bag module connector.

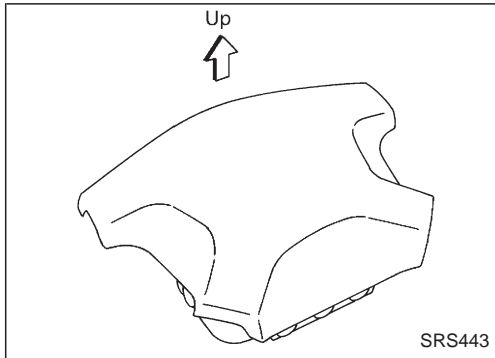

- Replace air bag module if it has been dropped or sustained an impact.
- Do not expose the air bag module to temperatures exceeding 90°C (194°F).
- Do not allow oil, grease or water to come in contact with the air bag module.

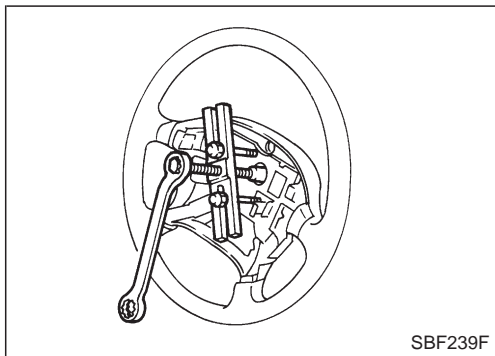

3. Set steering wheel in the neutral position.
4. Disconnect horn connector and remove nuts.
5. Using steering wheel puller, remove steering wheel. Be careful not to over-tighten puller bolt on steering wheel.

#### CAUTION:

- Do not tap or bump the steering wheel.
6. Remove steering column cover.

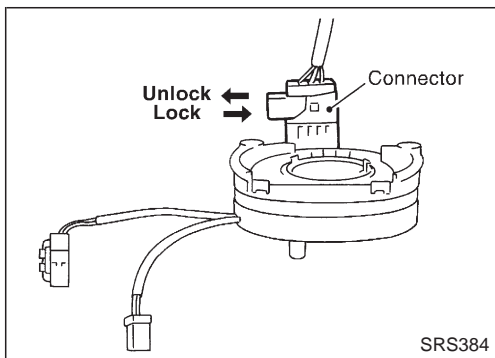

7. Remove the four screws. Then unlock the spiral cable connector and disconnect connector. The spiral cable can then be removed.

#### CAUTION:

- Do not attempt to disassemble spiral cable.
- Do not apply lubricant to the spiral cable.

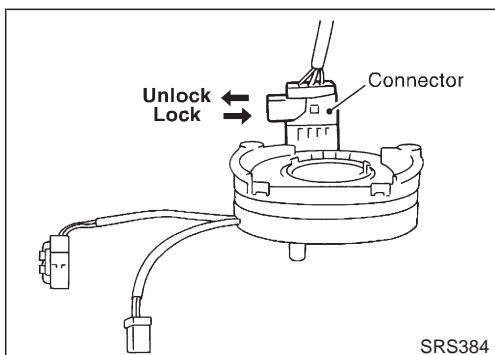

### Installation — Driver Air Bag Module and Spiral Cable

1. Set the front wheels in the straight-ahead position.
2. Connect spiral cable connector. Then, lock the connector and tighten with screws. Install steering column cover.

## SUPPLEMENTAL RESTRAINT SYSTEM (SRS)

### Installation — Driver Air Bag Module and Spiral Cable (Cont'd)

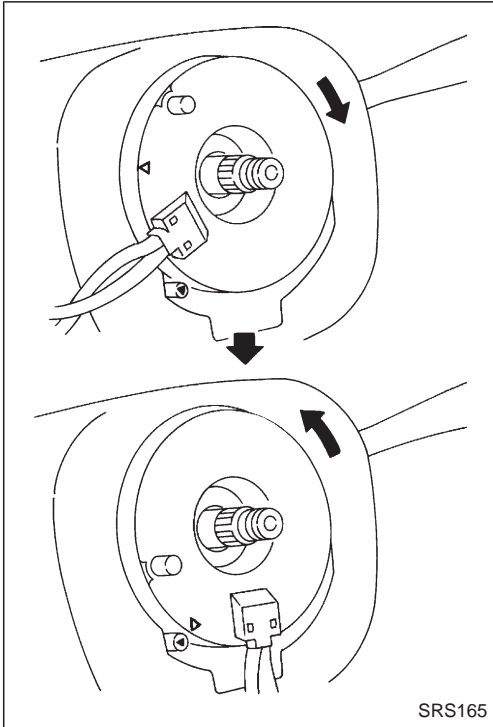

3. Make sure that the spiral cable is in the neutral position. The neutral position is detected by turning left about 2.5 revolutions from the right end position. Align the two marks (▲).

#### CAUTION:

- The spiral cable may snap due to steering operation if the cable is installed in an improper position. Also, with the steering linkage disconnected, the cable may snap by turning the steering wheel beyond the limited number of turns. The spiral cable can be turned up to about 2.5 turns from the neutral position to both the right and left.
4. Connect spiral cable connector and tighten with screws. Install steering column cover.

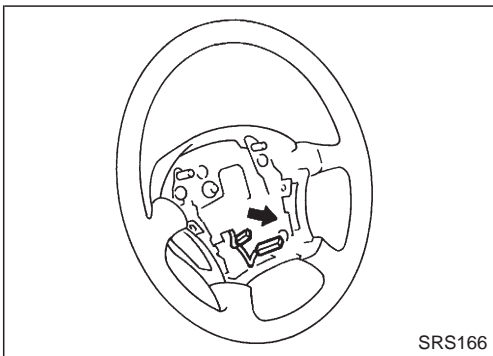

5. Install steering, wheel setting spiral cable pin guide, and pull spiral cable through.
6. Connect horn connector and engage spiral cable with pawls in steering wheel. Move air bag module connector away from steering wheel lower lid opening.
7. Tighten nut.  
⚙️: 29 - 39 N·m (3.0 - 4.0 kg·m, 22 - 29 ft·lb)

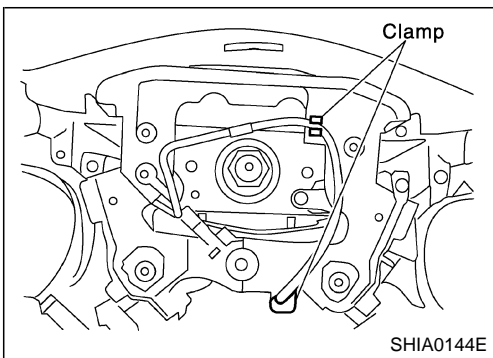

8. Fix driver air bag module harness and harness connector to clamp.
9. Connect air bag module connector and horn connector.

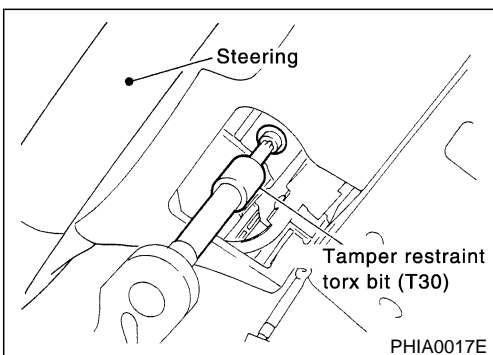

10. Position air bag module and tighten with new special bolts.
- **Always service the air bag module from the side.**
11. Install all lids.
12. Perform self-diagnosis to ensure entire SRS operates properly. (Use CONSULT-II or warning lamp check.) Refer to RS-3020. Before performing self-diagnosis, connect both battery cables.
13. Turn steering wheel to the left end and then to the right end fully to make sure that spiral cable is set in the neutral position.



## SUPPLEMENTAL RESTRAINT SYSTEM (SRS)

### Installation — Driver Air Bag Module and Spiral Cable (Cont'd)

If air bag warning lamp blinks or stays ON (at the Usermode), it shows the spiral cable may be snapped due to its improper position. Perform self-diagnosis again (use CONSULT-II or warning lamp). If a malfunction is detected, replace the spiral cable with a new one.

14. Perform self-diagnosis again to check that no malfunction is detected.

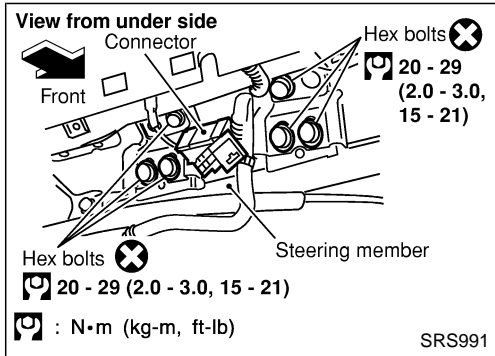

### Removal — Front Passenger Air Bag Module

#### CAUTION:

- Before servicing SRS, turn the ignition switch off, disconnect battery ground cable and wait for at least 3 minutes.
  - Always work from the side of or under air bag module.
1. Remove glove box assembly. Refer to "INSTRUMENT PANEL" in BT section of Service Manual (Pub. No. SM9E-D22BG0) for details.
  2. Disconnect passenger air bag module connector.
  3. Remove bolts and special hex using the TAMPER RESISTANT TORX (Size T30) from front passenger air bag module.
  4. Remove instrument panel assembly. Refer to Service Manual (Pub. No. SM9E-D22BE0E) "INSTRUMENT PANEL" in BT section for details.
  5. Remove air duct from instrument panel.
  6. Remove the bolts from left and right sides of front passenger air bag module. Then remove the air bag module from the instrument panel assembly.
- The air bag module is heavy and should be supported using both hands during removal.

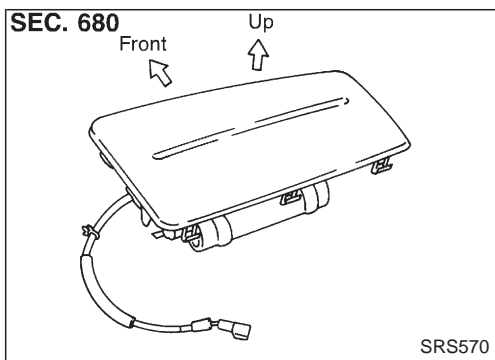

#### CAUTION:

- Always place air bag module with pad side facing upward.
  - Do not attempt to disassemble air bag module.
  - Do not use old bolts after removal; replace with new bolts.
  - Do not insert any foreign objects (screwdriver, etc.) into air bag module connector.
- 
- Replace air bag module if it has been dropped or sustained an impact.
  - Do not expose the air bag module to temperatures exceeding 90°C (194°F).
  - Do not allow oil, grease or water to come in contact with the air bag module.

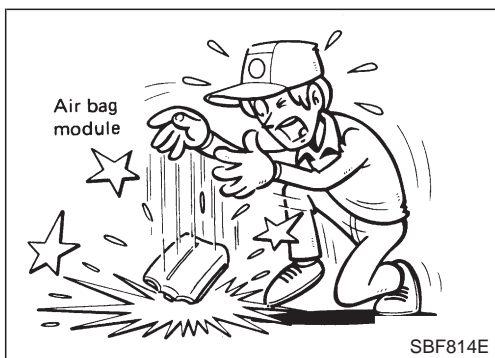

## SUPPLEMENTAL RESTRAINT SYSTEM (SRS)

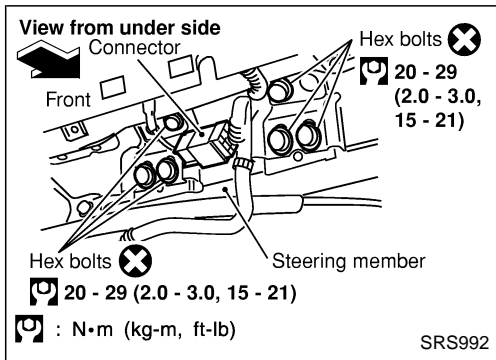

### Installation — Front Passenger Air Bag Module

- **Always work from the side of or under air bag module.**
1. Install front passenger air bag module to instrument panel assembly.
  2. Install air duct to instrument panel.
  3. Install instrument panel.
- **Ensure harness is not caught between rear of air bag module and steering member.**
4. Install front passenger air bag module to steering member.
  5. Connect air bag module connector.
  6. Install glove box assembly.

# SUPPLEMENTAL RESTRAINT SYSTEM (SRS)

## Disposal of Air Bag Module and Seat Belt Pre-tensioner

- Before disposing of air bag module and seat belt pre-tensioner, or vehicles equipped with such systems, deploy the systems. If such systems have already been deployed due to an accident, dispose of them as indicated in "DISPOSING OF AIR BAG MODULE AND SEAT BELT PRE-TENSIONER" (RS-3013).
- When deploying the air bag module and seat belt pre-tensioner, always use the Special Service Tool; Deployment tool KV99106400.
- When deploying the air bag module and seat belt pre-tensioner, stand at least 5 m (16 ft) away from the deployment component.
- When deploying air bag module and seat belt pre-tensioner, a fairly loud noise is made, followed by smoke being released. The smoke is not poisonous, however, be careful not to inhale smoke since it irritates the throat and can cause choking.
- Always activate one air bag module at a time.
- Due to heat, leave air bag module unattended for more than 30 minutes after deployment. Also leave seat belt pre-tensioner unattended for more than 10 minutes after deployment.
- Be sure to wear gloves when handling a deployed air bag module and seat belt pre-tensioner.
- Never apply water to the deployed air bag module and seat belt pre-tensioner.
- Wash your hands clean after finishing work.
- Place the vehicle outdoors with an open space of at least 6 m (20 ft) on all sides when deploying air bag module and seat belt pre-tensioner while mounted in vehicle.
- Use a voltmeter to make sure the vehicle battery is fully charged.
- Do not dispose of the air bag module and seat belt pre-tensioner un-deployed.

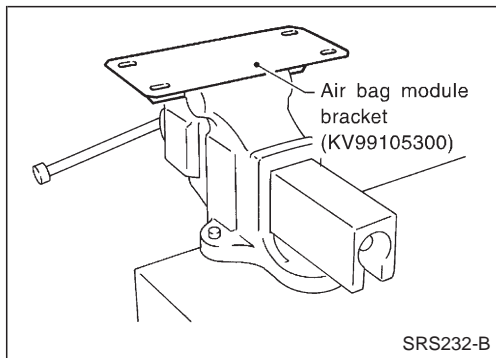

### DEPLOYMENT PROCEDURES FOR AIR BAG MODULE (OUTSIDE OF VEHICLE)

Unless the vehicle is being scrapped, deploying the air bag in the vehicle is not recommended. This may cause damage to the vehicle interior.

Anchor air bag module bracket (SST: KV99105300) in a vise secured to a firm foundation during deployment.

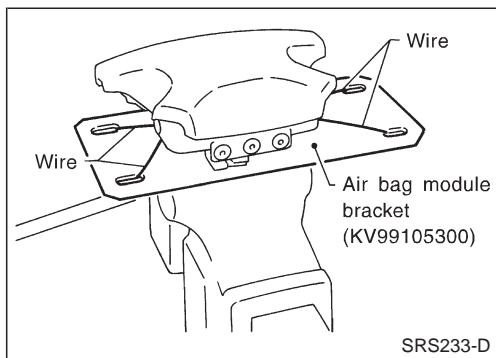

### Deployment of driver air bag module (Outside of vehicle)

1. Using wire, secure air bag module to air bag module bracket (SST: KV99105300) at two places.

#### CAUTION:

**Use wire of at least 1 mm (0.04 in) diameter.**

2. Firmly secure air bag module bracket (SST: KV99105300) with air bag module attached in a vise.

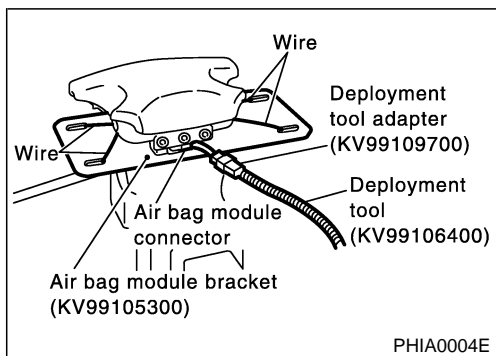

3. Connect deployment tool adapter (SST: KV99109700) to deployment tool (SST: KV99106400) to air bag module connector.

## SUPPLEMENTAL RESTRAINT SYSTEM (SRS)

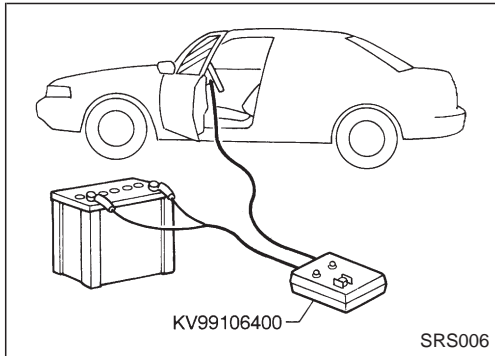
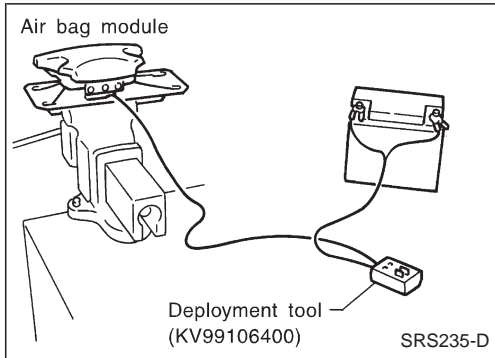

### Disposal of Air Bag Module and Seat Belt Pre-tensioner (Cont'd)

4. Connect red clip of deployment tool to battery positive terminal and black clip to negative terminal.
5. The lamp on the right side of the tool, marked "deployment tool power", should glow green, not red.
6. Press the button on the deployment tool. The left side lamp on the tool, marked "air bag connector voltage", will illuminate and the air bag module will deploy.

#### CAUTION:

**When deploying the driver air bag module, stand at least 5 m (16 ft) away from the air bag module.**

### DEPLOYMENT OF AIR BAG MODULE AND SEAT BELT PRE-TENSIONER WHILE MOUNTED IN VEHICLE

When disposing of a vehicle, deploy air bag modules and seat belt pre-tensioners while they are mounted in vehicle.

#### CAUTION:

**When deploying air bag module or seat belt pre-tensioner, ensure vehicle is empty.**

1. Disconnect battery ground cable and wait 3 minutes.
2. Disconnect air bag modules and seat belt pre-tensioners connector.
3. Connect deployment tool (SST: KV99106400) to air bag module or seat belt pre-tensioner.  
For driver air bag module, attach deployment tool adapter (SST: KV99109700) to the tool connector.  
For front passenger air bag module, attach deployment tool adapter (SST: KV99108300) to the tool connector. For seat belt pre-tensioner, attach deployment tool adapter (SST: KV99108200) to the tool connector.
4. Connect red clip of deployment tool to battery positive terminal and black clip to negative terminal.
5. The lamp on the right side of the tool, marked "deployment tool power", should glow green, not red.
6. Press the button on the deployment tool. The left side lamp on the tool, marked "air bag connector voltage", will illuminate and the air bag module or seat belt pre-tensioner will deploy.

#### CAUTION:

**Activate only one air bag module or seat belt pre-tensioner at a time.**

## SUPPLEMENTAL RESTRAINT SYSTEM (SRS)

---

### Disposal of Air Bag Module and Seat Belt Pre-tensioner (Cont'd)

#### DISPOSING OF AIR BAG MODULE AND SEAT BELT PRE-TENSIONER

Deployed air bag modules and seat belt pre-tensioners are very hot. Before disposing of air bag module, and seat belt pre-tensioner, wait at least 30 minutes, and 10 minutes, respectively. Seal them in a plastic bag before disposal.

#### CAUTION:

- **Never apply water to a deployed air bag module and seat belt pre-tensioner.**
- **Be sure to wear gloves when handling a deployed air bag module and seat belt pre-tensioner.**
- **No poisonous gas is produced upon air bag module deployment. However, be careful not to inhale gas since it irritates throat and can cause choking.**
- **Do not attempt to disassemble air bag module and seat belt pre-tensioner.**
- **Air bag module and seat belt pre-tensioner can not be re-used.**
- **Wash your hands clean after finishing work.**



# TROUBLE DIAGNOSES — Supplemental Restraint System (SRS)

## Trouble Diagnoses Introduction

### CAUTION:

- Do not use electrical test equipment on any circuit related to the SRS unless instructed to in this Service Manual. SRS wiring harnesses can be identified with yellow harness connector.
- Do not attempt to repair, splice or modify the SRS wiring harness. If the harness is damaged, replace it with a new one.
- Keep ground portion clean.

### DIAGNOSIS FUNCTION

The SRS self-diagnosis results can be read by using “AIR BAG” warning lamp, and/or CONSULT-II. The reading of these results is accomplished using one of two modes — “User mode” and “Diagnosis mode”. The User mode is exclusively prepared for the customer (driver). This mode warns the driver of a system malfunction through the operation of the “AIR BAG” warning lamp.

The Diagnosis mode allows the technician to locate and inspect the malfunctioning part.

The mode applications for the “AIR BAG” warning lamp and CONSULT-II are as follows:

	User mode	Diagnosis mode	Display type
“AIR BAG” warning lamp	X	X	ON-OFF operation
CONSULT-II	—	X	Monitoring

### NOTE:

Seat belt pre-tensioner malfunction is indicated by “AIR BAG” warning lamp.

### DIAGNOSIS MODE FOR CONSULT-II

#### ● “SELF-DIAG [CURRENT]”

A current Self-diagnosis result (also indicated by the warning lamp flashes in the Diagnosis mode) is displayed on the CONSULT-II screen in real time. This refers to a malfunctioning part requiring repairs.

#### ● “SELF-DIAG [PAST]”

Diagnosis results previously stored in the memory are displayed on the CONSULT-II screen. The stored results are not erased until memory erasing is executed.

#### ● “TROUBLE DIAG RECORD”

With TROUBLE DIAG RECORD, diagnosis results previously erased by a reset operation can be displayed on the CONSULT-II screen.

#### ● “ECU DISCRIMINATED NO.”

The diagnosis sensor unit for each vehicle model is assigned with its own, individual classification number. This number will be displayed on the CONSULT-II screen, as shown at left. When replacing the diagnosis sensor unit, refer to the part number for the compatibility. After installation, replacement with a correct unit can be checked by confirming this classification number on the CONSULT-II screen.

For NISSAN MODEL D22, the diagnosis sensor unit classification number assigned are as follows:

MODEL	ECU DISCRIMINATED NO.
Single air bag	5A37
Single air bag and seat belt pre-tensioner	5A39
Dual air bags	5A38
Dual air bags and seat belt pre-tensioner	5A3A

# TROUBLE DIAGNOSES — Supplemental Restraint System (SRS)

## Trouble Diagnoses Introduction (Cont'd)

### HOW TO CHANGE SELF-DIAGNOSIS MODE

#### ④ With CONSULT-II

##### From User mode to Diagnosis mode

After selecting “AIR BAG” on the “SELECT SYSTEM” screen, User mode automatically changes to Diagnosis mode.



##### From Diagnosis mode to User mode

To return to User mode from Diagnosis mode, touch “BACK” key of CONSULT-II until “SELECT SYSTEM” appears, Diagnosis mode automatically changes to User mode.



#### ⊗ Without CONSULT-II

##### From User mode to Diagnosis mode

Diagnosis mode activates only when a malfunction is detected, by turning ignition switch as follows:

- 1) Turn ignition switch “ON”.
- 2) After “AIR BAG” warning lamp lights for 7 seconds, turn ignition switch “OFF” within 1 second.
- 3) Wait more than 3 seconds.
- 4) Repeat steps 1 to 3 twice (Perform 3 times in total).
- 5) Turn ignition switch “ON”.

SRS will not enter Diagnosis mode, if no malfunction is detected.

##### From Diagnosis mode to User mode

After a malfunction is repaired, switch the ignition “OFF” for at least one second, then back “ON”. Diagnosis mode is returned to User mode.

If switching Diagnosis mode to User mode is required while malfunction is being detected, by turning ignition switch as follows:

- 1) Turn ignition switch “ON”.
- 2) After “AIR BAG” warning lamp lights for 7 seconds, turn ignition switch “OFF” within 1 second.
- 3) Wait more than 3 seconds.
- 4) Repeat steps 1 to 3 twice (Perform 3 times in total).
- 5) Turn ignition switch “ON”.

# TROUBLE DIAGNOSES — Supplemental Restraint System (SRS)

## Trouble Diagnoses Introduction (Cont'd)

### HOW TO ERASE SELF-DIAGNOSIS RESULTS

#### ④ With CONSULT-II

- “SELF-DIAG [CURRENT]”

A current Self-diagnosis result is displayed on the CONSULT-II screen in real time. After the malfunction is repaired completely, no malfunction is detected on “SELF-DIAG [CURRENT]”.

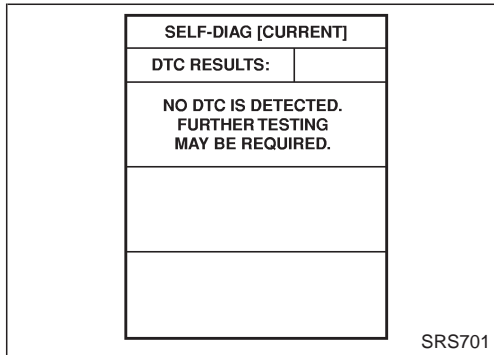

- “SELF-DIAG [PAST]”

Return to the “SELF-DIAG [CURRENT]” CONSULT-II screen by pushing “BACK” key of CONSULT-II and select “SELF-DIAG [CURRENT]” in “SELECT DIAG MODE”. Touch “ERASE” in “SELF-DIAG [CURRENT]” mode.

**NOTE:**

**If the memory of the malfunction in “SELF-DIAG [PAST]” is not erased, the User mode shows the system malfunction by the operation of the warning lamp even if the malfunction is repaired completely.**

- “TROUBLE DIAG RECORD”

The memory of “TROUBLE DIAG RECORD” cannot be erased.

#### ⊗ Without CONSULT-II

After a malfunction is repaired, return Diagnosis mode to User mode by switching the ignition “OFF” for at least 1 second, then back “ON”. At that time, the self-diagnostic result is cleared.

## How to Perform Trouble Diagnoses for Quick and Accurate Repair

A good understanding of the malfunction conditions can make troubleshooting faster and more accurate. In general, each customer feels differently about a malfunction. It is important to fully understand the symptoms or conditions for a customer complaint.

### INFORMATION FROM CUSTOMER

WHAT ..... Vehicle model  
WHEN ..... Date, Frequencies  
WHERE ..... Road conditions  
HOW ..... Operating conditions, Symptoms

### PRELIMINARY CHECK

Check that the following parts are in good order.

- Battery [Refer to EL section (“BATTERY”) of Service Manual.]
- Fuse [Refer to EL section (“Fuse”, “POWER SUPPLY ROUTING”) of Service Manual.]
- System component-to-harness connections



# TROUBLE DIAGNOSES — Supplemental Restraint System (SRS)

## How to Perform Trouble Diagnoses for Quick and Accurate Repair (Cont'd)

**NOTE:**

Seat belt pre-tensioner malfunction is indicated by "AIR BAG" warning lamp.

**WORK FLOW**

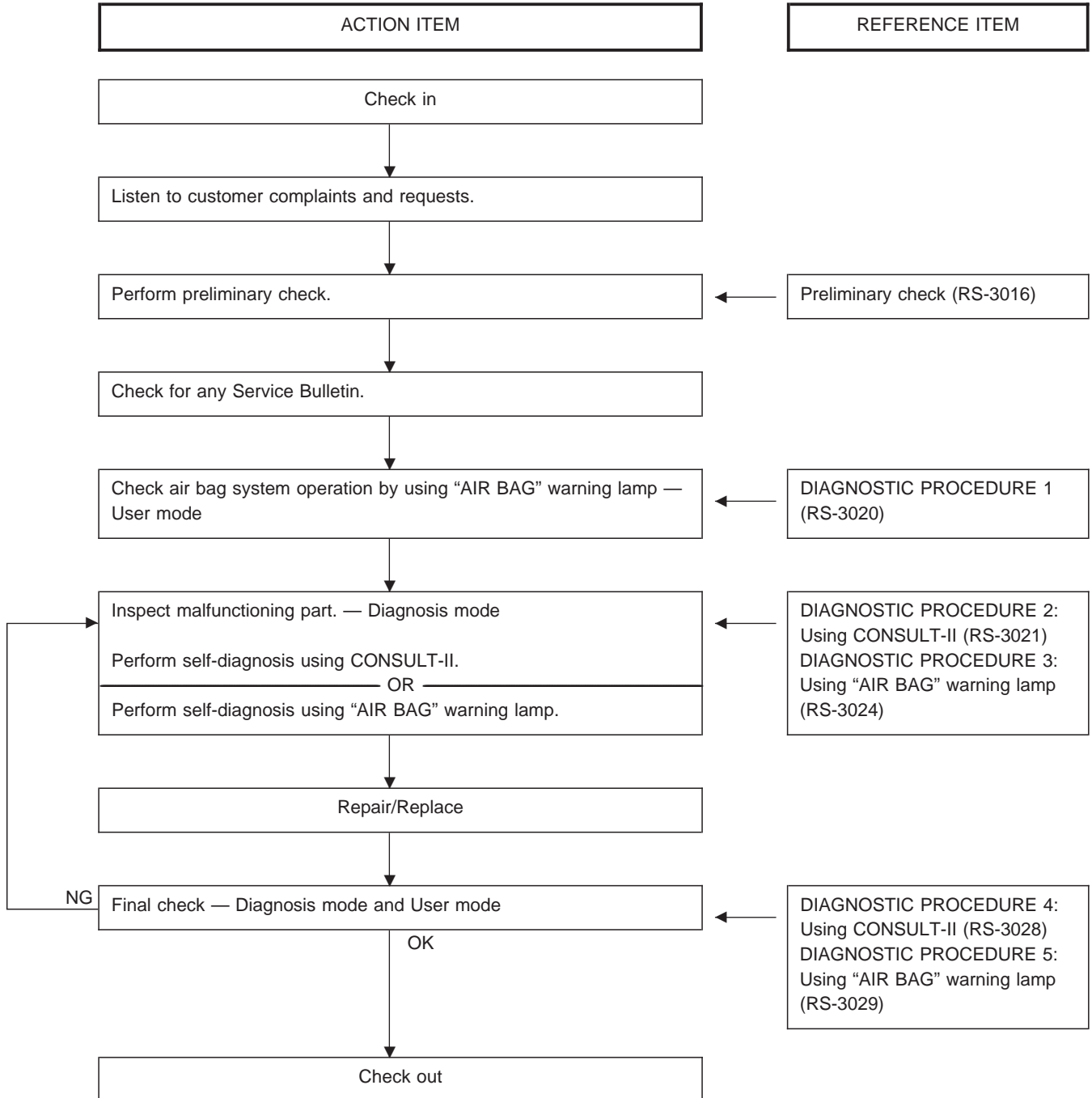

# TROUBLE DIAGNOSES — Supplemental Restraint System (SRS)

## Wiring Diagram — SRS —/LHD

RS-SRS-01

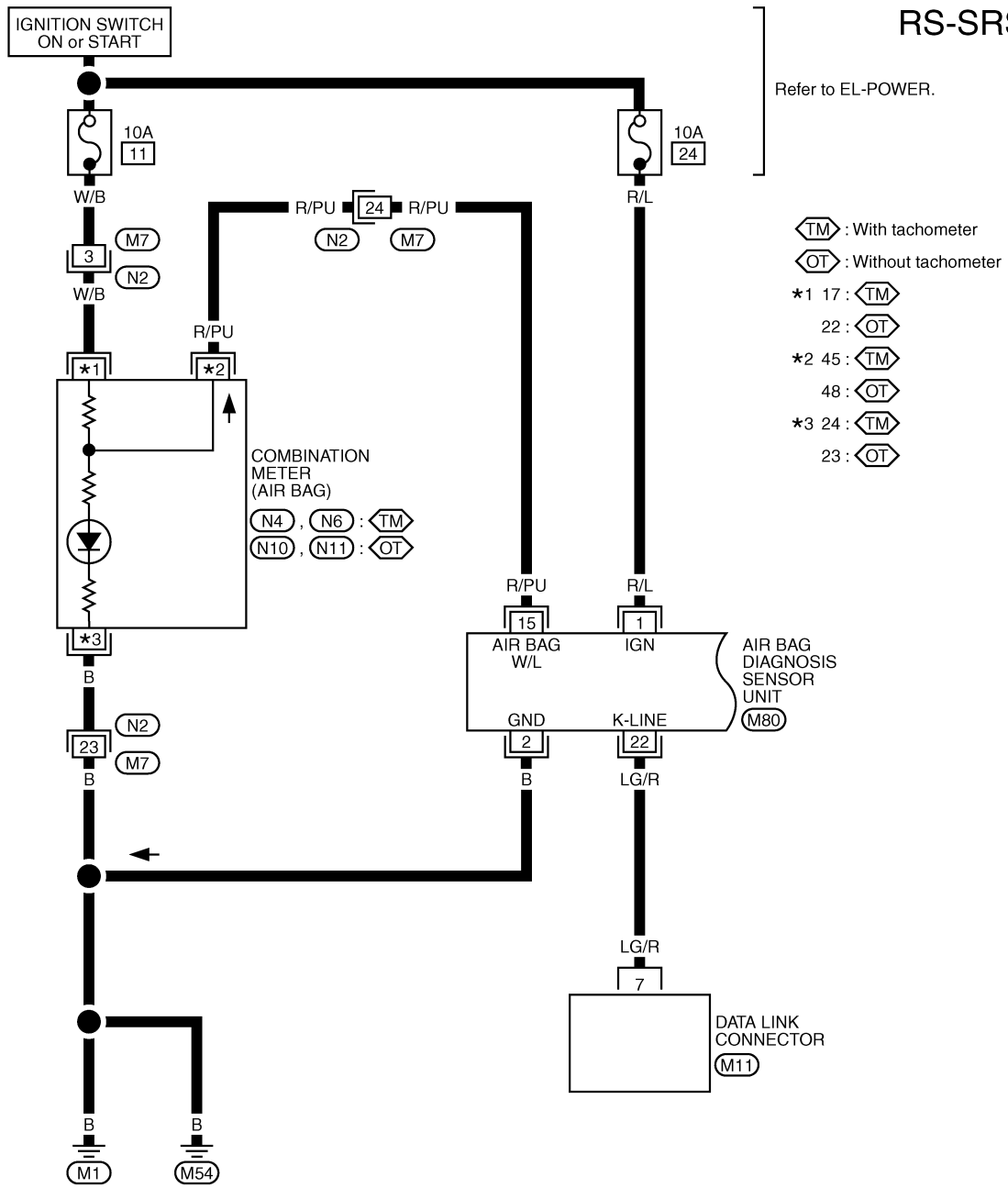

16	15	14	13	12	11	10	9
8	7	6	5	4	3	2	1

(M11)  
W

24	23	17	18
3	4	12	11
21	22	20	15
19	1	16	2

(M80)  
Y

1	2	3	4	5	6	7	8	9	10	11		
12	13	14	15	16	17	18	19	20	21	22	23	24

(N2)  
BR

1	2	3	4	5	6	7	8	9	10	11		
12	13	14	15	16	17	18	19	20	21	22	23	24

(N4)  
W

45	46	47	48	49	50	51	52	53	54	55		
56	57	58	59	60	61	62	63	64	65	66	67	68

(N6)  
BR

21	22	23	24	25	26	27	28	29		
30	31	32	33	34	35	36	37	38	39	40

(N10)  
BR

41	42	43	44	45	46	47	48	49	50	51		
52	53	54	55	56	57	58	59	60	61	62	63	64

(N11)  
W

# TROUBLE DIAGNOSES — Supplemental Restraint System (SRS)

## Wiring Diagram — SRS —/LHD (Cont'd)

RS-SRS-02

⬡(DA) : With dual air bag

⬡(PT) : With seat belt pre-tensioner

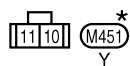
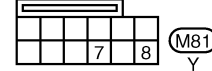
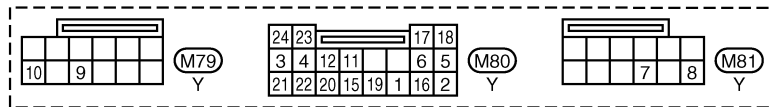
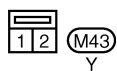
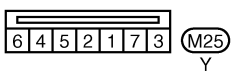
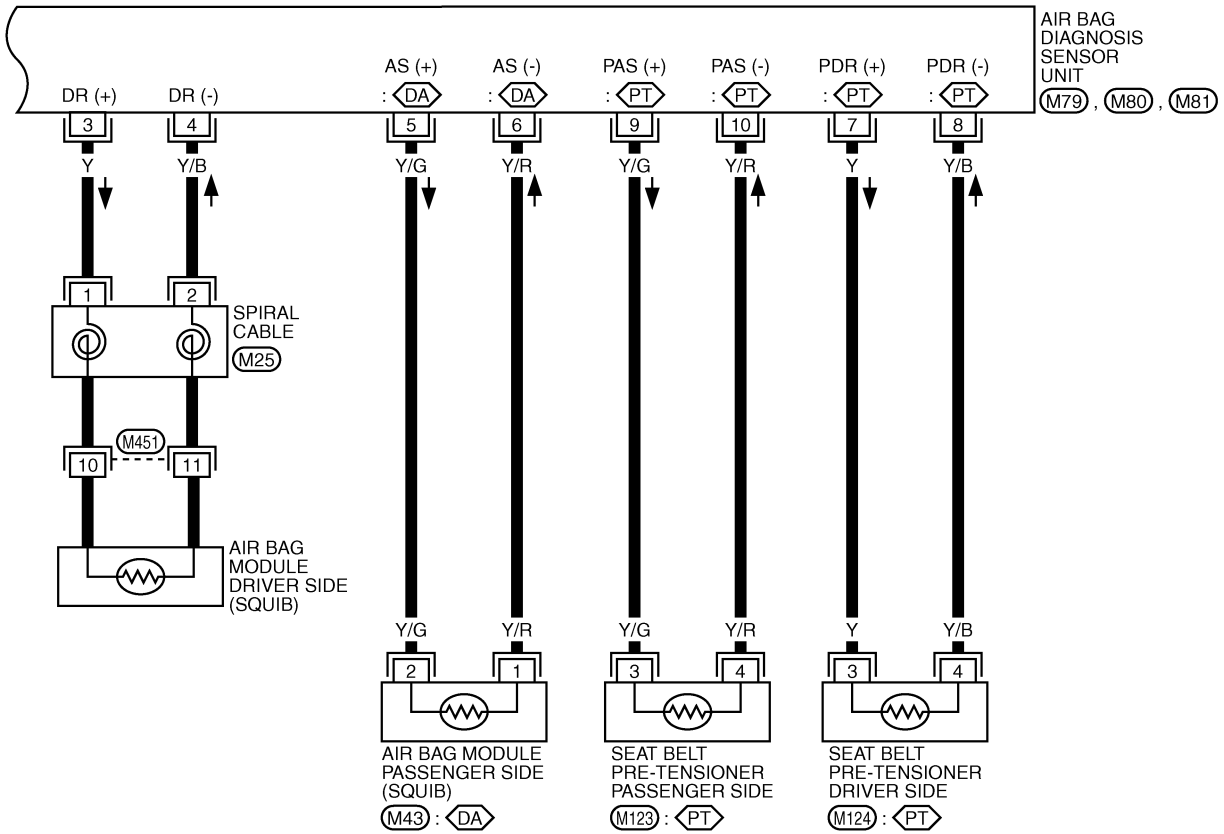

\*: This connector is not shown in "HARNES LAYOUT", EL section.

# TROUBLE DIAGNOSES — Supplemental Restraint System (SRS)

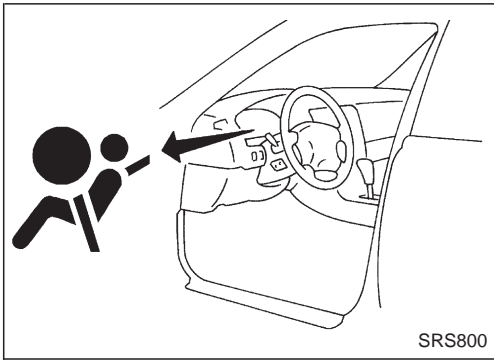

## Self-diagnosis

### DIAGNOSTIC PROCEDURE 1 (⊗ without CONSULT-II)

#### Checking SRS operation by using “AIR BAG” warning lamp — User mode

1. After turning ignition switch from “OFF” to “ON”, “AIR BAG” warning lamp operates.
2. Compare “AIR BAG” warning lamp operation to the chart below.

“AIR BAG” warning lamp operation — User mode —	SRS condition	Reference item
<p>MRS095A</p>	No malfunction is detected. No further action is necessary.	—
<p>MRS096A</p>	The system is malfunctioning and needs to be repaired as indicated.	Go to DIAGNOSTIC PROCEDURE 2 or 3 (RS-3021 or 3024).
<p>MRS097A</p>	Air bag is deployed. Seat belt pre-tensioner is deployed.	Go to COLLISION DIAGNOSIS (RS-3037).
<p>MRS098A</p>	Air bag fuse, diagnosis sensor unit or harness is malfunctioning and needs to be repaired.	Go to DIAGNOSTIC PROCEDURE 9 (RS-3036).
<p>MRS098A</p>	One of the following has occurred and needs to be repaired. <ul style="list-style-type: none"> <li>● Meter fuse is blown.</li> <li>● “AIR BAG” warning lamp circuit has open or short.</li> <li>● Diagnosis sensor unit is malfunctioning.</li> </ul>	Go to DIAGNOSTIC PROCEDURE 10 (RS-3036).

# TROUBLE DIAGNOSES — Supplemental Restraint System (SRS)

## Self-diagnosis (Cont'd)

### DIAGNOSTIC PROCEDURE 2 ( with CONSULT-II)

#### Inspecting SRS malfunctioning parts by using CONSULT-II — Diagnosis mode

1. Turn ignition switch "OFF".
2. Connect CONSULT-II to data link connector.

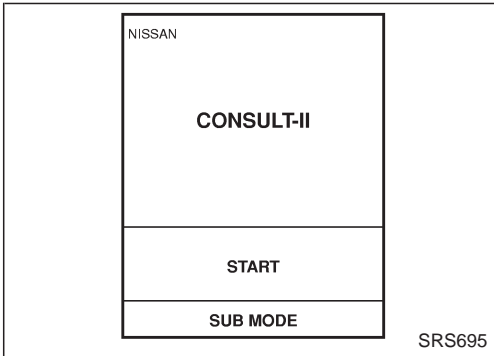
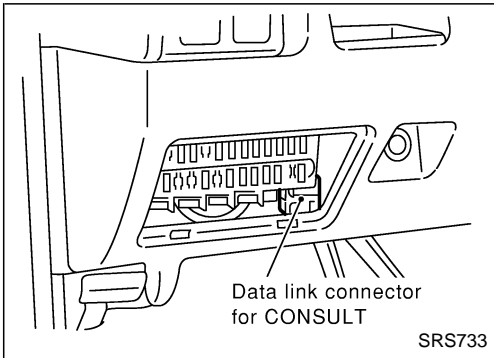

3. Turn ignition switch "ON".
4. Touch "START".

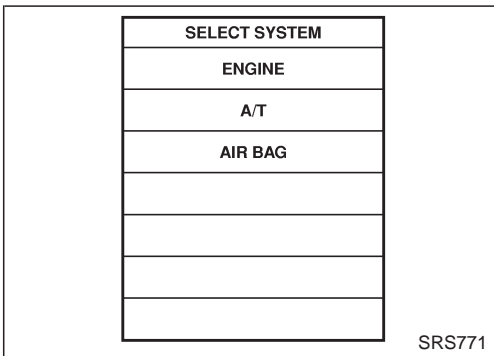

5. Touch "AIR BAG".

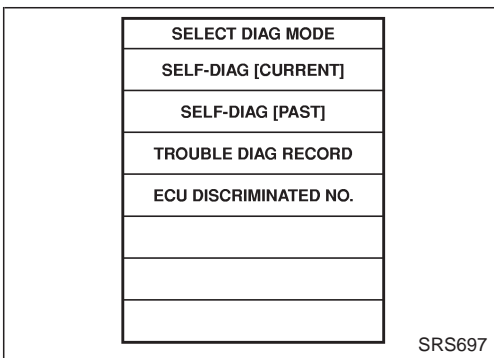

6. Touch "SELF-DIAG [CURRENT]".

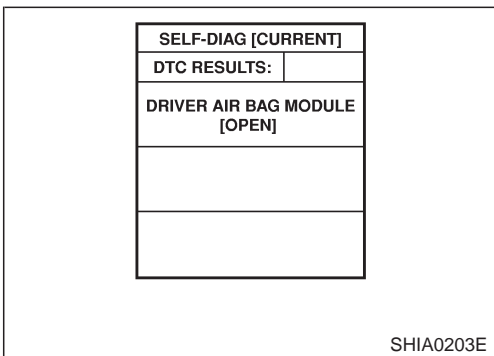

7. Diagnostic codes are displayed on "SELF-DIAG [CURRENT]".

## TROUBLE DIAGNOSES — Supplemental Restraint System (SRS)

### Self-diagnosis (Cont'd)

SELF-DIAG [CURRENT]	
DTC RESULTS:	
NO DTC IS DETECTED. FURTHER TESTING MAY BE REQUIRED.	

SRS701

If no malfunction is detected on "SELF-DIAG [CURRENT]" even though malfunction is detected by the "AIR BAG" warning lamp, check the battery voltage.

If the battery voltage is less than 9V, charge the battery. Then go to DIAGNOSTIC PROCEDURE 4 for final checking, page RS-3028.

If the battery voltage is OK, go to DIAGNOSTIC PROCEDURE 6, page RS-3032, to diagnose the following situations:

- Self-diagnostic result (previously stored in the memory) might not be erased after repair.
- The SRS system malfunctions intermittently.

8. Touch "PRINT".
9. Compare diagnostic codes to the CONSULT-II DIAGNOSTIC CODE CHART, page RS-3023.
10. Touch "BACK" key of CONSULT-II until "SELECT SYSTEM" appears in order to return to User mode from Diagnosis mode.
11. Turn ignition switch "OFF", then turn off and disconnect CONSULT-II and both battery cables.
12. Repair the system as outlined by the "Repair order" in CONSULT-II DIAGNOSTIC CODE CHART, that corresponds to the self-diagnostic result. For replacement procedure of component parts, refer to RS-3005 and "Removal and Installation" in RS section of Service Manual (Pub. No. SM9E-D22BG0) for details.
13. After repairing the system, go to DIAGNOSTIC PROCEDURE 4 for final checking, page RS-3028.

# TROUBLE DIAGNOSES — Supplemental Restraint System (SRS)

## Self-diagnosis (Cont'd)

### CONSULT-II DIAGNOSTIC CODE CHART (“SELF-DIAG [CURRENT]”)

Diagnostic item	Explanation	Repair order <b>Recheck SRS at each replacement.</b>	
NO DTC IS DETECTED	When malfunction is indicated by the “AIR BAG” warning lamp in User mode	<ul style="list-style-type: none"> <li>● Low battery voltage (Less than 9V)</li> <li>● Self-diagnostic result “SELF-DIAG [PAST]” (previously stored in the memory) might not be erased after repair.</li> <li>● Intermittent malfunction has been detected in the past.</li> </ul>	<ul style="list-style-type: none"> <li>● Go to DIAGNOSTIC PROCEDURE 4 (RS-3028) after charging battery.</li> <li>● Go to DIAGNOSTIC PROCEDURE 6 (RS-3032).</li> </ul>
	● No malfunction is detected.	● Go to DIAGNOSTIC PROCEDURE 4 (RS-3028).	
DRIVER AIRBAG MODULE [OPEN]	● Driver air bag module circuit is open. (including the spiral cable)	<ol style="list-style-type: none"> <li>1. Visually check the wiring harness connection.</li> <li>2. Replace the harness if it has visible damage.</li> <li>3. Replace the spiral cable.</li> <li>4. Replace driver air bag module. (Before disposal, it must be deployed.)</li> <li>5. Replace the diagnosis sensor unit.</li> <li>6. Replace the related harness.</li> </ol>	
DRIVER AIRBAG MODULE [VB-SHORT]	● Driver air bag module circuit is shorted to a power supply circuit. (including the spiral cable)		
DRIVER AIRBAG MODULE [GND-SHORT]	● Driver air bag module circuit is shorted to ground. (including the spiral cable)		
DRIVER AIRBAG MODULE [SHORT]	● Driver air bag module circuits are shorted to each other.		
ASSIST A/B MODULE [VB-SHORT]	● Front passenger air bag module circuit is shorted to a power supply circuit.	<ol style="list-style-type: none"> <li>1. Visually check the wiring harness connection.</li> <li>2. Replace the harness if it has visible damage.</li> <li>3. Replace front passenger air bag module. (Before disposal, it must be deployed.)</li> <li>4. Replace the diagnosis sensor unit.</li> <li>5. Replace the related harness.</li> </ol>	
ASSIST A/B MODULE [OPEN]	● Front passenger air bag module circuit is open.		
ASSIST A/B MODULE [GND-SHORT]	● Front passenger air bag module circuit is shorted to ground.		
ASSIST A/B MODULE [SHORT]	● Front passenger air bag module circuits are shorted to each other.		
PRE-TEN FRONT LH [OPEN]	● The circuit for seat belt pre-tensioner (LH) is open.	<ol style="list-style-type: none"> <li>1. Visually check the wiring harness connections.</li> <li>2. Replace the harness if it has visible damage.</li> <li>3. Replace seat belt (LH). (Before disposing, it must be deactivated.)</li> <li>4. Replace the diagnosis sensor unit.</li> <li>5. Replace the related harness.</li> </ol>	
PRE-TEN FRONT LH [VB-SHORT]	● The circuit for seat belt pre-tensioner (LH) is shorted to a power supply circuit.		
PRE-TEN FRONT LH [GND-SHORT]	● The circuit for seat belt pre-tensioner (LH) is shorted to ground.		
PRE-TEN FRONT RH [OPEN/VB-SHORT]	● The circuit for seat belt pre-tensioner (RH) is open or shorted to some power supply circuit.	<ol style="list-style-type: none"> <li>1. Visually check the wiring harness connections.</li> <li>2. Replace the harness if it has visible damage.</li> <li>3. Replace seat belt (RH). (Before disposing, it must be deactivated.)</li> <li>4. Replace the diagnosis sensor unit.</li> <li>5. Replace the related harness.</li> </ol>	
PRE-TEN FRONT RH [VB-SHORT]	● The circuit for seat belt pre-tensioner (RH) is shorted to a power supply circuit.		
PRE-TEN FRONT RH [GND-SHORT]	● The circuit for front RH pre-tensioner is shorted to ground.		

\* Follow the procedures in numerical order when repairing malfunctioning parts. Confirm whether malfunction is eliminated using the air bag warning lamp or CONSULT-II each time repair is finished. If malfunction is still observed, proceed to the next step. When malfunction is eliminated, further repair work is not required.

# TROUBLE DIAGNOSES — Supplemental Restraint System (SRS)

## Self-diagnosis (Cont'd)

### DIAGNOSTIC PROCEDURE 3 (⊗ without CONSULT-II) Inspecting SRS malfunctioning parts by using "AIR BAG" warning lamp — Diagnosis mode

**NOTE:**

SRS will not enter Diagnosis mode if no malfunction is detected in User mode.

1. Turn ignition switch "ON".
  2. After "AIR BAG" warning lamp lights for 7 seconds, turn ignition switch "OFF" within 1 second.
  3. Wait more than 3 seconds.
  4. Repeat steps 1 to 3 twice (Perform 3 times in total).
  5. Turn ignition switch "ON".
- SRS is now in Diagnosis mode.

6. "AIR BAG" warning lamp operates in Diagnosis mode as follows:

**NOTE:**

If SRS does not enter Diagnosis mode even though malfunction is detected in User mode, check the battery voltage.

If the battery voltage is less than 9V, charge the battery. Then go to DIAGNOSTIC PROCEDURE 5, page RS-3029.

If the battery voltage is OK, replace the diagnosis sensor unit.

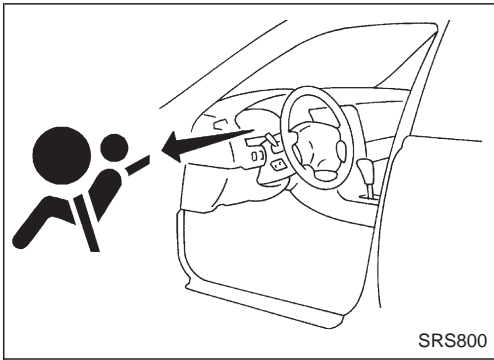

No.	"AIR BAG" warning lamp flash pattern — Diagnosis mode —	SRS condition
1		<p>(a) through (b) are repeated.</p> <ul style="list-style-type: none"> <li>• Diagnosis results (previously stored in the memory) might not be erased after repair.</li> <li>• Intermittent malfunction has been detected in the past.</li> </ul> <p>Go to DIAGNOSTIC PROCEDURE 7 (RS-3032).</p>
2		<p>(a) through (d) are repeated.</p> <p>(b) — Driver and passenger air bag and seat belt pre-tensioner marker (For identifying driver, passenger air bag and/or seat belt pre-tensioners malfunctioning)</p> <p>(d) — Indicates malfunctioning part. The number of flash varies with malfunctioning part (0.5 sec. ON and 0.5 sec. OFF is counted as one flash.)</p>
3		<p>(a) through (f) are repeated.</p> <p>(b), (c), (d) — Side air bag marker (For identifying side air bag malfunctioning)</p> <p>(f) — Indicates malfunctioning part. The number of flash varies with malfunctioning part (0.5 sec. ON and 0.5 sec. OFF is counted as one flash.)</p>



# TROUBLE DIAGNOSES — Supplemental Restraint System (SRS)

## Self-diagnosis (Cont'd)

7. Malfunctioning part is indicated by the number of flashes (part ④ or ⑤). Compare the number of flashes to AIR BAG WARNING LAMP FLASH CODE CHART, page RS-3025, and locate malfunctioning part.
- 8 Turn ignition switch "OFF", and disconnect both battery cables.
9. Repair the system as outlined by the "Repair order" in AIR BAG WARNING LAMP FLASH CODE CHART that corresponds to the flash code. For replacement procedure of component parts, refer to RS-3005 and "Removal and Installation" in RS section of Service Manual (Pub. No. SM9E-D22BG0) for details.
10. After repairing the system, go to DIAGNOSTIC PROCEDURE 5, page RS-3029.

## AIR BAG WARNING LAMP FLASH CODE CHART (DIAGNOSIS MODE)

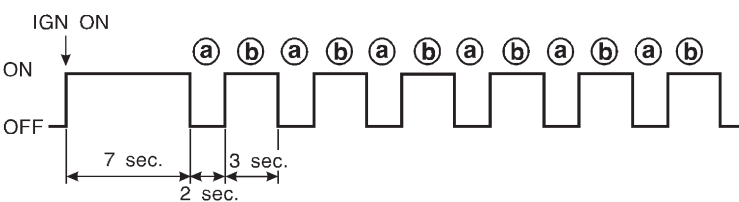
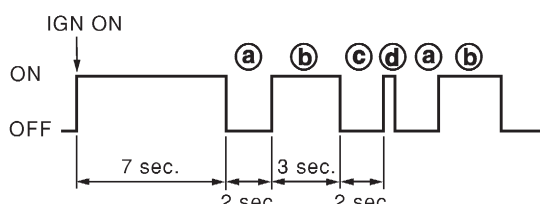
<ul style="list-style-type: none"> <li>• Diagnosis results (previously stored in the memory) might not be erased after repair.</li> <li>• Intermittent malfunction has been detected in the past.</li> </ul>	<p style="text-align: center;">Flash pattern</p> <p style="text-align: right;">① through ② are repeated.</p>  <p style="text-align: right;">SRS333</p>
	<p>Repair order</p> <ul style="list-style-type: none"> <li>• Go to DIAGNOSTIC PROCEDURE 7 (RS-3032).</li> </ul>
<p>The seat belt pre-tensioner (RH) circuit is malfunctioning. (④ : 1 flash)</p>	<p style="text-align: center;">Flash pattern</p> <p style="text-align: right;">① through ④ are repeated. ④ — One flash indicates malfunctioning pre-tensioner circuit (RH).</p>  <p style="text-align: right;">SRS801</p>
	<p>Repair order ("Recheck SRS at each replacement.")</p> <ol style="list-style-type: none"> <li>1. Visually check the wiring harness connections.</li> <li>2. Replace the harness if it has visible damage.</li> <li>3. Replace seat belt pre-tensioner (RH). (Before disposing, it must be deactivated.)</li> <li>4. Replace the diagnosis sensor unit.</li> <li>5. Replace the related harness.</li> </ol>

# TROUBLE DIAGNOSES — Supplemental Restraint System (SRS)

## Self-diagnosis (Cont'd)

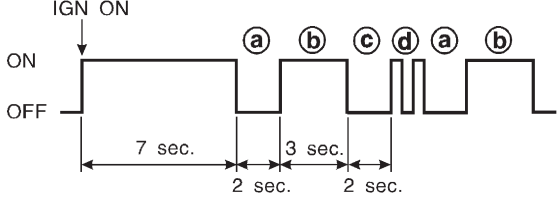
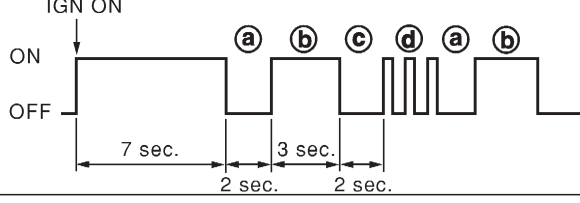
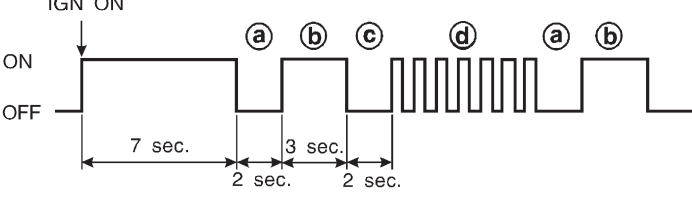
<p>The driver air bag module circuit is malfunctioning. (<b>(d)</b> : 2 flashes)</p>	<p style="text-align: center;">Flash pattern</p> <div style="display: flex; justify-content: space-between; align-items: flex-start;">  <div style="margin-left: 20px;"> <p>(a) through (d) are repeated. (d) — Two flashes indicate malfunctioning driver's air bag module circuit.</p> </div> </div> <p style="text-align: right;">SRS334</p>
<p>Repair order ("Recheck SRS at each replacement.")</p> <ol style="list-style-type: none"> <li>1. Visually check the wiring harness connection.</li> <li>2. Replace the harness if it has visible damage.</li> <li>3. Replace the spiral cable.</li> <li>4. Replace driver air bag module. (Before disposal, it must be deployed.)</li> <li>5. Replace the diagnosis sensor unit.</li> <li>6. Replace the related harness.</li> </ol>	
<p>The seat belt pre-tensioner (LH) circuit is malfunctioning. (<b>(d)</b> : 3 flashes)</p>	<p style="text-align: center;">Flash pattern</p> <div style="display: flex; justify-content: space-between; align-items: flex-start;">  <div style="margin-left: 20px;"> <p>(a) through (d) are repeated. (d) — Three flashes indicate malfunctioning pre-tensioner circuit (LH).</p> </div> </div> <p style="text-align: right;">SRS802</p>
<p>Repair order ("Recheck SRS at each replacement.")</p> <ol style="list-style-type: none"> <li>1. Visually check the wiring harness connections.</li> <li>2. Replace the harness if it has visible damage.</li> <li>3. Replace seat belt pre-tensioner (LH). (Before disposing, it must be deactivated.)</li> <li>4. Replace the diagnosis sensor unit.</li> <li>5. Replace the related harness.</li> </ol>	
<p>The diagnosis sensor unit is malfunctioning. (<b>(d)</b> : 7 flashes)</p>	<p style="text-align: center;">Flash pattern</p> <div style="display: flex; justify-content: space-between; align-items: flex-start;">  <div style="margin-left: 20px;"> <p>(a) through (d) are repeated. (d) — Seven flashes indicate malfunctioning diagnosis sensor unit.</p> </div> </div> <p style="text-align: right;">SRS335</p>
<p>Repair order ("Recheck SRS at each replacement.")</p> <ol style="list-style-type: none"> <li>1. Visually check the wiring harness connections.</li> <li>2. Replace the diagnosis sensor unit.</li> <li>3. Replace the related harness.</li> </ol>	

# TROUBLE DIAGNOSES — Supplemental Restraint System (SRS) Self-diagnosis (Cont'd)

The front passenger air bag module circuit is malfunctioning.  
(**(d)** : 8 flashes)

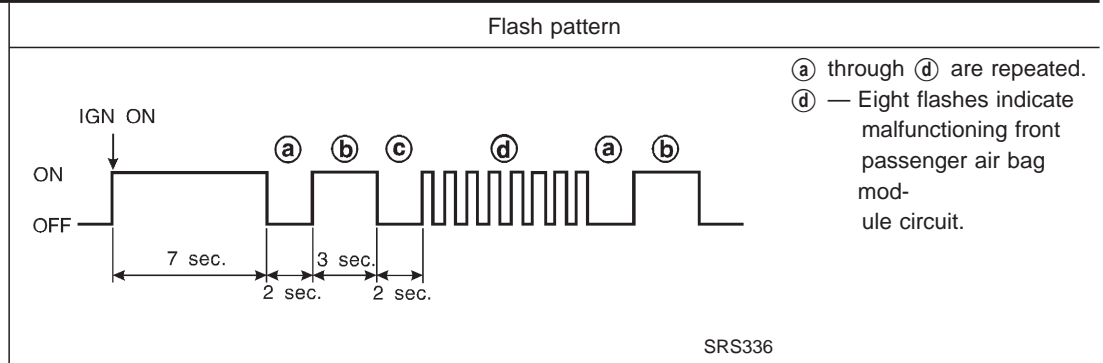

Repair order ("Recheck SRS at each replacement.")

1. Visually check the wiring harness connection.
2. Replace the harness if it has visible damage.
3. Replace front passenger air bag module.  
(Before disposal, it must be deployed.)
4. Replace the diagnosis sensor unit.
5. Replace the related harness.

\* Follow the procedures in numerical order when repairing malfunctioning parts. Confirm whether malfunction is eliminated using the air bag warning lamp (in User mode) or CONSULT-II each time repair is finished. If malfunction is still observed, proceed to the next step. When malfunction is eliminated, further repair work is not required.

# TROUBLE DIAGNOSES — Supplemental Restraint System (SRS)

## Self-diagnosis (Cont'd)

### DIAGNOSTIC PROCEDURE 4 ( with CONSULT-II)

#### Final checking after repairing SRS by using CONSULT-II — Diagnosis mode

1. After repairing SRS, connect both battery cables.
2. Connect CONSULT-II to data link connector.
3. Turn ignition switch from "OFF" to "ON".

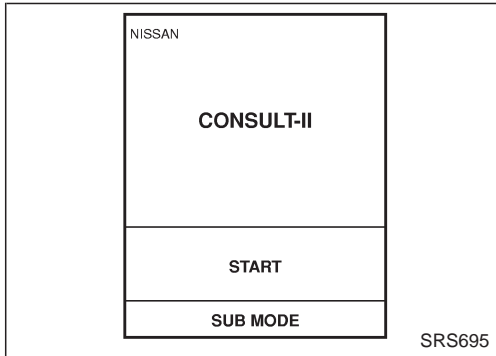
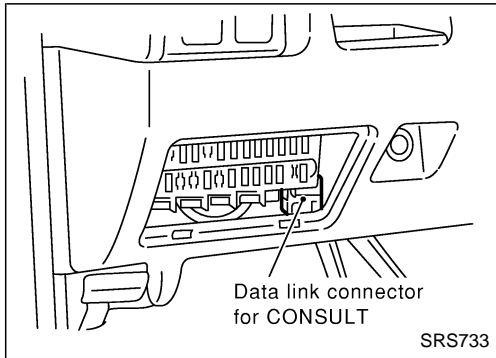

4. Touch "START".

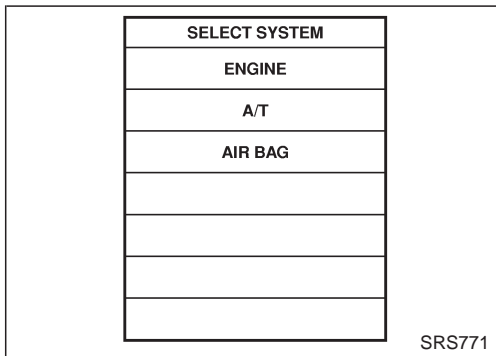

5. Touch "AIR BAG".

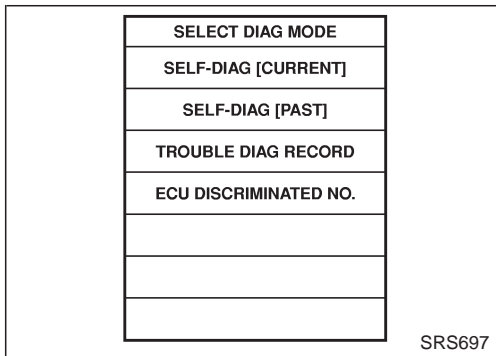

6. Touch "SELF-DIAG [CURRENT]".

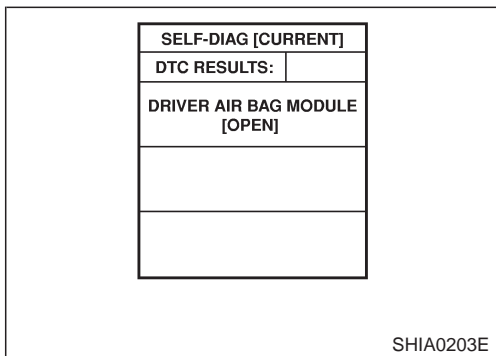

7. If no malfunction is detected on "SELF-DIAG [CURRENT]", repair of SRS is completed. Go to step 8.

If any malfunction is detected on "SELF-DIAG [CURRENT]", the malfunctioning part is not repaired completely or another malfunctioning part is detected. Go to DIAGNOSTIC PROCEDURE 2, page RS-3021, and repair malfunctioning part completely.

## TROUBLE DIAGNOSES — Supplemental Restraint System (SRS)

### Self-diagnosis (Cont'd)

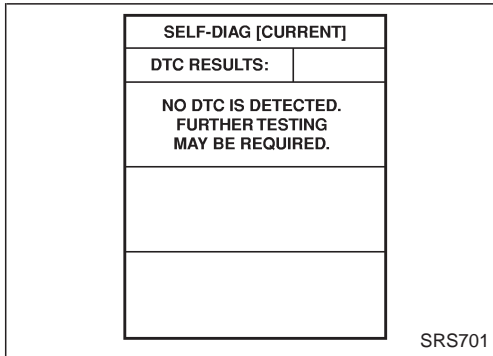

8. Touch "ERASE".

#### NOTE:

Touch "ERASE" to clear the memory of the malfunction ("SELF-DIAG [PAST]").

If the memory of the malfunction is "SELF-DIAG [PAST]" is not erased, the User mode shows the system malfunction by the operation of the warning lamp even if the malfunction is repaired completely.

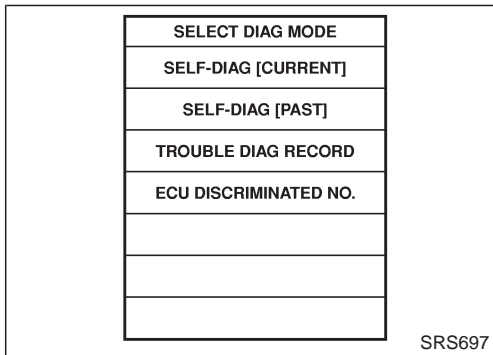

9. Touch "BACK" key of CONSULT-II to select "SELF-DIAG [PAST]" in the "SELECT DIAG MODE" screen. Touch "SELF-DIAG [PAST]".

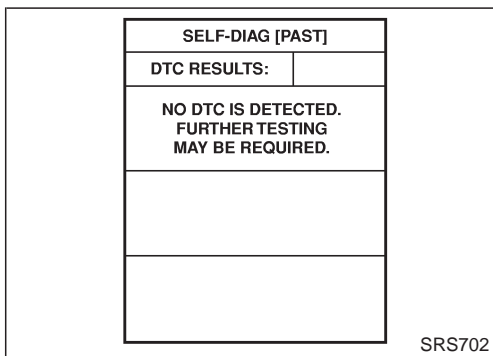

10. Check that no malfunction is detected on "SELF-DIAG [PAST]".

11. Touch "BACK" key of CONSULT-II until SELECT SYSTEM appears.

12. Turn ignition switch "OFF" and then turn off and disconnect CONSULT-II.

13. Go to DIAGNOSTIC PROCEDURE 1, page RS-3020 to check SRS operation by using "AIR BAG" warning lamp with User mode.

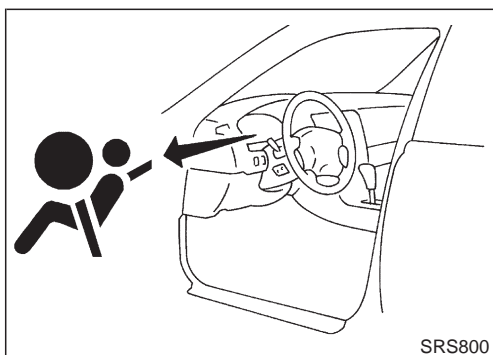

### DIAGNOSTIC PROCEDURE 5 (⊗ without CONSULT-II)

#### Final checking after repairing SRS by using "AIR BAG" warning lamp — Diagnosis mode and User mode

1. After repairing SRS connect both battery cables.
2. Open driver's door.
3. Turn ignition switch from "OFF" to "ON".
4. "AIR BAG" warning lamp operates in Diagnosis mode as follows:

# TROUBLE DIAGNOSES — Supplemental Restraint System (SRS)

## Self-diagnosis (Cont'd)

No.	"AIR BAG" warning lamp flash pattern — Diagnosis mode —	SRS condition
1	<p style="text-align: right;">SRS333</p>	<p>Ⓐ through Ⓑ are repeated.</p> <p>No malfunction is detected or repair is completed. No further action is necessary.</p>
2	<p style="text-align: right;">SRS341</p>	<p>Ⓐ through Ⓓ are repeated.</p> <p>Ⓑ — Driver and passenger air bag and seat belt pre-tensioner marker (For identifying driver, passenger air bag and/or seat belt pretensioners malfunctioning)</p> <p>Ⓓ — Indicates malfunctioning part. The number of flashes varies with malfunctioning part (0.5 sec. ON and 0.5 sec. OFF is counted as one flash.)</p>
3	<p style="text-align: right;">SRS342-A</p>	<p>Ⓐ through Ⓕ are repeated.</p> <p>Ⓑ, Ⓒ, Ⓓ — Side air bag marker (For identifying side air bag malfunctioning)</p> <p>Ⓕ — Indicates malfunctioning part. The number of flashes varies with malfunctioning part (0.5 sec. ON and 0.5 sec. OFF is counted as one flash.)</p>

**NOTE:**

When diagnosis sensor unit is replaced with new one, "AIR BAG" warning lamp will operate in User mode. Checking "AIR BAG" warning lamp operation in Diagnosis mode is not required. Go to step 6.

- If "AIR BAG" warning lamp operates as shown in No. 1 in chart above, turn ignition switch "OFF" to reset from Diagnosis mode to User mode and to erase the memory of the malfunction. Then go to step 6.

If "AIR BAG" warning lamp operates as shown in No. 2 or No. 3 in chart above, the malfunctioning part is not repaired completely, or another malfunctioning part is detected. Go to DIAGNOSTIC PROCEDURE 3, page RS-3024, and repair malfunctioning part completely.

## TROUBLE DIAGNOSES — Supplemental Restraint System (SRS)





### Self-diagnosis (Cont'd)

6. Turn ignition switch "ON". "AIR BAG" warning lamp operates in User mode. Compare "AIR BAG" warning lamp operation to the chart below.

**NOTE:**

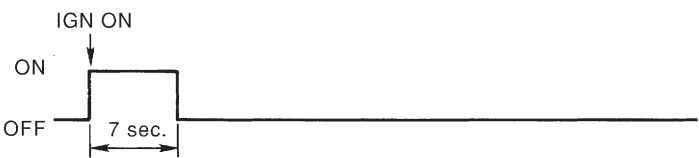
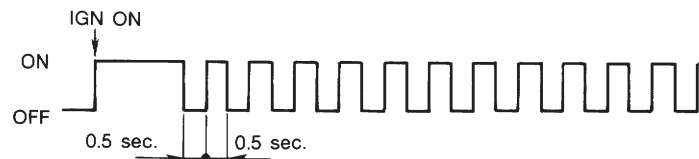
If switching Diagnosis mode to User mode is required while malfunction is being detected, by turning ignition switch as follows:

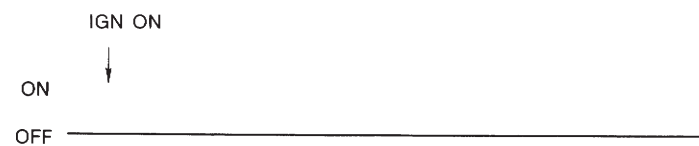
- 1) Turn ignition switch "ON".
  - 2) After "AIR BAG" warning lamp lights for 7 seconds, turn ignition switch "OFF" within 1 second.
  - 3) Wait more than 3 seconds.
  - 4) Repeat steps 1 to 3 twice (Perform 3 times in total).
  - 5) Turn ignition switch "ON".
- SRS is now in User mode.

"AIR BAG" warning lamp operation — User mode —	SRS condition	Reference item
 <p>MRS095A</p>	No malfunction is detected. No further action is necessary.	—
 <p>MRS096A</p>	The system is malfunctioning and needs to be repaired as indicated.	Go to DIAGNOSTIC PROCEDURE3 (RS-3024).
 <p>MRS097A</p>	Air bag is deployed. Seat belt pre-tensioner is deployed.	Go to COLLISION DIAGNOSIS (RS-3037).
 <p>MRS098A</p>	Air bag fuse diagnosis sensor unit or harness is malfunctioning and needs to be repaired.	Go to DIAGNOSTIC PROCEDURE 9 (RS-3036).
 <p>MRS098A</p>	One of the following has occurred and needs to be repaired. <ul style="list-style-type: none"> <li>● Meter fuse is blown.</li> <li>● "AIR BAG" warning lamp circuit has open or short.</li> <li>● Diagnosis sensor unit is malfunctioning.</li> </ul>	Go to DIAGNOSTIC PROCEDURE 10 (RS-3036).

# TROUBLE DIAGNOSES — Supplemental Restraint System (SRS)

## Self-diagnosis (Cont'd)

### DIAGNOSTIC PROCEDURE 6 (Continued from DIAGNOSTIC PROCEDURE 2)

#### Inspecting SRS malfunctioning record

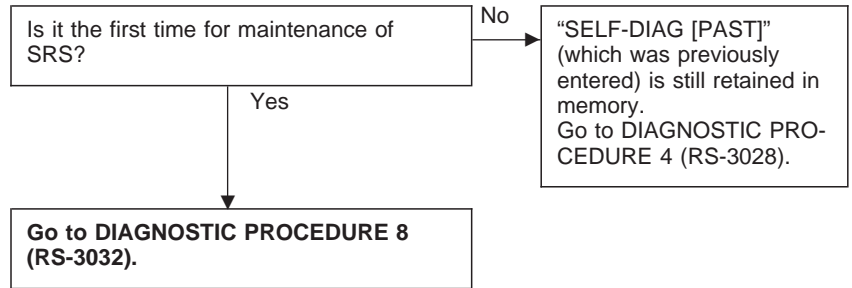

### DIAGNOSTIC PROCEDURE 7 (Continued from DIAGNOSTIC PROCEDURE 3) (⊗ without CONSULT-II)

#### Inspecting SRS malfunctioning record

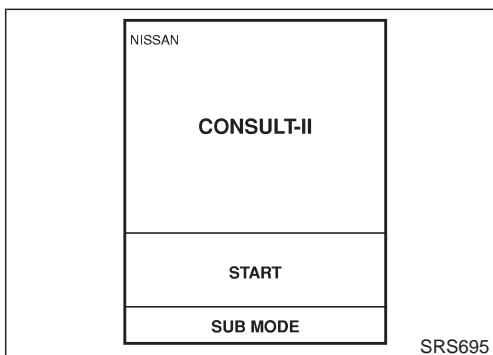
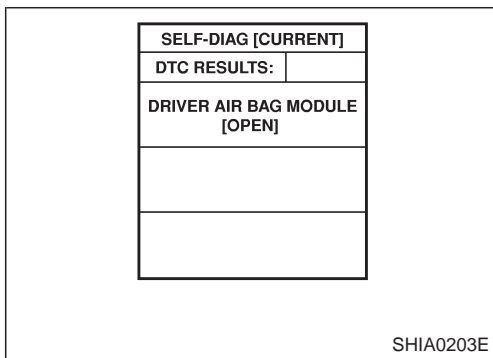
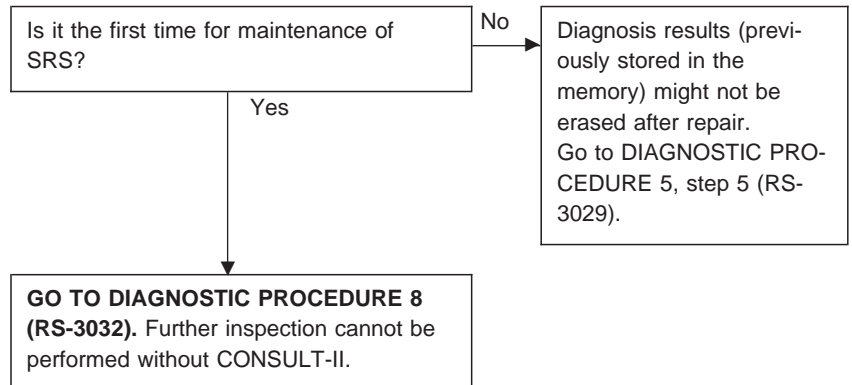

### DIAGNOSTIC PROCEDURE 8 (Ⓜ with CONSULT-II)

#### Inspecting SRS intermittent malfunction by using CONSULT-II — Diagnosis mode

1. Turn ignition switch "OFF".
2. Connect CONSULT-II to data link connector.
3. Turn ignition switch "ON".
4. Touch "START".



# TROUBLE DIAGNOSES — Supplemental Restraint System (SRS)

## Self-diagnosis (Cont'd)

SELECT SYSTEM
ENGINE
A/T
AIR BAG

SRS771

5. Touch "AIR BAG".

SELECT DIAG MODE
SELF-DIAG [CURRENT]
SELF-DIAG [PAST]
TROUBLE DIAG RECORD
ECU DISCRIMINATED NO.

SRS697

6. Touch "SELF-DIAG [PAST]".

SELF-DIAG [PAST]
DTC RESULTS: <input type="text"/>
DRIVER AIR BAG MODULE [OPEN]

SHIA0181E

7. If diagnostic codes are displayed on "SELF-DIAG [PAST]", go to step 10.

SELF-DIAG [PAST]
DTC RESULTS: <input type="text"/>
NO DTC IS DETECTED. FURTHER TESTING MAY BE REQUIRED.

SRS702

If no malfunction is detected on "SELF-DIAG [PAST]", touch "BACK" and go back to "SELECT DIAG MODE".

SELECT DIAG MODE
SELF-DIAG [CURRENT]
SELF-DIAG [PAST]
TROUBLE DIAG RECORD
ECU DISCRIMINATED NO.

SRS697

8. Touch "TROUBLE DIAG RECORD".

**NOTE:**

With "TROUBLE DIAG RECORD", diagnosis results previously erased by a reset operation can be displayed.

## TROUBLE DIAGNOSES — Supplemental Restraint System (SRS)

### Self-diagnosis (Cont'd)

TROUBLE DIAG RECORD	
DTC RESULTS:	
DRIVER AIR BAG MODULE [OPEN]	

SHIA0182E

9. Diagnostic code is displayed on “TROUBLE DIAG RECORD”.

10. Touch “PRINT”.
11. Compare diagnostic codes to the INTERMITTENT MALFUNCTION DIAGNOSTIC CODE CHART, page RS-3034.
12. Touch “BACK” key of CONSULT-II until SELECT SYSTEM appears, then turn off CONSULT-II.
13. Turn ignition switch “OFF”, then turn off and disconnect CONSULT-II and both battery cables.
14. Repair the system as outlined by the “Repair order” in INTERMITTENT MALFUNCTION DIAGNOSTIC CODE CHART, that corresponds to the self-diagnosis result. For replacement procedure of component parts, refer to RS-3005 and “Removal and Installation” in RS section of Service Manual (Pub. No. SM9E-D22BE0E) for details.
15. Go to DIAGNOSTIC PROCEDURE 4, page RS-3028.

### INTERMITTENT MALFUNCTION DIAGNOSTIC CODE CHART (“SELF-DIAG [PAST]” or “TROUBLE DIAG RECORD”)

Diagnostic item	Explanation	Repair order
NO DTC IS DETECTED	When malfunction is indicated by the “AIR BAG” warning lamp in User mode	<ul style="list-style-type: none"> <li>● Low battery voltage (Less than 9V)</li> <li>● Go to DIAGNOSTIC PROCEDURE 4 (RS-3028) after charging battery.</li> </ul>
	<ul style="list-style-type: none"> <li>● No malfunction is detected.</li> </ul>	<ul style="list-style-type: none"> <li>● Go to DIAGNOSTIC PROCEDURE 4 (RS-3028).</li> </ul>
DRIVER AIRBAG MODULE [OPEN]	<ul style="list-style-type: none"> <li>● Driver air bag module circuit is open. (including the spiral cable)</li> </ul>	<ol style="list-style-type: none"> <li>1. Visually check the wiring harness connection.</li> <li>2. Replace the harness if it has visible damage.</li> <li>3. If the harness check is OK, replace the spiral cable, diagnosis sensor unit and driver air bag module. (Before disposing the driver air bag module, it must be deployed.)</li> </ol>
DRIVER AIRBAG MODULE [VB-SHORT]	<ul style="list-style-type: none"> <li>● Driver air bag module circuit is shorted to some power supply circuit. (including the spiral cable)</li> </ul>	
DRIVER AIRBAG MODULE [GND-SHORT]	<ul style="list-style-type: none"> <li>● Driver air bag module circuit is shorted to ground. (including the spiral cable)</li> </ul>	
AIRBAG MODULE [SHORT]	<ul style="list-style-type: none"> <li>● Driver air bag module circuits are shorted to each other.</li> </ul>	
ASSIST A/B MODULE [VB-SHORT]	<ul style="list-style-type: none"> <li>● Front passenger air bag module circuit is shorted to some power supply circuit.</li> </ul>	<ol style="list-style-type: none"> <li>1. Visually check the wiring harness connection.</li> <li>2. Replace the harness if it has visible damage.</li> <li>3. If the harness check is OK, replace the diagnosis sensor unit and passenger air bag module. (Before disposing the passenger air bag module, it must be deployed.)</li> </ol>
ASSIST A/B MODULE [OPEN]	<ul style="list-style-type: none"> <li>● Front passenger air bag module circuit is open.</li> </ul>	
ASSIST A/B MODULE [GND-SHORT]	<ul style="list-style-type: none"> <li>● Front passenger air bag module circuit is shorted to ground.</li> </ul>	
ASSIST A/B MODULE [SHORT]	<ul style="list-style-type: none"> <li>● Front passenger air bag module circuits are shorted to each other.</li> </ul>	

## TROUBLE DIAGNOSES — Supplemental Restraint System (SRS)

### Self-diagnosis (Cont'd)

Diagnostic item	Explanation	Repair order
PRE-TEN FRONT LH [OPEN]	<ul style="list-style-type: none"> <li>● The circuit for seat belt pre-tensioner (LH) is open or shorted to a power supply circuit.</li> </ul>	<ol style="list-style-type: none"> <li>1. Visually check the wiring harness connections.</li> <li>2. Replace the harness if it has visible damage.</li> <li>3. If the harness check is OK, replace the diagnosis sensor unit and seat belt (LH). (Before disposing the seat belt (LH) pre-tensioner, it must be deployed.)</li> </ol>
PRE-TEN FRONT LH [VB-SHORT]	<ul style="list-style-type: none"> <li>● The circuit for seat belt pre-tensioner (LH) is shorted to a power supply circuit.</li> </ul>	
PRE-TEN FRONT LH [GND-SHORT]	<ul style="list-style-type: none"> <li>● The circuit for seat belt pre-tensioner (LH) is shorted to ground.</li> </ul>	
PRE-TEN FRONT RH [OPEN/VB-SHORT]	<ul style="list-style-type: none"> <li>● The circuit for seat belt pre-tensioner (RH) is open or shorted to a power supply circuit.</li> </ul>	<ol style="list-style-type: none"> <li>1. Visually check the wiring harness connections.</li> <li>2. Replace the harness if it has visible damage.</li> <li>3. If the harness check is OK, replace the diagnosis sensor unit and seat belt (RH). (Before disposing the seat belt (RH) pre-tensioner, it must be deployed.)</li> </ol>
PRE-TEN FRONT RH [VB-SHORT]	<ul style="list-style-type: none"> <li>● The circuit for seat belt pre-tensioner (RH) is shorted to a power supply circuit.</li> </ul>	
PRE-TEN FRONT RH [GND-SHORT]	<ul style="list-style-type: none"> <li>● The circuit for seat belt pre-tensioner (RH) is shorted to ground.</li> </ul>	
CONTROL UNIT	<ul style="list-style-type: none"> <li>● Diagnosis sensor unit is malfunctioning.</li> </ul>	<ol style="list-style-type: none"> <li>1. Visually check the wiring harness connection.</li> <li>2. Replace the harness if it has visible damage.</li> <li>3. If the harness check is OK, replace the diagnosis sensor unit.</li> </ol>

\* Follow the procedures in numerical order when repairing malfunctioning parts, then make the final system check.

# TROUBLE DIAGNOSES — Supplemental Restraint System (SRS)

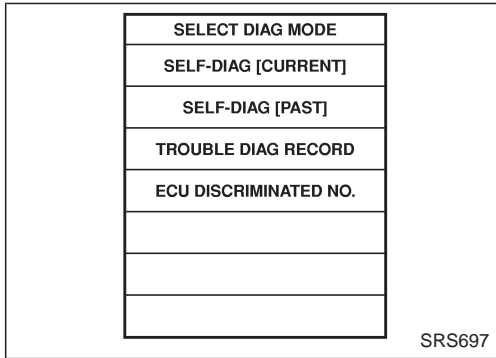
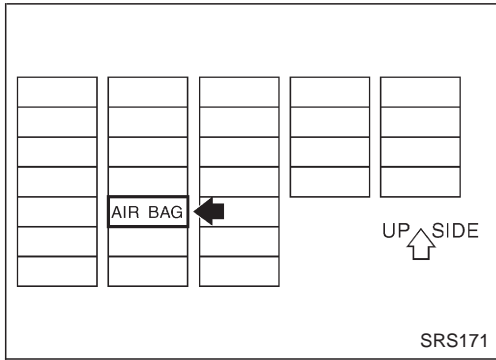

## Trouble Diagnoses for Air Bag Warning Lamp

### DIAGNOSTIC PROCEDURE 9

**SYMPTOM: "AIR BAG" warning lamp does not turn off.**

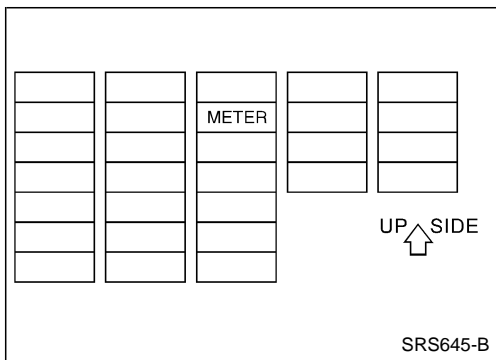
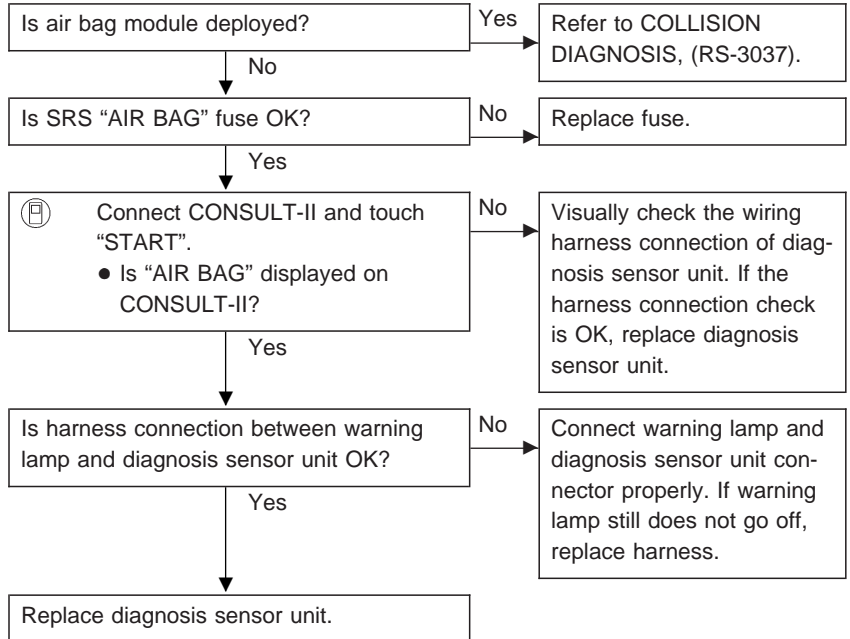

### DIAGNOSTIC PROCEDURE 10

**SYMPTOM: "AIR BAG" warning lamp does not turn on.**

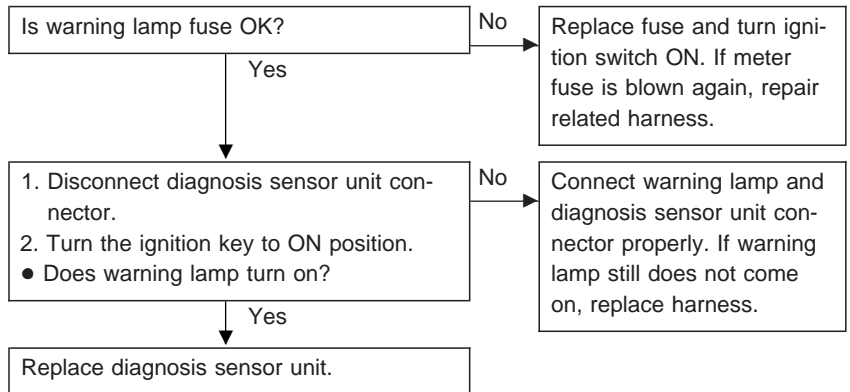

# COLLISION DIAGNOSIS

## FOR FRONTAL COLLISION

To repair the SRS for a frontal collision, perform the following steps.

### When SRS (except the side air bag) is activated in a collision:

- ① Replace the diagnosis sensor unit.
- ② Remove the air bag modules (except the side air bag module).
- ③ Check the SRS components using the table shown below:
  - Replace any SRS components showing visible signs of damage (dents, cracks, deformation).
- ④ Install new air bag modules (except the side air bag module).
- ⑤ Conduct self-diagnosis using CONSULT-II, and "AIR BAG". Refer to "Self-diagnosis" for details (RS-3020). Ensure entire SRS operates properly.

### When SRS is not activated in a collision:

- ① Check the SRS components using the table shown below:
  - Replace any SRS components showing visible signs of damage (dents, cracks, deformation).
- ② Conduct self-diagnosis using CONSULT-II, and "AIR BAG". Refer to "Self-diagnosis" for details (RS-3020). Ensure entire SRS operates properly.

## SRS inspection

Part	SRS (except the side air bag) is activated	SRS is NOT activated
Air bag module (driver and passenger side)	REPLACE Install air bag module with new bolts.	1. Remove air bag module. Check harness cover and connectors for damage, terminals for deformities, and harness for binding. 2-1. Install driver air bag module into the steering wheel to check fit and alignment with the wheel. 2-2. Install passenger air bag module into the instrument panel to check fit with the instrument panel. 3. No damage found, reinstall with new bolts. 4. If damaged—REPLACE. Air bag must be deployed before discarding.
Seat belt pre-tensioner assembly	REPLACE Install seat belt pre-tensioner with new bolts.	1. Remove seat belt pre-tensioners. Check harness cover and connectors for damage, terminals for deformities, and harness for binding. 2. Check belts for damage and anchors for loose mounting. 3. Check retractor for smooth operation. 4. If no damage is found, reinstall with new bolts coated with bonding agent. 5. If damaged—REPLACE. Install the seat belt pre-tensioners with new bolts coated with bonding agent. Seat belt pre-tensioners must be deployed before discarding.
Diagnosis sensor unit	REPLACE Install diagnosis sensor unit with new bolts.	1. Check case and bracket for dents, cracks or deformities. 2. Check connectors for damage, and terminals for deformities. 3. If no damage is found, reinstall with new bolts. 4. If damaged—REPLACE. Install diagnosis sensor unit with new bolts.
Steering wheel		1. Visually check steering wheel for deformities. 2. Check harness (built into steering wheel) and connectors for damage, and terminals for deformities. 3. Install air bag module to check fit or alignment with steering wheel. 4. Check steering wheel for excessive free play. 5. If no damage is found, reinstall the steering wheel. 6. If damaged—REPLACE.
Spiral cable		1. Visually check spiral cable and combination switch for damage. 2. Check connectors, flat cable and protective tape for damage. 3. Check steering wheel for noise, binding or heavy operation. 4. If no damage is found, reinstall the spiral cable. 5. If damaged—REPLACE.
Harness and Connectors		1. Check connectors for poor connection, damage, and terminals for deformities. 2. Check harness for binding, chafing, cuts, or deformities. 3. If no damage is found, reinstall harness and connectors. 4. Damaged—REPLACE damaged section of harness. Do not attempt to repair, splice or modify any SRS harness.
Instrument panel		1. Check instrument panel for bending, deformities, or cracks. 2. Check passenger side module brackets for dents, cracks or deformities. 3. If no damage is found, reinstall with new bolts. 4. If damaged—REPLACE.