

SECTION **EL**

MODIFICATION NOTICE:

- Wiring diagrams have been changed.
- Harness layouts have been changed.
- Fog lamp system has been changed.
- CD auto-changer has been added.

CONTENTS

PRECAUTIONS	4002	WARNING LAMPS	4030
Supplemental Restraint System (SRS) "AIR BAG" and "SEAT BELT PRE-TENSIONER" ..	4002	Schematic/With Tachometer	4030
POWER SUPPLY ROUTING	4003	Schematic/Without Tachometer	4031
Schematic	4003	Wiring Diagram - WARN -/Gasoline Engine with Tachometer	4032
Wiring Diagram - POWER -	4004	Wiring Diagram - WARN -/Gasoline Engine without Tachometer	4036
COMBINATION SWITCH	4011	Wiring Diagram - WARN -/Diesel Engine with Tachometer	4040
HEADLAMP - Headlamp Aiming Control -	4012	Wiring Diagram - WARN -/Diesel Engine without Tachometer	4044
Wiring Diagram - H/AIM -	4012	WARNING CHIME	4049
PARKING, LICENSE AND TAIL LAMPS	4014	Wiring Diagram - CHIME -/LHD Models.....	4049
Wiring Diagram - TAIL/L -/LHD Models.....	4014	AUDIO	4050
FRONT FOG LAMP	4016	Wiring Diagram - AUDIO -/LHD Models.....	4050
Wiring Diagram - F/FOG -/LHD Models	4016	Wiring Diagram - AUDIO -/RHD Models	4052
Wiring Diagram - F/FOG -/RHD Models.....	4017	NATS (Nissan Anti-Theft System)	4054
REAR FOG LAMP	4018	Wiring Diagram - NATS -/LHD Models.....	4054
Wiring Diagram - R/FOG -/LHD Models without Front Fog Lamp.....	4018	Wiring Diagram - NATS -/RHD Models	4055
Wiring Diagram - R/FOG -/RHD Models without Front Fog Lamp.....	4019	HARNES LAYOUT	4056
Wiring Diagram - R/FOG -/LHD Models with Front Fog Lamp	4020	Main Harness.....	4056
Wiring Diagram - R/FOG -/RHD Models with Front Fog Lamp	4022	Engine Room Harness.....	4062
INTERIOR ROOM LAMP	4023	Engine Control Harness.....	4068
Wiring Diagram - ROOM/L -	4023	Chassis Harness and Tail Harness	4071
ILLUMINATION	4024	Room Lamp Harness/LHD Models.....	4072
Wiring Diagram - ILL -/LHD Models	4024	Room Lamp Harness/RHD Models	4073
Wiring Diagram - ILL -/RHD Models.....	4026	WIRING DIAGRAM CODES (CELL CODES)	4074
METER AND GAUGES	4028	SUPER MULTIPLE JUNCTION (SMJ)	4075
Wiring Diagram - METER -/Gasoline Engine with Tachometer	4028	Terminal Arrangement	4075

PRECAUTIONS

Supplemental Restraint System (SRS) “AIR BAG” and “SEAT BELT PRE-TENSIONER”

The Supplemental Restraint System such as “AIR BAG” and “SEAT BELT PRE-TENSIONER” used along with a seat belt, helps to reduce the risk or severity of injury to the driver and front passenger in a frontal collision. The SRS composition which is available to NISSAN MODEL D22 is as follows (The composition varies according to the destination and optional equipment.):

Driver air bag module (located in the center of the steering wheel), front passenger air bag module (located on the instrument panel on passenger side), seat belt pre-tensioner, a diagnosis sensor unit, warning lamp, wiring harness and spiral cable.

WARNING:

- **To avoid rendering the SRS inoperative, which could increase the risk of personal injury or death in the event of a collision which would result in air bag inflation, all maintenance must be performed by an authorized NISSAN dealer.**
- **Improper maintenance, including incorrect removal and installation of the SRS, can lead to personal injury caused by unintentional activation of the system.**
- **Do not use electrical test equipment on any circuit related to the SRS unless instructed to in this Service Manual. SRS wiring harnesses can be identified by yellow harness connector.**

POWER SUPPLY ROUTING

Wiring Diagram — POWER —

BATTERY POWER SUPPLY — IGNITION SWITCH IN ANY POSITION

EL-POWER-01

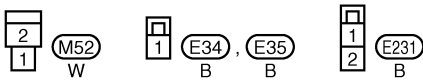
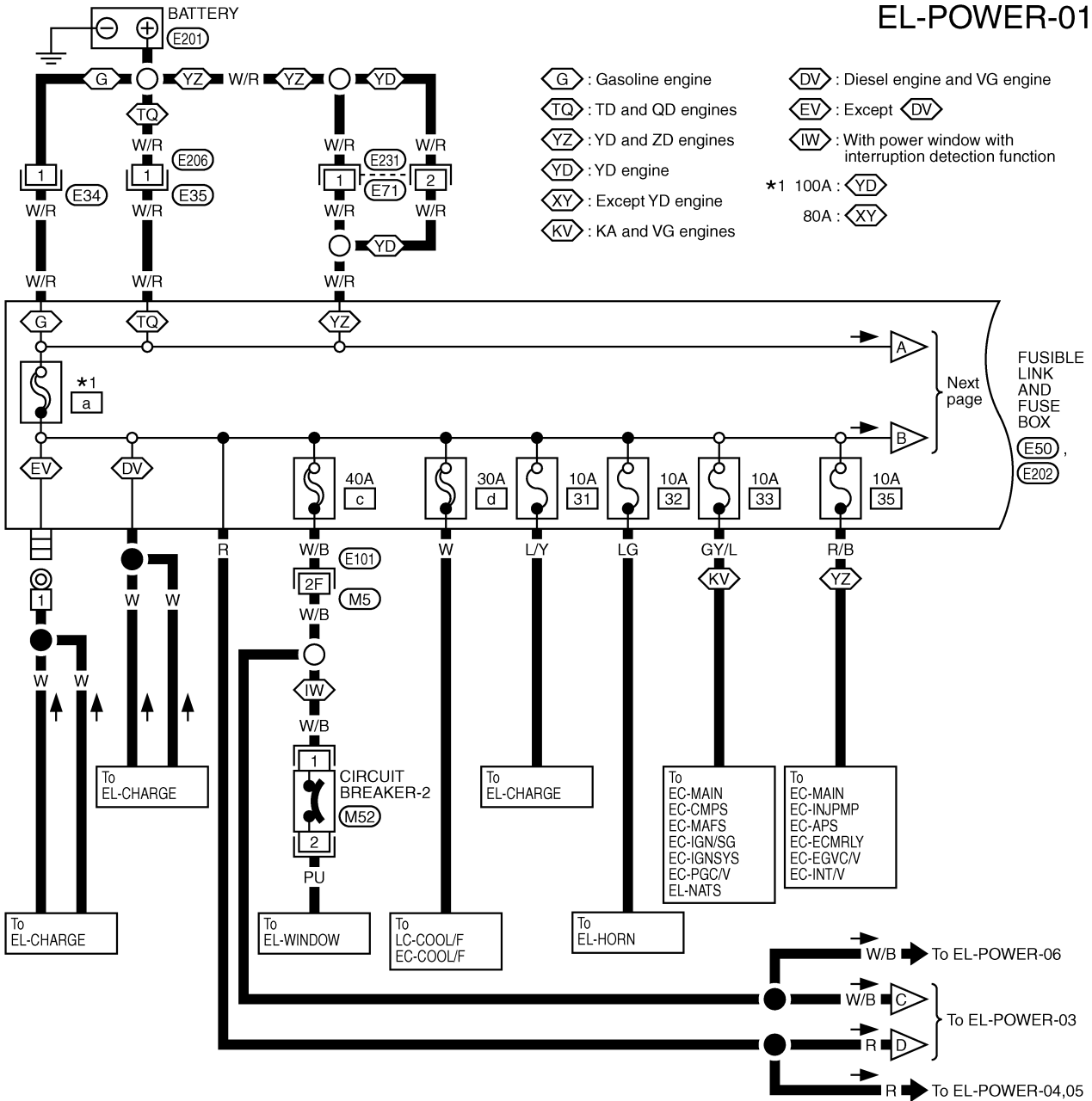



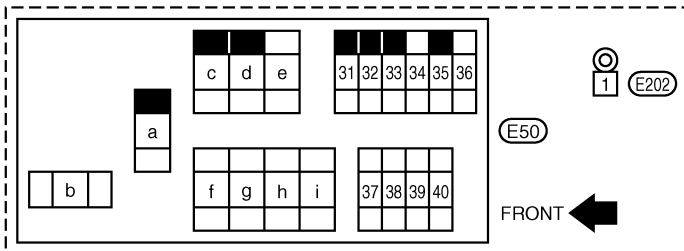



Refer to last page (Foldout page).
M5, **E101**



POWER SUPPLY ROUTING

Wiring Diagram — POWER — (Cont'd)

EL-POWER-02

-  : YD and ZD engines
-  : LHD models for Europe
-  : YD engine
-  : TD, QD and ZD engines
- *1 80A : 
- 60A : 

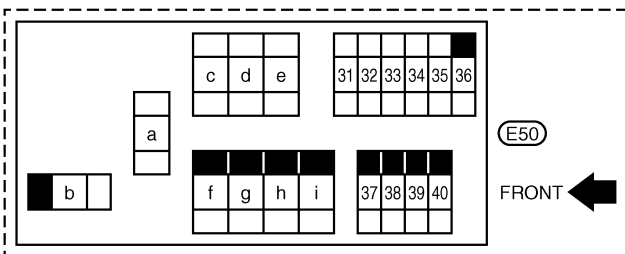
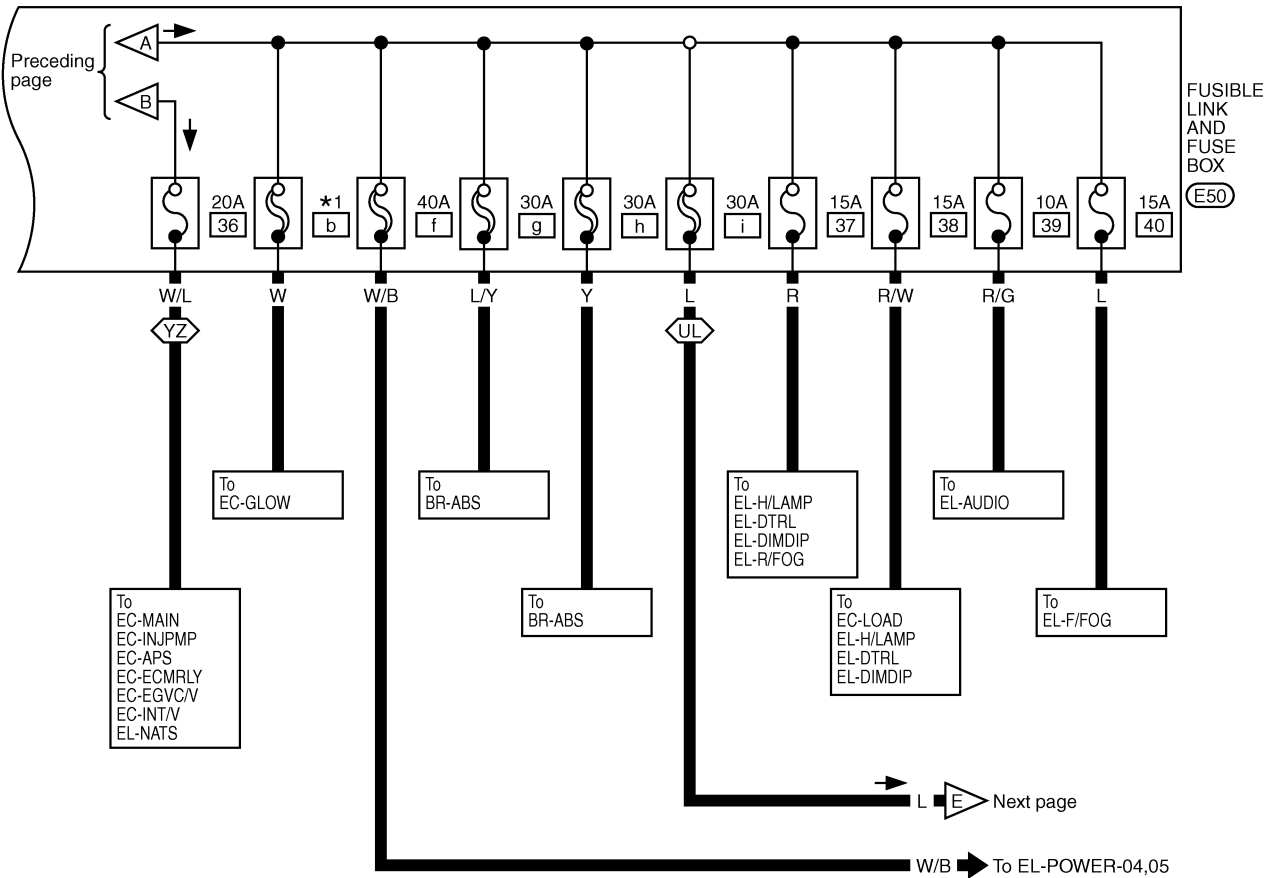

POWER SUPPLY ROUTING

Wiring Diagram — POWER — (Cont'd)

EL-POWER-03

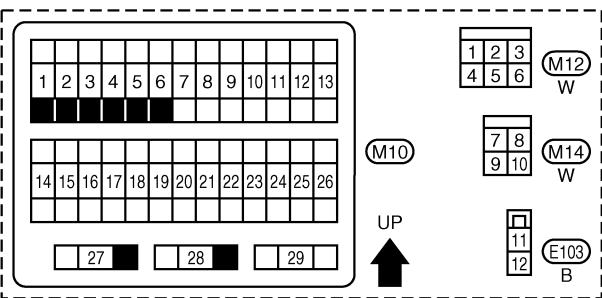
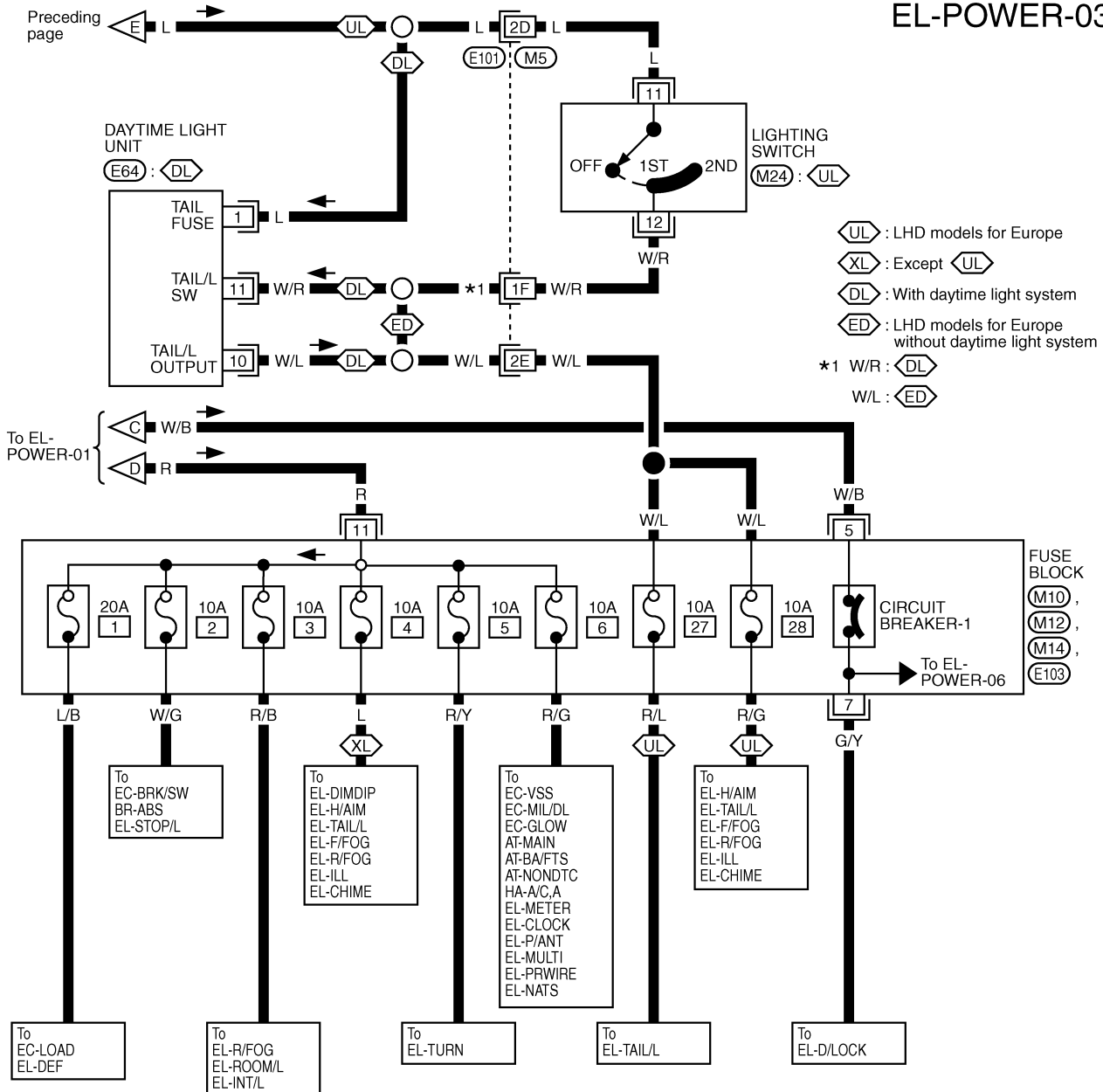

Refer to last page (Foldout page).

(M5), (E101)

POWER SUPPLY ROUTING

Wiring Diagram — POWER — (Cont'd)

ACCESSORY POWER SUPPLY — IGNITION SW. IN "ACC" OR "ON"

EL-POWER-04

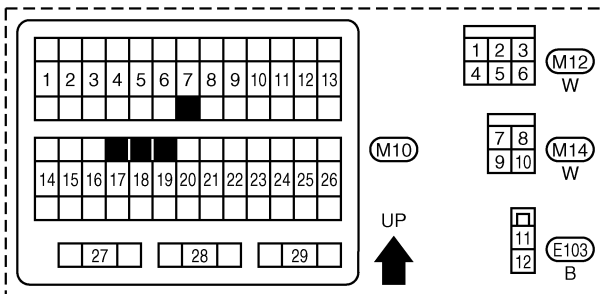
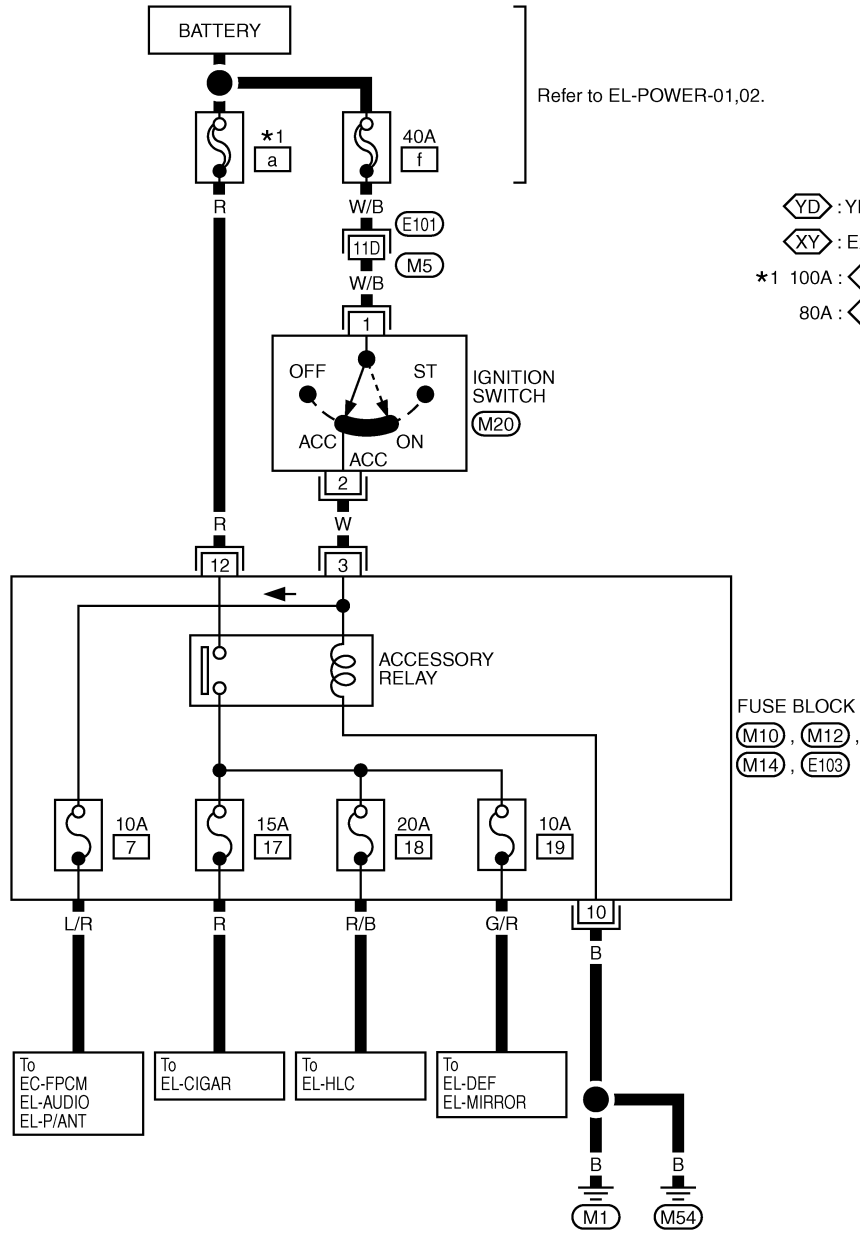

Refer to last page (Foldout page).
 M5, E101

POWER SUPPLY ROUTING

Wiring Diagram — POWER — (Cont'd)

IGNITION POWER SUPPLY — IGNITION SW. IN "ON" AND/OR "START"

EL-POWER-05

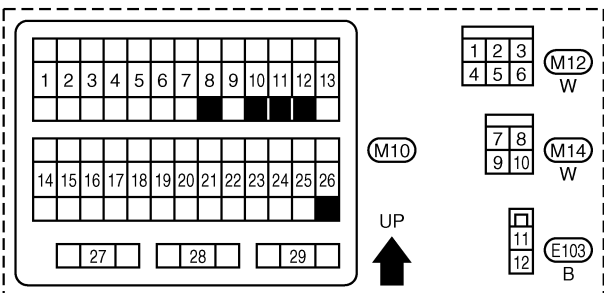
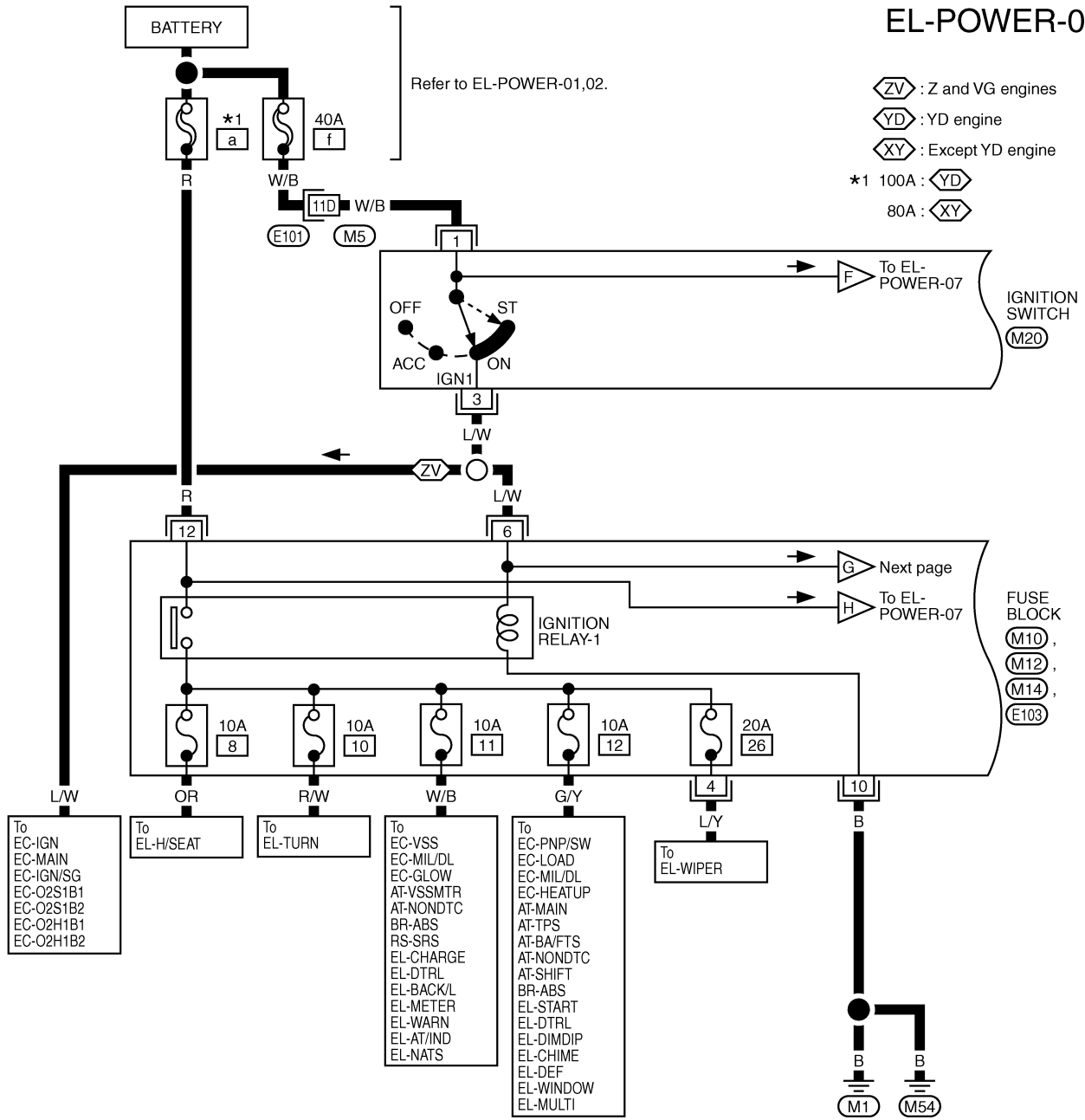





Refer to last page (Foldout page).
 M5, E101

POWER SUPPLY ROUTING

Wiring Diagram — POWER — (Cont'd)

EL-POWER-06

-  : Z engine
-  : ZD engine
-  : KA engine for Europe
-  : With ECM control engine except KA engine for Europe

- *1 W/L : 
- W/R : 
- *2 15A : 
- 10A : 
- *3 W/L : 
- BR/Y : 

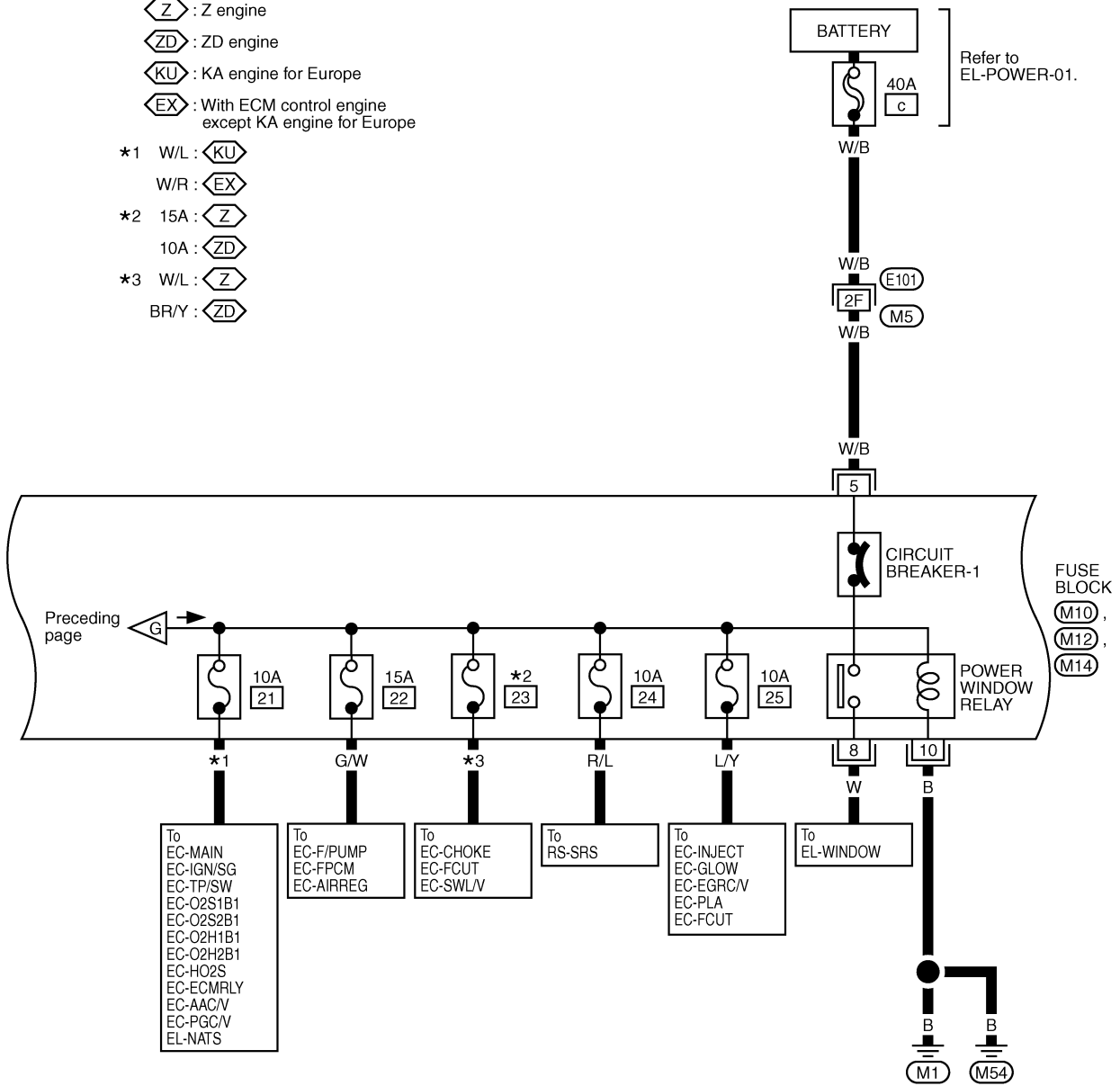

Preceding page

FUSE BLOCK
(M10),
(M12),
(M14)

Refer to last page (Foldout page).

(M5), (E101)

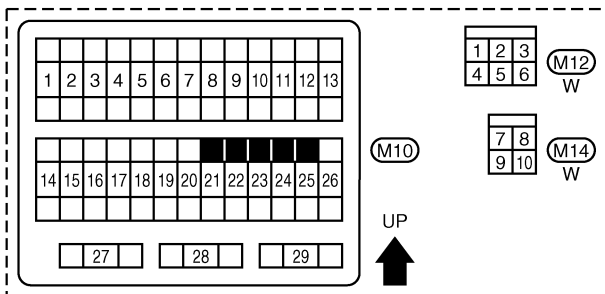

POWER SUPPLY ROUTING

Wiring Diagram — POWER — (Cont'd)

EL-POWER-07

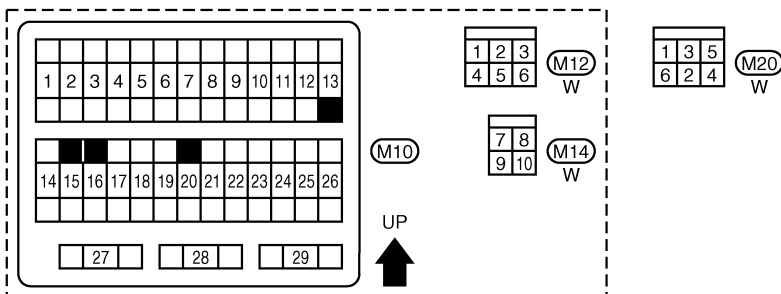
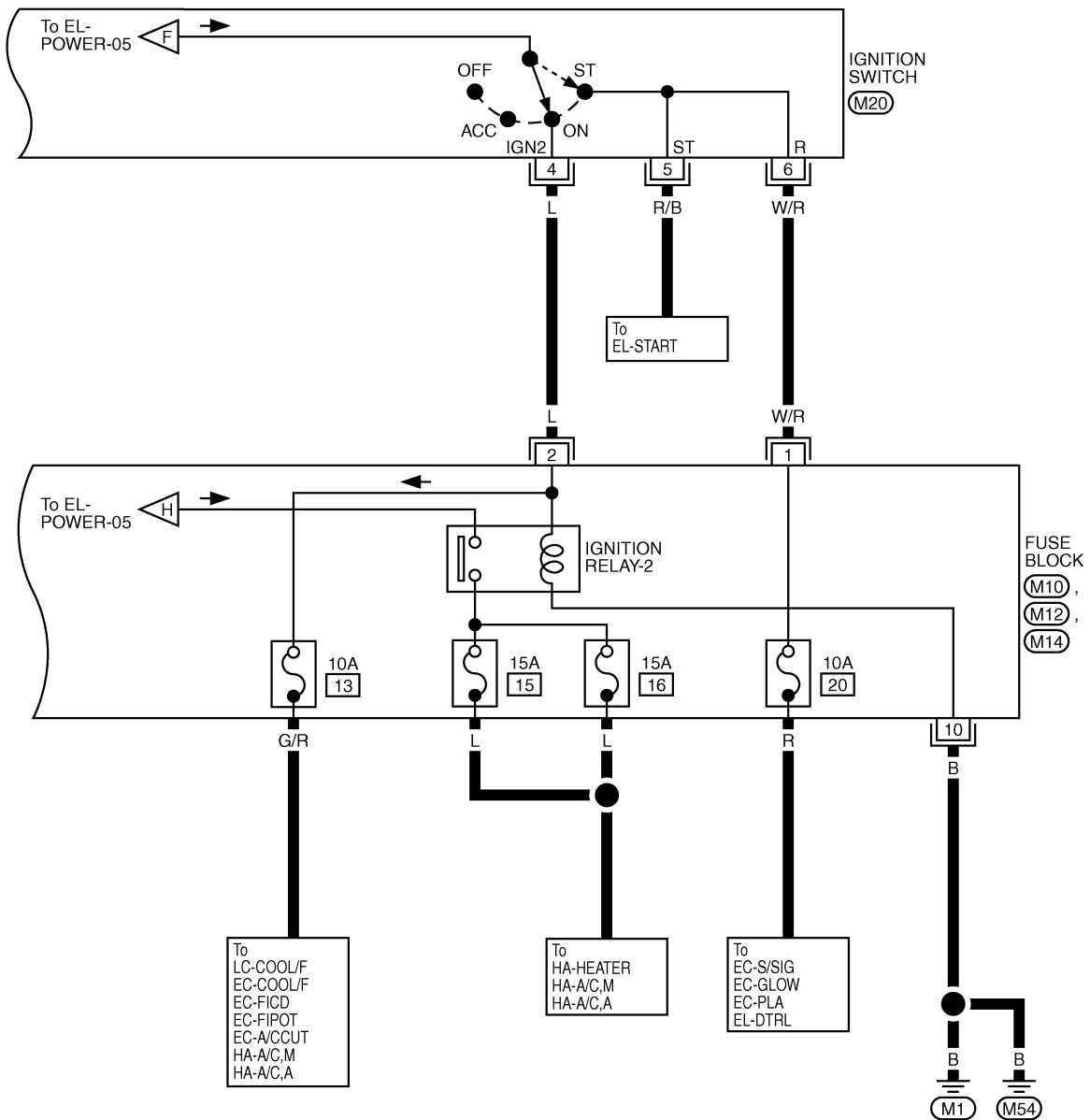

COMBINATION SWITCH

LHD MODELS

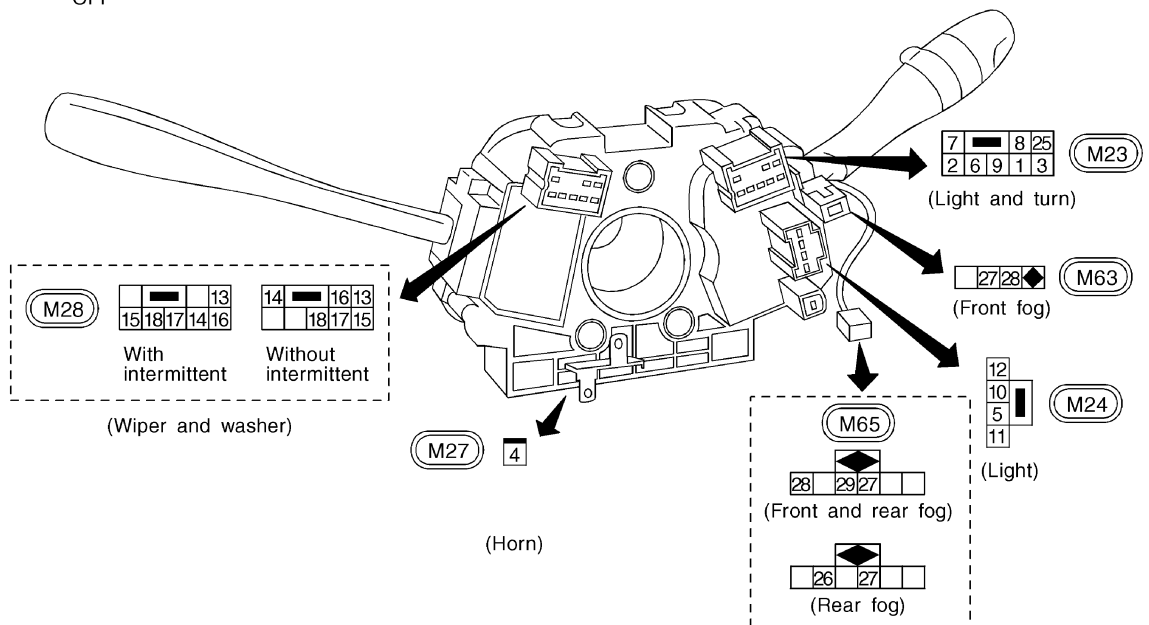
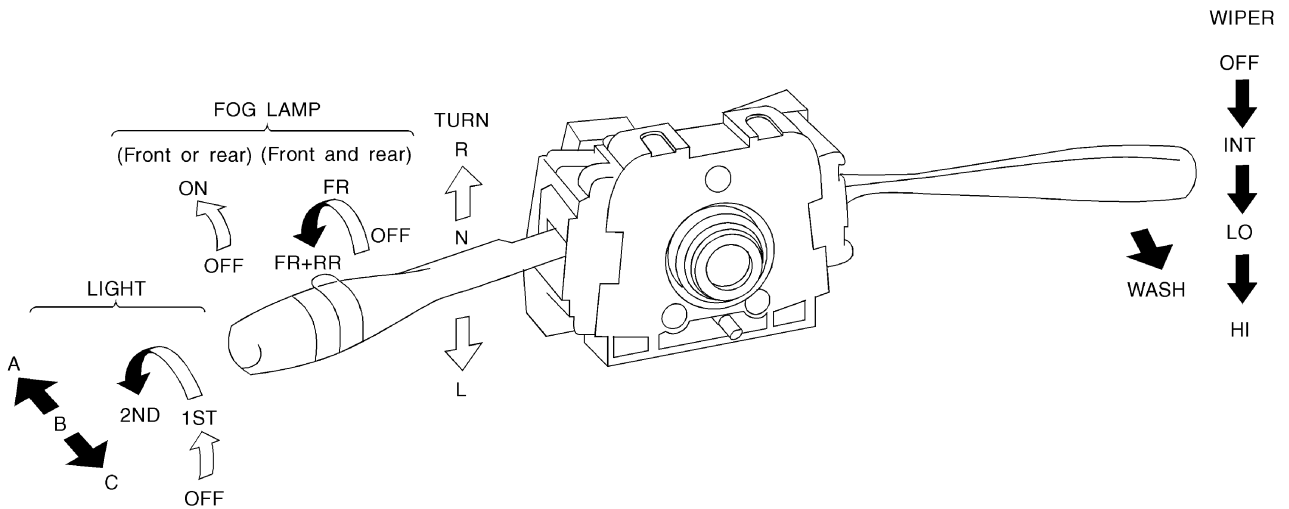

LIGHTING SWITCH

	OFF			1ST			2ND		
	A	B	C	A	B	C	A	B	C
5									
6									
7									
8									
9									
10									
11									
12									
25									

WIPER AND WASHER SWITCH (With intermittent)

	OFF	INT	LO	HI	WASH
13					
14					
15					
16					
17					
18					

WIPER AMPLIFIER (In combination switch)

WIPER AND WASHER SWITCH (Without intermittent)

	OFF	LO	HI	WASH
13				
14				
15				
16				
17				
18				

TURN SIGNAL LAMP SWITCH

	L	N	R
1			
2			
3			

FRONT FOG LAMP SWITCH

	OFF	ON
28		
27		

REAR FOG LAMP SWITCH

	OFF	ON
26		
27		

FOG LAMP SWITCH (Front and rear)

	OFF	FR	FR+RR
28			
29			
27			

HORN SWITCH (Without air bag)

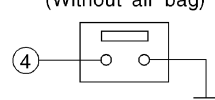

HEADLAMP — Headlamp Aiming Control —

Wiring Diagram — H/AIM —

EL-H/AIM-01

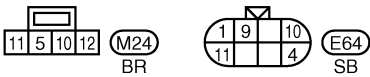
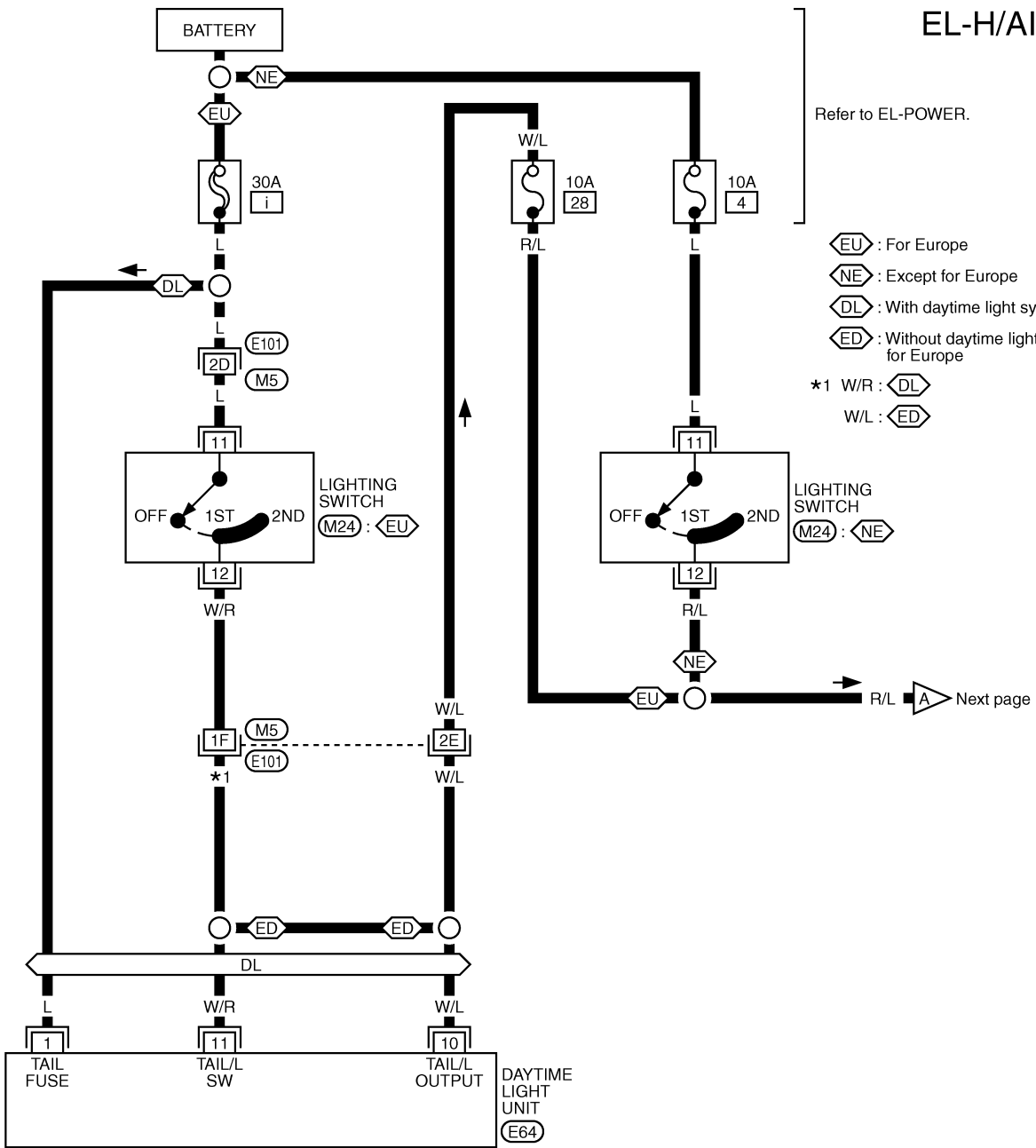

Refer to last page (Foldout page).

⬡M5⬡, ⬡E101⬡

HEADLAMP — Headlamp Aiming Control —

Wiring Diagram — H/AIM — (Cont'd)

EL-H/AIM-02

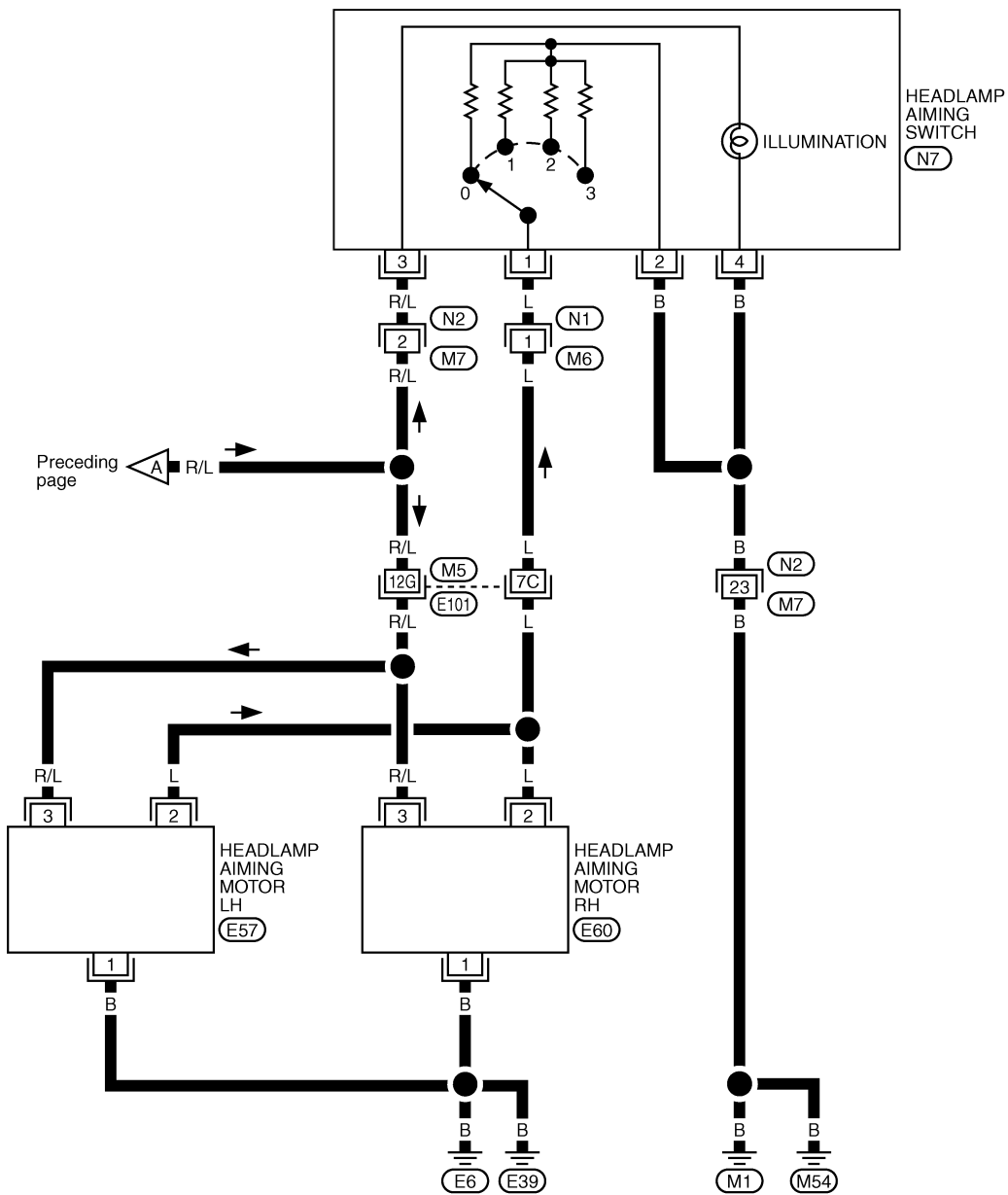

1	2	3	4	5	6	7	8	9	10	11		
12	13	14	15	16	17	18	19	20	21	22	23	24

(N1) W, (N2) BR



(N7) W



(E57), (E60)

Refer to last page (Foldout page).

(M5), (E101)

PARKING, LICENSE AND TAIL LAMPS

Wiring Diagram — TAIL/L —/LHD Models

EL-TAIL/L-01

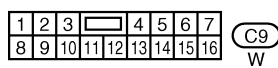
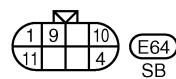
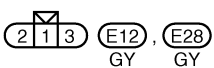
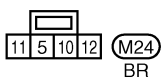
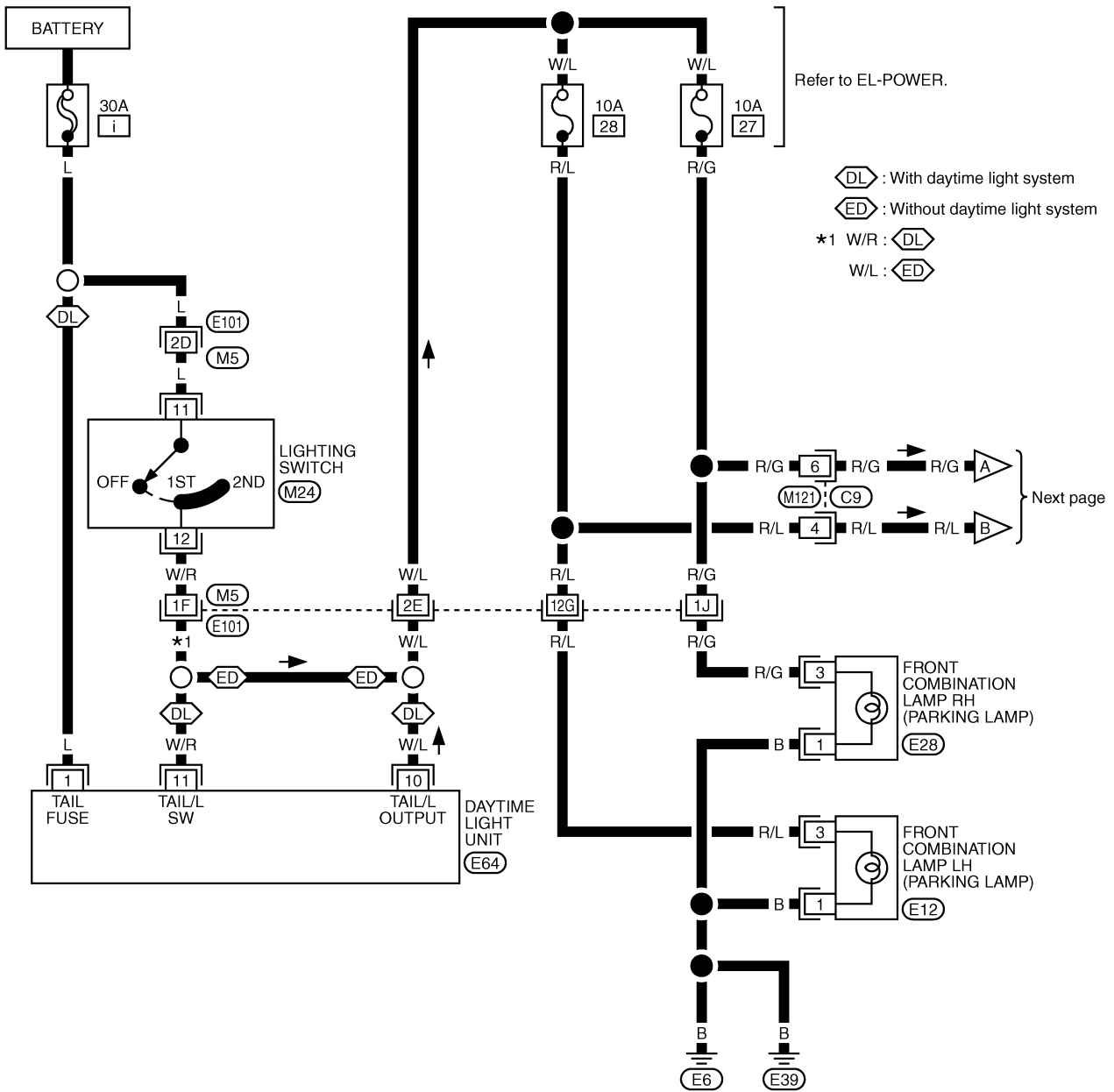

Refer to last page (Foldout page).
M5, E101

PARKING, LICENSE AND TAIL LAMPS

Wiring Diagram — TAIL/L —/LHD Models (Cont'd)

EL-TAIL/L-02

- ⬡CH⬡ : A-chassis models
- ⬡XH⬡ : Except A-chassis models
- ⬡SB⬡ : Models with step bumper
- ⬡XB⬡ : Except ⬡SB⬡
- *1 4: ⬡CH⬡
- 5: ⬡XH⬡

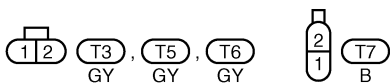
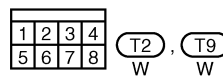
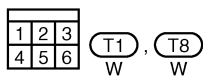
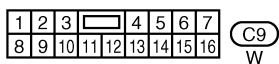
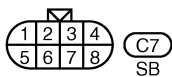
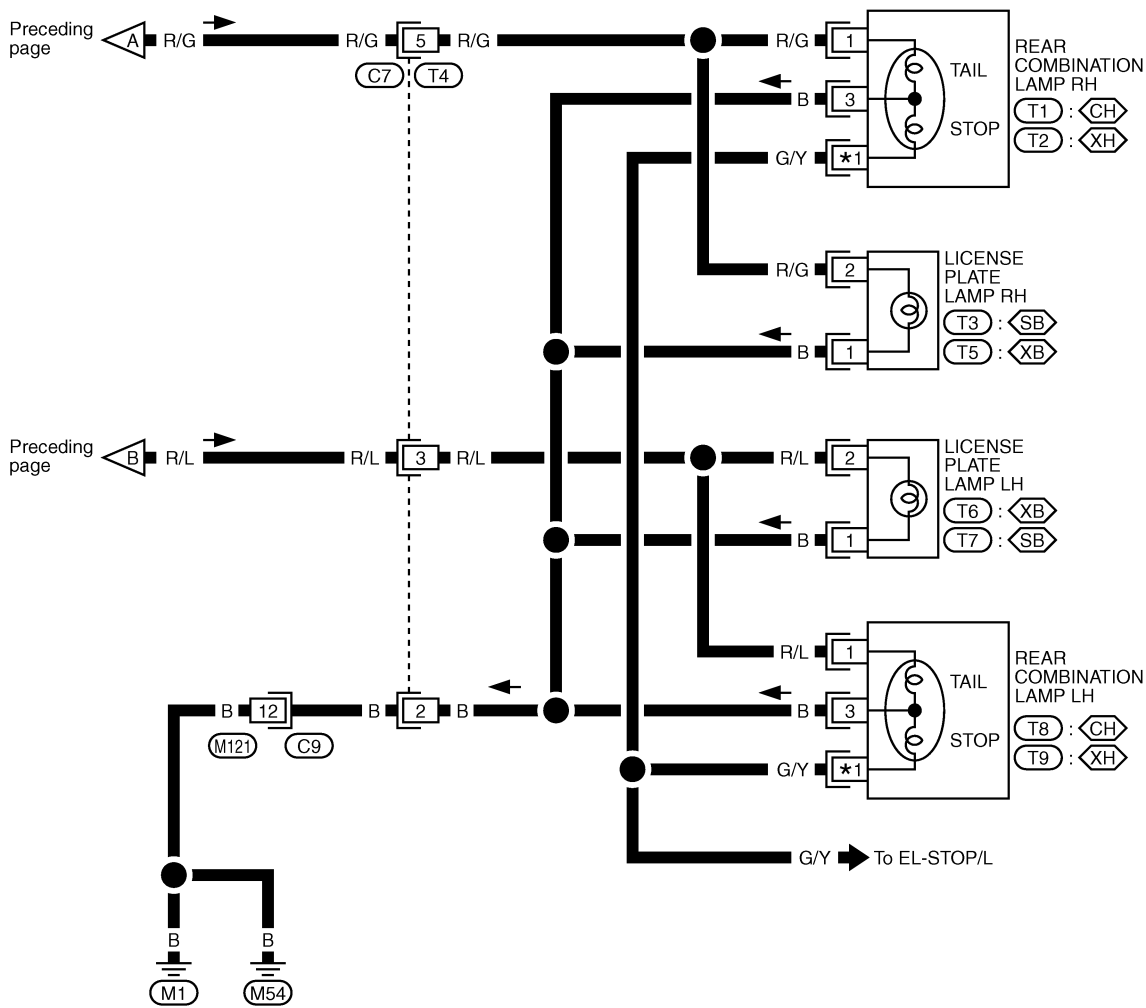

FRONT FOG LAMP

Wiring Diagram — F/FOG —/LHD Models

EL-F/FOG-01

Refer to EL-POWER.

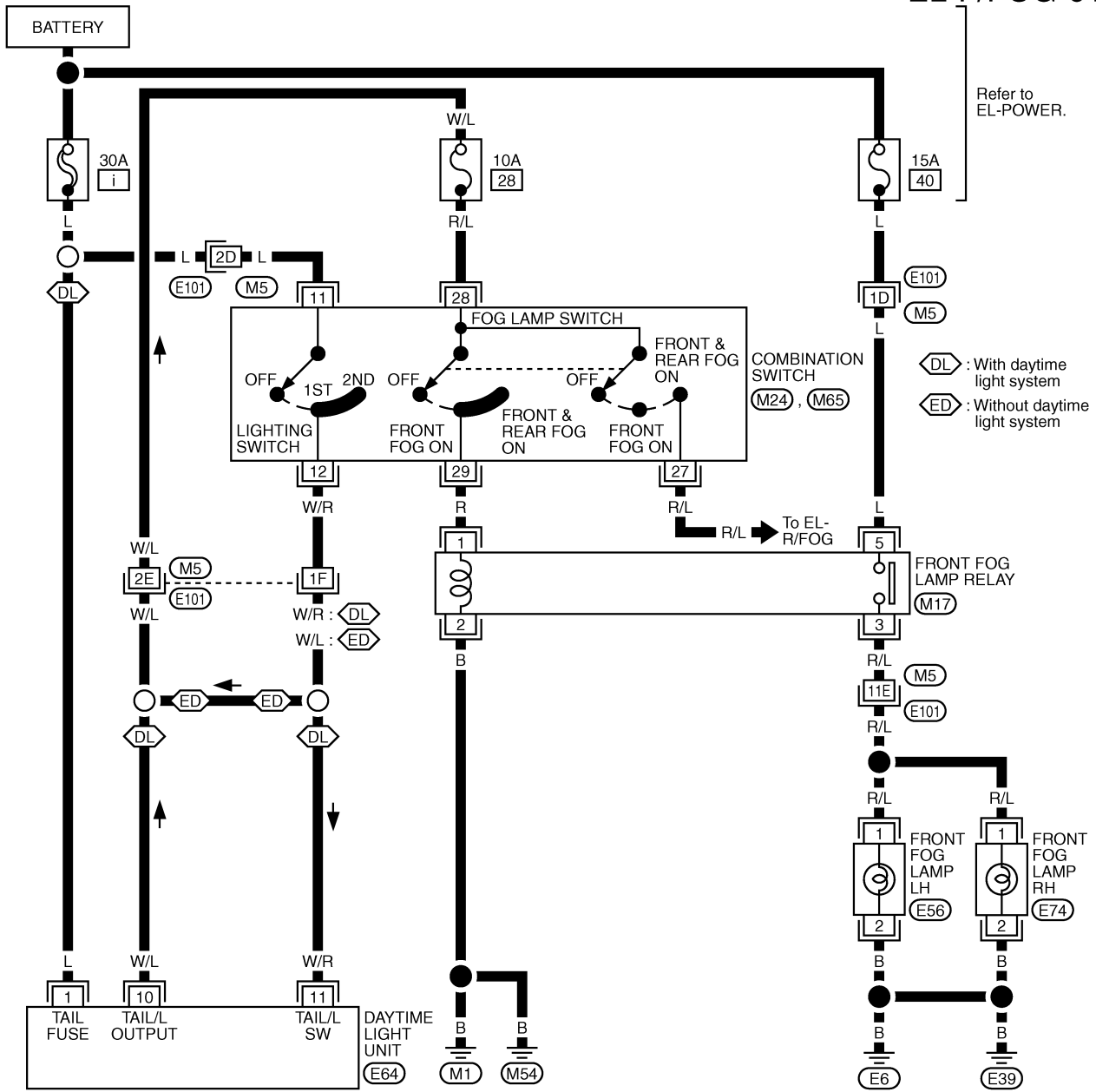

DL : With daytime light system
ED : Without daytime light system

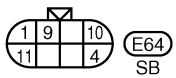
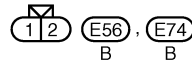
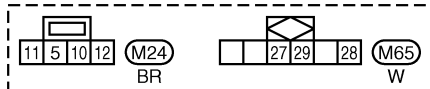
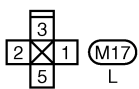

Refer to last page (Foldout page).

M5, E101

FRONT FOG LAMP

Wiring Diagram — F/FOG —/RHD Models

EL-F/FOG-02

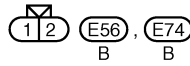
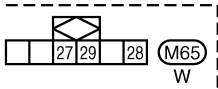
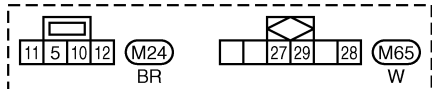
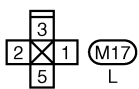
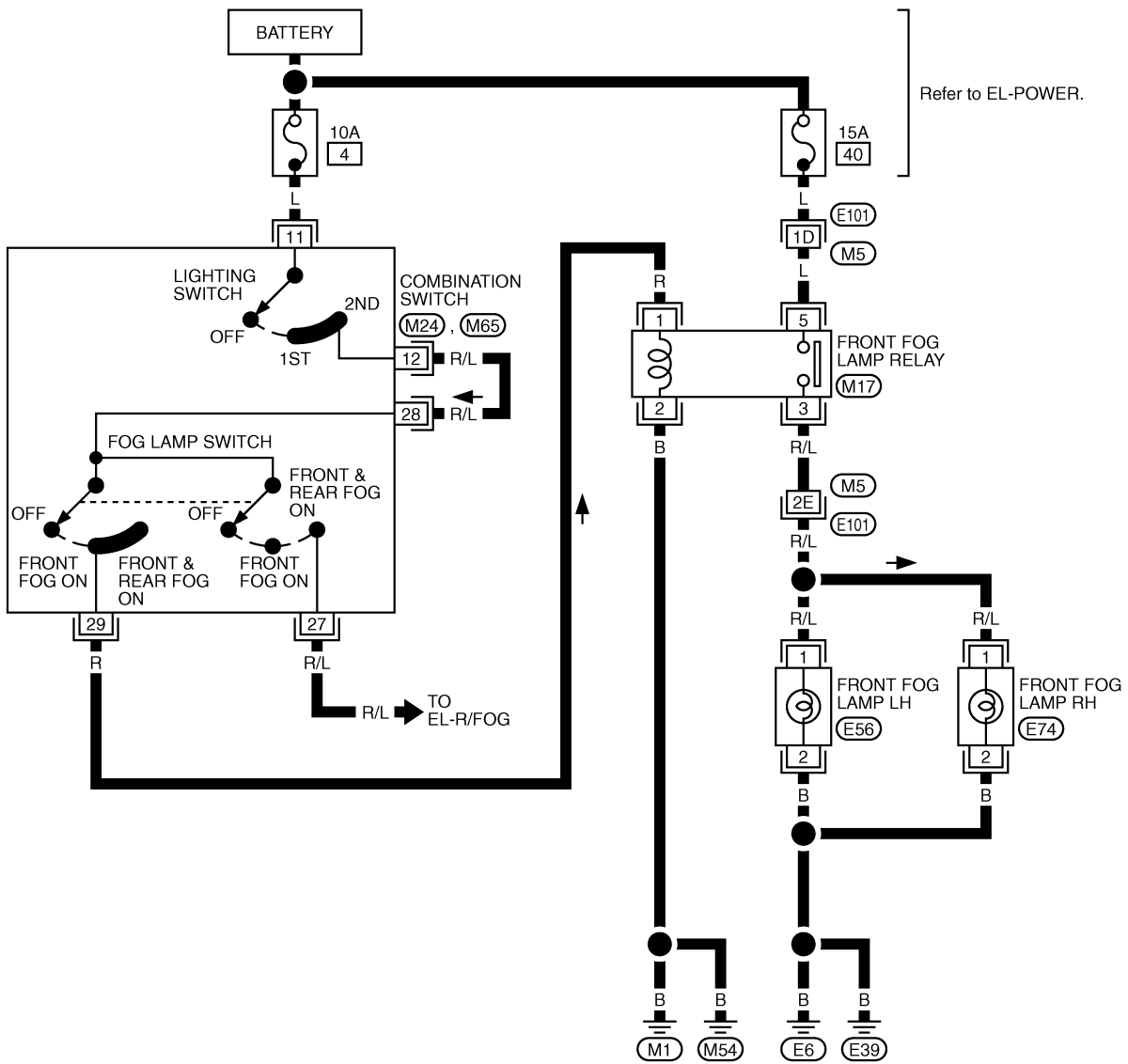

Refer to last page (Foldout page).

(M5), (E101)

REAR FOG LAMP

Wiring Diagram — R/FOG —/LHD Models without Front Fog Lamp

EL-R/FOG-01

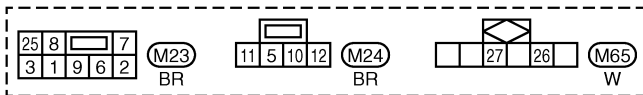
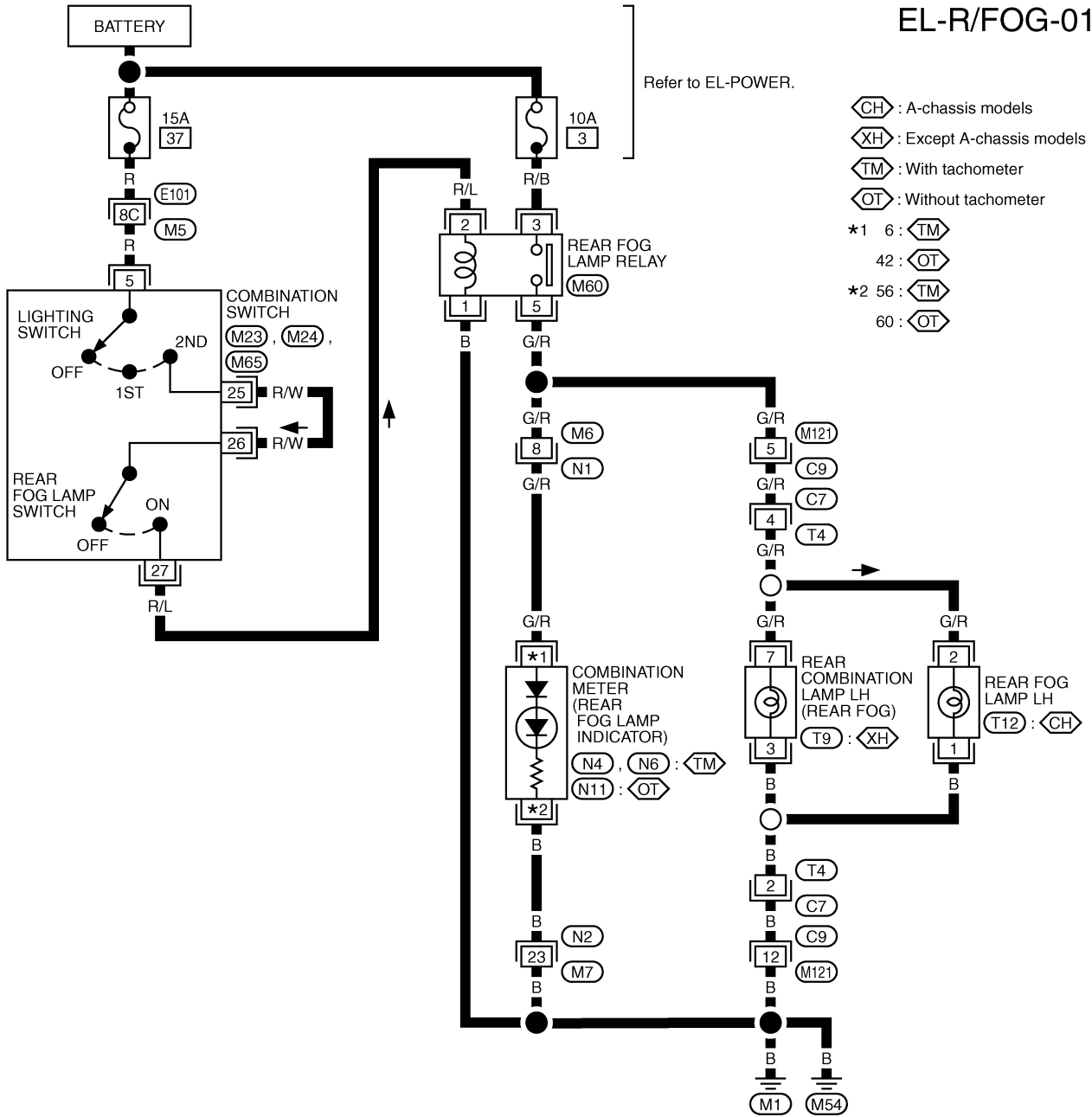

Refer to last page (Foldout page).

M5, E101

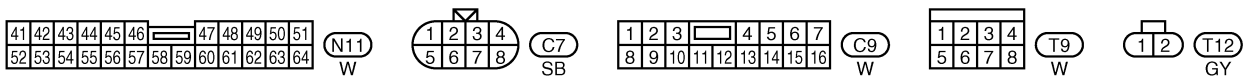
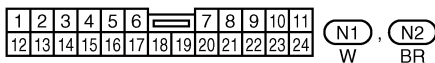

REAR FOG LAMP

Wiring Diagram — R/FOG —/RHD Models without Front Fog Lamp

EL-R/FOG-02

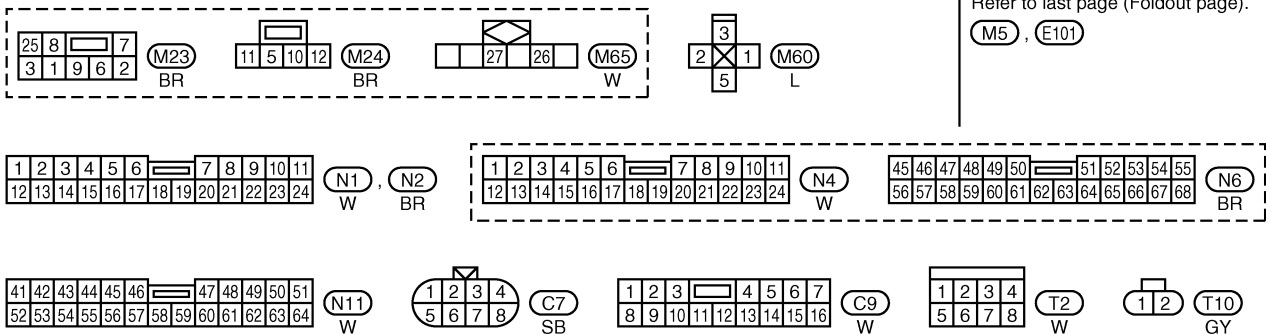
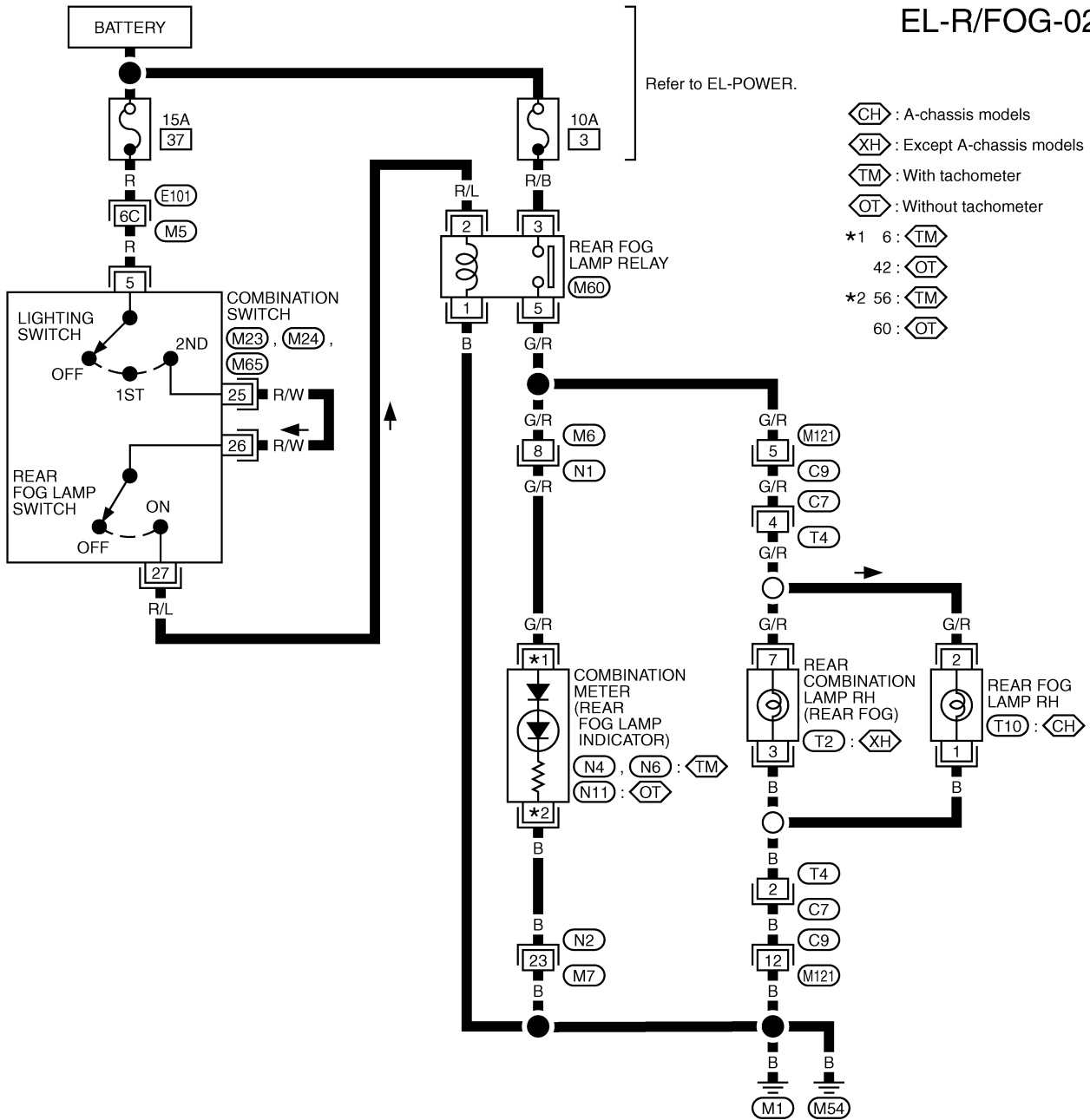

REAR FOG LAMP

Wiring Diagram — R/FOG —/LHD Models with Front Fog Lamp

EL-R/FOG-03

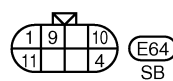
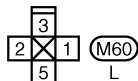
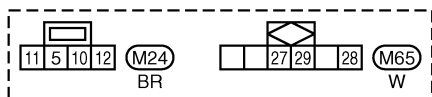
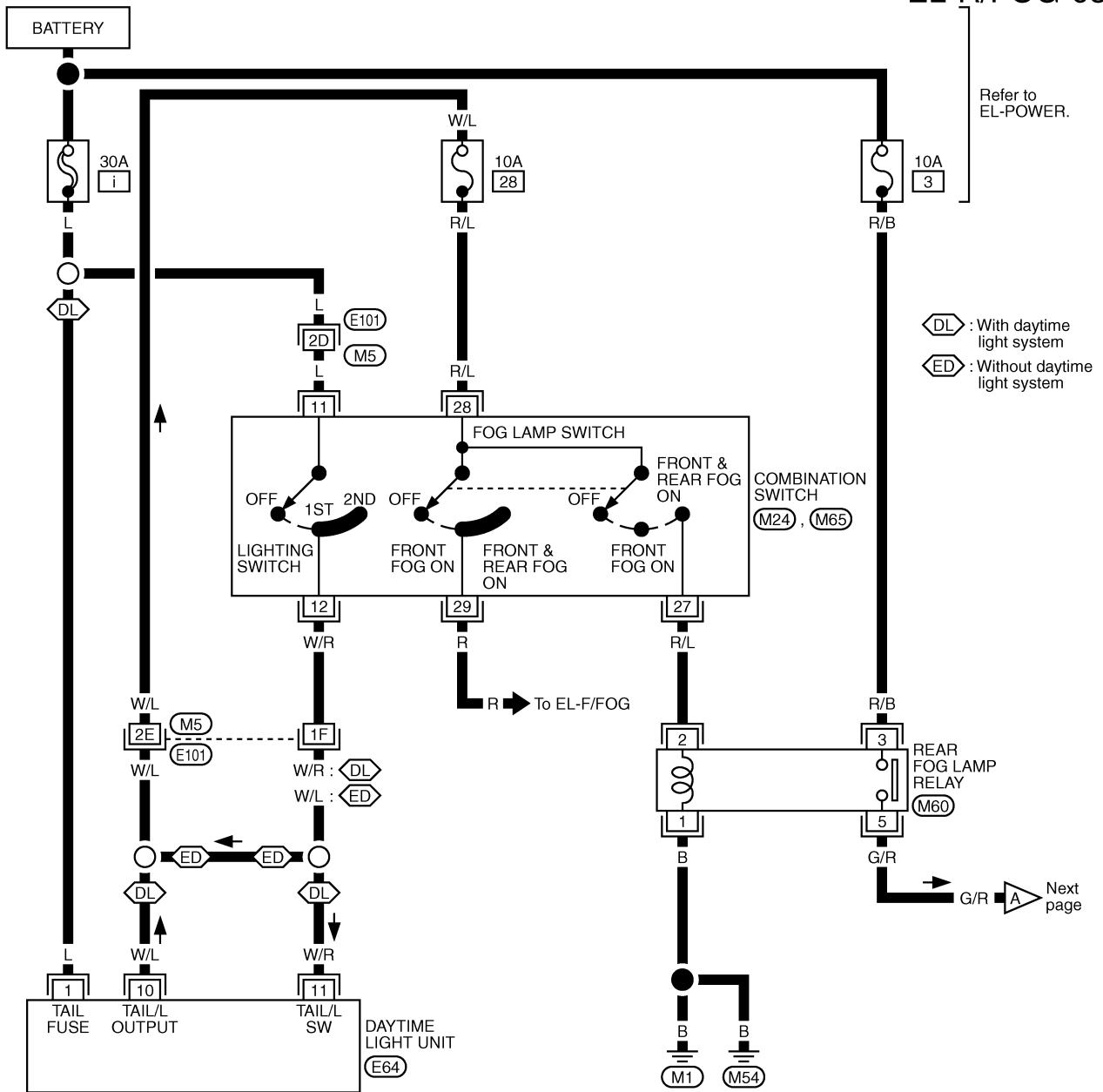

Refer to last page (Foldout page).

M5, E101

REAR FOG LAMP

Wiring Diagram — R/FOG —/LHD Models with Front Fog Lamp (Cont'd)

EL-R/FOG-04

⬡ : A-chassis models

⬢ : Except A-chassis models

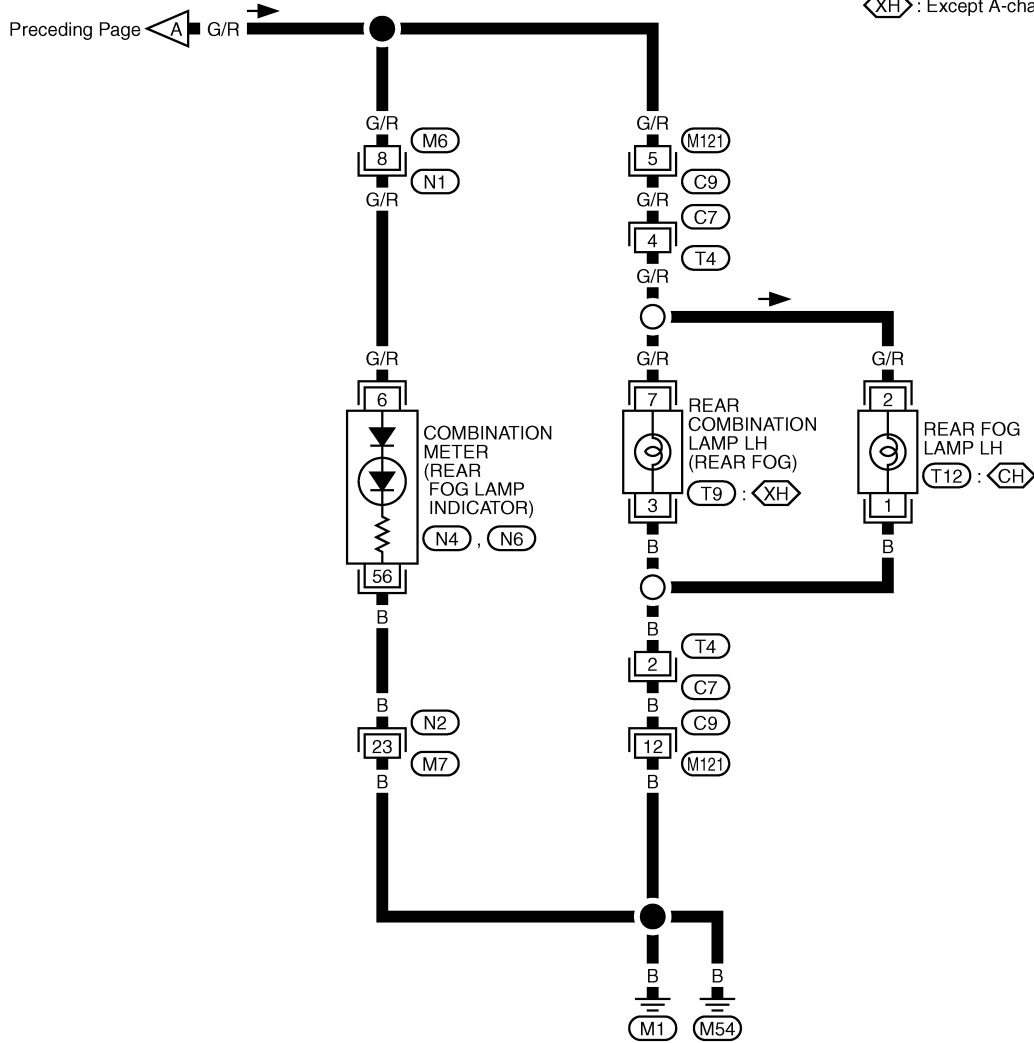

1	2	3	4	5	6	7	8	9	10	11		
12	13	14	15	16	17	18	19	20	21	22	23	24

N1 W

N2 BR

1	2	3	4	5	6	7	8	9	10	11		
12	13	14	15	16	17	18	19	20	21	22	23	24

N4 W

45	46	47	48	49	50	51	52	53	54	55		
56	57	58	59	60	61	62	63	64	65	66	67	68

N6 BR

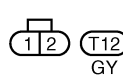
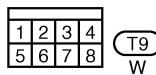
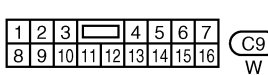
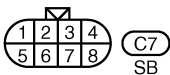

REAR FOG LAMP

Wiring Diagram — R/FOG —/RHD Models with Front Fog Lamp

EL-R/FOG-05

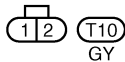
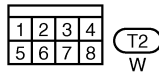
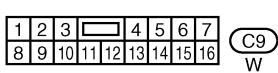
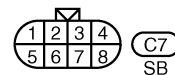
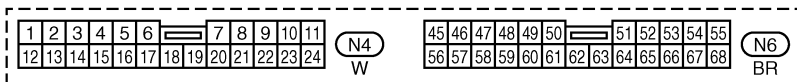
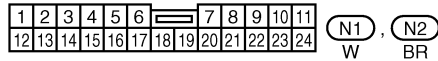
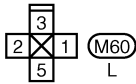
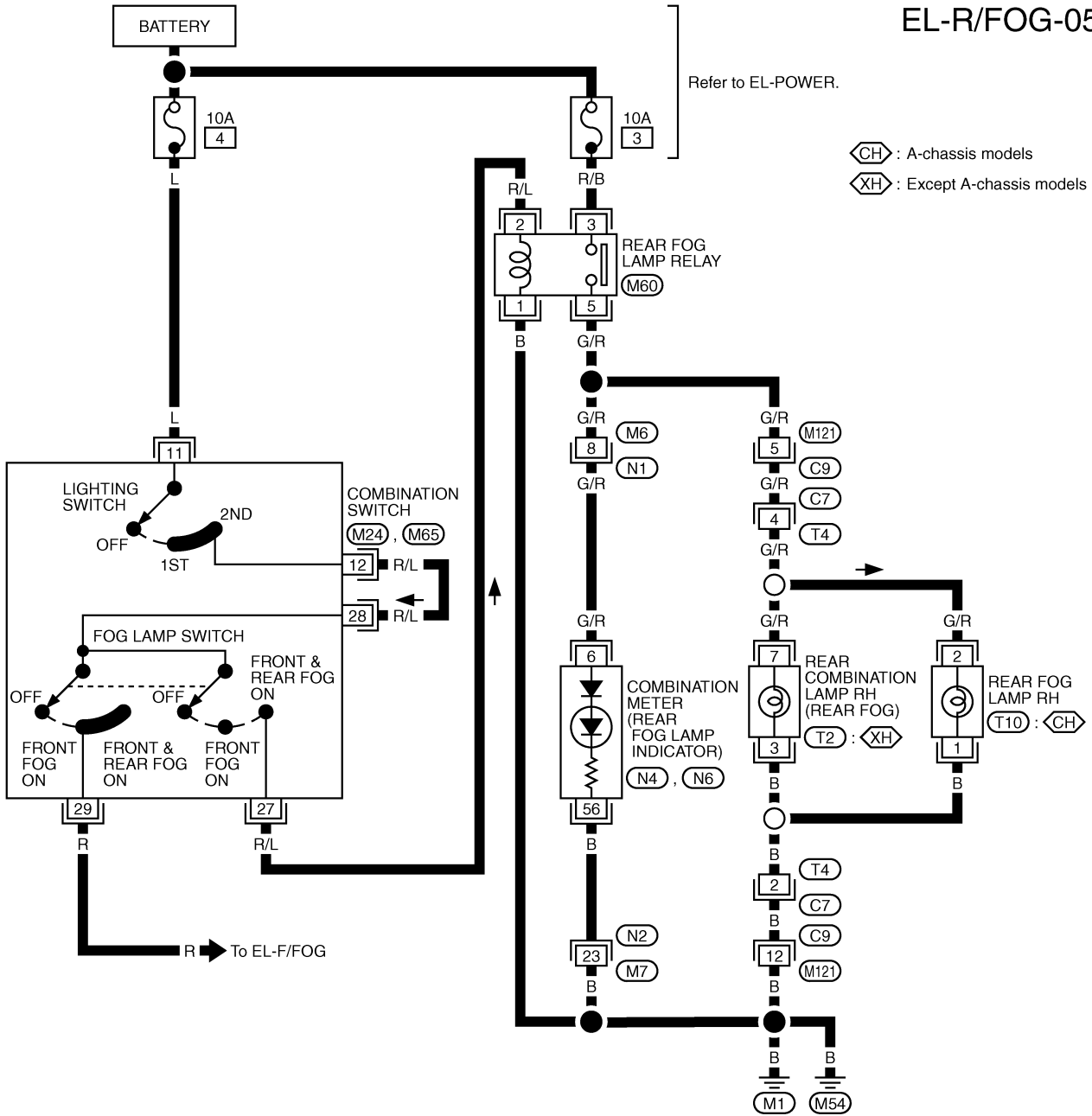

INTERIOR ROOM LAMP

Wiring Diagram — ROOM/L —

EL-ROOM/L-01

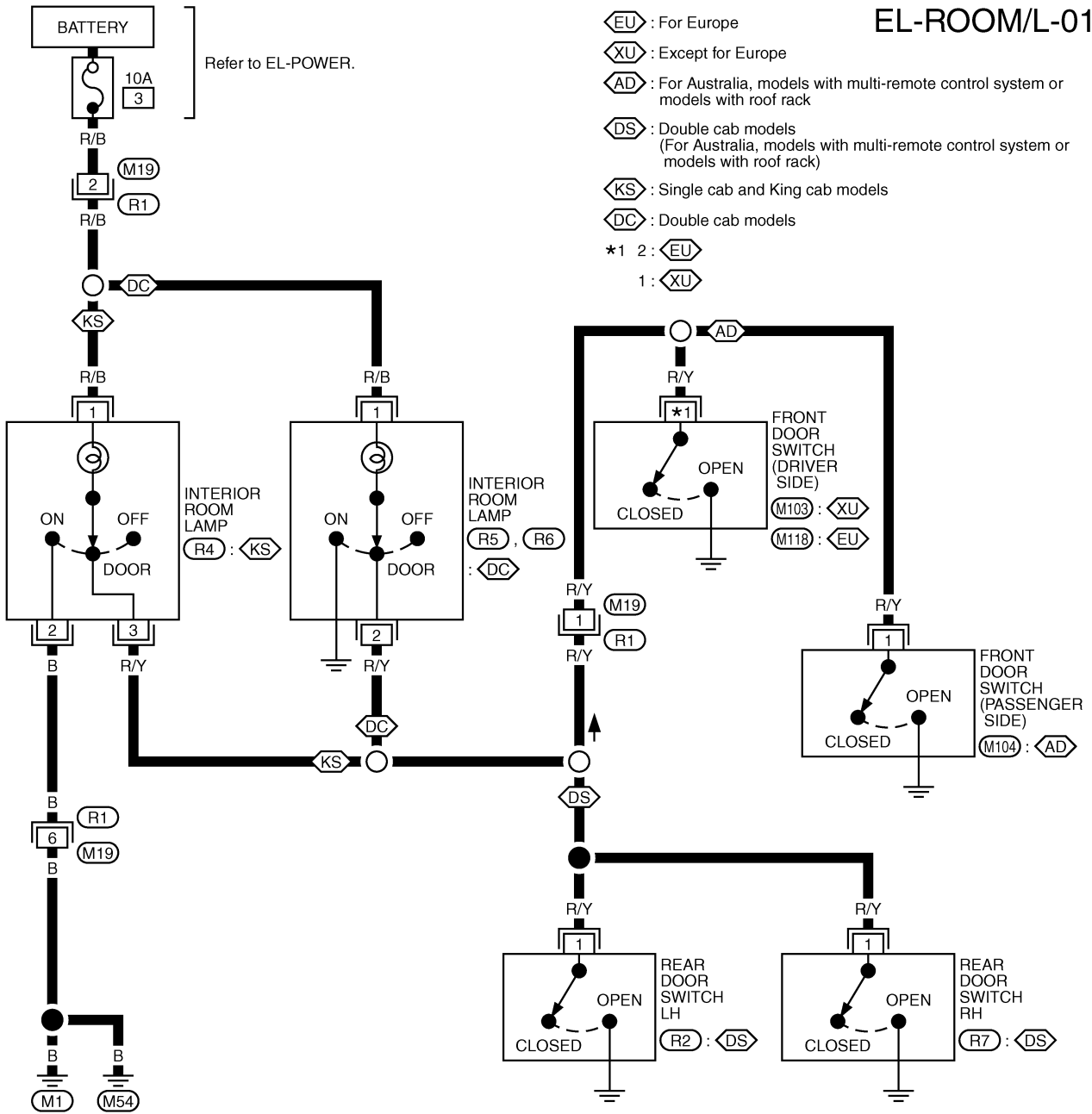

- ⬡EU : For Europe
- ⬡XU : Except for Europe
- ⬡AD : For Australia, models with multi-remote control system or models with roof rack
- ⬡DS : Double cab models
(For Australia, models with multi-remote control system or models with roof rack)
- ⬡KS : Single cab and King cab models
- ⬡DC : Double cab models
- *1 2 : ⬡EU
- 1 : ⬡XU

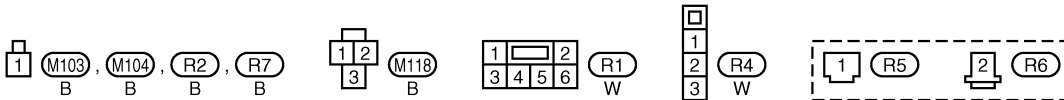

ILLUMINATION

Wiring Diagram — ILL —/LHD Models

EL-ILL-01

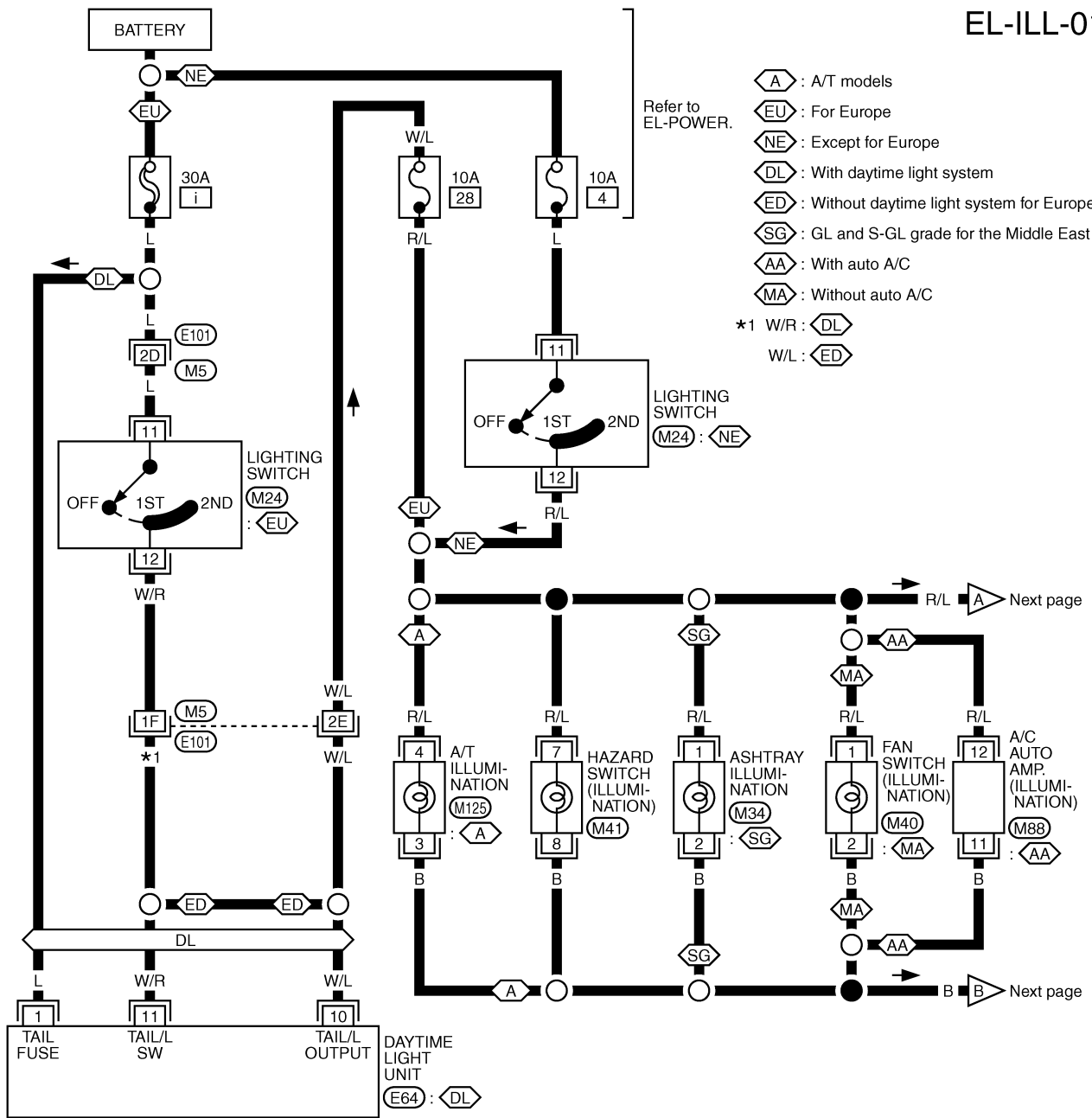

- ⬡ (A) : A/T models
- ⬡ (EU) : For Europe
- ⬡ (NE) : Except for Europe
- ⬡ (DL) : With daytime light system
- ⬡ (ED) : Without daytime light system for Europe
- ⬡ (SG) : GL and S-GL grade for the Middle East
- ⬡ (AA) : With auto A/C
- ⬡ (MA) : Without auto A/C
- *1 W/R : ⬡ (DL)
- W/L : ⬡ (ED)

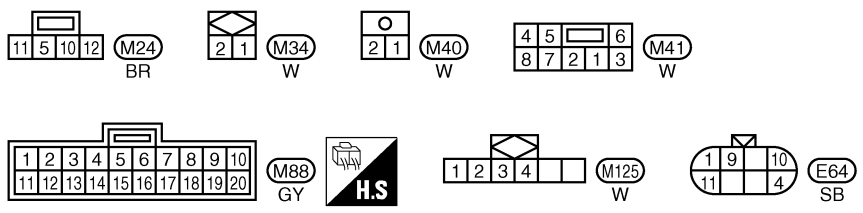

Refer to last page (Foldout page).
 (M5), (E101)

ILLUMINATION

Wiring Diagram — ILL —/LHD Models (Cont'd)

EL-ILL-02

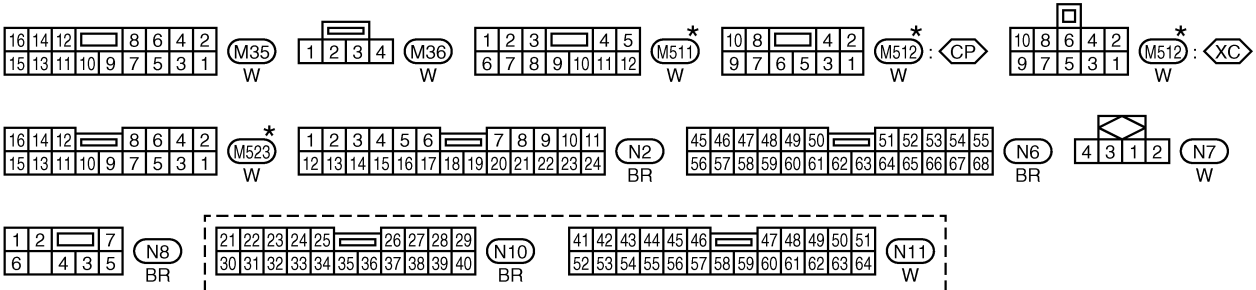
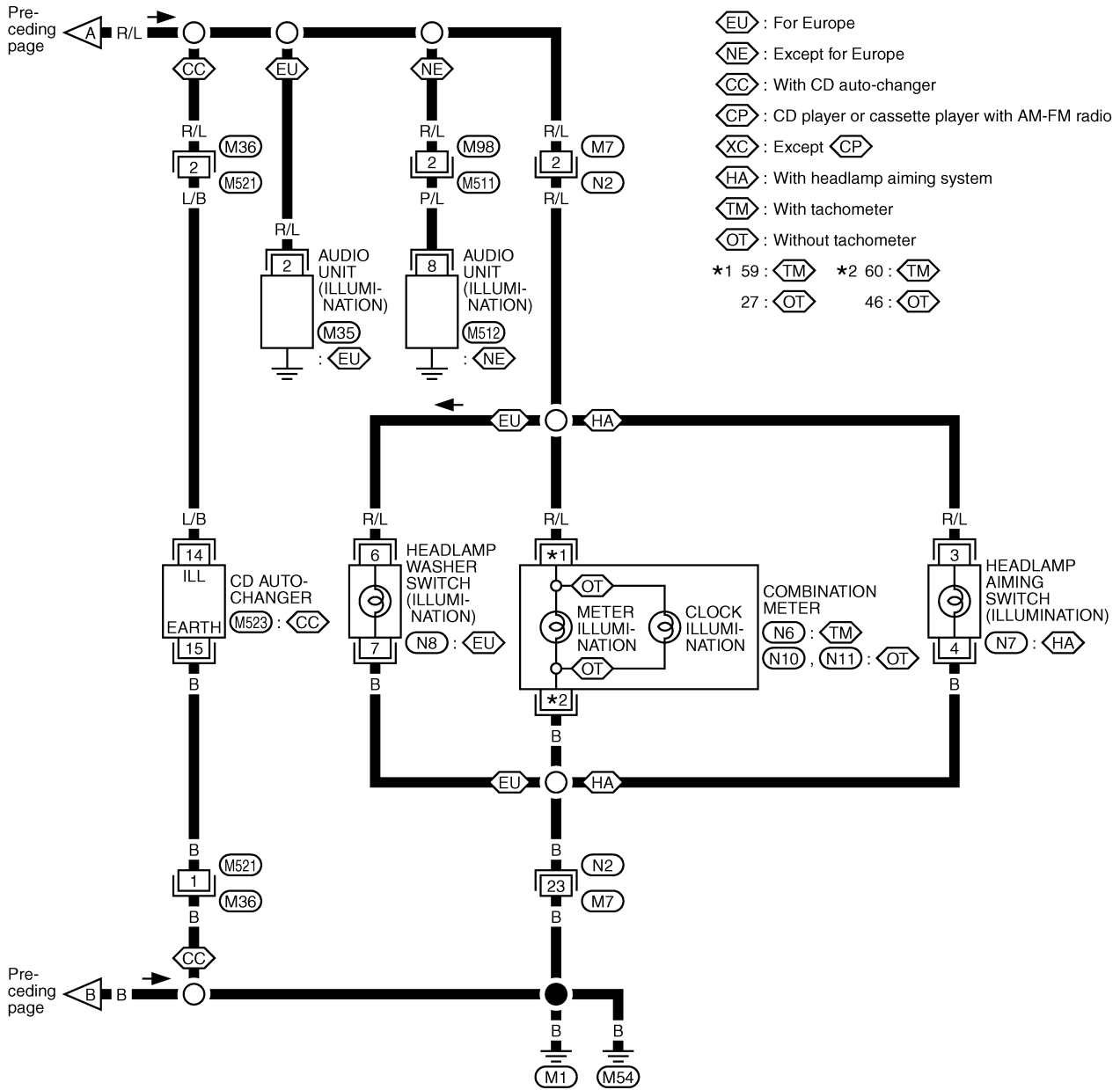

*: This connector is not shown in "HARNESS LAYOUT".

METER AND GAUGES

Wiring Diagram — METER —/Gasoline Engine with Tachometer

EL-METER-01

- : VG30E engine
- : VG33E engine
- : KA and Z engines

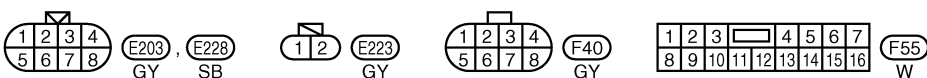
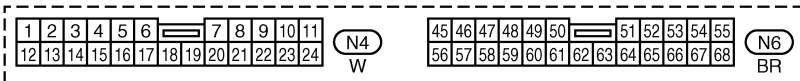
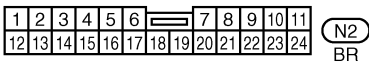
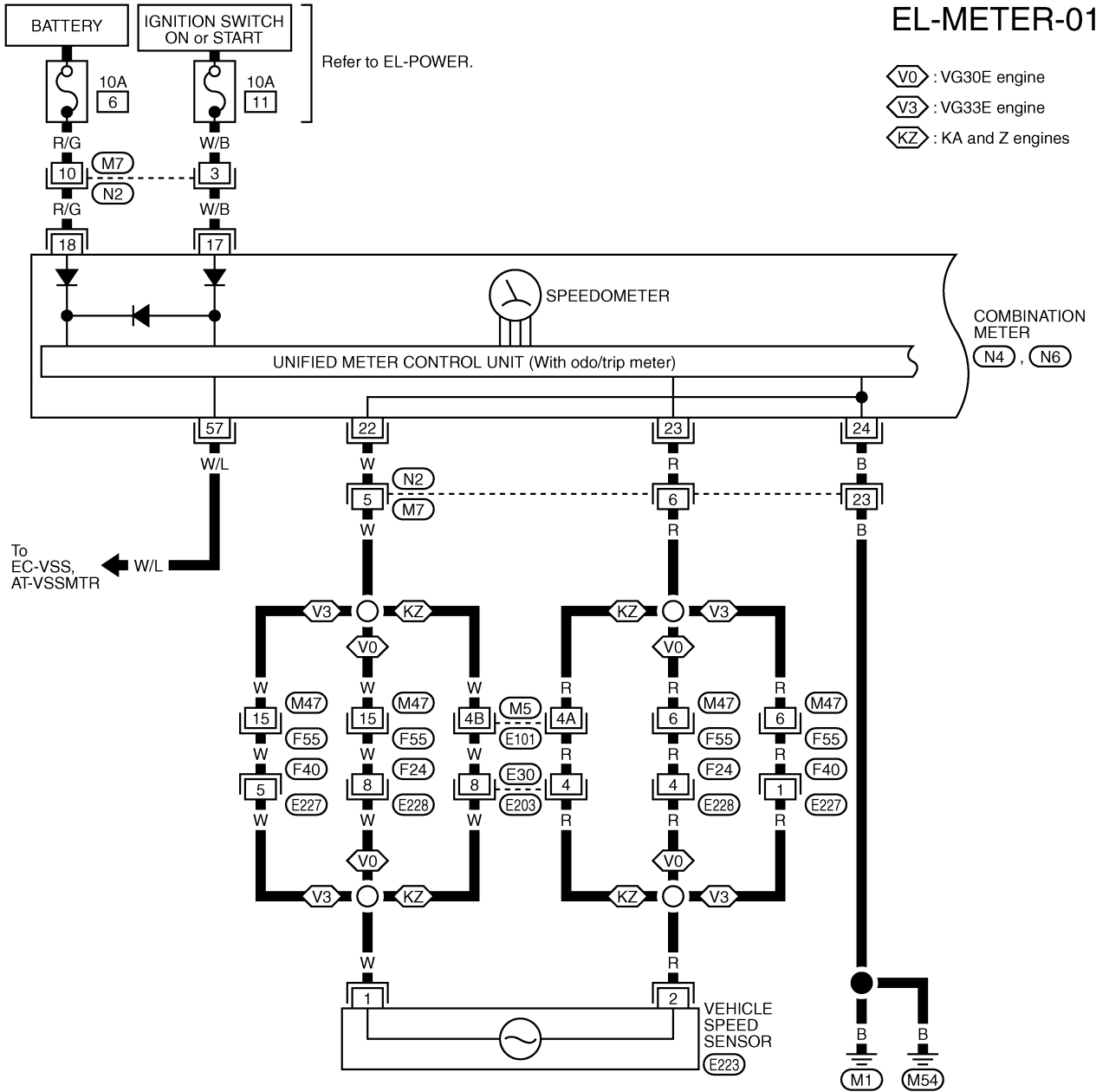

Refer to last page (Foldout page).

(M5), (E101)

METER AND GAUGES

Wiring Diagram — METER —/Gasoline Engine with Tachometer (Cont'd)

EL-METER-02

- L : LHD models
- R : RHD models
- EU : For Europe
- NE : Except for Europe
- CB : Carburetor engine
- VG : VG engine
- LK : LHD models with KA engine
- RK : RHD models with KA engine
- RV : RHD models with KA engine and VG engine
- *1 3C: L *2 3: EU *3 18: RK
- 6A: R 18: NE 7: VG

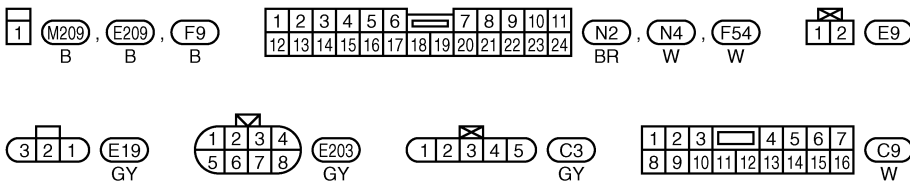
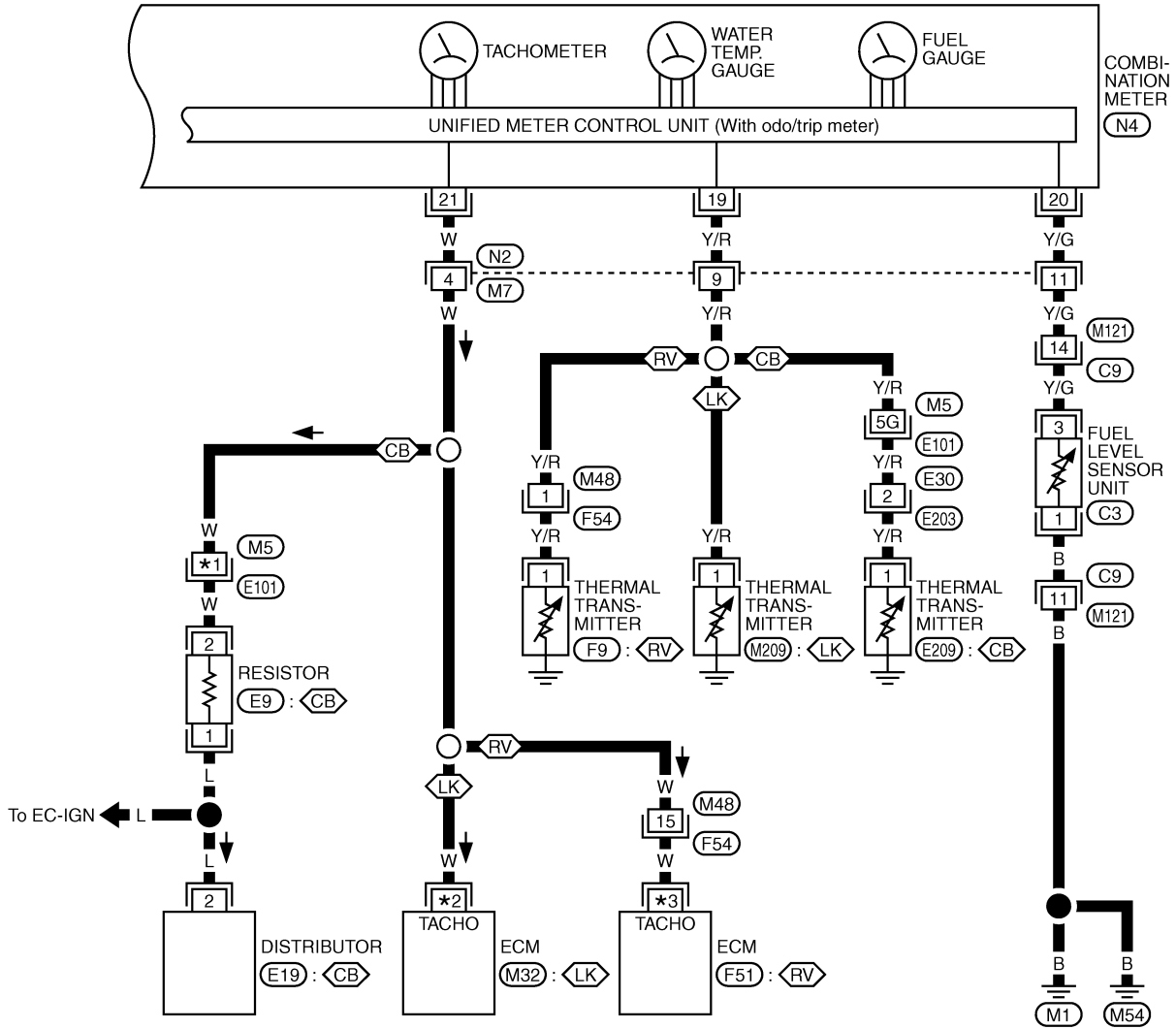

Refer to last page (Foldout page).

- M5, E101
- M32
- F51

WARNING LAMPS

Schematic/Without Tachometer

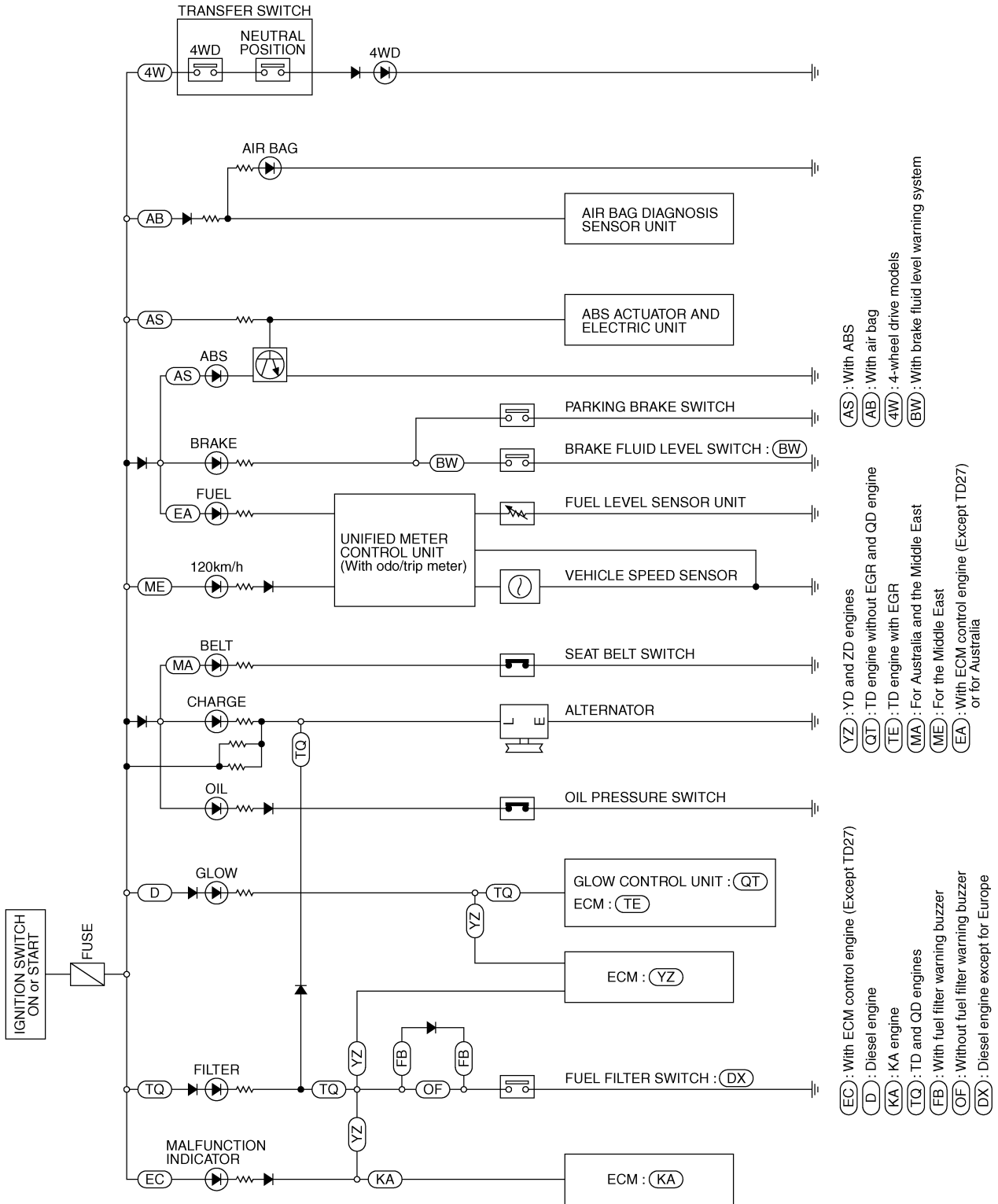

WARNING LAMPS

Wiring Diagram — WARN —/Gasoline Engine with Tachometer

EL-WARN-01

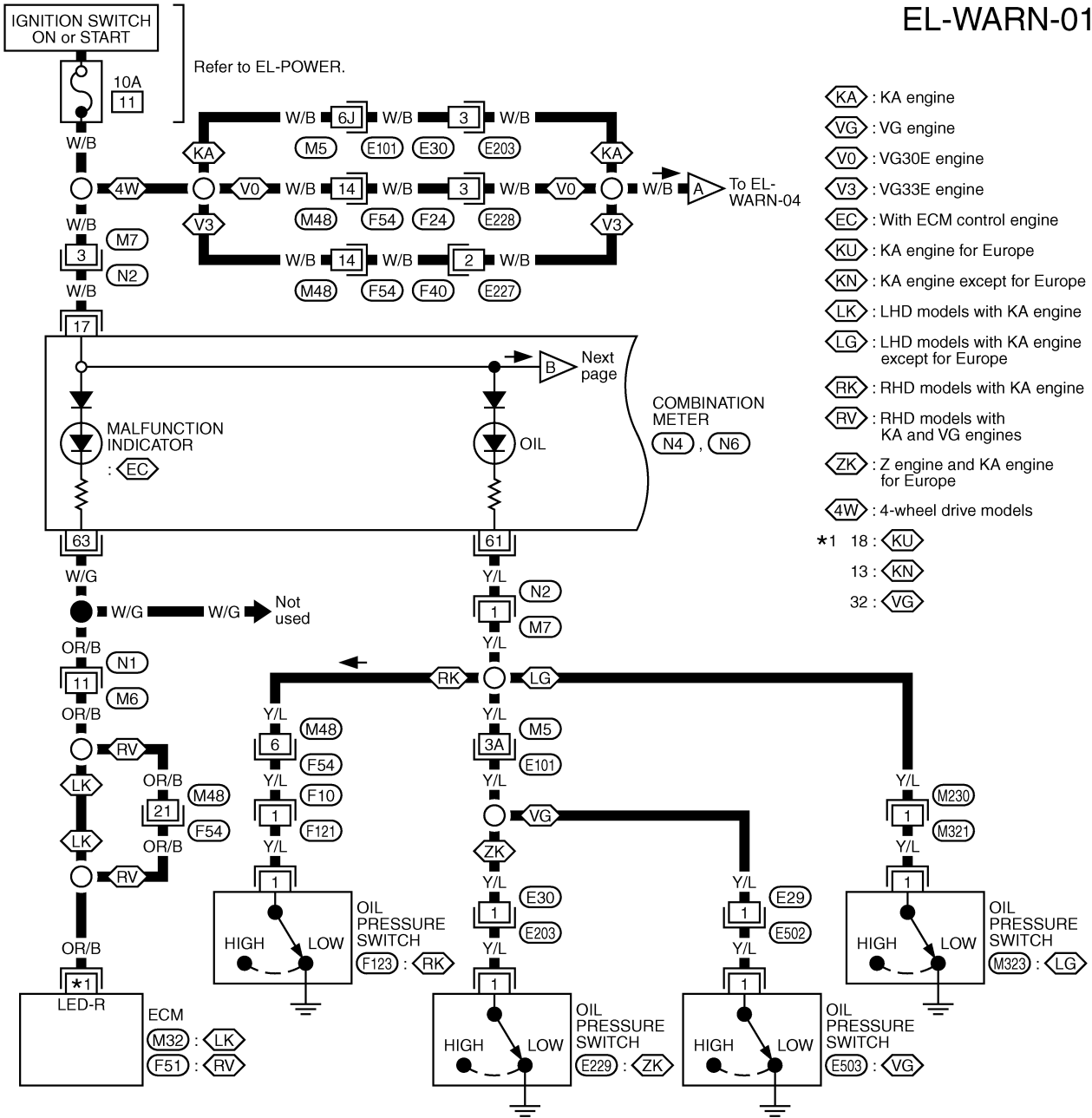

- KA : KA engine
 - VG : VG engine
 - V0 : VG30E engine
 - V3 : VG33E engine
 - EC : With ECM control engine
 - KU : KA engine for Europe
 - KN : KA engine except for Europe
 - LK : LHD models with KA engine
 - LG : LHD models with KA engine except for Europe
 - RK : RHD models with KA engine
 - RV : RHD models with KA and VG engines
 - ZK : Z engine and KA engine for Europe
 - 4W : 4-wheel drive models
- *1 18 : KU
13 : KN
32 : VG

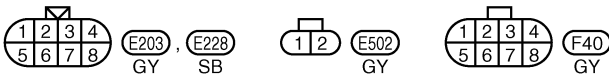
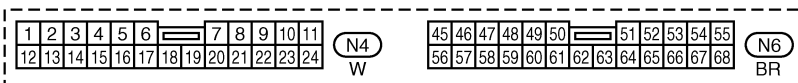
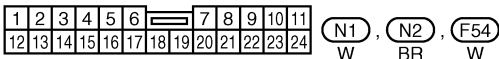
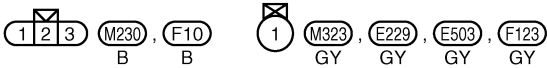

Refer to last page (Foldout page).

- M5, E101
- M32
- F51

WARNING LAMPS

Wiring Diagram — WARN —/Gasoline Engine with Tachometer (Cont'd)

EL-WARN-02

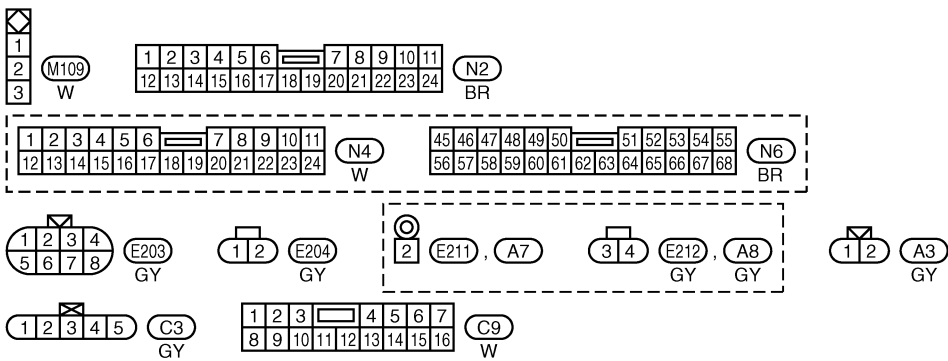
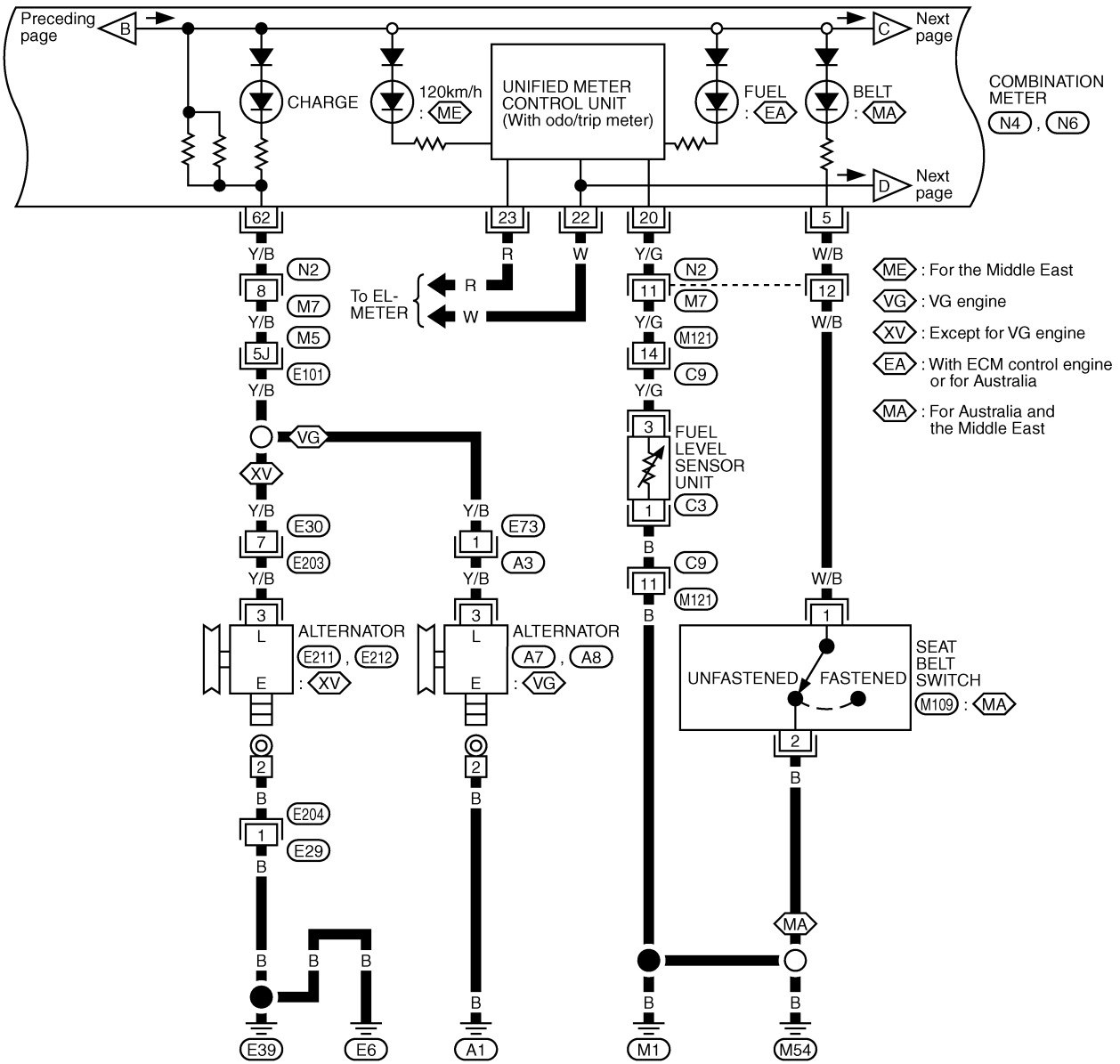

Refer to last page (Foldout page).

M5, E101

WARNING LAMPS

Wiring Diagram — WARN —/Gasoline Engine with Tachometer (Cont'd)

EL-WARN-03

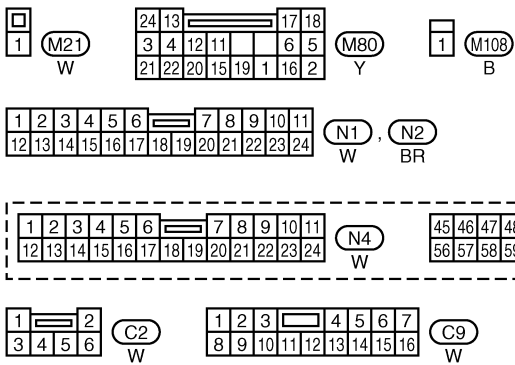
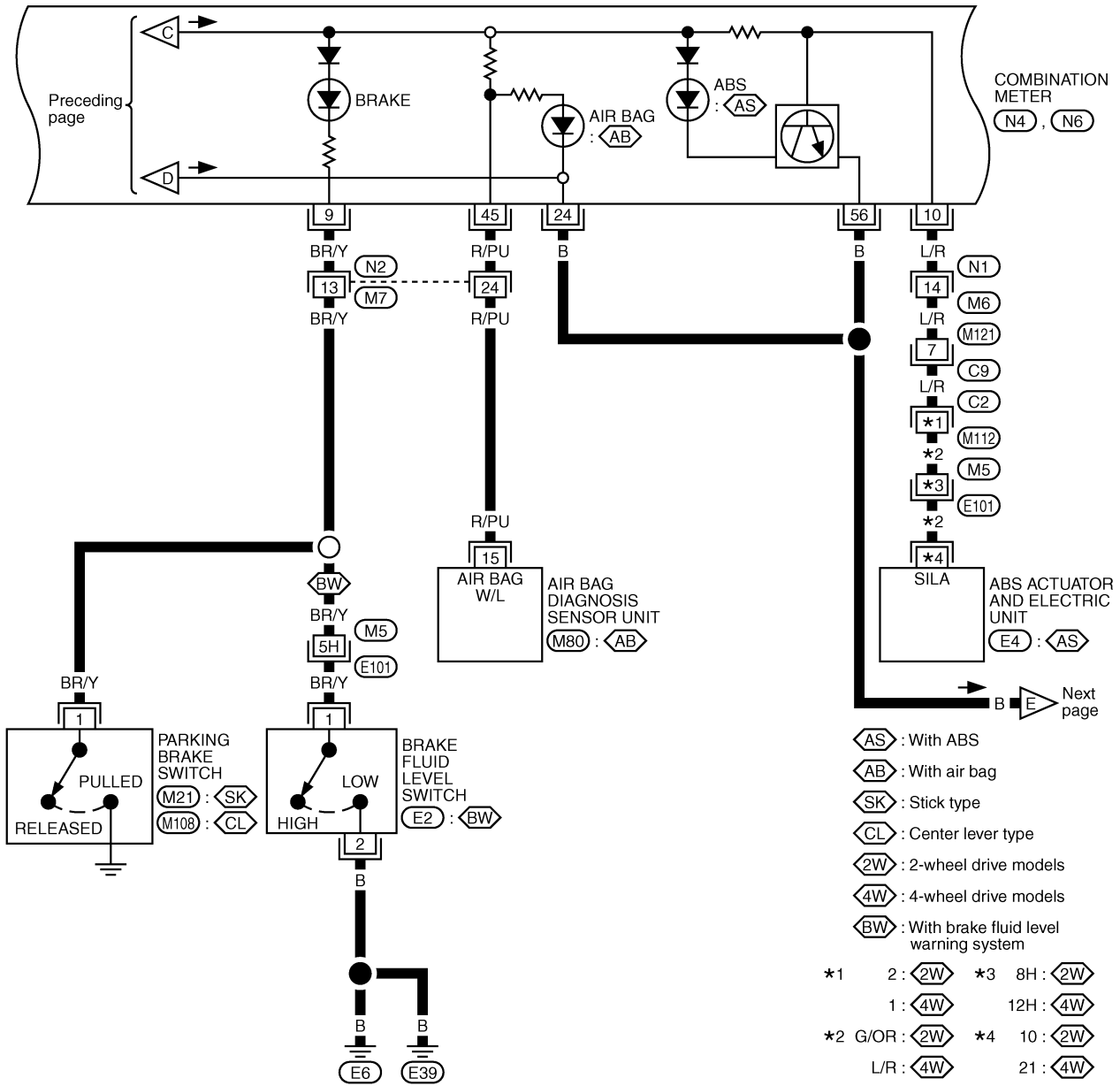

Refer to last page (Foldout page).

M5, E101
E4

WARNING LAMPS

Wiring Diagram — WARN —/Gasoline Engine with Tachometer (Cont'd)

EL-WARN-04

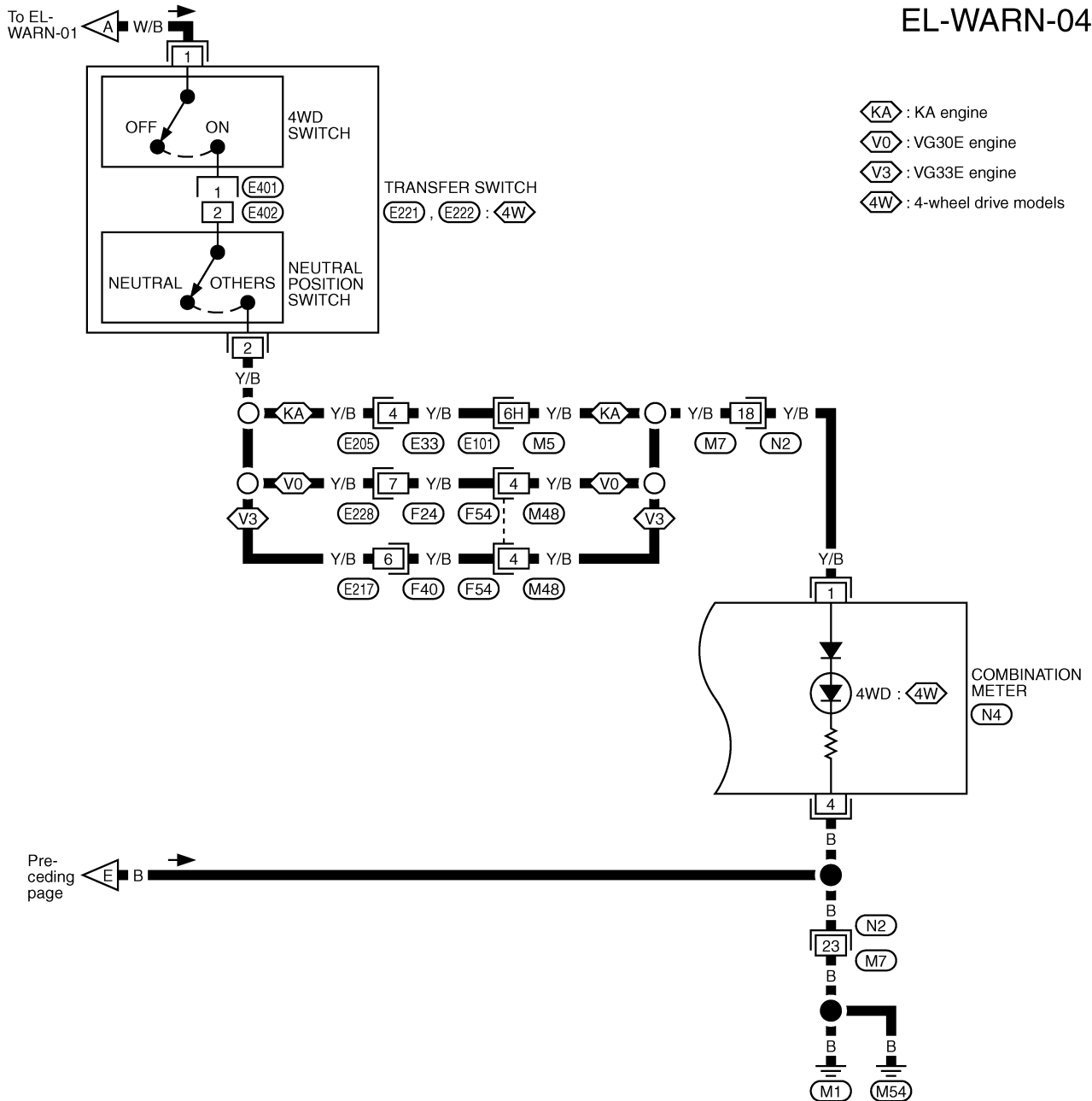

Preceding page

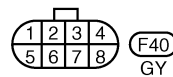
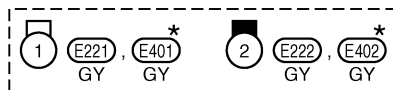
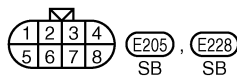
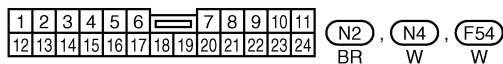

Refer to last page (Foldout page).
(M5), (E101)

WARNING LAMPS

Wiring Diagram — WARN —/Gasoline Engine without Tachometer

EL-WARN-05

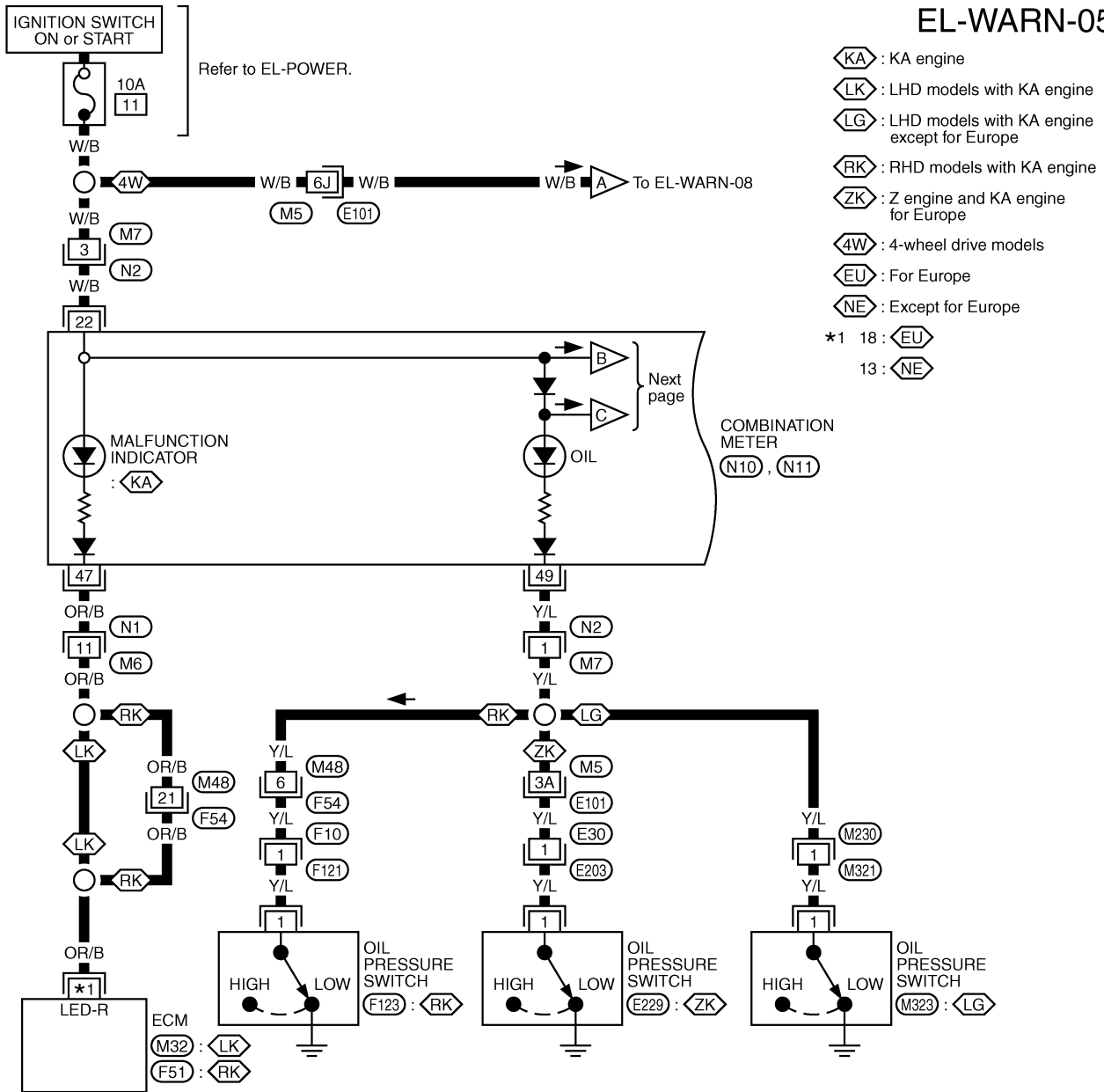

- <KA> : KA engine
- <LK> : LHD models with KA engine
- <LG> : LHD models with KA engine except for Europe
- <RK> : RHD models with KA engine
- <ZK> : Z engine and KA engine for Europe
- <4W> : 4-wheel drive models
- <EU> : For Europe
- <NE> : Except for Europe
- *1 18 : <EU>
- 13 : <NE>

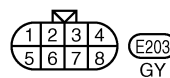
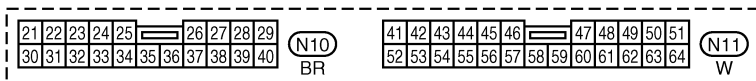
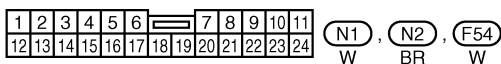
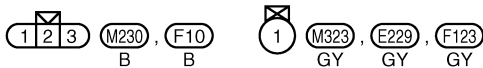

Refer to last page (Foldout page).

M5, E101

M32

F51

WARNING LAMPS

Wiring Diagram — WARN —/Gasoline Engine without Tachometer (Cont'd)

EL-WARN-06

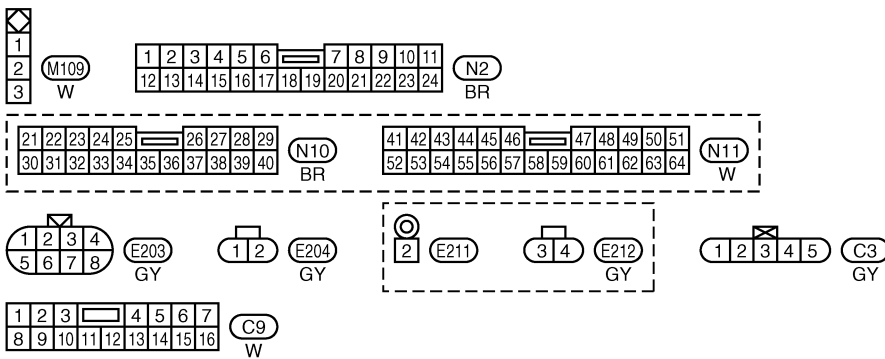
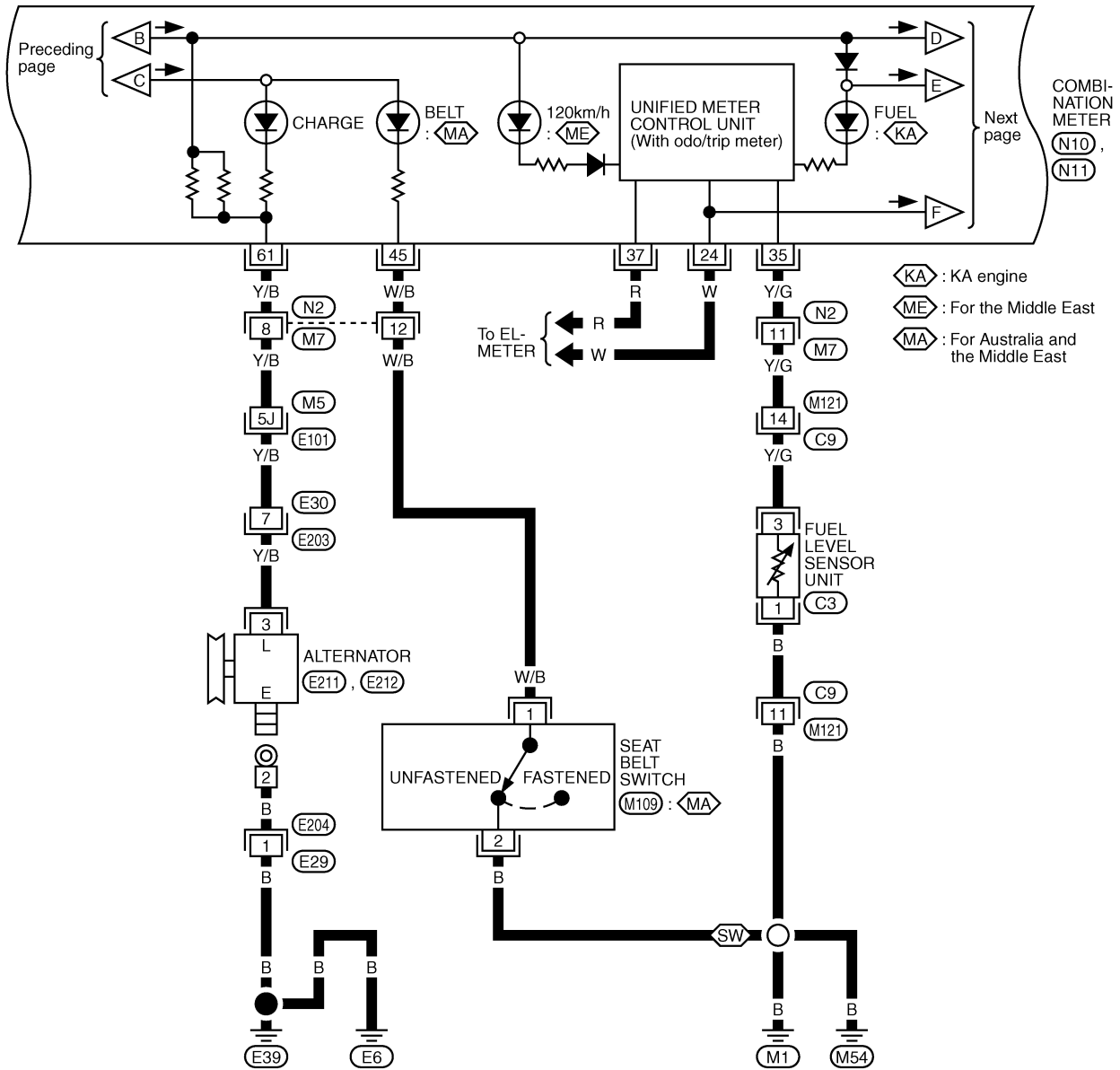

Refer to last page (Foldout page).

M5, E101

WARNING LAMPS

Wiring Diagram — WARN —/Gasoline Engine without Tachometer (Cont'd)

EL-WARN-07

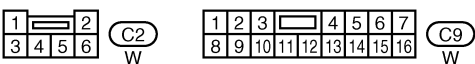
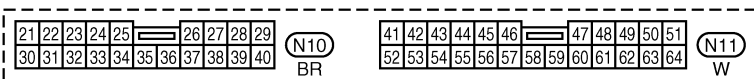
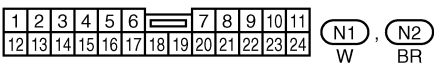
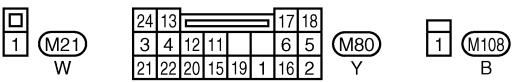
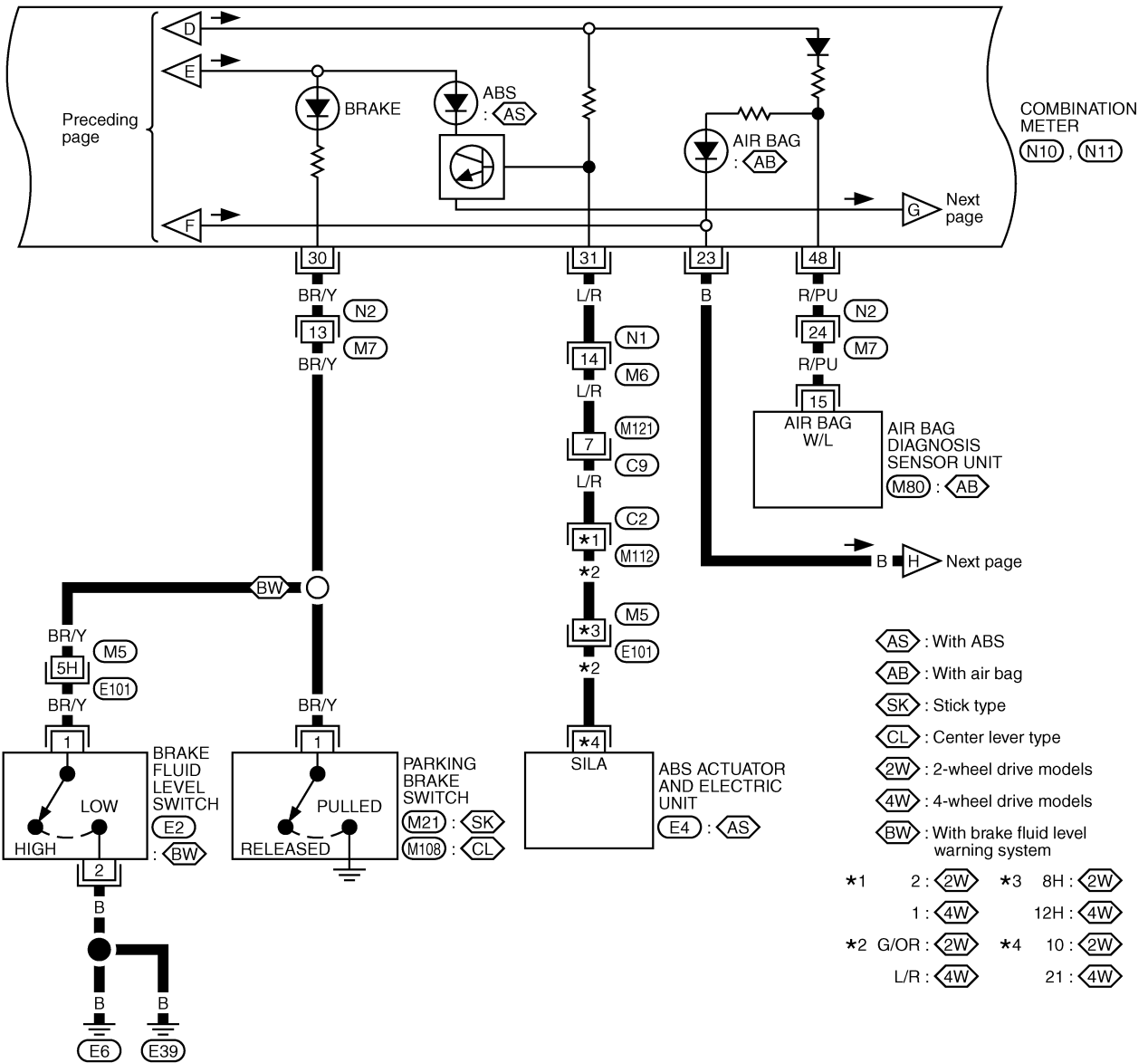

Refer to last page (Foldout page).

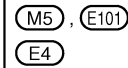

WARNING LAMPS

Wiring Diagram — WARN —/Gasoline Engine without Tachometer (Cont'd)

EL-WARN-08

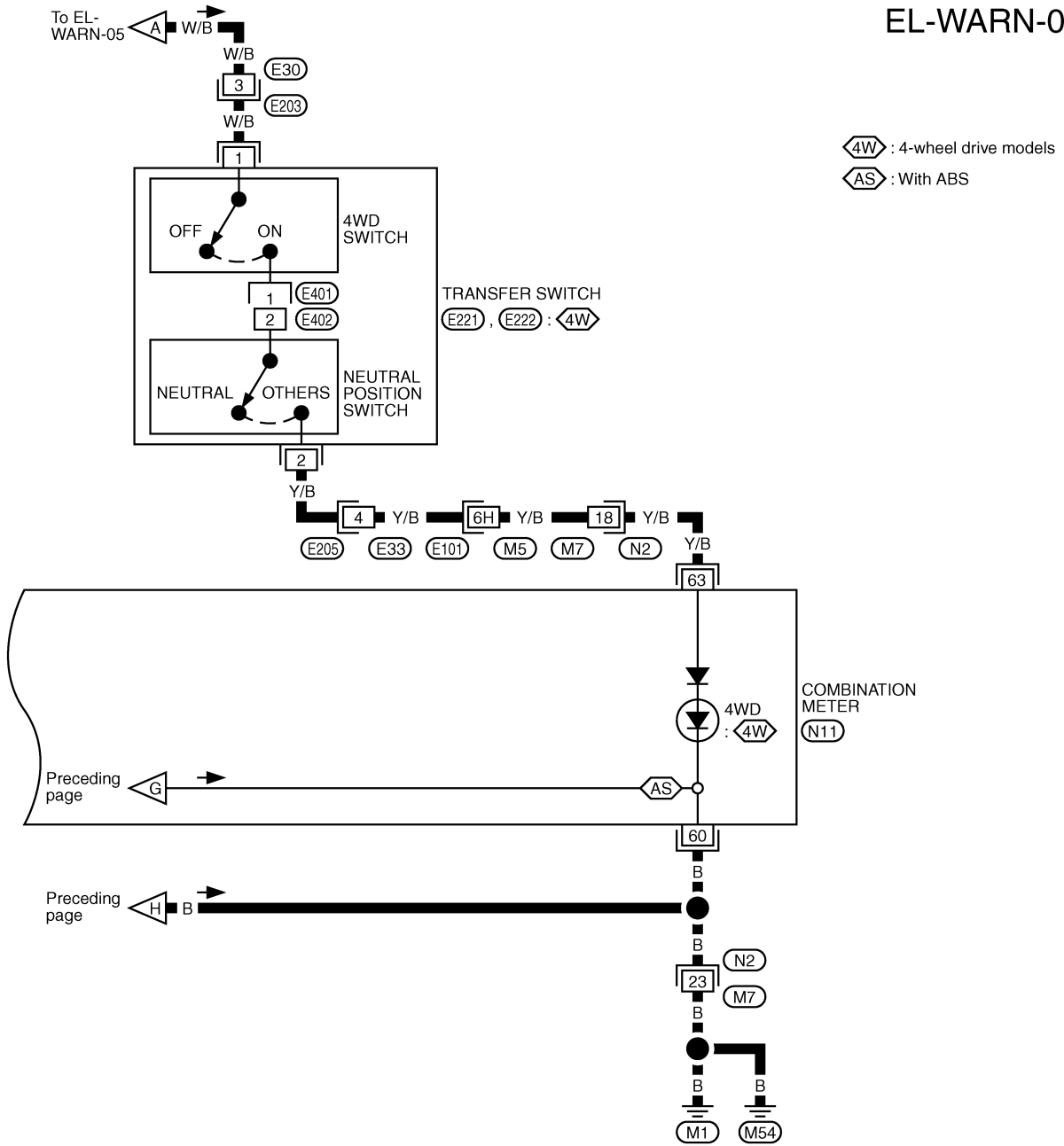

1	2	3	4	5	6	7	8	9	10	11	(N2)	41	42	43	44	45	46	47	48	49	50	51	(N11)				
12	13	14	15	16	17	18	19	20	21	22	23	24	BR	52	53	54	55	56	57	58	59	60	61	62	63	64	W



Refer to last page (Foldout page).
 (M5), (E101)

★: This connector is not shown in "HARNESS LAYOUT".

WARNING LAMPS

Wiring Diagram — WARN —/Diesel Engine with Tachometer

EL-WARN-09

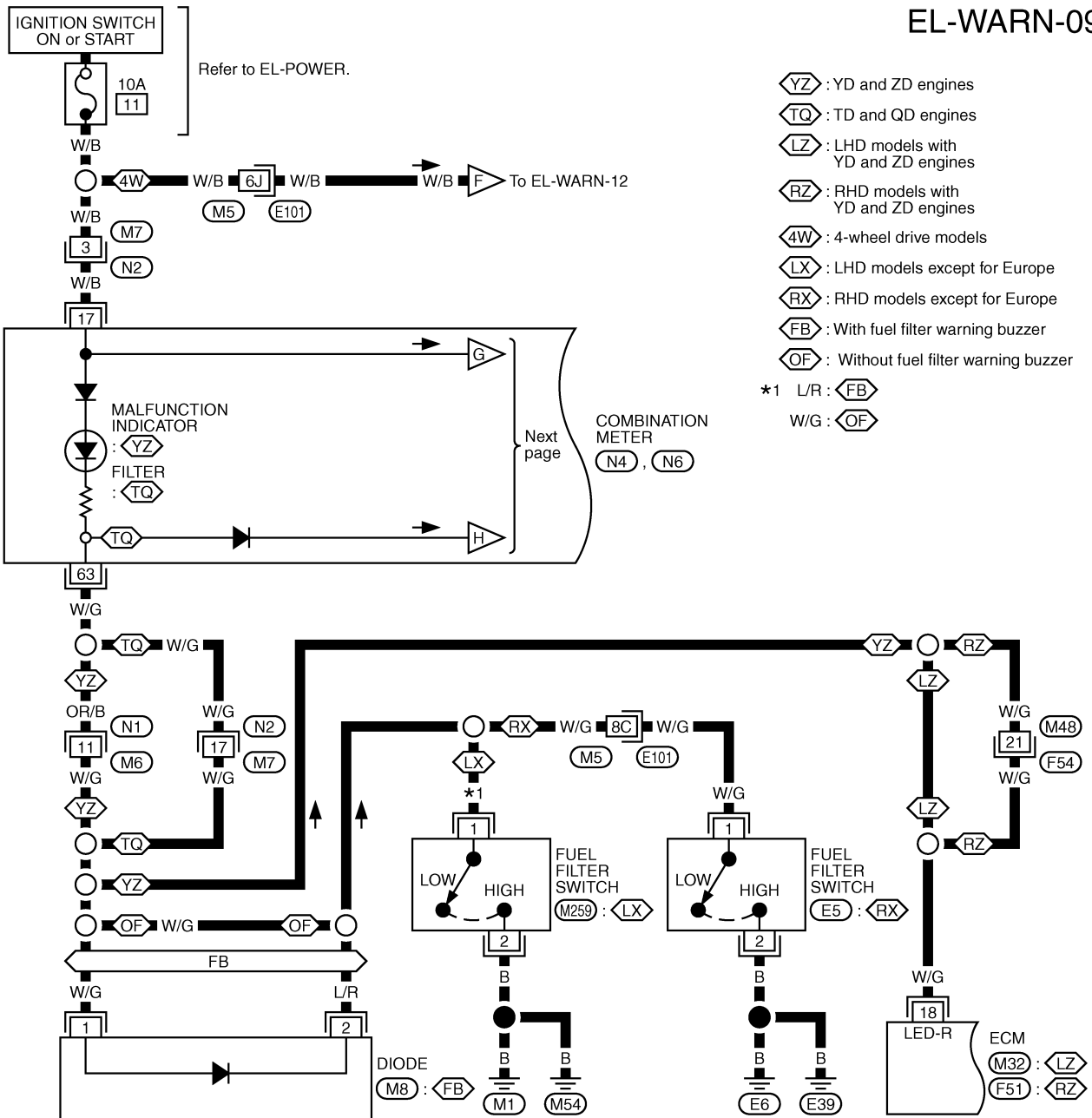

- YZ : YD and ZD engines
 - TQ : TD and QD engines
 - LZ : LHD models with YD and ZD engines
 - RZ : RHD models with YD and ZD engines
 - 4W : 4-wheel drive models
 - LX : LHD models except for Europe
 - RX : RHD models except for Europe
 - FB : With fuel filter warning buzzer
 - OF : Without fuel filter warning buzzer
- *1 L/R : FB
W/G : OF

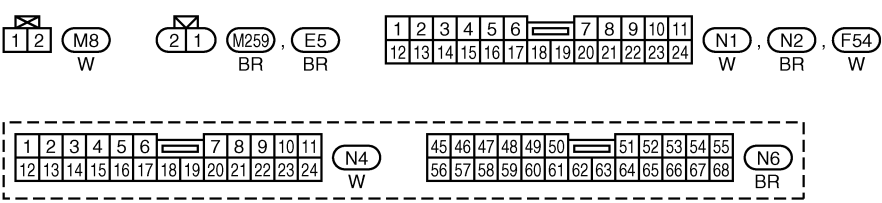

Refer to last page (Foldout page).

M5, E101

M32

F51

WARNING LAMPS

Wiring Diagram — WARN —/Diesel Engine with Tachometer (Cont'd)

EL-WARN-10

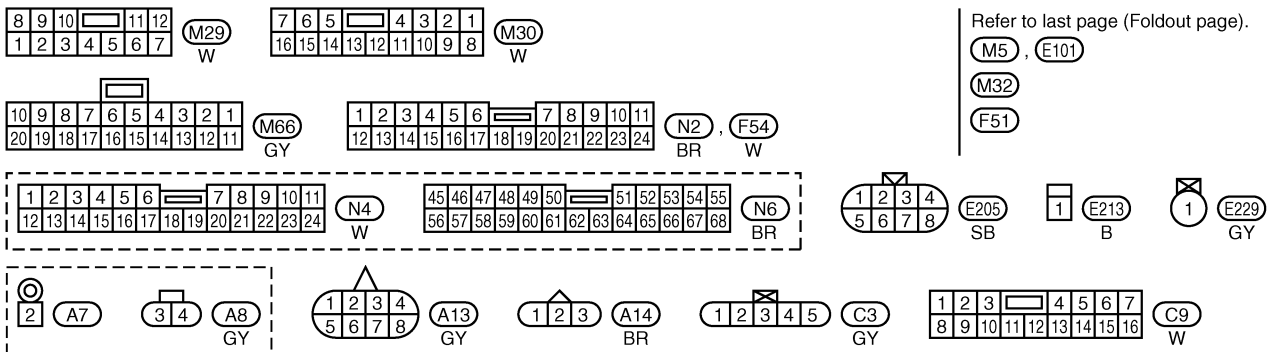
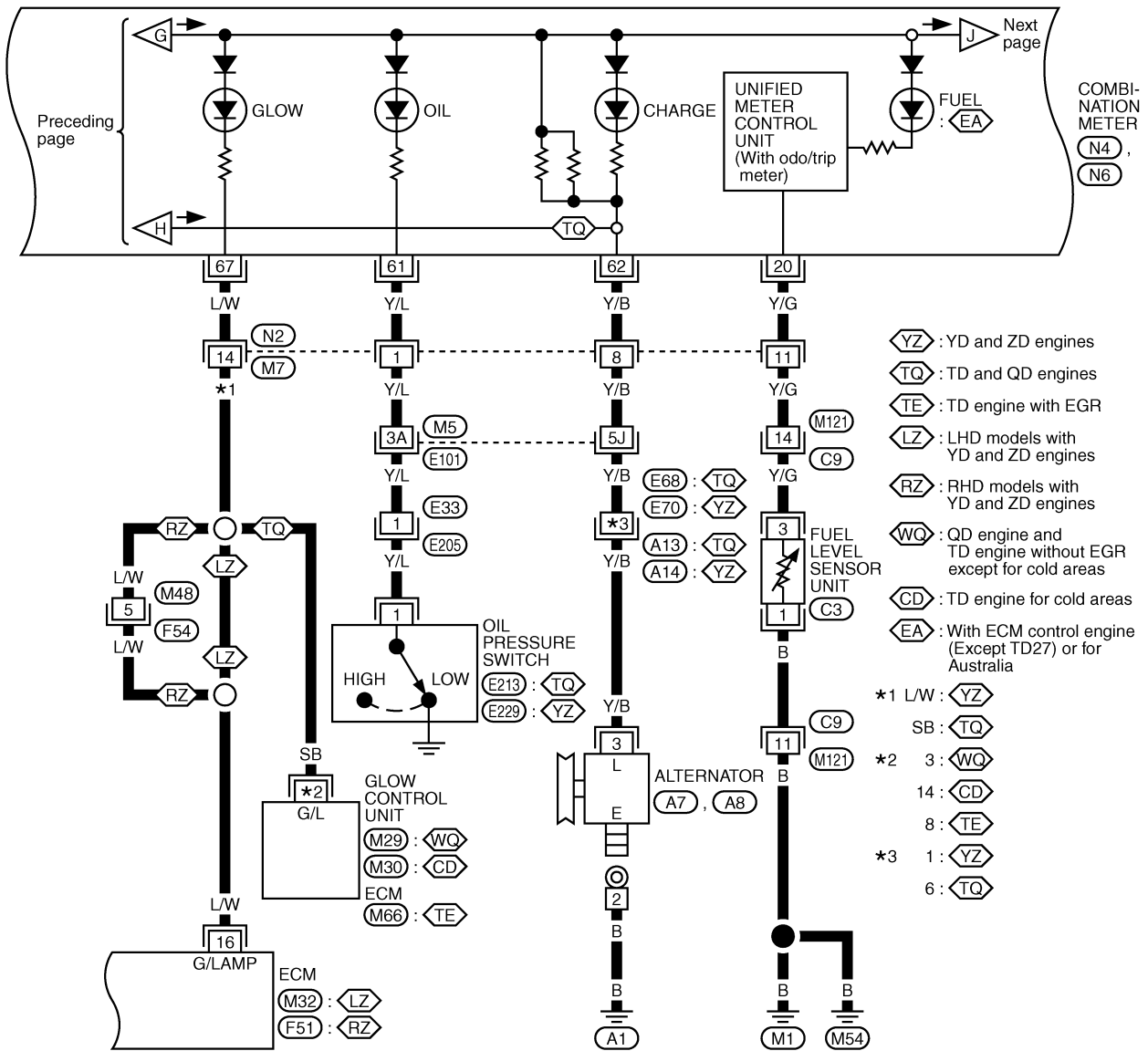

WARNING LAMPS

Wiring Diagram — WARN —/Diesel Engine with Tachometer (Cont'd)

EL-WARN-11

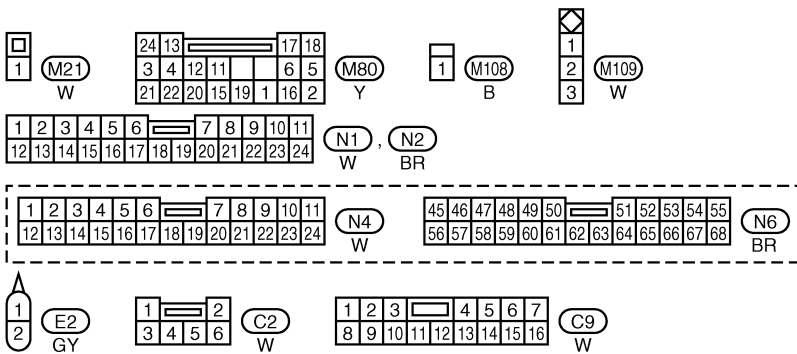
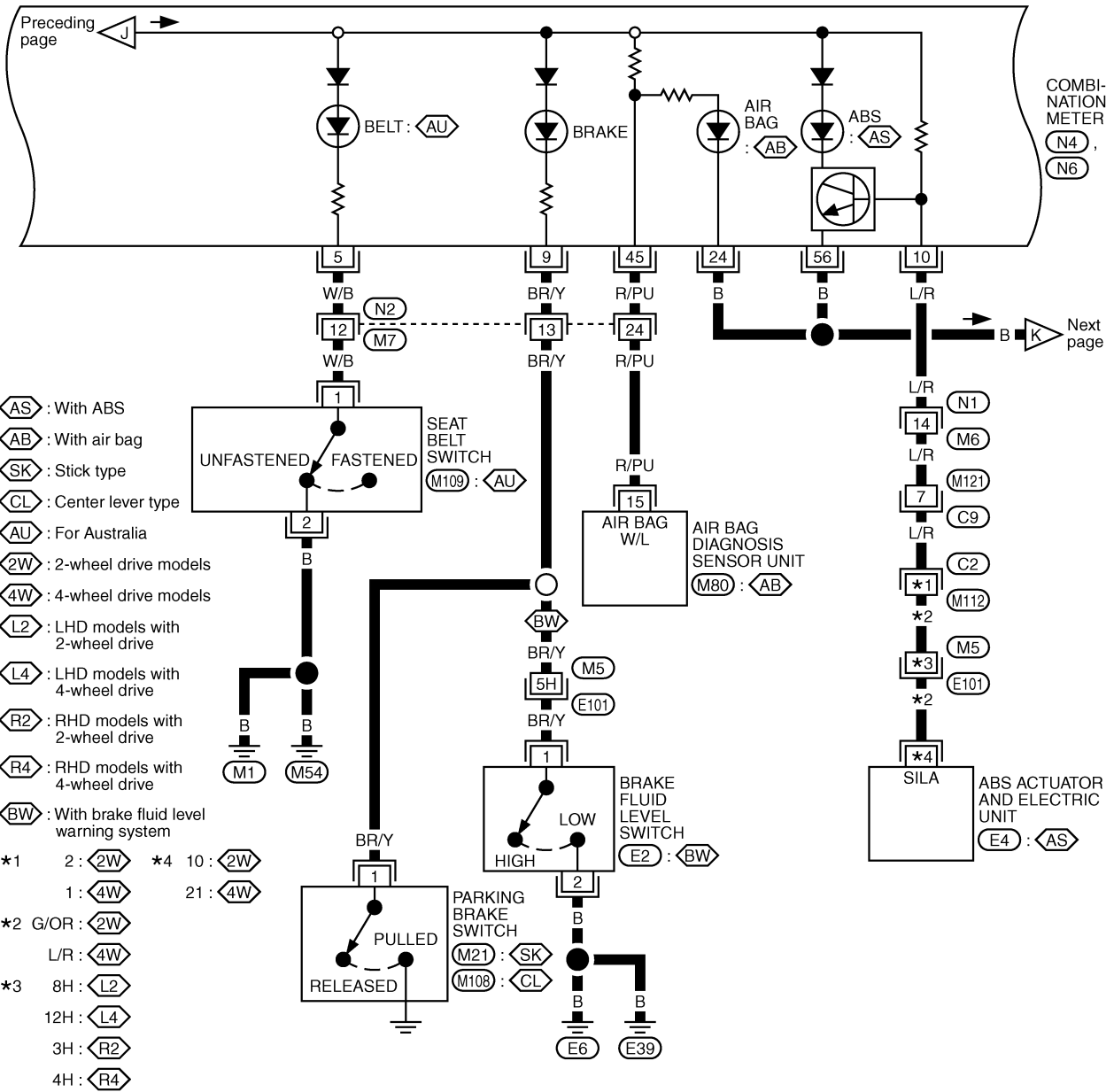

Refer to last page (Foldout page).

M5, E101
E4

WARNING LAMPS

Wiring Diagram — WARN —/Diesel Engine with Tachometer (Cont'd)

EL-WARN-12

◊4W◊ : 4-wheel drive models

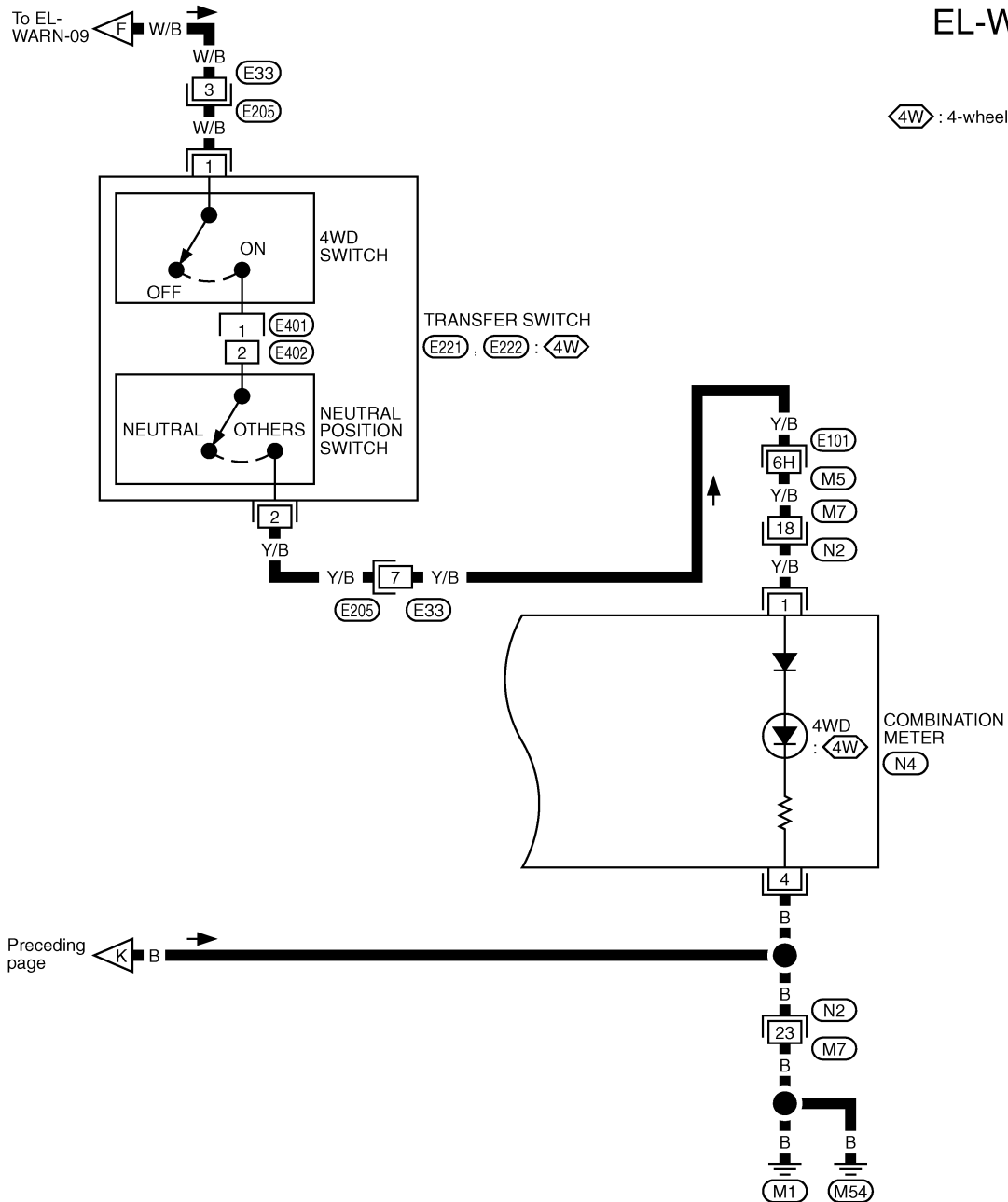

Preceding page ◊K◊ B →

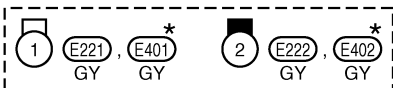
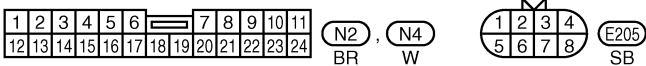

*: This connector is not shown in "HARNESS LAYOUT".

Refer to last page (Foldout page).
(M5), (E101)

WARNING LAMPS

Wiring Diagram — WARN —/Diesel Engine without Tachometer

EL-WARN-13

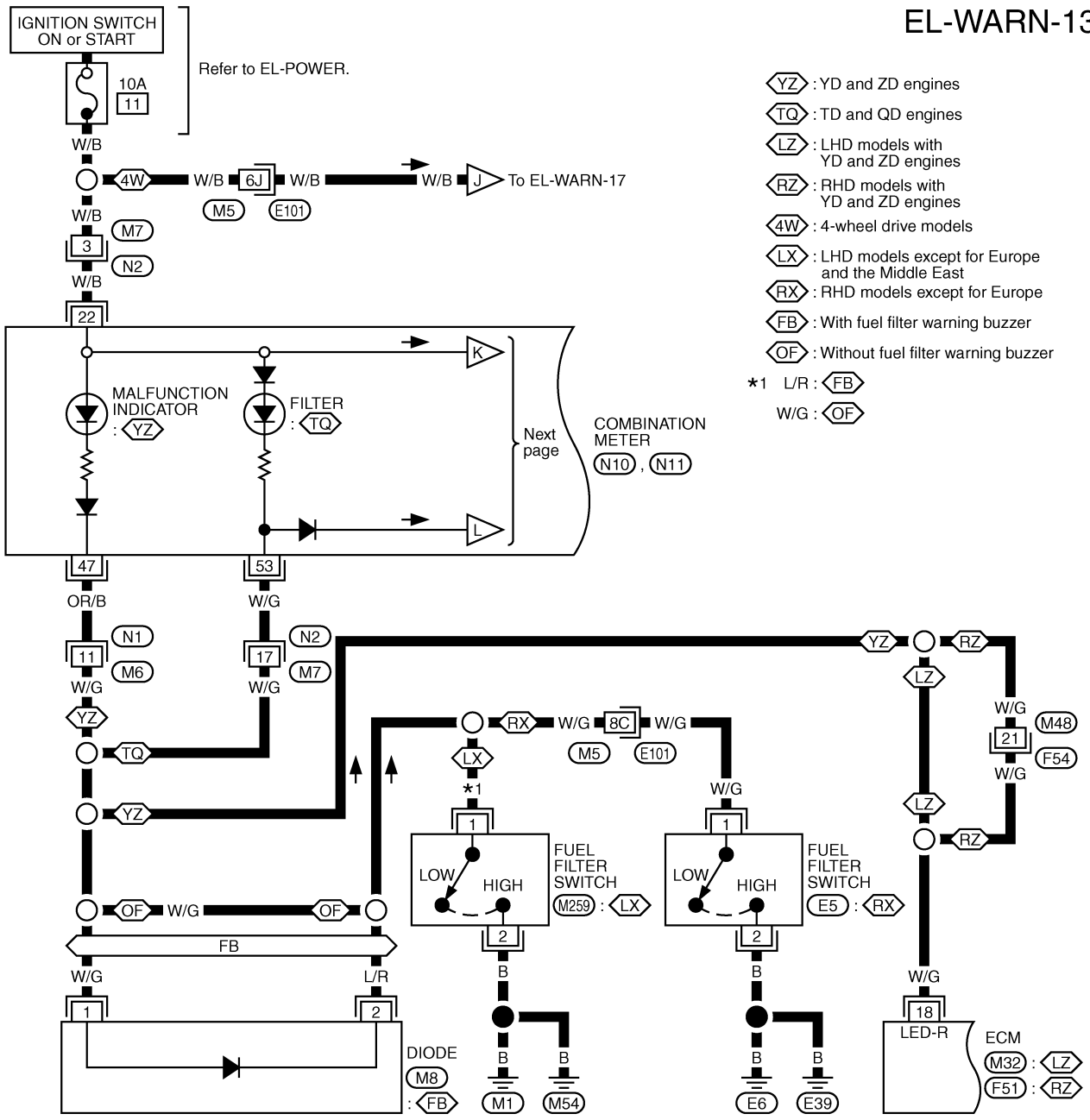

- YZ : YD and ZD engines
- TQ : TD and QD engines
- LZ : LHD models with YD and ZD engines
- RZ : RHD models with YD and ZD engines
- 4W : 4-wheel drive models
- LX : LHD models except for Europe and the Middle East
- RX : RHD models except for Europe
- FB : With fuel filter warning buzzer
- OF : Without fuel filter warning buzzer
- *1 L/R : FB
- W/G : OF

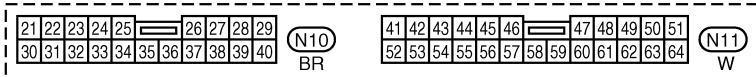
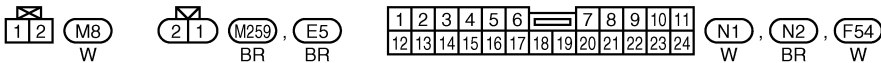

Refer to last page (Foldout page).

- M5, E101
- M32
- F51

WARNING LAMPS

Wiring Diagram — WARN —/Diesel Engine without Tachometer (Cont'd)

EL-WARN-14

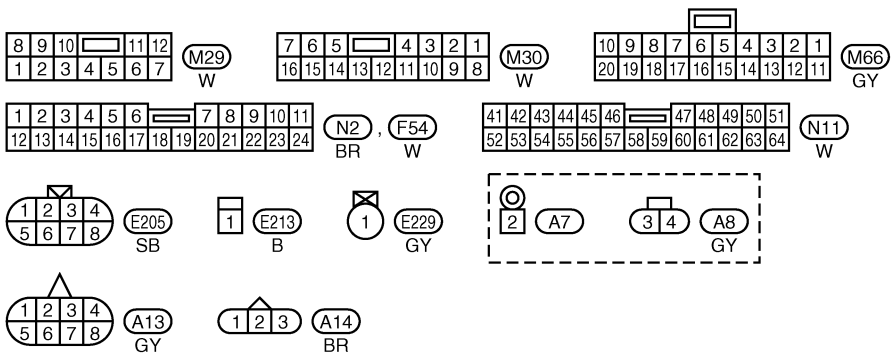
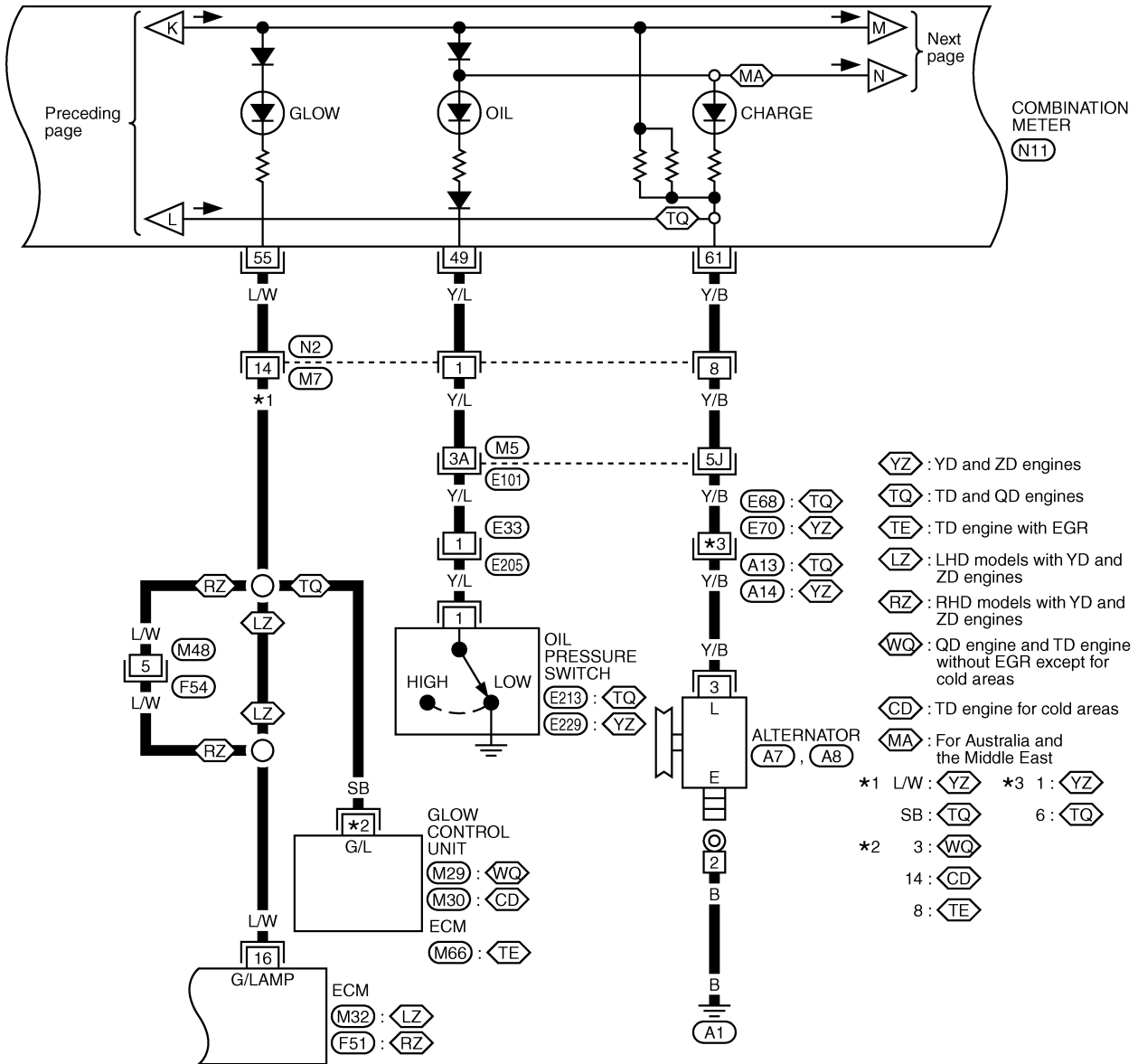

Refer to last page (Foldout page).



GEL795A

WARNING LAMPS

Wiring Diagram — WARN —/Diesel Engine without Tachometer (Cont'd)

EL-WARN-15

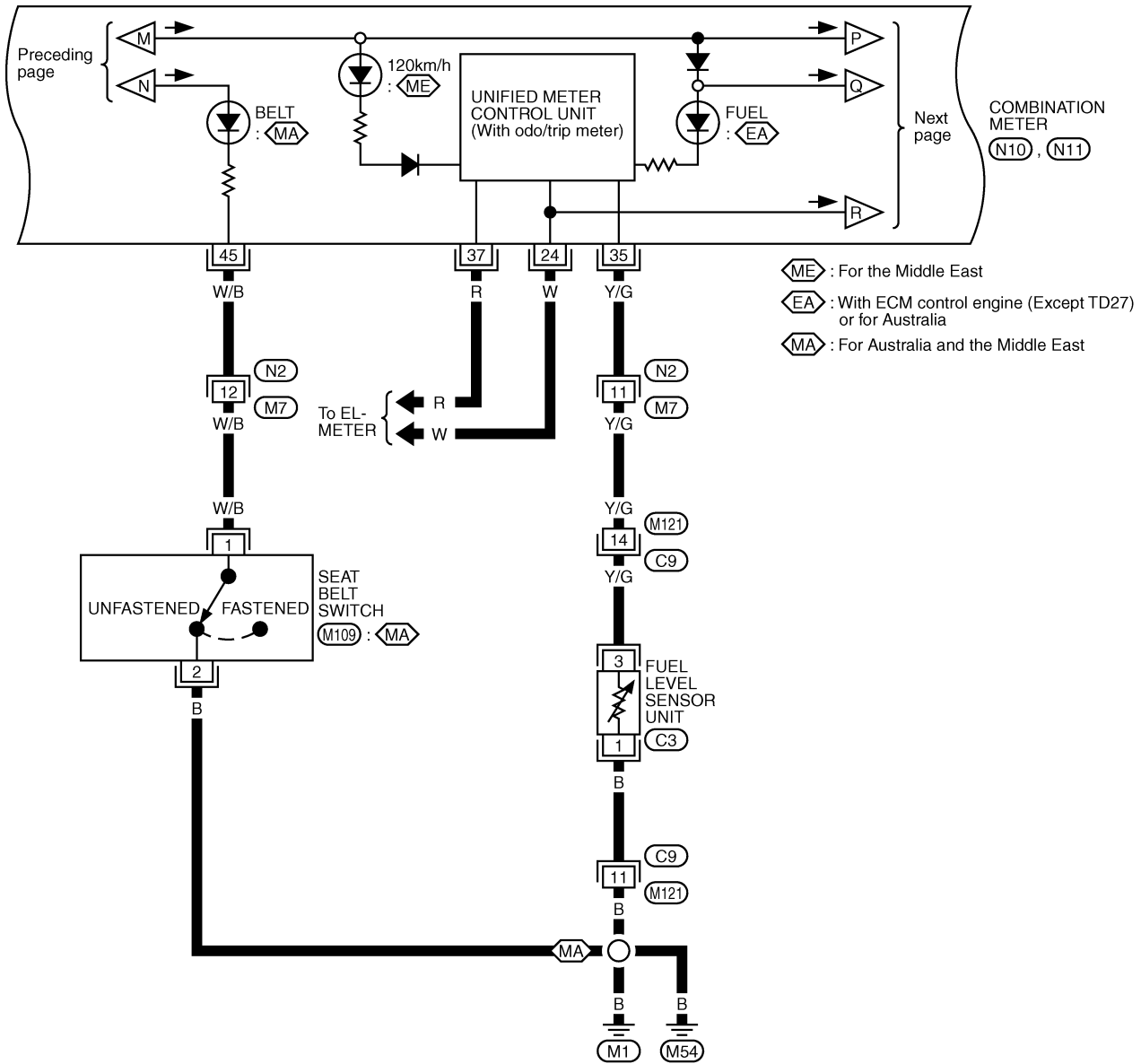

1
2
3

(M109)
W

1	2	3	4	5	6	7	8	9	10	11		
12	13	14	15	16	17	18	19	20	21	22	23	24

(N2)
BR

21	22	23	24	25	26	27	28	29	30	31	32	33	34	35	36	37	38	39	40	41	42	43	44	45	46	47	48	49	50	51	52	53	54	55	56	57	58	59	60	61	62	63	64
----	----	----	----	----	----	----	----	----	----	----	----	----	----	----	----	----	----	----	----	----	----	----	----	----	----	----	----	----	----	----	----	----	----	----	----	----	----	----	----	----	----	----	----

(N10)
BR

(N11)
W

1	2	3	4	5
---	---	---	---	---

(C3)
GY

1	2	3	4	5	6	7		
8	9	10	11	12	13	14	15	16

(C9)
W

WARNING LAMPS

Wiring Diagram — WARN —/Diesel Engine without Tachometer (Cont'd)

EL-WARN-16

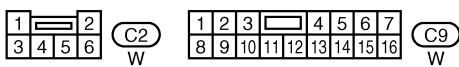
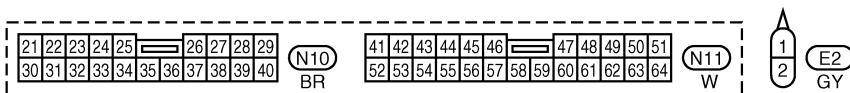
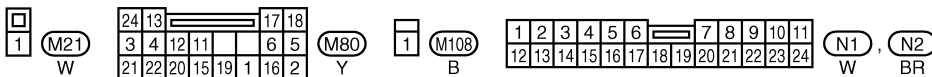
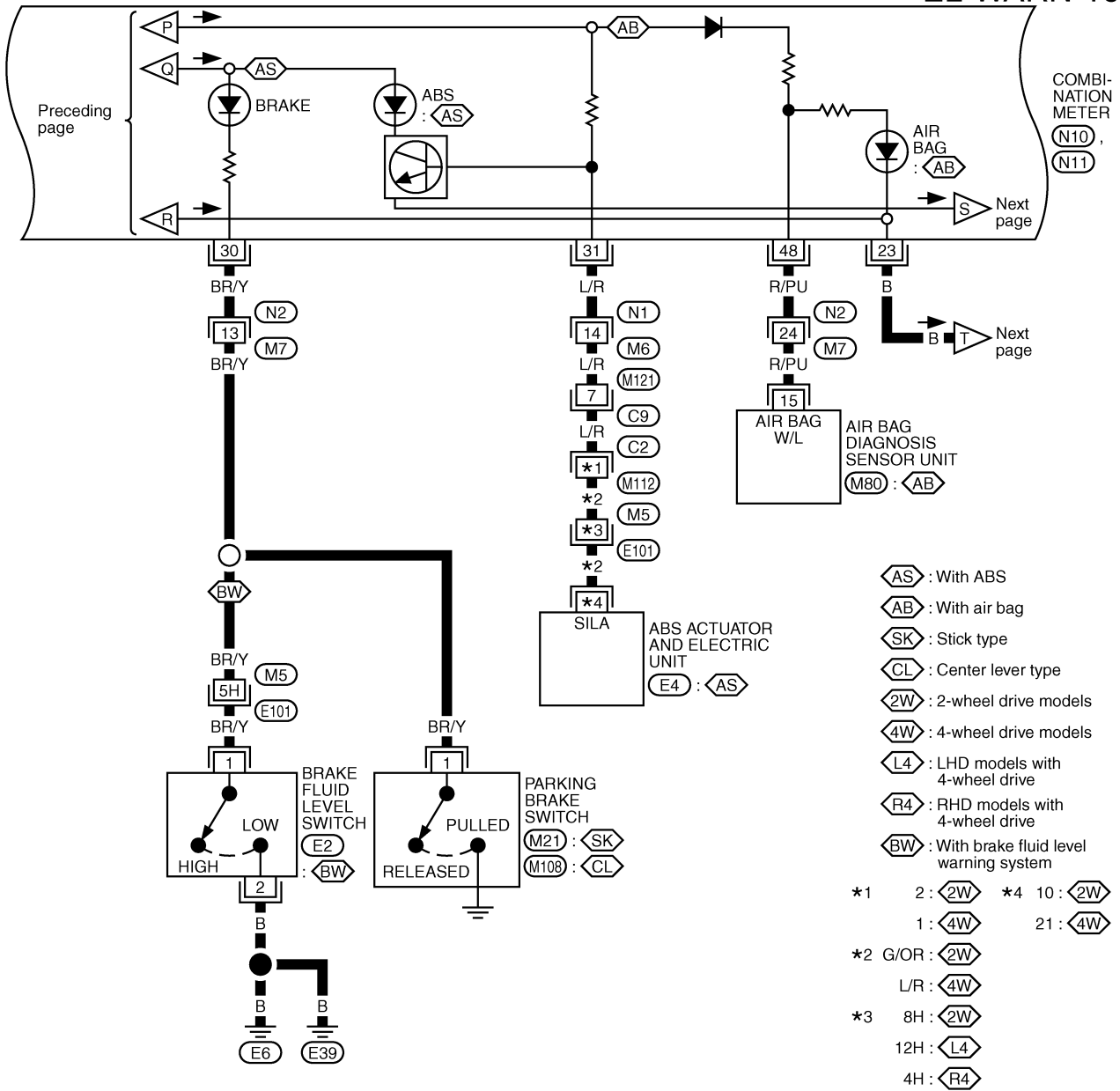

Refer to last page (Foldout page).

M5, E101
E4

WARNING CHIME

Wiring Diagram — CHIME —/LHD Models

LIGHT WARNING BUZZER

EL-CHIME-01

Refer to EL-POWER.

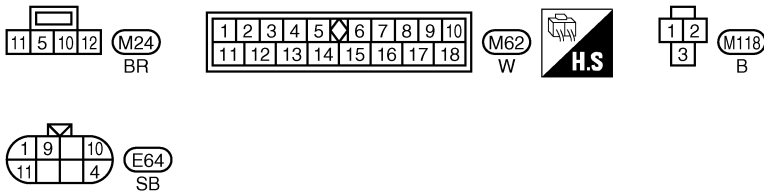
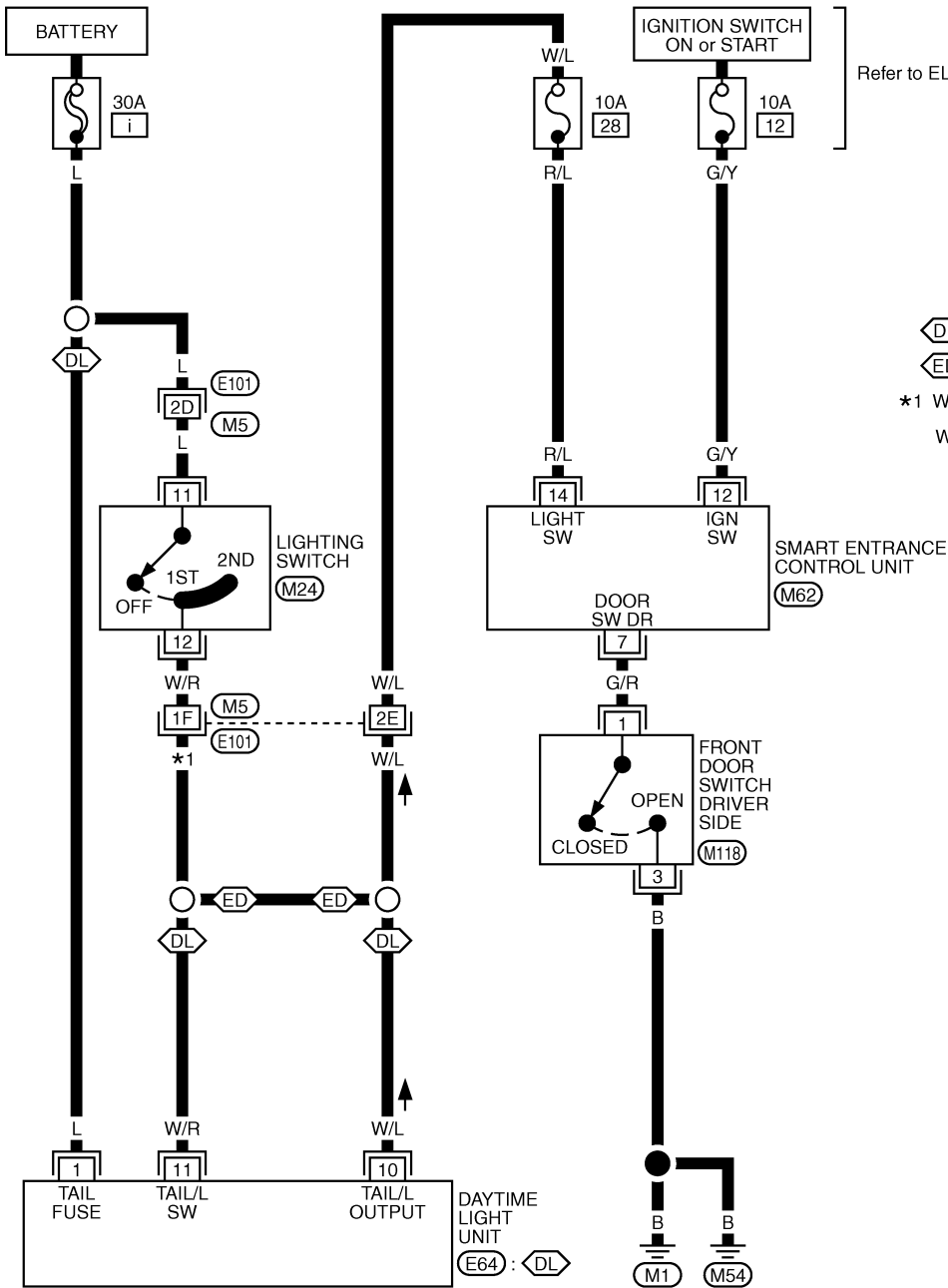

Refer to last page (Foldout page).

M5, E101

AUDIO

Wiring Diagram — AUDIO —/LHD Models

EL-AUDIO-02

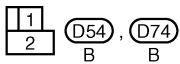
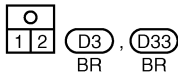
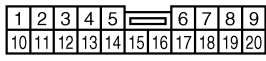
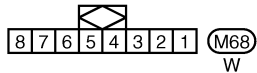
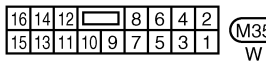
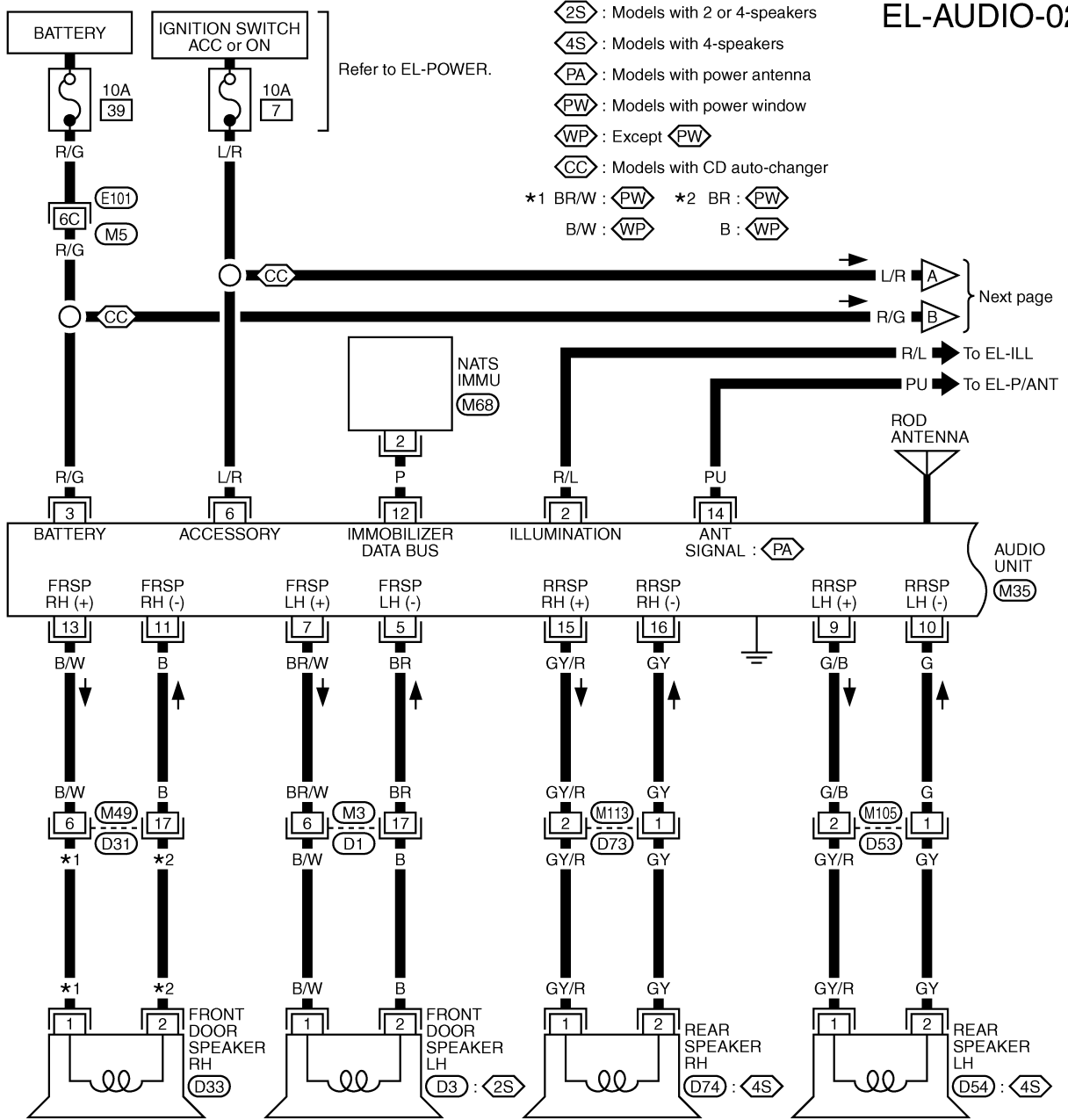

Refer to last page (Foldout page).

M5, E101

AUDIO

Wiring Diagram — AUDIO —/LHD Models (Cont'd)

EL-AUDIO-03

◊ : Models with CD auto-changer

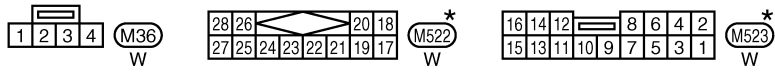
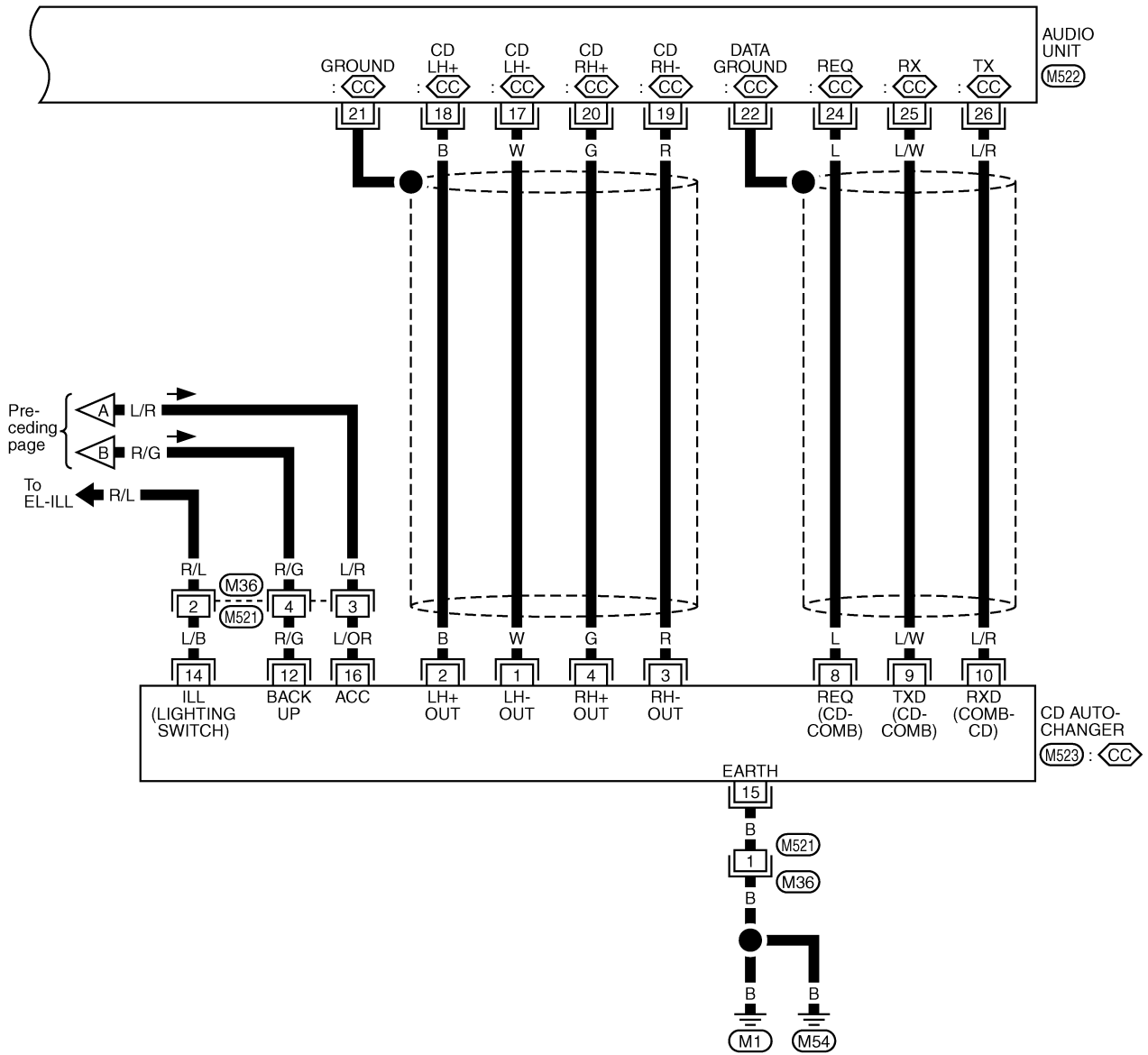

*: This connector is not shown in "HARNESS LAYOUT".

AUDIO

Wiring Diagram — AUDIO —/RHD Models

EL-AUDIO-04

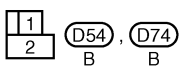
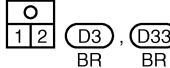
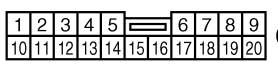
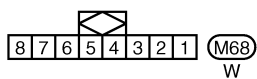
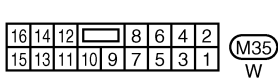
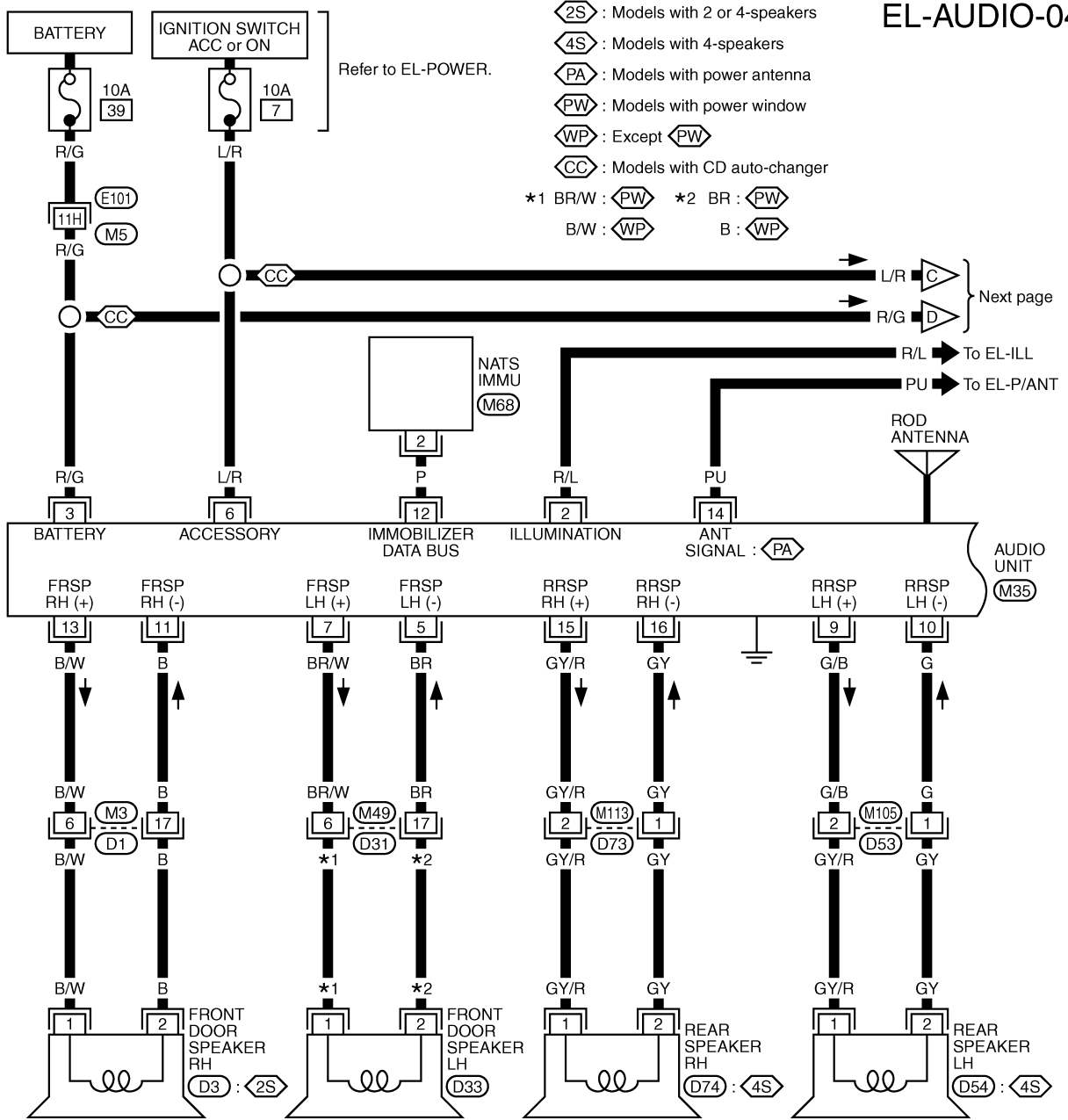

Refer to last page (Foldout page).

(M5), (E101)

AUDIO

Wiring Diagram — AUDIO —/RHD Models (Cont'd)

EL-AUDIO-05

◊ CC ◊ : Models with CD auto-changer

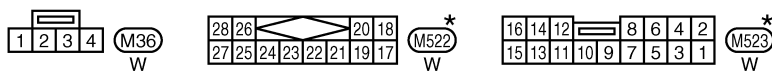
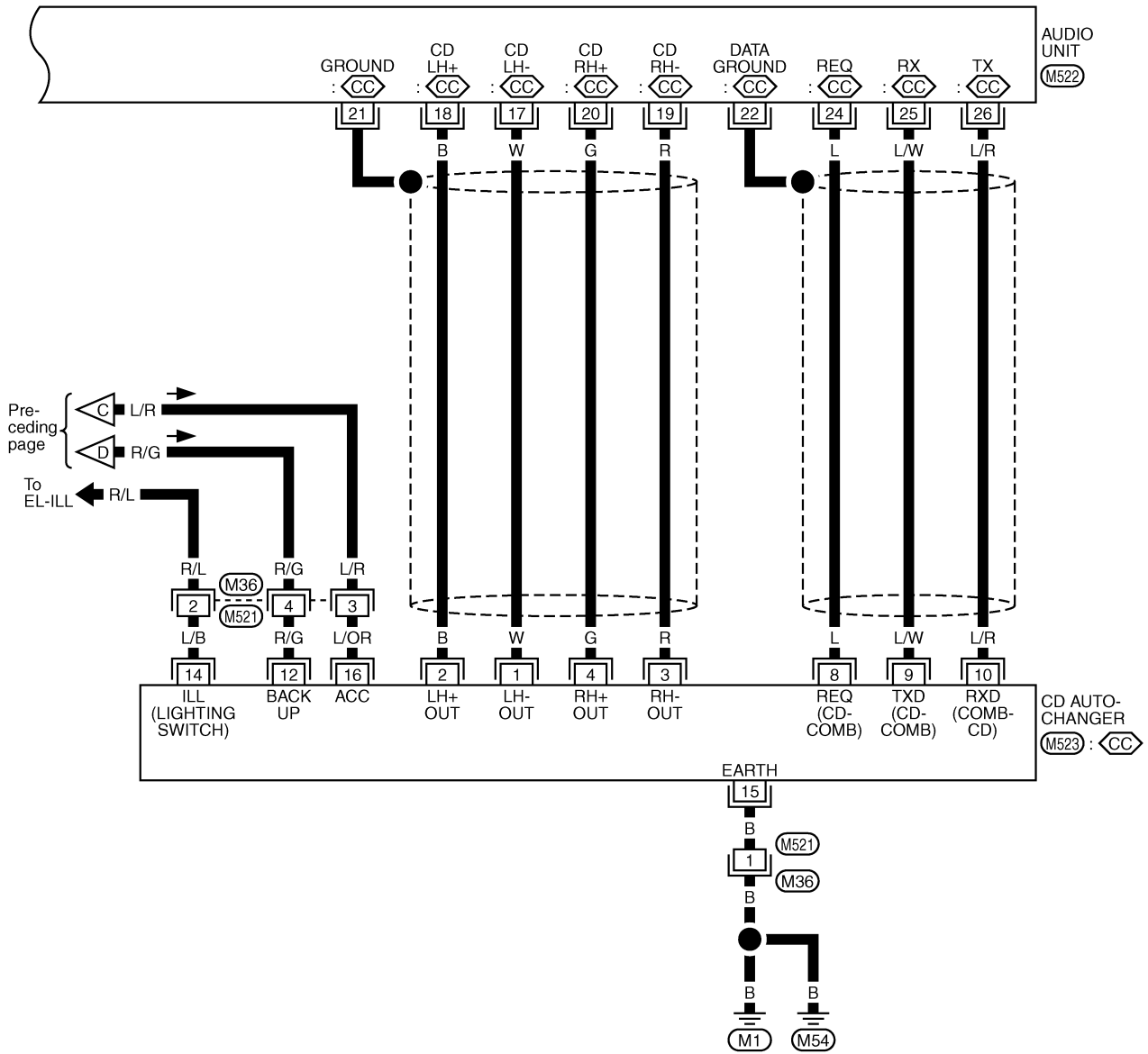

*: This connector is not shown in "HARNES LAYOUT".

NATS (Nissan Anti-Theft System)

Wiring Diagram — NATS —/LHD Models

EL-NATS-01

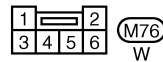
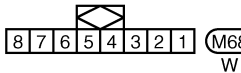
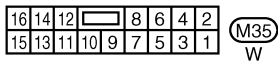
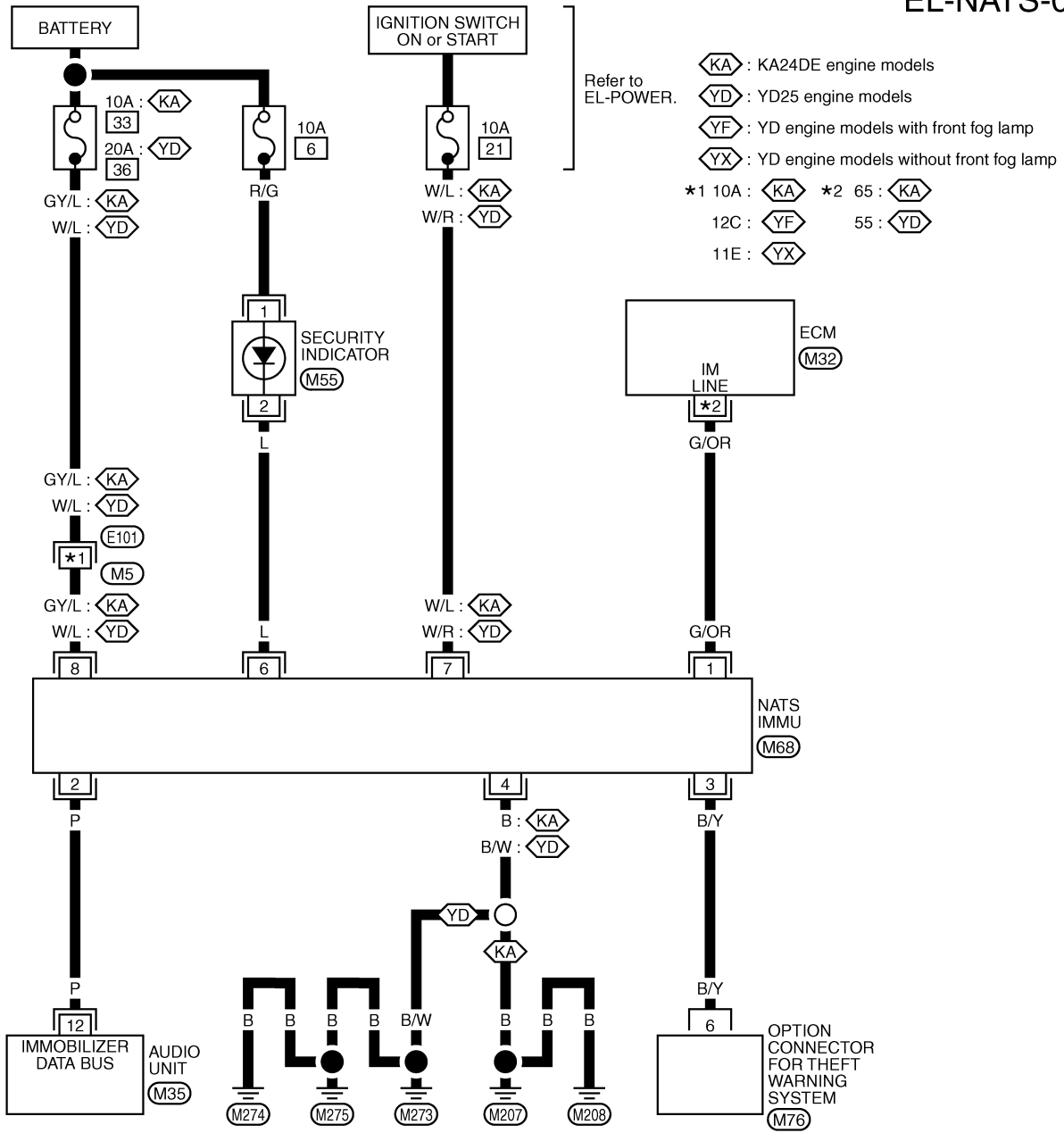

Refer to last page (Foldout page).

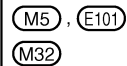

NATS (Nissan Anti-Theft System)

Wiring Diagram — NATS —/RHD Models

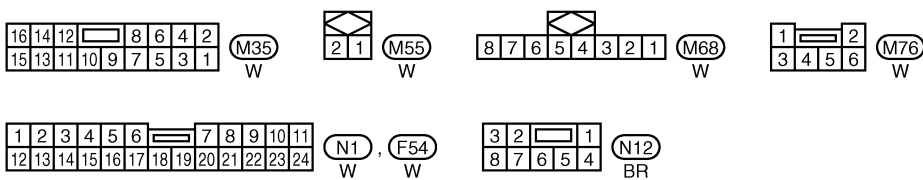
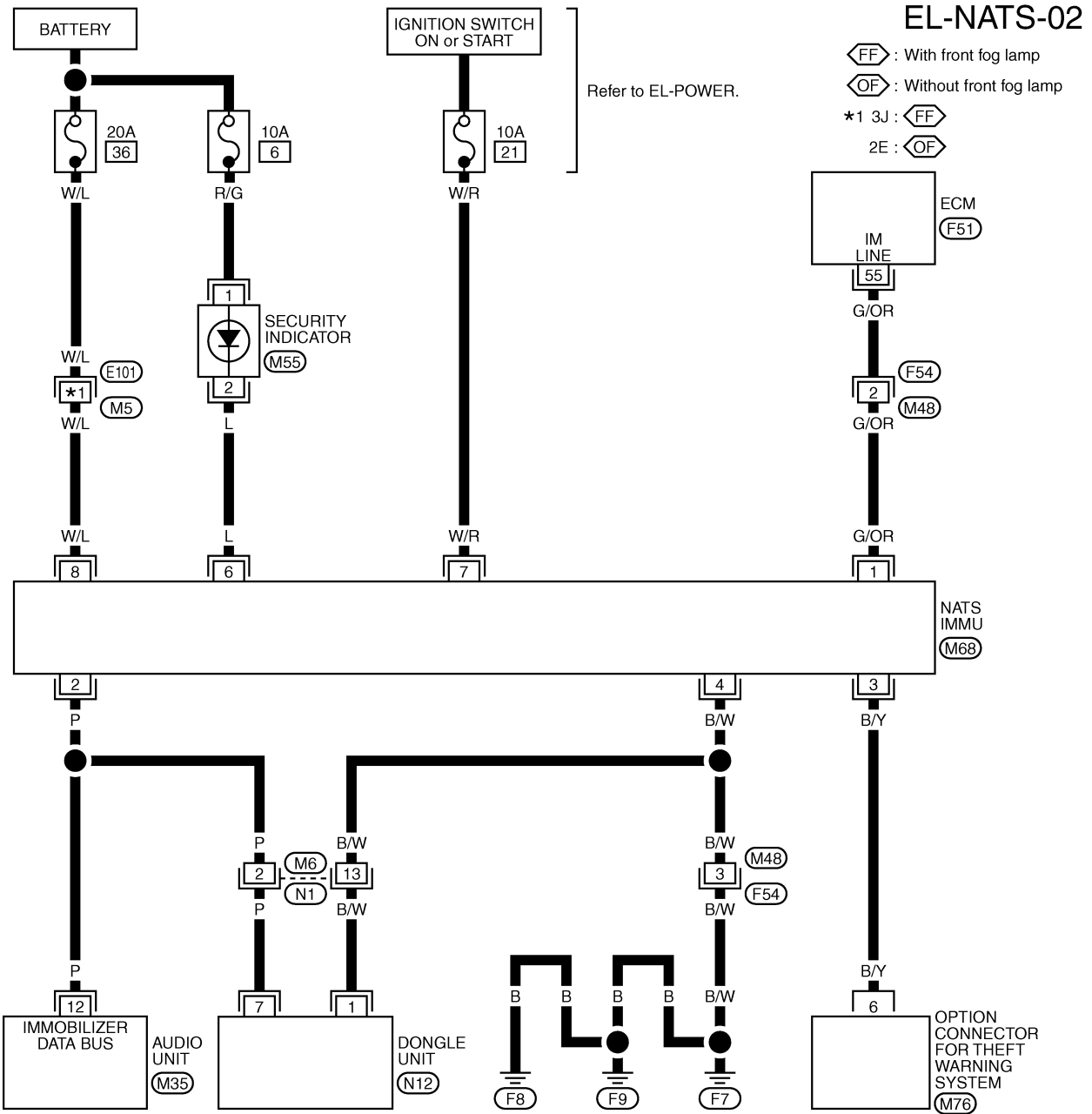

HARNESS LAYOUT

Main Harness

INSTRUMENT PANEL — LHD MODELS

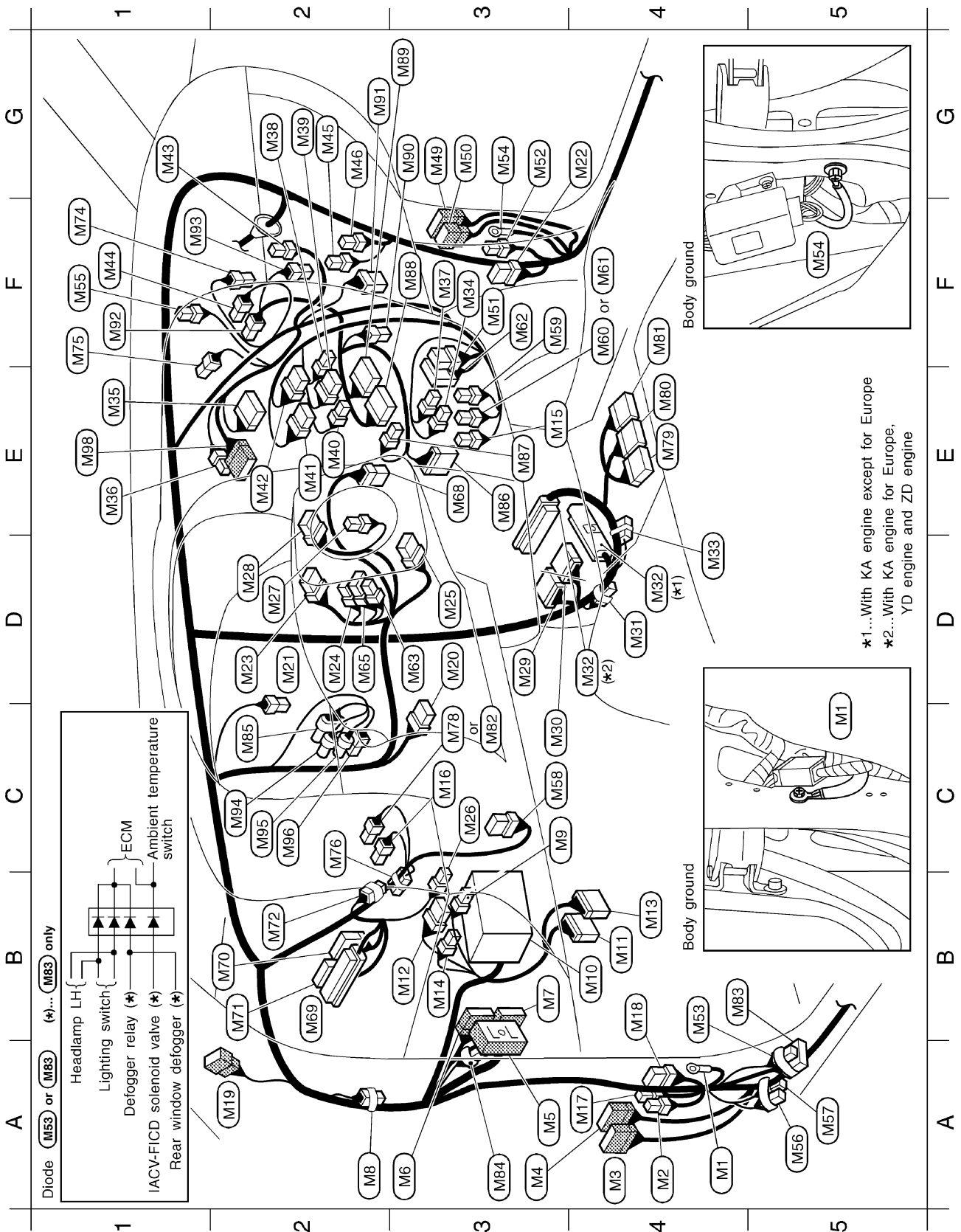

HARNESS LAYOUT

Main Harness (Cont'd)

A4 (M1)	: Body ground	F3 (M34)	W/2 : Ashtray illumination (With gasoline engine for the Middle East)	B2 (M71)	GY/24 : TCM (Transmission control module) (KA engine with A/T)
A4 (M2)	W/2 : Warning buzzer (Diesel engine except for Europe and the Middle East)	E1 (M35)	W/10 : Audio unit (For Europe)	B2 (M72)	-/6 : Joint connector-2 (With A/T)
A4 (M3)	W/20 : To (D1)	E1 (M36)	W/4 : To CD changer sub-harness (For Europe)	F1 (M74)	W/2 : Intake air temperature sensor (With auto A/C)
A3 (M4)	W/12 : To (D2) (With power window)	F2 (M37)	B/2 : Cigarette lighter	F1 (M75)	B/2 : Sunload sensor (With auto A/C)
A3 (M5)	SMJ : To (E101)	G2 (M38)	W/3 : A/C switch (Without auto A/C)	C2 (M76)	W/6 : Option connector (For Europe) (For theft warning system)
A3 (M6)	W/24 : To (N1)	E2 (M39)	W/6 : Fan switch (Without auto A/C)	C3 (M78)	L/2 : Shift lock brake switch (With A/T)
B3 (M7)	BR/24 : To (N2)	E2 (M40)	W/2 : Fan switch illumination (Without auto A/C)	E4 (M79)	Y/12 : Air bag diagnosis sensor unit (For pre-tensioner seat belt)
A2 (M8)	-/2 : Diode (Diesel engine except for Europe and the Middle East)	E2 (M41)	W/8 : Hazard switch	E4 (M80)	Y/20 : Air bag diagnosis sensor unit (For pre-tensioner seat belt)
C3 (M9)	L/4 : Fuel pump relay (KA engine)	E2 (M42)	W/6 : Defogger switch (Except for the Middle East except Single cab with TD engine)	F4 (M81)	Y/12 : Air bag diagnosis sensor unit (For pre-tensioner seat belt)
B4 (M10)	- : Fuse block	G1 (M43)	Y/2 : Front passenger air bag module	C3 (M82)	B/2 : Brake pedal position switch (YD25)
B4 (M11)	W/16 : Data link connector	F1 (M44)	BR/4 : Thermo control amplifier (Without auto A/C)	B4 (M83)	L/10 : Diode (KA engine except for Europe)
B3 (M12)	W/6 : Fuse block	G2 (M45)	BR/4 : Fan resistor (Without auto A/C)	A3 (M84)	BR/2 : Resistor (With A/T)
B4 (M13)	B/10 : Check connector (Z24S)	G2 (M46)	W/2 : Blower motor	C2 (M85)	GY/6 : Accelerator work unit (YD25)
E3 (M14)	W/4 : Fuse block	G3 (M49)	W/20 : To (D31)	E3 (M86)	BR/10 : Mode door motor (With auto A/C)
B3 (M15)	B/3 : Combination flasher unit	G3 (M50)	W/6 : To (D32) (With power window)	E3 (M87)	W/2 : In-vehicle sensor (With auto A/C)
C3 (M16)	B/2 : Stop lamp switch	F3 (M51)	W/8 : Door lock timer (With power window except for Europe)	F3 (M88)	GY/20 : A/C auto amp. (With auto A/C)
A4 (M17)	L/4 : Front fog lamp relay (YD engine for Europe)	G3 (M52)	W/2 : Circuit breaker-2 (For Europe and with gasoline engine for the Middle East)	G3 (M89)	GY/16 : A/C auto amp. (With auto A/C)
B4 (M18)	W/6 : Engine coolant temperature relay (QD engine with A/T)	B4 (M53)	L/4 : Diode (KA engine for Europe)	G3 (M90)	L/2 : Aspirator motor (With auto A/C)
A2 (M19)	W/6 : To (R1)	G3 (M54)	- : Body ground	G2 (M91)	B/6 : Air mix door motor (With auto A/C)
D3 (M20)	W/6 : Ignition switch	F1 (M55)	W/2 : Security indicator (With NATS)	F1 (M92)	W/4 : Fan control amp. (With auto A/C)
D2 (M21)	W/1 : Parking brake switch (Stick type)	A5 (M56)	-/2 : Diode (Z24S)	F1 (M93)	W/4 : Intake door motor (With auto A/C)
G4 (M22)	W/6 : Fuel pump control module (Z24S)	A5 (M57)	-/2 : Diode (Z24S)	C2 (M94)	BR/3 : Accelerator position sensor (ZD30)
D2 (M23)	BR/8 : Lighting switch • Turn signal lamp switch	C3 (M58)	BR/8 : Multi-remote control unit (For Europe)	C2 (M95)	GY/3 : Accelerator position switch (ZD30)
D2 (M24)	BR/4 : Lighting switch	F3 (M59)	BR/6 : Defogger relay (Except for the Middle East)	C2 (M96)	W/3 : Accelerator switch (F/C) (ZD30)
D3 (M25)	Y/7 : Spiral cable (With air bag)	F4 (M60)	L/4 : Rear fog lamp relay (For Europe or with KA engine without dual air bag except for the Middle East)	E1 (M98)	W/12 : Audio unit (Via sub-harness) (Except for Europe)
C3 (M26)	L/2 : A/T check switch	F4 (M61)	L/4 : Front fog lamp relay (ZD engine)	Diode (M8)	
D2 (M27)	B/1 : Horn switch (Without air bag)	F3 (M62)	W/18 : Smart entrance control unit (For Europe)	Diode (M56), (M57)	
D2 (M28)	GY/8 : Wiper and washer switch	D3 (M63)	W/3 : Fog lamp switch (KA or ZD engines except for Europe and the Middle East)	Fuel pump control module	
D3 (M29)	W/12 : Glow control unit (TD engine except for cold areas and QD engine)	D2 (M65)	W/6 : Fog lamp switch (For Europe)	Fuel filter switch	
C3 (M30)	W/16 : Glow control unit (TD engine for cold areas)	E3 (M68)	W/8 : NATS IMMU (For Europe)	Warning buzzer	
D4 (M31)	GY/6 : Joint connector-1 (KA engine)	B2 (M69)	W/48 : TCM (Transmission control module) (QD engine with A/T)	CHARGE warning lamp	
D4 (M32)	SMJ : ECM (KA, YD and ZD engines)	B2 (M70)	W/24 : TCM (Transmission control module) (KA engine with A/T)	Alternator (L)	
D4 (M33)	- : Joint connector-3 (KA engine for Europe)			OIL warning lamp	
				OIL pressure switch	

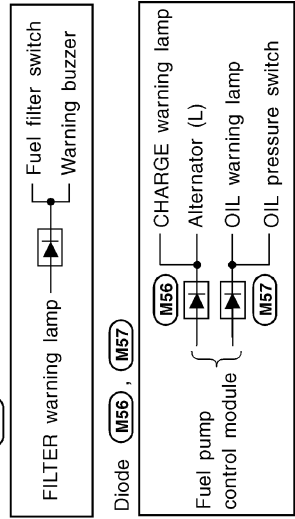

HARNESS LAYOUT

Main Harness (Cont'd)

INSTRUMENT PANEL — RHD MODELS

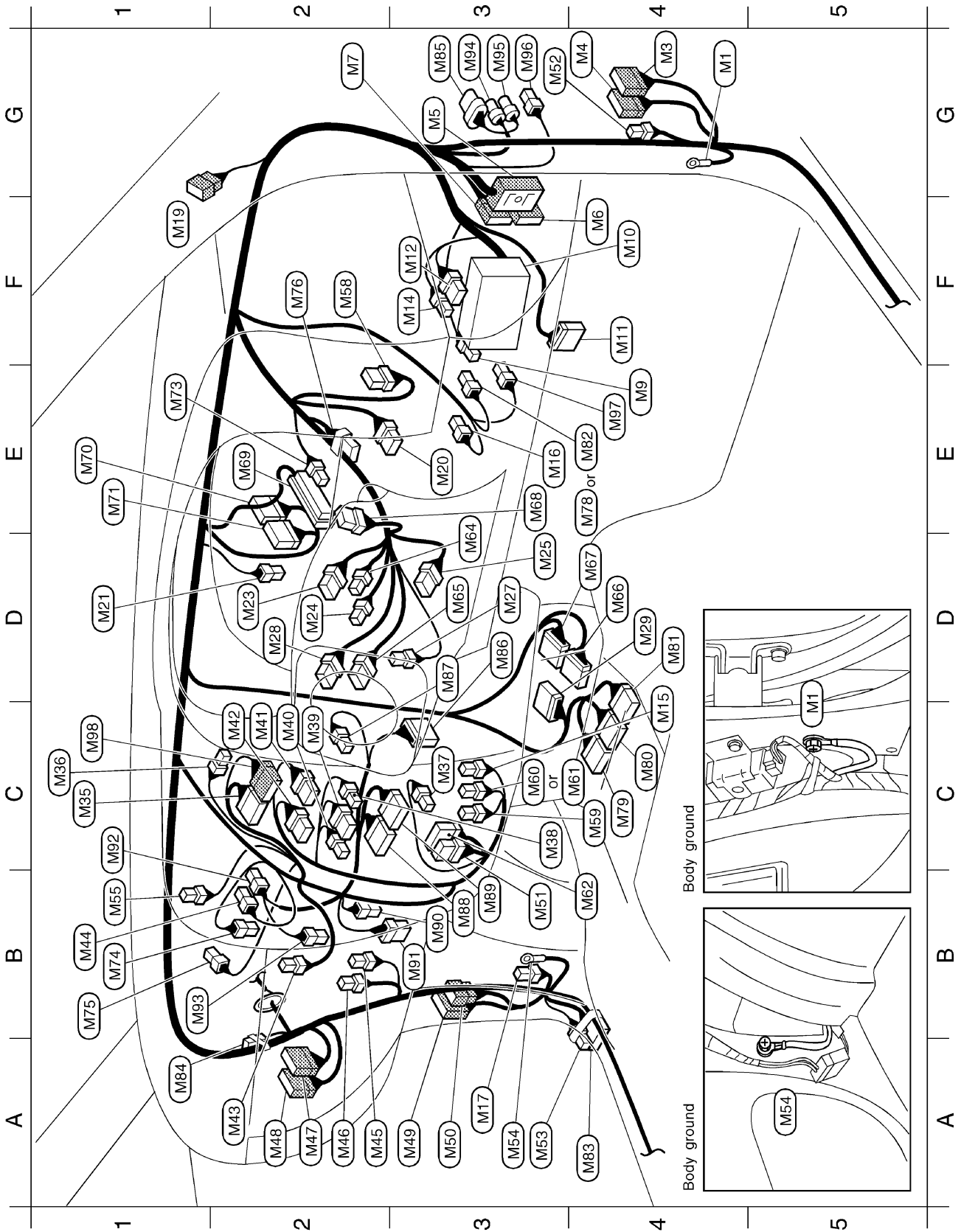

HARNESS LAYOUT

Main Harness (Cont'd)

G4	M1	—	: Body ground	A2	M47	W/16	: To F55 (KA, VG, YD and ZD engines)	E4	M82	B/2	: Brake pedal position switch (YD engine)
G4	M3	W/20	: To D1	A2	M48	W/24	: To F54 (KA, VG, YD and ZD engines)	A4	M83	L/10	: Diode (KA engine except without intermittent wiper for Australia)
G4	M4	W/12	: To D2 (With power window)	A3	M49	W/20	: To D31	A1	M84	BR/2	: Resistor (With A/T)
G3	M5	SMJ	: To E101	A3	M50	W/6	: To D32 (With power window)	G3	M85	GY/6	: Accelerator work unit (YD engine)
F4	M6	W/24	: To N1	B3	M51	W/8	: Door lock timer (With power window except for Europe)	D3	M86	BR/10	: Mode door motor (With auto A/C)
G2	M7	BR/24	: To N2	G3	M52	W/2	: Circuit breaker-2 (For Europe)	D3	M87	W/2	: In-vehicle sensor (With auto A/C)
E4	M9	L/4	: Fuel pump relay (KA and VG engines)	A3	M53	L/4	: Diode (KA engine without intermittent wiper for Australia)	B3	M88	GY/20	: A/C auto amp. (With auto A/C)
F4	M10	—	: Fuse block	A3	M54	—	: Body ground	B3	M89	GY/16	: A/C auto amp. (With auto A/C)
F4	M11	W/16	: Data link connector	B1	M55	W/2	: Security indicator (For Europe)	B3	M90	L/2	: Aspirator motor (With auto A/C)
F3	M12	W/6	: Fuse block	F2	M58	BR/8	: Multi-remote control unit (For Europe)	B3	M91	B/6	: Air mix door motor (With auto A/C)
F3	M14	W/4	: Fuse block	C4	M59	BR/6	: Defogger relay (Except models without intermittent wiper for Australia)	C1	M92	W/4	: Fan control amp. (With auto A/C)
C4	M15	B/3	: Combination flasher unit	C3	M60	L/4	: Rear fog lamp relay (For Europe)	B1	M93	W/4	: Intake door motor (With auto A/C)
E3	M16	B/2	: Stop lamp switch	C4	M61	W/4	: Front fog lamp relay (ZD engine)	G3	M94	BR/3	: Accelerator position sensor (ZD engine)
A3	M17	L/4	: Front fog lamp relay (For Europe)	B4	M62	W/18	: Smart entrance control unit (For Europe)	G3	M95	GY/3	: Accelerator position switch (ZD engine)
F1	M19	W/6	: To R1	D3	M64	L/4	: Front fog lamp switch (ZD engine)	E4	M97	W/2	: Kickdown switch (With A/T with VG engine)
E3	M20	W/6	: Ignition switch	D3	M65	W/6	: Front and rear fog lamp switch (For Europe)	C1	M98	W/12	: Audio unit (Via sub-harness) (Except for Europe)
D1	M21	W/1	: Parking brake switch (Stick type)	D4	M66	GY/20	: ECM (Diesel engine with EGR)				
D2	M23	BR/8	: Lighting switch	D4	M67	GY/16	: ECM (Diesel engine with EGR)				
			• Turn signal lamp switch	E3	M68	W/8	: NATS IMMU (For Europe)				
D2	M24	BR/4	: Lighting switch	E2	M69	W/48	: TCM (Transmission control module) (With A/T with VG engine)				
D3	M25	Y/7	: Spiral cable (With air bag)	E1	M70	W/24	: TCM (Transmission control module) (With A/T with KA engine)				
D3	M27	B/1	: Horn switch (Without air bag)	E1	M71	GY/24	: TCM (Transmission control module) (With A/T with KA engine)				
D2	M28	GY/8	: Wiper and washer switch	E1	M73	W/4	: A/T device				
D4	M29	W/12	: Glow control unit (TD engine without EGR and QD engine)	B1	M74	W/2	: Intake air temperature sensor (With auto A/C)				
C1	M35	W/16	: Audio unit (For Europe)	B1	M75	B/2	: Sunload sensor (With auto A/C)				
C1	M36	W/4	: To CD changer sub-harness (For Europe)	F2	M76	W/6	: Option connector for theft warning system (For Europe)				
C3	M37	B/2	: Cigarette lighter	E4	M78	L/2	: Shift lock brake switch (With A/T)				
C3	M38	W/3	: A/C switch (Without auto A/C)	C4	M79	Y/12	: Air bag diagnosis sensor unit (With air bag for Europe and Australia)				
C2	M39	W/6	: Fan switch (Without auto A/C)	C4	M80	Y/20	: Air bag diagnosis sensor unit (With air bag)				
C2	M40	W/2	: Fan switch illumination (Without auto A/C)	D4	M81	Y/12	: Air bag diagnosis sensor unit (With air bag for Europe and Australia)				
C2	M41	W/8	: Hazard switch								
C2	M42	W/6	: Defogger switch (Except models without intermittent wiper for Australia)								
A2	M43	Y/2	: Air bag module passenger side								
B1	M44	BR/4	: Thermo control amplifier (Without auto A/C)								
A2	M45	BR/4	: Fan resistor (Without auto A/C)								
A2	M46	W/2	: Blower motor								

Engine compartment

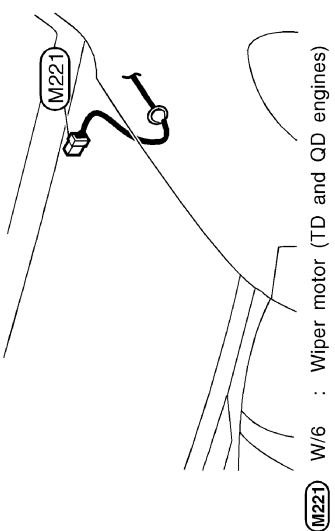

M221 W/6 : Wiper motor (TD and QD engines)

Diode M53 or M83 (+)... M83 only

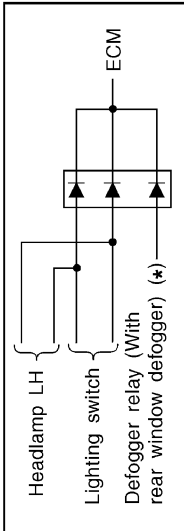

HARNESS LAYOUT

Main Harness (Cont'd)

BODY SIDE — LHD MODELS

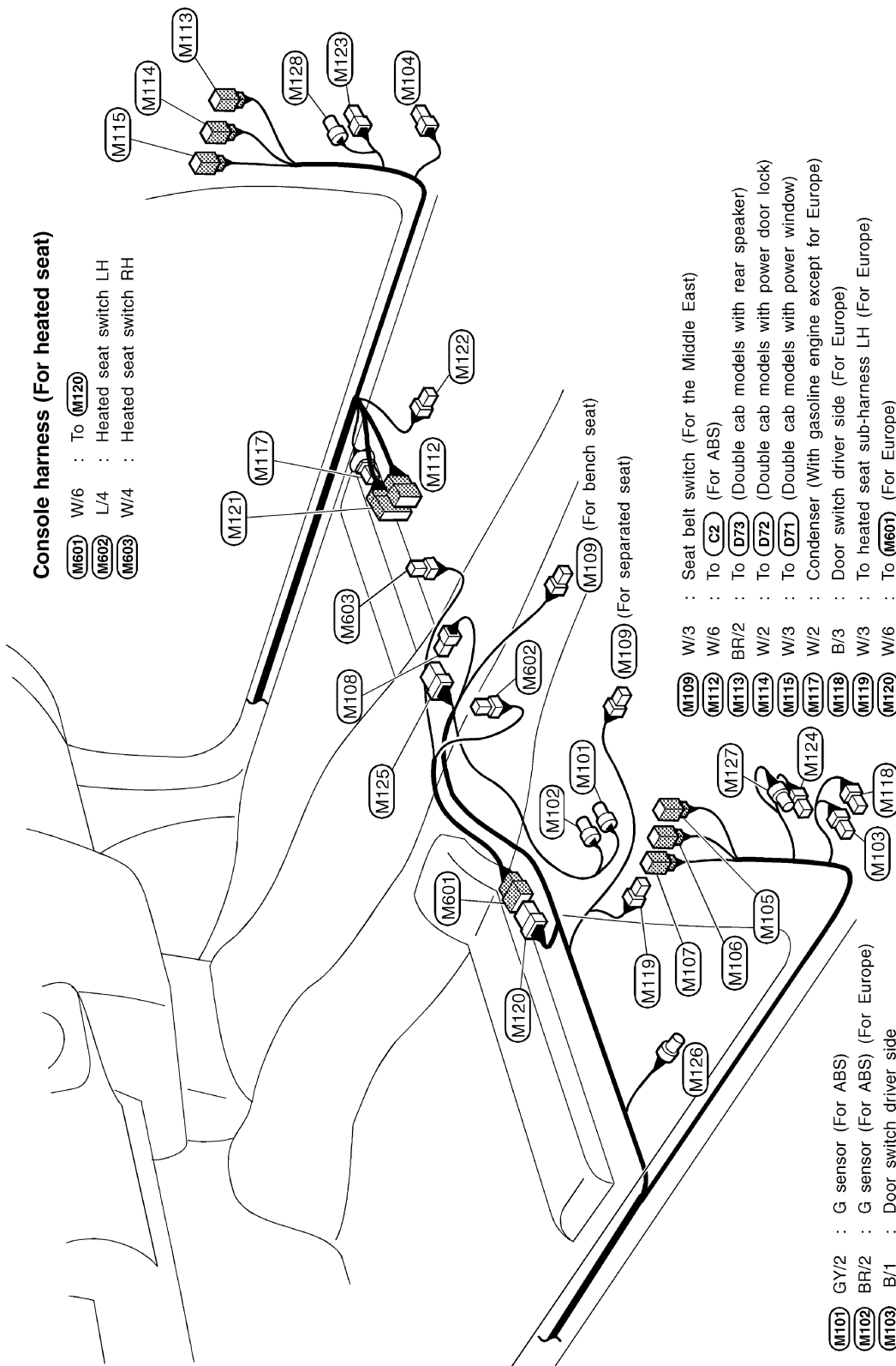

HARNESS LAYOUT

Main Harness (Cont'd)

BODY SIDE — RHD MODELS

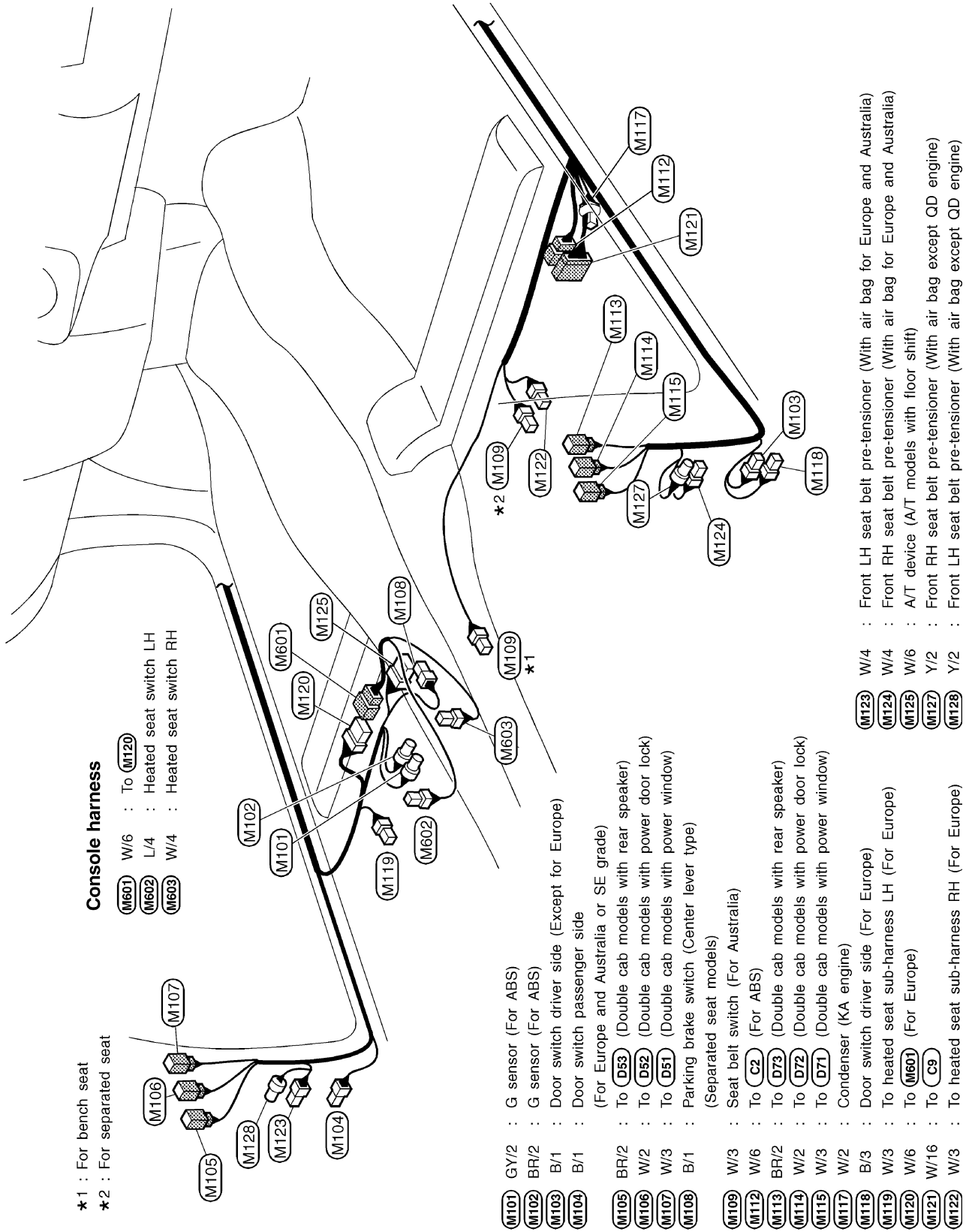

HARNESS LAYOUT

Engine Room Harness

LHD MODELS — GASOLINE ENGINE

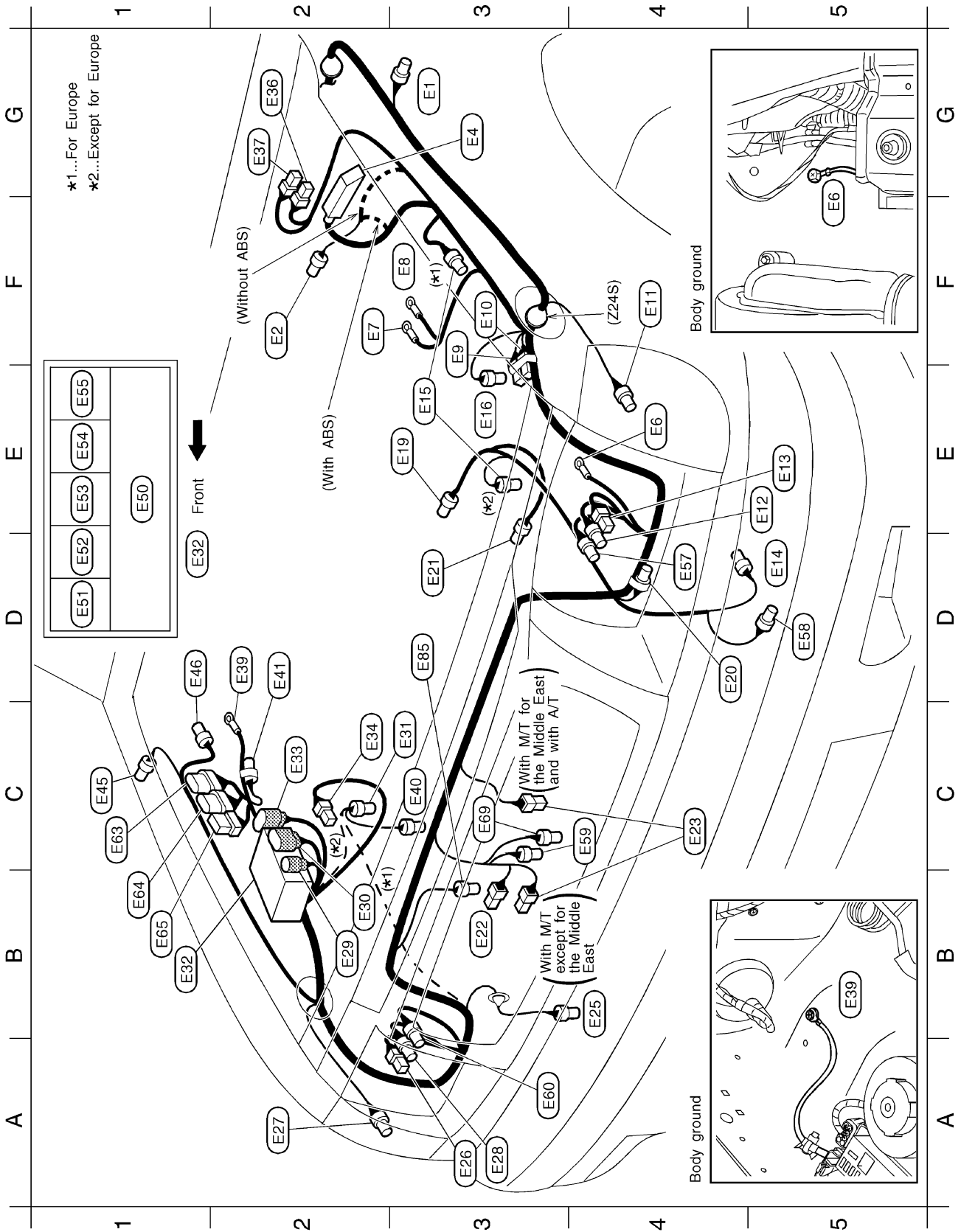

HARNESS LAYOUT

Engine Room Harness (Cont'd)

G3	E1	GY/2	: Side turn signal lamp LH (With multi-beam type headlamp)
F2	E2	GY/2	: Brake fluid level switch
G3	E4	B/31	: ABS actuator and electric unit (For ABS)
E4	E6	—	: Body ground
F2	E7	—	: Ignition coil (Z engine)
F3	E8	—	: Ignition coil (Z engine)
F3	E9	-/2	: Resistor (Z engine)
F3	E10	W/2	: Condenser (Z engine)
F4	E11	GY/3	: Front combination lamp LH (Without multi-beam type headlamp)
E5	E12	GY/3	: Front combination lamp LH (With multi-beam type headlamp)
E5	E13	B/3	: Headlamp LH
D5	E14	GY/2	: Washer motor
E3	E15	BR/2	: Front wheel sensor LH (For ABS)
E3	E16	GY/2	: Intake air temperature sensor (KA engine for Europe)
E3	E19	GY/3	: Distributor (Z engine)
D4	E20	GY/2	: Option connector (For hood switch) (For Europe)
D3	E21	B/1	: Compressor (Z engine)
B3	E22	B/1	: Horn low
C4	E23	B/1	: Horn high
B4	E25	GY/4	: Triple-pressure switch
A3	E26	B/3	: Headlamp RH
A2	E27	GY/3	: Front combination lamp RH (Without multi-beam type headlamp)
A3	E28	GY/3	: Front combination lamp RH (With multi-beam type headlamp)
B2	E29	GY/2	: To E204
B2	E30	GY/8	: To E203
C3	E31	GY/2	: Front wheel sensor RH (For ABS)
B1	E32	—	: Relay box (Fusible link and fuse box)
C2	E33	SB/8	: To E205
C2	E34	B/1	: Battery
G2	E36	B/1	: ISC-FI pot control solenoid valve (Z engine)
G2	E37	B/1	: ISC-FI pot control solenoid valve (Z engine)
D2	E39	—	: Body ground
C3	E40	B/2	: Power steering oil pressure switch (For Europe)
D2	E41	B/1	: Option connector (For front fog lamp) (For Europe)
C1	E45	GY/2	: Side turn signal lamp RH (With multi-beam type headlamp)
D1	E46	GY/3	: Power antenna (For the Middle East and Europe)
E1	E50	—	: Fusible link and fuse box
D1	E51	L/4	: Cooling fan relay (KA engine for the Middle East and Europe)

D1	E52	L/4	: Air conditioner relay
E1	E53	W/3	: Horn relay
E1	E54	BR/6	: Park/Neutral position relay (With A/T)
E1	E55	B/5	: Automatic choke relay (Z engine)
		BR/6	: ECM relay (KA engine)
D4	E57	-/3	: Headlamp aiming motor LH (For the Middle East and Europe)
D5	E58	GY/2	: Headlamp washer motor (For Europe)
C4	E59	B/2	: Ambient sensor (For Europe)
A3	E60	-/3	: Headlamp aiming motor RH (For the Middle East and Europe)
C1	E63	SB/6	: Daytime light unit (With daytime light system)
B1	E64	SB/8	: Daytime light unit (With daytime light system)
B1	E65	W/6	: Headlamp washer amplifier (For Europe)
C3	E69	BR/2	: Ambient temperature switch (KA engine)
D3	E85	GY/2	: Cooling fan motor (KA engine for the Middle East and Europe)

PASSENGER COMPARTMENT

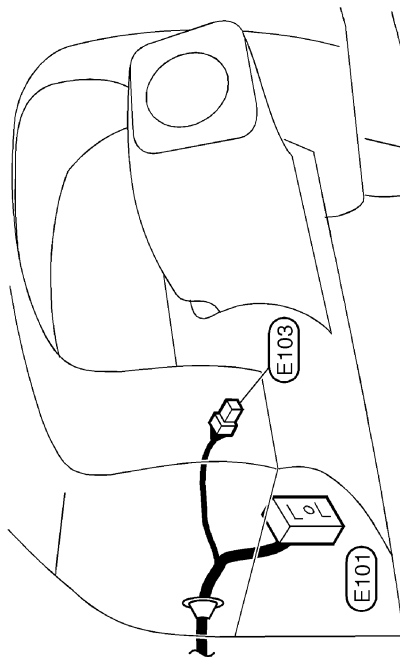

E101 SMJ : To **M5**
E103 B/2 : Fuse block

Resistor **E9**

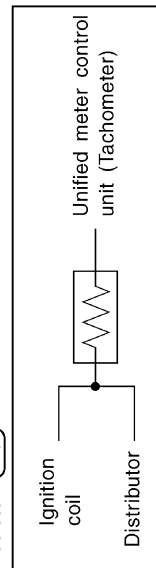

HARNESS LAYOUT

Engine Room Harness (Cont'd)

LHD MODELS — DIESEL ENGINE

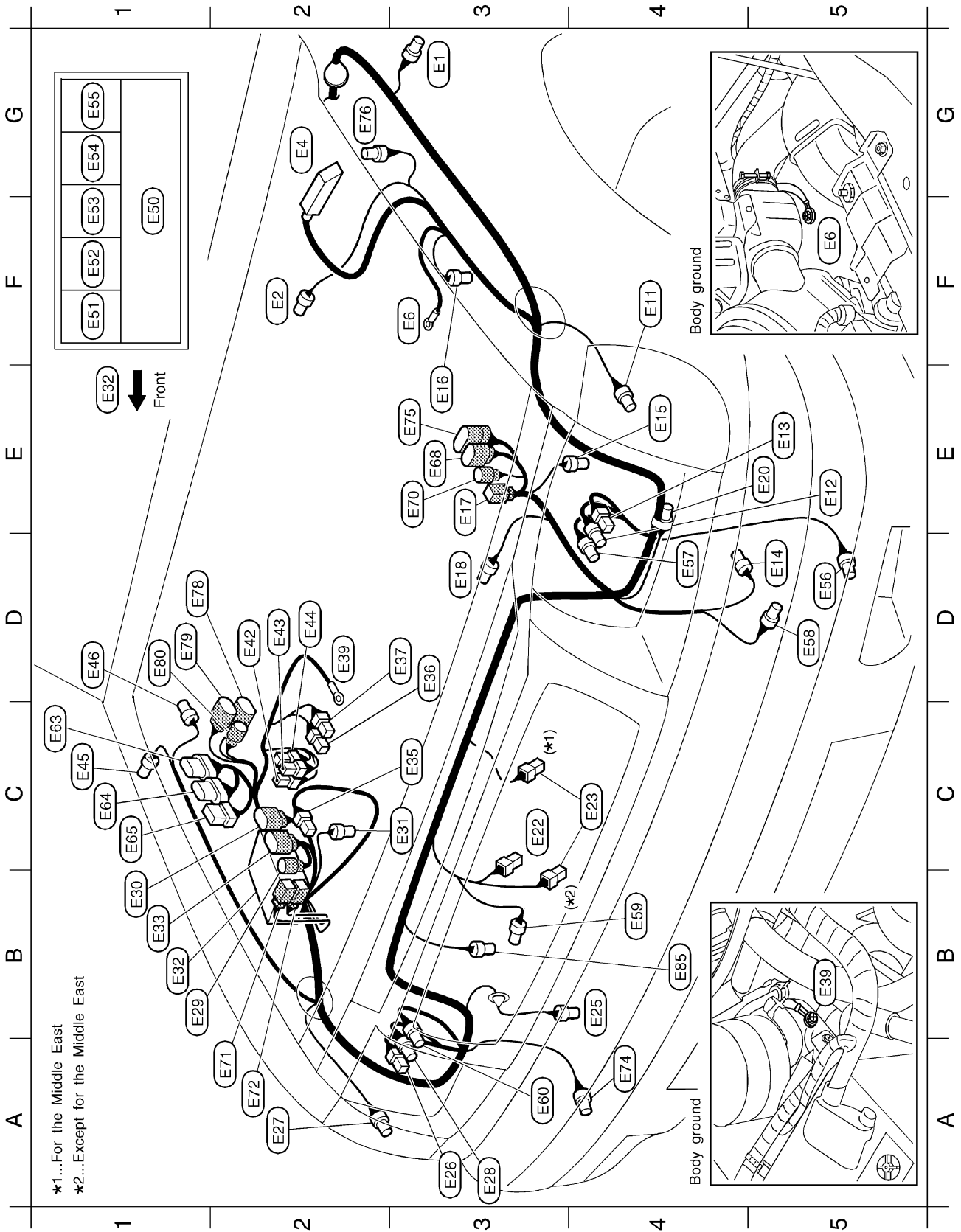

*1...For the Middle East
 *2...Except for the Middle East

E32
 Front

Body ground

Body ground

HARNESS LAYOUT

Engine Room Harness (Cont'd)

D4	E57	-/3	: Headlamp aiming motor LH (For the Middle East and Europe)
D5	E58	GY/2	: Headlamp washer motor (For Europe)
B4	E59	B/2	: Ambient sensor (For auto A/C) (YD and ZD engines)
A3	E60	-/3	: Headlamp aiming motor RH (For the Middle East and Europe)
C1	E63	SB/6	: Daytime light unit (With daytime light system)
C1	E64	SB/8	: Daytime light unit (With daytime light system)
C1	E65	W/6	: Headlamp washer amplifier (For Europe)
E3	E68	GY/8	: To A13 (TD and QD engines with M/T)
E3	E70	BR/3	: To A14 (YD and ZD engines)
A2	E71	B/2	: To E231 (YD and ZD engines)
A2	E72	B/1	: To E232 (YD and ZD engines)
A4	E74	B/2	: Front fog lamp RH (For Europe or with ZD engine)
E3	E75	GY/10	: To A15 (With A/T)
G2	E76	GY/2	: Dropping resistor (With A/T)
D1	E78	GY/8	: Park/Neutral position (PNP) switch (With A/T)
D1	E79	BR/8	: To terminal cord assembly (With A/T)
D1	E80	GY/3	: Revolution sensor (With A/T)
B4	E85	GY/2	: Cooling fan motor (Except TD engine)

G3	E1	GY/2	: Side turn signal lamp LH (Except for the Middle East)
F2	E2	GY/2	: Brake fluid level switch (With M/T)
G2	E4	B/31	: ABS actuator and electric unit (For ABS)
F3	E6	—	: Body ground
F4	E11	GY/3	: Front combination lamp LH (For the Middle East)
E5	E12	GY/3	: Front combination lamp LH (Except for the Middle East)
E5	E13	B/3	: Headlamp LH
D5	E14	GY/2	: Washer motor
E4	E15	BR/2	: Front wheel sensor LH (For ABS)
E3	E16	GY/2	: Intake air temperature sensor (YD and ZD engines)
E3	E17	B/2	: To A2
D3	E18	GY/2	: Thermoswitch (TD engine for the Middle East and QD engines)
E5	E20	GY/2	: Option connector (For hood switch) (For Europe)
C3	E22	B/1	: Horn low
C4	E23	B/1	: Horn high
B4	E25	GY/4	: Triple-pressure switch
A3	E26	B/3	: Headlamp RH
A2	E27	GY/3	: Front combination lamp RH (For the Middle East)
A3	E28	GY/3	: Front combination lamp RH (Except for the Middle East)
B1	E29	GY/2	: To E204
B1	E30	GY/8	: To E203 (YD and ZD engines)
C3	E31	GY/2	: Front wheel sensor RH (For ABS)
B1	E32	—	: Relay box (Fusible link and fuse box)
B1	E33	SB/8	: To E205
C3	E35	B/1	: To E206 (TD and QD engines)
D3	E36	B/1	: IACV-FICD solenoid valve (TD and QD engines)
D3	E37	B/1	: IACV-FICD solenoid valve (TD and QD engines)
D2	E39	—	: Body ground
D2	E42	W/1	: Glow relay-1 (YD and ZD engines)
D2	E43	W/1	: Glow relay-1 (YD and ZD engines)
D2	E44	G/2	: Glow relay-1 (YD and ZD engines)
C1	E45	GY/2	: Side turn signal lamp RH (Except for the Middle East)
D1	E46	GY/3	: Power antenna (For Europe)
F1	E50	—	: Fusible link and fuse box
F1	E51	L/4	: Cooling fan relay (TD engine for the Middle East, QD, YD and ZD engines)
F1	E52	L/4	: Air conditioner relay
F1	E53	W/3	: Horn relay
G1	E54	L/4	: Park/Neutral position (PNP) relay (With A/T)
G1	E55	BR/6	: ECM relay (YD and ZD engines)
		B/5	: ATP relay (With A/T)
D5	E56	B/2	: Front fog lamp LH (For Europe or with ZD engine)

PASSENGER COMPARTMENT

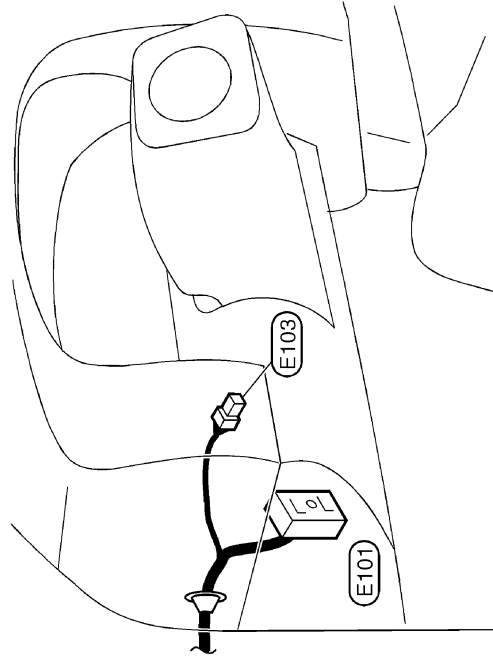

E101	SMJ	: To M5
E103	B/2	: Fuse block

HARNESS LAYOUT

Engine Room Harness (Cont'd)

RHD MODELS — DIESEL ENGINE

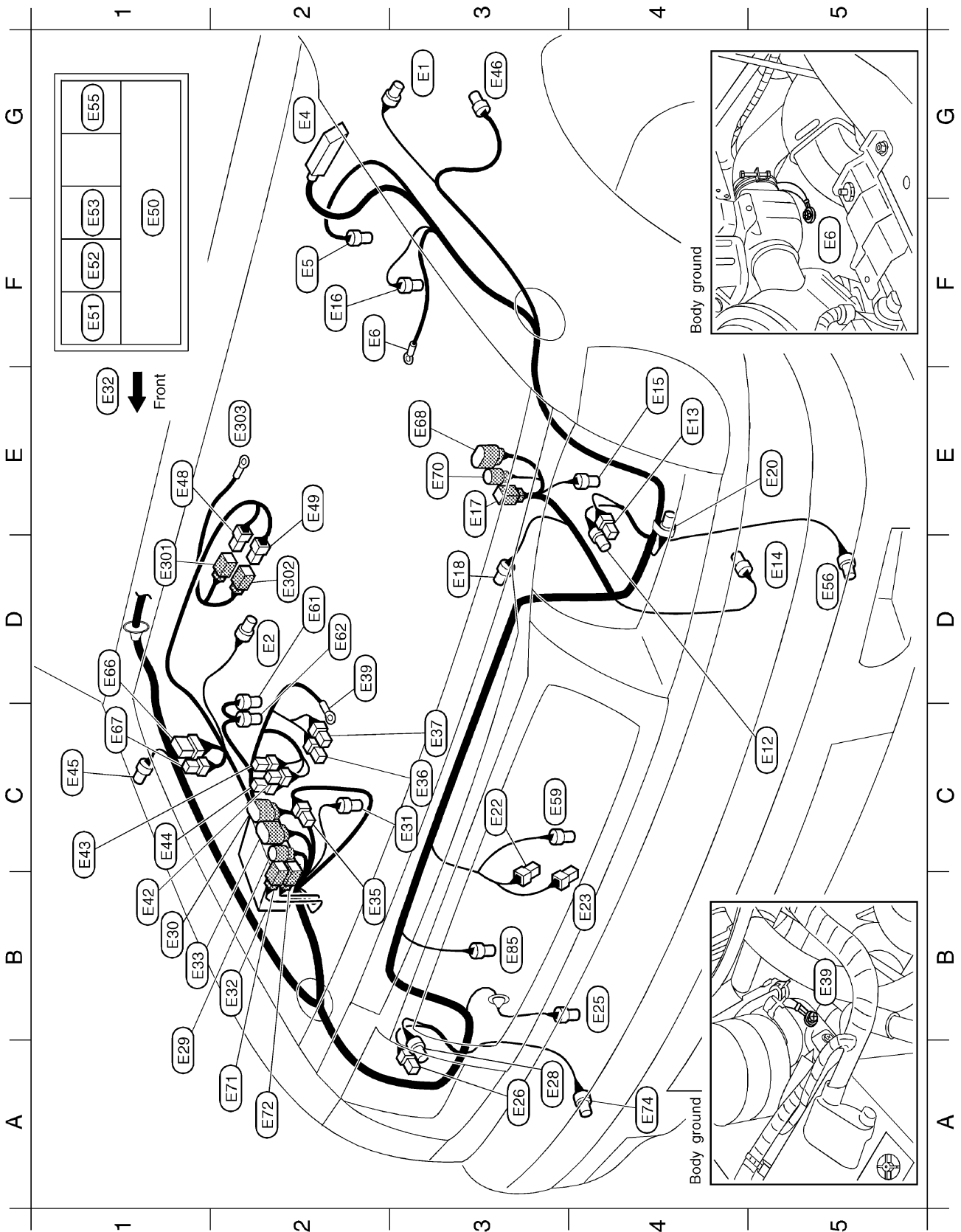

HARNESS LAYOUT

Engine Room Harness (Cont'd)

- D2 **(E61)** B/2 : EGRC-solenoid valve (Throttle chamber)
(TD engine with EGR)
- D2 **(E62)** BR/2 : EGRC-solenoid valve (EGR valve)
(TD engine with EGR)
- D1 **(E66)** GY/6 : Dim-dip lamp unit (For Europe)
- C1 **(E67)** GY/4 : Dim-dip lamp unit (For Europe)
- E3 **(E68)** GY/8 : To **(A13)** (TD and QD engines)
- E3 **(E70)** BR/3 : To **(A14)** (YD and ZD engines)
- A2 **(E71)** B/2 : To **(E231)** (YD and ZD engines)
- A2 **(E72)** B/1 : To **(E232)** (YD and ZD engines)
- A4 **(E74)** B/2 : Front fog lamp RH (For Europe)
- B3 **(E85)** GY/2 : Cooling fan motor (Except TD engine)

PASSENGER COMPARTMENT

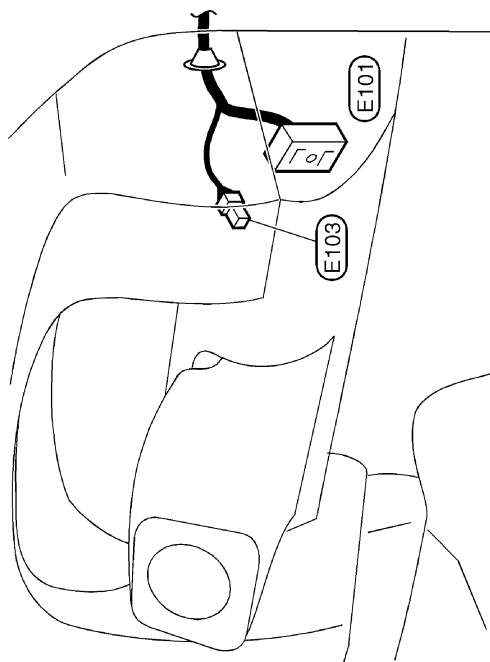

- (E101)** SMJ : To **(M5)**
- (E103)** B/2 : Fuse block

Sub-harness

- D1 **(E301)** B/1 : To **(E48)** (QD engine)
- D2 **(E302)** L/2 : To **(E49)** (TD engine)
- E2 **(E303)** — : Glow plug (TD and QD engines)

- G3 **(E1)** GY/2 : Side turn signal lamp LH
- D2 **(E2)** GY/2 : Brake fluid level switch
- G2 **(E4)** B/31 : ABS actuator and electric unit (For ABS)
- F2 **(E5)** BR/2 : Fuel filter switch (Except for Europe)
- F2 **(E6)** — : Body ground
- C5 **(E12)** GY/3 : Front combination lamp LH
- E4 **(E13)** B/3 : Headlamp LH
- D5 **(E14)** GY/2 : Washer motor
- E4 **(E15)** BR/2 : Front wheel sensor LH (For ABS)
- F2 **(E16)** GY/2 : Intake air temperature sensor (YD and ZD engines)
- E3 **(E17)** B/2 : To **(A2)**
- D3 **(E18)** GY/2 : Thermostat (QD engine)
- E5 **(E20)** GY/2 : Option connector (For hood switch) (For Europe)
- C3 **(E22)** B/1 : Horn low
- B4 **(E23)** B/1 : Horn high (ZD engine except for Australia, YD and QD engines)
- B4 **(E25)** GY/4 : Triple-pressure switch
- A3 **(E26)** B/3 : Headlamp RH
- A3 **(E28)** BR/3 : Front combination lamp RH
- A1 **(E29)** GY/2 : To **(E204)**
- B1 **(E30)** GY/8 : To **(E203)** (With ECM control engine)
- C3 **(E31)** GY/2 : Front wheel sensor RH (For ABS)
- B2 **(E32)** — : Relay box (Fusible link and fuse box)
- B1 **(E33)** SB/8 : To **(E205)**
- B2 **(E35)** B/1 : To **(E206)** (TD and QD engines)
- C3 **(E36)** B/1 : IACV-FICD solenoid valve (TD and QD engines)
- C3 **(E37)** B/1 : IACV-FICD solenoid valve (TD and QD engines)
- D2 **(E39)** — : Body ground
- B1 **(E42)** W/1 : Glow relay-1
- C1 **(E43)** W/1 : Glow relay-1
- C1 **(E44)** G/2 : Glow relay-1
- C1 **(E45)** GY/2 : Side turn signal lamp RH
- G3 **(E46)** GY/3 : Power antenna (For Europe)
- E1 **(E48)** B/1 : To **(E301)** (QD engine)
- E2 **(E49)** L/2 : To **(E302)** (TD engine)
- F1 **(E50)** — : Fusible link and fuse box
- F1 **(E51)** L/4 : Cooling fan relay (Except TD engine)
- F1 **(E52)** L/4 : Air conditioner relay
- F1 **(E53)** W/3 : Horn relay
- G1 **(E55)** BR/6 : ECM relay (YD and ZD engines)
- D5 **(E56)** B/2 : Front fog lamp LH (For Europe)
- C3 **(E59)** B/2 : Ambient sensor (YD and ZD engines)

HARNESS LAYOUT

Engine Control Harness

VG ENGINE



HARNESS LAYOUT

Engine Control Harness (Cont'd)

PASSENGER COMPARTMENT

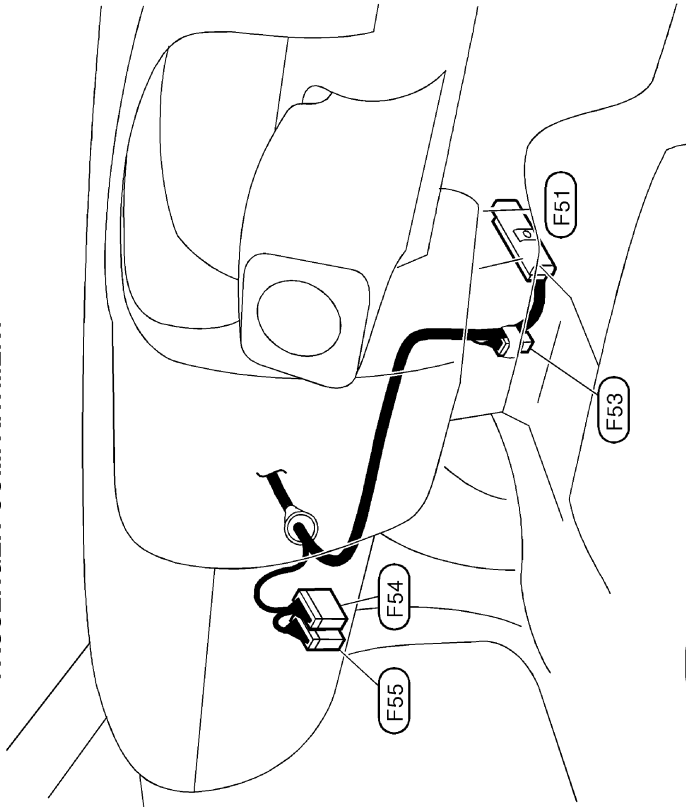

- F51** W/76 : ECM
- F53** GY/6 : Joint connector-1
- F54** W/24 : To **M48**
- F55** W/16 : To **M47**

D1	F5	GY/2	:	To	F151
E3	F6	BR/4	:	Mass air flow sensor	
D1	F7	—	:	Engine ground	
D1	F8	—	:	Engine ground	
C3	F9	B/1	:	Thermal transmitter	
B3	F11	B/2	:	Power steering oil pressure switch	
E3	F12	B/1	:	Compressor	
D3	F13	GY/2	:	Distributor	
D3	F14	GY/6	:	Distributor	
F2	F21	W/6	:	Wiper motor	
C1	F22	GY/3	:	Heated oxygen sensor 1 (Bank 1)	
C1	F23	GY/3	:	Heated oxygen sensor 1 (Bank 2)	
B2	F25	SB/8	:	To F201	
B2	F26	GY/8	:	To F202	
D3	F27	BR/3	:	Throttle position sensor	
C1	F40	GY/8	:	To E227	
B2	F201	SB/8	:	To F25	
C2	F202	GY/8	:	To F26	
C3	F203	GY/2	:	Engine coolant temperature sensor	
C3	F204	B/2	:	Injector No.1	
C2	F205	B/2	:	Injector No.3	
C2	F206	B/2	:	Injector No.5	
E3	F209	B/2	:	Injector No.6	
D3	F210	B/2	:	Injector No.4	
D3	F211	B/2	:	Injector No.2	
E2	F212	BR/2	:	IACV-AAC valve	
E2	F213	GY/2	:	IACV-FICD solenoid valve	
E2	F214	B/2	:	EVAP canister purge volume control solenoid valve	

Sub-harness

D1	F151	GY/2	:	To	F5
D3	F152	GY/2	:	Knock sensor	

HARNESS LAYOUT

Engine Control Harness (Cont'd)

ENGINE COMPARTMENT — YD ENGINE (RHD models)

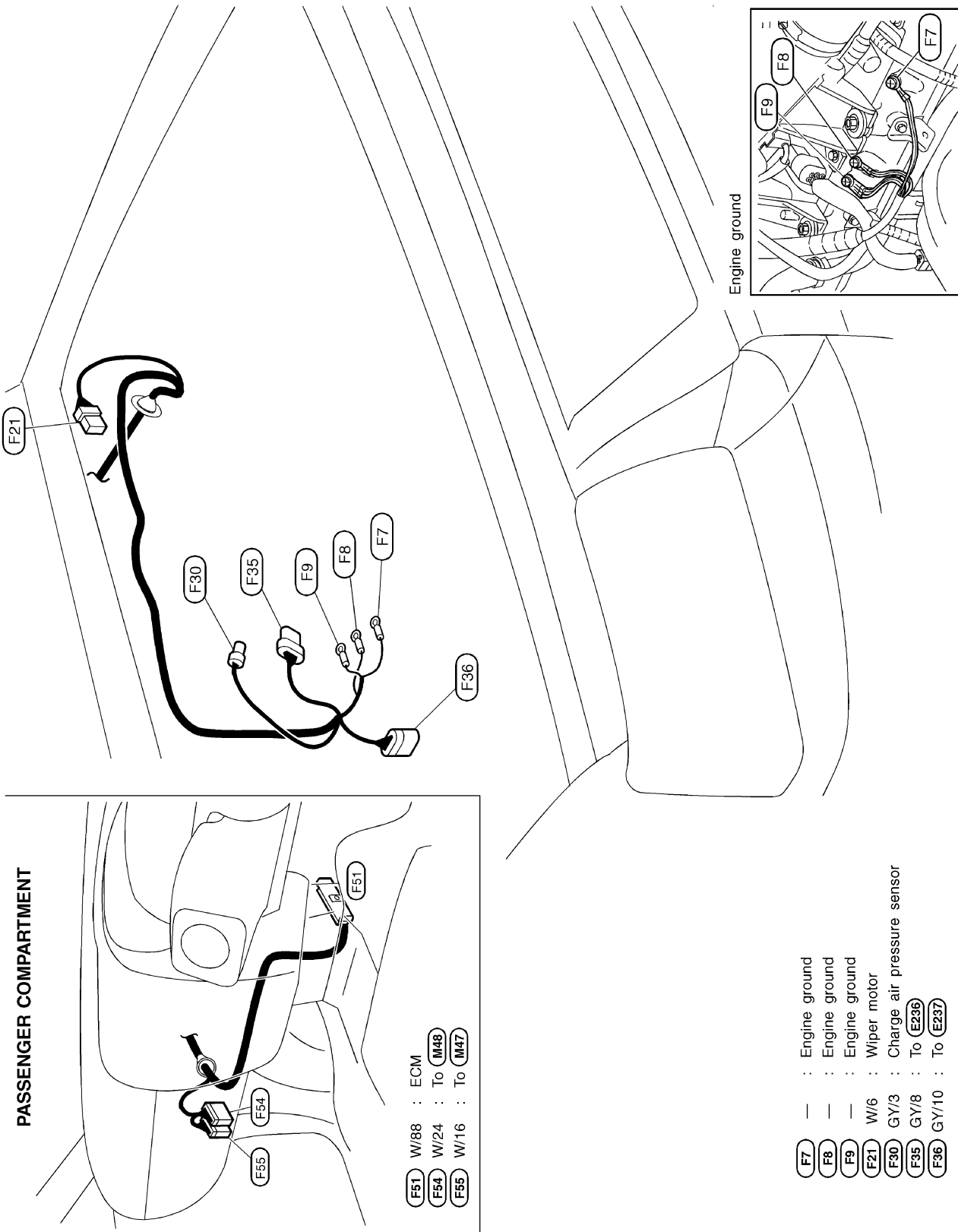

HARNESS LAYOUT

Chassis Harness and Tail Harness

Tail harness

- (T1)** W/6 : Rear combination lamp RH
(A-chassis models or with smooth rear body
except for Europe, Australia and China)
- (T2)** W/8 : Rear combination lamp RH (For Europe, Australia and China
except A-chassis models or with regular rear body)
- (T3)** GY/2 : License plate lamp RH (With step bumper)
- (T4)** SB/8 : To **(C7)**
- (T5)** GY/2 : License plate lamp RH (Without step bumper)
- (T6)** GY/2 : License plate lamp LH (Without step bumper)
- (T7)** B/2 : License plate lamp LH (With step bumper)
- (T8)** W/6 : Rear combination lamp LH
(A-chassis models or with smooth rear body
except for Europe, Australia and China)
- (T9)** W/8 : Rear combination lamp LH (For Europe, Australia and China
except A-chassis models or with regular rear body)
- (T10)** GY/2 : Rear fog lamp (RHD A-chassis models for Europe)
- (T12)** GY/2 : Rear fog lamp (LHD A-chassis models for Europe)

Chassis harness

- (C2)** W/6 : To **(M112)** (With ABS)
- (C3)** GY/5 : Fuel level sensor unit and fuel pump
- (C5)** SB/4 : To rear wheel sensor sub-harness (For ABS)
(4WD models and 2WD models with LT30 rear brake)
- (C6)** GY/2 : Rear wheel sensor (For ABS)
(2WD models with LT26B rear brake)
- (C7)** SB/8 : To **(T4)**
- (C9)** W/16 : To **(M12)**
- (C10)** BR/2 : High-mounted stop lamp (With guard bar)

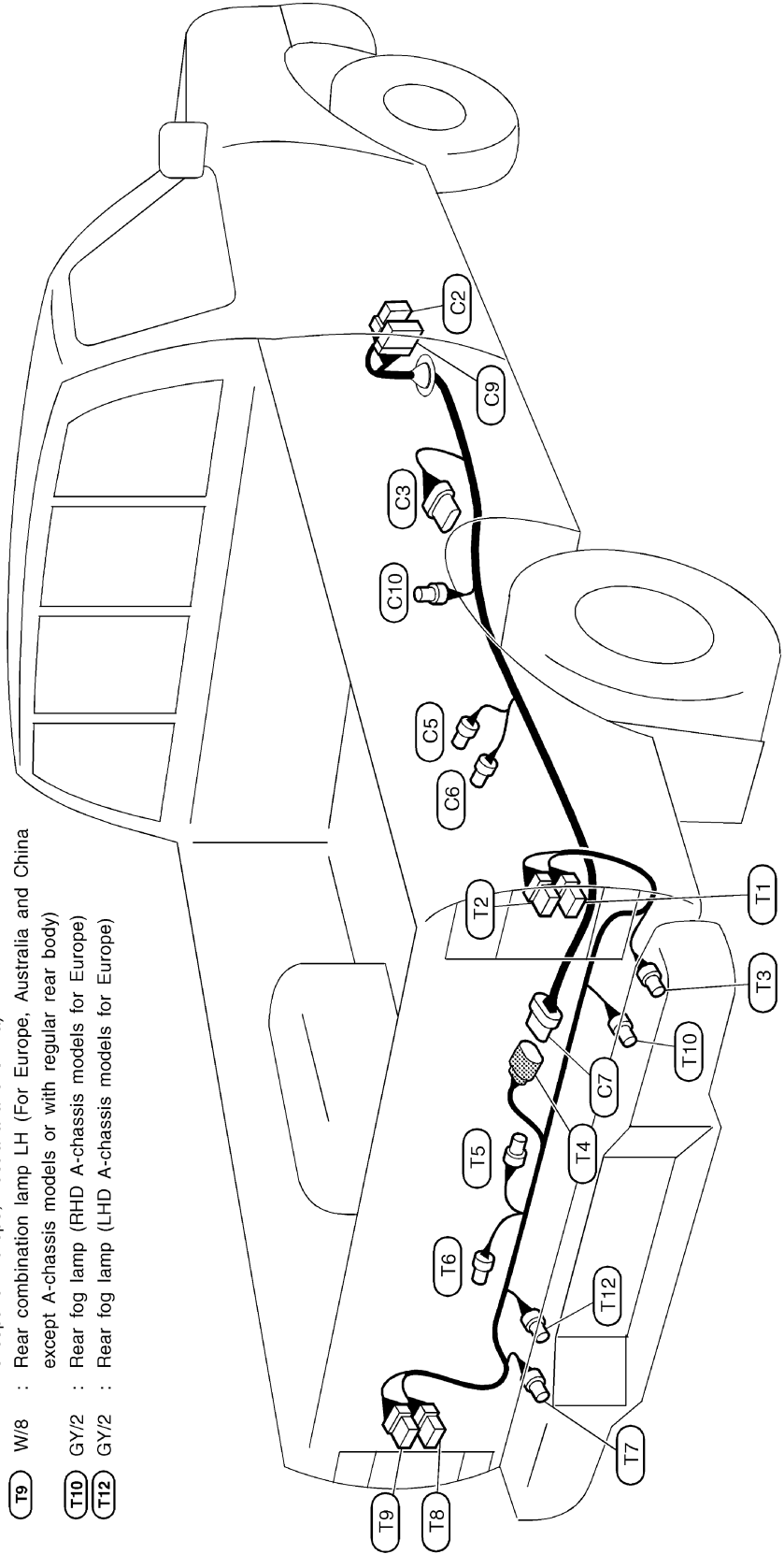

HARNESS LAYOUT

Room Lamp Harness/LHD Models

DOUBLE CAB

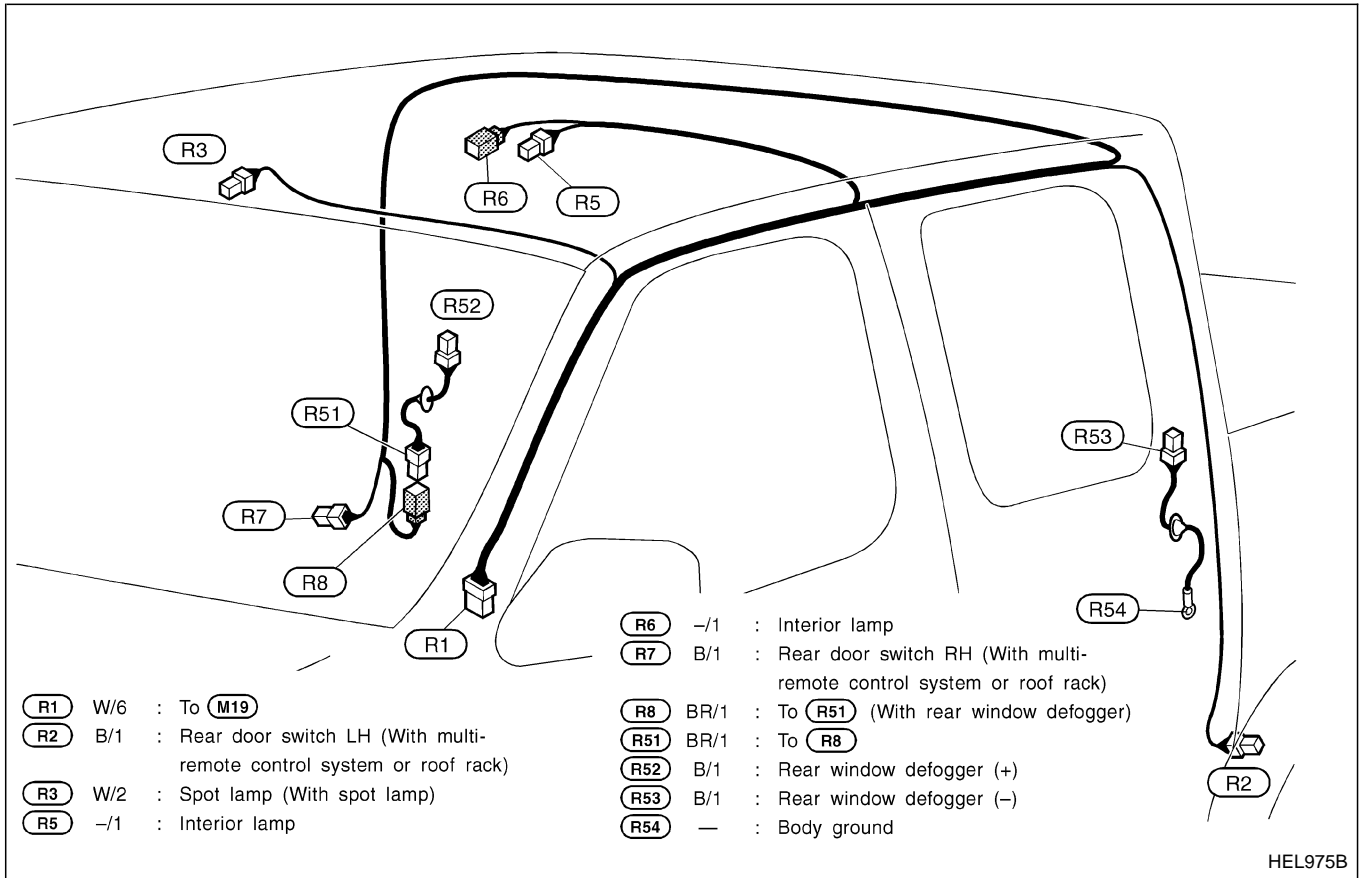

HARNESS LAYOUT

Room Lamp Harness/RHD Models

DOUBLE CAB

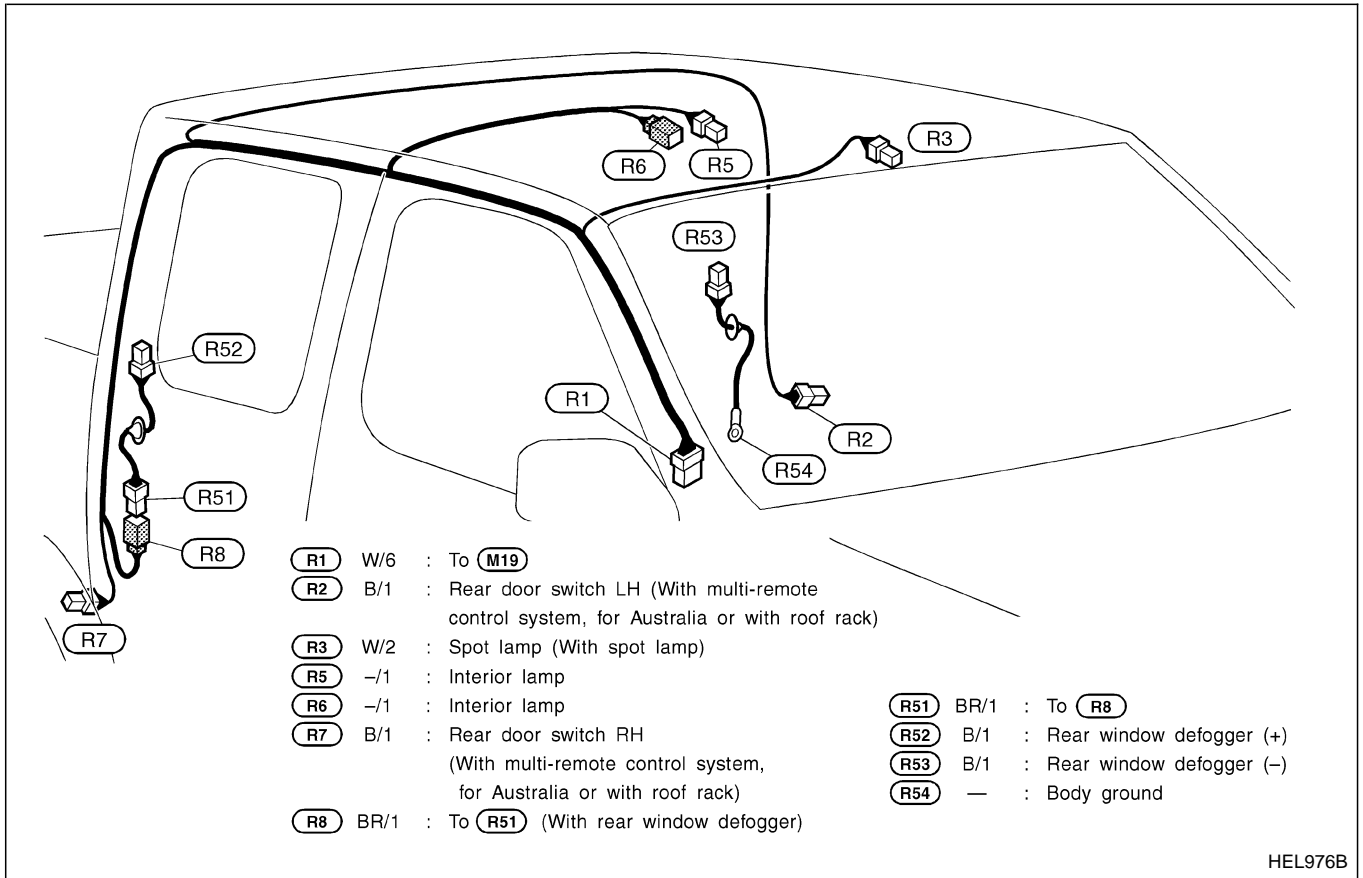

HEL976B

WIRING DIAGRAM CODES (CELL CODES)

Use the chart below to find out what each wiring diagram code stands for.

Refer to the wiring diagram code in the alphabetical index to find the location (page number) of each wiring diagram.

Code	Section	Wiring Diagram Name
AAC/V	EC	IACV-AAC Valve
A/C, A	HA	Auto Air Conditioner
A/C, M	HA	Manual Air Conditioner
A/CCUT	EC	Air Conditioner Control
AIRREG	EC	IACV-Air Regulator
AUDIO	EL	Audio
BACK/L	EL	Back-up Lamp
CHIME	EL	Warning Chime
CMPS	EC	Camshaft Position Sensor
COOL/F	LC, EC	Cooling Fan Control
ECTS	EC	Engine Coolant Temperature Sensor
F/FOG	EL	Front Fog Lamp
FICD	EC	IACV-FICD Solenoid Valve
F/PUMP	EC	Fuel Pump
GLOW	EC	Quick-glow System
H/AIM	EL	Headlamp Aiming Control
IGNSYS	EC	Ignition Signal
ILL	EL	Illumination
INJECT	EC	Injector
KS	EC	Knock Sensor
LOAD	EC	Electric Load Signal
MAFS	EC	Mass Air Flow Sensor

Code	Section	Wiring Diagram Name
MAIN	EC	Main Power Supply and Ground Circuit
METER	EL	Speedometer, Tachometer, Temp. and Fuel Gauges
MIL/DL	EC	MIL and Data Link Connectors
NATS	EL	Nissan Anti-theft System
O2H1B1	EC	Heated Oxygen Sensor 1 Heater
O2H2B1	EC	Heated Oxygen Sensor 2 Heater
O2S1B1	EC	Heated Oxygen Sensor 1
O2S2B1	EC	Heated Oxygen Sensor 2
PGC/V	EC	EVAP Canister Purge Control Solenoid Valve
PNP/SW	EC	Park/Neutral Position Switch
POWER	EL	Power Supply Routing
PST/SW	EC	Power Steering Oil Pressure Switch
R/FOG	EL	Rear Fog Lamp
ROOM/L	EL	Interior Room Lamp
SRS	RS	Supplemental Restraint System
S/SIG	EC	Start Signal
TAIL/L	EL	Parking, License and Tail Lamps
TPS	EC, AT	Throttle Position Sensor
VSS	EC	Vehicle Speed Sensor
WARN	EL	Warning Lamps