

**SECTION BR**

**MODIFICATION NOTICE:**

Wiring diagrams have been changed.  
Service data and specifications (SDS) have been changed.

**CONTENTS**

<b>TROUBLE DIAGNOSES</b> .....	5002	<b>SERVICE DATA AND SPECIFICATIONS</b>	
Schematic/4 Wheel Sensors Models.....	5002	<b>(SDS)</b> .....	5009
Wiring Diagram - ABS -/4 Wheel Sensors LHD		General Specifications .....	5009
Models.....	5003		
Wiring Diagram - ABS -/4 Wheel Sensors			
RHD Models.....	5006		

# TROUBLE DIAGNOSES

## Schematic/4 Wheel Sensors Models

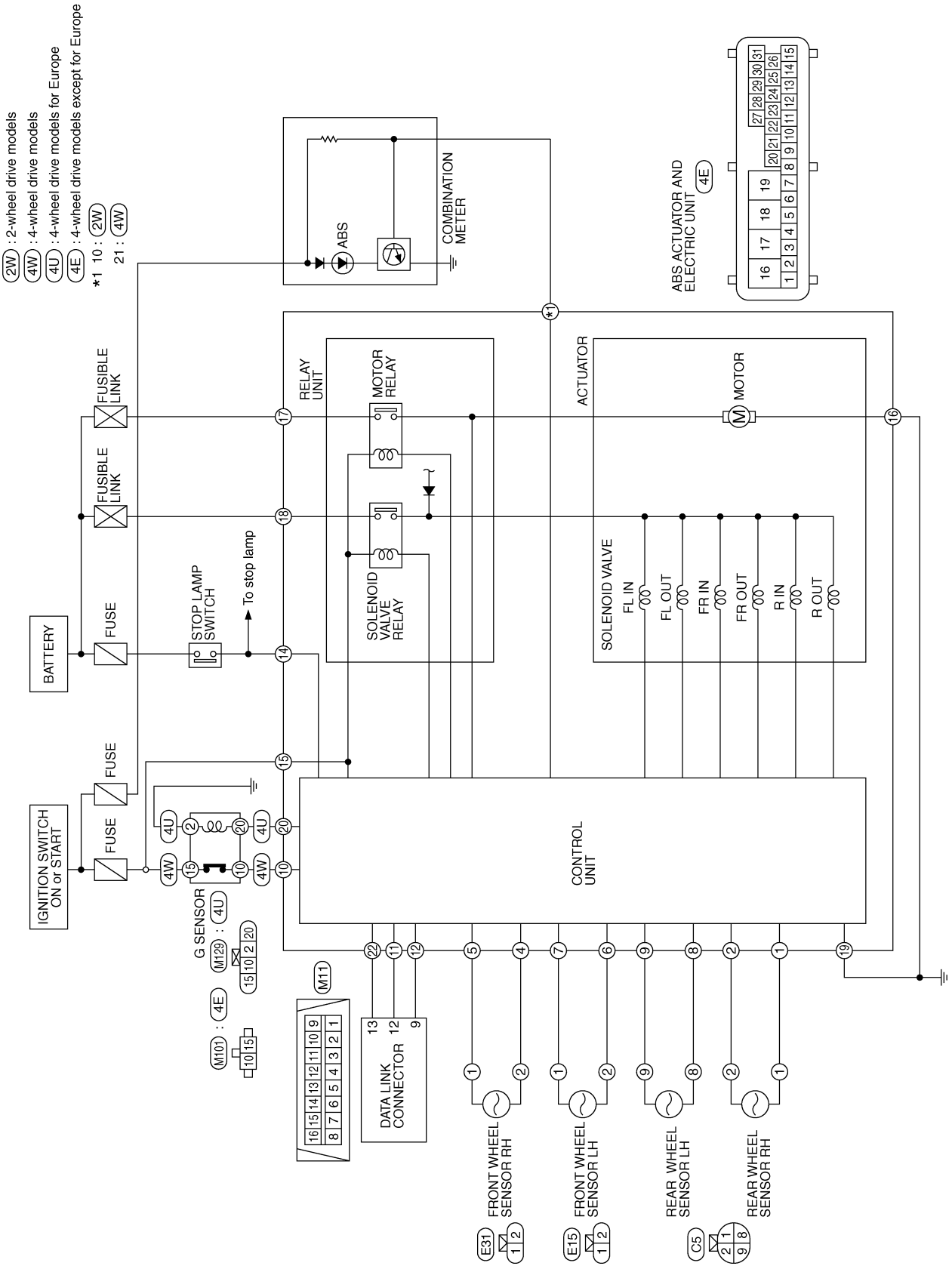

# TROUBLE DIAGNOSES

## Wiring Diagram — ABS —/4 Wheel Sensors LHD Models

BR-ABS-01

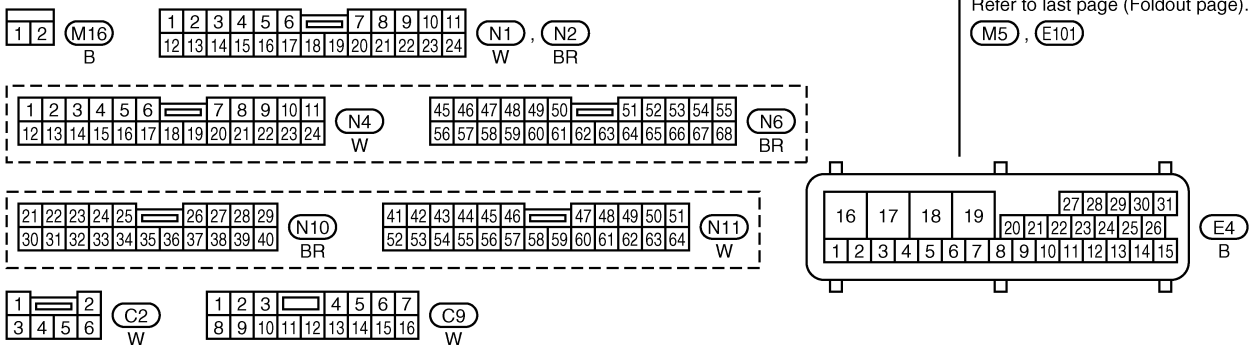
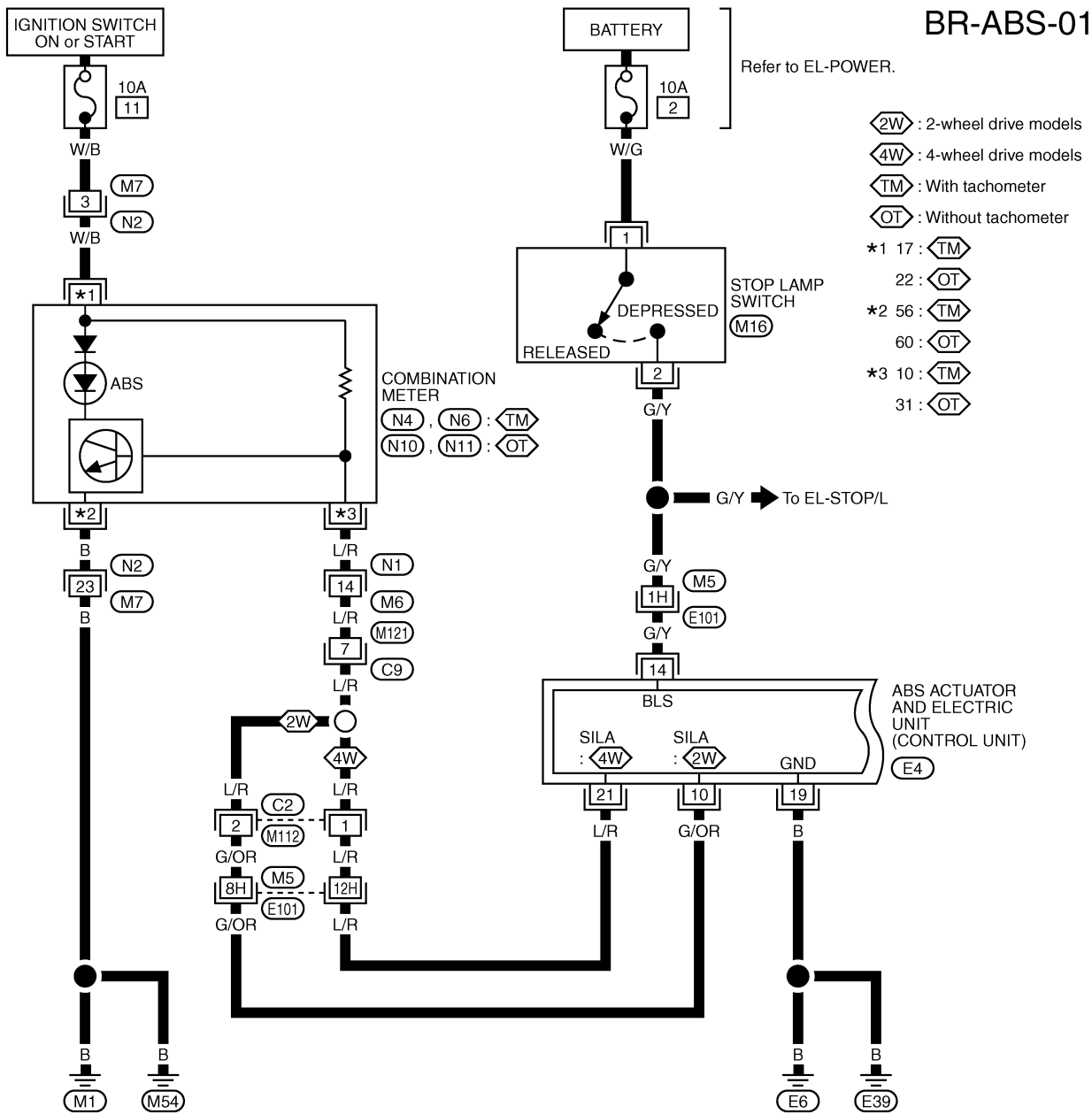

# TROUBLE DIAGNOSES

## Wiring Diagram — ABS —/4 Wheel Sensors LHD Models (Cont'd)

BR-ABS-02

Refer to EL-POWER.

4W : 4-wheel drive models

ABS ACTUATOR  
AND ELECTRIC  
UNIT  
E4

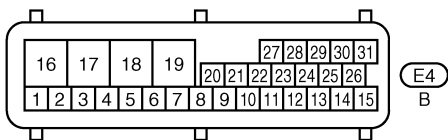
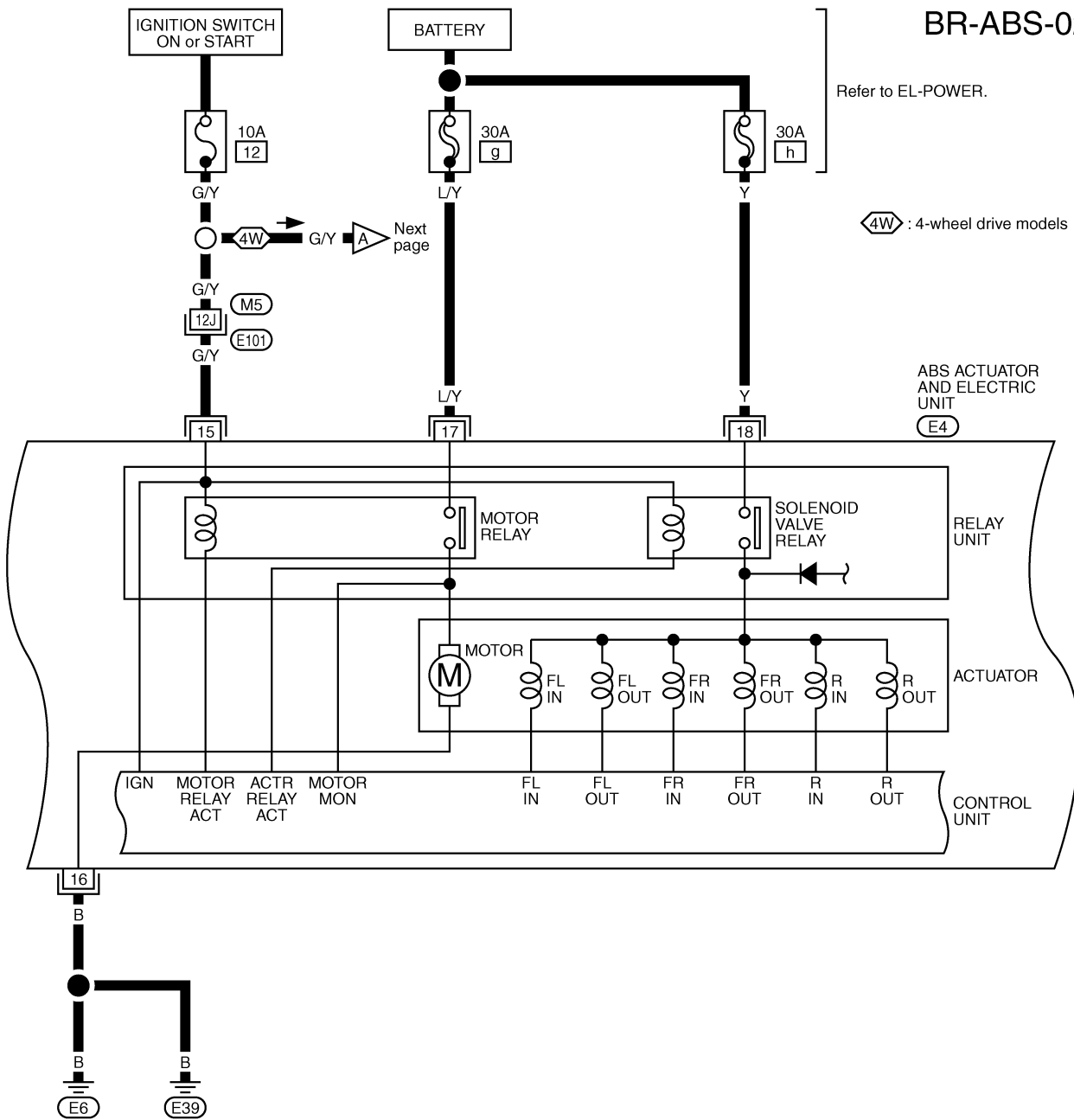

Refer to last page (Foldout page).

M5, E101

# TROUBLE DIAGNOSES

## Wiring Diagram — ABS —/4 Wheel Sensors LHD Models (Cont'd)

BR-ABS-03

- : 4-wheel drive models
- : 4-wheel drive models for Europe
- : 4-wheel drive models except for Europe

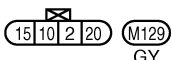
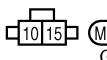
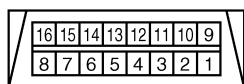
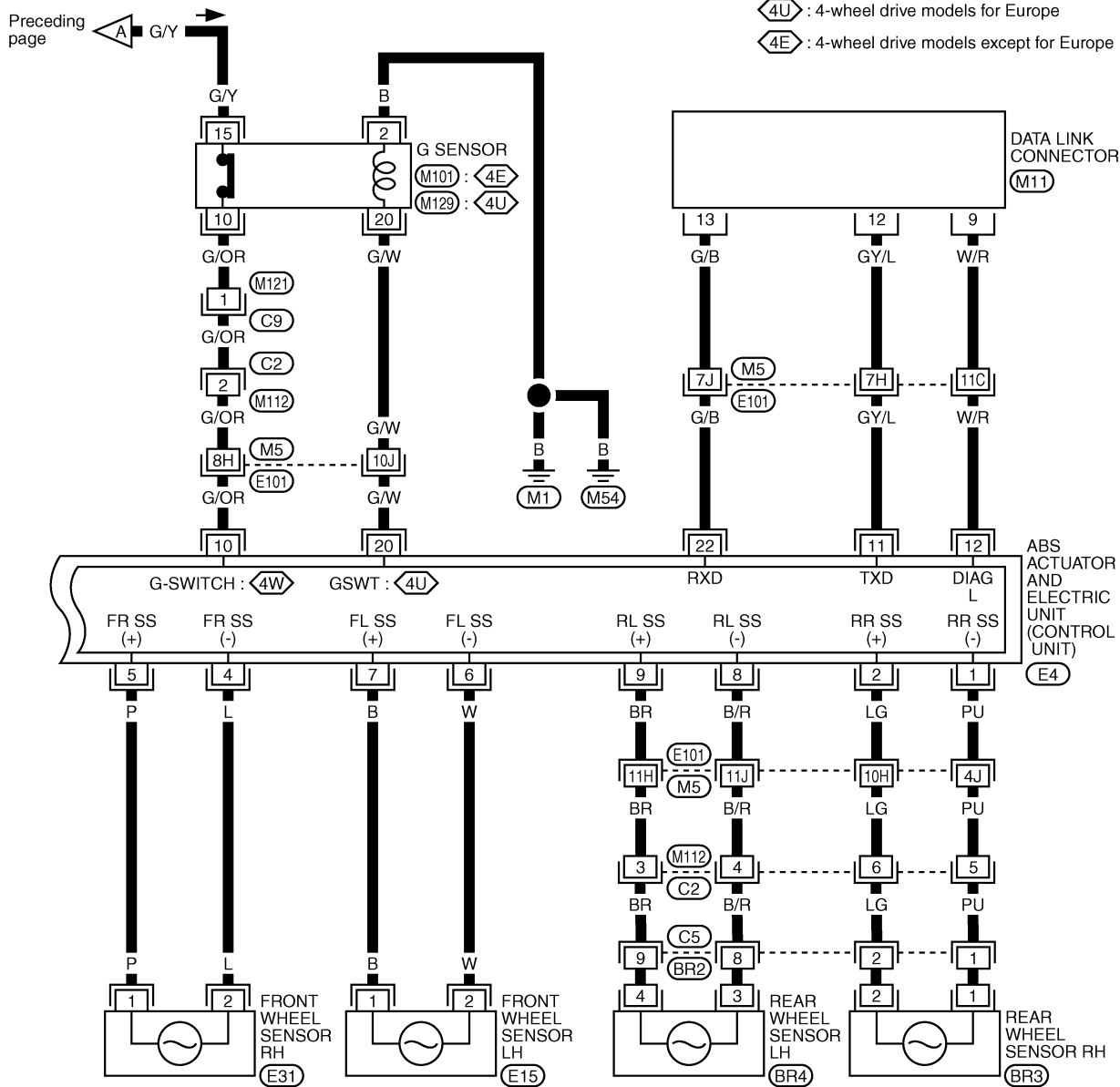

Refer to last page (Foldout page).  
 ,

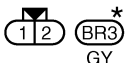
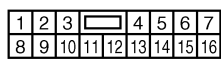
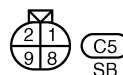
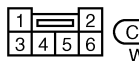
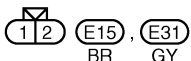
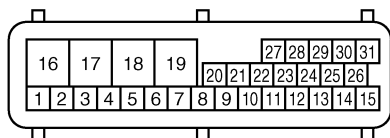

\*: This connector is not shown in "HARNESS LAYOUT", EL section.

# TROUBLE DIAGNOSES

## Wiring Diagram — ABS —/4 Wheel Sensors RHD Models

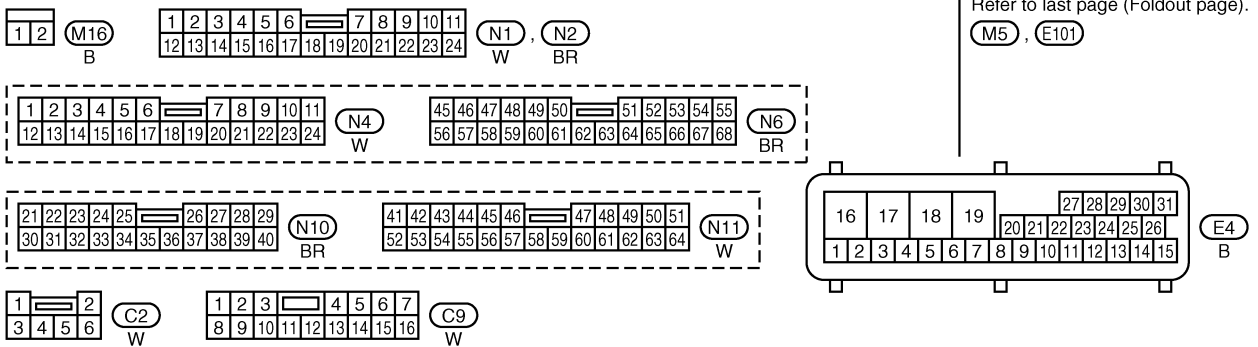
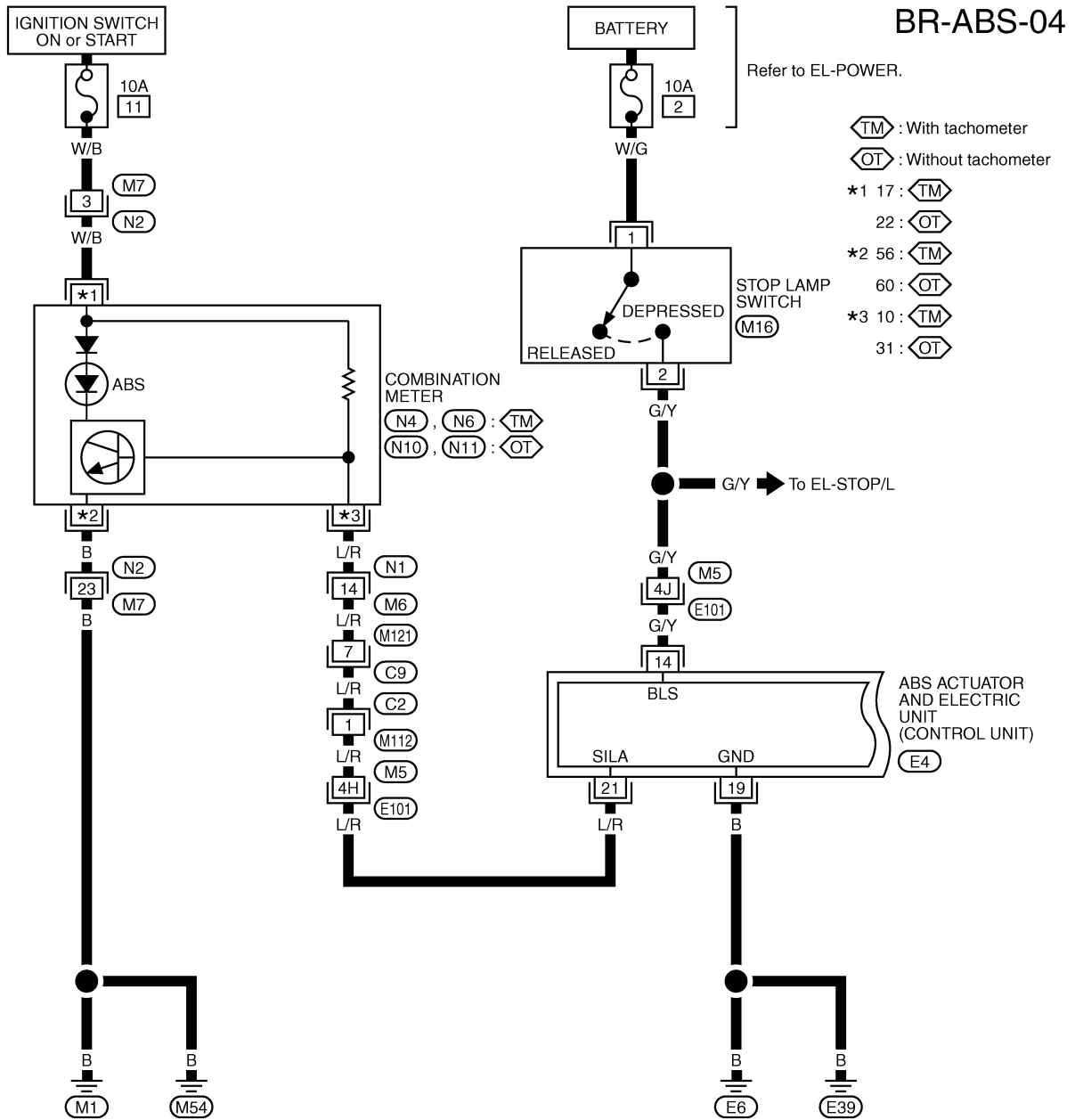

# TROUBLE DIAGNOSES

## Wiring Diagram — ABS —/4 Wheel Sensors RHD Models (Cont'd)

BR-ABS-05

Refer to EL-POWER.

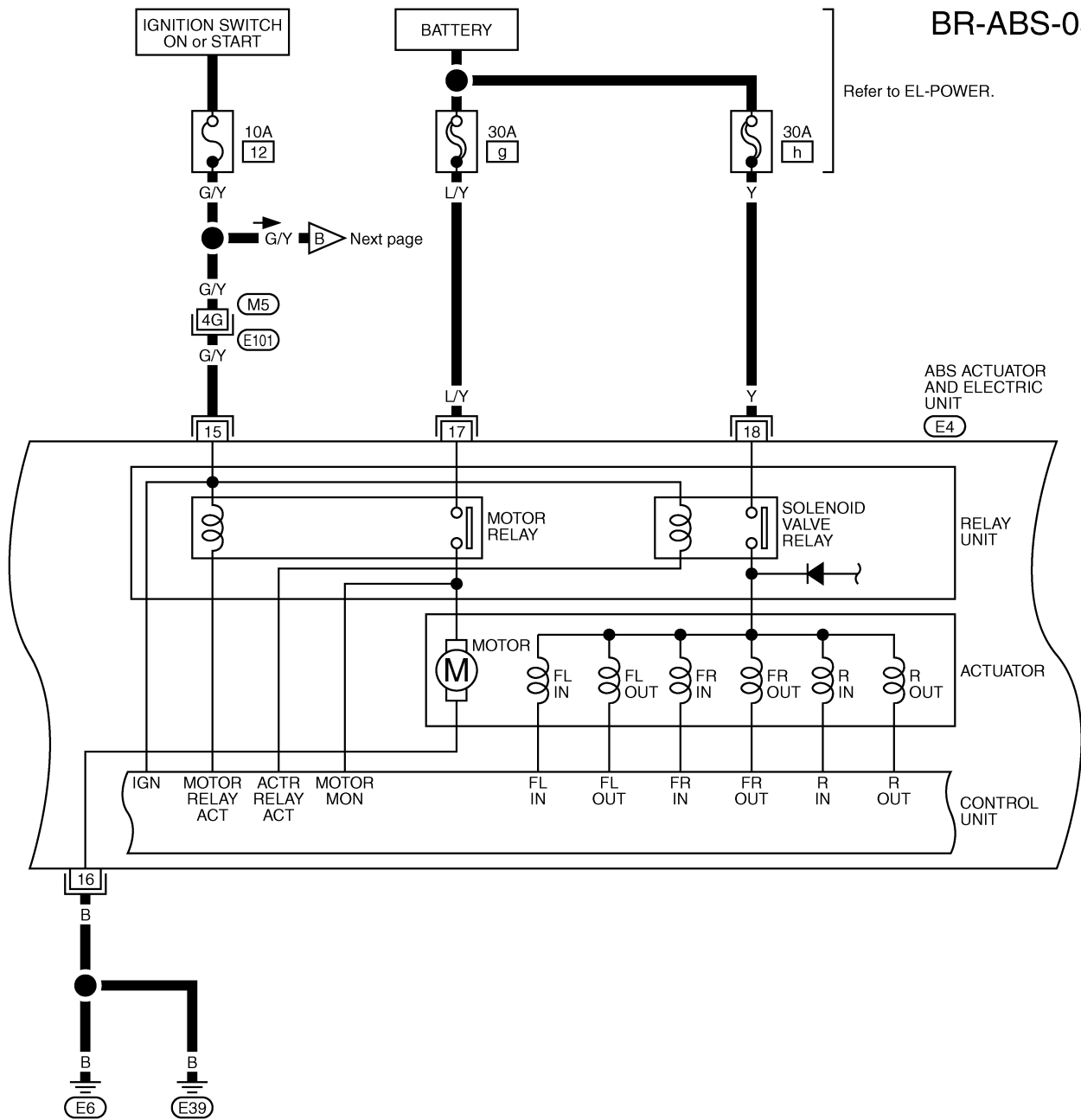

ABS ACTUATOR  
AND ELECTRIC  
UNIT  
(E4)

RELAY  
UNIT

ACTUATOR

CONTROL  
UNIT

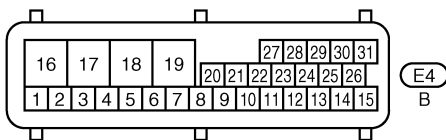

Refer to last page (Foldout page).

(M5), (E101)

# TROUBLE DIAGNOSES

## Wiring Diagram — ABS —/4 Wheel Sensors RHD Models (Cont'd)

BR-ABS-06

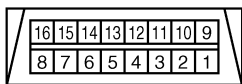
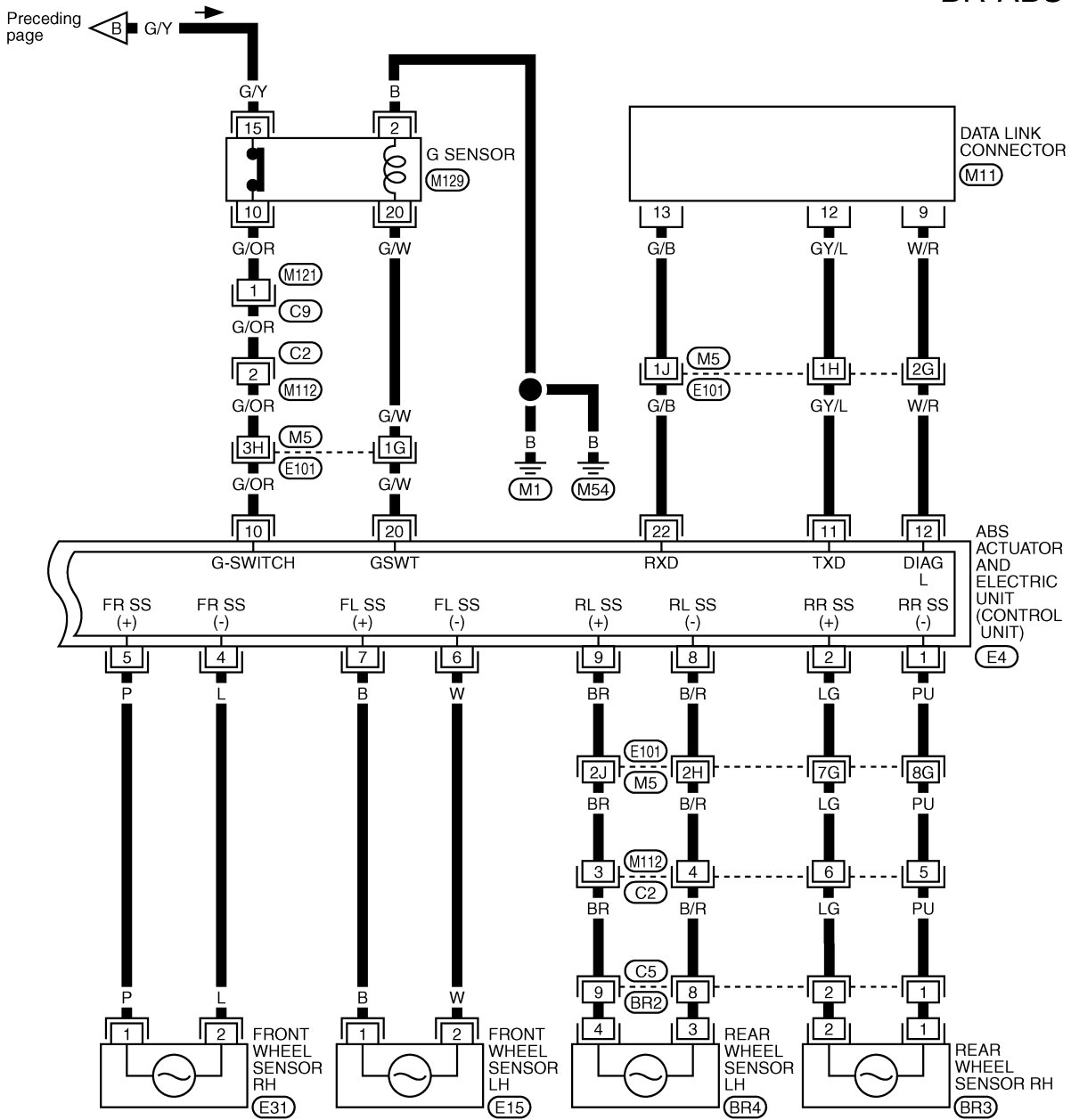

M11  
W

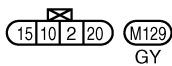

M129  
GY

Refer to last page (Foldout page).

M5, E101

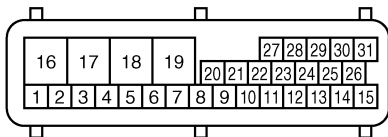

E4  
B

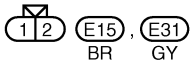

E15  
BR

E31  
GY



C2  
W

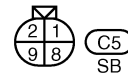

C5  
SB

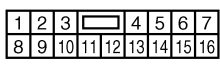

C9  
W

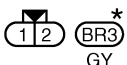

BR3  
GY



BR4  
BR

\*: This connector is not shown in "HARNESS LAYOUT", EL section.



# SERVICE DATA AND SPECIFICATIONS (SDS)

## General Specifications

### 2WD MODELS

Destination	Europe			
Applied model	KA24DE	YD25	KA24DE	YD25
Front brake	CL28VD		CL33VD	
Type	CL28VD		CL33VD	
Cylinder bore diameter mm (in)	42.8 (1.685) x 2		46.4 (1.827) x 2	
Pad dimension mm (in) Length x width x thickness	146.6 x 48.5 x 10 (5.77 x 1.909 x 0.39)		132.0 x 52.5 x 11 (5.20 x 2.067 x 0.43)	
Rotor outer diameter x thickness mm (in)	260 x 26 (10.24 x 1.02)		283 x 28 (11.14 x 1.10)	
Rear brake	LT26B		LT30A	
Type	LT26B		LT30A	
Wheel cylinder bore diameter mm (in)	22.22 (7/8)			
Lining dimension mm (in) Length x width x thickness	249.6 x 40 x 5.5 (9.83 x 1.57 x 0.217)		296 x 50 x 6.1 (11.65 x 1.97 x 0.240)	
Drum inner diameter mm (in)	260.0 (10.24)		295.0 (11.61)	
Master cylinder bore diameter mm (in)	With ABS: 23.81 (15/16) Without ABS: 25.4 (1)		25.4 (1)	
Control valve	LSV			
Type	LSV			
Split point x reducing ratio kPa (bar, kg/cm <sup>2</sup> , psi)	(Variable) x 0.15			
Brake booster	M195T		M215T	
Model	M195T		M215T	
Diaphragm diameter mm (in)	Primary: 205 (8.07) Secondary: 180 (7.09)		Primary: 230 (9.06) Secondary: 205 (8.07)	
Recommended brake fluid	DOT 3 or DOT 4			

**SERVICE DATA AND SPECIFICATIONS (SDS)**  
**General Specifications (Cont'd)**

**4WD MODELS**

Destination	Europe	
Applied model	KA24DE	YD25
Front brake		
Type	CL33VD	
Cylinder bore diameter   mm (in)	46.4 (1.827) x 2	
Pad dimension           mm (in) Length x width x thickness	132.0 x 52.5 x 11 (5.20 x 2.067 x 0.43)	
Rotor outer diameter x thickness mm (in)	283 x 28 (11.14 x 1.10)	
Rear brake		
Type	LT30A	
Wheel cylinder bore diameter mm (in)	22.22 (7/8)	
Lining dimension       mm (in) Length x width x thickness	296.0 x 50.0 x 6.1 (11.65 x 1.969 x 0.240)	
Drum inner diameter    mm (in)	295 (11.61)	
Master cylinder bore diameter mm (in)	25.4 (1)	
Control valve		
Type	LSV	
Split point x reducing ratio kPa (bar, kg/cm <sup>2</sup> , psi)	(Variable) x 0.15	
Brake booster		
Model	M215T	
Diaphragm diameter    mm (in)	Primary: 230 (9.06) Secondary: 205 (8.07)	
Recommended brake fluid	DOT 3 or DOT 4	