

SECTION **EL**

MODIFICATION NOTICE:

- Wiring diagrams have been changed.
- Harness layouts have been changed.

CONTENTS

INTERIOR ROOM LAMP	5002	THEFT WARNING SYSTEM	5010
Wiring Diagram - ROOM/L -	5002	Wiring Diagram - PRWIRE -	5010
ILLUMINATION	5003	HARNESS LAYOUT	5012
Wiring Diagram - ILL -/LHD Models	5003	Main Harness.....	5012
POWER WINDOW	5005	Engine Room Harness.....	5018
Schematic/With Interruption Detection		Room Lamp Harness/LHD Models.....	5026
Function	5005		
Wiring Diagram - WINDOW -/With Interruption			
Detection Function	5006		

ILLUMINATION

Wiring Diagram — ILL —/LHD Models

EL-ILL-01

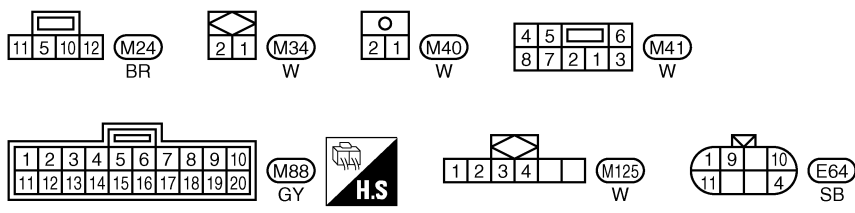
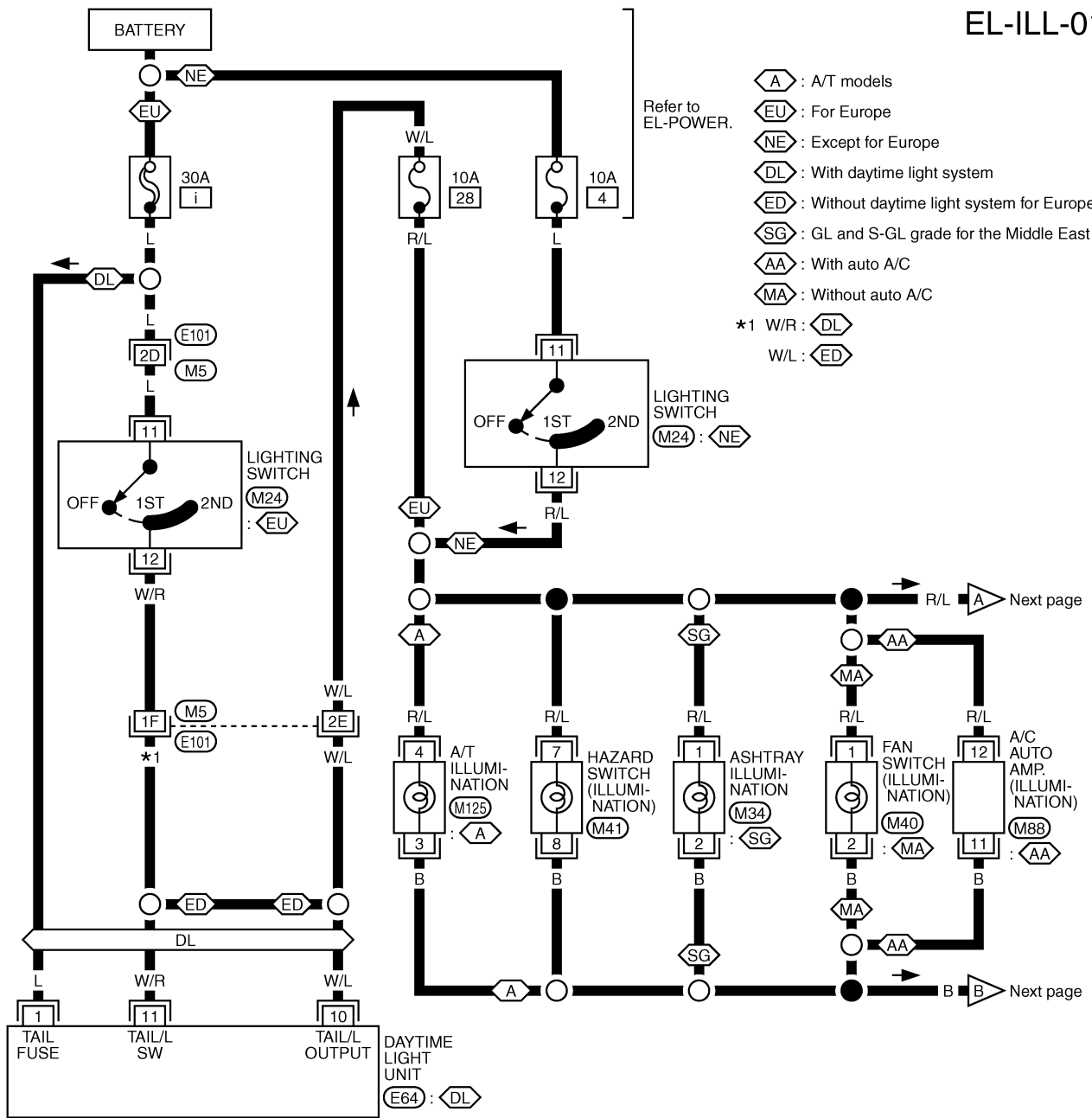

Refer to last page (Foldout page).
(M5), (E101)

ILLUMINATION

Wiring Diagram — ILL —/LHD Models (Cont'd)

EL-ILL-02

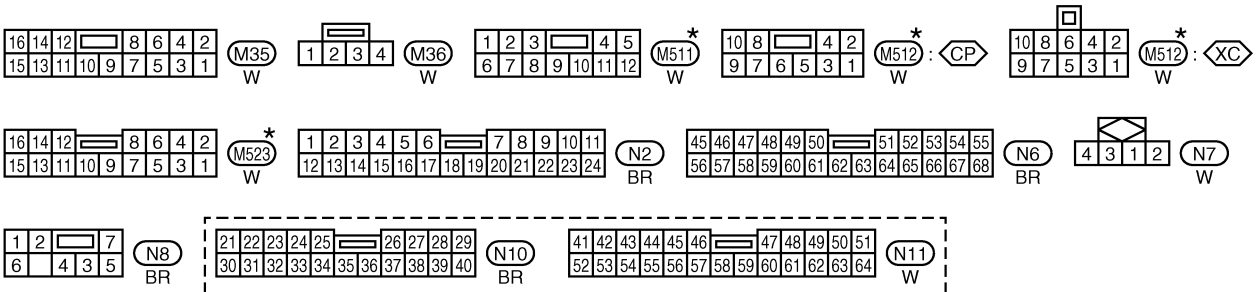
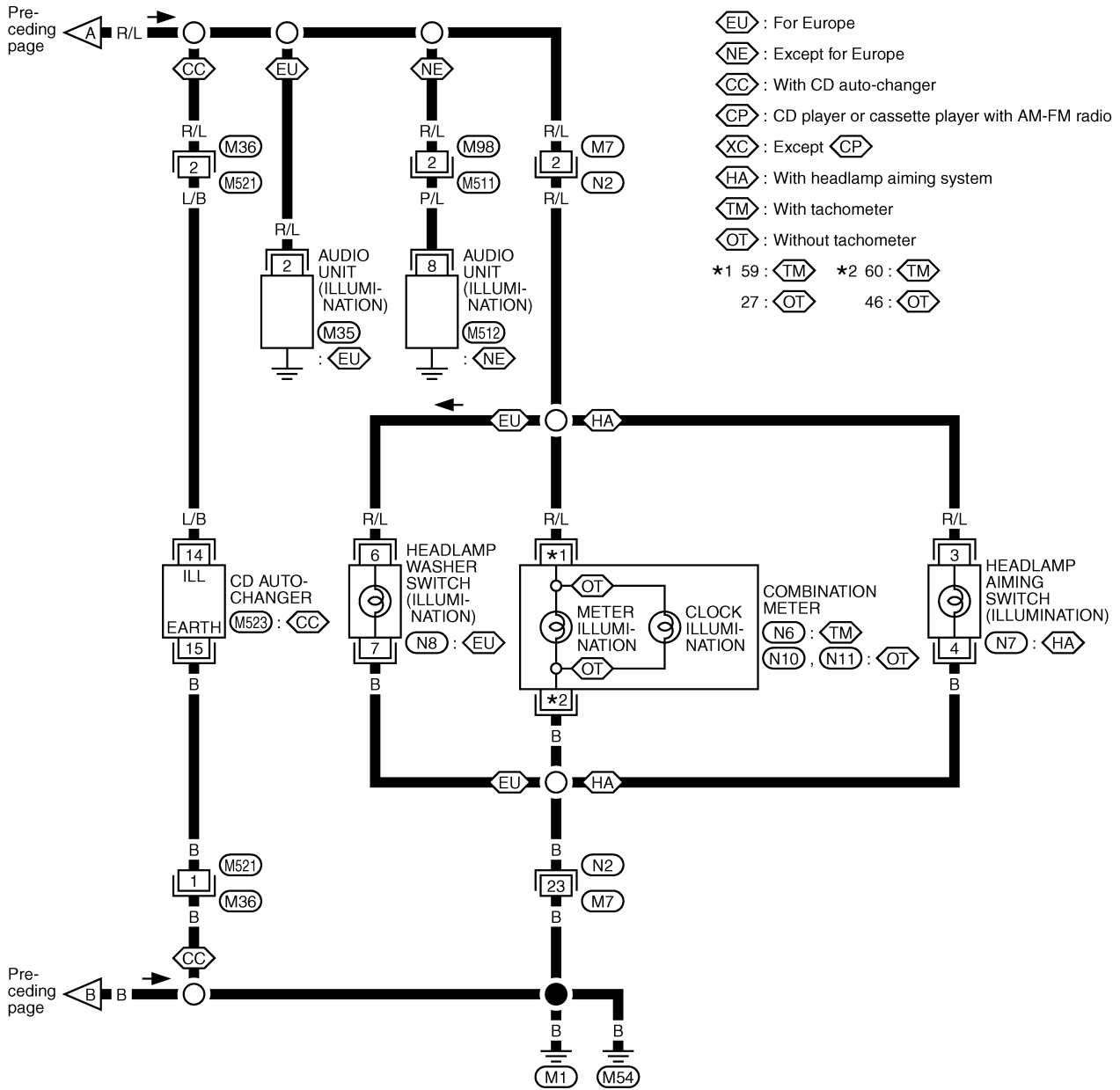

*: This connector is not shown in "HARNES LAYOUT".

POWER WINDOW

Wiring Diagram — WINDOW —/With Interruption Detection Function

EL-WINDOW-01

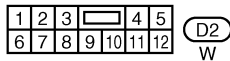
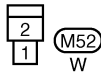
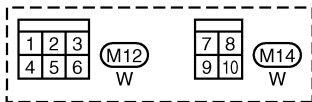
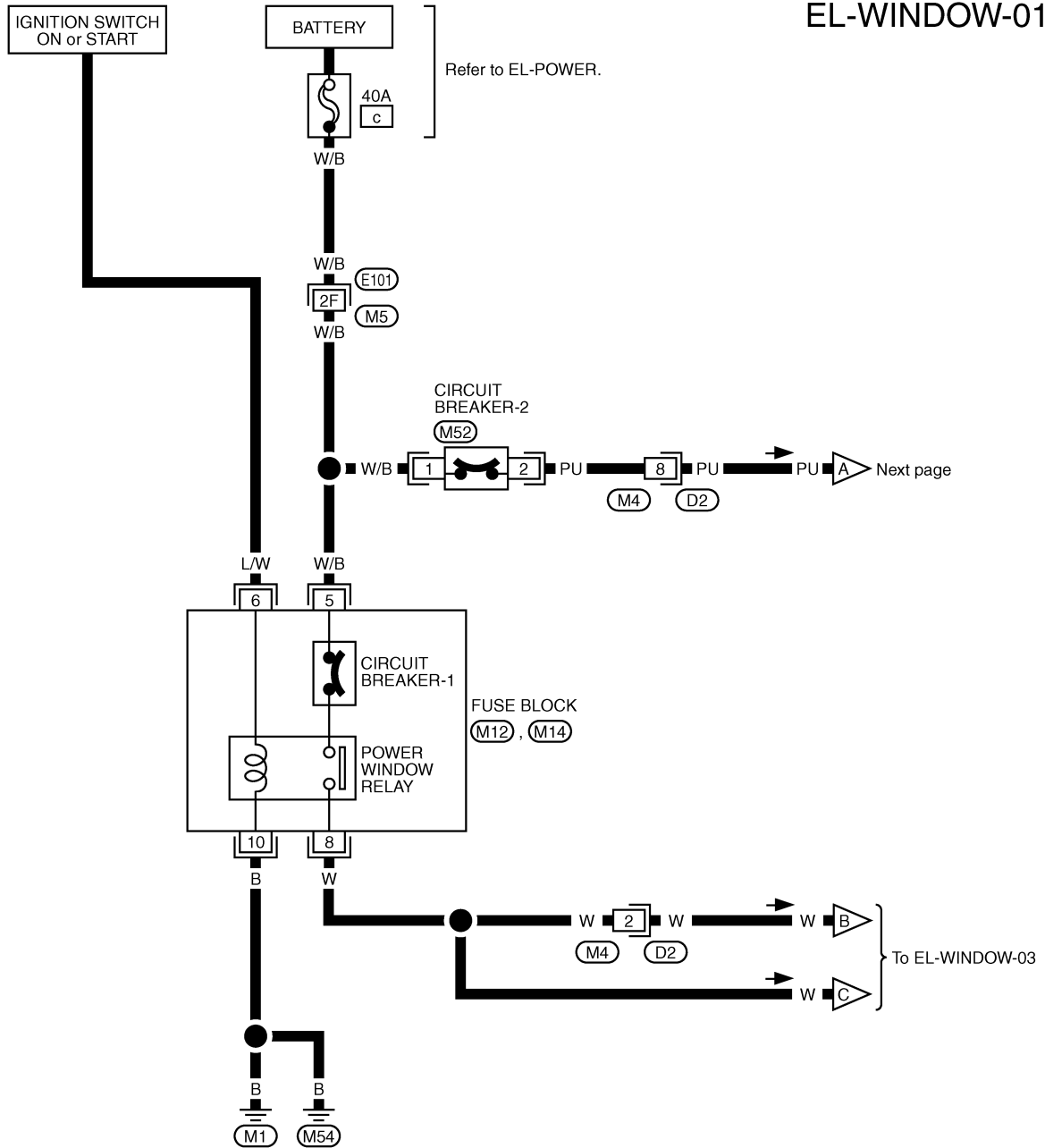

Refer to last page (Foldout page).
 (M5), (E101)

POWER WINDOW

Wiring Diagram — WINDOW —/With Interruption Detection Function (Cont'd)

EL-WINDOW-03

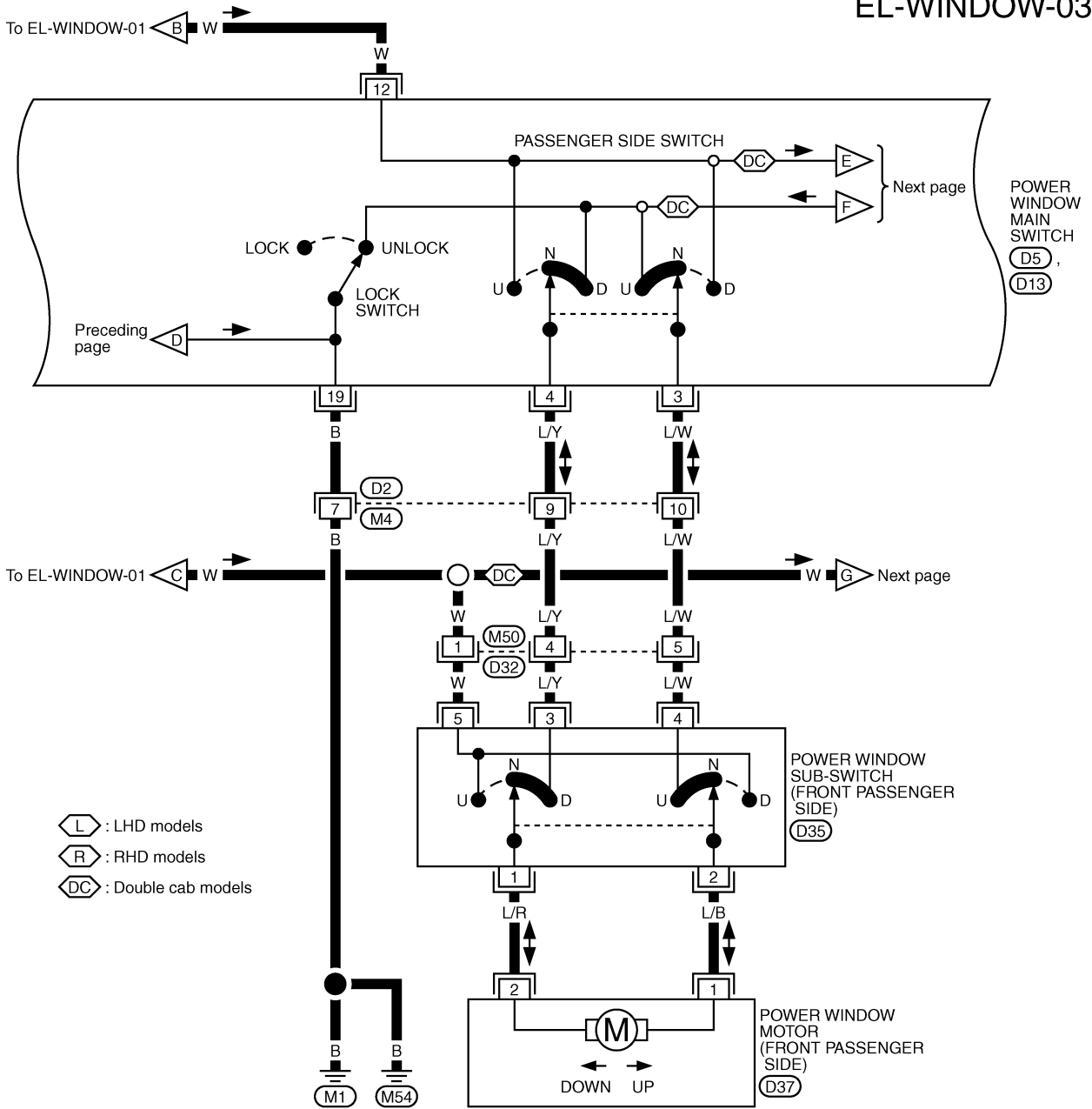

- : LHD models
- : RHD models
- : Double cab models

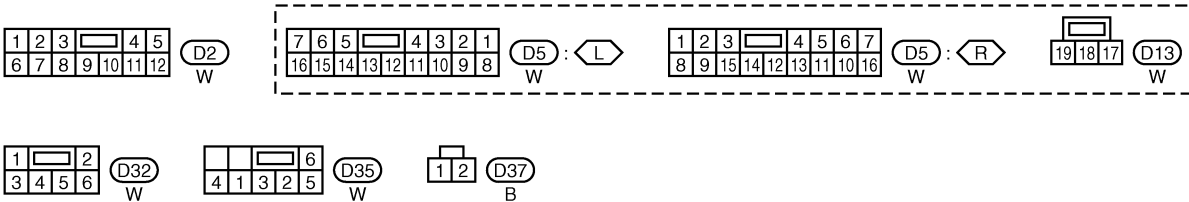

POWER WINDOW

Wiring Diagram — WINDOW —/With Interruption Detection Function (Cont'd)

EL-WINDOW-04

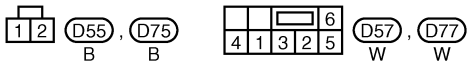
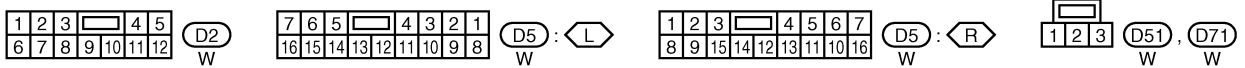
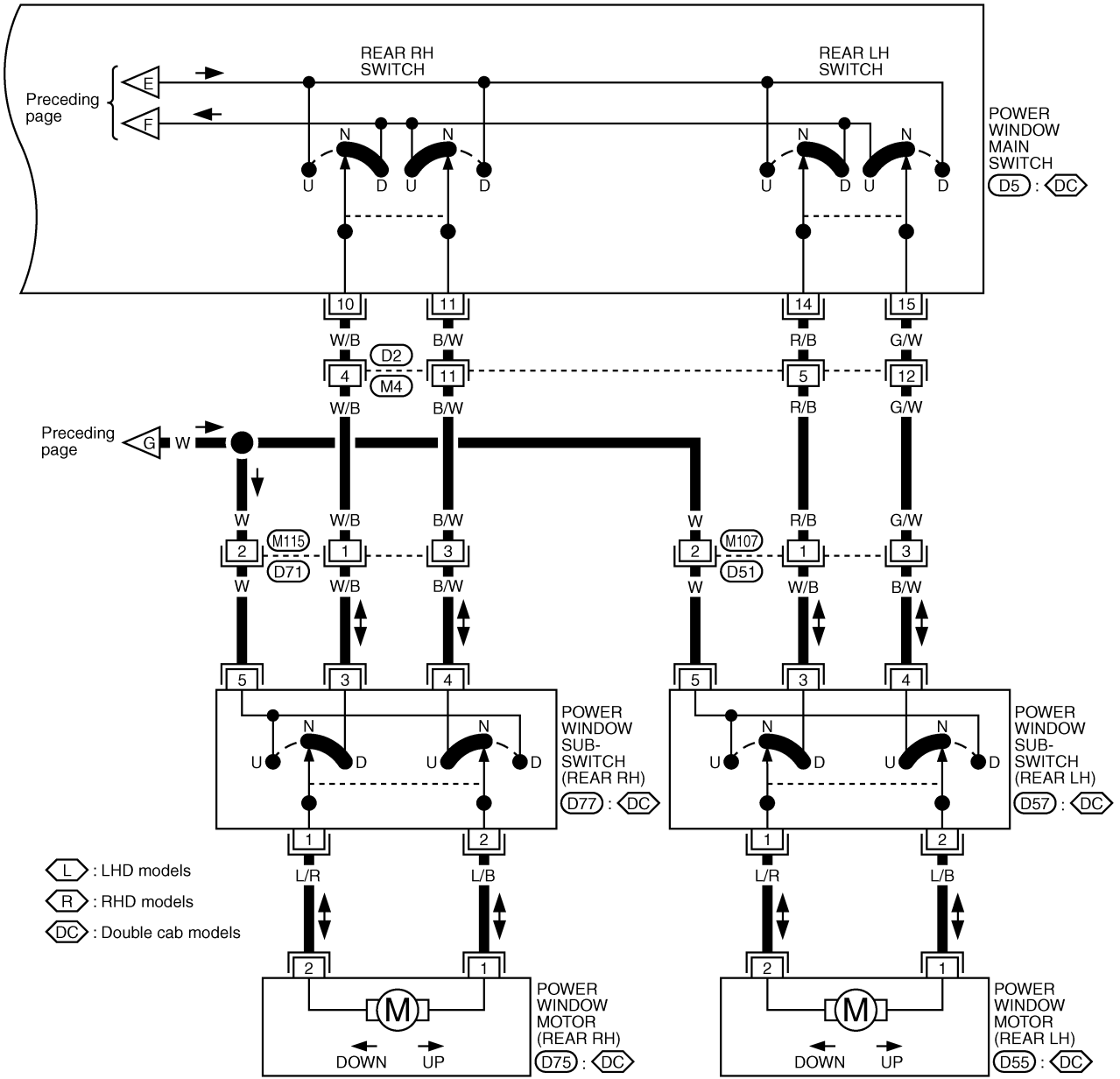

THEFT WARNING SYSTEM

Wiring Diagram — PRWIRE —

EL-PRWIRE-01

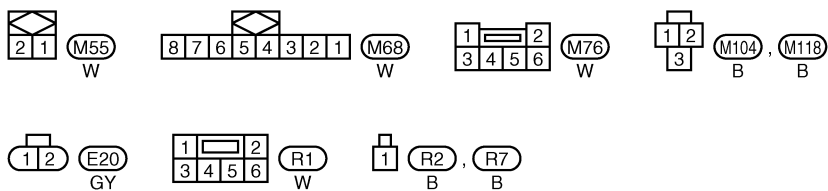
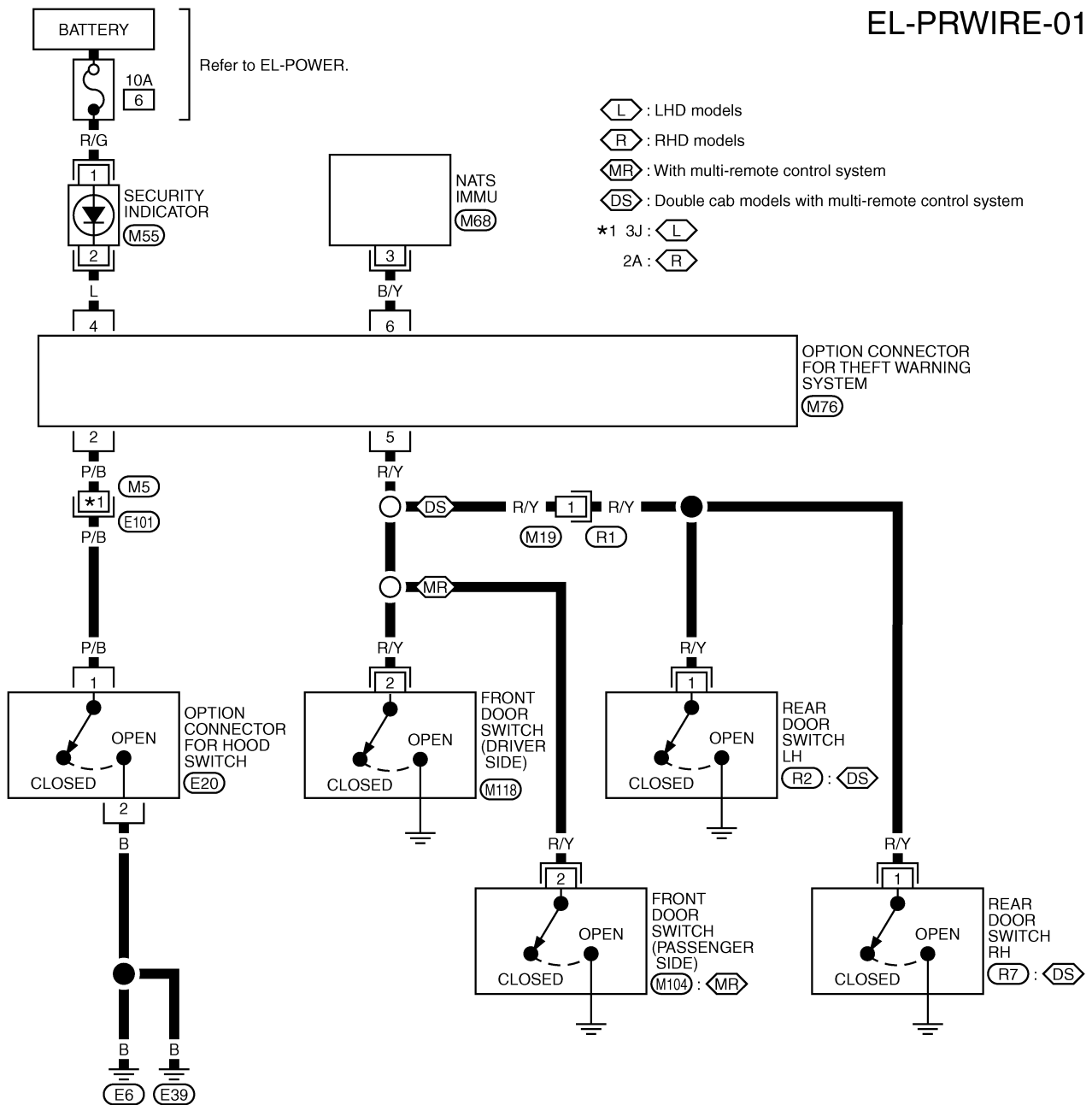

Refer to last page (Foldout page).

M5, E101

THEFT WARNING SYSTEM

NOTE

HARNESS LAYOUT

Main Harness

INSTRUMENT PANEL — LHD MODELS

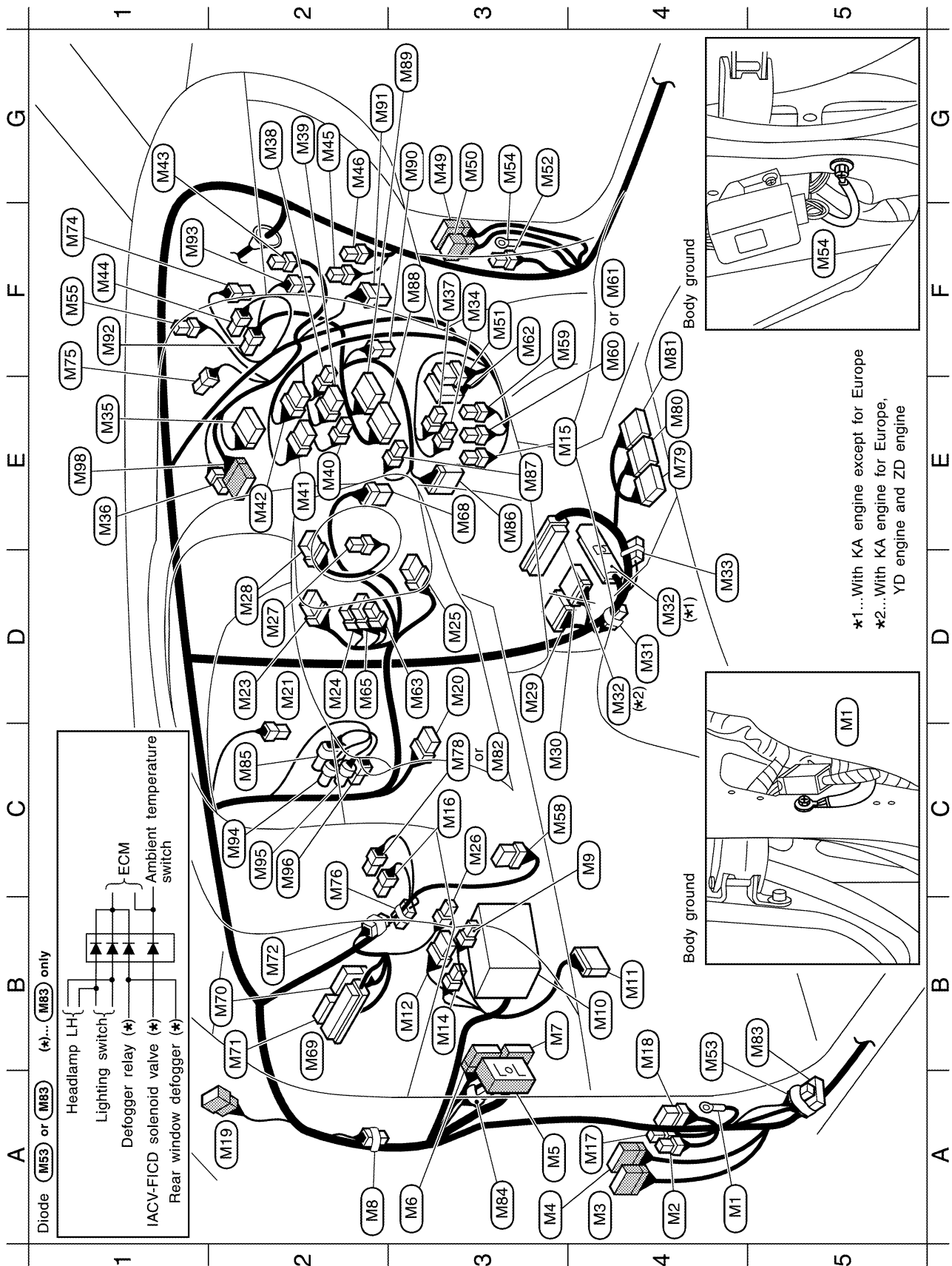

HARNESS LAYOUT

Main Harness (Cont'd)

A4 (M1)	—	: Body ground	F3 (M34)	W/2	: Ashtray illumination (With gasoline engine for the Middle East)	B2 (M71)	GY/24	: TCM (Transmission control module) (KA engine with A/T)
A4 (M2)	W/2	: Warning buzzer (Diesel engine except for Europe and the Middle East)	E1 (M35)	W/10	: Audio unit (For Europe)	B2 (M72)	-/6	: Joint connector-2 (With A/T)
A4 (M3)	W/20	: To (D1)	E1 (M36)	W/4	: To CD changer sub-harness (For Europe except double cab without power window)	F1 (M74)	W/2	: Intake air temperature sensor (With auto A/C)
A3 (M4)	W/12	: To (D2) (With power window)	F3 (M37)	B/2	: Cigarette lighter	F1 (M75)	B/2	: Sunload sensor (With auto A/C)
A3 (M5)	SMJ	: To (E101)	G2 (M38)	W/3	: A/C switch (Without auto A/C)	C2 (M76)	W/6	: Option connector (For Europe) (For theft warning system)
A3 (M6)	W/24	: To (N1)	G2 (M39)	W/6	: Fan switch (Without auto A/C)	C3 (M78)	L/2	: Shift lock brake switch (With A/T)
B3 (M7)	BR/24	: To (N2)	E2 (M40)	W/2	: Fan switch illumination (Without auto A/C)	E4 (M79)	Y/12	: Air bag diagnosis sensor unit (For pre-tensioner seat belt)
A2 (M8)	-/2	: Diode (Diesel engine except for Europe and the Middle East)	E2 (M41)	W/8	: Hazard switch	E4 (M80)	Y/20	: Air bag diagnosis sensor unit
C4 (M9)	L/4	: Fuel pump relay (KA engine)	E2 (M42)	W/6	: Defogger switch (For Europe or double cab except for the Middle East)	F4 (M81)	Y/12	: Air bag diagnosis sensor unit (For pre-tensioner seat belt)
B4 (M10)	—	: Fuse block	G1 (M43)	Y/2	: Front passenger air bag module	C3 (M82)	B/2	: Brake pedal position switch (YD25)
B4 (M11)	W/16	: Data link connector	F1 (M44)	BR/4	: Thermo control amplifier (Without auto A/C)	B5 (M83)	L/10	: Diode (KA engine except for Europe)
B3 (M12)	W/6	: Fuse block	G2 (M45)	BR/4	: Fan resistor (Without auto A/C)	A3 (M84)	BR/2	: Resistor (With A/T)
B3 (M14)	W/4	: Fuse block	G2 (M46)	W/2	: Blower motor	C2 (M85)	GY/6	: Accelerator work unit (YD25)
E3 (M15)	B/3	: Combination flasher unit	G3 (M49)	W/20	: To (D31)	E3 (M86)	BR/10	: Mode door motor (With auto A/C)
C3 (M16)	B/2	: Stop lamp switch	G3 (M50)	W/6	: To (D32) (With power window)	E3 (M87)	W/2	: In-vehicle sensor (With auto A/C)
A4 (M17)	L/4	: Front fog lamp relay (YD engine for Europe)	F3 (M51)	W/8	: Door lock timer (With power door lock except for Europe)	F3 (M88)	GY/20	: A/C auto amp. (With auto A/C)
B4 (M18)	W/6	: Not used	G3 (M52)	W/2	: Circuit breaker-2 (For Europe and KA engine for the Middle East — except double cab without power window)	G3 (M89)	GY/16	: A/C auto amp. (With auto A/C)
A2 (M19)	W/6	: (QD engine with A/T)	B4 (M53)	L/4	: Diode (KA engine for Europe)	G2 (M90)	L/2	: Aspirator motor (With auto A/C)
D3 (M20)	W/6	: Ignition switch	G3 (M54)	—	: Body ground	F1 (M92)	W/4	: Fan control amp. (With auto A/C)
D2 (M21)	W/1	: Parking brake switch (Stick type)	F1 (M55)	W/2	: Security indicator (With NATS)	F1 (M93)	W/4	: Intake door motor (With auto A/C)
D2 (M23)	BR/8	: Lighting switch • Turn signal lamp switch	C3 (M58)	BR/8	: Multi-remote control unit (For Europe)	C2 (M94)	BR/3	: Accelerator position sensor (ZD30)
D2 (M24)	BR/4	: Lighting switch	F3 (M59)	BR/6	: Defogger relay (For Europe or double cab except for the Middle East)	C2 (M95)	GY/3	: Accelerator position switch (ZD30)
D3 (M25)	Y/7	: Spiral cable (With air bag)	F4 (M60)	L/4	: Rear fog lamp relay (For Europe)	C2 (M96)	W/3	: Accelerator switch (F/C) (ZD30)
C3 (M26)	L/2	: A/T check switch	F4 (M61)	L/4	: Front fog lamp relay (ZD engine)	E1 (M98)	W/12	: Audio unit (Via sub-harness) (Except for Europe)
D2 (M27)	B/1	: Horn switch (Without air bag)	F3 (M62)	W/18	: Smart entrance control unit (For Europe)			
D2 (M28)	GY/8	: Wiper and washer switch	D3 (M63)	W/3	: Front fog lamp switch (ZD engine)			
D3 (M29)	W/12	: Glow control unit (TD engine except for cold areas and QD engine)	D2 (M65)	W/6	: Fog lamp switch (For Europe)			
C3 (M30)	W/16	: Glow control unit (TD engine for cold areas)	E3 (M68)	W/8	: NATS IMMU (For Europe)			
D4 (M31)	GY/6	: Joint connector-1 (KA engine)	B2 (M69)	W/48	: TCM (Transmission control module) (QD engine with A/T)			
D4 (M32)	SMJ	: ECM (KA, YD and ZD engines)	B2 (M70)	W/24	: TCM (Transmission control module) (KA engine with A/T)			
D4 (M33)	—	: Joint connector-3 (KA engine for Europe)						

Diode (M8)

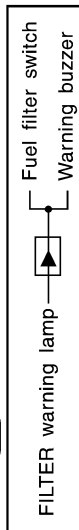

HARNESS LAYOUT

Main Harness (Cont'd)

INSTRUMENT PANEL — RHD MODELS

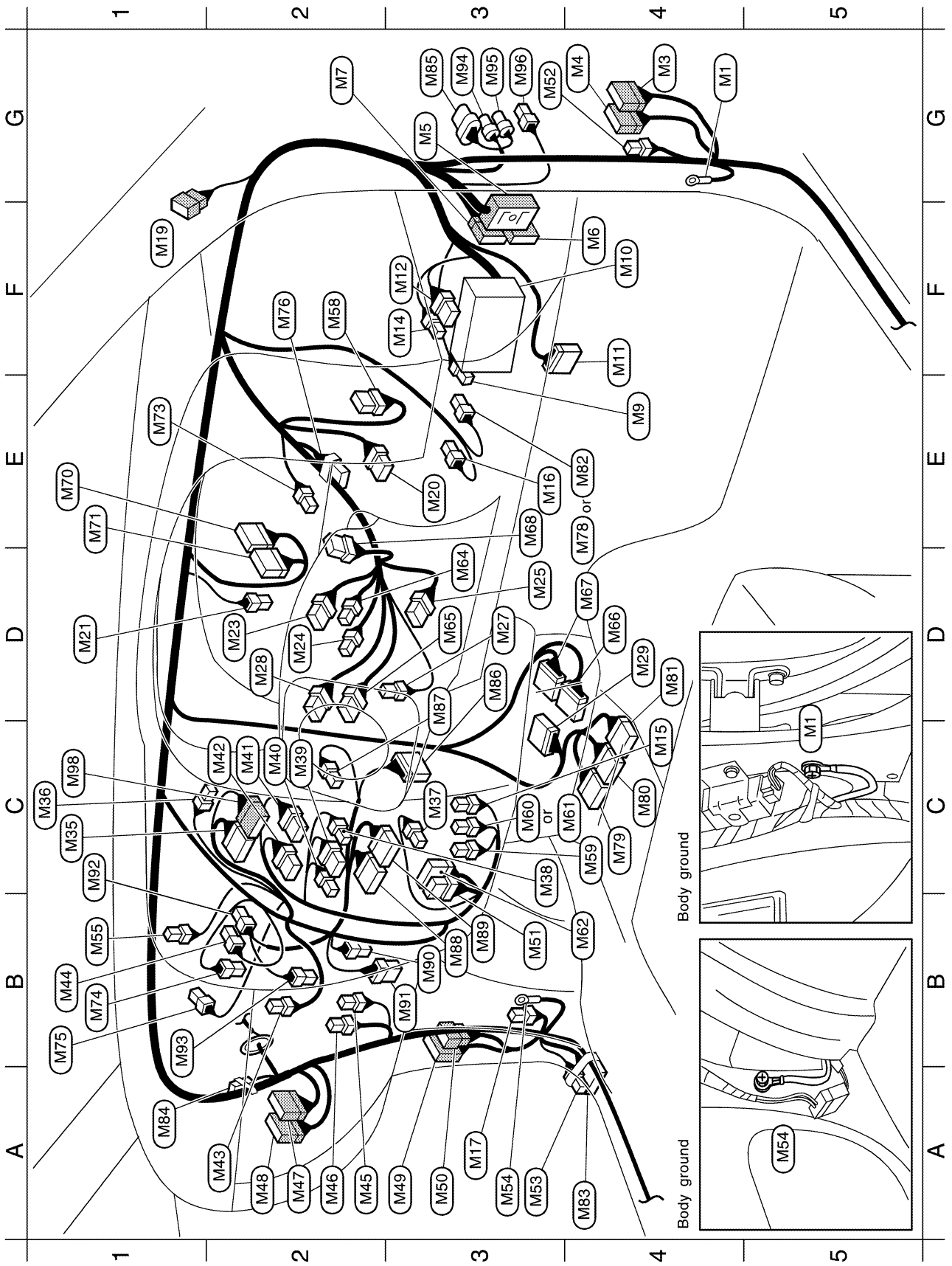

HARNESS LAYOUT

Main Harness (Cont'd)

G4 (M1)	—	: Body ground	A2 (M46)	W/2	: Blower motor	E4 (M82)	B/2	: Brake pedal position switch (YD engine)
G4 (M3)	W/20	: To (D1)	A2 (M47)	W/16	: To (F55) (KA, VG, YD and ZD engines)	A4 (M83)	L/10	: Diode (Double cab with KA engine)
G4 (M4)	W/12	: To (D2) (With power window)	A2 (M48)	W/24	: To (F54) (KA, VG, YD and ZD engines)	A1 (M84)	BR/2	: Resistor (With A/T)
G3 (M5)	SMJ	: To (E101)	A3 (M49)	W/20	: To (D31)	G3 (M85)	GY/6	: Accelerator work unit (YD engine)
F4 (M6)	W/24	: To (N1)	A3 (M50)	W/6	: To (D32) (With power window)	D3 (M86)	BR/10	: Mode door motor (With auto A/C)
G2 (M7)	BR/24	: To (N2)	B3 (M51)	W/8	: Door lock timer (With power door lock except for Europe)	D3 (M87)	W/2	: In-vehicle sensor (With auto A/C)
E4 (M9)	L/4	: Fuel pump relay (KA and VG engines)	G3 (M52)	W/2	: Circuit breaker-2 (For Europe except double cab without power window)	B3 (M88)	GY/20	: A/C auto amp. (With auto A/C)
F4 (M10)	—	: Fuse block	A3 (M53)	L/4	: Diode (Single cab with KA engine)	B3 (M89)	GY/16	: A/C auto amp. (With auto A/C)
F4 (M11)	W/16	: Data link connector	A3 (M54)	—	: Body ground	B3 (M90)	L/2	: Aspirator motor (With auto A/C)
F3 (M12)	W/6	: Fuse block	B1 (M55)	W/2	: Security indicator (For Europe)	B3 (M91)	B/6	: Air mix door motor (With auto A/C)
F3 (M14)	W/4	: Fuse block	F2 (M58)	BR/8	: Multi-remote control unit (For Europe)	C1 (M92)	W/4	: Fan control amp. (With auto A/C)
C4 (M15)	B/3	: Combination flasher unit	F2 (M58)	BR/8	: Multi-remote control unit (For Europe)	B1 (M93)	W/4	: Intake door motor (With auto A/C)
E3 (M16)	B/2	: Stop lamp switch	C4 (M59)	BR/6	: Defogger relay (For Europe or king cab and double cab)	G3 (M94)	BR/3	: Accelerator position sensor (ZD engine)
A3 (M17)	L/4	: Front fog lamp relay (For Europe)	C3 (M60)	L/4	: Rear fog lamp relay (For Europe)	G3 (M95)	GY/3	: Accelerator position switch (ZD engine)
F1 (M19)	W/6	: To (R1)	C4 (M61)	W/4	: Front fog lamp relay (ZD engine)	G3 (M96)	W/3	: Accelerator switch (F/C) (ZD engine)
E3 (M20)	W/6	: Ignition switch	B4 (M62)	W/18	: Smart entrance control unit (For Europe)	C1 (M98)	W/12	: Audio unit (Via sub-harness) (Except for Europe)
D1 (M21)	W/1	: Parking brake switch (Stick type)	D3 (M64)	L/6	: Front fog lamp switch (ZD engine)			
D2 (M23)	BR/8	: Lighting switch	D3 (M65)	W/6	: Front and rear fog lamp switch (For Europe)			
		• Turn signal lamp switch	D4 (M66)	GY/20	: ECM (Diesel engine with EGR)			
D2 (M24)	BR/4	: Lighting switch	D4 (M67)	GY/16	: ECM (Diesel engine with EGR)			
D3 (M25)	Y/7	: Spiral cable (With air bag)	E3 (M68)	W/8	: NATS IMMU (For Europe)			
D3 (M27)	B/1	: Horn switch (Without air bag)	E1 (M70)	W/24	: TCM (Transmission control module) (With A/T)			
D2 (M28)	GY/8	: Wiper and washer switch	E1 (M71)	GY/24	: TCM (Transmission control module) (With A/T)			
D4 (M29)	W/12	: Glow control unit (TD engine without EGR and QD engine)	E1 (M73)	W/4	: A/T device (With A/T with column shift)			
C1 (M35)	W/16	: Audio unit (For Europe)	B1 (M74)	W/2	: Intake air temperature sensor (With auto A/C)			
C1 (M36)	W/4	: To CD changer sub-harness (For Europe except double cab without power window)	B1 (M75)	B/2	: Sunload sensor (With auto A/C)			
C3 (M37)	B/2	: Cigarette lighter	F2 (M76)	W/6	: Option connector for theft warning system (For Europe)			
C3 (M38)	W/3	: A/C switch (Without auto A/C)	E4 (M78)	L/2	: Shift lock brake switch (With A/T)			
C2 (M39)	W/6	: Fan switch (Without auto A/C)	C4 (M79)	Y/12	: Air bag diagnosis sensor unit (With air bag for Europe and Australia)			
C2 (M40)	W/2	: Fan switch illumination (Without auto A/C)	C4 (M80)	Y/20	: Air bag diagnosis sensor unit (With air bag)			
C2 (M41)	W/8	: Hazard switch	D4 (M81)	Y/12	: Air bag diagnosis sensor unit (With air bag for Europe and Australia)			
C2 (M42)	W/6	: Defogger switch (For Europe or king cab and double cab)						
A2 (M43)	Y/2	: Air bag module passenger side						
B1 (M44)	BR/4	: Thermo control amplifier (Without auto A/C)						
A2 (M45)	BR/4	: Fan resistor (Without auto A/C)						

Engine compartment

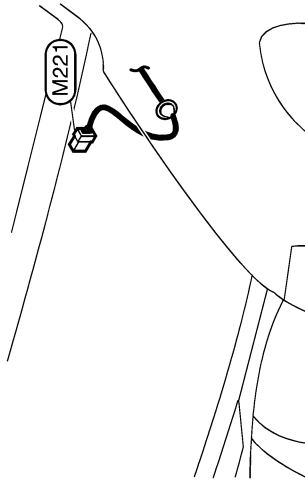

(M221) : Wiper motor (TD and QD engines)

Diode (M53 or M83) (*)... (M83) only

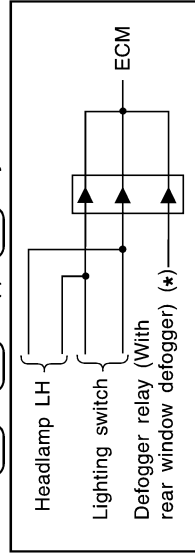

HARNESS LAYOUT

Main Harness (Cont'd)

BODY SIDE — LHD MODELS

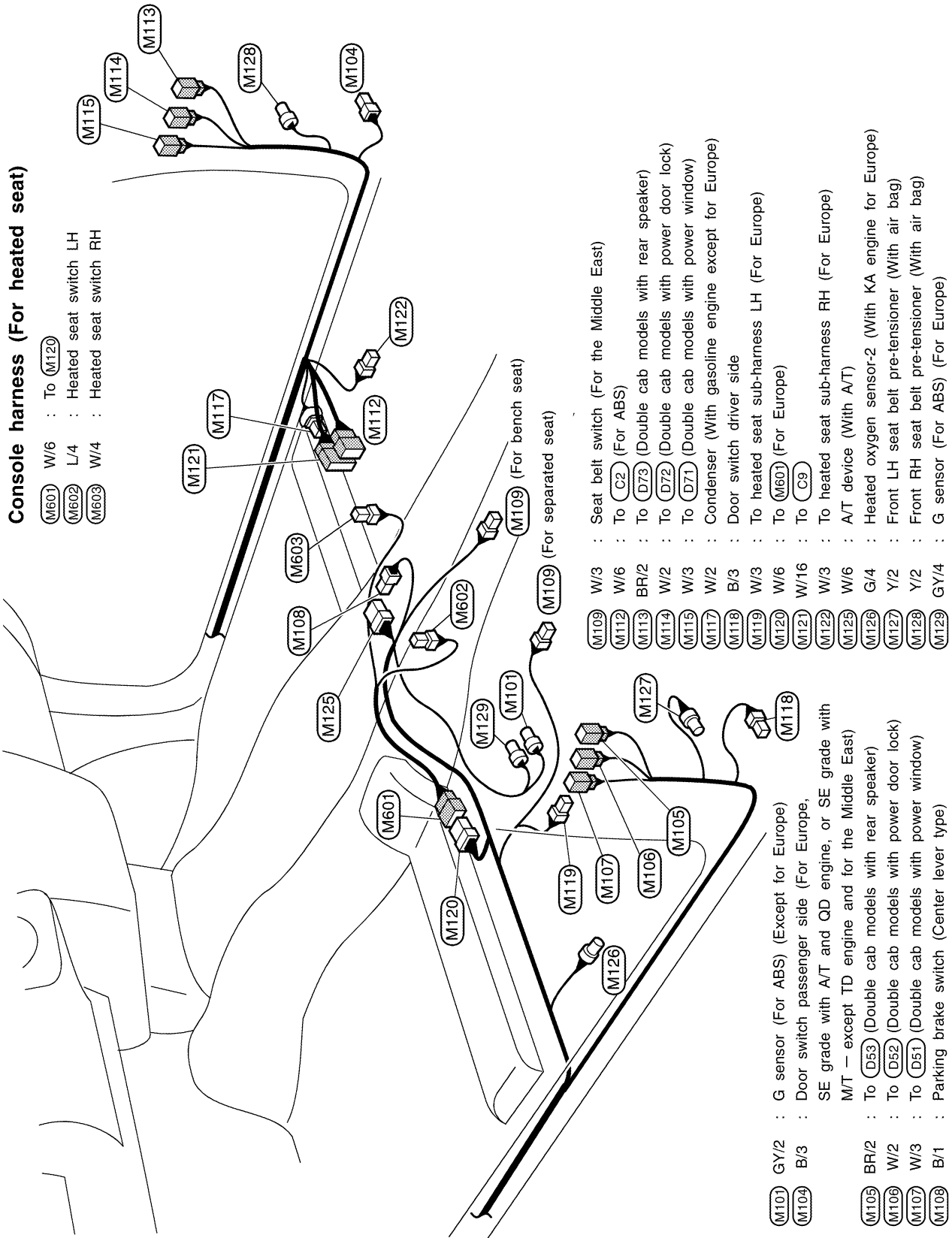

HARNESSES LAYOUT

Main Harness (Cont'd)

BODY SIDE — RHD MODELS

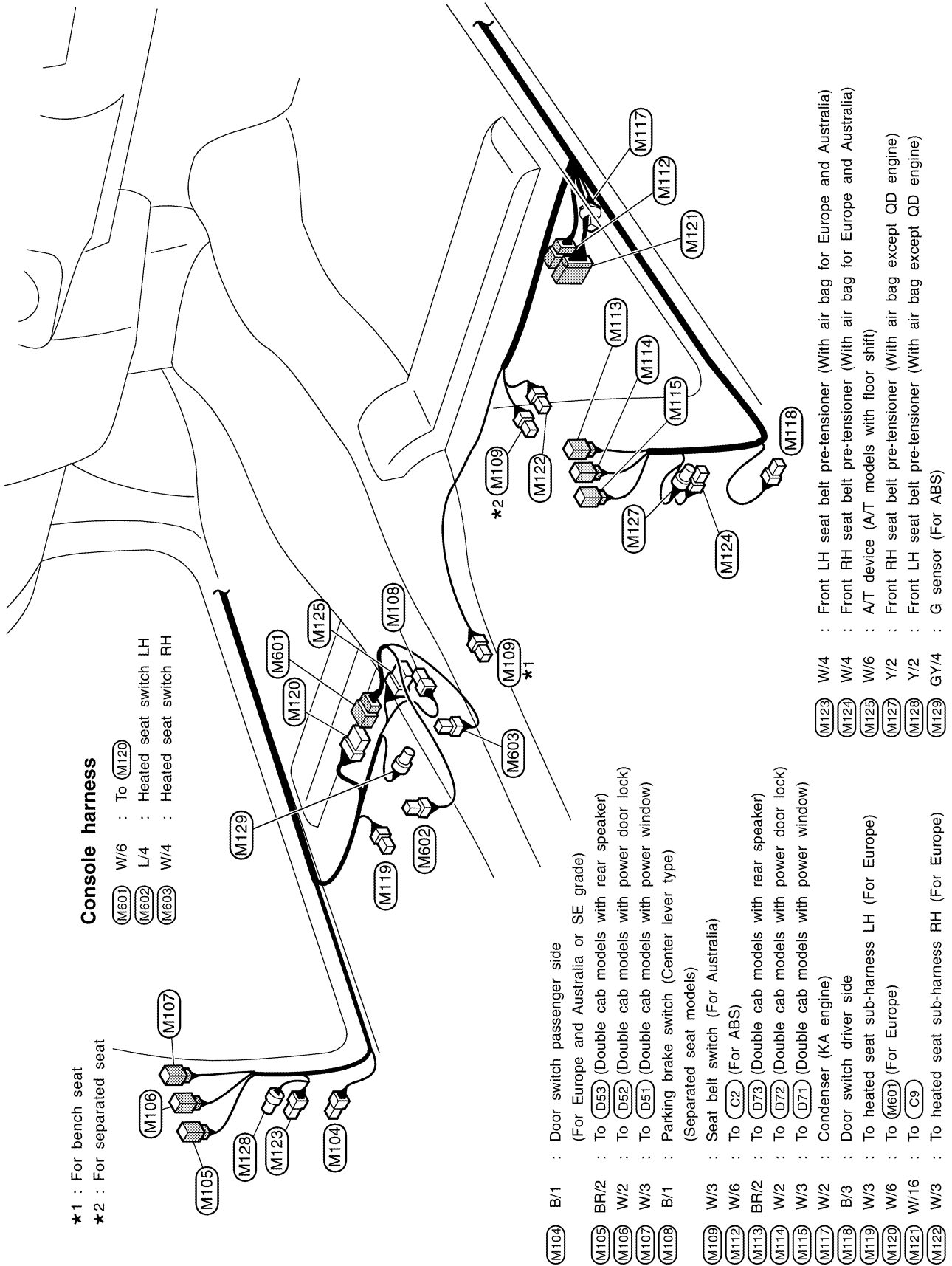

HARNESS LAYOUT

Engine Room Harness

LHD MODELS — GASOLINE ENGINE

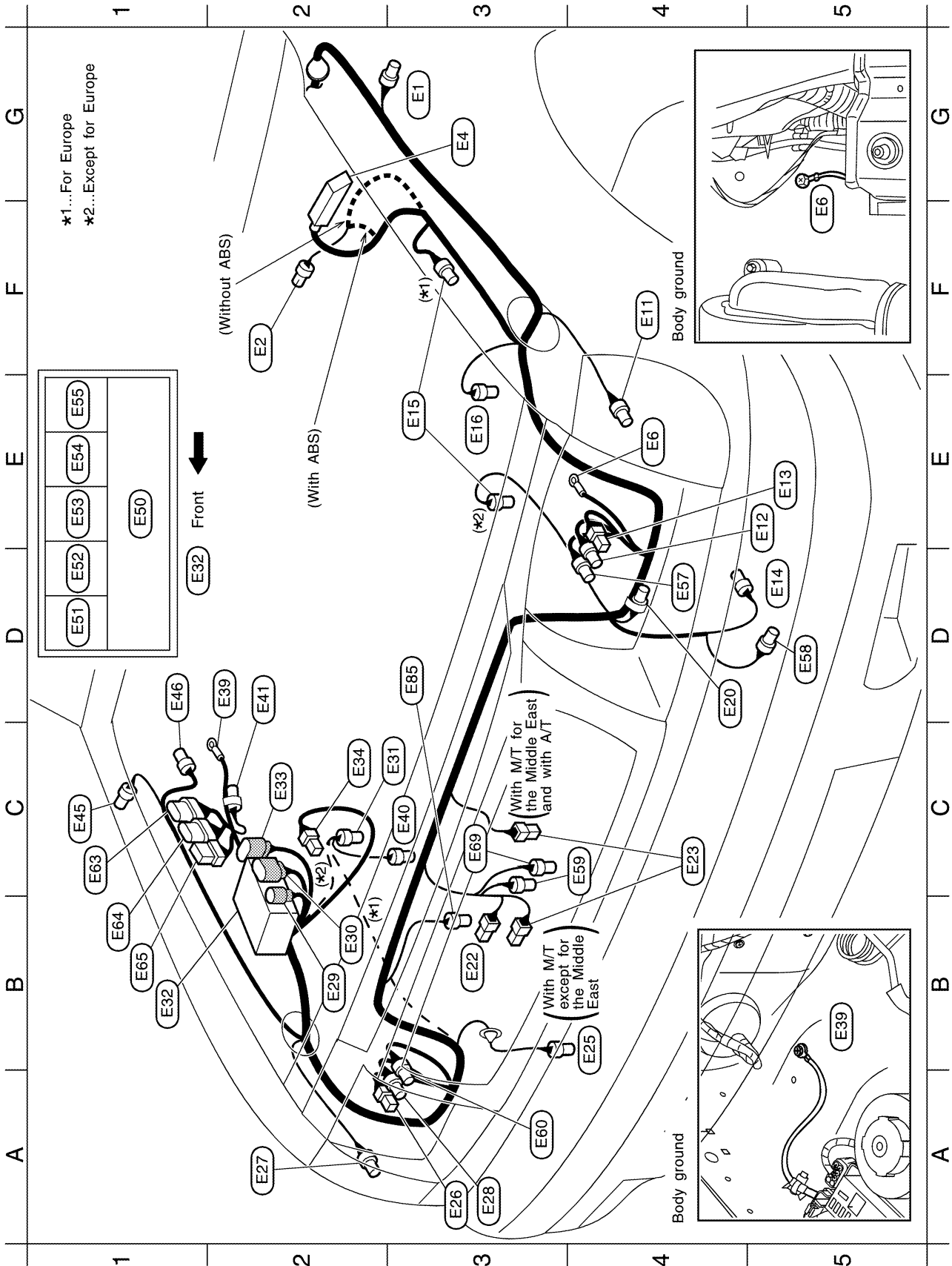

HARNESS LAYOUT

Engine Room Harness (Cont'd)

G3 (E1)	GY/2	: Side turn signal lamp LH (With multi-beam type headlamp)	D1 (E52)	L/4	: Air conditioner relay
F2 (E2)	GY/2	: Brake fluid level switch	E1 (E53)	W/3	: Horn relay
G3 (E4)	B/31	: ABS actuator and electric unit (For ABS)	E1 (E54)	BR/6	: Park/Neutral position relay (With AVT)
E4 (E6)	—	: Body ground	E1 (E55)	BR/6	: ECM relay (KA engine)
F4 (E11)	GY/3	: Front combination lamp LH (Without multi-beam type headlamp)	D4 (E57)	-/3	: Headlamp aiming motor LH (For the Middle East and Europe)
E5 (E12)	GY/3	: Front combination lamp LH (With multi-beam type headlamp)	D5 (E58)	GY/2	: Headlamp washer motor (For Europe)
E5 (E13)	B/3	: Headlamp LH	C4 (E59)	B/2	: Not used (For Europe)
D5 (E14)	GY/2	: Washer motor	A3 (E60)	-/3	: Headlamp aiming motor RH (For the Middle East and Europe)
E3 (E15)	BR/2	: Front wheel sensor LH (For ABS)	C1 (E63)	SB/6	: Daytime light unit (With daytime light system)
E3 (E16)	GY/2	: Intake air temperature sensor (KA engine for Europe)	B1 (E64)	SB/8	: Daytime light unit (With daytime light system)
D4 (E20)	GY/2	: Option connector (For hood switch) (For Europe)	B1 (E65)	W/6	: Headlamp washer amplifier (For Europe)
B3 (E22)	B/1	: Horn low	C3 (E69)	BR/2	: Ambient temperature switch (KA engine)
C4 (E23)	B/1	: Horn high	D3 (E85)	GY/2	: Cooling fan motor (KA engine for the Middle East and Europe)
B4 (E25)	GY/4	: Triple-pressure switch			
A3 (E26)	B/3	: Headlamp RH			
A2 (E27)	GY/3	: Front combination lamp RH (Without multi-beam type headlamp)			
A3 (E28)	GY/3	: Front combination lamp RH (With multi-beam type headlamp)			
B2 (E29)	GY/2	: To (E204)			
B2 (E30)	GY/8	: To (E203)			
C3 (E31)	GY/2	: Front wheel sensor RH (For ABS)			
B1 (E32)	—	: Relay box (Fusible link and fuse box)			
C2 (E33)	SB/8	: To (E205)			
C2 (E34)	B/1	: Battery			
D2 (E39)	—	: Body ground			
C3 (E40)	B/2	: Power steering oil pressure switch (For Europe)			
D2 (E41)	B/1	: Option connector (For front fog lamp) (For Europe)			
C1 (E45)	GY/2	: Side turn signal lamp RH (With multi-beam type headlamp)			
D1 (E46)	GY/3	: Power antenna (For the Middle East and Europe)			
E1 (E50)	—	: Fusible link and fuse box			
D1 (E51)	L/4	: Cooling fan relay (KA engine for the Middle East and Europe)			

PASSENGER COMPARTMENT

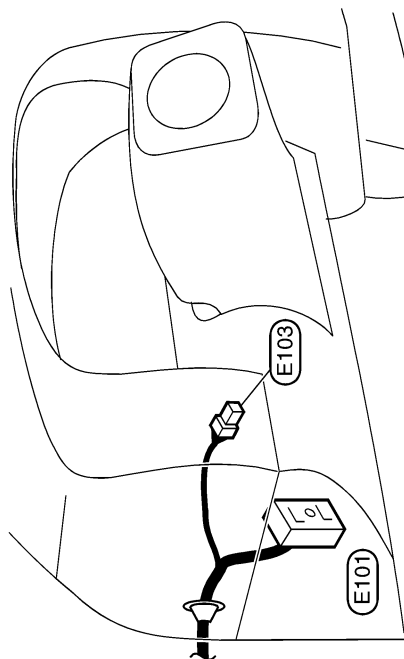

(E101)	SMJ	: To (M5)
(E103)	B/2	: Fuse block

HARNESS LAYOUT

Engine Room Harness (Cont'd)

LHD MODELS — DIESEL ENGINE

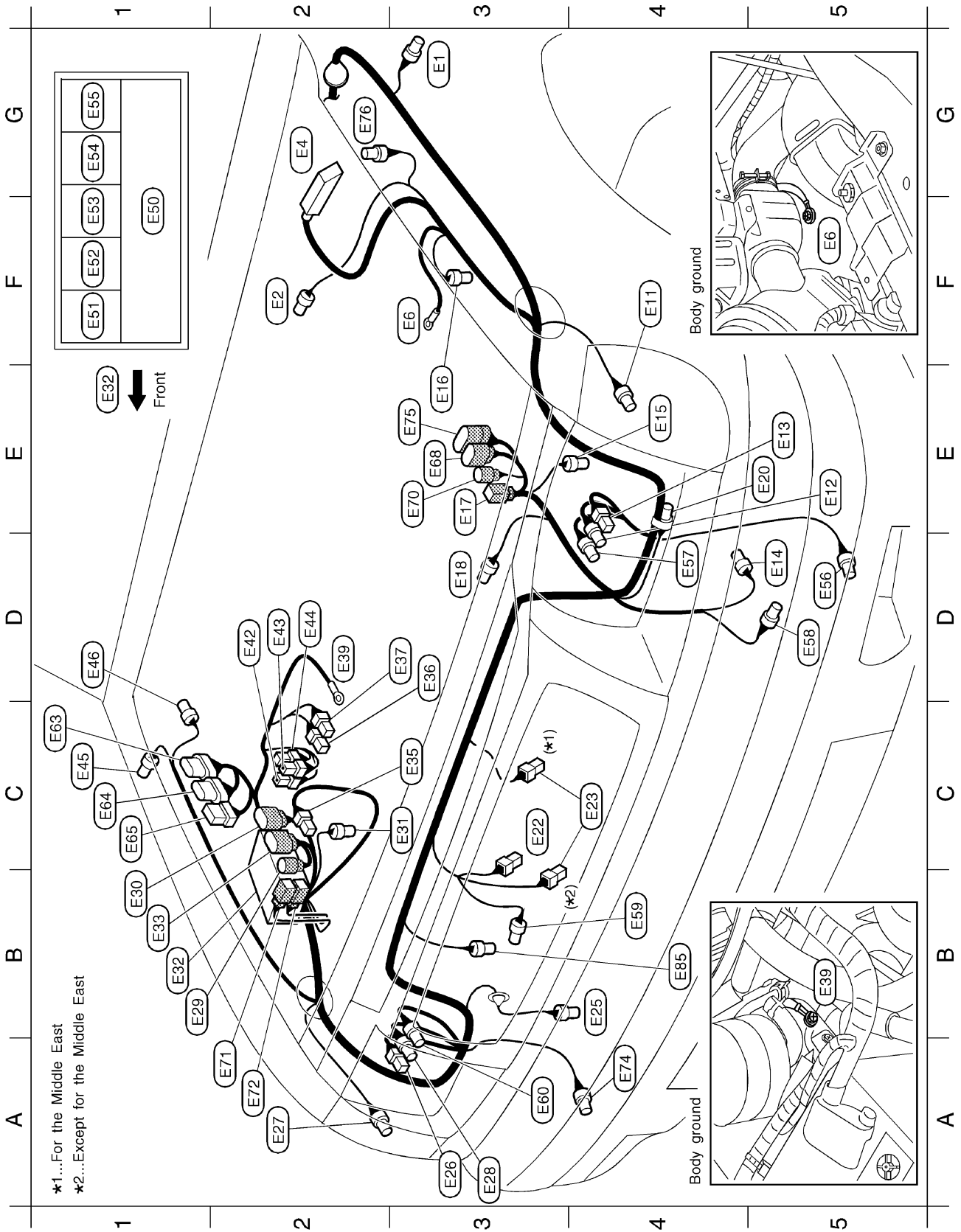

HARNESS LAYOUT

Engine Room Harness (Cont'd)

G3 (E1)	GY/2	: Side turn signal lamp LH (Except for the Middle East)
F2 (E2)	GY/2	: Brake fluid level switch (With M/T)
G2 (E4)	B/31	: ABS actuator and electric unit (For ABS)
F3 (E6)	—	: Body ground
F4 (E11)	GY/3	: Front combination lamp LH (For the Middle East)
E5 (E12)	GY/3	: Front combination lamp LH (Except for the Middle East)
E5 (E13)	B/3	: Headlamp LH
D5 (E14)	GY/2	: Washer motor
E4 (E15)	BR/2	: Front wheel sensor LH (For ABS)
E3 (E16)	GY/2	: Intake air temperature sensor (YD and ZD engines)
E3 (E17)	B/2	: To (A2)
D3 (E18)	GY/2	: Thermo-switch (TD engine for the Middle East and QD engines)
E5 (E20)	GY/2	: Option connector (For hood switch) (For Europe)
C3 (E22)	B/1	: Horn low
C4 (E23)	B/1	: Horn high
B4 (E25)	GY/4	: Triple-pressure switch
A3 (E26)	B/3	: Headlamp RH
A2 (E27)	GY/3	: Front combination lamp RH (For the Middle East)
A3 (E28)	GY/3	: Front combination lamp RH (Except for the Middle East)
B1 (E29)	GY/2	: To (E204)
B1 (E30)	GY/8	: To (E203) (YD and ZD engines)
C3 (E31)	GY/2	: Front wheel sensor RH (For ABS)
B1 (E32)	—	: Relay box (Fusible link and fuse box)
B1 (E33)	SB/8	: To (E205)
C3 (E35)	B/1	: To (E206) (TD and QD engines)
D3 (E36)	B/1	: IACV-FICD solenoid valve (TD and QD engines)
D3 (E37)	B/1	: IACV-FICD solenoid valve (TD and QD engines)
D2 (E39)	—	: Body ground
D2 (E42)	W/1	: Glow relay-1 (YD and ZD engines)
D2 (E43)	W/1	: Glow relay-1 (YD and ZD engines)
D2 (E44)	G/2	: Glow relay-1 (YD and ZD engines)
C1 (E45)	GY/2	: Side turn signal lamp RH (Except for the Middle East)
D1 (E46)	GY/3	: Power antenna (For Europe)
F1 (E50)	—	: Fusible link and fuse box
F1 (E51)	L/4	: Cooling fan relay
F1 (E52)	L/4	(TD engine for the Middle East, QD, YD and ZD engines)
F1 (E53)	W/3	: Air conditioner relay
G1 (E54)	L/4	: Park/Neutral position (PNP) relay (With A/T)
G1 (E55)	BR/6	: ECM relay (YD and ZD engines)
	B/5	: ATP relay (With A/T)
D5 (E56)	B/2	: Front fog lamp LH (For Europe or with ZD engine)

D4 (E57)	-/3	: Headlamp aiming motor LH (For the Middle East and Europe)
D5 (E58)	GY/2	: Headlamp washer motor (For Europe)
B4 (E59)	B/2	: Ambient sensor (For auto A/C) (YD and ZD engines)
A3 (E60)	-/3	: Headlamp aiming motor RH (For the Middle East and Europe)
C1 (E63)	SB/6	: Daytime light unit (With daytime light system)
C1 (E64)	SB/8	: Daytime light unit (With daytime light system)
C1 (E65)	W/6	: Headlamp washer amplifier (For Europe)
E3 (E68)	GY/8	: To (A13) (TD and QD engines with M/T)
E3 (E70)	BR/3	: To (A14) (YD and ZD engines)
A2 (E71)	B/2	: To (E231) (YD and ZD engines)
A2 (E72)	B/1	: To (E232) (YD and ZD engines)
A4 (E74)	B/2	: Front fog lamp RH (For Europe or with ZD engine)
E3 (E75)	GY/10	: To (A15) (With A/T)
G2 (E76)	GY/2	: Dropping resistor (With A/T)
B4 (E85)	GY/2	: Cooling fan motor (TD engine for the Middle East, QD, YD and ZD engines)

PASSENGER COMPARTMENT

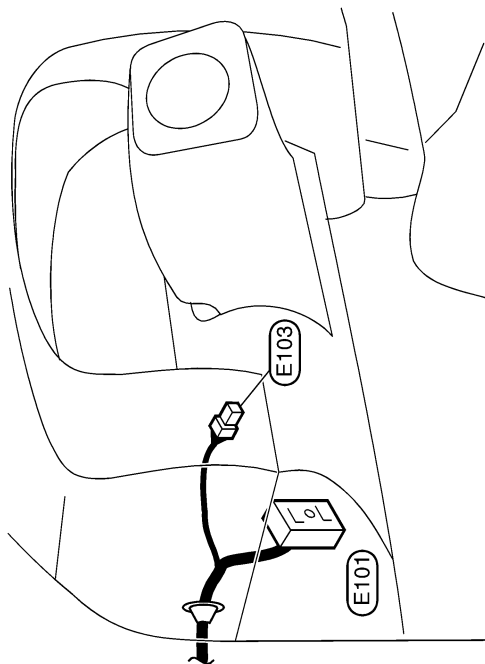

(E101)	SMJ	: To (M5)
(E103)	B/2	: Fuse block

HARNESS LAYOUT

Engine Room Harness (Cont'd)

RHD MODELS — GASOLINE ENGINE

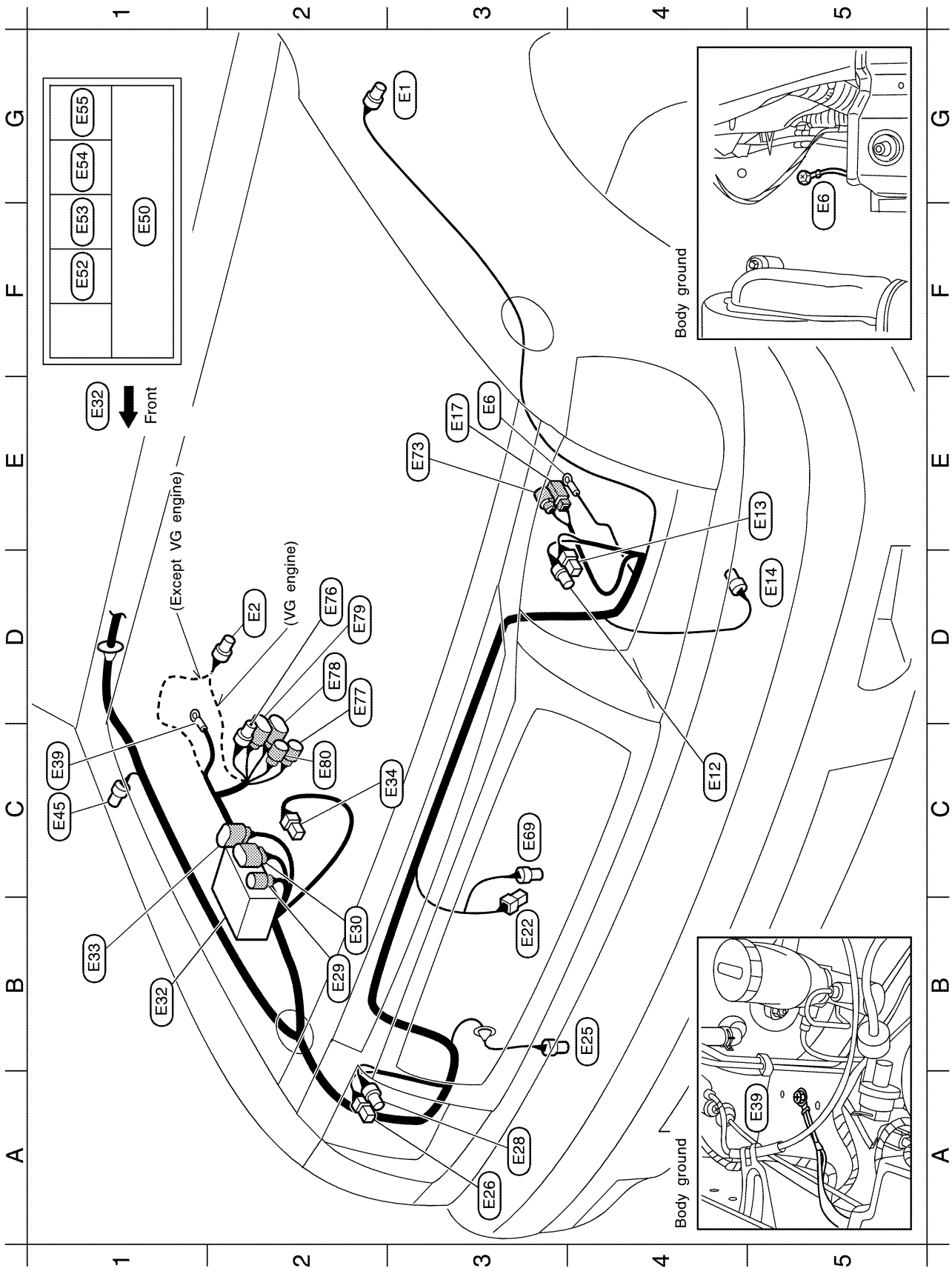

HARNESS LAYOUT

Engine Room Harness (Cont'd)

G3 (E1)	GY/2	: Side turn signal lamp LH
D2 (E2)	GY/2	: Brake fluid level switch
E3 (E6)	—	: Body ground
C4 (E12)	GY/3	: Front combination lamp LH
E5 (E13)	B/3	: Headlamp LH
D5 (E14)	GY/2	: Washer motor
E3 (E17)	B/2	: To (A2) (VG engine)
B3 (E22)	B/1	: Horn low
B4 (E25)	GY/4	: Triple-pressure switch
A3 (E26)	B/3	: Headlamp RH
A3 (E28)	GY/3	: Front combination lamp RH (For Australia)
B2 (E29)	GY/2	: To (E204) (Except VG engine)
		To (E502) (VG engine)
B2 (E30)	GY/8	: To (E203) (Except VG engine)
B1 (E32)	—	: Relay box (Fusible link and fuse box)
B1 (E33)	SB/8	: To (E205) (Except VG engine)
C3 (E34)	B/1	: Battery
C1 (E39)	—	: Body ground
C1 (E45)	GY/2	: Side turn signal lamp RH
F1 (E50)	—	: Fusible link and fuse box
F1 (E52)	L/4	: Air conditioner relay
F1 (E53)	W/3	: Horn relay
G1 (E54)	BR/6	: Park/Neutral position relay (With A/T)
G1 (E55)	BR/6	: ECM relay (KA engine)
	L/4	: ECM relay (VG engine)
C3 (E69)	BR/2	: Ambient temperature switch (KA engine)

E3 (E73)	GY/2	: To (A3) (VG engine)
D2 (E76)	GY/2	: Dropping resistor (With A/T)
D2 (E77)	GY/2	: Park/Neutral position switch (With A/T)
D2 (E78)	GY/8	: Park/Neutral position switch (With A/T)
D2 (E79)	BR/8	: To terminal cord assembly (With A/T)
C2 (E80)	GY/3	: Revolution sensor (With A/T)

PASSENGER COMPARTMENT

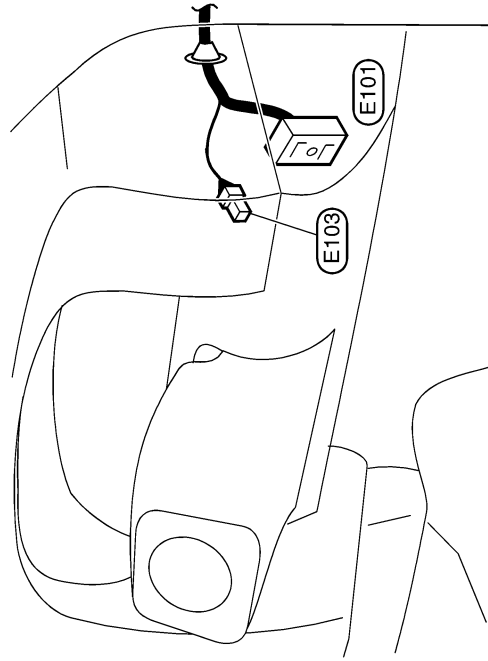

(E101)	SMJ	: To (M5)
(E103)	B/2	: Fuse block

HARNESS LAYOUT

Engine Room Harness (Cont'd)

RHD MODELS — DIESEL ENGINE

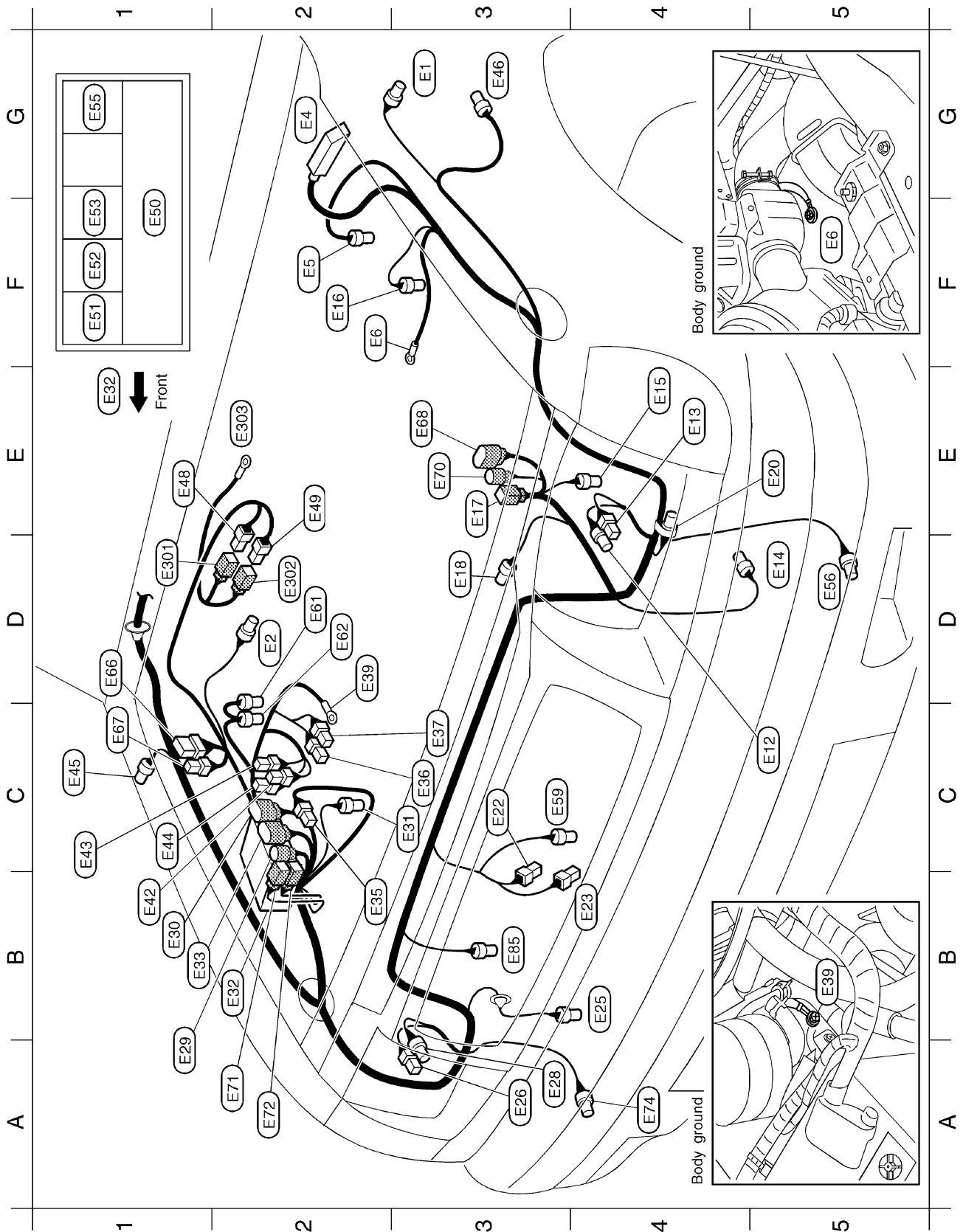

HARNESS LAYOUT

Engine Room Harness (Cont'd)

- D2 (E61) B/2 : EGRC-solenoid valve (Throttle chamber)
(TD engine with EGR)
- D2 (E62) BR/2 : EGRC-solenoid valve (EGR valve)
(TD engine with EGR)
- D1 (E66) GY/6 : Dim-dip lamp unit (For Europe)
- C1 (E67) GY/4 : Dim-dip lamp unit (For Europe)
- E3 (E68) GY/8 : To (A13) (TD and QD engines)
- E3 (E70) BR/3 : To (A14) (YD and ZD engines)
- A2 (E71) B/2 : To (E231) (YD and ZD engines)
- A2 (E72) B/1 : To (E232) (YD and ZD engines)
- A4 (E74) B/2 : Front fog lamp RH (For Europe)
- B3 (E85) GY/2 : Cooling fan motor (Except TD engine)

PASSENGER COMPARTMENT

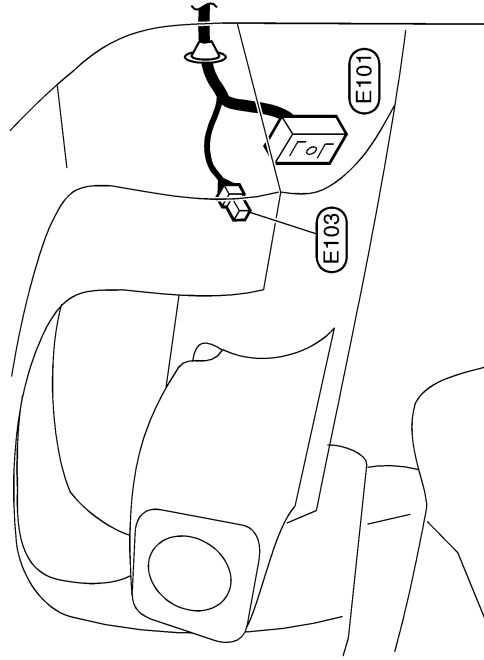

- (E101) SMJ : To (M5)
- (E103) B/2 : Fuse block

Sub-harness

- D1 (E301) B/1 : To (E48) (QD engine)
- D2 (E302) L/2 : To (E49) (TD engine)
- E2 (E303) — : Glow plug (TD and QD engines)

- G3 (E1) GY/2 : Side turn signal lamp LH
- D2 (E2) GY/2 : Brake fluid level switch
- G2 (E4) B/31 : ABS actuator and electric unit (For ABS)
- F2 (E5) BR/2 : Fuel filter switch
- F2 (E6) — : Body ground
- C5 (E12) GY/3 : Front combination lamp LH
- E4 (E13) B/3 : Headlamp LH
- D5 (E14) GY/2 : Washer motor
- E4 (E15) BR/2 : Front wheel sensor LH (For ABS)
- F2 (E16) GY/2 : Intake air temperature sensor (YD and ZD engines)
- E3 (E17) B/2 : To (A2)
- D3 (E18) GY/2 : Thermostat (QD engine)
- E5 (E20) GY/2 : Option connector (For hood switch) (For Europe)
- C3 (E22) B/1 : Horn low
- B4 (E23) B/1 : Horn high (ZD engine except for Australia, YD and QD engines)
- B4 (E25) GY/4 : Triple-pressure switch
- A3 (E26) B/3 : Headlamp RH
- A3 (E28) BR/3 : Front combination lamp RH
- A1 (E29) GY/2 : To (E204)
- B1 (E30) GY/8 : To (E203) (With ECM control engine)
- C3 (E31) GY/2 : Front wheel sensor RH (For ABS)
- B2 (E32) — : Relay box (Fusible link and fuse box)
- B1 (E33) SB/8 : To (E205)
- B2 (E35) B/1 : To (E206) (TD and QD engines)
- C3 (E36) B/1 : IACV-FICD solenoid valve (TD and QD engines)
- C3 (E37) B/1 : IACV-FICD solenoid valve (TD and QD engines)
- D2 (E39) — : Body ground
- B1 (E42) W/1 : Glow relay-1
- C1 (E43) W/1 : Glow relay-1
- C1 (E44) G/2 : Glow relay-1
- C1 (E45) GY/2 : Side turn signal lamp RH
- G3 (E46) GY/3 : Power antenna (For Europe)
- E1 (E48) B/1 : To (E301) (QD engine)
- E2 (E49) L/2 : To (E302) (TD engine)
- F1 (E50) — : Fusible link and fuse box
- F1 (E51) L/4 : Cooling fan relay (Except TD engine)
- F1 (E52) L/4 : Air conditioner relay
- F1 (E53) W/3 : Horn relay
- G1 (E55) BR/6 : ECM relay (YD and ZD engines)
- D5 (E56) B/2 : Front fog lamp LH (For Europe)
- C3 (E59) B/2 : Ambient sensor (YD and ZD engines)

HARNESS LAYOUT

Room Lamp Harness/LHD Models

DOUBLE CAB

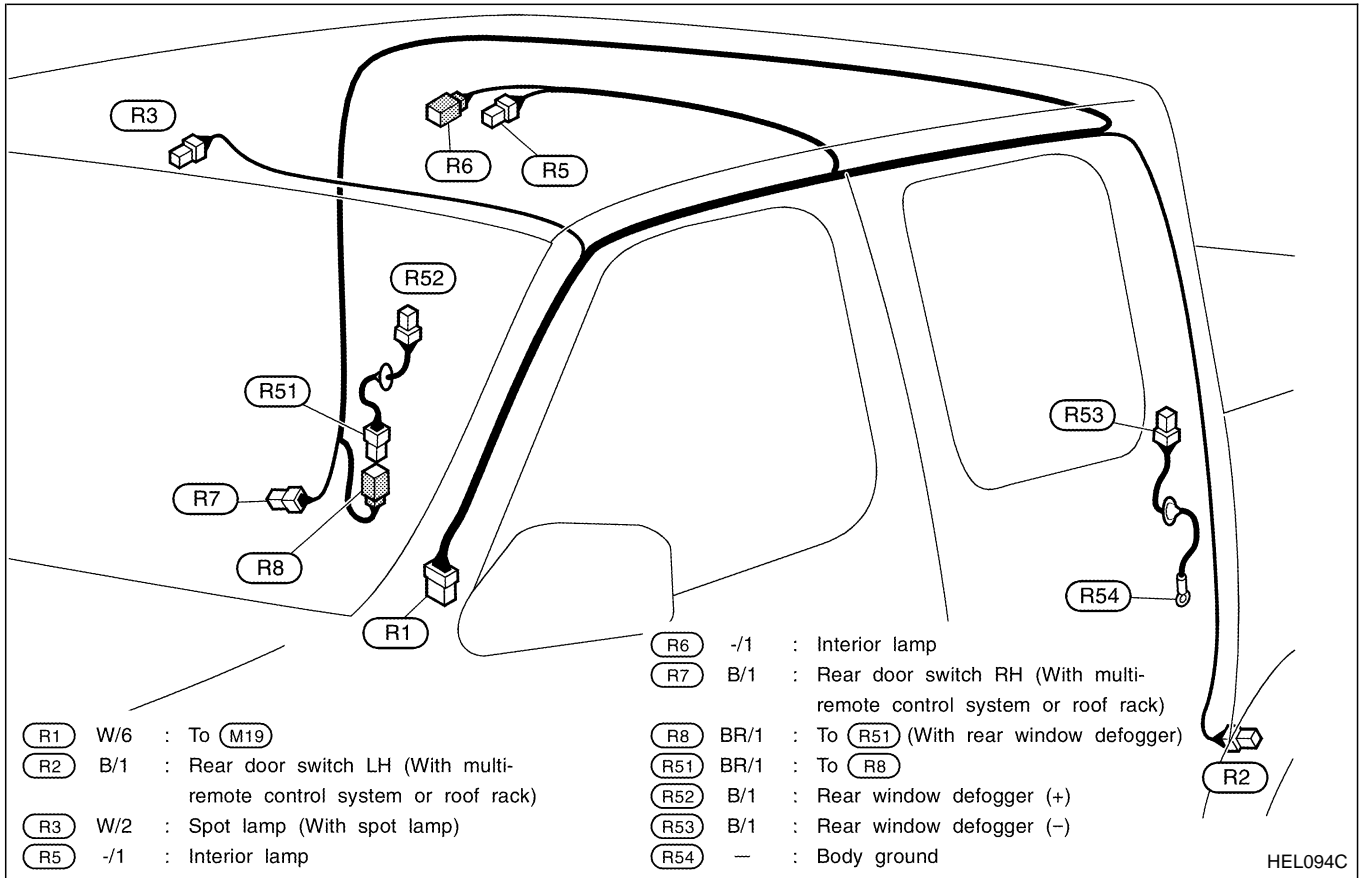

WIRING DIAGRAM CODES (CELL CODES) HARNES LAYOUT

Use the chart below to find out what each wiring diagram code stands for.

Refer to the wiring diagram code in the alphabetical index to find the location (page number) of each wiring diagram.

Code	Section	Wiring Diagram Name
ABS	BR	Anti-lock Brake System
A/C, M	HA	Manual Air Conditioner
FICD	EC	IACV-FICD Solenoid Valve
GLOW	EC	Quick-glow System
ILL	EL	Illumination
PRWIRE	EL	Theft Warning System Pre-wire
ROOM/L	EL	Interior Room Lamp
SRS	RS	Supplemental Restraint System
WINDOW	EL	Power Window