

SECTION **EL**

GI
MA
EM
LC
EC
FE
CL
MT
AT
TF
PD
FA
RA
BR
ST
RS
BT
HA
EL
IDX

MODIFICATION NOTICE:

- Wiring diagrams have been changed.
- Harness layouts have been changed.

CONTENTS

POWER SUPPLY ROUTING	2	Wiring Diagram — WARN —/Diesel Engine	
Schematic	2	without Tachometer.....	17
Wiring Diagram — POWER —.....	3	HORN	22
WARNING LAMPS	10	Wiring Diagram — HORN —.....	22
Schematic/With Tachometer for Europe and		HARNES LAYOUT	24
Australia	10	Main Harness.....	24
Wiring Diagram — WARN —/With Tachometer		Engine Harness	31
for Europe and Australia.....	11	Engine Room Harness	32
Schematic/Without Tachometer for Europe.....	16		

POWER SUPPLY ROUTING

Wiring Diagram — POWER —

BATTERY POWER SUPPLY — IGNITION SWITCH IN ANY POSITION

EL-POWER-01

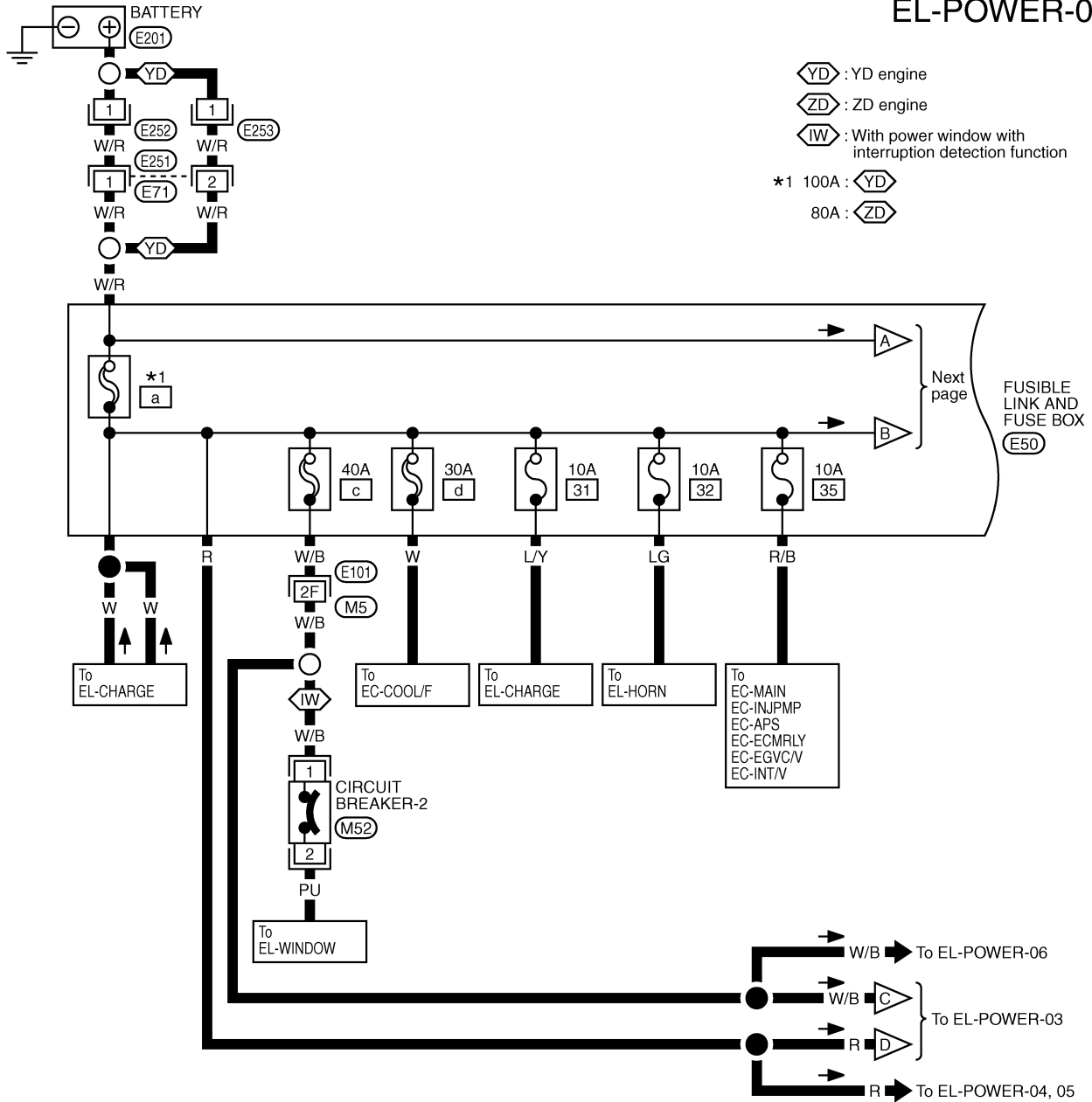

GI
MA
EM
LC
EC
FE
CL
MT
AT
TF
PD
FA
RA
BR
ST
RS
BT
HA
EL
IDX



Refer to last page (Foldout page).
M5, E101

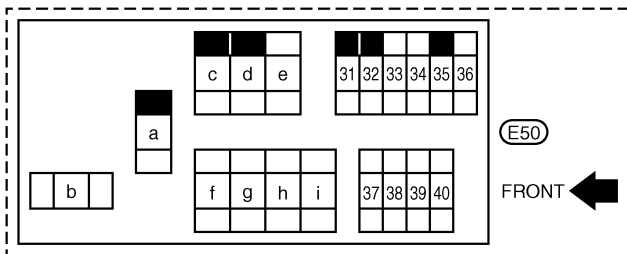

POWER SUPPLY ROUTING

Wiring Diagram — POWER — (Cont'd)

EL-POWER-02

UL : LHD models for Europe

YD : YD engine

ZD : ZD engine

*1 60A : YD

80A : ZD

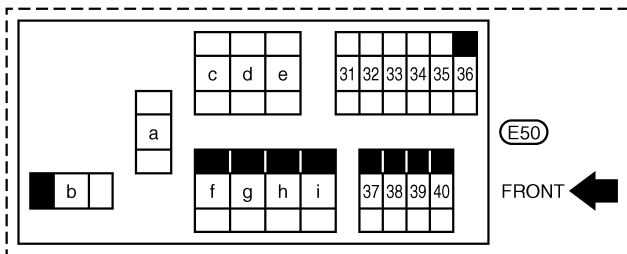
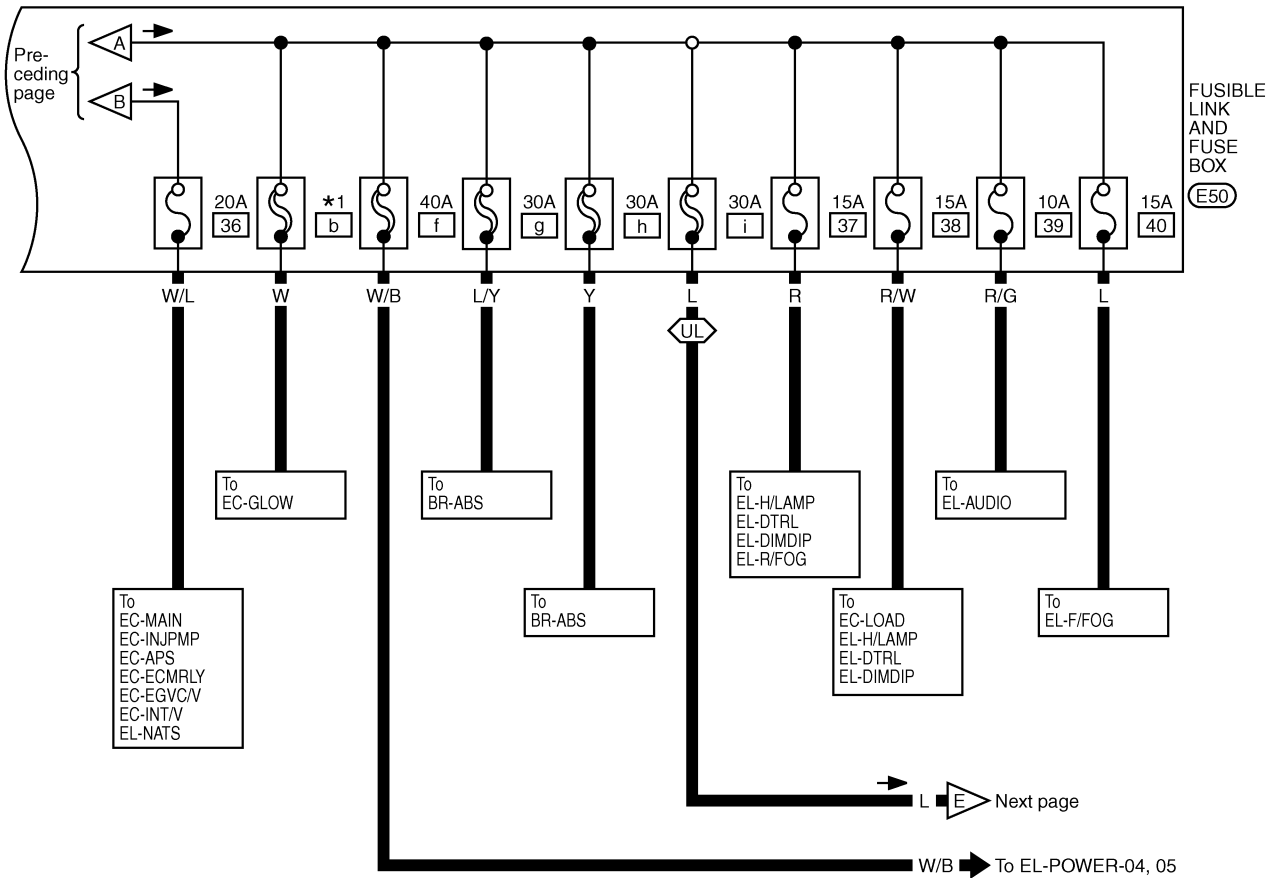

POWER SUPPLY ROUTING

Wiring Diagram — POWER — (Cont'd)

EL-POWER-03

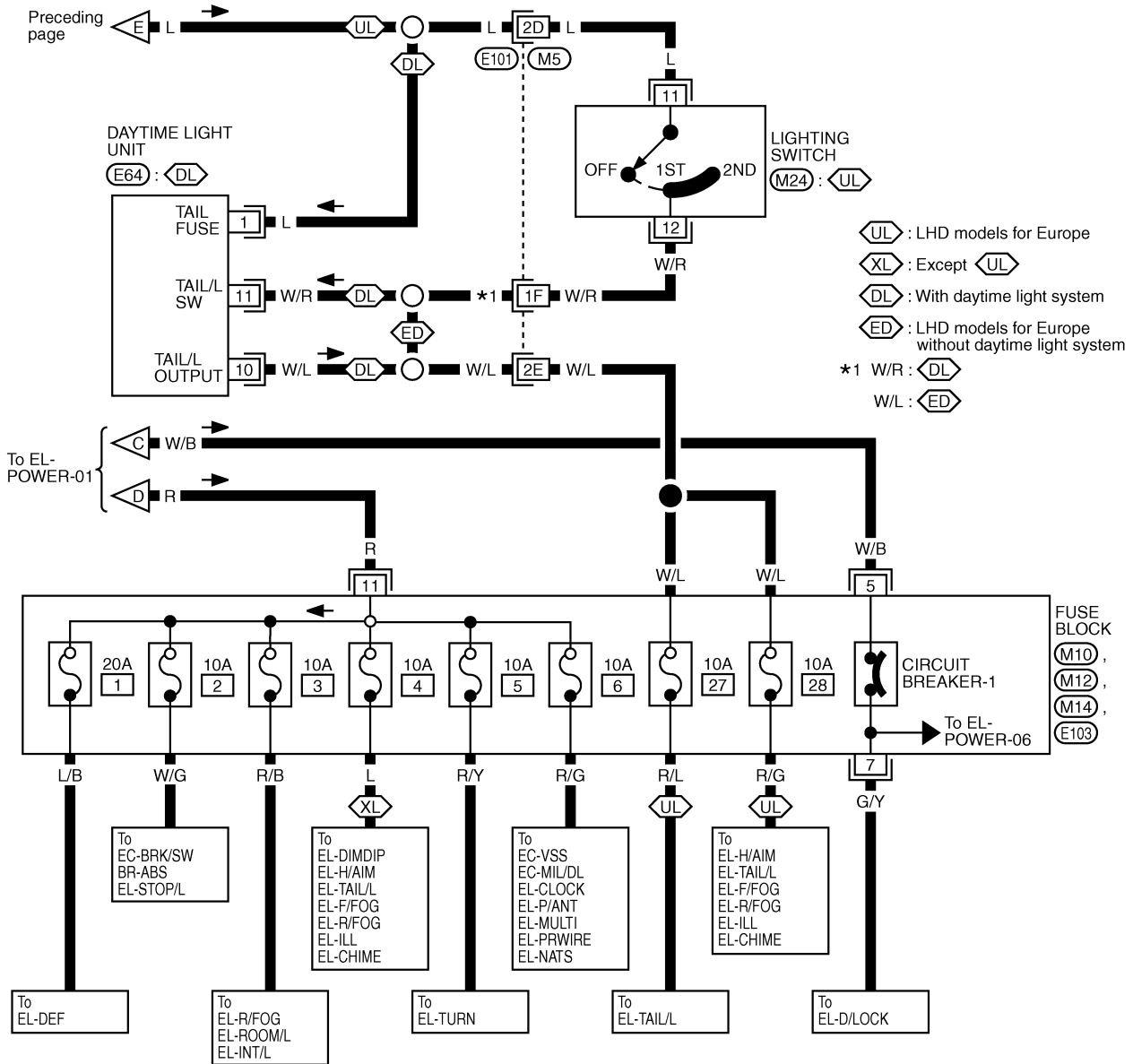

GI
MA
EM
LC
EC
FE
CL
MT
AT
TF
PD
FA
RA
BR
ST
RS
BT
HA

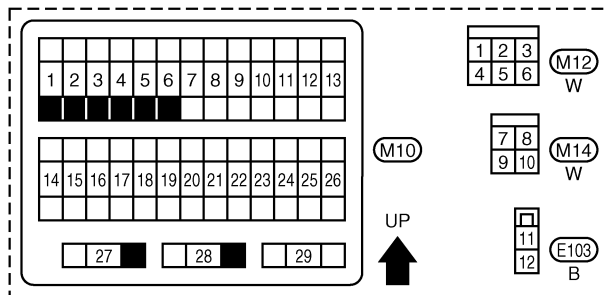

Refer to last page (Foldout page).
 (M5), (E101)

EL

POWER SUPPLY ROUTING

Wiring Diagram — POWER — (Cont'd)

ACCESSORY POWER SUPPLY — IGNITION SW. IN "ACC" OR "ON"

EL-POWER-04

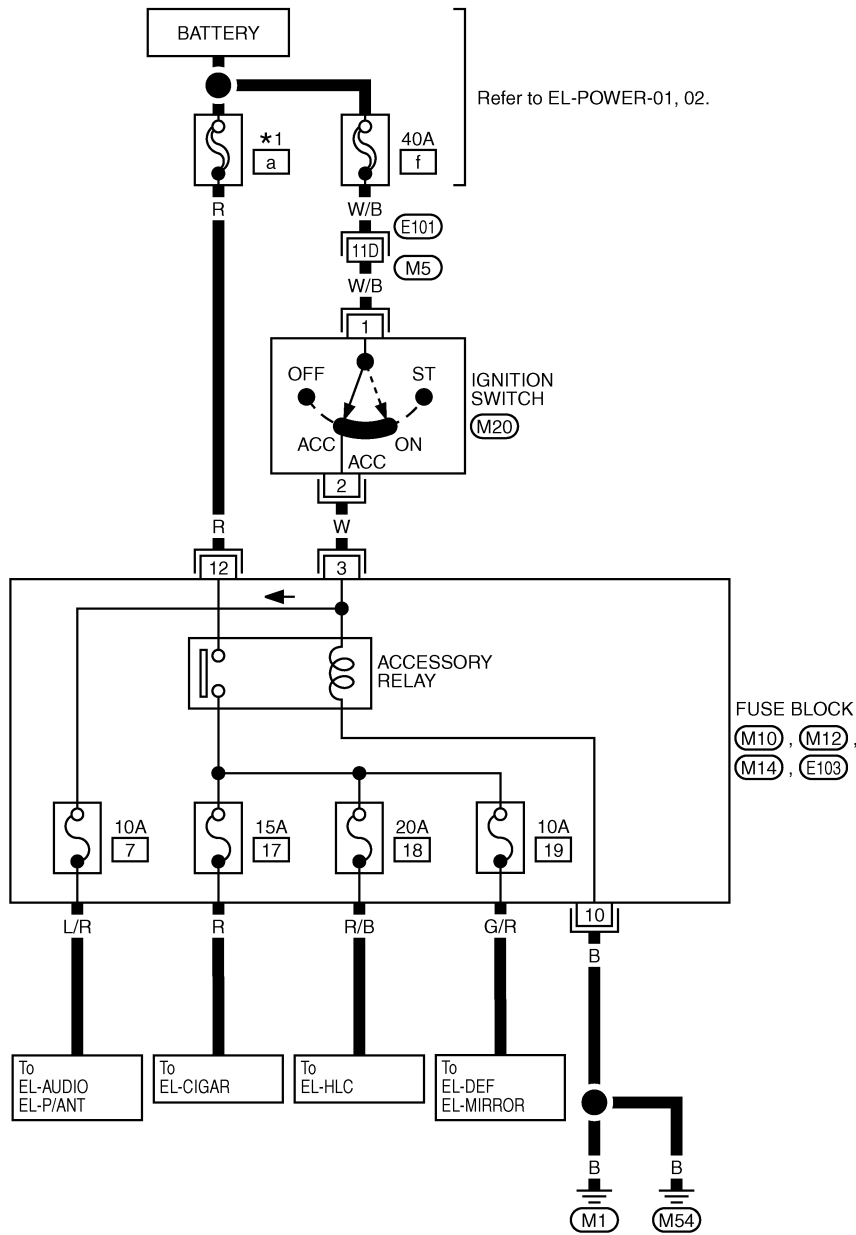

YD : YD engine

ZD : ZD engine

*1 100A : YD

80A : ZD

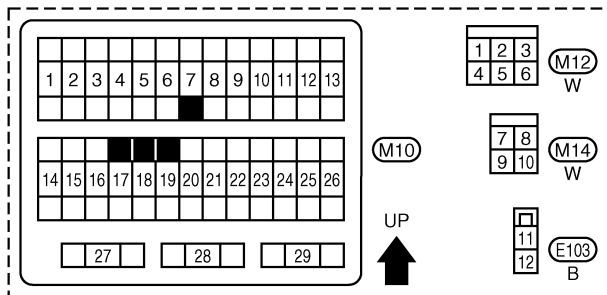

Refer to last page (Foldout page).

M5, E101

POWER SUPPLY ROUTING

Wiring Diagram — POWER — (Cont'd)

IGNITION POWER SUPPLY — IGNITION SW. IN "ON" AND/OR "START"

EL-POWER-05

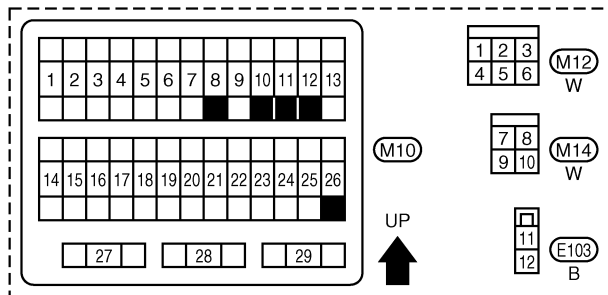
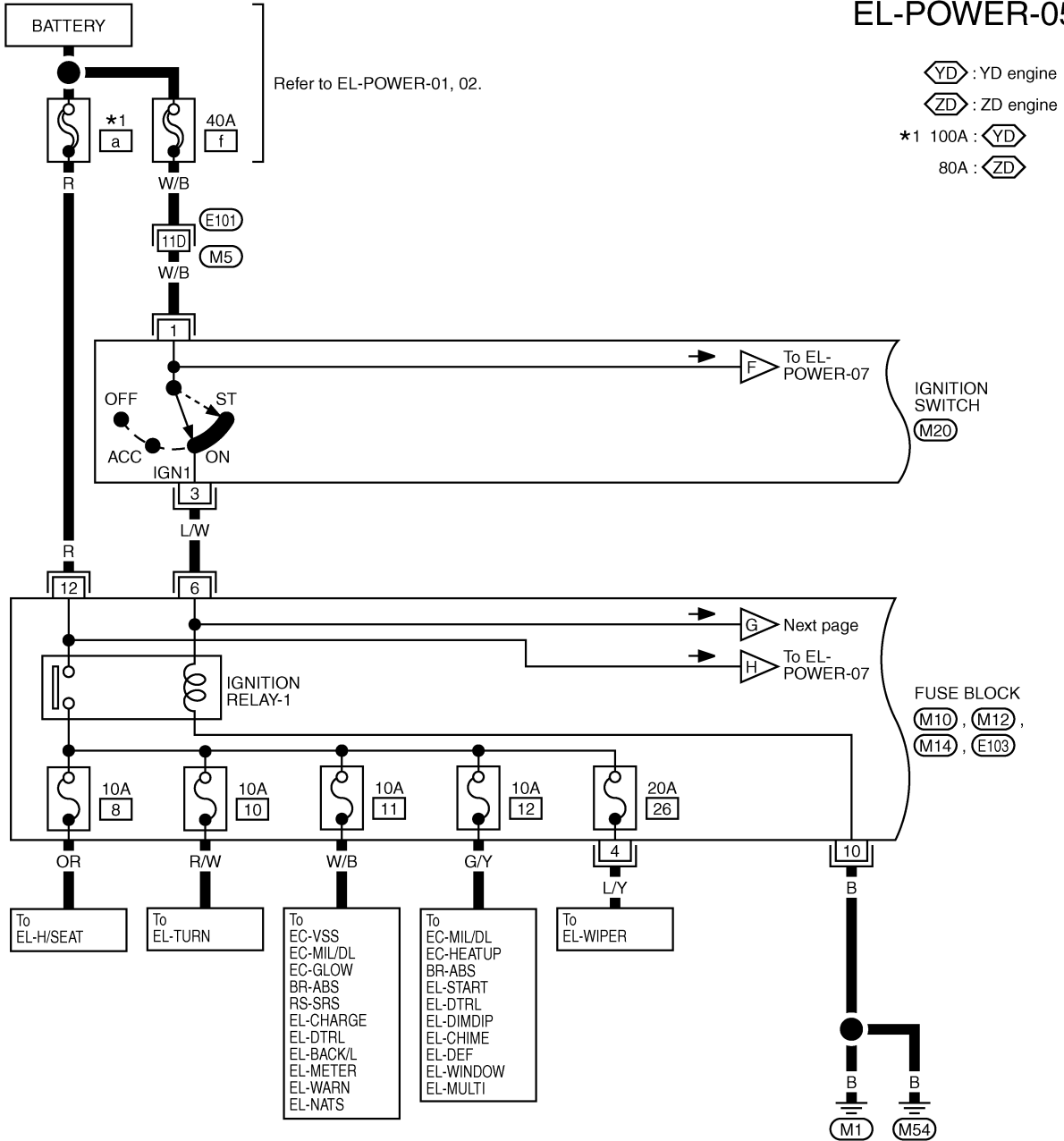

Refer to last page (Foldout page).

(M5), (E101)

GI
 MA
 EM
 LC
 EC
 FE
 CL
 MT
 AT
 TF
 PD
 FA
 RA
 BR
 ST
 RS
 BT
 HA
 EL
 IDX

POWER SUPPLY ROUTING

Wiring Diagram — POWER — (Cont'd)

EL-POWER-06

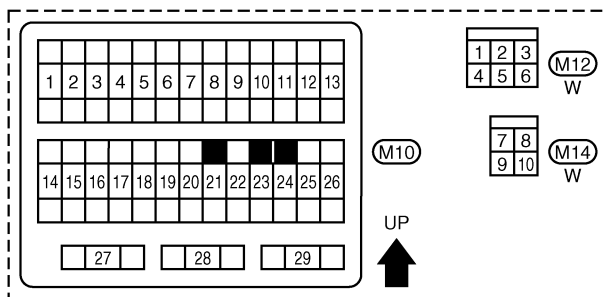
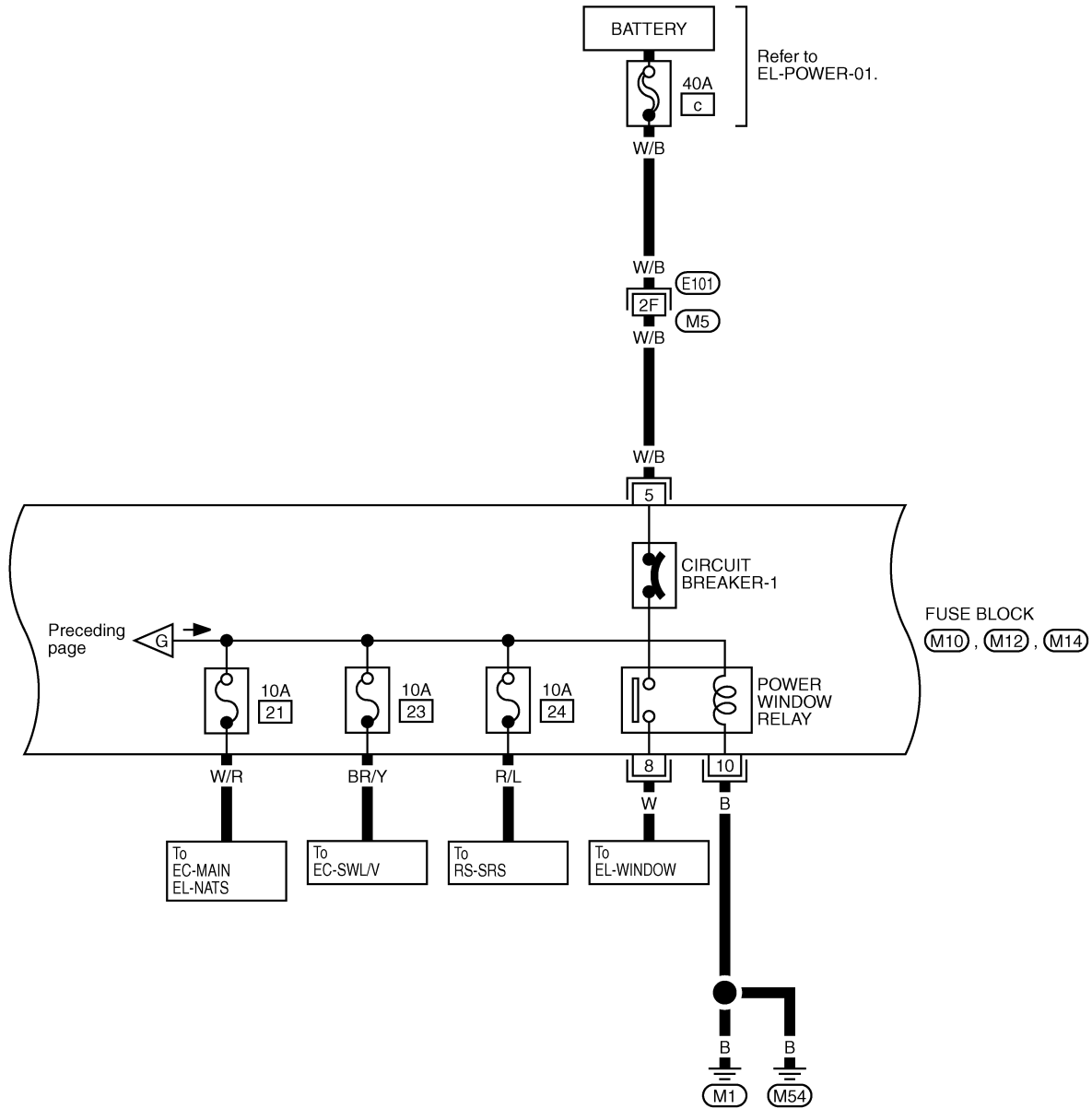

Refer to last page (Foldout page).

(M5), (E101)

POWER SUPPLY ROUTING

Wiring Diagram — POWER — (Cont'd)

EL-POWER-07

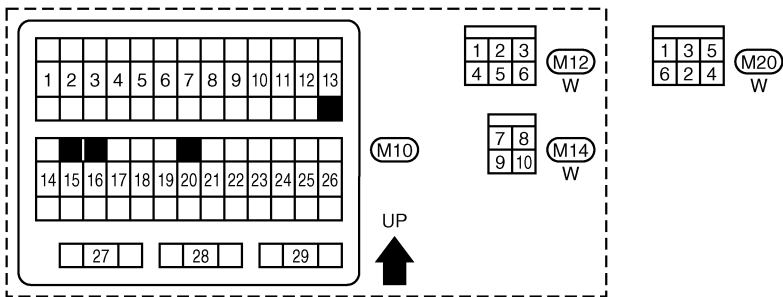
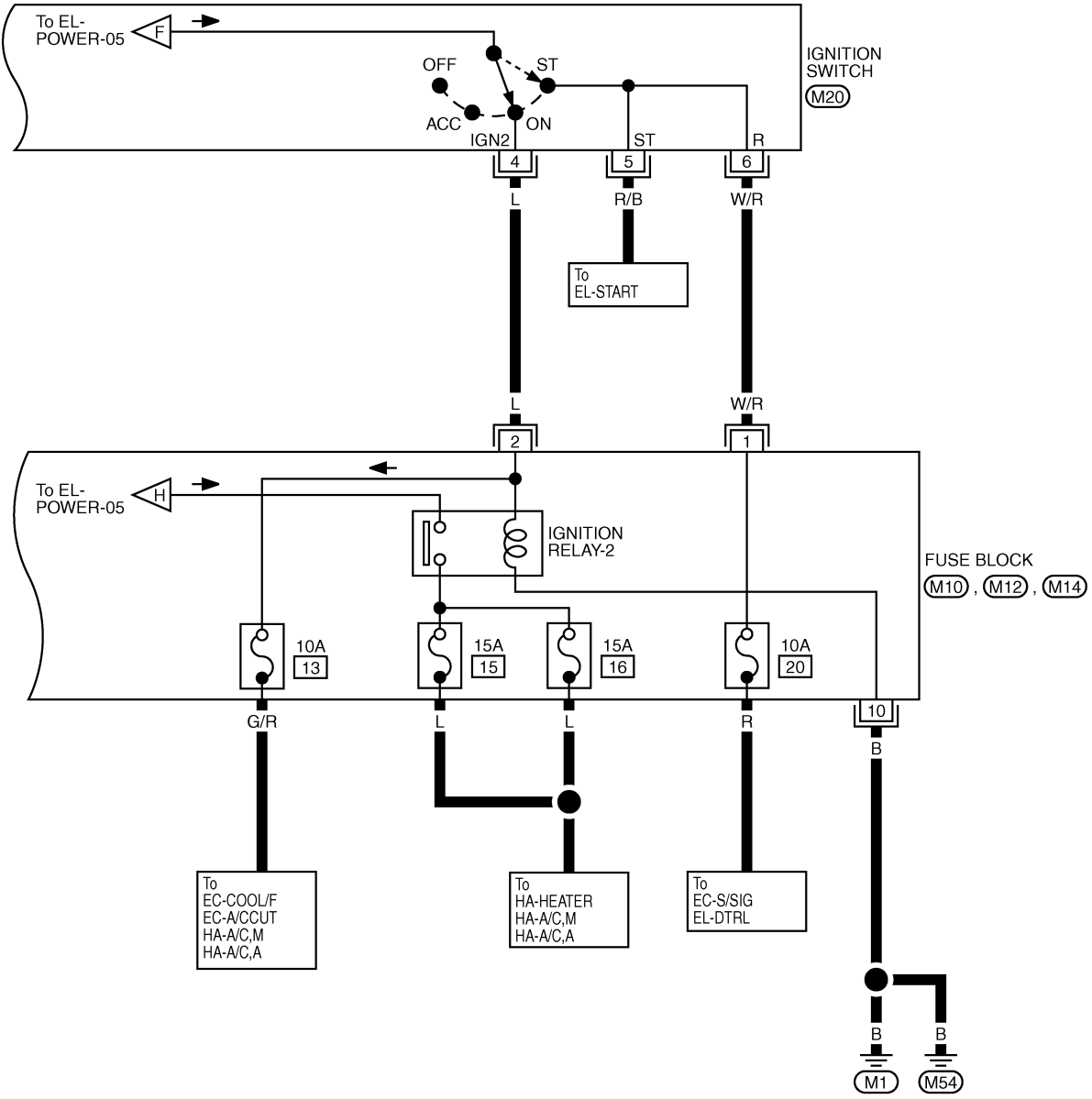

GI
MA
EM
LC
EC
FE
CL
MT
AT
TF
PD
FA
RA
BR
ST
RS
BT
HA

EL

WARNING LAMPS

Schematic/With Tachometer for Europe and Australia

- (AS) : With ABS
- (AB) : With air bag
- (AU) : For Australia
- (4W) : 4-wheel drive models

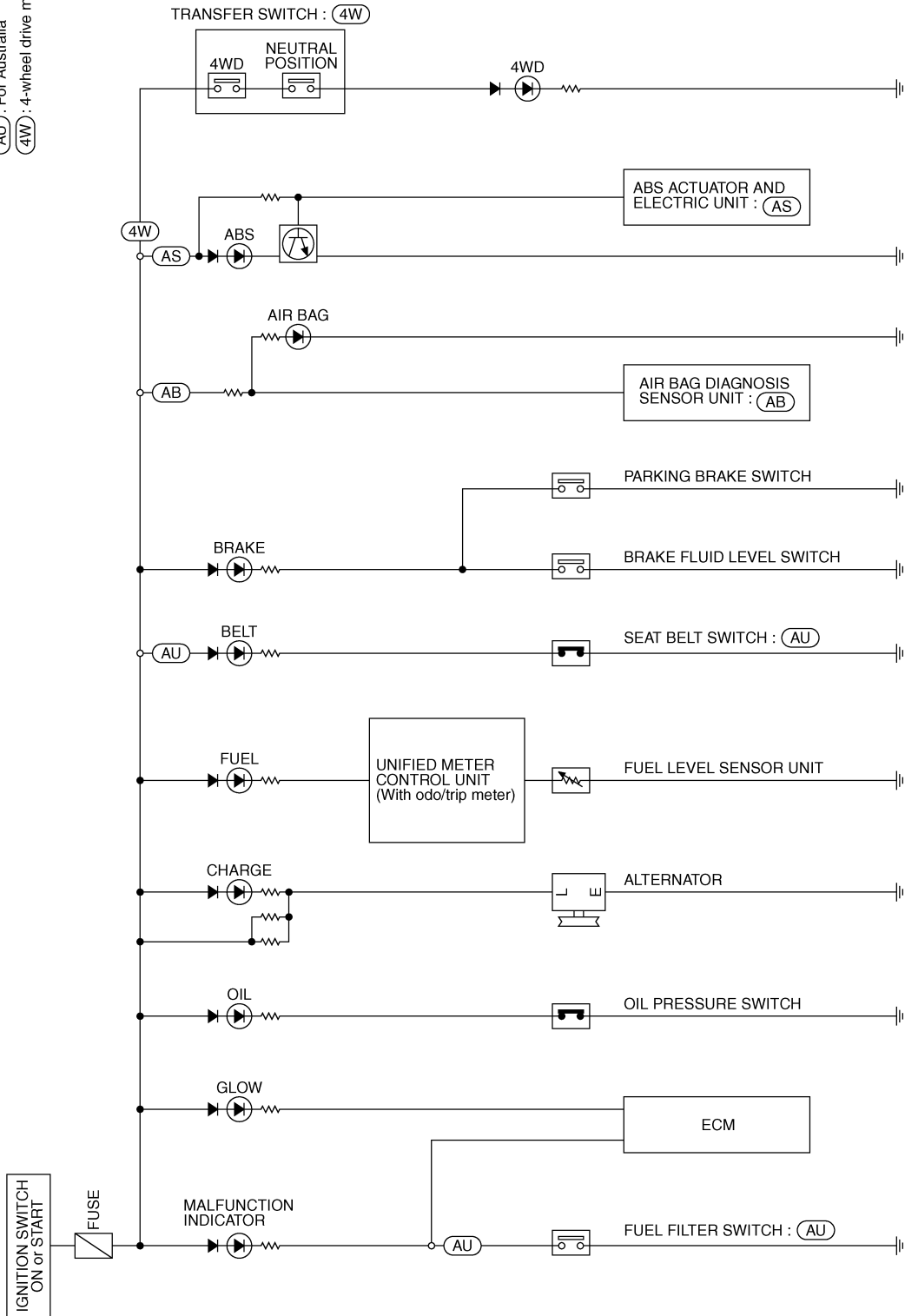

WARNING LAMPS

Wiring Diagram — WARN —/With Tachometer for Europe and Australia (Cont'd)

EL-WARN-02

: LHD models

: RHD models

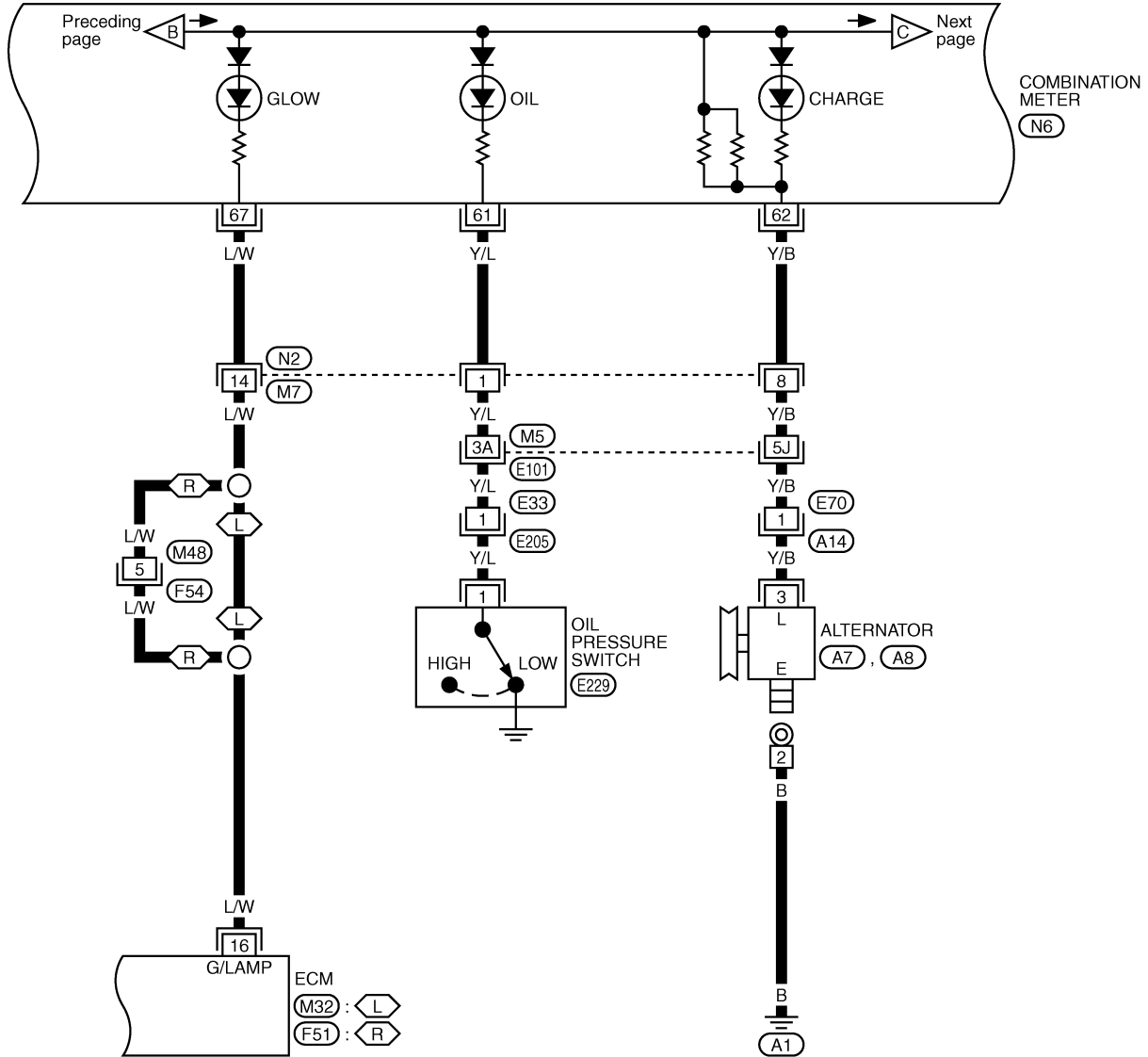

1	2	3	4	5	6	7	8	9	10	11		
12	13	14	15	16	17	18	19	20	21	22	23	24

(N2) BR
(F54) W

45	46	47	48	49	50	51	52	53	54	55		
56	57	58	59	60	61	62	63	64	65	66	67	68

(N6) BR

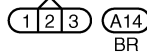
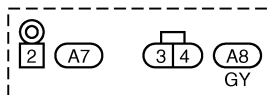
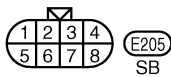

Refer to last page (Foldout page).

(M5), (E101)

(M32)

(F51)

WARNING LAMPS

Wiring Diagram — WARN —/With Tachometer for Europe and Australia (Cont'd)

EL-WARN-03

: For Australia

: Stick type

: Center lever type

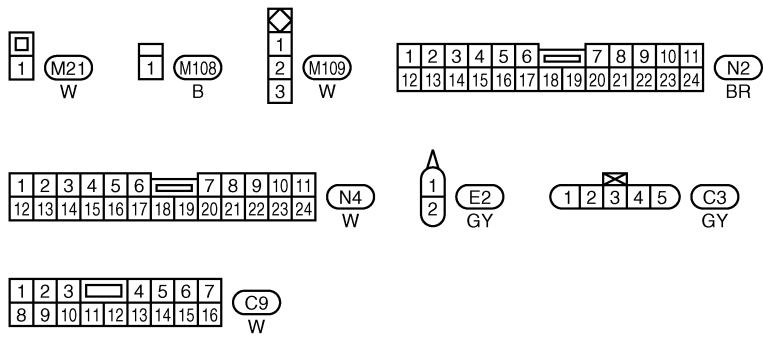
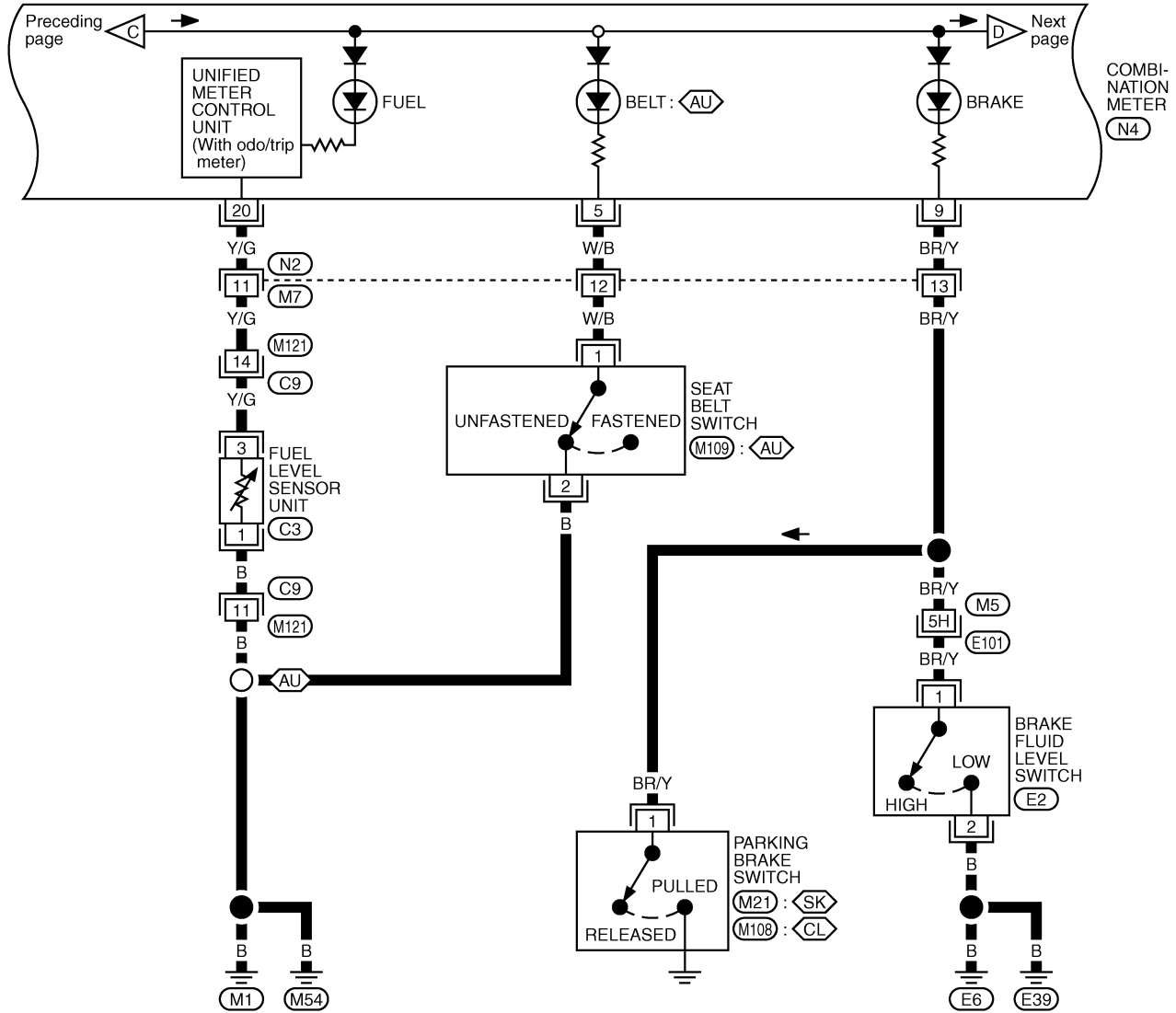

Refer to last page (Foldout page).
M5, E101

GI
MA
EM
LC
EC
FE
CL
MT
AT
TF
PD
FA
RA
BR
ST
RS
BT
HA
EL
IDX

WARNING LAMPS

Wiring Diagram — WARN —/With Tachometer for Europe and Australia (Cont'd)

EL-WARN-04

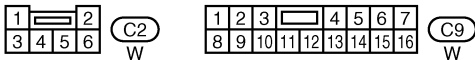
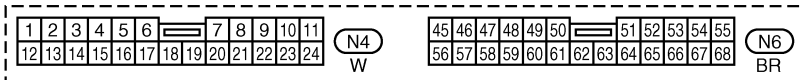
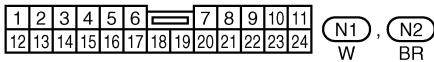
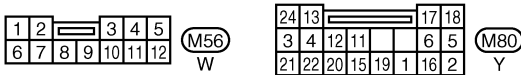
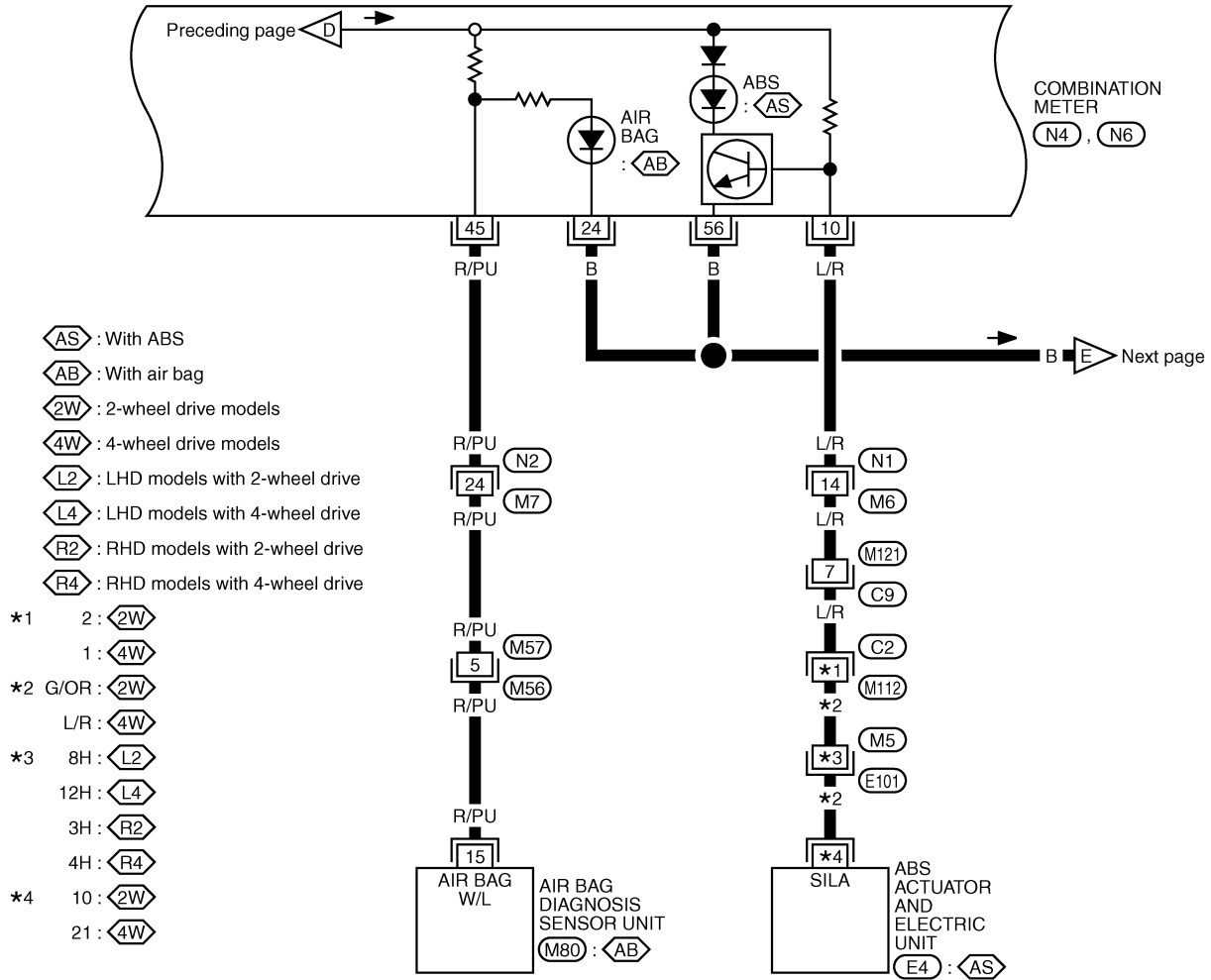

Refer to last page (Foldout page).

(M5), (E101)

(E4)

WARNING LAMPS

Wiring Diagram — WARN —/With Tachometer for Europe and Australia (Cont'd)

EL-WARN-05

: 4-wheel drive models

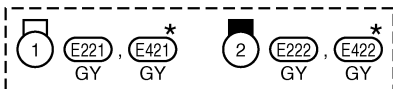
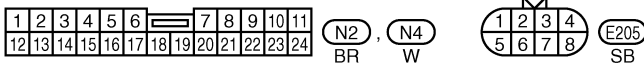
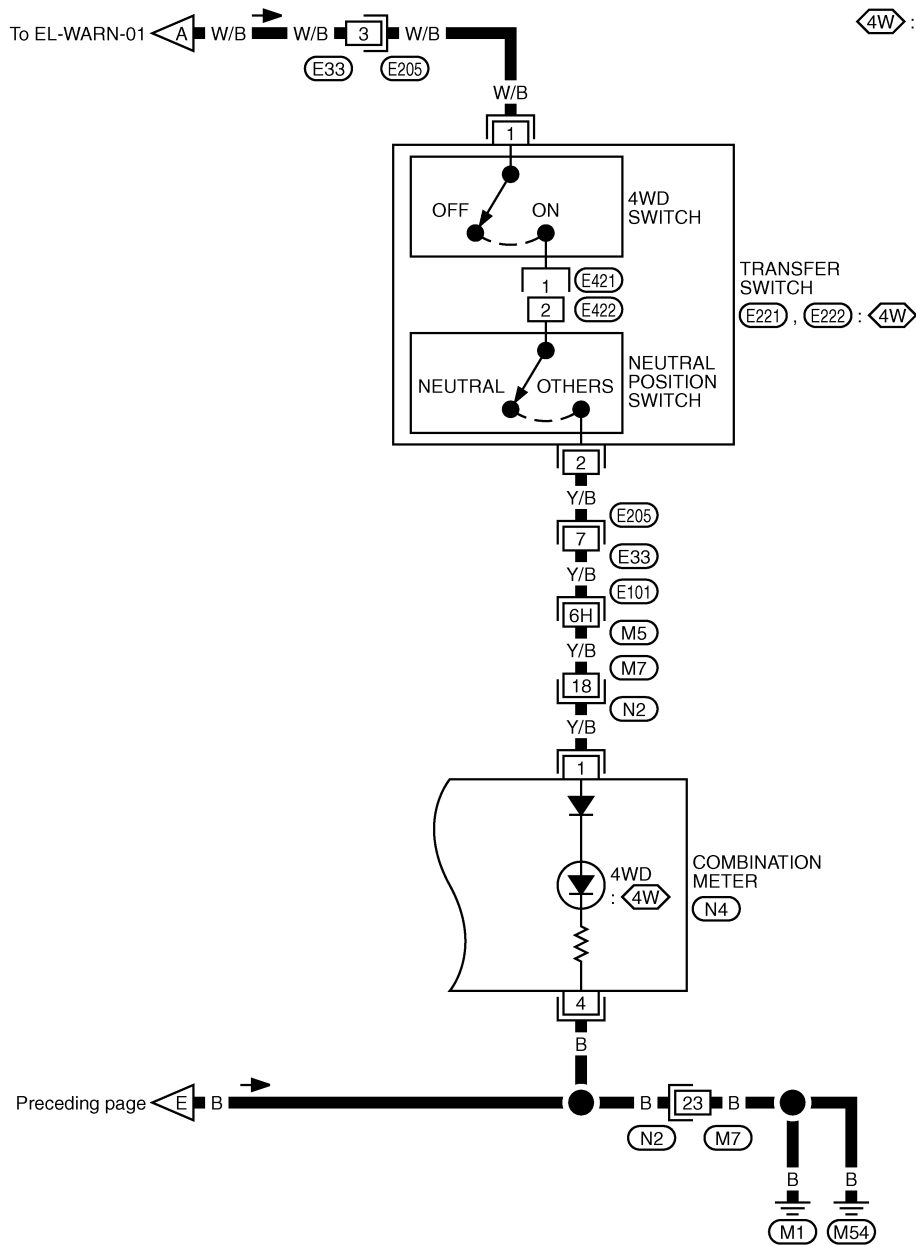

*: This connector is not shown in "HARNESS LAYOUT".

Refer to last page (Foldout page).
M5, E101

GI
MA
EM
LC
EC
FE
CL
MT
AT
TF
PD
FA
RA
BR
ST
RS
BT
HA
EL
IDX

WARNING LAMPS

Schematic/Without Tachometer for Europe

(AS) : With ABS
 (AB) : With air bag
 (4W) : 4-wheel drive models
 (TK) : For Turkey

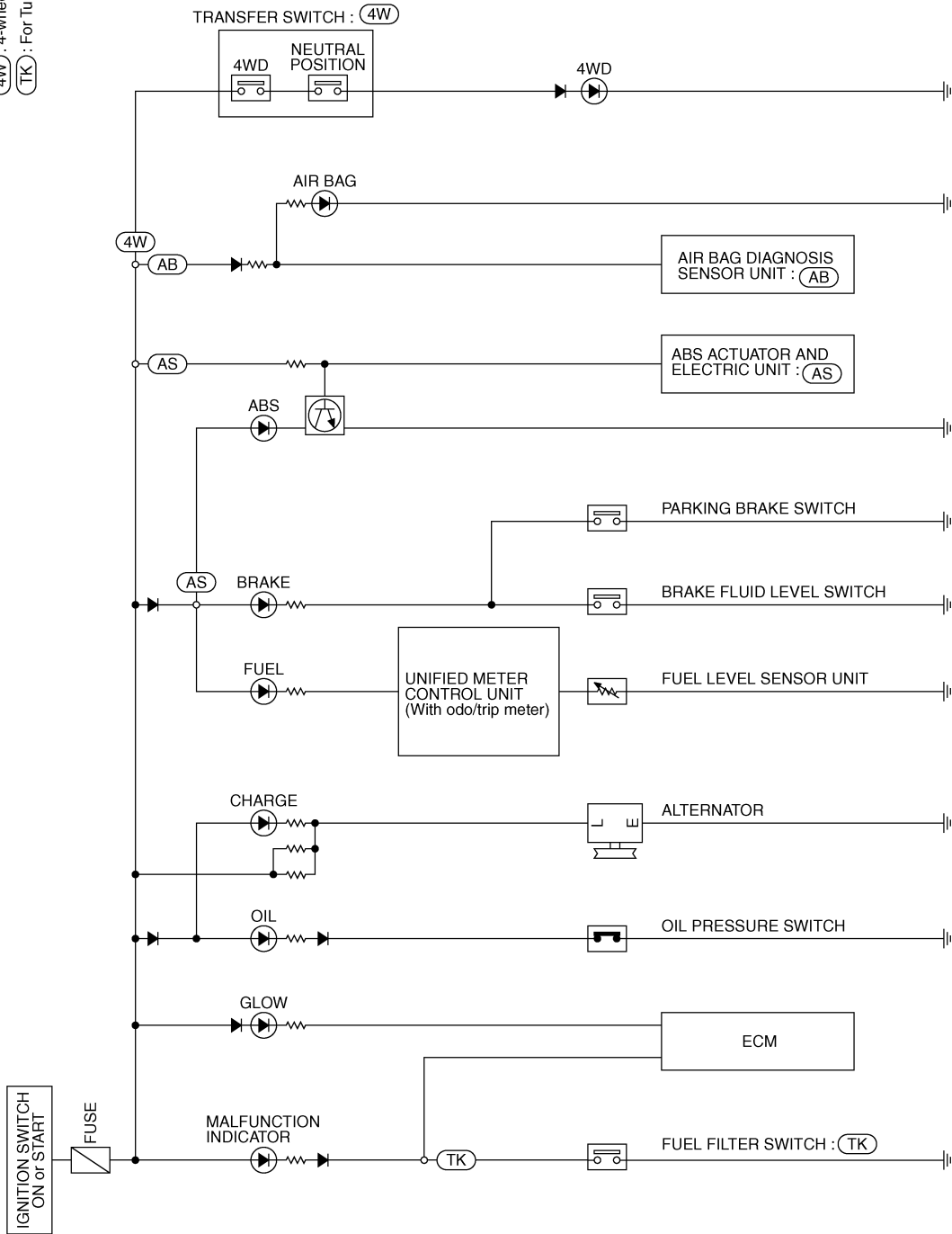

WARNING LAMPS

Wiring Diagram — WARN —/Diesel Engine without Tachometer

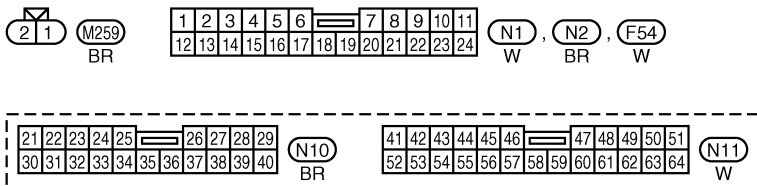
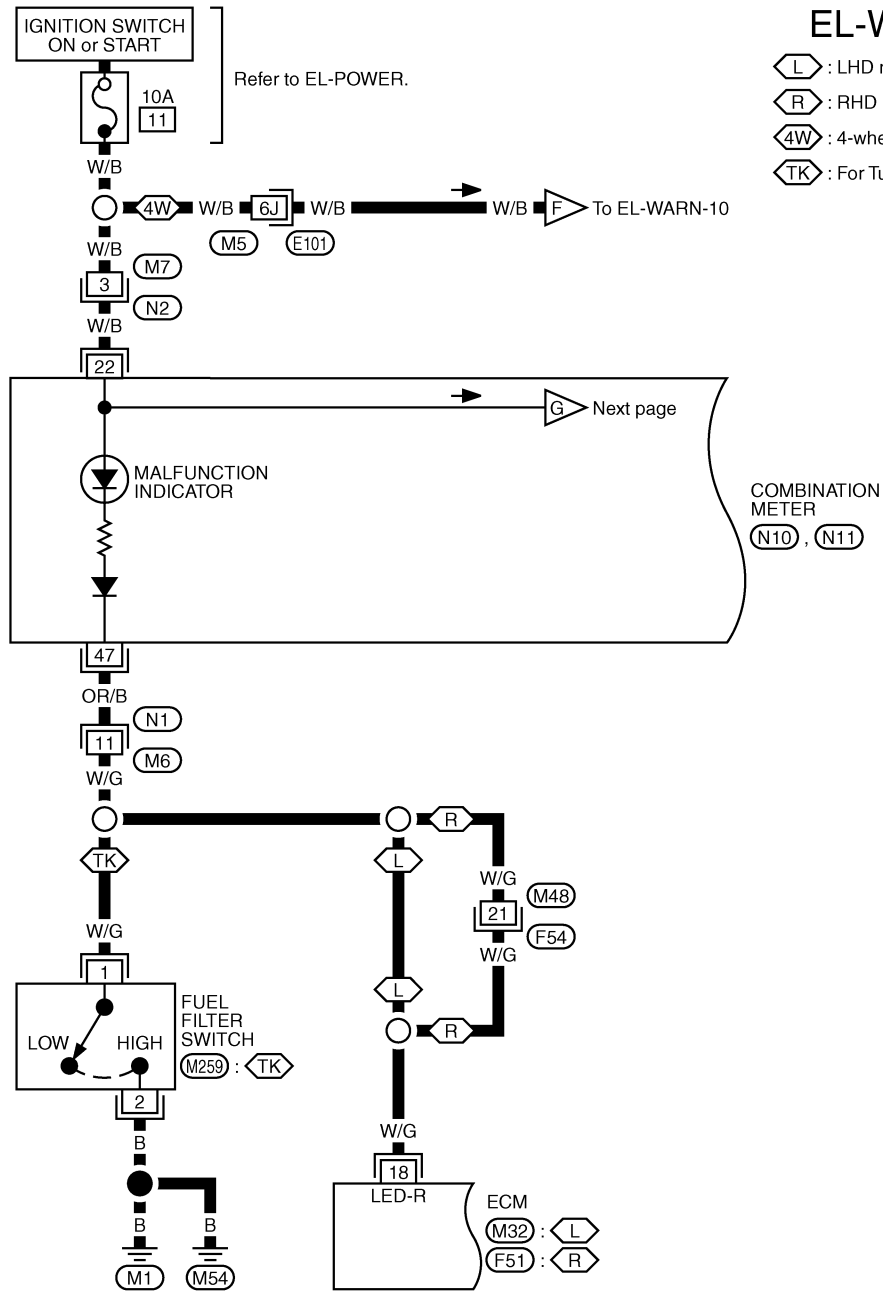

Refer to last page (Foldout page).

M5, E101

M32

F51

GI
MA
EM
LC
EC
FE
CL
MT
AT
TF
PD
FA
RA
BR
ST
RS
BT
HA
EL
IDX

WARNING LAMPS

Wiring Diagram — WARN —/Diesel Engine without Tachometer (Cont'd)

EL-WARN-07

: LHD models

: RHD models

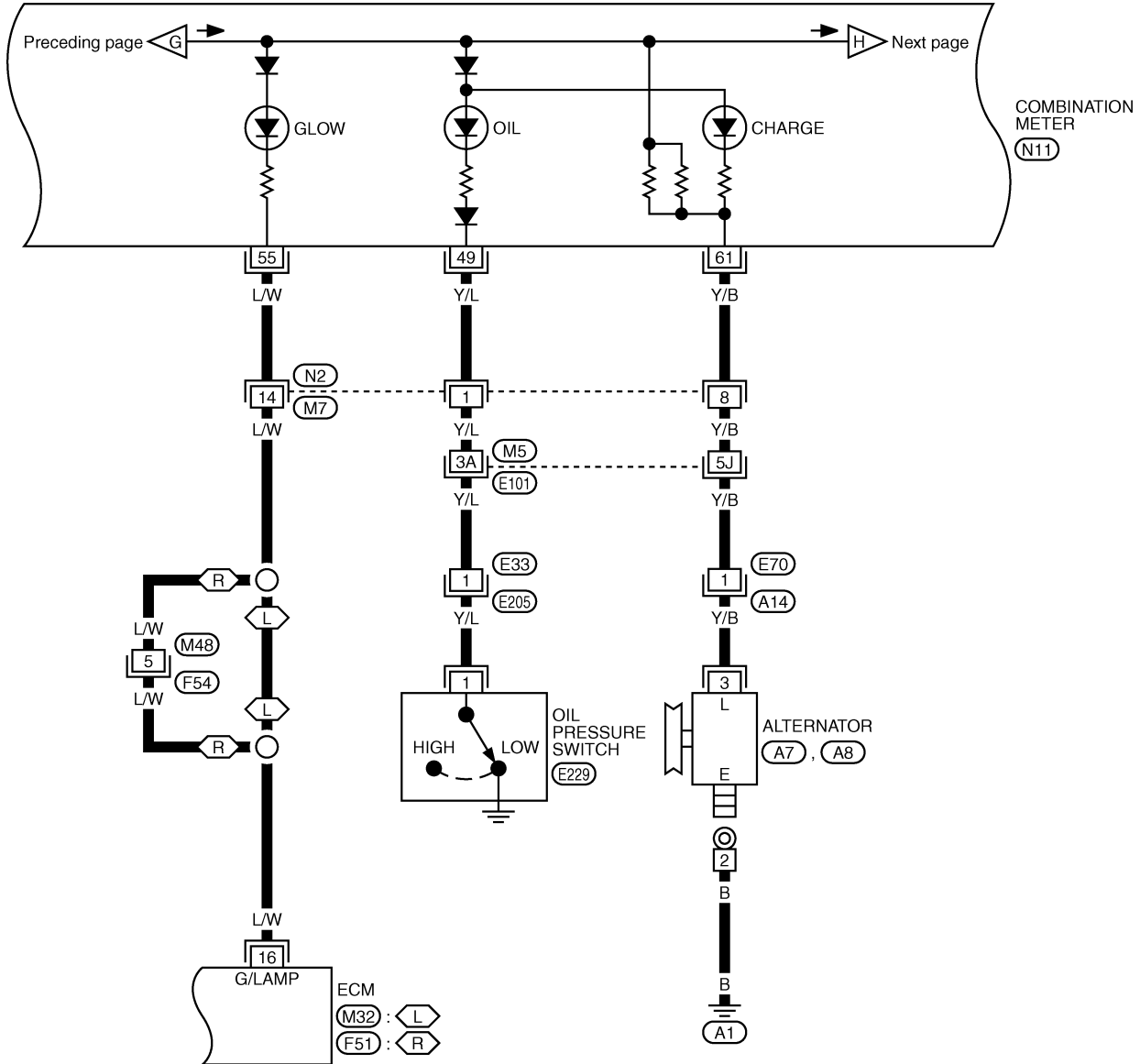

1	2	3	4	5	6	7	8	9	10	11	N2	F54	41	42	43	44	45	46	47	48	49	50	51	N11				
12	13	14	15	16	17	18	19	20	21	22	23	24	BR	W	52	53	54	55	56	57	58	59	60	61	62	63	64	W

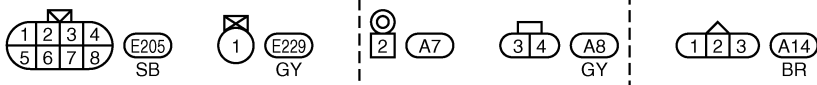

Refer to last page (Foldout page).

M5, E101

M32

F51

WARNING LAMPS

Wiring Diagram — WARN —/Diesel Engine without Tachometer (Cont'd)

EL-WARN-08

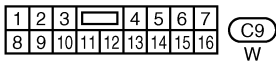
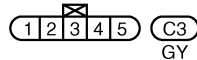
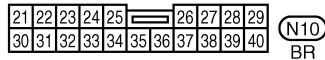
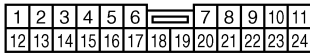
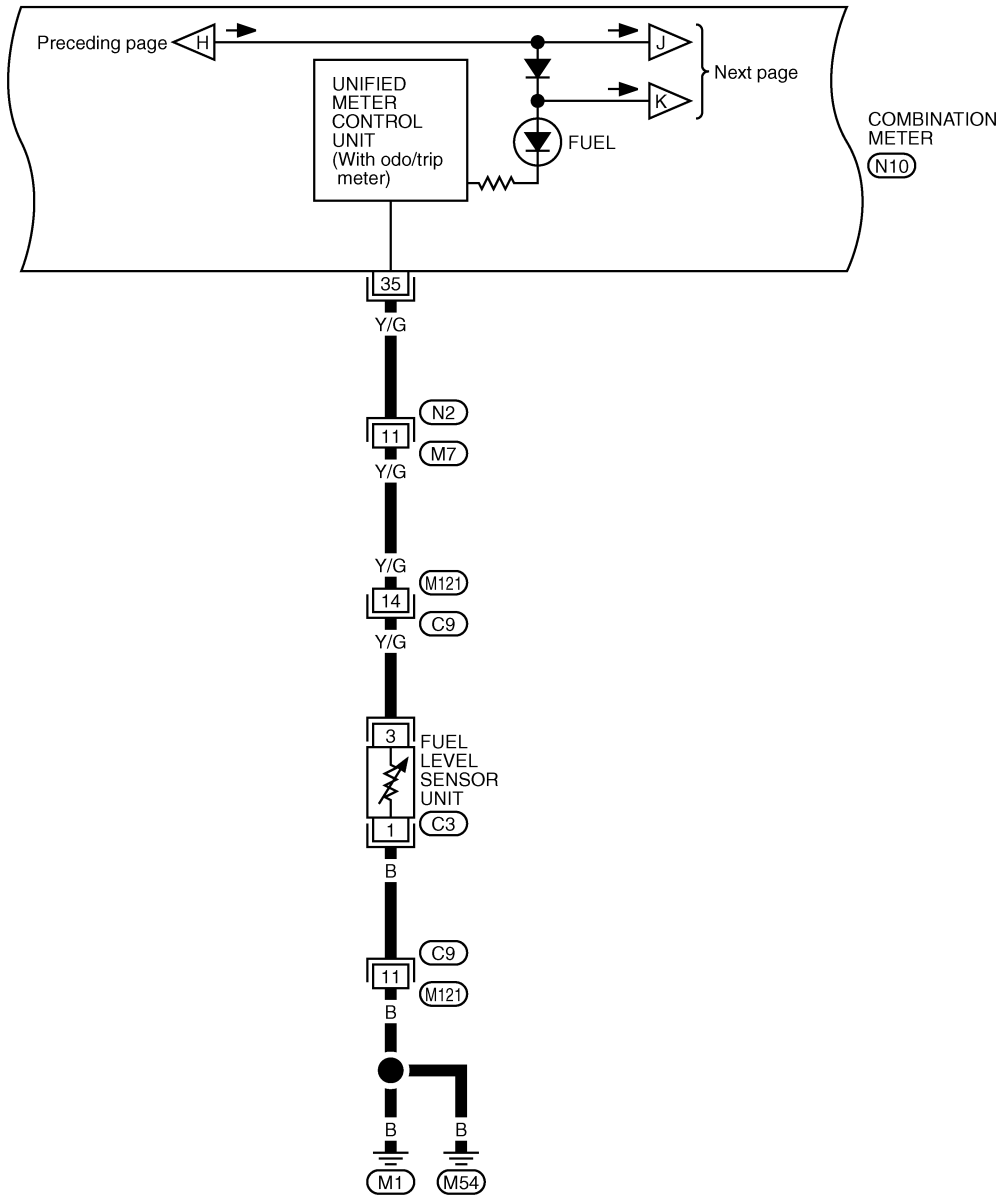

GI
MA
EM
LC
EC
FE
CL
MT
AT
TF
PD
FA
RA
BR
ST
RS
BT
HA

EL

IDX

GEL202B

WARNING LAMPS

Wiring Diagram — WARN —/Diesel Engine without Tachometer (Cont'd)

EL-WARN-10

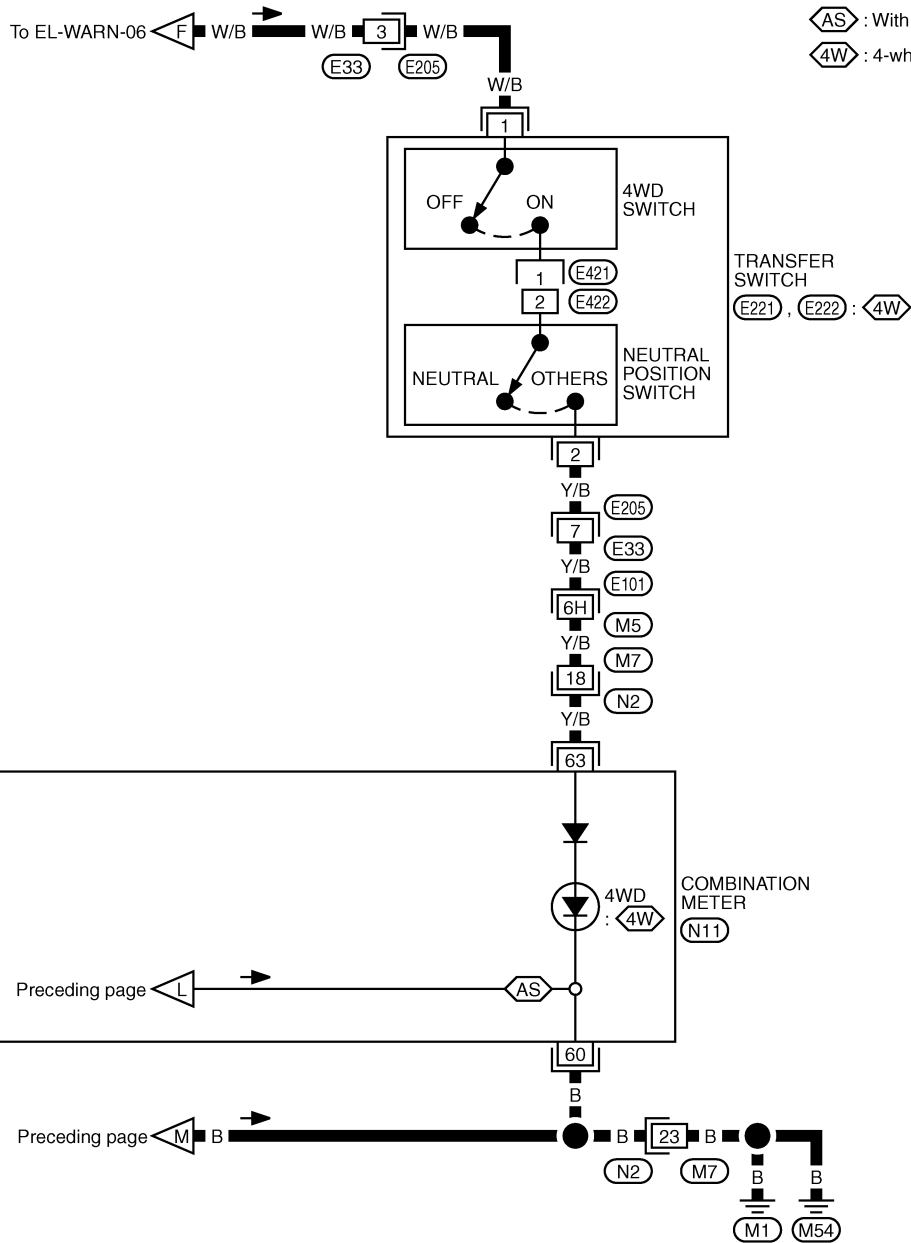

AS : With ABS

4W : 4-wheel drive models

TRANSFER SWITCH
E221, E222 : 4W

Preceding page L

Preceding page M

COMBINATION METER
N11

Refer to last page (Foldout page).

M5, E101

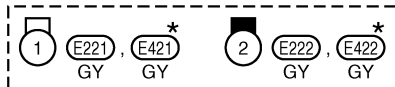
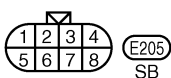
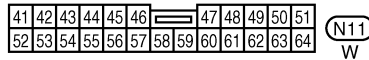
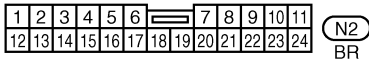

*: This connector is not shown in "HARNESS LAYOUT".

GI
MA
EM
LC
EC
FE
CL
MT
AT
TF
PD
FA
RA
BR
ST
RS
BT
HA
EL
IDX

Wiring Diagram — HORN —

EL-HORN-01

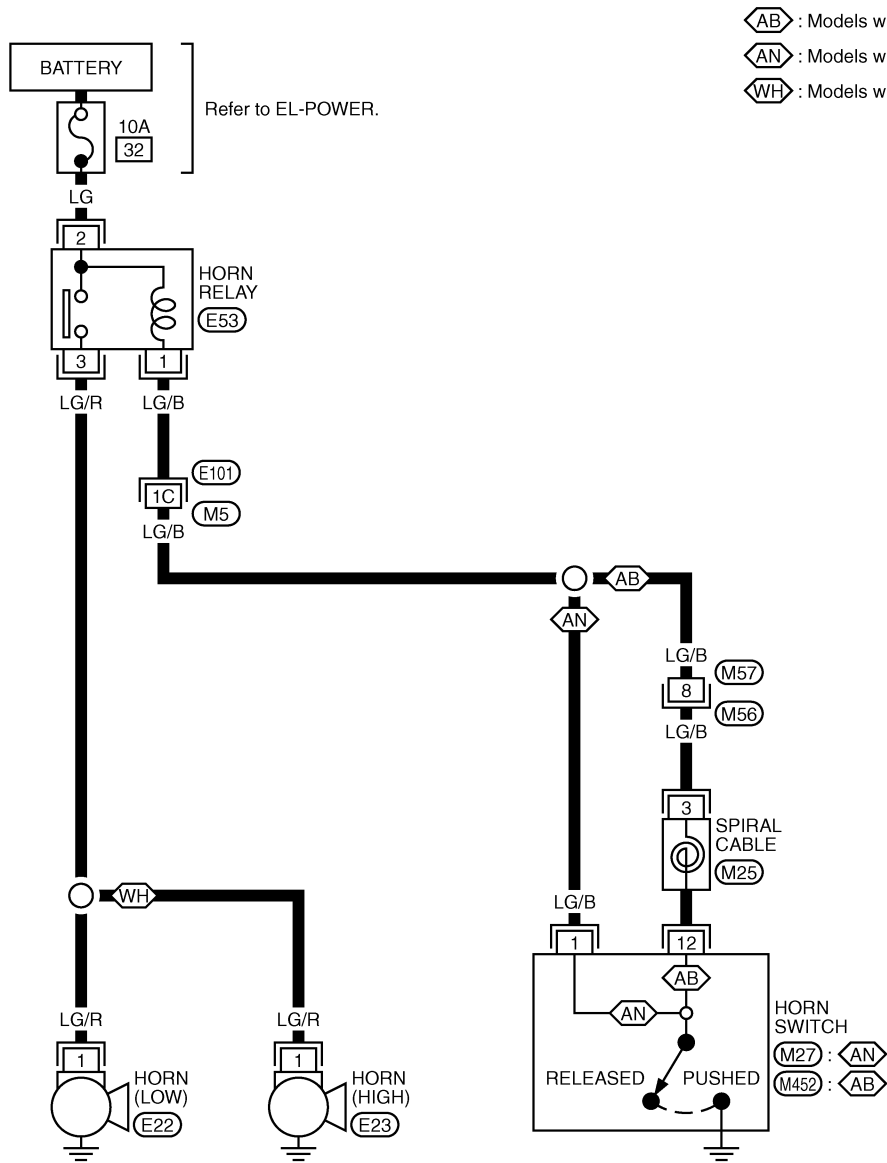

- ⬡AB⬢ : Models with air bag system
- ⬡AN⬢ : Models without air bag system
- ⬡WH⬢ : Models with double horn

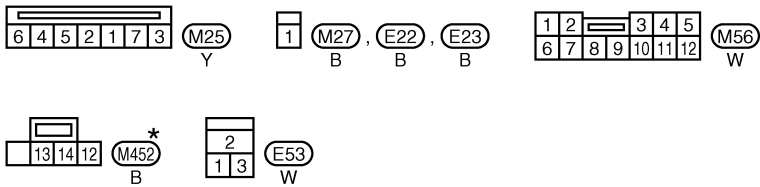

Refer to last page (Foldout page).
 (M5), (E101)

*: This connector is not shown in "HARNESS LAYOUT".

NOTE:

GI

MA

EM

LC

EC

FE

CL

MT

AT

TF

PD

FA

RA

BR

ST

RS

BT

HA

EL

IDX

HARNESS LAYOUT

Main Harness

INSTRUMENT PANEL — LHD MODELS

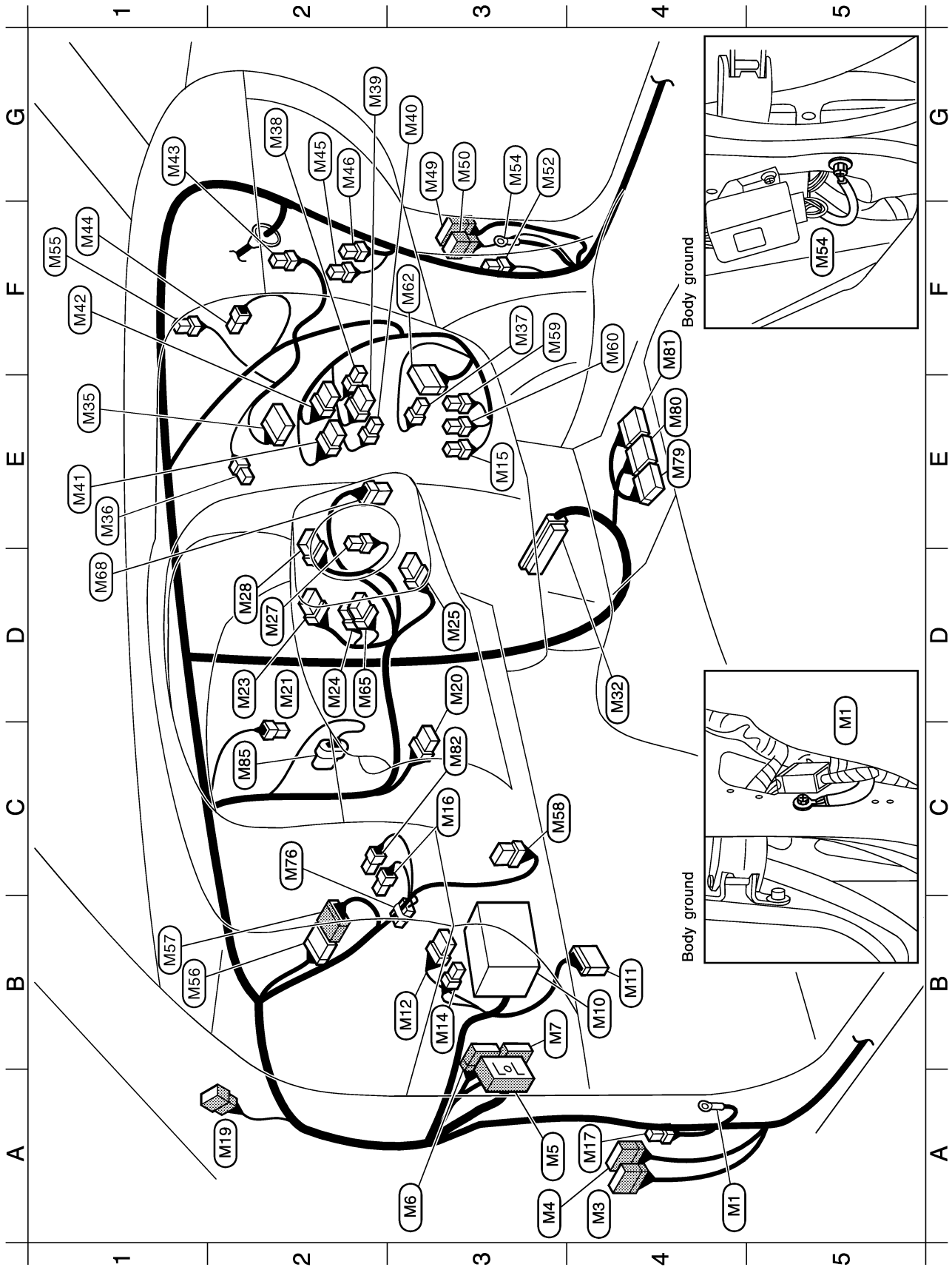

HARNES LAYOUT

Main Harness (Cont'd)

A4 (M1)	—	: Body ground	G3 (M40)	W/2	: Fan switch illumination
A4 (M3)	W/20	: To (D1)	E1 (M41)	W/8	: Hazard switch
A3 (M4)	W/12	: To (D2) (For power window)	F1 (M42)	W/6	: Defogger switch
A3 (M5)	SMJ	: To (E101)	G1 (M43)	Y/2	: Front passenger air bag module
A3 (M6)	W/24	: To (N1)	F1 (M44)	BR/4	: Thermo control amplifier
B3 (M7)	BR/24	: To (N2)	G2 (M45)	BR/4	: Fan resistor
B4 (M10)	—	: Fuse block	G2 (M46)	W/2	: Blower motor
B4 (M11)	W/16	: Data link connector	G3 (M49)	W/20	: To (D31)
B3 (M12)	W/6	: Fuse block	G3 (M50)	W/6	: To (D32) (For power window)
B3 (M14)	W/4	: Fuse block	G3 (M52)	W/2	: Circuit breaker-2
E3 (M15)	B/3	: Combination flasher unit	G3 (M54)	—	: Body ground
C3 (M16)	B/2	: Stop lamp switch	F1 (M55)	W/2	: Security indicator
A4 (M17)	L/4	: Front fog lamp relay	B1 (M56)	W/12	: To (M57) (With air bag)
A2 (M19)	W/6	: To (R1)	B1 (M57)	W/12	: To (M56) (With air bag)
D3 (M20)	W/6	: Ignition switch	C3 (M58)	BR/8	: Not used
D2 (M21)	W/1	: Parking brake switch (Stick type)	F3 (M59)	BR/6	: Defogger relay
D2 (M23)	BR/8	: Lighting switch, Turn signal lamp switch	F4 (M60)	L/4	: Rear fog lamp relay
D2 (M24)	BR/4	: Lighting switch	F3 (M82)	W/18	: Smart entrance control unit
D3 (M25)	Y/7	: Spiral cable (With air bag)	D2 (M65)	W/6	: Front and rear fog lamp switch
D2 (M27)	B/1	: Horn switch (Without air bag)	D1 (M68)	W/8	: NATS IMMU
D2 (M28)	GY/8	: Wiper and washer switch	C2 (M76)	W/6	: Option connector for theft warning system
D4 (M32)	SMJ	: ECM	E4 (M79)	Y/12	: Air bag diagnosis sensor unit (With air bag)
E1 (M35)	W/16	: Audio unit	E4 (M80)	Y/20	: Air bag diagnosis sensor unit (With air bag)
E1 (M36)	W/4	: Not used	F4 (M81)	Y/12	: Air bag diagnosis sensor unit (With air bag)
F3 (M37)	B/2	: Cigarette lighter	C3 (M82)	B/2	: Brake pedal position switch
G2 (M38)	W/3	: A/C switch	C2 (M85)	GY/6	: Accelerator work unit
G2 (M39)	W/6	: Fan switch			

GI

MA

EM

LC

EC

FE

CL

MT

AT

TF

PD

FA

RA

BR

ST

RS

BT

HA

EL

HEL202C

IDX

HARNESS LAYOUT

Main Harness (Cont'd)

INSTRUMENT PANEL — RHD MODELS

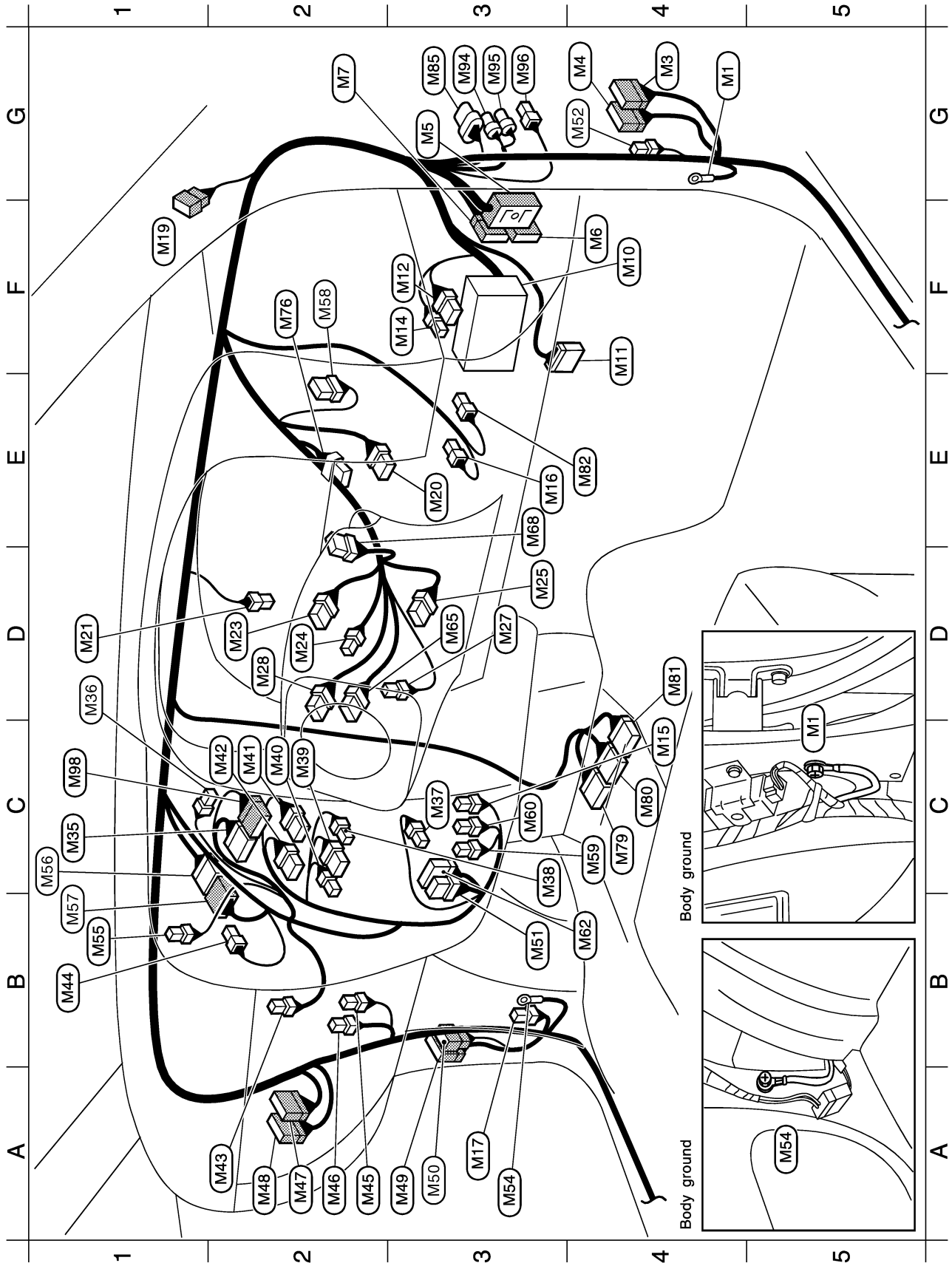

HARNES LAYOUT

Main Harness (Cont'd)

G4 (M1)	—	: Body ground	A2 (M46)	W/2	: Blower motor
G4 (M3)	W/20	: To (D1)	A2 (M47)	W/16	: To (F55)
G4 (M4)	W/12	: To (D2) (For power window)	A2 (M48)	W/24	: To (F54)
G3 (M5)	SMJ	: To (E101)	A3 (M49)	W/20	: To (D31)
F4 (M6)	W/24	: To (N1)	A3 (M50)	W/6	: To (D32) (For power window)
G2 (M7)	BR/24	: To (N2)	B3 (M51)	W/8	: Door lock timer (Except for Europe)
F4 (M10)	—	: Fuse block	G4 (M52)	W/2	: Circuit breaker-2 (For Europe)
F4 (M11)	W/16	: Data link connector	A3 (M54)	—	: Body ground
F3 (M12)	W/6	: Fuse block	B1 (M55)	W/2	: Security indicator (For Europe)
F3 (M14)	W/4	: Fuse block	C1 (M56)	W/12	: To (M57) (With air bag)
C4 (M15)	B/3	: Combination flasher unit	B1 (M57)	W/12	: To (M56) (With air bag)
E3 (M16)	B/2	: Stop lamp switch	F2 (M58)	BR/8	: Not used (For Europe)
A3 (M17)	L/4	: Front fog lamp relay (For Europe)	C4 (M59)	BR/6	: Defogger relay
F1 (M19)	W/6	: To (R1)	C3 (M60)	L/4	: Rear fog lamp relay (For Europe)
E3 (M20)	W/6	: Ignition switch	B4 (M62)	W/18	: Smart entrance control unit (For Europe)
D1 (M21)	W/1	: Parking brake switch (Stick type)	D3 (M65)	W/6	: Front and rear fog lamp switch (For Europe)
D2 (M23)	BR/8	: Lighting switch, Turn signal lamp switch	E3 (M68)	W/8	: NATS IMMU (For Europe)
D2 (M24)	BR/4	: Lighting switch	F2 (M76)	W/6	: Option connector for theft warning system (For Europe)
D3 (M25)	Y/7	: Spiral cable (With air bag)	C4 (M79)	Y/12	: Air bag diagnosis sensor unit (With air bag)
D3 (M27)	B/1	: Horn switch (Without air bag)	C4 (M80)	Y/20	: Air bag diagnosis sensor unit (With air bag)
D2 (M28)	GY/8	: Wiper and washer switch	D4 (M81)	Y/12	: Air bag diagnosis sensor unit (With air bag)
C1 (M35)	W/16	: Audio unit (For Europe)	E4 (M82)	B/2	: Brake pedal position switch (YD engine)
D1 (M36)	W/4	: Not used (For Europe)	G3 (M85)	GY/6	: Accelerator work unit (YD engine)
C3 (M37)	B/2	: Cigarette lighter	G3 (M84)	BR/3	: Accelerator position sensor (ZD engine)
C3 (M38)	W/3	: A/C switch	G3 (M95)	GY/3	: Accelerator position switch (ZD engine)
C2 (M39)	W/6	: Fan switch	G3 (M96)	W/3	: Accelerator switch (F/C) (ZD engine)
C2 (M40)	W/2	: Fan switch illumination	C1 (M98)	W/12	: Audio unit (Via sub-harness) (For Australia)
C2 (M41)	W/8	: Hazard switch			
C2 (M42)	W/6	: Defogger switch			
A2 (M43)	Y/2	: Front passenger air bag module			
B1 (M44)	BR/4	: Thermo control amplifier			
A2 (M45)	BR/4	: Fan resistor			

GI

MA

EM

LC

EC

FE

CL

MT

AT

TF

PD

FA

RA

BR

ST

RS

BT

HA

EL

HEL204C

IDX

HARNESS LAYOUT

Main Harness (Cont'd)

BODY SIDE — LHD MODELS

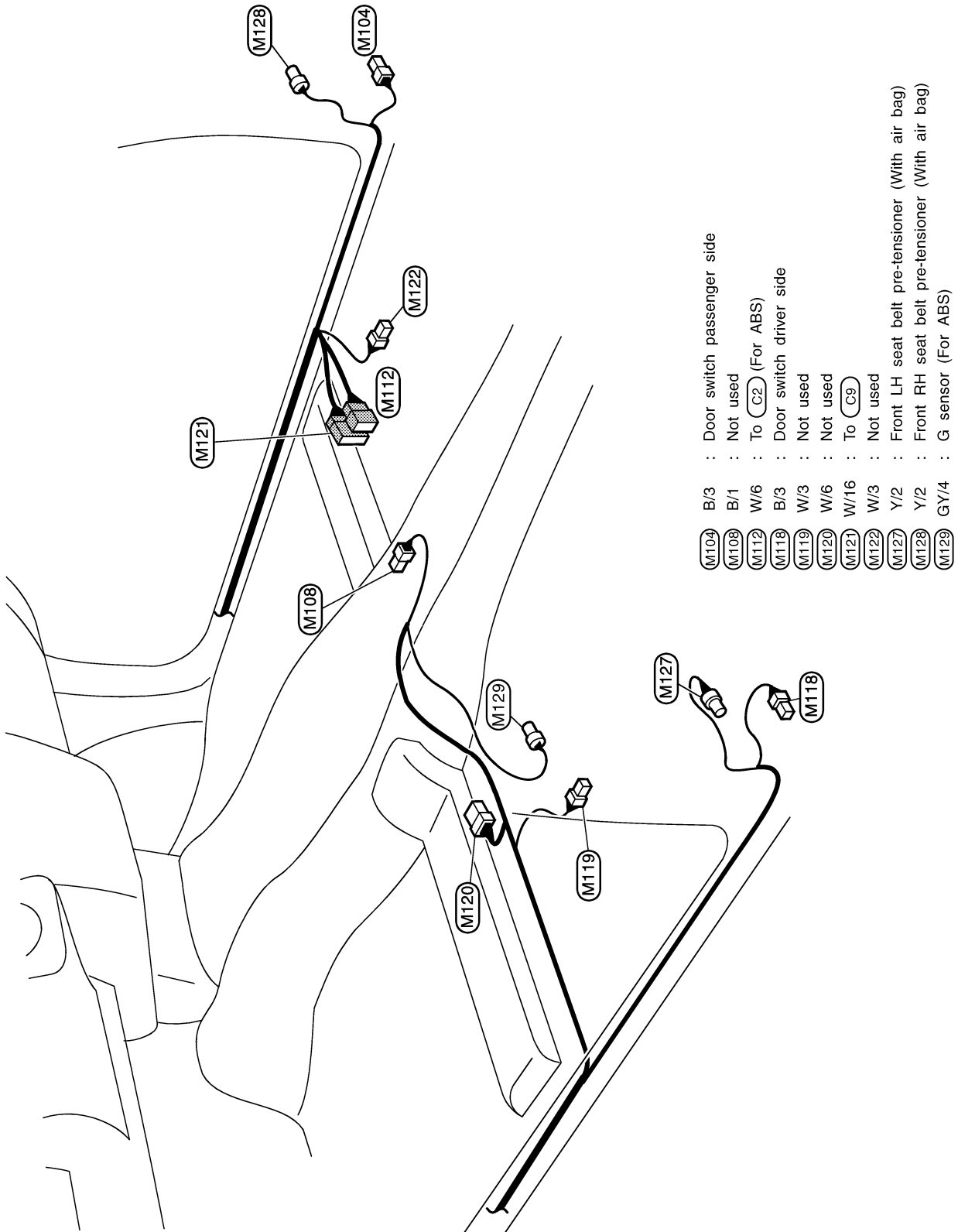

HARNESS LAYOUT

Main Harness (Cont'd)

BODY SIDE — RHD MODELS

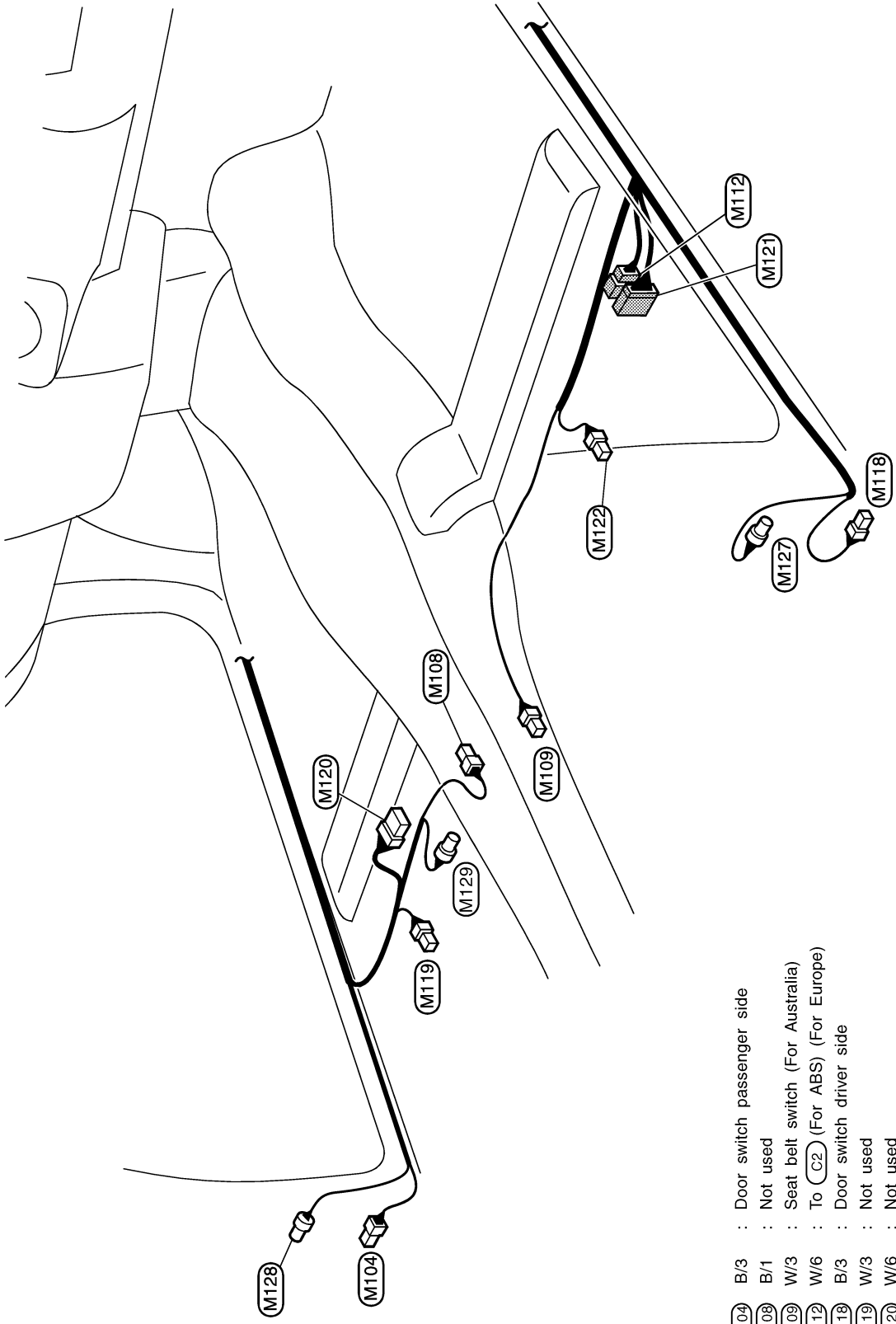

- M104 : Door switch passenger side
- M108 : Not used
- M109 : Seat belt switch (For Australia)
- M112 : To C2 (For Europe)
- M118 : Door switch driver side
- M119 : Not used
- M120 : Not used
- M121 : To C9
- M122 : Not used
- M127 : Front RH seat belt pre-tensioner (With air bag)
- M128 : Front LH seat belt pre-tensioner (With air bag)
- M129 : G sensor (For ABS) (For Europe)

GI
MA
EM
LC
EC
FE
CL
MT
AT
TF
PD
FA
RA
BR
ST
RS
BT
HA

EL

IDX

HARNESS LAYOUT

Main Harness (Cont'd)

ENGINE COMPARTMENT — YD ENGINE (LHD models)

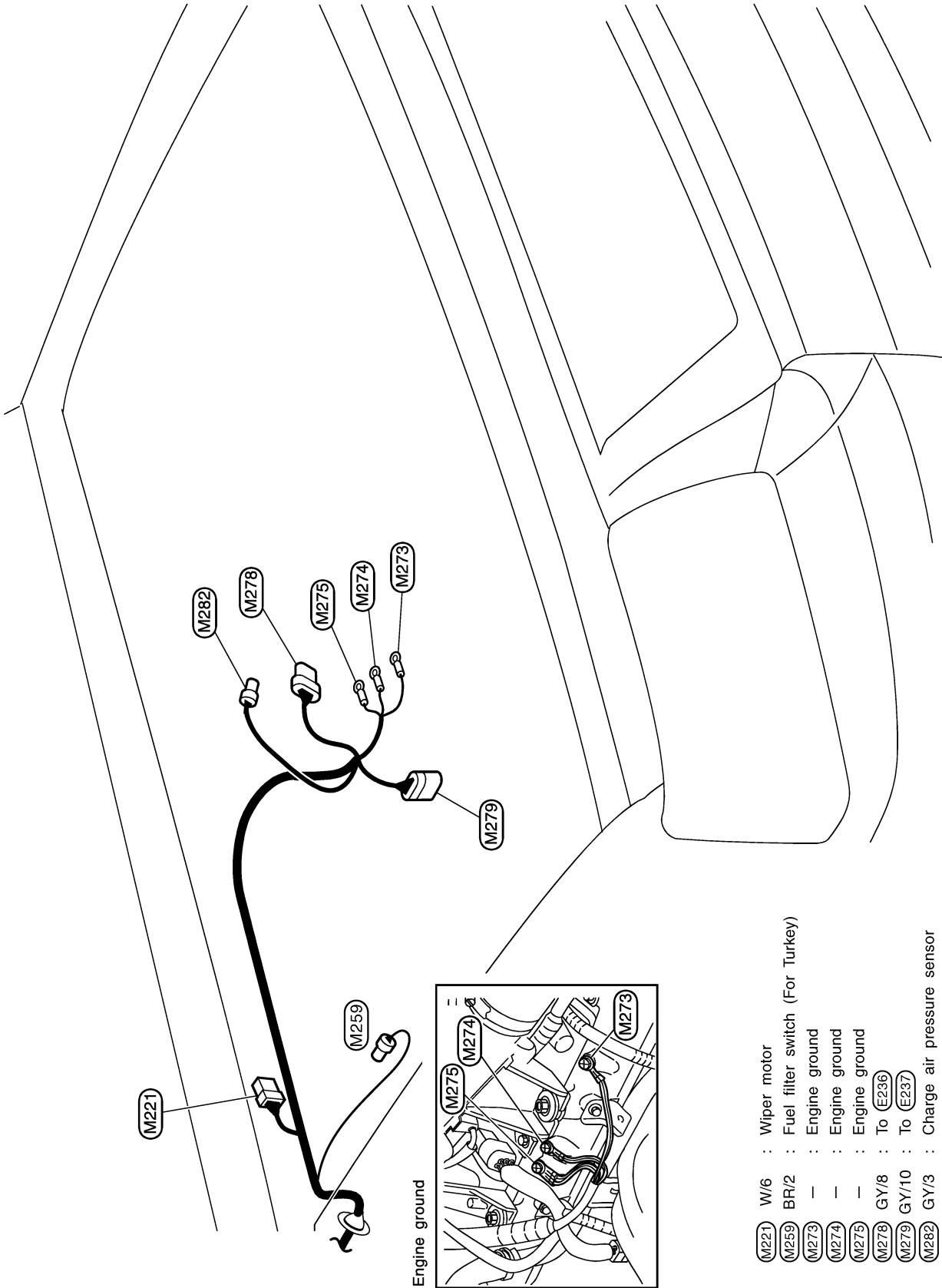

HARNESS LAYOUT

Engine Harness

YD ENGINE

GI

MA

EM

LC

EC

FE

CL

MT

AT

TF

PD

FA

RA

BR

ST

RS

BT

HA

EL

IDX

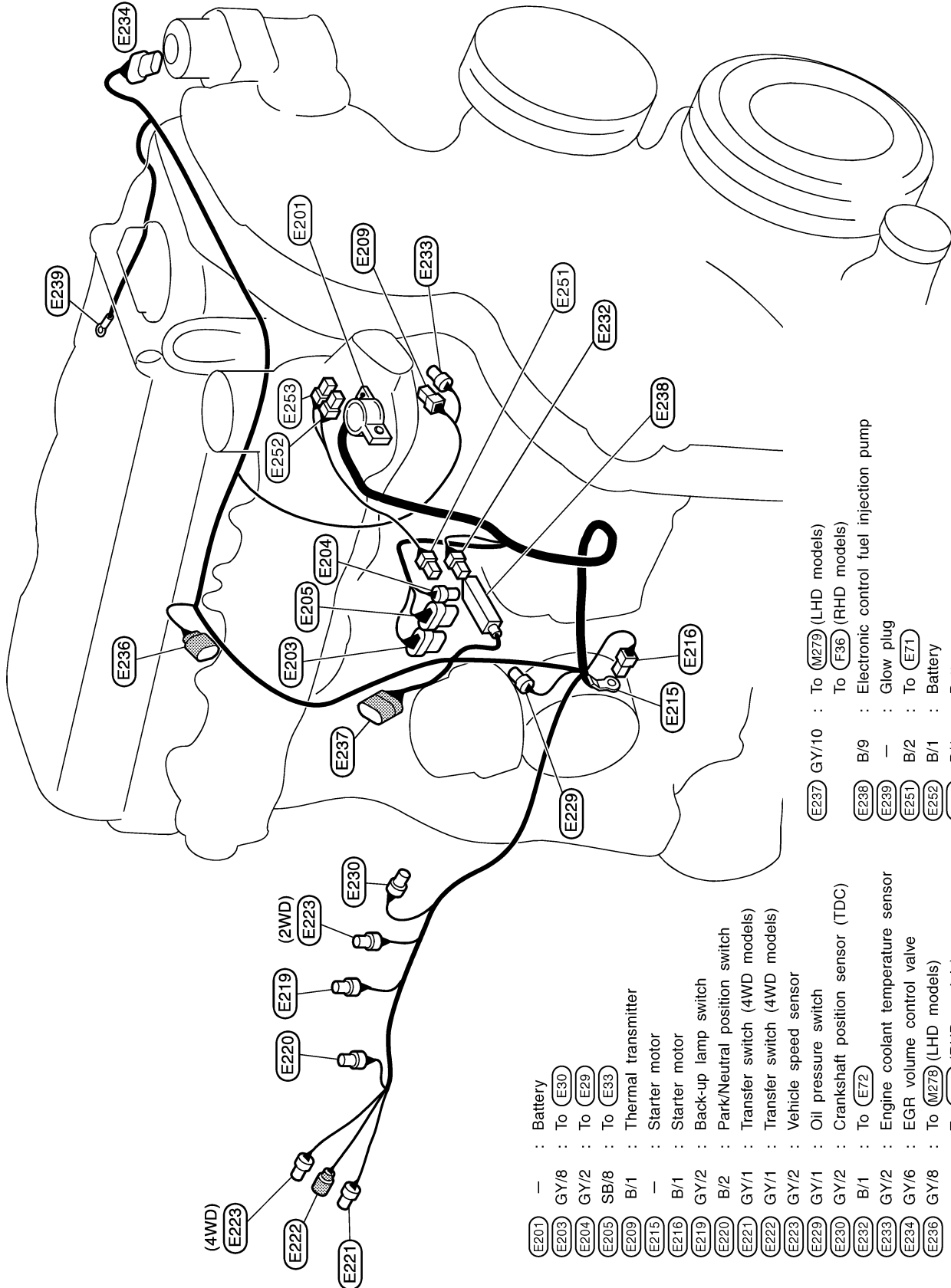

HARNESS LAYOUT

Engine Room Harness

LHD MODELS

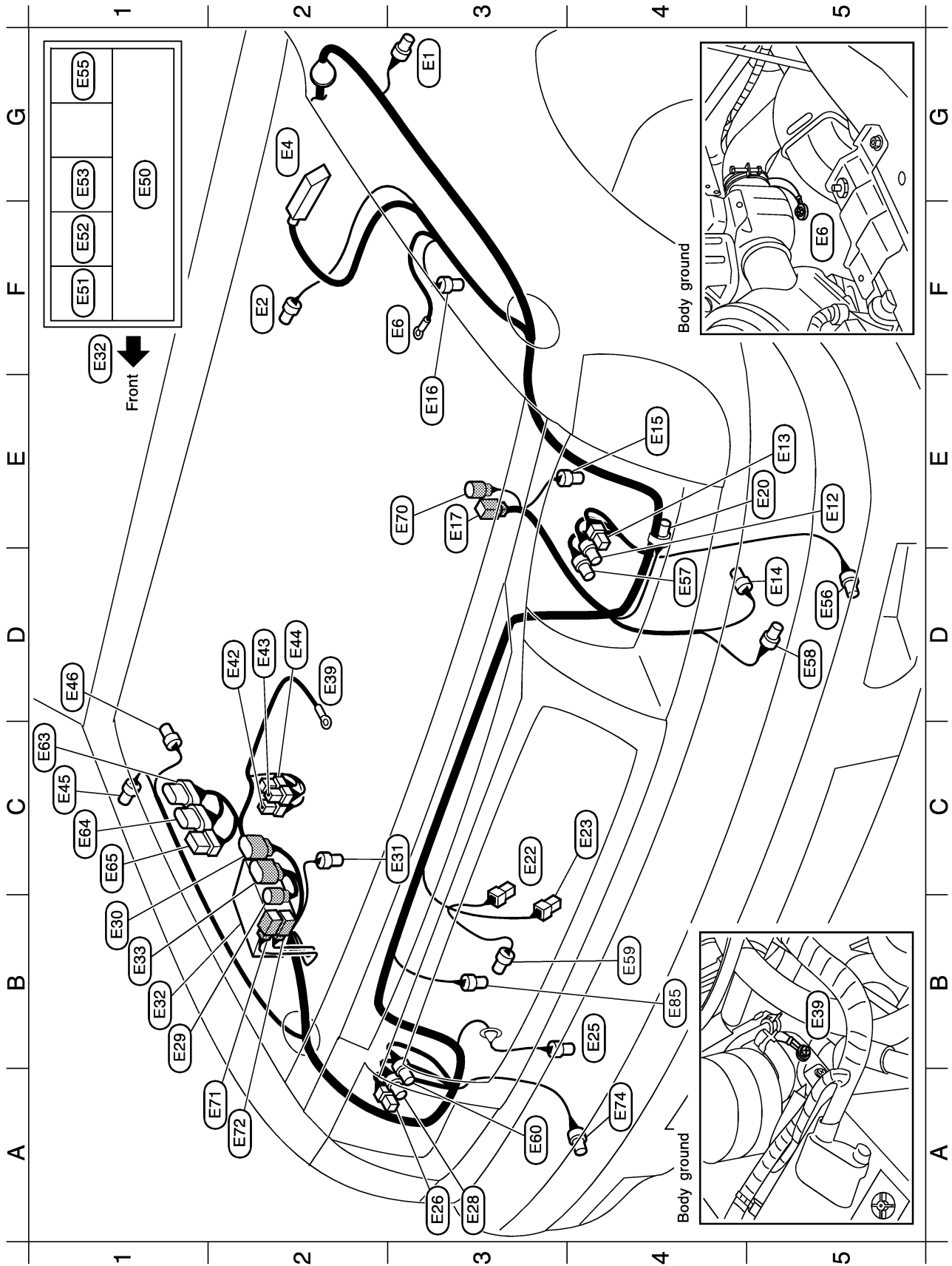

HARNESS LAYOUT

Engine Room Harness (Cont'd)

G1 (E55)	BR/6	: ECM relay
D5 (E56)	B/2	: Front fog lamp LH
D4 (E57)	-/3	: Headlamp aiming motor LH (Except for Turkey)
D5 (E58)	GY/2	: Headlamp washer pump (Except for Turkey)
B4 (E59)	B/2	: Not used
A3 (E60)	-/3	: Headlamp aiming motor RH (Except for Turkey)
C1 (E63)	SB/6	: Daytime light unit (With daytime light system)
C1 (E64)	SB/8	: Daytime light unit (With daytime light system)
C1 (E65)	W/6	: Headlamp washer amplifier (Except for Turkey)
E3 (E70)	BR/3	: To (A14)
A2 (E71)	B/2	: To (E251)
A2 (E72)	B/2	: To (E232)
A4 (E74)	B/2	: Front fog lamp RH
B4 (E85)	GY/2	: Cooling fan motor

G3 (E1)	GY/2	: Side turn signal lamp LH
F2 (E2)	GY/2	: Brake fluid level switch (For Europe)
G2 (E4)	B/31	: ABS actuator and electric unit (For ABS)
F3 (E6)	-	: Body ground
E5 (E12)	GY/3	: Front combination lamp LH
E5 (E13)	B/3	: Headlamp LH
D5 (E14)	BR/2	: Washer pump
E4 (E15)	BR/2	: Front wheel sensor LH (For ABS)
E3 (E16)	GY/2	: Intake air temperature sensor
E3 (E17)	B/2	: To (A2)
E5 (E20)	GY/2	: Option connector for hood switch
C3 (E22)	B/1	: Horn low
C4 (E23)	B/1	: Horn high
B4 (E25)	GY/4	: Triple-pressure switch
A3 (E26)	B/3	: Headlamp RH
A3 (E28)	GY/3	: Front combination lamp RH
B1 (E29)	GY/2	: To (E204)
B1 (E30)	GY/8	: To (E203)
C3 (E31)	GY/2	: Front wheel sensor RH (For ABS)
B1 (E32)	-	: Relay box (Fusible link and fuse box)
B1 (E33)	SB/8	: To (E205)
D2 (E39)	-	: Body ground
D2 (E42)	W/1	: Glow relay-1
D2 (E43)	W/1	: Glow relay-1
D2 (E44)	G/2	: Glow relay-1
C1 (E45)	GY/2	: Side turn signal lamp RH
D1 (E46)	GY/3	: Not used
G1 (E50)	-	: Fusible link and fuse box
F1 (E51)	L/4	: Cooling fan relay
F1 (E52)	L/4	: Air conditioner relay
G1 (E53)	W/3	: Horn relay

PASSENGER COMPARTMENT

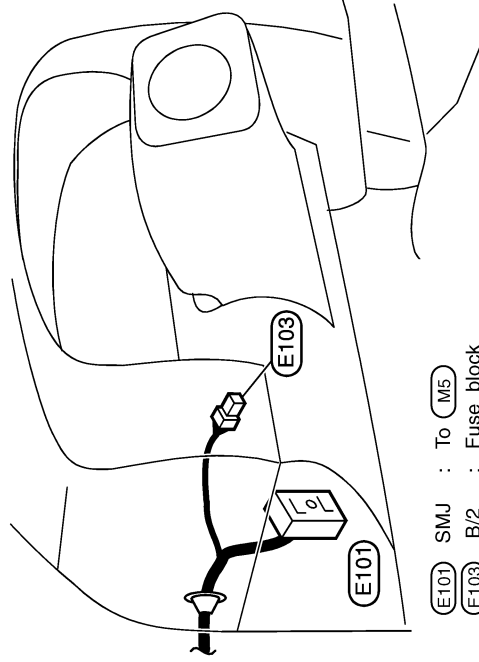

(E101)	SMJ	: To (M5)
(E103)	B/2	: Fuse block

GI
MA
EM
LC
EC
FE
CL
MT
AT
TF
PD
FA
RA
BR
ST
RS
BT
HA

EL

HEL210C

IDX

HARNESS LAYOUT

Engine Room Harness (Cont'd)

RHD MODELS

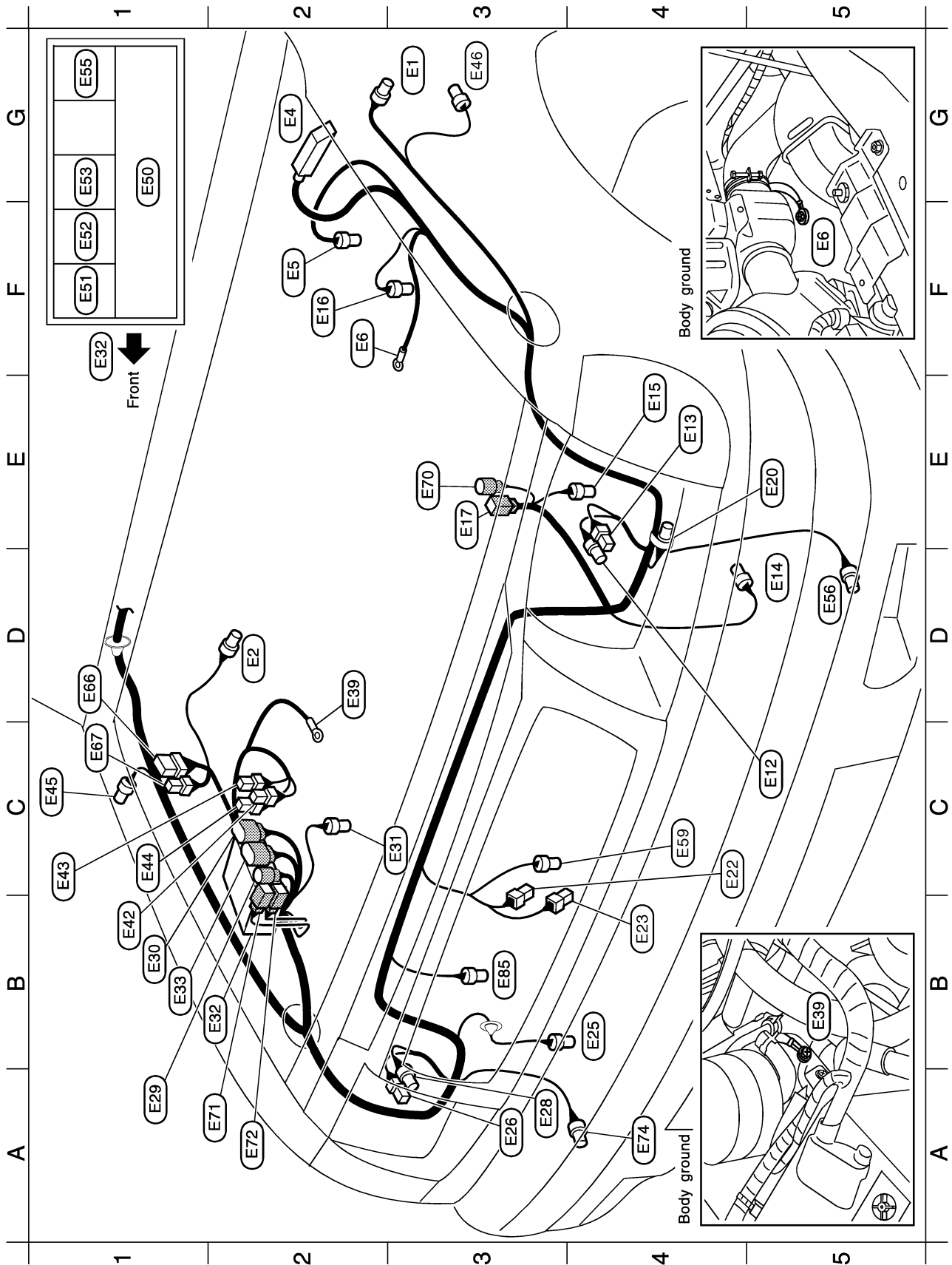

HEL211C

HARNESS LAYOUT

Engine Room Harness (Cont'd)

- D1 (E66) GY/6 : Dim-dip lamp unit (For Europe)
- C1 (E67) GY/4 : Dim-dip lamp unit (For Europe)
- E3 (E70) BR/3 : To (A14)
- A2 (E71) B/2 : To (E251)
- A2 (E72) B/1 : To (E232)
- A4 (E74) B/2 : Front fog lamp RH
- B3 (E85) GY/2 : Cooling fan motor

PASSENGER COMPARTMENT

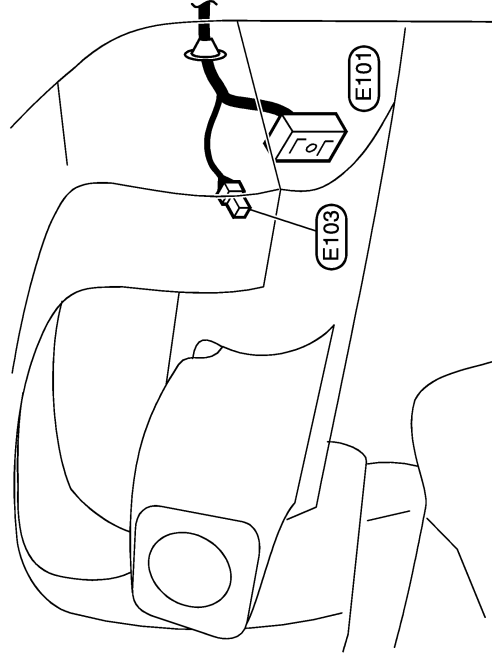

- (E101) SMJ : To (M5)
- (E103) B/2 : Fuse block

- G3 (E1) GY/2 : Side turn signal lamp LH
- D2 (E2) GY/2 : Brake fluid level switch
- G2 (E4) B/31 : ABS actuator and electric unit (For ABS)
- F2 (E5) BR/2 : Fuel filter switch (For Australia)
- F2 (E6) — : Body ground
- C5 (E12) GY/3 : Front combination lamp LH
- E4 (E13) B/3 : Headlamp LH
- D5 (E14) GY/2 : Washer pump
- E4 (E15) BR/2 : Front wheel sensor LH (For ABS)
- F2 (E16) GY/2 : Intake air temperature sensor
- E3 (E17) B/2 : To (A2)
- E5 (E20) GY/2 : Option connector for hood switch (For Europe)
- C4 (E22) B/1 : Horn low
- B4 (E23) B/1 : Horn high (For Europe)
- B4 (E25) GY/4 : Triple-pressure switch
- A3 (E26) B/3 : Headlamp RH
- A3 (E28) GY/3 : Front combination lamp RH
- A1 (E29) GY/2 : To (E204)
- B1 (E30) GY/8 : To (E203)
- C3 (E31) GY/2 : Front wheel sensor RH (For ABS)
- B2 (E32) — : Relay box (Fusible link and fuse box)
- B1 (E33) SB/8 : To (E205)
- D2 (E39) — : Body ground
- B1 (E42) W/1 : Glow relay-1
- C1 (E43) W/1 : Glow relay-1
- C1 (E44) G/2 : Glow relay-1
- C1 (E45) GY/2 : Side turn signal lamp RH
- G3 (E46) GY/3 : Not used (For Europe)
- G1 (E50) — : Fusible link and fuse box
- F1 (E51) L/4 : Cooling fan relay
- F1 (E52) L/4 : Air conditioner relay
- G1 (E53) W/3 : Horn relay
- G1 (E55) BR/6 : ECM relay
- D5 (E56) B/2 : Front fog lamp LH
- C4 (E59) B/2 : Not used

- GI
- MA
- EM
- LC
- EC
- FE
- CL
- MT
- AT
- TF
- PD
- FA
- RA
- BR
- ST
- RS
- BT
- HA

EL