

SECTION **BCS**

BODY CONTROL SYSTEM

CONTENTS

PRECAUTIONS	2	Description	4
Supplemental Restraint System (SRS) "AIR BAG" and "SEAT BELT PRE-TENSIONER"	2	Circuit Diagram	5
Wiring Diagrams and Trouble Diagnosis	2	Smart Entrance Control Unit Inspection Table	7
PREPARATION	3	WARNING CHIME	9
Special Service Tools	3	Description	9
SMART ENTRANCE CONTROL UNIT	4	Circuit Diagram	10
		Warning Chime Unit Inspection Table	11

A
B
C
D
E
F
G
H
I
J
L
M

BCS

PRECAUTIONS

PRECAUTIONS

PFP:00001

Supplemental Restraint System (SRS) “AIR BAG” and “SEAT BELT PRE-TENSIONER”

EKS006WV

The Supplemental Restraint System such as “AIR BAG” and “SEAT BELT PRE-TENSIONER”, used along with a front seat belt, helps to reduce the risk or severity of injury to the driver and front passenger for certain types of collision. This system may include seat belt switch inputs and dual stage front air bag modules. If equipped with dual stage front air bag modules, the SRS system uses the seat belt switches to determine the front air bag deployment, and may only deploy one front air bag, depending on the severity of a collision and whether the front occupants are belted or unbelted. Information necessary to service the system safely is included in the SRS and SB section of this Service Manual.

The vehicle may be equipped with a passenger air bag deactivation switch. Because no rear seat exists where a rear-facing child restraint can be placed, the switch is designed to turn off the passenger air bag so that a rear-facing child restraint can be used in the front passenger seat. The switch is located in the center of the instrument panel, near the ashtray. When the switch is turned to the ON position, the passenger air bag is enabled and could inflate for certain types of collision. When the switch is turned to the OFF position, the passenger air bag is disabled and will not inflate. A passenger air bag OFF indicator on the instrument panel lights up when the passenger air bag is switched OFF. The driver air bag always remains enabled and is not affected by the passenger air bag deactivation switch.

WARNING:

- To avoid rendering the SRS inoperative, which could increase the risk of personal injury or death in the event of a collision which would result in air bag inflation, all maintenance must be performed by an authorized NISSAN/INFINITI dealer.
- Improper maintenance, including incorrect removal and installation of the SRS, can lead to personal injury caused by unintentional activation of the system. For removal of Spiral Cable and Air Bag Module, see the SRS section.
- Do not use electrical test equipment on any circuit related to the SRS unless instructed to in this Service Manual. SRS wiring harnesses can be identified by yellow and/or orange harness connectors.
- The vehicle may be equipped with a passenger air bag deactivation switch which can be operated by the customer. When the passenger air bag is switched OFF, the passenger air bag is disabled and will not inflate. When the passenger air bag is switched ON, the passenger air bag is enabled and could inflate for certain types of collision. After SRS maintenance or repair, make sure the passenger air bag deactivation switch is in the same position (ON or OFF) as when the vehicle arrived for service.

Wiring Diagrams and Trouble Diagnosis

EKS006WV

When you read wiring diagrams, refer to the following:

- [GI-13, "How to Read Wiring Diagrams"](#), and
- [PG-9, "POWER SUPPLY ROUTING"](#).

When you perform trouble diagnosis, refer to the following:

- [GI-9, "HOW TO FOLLOW TEST GROUPS IN TROUBLE DIAGNOSES"](#), and
- [GI-25, "How to Perform Efficient Diagnosis for an Electrical Incident"](#).

Check for any Service bulletins before servicing the vehicle.

PREPARATION

PREPARATION

PFP:00002

Special Service Tools

EKS006WX

The actual shapes of Kent-Moore tools may differ from those of special service tools illustrated here.

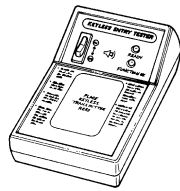
Tool number (Kent-Moore No.) Tool name	Description	
(J-43241) Remote keyless entry tester	 LEL946A	Used to test keyfobs

*: Special tool or commercial equivalent

A
B
C
D
E
F
G
H
I
J
L
M

BCS

SMART ENTRANCE CONTROL UNIT

SMART ENTRANCE CONTROL UNIT

PFP:28596

Description

EKS006WY

The following systems are controlled by the smart entrance control unit.

- Warning chime
- Rear window defogger timer
- Power window
- Power door lock
- Remote keyless entry
- Vehicle security
- Room lamp

For detailed description and wiring diagrams, refer to the relevant pages for the each system.

The control unit receives data from the switches and sensors to control their corresponding system relays and actuators.

System	Input	Output
Warning chime	Key switch (Insert) Ignition switch (ON) Lighting switch (1st) Seat belt buckle switch Front door switch LH	Warning chime
Rear window defogger timer	Ignition switch (ON or START) Rear window defogger switch	Rear window defogger relay
Power window	Ignition switch (ON) Door switches	Power window relay
Power door lock	Door lock/unlock switch Key switch (Insert) Door switches Door key cylinder switches	Door lock actuator
Remote keyless entry	Key switch (Insert) Ignition switch (ACC) Door switches Antenna (keyfob signal) Door lock/unlock switches	Horn relay Vehicle security lamp relay Door lock actuator Room lamp
Vehicle security	Ignition switch (ACC, ON) Door switches Hood switch Door lock/unlock switches Door key cylinder switch (Lock/unlock)	Horn relay Vehicle security lamp relay Vehicle security relay (Starter interrupt) Security indicator lamp
Room lamp	Door switches Ignition switch Key switch (Insert)	Room lamp

SMART ENTRANCE CONTROL UNIT

Circuit Diagram

EKS006WZ

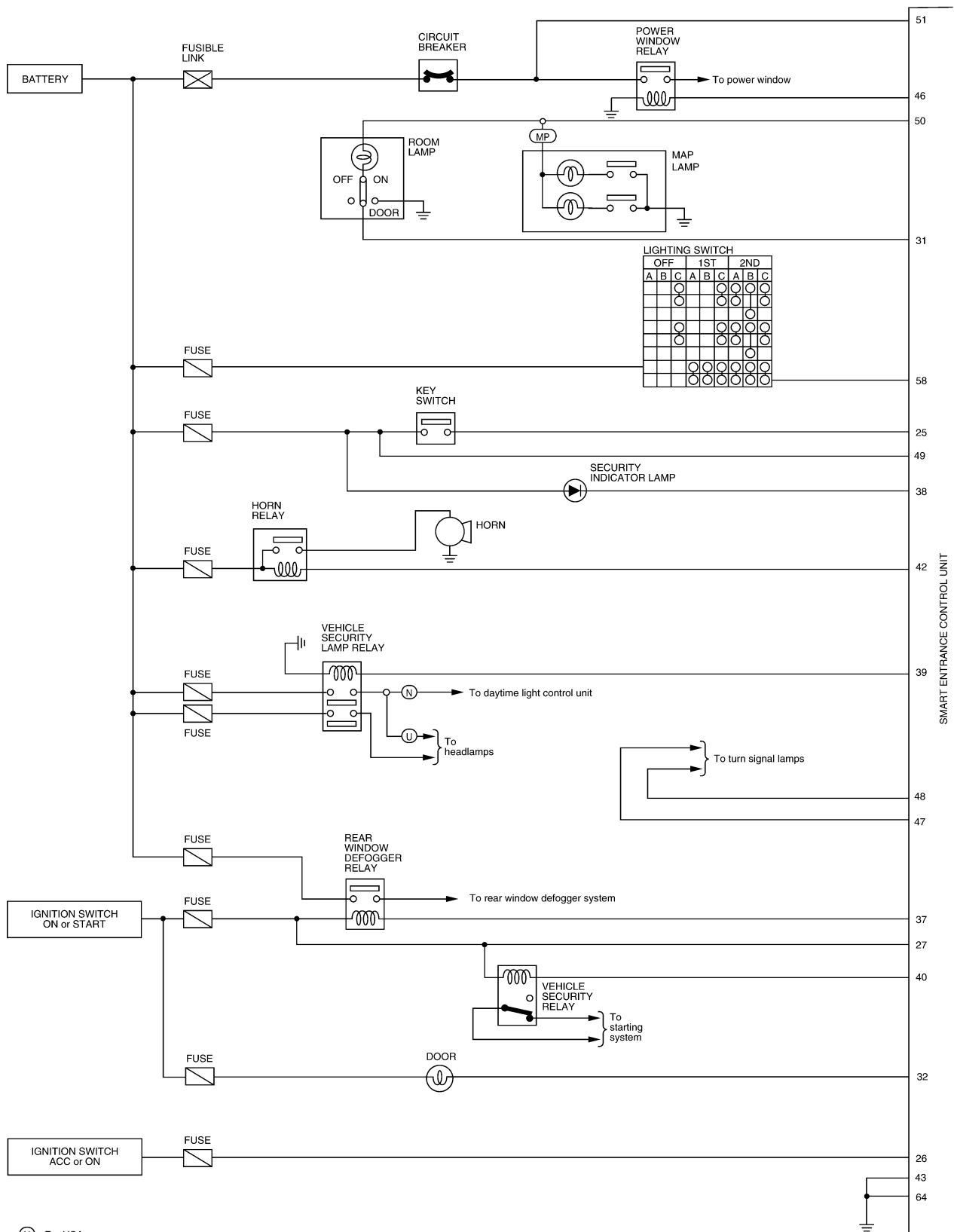

A
B
C
D
E
F
G
H
I
J
K
L
M

BCS

Ⓢ : For USA
Ⓝ : For Canada
ⓂⓅ : With map lamps

WKWA0340E

SMART ENTRANCE CONTROL UNIT

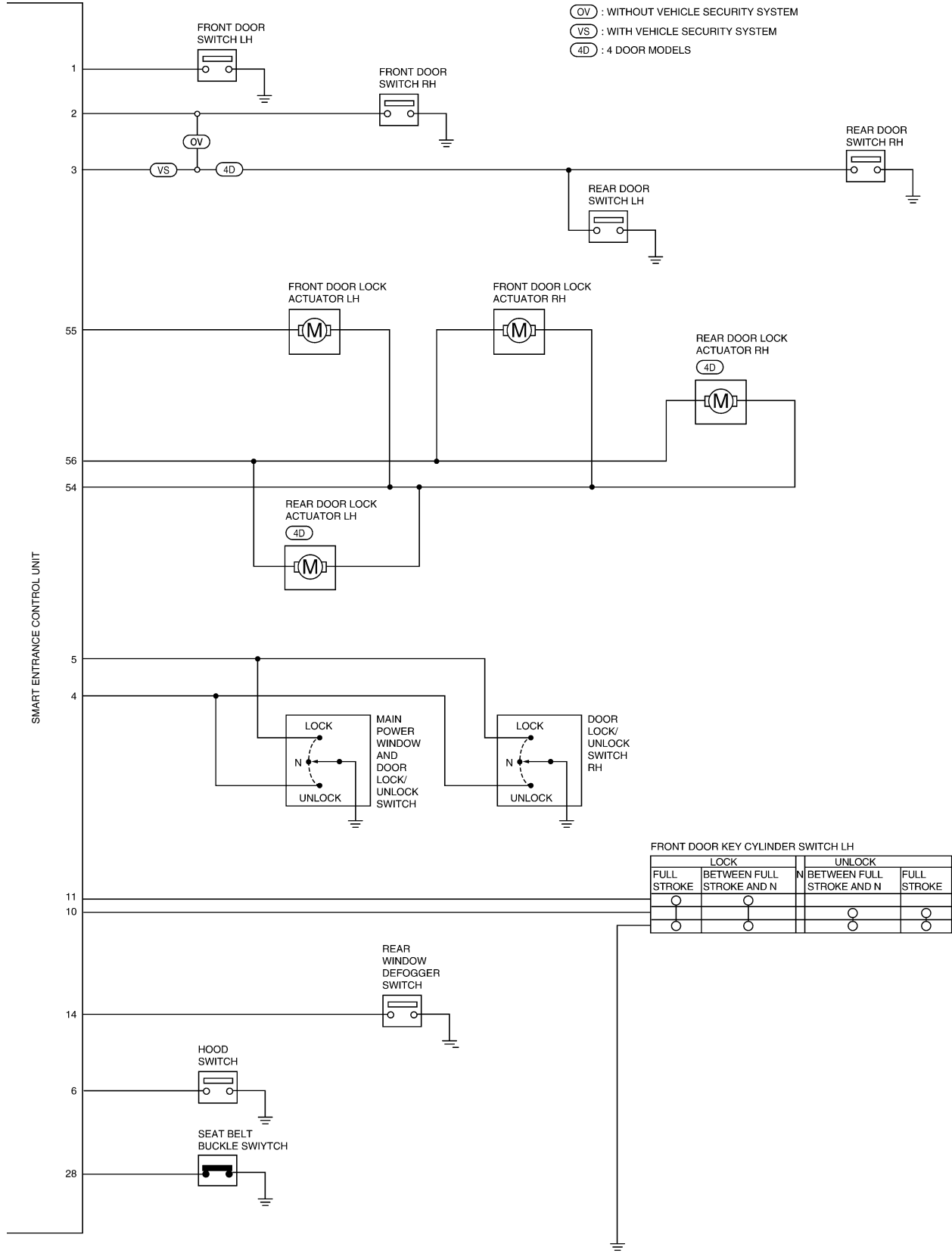

WKWA0341E

SMART ENTRANCE CONTROL UNIT

Smart Entrance Control Unit Inspection Table

EKS006X0

Terminal No.	Wire color	Connections	Operated condition	Voltage (V) (Approx.)	
1	G/R	Front door switch LH	OFF (Closed) → ON (Open)	12V → 0V	
2	G/B	Front door switch RH	OFF (Closed) → ON (Open)	12V → 0V	
3	R/B	Rear door switch LH and RH, back door switch	OFF (Closed) → ON (Open)	12V → 0V	
4	BR	Main power window and door lock/unlock switch, door lock/unlock switch RH	Neutral → Unlock	12V → 0V	
5	LG/R	Main power window and door lock/unlock switch, door lock/unlock switch RH	Neutral → Lock	12V → 0V	
6	B/P	Hood switch	ON (Open) → OFF (Closed)	0V → 12V	
10	Y/R	Front door key cylinder unlock switch LH or back door key cylinder unlock switch	OFF (Neutral) → ON (Unlock)	12V → 0V	
11	Y	Front door key cylinder lock switch LH or back door key cylinder lock switch	OFF (Neutral) → ON (Lock)	12V → 0V	
14	G/B	Rear window defogger switch	OFF → ON	12V → 0V	
25	W/G	Ignition key switch (Insert)	Key inserted → Key removed from ignition key cylinder	12V → 0V	
26	G	Ignition switch (ACC)	ACC position	12V	
27	G/W	Ignition switch (ON)	Ignition key is in ON position	12V	
28	B/P	Seat belt buckle switch	Unfastened → Fastened (Ignition key is in ON position)	0V → 12V	
31	R/B	Room lamp	When interior lamp is operated using keyfob. (Interior lamp switch in DOOR position)	12V → 0V	
32	R/B	Door ajar indicator lamp	OFF → ON (Ignition key is in ON position)	12V → 0V	
37	G/R	Rear window defogger relay	OFF → ON (Ignition key is in ON position)	12V → 0V	
38	G/OR	Security indicator lamp	Turns off → Turns on	12V → 0V	
39	R	Vehicle security lamp relay	When panic alarm is operated using keyfob or when alarm is activated	12V → 0V	
40	R/W	Vehicle security relay (Starter cut)	OFF → ON (Ignition key is in ON position)	12V → 0V	
42	LG/R	Horn relay	When panic alarm is operated using keyfob or when alarm is activated	12V → 0V	
43	B	Ground	—	—	
46	G/W	Power window relay	Ignition key is in ON position → 45 seconds after ignition key is turned to OFF position	12V → 0V	
47	G/Y	Turn signal lamp LH	When doors are locked using keyfob	12V → 0V	
48	G/R	Turn signal lamp RH	When doors are locked using keyfob	12V → 0V	
49	G	Power source (Fuse)	—	12V	
50	R/G	Battery saver (Room lamp)	Turns off → Turns on	12V → 0V	
51	W/R	Power source (C/B)	—	12V	
54	L	Front door lock actuator LH and RH, rear door lock actuator LH and RH	Main power window and door lock/unlock switch, door lock/unlock switch RH	Lock	12V
				Neutral, unlock	0V
55	G/W	Front door lock actuator LH	Main power window and door lock/unlock switch, door lock/unlock switch RH	Unlock	12V
					Neutral, lock

A
B
C
D
E
F
G
H
I
J
L
M

BCS

SMART ENTRANCE CONTROL UNIT

Terminal No.	Wire color	Connections	Operated condition		Voltage (V) (Approx.)
56	L/R	Front door lock actuator RH, rear door lock actuator LH and RH, back door lock actuator	Main power window and door lock/unlock switch, door lock/unlock switch RH	Unlock	12V
				Neutral, lock	0V
58	L/R	Lighting switch	1ST, 2ND positions: ON → OFF		12V → 0V
64	B	Ground	—		—

WARNING CHIME

WARNING CHIME

PFP:24814

Description

EKS006X1

When the vehicle is not equipped with power door locks, the following inputs, in the proper combination, will activate the warning chime unit:

- Key switch
- Combination switch (lighting switch)
- Ignition switch
- Seat belt buckle switch LH
- Front door switch LH

For detailed description and wiring diagrams for each of these components, refer to [DI-36, "MODELS WITH-OUT POWER DOOR LOCKS"](#) and [DI-36, "MODELS WITH POWER DOOR LOCKS"](#).

A

B

C

D

E

F

G

H

I

J

BCS

L

M

WARNING CHIME

Circuit Diagram

EKS006X2

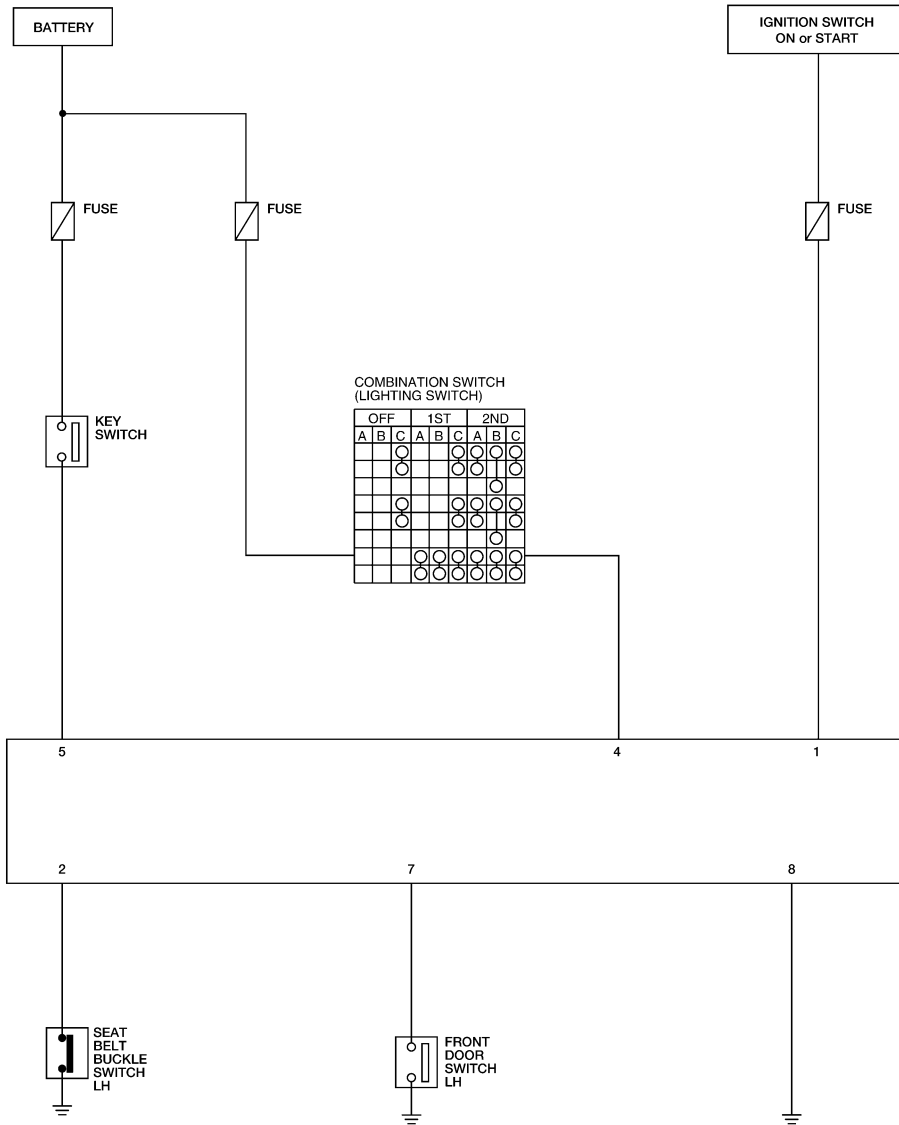

LKWA0128E

WARNING CHIME

Warning Chime Unit Inspection Table

EKS006X3

Terminal No.	Wire color	Connections	Operated condition	Voltage (Approx.)
1	G/W	Ignition switch input	Ignition switch in OFF or ACC position	0V
			Ignition switch in ON or START position	12V
2	B/P	Seat belt buckle switch LH input	Seat belt unfastened (switch closed)	0V
			Seat belt fastened (switch open)	12V
4	L/R	Combination switch (lighting switch) input	Lighting switch OFF	0V
			Lighting switch in 1st or 2nd position (ON)	12V
5	W/G	Key switch input	Key removed from switch	0V
			Key inserted in switch	12V
7	G/R	Front door switch LH input	Door open (switch closed)	0V
			Door closed (switch open)	12V
8	B	Ground	—	0V

A
B
C
D
E
F
G
H
I
J
L
M

BCS

WARNING CHIME
