

SECTION **WT**
ROAD WHEELS & TIRES

A
B
C
D

WT

CONTENTS

NOISE, VIBRATION, AND HARSHNESS (NVH)		
TROUBLESHOOTING	2	
NVH Troubleshooting Chart	2	
WHEEL	3	
Inspection	3	
STEEL WHEEL	3	
WHEEL AND TIRE ASSEMBLY	4	
Balancing Wheels	4	F
REMOVAL	4	
WHEEL BALANCE ADJUSTMENT	4	
Rotation	5	G
SERVICE DATA AND SPECIFICATIONS (SDS)	6	
Road Wheel	6	
Tire	6	H

I
J
K
L
M

NOISE, VIBRATION, AND HARSHNESS (NVH) TROUBLESHOOTING

NOISE, VIBRATION, AND HARSHNESS (NVH) TROUBLESHOOTING

PFP:00003

NVH Troubleshooting Chart

GES0000T

Use chart below to help you find the cause of the symptom. If necessary, repair or replace these parts.

Symptom		Possible cause and SUSPECTED PARTS		Reference page													
				WT-3	WT-4	WT-6	WT-4	—	—	WT-6	FFD-6 (FFD) RFD-XX "NVH Troubleshooting Chart" (RFD, M226 without LD), RFD-XX "NVH Troubleshooting Chart" (RFD, M226 with LD)	FAX-4 (FAX) FSU-5 (FSU)	RAX-5 (RAX) RSU-4 (RSU)	Refer to TIRES in this chart.	Refer to ROAD WHEEL in this chart.	BR-5	PS-5
Symptom	TIRES	Noise	x	x	x	x	x	x		x	x	x	x		x	x	
		Shake	x	x	x	x	x		x		x	x	x		x	x	
		Vibration			x				x		x	x	x				x
		Shimmy	x	x	x	x	x	x	x		x	x	x		x	x	
		Shudder	x	x	x	x	x		x		x	x	x		x	x	
		Poor quality ride or handling	x	x	x	x	x		x		x	x	x				
	ROAD WHEEL	Noise	x	x			x			x	x	x		x	x	x	
		Shake	x	x			x				x	x		x	x	x	
		Shimmy, shudder	x	x			x				x	x		x	x	x	
		Poor quality ride or handling	x	x			x				x	x		x			

x: Applicable

WHEEL

WHEEL

PFP:40300

Inspection

1. Check tires for wear and improper inflation.
2. Check wheels for deformation, cracks and other damage. If deformed, remove wheel and check wheel runout.
 - a. Remove tire from wheel and mount wheel on a tire balance machine.
 - b. Set dial indicator as shown in the illustration.

Wheel runout (Dial indicator value):

Refer to [WT-6, "SERVICE DATA AND SPECIFICATIONS \(SDS\)"](#)

3. Check front wheel bearings for looseness.
4. Check front suspension for looseness.

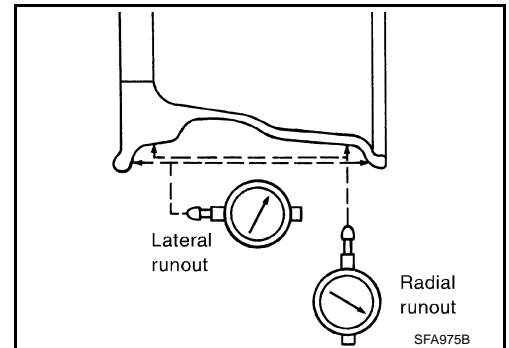

STEEL WHEEL

1. Check tires for wear and improper inflation.
2. Check wheels for deformation, cracks and other damage. If deformed, remove wheel and check wheel runout.
 - a. Remove tire from steel wheel and mount wheel on a tire balance machine.
 - b. Set two dial indicators as shown in the illustration.
 - c. Set each dial indicator to 0.
 - d. Rotate wheel and check dial indicators at several points around the circumference of the wheel.
 - e. Calculate runout at each point as shown below.

$$\text{Radial runout} = (A+B)/2 \quad : \quad 0.5 \text{ mm (0.020 in)}$$

$$\text{Lateral runout} = (C+D)/2 \quad : \quad 0.8 \text{ mm (0.031 in)}$$

- f. Select maximum positive runout value and the maximum negative value. Add the two values to determine total runout. In case a positive or negative value is not available, use the maximum value (negative or positive) for total runout. If the total runout value exceeds the limit, replace steel wheel.

Wheel runout:

Refer to [WT-6, "SERVICE DATA AND SPECIFICATIONS \(SDS\)"](#)

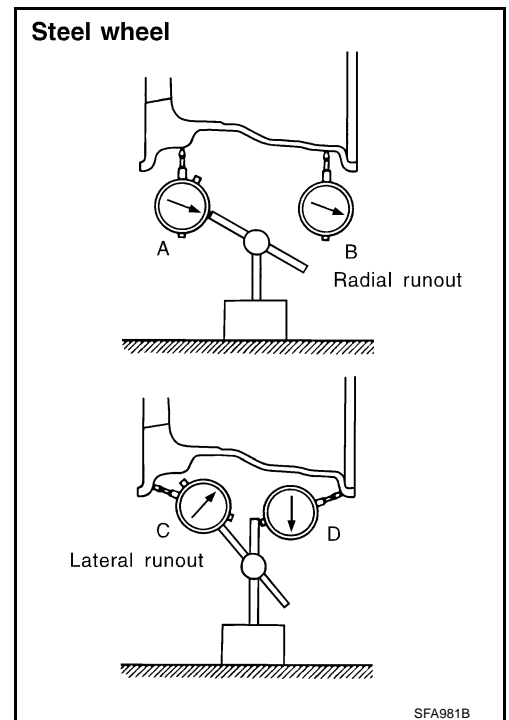

WHEEL AND TIRE ASSEMBLY

WHEEL AND TIRE ASSEMBLY

PFP:40300

Balancing Wheels REMOVAL

GES0000V

1. Using releasing agent, remove double-faced adhesive tape from the wheel.

CAUTION:

- Be careful not to scratch the wheel during removal.
- After removing double-faced adhesive tape, wipe clean traces of releasing agent from the wheel.

WHEEL BALANCE ADJUSTMENT

- If a tire balance machine has adhesion balance weight mode settings and drive-in weight mode setting, select and adjust a drive-in weight mode suitable for wheels.
1. Set wheel on wheel balancer using the center hole as a guide. Start the tire balance machine.
 2. When inner and outer imbalance values are shown on the wheel balancer indicator, multiply outer imbalance value by 1.6 to determine balance weight that should be used. Select the outer balance weight with a value closest to the calculated value and install it to the designated outer position of, or at the designated angle in relation to the road wheel.

CAUTION:

- Do not install the inner balance weight before installing the outer balance weight.
- Before installing the balance weight, be sure to clean the mating surface of the wheel.

Indicated imbalance value $\times 5/3 =$ balance weight to be installed

Calculation example:

23 g (0.81 oz) $\times 5/3 = 38.33$ g (1.35 oz) = 40 g (1.41 oz) balance weight (closer to calculated balance weight value)

Note that balance weight value must be closer to the calculated balance weight value.

Example:

37.4 g = 35 g (1.23 oz)

37.5 g = 40 g (1.41 oz)

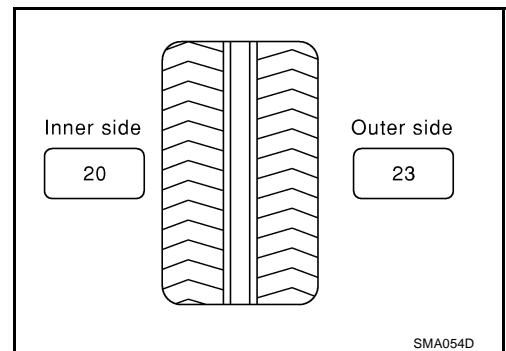

- a. Install balance weight in the position shown.
- b. When installing balance weight to wheels, set it into the grooved area on the inner wall of the wheel as shown so that the balance weight center is aligned with the wheel balancer indication position (angle).

CAUTION:

- Always use Genuine NISSAN adhesion balance weights.
- Balance weights are not reusable; always replace with new ones.
- Do not install more than three sheets of balance weights.

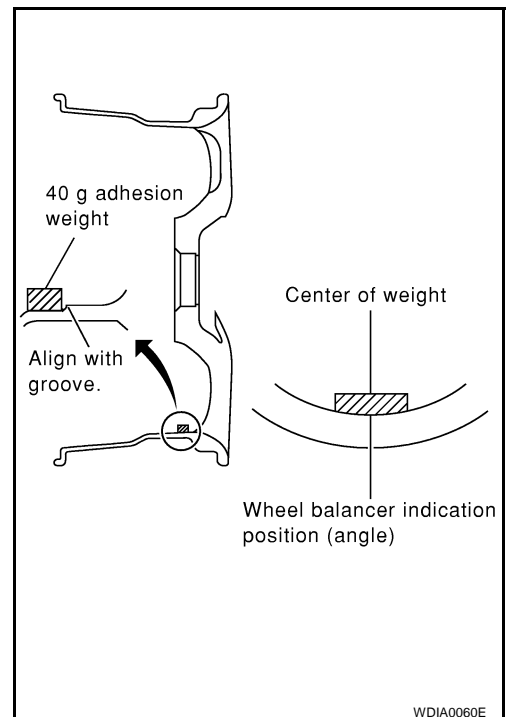

WHEEL AND TIRE ASSEMBLY

- c. If calculated balance weight value exceeds 50 g (1.76 oz), install two balance weight sheets in line with each other as shown.

CAUTION:

Do not install one balance weight sheet on top of another.

3. Start wheel balancer again.
4. Install drive-in balance weight on inner side of road wheel in the wheel balancer indication position (angle).

CAUTION:

Do not install more than two balance weights.

5. Start wheel balancer. Make sure that inner and outer residual imbalance values are 5g (0.18 oz) each or below.
● If either residual imbalance value exceeds 5 g (0.18 oz), repeat installation procedures.

Wheel balance (Maximum allowable imbalance):

Maximum allowable imbalance	Dynamic (At rim flange)	5 g (0.18 oz) (one side)
	Static	10 g (0.35 oz)

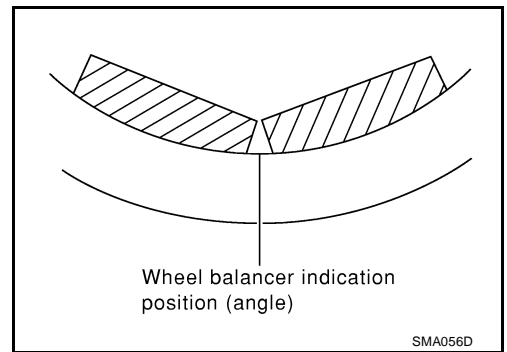

A
B
C
D

WT

Rotation

GES0000W

- Follow the maintenance schedule for tire rotation service intervals. Refer to [MA-7, "GENERAL MAINTENANCE"](#).
- Do not include the spare tire when rotating the tires.

CAUTION:

When installing wheels, tighten them diagonally by dividing the work two to three times in order to prevent the wheels from developing any distortion.

Wheel nut torque : 98 - 127 N·m (10.0 - 12.9 kg·m, 73 - 93 ft·lb)

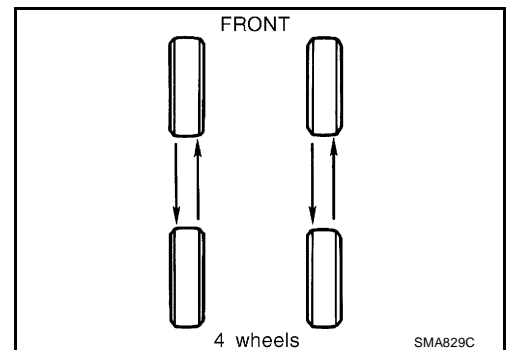

F
G
H
I
J
K
L
M

SERVICE DATA AND SPECIFICATIONS (SDS)

SERVICE DATA AND SPECIFICATIONS (SDS)

PF0:00030

Road Wheel

GES0000X

Wheel type		Aluminum	Steel	
			Inside	Outside
Maximum radial runout limit	Lateral mm (in)	0.3 (0.012) or less	1.0 (0.039) or less	0.9 (0.035) or less
	Radial mm (in)	0.3 (0.012) or less	0.8 (0.031) or less	0.4 (0.016) or less
Maximum residual imbalance	Dynamic (at rim flange)	Less than 5 g (0.18 oz) (per side)		
	Static (at rim flange)	Less than 10 g (0.35 oz)		

Tire

GES0000Y

Unit: kPa (kg/cm², psi)

Tire size	Air pressure	
	Conventional tire	Spare tire
Full size spare tire	—	240 (2.4, 35)
235/70R16	240 (2.4, 35)	—
255/70R16	240 (2.4, 35)	—
255/65R17	240 (2.4, 35)	—