

## 2.0L 4-CYL - VIN [C]

1992 Infiniti G20

1991-92 INFINITI ENGINES  
2.0L 4-Cylinder

G20

### \* PLEASE READ THIS FIRST \*

NOTE: For engine repair procedures not covered in this article, see ENGINE OVERHAUL PROCEDURES - GENERAL INFORMATION article in the GENERAL INFORMATION section.

### ENGINE IDENTIFICATION

Engine can be identified by fourth character of Vehicle Identification Number (VIN), located on top of dash panel, at lower left corner of windshield. Engine serial number is stamped on rear of cylinder block, left of the flywheel.

#### ENGINE IDENTIFICATION CODE TABLE

Application	VIN Code
2.0L 4-Cylinder .....	C

### ACCEL-DRUM UNIT ADJUSTMENTS

NOTE: Accel-drum unit must be adjusted whenever accel-drum unit, throttle chamber or rod is removed or replaced. Rod must be replaced whenever removed. Ensure rod couplings are coated with grease before installing rod.

- 1) With rod installed, loosen lock nut and adjusting screw. See Fig. 1. Manually rotate accel-drum unit until throttle valve in throttle chamber is fully open, and hold it in this position.
- 2) Note if stopper lever contacts adjusting screw. If stopper lever contacts adjusting screw, rotate adjusting screw until stopper lever does not contact adjusting screw.
- 3) Rotate adjusting screw until it contacts stopper lever. Rotate accel-drum unit so throttle valve is closed. Rotate adjusting screw 3 full revolutions clockwise. Tighten lock nut to 48 INCH lbs. (5 N.m.).

ROTATE TO  
FULLY OPEN  
POSITION

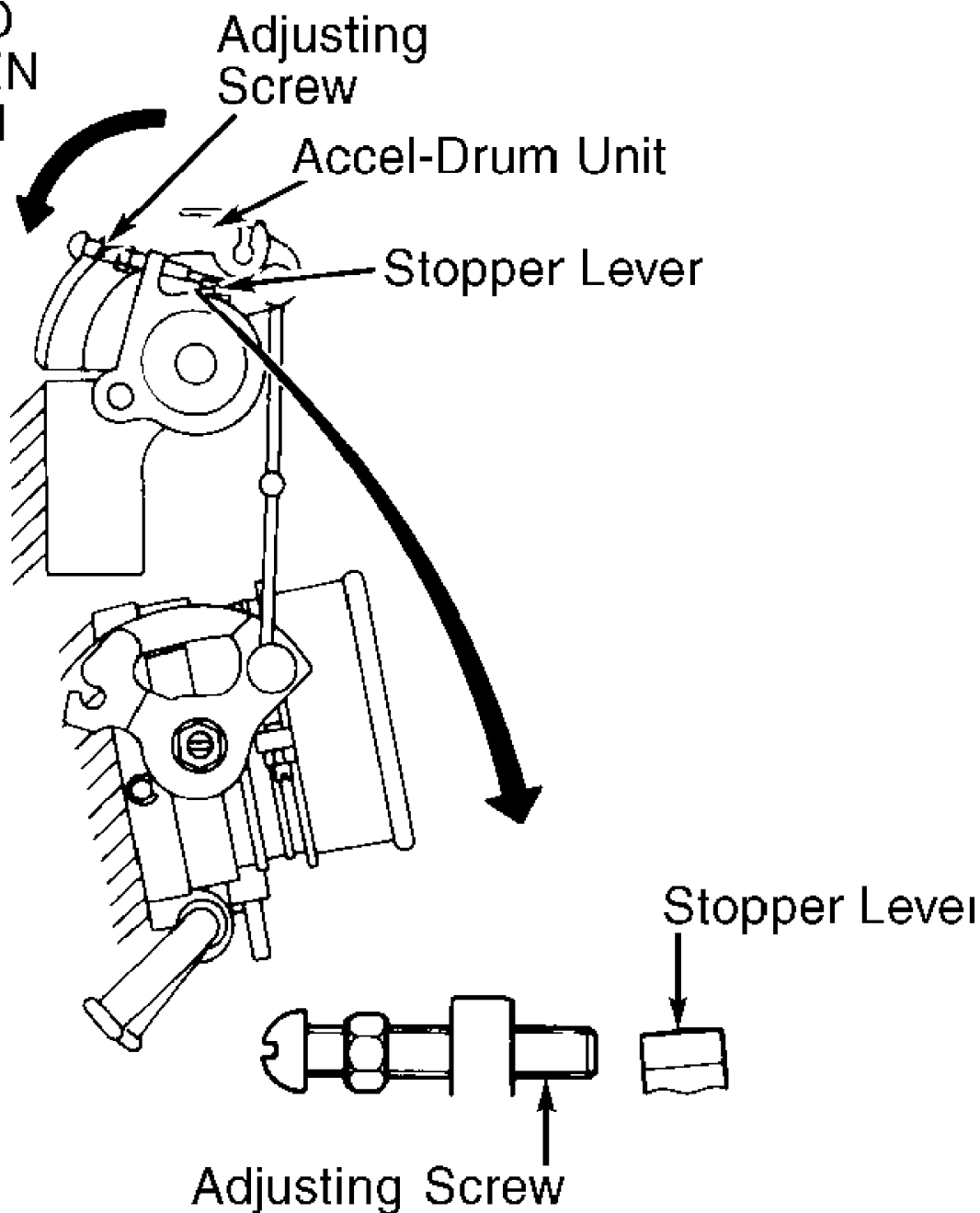

92C00416

Fig. 1: Adjusting Accel-Drum Unit  
Courtesy of Nissan Motor Co., U.S.A.

### VALVE CLEARANCE ADJUSTMENT

CAUTION: Valve clearance adjustment must be performed when cylinder head, rocker arm guide, shim, valve or valve seats are replaced.

- 1) With camshafts and rocker arms removed, remove lash

adjuster and shim. See Fig. 2. Install dial indicator on Dial Indicator Stand(J-38957). See Fig. 3.

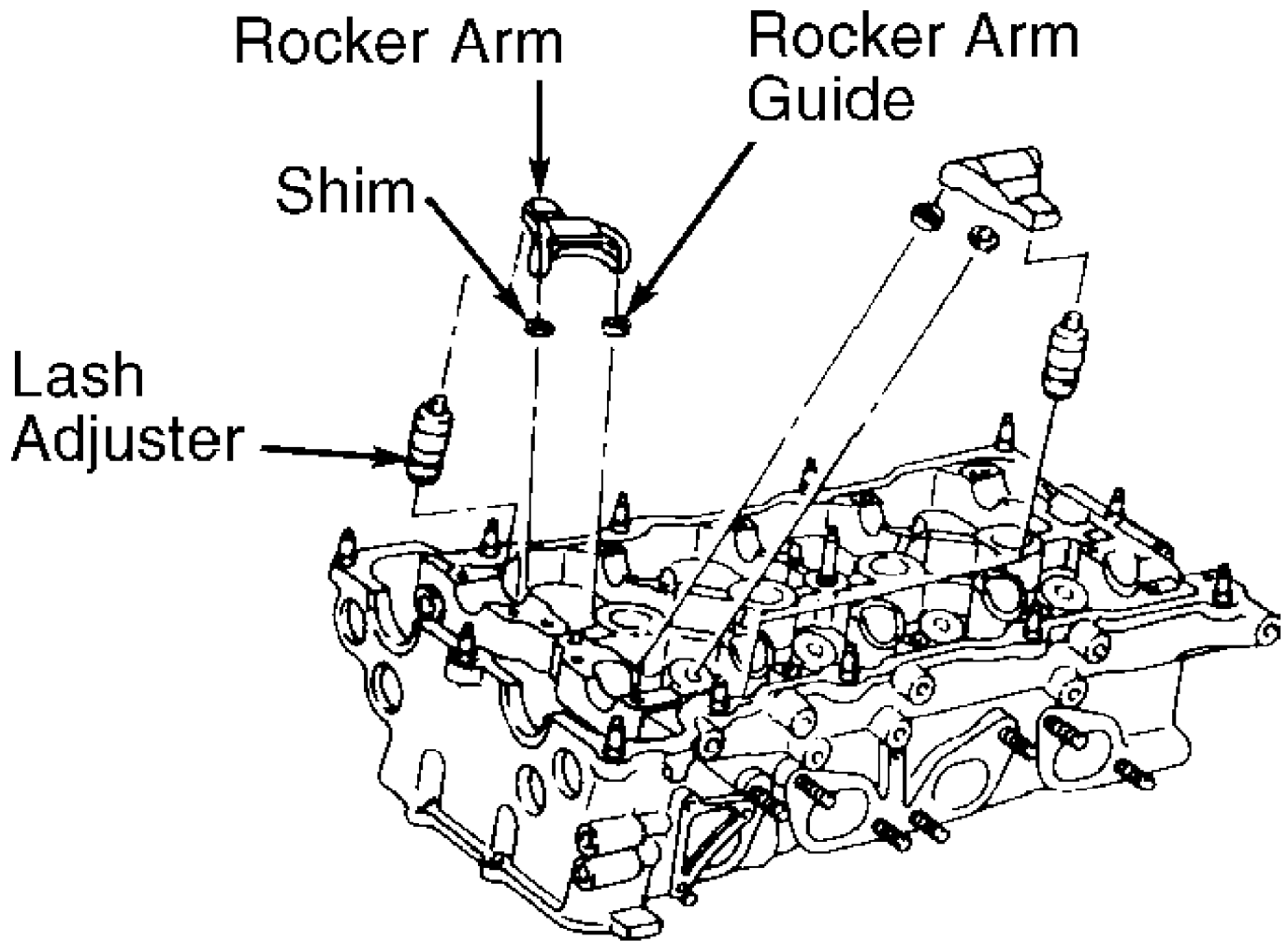

92D00417

Fig. 2: Exploded View of Rocker Arm & Components  
Courtesy of Nissan Motor Co., U.S.A.

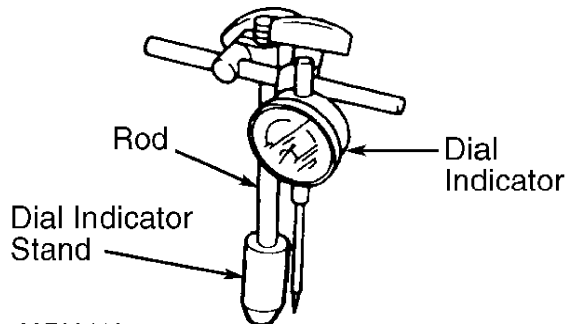

92E00418

Fig. 3: Installing Dial Indicator Stand  
Courtesy of Nissan Motor Co., U.S.A.

2) Install dial indicator assembly in lash adjuster hole in cylinder head. See Fig. 4. Position dial indicator stem on sliding

surface of rocker arm guide. Lightly pull dial indicator rod toward outside of cylinder head to eliminate excessive movement in dial indicator stand, and note dial indicator reading.

3) Remove dial indicator assembly, and install it in other lash adjuster hole. Position dial indicator stem on valve stem. See Fig. 4. Lightly pull dial indicator rod toward outside of cylinder head, and note dial indicator reading.

4) Determine difference between height of sliding surface on rocker arm guide and valve stem. See Fig. 4. Select a replacement shim with thickness within .001" (.30 mm) of difference.

5) For example, if difference reading was .120" (3.05 mm), select a shim with .119-.121" (3.02-3.07 mm) thickness. Replacement shims are available in thicknesses ranging from .1102-.1260" (2.799-3.200 mm) in increments of .001" (.30 mm). Install shim and remaining components in original locations.

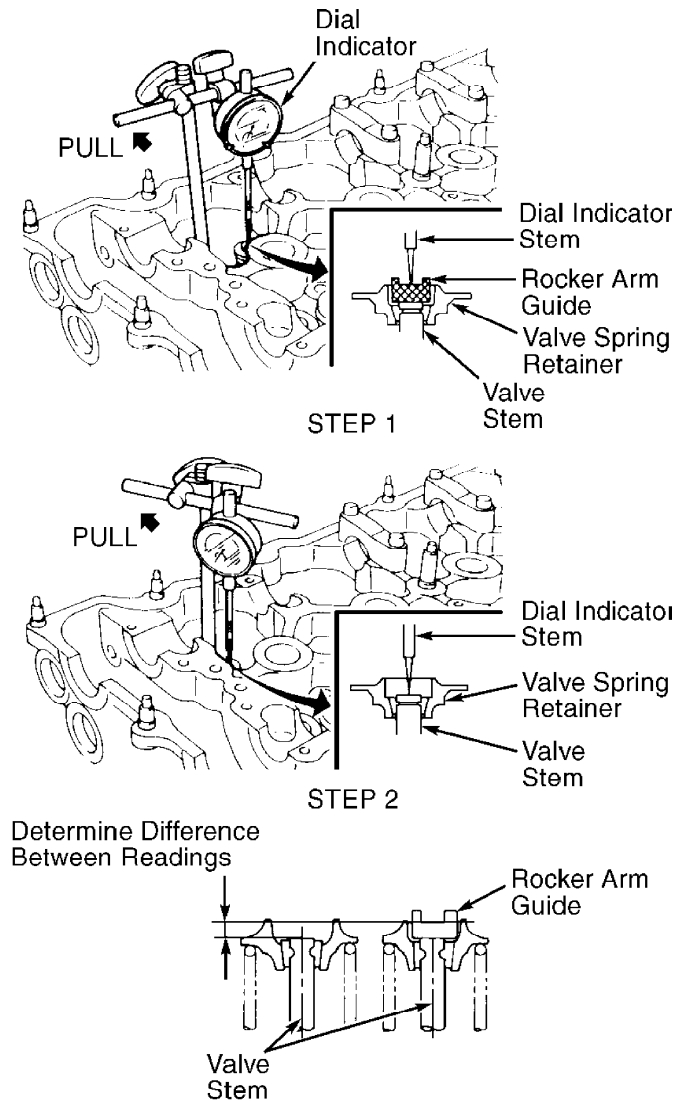

92F00419

Fig. 4: Measuring Valve Clearance  
 Courtesy of Nissan Motor Co., U.S.A.

## REMOVAL & INSTALLATION

NOTE: For reassembly reference, label all electrical connectors, vacuum hoses and fuel lines before removal. Also place mating marks on engine hood and other major assemblies before removal.

### FUEL PRESSURE RELEASE R & I

1) With ignition off, remove fuel pump fuse from fuse block, located below left side of instrument panel. See Fig. 5. Start engine, and allow it to idle until it stalls.

2) Crank engine an additional 2-3 times to release residual fuel pressure. Turn ignition off. Reinstall fuel pump fuse.

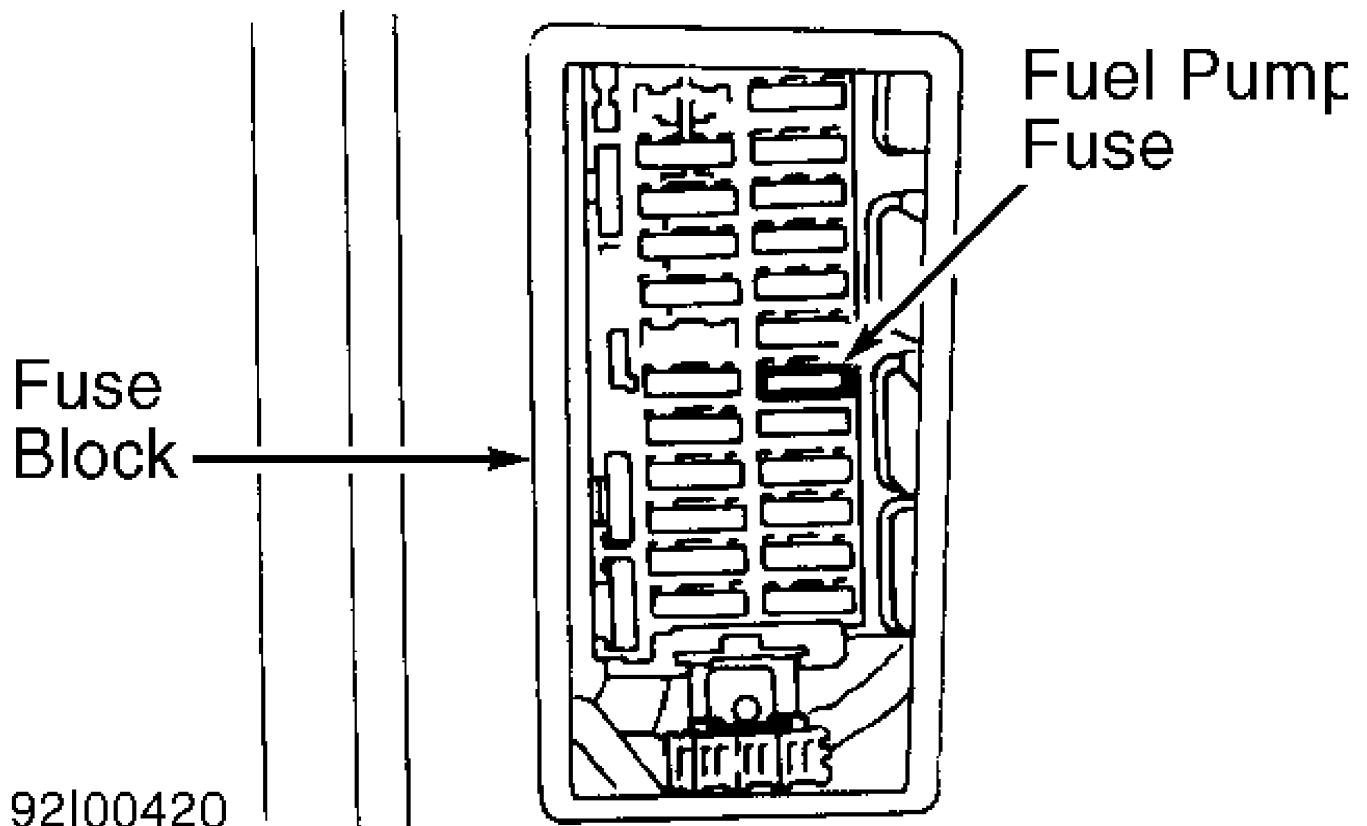
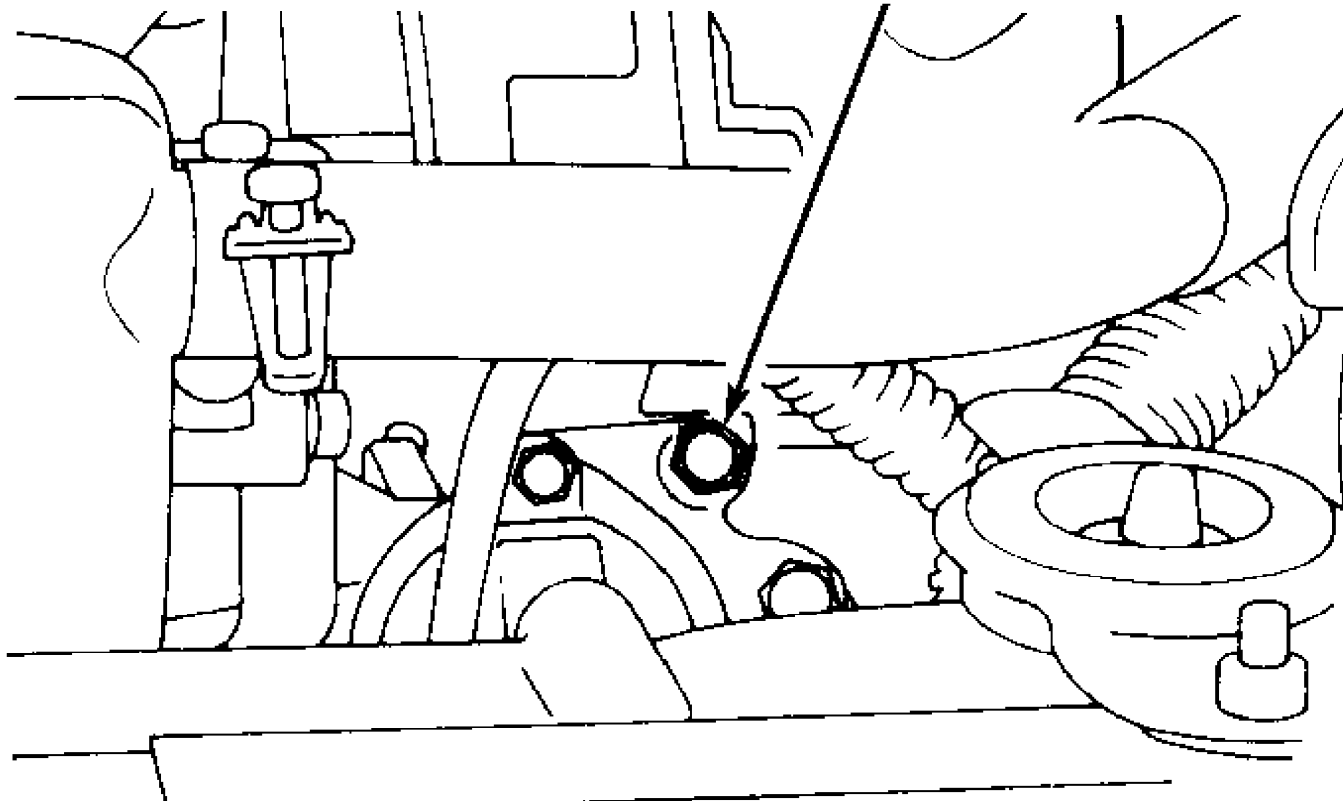

Fig. 5: Identifying Fuel Pump Fuse  
Courtesy of Nissan Motor Co., U.S.A.

### COOLING SYSTEM BLEEDING

1) Place heater temperature control cable in warmest heat position. Remove radiator cap. Remove air relief plug from thermostat housing and air bleeder cap from heater inlet hose. See Figs. 6 and 7.

## Air Relief Plug



92J00421

Fig. 6: Identifying Air Relief Plug  
Courtesy of Nissan Motor Co., U.S.A.

## Air Bleeder Cap

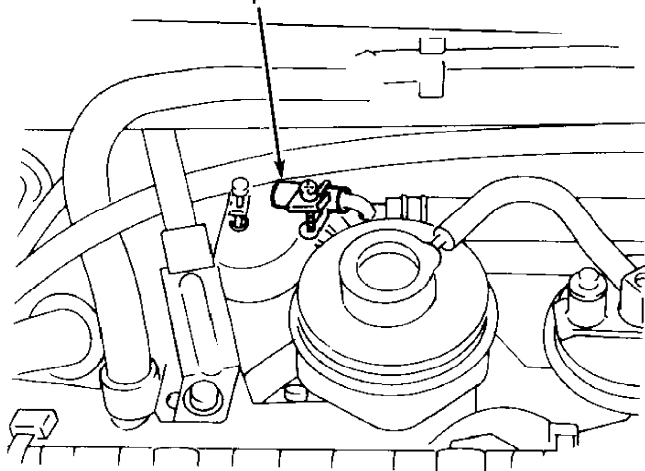

92A00422

Fig. 7: Identifying Air Bleeder Cap  
Courtesy of Nissan Motor Co., U.S.A.

2) Fill radiator with coolant. Install air relief plug once coolant flows from air relief plug opening. Tighten air relief plug to

specification. See TORQUE SPECIFICATIONS table at end of article.

3) Fill radiator and reservoir tank. Reinstall air bleeder cap. Install a temporary radiator cap with a steel wire installed between negative pressure valve and seat. See Fig. 8. This will allow air and coolant to be directed into coolant reservoir tank regardless of cooling system pressure.

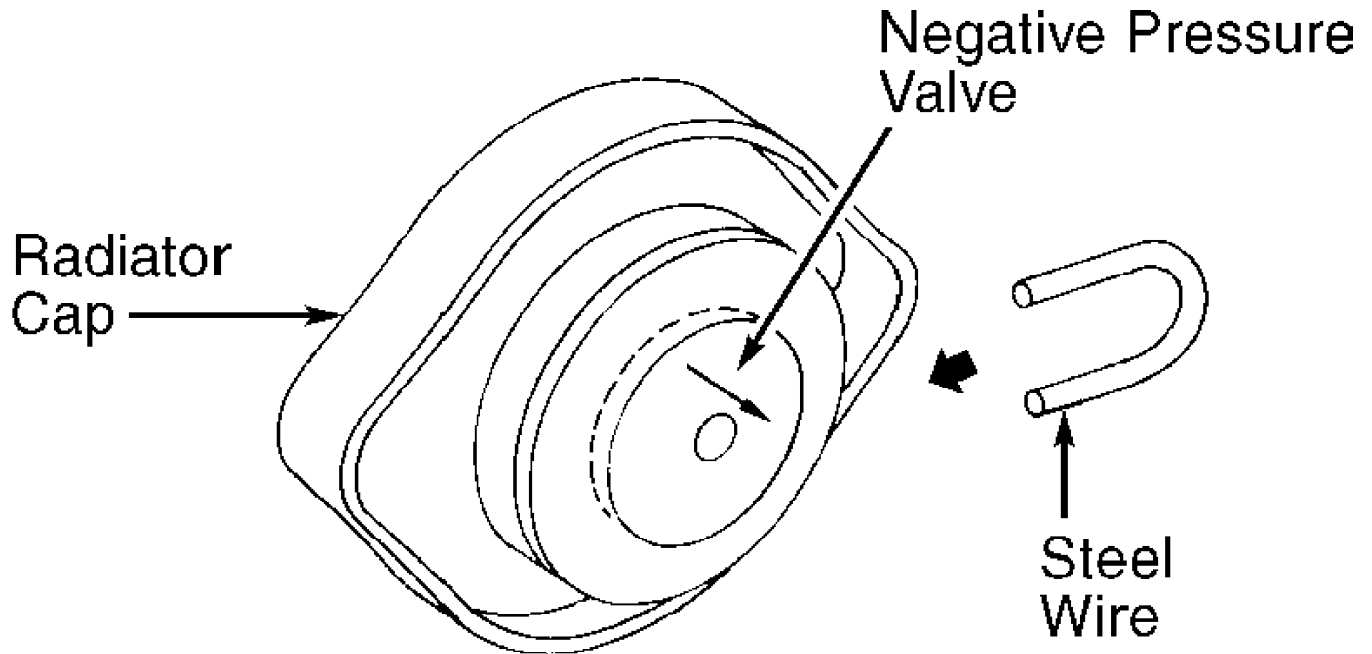

### 92B00423

Fig. 8: Installing Steel Wire in Radiator Cap  
Courtesy of Nissan Motor Co., U.S.A.

4) Warm engine to normal operating temperature. Operate it at 2500 RPM for 10 seconds, and then allow it to idle. Repeat procedure 3 times. Ensure engine does not overheat.

5) Shut engine off, and allow it to cool. Remove temporary radiator cap, and check coolant level. Adjust radiator and coolant reservoir tank coolant level.

6) Repeat steps 4) and 5) at least twice more. Install original radiator cap. Warm engine to normal operating temperature. Check for sound of coolant flowing through heater water valve with engine at 4000 RPM and heater temperature control cable in several different positions.

7) If sound is heard, indicating air exists in cooling system, shut engine off. Allow engine to cool. Remove air bleeder cap on heater inlet hose. See Fig. 7.

8) Attach transparent hose on air bleeder pipe on heater inlet hose with opposite end of hose in coolant reservoir tank. Install a temporary radiator cap with a steel wire installed between negative pressure valve and seat. See Fig. 8. Start engine and check for bubbles in coolant reservoir tank.

9) Place heater temperature control cable in coldest position. This will bypass coolant through transparent hose. Operate engine at 2300 RPM until bubbles in transparent hose disappear.

CAUTION: DO NOT exceed 2300 RPM or engine may be damaged due to reduced coolant flow.

10) After bubbles disappear, place heater temperature control

cable in warmest heat position. Check for sound of coolant flowing through heater water valve. If sound is heard, repeat step 9).

11) If sound is not heard, stop engine, and allow it to cool. Install original radiator cap. Remove transparent hose. Install air bleeder cap.

## ENGINE R & I

NOTE: Engine and transaxle are removed through bottom of engine compartment.

### Removal

1) Release fuel pressure. See FUEL PRESSURE RELEASE under REMOVAL & INSTALLATION. Mark and remove hood. Disconnect battery cables.

2) Drain cooling system. Drain engine oil. Disconnect necessary vacuum hoses, fuel hoses, coolant hoses, control cables and electrical connections. Remove cooling fans and radiator.

3) Remove all drive belts. Remove alternator. Remove A/C compressor with hoses attached if possible. If necessary, discharge A/C system and disconnect and plug hoses from A/C compressor. Remove power steering pump. Raise and support vehicle so engine can be removed from bottom of engine compartment.

4) Remove lower engine cover. Disconnect control cables, shift linkage, electrical connections and oil cooler hoses (A/T) at transaxle. Remove exhaust pipes. Remove front wheels. Remove nut from end of axle shaft at hub. Remove brake caliper, and secure aside. Remove brake rotor.

5) Remove nut, and separate tie rod from steering knuckle. Remove cap and nut from upper stud on steering knuckle. Separate upper stud on steering knuckle from upper suspension arm and lower steering knuckle.

6) Cover axle shaft boots using shop towel to prevent damage. Using soft-faced hammer, tap axle shaft from hub assembly. If axle shaft cannot be tapped from hub assembly, use puller to separate axle shaft from hub assembly. Remove axle shaft support bearing bolts. Using screwdriver, pry right axle shaft from transaxle. See Fig. 9.

7) On M/T models, pry left axle shaft from transaxle. See Fig. 10. On A/T models, use screwdriver and hammer to remove left axle shaft from transaxle. See Fig. 11.

CAUTION: Use care not to damage pinion shaft when removing left axle shaft from transaxle.

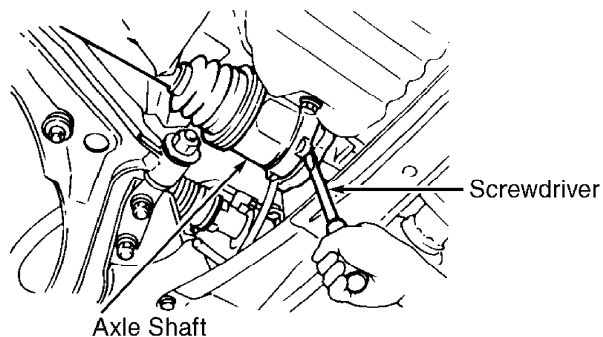

92C00424

Fig. 9: Removing Right Axle Shaft from Transaxle  
Courtesy of Nissan Motor Co., U.S.A.



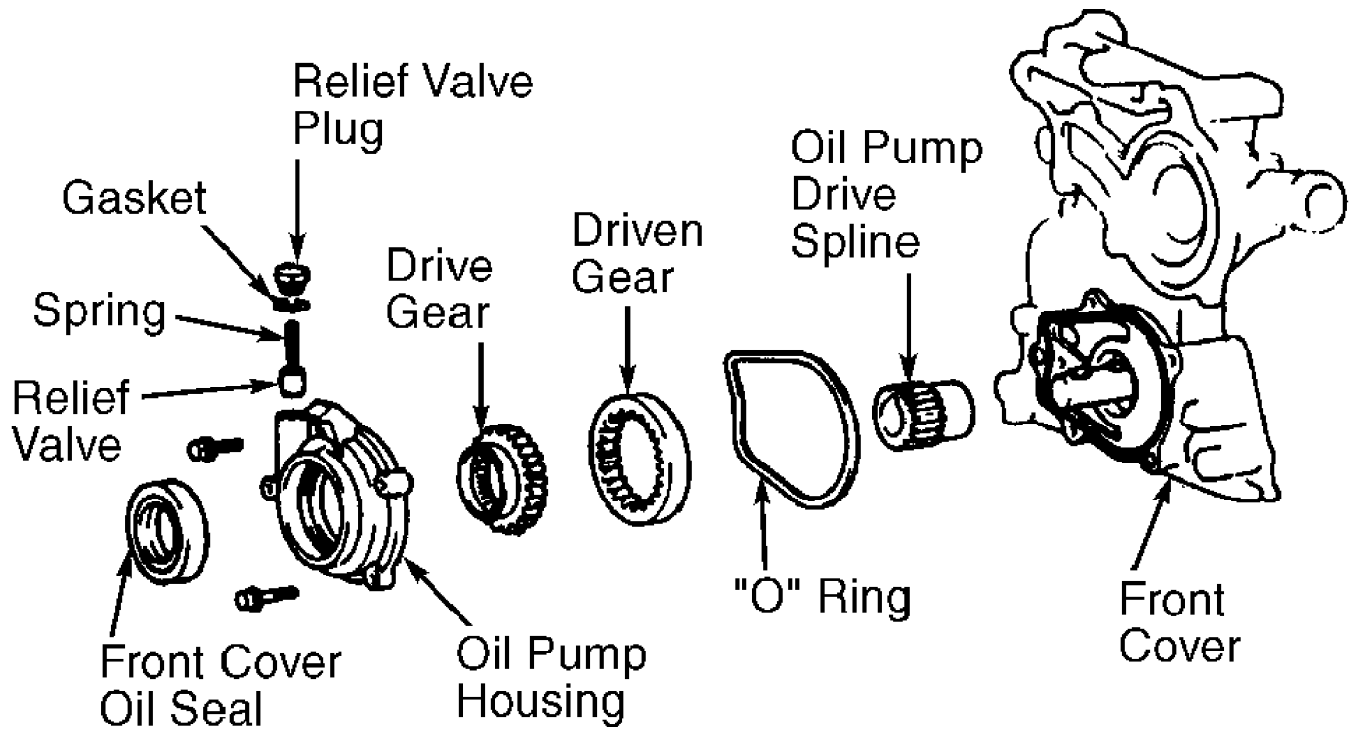

92D00425

Fig. 10: Removing Left Axle Shaft from Transaxle (M/T Models)  
 Courtesy of Nissan Motor Co., U.S.A.

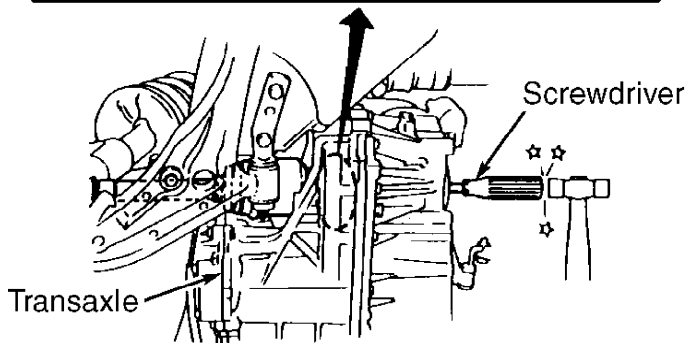
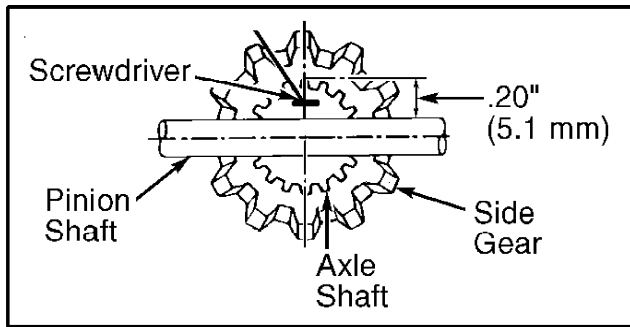

92E00426

Fig. 11: Removing Left Axle Shaft from Transaxle (A/T Models)  
 Courtesy of Nissan Motor Co., U.S.A.

8) Support transaxle using transmission jack. Support engine using engine hoist. Remove crossmember located below engine. Remove

engine and transaxle mount bolts.

9) Lower engine hoist and transmission jack to lower engine and transaxle from bottom of engine compartment.

#### Installation

1) To install, reverse removal procedure. Ensure engine mounts are installed so rubber seats are properly positioned and engine mount is centered in mounting bracket. See Fig. 12. On M/T models, position engine at specified height on engine mount. See Fig. 13.

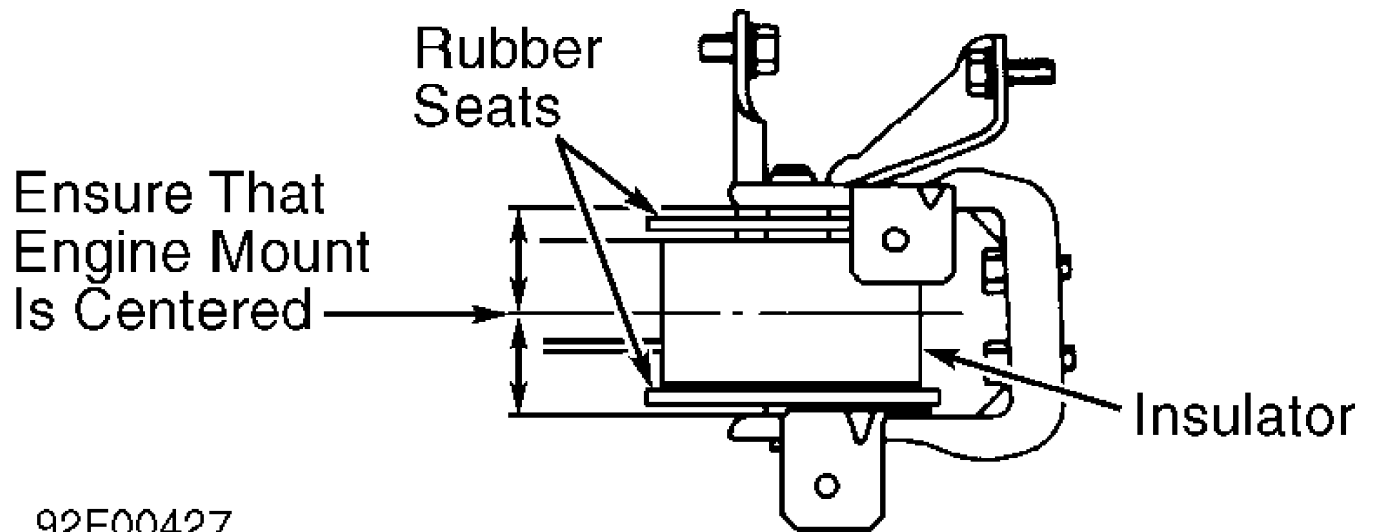

92F00427

Fig. 12: Positioning Engine Mounts  
Courtesy of Nissan Motor Co., U.S.A.

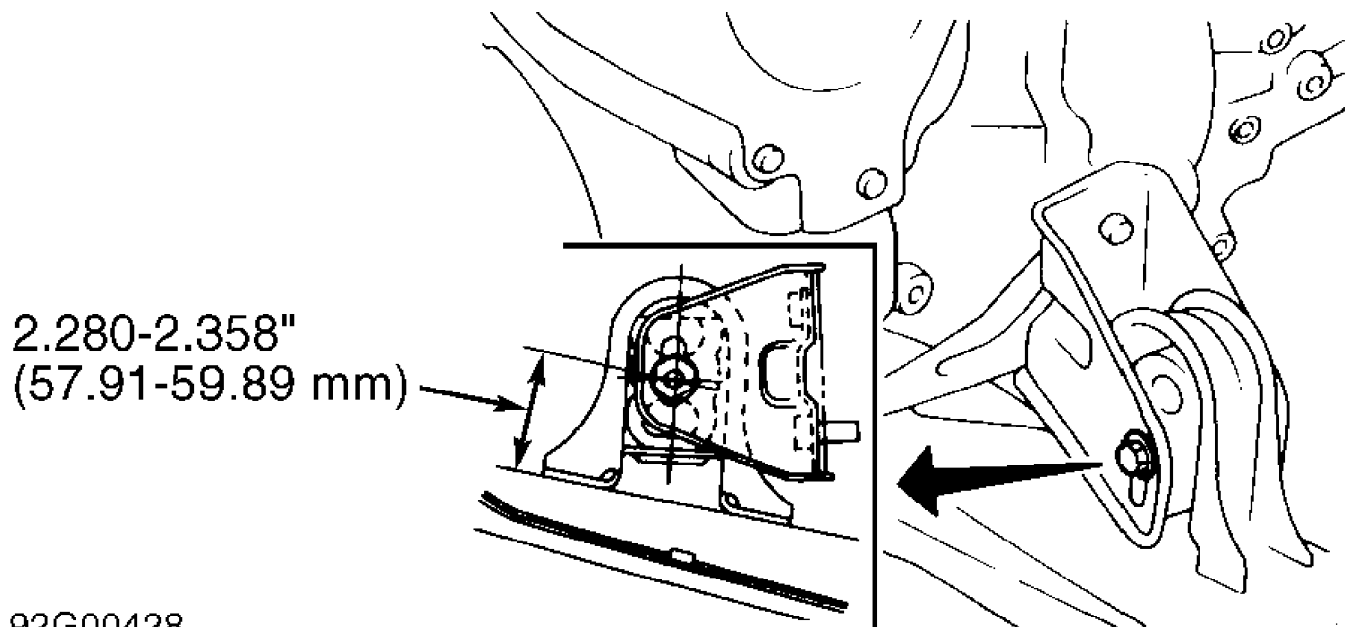

92G00428

Fig. 13: Adjusting Engine Height on Engine Mount (M/T Models)  
Courtesy of Nissan Motor Co., U.S.A.

2) Install Oil Seal Protector (J-34296 for left side or J-34297 for right side) in oil seal on transaxle before installing axle shaft in transaxle. See Fig. 14.

3) Install axle shaft, and then remove oil seal protector. Ensure axle shaft circular clip locks in groove of differential side gear and axle shaft cannot be pulled out of transaxle.

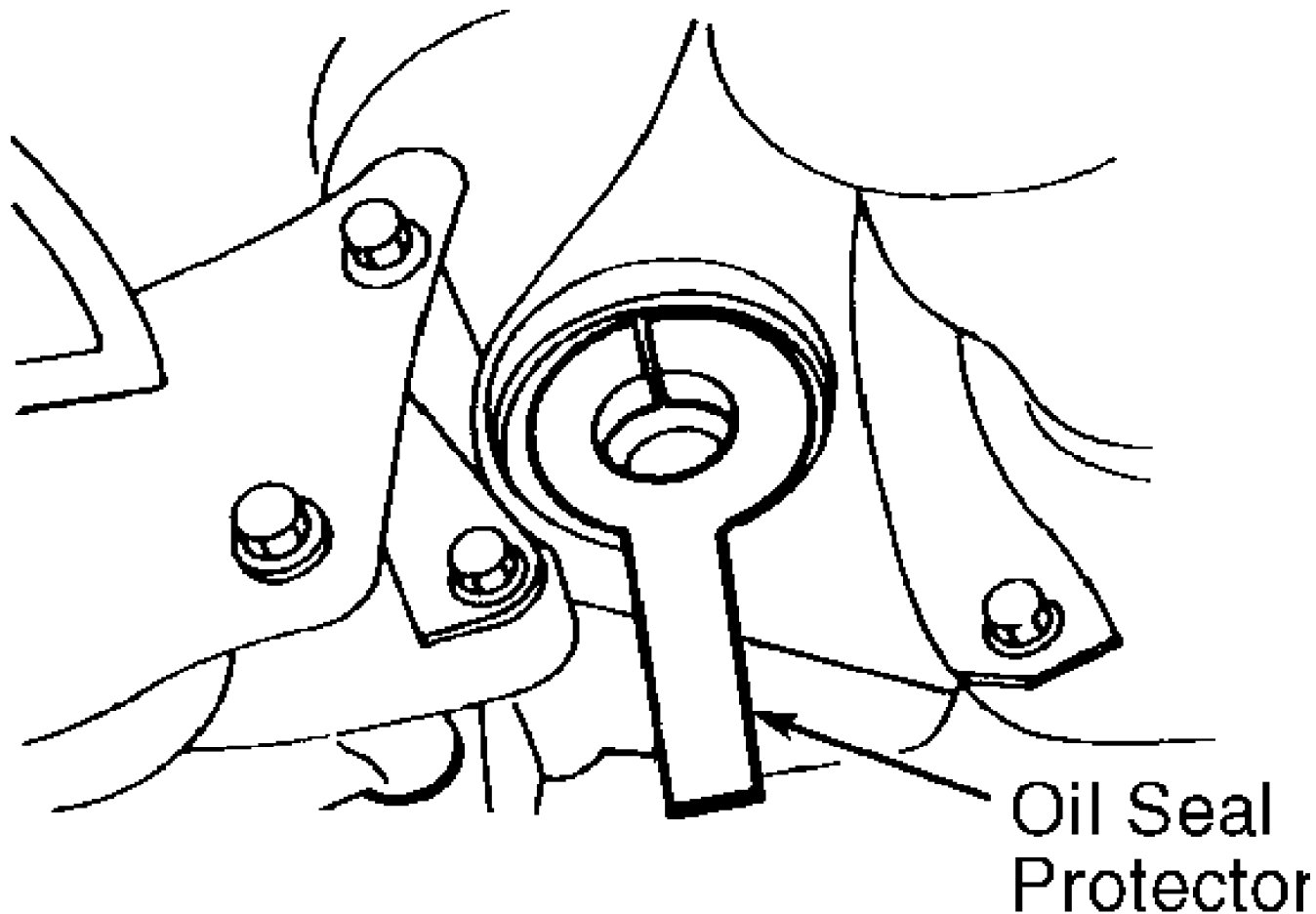

**92H00429**

Fig. 14: Installing Oil Seal Protector  
Courtesy of Nissan Motor Co., U.S.A.

4) Tighten all fasteners to specification. See TORQUE SPECIFICATIONS table at end of article. Evacuate and recharge A/C system (if necessary). Coat fuel hoses-to-fitting surface with small amount of silicone oil before installing. Adjust all control cables and fluid levels. Fill and bleed cooling system. See COOLING SYSTEM BLEEDING under REMOVAL & INSTALLATION.

### **INTAKE MANIFOLD R & I**

**NOTE:** If necessary, drain cooling system and remove fuel rail for intake manifold removal.

#### Removal

1) Release fuel pressure. See FUEL PRESSURE RELEASE under REMOVAL & INSTALLATION. Disconnect electrical connectors at fuel injectors and vacuum hose at pressure regulator. Disconnect necessary fuel hoses.

2) Remove fuel rail retaining bolts in proper sequence. See Fig. 15. Remove fuel rail with fuel injectors and insulators. See Fig. 16.

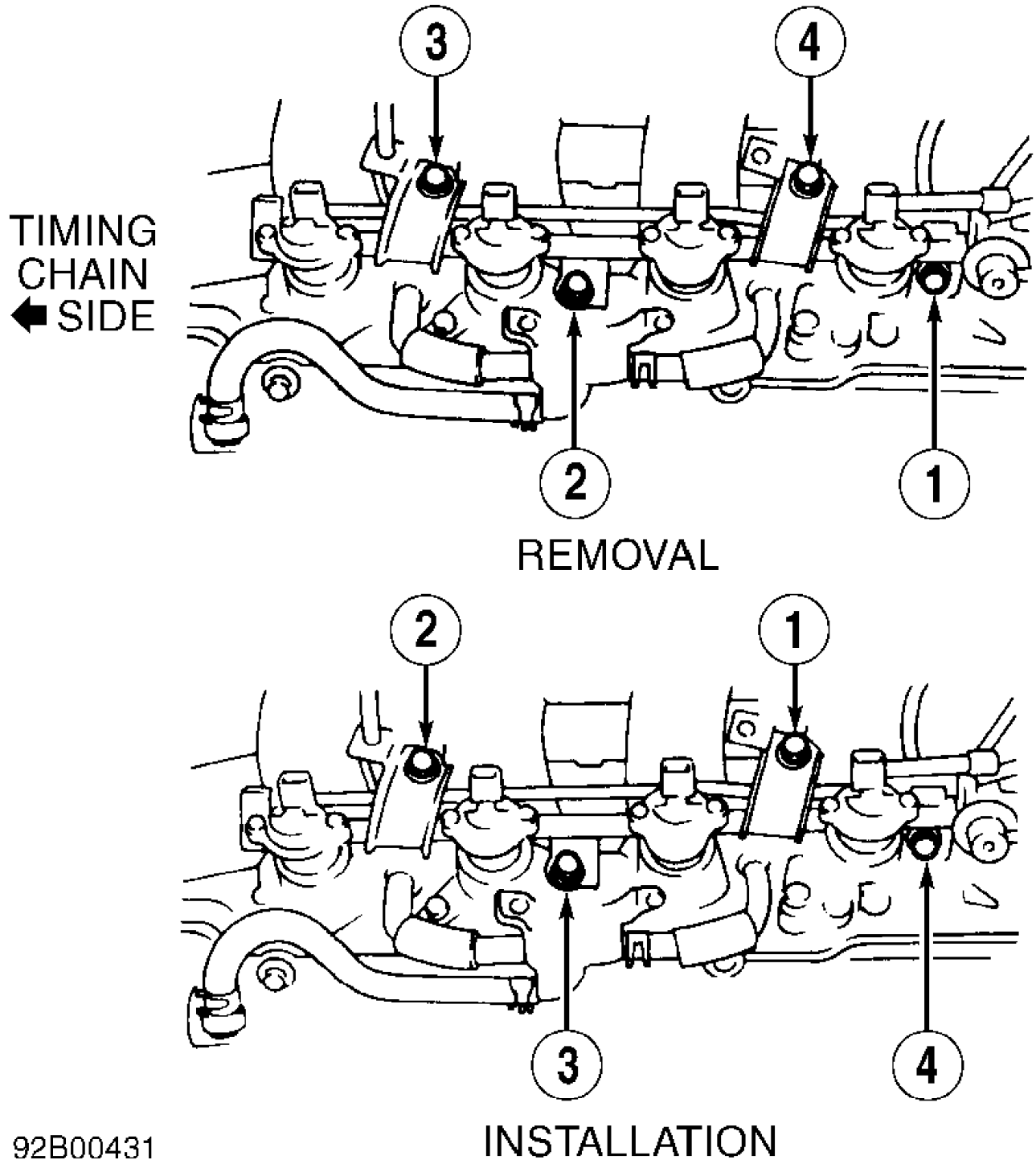

92B00431

INSTALLATION

Fig. 15: Fuel Rail Bolt Removal & Installation Sequence  
Courtesy of Nissan Motor Co., U.S.A.

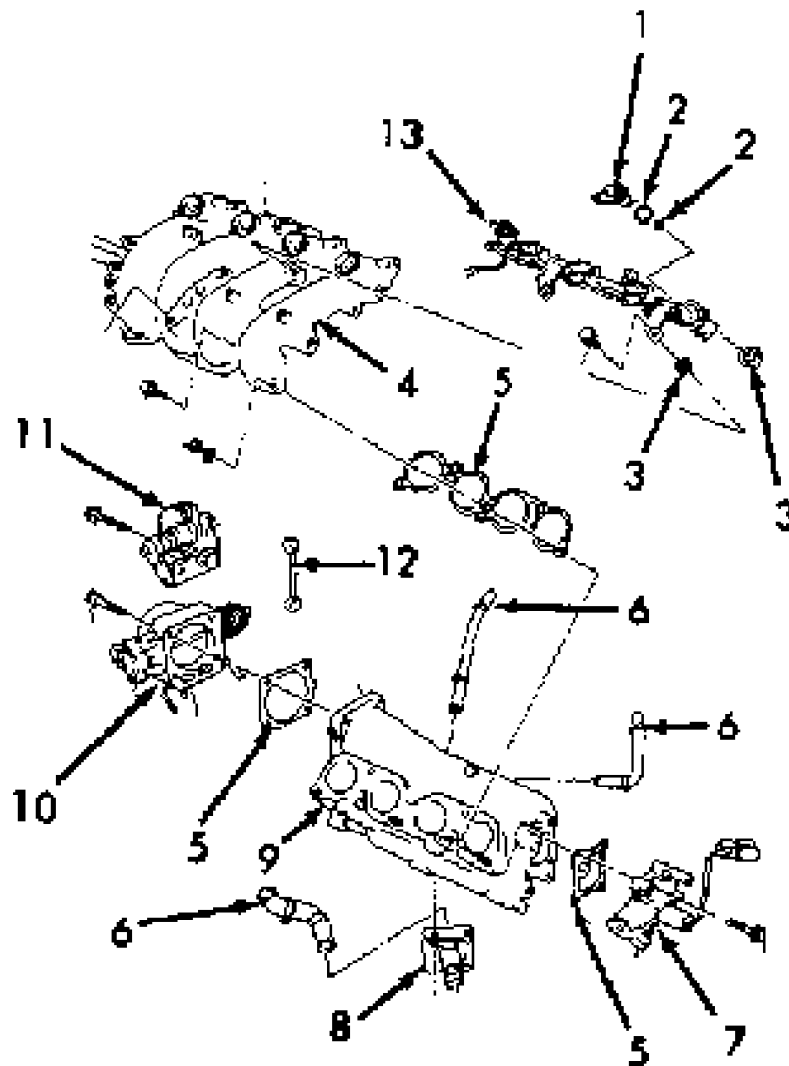

- |                                |                              |
|--------------------------------|------------------------------|
| 1. Fuel Injector               | 8. Air Regulator             |
| 2. "O" Ring                    | 9. Intake Manifold Collector |
| 3. Insulator                   | 10. Throttle Chamber         |
| 4. Intake Manifold             | 11. Accel-Drum Unit          |
| 5. Gasket                      | 12. Rod                      |
| 6. Hose                        | 13. Fuel Rail                |
| 7. Auxiliary Air Control Valve |                              |

Fig. 16: Exploded View of Intake Manifold & Components  
 Courtesy of Nissan Motor Co., U.S.A.

3) Disconnect necessary electrical connections, hoses and control cables. Remove support braces from intake manifold. Remove

intake manifold retaining bolts in proper sequence. See Fig. 17.  
Remove intake manifold and gasket.

4) Remove intake manifold collector-to-intake manifold bolts/nuts in proper sequence if intake manifold collector is to be separated from intake manifold. See Fig. 17. Separate intake manifold collector and gasket from intake manifold.

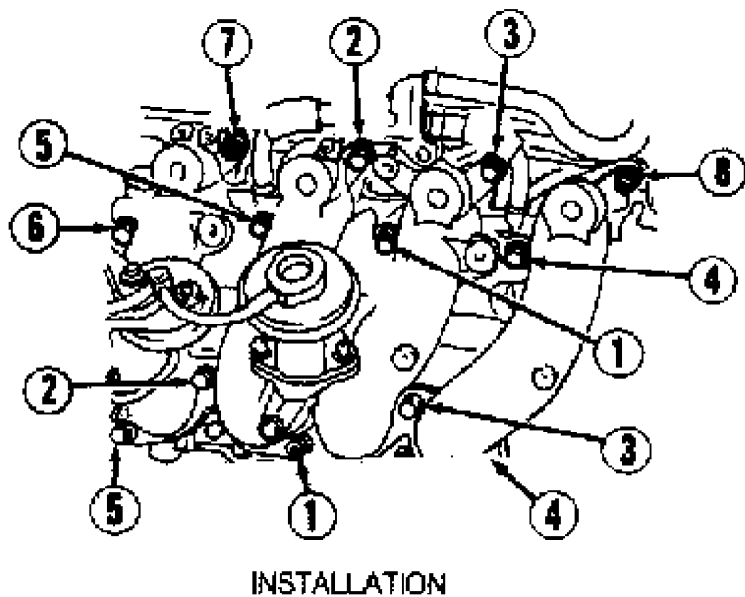
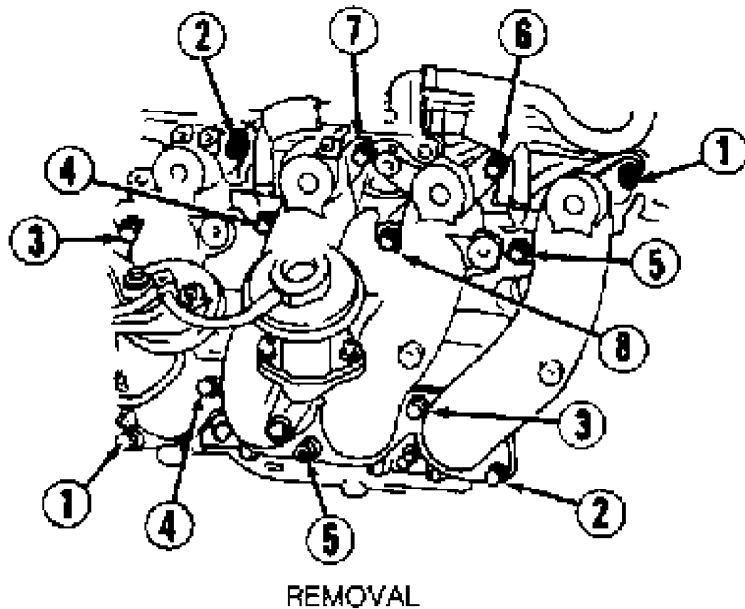

Fig. 17: Intake Manifold & Intake Manifold Collector Bolt/Nut  
Removal & Installation Sequence  
Courtesy of Nissan Motor Co., U.S.A.

Installation

1) To install intake manifold collector and intake manifold, reverse removal procedure using new gaskets. Tighten all bolts to specification in sequence. See Fig. 17. See TORQUE SPECIFICATIONS table at end of article.

2) When installing fuel rail and fuel injectors, use new insulators and "O" rings. Lubricate "O" rings with silicone oil before installing. Tighten fuel rail retaining bolts to specification in sequence. See Fig. 15. See TORQUE SPECIFICATIONS table.

3) Coat fuel hoses-to-fitting surface with small amount of silicone oil before installing. To install remaining components, reverse removal procedure. If cooling system was drained, fill and bleed cooling system. See COOLING SYSTEM BLEEDING under REMOVAL & INSTALLATION.

NOTE: If accel-drum unit was removed or throttle chamber or rod were changed, install new rod and adjust accel-drum unit. See ACCEL-DRUM UNIT under ADJUSTMENTS.

## EXHAUST MANIFOLD R & I

### Removal & Installation

1) Remove heat shield and oxygen sensor (if necessary) from exhaust manifold. Disconnect exhaust pipe from exhaust manifold. Remove exhaust manifold retaining nuts in sequence. See Fig. 18.

2) To install, reverse removal procedure. Tighten retaining nuts to specification in sequence. See Fig. 18. See TORQUE SPECIFICATIONS table at end of article.

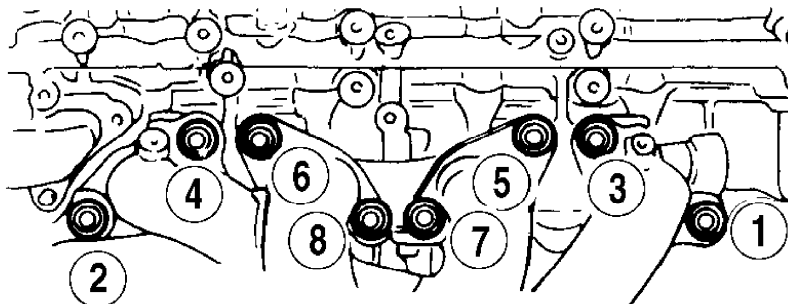

REMOVAL

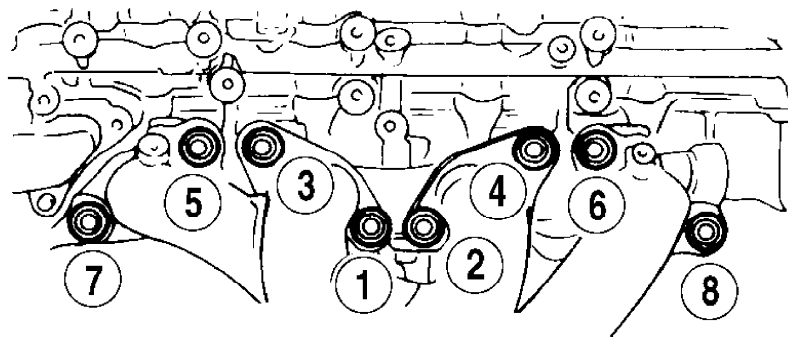

INSTALLATION

92D00433

Fig. 18: Exhaust Manifold Nut Removal & Installation Sequence  
Courtesy of Nissan Motor Co., U.S.A.

## CYLINDER HEAD R & I

#### Removal

1) Release fuel pressure. See FUEL PRESSURE RELEASE under REMOVAL & INSTALLATION. Drain cooling system and cylinder block. Disconnect necessary coolant hoses, fuel hoses, vacuum hoses, control cables and electrical connections.

2) Remove air duct to intake manifold, radiator, drive belts and water pump pulley. Remove alternator, power steering pump and spark plugs. Remove lower engine cover.

3) Remove air injection valve and resonator. See Fig. 19. Remove valve cover nuts in proper sequence. See Fig. 20. Remove valve cover, gasket and oil separator.

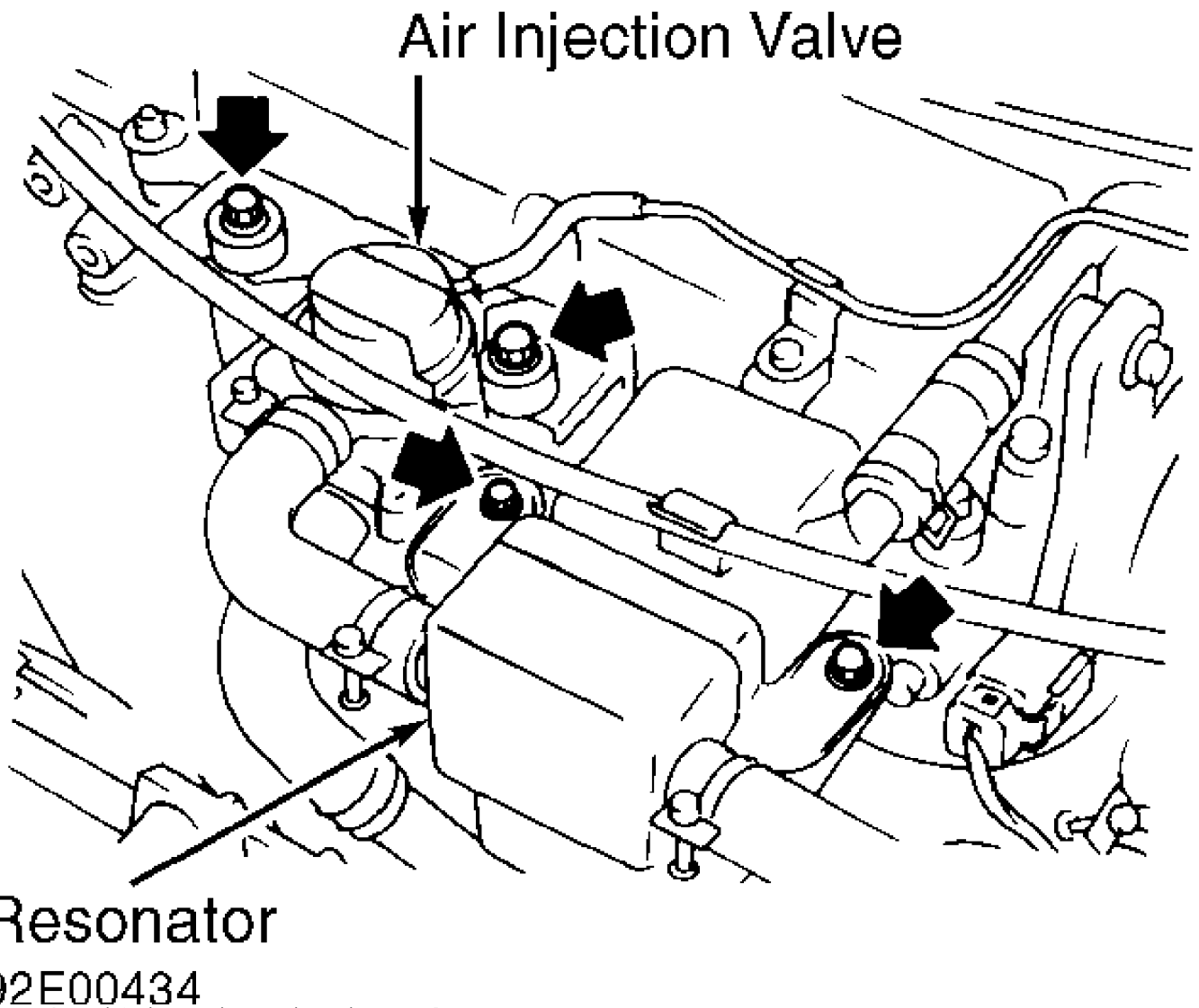
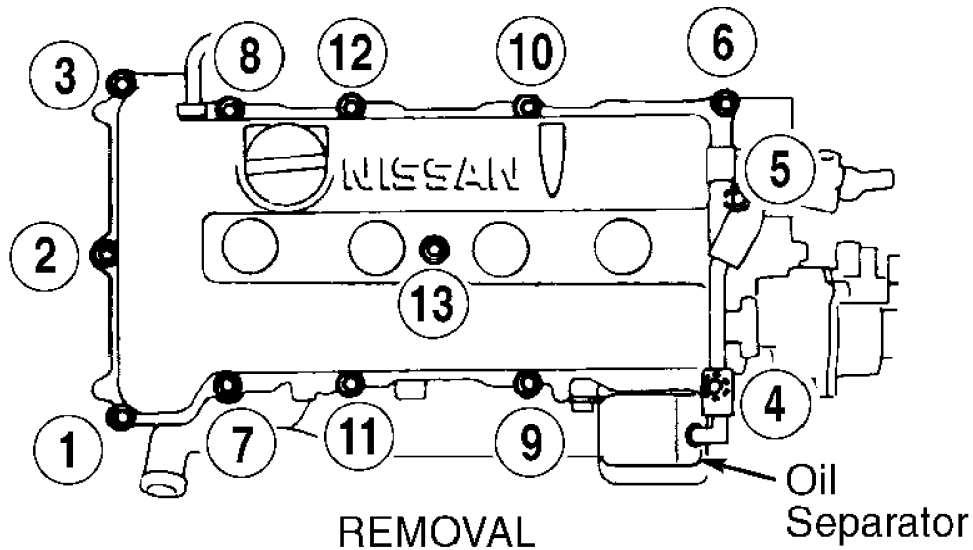
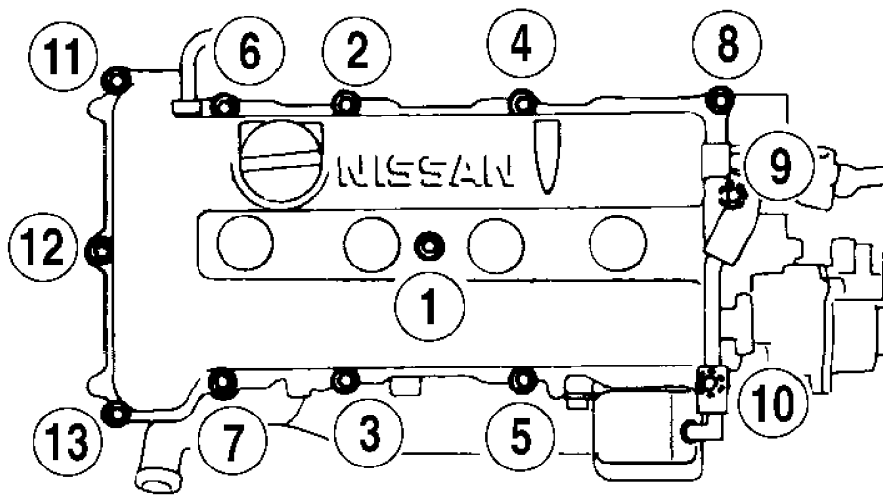

Fig. 19: Identifying Air Injection Valve & Resonator  
Courtesy of Nissan Motor Co., U.S.A.





← TIMING CHAIN SIDE



STEP 1 - Tighten No. 1, 10, 11, 13 & 8 to 35 INCH Lbs. (4 N.m).

STEP 2 - Tighten all nuts in sequence to 72-86 INCH Lbs. (8-10 N.m).

92F00435

Fig. 20: Valve Cover Nut Removal & Installation Sequence  
 Courtesy of Nissan Motor Co., U.S.A.

4) Remove intake manifold support braces. Remove oil filter bracket and power steering pump bracket. Rotate crankshaft until No. 1

cylinder is at TDC of compression stroke and timing marks on camshaft sprockets are properly positioned. See Fig. 21. Ensure timing mark pointer on front cover aligns with "0" mark on crankshaft pulley.

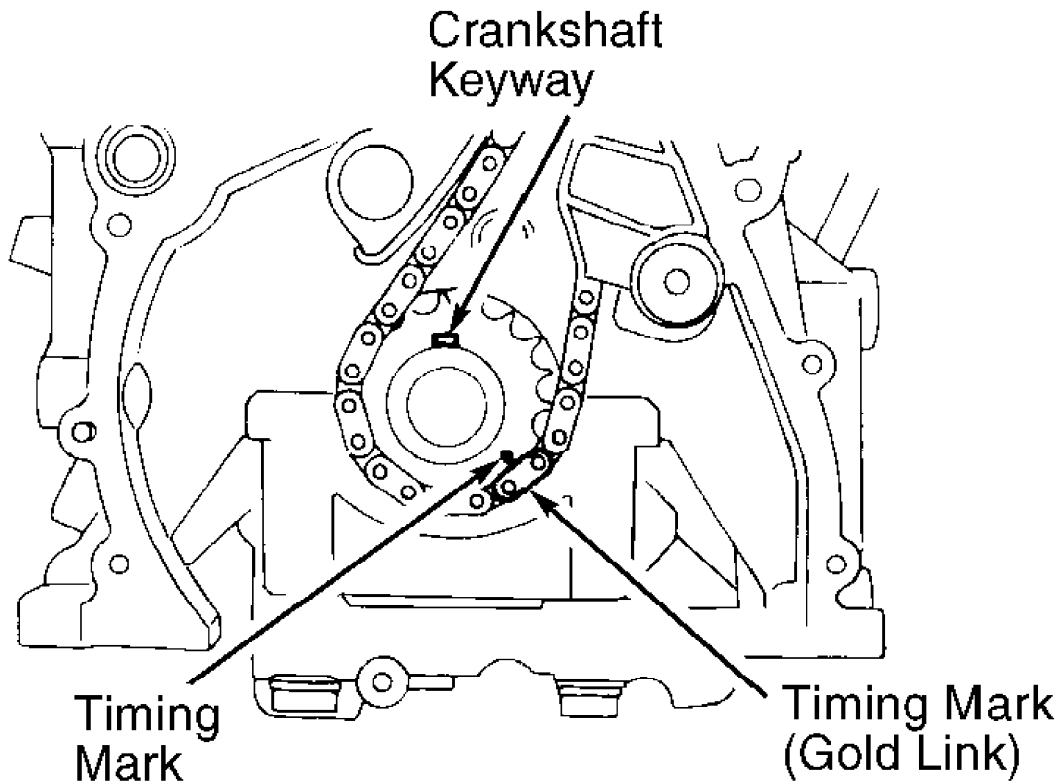
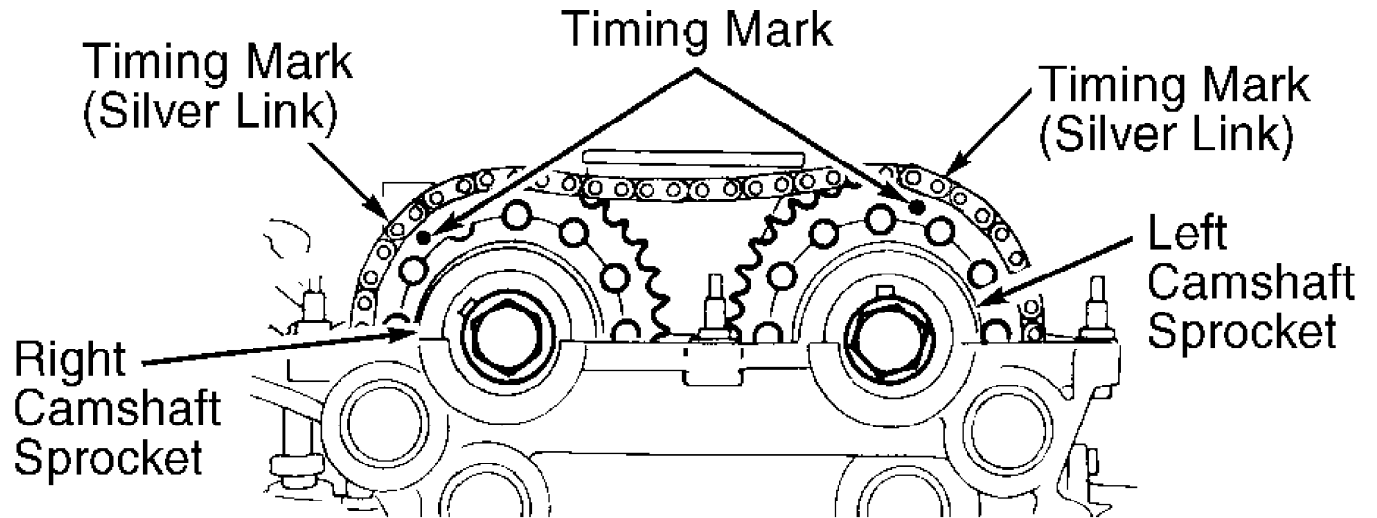

92G00436

Fig. 21: Aligning Timing Marks  
 Courtesy of Nissan Motor Co., U.S.A.

5) Note direction of arrow on timing chain tensioner, located on right side of cylinder head. Remove timing chain tensioner, "0" ring and gasket from cylinder head. See Fig. 22. Remove distributor

cap. Remove distributor. Remove upper timing chain guide.

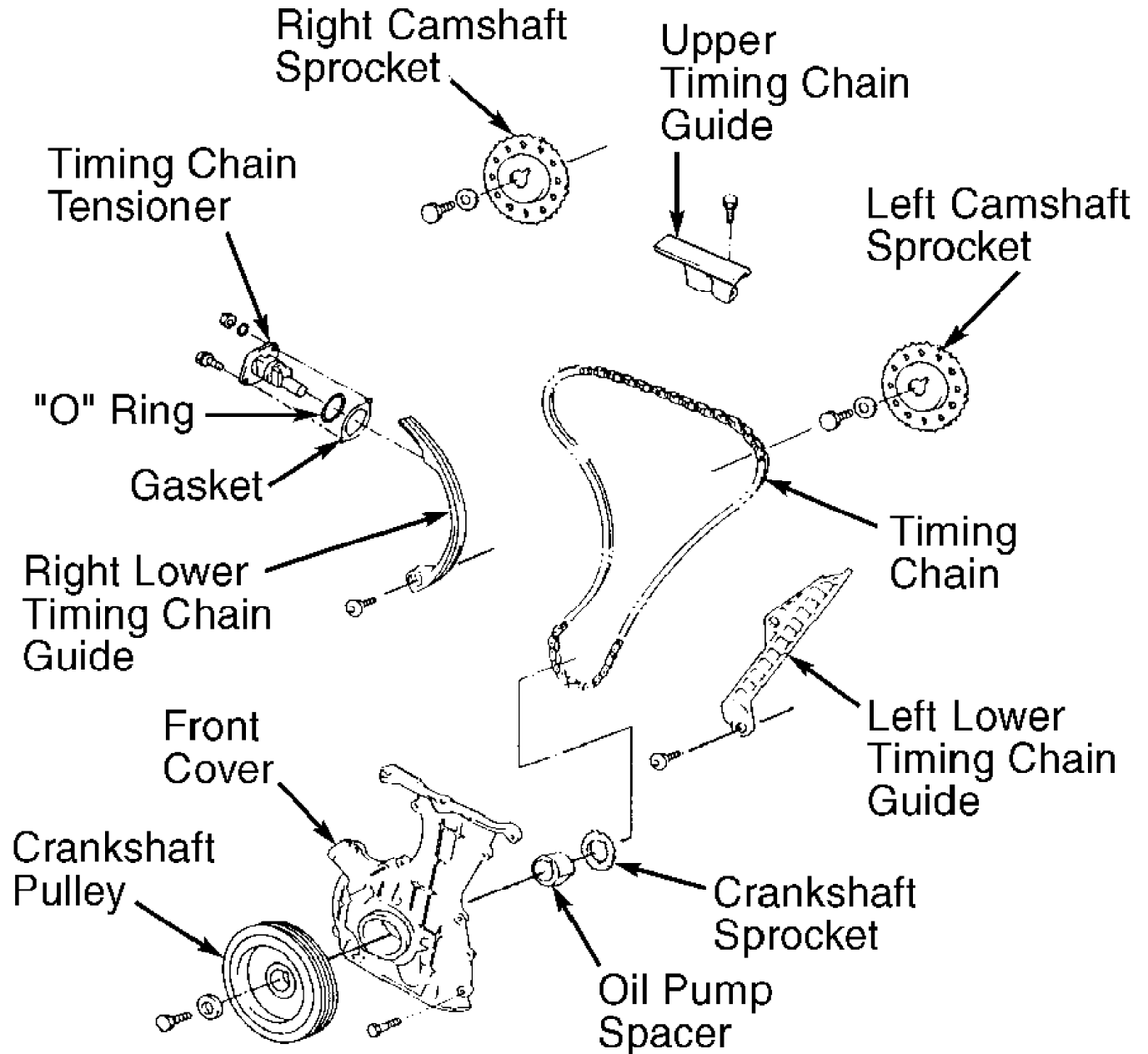

92H00437

Fig. 22: Exploded View of Timing Chain & Components  
Courtesy of Nissan Motor Co., U.S.A.

6) Remove camshaft sprocket retaining bolts while holding camshaft using wrench installed on area located behind camshaft sprocket. Remove camshaft sprockets with timing chain.

CAUTION: DO NOT rotate crankshaft or camshafts with timing chain removed or engine damage may result.

7) Remove camshaft bearing cap bolts in sequence. See Fig. 23. Note bolt location for reassembly reference.

CAUTION: Note direction and location of camshaft bearing cap installation. Camshaft bearing caps contain an arrow which points toward timing chain side of engine. No. 1-4 camshaft bearing caps are numbered for location with No. 1 at timing chain side. Rear (end) camshaft bearing caps are not numbered.

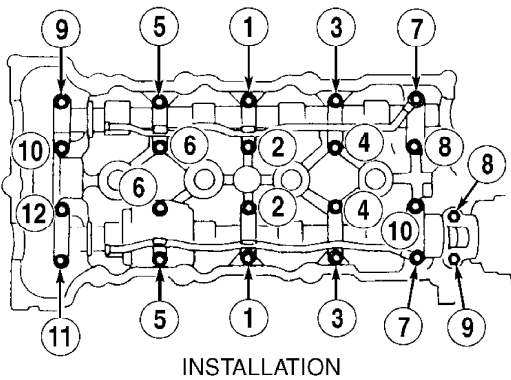
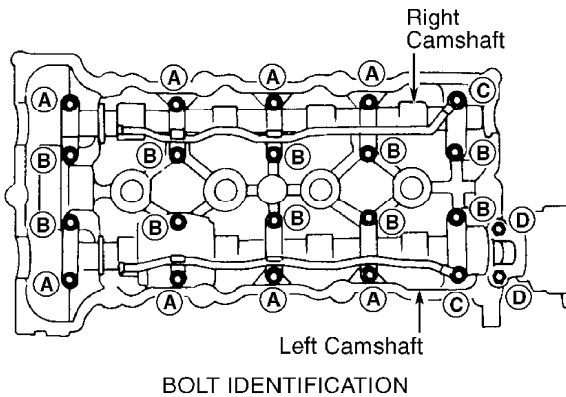
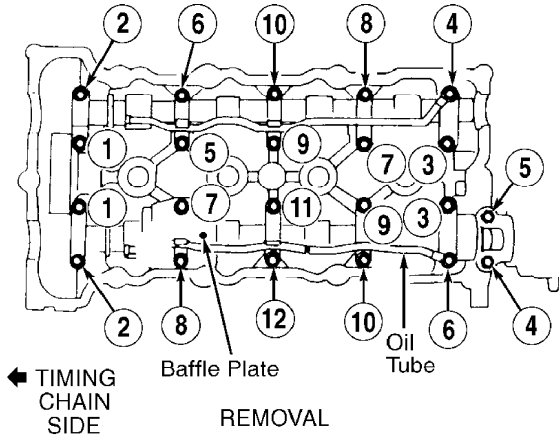

NOTE: Bolt identification must be used when tightening bolts to specification.

92100438  
 Fig. 23: Camshaft Bearing Cap Bolt Identification & R & I Sequence  
 Courtesy of Nissan Motor Co., U.S.A.

8) Remove oil tubes, baffle plate, camshaft bearing caps and camshafts. Disconnect necessary coolant hoses and brackets from

cylinder head and front cover. Remove starter. Remove outside cylinder head bolts.

CAUTION: Outside cylinder head bolts are located at front cover and near distributor.

9) Using Cylinder Head Bolt Wrench (J-24239-01), loosen cylinder head-to-cylinder block bolts in 3 steps and in sequence. See Fig. 24. Remove cylinder head with intake and exhaust manifold attached.

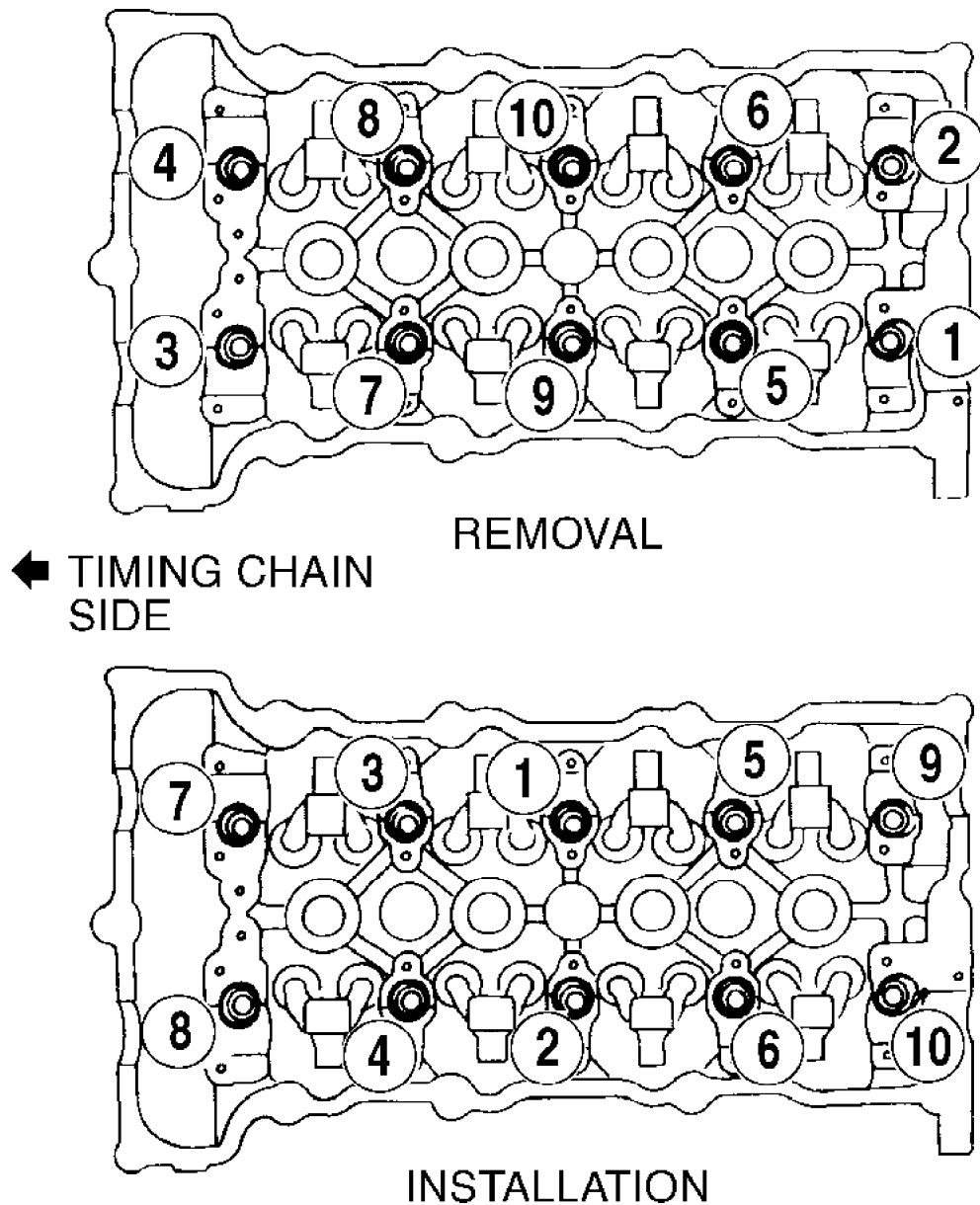

92J00439

Fig. 24: Cylinder Head Bolt Removal & Installation Sequence  
Courtesy of Nissan Motor Co., U.S.A.

10) Remove oil pan. See OIL PAN under REMOVAL & INSTALLATION.  
Remove oil pump pick-up tube and baffle plate. Remove crankshaft

pulley retaining bolt. Using puller, remove crankshaft pulley.

11) Support engine using floor jack positioned under main bearing caps. Remove engine mount located on front cover. Remove retaining bolts and front cover. Remove lower timing chain guides and timing chain. Remove oil pump spacer and crankshaft sprocket (if necessary). See Fig. 22.

#### Inspection

1) Inspect cylinder head warpage at cylinder block area. Replace or resurface cylinder head if warpage exceeds specification. See CYLINDER HEAD table under ENGINE SPECIFICATIONS at end of article. Ensure cylinder head height is within specification after machining.

CAUTION: DO NOT machine more than .008" (.20 mm) total from cylinder head and cylinder block deck surface.

2) Measure distance from bottom of head to end of bolt on all cylinder head-to-cylinder block bolts. Cylinder head bolt must be replaced if distance exceeds 6.228" (158.19 mm).

#### Installation

1) If crankshaft sprocket was removed, install crankshaft sprocket with teeth away from cylinder block. This will position shoulder on rear of crankshaft sprocket toward cylinder block.

2) Rotate crankshaft until No. 1 cylinder is at TDC of compression stroke. This will position crankshaft keyway at 12 o'clock and timing mark at 4 o'clock positions. See Fig. 21.

3) Install timing chain so timing mark (gold link) is aligned with timing mark on crankshaft sprocket. See Fig. 21. Install lower timing chain guides. Tighten retaining bolts to specification. See TORQUE SPECIFICATIONS table at end of article.

4) Install oil pump spacer (if removed). Apply a .08-.12" (2-3 mm) diameter bead of sealant to front cover. DO NOT apply sealant to outer groove on front cover. See Fig. 25. Install front cover. Tighten retaining bolts to specification. See TORQUE SPECIFICATIONS table. Clean sealant from top and bottom of front cover at cylinder block.

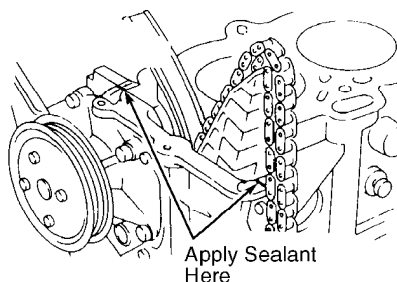
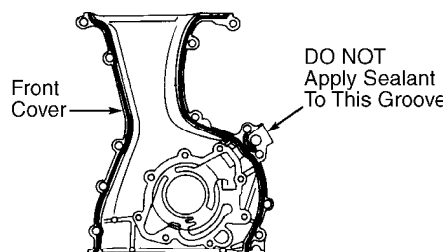

92C00440  
Fig. 25: Applying Sealant to Front Cover  
Courtesy of Nissan Motor Co., U.S.A.

5) Install front engine mount. Tighten bolts to specification. See TORQUE SPECIFICATIONS table. Coat seal lip of new

front cover oil seal with engine oil. Install crankshaft pulley.

6) Coat crankshaft pulley retaining bolt threads and seat area below head of bolt with oil. Install and tighten retaining bolt to specification. See TORQUE SPECIFICATIONS table.

7) Rotate crankshaft until No. 1 cylinder is at TDC of compression stroke and timing mark pointer on front cover aligns with "0" mark on crankshaft pulley.

8) Install new "O" ring, oil pump pick-up tube and baffle plate. Tighten bolts to specification. See TORQUE SPECIFICATIONS table. Install oil pan. See OIL PAN under REMOVAL & INSTALLATION.

9) Apply a .08-.12" (2-3 mm) diameter bead of sealant where front cover contacts cylinder block. See Fig. 25. Install cylinder head gasket and cylinder head.

**CAUTION:** Measure distance from bottom of head to end of bolt on all cylinder head-to-cylinder block bolts before installing. Cylinder head bolt must be replaced if distance exceeds 6.228" (158.19 mm).

10) Coat all cylinder head bolt threads and seat area below head of bolt with oil. Install and tighten cylinder head-to-cylinder block bolts to specification in sequence using cylinder head bolt wrench. See Fig. 24. See TORQUE SPECIFICATIONS table.

11) Install outside cylinder head bolts, located at front cover and near distributor. Install starter and necessary coolant hoses.

12) Coat camshaft and rocker arm components with engine oil. Install camshafts in cylinder head. Dowel pin should be at 12 o'clock position on left camshaft and 10 o'clock position on right camshaft. See Fig. 26.

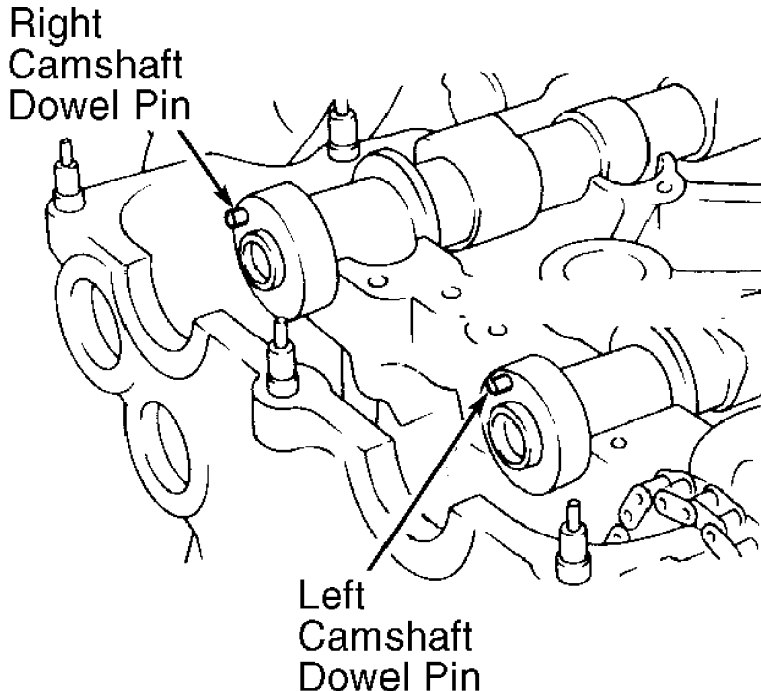

92D00441

Fig. 26: Installing Camshafts  
Courtesy of Nissan Motor Co., U.S.A.

13) Apply sealant to designated area on left camshaft rear camshaft bearing cap. See Fig. 27. Install all camshaft bearing caps

in original locations.

**CAUTION:** Ensure camshaft bearing caps are installed with arrow pointing toward timing chain side of engine. No. 1-4 bearing caps are numbered for location with No. 1 at timing chain side. Rear (end) camshaft bearing caps are not numbered.

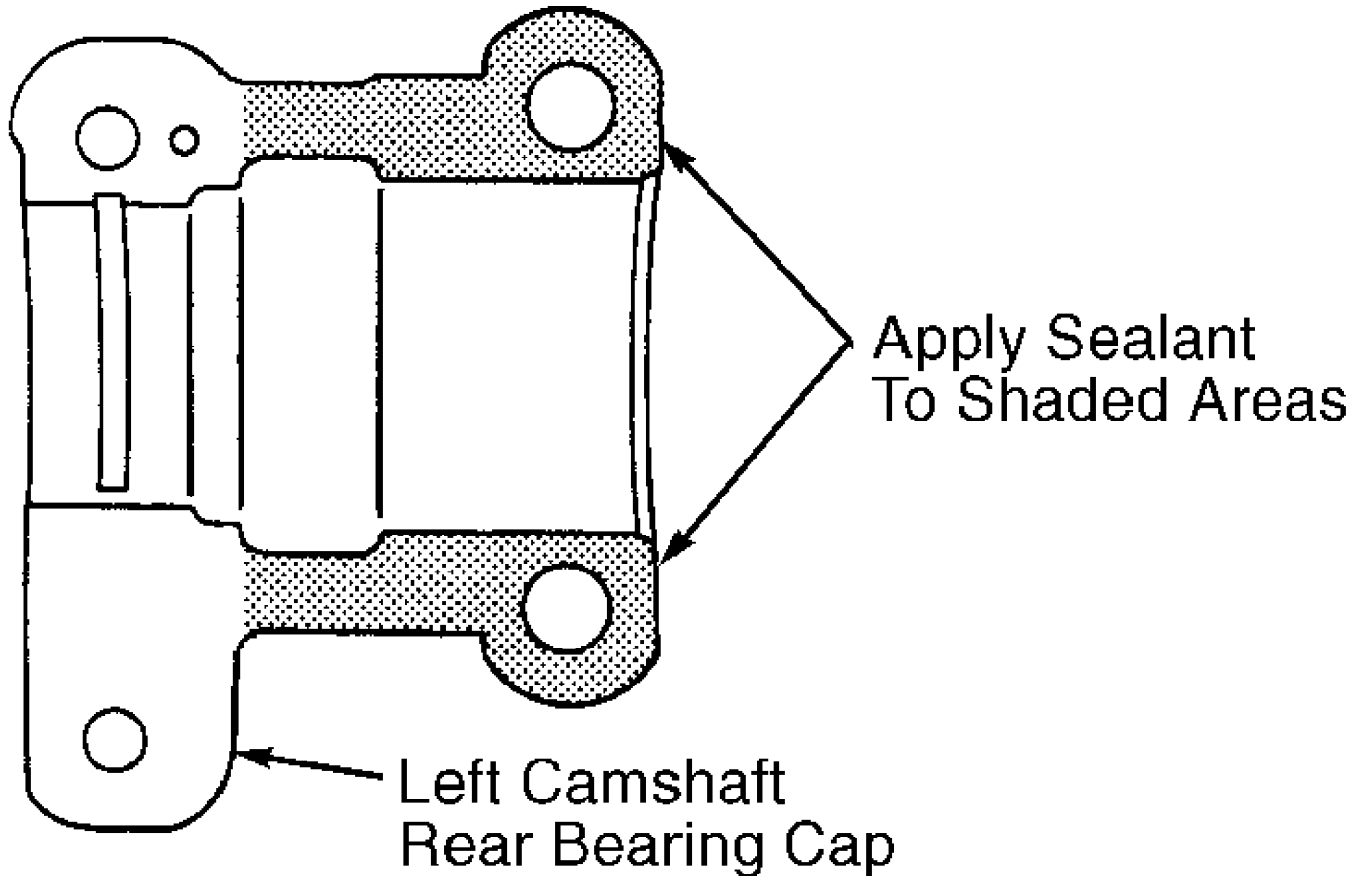

**92E00442**

Fig. 27: Applying Sealant to Left Camshaft Rear Camshaft Bearing Cap  
Courtesy of Nissan Motor Co., U.S.A.

14) Coat camshaft bearing cap bolt threads and seat area below head of bolt with oil. Install and tighten camshaft bearing cap bolts to specification in sequence. See Fig. 23. See TORQUE SPECIFICATIONS table.

15) Ensure camshaft end play is within specification. See CAMSHAFT table under ENGINE SPECIFICATIONS at end of article.

**CAUTION:** DO NOT rotate crankshaft or camshafts with timing chain removed or engine damage may result.

16) Install timing chain and camshaft sprockets. Ensure timing marks on camshaft sprockets are aligned with timing marks (silver links) on timing chain. See Fig. 21.

17) Coat camshaft sprocket retaining bolt threads and seat area below head of bolt with oil. Install and tighten camshaft sprocket retaining bolts to specification while holding camshaft. See TORQUE SPECIFICATIONS table.



18) Install upper timing chain guide. Tighten retaining bolt to specification. See TORQUE SPECIFICATIONS table. Ensure slot in camshaft is properly positioned, and install distributor. See Fig. 28.

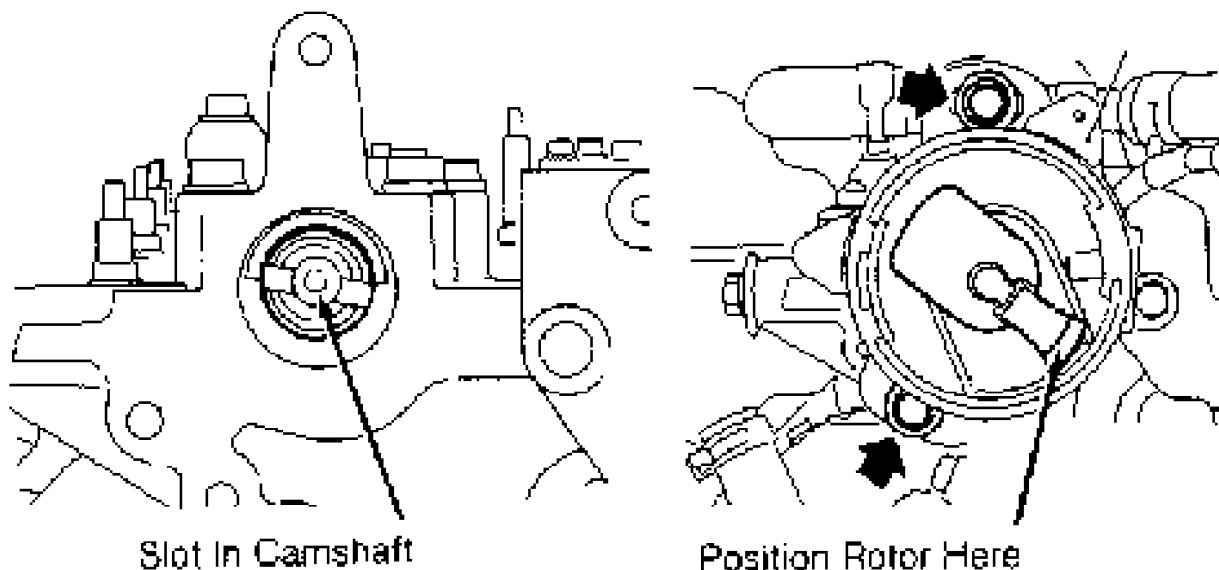

Fig. 28: Positioning Camshaft & Installing Distributor  
Courtesy of Nissan Motor Co., U.S.A.

19) Press cam stopper downward on timing chain tensioner and press sleeve inward until hook can be engaged on pin. See Fig. 29. This will hold timing chain tensioner in retracted position for installation.

20) Coat timing chain tensioner with engine oil. Install new "O" ring, timing chain tensioner and gasket. Tighten retaining bolt/nut to specification. See TORQUE SPECIFICATIONS table.

**CAUTION:** Timing chain tensioner must be installed with arrow pointing toward timing chain side of engine. Arrow is located between bolt holes on outside of timing chain tensioner. See Fig. 29. Timing chain tensioner will release automatically when installed on cylinder head.

21) Install oil filter and power steering pump brackets. Tighten bolts to specification. See TORQUE SPECIFICATIONS table. Apply sealant to designated area on valve cover gasket and cylinder head. See Fig. 30. Install gasket, valve cover and oil separator. Tighten valve cover nuts to specification in sequence. See Fig. 20.

22) To install remaining components, reverse removal procedure. Tighten bolts to specification. See TORQUE SPECIFICATIONS table. Adjust fluid levels. Fill and bleed cooling system. See COOLING SYSTEM BLEEDING under REMOVAL & INSTALLATION.

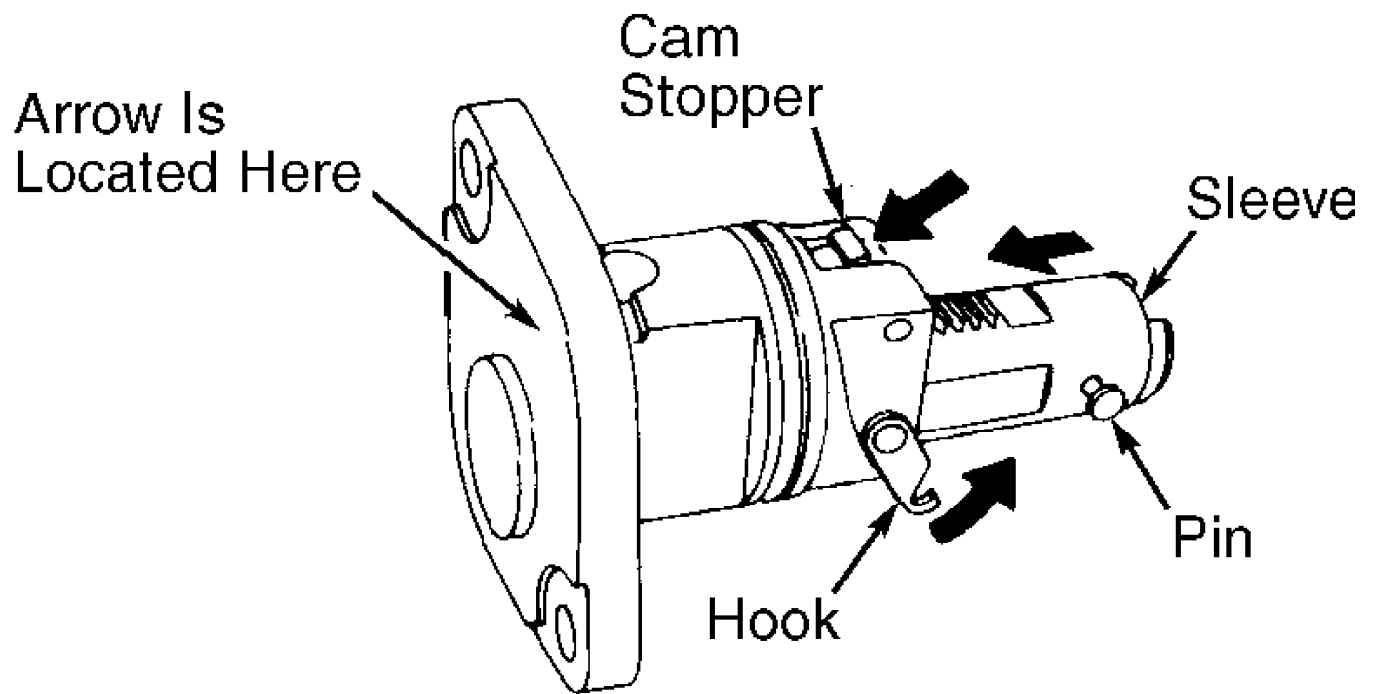

92G00444

Fig. 29: Retracting Timing Chain Tensioner  
 Courtesy of Nissan Motor Co., U.S.A.

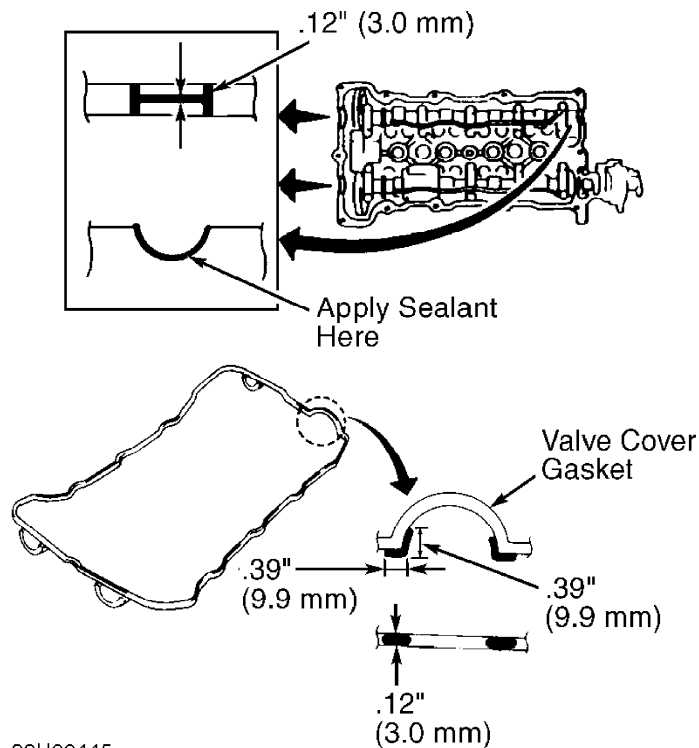

92H00445

Fig. 30: Applying Valve Cover Gasket Sealant  
 Courtesy of Nissan Motor Co., U.S.A.

**FRONT COVER OIL SEAL R & I**

#### Removal

1) Raise and support vehicle. Remove lower engine cover. Remove right front wheel and engine side cover. Remove accessory drive belts. Remove crankshaft pulley retaining bolt.

2) Using puller, remove crankshaft pulley. Pry front cover oil seal from front cover. Use care not to scratch front cover or crankshaft sealing surfaces. Note direction of oil seal installation.

#### Installation

1) Coat seal lip of new front cover oil seal with engine oil. Using suitable diameter oil seal installer, install front cover oil seal.

2) Install crankshaft pulley. Coat crankshaft pulley retaining bolt threads and seat area below head of bolt with oil. Install and tighten retaining bolt to specification. See TORQUE SPECIFICATIONS table at end of article. To install remaining components, reverse removal procedure.

### **TIMING CHAIN R & I**

**NOTE:** Cylinder head must be removed for front cover removal and access to timing chain. Cylinder head can be removed with intake and exhaust manifolds installed.

#### Removal

Manufacturer recommends cylinder head removal along with timing chain removal. Once camshaft sprockets are removed, timing chain is loose and must be properly reinstalled during cylinder head installation procedure. See CYLINDER HEAD under REMOVAL & INSTALLATION.

#### Inspection

1) Inspect timing chain, timing chain guides and all sprockets for damage. Replace components if damaged. Inspect cylinder head warpage and cylinder head bolts. See CYLINDER HEAD under REMOVAL & INSTALLATION.

2) Inspect camshaft and components. See CAMSHAFT under REMOVAL & INSTALLATION.

#### Installation

Install timing chain and cylinder head. See CYLINDER HEAD under REMOVAL & INSTALLATION. Fill and bleed cooling system. See COOLING SYSTEM BLEEDING under REMOVAL & INSTALLATION.

### **ROCKER ARM & LASH ADJUSTER R & I**

#### Removal

1) Camshaft must be removed for rocker arm and lash adjuster removal. Manufacturer recommends camshaft removal along with timing chain removal.

2) Once camshaft sprockets are removed, timing chain is loose and must be properly reinstalled during camshaft installation. Cylinder head must be removed for timing chain removal. See CYLINDER HEAD under REMOVAL & INSTALLATION. With camshaft removed, remove rocker arm, rocker arm guide, shim and lash adjuster. See Fig. 2.

**CAUTION:** Mark component location for reassembly reference. Components must be installed in original locations. Store lash adjusters in vertical position. If lash adjusters are not stored in vertical position, they must be stored in new engine oil to prevent air from entering lash adjuster.

#### Inspection

Inspect components for damage. Ensure lash adjuster diameter, bore diameter and oil clearance are within specification. See LASH ADJUSTER table under ENGINE SPECIFICATIONS at end of article.

#### Installation

1) To install, reverse removal procedure. Coat components with engine oil before installing. Ensure components are installed in original locations.

NOTE: Always install a new rocker arm guide.

2) With lash adjuster and rocker arm components installed, note amount of rocker arm movement when pushing downward at lash adjuster location.

CAUTION: Lash adjuster must be manually bled if rocker arm moves at least .04" (1.0 mm). Air cannot be bled from lash adjuster by engine operation.

3) Remove lash adjuster. Fully submerge lash adjuster in clean engine oil with rocker arm end of lash adjuster pointing up. Install small diameter rod in hole at rocker arm end of lash adjuster.

4) Lightly push check ball downward while pushing lash adjuster up and down to bleed air from lash adjuster. Air is bled when plunger in lash adjuster will no longer move. Reinstall components in original locations.

NOTE: Valve clearance adjustment must be performed when cylinder head, rocker arm guide, shim, valve or valve seats are replaced. See VALVE CLEARANCE ADJUSTMENT under ADJUSTMENTS.

## **CAMSHAFT R & I**

#### Removal

Manufacturer recommends camshaft removal along with timing chain removal. Once camshaft sprockets are removed, timing chain is loose and must be properly reinstalled during camshaft installation. Cylinder head must be removed for timing chain removal. See CYLINDER HEAD under REMOVAL & INSTALLATION.

#### Inspection

1) Inspect components for damage. Measure camshaft lobe height, journal diameter, journal runout, bore diameter and oil clearance. Replace camshaft or cylinder head if not within specification. See CAMSHAFT table under ENGINE SPECIFICATIONS at end of article.

2) Install camshaft in cylinder head. Ensure end play is within specification. Replace camshaft/cylinder head if end play is not within specification. See CAMSHAFT table under ENGINE SPECIFICATIONS.

3) Install camshaft sprockets. Using dial indicator, check camshaft sprocket runout near timing chain area on face of camshaft sprocket. Replace camshaft sprocket if runout exceeds .0098" (.249 mm).

#### Installation

Coat camshaft with engine oil before installing. Install camshaft using installation procedure listed in CYLINDER HEAD under REMOVAL & INSTALLATION.

## **REAR CRANKSHAFT OIL SEAL R & I**

#### Removal

Remove transaxle, clutch assembly (if equipped) and flywheel/drive plate. Pry rear crankshaft oil seal from oil seal retainer. Use care not to scratch oil seal retainer or crankshaft sealing surfaces. Note direction of oil seal installation.

#### Installation

Coat seal lip of new rear crankshaft oil seal with engine oil. Using suitable diameter oil seal installer, install rear crankshaft oil seal. To install remaining components, reverse removal procedure. See TORQUE SPECIFICATIONS table at end of article.

### WATER PUMP R & I

#### Removal & Installation

1) Drain cooling system. Remove accessory drive belts. Remove retaining bolts and water pump. To install, ensure all sealing surfaces are clean.

2) Apply bead of sealant to water pump, and install water pump. Tighten retaining bolts to specification. See TORQUE SPECIFICATIONS table at end of article.

3) To install remaining components, reverse removal procedure. Fill and bleed cooling system. See COOLING SYSTEM BLEEDING under REMOVAL & INSTALLATION.

### OIL PAN R & I

#### Removal

1) Raise and support vehicle. Remove lower engine cover. Drain engine oil. Remove lower oil pan retaining bolts in proper sequence. See Fig. 31.

2) Install Seal Cutter (KV10111100) between lower oil pan and upper oil pan. Using hammer, tap seal cutter around oil pan surface to loosen seal between both oil pans. Remove lower oil pan.

CAUTION: DO NOT insert screwdriver between upper and lower oil pans or oil pan flange may be distorted.

3) Remove retaining bolts and baffle plate. See Fig. 32. Remove exhaust pipe located below oil pan. Support transaxle using transmission jack. Support engine using engine hoist. Remove retaining bolts and crossmember.

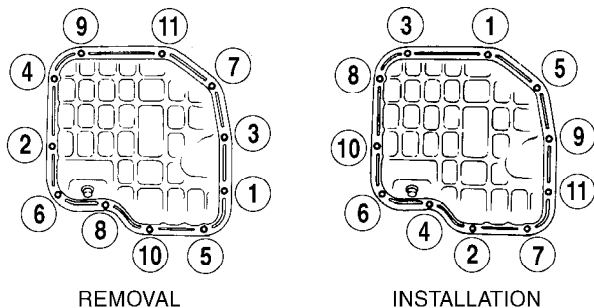

92J00447

Fig. 31: Lower Oil Pan Bolt Removal & Installation Sequence  
Courtesy of Nissan Motor Co., U.S.A.

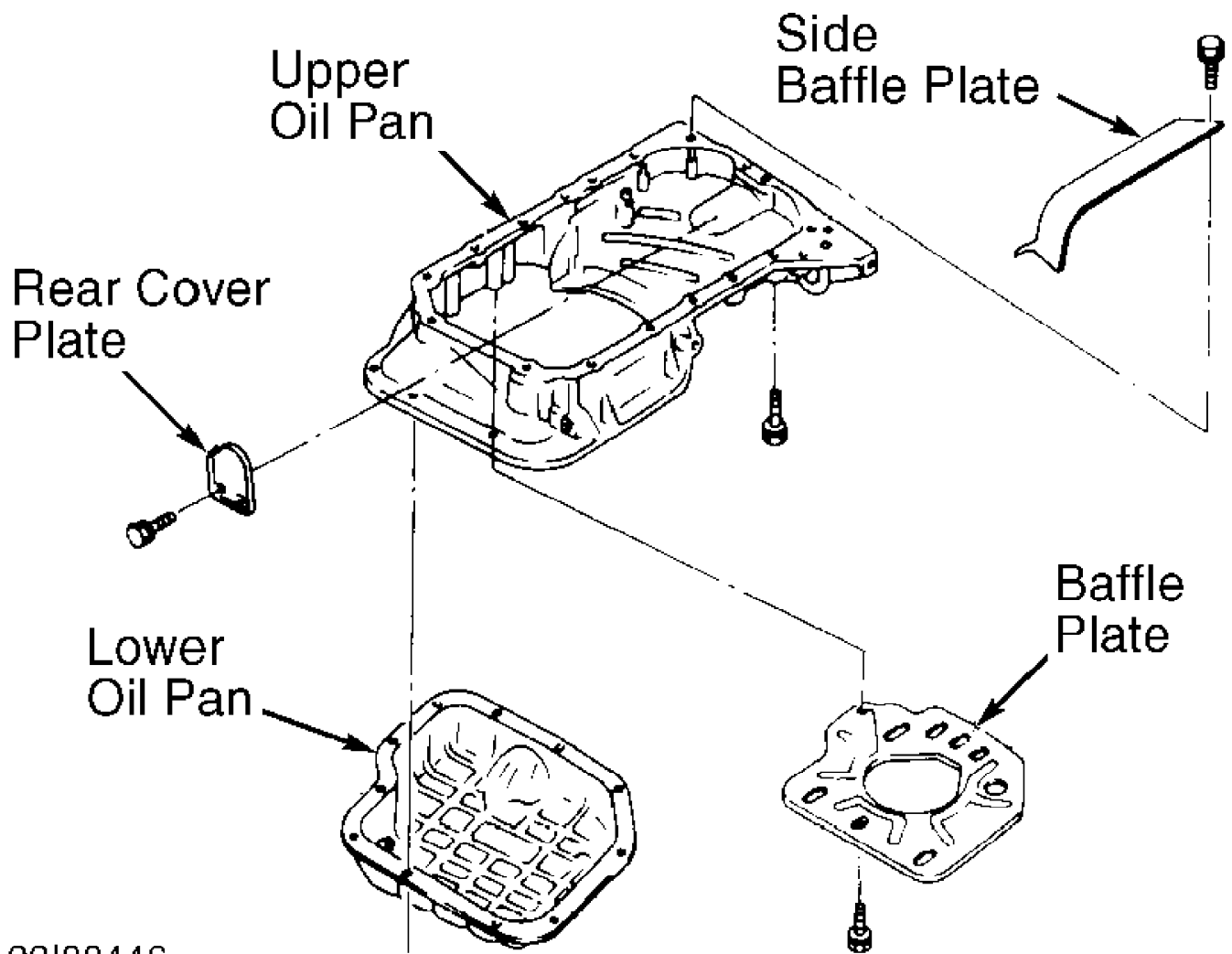

92100446

Fig. 32: Exploded View of Oil Pan Assembly  
 Courtesy of Nissan Motor Co., U.S.A.

4) On A/T models, disconnect shift control cable. On all models, remove A/C compressor retaining bolts at upper oil pan. Remove rear cover plate. See Fig. 32.

5) Remove upper oil pan retaining bolts in sequence. See Fig. 33. Remove 2 engine-to-transaxle bolts, and reinstall in proper holes of upper oil pan. See Fig. 34. Tighten bolts to release upper oil pan from cylinder block.

6) Install Seal Cutter (KV10111100) between upper oil pan and cylinder block. Using hammer, tap seal cutter around oil pan surface to loosen seal between upper oil pan and cylinder block. Remove upper oil pan. Remove bolts which were installed to release upper oil pan.

**CAUTION:** DO NOT insert screwdriver between upper oil pan and cylinder block or oil pan flange may be distorted.

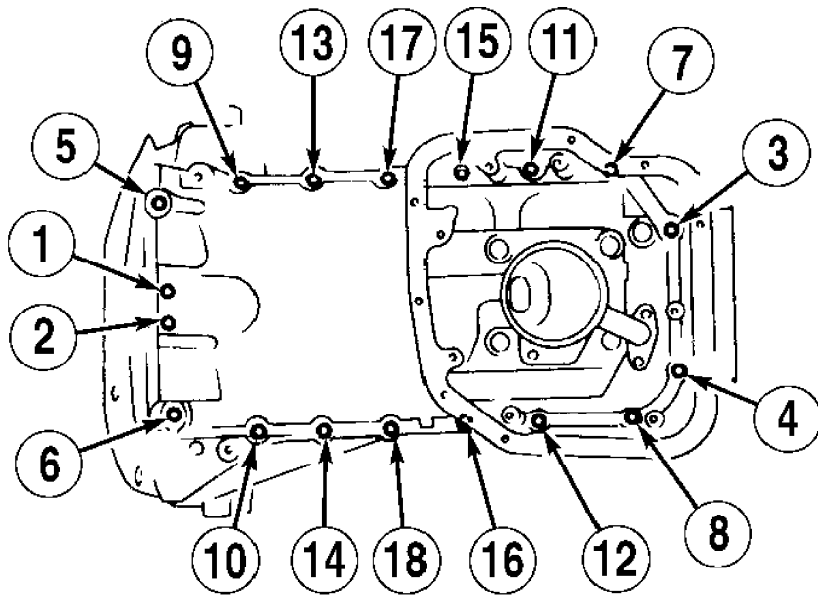

REMOVAL

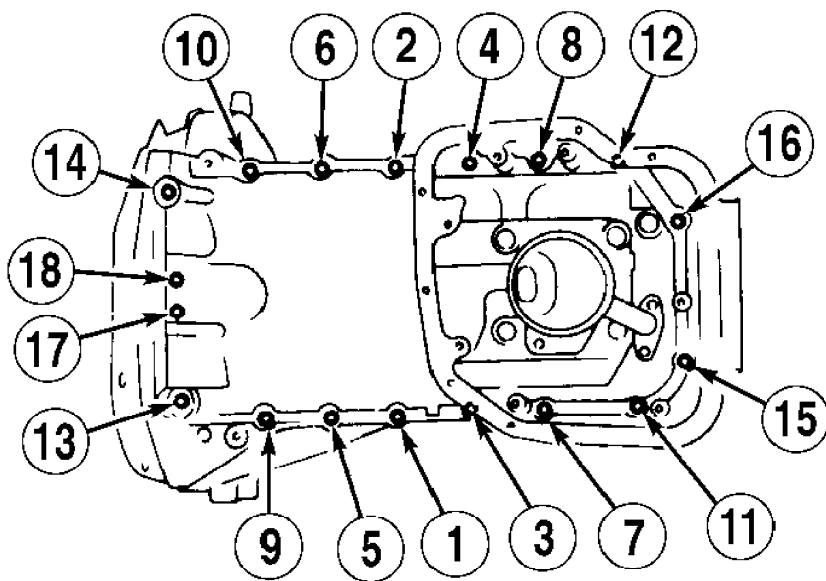

INSTALLATION

Tighten Bolts No. 1-16 To 12-14 Ft. Lbs. (16-19 N.m)

Tighten Bolts No. 17 & 18 To 56-66 INCH Lbs. (6-7 N.m)

92A00448

Fig. 33: Upper Oil Pan Bolt Removal & Installation Sequence  
 Courtesy of Nissan Motor Co., U.S.A.

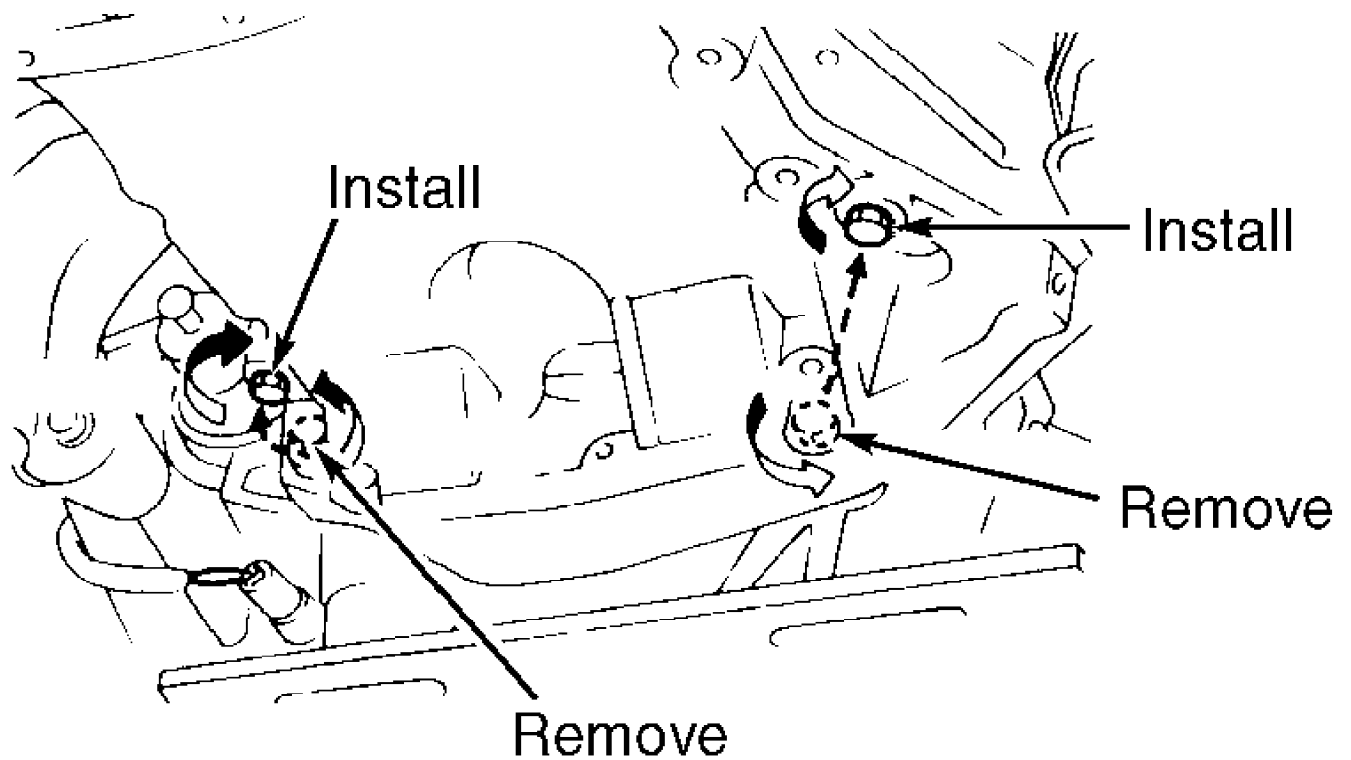

## 92B00449

Fig. 34: Releasing Upper Oil Pan from Cylinder Block  
 Courtesy of Nissan Motor Co., U.S.A.

### Installation

1) Apply a continuous .157-.197" (3.99-5.00 mm) diameter bead of sealant to groove on upper oil pan sealing surface. Ensure sealant is positioned on outside surface of proper bolt holes. See Fig. 35.

2) Install upper oil pan. Tighten retaining bolts to specification in sequence. See Fig. 33. Install 2 engine-to-transaxle bolts. Install retaining bolts and rear cover plate. Tighten retaining bolts to specification. See TORQUE SPECIFICATIONS table at end of article.

3) Install A/C compressor retaining bolts at upper oil pan. On A/T models, reconnect shift control cable. On all models, install crossmember and baffle plate. Tighten bolts to specification. See TORQUE SPECIFICATIONS table.

4) Install exhaust pipe located below oil pan. Apply a continuous .157-.197" (3.99-5.00 mm) diameter bead of sealant to groove on lower oil pan sealing surface. Ensure sealant is positioned on inside of bolt holes.

5) Install lower oil pan. Tighten retaining bolts to specification in sequence. See Fig. 31. See TORQUE SPECIFICATIONS table. Wait at least 30 minutes, and then refill with engine oil.

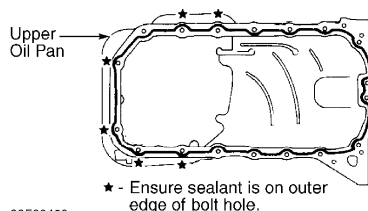

Fig. 35: Applying Sealant on Upper Oil Pan  
 Courtesy of Nissan Motor Co., U.S.A.



## OVERHAUL

### CYLINDER HEAD

CAUTION: Valve clearance adjustment must be performed when cylinder head, valve or valve seats are replaced. See VALVE CLEARANCE ADJUSTMENT under ADJUSTMENTS.

1) Inspect cylinder head warpage at cylinder block area. Replace or resurface cylinder head if warpage exceeds specification. Ensure cylinder head height is within specification after machining. See CYLINDER HEAD table under ENGINE SPECIFICATIONS at end of article.

CAUTION: DO NOT machine more than .008" (.20 mm) total from cylinder head and cylinder block deck surface.

2) Ensure lash adjuster bore diameter in cylinder head and lash adjuster oil clearance are within specification. See LASH ADJUSTER table under ENGINE SPECIFICATIONS at end of article.

### VALVE SPRINGS

Ensure valve spring free length, pressure and out-of-square are within specification. See VALVES & VALVE SPRINGS table under ENGINE SPECIFICATIONS at end of article.

CAUTION: Install valve springs with tightest coil area or paint mark toward cylinder head.

### VALVE STEM OIL SEALS

Lubricate valve stem oil seal with engine oil. Install oil seal using Oil Seal Installer (J-38958 for intake or J-38971 for exhaust valves). Ensure valve stem oil seal is positioned so distance from top of valve stem oil seal to cylinder head surface is .421" (10.69 mm). See Fig. 36.

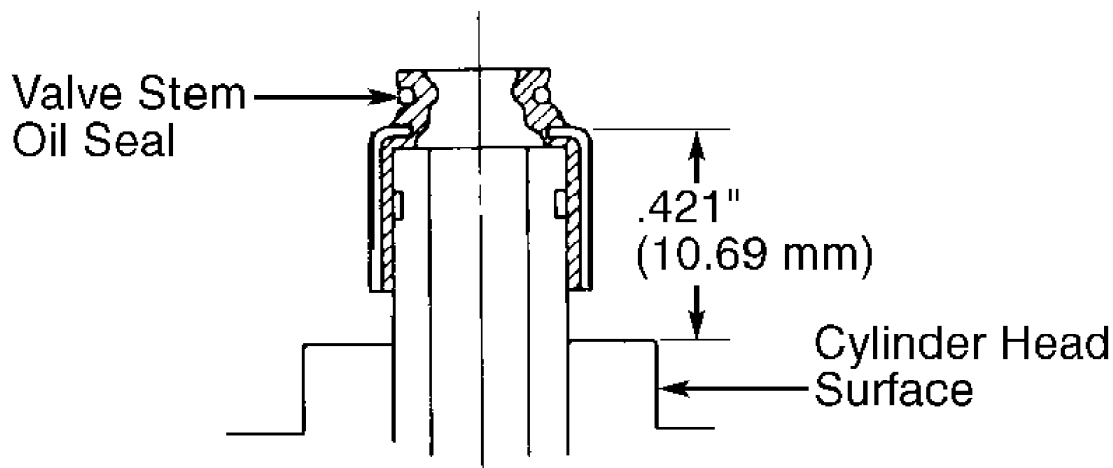

92G00451

Fig. 36: Installing Valve Stem Oil Seal  
Courtesy of Nissan Motor Co., U.S.A.

### VALVE GUIDES

1) Check valve stem-to-valve guide clearance. See CYLINDER HEAD table under ENGINE SPECIFICATIONS at end of article. Ensure valve stem diameter is within specification. Valve guide can be replaced if clearance exceeds specification.

2) To replace valve guide, heat cylinder head to 230-266°F (110-130°C). Using hammer and drift, drive valve guide from combustion side of cylinder head. Using reamer, ream cylinder head valve guide bore to .4006-.4014" (10.175-10.196 mm).

3) Heat cylinder head to 230-266°F (110-130°C). Press valve guide in cylinder head until valve guide installed height is within specification. See Fig. 37. Using reamer, ream valve guide bore to .2362-.2369" (5.999-6.018 mm).

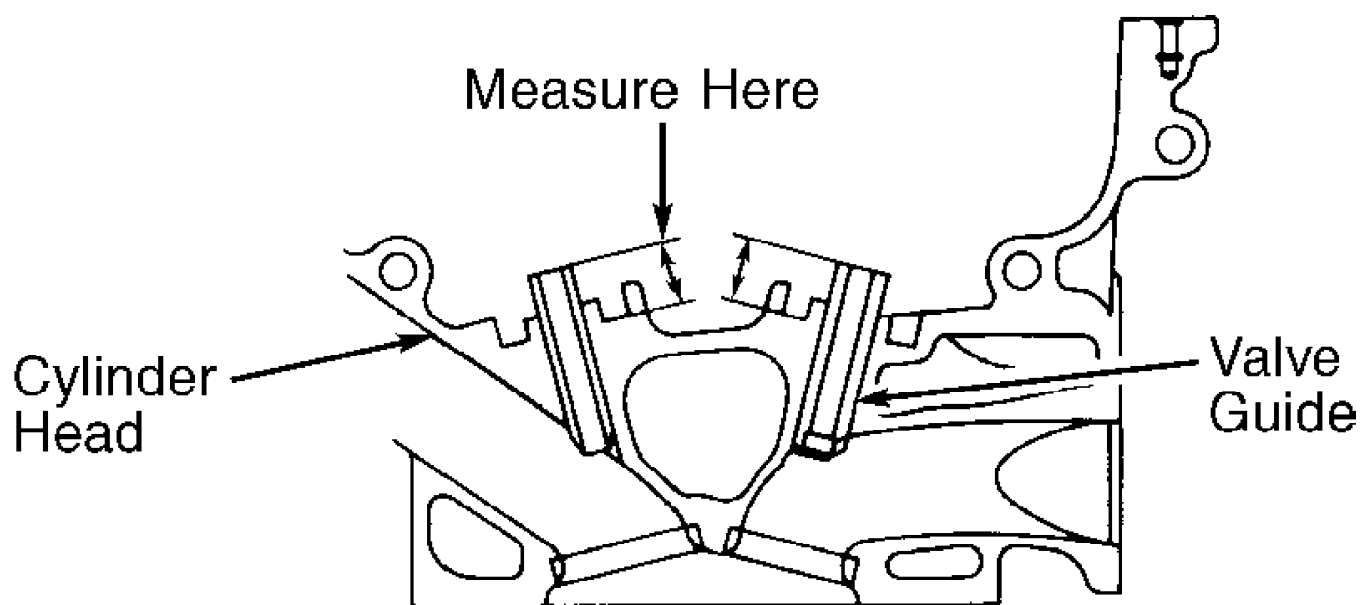

## 92H00452

Fig. 37: Installing Valve Guide  
Courtesy of Nissan Motor Co., U.S.A.

### VALVE SEAT

1) Ensure valve seat angle and seat width are within specification. See CYLINDER HEAD table under ENGINE SPECIFICATIONS at end of article. Valve seat can be replaced if damaged.

2) To replace valve seat, ream valve seat until valve seat collapses. Cylinder head must be reamed for replacement valve seat. Adjust reaming machine depth stop so cylinder head will not be reamed beyond bottom face of valve seat recess in cylinder head.

3) Ream cylinder head valve seat bore diameter to 1.3976-1.3983" (35.499-35.517 mm) for intake or 1.2402-1.2408" (31.501-31.516 mm) for exhaust valves.

4) Heat cylinder head to 230-266°F (110-130°C). Press replacement valve seat in cylinder head until it bottoms in cylinder head. Cut replacement valve seat to proper angle and seat width. See CYLINDER HEAD table under ENGINE SPECIFICATIONS.

### VALVES

Ensure valve head diameter, stem diameter and margin are within specification. See VALVES & VALVE SPRINGS table under ENGINE SPECIFICATIONS at end of article.

CAUTION: Head diameters of valves are relatively close. Ensure proper valve is installed in correct location. Valves can be identified by identification mark located in center of valve head. Intake valve is marked "53J" and exhaust valve is marked "64Y".

## VALVE SEAT CORRECTION ANGLES

Information is not available from manufacturer.

## VALVE TRAIN

### LASH ADJUSTER

1) Ensure lash adjuster bore diameter, lash adjuster diameter and lash adjuster oil clearance are within specification. See LASH ADJUSTER table under ENGINE SPECIFICATIONS at end of article.

2) With lash adjuster and rocker arm components installed, note amount of rocker arm movement when pushing downward at lash adjuster location.

CAUTION: Lash adjuster must be manually bled if rocker moves at least .04" (1.0 mm). Air cannot be bled from lash adjuster by engine operation.

3) Remove lash adjuster. Fully submerge lash adjuster in clean engine oil with rocker arm end of lash adjuster pointing up. Install small diameter rod in hole at rocker arm end of lash adjuster.

4) Lightly push check ball downward while pushing lash adjuster up and down to bleed air from lash adjuster. Air is bled when plunger in lash adjuster will no longer move. Reinstall in original location.

## CYLINDER BLOCK ASSEMBLY

### Piston & Rod Assembly

1) If piston is to be removed from connecting rod, remove snap ring from piston. Heat piston to 140-158°F(60-70°C) in oil. Remove piston pin.

2) Ensure pin diameter is within specification. See PISTONS, PINS & RINGS table under ENGINE SPECIFICATIONS at end of article.

3) Ensure connecting rod piston pin bushing bore diameter is within specification. See CONNECTING RODS table under ENGINE SPECIFICATIONS at end of article. Bushing can be replaced in connecting rod if bore diameter is not within specification. Bushing must be reamed to obtain correct piston pin clearance.

4) To reassemble, install piston with front mark on top of piston toward timing chain side of engine and oil hole toward intake manifold side. See Fig. 38.

5) Install new snap ring in piston. Heat piston to 140-158°F (60-70°C) in oil. Install piston pin and remaining snap ring.

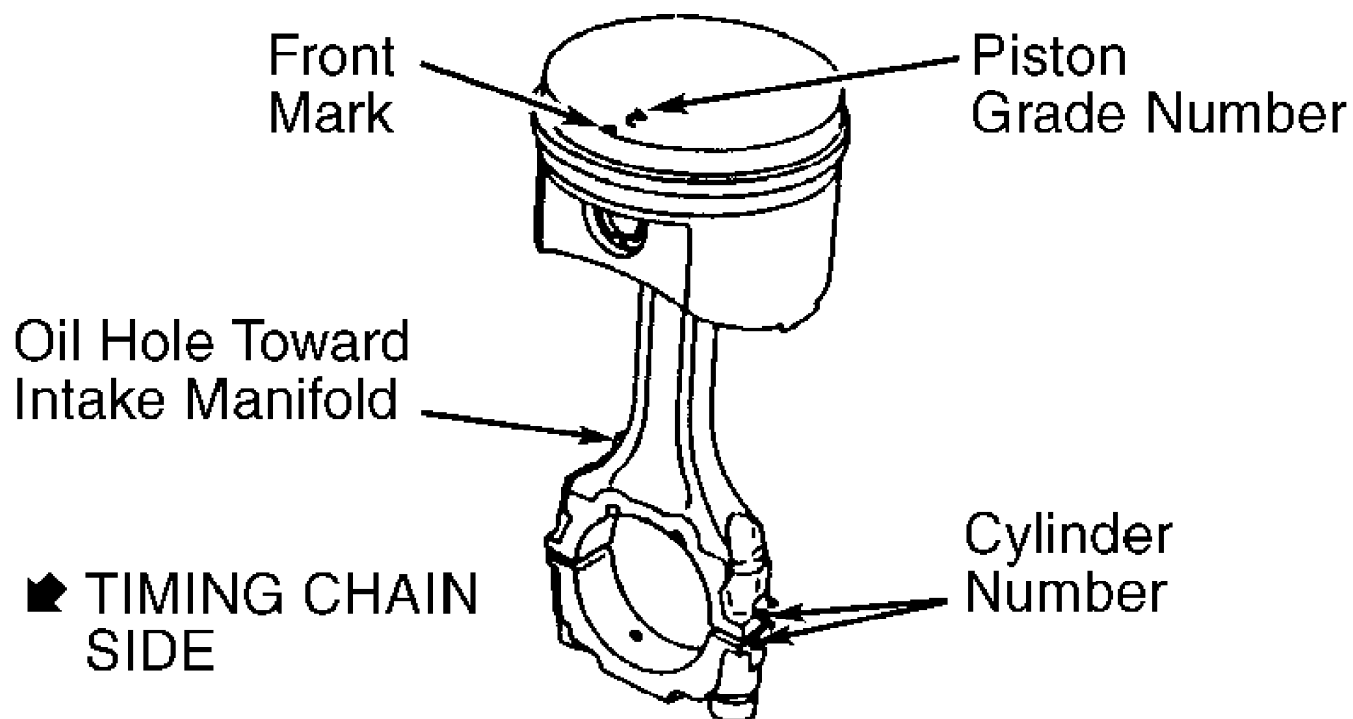

92J00453

Fig. 38: Aligning Piston & Connecting Rod  
 Courtesy of Nissan Motor Co., U.S.A.

NOTE: Three different standard piston sizes and cylinder bore diameters are used. Piston and cylinder bores sizes are marked using a No. 1, 2 or 3 grade number. Grade number is placed on top of piston or on cylinder block deck surface. See Fig. 39.

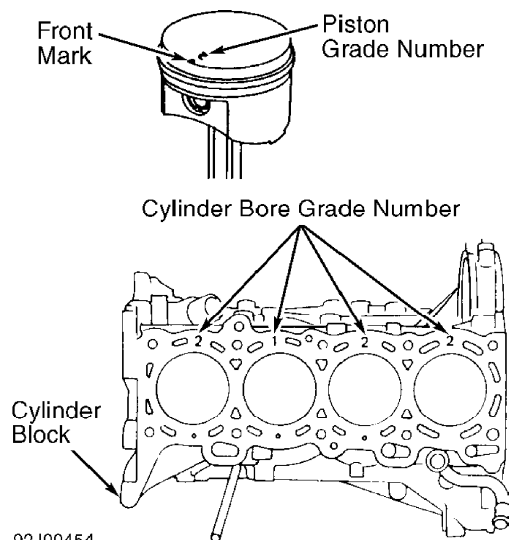

92J00454

Fig. 39: Identifying Piston & Cylinder Block Grade Number  
 Courtesy of Nissan Motor Co., U.S.A.

Fitting Pistons

- 1) To determine if piston-to-cylinder clearance is within

specification, measure piston skirt diameter at 90-degree angle to piston pin.

2) Measure piston diameter at .43" (11 mm) from bottom of piston skirt. Different sized standard pistons are used. Piston size can be identified by No. 1, 2 or 3 grade number stamped on top of piston. See Fig. 39.

3) Piston diameter must be within specification. See PISTONS, PINS & RINGS table under ENGINE SPECIFICATIONS at end of article.

4) Cylinder bore diameter is measured at .39" (10 mm), 2.36" (60 mm) and 3.94" (100 mm) from top of cylinder bore. Different cylinder bores are used and can be identified by No. 1, 2 or 3 grade number stamped on deck surface in accordance with cylinder location. See Fig. 39.

5) Cylinder bore diameter must be within specification. See CYLINDER BLOCK table under ENGINE SPECIFICATIONS at end of article. Determine piston clearance. Replace piston or bore cylinder block if clearance is not within specification. See PISTONS, PINS & RINGS table. Pistons are available in .0079" (.200 mm) oversize.

CAUTION: Ensure main bearing caps are installed with bolts tightened to specification when boring cylinder block.

#### Piston Rings

1) Ensure piston ring end gap and side clearance are within specification. See PISTONS, PINS & RINGS table under ENGINE SPECIFICATIONS at end of article.

2) Ensure identification punch marks on piston rings are toward top of piston. If no identification punch marks are used, piston rings can be installed with either side toward top of piston. Position piston rings at designated areas. See Fig. 40.

CAUTION: Top compression ring must be installed so chamfered edge on inside of ring is toward top of piston.

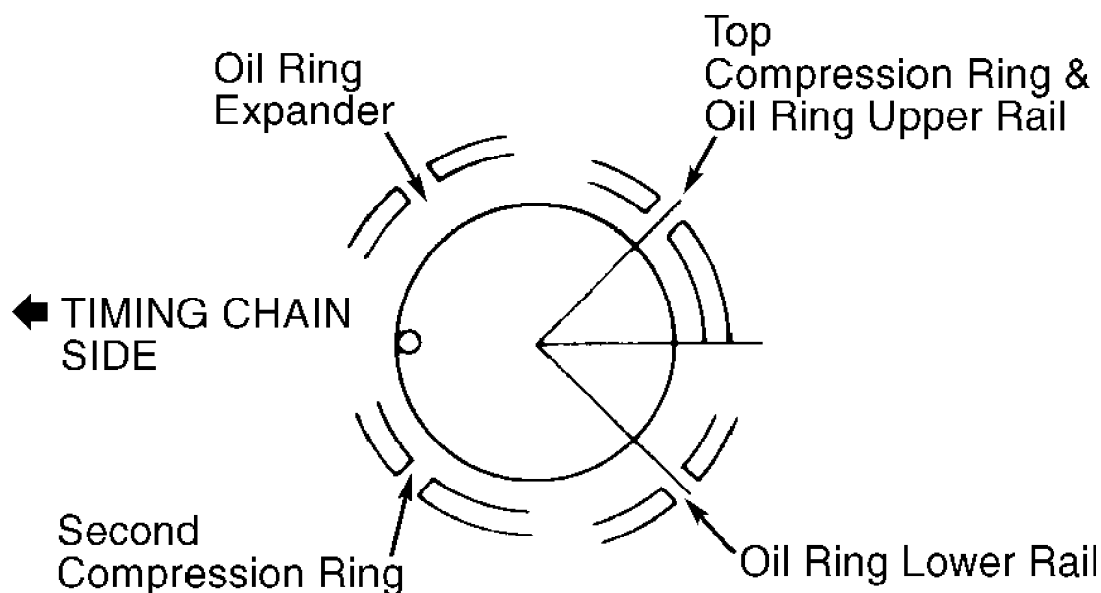

92A00455

Fig. 40: Positioning Piston Rings  
Courtesy of Nissan Motor Co., U.S.A.

#### Rod Bearings

1) Note direction of connecting rod and cap before

disassembly. Connecting rod must be installed with oil hole toward intake manifold side of engine. See Fig. 38. Coat connecting rod bolt threads and seat area of nut with oil before tightening to specification.

2) Ensure bearing oil clearance and connecting rod side play are within specification. See CRANKSHAFT, MAIN & CONNECTING ROD BEARINGS and CONNECTING RODS table under ENGINE SPECIFICATIONS at end of article.

3) If crankshaft is reused, select proper rod bearing to obtain correct bearing clearance. If crankshaft is replaced, note rod journal grade number stamped on crankshaft. See Fig. 41.

NOTE: Rod journal grade number is stamped on front of crankshaft on Type 1 crankshaft and on rear of crankshaft on Type 2 crankshaft. See Fig. 41.

4) Using rod journal grade number stamped on crankshaft, determine rod bearing grade number to be used. See ROD BEARING APPLICATION table.

ROD BEARING APPLICATION TABLE

Rod Journaling Grade No.	Rod Bearing Color Code	Rod Bearing Thickness In. (mm)
0	None	.0591-.0592 (1.501-1.504)
1	Black	.0592-.0593 (1.504-1.506)
2	Brown	.0593-.0594 (1.506-1.509)

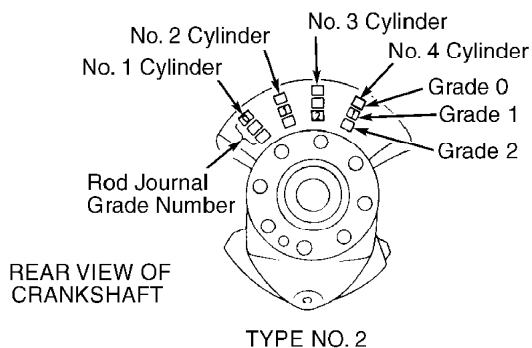
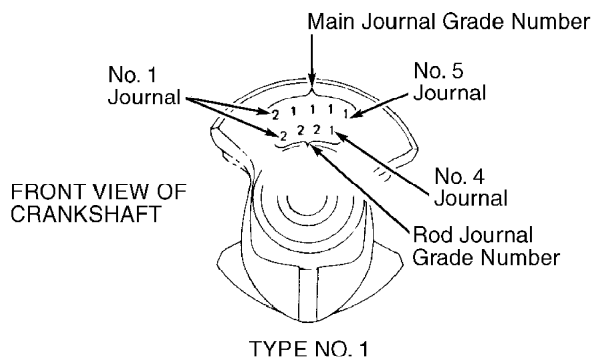

92B00456  
 Fig. 41: Identifying Rod Journal Grade Number  
 Courtesy of Nissan Motor Co., U.S.A.

Crankshaft & Main Bearings

1) Main bearing cap bolts must be loosened evenly in 3 steps

and proper sequence. See Fig. 42. Remove main bearing cap beam, located below main bearing caps.

CAUTION: Ensure main bearing caps are marked for location and direction of installation for reassembly reference before removing. Main bearing caps must be installed in original locations.

2) Ensure main bearing journal diameter, taper, runout and out-of-round are within specification. See CRANKSHAFT, MAIN & CONNECTING ROD BEARINGS table under ENGINE SPECIFICATIONS at end of article.

3) If crankshaft main bearing journals must be ground for undersize main bearings, ensure main bearing journal fillet roll exceeds .004" (.10 mm). See Fig. 43.

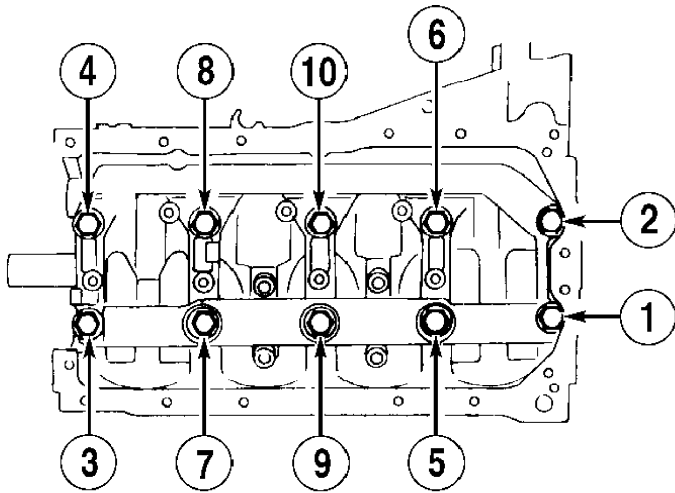

REMOVAL

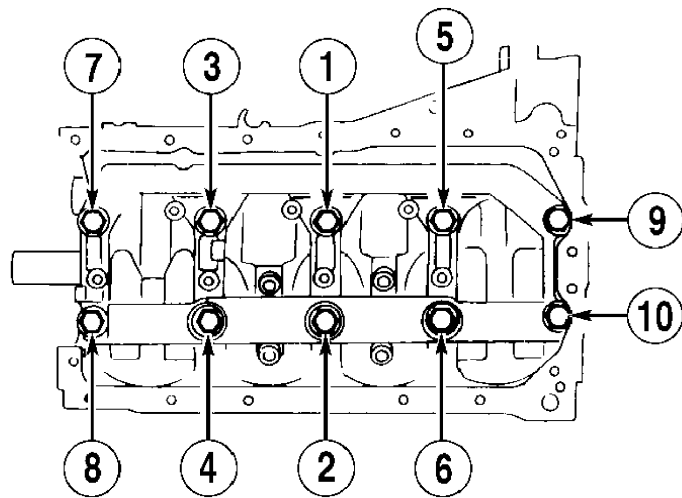

INSTALLATION

92C00457

Fig. 42: Main Bearing Bolt Removal & Installation Sequence  
Courtesy of Nissan Motor Co., U.S.A.

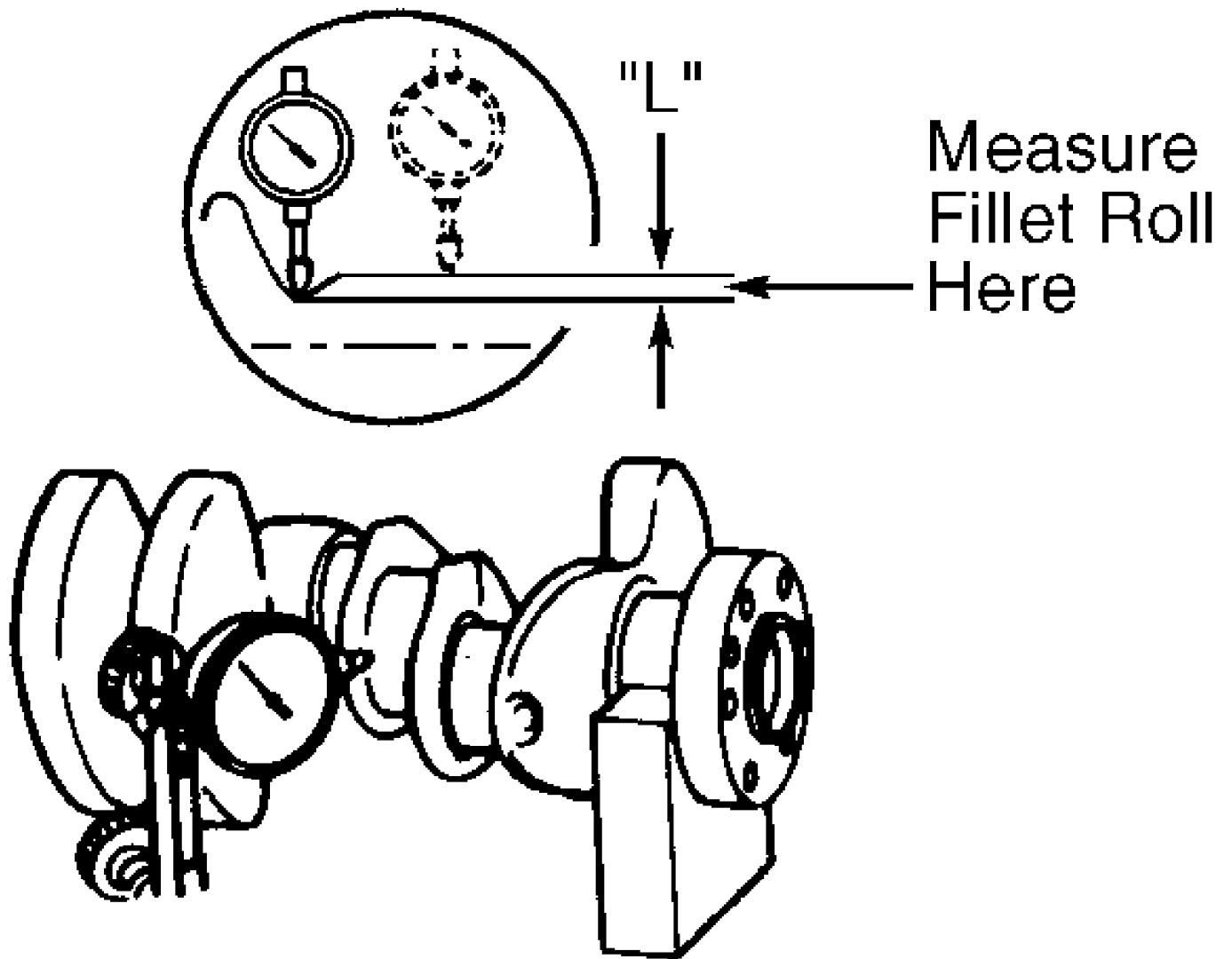

92D00458

Fig. 43: Measuring Main Bearing Journal Fillet Roll  
Courtesy of Nissan Motor Co., U.S.A.

4) If crankshaft is reused, select main bearing to obtain correct bearing clearance. See CRANKSHAFT, MAIN & CONNECTING ROD BEARINGS table.

5) If crankshaft is replaced, note main bearing journal grade number marked on rear corner of cylinder block and on front of crankshaft. See Fig. 44.



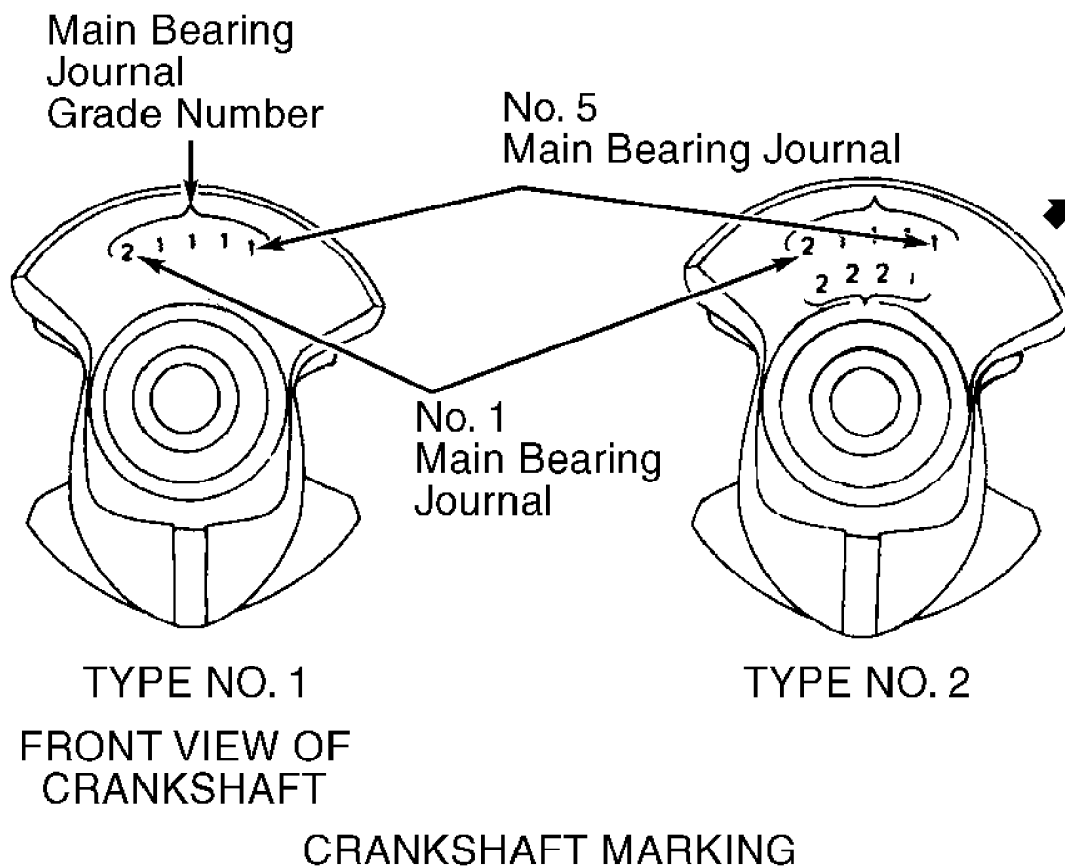
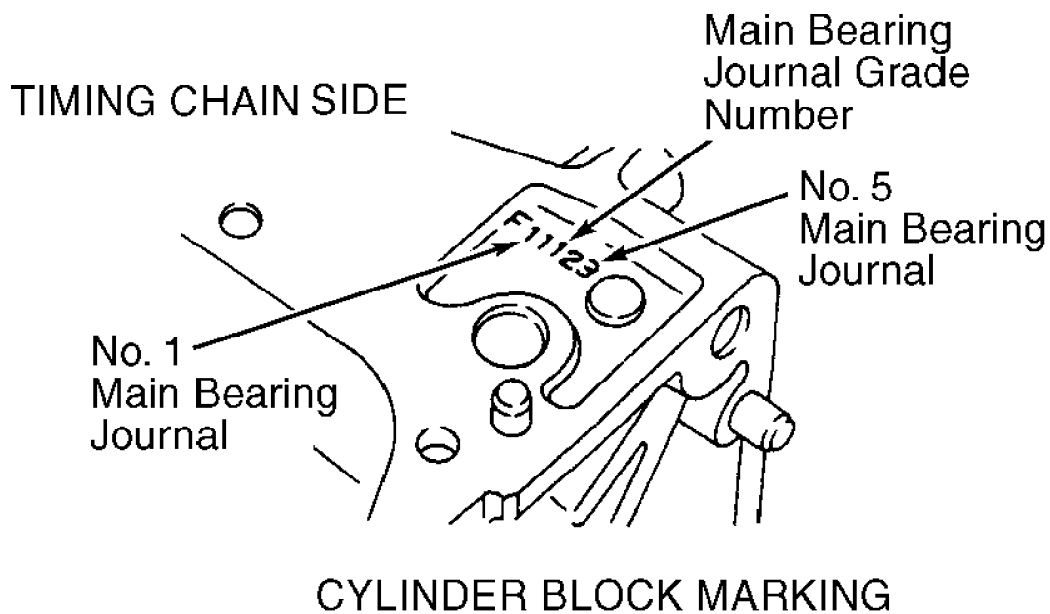

92E00459  
 Fig. 44: Identifying Main Bearing Journal Grade Number  
 Courtesy of Nissan Motor Co., U.S.A.

6) Using main journal grade numbers, determine main bearing grade number to be used. See MAIN BEARING APPLICATION table. For

example, if crankshaft grade number is 0 and cylinder block grade number is 0, use a grade number 0 main bearing with color code A-Black.

7) Main bearing grade number can be identified by bearing color code. See MAIN BEARING SPECIFICATIONS table.

MAIN BEARING APPLICATION TABLE

Crankshaft Grade Number	Cylinder Block Grade Number	Bearing Number & Color Code
0	0	0 (A-Black)
0	1	1 (B-Brown)
0	2	2 (C-Green)
0	3	3 (D-Yellow)
1	0	1 (B-Brown)
1	1	2 (C-Green)
1	2	3 (D-Yellow)
1	3	4 (E-Blue)
2	0	2 (C-Green)
2	1	3 (D-Yellow)
2	2	4 (E-Blue)
2	3	5 (F-Pink)
3	0	3 (D-Yellow)
3	1	4 (E-Blue)
3	2	5 (F-Pink)
3	3	6 (G-None)

MAIN BEARING SPECIFICATIONS TABLE

Grade Number	ID Mark & Color Code	Bearing Thickness In. (mm)
0	A-Black	.0778-.0780 (1.976-1.981)
1	B-Brown	.0780-.0781 (1.981-1.983)
2	C-Green	.0781-.0782 (1.983-1.986)
3	D-Yellow	.0782-.0783 (1.986-1.989)
4	E-Blue	.0783-.0784 (1.989-1.992)
5	F-Pink	.0784-.0785 (1.992-1.995)
6	G-None	.0785-.0787 (1.995-1.999)

8) Ensure main bearing caps are installed in original locations. Coat main bearing cap bolt threads and seat area of bolt with engine oil.

9) With all main bearing caps and main bearing cap beam installed, move crankshaft forward and backward to align all main bearings. Tighten main bearing cap bolts to specification in sequence. See Fig. 42. See TORQUE SPECIFICATIONS table at end of article.

10) Ensure crankshaft end play is within specification. See CRANKSHAFT, MAIN & CONNECTING ROD BEARINGS table. Replace thrust bearing if crankshaft end play is not within specification.

Thrust Bearing

Thrust bearing is installed on No. 3 main bearing. Thrust bearing must be replaced if crankshaft end play is not within specification. See CRANKSHAFT, MAIN & CONNECTING ROD BEARINGS table under ENGINE SPECIFICATIONS at end of article.

Cylinder Block

1) Inspect cylinder block deck surface warpage. Cylinder block must be resurfaced if warpage exceeds specification. Ensure

cylinder block deck height is within specification after machining.  
See CYLINDER BLOCK table under ENGINE SPECIFICATION at end of article.

CAUTION: DO NOT machine more than .008" (.20 mm) total from cylinder head and cylinder block deck surface.

2) Check cylinder bore wear, taper and out-of-round. Cylinder bore diameter is measured .39" (10 mm), 2.36" (60 mm) and 3.94" (100 mm) from top of cylinder bore. Different cylinder bores are used and can be identified by No. 1, 2 or 3 grade number stamped on deck surface in accordance with cylinder location. See Fig. 39.

3) Cylinder block can be bored if cylinder bore, taper or out-of-round are not within specification. See CYLINDER BLOCK table. Pistons are available in .0079" (.200 mm) oversize.

CAUTION: Ensure main bearing caps are installed with bolts tightened to specification when boring cylinder block.

4) Ensure main bearing bore I.D. is within specification with main bearing caps installed and bolts tightened to specification. See CYLINDER BLOCK table.

NOTE: Main bearing bore I.D. will depend on main bearing journal grade number stamped on top of cylinder block. See Fig. 44. Main bearing journal grade number may be 0, 1, 2 or 3.

## ENGINE OILING

### ENGINE LUBRICATION SYSTEM

Crankshaft driven oil pump provides pressurized lubrication for engine oiling. See Fig. 45.

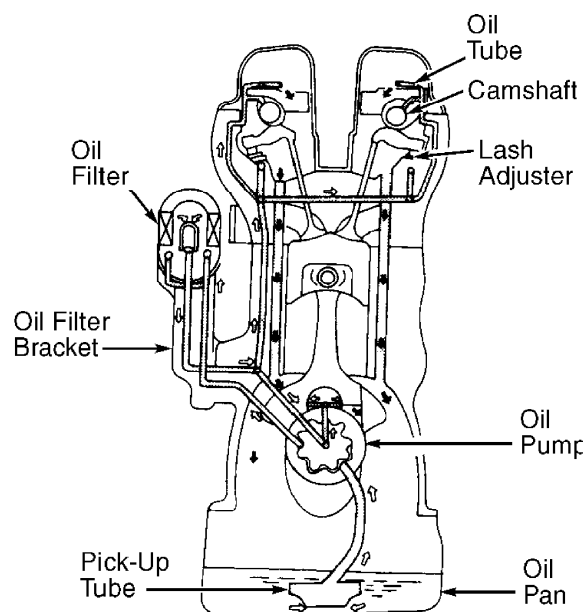

92H00460  
Fig. 45: Engine Oil Circuit  
Courtesy of Nissan Motor Co., U.S.A.

### CRANKCASE CAPACITY

Crankcase capacity with oil filter is 3.4 qts. (3.2L).

## OIL PRESSURE

With engine at normal operating temperature, oil pressure should be at least 11 psi (.8 kg/cm<sup>2</sup>) at idle or 46-57 psi (3.2-4.0 kg/cm<sup>2</sup>) at 3200 RPM.

## OIL PUMP R & I

### Removal & Disassembly

Oil pump is mounted in rear of front cover. Cylinder head must be removed for front cover removal. For front cover removal, see CYLINDER HEAD under REMOVAL & INSTALLATION. Disassemble oil pump from rear of front cover. See Fig. 46. Mark direction of component location for reassembly reference.

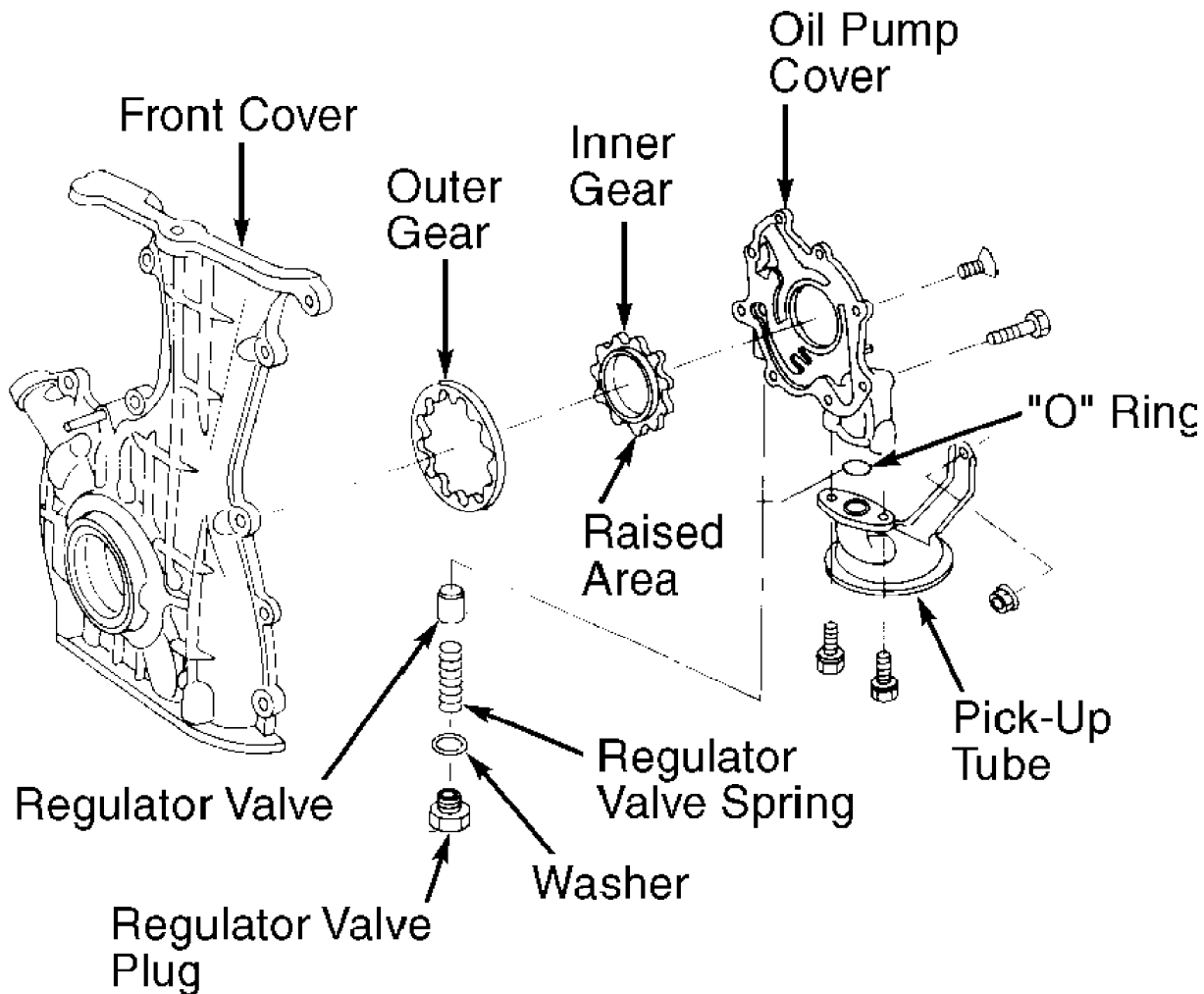

92100461

Fig. 46: Exploded View of Oil Pump Components  
Courtesy of Nissan Motor Co., U.S.A.

### Inspection

1) Inspect components for damage. Install inner and outer

gears in front cover. Using feeler gauge, measure outer gear-to-front cover clearance. Replace front cover if clearance exceeds specification. See OIL PUMP SPECIFICATIONS table.

2) Measure gear tip clearance between tip of inner gear and outer gear. Replace gear set if clearance exceeds specification.

3) Place straightedge across front cover above both gears. Measure inner and outer gear end clearance between straightedge and surface of both gears. Replace front cover if clearance exceeds specification.

4) Measure outside diameter of raised area on inner gear. See Fig. 46. Measure inside diameter of front cover where raised area on inner gear fits. Subtract raised area diameter from front cover diameter to determine inner gear-to-front cover clearance. Replace front cover if clearance exceeds specification.

5) Ensure regulator valve slides freely in oil pump cover bore. Measure regulator valve O.D. and oil pump cover bore I.D. Replace oil pump cover if regulator valve-to-oil pump cover clearance exceeds specification. See OIL PUMP SPECIFICATIONS table.

#### OIL PUMP SPECIFICATIONS TABLE

Application	In. (mm)
Gear Tip Clearance (Maximum) .....	0071 (.180)
Inner Gear End Clearance .....	.0020-.0035 (.051-.089)
Inner Gear-To-Front Cover Clearance .	.0018-.0036 (.046-.091)
Outer Gear End Clearance .....	.0020-.0043 (.051-.109)
Outer Gear-To-Front Cover Clearance .	.0045-.0079 (.114-.201)
Regulator Valve-To-Oil Pump Cover Clearance .....	.0016-.0038 (.041-.097)

#### Reassembly & Installation

1) Coat all components with engine oil. To reassemble, reverse disassembly. Ensure components are installed in original location. Tighten all bolts to specification. See TORQUE SPECIFICATIONS table at end of article.

2) To install, see procedure listed in CYLINDER HEAD under REMOVAL & INSTALLATION.

## TORQUE SPECIFICATIONS

#### TORQUE SPECIFICATIONS TABLE

Application	Ft. Lbs. (N.m)
Accel-Drum Unit Bolt .....	13-16 (18-22)
Axle Shaft Nut .....	174-231 (236-314)
Camshaft Bearing Cap Bolt .....	(1)
Camshaft Sprocket Bolt .....	101-116 (137-157)
Connecting Rod Nut	
Step 1 .....	10-12 (14-16)
Step 2 .....	28-33 (38-45)
Crankshaft Pulley Bolt .....	105-112 (142-152)
Crossmember Bolt .....	57-72 (77-98)
Cylinder Head Outside Bolt .....	(2)
Cylinder Head-To-Cylinder Block Bolt (3)	
Step 1 .....	29 (39)
Step 2 .....	58 (79)
Step 3 .....	Loosen All Bolts
Step 4 .....	25-33 (34-45)
Step 5 .....	Tighten Additional 90 Degrees

Step 6 .....	Tighten Additional 90 Degrees	
Exhaust Manifold Nut (4) .....	27-35 (37-47)	
Flywheel/Drive Plate Bolt .....	61-69 (83-94)	
Front Engine Mount Through Bolt .....	46-58 (62-79)	
Front Engine Mount-To-Front Cover Bolt .....	32-41 (43-56)	
Fuel Rail Bolt .....	(5)	
Intake Manifold Bolt (6) .....	13-15 (18-20)	
Intake Manifold Collector Bolt/Nut (6) .....	13-15 (18-20)	
Intake Manifold Support Brace Bolt .....	12-15 (16-20)	
Knock Sensor Bolt .....	15-20 (20-27)	
Main Bearing Cap Bolt (7)		
Step 1 .....	24-28 (33-38)	
Step 2 .....	54-61 (73-83)	
Oil Filter Bracket Bolt .....	12-14 (16-19)	
Oil Pump Pick-Up Tube Bolt .....	12-14 (16-19)	
Oxygen Sensor .....	13-17 (18-23)	
Power Steering Pump Bracket Bolt .....	33-44 (45-60)	
Regulator Valve Plug .....	29-51 (39-69)	
Right (Timing Chain Side) Engine		
Mount Through Bolt .....	32-41 (43-56)	
Spark Plug .....	14-22 (19-30)	
Steering Knuckle Upper Stud Nut .....	72-87 (98-118)	
Throttle Body Bolt		
Step 1 .....	(8)	
Step 2 .....	13-16 (18-22)	
Tie Rod-To-Steering Knuckle Nut .....	22-29 (30-39)	
Timing Chain Guide Bolt		
Lower Guide .....	10-14 (14-19)	
Upper Guide .....	12-14 (16-19)	
Torque Converter-To-Drive Plate Bolt .....	33-43 (45-58)	
Transaxle Mount Through Bolt .....	32-41 (43-56)	
Upper Oil Pan Bolt .....	(9)	
Valve Cover Nut .....	(10)	
Water Pump Bolt .....	12-15 (16-20)	
Wheel Lug Nut .....	72-87 (98-118)	

INCH Lbs. (N.m)

Air Relief Plug .....	72 (8)
Baffle Plate Bolt .....	56-66 (6-7)
Crankshaft Rear Seal Housing Bolt .....	56-72 (6-8)
Front Cover Bolt .....	56-66 (6-7)
Fuel Injector Clamp Bolt .....	26-34 (3-4)
Lower Oil Pan Bolt (11) .....	56-66 (6-7)
Oil Pump Cover	
Bolt .....	56-66 (6-7)
Screw .....	34-44 (4-5)
Rear Cover Plate Bolt .....	56-66 (6-7)
Timing Chain Tensioner Bolt/Nut .....	56-72 (6-8)
Water Pump Pulley Bolt .....	56-72 (6-8)

(1) - Tighten bolts using following procedure.  
See Fig. 23.

- \* Bolts No. 9 and 10 and then 1 and 8 on right camshaft to 17 INCH lbs. (2 N.m).
- \* Bolts No. 11 and 12 and then 1 and 10 on left camshaft to 17 INCH lbs. (2 N.m).
- \* All bolts in sequence to 52 INCH lbs. (5 N.m).
- \* Type "A", "B" and "C" bolts to 80-104 INCH lbs. (9-12 N.m).
- \* Type "D" bolts to 13-19 ft. lbs. (18-26 N.m).

- (2) - Information is not available.
- (3) - Tighten bolts to specification in sequence.  
See Fig. 24.
- (4) - Tighten nuts to specification in sequence.  
See Fig. 18.
- (5) - Tighten bolts to 83-96 INCH lbs. (8-11 N.m), and then to 15-20 ft. lbs. (20-27 N.m) in sequence.  
See Fig. 16.
- (6) - Tighten bolts/nuts to specification in sequence.  
See Fig. 17.
- (7) - Tighten bolts to specification in sequence.  
See Fig. 42.
- (8) - Tighten bolts to 78-96 INCH lbs. (7-11 N.m).
- (9) - Tighten bolts to specification in sequence.  
See Fig. 33.
- (10) - Tighten nuts to specification in sequence.  
See Fig. 20.
- (11) - Tighten bolts to specification in sequence.  
See Fig. 31.

## ENGINE SPECIFICATIONS

### GENERAL ENGINE SPECIFICATIONS

GENERAL SPECIFICATIONS TABLE

Application	Specification
Displacement	22 Cu. In. (2.0L)
Bore	3.39" (86.1 mm)
Stroke	3.39" (86.1 mm)
Compression Ratio	9.5:1
Fuel System	PFI
Horsepower @ RPM	140 @ 6400
Torque Ft. Lbs. @ RPM	132 @ 4800

### CRANKSHAFT, MAIN & CONNECTING

#### ROD BEARINGS SPECIFICATION

CRANKSHAFT, MAIN & CONNECTING  
ROD BEARINGS SPECIFICATION TABLE

Application	In. (mm)
Crankshaft	
End Play	
Standard	.0039-.0102 (.099-.026)
Wear Limit	.0118 (.300)
Maximum Runout	.0020 (.051)
Main Bearings	
Journal Diameter (1)	
Grade No. 0	2.1643-2.1646 (54.973-54.980)
Grade No. 1	2.1641-2.1643 (54.968-54.973)
Grade No. 2	2.1639-2.1641 (54.963-54.968)
Grade No. 3	2.1636-2.1639 (54.955-54.963)
Journal Out-Of-Round	.0002 (.005)
Journal Runout	.002 (.05)
Journal Taper	.0002 (.005)
Oil Clearance	
Standard	.0002-.0009 (.005-.023)

Wear Limit .....	.002	(.05)
Connecting Rod Bearings		
Journal Diameter (2)		
Grade No. 0 .....	1.8885-1.8887	(47.968-47.973)
Grade No. 1 .....	1.8883-1.8885	(47.963-47.968)
Grade No. 2 .....	1.8880-1.8883	(47.955-47.963)
Journal Out-Of-Round .....	.0002	(.005)
Journal Runout .....	.002	(.05)
Journal Taper .....	.0002	(.005)
Oil Clearance		
Standard .....	.0008-.0018	(.020-.046)
Wear Limit .....	.0035	(.089)

- (1) - Use main journal grade number stamped on crankshaft counterweight to determine journal diameter. See Fig. 44.
- (2) - Use rod journal grade number stamped on crankshaft counterweight to determine journal diameter. See Fig. 41.

## CONNECTING RODS SPECIFICATIONS

CONNECTING RODS SPECIFICATIONS TABLE

Application	In.	(mm)
Bore Diameter		
Bushing Pin Bore .....	.9835-.9843	(24.981-25.001)
Crankpin Bore .....	2.0079-2.0084	(51.000-51.013)
Maximum Bend .....	.0059 Per 3.94	(.015 Per 100.1)
Maximum Twist .....	.0012 Per 3.94	(.030 Per 100.1)
Side Play		
Standard .....	.0079-.0138	(.201-.351)
Wear Limit .....	.020	(.51)

## PISTONS, PINS & RINGS SPECIFICATIONS

PISTONS, PINS & RINGS SPECIFICATIONS TABLE

Application	In.	(mm)
Pistons		
Clearance .....	.0004-.0012	(.010-.030)
Diameter (1)		
Grade No. 1 .....	3.3850-3.3854	(85.979-85.989)
Grade No. 2 .....	3.3854-3.3858	(85.989-85.999)
Grade No. 3 .....	3.3858-3.3862	(85.999-86.009)
Pins		
Diameter .....	.8657-.8662	(21.989-22.001)
Piston Fit .....	(2)	
Rod Fit		
Standard .....	.0002-.0007	(.005-.018)
Wear Limit .....	.0009	(.023)
Rings		
No. 1		
End Gap		
Standard .....	.0079-.0118	(.201-.300)
Wear Limit .....	.039	(.99)
Side Clearance		
Standard .....	.0018-.0031	(.046-.079)
Wear Limit .....	.008	(.20)



No. 2	
End Gap	
Standard	.0138-.0197 (.350-.500)
Wear Limit	.039 (.99)
Side Clearance	
Standard	.0012-.0026 (.030-.066)
Wear Limit	.008 (.20)
No. 3	
End Gap	
Standard	.0079-.0236 (.201-.599)
Wear Limit	.039 (.99)

- (1) - Piston diameter is determined by grade number stamped on top of piston. See Fig. 39.  
(2) - Interference fit.

## CYLINDER BLOCK SPECIFICATIONS

CYLINDER BLOCK SPECIFICATIONS TABLE

Application	In. (mm)
Cylinder Bore	
Standard Diameter (1)	
Grade No. 1	3.3858-3.3862 (85.999-86.009)
Grade No. 2	3.3862-3.3866 (86.009-86.020)
Grade No. 3	3.3866-3.3870 (86.020-86.030)
Maximum Taper	.0004 (.010)
Maximum Out-Of-Round	.0006 (.015)
Main Bearing Bore I.D (2)	
Grade No. 0	2.3206-2.3209 (58.943-58.951)
Grade No. 1	2.3209-2.3211 (58.951-58.956)
Grade No. 2	2.3211-2.3213 (58.956-58.961)
Grade No. 3	2.3213-2.3216 (58.961-58.969)
Deck Height	8.3169-8.3209 (211.249-211.350)
Maximum Deck Warp	.0039 (.099)

- (1) - Cylinder bore diameter is determined by grade number on deck surface of cylinder block. See Fig. 39.  
(2) - Main bearing bore I.D. is determined by grade number on deck surface of cylinder block. See Fig. 44.

## VALVES & VALVE SPRINGS SPECIFICATIONS

VALVES & VALVE SPRINGS SPECIFICATIONS TABLE

Application	Specification
Intake Valves	
Face Angle	45°
Head Diameter	1.339-1.346" (34.01-34.19 mm)
Minimum Margin	.020" (.51 mm)
Stem Diameter	.2348-.2354" (5.964-5.979 mm)
Valve Tip Maximum Refinish	.008" (.20 mm)
Exhaust Valves	
Face Angle	45°
Head Diameter	1.181-1.189" (29.99-30.20 mm)
Minimum Margin	.020" (.51 mm)
Stem Diameter	.2341-.2346" (5.946-5.959 mm)
Valve Tip Maximum Refinish	.008" (.20 mm)
Valve Springs	

Free Length ..... 1.9433" (49.360 mm)  
 Out-Of-Square ..... .087" (2.21 mm)

Lbs. @ In. (kg @ mm)

Pressure  
 Valve Open ..... 127-144 @ 1.181 (58-65 @ 29.99)

## CYLINDER HEAD SPECIFICATIONS

CYLINDER HEAD SPECIFICATIONS TABLE

Application	Specification
Cylinder Head Height	..... 5.390-5.398" (136.91-137.11 mm)
Maximum Warpage	..... .004" (.10 mm)
Valve Seats	
Intake Valve	
Seat Angle	..... 45°
Seat Width	..... .055-.067" (1.40-1.70 mm)
Seat Bore Diameter	
Standard	..... 1.3780-1.3786" (35.001-35.016 mm)
Service	..... 1.3976-1.3983" (35.499-35.517 mm)
Exhaust Valve	
Seat Angle	..... 45°
Seat Width	..... .067-.079" (1.70-2.01 mm)
Seat Bore Diameter	
Standard	..... 1.2205-1.2211" (31.000-31.016 mm)
Service	..... 1.2402-1.2408" (31.501-31.516 mm)
Valve Guides	
Valve Guide Cylinder Head Bore I.D.	
Standard	..... .3927-.3935" (9.975-9.995 mm)
Service	..... .4006-.4014" (10.175-10.196 mm)
Valve Guide I.D.	..... .2362-.2369" (5.999-6.017 mm)
Valve Guide Installed Height	..... .551-.559" (14.00-14.20 mm)
Valve Stem-To-Guide Oil Clearance	
Standard	
Intake	..... .0008-.0021" (.020-.053 mm)
Exhaust	..... .0016-.0029" (.041-.074 mm)
Wear Limit	..... .004" (.10 mm)

## CAMSHAFT SPECIFICATIONS

CAMSHAFT SPECIFICATIONS TABLE

Application	In. (mm)
Bore Diameter	..... 1.1024-1.1032 (28.000-28.021)
End Play	
Standard	..... .0022-.0055 (.056-.140)
Wear Limit	..... .0079 (.201)
Journal Diameter	..... 1.0998-1.1006 (27.935-27.955)
Journal Runout	..... .004 (.10)
Lobe Height	
Intake	..... 1.5121-1.5196 (38.407-38.598)
Exhaust	..... 1.4929-1.5004 (37.920-38.110)
Oil Clearance	
Standard	..... .0018-.0034 (.046-.086)
Wear Limit	..... .0047 (.119)

## LASH ADJUSTER SPECIFICATIONS

LASH ADJUSTER SPECIFICATIONS TABLE

---

Application	In. (mm)
Bore Diameter .....	.6693-.6701 (17.000-17.021)
Lash Adjuster Diameter .....	.6685-.6690 (16.980-16.993)
Oil Clearance .....	.0003-.0016 (.008-.041)

---