

# STEERING SYSTEM - POWER

1992 Infiniti G20

1991-92 STEERING  
Infiniti - Power Rack & Pinion

G20, M30, Q45

**WARNING:** M30 and Q45 are equipped with Supplemental Restraint System (SRS). Observe following precautions before performing any repair. Disconnect and shield battery ground. Disconnect SRS connector at control unit located behind center console. All SRS wiring harnesses and connectors are Yellow. DO NOT use electrical test equipment on these circuits. Use caution when working around steering column as air bag could deploy.

## DESCRIPTION & OPERATION

The Infiniti standard power steering system consists of a rack and pinion steering gear, steering pump, reservoir and flexible connecting lines. Q45 may use an optional HICAS 4-wheel steering system.

## LUBRICATION

### FLUID TYPE

Use Dexron ATF type fluid.

### FLUID LEVEL CHECK

Fluid should be checked using HOT range on dipstick at fluid temperatures of 122-176°F (50-80°C) or using COLD range on dipstick at fluid temperatures of 32-86°F (0-30°C). Add fluid through dipstick opening as needed, and recheck. DO NOT overfill.

#### POWER STEERING FLUID CAPACITY TABLE

Application	Qts. (L)
G20 & M30 .....	1 (.9)
Q45	
With Super HICAS .....	2.38 (2.2)
Without Super HICAS .....	1.25 (1.2)

## HYDRAULIC SYSTEM BLEEDING

1) Raise and support vehicle so front wheels are off ground. Add fluid to specified level. Have a helper quickly turn steering wheel fully right and left, lightly touching steering stops. Repeat filling procedure until fluid no longer decreases.

2) Start engine, and repeat step 1). If air bubbles appear in reservoir tank or a clicking or excessive buzzing is present in oil pump, system is not fully bled. Repeat bleeding procedure.

## ADJUSTMENTS

### BELT TENSION

BELT TENSION SPECIFICATIONS TABLE

Application	New Belt		Used Belt	
	(1) Deflection - In. (mm)	(1) Deflection - In. (mm)	(1) Deflection - In. (mm)	(1) Deflection - In. (mm)
Power Steering				
G20 .....	.138-.177 (3.5-4.5)	.....	.16-.20 (4-5)	
M30 .....	.47-.55 (12-14)	.....	.55-.63 (14-16)	
Q45				
With Super				
HICAS (2) .....	.217-.256 (5.5-6.5)	.....	.28-.31 (7-8)	
Without Super				
HICAS (2) .....	.31-.35 (8-9)	.....	.35-.39 (9-10)	

(1) - With 22 lbs. (10 kg) pressure applied at center of longest belt run.

(2) - Super HICAS 4-Wheel Steering System or Full Active Suspension.

**PINION ROTATING FORCE**

1) Set rack to neutral without fluid in gear. Coat adjusting screw with locking sealant, and screw it in. Lightly tighten lock nut. Tighten adjusting screw to 44-53 INCH lbs. (5-6 N.m). Loosen adjusting screw, and then retighten it to .4-1.7 INCH lbs. (.05-.20 N.m).

2) Move rack over its entire stroke several times. Measure pinion rotating torque within a 180-degree range from neutral position. Stop gear at point of maximum torque. Loosen adjusting screw, and then retighten it to 44 INCH lbs. (5 N.m). On G20, loosen adjusting screw 40-60 degrees. On M30 and Q45, loosen adjusting screw 60-100 degrees.

3) Hold adjusting screw and tighten lock nut to 29-44 ft. lbs. (39-59 N.m). Measure pinion rotating torque within a range of ± 100 degrees from neutral point. Average rotating torque should be 7-12 INCH lbs. (.8-1.3 N.m). Maximum torque deviation should be less than 3.5 INCH lbs. (.4 N.m).

4) Measure pinion rotating torque except for ± 100 degree range in step 3). Maximum rotating torque should be 17 INCH lbs. (1.9 N.m). Maximum torque deviation should be less than 5.3 INCH lbs. (.6 N.m). If pinion rotation torque is not within specification, readjust as necessary. If rotating torque is still out of specification after readjustment, replace steering gear.

**RACK SLIDING FORCE**

1) Install steering gear on vehicle, but DO NOT connect tie rod end. Connect hydraulic lines, and fill unit with fluid. Start engine, and bleed air from system. Disconnect steering column lower joint from gear.

2) Keep engine at idle and ensure steering fluid reaches normal operating temperature. Pull tie rod slowly in ± .47" (12 mm) range from neutral position. On G20, average rack sliding force is 64 lbs. (284 N). On M30 and Q45, average rack sliding force is 37-51 lbs. (167-226 N). Maximum force deviation in or out of neutral range is 9 lbs. (39 N). If rack sliding force is not within specification, readjustment is necessary. If rack sliding force is still out of specification after readjustment, replace steering gear.

**TESTING**

**STEERING PUMP PRESSURE**

1) Before starting test, check belt tension, pulley and tire pressure. Attach Pressure Gauge (ST27091000) between pump and steering gear. Open shutoff valve on pressure gauge, and bleed air. Allow fluid temperature to rise to 140-176°F (60-80°C).

CAUTION: Warm engine with shutoff valve fully opened. If engine is started with shutoff valve closed, oil pressure in oil pump will increase to relief pressure, producing abnormal rise in oil temperature.

2) Idle engine at 1000 RPM. Check pressure with steering wheel turned to left and right positions. See HYDRAULIC PRESSURE SPECIFICATIONS table. DO NOT hold steering wheel in a locked position longer than 15 seconds.

3) If oil pressure is less than standard pressure, slowly close shutoff valve and check pressure. If pressure reaches standard pressure, gear is damaged. If pressure remains less than standard pressure, pump is damaged.

CAUTION: DO NOT close shutoff valve longer than 15 seconds.

4) If oil pressure is higher than standard pressure, check oil pump flow control valve. After checking hydraulic system, remove pressure gauge, and add fluid as necessary. Bleed air from system.

HYDRAULIC PRESSURE SPECIFICATIONS TABLE

Application	psi (kg/cm <sup>2</sup> )
G20 & M30	1109-1194 (7649-8238)
Q45	
Main	1109-1194 (7649-8238)
Sub	924-995 (6375-6865)

**STEERING WHEEL TURNING FORCE**

1) Ensure tires are inflated to normal pressure. Park vehicle on a level, dry surface. Set parking brake, and start engine. Bring power steering fluid to an operating temperature of 140-176°F (60-80°C).

2) Turn steering wheel 360 degrees from its neutral position. Steering wheel turning force should be 7-9 lbs. (29-39 N) or less. If force is not to specification, check rack sliding force to determine condition of steering gear assembly.

3) Disconnect steering column lower joint and knuckle arms from steering gear. Start engine, and run it at idle to ensure steering fluid has reached an operating temperature of 140-176°F (60-80°C).

4) Slowly move tie rod approximately .45" (12 mm). Average rack sliding force on G20 and M30 is 64 lbs. (284 N). On Q45, sliding force is 37-51 lbs. (167-226 N). Maximum rack sliding force should be no more than 9 lbs. (39 N) greater than average sliding force. If rack sliding force is not within specification, repair steering gear assembly.

**REMOVAL & INSTALLATION**

**STEERING GEAR**

CAUTION: On air bag equipped vehicles, rotation of air bag spiral

cable is limited. If steering gear must be removed, set front wheels in straight-ahead position. DO NOT rotate steering column while steering gear is removed.

#### Removal (G20 & M30)

1) Using Puller (HT72520000), remove tie rod ends from steering knuckle. Remove high and low hydraulic pressure connectors. Remove front exhaust tube, lower steering joint and gear housing brackets. See Fig. 1 or 2.

2) Support transmission housing using jack. Remove center member with engine mounting rear bracket. Remove steering gear assembly.

#### Installation

To install, reverse removal procedure. Ensure hydraulic "O" rings are correctly installed. "O" ring in low-pressure pipe connector is larger than "O" ring in high-pressure connector. See TORQUE SPECIFICATIONS table at end of article.

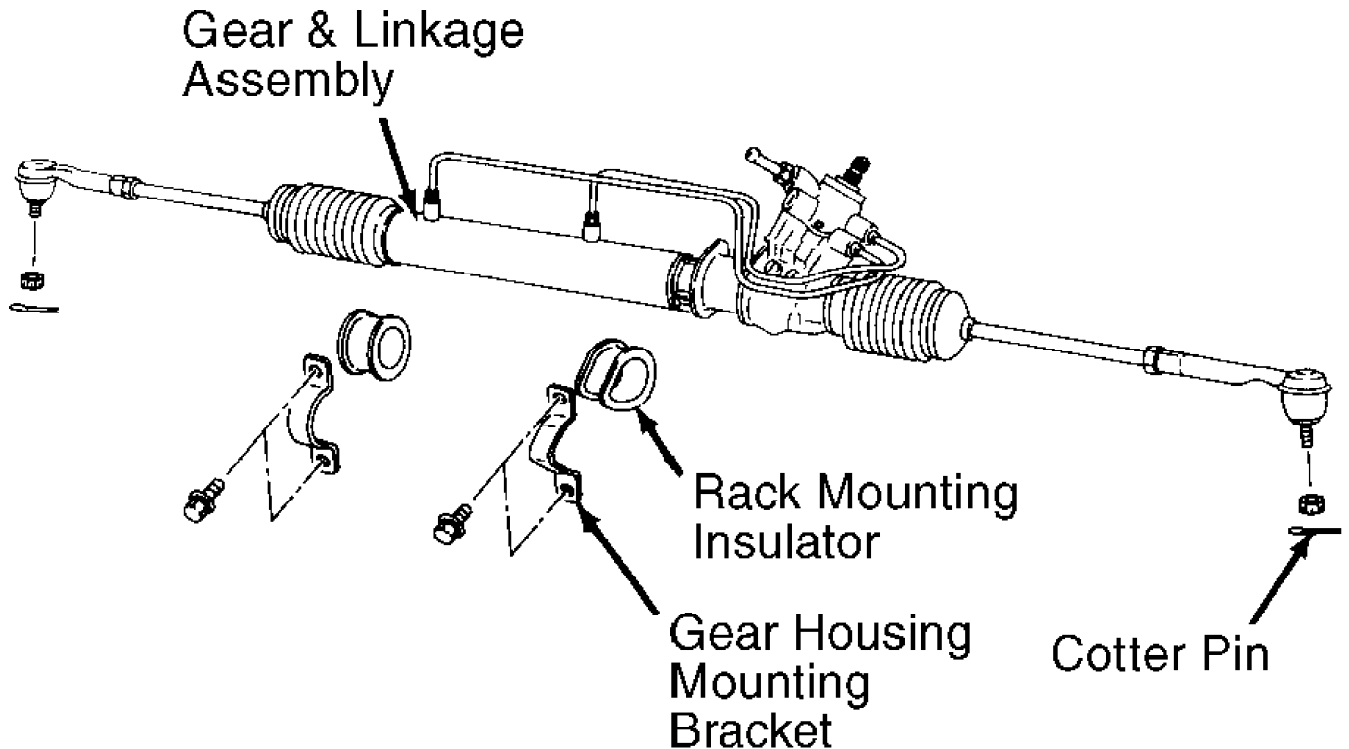

92E00335

Fig. 1: Removing Power Steering Rack Assembly (G20)  
Courtesy of Nissan Motor Co., U.S.A.

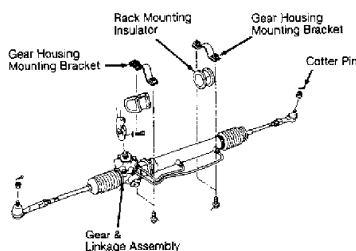

Fig. 2: Removing Power Steering Rack Assembly (M30)  
Courtesy of Nissan Motor Co., U.S.A.

#### Removal (Q45)

1) Using Puller (HT72720000), remove tie rod ends from steering knuckle. Remove steering gear mounting bolts and hydraulic lines. See Fig. 3.

2) Ensure wheels face straight ahead before removing lower joint from gear. After removing lower joint, put matching mark on pinion shaft and pinion housing to record neutral position of gear.

#### Installation

To install, reverse removal procedure. Set left and right dust boots to equal deflection. Attach lower joint by aligning pinion shaft and pinion housing matching marks.

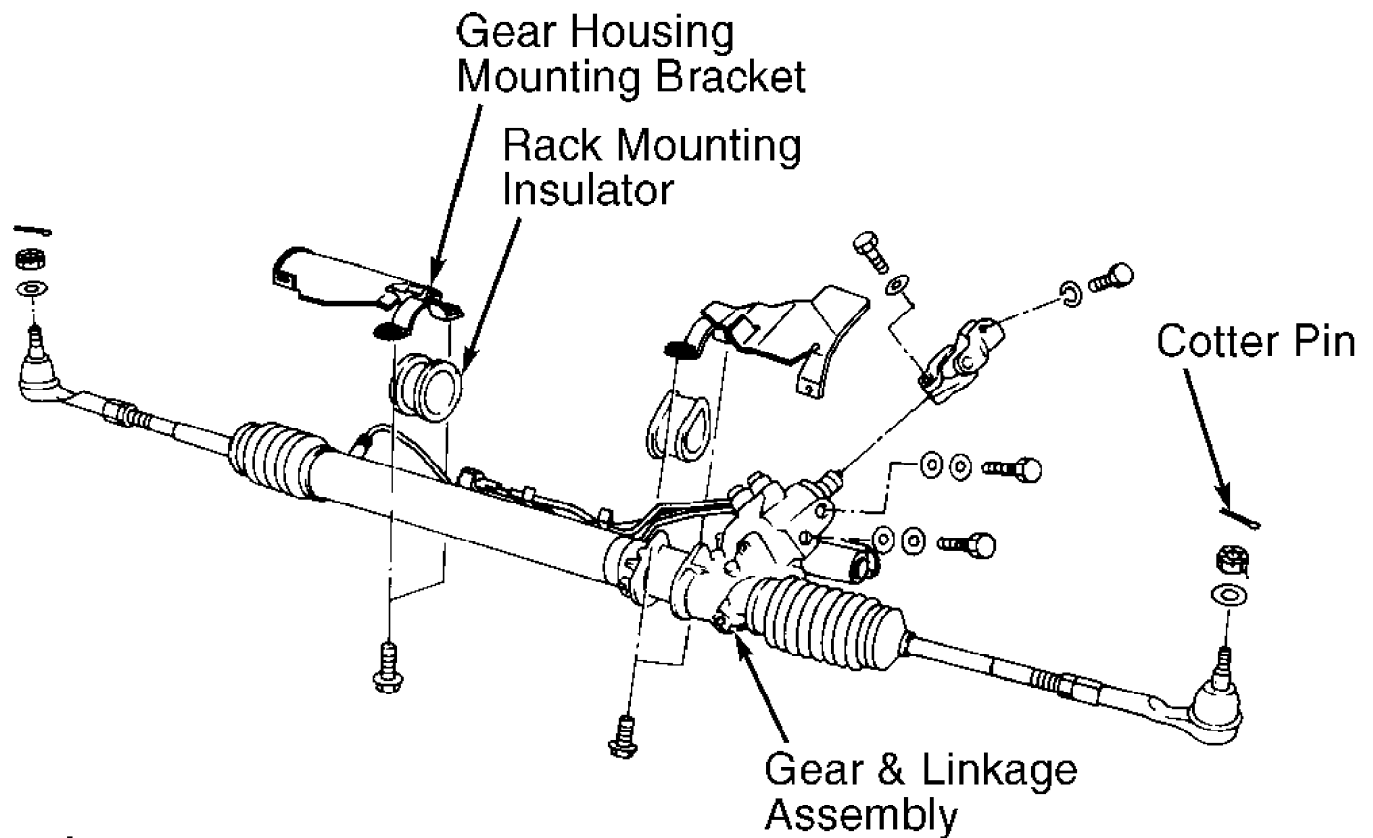

92G00337

Fig. 3: Removing Power Steering Rack Assembly (Q45)  
Courtesy of Nissan Motor Co., U.S.A.

## OVERHAUL

### STEERING GEAR & POWER STEERING PUMP

NOTE: For exploded view of steering gear, see Fig. 4 or 5. For exploded view of power steering pump, see Fig. 6, 7 or 8.

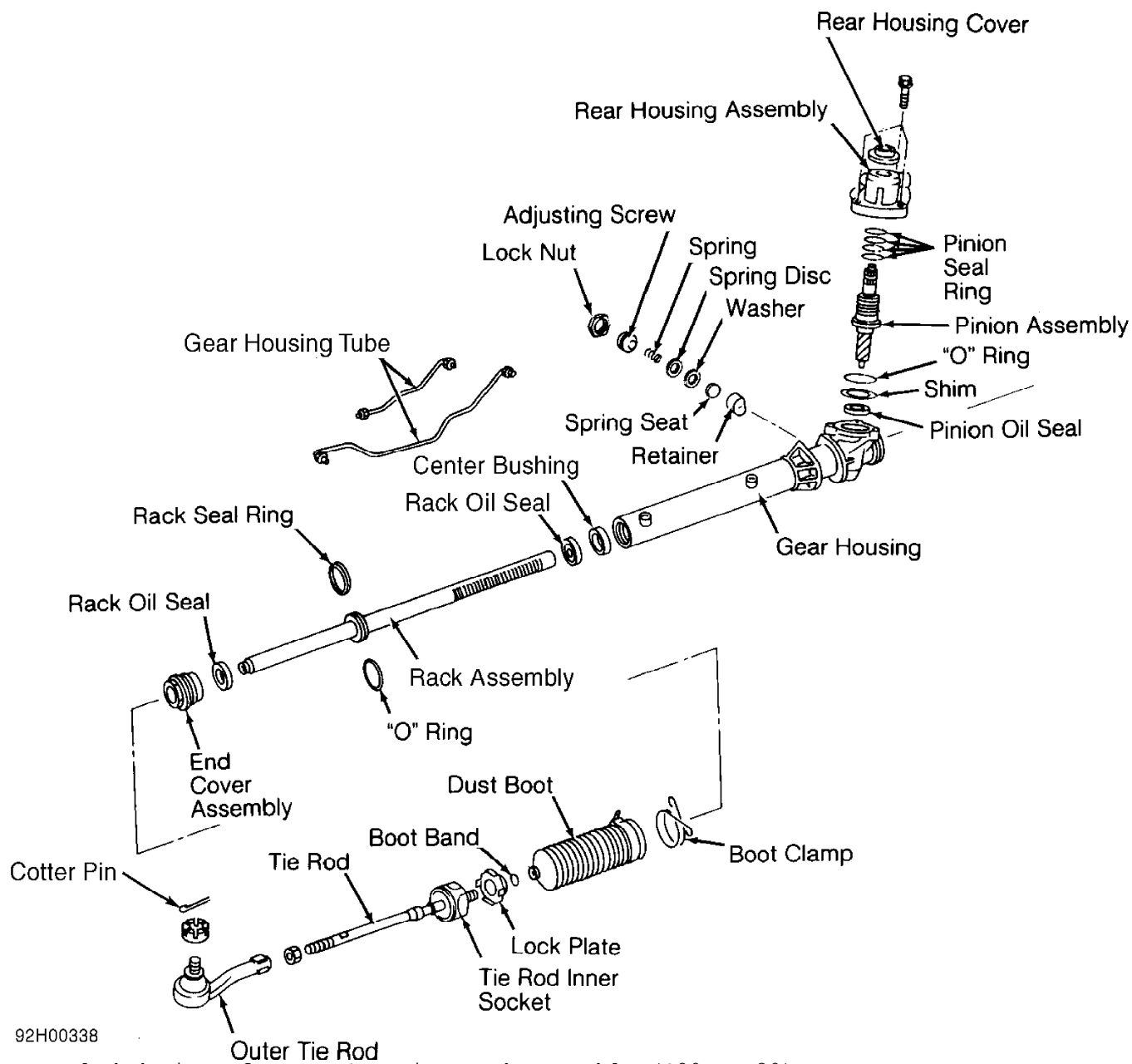

92H00338

Fig. 4: Exploded View of Power Steering Rack Assembly (G20 & M30)  
 Courtesy of Nissan Motor Co., U.S.A.

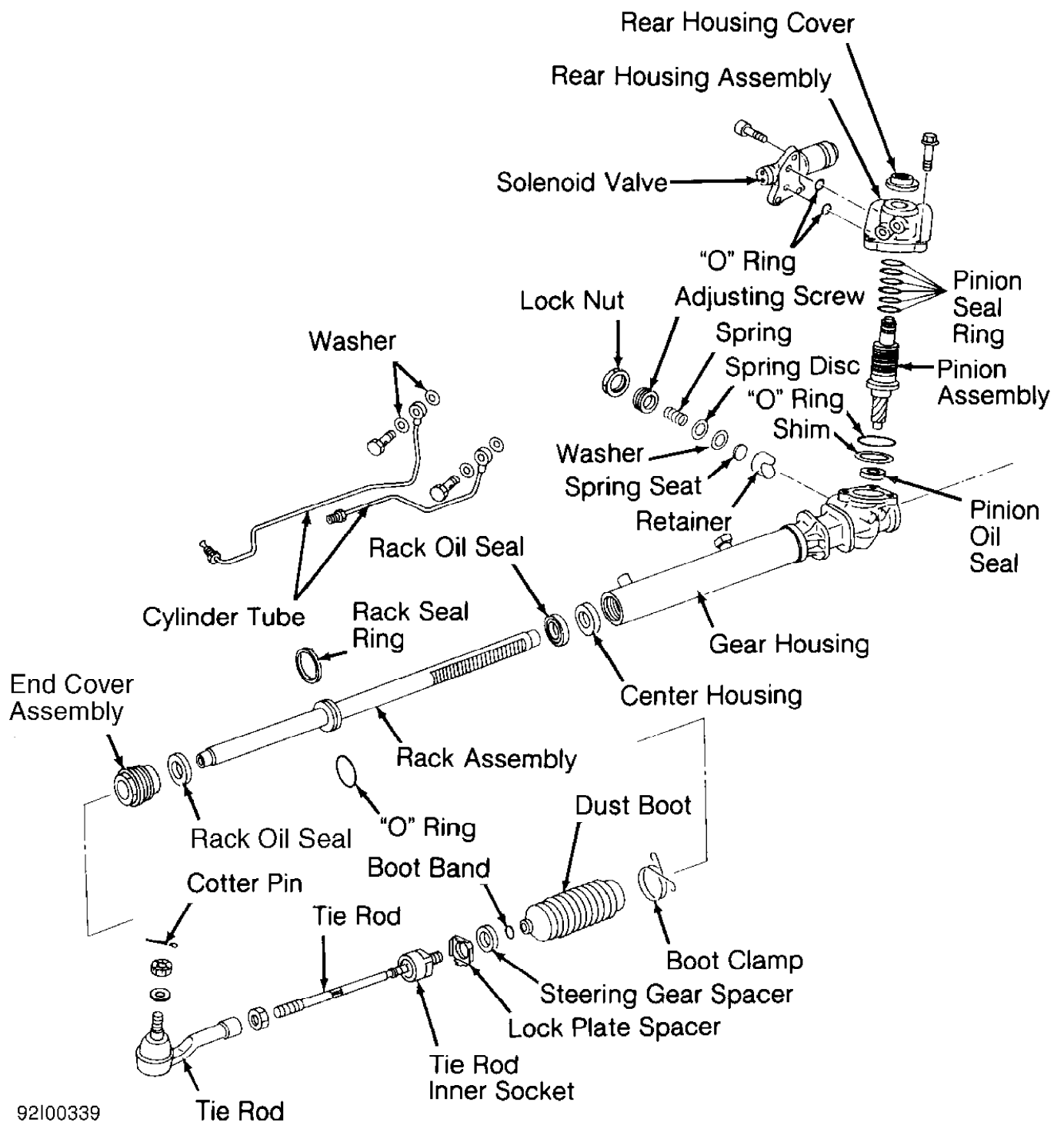

92I00339

Fig. 5: Exploded View of Power Steering Rack Assembly (Q45)  
 Courtesy of Nissan Motor Co., U.S.A.

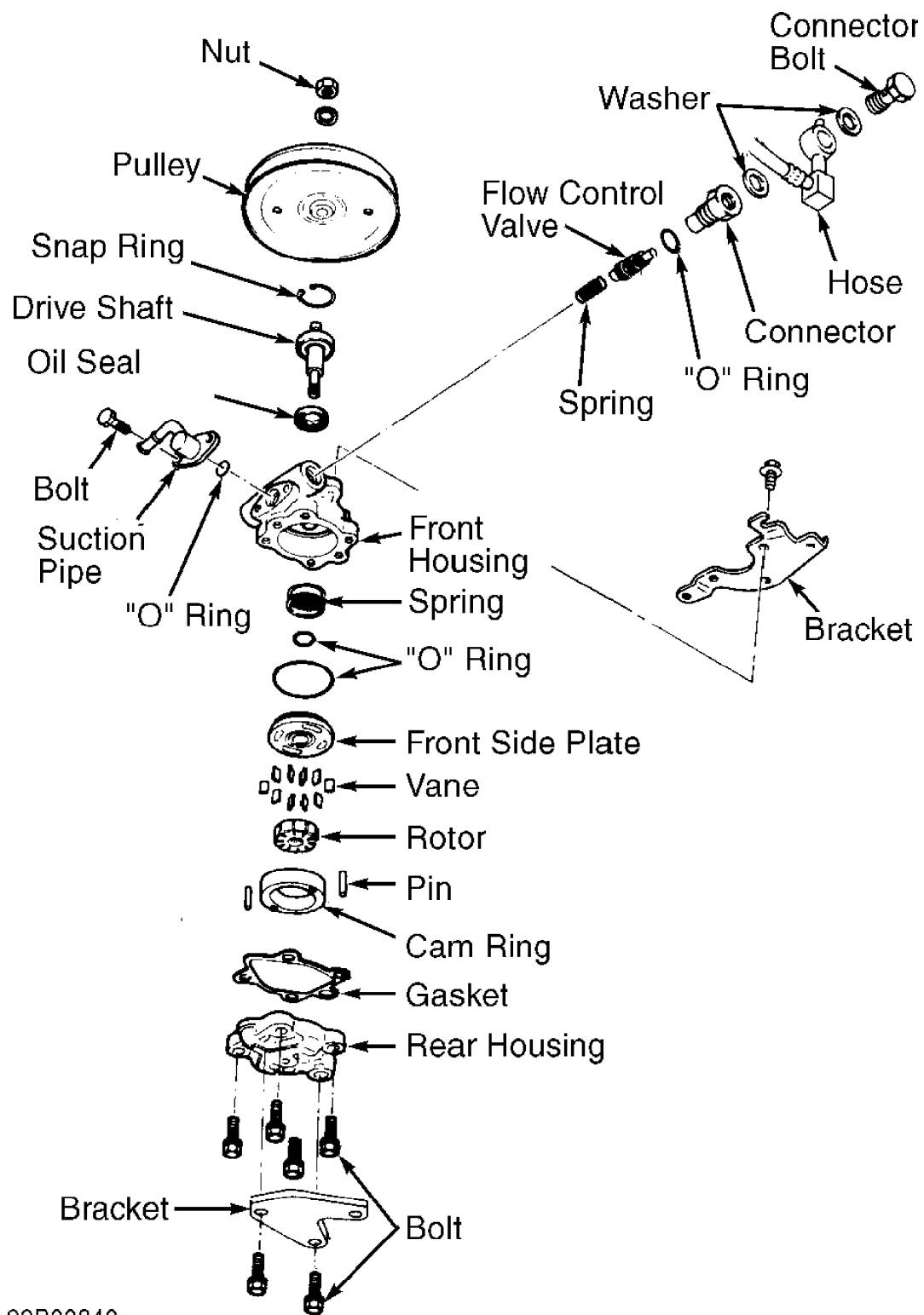

92B00340

Fig. 6: Exploded View of Power Steering Pump Assembly (G20)  
 Courtesy of Nissan Motor Co., U.S.A.



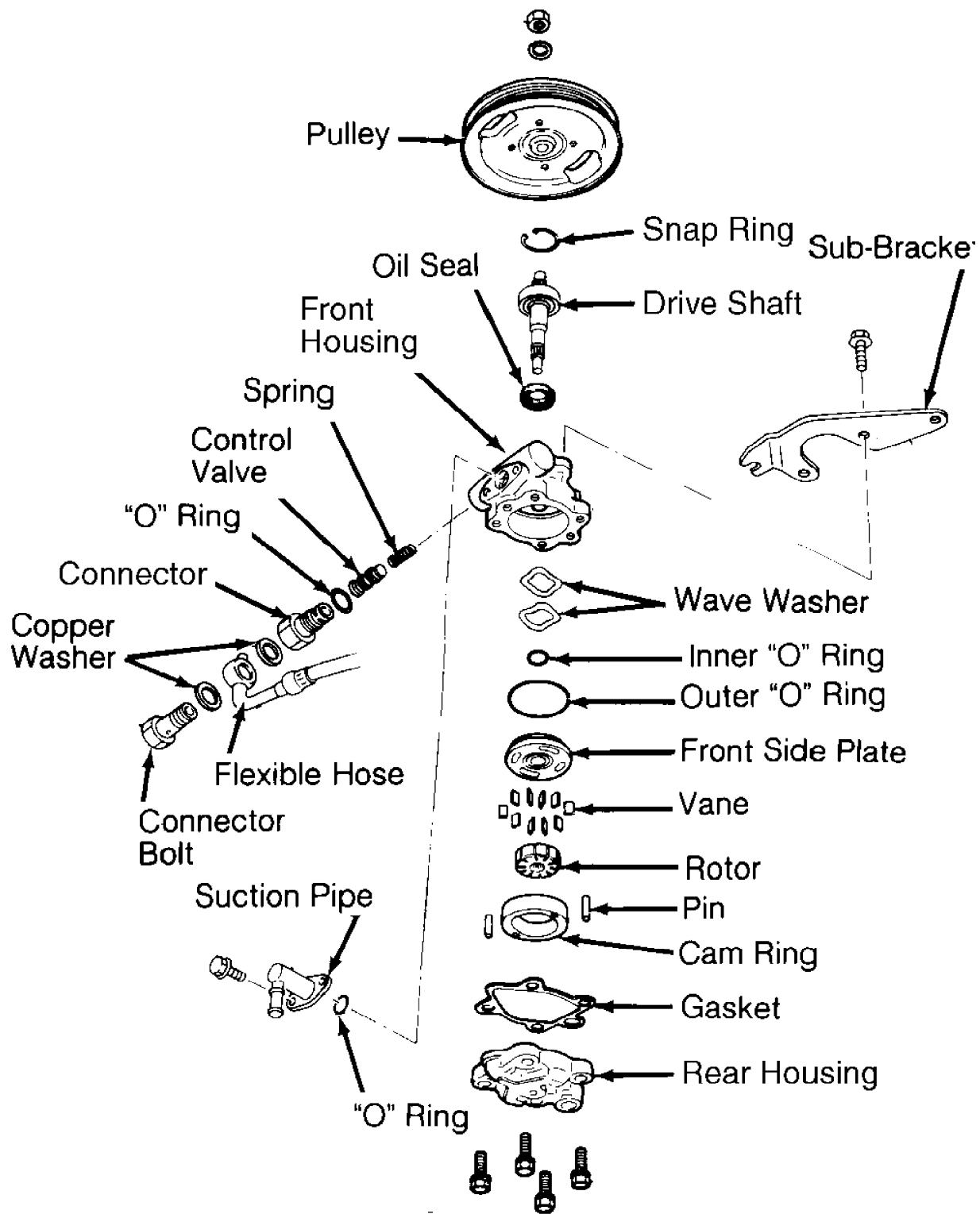

92C00341

Fig. 7: Exploded View of Power Steering Pump Assembly (M30)  
 Courtesy of Nissan Motor Co., U.S.A.

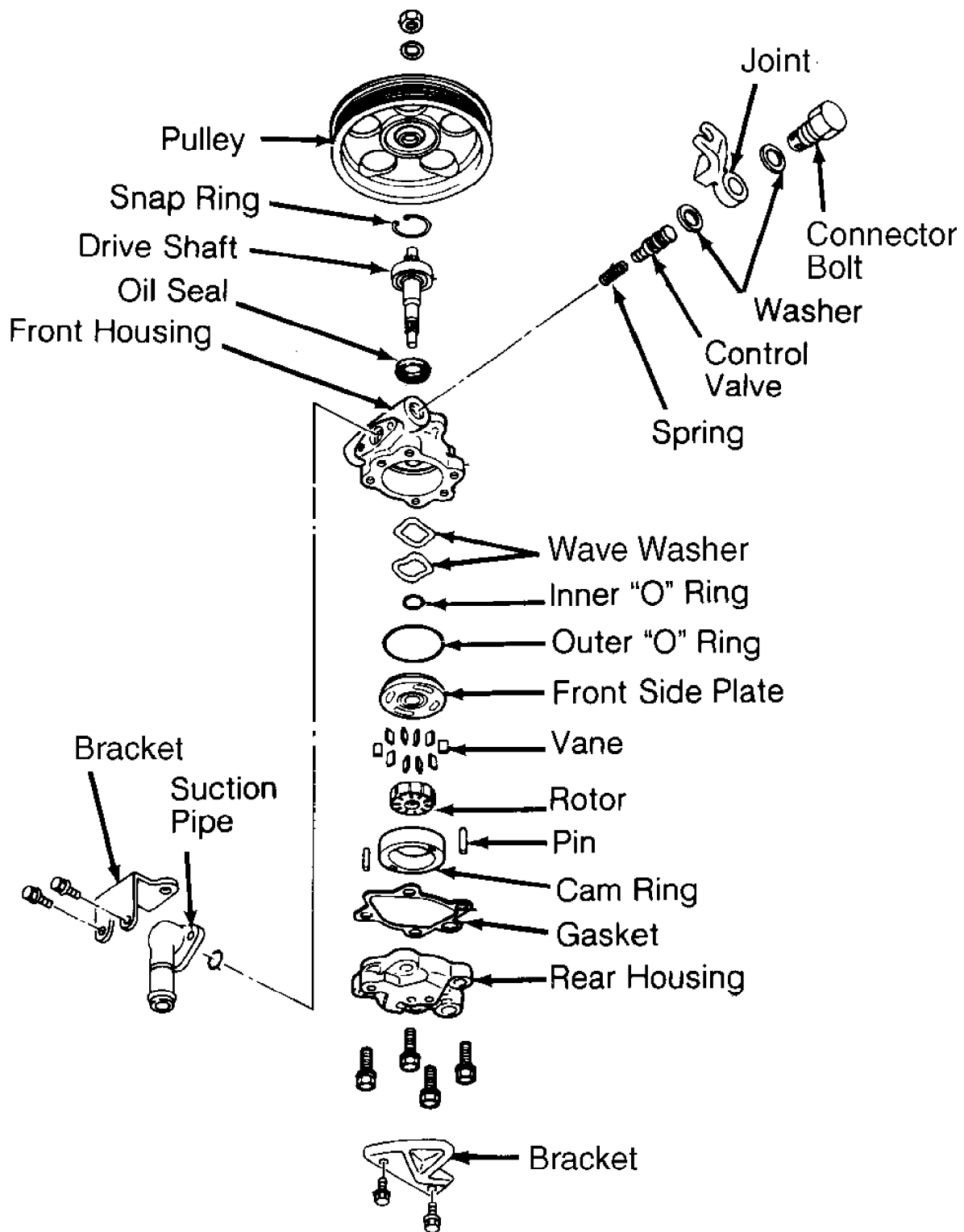

92D00342

Fig. 8: Exploded View of Power Steering Pump Assembly (Q45)  
 Courtesy of Nissan Motor Co., U.S.A.

### TORQUE SPECIFICATIONS

TORQUE SPECIFICATIONS TABLE

Application	Ft. Lbs. (N.m)
Cylinder Tube Fittings .....	15-19 (21-26)
Gear Housing Bracket Bolt	
G20 .....	54-72 (74-98)
M30 .....	62-80 (84-108)
Q45 .....	65-80 (88-108)
High Pressure Connector	
G20 & M30 .....	11-18 (15-25)
Q45 .....	22-26 (30-35)
Low Pressure Connector	
G20 & M30 .....	20-29 (27-39)
Q45 .....	27-30 (36-40)
Pump Bracket Bolt .....	20-26 (27-35)
Pump Connector Banjo Bolt	
G20 & M30	
Inner .....	51-58 (69-78)
Outer .....	36-51 (49-69)
Q45 .....	51-58 (69-78)
Pump Housing Bolt .....	23-31 (31-42)
Pump Pulley Bolt .....	40-50 (54-68)
Pump Sub-Bracket Bolt .....	20-26 (27-35)
Pump Suction Pipe Bolt .....	10-13 (14-18)
Rack End Cover Assembly .....	44-54 (59-74)
Rack Lock Nut .....	29-44 (39-59)
Rack Rear Housing Cover Bolt .....	12-15 (16-21)
Rack Tube Banjo Bolt .....	15-19 (21-26)
Steering Shaft Lower Joint Bolt .....	18-21 (24-29)
Tie Rod End-To-Steering Knuckle Nut	
G20 & Q45 .....	21-29 (29-39)
M30 .....	40-72 (54-98)
Tie Rod End-To-Tie Rod Nut .....	58-72 (78-98)
Tie Rod End Jam Nut .....	58-72 (78-98)
Tie Rod Inner Socket .....	58-72 (78-98)