

# SUSPENSION - REAR

1992 Infiniti G20

1991-92 SUSPENSION  
Rear

G20

## DESCRIPTION

G20 uses an independent rear suspension system with parallel link and radius rod. This system also uses a stabilizer bar. The rear wheels are supported by a shock absorber assembly attached to vehicle body. See Fig. 1.

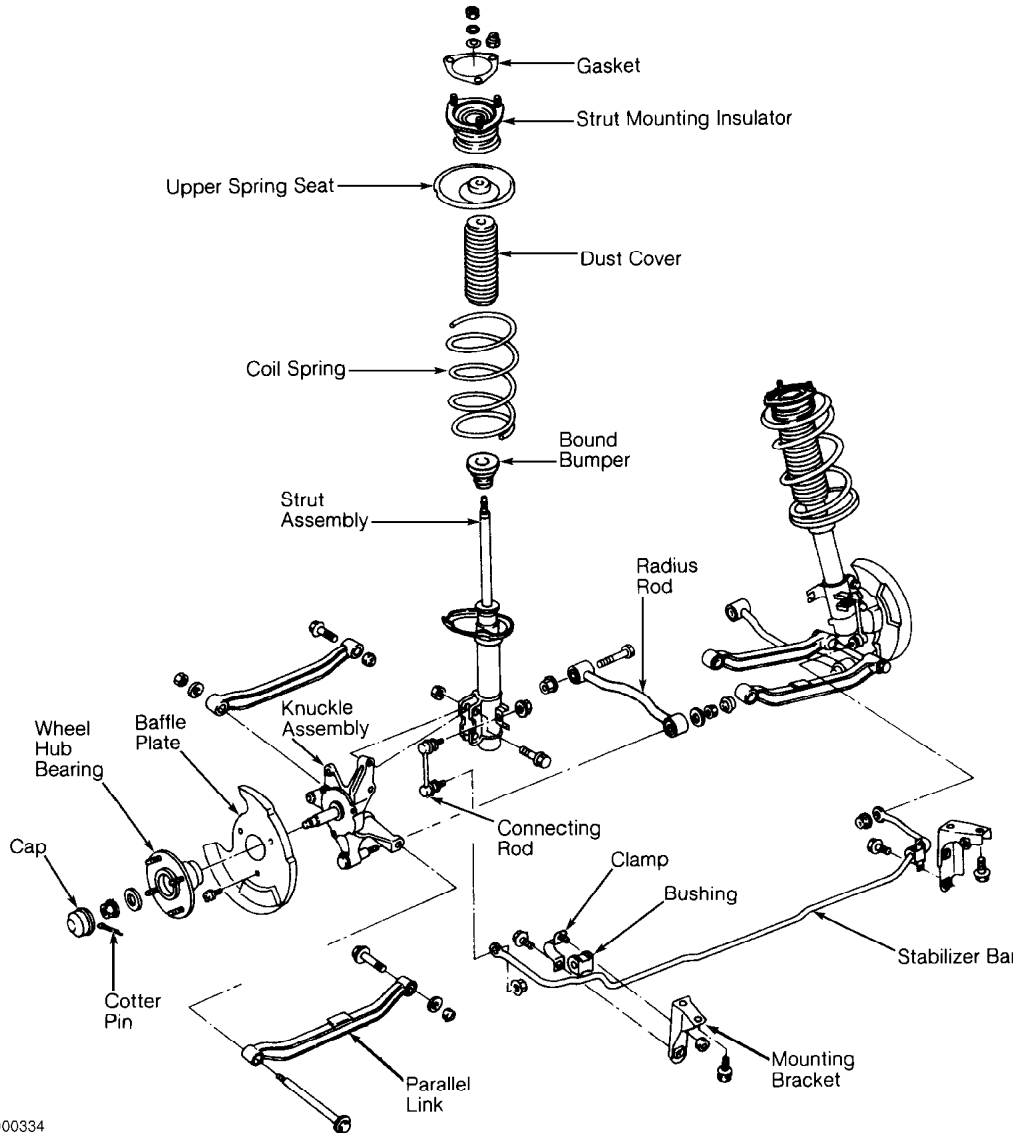

92D00334

Fig. 1: Exploded View of Rear Suspension  
Courtesy of Nissan Motor Co., U.S.A.

## ADJUSTMENTS & INSPECTION

## WHEEL ALIGNMENT SPECIFICATIONS & PROCEDURES

NOTE: See SPECIFICATIONS & PROCEDURES article in the WHEEL ALIGNMENT Section.

### WHEEL BEARING

Check wheel bearing for smooth rotation and axial play. Axial play should not exceed .002" (.05 mm).

### RIDING HEIGHT

RIDING HEIGHT SPECIFICATIONS TABLE (1)

| Application | Front In. (mm) | Rear In. (mm) |
|-------------|----------------|---------------|
| G20 .....   | 25.71 (653)    | 25.35 (644)   |

(1) - Measured from top of wheel well.

## REMOVAL & INSTALLATION

### STABILIZER BAR

Removal & Installation

Remove connecting rods, clamps and bushings. See Fig. 1. To install, reverse removal procedure. See TORQUE SPECIFICATIONS table at end of article.

### HUB & KNUCKLE ASSEMBLY

Removal & Installation

1) Remove brake caliper assembly and rotor. DO NOT disconnect brake hose. Remove wheel bearing lock nut. Remove brake caliper assembly and rotor. Separate tie-rod from knuckle. Remove kingpin cap and nut. Separate kingpin from knuckle.

2) Using a piece of wood and hammer, separate drive shaft from knuckle. Remove ball joint nut. Separate ball joint from knuckle. To install, reverse removal procedure. See TORQUE SPECIFICATIONS table at end of article.

### WHEEL BEARING

Removal & Installation

Remove brake caliper assembly and rotor. Brake hose does not need to be removed from brake caliper. Remove wheel bearing lock nut. See Fig. 2. To install, reverse removal procedure. Torque wheel bearing lock nut. See TORQUE SPECIFICATIONS table at end of article.

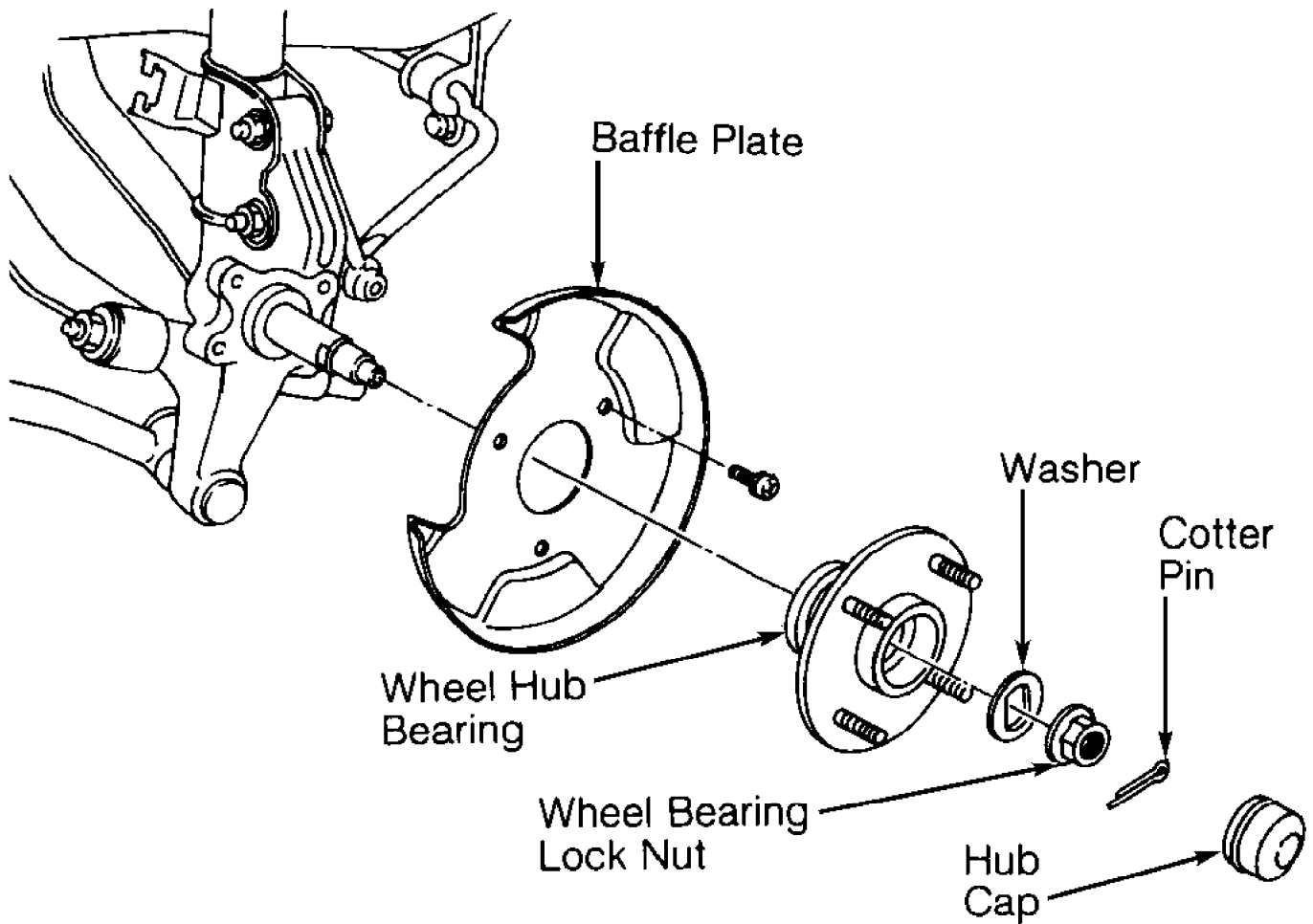

92C00333

Fig. 2: Exploded View of Wheel Hub Assembly  
 Courtesy of Nissan Motor Co., U.S.A.

## STRUT ASSEMBLY

### Removal

1) Raise and support vehicle. Remove brake caliper assembly and rotor. Remove parallel link fixing bolt, radius rod fixing bolt, stabilizer fixing bolt and stabilizer connecting rod. See Fig. 1.

2) Remove rear seat. Remove strut retaining nuts. Pull out strut assembly. Set strut assembly in vise and loosen (DO NOT remove) piston rod lock. Compress spring so strut mounting insulator can be turned by hand. Remove piston rod lock nut. Remove spring and spring compressor.

NOTE: Two types of struts are used with different piston rod diameters. Piston rod diameter may be .71" (18 mm) or .79" (20 mm). Rebound rubber bumpers are not interchangeable and should be replaced with strut assembly.

### Installation

When installing coil spring on strut, ensure there are 2 color identification marks on lower side. Tighten lock nut after placing coil spring in position on lower spring seat. Gradually release spring pressure.

## TORQUE SPECIFICATIONS

### TORQUE SPECIFICATIONS TABLE

---

| Application                        | Ft. Lbs. (N.m)    |
|------------------------------------|-------------------|
| Connecting Rod-To-Strut Nut .....  | 30-35 (41-47)     |
| Parallel Link Bushing Bolts .....  | 80-94 (108-127)   |
| Radius Rod Bushing Bolt .....      | 65-80 (88-108)    |
| Stabilizer Bar Clamp Nut .....     | 23-31 (31-42)     |
| Strut Lower Bolt .....             | 72-87 (98-118)    |
| Strut Mounting Insulator Nut ..... | 31-40 (42-54)     |
| Strut Upper Nut .....              | 44-58 (59-78)     |
| Wheel Bearing Lock Nut .....       | 137-188 (186-255) |
|                                    | INCH Lbs. (N.m)   |
| Baffle Plate Bolt .....            | 89-124 (10-14)    |

---