

# CLUTCH

## SECTION **CL**

GI

MA

EM

LC

EC

FE

**CL**

MT

AT

FA

RA

BR

ST

BF

HA

EL

IDX

## CONTENTS

<b>PRECAUTION AND PREPARATION</b> .....	2	<b>CLUTCH DISC AND CLUTCH COVER</b> .....	6
Precaution .....	2	Clutch Disc .....	6
Special Service Tools .....	2	Clutch Cover and Flywheel .....	7
<b>CLUTCH SYSTEM</b> .....	3	<b>SERVICE DATA AND SPECIFICATIONS (SDS)</b> .....	8
<b>INSPECTION AND ADJUSTMENT</b> .....	4	General Specifications .....	8
Adjusting Clutch Pedal .....	4	Inspection and Adjustment .....	8
<b>CLUTCH RELEASE MECHANISM</b> .....	5		

# PRECAUTION AND PREPARATION

## Precaution

### WARNING:

After cleaning the clutch disc, wipe it with a dust collector. Do not use compressed air.

## Special Service Tools

\*: Special tool or commercial equivalent

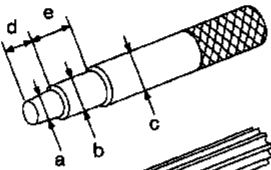
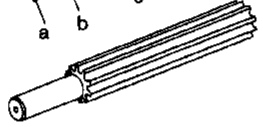
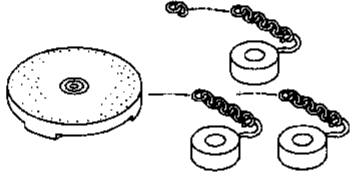
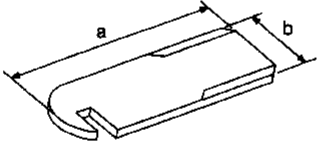
Tool number (Kent-Moore No.) Tool name	Description
KV30101000* (J33213) Clutch aligning bar	<div style="display: flex; align-items: center;"> <div style="margin-right: 20px;"> <p>New</p>  </div> <div> <p>Installing clutch cover and clutch disc</p> </div> </div> <div style="margin-top: 20px;"> <p>Former</p>  </div> <div style="margin-top: 10px;"> <p>NT440</p> <ul style="list-style-type: none"> <li>a: 12 mm (0.47 in) dia.</li> <li>b: 15.7 mm (0.618 in) dia.</li> <li>c: 22.8 mm (0.898 in) dia.</li> <li>d: 21 mm (0.83 in)</li> <li>e: 22 mm (0.87 in)</li> </ul> </div>
ST20050010 ( — ) Base plate ST20050100 ( — ) Distance piece	<div style="display: flex; align-items: center;"> <div style="margin-right: 20px;">  </div> <div> <p>Inspecting diaphragm spring of clutch cover</p> </div> </div> <div style="margin-top: 10px;"> <p>NT058</p> </div>
ST20050240* ( — ) Diaphragm spring adjusting wrench	<div style="display: flex; align-items: center;"> <div style="margin-right: 20px;">  </div> <div> <p>Adjusting unevenness of diaphragm spring of clutch cover</p> </div> </div> <div style="margin-top: 20px;"> <p>NT404</p> <ul style="list-style-type: none"> <li>a: 150 mm (5.91 in)</li> <li>b: 25 mm (0.98 in)</li> </ul> </div>

# CLUTCH SYSTEM

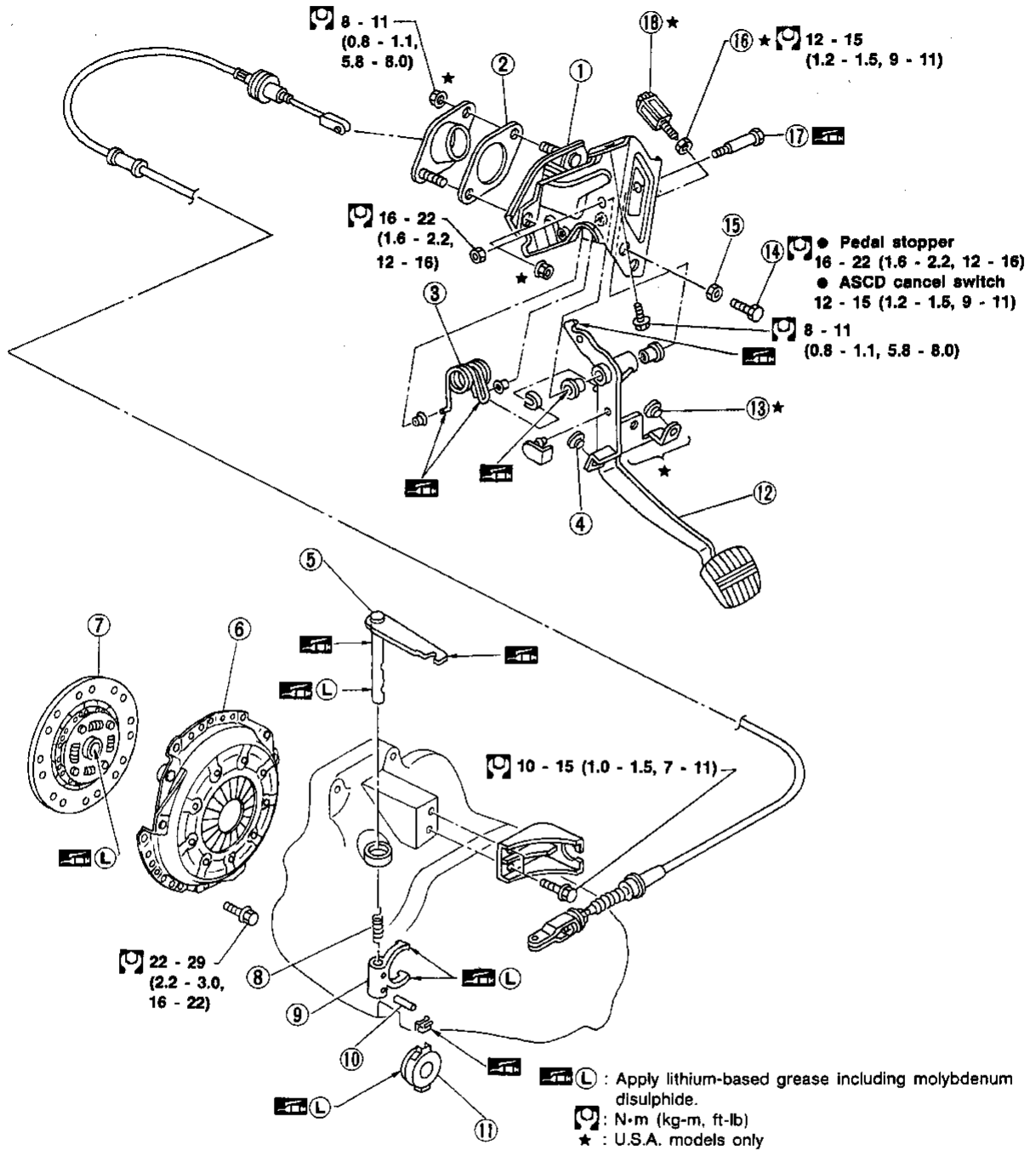

- ① Clutch pedal bracket
- ② Insulator
- ③ Assist spring
- ④ Stopper rubber
- ⑤ Withdrawal lever
- ⑥ Clutch cover

- ⑦ Clutch disc
- ⑧ Return spring
- ⑨ Clutch lever
- ⑩ Spring pin
- ⑪ Release bearing
- ⑫ Clutch pedal

- ⑬ Stopper rubber
- ⑭ Pedal stopper or ASCD cancel switch
- ⑮ Lock nut
- ⑯ Lock nut
- ⑰ Fulcrum pin
- ⑱ Clutch interlock switch

SCL586

GI  
MA  
EM  
LC  
EC  
FE  
CL  
MT  
AT  
FA  
RA  
BR  
ST  
BF  
HA  
EL  
IDX

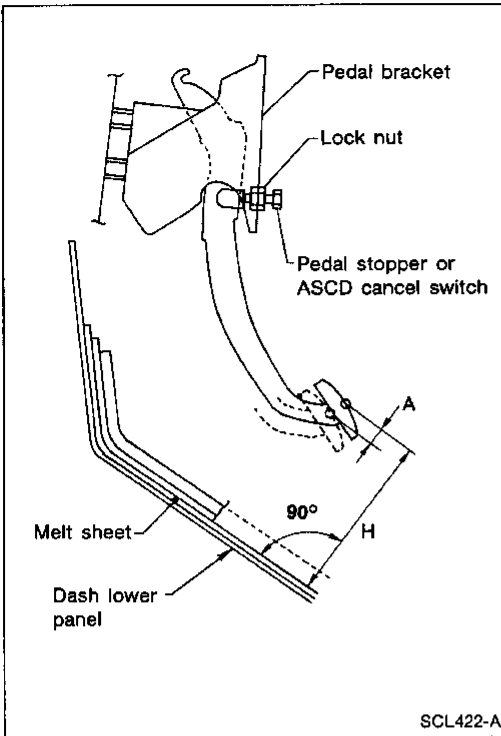

## Adjusting Clutch Pedal

1. Adjust pedal height with pedal stopper or ASCD cancel switch.

**Pedal height "H":**

**159.5 - 169.5 mm (6.28 - 6.67 in)**

2. Adjust withdrawal lever play "B" according to the following procedure.

- (1) Push withdrawal lever by hand until resistance is felt, and then tighten adjusting nut.
- (2) Turn back adjusting nut 2.5 to 3.5 turns, and then tighten lock nut.

**Withdrawal lever play "B":**

**2.5 - 3.5 mm (0.098 - 0.138 in)**

**Lock nut:**

**□: 3 - 4 N·m (0.3 - 0.4 kg-m, 2.2 - 2.9 ft-lb)**

3. As a final check, measure pedal free travel at center of pedal pad.

**Pedal free travel "A":**

**10.8 - 15.1 mm (0.425 - 0.594 in)**

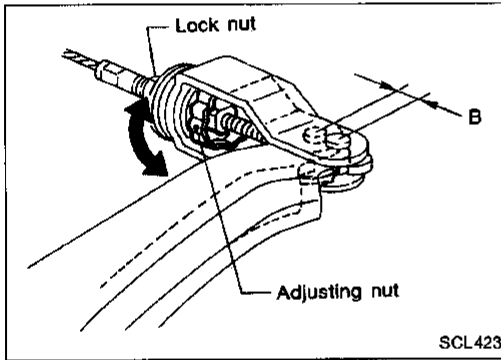

4. U.S.A. models only

Adjust clearance "C" shown in the figure while fully depressing clutch pedal.

**Clearance "C":**

**0.1 - 1.0 mm (0.004 - 0.039 in)**

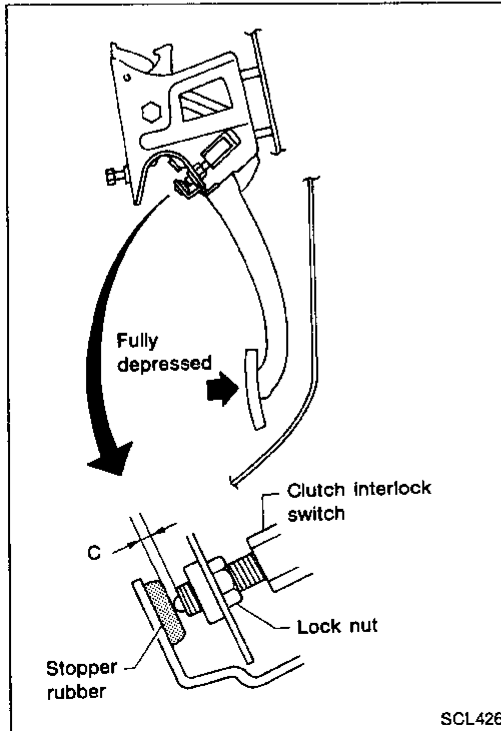

# CLUTCH RELEASE MECHANISM

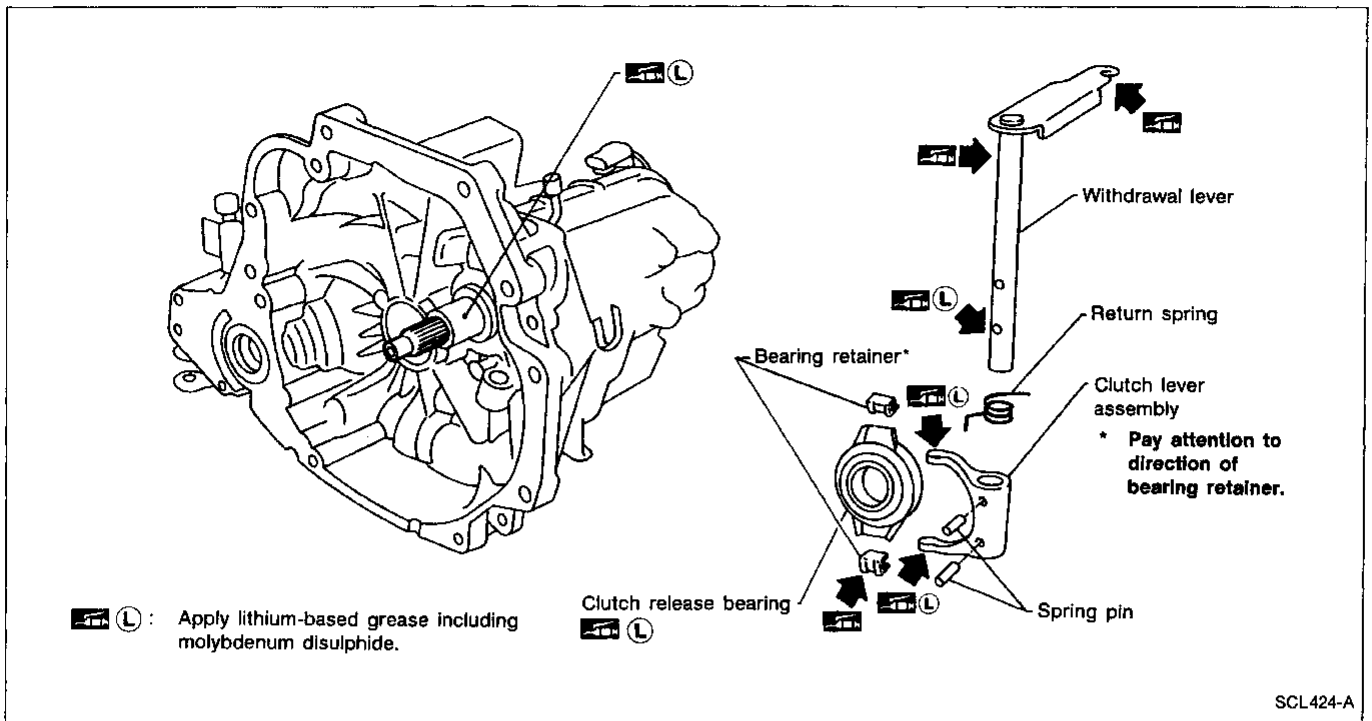

GI  
MA  
EM  
LC  
EC  
FE  
**CL**

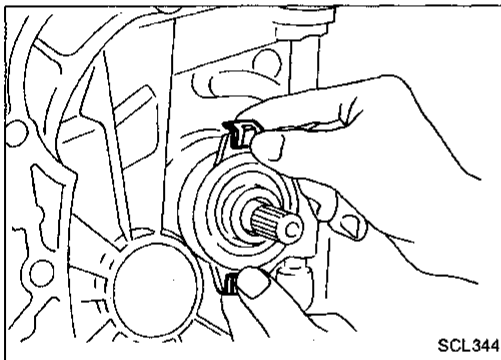

## REMOVAL AND INSTALLATION

- Remove release bearing by pulling bearing retainers outward.

MT  
AT  
FA  
RA

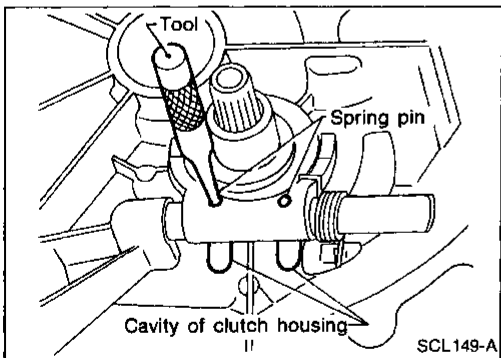

- Align spring pin with cavity of clutch housing and tap out spring pin.

BR  
ST

## INSPECTION

Check the following items, and replace if necessary.

- Release bearing, to see that it rolls freely and is free from noise, cracks, pitting or wear.
- Release sleeve and withdrawal lever rubbing surface, for wear, rust or damage.

BF  
HA

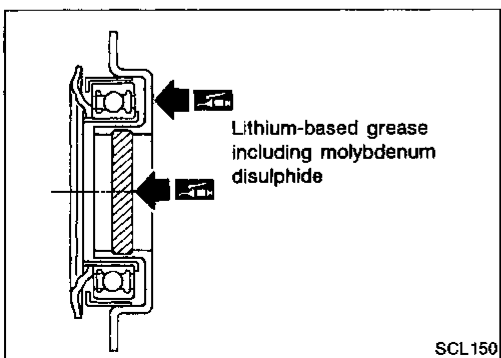

## LUBRICATION

- Apply recommended grease to contact surface and rubbing surface.
- Too much lubricant might damage clutch disc facing.

EL  
IDX

# CLUTCH DISC AND CLUTCH COVER

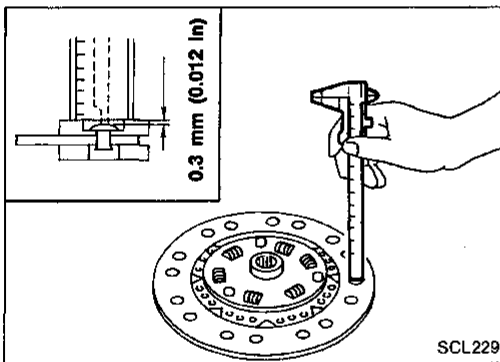
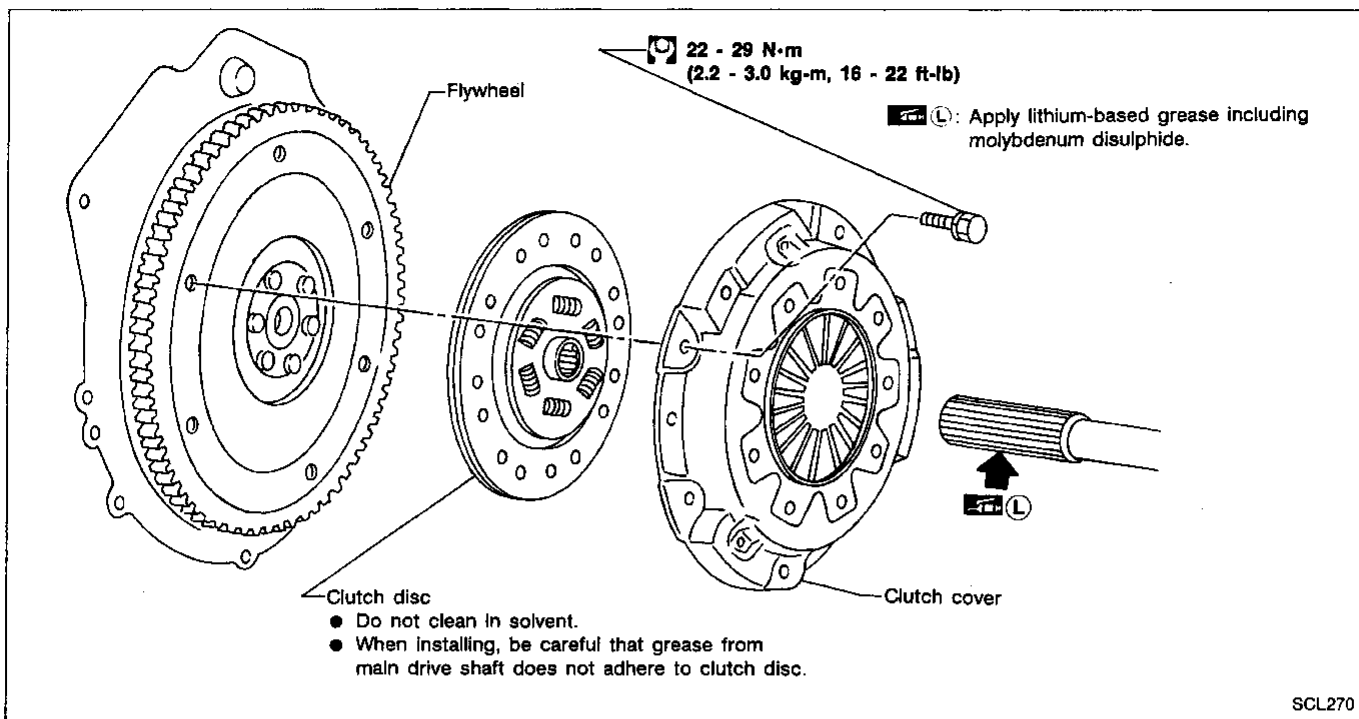

## Clutch Disc

### INSPECTION

Check clutch disc for wear of facing.

**Wear limit of facing surface to rivet head:**  
**0.3 mm (0.012 in)**

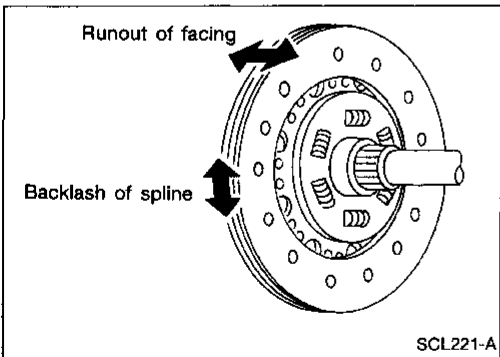

- Check clutch disc for backlash of spline and runout of facing.
  - Maximum backlash of spline (at outer edge of disc):**  
**0.9 mm (0.035 in)**
  - Runout limit:**  
**1.0 mm (0.039 in)**
  - Distance of runout check point (from hub center):**  
**102.5 mm (4.04 in)**
- Check clutch disc for burns, discoloration or oil or grease leakage. Replace if necessary.

# CLUTCH DISC AND CLUTCH COVER

## Clutch Cover and Flywheel

### INSPECTION AND ADJUSTMENT

- Set Tool and check height and unevenness of diaphragm spring.

**Diaphragm spring height "A":**

**30.5 - 32.5 mm (1.201 - 1.280 in)**

- Check thrust rings for wear or damage by doing one of the following. Shake cover assembly and listen for a chattering noise. Or lightly hammer on rivets and listen for a slightly cracked noise. Replace clutch cover assembly if necessary.
- Check pressure plate and clutch disc contact surface for slight burns or discoloration. Repair pressure plate with emery paper.
- Check pressure plate and clutch disc contact surface for deformation or damage. Replace if necessary.

GI

MA

EM

LC

EC

FE

CL

MT

AT

FA

RA

BR

ST

BF

HA

EL

IDX

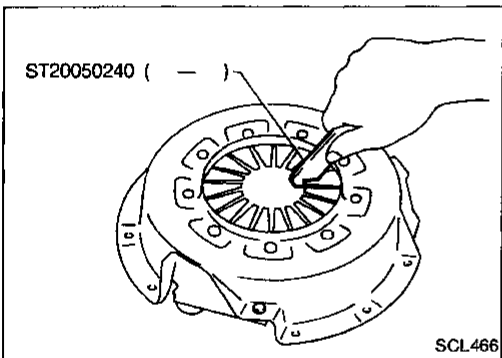
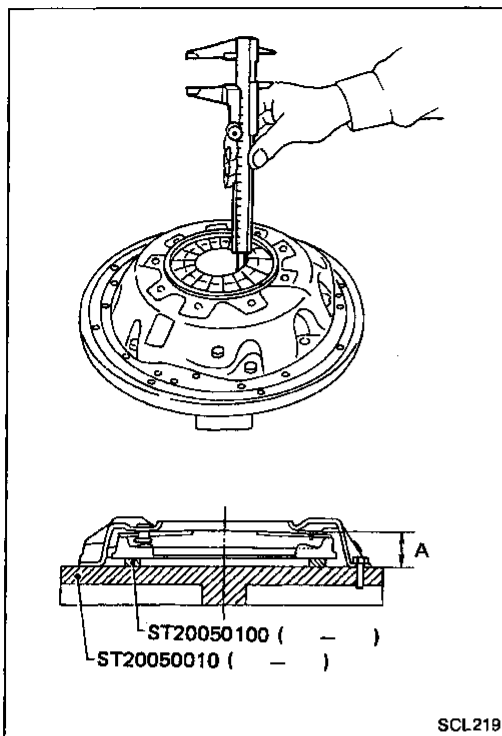

- Adjust unevenness of diaphragm spring with Tool.

**Uneven limit:**

**0.7 mm (0.028 in)**

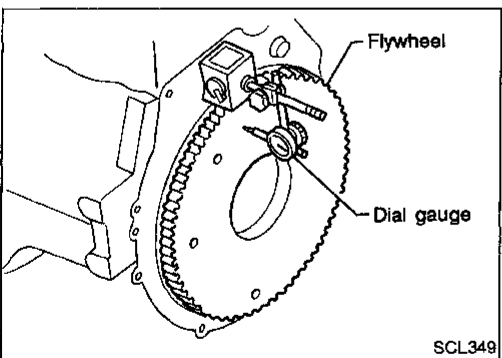

### FLYWHEEL INSPECTION

- Check contact surface of flywheel for slight burns or discoloration. Repair flywheel with emery paper.
- Check flywheel runout.

**Runout (Total Indicator reading):**

**Flywheel**

**Less than 0.15 mm (0.0059 in)**

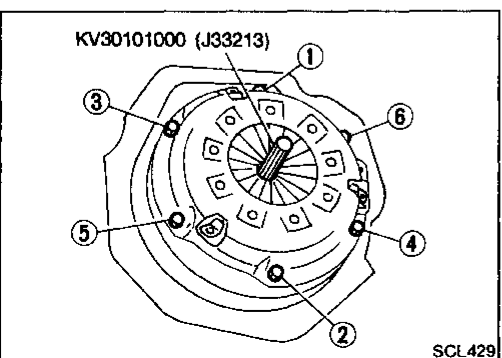

### INSTALLATION

- Insert Tool into clutch disc hub when installing clutch cover and disc.
- Tighten bolts in numerical order.
- **Be careful that grease does not contaminate clutch facing.**

# SERVICE DATA AND SPECIFICATIONS (SDS)

## General Specifications

### CLUTCH CONTROL SYSTEM

Type of clutch control	Mechanical type
------------------------	-----------------

### CLUTCH COVER

Engine	SR20DE
Model	215
Full-load	N (kg, lb) 4,413 (450, 992)

### CLUTCH DISC

Unit: mm (in)

Engine	SR20DE
Model	215
Facing size (Outer dia. x inner dia. x thickness)	215 x 140 x 3.5 (8.46 x 5.51 x 0.138)
Thickness of disc assembly with load	7.6 - 8.0 (0.299 - 0.315) with 3,923 N (400 kg, 882 lb)

## Inspection and Adjustment

### CLUTCH PEDAL

Unit: mm (in)

Pedal height*	159.5 - 169.5 (6.28 - 6.67)
Pedal free travel	10.8 - 15.1 (0.425 - 0.594)
Withdrawal lever play	2.5 - 3.5 (0.098 - 0.138)

\*: Measured from surface of melt sheet to surface of pedal pad.

### CLUTCH COVER

Unit: mm (in)

Cover model	215
Diaphragm spring height	30.5 - 32.5 (1.201 - 1.280)
Uneven limit of diaphragm spring toe height "A"	0.7 (0.028)

### CLUTCH DISC

Unit: mm (in)

Disc model	215
Wear limit of facing surface to rivet head	0.3 (0.012)
Runout limit of facing	1.0 (0.039)
Distance of runout check point (from hub center)	102.5 (4.04)
Maximum backlash of spline (at outer edge of disc)	0.9 (0.035)