

# SERVICE MANUAL

S30 SUPPLEMENT CHASSIS MANUAL  
DATSUN 240-Z SPORTS

*NATIONAL  
SERVICE  
TRAINING  
DEPARTMENT*



**NISSAN MOTOR CORP. IN U.S.A.**

**GARDENA, CALIFORNIA**

# **SERVICE MANUAL**

**S30 SUPPLEMENT CHASSIS MANUAL  
DATSUN 240-Z SPORTS**



**NISSAN MOTOR CORP. IN U.S.A.**

**GARDENA, CALIFORNIA**

## **FOREWORD**

This supplement as prepared by the National Service Training Department contains important service information in addition to and/or superseding the basic "Service Manual" 240Z, Chassis and Body (Part No. 99999-20016).

More comprehensive instructions are provided for servicing the dash area including removal and replacement (R&R) of the instrument panel assembly

and floor console (Automatic and Standard transmission models). Additionally, the "heat and ventilating system" is fully documented in this supplement, as well as R&R of the center instruments, center console finisher, and radio. Section VI contains a revised wiring diagram and illustrations for positive identification of wire harness electrical connectors.

## TABLE OF CONTENTS

Section	Page
<b>I INSTRUMENT PANEL – DESCRIPTION</b> .....	<b>1</b>
A. Preparation for Removal (Instrument Panel Component Disconnect) .....	3
B. Removal (Instrument Panel Assembly) .....	3
C. Replace (Instrument Panel and Components) .....	5
<b>II FLOOR CONSOLE – DESCRIPTION</b> .....	<b>7</b>
A. Removal .....	7
B. Remove and Replace (Floor Console Electrical) .....	9
<b>III HEAT AND VENTILATING SYSTEM (HVS) – DESCRIPTION</b> .....	<b>11</b>
A. Removal (Compartment Air Intake/Blower Assembly) .....	11
B. Removal (Instrument Panel, Center Console Finisher) .....	14
C. Removal (Heating Unit Assembly) .....	15
D. Replace (Heat and Ventilating System Components) .....	16
E. Bench Service (Heating Unit) .....	17
<b>IV CENTER GROUP PANEL INSTRUMENTS AND LIGHTING CONTROL – DESCRIPTION</b> .....	<b>19</b>
A. Remove and Replace (Ammeter/Fuel Gauge, Water Temp/Oil Pressure Gauge, Clock) .....	19
B. Remove and Replace, Instrument Panel Lighting, Illumination Control (Rheostat) .....	20
<b>V RADIO AND COMPONENTS – DESCRIPTION</b> .....	<b>21</b>
A. Remove and Replace (Radio Receiver/Tuner) .....	21
B. Remove and Replace (Radio Speaker and Power Antenna) .....	23
<b>VI ELECTRICAL</b> .....	<b>25</b>

## LIST OF ILLUSTRATIONS

Figure	Title	Page
I-1	Instrument Panel Assembly .....	1
I-2	Instrument Panel, Wire Harness Disconnect .....	2
I-3	Right-Hand Instrument Panel Floor Attach Points (LH Opposite) .....	3
I-4	Instrument Panel Attaching Hardware (Exploded View) .....	4
II-1	Floor Console and Attaching Hardware (Exploded View) .....	8
III-1	Heat and Ventilating System (HVS) Installation .....	12
III-2	Heat and Ventilating System (Exploded View) .....	13
III-3	Removal of Blower Motor/Fan Assembly .....	14
III-4	Air Intake/Blower Assembly Cable Disconnect .....	14
III-5	Removing Air Intake/Blower Assembly .....	14
III-6	Heater Control Cable Disconnect (LH) .....	14
III-7	Heater Control Cable Disconnect (RH) .....	15
III-8	Method of Draining Heater Core With Air Pressure .....	15
III-9	Air Box Ventilator (Console Finisher Removed) .....	16
III-10	Removing Heater Assembly .....	16
III-11	Heater Hose and Valve Assembly .....	17
III-12	Removing Heater End Plate .....	18
III-13	Removing Heater Core .....	18
IV-1	Center Group Instruments .....	19
IV-2	Removal of Glove Compartment Liner .....	19
IV-3	Removal of Instrument Panel Illumination Control (Rheostat) .....	20
V-1	Radio Chassis Rear Mount .....	21
V-2	Radio Tuner Mounting Screws .....	21
V-3	Radio Installation and Components .....	22
V-4	Speaker and Antenna Installation (Interior Trim Panels Removed) .....	23
V-5	Speaker and Bracket Installed .....	23
VI-1	Instrument Panel Wire Harness (Single Connector Function and Color Identification) .....	26
VI-2	Instrument Panel, Electrical Harness (Major Connector Identification) .....	28
VI-3	Engine Compartment, Electrical Harness (Major Connector Identification) .....	29
VI-4	Body Electrical Harness (Major Connector Identification) .....	30
VI-5	Wiring Diagram (Basic Model S30 Series for U.S.A.) .....	31
VI-6	Wiring Diagram (Late Model S30 Series for U.S.A.) .....	33



## SECTION I

### INSTRUMENT PANEL—DESCRIPTION

The instrument panel assembly consists of a vinyl covered, padded metal shell with provisions for mounting the instrument grouping, defroster and compartment air outlets, and various lighting controls and console finisher. (See Figure I-1.) The panel also serves as upper support structure for the steering column.

All panel mounted components can be removed

for service with the panel installed, as described in Section IV. However, should requirements for removing the panel occur, it can be removed as a unit per the following procedure.

Preparatory to removal or servicing of any major electrical circuit, or component, and as a safety measure, the vehicle electrical system should be made inoperative.

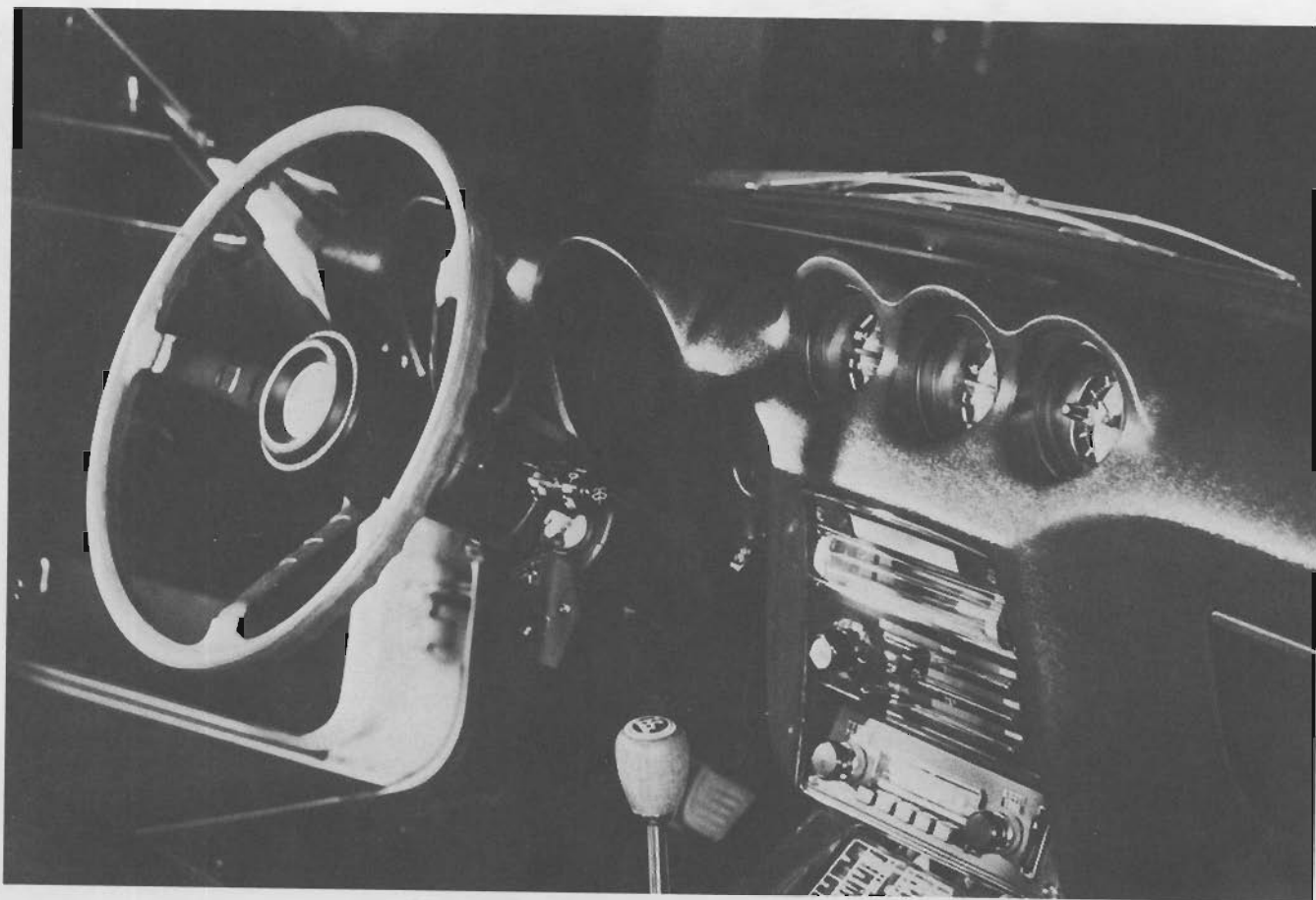

*Figure I-1. Instrument Panel Assembly*

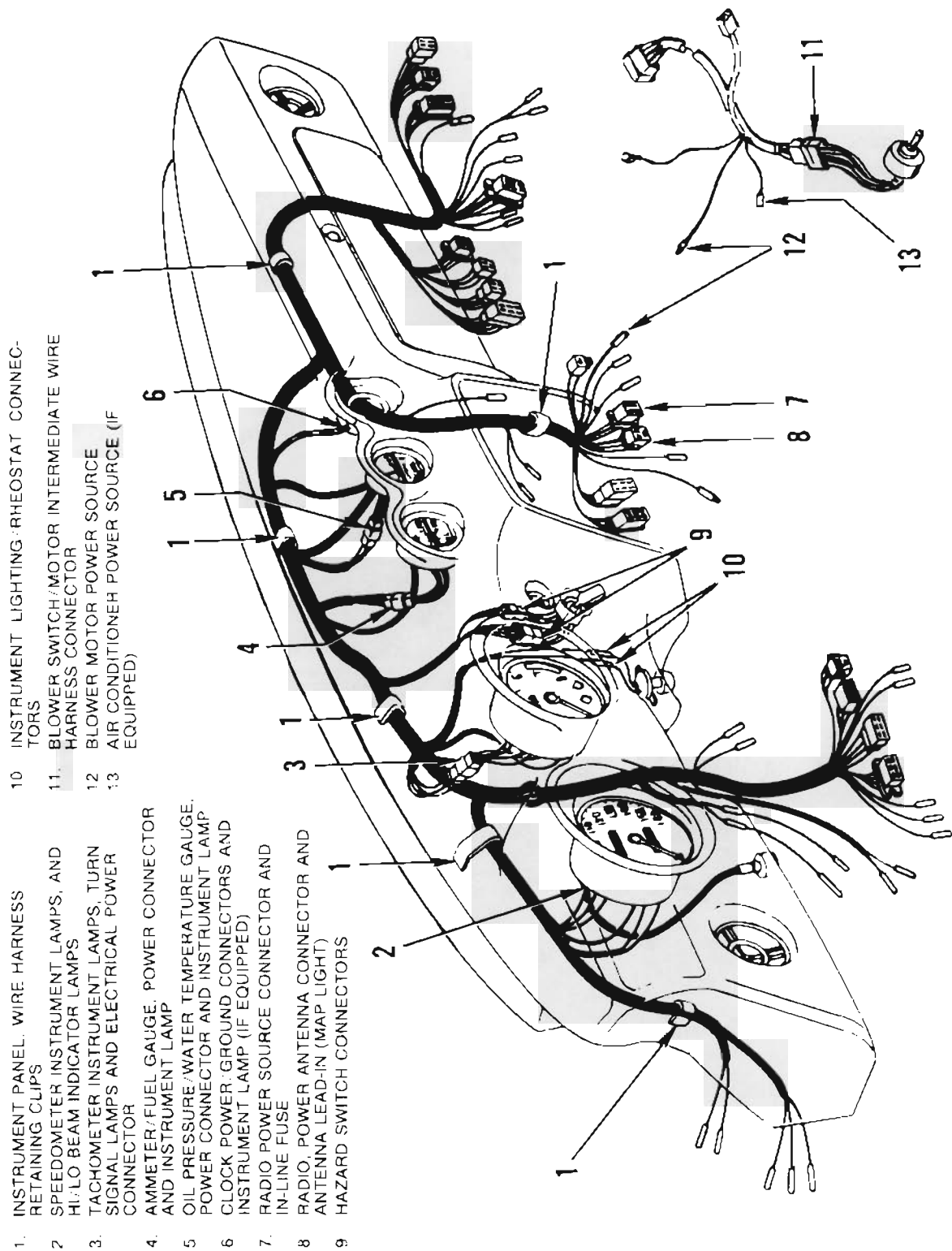

- 1. INSTRUMENT PANEL, WIRE HARNESS RETAINING CLIPS
- 2. SPEEDOMETER INSTRUMENT LAMPS, AND HI-LO BEAM INDICATOR LAMPS
- 3. TACHOMETER INSTRUMENT LAMPS, TURN SIGNAL LAMPS AND ELECTRICAL POWER CONNECTOR
- 4. AMMETER/FUEL GAUGE, POWER CONNECTOR AND INSTRUMENT LAMP
- 5. OIL PRESSURE/WATER TEMPERATURE GAUGE, POWER CONNECTOR AND INSTRUMENT LAMP
- 6. CLOCK POWER/GROUND CONNECTORS AND INSTRUMENT LAMP (IF EQUIPPED)
- 7. RADIO POWER SOURCE CONNECTOR AND IN-LINE FUSE
- 8. RADIO, POWER ANTENNA CONNECTOR AND ANTENNA LEAD-IN (MAP LIGHT)
- 9. HAZARD SWITCH CONNECTORS
- 10. INSTRUMENT LIGHTING RHEOSTAT CONNECTORS
- 11. BLOWER SWITCH/MOTOR INTERMEDIATE WIRE HARNESS CONNECTOR
- 12. BLOWER MOTOR POWER SOURCE
- 13. AIR CONDITIONER POWER SOURCE (IF EQUIPPED)

Figure 1-2. Instrument Panel, Wire Harness Disconnect

## A. Preparation for Removal (Instrument Panel Component Disconnect)

1. Disconnect the battery by removing the Positive (+) battery cable from the respective terminal at the battery.

2. The following instructions pertain to removing the instrument panel whereby the panel electrical wire harness remains stationary, in place. This operation requires electrical disconnection only at specific points as will be explained. Should it be desirable to remove the panel/wire harness integral, then a total disconnection must be made isolating the engine and body harnesses from the panel wire harness. For a complete identification of disconnect points, refer to Figure VI-1.

3. Before any electrical panel wiring is disconnected, release the wire harness from the retaining clips, Item 1, as shown in Figure I-2. Make the remaining electrical disconnections as follows:

- a. Locate and disconnect wire harness connectors, Items 2 through 10, and remove all instrument lamp bases from the instruments.
- b. Disconnect all power and ground wires leading to each instrument including the clock (if equipped) and the map light.
- c. Disconnect the intermediate blower switch wire harness connector, Item 11, from in back of the switch, and the blower motor hot lead, Item 12, from the panel wire harness.
- d. Disconnect the air conditioner hot lead, Item 13 (if equipped).

### NOTE

Steps described in Paragraphs A-1 through A-3d complete the instrument panel electrical disconnect. However, a visual check should be made for connections to accessories not normally installed.

4. Locate and disconnect the speedometer drive cable retaining collar at the rear of the instrument.

5. Remove the heater and defroster ducts from the connections at the air outlets. (Refer to Section III.)

6. Disconnect the heating unit and air intake box control cables in accordance with the instructions outlined in Section III. (See Figures III-4, III-6 and III-7.)

## B. Removal (Instrument Panel Assembly)

Figure I-3 shows the right-hand (left-hand opposite) instrument panel, floor attach points at the panel support strut and radio chassis support bracket. The remaining attach points occur at six mounting holes on the cowl below the windshield and at two outboard, panel support brackets suspended from under the cowl. (See Figure I-4.)

1. As shown in Figure I-3, remove the panel, attaching hardware in order, as follows:

- a. Center instrument panel support strut attaching screws, Item 1.
- b. Instrument panel, radio support bracket attaching screws, Item 2.

2. Refer to Service Manual, Section ST, "Removal of Steering Wheel and Column," and remove attaching hardware as follows:

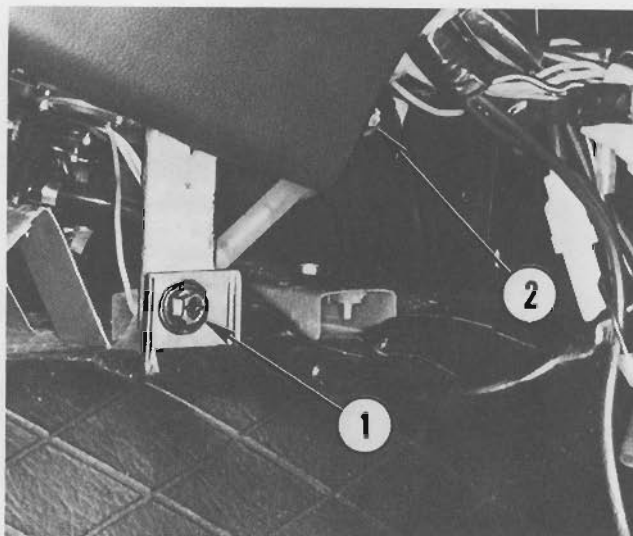
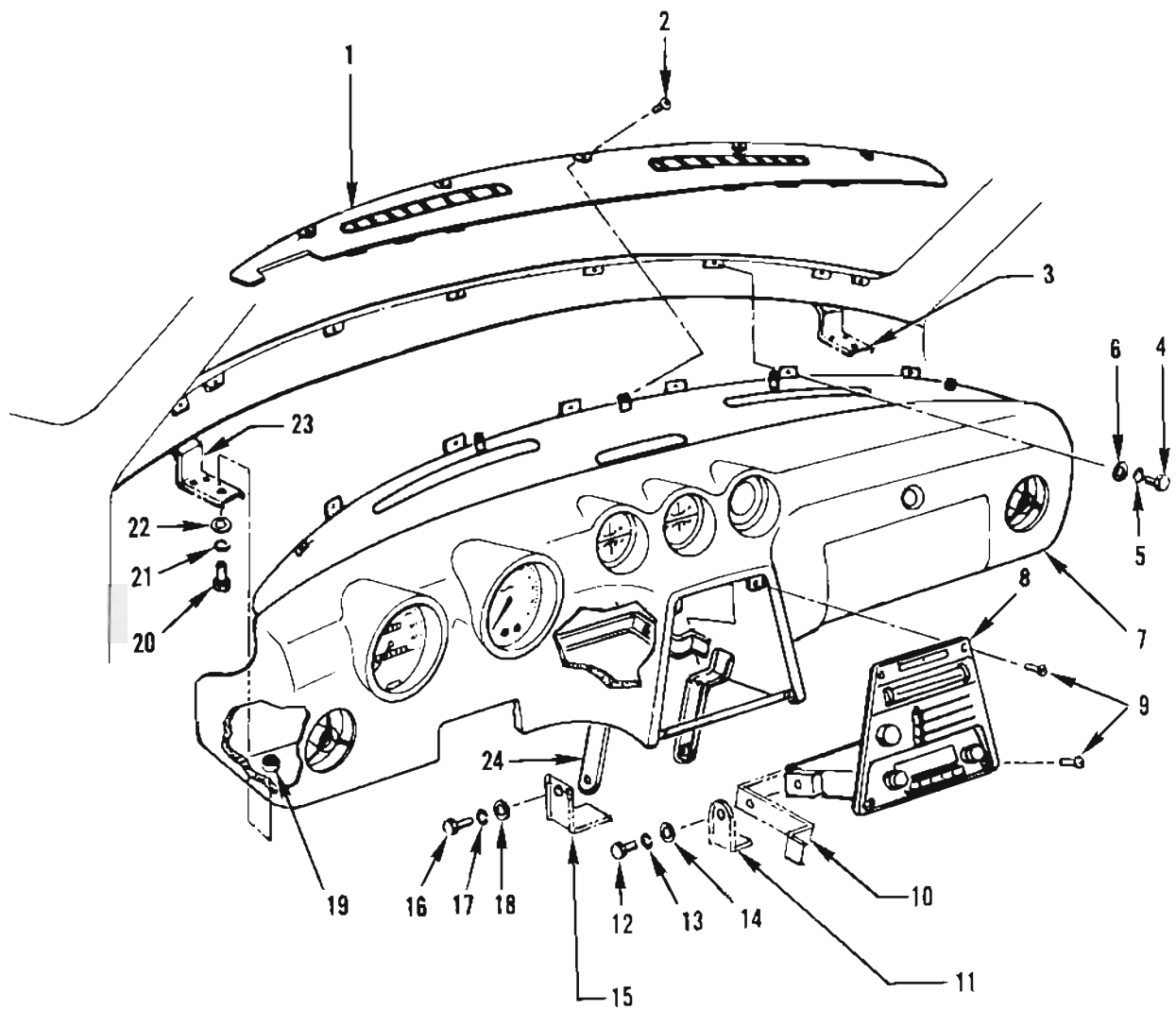

Figure I-3. Right-Hand Instrument Panel Floor Attach Points (LH Opposite)





- |                                       |  |
|---------------------------------------|--|
| 1. INSTRUMENT PANEL TOP GARNISH       | 14. WASHER                                 |
| 2. ATTACHING SCREWS                   | 15. INSTRUMENT PANEL FLOOR SUPPORT BRACKET |
| 3. PANEL SUPPORT BRACKET (RIGHT-HAND) | 16. PANEL SUPPORT ATTACHING SCREWS         |
| 4. PANEL ATTACHING SCREWS             | 17. LOCKWASHER                             |
| 5. LOCKWASHER                         | 18. WASHER                                 |
| 6. WASHER                             | 19. PANEL MOUNTING NUTPLATE                |
| 7. INSTRUMENT PANEL ASSEMBLY          | 20. PANEL MOUNTING ATTACHING SCREWS        |
| 8. CONSOLE FINISHER ASSEMBLY          | 21. LOCKWASHER                             |
| 9. ATTACHING SCREWS                   | 22. WASHER                                 |
| 10. RADIO CHASSIS SUPPORT BRACKET     | 23. PANEL SUPPORT BRACKET (LEFT-HAND)      |
| 11. RADIO FLOOR SUPPORT BRACKET       | 24. CENTER PANEL MOUNTING SUPPORT STRUTS   |
| 12. RADIO CHASSIS ATTACHING SCREWS    |  |
| 13. LOCKWASHER                        |  |

Figure I-4. Instrument Panel Attaching Hardware (Exploded View)

- a. As shown in Figure ST-7, remove the four retaining screws holding the steering column bracket to the firewall.
  - b. As shown in Figure ST-6, remove the four attaching screws holding the steering column post clamp to the instrument panel. The steering column can now be lowered, and the wheel rested on the seat.
3. To obtain access to the panel/cowl attach points, remove the instrument panel top garnish and five Phillips head attaching screws, as shown in Figure I-4, Items 1 and 2. Complete the removal of panel attaching hardware as follows:
    - a. Panel/cowl attaching screws, Item 4.
    - b. Panel/cowl outboard support bracket attaching screws, Item 20.
  4. The instrument panel assembly is now free of attachments and may be removed in the following manner:
    - a. Move the gear selector lever to the rear. Lift the panel assembly slightly, and insert some protective covering (cardboard or cloth) in between the panel and floor console to avoid marring the console.
    - b. Continue raising the panel while tilting downward until the lower panel support struts clear the floor console.
    - c. Bring the panel assembly towards the rear to a point where it can be removed through the passenger door opening.

#### **NOTE**

**Perform any service to panel electrical/mechanical components in accordance with the applicable section(s) of the Service Manual.**

### **C. Replace (Instrument Panel and Components)**

Although replacement of the panel assembly is essentially the reverse order of removal, the following procedure suggests certain random operations be performed which are found to be effective.

1. Protect the floor console as for removal, and position the panel to rest on the floor console in a face down attitude. In this manner, access is obtained over the top of the panel whereby the heater control cables can be inserted through their clamps, and secured at the terminals. (Refer to Section III, Paragraph A.)
2. Raise the panel and guide the lower support struts and radio support bracket in position between the floor attach brackets.
3. Rest the panel in an installed position on the cowl mounted panel support brackets. Loosely attach the panel at the brackets and at the forward edge at the cowl with attaching screws.
4. Insert the attaching screws, secure the panel radio support bracket, and lower support struts at the floor attach brackets.
5. Raise the steering column and loosely attach the post clamp bracket to the panel. Insert and secure the lower column bracket attaching screws.
6. Secure the remaining panel assembly attaching hardware in order, i.e., the forward instrument panel, cowl, panel outboard support brackets, and steering column post clamp.
7. Connect the heater and defroster ducts to their respective outlets.
8. Refer to Figure I-2 for connector identification and make all electrical component to instrument panel wire harness connections.
9. Connect the instrument panel wire harness to the respective engine compartment wire harness connectors. (See Figure VI-1.)
10. Connect the speedometer drive cable to the instrument, making sure the cable drive spline is properly seated prior to threading on the retaining collar.
11. Connect the battery, and make a systematic check of all electrical/mechanical components and control to verify proper working order.

## NOTES



## SECTION II

### FLOOR CONSOLE—DESCRIPTION

The floor console is a fiberglass shell which houses the gear change selector, choke lever, fuse box, ashtray and cigarette lighter, coin tray, and rear window defroster switch. With the exception of a driving range indicator lamp (automatic transmission models only), electrical connections are identical as is the procedure for removal and replace. (See Figure II-1.)

#### A. Removal

1. Disconnect the vehicle electrical system by removing the Positive (+) battery cable from the terminal at the battery.

2. Remove the ashtray cover assembly and fuse box cover to expose the forward floor console attach points.

3. Locate and disconnect the console electrical components at the connectors. (See Figure 1-2.)

4. As shown in Figure II-1, remove the floor console components and attaching hardware as follows:

- a. Setscrew and choke control knob, Items 1 and 2.
- b. Retaining screws and gear change lever handle (automatic transmission), Items 3 and 4, or change lever knob and boot (standard transmission), Items 5 and 6.

c. Attaching hardware (screw) and coin case, Items 7 and 8.

d. Rear console attaching screws, Item 9.

e. Forward console attaching screws, Item 10, (attaching hardware for fuse block and cigarette lighter mounting bracket).

5. Protect the forward top edges of the console shell with masking tape to avoid scratching during removal.

6. Carefully force the fuse box forward through the space between the console shell and the mounting cross member.

7. Lift the console to gain access beneath. Remove the retaining nuts which secure the choke control mechanism to the console. (See Figure II-1, Item 11.)

8. Free the choke cable from the two clips located inside the console shell (lower-right side).

9. The floor console is now free to be removed by lifting upwards and back, while working the gear change lever console escutcheon (automatic transmission) off the gear change lever.

10. The floor console is replaced in the reverse order of removal. Perform a check to verify proper working order of console electrical and mechanical units.

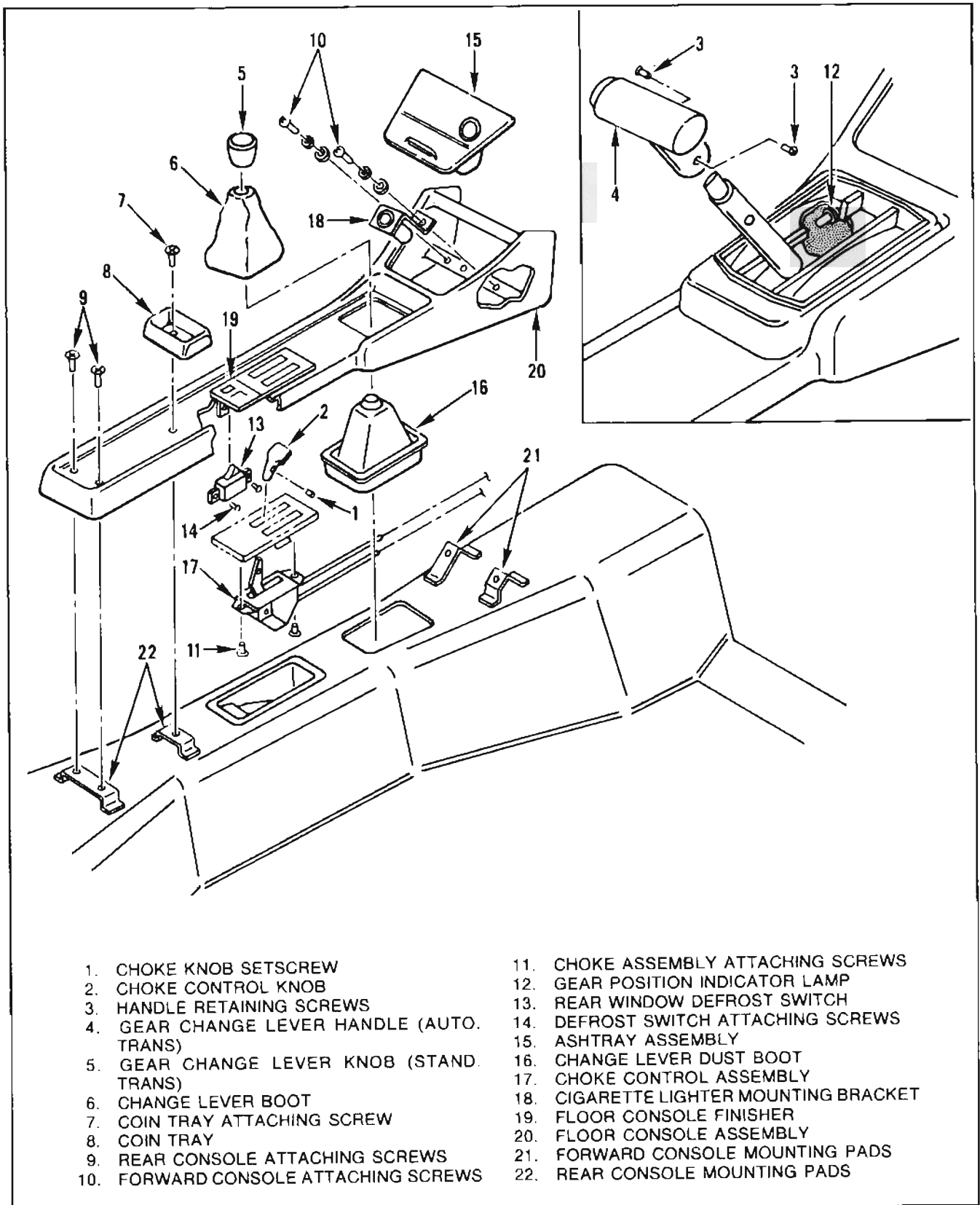

Figure 11-1. Floor Console and Attaching Hardware (Exploded View)



**B. Remove and Replace (Floor Console Electrical)**

**NOTE**

**It is not necessary to remove the floor console to replace the selector position indicator lamp or rear window defrost switch.**

1. Perform procedure as described in Paragraphs A-1 through A-6, and prop the console assembly in a raised position to gain access beneath.

2. Refer to Figure II-1 for part identification and R&R as follows:

a. Replace a burned out indicator lamp, Item 12, by pulling the base from the holder. Insert a new lamp bulb and replace in position.

b. To replace a faulty defrost switch, Item 13, remove the two Phillips head attaching screws, Item 14, and bring the switch from under the console. Splice and solder in a new switch and secure in place.

c. Connect the battery and make electrical test to assure proper component working order.

## NOTES

## SECTION III

### HEAT AND VENTILATING SYSTEM (HVS)—DESCRIPTION

The 240Z "HVS" is of the hot water heater type; the preheated water source being supplied by the engine cooling system. With the heat source in the "OFF" position, the system may be used for compartment fresh air ventilation by induction of outside air.

The system components, compartment, air intake/blower, and heating unit assembly, are mounted under the instrument panel adjacent to the inner firewall. Fresh air is ducted to compartment air outlets in the instrument panel facia, console finisher, and windshield defroster outlets located in the instrument panel, top garnish. (See Fig. III-1.)

The following procedure concerns removal and replacement (R&R) of the components in the immediate area of the instrument panel which have not previously been documented, or which are more readily accessible during R&R of heat and ventilating system components.

#### NOTE

**Complete instructions for operating the heat ventilating system controls are provided in the 240Z OWNERS MANUAL.**

#### **A. Removal (Compartment Air Intake/Blower Assembly)**

The air intake/blower assembly must be removed to accommodate removal of the heater and console

finisher attachments. Though not a requirement, prior removal of the glove compartment door and liner, as described in Section IV, Paragraph A, will assist visibility and give better access to heat and ventilating system, and other panel components. A complete breakdown of major HVS components and attaching parts is provided in Figure III-2.

1. For reasons of safety, disconnect the battery cable, Positive ( + ) connection at the battery terminal.

2. Disconnect the defroster ducts (see Figure III-1, Items 1 and 2) at the air outlets.

3. The following instructions, Paragraphs 3a through 3c, pertain to R&R of the blower motor/fan assembly independent of further dismantling of HVS components.

- a. Disconnect the blower motor, electrical power connections (red and black wires).

- b. Using a swivel-socket with extension, remove the three attaching screws from the blower motor mount flange and withdraw the blower motor assembly from the blower housing. (See Figure III-3.)

- c. Replace a defective unit with (Part No. 27070-E 4405) motor and fan.

4. Disconnect the blower motor electrical power connector from the instrument panel wire harness.

5. Disconnect the air vent, control cable at the vent lever terminal on the RH side of the air intake unit, as shown in Figure III-4.

6. The air intake/blower assembly is mounted to the firewall at three points. A fourth mounting point is provided by means of a support bracket suspended from under the cowl. A single attaching screw secures the blower cage and the blower motor

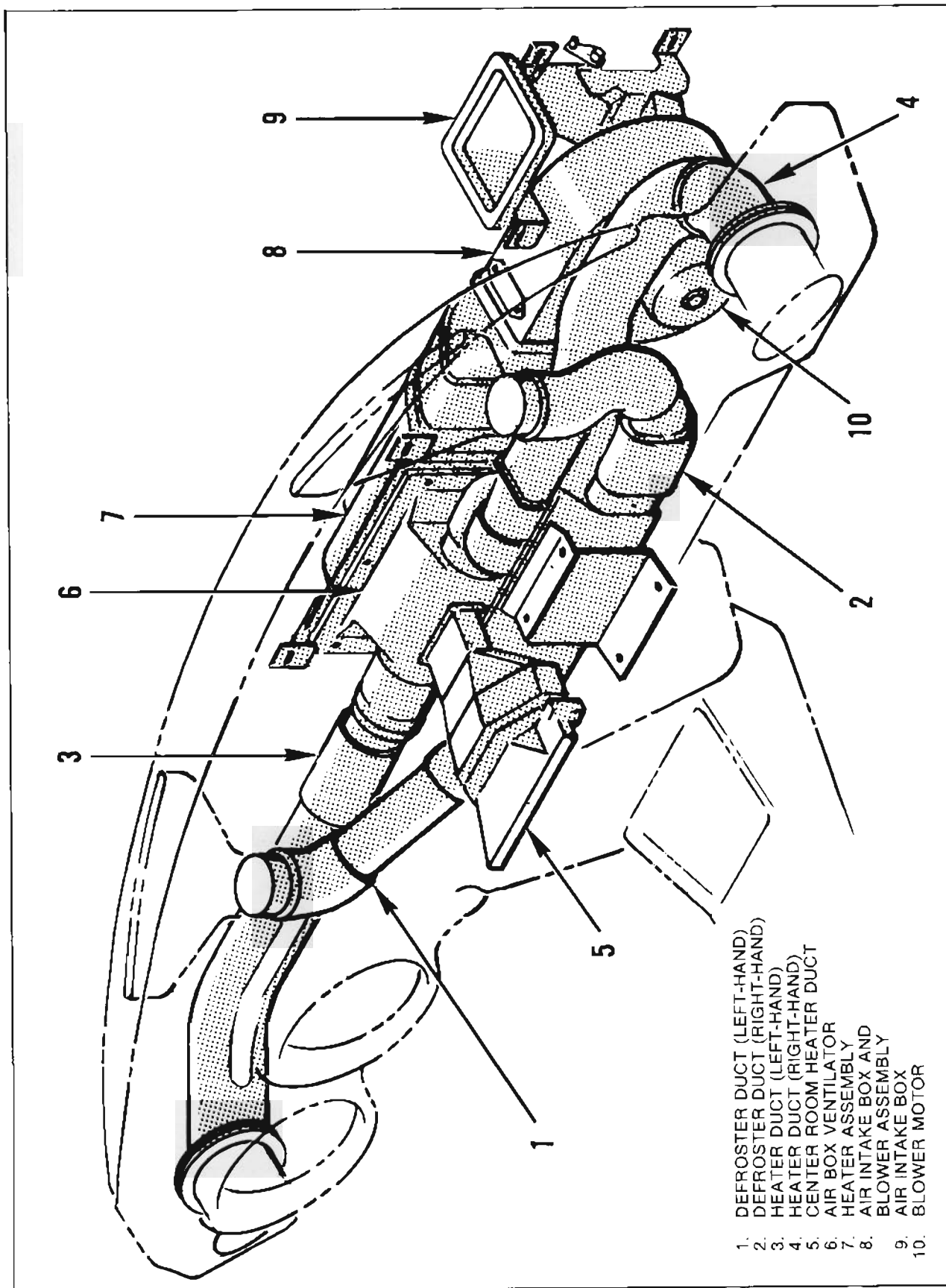

Figure III-1. Heat and Ventilating System (HVS) Installation

1. DEFROSTER DUCT (LEFT-HAND)
2. DEFROSTER DUCT (RIGHT-HAND)
3. HEATER DUCT (LEFT-HAND)
4. HEATER DUCT (RIGHT-HAND)
5. CENTER ROOM HEATER DUCT
6. AIR BOX VENTILATOR
7. HEATER ASSEMBLY
8. AIR INTAKE BOX AND BLOWER ASSEMBLY
9. AIR INTAKE BOX
10. BLOWER MOTOR

1. HEATER CORE
2. HEATER UNIT ASSEMBLY
3. VENTILATOR VALVE LEVER
4. NUT
5. SPRING WASHER
6. VALVE SPRING SNAP RING
7. AIR BOX VENTILATOR ASSEMBLY
8. SCREW
9. WASHER
10. HEATER MOUNTING SCREW
11. WASHER
12. COMPARTMENT AIR INTAKE ASSEMBLY
13. VALVE SPRING
14. CONTROL CABLE CLAMP
15. SCREW
16. MOUNTING SCREW
17. WASHER
18. AIR INTAKE/BLOWER ASSEMBLY ATTACHING SCREW

19. WASHER
20. DEFROSTER DUCT (LEFT-HAND)
21. SELF-TAPPING SCREW
22. WASHER
23. DEFROSTER DUCT (RIGHT-HAND)
24. VENTILATOR DUCT ASSEMBLY (RIGHT-HAND)
25. VENTILATOR DUCT CLAMP
26. VENTILATOR DUCT ASSEMBLY (LEFT-HAND)
27. MACHINE SCREW
28. NUT
29. WASHER
30. CENTER VENTILATOR DUCT
31. CENTER-FRONT VENTILATOR DUCT
32. CENTER GRILL SPRING
33. CENTER GRILL BEARING
34. VENTILATOR DUCT CLAMP
35. MACHINE SCREW
36. HEATER CONTROL ASSEMBLY
37. MACHINE SCREW

38. SPRING WASHER
39. BLOWER SWITCH ASSEMBLY
40. SWITCH, WIRE HARNESS ASSEMBLY
41. TEMPERATURE CONTROL CABLE
42. ROOM-DEFROST CONTROL CABLE
43. COMPARTMENT AIR CONTROL CABLE
44. HOT WATER VALVE CONTROL CABLE
45. WATER INLET HOSE
46. WATER OUTLET HOSE
47. HOSE CLAMP
48. FIREWALL THRU-HOLE GROMMET
49. ENGINE WATER SUPPLY FITTING
50. CONNECTOR CAP
51. HOSE CLAMP
52. HOT WATER CONTROL VALVE ASSEMBLY

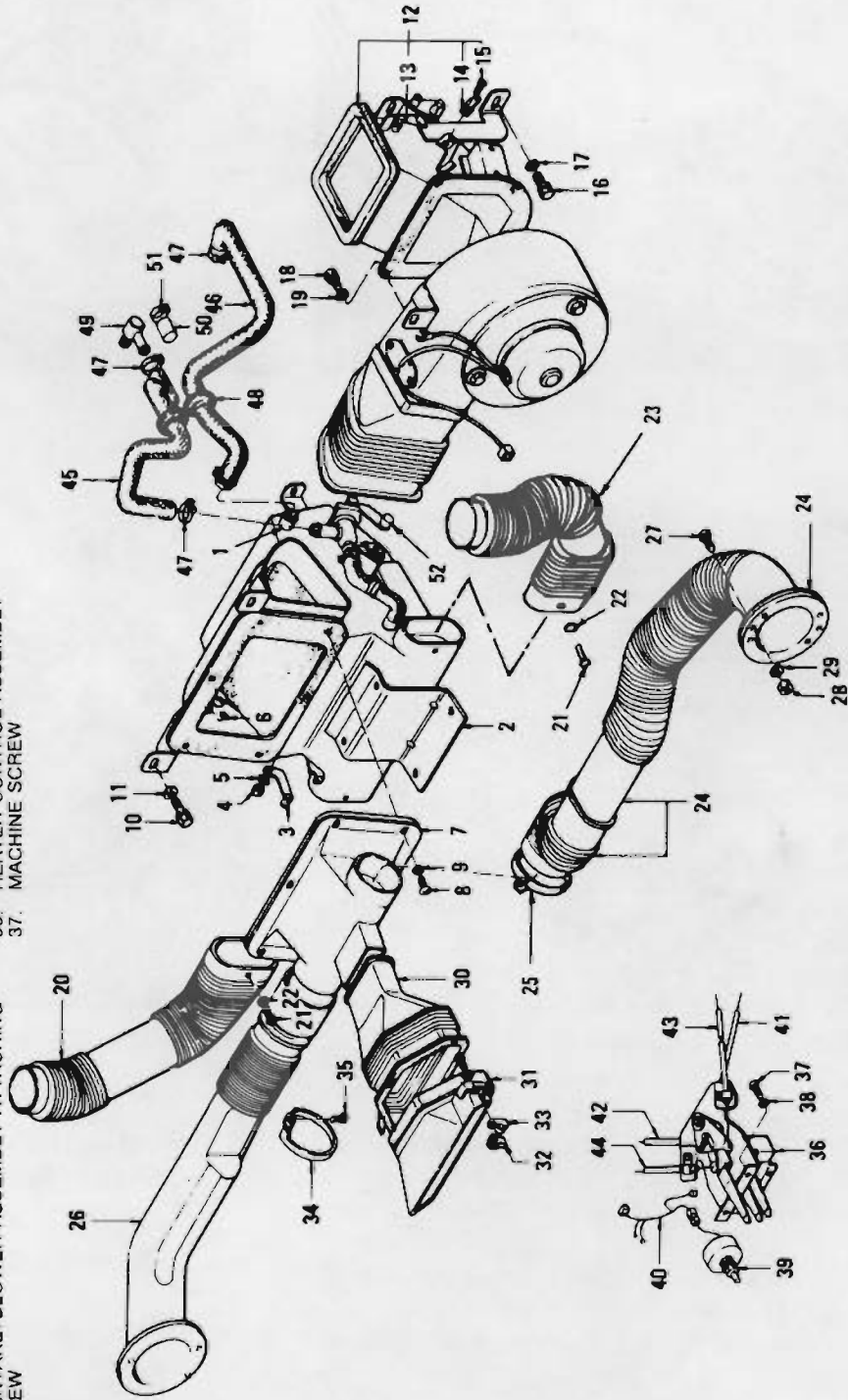
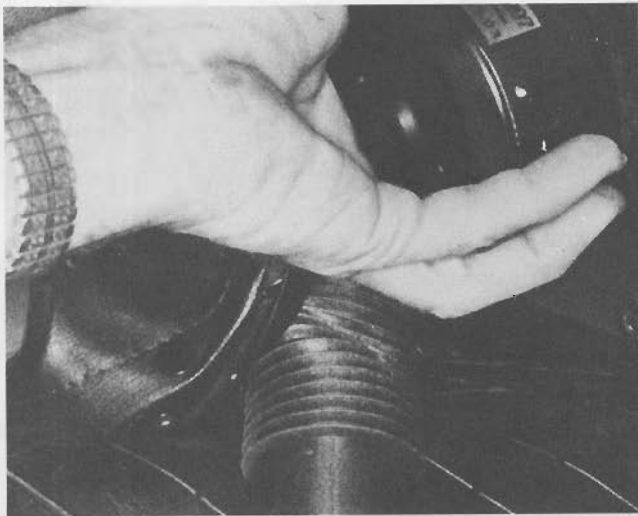
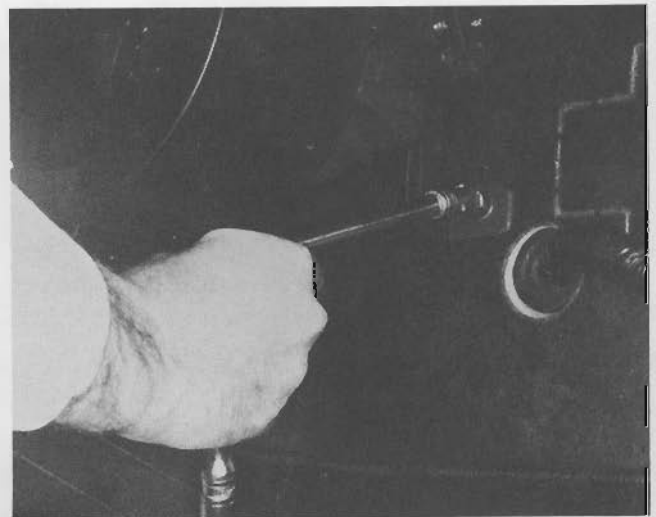

Figure III-2. Heat and Ventilating System (Exploded View)

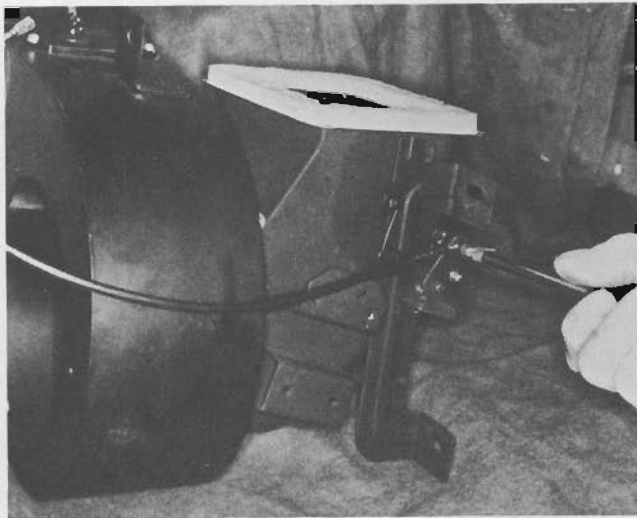



*Figure III-3. Removal of Blower Motor/Fan Assembly*



*Figure III-5. Removing Air/Blower Assembly*



*Figure III-4. Air Intake/Blower Assembly Cable Disconnect*

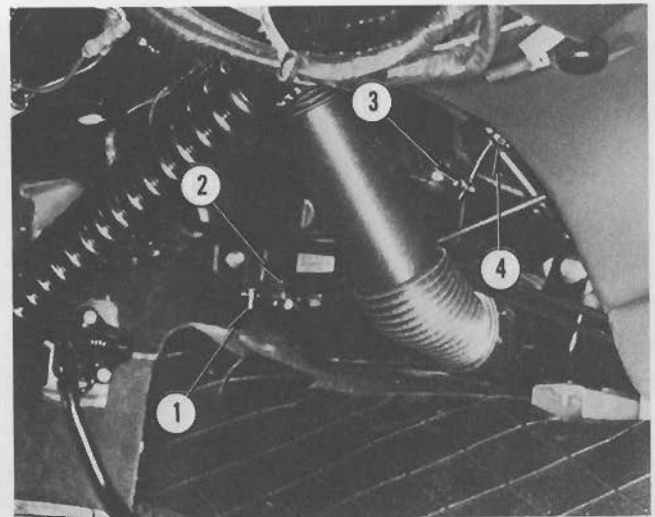

*Figure III-6. Heater Control Cable Disconnect (LH)*

ground wire at this point. Remove the four 10 mm attaching screws using a swivel-socket where required. (See Figure III-5.)

7. With the attaching hardware removed, slip the blower air duct from the heater connection and remove the assembly downward and to the right.

8. If no other HVS components are to be removed, replace the air intake/blower assembly in the reverse order making sure that the blower motor ground wire is secured with the attaching hardware.

## **B. Removal (Instrument Panel, Center Console Finisher)**

1. With the air intake/blower assembly removed, proceed to dismantle the system by removing the instrument panel center console finisher (see Figure I-4, Item 8). Disconnect the three heater box control cables as follows:

- a. Disconnect the air vent control cable at the terminal, Item 1, on the lower LH side of the heater box (see Figure III-6). Release the cable clamp, Item 2, and free the cable of connections.

b. Disconnect the defroster control cable at the terminal, Item 3, on the upper LH heater/defrost box (see Figure III-6). Release the cable clamp, Item 4, and free the cable of connections.

c. Disconnect the heater temperature control cable at the terminal, Item 1, on the water control valve on the RH side of the heater box (see Figure III-7). Release the cable clamp, Item 2, and free the cable of connections.

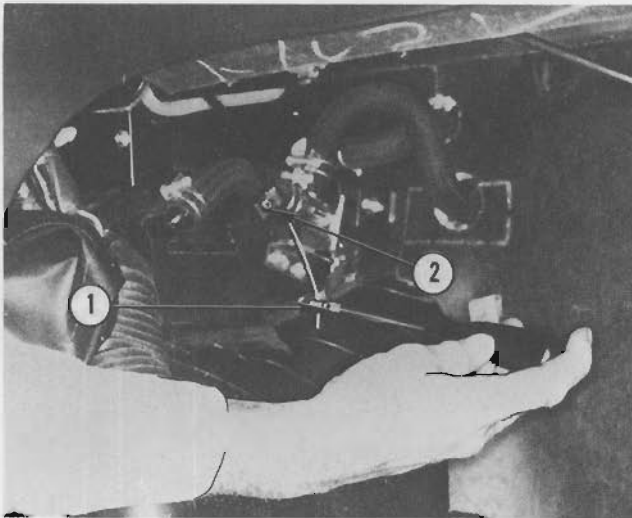

Figure III-7. Heater Control Cable Disconnect (RH)

2. The radio chassis and surrounding instrument panel radio chassis brace are supported by floor mounted "L" brackets on both sides. Remove the two opposed screws, Item 12, to free radio chassis. Remove the RH "L" bracket to accommodate later removal of the heater unit. (See Figure I-4.)

3. Disconnect all radio electrical and antenna connections, Items 12, 13 and 14, as shown in Figure V-3.

4. To remove the console finisher integral with radio and heat and ventilating system controls, proceed as follows:

a. Disconnect the blower switch power connector. (See Figure I-2, Item 11.)

b. Remove the four attaching screws, i.e., two each, located in the upper corners of the console finisher and lower corners of the radio escutcheon. (See Figure I-4, Item 9.)

c. Bring the console finisher toward the rear until the center compartment heater air duct is exposed, and disconnect the duct from the air outlet.

d. Remove map light lens and push light fixture through finisher. Do not disconnect the map light electrical circuit.

5. With these operations completed, the console finisher is free to be removed from position in the instrument panel.

### C. Removal (Heating Unit Assembly)

1. Preparatory to removing the heater unit, the heater core or preferably the engine cooling system must be drained. If the coolant meets the specified limits, i.e., under 24,000 miles and/or antifreeze tests, it may be claimed for reuse as follows:

a. Remove the radiator cap to assist drainage.

b. Place a clean container (2 U.S. Gal. +) beneath the radiator drain cock (lower RH core) and open the valve until drainage is complete.

c. Loosen the heater hose clamps (supply and return lines), see Figure III-8, Items 1 and 2, at the RH side of the engine and remove the hoses from the fittings.

d. The heater core may be force drained from within the engine compartment by applying air pressure to the heater supply line.

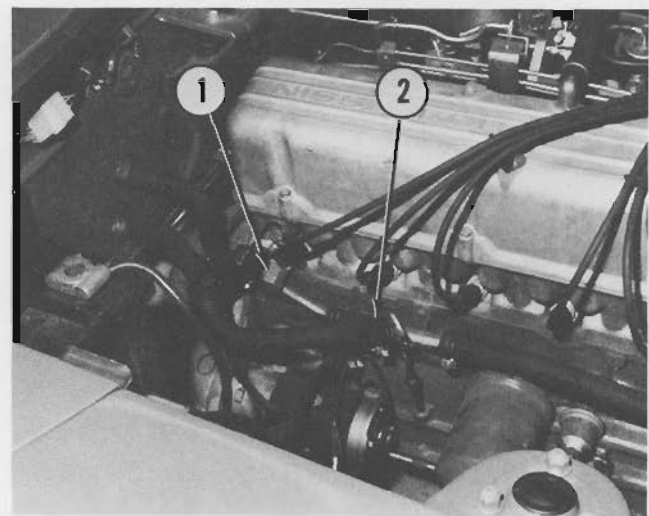

Figure III-8. Method of Draining Heater Core With Air Pressure

2. Inside the passenger compartment, and with the console finisher removed, the heater unit and air box ventilator attaching hardware is accessible. The order of disassembly is as follows:

- a. Loosen the left- and right-hand ventilator duct clamps (see Figure III-2, Items 25 and 34), and move the ducts away from the ventilator assembly.
- b. Remove the six attaching screws from the air box ventilator (see Figure III-9). Note that the lower LH screw also attaches the heater box vent control cable clamp.
- c. Remove the air box ventilator assembly out through the console finisher mount opening.

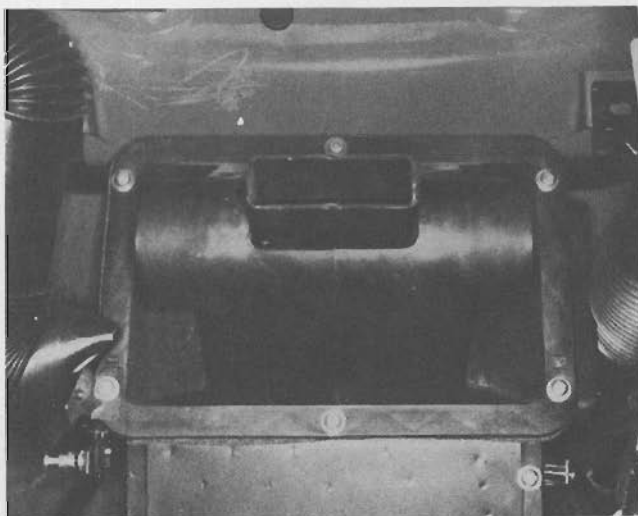

Figure III-9. Air Box Ventilator  
(Console Finisher Removed)

3. The heater unit is now exposed and can be detached from the mounting points after removing the two attaching screws (see Figure III-2, Item 21) which secure the defroster ducts to the lower heater unit. With the screws removed, slide the defroster ducts out of the way.

4. Lay a protective covering of sheet plastic in the passenger compartment foot well to catch any antifreeze coolant remaining in the heater lines or core. Pull both heater hoses through the firewall from inside the compartment.

5. The heater unit, Item 2, and integral mount-

ing flanges are clearly shown in Figure III-2. Remove the six attaching screws, Item 10.

6. The Heater unit is now free of attachments and can be removed downward and to the right, as shown in Figure III-10.



Figure III-10. Removing Heater Assembly

#### NOTE

The heater unit is a repairable item to the extent that specific components may become defective and require replacement. Instructions for disassembly and assembly of the heater unit are provided in Paragraphs E.1. through E.5. of this section.

#### D. Replace (Heat and Ventilating System Components)

Replace the heat and ventilating system components per the following instructions:

1. If the heater unit has been disassembled for repair, check all controls (vent doors and air valves) for proper operation, and heater hose clamps for tightness prior to replacing the unit.

2. Move the unit into normal position and secure in place with attaching hardware.

3. Force the heater supply and return hoses into the thru-holes in the firewall, i.e., heater core return hose in the top thru-hole.

4. Secure the RH radio chassis support "L" bracket in place at the floor attach point.

5. Assemble the heater, air box ventilator to the heater and secure with attaching screws. Be sure to include the heater vent, control cable clamp in assembly.

6. Connect the left- and right-hand ventilator air ducts to the air box and secure the hose clamps.

### NOTE

**The heater unit and respective control cable connections are more accessible prior to further assembly of ducting and are next in order of attention.**

7. Place the console finisher on the floor console in a semi-installed position. Route the heater control cables through the respective clamps and into the terminal connections.

8. Secure the terminal setscrews leaving the clamps loose for cable adjustment purposes until the console finisher is secured in place.

9. Move the console finisher into place and secure with attaching screws to the rear radio chassis support brackets.

10. Secure the console finisher to the instrument panel facia with the four attaching screws. Make sure the map light and lens are properly positioned upon assembly.

11. Position the heater and vent control cables to give total open/close operating movement, and secure the cable clamps.

12. Secure the LH defroster duct to the heater unit with the attaching screw, and complete the duct connection at the LH defroster air outlet.

13. Place the air intake/blower assembly in position and work the flexible duct until fully seated

at the connection on the heater. Secure the assembly to the firewall with the three attaching screws.

14. Using Figure VI-1 for connector identification, complete the connection of electrical components, i.e., blower switch, blower motor, radio power, antenna power and antenna lead. Be sure to attach the blower ground wire to the blower housing.

15. Secure the heater supply lines to the fittings on the engine and replace the engine coolant, filling to the required capacity.

16. Connect the battery and start the engine. Perform a check for proper operation of heater controls and electrical system. Verify that all heater hose connections are secure and without leaks.

### E. Bench Service (Heating Unit)

1. Remove the heater unit for disassembly in accordance with the applicable instructions.

2. Loosen the hose clamps, Items 1 and 2, as shown in Figure III-11. Remove the heater hoses from the connections on the heater core.

3. Remove the two attaching screws, Item 3, and the heater cock assembly, Item 4. Replace a defective heater cock assembly with (Part No. 27116-E 4400) Assembly-cock heater (valve). (See Figure III-11.)

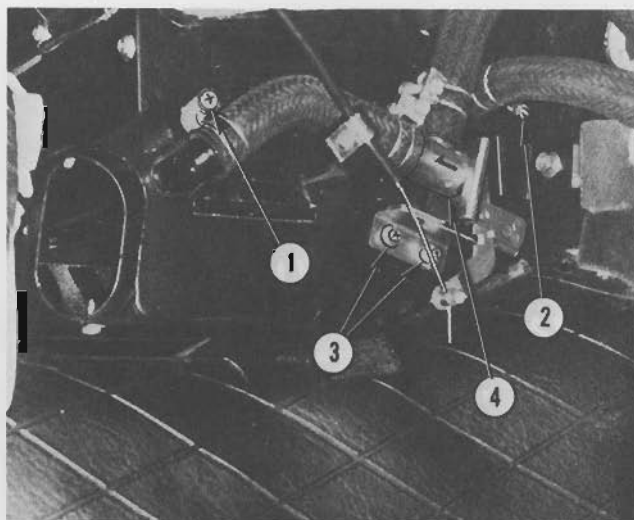

Figure III-11. Heater Hose and Valve Assembly

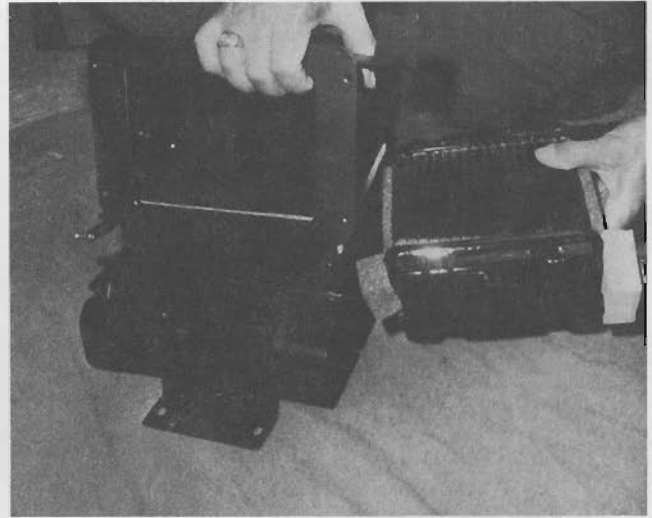



*Figure III-12. Removing Heater End Plate*

4. Open the heater vent doors and disconnect the RH door push rod by removing the retaining clip and push rod at the door.

5. Remove the five attaching screws from the heater box end plate assembly and work the end plate away from the heater body. (As shown in Figure III-12.)



*Figure III-13. Removing Heater Core*

6. Grasp the heater box and heater core firmly while working the heater core out of position (see Figure III-13.) Replace a defective heater core with (Part No. 27115-E 4400) Assembly-core heater.

7. Reassemble the heater unit in the reverse order of this procedure. Check all vent doors, air valves, etc., for proper operation.



## SECTION IV

### CENTER GROUP PANEL INSTRUMENTS AND LIGHTING CONTROL—DESCRIPTION

The following procedure suggests a more efficient method of gaining access to the center group instruments and does not affect the procedure for removal of instruments and attaching hardware, as outlined in Sections BE-10 and BE-11 of Service Manual.

#### A. Remove and Replace (Ammeter/Fuel Gauge, Water Temp/Oil Pressure Gauge, Clock)

1. Access to the center group instruments (see Figure IV-1) is easily obtained by removing the glove compartment door and liner as follows:

- a. Open the glove compartment door. Remove the three attaching screws from the glove compartment door hinge and remove the door.
- b. Remove the four (two each side) attaching screws from the compartment liner at the door opening. Pull the compartment liner through the door opening in the instrument panel. (See Figure IV-2.)

2. The center group instruments may now be easily reached, removed and replaced.

3. Replace the glove compartment liner and door. Secure in place with attaching hardware.

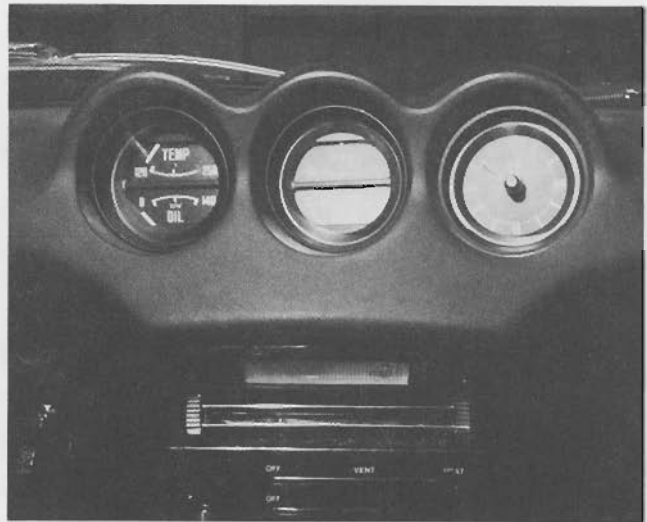

Figure IV-1. Center Group Instruments

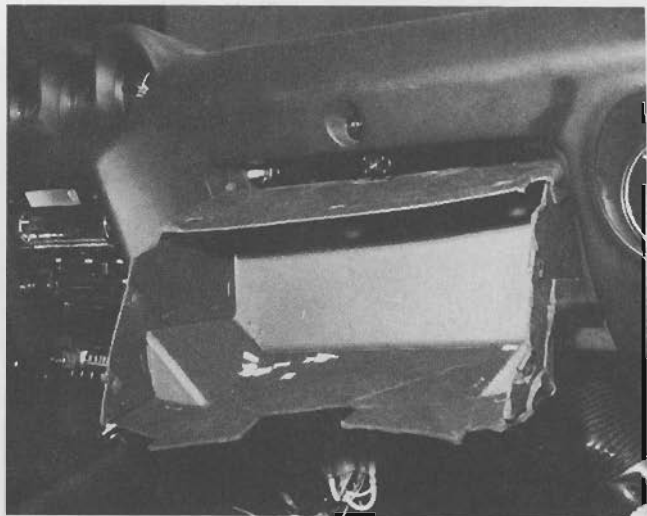
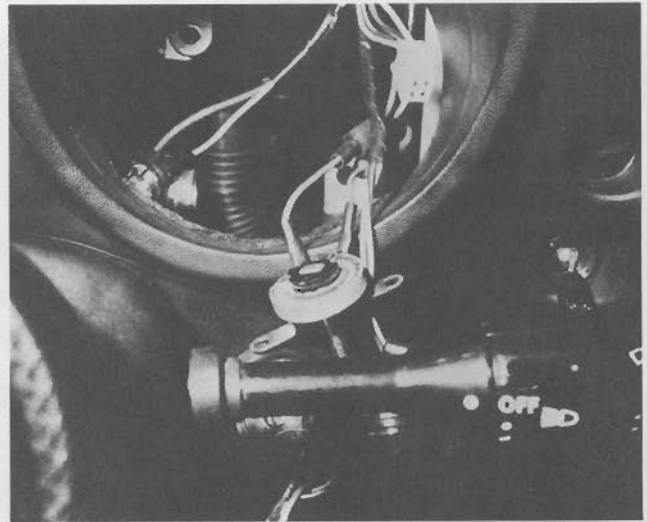

Figure IV-2. Removal of Glove Compartment Liner

## **B. Remove and Replace, Instrument Panel Lighting, Illumination Control (Rheostat)**

1. The instrument panel illumination control rheostat, as described in Section BE-12 of Service Manual, is located under the panel and to the right of the steering column. The procedure for R&R of this unit is as follows:

- a. Remove the tachometer as in Sections BE-9 and BE-10 of Service Manual.
- b. Remove the illumination control knob by pulling the knob straight down.
- c. Using a Phillips head screwdriver, reach through the tachometer opening and remove the two attaching screws from the rheostat base.
- d. Lift the rheostat from position and bring to view through the tachometer opening (see Figure IV-3). Replace a defective rheostat with (Part No. 25950-E 4600) Assembly-resistor instrument lamp.



*Figure IV-3. Removal of Instrument Panel Illumination Control (Rheostat)*

- e. Replace the rheostat in the reverse order of this procedure. Replace the tachometer in accordance with Section BE-12 of the Service Manual.

## SECTION V

### RADIO AND COMPONENTS—DESCRIPTION

The radio receiver/tuner, speaker, and antenna as provided are shown as an installation in Figure V-3. Component R&R is in accordance with the following procedure.

#### A. Remove and Replace (Radio Receiver/Tuner)

1. For reasons of safety, disconnect the Positive (+) battery cable at the battery terminal.
2. Disconnect the radio chassis electrical circuit from the instrument panel wire harness (see Figure V-3, Detail "B") as follows:
  - a. Receiver-antenna lead-in, Item 12.
  - b. Main power source connector, Item 13.
  - c. Antenna motor power connector, Item 14.
3. Remove the two opposed rear radio chassis support screws. (See Figure V-1, Item 2.)
4. Remove the two Phillips head screws from the front of the radio tuner escutcheon. (See Figure V-2.)
5. Remove the ashtray assembly. Support the radio from underneath to avoid marring the floor console and pull the unit out of the center console finisher.
6. Replace the radio in the reverse order of this procedure. Connect the battery and verify proper working order of the receiver and power antenna.

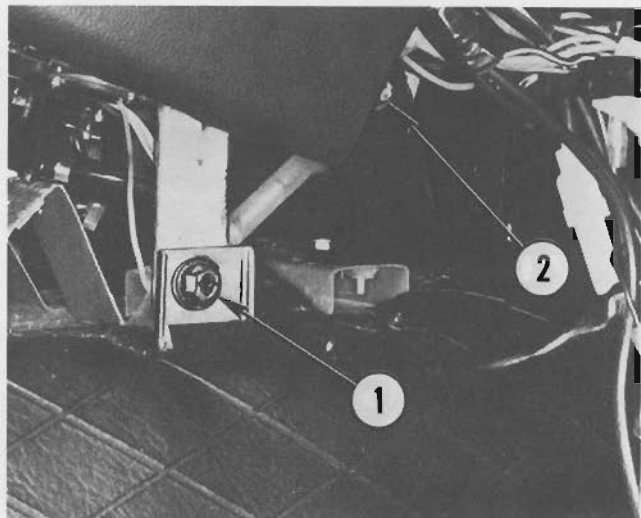

Figure V-1. Radio Chassis Rear Mount



Figure V-2. Radio Tuner Mounting Screws

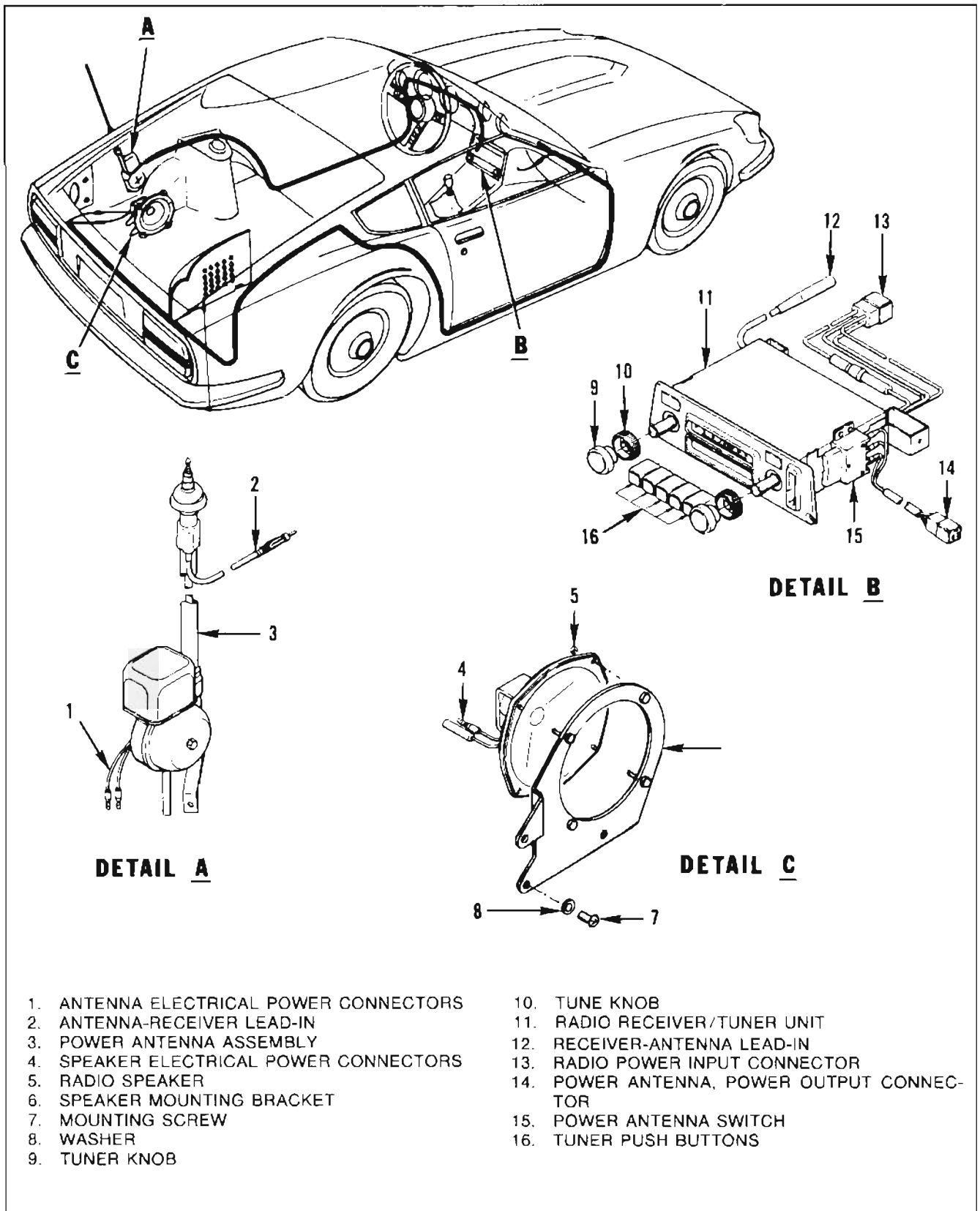
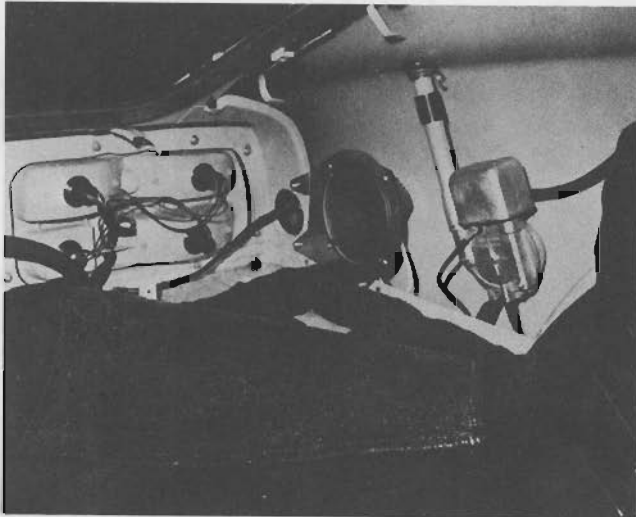

Figure V-3. Radio installation and Components

## B. Remove and Replace (Radio Speaker and Power Antenna)

1. The radio speaker and antenna unit are mounted in the rear left-hand fender void between the fender and the inner rear side trim panel. (See Figures V-3 and V-4.)



*Figure V-4. Speaker and Antenna Installation  
(Interior Trim Panels Removed)*

2. Both the rear and side trim panel must be removed to gain access to the speaker and antenna; and in that order.

3. The trim panels are held in place with plastic rivets which can be removed by piercing with an awl and withdrawing when friction is obtained. The rivets are expendable and not intended for reuse.

4. Remove the radio speaker mounting bracket integral with speaker attached by first disconnecting the electrical connectors, as shown in Figure V-3, Detail "C."

5. Remove the three speaker bracket mounting screws (see Figure V-5), and lift the assembly from position.

a. The speaker is secured to the bracket mounting studs with four nuts and lock-washers.

b. Remove and replace a defective speaker with (Part No. 29240-E 4125) kit-speaker.

6. To remove the power antenna unit, first fully retract (lower) the antenna rod into the retracting body. From outside, remove the gland nut from

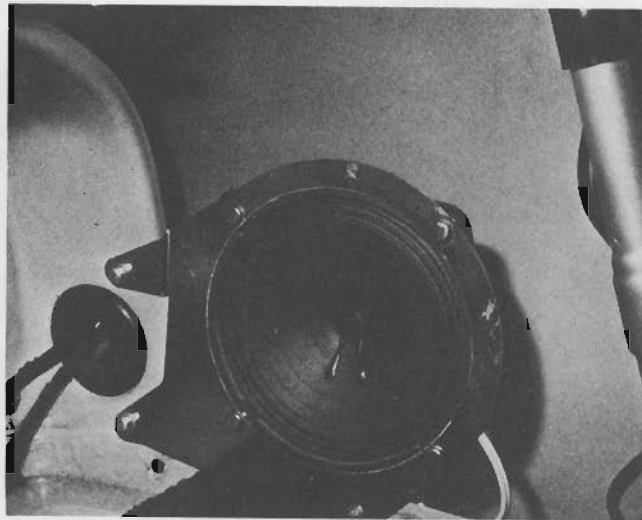

*Figure V-5. Speaker and Bracket Installed*

the antenna base at the fender thru-hole. Proceed from inside the vehicle as follows:

a. Disconnect the antenna electrical power connector and antenna lead. (See Figure V-3, Detail "C.")

b. Locate the wing nut at the lower end of the antenna body mounting bracket and remove it from the body stud.

c. Lower the antenna unit out of the fender thru-hole. Replace a defective unit with (Part No. 27350-E 4125) kit-automatic aerial.

7. Replacement of the radio speaker and antenna unit is in the reverse order of this procedure. Remember to replace the rear side trim panel first upon reassembly and to install trim panels with new plastic rivets. A check for proper operation of components should be made prior to replacing trim panels.



## NOTES

## SECTION VI ELECTRICAL

### ELECTRICAL CIRCUIT—DESCRIPTION

The 240Z Electrical System consists of two primary wire harness assemblies (engine compartment and instrument panel) and a secondary harness assembly for the body. Other sub-harness assemblies make up the system but are not shown in the wire diagrams. Individual wire color tracers do not always terminate as they began and may at times vary in color within harnesses manufactured for a given model series. Therefore, it is important to know connector function by name. The wire harness connector identification diagrams supplied in this section are intended for this purpose. The two wire diagrams are updated to include the heat and ventilating system blower electrical harness, not formerly identified.

#### CAUTION

**Whenever doubt exists as to a wire origin or destination, it is important that a continuity check be made and the circuit positively identified.**

#### NOTE

**The wire color code as shown is typical of all wiring circuitry.**

#### WIRE COLOR CODE

L.....	Blue
Y.....	Yellow
B.....	Black
R.....	Red
W.....	White
G.....	Green

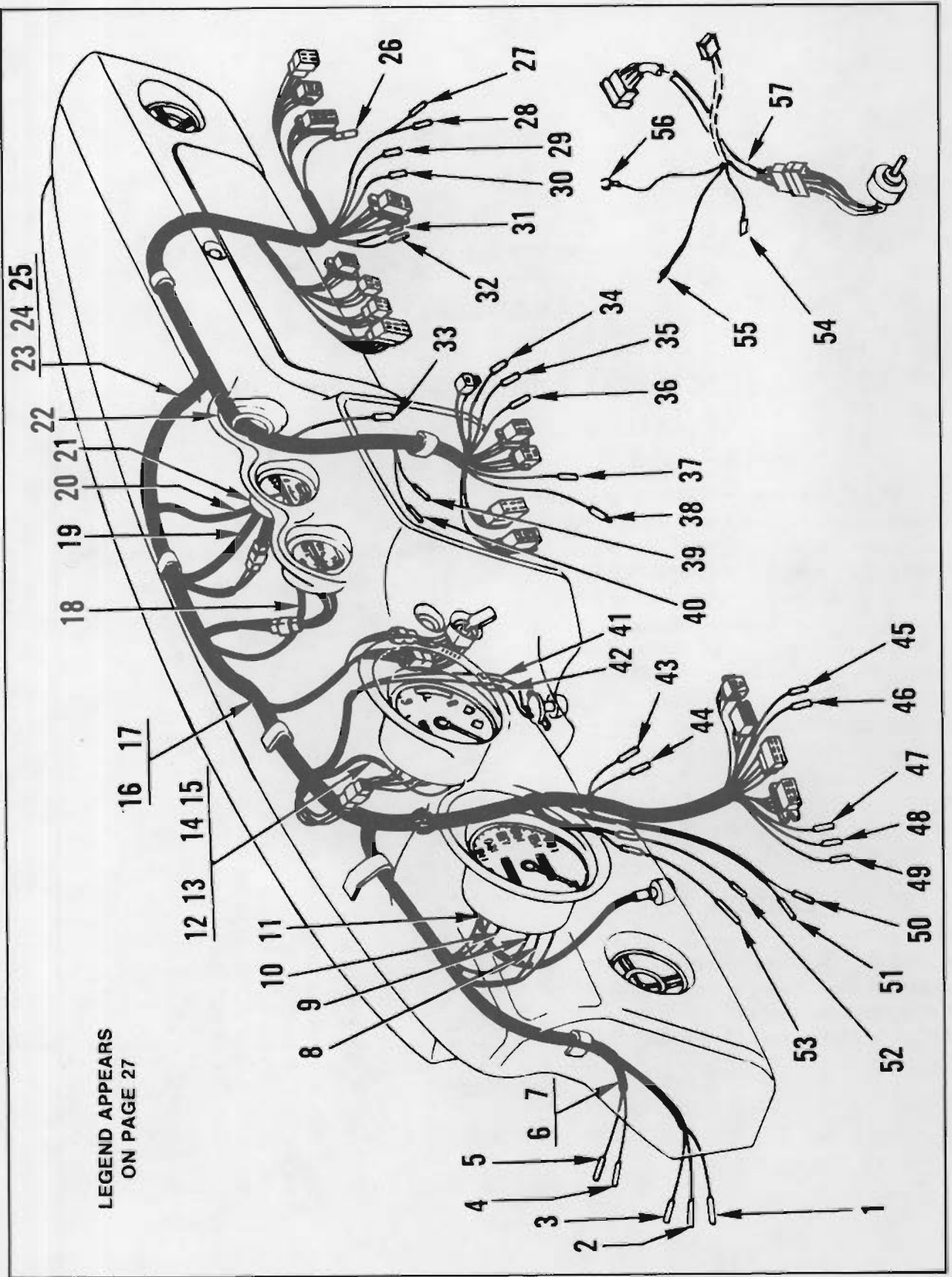

Figure VI-1. Instrument Panel Wire Harness (Single Connector Function and Color Identification)

- |   |  |
|---|--|
| 1. HORN RELAY (G)   | 29. AMMETER TO ENGINE COMPARTMENT WIRE HARNESS, POSITIVE LEAD (+) (WR) |
| 2. HORN RELAY (GR)  | 30. AMMETER TO ENGINE COMPARTMENT WIRE HARNESS, NEGATIVE LEAD (-) (W)  |
| 4. ROOM LAMP, LEFT-HAND DOOR SWITCH (B)                         | 31. HEADLIGHT SWITCH TO ENGINE COMPARTMENT WIRE HARNESS (RW)           |
| 5. ROOM LAMP, LEFT-HAND DOOR SWITCH (B)                         | 32. ALTERNATOR GROUND LEAD, "E" TERMINAL (B)                           |
| 6. STEP LIGHT POWER SOURCE (RL)                                 | 33. VOLTAGE REGULATOR (W)  |
| 7. STEP LIGHT POWER SOURCE (B)                                  | 34. BLOWER MOTOR POWER SOURCE (L)                                      |
| 8. SPEEDOMETER BRAKE WARNING LAMP (GY/YG)                       | 35. ALTERNATOR TO FUSE BLOCK (WR)                                      |
| 9. SPEEDOMETER HI/LO BEAM INDICATOR LAMP (RW/R)                 | 36. AMMETER TO FUSE BLOCK (WR)   |
| 10. SPEEDOMETER ILLUMINATION LAMP, UPPER (RL)                   | 37. FUSE BLOCK TO AMMETER (W)  |
| 11. SPEEDOMETER ILLUMINATION LAMP, LOWER (RL)                   | 38. FUSE BLOCK TO ALTERNATOR (W)                                       |
| 12. TACHOMETER ILLUMINATION LAMP (RL)                           | 39. BACKUP LIGHTS (RB)   |
| 13. TACHOMETER ILLUMINATION LAMP (RL)                           | 40. BACKUP LIGHTS (LR)   |
| 14. TACHOMETER LEFT-HAND TURN INDICATOR LAMP (GR)               | 41. PANEL LIGHTING RHEOSTAT (RL)                                       |
| 15. TACHOMETER RIGHT-HAND TURN INDICATOR LAMP (GB)              | 42. PANEL LIGHTING RHEOSTAT (RL/RL)                                    |
| 16. *FOG LIGHT SWITCH PROVISION (GW)                            | 43. STOP LIGHT SWITCH (GY)   |
| 17. FOG LIGHT SWITCH PROVISION (R)                              | 44. STOP LIGHT SWITCH (GY)   |
| 18. WATER TEMPERATURE OIL PRESSURE GAUGE ILLUMINATION LAMP (RL) | 45. STARTING LOCK SWITCH (B)   |
| 19. AMMETER LEAD, POSITIVE (+) (WR)                             | 46. STARTING LOCK SWITCH (R)   |
| 20. AMMETER LEAD, NEGATIVE (-) (W)                              | 47. TURN SIGNAL COMBINATION SWITCH (W)                                 |
| 21. AMMETER/FUEL GAUGE ILLUMINATION LAMP (RL)                   | 48. MASTER GROUND WIRE (B)   |
| 22. *CLOCK ILLUMINATION LAMP (RL)                               | 49. WASHER MOTOR (BY)  |
| 23. *CLOCK POWER LEAD (L)                                       | 50. TURN SIGNAL FLASHER SWITCH (W)                                     |
| 24. *CLOCK GROUND LEAD (B)                                      | 51. TURN SIGNAL FLASHER SWITCH (G)                                     |
| 25. *STEP LIGHT POWER SOURCE—FOR ELECTRIC FUEL PUMP (G)         | 52. WARNING BUZZER, "DOOR OPEN" (Y)                                    |
| 27. HAZARD FLASHER (GW)   | 53. WARNING BUZZER, "DOOR OPEN" (R)                                    |
| 28. HAZARD FLASHER (BW)   | 54. *AIR CONDITIONER POWER SOURCE (L)                                  |
|   | 55. BLOWER MOTOR POWER SOURCE (R)                                      |
|   | 56. BLOWER MOTOR GROUND LEAD (B)                                       |
|   | 57. INTERMEDIATE WIRE HARNESS BLOWER SWITCH/MOTOR                      |

\*INDICATES WIRE IS SUPPLIED IN HARNESS.

Figure VI-1. Legend

# INSTRUMENT HARNESS

## MODEL S30 SERIES

### 1971 LATE MODEL

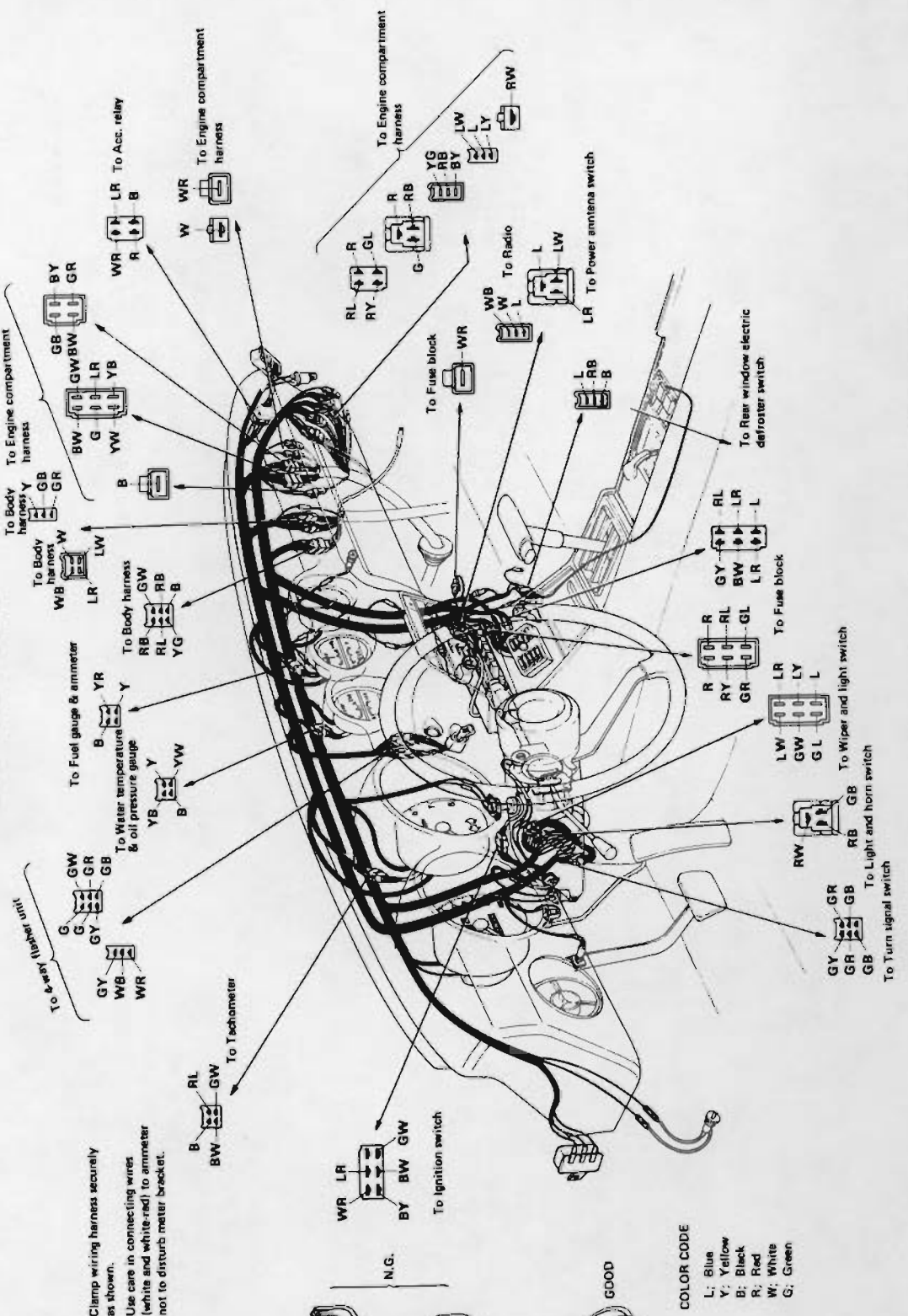

Notes: 1) Clamp wiring harness securely as shown.  
 2) Use care in connecting wires (white and white-red) to ammeter not to disturb meter bracket.

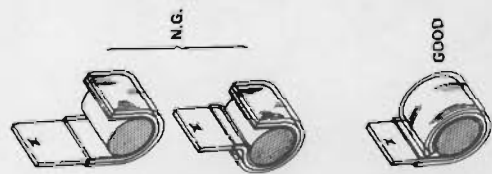

**COLOR CODE**  
 L: Blue  
 Y: Yellow  
 B: Black  
 R: Red  
 W: White  
 G: Green

Figure VI-2. Instrument Panel, Electrical Harness (Major Connector Identification)

# ENGINE COMPARTMENT HARNESS

MODEL 530 SERIES  
1971 LATE MODEL

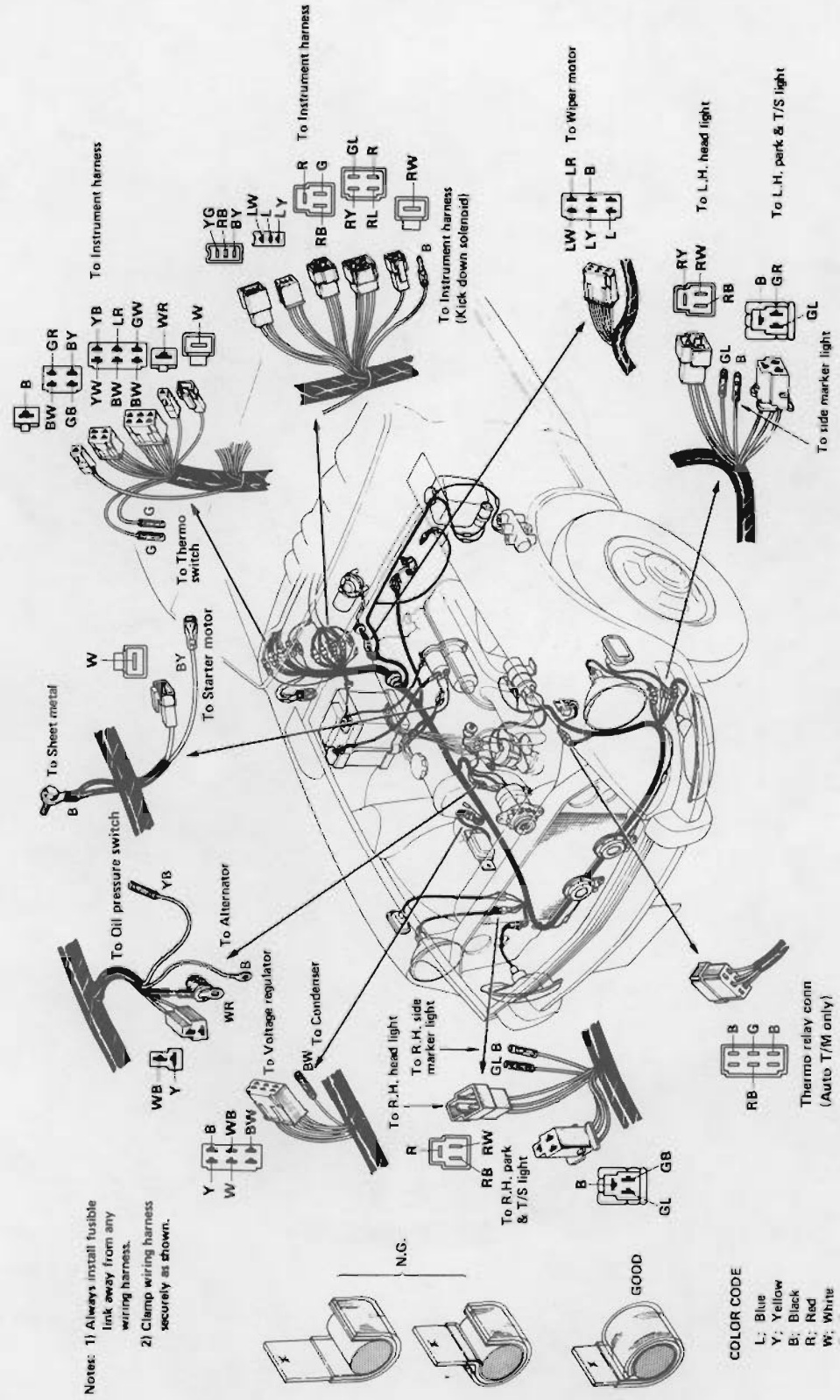

Figure VI-3. Engine Compartment, Electrical Harness (Major Connector Identification)

# BODY HARNESS

## MODEL S30 SERIES

### 1971 LATE MODEL

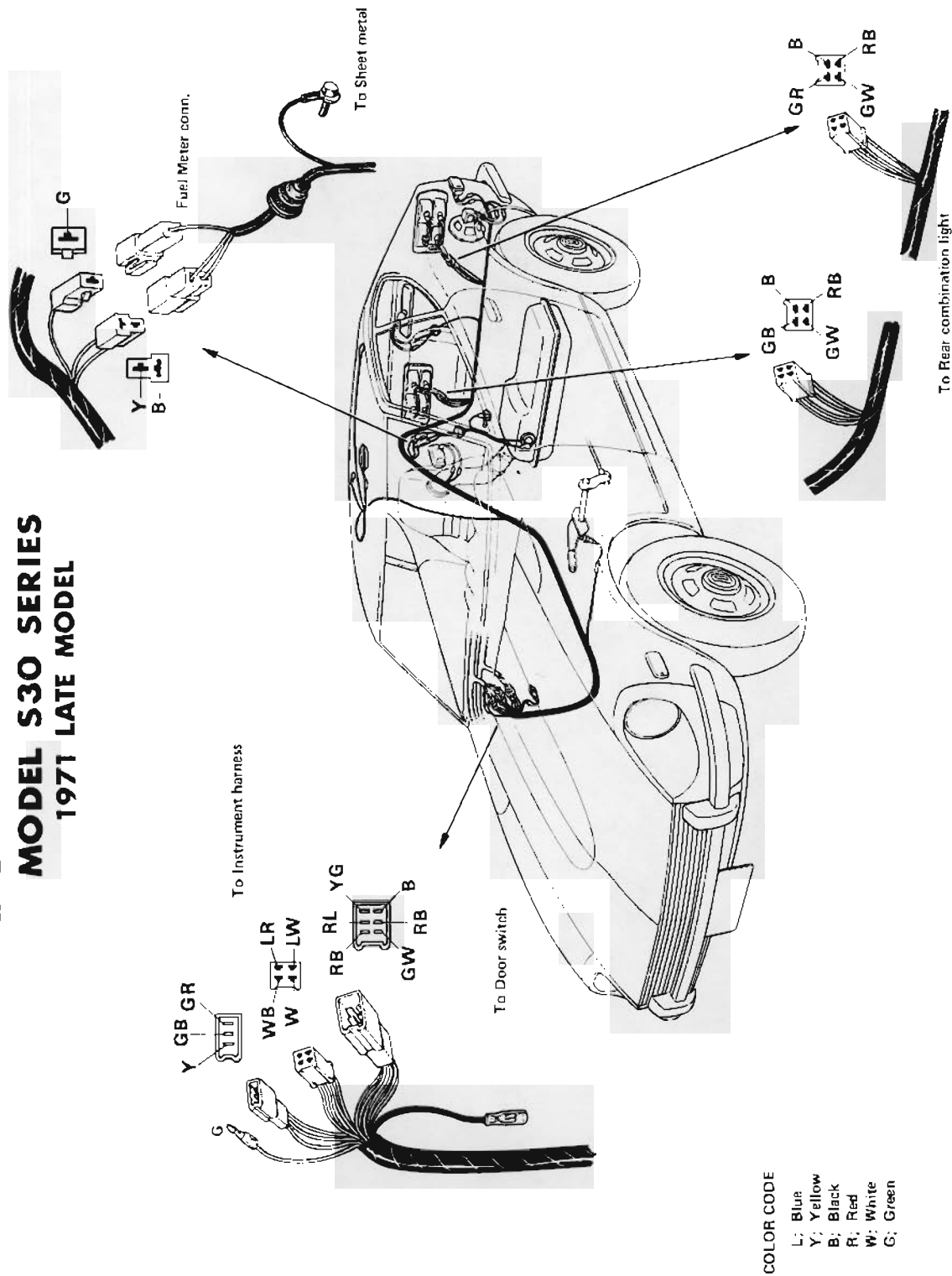

Figure VI-4. Body Electrical Harness (Major Connector Identification)



## NOTES

## NOTES



# WIRING DIAGRAM 240Z SPORTS

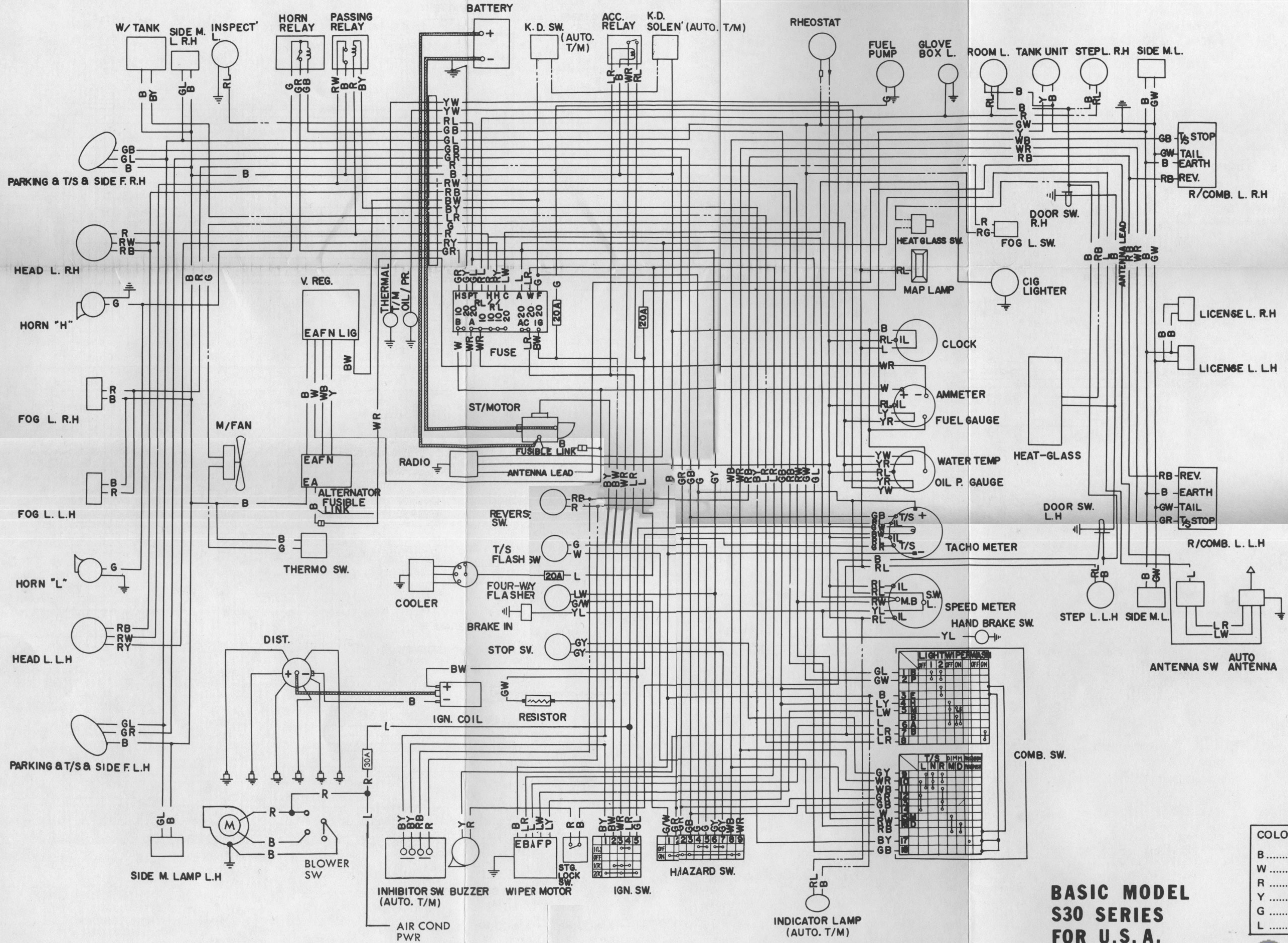

**BASIC MODEL  
S30 SERIES  
FOR U.S.A.**



Figure VI-5. Wiring Diagram (BasicModel S30 Series for U.S.A.)



# WIRING DIAGRAM 240Z SPORTS

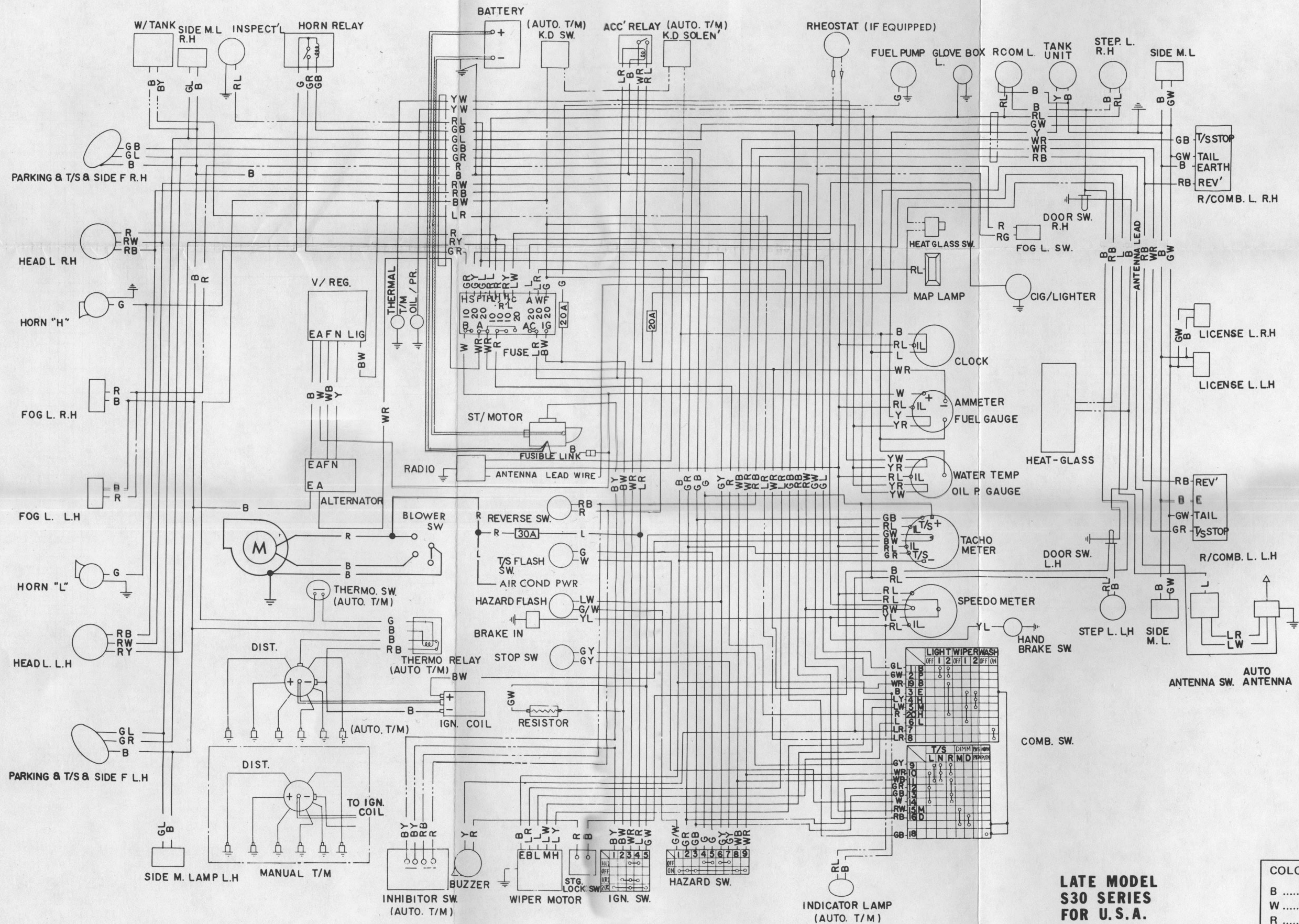

**LATE MODEL S30 SERIES FOR U.S.A.**



COLOR CODE	
B	Black
W	White
R	Red
Y	Yellow
G	Green
L	Blue

Figure VI-6. Wiring Diagram (Late Model S30 Series for U.S.A.)



