

DATSUN 280Z
MODEL S30 SERIES



NISSAN MOTOR CO., LTD.
TOKYO, JAPAN

SECTION EC

EMISSION CONTROL SYSTEM

EC

GENERAL DESCRIPTION	EC- 2
CRANKCASE EMISSION CONTROL SYSTEM	EC- 2
EXHAUST EMISSION CONTROL SYSTEM	EC- 3
EVAPORATIVE EMISSION CONTROL SYSTEM	EC-31

GENERAL DESCRIPTION

There are three types of emission control system. These are:

1. Closed type crankcase emission control system.

2. Exhaust emission control system.
3. Evaporative emission control system.

Periodic inspection and required

servicing of these systems should be carried out to reduce harmful emissions to a minimum.

CRANKCASE EMISSION CONTROL SYSTEM

DESCRIPTION

This system returns blow-by gas to both the intake manifold and throttle chamber.

The positive crankcase ventilation (P.C.V.) valve is provided to conduct crankcase blow-by gas to the intake manifold.

During partial throttle operation of the engine, the intake manifold sucks the blow-by gas through the P.C.V. valve.

Normally, the capacity of the valve is sufficient to handle any blow-by and a small amount of ventilating air.

The ventilating air is then drawn from throttle chamber, through the tube connecting throttle chamber to rocker cover, into the crankcase.

Under full-throttle condition, the manifold vacuum is insufficient to draw the blow-by flow through the valve, and its flow goes through the tube connection in the reverse direction.

On cars with an excessively high blow-by, some of the flow will go through the tube connection to throttle chamber under all conditions.

INSPECTION

P.C.V. VALVE

Check P.C.V. valve in accordance with the following method.

With engine running at idle, remove the ventilator hose from P.C.V. valve. If the valve is working, a hissing noise will be heard as air passes through the valve and a strong vacuum should be felt immediately when a finger is placed over valve inlet.

Replace P.C.V. valve in accordance with the maintenance schedule.

VENTILATION HOSE

1. Check hoses and hose connections for leaks.
2. Disconnect all hoses and clean with compressed air.

If any hose cannot be freed of obstructions, replace.

Ensure that flame arrester is surely inserted in hose between throttle chamber and rocker cover.

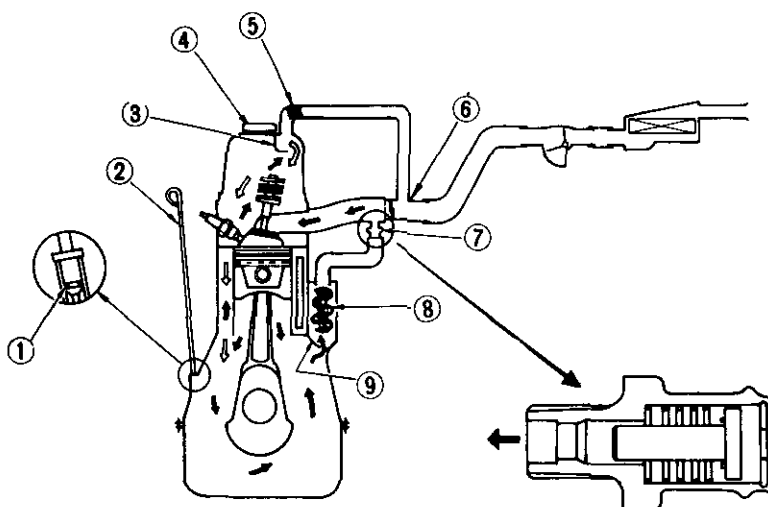

⇒ Fresh air
→ Blow-by gas

- 1 O-ring
- 2 Oil level gauge
- 3 Baffle plate
- 4 Oil cap
- 5 Flame arrester
- 6 Throttle chamber
- 7 P.C.V. valve
- 8 Steel net
- 9 Baffle plate

EC366

Fig. EC-1 Crankcase emission control system

EXHAUST EMISSION CONTROL SYSTEM

CONTENTS

DESCRIPTION	EC- 3	EXHAUST GAS RECIRCULATION (E.G.R.) SYSTEM	EC-10
BOOST CONTROLLED DECELERATION DEVICE (B.C.D.D.)	EC- 5	DESCRIPTION	EC-10
DESCRIPTION	EC- 5	OPERATION	EC-11
OPERATION	EC- 5	REMOVAL AND INSTALLATION	EC-13
REMOVAL	EC- 6	INSPECTION	EC-13
INSPECTION	EC- 6	CATALYTIC CONVERTER SYSTEM	EC-14
TRANSMISSION CONTROLLED VACUUM ADVANCE SYSTEM [Manual Transmission models only (Except California)]	EC- 9	DESCRIPTION	EC-14
DESCRIPTION	EC- 9	OPERATION	EC-15
OPERATION	EC- 9	REMOVAL AND INSTALLATION	EC-16
REMOVAL AND INSTALLATION	EC- 9	FLOOR TEMPERATURE WARNING SYSTEM .	EC-16
INSPECTION	EC-10	DESCRIPTION	EC-16
		OPERATION	EC-17
		REMOVAL AND INSTALLATION	EC-18

DESCRIPTION

The exhaust emission control system is made up of the following:

1. Boost controlled deceleration device (B.C.D.D.).
2. Transmission controlled vacuum advance system (Manual transmission

models except California).

3. Spark timing control system (except California).
4. Exhaust gas recirculation (E.G.R.) system (for California).
5. Catalytic converter system (for

California).

6. Floor temperature warning system (for California).

As regards the "Spark Timing Control System" in item 3 above, refer to the Engine Electrical section.

Emission Control System

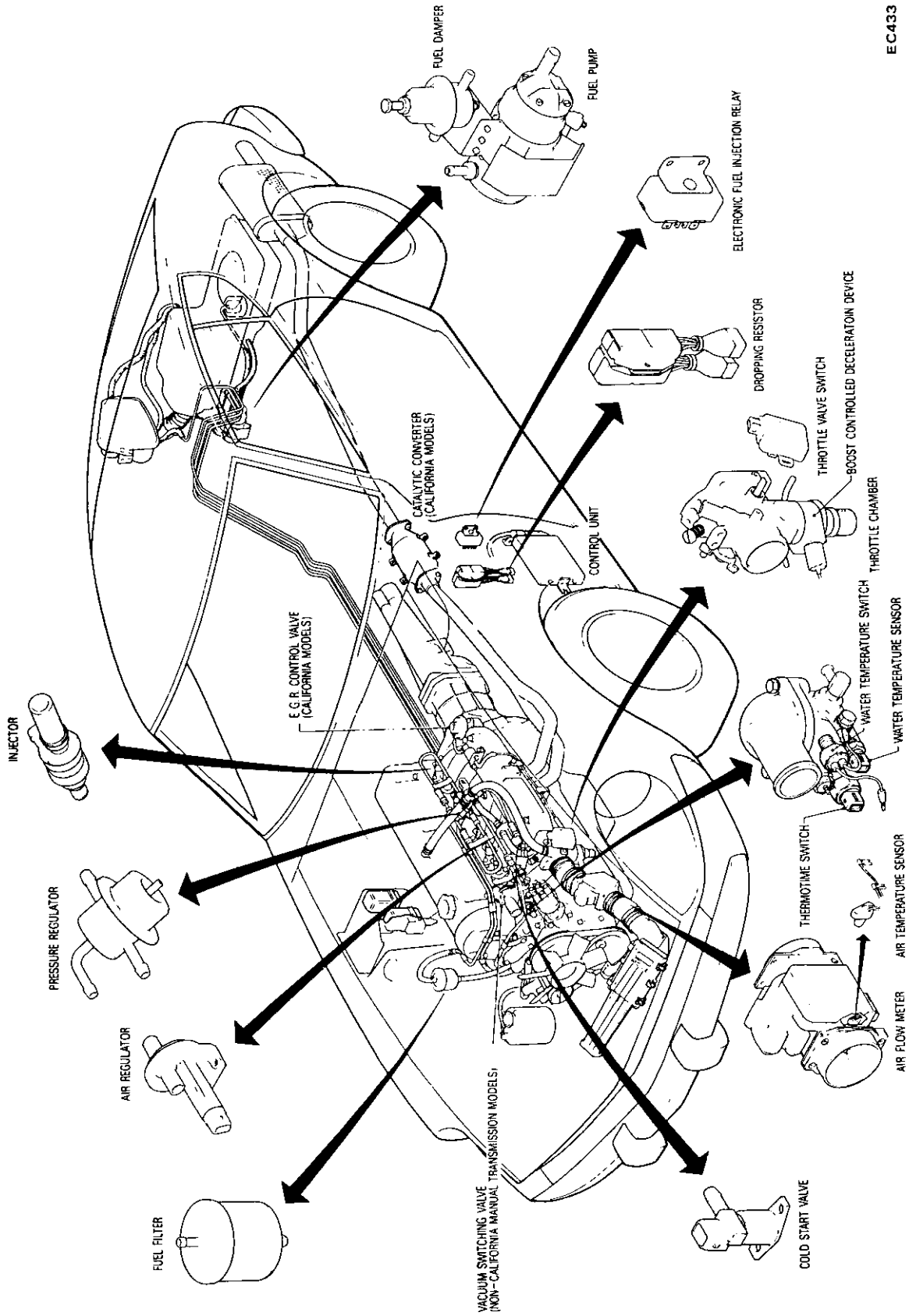

EC433

Fig. EC-2 Location of emission control system components

BOOST CONTROLLED DECELERATION DEVICE (B.C.D.D.)

DESCRIPTION

The Boost Controlled Deceleration Device (B.C.D.D.) is employed to reduce HC emissions emitted during coasting. The B.C.D.D., installed under the throttle chamber as a part of it, supplies additional air to the intake manifold during coasting to maintain the manifold vacuum at the proper operating pressure. [470 mmHg (18.5 inHg)]

There are two diaphragms in the device unit. Diaphragm I detects the manifold vacuum and makes the Vacuum Control Valve open when the vacuum exceeds the operating pressure. Diaphragm II operates the Air Control Valve according to the vacuum transmitted through the Vacuum Control Valve. The Air Control Valve regulates the amount of additional air so that the manifold vacuum can be kept at the proper operating pressure. The operating pressure changes depending on altitude; thus, dia-

phragm II and control valve operations are adjusted automatically in coincidence with the altitude at which the vehicle is driven. The graph shown in Figure indicates change in operating pressure for changes in atmospheric pressure and altitude. See Figure EC-13.

On manual transmission models, this system consists of B.C.D.D., vacuum control solenoid valve, speed-detecting switch and amplifier.

On automatic transmission models, it consists of B.C.D.D., vacuum control solenoid valve and inhibitor switch.

OPERATION

B.C.D.D.

Diaphragm I (10) monitors the manifold vacuum; when the vacuum exceeds a pre-determined value, it acts so as to open the vacuum control valve (9). This causes the manifold vacuum to be introduced into vacuum chamber II (18) and actuates diaphragm II (12).

When diaphragm II operates, the air control valve (13) opens the passage and introduces the additional air into the manifold.

The amount of air is controlled by the servo-action of the air control valve (13) and vacuum control valve (9) so that the manifold vacuum may be kept at the pre-determined value.

The B.C.D.D. operates when engine speed is in the range of 1,800 to 2,000 rpm.

Vacuum controlled solenoid valve

Manual transmission models:

The vacuum control solenoid valve is controlled by a speed detecting switch that is actuated by the speedometer needle.

As the car speed falls below 10 M.P.H., this switch is actuated, producing a signal. This signal actuates the amplifier to open the vacuum control solenoid valve.

Automatic transmission models:

When the shift lever is in the "N" or "P" range, the inhibitor switch mounted on the transmission turns on to open the vacuum control solenoid valve.

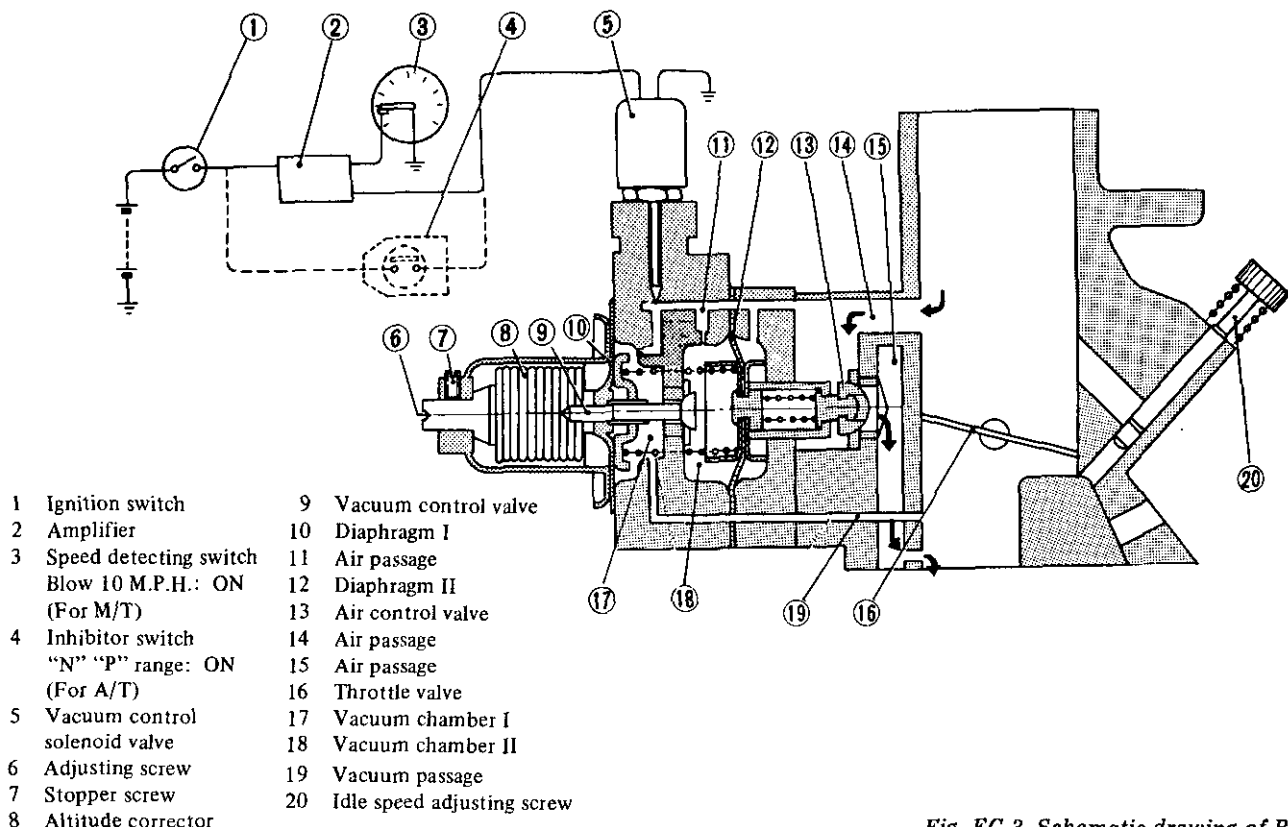

Fig. EC-3 Schematic drawing of B.C.D.D.

Emission Control System

REMOVAL

B.C.D.D.

Note: The B.C.D.D. cannot be disassembled. If it is found to be functioning unsatisfactorily, it must be replaced as an assembly.

1. Remove B.C.D.D. by unscrewing the three securing screw ①.
Do not unscrew the three B.C.D.D. assembly screws ②.

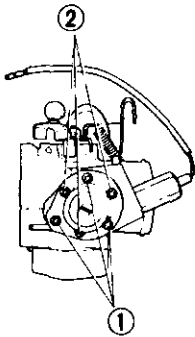

EC372

Fig. EC-4 Removing B.C.D.D.

2. To install, reverse the removal procedure.

Tightening torque:
20 to 40 kg-cm
(17 to 35 in-lb)

Vacuum controlled solenoid valve

1. Vacuum control solenoid valve can be easily removed with a wrench.
2. To install, reverse the removal procedure.

Tightening torque:
180 to 350 kg-cm
(156 to 304 in-lb)

INSPECTION

B.C.D.D. circuit with function test connector.

Caution: Do not attach test leads of a circuit tester to those other than designated. Refer to Figure EC-5.

Manual transmission models

1. Check for continuity between A and B when car is brought to a complete stop. Refer to Figure EC-5.
B.C.D.D. circuit is functioning properly if continuity exists and voltmeter reading is 0 volts (d-c) in step 2 below.

If continuity does not exist, check for disconnected connector and/or faulty amplifier, speed detecting switch or B.C.D.D. solenoid valve.

2. Check for presence of voltage across A and B [at a speed of more than 16 km/h* (10 MPH)]. Refer to Figure EC-5.

* Conduct this test by one of the following two methods.

- 1) Raising up rear axle housing with stand.
- 2) Chassis dynamometer test

- If voltmeter reading is 0 volt at a speed of more than 16 km/h (10 MPH), circuit is functioning properly.
 - If voltmeter reading is not 0 volt, check for disconnected connector, burned fuse, faulty amplifier, B.C.D.D. solenoid valve or speed detecting switch.
3. If, by above checks, faulty part or unit is located, it should be removed and tested again. If necessary, replace.

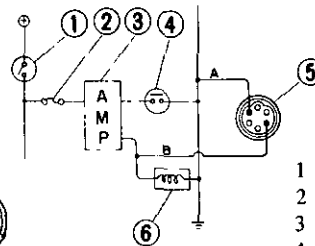
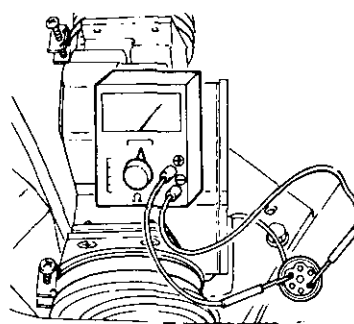

EC373

- 1 Ignition key
- 2 Fuse
- 3 Amplifier
- 4 Speed detecting switch
Above 10 mph: OFF
Below 10 mph: ON
- 5 Function test connector
- 6 Vacuum control solenoid valve

Fig. EC-5 Checking B.C.D.D. circuit with function test connector (for manual transmission)

Automatic transmission models

1. Turn ignition key to "ON" position.
2. With inhibitor switch "ON" ("N" or "P" range), check for presence of voltage across A and B. Refer to Figure EC-6.

- If voltmeter reading is 12 volts (d-c), B.C.D.D. circuit is functioning properly.
 - If voltmeter reading is zero, check for disconnected connector, faulty solenoid valve or inhibitor switch.
3. With inhibitor switch "OFF"

("1", "2", "D" or "R" range), check for resistance between A and B. Refer to Figure EC-6.

- If ohmmeter reading is 15 to 28 ohms, circuit is functioning properly.
 - If ohmmeter reading is not above, check for poor connection of connector, faulty B.C.D.D. solenoid valve or inhibitor switch.
4. If, by above checks, faulty part or unit is located, it should be removed and tested again. If necessary, replace.

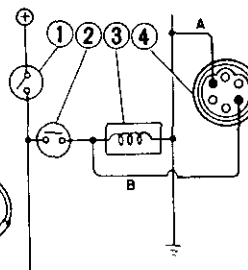
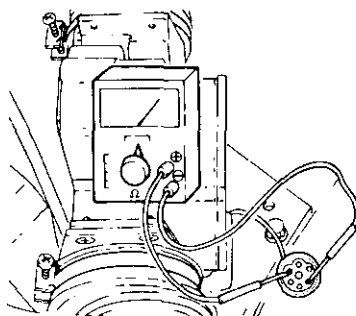

- 1 Ignition key
- 2 Inhibitor switch
N.P. range: ON
1, 2, D, R, range: OFF
- 3 Vacuum control solenoid valve
- 4 Function test connector

EC374

Fig. EC-6 Checking B.C.D.D. circuit with function test connector

Emission Control System

B.C.D.D. solenoid valve

1. Turn on engine key. (Do not start engine.)
2. Ensure that solenoid valve clicks when intermittently electrified as shown in Figure EC-7.

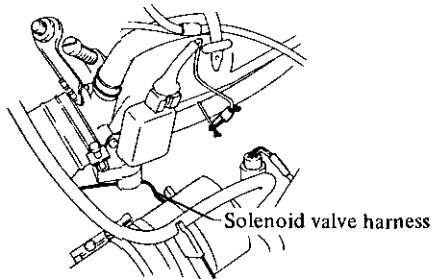

ET296

Fig. EC-7 Checking solenoid valve

3. If a click is heard, solenoid valve is normal.
4. If a click is not heard at all, check

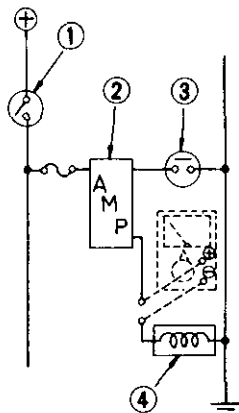
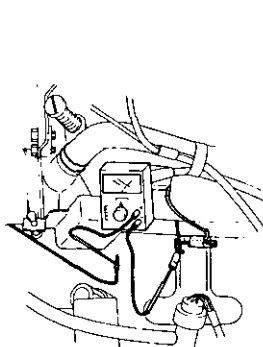

EC376

Fig. EC-8 Checking amplifier

Inhibitor switch (Automatic transmission models)

Refer to the TM section.

Set pressure of B.C.D.D.

Generally, it is unnecessary to adjust the B.C.D.D., however, if it should become necessary to adjust it, the procedure is as follows:

Prepare the following tools

1. Tachometer to measure the engine speed while idling, and a screw-driver.
2. A vacuum gauge and connecting pipe.

Note: A quick-response type boost

for continuity with a circuit tester. If discontinuity is detected, replace solenoid valve.

Amplifier (Manual transmission models)

The amplifier is installed at the rear of the speedometer. To check, proceed as follows:

1. Set circuit tester in D-C ampere range (1A min, full scale), connect test probes of tester as shown in Figure EC-8.
- Do not confuse positive line with negative line.
2. Turn ignition key to "ON" position.
3. Ensure that tester pointer deflects when ignition key is turned on.
4. If tester pointer does not deflect when solenoid valve and speed detecting switch circuits are functioning properly, amplifier is faulty.

2. Connect rubber hose between vacuum gauge and intake manifold as shown.

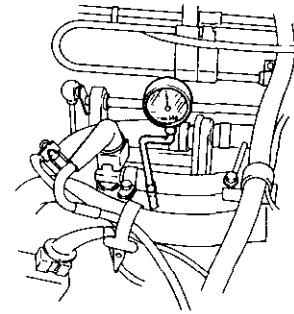

EC378

Fig. EC-10 Connecting vacuum gauge

3. Warm up the engine until it is heated to operating temperature. Then adjust the engine at normal idling setting. (Refer to the item "Idling Adjustment" in page ET-7.)

Idling engine speed

Manual transmission

800 rpm

Automatic transmission

(in "D" position)

700 rpm

4. Run the engine under no load. Increase engine speed to 3,000 to 3,500 rpm, then quickly close throttle valve.
5. At that time, the manifold vacuum pressure increases abruptly to -600 mmHg (-23.62 inHg) or above and then gradually decreases to the level set at idling.
6. Check that the B.C.D.D. set pressure is within the specified pressure.

Specified pressure (0 m, sea level and 760 mmHg (30 inHg), atmospheric pressure)

Manual transmission and

Automatic transmission:

-460 to -480 mmHg

(-18.1 to -18.9 inHg)

Notes:

- a. When atmospheric pressure is known, operating pressure will be found by tracing the arrow line "A". See Figure EC-13. When altitude is known, operating pressure will be found by tracing the arrow line "B". See Figure EC-13.

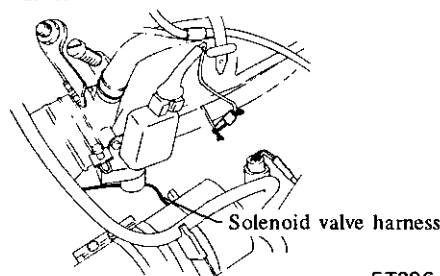

ET296

Fig. EC-9 Removing harness of solenoid valve

Emission Control System

b. When checking the set pressure of B.C.D.D., find the specified set pressure in Figure EC-13 from the atmospheric pressure and altitude of the given location.

For example, if the car is located at an altitude of 1,400 m (4,600 ft), the specified set pressure for B.C.D.D. is 375 mmHg (14.8 inHg).

7. If it is higher than the set level, turn the adjusting screw counterclockwise until correct adjustment is made.

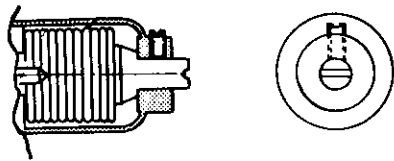

EC409

Fig. EC-11 Adjusting set pressure

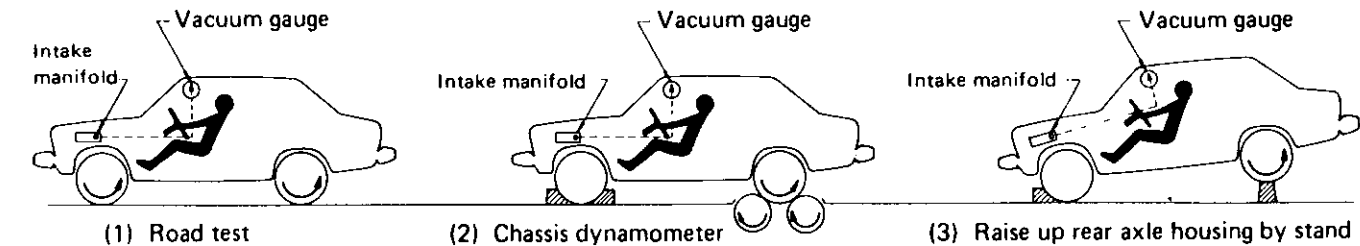

ET133

Fig. EC-12 Testing operating pressure of the B.C.D.D.

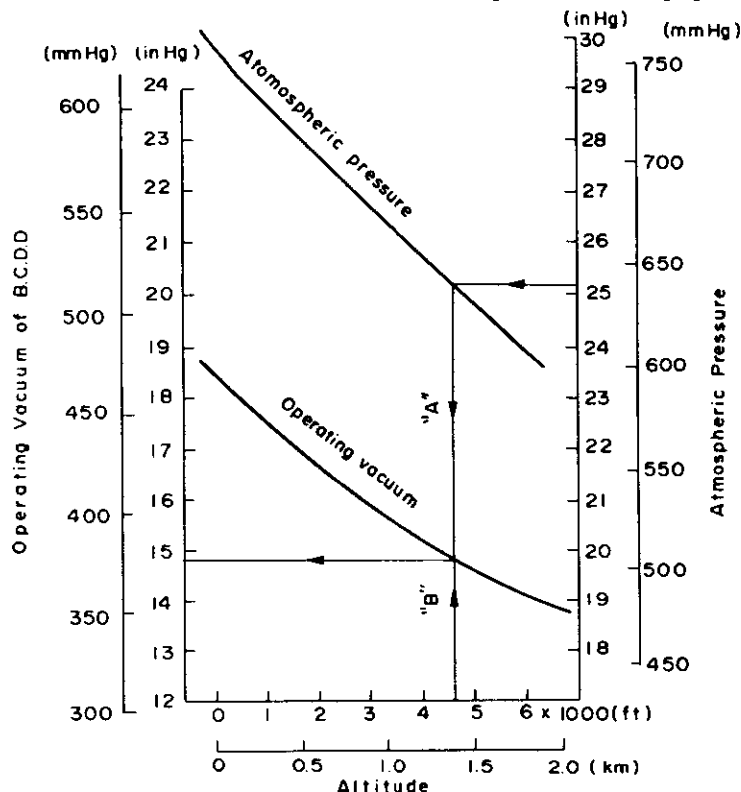

Fig. EC-13 Changes in operating pressure versus changes in atmospheric pressure altitude

EC379

8. Race the engine and check for adjustment.
9. If it is lower than the set level, turn the adjusting screw clockwise until correct adjustment is made.
10. Race the engine and check for adjustment.

If engine speed cannot be decreased to idling when checking B.C.D.D. set pressure, proceed as follows:

When the engine speed does not fall to idling speed, it is necessary to reduce the negative idling pressure of the manifold to lower than the set pressure of the B.C.D.D. (The engine speed will not drop to idling speed when the negative idling pressure is higher than the set pressure of the B.C.D.D.).

In this case, the engine must be labored by (1) road test or (2) chassis dynamometer or (3) by raising up rear suspension member on a stand, accelerating the car to 64 to 80 km/h (40

to 50 MPH) in top gear (manual transmission) or in "D" range (automatic transmission), and then releasing the accelerator pedal and letting the car decelerate. After doing this, check whether the B.C.D.D. set pressure is at the predetermined value or not.

TRANSMISSION CONTROLLED VACUUM ADVANCE SYSTEM

[Manual Transmission models only (Except California)]

DESCRIPTION

This system provides vacuum advance only when the gear is in the top (4th) position and retards spark timing at the other positions as shown in the following table.

OPERATION

When electric current flows through the vacuum switching valve, the valve opens and introduces air into the vacuum controller of the distributor through a vacuum hose, and vacuum advance is eliminated. When the vacuum switching valve is deenergized, the valve closes and vacuum created by the throttle chamber is introduced into the vacuum controller of the distributor to provide usual vacuum advance.

The top detecting switch, located on the transmission case, operates so as to interrupt the flow of electric current when the gear is placed into "TOP", but allows it to flow in the other gear positions.

Transmission	Top detecting switch	Vacuum switching valve	Spark timing
Top (4th) gear position	OFF	OFF	Advanced
Other gear position	ON	ON	Retarded

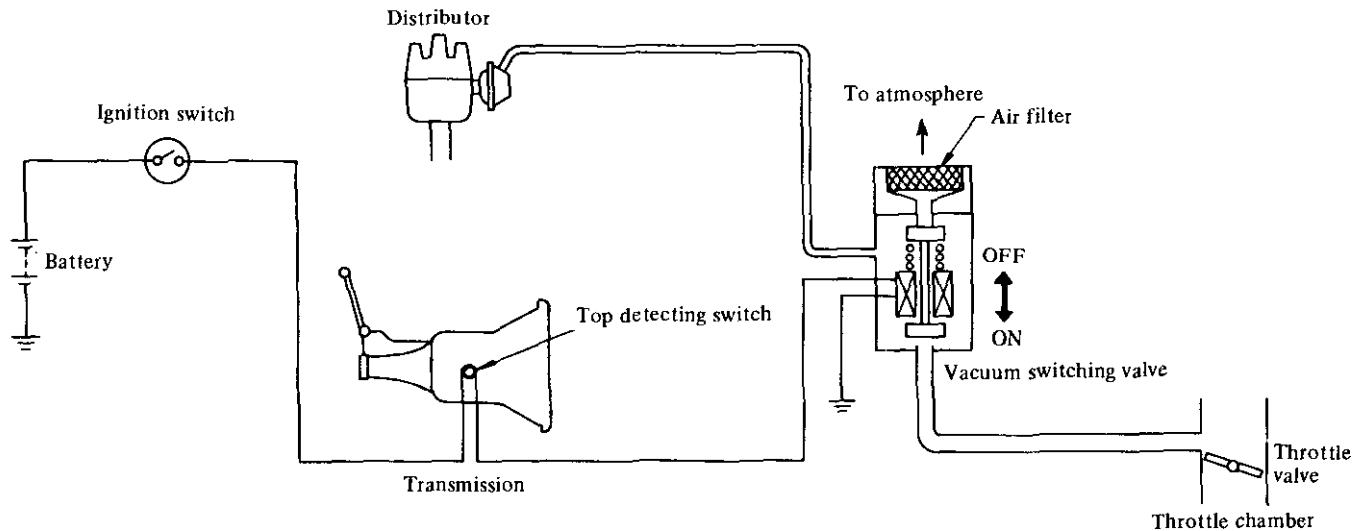

EC405

Fig. EC-14 Schematic drawing of transmission controlled vacuum advance system

REMOVAL AND INSTALLATION

Vacuum switching valve

1. Disconnect a pair of lead wires at connectors.
2. Disconnect vacuum hose from vacuum switching valve.
3. Remove two screws retaining valve to bracket and remove valve.

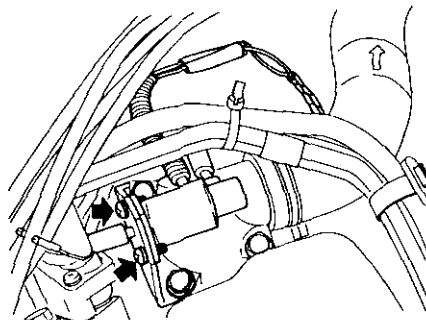

EC406

Fig. EC-15 Vacuum switching valve

4. Install valve in the reverse order of removal.

Note: Make sure that vacuum hoses are properly connected to their positions. See Figure ET-1 for vacuum hose piping.

Top detecting switch

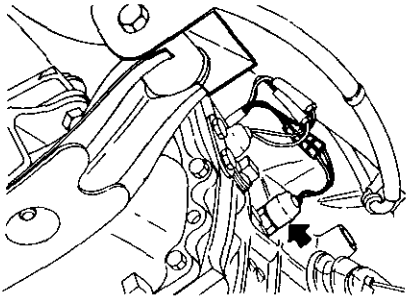

EC407

Fig. EC-16 Top detecting switch

When installing switch, apply lock agent to threads.

INSPECTION

1. Ensure that wiring connectors are tight in place.
2. Ensure that vacuum hoses are properly connected to their positions. See Figure ET-1.
3. Ensure that distributor vacuum controller properly functions.
4. Set timing light.
5. Run engine and keep it at 3,200 to 3,500 rpm. Read spark timing.
6. Shift gears in top (4th) position, and read spark timing.

The system is properly functioning if spark timing in top (4th) position is approximately 5° greater than that in neutral position.

Note: To protect against accidental forward surge, engage parking brake firmly while above check is being made.

7. If spark timing does not vary at all in steps 5 and 6 above, proceed as follows:

- (1) Disconnect vacuum switching valve white wire connector.
- (2) Set timing light.
- (3) Run engine and keep it at 3,200 to 3,500 rpm. Read spark timing.
- (4) Connect vacuum switching valve white wire connector directly to battery positive (+) terminal and read spark timing.

Vacuum switching valve is normal if spark timing advances by 5° when connector is disconnected from battery positive (+) terminal. If not, top detecting switch is faulty and should

be replaced. If spark timing does not vary at all in step 7 above, replace vacuum switching valve.

8. Check for continuity in electrical wiring with a function test connector.

Turn ignition switch on, but do not run engine. Check for voltage across terminals A and B as shown in Figure EC-17.

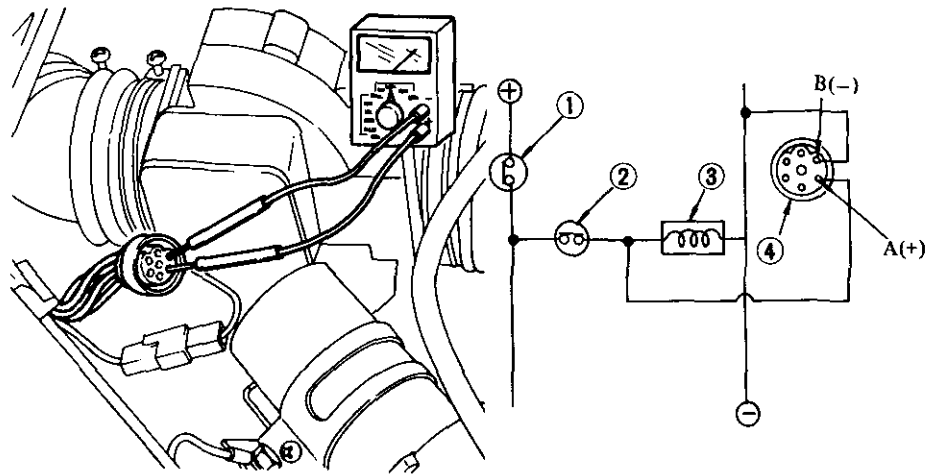

- 1 Ignition switch
- 2 Top detecting switch
- 3 Vacuum switching valve
- 4 Function test connector

EC408

Fig. EC-17 Checking for continuity in electrical wiring with function test connector

Electrical wiring circuit is normal if voltmeter readings are as shown in the chart below.

Transmission	Voltmeter indication
Top (4th) gear position	0V
Other gear position	12V

If readings are not shown, check for loose harness and burned fuse.

EXHAUST GAS RECIRCULATION (E.G.R.) CONTROL SYSTEM (FOR CALIFORNIA)

DESCRIPTION

In the exhaust gas recirculation system, a part of the exhaust gas is returned to the combustion chamber

to lower the spark flame temperature during the combustion process. This results in a reduction of the nitrogen oxide content in the exhaust gas.

This system consists of an intake manifold, E.G.R. control valve, E.G.R. solenoid valve, water temperature switch, E.G.R. tube and hose.

When the E.G.R. control valve is open, some of the exhaust gas is led from the exhaust manifold to the E.G.R. control valve through the E.G.R. tube. The exhaust gas is then controlled in quantity by the E.G.R. control valve, and is introduced into the intake manifold.

Emission Control System

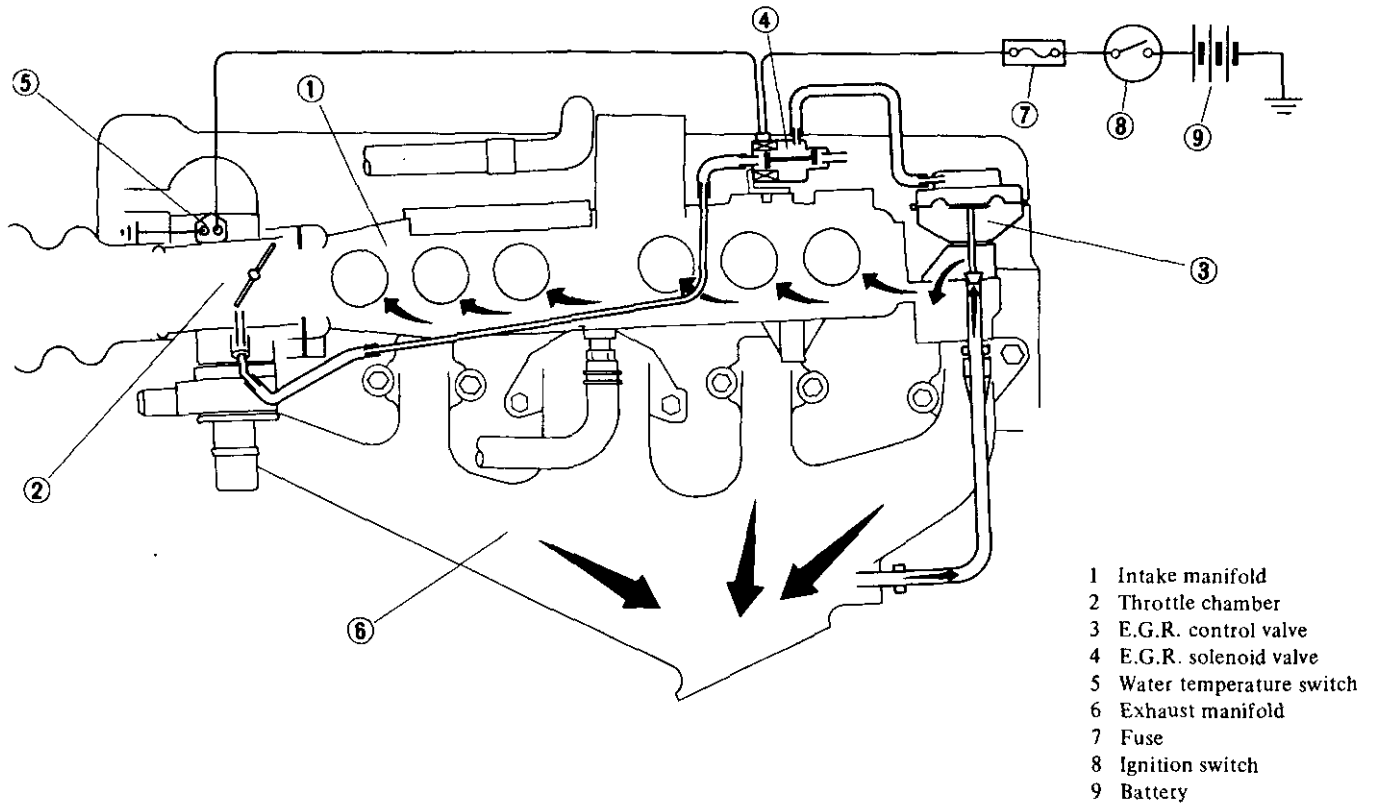

EC356

Fig. EC-18 Exhaust gas recirculation system

Open-close operation of the E.G.R. control valve is controlled by the throttle chamber vacuum.

The E.G.R. solenoid valve is operat-

ed by the water temperature switch operated by the engine coolant temperature.

OPERATION

The E.G.R. control system functions as shown in the following chart.

E.G.R.	Switch Operating Temperature	Water Temperature Switch	E.G.R. Solenoid Valve	Intake Manifold Vacuum	E.G.R. Control Valve	Driving Condition
Not Actuated	Below	ON	ON	—	Close	All condition
	Above	OFF	OFF	Above -50 mmHg (-1.969 inHg)	Close	Idling
	Above	OFF	OFF	Below -50 mmHg (-1.969 inHg)	Close	Full Throttle
Actuated	Above	OFF	OFF	Above -50 mmHg (-1.969 inHg)	Open	Partial Load

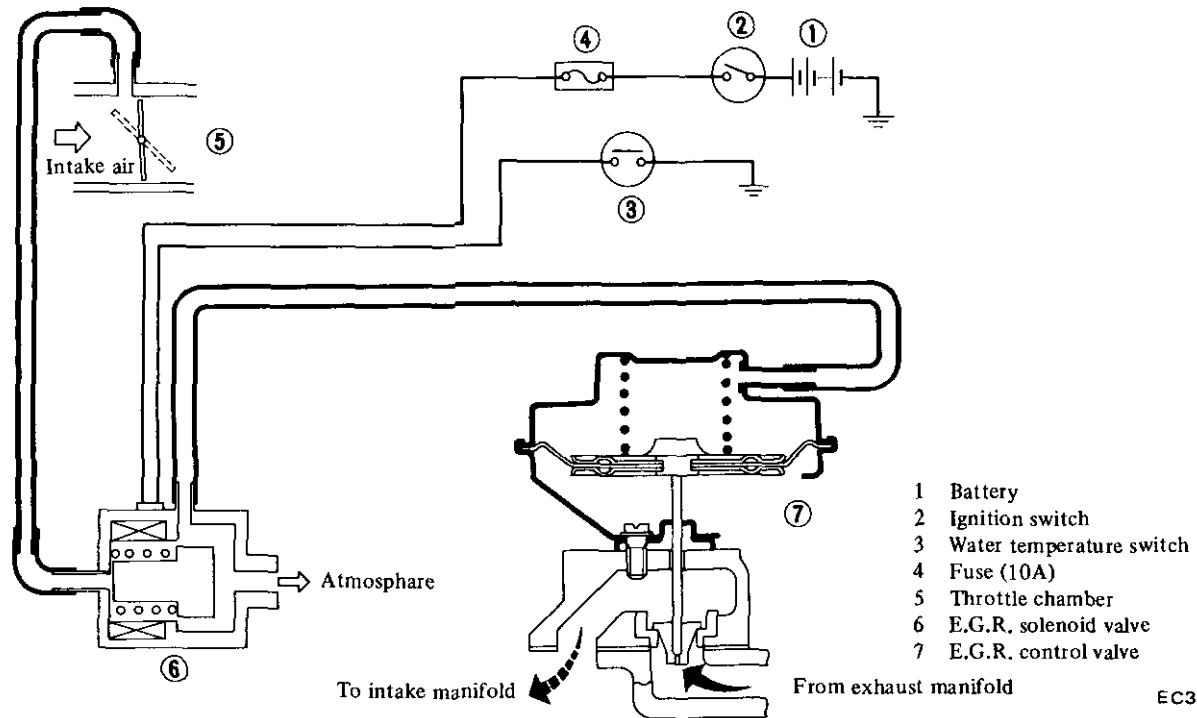

- 1 Battery
- 2 Ignition switch
- 3 Water temperature switch
- 4 Fuse (10A)
- 5 Throttle chamber
- 6 E.G.R. solenoid valve
- 7 E.G.R. control valve

EC357

Fig. EC-19 Schematic drawing of E.G.R. control system

E. G. R. "OFF" operation

1. When the engine coolant temperature is low, recirculated exhaust gas causes irregular engine operation. To prevent this, recirculation of the exhaust gas must be cut off for a few minutes after the engine has been started. During this period, the E.G.R. solenoid valve remains closed and keeps the E.G.R. control valve closed, thereby cutting off the E.G.R. circuit.

2. When the engine coolant temperature is above the working temperature of the water temperature switch:

(1) The vacuum port comes to air cleaner side during engine idling for improved idling operation.

At this point, vacuum does not actuate the E.G.R. control valve though intake manifold vacuum is high, and the E.G.R. control valve remains closed.

(2) In the full throttle driving position, the suction vacuum on the vacuum passage is not sufficient to actuate the E.G.R. control valve.

E. G. R. "ON" operation

The E.G.R. circuit is completed only when the engine coolant temperature is above the working temperature

of the water temperature switch and the suction vacuum on the vacuum passage is great enough to open the E.G.R. control valve.

E.G.R. Control valve

The E.G.R. control valve controls the quantity of exhaust gas to be led to the intake manifold through vertical movement of the taper valve connected to the diaphragm, to which vacuum is applied in response to the

opening of the throttle valve. The E.G.R. control valve is installed on the intake manifold through a gasket.

The E.G.R. control valve has different flow rate of exhaust gas in response to the transmission type. For identification purposes, part and flow rate number are found on the top of the valve.

The construction of the E.G.R. control valve is shown in the following figure.

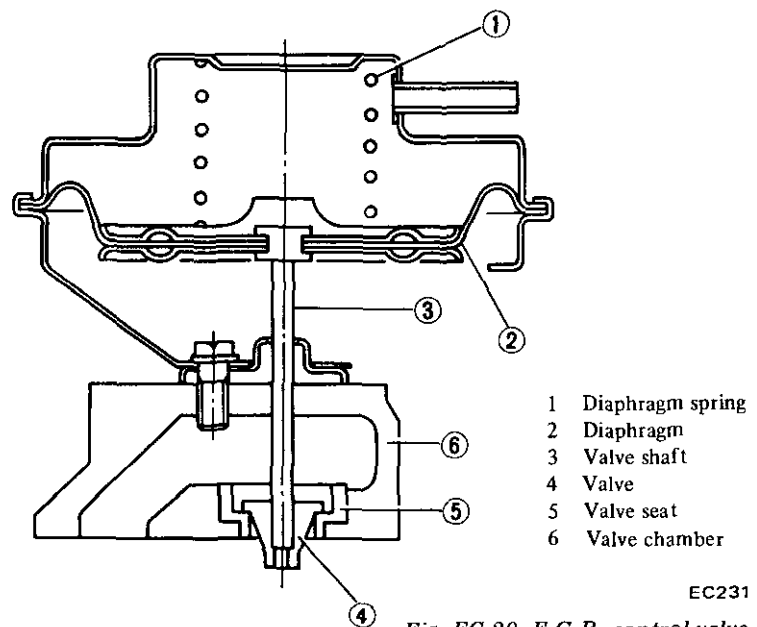

- 1 Diaphragm spring
- 2 Diaphragm
- 3 Valve shaft
- 4 Valve
- 5 Valve seat
- 6 Valve chamber

EC231

Fig. EC-20 E.G.R. control valve

Water temperature switch and E.G.R. solenoid valve

The water temperature switch is installed in the thermostat housing. The contact points of the thermo switch built in the water temperature switch open or close in response to the engine coolant temperature.

In other words, when the engine coolant temperature is lower than the working temperature of the water temperature switch, the contact points of the thermo switch close to flow electric current to the E.G.R. solenoid valve.

Therefore, the magnet coil of the E.G.R. solenoid valve is magnetized and the valve cuts off the suction vacuum on the vacuum passage. When the engine coolant temperature is above the working temperature of the water temperature switch, the contact points of the thermo switch open to cut off electric current to the E.G.R. solenoid valve. Therefore, the E.G.R. solenoid valve operated by spring force completes the vacuum passage between the throttle chamber and the E.G.R. control valve.

REMOVAL AND INSTALLATION

Removal

1. E.G.R. control valve

E.G.R. control valve is installed on intake manifold through a gasket. To dismantle E.G.R. control valve, remove the following parts:

- Vacuum hose connecting E.G.R. control valve to E.G.R. solenoid valve
- Nuts attaching E.G.R. control valve to intake manifold

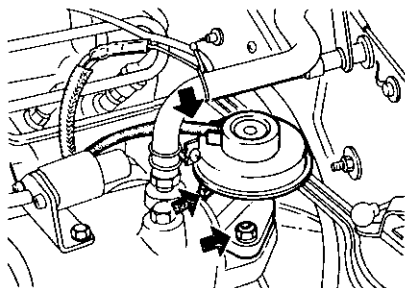

EC358
Fig. EC-21 Removing E.G.R. control valve

2. E.G.R. solenoid valve

E.G.R. solenoid valve is installed on intake manifold. To dismantle E.G.R. solenoid valve, remove the following parts:

- Solenoid valve harness
- Vacuum hose connecting E.G.R. control valve to E.G.R. solenoid valve
- Bolts attaching E.G.R. solenoid valve to intake manifold

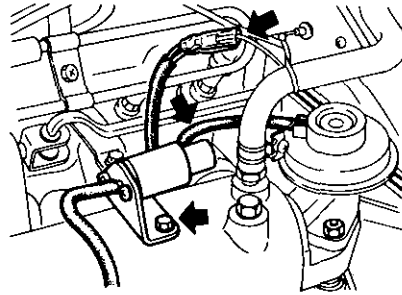

EC359
Fig. EC-22 Removing E.G.R. solenoid valve

3. Water temperature switch

Water temperature switch is installed in thermostat housing. To dismantle water temperature switch, remove the following parts:

- Water temperature switch lead wires

Note: Drain engine coolant before dismantling water temperature switch from thermostat housing.

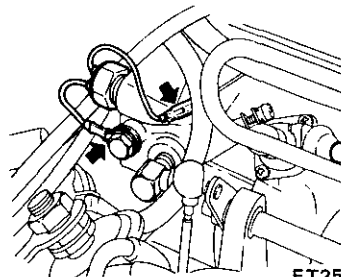

ET257
Fig. EC-23 Removing water temperature switch

Installation

To install E.G.R. control system components, reverse the order of removal.

INSPECTION

Check E.G.R. control system on engine.

1. Visually check E.G.R. control system.

If necessary, wipe away oil to facilitate inspection. If any hoses are cracked or broken, replace.

2. With engine running, check E.G.R. control system for proper function.

- When engine coolant temperature is low:

(1) Make sure that E.G.R. control valve does not operate when engine speed is increased from idling to 3,000 - 3,500 rpm. To check the valve operation, place a finger on the diaphragm of E.G.R. control valve as shown in the figure below.

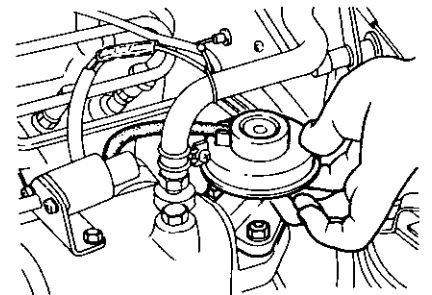

EC361
Fig. EC-24 Checking E.G.R. control valve

(2) Disconnect one end (E.G.R. control valve side) of the vacuum hose connecting E.G.R. solenoid valve to E.G.R. control valve. Then increase engine speed from idling to 3,000 - 3,500 rpm.

Make sure that E.G.R. solenoid valve is closed, and that throttle chamber vacuum is not present at the end (E.G.R. control valve side) of the vacuum hose. If vacuum is present, check E.G.R. solenoid valve and water temperature switch independently as described later.

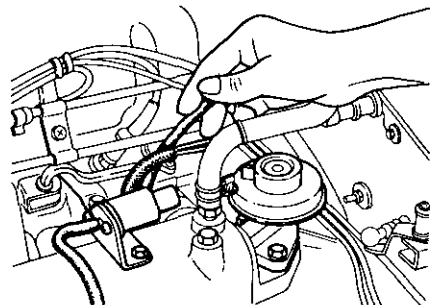

EC362
Fig. EC-25 Checking E.G.R. solenoid valve

Emission Control System

- When engine coolant temperature is high:

(1) Make sure that E.G.R. control valve operates when engine speed is increased from idling to 3,000 - 3,500 rpm. To check valve operation, place a finger on the diaphragm of E.G.R. control valve. See Figure EC-24.

(2) Disconnect one end (E.G.R. control valve side) of the vacuum hose connecting E.G.R. solenoid valve to E.G.R. control valve. Then, increase engine speed from idling to 3,000 - 3,500 rpm.

Make sure that E.G.R. solenoid valve opens, and that throttle chamber vacuum is present at the end of the vacuum hose. See Figure EC-25.

(3) With the engine idling, push the diaphragm of E.G.R. control valve up with your fingertips. Ascertain that the engine operates irregularly due to exhaust gases.

If the condition of the E.G.R. system is questionable, check each component independently.

- E.G.R. control valve

Remove E.G.R. control valve and vacuum hose from engine.

(1) Visually check vacuum hose for deterioration or deformation. If the hose is damaged, vacuum leak may occur, resulting in improper operation of E.G.R. control valve. Damaged hose should be replaced.

(2) Apply a vacuum of 120 to 130 mmHg (4.72 to 5.12 inHg) to the E.G.R. control valve as shown in the figure below. The valve should move to the full position, and remain open for more than 30 seconds after the vacuum has cut off.

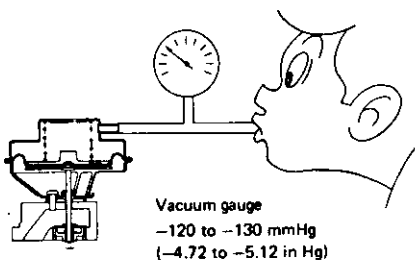

ET151

Fig. EC-26 Checking E.G.R. control valve

(3) Visually check E.G.R. control valve for damage, wrinkle or deformation.

(4) Clean the seating surface of E.G.R. control valve with a brush and compressed air, and remove foreign matter from around the valve and port.

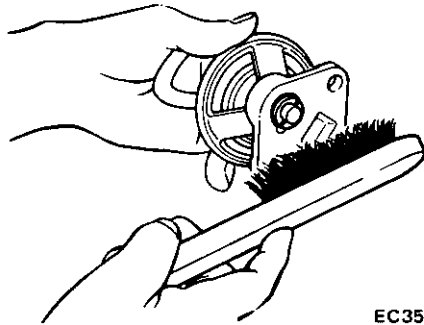

EC350

Fig. EC-27 Cleaning E.G.R. control valve

- E.G.R. solenoid valve

Check E.G.R. solenoid valve with ohmmeter and battery, as follows:

(1) Connect ohmmeter to solenoid lead wire and check continuity of the solenoid. If continuity does not exist, replace E.G.R. solenoid valve as a unit.

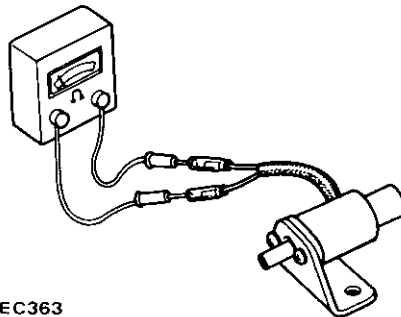

EC363

Fig. EC-28 Checking E.G.R. solenoid valve

(2) If continuity exists in step (1) above, apply electric current to the solenoid intermittently. Make sure that E.G.R. solenoid valve clicks. If clicks are heard, E.G.R. solenoid valve is functioning properly. If clicks are not heard, replace E.G.R. solenoid valve unit.

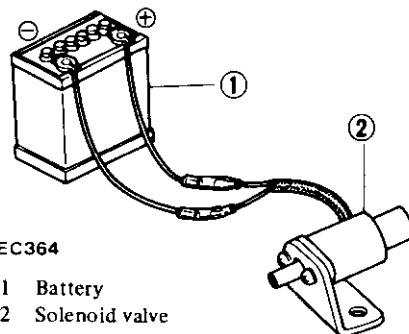

EC364

- 1 Battery
- 2 Solenoid valve

Fig. EC-29 Checking E.G.R. solenoid valve

- Water temperature switch

Remove water temperature switch from engine.

Check water temperature switch with thermometer and ohmmeter.

(1) Checking "ON" of water temperature switch

Starting from water temperature at 50°C (122°F) and below, check continuity of water temperature switch and ensure that a reading is almost zero, that is, switch is ON.

(2) Checking "OFF" of water temperature switch

Increasing water temperature from about 50°C (122°F), make continuity check of a water temperature switch. Operation is normal if an ohmmeter reading increases to infinite on condition that water temperature is somewhere between 57 to 63°C (135 to 145°F) and remains infinite at about 63°C (145°F) and above.

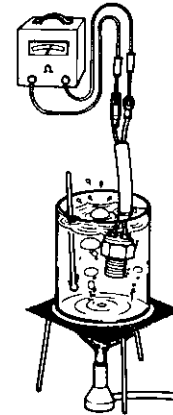

EC365

Fig. EC-30 Checking water temperature

(3) If it is satisfied both in steps (1) and (2) above, switch is good.

CATALYTIC CONVERTER SYSTEM

DESCRIPTION

The catalytic converter accelerates the chemical reaction of hydrocarbons (HC) and carbon monoxide (CO) in the exhaust gas, and changes them into harmless carbon dioxide (CO₂) and water (H₂O).

This chemical reaction process requires the proper amount of air.

Emission Control System

By means of a chemical reaction process as it passes through the catalytic converter, the excess air in the air-fuel mixture (which has not been

burned during the combustion process) is utilized to minimize HC and CO emissions.

This converter is installed on all California models. Refer to Fig. EC-31, for the location of this unit.

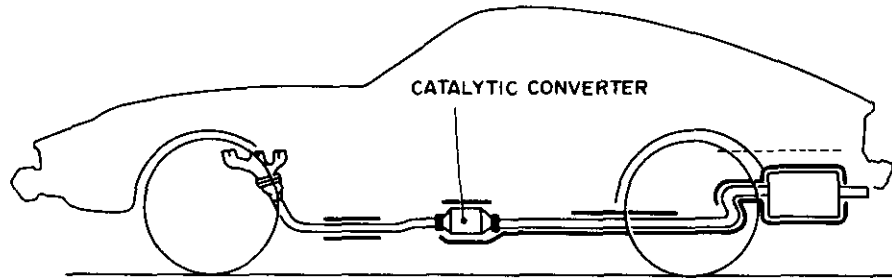

EC380

Fig. EC-31 Location of catalytic converter

OPERATION

Catalytic converter

The exhaust gas which is left unburned during combustion process is

gradually oxidized with excess oxygen, and is converted into harmless carbon dioxide (CO_2) and water (H_2O). The catalytic converter, located in the exhaust line, further cleans exhaust gases through catalytic action, and changes

residual hydrocarbons (HC) and carbon monoxide (CO) contained in the exhaust gas into carbon dioxide (CO_2) and water (H_2O) before the exhaust gas is discharged to the atmosphere.

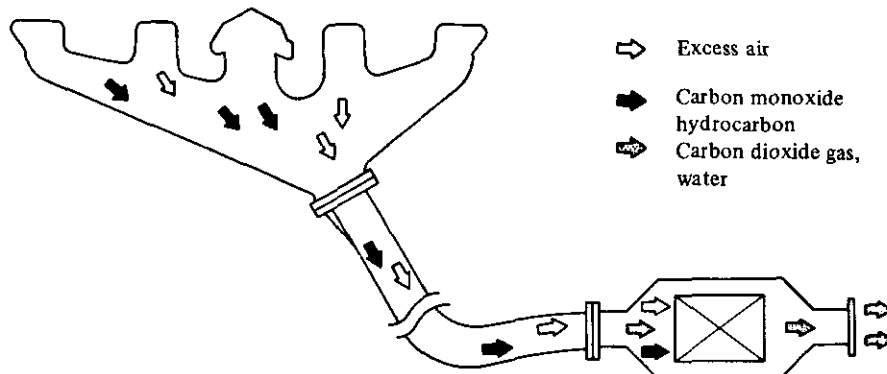

EC382

Fig. EC-32 Operation of catalytic converter

REMOVAL AND INSTALLATION

Removal and installation can be done as follows:

Removal

Catalytic converter

1. Apply parking brake.
2. Place wheel lock under each tire.
3. Jack up the car.
4. Remove lower shelter of catalytic converter.
5. Dismount catalytic converter.

Notes:

- a. Be careful not to damage catalytic converter when handling.
- b. Never wet catalyzer with water, oil, etc.

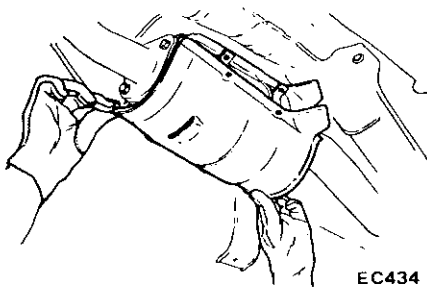

EC434

Fig. EC-33 Removing catalytic converter

Inspection

Catalytic converter

Check catalytic converter with an emission adjuster, as follows:

1. Apply parking brake with gear set in neutral.
2. Place wheel lock under each tire.
3. Warm up engine thoroughly. [About 80°C (176°F)]
4. After engine has warmed up, run engine at 2,000 rpm for a few minutes under no load until catalytic converter reaches operating temperature.
5. Stop engine and turn ignition switch to "OFF" position.
6. Remove connector of water temperature sensor.
7. Connect emission adjuster to harness connector of water temperature sensor. See Figure EC-34.
8. Insert CO meter probe through exhaust diffuser end until a minimum insertion length of 500 mm (19.7 in) is reached.
9. Run engine at 2,000 rpm and adjust CO percent to 3 percent with emission adjuster.
10. Remove injector connector from number six cylinder.
11. Keep engine running at 2,000 rpm with no load.
12. If CO percent is less than 1 percent, catalytic converter is functioning properly. (If CO percent is more than 1 percent, catalytic converter must be replaced.)
13. Stop engine and turn ignition switch to "OFF" position.
14. Locate water temperature sensor connector and injector connector in place.

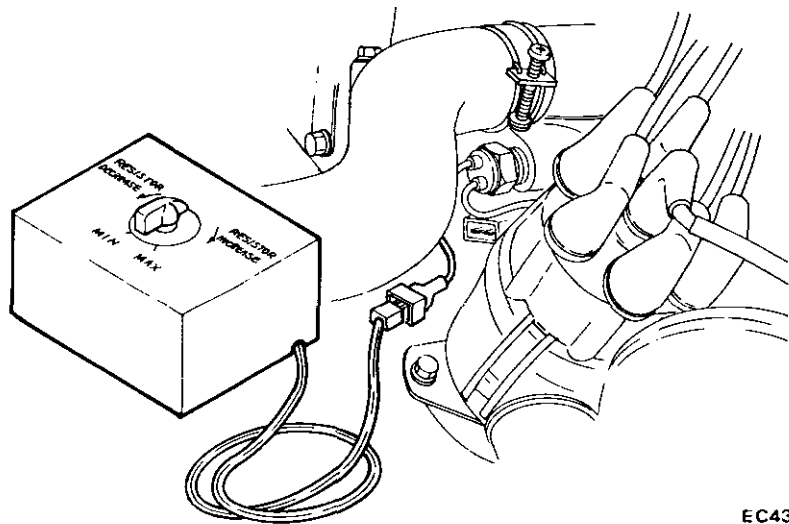

EC435

Fig. EC-34 Connecting emission adjuster

Installation

Install catalytic converter to exhaust front and rear tubes. For installation procedures of catalytic converter, refer to Section "FE".

Tightening torque specifications chart

	Tightening torque
Catalytic converter to exhaust front and rear tubes	3.2 to 4.3 kg-m (23 to 31 ft-lb)

FLOOR TEMPERATURE WARNING SYSTEM

DESCRIPTION

The floor temperature warning system consists of a floor sensor installed on the car's floor, floor sensor

relay installed on passenger seat bracket and a floor temperature warning lamp on the instrument panel and wires that connect these parts.

When the floor temperature rises to an abnormal level, the warning lamp will light to call the attention of the driver. The wiring diagram of this system, and location of the floor sensor are illustrated in Figures EC-35 and EC-36.

Emission Control System

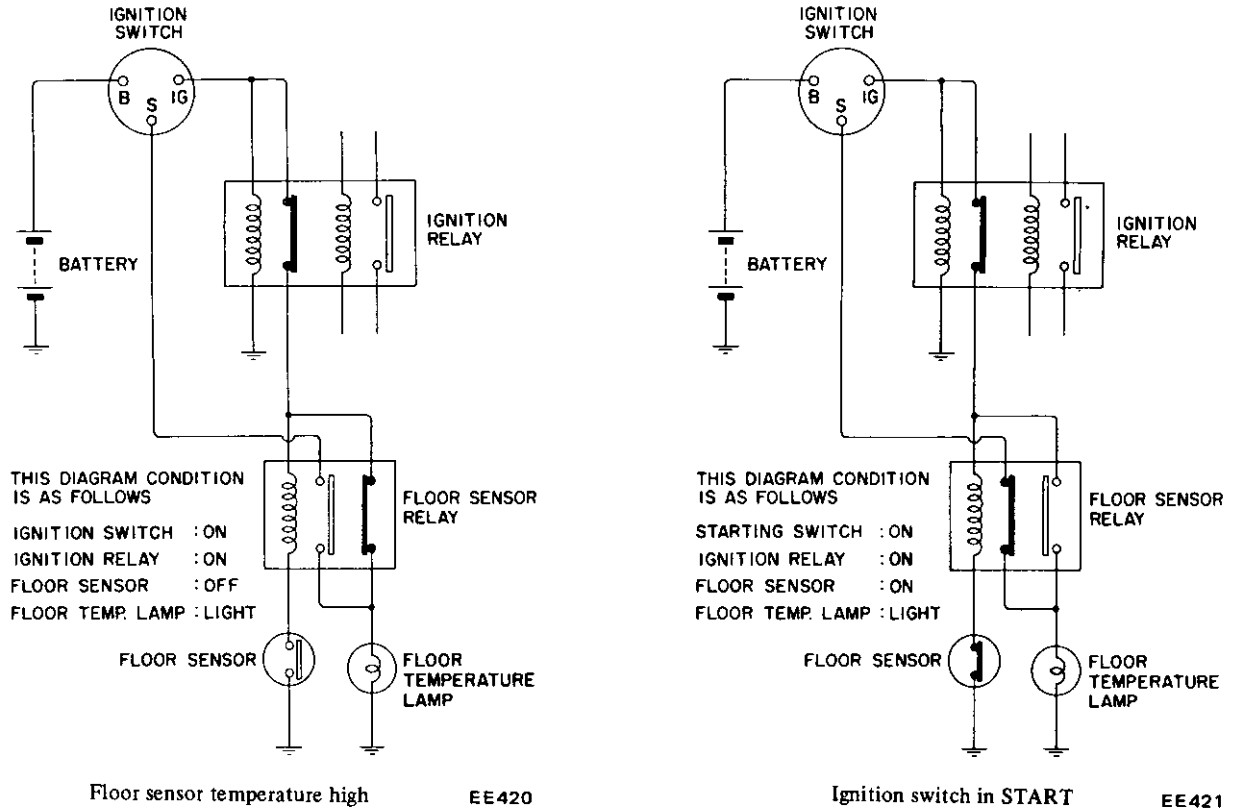
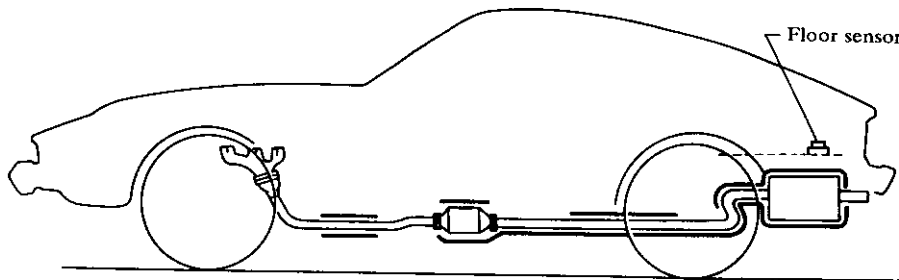

Fig. EC-35 Floor warning system circuit



EC398

Fig. EC-36 Location of floor sensor

OPERATION

Floor temperature will exceed normal level when temperature rise in the exhaust system succeeding the catalytic converter is caused by either an engine problem or severe driving conditions. Under this condition the floor sensor turns off, causing the starting switch line of the floor sensor relay to turn off and the ignition switch line to turn on, as a result, the floor temperature warning lamp comes on.

When the floor temperature drops below the specified level, the floor sensor relay contacts close.

As the contacts close, the ignition line of the floor sensor relay turns off,

while the starting switch side comes on. Thus, the floor temperature warning lamp goes out.

The lamp is functioning satisfactori-

ly, if it remains on while the starting motor is in operation. The lamp goes out when the ignition switch is in "IG" position.

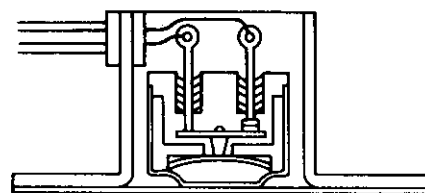

Contact close

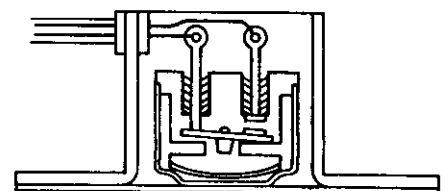

Contact open

Fig. EC-37 Operation of floor sensor

REMOVAL AND INSTALLATION

Removal

Floor sensor

Remove protector before removing floor sensor. Refer to Figure EC-38.

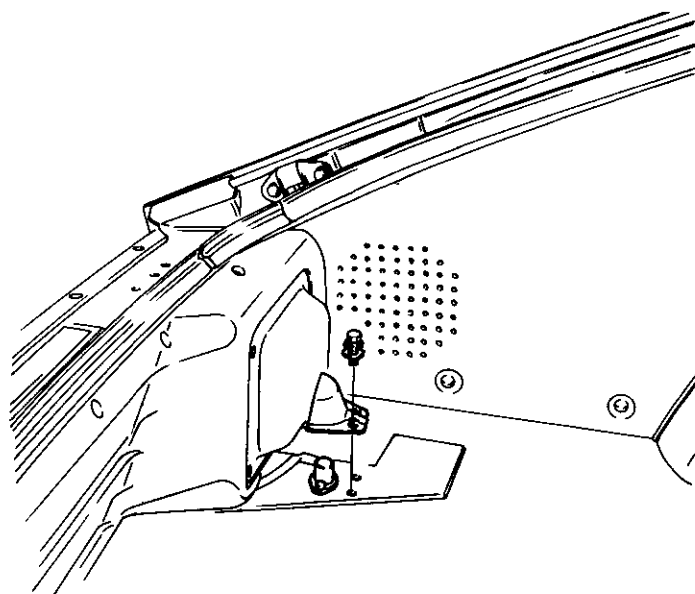

EC400

Fig. EC-38 Removing floor sensor

Floor sensor relay

Remove front passenger seat before removing floor sensor relay. Refer to Figure EC-39.

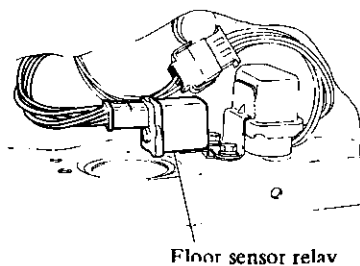

Floor sensor relay

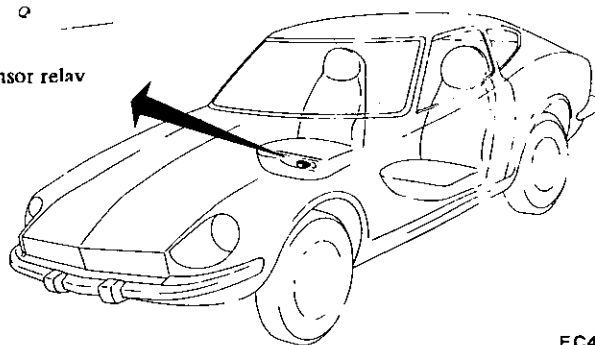

EC436

Fig. EC-39 Location of floor sensor relay

Floor temperature lamp

Remove instrument finisher before removing floor temperature warning lamp. Refer to Figure EC-40.

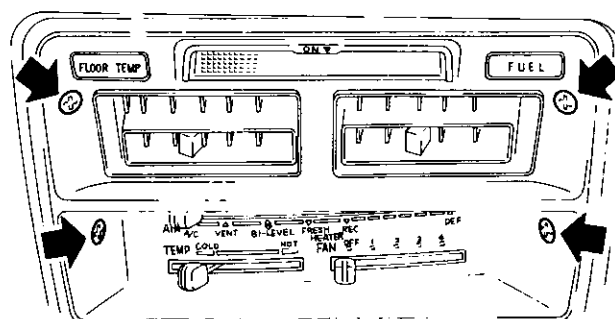
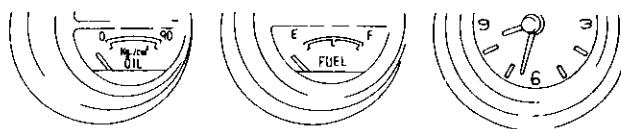

EC437

Fig. EC-40 Location of floor temperature lamp

Emission Control System

Installation

To install, reverse the order of removal.

Inspection

Floor warning temperature system

Apply parking brake.

Shift gears into Neutral (for manual transmission) and Neutral or Park (for automatic transmission).

1. Ensure that floor temperature warning lamp lights when ignition switch is turned to the "S" position. If lamp does not light, check burned bulb. Replace burned out bulb. If bulb is not burned, trace wire(s) back to ignition switch.

Repair or replace if necessary.

2. Be sure that floor temperature sensor is cool [below 80°C (176°F)] before carrying out the following:

- (1) Remove rear seat.
- (2) Turn ignition switch to the "IG" position.
- (3) Ensure that floor temperature

warning lamp goes out.

(4) Heat areas around floor sensor with a proper heater to ensure that

floor temperature warning lamp comes on when floor is heated to specifications in the table below.

Floor sensor	Floor temperature warning lamp	Floor temperature
Contacts close	OFF	Below 115°C (239°F)
Contacts open	ON	Above 115°C (239°F)

If lamp does not come on, check floor sensor connector for continuity with a circuit tester.

If continuity exists after heating areas around floor sensor, replace floor sensor.

If continuity does not exist, trace the wiring back to relay or proceed to step 3. Repair or replace wire(s) if necessary.

3. Turn ignition switch to the "IG"

position, and disconnect floor sensor connector. The lamp should remain on. If not, check floor sensor relay for continuity with a circuit tester.

Conduct checks under the heading following "floor sensor relay", and if relay is found normal, trace wire(s) back to ignition switch. Repair faulty wiring if necessary. Refer to Figure EC-41.

Emission Control System

Note: Do not heat floor sensor directly.

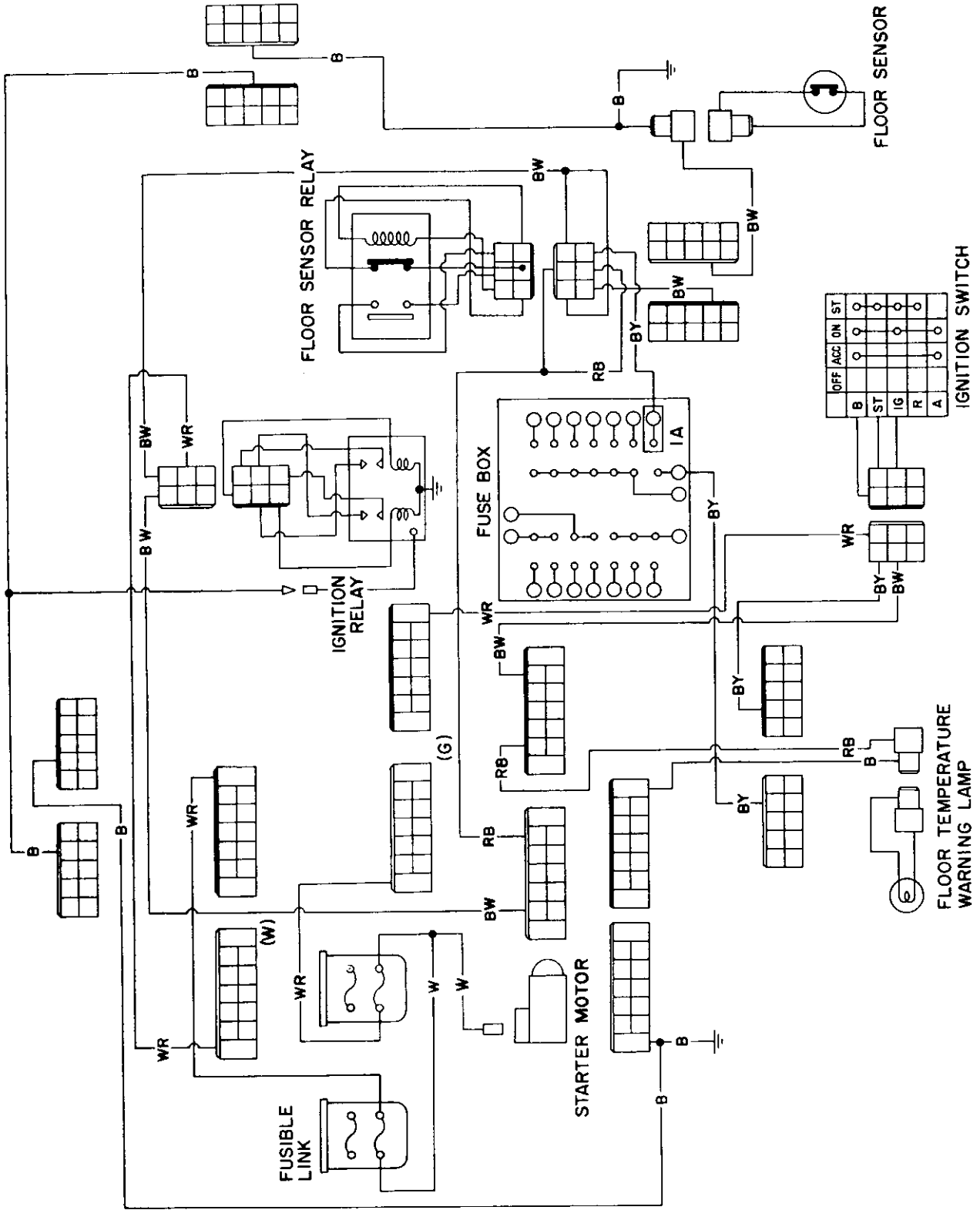

EC438

Fig. EC-41 Wiring diagram of floor warning system

Emission Control System

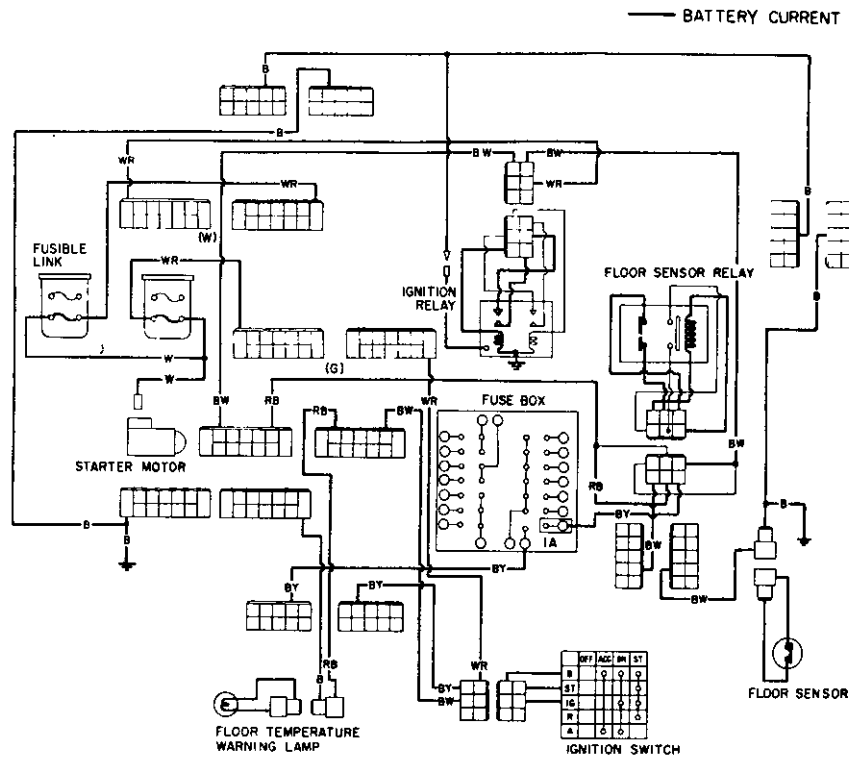

EC439

Fig. EC-42 Floor warning lamp ON with stator SW turned ON

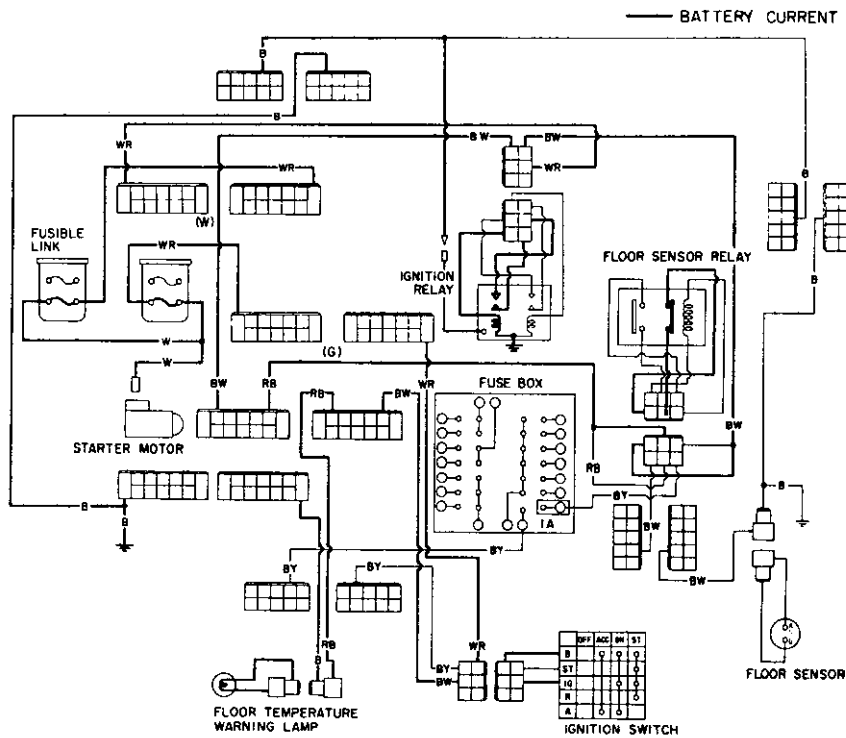

EC440

Fig. EC-43 Floor warning lamp ON with floor sensor turned OFF

Floor sensor relay

Refer to Figure EC-54.

When checking floor sensor relay unit, remove it, and conduct continuity and voltage tests as follows:

1. Terminals ⑤ and ⑥

Continuity should exist.

Terminals ② and ④

Continuity should exist.

Terminals ① and ③

Continuity should not exist.

2. Terminals ⑤ and ⑥

12 volt should be present.

Terminals ① and ③

Continuity should exist.

Terminals ② and ④

Continuity should not exist.

Emission Control System

If test results are not as indicated above, replace faulty parts.

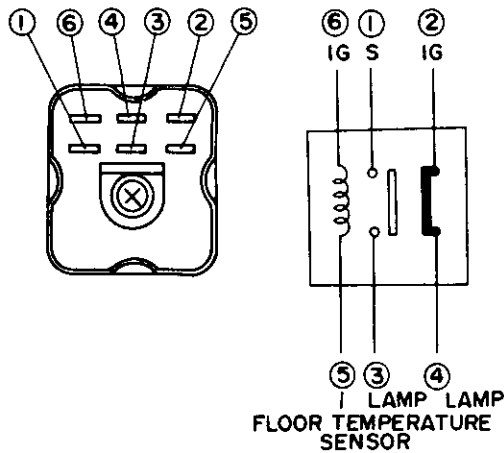

EC404

Fig. EC-44 Checking floor sensor relay

When floor temperature warning lamp lights

Check floor temperature warning lamp for the following items.

1. Open or short circuit in wiring harness.
2. Condition of ignition system.

EVAPORATIVE EMISSION CONTROL SYSTEM

DESCRIPTION

The evaporative emission control system is used to reduce hydrocarbons emitted to the atmosphere from the fuel system. This reduction of hydro-

carbons is accomplished by activated charcoals in the carbon canister.

This system is made up of the following:

1. Fuel tank with positive sealing filler cap
2. Vapor-liquid separator
3. Vapor vent line
4. Carbon canister
5. Vacuum signal line
6. Canister purge line

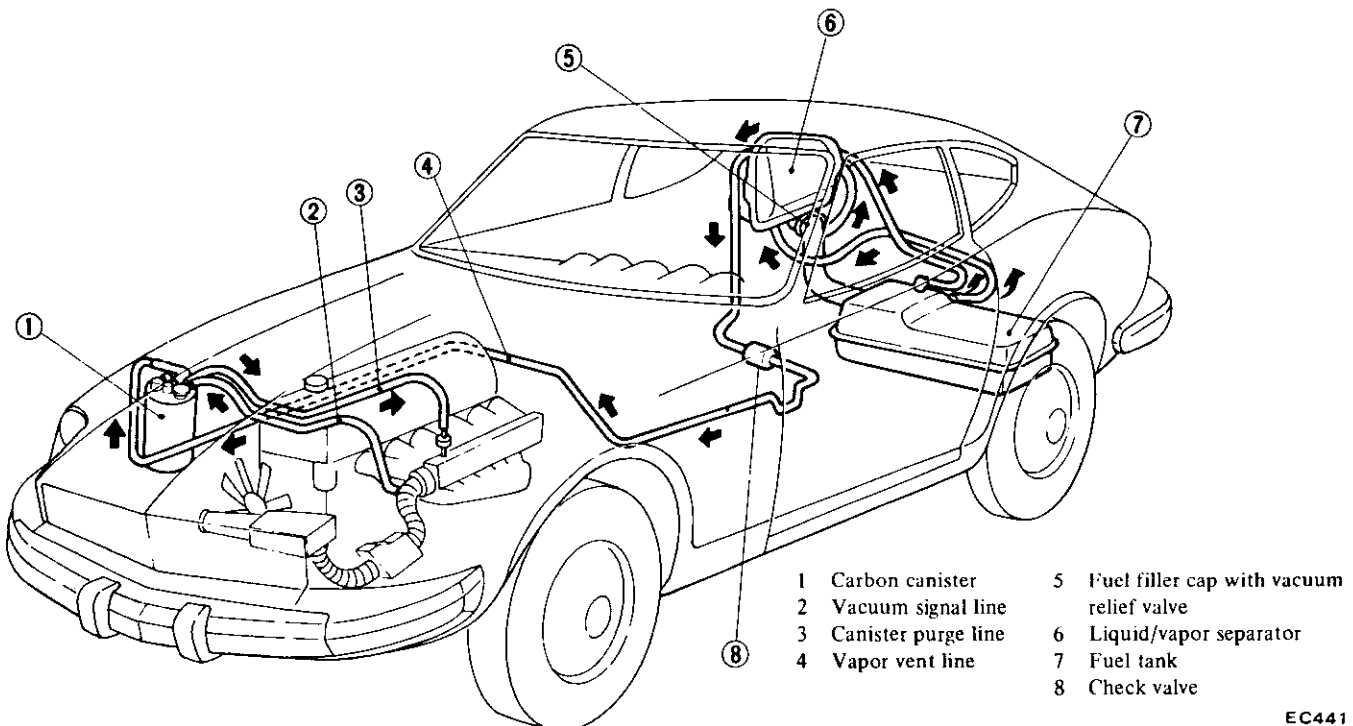

EC441

Fig. EC-45 Schematic drawing of transmission controlled vacuum advance system

OPERATION

Fuel vapors from the sealed fuel tank are led into the carbon canister.

The canister is filled with activated charcoals to absorb the fuel vapors

when the engine is at rest or at idling. See Figure EC-46.

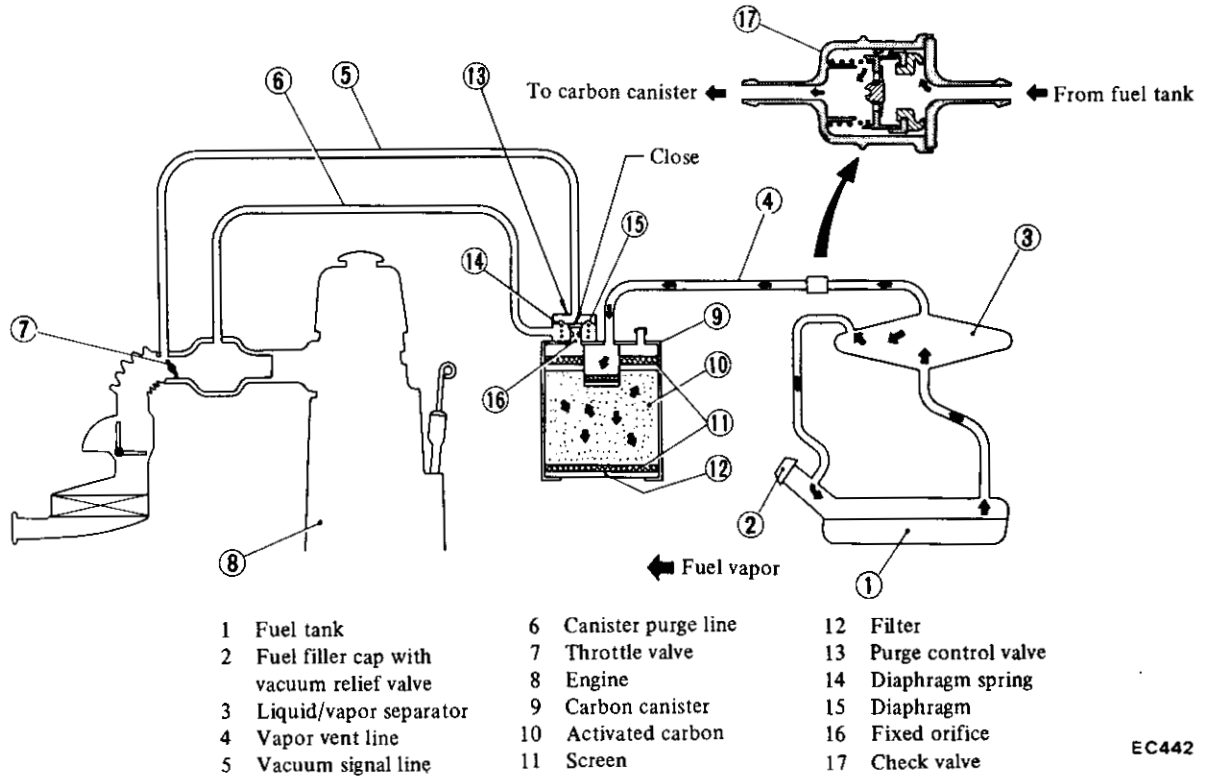

EC442

Fig. EC-46 Evaporative emission control system (Fuel vapor flow when engine is idling)

As the throttle valve opens and car speed increases, vacuum pressure in the vacuum signal line forces the purge

control valve to open, and admits an orifice to intake manifold and fuel vapor is then drawn into the intake

manifold through the canister purge line. See Figure EC-47.

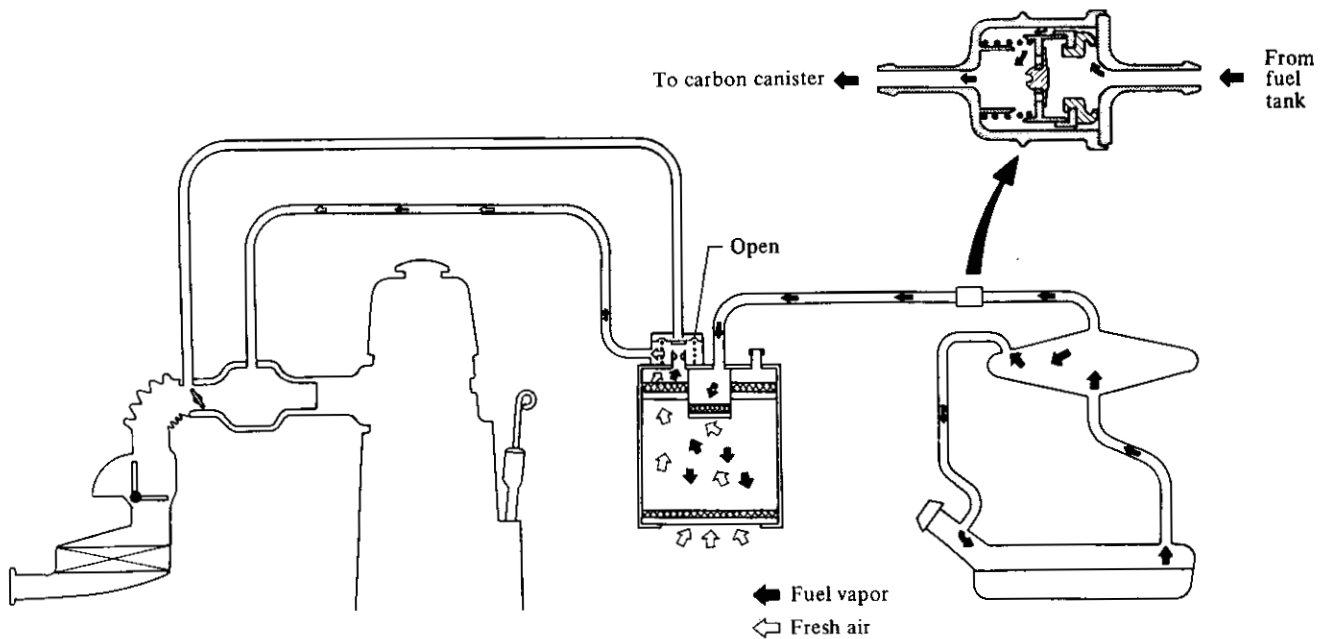

EC461

Fig. EC-47 Evaporative emission control system (Fuel vapor flow when engine is at rest or running)



509 Debby Lane
Adamsville, AL 35005
<http://www.zcarcreations.com>
cborden@zcarcreations.com

NISSAN FACTORY SERVICE MANUAL CDROM END-USER LICENSE AGREEMENT

NOTICE TO USER: THIS IS A CONTRACT. BY PURCHASING AND USING THE SERVICE MANUAL ON CDROM, YOU ACCEPT ALL THE TERMS AND CONDITIONS OF THIS AGREEMENT.

This End User License Agreement accompanies the Service Manual on CDROM product and related explanatory materials. Please read this Agreement carefully. By purchasing and using the Service Manual on CDROM, you are implying that you have carefully read, agree with, and will adhere to the conditions set forth in this agreement. If you do not wish to accept the terms of this End User Agreement please do not use the Service Manual on CDROM. You will not be permitted to use the Service Manual on CDROM without consenting to this end user agreement.

Upon your acceptance of this Agreement, Z Car Creations, LLC grants to you a nonexclusive license to use the Service Manual on CDROM, provided that you agree to the following:

USE OF SOFTWARE

You may install the contents of the CD on a hard disk or other storage device for personal use only. Each Service Manual on CDROM comes with a single user license. Under no circumstances should the contents of the Service Manual CDROM be placed on a server for purposes of distributing or allowing access to the material over a network.

COPYRIGHT AND TRADEMARK RIGHTS

The Service Manual CDROM is owned by Z Car Creations, LLC and its structure and organization, all graphics and coding are considered intellectual property of Z Car Creations, LLC. The manual content itself is property of Nissan Motors. The Service Manual on CDROM is also protected by United States Copyright Law and International Treaty provisions. This Agreement does not grant you any intellectual property or resale rights to the Service Manual CDROM.

RESTRICTIONS

You agree not to modify, adapt, translate, reverse engineer, decompile or disassemble the PDF file on the Service Manual CDROM. The Service Manual on CDROM is licensed and distributed by Z Car Creations, LLC for single user utilization of its contents only. Licensed users will be permitted to use the contents of the Service Manual CDROM for multimedia presentation to an audience from a single machine using a large display or projection device but the Service Manual CDROM may not otherwise be distributed, sold to or made accessible to multiple users.

NO WARRANTY

The software is being delivered to you AS IS and Z Car Creations, LLC makes no warranty as to its use or performance. Z CAR CREATIONS, LLC DOES NOT AND CANNOT WARRANT THE PERFORMANCE OR RESULTS YOU MAY OBTAIN BY USING THE SERVICE MANUAL CDROM OR DOCUMENTATION, NOR MAKES ANY WARRANTIES, EXPRESS OR IMPLIED, AS TO NONINFRINGEMENT OF THIRD-PARTY RIGHTS, MERCHANTABILITY, OR FITNESS FOR ANY PARTICULAR PURPOSE. IN NO EVENT WILL Z CAR CREATIONS, LLC BE LIABLE TO YOU FOR ANY CONSEQUENTIAL, INCIDENTAL, OR SPECIAL DAMAGES FOR ANY REASON.



509 Debby Lane
Adamsville, AL 35005
<http://www.zcarcreations.com>
cborden@zcarcreations.com

GOVERNING LAW AND GENERAL PROVISIONS

This Agreement will be governed by the laws of the State of Alabama, USA, excluding the application of its conflicts of law rules. This Agreement will not be governed by the United Nations Convention on Contracts for the International Sale of Goods, the application of which is expressly excluded. If any part of this Agreement is found void and unenforceable, it will not affect the validity of the balance of the Agreement, which shall remain valid and enforceable according to its terms. You agree that the Service Manual on CDROM will not be shipped, transferred or exported into any country or used in any manner prohibited by the United States Export Administration act or any other export laws, restrictions or regulations. This Agreement shall automatically terminate upon failure by you to comply with its terms. This Agreement may only be modified in writing signed by and authorized officer for Z Car Creations, LLC.

Craig Borden
Z Car Creations, LLC
509 Debby Lane
Adamsville, AL 35005
USA

YOUR ACCEPTANCE OF THE FOREGOING AGREEMENT IS IMPLIED UPON PURCHASING AND USING THE SERVICE MANUAL CDROM.