

ELECTRICAL SYSTEM

SECTION **EL**

CONTENTS

PRECAUTIONS	4	Wiring Diagram - STOP/L -	54
Supplemental Restraint System (SRS) "AIR BAG"	4	BACK-UP LAMP	55
Wiring Diagrams and Trouble Diagnosis	4	Wiring Diagram - BACK/L -	55
HARNESS CONNECTOR	5	CORNERING LAMP	56
Description	5	System Description	56
STANDARDIZED RELAY	7	Wiring Diagram - CORNER -	57
Description	7	TURN SIGNAL AND HAZARD WARNING LAMPS	58
POWER SUPPLY ROUTING	9	System Description	58
Schematic	10	Wiring Diagram - TURN -	59
Wiring Diagram - POWER -	12	Trouble Diagnoses	61
Inspection	19	Electrical Components Inspection	61
GROUND	20	TRAILER TOW	62
Ground Distribution	20	System Description	62
COMBINATION SWITCH	29	Wiring Diagram - T/TOW -	63
Check	29	Trouble Diagnoses	64
Replacement	30	ILLUMINATION	65
STEERING SWITCH	31	System Description	65
Check	31	Schematic	67
HEADLAMP (FOR USA)	32	Wiring Diagram - ILL -	68
Component Parts and Harness Connector		INTERIOR ROOM LAMP	72
Location	32	System Description	72
System Description	32	Schematic	74
Wiring Diagram - H/LAMP -	34	Wiring Diagram - INT/L -	75
Trouble Diagnoses	36	Trouble Diagnoses	78
Bulb Replacement	44	METERS AND GAUGES	80
Aiming Adjustment	44	Component Parts and Harness Connector	
HEADLAMP (FOR CANADA) - DAYTIME LIGHT SYSTEM -	46	Location	80
Component Parts and Harness Connector		System Description	80
Location	46	Combination Meter	82
System Description	46	Wiring Diagram - METER -	84
Wiring Diagram - DTRL -	49	Trouble Diagnoses	85
Trouble Diagnoses	51	Electrical Component Inspection	90
Bulb Replacement	52	WARNING LAMPS	92
Aiming Adjustment	52	System Description	92
PARKING, LICENSE AND TAIL LAMPS	53	Schematic	94
Wiring Diagram - TAIL/L -	53	Wiring Diagram - WARN -	95
STOP LAMP	54	Electrical Component Inspection	99
		WARNING CHIME	100

GI

MA

EM

LC

EC

FE

AT

AX

SU

BR

ST

RS

BT

HA

SC

EL

IDX

CONTENTS (Cont'd)

Component Parts and Harness Connector		Component Parts and Harness Connector	
Location	100	Location	146
System Description.....	100	System Description.....	146
Wiring Diagram - CHIME -	102	Schematic	149
Trouble Diagnoses.....	103	Wiring Diagram - AUT/DP -	150
FRONT WIPER AND WASHER	108	Trouble Diagnosis.....	155
System Description.....	108	POWER SEAT	183
Wiring Diagram - WIPER -	109	Wiring Diagram - SEAT -	183
Trouble Diagnoses.....	110	AUTOMATIC SPEED CONTROL DEVICE (ASCD) ...	185
Removal and Installation	110	Components Parts and Harness Connector	
Washer Nozzle Adjustment	111	Location	185
REAR WIPER AND WASHER	113	System Description.....	186
System Description/Except for Glass Hatch		Schematic	188
Model	113	Wiring Diagram - ASCD -	189
Wiring Diagram - WIP/R - /Except for Glass		Fail-safe System.....	194
Hatch Model.....	114	Trouble Diagnoses.....	195
System Description/For Glass Hatch Model	115	Electrical Component Inspection	206
Wiring Diagram - WIP/R - /For Glass Hatch		ASCD Wire Adjustment	208
Model	116	POWER WINDOW	209
Removal and Installation	117	System Description.....	209
Washer Fluid and Check Valve	118	Wiring Diagram - WINDOW -	211
HORN	119	Trouble Diagnoses.....	213
Wiring Diagram - HORN -	119	POWER DOOR LOCK	214
CIGARETTE LIGHTER	120	Component Parts and Harness Connector	
Wiring Diagram - CIGAR -	120	Location	214
REAR WINDOW DEFOGGER	121	System Description.....	214
Component Parts and Harness Connector		Schematic	216
Location	121	Wiring Diagram - D/LOCK -	217
System Description.....	121	Trouble Diagnosis.....	222
Wiring Diagram - DEF -	123	MULTI-REMOTE CONTROL SYSTEM	234
Trouble Diagnoses.....	124	Component Parts and Harness Connector	
Electrical Components Inspection	126	Location	234
Filament Check.....	126	System Description.....	234
Filament Repair	127	Schematic	237
AUDIO	129	Wiring Diagram - MULTI -	238
System Description.....	129	Trouble Diagnoses.....	242
Schematic	130	ID Code Entry Procedure	251
Wiring Diagram - AUDIO -	131	Remote Controller Battery Replacement.....	252
Trouble Diagnoses.....	134	THEFT WARNING SYSTEM	253
AUDIO ANTENNA	141	Component Parts and Harness Connector	
Location of Antenna.....	141	Location	253
Removal and Installation	141	System Description.....	255
POWER SUNROOF	142	Schematic	258
System Description.....	142	Wiring Diagram - THEFT -	259
Wiring Diagram - SROOF -	143	Trouble Diagnoses.....	266
POWER DOOR MIRROR	144	SMART ENTRANCE CONTROL UNIT	278
Wiring Diagram - MIRROR - /Without Automatic		Description	278
Drive Positioner	144	Schematic	280
HEATED MIRROR	145	Smart Entrance Control Unit Inspection Table	282
Wiring Diagram - H/MIRR -	145	INTEGRATED HOMELINK TRANSMITTER	284
AUTOMATIC DRIVE POSITIONER	146	Wiring Diagram - TRNSMT -	284
		Trouble Diagnoses.....	285

CONTENTS (Cont'd)

ELECTRICAL UNITS LOCATION	287	BULB SPECIFICATIONS	310	GI
Engine Compartment.....	287	Headlamp.....	310	
Passenger Compartment.....	288	Exterior Lamp	310	MA
HARNESS LAYOUT	290	Interior Lamp.....	310	
How to Read Harness Layout	290	WIRING DIAGRAM CODES (CELL CODES)	311	
Outline.....	291	SUPER MULTIPLE JUNCTION (SMJ)	313	EM
Main Harness and Body No. 2 Harness	292	Installation.....	313	
Engine Room Harness	296	Terminal Arrangement.....	314	LC
Engine Control Harness	299	FUSE BLOCK	315	
Body Harness	303	Terminal Arrangement.....	315	EC
Back Door Harness	304	FUSE AND FUSIBLE LINK BOX	316	
Back Door No. 2 Harness	305	Terminal Arrangement.....	316	FE
Room Lamp Harness.....	306	JOINT CONNECTOR	317	
Air Bag Harness	307	Terminal Arrangement.....	317	FE
Front Door Harness	308	ELECTRICAL UNITS	318	
Sliding Door Harness.....	309	Terminal Arrangement.....	318	AT

AT

AX

SU

BR

ST

RS

BT

HA

SC

EL

IDX

PRECAUTIONS

Supplemental Restraint System (SRS) "AIR BAG"

Supplemental Restraint System (SRS) "AIR BAG"

NDEL0001

The Supplemental Restraint System "AIR BAG", used along with a seat belt, helps to reduce the risk or severity of injury to the driver and front passenger in a frontal collision. The Supplemental Restraint System consists of air bag modules (located in the center of the steering wheel and on the instrument panel on the passenger side), a diagnosis sensor unit, warning lamp, wiring harness and spiral cable. Information necessary to service the system safely is included in the **RS section** of this Service Manual.

WARNING:

- **To avoid rendering the SRS inoperative, which could increase the risk of personal injury or death in the event of a collision which would result in air bag inflation, all maintenance should be performed by an authorized NISSAN dealer.**
- **Improper maintenance, including incorrect removal and installation of the SRS, can lead to personal injury caused by unintentional activation of the system.**
- **Do not use electrical test equipment on any circuit related to the SRS unless instructed to in this Service Manual. SRS wiring harnesses are covered with yellow insulation either just before the harness connectors or for the complete harness, for easy identification.**

Wiring Diagrams and Trouble Diagnosis

NDEL0002

When you read wiring diagrams, refer to the followings:

- **GI-10**"HOW TO READ WIRING DIAGRAMS"
- EL-12"POWER SUPPLY ROUTING" for power distribution circuit

When you perform trouble diagnosis, refer to the followings:

- **GI-34**"HOW TO FOLLOW TEST GROUP IN TROUBLE DIAGNOSIS"
- **GI-23**"HOW TO PERFORM EFFICIENT DIAGNOSIS FOR AN ELECTRICAL INCIDENT"

Check for any Service bulletins before servicing the vehicle.

Description

NDEL0003

NDEL0003S01

HARNESS CONNECTOR (TAB-LOCKING TYPE)

- The tab-locking type connectors help prevent accidental looseness or disconnection.
- The tab-locking type connectors are disconnected by pushing or lifting the locking tabs. Refer to illustration below.

Refer to the next page for description of slide-locking type connectors.

CAUTION:

- Do not pull the harness or wires when disconnecting the connector.
- Be careful not to damage the connector support bracket when disconnecting the connector.

[Example]

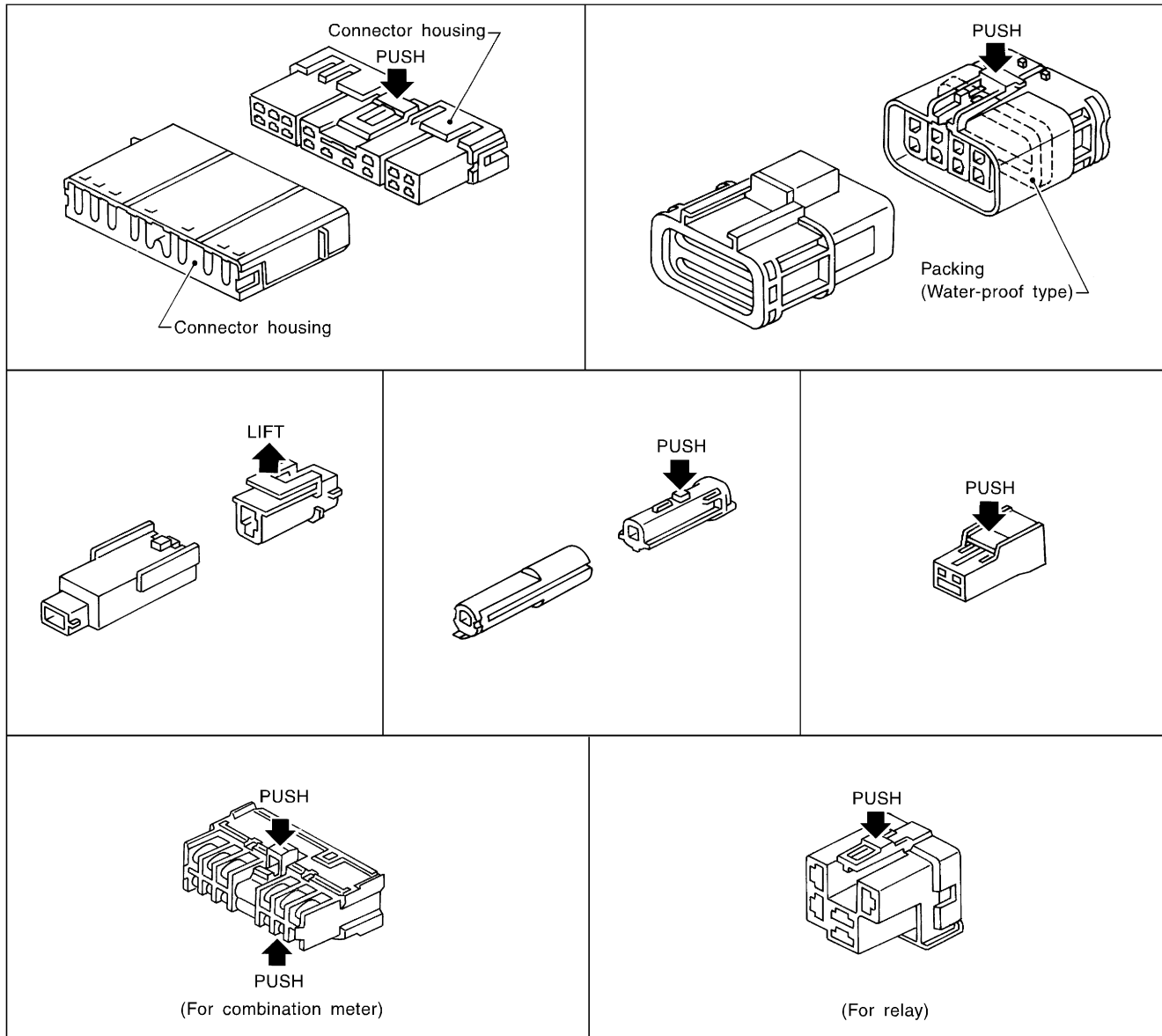

GI

MA

EM

LC

EC

FE

AT

AX

SU

BR

ST

RS

BT

HA

SC

EL

IDX

HARNESS CONNECTOR

Description (Cont'd)

HARNESS CONNECTOR (SLIDE-LOCKING TYPE)

-NDEL0003S02

- A new style slide-locking type connector is used on certain systems and components, especially those related to OBD.
- The slide-locking type connectors help prevent incomplete locking and accidental looseness or disconnection.
- The slide-locking type connectors are disconnected by pushing or pulling the slider. Refer to illustration below.

CAUTION:

- Do not pull the harness or wires when disconnecting the connector.
- Be careful not to damage the connector support bracket when disconnecting the connector.

[Example]

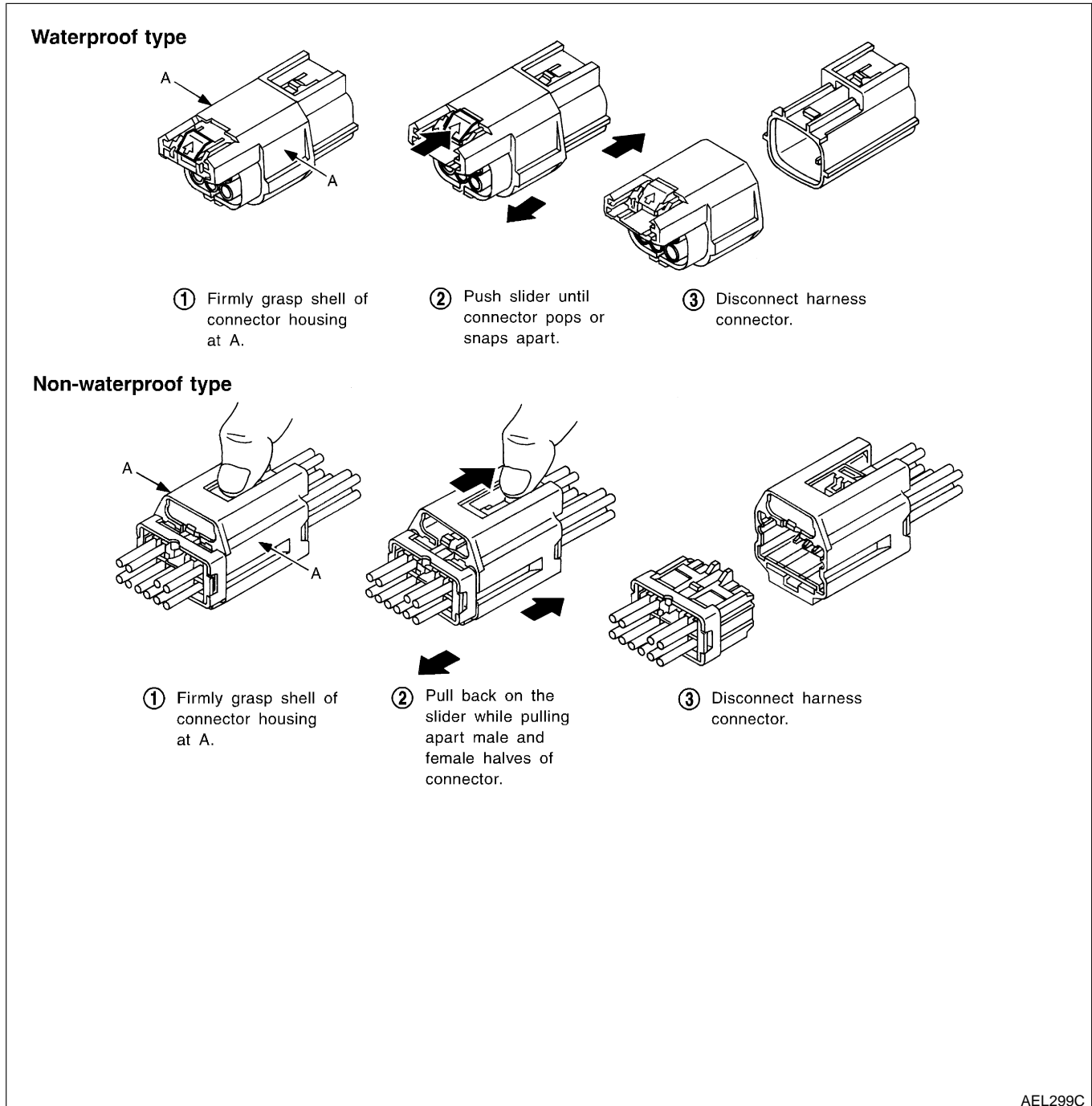

AEL299C

STANDARDIZED RELAY

Description

Description

NORMAL OPEN, NORMAL CLOSED AND MIXED TYPE RELAYS

Relays can mainly be divided into three types: normal open, normal closed and mixed type relays.

NDEL0004

NDEL0004S01

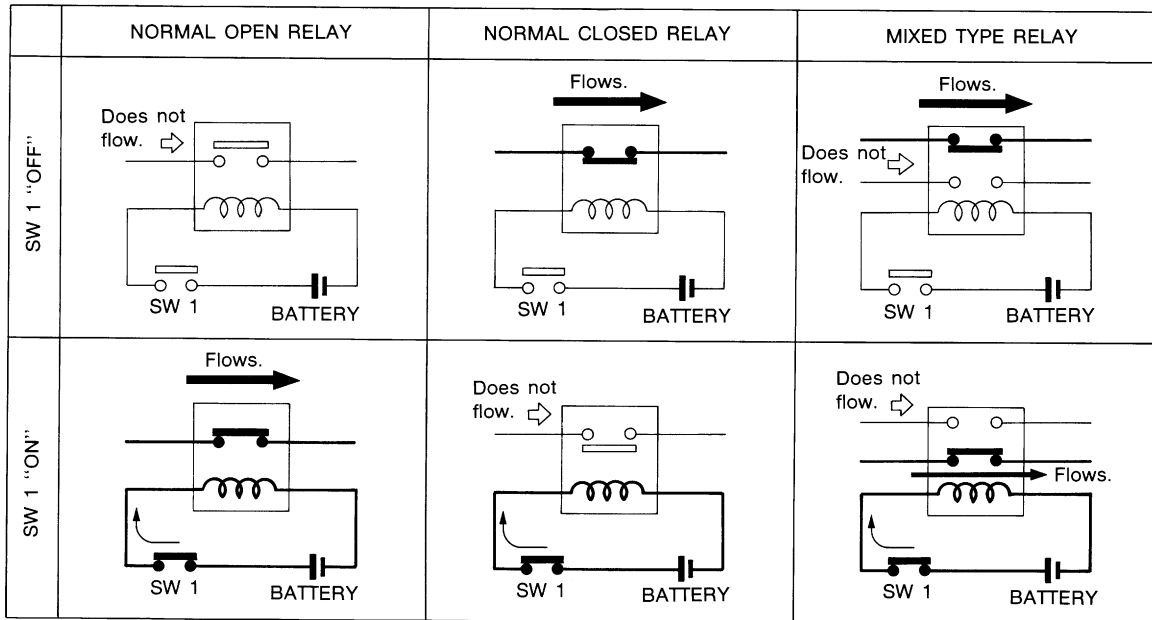

SEL881H

TYPE OF STANDARDIZED RELAYS

NDEL0004S02

1M	1 Make	2M	2 Make
1T	1 Transfer	1M·1B	1 Make 1 Break

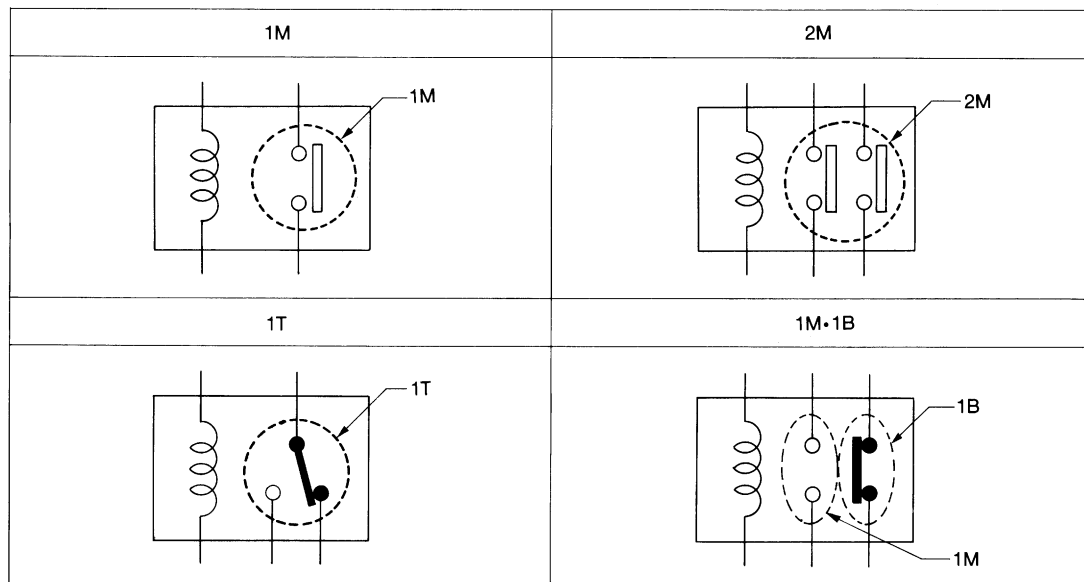

SEL882H

GI

MA

EM

LC

EC

FE

AT

AX

SU

BR

ST

RS

BT

HA

SC

EL

IDX

STANDARDIZED RELAY

Description (Cont'd)

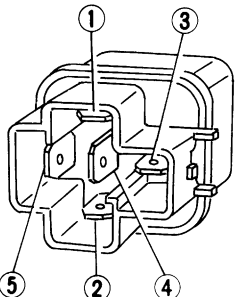
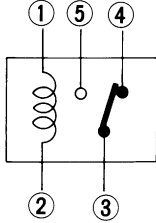
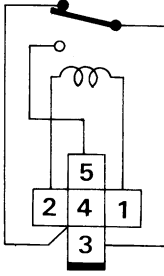
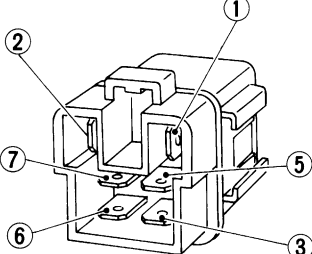
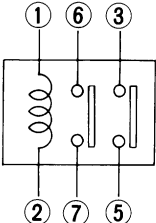
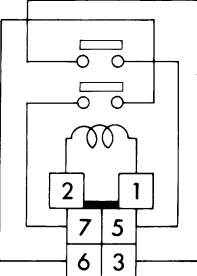
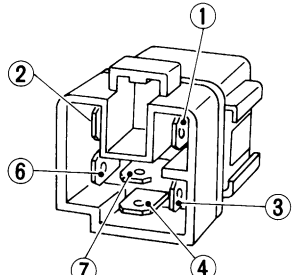
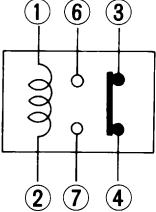
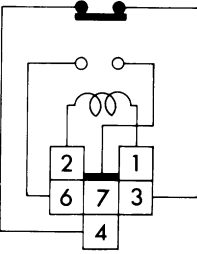
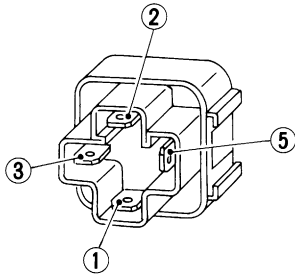
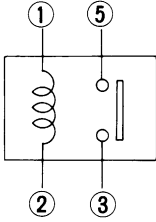
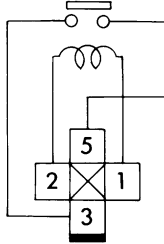
Type	Outer view	Circuit	Connector symbol and connection	Case color
1T				BLACK
2M				BROWN
1M•1B				GRAY
1M				BLUE or YELLOW

The arrangement of terminal numbers on the actual relays may differ from those shown above.

AEL174C

POWER SUPPLY ROUTING

NOTE:

GI

MA

EM

LC

EC

FE

AT

AX

SU

BR

ST

RS

BT

HA

SC

EL

IDX

POWER SUPPLY ROUTING

Schematic

Schematic

NDEL0005

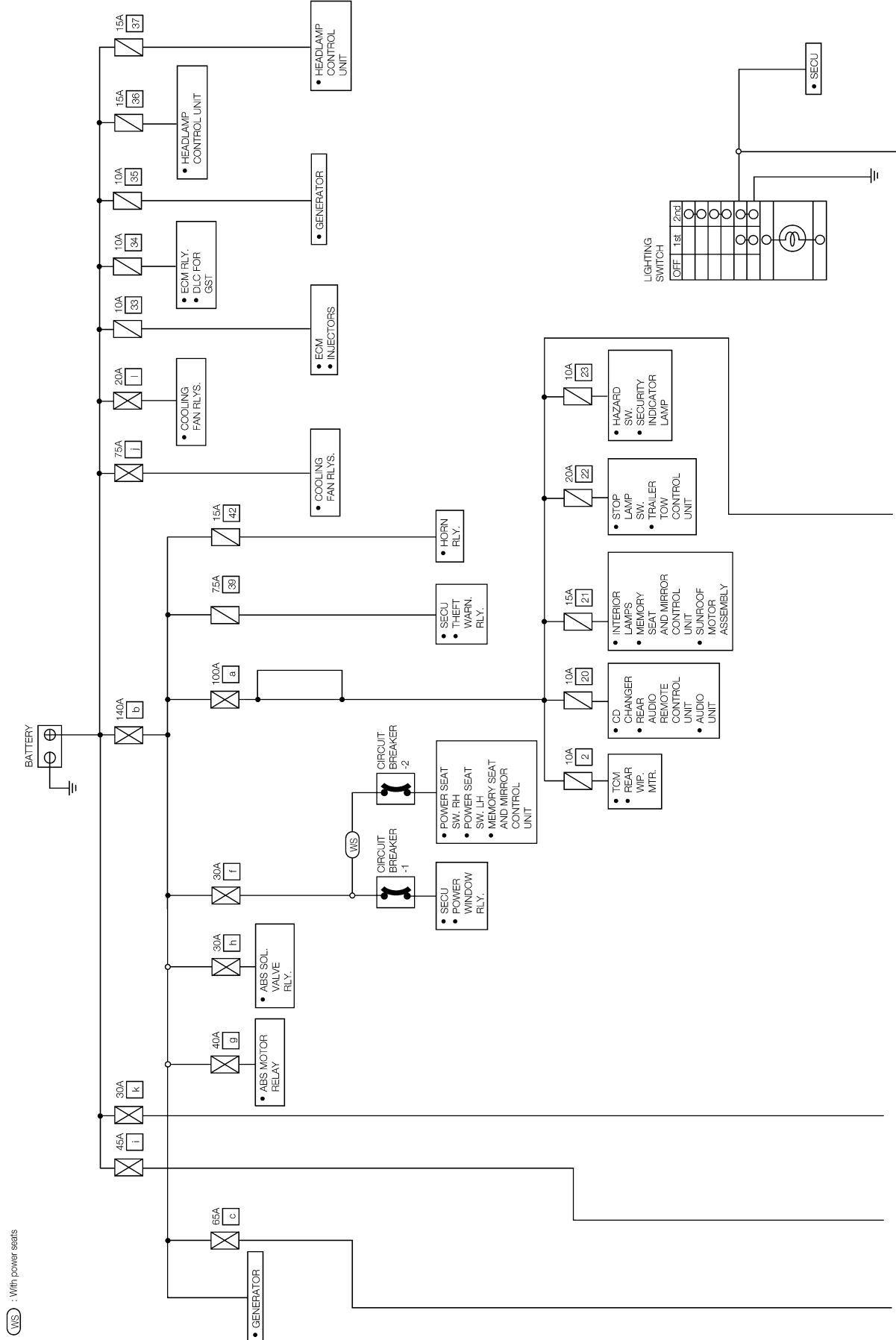

(MS) : With power seats

WEL552A

POWER SUPPLY ROUTING

Wiring Diagram — POWER —

Wiring Diagram — POWER —

BATTERY POWER SUPPLY — IGNITION SW. IN ANY POSITION

NDEL0006

NDEL0006S01

NOTE:

For detailed ground distribution information, refer to “GROUND DISTRIBUTION”, EL-20.

EL-POWER-01

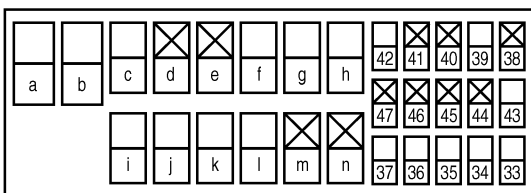
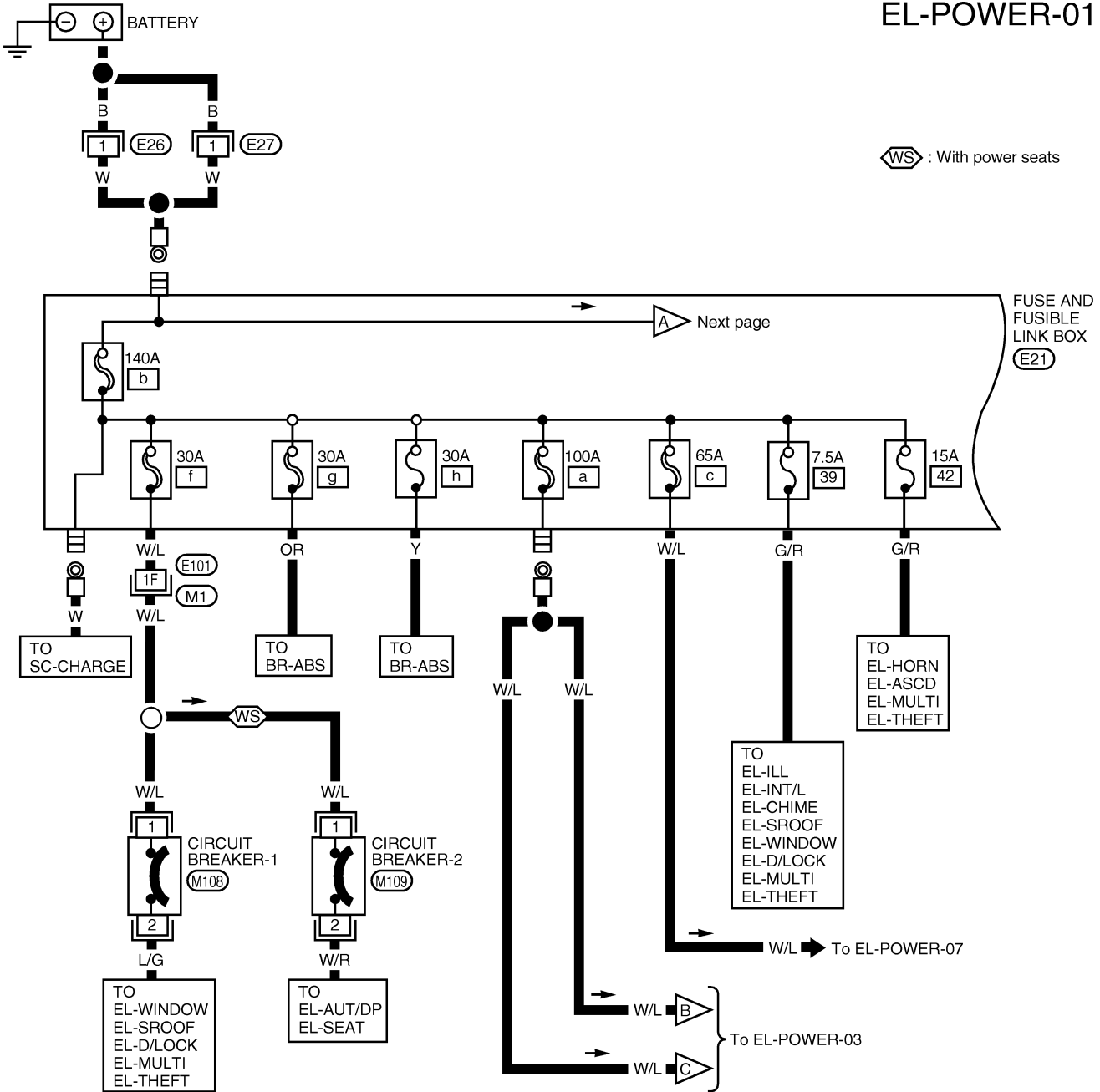

(E21)

(E26), (E27)
B B

(1), (M108), (M109)
2 W W

Refer to the following.
(M1), (E101) - SUPER MULTIPLE.
JUNCTION (SMJ)

WEL286

POWER SUPPLY ROUTING

Wiring Diagram — POWER — (Cont'd)

EL-POWER-02

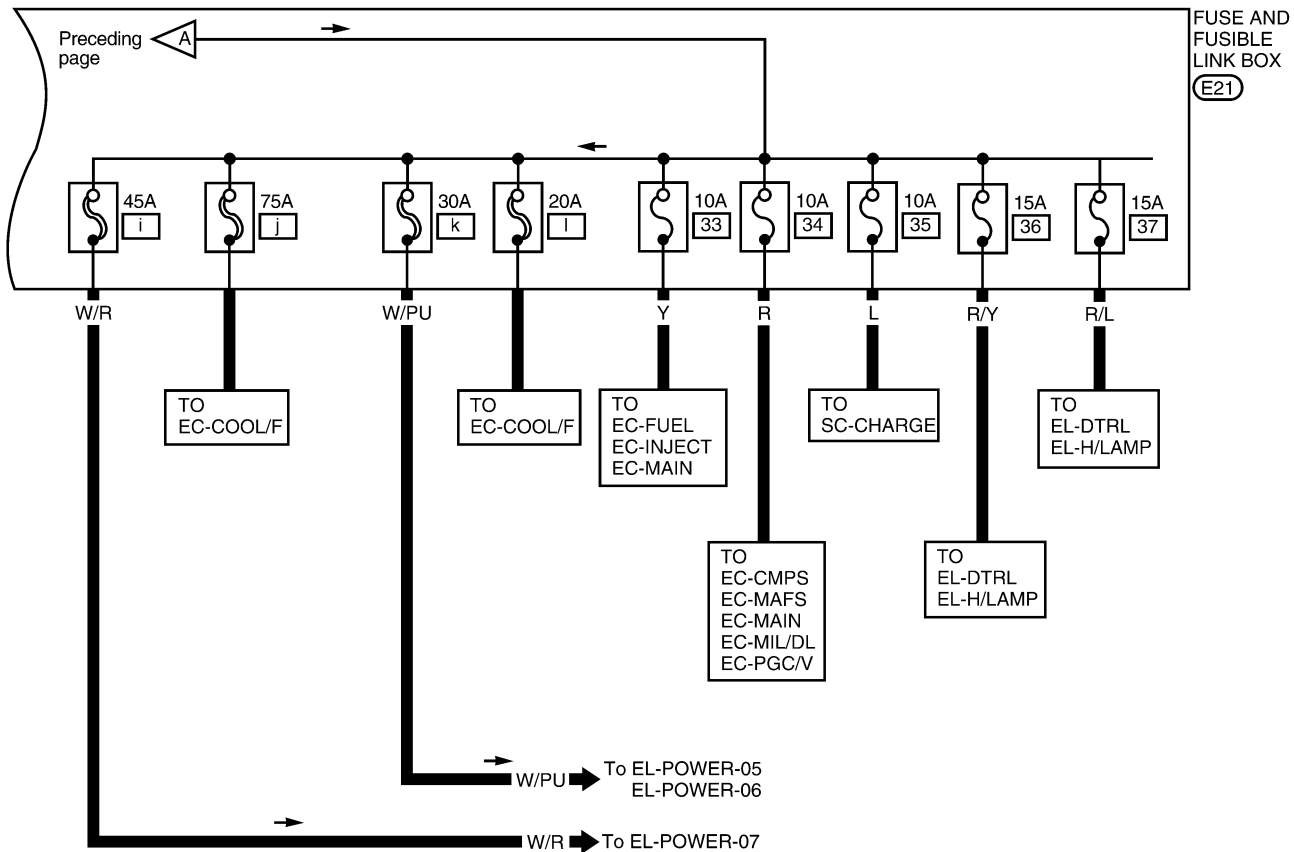

			⊗	⊗					42	⊗	⊗	⊗	⊗	⊗	
a	b	c	d	e	f	g	h								(E21)
									⊗	⊗	⊗	⊗	⊗		
									37	36	35	34	33		

GI
MA
EM
LC
EC
FE
AT
AX
SU
BR
ST
RS
BT
HA
SC
EL
IDX

POWER SUPPLY ROUTING

Wiring Diagram — POWER — (Cont'd)

EL-POWER-03

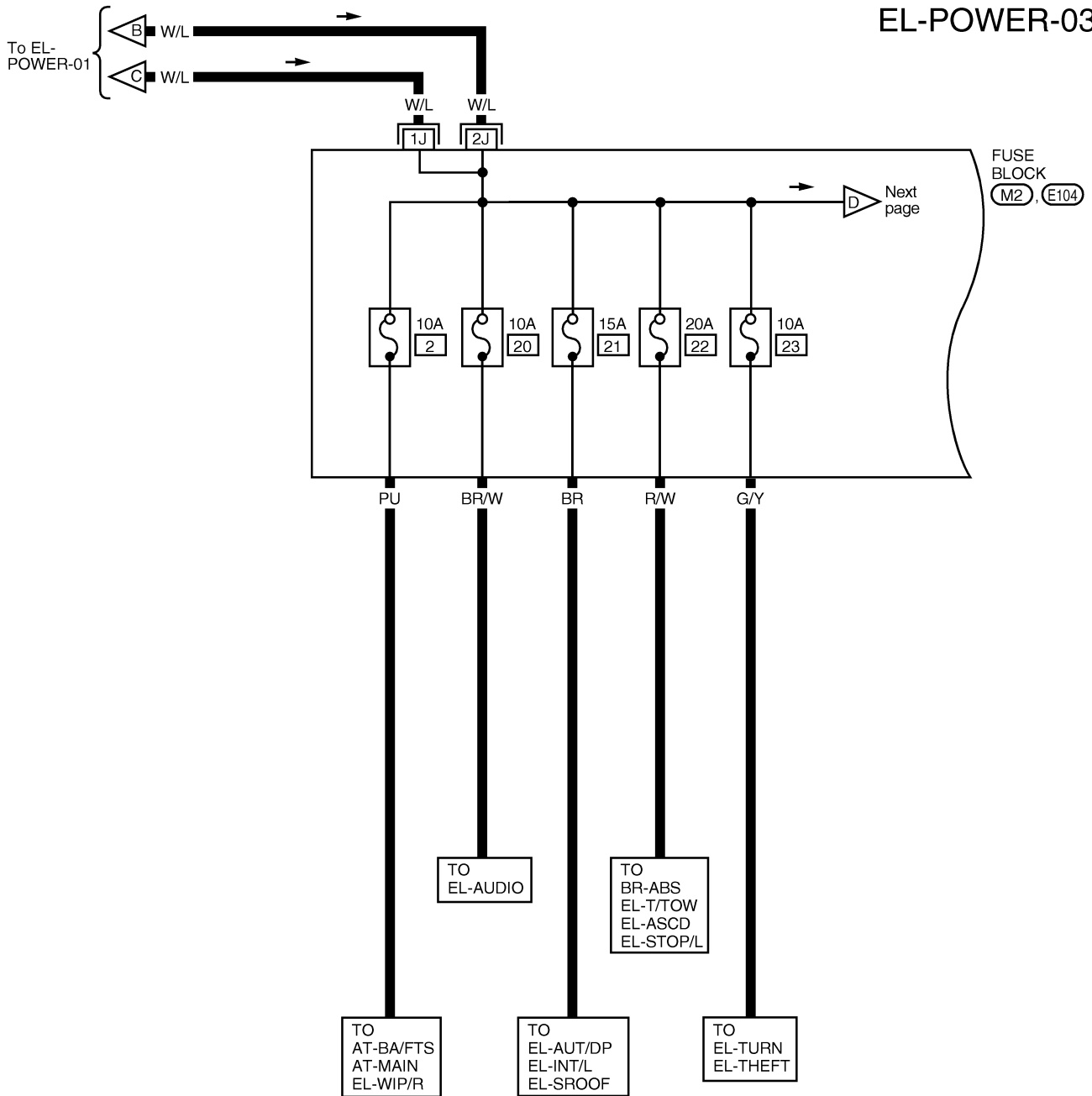

Refer to the following.
 (M2), (E104) - SUPER MULTIPLE JUNCTION (SMJ)

POWER SUPPLY ROUTING

Wiring Diagram — POWER — (Cont'd)

EL-POWER-04

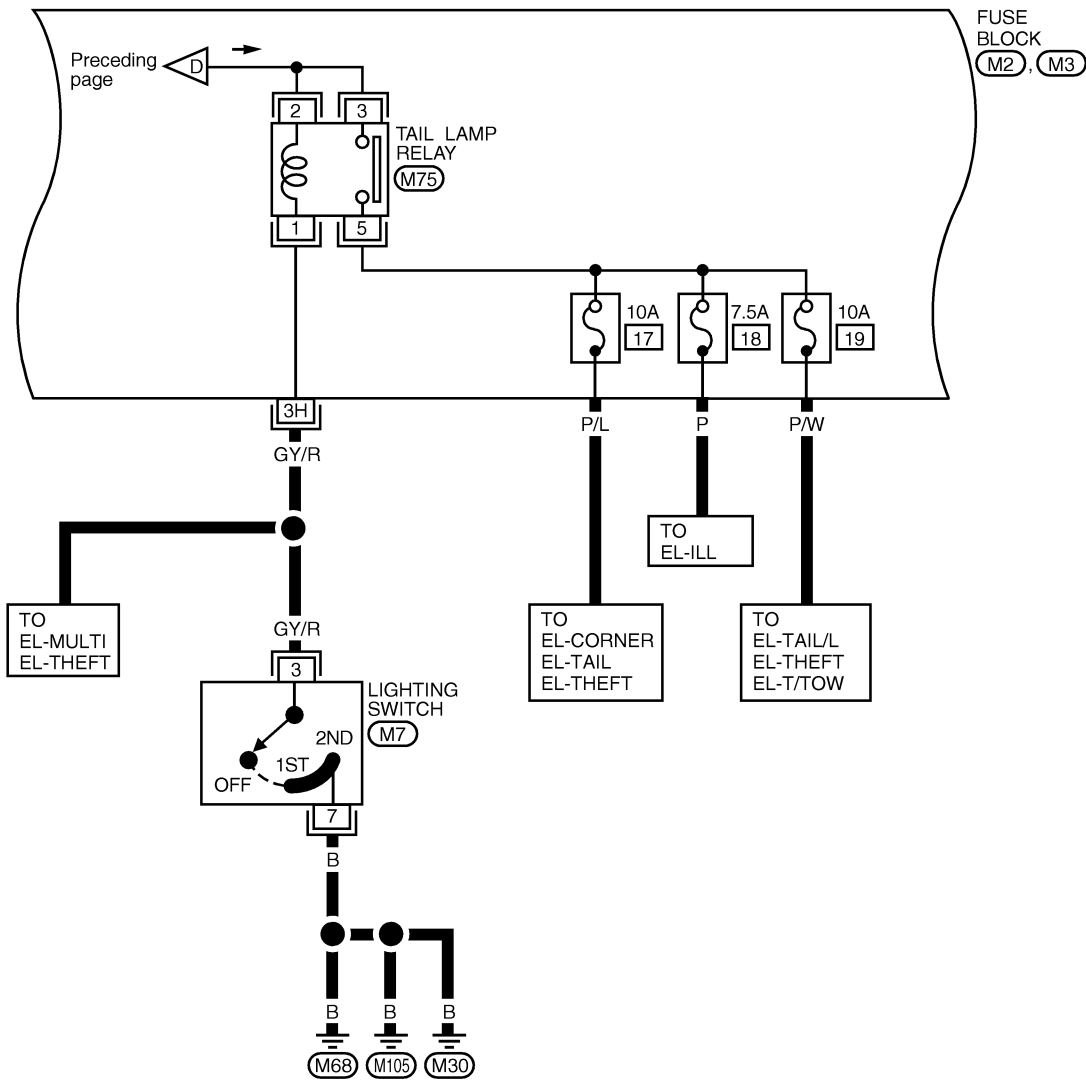

FUSE BLOCK (M2), (M3)

TO EL-MULTI
EL-THEFT

TO EL-CORNER
EL-TAIL
EL-THEFT

TO EL-TAIL/L
EL-THEFT
EL-T/TOW

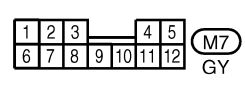
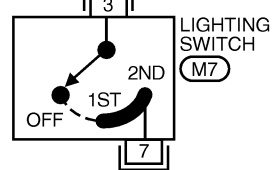

Refer to the following.
(M2), (M3) - FUSE BLOCK

GI
MA
EM
LC
EC
FE
AT
AX
SU
BR
ST
RS
BT
HA
SC

EL

IDX

WEL289

POWER SUPPLY ROUTING

Wiring Diagram — POWER — (Cont'd)

ACCESSORY POWER SUPPLY — IGNITION SW. IN ACC OR ON

=NDEL0006S02

NOTE:

For detailed ground distribution information, refer to "GROUND DISTRIBUTION", EL-20.

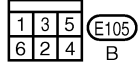
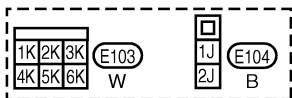
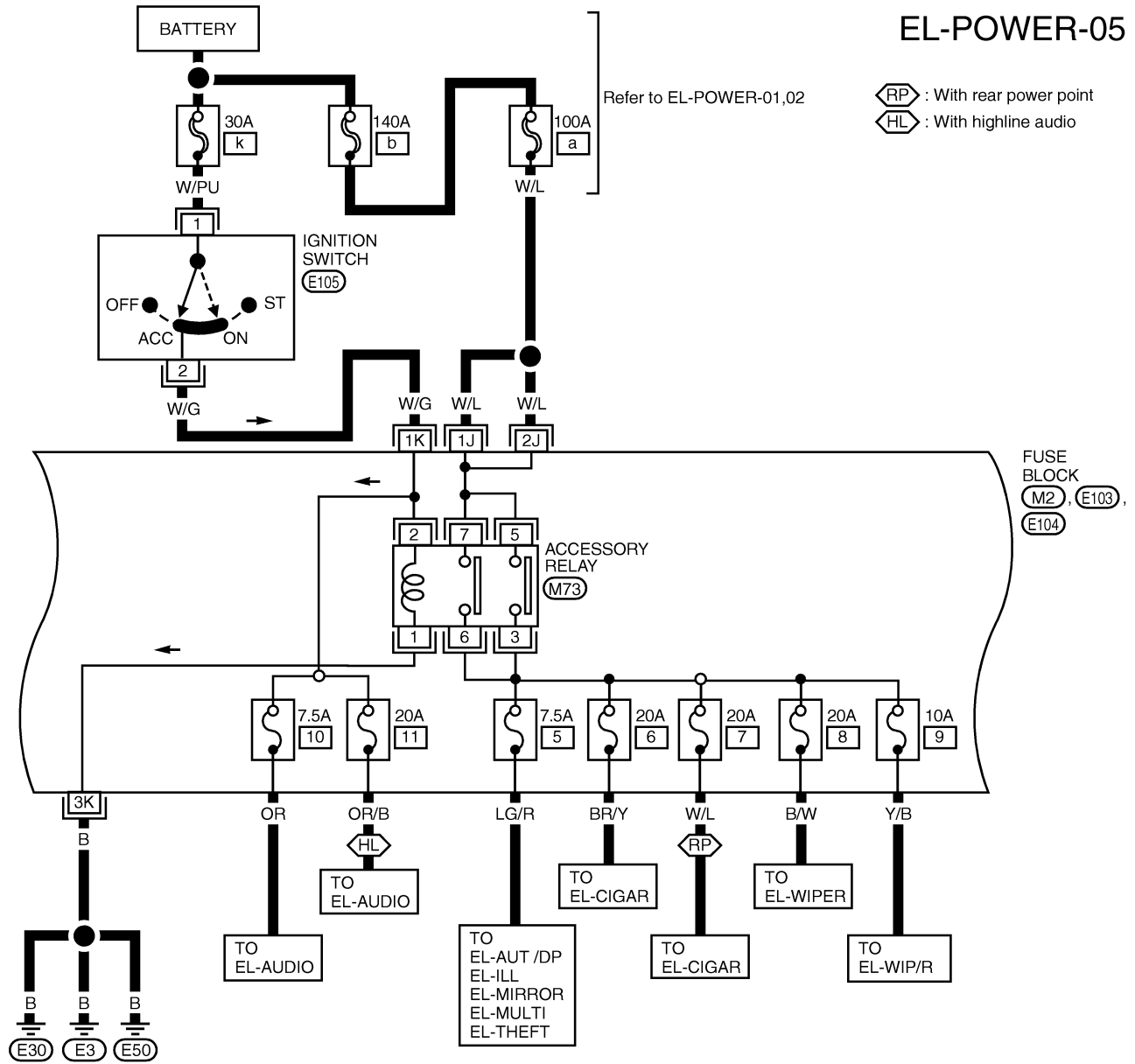

Refer to the following.

M2, E103, E104 - FUSE BLOCK

WEL290

POWER SUPPLY ROUTING

Wiring Diagram — POWER — (Cont'd)

IGNITION POWER SUPPLY — IGNITION SW. IN ON AND/OR START

=NDEL0006S03

NOTE:

For detailed ground distribution information, refer to "GROUND DISTRIBUTION", EL-20.

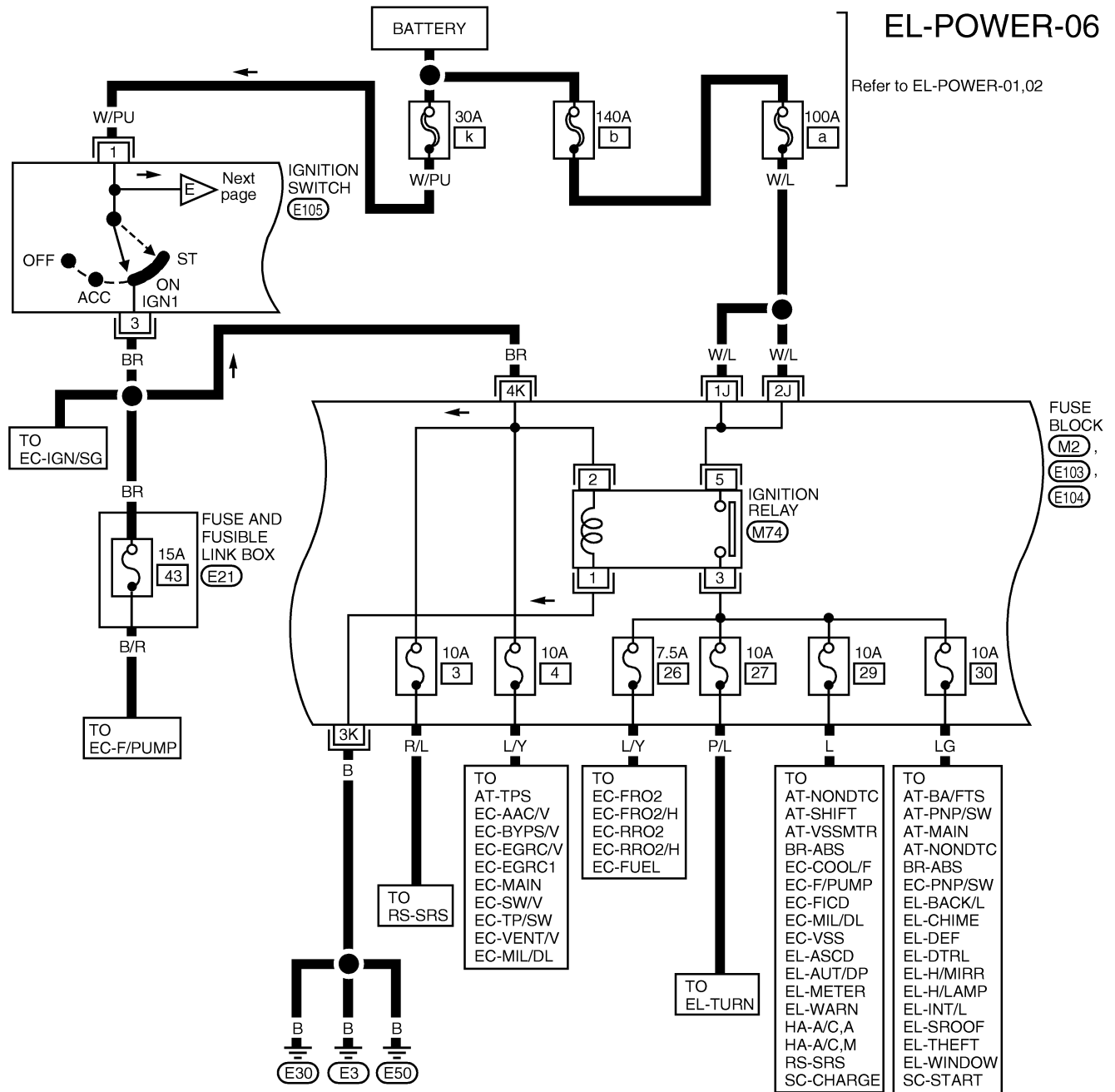

EL-POWER-06

Refer to EL-POWER-01,02

FUSE BLOCK (M2, E103, E104)

GI
MA
EM
LC
EC
FE
AT
AX
SU
BR
ST
RS
BT
HA
SC

EL

IDX

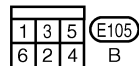
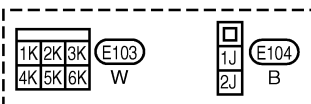

Refer to the following.
 (M2), (E103), (E104) - FUSE BLOCK
 (E21) - FUSE AND FUSIBLE LINK BOX

WEL291

POWER SUPPLY ROUTING

Wiring Diagram — POWER — (Cont'd)

EL-POWER-07

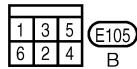
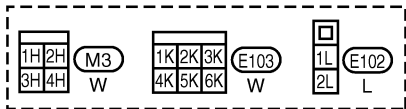
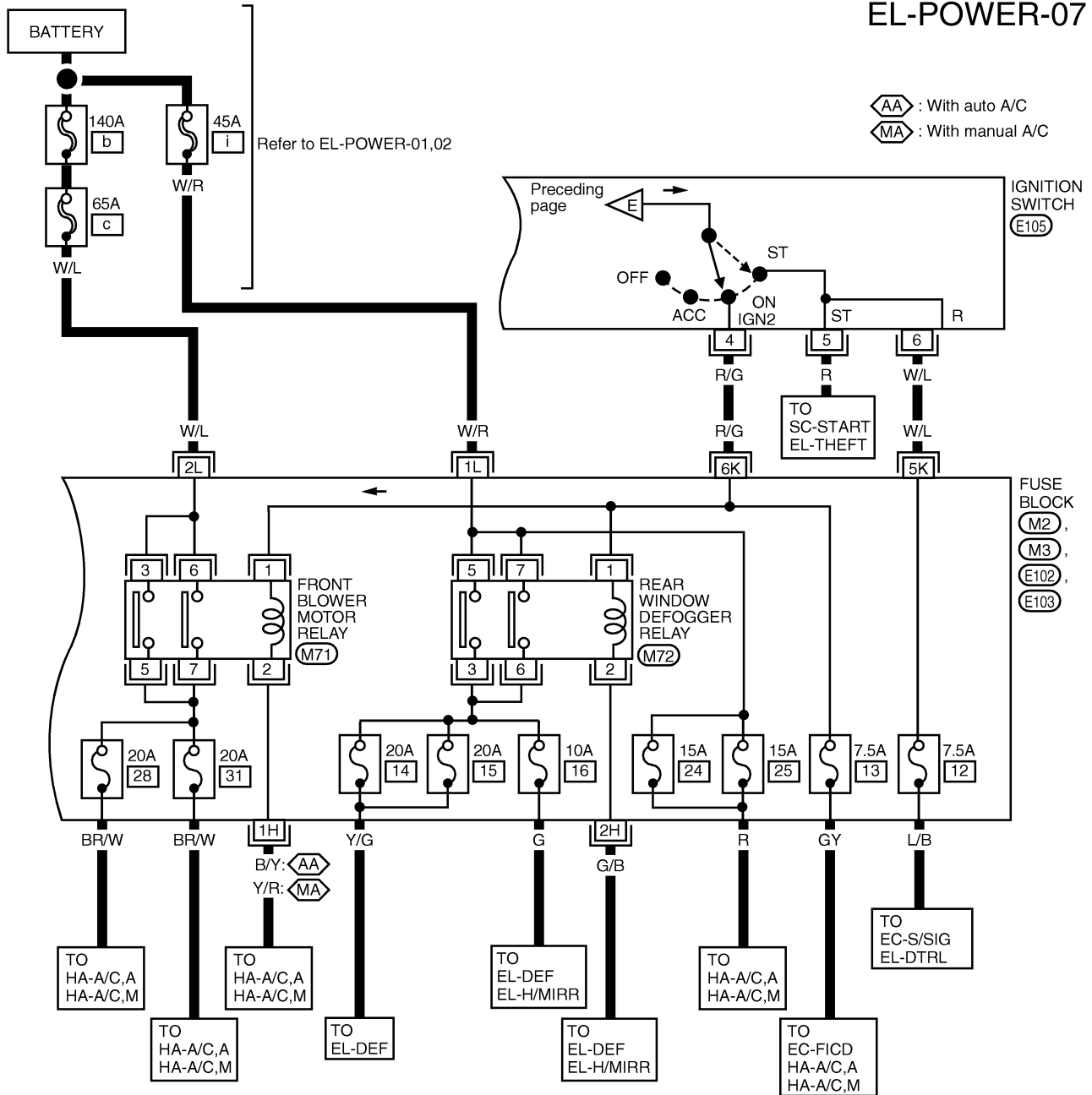

Refer to the following.
M2, M3, E102, E103
FUSE BLOCK

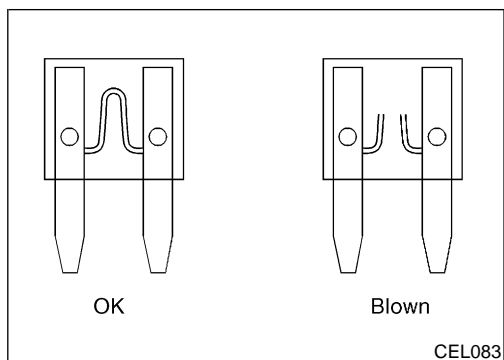

Inspection

FUSE

NDEL0007

NDEL0007S01

- If fuse is blown, be sure to eliminate cause of problem before installing new fuse.
- Use fuse of specified rating. Never use fuse of more than specified rating.
- Do not partially install fuse; always insert it into fuse holder properly.
- Remove fuse for “ELECTRICAL PARTS (BAT)” if vehicle is not used for a long period of time.

GI

MA

EM

LC

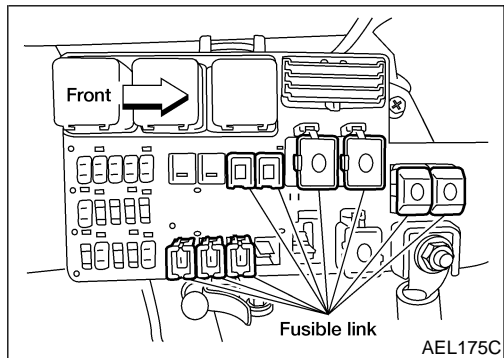

FUSIBLE LINK

NDEL0007S02

A melted fusible link can be detected either by visual inspection or by feeling with finger tip. If its condition is questionable, use circuit tester or test lamp.

CAUTION:

- If fusible link should melt, it is possible that critical circuit (power supply or large current carrying circuit) is shorted. In such a case, carefully check and eliminate cause of problem.
- Never wrap outside of fusible link with vinyl tape. Important: Never let fusible link touch any other wiring harness, vinyl or rubber parts.

EC

FE

AT

AX

SU

BR

ST

RS

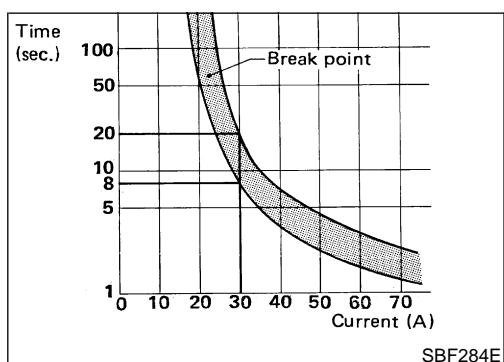

CIRCUIT BREAKER

NDEL0007S03

For example, when current is 30A, the circuit is broken within 8 to 20 seconds.

BT

HA

SC

EL

IDX

GROUND

Ground Distribution

Ground Distribution MAIN HARNESS

NDEL0008

NDEL0008S01

Body ground

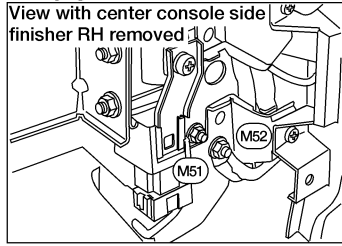

Body ground

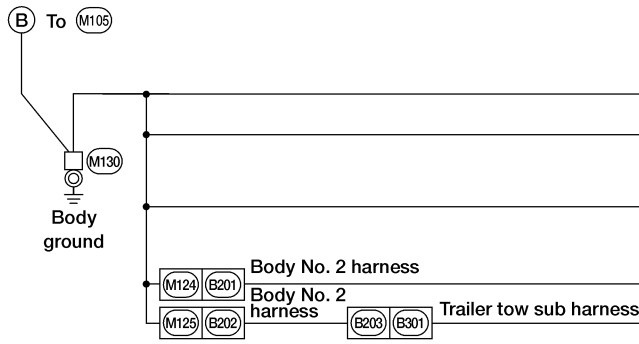
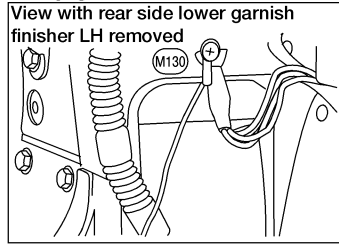

CONNECTOR NUMBER	CONNECT TO
M120	Rear power point (With rear power point)
M129	Trailer tow control unit (With trailer tow)
M132	Rear combination lamp LH (Terminal No. 4) • Tail lamp • Stop lamp • Turn signal lamp
E205	Fuel level sensor unit
E302	Trailer (With trailer tow)

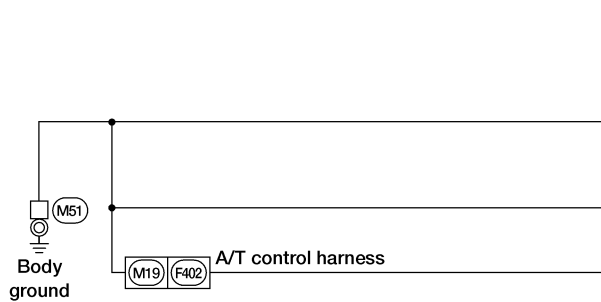

CONNECTOR NUMBER	CONNECT TO
M17	Combination meter (Terminal No. 30) • Speedometer • Tachometer
M18	Combination meter (Terminal No. 17) • Water temperature gauge • Fuel gauge
F301	Vehicle speed sensor

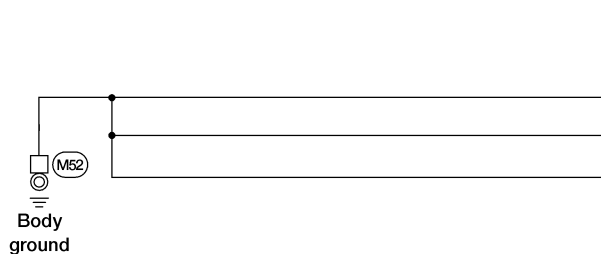

CONNECTOR NUMBER	CONNECT TO
M45	Audio unit (Terminal No. 31)
M45	Audio unit (Terminal No. 36)
M53	C/D changer (With C/D changer)

GROUND

Ground Distribution (Cont'd)

Body ground

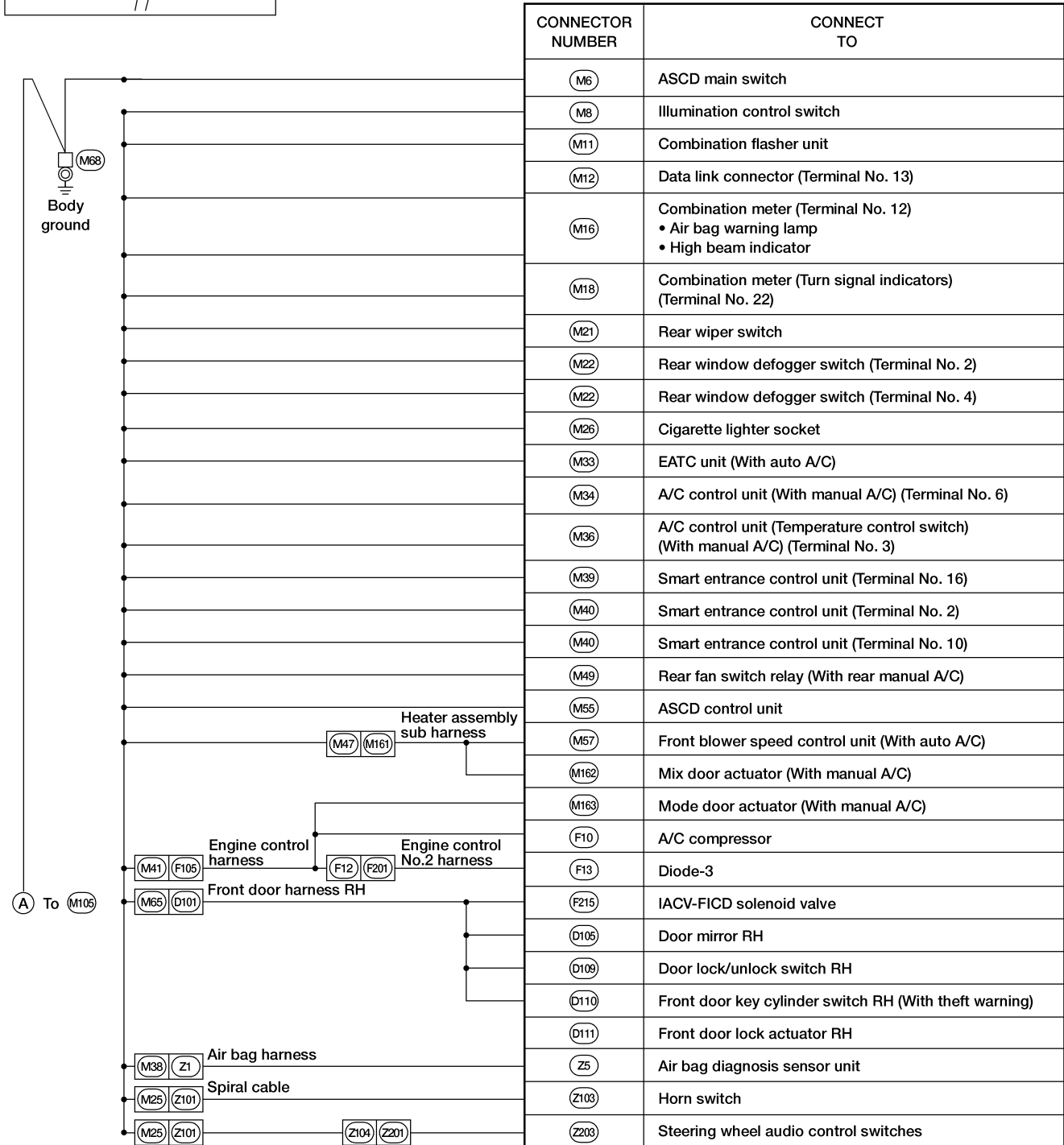
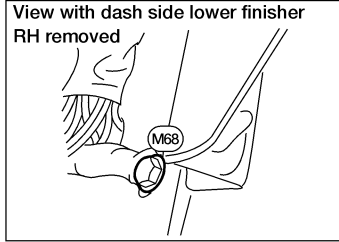

GI
MA
EM
LC
EC
FE
AT
AX
SU
BR
ST
RS
BT
HA
SC
EL
IDX

WEL295

GROUND

Ground Distribution (Cont'd)

Body ground

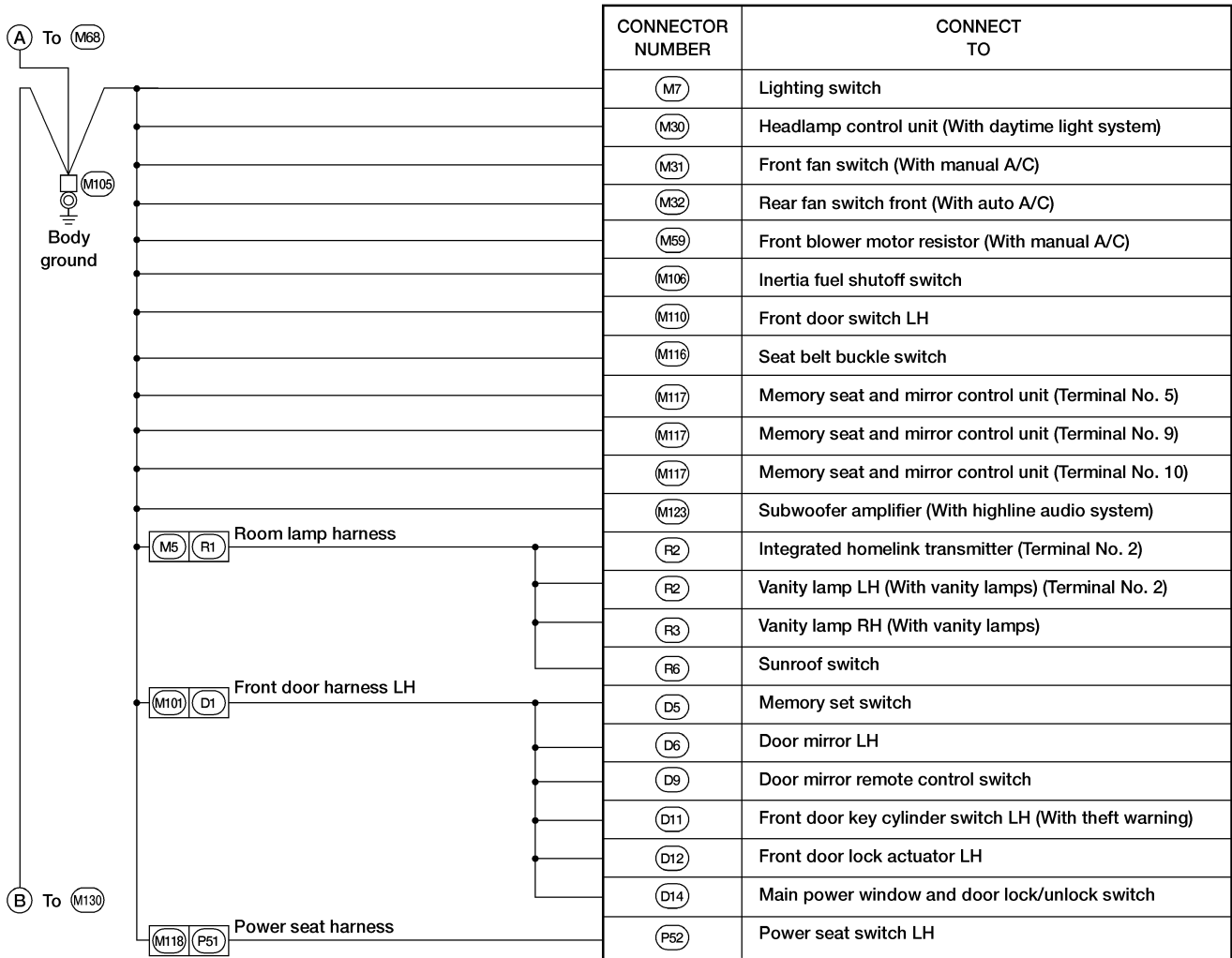
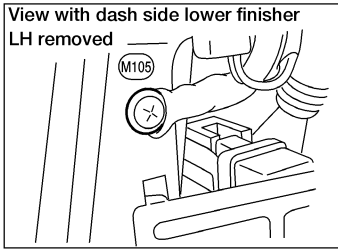

GROUND

Ground Distribution (Cont'd)

ENGINE ROOM HARNESS

NDEL0008S02

Body ground

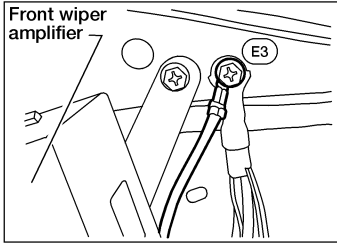

Body ground

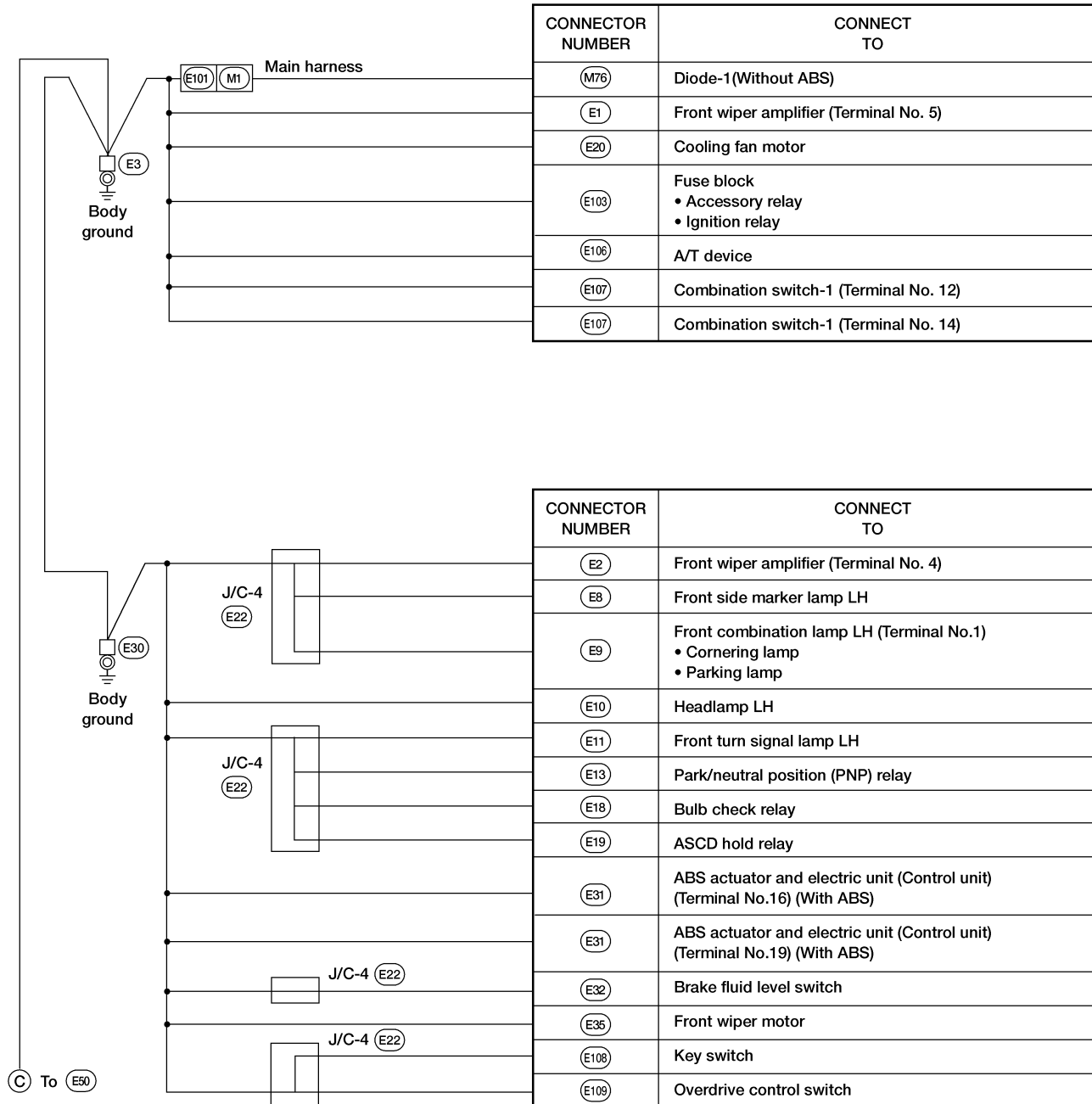
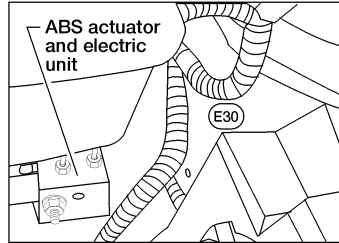

GI
MA
EM
LC
EC
FE
AT
AX
SU
BR
ST
RS
BT
HA
SC
EL
IDX

GROUND

Ground Distribution (Cont'd)

GENERATOR HARNESS

NDEL0008S03

Body ground

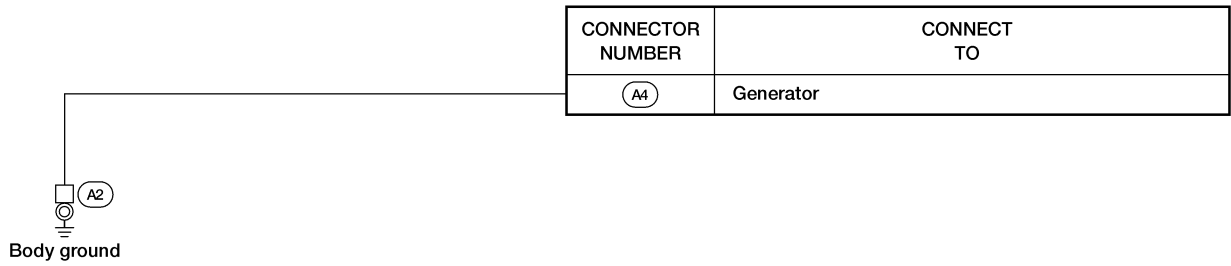
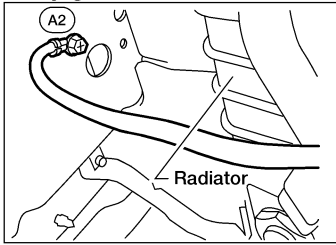

WEL298

GROUND

Ground Distribution (Cont'd)

BODY NO. 2 HARNESS

NDEL0008S05

Body ground

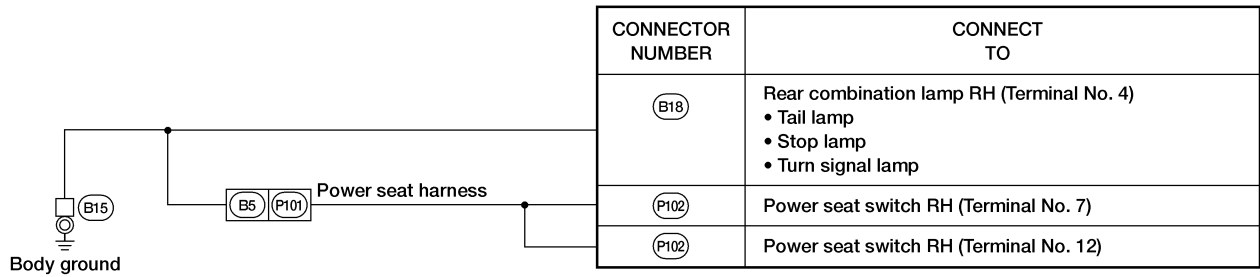
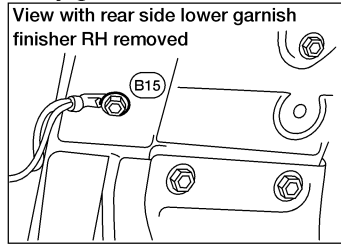

WEL300

GROUND

Ground Distribution (Cont'd)

BACK DOOR NO. 2 HARNESS

NDEL0008S06

Body ground

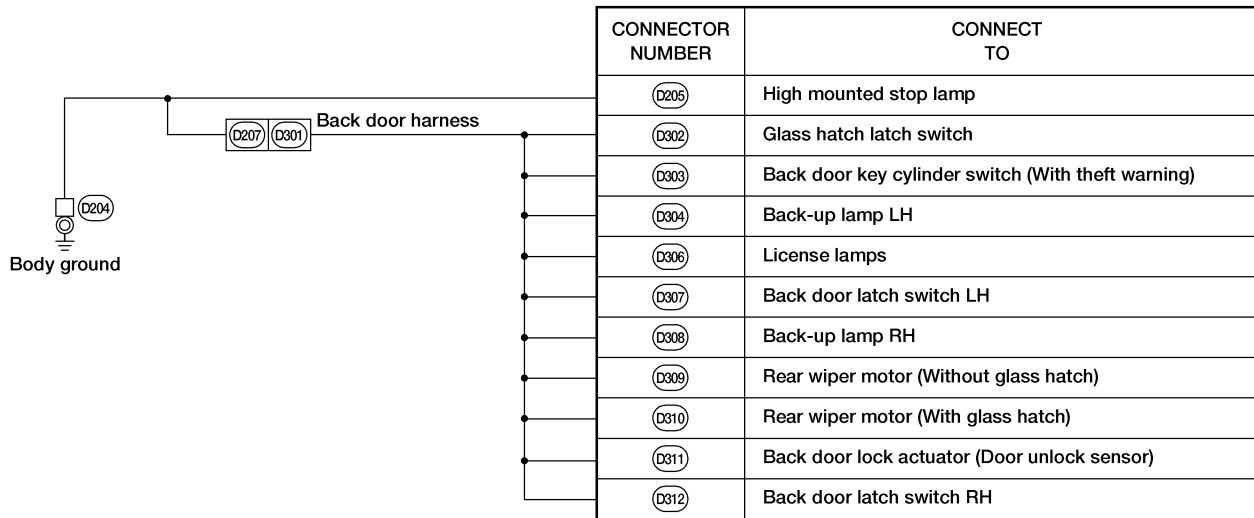
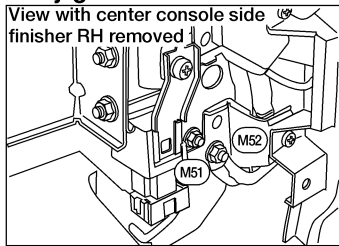

GI

MA

EM

LC

EC

FE

AT

AX

SU

BR

ST

RS

BT

HA

SC

EL

IDX

GROUND

Ground Distribution (Cont'd)

REAR DEFOGGER GROUND HARNESS

NDEL0008S07

Body ground

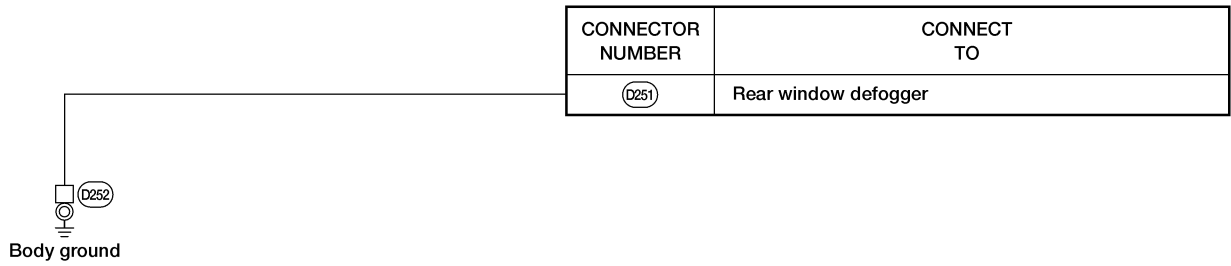
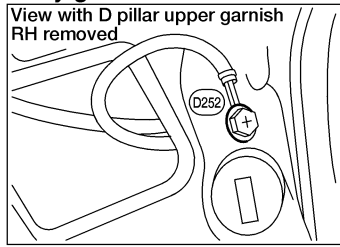

WEL302

COMBINATION SWITCH

Check

Check

NDEL0009

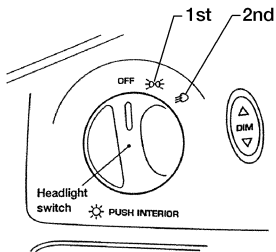

Lighting switch (without auto lamps)

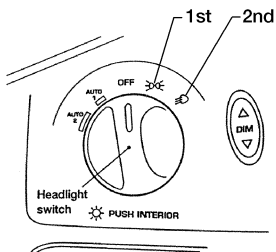

Lighting switch (with auto lamps)

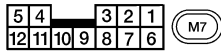
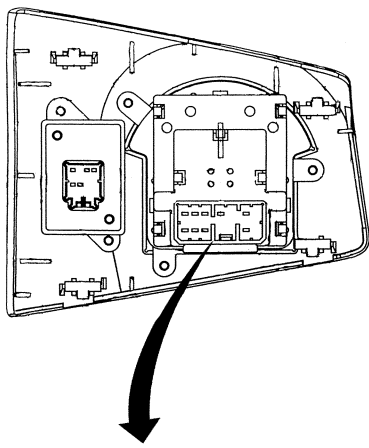

Lighting switch

	Off	1st	2nd	Auto 1	Auto 2
1				○	
2				○	
3		○	○		
4		○	○		
5					
6					
7	33Ω	○	○		
8	○			543Ω	
9	○				2043Ω
10					
11					
12					

Turn signal and cornering lamp switch

	L	N	R
1	○		○
2	○		○
3			
4	○		○
5	○		○
6			

Combination switch (flash to pass)

	A	B	C
11	○		○
12	○		○
13			
14			
15			
16			

Wiper switch

	Off	Int Max	Int Min	LO	HI	Wash
9	○	○	○	○	○	○
8	○	○	○	○	○	○
7	47.6kΩ	103.3kΩ	11.3kΩ	103.3kΩ	11.3kΩ	3.3kΩ
	○	○	○	○	○	○
	○	○	○	○	○	○
	○	○	○	○	○	○
	○	○	○	○	○	○
	○	○	○	○	○	○
	○	○	○	○	○	○
	○	○	○	○	○	○
	○	○	○	○	○	○
	○	○	○	○	○	○
	○	○	○	○	○	○

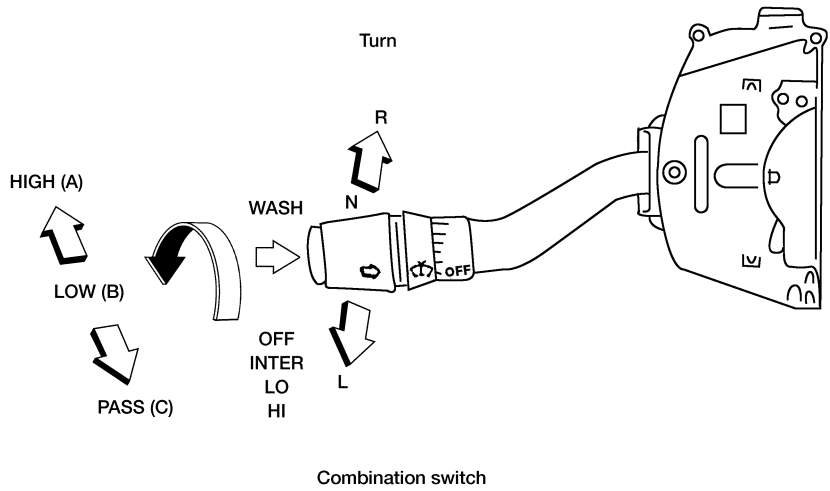

Combination switch

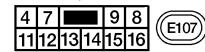
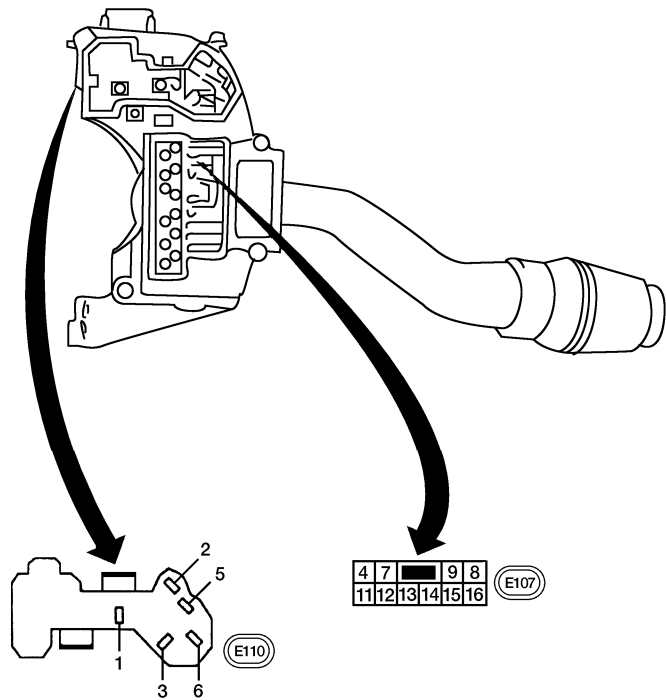

GI

MA

EM

LC

EC

FE

AT

AX

SU

BR

ST

RS

BT

HA

SC

EL

IDX

COMBINATION SWITCH

Replacement

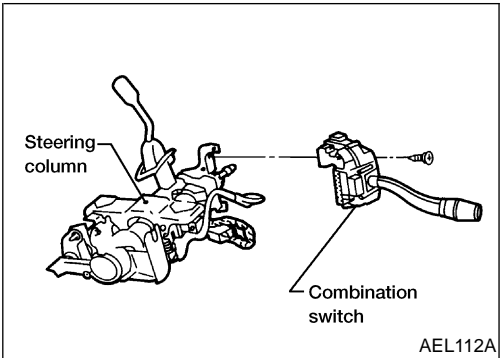

Replacement

- To remove combination switch base, remove base attaching screws. NDEL0010

STEERING SWITCH

Check

Check

NDEL0011

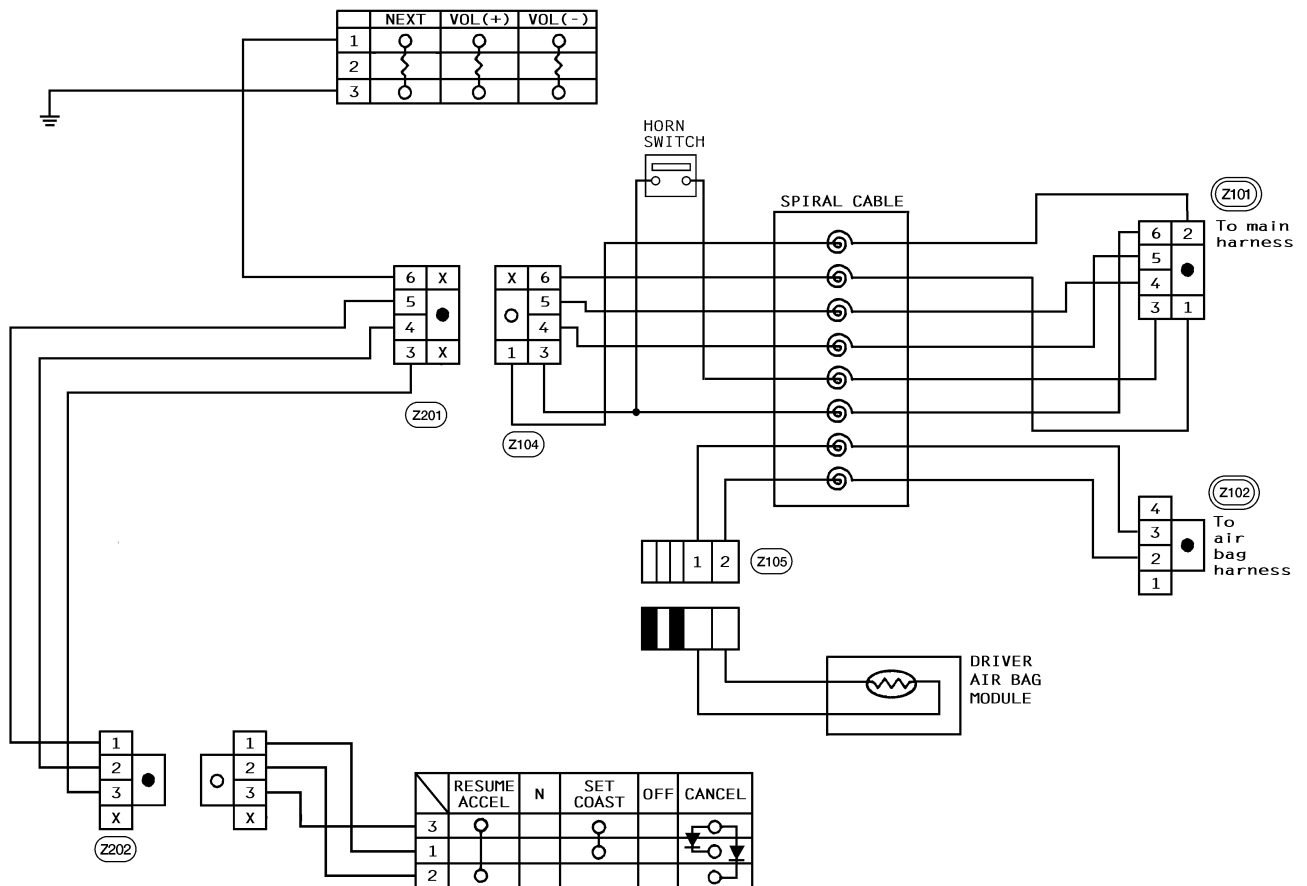
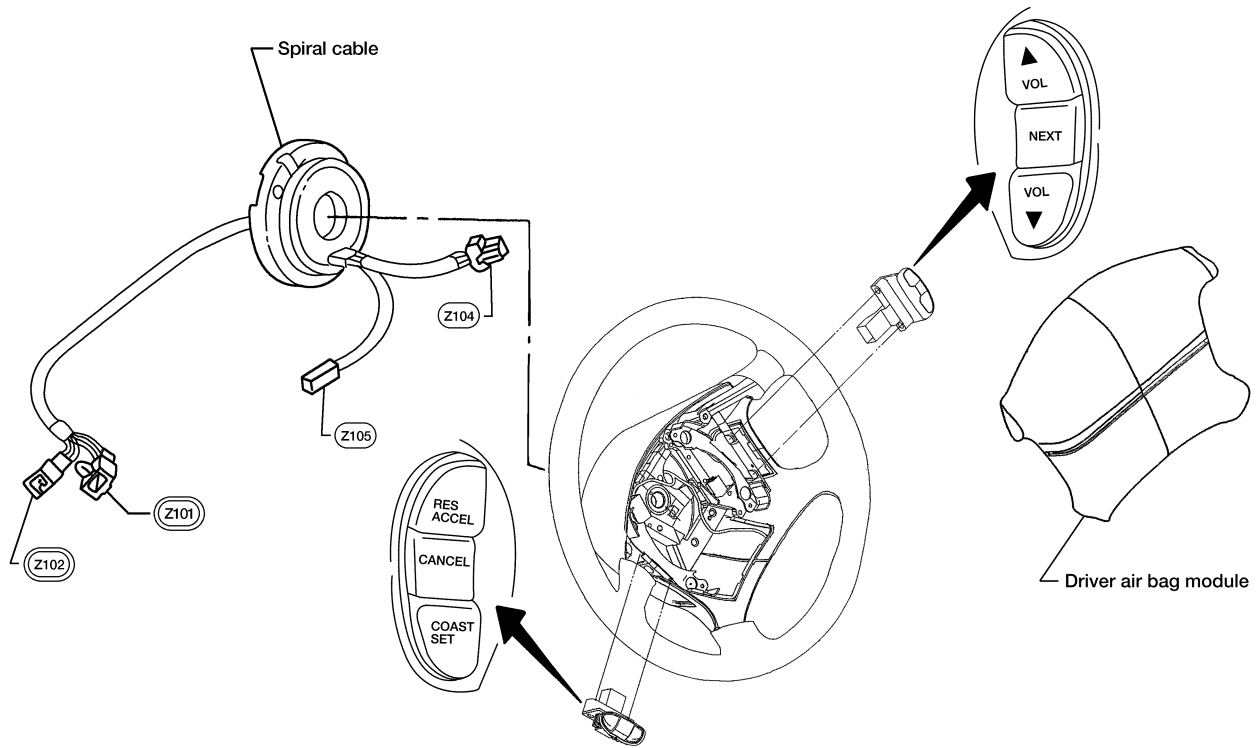

GI

MA

EM

LC

EC

FE

AT

AX

SU

BR

ST

RS

BT

HA

SC

EL

IDX

AEL863B

HEADLAMP (FOR USA)

Component Parts and Harness Connector Location

Component Parts and Harness Connector Location

NDEL0012

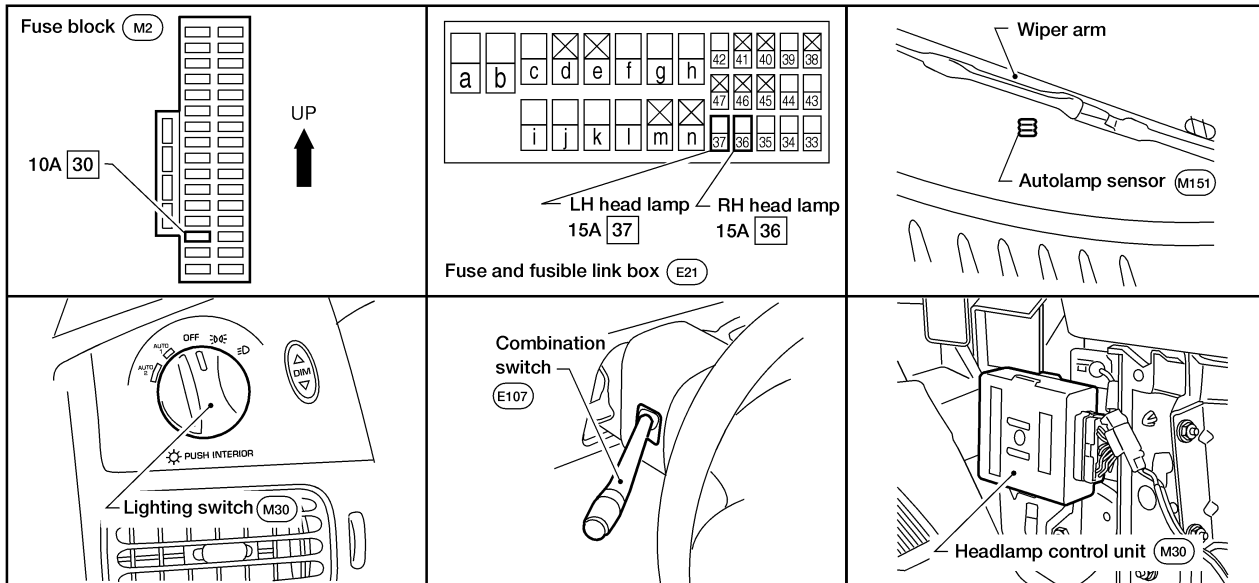

WEL280

System Description

NDEL0013

The headlamps are controlled by the headlamp control unit. Power is supplied at all times

- through 15A fuse (No. 37, located in the fuse and fusible link box)
- to headlamp control unit terminal 7 (for LH headlamp)
- through 15A fuse (No. 36, located in the fuse and fusible link box)
- to headlamp control unit terminal 5 (for RH headlamp).

MANUAL OPERATION

NDEL0013S01

Low Beam Operation

NDEL0013S0101

When the combination switch is placed in the LOW BEAM (B) position, with lighting switch in the headlamp ON (2ND) position, ground is supplied

- to headlamp control unit terminal 9
- through lighting switch terminal 8
- to lighting switch terminal 7
- through body grounds M68, M105 and M130.

Then, power is supplied

- from headlamp control unit terminal 3
- to LH headlamp terminal 3
- from headlamp control unit terminal 6
- to RH headlamp terminal 3.

Ground is supplied to each headlamp terminal 2 through body grounds E3, E30 and E50. With power and ground supplied, the low beam headlamps will illuminate.

High Beam Operation

NDEL0013S0102

When the lighting switch is placed in the headlamp ON (2ND) position, ground is supplied to headlamp control unit terminal 9 in the same manner as low beam operation.

With combination switch in the HIGH BEAM (A) position, ground is supplied

- to headlamp control unit terminal 18
- through combination switch terminal 11
- to combination switch terminal 14
- through body grounds E3, E30 and E50.

Then, power is supplied

- from headlamp control unit terminal 8
- to LH headlamp terminal 1
- from headlamp control unit terminal 4
- to RH headlamp terminal 1.

GI

Ground is supplied to each headlamp terminal 2 through body grounds E3, E30 and E50.

MA

With power and ground supplied, the high beam headlamps will illuminate.

Power is also supplied

- from headlamp control unit terminal 8 (models without autolamp), 13 (models with autolamp)
- to combination meter terminal 6 for HIGH BEAM indicator.

EM

Ground is supplied to combination meter terminal 12 through body grounds M68, M105 and M130.

LC

With power and ground supplied the HIGH BEAM indicator will illuminate.

Flash to Pass Operation

When the combination switch is placed in the FLASH TO PASS (C) position, ground is supplied

NDEL0013S0103

EC

- to headlamp control unit terminal 20
- through combination switch terminal 13
- to combination switch terminal 12
- through body grounds E3, E30 and E50.

FE

Then, power is supplied to each headlamp (HIGH) from headlamp control unit to turn on the lamps in the same manner as high beam operation.

AT

AUTO LAMP OPERATION (IF EQUIPPED)

Automatic Illumination

When the ignition switch is in ON position, power is supplied

NDEL0013S02

AX

- through 10A fuse (No. 30, located in the fuse block)
- to headlamp control unit terminal 2.

NDEL0013S0201

SU

With power at terminal 2 and lighting switch in AUTO1 or AUTO2 position, the headlamp control unit will measure the ambient light intensity through terminals 10 and 21. If the autolamp sensor does not detect sufficient light, power is supplied to headlamps in the same manner as low or high beam operation. Headlamp control unit decides to illuminate headlamps (Low or High) according to combination switch position (LOW or HIGH). At this time, ground is also supplied to tail lamp relay through headlamp control unit terminal 12 to energize tail lamp relay. Then tail lamp relay supplies power to turn on parking, license, tail lamps and illumination. For detailed wiring diagrams, refer to "PARKING, LICENSE, TAIL LAMPS", EL-53 and "ILLUMINATION", EL-68.

BR

ST

RS

Shut-off Delay

While the headlamps are lit in the automatic illumination mode, the ignition switch is turned from ON to OFF position and auto lamp shut-off delay timer starts. At this time, ground to tail lamp relay is discontinued.

NDEL0013S0202

BT

The delay time is set based on the resistance value at headlamp control unit terminal 14. With the timer running, the headlamps remain lit. When the timer reaches the end of its cycle, the headlamps turn off.

HA

Headlamp lighting time can be adjusted from 0 to 3 minutes.

THEFT WARNING SYSTEM

If the theft warning system is triggered, alarm signal is sent

NDEL0013S03

SC

- to headlamp control unit terminal 19
- from smart entrance control unit terminal 2.

EL

Then headlamp control unit operates to flash the high beams. For details, refer to "THEFT WARNING SYSTEM", EL-253.

IDX

HEADLAMP (FOR USA)

Wiring Diagram — H/LAMP —

Wiring Diagram — H/LAMP —

NDEL0014

EL-H/LAMP-01

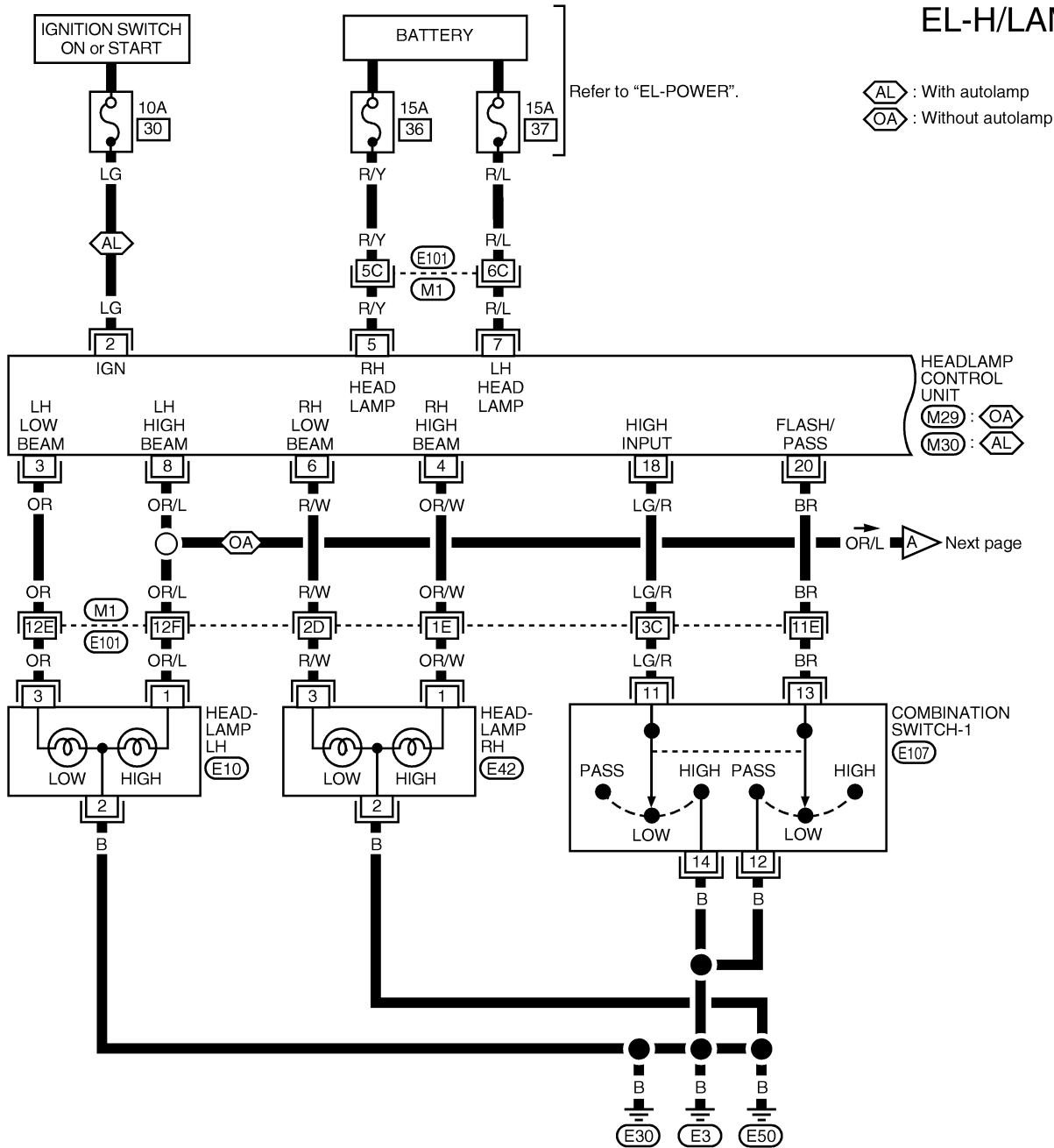

Refer to "EL-POWER".

AL : With autolamp
 OA : Without autolamp

HEADLAMP CONTROL UNIT
 M29 : OA
 M30 : AL

Next page

COMBINATION SWITCH-1
 E107

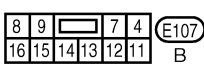
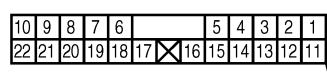
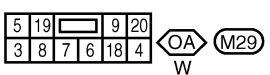

Refer to the following.
 M1, E101 - SUPER MULTIPLE JUNCTION (SMJ)

HEADLAMP (FOR USA)

Wiring Diagram — H/LAMP — (Cont'd)

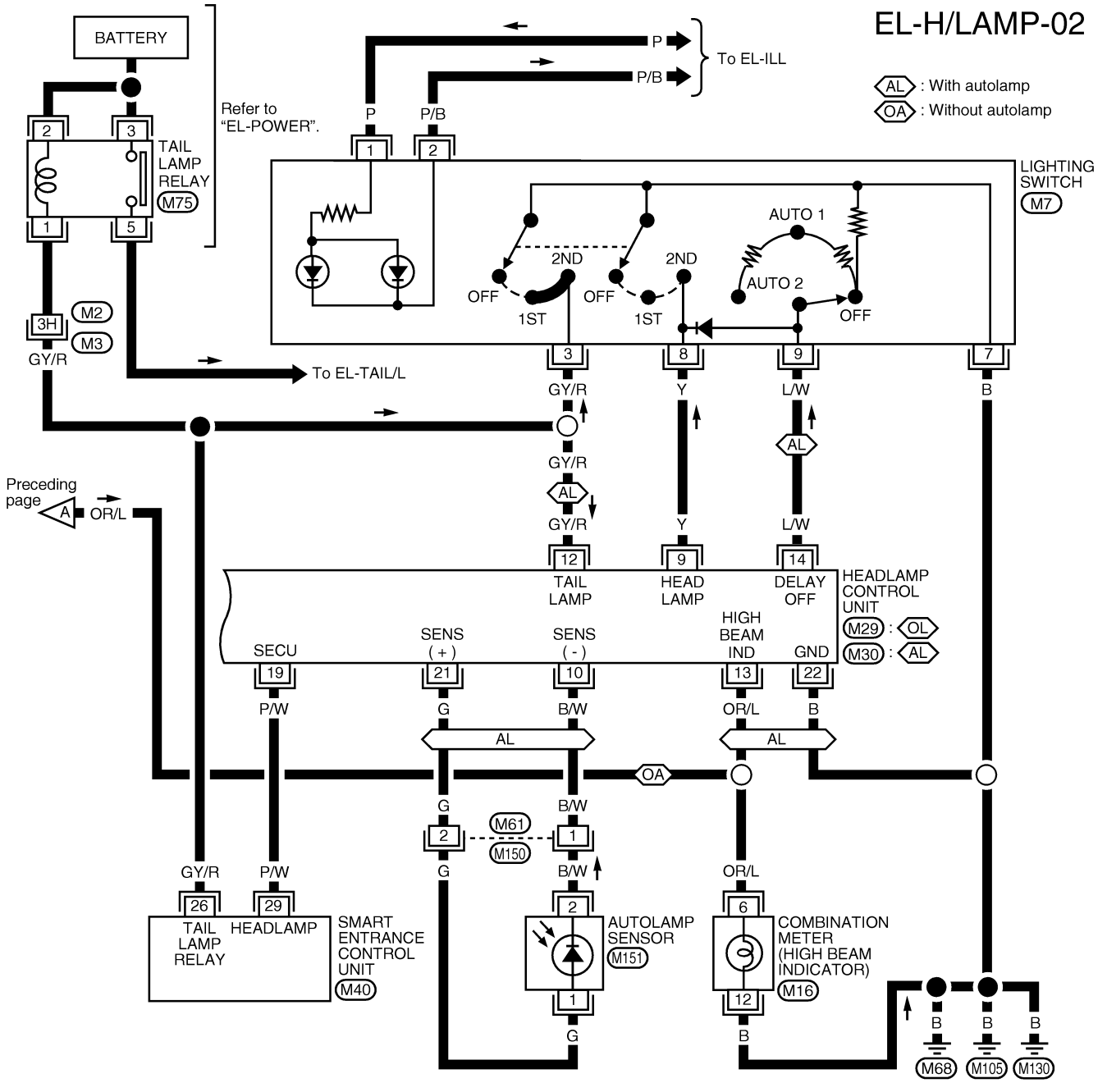

GI
MA
EM
LC
EC
FE
AT
AX
SU
BR
ST
RS
BT
HA
SC

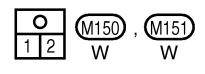
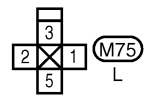
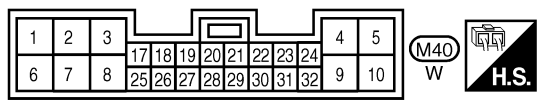
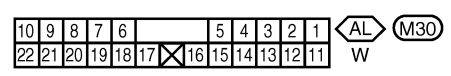
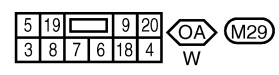
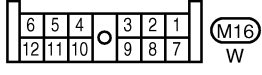
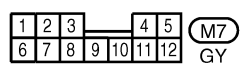
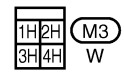

EL

IDX

HEADLAMP (FOR USA)

Trouble Diagnoses

Trouble Diagnoses SYMPTOM AND INSPECTION CHART

NDEL0015

NDEL0015S01

Symptom	Possible cause	Repair order
LH headlamps do not illuminate with any operation. (RH headlamps operate properly.)	<ol style="list-style-type: none"> 1. Bulb 2. 15 A fuse 3. Grounds E3, E30 and E50 	<ol style="list-style-type: none"> 1. Check bulb. 2. Check 15 A fuse (No. 37, located in fuse and fusible link box). Verify battery voltage is present at terminal 7 of headlamp control unit. 3. Check grounds E3, E30 and E 50.
RH headlamps do not illuminate with any operation. (LH headlamps operate properly.)	<ol style="list-style-type: none"> 1. Bulb 2. 15 A fuse 3. Grounds E3, E30 and E50 	<ol style="list-style-type: none"> 1. Check bulb. 2. Check 15 A fuse (No. 36, located in fuse and fusible link box). Verify battery voltage is present at terminal 5 of headlamp control unit. 3. Check grounds E3, E30 and E50.
Both LH and RH headlamps do not illuminate with lighting switch operation. (Headlamps illuminate with auto lamp operation.)	<ol style="list-style-type: none"> 1. Lighting switch 2. Lighting switch ground circuit 3. Headlamp on signal 	<ol style="list-style-type: none"> 1. Check lighting switch. 2. Check continuity between lighting switch terminal 7 and ground. 3. Check harness for open or short between lighting switch terminal 8 and headlamp control unit terminal 9.
LH high beam does not illuminate with any operation.	<ol style="list-style-type: none"> 1. Bulb 2. LH high beam on signal 3. Harness for open or short 	<ol style="list-style-type: none"> 1. Check bulb. 2. Verify battery voltage is present at terminal 8 of headlamp control unit with lighting switch in the headlamp ON (2ND) position and combination switch in HIGH BEAM (A) position. 3. Check harness for open or short between headlamp control unit terminal 8 and LH headlamp terminal 1.
LH low beam does not illuminate with any operation.	<ol style="list-style-type: none"> 1. Bulb 2. LH low beam on signal 3. Harness for open or short 	<ol style="list-style-type: none"> 1. Check bulb. 2. Verify battery voltage is present at terminal 3 of headlamp control unit with lighting switch in the headlamp ON (2ND) position and combination switch in LOW BEAM (B) position. 3. Check harness for open or short between headlamp control unit terminal 3 and LH headlamp terminal 3.
RH high beam does not illuminate with any operation.	<ol style="list-style-type: none"> 1. Bulb 2. RH high beam on signal 3. Harness for open or short 	<ol style="list-style-type: none"> 1. Check bulb. 2. Verify battery voltage is present at terminal 4 of headlamp control unit with lighting switch in the headlamp ON (2ND) position and combination switch in HIGH BEAM (A) position. 3. Check harness for open or short between headlamp control unit terminal 4 and RH headlamp terminal 1.
RH low beam does not illuminate with any operation.	<ol style="list-style-type: none"> 1. Bulb 2. RH low beam on signal 3. Harness for open or short 	<ol style="list-style-type: none"> 1. Check bulb. 2. Verify battery voltage is present at terminal 6 of headlamp control unit with lighting switch in the headlamp ON (2ND) position and combination switch in LOW BEAM (B) position. 3. Check harness for open or short between headlamp control unit terminal 6 and RH headlamp terminal 3.
High beam indicator does not illuminate.	<ol style="list-style-type: none"> 1. Bulb 2. High beam indicator on signal 3. Harness for open or short 4. Combination meter ground circuit 	<ol style="list-style-type: none"> 1. Check bulb. 2. Verify battery voltage is present at terminal 13 (with autolamp) or 8 (without autolamp) of headlamp control unit with lighting switch in headlamp ON (2ND) position and combination switch in HIGH BEAM (A) position. 3. Check harness for open or short between headlamp control unit terminal 13 and combination meter terminal 6. 4. Check continuity between combination meter terminal 12 and ground.

HEADLAMP (FOR USA)

Trouble Diagnoses (Cont'd)

Symptom	Possible cause	Repair order
Headlamp beams cannot switch between low/high.	1. Combination switch-1 2. Combination switch-1 ground circuit 3. Harness for open or short	1. Check combination switch-1. 2. Check continuity between combination switch terminal 14 and ground. 3. Check harness for open or short between headlamp control unit terminal 18 and combination switch-1 terminal 11.
Flash to pass cannot be operated. (High beams illuminate with other operation.)	1. Combination switch-1 2. Combination switch-1 ground circuit 3. Harness for open or short	1. Check combination switch-1. 2. Check continuity between combination switch terminal 12 and ground. 3. Check harness for open or short between headlamp control unit terminal 20 and combination switch-1 terminal 13.
Automatic illumination does not operate properly.	—	Go to "AUTOLAMP CHECK", EL-37.
Shut off delay does not operate properly.	—	Go to "SHUT OFF DELAY SWITCH CHECK", EL-40.
Tail lamps do not operate by automatic illumination. (Headlamps operate properly by automatic illumination.)	—	Go to "TAIL LAMP RELAY CHECK", EL-40.

AUTOLAMP CHECK

NDEL0015S02

1		CHECK HEADLAMP OPERATION
Do headlamps operate properly with lighting switch?		
Yes or No		
Yes	▶	GO TO 2.
No	▶	Check headlamp, refer to EL-36.

2		CHECK AUTOLAMP OPERATION
1. Turn ignition switch to ON position. 2. Turn lighting switch to AUTO1 or AUTO2 position. 3. Obstruct autolamp sensor.		
Do headlamps and tail lamps illuminate?		
Yes	▶	Go to "SHUT OFF DELAY SWITCH CHECK", EL-40.
No	▶	GO TO 3.

GI

MA

EM

LC

EC

FE

AT

AX

SU

BR

ST

RS

BT

HA

SC

EL

IDX

HEADLAMP (FOR USA)

Trouble Diagnoses (Cont'd)

3	CHECK IGNITION SWITCH ON SIGNAL		
<p>Check voltage between headlamp control unit terminal 2 and ground with ignition switch ON.</p> <div style="text-align: center;"> </div> <p style="text-align: right;">AEL935B</p>			
Does battery voltage exist?			
Yes	▶	GO TO 4.	
No	▶	<p>Check the following.</p> <ul style="list-style-type: none"> ● 10 A fuse (No. 30, located in the fuse block) ● Harness for open or short between fuse and headlamp control unit 	

4	CHECK CONTROL UNIT GROUND		
<p>Check continuity between lighting control unit terminal 22 and ground.</p> <div style="text-align: center;"> </div> <p style="text-align: right;">AEL171C</p>			
Does continuity exist?			
Yes	▶	GO TO 5.	
No	▶	Repair harness or connectors.	

HEADLAMP (FOR USA)

Trouble Diagnoses (Cont'd)

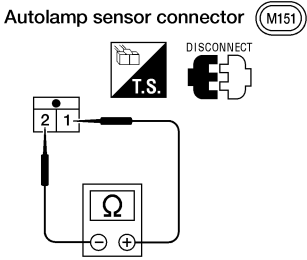
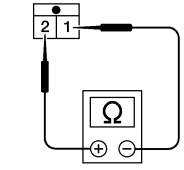
5	CHECK AUTOLAMP SENSOR	
	<p>1. Disconnect autolamp sensor connector.</p> <p>2. Check continuity between autolamp sensor connector terminals 2 and 1. With positive lead on pin 1 and negative lead on pin 2.</p> <p style="color: blue;">Continuity should exist.</p> <p>3. Reverse leads.</p> <p style="color: blue;">Continuity should not exist.</p> <p>NOTE: Specifications may vary depending on tester type. Before performing this inspection, refer to instruction manual for your tester.</p> <div style="text-align: center;"> <p>Autolamp sensor connector (M151)</p>  <p>Continuity should exist.</p>  <p>Continuity should not exist.</p> </div> <p style="text-align: right;">AEL936B</p>	<p style="text-align: center;">OK or NG</p>
OK	▶	Check harness for open or short between headlamp control unit and autolamp sensor.
NG	▶	Replace autolamp sensor.

GI
MA

EM

LC

EC

FE

AT

AX

SU

BR

ST

RS

BT

HA

SC

EL

IDX

HEADLAMP (FOR USA)

Trouble Diagnoses (Cont'd)

SHUT OFF DELAY SWITCH CHECK

=NDEL0015S03

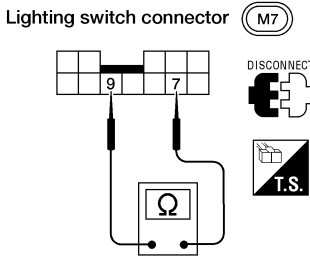
1	CHECK SHUT-OFF DELAY FUNCTION									
<p>1. Disconnect lighting switch. 2. Check resistance between lighting switch terminals 7 and 9.</p>										
										
AEL937B										
<table border="1" style="margin: auto;"> <thead> <tr> <th>Shut-off delay switch condition</th> <th>Resistance (Ω)</th> </tr> </thead> <tbody> <tr> <td>OFF</td> <td>Approx. 31 - 35</td> </tr> <tr> <td>AUTO 1</td> <td>Approx. 516 - 570</td> </tr> <tr> <td>AUTO 2</td> <td>Approx. 1947 - 2145</td> </tr> </tbody> </table>			Shut-off delay switch condition	Resistance (Ω)	OFF	Approx. 31 - 35	AUTO 1	Approx. 516 - 570	AUTO 2	Approx. 1947 - 2145
Shut-off delay switch condition	Resistance (Ω)									
OFF	Approx. 31 - 35									
AUTO 1	Approx. 516 - 570									
AUTO 2	Approx. 1947 - 2145									
AEL955B										
OK or NG										
OK	▶	Shut-off delay switch is OK. GO TO 2.								
NG	▶	Replace the switch.								

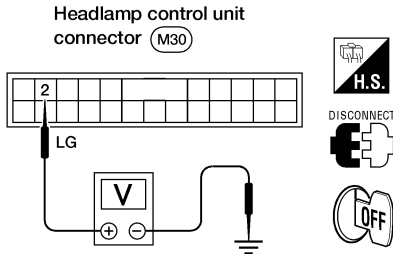
2	CHECK IGNITION SWITCH ON SIGNAL CIRCUIT	
<p>1. Disconnect headlamp control unit. 2. Check voltage between headlamp control unit terminal 2 and ground with ignition switch OFF.</p>		
		
AEL324C		
Does battery voltage exist?		
Yes	▶	Repair the harness between fuse and headlamp control unit.
No	▶	Replace headlamp control unit.

TAIL LAMP RELAY CHECK

NDEL0015S04

1	CHECK TAIL LAMP OPERATION	
<p>Do tail lamps illuminate with lighting switch operation? NOTE: For wiring diagram of tail lamp relay, refer to "PARKING, LICENSE AND TAIL LAMPS", EL-53</p>		
Yes or No		
Yes	▶	GO TO 4.
No	▶	GO TO 2.

HEADLAMP (FOR USA)

Trouble Diagnoses (Cont'd)

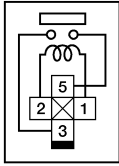
2	CHECK TAIL LAMP RELAY	
<p>1. Apply 12 V direct current between relay terminal 1 and 2. 2. Check continuity between relay terminals 3 and 5.</p>		
		
<p>12 V applied: Continuity exists. No voltage applied Continuity should not exist.</p>		
AEL938B		
OK or NG		
OK	▶	GO TO 3.
NG	▶	Replace the relay.

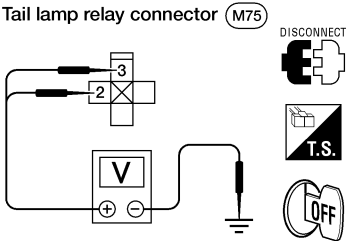
3	CHECK POWER SUPPLY FOR TAIL LAMP RELAY	
<p>Check voltage between tail lamp relay terminals 2, 3 and ground.</p>		
<p>Tail lamp relay connector (M75)</p> 		
AEL939B		
Does battery voltage exist?		
Yes	▶	Check tail lamp relay connector and tail lamp circuits.
No	▶	Check harness between tail lamp relay and battery.

GI

MA

EM

LC

EC

FE

AT

AX

SU

BR

ST

RS

BT

HA

SC

EL

IDX

HEADLAMP (FOR USA)

Trouble Diagnoses (Cont'd)

4	CHECK HEADLAMP CONTROL UNIT TAIL LAMP CONTROL CIRCUIT-1		
<ol style="list-style-type: none"> 1. Turn ignition switch to ON position. 2. Turn lighting switch to AUTO1 or AUTO2 position. 3. Obstruct autolamp sensor. 4. Check voltage between headlamp control unit terminal 12 and ground. 			
AEL172C			
Does battery voltage exist?			
Yes	▶	Replace headlamp control unit.	
No	▶	GO TO 5.	

5	CHECK HEADLAMP CONTROL UNIT TAIL LAMP CONTROL CIRCUIT-2		
<ol style="list-style-type: none"> 1. Turn ignition switch to OFF position. 2. Check voltage between headlamp control unit terminal 12 and ground. 			
AEL323C			
Does battery voltage exist?			
Yes	▶	Autolamp control system is OK.	
No	▶	Check harness between headlamp control unit and tail lamp relay.	

HEADLAMP CONTROL UNIT INSPECTION TABLE

NDEL0015S05

Terminal No.	Wire color	Item	Condition	Voltage (Approximate value)
2*	LG	Ignition switch on signal	Ignition switch OFF, ACC position	0
			Ignition switch ON, START position	12
3	OR	LH headlamp low beam	Lighting switch in the headlamp ON (2ND) position and combination switch in LOW BEAM (B) position	12
			All other conditions	0
4	OR/W	RH headlamp high beam	Lighting switch in the ON (2ND) position and combination switch in HIGH BEAM (A) position	12
			All other conditions	0
5	R/Y	Power source for RH headlamp	—	12

HEADLAMP (FOR USA)

Trouble Diagnoses (Cont'd)

Terminal No.	Wire color	Item	Condition	Voltage (Approximate value)	
6	R/W	RH headlamp low beam	Lighting switch in the headlamp ON (2ND) position and combination switch in LOW BEAM (B) position	12	GI
			All other conditions	0	MA
7	R/L	Power source for LH headlamp	—	12	EM
8	OR/L	LH headlamp high beam	Lighting switch in the ON (2ND) position and combination switch in HIGH BEAM (A) position	12	LC
			All other conditions	0	EC
9	Y	Lighting switch	OFF, 1ST position	12	FE
			Headlamp ON (2ND) position	0	AT
10*	G	Autolamp sensor (+)	Sensor struck by light	—	AX
			Sensor obstructed	—	SU
12*	GY/R	Tail lamp relay	Autolamp is not operating and lighting switch is in the OFF position	12	BR
			Autolamp is operating	0	ST
13*	OR/L	High beam indicator	Lighting switch in the ON (2ND) position and combination switch in HIGH BEAM (A) position Combination switch in FLASH TO PASS (C) position	12	RS
			All other conditions	0	BT
14*	L/W	Shut-off delay switch (lighting switch)	OFF	0.5	HA
			AUTO1	3.5	SC
			AUTO2	4.5	
18	LG/R	Combination switch	HIGH BEAM (A) or FLASH TO PASS (C) position	0	
			All other conditions	12	
19	P/W	Smart entrance control unit (with theft warning)	When theft warning system is in alarm phase or panic operation is activated by multi-remote control system	0	
			All other conditions	12	
20	BR	Combination switch	FLASH TO PASS (C) position	0	
			All other conditions	12	
21*	B/W	Autolamp sensor (-)	—	—	
22*	B	Ground	—	—	

*: Marked terminals are available only for models with autolamps.

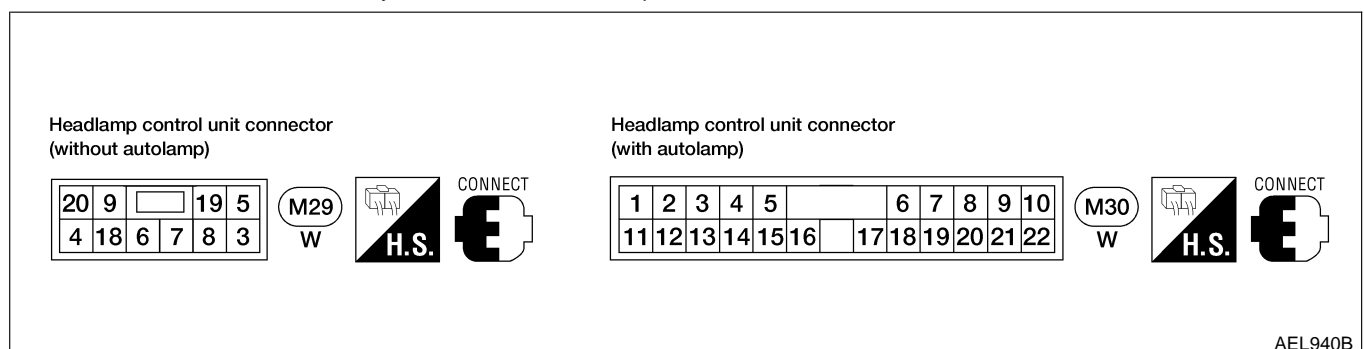

HEADLAMP (FOR USA)

Bulb Replacement

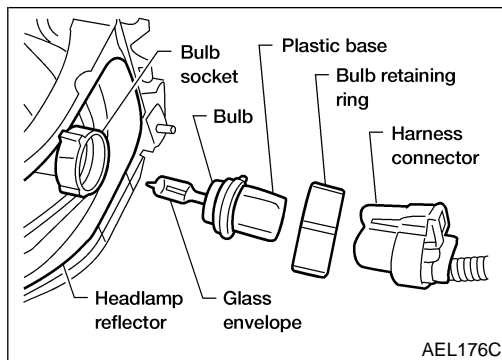

Bulb Replacement

NDEL0016

The headlamp is a semi-sealed beam type which uses a replaceable halogen bulb. The bulb can be replaced from the engine compartment side without removing the headlamp body.

- **Grasp only the plastic base when handling the bulb. Never touch the glass envelope.**
1. Disconnect the battery cable.
 2. Disconnect the harness connector from the back side of the bulb.
 3. Turn the bulb retaining ring counterclockwise until it is free from the headlamp reflector, and then remove it.
 4. Remove the headlamp bulb carefully. Do not shake or rotate the bulb when removing it.
 5. Install in the reverse order of removal.

CAUTION:

Do not leave headlamp reflector without bulb for a long period of time. Dust, moisture, smoke, etc. entering headlamp body may affect the performance of the headlamp. Remove headlamp bulb from the headlamp reflector just before a replacement bulb is installed.

Aiming Adjustment

NDEL0017

When performing headlamp aiming adjustment, use an aiming machine, aiming wall screen or headlamp tester. Aimers should be in good repair, calibrated and operated in accordance with respective operation manuals.

If any aimer is not available, aiming adjustment can be done as follows:

For details, refer to the regulations in your own country.

- 1) Keep all tires inflated to correct pressures.
- 2) Place vehicle and tester on one and same flat surface.
- 3) See that there is no-load in vehicle (coolant, engine oil filled up to correct level and full fuel tank) other than the driver (or equivalent weight placed in driver's position).

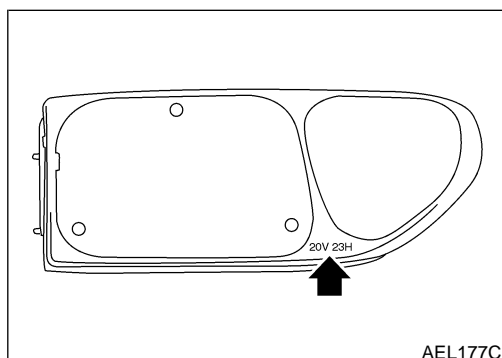

AIMER ADJUSTMENT MARK

NDEL0017S01

When using a mechanical aimer, adjust adapter legs to the data marked on the headlamps.

Example

20V23H

Horizontal side: 23

Vertical side: 20

HEADLAMP (FOR USA)

Aiming Adjustment (Cont'd)

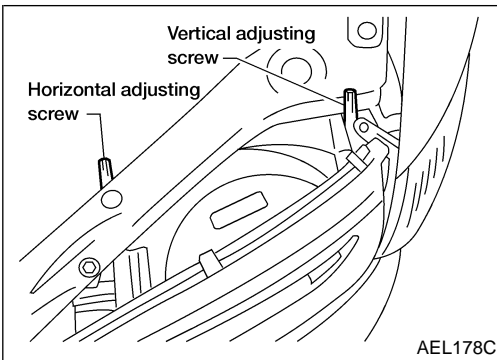

LOW BEAM

NDEL0017S02

1. Turn headlamp low beam on.
2. Use adjusting screws to perform aiming adjustment.

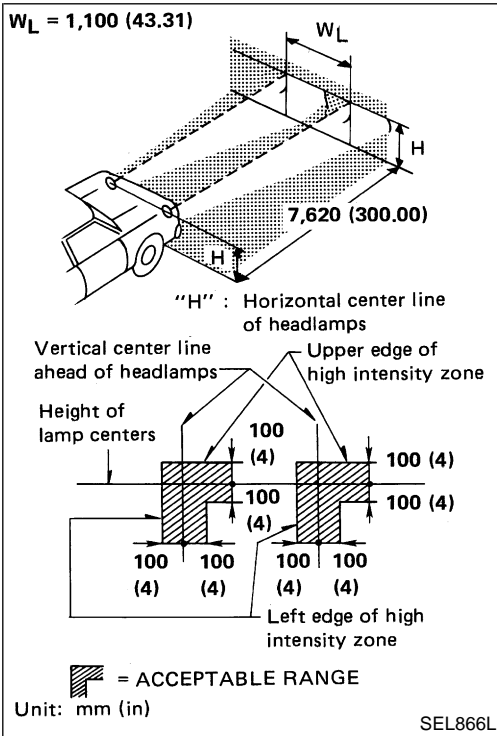

- Upper edge and left edge of high intensity zone should be within the range shown at left. Adjust headlamps accordingly.
 - Dotted lines in illustration show center of headlamp.
- "H": Horizontal center line of headlamps
 "W_L": Distance between each headlamp center

GI

MA

EM

LC

EC

FE

AT

AX

SU

BR

ST

RS

BT

HA

SC

EL

IDX

HEADLAMP (FOR CANADA) — DAYTIME LIGHT SYSTEM —

Component Parts and Harness Connector Location

Component Parts and Harness Connector Location

NDEL0018

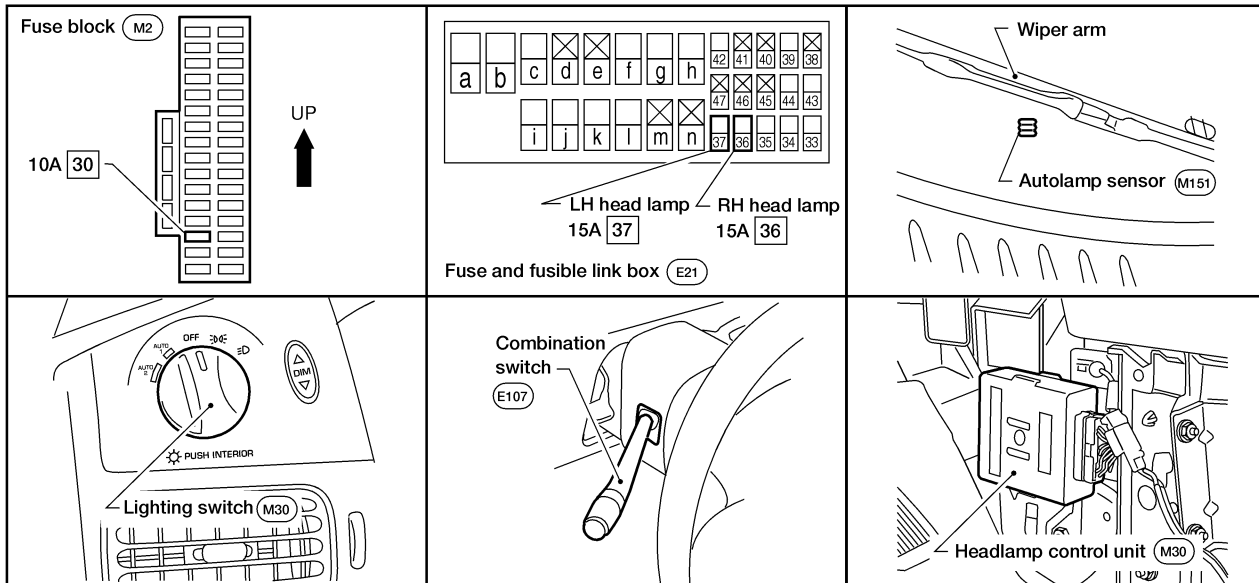

WEL280

System Description

NDEL0020

The headlamps are controlled by the headlamp control unit. Power is supplied at all times

- through 15A fuse (No. 37, located in the fuse and fusible link box)
- to headlamp control unit terminal 7 (for LH headlamp)
- through 15A fuse (No. 36, located in the fuse and fusible link box)
- to headlamp control unit terminal 5 (for RH headlamp).

MANUAL OPERATION

NDEL0020S01

Low Beam Operation

NDEL0020S0101

When the combination switch is placed in the LOW BEAM (B) position, with lighting switch in the headlamp ON (2ND) position, ground is supplied

- to headlamp control unit terminal 9
- through lighting switch terminal 8
- to lighting switch terminal 7
- through body grounds M68, M105 and M130.

Then power is supplied

- from headlamp control unit terminal 3
- to LH headlamp terminal 3
- from headlamp control unit terminal 6
- to RH headlamp terminal 3.

Ground is supplied to each headlamp terminal 2 through body grounds E3, E30 and E50. With power and ground supplied, the low beam headlamps will illuminate.

High Beam Operation

NDEL0020S0102

When the lighting switch is placed in the headlamp ON (2ND) position, ground is supplied to headlamp control unit terminal 9 in the same manner as low beam operation.

With combination switch in the HIGH BEAM (A) position, ground is supplied

- to headlamp control unit terminal 18
- through combination switch terminal 11
- to combination switch terminal 14
- through body grounds E3, E30 and E50.

Then power is supplied

HEADLAMP (FOR CANADA) — DAYTIME LIGHT SYSTEM —

System Description (Cont'd)

- from headlamp control unit terminal 8
- to LH headlamp terminal 1
- from headlamp control unit terminal 4
- to RH headlamp terminal 1

Ground is supplied to each headlamp terminal 2 through body grounds E3, E30 and E50. With power and ground supplied, the high beam headlamps will illuminate. Power is also supplied

- from headlamp control unit terminal 13
- to combination meter terminal 6 for the HIGH BEAM indicator.

Ground is supplied to combination meter terminal 12 through body grounds M68, M105 and M130. With power and ground supplied, the HIGH BEAM indicator will illuminate.

Flash to Pass Operation

When the combination switch is placed in the FLASH TO PASS (C) position, ground is supplied

- to headlamp control unit terminal 20
- through combination switch terminal 13
- to combination switch terminal 12
- through body grounds E3, E30 and E50.

Then power is supplied to each headlamp HIGH from headlamp control unit to turn on the lamps in the same manner as high beam operation.

DAYTIME LIGHT OPERATION

The headlamp system for CANADA vehicles contains a daytime light control system that activates the high beam headlamps at approximately half illumination whenever the engine is running (engine running signal is supplied to the headlamp control unit terminal 17 from generator L terminal).

If the parking brake is applied before the engine is started, the daytime lights will not be illuminated. The daytime lights will illuminate once the parking brake is released. Thereafter, the daytime lights will continue to operate when the parking brake is applied.

With the engine running, the lighting switch in the OFF or 1ST position and parking brake released, power is supplied

- to headlamp control unit terminal 11
- through headlamp control unit terminal 8
- to terminal 1 of LH headlamp.

And also

- through headlamp control unit terminal 4
- to terminal 1 of RH headlamp.

Ground is supplied to terminal 2 of LH and RH headlamps through body grounds E3, E30 and E50.

GI

MA

EM

LC

NDEL0020S0103

EC

FE

AT

AX

NDEL0020S02

SU

BR

ST

RS

BT

HA

SC

EL

IDX

HEADLAMP (FOR CANADA) — DAYTIME LIGHT SYSTEM —

System Description (Cont'd)

OPERATION

=NDEL0020S05

After starting the engine with the lighting switch in the OFF or 1ST position, the headlamp high beam automatically turns on. Lighting switch operations other than the above are the same as conventional light systems.

Engine		With engine stopped									With engine running								
Lighting switch		OFF			1ST			2ND			OFF			1ST			2ND		
		A	B	C	A	B	C	A	B	C	A	B	C	A	B	C	A	B	C
Headlamp	High beam	X	X	O	X	X	O	O	X	O	△*	△*	O	△*	△*	O	O	X	O
	Low beam	X	X	X	X	X	X	X	O	X	X	X	X	X	X	X	X	O	X
Clearance and tail lamp		X	X	X	O	O	O	O	O	O	X	X	X	O	O	O	O	O	O
License and instrument illumination lamp		X	X	X	O	O	O	O	O	O	X	X	X	O	O	O	O	O	O

A: HIGH BEAM position

B: LOW BEAM position

C: FLASH TO PASS position

O : Lamp ON

X : Lamp OFF

△ : Lamp dims. (Added functions)

*: When starting the engine with the parking brake released, the daytime lights will come ON.

When starting the engine with the parking brake applied, the daytime lights won't come ON.

AUTO LAMP OPERATION

NDEL0020S03

Automatic Illumination

NDEL0020S0301

When the ignition switch is in ON position, power is supplied

- through 10A fuse (No. 30, located in the fuse block)
- to headlamp control unit terminal 2.

With power at terminal 2 and lighting switch in AUTO1 or AUTO2 position, the headlamp control unit will measure the ambient light intensity through terminals 10 and 21. If the autolamp sensor does not detect sufficient light, power is supplied to headlamps in the same manner as low or high beam operation. The headlamp control unit illuminates the headlamps High or Low according to combination switch position HIGH or LOW.

At this time, ground is also supplied to tail lamp relay through headlamp control unit terminal 12 to energize tail lamp relay. Then tail lamp relay supplies power to turn on parking, license, tail lamps and interior illumination. (For detailed wiring diagrams, refer to "PARKING, LICENSE, TAIL LAMPS, EL-53 and "ILLUMINATION", EL-68.)

Shut-off Delay

NDEL0020S0302

While the headlamps are lit in the automatic illumination mode and the ignition switch is turned from ON to OFF position, the autolamp shut-off delay timer starts. At this time, ground to tail lamp relay is discontinued. The delay time is set based on the resistance value at headlamp control unit terminal 14. With the timer running, the headlamps remain lit. When the timer reaches the end of its cycle, the headlamps turn off. Headlamp lighting time can be adjusted from about 0 to 3 minutes.

THEFT WARNING SYSTEM

NDEL0020S04

If the theft warning system is triggered, alarm signal is sent

- to headlamp control unit terminal 19
- from smart entrance control unit terminal 29.

Then headlamp control unit operates to flash the high beams. For details, refer to "THEFT WARNING SYSTEM", EL-255.

HEADLAMP (FOR CANADA) — DAYTIME LIGHT SYSTEM —

Wiring Diagram — DTRL —

Wiring Diagram — DTRL —

NDEL0022

EL-DTRL-01

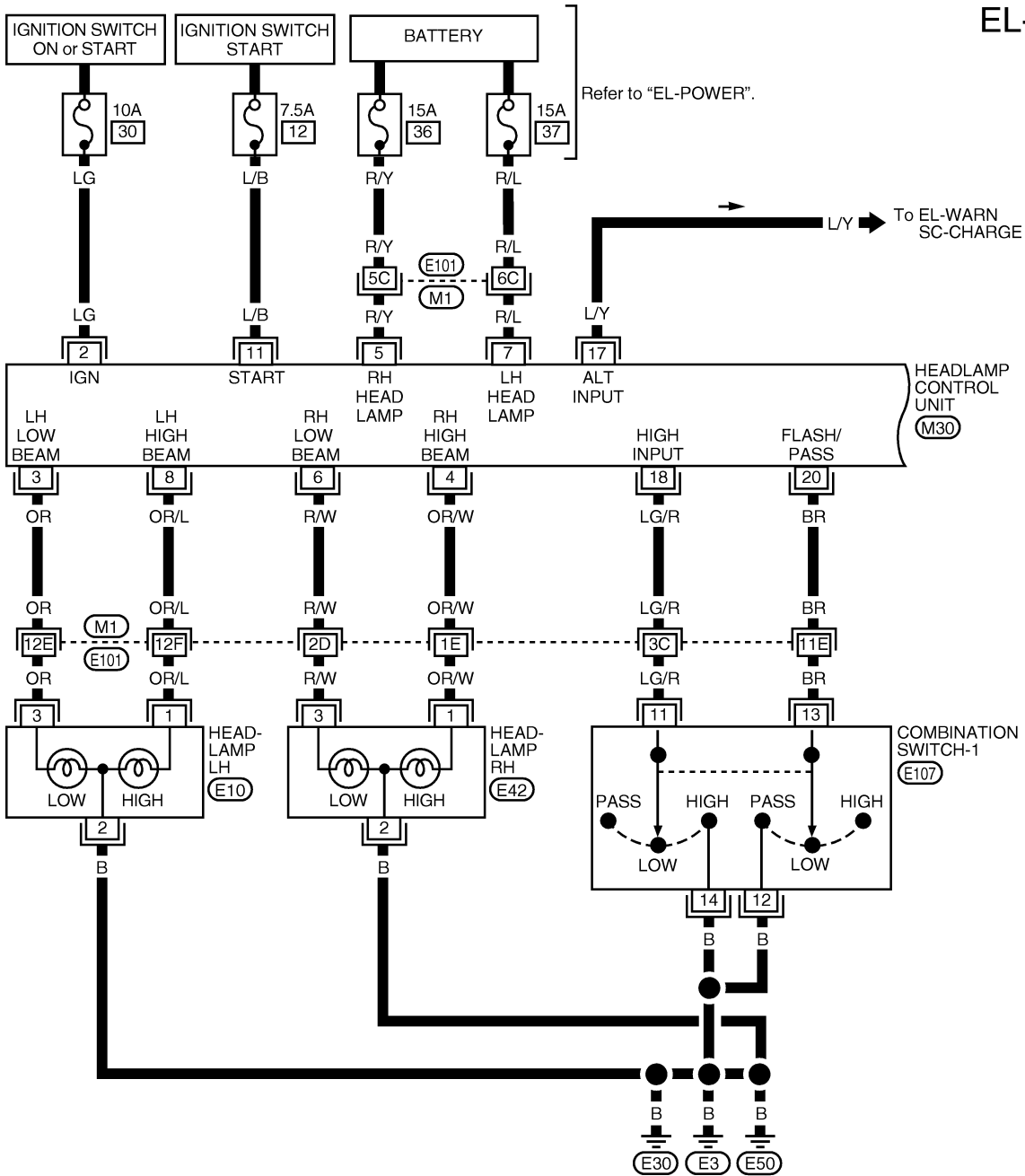

10	9	8	7	6	5	4	3	2	1		
22	21	20	19	18	17	16	15	14	13	12	11

(M30) W

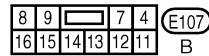

Refer to the following.
 (M1), (E101) - SUPER MULTIPLE JUNCTION (SMJ)

GI
 MA
 EM
 LC
 EC
 FE
 AT
 AX
 SU
 BR
 ST
 RS
 BT
 HA
 SC

EL

IDX

HEADLAMP (FOR CANADA) — DAYTIME LIGHT SYSTEM —

Wiring Diagram — DTRL — (Cont'd)

EL-DTRL-02

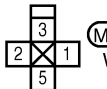
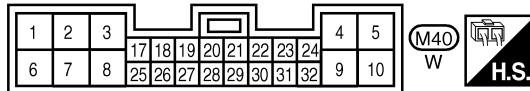
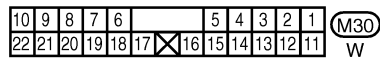
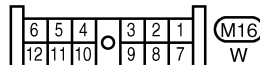
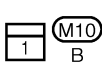
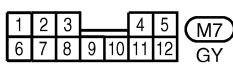
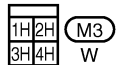
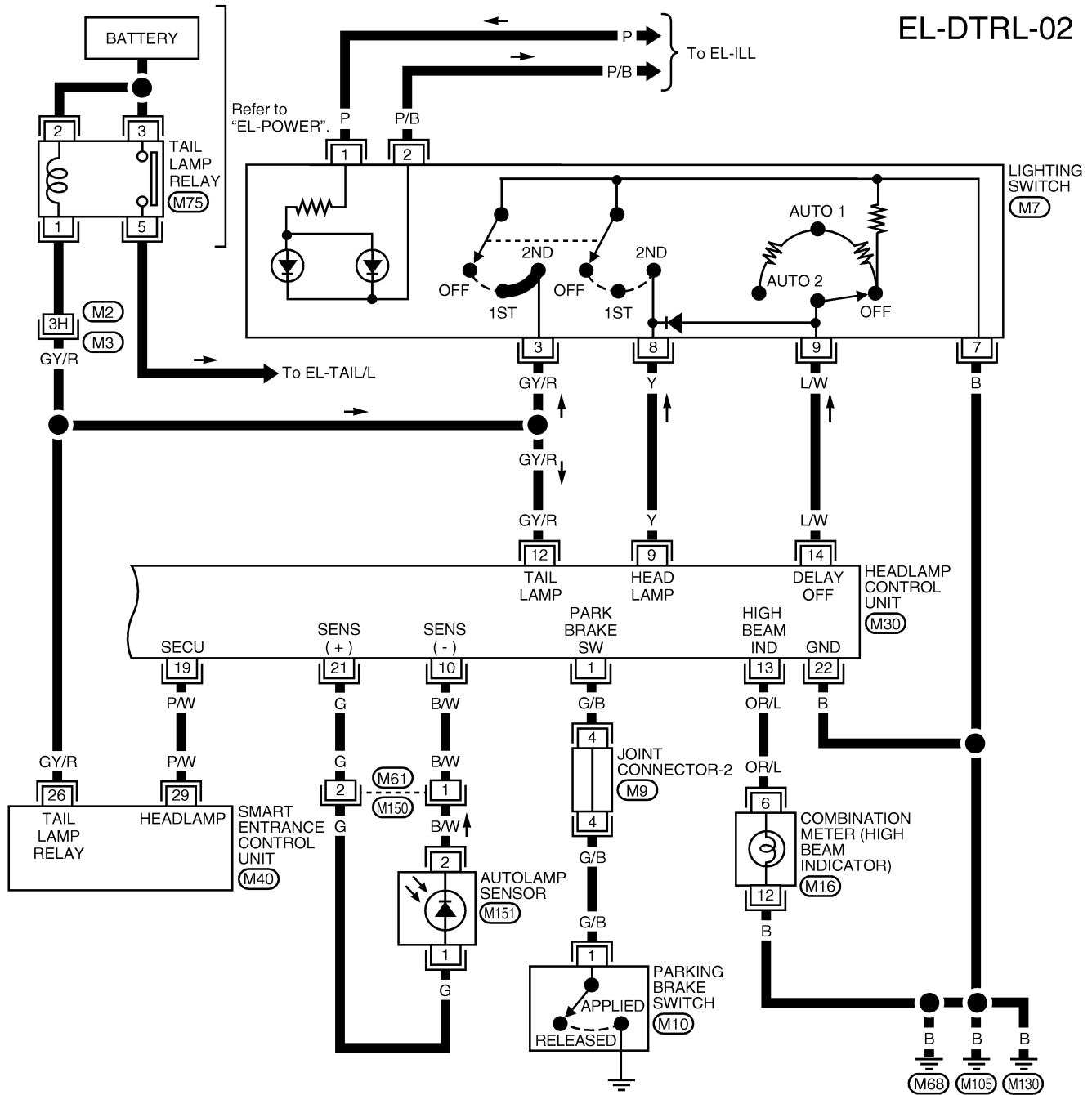

Refer to the following.
 (M9) - JOINT CONNECTOR

WEL193

HEADLAMP (FOR CANADA) — DAYTIME LIGHT SYSTEM —

Trouble Diagnoses

Trouble Diagnoses

NDEL0023

NOTE:

For trouble diagnoses relating to autolamp system, refer to “SYMPTOM AND INSPECTION CHART” for “HEADLAMP (FOR USA)”, EL-36.

HEADLAMP CONTROL UNIT INSPECTION TABLE

NDEL0023S01

Terminal No.	Wire color	Item	Condition	Voltage (Approximate value)
1	G/B	Parking brake switch	Parking brake is released	12
			Parking brake is applied	0
2	LG	Ignition switch on signal	Ignition switch OFF, ACC position	0
			Ignition switch ON, START position	12
3	OR	LH headlamp low beam	Lighting switch in the headlamp ON (2ND) position and combination switch in LOW BEAM (B) position	12
			All other conditions	0
4	OR/W	RH headlamp high beam	Lighting switch in the ON (2ND) position and combination switch in HIGH BEAM (A) position	12
			When releasing parking brake with engine running and lighting switch to OFF (daytime light operation) CAUTION: Block wheels and ensure selector lever is in N or P position.	6
			All other conditions	0
5	R/Y	Power source for RH headlamp	—	12
6	R/W	RH headlamp low beam	Lighting switch in the headlamp ON (2ND) position and combination switch in LOW BEAM (B) position	12
			All other conditions	0
7	R/L	Power source for LH headlamp	—	12
8	OR/L	LH headlamp high beam	Lighting switch in the ON (2ND) position and combination switch in HIGH BEAM (A) position	12
			When releasing parking brake with engine running and lighting switch to OFF (daytime light operation) CAUTION: Block wheels and ensure selector lever is in N or P position.	6
			All other conditions	0
9	Y	Lighting switch	OFF, 1ST position	12
			Headlamp ON (2ND) position	0
10	G	Autolamp sensor (+)	Sensor struck by light	—
			Sensor obstructed	—
11	L/B	Ignition switch start signal	Ignition switch in START position	12
			All other conditions	0

HEADLAMP (FOR CANADA) — DAYTIME LIGHT SYSTEM —

Trouble Diagnoses (Cont'd)

Terminal No.	Wire color	Item	Condition	Voltage (Approximate value)
12	GY/R	Tail lamp relay	Autolamp is not operating and lighting switch is in the OFF position	12
			Autolamp is operating	0
13	OR/L	High beam indicator	Lighting switch in the ON (2ND) position and combination switch in HIGH BEAM (A) position Combination switch in FLASH TO PASS (C) position	12
			All other conditions	0
14	L/W	Shut-off delay switch (lighting switch)	OFF	0.5
			AUTO1	3.5
			AUTO2	4.5
17	L/Y	Generator (L terminal)	When engine is running	12
			All other conditions	0
18	LG/R	Combination switch	HIGH BEAM (A) position	0
			All other conditions	12
19	P/W	Smart entrance control unit (with theft warning)	When theft warning system is in alarm phase or panic operation is activated by multi-remote control system	0
			All other conditions	12
20	BR	Combination switch	FLASH TO PASS (C) position	0
			All other conditions	0
21	B/W	Autolamp sensor (-)	—	—
22	B	Ground	—	—

Headlamp control unit connector

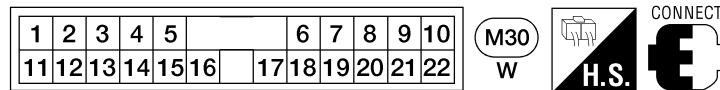

AEL941B

Bulb Replacement

Refer to "HEADLAMP (FOR USA)", EL-44.

NDEL0024

Aiming Adjustment

Refer to "HEADLAMP (FOR USA)", EL-44.

NDEL0025

PARKING, LICENSE AND TAIL LAMPS

Wiring Diagram — TAIL/L —

Wiring Diagram — TAIL/L —

NDEL0026

For information about autolamp operation, refer to "AUTOLAMP OPERATION (IF EQUIPPED)", "HEADLAMP (FOR USA)", EL-33, "AUTOLAMP OPERATION (IF EQUIPPED)", "HEADLAMP (FOR CANADA) — DAYTIME LIGHT SYSTEM", EL-48.

EL-TAIL/L-01

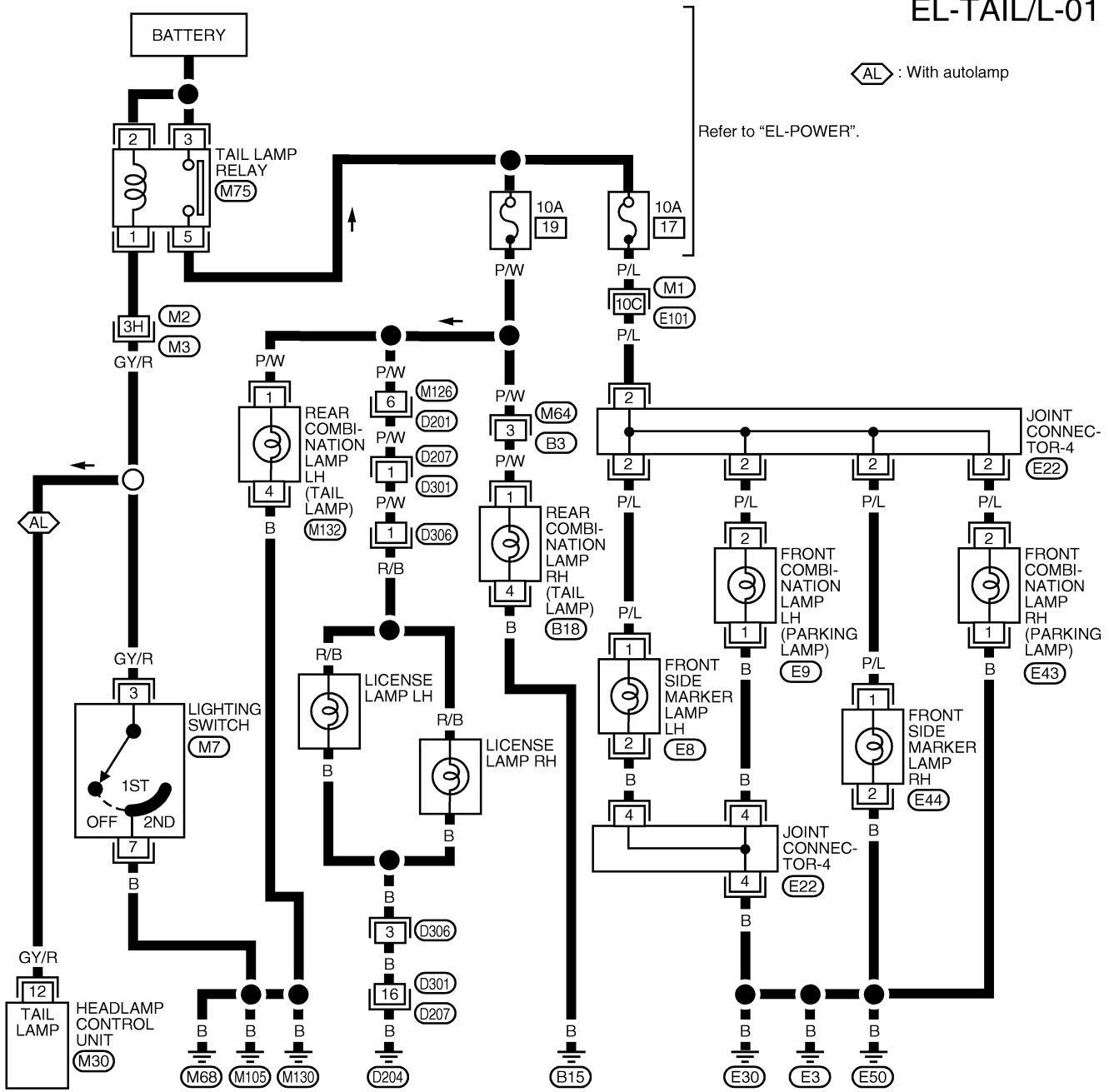

△ : With autolamp

Refer to "EL-POWER".

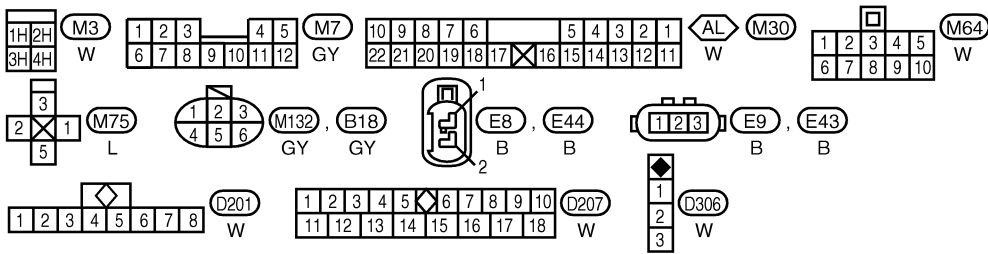

Refer to the following.
 (M1), (E101) - SUPER MULTIPLE JUNCTION (SMJ)
 (E22) - JOINT CONNECTOR

STOP LAMP

Wiring Diagram — STOP/L —

Wiring Diagram — STOP/L —

NDEL0027

EL-STOP/L-01

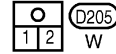
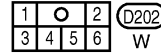
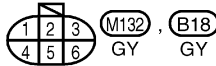
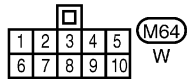
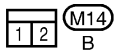
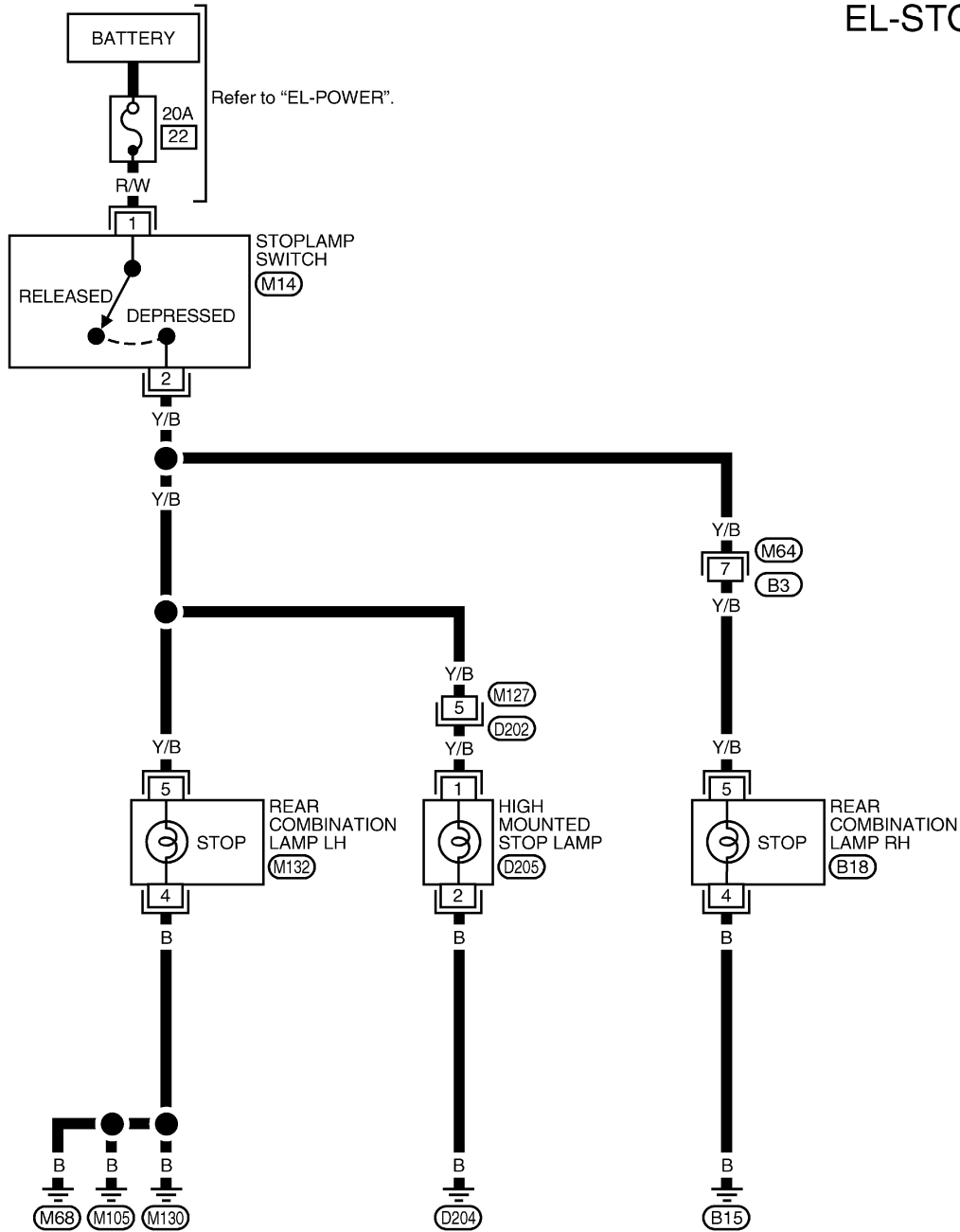

BACK-UP LAMP

Wiring Diagram — BACK/L —

Wiring Diagram — BACK/L —

NDEL0028

EL-BACK/L-01

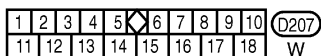
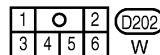
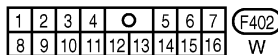
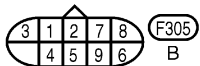
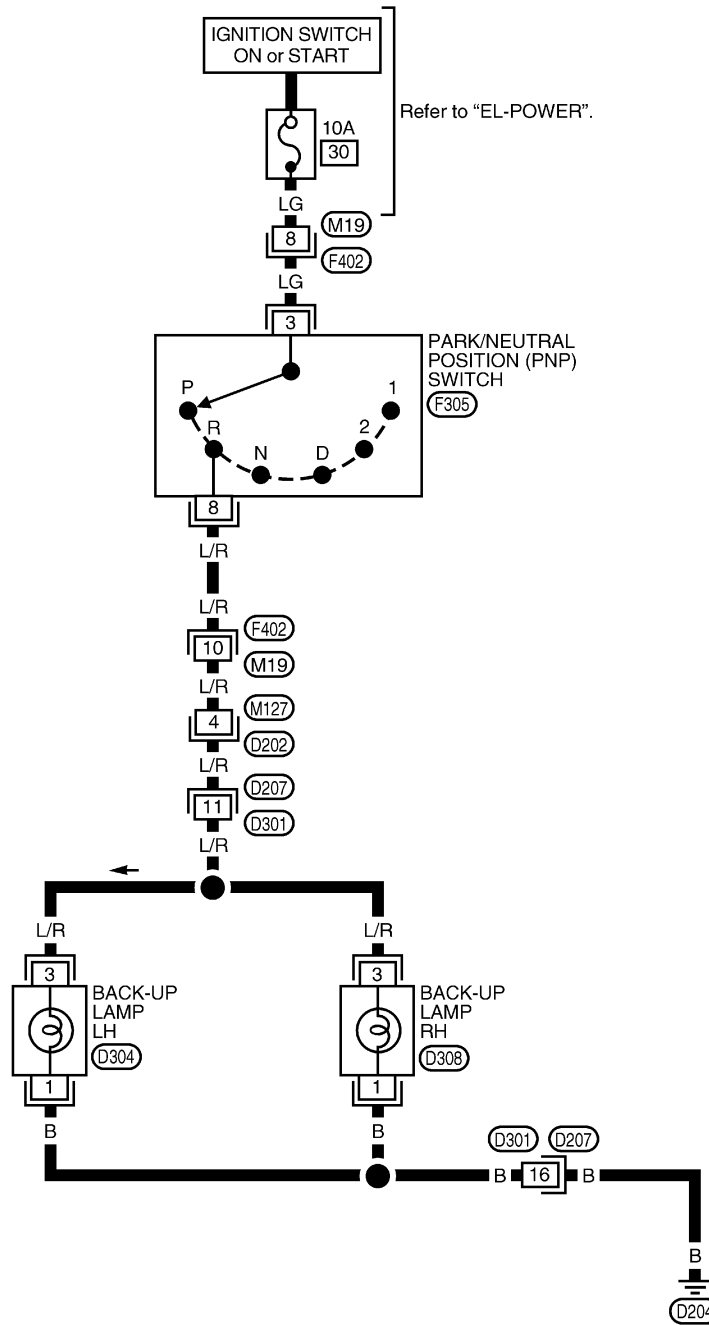

GI

MA

EM

LC

EC

FE

AT

AX

SU

BR

ST

RS

BT

HA

SC

EL

IDX

CORNERING LAMP

System Description

System Description

NDEL0033

The lighting switch must be in the 1ST or 2ND position for the cornering lamps to operate. The cornering lamp switch is part of the combination switch and is controlled by the turn signal lever. The cornering lamps provide additional lighting in the direction of the turn.

With the lighting switch in the 1ST or 2ND position, the tail lamp relay is energized and power is supplied

- from tail lamp relay terminal 5
- through 10A fuse (No. 17, located in the fuse block)
- to cornering lamp switch terminal 4.

RH TURN

NDEL0033S01

When the turn signal lever is moved to the RH position, power is supplied

- from cornering lamp switch terminal 4
- through cornering lamp switch terminal 6
- to cornering lamp RH terminal 3.

Ground is supplied to cornering lamp RH terminal 1 through body grounds E3, E30 and E50. The RH cornering lamp illuminates until the turn is completed.

LH TURN

NDEL0033S02

When the turn signal lever is moved to the LH position, power is supplied

- from cornering lamp switch terminal 4
- through cornering lamp switch terminal 5
- to cornering lamp LH terminal 3.

Ground is supplied to cornering lamp LH terminal 1 through body grounds E3, E30 and E50. The LH cornering lamp illuminates until the turn is completed.

CORNERING LAMP

Wiring Diagram — CORNER —

Wiring Diagram — CORNER —

NDEL0034

EL-CORNER-01

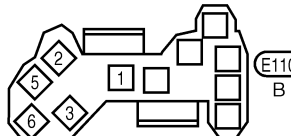
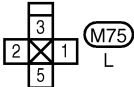
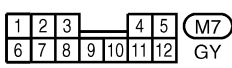
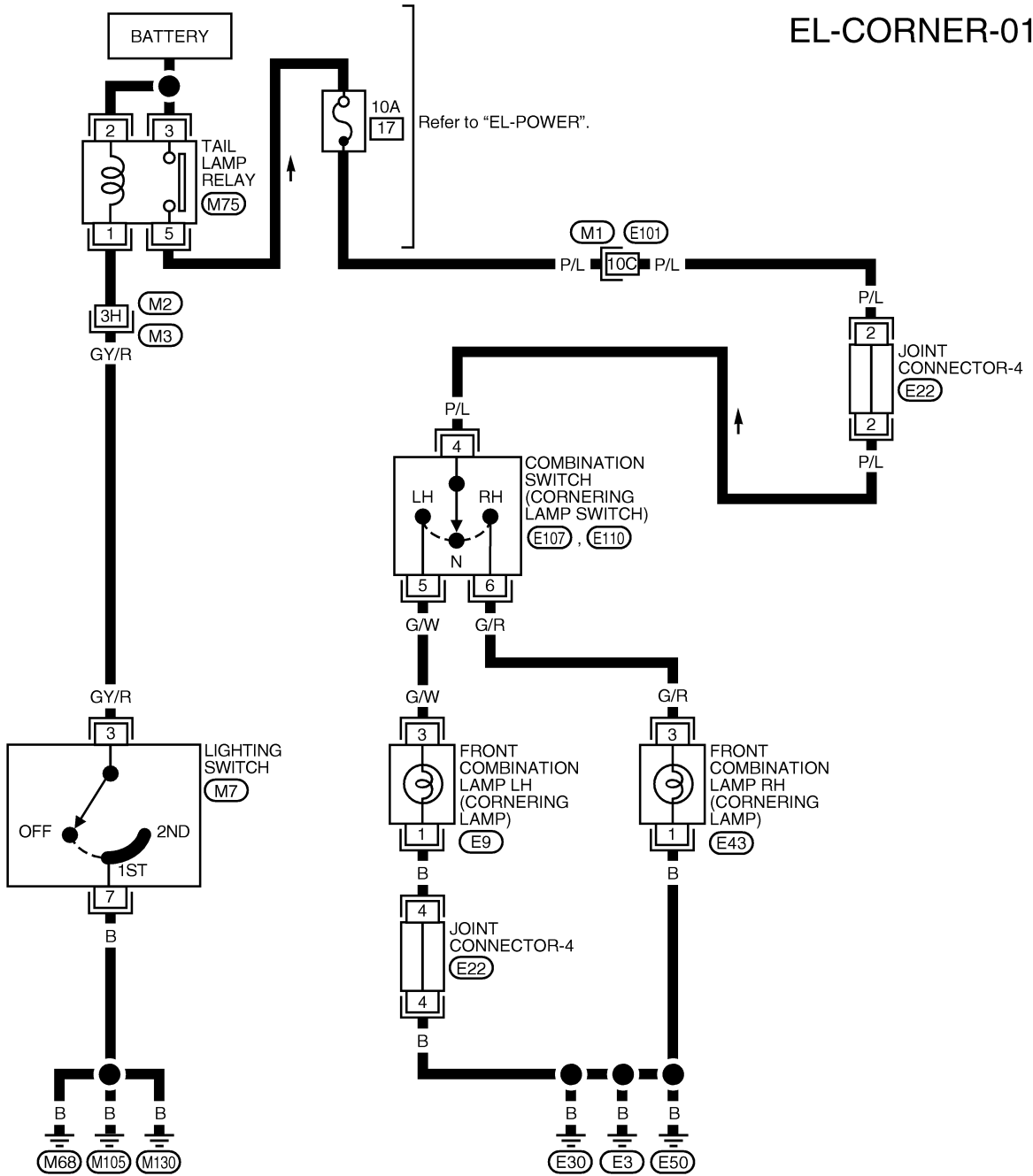

Refer to the following.

(M1), (E101) - SUPER MULTIPLE JUNCTION (SMJ)

(E22) - JOINT CONNECTOR

GI
MA
EM
LC
EC
FE
AT
AX
SU
BR
ST
RS
BT
HA
SC

EL

IDX

TURN SIGNAL AND HAZARD WARNING LAMPS

System Description

System Description

NDEL0029

TURN SIGNAL OPERATION

NDEL0029S01

With the hazard switch in the OFF position and the ignition switch in the ON or START position, power is supplied

- through 10A fuse (No. 27, located in the fuse block)
- to hazard switch terminal 2
- through terminal 1 of the hazard switch
- to combination flasher unit terminal 1
- through terminal 3 of the combination flasher unit
- to turn signal switch terminal 1.

Ground is supplied to combination flasher unit terminal 2 through body grounds M68, M105 and M130.

LH Turn

NDEL0029S0101

When the turn signal switch is moved to the LH position, power is supplied from turn signal switch terminal 2 to

- front turn signal lamp LH terminal 3
- combination meter terminal 15
- rear combination lamp LH terminal 2.

Ground is supplied to the front turn signal lamp LH terminal 1 through body grounds E3, E30 and E50.

Ground is supplied to the rear combination lamp LH terminal 4 through body grounds M68, M105 and M130.

Ground is supplied to combination meter terminal 22 through body grounds M68, M105 and M130.

With power and ground supplied, the combination flasher unit controls the flashing of the LH turn signal lamps.

RH Turn

NDEL0029S0102

When the turn signal switch is moved to the RH position, power is supplied from turn signal switch terminal 3 to

- front turn signal lamp RH terminal 3
- combination meter terminal 21
- rear combination lamp RH terminal 2.

Ground is supplied to the front turn signal lamp RH terminal 1 through body grounds E3, E30 and E50.

Ground is supplied to the rear combination lamp RH terminal 4 through body ground B15.

Ground is supplied to combination meter terminal 22 through body grounds M68, M105 and M130.

With power and ground supplied, the combination flasher unit controls the flashing of the RH turn signal lamps.

HAZARD LAMP OPERATION

NDEL0029S04

Power is supplied at all times to hazard switch terminal 3 through:

- 10A fuse (No. 23, located in the fuse block).

With the hazard switch in the ON position, power is supplied

- through terminal 1 of the hazard switch
- to combination flasher unit terminal 1
- through terminal 3 of the combination flasher unit
- to hazard switch terminal 5.

Ground is supplied to combination flasher unit terminal 2 through body grounds M68, M105 and M130.

Power is supplied through terminal 4 of the hazard switch to

- front turn signal lamp LH terminal 3
- combination meter terminal 15
- rear combination lamp LH terminal 2.

Power is supplied through terminal 6 of the hazard switch to

- front turn signal lamp RH terminal 3
- combination meter terminal 21
- rear combination lamp RH terminal 2.

Ground is supplied to each lamp in the same manner as for LH or RH turn operation.

With power and ground supplied, the combination flasher unit controls the flashing of hazard warning lamps.

TURN SIGNAL AND HAZARD WARNING LAMPS

Wiring Diagram — TURN —

Wiring Diagram — TURN —

NDEL0030

EL-TURN-01

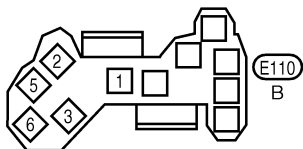
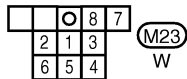
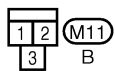
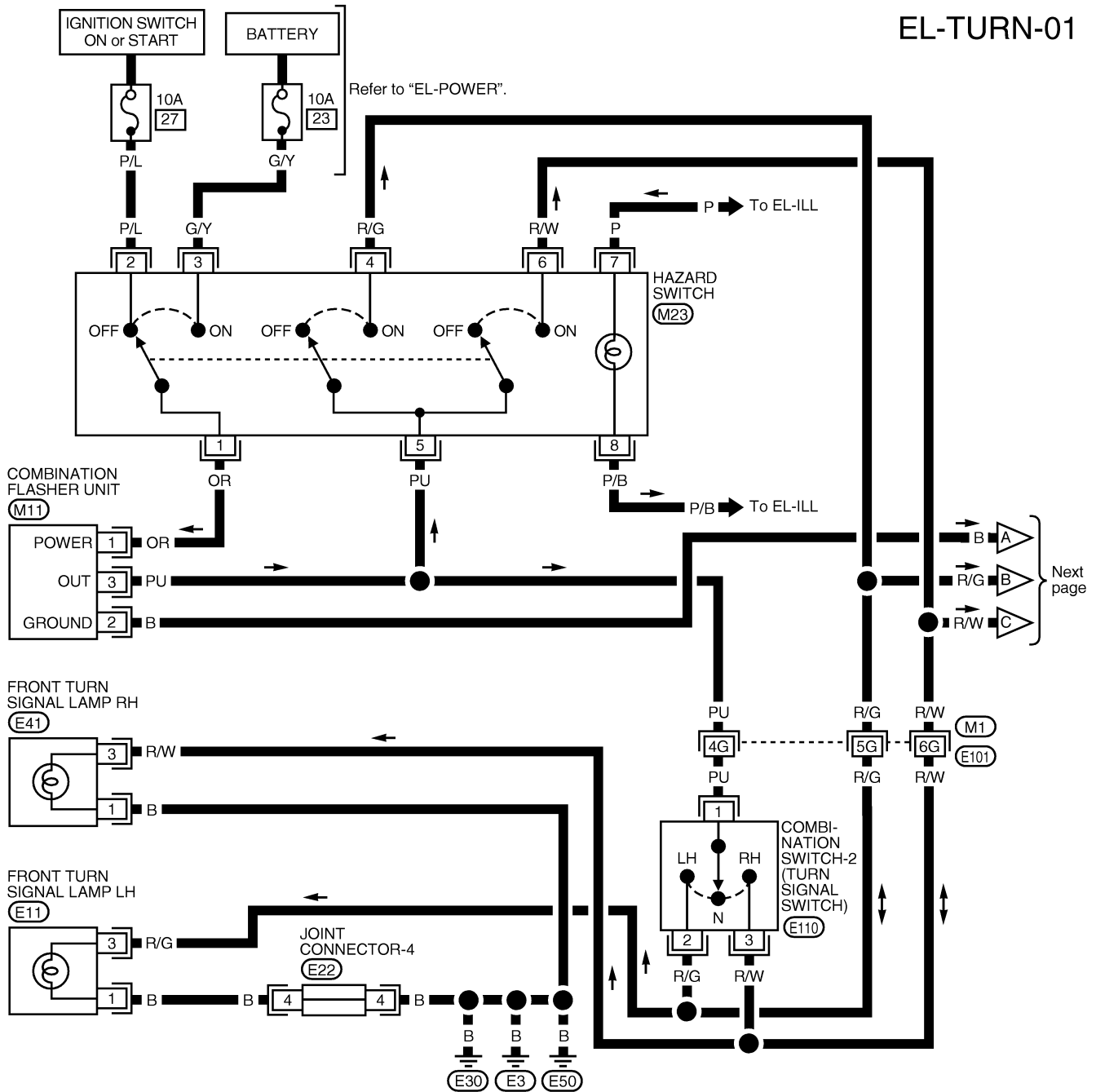

Refer to the following.
 (M1), (E101) - SUPER MULTIPLE JUNCTION (SMJ)
 (E22) - JOINT CONNECTOR

GI
 MA
 EM
 LC
 EC
 FE
 AT
 AX
 SU
 BR
 ST
 RS
 BT
 HA
 SC

EL

IDX

TURN SIGNAL AND HAZARD WARNING LAMPS

Wiring Diagram — TURN — (Cont'd)

EL-TURN-02

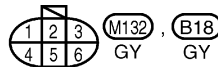
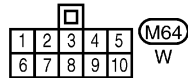
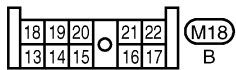
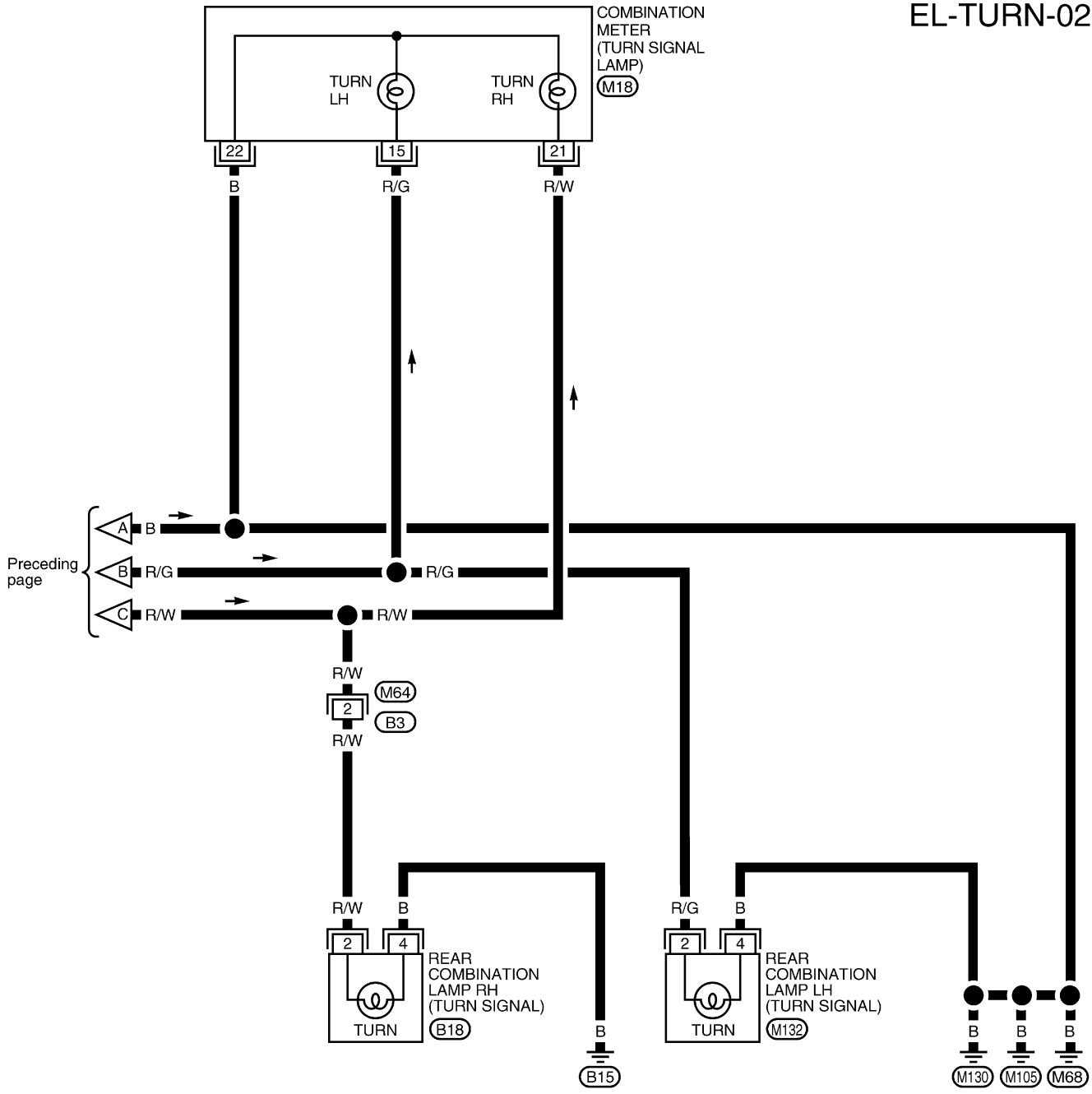

AEL722B

TURN SIGNAL AND HAZARD WARNING LAMPS

Trouble Diagnoses

Trouble Diagnoses

NDEL0031

Symptom	Possible cause	Repair order
Turn signal and hazard warning lamps do not operate.	<ol style="list-style-type: none"> 1. Hazard switch 2. Combination flasher unit 3. Open in combination flasher unit circuit 	<ol style="list-style-type: none"> 1. Check hazard switch. 2. Refer to combination flasher unit check. 3. Check wiring to combination flasher unit for open circuit.
Turn signal lamps do not operate but hazard warning lamps operate.	<ol style="list-style-type: none"> 1. 10A fuse 2. Hazard switch 3. Turn signal switch 4. Open in turn signal switch circuit 	<ol style="list-style-type: none"> 1. Check 10A fuse (No. 27, located in fuse block). Turn ignition switch ON and verify battery positive voltage is present at terminal 2 of hazard switch. 2. Check hazard switch. 3. Check turn signal switch. 4. Check PU wire between combination flasher unit and turn signal switch for open circuit.
Hazard warning lamps do not operate but turn signal lamps operate.	<ol style="list-style-type: none"> 1. 10A fuse 2. Hazard switch 3. Open in hazard switch circuit 	<ol style="list-style-type: none"> 1. Check 10A fuse (No. 23, located in fuse block). Verify battery positive voltage is present at terminal 3 of hazard switch. 2. Check hazard switch. 3. Check PU wire between combination flasher unit and hazard switch for open circuit.
Front turn signal lamp LH or RH does not operate.	<ol style="list-style-type: none"> 1. Bulb 2. Grounds E3, E30 and E50 	<ol style="list-style-type: none"> 1. Check bulb. 2. Check grounds E3, E30 and E50.
Rear turn signal lamp LH does not operate.	<ol style="list-style-type: none"> 1. Bulb 2. Grounds M68, M105 and M130 	<ol style="list-style-type: none"> 1. Check bulb. 2. Check grounds M68, M105 and M130.
Rear turn signal lamp RH does not operate.	<ol style="list-style-type: none"> 1. Bulb 2. Ground B15 	<ol style="list-style-type: none"> 1. Check bulb. 2. Check ground B15.
LH and RH turn indicators do not operate.	<ol style="list-style-type: none"> 1. Grounds M68, M105 and M130 	<ol style="list-style-type: none"> 1. Check grounds M68, M105 and M130.
LH or RH turn indicator does not operate.	<ol style="list-style-type: none"> 1. Bulb 	<ol style="list-style-type: none"> 1. Check bulb in combination meter.

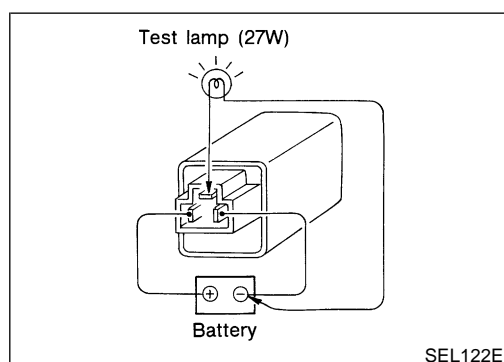

Electrical Components Inspection COMBINATION FLASHER UNIT CHECK

NDEL0032

NDEL0032S01

- Before checking, ensure that bulbs meet specifications.
- Connect a battery and test lamp to the combination flasher unit, as shown. Combination flasher unit is properly functioning if it blinks when power is supplied to the circuit.

TRAILER TOW

System Description

System Description

NDEL0035

TRAILER TAIL LAMP OPERATION

NDEL0035S01

With the lighting switch in the 1ST or 2ND position, the tail lamp relay is energized and power is supplied

- from tail lamp relay terminal 5
- through 10A fuse (No. 19, located in the fuse block)
- to trailer harness connector terminal 2.

Ground is supplied to trailer tow control unit terminal 2 and trailer harness connector terminal 1 through body grounds M68, M105 and M130.

With power and ground supplied, the trailer tail lamps will illuminate.

TRAILER STOP, TURN SIGNAL AND HAZARD LAMP OPERATION

NDEL0035S02

The trailer stop, turn signal and hazard lamps are all controlled by the trailer tow control unit. The trailer tow control unit regulates the amount of voltage supplied to the trailer lamps. If either turn signal or the hazard lamps are turned on and the control unit gets a brake lamp input, the control unit supplies more voltage to the trailer lamps to make them illuminate brighter.

Power is supplied to trailer tow control unit terminals 3 and 4 through 20A fuse (No. 22, located in the fuse block) at all times.

Stop lamp input is supplied to trailer tow control unit terminal 1.

Left turn signal and hazard lamp input is supplied to trailer tow control unit terminal 7.

Right turn signal and hazard lamp input is supplied to trailer tow control unit terminal 8.

Based on the stop lamp, turn signal lamp and hazard lamp inputs to the trailer tow control unit, power is supplied to trailer LH stop/turn lamp:

- from trailer tow control unit terminal 6
- to trailer harness connector terminal 3.

Power is also supplied to trailer RH stop/turn lamp:

- from trailer tow control unit terminal 5
- to trailer harness connector terminal 4.

TRAILER TOW

Wiring Diagram — T/TOW —

Wiring Diagram — T/TOW —

NDEL0036

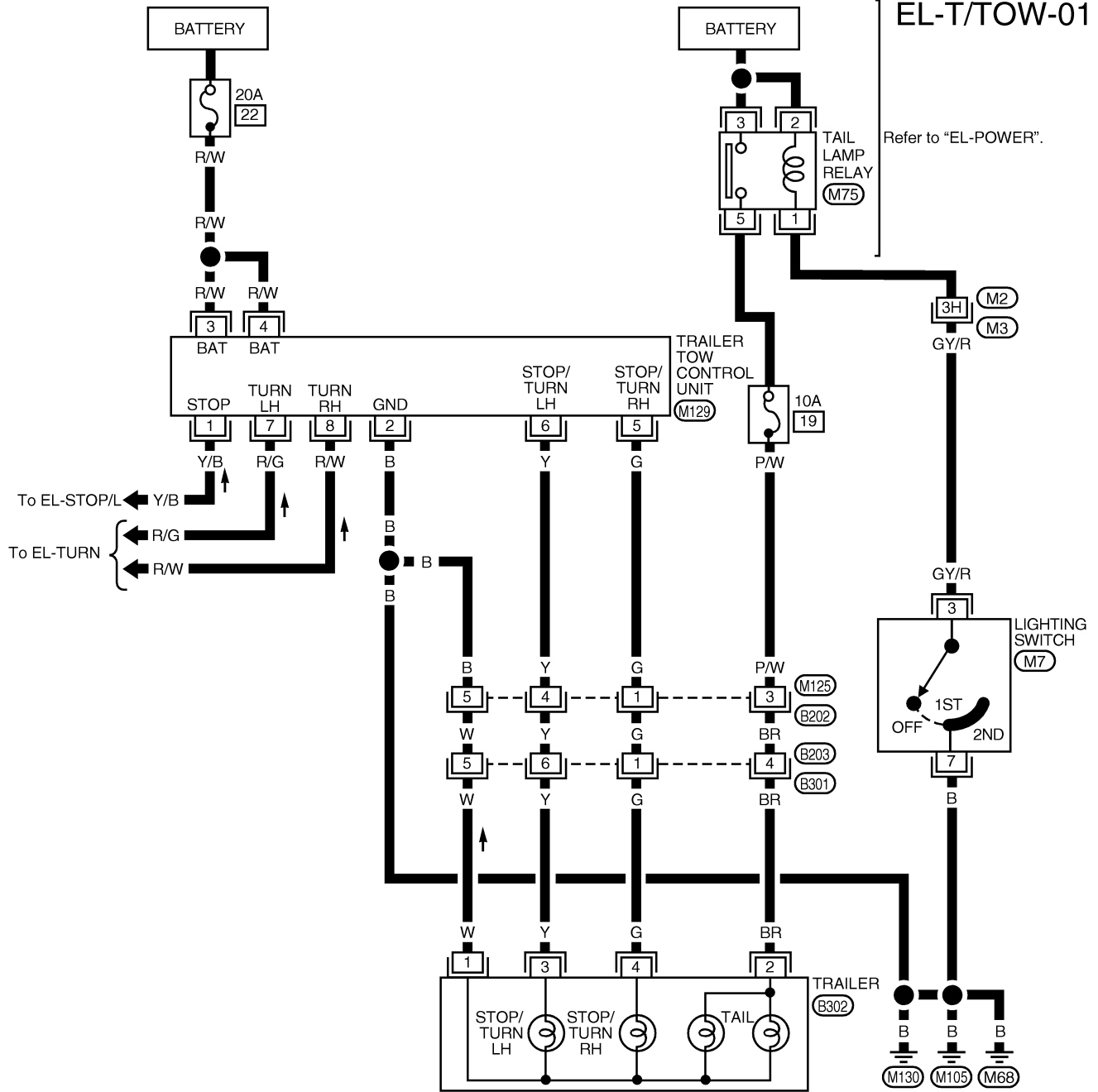

EL-T/TOW-01

Refer to "EL-POWER".

GI
MA
EM
LC
EC
FE
AT
AX
SU
BR
ST
RS
BT
HA
SC

EL

IDX

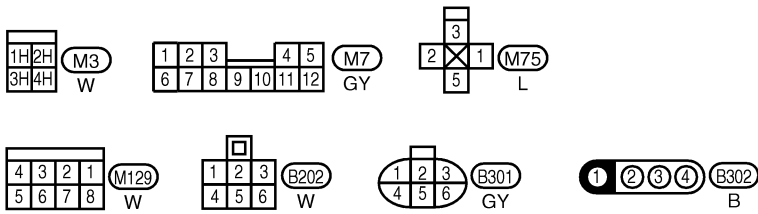

TRAILER TOW

Trouble Diagnoses

Trouble Diagnoses

NDEL0037

TRAILER TOW CONTROL UNIT INSPECTION TABLE

NDEL0037S01

Terminal No.	Wire color	Item	Condition	Voltage (Approximate value)
1	Y/B	Stop lamps signal	When brake pedal is depressed	12
			When brake pedal is released	0
2	B	Ground	—	—
3	R/W	Power supply	—	12
4	R/W	Power supply	—	12
5	G	Stop/RH turn lamp (output)	When brake pedal is depressed	12
			When RH turn lamps or hazard lamps operate	12 (intermittently)
			All other conditions	0
6	Y	Stop/LH turn lamp (output)	When brake pedal is depressed	12
			When LH turn lamps or hazard lamps operate	12 (intermittently)
			All other conditions	0
7	R/G	LH turn lamps	When LH turn lamps or hazard lamps operate	12 (intermittently)
			All other conditions	0
8	R/W	RH turn lamps	When RH turn lamps or hazard lamps operate	12 (intermittently)
			All other conditions	0

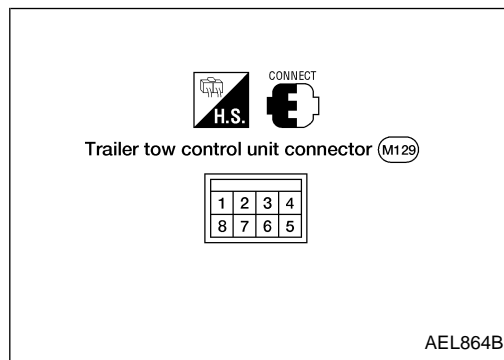

System Description

NDEL0038

Power is supplied at all times

- through 7.5A fuse (No. 39, located in the fuse and fusible link box)
- to smart entrance control unit terminal 13.

Power is supplied at all times

- to tail lamp relay terminals 2 and 3.

With the ignition switch in the ACC or ON position, power is supplied

- through 7.5A fuse (No. 5, located in the fuse block)
- to door mirror remote control switch terminal 1.

Ground is supplied to smart entrance control unit terminal 10 through body grounds M68, M105 and M130. With the lighting switch in the 1ST or 2ND position, the tail lamp relay is energized and power is supplied

- from tail lamp relay terminal 5
- through 7.5A fuse (No. 18, located in the fuse block)
- to power terminal on all illuminated components except door mirror remote control switch.

For auto lamp operation (if equipped), ground is supplied to tail lamp relay through headlamp control unit terminal 12 to energize tail lamp relay. Then tail lamp relay supplies power to turn on parking, license, tail lamps and illumination. For detailed information on autolamp operation, refer to "HEADLAMP (USA)", EL-32 or "HEADLAMP (FOR CANADA) — DAYTIME LIGHT SYSTEM, EL-46.

The illumination control switch in combination with the smart entrance control unit control the amount of current flow through the illumination system. This is accomplished by varying the amount of ground supplied to the illumination system.

When the illumination control switch is pushed in the LIGHTER direction, ground is supplied

- to smart entrance control unit terminal 42
- through illumination control switch terminal 5
- from illumination control switch terminal 8
- through body grounds M68, M105 and M130.

When the illumination control switch is pushed in the DARKER direction, ground is supplied

- to smart entrance control unit terminal 33
- through illumination control switch terminal 2
- from illumination control switch terminal 8
- through body grounds M68, M105 and M130.

Ground is supplied to the illumination system from smart entrance control unit terminal 11 through smart entrance control unit terminal 10.

The rear audio remote control unit illumination is not controlled by the illumination control switch. The intensity of this lamp does not change. Rear audio remote control unit terminal 10 is grounded directly through body grounds M68, M105 and M130.

The following chart indicates power and ground terminals for the illumination system components.

Component	Connector No.	Power terminal	Ground Terminal
Audio unit	M45	21	22
Combination meter	M16, M17	23 and 10	24 and 11
ASCD main switch	M6	5	6
Illumination control switch and autolamp switch	M8	1	7
Lighting switch	M7	1	2
Main power window and door lock/unlock switch	D14	3	10
Door lock/unlock switch RH	D109	1	6
Front power window switch RH	D108	1	6
Rear audio remote control unit	M115	9	10
Rear fan switch (rear)*	B6	1	2
A/C control unit (without EATC)	M37, M34	1 and 7	2 and 1

GI

MA

EM

LC

EC

FE

AT

AX

SU

BR

ST

RS

BT

HA

SC

EL

IDX

ILLUMINATION

System Description (Cont'd)

Component	Connector No.	Power terminal	Ground Terminal
EATC unit*	M33	6	1
Hazard switch	M23	7	8
Rear window defogger switch	M22	6	5
Rear fan switch (front)*	M32	2	3
Ash tray	M77	1	2
Rear wiper switch	M21	3	2
Door mirror remote control switch*	D9	1	3

* If equipped.

ILLUMINATION

Schematic

NDEL0040

Schematic

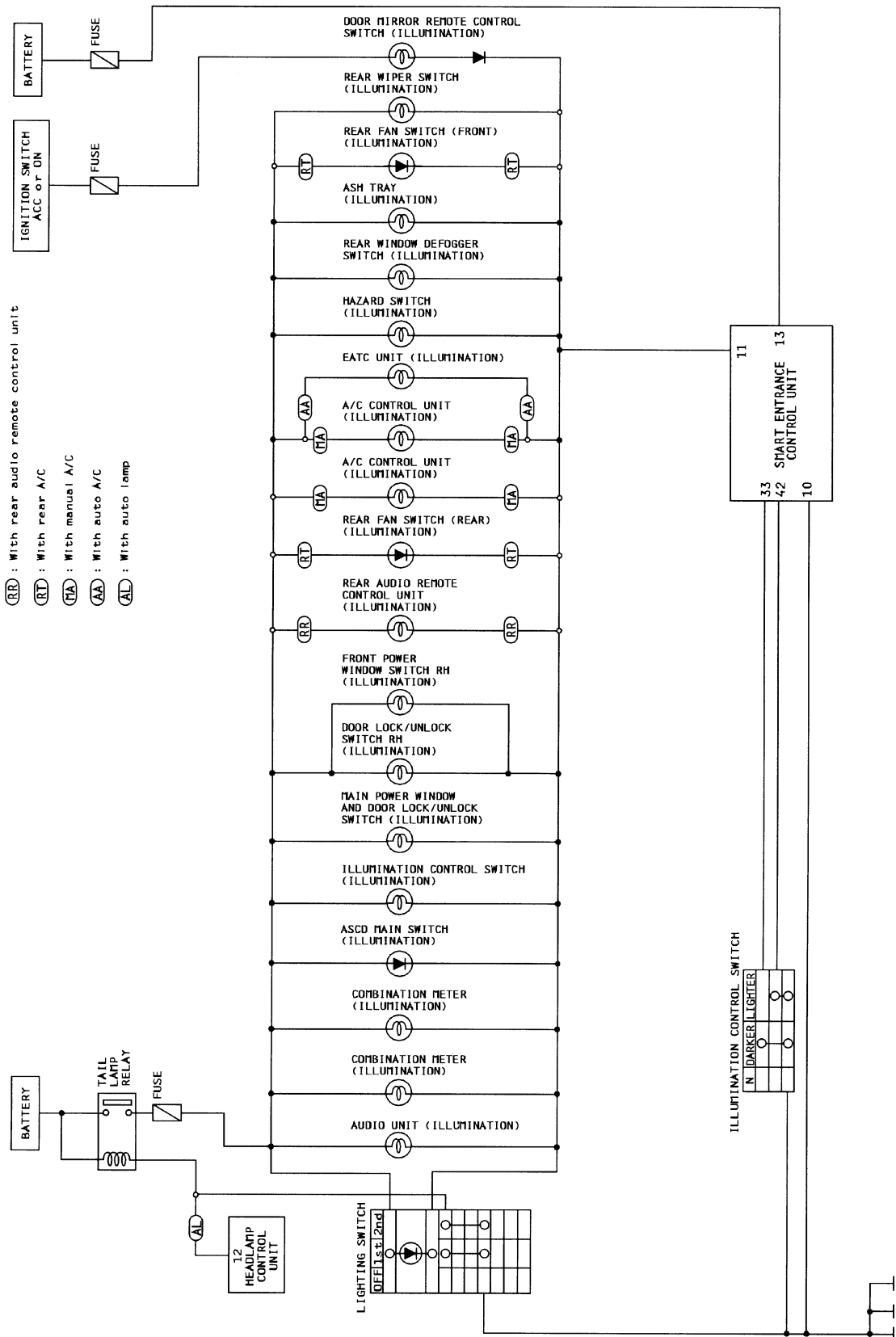

GI

MA

EM

LC

EC

FE

AT

AX

SU

BR

ST

RS

BT

HA

SC

EL

IDX

ILLUMINATION

Wiring Diagram — ILL —

Wiring Diagram — ILL —

NDEL0041

EL-ILL-01

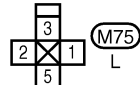
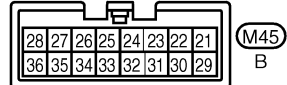
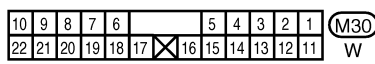
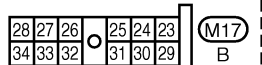
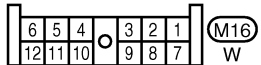
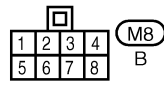
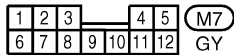
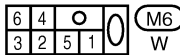
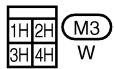
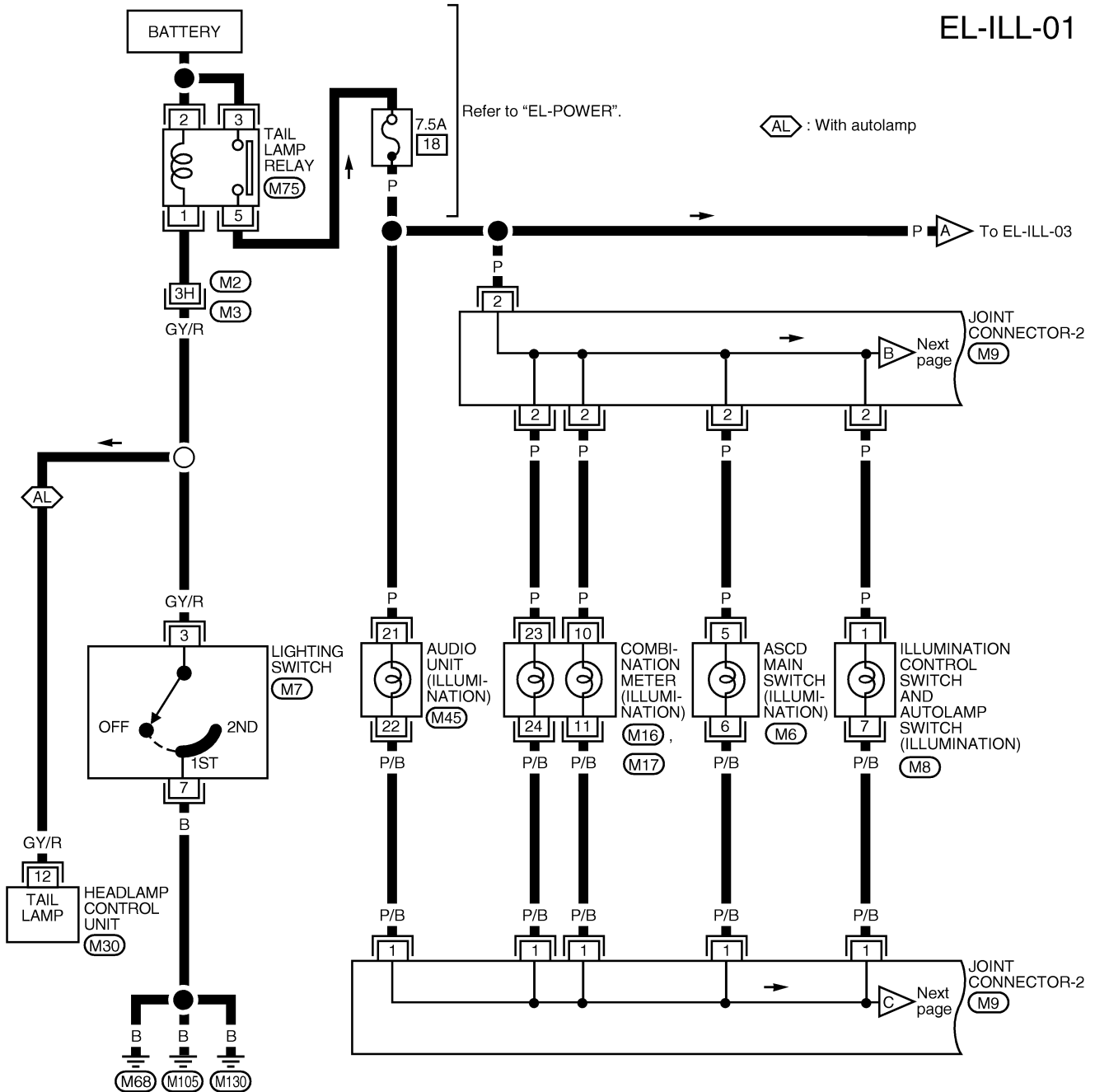



Refer to the following.
 (M9) - JOINT CONNECTOR

WEL199

ILLUMINATION

Wiring Diagram — ILL — (Cont'd)

EL-ILL-02

-  PV : With rear power vent windows
-  OP : Without rear power vent windows
-  RR : With rear audio remote control unit

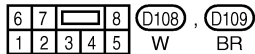
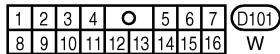
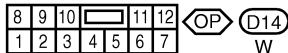
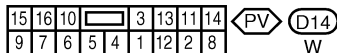
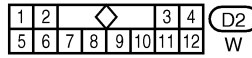
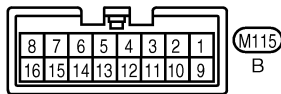
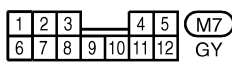
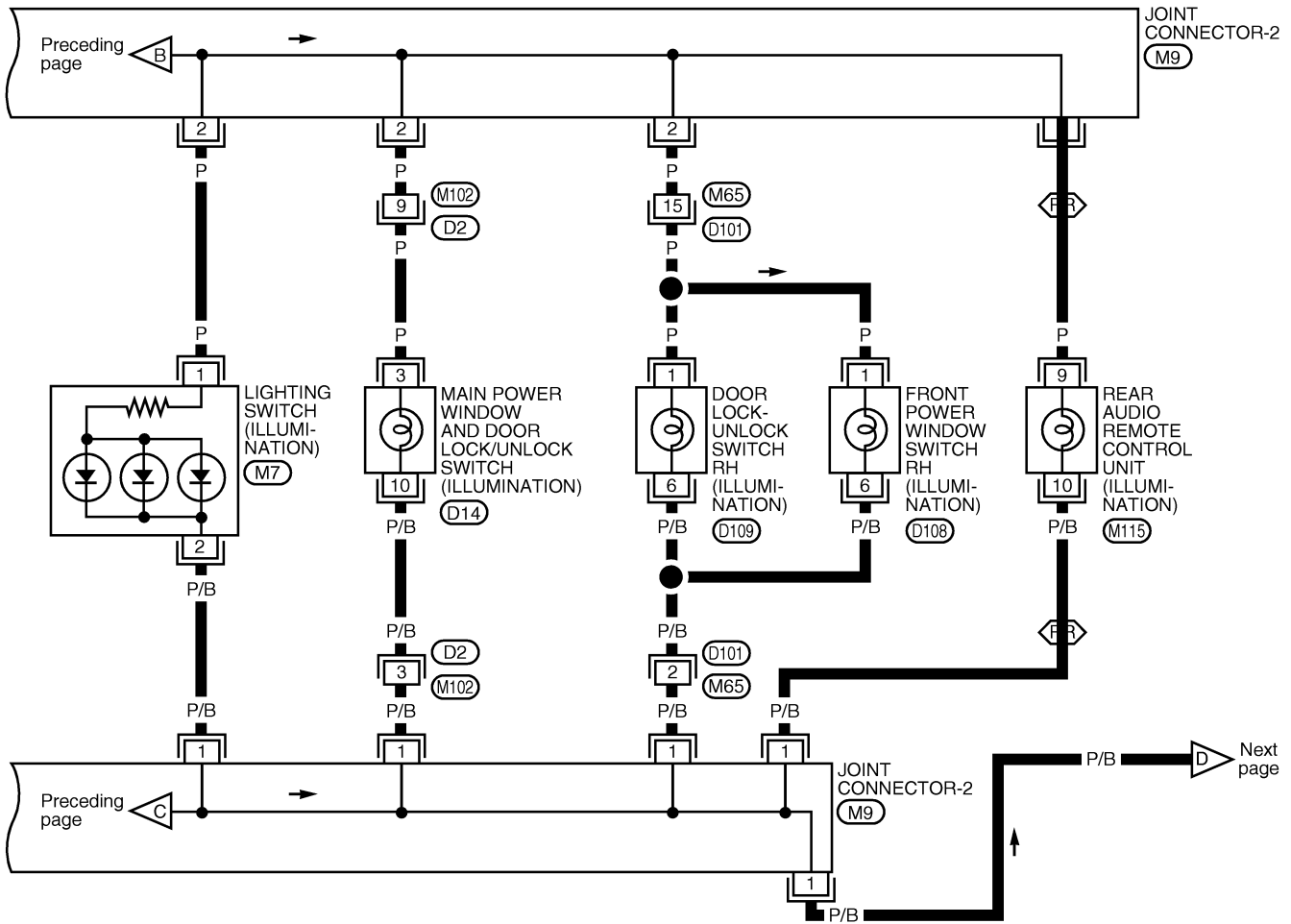

Refer to the following.
 M9 - JOINT CONNECTOR

GI

MA

EM

LC

EC

FE

AT

AX

SU

BR

ST

RS

BT

HA

SC

EL

IDX

WEL200

ILLUMINATION

Wiring Diagram — ILL — (Cont'd)

EL-ILL-03

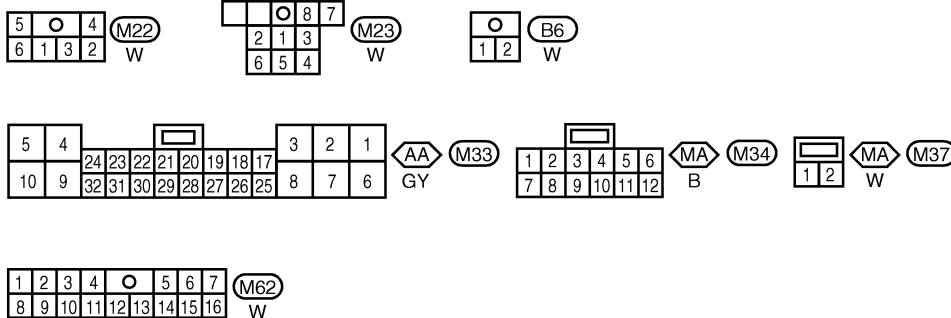
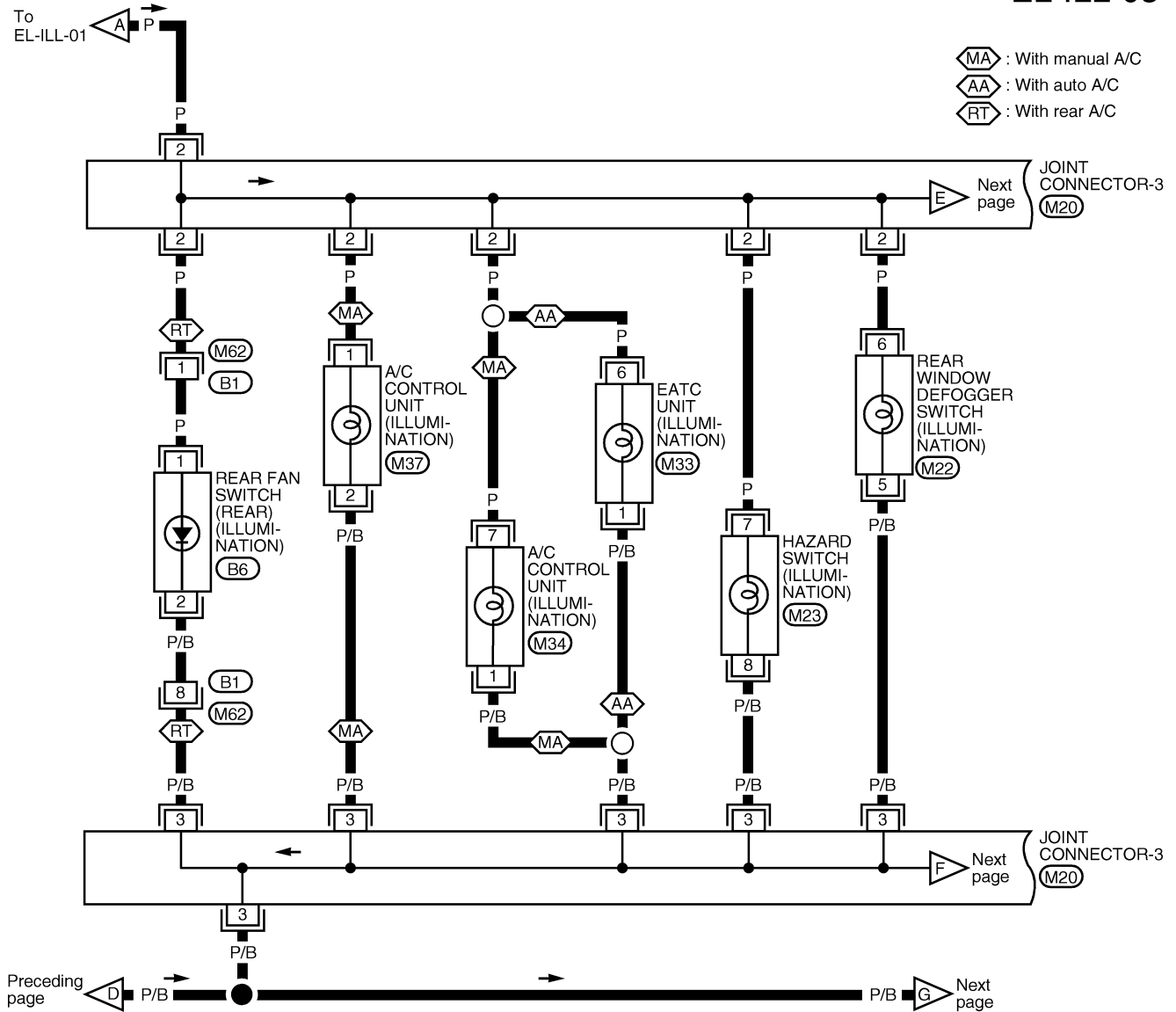

Refer to the following.
(M20) - JOINT CONNECTOR

WEL201

ILLUMINATION

Wiring Diagram — ILL — (Cont'd)

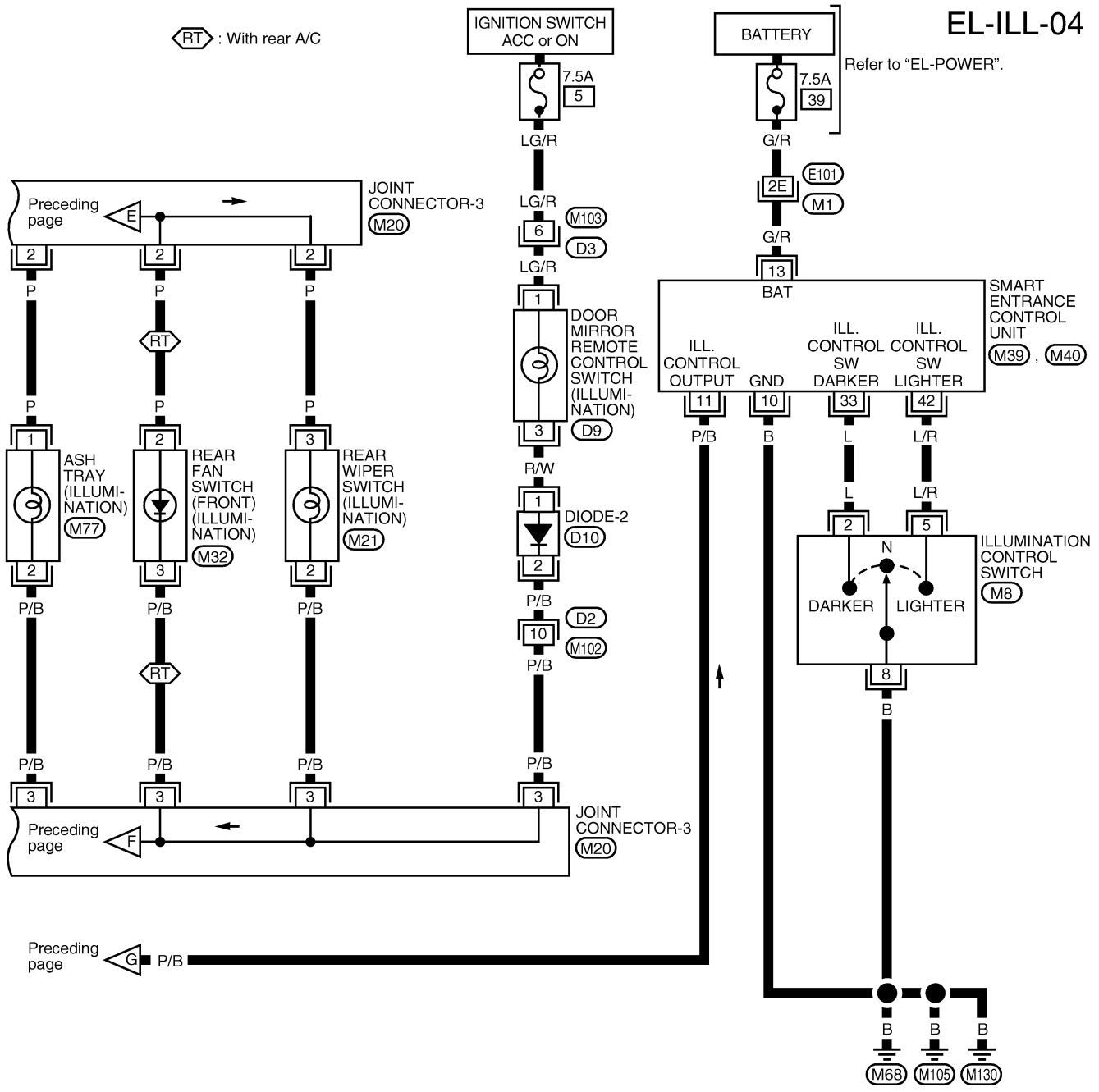

GI
MA
EM
LC
EC
FE
AT
AX
SU
BR
ST
RS
BT
HA
SC

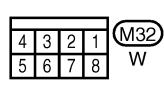
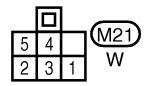
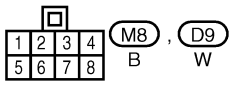

Refer to the following.
 (M1), (E101) - SUPER MULTIPLE JUNCTION (SMJ)
 (M20) - JOINT CONNECTOR

EL

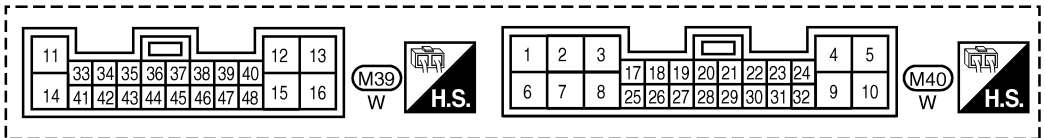

IDX

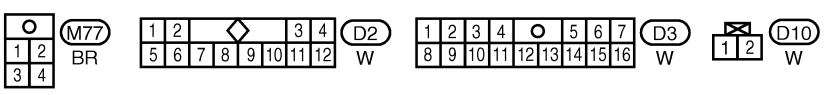

WEL202

INTERIOR ROOM LAMP

System Description

System Description

NDEL0039

OUTLINE

NDEL0039S01

Interior room lamps other than vanity lamp LH/RH (and map lamp when switch is in ON position) are controlled by the smart entrance control unit corresponding to the following signals

- Ignition switch (Power supply signal to smart entrance control unit terminal 43)
- Key switch (Ground signal to smart entrance control unit terminal 35)
- Lighting switch (Momentary ground signal to smart entrance control unit terminal 32)
- Front door switch LH/RH, sliding door switch LH/RH, back door latch switch LH/RH (Ground signal to smart entrance control unit terminal 9, 24, 34 or 41)
- Multi-remote controller.

Power is supplied at all times

- through 15A fuse (No. 21, located in the fuse block)
- to all interior room lamps.

Ground is supplied to the controlled interior room lamps

- through smart entrance control unit terminal 5 (Zone A)
- through smart entrance control unit terminal 4 (Zone B) or
- through smart entrance control unit terminal 6 (Zone C).

Controlled interior room lamps are grouped as zone A, B or C depending on connected smart entrance control unit terminals as follows

- Map lamp (Zone A, when its switch is in DOOR position)
- Front/rear room lamp (Zone B, when its switch is in DOOR position or Zone C, when its switch is in ON position)
- Front/rear personal lamps (Zone B, when its switch is in DOOR position or Zone C, when its switch is in ON position)
- Front step lamp LH/RH (Zone A)
- Foot lamp LH/RH (Zone A)
- Sliding door step lamp LH/RH (Zone B)
- Back door lamp (Zone B)
- Glove box lamp (Zone C, when glove box lid is opened).

Vanity lamp LH/RH are not controlled by the smart entrance control unit. They turn on and off corresponding to the switch position on the lamp.

When the vanity lamp LH/RH or map lamp switch is turned on, ground is supplied

- to vanity lamp LH/RH or map lamp terminal 2.

With power and ground supplied, the operated lamp turns on.

OPERATION

NDEL0039S02

Interior room lamps turn on when

- key switch REMOVED (ignition key removed from ignition key cylinder)
- any door is opened
- lighting switch is pushed (momentary on switch)
- unlock signal is transmitted from multi-remote controller (only for zone A and B).

Zone C interior room lamps will turn off when the last door is closed. Zone A and B interior room lamps will remain fully illuminated for 1 second. After 1 second, zone A and B interior room lamps are lit at half illumination for approximately 10 seconds. Finally the interior room lamps will gradually fade away over approximately the next 5 seconds.

Interior room lamps will turn off immediately during the above timer operation when

- ignition switch is turned to ON position
- lock signal is transmitted from multi-remote controller
- lighting switch is pushed (momentary on switch).

If the interior room lamps are turned on by pushing the lighting switch (momentary on switch), they can be turned off by pushing the lighting switch again.

INTERIOR ROOM LAMP

System Description (Cont'd)

BATTERY SAVER

If any of the lamps controlled by smart entrance control unit remain on for an extended period of time, the smart entrance control unit will turn off the lamps to save the battery consumption by opening the ground circuit.

NDL0039S03

GI

MA

EM

LC

EC

FE

AT

AX

SU

BR

ST

RS

BT

HA

SC

EL

IDX

INTERIOR ROOM LAMP

Schematic

Schematic

NDEL0042

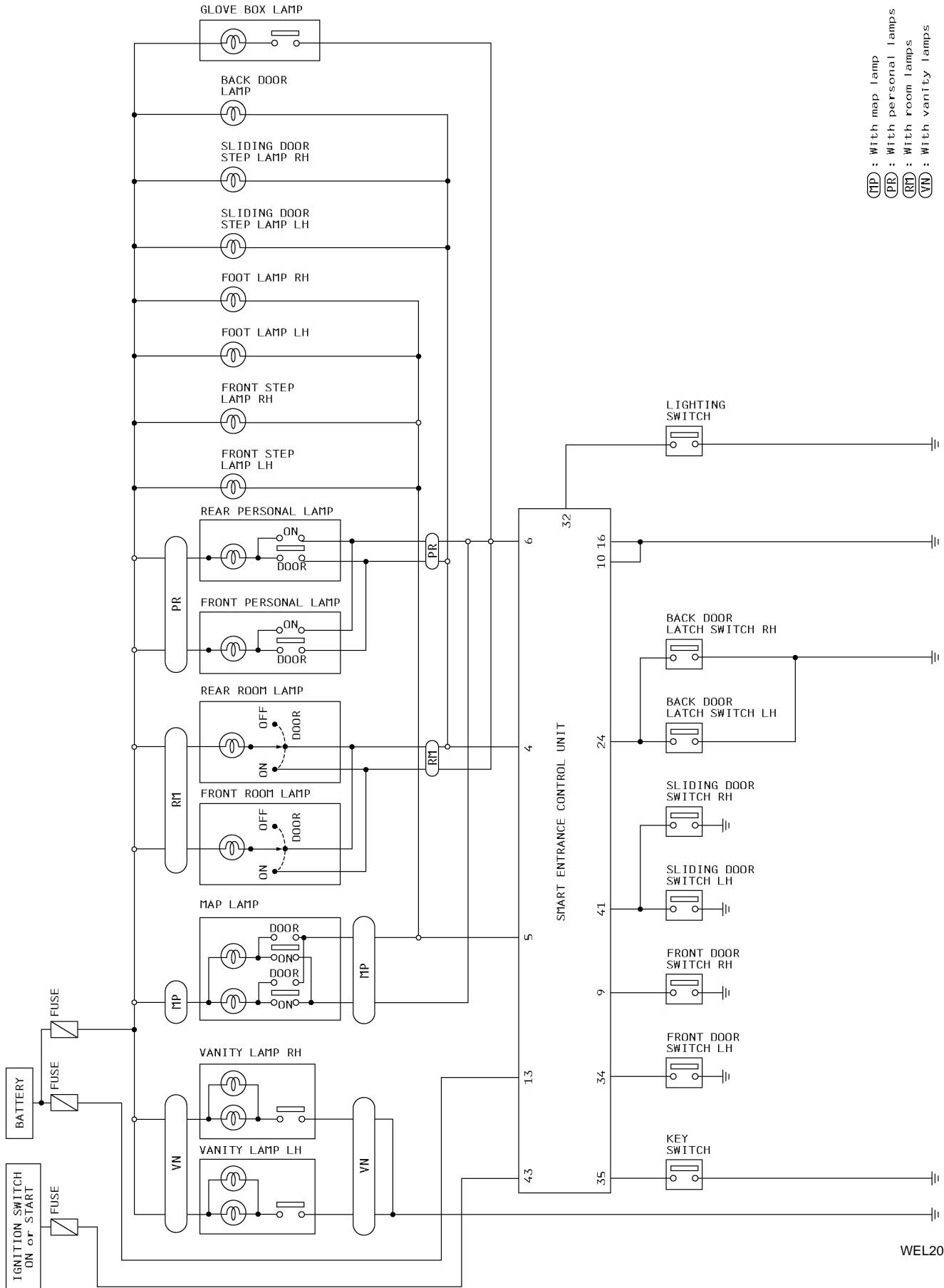

WEL203

INTERIOR ROOM LAMP

Wiring Diagram — INT/L —

Wiring Diagram — INT/L —

NDEL0043

EL-INT/L-01

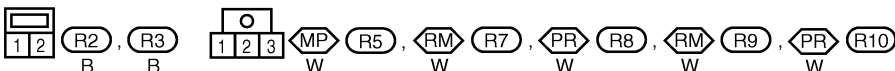
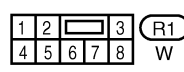
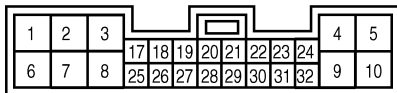
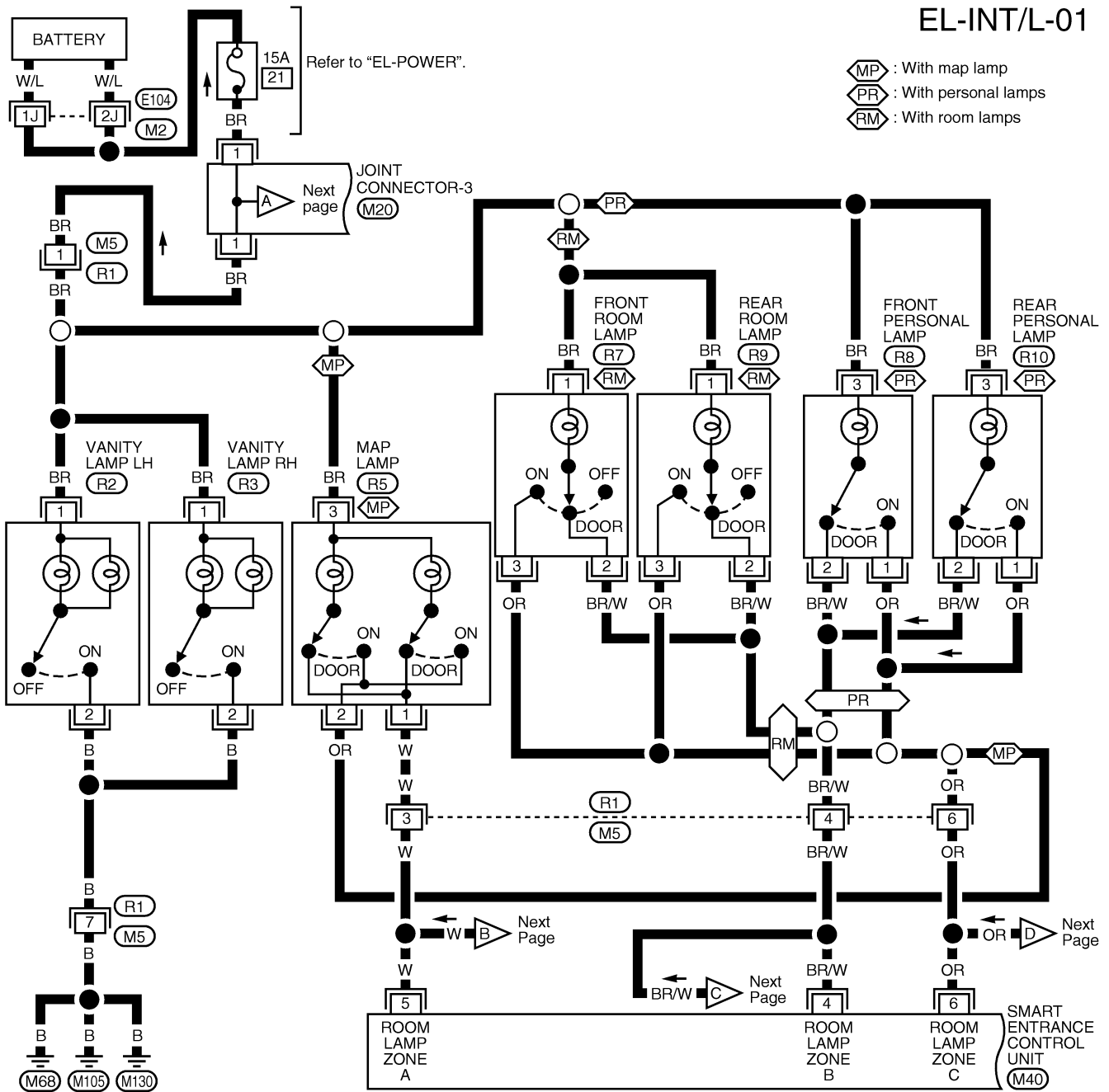

WEL204

INTERIOR ROOM LAMP

Wiring Diagram — INT/L — (Cont'd)

EL-INT/L-02

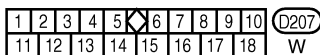
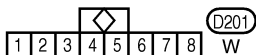
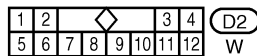
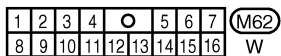
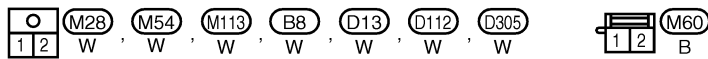
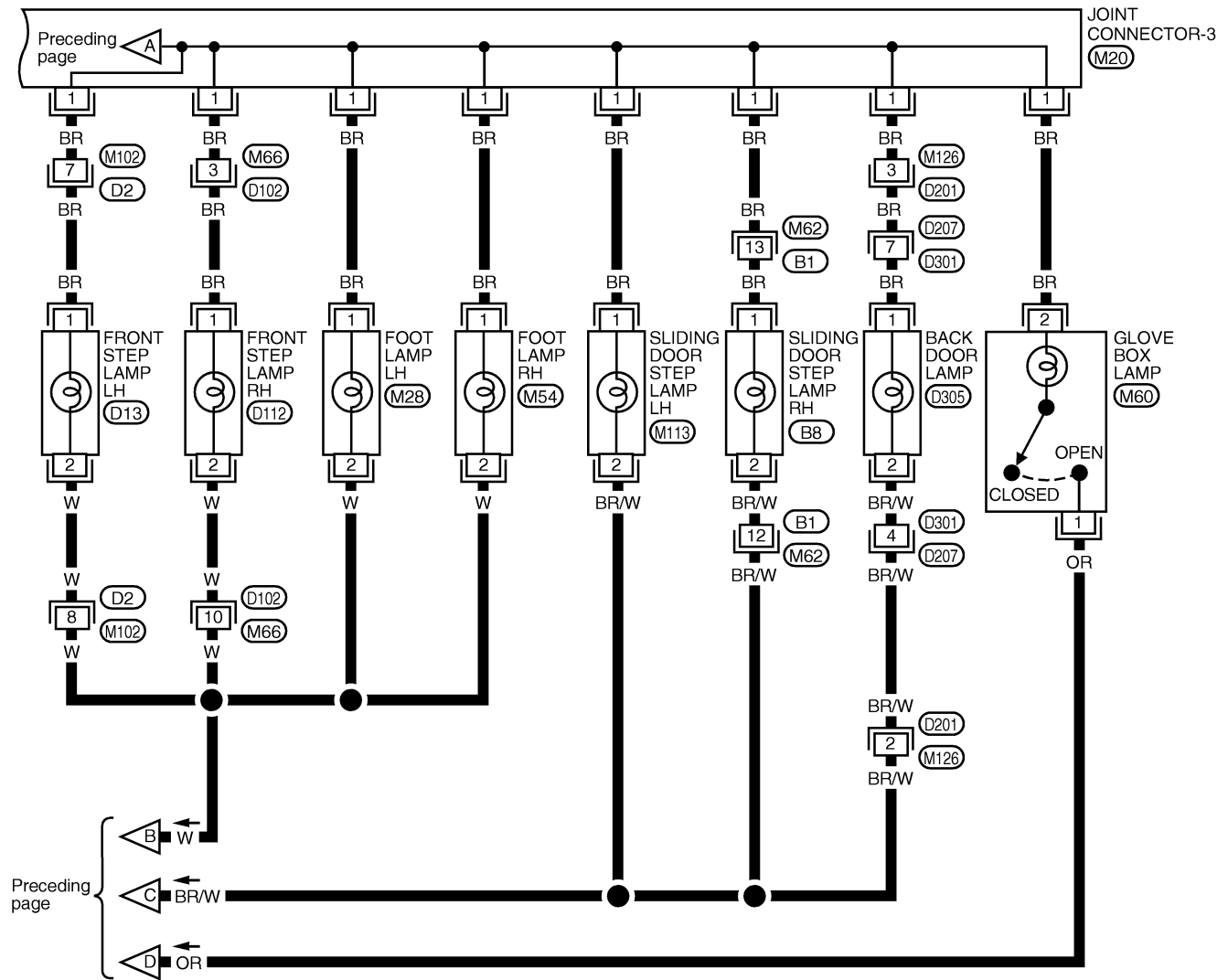

Refer to the following.
 M20 - JOINT CONNECTOR

WEL205

INTERIOR ROOM LAMP

Wiring Diagram — INT/L — (Cont'd)

EL-INT/L-03

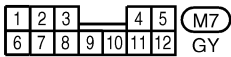
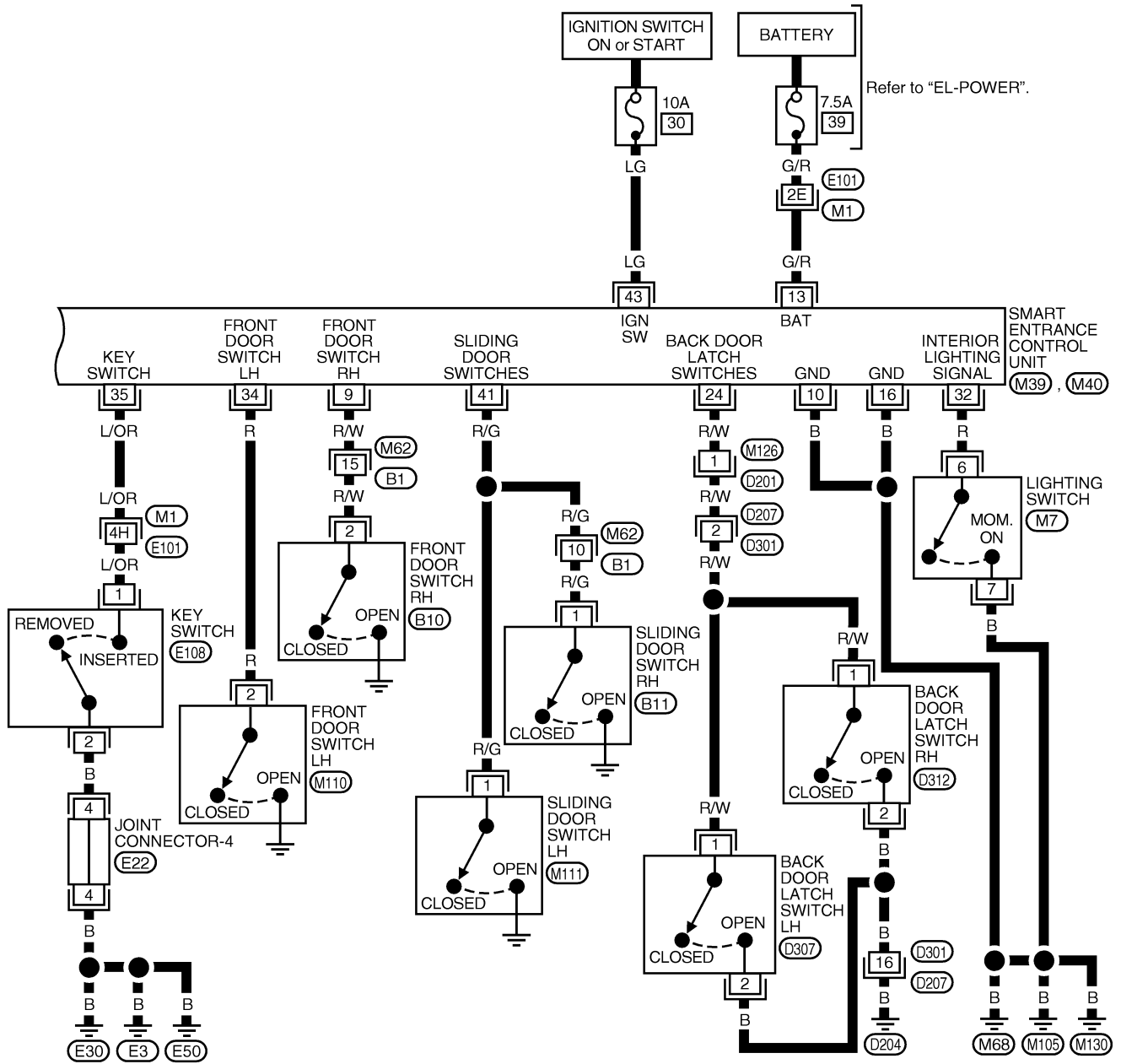

Refer to the following.
 (M1), (E101) - SUPER MULTIPLE JUNCTION (SMJ)
 (E22) - JOINT CONNECTOR

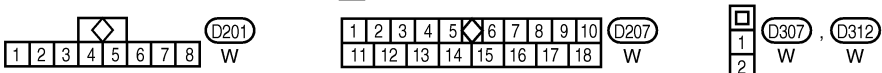
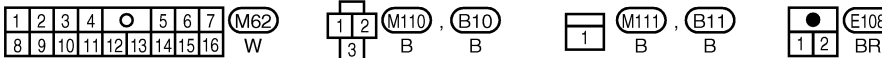
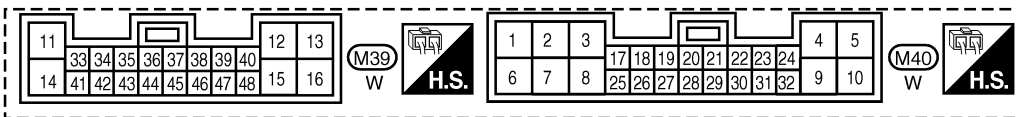

WEL206

INTERIOR ROOM LAMP

Trouble Diagnoses

Trouble Diagnoses

SYMPTOM: Interior room lamp does not turn on or off properly. NDEL0044

1	CHECK INTERIOR ROOM LAMP FUSE	
Check 15 A fuse (No. 21, located in fuse block).		
OK or NG		
OK	▶	GO TO 2.
NG	▶	Replace fuse and check harness for short between fuse and interior room lamps.

2	CHECK LIGHTING SWITCH (INTERIOR) SIGNAL	
1. Close all doors, turn ignition switch to ON position and push lighting switch. Do interior room lamps turn on?		
2. Push lighting switch again. Do interior room lamps turn off?		
OK or NG		
OK	▶	GO TO 3.
NG	▶	Check the following. <ul style="list-style-type: none"> ● Lighting switch ● Lighting switch ground circuit ● Harness for open or short between lighting switch and smart entrance control unit

3	CHECK INTERIOR ROOM LAMP POWER SUPPLY															
Check voltage between room lamp terminals and ground																
AEL867B																
<table border="1" style="margin: auto; border-collapse: collapse;"> <thead> <tr> <th rowspan="2"></th> <th colspan="2">Terminals</th> <th rowspan="2">Voltage [V]</th> </tr> <tr> <th>(+)</th> <th>(-)</th> </tr> </thead> <tbody> <tr> <td>Front room lamp</td> <td style="text-align: center;">1</td> <td style="text-align: center;">Ground</td> <td style="text-align: center;">Approx. 12</td> </tr> <tr> <td>Rear room lamp</td> <td style="text-align: center;">1</td> <td style="text-align: center;">Ground</td> <td style="text-align: center;">Approx. 12</td> </tr> </tbody> </table>				Terminals		Voltage [V]	(+)	(-)	Front room lamp	1	Ground	Approx. 12	Rear room lamp	1	Ground	Approx. 12
	Terminals			Voltage [V]												
	(+)	(-)														
Front room lamp	1	Ground	Approx. 12													
Rear room lamp	1	Ground	Approx. 12													
AEL868B																
OK or NG																
OK	▶	GO TO 4.														
NG	▶	Check harness for open between fuse and interior room lamps.														

INTERIOR ROOM LAMP

Trouble Diagnoses (Cont'd)

4	CHECK INTERIOR ROOM LAMP BULB		
Check interior room lamp bulb.			
OK or NG			
OK	▶	GO TO 5.	
NG	▶	Replace bulb.	

5	CHECK KEY SWITCH (INSERTED) AND IGNITION ON SIGNAL		
1. Insert key into ignition key cylinder. 2. Open front door LH. Does warning chime sound? 3. Turn ignition key to ON position. Does warning chime stop sounding?			
OK or NG			
OK	▶	GO TO 6.	
NG	▶	Check "WARNING CHIME" system, refer to EL-100.	

6	CHECK DOOR SWITCH INPUT SIGNAL																																					
Check voltage between smart entrance control unit terminals and ground.																																						
AEL869B																																						
<table border="1" style="width: 100%; border-collapse: collapse;"> <thead> <tr> <th rowspan="2"></th> <th colspan="2">Terminals</th> <th rowspan="2">Door condition</th> <th rowspan="2">Voltage [V] (Approx.)</th> </tr> <tr> <th>(+)</th> <th>(-)</th> </tr> </thead> <tbody> <tr> <td rowspan="2">Front door switch LH</td> <td rowspan="2">34</td> <td rowspan="2">Ground</td> <td>Open</td> <td>0</td> </tr> <tr> <td>Closed</td> <td>1.5</td> </tr> <tr> <td rowspan="2">Front door switch RH</td> <td rowspan="2">9</td> <td rowspan="2">Ground</td> <td>Open</td> <td>0</td> </tr> <tr> <td>Closed</td> <td>1.5</td> </tr> <tr> <td rowspan="2">Sliding door switch LH and RH</td> <td rowspan="2">41</td> <td rowspan="2">Ground</td> <td>Open</td> <td>0</td> </tr> <tr> <td>Closed</td> <td>1.5</td> </tr> <tr> <td rowspan="2">Back door latch switch LH and RH</td> <td rowspan="2">24</td> <td rowspan="2">Ground</td> <td>Open</td> <td>0</td> </tr> <tr> <td>Closed</td> <td>1.5</td> </tr> </tbody> </table>					Terminals		Door condition	Voltage [V] (Approx.)	(+)	(-)	Front door switch LH	34	Ground	Open	0	Closed	1.5	Front door switch RH	9	Ground	Open	0	Closed	1.5	Sliding door switch LH and RH	41	Ground	Open	0	Closed	1.5	Back door latch switch LH and RH	24	Ground	Open	0	Closed	1.5
	Terminals		Door condition		Voltage [V] (Approx.)																																	
	(+)	(-)																																				
Front door switch LH	34	Ground	Open	0																																		
			Closed	1.5																																		
Front door switch RH	9	Ground	Open	0																																		
			Closed	1.5																																		
Sliding door switch LH and RH	41	Ground	Open	0																																		
			Closed	1.5																																		
Back door latch switch LH and RH	24	Ground	Open	0																																		
			Closed	1.5																																		
WEL547A																																						
OK or NG																																						
OK	▶	Check harness for open or short between smart entrance control unit and interior room lamps.																																				
NG	▶	Check the following. <ul style="list-style-type: none"> ● Door switch ● Door switch ground condition ● Harness for open or short between door switch and smart entrance control unit 																																				

GI
 MA
 EM
 LC
 EC
 FE
 AT
 AX
 SU
 BR
 ST
 RS
 BT
 HA
 SC
 EL
 IDX

METERS AND GAUGES

Component Parts and Harness Connector Location

Component Parts and Harness Connector Location

NDEL0045

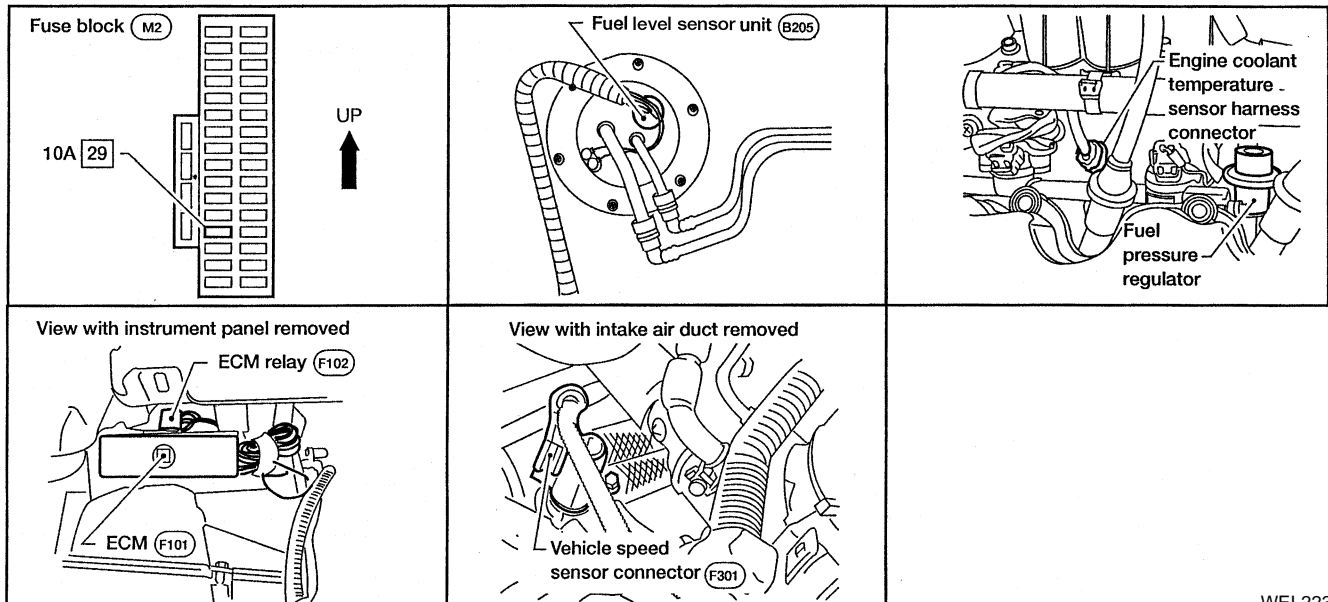

WEL223

System Description

NDEL0046

POWER SUPPLY AND GROUND CIRCUIT

NDEL0046S01

With the ignition switch in the ON or START position, power is supplied

- through 10A fuse (No. 29, located in the fuse block)
- to combination meter terminals 14 and 33.

Ground is supplied

- to combination meter terminals 17 and 30
- through body ground M51.

WATER TEMPERATURE GAUGE

NDEL0046S02

The water temperature gauge indicates the engine coolant temperature. The reading on the gauge is based on the resistance of the thermal transmitter.

As the temperature of the coolant increases, the resistance of the thermal transmitter decreases. A variable ground is supplied to terminal 13 of the combination meter for the water temperature gauge. The needle on the gauge moves from "C" to "H".

TACHOMETER

NDEL0046S03

The tachometer indicates engine speed in revolutions per minute (rpm).

The tachometer is regulated by a signal

- from terminal 3 of the ECM
- to combination meter terminal 29 for the tachometer.

FUEL GAUGE

NDEL0046S04

The fuel gauge indicates the approximate fuel level in the fuel tank.

The fuel gauge is regulated by a variable ground signal supplied

- to combination meter terminal 20 for the fuel gauge
- from terminal 5 of the fuel level sensor unit
- through terminal 6 of the fuel level sensor unit and
- through body grounds M68, M105 and M130.

SPEEDOMETER

NDEL0046S05

The vehicle speed sensor sends a voltage signal to the combination meter for the speedometer.

Pulsed ground is supplied

- to combination meter terminal 32 for the speedometer

METERS AND GAUGES

System Description (Cont'd)

- from terminal 1 of the vehicle speed sensor.

The speedometer converts the pulsed ground into the vehicle speed displayed.

GI

MA

EM

LC

EC

FE

AT

AX

SU

BR

ST

RS

BT

HA

SC

EL

IDX

METERS AND GAUGES

Combination Meter

Combination Meter

NDEL0047

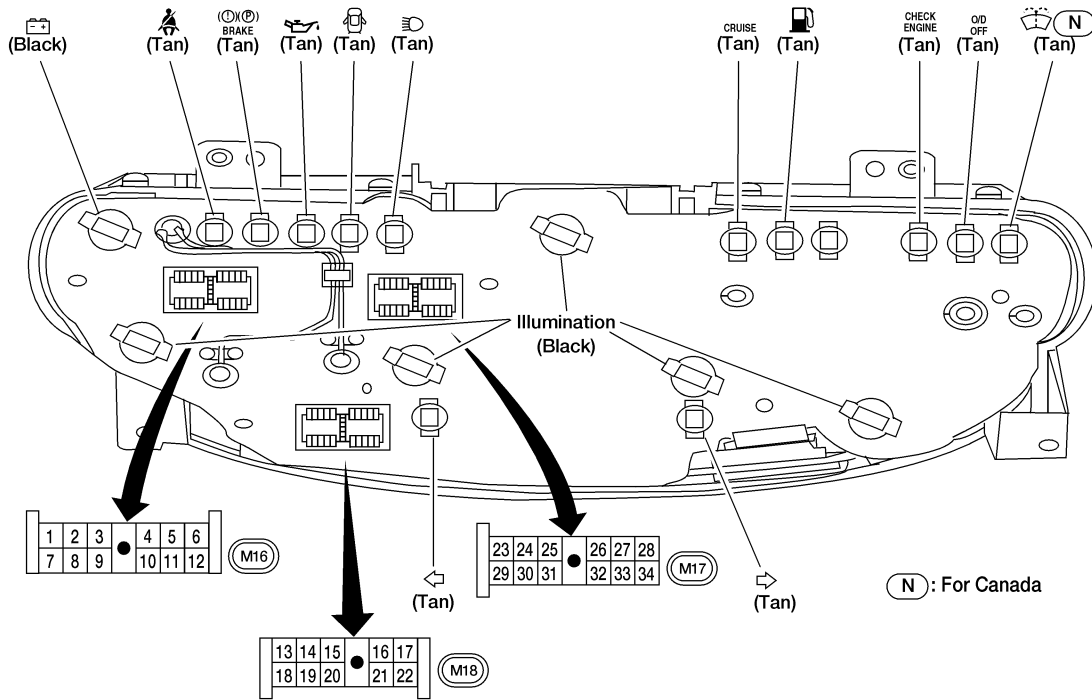
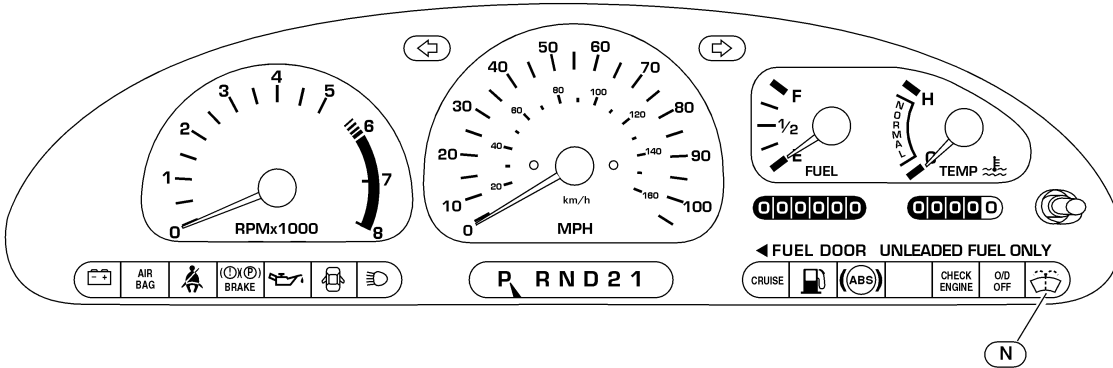

Bulb socket color	Bulb wattage
Tan	1.3w
Black	3.8w

(): Bulb socket color

WEL317

METERS AND GAUGES

Combination Meter (Cont'd)

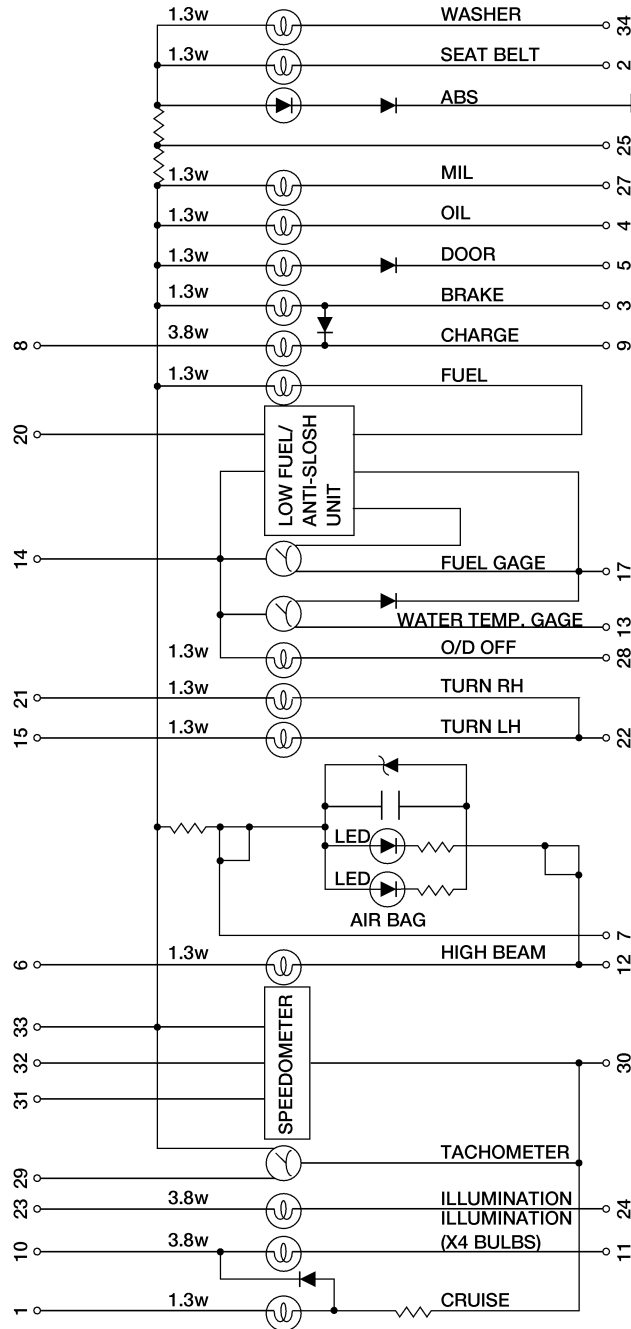

GI

MA

EM

LC

EC

FE

AT

AX

SU

BR

ST

RS

BT

HA

SC

EL

IDX

WEL318

METERS AND GAUGES

Wiring Diagram — METER —

Wiring Diagram — METER —

NDEL0048

EL-METER-01

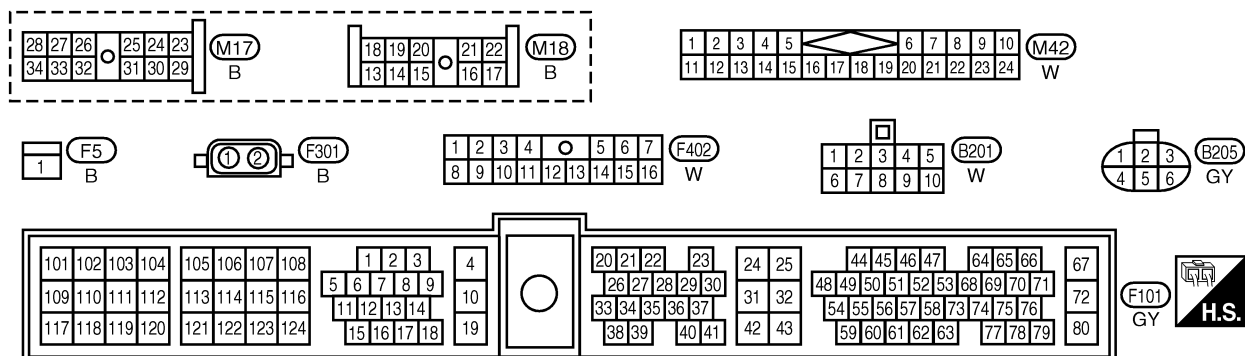
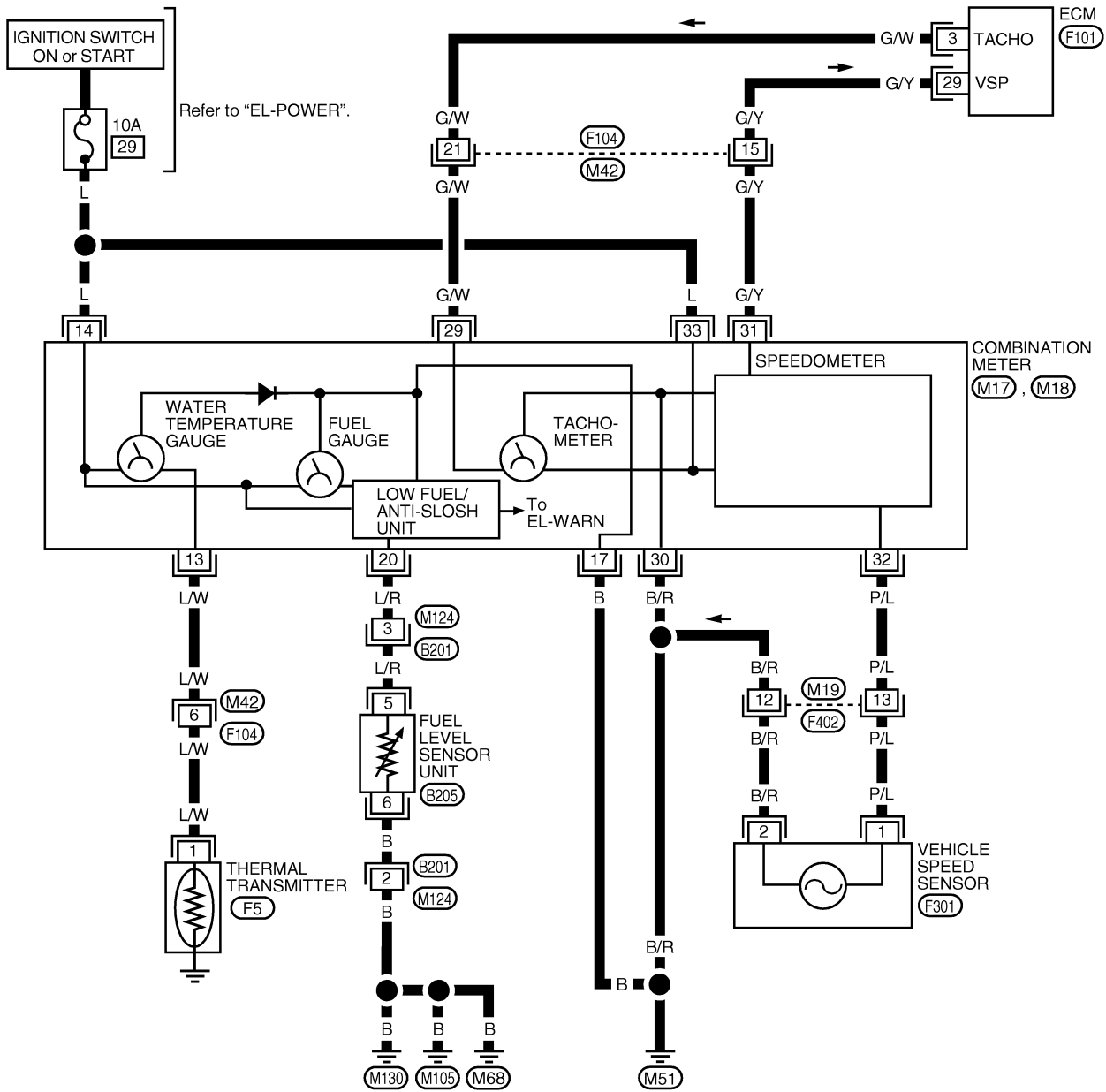

WEL207

Trouble Diagnoses SYMPTOM CHART

NDEL0049

NDEL0049S01

Symptom	Diagnoses procedure	Reference page
Speedometer is malfunctioning.	POWER SUPPLY AND GROUND CIRCUIT CHECK	EL-85
	INSPECTION/VEHICLE SPEED SENSOR	EL-86
Tachometer is malfunctioning.	INSPECTION/ENGINE REVOLUTION SIGNAL	EL-88
Fuel tank gauge is malfunctioning.	POWER SUPPLY AND GROUND CIRCUIT CHECK	EL-85
	INSPECTION/FUEL LEVEL SENSOR UNIT	EL-89
Water temperature gauge is malfunctioning.	POWER SUPPLY AND GROUND CIRCUIT CHECK	EL-85
	INSPECTION/THERMAL TRANSMITTER	EL-90

GI

MA

EM

LC

EC

FE

AT

AX

SU

BR

ST

RS

BT

HA

SC

EL

IDX

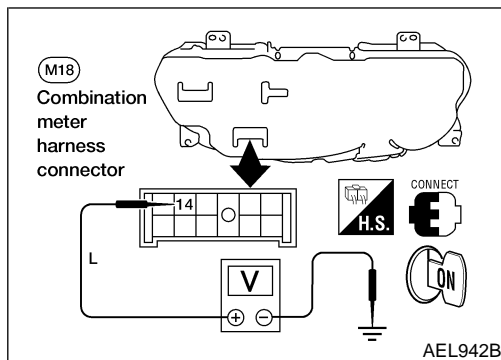

POWER SUPPLY AND GROUND CIRCUIT CHECK Power Supply Circuit Check

NDEL0049S02

NDEL0049S0201

Terminals		Ignition switch position		
(+)	(-)	OFF	ON	START
14	Ground	0 V	Battery voltage	Battery voltage
33	Ground	0 V	Battery voltage	Battery voltage

If NG, check the following

- 10A fuse (No. 29, located in fuse block)
- Harness for open or short between fuse and combination meter.

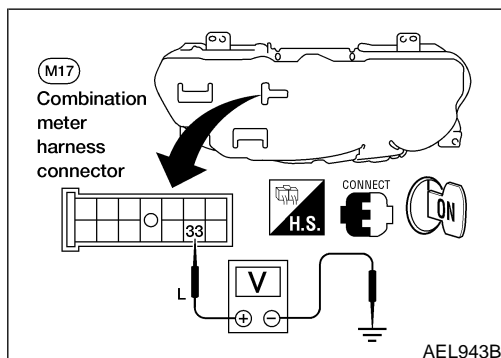

METERS AND GAUGES

Trouble Diagnoses (Cont'd)

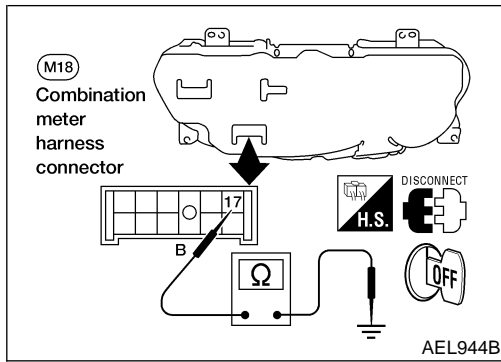

Ground Circuit Check

NDEL0049S0202

Terminals	Continuity
17 - Ground	Yes
30 - Ground	Yes

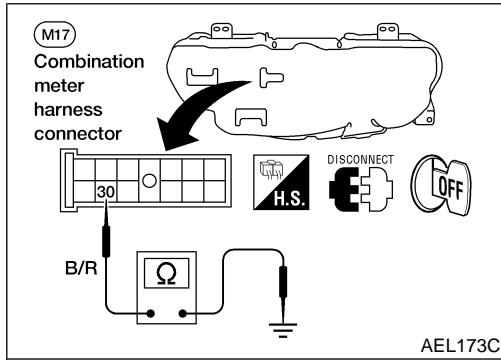

INSPECTION/VEHICLE SPEED SENSOR

NDEL0049S03

1 CHECK VEHICLE SPEED SENSOR OUTPUT

1. Remove vehicle speed sensor from transaxle.
2. Check voltage between combination meter terminals 30 and 32 while quickly turning speed sensor pinion.

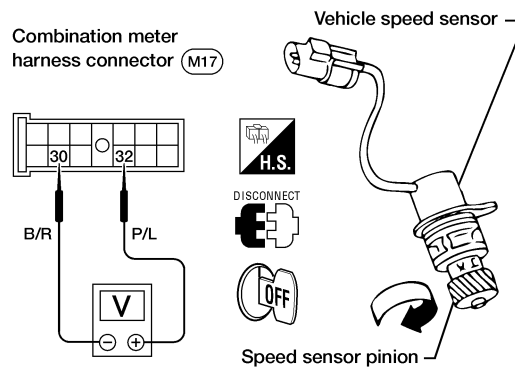



Voltage: Approx. 0.5 V

OK or NG

OK	▶	Vehicle speed sensor is OK.
NG	▶	GO TO 2.

METERS AND GAUGES

Trouble Diagnoses (Cont'd)

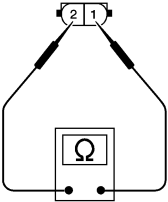
2	CHECK VEHICLE SPEED SENSOR		
<p>Check resistance between vehicle speed sensor terminals 1 and 2.</p> <p style="text-align: center;">Vehicle speed sensor connector (F301)</p> <div style="display: flex; justify-content: center; align-items: center;"> <div style="text-align: center; margin-right: 20px;">    </div> <div style="text-align: center;">  </div> </div> <p style="text-align: right;">AEL757A</p> <p style="color: blue; font-weight: bold;">Resistance: Approx. 250Ω</p> <p style="text-align: center;">OK or NG</p>			GI MA EM LC EC FE AT AX SU BR ST RS BT HA SC EL IDX
OK	▶	Check harness or connector between speedometer and vehicle speed sensor.	
NG	▶	Replace vehicle speed sensor.	

METERS AND GAUGES

Trouble Diagnoses (Cont'd)

INSPECTION/ENGINE REVOLUTION SIGNAL

=NDEL0049S04

1 CHECK ECM OUTPUT

1. Start engine.
2. Check voltage between combination meter terminals 29 and 30 at idle and 2,000 rpm.

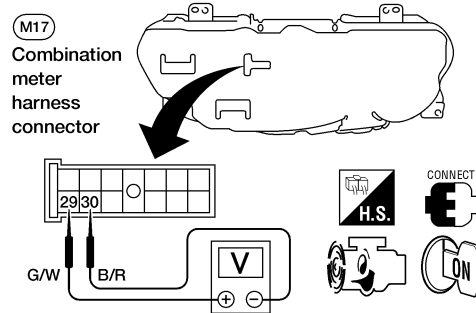

Higher rpm = Higher voltage
 Lower rpm = Lower voltage
 Voltage should change with rpm.

AEL946B

OK or NG

OK	▶	Engine revolution signal is OK.
NG	▶	Check harness for open or short between ECM and combination meter.

METERS AND GAUGES

Trouble Diagnoses (Cont'd)

INSPECTION/FUEL LEVEL SENSOR UNIT

=NDEL0049S05

1	CHECK GAUGE OPERATION	<p>1. Disconnect fuel level sensor unit connector. 2. Turn ignition switch ON. 3. Check gauge operation. Gauge should move smoothly to full scale. 4. Connect terminals 5 and 6 with wire for less than 10 seconds. 5. Check gauge operation.</p> <div style="display: flex; justify-content: space-around; align-items: flex-start;"> <div style="text-align: center;"> <p>Fuel level sensor unit (B205)</p> </div> <div style="text-align: center;"> <p>Fuel level sensor unit (B205)</p> </div> </div> <p style="text-align: right;">WEL235</p> <p style="text-align: center;">Gauge should move smoothly to empty scale.</p> <p style="text-align: center;">OK or NG</p>	
OK	▶	GO TO 2.	
NG	▶	Check the following. <ul style="list-style-type: none"> ● Low fuel/anti-slosh unit ● Combination meter 	

2	CHECK GAUGE UNITS	<p>Refer to "FUEL LEVEL SENSOR UNIT CHECK", EL-90.</p> <p style="text-align: center;">OK or NG</p>	
OK	▶	Fuel level sensor is OK.	
NG	▶	Replace fuel level sensor unit.	

GI

MA

EM

LC

EC

FE

AT

AX

SU

BR

ST

RS

BT

HA

SC

EL

IDX

METERS AND GAUGES

Trouble Diagnoses (Cont'd)

INSPECTION/THERMAL TRANSMITTER

=NDEL0049S06

1	CHECK THERMAL TRANSMITTER
Refer to "THERMAL TRANSMITTER CHECK", EL-91.	
OK or NG	
OK	▶ GO TO 2.
NG	▶ Replace thermal transmitter.

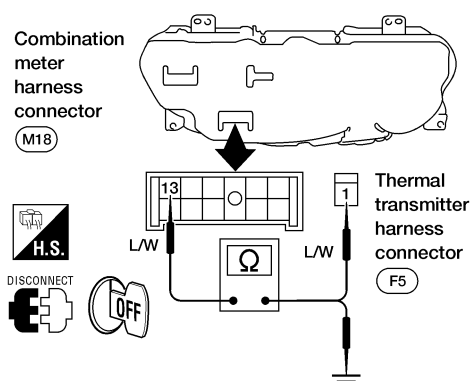
2	CHECK HARNESS FOR OPEN OR SHORT
<p>1. Disconnect combination meter connector and thermal transmitter connector.</p> <p>2. Check continuity between combination meter terminal 13 and thermal transmitter terminal 1. Continuity should exist.</p> <p>3. Check continuity between combination meter terminal 13 and ground. Continuity should not exist.</p>	
	
OK or NG	
OK	▶ Thermal transmitter is OK.
NG	▶ Repair harness or connector.

AEL947B

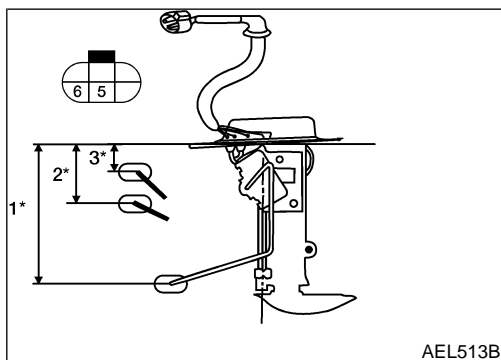

AEL513B

Electrical Component Inspection FUEL LEVEL SENSOR UNIT CHECK

NDEL0050

- For removal, refer to "FUEL PUMP AND GAUGE", **FE-6**.

NDEL0050S01

Check the resistance between terminals 5 and 6.

Ohmmeter		Float position mm (in)		Resistance value (Ω)	
(+)	(-)				
5	6	*3	Full	22.5 (0.89)	Approx. 160.0
		*2	1/2	81.3 (3.20)	Approx. 84.0
		*1	Empty	150.5 (5.93)	Approx. 15.0

METERS AND GAUGES

Electrical Component Inspection (Cont'd)

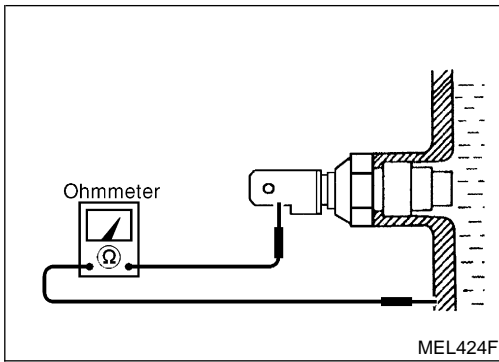

THERMAL TRANSMITTER CHECK

NDEL0050S02

Check the resistance between the terminals of thermal transmitter and body ground.

Water temperature	Resistance value
75°C (167°F)	Approx. 179 - 219 Ω
100°C (212°F)	Approx. 60 - 72 Ω

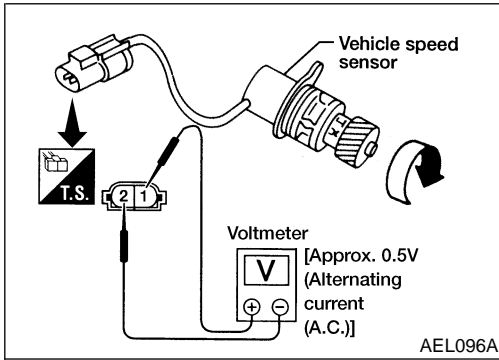

VEHICLE SPEED SENSOR SIGNAL CHECK

NDEL0050S03

1. Remove vehicle speed sensor from transaxle.
2. Turn vehicle speed sensor pinion quickly and measure voltage across terminals 1 and 2.

GI

MA

EM

LC

EC

FE

AT

AX

SU

BR

ST

RS

BT

HA

SC

EL

IDX

WARNING LAMPS

System Description

System Description

NDEL0051

POWER SUPPLY AND GROUND CIRCUIT

NDEL0051S01

With the ignition switch in the ON or START position, power is supplied

- through 10A fuse (No. 29, located in the fuse block)
- to combination meter terminals 33, 14, 8 and
- bulb check relay terminal 1.

Ground is supplied

- to combination meter terminal 12,
- fuel tank gauge unit terminal 6 and
- seat belt buckle switch terminal 2
- through body ground M68, M105 and M130.

Ground is supplied to combination meter terminal 17 through body ground M51.

Ground is supplied

- to bulb check relay terminal 3,
- brake fluid level switch terminal 2 and
- washer fluid level switch terminal 1
- through body grounds E3, E30 and E50.

AIR BAG WARNING LAMP

NDEL0051S02

During prove out or when an air bag malfunction occurs, the ground path is interrupted

- from the air bag diagnosis sensor unit terminal 15
- to combination meter terminal 7.

Ground is then supplied

- to combination meter terminal 12
- through body grounds M68, M105 and M130.

With power and ground supplied, the air bag warning lamp (LEDs) illuminates or flashes. For further information, refer to RS section.

O/D OFF INDICATOR LAMP

NDEL0051S03

During prove out or when overdrive is cancelled, ground is supplied

- to combination meter terminal 28
- from TCM (transmission control module) terminal 13.

With power and ground supplied, O/D off indicator lamp illuminates.

When TCM detects malfunctioning, the indicator flashes. For further information, refer to **AT-35**.

LOW FUEL LEVEL WARNING LAMP

NDEL0051S04

The amount of fuel in the fuel tank is determined by a float in the tank. A signal is sent from fuel level sensor terminal 5 to combination meter terminal 20. The low fuel/anti-slosh unit will illuminate the low fuel level warning lamp when the fuel level is low.

DOOR AJAR WARNING LAMP

NDEL0051S05

When a door is open, ground is supplied to the smart entrance control unit at terminals 9, 24, 34 or 41.

Ground is then supplied

- to combination meter terminal 5
- from smart entrance control unit terminal 14.

With power and ground supplied, the door ajar warning lamp illuminates.

LOW WASHER FLUID LEVEL WARNING LAMP

NDEL0051S06

When the washer fluid level is low, ground is supplied

- to combination meter terminal 34
- from washer fluid level switch terminal 2.

With power and ground supplied, the low washer fluid level warning lamp illuminates.

WARNING LAMPS

System Description (Cont'd)

LOW OIL PRESSURE WARNING LAMP

NDEL0051S07

Low oil pressure, causes the oil pressure switch terminal 1 to provide ground to combination meter terminal 4.

With power and ground supplied, the low oil pressure warning lamp illuminates.

GI

BRAKE WARNING LAMP

NDEL0051S08

When the parking brake is applied or the brake fluid level is low, ground is supplied

- to combination meter terminal 3
- from parking brake switch terminal 1 or
- brake fluid level switch terminal 1.

With power and ground supplied, the brake warning lamp illuminates.

MA

EM

CHARGE WARNING LAMP

NDEL0051S09

During prove out or when a generator malfunction occurs, ground is supplied

- to combination meter terminal 9
- from generator terminal 3.

With power and ground supplied, the charge warning lamp illuminates.

LC

EC

FE

BULB CHECK RELAY (BRAKE WARNING LAMP PROVE OUT)

NDEL0051S10

When the ignition switch is in the ON or START position, and with the engine not running, ground is supplied

- to bulb check relay terminal 2
- from generator terminal 3.

With power and ground supplied, the bulb check relay is energized, providing a ground path for the brake warning lamp. With power and ground supplied, the brake warning lamp illuminates.

AT

AX

SEAT BELT WARNING LAMP

NDEL0051S11

When the driver's seat belt is unfastened, ground is supplied

- to combination meter terminal 2
- from seat belt buckle switch terminal 1.

With power and ground supplied, the seat belt warning lamp illuminates.

SU

BR

ST

MALFUNCTION INDICATOR LAMP

NDEL0051S12

During prove out or when an engine control malfunction occurs, ground is supplied

- to combination meter terminal 27
- from ECM terminal 18.

With power and ground supplied, the malfunction indicator lamp illuminates.

For further information, refer to **EC-65**.

RS

BT

ABS WARNING LAMP

NDEL0051S13

During prove out or when an ABS malfunction occurs, ground is interrupted

- to combination meter terminal 25
- from ABS actuator and electric unit (control unit) terminal 21.

With power and ground supplied, the ABS warning lamp illuminates.

For further information, refer to **BR-31**.

HA

SC

EL

IDX

WARNING LAMPS

Schematic

NDEL0052

Schematic

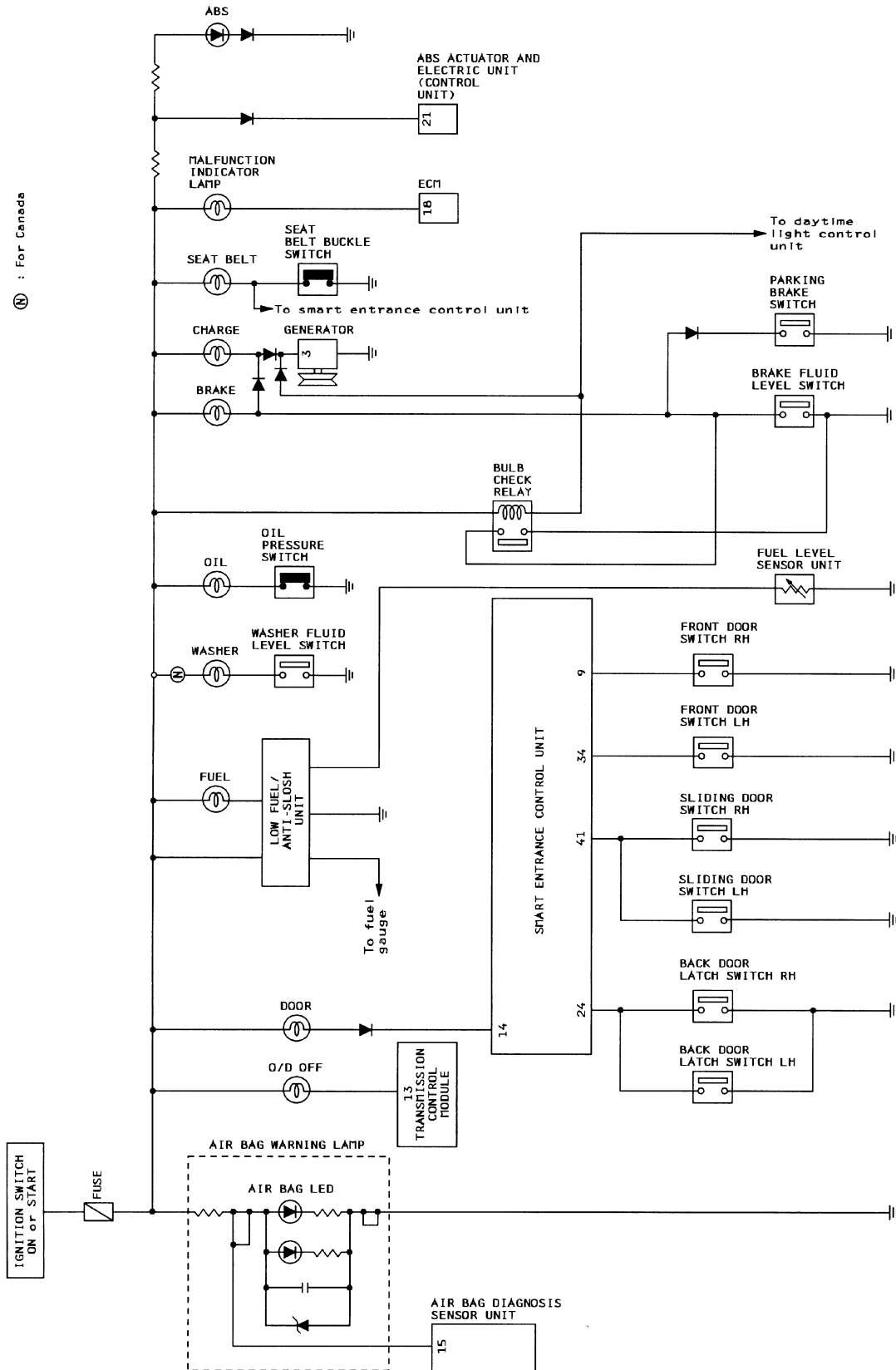

WEL208

WARNING LAMPS

Wiring Diagram — WARN —

Wiring Diagram — WARN —

NDEL0053

EL-WARN-01

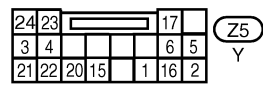
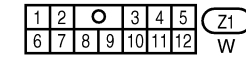
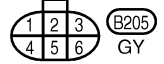
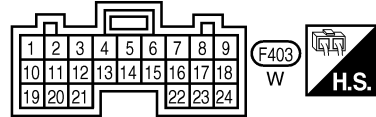
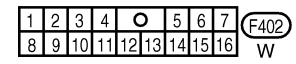
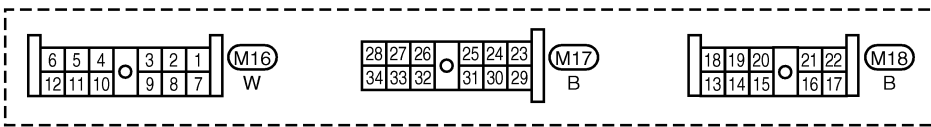
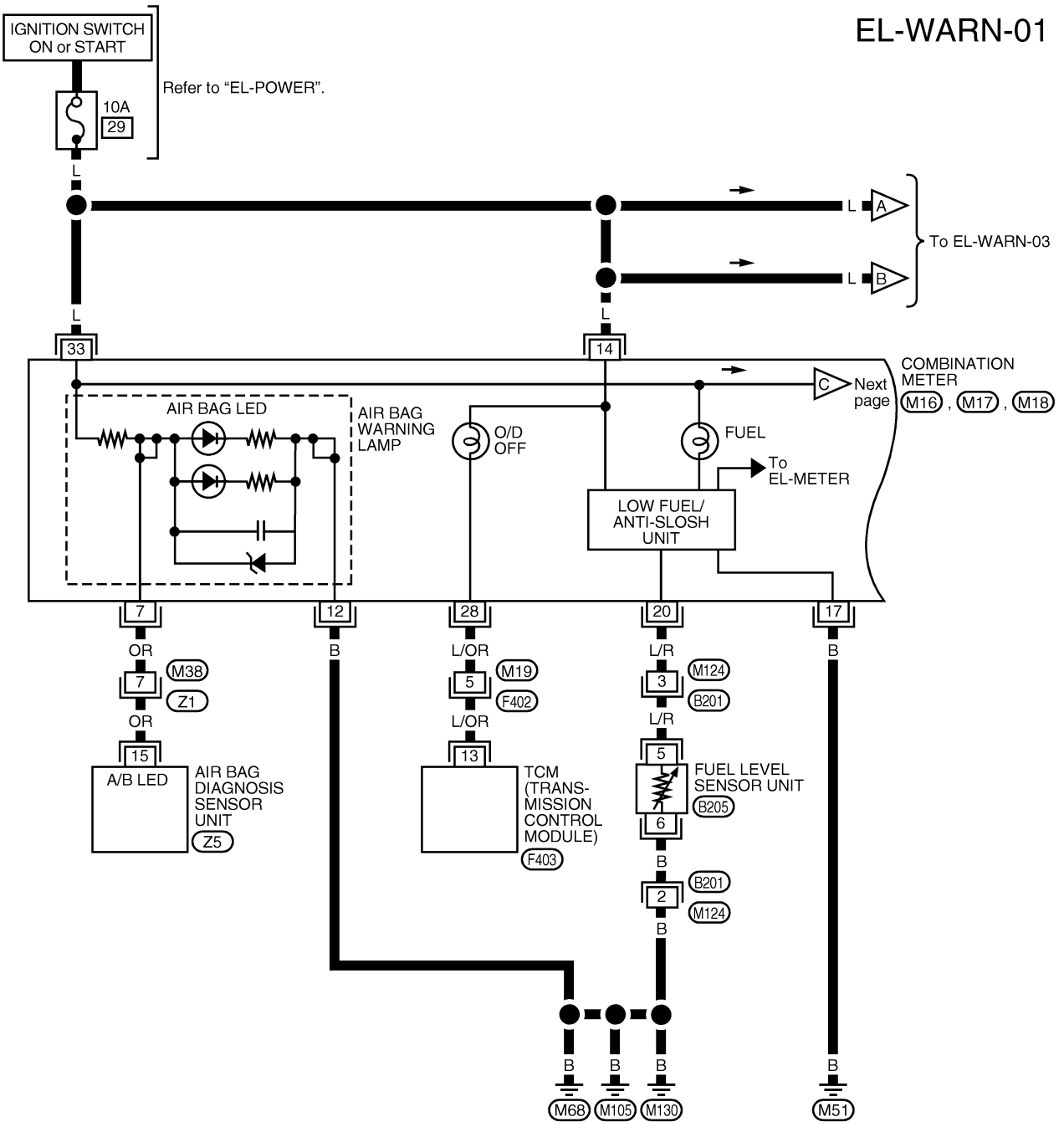

GI
MA
EM
LC
EC
FE
AT
AX
SU
BR
ST
RS
BT
HA
SC

EL

IDX

WARNING LAMPS

Wiring Diagram — WARN — (Cont'd)

(N) : For Canada

EL-WARN-02

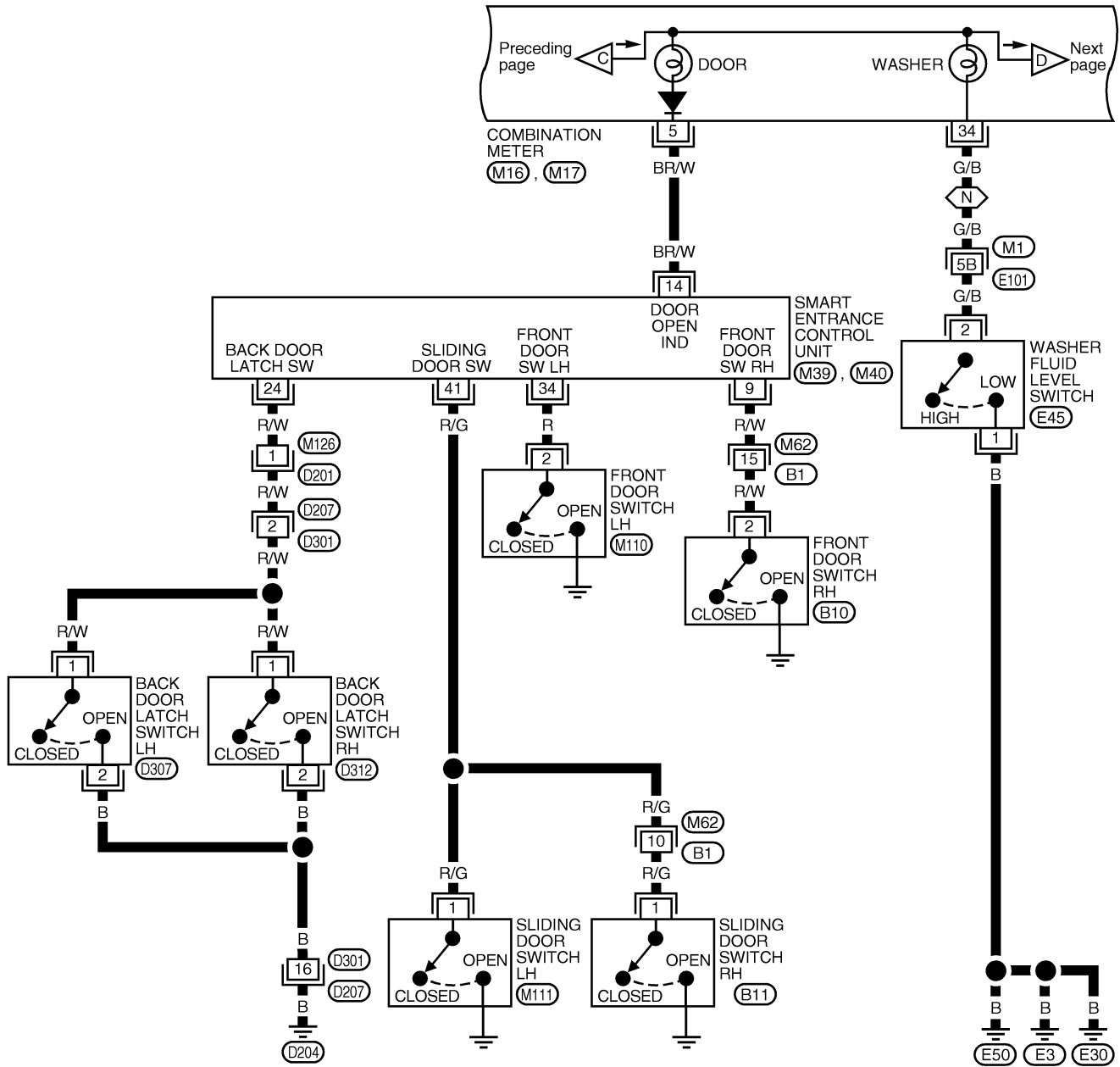

Refer to the following.
 (M1), (E101) - SUPER MULTIPLE JUNCTION (SMJ)

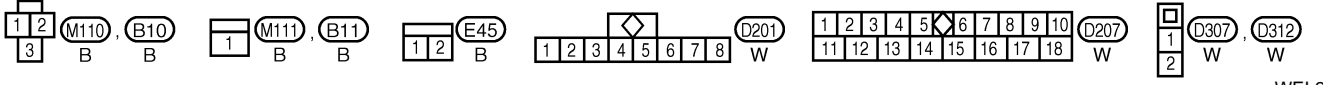
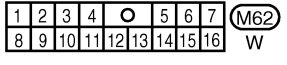
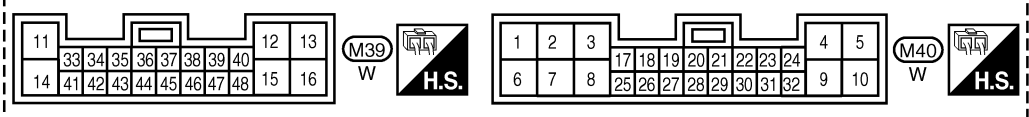
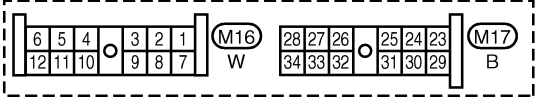

WEL210

WARNING LAMPS

Wiring Diagram — WARN — (Cont'd)

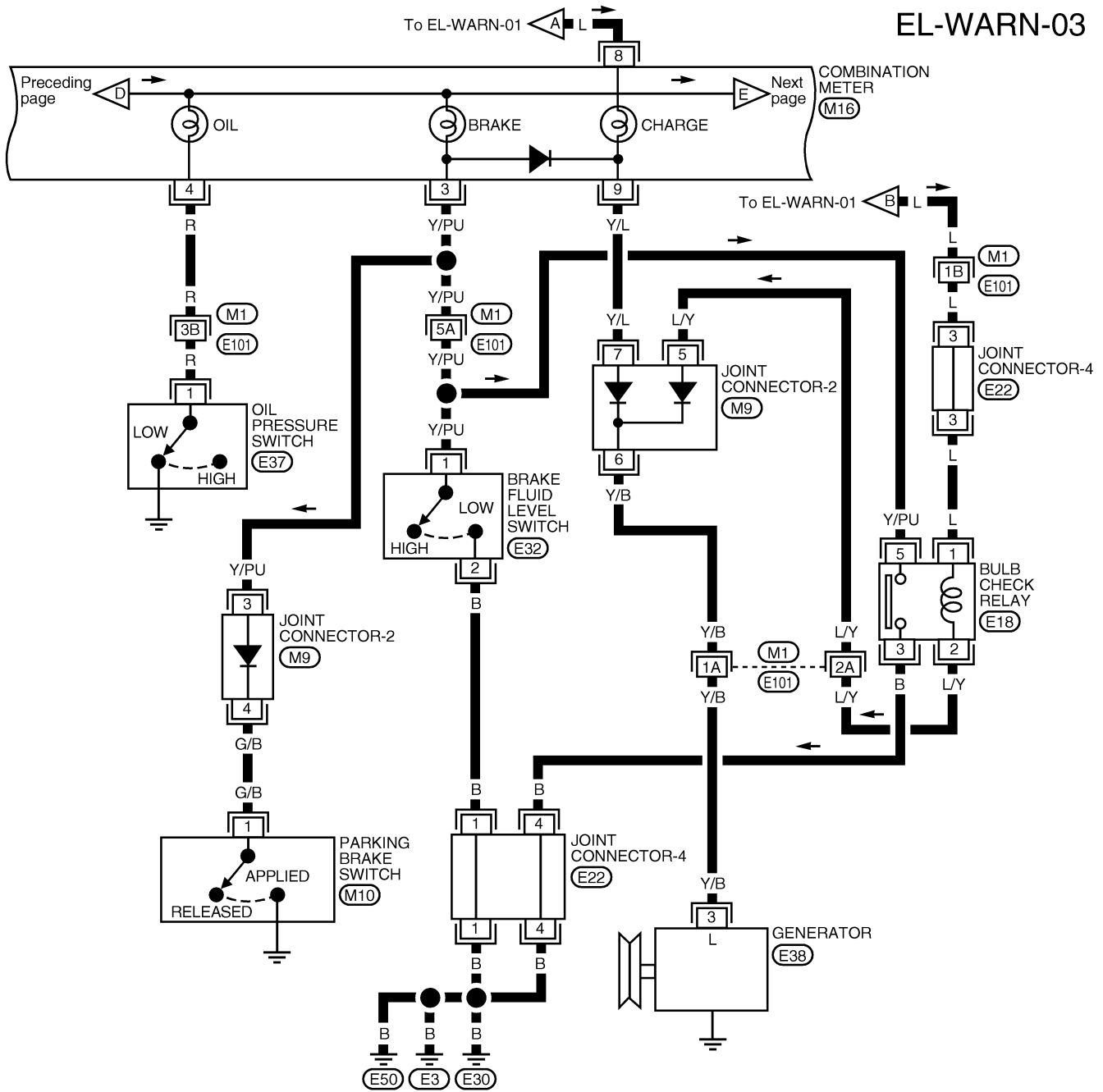

GI
MA
EM
LC
EC
FE
AT
AX
SU
BR
ST
RS
BT
HA
SC

EL

IDX

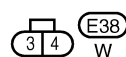
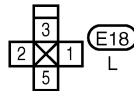
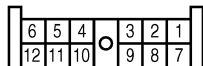
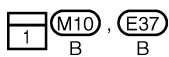

Refer to the following.

(M1), (E101) - SUPER MULTIPLE JUNCTION (SMJ)

(M9) - JOINT CONNECTOR

(E22) - JOINT CONNECTOR

WEL211

WARNING LAMPS

Wiring Diagram — WARN — (Cont'd)

EL-WARN-04

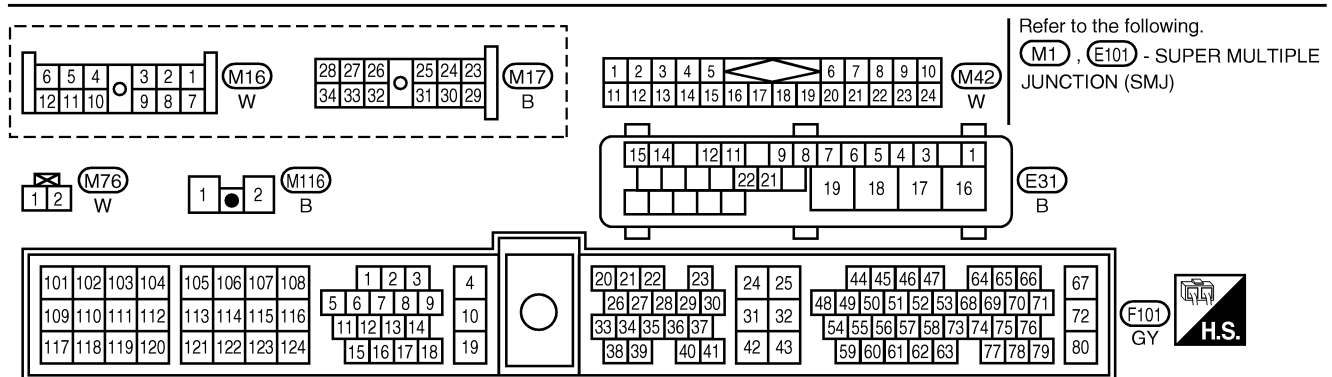
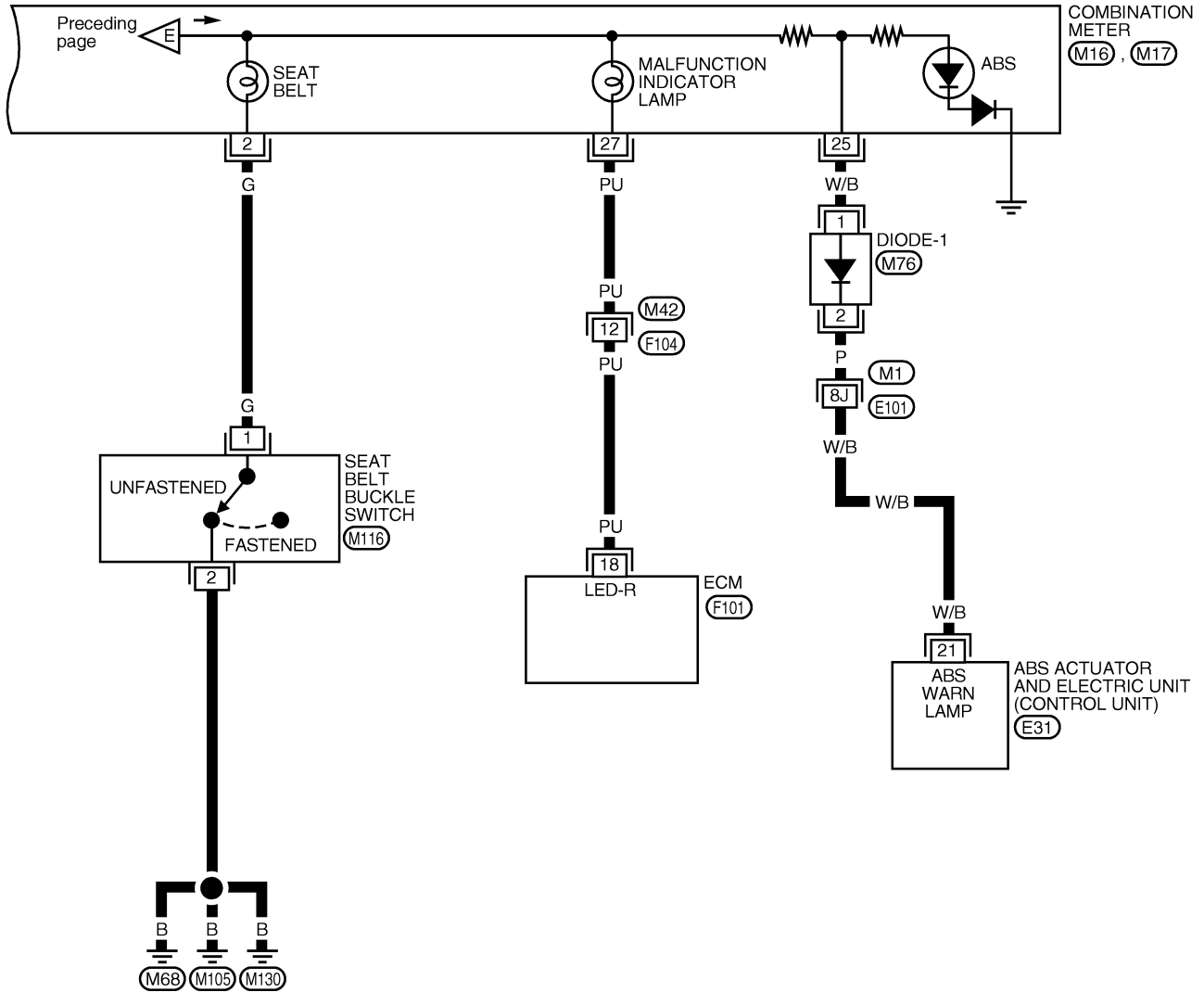

WEL212

Electrical Component Inspection

FUEL WARNING LAMP SENSOR CHECK

NDEL0054

NDEL0054S01

- The low fuel level warning lamp is controlled by the low fuel/anti-slosh unit, which is built into the combination meter. If the low fuel level warning lamp fails to illuminate, first check the fuel level sensor unit, refer to "INSPECTION/FUEL LEVEL SENSOR UNIT" EL-89. If the fuel level sensor unit is operating properly, inspect the low fuel level warning lamp bulb and anti-slosh unit for proper function.

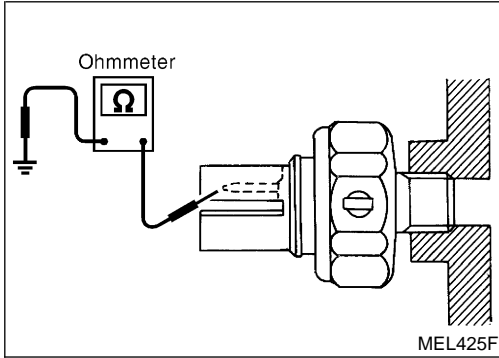

OIL PRESSURE SWITCH CHECK

NDEL0054S02

	Oil pressure kPa (kg/cm ² , psi)	Continuity
Engine start	More than 10 - 20 (0.1 - 0.2, 1 - 3)	NO
Engine stop	Less than 10 - 20 (0.1 - 0.2, 1 - 3)	YES

Check the continuity between the terminals of oil pressure switch and body ground.

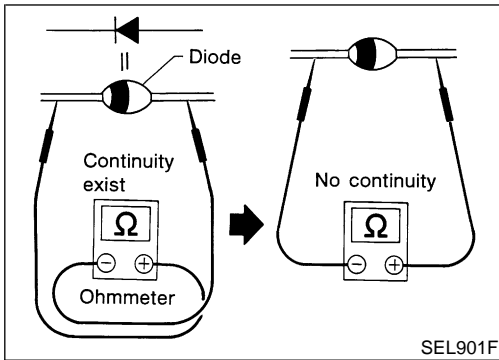

DIODE CHECK

NDEL0054S03

- Check continuity using an ohmmeter.
- Diode is functioning properly if test results are as shown in the figure at left.
- Check diodes at the combination meter harness connector instead of on the combination meter assembly. Refer to "Wiring Diagram—WARN—", EL-95.

NOTE:

Specifications may vary depending on the type of tester. Before performing this inspection, be sure to refer to the instruction manual for your tester.

GI

MA

EM

LC

EC

FE

AT

AX

SU

BR

ST

RS

BT

HA

SC

EL

IDX

WARNING CHIME

Component Parts and Harness Connector Location

Component Parts and Harness Connector Location

NDEL0055

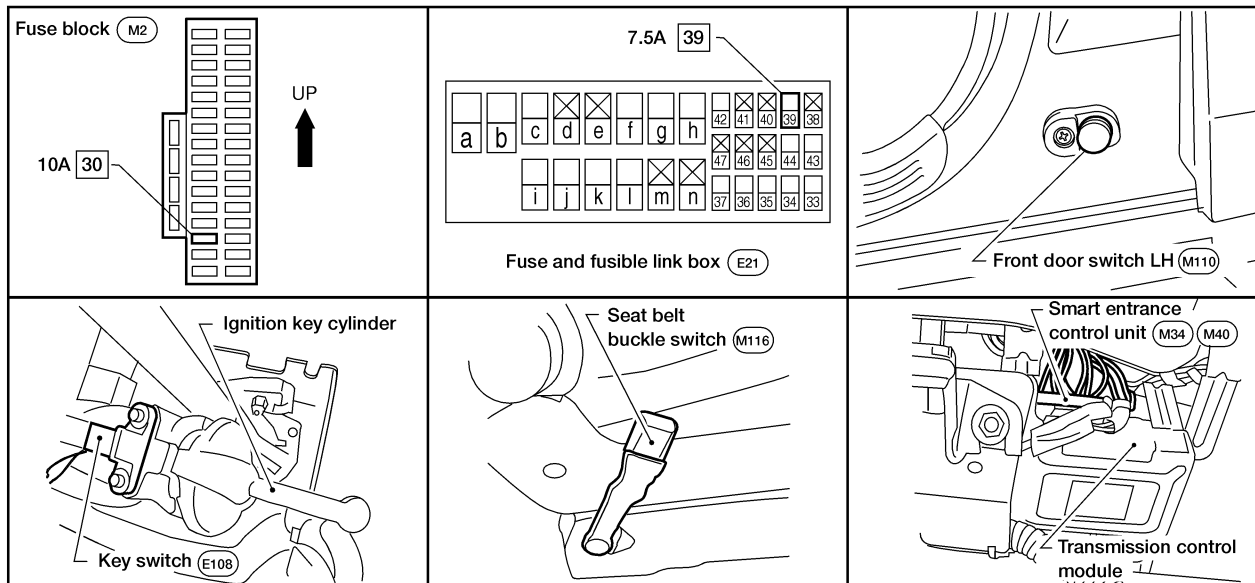

WEL281

System Description

NDEL0056

POWER SUPPLY AND GROUND CIRCUIT

NDEL0056S01

The warning chime is integrated with the smart entrance control unit, which controls its operation. Power is supplied at all times

- through 7.5A fuse (No. 39, located in the fuse and fusible link box)
- to smart entrance control unit terminal 13.

With the ignition switch in the ON or START position, power is supplied

- through 10A fuse (No. 30, located in the fuse block)
- to smart entrance control unit terminal 43.

Ground is supplied to smart entrance control unit terminal 10 through body grounds M68, M105 and M130. When a signal, or combination of signals, is received by the smart entrance control unit, the warning chime will sound.

IGNITION KEY WARNING CHIME

NDEL0056S02

With the key in and the ignition switch in the OFF or ACC position, and the front door LH open, the warning chime will sound. Ground is supplied

- from key switch terminal 1
- to smart entrance control unit terminal 35 and
- from front door switch LH terminal 2
- to smart entrance control unit terminal 34.

Key switch terminal 2 is grounded through body grounds E3, E30 and E50.

LIGHT WARNING CHIME

NDEL0056S03

With ignition switch OFF or ACC, front door LH open, and lighting switch in 1ST or 2ND position, warning chime will sound. Ground is supplied

- from lighting switch terminal 3
- to smart entrance control unit terminal 26 and
- from front door switch LH terminal 2
- to smart entrance control unit terminal 34.

Lighting switch terminal 7 is grounded through body grounds M68, M105 and M130.

WARNING CHIME

System Description (Cont'd)

SEAT BELT WARNING CHIME

With ignition switch turned ON and seat belt unfastened (seat belt buckle switch ON), warning chime will sound for approximately 6 seconds.

Ground is supplied

- from seat belt buckle switch terminal 1
- to smart entrance control unit terminal 38.

Seat belt buckle switch terminal 2 is grounded through body grounds M68, M105 and M130.

GI

MA

EM

LC

EC

FE

AT

AX

SU

BR

ST

RS

BT

HA

SC

EL

IDX

WARNING CHIME

Wiring Diagram — CHIME —

Wiring Diagram — CHIME —

NDEL0057

EL-CHIME-01

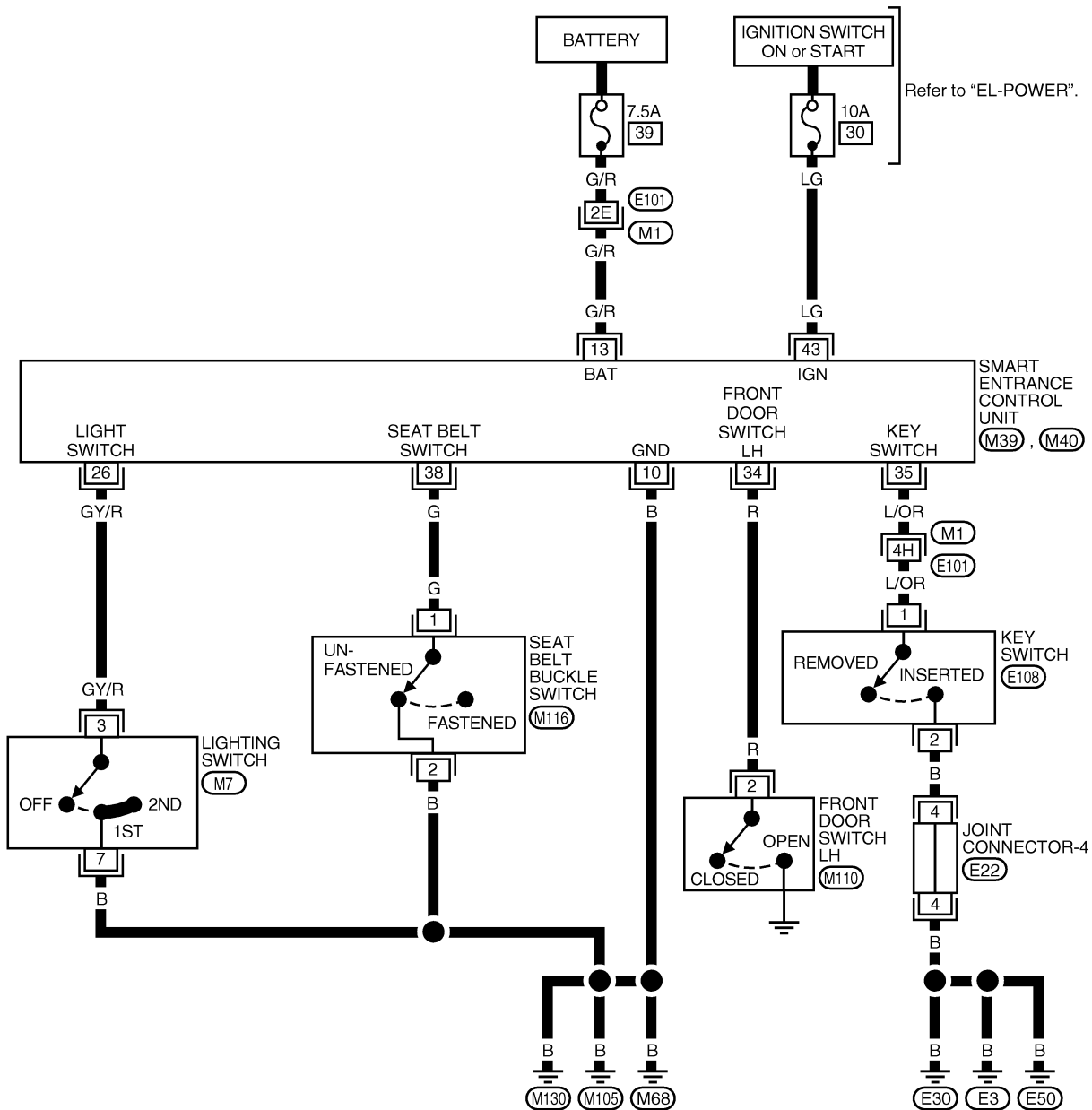

Refer to "EL-POWER".

SMART ENTRANCE CONTROL UNIT (M39, M40)

Refer to the following.
 (M1, E101) - SUPER MULTIPLE JUNCTION (SMJ)
 (E22) - JOINT CONNECTOR

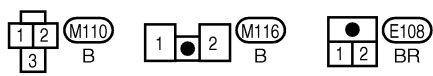
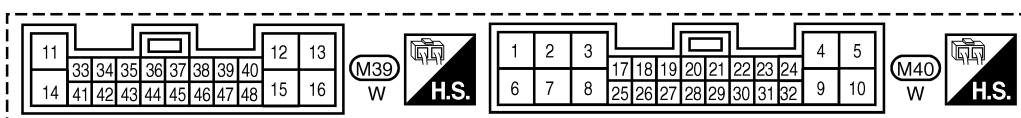
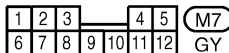

WEL213

WARNING CHIME

Trouble Diagnoses

Trouble Diagnoses SYMPTOM CHART

NDEL0058

NDEL0058S01

REFERENCE PAGE (EL-)	103	104	104	106	107
SYMPTOM	POWER SUPPLY AND GROUND CIRCUIT CHECK	LIGHTING SWITCH INPUT SIGNAL CHECK	KEY SWITCH (INSERTED) CHECK	SEAT BELT BUCKLE SWITCH CHECK	FRONT DOOR SWITCH LH CHECK
Light warning chime does not activate.	X	X			X
Ignition key warning chime does not activate.	X		X		X
Seat belt warning chime does not activate.	X			X	
All warning chimes do not activate.	X				X

GI
MA
EM
LC
EC
FE
AT
AX
SU
BR

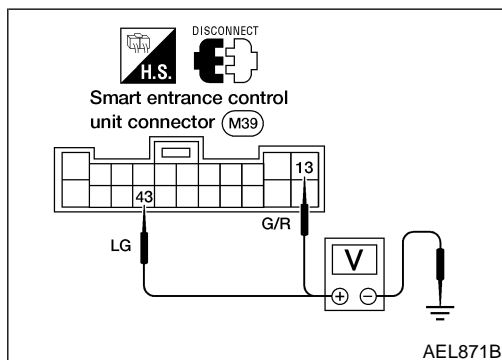

POWER SUPPLY AND GROUND CIRCUIT CHECK Power Supply Circuit Check

NDEL0058S02

NDEL0058S0201

Terminals		Ignition switch position		
(+)	(-)	OFF	ACC	ON
13	Ground	Battery voltage	Battery voltage	Battery voltage
43	Ground	0V	0V	Battery voltage

ST
RS
BT
HA
SC
EL

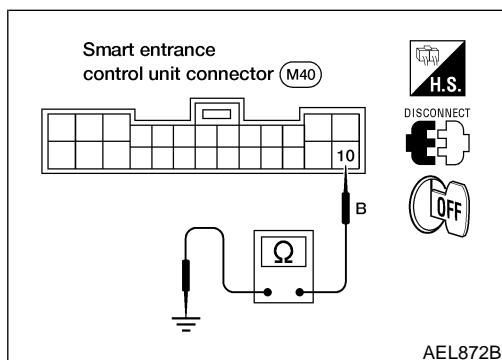

Ground Circuit Check

NDEL0058S0202

Terminals	Continuity
10 - Ground	YES

IDX

WARNING CHIME

Trouble Diagnoses (Cont'd)

LIGHTING SWITCH INPUT SIGNAL CHECK

NDEL0058S03

1	CHECK LIGHTING SWITCH INPUT SIGNAL	
Check voltage between control unit terminal 26 and ground.		
<p>Voltage [V]: Condition of lighting switch: 1ST or 2ND 0 Condition of lighting switch: OFF Approx 12</p>		
OK or NG		
OK	▶	Lighting switch is OK.
NG	▶	<p>Check to following.</p> <ul style="list-style-type: none"> ● Lighting switch ● Lighting switch ground circuit ● Harness for open or short between control unit and lighting switch

AEL873B

KEY SWITCH (INSERTED) CHECK

NDEL0058S04

1	CHECK KEY SWITCH INPUT SIGNAL	
Check voltage between control unit terminal 35 and ground.		
<p>Voltage [V]: Condition of key switch: Key is inserted. 0 Condition of key switch: Key is withdrawn. Approx 1.5</p>		
OK or NG		
OK	▶	Key switch is OK.
NG	▶	GO TO 2.

AEL874B

WARNING CHIME

Trouble Diagnoses (Cont'd)

2	CHECK KEY SWITCH (INSERTED)	
<p>Check continuity between terminals 1 and 2.</p> <div style="text-align: center;"> </div> <p>Continuity: Condition of key switch: Key is inserted. Yes Condition of key switch: Key is withdrawn. No</p> <p style="text-align: right;">AEL875B</p> <p style="text-align: center;">OK or NG</p>		GI MA EM LC EC FE
OK	► Check the following. <ul style="list-style-type: none"> ● Key switch ground circuit ● Harness for open or short between control unit and key switch 	AT
NG	► Replace key switch.	AX

GI

MA

EM

LC

EC

FE

AT

AX

SU

BR

ST

RS

BT

HA

SC

EL

IDX

WARNING CHIME

Trouble Diagnoses (Cont'd)

SEAT BELT BUCKLE SWITCH CHECK

=NDEL0058S05

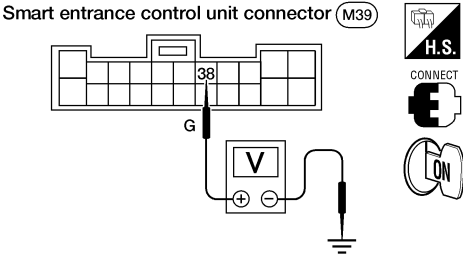
1	CHECK SEAT BELT BUCKLE SWITCH INPUT SIGNAL	
<p>1. Turn ignition switch ON. 2. Check voltage between control unit terminal 38 and ground.</p>		
		
<p>Voltage [V]: Condition of seat belt buckle switch: Fastened. Approx. 12 Condition of seat belt buckle switch: Unfastened. 0</p>		
AEL876B		
OK or NG		
OK	▶	Seat belt buckle switch is OK.
NG	▶	GO TO 2.

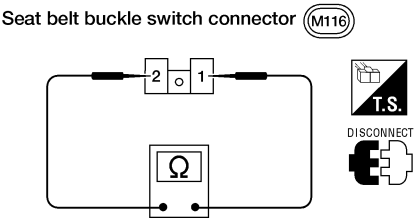
2	CHECK SEAT BELT BUCKLE SWITCH	
<p>Check continuity between terminals 1 and 2 when seat belt is fastened and unfastened.</p>		
		
<p>Continuity: Seat belt is fastened. No Seat belt is unfastened. Yes</p>		
AEL877B		
OK or NG		
OK	▶	<p>Check the following.</p> <ul style="list-style-type: none"> ● Seat belt buckle switch ground circuit ● Harness for open or short between control unit and seat belt buckle switch
NG	▶	Replace seat belt buckle switch.

WARNING CHIME

Trouble Diagnoses (Cont'd)

FRONT DOOR SWITCH LH CHECK

NDEL0058S06

1	CHECK FRONT DOOR SWITCH LH INPUT SIGNAL	<p>Check voltage between control unit terminal 34 and ground.</p> <div style="text-align: center;"> <p>Smart entrance control unit connector (M39)</p> </div> <p>Voltage [V]: Condition of front door LH: CLOSED Approx. 1.5 Condition of front door LH: OPENED 0</p> <p style="text-align: right;">AEL878B</p>	GI MA EM LC EC FE AT AX
OK or NG			
OK	▶	Front door switch LH is OK.	
NG	▶	GO TO 2.	

2	CHECK FRONT DOOR SWITCH LH	<p>Check continuity between terminal 2 and switch body.</p> <div style="text-align: center;"> <p>Front door switch LH connector (M10)</p> </div> <p>Continuity: Front door switch LH is pushed. No Front door switch LH is released. Yes</p> <p style="text-align: right;">AEL879B</p>	SU BR ST RS BT HA SC
OK or NG			
OK	▶	Check the following. <ul style="list-style-type: none"> ● Front door switch LH ground condition ● Harness for open or short between control unit and front door switch LH 	EL
NG	▶	Replace front door switch LH.	IDX

FRONT WIPER AND WASHER

System Description

System Description

NDEL0059

NDEL0059S01

WIPER OPERATION

The wiper switch is controlled by a lever built into the combination switch. There are three wiper switch positions

- LOW speed
- HIGH speed
- INT (“S” through “F”)

With the ignition switch in the ACC or ON position, power is supplied

- through 20A fuse (No. 8, located in the fuse block)
- to front wiper motor terminal 6 and
- front wiper amplifier terminal 6.

Ground is supplied to front wiper amplifier terminals 4 and 5 through body grounds E3, E30 and E50.

Low and High Speed Wiper Operation

NDEL0059S0101

When the wiper switch is placed in the LOW position, ground is supplied

- through terminal 8 of the front wiper amplifier
- to front wiper motor terminal 2.

With power and ground supplied, the wiper motor operates at low speed.

When the wiper switch is placed in the HIGH position, ground is supplied

- through terminal 10 of the front wiper amplifier
- to front wiper motor terminal 1.

With power and ground supplied, the wiper motor operates at high speed.

Auto Stop Operation

NDEL0059S0102

With wiper switch turned OFF, the front wiper motor will continue to operate until wiper arms reach windshield base.

When the wiper switch is placed in OFF position, ground is no longer supplied by the front wiper amplifier. Ground is now supplied through front wiper motor terminal 4. When wiper blades reach park position on windshield, front wiper motor ground is interrupted and the front wiper motor stops.

Intermittent Operation

NDEL0059S0103

The front wiper motor operates the wiper arms one time at low speed at an interval of approximately 1 to 14 seconds. This feature is controlled by the front wiper amplifier.

With the wiper switch in the INT position, the front wiper amplifier cycles the front wiper motor. Ground is supplied in the same manner as low speed wiper operation.

WASHER OPERATION

NDEL0059S02

With the ignition switch in the ACC or ON position, power is supplied

- through 20A fuse (No. 8, located in the fuse block)
- to front washer motor terminal 1.

When the lever is pushed to the WASH position, ground is supplied

- to front washer motor terminal 2
- from front wiper amplifier terminal 9, and
- to amplifier terminals 4 and 5
- through body grounds E3, E30 and E50.

With power and ground supplied, the front washer motor operates.

The front wiper motor is activated when the lever is pushed to WASH for 1 second or more. The motor operates at low speed for approximately 3 seconds. This feature is controlled by the front wiper amplifier in the same manner as intermittent operation.

FRONT WIPER AND WASHER

Wiring Diagram — WIPER —

Wiring Diagram — WIPER —

NDEL0060

EL-WIPER-01

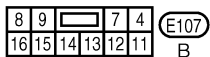
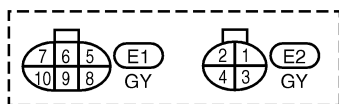
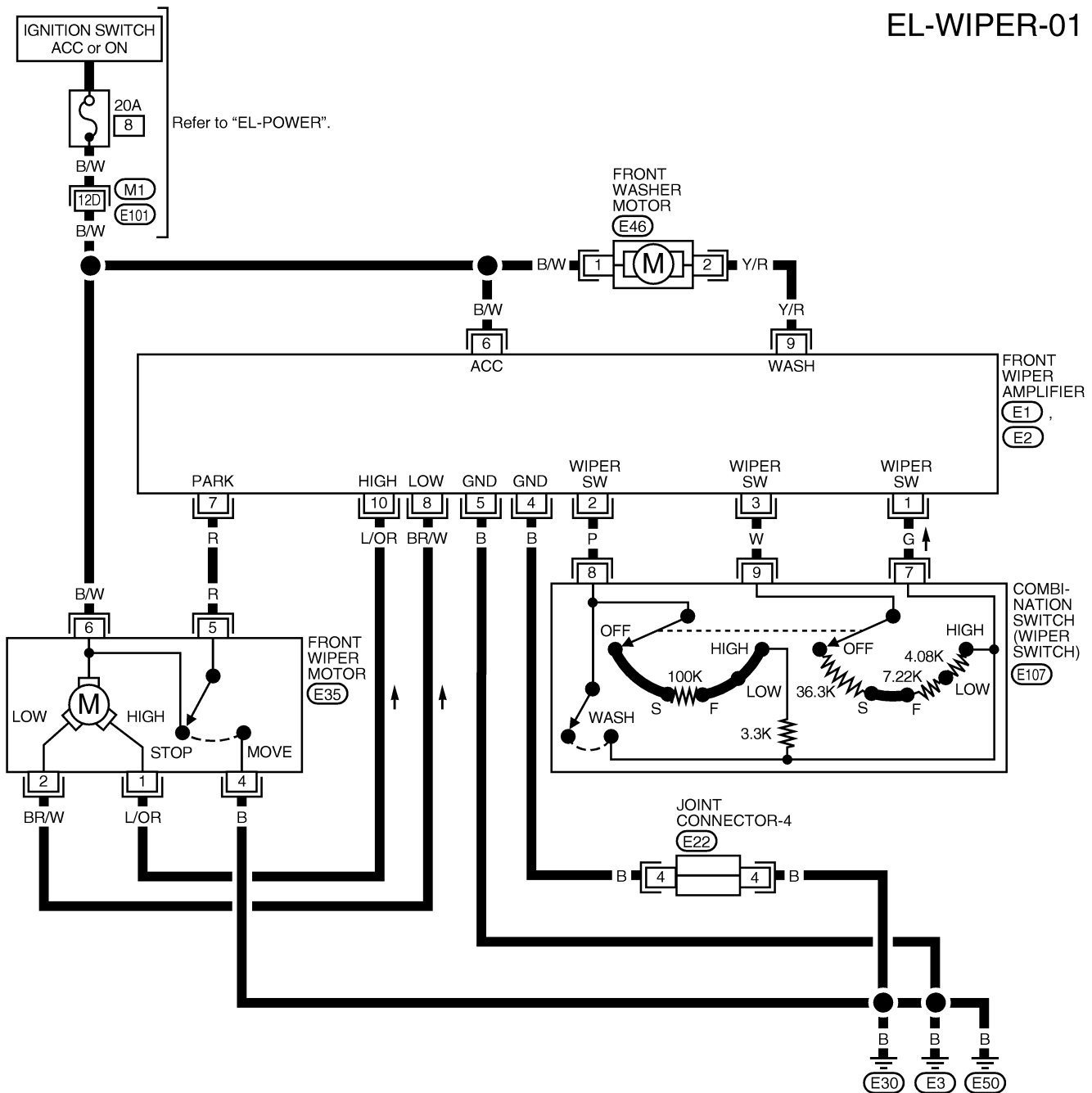

Refer to the following
 (M1), (E101) - SUPER MULTIPLE JUNCTION (SMJ)
 (E22) - JOINT CONNECTOR

GI
MA
EM
LC
EC
FE
AT
AX
SU
BR
ST
RS
BT
HA
SC

EL

IDX

FRONT WIPER AND WASHER

Trouble Diagnoses

Trouble Diagnoses

NDEL0061

FRONT WIPER AMP INSPECTION TABLE

NDEL0061S01

Terminal No.	Wire color	Ignition switch condition	Item	Condition	Voltage (Approximate value)
1	G	ACC or ON	Combination switch (wiper switch ground)	—	—
2	P	ACC or ON	Combination switch (wiper switch)	Intermittent (slow)	3.5
				Intermittent (fast)	3.5
				Low or high	3.6
3	W	ACC or ON	Combination switch (wiper switch)	Intermittent (slow)	3.3
				Intermittent (fast)	3.5
				Low or high	3.7
4	B	—	Ground	—	—
5	B	—	Ground	—	—
6	B/W	—	Power supply	Ignition switch in ACC or ON position	12
				Ignition switch in OFF position	0
7	R	ACC or ON	Front wiper motor (position switch)	When wiper blade is not in park position	0
				When wiper blade is in park position	12
8	BR/W	ACC or ON	Front wiper motor (low)	When wiper is operating at low speed	0
				All other conditions	12
9	Y/R	ACC or ON	Front washer motor	When washer motor is operating	0
				All other conditions	12
10	L/OR	ACC or ON	Front wiper motor (high)	When wiper is operating at high speed	0
				All other conditions	12

Removal and Installation

NDEL0062

REMOVAL

NDEL0062S01

1. Tilt wiper arm to upright position.
2. Pull out and hold locking lever at base of wiper arm.
3. Pull wiper arm off pivot shaft.

INSTALLATION

NDEL0062S02

1. Push wiper arm onto pivot shaft, paying attention to blind spline.
2. Tilt and hold wiper arm in upright position.
3. Push locking lever at base of wiper arm inward.

FRONT WIPER AND WASHER

Removal and Installation (Cont'd)

- Gently tilt the wiper arm downward until contacting windshield.

WIPER ARM ADJUSTMENT

NDEL0062S03

The wiper arms on this vehicle have a blind spline. The blind spline acts as an index and only allows the windshield wiper arm to be installed in one position. Therefore the wiper arms are not adjustable. If the measurement of clearance "C" is out of specification, inspect the windshield wiper motor, linkage and pivot for damage.

Clearance "C": 47 - 87 mm (1.85 - 3.43 in)

Washer Nozzle Adjustment

NDEL0149

- Operate washers and ensure that spray patterns fall within target areas illustrated.
- Adjust washer nozzle spray pattern by inserting a suitable tool (needle) into nozzle and pivoting the nozzle until spray is within target area.

Front wiper and washer

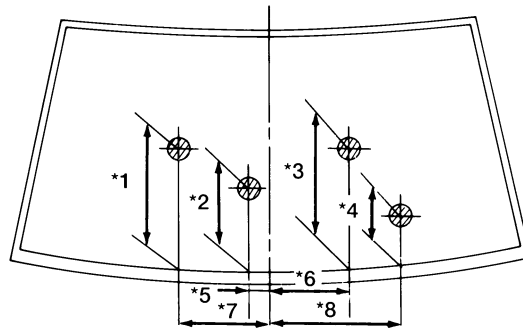

Unit: mm (in)

*1:	342 (13.5)
*2:	340 (13.4)
*3:	197 (7.8)
*4:	475 (18.7)
*5:	102 (4.0)
*6:	193 (7.6)
*7:	390 (15.4)
*8:	395 (15.6)

*Diameters of these circles are less than 60 (2.36).

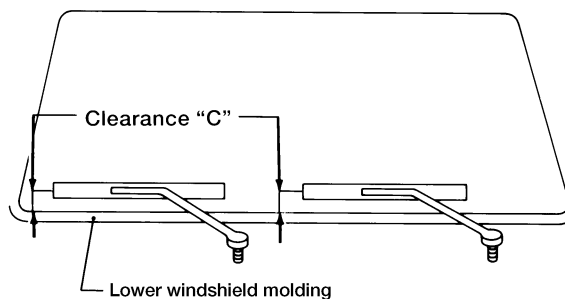

AEL179C

GI

MA

EM

LC

EC

FE

AT

AX

SU

BR

ST

RS

BT

HA

SC

EL

IDX

FRONT WIPER AND WASHER

Washer Nozzle Adjustment (Cont'd)

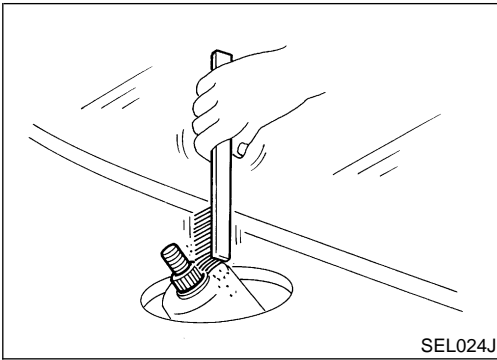

SEL024J

- Before reinstalling wiper arm, clean the pivot area as illustrated. This will ease installation and reduce possibility of wiper arm looseness.

REAR WIPER AND WASHER

System Description/Except for Glass Hatch Model

System Description/Except for Glass Hatch Model

POWER SUPPLY AND GROUND CIRCUIT

With the ignition switch in the ACC or ON position, power is supplied

- through 10A fuse (No. 9, located in the fuse block)
- to rear wiper motor terminal 1 and
- to rear washer motor terminal 1.

Ground is supplied

- to rear wiper switch terminal 4
- through body grounds M68, M105 and M130.

Ground is also supplied

- to rear wiper motor terminal 2
- through body ground D204.

WIPER OPERATION

When the rear wiper switch WIPER is in the ON position, ground is supplied

- to rear wiper motor terminal 3
- through rear wiper switch terminal 1.

WASHER OPERATION

When the rear wiper switch WASHER is in the ON position, ground is supplied

- to rear washer motor terminal 2
- through rear wiper switch terminal 5.

With power and ground supplied, the rear wiper and rear washer motor operates until the rear window wiper switch is released from the ON position. If the switch is pressed momentarily, the rear wiper motor will cycle two times.

AUTO STOP OPERATION

When the rear wiper switch is placed in the OFF position, the rear wiper motor will continue to operate until the rear wiper blade reaches the park position.

The ground circuit is now routed through the rear wiper motor terminal 2. This allows the rear wiper motor to operate until the rear wiper blade reaches the park position. The rear wiper motor ground is interrupted when the rear wiper blade reaches the park position and the rear wiper motor stops.

NDEL0063

GI

NDEL0063S01

MA

EM

LC

EC

NDEL0063S02

FE

AT

NDEL0063S03

AX

SU

BR

NDEL0063S04

ST

RS

BT

HA

SC

EL

IDX

REAR WIPER AND WASHER

Wiring Diagram — WIP/R — /Except for Glass Hatch Model

Wiring Diagram — WIP/R — /Except for Glass Hatch Model

NDEL0064

EL-WIP/R-01

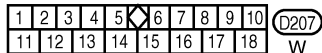
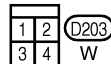
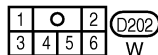
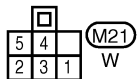
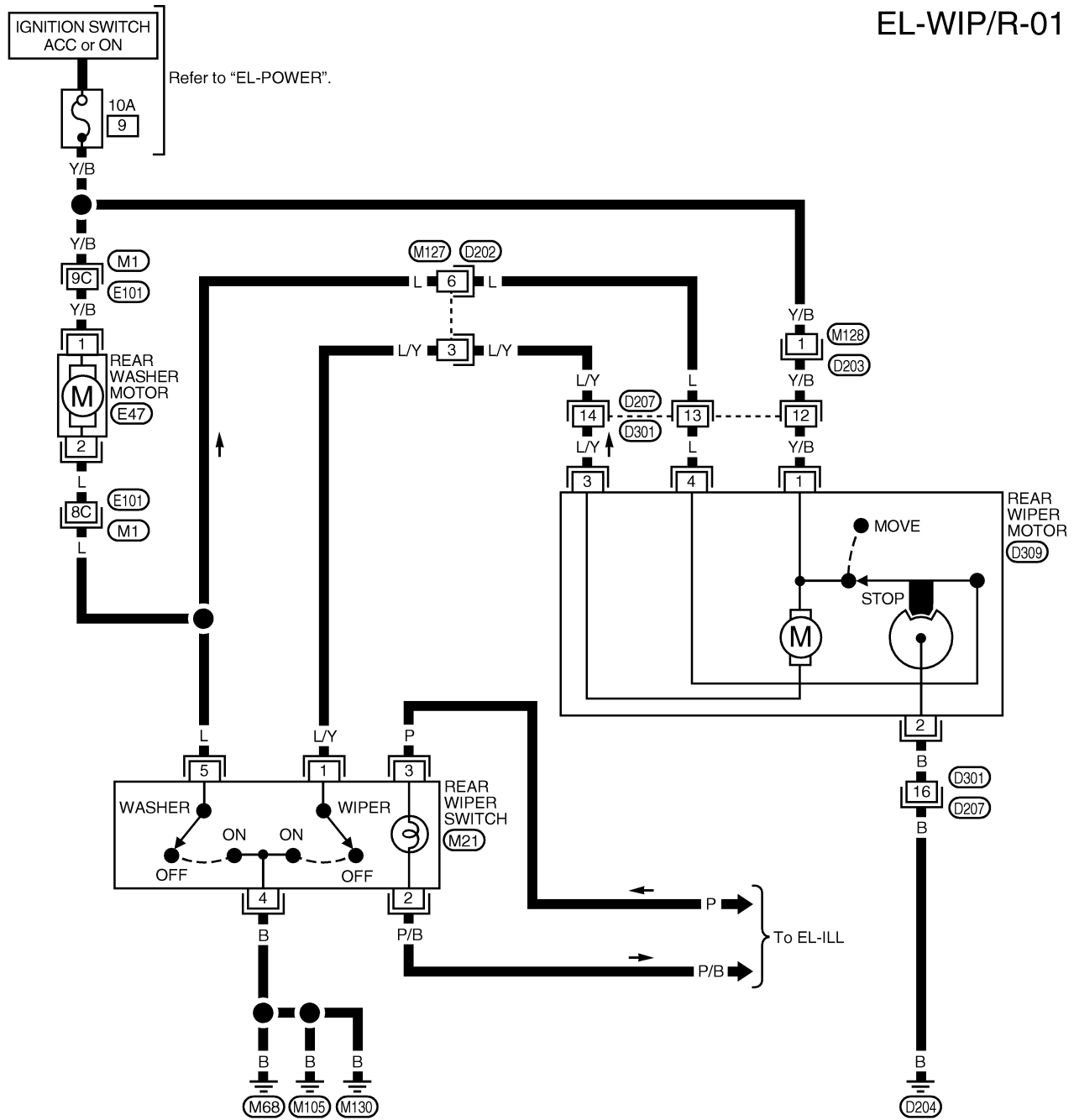

Refer to the following.

M1, E101 - SUPER MULTIPLE JUNCTION (SMJ)

WEL215

REAR WIPER AND WASHER

System Description/For Glass Hatch Model

System Description/For Glass Hatch Model

POWER SUPPLY AND GROUND CIRCUIT

NDEL0065

NDEL0065S01

Power is supplied at all times

- through 10A fuse (No. 2, located in the fuse block)
- to rear wiper motor terminal 2.

With the ignition switch in the ACC or ON position, power is supplied

- through 10A fuse (No. 9, located in the fuse block)
- to rear washer motor terminal 1 and
- rear wiper motor terminal 5.

Ground is supplied

- to glass hatch latch switch terminal 2 and
- rear wiper motor terminal 4
- through body ground D204.

Ground is also supplied

- to rear wiper switch terminal 4
- through body grounds M68, M105 and M130.

With the glass hatch open, the glass hatch latch switch closes and ground is supplied

- to rear wiper motor terminal 1
- through glass hatch latch switch terminal 1.

The rear wiper motor operates momentarily to move the wiper arm off the glass hatch so that it may be opened.

WIPER OPERATION

NDEL0065S02

When the rear wiper switch is in the ON position, ground is supplied

- to rear wiper motor terminal 6
- through rear wiper switch terminal 1.

With power and ground supplied, the rear wiper motor operates intermittently, with approximately a 15 second interval between cycles.

WASHER OPERATION

NDEL0065S03

When the rear window wiper switch washer is in the ON position, ground is supplied

- to rear wiper motor terminal 3 and
- rear washer motor terminal 2
- through rear wiper switch terminal 5.

With power and ground supplied, the rear wiper and rear washer motors operate until the rear window wiper switch is released from the ON position.

AUTO STOP OPERATION

NDEL0065S04

When the rear wiper switch is placed in the OFF position, the rear wiper motor will continue to operate until the rear wiper blade reaches the park position.

The ground circuit is now routed through the rear wiper motor terminal 4. This allows the rear wiper motor to operate until the rear wiper blade reaches the park position. The rear wiper motor ground is interrupted when the rear wiper blade reaches the park position, and the rear wiper motor stops.

GI

MA

EM

LC

EC

FE

AT

AX

SU

BR

ST

RS

BT

HA

SC

EL

IDX

REAR WIPER AND WASHER

Wiring Diagram — WIP/R — /For Glass Hatch Model

Wiring Diagram — WIP/R — /For Glass Hatch Model

NDEL0066

EL-WIP/R-01

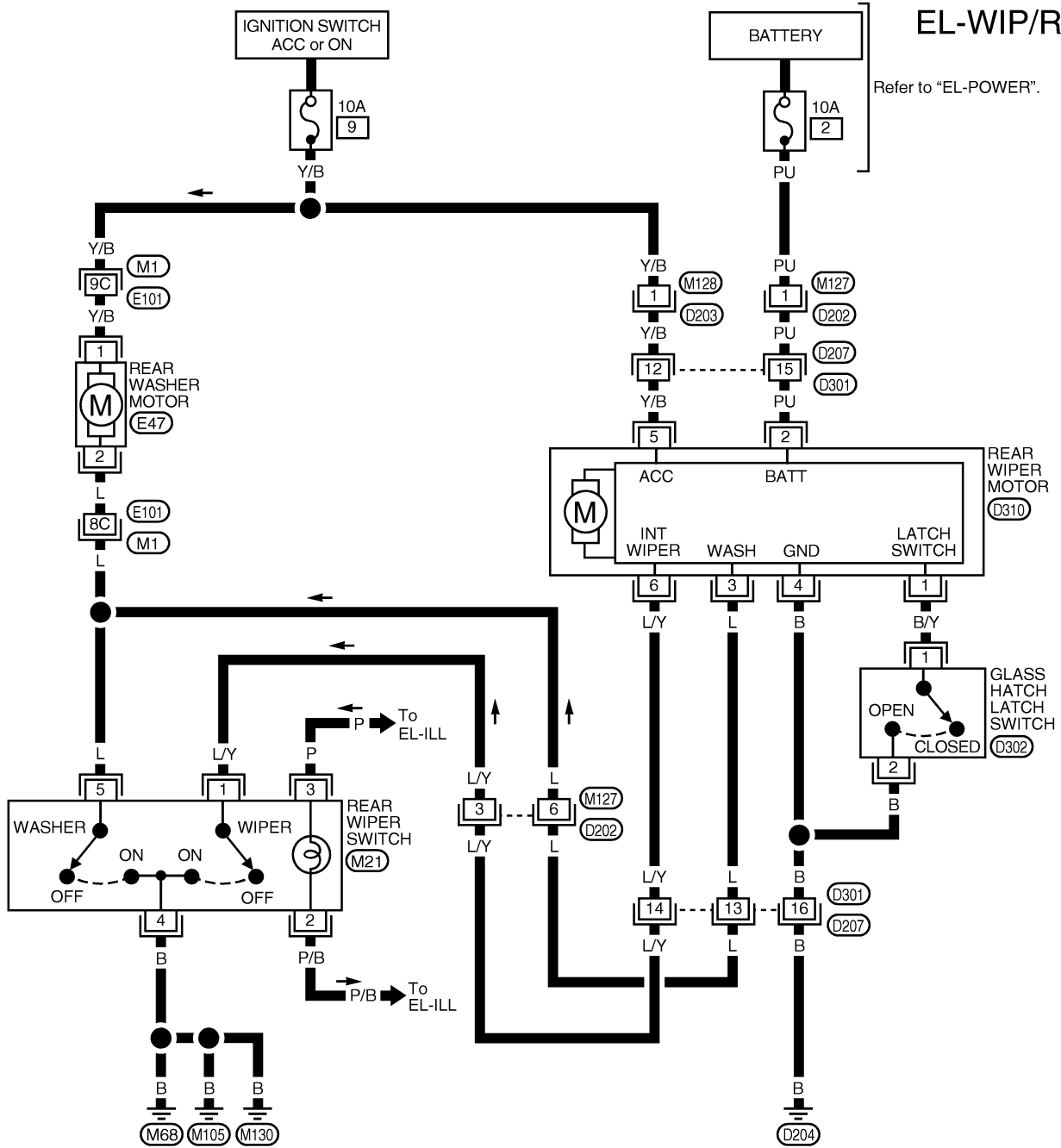

Refer to the following.
(M1), **(E101)** - SUPER MULTIPLE JUNCTION (SMJ)

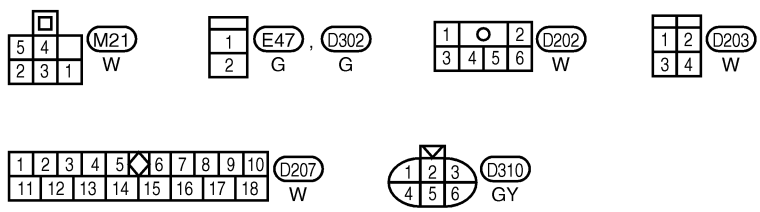

REAR WIPER AND WASHER

Removal and Installation

Removal and Installation

NDEL0067

NDEL0067S01

REMOVAL

1. Tilt rear wiper arm to upright position.
2. Grasp base of rear wiper arm and pull it from the pivot shaft.
3. Disconnect washer solvent hose.

INSTALLATION

1. Connect washer solvent hose.
2. Place wiper arm base over pivot shaft and firmly push wiper arm onto pivot shaft.
3. Gently tilt wiper arm downward until contacting rear glass.

WIPER ARM ADJUSTMENT

1. With wiper arm removed, turn on wiper and allow it to cycle two or three times, then turn the wiper switch to OFF and allow wiper motor to return to "park" position.
2. Install wiper arm and align splines so that the wiper blade is located on the edge of the black printing on the rear glass.
3. With wiper arm installed, operate the wiper and allow it to cycle two or three times.
4. Turn the wiper switch to OFF and allow the wiper motor to return to the "park" position, then ensure that the wiper blade is still located at the edge of the black printing.
5. If necessary, readjust wiper arm.

NOTE:

Model with rear hatch glass shown in illustration. Adjustment for fixed rear glass models is the same.

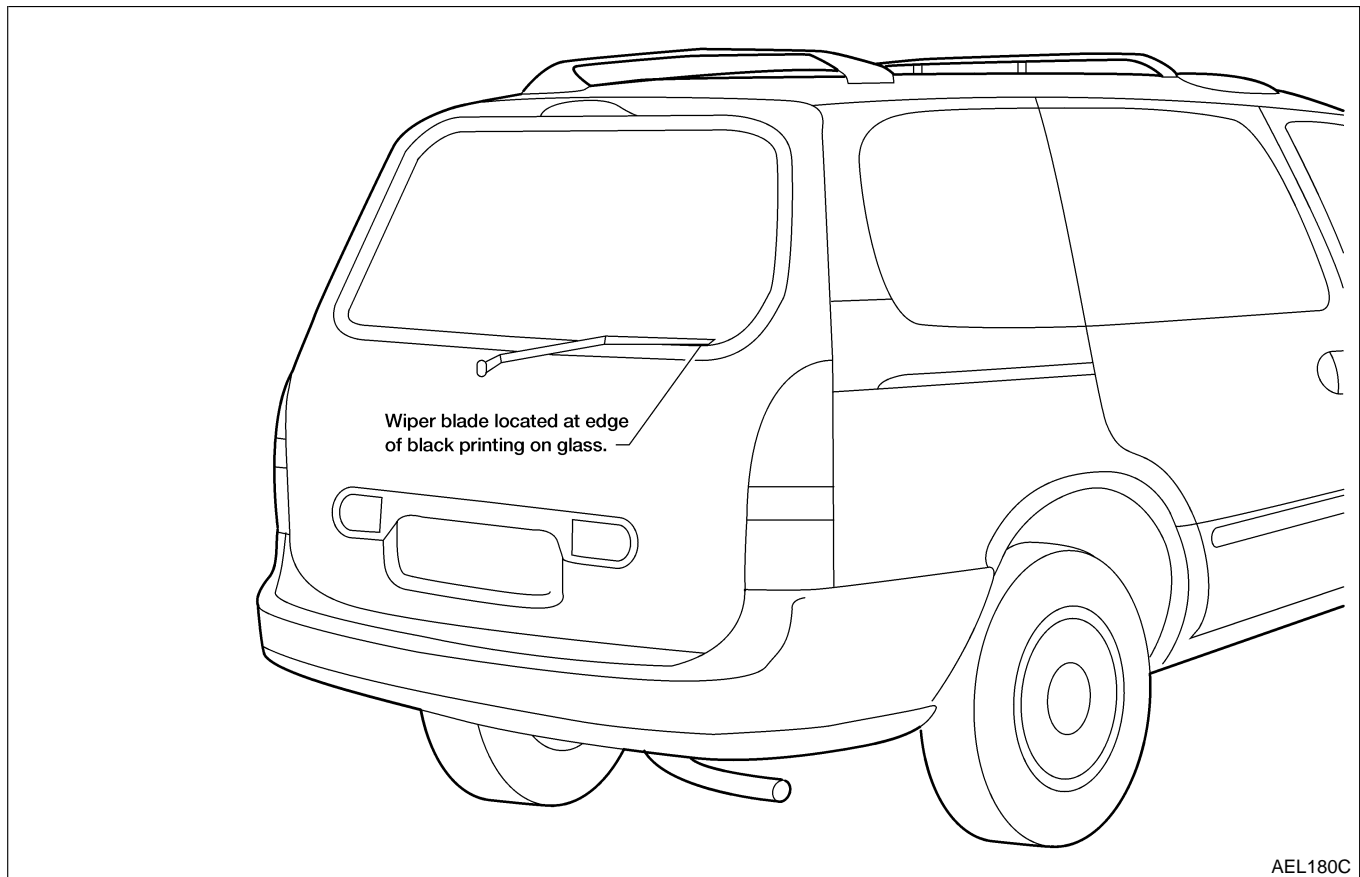

AEL180C

GI

MA

EM

LC

EC

FE

AT

AX

SU

BR

ST

RS

BT

HA

SC

EL

IDX

REAR WIPER AND WASHER

Removal and Installation (Cont'd)

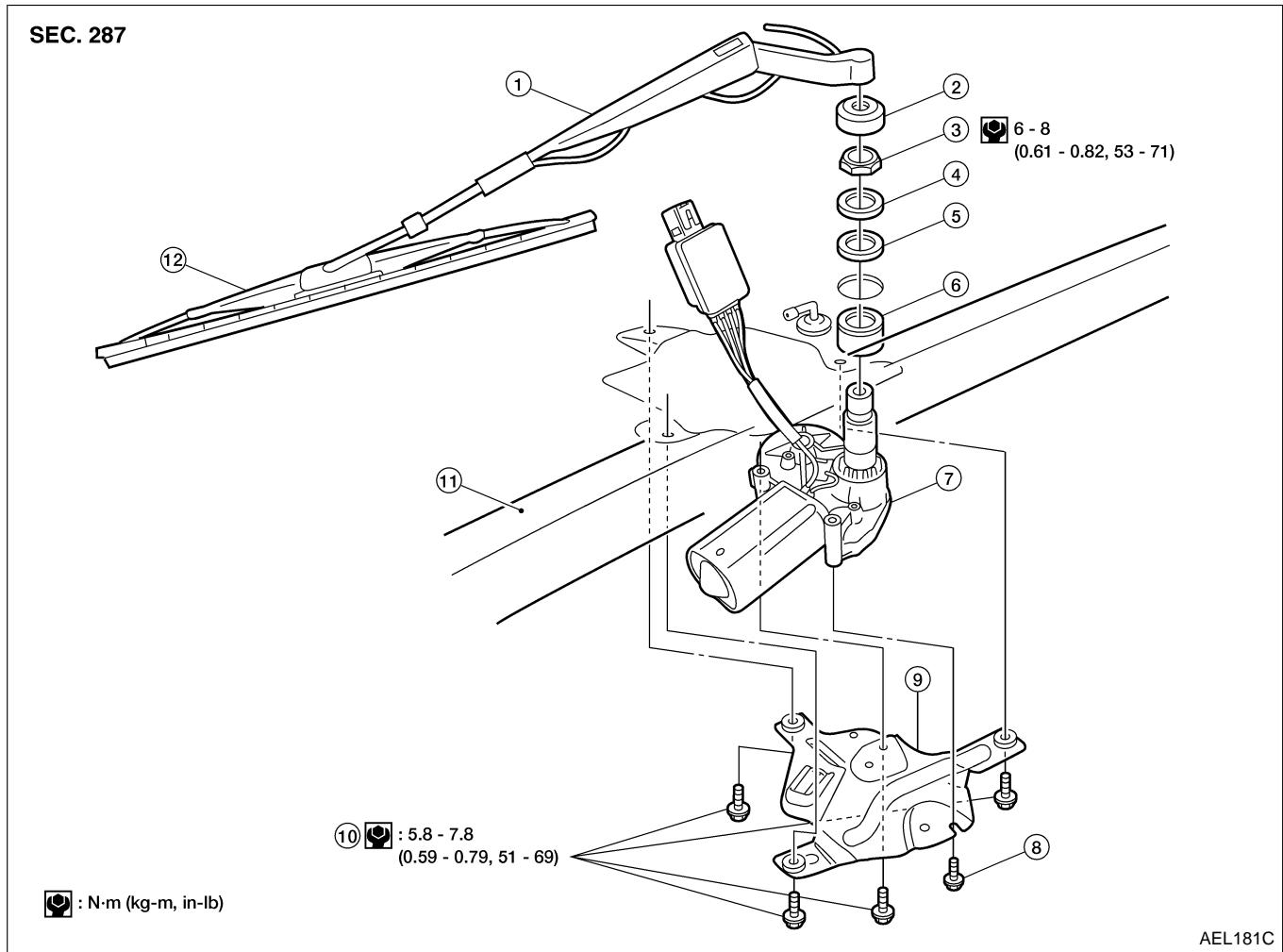

- | | | |
|---------------------|--------------------|---------------------|
| 1 Rear wiper arm | 5 Seal | 9 Bracket |
| 2 Pivot shaft cover | 6 Inner collar | 10 Mounting bolts |
| 3 Pivot shaft nut | 7 Rear wiper motor | 11 Back door |
| 4 Outer collar | 8 Bracket bolts | 12 Rear wiper blade |

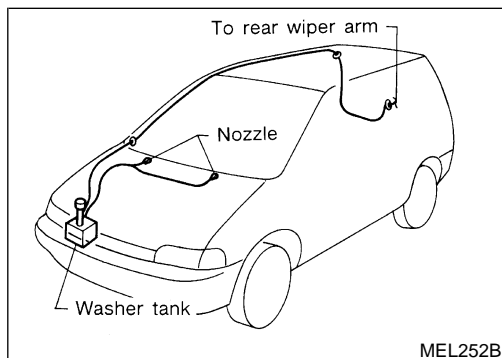

Washer Fluid and Check Valve

- A check valve is provided in the washer fluid line. Be careful not to connect check valve to washer tube in the wrong direction. NDEL0150

HORN

Wiring Diagram — HORN —

Wiring Diagram — HORN —

NDEL0068

EL-HORN-01

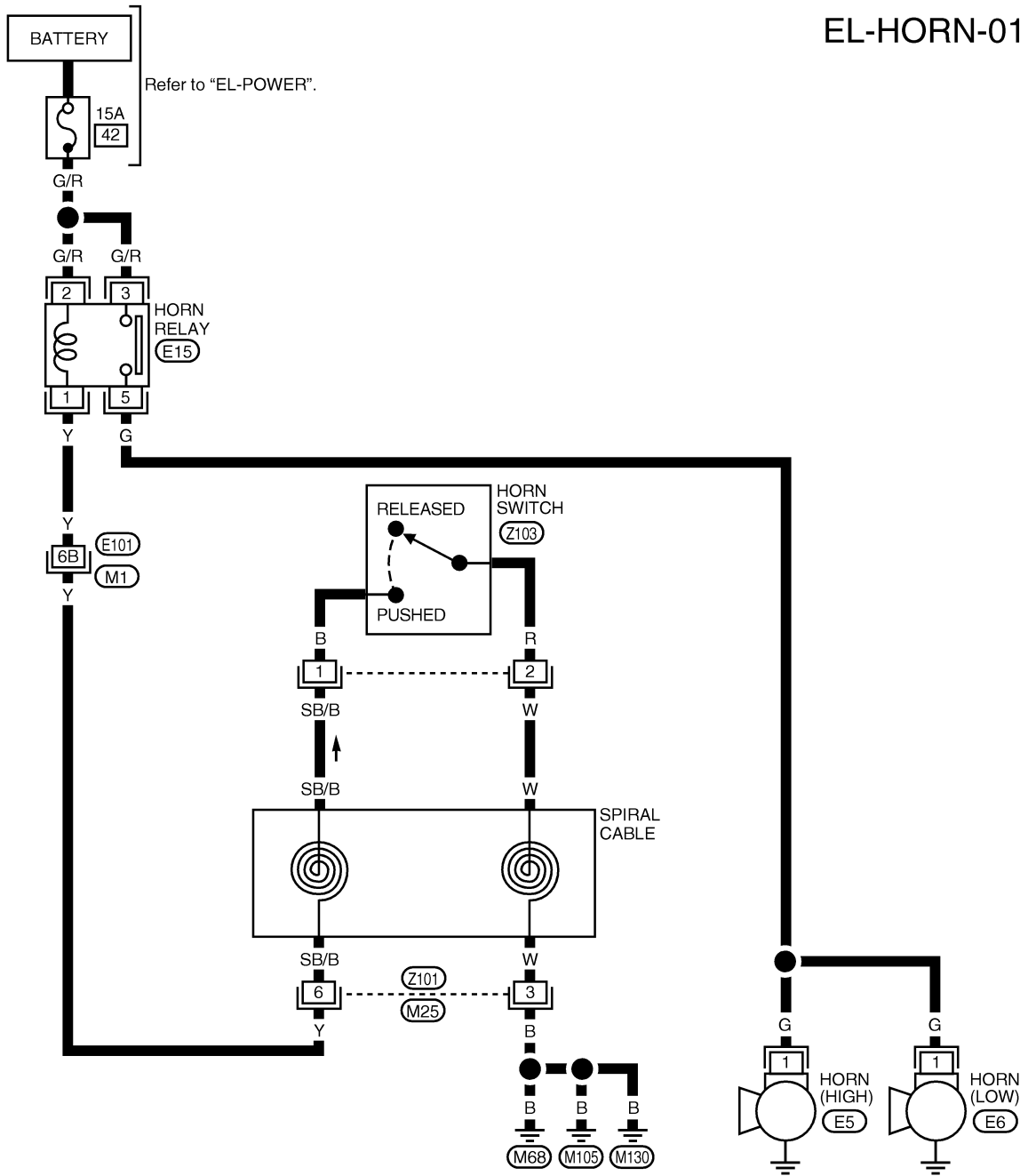

GI
MA
EM
LC
EC
FE
AT
AX
SU
BR
ST
RS
BT
HA
SC

EL
IDX

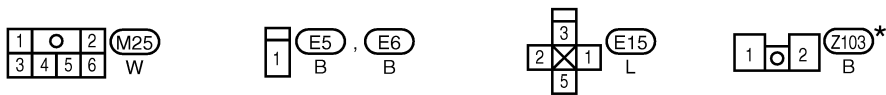

Refer to the following.
 (M1), (E101) - SUPER MULTIPLE JUNCTION (SMJ)

*: This connector is not shown in "HARNES LAYOUT".

CIGARETTE LIGHTER

Wiring Diagram — CIGAR —

Wiring Diagram — CIGAR —

NDEL0069

EL- CIGAR-01

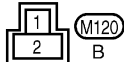
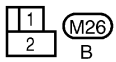
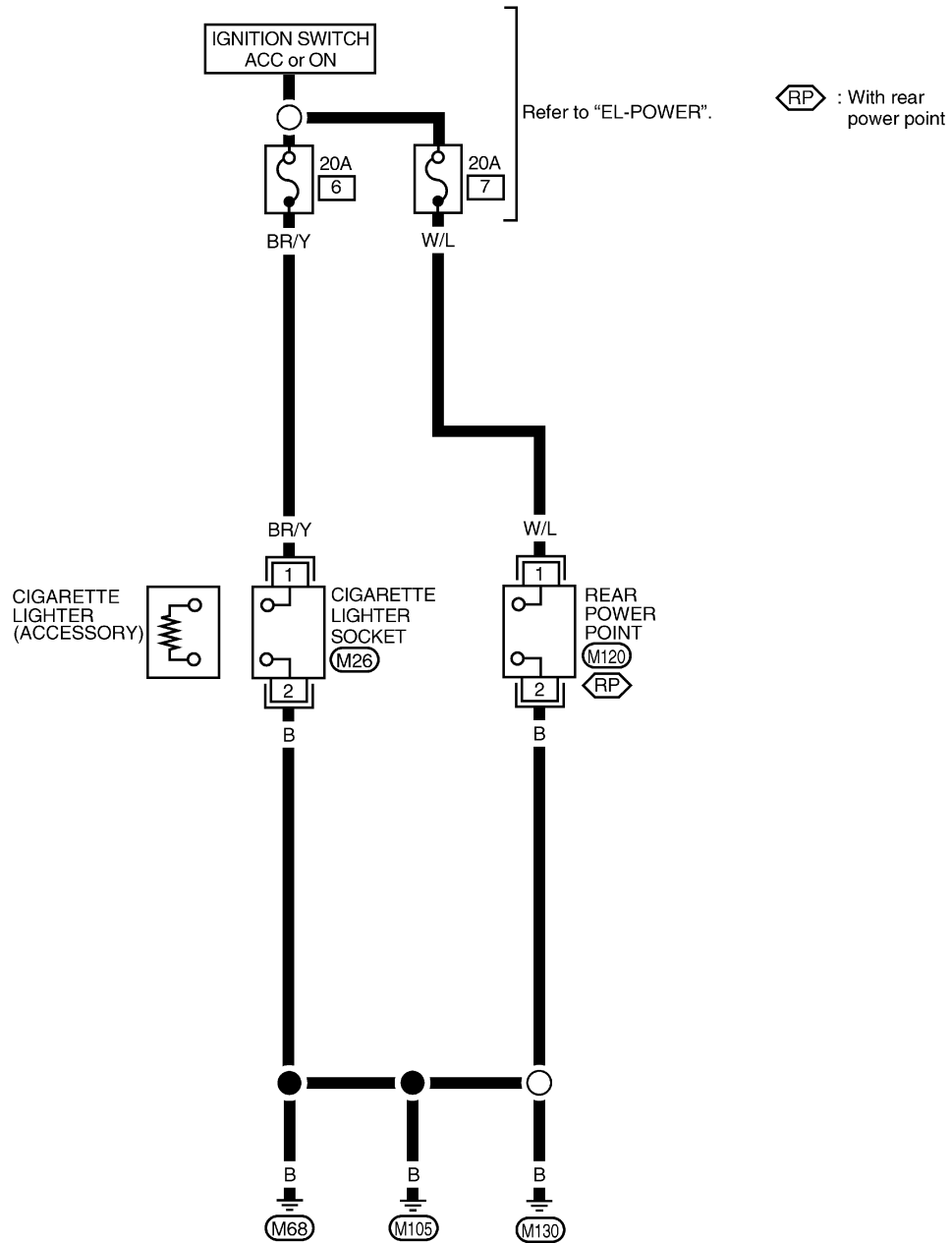

AEL755B

REAR WINDOW DEFOGGER

Component Parts and Harness Connector Location

Component Parts and Harness Connector Location

NDEL0070

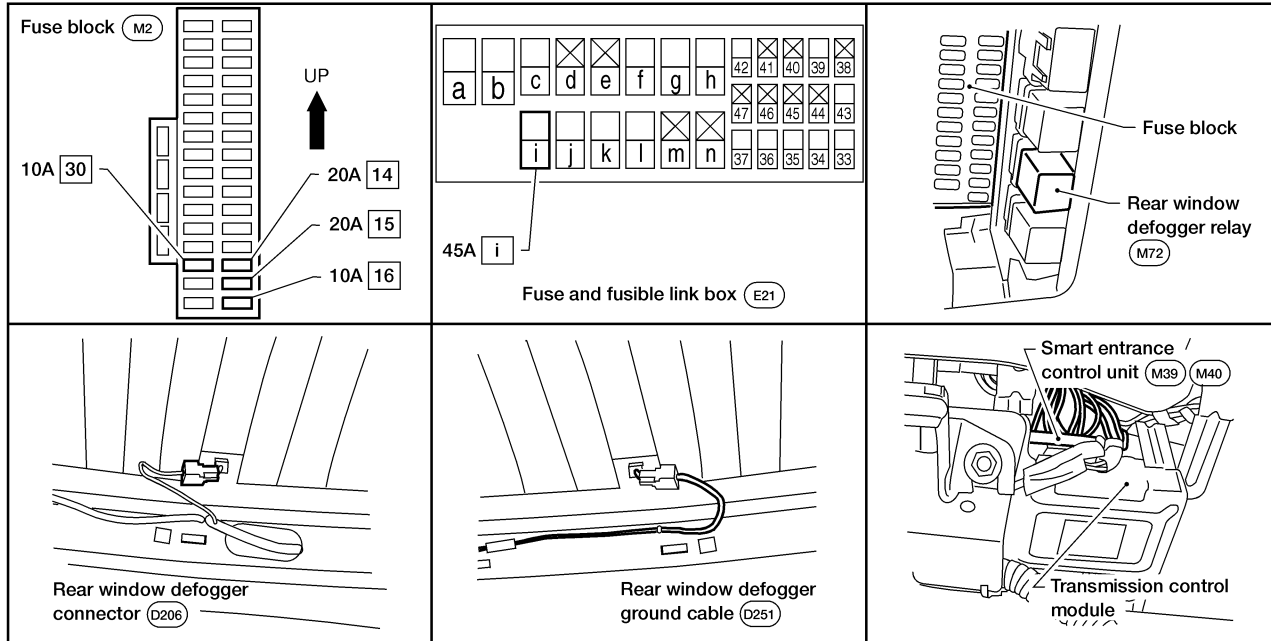

GI

MA

EM

LC

EC

FE

AT

AX

SU

BR

WEL653

ST

RS

System Description

NDEL0071

The rear window defogger system is controlled by the smart entrance control unit. The rear window defogger operates for approximately 15 minutes.

Power is supplied at all times

- to rear window defogger relay terminals 7 and 5
- through 45A fusible link (letter i, located in the fuse and fusible link box).

With the ignition switch in the ON position, power is supplied

- to the rear window defogger relay terminal 1.

With the ignition switch in the ON or START position, power is supplied

- through 10A fuse (No. 30, located in the fuse block)
- to smart entrance control unit terminal 43.

Ground is supplied to rear window defogger switch terminal 2 through body grounds M68, M105 and M130.

When the rear window defogger switch is turned ON, ground is supplied

- through rear window defogger switch terminal 1
- to smart entrance control unit terminal 23.

Then, smart entrance control unit terminal 22 supplies ground to the rear window defogger relay terminal 2.

With power and ground supplied, the rear window defogger relay is energized.

Power is then supplied

- through terminals 6 and 3 of the rear window defogger relay
- through 20A fuses (No. 15 and 14, located in the fuse block)
- to rear window defogger terminal 1.

BT

HA

SC

EL

IDX

REAR WINDOW DEFOGGER

System Description (Cont'd)

The rear window defogger has an independent ground.

With power and ground supplied, the rear window defogger filaments heat and defog the rear window.

With the rear window defogger relay energized, power is also supplied

- from terminals 6 and 3 of the rear window defogger relay
- through 10A fuse (No.16, located in the fuse block).
- to terminal 3 of the rear window defogger switch

Ground is supplied to rear window defogger switch terminal 4 through body grounds M68, M105 and M130.

With power and ground supplied, the rear window defogger indicator illuminates in the rear window defogger switch.

REAR WINDOW DEFOGGER

Wiring Diagram — DEF —

Wiring Diagram — DEF —

NDEL0072

EL-DEF-01

GH : With glass hatch
OH : Without glass hatch

Refer to "EL-POWER".

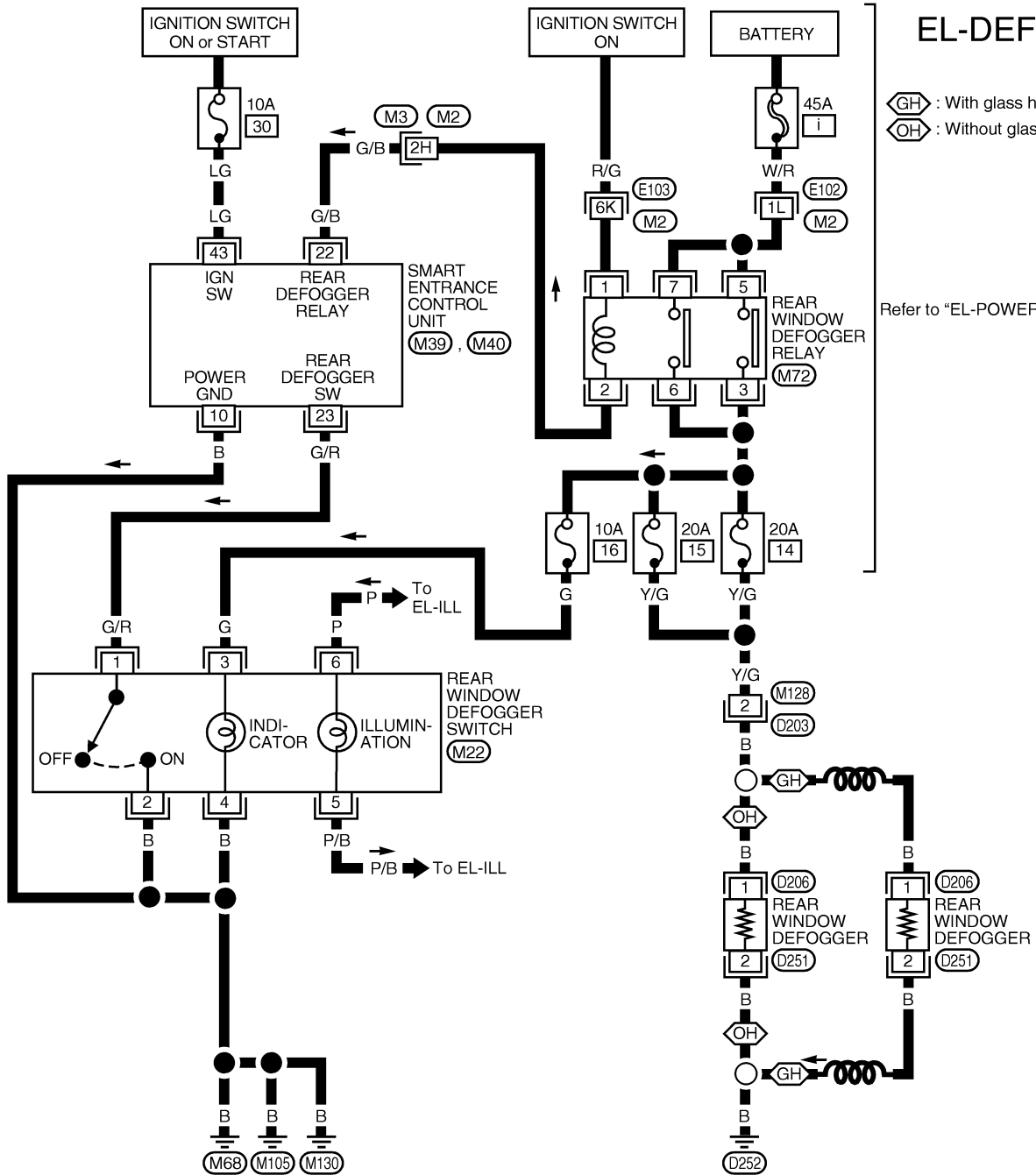

GI
MA
EM
LC
EC
FE
AT
AX
SU
BR
ST
RS
BT
HA
SC

EL
IDX

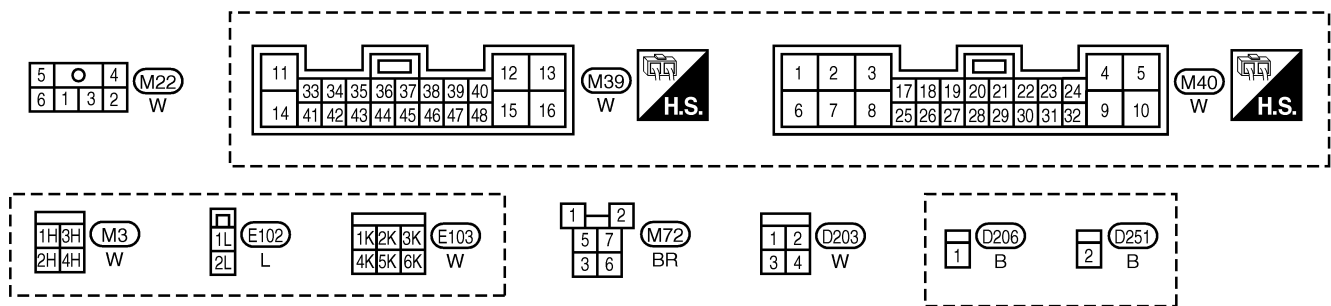

WEL218

REAR WINDOW DEFOGGER

Trouble Diagnoses

Trouble Diagnoses DIAGNOSTIC PROCEDURE

NDEL0073

NDEL0073S01

SYMPTOM: Rear window defogger does not activate, or does not go off after activating.

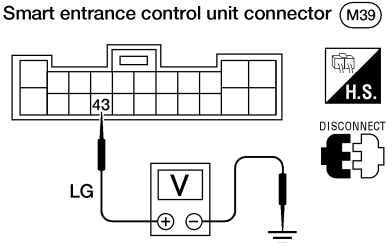

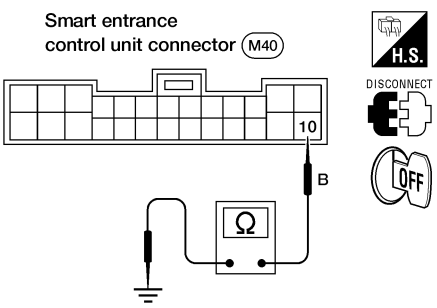
1	CHECK IGNITION INPUT SIGNAL	
Check voltage between control unit terminal 43 and ground.		
		
<p>Voltage [V]: Ignition switch is ON. Approx. 12 Ignition switch is OFF. 0</p>		
AEL948B		
OK or NG		
OK	▶	GO TO 2.
NG	▶	Check the following <ul style="list-style-type: none"> ● 10A fuse (No. 30, located in the fuse block) ● Harness for open or short between control unit and fuse.

2	CHECK CONTROL UNIT GROUND CIRCUIT	
Check continuity between control unit terminal 10 and ground.		
		
Does continuity exist?		
Yes	▶	GO TO 3.
No	▶	Repair harness or connectors.

AEL872B

REAR WINDOW DEFOGGER

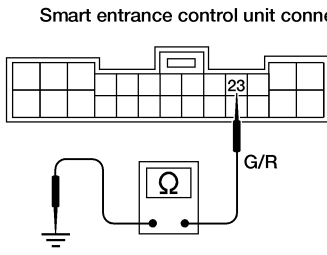
Trouble Diagnoses (Cont'd)

3	CHECK REAR WINDOW DEFOGGER SWITCH INPUT SIGNAL	
<p>Check continuity between control unit terminal 23 and ground.</p> <div style="display: flex; justify-content: space-around; align-items: center;"> <div style="text-align: center;"> <p>Smart entrance control unit connector (M40)</p>  </div> <div style="text-align: center;">  </div> </div> <p style="text-align: right;">AEL950B</p>		
<p>Continuity: Rear window defogger switch is pushed. Yes Rear window defogger switch is released. No</p> <p style="text-align: center;">OK or NG</p>		
OK	▶	GO TO 4.
NG	▶	<p>Check the following</p> <ul style="list-style-type: none"> ● Rear window defogger switch (Refer to EL-126) ● Harness for open or short between control unit and rear window defogger switch ● Rear window defogger switch ground circuit.

GI
MA
EM
LC
EC
FE
AT
AX
SU

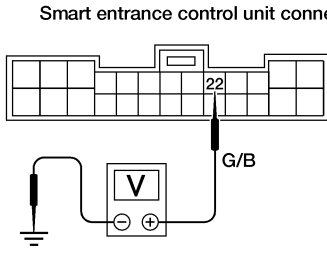
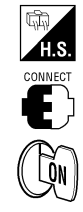
4	CHECK REAR WINDOW DEFOGGER OUTPUT SIGNAL	
<p>1. Turn ignition switch to ON position. 2. Check voltage between control unit harness terminal 22 and ground.</p> <div style="display: flex; justify-content: space-around; align-items: center;"> <div style="text-align: center;"> <p>Smart entrance control unit connector (M40)</p>  </div> <div style="text-align: center;">  </div> </div> <p style="text-align: right;">AEL951B</p>		
<p>Voltage [V]: Rear window defogger switch is OFF. Approx. 12 Rear window defogger switch is ON. 0</p> <p style="text-align: center;">OK or NG</p>		
OK	▶	<p>Check the following</p> <ul style="list-style-type: none"> ● Rear window defogger relay (Refer to EL-126) ● Rear window defogger circuit ● Rear window defogger filament check (Refer to EL-126.)
NG	▶	GO TO 5.

BR
ST
RS
BT
HA
SC

EL
IDX

REAR WINDOW DEFOGGER

Trouble Diagnoses (Cont'd)

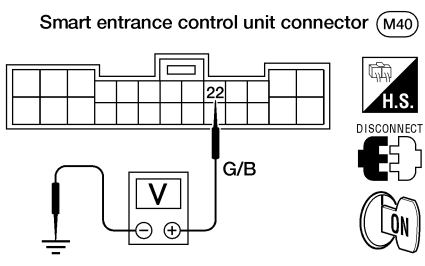
5	CHECK DEFOGGER RELAY COIL SIDE CIRCUIT
<ol style="list-style-type: none"> 1. Disconnect control unit connector. 2. Turn ignition switch to ON position. 3. Check voltage between control unit terminal 22 and ground. 	
	
AEL952B	
Does battery voltage exist?	
Yes	▶ Replace control unit.
No	▶ Check the following <ul style="list-style-type: none"> ● Harness for open or short between ignition switch and rear window defogger relay ● Rear window defogger relay ● Harness for open or short between rear window defogger relay and control unit.

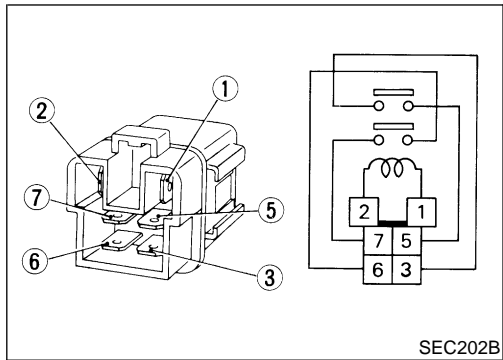

Electrical Components Inspection

NDEL0074

REAR WINDOW DEFOGGER RELAY

NDEL0074S01

Check continuity between terminals 3 and 5, 6 and 7.

Condition	Continuity
12V direct current supply between terminals 1 and 2	Yes
No current supply	No

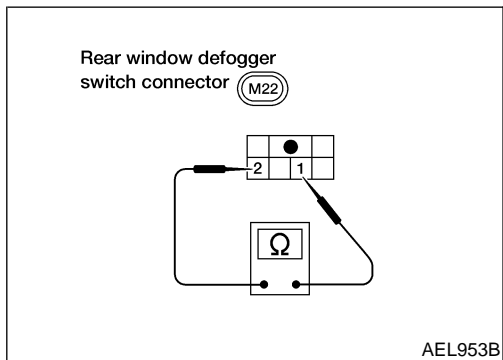

REAR WINDOW DEFOGGER SWITCH

NDEL0074S02

Check continuity between terminals when rear window defogger switch is pushed and released.

Terminals	Condition	Continuity
1 - 2	Rear window defogger switch is pushed.	Yes
	Rear window defogger switch is released.	No

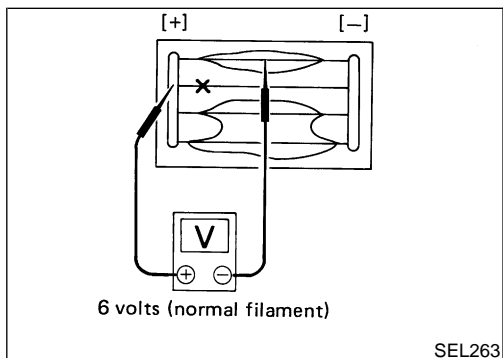

Filament Check

NDEL0075

1. Attach probe circuit tester (in volt range) to middle portion of each filament.

REAR WINDOW DEFOGGER

Filament Check (Cont'd)

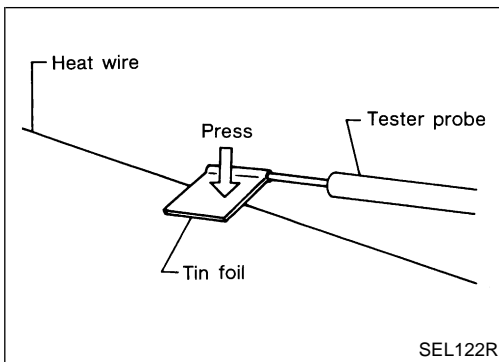

- When measuring voltage, wrap tin foil around the top of the negative probe. Then press the foil against the wire with your finger.

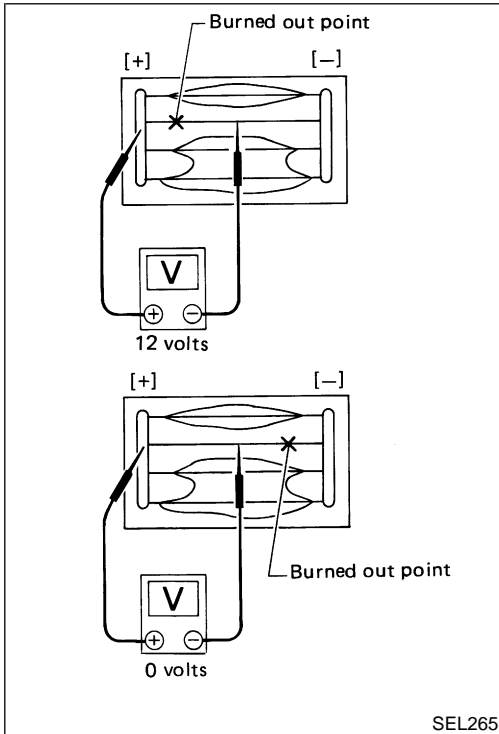

2. If a filament is burned out, circuit tester registers 0 or 12 volts.

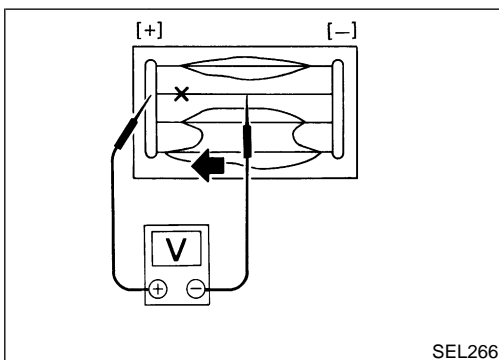

3. To locate burned out point, move probe to left and right along filament. Test needle will swing abruptly when probe passes the point.

Filament Repair REPAIR EQUIPMENT

- 1) Conductive silver composition (Dupont No. 4817 or equivalent)
- 2) Ruler 30 cm (11.8 in) long
- 3) Drawing pen
- 4) Heat gun
- 5) Alcohol
- 6) Cloth

GI

MA

EM

LC

EC

FE

AT

AX

SU

BR

ST

RS

BT

HA

SC

EL

IDX

NDEL0076

NDEL0076S01

REAR WINDOW DEFOGGER

Filament Repair (Cont'd)

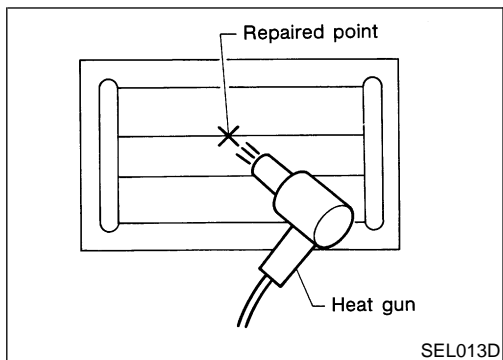
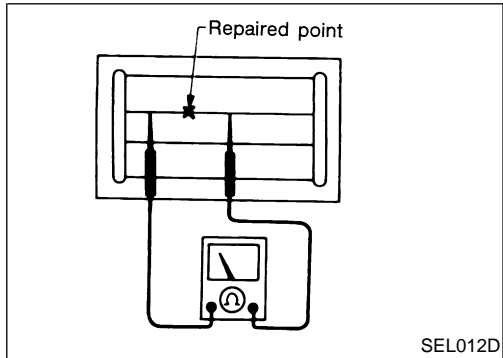
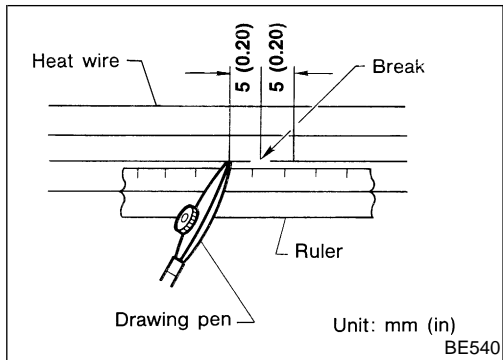

REPAIRING PROCEDURE

NDEL0076S02

1. Wipe broken heat wire and its surrounding area clean with a cloth dampened in alcohol.
2. Apply a small amount of conductive silver composition to tip of drawing pen.

Shake silver composition container before use.

3. Place ruler on glass along broken line. Deposit conductive silver composition on break with drawing pen. Slightly overlap existing heat wire on both sides [preferably 5 mm (0.20 in)] of the break.
4. After repair has been completed, check repaired wire for continuity. This check should be conducted 10 minutes after silver composition is deposited.

Do not touch repaired area while test is being conducted.

5. Apply a constant stream of hot air directly to the repaired area for approximately 20 minutes with a heat gun. A minimum distance of 3 cm (1.2 in) should be kept between repaired area and hot air outlet. If a heat gun is not available, let the repaired area dry for 24 hours.

System Description

NDEL0077

Refer to Owner's Manual for audio system operating instructions.

Power is supplied at all times

- through 10A fuse (No. 20, located in the fuse block)
- to audio unit terminal 29 and
- to CD changer terminal 9 and
- to rear audio remote control unit terminal 15.

With the ignition switch in the ACC or ON position, power is supplied

- through 7.5A fuse (No. 10, located in the fuse block)
- to audio unit terminal 30 and
- through 20 A fuse (No. 11, located in the fuse block)
- to subwoofer amplifier terminal 6.

Ground is supplied to audio unit terminals 31 and 36 and CD changer terminal 3 through body ground M52. Ground is supplied to rear audio remote control unit terminal 14 and subwoofer amplifier terminal 5 through body grounds M68, M105 and M130.

When the system is ON, audio signals are supplied

- through audio unit terminals 25, 26, 27, 28, 32, 33, 34, 35, 37 and 38
- to subwoofer amplifier terminals 1 and 2, and
- to rear audio remote control unit terminals 3, 4, 6 and 7 for the headphone jacks, and
- to the front speakers and rear speakers.

The volume may be increased or decreased, or the next preset station may be selected using the steering wheel audio control switches.

The audio unit receives a ground signal at terminal 14 (volume increase or volume decrease), or at terminal 14 (next preset) when the switches are depressed.

GI

MA

EM

LC

EC

FE

AT

AX

SU

BR

ST

RS

BT

HA

SC

EL

IDX

AUDIO

Schematic

Schematic

NDEL0078

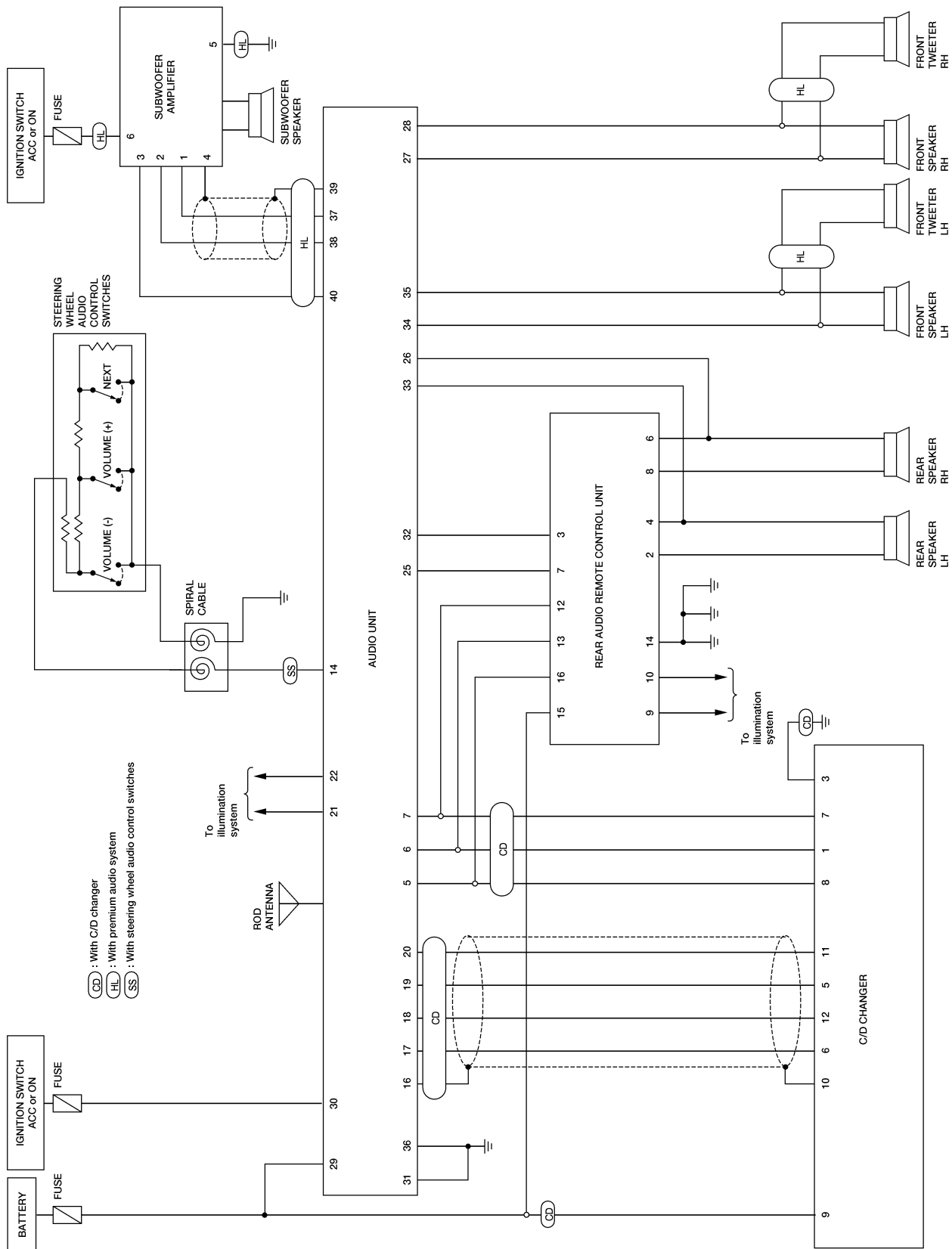

WEL654

AUDIO

Wiring Diagram — AUDIO —

NDEL0079

EL-AUDIO-01

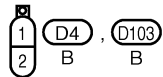
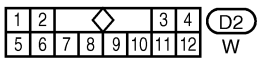
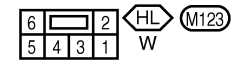
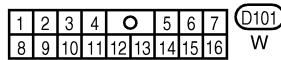
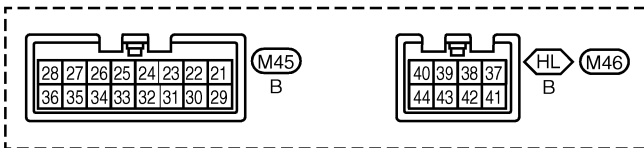
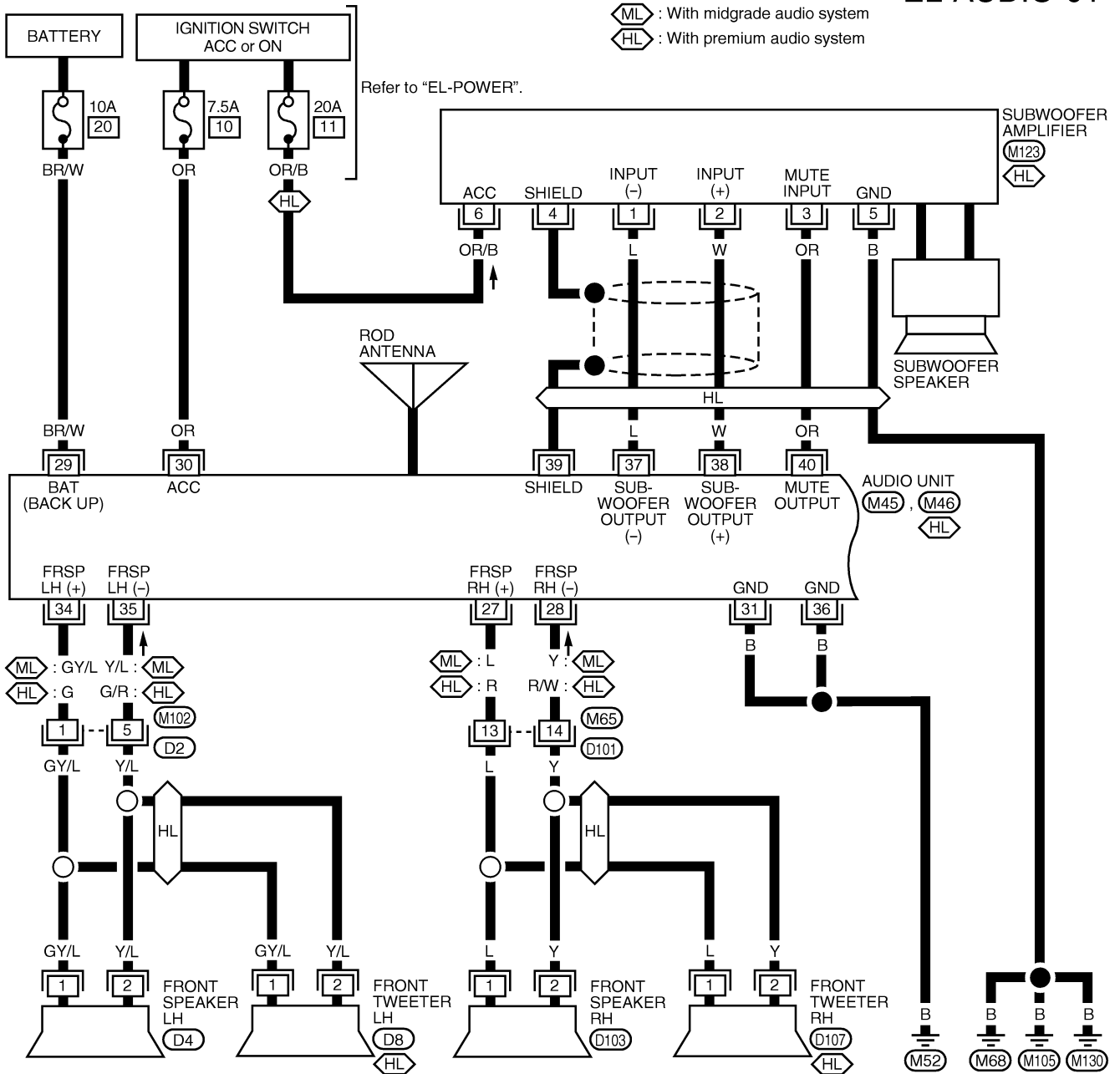

AUDIO

Wiring Diagram — AUDIO — (Cont'd)

EL-AUDIO-02

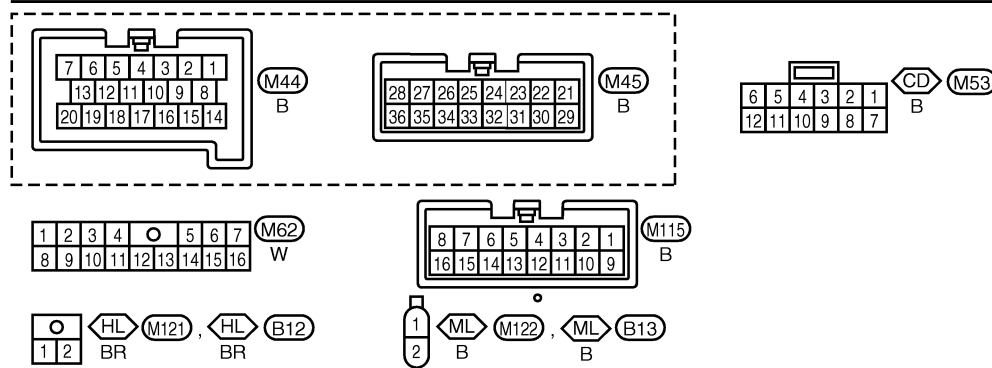
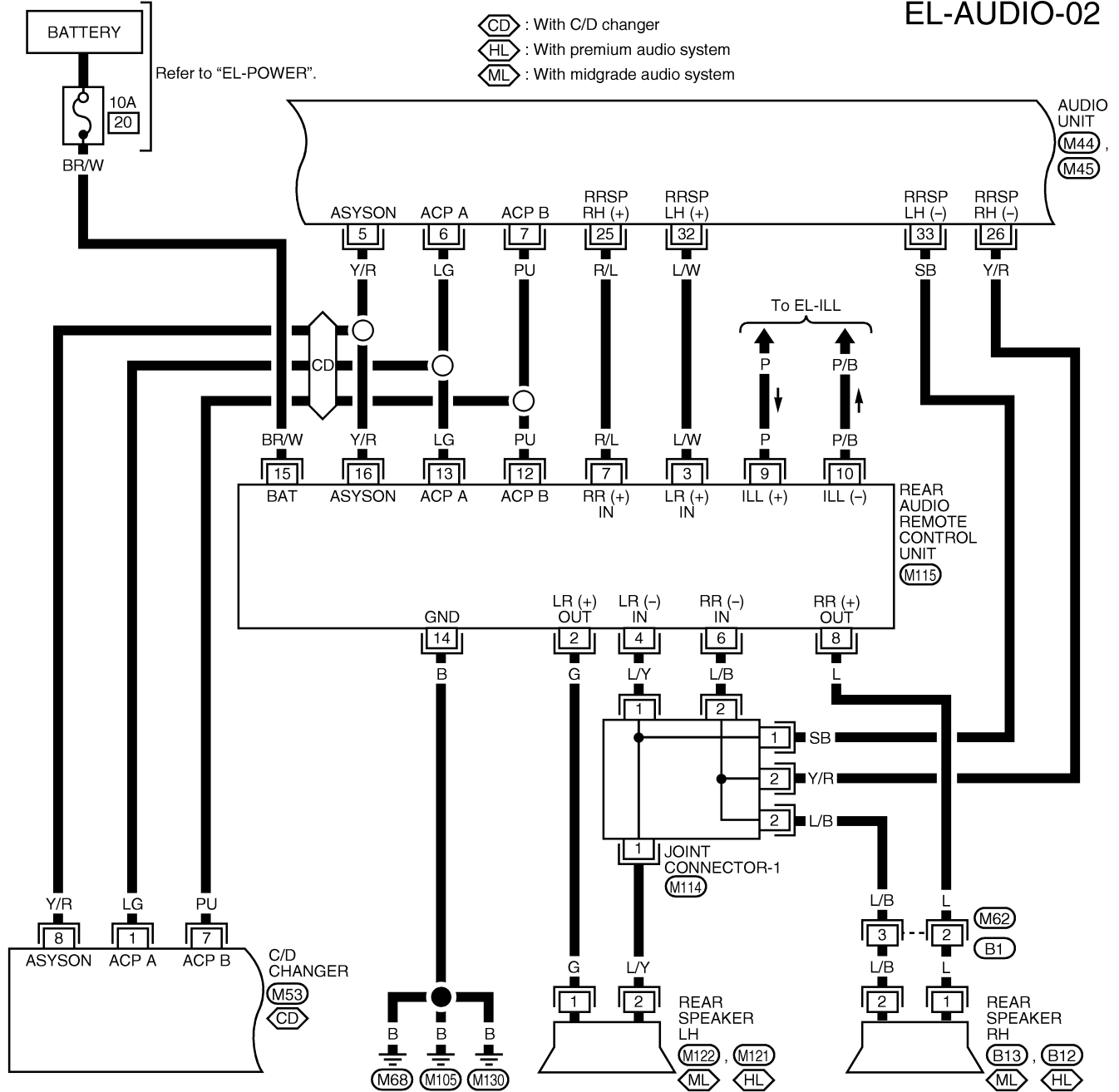

WEL221

AUDIO

Wiring Diagram — AUDIO — (Cont'd)

EL-AUDIO-03

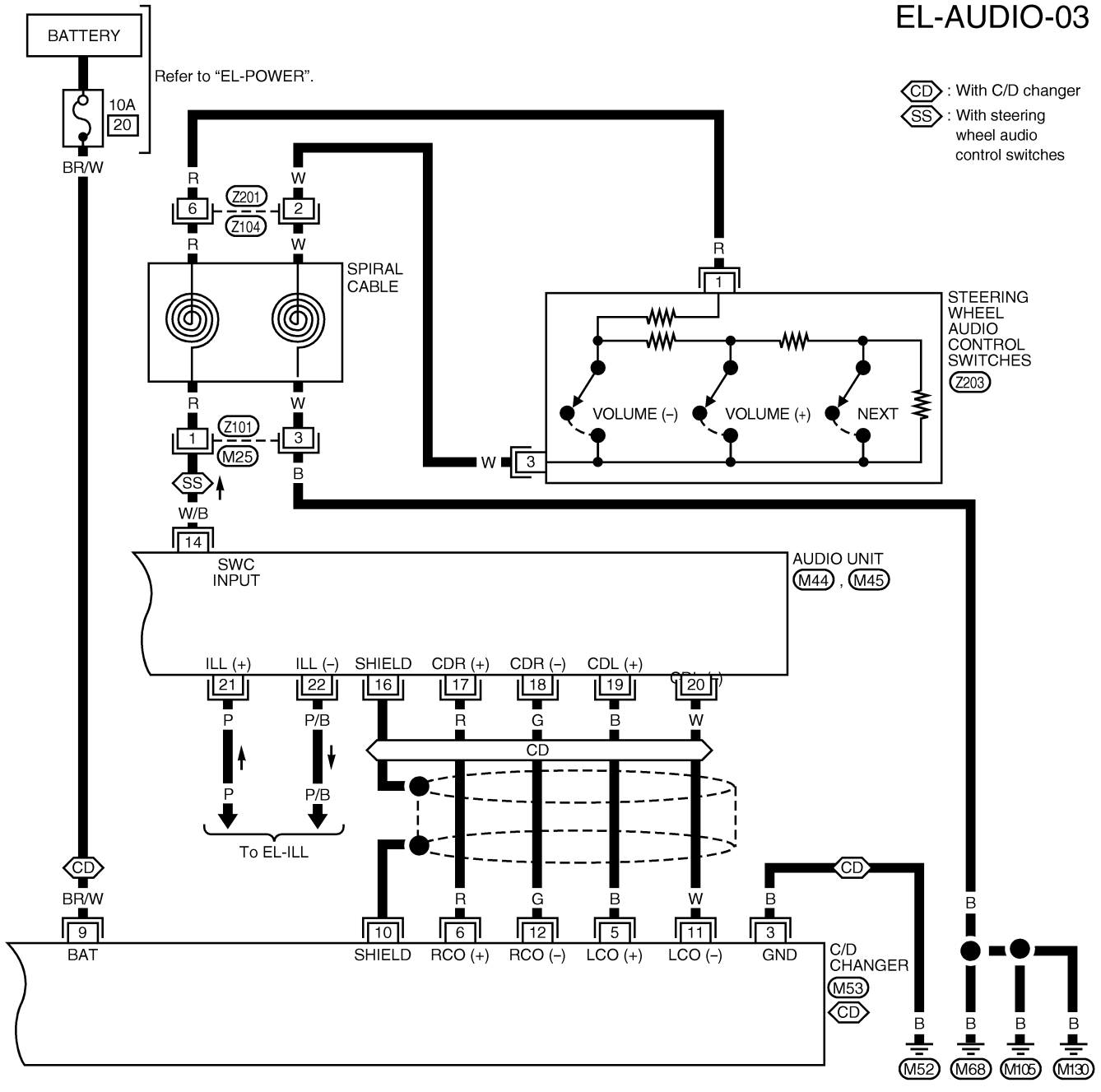

GI
MA
EM
LC
EC
FE
AT
AX
SU
BR
ST
RS
BT
HA
SC

EL
IDX

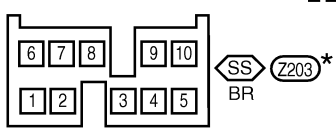
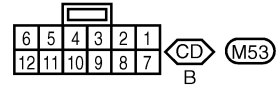
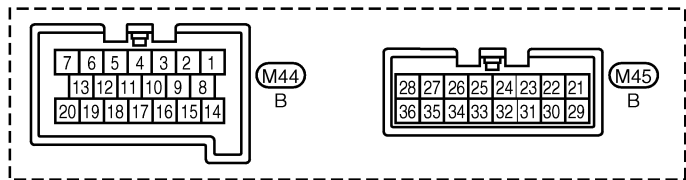
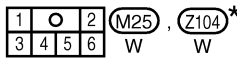

*: This connector is not shown in "HARNES LAYOUT" of EL section.

AUDIO

Trouble Diagnoses

NDEL0081

NDEL0081S10

SPEAKER WALK-AROUND TEST

NOTE:

The audio unit must be turned on and in radio tuner mode (AM/FM) in order to enter the speaker walk-around test.

1. To enter the speaker walk-around test, simultaneously press station select buttons 3 and 6.
2. The speaker walk-around test stops and applies sound to each speaker for about 2 seconds. Each speaker is tested and displayed on the audio unit display in the following sequence: RF, LF, LR, and RR.
3. If the vehicle is equipped with dual media audio unit, the speaker walk-around test automatically continues and tests antenna and subwoofer (if equipped). If a speaker short exists, "SPKR SHORT" will be displayed. If the vehicle is not equipped with a CD changer or if the CD changer is not responding, "NO CDDJ" will be displayed

AUDIO UNIT SELF-TEST MATRIX

NDEL0081S11

NOTE:

The audio unit must be turned on and in radio tuner mode (AM/FM) in order to enter the audio unit self-test mode.

Document the diagnostic trouble codes (DTC's) and perform the self-test again.

1. To enter each of the following tests, press and release the station select button while in the speaker walk-around test.

Station Select Button	AM/FM/Cassette Audio Unit Test Function	Dual Media Audio Unit Test Function
1	This is an audio internal and external on-demand self-test. "SELF TEST" will be displayed during the test. If "SELF FAIL" is displayed, press and release "TUNE>" to scroll view each DTC stored. Refer to the "AM/FM/CASSETTE AUDIO UNIT DTC INDEX", EL-136. If the system is OK, "SELF PASS" will be displayed.	This is an audio internal and external on-demand self-test. "SELF TEST" will be displayed during this test. If DTC's are retrieved, "DTCS FOUND" will be displayed. Press and release "TUNE>" to scroll view each DTC stored. Refer to the "DUAL MEDIA AUDIO UNIT DTC INDEX", EL-135.
2	View/Clear continuous DTC's. "NO DTCS" is displayed if no DTC's are retrieved. If "DTCS FOUND" is displayed, press and release "TUNE>" to scroll view each DTC retrieved. Refer to the "AM/FM/CASSETTE AUDIO UNIT DTC INDEX", EL-136. To clear all DTC's, press the eject "EJ" button. "DTCS CLEAR" will be displayed.	No self-test function.
3	This is an antenna signal test. This test measures the average strength at the current tuner setting.	This is an antenna signal test. This test measures the average strength at the current tuner setting.
4	Software configuration level. This test queries each radio system controller for its software configuration level. "SOFT LEVELS" will be displayed upon completion of the query. Press and release "TUNE>" to scroll view the software configuration version level.	Software configuration level. The software configuration level will be displayed.
5	This is a display test. This test will light all display segments for five seconds. When the test is complete, "DISPLAY TEST" is displayed.	This is a display test. This test will light all display segments for five seconds. When the test is complete, "DISPLAY TEST" is displayed.
6	Audio unit configuration. "RADIO CONFIG" will be displayed. Press and release "TUNE>" to scroll view audio unit configuration data.	No self-test function.

2. To exit the self-test mode, turn the ignition switch or the audio unit off.
3. If the concern remains and the fault is not detected, proceed to the "SYMPTOM CHART", EL-137.

AUDIO

Trouble Diagnoses (Cont'd)

DUAL MEDIA AUDIO UNIT DTC INDEX

-NDEL0081S12

DTC	Description	Repair Order	
9342	Audio unit is defective	Document and clear the DTC's. Perform the self-test. Remove the audio unit for repair if DTC 9342 is retrieved again.	GI MA
B2401	Audio tape deck mechanism fault	Verify that no cassette is inserted in the audio unit. Document and clear the DTC's. Perform the self-test. Remove the audio unit for repair if DTC B2401 is retrieved again.	EM
B2402	CD changer thermal shutdown fault	Allow CD changer to cool down. If DTC still exists after cool down, proceed to the following steps. 1. Check 10A fuse (No. 20, located in the fuse block). Verify battery voltage is present at terminal 9 of CD changer. 2. Check CD changer body ground. 3. Remove CD changer for repair.	LC EC FE
B2403	CD changer internal fault	1. Check 10A fuse (No. 20, located in the fuse block). Verify battery voltage is present at terminal 9 of CD changer. 2. Check CD changer body ground. 3. Remove CD changer for repair.	AT AX
B2404	Steering wheel audio control switches circuit fault	1. Check continuity between audio unit harness connector M44 and steering wheel audio control switches connector Z203. 2. Check steering wheel audio control switches. Refer to "STEERING WHEEL AUDIO CONTROL SWITCHES INSPECTION", EL-138 3. Remove audio unit for repair.	SU BR
B2405	Audio single disc CD player thermal shutdown fault	Document and clear the DTC's. Perform the self-test. Remove the audio unit for repair if DTC B2405 is retrieved again.	ST
B2406	Audio single disc CD player internal fault	Document and clear the DTC's. Perform the self-test. Remove the audio unit for repair if DTC B2406 is retrieved again.	RS
U2003	CD changer is not responding	1. Check 10A fuse (No. 20, located in the fuse block). Verify battery voltage is present at terminal 9 of CD changer. 2. Check CD changer body ground. 3. Remove CD changer for repair.	BT HA
U2005	Rear audio remote control unit is not responding	NOTE: U2005 is retrieved if rear audio remote control unit is not present, disconnected or inoperative. Verify the vehicle is equipped with rear audio remote control unit. 1. Check 10A fuse (No. 20, located in the fuse block). Verify battery voltage at terminal 15 of rear audio remote control unit. 2. Check rear audio remote control unit body ground.	SC EL
U2008	Cell phone is not responding	This DTC will always be present because there is no telephone availability on the vehicle for this audio unit.	IDX

AUDIO

Trouble Diagnoses (Cont'd)

AM/FM/CASSETTE AUDIO UNIT DTC INDEX

=NDEL0081S13

DTC	Description	Repair Order
B1342	Audio unit is defective	Document and clear the DTC's. Perform the self-test. Remove the audio unit for repair if DTC B1342 is retrieved again.
B2401	Audio tape deck mechanism fault	Verify that no cassette is inserted in the audio unit. Document and clear the DTC's. Perform the self-test. Remove the audio unit for repair if DTC B2401 is retrieved again.
B2402	CD changer thermal shutdown fault	Allow CD changer to cool down. If DTC still exists after cool down, proceed to the following steps. 1. Check 10A fuse (No. 20, located in the fuse block). Verify battery voltage is present at terminal 9 of CD changer. 2. Check CD changer body ground. 3. Remove CD changer for repair.
B2403	CD changer internal fault	1. Check 10A fuse (No. 20, located in the fuse block). Verify battery voltage is present at terminal 9 of CD changer. 2. Check CD changer body ground. 3. Remove CD changer for repair.
B2404	Steering wheel audio control switches circuit fault	1. Check continuity between audio unit harness connector M44 and steering wheel audio control switches connector Z203. 2. Check steering wheel audio control switches. Refer to "STEERING WHEEL AUDIO CONTROL SWITCHES INSPECTION", EL-138 3. Remove audio unit for repair.
B2405	Audio single disc CD player thermal shutdown fault	Not applicable with this audio unit.
B2406	Audio single disc CD player internal fault	Not applicable with this audio unit.
U2003	CD changer is not responding	1. Check 10A fuse (No. 20, located in the fuse block). Verify battery voltage is present at terminal 9 of CD changer. 2. Check CD changer body ground. 3. Remove CD changer for repair.
U2005	Rear audio remote control unit is not responding	NOTE: U2005 is retrieved if rear audio remote control unit is not present, disconnected or inoperative. Verify the vehicle is equipped with rear audio remote control unit. 1. Check 10A fuse (No. 20, located in the fuse block). Verify battery voltage at terminal 15 of rear audio remote control unit. 2. Check rear audio remote control unit body ground.
U2008	Cell phone is not responding	This DTC will always be present because there is no telephone availability on the vehicle for this audio unit.

AUDIO

Trouble Diagnoses (Cont'd)

SYMPTOM CHART

-NDEL0081S14

Symptom	Possible causes	Repair order	
Audio unit, CD changer and/or rear audio remote control unit inoperative (no digital display and no sound from speakers).	<ol style="list-style-type: none"> 10A fuse and 7.5A fuse Poor audio unit (base system), or poor audio unit, CD changer or rear audio remote control unit body ground (midgrade and premium systems) Audio unit, CD changer or rear audio remote control unit 	<ol style="list-style-type: none"> Check 10A fuse and 7.5A fuse (Nos. 20 and 10, located in the fuse block). Verify battery positive voltage is present at terminal 29 of audio unit and terminal 9 of CD changer, and terminal 5 of rear audio remote control unit. Turn ignition switch ON and verify battery positive voltage is present at terminal 30 of audio unit. Check audio unit case ground, or audio unit, CD changer or rear audio remote control unit body ground. Remove audio unit, CD changer, or rear audio remote control unit for repair. 	GI MA EM LC
Audio unit presets and/or CD changer memory is lost when ignition switch is turned OFF.	<ol style="list-style-type: none"> 10A fuse Audio unit 	<ol style="list-style-type: none"> Check 10A fuse (No. 20, located in the fuse block) and verify battery positive voltage is present at terminal 29 of audio unit and terminal 9 of CD changer. Remove audio unit for repair. 	EC
Individual speaker is noisy or inoperative.	<ol style="list-style-type: none"> Speaker 20A fuse (midgrade and premium systems) Subwoofer amplifier output (midgrade and premium systems) Speaker circuit Audio unit output Audio unit 	<ol style="list-style-type: none"> Check speaker. Check 20A fuse (No. 11, located in the fuse block). Turn ignition ON and verify battery positive voltage is present at terminal 6 of subwoofer amplifier. Check subwoofer amplifier output voltage. Check wires for open or short between audio unit and speaker (base system), or between subwoofer amplifier and subwoofer speaker (midgrade and premium systems). Check audio unit output voltages. Remove audio unit for repair. 	FE AT AX SU
AM stations are weak or noisy (FM stations OK).	<ol style="list-style-type: none"> Antenna Poor audio unit ground Audio unit 	<ol style="list-style-type: none"> Check antenna. Check audio unit case ground. Remove audio unit for repair. 	BR
FM stations are weak or noisy (AM stations OK).	Audio unit	Remove audio unit for repair.	ST
Audio unit generates noise in AM and FM modes with engine running.	<ol style="list-style-type: none"> Poor audio unit ground Loose or missing ground bonding straps Ignition condenser Generator Ignition coil or secondary wiring Audio unit 	<ol style="list-style-type: none"> Check audio unit case ground. Check ground bonding strip. Replace ignition condenser. Check generator. Check ignition coil and secondary wiring. Remove audio unit for repair. 	RS BT
Audio unit generates noise in AM and FM modes with accessories on (switch pops and motor noise).	<ol style="list-style-type: none"> Poor audio unit ground Antenna Accessories ground Faulty accessory 	<ol style="list-style-type: none"> Check audio unit case ground. Check antenna. Check accessory ground. Replace accessory. 	HA SC
Audio unit displays "CD TOO HOT".	Audio unit internal temperature has exceeded 85° C (185° F).	The audio unit is in thermal protection mode. Check display after allowing audio unit to cool. If the display continues to indicate "CD TOO HOT", remove audio unit for repair.	EL IDX

SPEAKER INSPECTION

NDEL0081S01

- Disconnect speaker harness connector.
- Measure the resistance between speaker terminals 1 and 2.
 - The resistance should be 2 - 4Ω.
- Using jumper wires, momentarily connect a 9V battery between speaker terminals 1 and 2.
 - A momentary hum or pop should be heard.

ANTENNA INSPECTION

NDEL0081S02

- Using a jumper wire, clip an auxiliary ground between antenna and body.

AUDIO

Trouble Diagnoses (Cont'd)

- If reception improves, check antenna ground (at body surface)
- If reception does not improve, check main feeder cable for short circuit or open circuit.

STEERING WHEEL AUDIO CONTROL SWITCHES INSPECTION

NDEL0081S16

1. Disconnect audio unit M44.
2. Measure the resistance between audio unit M44 and ground while pressing each button.

Switch	Resistance value (Ω)
VOL Down	69.27-77.38 ohms
VOL Up	198.5-217.61 ohms
NEXT	419.4-467.5 ohms
No buttons pressed	4,560-5,080 ohms

LEL293

3. Resistances should be within specifications.

AUDIO UNIT, C/D CHANGER, REAR AUDIO REMOTE CONTROL UNIT AND SUBWOOFER AMPLIFIER INSPECTION

NDEL0081S03

All voltage inspections are made with

- Ignition switch ON or ACC
- Audio unit ON
- Audio unit, CD changer, rear audio remote control unit and subwoofer amplifier connected. (If the base audio unit is removed from the audio unit mounting bracket to make the inspection, supply a ground to the case using a jumper wire.)

AUDIO UNIT VOLTAGES

NDEL0081S04

Terminal	Wire color	Voltage (V)	Terminal	Wire color	Voltage (V)
1	—	—	23	—	—
2	—	—	24	—	—
3	—	—	25	R/L	0 - 7
4	—	—	26	Y/R	0 - 7
5	Y/R	10.8 - 15.6 (Audio unit on)	27	L* or R	0 - 7
6	LG	Data line	28	Y* or R/W	0 - 7
7	PU	Data line	29	BR/W	10.8 - 15.6 (Battery)
8	—	—	30	OR	10.8 - 15.6 (Ignition ACC or ON)
9	—	—	31	B	Body ground
10	—	—	32	L/W	0 - 7
11	—	—	33	SB	0 - 7
12	—	—	34	GY/L* or G	0 - 7
13	—	—	35	Y/L* or G/R	0 - 7
14	W/B	Check continuity between audio unit harness connector M44 and steering wheel audio control switches connector Z203.	36	B	Body ground

AUDIO

Trouble Diagnoses (Cont'd)

Terminal	Wire color	Voltage (V)	Terminal	Wire color	Voltage (V)
15	W/R	—	37	L	Approx. 0
16	—	Shield ground	38	W	0 - 5
17	R	0 - 5 [CD changer right channel (+) input]	39	—	Shield ground
18	G	0 - 5 [CD changer right channel (-) input]	40	OR	Approx. 5 (Mute output)
19	B	0 - 5 [CD changer left channel (+) input]	41	—	—
20	W	0 - 5 [CD changer left channel (-) input]	42	—	—
21	P	10.8 - 15.6 (Illumination on)	43	—	—
22	P/B	0 - 11 (Illumination on)	44	—	—

* with midgrade

REAR AUDIO REMOTE CONTROL UNIT VOLTAGES

NDEL0081S07

Terminal	Wire color	Voltage (V)	Terminal	Wire color	Voltage (V)
1	—	—	9	P	10.8 - 15.6 (Illumination on)
2	G	0 - 7	10	P/B	0 - 11 (Illumination on) or 0*
3	L/W	0 - 7 (input)	11	—	—
4	L/Y	0 - 7 (input)	12	PU	Data line
5	—	—	13	LG	Data line
6	L/B	0 - 7 (input)	14	B	Body ground
7	R/L	0 - 7 (input)	15	BR/W	10.8 - 15.6 (Battery)
8	L	0 - 7	16	Y/R	10.8 - 15.6 (Audio unit on)

* with rear audio remote control unit (illumination control)

C/D CHANGER VOLTAGES

NDEL0081S08

Terminal	Wire color	Voltage (V)	Terminal	Wire color	Voltage (V)
1	LG	Data line	7	PU	Data line
2	—	—	8	Y/R	10.8 - 15.6 (Audio unit on)
3	B	Body ground	9	BR/W	10.8 - 15.6 (Battery)
4	—	—	10	—	Shield ground
5	B	0 - 5 [left channel (+) output]	11	W	0 - 5 [left channel (-) output]
6	R	0 - 5 [right channel (+) output]	12	G	0 - 5 [right channel (-) output]

SUBWOOFER AMPLIFIER VOLTAGES

NDEL0081S09

Terminal	Wire color	Voltage (V)	Terminal	Wire color	Voltage (V)
1	L	0 - 1.5 (input)	4	—	Shield ground
2	W	0 - 1.5	5	B	Body ground

AUDIO

Trouble Diagnoses (Cont'd)

Terminal	Wire color	Voltage (V)	Terminal	Wire color	Voltage (V)
3	OR	Greater than 11 (Audio unit on)	6	OR/B	10.8 - 15.6 (Ignition ACC or ON)

AUDIO ANTENNA

Location of Antenna

Location of Antenna

NDEL0082

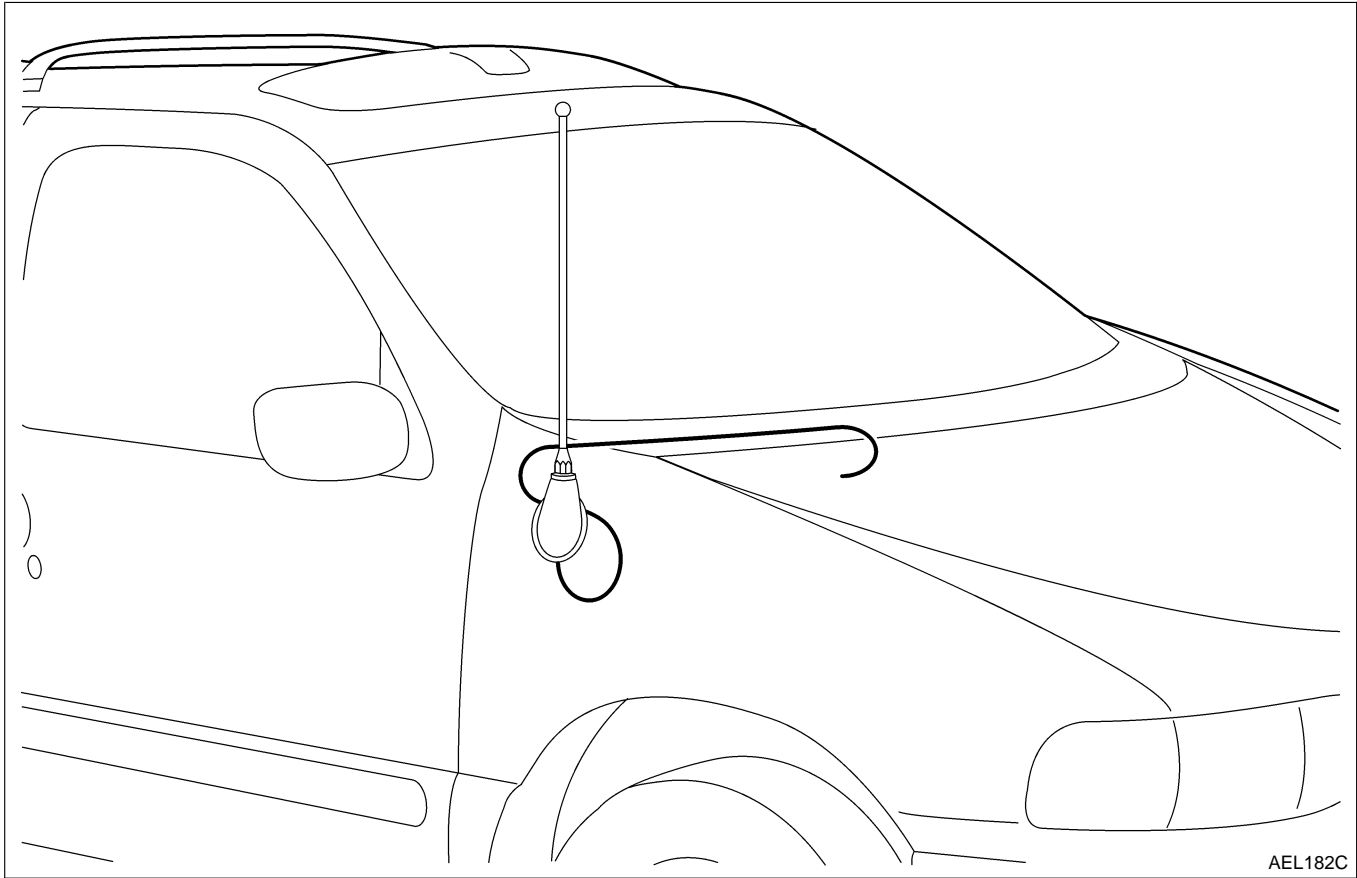

GI
MA
EM
LC
EC
FE
AT
AX
SU
BR

ST

RS

BT

HA

SC

EL

IDX

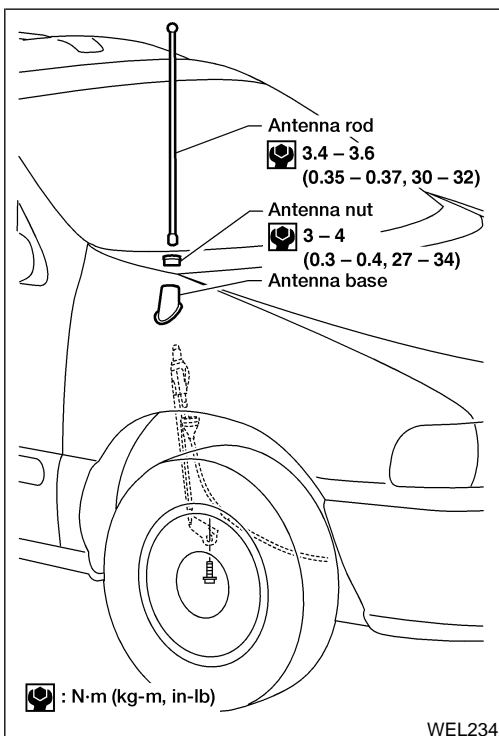

NDEL0083

Removal and Installation

1. Remove antenna rod.
2. Remove antenna nut and antenna base.
3. Remove inner splash shield.
4. Disconnect antenna cable from audio unit, refer to **BT-23**.
5. Remove bolt and antenna.

To install, reverse removal procedure.

POWER SUNROOF

System Description

System Description

NDEL0084

POWER

NDEL0084S01

Power is supplied to the sunroof motor assembly by the power window relay. When the ignition switch is turned ON, the relay is energized by the smart entrance control unit. The power circuit is protected by the circuit breaker-1. The sunroof motor assembly is grounded through body grounds M68, M105 and M130.

When the ignition switch is turned to the OFF position, the sunroof will still operate for up to approximately 15 minutes unless the driver's door is opened. **(Delayed power operation.)**

NOTE:

When the battery or sunroof motor harness connector is disconnected during service, the sunroof will not operate properly.

Procedure for resetting motor memory:

From any sunroof position (full open, partially open, closed, partially vented, and vented), push and hold the button in the forward position until the sunroof vents in the **Full-Up** position. This resets the sunroof motor memory and now the sunroof will operate correctly.

TILT AND SLIDE OPERATION

NDEL0084S02

The sunroof is controlled by the sunroof switch. With the sunroof in closed position, depressing UP/CLOSE switch will tilt rear of sunroof up. The sunroof will stop when the switch is released, or when the sunroof reaches its maximum tilt position.

The sunroof will tilt down when in tilt up position and DOWN/OPEN switch is depressed. The sunroof will stop when switch is released, or when sunroof is fully closed.

With sunroof in closed position, pressing DOWN/OPEN switch will cause sunroof to slide open. The sunroof will slide open until switch is released or until it is all the way open. The sunroof will close when in open position, and UP/CLOSE switch is depressed. The sunroof will slide until switch is released, or when sunroof is fully closed.

All automatic operations in sunroof are controlled by internal limit switches located in sunroof motor assembly.

POWER SUNROOF

Wiring Diagram — SROOF —

Wiring Diagram — SROOF —

NDEL0085

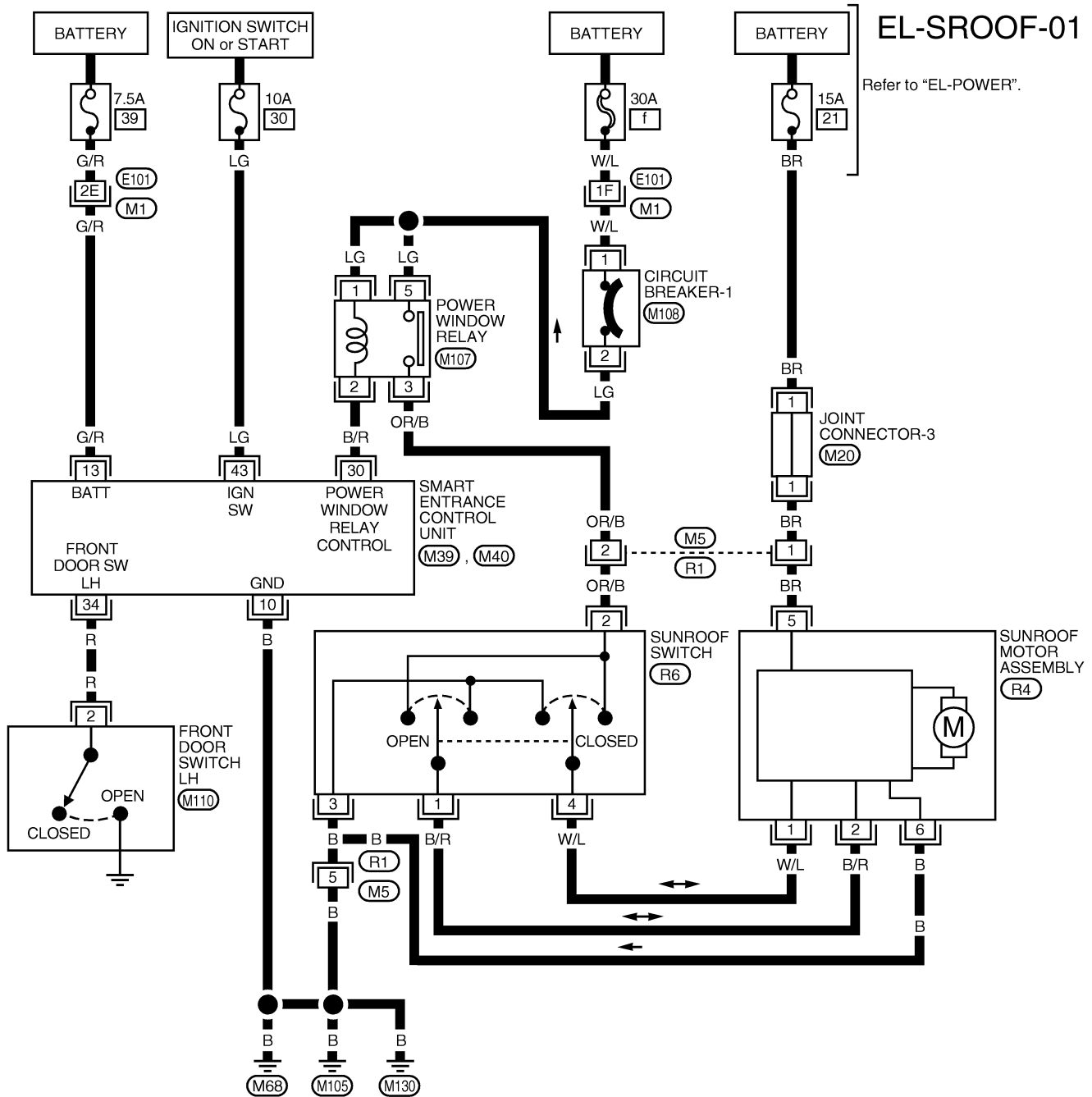

EL-SROOF-01

Refer to "EL-POWER".

GI
MA
EM
LC
EC
FE
AT
AX
SU
BR
ST
RS
BT
HA
SC

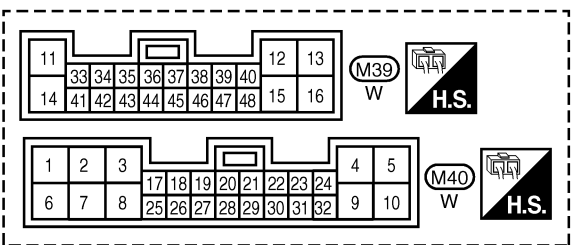

Refer to the following.
 (M1, E101) - SUPER MULTIPLE JUNCTION (SMJ)
 (M20) - JOINT CONNECTOR

EL
IDX

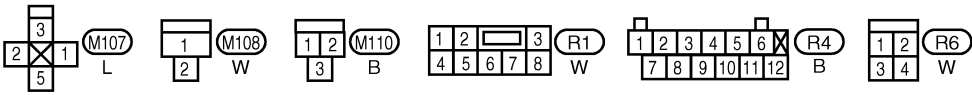

WEL226

POWER DOOR MIRROR

Wiring Diagram — MIRROR — /Without Automatic Drive Positioner

Wiring Diagram — MIRROR — /Without Automatic Drive Positioner

NDEL0086

NOTE:

For the information about door mirror for models with automatic drive positioner, refer to "AUTOMATIC DRIVE POSITIONER", EL-146.

EL-MIRROR-01

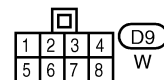
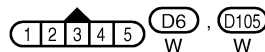
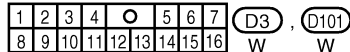
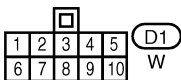
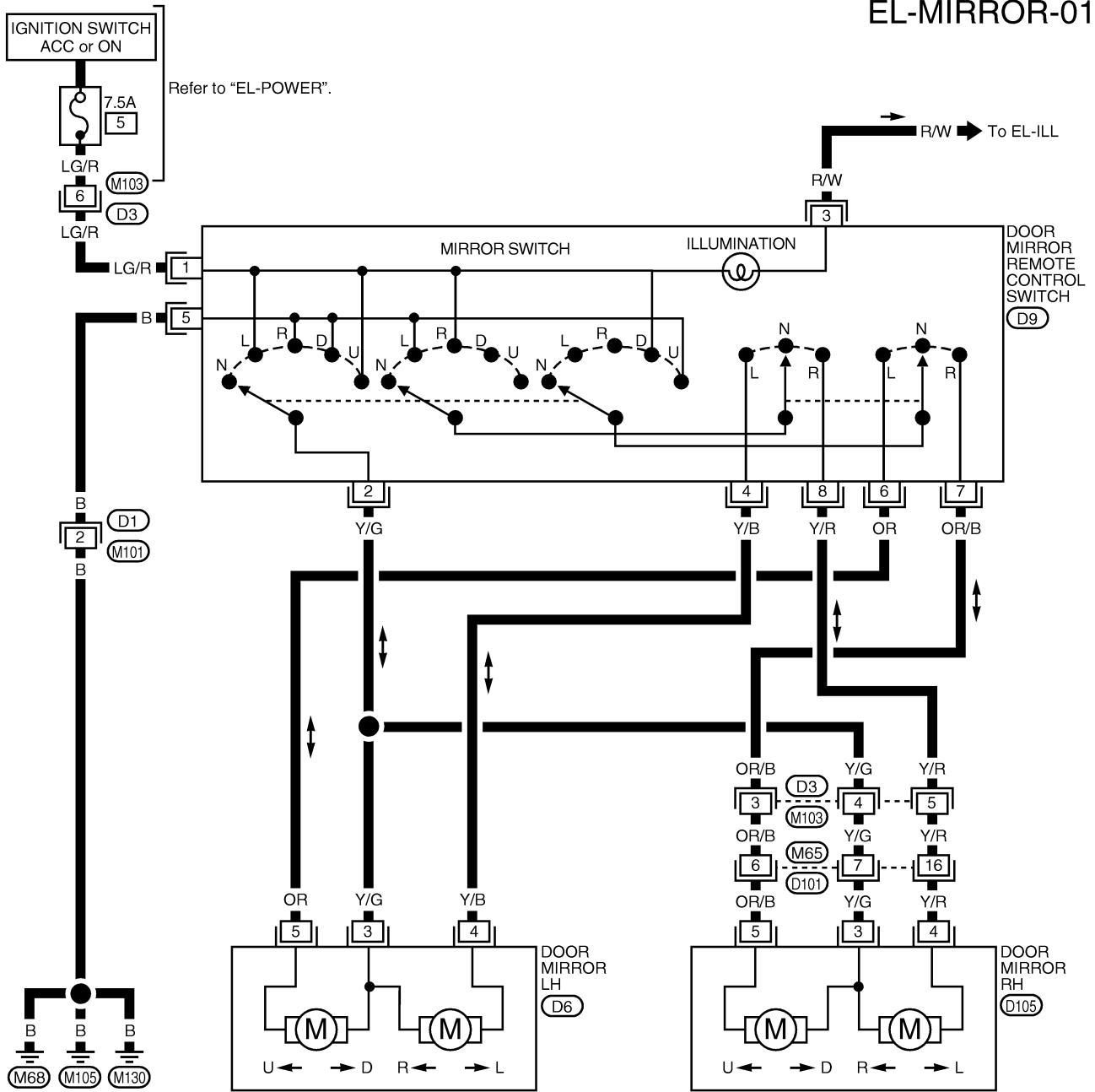

WEL225

HEATED MIRROR

Wiring Diagram — H/MIRR —

Wiring Diagram — H/MIRR —

NDEL0087

EL-H/MIRR-01

GI
MA
EM
LC
EC
FE
AT
AX
SU
BR
ST
RS
BT
HA
SC

EL

IDX

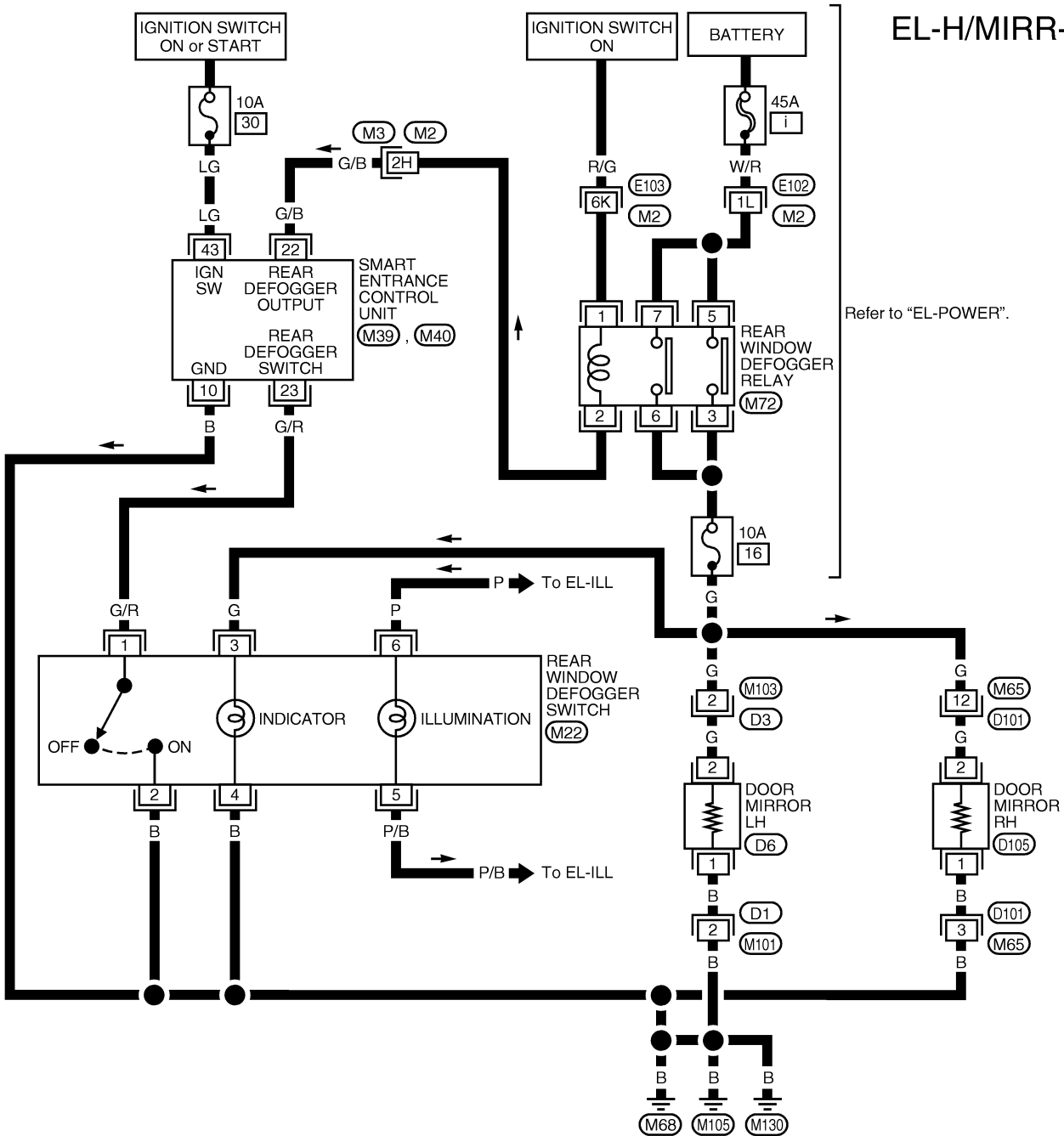

Refer to "EL-POWER".

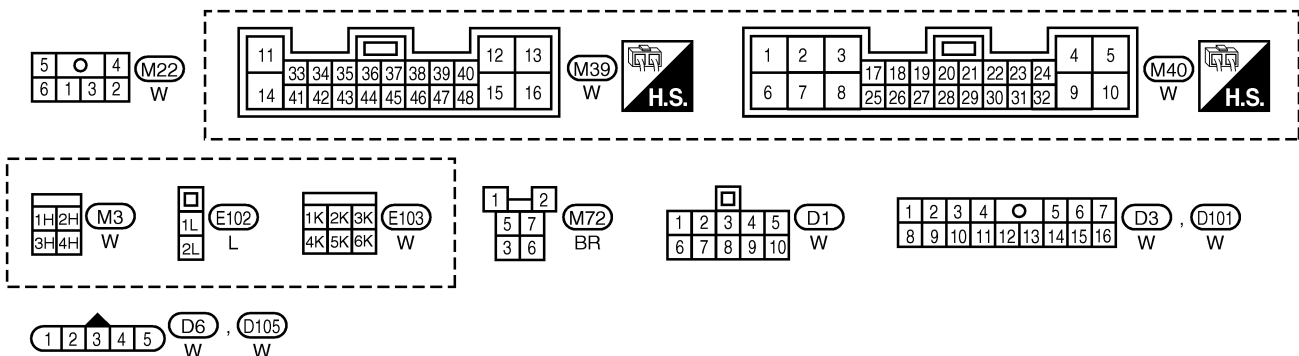

WEL227

AUTOMATIC DRIVE POSITIONER

Component Parts and Harness Connector Location

Component Parts and Harness Connector Location

NDEL0088

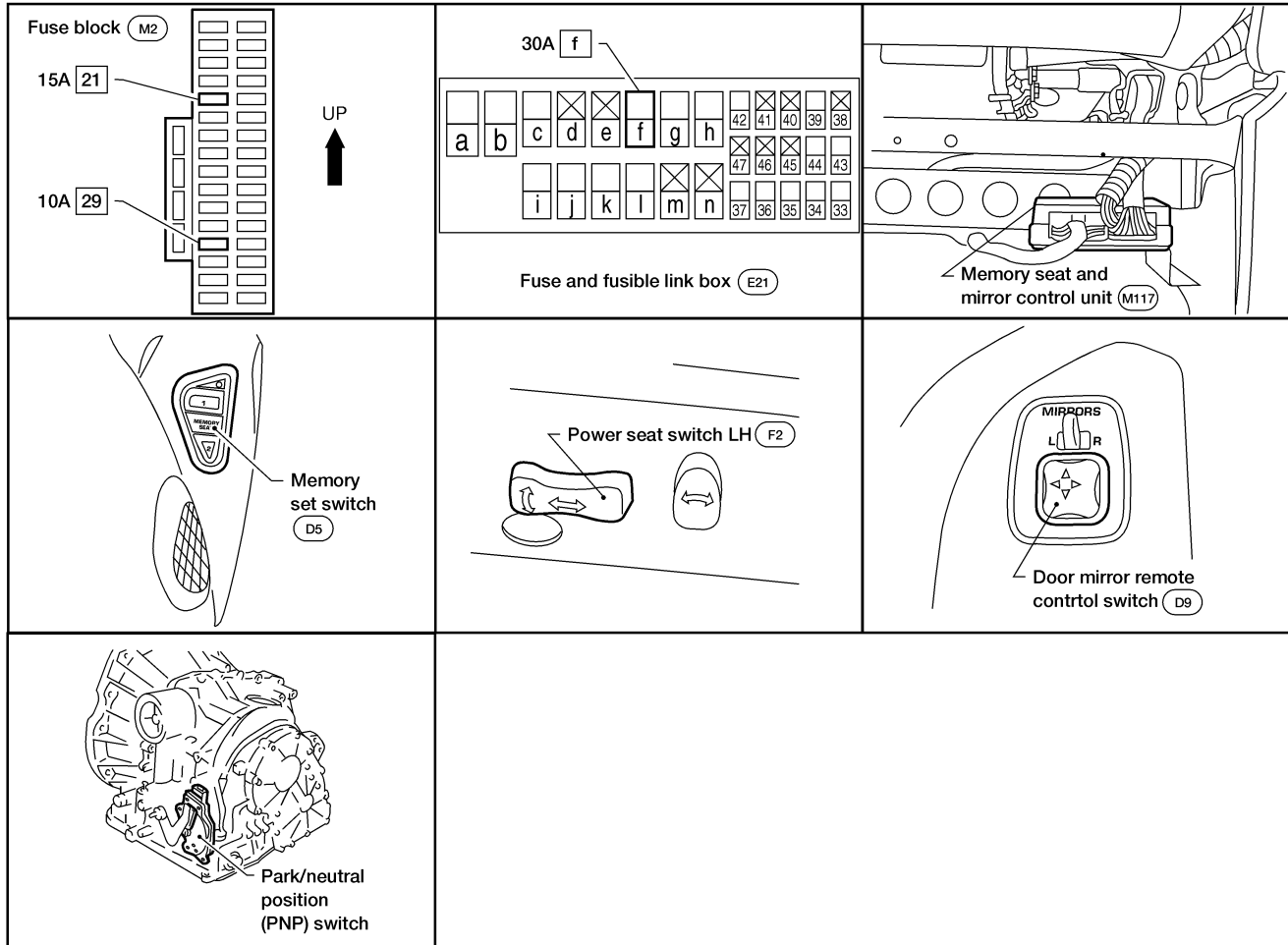

WEL282

System Description

NDEL0089

OPERATION

Automatic drive positioner allows automatic positioning of driver seat, LH and RH door mirror to two programmable positions using the memory set switch located on the drivers door and multi-remote controller. Driver's seat can be adjusted for sliding, reclining and cushion height.

NDEL0089S01

MEMORY POSITION OPERATION

Automatic drive positioner has the following three functions

NDEL0089S02

- Memory set switch operation (Memorized position can be set corresponding to memory switch operation.)
- Multi-remote controller operation (Memorized position can be set by unlocking driver's door with multi-remote controller.)
- Auto back operation (Driver's seat fully rearward and down for easy access.)

NOTE:

- As a safety feature, the memory positioning operation is permitted to operate only if the park/neutral position (PNP) switch is in the park or neutral position. If the memory position operation is activated and PNP switch is moved from park or neutral position, the memory position operation will be halted.
- If either memory position switch is pressed after motion has started, all motion will immediately stop.
- If a manual control switch is pressed, memory operation will be cancelled.
- All seat and mirror sensors shall be monitored for validity. If any sensor is seen to be out of range, no motion shall be performed for that axis during memory recall. Invalid sensors do not affect manual operation.

AUTOMATIC DRIVE POSITIONER

System Description (Cont'd)

- Up to 2 seat axes will move simultaneously during memory position operation. All mirror axes may move simultaneously during memory position operation.

Memory Set Switch Operation

1. Push and release memory set switch 1 or 2 with ignition switch in OFF or ACC position. (LED indicator on the memory set switch will turn on until memory set switch is released or 10 seconds have passed.)
2. Driver's seat, LH and RH door mirrors will move to the memorized position.

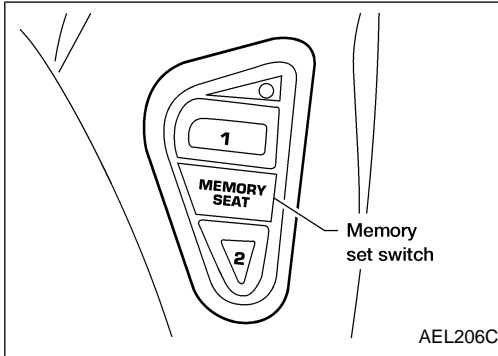

Multi-remote Controller Operation

1. Unlock driver's door with multi-remote controller. (Automatic positioning signal will be sent to memory seat and mirror control unit from smart entrance control unit.)
2. Driver's seat, LH and RH door mirrors will move to the memorized position.

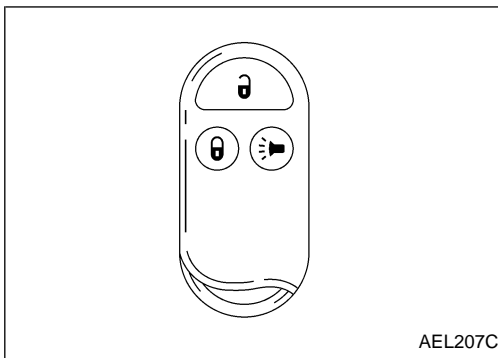

Auto Back Operation

1. Push and release memory set switch 1 and 2 together with the park/neutral position (PNP) switch in park or neutral position. (LED indicator on the memory set switch will turn on until both memory set switches are released or 10 seconds have passed.)
2. Driver's seat moves fully rearward and downward for easy entry and exist.

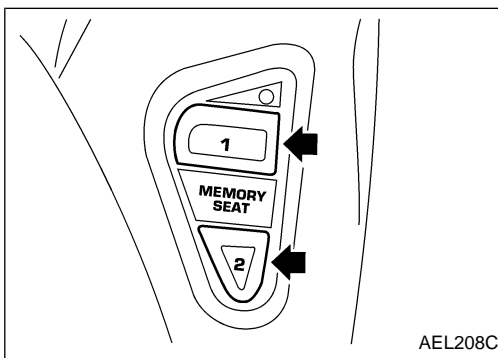

GI

MA

EM

LC

EC

FE

AT

AX

SU

BR

ST

RS

BT

HA

SC

EL

IDX

AUTOMATIC DRIVE POSITIONER

System Description (Cont'd)

PROCEDURE FOR STORING MEMORY POSITION

NDEL0089S03

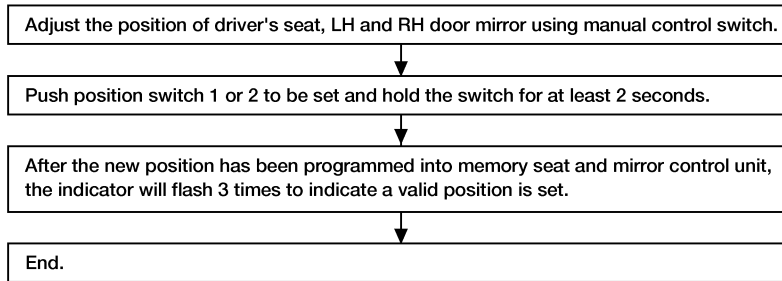

AEL006C

NOTE:

- The stored memory positions are maintained unless battery power is disconnected from memory seat and mirror control unit.
- Two different positions are memorized for positions 1 and 2 in the memory seat and mirror control unit initially. After the battery power supply is disconnected and reconnected, the memories of positions will return to the initial memorized positions.
If the current position is the programmed position for that switch, the position will not be re-programmed.
- If a sensor is not valid, the memory of axis position will not be changed. Only the position of motors with a valid sensor will change to new positions.

PROCEDURE FOR STORING MULTI-REMOTE CONTROLLER

NDEL0089S04

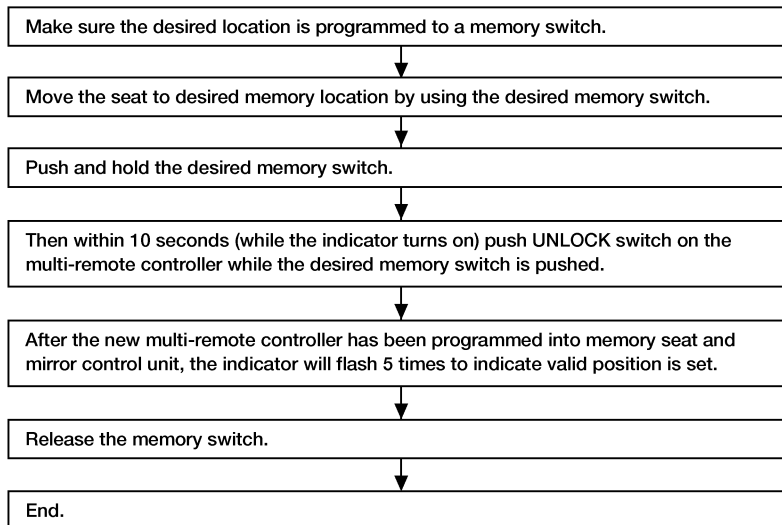

AEL007C

Procedure for Erasing Multi-remote Controller Memory

Hold both memory switch 1 and 2 then push UNLOCK switch on the multi-remote controller to be deprogrammed.

NDEL0089S0401

NOTE:

In this case auto back function will not operate.

AUTOMATIC DRIVE POSITIONER

Schematic

Schematic

NDEL0090

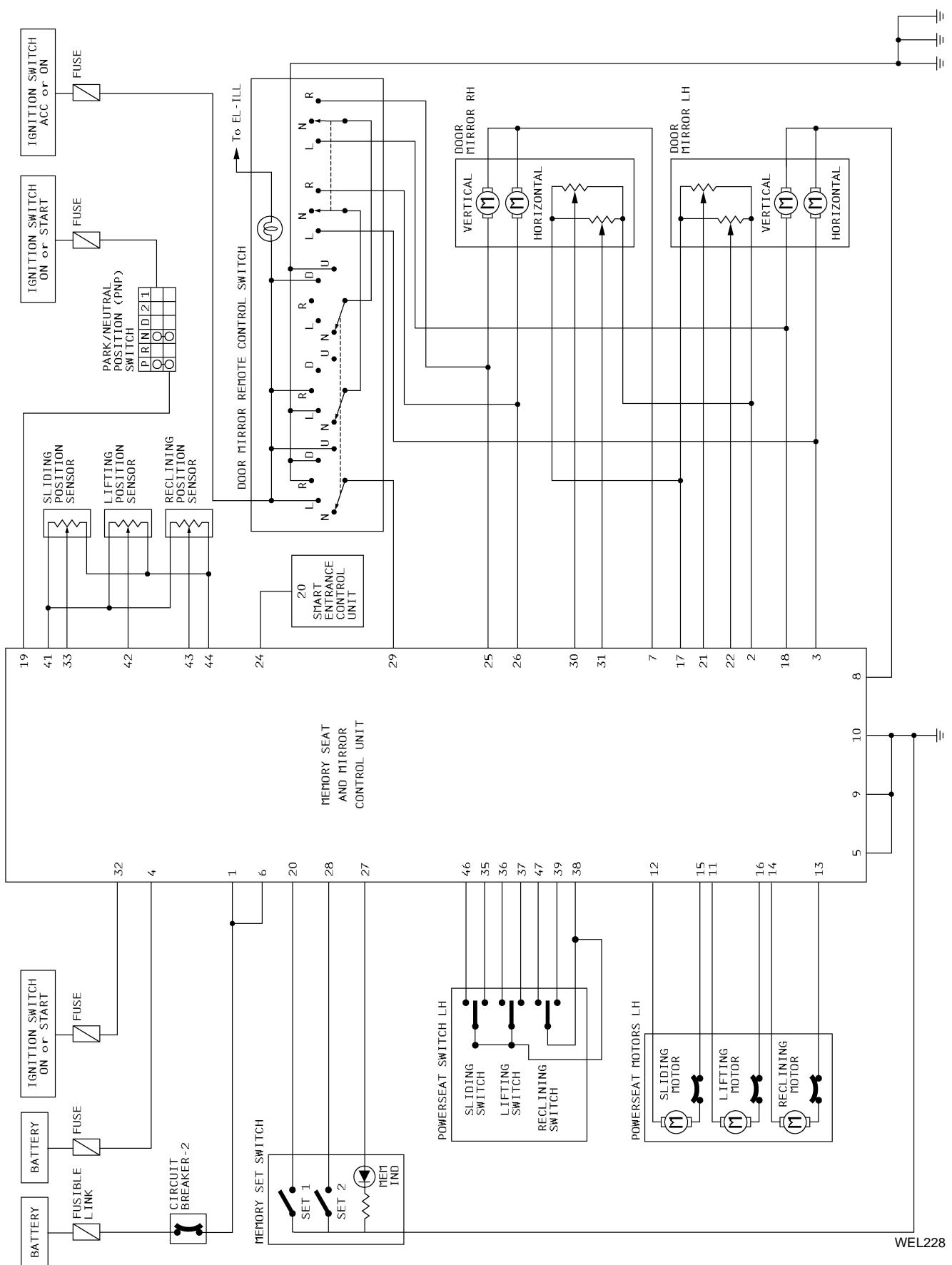

AUTOMATIC DRIVE POSITIONER

Wiring Diagram — AUT/DP —

Wiring Diagram — AUT/DP —

NDEL0091

NDEL0091S01

FIG. 1

EL-AUT/DP-01

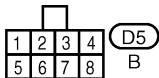
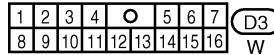
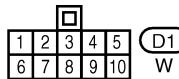
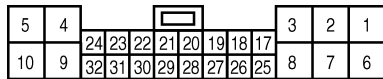
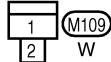
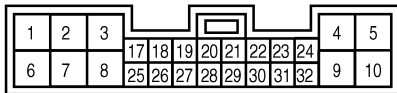
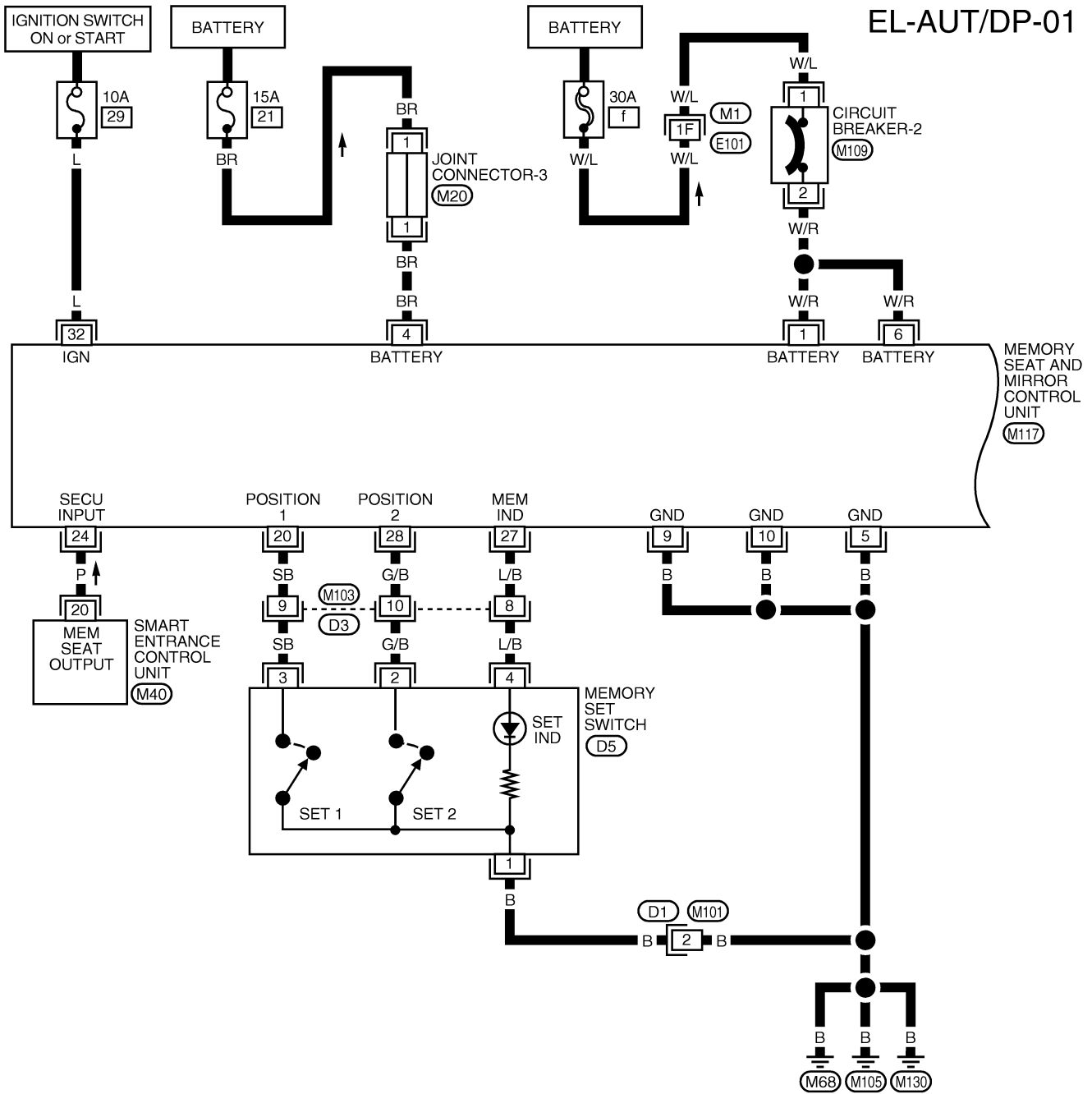

Refer to the following.
 (M1), (E101) - SUPER MULTIPLE JUNCTION (SMJ)
 (M20) - JOINT CONNECTOR

WEL229

AUTOMATIC DRIVE POSITIONER

Wiring Diagram — AUT/DP — (Cont'd)

FIG. 2

NDEL0091S02

EL-AUT/DP-02

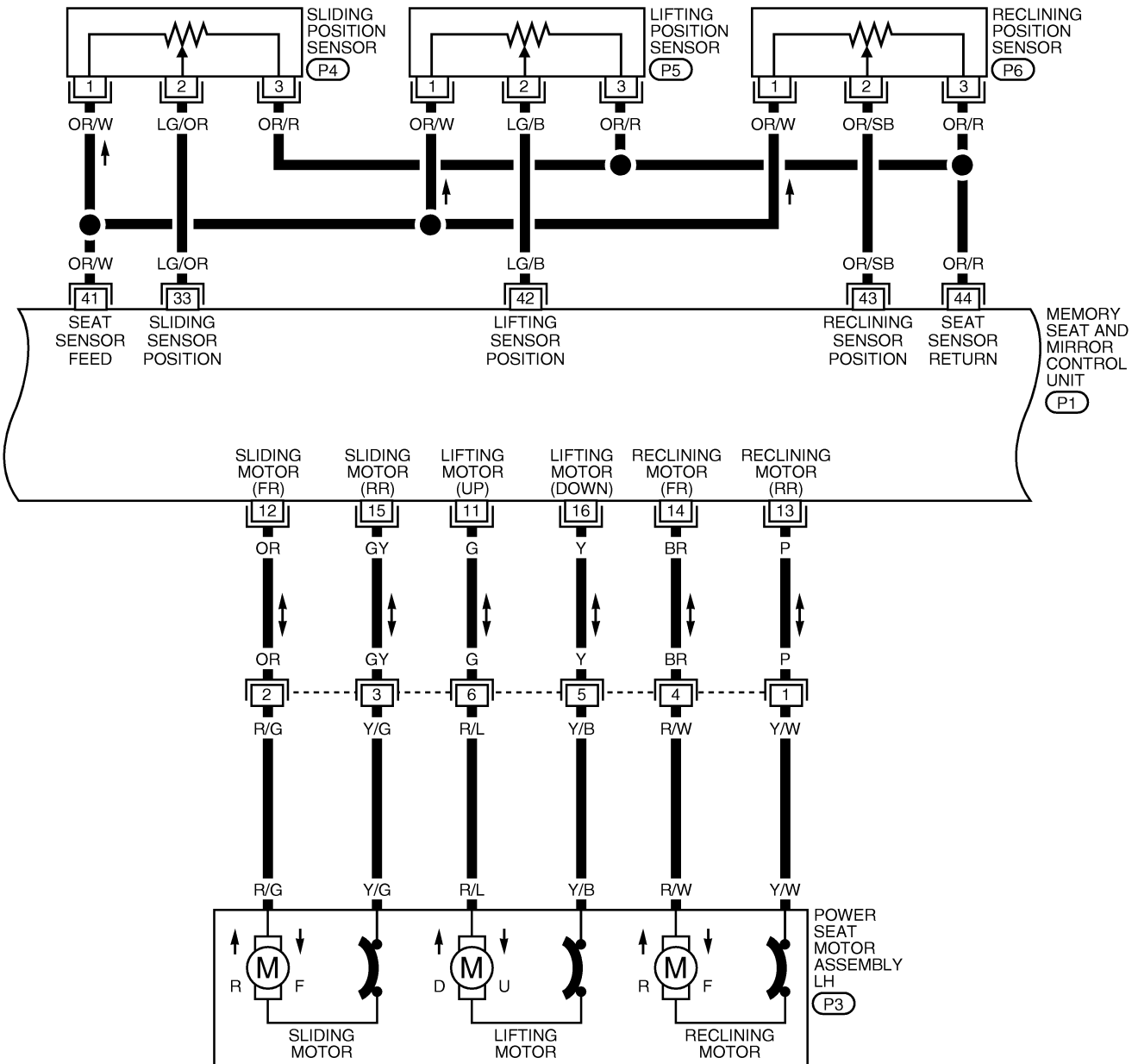

GI
MA
EM
LC
EC
FE
AT
AX
SU
BR
ST
RS
BT
HA
SC

EL

IDX

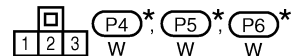
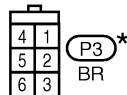

*: This connector is not shown in "HARNES LAYOUT".

AUTOMATIC DRIVE POSITIONER

Wiring Diagram — AUT/DP — (Cont'd)

NDEL0091S03

FIG. 3

EL-AUT/DP-03

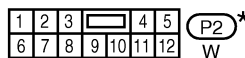
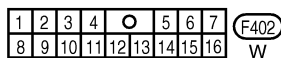
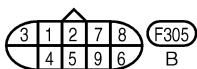
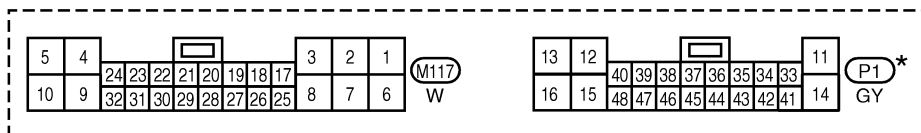
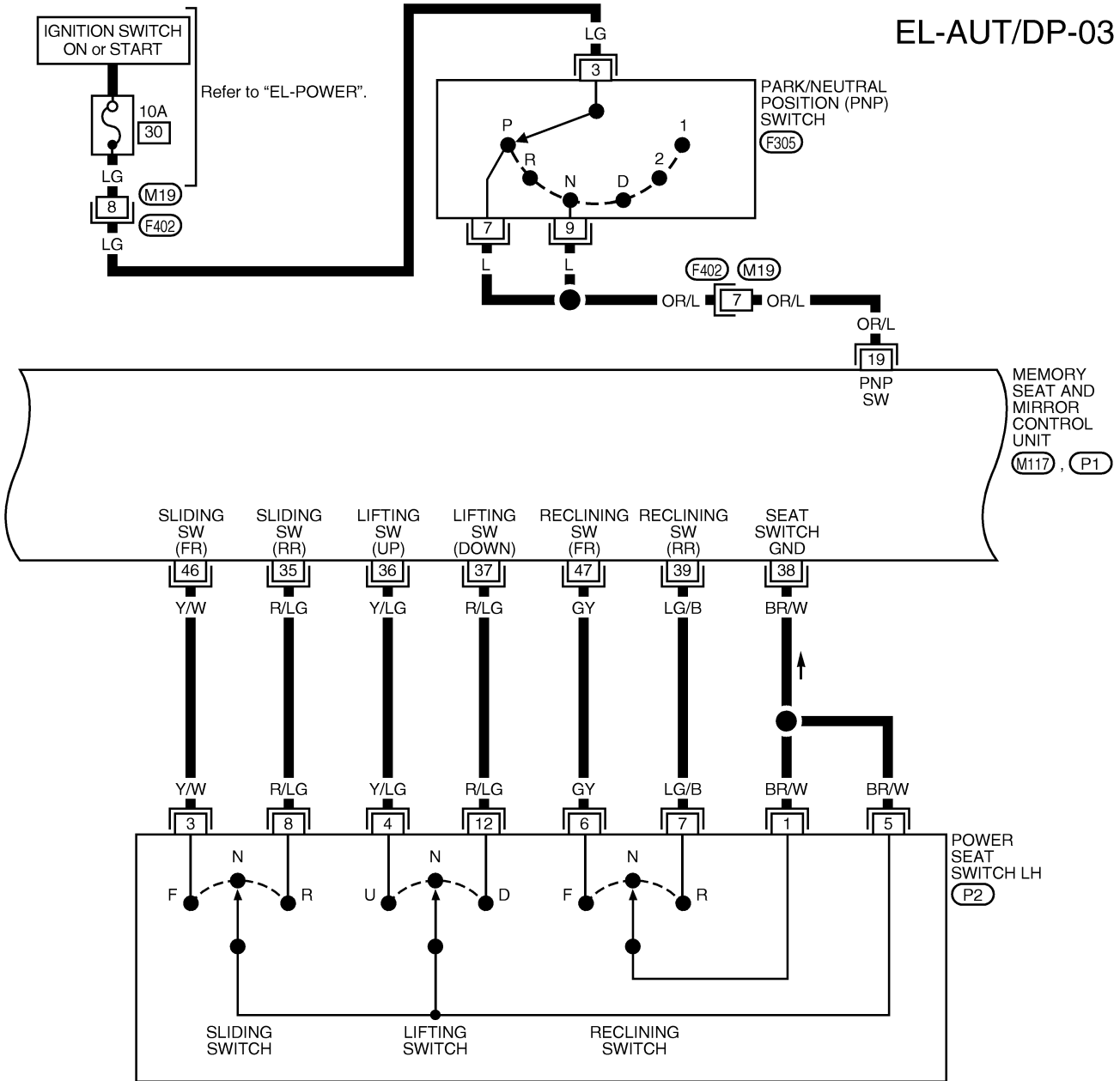

*: This connector is not shown in "HARNES LAYOUT".

AUTOMATIC DRIVE POSITIONER

Wiring Diagram — AUT/DP — (Cont'd)

NDEL0091S05

FIG. 5

EL-AUT/DP-05

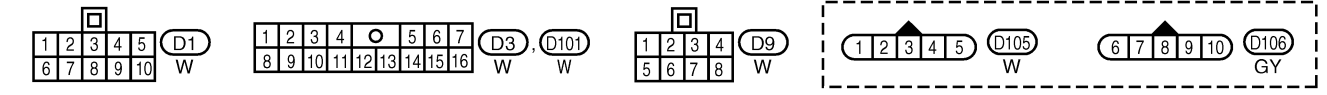
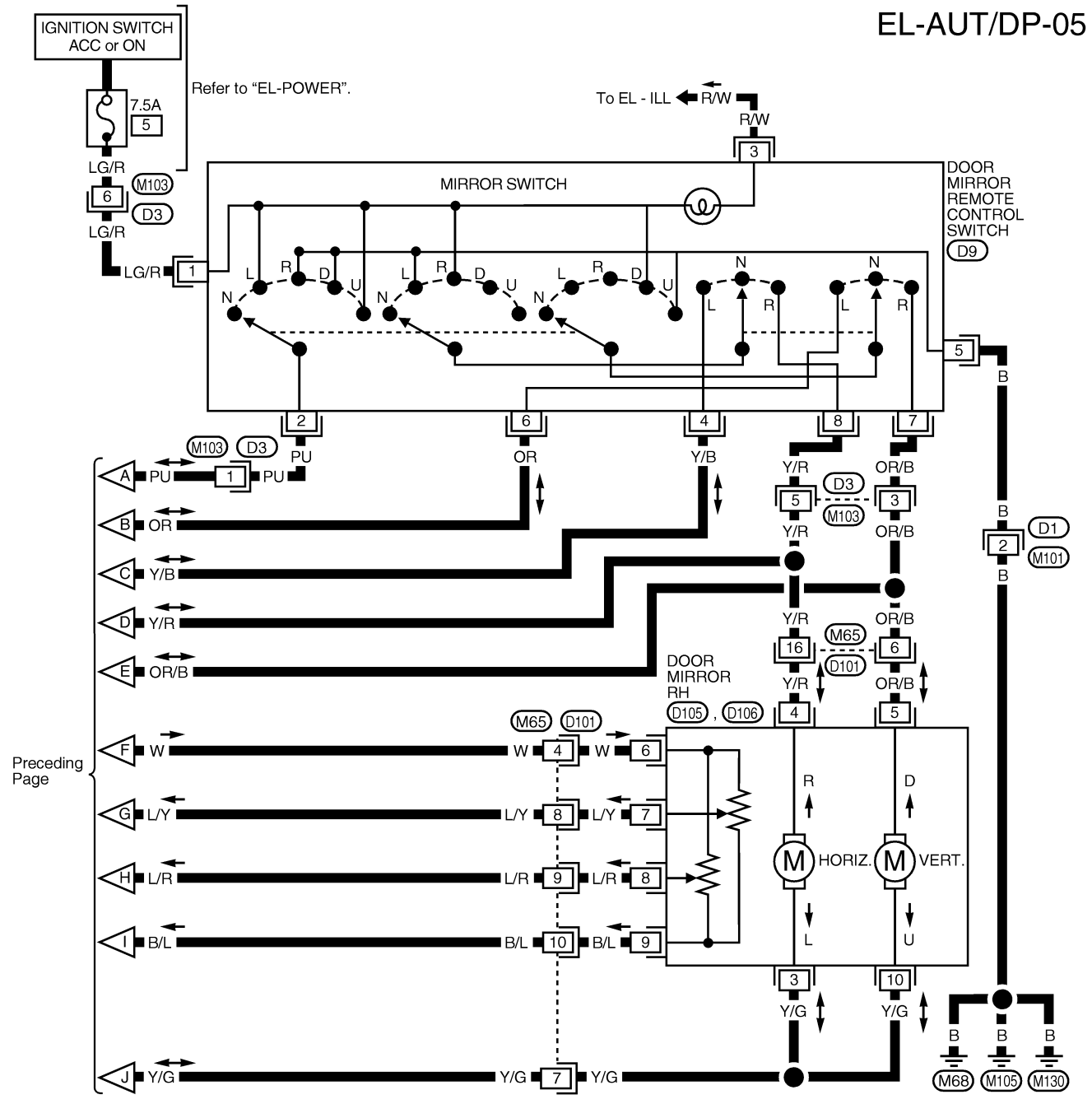

Trouble Diagnosis PRELIMINARY CHECK

NDEL0092

NDEL0092S01

NOTE:

After performing preliminary check, go to symptom chart on next page.

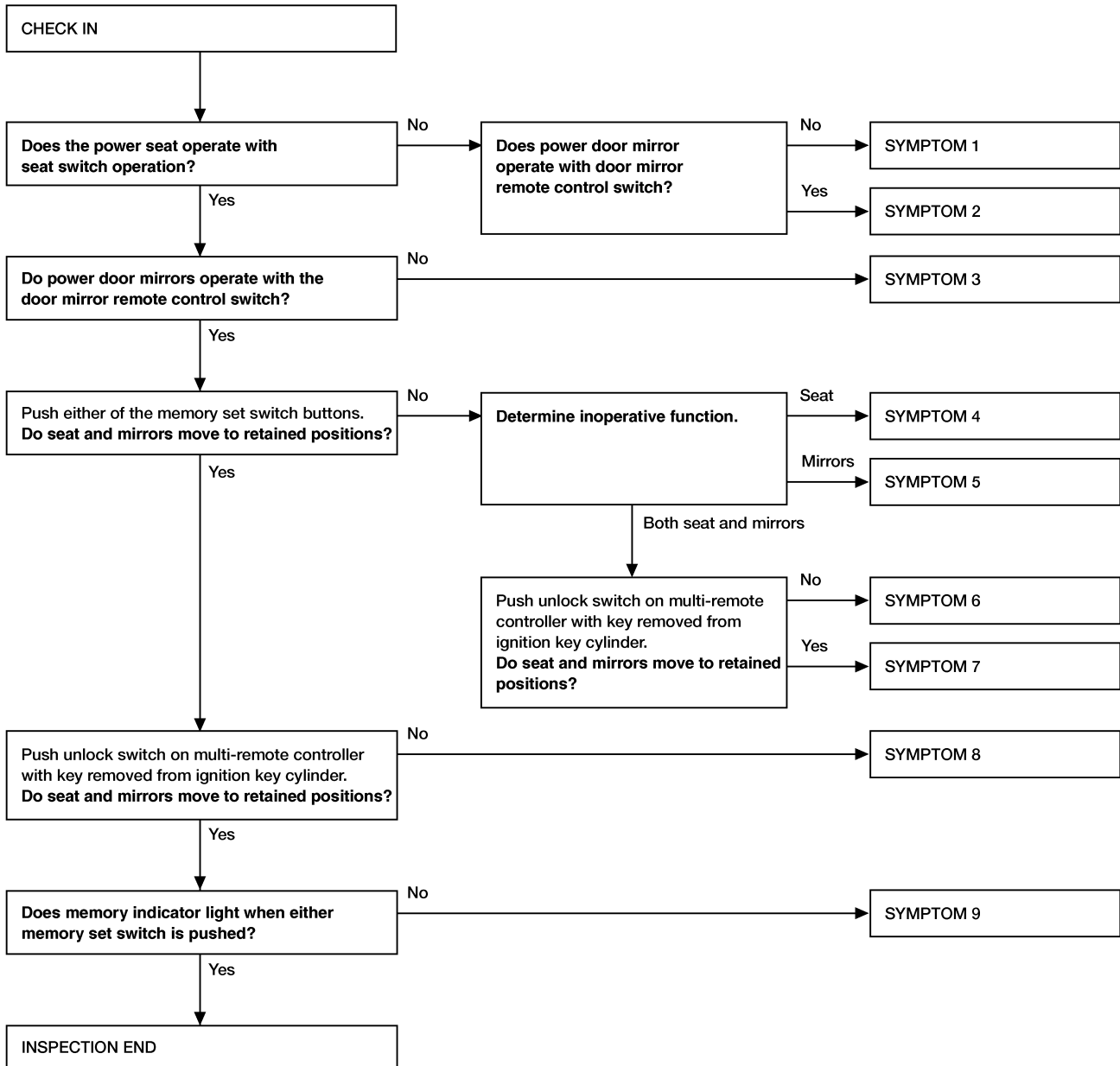

GI

MA

EM

LC

EC

FE

AT

AX

SU

BR

ST

RS

BT

HA

SC

EL

IDX

AEL005C

AUTOMATIC DRIVE POSITIONER

Trouble Diagnosis (Cont'd)

SYMPTOM CHART

=NDEL0092S02

Before starting trouble diagnoses below, perform preliminary check, EL-155. Symptom numbers in symptom chart correspond with those of preliminary check.

Symptom	Diagnoses/service procedure	Reference page	
1	Neither seat nor mirror function operate by any operation.	POWER SUPPLY AND GROUND CIRCUIT FOR MEMORY SEAT AND MIRROR CONTROL UNIT CHECK EL-157	
2	All/some functions of the power seat do not operate during manual operation or memory position operation.	Sliding	POWER SEAT SLIDING MOTOR CHECK EL-160
			POWER SEAT SWITCH CHECK EL-175
		Reclining	POWER SEAT RECLINING MOTOR CHECK EL-161
			POWER SEAT SWITCH CHECK EL-175
	Lifting	POWER SEAT LIFTING MOTOR CHECK EL-162	
		POWER SEAT SWITCH CHECK EL-175	
		All	POWER SEAT SWITCH CHECK EL-175
3	All/some functions of the power door mirror do not operate during manual operation or memory position operation.	Driver side	POWER DOOR MIRROR MOTOR CHECK EL-169
			DOOR MIRROR REMOTE CONTROL SWITCH CHECK EL-179
	Passenger side	POWER DOOR MIRROR MOTOR CHECK EL-169	
		DOOR MIRROR REMOTE CONTROL SWITCH CHECK EL-179	
	Both driver and passenger side	DOOR MIRROR REMOTE CONTROL COMMON CIRCUIT CHECK EL-177	
4	Some functions of the power seat do not operate during memory position operation. (Power seat operates properly with manual operation.)	Sliding	POWER SEAT SLIDING SENSOR CHECK EL-163
		Reclining	POWER SEAT RECLINING SENSOR CHECK EL-165
		Lifting	POWER SEAT LIFTING SENSOR CHECK EL-167
5	Some functions of the power door mirrors do not operate during memory position operation. (Door mirrors operate properly with manual operation.)	Driver side	DOOR MIRROR POSITION SENSOR CHECK (DRIVER SIDE) EL-171
		Passenger side	DOOR MIRROR POSITION SENSOR CHECK (PASSENGER SIDE) EL-173
6	Memory positioning does not operate with either memory switch or multi-remote controller operation.	IGNITION SWITCH ON SIGNAL CHECK EL-157	
		PARK/NEUTRAL POSITION (PNP) SWITCH CHECK EL-158	
7	Memory positioning does not operate with memory set switch operation. (Memory positioning operates with multi-remote controller operation.)	MEMORY SET SWITCH CHECK EL-180	
8	Memory positioning does not operate with multi-remote controller operation. (Memory positioning operates with memory set switch operation.)	REMOTE CONTROLLER SIGNAL CHECK EL-182	
9	Memory indicator does not light up.	MEMORY INDICATOR CHECK EL-181	
—	Seat and mirror positions cannot be retained in memory.	MEMORY SET SWITCH CHECK EL-180	

AUTOMATIC DRIVE POSITIONER

Trouble Diagnosis (Cont'd)

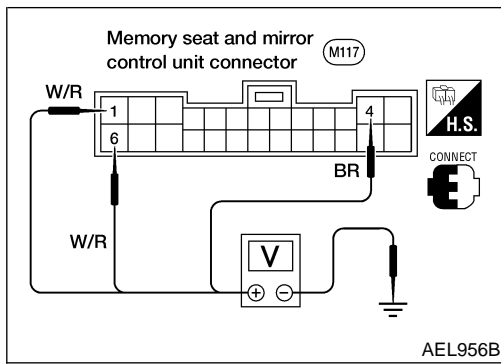

POWER SUPPLY AND GROUND CIRCUIT FOR MEMORY SEAT AND MIRROR CONTROL UNIT CHECK

NDEL0092S03

Power Supply Circuit Check

NDEL0092S0301

Terminals		Ignition switch position		
(+)	(-)	OFF	ACC	ON
1	Ground	Battery voltage	Battery voltage	Battery voltage
6	Ground	Battery voltage	Battery voltage	Battery voltage
4	Ground	Battery voltage	Battery voltage	Battery voltage

If result for terminal 4 is NG, check the following

- 15A fuse (No. 21, located in the fuse block)
- Joint connector-3
- Harness for open or short between memory seat and mirror control unit and fuse.

If result for terminals 1 or 6 is NG, check the following

- 30A fusible link (letter f, located in the fuse and fusible link box)
- Circuit breaker-2
- Harness for open or short between memory seat and mirror control unit and fuse.

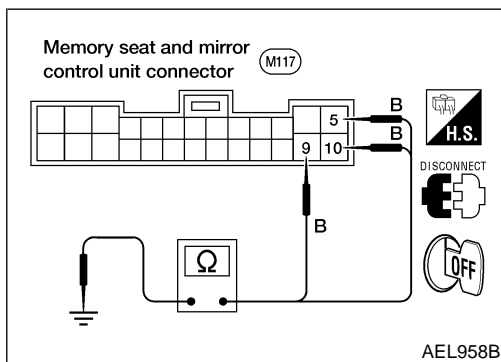

Ground Circuit Check

NDEL0092S0304

Terminals	Continuity
5 - Ground	Yes
9 - Ground	Yes
10 - Ground	Yes

If NG, check harness for open between memory seat and mirror control unit and ground.

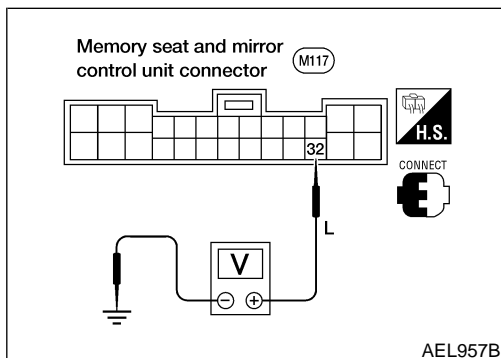

IGNITION SWITCH ON SIGNAL CHECK

NDEL0092S19

Terminals		Ignition switch position		
(+)	(-)	OFF	ACC	ON
32	Ground	0	0	Battery voltage

If NG, check the following

- 10A fuse (No. 29, located in the fuse block)
- Harness for open or short between memory seat and mirror control unit and fuse.

GI

MA

EM

LC

EC

FE

AT

AX

SU

BR

ST

RS

BT

HA

SC

EL

IDX





AUTOMATIC DRIVE POSITIONER



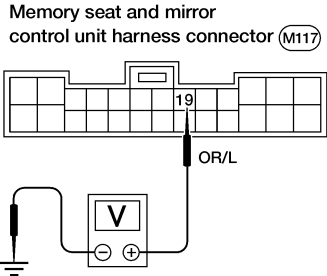

Trouble Diagnosis (Cont'd)

PARK/NEUTRAL POSITION (PNP) SWITCH CHECK

=NDEL0092S20

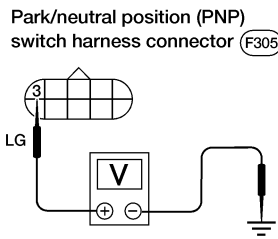
1	CHECK FUSE	
Check 10A fuse No. 30. For fuse layout, refer to "POWER SUPPLY ROUTING" "WIRING DIAGRAM — POWER —" EL-12.		
Is fuse OK?		
Yes	▶	GO TO 2.
No	▶	GO TO 5.

2	CHECK PARK/NEUTRAL POSITION (PNP) SWITCH SIGNAL	
Check voltage between memory seat and mirror control unit terminal 19 and ground.		
<div style="display: flex; justify-content: space-around; align-items: center;"> <div style="text-align: center;"> <p>Memory seat and mirror control unit harness connector (M117)</p>  </div> <div style="text-align: center;">  <p>DISCONNECT</p>   </div> </div>		
AEL325C		
Does battery voltage exist in both P and N positions?		
Yes	▶	Replace memory seat and mirror control unit.
No	▶	GO TO 3.

3	CHECK POWER SUPPLY CIRCUIT FOR PARK/NEUTRAL POSITION (PNP) SWITCH	
<ol style="list-style-type: none"> 1. Disconnect park/neutral position (PNP) switch. 2. Turn ignition switch to ON position. 3. Check voltage between park/neutral position (PNP) switch terminal 3 and ground. 		
<div style="display: flex; justify-content: space-around; align-items: center;"> <div style="text-align: center;"> <p>Park/neutral position (PNP) switch harness connector (F305)</p>  </div> <div style="text-align: center;">  <p>DISCONNECT</p>   </div> </div>		
AEL326C		
Does battery voltage exist?		
Yes	▶	GO TO 4.
No	▶	Check harness for open or short between 10A fuse No. 30 and park/neutral position (PNP) switch.

AUTOMATIC DRIVE POSITIONER

Trouble Diagnosis (Cont'd)

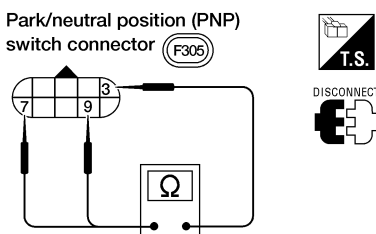
4	CHECK PARK/NEUTRAL POSITION (PNP) SWITCH																				
Check continuity between park/neutral position (PNP) switch terminals.																					
																					
AEL327C																					
<table border="1" style="margin: auto;"> <thead> <tr> <th rowspan="2">Condition</th> <th colspan="3">Terminals</th> </tr> <tr> <th>3</th> <th>7</th> <th>9</th> </tr> </thead> <tbody> <tr> <td>P</td> <td style="text-align: center;">○</td> <td style="text-align: center;">○</td> <td></td> </tr> <tr> <td>N</td> <td style="text-align: center;">○</td> <td></td> <td style="text-align: center;">○</td> </tr> <tr> <td>Other</td> <td></td> <td></td> <td></td> </tr> </tbody> </table>			Condition	Terminals			3	7	9	P	○	○		N	○		○	Other			
Condition	Terminals																				
	3	7	9																		
P	○	○																			
N	○		○																		
Other																					
AEL328C																					
OK or NG																					
OK	▶	Check harness for open or short between memory seat and mirror control unit and park/neutral position (PNP) switch.																			
NG	▶	Refer to "Park/Neutral Position (PNP) Switch Adjustment", AT-267 for adjustment procedure. If still NG, replace park/neutral position (PNP) switch.																			

5	REPLACE FUSE	
Replace fuse.		
Does the fuse blow again when ignition switch is turned to ON position?		
Yes	▶	Check harness for short to ground.
No	▶	INSPECTION END

GI

MA

EM

LC

EC

FE

AT

AX

SU

BR

ST

RS

BT

HA

SC

EL

IDX

AUTOMATIC DRIVE POSITIONER

Trouble Diagnosis (Cont'd)

POWER SEAT SLIDING MOTOR CHECK

=NDEL0092S04

1 CHECK OUTPUT SIGNAL TO SLIDING MOTOR

Check voltage between memory seat and mirror control unit terminals 12 or 15 and ground.

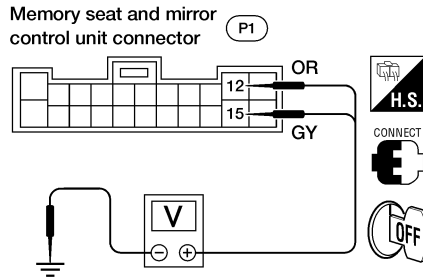

AEL960B

Condition of sliding switch	Terminals		Voltage (V)
	(+)	(-)	
Forward	12	Ground	More than 10.8
	15	Ground	Less than 1.2
Rearward	12	Ground	Less than 1.2
	15	Ground	More than 10.8

AEL959B

Refer to wiring diagram, EL-151.

OK or NG

OK ► GO TO 2.

NG ► Replace memory seat and mirror control unit.

2 CHECK SLIDING MOTOR

1. Disconnect sliding motor connector.
2. Apply 12V DC direct current to motor and check operation.

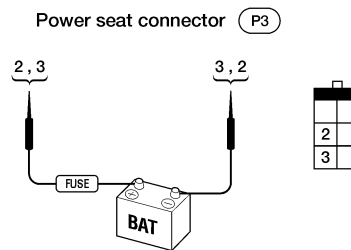

AEL962B

Terminals		Operation
(+)	(-)	
2	3	Forward
3	2	Rearward

AEL961B

OK or NG

OK ► Check harness for open or short between memory seat and mirror control unit and sliding motor.

NG ► Replace sliding motor.

AUTOMATIC DRIVE POSITIONER

Trouble Diagnosis (Cont'd)

POWER SEAT RECLINING MOTOR CHECK

=NDEL0092S05

1 CHECK OUTPUT SIGNAL TO RECLINING MOTOR

Check voltage between memory seat and mirror control unit terminals 13 or 14 and ground.

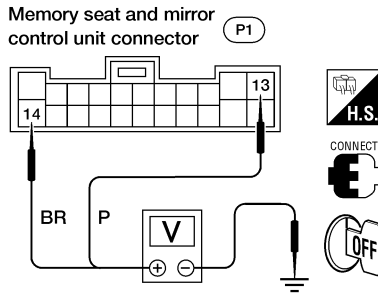

AEL964B

Condition of reclining switch	Terminals		Voltage (V)
	(+)	(-)	
Forward	14	Ground	More than 10.8
	13	Ground	Less than 1.2
Rearward	14	Ground	Less than 1.2
	13	Ground	More than 10.8

AEL963B

Refer to wiring diagram, EL-151.

OK or NG

OK ► GO TO 2.

NG ► Replace memory seat and mirror control unit.

2 CHECK RECLINING MOTOR

1. Disconnect reclining motor connector.
2. Apply 12V DC direct current to motor and check operation.

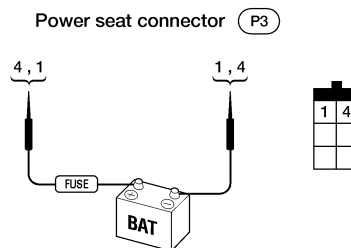

AEL966B

Terminals		Operation
(+)	(-)	
4	1	Forward
1	4	Rearward

AEL965B

OK or NG

OK ► Check harness for open or short between memory seat and mirror control unit and reclining motor.

NG ► Replace reclining motor.

GI

MA

EM

LC

EC

FE

AT

AX

SU

BR

ST

RS

BT

HA

SC

EL

IDX

AUTOMATIC DRIVE POSITIONER

Trouble Diagnosis (Cont'd)

POWER SEAT LIFTING MOTOR CHECK

=NDEL0092S06

1 CHECK OUTPUT SIGNAL TO LIFTING MOTOR

Check voltage between memory seat and mirror control unit terminals 11 or 16 and ground.

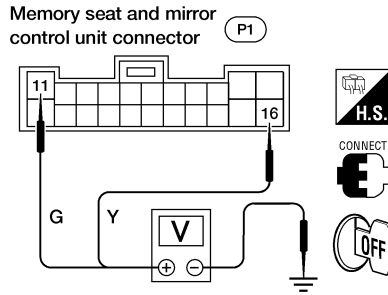

AEL968B

Condition of lifting switch	Terminals		Voltage (V)
	(+)	(-)	
Up	11	Ground	More than 10.8
	16	Ground	Less than 1.2
Down	11	Ground	Less than 1.2
	16	Ground	More than 10.8

AEL967B

Refer to wiring diagram, EL-151.

OK or NG

OK ► GO TO 2.

NG ► Replace memory seat and mirror control unit.

2 CHECK LIFTING MOTOR

1. Disconnect lifting motor connector.
2. Apply 12V DC direct current to motor and check operation.

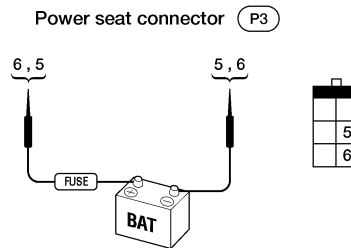

AEL970B

Terminals		Operation
(+)	(-)	
6	5	Up
5	6	Down

AEL969B

OK or NG

OK ► Check harness for open or short between memory seat and mirror control unit and lifting motor.

NG ► Replace lifting motor.

AUTOMATIC DRIVE POSITIONER

Trouble Diagnosis (Cont'd)

POWER SEAT SLIDING SENSOR CHECK

=NDEL0092S08

1	CHECK SLIDING SENSOR PULL UP VOLTAGE	<p>1. Disconnect sliding sensor connector. 2. Check voltage between sliding sensor connector terminals 1 and 3.</p> <div style="text-align: center;"> </div> <p style="text-align: right;">AEL975B</p> <p style="text-align: center;">Refer to wiring diagram, EL-151.</p> <p style="text-align: center;">Does 5V exist?</p>	<p>GI</p> <p>MA</p> <p>EM</p> <p>LC</p> <p>EC</p> <p>FE</p> <p>AT</p> <p>AX</p>
Yes	▶	GO TO 2.	
No	▶	<p>Check the following</p> <ul style="list-style-type: none"> ● Harness for open or short between sliding sensor terminal 1 and memory seat and mirror control unit terminal 41 ● Harness for open or short between sliding sensor terminal 3 and memory seat and mirror control unit terminal 44. 	<p>SU</p> <p>BR</p> <p>ST</p> <p>RS</p> <p>BT</p>

2	CHECK SLIDING SENSOR INPUT SIGNAL	<p>Measure voltage between memory seat and mirror control unit terminal 33 and ground with oscilloscope when seat slide is operated.</p> <div style="text-align: center;"> </div> <div style="text-align: center; margin-top: 20px;"> <p style="text-align: center;">HI: Approx. 5V LO: Approx. 0V</p> </div> <p style="text-align: right;">AEL976B</p> <p style="text-align: center;">OK or NG</p>	<p>HA</p> <p>SC</p> <p>EL</p> <p>IDX</p>
OK	▶	Sliding sensor is OK.	
NG	▶	GO TO 3.	

AUTOMATIC DRIVE POSITIONER

Trouble Diagnosis (Cont'd)

3 CHECK SLIDING SENSOR OPEN OR SHORT CIRCUIT

1. Disconnect sliding sensor connector and memory seat and mirror control unit.
2. Check continuity between memory seat and mirror control unit terminal 33 and sliding sensor terminal 2.

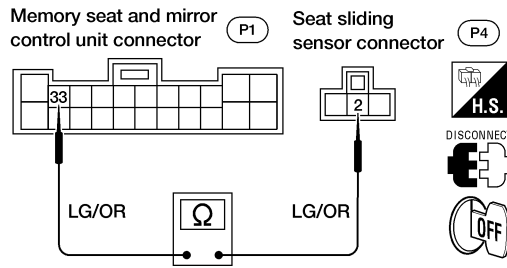

AEL977B

Continuity should exist.

3. Check continuity between memory seat and mirror control unit terminal 33 and ground.

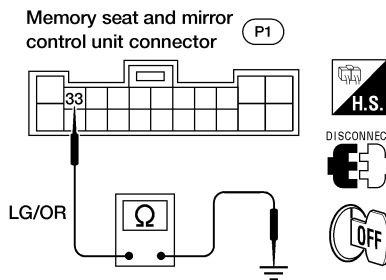

AEL978B

Continuity should not exist.

OK or NG

OK	▶	Replace sliding sensor.
NG	▶	Repair harness.

AUTOMATIC DRIVE POSITIONER

Trouble Diagnosis (Cont'd)

POWER SEAT RECLINING SENSOR CHECK

=NDEL0092S09

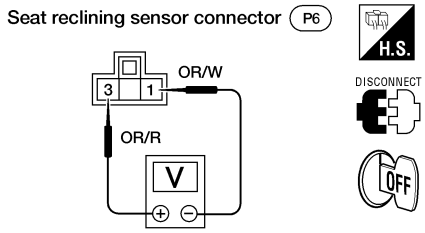
1	CHECK RECLINING SENSOR PULL UP VOLTAGE	<p>1. Disconnect reclining sensor connector. 2. Check voltage between reclining sensor connector terminals 1 and 3.</p> <div style="text-align: center;">  </div> <p style="text-align: right;">AEL980B</p> <p>Refer to wiring diagram, EL-151.</p> <p style="text-align: center;">Does 5V exist?</p>	<p>GI</p> <p>MA</p> <p>EM</p> <p>LC</p> <p>EC</p> <p>FE</p>
Yes	▶	GO TO 2.	
No	▶	<p>Check the following</p> <ul style="list-style-type: none"> ● Harness for open or short between reclining sensor terminal 1 and memory seat and mirror control unit terminal 41 ● Harness for open or short between reclining sensor terminal 3 and memory seat and mirror control unit terminal 44. 	<p>AT</p> <p>AX</p>

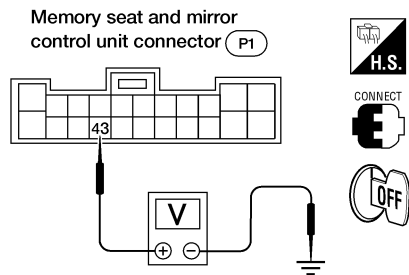
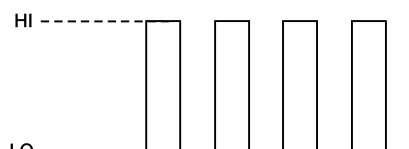
2	CHECK RECLINING SENSOR INPUT SIGNAL	<p>Measure voltage between memory seat and mirror control unit terminal 43 and ground with oscilloscope when seat reclining is operated.</p> <div style="text-align: center;">  </div> <div style="text-align: center; margin-top: 20px;">  <p>HI: Approx. 5V LO: Approx. 0V</p> </div> <p style="text-align: right;">AEL981B</p> <p style="text-align: center;">OK or NG</p>	<p>SU</p> <p>BR</p> <p>ST</p> <p>RS</p> <p>BT</p> <p>HA</p> <p>SC</p>
OK	▶	Reclining sensor is OK.	
NG	▶	GO TO 3.	<p>EL</p> <p>IDX</p>

AUTOMATIC DRIVE POSITIONER

Trouble Diagnosis (Cont'd)

3 CHECK RECLINING SENSOR OPEN OR SHORT CIRCUIT

1. Disconnect reclining sensor connector and memory seat and mirror control unit.
2. Check continuity between memory seat and mirror control unit terminal 43 and reclining sensor terminal 2.

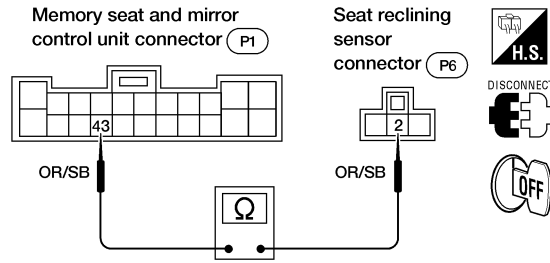

AEL982B

Continuity should exist.

3. Check continuity between memory seat and mirror control unit terminal 43 and ground.

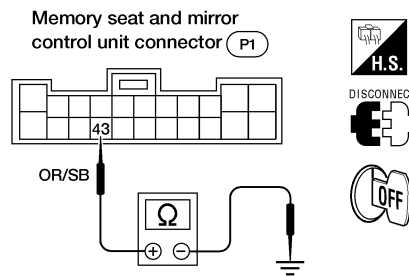

AEL983B

Continuity should not exist.

OK or NG

OK	▶	Replace reclining sensor.
NG	▶	Repair harness.

AUTOMATIC DRIVE POSITIONER

Trouble Diagnosis (Cont'd)

POWER SEAT LIFTING SENSOR CHECK

=NDEL0092S10

1	CHECK LIFTING SENSOR PULL UP VOLTAGE	<p>1. Disconnect lifting sensor connector. 2. Check voltage between lifting sensor connector terminals 1 and 3.</p> <div style="text-align: center;"> </div> <p style="text-align: right;">AEL984B</p> <p>Refer to wiring diagram, EL-151.</p> <p style="text-align: center;">Does 5V exist?</p>	<p>GI</p> <p>MA</p> <p>EM</p> <p>LC</p> <p>EC</p> <p>FE</p>
Yes	▶	GO TO 2.	
No	▶	<p>Check the following</p> <ul style="list-style-type: none"> ● Harness for open or short between lifting sensor terminal 1 and memory seat and mirror control unit terminal 41 ● Harness for open or short between lifting sensor terminal 3 and memory seat and mirror control unit terminal 44. 	<p>AT</p> <p>AX</p>

2	CHECK LIFTING SENSOR INPUT SIGNAL	<p>Measure voltage between memory seat and mirror control unit terminal 42 and ground with oscilloscope when seat lifting is operated.</p> <div style="text-align: center;"> </div> <div style="text-align: center; margin-top: 20px;"> <p>HI: Approx. 5V LO: Approx. 0V</p> </div> <p style="text-align: right;">AEL426C</p> <p style="text-align: center;">OK or NG</p>	<p>SU</p> <p>BR</p> <p>ST</p> <p>RS</p> <p>BT</p> <p>HA</p> <p>SC</p> <p style="background-color: black; color: white; padding: 2px;">EL</p> <p>IDX</p>
OK	▶	Lifting sensor is OK.	
NG	▶	GO TO 3.	

AUTOMATIC DRIVE POSITIONER

Trouble Diagnosis (Cont'd)

3 CHECK LIFTING SENSOR OPEN OR SHORT CIRCUIT

1. Disconnect lifting sensor connector and memory seat and mirror control unit.
2. Check continuity between memory seat and mirror control unit terminal 42 and lifting sensor terminal 2.

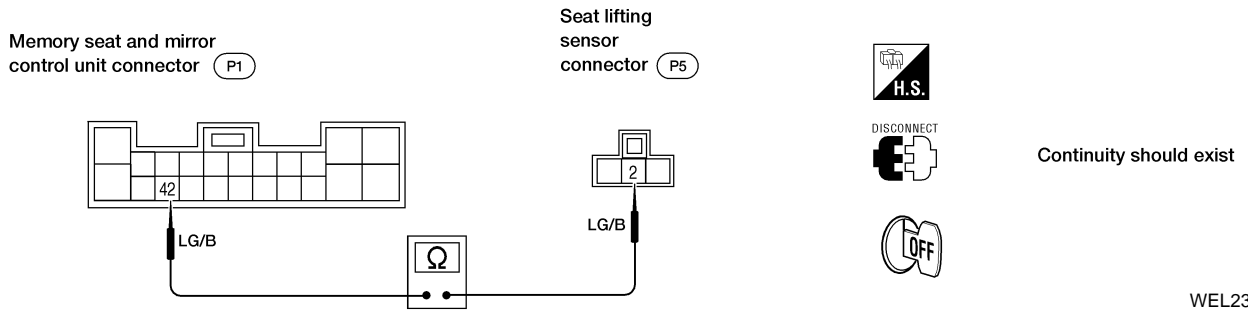

3. Check continuity between memory seat and mirror control unit terminal 42 and ground.

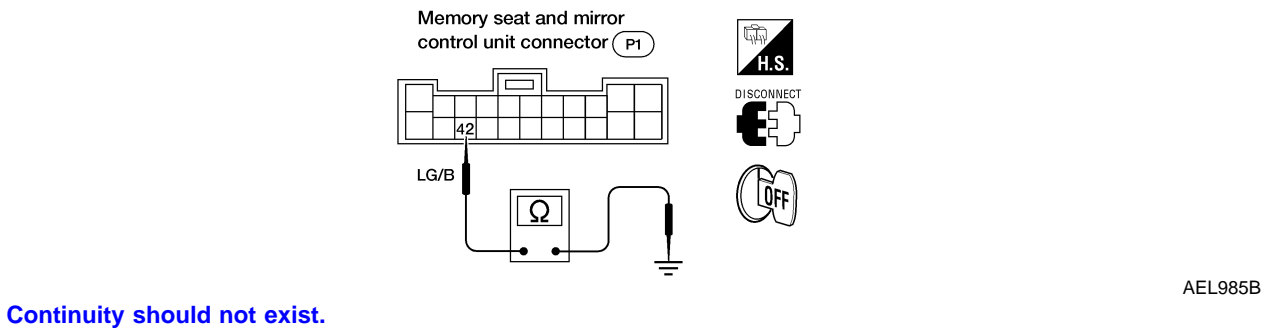

OK	▶	Replace lifting sensor.
NG	▶	Repair harness.

AUTOMATIC DRIVE POSITIONER

Trouble Diagnosis (Cont'd)

POWER DOOR MIRROR MOTOR CHECK

=NDEL0092S07

1	PRELIMINARY CHECK
Determine which direction (horizontal or vertical) is not functioning.	
▶	GO TO 2.

2	CHECK OUTPUT SIGNAL TO DOOR MIRROR MOTOR																																								
Check the voltage between memory seat and mirror control unit terminals and ground.																																									
<p>Memory seat and mirror control unit connector (M117)</p> <p>3, 7, 8, 18, 25, 26</p>																																									
<table border="1"> <thead> <tr> <th rowspan="2">Condition of door mirror remote control switch</th> <th colspan="2">Terminals</th> <th rowspan="2">Voltage (V)</th> </tr> <tr> <th>(+)</th> <th>(-)</th> </tr> </thead> <tbody> <tr> <td rowspan="4">LH side</td> <td>Right</td> <td>8</td> <td>Ground</td> <td>More than 10.8</td> </tr> <tr> <td>Left</td> <td>3</td> <td>Ground</td> <td>More than 10.8</td> </tr> <tr> <td>Down</td> <td>8</td> <td>Ground</td> <td>More than 10.8</td> </tr> <tr> <td>Up</td> <td>18</td> <td>Ground</td> <td>More than 10.8</td> </tr> <tr> <td rowspan="4">RH side</td> <td>Right</td> <td>7</td> <td>Ground</td> <td>More than 10.8</td> </tr> <tr> <td>Left</td> <td>26</td> <td>Ground</td> <td>More than 10.8</td> </tr> <tr> <td>Down</td> <td>7</td> <td>Ground</td> <td>More than 10.8</td> </tr> <tr> <td>Up</td> <td>25</td> <td>Ground</td> <td>More than 10.8</td> </tr> </tbody> </table>		Condition of door mirror remote control switch	Terminals		Voltage (V)	(+)	(-)	LH side	Right	8	Ground	More than 10.8	Left	3	Ground	More than 10.8	Down	8	Ground	More than 10.8	Up	18	Ground	More than 10.8	RH side	Right	7	Ground	More than 10.8	Left	26	Ground	More than 10.8	Down	7	Ground	More than 10.8	Up	25	Ground	More than 10.8
Condition of door mirror remote control switch	Terminals		Voltage (V)																																						
	(+)	(-)																																							
LH side	Right	8	Ground	More than 10.8																																					
	Left	3	Ground	More than 10.8																																					
	Down	8	Ground	More than 10.8																																					
	Up	18	Ground	More than 10.8																																					
RH side	Right	7	Ground	More than 10.8																																					
	Left	26	Ground	More than 10.8																																					
	Down	7	Ground	More than 10.8																																					
	Up	25	Ground	More than 10.8																																					
Refer to wiring diagrams, EL-153 and 154.																																									
OK or NG																																									
OK	▶ GO TO 3.																																								
NG	▶ Replace memory seat and mirror control unit.																																								

GI

MA

EM

LC

EC

FE

AEL972B

AT

AX

SU

BR

ST

RS

BT

AEL971B

HA

SC

EL

IDX

AUTOMATIC DRIVE POSITIONER

Trouble Diagnosis (Cont'd)

3 CHECK DOOR MIRROR MOTOR

1. Disconnect door mirror motor connector.
2. Apply 12V DC direct current to motor and check operation.

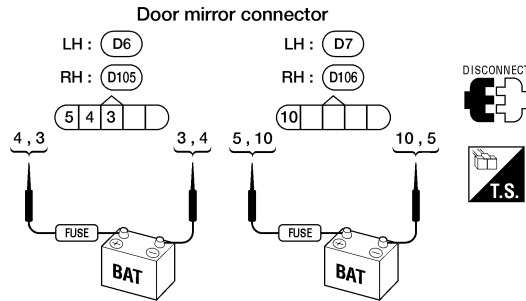

AEL974B

Terminals		Operation	
(+)	(-)		
4	3	Left	Horizontal
3	4	Right	
5	10	Up	Vertical
10	5	Down	

AEL973B

OK or NG

OK	▶	Check harness for open or short between memory seat and mirror control unit and door mirror motor.
NG	▶	Replace door mirror motor.

AUTOMATIC DRIVE POSITIONER

Trouble Diagnosis (Cont'd)

DOOR MIRROR POSITION SENSOR CHECK (DRIVER SIDE)

=NDEL0092S11

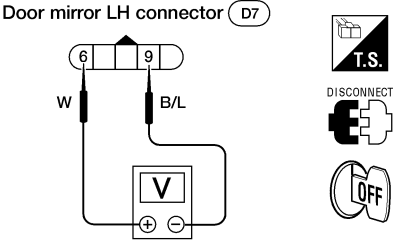
1	CHECK DOOR MIRROR SENSOR PULL UP VOLTAGE	
<p>1. Disconnect LH door mirror sensor connector. 2. Check voltage between LH door mirror sensor connector terminals 6 and 9.</p>		
		
<p>Refer to wiring diagram, EL-153.</p> <p style="text-align: right;">AEL988B</p>		
Does 5V exist?		
Yes	▶	GO TO 2.
No	▶	<p>Check the following</p> <ul style="list-style-type: none"> • Harness for open or short between LH door mirror sensor terminal 6 and memory seat and mirror control unit terminal 2 • Harness for open or short between LH door mirror sensor terminal 9 and memory seat and mirror control unit terminal 17.

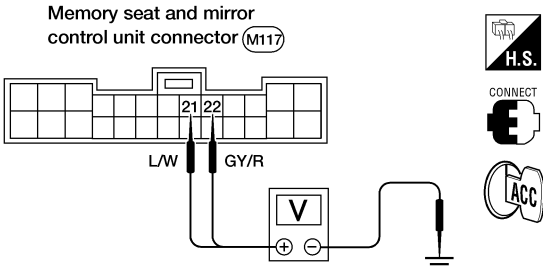
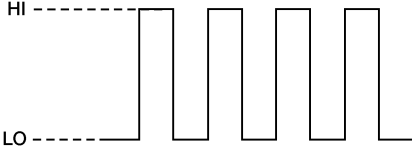
2	CHECK DOOR MIRROR SENSOR INPUT SIGNAL	
<p>Measure voltage between memory seat and mirror control unit terminal 21 (horizontal), 22 (vertical) and ground with oscilloscope when LH door mirror is operated.</p>		
		
		
<p>HI: Approx. 5V LO: Approx. 0V</p> <p style="text-align: right;">AEL989B</p>		
OK or NG		
OK	▶	LH door mirror sensor is OK.
NG	▶	GO TO 3.

AEL979B

GI

MA

EM

LC

EC

FE

AT

AX

SU

BR

ST

RS

BT

HA

SC

EL

IDX

AUTOMATIC DRIVE POSITIONER

Trouble Diagnosis (Cont'd)

3 CHECK DOOR MIRROR SENSOR OPEN OR SHORT CIRCUIT

1. Disconnect LH door mirror sensor connector and memory seat and mirror control unit.
2. Check continuity between memory seat and mirror control unit terminal 21 and LH door mirror sensor terminal 7 (horizontal), memory seat and mirror control unit terminal 22 and LH door mirror terminal 8 (vertical).

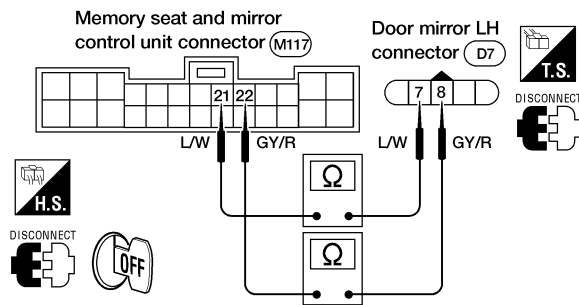

AEL990B

Continuity should exist.

3. Check continuity between memory seat and mirror control unit terminal 21 (horizontal), 22 (vertical) and ground.

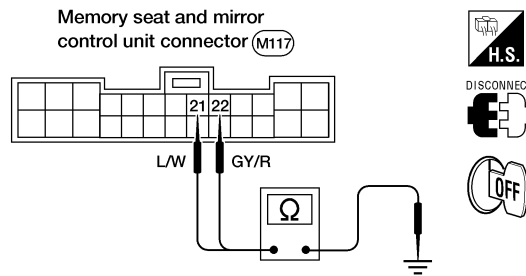

AEL991B

Continuity should not exist.

OK or NG

OK	▶	Replace LH door mirror sensor.
NG	▶	Repair harness.

AUTOMATIC DRIVE POSITIONER

Trouble Diagnosis (Cont'd)

DOOR MIRROR POSITION SENSOR CHECK (PASSENGER SIDE)

=NDEL0092S12

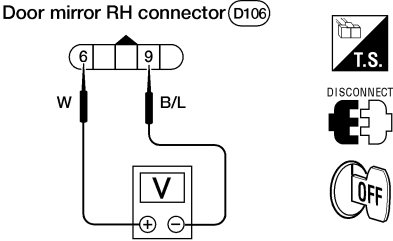
1	CHECK DOOR MIRROR SENSOR PULL UP VOLTAGE	
<p>1. Disconnect RH door mirror sensor connector. 2. Check voltage between RH door mirror sensor connector terminals 6 and 9.</p> <div style="text-align: center;">  </div> <p>Refer to wiring diagram, EL-154.</p> <p style="text-align: right;">AEL992B</p>		
Does 5V exist?		
Yes	▶	GO TO 2.
No	▶	<p>Check the following</p> <ul style="list-style-type: none"> • Harness for open or short between RH door mirror sensor terminal 6 and memory seat and mirror control unit terminal 2 • Harness for open or short between RH door mirror sensor terminal 9 and memory seat and mirror control unit terminal 17.

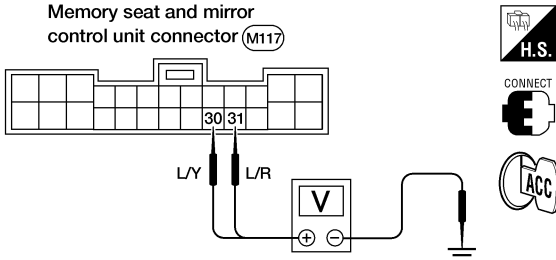
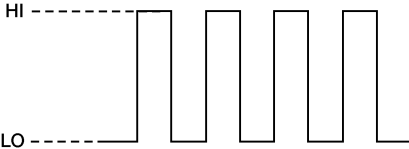
2	CHECK DOOR MIRROR SENSOR INPUT SIGNAL	
<p>Measure voltage between memory seat and mirror control unit terminal 30 (horizontal), 31 (vertical) and ground with oscilloscope when RH door mirror is operated.</p> <div style="text-align: center;">  </div> <div style="text-align: center; margin-top: 20px;">  <p>HI: Approx. 5V LO: Approx. 0V</p> </div> <p style="text-align: right;">AEL993B</p>		
OK or NG		
OK	▶	RH door mirror sensor is OK.
NG	▶	GO TO 3.

AEL979B

GI

MA

EM

LC

EC

FE

AT

AX

SU

BR

ST

RS

BT

HA

SC

EL

IDX

AUTOMATIC DRIVE POSITIONER

Trouble Diagnosis (Cont'd)

3 CHECK DOOR MIRROR SENSOR OPEN OR SHORT CIRCUIT

1. Disconnect RH door mirror sensor connector and memory seat and mirror control unit.
2. Check continuity between memory seat and mirror control unit terminal 30 and RH door mirror sensor terminal 7 (horizontal), memory seat and mirror control unit terminal 31 and RH door mirror sensor terminal 8 (vertical).

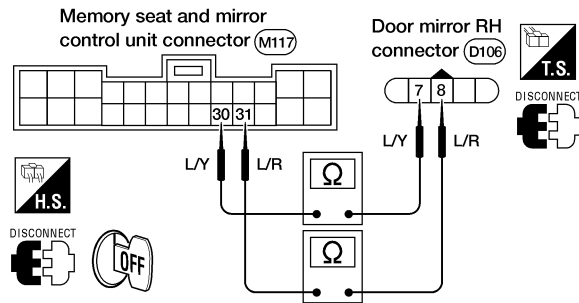

AEL994B

Continuity should exist.

3. Check continuity between memory seat and mirror control unit terminal 30 (horizontal), 31 (vertical) and ground.

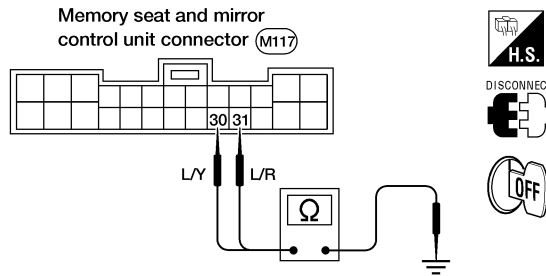

AEL995B

Continuity should not exist.

OK or NG

OK	▶	Replace RH door mirror sensor.
NG	▶	Repair harness.

AUTOMATIC DRIVE POSITIONER

Trouble Diagnosis (Cont'd)

POWER SEAT SWITCH CHECK

=NDEL0092S13

1 CHECK POWER SEAT SWITCH INPUT SIGNAL

Check voltage between memory seat and mirror control unit terminals and ground.

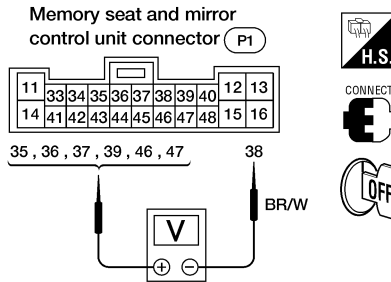

AEL997B

Terminals		Power seat switch condition	Voltage (V)
(+)	(-)		
46	38	Sliding switch forward	ON 0
			OFF 5
35	38	Sliding switch rearward	ON 0
			OFF 5
47	38	Reclining switch forward	ON 0
			OFF 5
39	38	Reclining switch rearward	ON 0
			OFF 5
36	38	Lifting switch up	ON 0
			OFF 5
37	38	Lifting switch down	ON 0
			OFF 5

AEL996B

Refer to wiring diagram, EL-152.

OK or NG

OK	▶	Power seat switch is OK.
NG	▶	GO TO 2.

GI

MA

EM

LC

EC

FE

AT

AX

SU

BR

ST

RS

BT

HA

SC

EL

IDX

AUTOMATIC DRIVE POSITIONER

Trouble Diagnosis (Cont'd)

2 CHECK POWER SEAT SWITCH

1. Disconnect power seat switch.
2. Check continuity between power seat switch terminals.

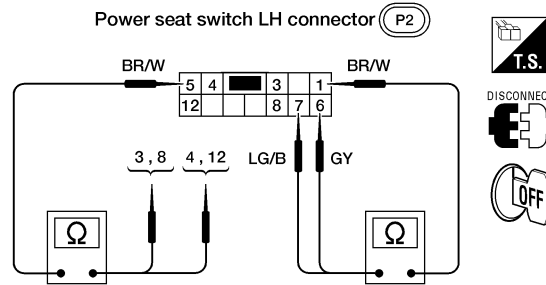

AEL999B

Switch	Condition	Terminals							
		3	8	6	7	4	12	1	5
Sliding	Forward	○							○
	Rearward		○						○
Reclining	Forward			○				○	
	Rearward				○			○	
Lifting	Up					○		○	
	Down						○	○	

AEL998B

OK or NG

OK	▶	Check harness for open or short between power seat switch and memory seat and mirror control unit.
NG	▶	Replace power seat switch.

AUTOMATIC DRIVE POSITIONER

Trouble Diagnosis (Cont'd)

DOOR MIRROR REMOTE CONTROL COMMON CIRCUIT CHECK

=NDEL0092S14

1	PRELIMINARY CHECK	
Do both power mirrors (LH and RH) not operate with door mirror remote control switch?		
Yes or NO		
Yes	▶	GO TO 2.
No	▶	GO TO "DOOR MIRROR REMOTE CONTROL SWITCH CHECK", EL-179.

GI
MA
EM

2	CHECK POWER SUPPLY CIRCUIT FOR DOOR MIRROR REMOTE CONTROL SWITCH	
<p>1. Turn ignition switch to ACC position. 2. Check voltage between door mirror remote control switch terminal 1 and ground.</p>		
Refer to wiring diagram, EL-154.		
Does battery voltage exist?		
Yes	▶	GO TO 3.
No	▶	Check the following <ul style="list-style-type: none"> ● 10A fuse (No. 5, located in the fuse block) ● Harness for open or short between fuse and the switch.

LC
EC
FE
AT
AX
SU
BR
ST

3	CHECK GROUND CIRCUIT FOR DOOR MIRROR REMOTE CONTROL SWITCH	
Check continuity between door mirror remote control switch terminal 5 and ground.		
Refer to wiring diagram, EL-154.		
Does continuity exist?		
Yes	▶	GO TO 4.
No	▶	Repair harness.

RS
BT
HA
SC
EL
IDX

AUTOMATIC DRIVE POSITIONER

Trouble Diagnosis (Cont'd)

4 CHECK DOOR MIRROR COMMON SIGNAL OPEN OR SHORT CIRCUIT

1. Disconnect memory seat and mirror control unit connector and door mirror remote control switch connector.
2. Check continuity between memory seat and mirror control unit terminal 29 and door mirror remote control switch terminal 2.

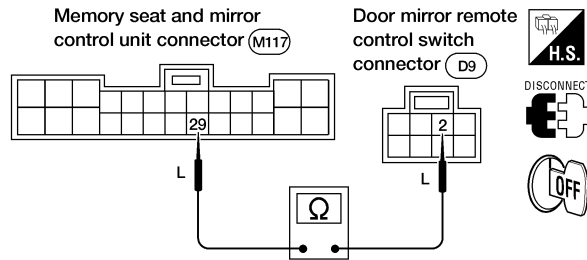

AEL003C

Continuity should exist.

3. Check continuity between memory seat and mirror control unit terminal 29 and ground.

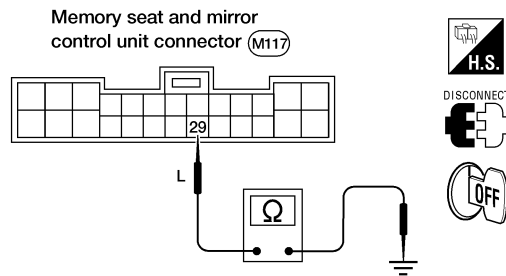

AEL004C

Continuity should not exist.

OK or NG

OK	▶	Replace door mirror remote control switch.
NG	▶	Repair harness.

AUTOMATIC DRIVE POSITIONER

Trouble Diagnosis (Cont'd)

DOOR MIRROR REMOTE CONTROL SWITCH CHECK

=NDEL0092S15

1	PRELIMINARY CHECK	
Do both power mirrors (LH and RH) not operate with door mirror remote control switch?		
Yes or No?		
Yes	▶	GO TO "DOOR MIRROR REMOTE CONTROL COMMON CIRCUIT CHECK", EL-177
No	▶	GO TO 2.

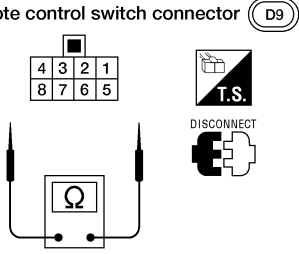
2	CHECK DOOR MIRROR REMOTE CONTROL SWITCH																																																																																																				
<p>1. Disconnect door mirror remote control switch connector.</p> <p>2. Check continuity between door mirror remote control switch terminals.</p>																																																																																																					
<p>Door mirror remote control switch connector (D9)</p> 																																																																																																					
AEL009C																																																																																																					
<table border="1" style="width: 100%; border-collapse: collapse;"> <thead> <tr> <th rowspan="2">Switch condition</th> <th colspan="8">Terminals</th> </tr> <tr> <th>1</th> <th>2</th> <th>4</th> <th>5</th> <th>6</th> <th>7</th> <th>8</th> <th></th> </tr> </thead> <tbody> <tr> <td rowspan="5">LH side</td> <td>U</td> <td>○—○</td> <td></td> <td></td> <td>○—○</td> <td></td> <td></td> <td></td> </tr> <tr> <td>D</td> <td>○—○</td> <td></td> <td></td> <td>○—○</td> <td></td> <td></td> <td></td> </tr> <tr> <td>L</td> <td>○—○</td> <td></td> <td>○—○</td> <td></td> <td></td> <td></td> <td></td> </tr> <tr> <td>R</td> <td>○—○</td> <td></td> <td>○—○</td> <td></td> <td></td> <td></td> <td></td> </tr> <tr> <td>N</td> <td></td> <td></td> <td></td> <td></td> <td></td> <td></td> <td></td> </tr> <tr> <td rowspan="5">RH side</td> <td>U</td> <td>○—○</td> <td></td> <td></td> <td>○—○</td> <td></td> <td>○—○</td> <td></td> </tr> <tr> <td>D</td> <td>○—○</td> <td></td> <td></td> <td>○—○</td> <td></td> <td>○—○</td> <td></td> </tr> <tr> <td>L</td> <td>○—○</td> <td></td> <td>○—○</td> <td></td> <td></td> <td>○—○</td> <td></td> </tr> <tr> <td>R</td> <td>○—○</td> <td></td> <td>○—○</td> <td></td> <td></td> <td>○—○</td> <td></td> </tr> <tr> <td>N</td> <td></td> <td></td> <td></td> <td></td> <td></td> <td></td> <td></td> </tr> </tbody> </table>			Switch condition	Terminals								1	2	4	5	6	7	8		LH side	U	○—○			○—○				D	○—○			○—○				L	○—○		○—○					R	○—○		○—○					N								RH side	U	○—○			○—○		○—○		D	○—○			○—○		○—○		L	○—○		○—○			○—○		R	○—○		○—○			○—○		N							
Switch condition	Terminals																																																																																																				
	1	2	4	5	6	7	8																																																																																														
LH side	U	○—○			○—○																																																																																																
	D	○—○			○—○																																																																																																
	L	○—○		○—○																																																																																																	
	R	○—○		○—○																																																																																																	
	N																																																																																																				
RH side	U	○—○			○—○		○—○																																																																																														
	D	○—○			○—○		○—○																																																																																														
	L	○—○		○—○			○—○																																																																																														
	R	○—○		○—○			○—○																																																																																														
	N																																																																																																				
AEL008C																																																																																																					
OK or NG																																																																																																					
OK	▶	Check harness for open or short between memory seat control unit and door mirror remote control switch.																																																																																																			
NG	▶	Replace door mirror remote control switch.																																																																																																			

GI

MA

EM

LC

EC

FE

AT

AX

SU

BR

ST

RS

BT

HA

SC

EL

IDX

AUTOMATIC DRIVE POSITIONER

Trouble Diagnosis (Cont'd)

MEMORY SET SWITCH CHECK

=NDEL0092S16

1 CHECK MEMORY SET SWITCH INPUT SIGNAL

Check voltage between memory seat and mirror control unit terminals and grounds.

Memory seat and mirror control unit connector (M117)

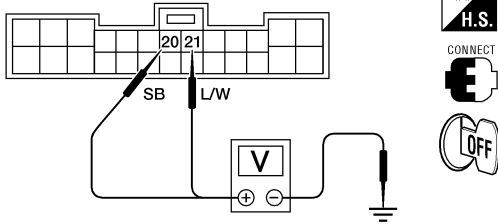

Terminals	Memory set switch condition		Voltage [V]
	Set switch 1	Set switch 2	
20 - Ground	ON		0
	OFF		5
28 - Ground	ON		0
	OFF		5

WEL259

Refer to wiring diagram in EL-150.

OK or NG

OK	▶	Memory set switch is OK.
NG	▶	GO TO 2.

2 CHECK MEMORY SET SWITCH

1. Disconnect memory set switch.
2. Check continuity between memory set switch terminals.

Memory set switch connector (D5)

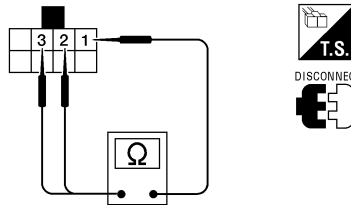

AEL014C

Memory set switch		Terminals		
		1	2	3
Set switch 1	Pushed	○	○	○
	Released			
Set switch 2	Pushed	○	○	
	Released			

AEL013C

OK or NG

OK	▶	Check harness for open or short between memory set switch and memory seat and mirror control unit.
NG	▶	Replace memory set switch.

AUTOMATIC DRIVE POSITIONER

Trouble Diagnosis (Cont'd)

MEMORY INDICATOR CHECK

NDEL0092S17

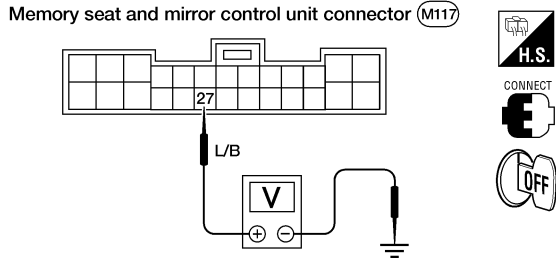
1	CHECK INDICATOR OUTPUT SIGNAL	<p>Check voltage between memory seat and mirror control unit terminal 27 and grounds with any of memory set switch pushed.</p> <p>NOTE: Check voltage within 10 seconds after the switch is pushed.</p> <div style="text-align: center;">  </div> <p style="text-align: right;">AEL012C</p> <p>Refer to wiring diagram in EL-150.</p> <p style="text-align: center;">Does battery voltage exist?</p>	GI MA EM LC EC FE AT AX SU
Yes	▶	<p>Check the following harnesses for opens or shorts</p> <ul style="list-style-type: none"> ● Between memory seat and mirror control unit and memory set switch indicator ● Between memory set switch indicator and ground. <p>If results are OK, replace memory set switch.</p>	BR ST RS BT HA SC
No	▶	<p>Check memory set switch. Refer to EL-179.</p> <p>If results are OK, replace memory seat and mirror control unit.</p>	EL IDX

AUTOMATIC DRIVE POSITIONER

Trouble Diagnosis (Cont'd)

REMOTE CONTROLLER SIGNAL CHECK

=NDEL0092S18

1	CHECK ID REGISTRATION
Re-register multi-remote controller ID into memory seat and mirror control unit. (Refer to EL-148.) NOTE: Before re-registering the ID, confirm that multi-remote control system operates properly. If NG, check multi-remote control system, refer to EL-234.	
Can the remote controller ID be entered?	
Yes	▶ The system is OK. (The remote controller ID has not been entered.)
No	▶ Check harness for open or short between memory seat control unit and smart entrance control unit. (Refer to wiring diagram in EL-150.)

POWER SEAT

Wiring Diagram — SEAT —

Wiring Diagram — SEAT —

NDEL0093

EL-SEAT-01

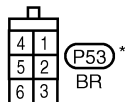
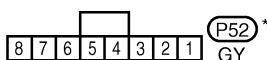
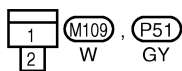
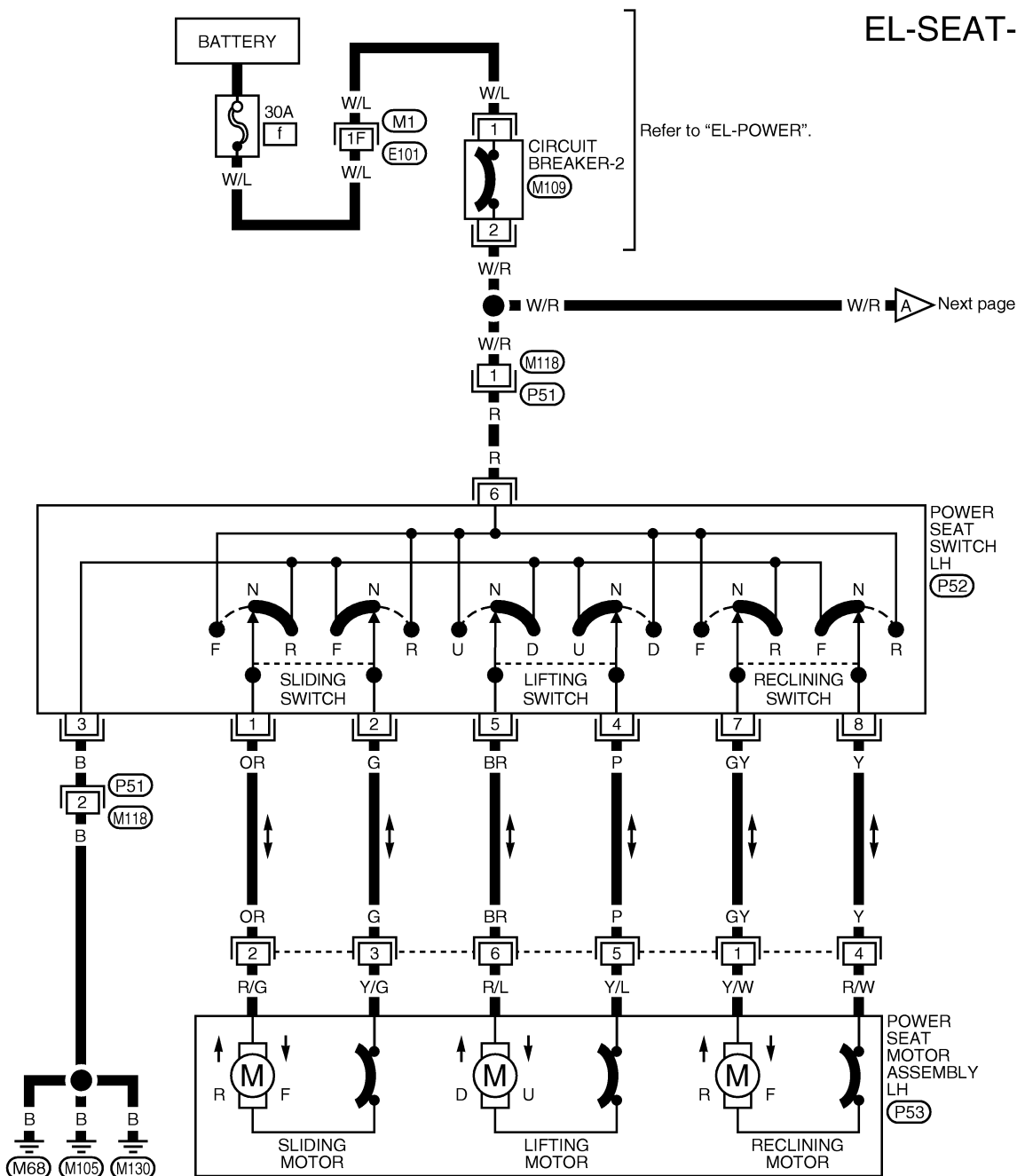

Refer to the following.
 (M1), (E101) - SUPER MULTIPLE
 JUNCTION (SMJ)

*: This connector is not shown in "HARNES LAYOUT".

WEL237

GI
MA
EM
LC
EC
FE
AT
AX
SU
BR
ST
RS
BT
HA
SC

EL

IDX

POWER SEAT

Wiring Diagram — SEAT — (Cont'd)

EL-SEAT-02

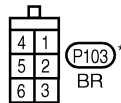
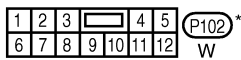
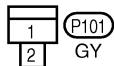
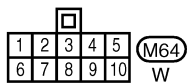
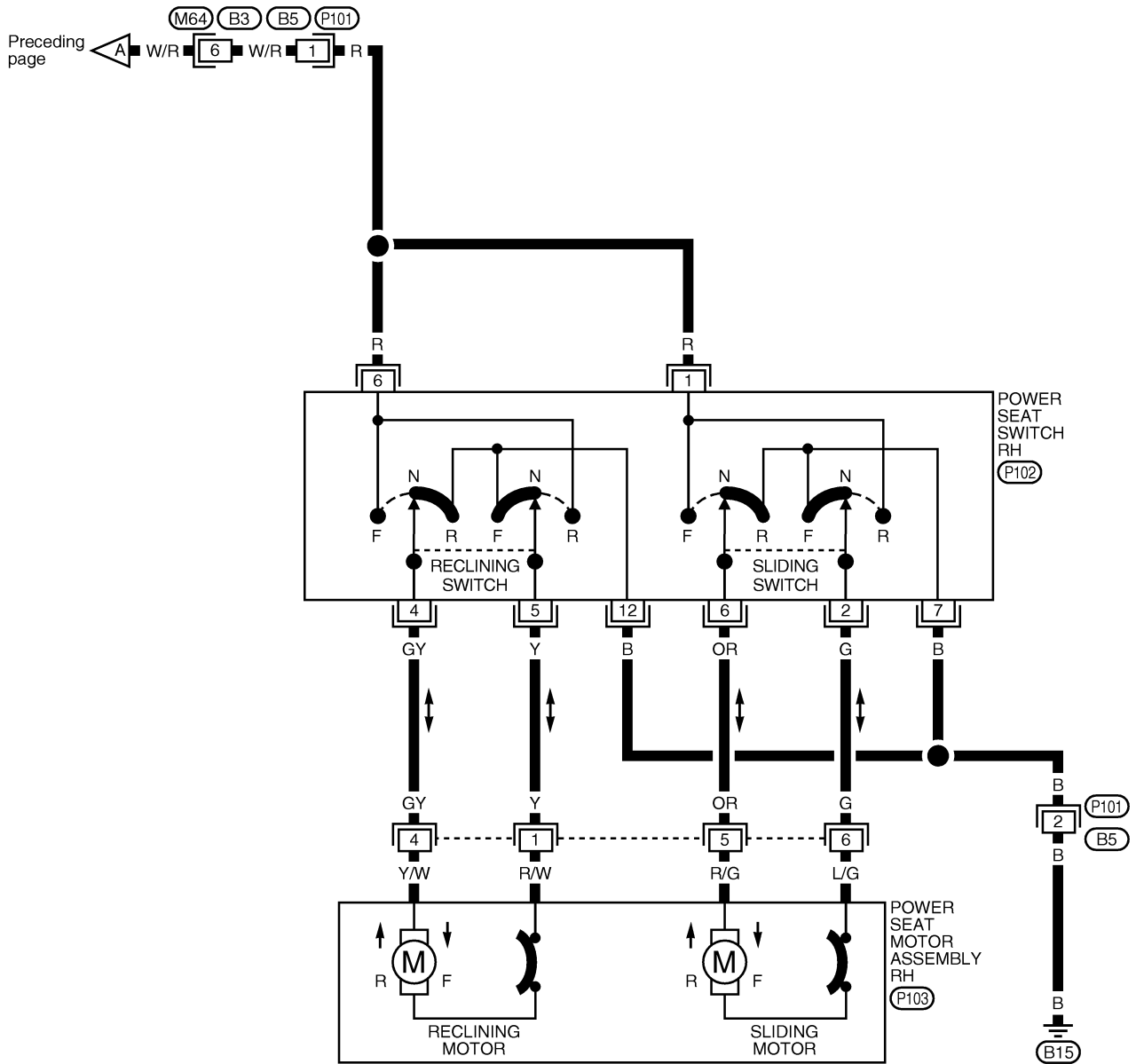

*: This connector is not shown in "HARNESS LAYOUT".

WEL238

AUTOMATIC SPEED CONTROL DEVICE (ASCD)

Components Parts and Harness Connector Location

Components Parts and Harness Connector Location

NDEL0151

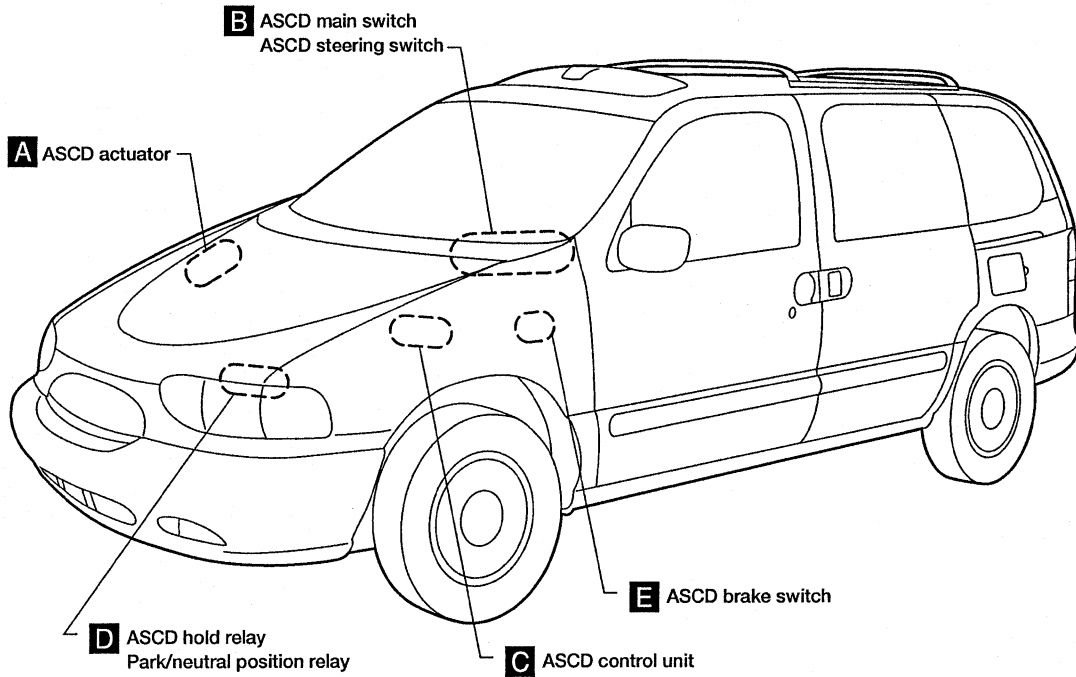

GI

MA

EM

LC

EC

FE

AT

AX

SU

BR

ST

RS

BT

HA

SC

EL

IDX

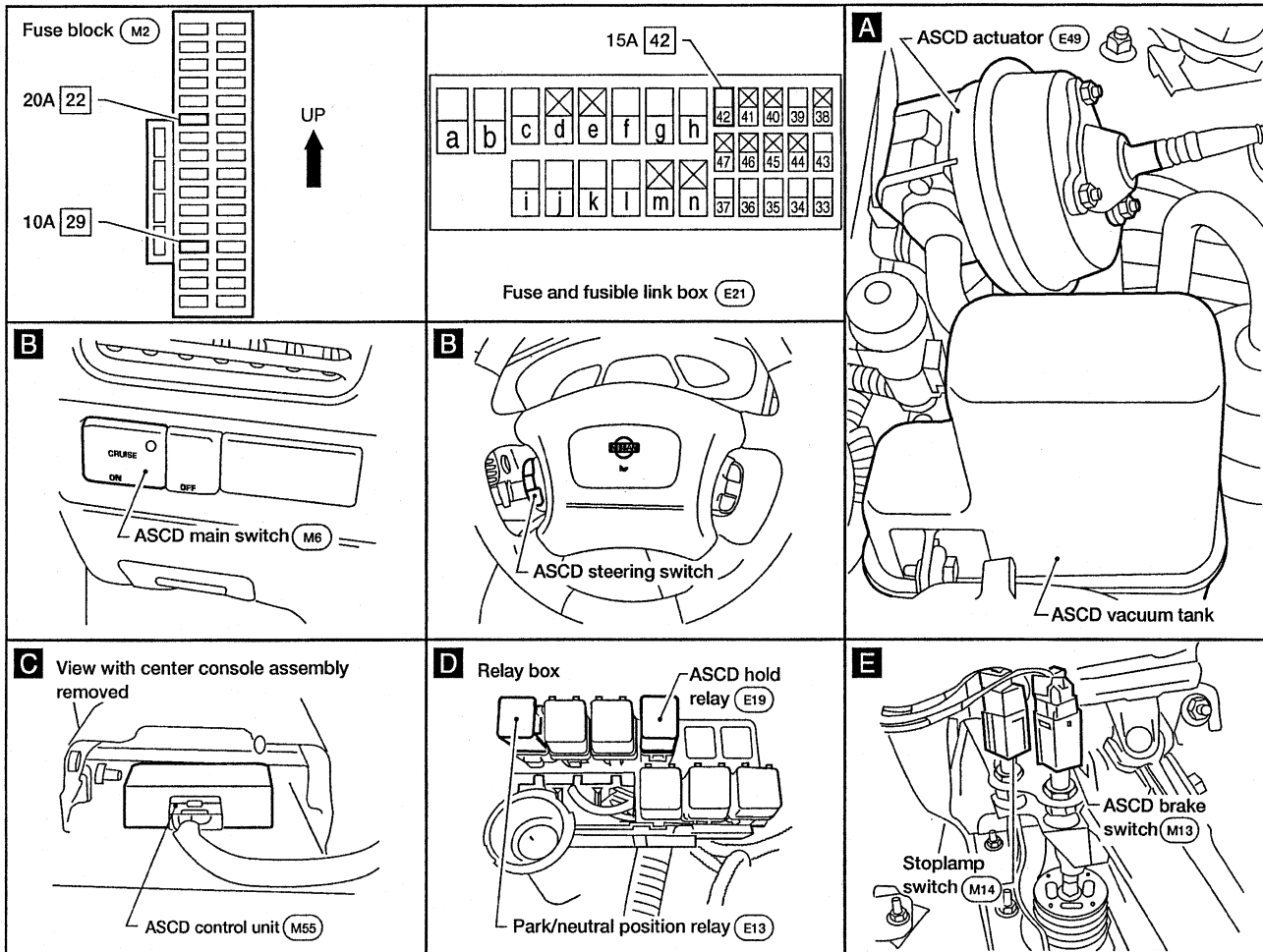

WEL260

AUTOMATIC SPEED CONTROL DEVICE (ASCD)

System Description

System Description

NDEL0094

Refer to Owner's Manual for ASCD operating instructions.

POWER SUPPLY AND GROUND CIRCUIT

NDEL0094S01

When ignition switch is in the ON or START position, power is supplied

- through 10A fuse (No. 29, located in the fuse block)
- to ASCD main switch terminal 1,
- to ASCD hold relay terminal 5 and
- to ASCD brake switch terminal 1.

When ASCD main switch is in ON position, power is supplied

- from ASCD main switch terminal 3
- to ASCD hold relay terminal 2.

Ground is supplied

- to ASCD hold relay terminal 1
- through body grounds E3, E30 and E50.

With power and ground supplied, ASCD hold relay is energized, and then power is supplied

- from ASCD hold relay terminal 3
- to ASCD control unit terminal 4 and
- to ASCD main switch terminal 2.

After the ASCD main switch is released, power remains supplied

- to the coil circuit of ASCD hold relay
- through ASCD main switch terminals 2 and 3.

This power supply continues until any of the following things happen.

- Ignition switch is returned to the ACC or OFF position
- ASCD main switch is turned to OFF position.

While ASCD hold relay is energized power is also supplied to ASCD control unit terminal 5

- through ASCD brake switch, ASCD hold relay and park/neutral position (PNP) relay.

Ground is supplied

- to ASCD control unit terminal 3
- through body grounds M68, M105 and M130.

OPERATION

NDEL0094S02

Set Operation

NDEL0094S0201

To activate the ASCD, all of following conditions must exist

- Power supply to ASCD control unit terminal 4.
- Power supply to ASCD control unit terminal 5 (Brake pedal is released and A/T selector lever is in other than P and N positions.)
- Vehicle speed is greater than 48 km/h (30 MPH) (Signal from combination meter).

When the SET/COAST switch is depressed, power is supplied

- from ASCD steering switch terminal 1
- to ASCD control unit terminal 2.

And then ASCD actuator is activated to control throttle wire and ASCD control unit terminal 13 supplies power

- to combination meter terminal 1 to illuminate CRUISE indicator.

A/T Overdrive Control During Cruise Control Driving

NDEL0094S0202

When the vehicle speed is approximately 8 km/h (5 MPH) below set speed, a signal is sent

- from ASCD control unit terminal 12
- to TCM (transmission control module) terminal 24.

When this occurs, the TCM cancels overdrive.

After vehicle speed is approximately 3 km/h (2 MPH) above set speed, overdrive is reactivated.

AUTOMATIC SPEED CONTROL DEVICE (ASCD)

System Description (Cont'd)

Coast Operation

=NDEL0094S0203

When the SET/COAST switch is depressed during cruise control driving, ASCD actuator returns the throttle cable to decrease vehicle set speed until the switch is released. Then ASCD will keep the new set speed.

GI

Accel Operation

NDEL0094S0204

When the RESUME/ACCEL switch is depressed, power is supplied

- from ASCD steering switch terminal 2
- to ASCD control unit terminal 1.

MA

If the RESUME/ACCEL switch is depressed during cruise control driving, ASCD actuator pulls the throttle cable to increase the vehicle speed until the switch is released or vehicle speed is reached to maximum controlled speed by the system. Then ASCD will keep the new set speed.

EM

LC

Cancel Operation

NDEL0094S0205

When any of the following condition exists, cruise operation will be canceled (main switch indicator will continue to illuminate.)

- CANCEL switch is depressed (power is supplied to ASCD control unit terminals 1 and 2.)
- Brake pedal is depressed (power is supplied to ASCD control unit terminal 11 from stop lamp switch and power supply to ASCD control unit terminal 5 is interrupted.)
- A/T selector lever is shifted to P or N position (power supply to ASCD control unit terminal 5 is interrupted.)

EC

FE

If MAIN switch is depressed while ASCD is activated, all of ASCD operation will be canceled and vehicle speed memory will be erased.

AT

Resume Operation

NDEL0094S0206

When the RESUME/ACCEL switch is depressed after cancel operation (other than depressing MAIN switch), vehicle speed will return to last set speed. To resume vehicle set speed, vehicle condition must meet following conditions

AX

- Brake pedal is released
- A/T selector lever is in other than P or N position
- Vehicle speed is greater than 48 km/h (30 MPH).

SU

BR

ASCD ACTUATOR OPERATION

NDEL0094S03

The ASCD actuator consists of a vacuum valve, an air valve and a release valve. When the ASCD activates, power is supplied

- from terminal 8 of ASCD control unit
- to ASCD actuator terminal 1.

ST

RS

Ground is supplied to vacuum valve, air valve and released valve from ASCD control unit depending on the operating condition as shown in the table below.

BT

When the vacuum valve is opened, the vacuum is applied to the diaphragm of ASCD actuator through ASCD vacuum tank.

HA

		Air valve*	Release valve*	Vacuum valve**	Actuator inner pressure
ASCD not operating		Open	Open	Close	Atmosphere
ASCD operating	Releasing throttle cable	Open	Close	Close	Vacuum (decrease)
	Holding throttle position	Close	Close	Close	Vacuum (hold)
	Pulling throttle cable	Close	Close	Open	Vacuum (increase)

SC

EL

IDX

*: When power and ground is supplied, valve is closed.

** : When power and ground is supplied, valve is open.

AUTOMATIC SPEED CONTROL DEVICE (ASCD)

Schematic

Schematic

NDEL0095

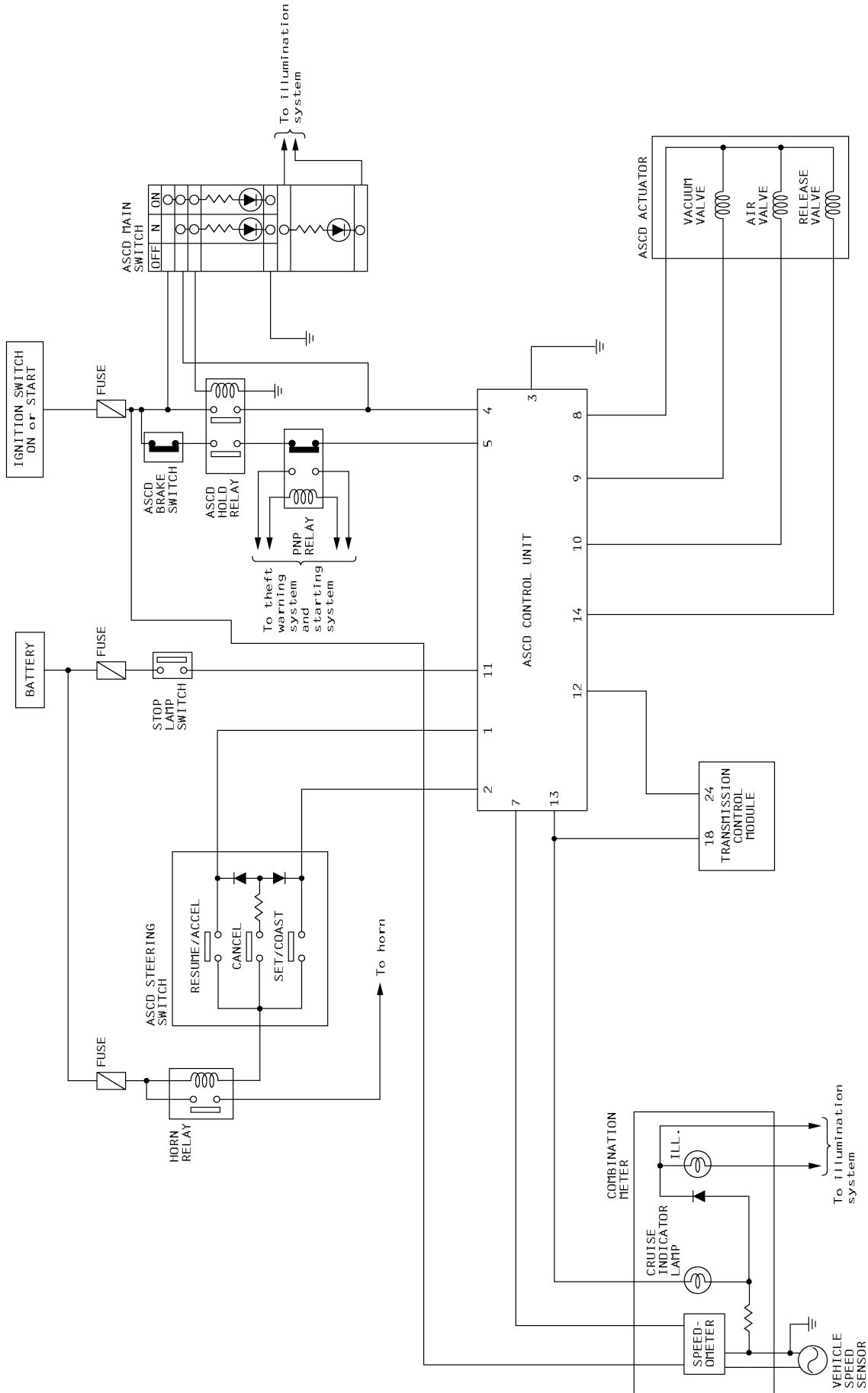

EL-188

WEL239

AUTOMATIC SPEED CONTROL DEVICE (ASCD)

Wiring Diagram — ASCD —

FIG. 1

NDEL0096

NDEL0096S01

Wiring Diagram — ASCD —

EL-ASCD-01

GI

MA

EM

LC

EC

FE

AT

AX

SU

BR

ST

RS

BT

HA

SC

EL

IDX

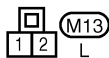
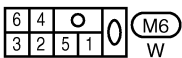
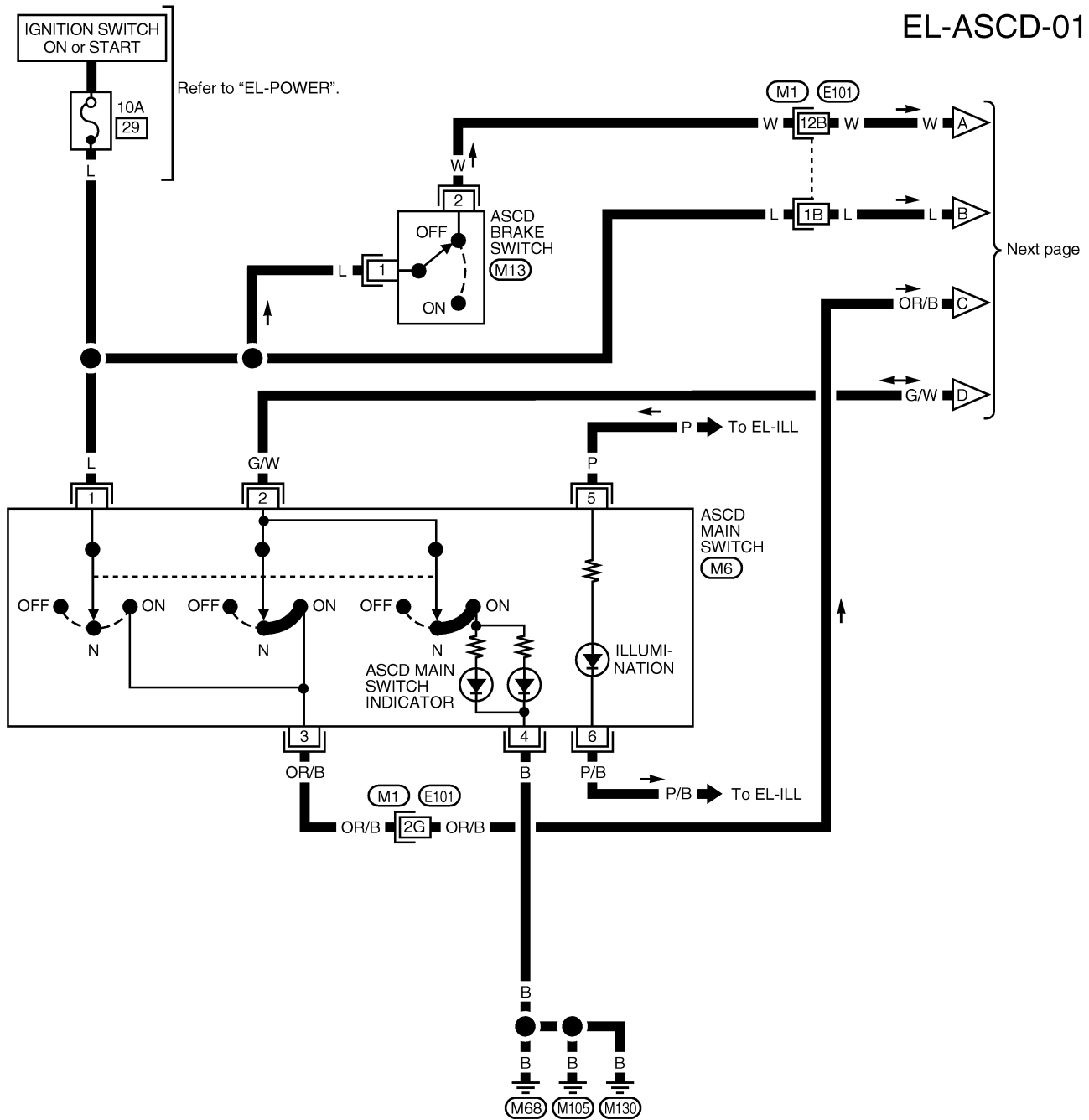

Refer to the following.
 (M1), (E101) - SUPER MULTIPLE
 JUNCTION (SMJ)

AUTOMATIC SPEED CONTROL DEVICE (ASCD)

Wiring Diagram — ASCD — (Cont'd)

NDEL0096S02

FIG. 2

EL-ASCD-02

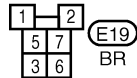
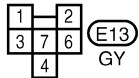
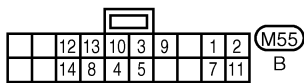
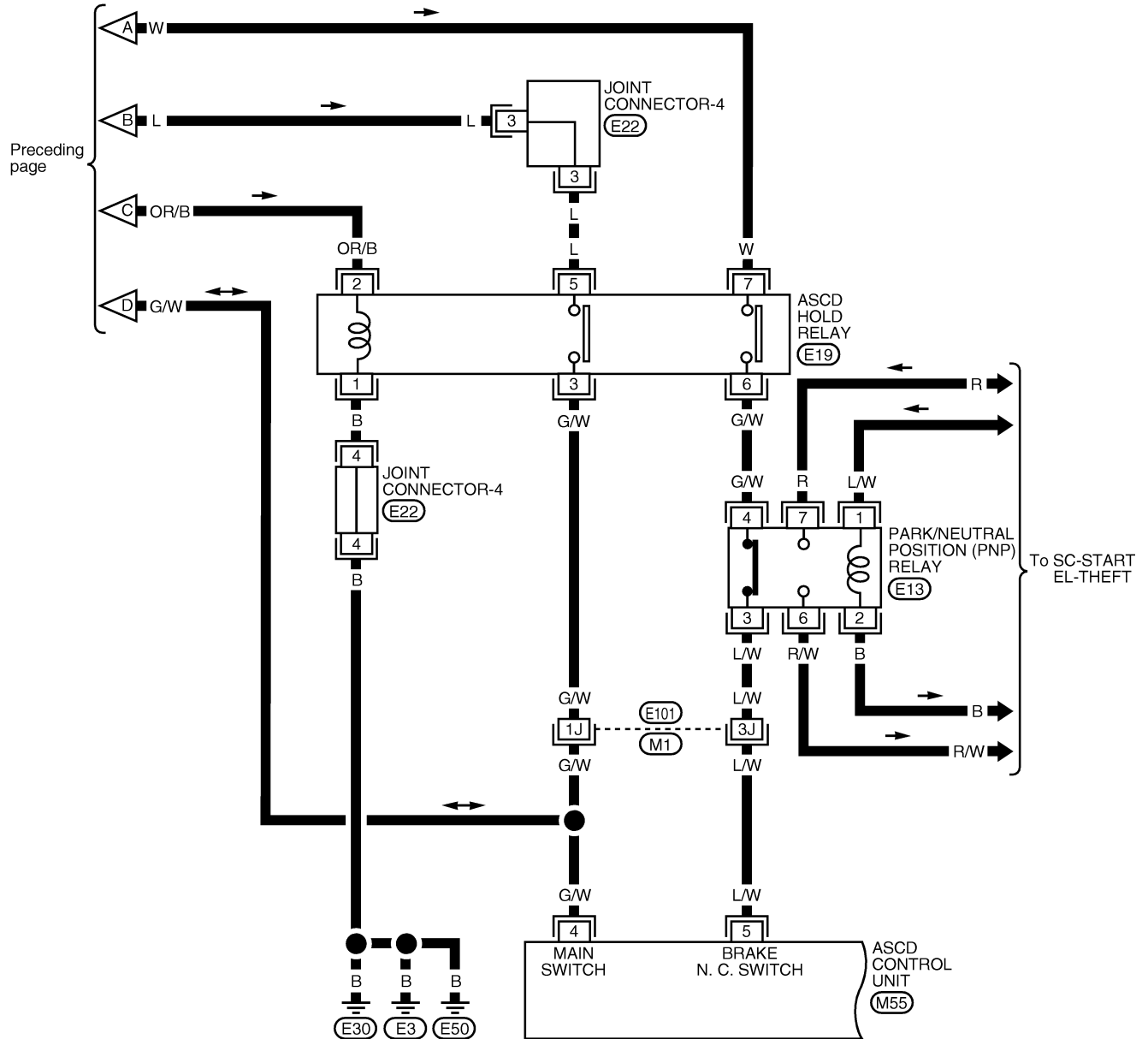

Refer to the following.
 (M1), (E101) - SUPER MULTIPLE JUNCTION (SMJ)
 (E22) - JOINT CONNECTOR

WEL241

AUTOMATIC SPEED CONTROL DEVICE (ASCD)

Wiring Diagram — ASCD — (Cont'd)

FIG. 3

NDEL0096S03

EL-ASCD-03

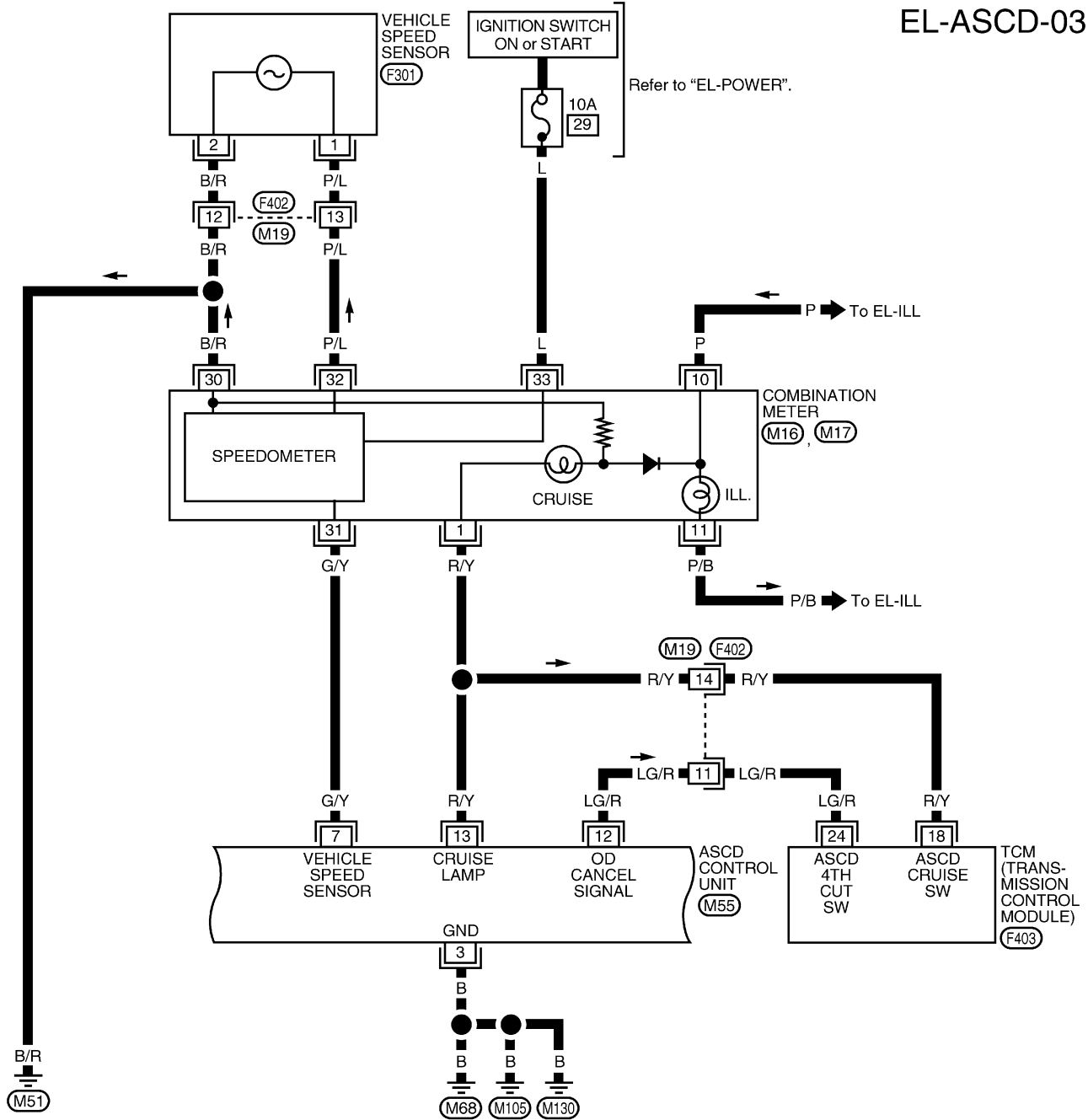

GI
MA
EM
LC
EC
FE
AT
AX
SU
BR
ST
RS
BT
HA
SC

EL

IDX

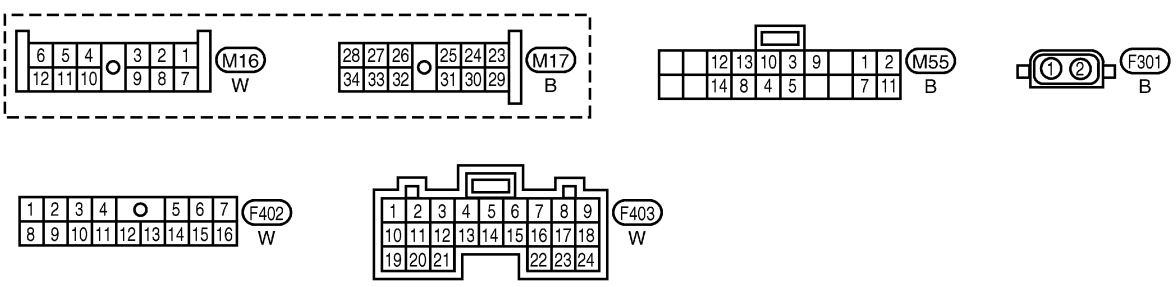

AUTOMATIC SPEED CONTROL DEVICE (ASCD)

Wiring Diagram — ASCD — (Cont'd)

NDEL0096S04

FIG. 4

EL-ASCD-04

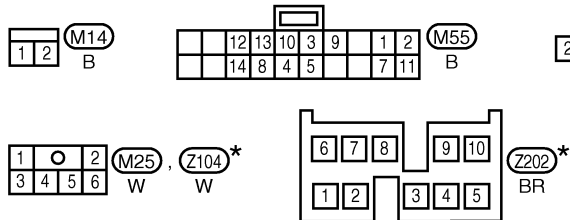
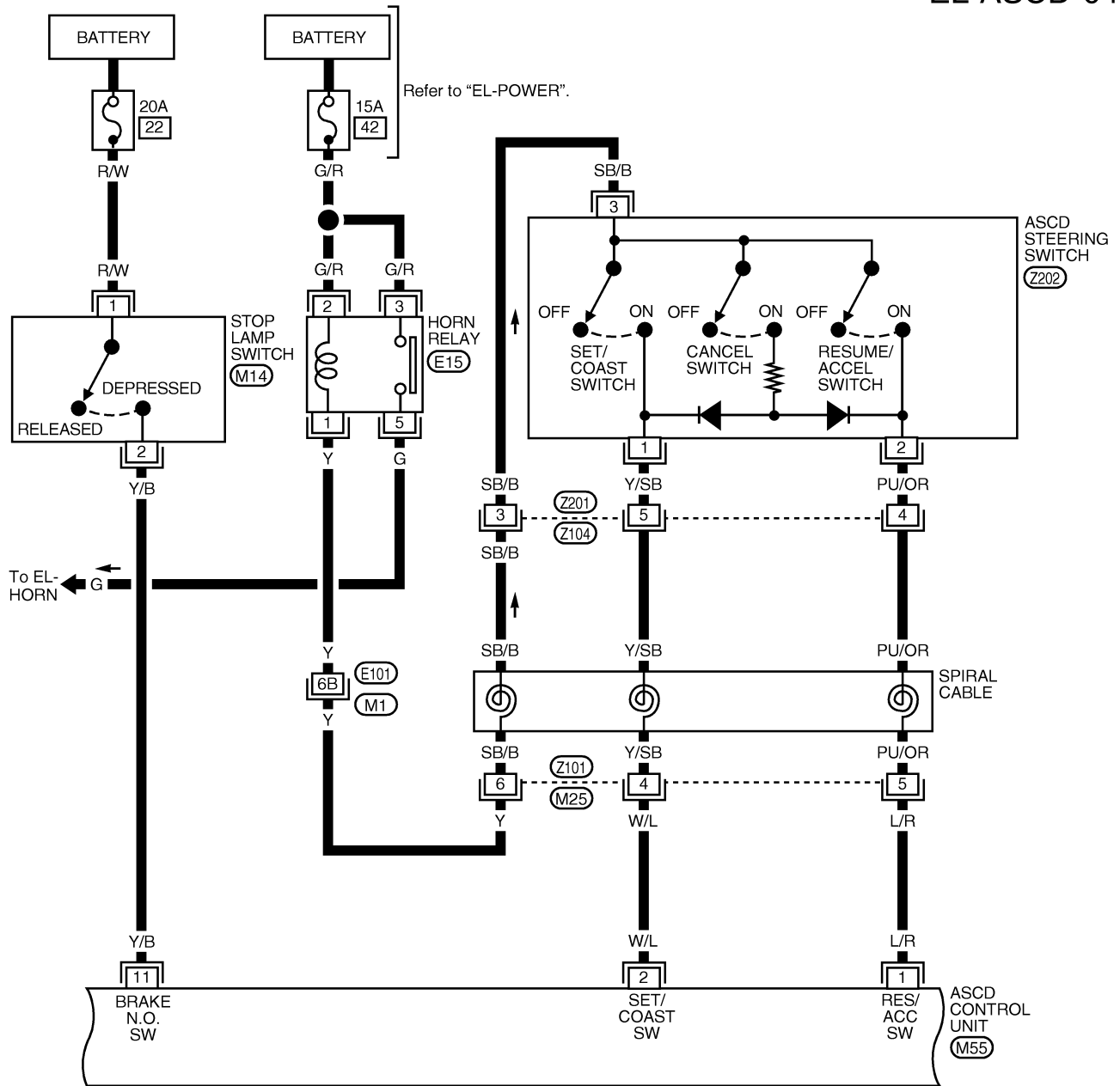

Refer to the following.
 (M1), (E101) - SUPER MULTIPLE JUNCTION (SMJ)

* : This connector is not shown in "HARNESS LAYOUT".

WEL242

AUTOMATIC SPEED CONTROL DEVICE (ASCD)

Wiring Diagram — ASCD — (Cont'd)

FIG. 5

NDEL0096S05

EL-ASCD-05

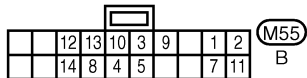
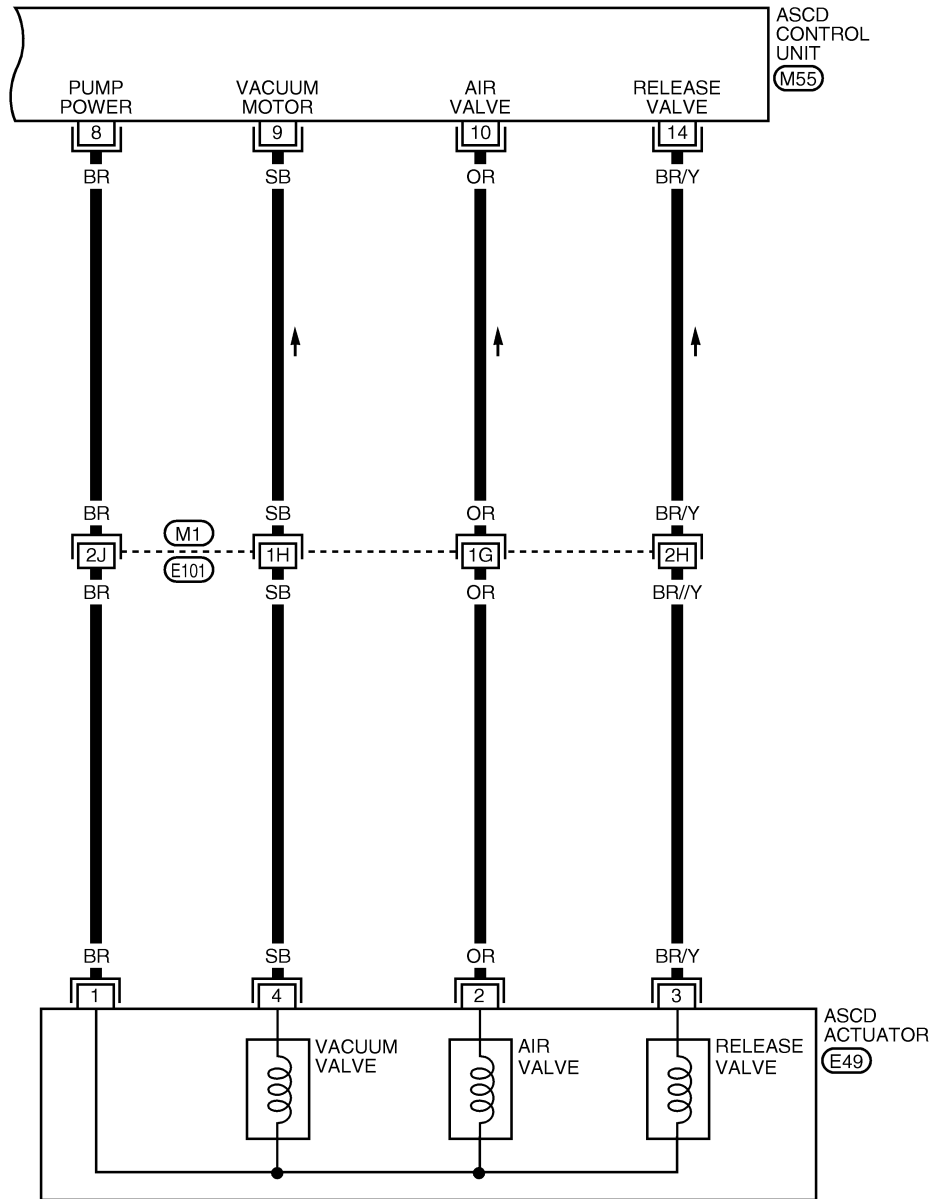

Refer to the following.
 (M1), (E101) - SUPER MULTIPLE
 JUNCTION (SMJ)

GI
 MA
 EM
 LC
 EC
 FE
 AT
 AX
 SU
 BR
 ST
 RS
 BT
 HA
 SC

EL

IDX

AUTOMATIC SPEED CONTROL DEVICE (ASCD)

Fail-safe System

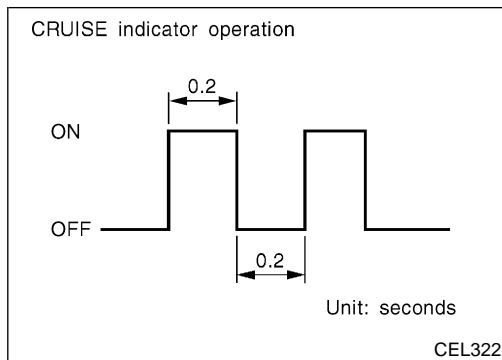

Fail-safe System

DESCRIPTION

When the fail safe system senses a malfunction, it deactivates ASCD operation. The CRUISE indicator in the combination meter will then flash.

NDEL0097

NDEL0097S01

MALFUNCTION DETECTION CONDITIONS

NDEL0097S02

Detection conditions	ASCD operation during malfunction detection
<ul style="list-style-type: none"> ● ASCD steering (RESUME/ACCEL, CANCEL, SET/COAST) switch is stuck. ● Vacuum valve ground circuit or power circuit is open or shorted. ● Air valve ground circuit or power circuit is open or shorted. ● Release valve ground circuit or power circuit is open or shorted. ● Vehicle speed sensor is faulty. ● ASCD control unit internal circuit is malfunctioning. 	<ul style="list-style-type: none"> ● ASCD is deactivated. ● Vehicle speed memory is canceled.
<ul style="list-style-type: none"> ● ASCD brake switch or stop lamp switch is faulty. 	<ul style="list-style-type: none"> ● ASCD is deactivated. ● Vehicle speed memory is canceled.

AUTOMATIC SPEED CONTROL DEVICE (ASCD)

Trouble Diagnoses

Trouble Diagnoses SYMPTOM CHART

=NDEL0098

NDEL0098S01

REFERENCE PAGE (EL-)	196	197	198	199	201	202	204	204	205
SYMPTOM	FAIL-SAFE SYSTEM CHECK	POWER SUPPLY AND GROUND CIRCUIT CHECK	ASCD MAIN SWITCH CHECK	ASCD HOLD RELAY CHECK	ASCD BRAKE/STOP LAMP SWITCH CHECK	ASCD STEERING SWITCH CHECK	VEHICLE SPEED SENSOR CHECK	ASCD ACTUATOR CIRCUIT CHECK	ASCD ACTUATOR CHECK
ASCD cannot be set. ("CRUISE" indicator lamp does not blink.)		X	X	X		X	X		X★3
ASCD cannot be set. ("CRUISE" indicator lamp blinks.★1)	X				X	X	X	X	
Vehicle speed does not decrease after SET/COAST switch has been pressed.						X			X
Vehicle speed does not return to the set speed after RESUME/ACCEL switch has been pressed.★2						X			X
Vehicle speed does not increase after RESUME/ACCEL switch has been pressed.						X			X
System is not released after CANCEL switch (steering) has been pressed.						X			X
Large difference between set speed and actual vehicle speed.							X	X	X
Deceleration is greatest immediately after ASCD has been set.							X	X	X

★1: It indicates that system is in fail-safe. After completing diagnostic procedures, perform "FAIL-SAFE SYSTEM CHECK" (EL-196) to verify repairs.

★2: If vehicle speed is greater than 48 km/h (30 MPH) after system has been released, pressing RESUME/ACCEL switch returns vehicle speed to the set speed previously achieved. However, doing so when the ASCD main switch is turned to "OFF", vehicle speed will not return to the set speed since the memory is canceled.

★3: Verify that vacuum hose between ASCD vacuum tank and intake manifold collector or between ASCD vacuum tank and ASCD actuator has not come off.

GI
MA
EM
LC
EC
FE
AT
AX
SU
BR
ST
RS
BT
HA
SC
EL

AUTOMATIC SPEED CONTROL DEVICE (ASCD)

Trouble Diagnoses (Cont'd)

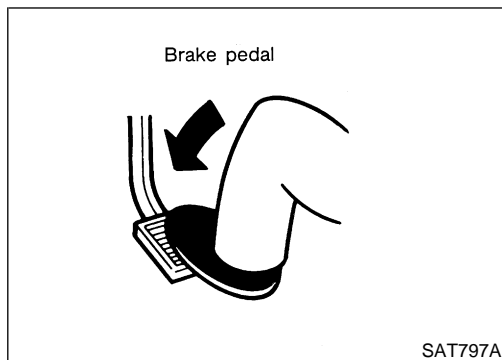
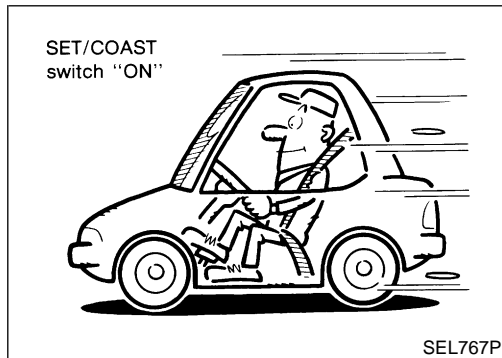
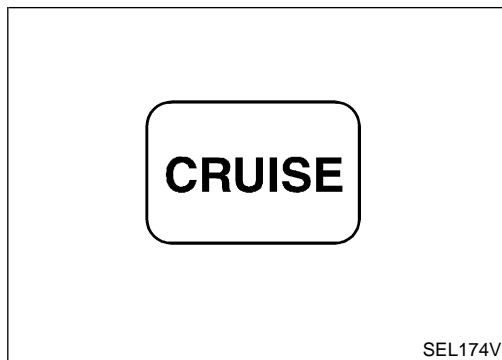

FAIL-SAFE SYSTEM CHECK

NDEL0098S02

1. Turn ignition switch to ON position.
2. Turn ASCD main switch to ON and check if the "cruise indicator" blinks.

If the indicator lamp blinks, refer to the following

- ASCD Steering Switch Check. Refer to EL-202.

3. Drive the vehicle at more than 48 km/h (30 MPH) and push SET/COAST switch.

If the indicator lamp blinks, refer to the following

- Vehicle Speed Sensor Check. Refer to EL-204.
- ASCD Actuator Circuit Check. Refer to EL-204.
- Replace control unit.

4. Depress brake pedal slowly (brake pedal should be depressed more than 5 seconds).

If the indicator lamp blinks, refer to the following

- ASCD Brake/Stop Lamp Switch Check. Refer to EL-201.

5. END. (System is OK.)

AUTOMATIC SPEED CONTROL DEVICE (ASCD)

Trouble Diagnoses (Cont'd)

POWER SUPPLY AND GROUND CIRCUIT CHECK

=NDEL0098S03

1	OPERATION CHECK	
1. Turn ignition switch ON. 2. Push ASCD main switch ON.		
Does ASCD indicator illuminate?		
Yes	▶	GO TO 2.
No	▶	Go to ASCD MAIN SWITCH CHECK. Refer to EL-198.

GI
MA
EM

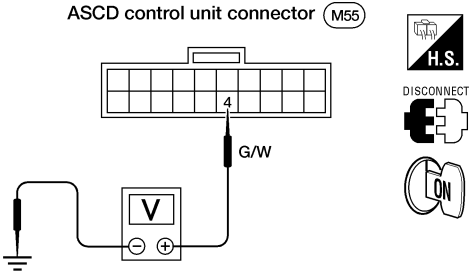
2	CHECK POWER SUPPLY CIRCUIT FOR ASCD CONTROL UNIT	
1. Disconnect ASCD control unit connector. 2. Turn ignition switch ON. 3. Push ASCD main switch ON. 4. Check voltage between control unit connector terminal 4 and ground.		
		
Refer to wiring diagram, EL-190. AEL015C		
Does battery voltage exist?		
Yes	▶	GO TO 3.
No	▶	Go to ASCD HOLD RELAY CHECK. Refer to EL-199.

LC
EC
FE
AT
AX
SU
BR
ST

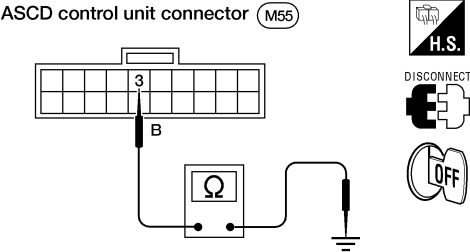
3	CHECK GROUND CIRCUIT FOR ASCD CONTROL UNIT	
Check continuity between ASCD control unit harness terminal 3 and body ground.		
		
Refer to wiring diagram, EL-191. AEL016C		
Does continuity exist?		
Yes	▶	Power supply and ground circuit is OK.
No	▶	Repair harness.

RS
BT
HA
SC



EL
IDX

AUTOMATIC SPEED CONTROL DEVICE (ASCD)

Trouble Diagnoses (Cont'd)

ASCD MAIN SWITCH CHECK

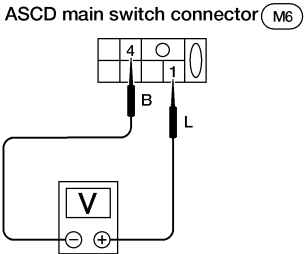
=NDEL0098S04

1	CHECK POWER SUPPLY FOR ASCD MAIN SWITCH	
<p>1. Disconnect main switch connector. 2. Check voltage between main switch terminals 1 and 4.</p> <div style="display: flex; justify-content: space-around; align-items: center;"> <div style="text-align: center;"> <p>ASCD main switch connector (M6)</p>  </div> <div style="text-align: center;">  </div> </div> <p style="text-align: right;">AEL017C</p>		
<p>Refer to wiring diagram, EL-189.</p> <p>Does battery voltage exist?</p>		
Yes	▶	GO TO 2.
No	▶	<p>Check the following</p> <ul style="list-style-type: none"> ● 10A fuse (No. 29, located in the fuse block) ● Harness for open or short between fuse and ASCD main switch ● Ground circuit for ASCD main switch.

2	CHECK ASCD MAIN SWITCH	
<p>Check ASCD main switch. Refer to "Electrical Component Inspection", EL-206.</p> <p style="text-align: center;">OK or NG</p>		
OK	▶	Go to ASCD HOLD RELAY CHECK. Refer to EL-199.
NG	▶	Replace ASCD main switch.

AUTOMATIC SPEED CONTROL DEVICE (ASCD)

Trouble Diagnoses (Cont'd)

ASCD HOLD RELAY CHECK

=NDEL0098S05

1	CHECK POWER SUPPLY CIRCUIT FOR ASCD HOLD RELAY	
<p>1. Disconnect ASCD hold relay. 2. Check voltage between ASCD hold relay terminal 5 and body ground.</p>		
<p>Refer to wiring diagram, EL-190.</p>		
Does battery voltage exist?		
Yes	▶	GO TO 2.
No	▶	<p>Check the following</p> <ul style="list-style-type: none"> ● 10A fuse (No. 29, located in the fuse block) ● Harness for open or short between fuse and ASCD hold relay.

GI

MA

EM

LC

EC

FE

AT

AX

2	CHECK GROUND CIRCUIT FOR ASCD HOLD RELAY	
<p>Check continuity between ASCD hold relay terminal 1 and body ground.</p>		
Does continuity exist?		
Yes	▶	GO TO 3.
No	▶	Repair harness.

SU

BR

ST

RS

BT

HA

SC

EL

IDX

AUTOMATIC SPEED CONTROL DEVICE (ASCD)

Trouble Diagnoses (Cont'd)

3	CHECK ASCD HOLD RELAY OPEN OR SHORT CIRCUIT	<p>1. Check continuity between ASCD hold relay harness terminals 2 and 3.</p> <div style="display: flex; justify-content: space-around; align-items: center;"> <div style="text-align: center;"> <p>ASCD hold relay connector (E19)</p> </div> <div style="text-align: center;"> <p>DISCONNECT</p> </div> </div> <p style="text-align: right;">AEL020C</p> <p>Continuity should exist.</p> <p>2. Check continuity between ASCD hold relay terminal 2 and body ground.</p> <div style="display: flex; justify-content: space-around; align-items: center;"> <div style="text-align: center;"> <p>ASCD hold relay connector (E19)</p> </div> <div style="text-align: center;"> <p>DISCONNECT</p> </div> </div> <p style="text-align: right;">AEL021C</p> <p>Continuity should not exist.</p> <p style="text-align: center;">OK or NG</p>
OK	▶	GO TO 4.
NG	▶	GO TO 5.

4	CHECK ASCD HOLD RELAY	<p>Check ASCD hold relay. Refer to “Electrical Component Inspection”, EL-207.</p> <p style="text-align: center;">OK or NG</p>
OK	▶	ASCD hold relay is OK.
NG	▶	Replace ASCD hold relay.

5	CHECK ASCD MAIN SWITCH	<p>Check ASCD main switch. Refer to “Electrical Component Inspection”, EL-206.</p> <p style="text-align: center;">OK or NG</p>
OK	▶	Repair harness.
NG	▶	Replace ASCD main switch.

AUTOMATIC SPEED CONTROL DEVICE (ASCD)

Trouble Diagnoses (Cont'd)

ASCD BRAKE/STOP LAMP SWITCH CHECK

=NDEL0098S06

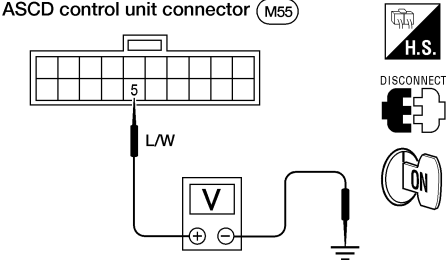
1	CHECK ASCD BRAKE SWITCH CIRCUIT
	<p>1. Disconnect control unit connector. 2. Turn ignition switch ON. 3. Push ASCD main switch ON. 4. Check voltage between control unit connector harness terminal 5 and body ground.</p> <div style="text-align: center;">  </div> <p style="text-align: right;">AEL022C</p> <p>When brake pedal is depressed or A/T selector lever is in N or P range: Approx. 0V</p> <p>When both brake pedal is released and A/T selector lever is not in N or P range: Battery voltage should exist.</p> <p>Refer to wiring diagrams, EL-189, 190.</p> <p style="text-align: center;">OK or NG</p>
OK	▶ GO TO 2.
NG	<p>▶ Check the following</p> <ul style="list-style-type: none"> ● ASCD brake switch, ASCD hold relay, park neutral position (PNP) switch Refer to "Electrical Components Inspection", EL-206. ● Harness for open or short.

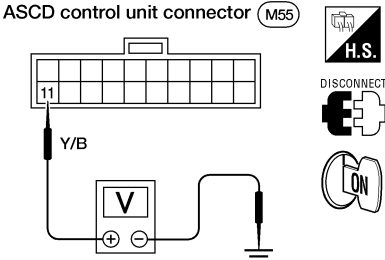
2	CHECK STOP LAMP SWITCH CIRCUIT
	<p>1. Disconnect control unit connector. 2. Check voltage between control unit harness terminal 11 and ground.</p> <div style="text-align: center;">  </div> <p style="text-align: right;">AEL023C</p> <p>Voltage [V]: Stop lamp switch: Depressed Approx. 12 Stop lamp switch: Released 0</p> <p>Refer to wiring diagram, EL-192.</p> <p style="text-align: center;">OK or NG</p>
OK	▶ ASCD brake/stop lamp switch is OK.
NG	<p>▶ Check the following</p> <ul style="list-style-type: none"> ● 15A fuse (No. 22, located in the fuse block) ● Harness for open or short between ASCD control unit and stop lamp switch ● Stop lamp switch <p>Refer to "Electrical Components Inspection", EL-206.</p>

GI
MA
EM
LC
EC
FE
AT
AX
SU
BR
ST
RS
BT
HA
SC
EL
IDX

AUTOMATIC SPEED CONTROL DEVICE (ASCD)

Trouble Diagnoses (Cont'd)

ASCD STEERING SWITCH CHECK

=NDEL0098S07

1	CHECK ASCD STEERING SWITCH CIRCUIT FOR ASCD CONTROL UNIT																												
<p>1. Disconnect control unit connector. 2. Check voltage between control unit harness terminals and ground.</p>																													
AEL024C																													
<table border="1" style="margin: auto; border-collapse: collapse;"> <thead> <tr> <th rowspan="2"></th> <th colspan="2">Terminal No.</th> <th colspan="2">Switch condition</th> </tr> <tr> <th>(+)</th> <th>(-)</th> <th>Pressed</th> <th>Released</th> </tr> </thead> <tbody> <tr> <td>SET/COAST SW</td> <td>2</td> <td>ground</td> <td>12V</td> <td>0V</td> </tr> <tr> <td>RESUME/ACC SW</td> <td>1</td> <td>ground</td> <td>12V</td> <td>0V</td> </tr> <tr> <td rowspan="2">CANCEL SW</td> <td>2</td> <td>ground</td> <td>12V</td> <td>0V</td> </tr> <tr> <td>1</td> <td>ground</td> <td>12V</td> <td>0V</td> </tr> </tbody> </table>			Terminal No.		Switch condition		(+)	(-)	Pressed	Released	SET/COAST SW	2	ground	12V	0V	RESUME/ACC SW	1	ground	12V	0V	CANCEL SW	2	ground	12V	0V	1	ground	12V	0V
	Terminal No.		Switch condition																										
	(+)	(-)	Pressed	Released																									
SET/COAST SW	2	ground	12V	0V																									
RESUME/ACC SW	1	ground	12V	0V																									
CANCEL SW	2	ground	12V	0V																									
	1	ground	12V	0V																									
MTBL0002																													
Refer to wiring diagram, EL-192.																													
OK or NG																													
OK	▶ ASCD steering switch is OK.																												
NG	▶ GO TO 2.																												

2	CHECK POWER SUPPLY FOR ASCD STEERING SWITCH
Does horn work?	
Yes	▶ GO TO 3.
No	▶ Check the following <ul style="list-style-type: none"> ● 15A fuse (No. 42, located in the fuse and fusible link box) ● Horn relay ● Harness for open or short between horn relay and fuse.

AUTOMATIC SPEED CONTROL DEVICE (ASCD)

Trouble Diagnoses (Cont'd)

3 CHECK ASCD STEERING SWITCH

1. Disconnect ASCD steering switch.
2. Check continuity between terminals by pushing each switch.

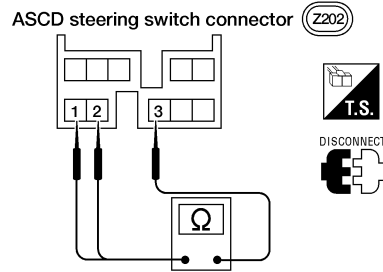

AEL026C

Switch	Terminals		
	3	1	2
RESUME/ACCEL	○	○	○
SET/COAST	○	○	○
CANCEL	○	▶	○
	○	▶	○

AEL025C

OK or NG

OK	▶	Check harness for open or short between ASCD steering switch and ASCD control unit.
NG	▶	Replace ASCD steering switch.

GI

MA

EM

LC

EC

FE

AT

AX

SU

BR

ST

RS

BT

HA

SC

EL

IDX

AUTOMATIC SPEED CONTROL DEVICE (ASCD)

Trouble Diagnoses (Cont'd)

VEHICLE SPEED SENSOR CHECK

=NDEL0098S08

1	CHECK SPEEDOMETER OPERATION	
Refer to wiring diagram, EL-191.		
Does speedometer operate normally?		
Yes	▶	GO TO 2.
No	▶	Check speedometer and vehicle speed sensor circuit. Refer to EL-80.

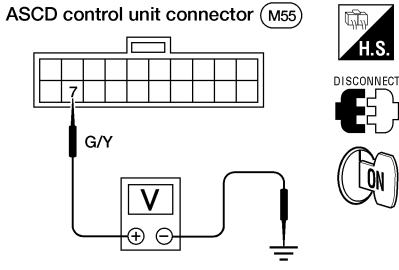
2	CHECK VEHICLE SPEED INPUT	
<ol style="list-style-type: none"> 1. Apply wheel chocks and jack up drive wheels. 2. Disconnect control unit connector. 3. Check voltage between control unit terminal 7 and ground with turning drive wheels slowly. 		
		
Does voltmeter pointer deflect?		
Yes	▶	Vehicle speed sensor is OK.
No	▶	Check harness for open or short between ASCD control unit terminal 7 and combination meter terminal 31. Refer to "Inspection/Vehicle Speed Sensor", EL-86.

AEL029C

ASCD ACTUATOR CIRCUIT CHECK

NDEL0098S09

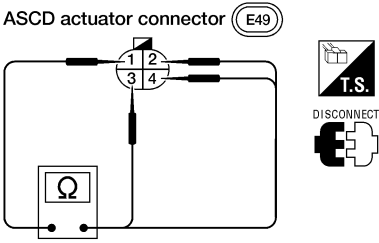
1	CHECK ASCD ACTUATOR											
<ol style="list-style-type: none"> 1. Disconnect ASCD actuator connector. 2. Measure resistance between ASCD actuator terminals 1 and 2, 3, 4. 												
												
AEL028C												
<table border="1" style="margin: auto; border-collapse: collapse;"> <thead> <tr> <th style="width: 10%;"></th> <th style="width: 30%;">Terminals</th> <th style="width: 60%;">Resistance [Ω]</th> </tr> </thead> <tbody> <tr> <td rowspan="3" style="text-align: center; vertical-align: middle;">1</td> <td style="text-align: center;">4</td> <td style="text-align: center;">Approx. 65</td> </tr> <tr> <td style="text-align: center;">2</td> <td style="text-align: center;">Approx. 65</td> </tr> <tr> <td style="text-align: center;">3</td> <td style="text-align: center;">Approx. 65</td> </tr> </tbody> </table>				Terminals	Resistance [Ω]	1	4	Approx. 65	2	Approx. 65	3	Approx. 65
	Terminals	Resistance [Ω]										
1	4	Approx. 65										
	2	Approx. 65										
	3	Approx. 65										
AEL027C												
Refer to wiring diagram, EL-193.												
OK or NG												
OK	▶	Check harness for open or short between ASCD actuator and ASCD control unit.										
NG	▶	Replace ASCD actuator.										

AUTOMATIC SPEED CONTROL DEVICE (ASCD)

Trouble Diagnoses (Cont'd)

ASCD ACTUATOR CHECK

=NDEL0098S10

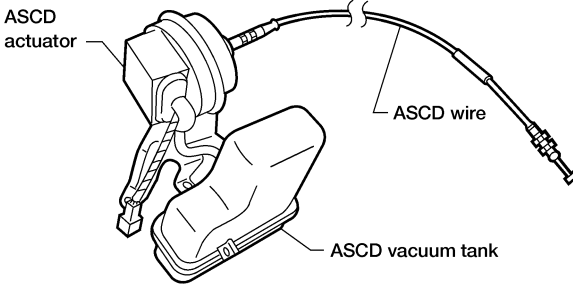
1	CHECK VACUUM HOSE	<p>Check vacuum hose (between ASCD actuator and ASCD vacuum tank) and between ASCD vacuum tank and intake manifold collector for breakage, cracks and fracture.</p> <div style="text-align: center;">  <p>Labels: ASCD actuator, ASCD wire, ASCD vacuum tank</p> </div> <p style="text-align: right;">AEL329C</p>	
OK or NG			
OK	▶	GO TO 2.	
NG	▶	Repair or replace hose.	

2	CHECK ASCD WIRE	<p>Check wire for improper installation, rust formation and breaks.</p> <p style="text-align: center;">OK or NG</p>	
OK	▶	GO TO 3.	
NG	▶	Repair or replace wire. Refer to "ASCD Wire Adjustment", EL-208.	

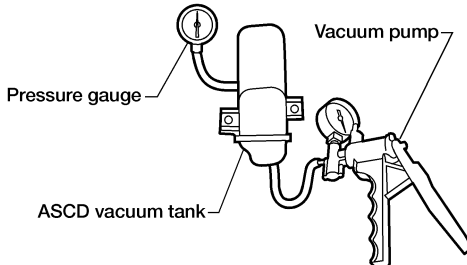
3	CHECK ASCD VACUUM TANK	<ol style="list-style-type: none"> 1. Disconnect vacuum hose to ASCD actuator and to intake manifold collector from ASCD vacuum tank. 2. Install pressure gauge and hand vacuum pump as shown in figure below. 3. Apply -56.3 kPa (-0.574 kg/cm^2, -8.16 psi) vacuum to ASCD vacuum tank. 4. Wait 10 seconds and check for decrease in vacuum pressure. <p style="color: blue;">Vacuum pressure decrease: Less than 2.7 kPa (0.028 kg/cm^2, 0.39 psi)</p> <div style="text-align: center;">  <p>Labels: Pressure gauge, Vacuum pump, ASCD vacuum tank</p> </div> <p style="text-align: right;">AEL330C</p>	
OK or NG			
OK	▶	GO TO 4.	
NG	▶	Replace ASCD vacuum tank.	

GI
MA
EM
LC
EC
FE
AT
AX
SU
BR
ST
RS
BT
HA
SC
EL
IDX

AUTOMATIC SPEED CONTROL DEVICE (ASCD)

Trouble Diagnoses (Cont'd)

4 CHECK ASCD ACTUATOR

1. Disconnect ASCD wire from throttle drum.
2. Reconnect vacuum hose from intake manifold collector to ASCD vacuum tank.
3. With vacuum hose disconnected from ASCD actuator, install pressure gauge as shown in figure below.
4. Disconnect ASCD actuator connector.
5. Start engine.
6. Apply 12V direct current to ASCD actuator connector terminal 1 and ground terminals 2, 3 and 4 together.

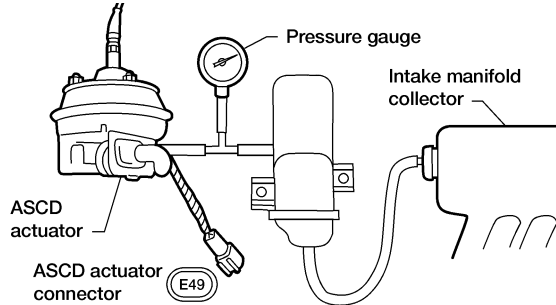

AEL331C

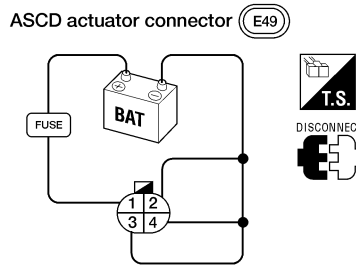

AEL031C

	12V direct current supply terminals		Operation
	(+)	(-)	
Air valve	1	2	Close
Release valve		3	Close
Vacuum valve		4	Open

AEL030C

Vacuum pressure should be lower than -26.7 kPa (-0.272 kg/cm^2 , -3.87 psi)

OK or NG

OK ► ASCD actuator/vacuum tank is OK.

NG ► Replace ASCD actuator.

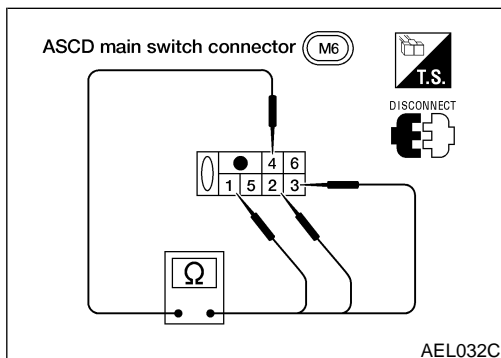

Electrical Component Inspection

ASCD MAIN SWITCH

Check continuity between terminals by pushing switch to each position.

NDEL0099

NDEL0099S01

Switch position	Terminals	Illumination
ON	1 - 2 - 3 - 4	5 - 6
N	2 - 3 - 4	
OFF		

AUTOMATIC SPEED CONTROL DEVICE (ASCD)

Electrical Component Inspection (Cont'd)

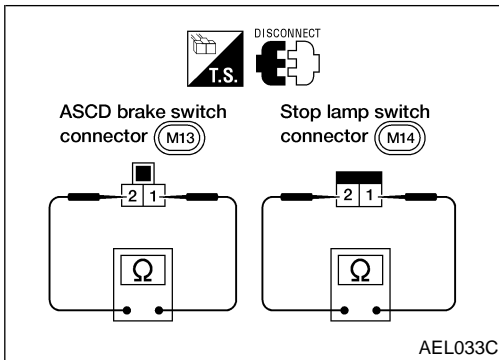

ASCD BRAKE SWITCH AND STOP LAMP SWITCH

NDEL0099S02

Condition	Continuity	
	ASCD brake switch	Stop lamp switch
When brake pedal is depressed	No	Yes
When brake pedal is released	Yes	No

Check each switch after adjusting brake pedal — refer to BR-13.

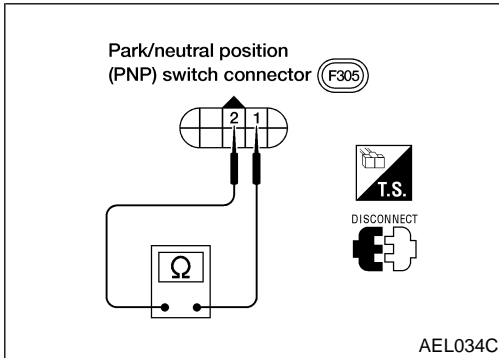

PARK NEUTRAL POSITION (PNP) SWITCH

NDEL0099S03

Selector lever position	Continuity	
	Between terminals 1 and 2	
P	Yes	
N	Yes	
Except P and N	No	

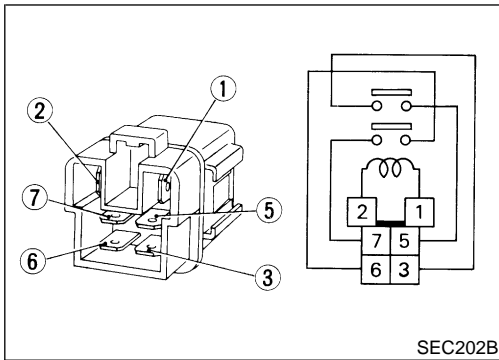

ASCD HOLD RELAY

NDEL0099S04

Check continuity between terminals 3 and 5, 6 and 7.

Condition	Continuity
12V DC direct current supply between terminals 1 and 2	Yes
No current supply	No

GI

MA

EM

LC

EC

FE

AT

AX

SU

BR

ST

RS

BT

HA

SC

EL

IDX

AUTOMATIC SPEED CONTROL DEVICE (ASCD)

ASCD Wire Adjustment

ASCD Wire Adjustment

=NDEL0100

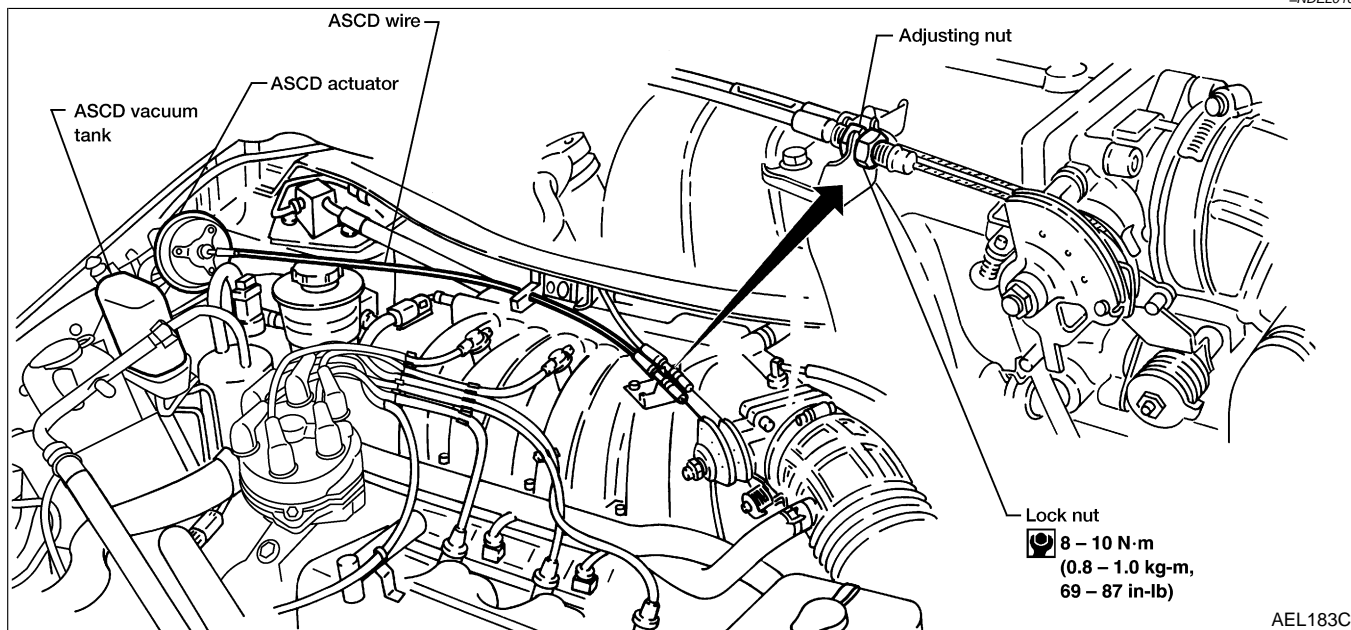

CAUTION:

- Be careful not to twist ASCD wire when removing it.
- Do not tense ASCD wire excessively during adjustment.

Adjust the tension of ASCD wire in the following manner.

1. Loosen lock nut and adjusting nut.
2. Make sure that accelerator wire is properly adjusted. Refer to "ACCELERATOR CONTROL SYSTEM", **FE-3**.
3. Tighten adjusting nut just until throttle drum starts to move.
4. Loosen adjusting nut again 1/2 to 1 turn.
5. Tighten lock nut.

System Description

POWER SUPPLY AND GROUND CIRCUIT

NDEL0101

NDEL0101S01

Power is supplied at all times

- from 7.5A fuse (No. 39, located in the fuse and fusible link box)
- to smart entrance control unit terminal 13 and
- from 30A fusible link (letter f, located in the fuse and fusible link box)
- to circuit breaker-1 terminal 1
- through circuit breaker-1 terminal 2
- to power window relay terminals 5 and 1.

GI

MA

EM

Ground is supplied

- to main power window and door lock/unlock switch terminal 8 and
- to smart entrance control unit terminal 10
- through body grounds M68, M105 and M130.

LC

EC

With the ignition in the ON or START position, power is supplied

- from 10A fuse (No. 30, located in the fuse block)
- to smart entrance control unit terminal 43.

FE

Ground is then supplied to power window relay terminal 2 from smart entrance control unit terminal 30.

With power and ground supplied, the power window relay is energized and power is supplied

- from power window relay terminal 3
- to main power window and door lock/unlock switch terminal 1 and
- to front power window switch RH terminal 5.

AT

AX

When the ignition switch is turned to the OFF position, the power windows will still operate for approximately 15 minutes unless the driver's door is opened. **(Delayed power operation)**

SU

FRONT DOOR LH

Window Up

NDEL0101S02

When the main power window and door lock/unlock switch is pressed in the UP position, power is supplied

- from main power window and door lock/unlock switch terminal 2
- to front power window motor LH terminal 2.

BR

NDEL0101S0201

ST

Ground is supplied

- to front power window motor LH terminal 1
- from main power window and door lock/unlock switch terminal 9.

RS

With power and ground supplied, the front power window motor LH will raise the window until the switch is released.

BT

Window Down

NDEL0101S0202

When the main power window and door lock/unlock switch is pressed in the DOWN position, power is supplied

- from main power window and door lock/unlock switch terminal 9
- to front power window motor LH terminal 1.

HA

SC

Ground is supplied

- to front power window motor LH terminal 2
- from main power window and door lock/unlock switch terminal 2.

EL

With power and ground supplied, the power window motor LH will lower the window until the switch is released.

IDX

Auto Down

NDEL0101S0203

If the main power window and door lock/unlock switch is pressed in the down position for more than three seconds, the auto down circuit will bypass the switch and continue to lower the window until it is completely lowered.

The AUTO feature only operates on the driver's window downward movement.

Power and ground are supplied to the front power window motor LH in the same manner as outlined in "Window Down".

POWER WINDOW

System Description (Cont'd)

FRONT DOOR RH

NDEL0101S03

NOTE:

Figures in parenthesis () refer to terminal Nos. arranged in order when UP or DOWN section of power window switch is pressed.

Operation By Main Switch

NDEL0101S0301

Power is supplied

- from main power window and door lock/unlock switch terminal (7, 6)
- to front power window switch RH terminal (8, 3).

Subsequent operations are the same as those outlined under "Operation By Front Power Window Switch RH".

Operation By Front Power Window Switch RH

NDEL0101S0302

Power is supplied

- from front power window switch RH terminal 5
- Through front power window switch RH terminal (7, 4)
- to front power window motor RH terminal (2, 1).

Ground is supplied

- to front power window motor RH terminal (1, 2)
- through front power window switch RH terminal (4, 7)
- to front power window switch RH terminal (3, 8)
- through main power window and door lock/unlock switch terminal (6, 7)
- to main power window and door lock/unlock switch terminal 8
- through body grounds M68, M105 and M130.

Lock Feature

NDEL0101S0303

If the main power window and door lock/unlock switch window lockout switch is in the LOCK position, the front power window switch RH ground circuit is interrupted. When this happens, the front power window motor RH cannot be operated by the front power window switch RH or the main power window and door lock/unlock switch.

REAR POWER VENT WINDOW LH

NDEL0101S04

NOTE:

Figures in parenthesis () refer to terminal Nos. arranged in order when OPEN or CLOSED section of power window switch is pressed.

When the rear LH vent switch (in main power window and door lock/unlock switch) is pressed in the OPEN-(CLOSE) position, power is supplied

- from main power window and door lock/unlock switch terminal (14, 13)
- to rear power vent window motor LH (1, 2).

Ground is supplied

- to rear power vent window motor (2, 1)
- through main power window and door lock/unlock switch terminal (13, 14)
- to main power window and door lock/unlock switch terminal 8
- through body grounds M68, M105 and M130.

REAR POWER VENT WINDOW RH

NDEL0101S05

Rear power vent window RH operates in the same manner as rear power vent window LH.

POWER WINDOW

Wiring Diagram — WINDOW —

Wiring Diagram — WINDOW —

NDEL0102

EL-WINDOW-01

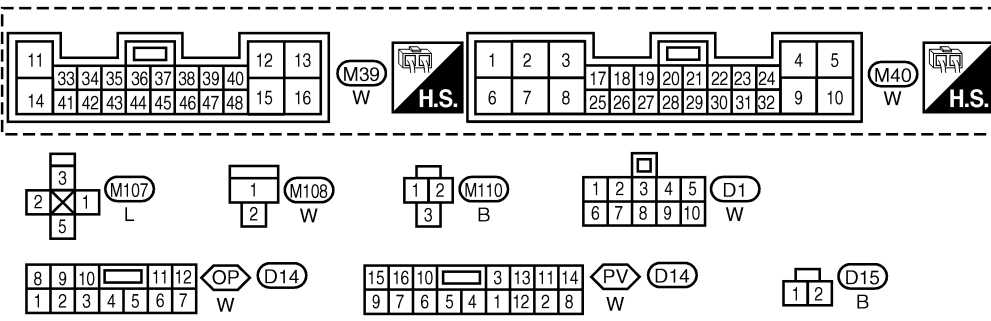
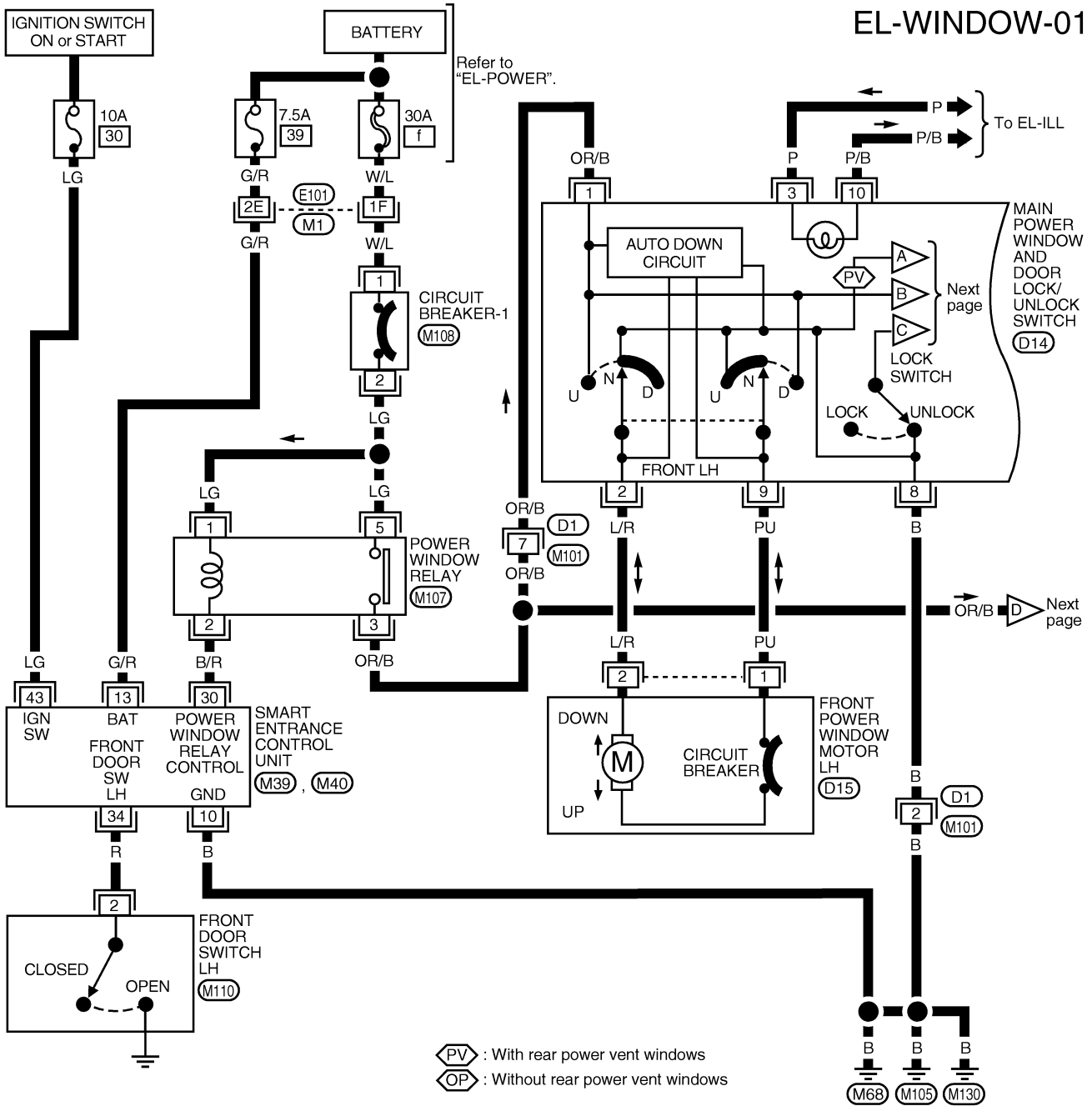

WEL244

POWER WINDOW

Wiring Diagram — WINDOW — (Cont'd)

EL-WINDOW-02

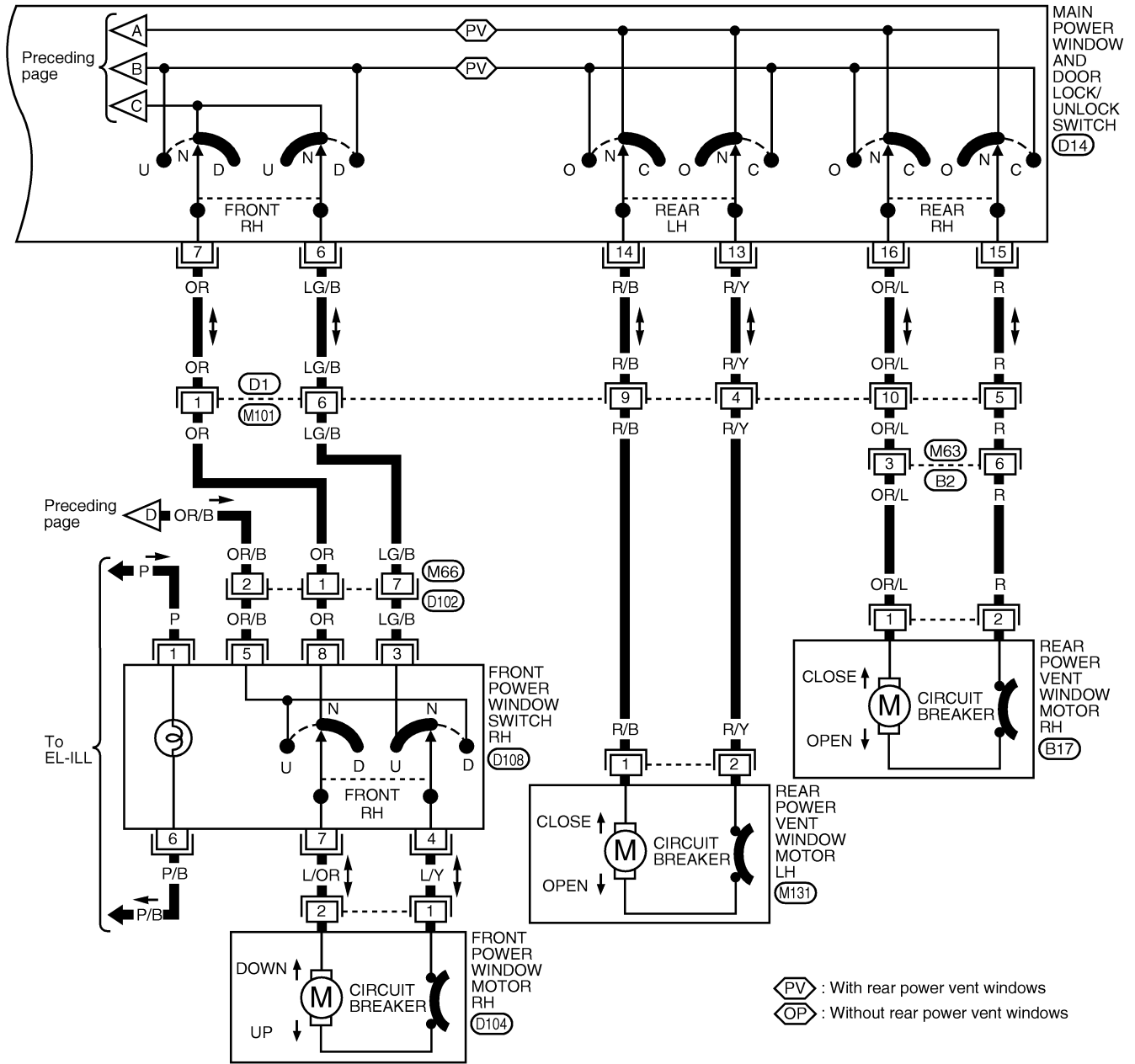

1	2	3
4	5	6

M63
W

1	2
---	---

PV
B

M131

PV
B

B17

D104
B

1	2	3	4	5
6	7	8	9	10

D1
W

D102
W

8	9	10	11	12		
1	2	3	4	5	6	7

OP
W

D14

15	16	10	3	13	11	14		
9	7	6	5	4	1	12	2	8

PV
W

D14

6	7	8		
1	2	3	4	5

D108
W

POWER WINDOW

Trouble Diagnoses

Trouble Diagnoses

NDEL0103

Symptom	Possible cause	Repair order
None of the power windows can be operated using any switch.	<ol style="list-style-type: none"> 7.5A fuse, 10A fuse, 30A fusible link and circuit breaker-1 Grounds M68, M105 and M130 Power window relay Open/short in main power window and door lock/unlock switch circuit 	<ol style="list-style-type: none"> Check 7.5A fuse (No. 39, located in fuse and fusible link box), 10A fuse (No. 30, located in fuse block), 30A fusible link (letter f, located in the fuse and fusible link box) and circuit breaker-1. Turn ignition switch "ON" and verify battery positive voltage is present at terminal 1 of main power window and door lock/unlock, terminal 5 of front power window switch RH. Check grounds M68, M105 and M130. Check power window relay. Check OR/B wire between power window relay and main power window and door lock/unlock switch for open/short circuit.
Driver side power window cannot be operated but other windows can be operated.	<ol style="list-style-type: none"> Driver side (front LH) power window motor circuit Driver side (front LH) power window motor 	<ol style="list-style-type: none"> Check driver side (front LH) power window motor circuit. Check driver side (front LH) power window motor.
Passenger side power window cannot be operated.	<ol style="list-style-type: none"> Power window switch (front RH) Power window motor (front RH) Main power window and door lock/unlock switch Power window circuits 	<ol style="list-style-type: none"> Check power window switch (front RH). Check power window motor (front RH). Check main power window and door lock/unlock switch. Check wires between main power window and door lock/unlock switch, power window switch RH and motor for open/short circuit.
Passenger side power window cannot be operated by main switch but can be operated by passenger's switch.	<ol style="list-style-type: none"> Main power window and door lock/unlock switch 	<ol style="list-style-type: none"> Check main power window and door lock/unlock switch.
One or both rear power vent windows cannot be operated.	<ol style="list-style-type: none"> Main power window and door lock/unlock switch Rear power vent window motors Rear power vent window circuits 	<ol style="list-style-type: none"> Check main power window and door lock/unlock switch. Check rear power vent window motors (LH and RH). Check wires between rear power vent window motors for open or short circuits.

GI

MA

EM

LC

EC

FE

AT

AX

SU

BR

ST

RS

BT

HA

SC

EL

IDX

POWER DOOR LOCK

Component Parts and Harness Connector Location

Component Parts and Harness Connector Location

NDEL0104

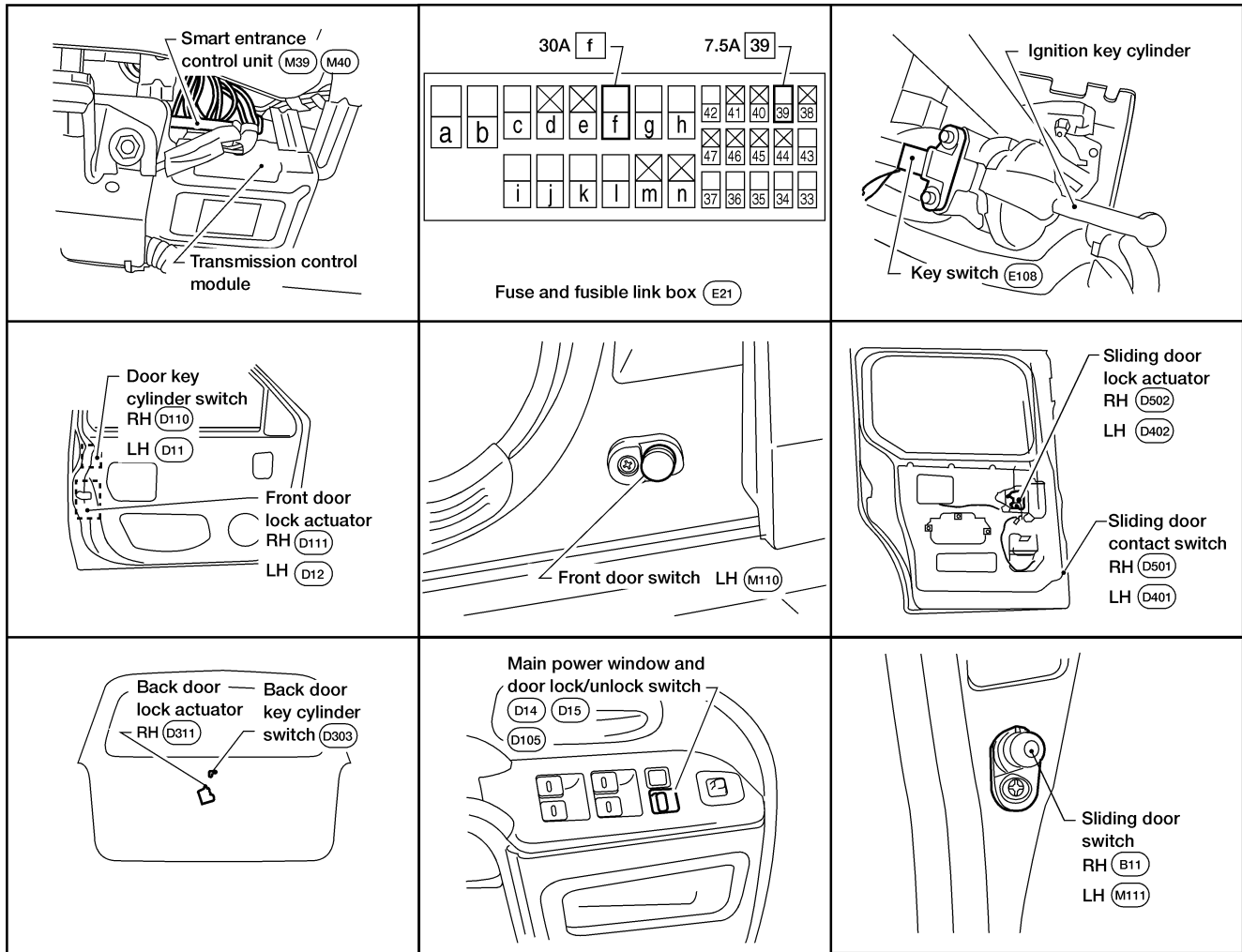

WEL261

System Description

POWER SUPPLY AND GROUND CIRCUIT

NDEL0105

NDEL0105S01

Power is supplied at all times

- through 30A fusible link (letter f, located in the fuse and fusible link box)
- and through circuit breaker-1
- to smart entrance control unit terminal 7
- through 7.5A fuse (No. 39, located in the fuse and fusible link box)
- to smart entrance control unit terminal 13.

Ground is supplied

- to smart entrance control unit terminal 2, 10 and 16

POWER DOOR LOCK

System Description (Cont'd)

- through body grounds M68, M105 and M130.

STANDARD DOOR LOCK/UNLOCK FUNCTION

NDELO105S02

When main power window and door lock/unlock switch or door lock/unlock switch RH is in LOCK position, ground is supplied

- to smart entrance control unit terminal 47
- from main power window and door lock/unlock switch terminal 12 or door lock/unlock switch RH terminal 4
- through body grounds M68, M105 and M130.

Then power and ground is supplied from smart entrance control unit to all door lock actuators to lock all doors. When main power window and door lock/unlock switch or door lock/unlock switch RH is in UNLOCK position, ground is supplied

- to smart entrance control unit terminal 39
- from main power window and door lock/unlock switch terminal 11 or door lock/unlock switch RH terminal 7.

Then power and ground is supplied from smart entrance control unit to all door lock actuators to unlock all doors.

FRONT DOOR KNOB LOCK SWITCH OPERATION

NDELO105S03

When front door knob lock switch LH or RH is in LOCK position, ground is interrupted

- to smart entrance control unit terminal 46 or 37
- from front door lock actuator LH or RH terminal 4.

Then smart entrance control unit supplies power and ground to all door lock actuators to lock all doors.

DOOR KEY CYLINDER OPERATION

NDELO105S04

With key inserted in front door key cylinder switch LH or RH and turned to LOCK, ground is supplied

- to smart entrance control unit terminal 19
- through front door key cylinder switch LH terminal 2 or RH terminal 1
- through body grounds M68, M105 and M130.

Then power and ground is supplied from smart entrance control unit to all door lock actuators to lock all doors. With key inserted in front door key cylinder switch LH or RH or back door key cylinder switch and turned to UNLOCK, ground is supplied

- to smart entrance control unit terminal 27
- through front door key cylinder switch LH terminal 1, RH terminal 2 or back door key cylinder switch terminal 2
- through body grounds M68, M105 and M130 or D204.

Key will unlock only corresponding door. If front door key cylinder switch LH or RH is turned to UNLOCK again within 5 seconds after first unlock operation, then smart entrance control unit supplies power and ground to all door lock actuators to unlock all doors.

KEY REMINDER

NDELO105S05

If both of the following conditions exist, performing any front door lock operation locks the doors once but immediately unlocks them when

- ignition key is in ignition key cylinder (ground is supplied at smart entrance control unit terminal 35)
- either front door is opened (ground is supplied at smart entrance control unit terminal 34 or 9).

Front door lock status is detected by ground supplied from front door lock actuator to smart entrance control unit terminal 46 or 37.

SLIDING DOOR LOCK DELAY FUNCTION

NDELO105S06

If a sliding door is open when a lock operation is performed, that sliding door will not be locked.

If the sliding door is closed after the lock operation is performed, the smart entrance control unit supplies power and ground to all door lock actuators to lock all doors again.

If a mechanical or electrical unlock of either front door is performed before closing sliding door, sliding door delay feature is canceled.

GI

MA

EM

LC

EC

FE

AT

AX

SU

BR

ST

RS

BT

HA

SC

EL

IDX

POWER DOOR LOCK

Schematic

Schematic

NDEL0106

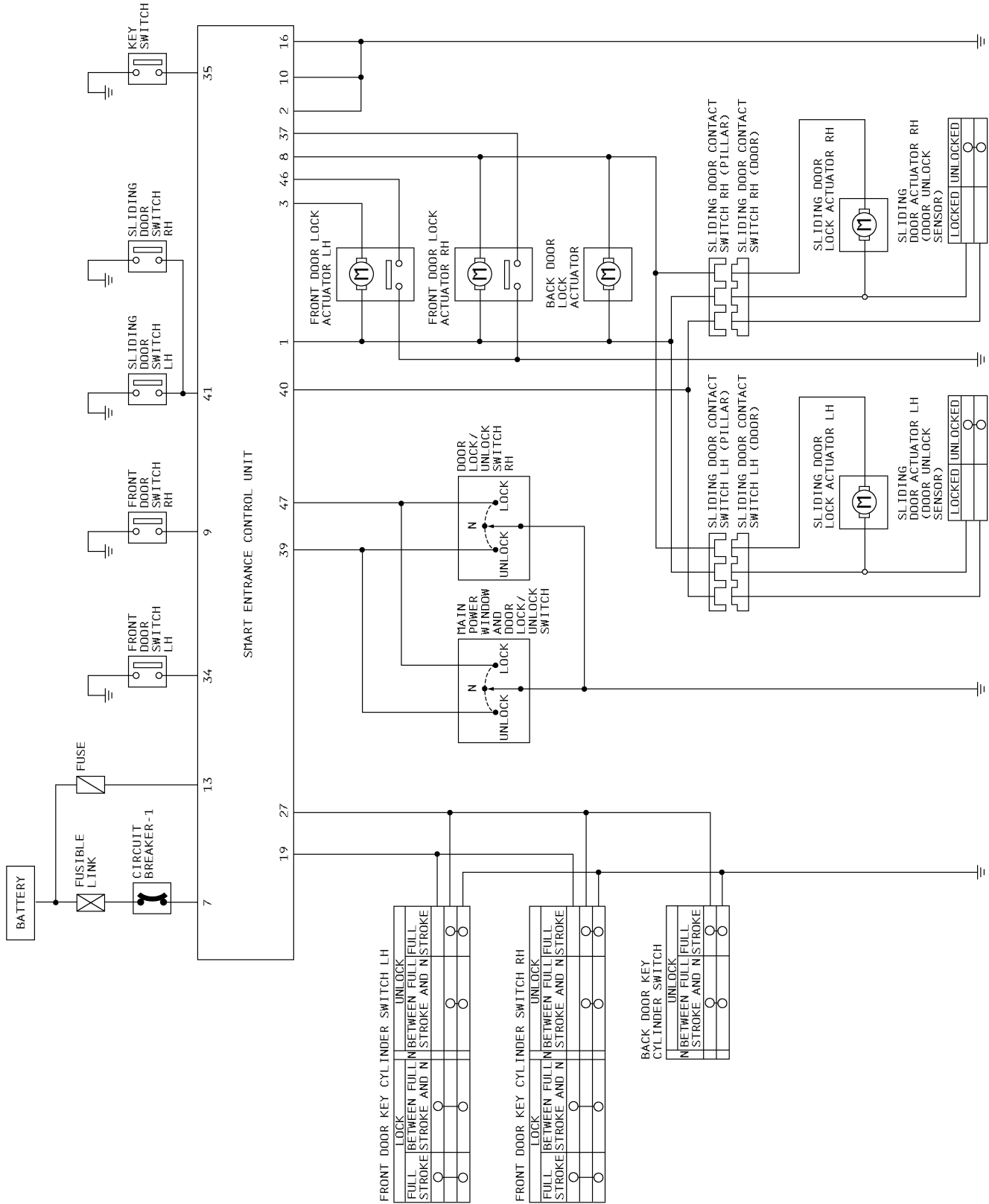

WEL246

POWER DOOR LOCK

Wiring Diagram — D/LOCK —

Wiring Diagram — D/LOCK —

NDEL0107

NDEL0107S01

FIG. 1

EL-D/LOCK-01

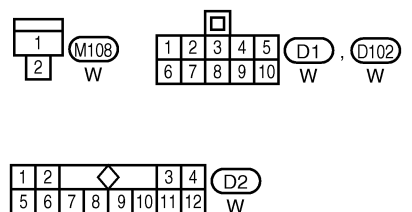
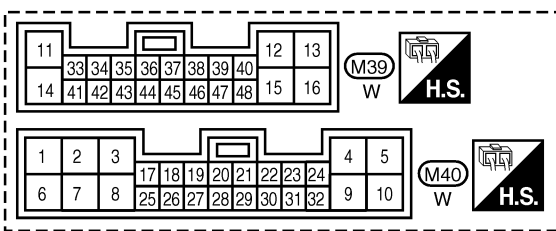
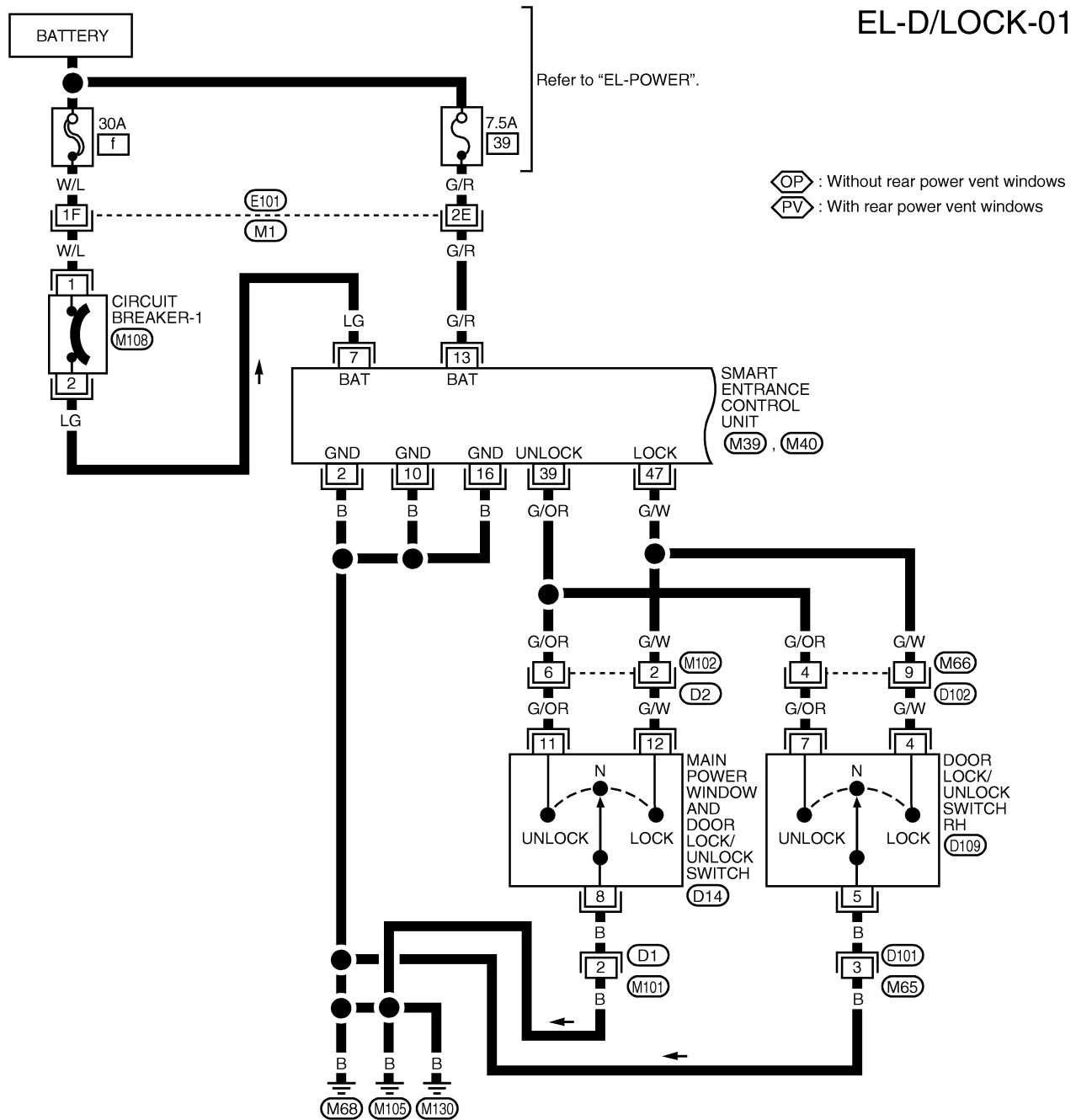

Refer to the following.
 (M1), (E101) - SUPER MULTIPLE JUNCTION (SMJ)

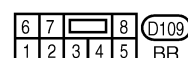
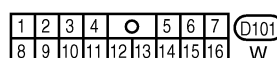
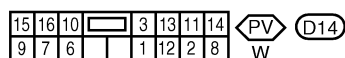
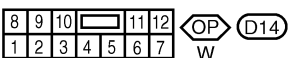

GI
 MA
 EM
 LC
 EC
 FE
 AT
 AX
 SU
 BR
 ST
 RS
 BT
 HA
 SC

EL

IDX

POWER DOOR LOCK

Wiring Diagram — D/LOCK — (Cont'd)

FIG. 2

NDEL0107S02

EL-D/LOCK-02

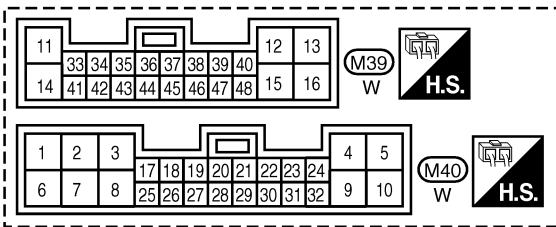
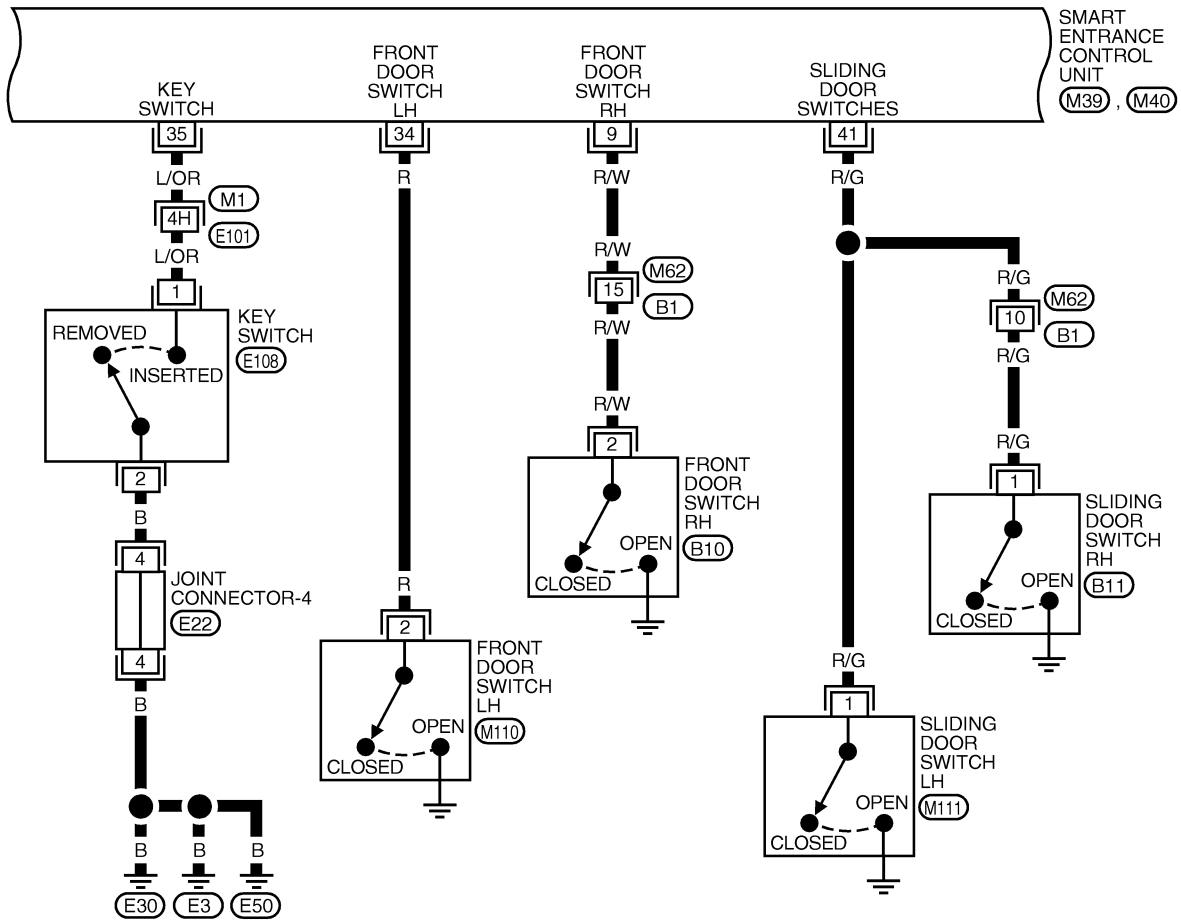

Refer to the following.
 (M1), (E101) - SUPER MULTIPLE JUNCTION (SMJ)
 (E22) - JOINT CONNECTOR

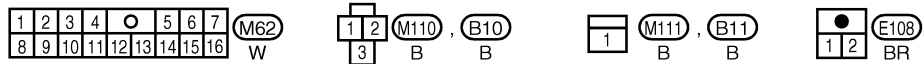

WEL248

POWER DOOR LOCK

Wiring Diagram — D/LOCK — (Cont'd)

FIG. 3

NDEL0107S03

EL-D/LOCK-03

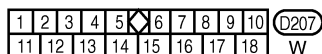
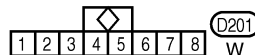
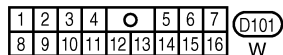
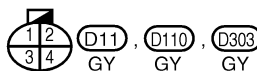
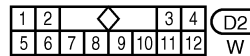
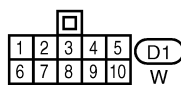
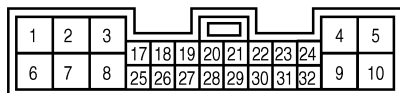
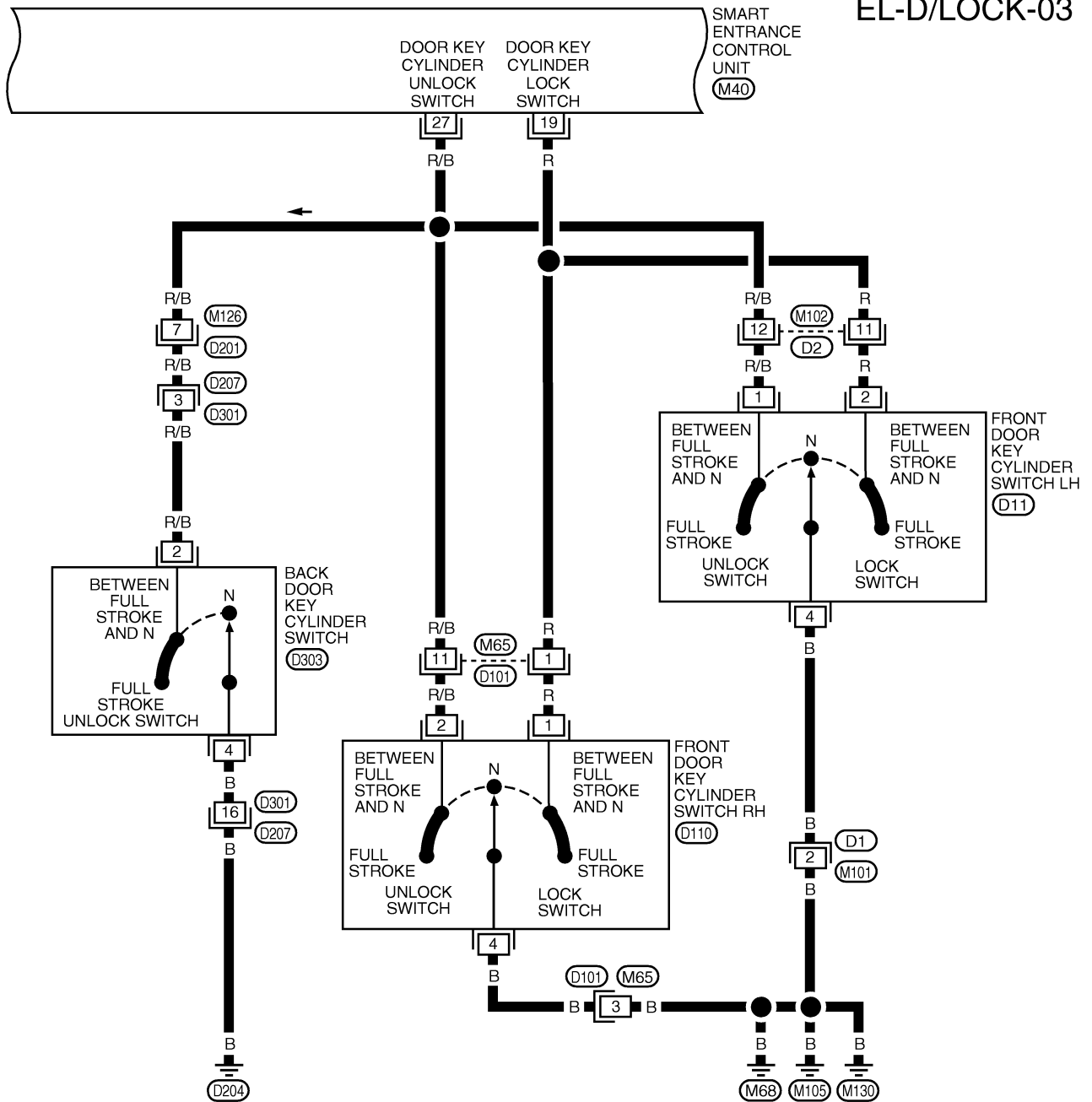

GI
MA
EM
LC
EC
FE
AT
AX
SU
BR
ST
RS
BT
HA
SC

EL

IDX

POWER DOOR LOCK

Wiring Diagram — D/LOCK — (Cont'd)

FIG. 4

NDEL0107S04

EL-D/LOCK-04

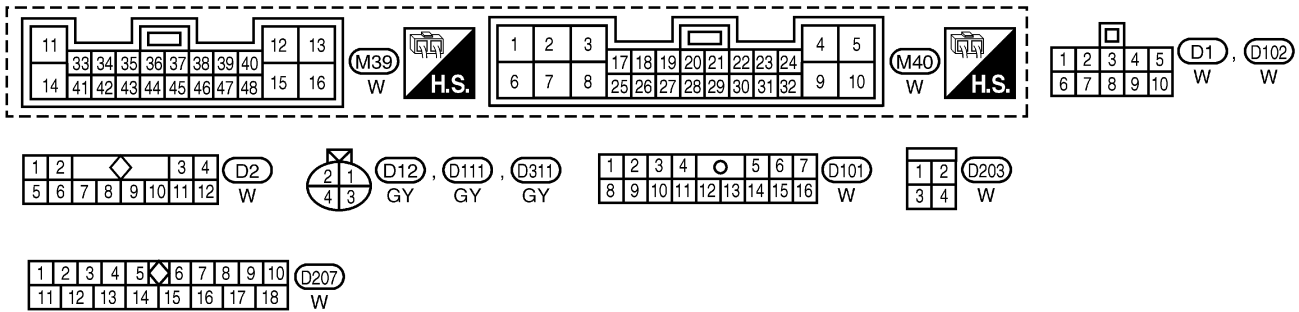
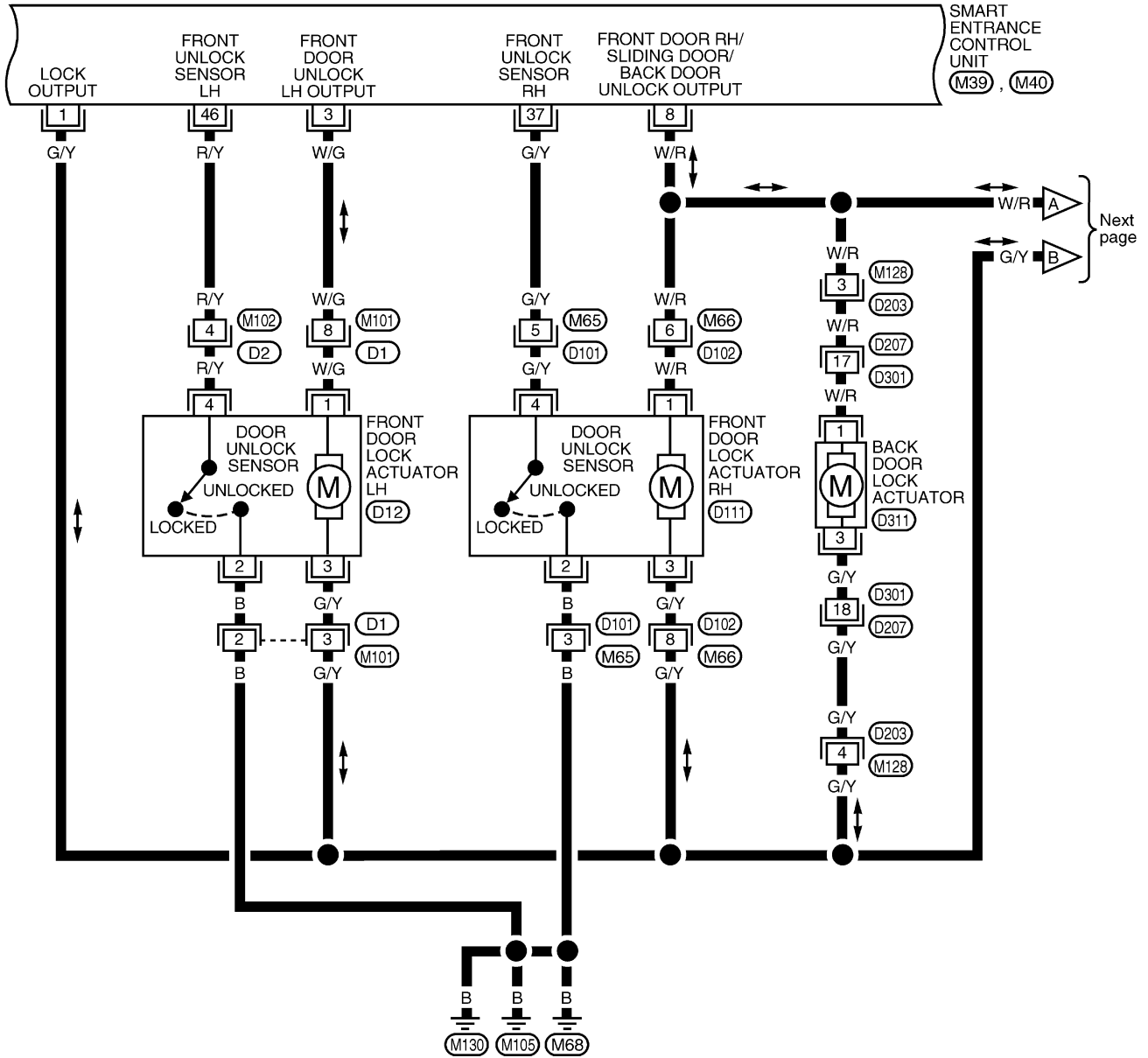

AEL783B

POWER DOOR LOCK

Wiring Diagram — D/LOCK — (Cont'd)

FIG. 5

NDEL0107S05

EL-D/LOCK-05

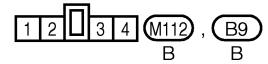
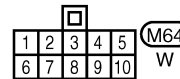
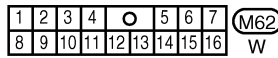
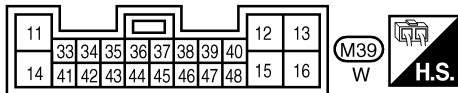
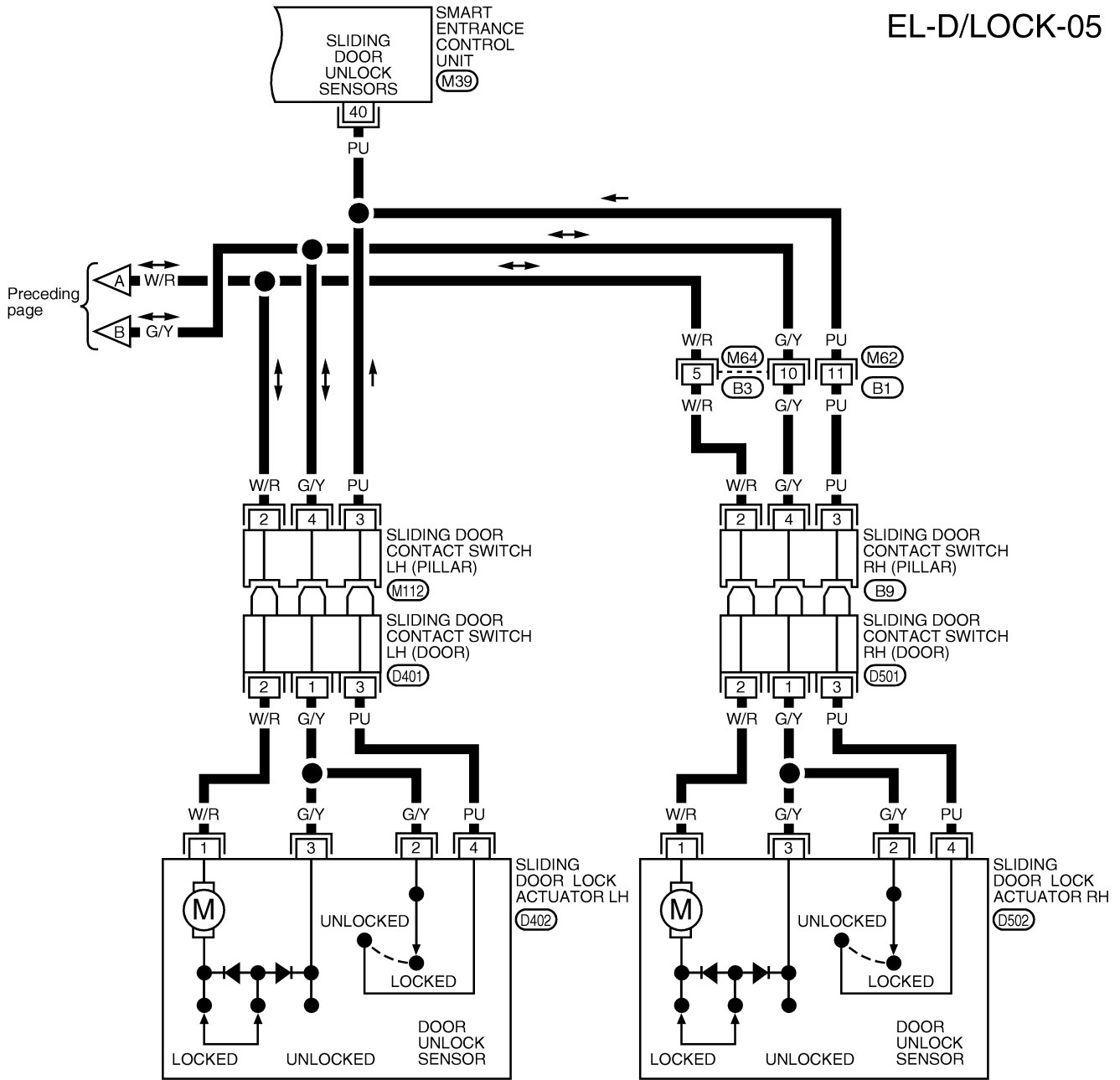

WEL250

POWER DOOR LOCK

Trouble Diagnosis

Trouble Diagnosis SYMPTOM CHART

NDEL0108

NDEL0108S01

REFERENCE PAGE (EL-)	223	224	225	226	227	229	231	232
SYMPTOM	MAIN POWER SUPPLY AND GROUND CIRCUIT CHECK	FRONT DOOR SWITCH CHECK	SLIDING DOOR SWITCH CHECK	KEY SWITCH (INSERTED) CHECK	DOOR LOCK/UNLOCK SWITCH CHECK	DOOR KEY CYLINDER SWITCH CHECK	FRONT DOOR UNLOCK SENSOR CHECK	DOOR LOCK ACTUATOR CHECK
Key reminder door system does not operate properly.	X	X		X			X	X
Specific door lock actuator does not operate properly.	X							X
Power door lock/unlock does not operate with door lock and unlock switch on power window main switch.	X				X			
Power door lock/unlock does not operate with front door key cylinder operation.	X					X		
Power door unlock does not operate with back door key cylinder operations.	X					X		
Power door lock does not operate with front door lock knob switch.	X						X	
Sliding door lock delay feature does not operate properly.	X		X					

POWER DOOR LOCK

Trouble Diagnosis (Cont'd)

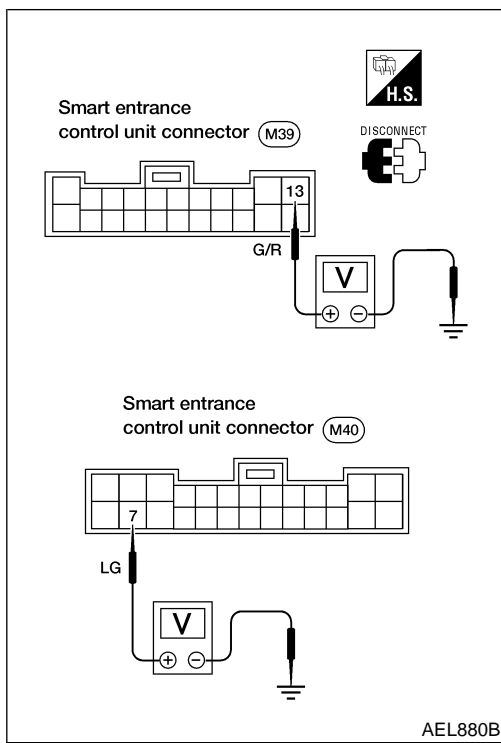

AEL880B

MAIN POWER SUPPLY AND GROUND CIRCUIT CHECK

NDEL0108S02

Main Power Supply Circuit Check

NDEL0108S0201

Terminal		Ignition switch position		
(+)	(-)	OFF	ACC	ON
13	Ground	Battery voltage	Battery voltage	Battery voltage
7	Ground	Battery voltage	Battery voltage	Battery voltage

If check result for terminal 13 is NG, check the following

- 7.5A fuse (No. 39, located in the fuse and fusible link box)
- Harness for open or short between smart entrance control unit and fuse.

If check result for terminal 7 is NG, check the following

- 30A fusible link (letter f, located in the fuse and fusible link box)
- Circuit breaker-1
- Harness for open or short between smart entrance control unit and fusible link.

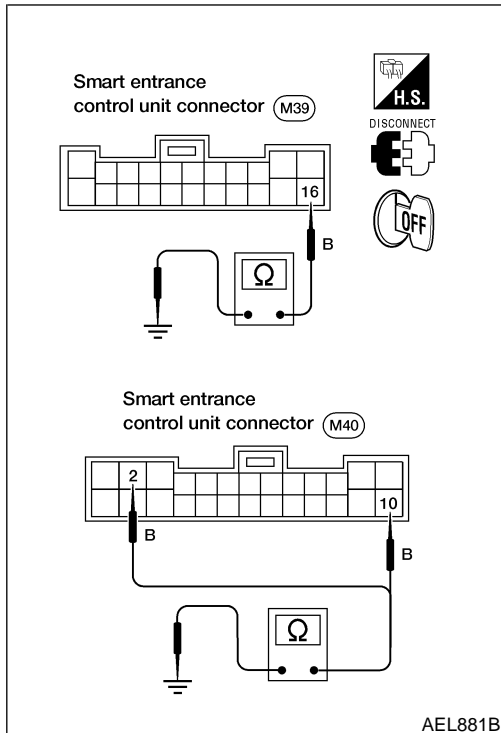

AEL881B

Ground Circuit Check

NDEL0108S0202

Terminals		Continuity
(+)	(-)	
2	Ground	Yes
10	Ground	Yes
16	Ground	Yes

GI

MA

EM

LC

EC

FE

AT

AX

SU

BR

ST

RS

BT

HA

SC

EL

IDX

POWER DOOR LOCK

Trouble Diagnosis (Cont'd)

FRONT DOOR SWITCH CHECK

=NDEL0108S03

1 CHECK FRONT DOOR SWITCH INPUT SIGNAL

Check voltage between smart entrance control unit terminals 34 or 9 and ground.

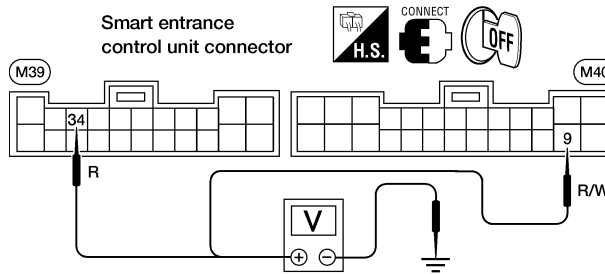

AEL882B

	Terminals		Door condition	Voltage [V] (Approx.)
	(+)	(-)		
Front door switch LH	34	Ground	Open	0
			Closed	1.5
Front door switch RH	9	Ground	Open	0
			Closed	1.5

WEL548A

OK or NG

OK	▶	Door switch is OK.
NG	▶	GO TO 2.

2 CHECK FRONT DOOR SWITCH

Check continuity between terminal 2 and switch body.

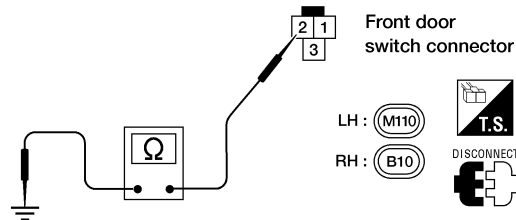

AEL884B

Continuity
Door switch is pushed.
No
Door switch is released
Yes

OK or NG

OK	▶	Check the following <ul style="list-style-type: none"> ● Door switch ground condition ● Harness for open or short between smart entrance control unit and door switch.
NG	▶	Replace door switch.

POWER DOOR LOCK

Trouble Diagnosis (Cont'd)

SLIDING DOOR SWITCH CHECK

NDEL0108S04

1	CHECK SLIDING DOOR SWITCH INPUT SIGNAL	<p>Check voltage between smart entrance control unit terminal 41 and ground.</p> <div style="text-align: center;"> </div> <p style="text-align: right;">AEL887B</p> <p>Voltage [V]: Either sliding door is opened. 0 Both sliding doors are closed. Approx. 1.5</p> <p style="text-align: center;">OK or NG</p>	GI MA EM LC EC FE AT AX
OK	▶	Sliding door switch is OK.	
NG	▶	GO TO 2.	

2	CHECK SLIDING DOOR SWITCH	<p>Check continuity between sliding door switch terminal 1 and switch body.</p> <div style="text-align: center;"> </div> <p style="text-align: right;">AEL888B</p> <p>Continuity: Sliding door switch is pushed. No Sliding door switch is released. Yes</p> <p style="text-align: center;">OK or NG</p>	SU BR ST RS BT HA SC EL IDX
OK	▶	Check the following <ul style="list-style-type: none"> ● Sliding door switch ground condition ● Harness for open or short between smart entrance control unit and sliding door switch. 	
NG	▶	Replace sliding door switch.	

POWER DOOR LOCK

Trouble Diagnosis (Cont'd)

KEY SWITCH (INSERTED) CHECK

=NDEL0108S05

1	CHECK KEY SWITCH INPUT SIGNAL
<p>Check voltage between smart entrance control unit terminal 35 and ground.</p> <div style="text-align: center;"> <p>Smart entrance control unit connector (M39)</p> <p>L/OR</p> <p>V</p> <p>CONNECT H.S.</p> <p>: 0V</p> <p>: Approx. 12V</p> </div> <p>Voltage [V]: Condition of key switch: Key is inserted. 0 Condition of key switch: Key is removed. Approx. 1.5</p> <p style="text-align: right;">AEL874B</p> <p style="text-align: center;">OK or NG</p>	
OK	▶ Key switch is OK.
NG	▶ GO TO 2.

2	CHECK KEY SWITCH (INSERTED)
<p>Check continuity between key switch terminals 1 and 2.</p> <div style="text-align: center;"> <p>Key switch connector (E108)</p> <p>Ω</p> <p>DISCONNECT T.S.</p> </div> <p>Continuity: Condition of key switch: Key is inserted. Yes Condition of key switch: Key is removed. No</p> <p style="text-align: right;">AEL875B</p> <p style="text-align: center;">OK or NG</p>	
OK	▶ Check the following <ul style="list-style-type: none"> ● Key switch ground circuit ● Harness for open or short between smart entrance control unit and key switch.
NG	▶ Replace key switch.

POWER DOOR LOCK

Trouble Diagnosis (Cont'd)

DOOR LOCK/UNLOCK SWITCH CHECK

=NDEL0108S06

1 CHECK DOOR LOCK/UNLOCK SWITCH INPUT SIGNAL

1. Disconnect smart entrance control unit connector.
2. Check continuity between control unit terminal 39 or 47 and ground.

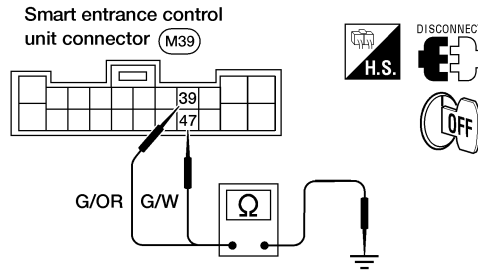

AEL889B

Terminals	Door lock/unlock switch (LH or RH) condition	Continuity
47 - ground	Lock	Yes
	N and Unlock	No
39 - ground	Unlock	Yes
	N and Lock	No

AEL890B

Refer to wiring diagram, EL-217.

OK or NG

OK	▶	Door lock/unlock switch is OK.
NG	▶	GO TO 2.

GI

MA

EM

LC

EC

FE

AT

AX

SU

BR

ST

RS

BT

HA

SC

EL

IDX

POWER DOOR LOCK

Trouble Diagnosis (Cont'd)

2 CHECK DOOR LOCK/UNLOCK SWITCH

1. Disconnect door lock/unlock switch connector.
 2. Check continuity between door lock/unlock switch terminals.
- Main power window and door lock/unlock switch (Door lock/unlock switch LH)

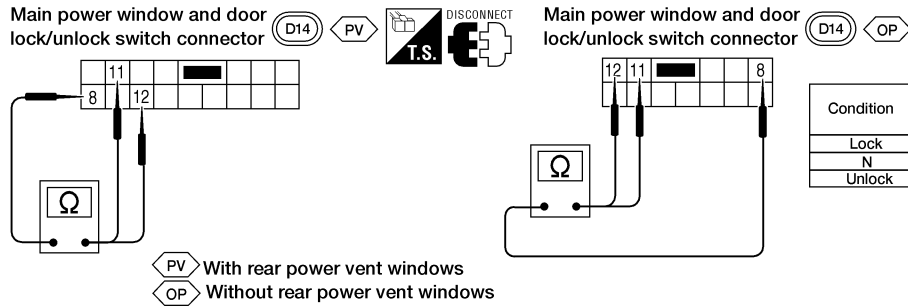

Condition	Terminals		
	8	11	12
Lock	○	○	○
N	No continuity		
Unlock	○	○	○

WEL656

- Door lock/unlock switch RH

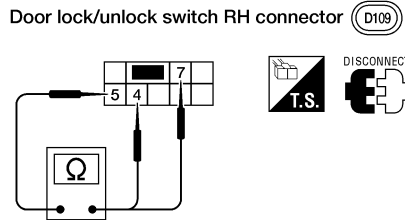

AEL893B

Condition	Terminals		
	5	4	7
Lock	○	○	○
N	No continuity		
Unlock	○	○	○

AEL894B

OK or NG

OK



Check the following

- Ground circuit for door lock/unlock switch
- Harness for open or short between smart entrance control unit and door lock/unlock switch.

NG



Replace door lock/unlock switch.

POWER DOOR LOCK

Trouble Diagnosis (Cont'd)

DOOR KEY CYLINDER SWITCH CHECK

=NDEL0108S10

1 CHECK DOOR KEY CYLINDER SWITCH INPUT SIGNAL (LOCK/UNLOCK SIGNAL)

Check voltage between control unit terminals 19 or 27 and ground.

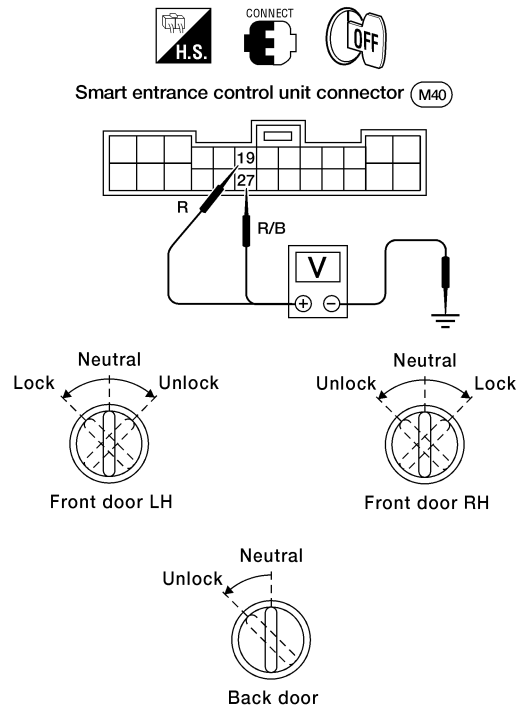

AEL927B

Terminals		Key position	Voltage [V] (Approx.)
(+)	(-)		
19	Ground	Neutral	1.5
		Lock	0
27	Ground	Neutral	1.5
		Unlock	0

Refer to wiring diagram, EL-219.

WEL549A

OK or NG

OK ► Door key cylinder switch is OK.

NG ► GO TO 2.

GI

MA

EM

LC

EC

FE

AT

AX

SU

BR

ST

RS

BT

HA

SC

EL

IDX

POWER DOOR LOCK

Trouble Diagnosis (Cont'd)

2 CHECK DOOR KEY CYLINDER SWITCH

1. Disconnect door key cylinder switch connector.
2. Check continuity between door key cylinder switch terminals.



Door key cylinder switch connector

Front LH : (D11) Front RH : (D110) Back : (D303)

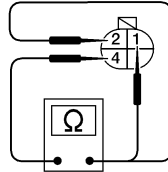

- ① : Door unlock switch terminal (Front LH)
Door lock switch terminal (Front RH)
- ② : Door lock switch terminal (Front LH)
Door unlock switch terminal (Front RH and back)
- ④ : Ground terminal

WEL316

Terminals	Key position	Continuity
Front LH: 2 - 4	Neutral	No
Front RH: 1 - 4	Lock	Yes
Front LH: 1 - 4	Neutral	No
Front RH: 2 - 4	Unlock	Yes
Back: 2 - 4	Unlock	Yes

AEL930B

OK or NG

OK



Check the following

- Door key cylinder switch ground circuit
- Harness for open or short between control unit and door key cylinder switch.

NO



Replace door key cylinder switch.

POWER DOOR LOCK

Trouble Diagnosis (Cont'd)

FRONT DOOR UNLOCK SENSOR CHECK

=NDEL0108S08

GI
MA
EM
LC
EC
FE
AT
AX
SU
BR
ST
RS
BT
HA
SC
EL
IDX

1 CHECK DOOR UNLOCK SENSOR INPUT SIGNAL

Check voltage between control unit terminals 46 or 37 and ground.

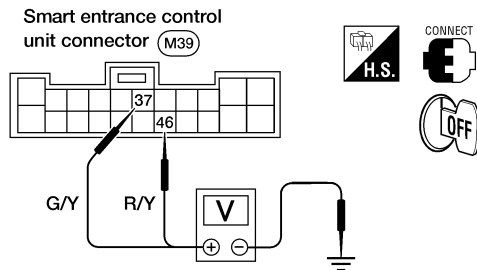

AEL895B

	Terminals		Condition	Voltage [V] (Approx.)
	(+)	(-)		
Front LH door	46	Ground	Locked	1.5
			Unlocked	0
Front RH door	37	Ground	Locked	1.5
			Unlocked	0

WEL550A

Refer to wiring diagram, EL-220.

OK or NG

OK ► Door unlock sensor is OK.

NG ► GO TO 2.

2 CHECK DOOR UNLOCK SENSOR

1. Disconnect front door lock actuator connector.
2. Check continuity between door unlock sensor terminals 4 and 2.

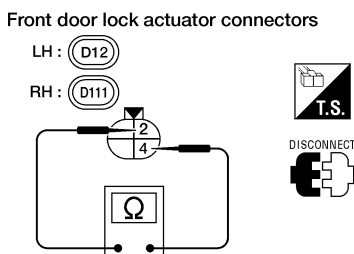

AEL897B

Continuity:
Condition: Locked
 No
Condition: Unlocked
 Yes

OK or NG

OK ► **Check the following**

- Door unlock sensor ground circuit
- Harness for open or short between smart entrance control unit and door unlock sensor.

NG ► Replace front door lock actuator.

POWER DOOR LOCK

Trouble Diagnosis (Cont'd)

DOOR LOCK ACTUATOR CHECK

=NDEL0108S09

1 CHECK DOOR LOCK ACTUATOR CIRCUIT

Check voltage for door lock actuator.

- Front door lock actuator LH

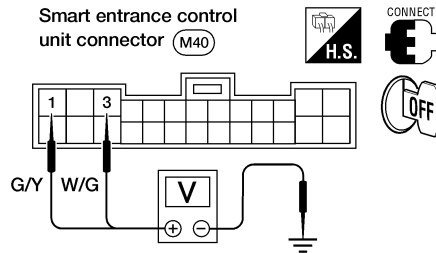

AEL898B

Door lock/unlock switch condition	Terminal No.		Voltage [V]
	(+)	(-)	
Lock	1	ground	Approx. 12
Unlock	3	ground	

AEL900B

- Front door lock actuator RH, sliding door lock actuator LH and RH, and back door lock actuator

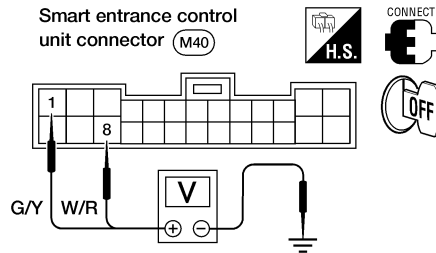

AEL901B

Door lock/unlock switch condition	Terminals		Voltage [V]
	(+)	(-)	
Lock	1	ground	Approx. 12
Unlock	8	ground	

AEL902B

Refer to wiring diagrams, EL-220.

OK or NG

OK	▶	GO TO 2.
NG	▶	Replace smart entrance control unit. (Before replacing smart entrance control unit, perform "DOOR LOCK/UNLOCK SWITCH CHECK", EL-232.)

POWER DOOR LOCK

Trouble Diagnosis (Cont'd)

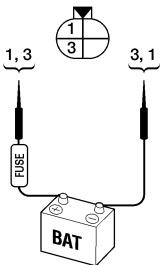
2	CHECK DOOR LOCK ACTUATOR
	<p>1. Disconnect door lock actuator connector. 2. Apply 12V direct current to door lock actuator and check operation.</p> <div style="display: flex; align-items: center;"> <div style="margin-right: 20px;">  </div> <div style="margin-right: 20px;">  </div> <div> <p>Door lock actuator connector</p> <p>Front LH : (D12)</p> <p>Front RH : (D111)</p> <p>Sliding LH : (D402)</p> <p>Sliding RH : (D502)</p> <p>Back : (D311)</p> </div> </div> <p>Door lock actuator operation: Terminals between (+): 3 and (-): 1 Unlocked → Locked Terminals between (+): 1 and (-): 3 Locked → Unlocked</p> <p style="text-align: center;">OK or NG</p>
OK	▶ Check harness for open or short between smart entrance control unit connector and door lock actuator.
NG	▶ Replace door lock actuator.

AEL903B

GI

MA

EM

LC

EC

FE

AT

AX

SU

BR

ST

RS

BT

HA

SC

EL

IDX

MULTI-REMOTE CONTROL SYSTEM

Component Parts and Harness Connector Location

Component Parts and Harness Connector Location

NDEL0109

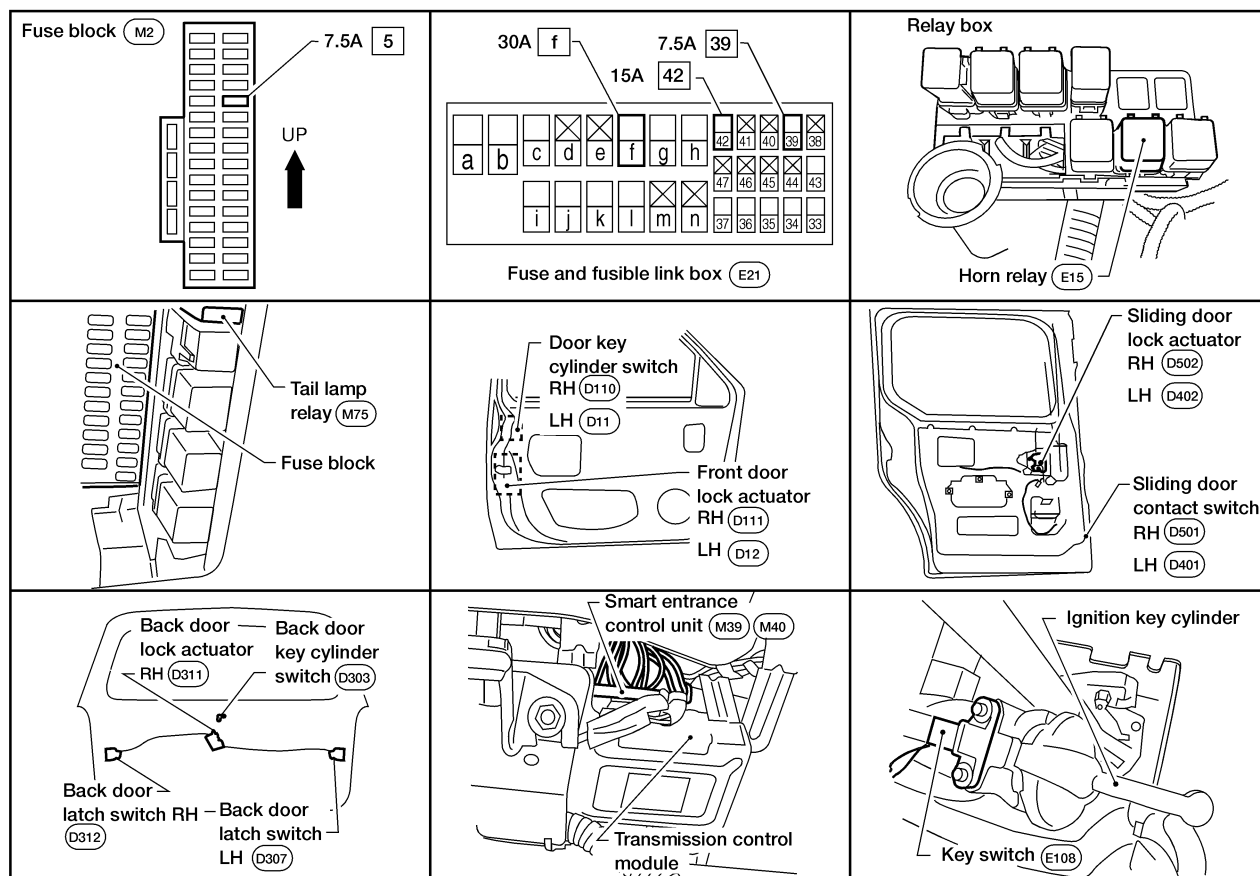

WEL262

System Description

INPUTS

When the key switch is ON (ignition key is inserted in the key cylinder), ground is supplied

- Through key switch terminal 1
- to smart entrance control unit terminal 35.

When the front door switch LH is OPEN, ground is supplied

- to smart entrance control unit terminal 34
- through front door switch LH terminal 2
- through front door switch LH body ground.

When the front door switch RH is OPEN, ground is supplied

- to smart entrance control unit terminal 9
- through front door switch RH body ground.

When the sliding door switches are OPEN, ground is supplied

- to smart entrance control unit terminal 41
- through the sliding door switches body grounds.

When either back door latch is OPEN, ground is supplied

- to smart entrance control unit terminal 24
- through body ground D204.

NDEL0110

NDEL0110S01

MULTI-REMOTE CONTROL SYSTEM

System Description (Cont'd)

Remote controller signal is inputted to the smart entrance control unit (The antenna of the system is combined with smart entrance control unit).

The multi-remote control system controls operation of the

- power door lock
- interior lamp
- panic alarm
- door lock verification
- automatic drive positioner

OPERATED PROCEDURE

Power Door Lock Operation

Smart entrance control unit receives a LOCK signal from remote controller. Smart entrance control unit locks all doors with input of LOCK signal from remote controller.

When an UNLOCK signal is sent from remote controller once, front door LH will unlocked.

Then, if an UNLOCK signal is sent from remote controller again within 5 seconds, all other doors will be unlocked.

Door Lock Verification

Power is supplied at all times

- to tail lamp relay terminals 2 and 3
- to horn relay terminals 2 and 3
- through 15A fuse (No. 42, located in the fusible link and fuse box).

When smart entrance control unit receives LOCK or UNLOCK signal from remote controller with all doors closed, ground is supplied

- to tail lamp relay terminal 1
- through smart entrance control unit terminal 26, and
- to horn relay terminal 1
- through smart entrance control unit terminal 21

Tail lamp relay and horn relay are now energized, and side marker, tail, and license lamps flash and horn sounds as a reminder (if horn chirp function is activated).

The hazard and horn reminder has a horn chirp mode and a non-horn chirp mode.

Operating function of door lock verification

	Horn chirp mode		Non-horn chirp mode	
	Side marker, tail and license lamps flash	Horn sound	Side Marker, tail and license lamps flash	Horn sound
Lock	Twice	Once	Twice	—
Unlock	Once	—	—	—

How to change door lock verification mode

When LOCK and UNLOCK signals are sent from the remote controller for more than 2 seconds at the same time, the door lock verification mode is changed and hazard warning lamp flashes and horn sounds as follows:

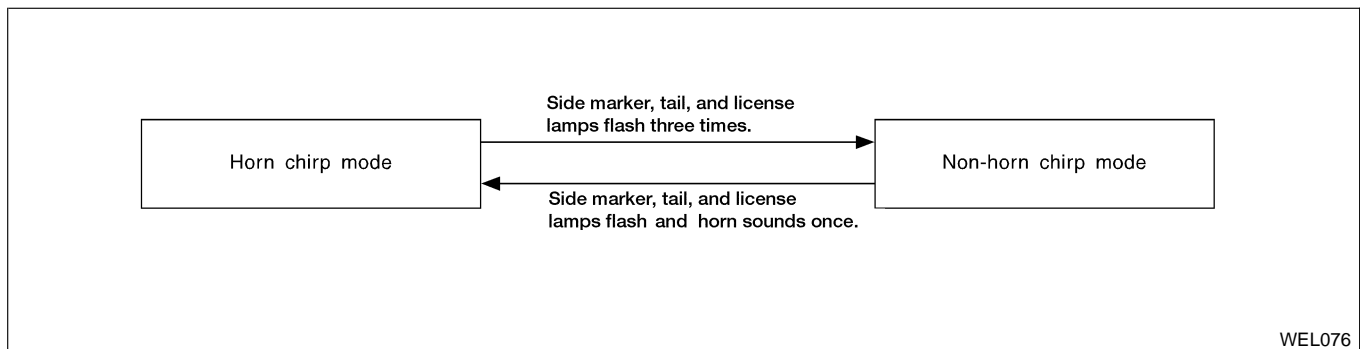

WEL076

GI

MA

EM

NDEL0110S08

LC

NDEL0110S0801

EC

FE

NDEL0110S0802

AT

AX

SU

BR

ST

RS

BT

HA

SC

EL

IDX

MULTI-REMOTE CONTROL SYSTEM

System Description (Cont'd)

Interior Lamp Operation

NDEL0110S0803

When the following input signals are both supplied:

- door switch CLOSED (when all doors are closed);
- front door LH LOCKED;

multi-remote control system turns on interior lamp (for 30 seconds) with input of UNLOCK signal from remote controller.

For detailed description, refer to "INTERIOR ROOM LAMP", EL-72.

Panic Alarm Operation

NDEL0110S0804

Multi-remote control system turns on and off horn and headlamp intermittently with input of PANIC ALARM signal from remote controller.

For detailed description, refer to "THEFT WARNING SYSTEM", EL-253.

MULTI-REMOTE CONTROL SYSTEM

Schematic

Schematic

NDEL0111

GI

MA

EM

LC

EC

FE

AT

AX

SU

BR

ST

RS

BT

HA

SC

EL

IDX

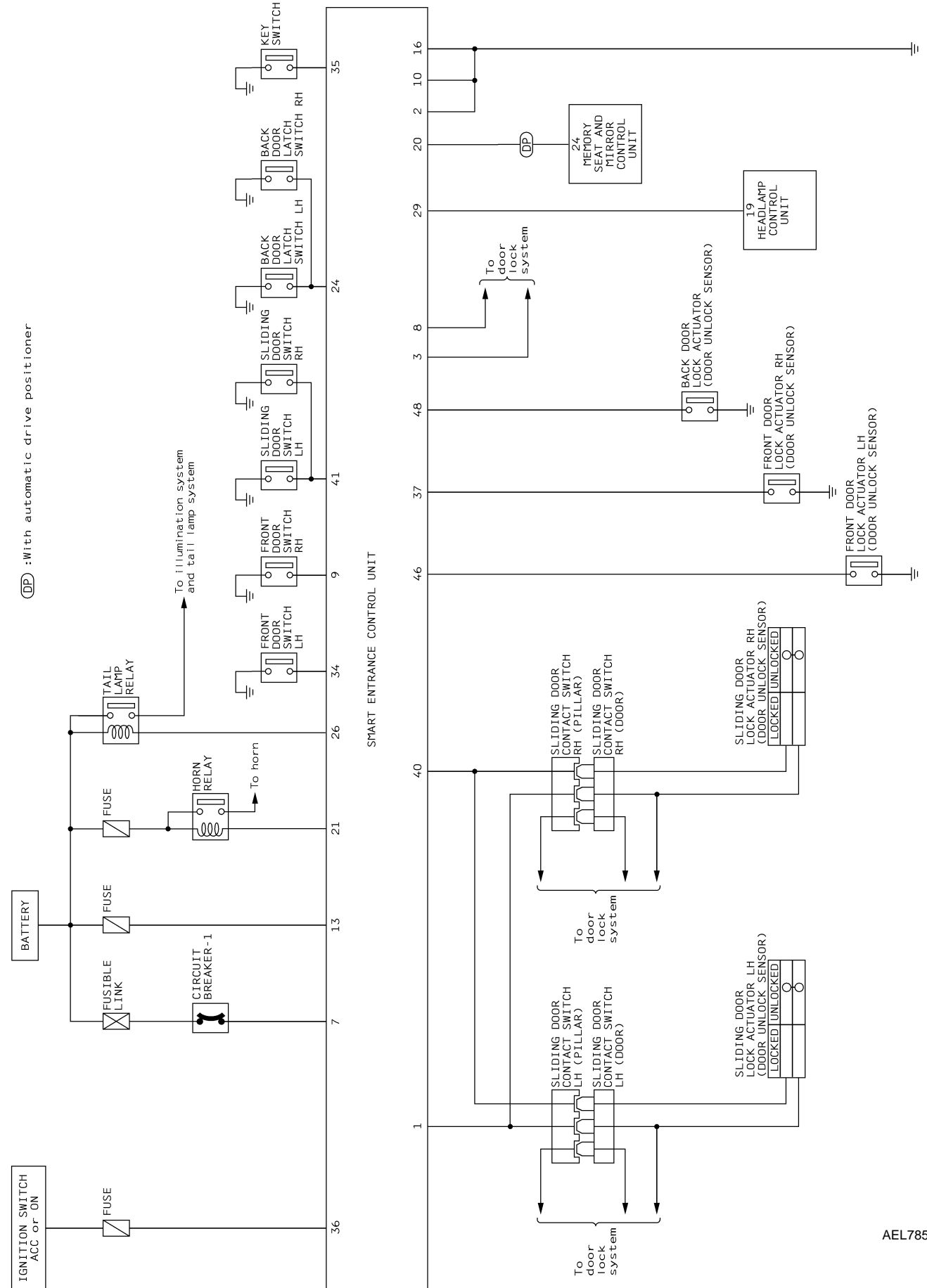

MULTI-REMOTE CONTROL SYSTEM

Wiring Diagram — MULTI —

Wiring Diagram — MULTI —

NDEL0112

NDEL0112S01

FIG. 1

EL-MULTI-01

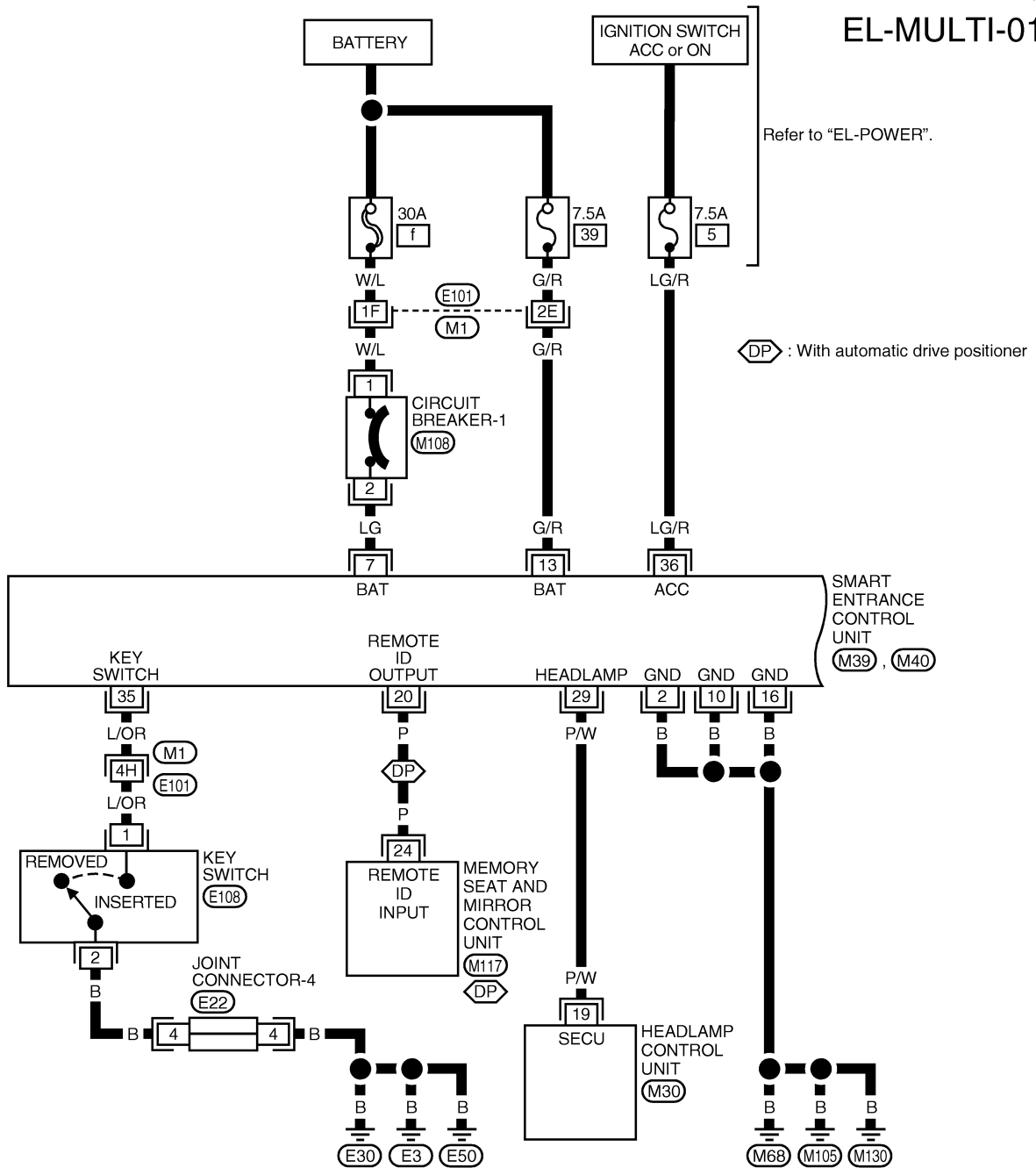

Refer to "EL-POWER".

⬠DP⬠ : With automatic drive positioner

SMART ENTRANCE CONTROL UNIT (M39, M40)

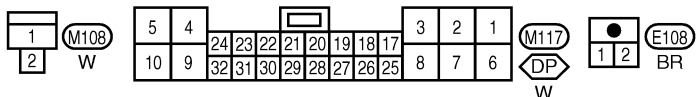
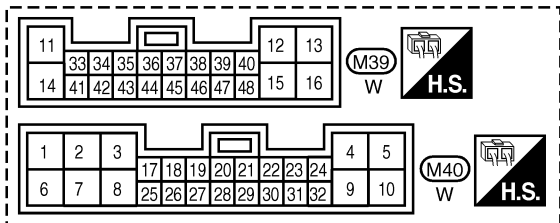
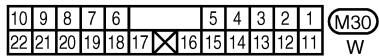

Refer to the following.

⬠M1⬠, ⬠E101⬠ SUPER MULTIPLE JUNCTION (SMJ)

⬠E22⬠ JOINT CONNECTOR

WEL077

MULTI-REMOTE CONTROL SYSTEM

Wiring Diagram — MULTI — (Cont'd)

FIG. 2

NDEL0112S02

EL-MULTI-02

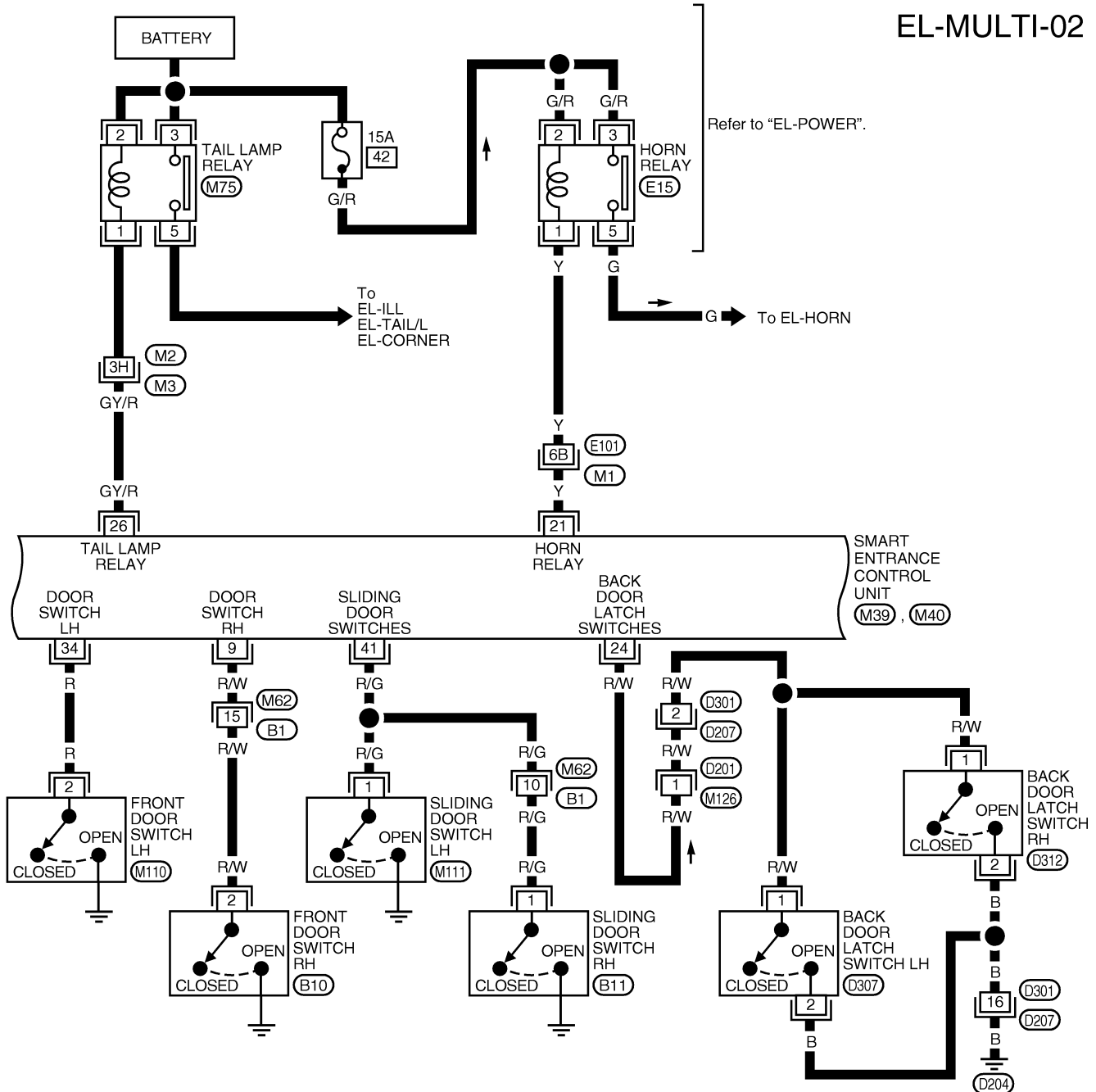

Refer to "EL-POWER".

Refer to the following.
 (M1), (E101) SUPER MULTIPLE JUNCTION (SMJ)

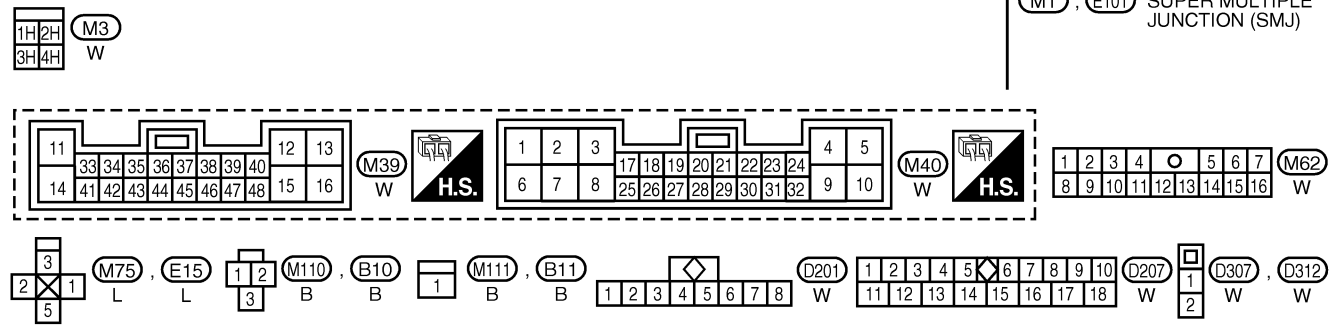

WEL078

MULTI-REMOTE CONTROL SYSTEM

Wiring Diagram — MULTI — (Cont'd)

FIG. 3

NDEL0112S03

EL-MULTI-03

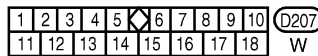
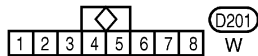
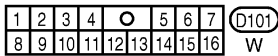
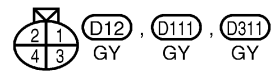
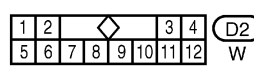
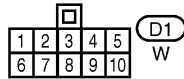
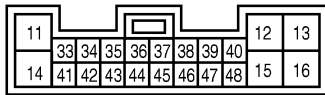
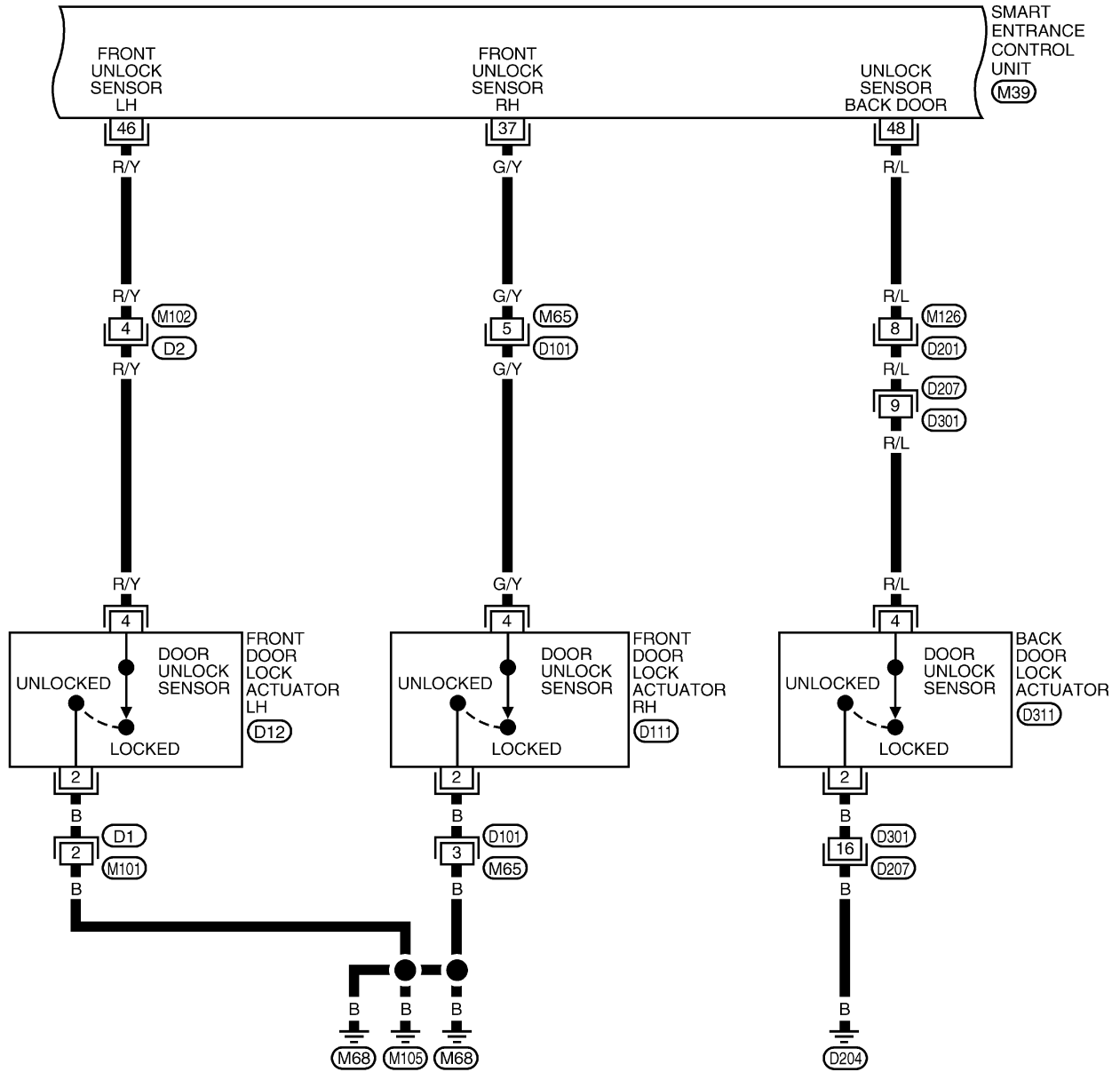

AEL788B

MULTI-REMOTE CONTROL SYSTEM

Wiring Diagram — MULTI — (Cont'd)

FIG. 4

NDEL0112S04

EL-MULTI-04

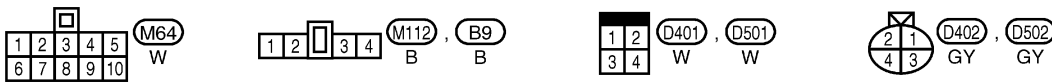
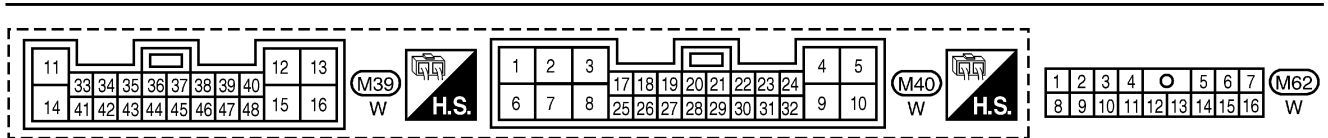
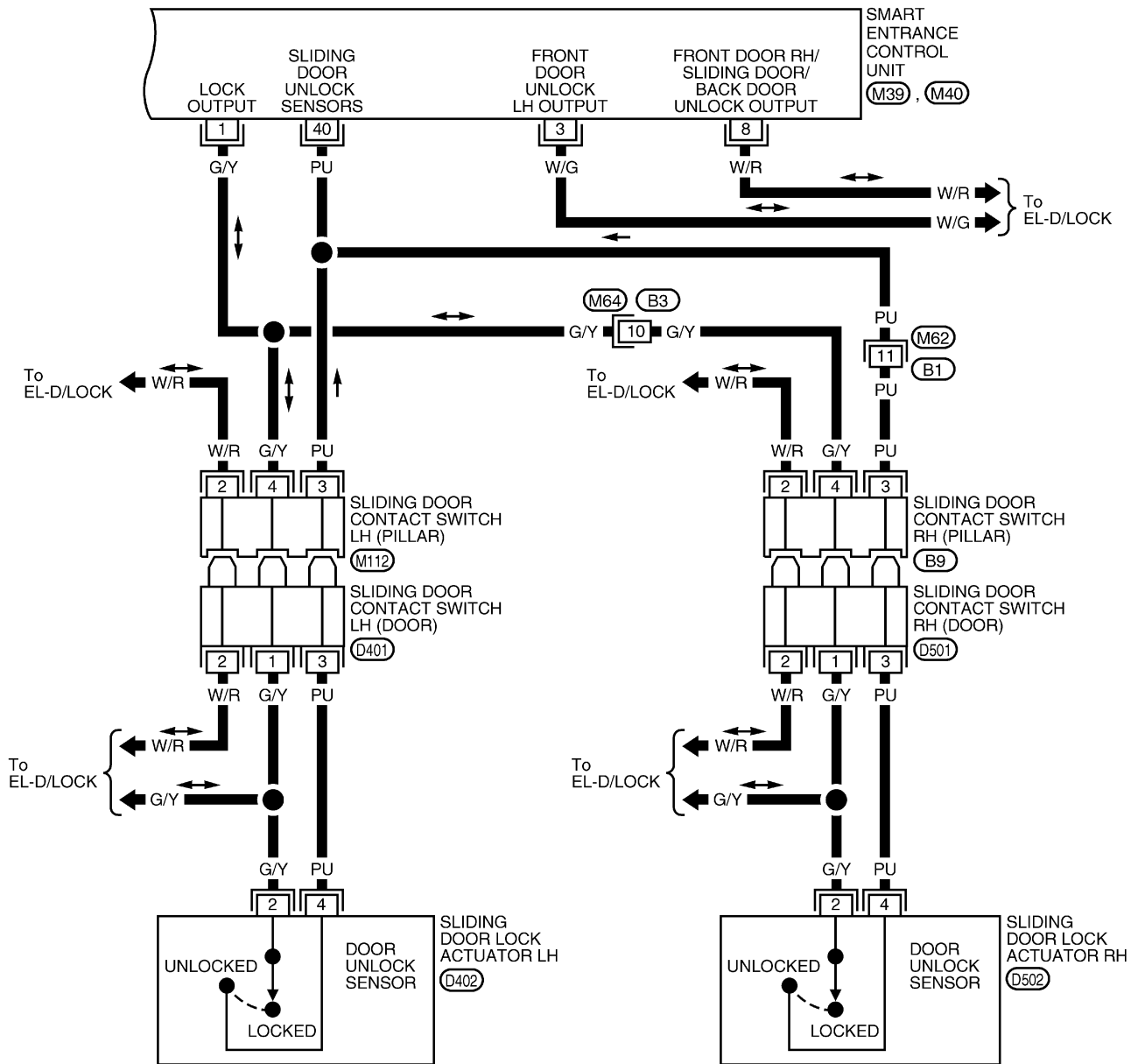

AEL789B

MULTI-REMOTE CONTROL SYSTEM

Trouble Diagnoses

Trouble Diagnoses SYMPTOM CHART

NDEL0113

NDEL0113S01

NOTE:

- Always check the remote controller battery before replacing remote controller.

Symptom	Diagnoses/service procedure	Reference page
All functions of multi-remote control system do not operate.	1. Remote controller battery check	EL-243
	2. Power supply and ground circuit for smart entrance control unit check	EL-244
	3. Replace remote controller. Refer to ID Code Entry Procedure.	EL-251
Remote controller ID code cannot be entered.	1. Remote controller battery check	EL-243
	2. Key switch (inserted) check	EL-248
	3. Door switch check	EL-246
	4. Door unlock sensor check	EL-249
	5. Power supply and ground circuit for smart entrance control unit check	EL-244
	6. Replace remote controller. Refer to ID Code Entry Procedure.	EL-251
Door lock or unlock does not function. (If the power door lock system does not operate manually, check power door lock system. Refer to EL-222.)	1. Replace remote controller. Refer to ID Code Entry Procedure.	EL-251
Side marker lamps, tail lamps, license lamps and interior illumination do not flash when pressing lock or unlock button of remote controller.	1. Tail lamp relay check	EL-250
	2. Door unlock sensor check	EL-249
	3. Replace remote controller. Refer to ID Code Entry Procedure.	EL-251
Horn does not chirp when pressing lock button of remote controller.	1. Check horn chirp setting. Refer to "System Description".	EL-235
	2. Check door unlock sensor. Refer to "DOOR UNLOCK SENSOR CHECK".	EL-249
	3. Check theft warning operation. Refer to "PRELIMINARY CHECK" in "THEFT WARNING SYSTEM".	EL-266
	4. Replace remote controller. Refer to ID Code Entry Procedure.	EL-251
Panic alarm (horn and headlamps) does not activate when panic alarm button is continuously pressed more than 1.5 seconds.	1. Theft warning operation check. Refer to "PRELIMINARY CHECK" in "THEFT WARNING SYSTEM".	EL-266
	2. Replace remote controller. Refer to ID Code Entry Procedure.	EL-251

MULTI-REMOTE CONTROL SYSTEM

Trouble Diagnoses (Cont'd)

REMOTE CONTROLLER BATTERY CHECK

-NDEL0113S02

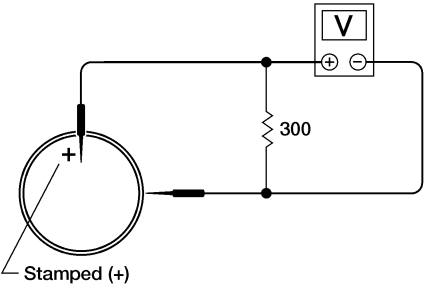
1	CHECK REMOTE CONTROLLER BATTERY	
Remove battery (refer to EL-252) and measure voltage across battery positive and negative terminals, (+) and (-).		
		
<p>Voltage [V]: 2.5 - 3.0</p> <p>NOTE: Remote controller does not function if battery is not installed correctly.</p> <p style="text-align: center;">OK or NG</p>		
OK	▶	Check remote controller battery terminals for corrosion and damage.
NG	▶	Replace battery.

AEL678A

GI

MA

EM

LC

EC

FE

AT

AX

SU

BR

ST

RS

BT

HA

SC

EL

IDX

MULTI-REMOTE CONTROL SYSTEM

Trouble Diagnoses (Cont'd)

POWER SUPPLY AND GROUND CIRCUIT CHECK

=NDEL0113S03

1	CHECK MAIN POWER SUPPLY CIRCUIT FOR SMART ENTRANCE CONTROL UNIT	
<p>1. Disconnect connector from smart entrance control unit. 2. Check voltage between smart entrance control unit terminal 13 and ground.</p>		
<p>Refer to wiring diagram, EL-238.</p> <p style="text-align: right;">AEL906B</p>		
Does battery voltage exist?		
Yes	▶	GO TO 2.
No	▶	<p>Check the following</p> <ul style="list-style-type: none"> ● 7.5A fuse (No. 39, located in the fuse and fusible link box) ● Harness for open or short between smart entrance control unit and fuse.

2	CHECK IGNITION SWITCH ACC CIRCUIT	
<p>1. Disconnect smart entrance control unit connector. 2. Check voltage between smart entrance control unit terminal 36 and ground with ignition switch in ACC.</p>		
<p>Refer to wiring diagram, EL-238.</p> <p style="text-align: right;">AEL907B</p>		
Does battery voltage exist?		
Yes	▶	GO TO 3.
No	▶	<p>Check the following</p> <ul style="list-style-type: none"> ● 7.5A fuse (No. 5, located in fuse block) ● Harness for open or short between smart entrance control unit and fuse.

MULTI-REMOTE CONTROL SYSTEM

Trouble Diagnoses (Cont'd)

3	CHECK GROUND CIRCUIT FOR SMART ENTRANCE CONTROL UNIT	
<p>Check continuity between smart entrance control unit terminals 2, 10, 16 and ground.</p> <div style="text-align: center;"> <p>Smart entrance control unit connector (M39)</p> </div> <div style="text-align: center;"> <p>Smart entrance control unit connector (M40)</p> </div> <p>Refer to wiring diagram, EL-238.</p> <p style="text-align: right;">AEL881B</p>		
Does continuity exist?		
Yes	▶	Power supply and ground circuits are OK.
No	▶	Check ground harness.

GI

MA

EM

LC

EC

FE

AT

AX

SU

BR

ST

RS

BT

HA

SC

EL

IDX

MULTI-REMOTE CONTROL SYSTEM

Trouble Diagnoses (Cont'd)

DOOR SWITCH CHECK

=NDEL0113S04

1 CHECK DOOR SWITCH INPUT SIGNAL

Check voltage between smart entrance control unit terminals and ground.

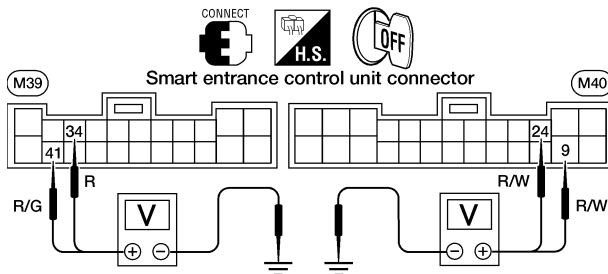

AEL869B

	Terminals		Door condition	Voltage [V] (Approx.)
	(+)	(-)		
Front door switch LH	34	Ground	Open	0
			Closed	1.5
Front door switch RH	9	Ground	Open	0
			Closed	1.5
Sliding door switch LH and RH	41	Ground	Open	0
			Closed	1.5
Back door latch switch LH and RH	24	Ground	Open	0
			Closed	1.5

WEL547A

Refer to wiring diagram, EL-239.

OK or NG

OK	▶	Door switch is OK.
NG	▶	GO TO 2.

MULTI-REMOTE CONTROL SYSTEM

Trouble Diagnoses (Cont'd)

2 CHECK DOOR SWITCH

1. Disconnect door switch connector.
2. Check continuity as indicated.

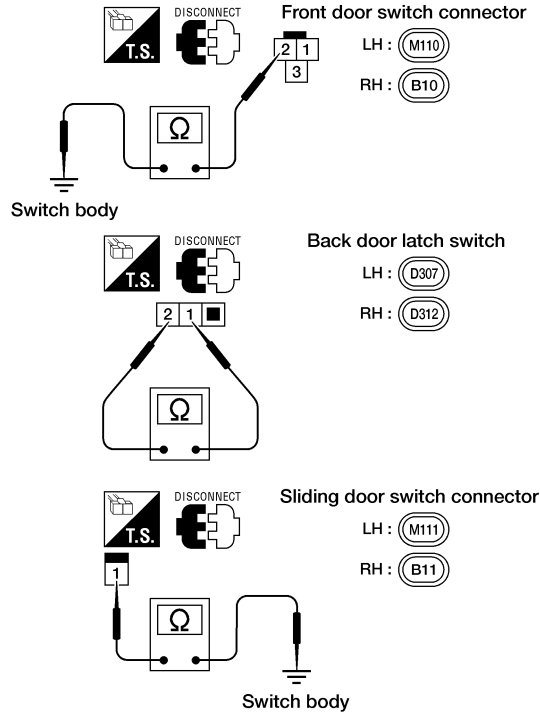

AEL910B

	Terminals	Door Condition	Continuity
Front door switch LH and RH	2 - ground	Closed	No
		Open	Yes
Back door latch switch LH and RH	1 - 2	Closed	No
		Open	Yes
Sliding door switch LH and RH	1 - ground	Closed	No
		Open	Yes

AEL911B

OK or NG

OK



Check the following

- Door switch ground circuit (back door latch switch) or door switch ground condition
- Harness for open or short between smart entrance control unit and door switch.

NG



Replace door switch.

GI

MA

EM

LC

EC

FE

AT

AX

SU

BR

ST

RS

BT

HA

SC

EL

IDX

MULTI-REMOTE CONTROL SYSTEM

Trouble Diagnoses (Cont'd)

KEY SWITCH (INSERTED) CHECK

=NDEL0113S05

1	CHECK KEY SWITCH INPUT SIGNAL
<p>Check voltage between control unit terminal 35 and ground.</p> <div style="text-align: center;"> </div> <p style="text-align: right;">AEL874B</p> <p>Voltage [V]: Condition of key switch: Key is inserted. 0 Condition of key switch: Key is removed. Approx. 1.5</p> <p>Refer to wiring diagram in EL-238.</p> <p style="text-align: center;">OK or NG</p>	
OK	▶ Key switch is OK.
NG	▶ GO TO 2.

2	CHECK KEY SWITCH (INSERTED)
<p>Check continuity between terminals 1 and 2.</p> <div style="text-align: center;"> </div> <p style="text-align: right;">AEL875B</p> <p>Continuity: Condition of key switch: Key is inserted. Yes Condition of key switch: Key is removed. No</p> <p style="text-align: center;">OK or NG</p>	
OK	▶ Check the following <ul style="list-style-type: none"> ● Key switch ground circuit ● Harness for open or short between smart entrance control unit and key switch.
NG	▶ Replace key switch.

MULTI-REMOTE CONTROL SYSTEM

Trouble Diagnoses (Cont'd)

DOOR UNLOCK SENSOR CHECK

=NDEL0113S06

1 CHECK DOOR UNLOCK SENSOR INPUT SIGNAL

Check voltage between smart entrance control unit terminals and ground.

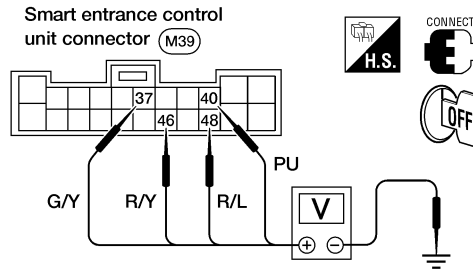

AEL912B

	Terminals		Condition	Voltage [V] (Approx.)
	(+)	(-)		
Front door LH	46	Ground	Locked	1.5
			Unlocked	0
Front door RH	37	Ground	Locked	1.5
			Unlocked	0
Sliding door LH and RH	40	Ground	Locked	1.5
			Unlocked	0
Back door	48	Ground	Locked	1.5
			Unlocked	0

Refer to wiring diagrams, EL-240, 241.

WEL551A

OK or NG

OK	▶	Door unlock sensor is OK.
NG	▶	GO TO 2.

2 CHECK DOOR UNLOCK SENSOR

1. Disconnect door unlock sensor connector.
2. Check continuity between door unlock sensor terminals.

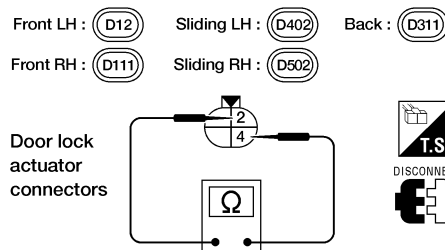

AEL914B

Continuity:
Condition: Locked
 No
Condition: Unlocked
 Yes

OK or NG

OK	▶	Check the following <ul style="list-style-type: none"> • Door unlock sensor ground circuit (front door LH/RH and back door) • Harness for open or short between smart entrance control unit and door unlock sensor.
NG	▶	Replace door unlock sensor.

GI

MA

EM

LC

EC

FE

AT

AX

SU

BR

ST

RS

BT

HA

SC

EL

IDX

MULTI-REMOTE CONTROL SYSTEM

Trouble Diagnoses (Cont'd)

TAIL LAMP RELAY CHECK

=NDEL0113S07

1	CHECK TAIL LAMP OPERATION	
Do tail lamps illuminate with lighting switch operation?		
Yes	▶	Check harness for open or short between smart entrance control unit and tail lamp relay.
No	▶	GO TO 2.

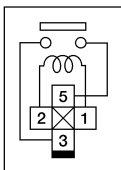
2	CHECK TAIL LAMP RELAY	
1. Apply 12V DC direct current between relay terminals 1 and 2. 2. Check continuity between relay terminals 3 and 5.		
		
AEL916B		
<p>Continuity: 12V applied Yes No voltage applied No</p> <p style="text-align: center;">OK or NG</p>		
OK	▶	GO TO 3.
NG	▶	Replace relay.

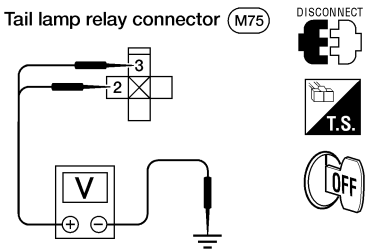
3	CHECK TAIL LAMP RELAY POWER SUPPLY	
Check voltage between tail lamp relay terminals 2, 3 and ground.		
		
AEL917B		
Does battery voltage exist?		
Yes	▶	Check tail lamp circuits.
No	▶	Check harness between tail lamp relay and battery.

MULTI-REMOTE CONTROL SYSTEM

ID Code Entry Procedure

NDEL0114

ID Code Entry Procedure

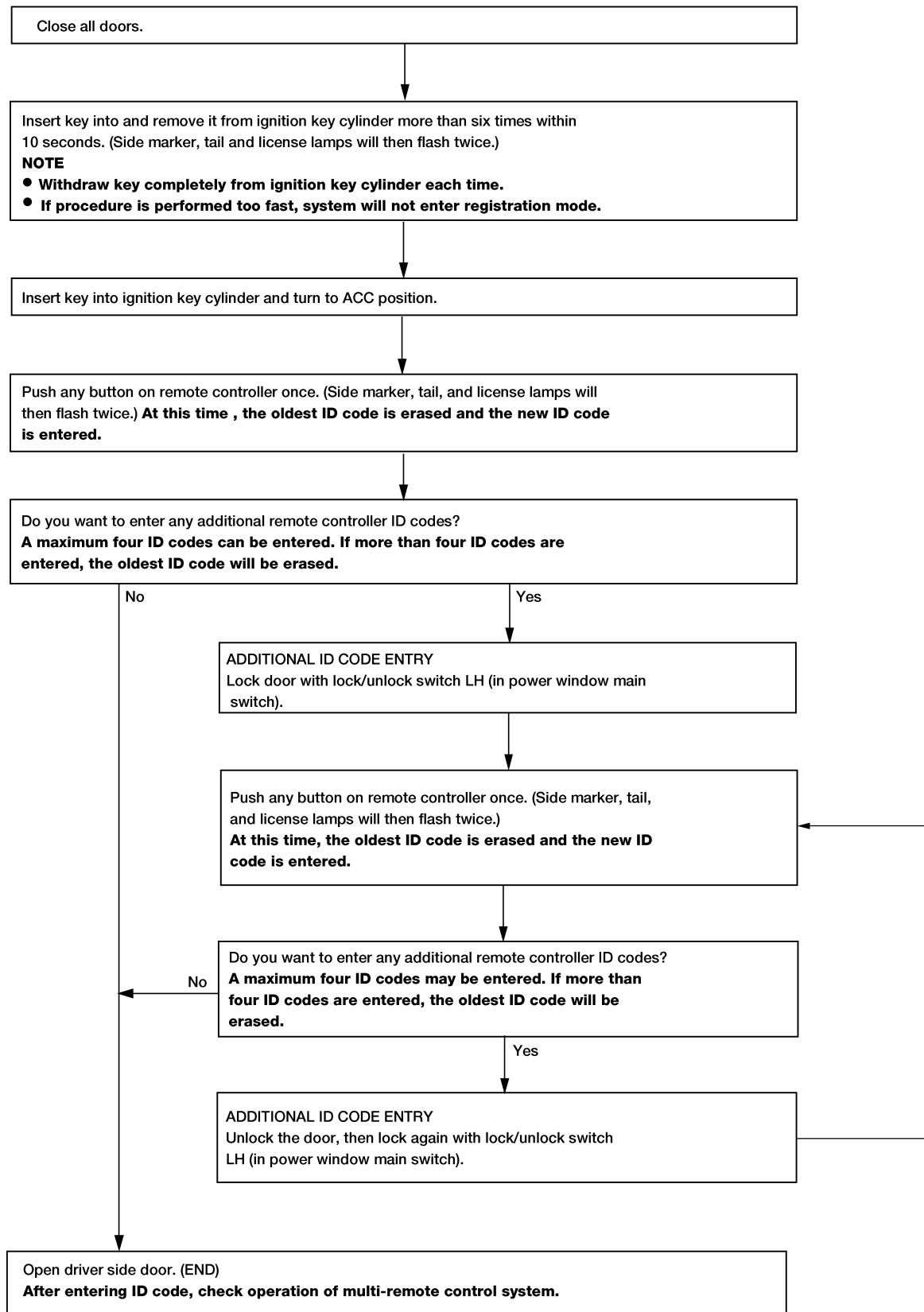

GI

MA

EM

LC

EC

FE

AT

AX

SU

BR

ST

RS

BT

HA

SC

EL

IDX

WEL079

MULTI-REMOTE CONTROL SYSTEM

ID Code Entry Procedure (Cont'd)

NOTE:

- If a remote controller is lost, the ID code of the lost remote controller must be erased to prevent unauthorized use. When the ID code of a lost remote controller is not known, all controller ID codes should be erased. After all ID codes are erased, the ID codes of all remaining and/or new remote controllers must be re-registered. To erase all ID codes in memory, register one ID code (remote controller) four times. After all codes are erased, the ID codes of all remaining and/or new remote controllers must be re-registered.
- When registering an additional remote controller, the existing ID codes in memory may or may not be erased. If four ID codes are stored in memory, when an additional code is registered, only the oldest code is erased. If less than four ID codes are stored in memory, when an additional ID code is registered, the new ID code is added and no ID codes are erased.
- If you need to activate more than two new remote controllers, repeat the procedure "Additional ID code entry" for each additional new remote controller.
- A maximum of four ID codes may be entered. When more than four ID codes are entered, the ID oldest code will be erased.
- For the procedure to memorize position for automatic drive positioner, refer to "PROCEDURE FOR STORING MULTI-REMOTE CONTROLLER", "AUTOMATIC DRIVE POSITIONER", EL-148.
- Even if the same ID code that is already in the memory is input, the same ID code can be entered. The code is counted as an additional code.

Remote Controller Battery Replacement

NDEL0115

NOTE:

- Be careful not to touch the circuit board or battery terminal.
- The remote controller is water-resistant. However, if it does get wet, immediately wipe dry.

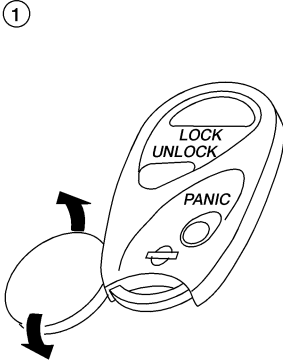
①  Open the lid using a coin.

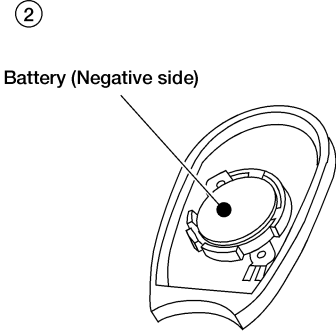
②  Battery (Negative side)
Remove the battery.

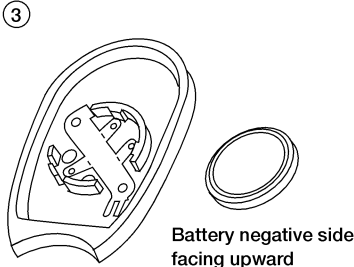
③  Battery negative side facing upward
Insert the new battery.

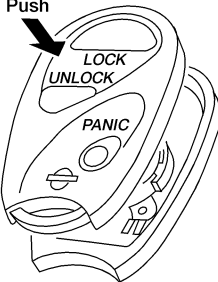
④  Push
Close the lid securely.
Push the remote control button two or three times to check its operation.

WEL080

THEFT WARNING SYSTEM

Component Parts and Harness Connector Location

Component Parts and Harness Connector Location

NDEL0116

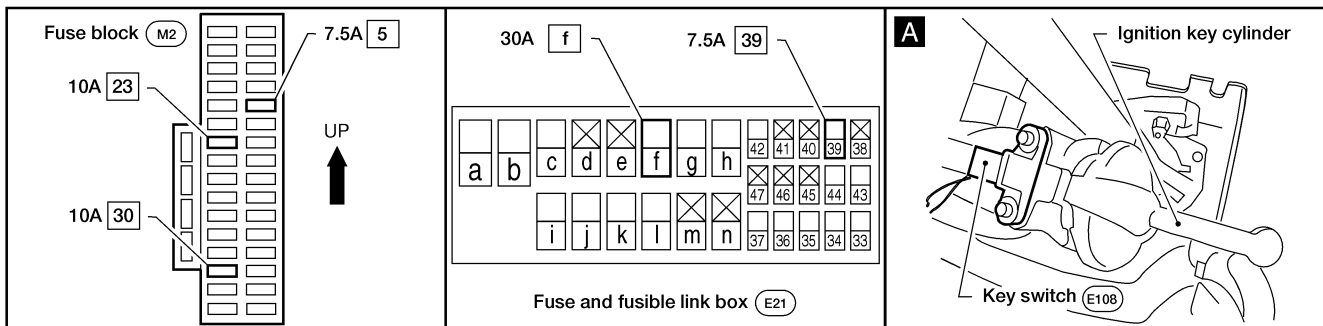
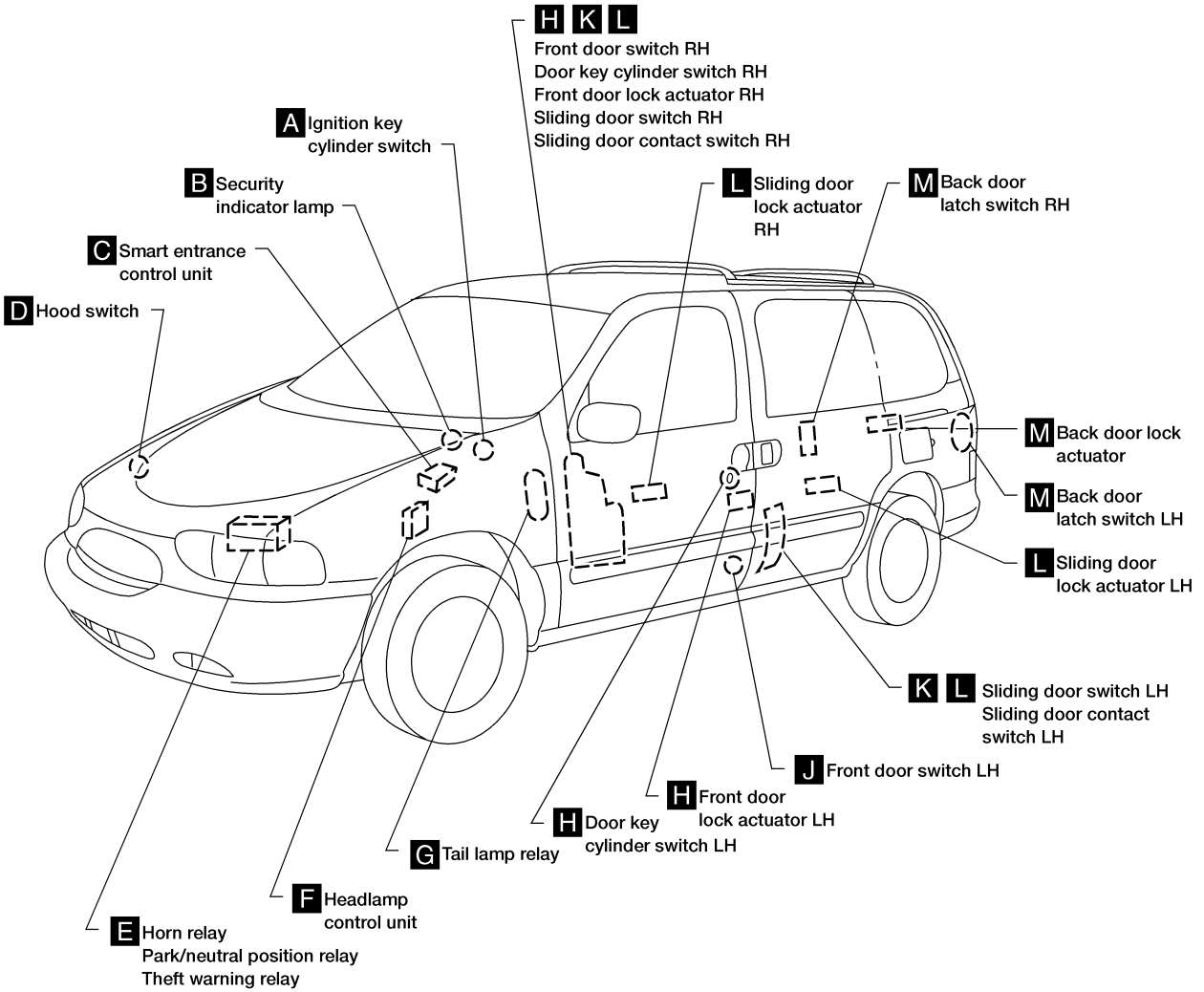

GI

MA

EM

LC

EC

FE

AT

AX

SU

BR

ST

RS

BT

HA

SC

EL

IDX

THEFT WARNING SYSTEM

Component Parts and Harness Connector Location (Cont'd)

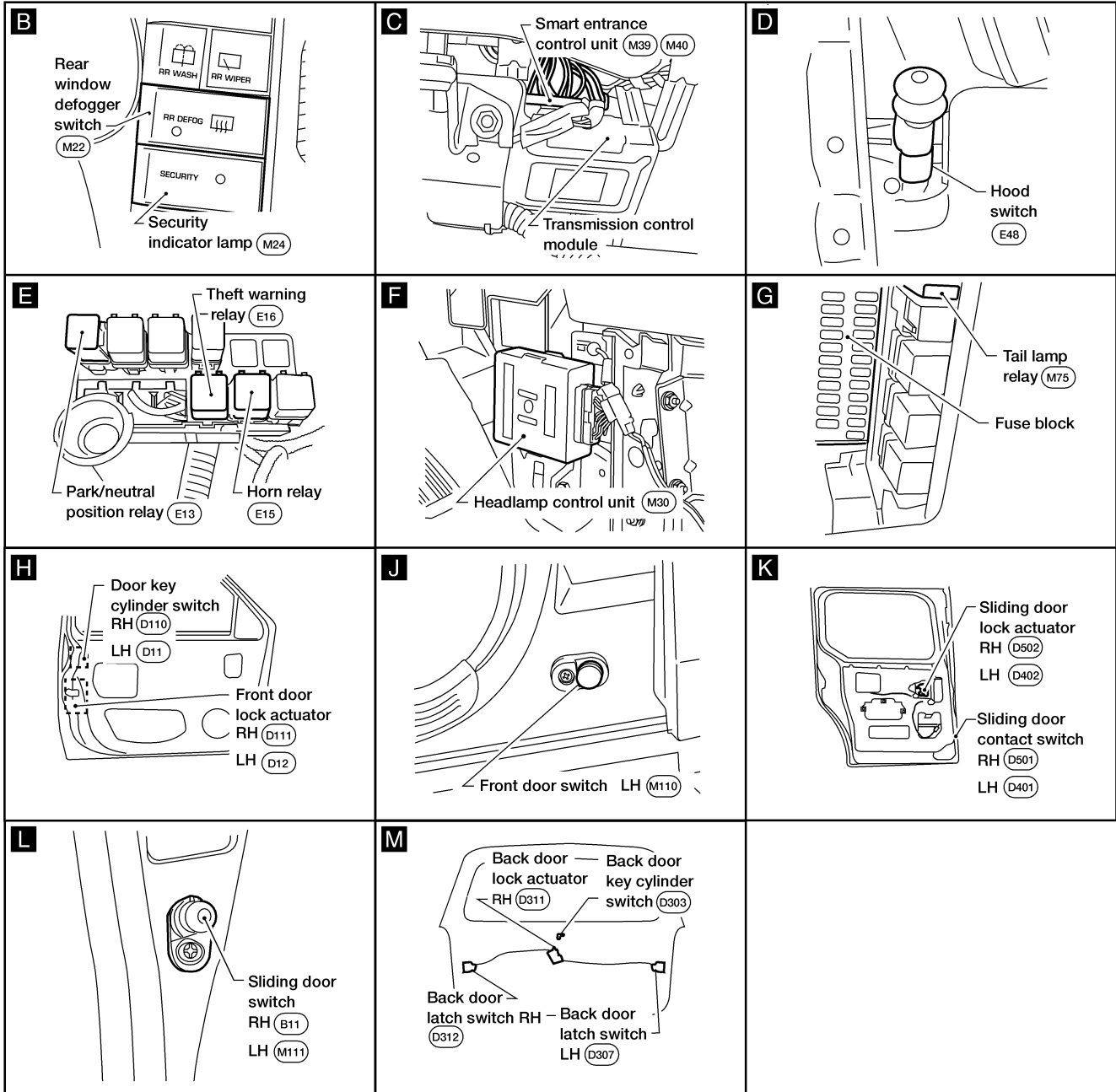

WEL263

System Description

DESCRIPTION

1. Operation Flow

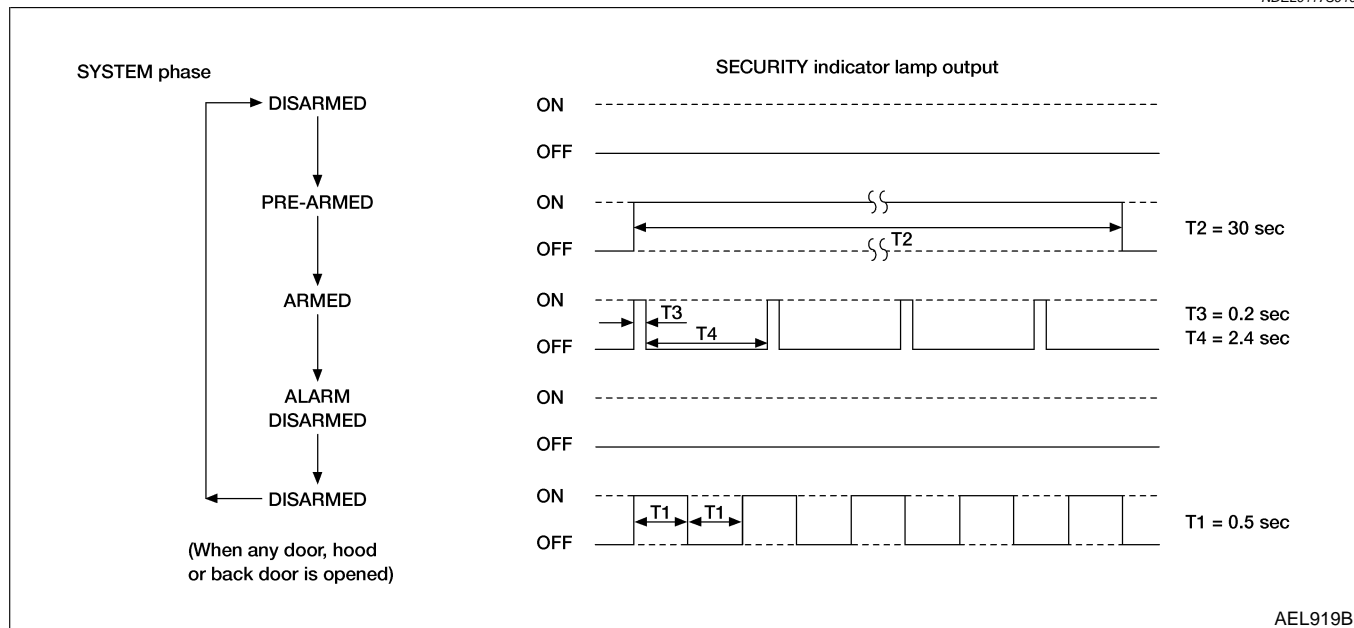

2. Setting the Theft Warning System

Initial condition

- 1) Close all doors.
- 2) Close hood and back door.

Disarmed phase

Theft warning system is in the disarmed phase when hood or any door is open. Security indicator lamp blinks every second.

Pre-armed phase and armed phase

Theft warning system turns into "pre-armed" phase when hood and all doors are closed and doors are locked by key or remote controller. (Security indicator lamp illuminates.)

After about 30 seconds, system automatically shifts into "armed" phase (system is set). (Security indicator lamp blinks every 2.6 seconds.)

3. Canceling the Set Theft Warning System

When the following 1) or 2) operation is performed, armed phase is canceled.

- 1) Unlock door with the key or remote controller.
- 2) ACC power is supplied with ignition key in ignition key cylinder.

4. Activating the Alarm Operation of the Theft Warning System

Make sure system is in armed phase. (Security indicator lamp blinks every 2.6 seconds.)

When the following operation 1), 2), 3) or 4) is performed, system sounds horns and flashes headlamps and exterior lamps for about 2.5 minutes. (At the same time, system disconnects the starting system circuit.)

- 1) Hood or any door is opened before unlocking door with key or remote controller.
- 2) Door is unlocked without using key or remote controller.
- 3) Battery is reconnected after being disconnected while system is in armed phase.
- 4) ACC, ON or START power is supplied without ignition key in ignition key cylinder

POWER SUPPLY AND GROUND CIRCUIT

Power is supplied at all times

- through 10A fuse (No. 23, located in the fuse block)
- to security indicator lamp terminal 1.

Power is supplied at all times

- through 30A fusible link (letter f, located in the fuse and fusible link box)

THEFT WARNING SYSTEM

System Description (Cont'd)

- to circuit breaker-1 terminal 1
- through circuit breaker-1 terminal 2
- to smart entrance control unit terminal 7 and
- through 7.5A fuse (No. 39, located in the fuse and fusible link box)
- to smart entrance control unit terminal 13.

With ignition switch in ACC or ON position, power is supplied

- through 7.5A fuse (No. 5, located in the fuse block)
- to smart entrance control unit terminal 36.

With the ignition switch in ON or START position, power is supplied

- through 10A fuse (No. 30, located in the fuse block)
- to smart entrance control unit terminal 43.

Ground is supplied

- to smart entrance control unit terminals 2, 10 and 16
- through body grounds M68, M105 and M130.

INITIAL CONDITION TO ACTIVATE THE SYSTEM

NDEL0117S03

Operation of theft warning system is controlled by doors.

To activate theft warning system, smart entrance control unit must receive signals indicating doors and hood are closed and doors are locked.

When a door is open, smart entrance control unit terminal 9, 24, 34 or 41 receives a ground signal from a door switch or back door latch switches.

When a door is unlocked, smart entrance control unit terminal 37, 40, 46 or 48 receives a ground signal from front door lock actuator LH or RH (door unlock sensor) terminal 4 or from back door lock actuator (door unlock sensor) terminal 4 or from sliding door lock actuator LH or RH (door unlock sensor) terminal 4.

When hood is open, smart entrance control unit terminal 31 receives a ground signal

- from hood switch terminal 1
- through body grounds E3, E30 and E50.

When back door is open, smart entrance control unit terminal 24 receives a ground signal

- from back door latch switch LH and RH terminal 1
- through body ground D204.

When doors are locked with key or multi-remote controller and none of the described conditions exist, theft warning system will automatically shift to armed phase.

THEFT WARNING SYSTEM ACTIVATION (WITH KEY OR REMOTE CONTROLLER USED TO LOCK DOORS)

NDEL0117S04

If key is used to lock doors, smart entrance control unit terminal 19 receives a ground signal

- from front door key cylinder switch LH terminal 2
- from front door key cylinder switch RH terminal 1
- through body grounds M68, M105 and M130
- from back door key cylinder switch terminal 2
- through body ground D204.

If this signal or lock signal from remote controller is received by smart entrance control unit, theft warning system will activate automatically.

Once theft warning system has been activated, smart entrance control unit terminal 45 supplies ground to security indicator lamp terminal 2.

Security lamp will illuminate for approximately 30 seconds and then blink.

Theft warning system is now in armed phase.

THEFT WARNING SYSTEM ALARM OPERATION

NDEL0117S05

Theft warning system is triggered by

- opening a door without using key or remote controller
- opening hood
- unlocking door without using key or remote controller
- ACC, ON or START signal without ignition key in ignition key cylinder
- Battery is reconnected after being disconnected while system is in armed phase.

THEFT WARNING SYSTEM

System Description (Cont'd)

Once theft warning system is in armed phase, if smart entrance control unit receives a ground signal at terminal 37, 40, 46, 48 (door unlock sensor), 9, 24, 34, 41 (door switch), or 31 (hood switch), or power is supplied to smart entrance control unit terminal 36 or 43 without ignition key inserted signal at terminal 35, theft warning system will be triggered. Headlamps flash, horn sounds intermittently, and starting system is interrupted.

GI

Power is supplied at all times

MA

- through 7.5A fuse (No. 39, located in the fuse and fusible link box)
- to theft warning relay terminal 2.

EM

If theft warning system is triggered, ground is supplied

- from smart entrance control unit terminal 28
- to theft warning relay terminal 1.

LC

With power and ground supplied, starter motor circuit is interrupted. Starter motor will not crank and engine will not start.

Power is supplied at all times

EC

- through 15A fuse (No. 42, located in fuse and fusible link box)
- to horn relay terminals 2 and 3, and
- to tail lamp relay terminals 2 and 3.

FE

When theft warning system is triggered, ground is supplied intermittently

- from smart entrance control unit terminal 21
- to horn relay terminals 1 and
- from smart entrance control unit terminal 26
- to tail lamp relay terminal 1.

AT

AX

At this time, alarm signal is sent from smart entrance control unit terminal 29 to headlamp control unit terminal 19.

SU

Headlamps and exterior lamps flash and horn sounds intermittently.

Alarm automatically turns off after 2 or 3 minutes but will reactivate if the vehicle is tampered with again.

BR

THEFT WARNING SYSTEM DEACTIVATION

NDEL0117S06

To deactivate theft warning system, a door must be unlocked with key or remote controller.

When key is used to unlock the door, smart entrance control unit terminal 27 receives a ground signal

ST

- from front door key cylinder switch LH terminal 1
- from front door key cylinder switch RH terminal 2
- from back door key cylinder switch terminal 2.

RS

When smart entrance control unit receives one of these signals or unlock signal from remote controller, theft warning system is deactivated (Disarmed phase).

BT

PANIC ALARM OPERATION

NDEL0117S07

Multi-remote control system may or may not operate theft warning system (horn and headlamps) as required. Headlamps flash and horn sounds intermittently.

HA

Panic alarm automatically turns off after 30 seconds or when smart entrance control unit receives any signal from remote controller.

SC

EL

IDX

THEFT WARNING SYSTEM

Schematic

Schematic

NDEL0118

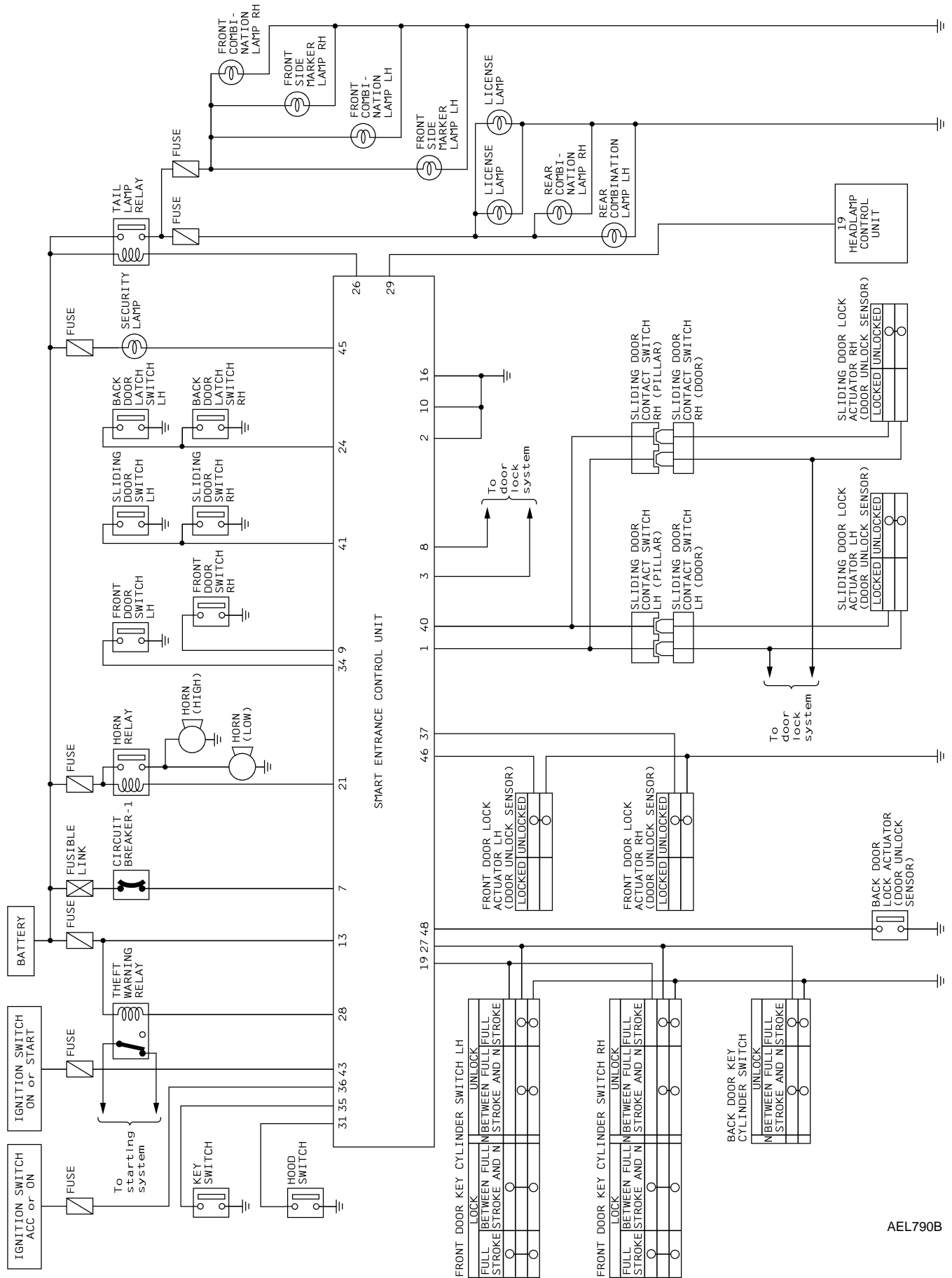

AEL790B

THEFT WARNING SYSTEM

Wiring Diagram — THEFT —

FIG. 1

Wiring Diagram — THEFT —

NDEL0119

NDEL0119S01

EL-THEFT-01

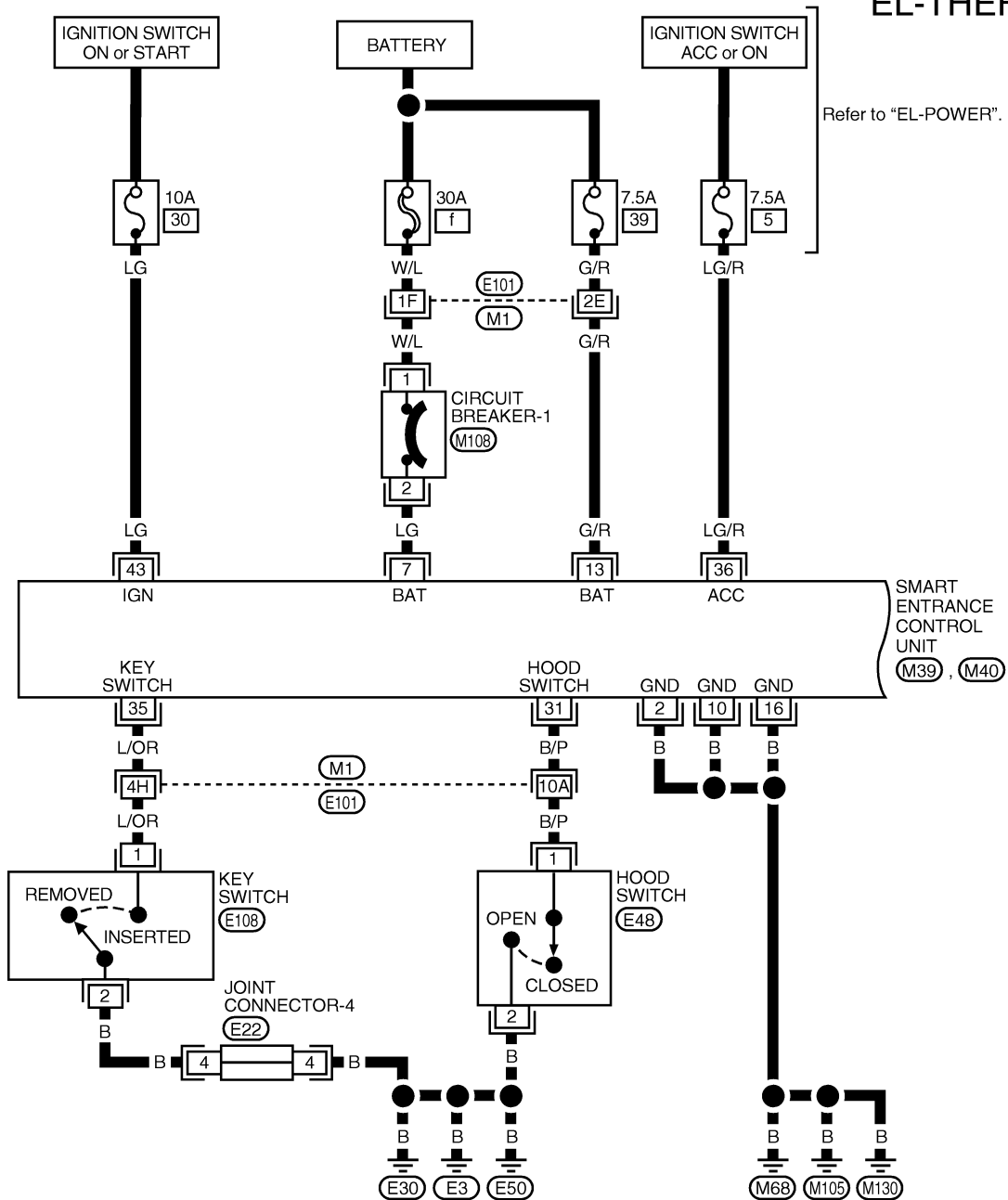

Refer to "EL-POWER".

SMART ENTRANCE CONTROL UNIT (M39, M40)

GI
MA
EM
LC
EC
FE
AT
AX
SU
BR
ST
RS
BT
HA
SC
EL

IDX

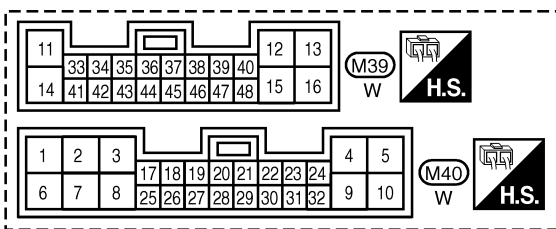

Refer to the following.
 (M1), (E101) - SUPER MULTIPLE JUNCTION (SMJ)
 (E22) - JOINT CONNECTOR

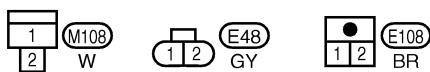

THEFT WARNING SYSTEM

Wiring Diagram — THEFT — (Cont'd)

FIG. 2

NDEL0119S02

EL-THEFT-02

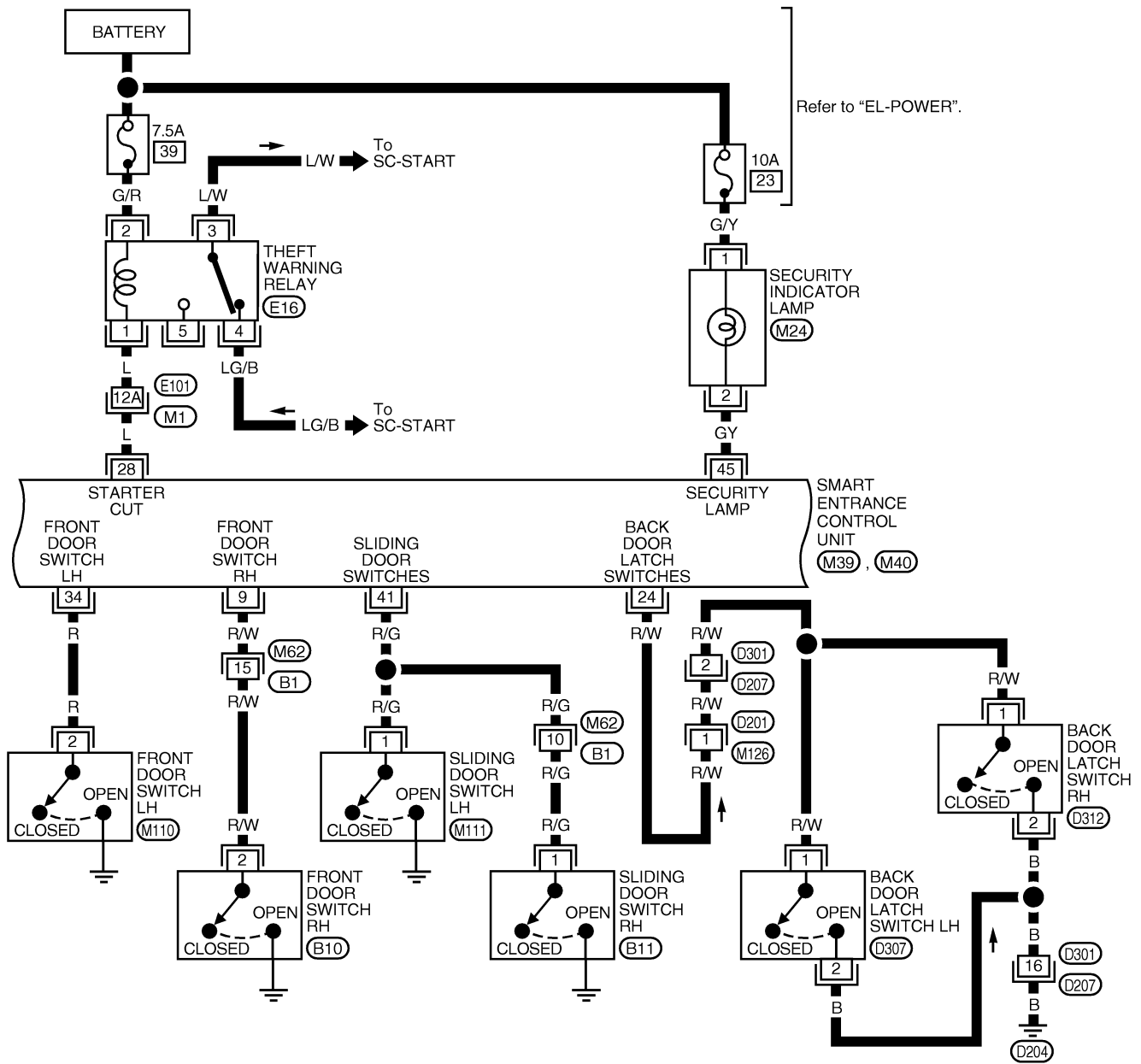

Refer to the following.
 (M1), (E101) - SUPER MULTIPLE JUNCTION (SMJ)

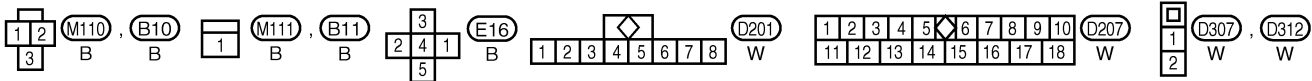
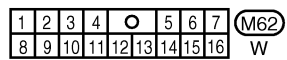
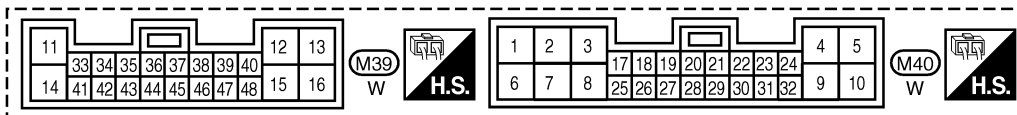
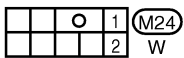

WEL252

THEFT WARNING SYSTEM

Wiring Diagram — THEFT — (Cont'd)

FIG. 3

NDEL0119S03

EL-THEFT-03

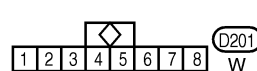
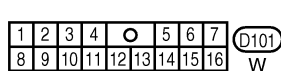
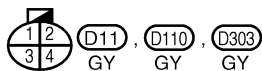
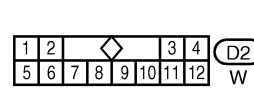
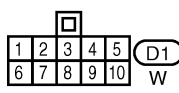
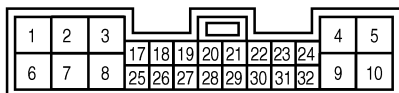
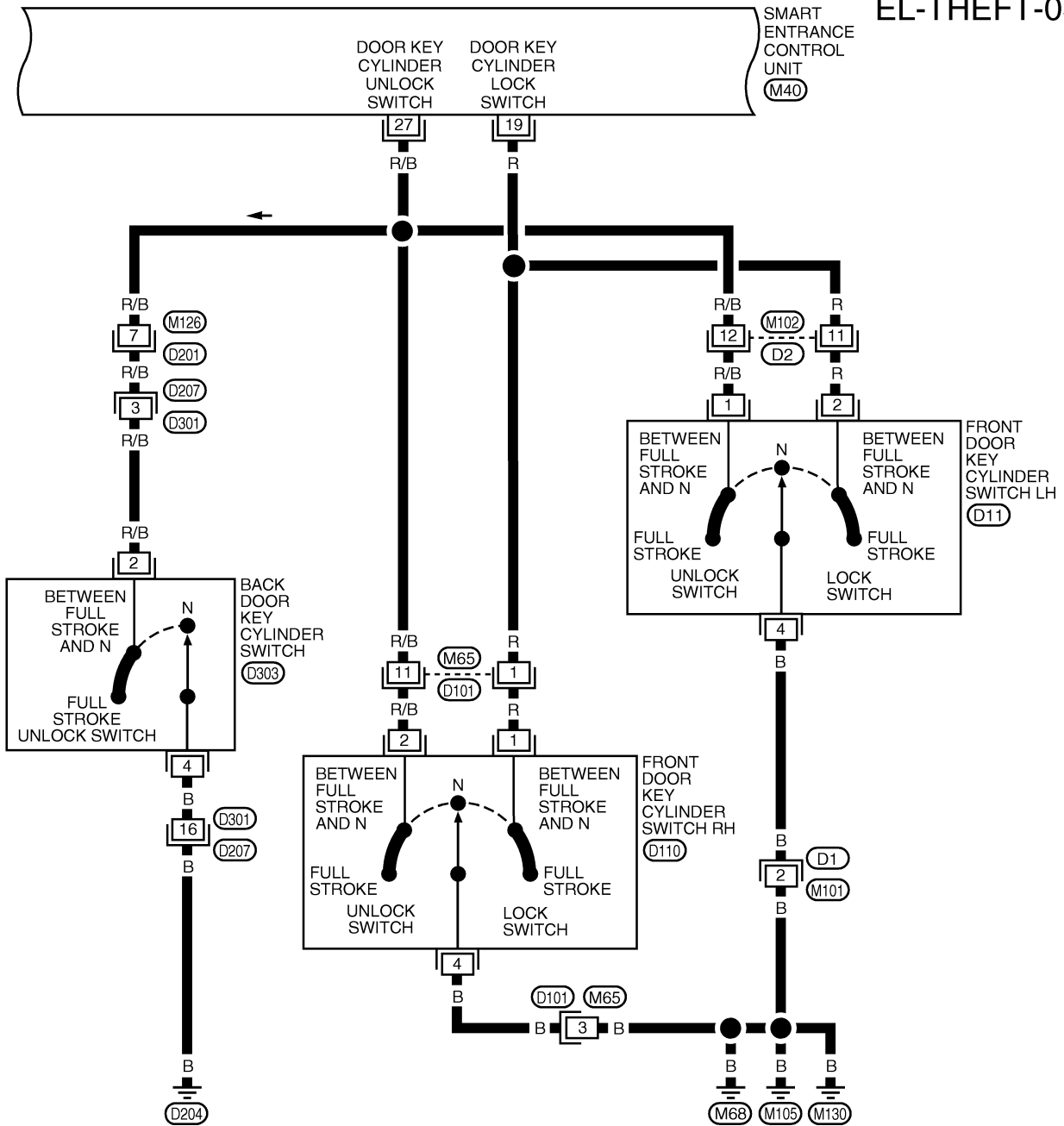

WEL253

THEFT WARNING SYSTEM

Wiring Diagram — THEFT — (Cont'd)

FIG. 4

NDEL0119S04

EL-THEFT-04

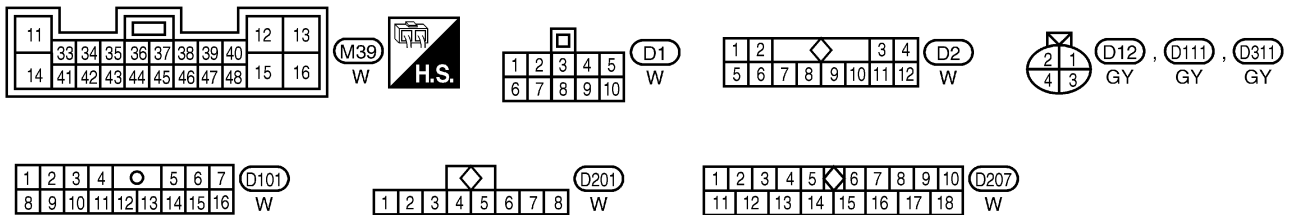
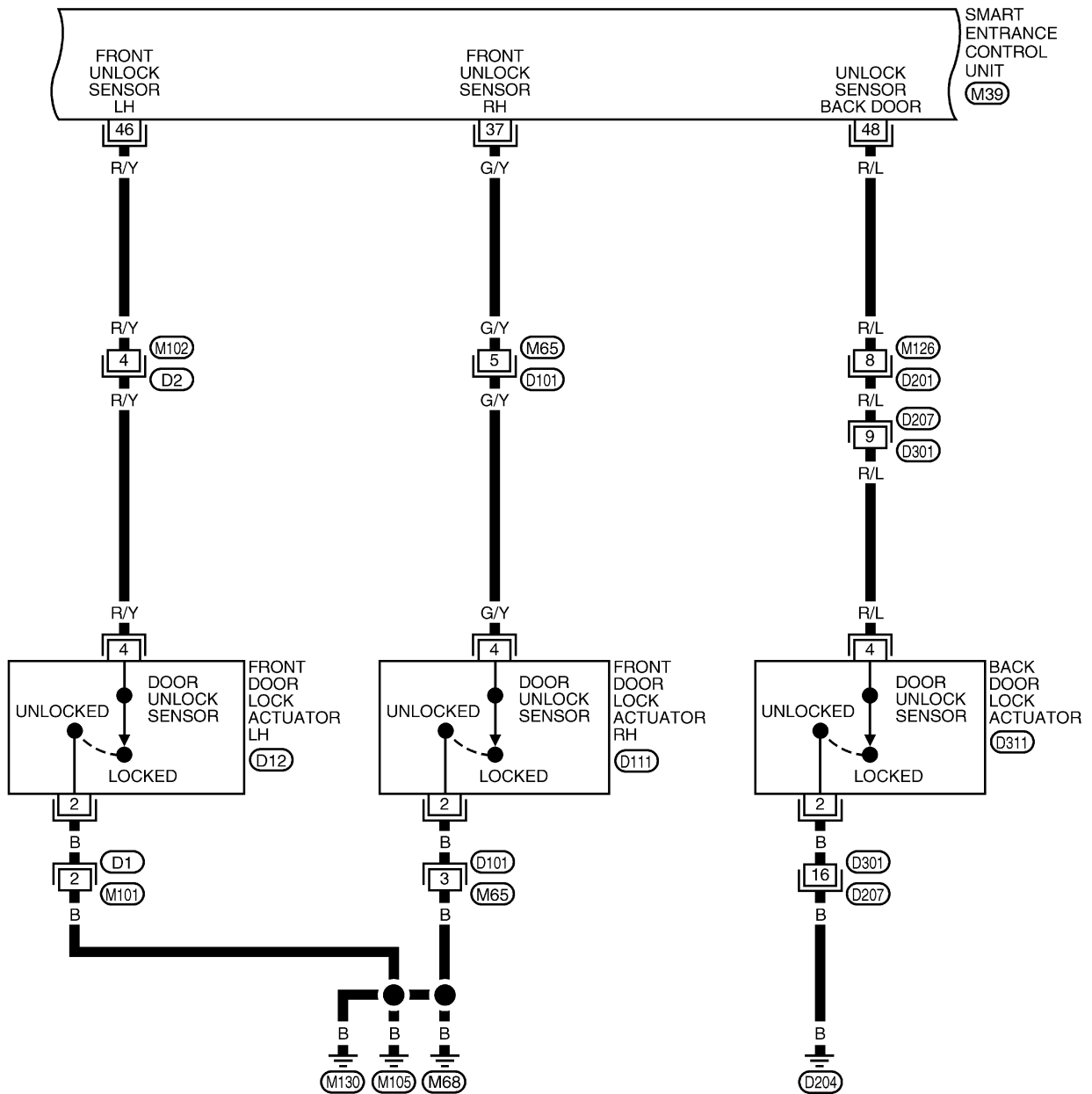

AEL794B

THEFT WARNING SYSTEM

Wiring Diagram — THEFT — (Cont'd)

FIG. 5

NDEL0119S05

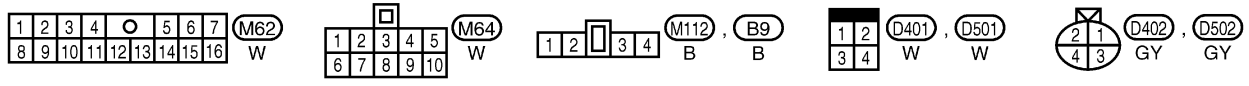
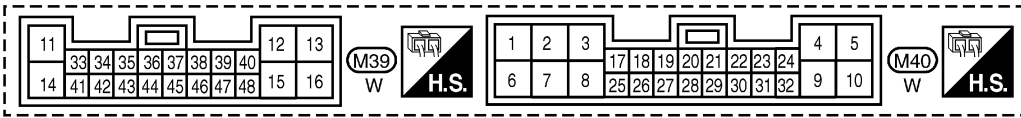
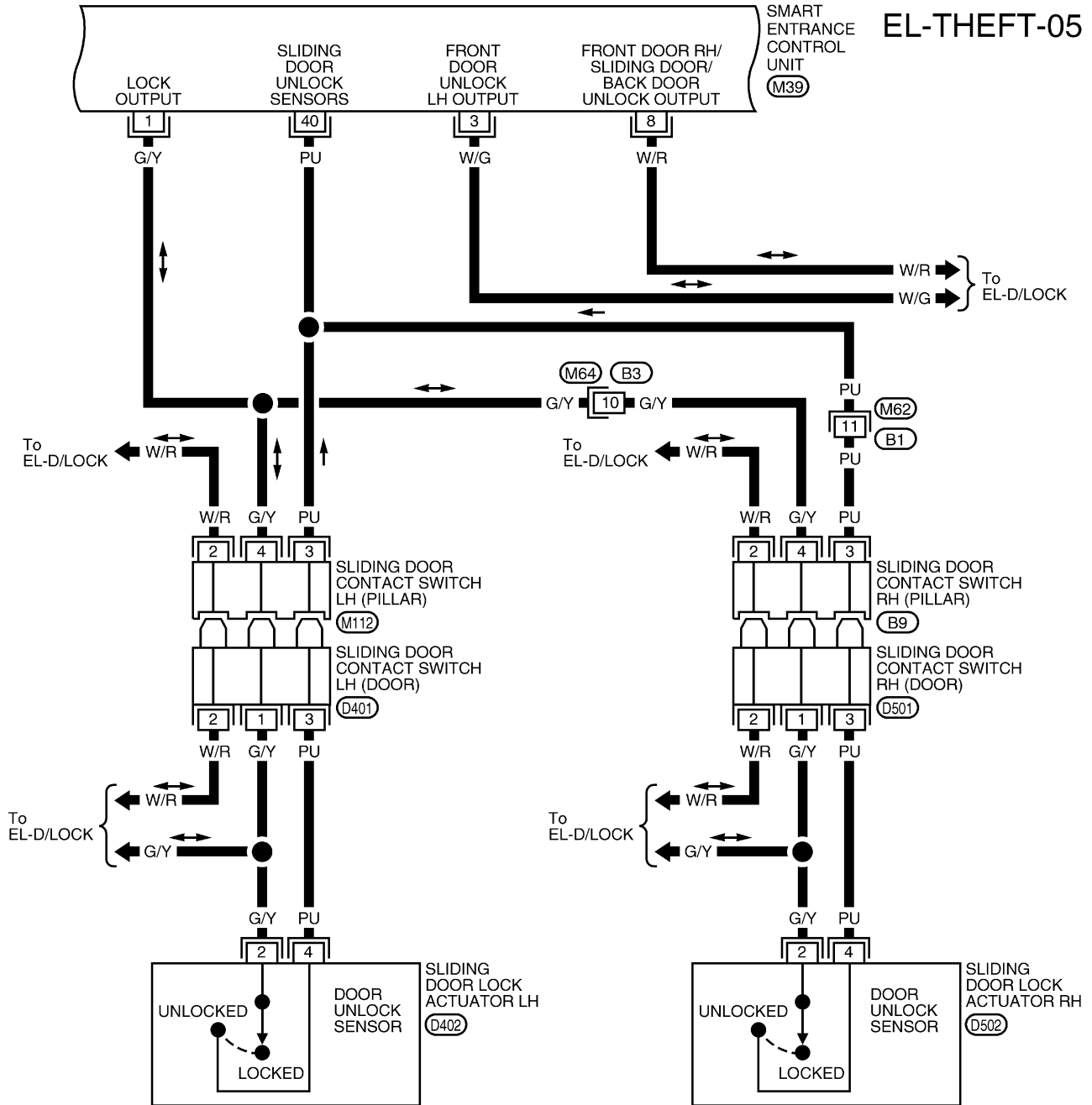

GI
MA
EM
LC
EC
FE
AT
AX
SU
BR
ST
RS
BT
HA
SC

EL
IDX

THEFT WARNING SYSTEM

Wiring Diagram — THEFT — (Cont'd)

FIG. 6

NDEL0119S06

EL-THEFT-06

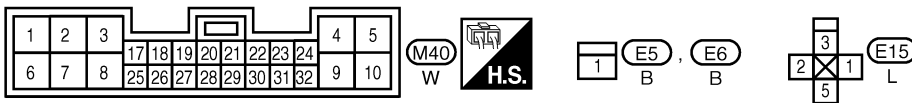
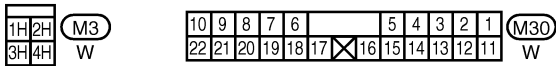
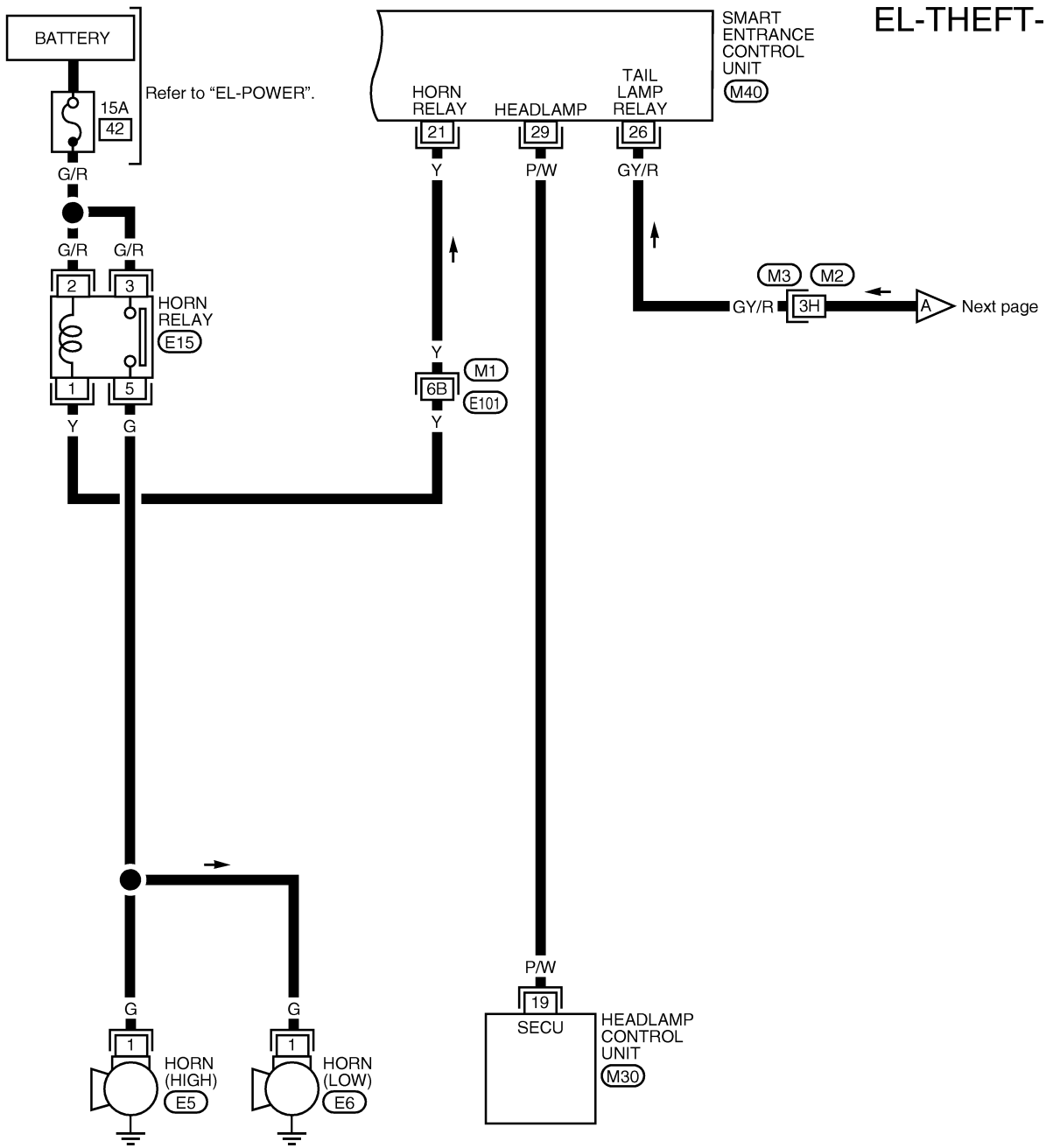

Refer to the following.
 (M1), (E101) - SUPER MULTIPLE
 JUNCTION (SMJ)

THEFT WARNING SYSTEM

Wiring Diagram — THEFT — (Cont'd)

FIG. 7

NDEL0119S07

EL-THEFT-07

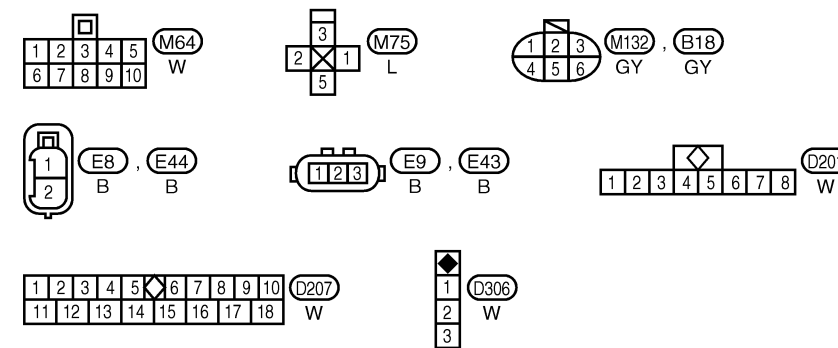
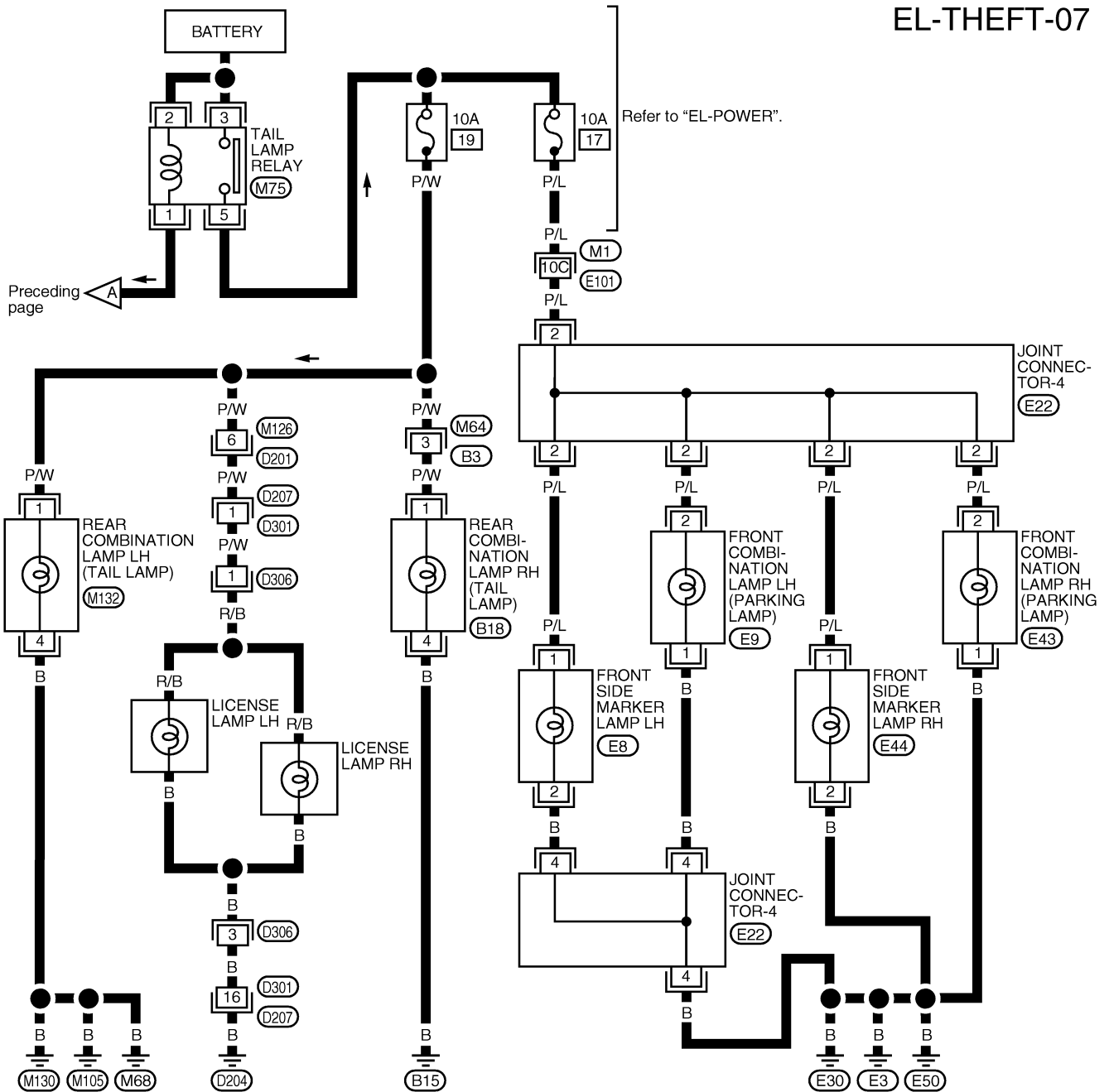

Refer to the following.
 (M1, E101) - SUPER MULTIPLE JUNCTION (SMJ)
 (E22) - JOINT CONNECTOR

GI
MA
EM
LC
EC
FE
AT
AX
SU
BR
ST
RS
BT
HA
SC

EL

IDX

WEL255

THEFT WARNING SYSTEM

Trouble Diagnoses PRELIMINARY CHECK

NDEL0120

NDEL0120S01

The system operation is canceled by turning ignition switch to ACC at any step between START and ARMED in the following flow chart.

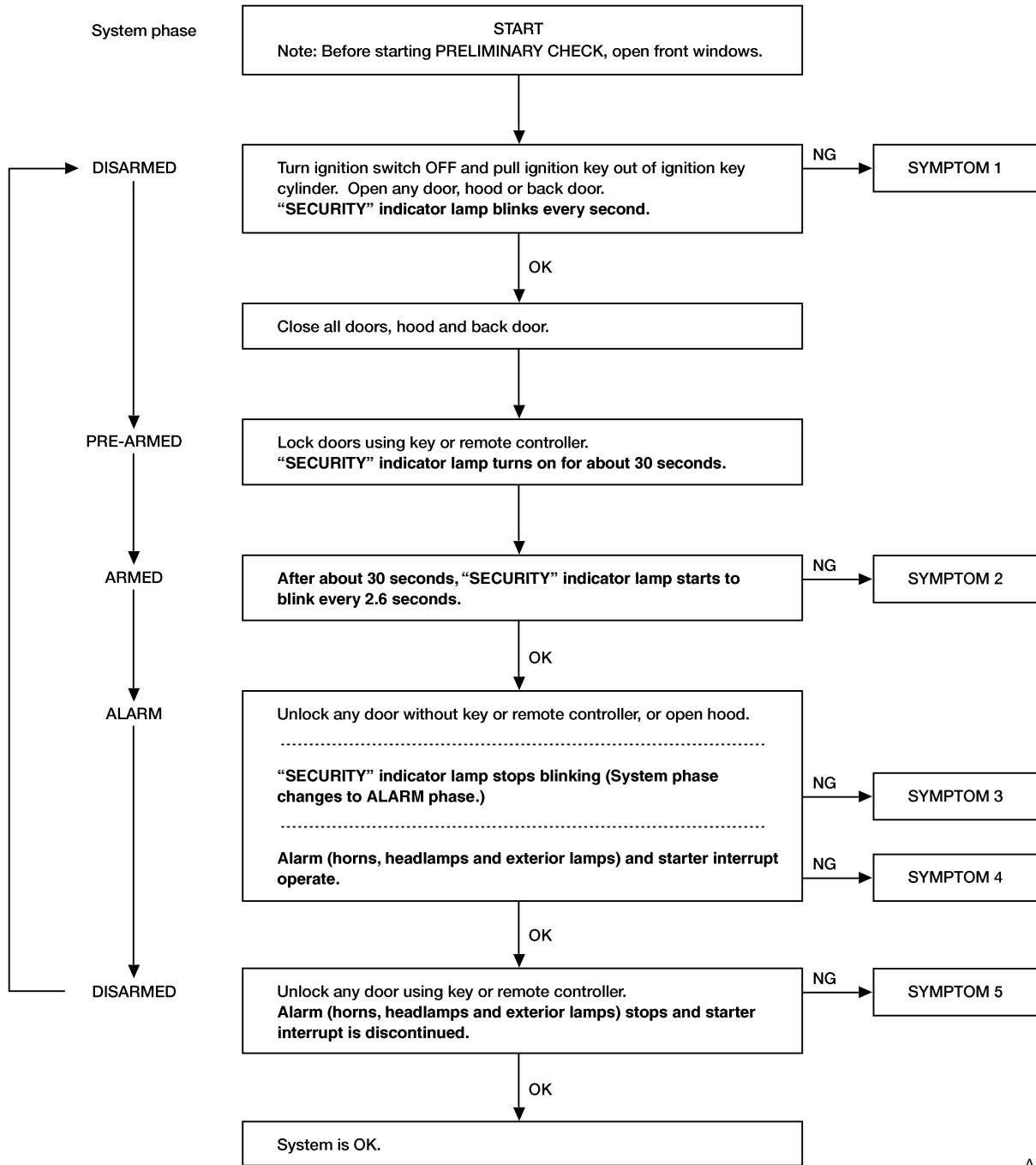

AEL920B

After performing "PRELIMINARY CHECK", go to "SYMPTOM CHART", EL-267.

THEFT WARNING SYSTEM

Trouble Diagnoses (Cont'd)

SYMPTOM CHART

NDEL0120S02

REFERENCE PAGE (EL-)	266	268	269	273	274	229	275	275	276	277	242
SYMPTOM	PRELIMINARY CHECK	POWER SUPPLY AND GROUND CIRCUIT CHECK	DOOR AND HOOD SWITCH CHECK	SECURITY INDICATOR LAMP CHECK	DOOR UNLOCK SENSOR CHECK	DOOR KEY CYLINDER SWITCH CHECK Refer to "POWER DOOR LOCK" system.	THEFT WARNING HORN ALARM CHECK	THEFT WARNING HEADLAMP ALARM CHECK	TAIL LAMP RELAY CHECK	STARTER INTERRUPT SYSTEM CHECK	Check "MULTI-REMOTE CONTROL" system.
1	"SECURITY" indicator lamp does not turn on or blink.										
2	Theft warning system cannot be set by ...										
	All items	X	X	X		X					
	Door outside key	X	X			X					
	Back door key	X	X			X					
	Remote controller	X	X								X
3	*1 Theft warning system does not alarm when ...										
	Any door is opened.	X	X	X							
	Any door is unlocked without using key or remote controller.	X	X			X					
4	Theft warning alarm does not activate.										
	All function	X	X	X		X					
	Horn alarm	X	X				X				
	Headlamp alarm	X	X					X			
	Exterior lamp alarm								X		
	Starter interrupt	X	X							X	
5	Theft warning system cannot be canceled by ...										
	Door outside key	X	X			X					
	Back door key	X	X			X					
	Remote controller	X	X								X

X : Applicable

*1: Make sure the system is in the armed phase.

Before starting trouble diagnoses above, perform "PRELIMINARY CHECK", EL-266.

Symptom numbers in the symptom chart correspond with those of "PRELIMINARY CHECK".

GI
MA
EM
LC
EC
FE
AT
AX
SU
BR
ST
RS
BT
HA
SC
EL
IDX

THEFT WARNING SYSTEM

Trouble Diagnoses (Cont'd)

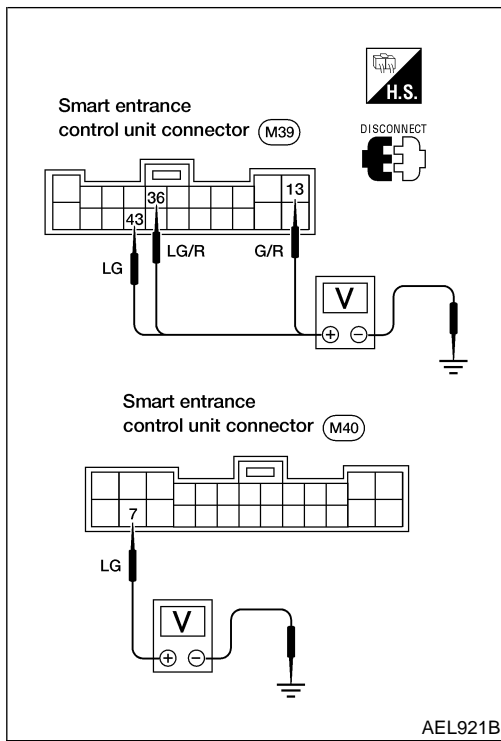

POWER SUPPLY AND GROUND CIRCUIT CHECK

NDEL0120S03

Power Supply Circuit Check

NDEL0120S0301

Terminals		Ignition switch position		
(+)	(-)	OFF	ACC	ON
7	Ground	Battery voltage	Battery voltage	Battery voltage
13	Ground	Battery voltage	Battery voltage	Battery voltage
36	Ground	0V	Battery voltage	Battery voltage
43	Ground	0V	0V	Battery voltage

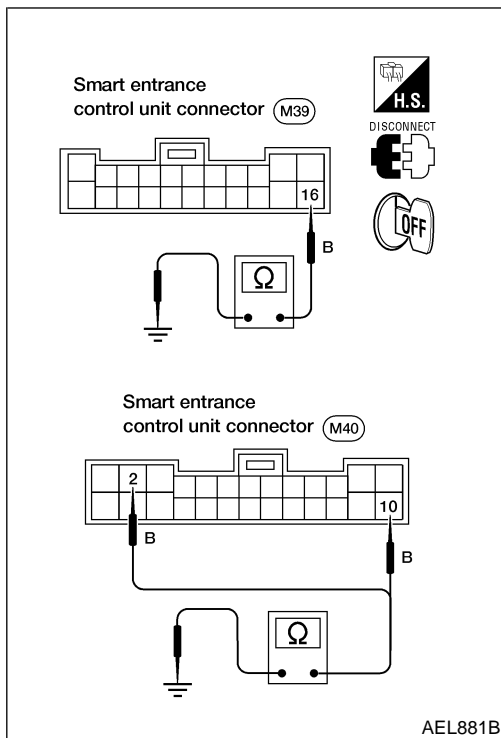

Ground Circuit Check

NDEL0120S0302

Terminals	Continuity
2 - Ground	Yes
10 - Ground	
16 - Ground	

THEFT WARNING SYSTEM

Trouble Diagnoses (Cont'd)

DOOR AND HOOD SWITCH CHECK

Door Switch Check

=NDEL0120S04

NDEL0120S0401

1	PRELIMINARY CHECK	
	1. Turn ignition switch OFF and remove ignition key from ignition key cylinder. 2. Close all doors and hood. "SECURITY" indicator lamp should turn off. 3. Open any door. "SECURITY" indicator lamp should blink every second. <p style="text-align: center;">OK or NG</p>	
OK	▶	Door switch is OK.
NG	▶	GO TO 2.

2	CHECK DOOR SWITCH INPUT SIGNAL																																				
	Check voltage between smart entrance control unit terminals and ground.																																				
	AEL869B																																				
	<table border="1"> <thead> <tr> <th rowspan="2"></th> <th colspan="2">Terminals</th> <th rowspan="2">Door condition</th> <th rowspan="2">Voltage [V] (Approx.)</th> </tr> <tr> <th>(+)</th> <th>(-)</th> </tr> </thead> <tbody> <tr> <td rowspan="2">Front door switch LH</td> <td rowspan="2">34</td> <td rowspan="2">Ground</td> <td>Open</td> <td>0</td> </tr> <tr> <td>Closed</td> <td>1.5</td> </tr> <tr> <td rowspan="2">Front door switch RH</td> <td rowspan="2">9</td> <td rowspan="2">Ground</td> <td>Open</td> <td>0</td> </tr> <tr> <td>Closed</td> <td>1.5</td> </tr> <tr> <td rowspan="2">Sliding door switch LH and RH</td> <td rowspan="2">41</td> <td rowspan="2">Ground</td> <td>Open</td> <td>0</td> </tr> <tr> <td>Closed</td> <td>1.5</td> </tr> <tr> <td rowspan="2">Back door latch switch LH and RH</td> <td rowspan="2">24</td> <td rowspan="2">Ground</td> <td>Open</td> <td>0</td> </tr> <tr> <td>Closed</td> <td>1.5</td> </tr> </tbody> </table>			Terminals		Door condition	Voltage [V] (Approx.)	(+)	(-)	Front door switch LH	34	Ground	Open	0	Closed	1.5	Front door switch RH	9	Ground	Open	0	Closed	1.5	Sliding door switch LH and RH	41	Ground	Open	0	Closed	1.5	Back door latch switch LH and RH	24	Ground	Open	0	Closed	1.5
	Terminals			Door condition	Voltage [V] (Approx.)																																
	(+)	(-)																																			
Front door switch LH	34	Ground	Open	0																																	
			Closed	1.5																																	
Front door switch RH	9	Ground	Open	0																																	
			Closed	1.5																																	
Sliding door switch LH and RH	41	Ground	Open	0																																	
			Closed	1.5																																	
Back door latch switch LH and RH	24	Ground	Open	0																																	
			Closed	1.5																																	
	WEL547A																																				
	Refer to wiring diagram in EL-260.																																				
	OK or NG																																				
OK	▶	Door switch is OK.																																			
NG	▶	GO TO 3.																																			

GI
MA
EM
LC
EC
FE
AT
AX
SU
BR
ST
RS
BT
HA
SC

EL

IDX

THEFT WARNING SYSTEM

Trouble Diagnoses (Cont'd)

3 CHECK DOOR SWITCH

1. Disconnect door switch connector.
2. Check continuity as indicated.

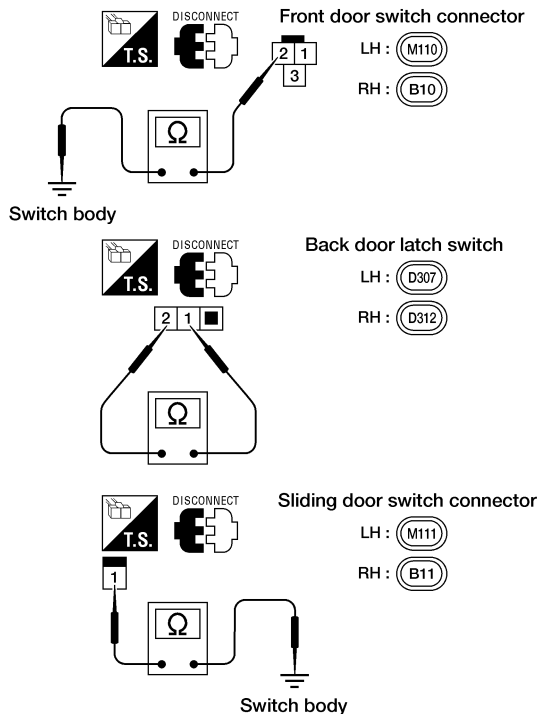

AEL910B

	Terminals	Door Condition	Continuity
Front door switch LH and RH	2 - ground	Closed	No
		Open	Yes
Back door latch switch LH and RH	1 - 2	Closed	No
		Open	Yes
Sliding door switch LH and RH	1 - ground	Closed	No
		Open	Yes

AEL911B

OK or NG

OK	▶	<p>Check the following</p> <ul style="list-style-type: none"> ● Door switch ground circuit (back door latch switch) or door switch ground condition ● Harness for open or short between smart entrance control unit and door switch.
NG	▶	Replace door switch.

THEFT WARNING SYSTEM

Trouble Diagnoses (Cont'd)

Hood Switch Check

=NDEL0120S0402

1	PRELIMINARY CHECK	
1. Turn ignition switch OFF and remove ignition key from ignition key cylinder. 2. Close all doors and hood. “SECURITY” indicator lamp should turn off. 3. Open hood. “SECURITY” indicator lamp should blink every second.		
OK or NG		
OK	▶	Hood switch is OK.
NG	▶	GO TO 2.

2	CHECK HOOD SWITCH FITTING CONDITION	
OK or NG		
OK	▶	GO TO 3.
NG	▶	Adjust installation of hood switch or hood.

3	CHECK HOOD SWITCH INPUT SIGNAL	
Check voltage between smart entrance control unit terminal 31 and ground.		
<p>Voltage [V]: Hood is open. 0 Hood is closed. Approx. 1.5</p> Refer to wiring diagram in EL-259.		
OK or NG		
OK	▶	Hood switch is OK.
NG	▶	GO TO 4.

AEL923B

GI

MA

EM

LC

EC

FE

AT

AX

SU

BR

ST

RS

BT

HA

SC

EL

IDX

THEFT WARNING SYSTEM

Trouble Diagnoses (Cont'd)

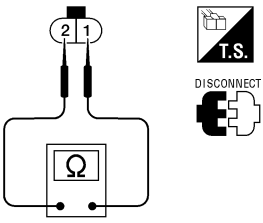
4	CHECK HOOD SWITCH
<p>1. Disconnect hood switch connector.</p> <p>2. Check continuity between hood switch terminals 1 and 2.</p> <div data-bbox="673 304 998 567" style="text-align: center;"><p>Hood switch connector (E48)</p></div> <p>Continuity: Condition: Pushed No Condition: Released Yes</p> <p style="text-align: right;">AEL924B</p> <p style="text-align: center;">OK or NG</p>	
OK	<p>▶ Check the following</p> <ul style="list-style-type: none">● Hood switch ground circuit● Harness for open or short between smart entrance control unit and hood switch.
NG	<p>▶ Replace hood switch.</p>

THEFT WARNING SYSTEM

Trouble Diagnoses (Cont'd)

SECURITY INDICATOR LAMP CHECK

=NDEL0120S05

1	CHECK INDICATOR LAMP OUTPUT SIGNAL	<p>1. Disconnect smart entrance control unit connector. 2. Check voltage between smart entrance control unit terminal 45 and ground.</p> <div style="text-align: center; margin: 10px 0;"> </div> <p style="text-align: right; margin-right: 20px;">AEL925B</p>	GI MA EM LC EC FE
		Does battery voltage exist?	
Yes	▶	Security indicator lamp is OK.	
No	▶	GO TO 2.	AT

2	CHECK INDICATOR LAMP	OK or NG	
OK	▶	GO TO 3.	SU
NG	▶	Replace security indicator lamp.	BR

3	CHECK POWER SUPPLY CIRCUIT FOR INDICATOR LAMP	<p>1. Disconnect security indicator lamp connector. 2. Check voltage between security indicator lamp terminal 1 and ground.</p> <div style="text-align: center; margin: 10px 0;"> </div> <p style="text-align: right; margin-right: 20px;">WEL264</p>	ST RS BT HA SC
		Does battery voltage exist?	
Yes	▶	Check harness for open or short between security indicator lamp and smart entrance control unit.	EL
No	▶	Check the following <ul style="list-style-type: none"> ● 10A fuse (No. 23, located in fuse block) ● Harness for open or short between security indicator lamp and fuse. 	IDX

THEFT WARNING SYSTEM

Trouble Diagnoses (Cont'd)

DOOR UNLOCK SENSOR CHECK

=NDEL0120S06

1 CHECK DOOR UNLOCK SENSOR INPUT SIGNAL

Check voltage between smart entrance control unit terminals and ground.

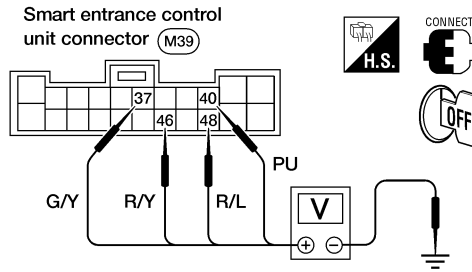

AEL912B

	Terminals		Condition	Voltage [V] (Approx.)
	(+)	(-)		
Front door LH	46	Ground	Locked	1.5
			Unlocked	0
Front door RH	37	Ground	Locked	1.5
			Unlocked	0
Sliding door LH and RH	40	Ground	Locked	1.5
			Unlocked	0
Back door	48	Ground	Locked	1.5
			Unlocked	0

WEL551A

Refer to wiring diagrams, EL-262, 263.

OK or NG

OK	▶	Door unlock sensor is OK.
NG	▶	GO TO 2.

2 CHECK DOOR UNLOCK SENSOR

1. Disconnect door unlock sensor connector.
2. Check continuity between door unlock sensor terminals.

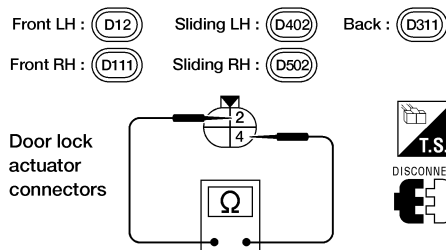

AEL914B

Continuity:
Condition: Locked
No
Condition: Unlocked
Yes

OK or NG

OK	▶	Check the following <ul style="list-style-type: none"> • Door unlock sensor ground circuit (front door LH/RH and back door) • Harness for open or short between smart entrance control unit and door unlock sensor.
NG	▶	Replace door unlock sensor.

THEFT WARNING SYSTEM

Trouble Diagnoses (Cont'd)

THEFT WARNING HORN ALARM CHECK

=NDEL0120S08

1	CHECK HORN OPERATION
Does horn work properly with horn switch?	
Yes or No	
Yes	▶ GO TO 2..
No	▶ Check horn circuit. Refer to "Wiring Diagram — HORN —", EL-119.

GI
MA
EM

2	Check Horn Reminder Operation
<p>1. Disconnect control unit connector. 2. Apply ground to control unit terminal 19.</p>	
<p>Smart entrance control unit connector (M40)</p> <p>Refer to wiring diagram in EL-237.</p>	
Does horn sound?	
Yes	▶ Replace smart entrance control unit.
No	▶ Check harness for open or short between control unit and horn relay.

LC
EC
FE
AT
AX
SU

WEL081

THEFT WARNING HEADLAMP ALARM CHECK

NDEL0120S09

1	CHECK HEADLAMP OPERATION
Do headlamps operate properly with lighting switch operation?	
Yes or No	
Yes	▶ Check harness for open or short between headlamp control unit and smart entrance control unit.
No	▶ Check headlamp circuit. Refer to "Wiring Diagram — H/LAMP —", "HEADLAMP (FOR USA)", EL-34 or "Wiring Diagram — DTRL —", "HEADLAMP (FOR CANADA) — DAY-TIME LIGHT SYSTEM —", EL-49.

ST
RS
BT
HA
SC

EL

IDX

THEFT WARNING SYSTEM

Trouble Diagnoses (Cont'd)

TAIL LAMP RELAY CHECK

=NDEL0120S10

1	CHECK TAIL LAMP OPERATION	
Do tail lamps illuminate with lighting switch operation?		
Yes or No		
Yes	▶	Check harness for open or short between smart entrance control unit and tail lamp relay.
No	▶	GO TO 2.

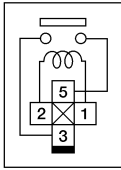
2	CHECK TAIL LAMP RELAY	
1. Apply 12V DC direct current between relay terminals 1 and 2. 2. Check continuity between relay terminals 3 and 5.		
		
AEL916B		
<p style="color: blue;">Continuity: 12V applied. Yes No voltage applied. No</p> <p style="text-align: center;">OK or NG</p>		
OK	▶	GO TO 3.
NG	▶	Replace relay.

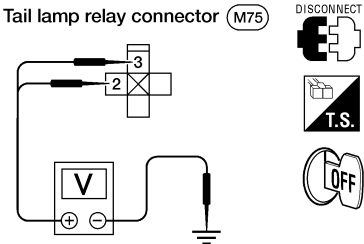
3	CHECK TAIL LAMP RELAY POWER SUPPLY	
Check voltage between tail lamp relay terminals 2, 3 and ground.		
		
AEL917B		
Does battery voltage exist?		
Yes	▶	Check tail lamp circuits.
No	▶	Check harness between tail lamp relay and battery.

THEFT WARNING SYSTEM

Trouble Diagnoses (Cont'd)

STARTER INTERRUPT SYSTEM CHECK

=NDEL0120S11

1	CHECK STARTER MOTOR INTERRUPT SIGNAL	
<p>1. Turn ignition switch ON. 2. Check voltage between smart entrance control unit terminal 28 and ground.</p> <div style="text-align: center;"> </div> <p>Voltage [V]: Except starter interrupted phase Approx. 12 Starter interrupted phase 0</p> <p>Refer to wiring diagram, EL-260.</p> <p style="text-align: right;">AEL934B</p>		
OK or NG		
OK	▶	GO TO 2.
NG	▶	<p>Check the following</p> <ul style="list-style-type: none"> ● 7.5A fuse (No. 39, located in fuse and fusible link box) ● Harness for open or short between theft warning relay and fuse ● Harness for open or short between smart entrance control unit and theft warning relay.

2	CHECK THEFT WARNING RELAY	
Check theft warning relay.		
OK or NG		
OK	▶	Check system again.
NG	▶	Replace theft warning relay.

GI

MA

EM

LC

EC

FE

AT

AX

SU

BR

ST

RS

BT

HA

SC

EL

IDX

SMART ENTRANCE CONTROL UNIT

Description

Description

NDEL0121

The following systems are controlled by the smart entrance control unit.

- Illumination control (brightness adjustment)
- Interior room lamp
- Warning chime
- Rear window defogger timer
- Power window and electric sunroof delay timer
- Power door lock
- Multi-remote control system
- Theft warning system

For detailed description and wiring diagrams, refer to the relevant pages for the each system.

The smart entrance control unit receives signals from the switches and sensors to control their corresponding system relays and actuators.

System	Input	Output
Illumination control	Illumination control switch	Combination meter and switch illumination
Interior room lamp	Ignition switch (ON) Key switch (inserted) Front door switch LH and RH Sliding door switch LH and RH Back door latch switch LH and RH Lighting switch (interior)	Interior lighting
Warning chime	Ignition switch (ON) Key switch (inserted) Lighting switch (1st) Seat belt buckle switch Front door switch LH	Warning chime (internal)
Rear window defogger timer	Ignition switch (ON) Rear window defogger switch	Rear window defogger relay
Power window and electric sunroof delay timer	Ignition switch (ON) Front door switch LH	Power window relay
Power door lock	Door lock/unlock switch LH and RH Key switch (inserted) Front door switch LH and RH Sliding door switch LH and RH Front door unlock sensor LH and RH Sliding door unlock sensor LH and RH Front door key cylinder switch LH and RH (lock/unlock) Back door key cylinder switch (unlock)	Door lock actuators
Multi-remote control system	Ignition switch (ACC) Key switch (inserted) Front door switch LH and RH Sliding door switch LH and RH Back door latch switch LH and RH Front door unlock sensor LH and RH Sliding door unlock sensor LH and RH Back door unlock sensor Remote controller	Door lock actuators Horn relay Tail lamp relay Interior lighting Headlamp control unit Memory seat and mirror control unit

SMART ENTRANCE CONTROL UNIT

Description (Cont'd)

System	Input	Output
Theft warning system	Ignition switch (ACC, ON)	Horn relay Tail lamp relay Headlamp control unit Security indicator lamp Theft warning relay (starter interrupt)
	Hood switch	
	Key switch (inserted)	
	Front door switch LH and RH	
	Sliding door switch LH and RH	
	Back door latch switch LH and RH	
	Front door unlock sensor LH and RH	
	Sliding door unlock sensor LH and RH	
	Back door unlock sensor	
	Front door key cylinder switch LH and RH (lock/unlock)	
Back door key cylinder switch (unlock)		

GI

MA

EM

LC

EC

FE

AT

AX

SU

BR

ST

RS

BT

HA

SC

EL

IDX

SMART ENTRANCE CONTROL UNIT

Schematic

Schematic

NDEL0122

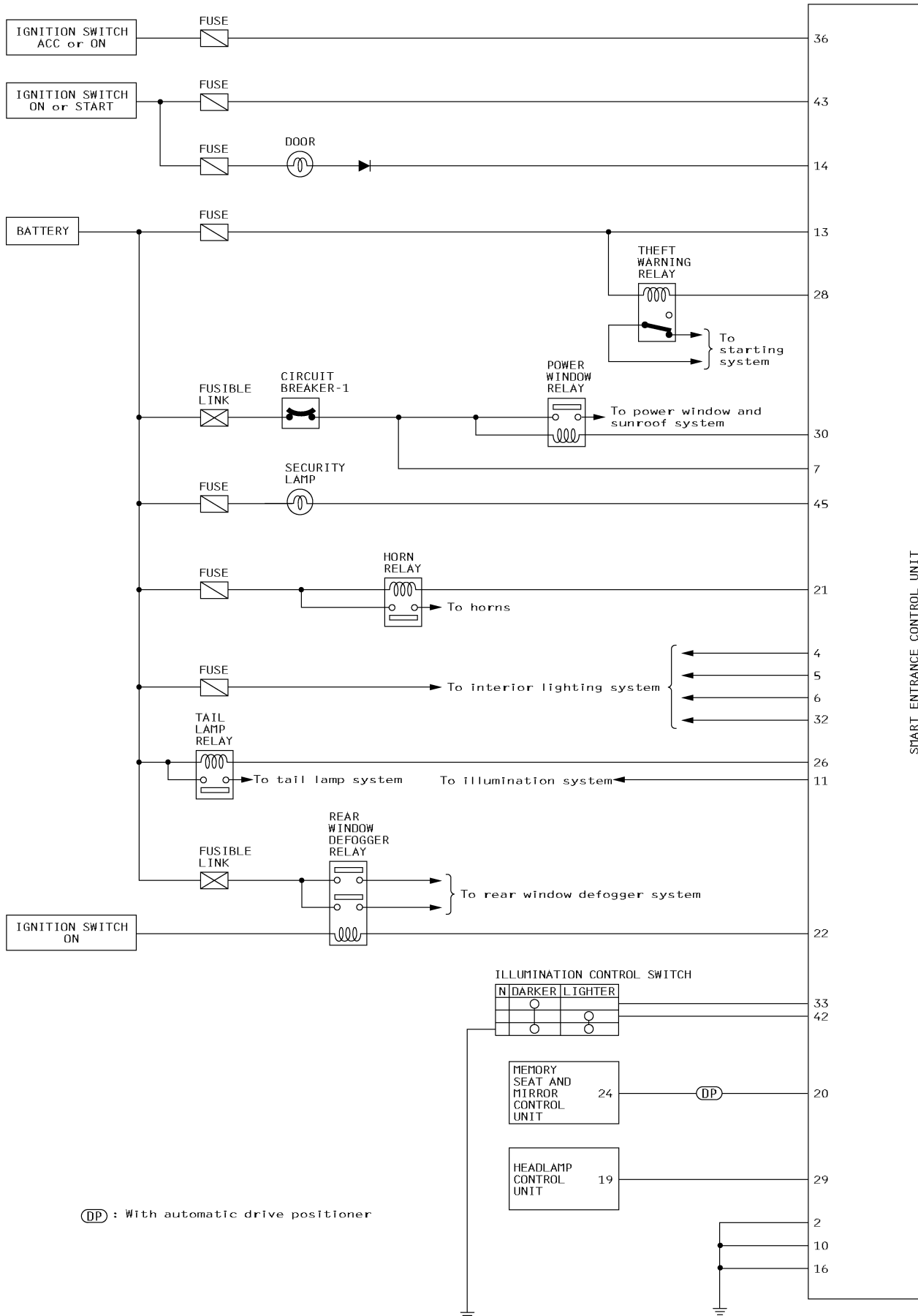

SMART ENTRANCE CONTROL UNIT

DP : With automatic drive positioner

WEL256

SMART ENTRANCE CONTROL UNIT

Schematic (Cont'd)

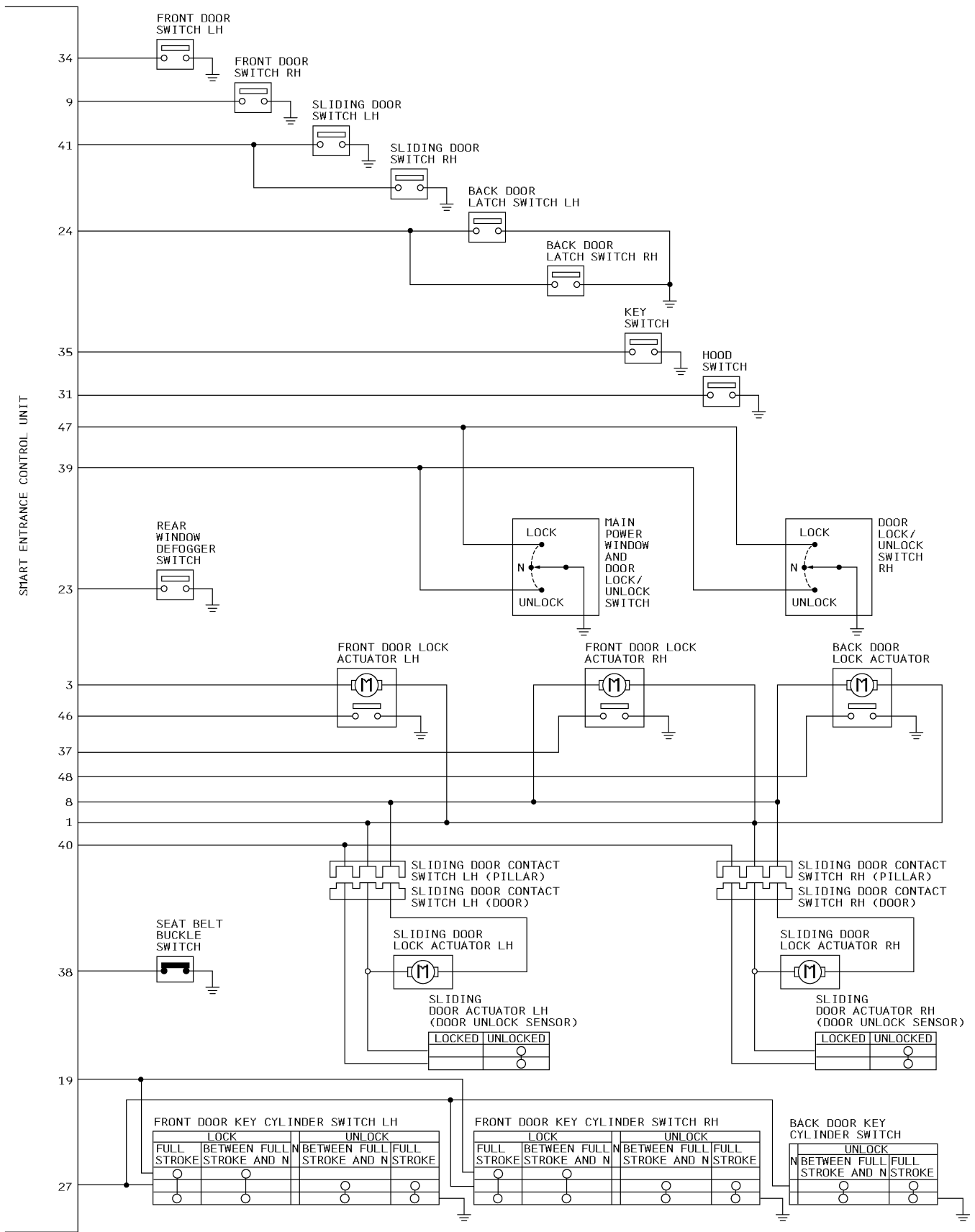

GI
MA
EM
LC
EC
FE
AT
AX
SU
BR
ST
RS
BT
HA
SC
EL
IDX

SMART ENTRANCE CONTROL UNIT

Smart Entrance Control Unit Inspection Table

Smart Entrance Control Unit Inspection Table

NDEL0123

Terminal No.	Wire color	Connections	Operated condition	Voltage (Approximate values)
1	G/Y	Front door lock actuator LH/RH, sliding door lock actuator, back door lock actuator	Door lock/unlock switch NEUTRAL→LOCK	0V → 12V
2	B	Actuator ground	—	—
3	W/G	Front door lock actuator LH	Door lock/unlock switch NEUTRAL→UNLOCK	0V → 12V
4	BR/W	Interior lamps (Zone B)	When interior lamps are operated by smart entrance control unit	12V → 0V
5	W	Interior lamps (Zone A)	When interior lamps are operated by smart entrance control unit	12V → 0V
6	OR	Interior lamps (Zone C)	When interior lamps are operated by smart entrance control unit	12V → 0V
7	LG	Circuit breaker-1 (Battery power)	—	12V
8	W/R	Front door lock actuator LH/RH, sliding door lock actuator LH/RH, back door lock actuator	Door lock/unlock switch NEUTRAL→UNLOCK	0V → 12V
9	R/W	Front door switch RH	OFF (Closed) → ON (Open)	1.5V → 0V
10	B	Power ground	—	—
11	P/B	Illumination	OFF → ON	0V → 3V or more
13	G/R	Fuse 39 (logic battery power)	—	12V
14	BR/W	Door ajar warning lamp	OFF (Closed) → ON (Open)	12V → 0V
16	B	Signal ground	—	—
19	R	Front door key cylinder switch LH/RH	OFF (Neutral) → ON (Locked)	1.5V → 0V
20	P	Memory seat and mirror control unit	Remote controller ID code sent to initialize automatic drive positioner	0V ↔ 12V
21	Y	Horn relay	When doors are locked using remote controller or theft warning system is in alarm phase	12V → 0V
22	G/B	Rear window defogger relay	OFF → ON	12V → 0V
23	G/R	Rear window defogger switch	OFF → ON	1.5V → 0V
24	R/W	Back door latch switch LH/RH	OFF (Closed) → ON (Open)	1.5V → 0V
26	GY/R	Tail lamp relay	During remote controller operation or when theft warning system is in alarm phase	12V → 0V
27	R/B	Front door key cylinder switch LH/RH, back door key cylinder switch	OFF (Neutral) → ON (Unlock)	1.5V → 0V
28	L	Theft warning relay	Theft warning system is in alarm phase	12V → 0V
29	P/W	Headlamp control unit	Theft warning system is in alarm phase or panic operation is activated	0V ↔ 12V
30	B/R	Power window relay	OFF → ON	12V → 0V
31	B/P	Hood switch	ON (Open) → OFF (Closed)	0V → 1.5V

SMART ENTRANCE CONTROL UNIT

Smart Entrance Control Unit Inspection Table (Cont'd)

Terminal No.	Wire color	Connections	Operated condition	Voltage (Approximate values)
32	R	Lighting switch (Interior lighting)	OFF (Open) → ON (Closed)	1.5V → 0V
33	L	Illumination control	NEUTRAL → DARKER	1.5V → 0V
34	R	Front door switch LH	OFF (Closed) → ON (Open)	1.5V → 0V
35	L/OR	Key switch	Ignition key inserted in ignition key cylinder → Ignition key removed from ignition key cylinder	0V → 1.5V
36	LG/R	Ignition switch (ACC)	Ignition switch in ACC position	12V
37	G/Y	Front door lock actuator RH (door unlock sensor)	LOCKED → UNLOCKED	1.5V → 0V
38	G	Seat belt buckle switch	ON (Unfastened) → OFF (Fastened)	0V → 12V
39	G/OR	Main power window and door lock/unlock switch, door lock/unlock switch RH	NEUTRAL → UNLOCK	1.5V → 0V
40	PU	Sliding door lock actuator LH/RH (door unlock sensor)	LOCKED → UNLOCKED	1.5V → 0V
41	R/G	Sliding door switch LH/RH	OFF (Closed) → ON (Open)	1.5V → 0V
42	L/R	Illumination control	NEUTRAL → LIGHTER	1.5V → 0V
43	LG	Ignition switch (ON)	Ignition switch in ON position	12V
45	GY	Security indicator lamp	OFF → ON	12V → 0V
46	R/Y	Front door lock actuator LH (door unlock sensor)	LOCKED → UNLOCKED	1.5V → 0V
47	G/W	Main power window and door lock/unlock switch, door lock/unlock switch RH	NEUTRAL → LOCK	1.5V → 0V
48	R/L	Back door lock actuator (door unlock sensor)	LOCKED → UNLOCKED	1.5V → 0V

GI

MA

EM

LC

EC

FE

AT

AX

SU

BR

ST

RS

BT

HA

SC

EL

IDX

INTEGRATED HOMELINK TRANSMITTER

Wiring Diagram — TRNSMT —

Wiring Diagram — TRNSMT —

NDEL0124

EL-TRNSMT-01

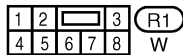
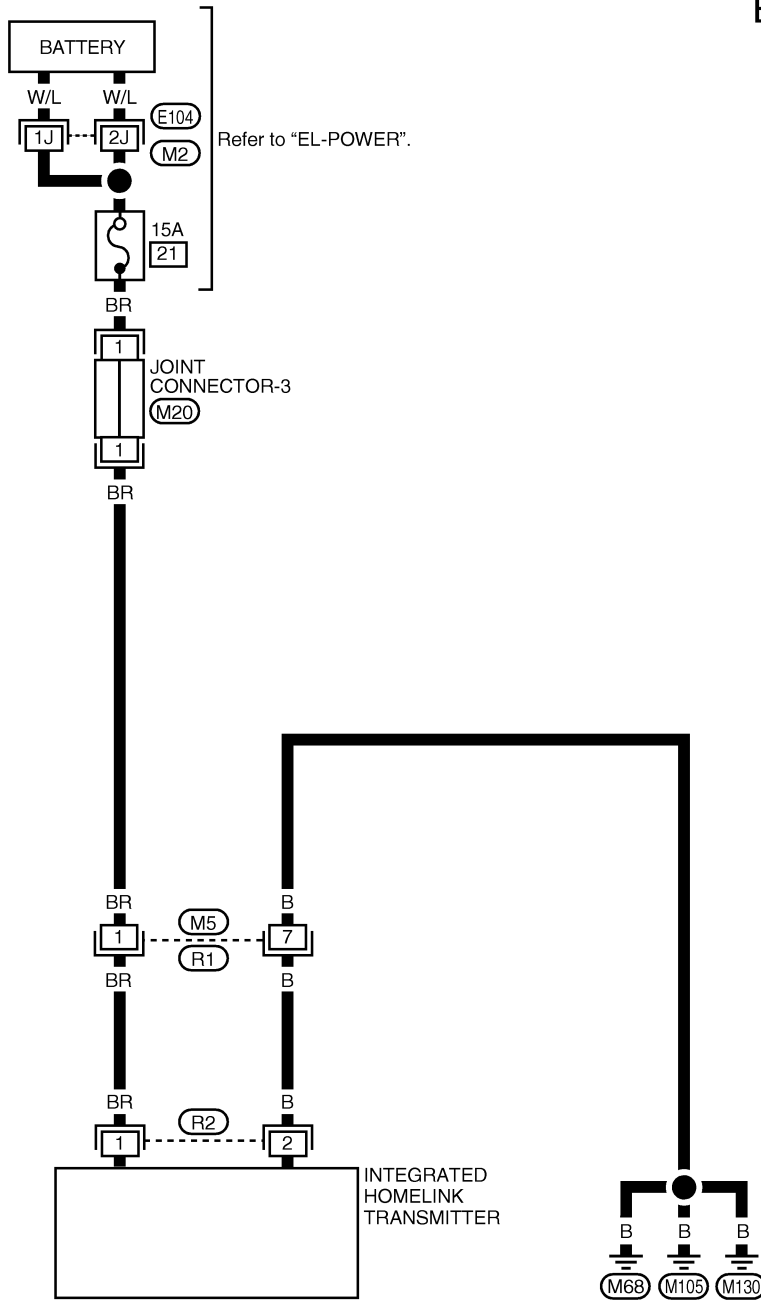

Refer to the following.

(M20) - JOINT CONNECTOR

WEL258

INTEGRATED HOMELINK TRANSMITTER

Trouble Diagnoses

Trouble Diagnoses DIAGNOSTIC PROCEDURE

NDEL0125

NDEL0125S01

SYMPTOM: Transmitter does not activate receiver.

Before conducting the procedure given below, make sure that system receiver (garage door opener, etc.) operates with original hand-held transmitter. If NG, receiver or hand-held transmitter is at fault, not vehicle related.

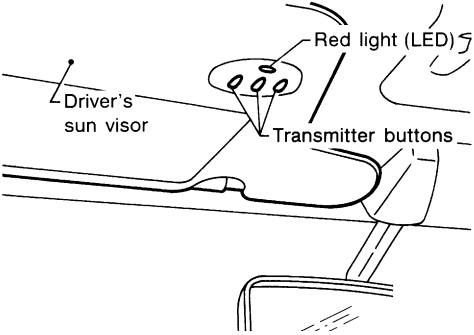
1	PRELIMINARY CHECK		
<p>1. Turn ignition switch "OFF". 2. Does red light (LED) of transmitter illuminate when any button is pressed?</p>			
			
Yes or No			
Yes		▶	GO TO 2.
No		▶	GO TO 3.

2	CHECK TRANSMITTER FUNCTION		
<p>Check transmitter with Tool. For details, refer to Technical Service Bulletin.</p>			
OK or NG			
OK		▶	Receiver or handheld transmitter fault, not vehicle related.
NG		▶	Replace transmitter with sun visor assembly.

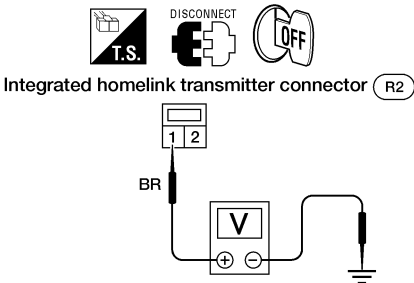
3	CHECK POWER SUPPLY		
<p>1. Disconnect transmitter connector. 2. Turn ignition switch "OFF". 3. Check voltage between terminal 1 and body ground.</p>			
			
Does battery voltage exist?			
Yes		▶	GO TO 4.
No		▶	Check fuse 15A fuse (No. 21, located in the fuse block) and repair harness.

GI

MA

EM

LC

EC

FE

AT

AX

SU

BR

ST

RS

BT

HA

SC

EL

IDX

AEL865B

INTEGRATED HOMELINK TRANSMITTER

Trouble Diagnoses (Cont'd)

4	CHECK GROUND CIRCUIT
<p>Check continuity between terminal 2 and ground.</p> <div data-bbox="592 262 998 546" style="text-align: center;"><p>Integrated homelink transmitter connector (R2)</p><p>Does continuity exist?</p></div>	
Yes	▶ Replace transmitter with sun visor assembly.
No	▶ Repair harness.

AEL866B

ELECTRICAL UNITS LOCATION

Engine Compartment

Engine Compartment

NDEL0126

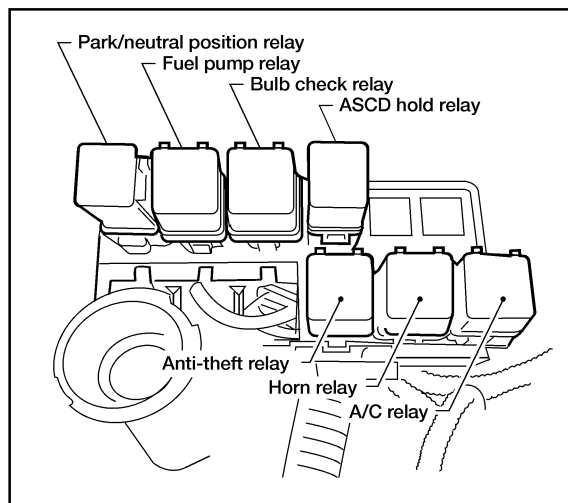
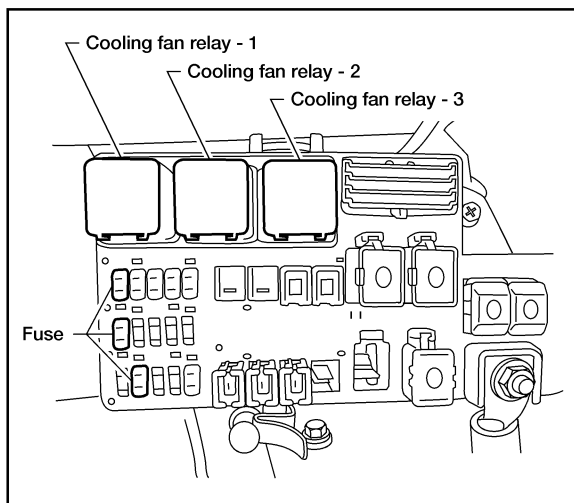
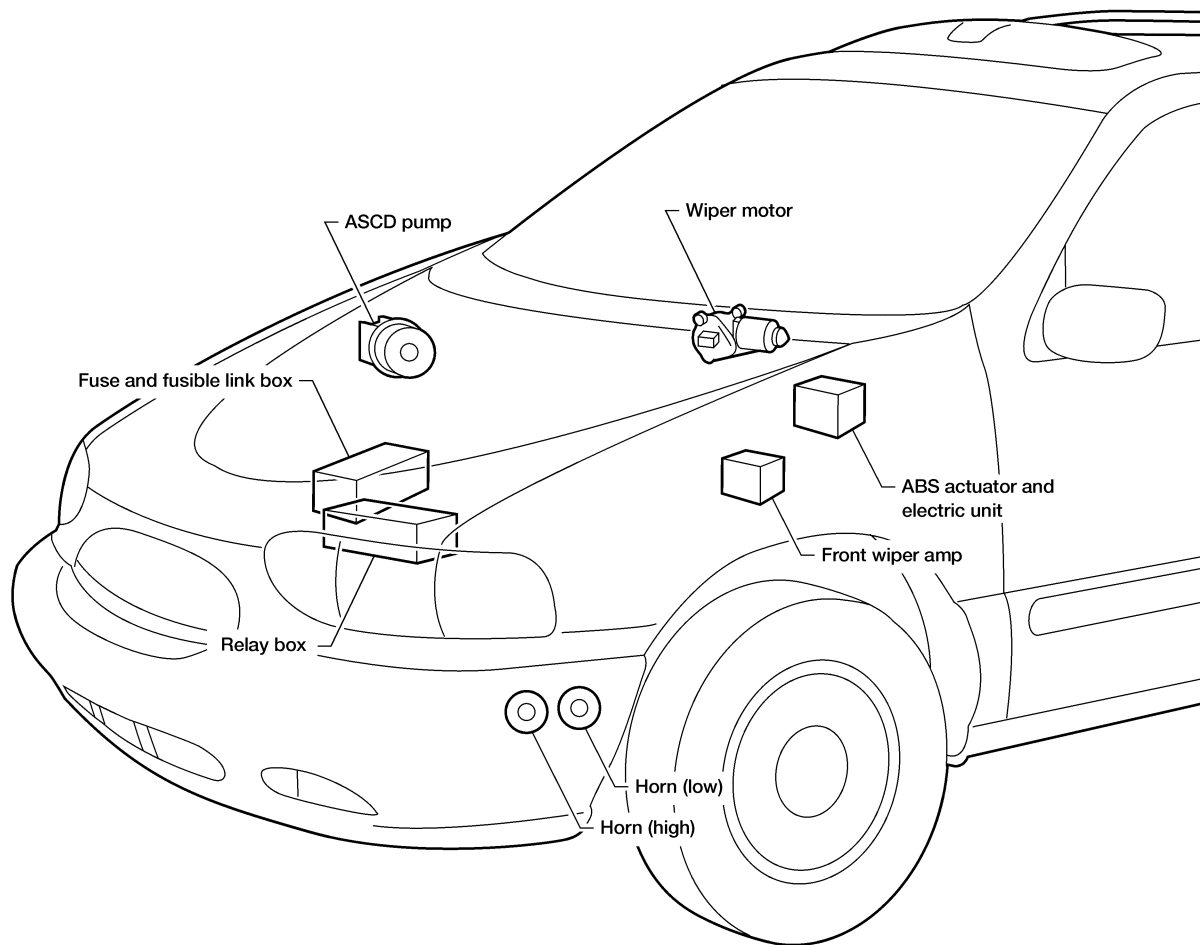

GI

MA

EM

LC

EC

FE

AT

AX

SU

BR

ST

RS

BT

HA

SC

EL

IDX

AEL188C

ELECTRICAL UNITS LOCATION

Passenger Compartment

Passenger Compartment

NDEL0127

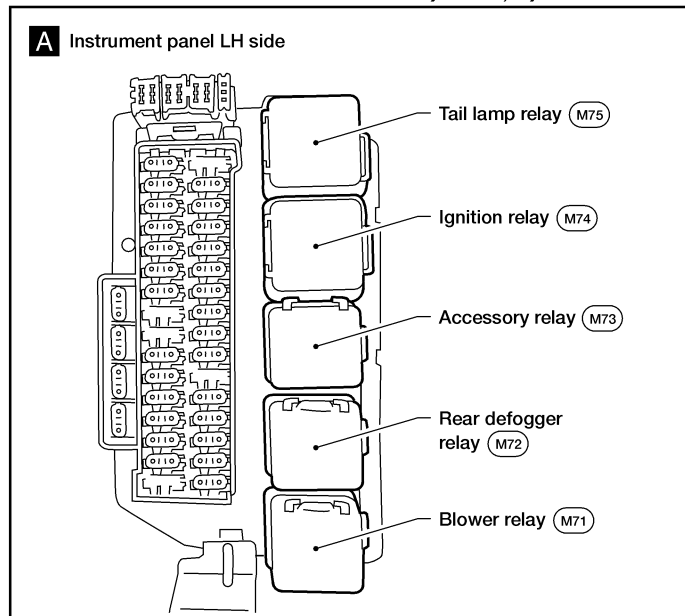
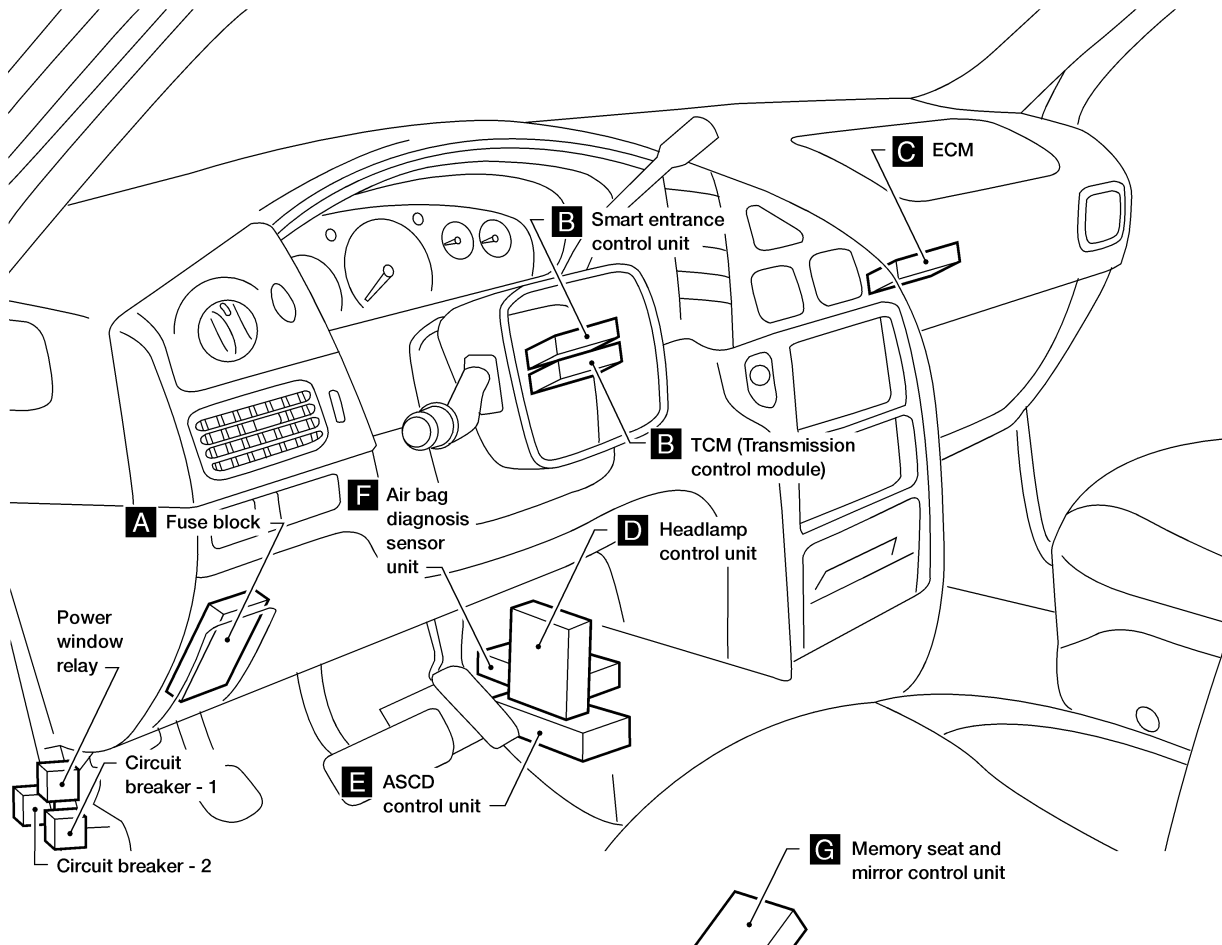

WEL277

ELECTRICAL UNITS LOCATION

Passenger Compartment (Cont'd)

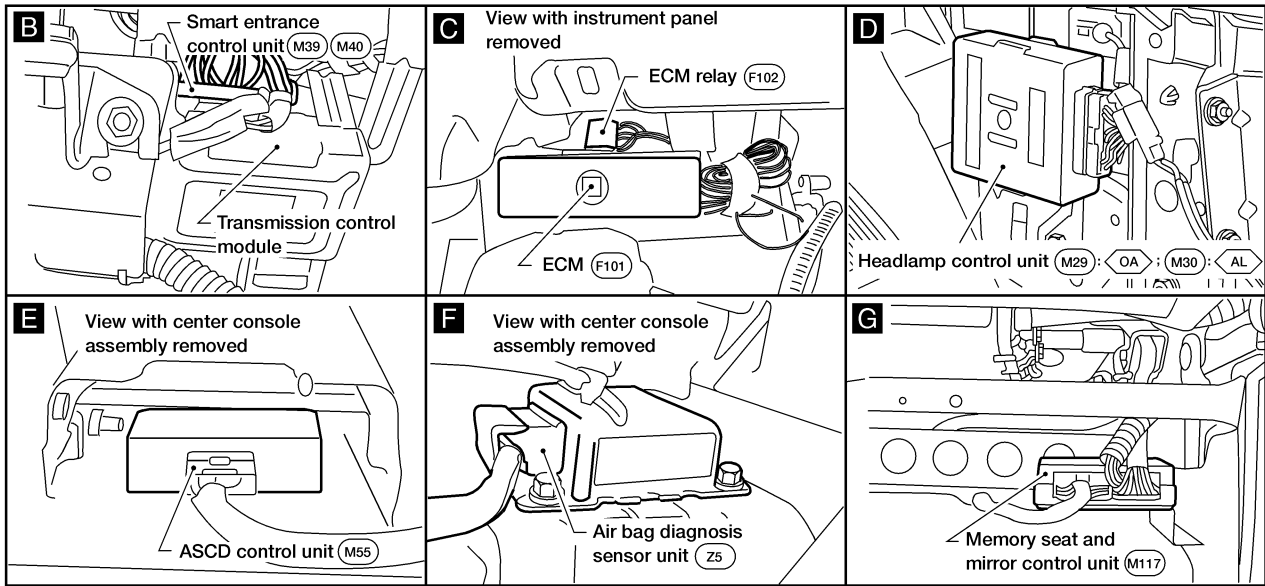

AL : With autolamp

OA : Without autolamp

GI

MA

EM

LC

EC

FE

AT

AX

SU

BR

ST

RS

BT

HA

SC

EL

IDX

HARNESS LAYOUT

How to Read Harness Layout

How to Read Harness Layout

NDEL0128

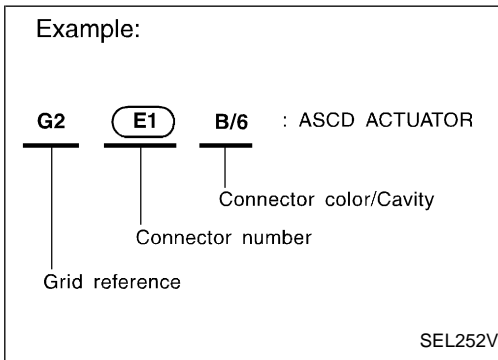

The following Harness Layouts use a map style grid to help locate connectors on the drawings:

- Main Harness and Body No. 2 Harness
- Engine Room Harness (Engine Compartment)

TO USE THE GRID REFERENCE

NDEL0128S01

1. Find the desired connector number on the connector list.
2. Find the grid reference.
3. On the drawing, find the crossing of the grid reference letter column and number row.
4. Find the connector number in the crossing zone.
5. Follow the line (if used) to the connector.

CONNECTOR SYMBOL

NDEL0128S02

Main symbols of connector (in Harness Layout) are indicated in the below.

Connector type	Water proof type		Standard type	
	Male	Female	Male	Female
<ul style="list-style-type: none"> ● Cavity: Less than 4 ● Relay connector 				
<ul style="list-style-type: none"> ● Cavity: From 5 to 8 				
<ul style="list-style-type: none"> ● Cavity: More than 9 				
<ul style="list-style-type: none"> ● Ground terminal etc. 	—			

HARNESS LAYOUT

Outline

Outline

NDEL0129

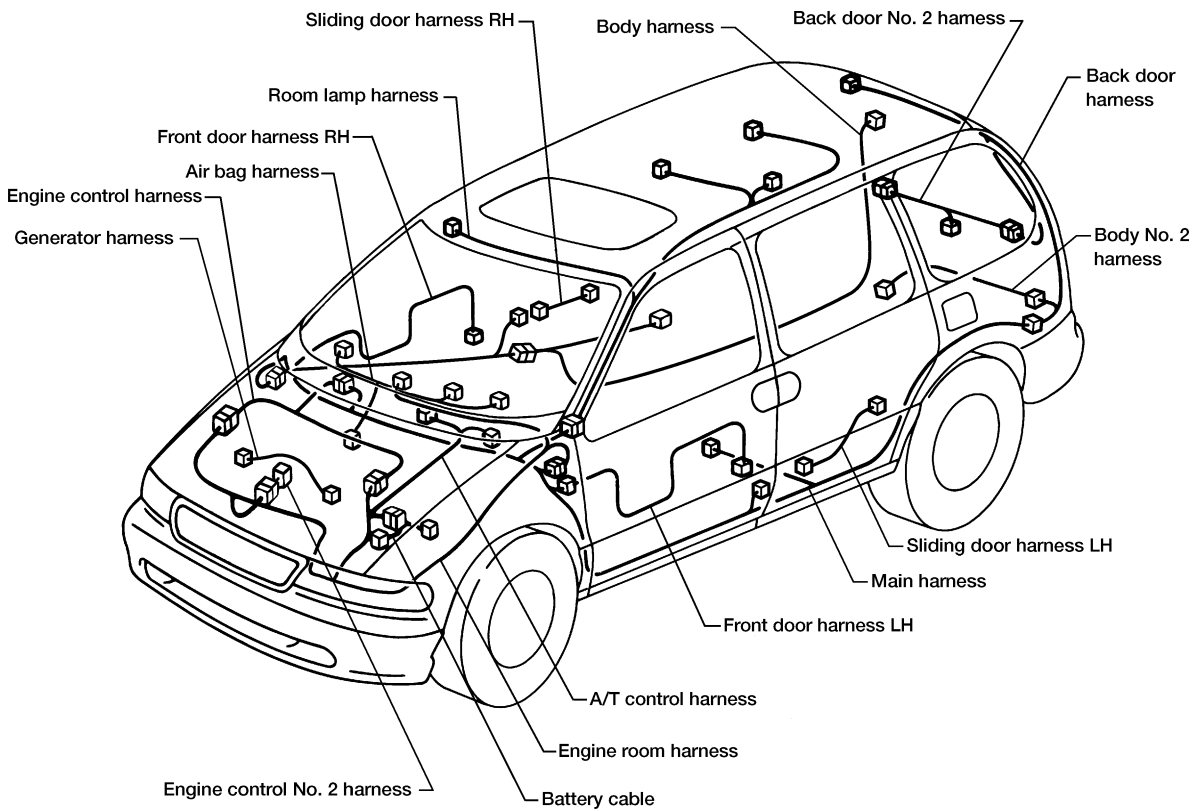

AEL296C

NOTE:

For detailed ground distribution information, refer to "GROUND DISTRIBUTION", EL-20.

GI

MA

EM

LC

EC

FE

AT

AX

SU

BR

ST

RS

BT

HA

SC

EL

IDX

HARNES LAYOUT

Main Harness and Body No. 2 Harness

Main Harness and Body No. 2 Harness

NDEL0130

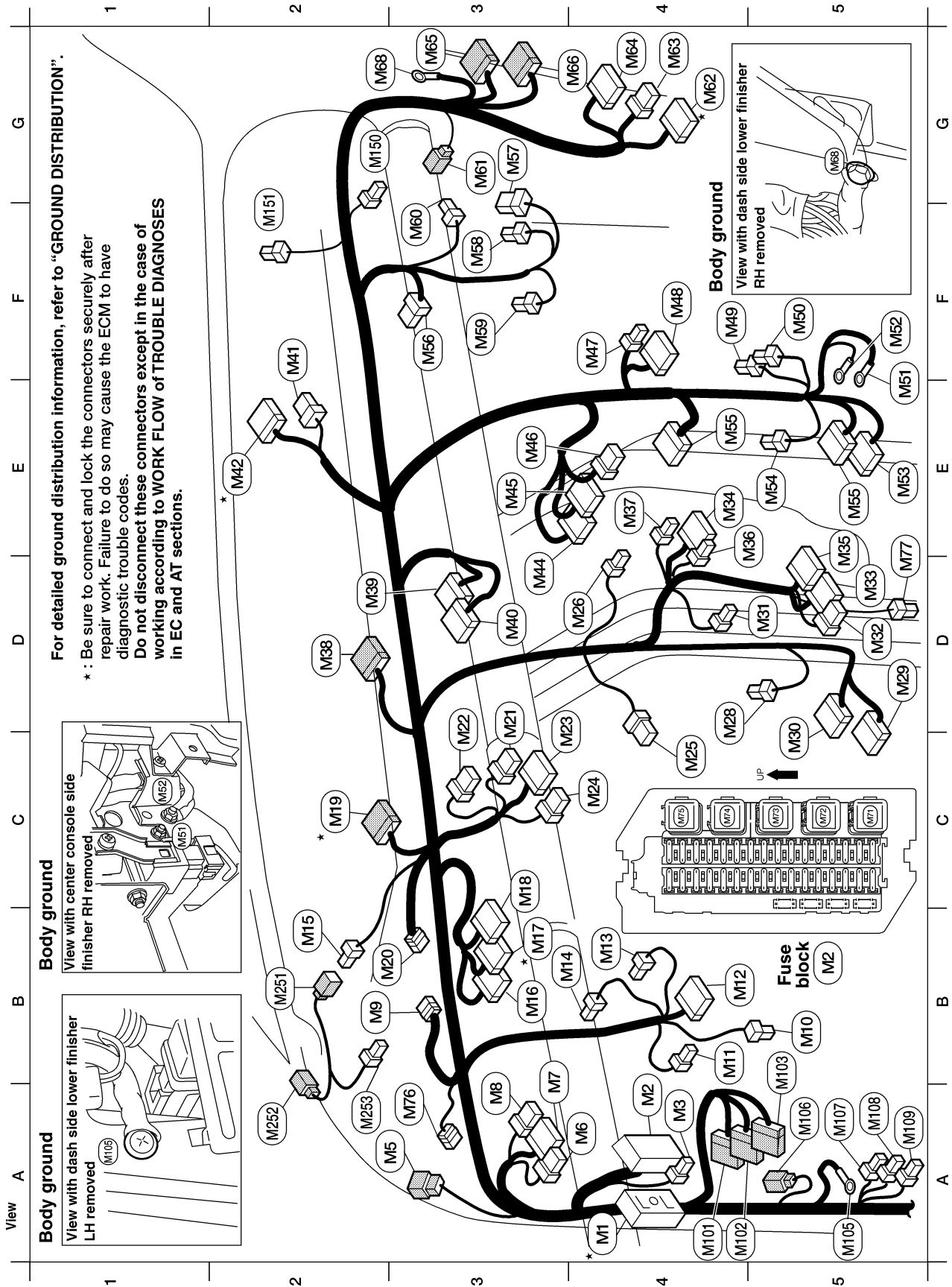

WEL265

HARNESS LAYOUT

Main Harness and Body No. 2 Harness (Cont'd)

* Main harness

- A4 (M1) SMJ : To (E101)
 A4 (M2) FB : Fuse block
 A4 (M3) W/4 : To (M2) (fuse block)
 A3 (M5) W/8 : To (R1)
 A3 (M6) W/8 : ASCD main switch
 A3 (M7) GY/12 : Lighting switch
 A3 (M8) B/8 : Illumination control switch
 B3 (M9) GY/33 : Joint connector-2
 B5 (M10) B/1 : Parking brake switch
 B4 (M11) B/3 : Combination flasher unit
 B4 (M12) W/16 : Data link connector
 B4 (M13) L/2 : ASCD brake switch
 B4 (M14) B/2 : Stop lamp switch
 B2 (M15) W/3 : To (M25) (sunload sensor) (with auto A/C)
 B3 (M16) W/12 : Combination meter
 B3 * (M17) B/12 : Combination meter
 B3 (M18) B/10 : Combination meter
 C2 * (M19) W/16 : To (F402)
 B3 (M20) GY/33 : Joint connector-3
 C3 (M21) W/6 : Rear wiper switch
 C3 (M22) W/6 : Rear window defogger switch
 C3 (M23) W/10 : Hazard switch
 C3 (M24) W/8 : Security indicator lamp
 C4 (M25) W/6 : To (Z101) (sprial cable)
 D4 (M26) B/2 : Cigarette lighter socket (accessory)
 D5 (M28) W/2 : Footlamp LH
 D5 (M29) W/10 : Headlamp control unit (without auto lamp and without DTRL)
 D5 (M30) W/22 : Headlamp control unit (with auto lamp and/or DTRL)
- D4 (M30) W/4 : Front fan switch
 D5 (M32) W/8 : Rear fan switch (front)
 D5 (M33) GY/26 : EATC unit (with auto A/C)
 E4 (M34) B/12 : A/C control unit (with manual A/C)
 D5 (M35) GY/22 : EATC unit (with auto A/C)
 D4 (M36) W/3 : A/C control unit (temperature control switch) (with manual A/C)
 E4 (M37) W/2 : A/C control unit (illumination) (with manual A/C)
 D2 (M38) Y/12 : To (Z1)
 D3 (M39) W/22 : Smart entrance control unit (SECU)
 D3 (M40) W/26 : Smart entrance control unit (SECU)
 E2 (M41) W/6 : To (F105)
 E2 * (M42) W/24 : To (F104)
 E4 (M44) B/20 : Audio unit
 E4 (M45) B/16 : Audio unit
 E4 (M46) B/8 : Audio unit (with premium audio)
 F4 (M47) BR/4 : To (M16) (with manual A/C)
 F4 (M48) W/16 : To (M17) (with manual A/C)
 F5 (M49) L/4 : Rear fan switch relay No. 1 (with manual A/C and rear A/C)
 F5 (M50) L/4 : Rear blower motor relay (with auto A/C)
 F5 (M51) - : Body ground
 F5 (M52) - : Body ground
 E5 (M53) B/12 : C/D changer
 E5 (M54) W/2 : Footlamp RH
 E5 (M55) B/20 : ASCD control unit
 F3 (M56) W/8 : Intake door motor
 G3 (M57) B/5 : Front blower speed control unit (with auto A/C)
 F3 (M58) B/2 : Front blower motor
- F3 (M59) BR/4 : Front blower motor resistor
 F3 (M60) B/2 : Glove box lamp
 G3 (M61) W/2 : To (M159)
 G4 * (M62) W/16 : To (B1)
 G4 (M63) W/6 : To (B2)
 G4 (M64) W/10 : To (B3)
 G3 (M65) W/16 : To (D101)
 G3 (M66) W/10 : To (D102)
 G3 (M68) - : Body ground
 C5 (M71) BR/6 : Front blower motor relay
 C5 (M72) BR/6 : Rear window defogger relay
 C5 (M73) BR/6 : Accessory relay
 C4 (M74) L/4 : Ignition relay
 C4 (M75) L/4 : Tail lamp relay
 A3 (M76) W/2 : Diode-1
 D5 (M77) BR/4 : Ashtray illumination
 A4 (M100) W/10 : To (D1)
 A4 (M102) W/12 : To (D2)
 A5 (M103) W/16 : To (D3)
 A5 (M106) - : Body ground
 A5 (M109) GY/3 : Inertia fuel shutoff switch
 A5 (M107) L/4 : Power window relay
 A5 (M108) W/2 : Circuit breaker-1
 A5 (M109) W/2 : Circuit breaker-2
- Autolamp Sub harness**
 G2 (M159) W/2 : To (M161)
 F2 (M151) W/2 : Autolamp sensor
- EATC Sub harness**
 B2 (M251) W/3 : To (M115)
 A2 (M252) B/2 : Sunload sensor
 B2 (M253) B/2 : In-vehicle temperature sensor

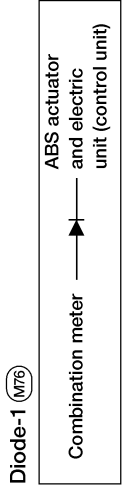

* : Be sure to connect and lock the connectors securely after repair work. Failure to do so may cause the ECM to have diagnostic trouble codes.

Do not disconnect these connectors except in the case of working according to WORK FLOW of TROUBLE DIAGNOSES in EC and AT sections.

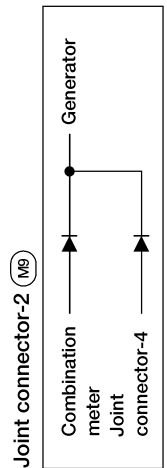

WEL266

GI MA EM LC EC FE AT AX SU BR ST RS BT HA SC EL IDX

HARNESS LAYOUT

Main Harness and Body No. 2 Harness (Cont'd)

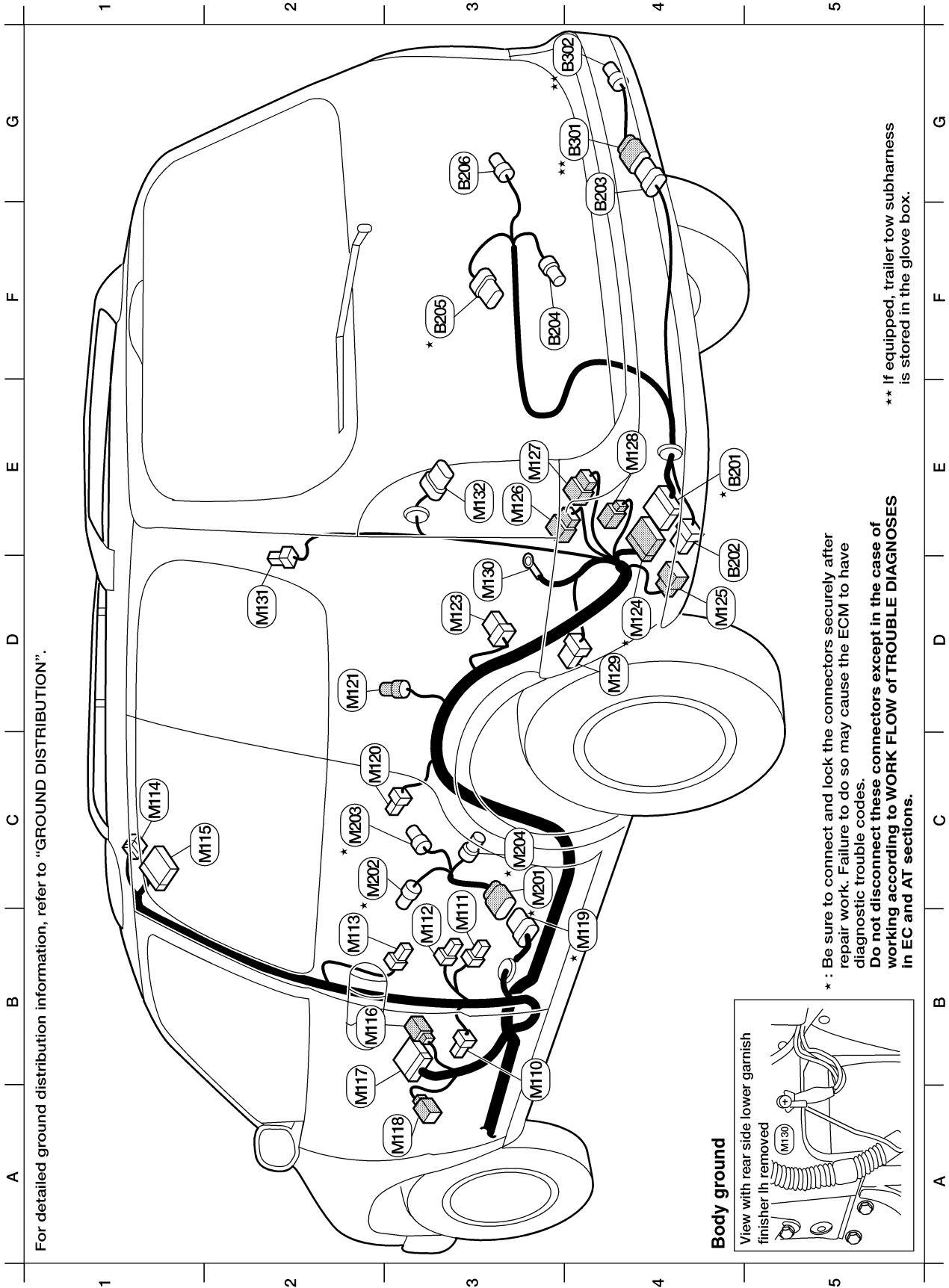

For detailed ground distribution information, refer to "GROUND DISTRIBUTION".

* : Be sure to connect and lock the connectors securely after repair work. Failure to do so may cause the ECM to have diagnostic trouble codes.
Do not disconnect these connectors except in the case of working according to WORK FLOW of TROUBLE DIAGNOSES in EC and AT sections.

** If equipped, trailer tow subharness is stored in the glove box.

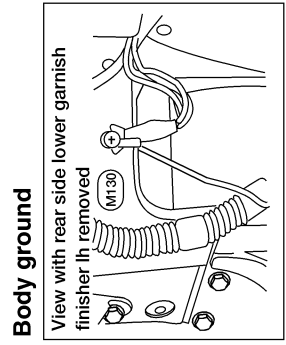

HARNES LAYOUT

Main Harness and Body No. 2 Harness (Cont'd)

Main harness

- B3 (M110) B/3 : Front door switch LH
- B3 (M111) B/1 : Sliding door switch LH
- B3 (M112) B/4 : Sliding door contact switch LH (pillar)
- B3 (M113) W/2 : Sliding door step lamp LH
- C1 (M114) W/6 : Joint connector-1
- C2 (M115) B/16 : Rear audio remote control unit
(with rear audio remote control unit)
- B3 (M116) B/2 : Seat belt buckle switch
- B3 (M117) W/26 : Memory seat and mirror control unit
(with automatic drive positioner)
- A3 (M118) W/2 : To (P51)
- B3* (M119) GY/8 : To (M201)
- C3 (M120) B/2 : Rear power point (with rear power point)
- D3 (M121) B/2 : Rear speaker LH
- D3 (M123) W/6 : Sub woofer amplifier (with premium audio)
- E4* (M124) W/10 : To (E201)
- D4 (M125) W/6 : To (E202)
- E4 (M126) W/8 : To (D201)
- E4 (M127) W/6 : To (D202)

- E4 (M128) W/4 : To (D203)
- D4 (M129) W/8 : Trailer tow control unit (with trailer tow)
- D3 (M130) - : Body ground
- D2 (M131) B/2 : Rear power vent window motor LH (with power vents)
- E3 (M132) GY/6 : Rear combination lamp LH
- EVAP Sub harness**
- C3* (M201) GY/8 : To (M119)
- C3* (M202) B/2 : EVAP canister vent control valve
- C3* (M203) GY/3 : EVAP control system pressure sensor
- C3* (M204) G/2 : Vacuum cut valve bypass valve
- Body No. 2 harness**
- E4* (E201) W/10 : To (M124)
- E4 (E202) W/6 : To (M125)
- F4 (E203) GY/6 : To (E301)
- F4 (E204) BR/2 : Rear wheel sensor LH
- F3* (E205) GY/6 : Fuel tank gauge unit
- G3 (E206) GY/6 : Rear wheel sensor RH
- Trailer tow sub harness**
- F4 (E301) GY/6 : To (E203)
- G4 (E302) B/4 : SAE J1239 trailer tow connector (with trailer tow)

* : Be sure to connect and lock the connectors securely after repair work. Failure to do so may cause the ECM to have diagnostic trouble codes.
Do not disconnect these connectors except in the case of working according to WORK FLOW of TROUBLE DIAGNOSES in EC and AT sections.

GI
MA
EM
LC
EC
FE
AT
AX
SU
BR
ST
RS
BT
HA
SC
EL
IDX

HARNESS LAYOUT

Engine Room Harness

Engine Room Harness ENGINE COMPARTMENT

NDEL0131

NDEL0131S01

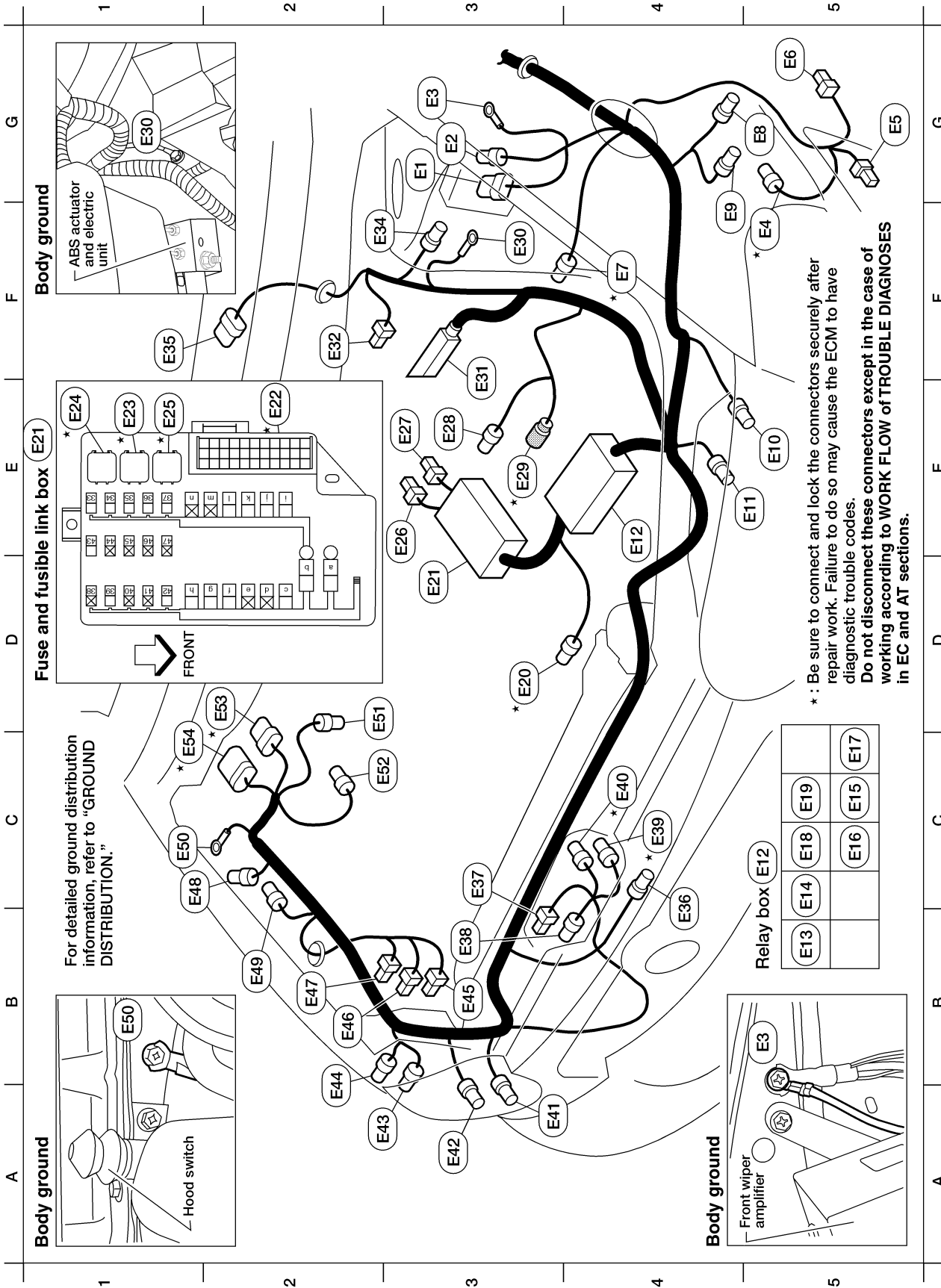

WEL269

HARNESS LAYOUT

Engine Room Harness (Cont'd)

G3	E1	GY/6	: Front wiper amplifier	E1	E28	GY/1	: Starter motor
G3	E2	GY/4	: Front wiper amplifier	E3	E29	GY/4	: To F304
G3	E3	—	: Body ground	G3	E30	—	: Body ground
G5	E4	GY/2	: Dropping resistor	F3	E31	B/31	: ABS actuator and electric unit (control unit)
G5	E5	B/1	: Horn (high)	F2	E32	GY/2	: Brake fluid level switch
G5	E6	B/1	: Horn (low)	G3	E34	BR/2	: Front wheel sensor LH
F4	E7	B/2	: Intake air temperature sensor	F1	E35	GY/6	: Front wiper motor
G5	E8	B/2	: Front side marker lamp LH	B4	E36	B/2	: Ambient temperature sensor (with auto A/C)
G5	E9	B/3	: Front combination lamp LH	B3	E37	B/1	: Oil pressure switch
E5	E10	B/3	: Headlamp LH	B4	E38	GY/2	: Generator
E5	E11	B/3	: Front turn signal lamp LH	C4	E39	GY/3	: Front heated oxygen sensor (except for California)
E4	E12	FB	: Relay box	C4	E40	GY/4	: Rear heated oxygen sensor (for California)
B5	E13	GY/6	: Park/neutral position (PNP) relay	A3	E41	B/3	: Front turn signal lamp RH
C5	E14	L/4	: Fuel pump relay	A3	E42	B/3	: Headlamp RH
C5	E15	L/4	: Horn relay	A2	E43	B/3	: Front combination lamp RH
C5	E16	B/5	: Theft warning relay	A2	E44	B/2	: Front side marker lamp RH
C5	E17	L/4	: Air conditioner relay	B3	E45	B/2	: Washer fluid level switch (for Canada)
C5	E18	L/4	: Bulb check relay	B2	E46	W/2	: Front washer motor
C5	E19	BR/6	: ASCD hold relay	B2	E47	G/2	: Rear washer motor
D4	E20	B/3	: Cooling fan motor	B2	E48	GY/2	: Hood switch
E3	E21	FB	: Fuse and fusible link box	B2	E49	GY/4	: ASCD pump
E2	E22	W/33	: Joint connector-4	B1	E50	—	: Body ground
E1	E23	L/4	: Cooling fan relay-3 (high relay)	C2	E51	B/4	: Low pressure switch
E1	E24	L/4	: Cooling fan relay-1 (low relay)	C2	E52	GY/2	: Front wheel sensor RH
E1	E25	L/4	: Cooling fan relay-2 (high relay)	C2	E53	GY/6	: To F2
E3	E26	B/1	: Battery	C1	E54	GY/12	: To F3
E3	E27	B/1	: Battery				

*: Be sure to connect and lock the connectors securely after repair work. Failure to do so may cause the ECM to have diagnostic trouble codes. Do not disconnect these connectors except in the case of working according to WORK FLOW of TROUBLE DIAGNOSES in EC and AT sections.

GI
MA
EM
LC
EC
FE
AT
AX
SU
BR
ST
RS
BT
HA
SC
EL
IDX

HARNESS LAYOUT

Engine Room Harness (Cont'd)

PASSENGER COMPARTMENT

=NDEL0131S02

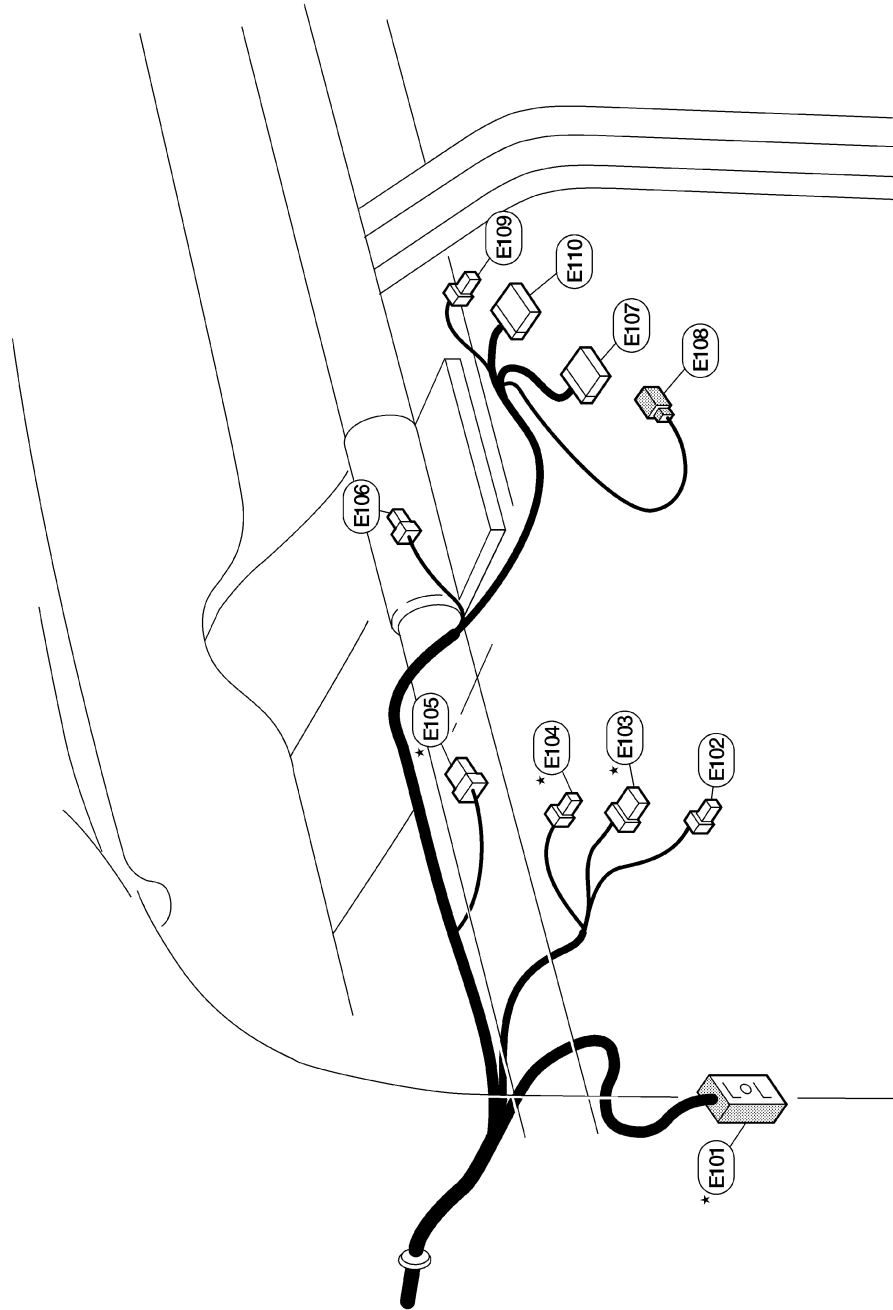

- * E101 SMJ : To (M1)
- E102 L/2 : To (M2)
- * E103 W/6 : To (M2)
- * E104 B/2 : To (M2)
- * E105 B/6 : Ignition switch
- E106 W/2 : A/T device (Shift lock solenoid and park position switch)
- E107 B/10 : Combination switch-1
- E108 BR/2 : Key switch
- E109 W/2 : Overdrive control switch
- E110 B/11 : Combination switch-2

* : Be sure to connect and lock the connectors securely after repair work. Failure to do so may cause the ECM to have diagnostic trouble codes. Do not disconnect these connectors except in the case of working according to WORK FLOW of TROUBLE DIAGNOSES in EC and AT sections.

HARNESS LAYOUT

Engine Control Harness

NDEL0132

NDEL0132S01

Engine Control Harness

ENGINE COMPARTMENT

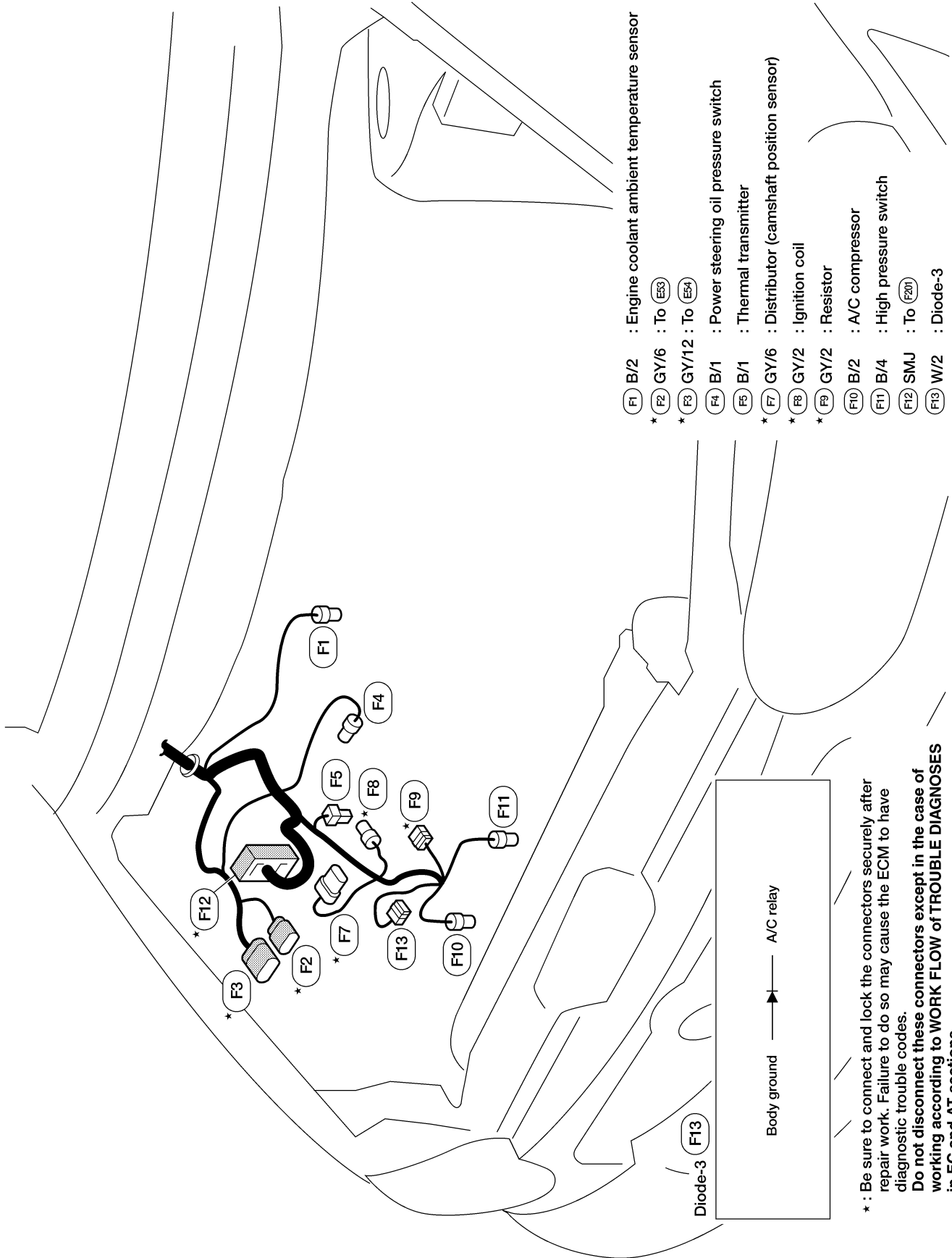

- (F1) B/2 : Engine coolant ambient temperature sensor
- * (F2) GY/6 : To (ES3)
- * (F3) GY/12 : To (ES4)
- (F4) B/1 : Power steering oil pressure switch
- (F5) B/1 : Thermal transmitter
- * (F7) GY/6 : Distributor (camshaft position sensor)
- * (F8) GY/2 : Ignition coil
- * (F9) GY/2 : Resistor
- (F10) B/2 : A/C compressor
- (F11) B/4 : High pressure switch
- (F12) SMJ : To (F20)
- (F13) W/2 : Diode-3

GI
MA
EM
LC
EC
FE
AT
AX
SU
BR
ST
RS
BT
HA
SC
EL
IDX

* : Be sure to connect and lock the connectors securely after repair work. Failure to do so may cause the ECM to have diagnostic trouble codes.
Do not disconnect these connectors except in the case of working according to WORK FLOW of TROUBLE DIAGNOSES in EC and AT sections.

HARNES LAYOUT

Engine Control Harness (Cont'd)

PASSENGER COMPARTMENT

NDEL0132S02

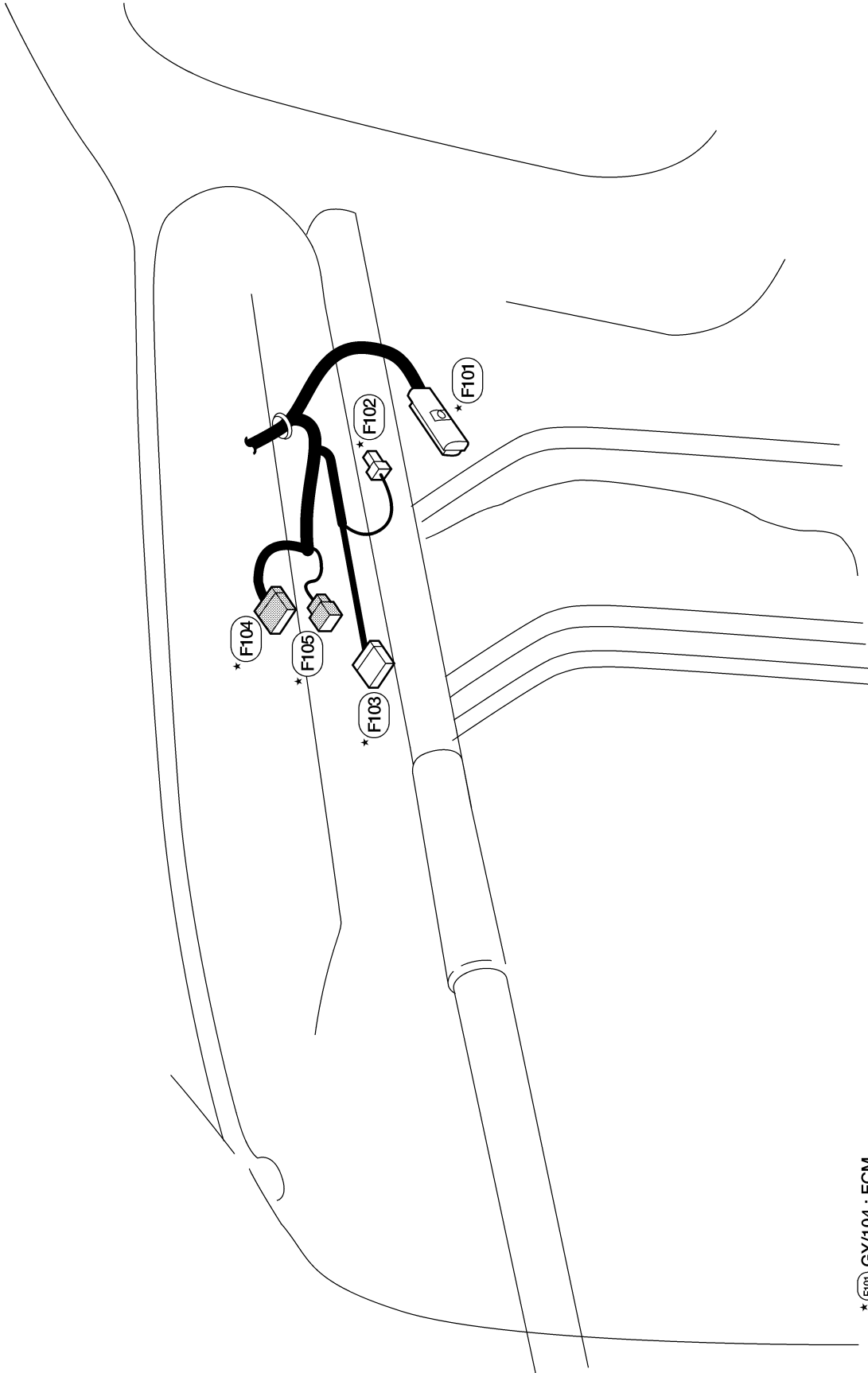

* : Be sure to connect and lock the connectors securely after repair work. Failure to do so may cause the ECM to have diagnostic trouble codes.
Do not disconnect these connectors except in the case of working according to WORK FLOW of TROUBLE DIAGNOSES in EC and AT sections.

- * (F101) GY/104 : ECM
- * (F102) L/4 : ECM relay
- * (F103) GY/16 : To (F40)
- * (F104) W/24 : To (M42)
- * (F105) W/6 : To (M41)

AEL218C

HARNESS LAYOUT

Engine Control Harness (Cont'd)

ENGINE CONTROL SUB HARNESS AND GENERATOR HARNESS

NDEL0132S03

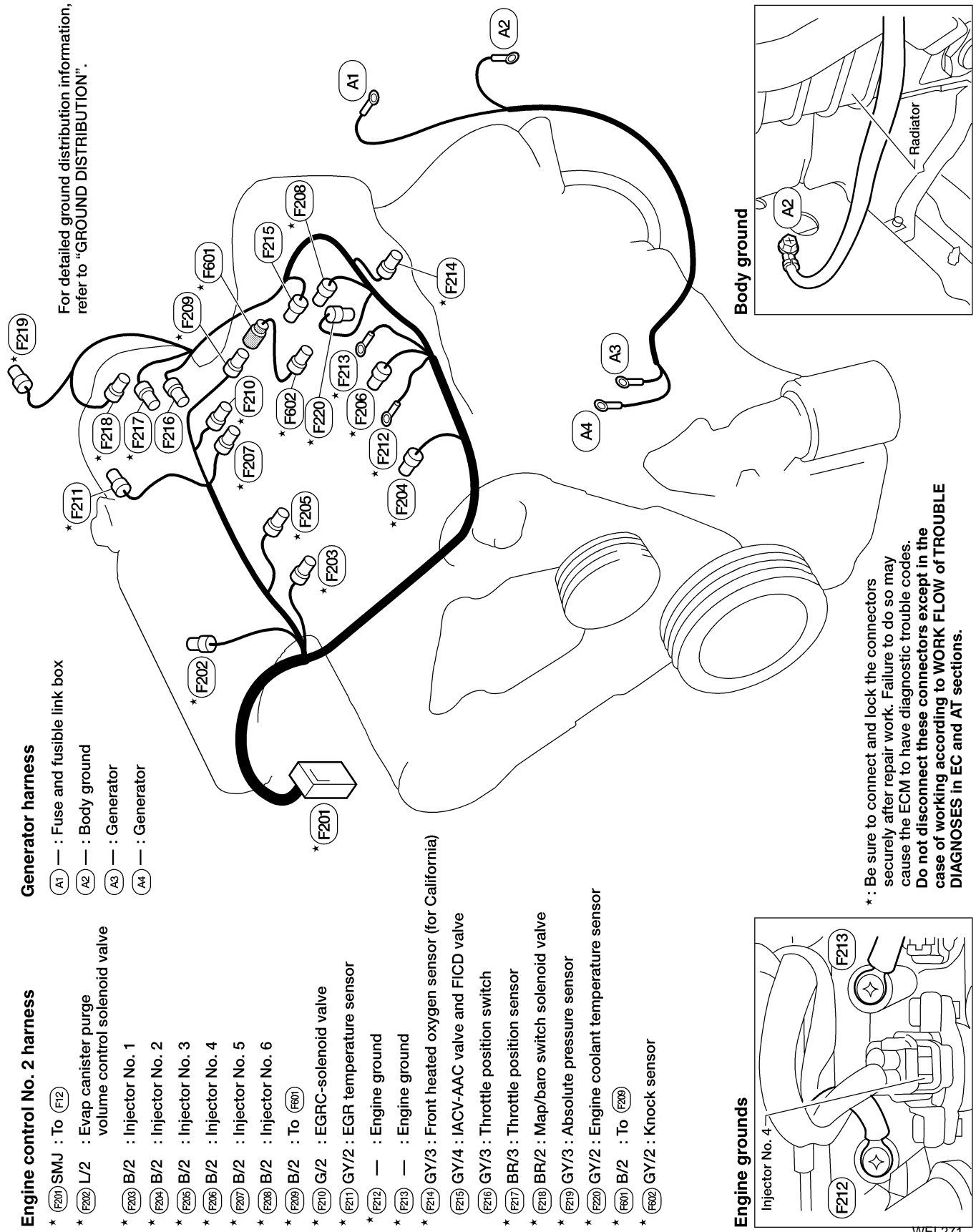

For detailed ground distribution information, refer to "GROUND DISTRIBUTION".

Generator harness

- A1 — : Fuse and fusible link box
- A2 — : Body ground
- A3 — : Generator
- A4 — : Generator

Engine control No. 2 harness

- * F201 SMJ : To F12
- * F202 L/2 : Evap canister purge volume control solenoid valve
- * F203 B/2 : Injector No. 1
- * F204 B/2 : Injector No. 2
- * F205 B/2 : Injector No. 3
- * F206 B/2 : Injector No. 4
- * F207 B/2 : Injector No. 5
- * F208 B/2 : Injector No. 6
- * F209 B/2 : To F601
- * F210 G/2 : EGRC-solenoid valve
- * F211 GY/2 : EGR temperature sensor
- * F212 — : Engine ground
- * F213 — : Engine ground
- * F214 GY/3 : Front heated oxygen sensor (for California)
- * F215 GY/4 : IACV-AAC valve and FICD valve
- * F216 GY/3 : Throttle position switch
- * F217 BR/3 : Throttle position sensor
- * F218 BR/2 : Map/baro switch solenoid valve
- * F219 GY/3 : Absolute pressure sensor
- * F220 GY/2 : Engine coolant temperature sensor
- * F601 B/2 : To F208
- * F602 GY/2 : Knock sensor

Engine grounds

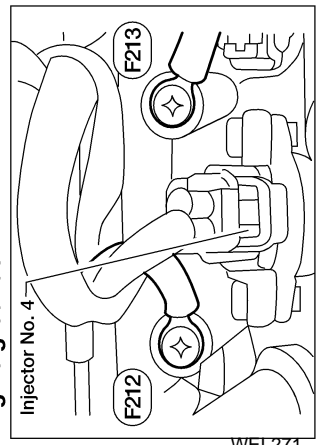

WEL271

GI
MA
EM
LC
EC
FE
AT
AX
SU
BR
ST
RS
BT
HA
SC

EL
IDX

HARNESS LAYOUT

Engine Control Harness (Cont'd)

TRANSMISSION CONTROL HARNESS

NDEL0132S04

Passenger compartment

- * F401 GY/16 : To (F103)
- * F402 W/16 : To (M19)
- * F403 W/24 : TCM (transmission control module)
- * F404 GY/24 : TCM (transmission control module)

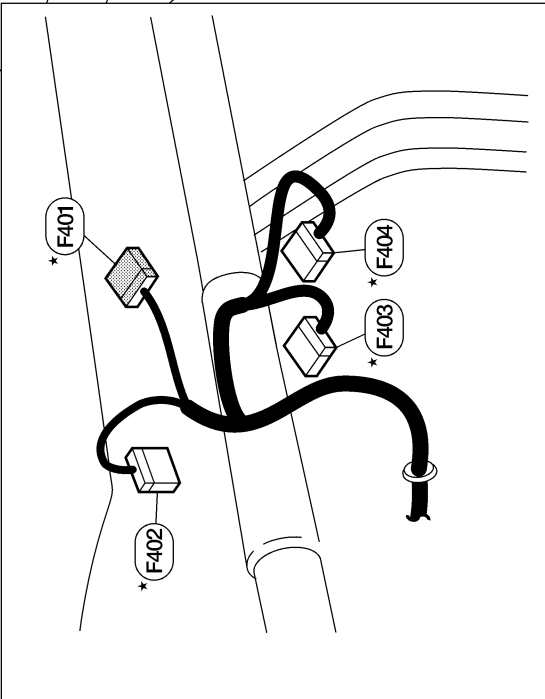

Passenger compartment

- * F401 GY/16 : To (F103)
- * F402 W/16 : To (M19)
- * F403 W/24 : TCM (transmission control module)
- * F404 GY/24 : TCM (transmission control module)

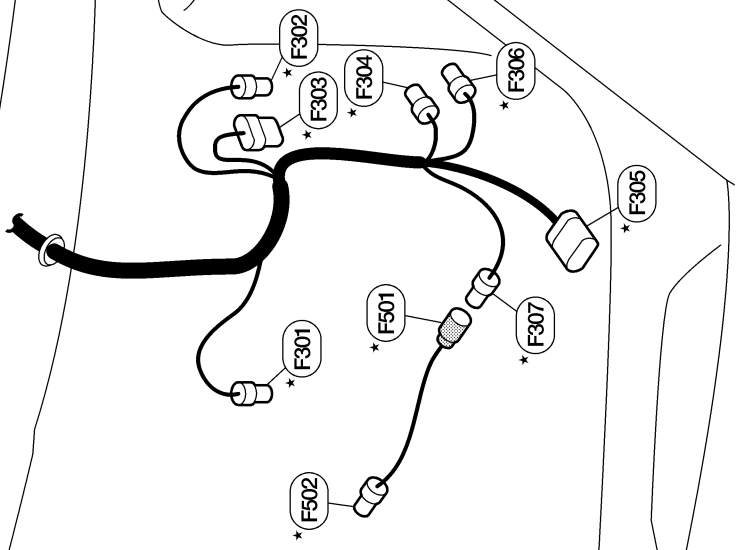

Engine compartment

- * F301 B/2 : Vehicle speed sensor
- * F302 GY/3 : Revolution sensor
- * F303 BR/8 : A/T solenoid valve
- * F304 GY/4 : To (E29)
- * F305 B/10 : Park/neutral position (PNP) switch
- * F306 BR/4 : Mass air flow sensor
- * F307 GY/3 : To (F501)
- * F501 GY/3 : To (F307)
- * F502 GY/2 : Crankshaft position sensor

* : Be sure to connect and lock the connectors securely after repair work. Failure to do so may cause the ECM to have diagnostic trouble codes.
Do not disconnect these connectors except in the case of working according to WORK FLOW of TROUBLE DIAGNOSES in EC and AT sections.

AEL220C

HARNESS LAYOUT

Body Harness

Body Harness

NDEL0133

For detailed ground distribution information, refer to "GROUND DISTRIBUTION".

- * (E1) W/16 : To (M62)
- (E2) W/6 : To (M63)
- (E3) W/10 : To (M64)
- * (E4) GY/4 : Rear heated oxygen sensor (except for California)
- (E5) W/2 : To (P10) (with RH power seat)
- (E6) W/2 : Rear fan switch (rear illumination) (with rear A/C)
- (E7) W/6 : Rear fan switch (rear) (with rear A/C)
- (E8) W/2 : Sliding door step lamp RH
- (E9) B/4 : Sliding door contact switch RH (pillar)
- (E10) B/3 : Front door switch RH
- (E11) B/1 : Sliding door switch RH
- (E12) B/2 : Rear speaker RH
- (E14) B/2 : Rear blower motor (with rear A/C)
- (E15) — : Body ground
- (E16) BR/4 : Rear blower motor resistor (with rear A/C)
- (E17) B/2 : Rear power vent window motor RH (with power vent windows)
- (E18) GY/6 : Rear combination lamp RH

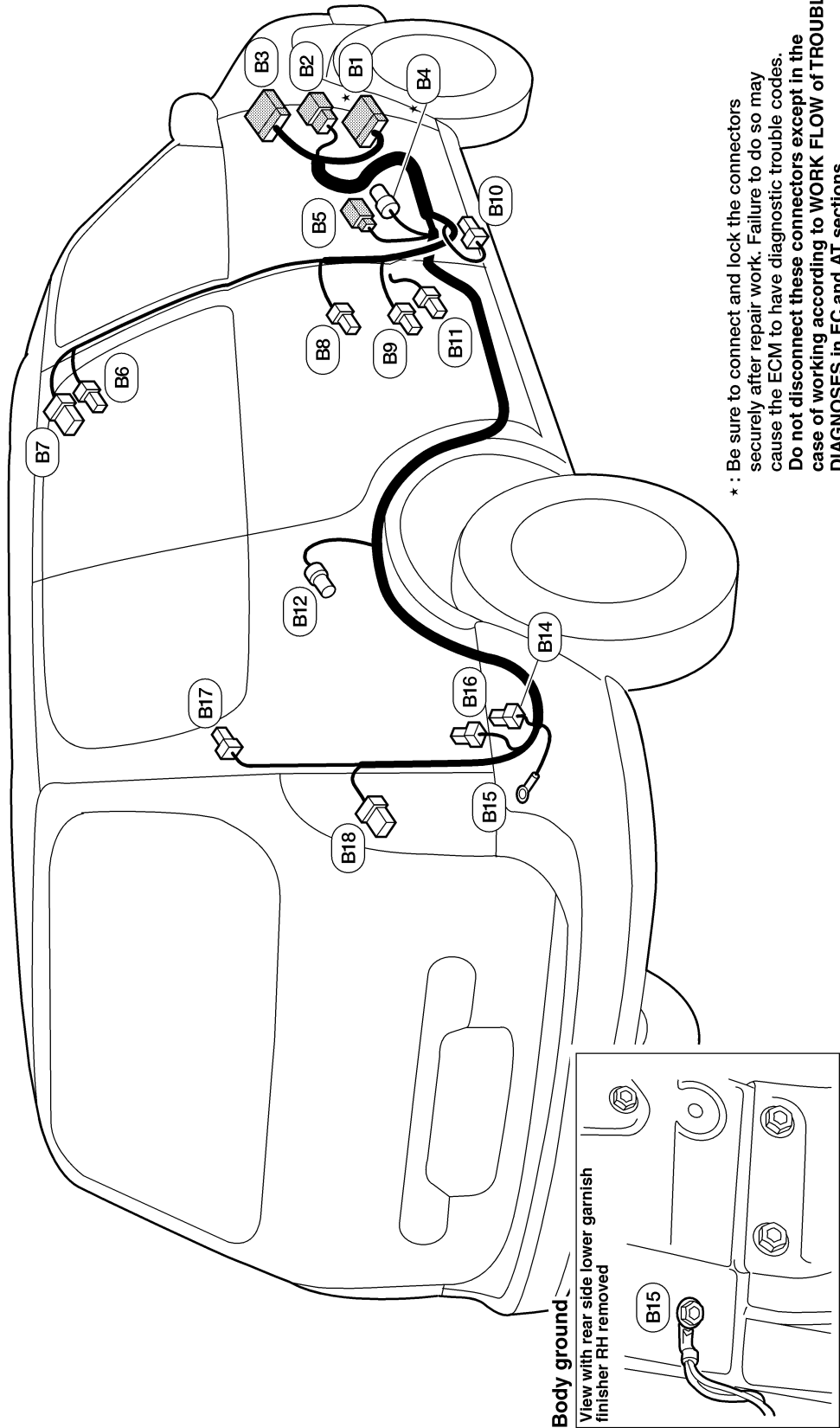

- GI
- MA
- EM
- LC
- EC
- FE
- AT
- AX
- SU
- BR
- ST
- RS
- BT
- HA
- SC
- EL**
- IDX

WEL272

HARNESS LAYOUT

Back Door Harness

NDEL0135

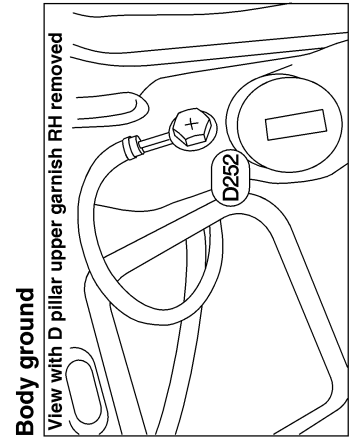
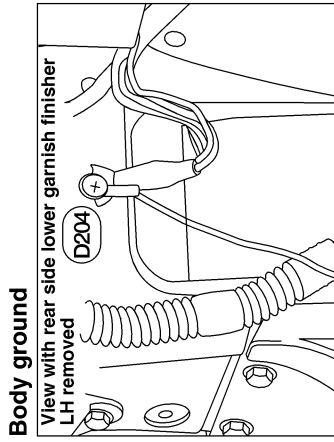
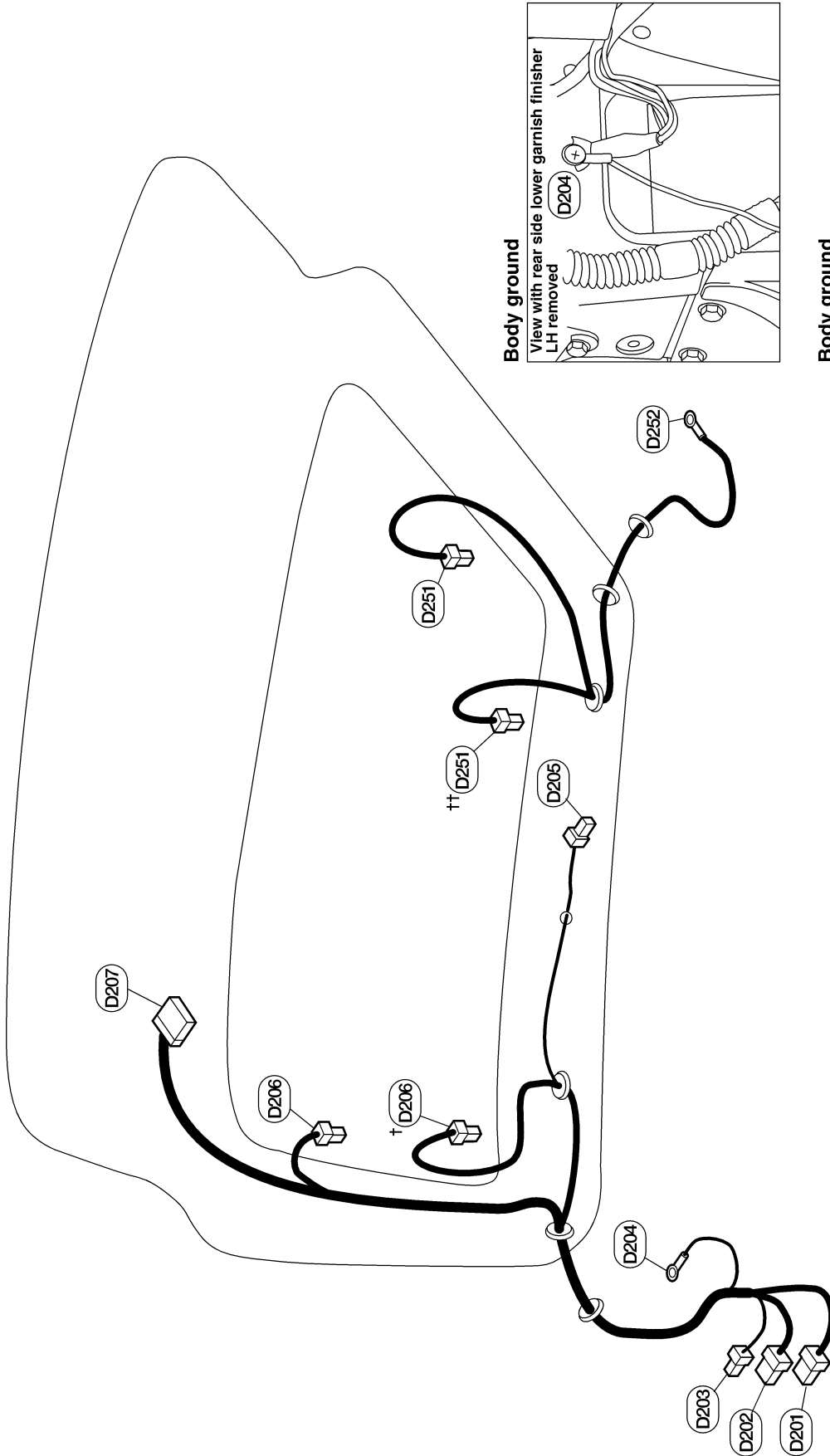

- D201 W/8 : To M126
- D202 W/6 : To M127
- D203 W/4 : To M128
- D204 — : Body ground
- D206 W/2 : High mounted stop lamp
- D206 B/1 : Rear window defogger (+)
(except for glass hatch models)
- D206 B/1 : Rear window defogger (+) (for glass hatch models)
- D207 W/18 : To C301
- D251 B/1 : Rear window defogger (-) (except for glass hatch models)
- D251 B/1 : Rear window defogger (-) (for glass hatch models)
- D252 — : Body ground

HARNESS LAYOUT

Back Door No. 2 Harness

Back Door No. 2 Harness

NDEL0136

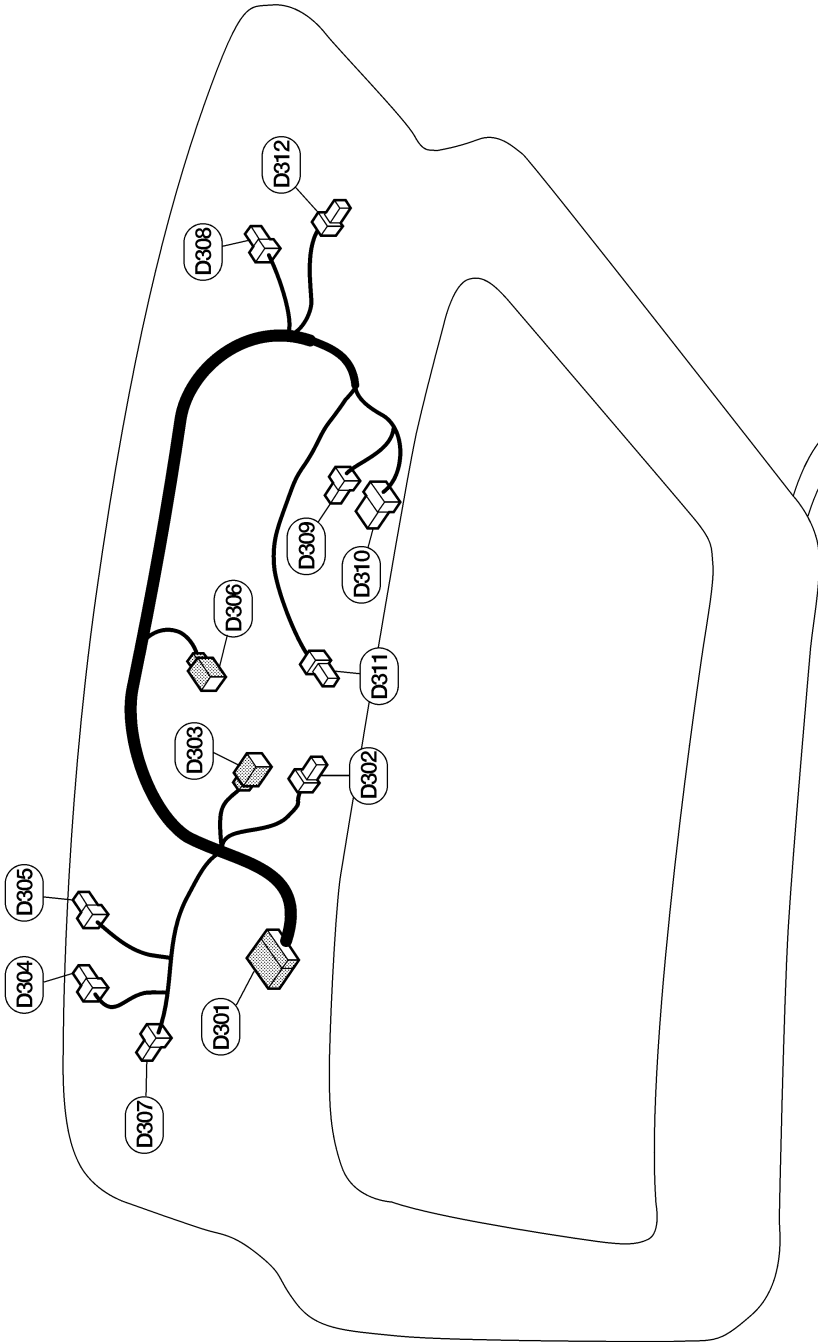

- (D301) W/18 : To (D207)
- (D302) G/2 : Glass hatch latch switch (for glass hatch model)
- (D303) GY/4 : Back door key cylinder switch
- (D304) GY/3 : Back-up lamp LH
- (D305) W/2 : Back door lamp
- (D306) W/3 : License lamp
- (D307) W/2 : Back door latch switch LH
- (D308) GY/3 : Back-up lamp RH
- (D309) GY/4 : Rear wiper motor (except for glass hatch model)
- (D310) GY/6 : Rear wiper motor (for glass hatch model)
- (D311) GY/4 : Back door lock actuator
- (D312) W/2 : Back door latch switch RH

GI

MA

EM

LC

EC

FE

AT

AX

SU

BR

ST

RS

BT

HA

SC

EL

IDX

HARNESS LAYOUT

Room Lamp Harness

Room Lamp Harness

NDEL0137

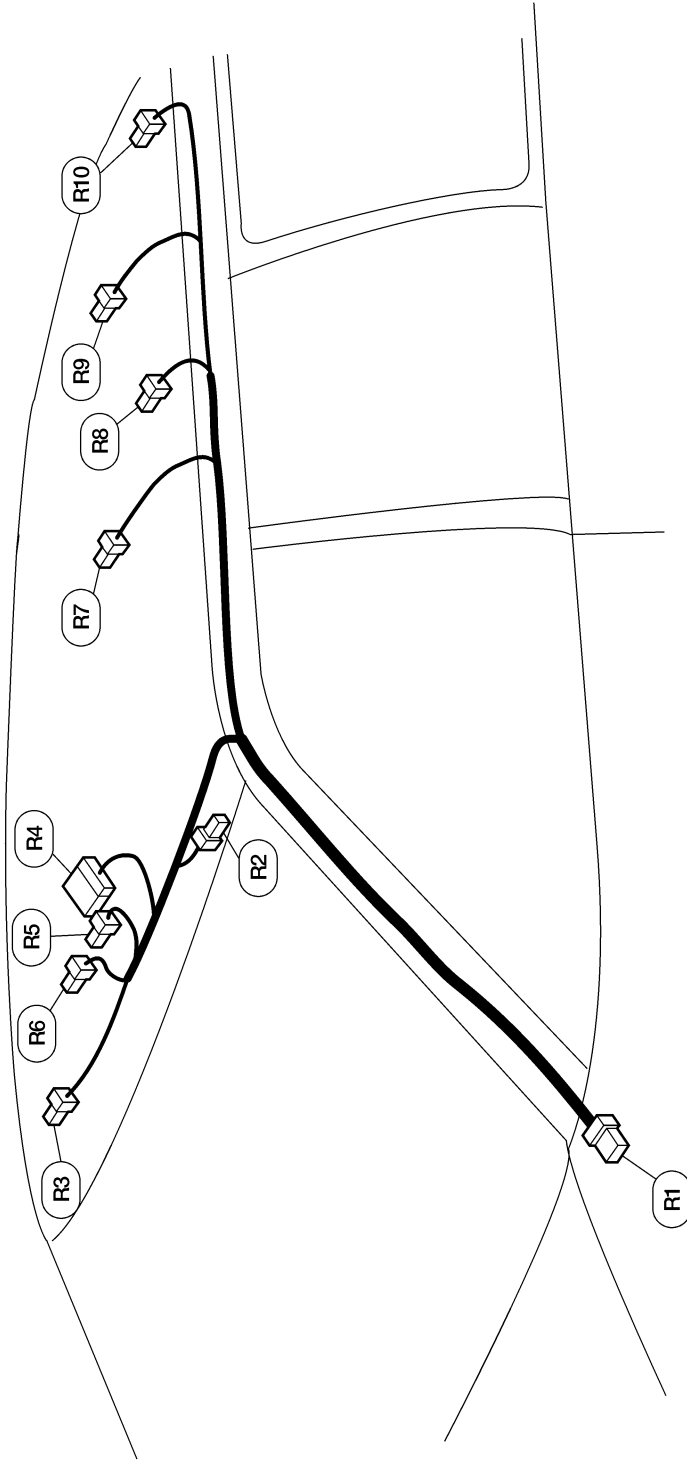

- (R1) W/8 : To (M5)
- (R2) B/2 : Vanity lamp LH
- (R3) B/2 : Vanity lamp RH
- (R4) B/12 : Sun roof motor assembly (with sun roof)
- (R5) W/3 : Map lamp (with map lamp)
- (R6) W/4 : Sun roof switch (with sun roof)
- (R7) W/3 : Front room lamp (without personal lamp)
- (R8) W/3 : Front personal lamp (with personal lamp)
- (R9) W/3 : Rear room lamp (without personal lamp)
- (R10) W/3 : Rear personal lamp (with personal lamp)

AEL204C

HARNESS LAYOUT

Air Bag Harness

Air Bag Harness

NDEL0138

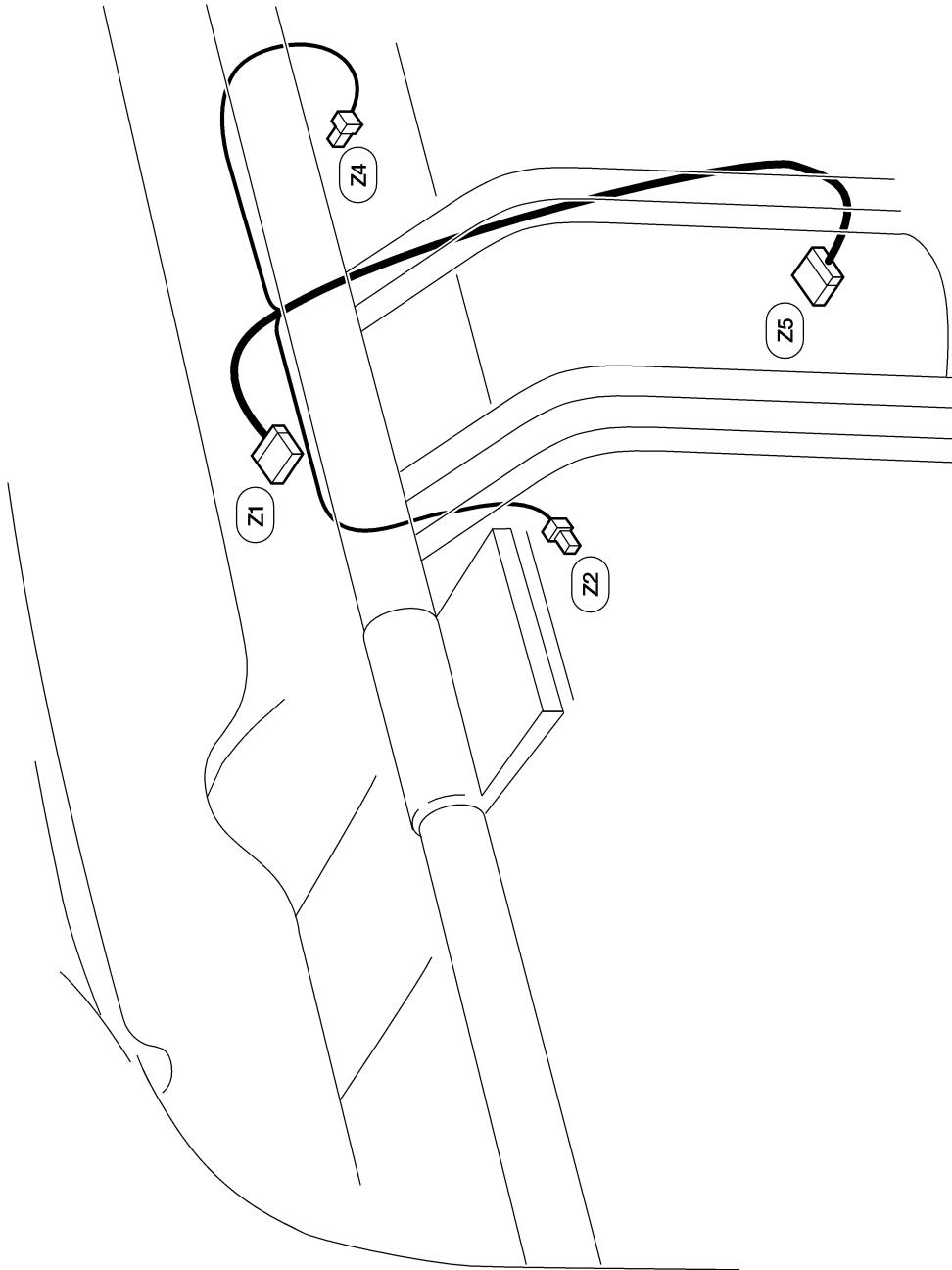

Z1 W/12 : To (M38)

Z2 Y/4 : To spiral cable

Z4 W/2 : Front passenger air bag module

Z5 Y/22 : Air bag diagnosis sensor module

GI

MA

EM

LC

EC

FE

AT

AX

SU

BR

ST

RS

BT

HA

SC

EL

IDX

WEL276

HARNESS LAYOUT

Front Door Harness

LH Door

- | | |
|--|---|
| (D1) W/10 : To (M101) | (D11) GY/4 : Front door key cylinder switch LH |
| (D2) W/12 : To (M102) | (D12) GY/4 : Front door lock actuator LH |
| (D3) W/16 : To (M103) | (D13) W/2 : Front step lamp LH |
| (D4) B/2 : Front speaker LH | (D14) W/12 : Main power window and door lock/unlock switch |
| (D5) B/2 : Memory set switch (with automatic drive positioner) | (D15) W/16 : Main power window and door lock/unlock switch (with rear power vent windows) |
| (D6) W/5 : Door mirror LH | (D15) B/2 : Front power window motor LH |
| (D7) GY/5 : Door mirror LH (with automatic drive positioner) | |
| (D8) W/2 : Front tweeter LH (except base audio) | |
| (D9) W/8 : Door mirror remote control switch | |
| (D10) W/2 : Diode-2 | |

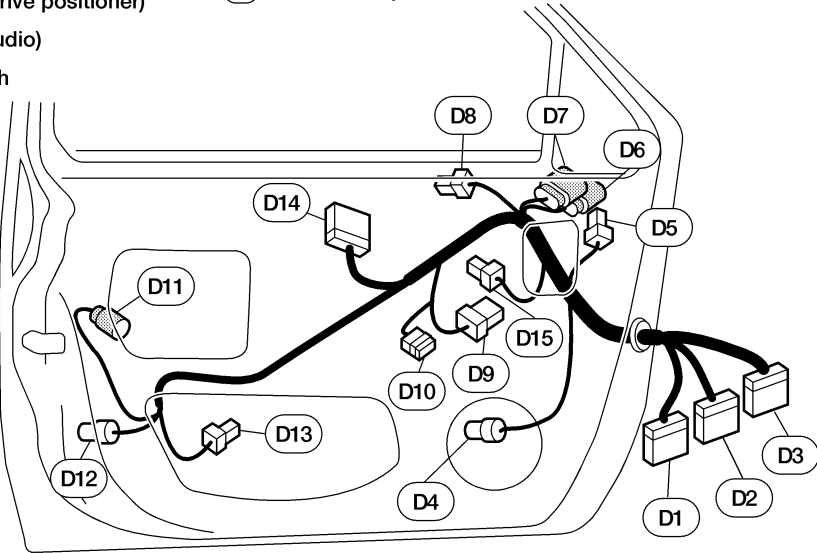

RH Door

- | | |
|--|---|
| (D101) W/16 : To (M65) | (D107) W/2 : Front tweeter RH (except base audio) |
| (D102) W/10 : To (M66) | (D108) W/8 : Front power window switch RH |
| (D103) B/2 : Front speaker RH | (D109) BR/8 : Door lock/unlock switch RH |
| (D104) B/2 : Front power window motor RH | (D110) GY/4 : Front door key cylinder switch RH |
| (D105) W/5 : Door mirror RH | (D111) GY/4 : Front door lock actuator RH |
| (D106) GY/5 : Door mirror RH (with automatic drive positioner) | (D112) W/2 : Front step lamp RH |

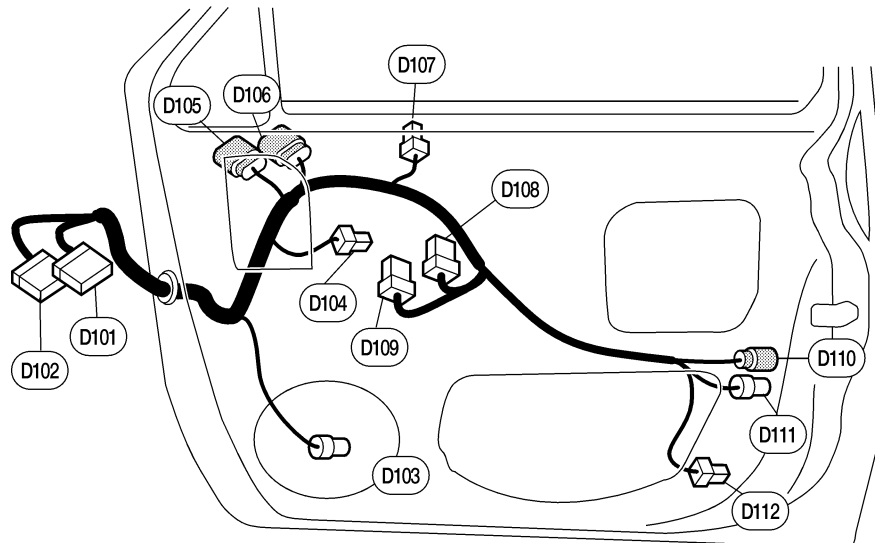

HARNESS LAYOUT

Sliding Door Harness

Sliding Door Harness

NDEL0140

LH Door

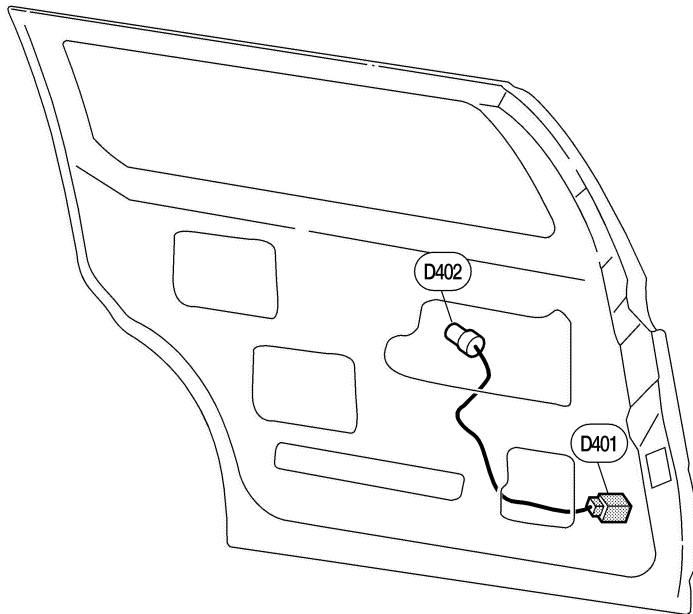

(D401) W/4 : To contact switch LH

(D402) GY/4 : Sliding door lock actuator LH

RH Door

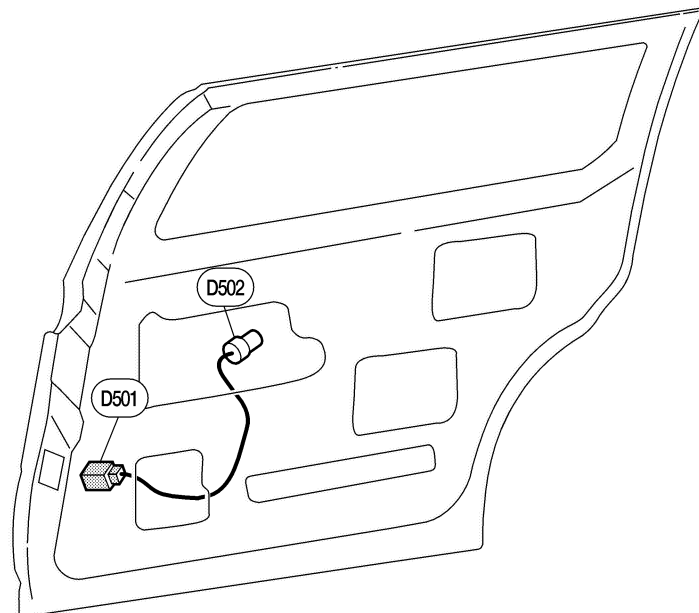

(D501) W/4 : To contact switch RH

(D502) GY/4 : Sliding door lock actuator RH

GI

MA

EM

LC

EC

FE

AT

AX

SU

BR

ST

RS

BT

HA

SC

EL

IDX

WEL275

BULB SPECIFICATIONS*Headlamp***Headlamp**

NDEL0141S01

Item	ANSI #	Wattage (W)
High/Low (Semi-sealed beam)	9007 (HB5)	65/55
Front turn signal	3157NA	8.25/27

Exterior Lamp

NDEL0141S02

Item	ANSI #	Wattage (W)
Front combination lamp	Parking/Cornering lamp	3157
	Front side marker lamp	194
Rear combination lamp	Turn signal lamp	3156K
	Stop/Tail lamp	3157K
	Rear side marker lamp	168
Back-up lamp	3156K	27
License plate lamp	194	3.8
High-mounted stop lamp	912	12.8

Interior Lamp

NDEL0141S03

Item	ANSI #	Wattage (W)
Map lamp	578	10
Personal lamp	578	10
Room and luggage compartment lamp	211-2	12

WIRING DIAGRAM CODES (CELL CODES)

Use the chart below to find out what each wiring diagram code stands for.

Refer to the wiring diagram code in the alphabetical index to find the location (page number) of each wiring diagram.

Code	Section	Wiring Diagram Name
1STSIG	AT	A/T 1ST Signal
2NDSIG	AT	A/T 2ND Signal
3RDSIG	AT	A/T 3RD Signal
4THSIG	AT	A/T 4TH Signal
A/C, A	HA	Auto Air Conditioner
A/C, M	HA	Manual Air Conditioner
AAC/V	EC	IACV-AAC Valve
ABS	BR	Anti-lock Brake System
AP/SEN	EC	Absolute Pressure Sensor
ASCD	EL	Automatic Speed Control Device
AT/C	EC	A/T Control
ATDIAG	EC	A/T Diagnosis Communication Line
AUDIO	EL	Audio
AUT/DP	EL	Automatic Drive Positioner
BA/FTS	AT	A/T Fluid Temperature Sensor Circuit
BACK/L	EL	Back-up Lamp
BYPS/V	EC	Vacuum Cut Valve Bypass Valve
CANI/V	EC	EVAP Canister Purge Control Solenoid Valve
CHARGE	SC	Charging System
CHIME	EL	Warning Chime
CIGAR	EL	Cigarette Lighter
CKPS	EC	Crankshaft Position Sensor (OBD)
COOL/F	EC	Cooling Fan Control
CORNER	EL	Cornering Lamp
CMPS	EC	Camshaft Position Sensor
D/LOCK	EL	Power Door Lock
DEF	EL	Rear Window Defogger
DTRL	EL	Headlamp — With Daytime Light System —
ECTS	EC	Engine Coolant Temperature Sensor
EGR/TS	EC	EGR Temperature Sensor
EGRC/V	EC	EGRC-solenoid Valve
EGRC1	EC	EGR Function

Code	Section	Wiring Diagram Name	
ENGSS	AT	Engine Speed Signal	GI
F/PUMP	EC	Fuel Pump Control	
FICD	EC	IACV-FICD Solenoid Valve	MA
FRO2	EC	Front Heated Oxygen Sensor	
FRO2/H	EC	Front Heated Oxygen Sensor Heater	EM
FTS	AT	A/T Fluid Temperature Sensor	LC
FTTS	EC	Fuel Tank Temperature Sensor	
FUEL	EC	Fuel Injection System Function	EC
H/LAMP	EL	Headlamp	
H/MIRR	EL	Heated Mirror	FE
HORN	EL	Horn	
IATS	EC	Intake Air Temperature Sensor	AT
IGN/SG	EC	Ignition Signal	AX
ILL	EL	Illumination	
INJECT	EC	Injector	SU
INT/L	EL	Interior, Spot, and Tailgate Lamps	
KS	EC	Knock Sensor	BR
LPSV	AT	Line Pressure Solenoid Valve	
MAFS	EC	Mass Air Flow Sensor	ST
MAIN	AT	Main Power Supply and Ground Circuit	
MAIN	EC	Main Power Supply and Ground Circuit	RS
METER	EL	Speedometer, Tachometer, Temp., Oil, and Fuel Gauges	BT
MIL/DL	EC	MIL and Data Link Connectors	HA
MIRROR	EL	Door Mirror	
MULTI	EL	Multi-remote Control System	SC
NONDTC	AT	Non-detectable Items	
OVRCSV	AT	Overrun Clutch Solenoid Valve	EL
PGC/V	EC	EVAP Canister Purge Volume Control Solenoid Valve	
PNP/SW	AT	Park/Neutral Position Switch	IDX
PNP/SW	EC	Park/Neutral Position Switch	
POWER	EL	Power Supply Routing	
PRE/SE	EC	EVAP Control System Pressure Sensor	
PST/SW	EC	Power Steering Oil Pressure Switch	
RRO2	EC	Rear Heated Oxygen Sensor	

WIRING DIAGRAM CODES (CELL CODES)

Code	Section	Wiring Diagram Name
RRO2/H	EC	Rear Heated Oxygen Sensor Heater
S/SIG	EC	Start Signal
SEAT	EL	Power Seat
SECU	EL	Smart Entrance Control Unit
SHIFT	AT	A/T Shift Lock System
SROOF	EL	Sunroof
SRS	RS	Supplemental Restraint System
SSV/A	AT	Shift Solenoid Valve A
SSV/B	AT	Shift Solenoid Valve B
START	SC	Starting System
STOP/L	EL	Stop lamp
SW/V	EC	MAP/BARO Switch Solenoid Valve
TAIL/L	EL	Parking, License and Tail Lamps
TCCSIG	AT	A/T TCC Signal (Lock up)
TCV	AT	Torque Converter Clutch Solenoid Valve
THEFT	EL	Theft Warning System
TP/SW	EC	Throttle Position Switch
TPS	AT	Throttle Position Sensor
TPS	EC	Throttle Position Sensor
TRNSMT	EL	Integrated HOMELINK [™] Transmitter
T/TOW	EL	Trailer Tow
TURN	EL	Turn Signal and Hazard Warning Lamps
VENT/V	EC	EVAP Canister Vent Control Valve
VSS	EC	Vehicle Speed Sensor
VSSAT	AT	Vehicle Speed Sensor A/T (Revolution Sensor)
VSSMTR	AT	Vehicle Speed Sensor MTR
WARN	EL	Warning Lamps
WINDOW	EL	Power Window
WIP/R	EL	Rear Wiper and Washer (Except for Glass Hatch Model)
WIP/R	EL	Rear Wiper and Washer (For Glass Hatch Model)
WIPER	EL	Front Wiper and Washer