

SECTION **PR**  
PROPELLER SHAFT

A  
B  
C

PR

CONTENTS

E

<b>PREPARATION</b> .....	<b>2</b>	APPEARANCE AND NOISE INSPECTION .....	6	F
Special Service Tools .....	2	PROPELLER SHAFT VIBRATION .....	6	
Commercial Service Tools .....	2	Components .....	7	
<b>NOISE, VIBRATION AND HARSHNESS (NVH)</b>		Removal and Installation .....	8	G
<b>TROUBLESHOOTING</b> .....	<b>3</b>	REMOVAL .....	8	
NVH Troubleshooting Chart .....	3	INSPECTION .....	9	
<b>FRONT PROPELLER SHAFT</b> .....	<b>4</b>	INSTALLATION .....	10	H
On-Vehicle Inspection .....	4	Disassembly and Assembly of Center Bearing (For 3S80A-1VL107 and 3F80A-1VL107 Type) .....	11	
APPEARANCE AND NOISE INSPECTION .....	4	DISASSEMBLY .....	11	I
PROPELLER SHAFT VIBRATION .....	4	ASSEMBLY .....	12	
Components .....	4	<b>SERVICE DATA AND SPECIFICATIONS (SDS) .....</b>	<b>13</b>	J
Removal and Installation .....	5	General Specifications .....	13	
REMOVAL .....	5	2WD MODELS .....	13	
INSPECTION .....	5	AWD MODELS .....	13	
INSTALLATION .....	5	Journal Axial Play .....	14	K
<b>REAR PROPELLER SHAFT</b> .....	<b>6</b>	Propeller Shaft Runout .....	14	
On-Vehicle Inspection .....	6			L

M

# PREPARATION

## PREPARATION

PFP:00002

### Special Service Tools

NDS000E7

The actual shapes of Kent-Moore tools may differ from those of special service tools illustrated here.

Tool number (Kent-Moore No.) Tool name	Description
KV40104000 ( — ) Flange wrench a: 85 mm (3.35 in) b: 65 mm (2.56 in)	Removing and installing center flange lock nut
ST30031000 (J-22912-01) Puller a: 90 mm (3.54 in) dia. b: 50 mm (1.97 in) dia.	Removing rear propeller shaft center bearing

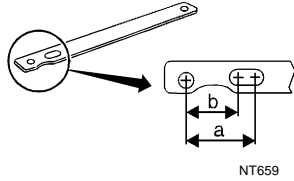

NT659

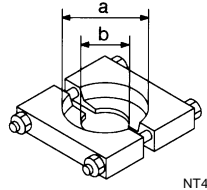

NT411

### Commercial Service Tools

NDS000E8

Tool name	Description
Power tool	Loosening bolts and nuts

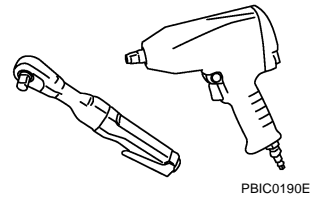

PBIC0190E

# NOISE, VIBRATION AND HARSHNESS (NVH) TROUBLESHOOTING

## NOISE, VIBRATION AND HARSHNESS (NVH) TROUBLESHOOTING

PFP:00003

### NVH Troubleshooting Chart

NDS000E9

Use the chart below to help you find the cause of the symptom. If necessary, repair or replace these parts.

Reference page	Front	PR-4	—	—	—	—	PR-4	PR-5							
	Rear	PR-6	PR-10	—	PR-7	—	PR-6	PR-9							
Possible cause and SUSPECTED PARTS		Uneven rotating torque							NVH in FFD and RFD section	NVH in FAX, RAX, FSU and RSU section	NVH in WT section	NVH in WT section	NVH in RAX section	NVH in BR section	NVH in PS section
		Center bearing improper installation													
		Excessive center bearing axial end play													
		Center bearing mounting (insulator) cracks, damage or deterioration													
		Excessive joint angle													
		Rotation imbalance													
		Excessive runout													
		DIFFERENTIAL													
		AXLE AND SUSPENSION													
		TIRES													
		ROAD WHEEL													
		DRIVE SHAFT													
		BRAKES													
		STEERING													
Symptom	Noise	x	x	x	x	x	x	x	x	x	x	x	x	x	x
	Shake		x				x			x	x	x	x	x	x
	Vibration	x	x	x	x	x	x	x		x	x		x		x

x: Applicable

A  
B  
C  
PR  
E  
F  
G  
H  
I  
J  
K  
L  
M

# FRONT PROPELLER SHAFT

PFP:37200

NDS000EA

## FRONT PROPELLER SHAFT

### On-Vehicle Inspection

#### APPEARANCE AND NOISE INSPECTION

- Check the propeller shaft tube surface for dents or cracks. If damaged, replace propeller shaft assembly.

#### PROPELLER SHAFT VIBRATION

If vibration is present at high speed, inspect propeller shaft runout first.

1. Measure propeller shaft runout at runout measuring point by rotating final drive companion flange with hands. For measuring point, refer to [PR-4, "Propeller Shaft Runout Measuring Point"](#).

**Propeller shaft runout limit : 0.8 mm (0.031 in)**

2. If runout still exceeds specifications, separate propeller shaft at final drive companion flange; then rotate companion flange 90, 180, 270 degrees and install propeller shaft.
3. Check runout again. If runout still exceeds specifications, replace propeller shaft assembly.
4. Check the vibration by driving vehicle.

#### Propeller Shaft Runout Measuring Point

- Propeller shaft runout measuring point (Point "△")

**Dimension A: 381.5 mm (15.01 in)**

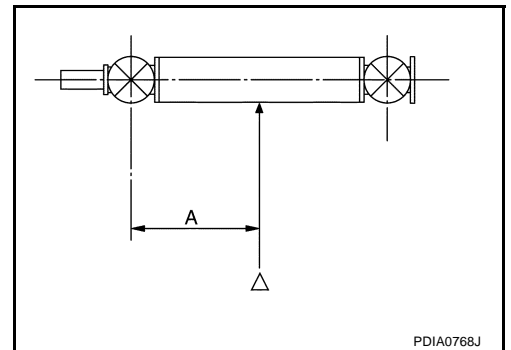
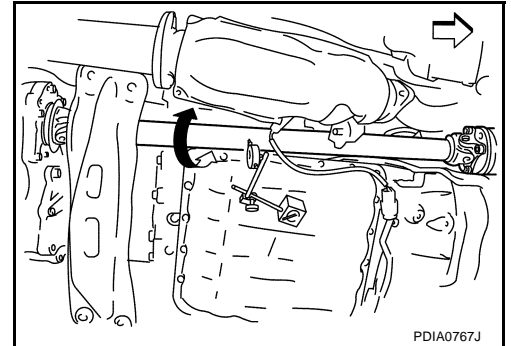

## Components

NDS000EB

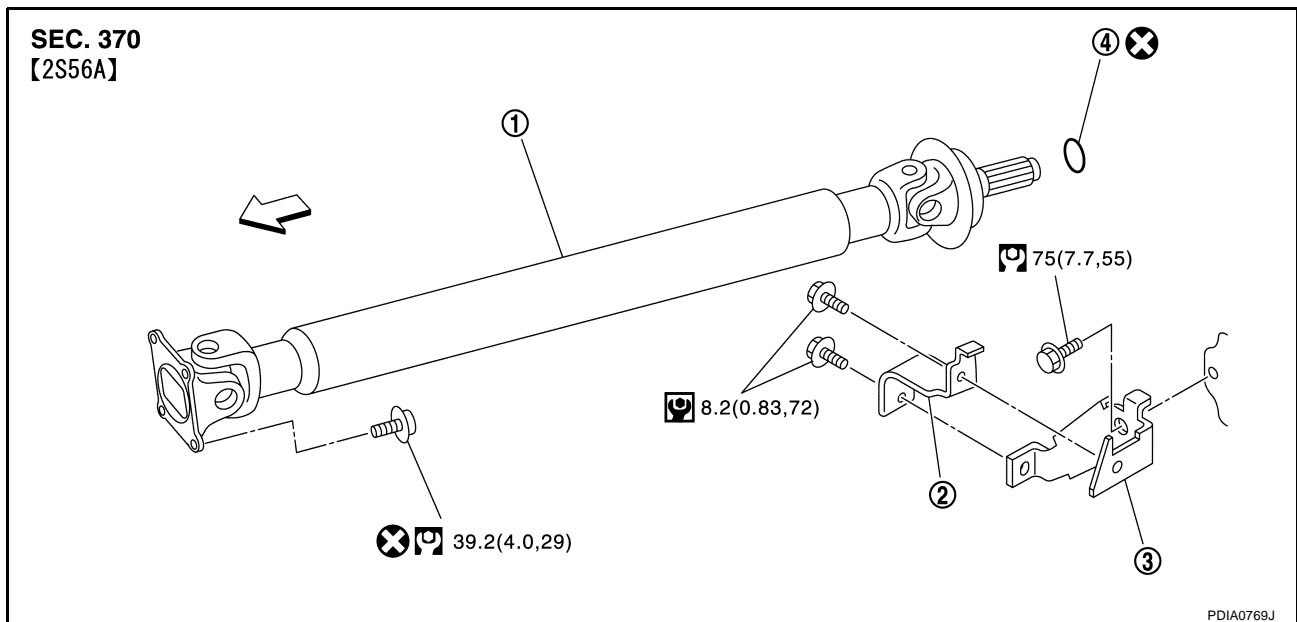

1. Propeller shaft assembly

2. Heat bracket (A)

3. Heat bracket (B)

4. O-ring

Refer to [GI-11, "Components"](#), for the symbols in the figure.

# FRONT PROPELLER SHAFT

NDS000EC

## Removal and Installation

### REMOVAL

1. Remove engine undercover with a power tool.
2. If necessary, remove heat bracket.
3. Remove the three way catalyst (right bank) with a power tool. Refer to [EX-3, "EXHAUST SYSTEM"](#) .
4. Put matching marks onto propeller shaft flange yoke and final drive companion flange.

#### **CAUTION:**

**For matching marks, use paint. Do not damage propeller shaft flange and companion flange.**

5. Remove the propeller shaft fixing bolts.
6. Remove propeller shaft from the front final drive and transfer.

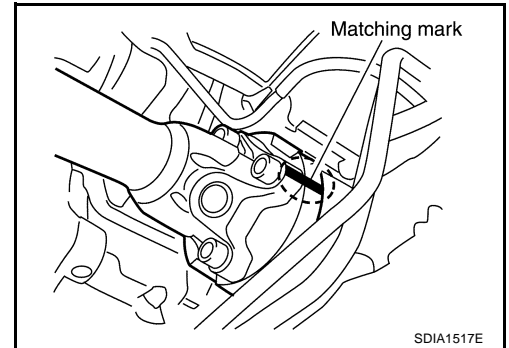

### INSPECTION

- Inspect propeller shaft runout at measuring point. If runout exceeds specifications, replace propeller shaft assembly. For measuring point, refer to [PR-4, "Propeller Shaft Runout Measuring Point"](#) .

**Propeller shaft runout limit : 0.8 mm (0.031 in)**

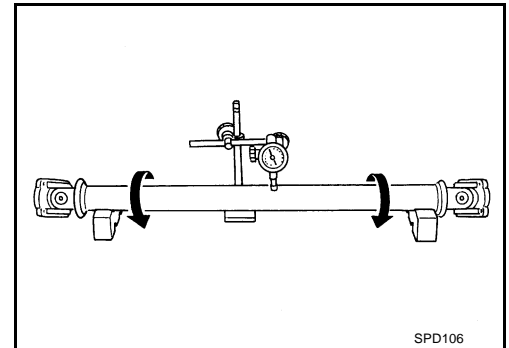

- As shown in the figure, while fixing yoke on one side, check axial play of joint. If outside the standard, replace propeller shaft assembly.

**Journal axial play : 0 mm (0 in)**

- Check propeller shaft for bend and damage. If damage is detected, replace propeller shaft assembly.

#### **CAUTION:**

**Do not disassemble joints.**

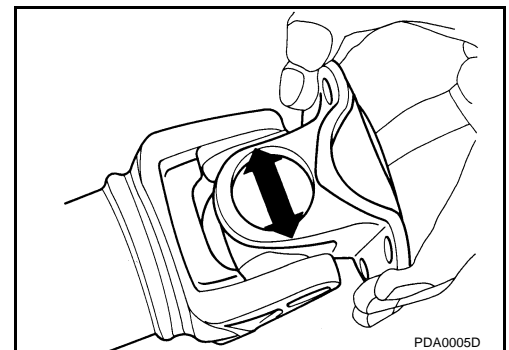

### INSTALLATION

Note the following, install in the reverse order of removal.

- Align matching marks to install propeller shaft to final drive companion flange, and then tighten to specified torque. Refer to [PR-4, "Components"](#) .

#### **CAUTION:**

**Do not reuse the bolts.**

- After assembly, perform a driving test to check propeller shaft vibration. If vibration occurred, separate propeller shaft from final drive or transfer. Reinstall companion flange after rotating it by 90, 180, 270 degrees. Then perform driving test and check propeller shaft vibration again at each point.

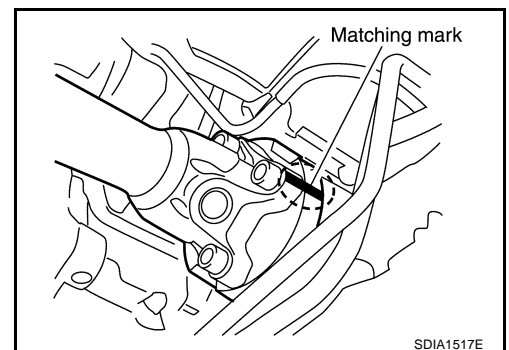

A  
B  
C  
PR  
E  
F  
G  
H  
I  
J  
K  
L  
M

# REAR PROPELLER SHAFT

## REAR PROPELLER SHAFT

PFP:37000

### On-Vehicle Inspection

NDS000ED

#### APPEARANCE AND NOISE INSPECTION

- Check the propeller shaft tube surface for dents or cracks. If damaged, replace propeller shaft assembly.
- If center bearing is noisy or damaged, replace center bearing.

#### PROPELLER SHAFT VIBRATION

If vibration is present at high speed, inspect propeller shaft runout first.

1. Measure propeller shaft runout at runout measuring points by rotating final drive companion flange with hands. For measuring point, refer to [PR-6, "Propeller Shaft Runout Measuring Point"](#).

**Propeller shaft runout limit : 0.8 mm (0.031 in)**

2. If runout still exceeds specifications, separate propeller shaft at final drive companion flange; then rotate companion flange 60, 120, 180, 240, 300 degrees and install propeller shaft.
3. Check runout again. If runout still exceeds specifications, replace propeller shaft assembly.
4. Check the vibration by driving vehicle.

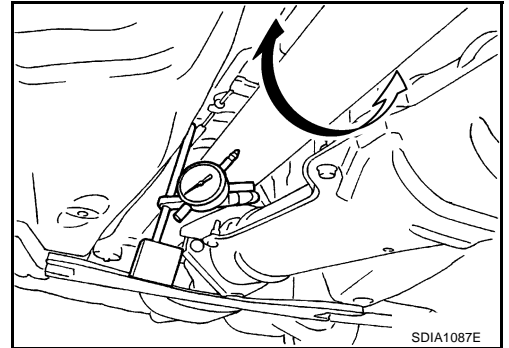

#### Propeller Shaft Runout Measuring Point

- Propeller shaft runout measuring point (Point "△")
- **VQ35DE 2WD models (3S80A-1VL107 type)**

**Dimension A: 192 mm (7.56 in)**

**B: 172 mm (6.77 in)**

**C: 185 mm (7.28 in)**

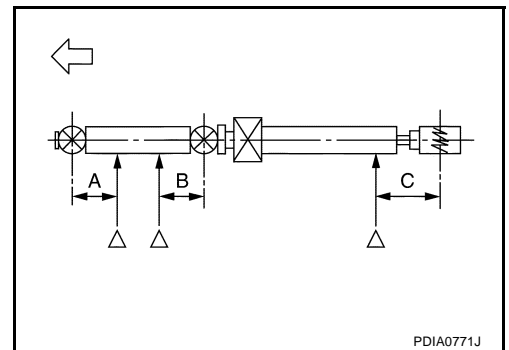

- **VK45DE 2WD models (3F-R-2VL107 type)**

**Dimension A: 162 mm (6.38 in)**

**B: 160 mm (6.30 in)**

**C: 185 mm (7.28 in)**

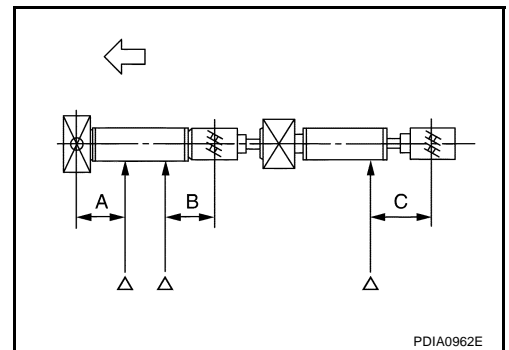

- **VQ35DE AWD models (3F80A-1VL107 type)**

**Dimension A: 162 mm (6.38 in)**

**B: 245 mm (9.65 in)**

**C: 185 mm (7.28 in)**

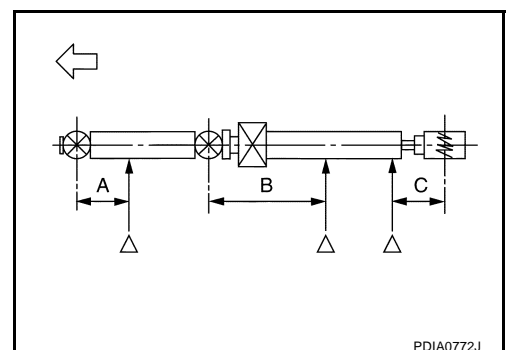

# REAR PROPELLER SHAFT

## Components

NDS000EE

### VQ35DE 2WD MODELS (3S80A-1VL107 TYPE)

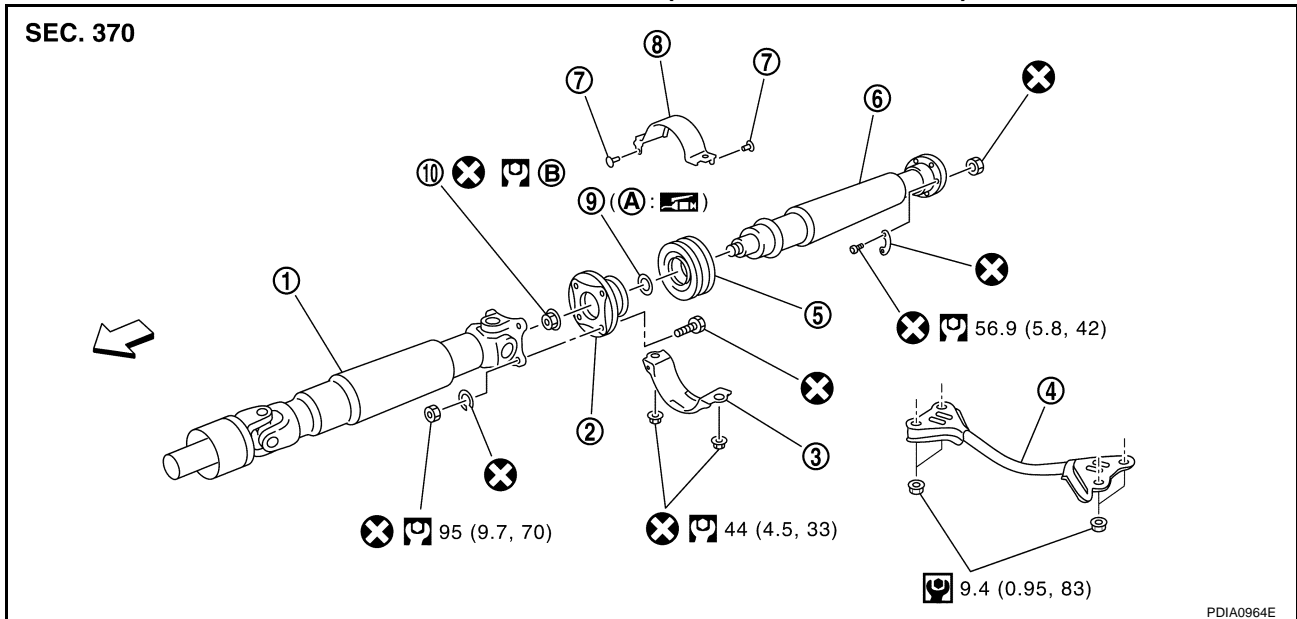

- |                                |  |  |
|--------------------------------|--|--|
| 1. Propeller shaft (1st shaft) | 2. Center flange                           | 3. Center bearing mounting bracket (Lower) |
| 4. Floor reinforcement         | 5. Center bearing assembly                 | 6. Propeller shaft (2nd shaft)             |
| 7. Clip                        | 8. Center bearing mounting bracket (Upper) | 9. Washer                                  |
| 10. Lock nut                   |  |  |
- A: Both side  
B: For the tightening torque, refer to [PR-12. "ASSEMBLY"](#).

Refer to [GI-11. "Components"](#), for the symbols in the figure.

### VK45DE 2WD MODELS (3F-R-2VL107 TYPE)

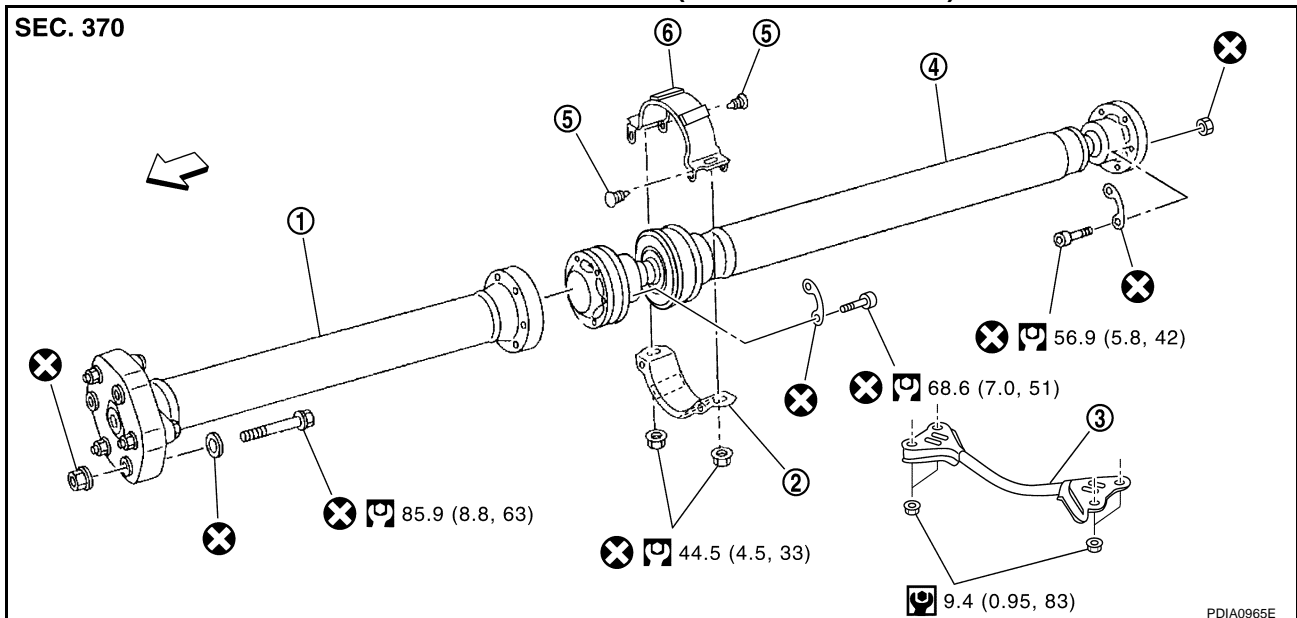

- |                                |  |  |
|--------------------------------|--|--|
| 1. Propeller shaft (1st shaft) | 2. Center bearing mounting bracket (Lower) | 3. Floor reinforcement                     |
| 4. Propeller shaft (2nd shaft) | 5. Clip                                    | 6. Center bearing mounting bracket (Upper) |

Refer to [GI-11. "Components"](#), for the symbols in the figure.

# REAR PROPELLER SHAFT

## VQ35DE AWD MODELS (3F80A-1VL107 TYPE)

SEC. 370

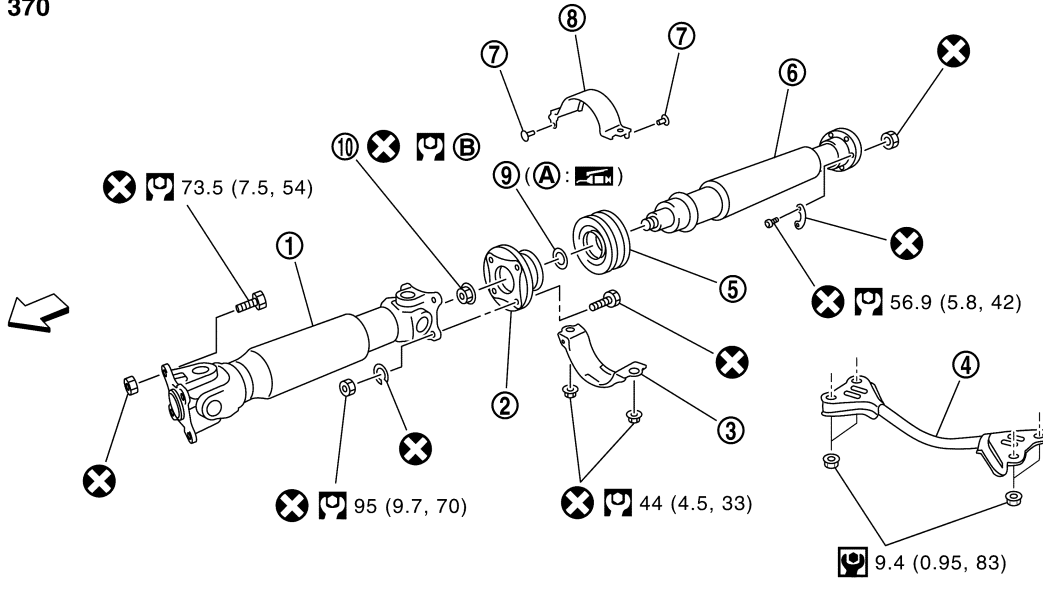

- |                                |  |  |
|--------------------------------|--|--|
| 1. Propeller shaft (1st shaft) | 2. Center flange                           | 3. Center bearing mounting bracket (Lower) |
| 4. Floor reinforcement         | 5. Center bearing assembly                 | 6. Propeller shaft (2nd shaft)             |
| 7. Clip                        | 8. Center bearing mounting bracket (Upper) | 9. Washer                                  |
| 10. Lock nut                   |  |  |

A: Both side

B: For the tightening torque, refer to [PR-12. "ASSEMBLY"](#).

Refer to [GI-11. "Components"](#), for the symbols in the figure.

## Removal and Installation

### REMOVAL

NDS000EF

1. Move the A/T select lever to N position and release the parking brake.
2. Remove the floor reinforcement.
3. Remove the center muffler with power tool. Refer to [EX-3. "EXHAUST SYSTEM"](#).
4. **For VQ35DE 2WD models**

- Put matching marks on propeller shaft rebro joint with final drive companion flange.

#### CAUTION:

**For matching marks, use paint. Do not damage propeller shaft rebro joint and companion flange.**

#### For VK45DE 2WD models

- Put matching marks on propeller shaft rubber coupling with transmission companion flange and on rebro joint with final drive companion flange.

#### CAUTION:

**For matching marks, use paint. Do not damage rubber coupling, rebro joint and companion flanges.**

#### For VQ35DE AWD models

- Put matching marks on propeller shaft flange yoke with transfer companion flange and on rebro joint with final drive companion flange.

#### CAUTION:

**For matching marks, use paint. Do not damage propeller shaft flange yoke, rebro joint and companion flanges.**

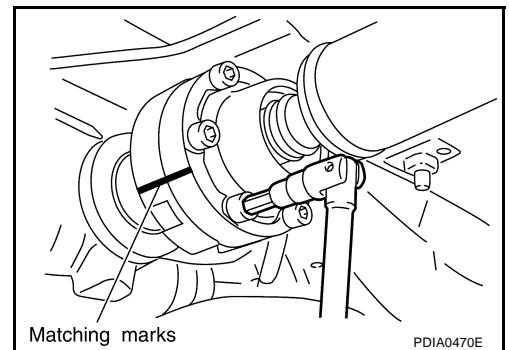



# REAR PROPELLER SHAFT

- Loosen mounting nuts of center bearing mounting brackets.

**CAUTION:**

**Tighten mounting nuts temporarily.**

- Remove propeller shaft fixing bolts and nuts.
- Remove center bearing mounting bracket fixing nuts.
- Remove propeller shaft.

**CAUTION:**

**If constant velocity joint was bent during propeller shaft assembly removal, installation, or transportation, its boot may be damaged. Wrap boot interference area to metal part with shop cloth or rubber to protect boot from breakage.**

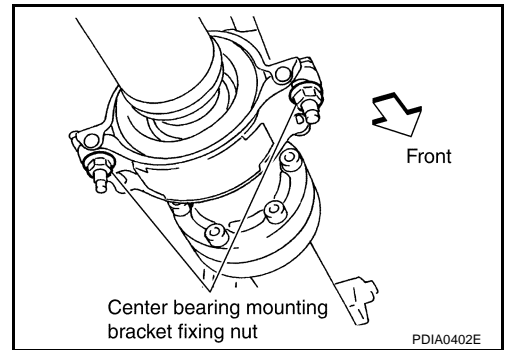

A  
B  
C

PR

## INSPECTION

- Inspect propeller shaft runout at measuring points. If runout exceeds specifications, replace propeller shaft assembly. For measuring point, refer to [PR-6, "Propeller Shaft Runout Measuring Point"](#).

**Propeller shaft runout limit : 0.8 mm (0.031 in)**

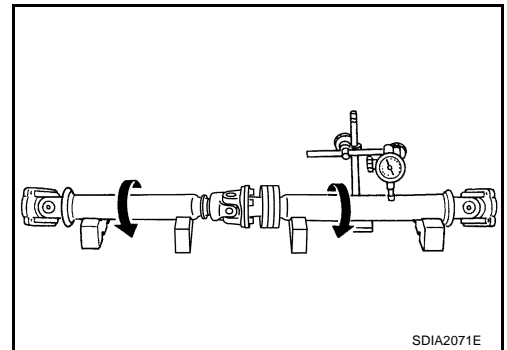

E  
F  
G  
H

- As shown in the figure, while fixing yoke on one side, check axial play of joint. If outside the standard, replace relevant propeller shaft.

**Journal axial play : 0 mm (0 in)**

- Check propeller shaft for bend and damage. If damage is detected, replace relevant propeller shaft assembly.

**CAUTION:**

**Do not disassemble joints.**

- Check center bearing for noise and damage. If noise or damage is detected, replace center bearing. Refer to [PR-11, "Disassembly and Assembly of Center Bearing \(For 3S80A-1VL107 and 3F80A-1VL107 Type\)"](#).

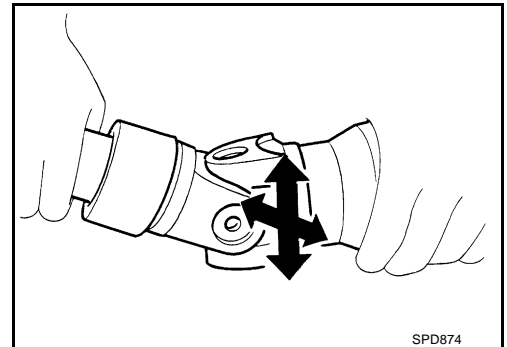

I  
J  
K  
L  
M

# REAR PROPELLER SHAFT

## INSTALLATION

Note the following, and install in the reverse order of removal.

### CAUTION:

**Avoid damaging the rebro joint boot, protect it with a shop towel or equivalent.**

- Align matching marks to install propeller shaft to final drive and transfer (AWD models only) companion flanges, and then tighten to specified torque. Refer to [PR-7, "Components"](#).
- Install center bearing mounting bracket (Upper) with its arrow mark facing forward.
- Adjust position of mounting bracket sliding back and forth to prevent play in thrust direction of center bearing insulator. Install bracket to vehicle.
- After assembly, perform a driving test to check propeller shaft vibration. If vibration occurred, separate propeller shaft from final drive. Reinstall companion flange after rotating it by 60, 120, 180, 240, 300 degrees. Then perform driving test and check propeller shaft vibration again at each point.

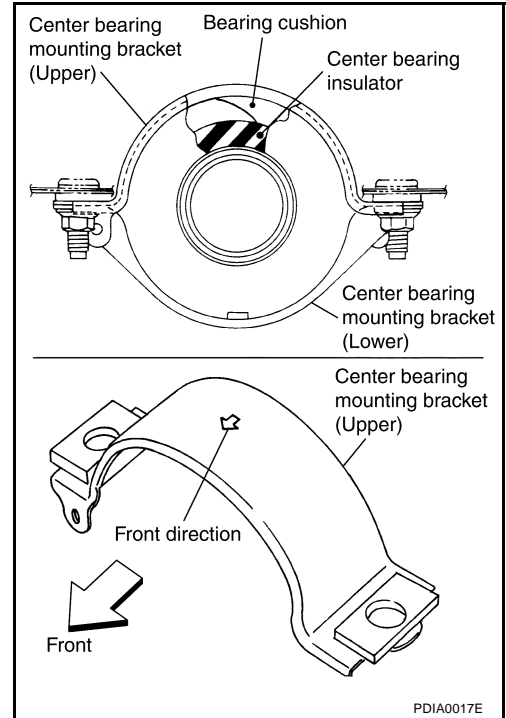

- If propeller shaft or final drive has been replaced, connect them as follows:
  1. Install the propeller shaft while aligning its matching mark A with the matching mark B on the joint as close as possible.
  2. Tighten the joint bolts to the specified torque. Refer to [PR-7, "Components"](#).

### CAUTION:

**Do not reuse the bolts, nuts and washers.**

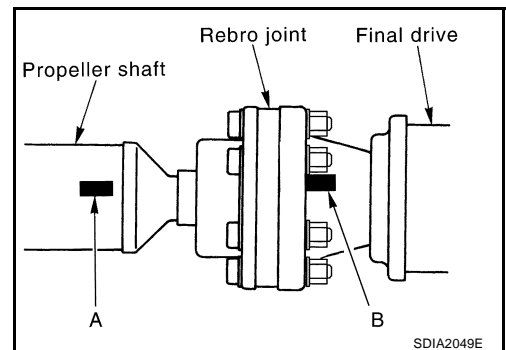

# REAR PROPELLER SHAFT

## Disassembly and Assembly of Center Bearing (For 3S80A-1VL107 and 3F80A-1VL107 Type)

NDS000EG

### DISASSEMBLY

1. Put matching marks on propeller shaft and center flange, then disassemble the 1st and 2nd propeller shaft.

**CAUTION:**

For matching marks, use paint. Do not damage the propeller shaft flange and center flange.

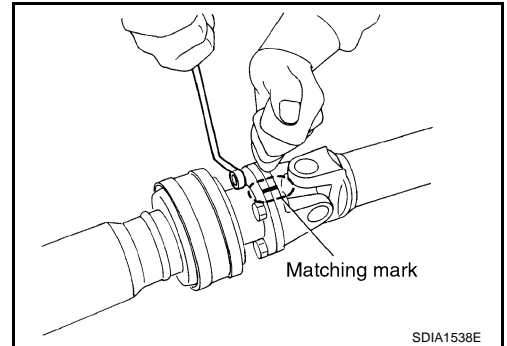

2. Put matching marks onto the center flange and propeller shaft end as shown.

**CAUTION:**

For matching marks, use paint. Do not damage propeller shaft end and center flange.

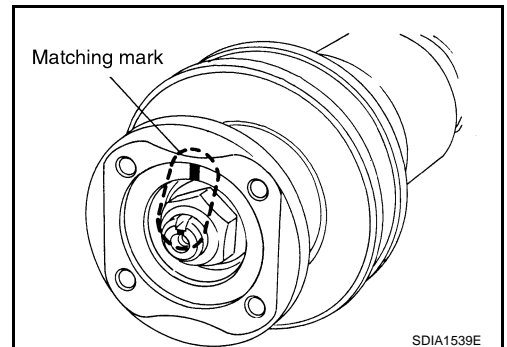

3. Hold the center flange using the flange wrench, and remove the lock nut.

**Tool number** : KV40104000 ( — )

4. Remove the center flange using a commercial available bearing puller then remove washer.

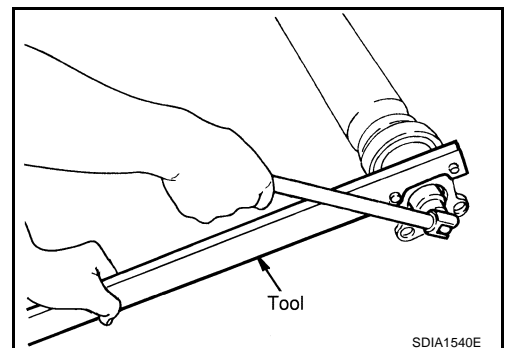

5. Press out the center bearing using the puller and hydraulic press.

**Tool number** : ST30031000 (J-22912-01)

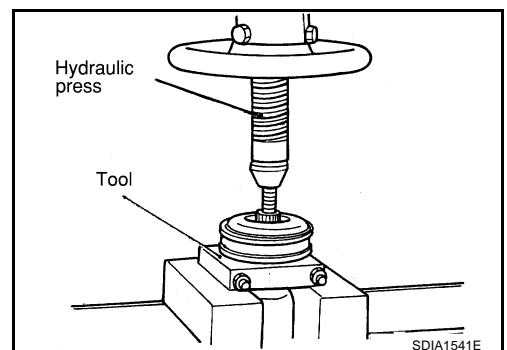

A  
B  
C  
PR  
E  
F  
G  
H  
I  
J  
K  
L  
M

# REAR PROPELLER SHAFT

## ASSEMBLY

1. Install the center bearing with its "F" mark facing the front of the vehicle.
2. Apply multi-purpose grease to the each face of the washer, then install washer.
3. Install the center flange onto the propeller shaft with aligning the marks that are marked while removal.
4. The lock nut is tightened according to the following.

**CAUTION:**

**Do not reuse the lock nut.**

- a. Using suitable torque wrench and tighten lock nut.

: **294N·m (30.0kg-m, 217ft-lb)**

- b. Loosen lock nut and tighten specified torque again.

: **82.9N·m (8.5kg-m, 61ft-lb)**

5. Place a piece of wood under the center flange, stake the lock nut against the propeller shaft groove.

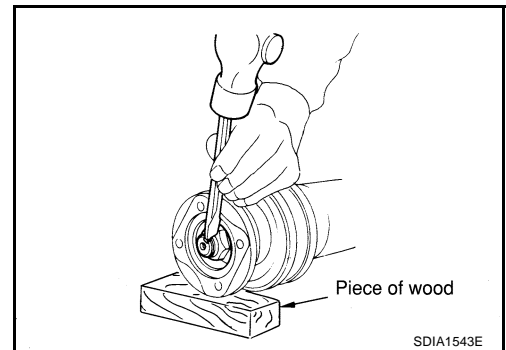
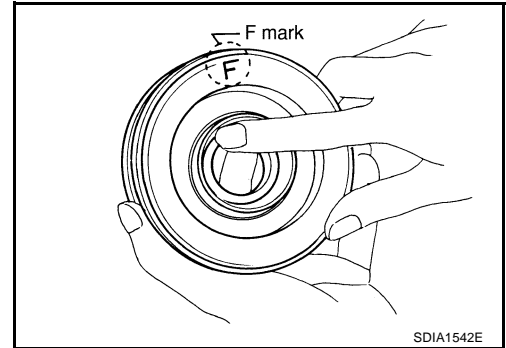

6. Assemble the 1st and 2nd shaft propeller shafts while aligning the matching marks that are marked during removal.
7. Install and tighten the bolts/nuts and tighten them to specified torque. Refer to [PR-7, "Components"](#).

**CAUTION:**

**Do not reuse the bolts, nuts and washers.**

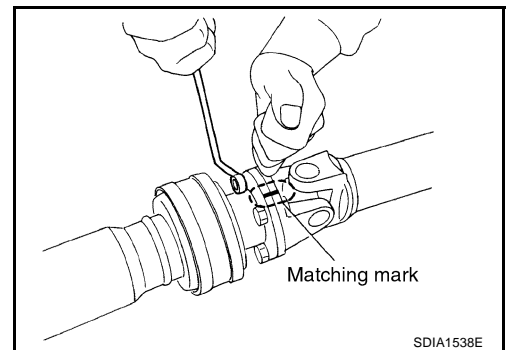

# SERVICE DATA AND SPECIFICATIONS (SDS)

## SERVICE DATA AND SPECIFICATIONS (SDS)

PFP:00030

### General Specifications 2WD MODELS

NDS000EH

Applied model		VQ35DE	VK45DE
Propeller shaft model		3S80A-1VL107	3F-R-2VL107
Number of joints		3	
Type of journal bearings (Non-disassembly type)	1st joint	Shell type	Rubber coupling type
	2nd joint	Shell type	Rebro joint type
	3rd joint	Rebro joint type	Rebro joint type
Coupling method with transmission		Sleeve type	Flange type
Coupling method with rear final drive		Flange type	
Shaft length	1st	724 mm (28.50 in) <sup>*1</sup>	739 mm (29.09 in) <sup>*3</sup>
	2nd	803 mm (31.61 in) <sup>*2</sup>	802 mm (31.57 in) <sup>*4</sup>
Shaft outer diameter	1st	82.6 mm (3.25 in)	
	2nd	82.6 mm (3.25 in)	

\*1: Spider to spider

\*2: Spider to rebro joint center

\*3: Rubber coupling center to rebro joint center

\*4: Rebro joint center to rebro joint center

### AWD MODELS

Applied model		VQ35DE	
Front	Propeller shaft model	2S56A	
	Number of joints	2	
	Type of journal bearings (Non-disassembly type)	Shell type	
	Coupling method with transfer	Sleeve type	
	Coupling method with front final drive	Flange type	
	Shaft length (Spider to spider)	763 mm (30.04 in)	
	Shaft outer diameter	42.7 mm (1.68 in)	
Rear	Propeller shaft model	3F80A-1VL107	
	Number of joints	3	
	Type of journal bearings (Non-disassembly type)	1st joint	Shell type
		2nd joint	Shell type
		3rd joint	Rebro joint type
	Coupling method with transfer		Flange type
	Coupling method with rear final drive		Flange type
	Shaft length	1st (Spider to spider)	399 mm (15.71 in)
		2nd (Spider to rebro joint center)	803 mm (31.61 in)
Shaft outer diameter	1st	82.6 mm (3.25 in)	
	2nd	82.6 mm (3.25 in)	

# SERVICE DATA AND SPECIFICATIONS (SDS)

## Journal Axial Play

NDS000EI

Model	Front propeller shaft	Rear propeller shaft		
	2S56A	3S80A-1VL107	3F80A-1VL107	3F-R-2VL107
Journal axial play	0 mm (0 in)			—

## Propeller Shaft Runout

NDS000EJ

Model	Front propeller shaft	Rear propeller shaft		
	2S56A	3S80A-1VL107	3F80A-1VL107	3F-R-2VL107
Propeller shaft runout limit	0.8 mm (0.031 in)			