

SECTION **PR**  
PROPELLER SHAFT

A  
B  
C

PR

CONTENTS

E

<b>PREPARATION</b> .....	2	APPEARANCE AND NOISE INSPECTION	4	F
Commercial Service Tools .....	2	Removal and Installation .....	4	
<b>NOISE, VIBRATION AND HARSHNESS (NVH)</b>		REMOVAL .....	4	
<b>TROUBLESHOOTING</b> .....	3	INSPECTION AFTER REMOVAL .....	5	G
NVH Troubleshooting Chart .....	3	INSTALLATION .....	6	
<b>REAR PROPELLER SHAFT</b> .....	4	<b>SERVICE DATA AND SPECIFICATIONS (SDS)</b> .....	7	
On-Vehicle Inspection .....	4	General Specifications .....	7	H
PROPELLER SHAFT VIBRATION .....	4	Propeller Shaft Axial Play .....	7	
		Propeller Shaft Vibration .....	7	I

F

G

H

I

J

K

L

M

# PREPARATION

## PREPARATION

PFP:00002

### Commercial Service Tools

ADS000LU

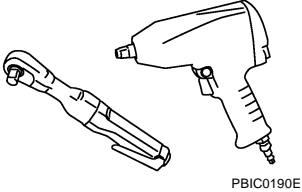
Tool name	Description
<p data-bbox="145 300 272 327">Power tool</p>  <p data-bbox="842 523 914 538">PBIC0190E</p>	<p data-bbox="986 300 1241 327">Loosening bolts and nuts</p>

# NOISE, VIBRATION AND HARSHNESS (NVH) TROUBLESHOOTING

## NOISE, VIBRATION AND HARSHNESS (NVH) TROUBLESHOOTING

PFP:00003

### NVH Troubleshooting Chart

ADS000F6

Use the chart below to help you find the cause of the symptom. If necessary, repair or replace these parts.

Reference page			—	Refer to <a href="#">PR-5</a>	—	Refer to <a href="#">PR-4</a>	—	NVH in RFD section	NVH in FAX, RAX, FSU, and RSU section	NVH in WT section	NVH in WT section	NVH in RAX section	NVH in BR section	NVH in PS section
Possible cause and suspected parts			Uneven rotation torque	Center bearing improper installation	Excessive joint angle	Rotation imbalance	Excessive runout	Differential	Axle and suspension	Tires	Road wheel	Drive shaft	Brakes	Steering
Symptom	Propeller shaft	Noise	x	x	x	x	x	x	x	x	x	x	x	x
		Shake		x	x				x	x	x	x	x	x
		Vibration	x	x	x	x	x		x	x		x		x

x: Applicable

A  
B  
C  
**PR**  
E  
F  
G  
H  
I  
J  
K  
L  
M

# REAR PROPELLER SHAFT

## REAR PROPELLER SHAFT

PFP:37000

### On-Vehicle Inspection PROPELLER SHAFT VIBRATION

ADS000E7

If vibration is present at high speed, inspect propeller shaft runout first.

1. Measure propeller shaft runout at several points by rotating final drive companion flange with hands.

**Runout limit : 0.6 mm (0.024 in) or less**

2. If runout still exceeds specifications, disconnect propeller shaft at final drive companion flange; then rotate companion flange 90, 180, 270 degrees and reconnect propeller shaft.
3. Check runout again. If runout still exceeds specifications, replace propeller shaft assembly.
4. Perform driving test to check.

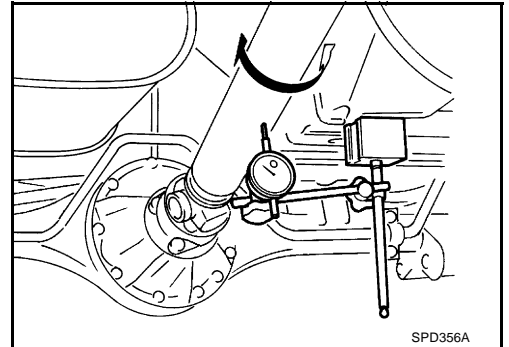

### APPEARANCE AND NOISE INSPECTION

- Inspect propeller shaft tube surface for dents or cracks. If damaged, replace propeller shaft assembly.
- If center bearing is noisy or damage, replace propeller shaft assembly.

### Removal and Installation

ADS000E8

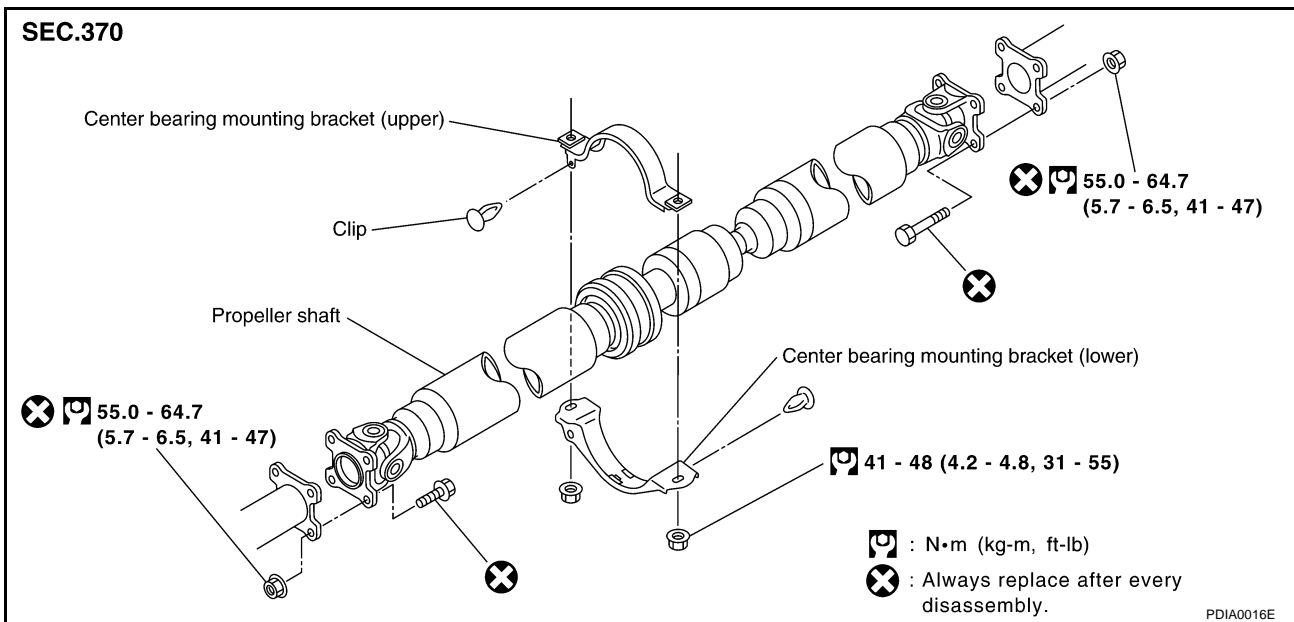

### REMOVAL

1. Put mating marks onto propeller shaft flange yoke and final drive and transfer companion flanges.

**CAUTION:**  
Use paint to avoid scratching the surface.

2. Loosen mounting nuts of center bearing mount brackets with power tool.

**CAUTION:**  
Tighten nuts temporarily.

3. Remove mounting nuts and bolts from propeller shaft companion flanges, transfer, and final drive.

4. Remove mounting nuts securing center bearing brackets onto vehicle. Then remove propeller shaft from vehicle.

**CAUTION:**  
If constant velocity joint was bent during propeller shaft assembly removal, installation, or transportation, its boot may be damaged. Wrap boot interference area to metal part with shop cloth or rubber to protect boot from breakage.

# REAR PROPELLER SHAFT

## INSPECTION AFTER REMOVAL

1. As shown in the figure, while fixing yoke on one side, check axial play of joint. If outside the standard, replace propeller shaft assembly.

**Axial play repair limit : 0 mm (0 in)**

2. Check propeller shaft for bend and damage. If damage is detected, replace propeller shaft assembly.
3. Check center bearing for noise and damage. If noise or damage is detected, replace propeller shaft assembly.

### CAUTION:

- Center bearings cannot be disassembled.
- Joints cannot be disassembled.

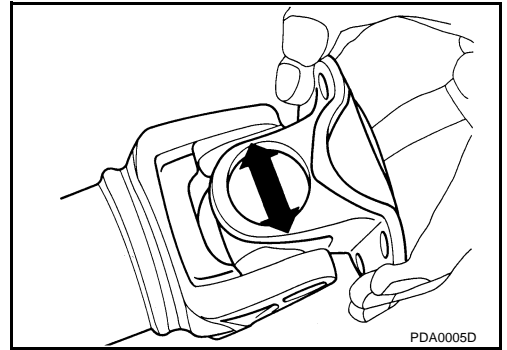

A

B

C

PR

E

F

G

H

I

J

K

L

M

# REAR PROPELLER SHAFT

## INSTALLATION

Paying attention to following items, install in the reverse order of removal.

- Align mating marks to install propeller shaft, and tighten to specified torque.
- Adjust location of mounting bracket back and forth to prevent longitudinal give of insulator as shown. Install bracket to vehicle.
- After assembly, perform a driving test to check propeller shaft for runout. If a runout is detected, separate propeller shaft from final drive. Reinstall companion flange after rotating it by 90°, 180°, and 270°. Then perform driving test and check propeller shaft runout again at each point.

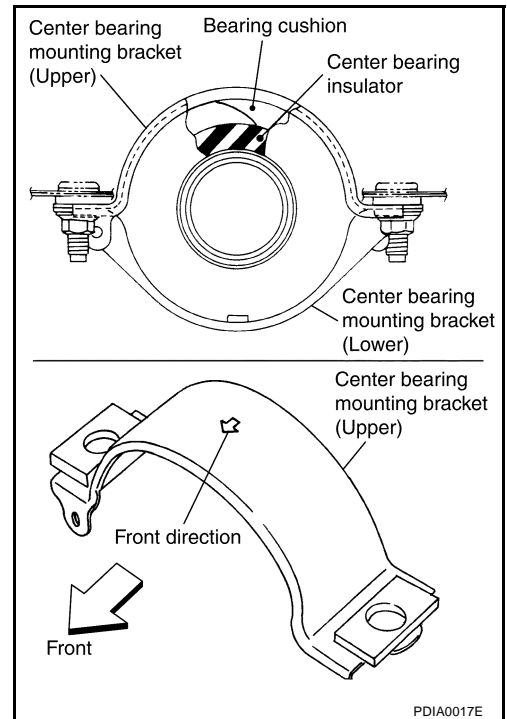

# SERVICE DATA AND SPECIFICATIONS (SDS)

## SERVICE DATA AND SPECIFICATIONS (SDS)

PFP:00030

### General Specifications

ADS000E9

A  
B  
C

Applied model	VQ35DE
	CVT
Propeller shaft model	3F63A-DOJ87
Number of joints	3
Coupling method with Transfer	Flange

### Propeller Shaft Axial Play

ADS000EA

Unit: mm (in)

PR

Type	3F63A-DOJ87
Axial play limit of journal bearing	0 (0)

E

### Propeller Shaft Vibration

ADS000EB

Unit: mm (in)

Type	3F63A-DOJ87
Runout limit	0.6 (0.024 ) or less

F

G

H

I

J

K

L

M

# SERVICE DATA AND SPECIFICATIONS (SDS)

---