

TRANSMISSION SERVICING - A/T

1992 Subaru SVX

TRANSMISSION SERVICING
Subaru - Automatic Transmission

SVX

IDENTIFICATION

AUTOMATIC TRANSMISSION APPLICATION TABLE

Model	Transmission
SVX	4-Speed Transaxle

LUBRICATION

SERVICE INTERVALS

Check fluid level in transaxle and differential every 5 months or 15,000 miles, whichever comes first. Change fluid every 30,000 miles or 30 months, whichever comes first. Differentials DO NOT require periodic fluid change.

CHECKING FLUID LEVEL

Transaxle

1) Warm engine to normal operating temperature. Park vehicle on level floor. Engage transaxle in all gear positions.

2) Set transmission selector lever in Park with engine idling. Remove dipstick and clean with lint-free cloth. Check fluid level. Fluid level should be between upper and lower marks on dipstick. Add fluid if necessary. DO NOT overfill.

Differential

Use dipstick marked DIFF OIL on top of differential to check fluid level. Level should be between "L" and "F" marks. Add fluid if necessary.

RECOMMENDED FLUID

Transaxle
Dexron-II ATF.

Differential
API GL-5.

FLUID CAPACITIES

TRANSAXLE REFILL CAPACITIES TABLE

Application	(1) Qts. (L)
SVX (AWD) (2)	10.0 (9.5)

(1) - Dry fill capacities.

(2) - Includes transfer case.

DIFFERENTIAL CAPACITIES

Application	Qts. (L)
Front	1.3 (1.2)
Rear	0.85 (0.8)

DRAINING & REFILLING

Transaxle

1) Remove drain plug. If cleaning oil screen, remove oil pan. Install NEW gaskets when reassembling. Tighten all bolts to specification. See the TORQUE SPECIFICATIONS table.

2) Fill transmission with fluid. Start and warm engine to normal operating temperature. Check fluid level with engine idling. Add fluid as necessary. DO NOT overfill.

Differential

Differential has separate drain plug. Remove differential drain plug to drain fluid.

ADJUSTMENTS

BAND

Band adjustment screw is located on left side of transmission housing. Hold band adjustment screw, and loosen lock nut. Tighten adjustment screw to 80 INCH lbs. (9 N.m), and back screw off exactly 3 turns. Hold adjustment screw, and tighten lock nut to 18-21 ft. lbs. (25-28 N.m).

KICKDOWN SWITCH & DOWNSHIFT SOLENOID

1) With ignition on, press accelerator pedal to stop. A click should be heard just as accelerator bottoms. If adjustment is necessary, loosen adjustment nut and adjust switch position for proper operation. Tighten nut.

2) If kickdown failure occurs infrequently, solenoid may be malfunctioning because of contamination. Remove and clean inside of solenoid while moving push rod. After cleaning, carefully check solenoid operation. Install with NEW "O" ring.

NEUTRAL SAFETY SWITCH

1) Loosen neutral safety switch mounting screws. Move gear selector lever to Neutral.

2) Insert Stopper Pin (499267300) as vertically as possible into holes in neutral safety switch lever and switch body. See Fig. 1. Tighten mounting bolts and recheck adjustment.

Stopper Pin (499267300)

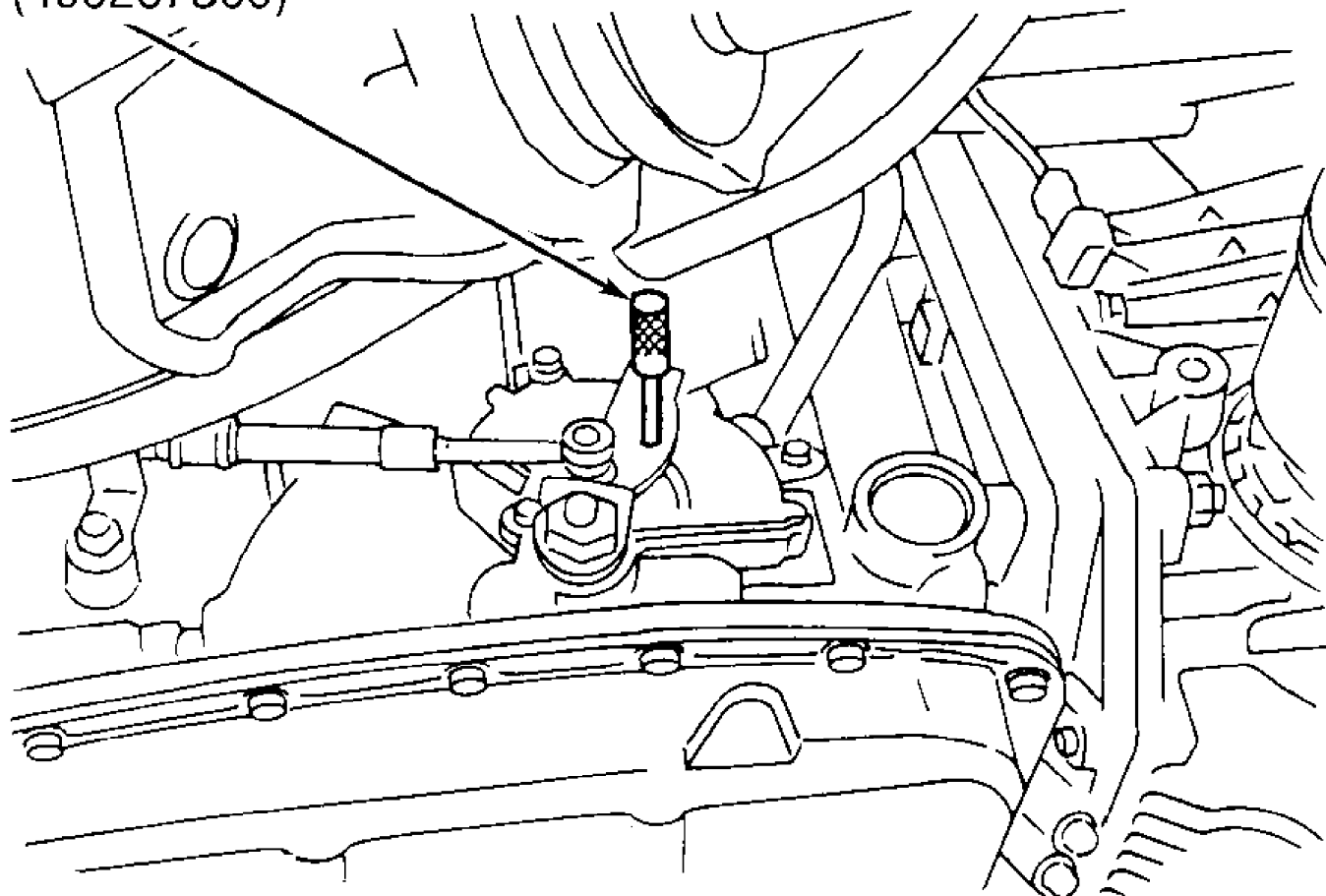

100108

Fig. 1: Adjusting Neutral Safety Switch
Courtesy of Subaru of America, Inc.

SHIFT LINKAGE

1) Adjust shift cable at lower end of selector lever. Set selector lever in Neutral. Loosen lock nuts on both sides of inner cable. See Fig. 2.

2) Lightly push selector lever away from lock nut "B". Tighten lock nut "A" until it contacts selector lever trunnion. Tighten lock nut "B" to 80-151 INCH lbs. (9-17 N.m).

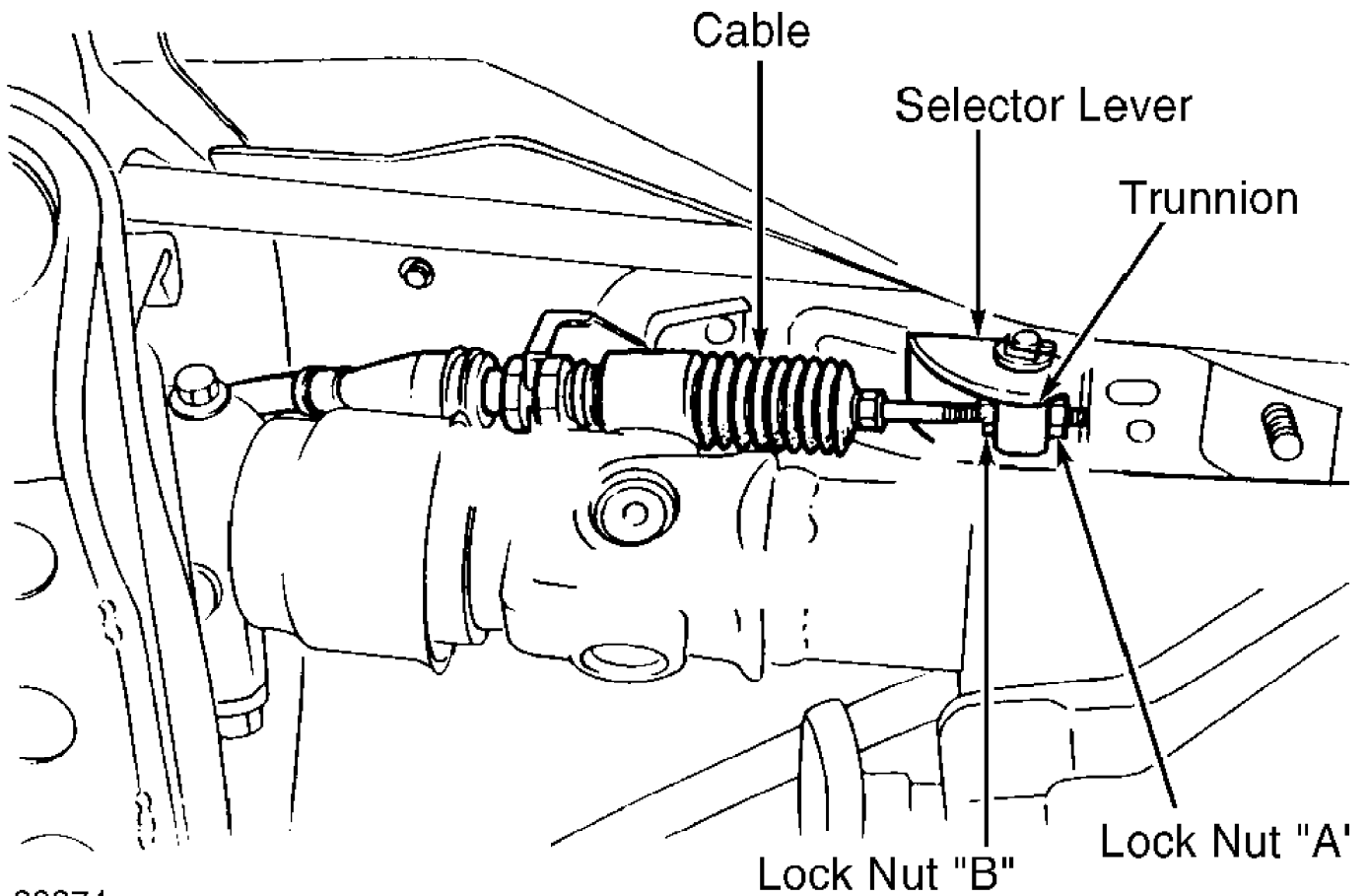

82874

Fig. 2: Adjusting Shift Cables (Typical)
 Courtesy of Subaru of America, Inc.

TORQUE SPECIFICATIONS

TORQUE SPECIFICATIONS TABLE

Application	Ft. Lbs. (N.m)
Band Adjustment Lock Nut	18-21 (25-28)
Drain Plug	18 (25)
	INCH Lbs. (N.m)
Oil Pan Bolt	30-39 (3.4-4.4)
Oil Screen Retaining Bolt	30-39 (3.4-4.4)
Shift Linkage Adjusting Nut "B"	62-80 (7-9)