

SUBARU

SVX

1992

	Page
C COMPONENT PARTS	2
1. Exhaust System	2
W SERVICE PROCEDURE	3
1. Exhaust System	3
2. Exhaust Manifold	4
3. Front Exhaust Pipe	5
4. Rear Catalytic Converter	7
5. Rear Exhaust Pipe	8
6. Muffler ASSY	10



1. Exhaust System

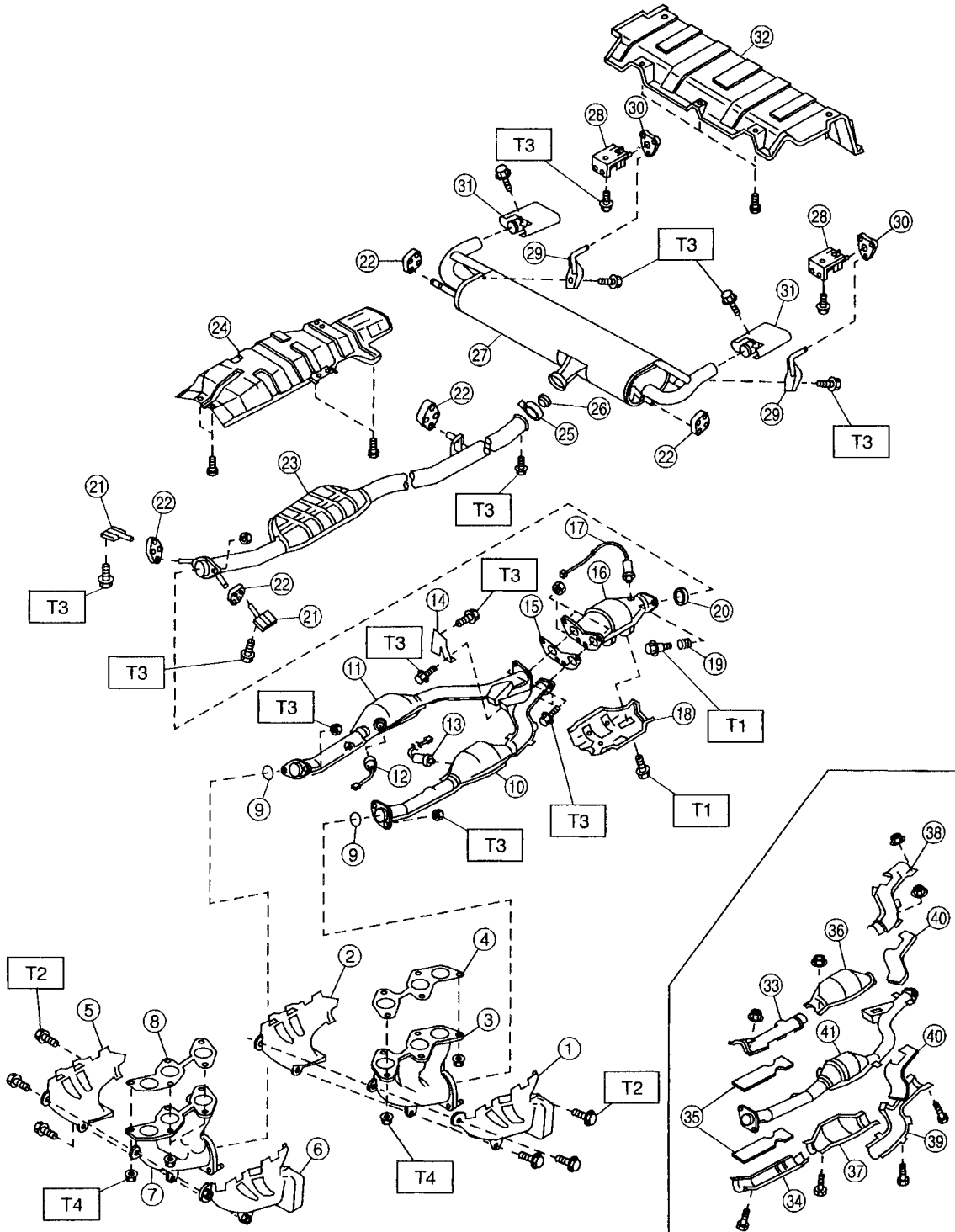

D2M0738A

- ① Outer exhaust manifold cover (LH)
- ② Inner exhaust manifold cover (LH)
- ③ Exhaust manifold (LH)
- ④ Gasket
- ⑤ Outer exhaust manifold cover (RH)
- ⑥ Inner exhaust manifold cover (RH)
- ⑦ Exhaust manifold (RH)
- ⑧ Gasket
- ⑨ Gasket
- ⑩ Front exhaust pipe ASSY (LH)
- ⑪ Front exhaust pipe ASSY (RH)
- ⑫ Front oxygen sensor 1
- ⑬ Front oxygen sensor 2
- ⑭ Hanger bracket
- ⑮ Gasket
- ⑯ Rear catalytic converter
- ⑰ Rear oxygen sensor
- ⑱ Protector
- ⑲ Spring
- ⑳ Gasket
- ㉑ Rear exhaust pipe hanger
- ㉒ Cushion rubber
- ㉓ Rear exhaust pipe
- ㉔ Exhaust cover

- ㉕ Band
- ㉖ Seal bearing
- ㉗ Muffler
- ㉘ Muffler bracket
- ㉙ Muffler hanger
- ㉚ Cushion rubber
- ㉛ Tail pipe cutter
- ㉜ Muffler cover
- ㉝ Upper front pipe cover
- ㉞ Lower front pipe cover
- ㉟ Front insulator
- ㊱ Upper converter cover
- ㊲ Lower converter cover
- ㊳ Upper rear pipe cover
- ㊴ Lower rear pipe cover
- ㊵ Rear insulator
- ㊶ Front exhaust pipe

Tightening torque: N·m (kg-m, ft-lb)

T1: 18 ± 5 (1.8 ± 0.5, 13.0 ± 3.6)

T2: 19 ± 1.5 (1.9 ± 0.15, 13.7 ± 1.1)

T3: 34 ± 5 (3.5 ± 0.5, 25.3 ± 3.6)

T4: 39 ± 5 (4.0 ± 0.5, 28.9 ± 3.6)

W SERVICE PROCEDURE

1. Exhaust System

A: ADJUSTMENT

- 1) Check to make sure clearances between parts and car body are larger than specified values.
- 2) If any clearance is not, loosen all connections.
- 3) Adjust where necessary to obtain proper clearance.
- 4) Tighten all connections to specified torque.

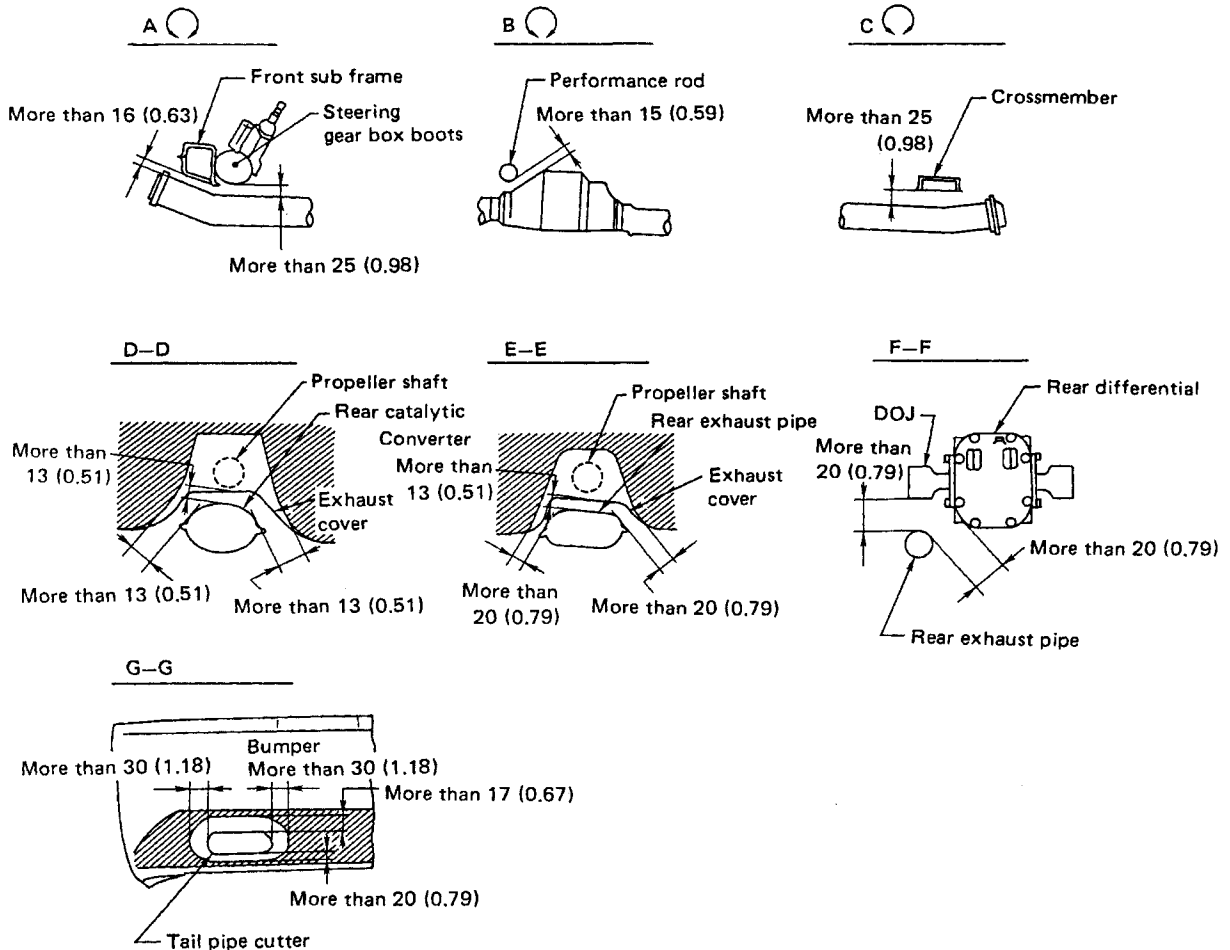
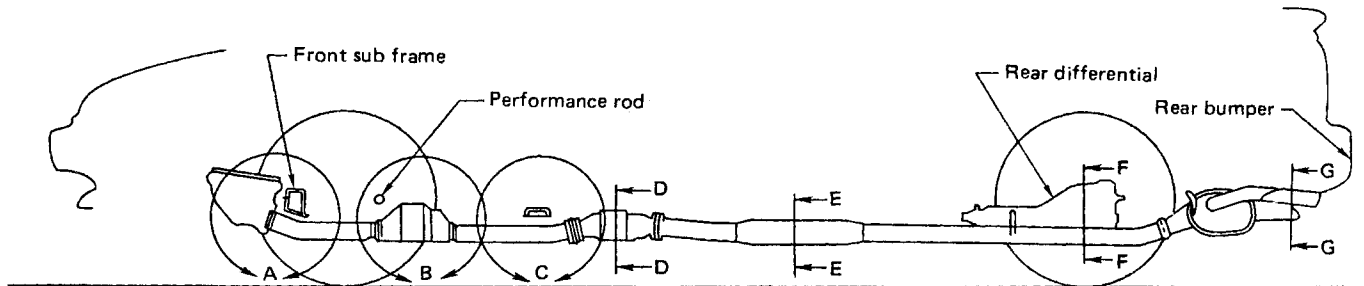

Fig. 2

2. Exhaust Manifold

A: REMOVAL

Tightening torque N·m (kg·m, ft·lb)

T1: 17.2 – 20.1 (1.75 – 2.05, 12.7 – 14.8)

T2: 34 – 44 (3.5 – 4.5, 25 – 33)

T3: 29 – 39 (3 – 4, 22 – 29)

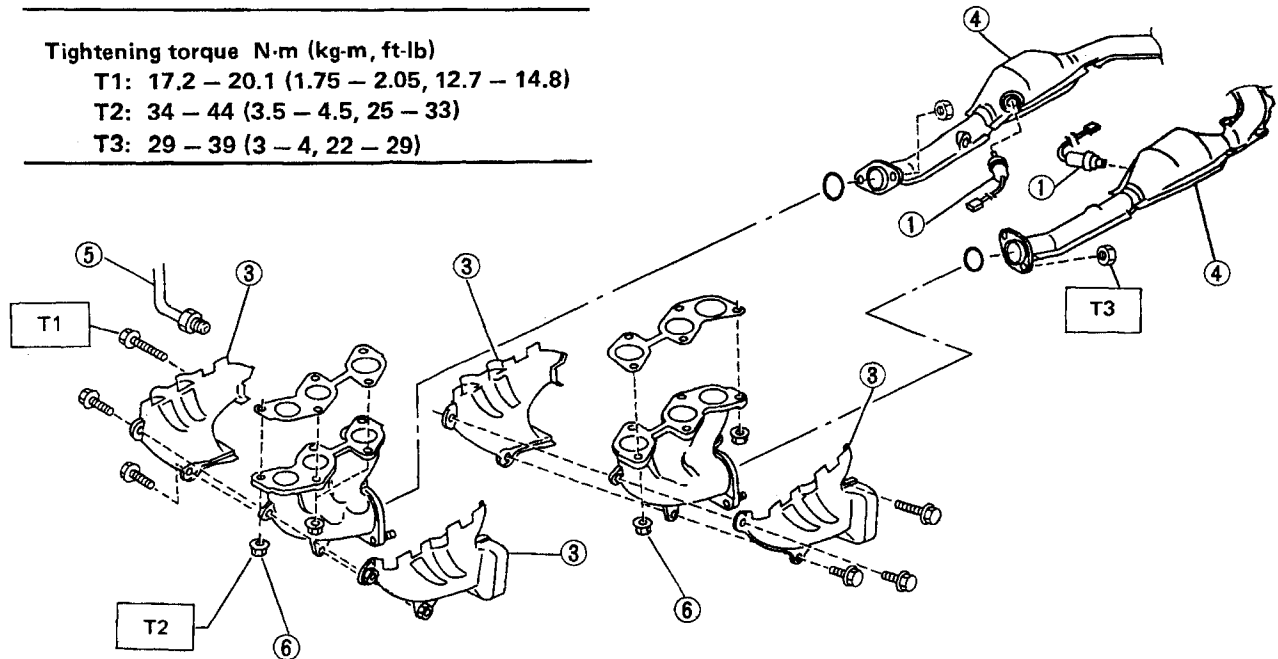

C2-126

Fig. 3

- 1) Disconnect O₂ sensor harness.
- 2) Remove front under cover.
- 3) Remove exhaust manifold covers.
- 4) Remove front exhaust pipes. (Ref. to 3 Front Exhaust Pipe [W3A0].)
- 5) Disconnect EGR pipe from exhaust manifold RH.

- 6) Remove exhaust manifolds.

B: INSTALLATION

Installation is in the reverse order of removal procedures.

Observe the following:

- 1) Be sure to install a new gasket.
- 2) Use only nuts specified by the manufacturer.

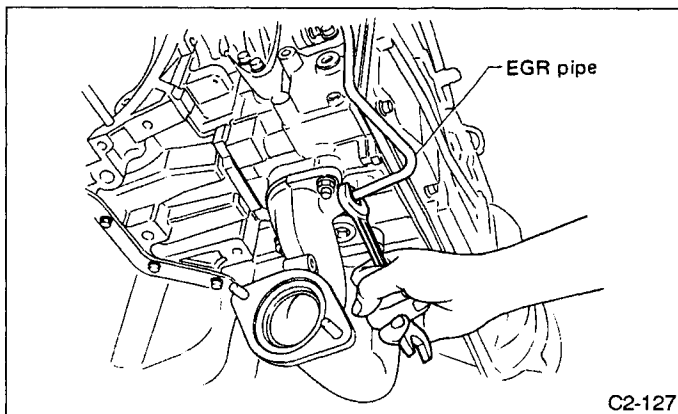

C2-127

Fig. 4

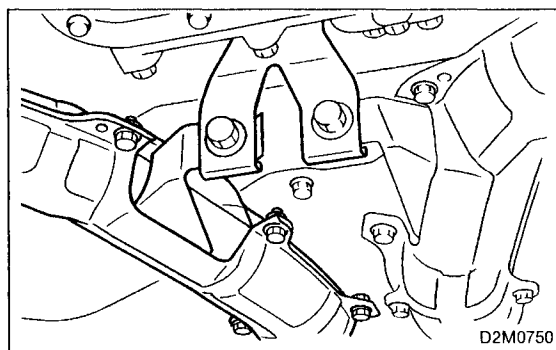
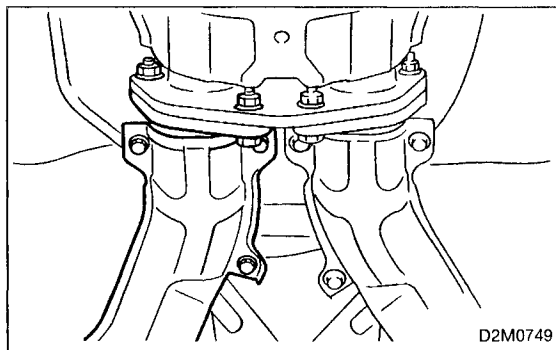
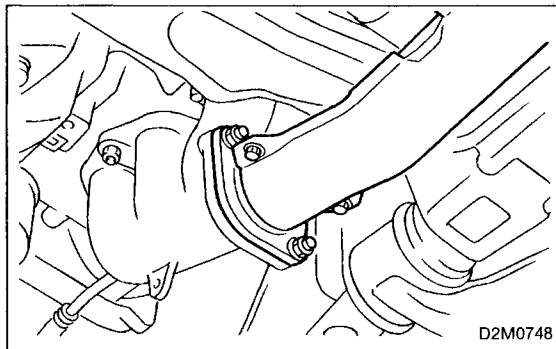
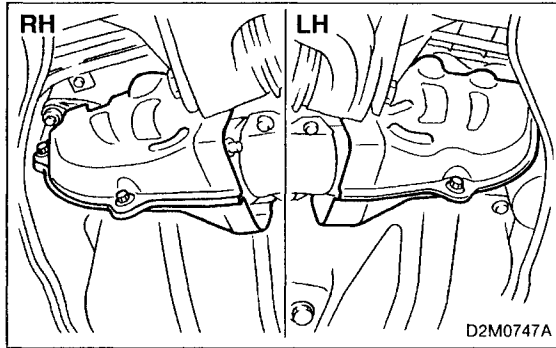
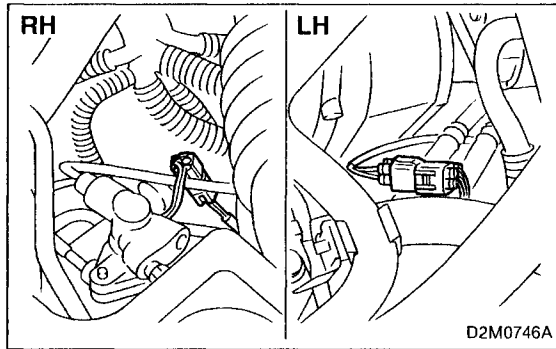

3. Front Exhaust Pipe

A: REMOVAL

1) Disconnect front oxygen sensor connectors (RH and LH).

2) Lift-up the vehicle.

3) Remove exhaust manifold covers (RH and LH).

CAUTION:

To prevent front exhaust pipes from dropping, do not remove the right and left exhaust pipes at the same time; always remove one at a time.

4) Separate one front exhaust pipe from exhaust manifold.

5) Separate front exhaust pipe from rear catalytic converter.

6) Remove front exhaust pipe from hanger bracket.

7) Similarly, remove the other front exhaust pipe.

8) If necessary, remove heat sealed covers and oxygen sensor from front exhaust pipe.

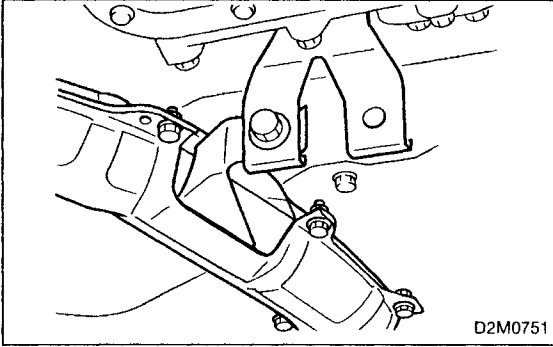

B: INSTALLATION

CAUTION:

Replace gaskets with new ones.

1) Install one front exhaust pipe to hanger bracket. And temporarily tighten nut which installs front exhaust pipe to hanger bracket.

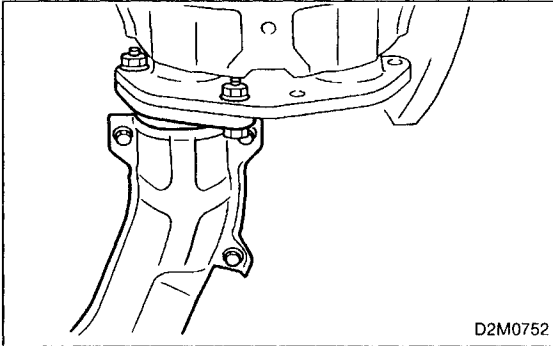

2) Install front exhaust pipe to rear catalytic converter.

Tightening torque:

$34 \pm 5 \text{ N}\cdot\text{m}$ ($3.5 \pm 0.5 \text{ kg}\cdot\text{m}$, $25.3 \pm 3.6 \text{ ft}\cdot\text{lb}$)

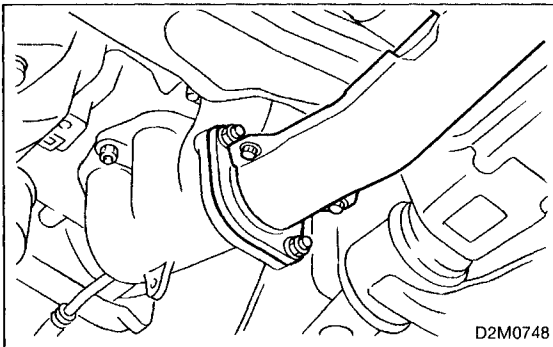

3) Install front exhaust pipe to exhaust manifold.

Tightening torque:

$34 \pm 5 \text{ N}\cdot\text{m}$ ($3.5 \pm 0.5 \text{ kg}\cdot\text{m}$, $25.3 \pm 3.6 \text{ ft}\cdot\text{lb}$)

4) Similarly, install the other front exhaust pipe.

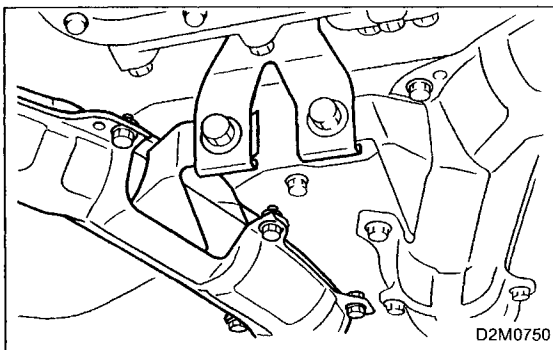

5) Tighten nuts which hold front exhaust pipes to hanger bracket.

Tightening torque:

$34 \pm 5 \text{ N}\cdot\text{m}$ ($3.5 \pm 0.5 \text{ kg}\cdot\text{m}$, $25.3 \pm 3.6 \text{ ft}\cdot\text{lb}$)

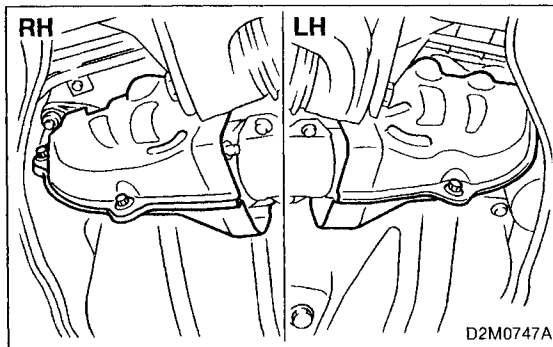

6) Install exhaust manifold covers (RH and LH).

Tightening torque:

$19 \pm 1.5 \text{ N}\cdot\text{m}$ ($1.9 \pm 0.15 \text{ kg}\cdot\text{m}$, $13.7 \pm 1.1 \text{ ft}\cdot\text{lb}$)

3. Front Exhaust Pipe

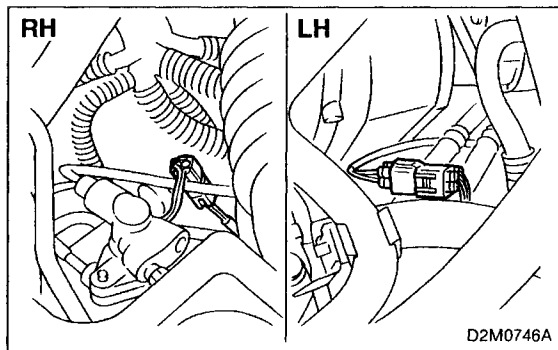

- 7) Lower the vehicle.
- 8) Connect front oxygen sensor connectors (RH and LH).

4. Rear Catalytic Converter

A: REMOVAL

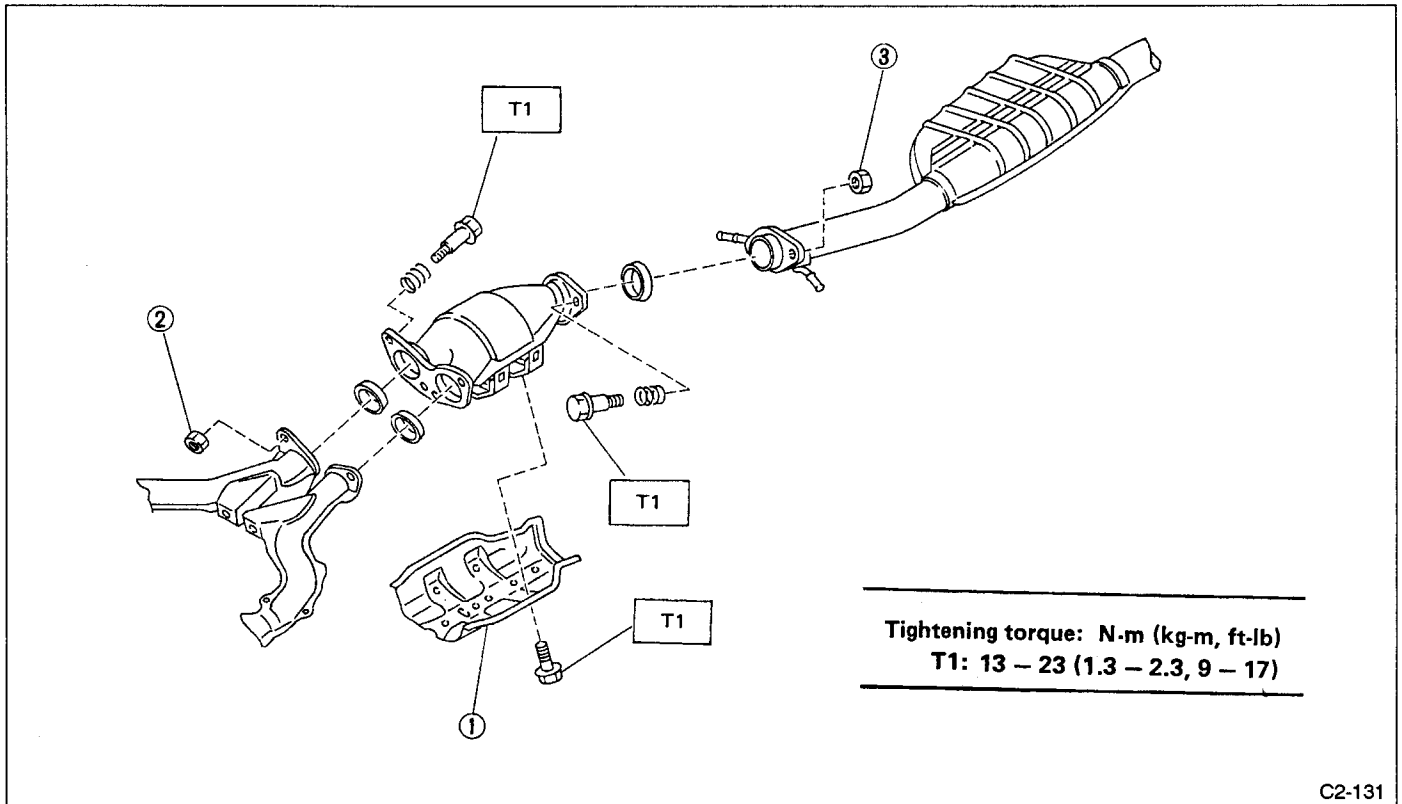

Fig. 8

- 1) Remove rear catalytic converter protector.
- 2) Disconnect rear catalytic converter from front exhaust pipes.
- 3) Disconnect rear catalytic converter from rear exhaust pipe.
- 4) Remove rear catalytic converter.

B: INSTALLATION

Installation is in the reverse order of removal procedures.

Observe the following:

- 1) Be sure to install a new gasket.
 - 2) Use only nuts specified by the manufacturer.
- Be sure to install bolts, springs and self-locking nuts in the order indicated in the figure.**
Always install new self-locking nuts.

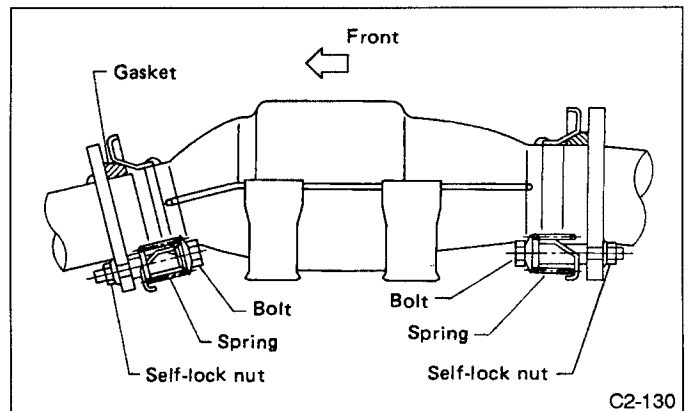
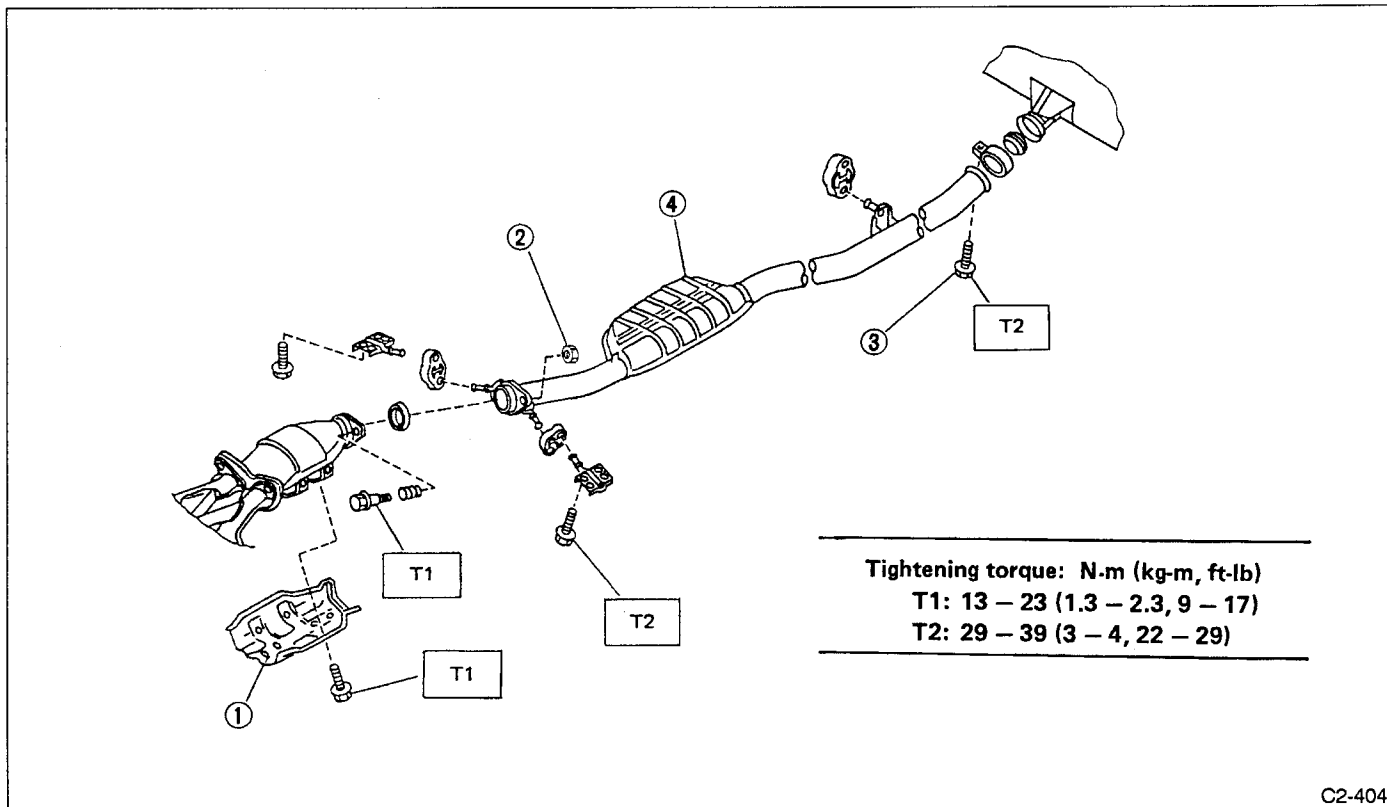

Fig. 9

5. Rear Exhaust Pipe

A: REMOVAL



C2-404

Fig. 10

- 1) Remove rear catalytic converter protector.
- 2) Disconnect rear exhaust pipe from rear catalytic converter.
- 3) Loosen seal bearing band and disconnect rear exhaust pipe from muffer ASSY.

When disconnecting rear exhaust pipe from muffer ASSY, be careful not to drop seal bearing.

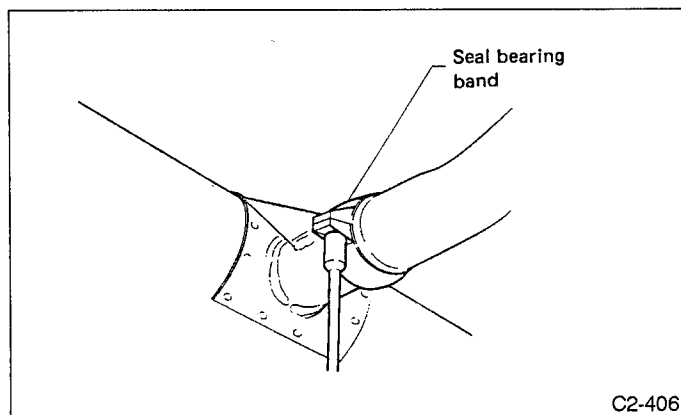

C2-406

Fig. 11

- 4) Remove rear exhaust pipe from rubber cushion. To facilitate its removal, apply a coat of SUBARU CRC5-56 (004301003) in advance.

B: INSTALLATION

- 1) Insert rear exhaust pipe bracket into rubber cushion. To facilitate insertion, apply a coat of SUBARU CRC5-56 (004301003) to the mating area of rubber cushion in advance.
- 2) Loosen the seal bearing band and install it over the rear exhaust pipe in advance.
- 3) Place the seal bearing between the rear exhaust pipe and muffer ASSY, and tighten the seal bearing band. Do not allow clearances to exist between the seal bearing and rear exhaust pipe, or muffer ASSY while tightening the band.

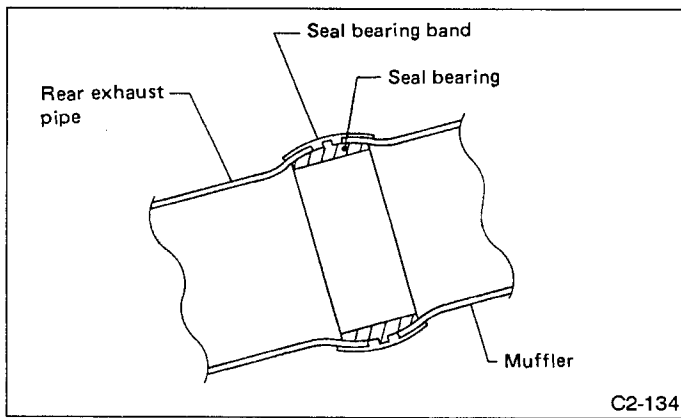

Fig. 12

- 4) Connect rear exhaust pipe to rear catalytic converter. **Be sure to install bolts, springs and self-locking nuts in the order. (Ref. to 4 Rear Catalytic Converter [W4B0].) Always install new self-locking nuts.**
- 5) Install rear catalytic converter protector.

6. Muffler ASSY

A: REMOVAL

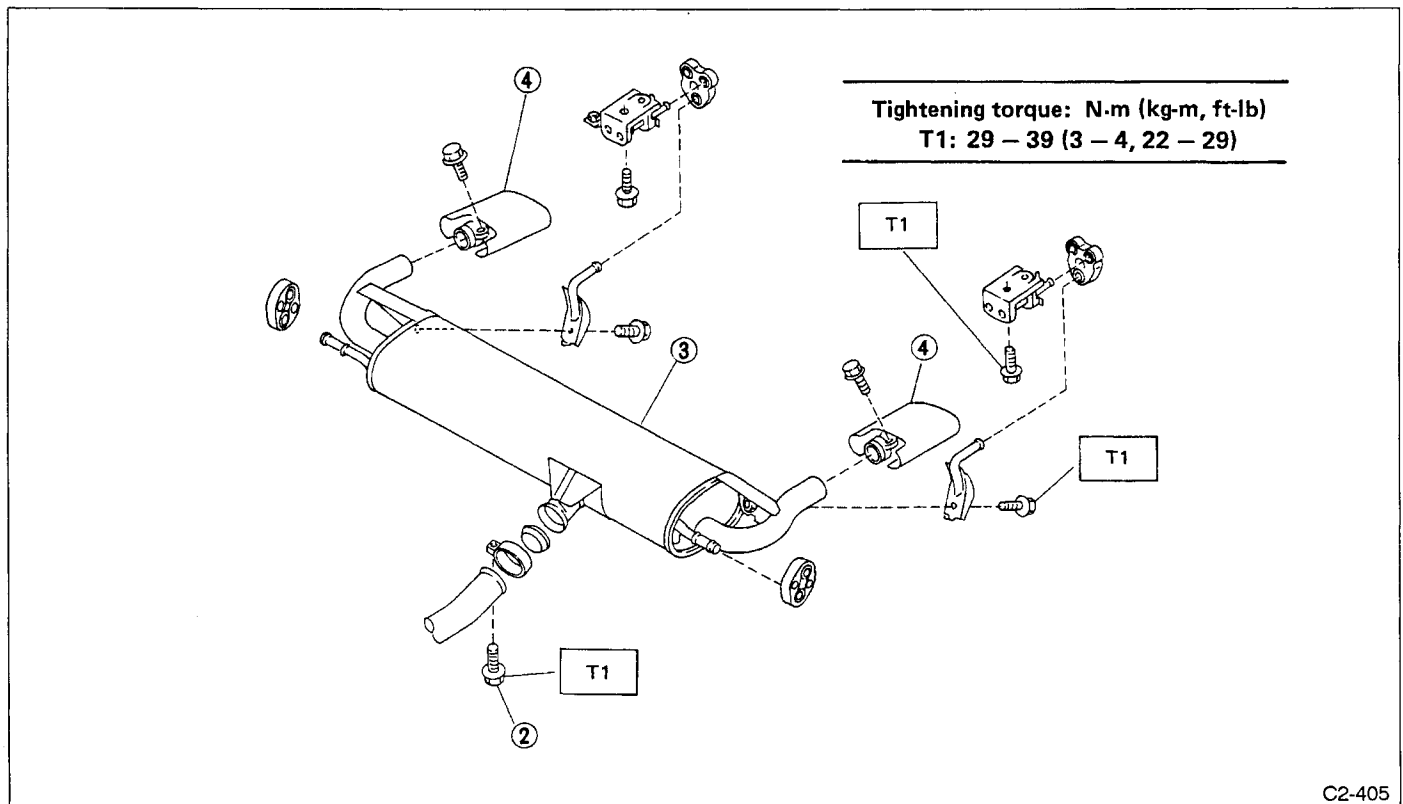

Fig. 13

Always work with a helper when removing or installing the muffler ASSY.

- 1) To prevent damage to bumper near muffler, wrap a cloth around tail pipe cutters.
- 2) Loosen seal bearing band and disconnect muffler ASSY from rear exhaust pipe.

When disconnecting muffler ASSY from rear exhaust pipe, be careful not to drop seal bearing.

- 3) Remove muffler ASSY from rubber cushions. To facilitate their removal, apply a coat of SUBARU CRC5-56 (004301003) to them in advance.
- 4) Remove tail pipe cutters from muffler ASSY.

B: INSTALLATION

- 1) Install tail pipe cutters.
- 2) Insert muffler ASSY brackets into rubber cushions. To facilitate insertion, apply a coat of SUBARU CRC5-56 (004301003) to the mating area of rubber cushions in advance.
- 3) Loosen the seal bearing band and install it over the rear exhaust pipe in advance.
- 4) Place the seal bearing between the rear exhaust pipe and muffler ASSY, and tighten the seal bearing band. Do not allow clearances to exist between the seal bearing and rear exhaust pipe, or muffler ASSY while tightening the band.

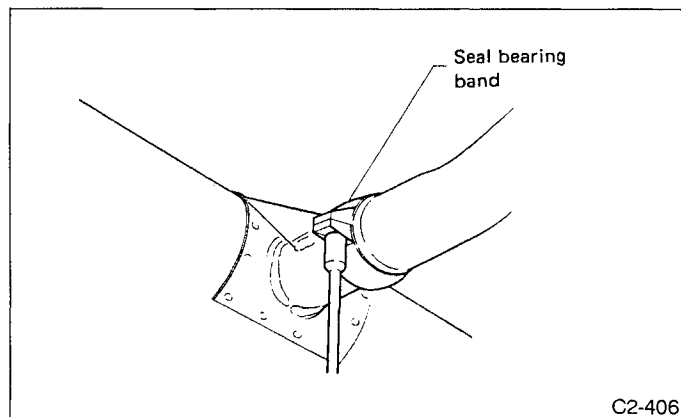

Fig. 14

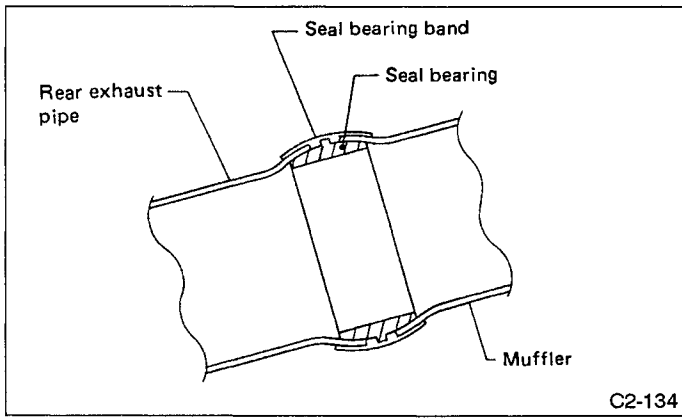

Fig. 15