

**SUBARU**

**SVX**

**1992**



	Page
1. General Description .....	2
2. Working Precautions .....	9
3. How to Use Wiring Diagram .....	12
4. Wiring Diagram and Troubleshooting .....	14
1. POWER SUPPLY ROUTING .....	14
2. GROUND DISTRIBUTION .....	16
3. ANTI-LOCK BRAKE SYSTEM .....	20
4. A/T CONTROL SYSTEM .....	22
5. A/T SHIFT LOCK SYSTEM .....	24
6. AUDIO & CLOCK SYSTEM .....	25
7. AUTOMATIC SHOULDER BELT & KEY WARNING CHIME SYSTEM .....	26
8. BACK-UP LIGHT SYSTEM .....	28
9. CHARGING SYSTEM .....	29
10. COMBINATION METER .....	31
11. COURTESY LIGHT & KEY HOLE ILLUMINATION LIGHT SYSTEM .....	35
12. CRUISE CONTROL SYSTEM .....	36
13. DOOR LOCK SYSTEM .....	40
14. ELECTRONICALLY CONTROLLED POWER STEERING SYSTEM .....	42
15. ENGINE ELECTRICAL (MPFI) SYSTEM .....	44
16. FRONT WIPER AND WASHER SYSTEM .....	48
17. FUEL GAUGE SYSTEM .....	49
18. HORN AND CIGARETTE LIGHTER SYSTEM .....	51
19. LIGHTING (HEADLIGHT & FOG LIGHT) SYSTEM .....	52
20. LIGHTING (TAIL LIGHT•ILLUMINATION LIGHT•etc.) SYSTEM .....	56
21. OIL PRESSURE AND TEMPERATURE GAUGE SYSTEM .....	58
22. PARKING BRAKE AND BRAKE FLUID LEVEL WARNING SYSTEM .....	59
23. POWER SEAT SYSTEM .....	61
24. POWER WINDOW SYSTEM .....	62
25. RADIATOR FAN & AIR CONDITIONER SYSTEM .....	64
26. REAR WINDOW DEFOGGER SYSTEM .....	68
27. REAR WIPER AND WASHER SYSTEM .....	69
28. REMOTE CONTROL REARVIEW MIRROR SYSTEM .....	70
29. SECURITY SYSTEM .....	71
30. SPEEDOMETER SYSTEM .....	72
31. SPOT LIGHT, ROOM LIGHT & VANITY MIRROR LIGHT SYSTEM .....	73
32. SRS (AIRBAG SYSTEM) .....	74
33. STARTING SYSTEM .....	75
34. STOP LIGHT SYSTEM .....	76
35. SUNROOF SYSTEM .....	77
36. TIME CONTROL SYSTEM .....	78
37. TRUNK ROOM LIGHT SYSTEM .....	79
38. TURN SIGNAL AND HAZARD SYSTEM .....	80
5. Control Unit & Relay Location .....	82
6. Electrical Wiring Harness and Ground Point .....	84

# 1. General Description

## 1. HOW TO USE THIS MANUAL

The description of the electrical system is divided into the charging system, starting system, etc.

1. First, open to the necessary electrical system section and wiring diagram.

2. Next, open the foldout page of the electrical wiring diagram. By observing the electrical wiring harness' illustrations (front, instrument panel, etc.), the wiring diagram connector can be located.

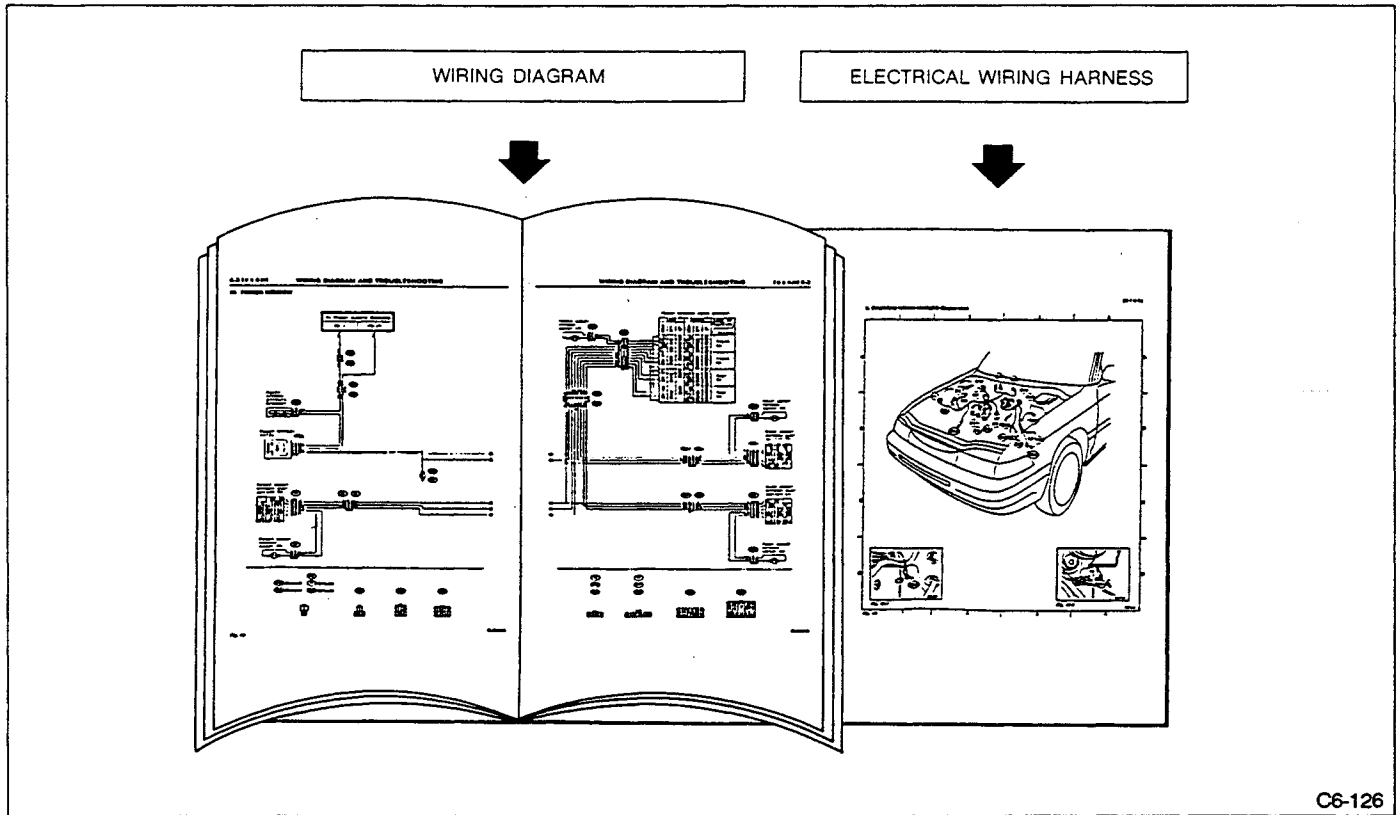

C6-126

Fig. 1

## 2. WIRING DIAGRAM

The wiring diagram of each system is illustrated so that you can understand the path through which the electric current flows from the battery.

Sketches and codes are used in the diagrams. They should read as follows:

1) Each connector and its terminal position are indicated by a sketch of the connector in a disconnected state which is viewed from the front, as shown in figure.

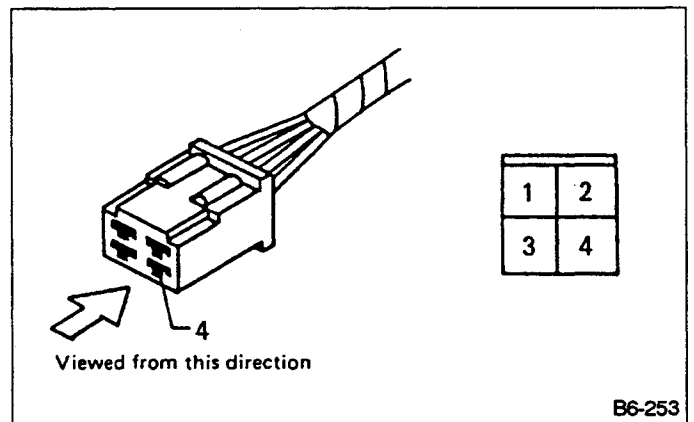

B6-253

Fig. 2

2) The number of poles or pins, presence of a lock, and pin number of each terminal are indicated in the sketch of each connector.

In the sketch, the highest pole number refers to the number of poles which the connector has. For example, the sketch of the connector shown in Figure 3 indicates the connector has 9 poles.



Connector used in vehicle	Connector shown in wiring diagram		
	Sketch	Symbol	Number of poles
			Numbered in order from upper right to lower left.
			Numbered in order from upper left to lower right.

Fig. 3

B6-254

When one set of connectors is viewed from the front side, the pole numbers of one connector are symmetrical to those of the other. When these two connectors are connected as a unit, the poles which have the same number are joined.

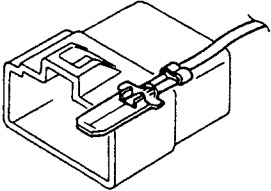
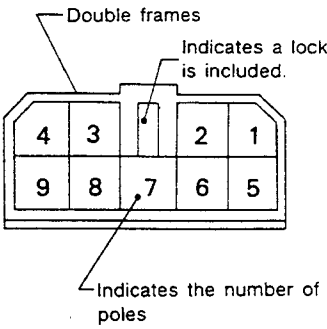
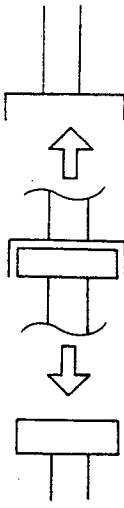
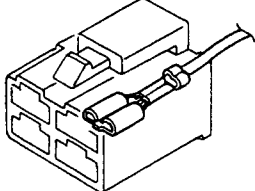
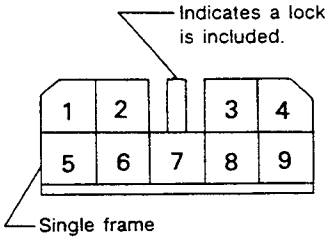
3) Electrical wiring harness

The connectors are numbered along with the number of poles, external colors, and mating connections in the accompanying list.

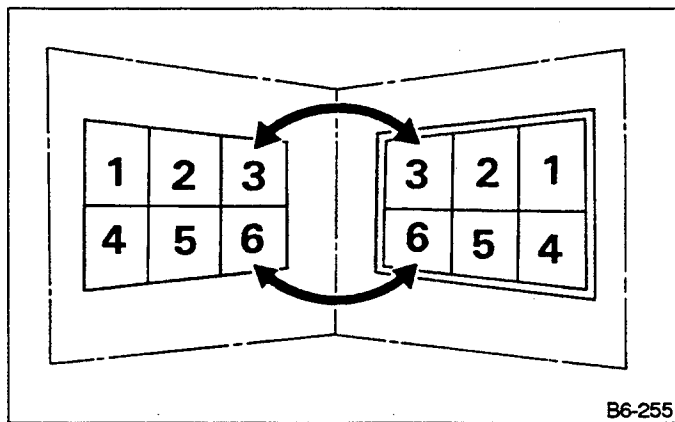

B6-255

Fig. 4

4) The sketch of each connector in the wiring diagram usually shows the "A" side of the connector. The relationship between the wire color, terminal number and connector is described below.

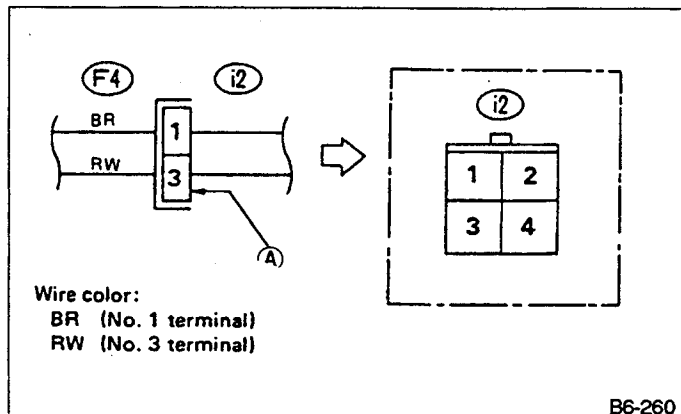

Fig. 5

A wire which runs in one direction from a connector terminal sometimes may have a different color from that which runs in the other direction from that terminal.

5) In wiring diagram, connectors which have no terminal number refer to one-pole types. Sketches of these connectors are omitted intentionally.

6) The following color codes are used to indicate the colors of the wires used.

Color code	Color
L	Blue
B	Black
Y	Yellow
G	Green
R	Red
W	White
Br	Brown
Lg	Light green
Gr	Gray
P	Pink
Or	Orange
Lb	Light Blue
V	Violet
SA	Sealed (Inner)
SB	Sealed (Outer)

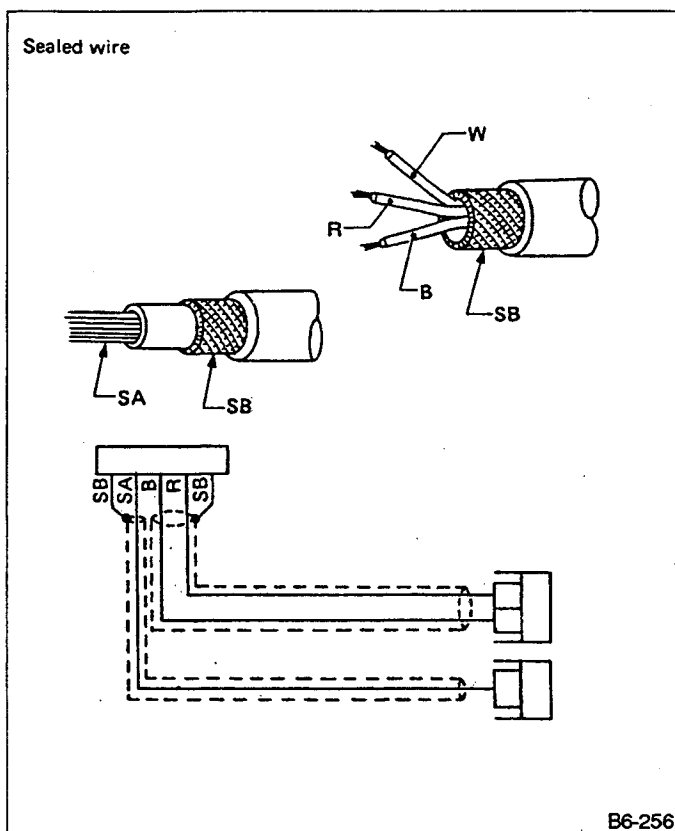

Fig. 6

7) The wire color code, which consists of two letters (or three letters including Br or Lg), indicates the standard color (base color of the wire covering) by its first letter and the stripe marking by its second letter.

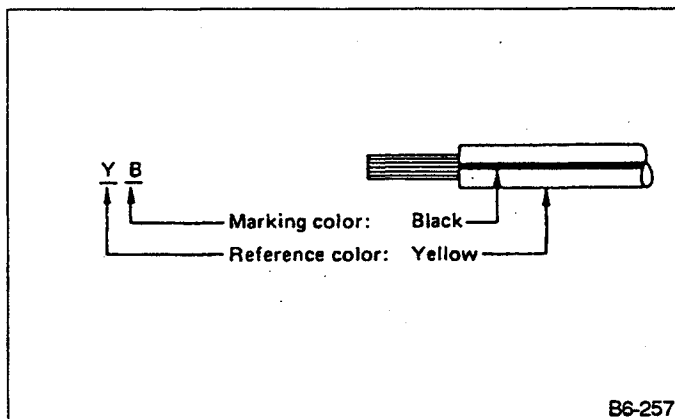

Fig. 7

8) The table below lists the nominal sectional areas and allowable currents of the wires.

Nominal sectional area mm <sup>2</sup>	No. of strands/strand diameter	Outside diameter of finished wiring mm	Allowable current Amps/40°C
0.3	7/0.26	1.8	7
0.5	7/0.32	2.2 (or 2.0)	12
0.75	30/0.18	2.6 (or 2.4)	16
0.85	11/0.32	2.4 (or 2.2)	16
1.25	16/0.32	2.7 (or 2.5)	21
2	26/0.32	3.1 (or 2.9)	28
3	41/0.32	3.8 (or 3.6)	38
5	65/0.32	4.6 (or 4.4)	51
8	50/0.45	5.5	67

The ground points shown in the wiring diagram refer to the following:

- (GB) Body ground
- (GE) Engine ground
- (GR) Radio ground

All wiring harnesses are provided with a ground point which should be securely connected.

a. The allowable current in the above table indicates the tolerable amperage of each wire at an ambient temperature of 40°C (104°F).

b. The allowable current changes with ambient temperature. Also, it changes if a bundle of more than two wires is used.

c. When replacing or repairing a wire, be sure to use the same size and type of the wire which was originally used.

9) Each unit is directly grounded to the body or indirectly grounds through a harness ground terminal. Different symbols are used in the wiring diagram to identify the two grounding systems.

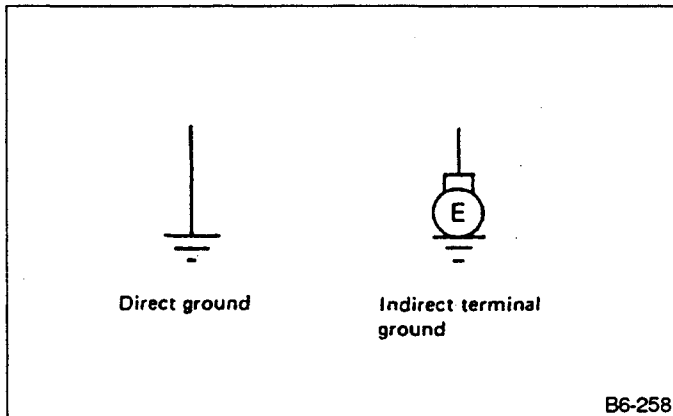

Fig. 8

10) Relays are classified as normally-open or normally-closed.  
 The normally-closed relay has one or more contacts.  
 The wiring diagram shows the relay mode when the energizing circuit is OFF.

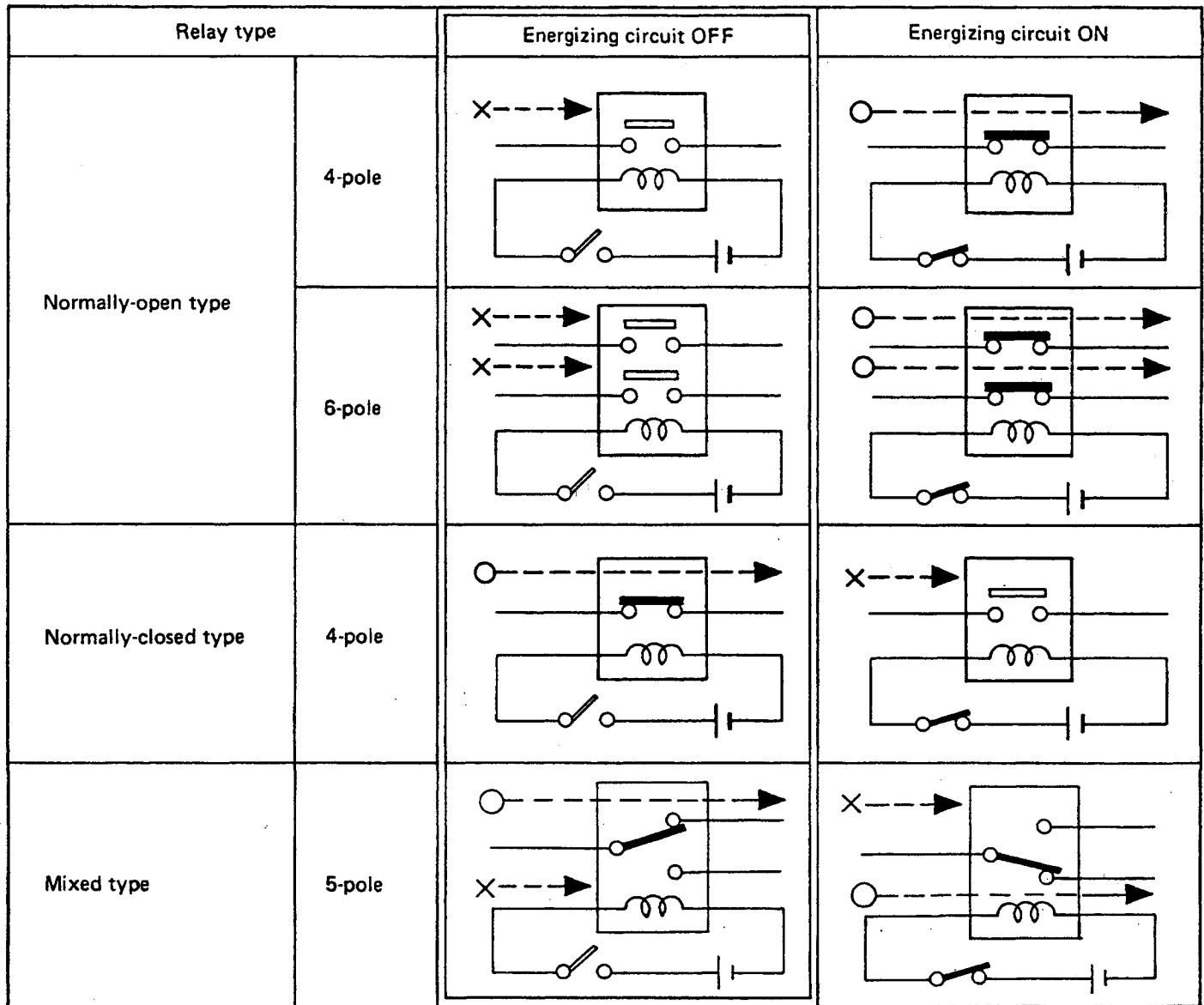

Fig. 9

B6-243

Key to symbols:  
 ○ → : Current flows >  
 X → : Current does not flow.

11) Each connector number shown in the wiring diagram corresponds to that in the wiring harness. The location of each connector in the actual vehicle is determined by reading the first character of the connector (for example, a "F" for F8, "i" for i16, etc.) and the type of wiring harness.

The first character of each connector number refers to the area or system of the vehicle, as indicated in table below.

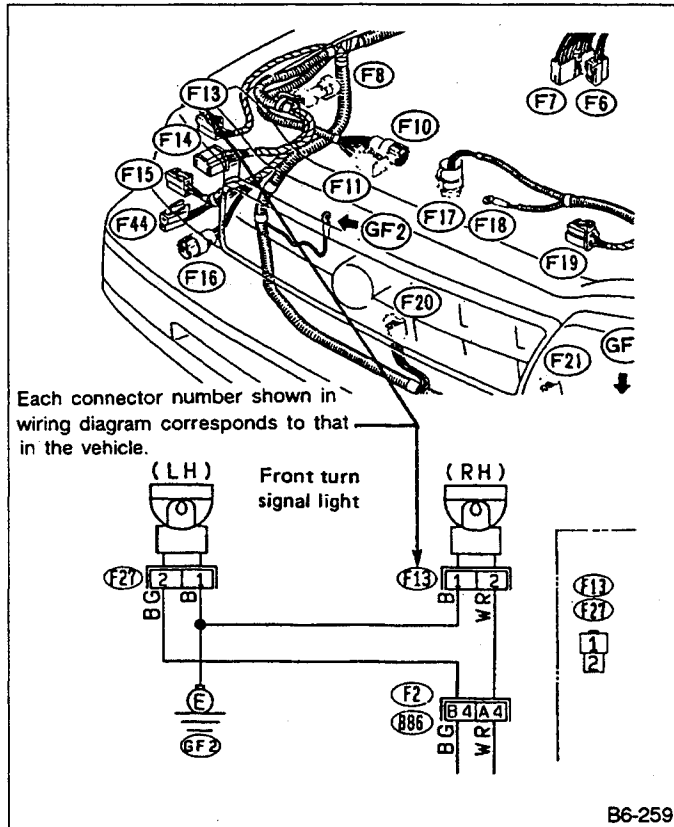

Fig. 10

Symbol	Wiring harness & Cord
F	Front wiring harness LH
B	Bulkhead wiring harness
E	Engine wiring harness
T	Transmission cord
D	Door cord LH & RH
I	Instrument panel meter cord, Instrument panel center cord
R	Rear wiring harness, Room light cord, Fuel cord, Sunroof cord, Trunk lid hinge cord, Trunk lid cord

**3. TROUBLESHOOTING PROCEDURES**

The most important purpose of troubleshooting is to determine which part is malfunctioning quickly, to save time and labor.

**1. Identification of trouble symptom**

Determine what the problem is based on the symptom.

**2. Probable cause of trouble**

Look at the wiring diagram and check the system's circuit. Then check the switch, relay, fuse, ground, etc.

**3. Location and repair of trouble**

- 1) Using the troubleshooting narrow down the causes.
- 2) If necessary, use a voltmeter, ohmmeter, etc.
- 3) Before replacing certain component parts (switch, relay, etc.), check the power supply, ground, for open wiring harness, poor connectors, etc. If no problems are encountered, check the component parts.

**4. Confirmation of system operation**

After repairing, ensure that the system operates properly.

**4. VOLTAGE MEASUREMENT**

- 1) Using a voltmeter, connect the negative lead to a good ground point or negative battery terminal and the positive lead to the connector or component terminal.
- 2) Contact the positive probe of the voltmeter on connector (A).

The voltmeter will indicate a voltage.

- 3) Shift the positive probe to connector (B). The voltmeter will indicate no voltage.

With test setup held as it is, turn switch ON. The voltmeter will indicate a voltage and, at the same time, the light will come on.

- 4) The circuit is in good order. If a problem such as a lamp failing to light occurs, use the procedures outlined above to track down the malfunction.

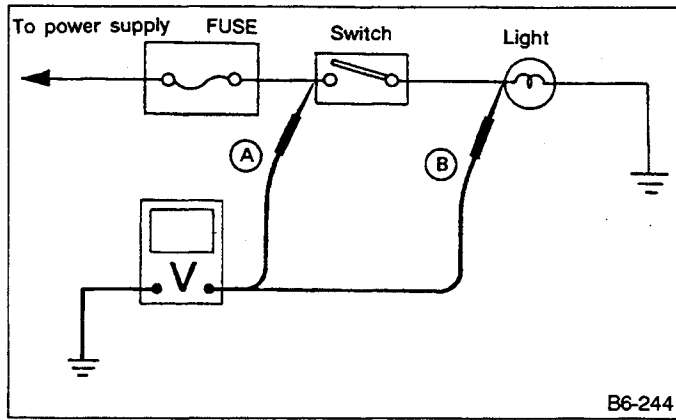

Fig. 11

**5. CIRCUIT CONTINUITY CHECKS**

- 1) Disconnect the battery terminal or connector so there is no voltage between the check points. Contact the two leads of an ohmmeter to each of the check points. If the circuit has diodes, reverse the two leads and check again.
- 2) Use an ohmmeter to check for diode continuity. When contacting the negative lead to the diode positive side and the positive lead to the negative side, there should be continuity. When contacting the two leads in reverse, there should be no continuity.

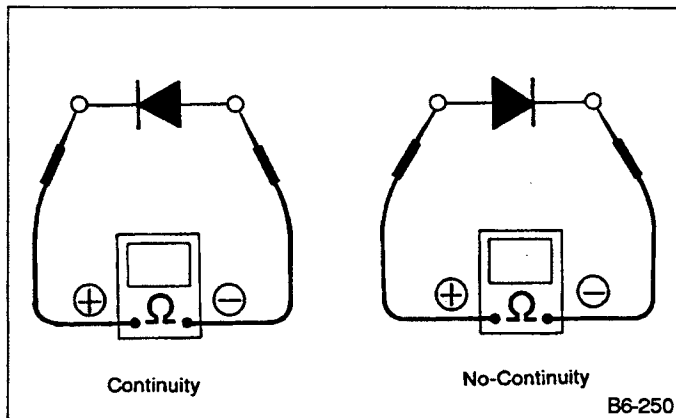

Fig. 12

- 3) Symbol "o—o" indicates that continuity exists between two points or terminals. For example, when a switch position is "3", continuity exists among terminals 1, 3 and 6, as shown in table below.

Terminal	1	2	3	4	5	6
Switch Position						
OFF						
1	○				○	○
2	○			○		○
3	○		○			○
4	○	○				○

**6. HOW TO DETERMINE AN OPEN CIRCUIT**

**1) Voltmeter Method**

An open circuit is determined by measuring the voltage between respective connectors and ground using a voltmeter, starting with the connector closest to the power supply. The power supply must be turned ON so that current flows in the circuit. If voltage is not present between a particular connector and ground, the circuit between that connector and the previous connector is open.

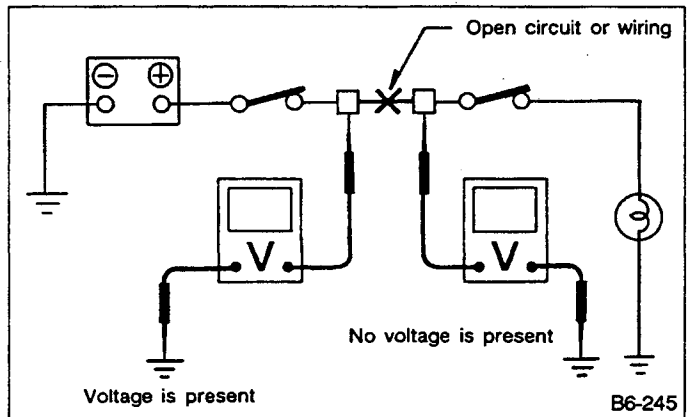

Fig. 13



2) Ohmmeter method

Disconnect all connectors affected, and check continuity in the wiring between adjacent connectors. When the ohmmeter indicates "infinite", the wiring is open.

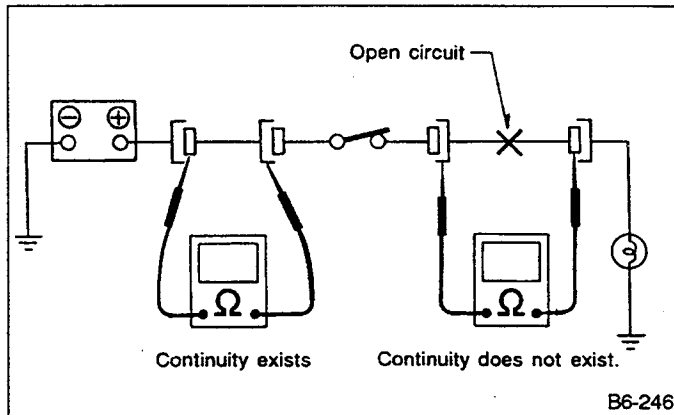

Fig. 14

2) Ohmmeter method

Disconnect all affected connectors, and check continuity between each connector and ground. When ohmmeter indicates continuity between a particular connector and ground, that connector is shorted.

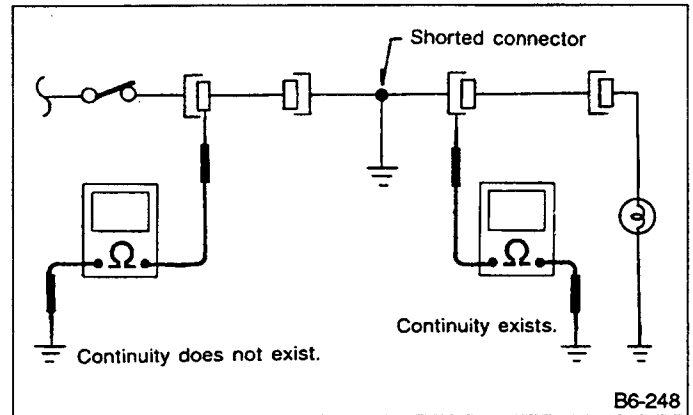

Fig. 16

7. HOW TO DETERMINE A SHORTCIRCUIT

1) Test lamp method

Connect a test lamp (rated at approximately 3 watts) in place of the blown fuse and allow current to flow through the circuit. Disconnect one connector at a time from the circuit, starting with the one located farthest from the power supply. If the test lamp goes out when a connector is disconnected, the wiring between that connection and the next connector (farther from the power supply) is shorted.

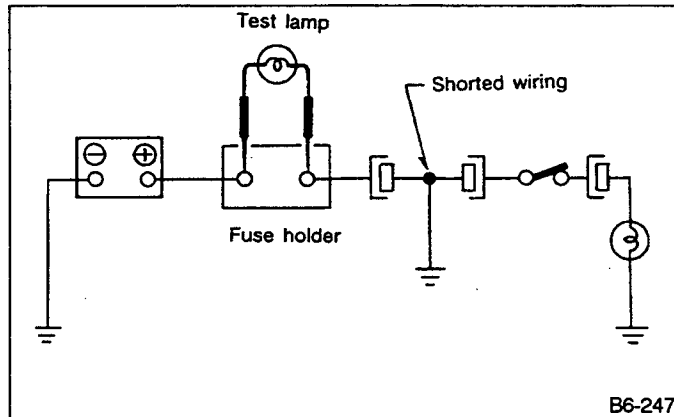

Fig. 15

2. Working Precautions

1. PRECAUTIONS WHEN WORKING WITH THE PARTS MOUNTED ON THE VEHICLE

- 1) When working under a vehicle which is jacked up, always be sure to use safety stands.
- 2) The parking brake must always be applied during working. Also, in automatic transmission vehicles, keep the select lever set to the P (Parking) range.
- 3) Be sure the workshop is properly ventilated when running the engine. Further, be careful not to touch the belt or fan while the engine is operating.
- 4) Be careful not to touch hot metal parts, especially the radiator and exhaust system immediately after the engine has been shut off.

2. PRECAUTIONS IN TROUBLE DIAGNOSIS AND REPAIR OF ELECTRIC PARTS

- 1) The battery cable must be disconnected from the battery's (-) terminal, and the ignition switch must be set to the OFF position, unless otherwise required by the troubleshooting.
- 2) Securely fasten the wiring harness with clamps and slips so that the harness does not interfere with the body end parts or edges and bolts or screws.
- 3) When installing parts, be careful not to catch them on the wiring harness.

4) When disconnecting a connector, do not pull the wires, but pull while holding the connector body.

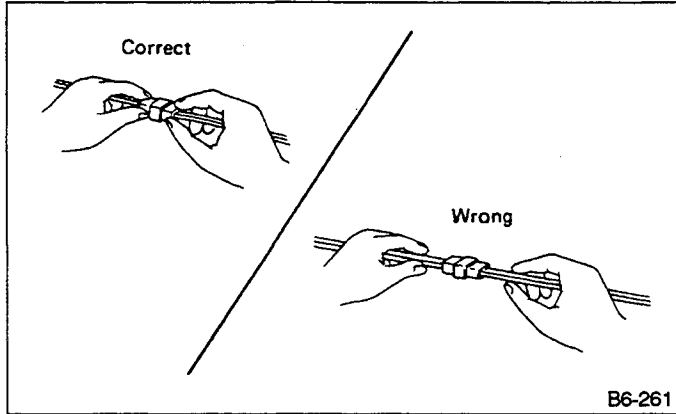

Fig. 17

5) Some connectors are provided with a lock. One type of such a connector is disconnected by pushing the lock, and the other, by moving the lock up. In either type the lock shape must be identified before attempting to disconnect the connector. To connect, insert the connector until it snaps and confirm that it is tightly connected.

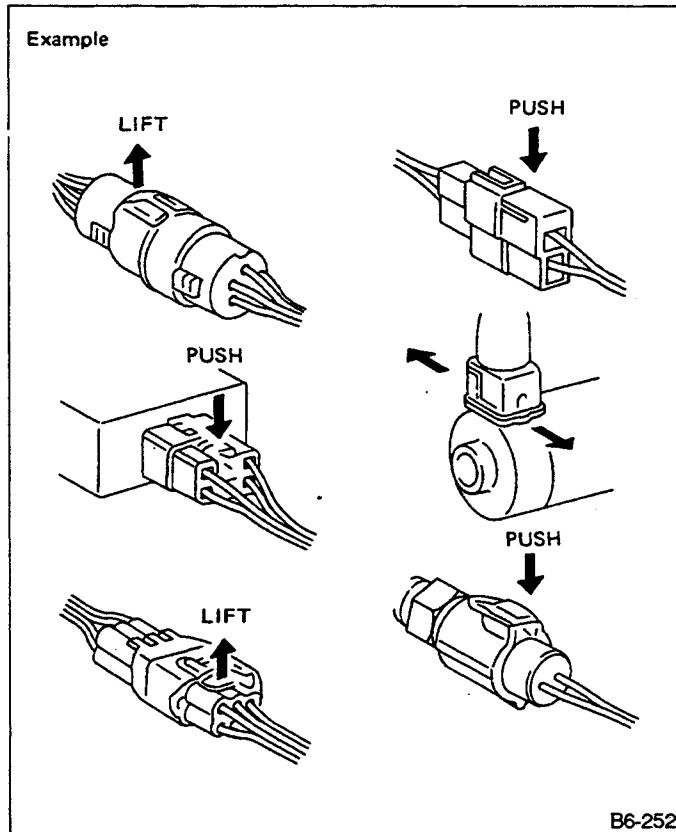

Fig. 18

6) When checking continuity between connector terminals, or measuring voltage across the terminal and ground, always contact tester probe(s) on terminals from the wiring connection side. If the probe is too thick to gain access to the terminal, use "mini" test leads. To check water-proof connectors (which are not accessible from the wiring side), contact test probes on the terminal side being careful not to bend or damage the terminals.

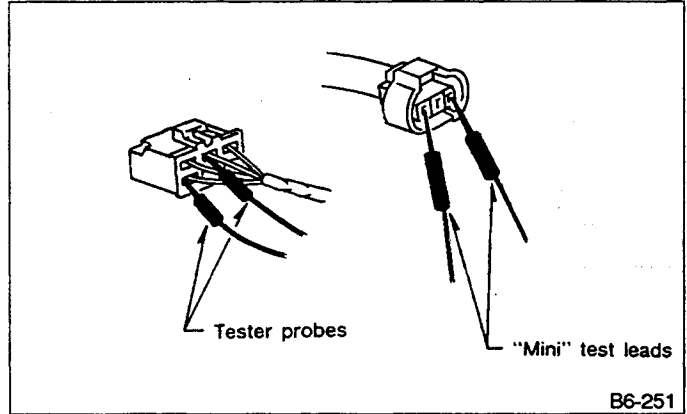

Fig. 19

7) Sensors, relays, electrical unit, etc., are sensitive to strong impacts. Handle them with care so that they are not dropped or mishandled.

## ABBREVIATION LIST

Abbr.	Full name
ABS	Antilock Brake System
ACC	Accessory
A/C	Air Conditioner
AD	Auto Down
AT	Automatic Transmission
AU	Auto Up
+ B	Battery
DN	Down
DRL	Daytime Running Light
E	Ground
F/B	Fuse & Joint Box
FL1.5	Fusible link 1.5 mm <sup>2</sup>
IG	Ignition
Illumi.	Illumination

Abbr.	Full name
LH	Left Hand
Lo	Low
M	Motor
M/B	Main Fuse Box
MG	Magnet
Mi	Middle
MPFI	Multi Point Fuel Injection Model
OP	Optional Parts
PASS	Passing
RH	Right Hand
SBF	Slow Blow Fuse
ST	Starter
SW	Switch
UP	Up
WASH	Washer

### 3. How to Use Wiring Diagram

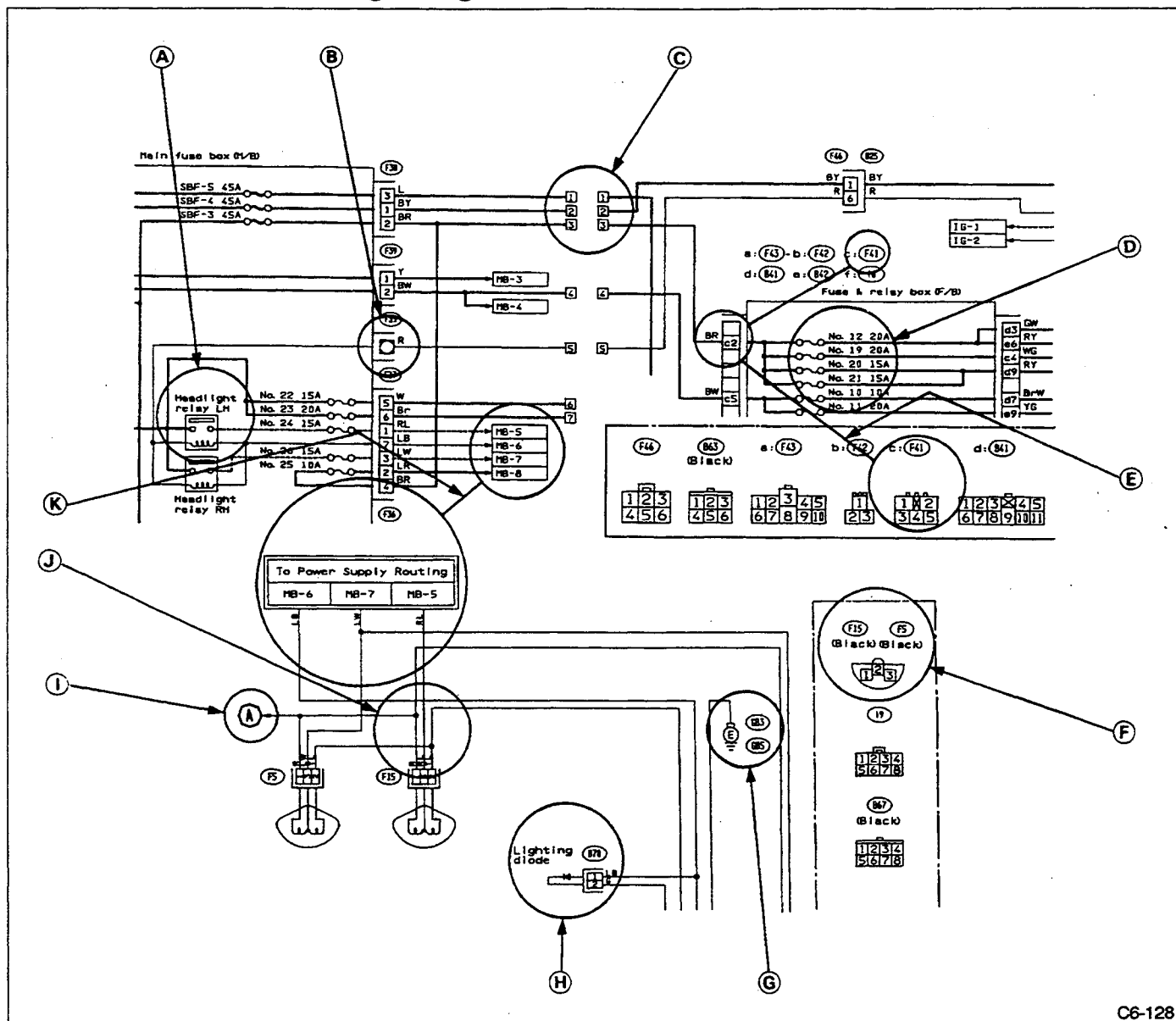

C6-128

Fig. 20

A	RELAY
---	-------

A symbol used to indicate a relay.  
(Refer to Fig. 9)

B	CONNECTOR-1
---	-------------

The sketch of the connector indicates the one-pole types.

C	WIRING CONNECTION
---	-------------------

Some wiring diagrams are indicated in foldouts for convenience. Wiring destinations are indicated where necessary by corresponding symbols (as when two pages are needed for clear indication).

D	FUSE NO. & RATING
---	-------------------

The "FUSE NO. & RATING" corresponds with that used in the fuse box (main fuse box, fuse and joint box.)

E	CONNECTOR-2
---	-------------

1. Each connector is indicated by a symbol.
2. Each terminal number is indicated in the corresponding wiring diagram in an abbreviated form.
3. For example, terminal number "C2" refers to No. 2 terminal of connector (C:F41) shown in the connector sketch.  
(Refer to Fig. 3)

**F** CONNECTOR SKETCH

1. Each connector sketch clearly identifies the shape and color of a connector as well as terminal locations. Non-colored connectors are indicated in natural color.
2. When more than two types of connector number are indicated in a connector sketch, it means that the same type connectors are used.

**G** GROUND

Each grounding point can be located easily by referring to the corresponding wiring harness.  
 (Refer to Fig. 8)



**H** DIODE

A symbol is used to indicate a diode.  
 (Refer to Fig. 12)

**I** WIRE TRACING ON EXTENDED WIRING DIAGRAMS

For a wiring diagram extending over at least two pages, a symbol (consisting of the same characters with arrows), as shown below, facilitates wire tracing from one page to the next.  
 A ↔ A, B ↔ B

**J** SYMBOLS OF WIRE CONNECTION AND CROSSING

- |   |        |  |
|---|--------|--|
|  | Symbol | Refers to wires which are connected and branched at the "dot" point. |
|  | Symbol | Refers to wires which are crossed but not connected.                 |

**K** POWER SUPPLY ROUTING

A symbol is used to indicate the power supply in each wiring diagram.  
 "MB-5", "MB-6", etc., which are used as power-supply symbols throughout the text, correspond with those shown in the POWER SUPPLY ROUTING in the wiring diagram.  
 Accordingly, using the POWER SUPPLY ROUTING and wiring diagrams permits service personnel to understand the entire electrical arrangement of a system.

**SYMBOLS AND ABBREVIATIONS**

A number of symbols and abbreviations are used in each wiring diagram to easily identify parts or circuits.

### 4. Wiring Diagram and Diagnostics

#### 1. POWER SUPPLY ROUTING

- Battery current
- Current from ignition switch IG terminal
- - - Current from ignition switch ACC terminal
- Other currents

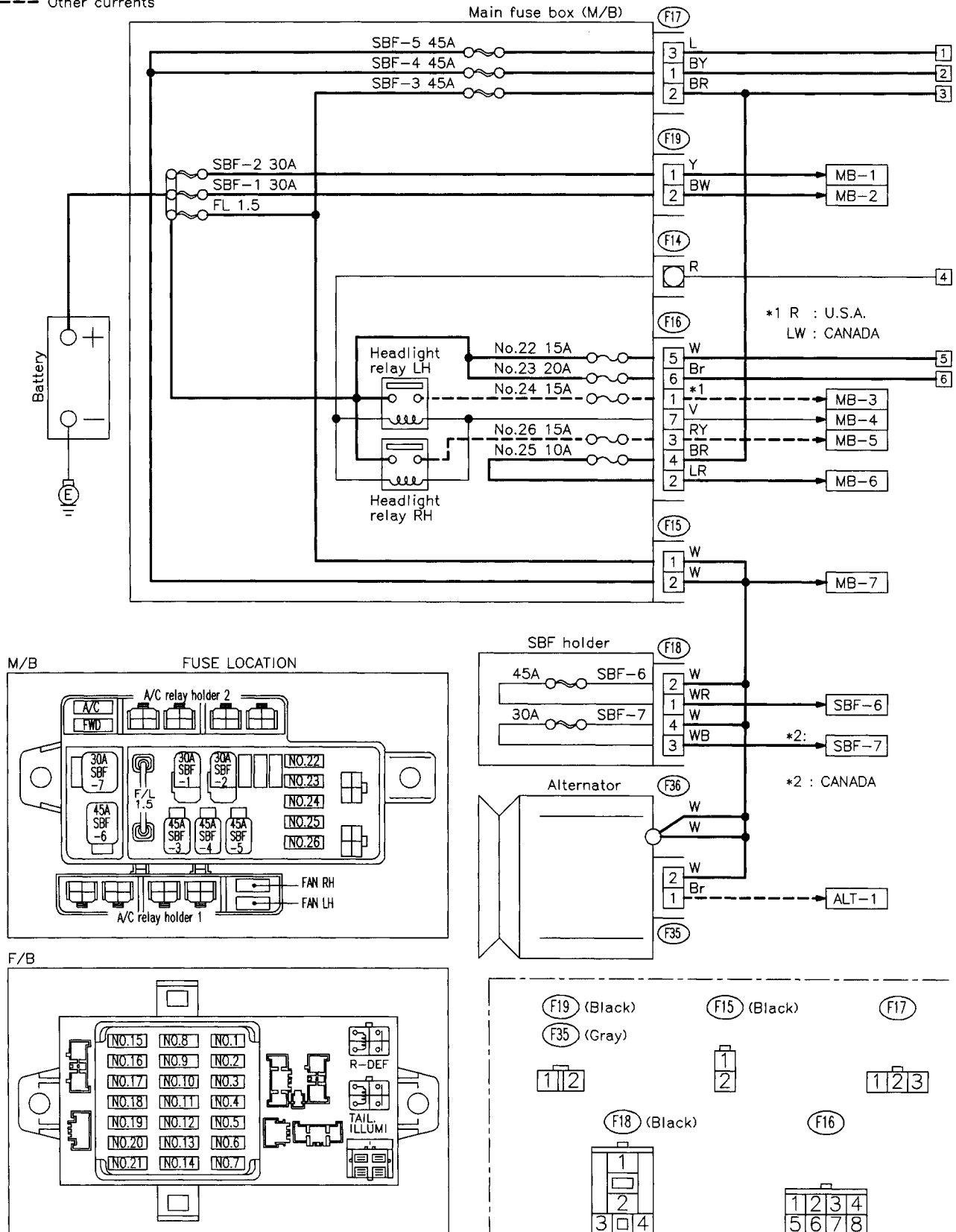
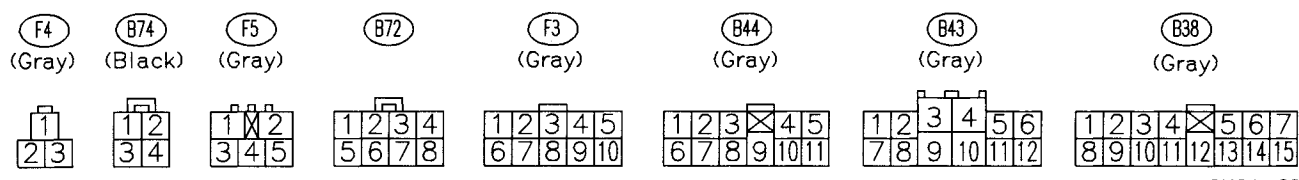
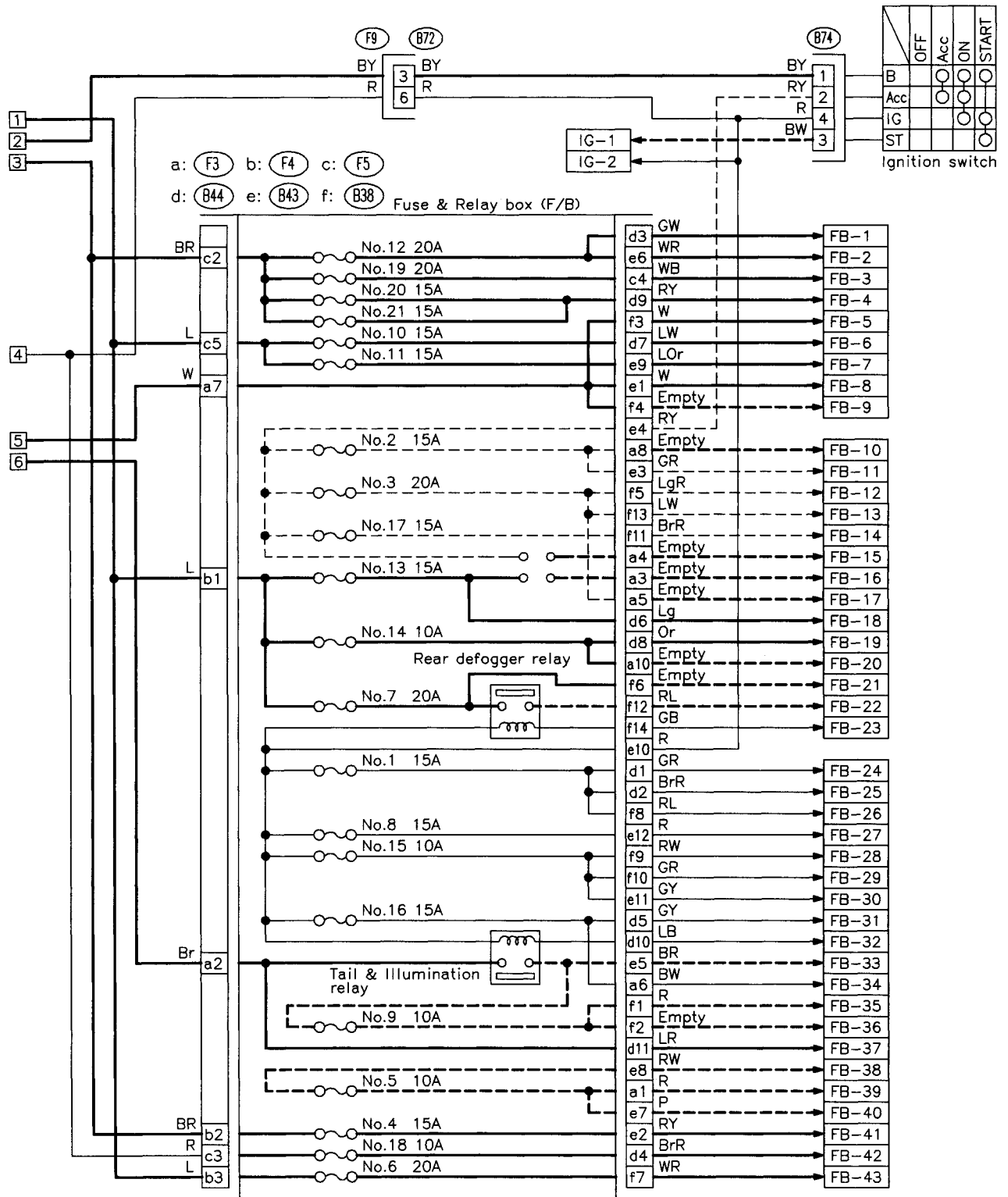
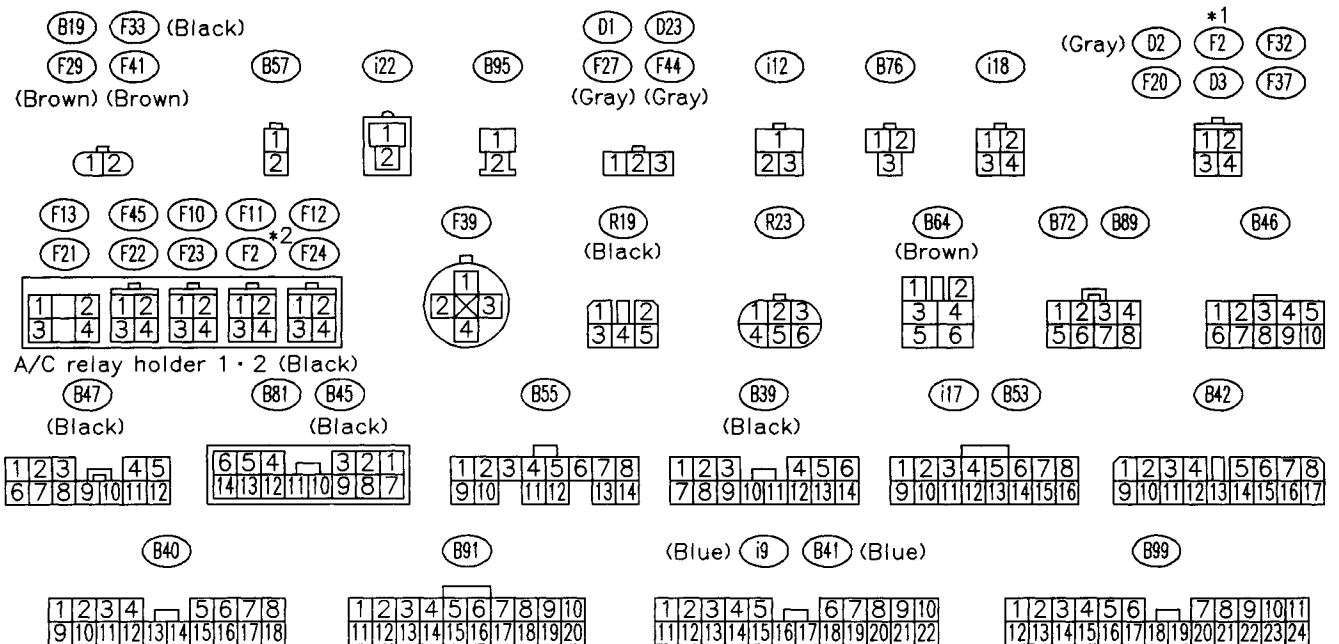
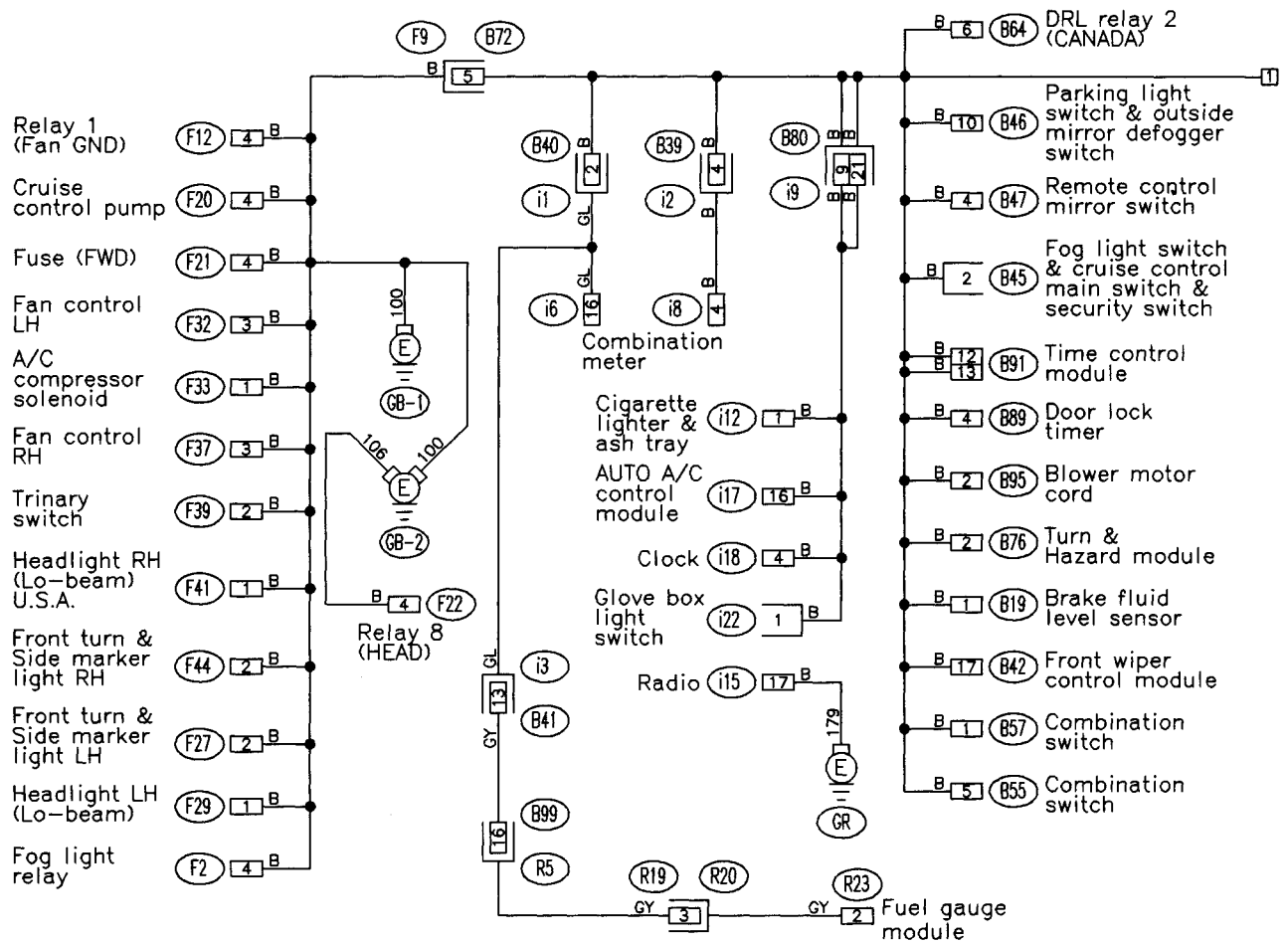

Fig. 1



2. GROUND DISTRIBUTION



CU04-04A

Fig. 2



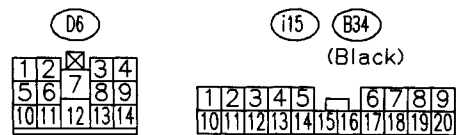
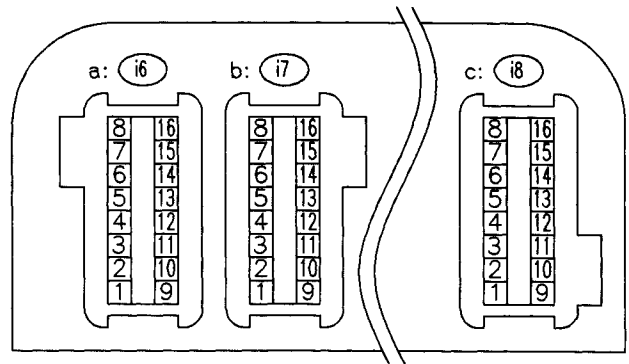
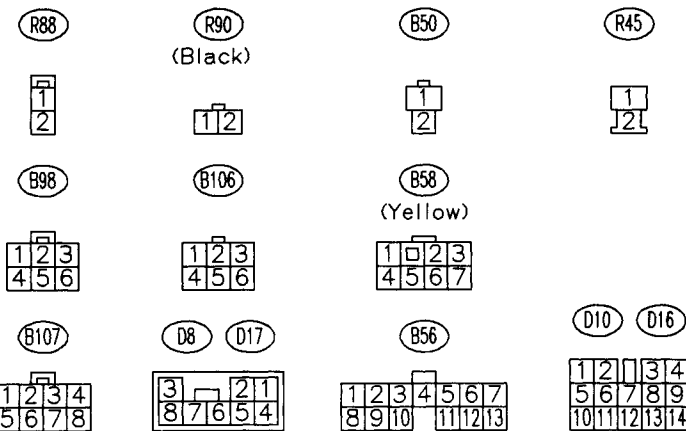
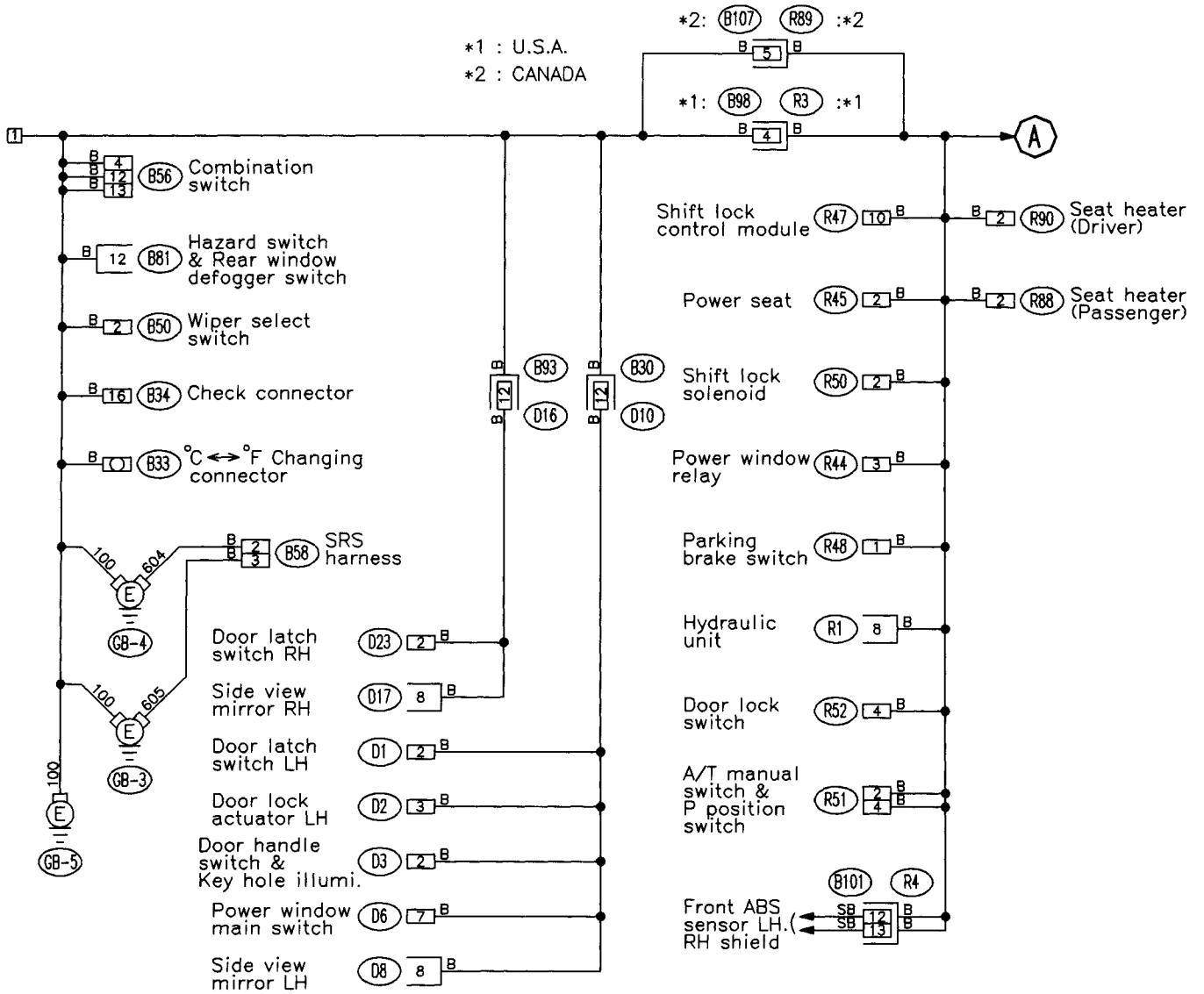



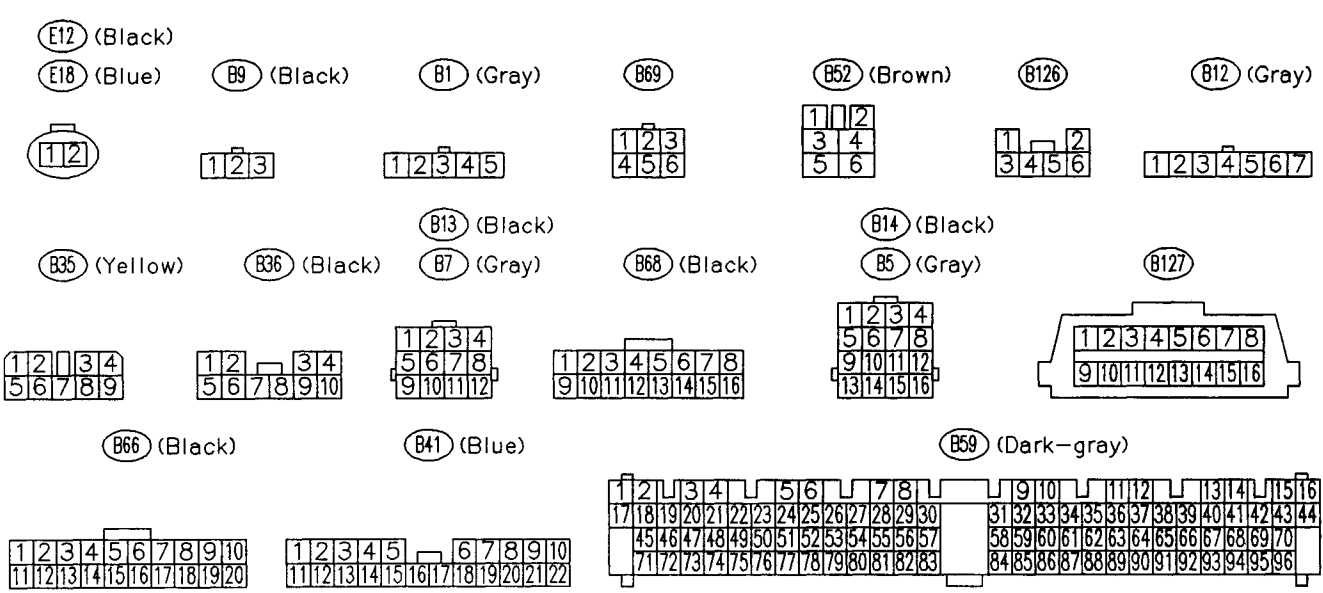
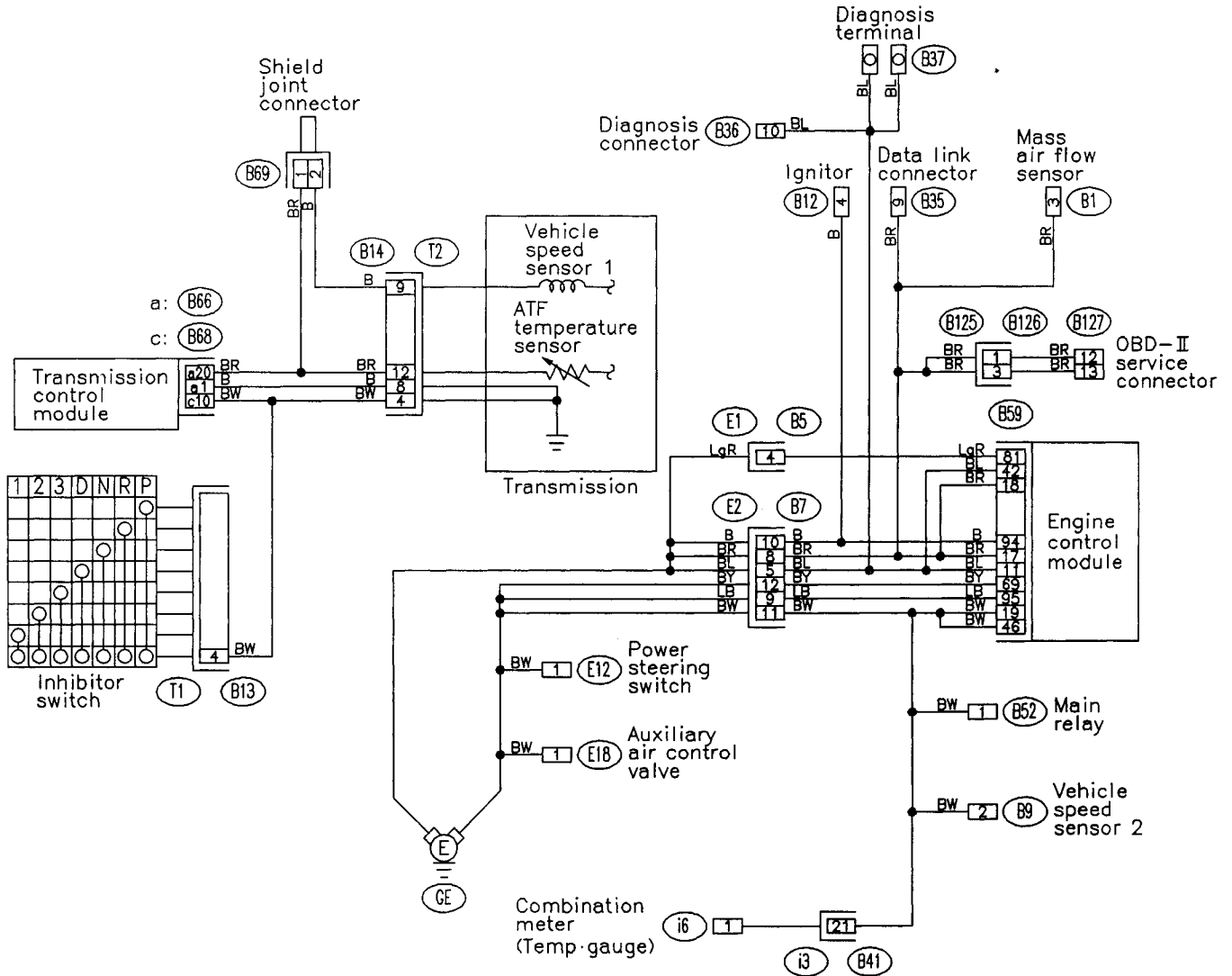

3. ANTI-LOCK BRAKE SYSTEM

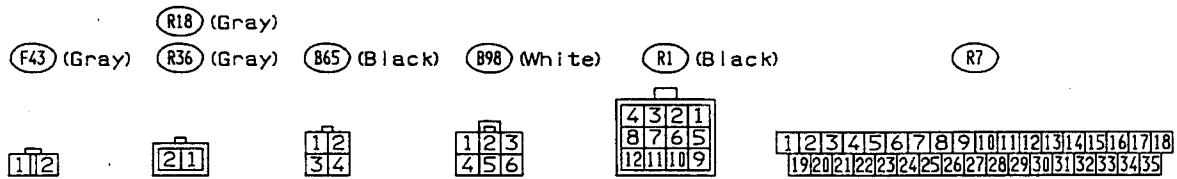
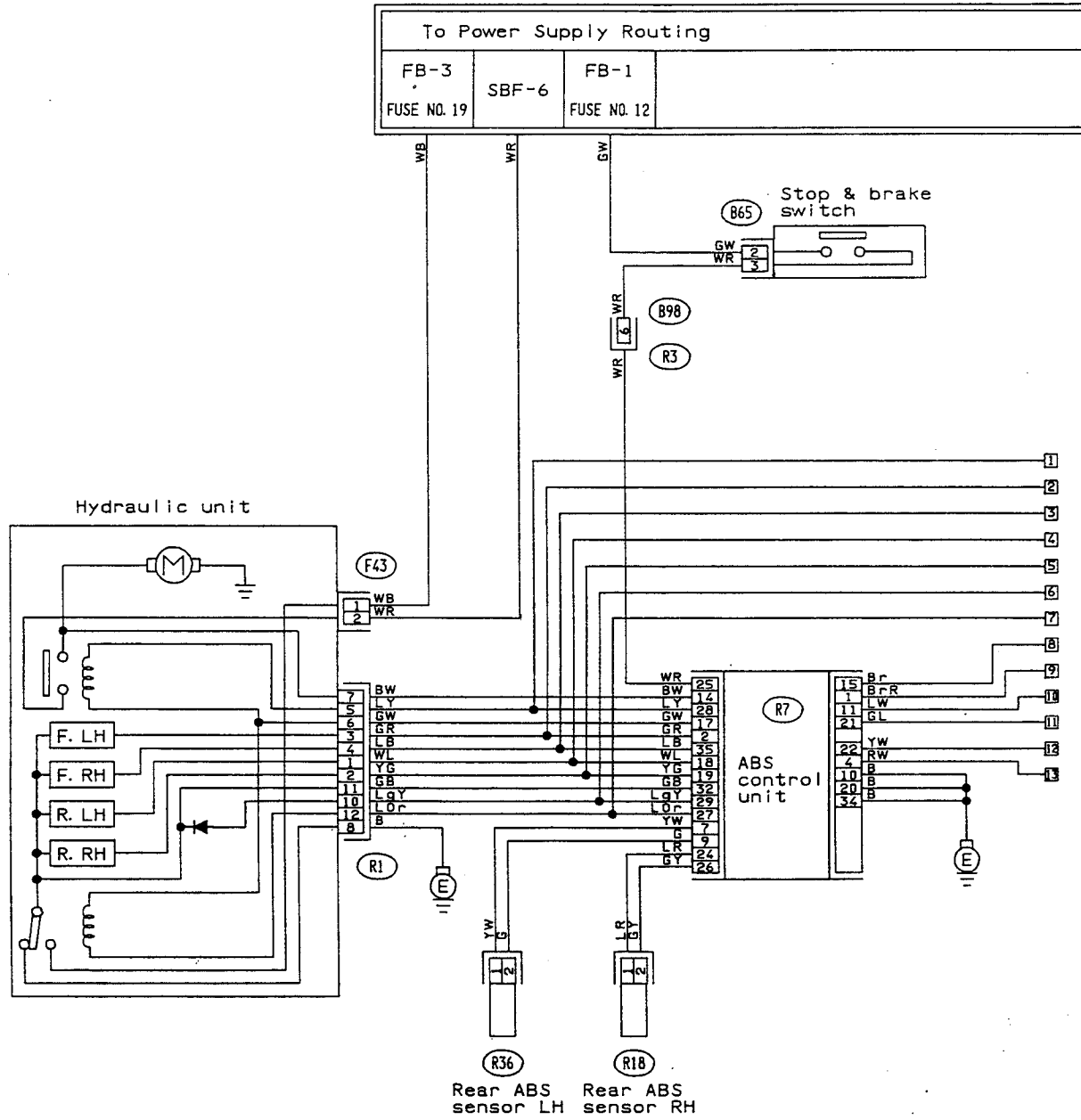

CU82-01A

Fig. 23

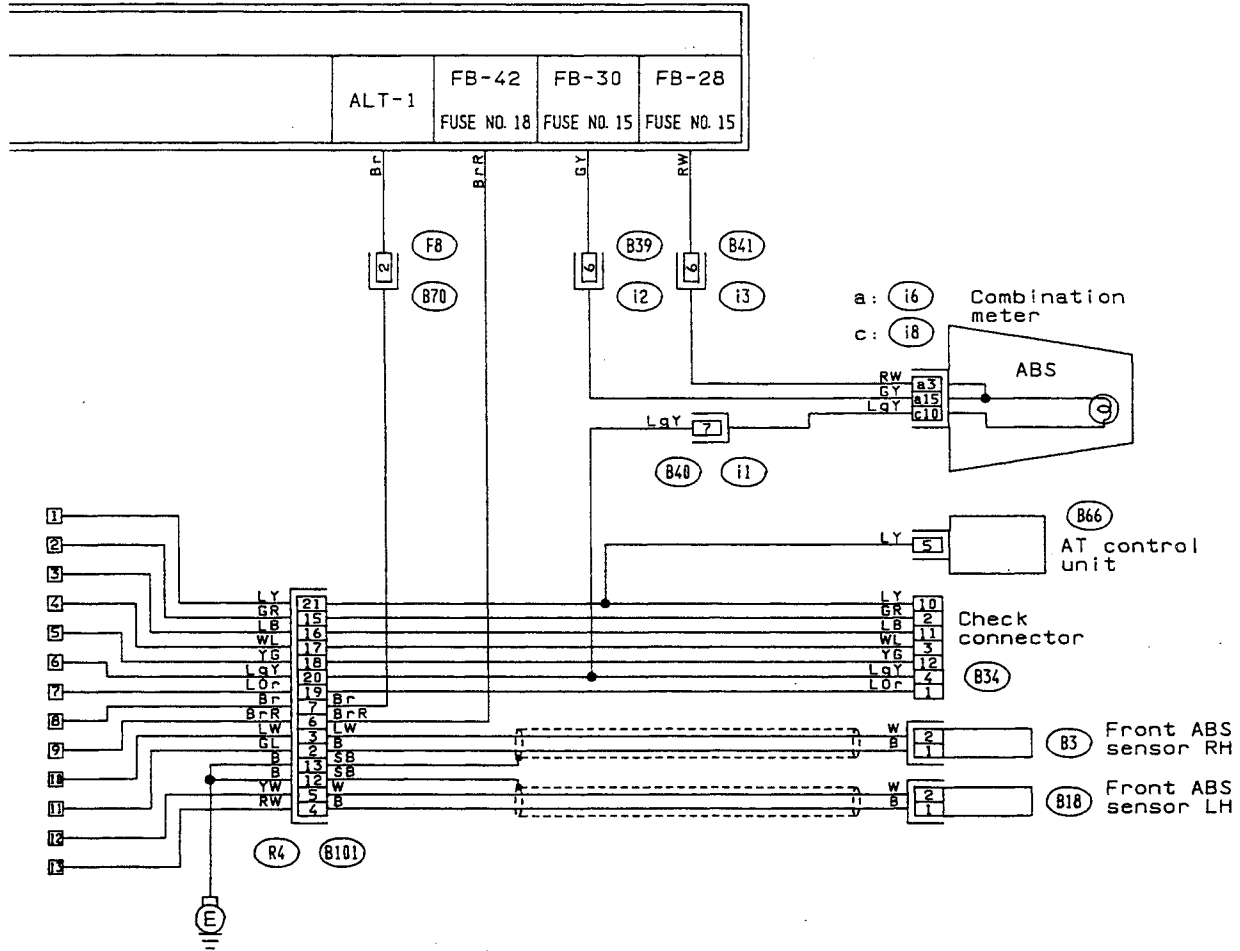

- (B3) (Gray)
- (B18) (Gray)
- (B39) (Black)
- (B40) (Black)
- (F8) (White)
- (B41) (Black)
- (B66) (Black)
- (B34) (Black)

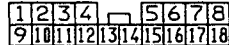

- (B66) (Black)

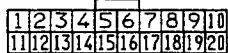

- (B41) (Blue)

- (B101) (Blue)

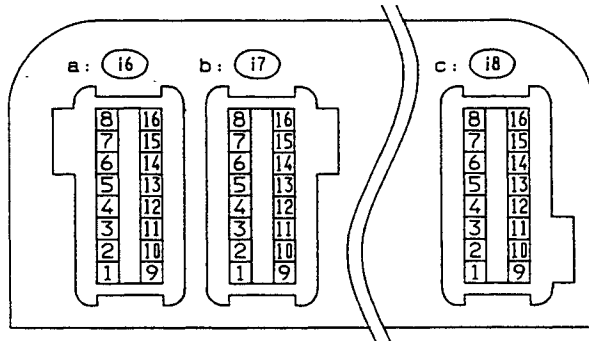
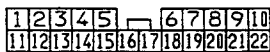

CU82-01B

4. A/T CONTROL SYSTEM

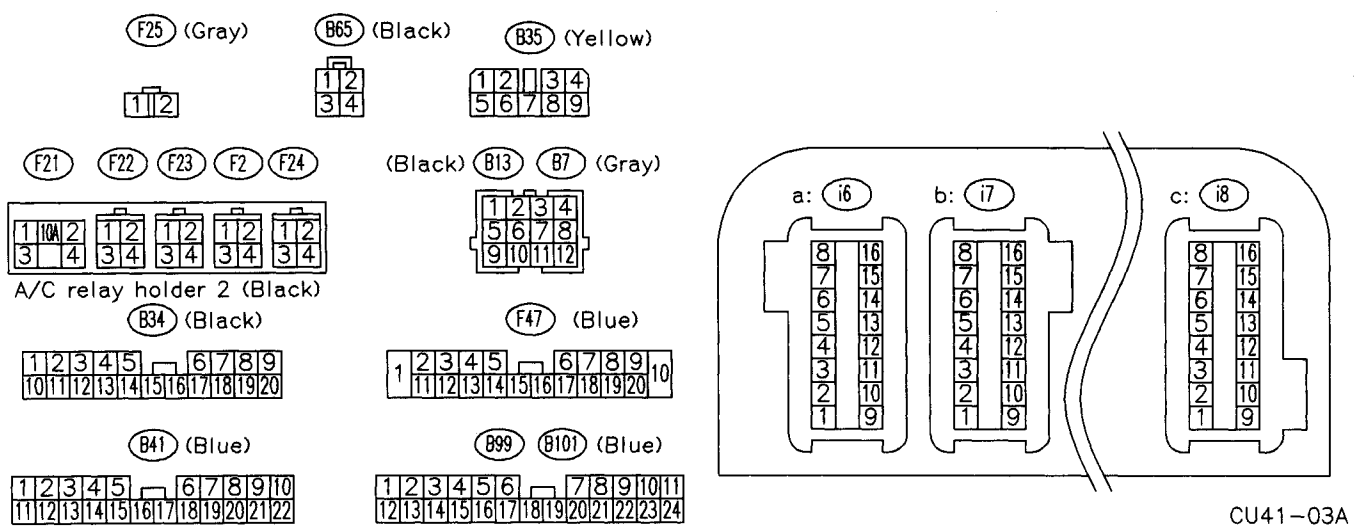
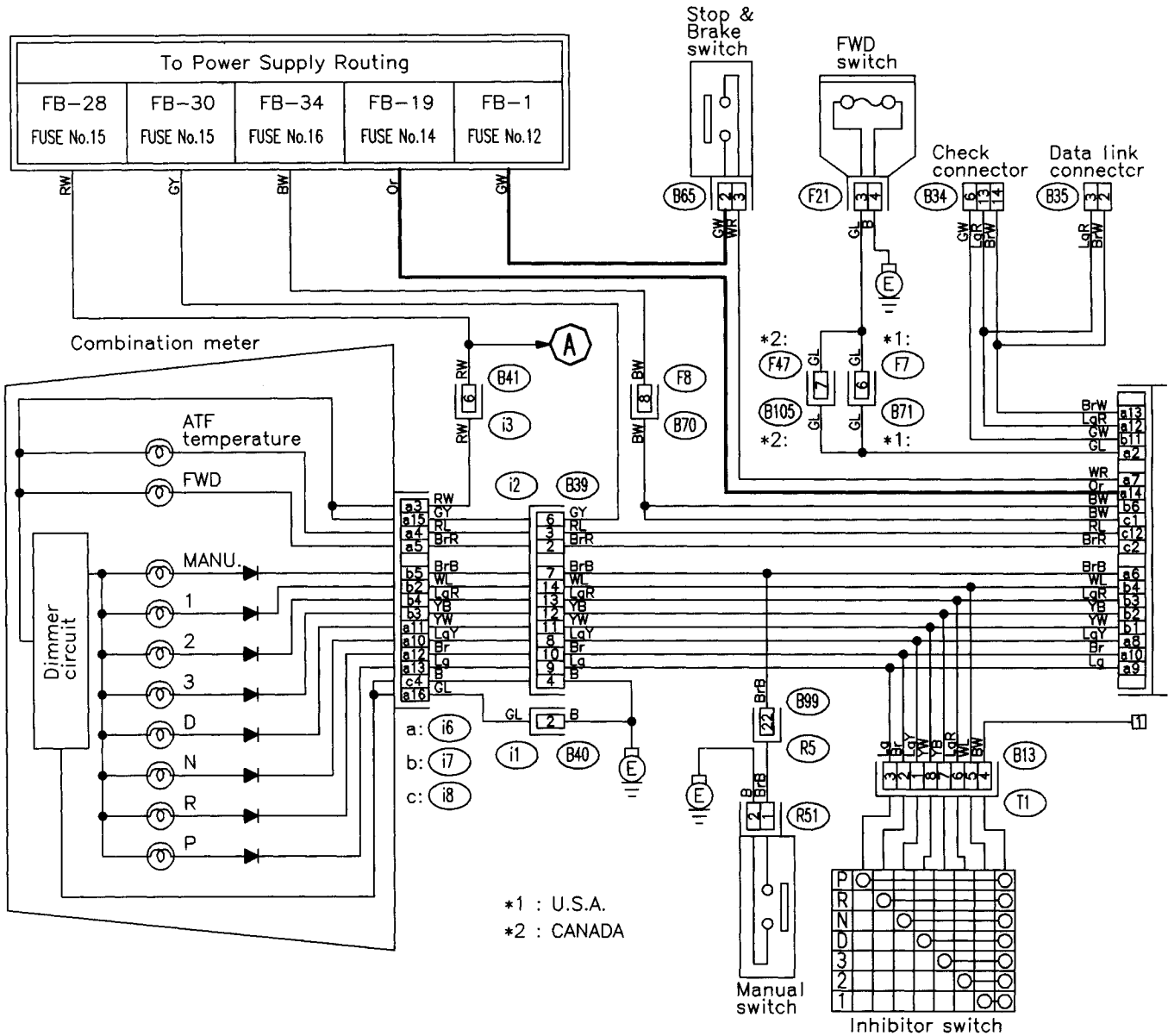

CU41-03A

Fig. 3

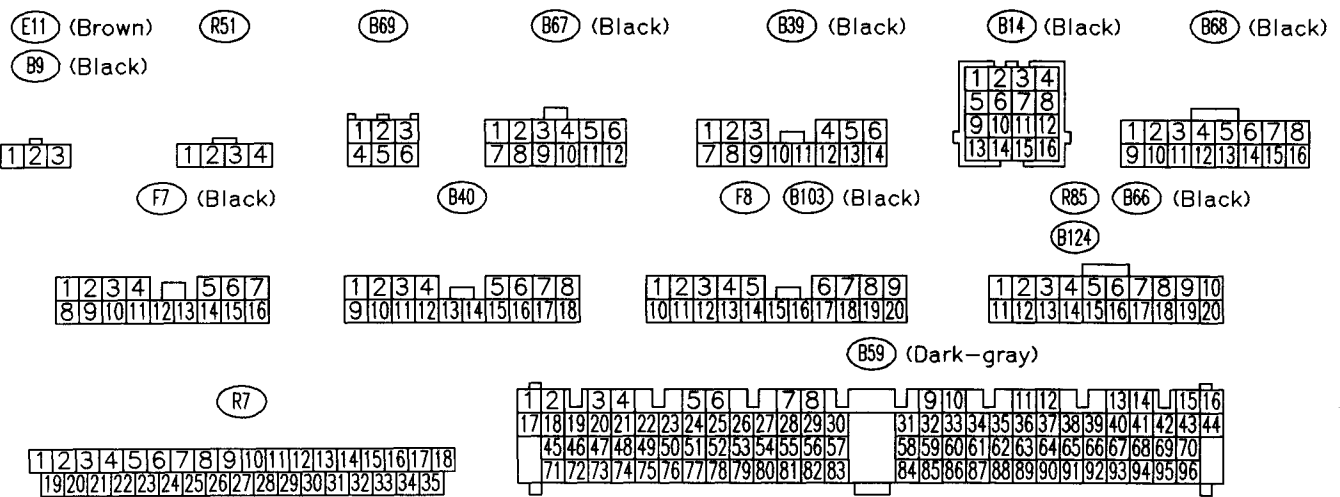
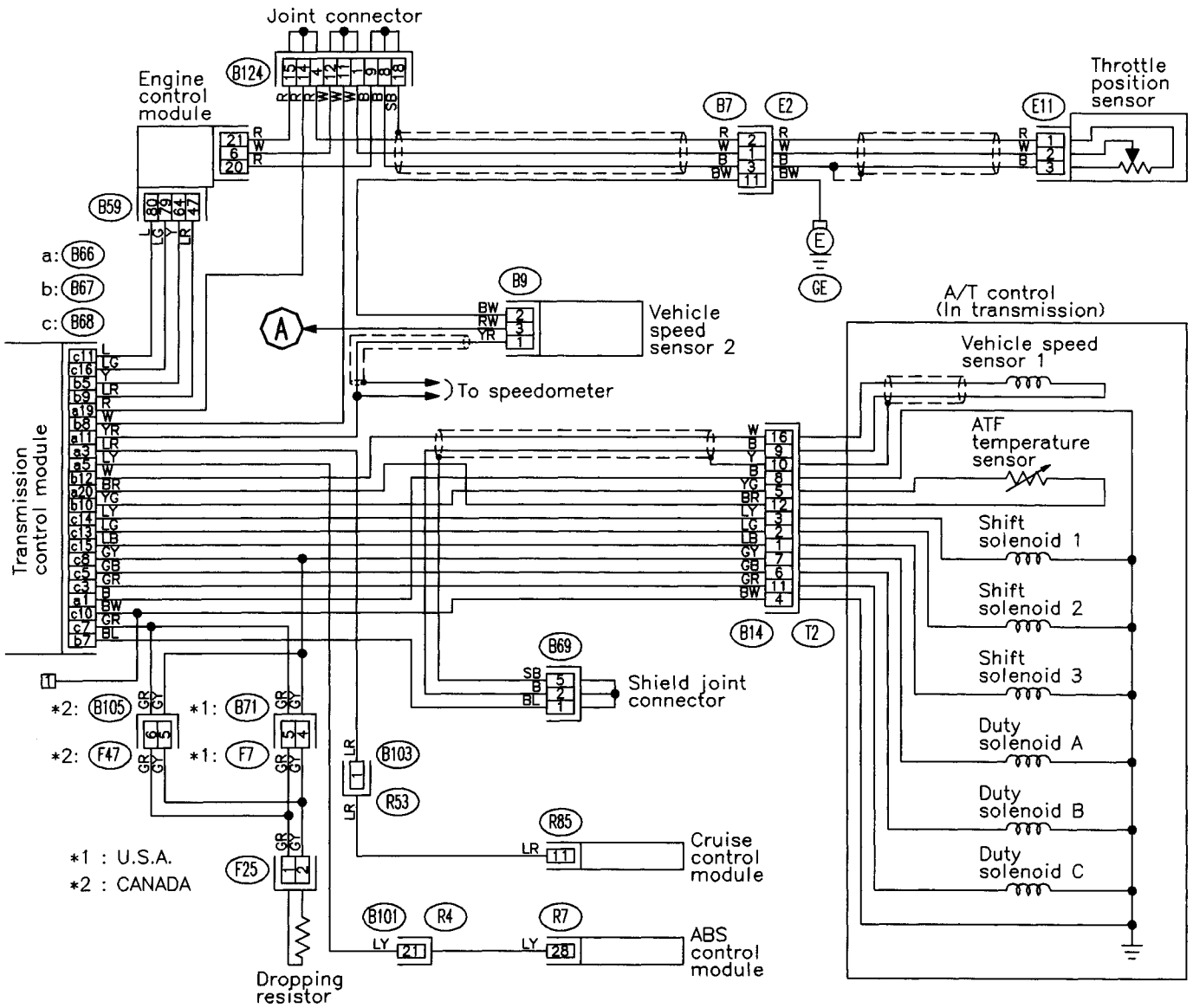

5. A/T SHIFT LOCK SYSTEM

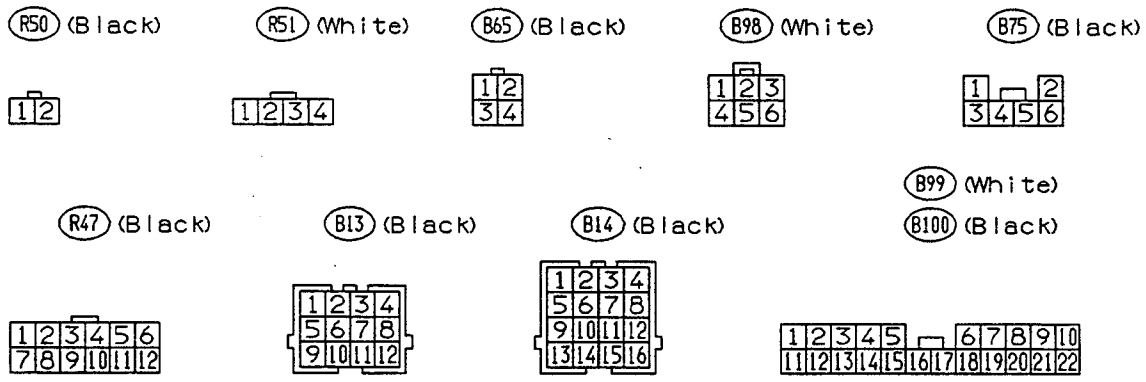
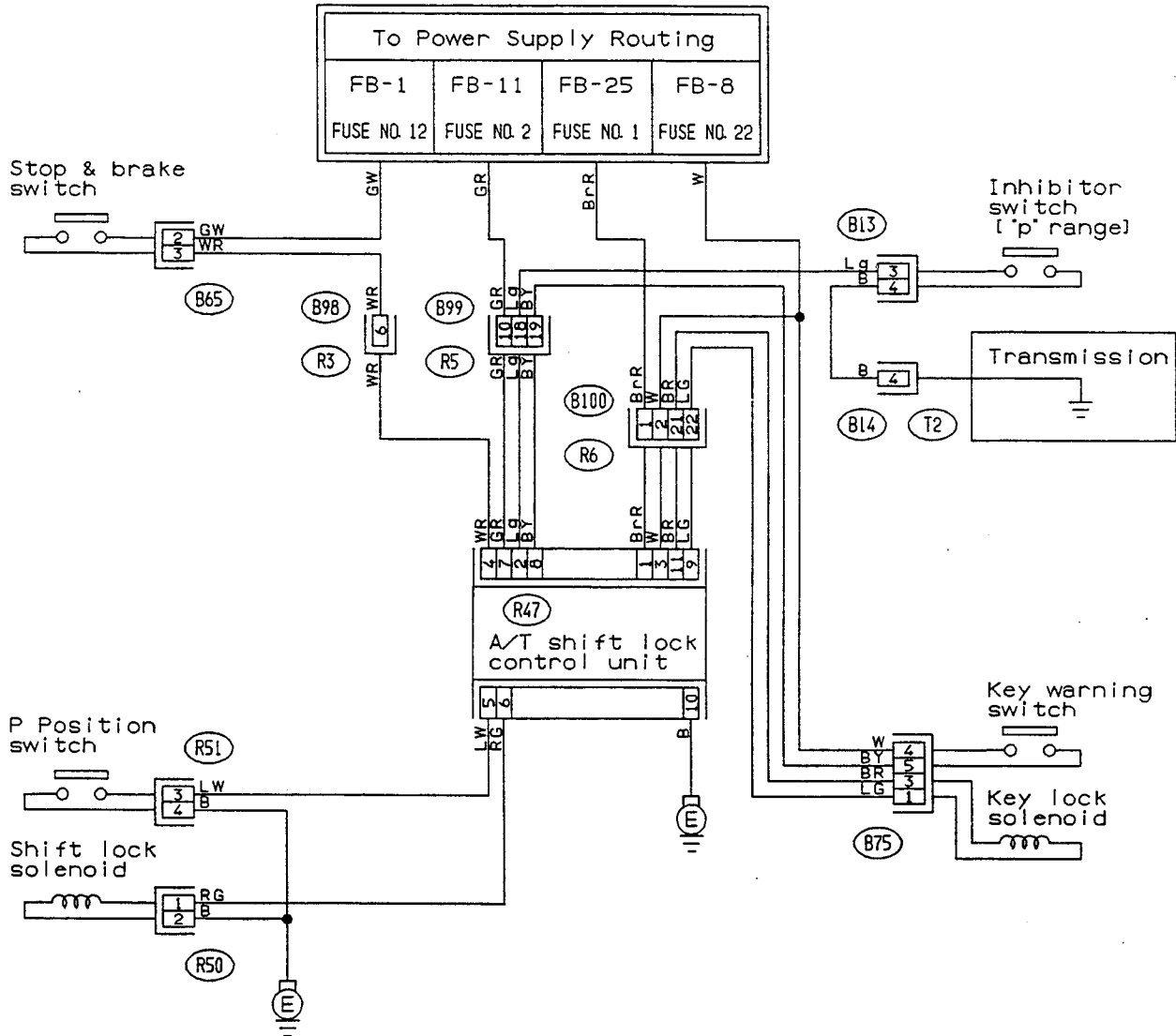

CU42-01

Fig. 25



6. AUDIO & CLOCK SYSTEM

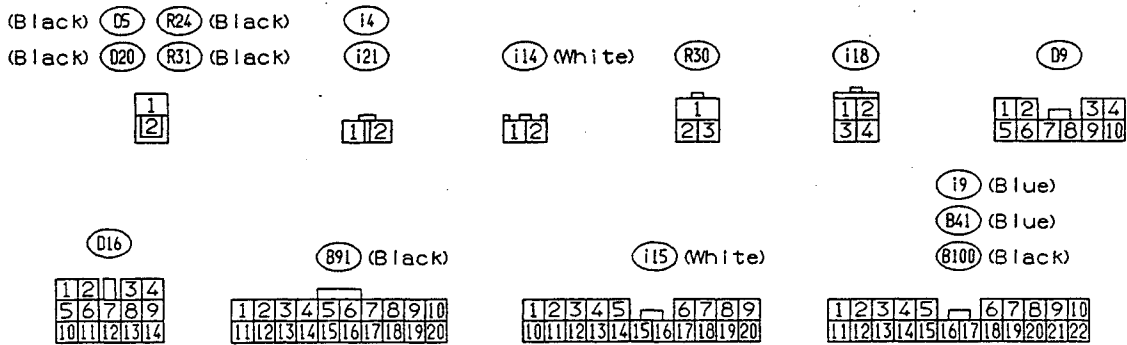
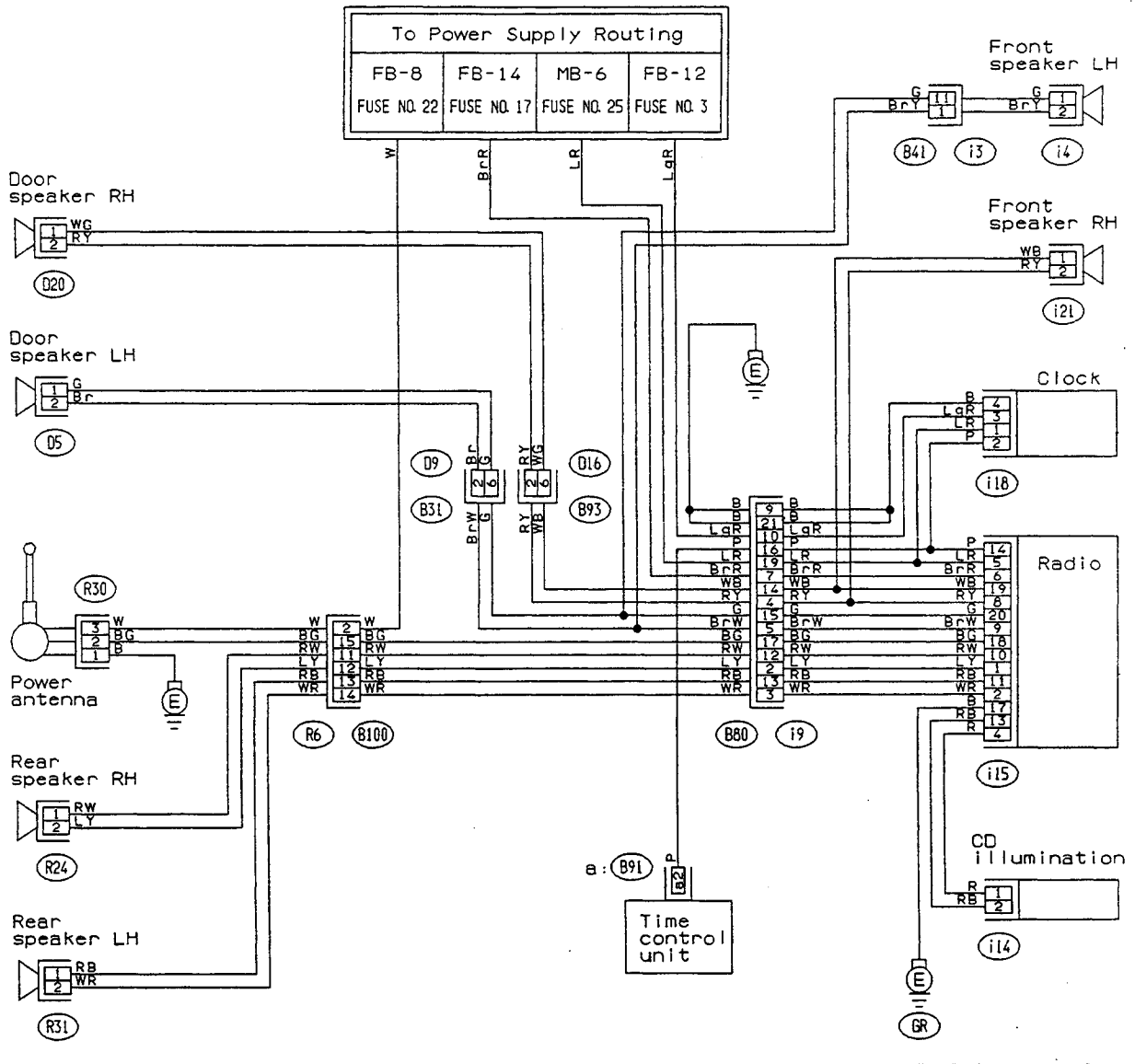

CU76-01

Fig. 26

7. AUTOMATIC SHOULDER BELT & KEY WARNING CHIME SYSTEM

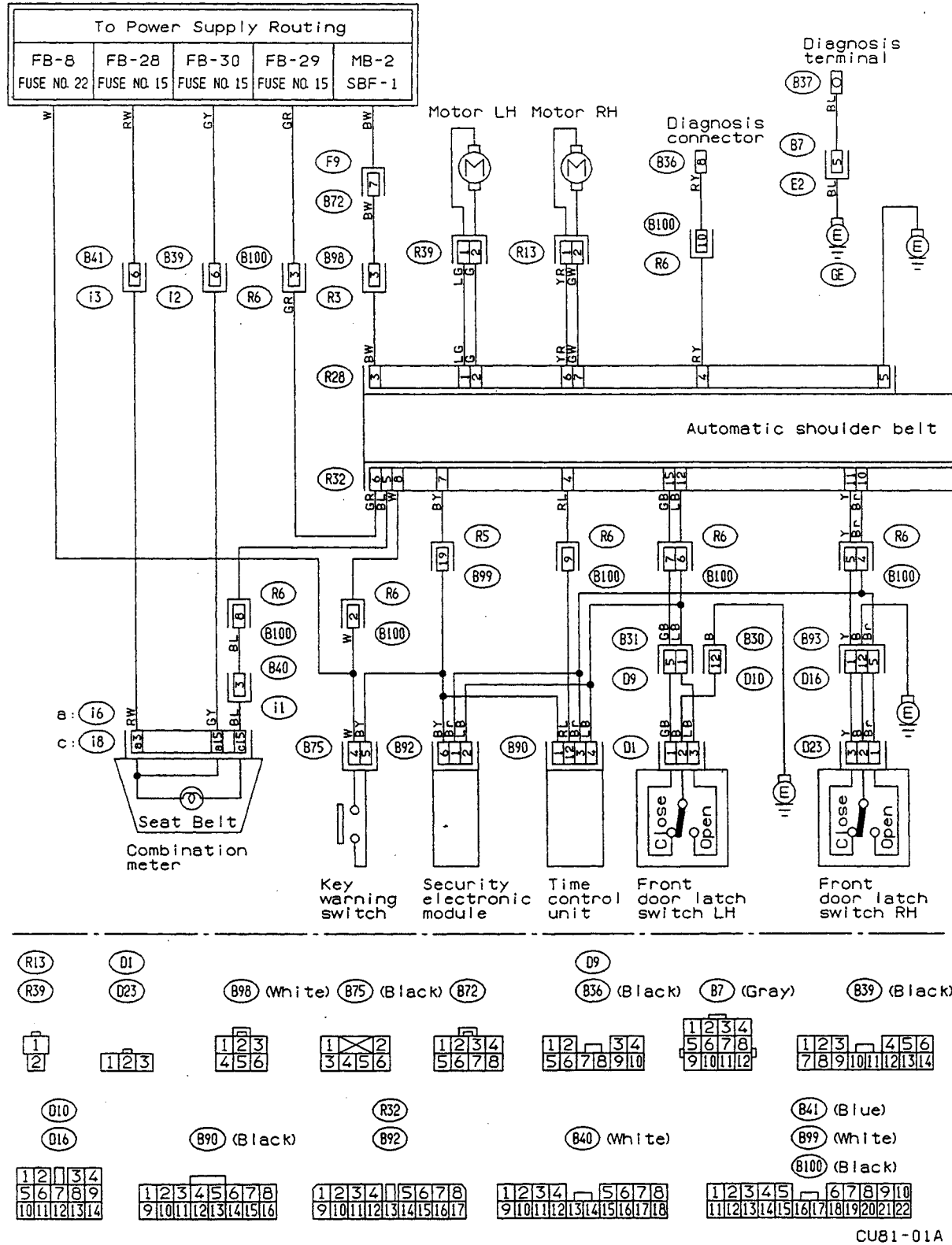

CUB1-01A

Fig. 27

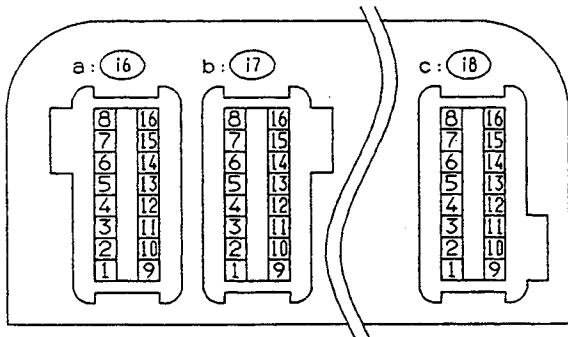
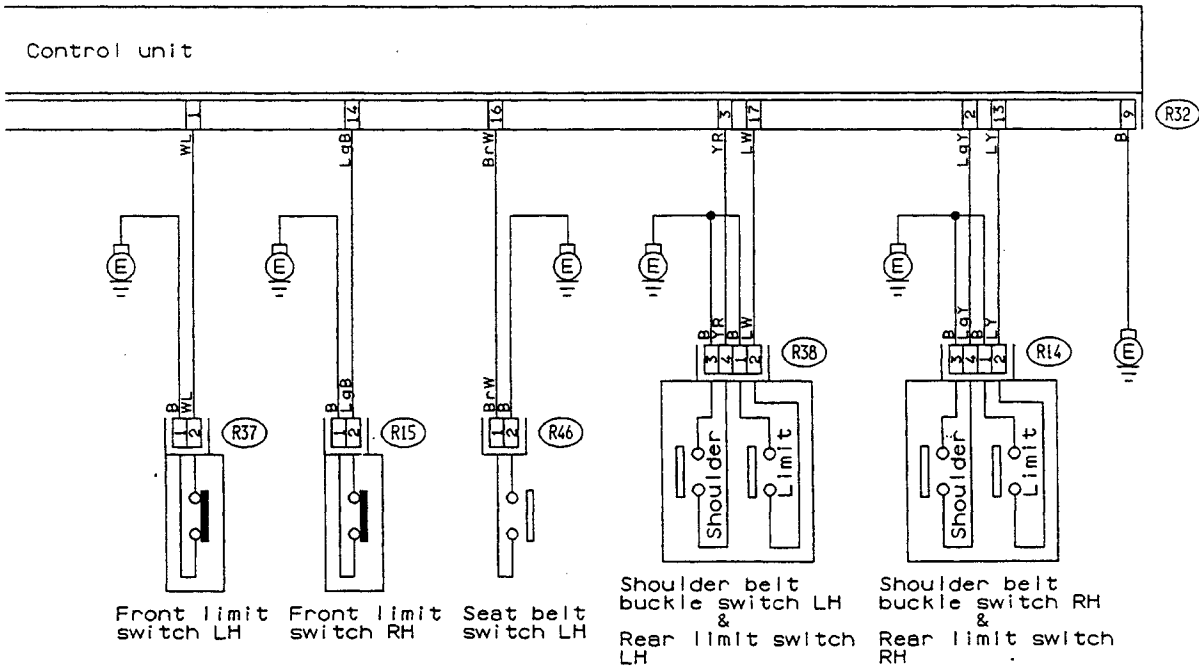

R15  
R37

R46 (White)



R14  
R38

R28

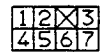

CU81-01B

8. BACK-UP LIGHT SYSTEM

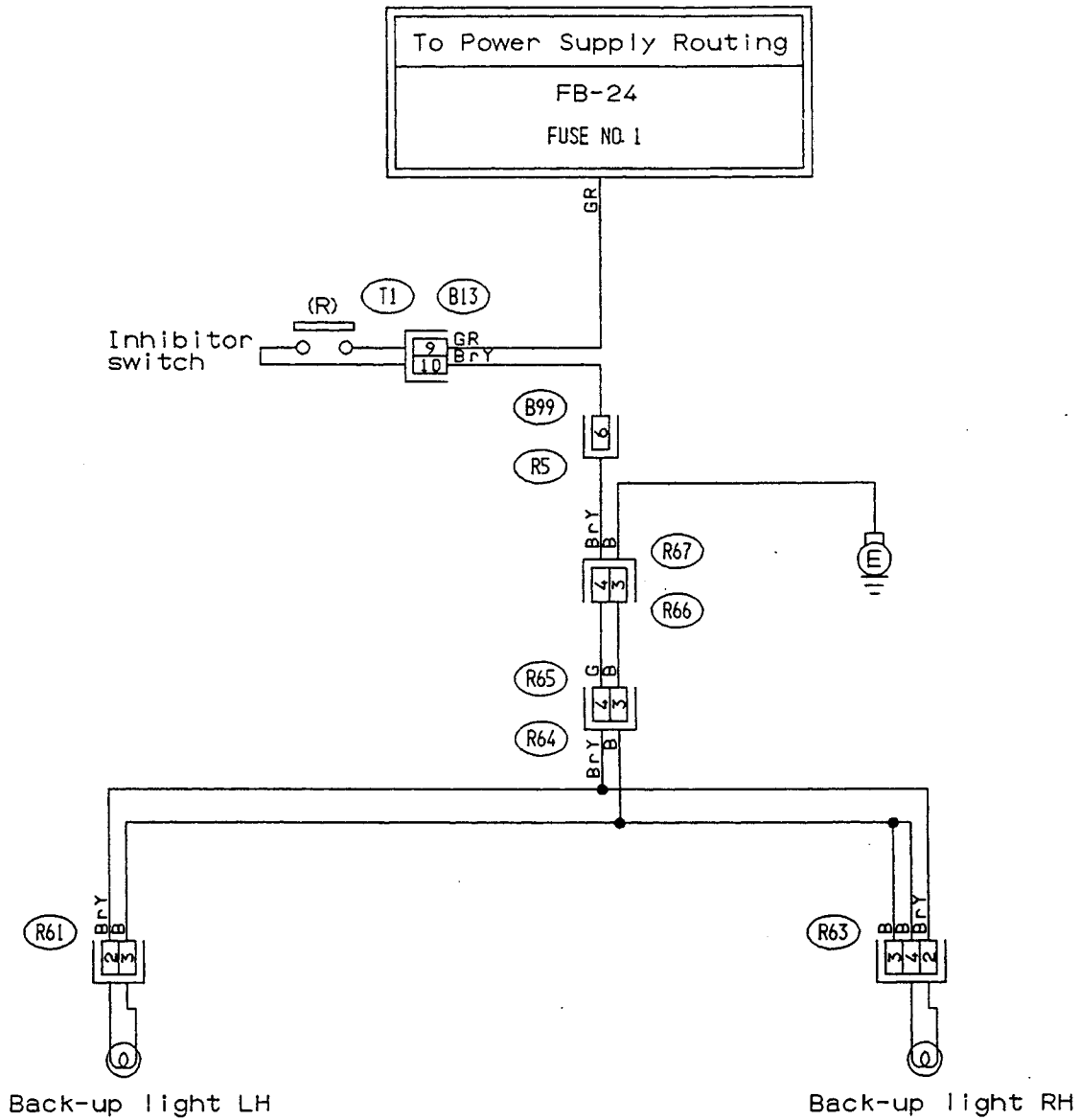

R61 (Blue)

R65

R66

R63

B13 (Black)

B99 (White)

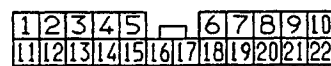
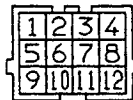

CU29-01

Fig. 28

9. CHARGING SYSTEM

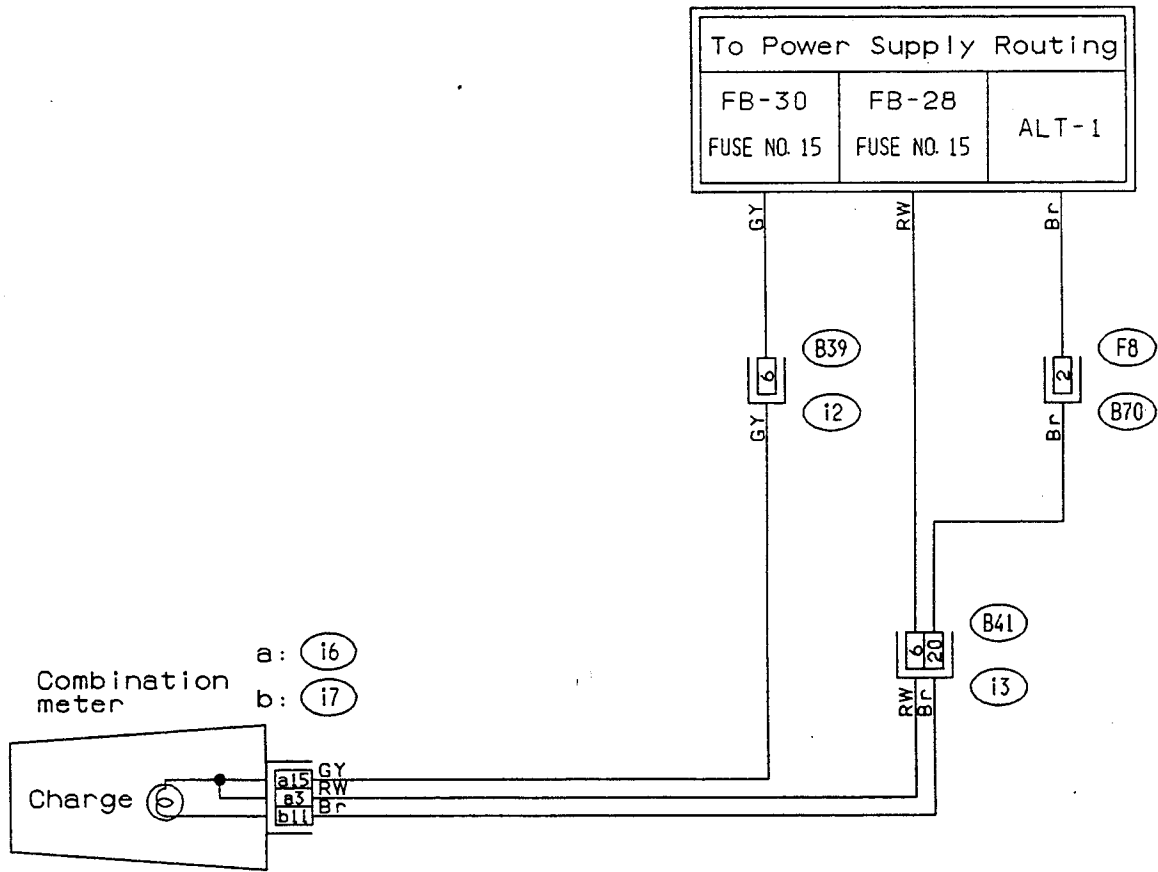

B39 (Black)

F8 (White)

B41 (Blue)

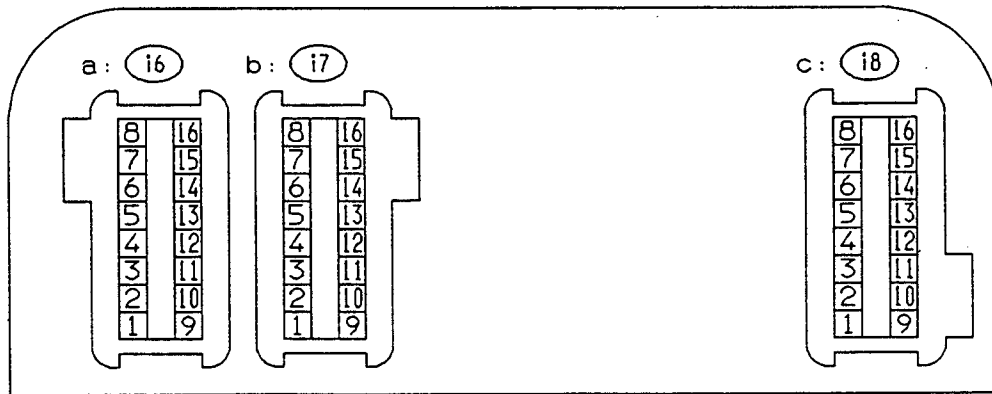
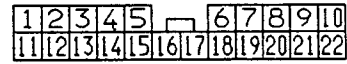
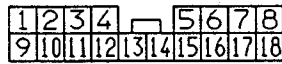

CU02-01

Fig. 29

10. COMBINATION METER

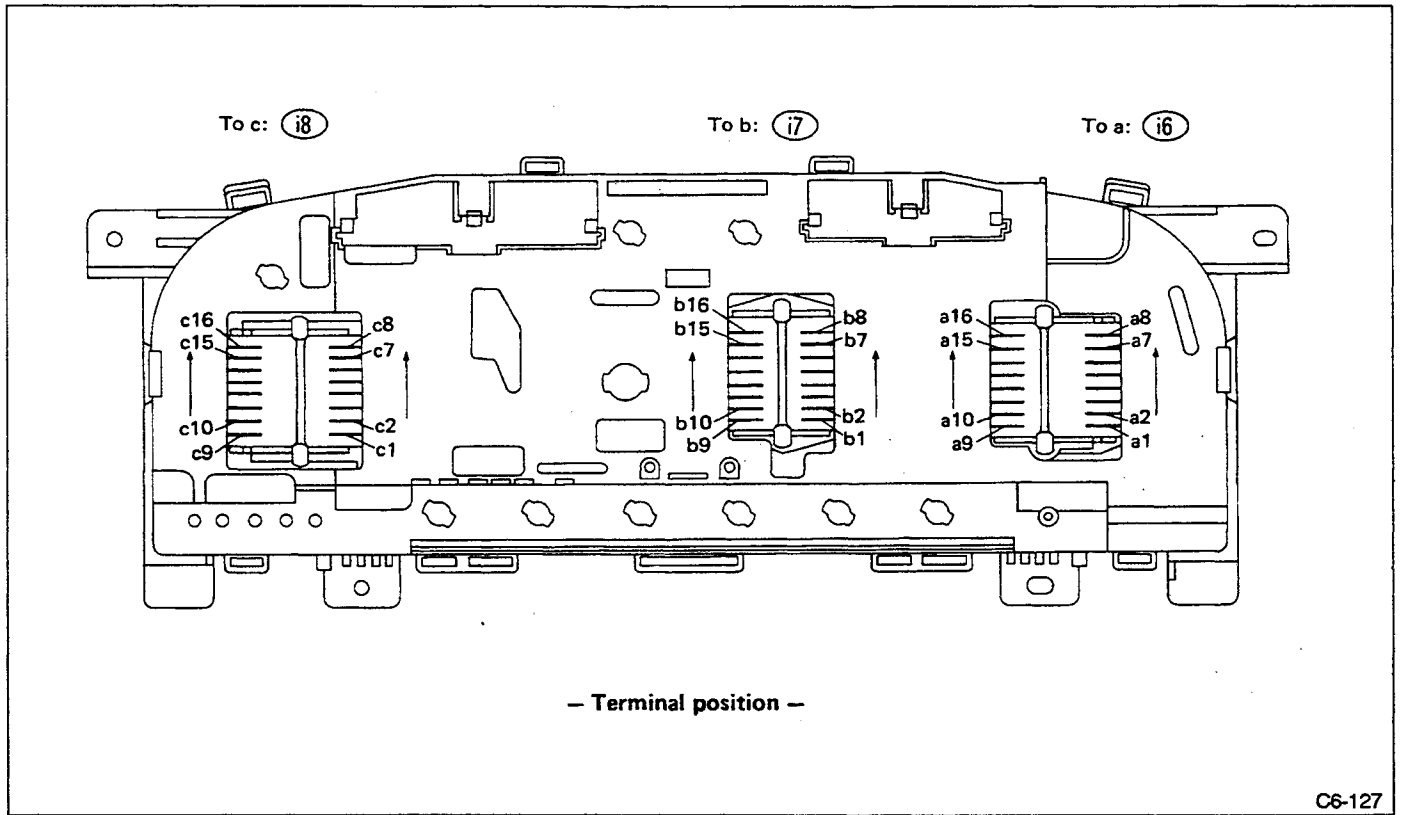
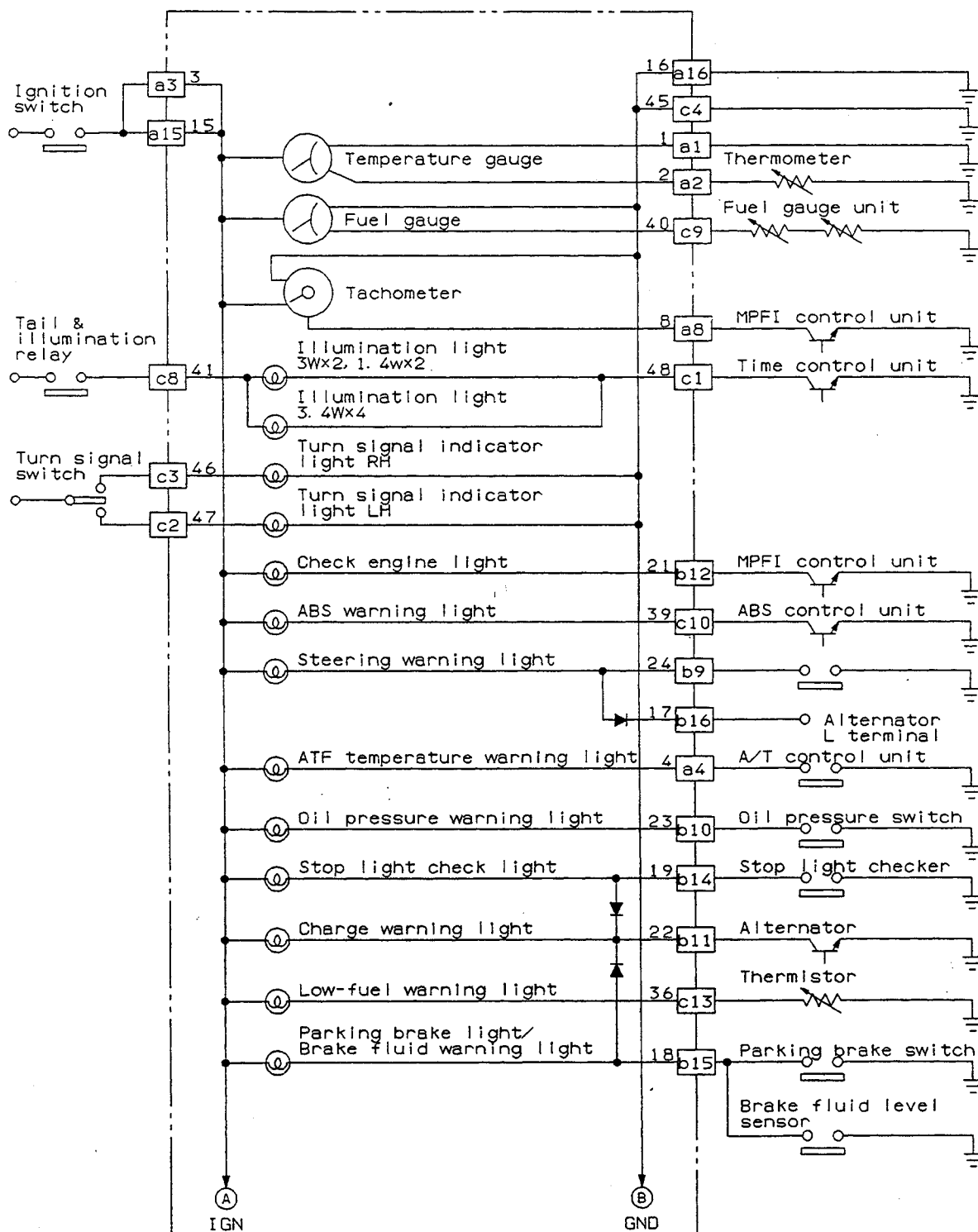
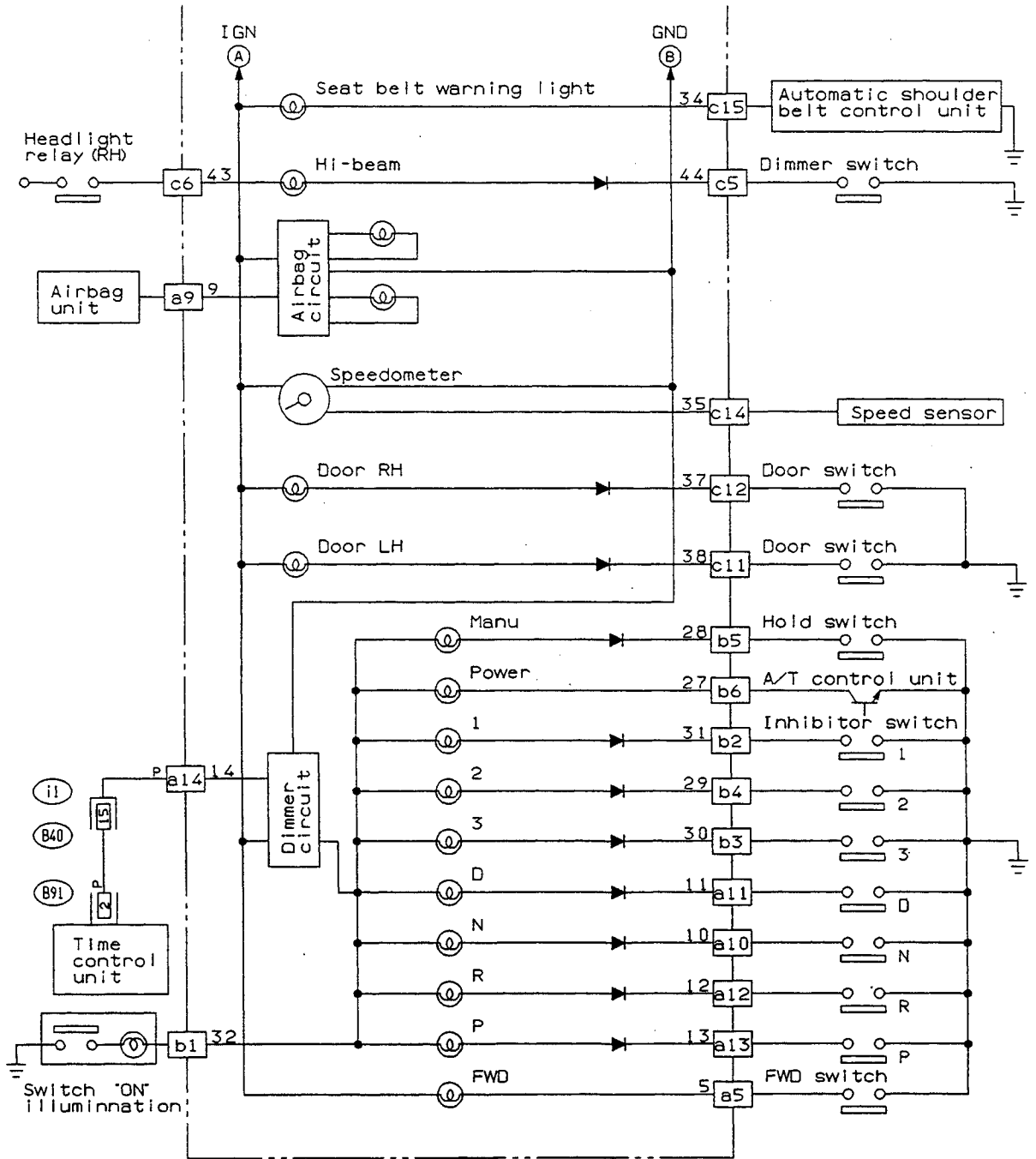

Fig. 30



CU65-01A

Fig. 31



(B40) (White)

(B91) (Black)

1	2	3	4	5	6	7	8
9	10	11	12	13	14	15	16
17	18						

1	2	3	4	5	6	7	8	9	10
11	12	13	14	15	16	17	18	19	20

CU65-01B



11. COURTESY LIGHT & KEY HOLE ILLUMINATION LIGHT SYSTEM

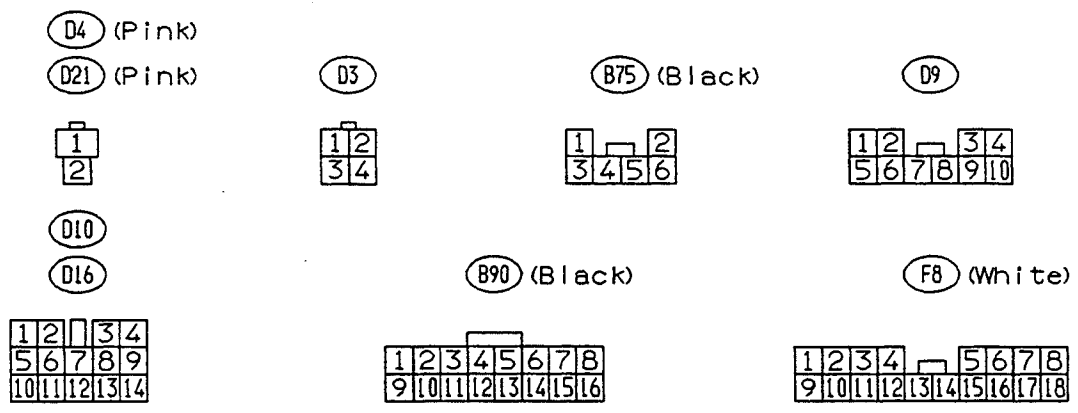
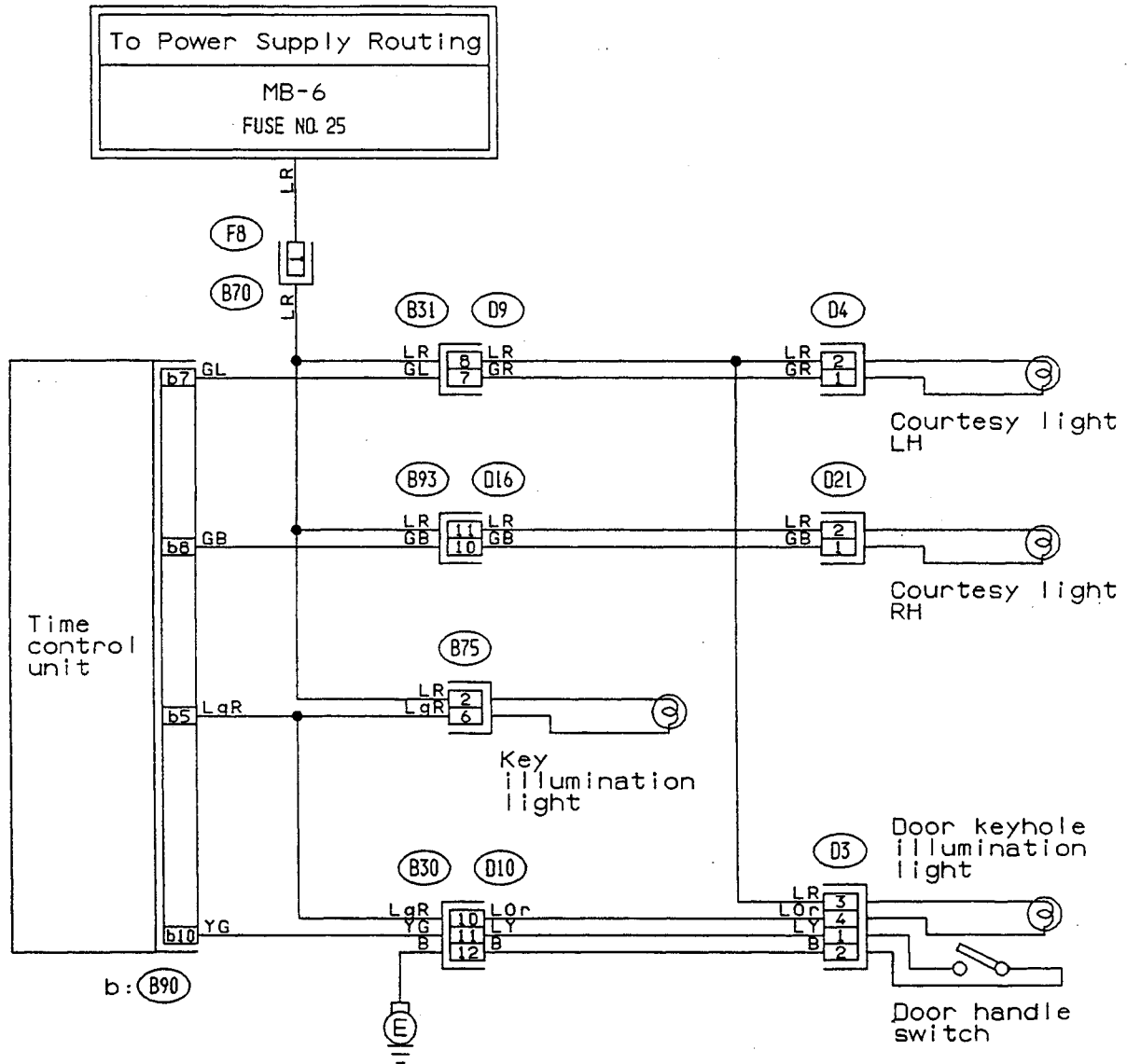

CU31-01

Fig. 32

12. CRUISE CONTROL SYSTEM

• U.S.A. model

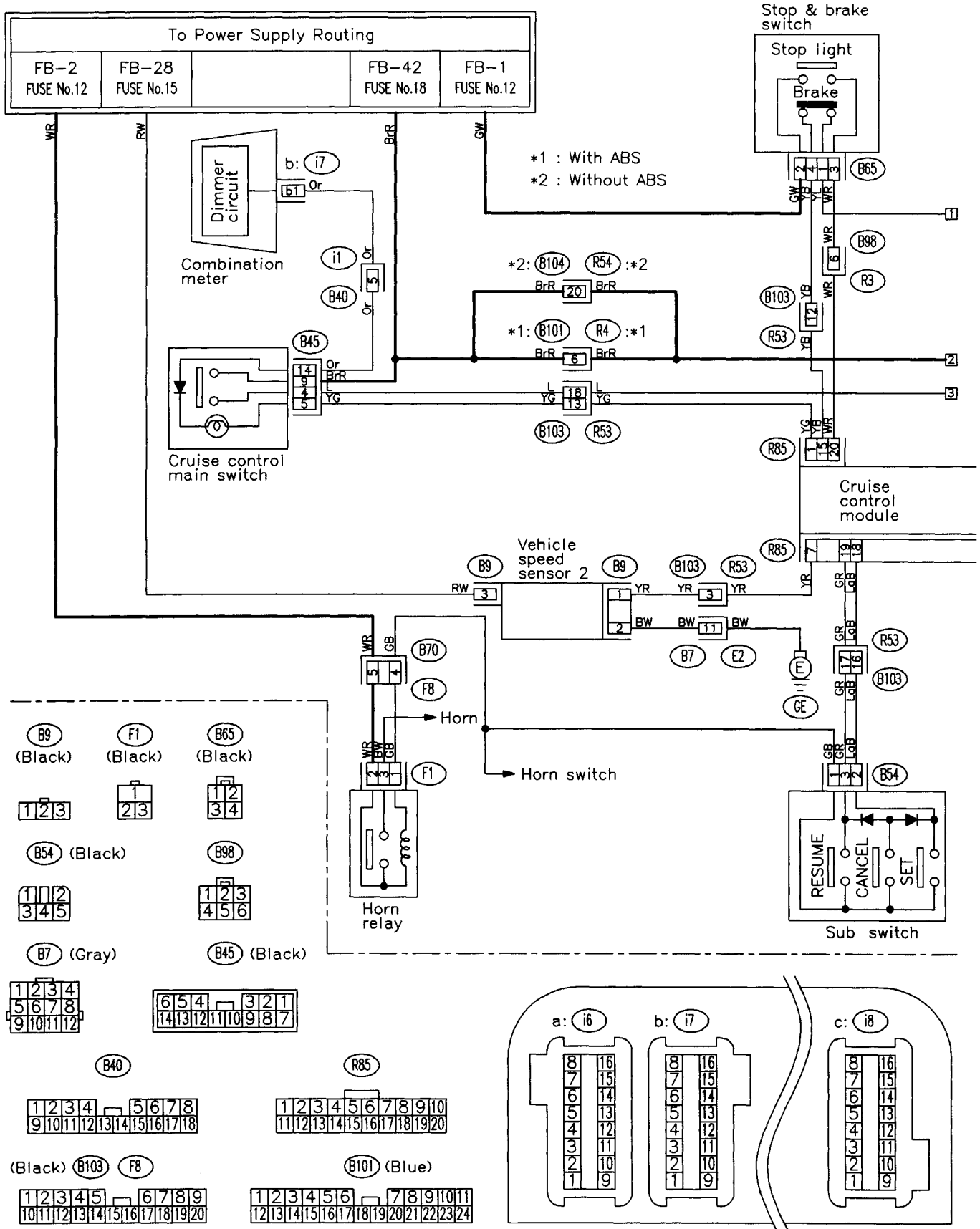
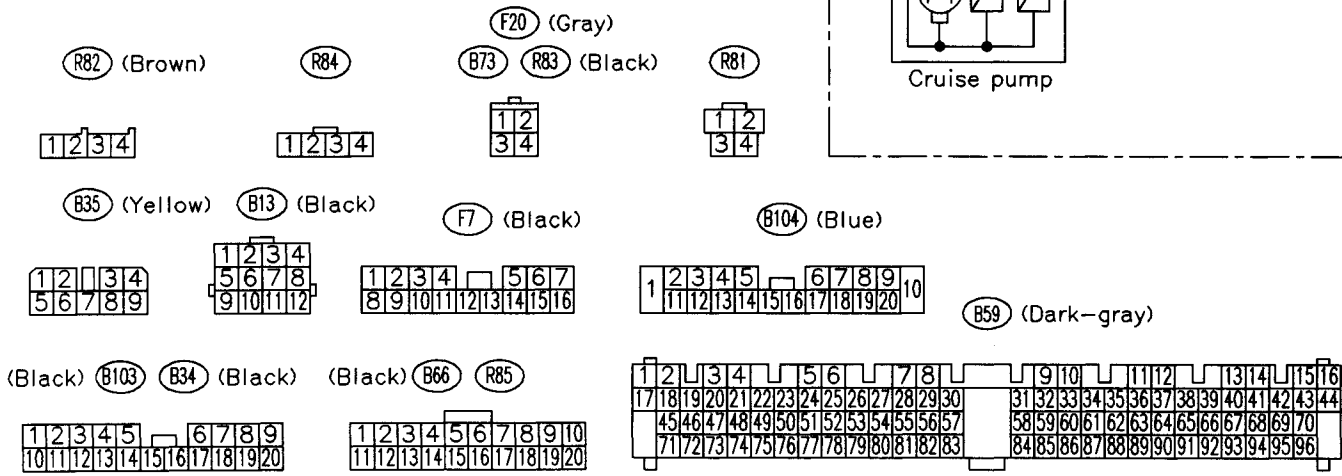
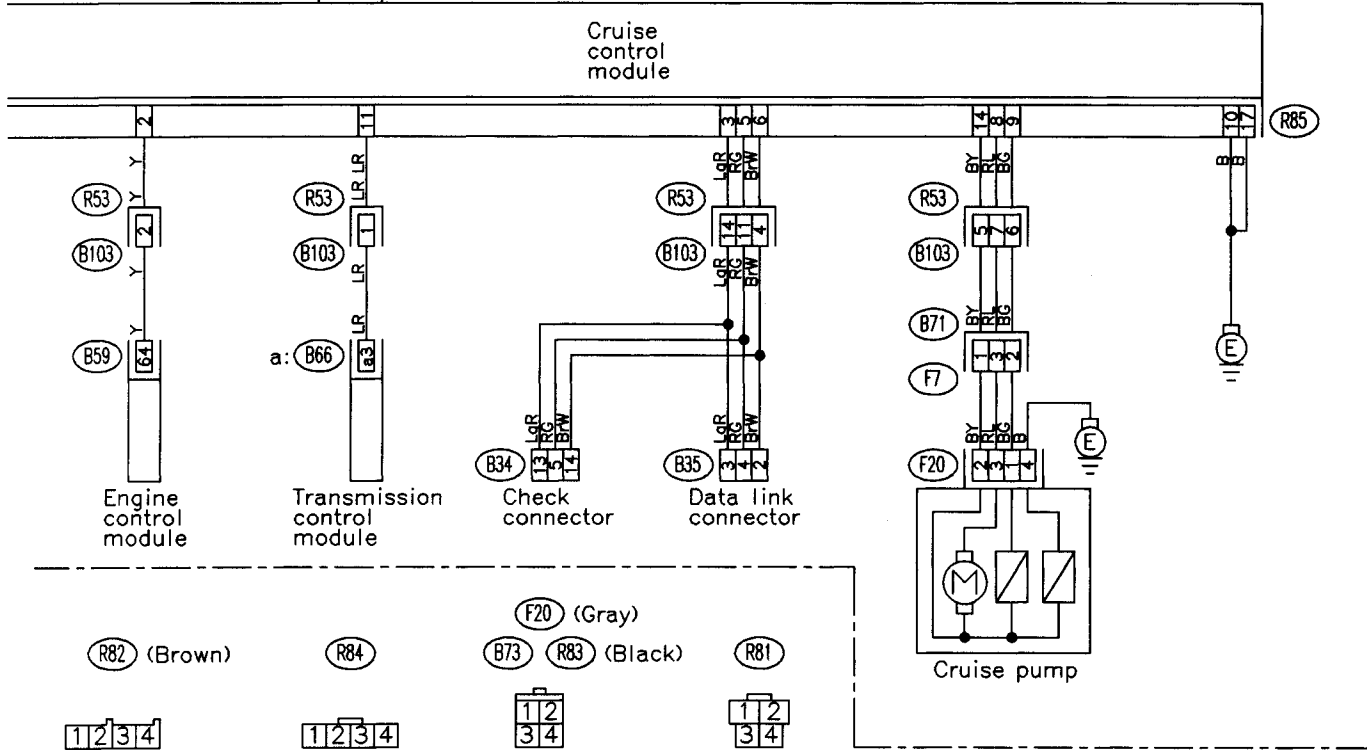
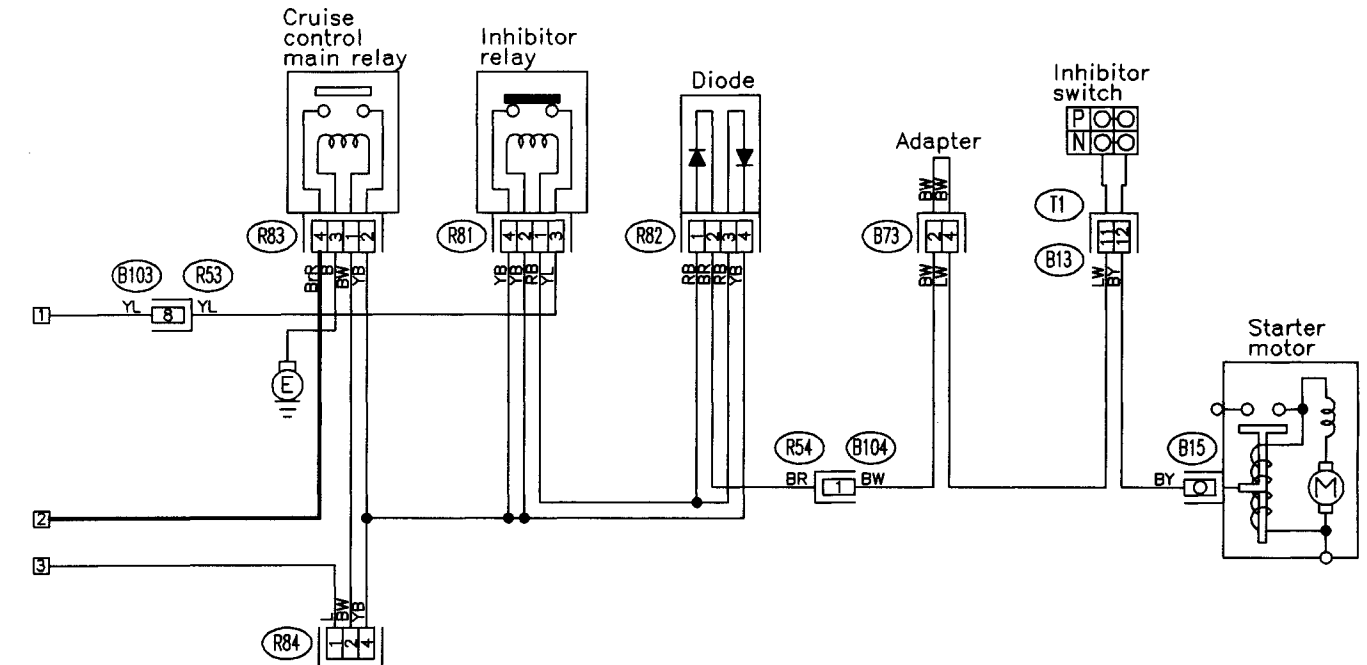
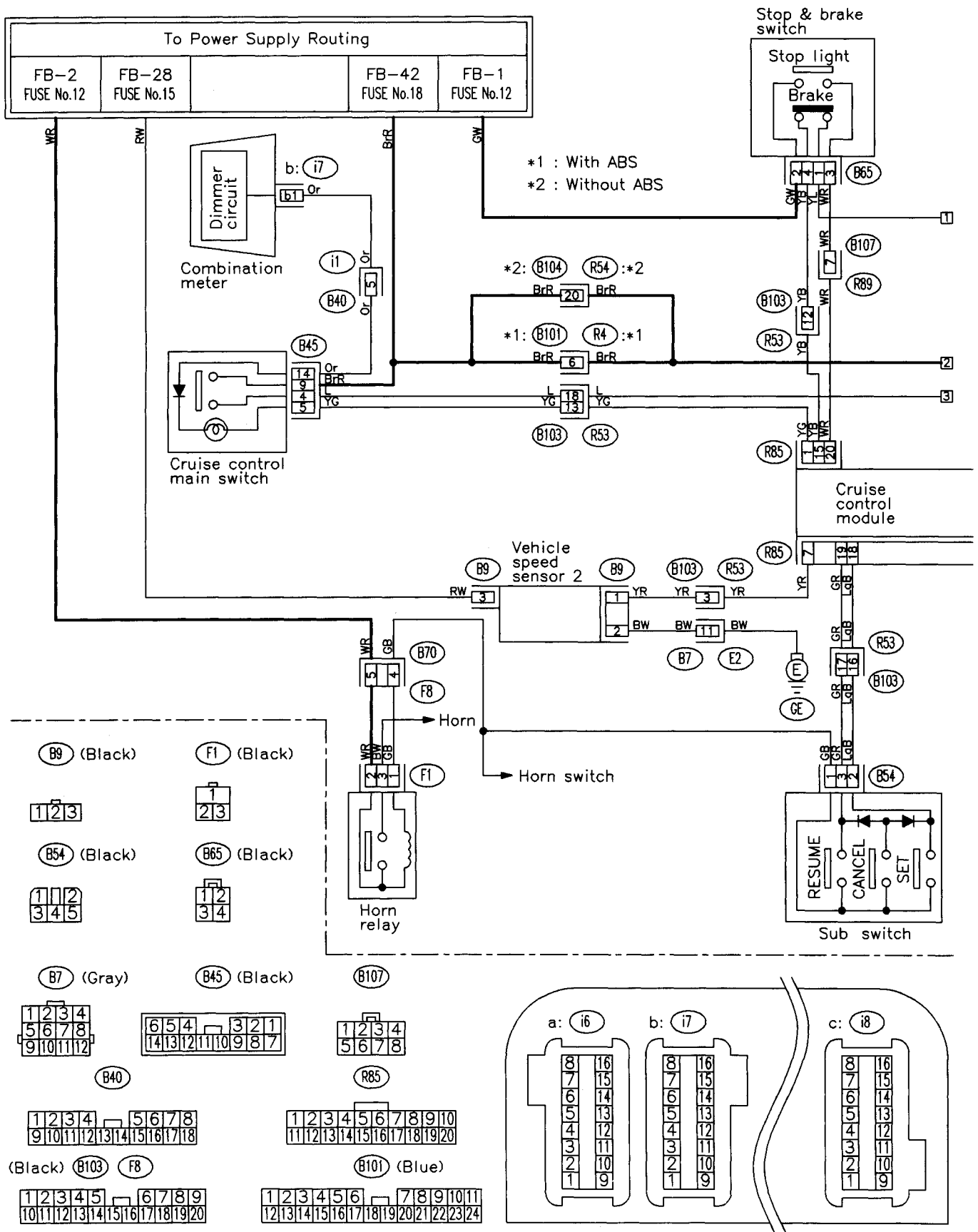

Fig. 4



● CANADA model



CC71-03A

Fig. 5

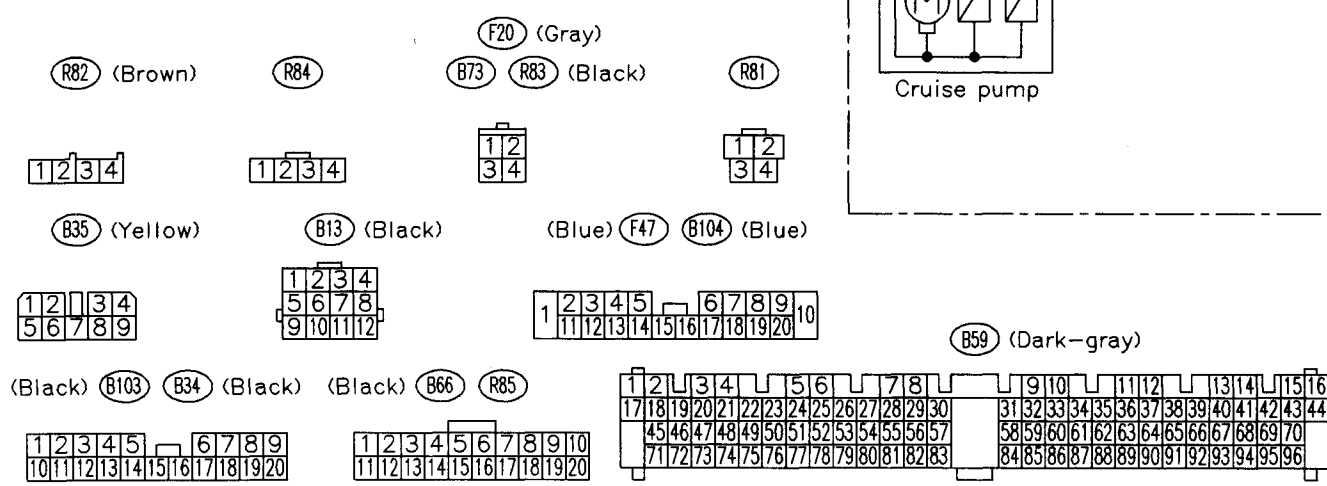
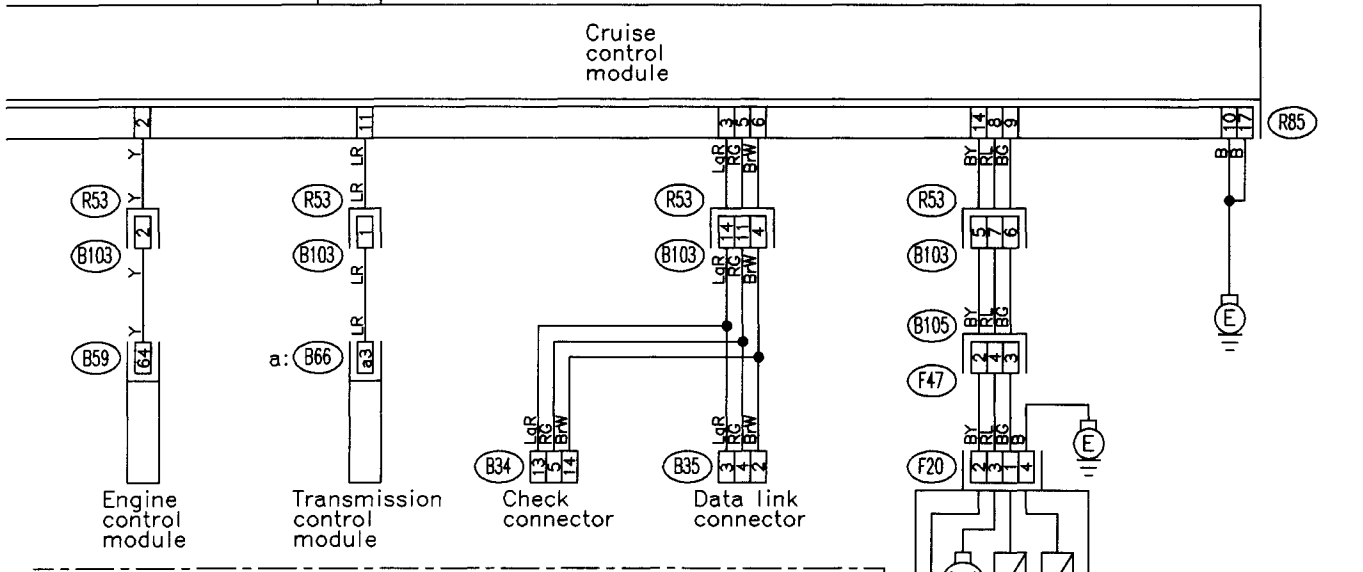
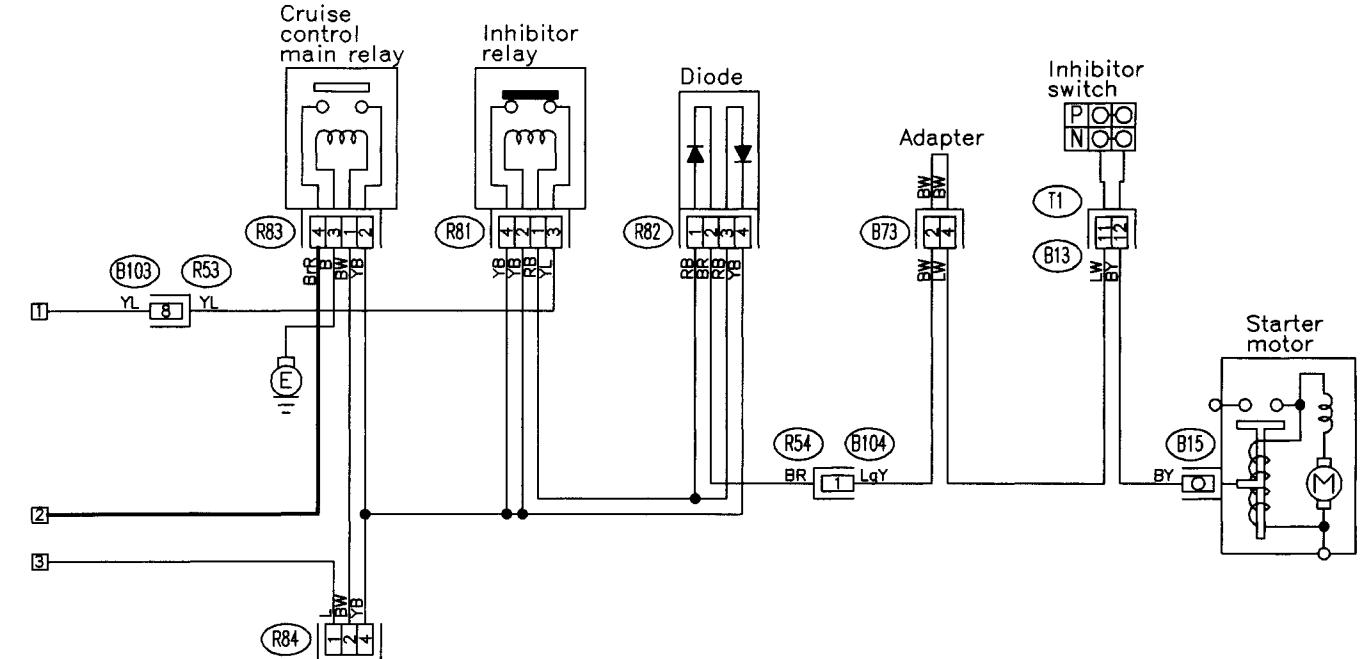

13. DOOR LOCK SYSTEM (LE grade)

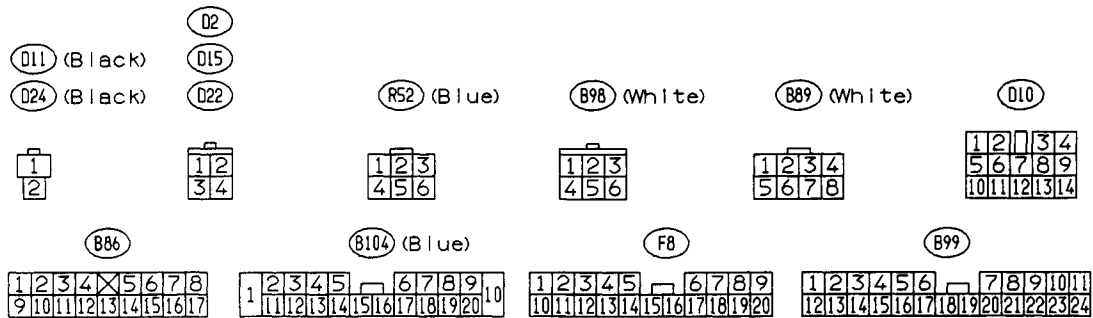
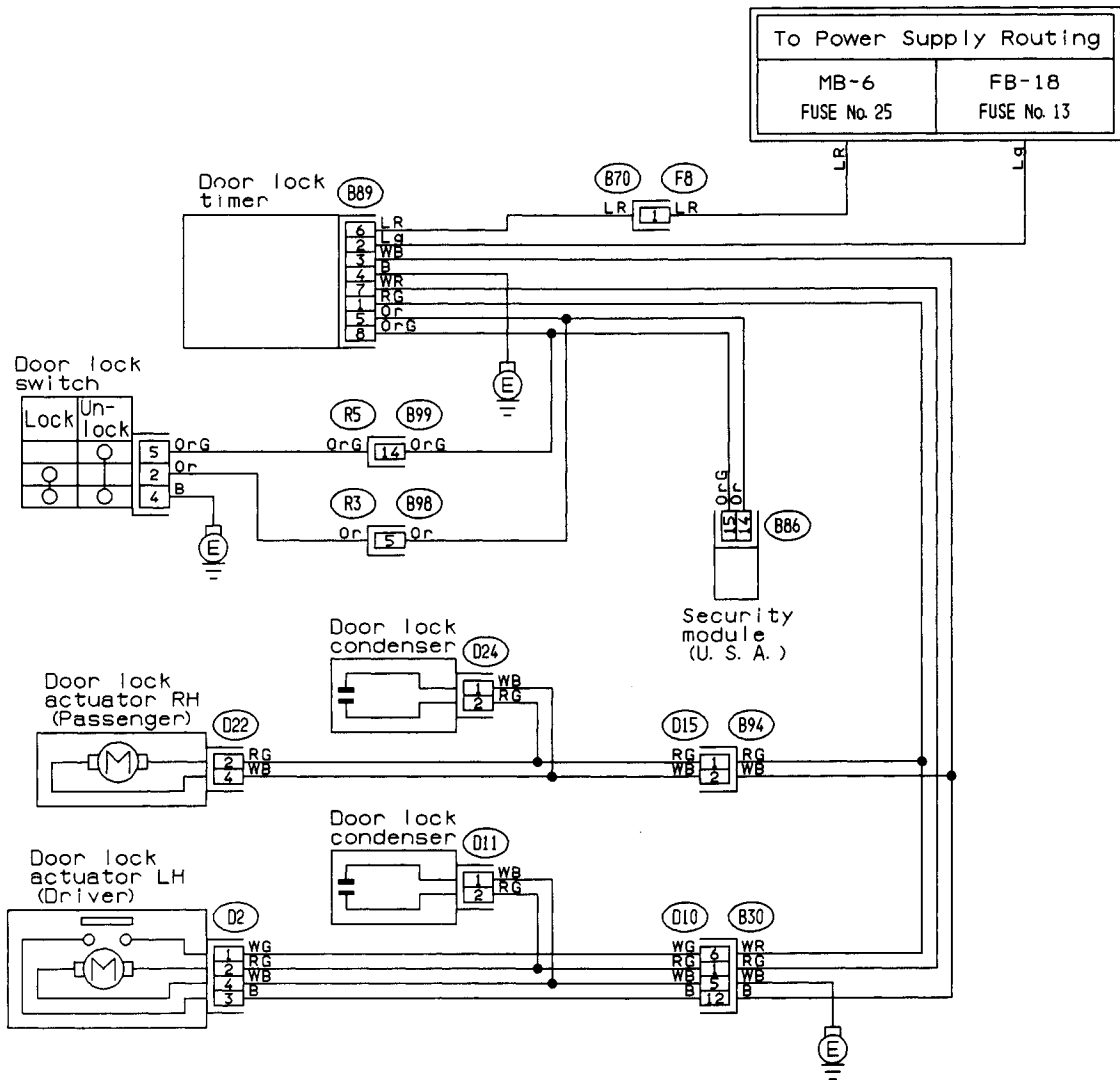

Fig. 35

CU73-04

14. ELECTRONICALLY CONTROLLED POWER STEERING SYSTEM

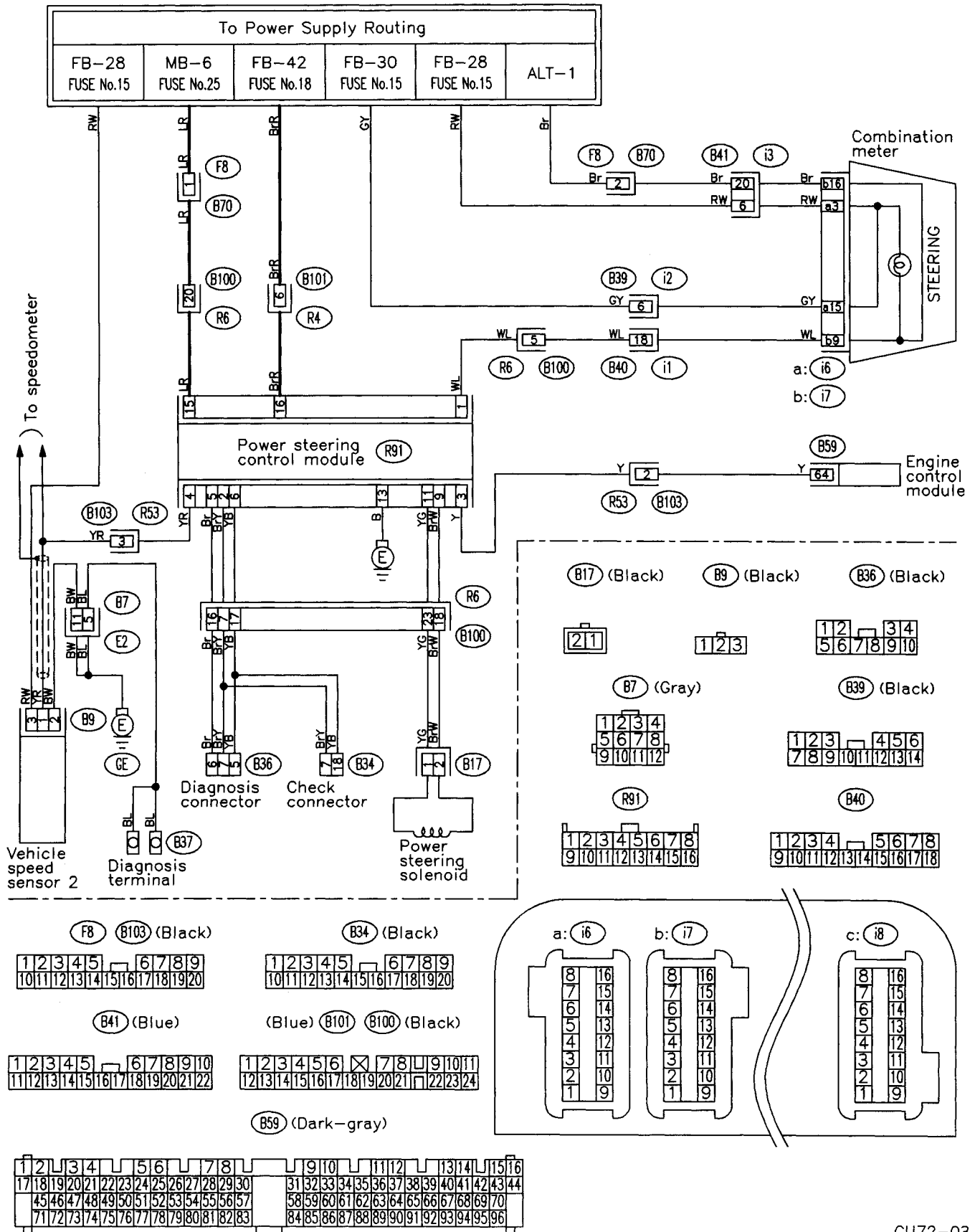

Fig. 6

15. ENGINE ELECTRICAL (MFI) SYSTEM

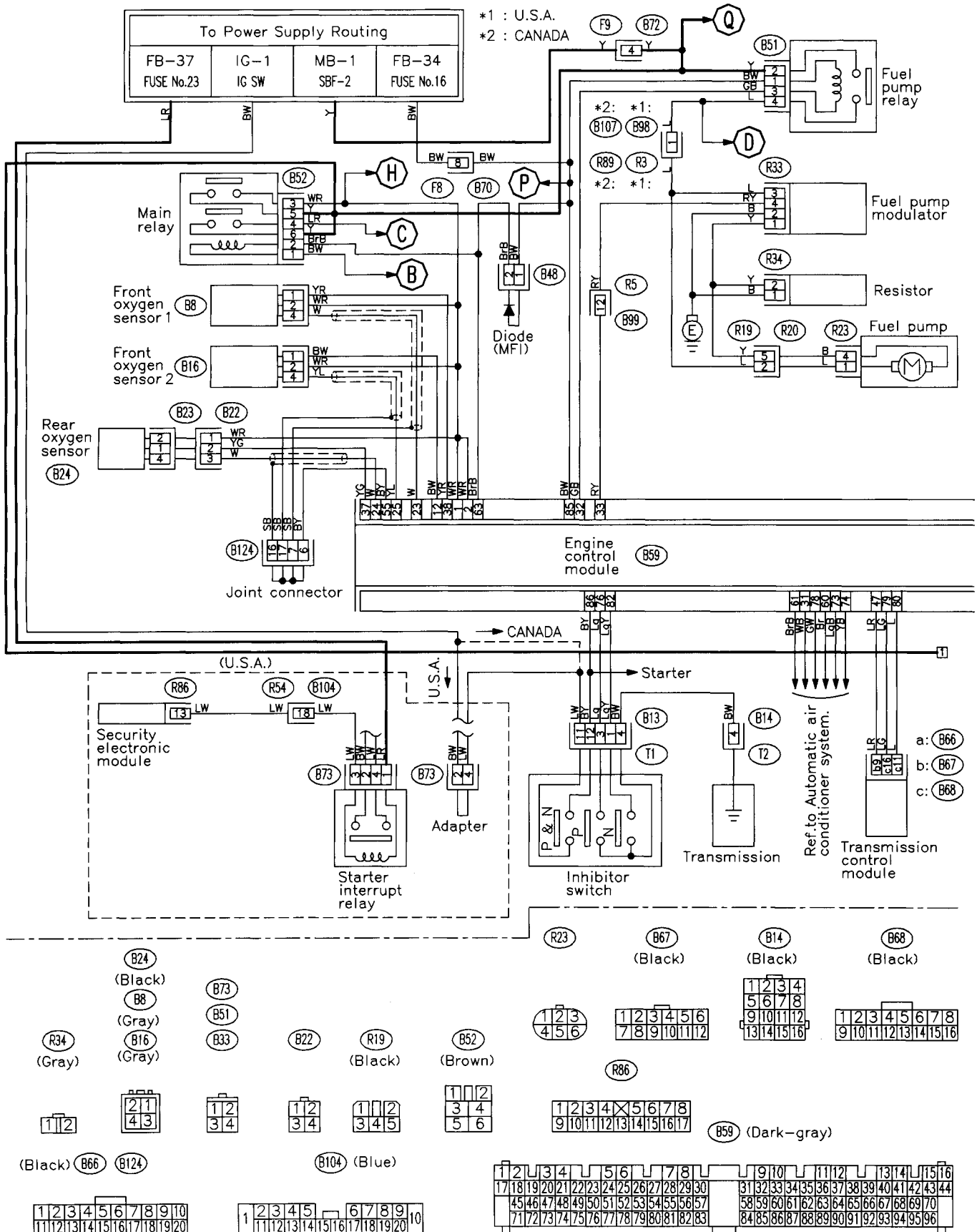
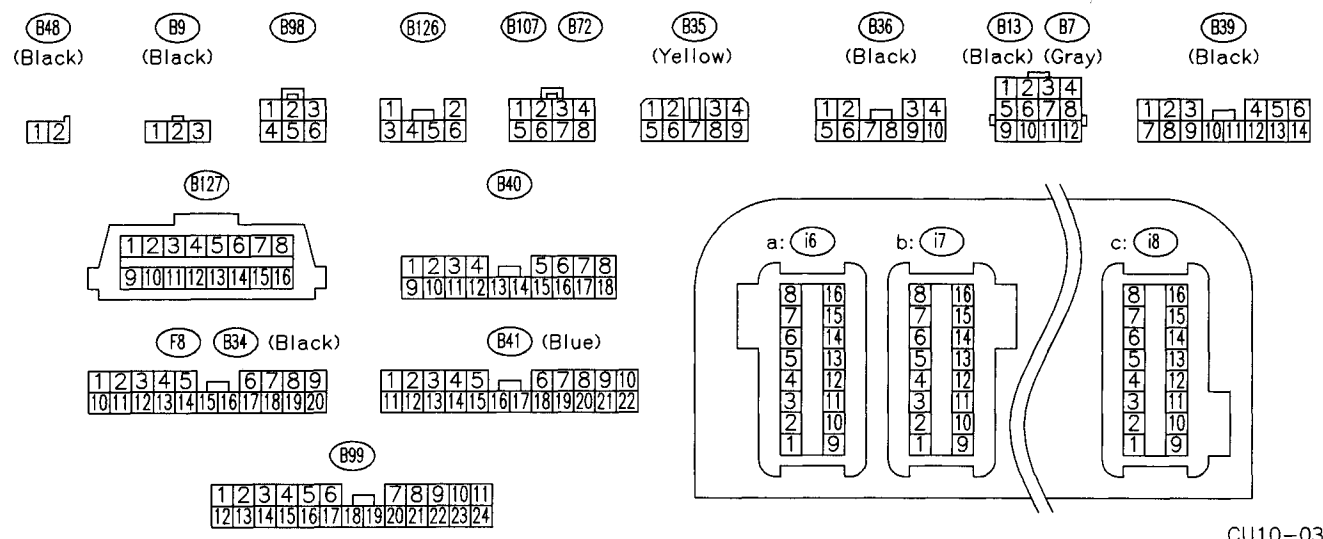
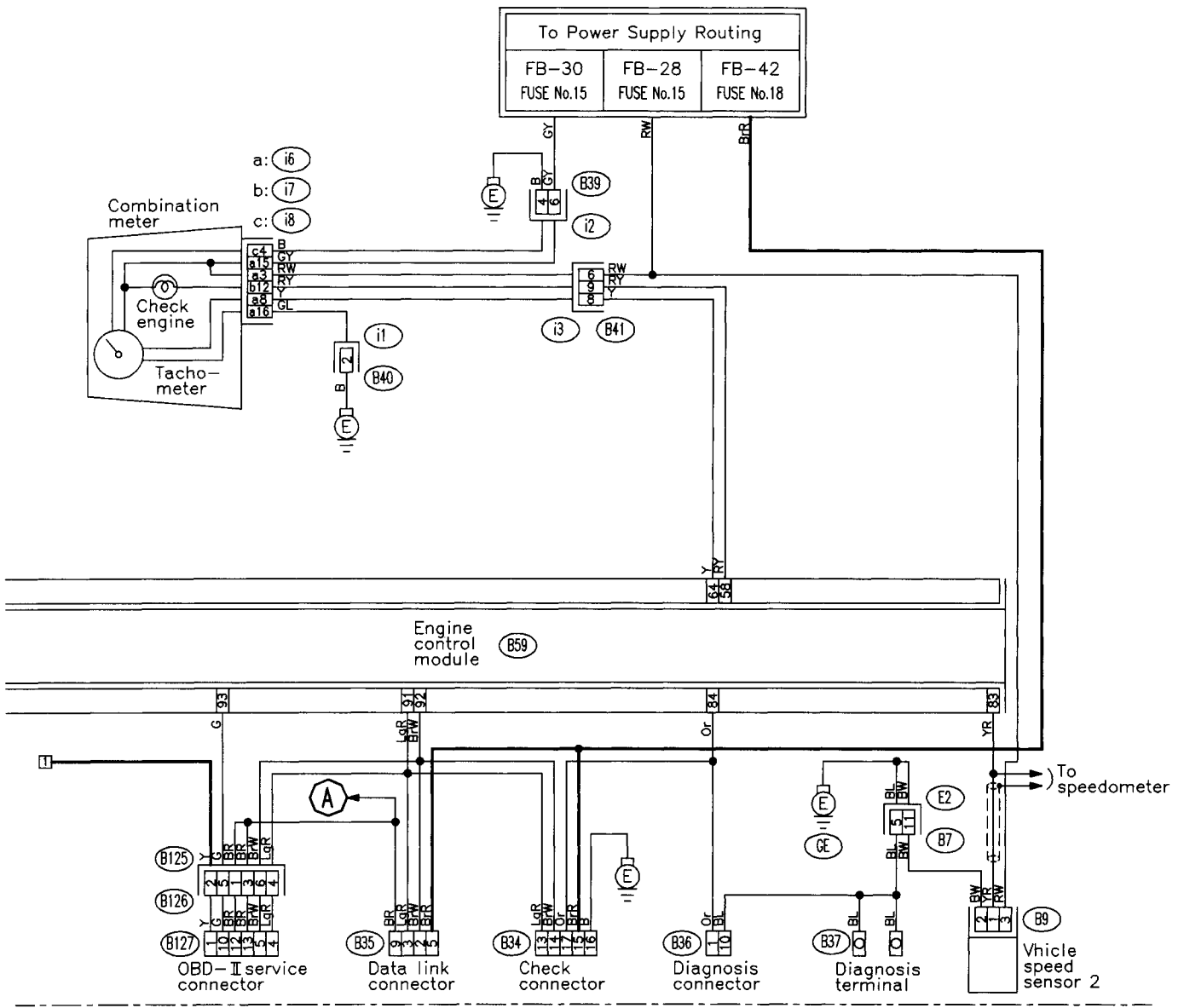
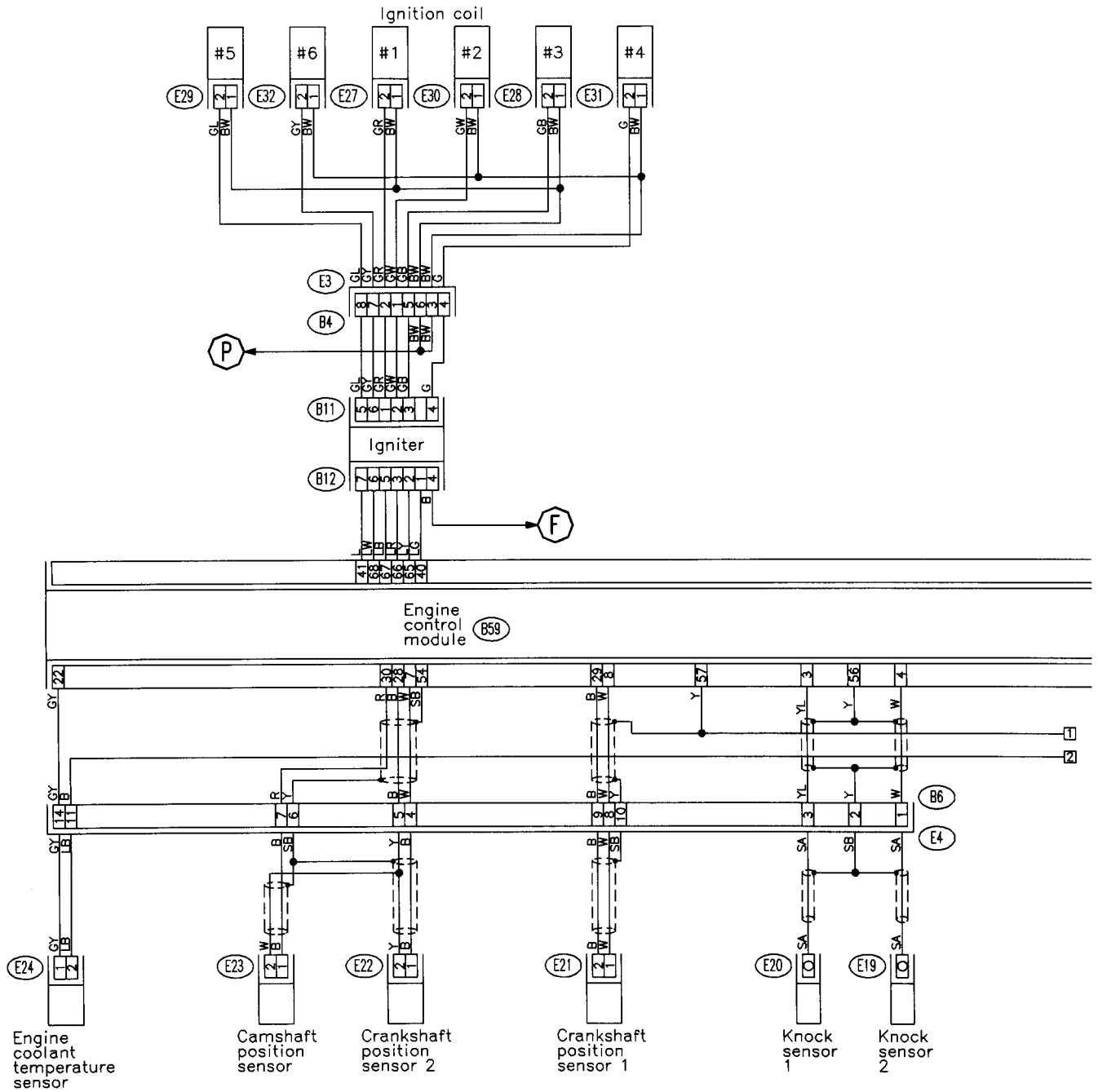



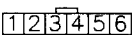
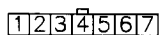
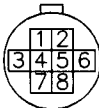



Fig. 7







- (Gray) (E27) (E30) (Gray) (E24) (Brown) (E21) (Gray) (B11) (Gray) (B12) (Gray) (B4) (Gray) (B6) (Gray)
  - (Green) (E28) (E31) (Green) (E22) (Gray)
  - (Blue) (E29) (E32) (Blue) (E23) (Gray)
- 





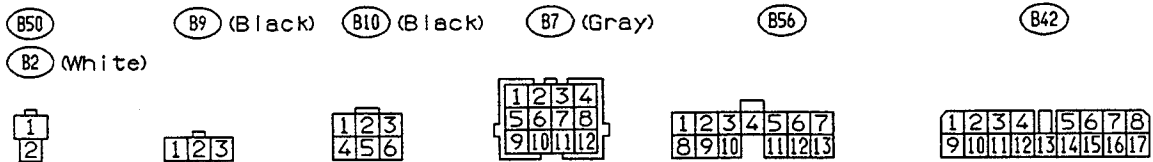
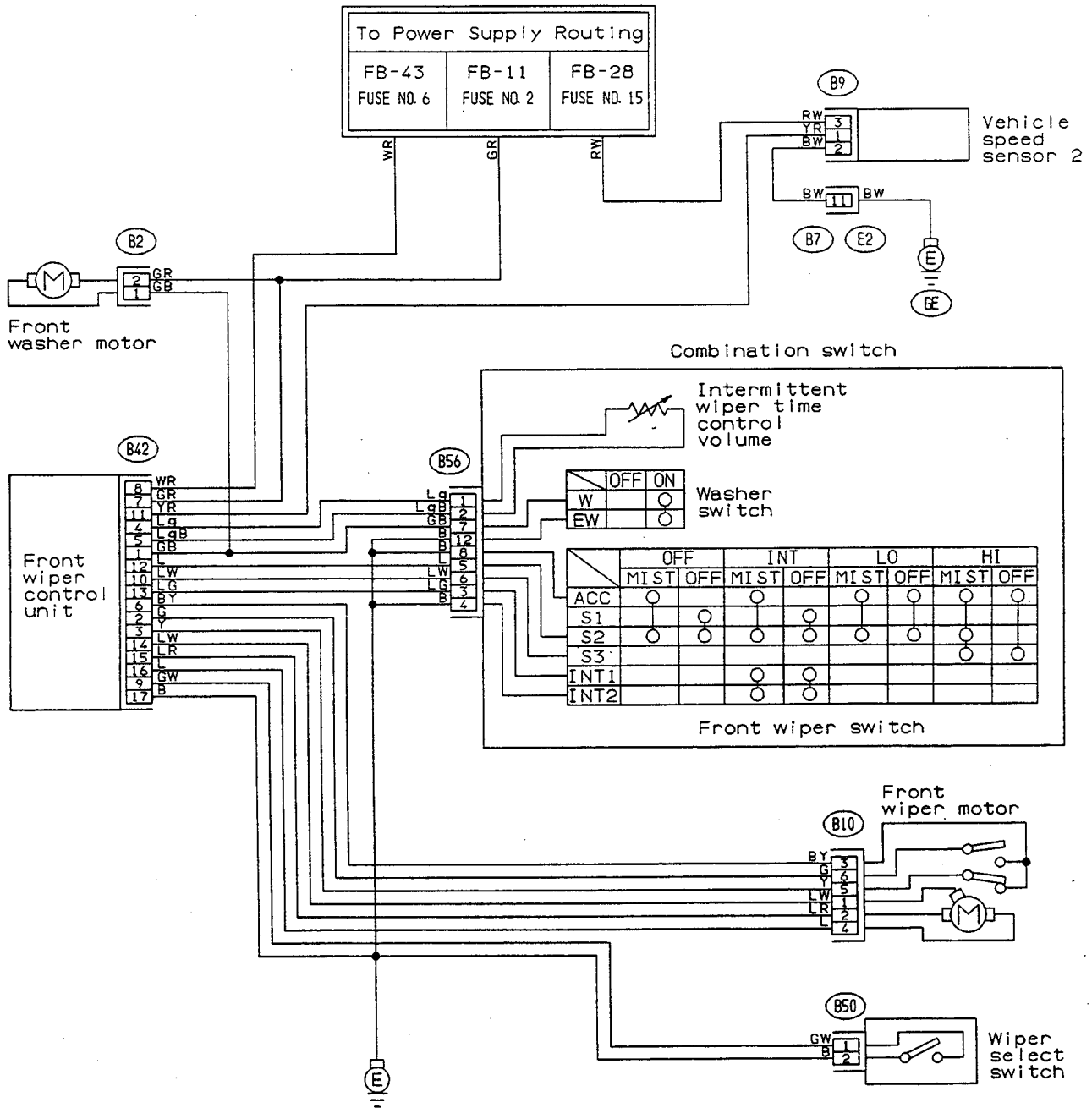



16. FRONT WIPER AND WASHER SYSTEM



CU50-01

Fig. 39

17. FUEL GAUGE SYSTEM

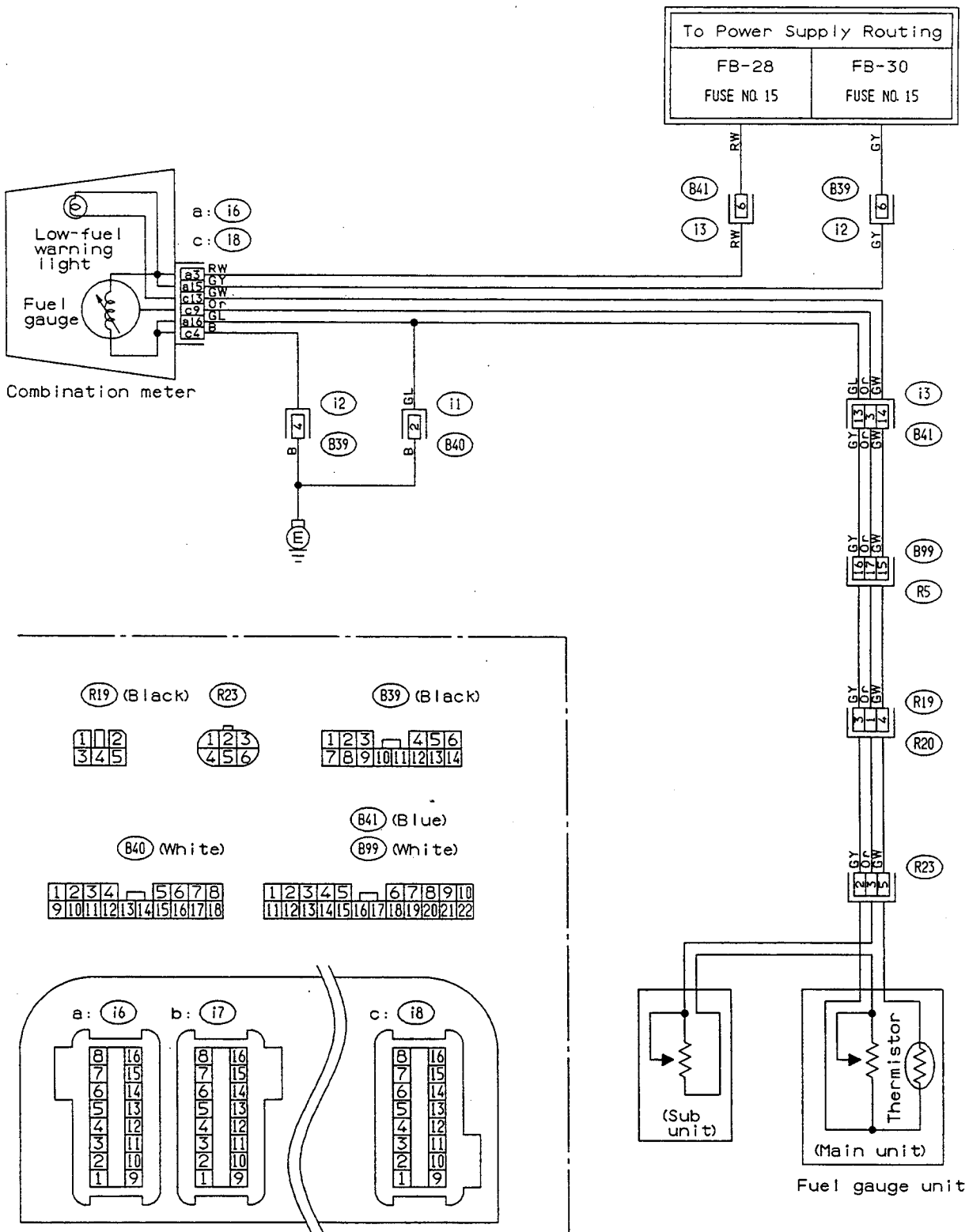

CU61-01

Fig. 40

18. HORN AND CIGARETTE LIGHTER SYSTEM

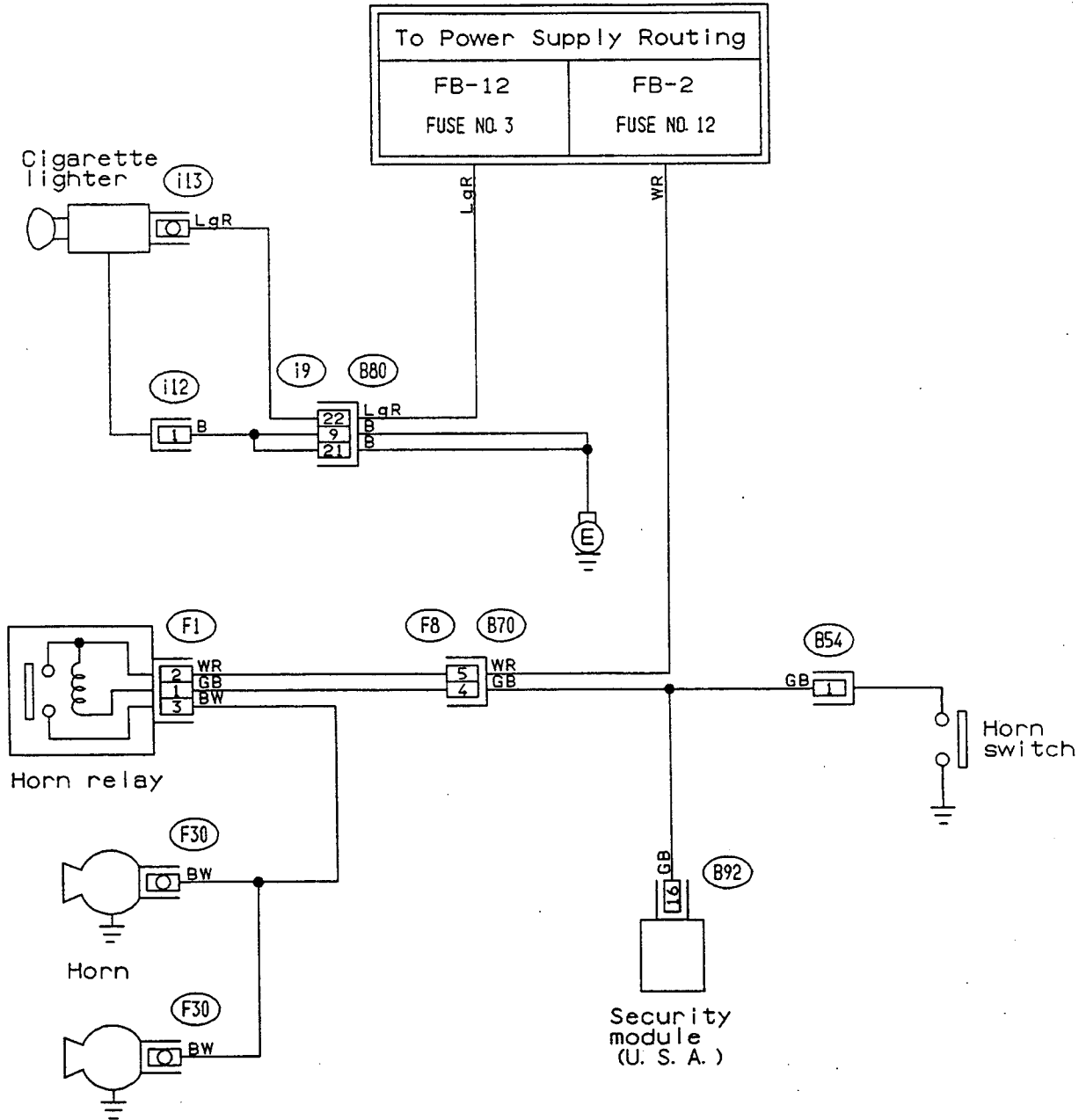

(F1) (Black)

(i12)

(B54) (Black)

(B92)

(F8) (White)

(i9) (Blue)

1	2
3	4

1	2
3	4

1	2	3	4	X	5	6	7	8
9	10	11	12	13	14	15	16	17

1	2	3	4		5	6	7	8
9	10	11	12	13	14	15	16	17

1	2	3	4	5		6	7	8	9	10	
11	12	13	14	15	16	17	18	19	20	21	22

CU74-01

Fig. 41

19. LIGHTING (HEADLIGHT & FOG LIGHT) SYSTEM

• U.S.A. model

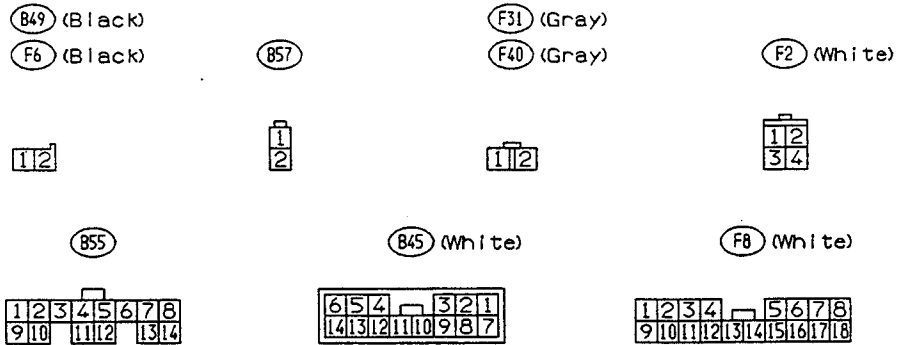
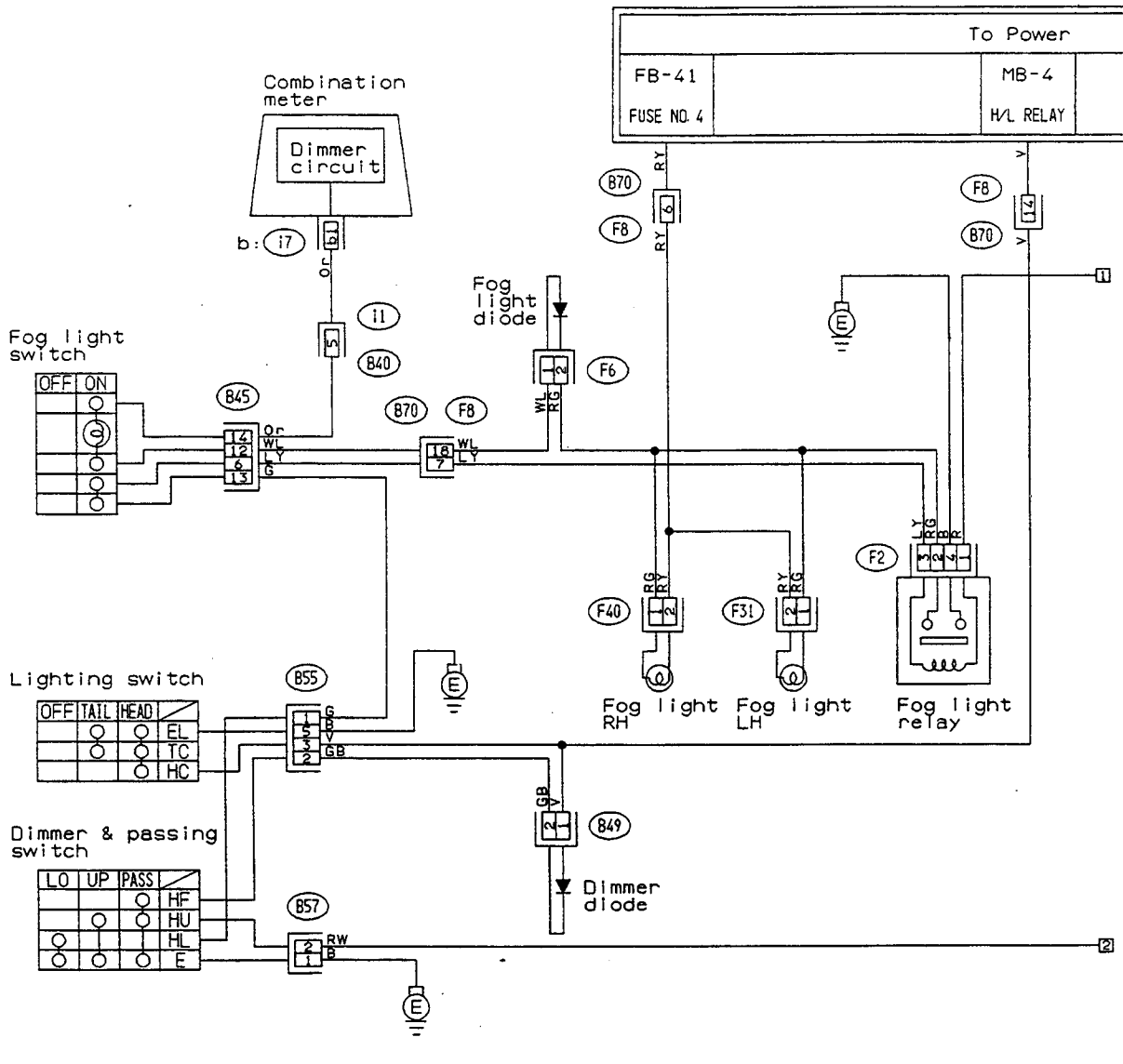

CU20-01A

Fig. 42

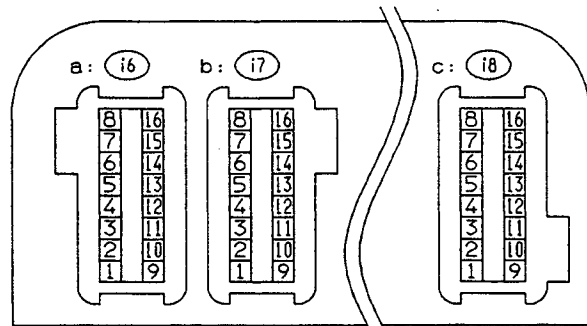
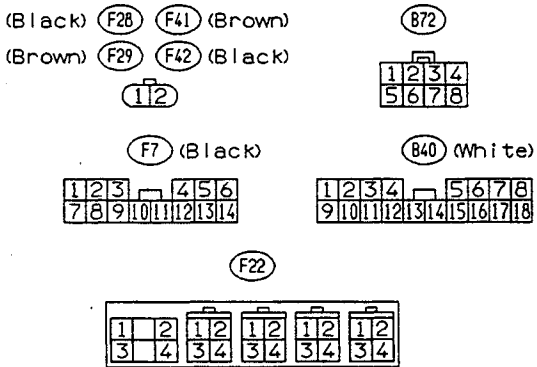
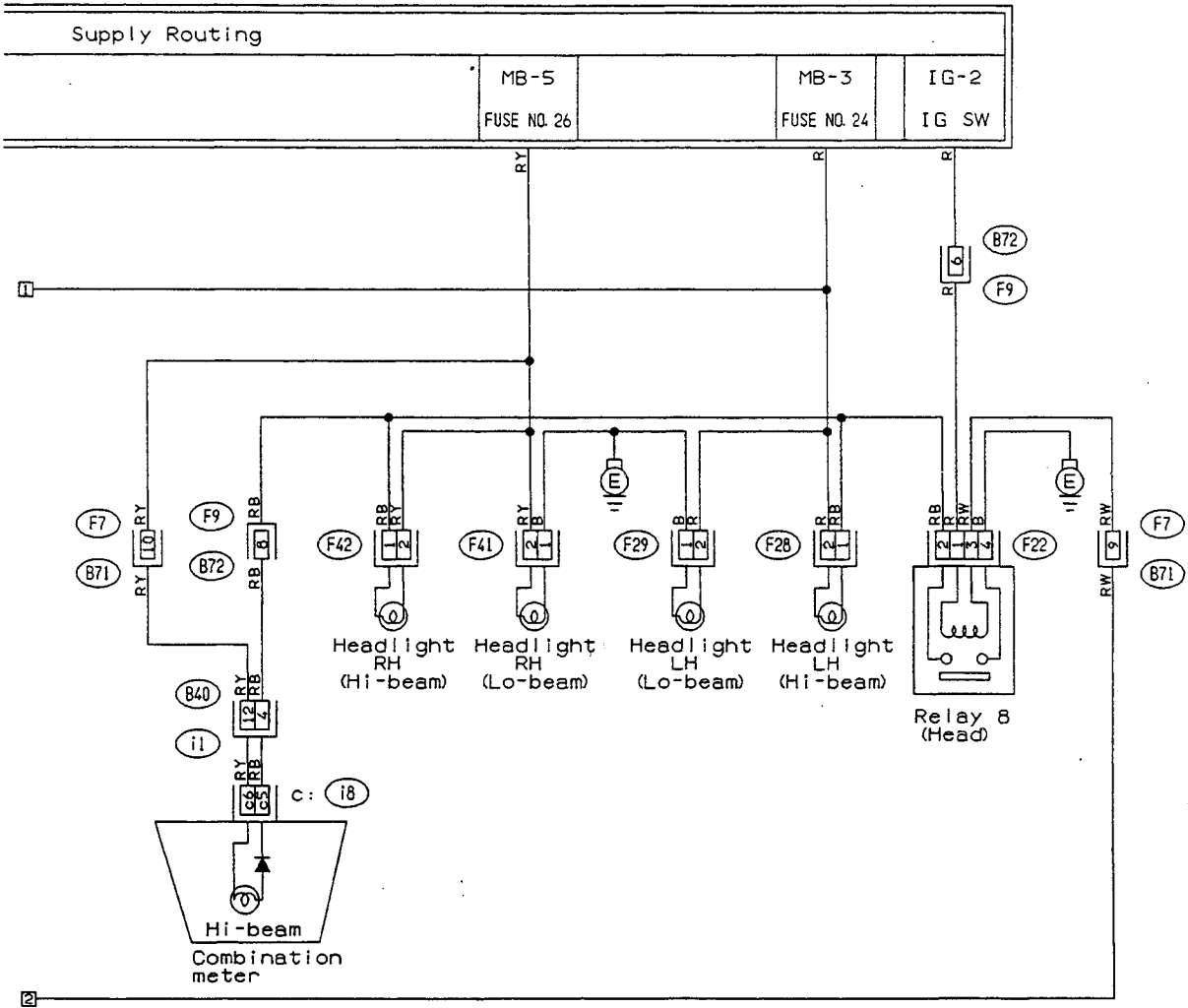

CU20-01B



19. LIGHTING (HEADLIGHT & FOG LIGHT) SYSTEM

• CANADA model

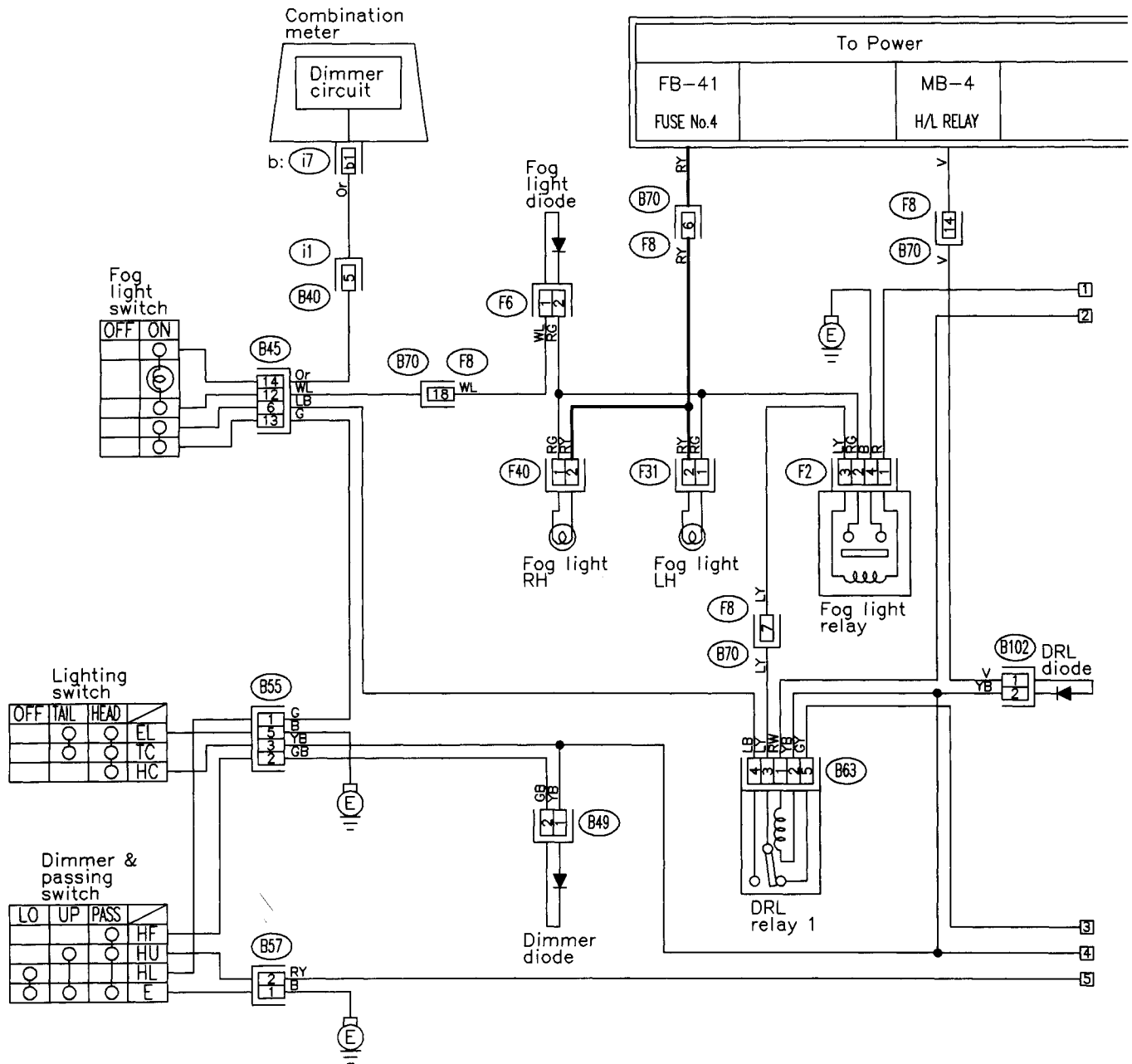

(F6) (Black)

(B49) (Black)

(B102) (Black)

(B57)

(F31) (Gray)

(F40) (Gray)

(B63) (Black)



(B55)

(B45)

(B40)

(F8)

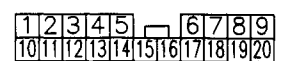
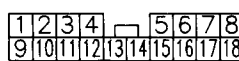
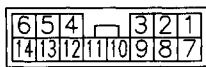
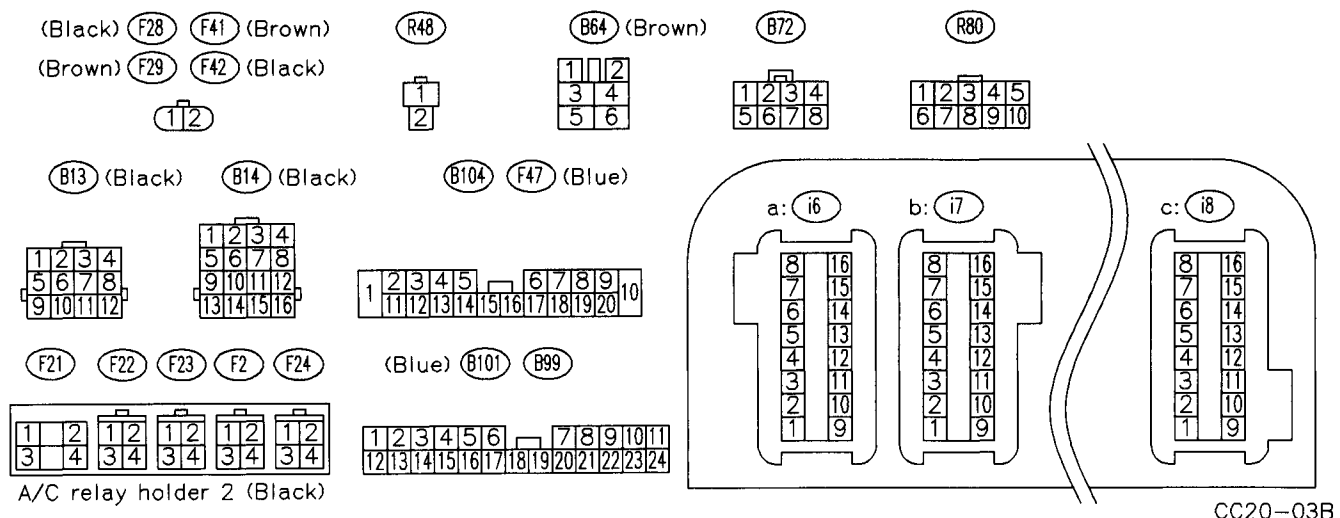
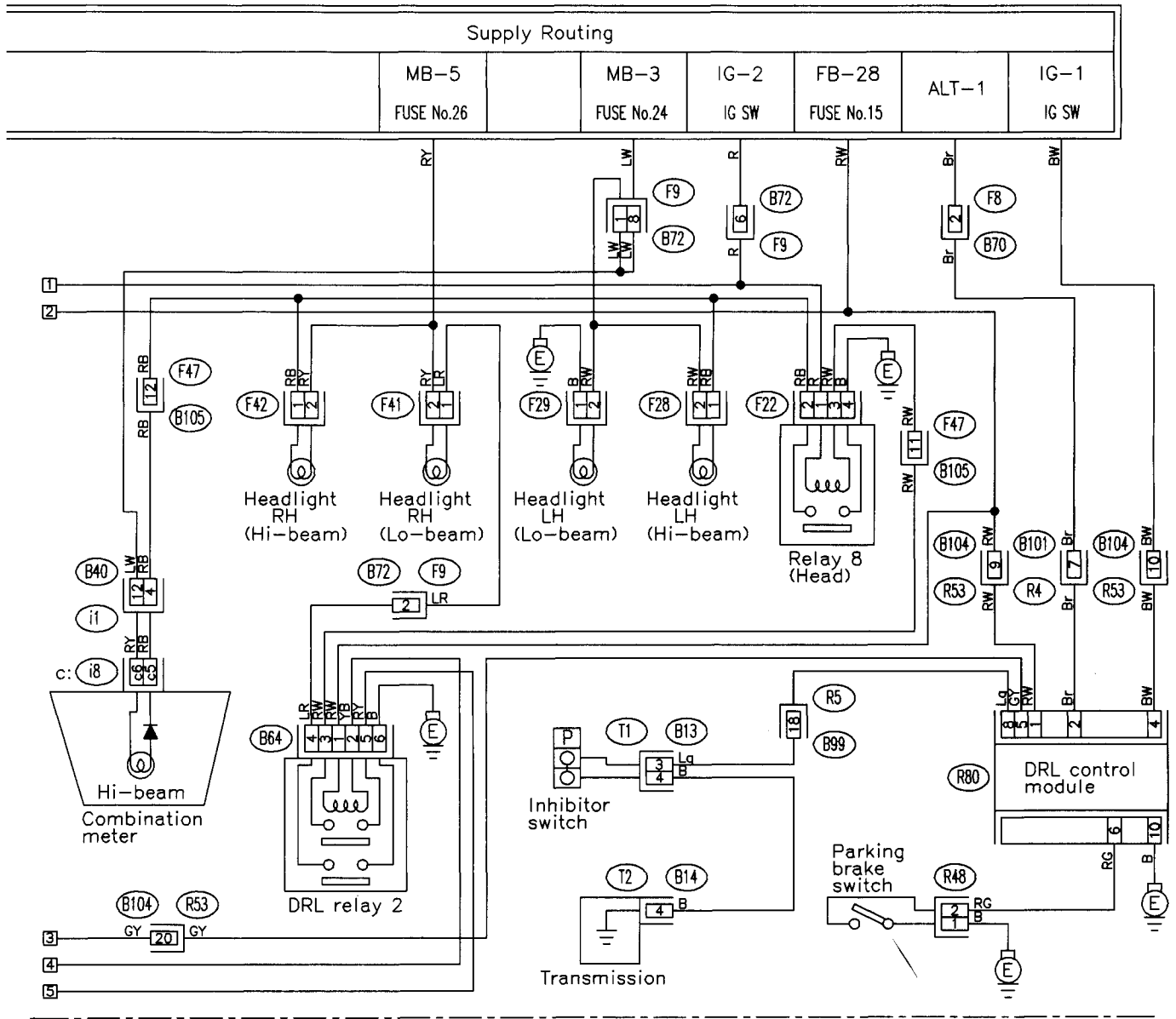
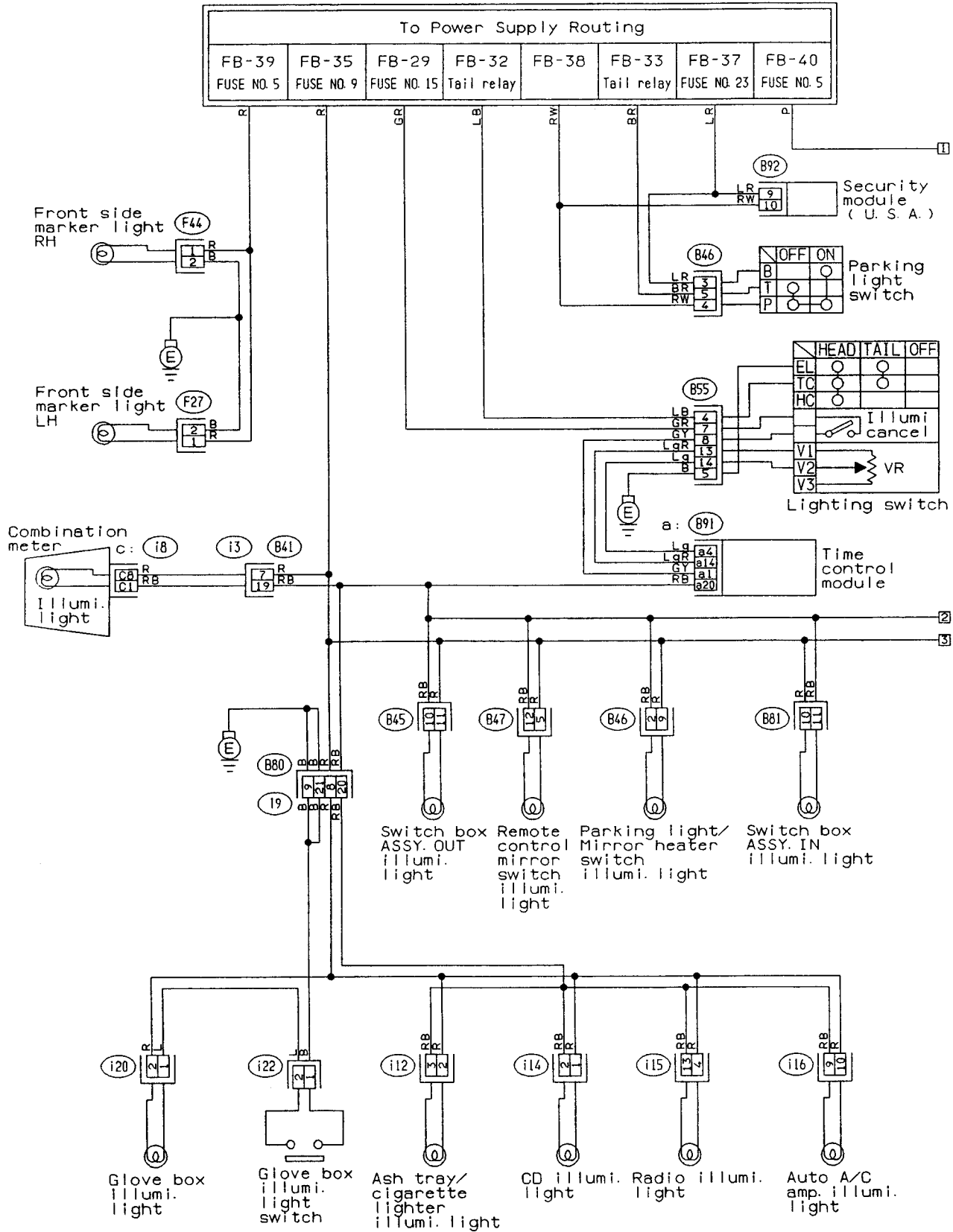

Fig. 8



20. LIGHTING (TAIL LIGHT-ILLUMINATION LIGHT-etc.) SYSTEM



CU21-02A

Fig. 4

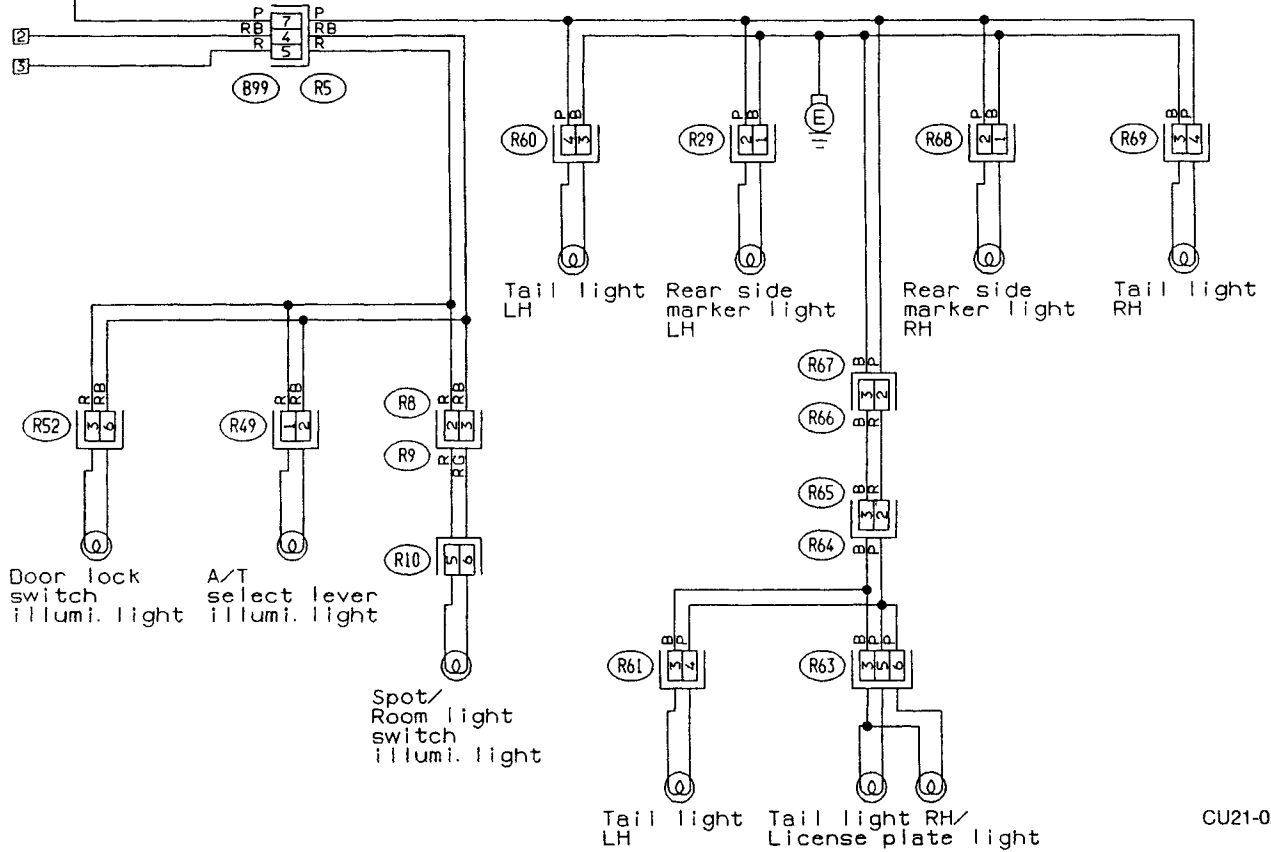
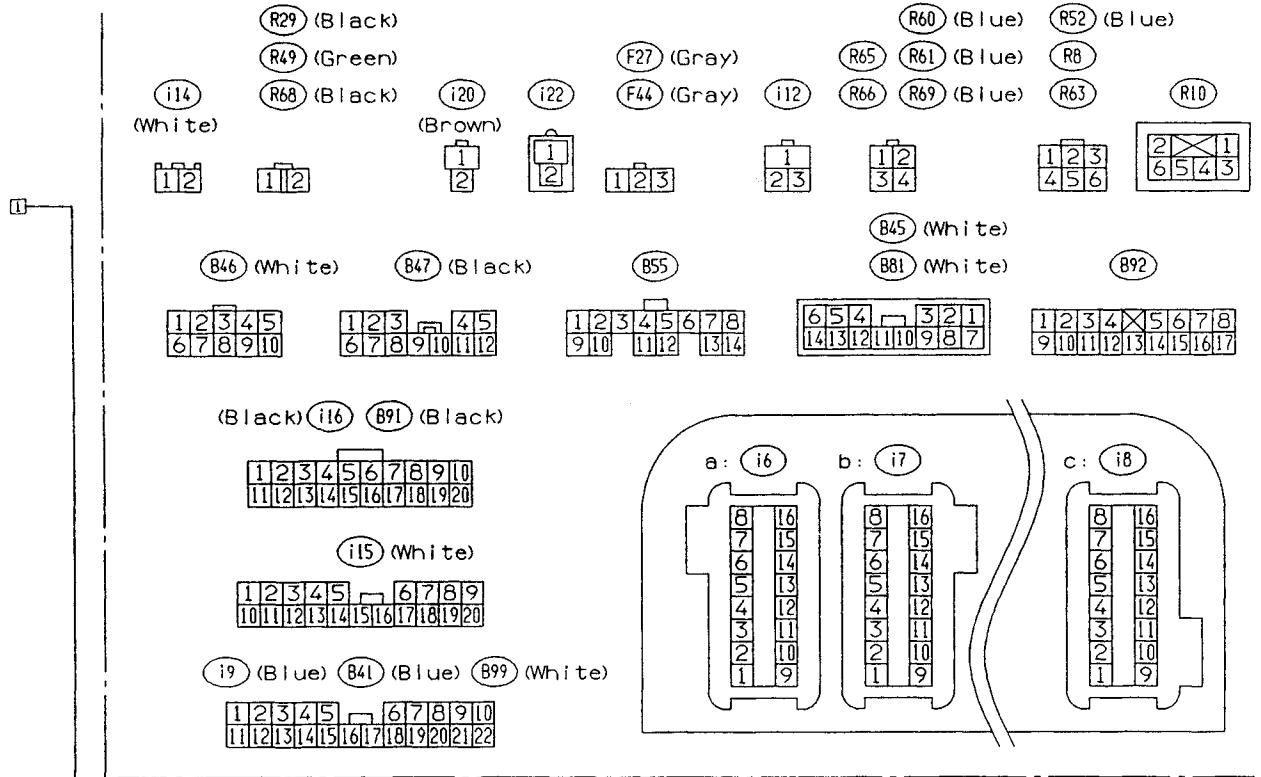

CU21-02B

21. OIL PRESSURE AND TEMPERATURE GAUGE SYSTEM

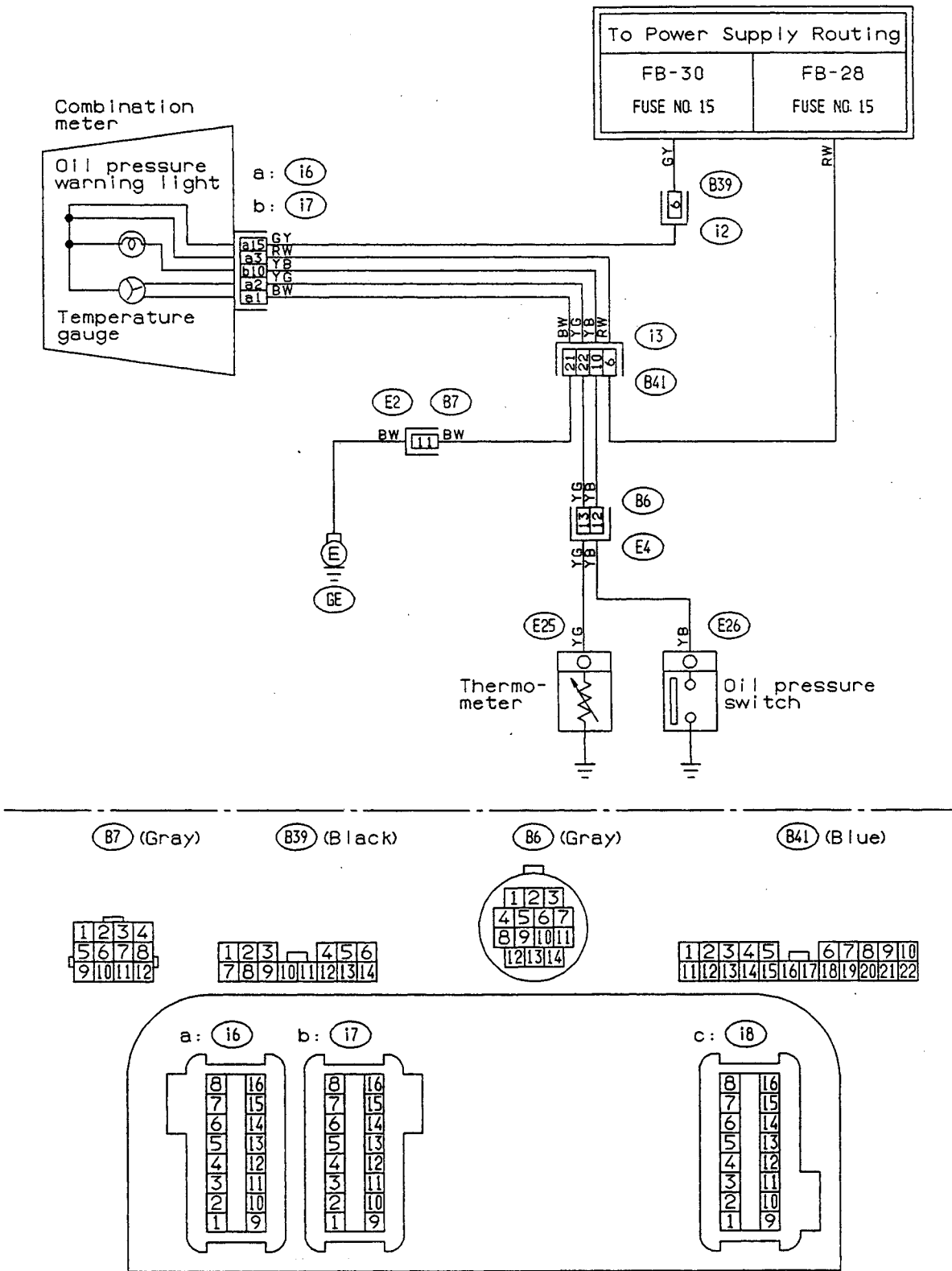

CU66-01

Fig. 45

22. PARKING BRAKE AND BRAKE FLUID LEVEL WARNING SYSTEM

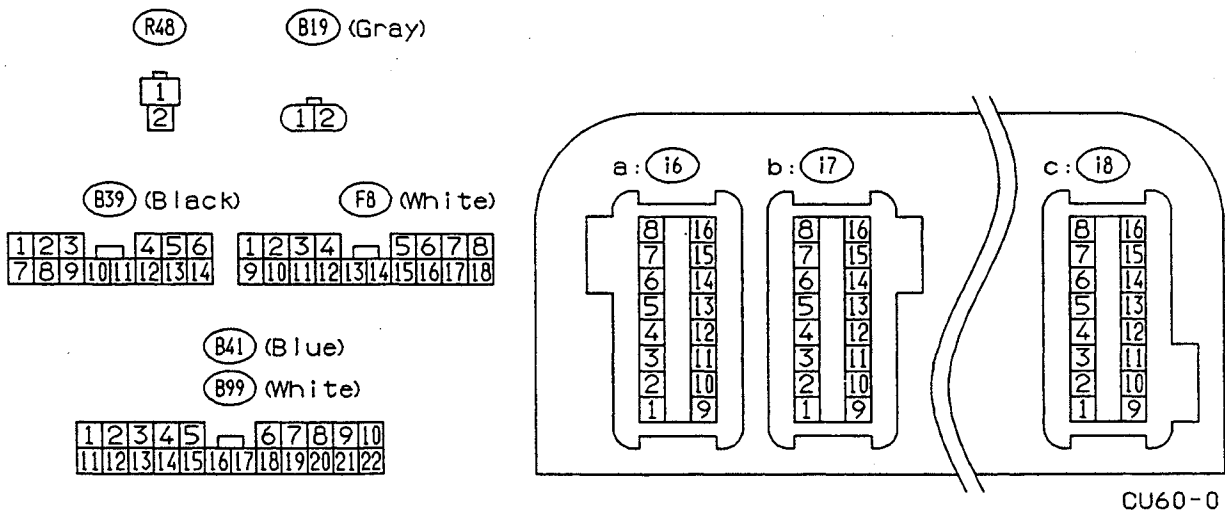
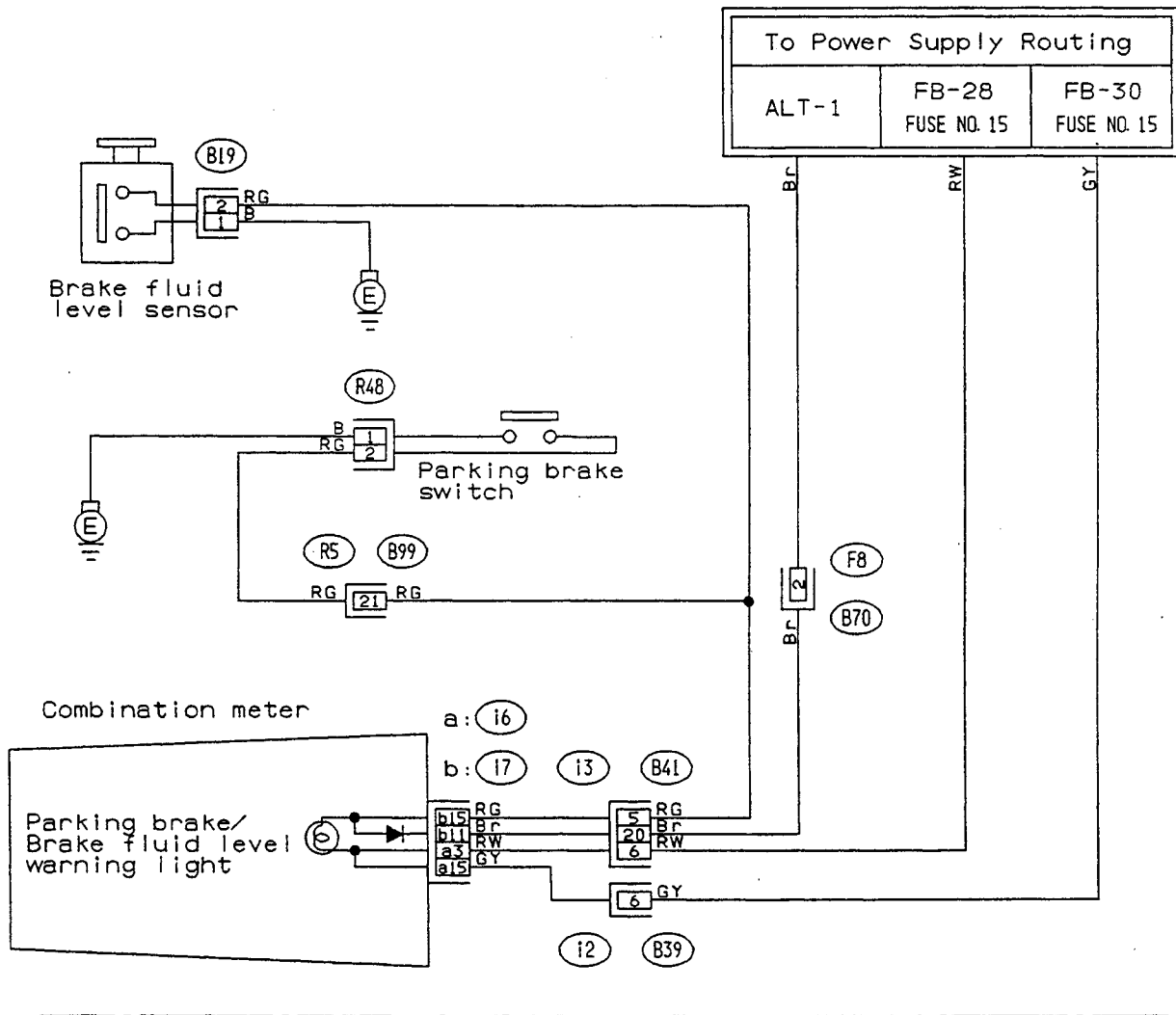

CU60-01

Fig. 46

23. POWER SEAT SYSTEM

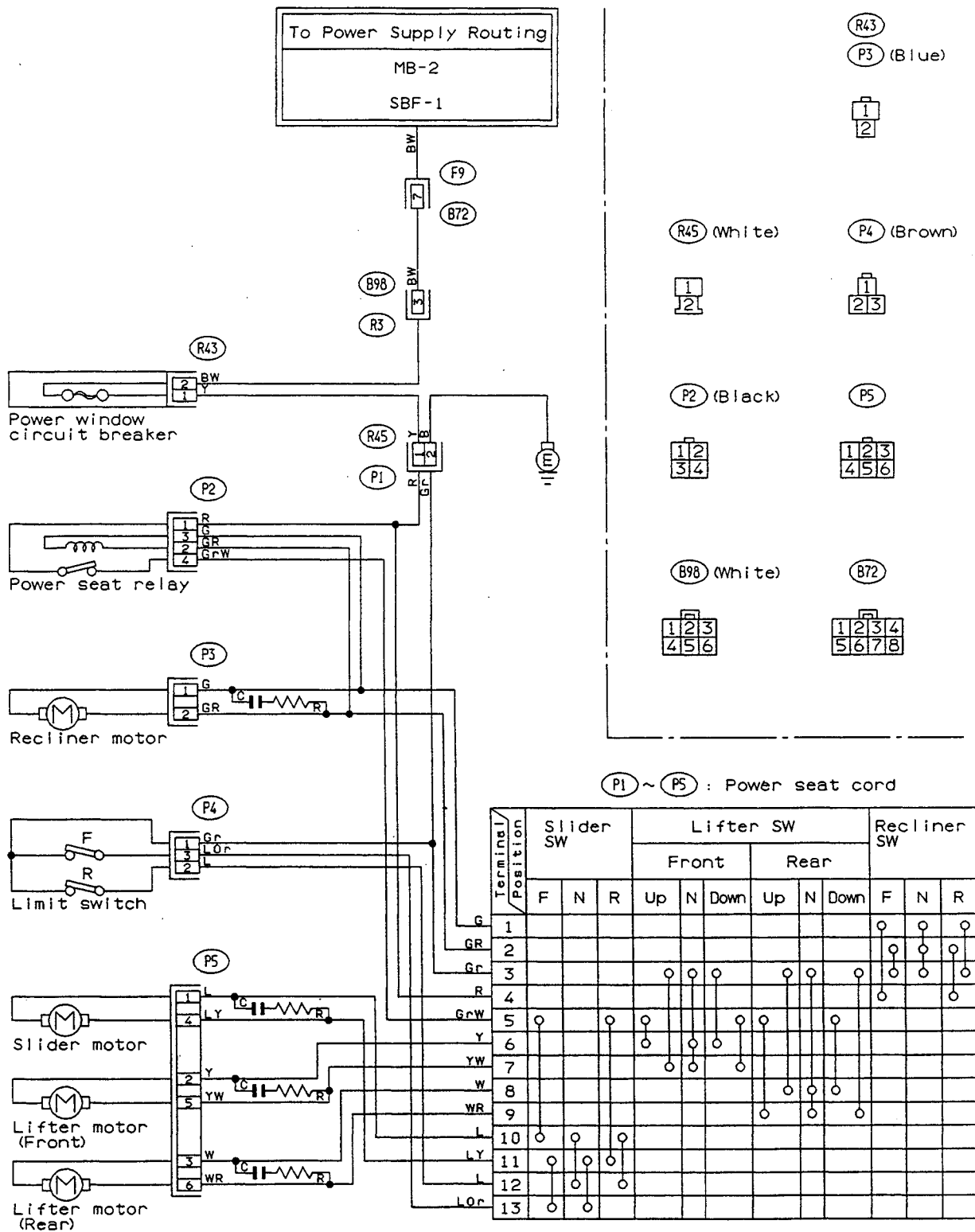

CU85-01

Fig. 47

24. POWER WINDOW SYSTEM

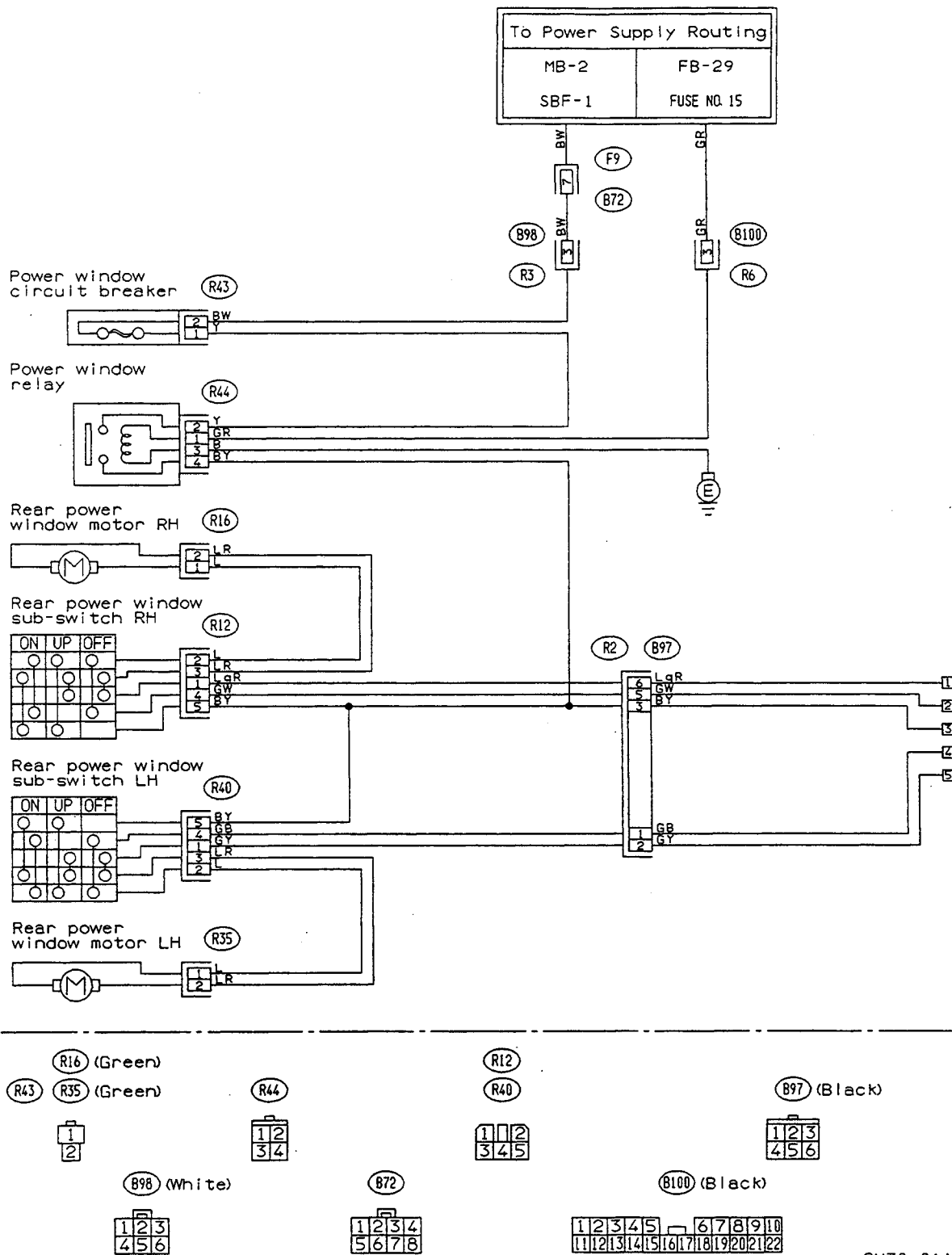

CU70-01A

Fig. 48



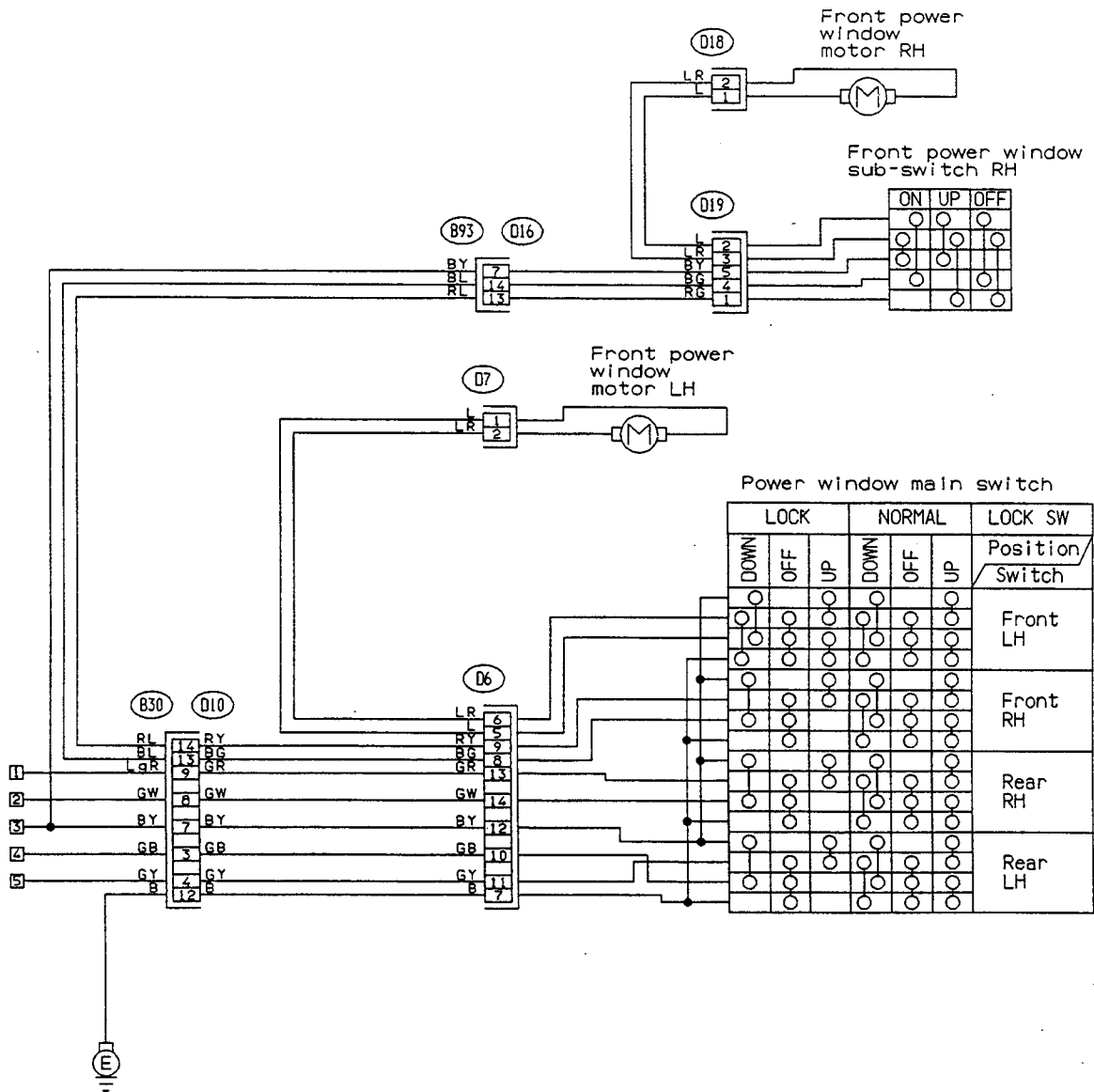

(D7) (Green)  
(D18) (Green)

(D19)

(D10)  
(D16)

(D6)

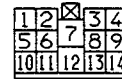
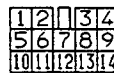

CU70-018

25. RADIATOR FAN & AIR CONDITIONER SYSTEM

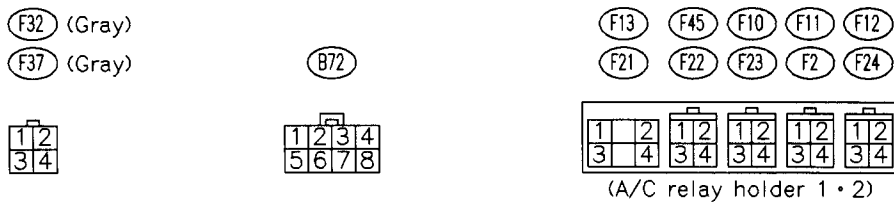
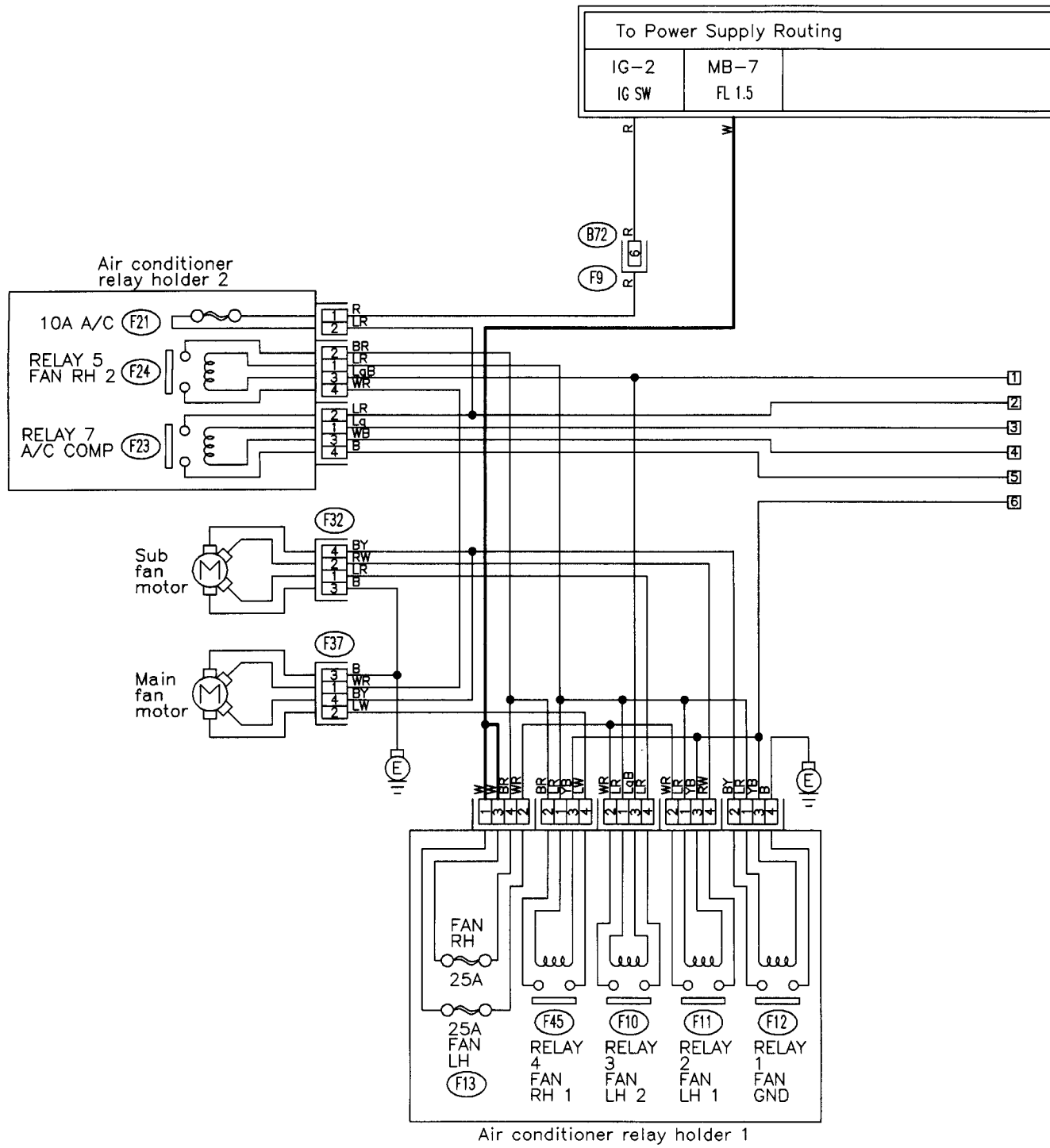
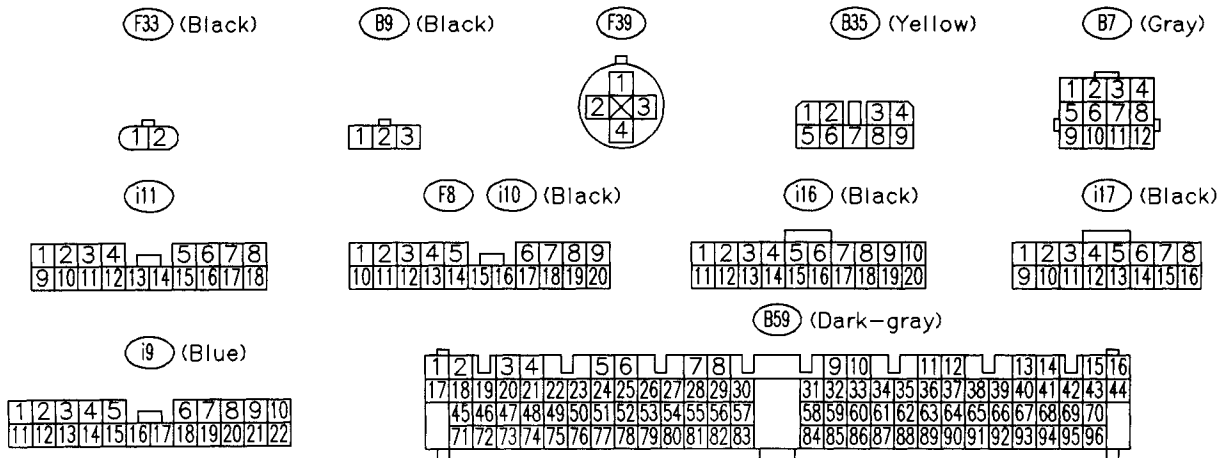
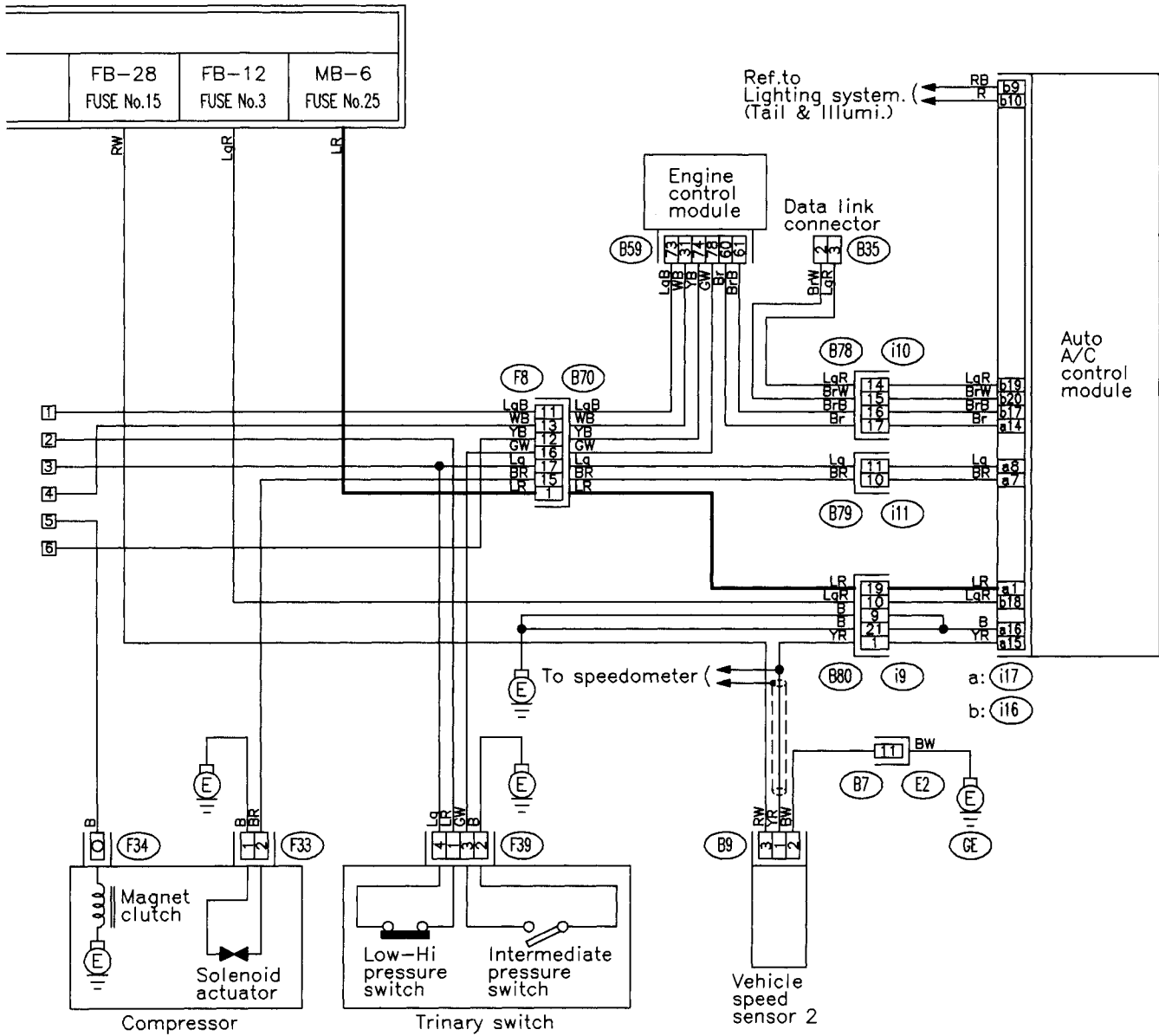
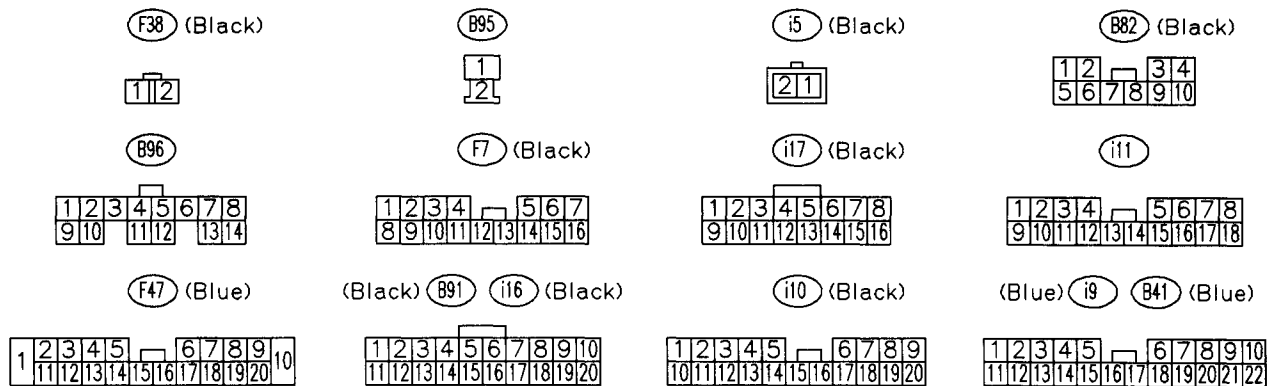
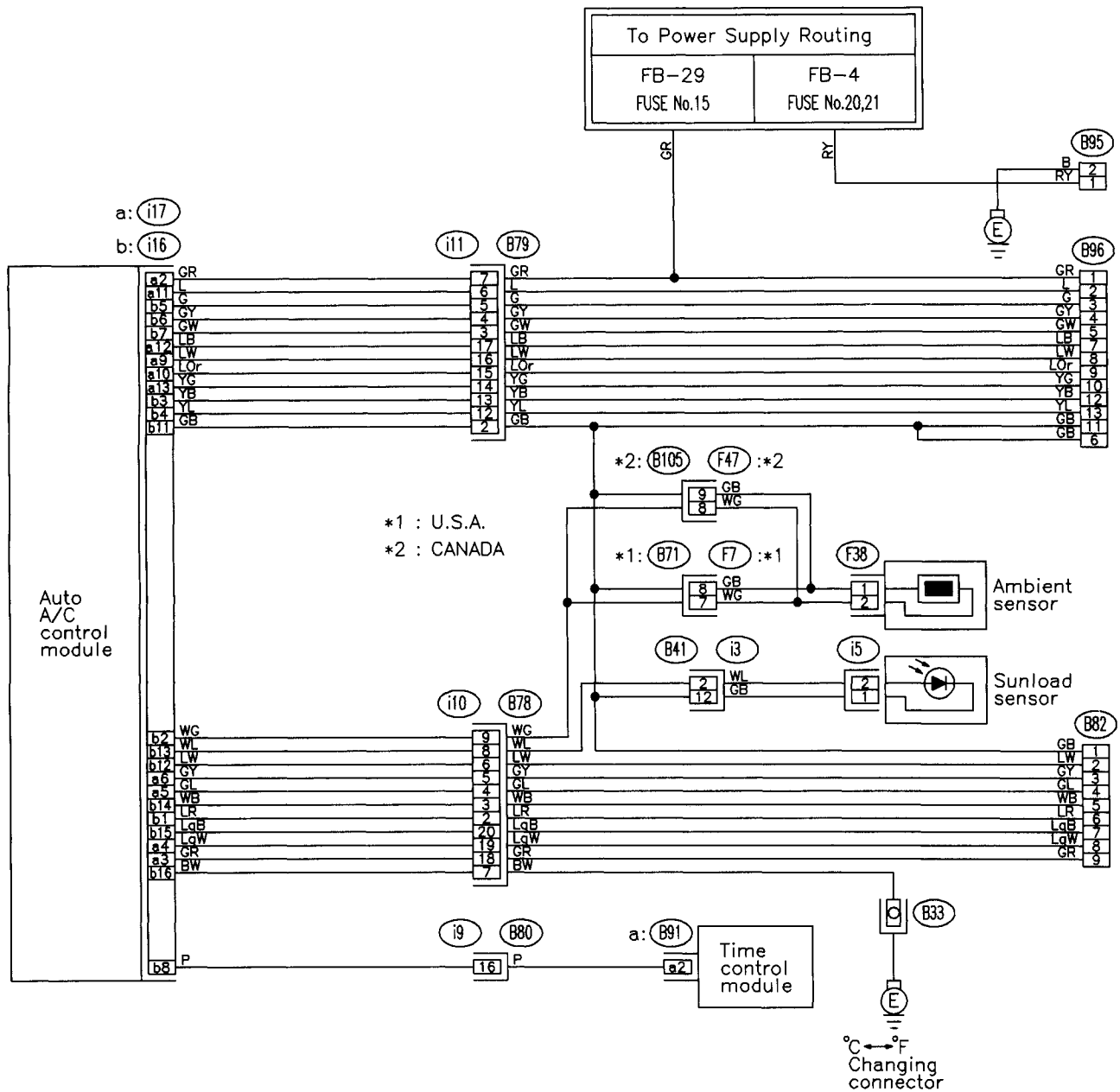
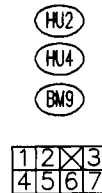
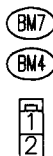
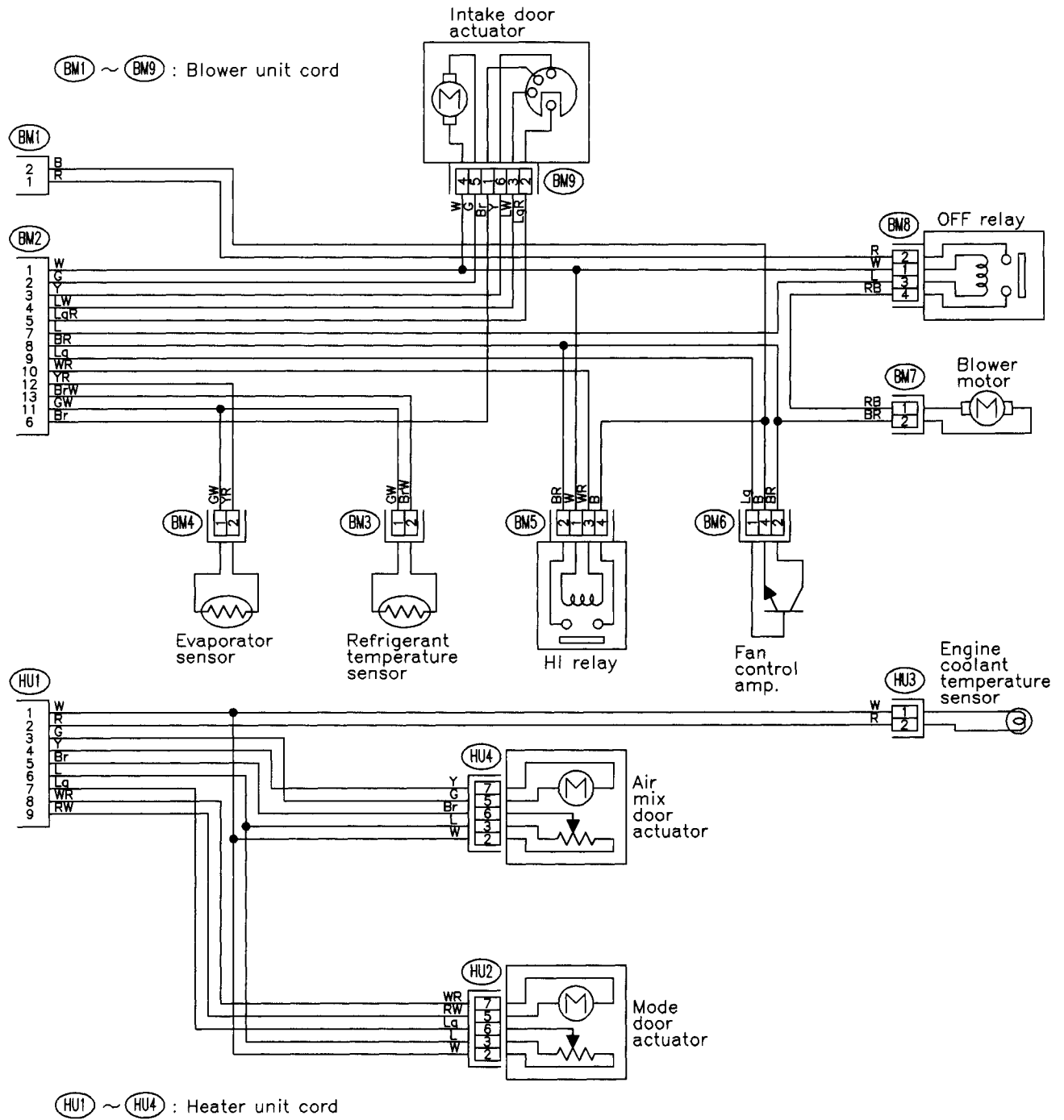

Fig. 9







26. REAR WINDOW DEFOGGER SYSTEM

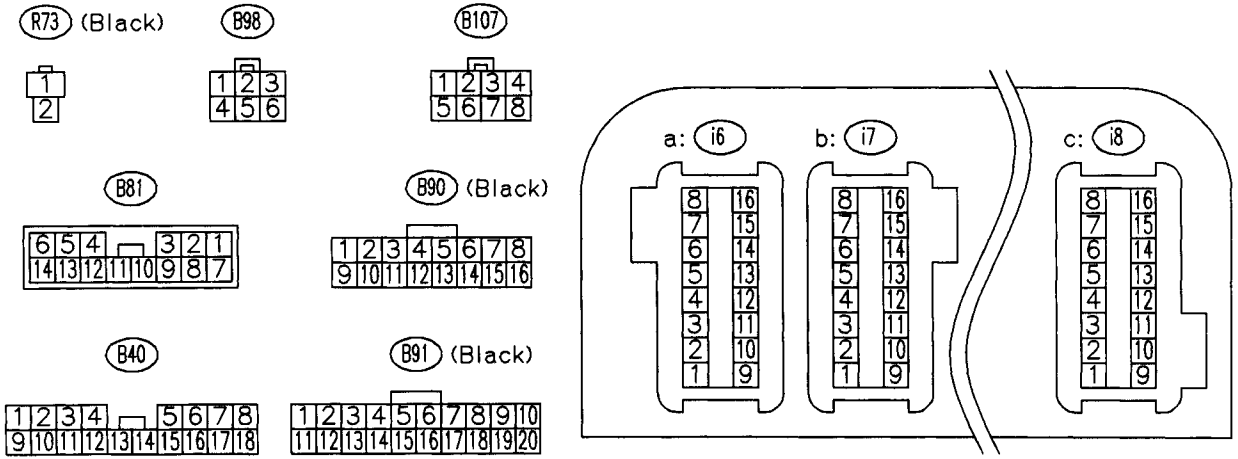
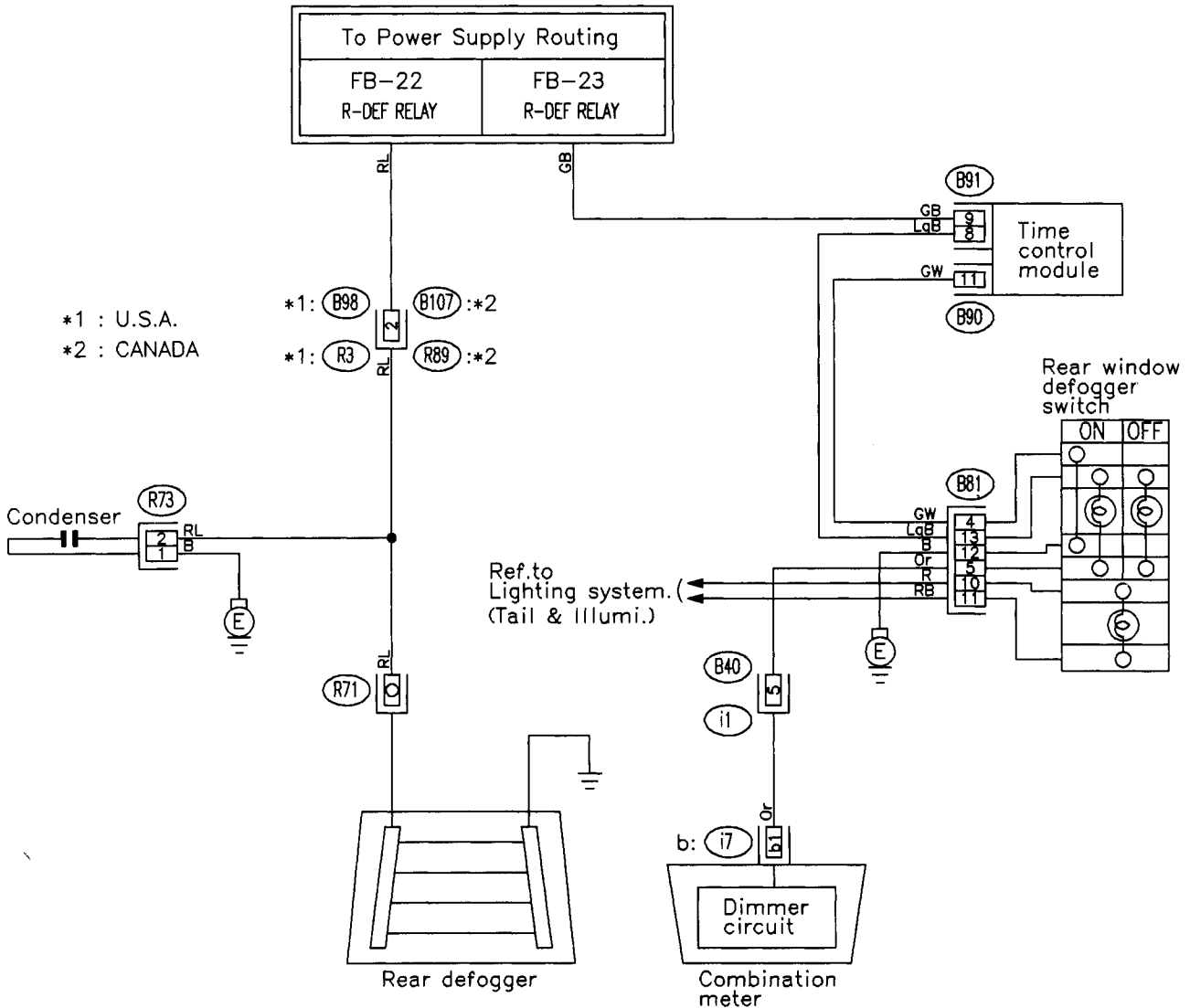

CU52-03

Fig. 10

27. REAR WIPER AND WASHER SYSTEM

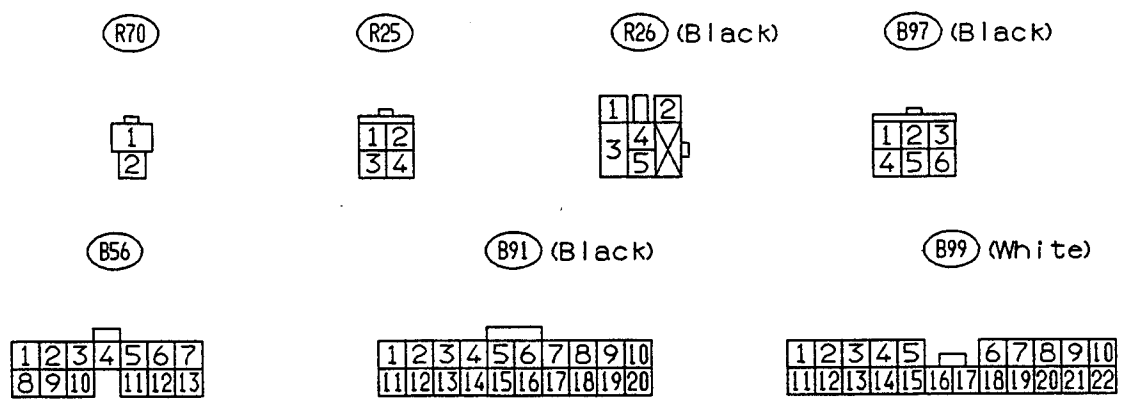
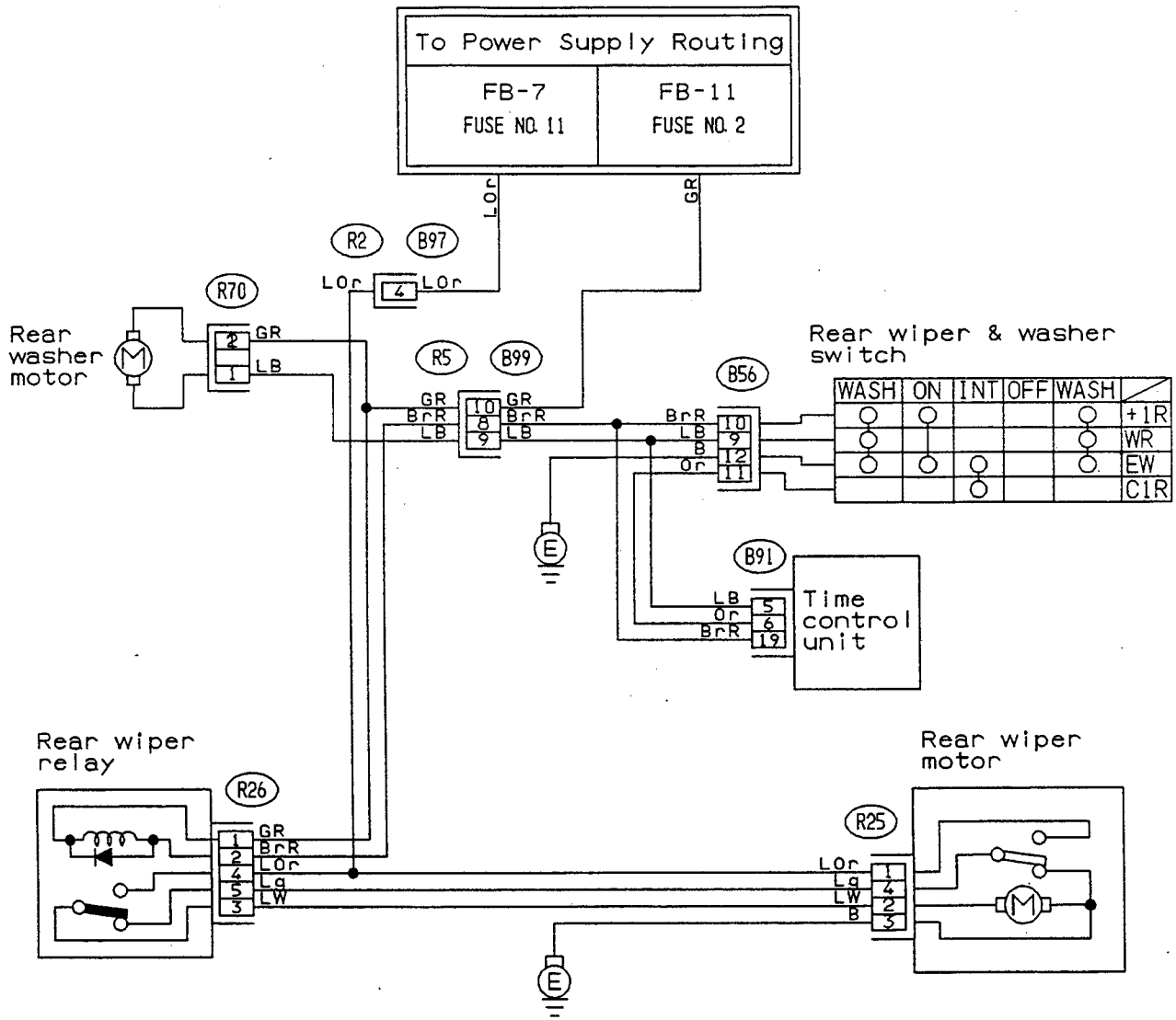

CU51-01

Fig. 51

28. REMOTE CONTROL REARVIEW MIRROR SYSTEM

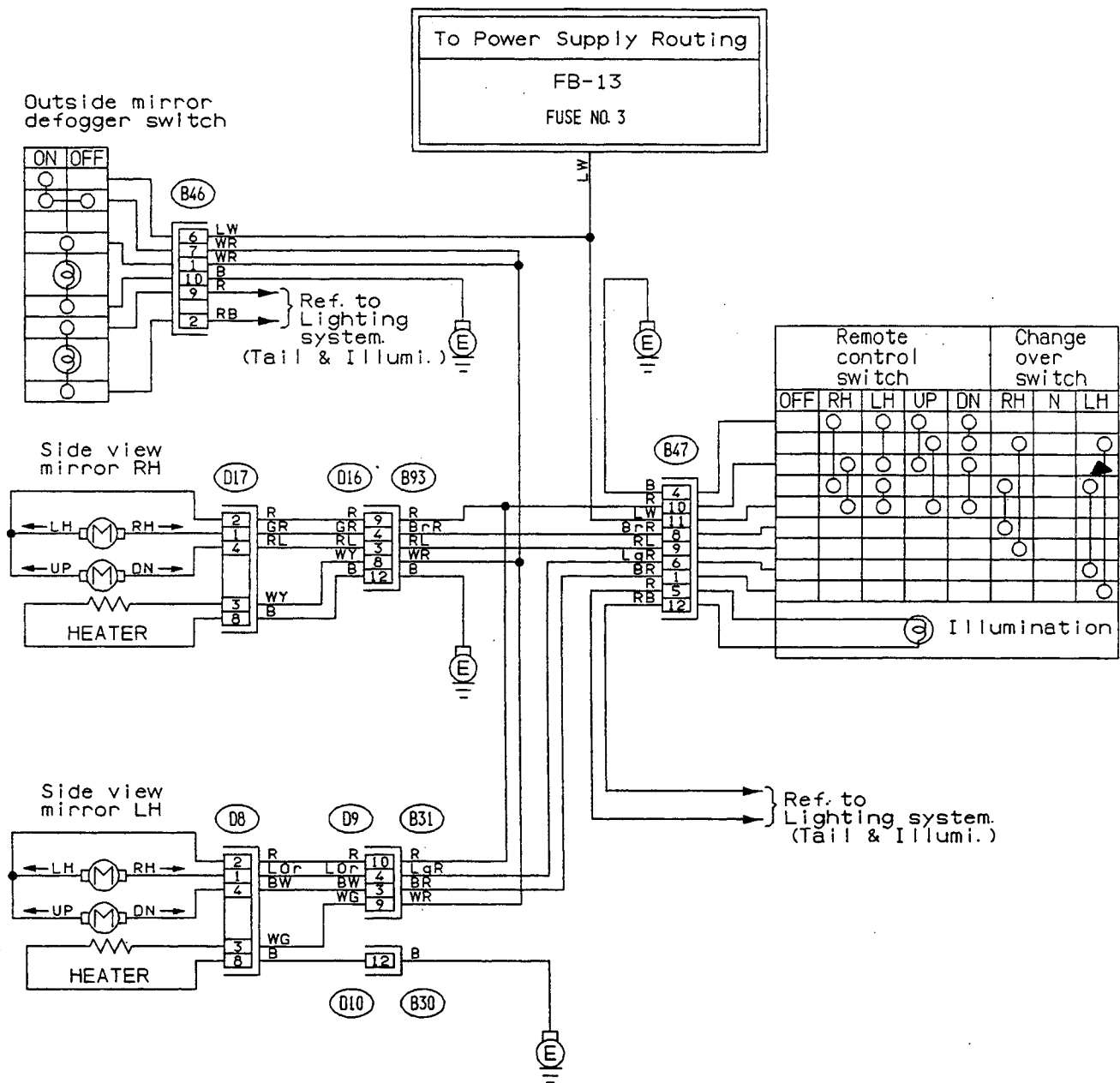

- (B46) (White)
- (B47) (Black)
- (D17) (White)
- (D8) (White)
- (D9)
- (D16)
- (D10)

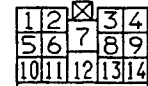
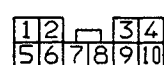
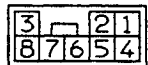
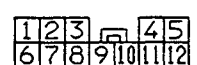
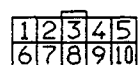

CU79-01

Fig. 52



29. SECURITY SYSTEM (LE grade)

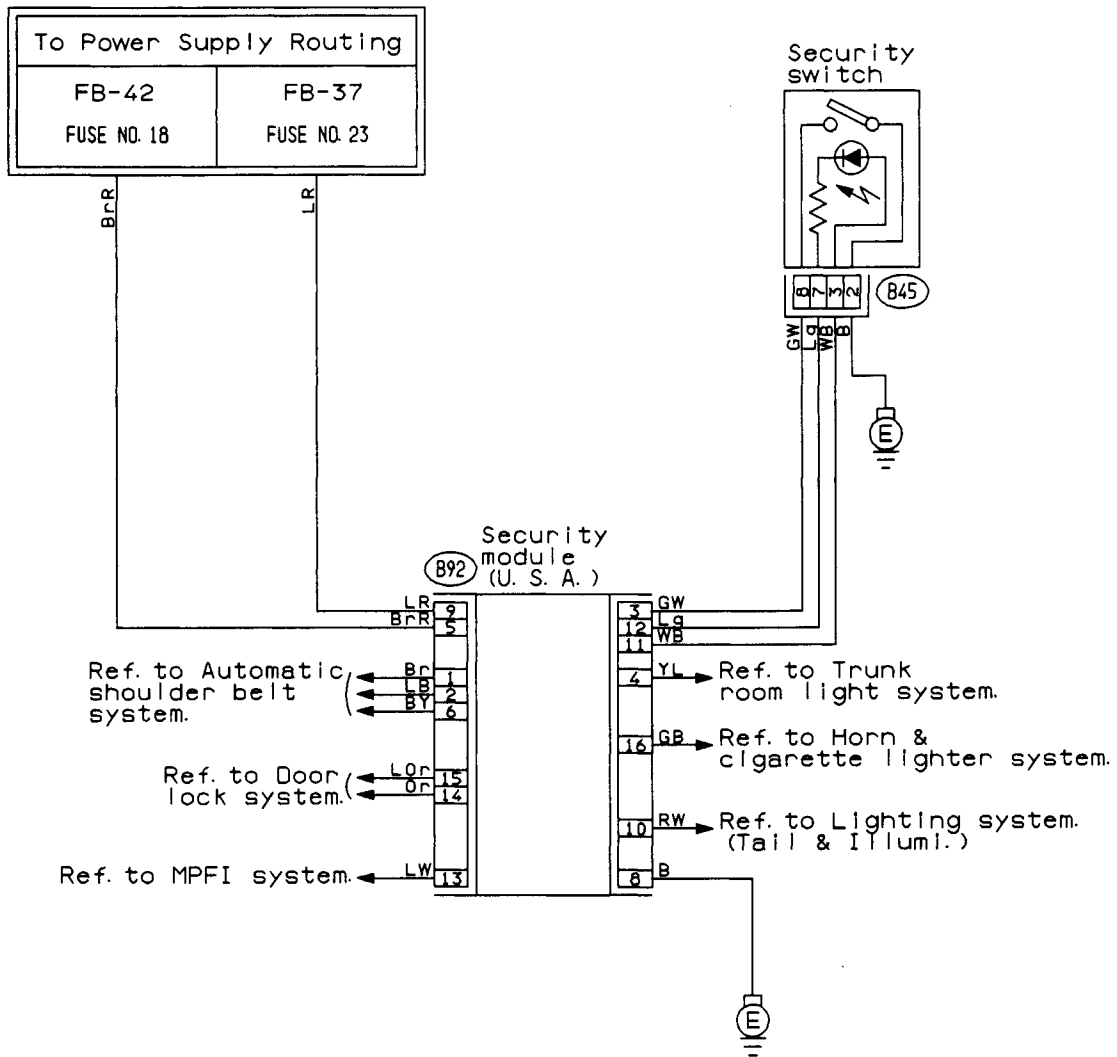

(B45) (White)

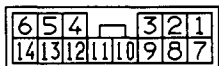

(B92)

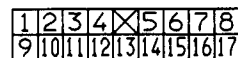
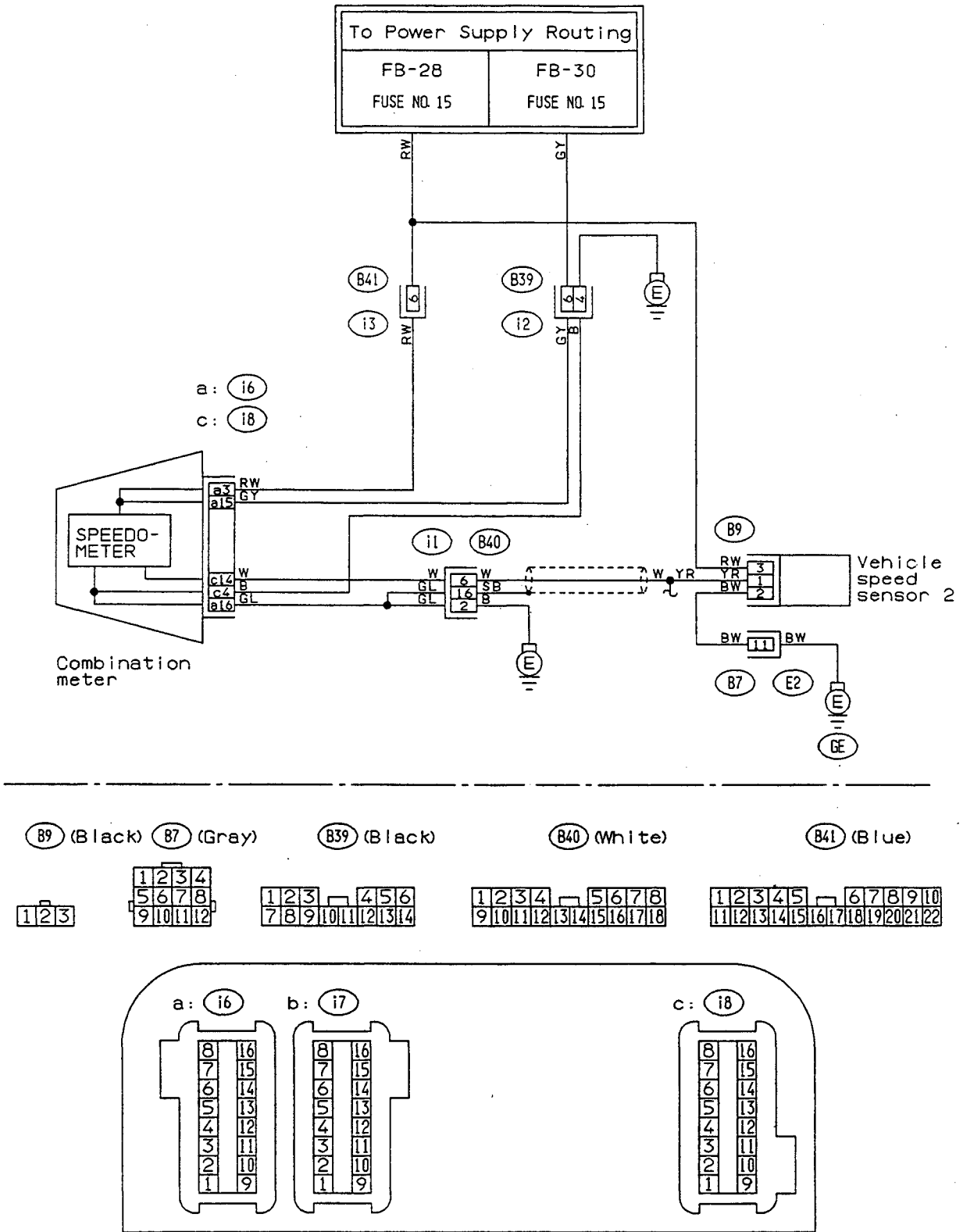

Fig. 53

CU77-04

30. SPEEDOMETER SYSTEM



CU68-01

Fig. 54

31. SPOT LIGHT, ROOM LIGHT & VANITY MIRROR LIGHT SYSTEM

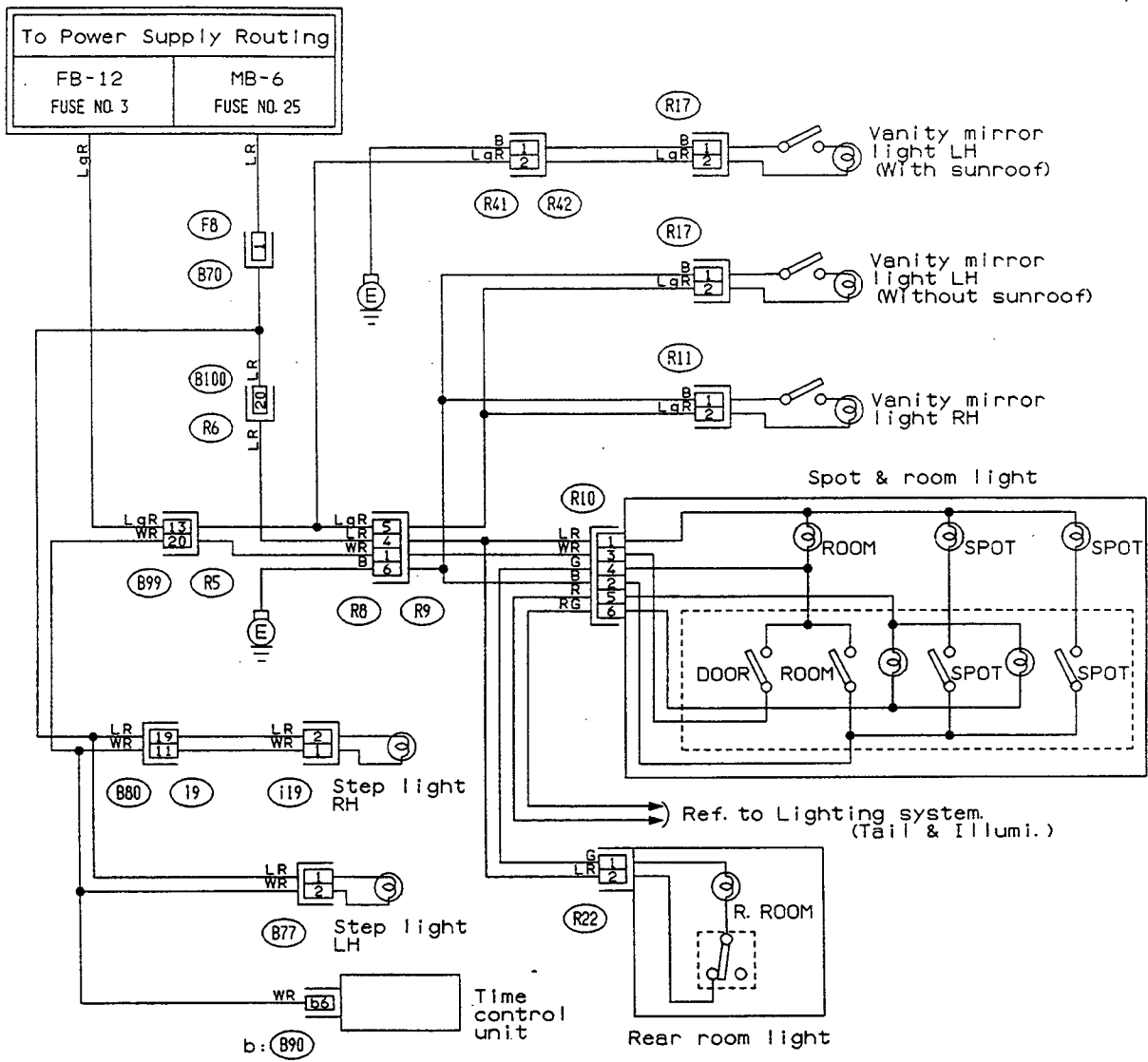

- (R11) (White)
- (R17) (White)
- (R22)
- (i19) (White)
- (B77) (White)
- (R41)
- (R8)
- (112)
- (112)
- (112)
- (211)
- (23)
- (123456)
- (R10)
- (B90) (Black)
- (F8) (White)
- (19) (Blue)
- (B99) (White)
- (B100) (Black)
- (211)
- (12345678910111213141516)
- (123456789101112131415161718)
- (12345678910111213141516171819202122)

CU24-01

Fig. 55

32. SRS (AIRBAG SYSTEM-LE grade)

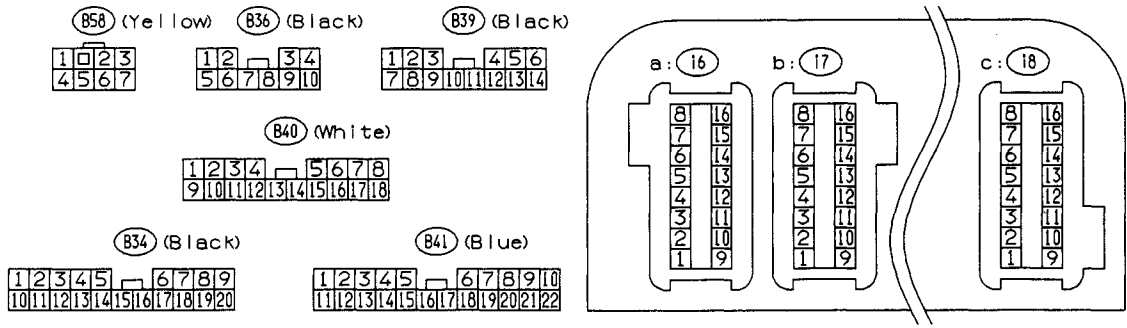
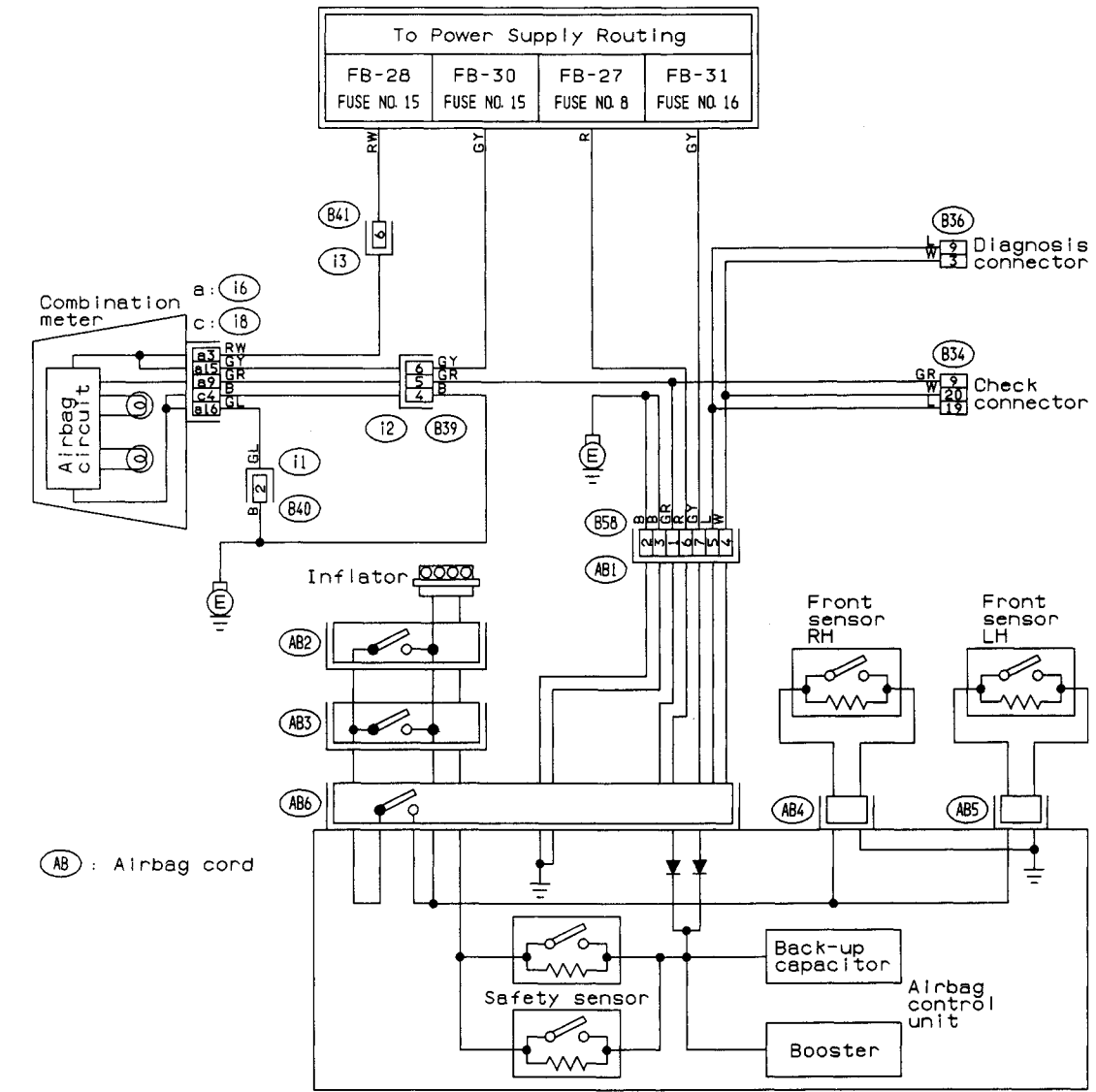
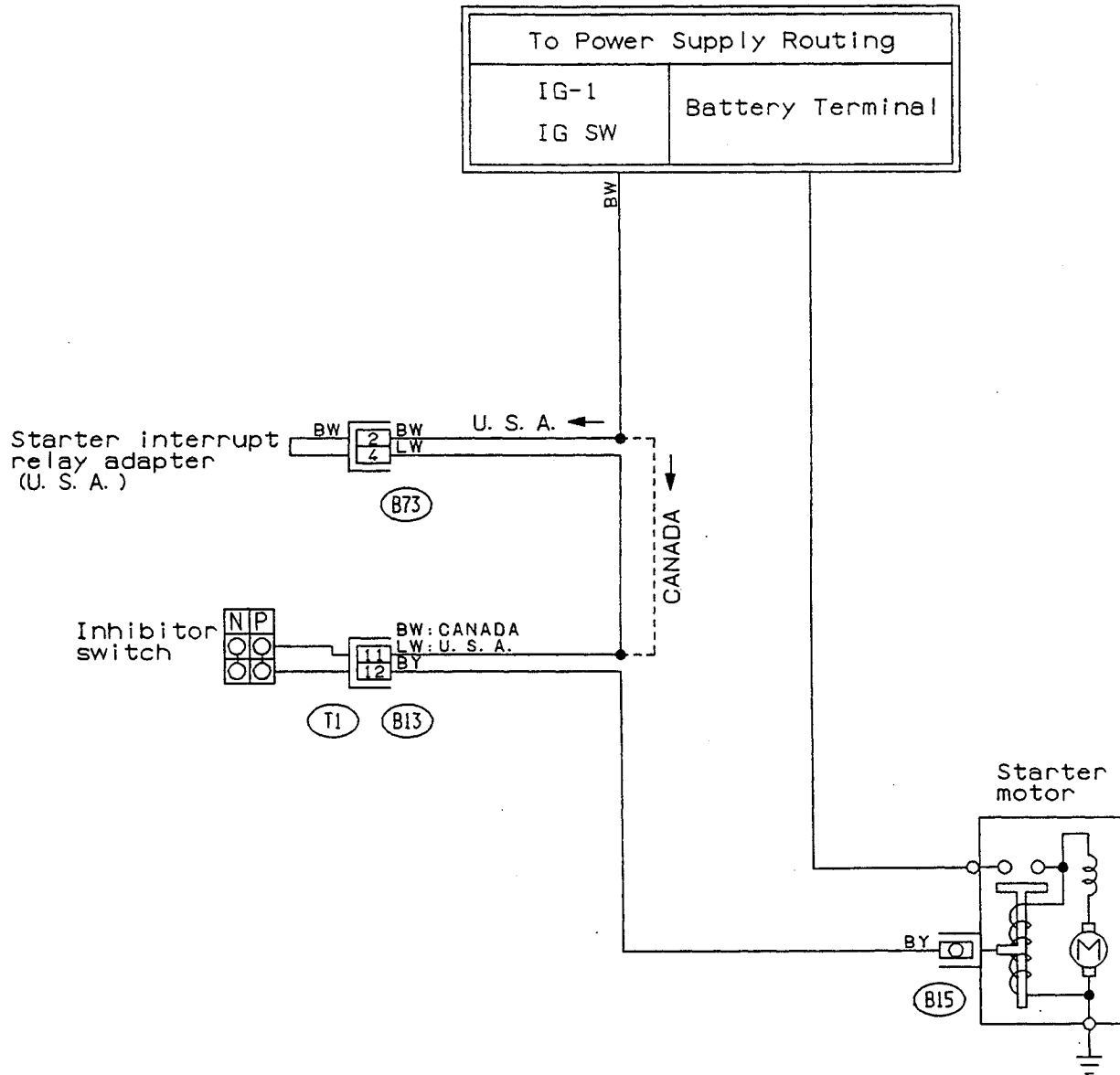

Fig. 56

CU80-03'

33. STARTING SYSTEM



(B73)



(B13) (Black)

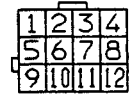

CU03-01

Fig. 57

34. STOP LIGHT SYSTEM

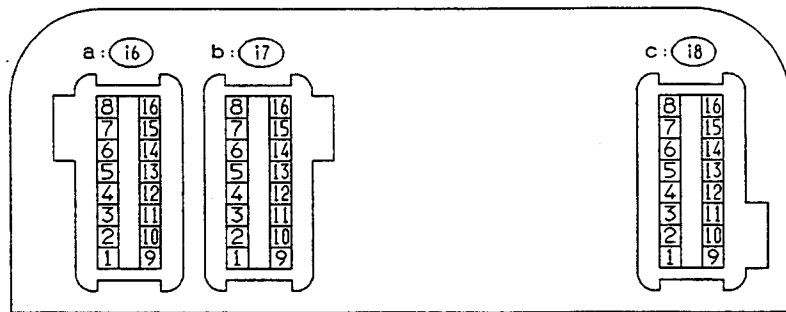
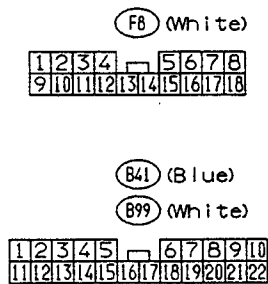
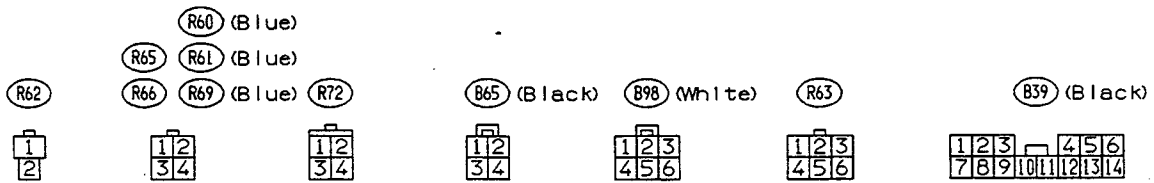
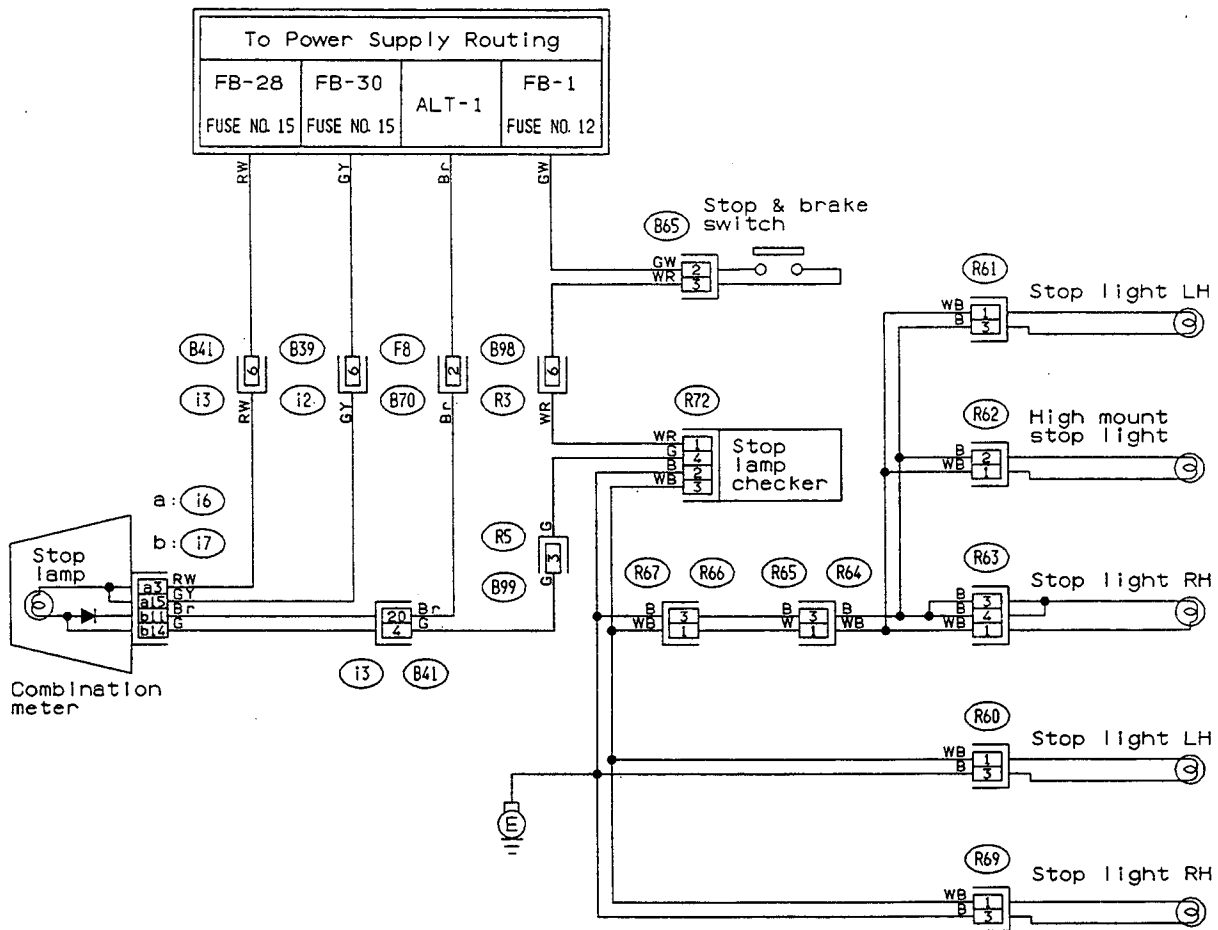

CU25-01

Fig. 58

35. SUNROOF SYSTEM

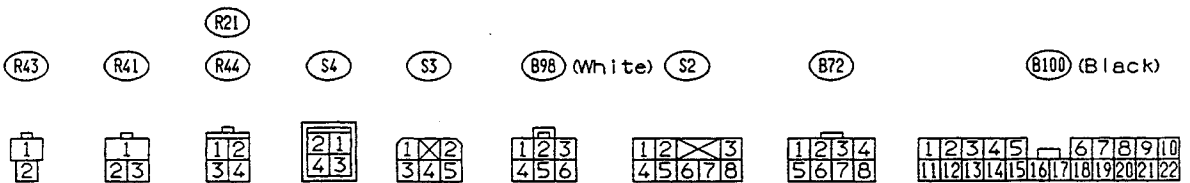
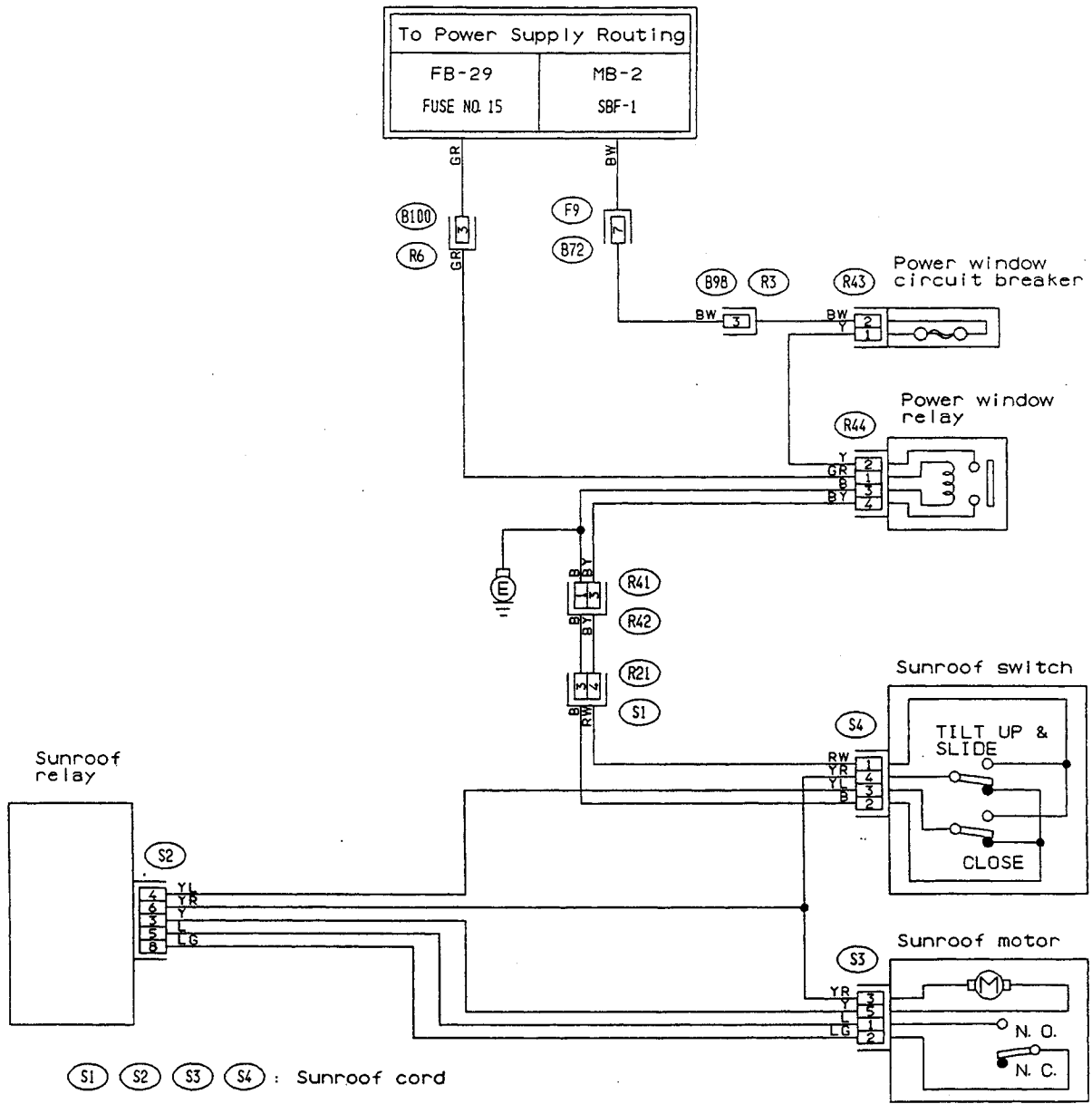

CU75-01

Fig. 59

36. TIME CONTROL SYSTEM

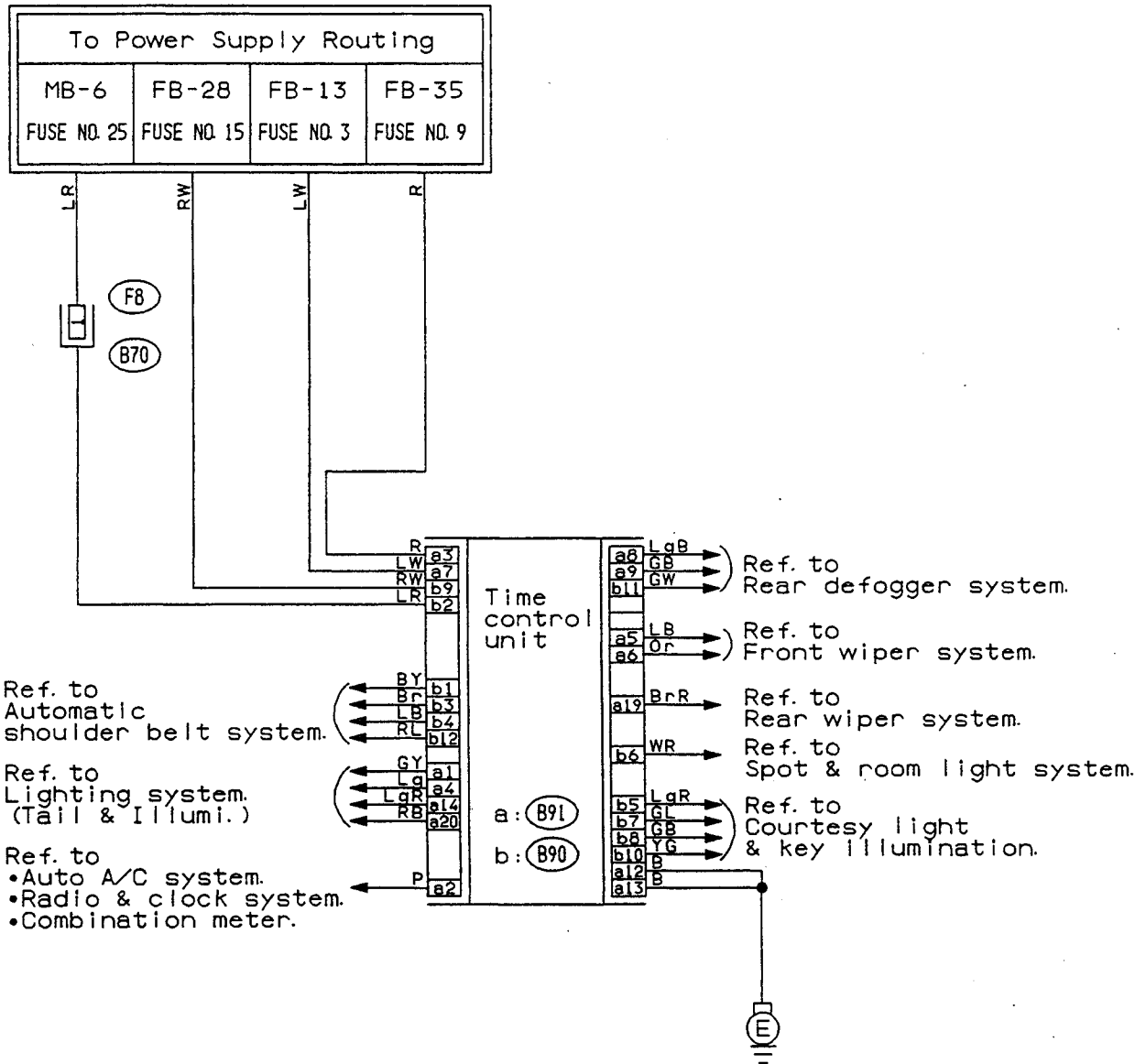

(B90) (Black)

(F8) (White)

(B91) (Black)

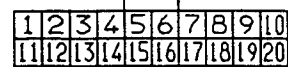
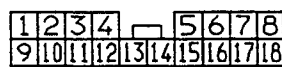
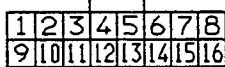

CU78-01

Fig. 60



37. TRUNK ROOM LIGHT SYSTEM

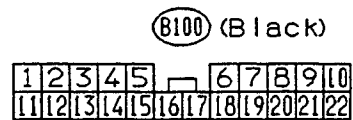
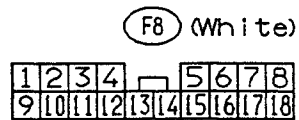
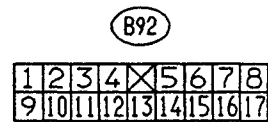
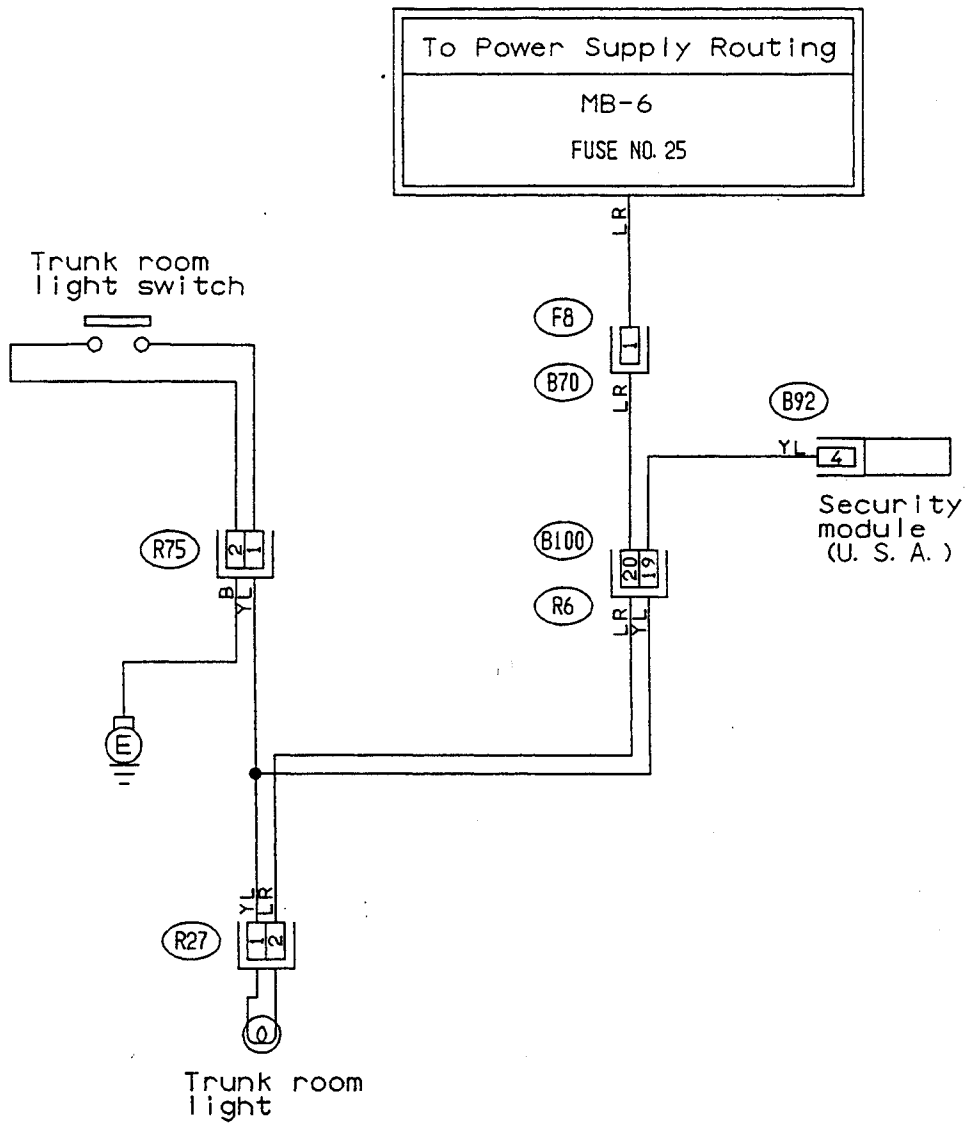

CU28-01

Fig. 61

38. TURN SIGNAL AND HAZARD SYSTEM

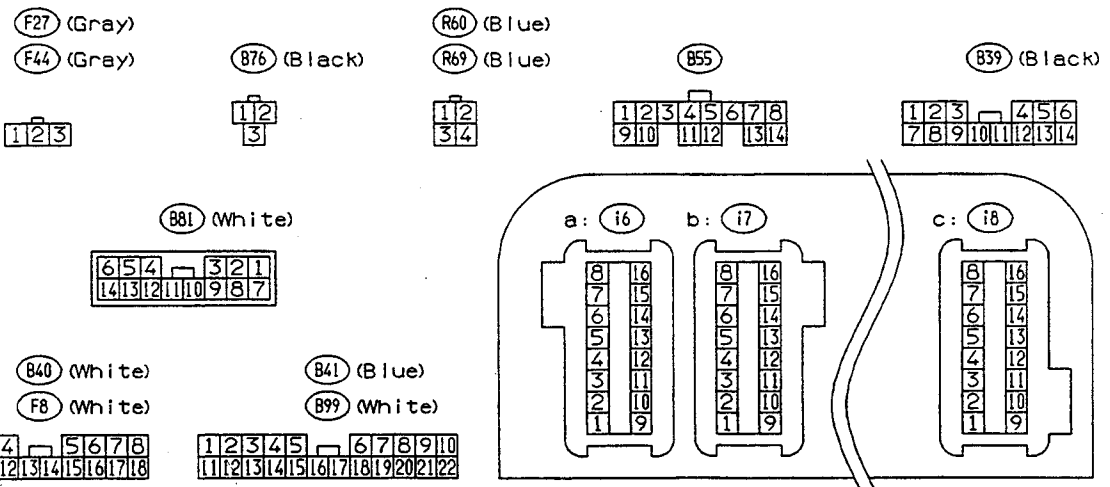
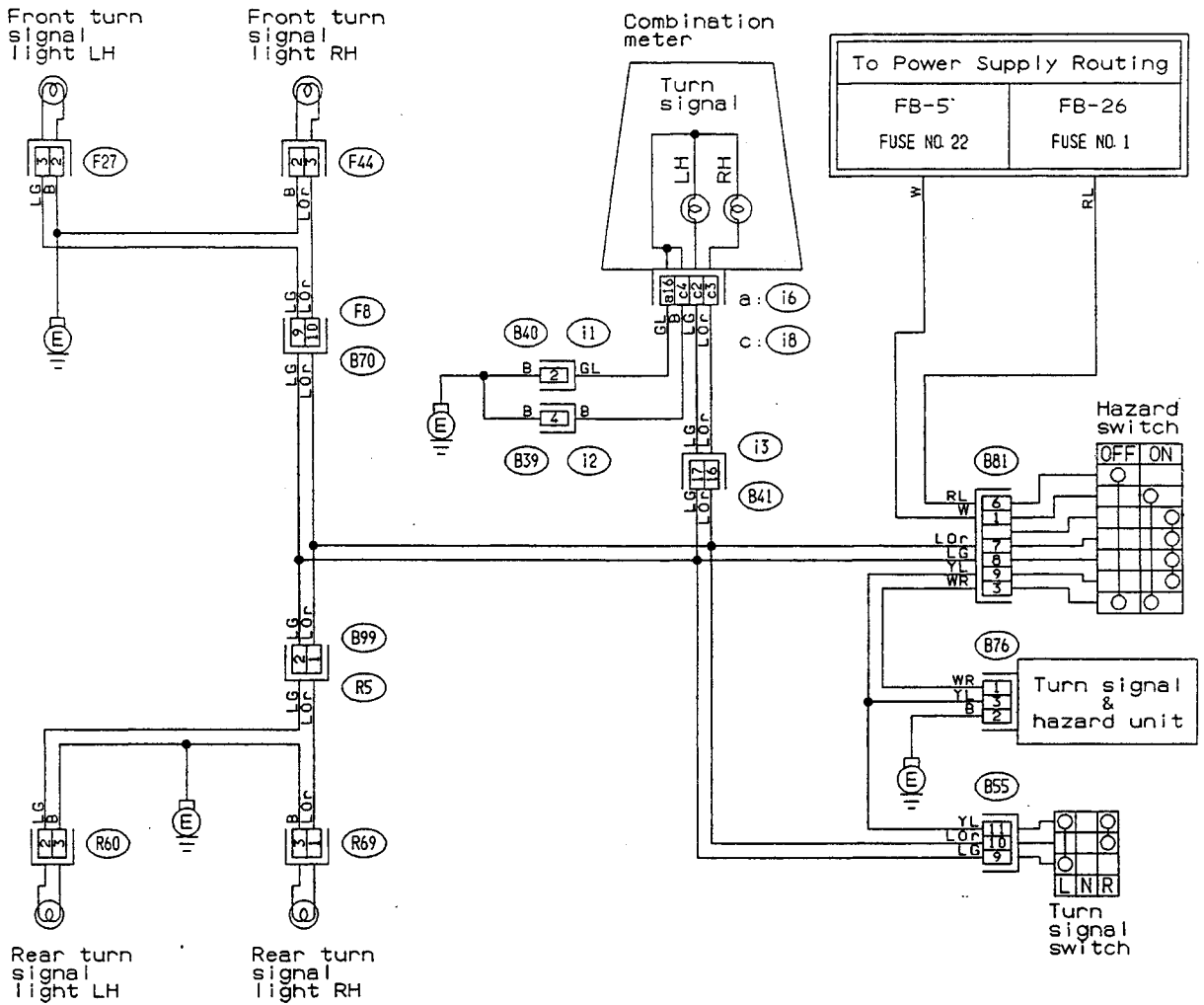

CU26-01

Fig. 62

40. SEAT HEATER SYSTEM

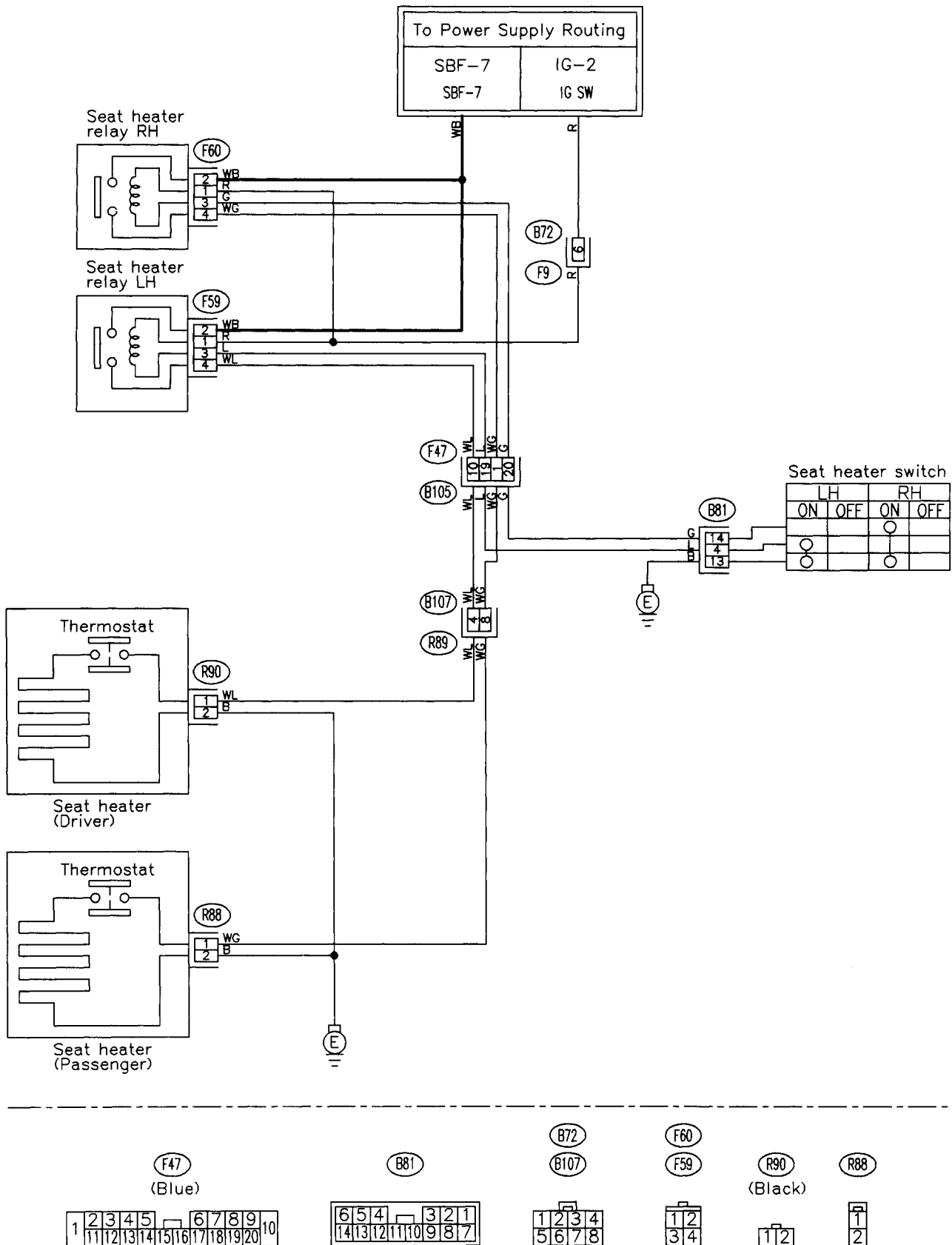
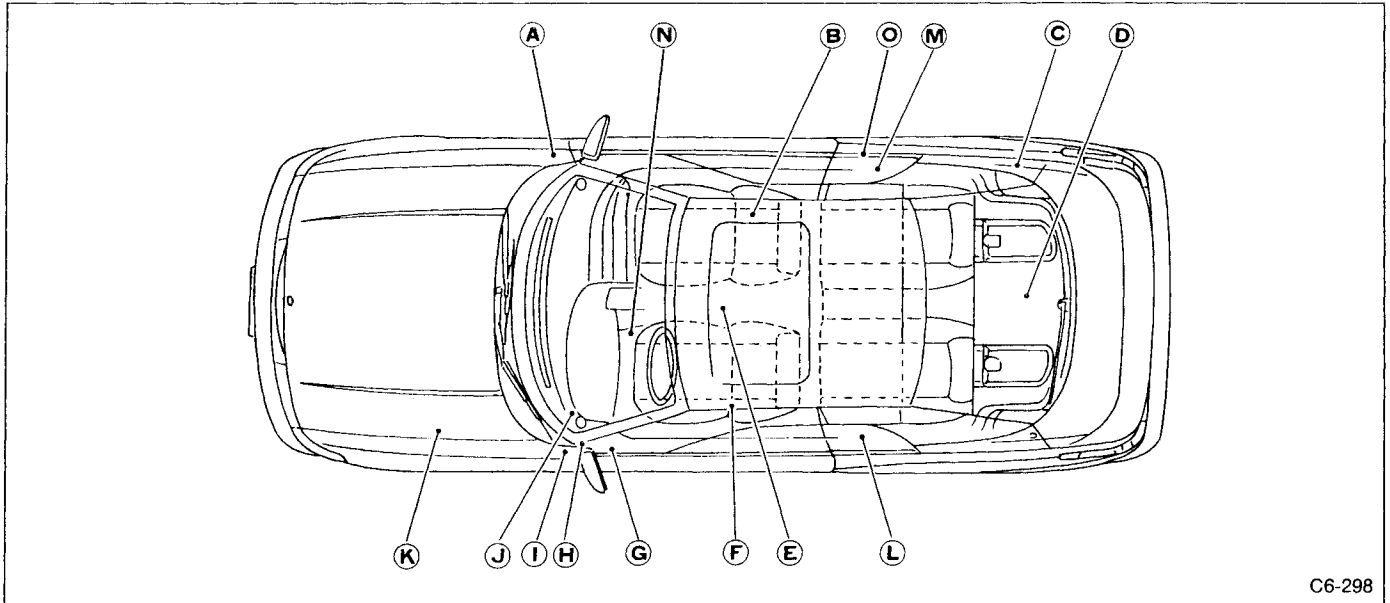

Fig. 11

5. Control Module & Relay Location



C6-298

Fig. 12

Electrical control module	Refer to	Electrical control module	Refer to
ABS control module	B	Power window relay	F
Seat belt timer	D	Relay 1 (Fan GND)	K
Cruise control main relay	L	Relay 2 (Fan LH1)	K
Cruise control module	L	Relay 3 (Fan LH2)	K
Diagnosis connector	G	Relay 4 (Fan RH1)	K
Diagnosis terminal	G	Relay 5 (Fan RH2)	K
Door lock timer	A	Relay 6 (Fog light)	K
Engine control module	H	Relay 7 (A/C COMP)	K
Front wiper control module	J	Relay 8 (HEAD)	K
Fuel pump modulator	D	Rear defogger relay	I
Fuel pump relay	J	Rear wiper relay	D
Headlight relay LH	K	Resistor (Fuel control)	D
Headlight relay RH	K	Data link connector	G
Horn relay	H	Seat heater relay	H
Inhibitor relay	L	Shift lock control module	E
Main relay	J	Stop light checker	C
OBD-II service connector	N	Tail & Illumination relay	I
Power steering control module	O	Time control module	A
Security module	D	Transmission control module	H
DRL control module (CANADA)	M	Turn & Hazard control module	J
Power window circuit breaker	F		

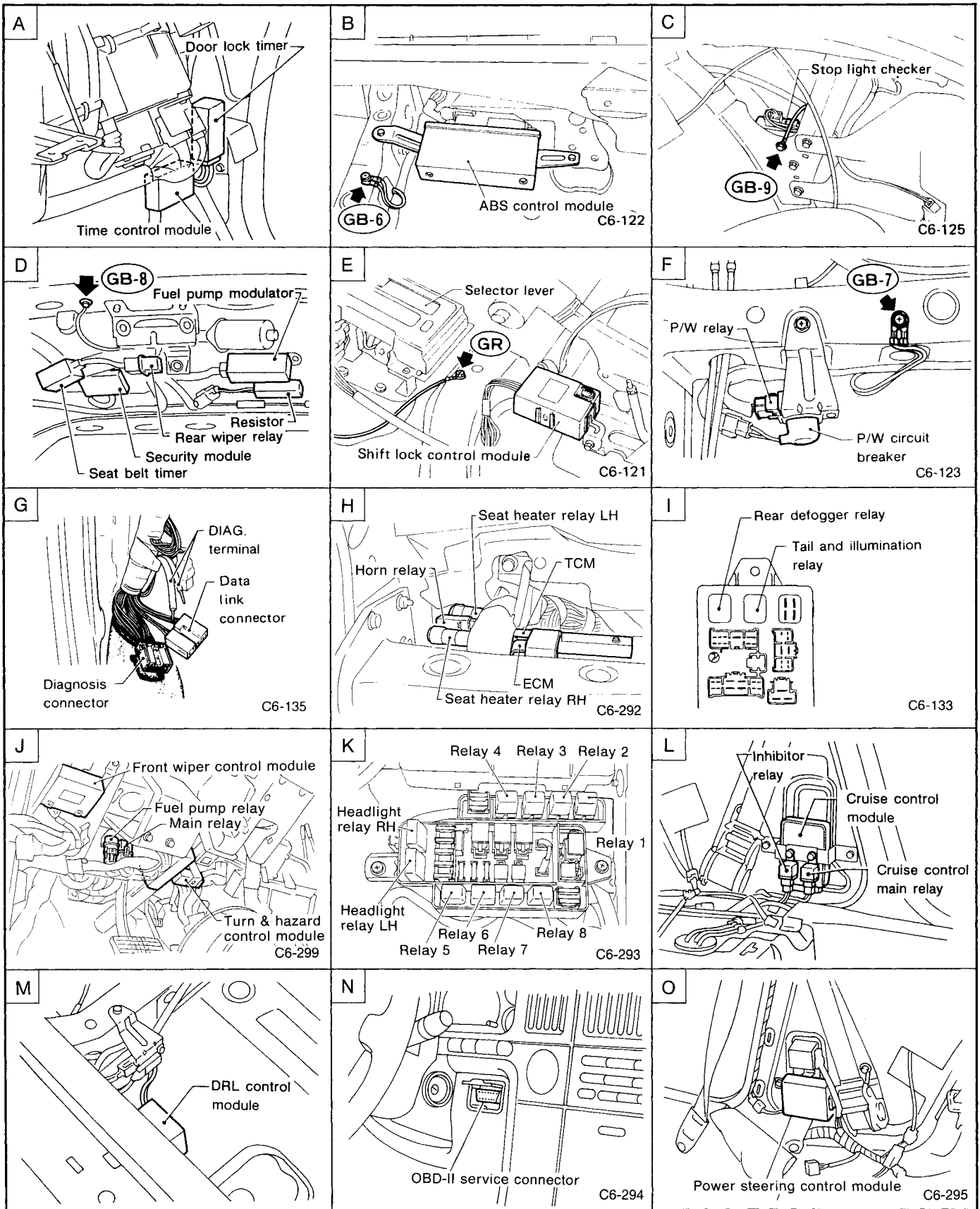
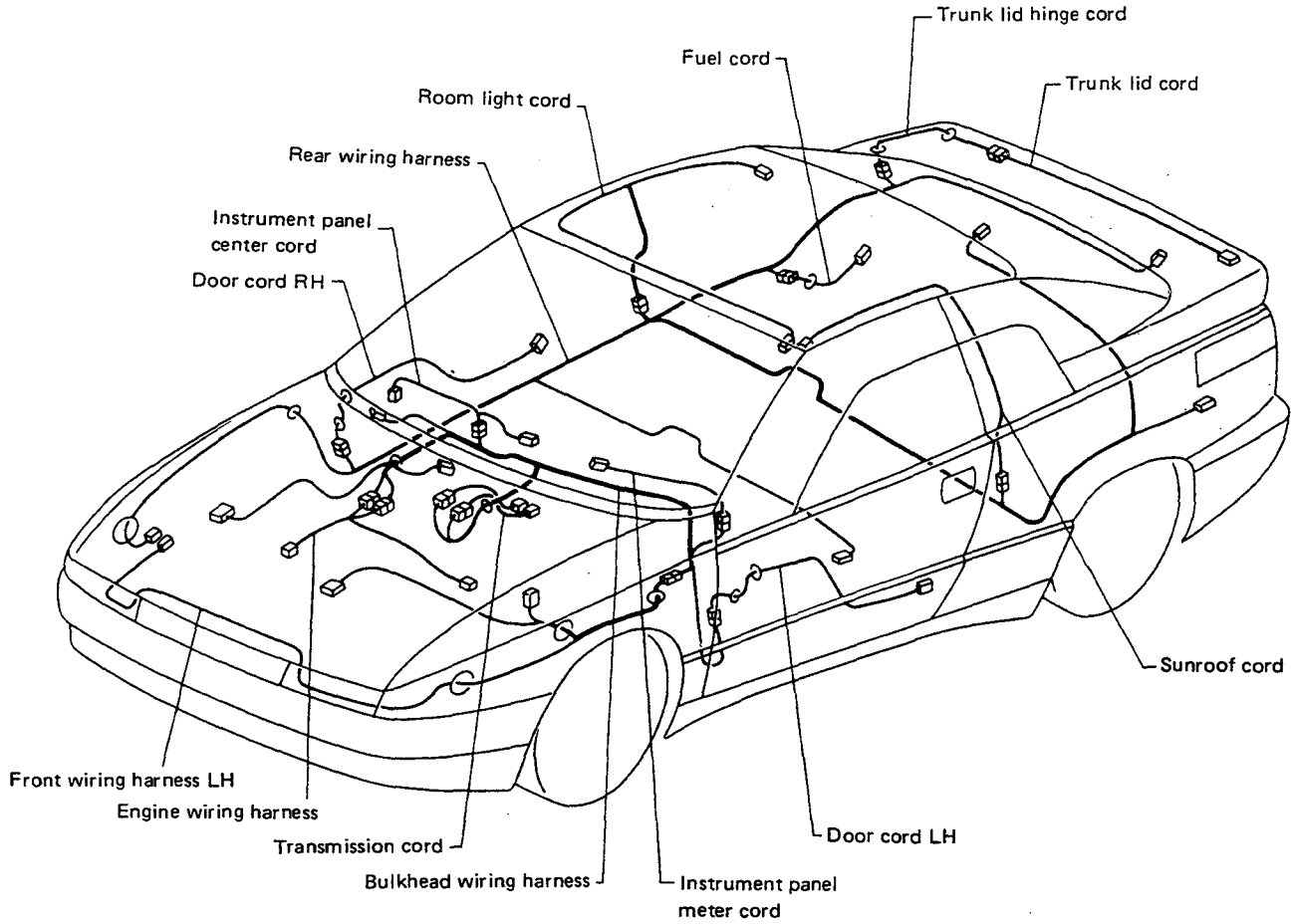

Fig. 13

# 6. Electrical Wiring Harness and Ground Point



C6-001

C6-001

Fig. 65

### 6. Electrical Wiring Harness and Ground Point

#### 1. FRONT WIRING HARNESS AND GROUND POINT

Connector				Connecting to	
No.	Pole	Color	Area	No.	Name
F1	3	Black	A4		Horn relay
F2	4	Black	B3		Relay 6 (Fog light) A/C relay holder 2
F3	10	Gray	A4		F/B
F4	3	Gray	B4		
F5	5	Gray	B4		Diode (Fog light)
F6	2	Black	B4		
F7	16	Black	B4	B71	Bulkhead wiring harness (U.S.A.)
F8	20	★	B3	B70	
F9	8	★	B3	B72	
F10	4	Black	B3		Relay 3 (Fan LH2) A/C relay holder 1
F11	4	Black	B3		Relay 2 (Fan LH1) A/C relay holder 1
F12	4	Black	B3		Relay 1 (Fan GND) A/C relay holder 1
F13	4	Black	B3		Fuse (Fan LH & RH) A/C relay holder 1
F14	1	Brown	B3		M/B
F15	2	Black	B3		
F16	8	★	B3		SBF holder
F17	3	★	B3		
F18	4	Black	B3		M/B
F19	2	Black	B3		Cruise control pump
F20	4	Gray	B3		Fuse (A/C & FWD) A/C relay holder 2
F21	4	Black	B3		Relay 8 (HEAD) A/C relay holder 2
F22	4	Black	B3		Relay 7 (A/C COMP) A/C relay holder 2
F23	4	Black	B3		Relay 5 (Fan RH2) A/C relay holder 2
F24	4	Black	B3		A/T resistor
F25	2	Gray	B3		Front turn & side marker light LH
F27	3	Gray	C3		Headlight LH (Hi-beam)
F28	2	Black	B2		Headlight LH (Lo-beam)
F29	2	Brown	C2		Horn
F30	1 x 2	Black	B2		Front fog light LH
F31	2	Gray	B2		Radiator fan LH (Sub fan)
F32	4	Gray	B2		A/C compressor solenoid
F33	2	Black	B2		A/C compressor clutch
F34	1	Black	B2		Alternator
F35	2	Gray	B2		
F36	1 x 2	★	B2		Radiator fan RH (Main fan)
F37	4	Gray	B1		Ambient sensor
F38	2	Black	B1		Trinary switch
F39	4	★	B1		Front fog light RH
F40	2	Gray	B1		Headlight RH (Lo-beam)
F41	2	Brown	B1		Headlight LH (Hi-beam)
F42	2	Black	B1		Hydraulic unit (ABS)
F43	2	Gray	B1		Front turn & side marker light RH
F44	3	Gray	B1		Relay 4 (Fan RH1) A/C relay holder 1
F45	4	Black	B3		Bulkhead wiring harness (CANADA)
F47	20	Blue	B4	B105	
F59	4	★	A4		Seat heater relay LH
F60	4	★	A4		Seat heater relay RH

★: Non-colored

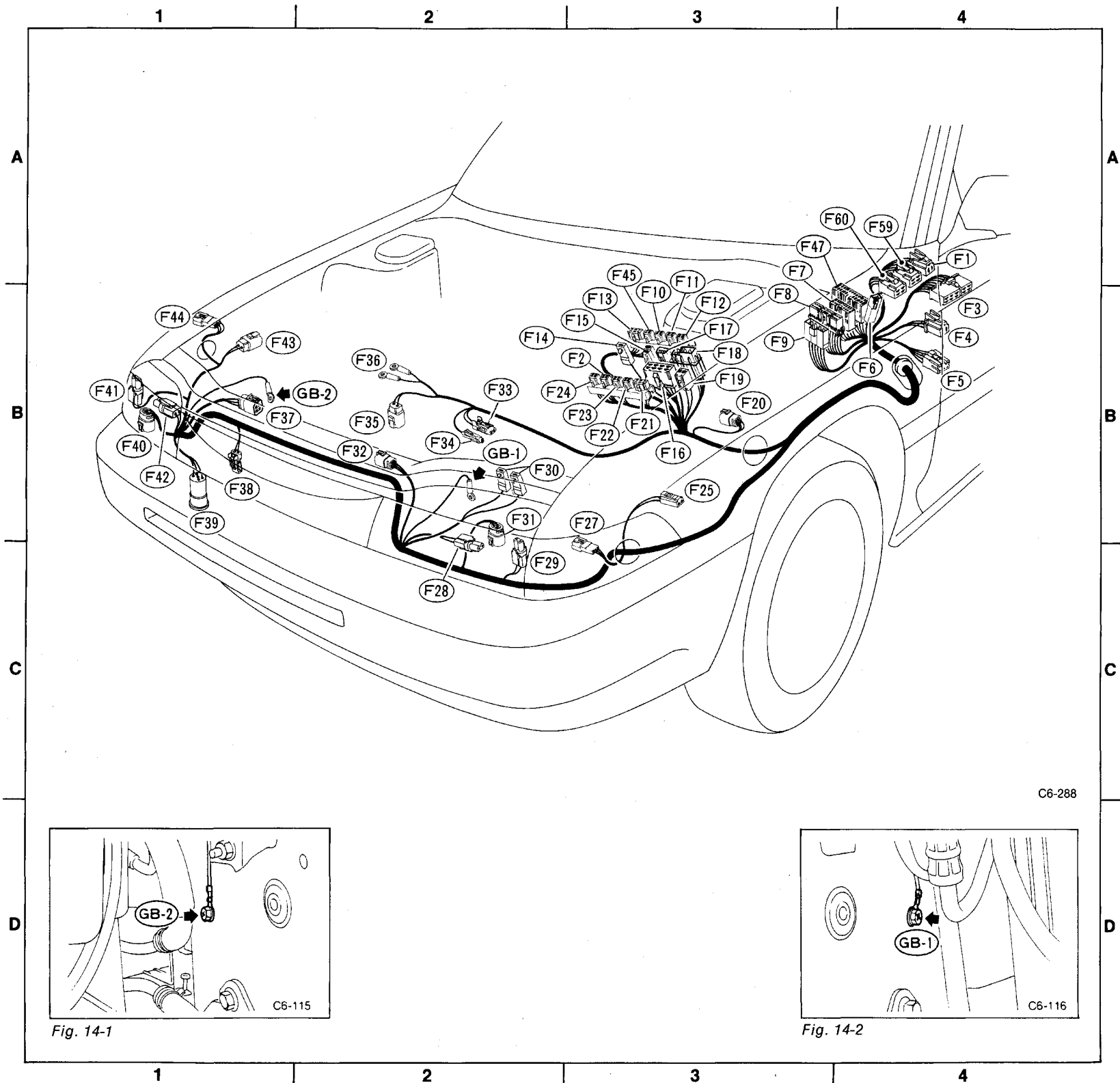

Fig. 14

2. BULKHEAD WIRING HARNESS (Engine side)

Connector				Connecting to	
No.	Pole	Color	Area	No.	Name
B1	5	Gray	B2		Mass air flow sensor
B2	2	★	B2		Front washer motor
B3	2	Gray	B2		ABS front sensor RH
B4	8	Gray	B2	E3	Engine wiring harness
B5	16	Gray	B2	E1	
B6	14	Gray	B2	E4	
B7	12	Gray	B2	E2	
B8	4	Gray	B2		Front oxygen sensor 1
B9	3	Black	B2		Vehicle speed sensor 2
B10	6	Black	A2		Front wiper motor
B11	6	Gray	A2		Igniter
B12	7	Gray	A3		
B13	12	Black	B3	T1	Transmission cord
B14	16	Black	B3	T2	
B15	1	Black	B3		Starter motor
B16	4	Gray	B3		Front oxygen sensor 2
B17	2	Black	B3		Power steering solenoid
B18	2	Gray	B3		ABS front sensor LH
B19	2	Gray	B3		Brake fluid level sensor
B20	3	★	A2		Boost sensor
B21	2	★	A2		Pressure sources switching solenoid valve
B22	4	★	B2	B23	Rear oxygen sensor cord
B23	4	★	B2	B22	Bulkhead wiring harness
B24	4	Black	B2		Rear oxygen sensor

★: Non-colored

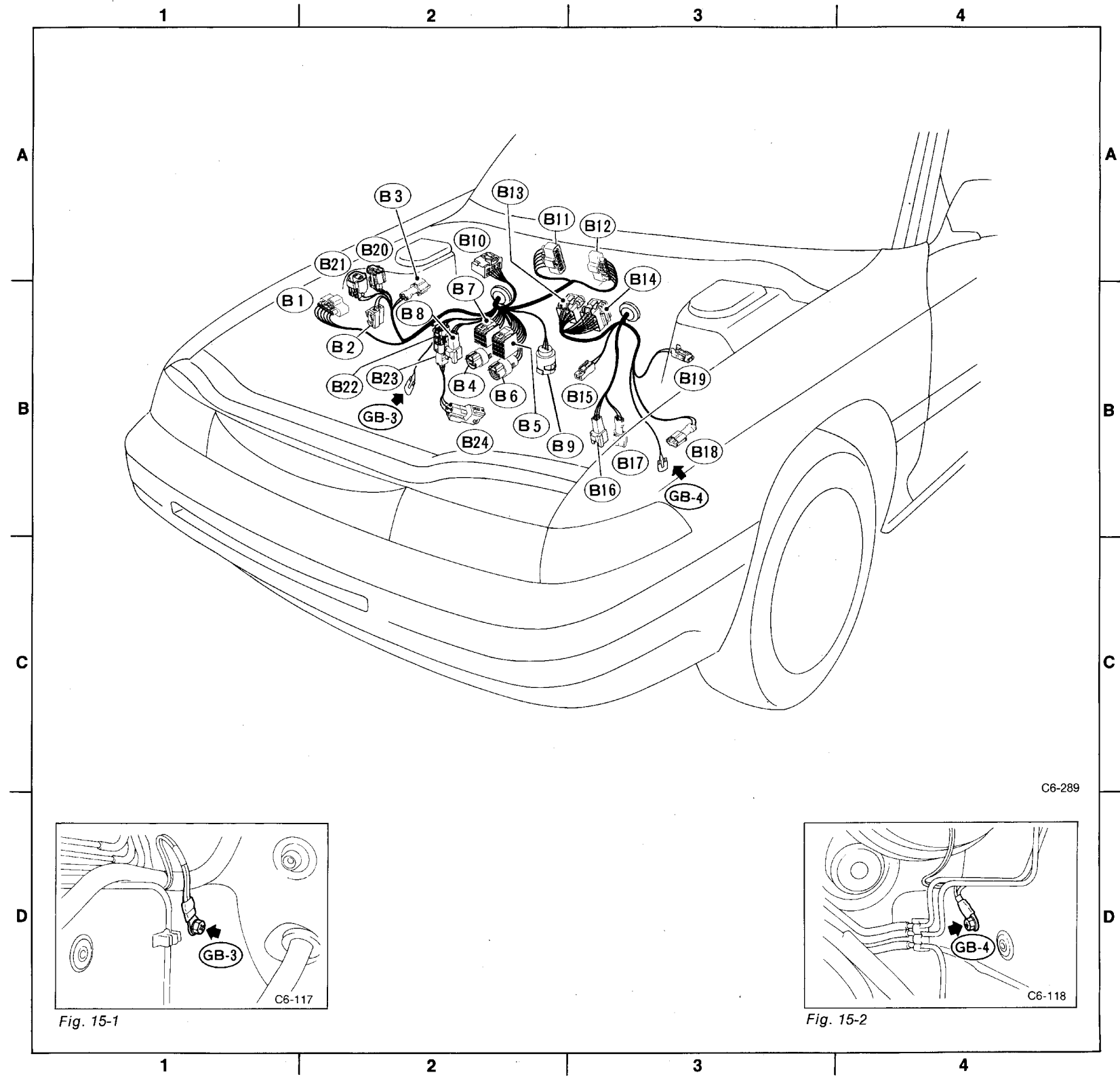

Fig. 15



Connector				Connecting to	
No.	Pole	Color	Area	No.	Name
E1	16	Gray	A4	B5	Bulkhead wiring harness
E2	12	Gray	A3	B7	
E3	8	Gray	B2	B4	
E4	14	Gray	B2	B6	
E5	2	Gray	A3		
E6	2	Gray	A3		
E7	2	Gray	A3		Injector #1
E8	2	Gray	B4		Injector #2
E9	2	Gray	B4		Injector #3
E10	2	Gray	B4		Injector #4
E11	3	Brown	A4		Injector #5
E12	2	Black	A2		Injector #6
E13	2	Gray	A3		Throttle sensor
E14	2	Blue	A3		Power steering switch
E15	3	Gray	A4		Recirculation gas temperature sensor
E16	2	Gray	A3		Purge control solenoid
E17	2	Brown	A4		By-pass air control solenoid
E18	2	Blue	A3		EGR solenoid
E19	1	Gray	B2		Induction control solenoid
E20	1	Gray	B1		Auxiliary air control valve
E21	2	Gray	B1		Knock sensor 2
E22	2	Gray	C2		Knock sensor 1
E23	2	Gray	B2		Crank angle sensor 1
E24	2	Brown	B2		Crank angle sensor 2
E25	1		B1		Cam angle sensor
E26	1		B2		Water temperature sensor
E27	2	Gray	B2		Thermometer
E28	2	Green	B2		Oil pressure switch
E29	2	Blue	B2		Ignition coil #1
E30	2	Gray	B3		Ignition coil #3
E31	2	Green	B3		Ignition coil #5
E32	2	Blue	B3		Ignition coil #2
					Ignition coil #4
					Ignition coil #6

Connector				Connecting to	
No.	Pole	Color	Area	No.	Name
T1	12	Black	D3	B13	Bulkhead wiring harness
T2	16	Black	D4	B14	Bulkhead wiring harness

### 3. ENGINE WIRING HARNESS - TRANSMISSION CORD AND GROUND POINT

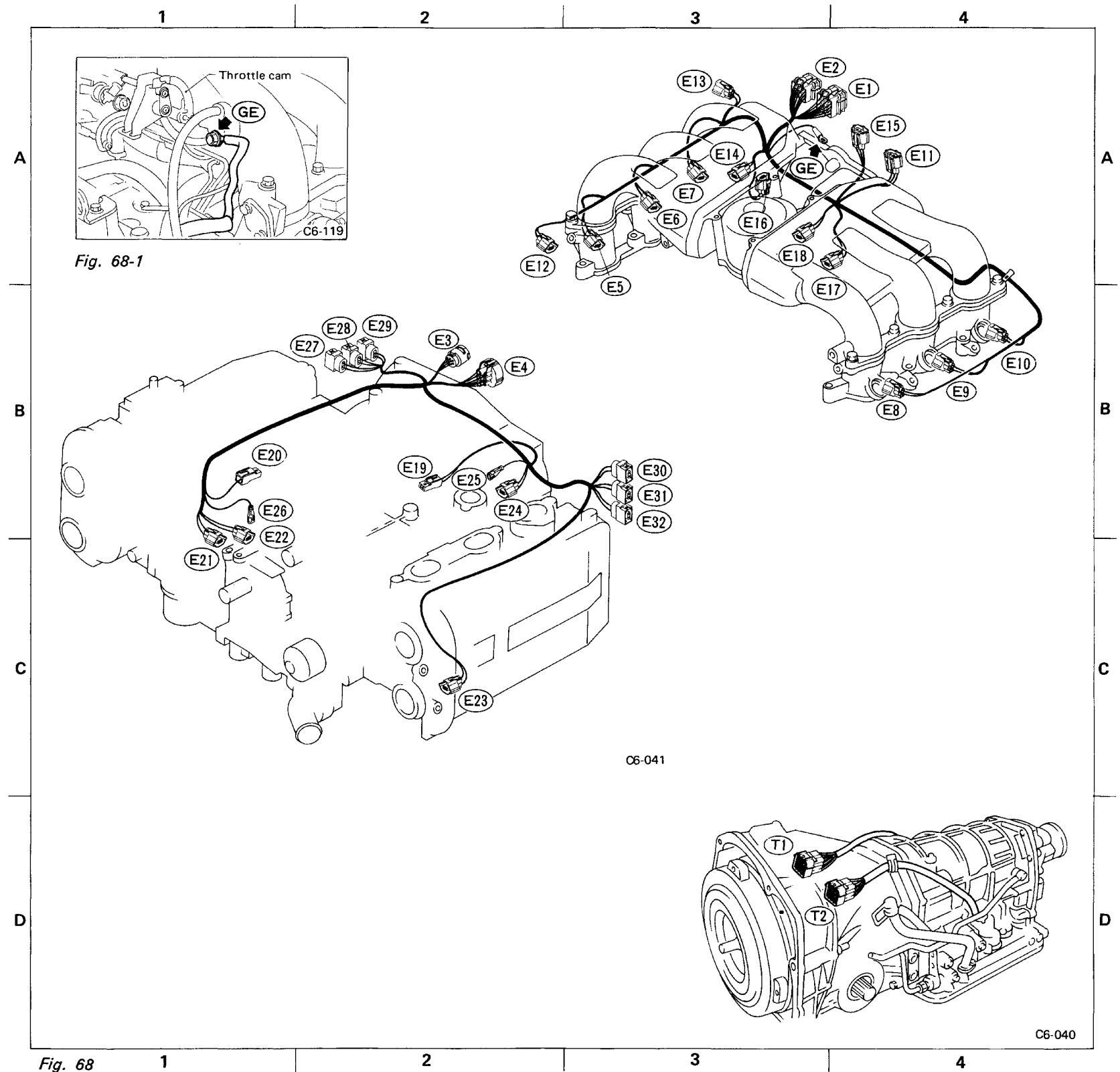

4. BULKHEAD WIRING HARNESS (Interior side)

Connector				Connecting to	
No.	Pole	Color	Area	No.	Name
B30	14	★	C1	D10	Door cord LH
B31	10	★	C1	D9	Door cord LH
B33	1 x 2	★	C1		*C ↔ *F Changing connector
B34	20	Black	C1		Check connector (Manufacturing)
B35	9	Yellow	C1		Data link connector
B36	10	Black	C1		Diagnosis connector
B37	1 x 2	★	C1		Diagnosis terminal
B38	15	Gray	C1		F/B
B39	14	Black	B1	i2	
B40	18	★	B1	i1	Instrument panel meter cord
B41	22	Blue	B1	i3	
B42	17	★	B1		Front wiper control module
B43	12	Gray	B1		F/B
B44	11	Gray	B1		F/B
B45	14	Black	B1		Fog light switch & cruise control main switch
B46	10	★	B1		Parking light switch & outside mirror defogger switch
B47	12	Black	B1		Remote control mirror switch
B48	2	Black	B1		Diode (Engine)
B49	2	Black	C1		Diode (Dimmer)
B50	2	★	C2		Wiper select switch
B51	4	★	C1		Fuel pump relay
B52	6	Brown	C2		Main relay
B54	5	Black	C2		Horn switch & cruise control sub switch
B55	14	★	C2		
B56	13	★	C2		Combination switch
B57	2	★	C2		
B58	7	Yellow	C1		SRS (Airbag) harness
B59	96	Dark-gray	B2		Engine control module
B63	5	Black	B2		Daytime running light relay 1
B64	6	Brown	B2		Daytime running light relay 2
B65	4	Black	B2		Stop & brake switch
B66	20	Black	B2		
B67	12	Black	B2		Transmission control module
B68	16	Black	B2		
B69	6	★	B2		Shield joint connector (A/T)
B70	20	★	B2	F8	Front wiring harness LH
B71	16	Black	B2	F7	Front wiring harness LH (U.S.A.)
B72	8	★	B2	F9	Front wiring harness LH
B73	4	★	B2		Starter interrupt relay adapter
B74	4	Black	B2		
B75	6	Black	B2		Ignition switch

Connector				Connecting to	
No.	Pole	Color	Area	No.	Name
B76	3	Black	B2		Turn & hazard module
B77	2	★	B2		Step light LH
B78	20	Black	B2	i10	
B79	18	★	B2	i11	Instrument panel center cord
B80	22	Blue	B2	i9	
B81	14	★	B2		Hazard switch & rear window defogger switch
B82	10	Black	B2	HU1	Heater unit cord
B89	8	★	A4		Door lock timer
B90	16	Black	B4		
B91	20	Black	B4		Time control module
B93	14	★	B4	D16	Door cord RH
B94	4	★	B4	D15	
B95	2	★	B4	BM1	Blower unit cord
B96	14	★	B4	BM2	
B97	6	Black	B4	R2	Rear wiring harness
B98	6	★	B4	R3	Rear wiring harness (U.S.A.)
B99	24	★	B4	R5	
B100	24	Black	B4	R6	Rear wiring harness
B101	24	Blue	C4	R4	
B102	2	Black	B1		Diode (DRL)
B103	20	Black	B2	R53	Rear wiring harness
B104	20	Blue	B2	R54	
B105	20	Blue	B2	F47	Front wiring harness LH (CANADA)
B107	8	★	B4	R89	Rear wiring harness (CANADA)
B124	20	★	B2		Joint connector
B125	6	★	B2	B126	OBD-II service connector cord
B126	6	★	B2	B125	Bulkhead wiring harness
B127	16	Gray	C3		OBD-II service connector
BM1	2	★	D3	B95	Bulkhead wiring harness
BM2	14	★	D3	B96	
BM3	2	★	D3		Refrigerant temperature sensor
BM4	2	★	D3		Evaporator sensor
BM5	4	★	D3		Hi-relay
BM6	4	★	D3		Fan control amp.
BM7	2	★	D3		Blower motor
BM8	4	★	D3		OFF relay
BM9	7	★	D3		Intake door actuator
HU1	10	Black	D2		Bulkhead wiring harness
HU2	7	★	D2		Mode door actuator
HU3	2	★	D3		Engine coolant temperature sensor
HU4	7	★	D3		Air mix door actuator

★: Non-colored

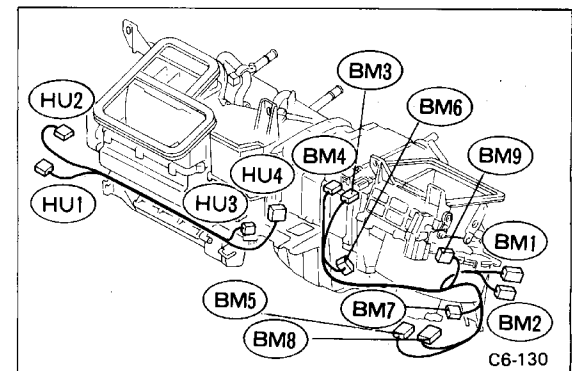
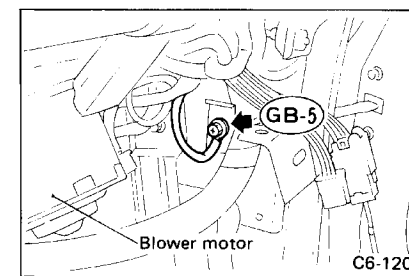
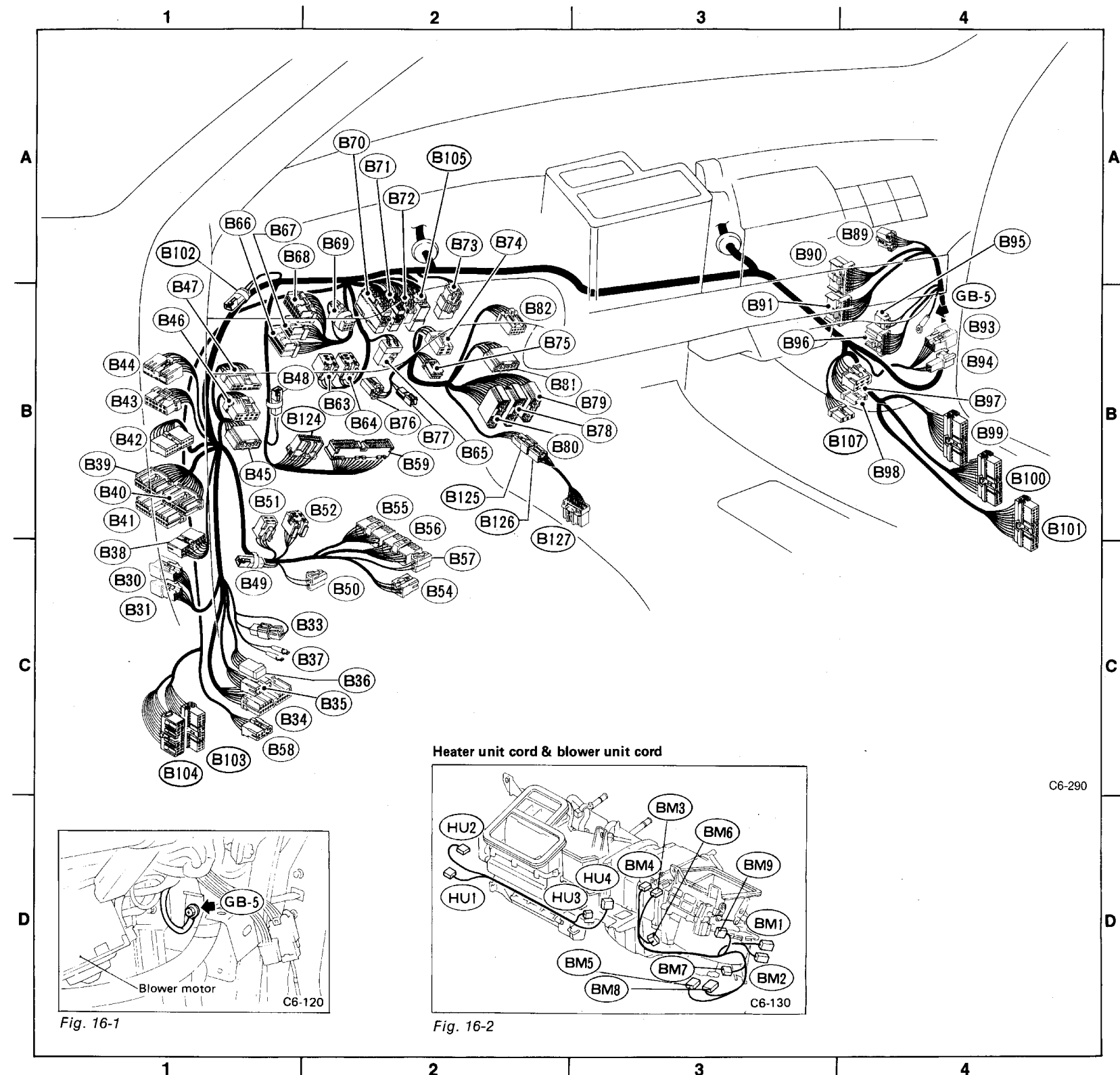

Fig. 16

Connector				Connecting to	
No.	Pole	Color	Area	No.	Name
i1	18	White	B1	B40	Bulkhead wiring harness
i2	14	Black	B1	B39	
i3	22	Blue	B1	B41	
i4	2		A1		Front speaker LH
i5	2	Black	A2		Sunload sensor
i6	16	Gray	A1		Combination meter (With yellow bracket)
i7	16	Gray	A1		Combination meter (With white bracket)
i8	16	Gray	B2		Combination meter (With yellow bracket)
i9	22	Blue	B2	B80	Bulkhead wiring harness
i10	20	Black	B2	B78	
i11	18	White	B2	B79	
i12	3		C2		Cigarette lighter & ash tray (Illumination light & ground)
i13	1		C2		Cigarette lighter (Power)
i14	2	White	C2		CD illumination light
i15	20	White	B2		Radio
i16	20	Black	B2		Auto A/C control unit
i17	16	Black	B2		
i18	4		B2		Clock
i19	2	White	B3		Step light RH
i20	2	Brown	C3		Glove box light
i21	2		B4		Front speaker RH
i22	2		C4		Glove box light switch

5. INSTRUMENT PANEL WIRING HARNESS

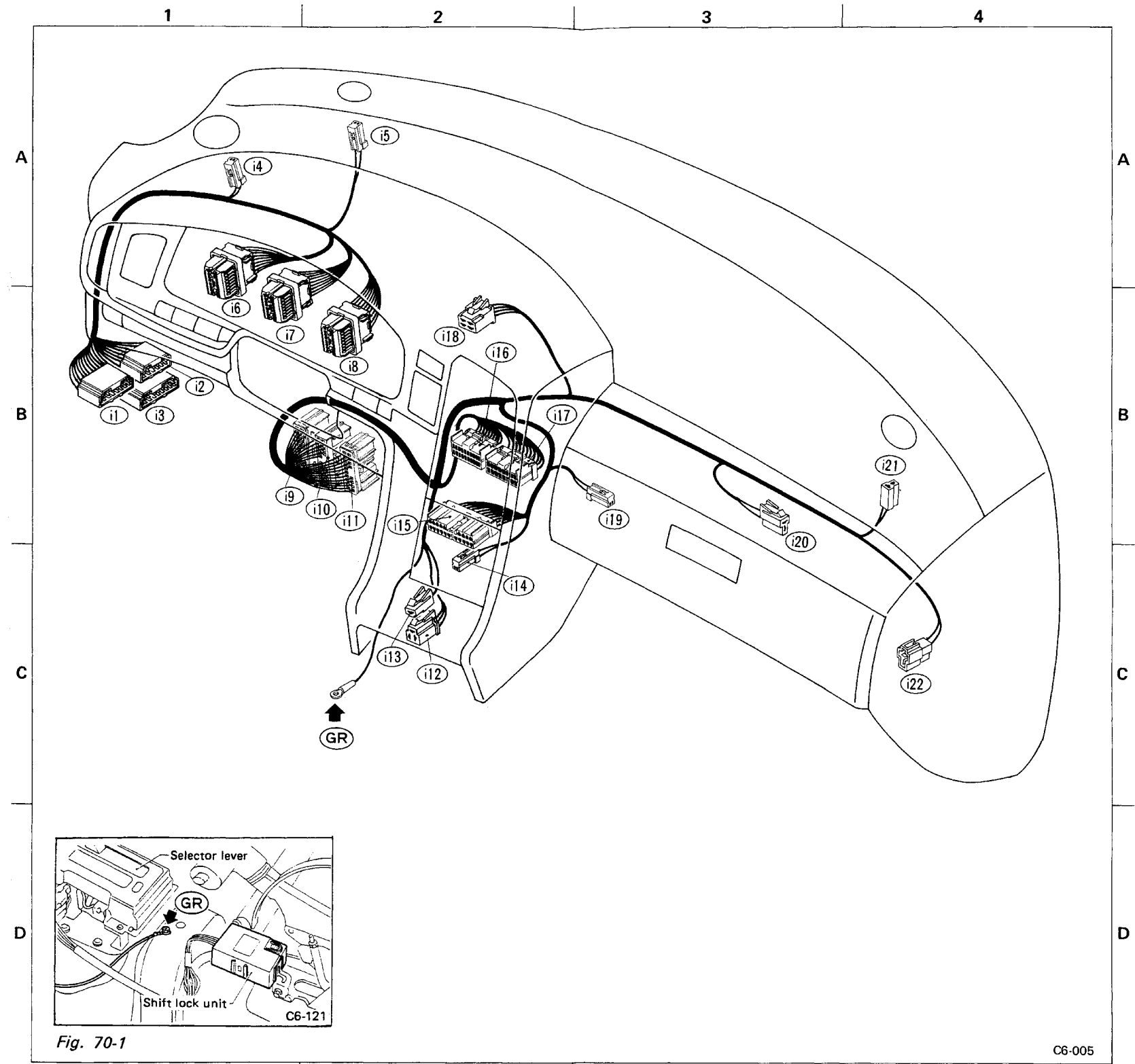

Fig. 70-1

C6-005

Connector				Connecting to	
No.	Pole	Color	Area	No.	Name
D1	3		B1		Door latch switch LH
D2	4		B1		Door lock actuator LH
D3	4		B1		Door handle switch & key hole illumination
D4	2	Pink	B2		Courtesy light LH
D5	2	Black	B3		Door speaker LH
D6	14		B2		Power window main switch
D7	2	Green	B3		Front power window motor LH
D8	8	White	B3		Side view mirror LH
D9	10		B3	B31	Bulkhead wiring harness
D10	14		B3	B30	
D15	4		D2	B94	Bulkhead wiring harness
D16	14		D2	B93	
D17	8	White	D2		Side view mirror RH
D18	2	Green	D2		Front power window motor RH
D19	5		D3		Front power window sub-switch RH
D20	2	Black	D2		Door speaker RH
D21	2	Pink	D3		Courtesy light RH
D22	4		D4		Door lock actuator RH
D23	3		D4		Door latch switch RH

6. DOOR CORD

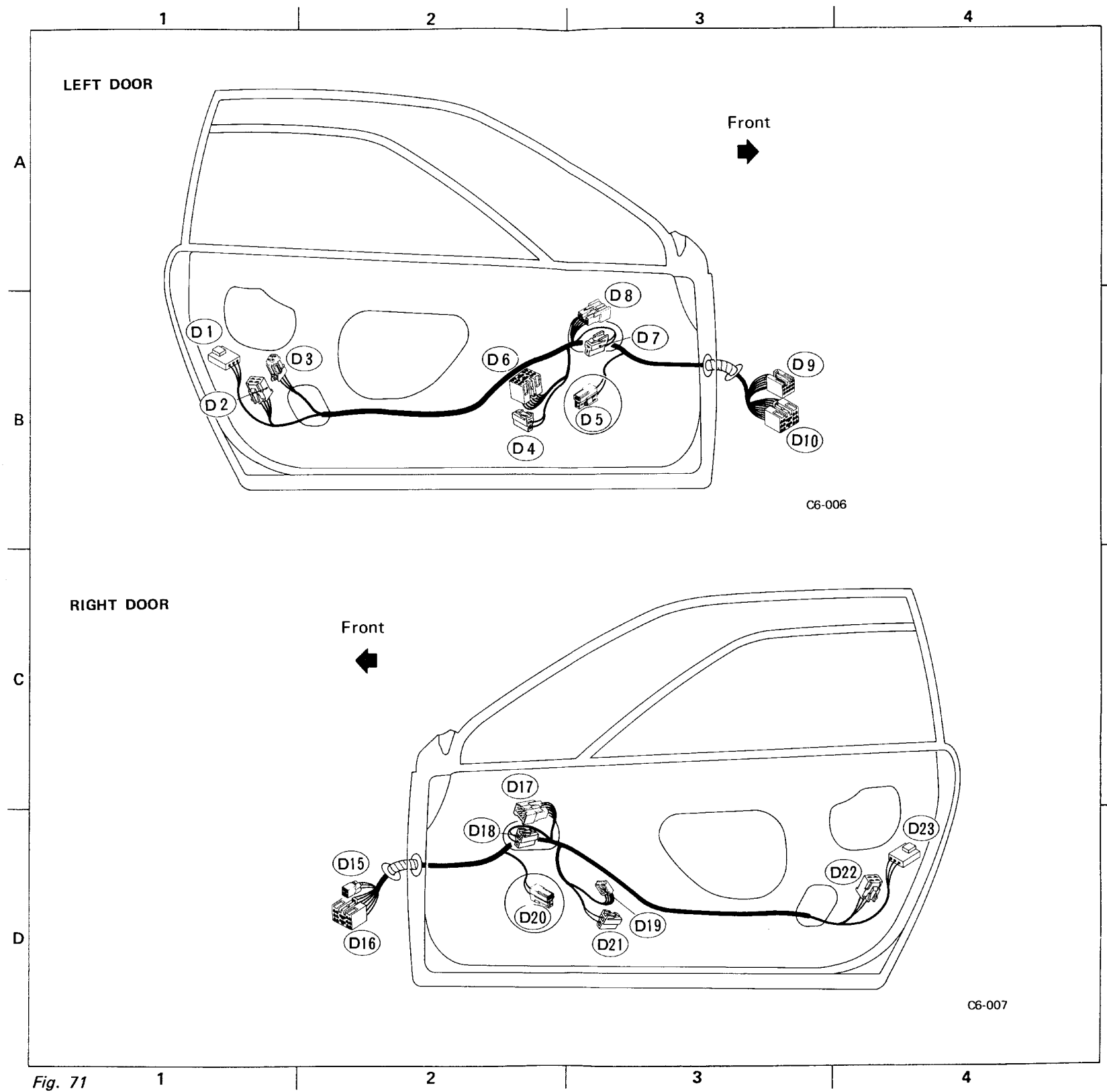

Fig. 71

7. REAR WIRING HARNESS

Connector				Connecting to		Connector				Connecting to	
No.	Pole	Color	Area	No.	Name	No.	Pole	Color	Area	No.	Name
R1	12	Black	B1		Hydraulic unit (ABS)	R40	5	★	C3		Rear power window sub switch LH
R2	6	Black	B2	B97		R41	3	★	B3	R42	Sunroof cord
R3	6	★	B2	B98		R42	3	★	B3	R41	Rear wiring harness
R4	24	Blue	B2	B101	Bulkhead wiring harness	R43	2	★	C3		Power window circuit breaker
R5	24	★	B2	B99		R44	4	★	C3		Power window relay
R6	24	Black	B2	B100		R45	2	★	C3		Power seat
R7	35	★	B2		ABS control module	R46	2	★	C3		Seat belt switch
R8	6	★	B2	R9	Room light cord	R47	12	Black	B3		Shift lock control module
R9	6	★	B2	R8	Rear wiring harness	R48	2	★	B3		Parking brake switch
R10	6	★	B2		Front room light switch	R49	2	Green	B2		Select lever illumination light
R11	2	★	B2		Vanity mirror illumination light RH	R50	2	Black	B2		Shift lock solenoid
R12	5	★	B3		Rear power window sub switch RH	R51	4	★	B2		A/T manual switch & P position switch
R16	2	Green	B3		Rear power window motor RH	R52	6	Blue	C2		Door lock switch
R17	2	★	B3		Vanity mirror illumination light LH	R53	20	Black	C2	B103	Bulkhead wiring harness
R18	2	Gray	B3		ABS rear sensor RH	R54	20	Blue	C2	B104	
R19	5	Black	B3	R20	Fuel cord	R80	10	★	B3		Daytime running light control module
R20	5	Black	B3	R19	Rear wiring harness	R81	4	★	C4		Inhibitor relay
R21	4	★	B3		Sunroof cord	R82	4	Brown	C4		Diode (Cruise control)
R22	2	★	B3		Rear room light	R83	4	Black	C4		Cruise control main relay
R23	6	★	B3		Fuel pump & gauge module	R84	4	★	C4		Cruise control module
R24	2	Black	B3		Rear speaker RH	R85	20	★	C4		Security control module
R25	4	★	B4		Rear wiper motor	R86	17	★	B4		
R26	5	Black	B4		Rear wiper relay	R87	8	★	B4		Seat heater RH (with seat heater)
R27	2	★	B4		Trunk room light	R88	2	★	B2	B107	Bulkhead wiring harness (with seat heater)
R29	2	Black	B4		Rear side marker LH	R89	8	★	B2	B107	Seat heater LH (with seat heater)
R30	3	★	B4		Power antenna	R90	2	Black	C3		Seat heater LH (with seat heater)
R31	2	Black	B4		Rear speaker LH	R91	16	★	B3		Power steering control module
R33	4	★	B4		Fuel pump modulator						
R34	2	Gray	B4		Resistor (Fuel pump control)						
R35	2	Green	B4		Rear power window motor LH						
R36	2	Gray	B4		ABS rear sensor LH						

★: Non-colored

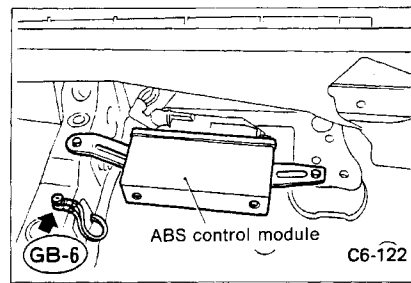

Fig. 17-1

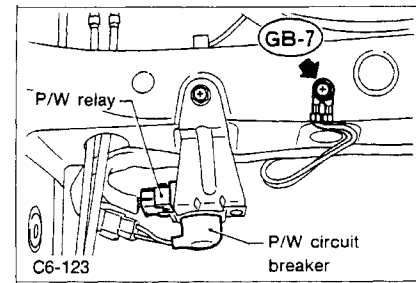

Fig. 17-2

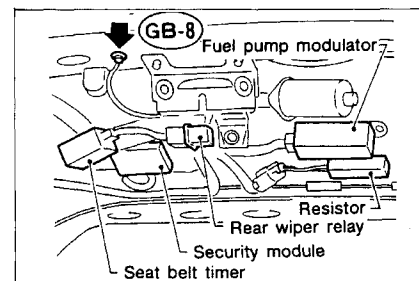

Fig. 17-3

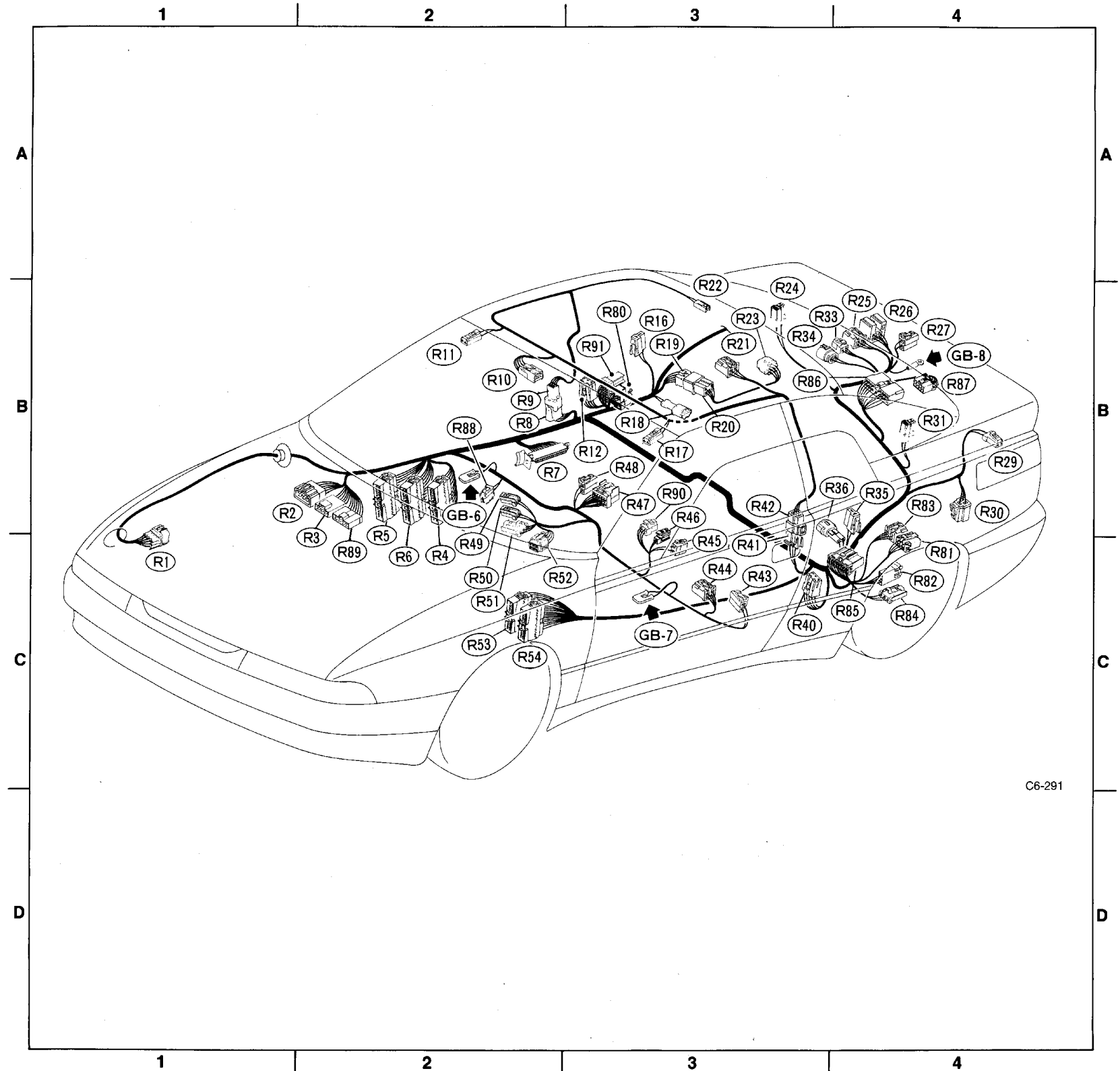
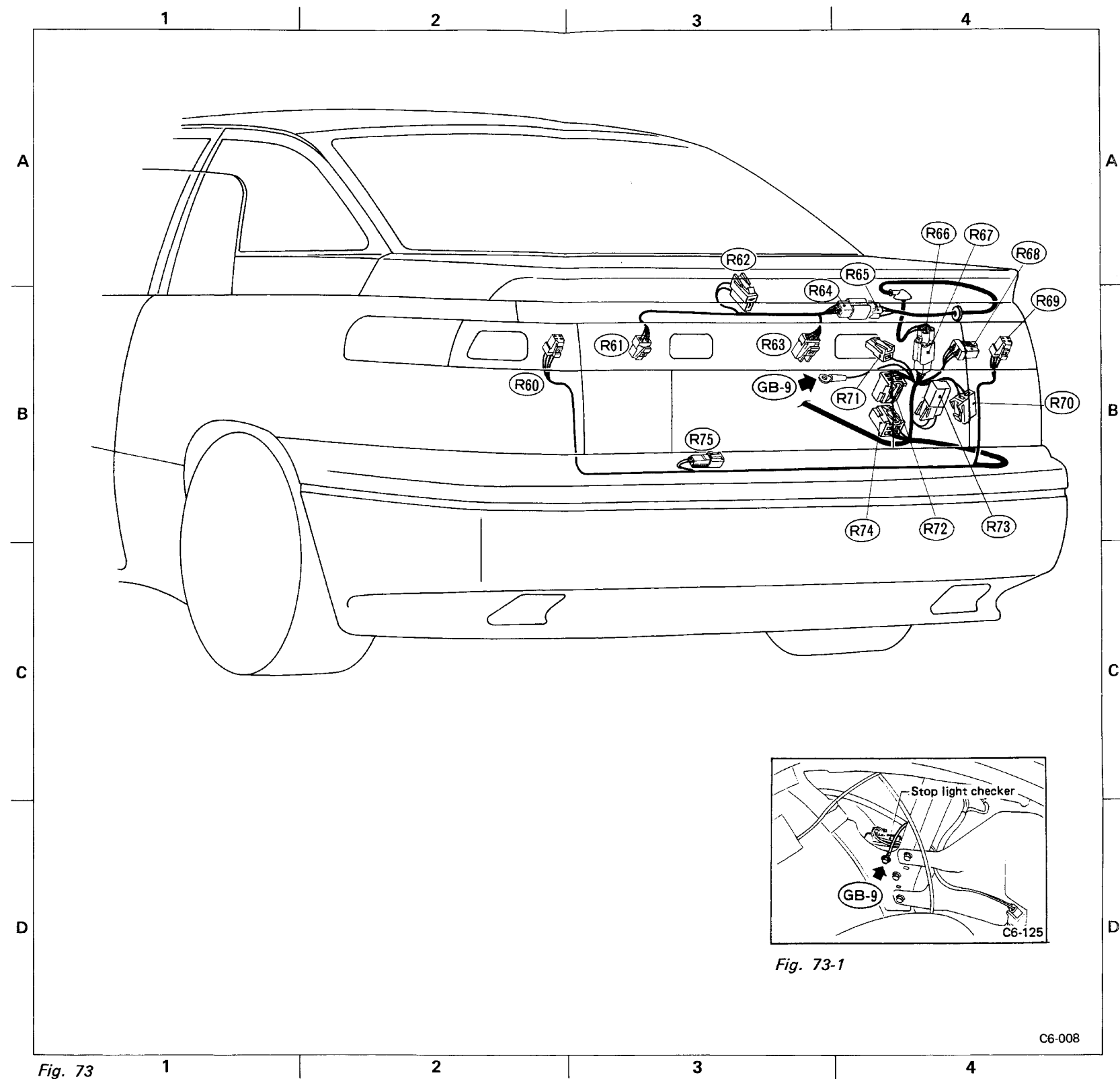

Fig. 17

Connector				Connecting to	
No.	Pole	Color	Area	No.	Name
R60	4	Blue	B2		Rear combination light LH
R61	4	Blue	B3		Finisher light LH
R62	2		B3		High-mount stop light
R63	6		B3		Finisher light RH
R64	4		B3	R65	Trunk lid hinge cord
R65	4		B4	R64	Trunk lid cord
R66	4		B4	R67	Rear wiring harness
R67	4		B4	R66	Trunk lid hinge cord
R68	2	Black	B4		Rear side maker RH
R69	4	Blue	B4		Rear combination light RH
R70	2		B4		Rear washer motor
R71	1		B4		Rear defogger (Power)
R72	4		B4		Stop light checker
R73	2	Black	B4		Rear defogger condenser
R74	4		B4		Telephone (OP)
R75	2		B3		Trunk room light switch

8. REAR END WIRING HARNESS AND GROUND POINT OF 4-DOOR SEDAN



C6-008