

PREPARATION MATERIALS

PREPARATION MATERIALS

PP

ENGINE

ENGINE MECHANICAL

EM

COOLING

CO

PREPARATION MATERIALS

ENGINE MECHANICAL

SST
GENERAL TOOL.....
GREASE • OTHER

PP-1
PP-4
PP-5



ENGINE MECHANICAL

SST

Illustration	Tool number	Description	Remarks
 <p data-bbox="300 625 443 646">ST18252AA000</p>	18252AA000	Crankshaft socket	Used for turning the crankshaft.
 <p data-bbox="300 1003 443 1024">ST18355AA000</p>	18355AA000	Pulley wrench	<ul style="list-style-type: none"> • Used for removing and installing the crankshaft pulley. • Used for removing and installing the water pump pulley. • Used for removing and installing the camshaft timing intake gear ASSY, and camshaft timing exhaust gear ASSY.
 <p data-bbox="300 1381 443 1402">ST18334AA030</p>	18334AA030	Pulley wrench pin set	<ul style="list-style-type: none"> • Used for removing and installing the water pump pulley. • Used for removing and installing the camshaft timing intake gear ASSY, and camshaft timing exhaust gear ASSY.
 <p data-bbox="300 1764 443 1785">ST18270KA010</p>	18270KA010	Socket	Used for removing and installing the camshaft timing intake gear ASSY, and camshaft timing exhaust gear ASSY.

Illustration	Tool number	Description	Remarks
 <p data-bbox="325 516 469 537">ST18854AA000</p>	18854AA000	Angle gauge	<ul style="list-style-type: none"> • Used for tightening the cylinder head bolt. • Used for tightening the cylinder block bolt.
 <p data-bbox="325 894 469 915">ST18334AA000</p>	18334AA000	Pulley wrench pin set	<ul style="list-style-type: none"> • Used for removing and installing the crankshaft pulley. • Used for removing and installing the drive plate and ring gear SUB-ASSY, and flywheel SUB-ASSY.
 <p data-bbox="325 1272 469 1293">ST18332AA020</p>	18332AA20	Oil filter wrench	Used for removing and installing the oil filter SUB-ASSY.
 <p data-bbox="341 1654 469 1675">ST-398437700</p>	398437700	Oil seal installer	Used for installing the timing chain/belt cover oil seal.

PP

Illustration	Tool number	Description	Remarks
 <p data-bbox="268 514 438 541">ST0920287002000</p>	0920287002000	Remover and replacer	Used for removing and installing the valve spring.
 <p data-bbox="311 892 438 919">ST-499765700</p>	499765700	Valve guide remover and installer	Used for removing and installing the valve guide busing No. 2.
 <p data-bbox="295 1270 438 1297">ST18261AA010</p>	18261AA010	Valve oil seal guide	Used for press-fitting the intake valve guide stem seal, and exhaust valve guide stem seal.
 <p data-bbox="295 1648 438 1675">ST18270AA020</p>	18270AA020	Socket	Used for removing and installing the connecting rod.

Illustration	Tool number	Description	Remarks
 <p>ST18671AA020</p>	18671AA020	Oil seal guide	Used for installing the engine rear oil seal.
 <p>ST18657AA030</p>	18657AA030	Oil seal installer	Used for installing the engine rear oil seal.

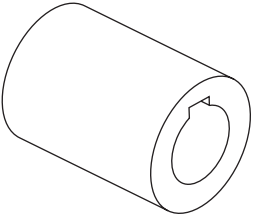
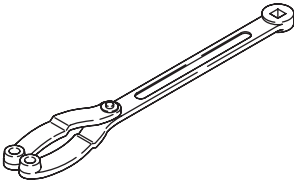
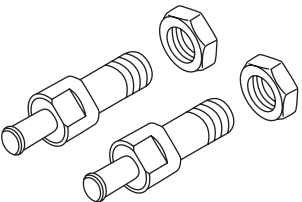
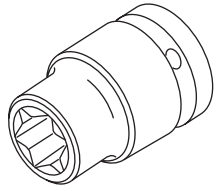
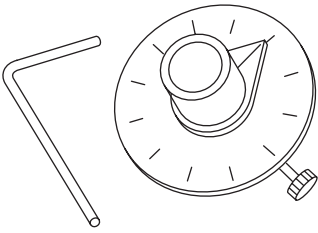
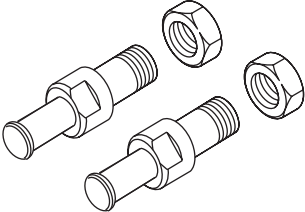
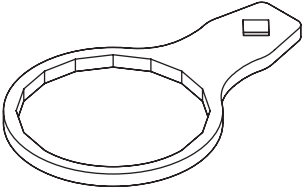
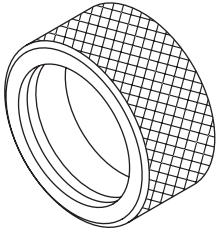
PP

GENERAL TOOL

Tool name	Remarks
Union nut wrench (19 mm)	Used for removing and installing the engine water temperature sensor.
Deep socket wrench (19 mm)	Used for removing and installing the engine oil temperature sensor, and ventilation valve SUB-ASSY.
Deep socket wrench (24 mm)	Used for removing and installing the engine oil pressure switch ASSY.
Socket hexagon (6 mm)	Used for removing and installing the pump drive case ASSY.
Hex wrench (2.5 mm in diameter)	Used for securing the chain tensioner ASSY No. 1.
Socket hexagon (5 mm)	Used for removing and installing the chain vibration damper No. 1.
Oil pan seal cutter	Used for removing the oil pan SUB-ASSY No. 2.
Straight hexagon (14 mm)	Used for removing and installing the cylinder block plug.
Dial gauge	Used for measuring the camshaft and crankshaft.
Thickness gauge	Used for various measurements.
Micrometer	Used for measuring the valve clearance, camshaft, valve, piston, piston pin and crankshaft.
Caliper	Used for measuring the valve, valve spring, and valve guide bushing No. 2.
Caliper gauge	Used for measuring the valve guide bushing No. 2, valve adjusting shim, piston pin, and connecting rod.
Valve seat cutter	Used for correcting the valve seat seating surface.
Right angle gauge	Used for measuring the valve spring.
Hand reamer	Used for grinding the valve guide bushing No. 2.
Piston ring tool	Used for removing and installing the piston ring.
Straight edge ruler	Used for inspecting warpage.
Cylinder gauge	Used for measuring the cylinder liner.
Connecting rod aligner	Used for measuring the connecting rod.
Piston ring compressor	Used for installing the piston onto the cylinder block.

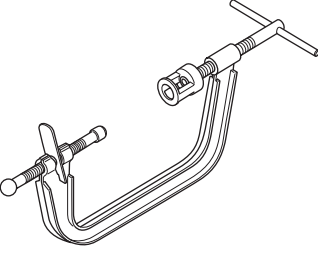
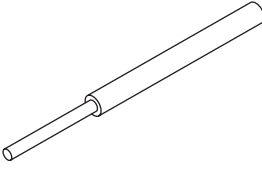
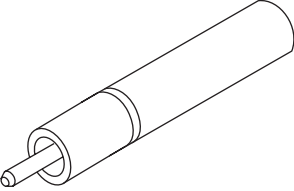
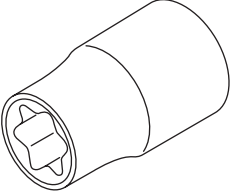
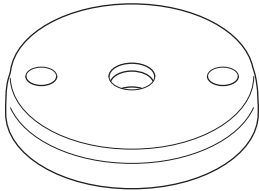
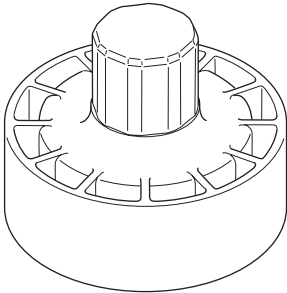
GREASE • OTHER

Description	Part number	Used location
Metal wire (approx. 1 mm in diameter)	–	Chain tensioner ASSY No. 2
THREE BOND 1217G	K0877Y0100	<ul style="list-style-type: none"> • Front camshaft cap, intake rear camshaft cap, and exhaust rear camshaft cap • Camshaft housing SUB-ASSY • Cylinder head gasket No. 2 • Cylinder head cover SUB-ASSY, cylinder head cover SUB-ASSY LH • Timing chain/belt cover SUB-ASSY • Cylinder head plate RR • Vacuum pump ASSY • Oil pan SUB-ASSY • Oil pan SUB-ASSY No. 2 • Pump drive case ASSY • Oil separator cover • Cylinder block
Plastigauge	–	Camshaft, connecting rod, crankshaft
THREE BOND 1324	004403042	Engine oil pressure switch ASSY
THREE BOND 1105	004403010	Cylinder block tight plug No. 1
Red dye	–	Valve
Valve compound	–	Valve
Protective tape	–	<ul style="list-style-type: none"> • Timing chain/belt cover oil seal • Timing chain/belt cover SUB-ASSY • Engine rear oil seal • Cylinder head cover SUB-ASSY • Camshaft housing SUB-ASSY • Oil pan SUB-ASSY • Piston pin hole snap ring

ENGINE MECHANICAL

LIQUID GASKET APPLYING LOCATION (FA20)	
APPLICATION	EM-1
PARTIAL ENGINE ASSY (FA20)	
EXPLODED VIEW	EM-3
DISASSEMBLY	EM-13
INSPECTION	EM-33
ASSEMBLY	EM-37
CYLINDER HEAD ASSY (FA20)	
EXPLODED VIEW	EM-77
DISASSEMBLY	EM-77
INSPECTION	EM-81
ASSEMBLY	EM-90
CYLINDER BLOCK ASSY (FA20)	
EXPLODED VIEW	EM-100
DISASSEMBLY	EM-101
INSPECTION	EM-106
ASSEMBLY	EM-120

EM

LIQUID GASKET APPLYING LOCATION (FA20)

APPLICATION

1. Handling of liquid gasket

<Caution>

When removing liquid gasket, be careful not to let the gasket particles get inside of the engine.

- (1) Before applying liquid gasket, completely remove the old liquid gasket attached to the seal portion, bolt and bolt hole, and wash the seal portion with white gasoline and brake cleaner.
- (2) Clean oil, water, dust etc off from the mating surface of each part and the counter part using cloth etc.
- (3) Apply liquid gasket to the parts to be attached.
- (4) Observe the direction for the width application and avoid excessive or short application and always overlap the start and end of application.
- (5) After assembly, be careful not to move the parts.
- (6) Install within 5 min. after applying.
- (7) After assembly, do not fill coolant, oil and start the engine within a determined time.

2. Application location and liquid gasket to be used

Number in figure	Liquid gasket applying location	Liquid gasket to be used
1	Ventilation valve SUB-ASSY × cylinder block	THREE BOND 1324
2	Cylinder block (bank 1 side) × cylinder block (bank 2 side)	THREE BOND 1217G
3	Cylinder block tight plug No. 1 × cylinder block	THREE BOND 1105
4	Camshaft housing SUB-ASSY LH × pump drive case ASSY	THREE BOND 1217G
5	Cylinder head gasket × cylinder block Cylinder head gasket × cylinder head	THREE BOND 1217G
6	Cylinder head × camshaft housing SUB-ASSY	THREE BOND 1217G
7	Camshaft housing SUB-ASSY × camshaft cap	THREE BOND 1217G
8	Camshaft housing SUB-ASSY and camshaft cap × cylinder head cover gasket	THREE BOND 1217G
9	Cylinder block, cylinder head, camshaft housing SUB-ASSY and cylinder head cover SUB-ASSY × timing chain/belt cover SUB-ASSY	THREE BOND 1217G
10	Engine oil pressure switch ASSY × timing chain/belt cover SUB-ASSY	THREE BOND 1324
11	Camshaft housing SUB-ASSY × vacuum pump ASSY*1 or cylinder head plate RR*2	THREE BOND 1217G
12	Camshaft housing SUB-ASSY × oil separator cover	THREE BOND 1217G
13	Cylinder block × oil pan SUB-ASSY	THREE BOND 1217G
14	Oil pan SUB-ASSY × oil pan SUB-ASSY No. 2	THREE BOND 1217G

*1: Transmission A/T

*2: Transmission M/T

3. Liquid gasket applying location

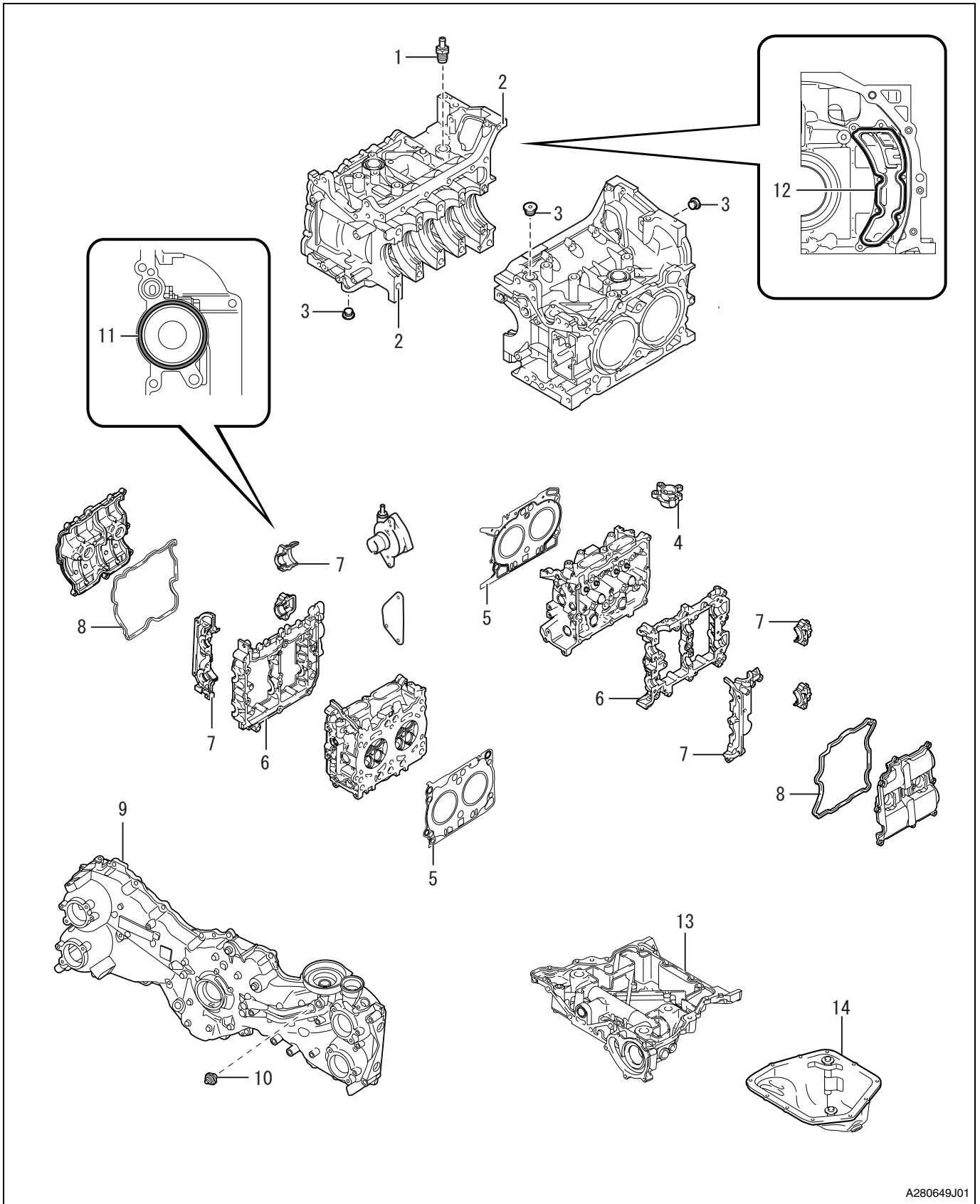

EM

PARTIAL ENGINE ASSY (FA20)

EXPLODED VIEW

EM

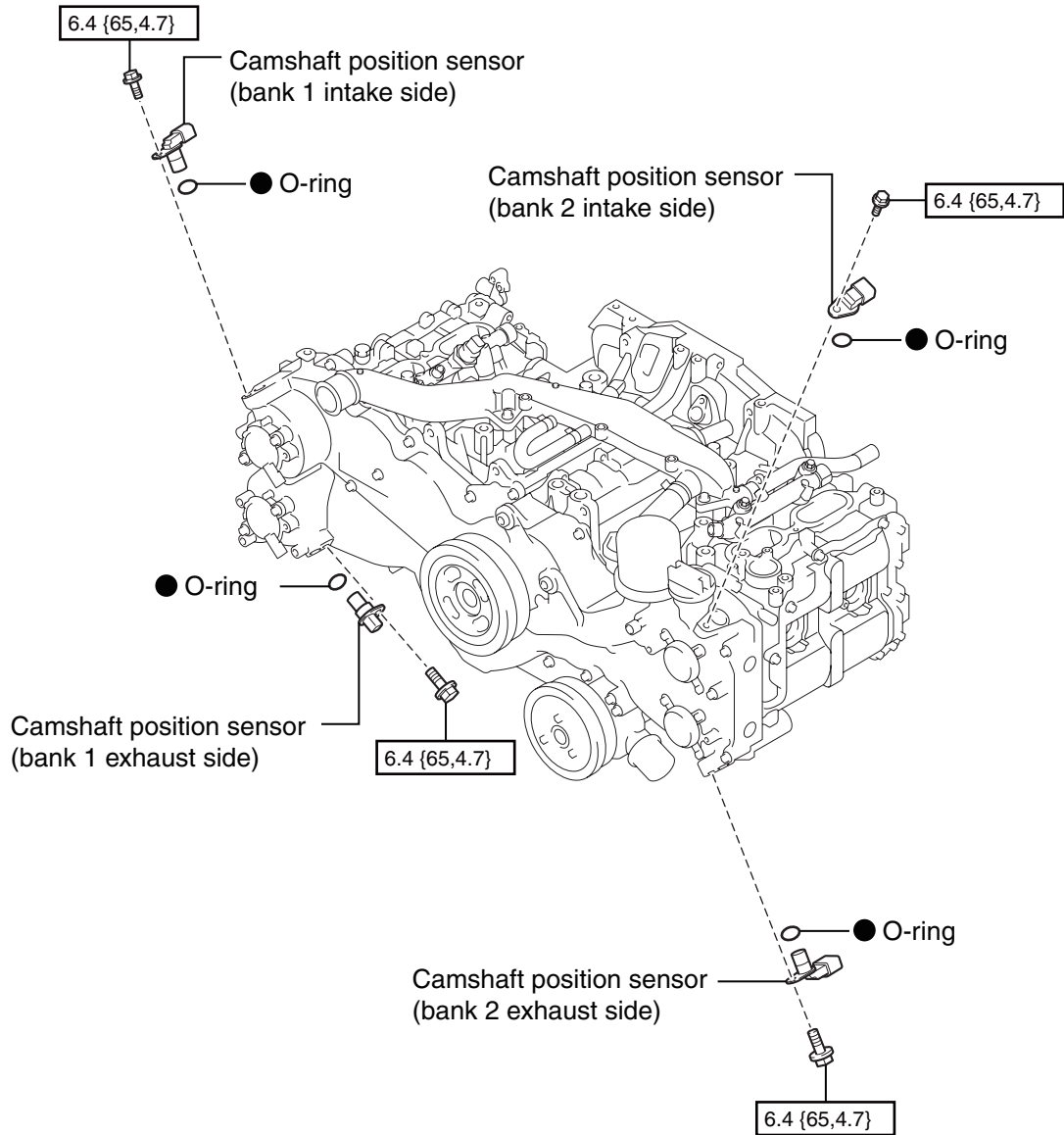

$N \cdot m \{kgf \cdot cm\} \{ft \cdot lb\}$: Specified torque

● Non-reusable parts

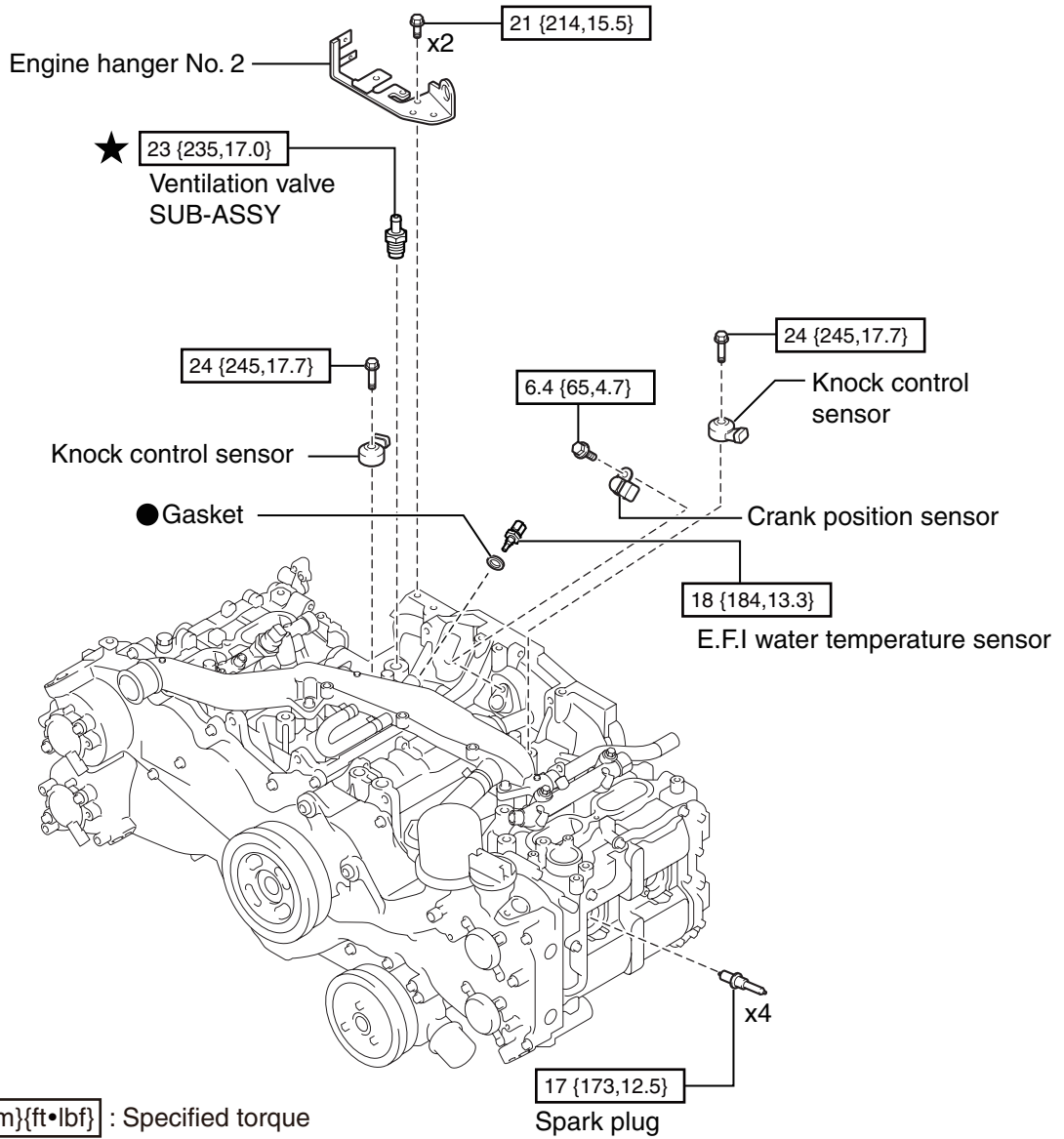

EM

EM

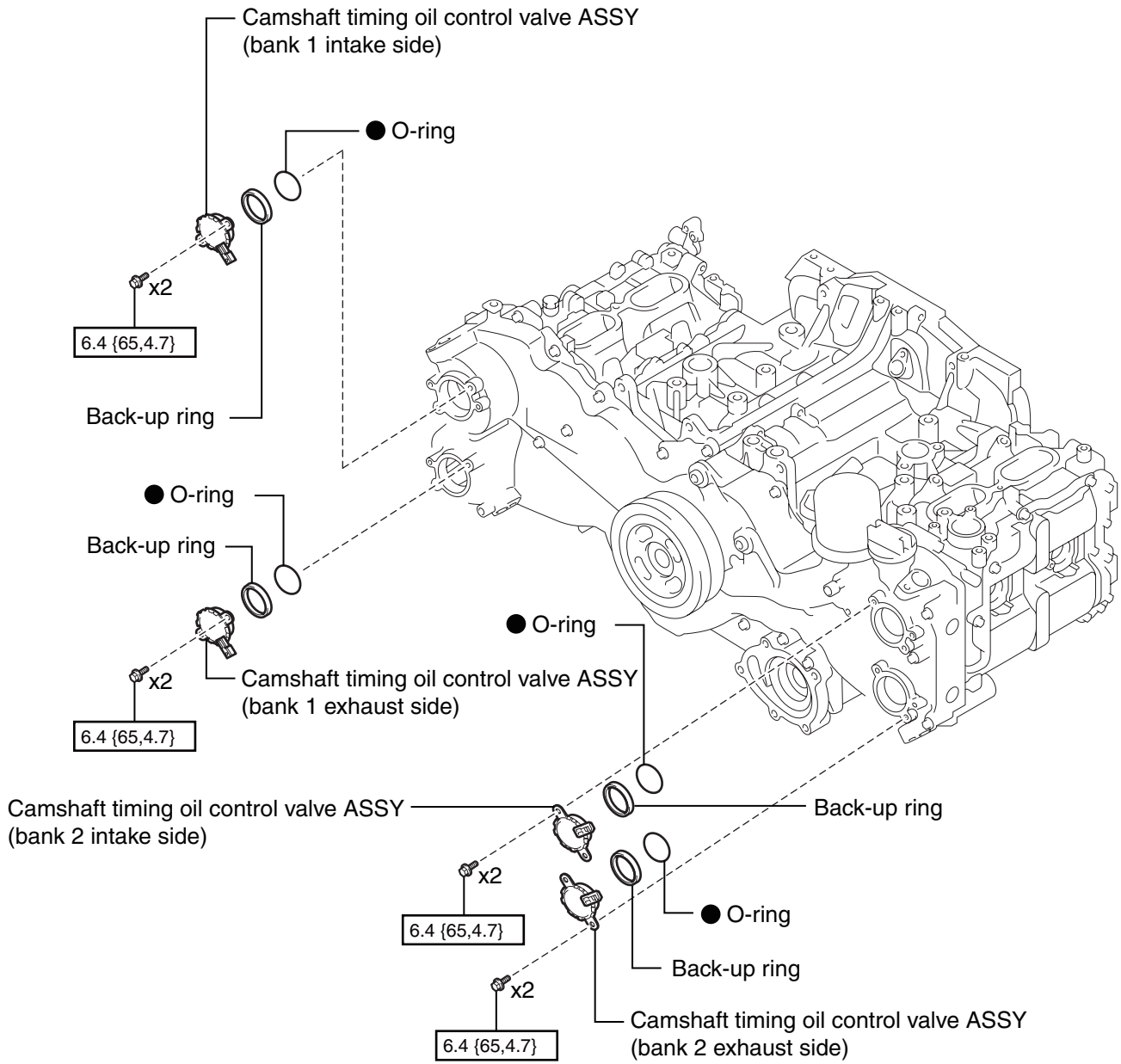

$\boxed{\text{N}\cdot\text{m}} \{ \text{kgf}\cdot\text{cm} \} \{ \text{ft}\cdot\text{lbf} \}$: Specified torque

● Non-reusable parts

EM

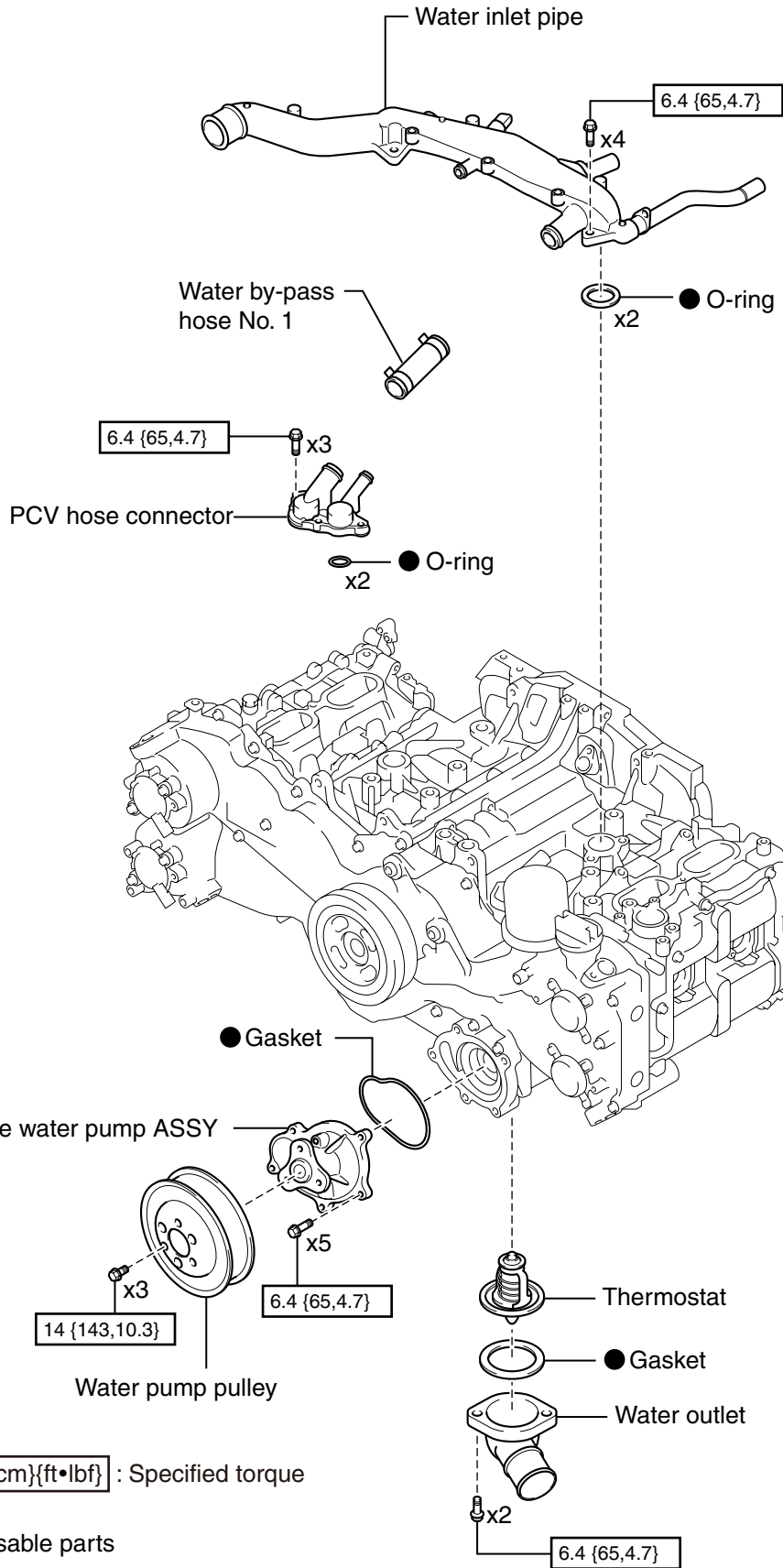

N•m {kgf•cm}{ft•lbf} : Specified torque

● Non-reusable parts

EM

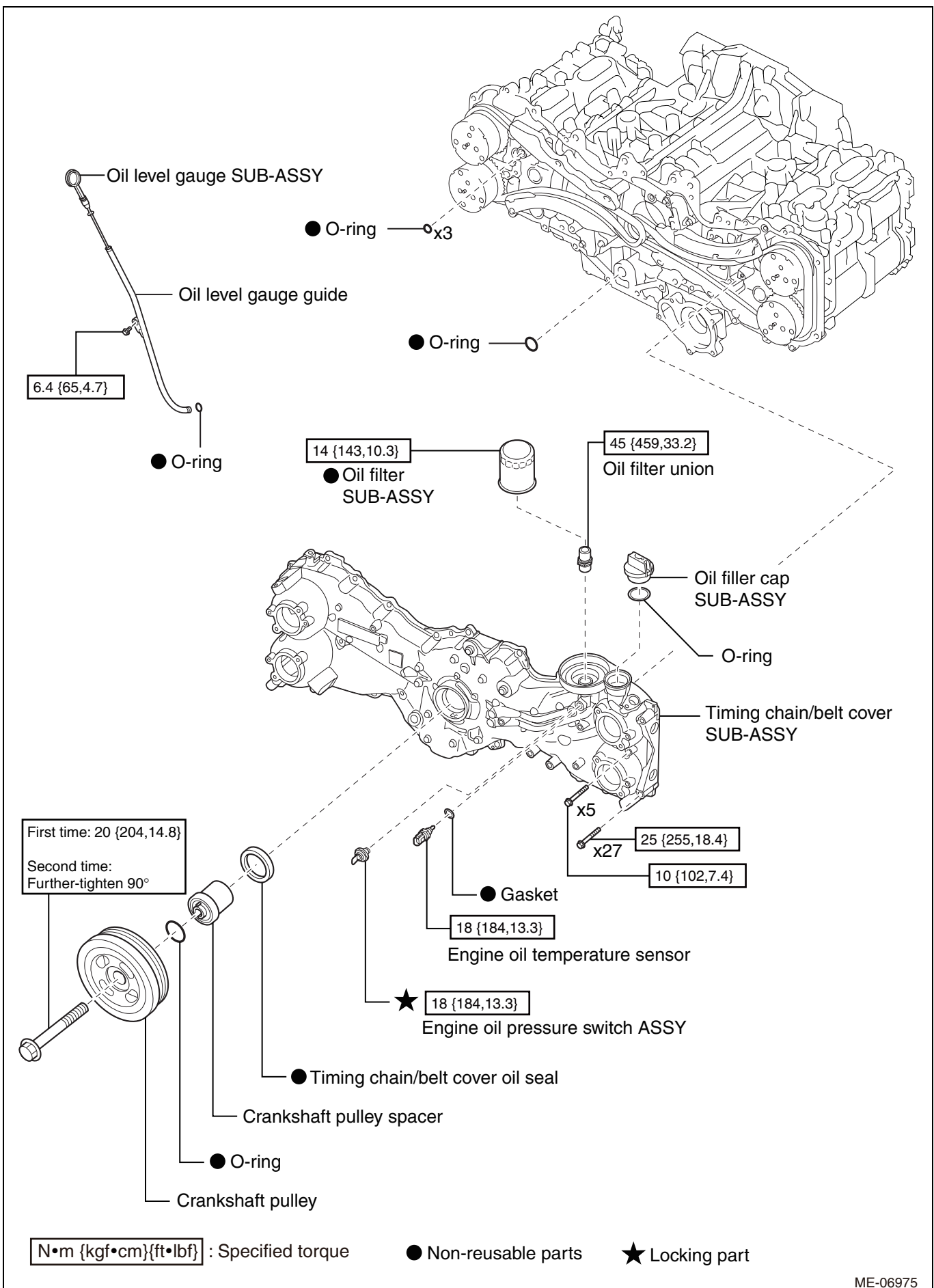

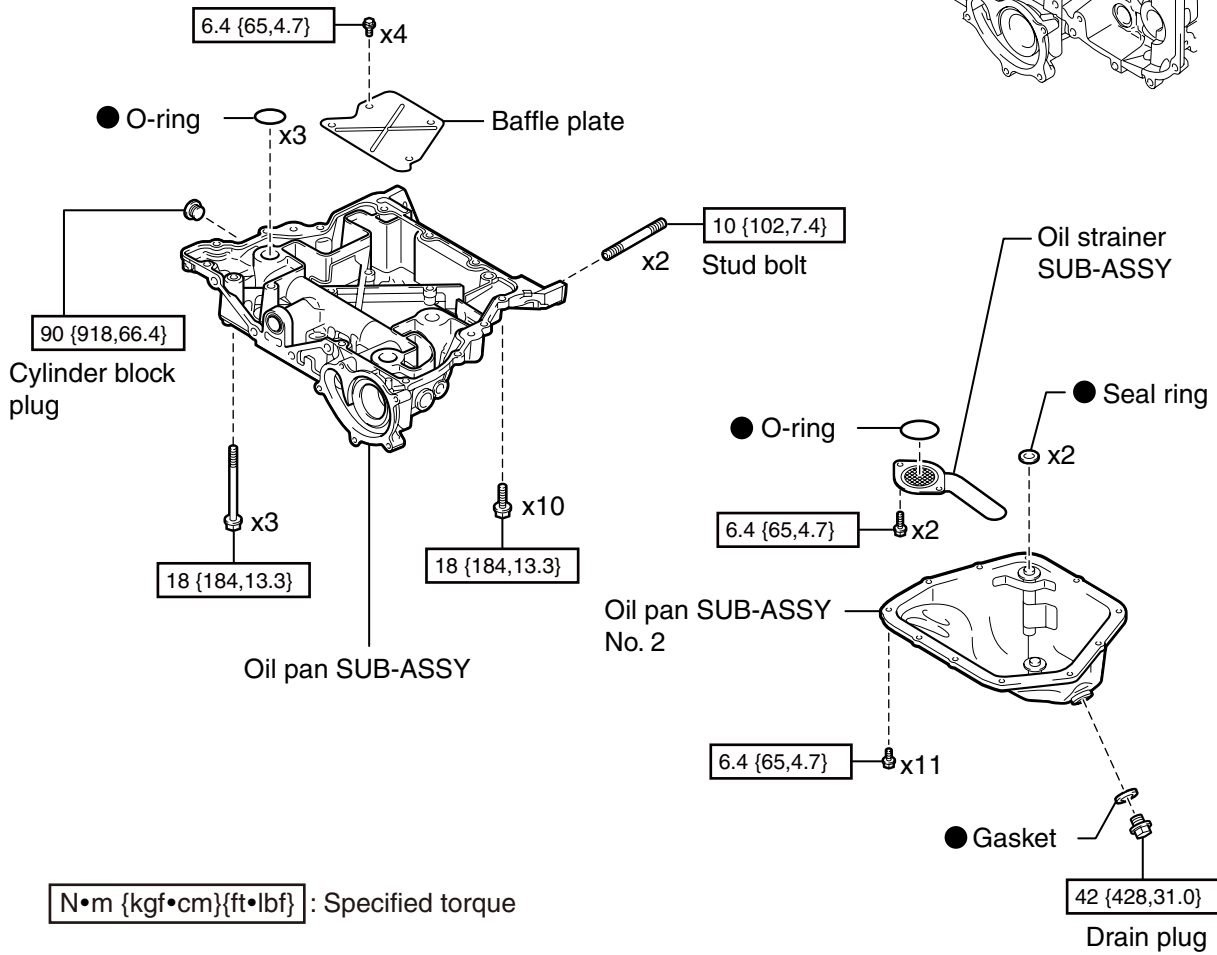
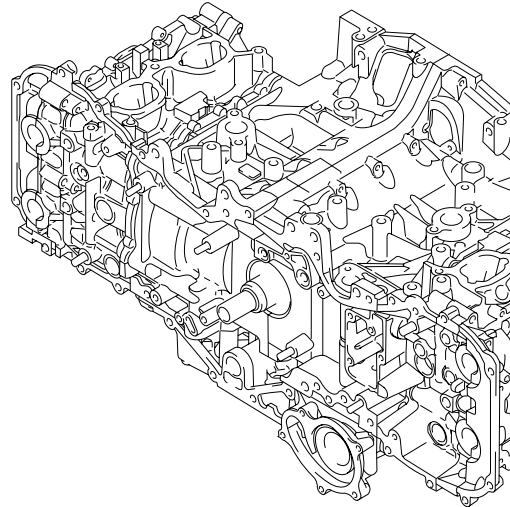

N•m {kgf•cm}{ft•lbf} : Specified torque

● Non-reusable parts

EM

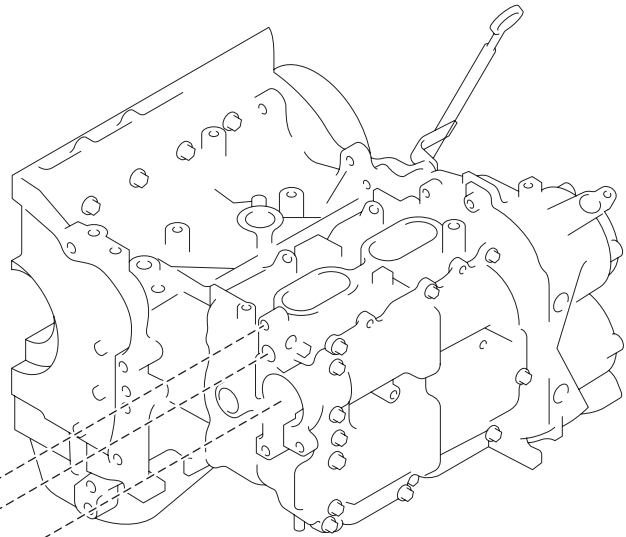
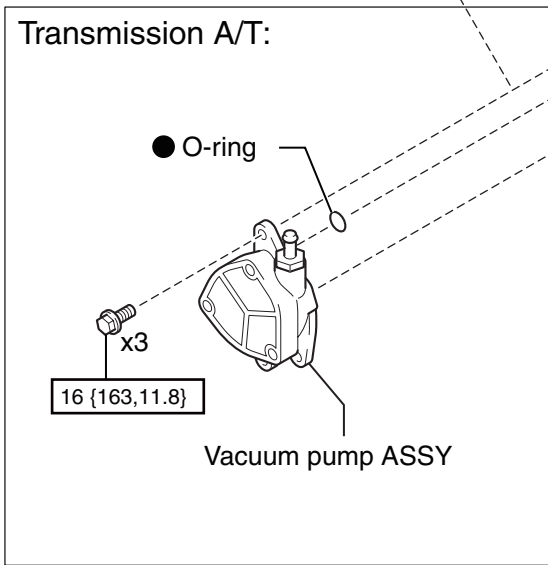
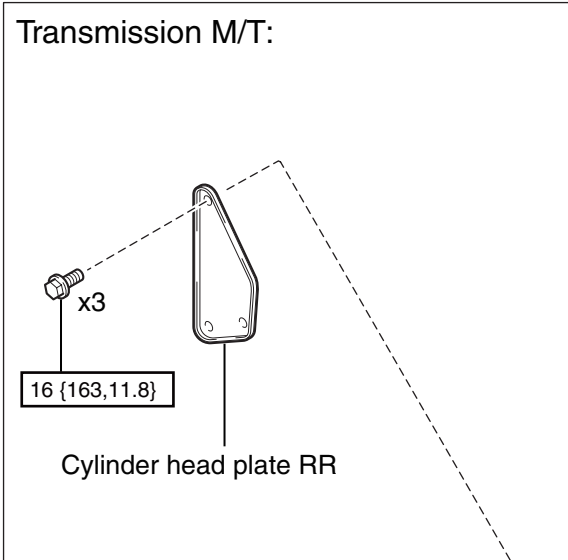

N•m {kgf•cm}{ft•lbf} : Specified torque

● Non-reusable parts

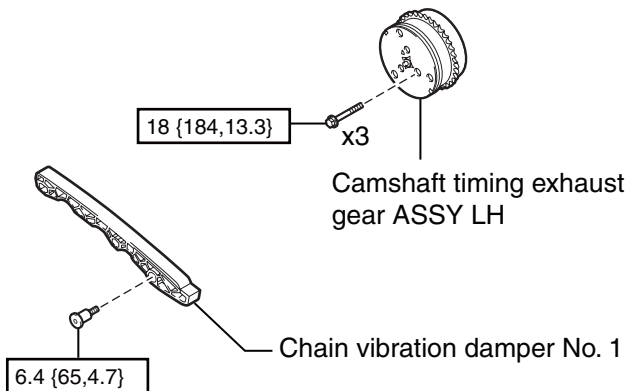
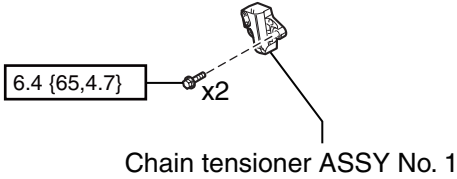
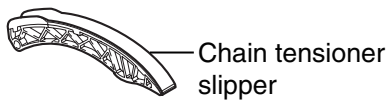
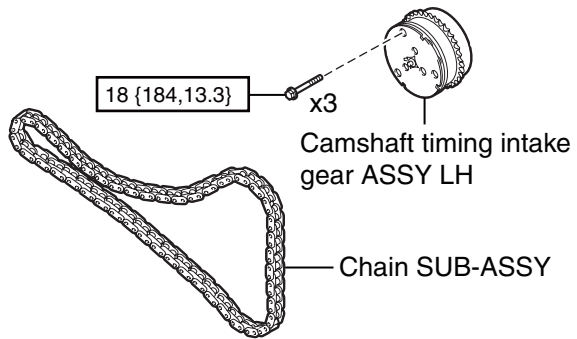
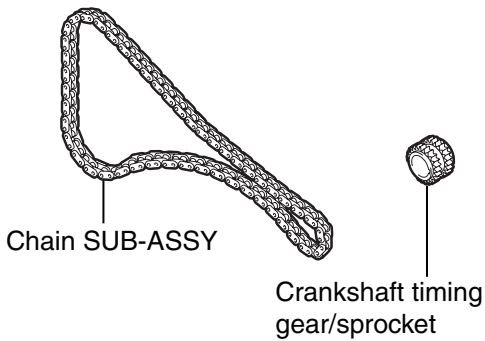
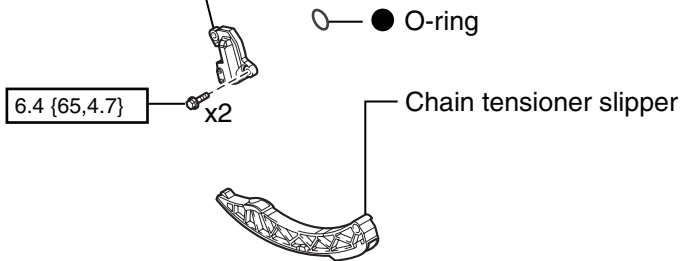
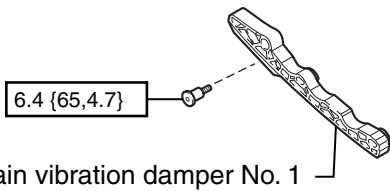
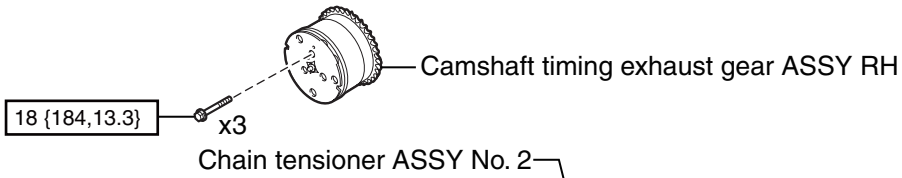
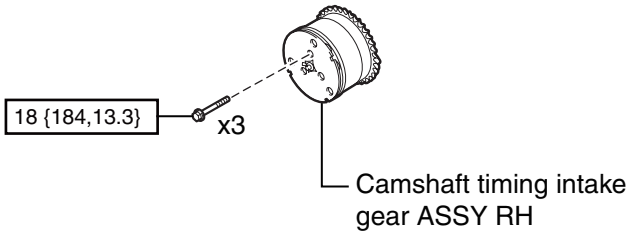
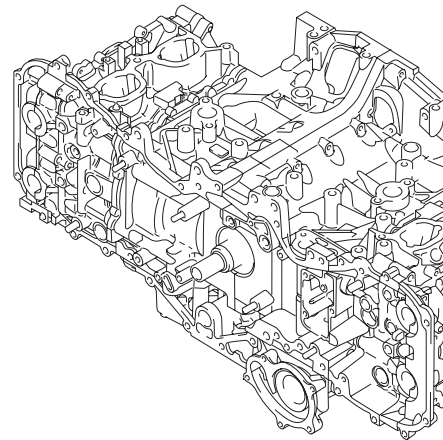

N•m {kgf•cm}{ft•lbf} : Specified torque ● Non-reusable parts

EM

Bank 1:

Cylinder head cover SUB-ASSY

● Cylinder head cover gasket

6.4 {65,4.7} x2

Injector driver bracket

6.4 {65,4.7} x8

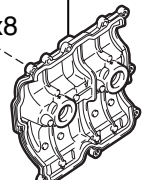

Transmission A/T:

31 {316,22.9} x2

6.4 {65,4.7}

x2 x2 ● Gasket

Camshaft oil field pipe SUB-ASSY

Intake center camshaft cap RH

Exhaust center camshaft cap RH

Intake rear camshaft cap RH

Exhaust rear camshaft cap RH

Transmission M/T:

25 {255,18.4}

Hole plug

● Gasket

Camshaft housing SUB-ASSY RH

- First time: 20 {204,14.8}
- Second time: 100 {1020,73.8}
- Third time: Loosen 360°
- Fourth time: 20 {204,14.8}
- Fifth time: 42 {428,31.0}
- Sixth time: Further-tighten 100°
- Seventh time: Further-tighten 100°
- Further-tighten 50°

18 {184,13.3} x12

Front camshaft cap RH

Intake camshaft RH

Exhaust camshaft RH

Cylinder head bolt

x6

Valve rocker arm SUB-ASSY No. 1

Roller rocker arm pivot

Cylinder head SUB-ASSY

x2

● Cylinder head gasket



x2

● O-ring



x8

x8

x8

x2

x2

x2

x2

x2

x2

x2

x2

x8

x8

x8

x2

x2

x2

x2

x2

x2

x2

x2

x2

x2

x2

x2

x2

x2

x2

x2

x8

x8

x8

x2

x2

x2

x2

x2

x2

x2

x2

x2

x2

x2

x2

x2

x2

x2

x2

x8

x8

x8

x2

x2

x2

x2

x2

x2

x2

x2

x2

x2

x2

x2

x2

x2

x2

x2

x8

x8

x8

x2

x2

x2

x2

x2

x2

x2

x2

x2

x2

x2

x2

x2

x2

x2

x2

x8

x8

x8

x2

x2

x2

x2

x2

x2

x2

x2

x2

x2

x2

x2

x2

x2

x2

x2

x8

x8

x8

x2

x2

x2

x2

x2

x2

x2

x2

x2

x2

x2

x2

x2

x2

x2

x2

x8

x8

x8

x2

x2

x2

x2

x2

x2

x2

x2

x2

x2

x2

x2

x2

x2

x2

x2

x8

x8

x8

x2

x2

x2

x2

x2

x2

x2

x2

x2

x2

x2

x2

x2

x2

x2

x2

x8

x8

x8

x2

x2

x2

x2

x2

x2

x2

x2

x2

x2

x2

x2

x2

x2

x2

x2

x8

x8

x8

x2

x2

x2

x2

x2

x2

x2

x2

x2

x2

x2

x2

x2

x2

x2

x2

x8

x8

x8

x2

x2

x2

x2

x2

x2

x2

x2

x2

x2

x2

x2

x2

x2

x2

x2

x8

x8

x8

x2

x2

x2

x2

x2

x2

x2

x2

x2

x2

x2

x2

x2

x2

x2

x2

x8

x8

x8

x2

x2

x2

x2

x2

x2

x2

x2

x2

x2

x2

x2

x2

x2

x2

x2

x8

x8

x8

x2

x2

x2

x2

x2

x2

x2

x2

x2

x2

x2

x2

x2

x2

Bank 2:

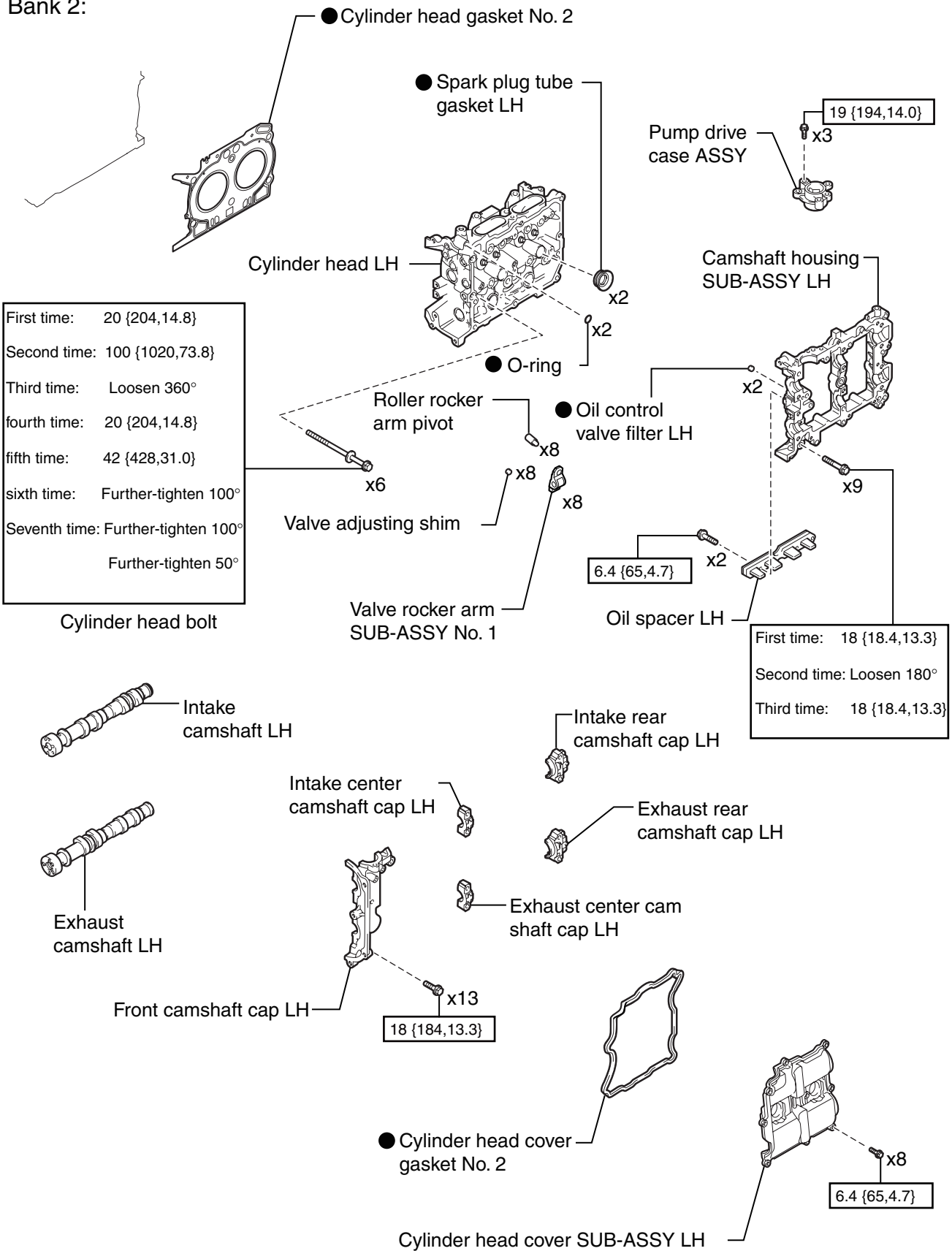

- First time: 20 {204,14.8}
- Second time: 100 {1020,73.8}
- Third time: Loosen 360°
- fourth time: 20 {204,14.8}
- fifth time: 42 {428,31.0}
- sixth time: Further-tighten 100°
- Seventh time: Further-tighten 100°
- Further-tighten 50°

Cylinder head bolt

- First time: 18 {18.4,13.3}
- Second time: Loosen 180°
- Third time: 18 {18.4,13.3}

N•m {kgf•cm}{ft•lbf} : Specified torque

● Non-reusable parts



DISASSEMBLY

1. Removal of oil filler cap SUB-ASSY
 - (1) Remove the oil filler cap SUB-ASSY.
2. Removal of oil filter SUB-ASSY
 - (1) Using SST, remove the oil filter SUB-ASSY.
SST 18332AA020

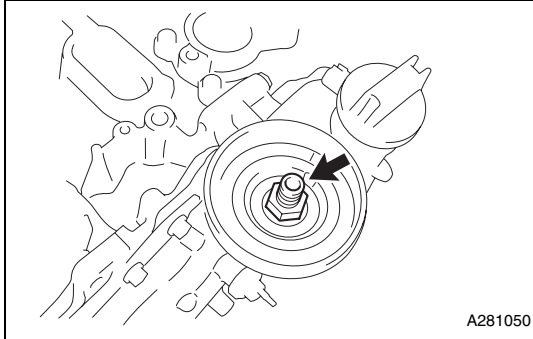

3. Removal of oil filter union
 - (1) Remove the oil filter union.

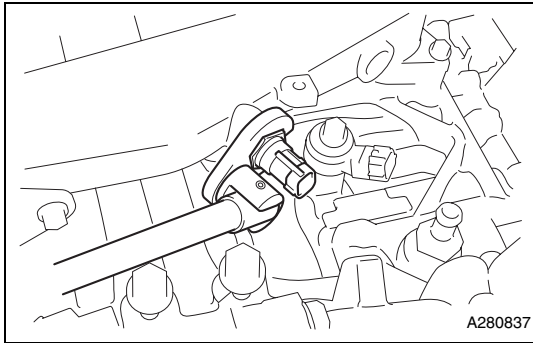

4. Removal of engine water temperature sensor
 - (1) Remove the engine water temperature sensor and gasket.

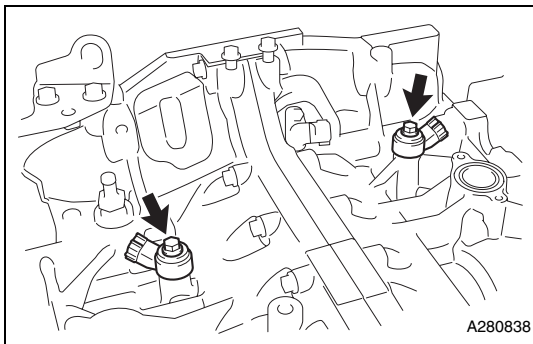

5. Removal of knock control sensor
 - (1) Remove the two bolts to remove the two knock control sensors.

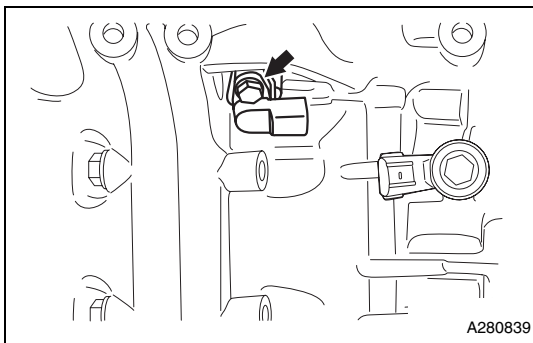

6. Removal of crank position sensor
 - (1) Remove the bolt to remove the crank position sensor.

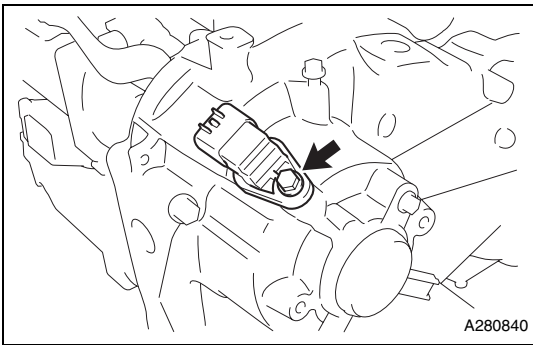

7. Removal of camshaft position sensor

- (1) Remove the bolt to remove the camshaft position sensor (bank 1 intake side).
- (2) Remove the O-ring from the camshaft position sensor.

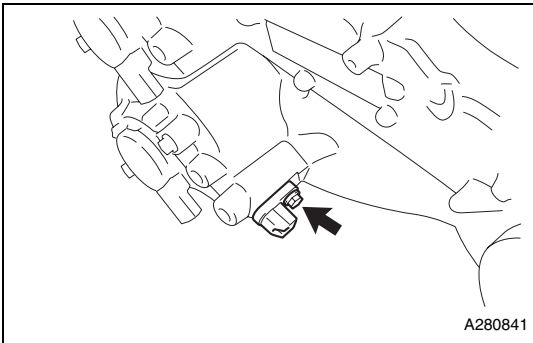

- (3) Remove the bolt to remove the camshaft position sensor (bank 1 exhaust side).
- (4) Remove the O-ring from the camshaft position sensor.

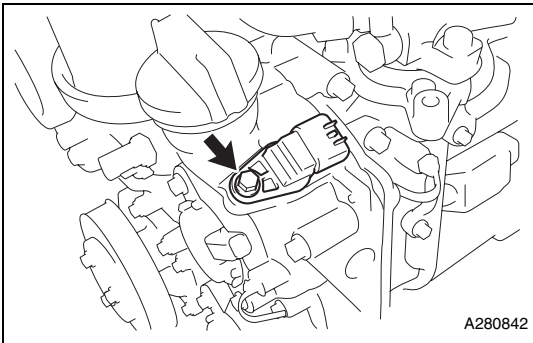

- (5) Remove the bolt to remove the camshaft position sensor (bank 2 intake side).
- (6) Remove the O-ring from the camshaft position sensor.

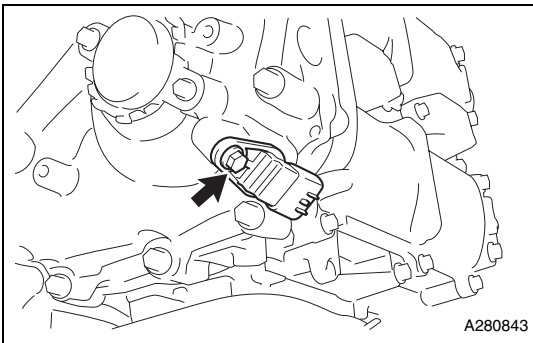

- (7) Remove the bolt to remove the camshaft position sensor (bank 2 exhaust side).
- (8) Remove the O-ring from the camshaft position sensor.

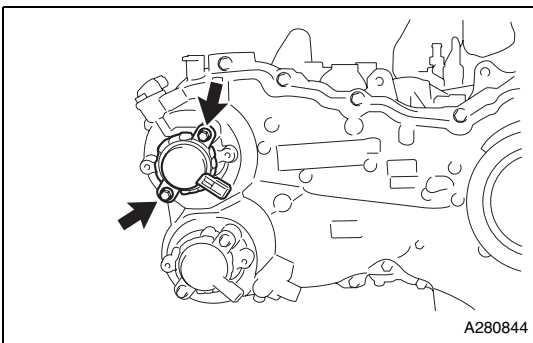

8. Removal of camshaft timing oil control valve ASSY

- (1) Remove the two bolts to remove the camshaft timing oil control valve ASSY (bank 1 intake side).



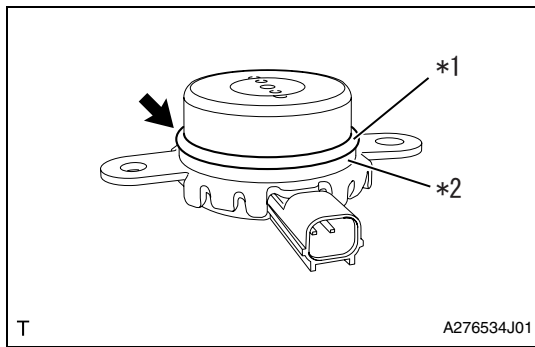

- (2) Remove the O-ring from the camshaft timing oil control valve ASSY.

Captions in illustration

*1	O-ring
*2	Back-up ring

- (3) Remove the back-up ring from the camshaft timing oil control valve ASSY.

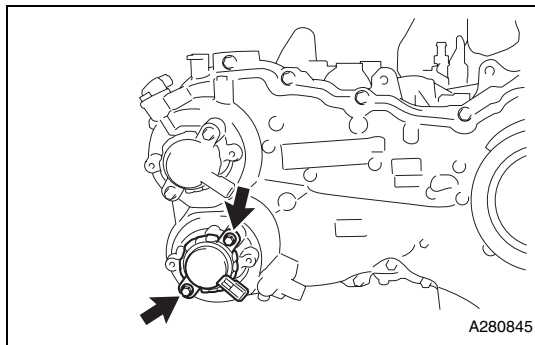

- (4) Remove the two bolts to remove the camshaft timing oil control valve ASSY (bank 1 exhaust side).

- (5) Remove the O-ring from the camshaft timing oil control valve ASSY.

- (6) Remove the back-up ring from the camshaft timing oil control valve ASSY.

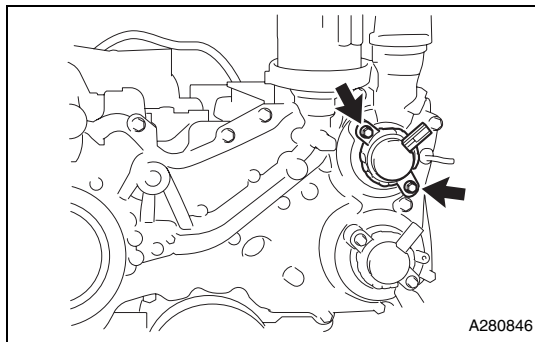

- (7) Remove the two bolts to remove the camshaft timing oil control valve ASSY (bank 2 intake side).

- (8) Remove the O-ring from the camshaft timing oil control valve ASSY.

- (9) Remove the back-up ring from the camshaft timing oil control valve ASSY.

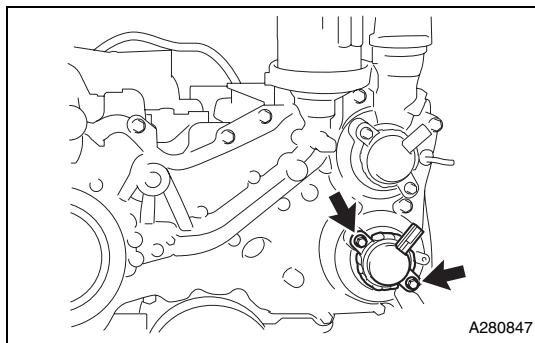

- (10) Remove the two bolts to remove the camshaft timing oil control valve ASSY (bank 2 exhaust side).

- (11) Remove the O-ring from the camshaft timing oil control valve ASSY.

- (12) Remove the back-up ring from the camshaft timing oil control valve ASSY.

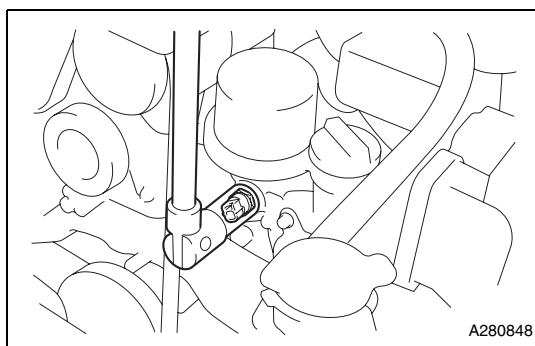

9. Removal of engine oil temperature sensor

- (1) Remove the engine oil temperature sensor.

<Caution>

Catch the engine oil using cloth to prevent it from splashing.

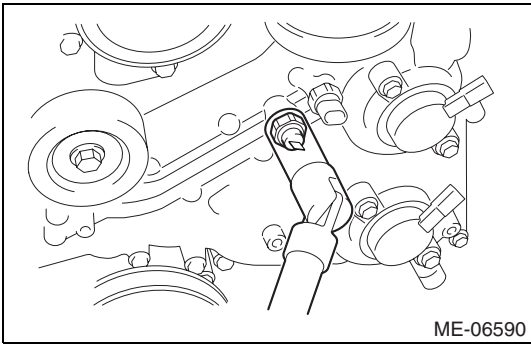

10. Removal of engine oil pressure switch ASSY

- (1) Remove the engine oil pressure switch ASSY.
<Caution>
Catch the engine oil using cloth to prevent it from splashing.

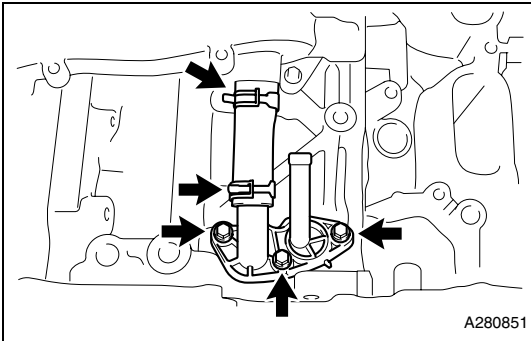

11. Removal of PCV hose connector

- (1) Remove the three bolts to remove the PCV hose connector.
- (2) Slide the hose clamp to disconnect the water by-pass hose No. 1 from the water inlet pipe.
- (3) Slide the hose clamp to disconnect the water by-pass hose No. 1 from the PCV hose connector.

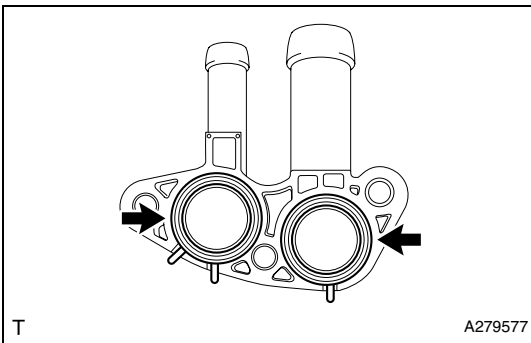

- (4) Remove the two O-rings from the PCV hose connector.

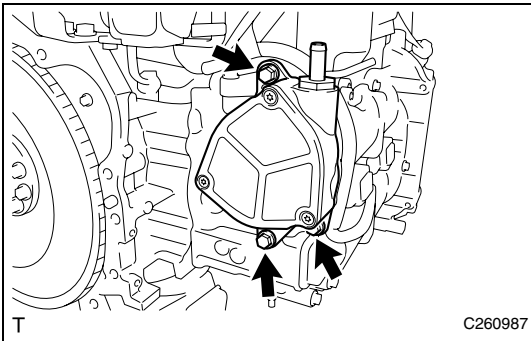

12. Removal of vacuum pump ASSY (transmission A/T).

- (1) Remove the three bolts to remove the vacuum pump ASSY from the camshaft housing SUB-ASSY.
- (2) Remove the O-ring from the vacuum pump ASSY.

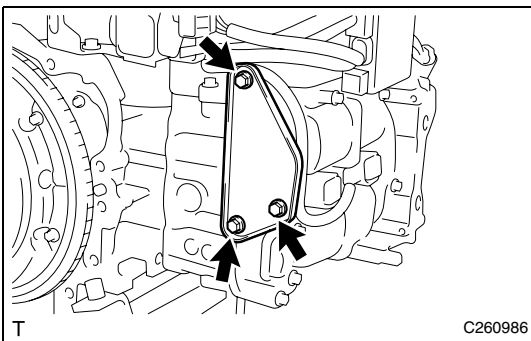

13. Removal of cylinder head plate RR (transmission M/T)

- (1) Remove the three bolts to remove the cylinder head plate RR from the camshaft housing SUB-ASSY RH.

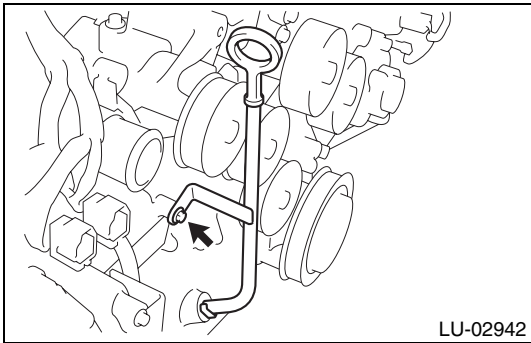

14. Removal of oil level gauge guide

- (1) Remove the oil level gauge SUB-ASSY.
- (2) Remove the bolt to remove the oil level gauge guide.
- (3) Remove the O-ring from the oil level gauge guide.

15. Removal of transmission oil cooler hose No. 3 (transmission A/T)

- (1) Slide the hose clamp to remove the transmission oil cooler hose No. 3.

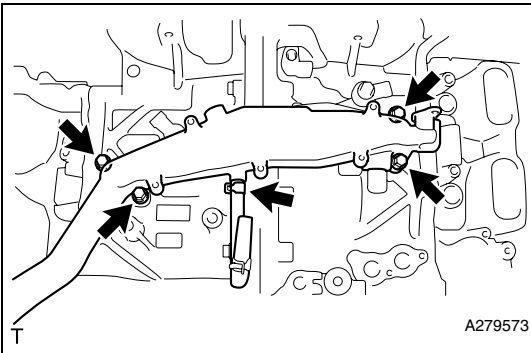

16. Removal of water inlet pipe

- (1) Slide the hose clamp to remove the water by-pass hose No. 3.
- (2) Remove the four bolts to remove the water inlet pipe.

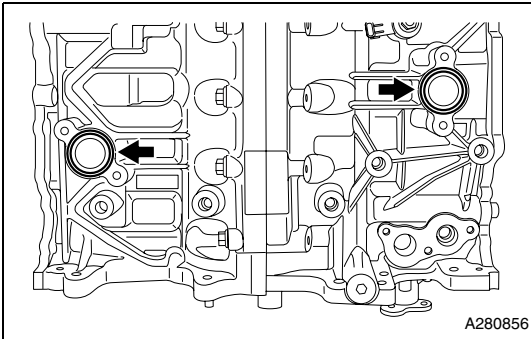

- (3) Remove the two O-rings from cylinder block (bank 1 side and bank 2 side).

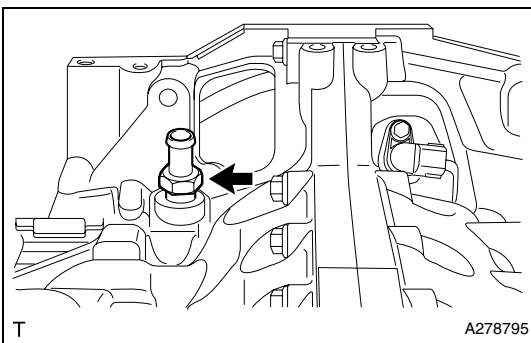

17. Removal of ventilation valve SUB-ASSY

- (1) Remove the ventilation valve SUB-ASSY from the cylinder block (bank 1 side).

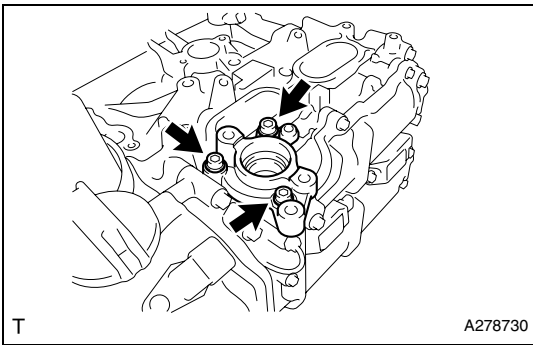

18. Removal of pump drive case ASSY

- (1) Remove the three bolts to remove the pump drive case ASSY.

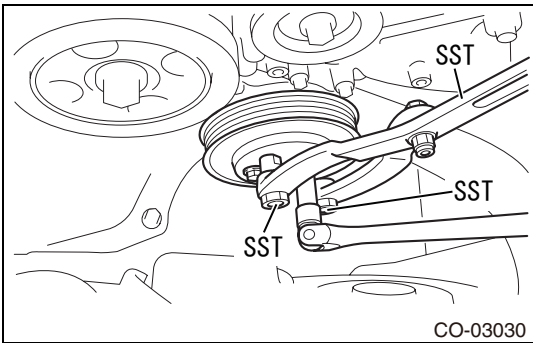

19. Removal of water pump pulley

- (1) Fix the water pump pulley using SST.
SST 18355AA000, 18334AA030
- (2) Remove the three bolts to remove the water pump pulley.

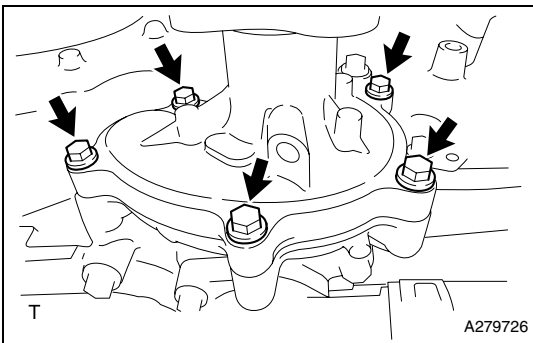

20. Removal of engine water pump ASSY

- (1) Remove the five bolts to remove the engine water pump ASSY and gasket.

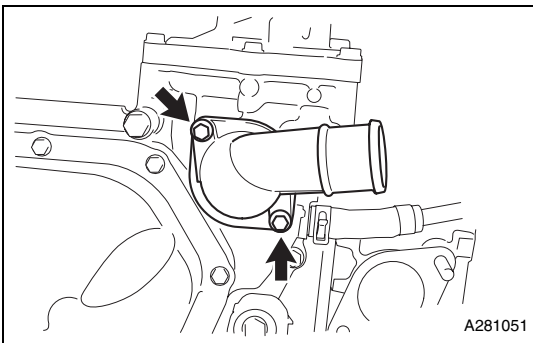

21. Removal of water outlet

- (1) Remove the two bolts to remove the water outlet.

22. Removal of thermostat

- (1) Remove the thermostat.
- (2) Remove the gasket from the thermostat.

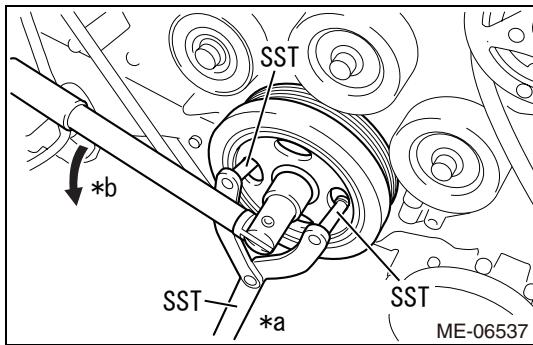

23. Removal of crankshaft pulley

- (1) Fix the crankshaft pulley using SST.
SST 18355AA000, 18334AA000
Captions in illustration

*a	Hold
*b	Rotate

- (2) Remove the crankshaft pulley set bolt to remove the crankshaft pulley.
- (3) Remove the O-ring from the crankshaft pulley spacer.
- (4) Remove the crankshaft pulley spacer.

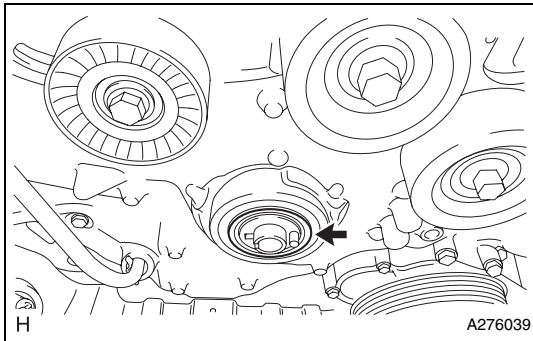

24. Removal of timing chain/belt cover oil seal

- (1) Remove the timing chain/belt cover oil seal using a flat tip screwdriver wrapped with protective tape etc.

Captions in illustration

*1	Protective tape
----	-----------------

<Caution>

Make sure that there is no flaw in the crankshaft and timing chain/belt cover oil seal fitting portion.

<Reference>

When flaw is found in the crankshaft, correct the crankshaft using abrasive paper (No. 400).

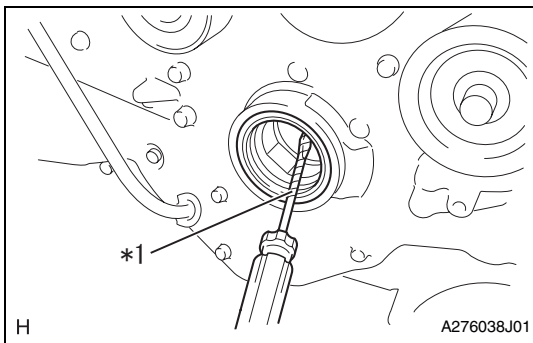

25. Removal of timing chain/belt cover SUB-ASSY

- (1) Remove the 32 bolts.

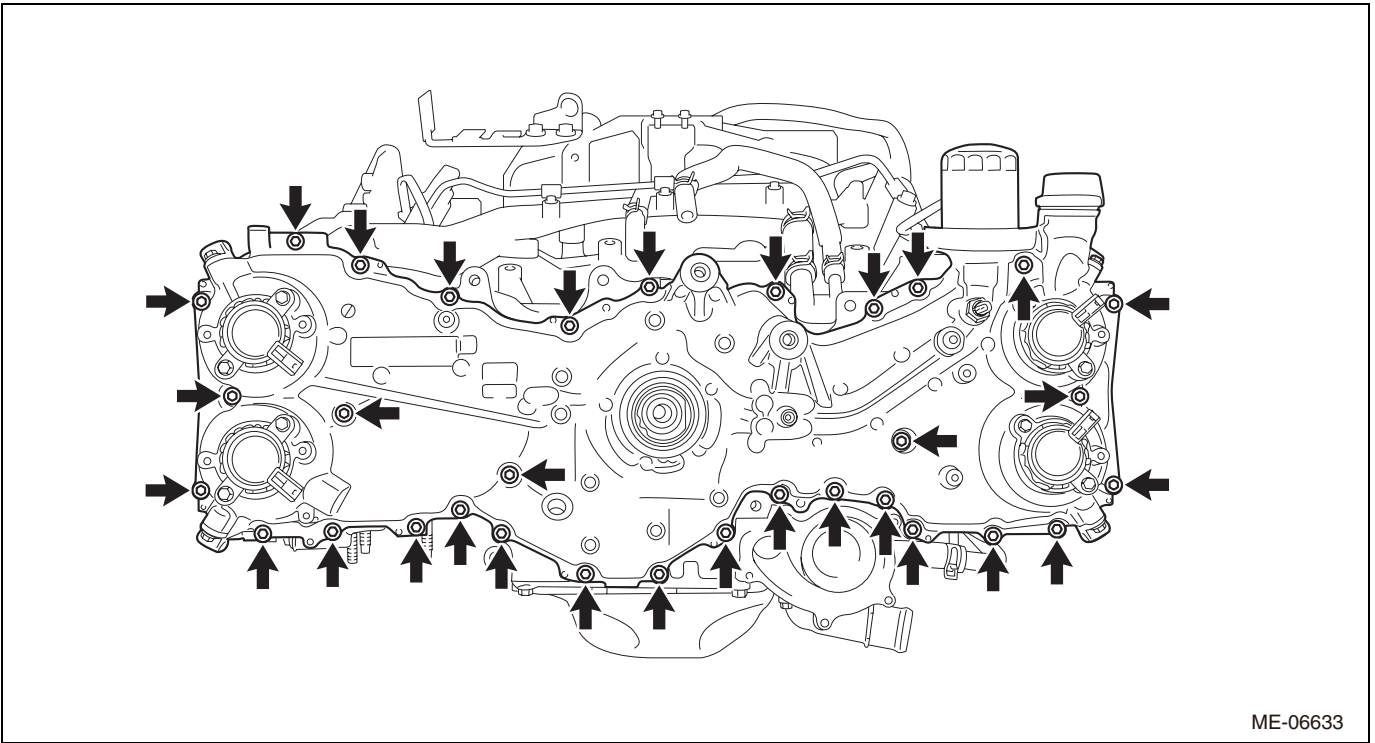

ME-06633

- (2) Remove the timing chain/belt cover SUB-ASSY at the rib position shown in the figure using a flat tip screwdriver wrapped with protective tape.

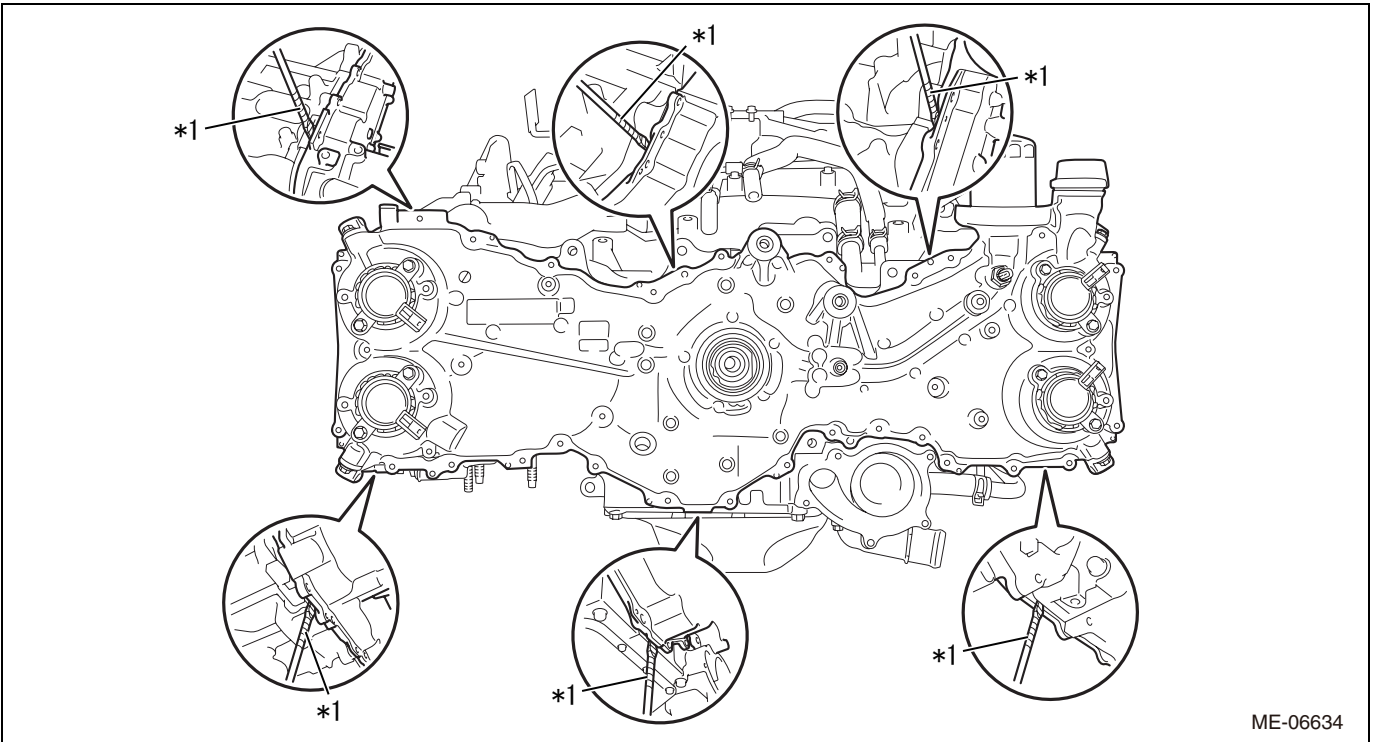

ME-06634

Captions in illustration

*1	Protective tape	-	-
----	-----------------	---	---

<Caution>

Do not damage the timing chain/belt cover SUB-ASSY, cylinder head, camshaft timing gear and cylinder block.

- (3) Remove the four O-rings.

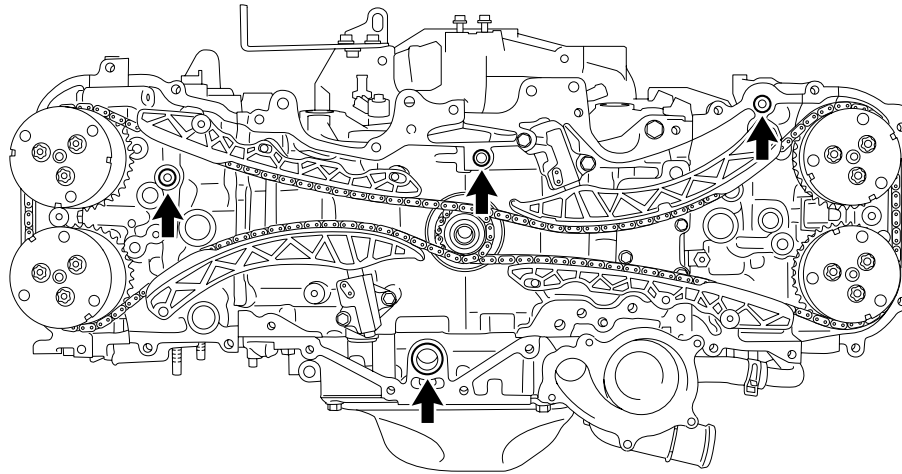

T

A281482

26. Removal of the chain SUB-ASSY (bank 1 side)

(1) Install the SST to the crankshaft.

SST 18252AA000

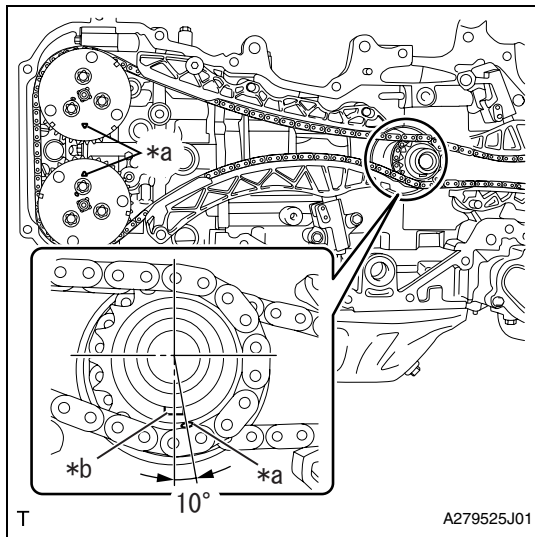

T

A279525J01

(2) Using SST and by turning the crankshaft, align the alignment marks of the crankshaft timing gear/sprocket, camshaft timing intake gear ASSY RH, and camshaft timing exhaust gear ASSY RH.

Captions in illustration

*a	Alignment mark
*b	Key

<Reference>

At this time, the crankshaft timing gear key points downward.

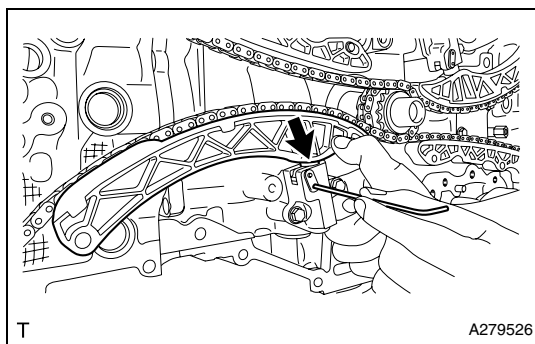

T

A279526

(3) Push down the chain tensioner slipper as shown in the figure, and insert a 2.5 mm {0.098 in} dia. hex wrench into the hole of the chain tensioner ASSY No. 1 and stopper plate to secure the plunger.

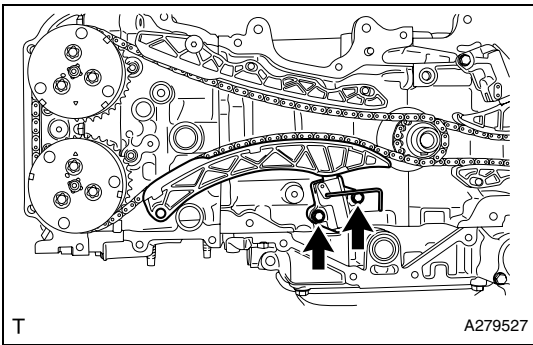

(4) Remove the two bolts to remove the chain tensioner ASSY No. 1.

(5) Remove the chain tensioner slipper.

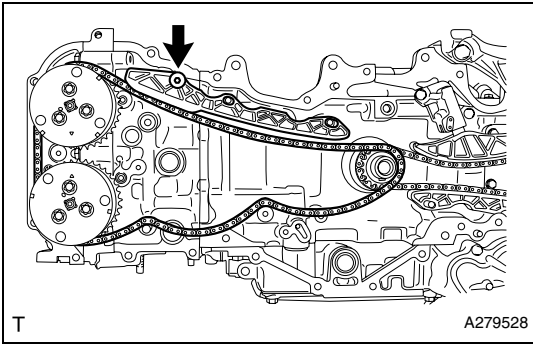

(6) Remove the bolt, and remove the chain vibration damper No. 1.



(7) Remove the chain SUB-ASSY.

<Caution>

Under the condition that the chain SUB-ASSY is detached, the valve heads contact each other and valve stem may bend. Do not turn the intake camshaft RH and exhaust camshaft RH to the outside of range of zero-lift (in range where it can be turned lightly by hand).

<Reference>

Organize disassembled parts by their installation positions.

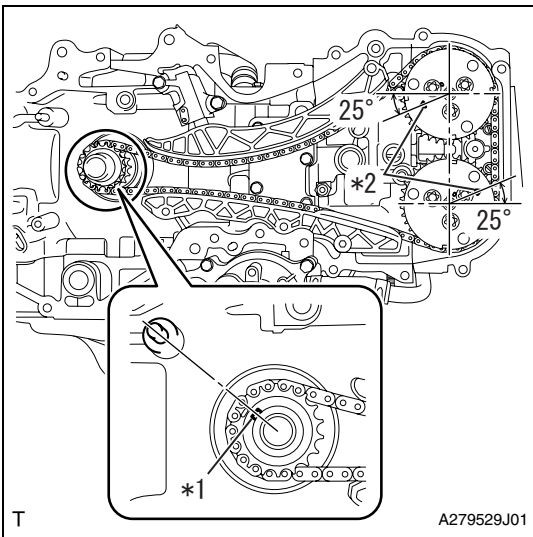

27. Removal of the chain SUB-ASSY (bank 2 side)

(1) Install the SST to the crankshaft.

SST 18252AA000

(2) Using SST and by turning the crankshaft, align the alignment marks of the crankshaft timing gear/sprocket, camshaft timing intake gear ASSY LH, and camshaft timing exhaust gear ASSY LH.

Captions in illustration

*1	Key
*2	Alignment mark

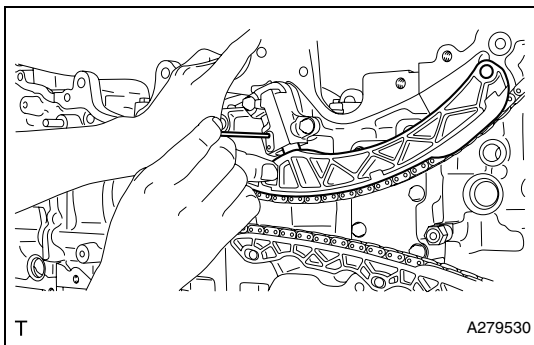

- (3) Push up the chain tensioner slipper as shown in the figure, and insert a piece of metal wire (approx. 1 mm {0.039 in} in dia.) into the hole of the chain tensioner ASSY No. 2 and stopper plate to secure the plunger.

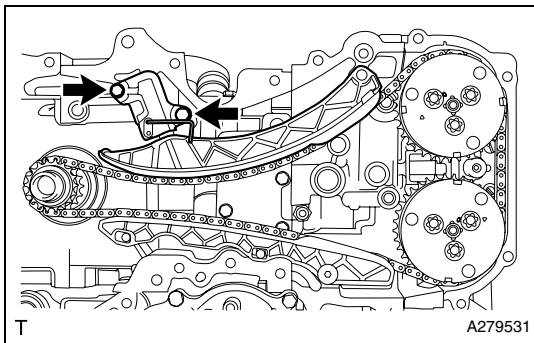

- (4) Remove the two bolts to remove the chain tensioner ASSY No. 2.
 (5) Remove the chain tensioner slipper.

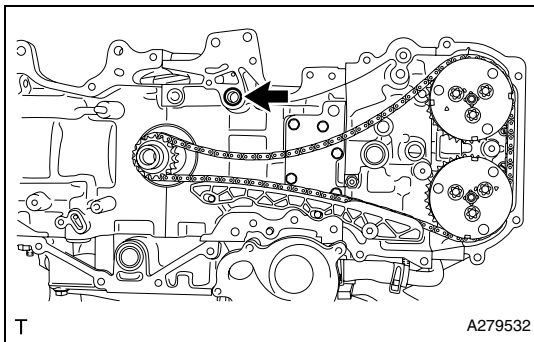

- (6) Remove the O-ring from cylinder block (bank 2 side).

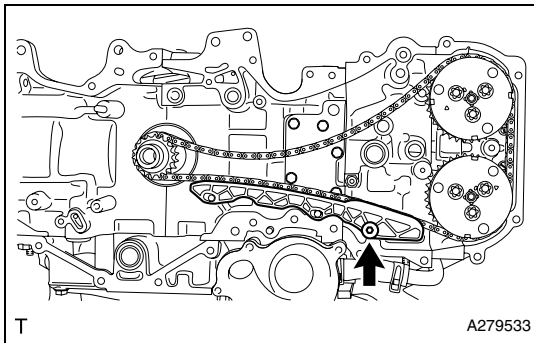

- (7) Remove the bolt, and remove the chain vibration damper No. 1.
 (8) Remove the chain SUB-ASSY.

<Caution>

- Under the condition that the chain SUB-ASSY is detached, the valve heads contact each other and valve stem may bend. Do not turn the exhaust camshaft LH to the outside of range of zero-lift (in range where it can be turned lightly by hand).
- At this time, No. 1 piston and No. 4 piston is in vicinity of TDC. If the intake camshaft LH is turned, the valve and the piston may contact and valve stem may bend. Do not turn the intake camshaft LH.

<Reference>

Organize disassembled parts by their installation positions.

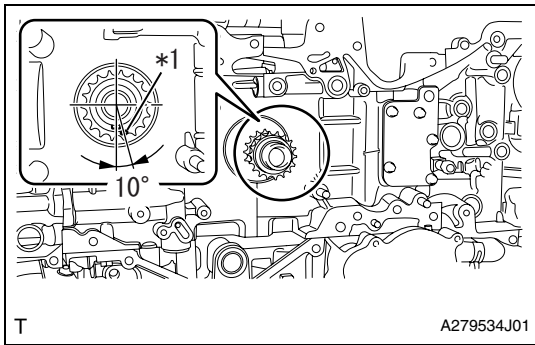

28. Operation for prevention of piston and valve from damage

- (1) Using SST and by turning the crankshaft approximately 200° clockwise, align the alignment marks of crankshaft timing gear/sprocket to the positions as shown in the figure.

Captions in illustration

*1	Alignment mark
----	----------------

SST 18252AA000

<Caution>

Never turn counterclockwise except to fine-adjust the alignment mark because the valve and piston may contact.

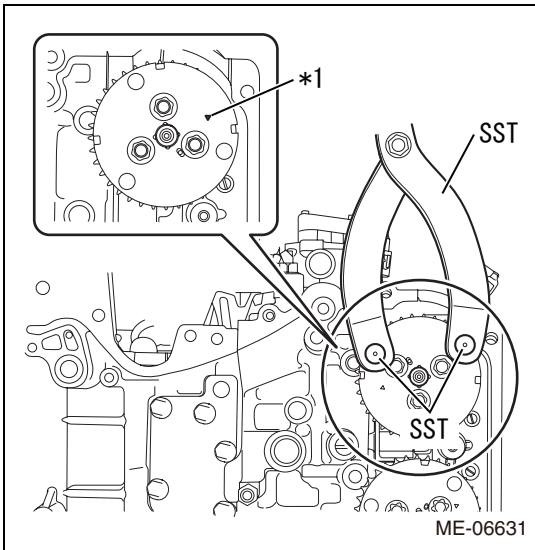

- (2) Using SST and by turning the camshaft timing intake gear ASSY LH by approximately 180°, align the alignment marks of camshaft timing intake gear ASSY LH to the positions (zero-lift position) as shown in the figure.

Captions in illustration

*1	Alignment mark
----	----------------

SST 18355AA000, 18334AA030

<Caution>

After this work, when the intake valve and exhaust valve lift at the same time, the valve heads may contact each other and valve stem may bend. Do not turn the intake camshaft LH and exhaust camshaft LH to the outside of range of zero-lift (in range where it can be turned lightly by hand).

- (3) Remove SST from the crankshaft.

29. Removal of crankshaft timing gear/sprocket

- (1) Remove the crankshaft timing gear/sprocket.

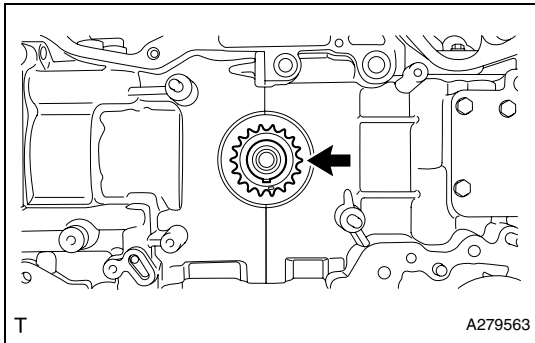

30. Removal of camshaft timing intake gear ASSY RH

- (1) Fix the camshaft timing intake gear ASSY RH using SST to remove the three bolts.

SST 18355AA000, 18334AA030, 18270KA010

- (2) Remove the camshaft timing intake gear ASSY RH.

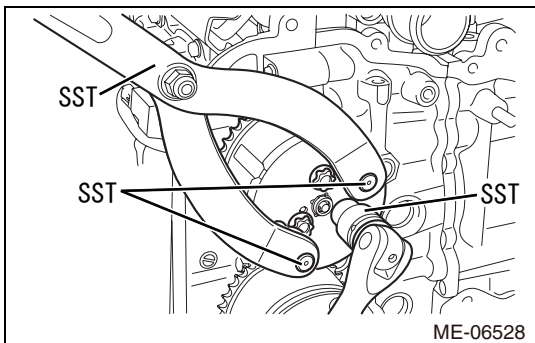

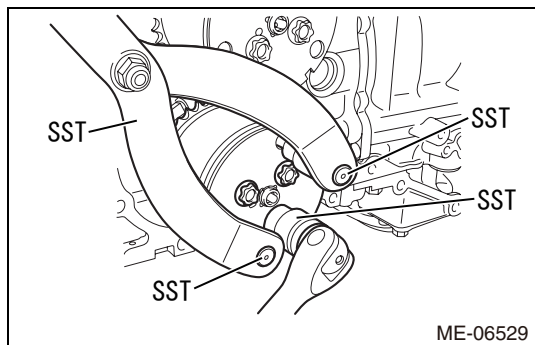

31. Removal of camshaft timing exhaust gear ASSY RH

- (1) Fix the camshaft timing exhaust gear ASSY RH using SST to remove the three bolts.

SST 18355AA000, 18334AA030, 18270KA010

- (2) Remove the camshaft timing exhaust gear ASSY RH.

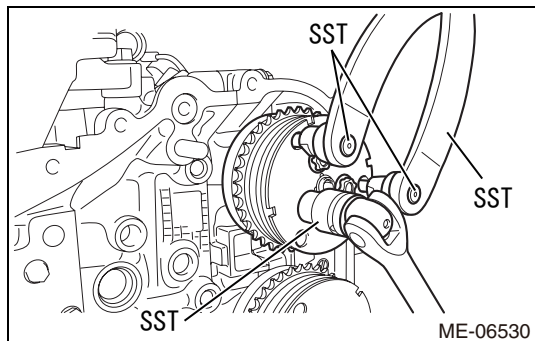

32. Removal of camshaft timing intake gear ASSY LH

- (1) Fix the camshaft timing intake gear ASSY LH using SST to remove the three bolts.

SST 18355AA000, 18334AA030, 18270KA010

- (2) Remove the camshaft timing intake gear ASSY LH.

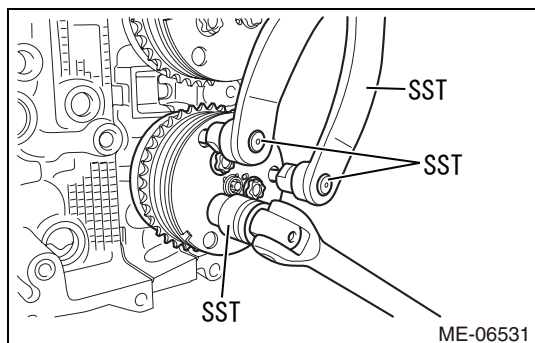

33. Removal of camshaft timing exhaust gear ASSY LH

- (1) Fix the camshaft timing exhaust gear ASSY LH using SST to remove the three bolts.

SST 18355AA000, 18334AA030, 18270KA010

- (2) Remove the camshaft timing exhaust gear ASSY LH.

34. Removal of cylinder head cover SUB-ASSY

- (1) Move the engine stand to face the bank 1 side upward.

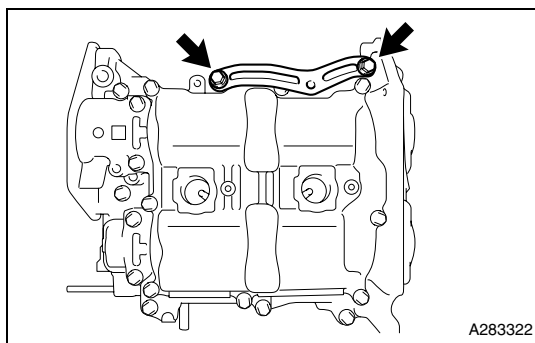

- (2) Remove the two bolts to remove the injector driver bracket.

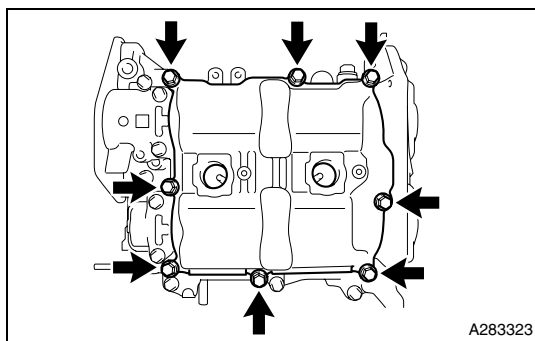

- (3) Remove the 8 bolts.

- (4) Remove the cylinder head cover SUB-ASSY using a flat tip screwdriver wrapped with protective tape.

<Caution>

Do not damage the camshaft housing SUB-ASSY, cam cap and cylinder head cover SUB-ASSY.

- (5) Remove the cylinder head cover gasket.

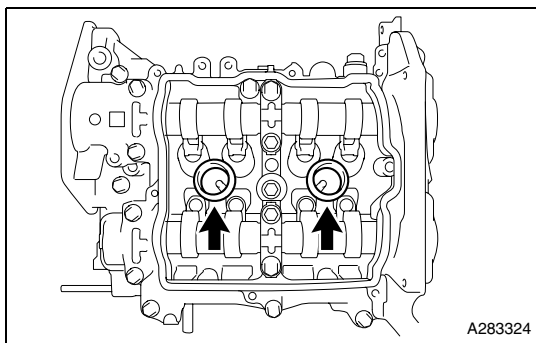

- (6) Remove the two spark plug tube gaskets.

<Caution>

When removing the gasket using scraper, use special care not to damage the cam lobe of camshaft.

35. Removal of camshaft housing SUB-ASSY RH

<Caution>

Do not remove the intake and exhaust camshafts initially, because it may cause the deformation of camshaft housing SUB-ASSY.

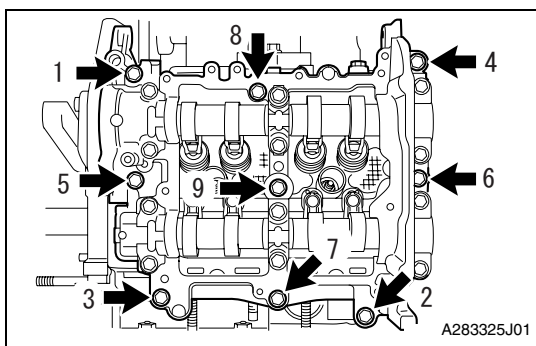

- (1) By loosening equally in the order as shown in the figure, remove the 9 bolts.

- (2) Remove the camshaft housing SUB-ASSY RH using a flat tip screwdriver wrapped with protective tape.

<Caution>

Do not damage the cylinder head and camshaft housing SUB-ASSY.

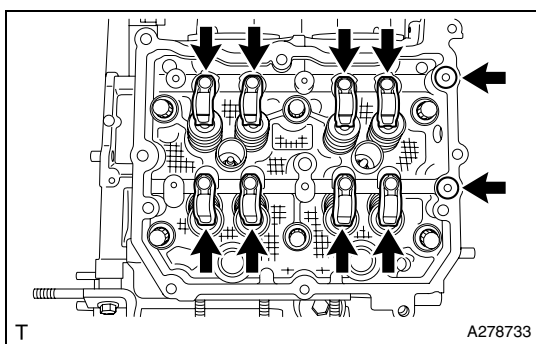

- (3) Remove the two O-rings and eight sets of valve rocker arm SUB-ASSY No. 1 from cylinder head SUB-ASSY.

<Reference>

Organize disassembled parts by their installation positions.

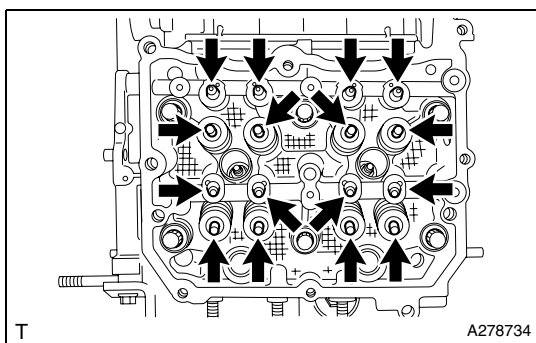

- (4) Remove the eight valve adjusting shims and eight roller rocker arm pivots from the cylinder head SUB-ASSY.

<Reference>

Organize disassembled parts by their installation positions.

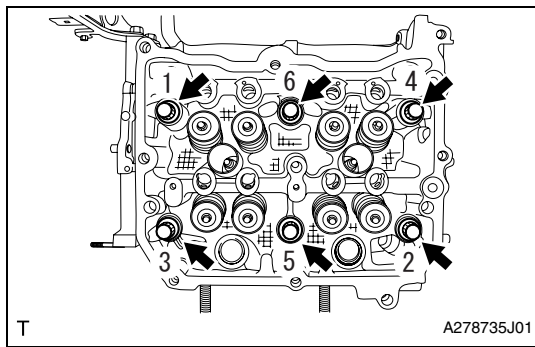

36. Removal of cylinder head SUB-ASSY

- (1) Loosen the six cylinder head bolts equally in the order as shown in the figure.
- (2) While tapping the cylinder head SUB-ASSY with a plastic hammer, separate it from cylinder block.
- (3) Remove the cylinder head SUB-ASSY.

<Caution>

Be careful not to scratch the mating surfaces of cylinder head and cylinder block.

37. Removal of cylinder head gasket

- (1) Remove the cylinder head gasket.

38. Removal of cylinder head cover SUB-ASSY LH

- (1) Move the engine stand to face the bank 2 side upward.
- (2) Remove the 8 bolts.

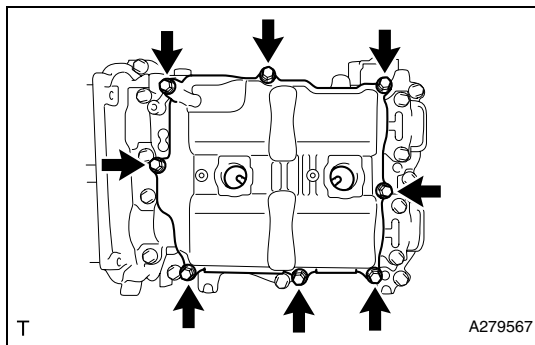

- (3) Remove the cylinder head cover SUB-ASSY LH using a flat tip screwdriver wrapped with protective tape.

<Caution>

Do not damage the camshaft housing SUB-ASSY, cam cap and cylinder head cover SUB-ASSY.

- (4) Remove the cylinder head cover gasket No. 2.

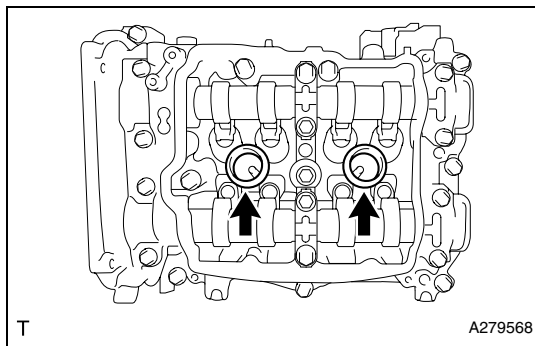

- (5) Remove the two spark plug tube gaskets.

<Caution>

When removing the gasket using scraper, use special care not to damage the cam lobe of camshaft.

39. Removal of camshaft housing SUB-ASSY LH

<Caution>

Do not remove the intake and exhaust camshafts initially, because it may cause the deformation of camshaft housing SUB-ASSY.

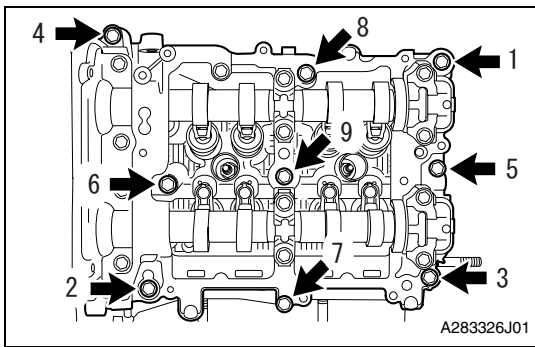

- (1) By loosening equally in the order as shown in the figure, remove the 9 bolts.

- (2) Remove the camshaft housing SUB-ASSY LH using a flat tip screwdriver wrapped with protective tape.

<Caution>

Do not damage the cylinder head and camshaft housing SUB-ASSY.

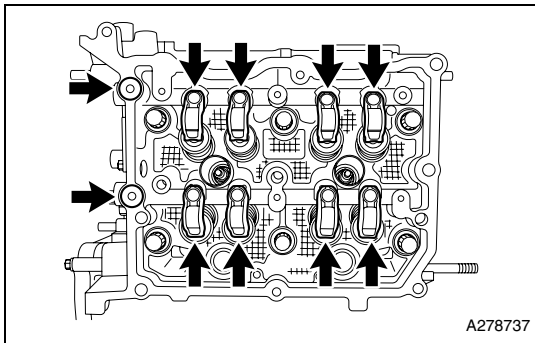

- (3) Remove the two O-rings and eight sets of valve rocker arm SUB-ASSY No. 1 from cylinder head LH.

<Reference>

Organize disassembled parts by their installation positions.

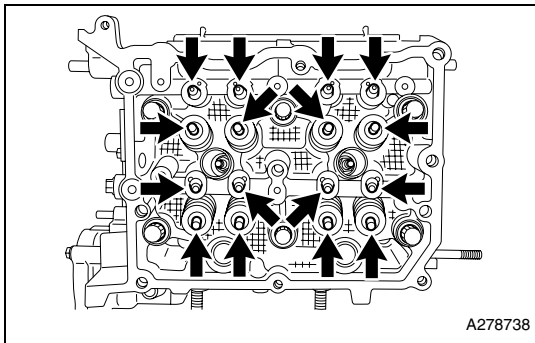

- (4) Remove the eight valve adjusting shims and eight roller rocker arm pivots from the cylinder head LH.

<Reference>

Organize disassembled parts by their installation positions.

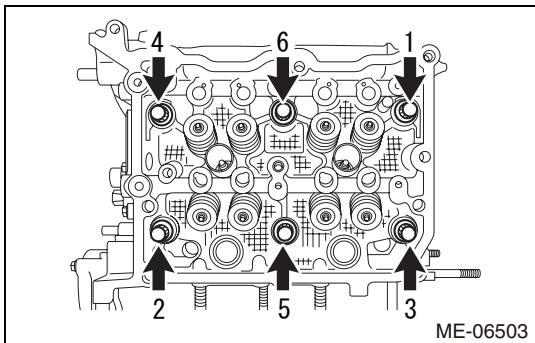

40. Removal of cylinder head LH

- (1) Loosen the six cylinder head bolts equally in the order as shown in the figure.

- (2) While tapping the cylinder head LH with a plastic hammer, separate it from cylinder block.

- (3) Remove the cylinder head LH.

<Caution>

Be careful not to scratch the mating surfaces of cylinder head and cylinder block.

41. Removal of cylinder head gasket No. 2

- (1) Remove the cylinder head gasket No. 2.

42. Removal of spark plug

- (1) Remove the four spark plugs.



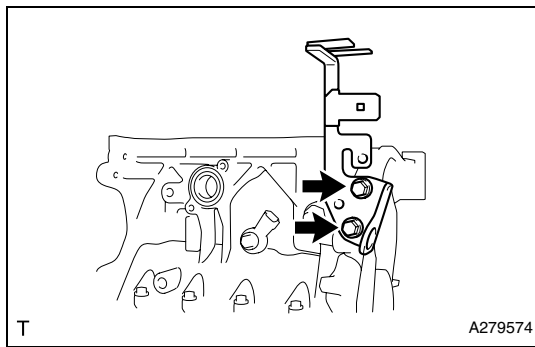

43. Removal of engine hanger No. 2

- (1) Remove the two bolts to remove the engine hanger No. 2 from cylinder block (bank 1 side).

EM

44. Removal of oil pan SUB-ASSY No. 2

- (1) Remove the drain plug and gasket.

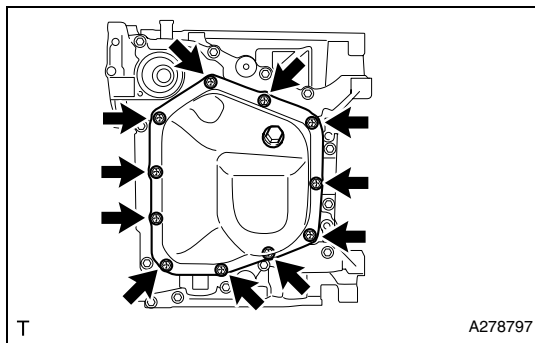

- (2) Remove the 11 bolts.

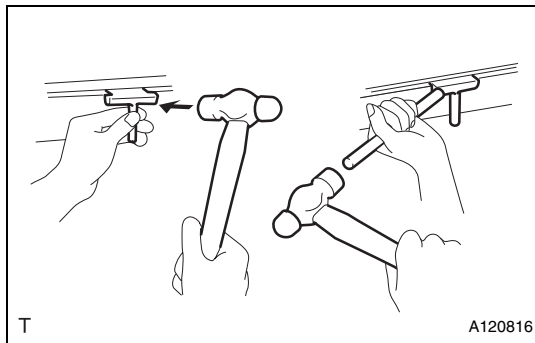

- (3) Remove the oil pan SUB-ASSY No. 2 using an oil pan seal cutter.
<Caution>
Do not damage the fitting surface of the oil pan SUB-ASSY and flange portion of the oil pan SUB-ASSY No. 2.

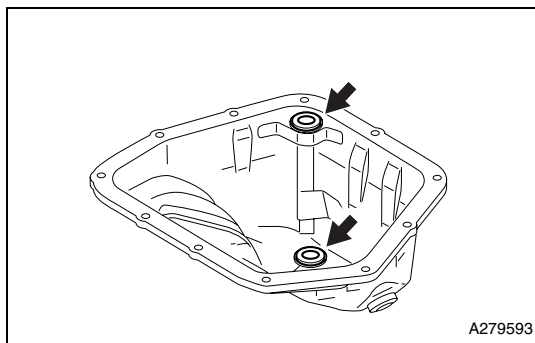

- (4) Remove the two seal rings from the oil pan SUB-ASSY No. 2.

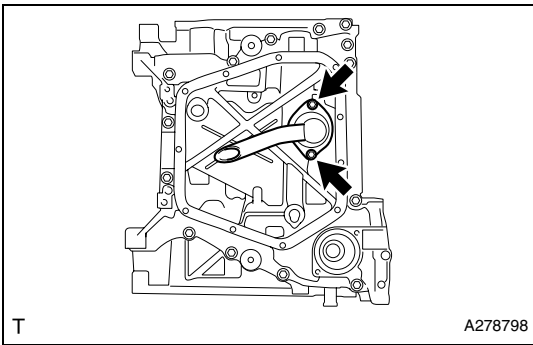

45. Removal of oil strainer SUB-ASSY

- (1) Remove the two bolts to remove the oil strainer SUB-ASSY.
- (2) Remove the O-ring.

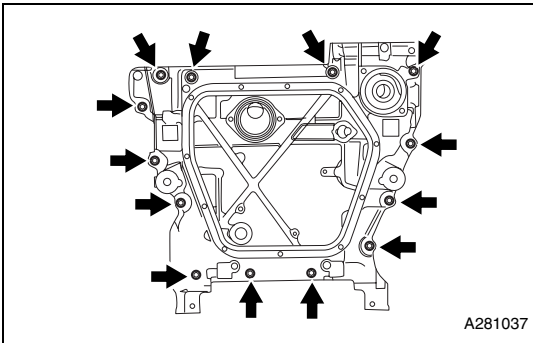

46. Removal of oil pan SUB-ASSY

- (1) Remove the 13 bolts.
- (2) Remove the oil pan SUB-ASSY using a flat tip screwdriver wrapped with protective tape.

<Caution>

Do not damage the fitting surfaces of the cylinder block and oil pan SUB-ASSY.

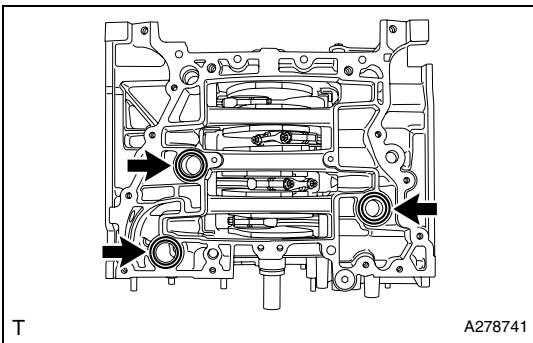

- (3) Remove the three O-rings from cylinder block.

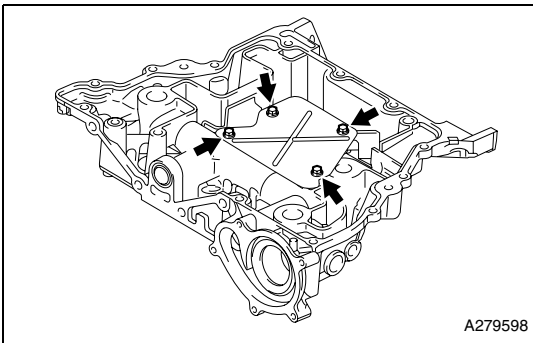

- (4) Remove the four bolts to remove the oil pan baffle plate No. 1 from the oil pan SUB-ASSY.

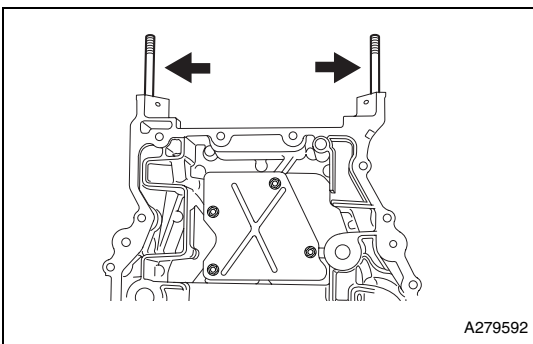

- (5) Remove the two stud bolts from the oil pan SUB-ASSY.

EM

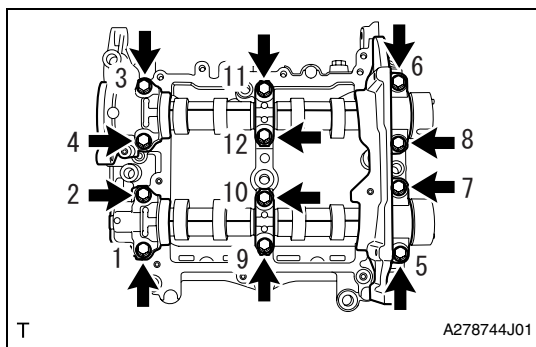

47. Removal of camshaft cap (bank 1 side)

- (1) Loosen the 12 bolts equally and slowly in order as shown in the figure to remove the front camshaft cap RH, intake center camshaft cap RH, intake rear camshaft cap RH, exhaust center camshaft cap RH and exhaust rear camshaft cap RH.

<Reference>

Organize disassembled parts by their installation positions.

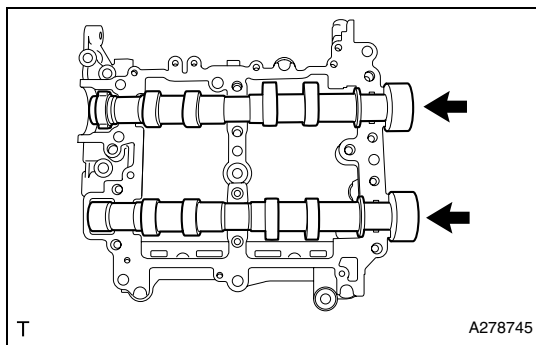

48. Removal of camshaft (bank 1 side)

- (1) Remove the intake camshaft RH and exhaust camshaft RH from the camshaft housing SUB-ASSY RH.

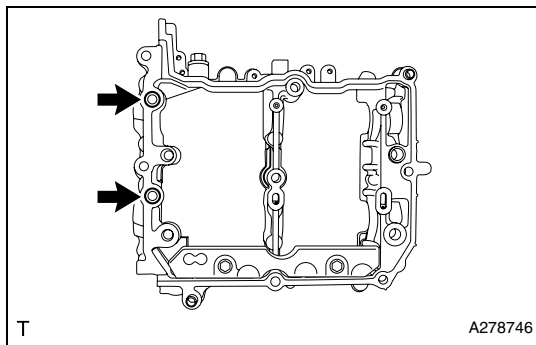

49. Removal of oil control valve filter RH

- (1) Remove the two oil control valve filters RH from the camshaft housing SUB-ASSY RH.

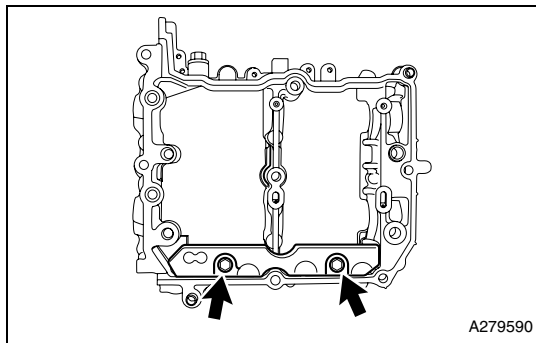

50. Removal of oil spacer RH

- (1) Remove the two bolts to remove the oil spacer RH.

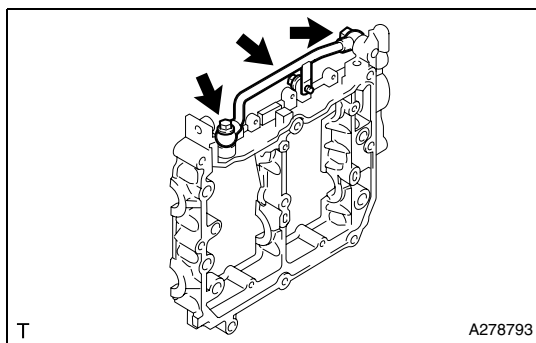

51. Removal of camshaft oil field pipe SUB-ASSY (transmission A/T)

- (1) Remove the two union bolts and bolt to remove the camshaft oil field pipe SUB-ASSY and two gaskets from the camshaft housing SUB-ASSY RH.

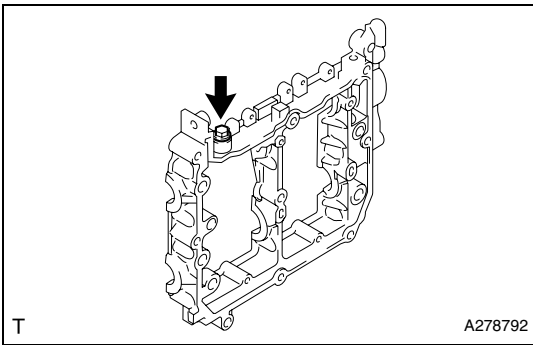

52. Removal of hole plug (transmission M/T).

- (1) Remove the hole plug and gasket from the camshaft housing SUB-ASSY RH.

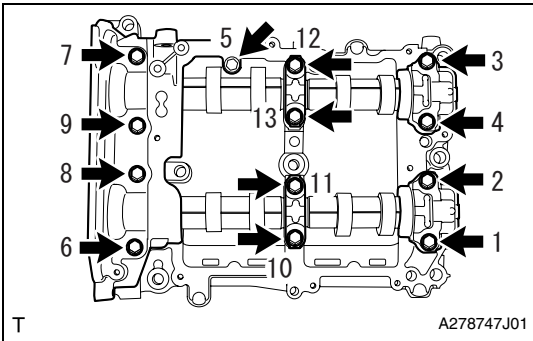

53. Removal of camshaft cap (bank 2 side)

- (1) Loosen the 13 bolts equally and slowly in order as shown in the figure to remove the front camshaft cap LH, intake center camshaft cap LH, intake rear camshaft cap LH, exhaust center camshaft cap LH and exhaust rear camshaft cap LH.
- <Reference>
Organize disassembled parts by their installation positions.

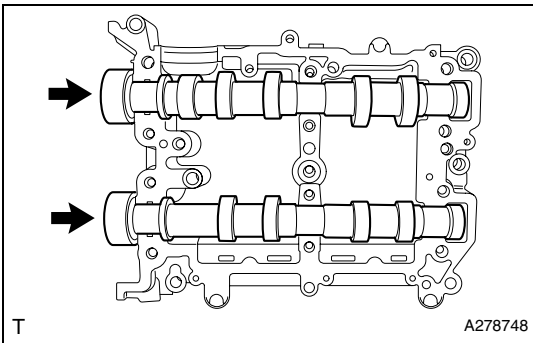

54. Removal of camshaft (bank 2 side)

- (1) Remove the intake camshaft LH and exhaust camshaft LH from the camshaft housing SUB-ASSY LH.

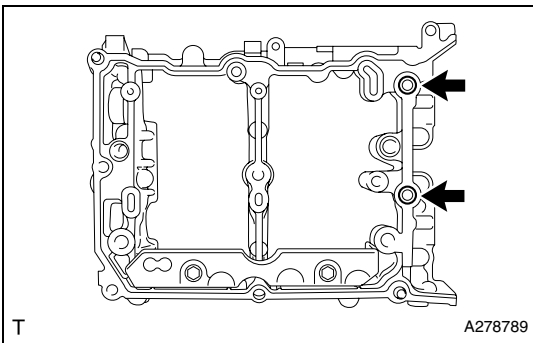

55. Removal of oil control valve filter LH

- (1) Remove the two oil control valve filters LH from the camshaft housing SUB-ASSY LH.

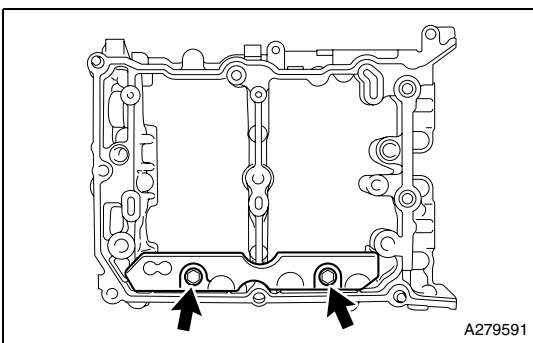

56. Removal of oil spacer LH

- (1) Remove the two bolts to remove the oil spacer LH.

INSPECTION

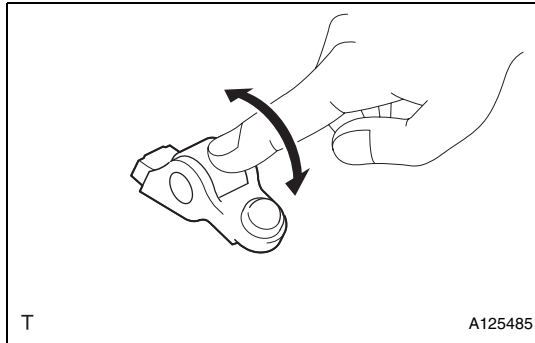

1. Inspection of valve rocker arm SUB-ASSY No. 1
 - (1) Make sure that the roller turns smoothly by hand.
 - <Reference>
 - Replace the valve rocker arm SUB-ASSY No. 1 if catch is found.

2. Inspection of chain SUB-ASSY
 - (1) Check that the chain SUB-ASSY has no deformation, cracks or other damages.
 - <Reference>
 - Replace the chain SUB-ASSY if faulty.
3. Inspection of camshaft timing gear
 - (1) Check the camshaft timing gear teeth for abnormal wear and scratches.
 - <Reference>
 - Replace the camshaft timing gear if faulty.
4. Inspection of crankshaft timing gear/sprocket
 - (1) Check the crankshaft timing gear/sprocket teeth for abnormal wear and scratches.
 - <Reference>
 - Replace the crankshaft timing gear/sprocket if faulty.
 - (2) Check that there is no free play between the crankshaft timing gear/sprocket and key.
 - <Reference>
 - Replace the crankshaft timing gear/sprocket or key if faulty.
5. Inspection of chain tensioner slipper
 - (1) Check that the chain tensioner slipper has no deformation, cracks or other damages.
6. Inspection of chain vibration damper No. 1
 - (1) Check that the chain vibration damper No. 1 has no deformation, cracks or other damages.
7. Inspection of chain tensioner ASSY
 - (1) Check that the chain tensioner ASSY has no deformation, cracks or other damages.

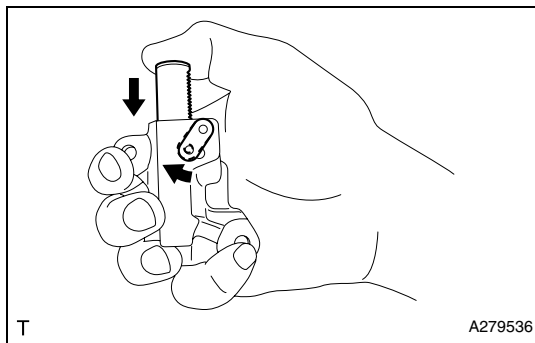

- (2) Make sure that the plunger moves smoothly by pushing with it unlocked.
 - <Reference>
 - If not, replace the chain tensioner ASSY.

- (3) Make sure that the plunger does not move by pushing with the cam locked.
8. Inspection of camshaft housing SUB-ASSY
 - (1) Visually check the oil control valve filter of camshaft housing SUB-ASSY, and if clogging is found, replace with a new part.
 - (2) Check the camshaft housing SUB-ASSY journal for damage and wear.
 - <Reference>
 - Replace the camshaft SUB-ASSY if faulty.

9. Inspection of camshaft

- (1) Check the camshaft journals for damage and wear.

<Reference>

Replace the camshaft if faulty.

- (2) Check the cam surface condition of camshaft.

<Reference>

- If slight fault is found, correct it using abrasive paper (No. 400).
- Replace the camshaft if uneven wear is found.

- (3) Runout test

- (a) Set the camshaft on a V-block.

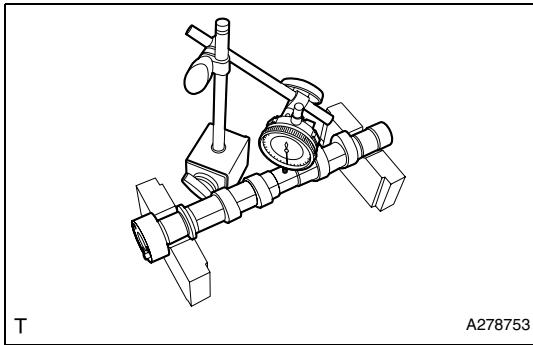

- (b) Using a dial gauge, check the camshaft runout.

Service limit: 0.020 mm {0.00079 in}

<Reference>

- Measurement should be performed at a temperature of 20°C {68°F}.
- If it exceeds the limit, replace the camshaft.



- (4) Height test

- (a) Measure the height of the cam using micrometer.

Standard value (intake)

Measurement location	Standard value
A	40.82 to 40.92 mm {1.6083 to 1.6110 in}
B	34.0 mm {1.3386 in}

Standard value (exhaust)

Measurement location	Standard value
A	40.72 to 40.82 mm {1.6031 to 1.6071 in}
B	34.0 mm {1.3386 in}

Standard value (fuel pump drive cam)

Measurement location	Standard value
C	40.55 to 40.65 mm {1.5965 to 1.6004 in}

Captions in illustration

*a	Valve drive cam
*b	Fuel pump drive cam

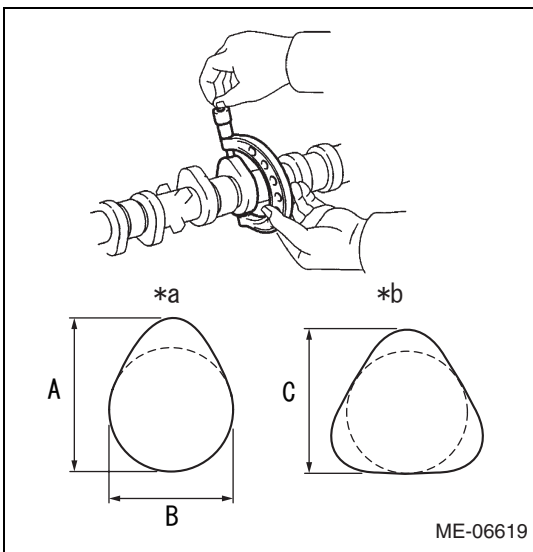

<Reference>

- Measurement should be performed at a temperature of 20°C {68°F}.
- If it is not within the specified value, replace the camshaft.

- (5) Outer diameter check

- (a) Check the journal outer diameter using micrometer.

Standard value: 25.946 to 25.963 mm {1.02149 to 1.02216 in}

<Reference>

- Measurement should be performed at a temperature of 20°C {68°F}.
- If it is not within specified value, check the oil clearance.

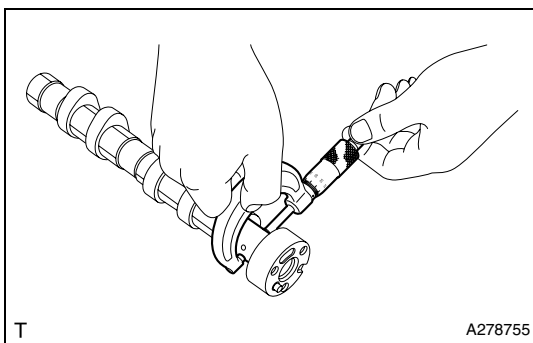

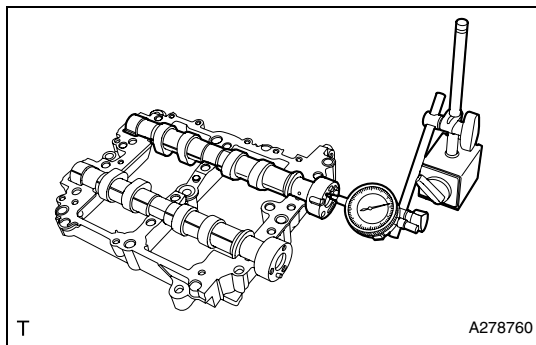

10. Camshaft thrust clearance check

- (1) Using a dial gauge, check the thrust clearance of the camshaft.
Standard value: 0.068 to 0.116 mm {0.00027 to 0.00457 in}

<Reference>

- Measurement should be performed at a temperature of 20°C {68°F}.
- Set the dial gauge at end surface of camshaft.
- If it is not within the specified value or if uneven wear is found, replace each camshaft cap and camshaft housing SUB-ASSY as a set. If necessary replace the camshaft.

11. Camshaft oil clearance check

<Reference>

Measurement should be performed at a temperature of 20°C {68°F}.

- (1) Remove the gasket from camshaft housing SUB-ASSY and front camshaft cap, intake rear camshaft cap and exhaust rear camshaft cap.
- (2) Clean each camshaft cap and camshaft housing SUB-ASSY journal.
- (3) Set the camshaft to the camshaft housing SUB-ASSY.
- (4) Place a plastigauge across the journals of each camshaft and set the camshaft caps.
- (5) Tighten each bolt in order as shown in the figure, tighten the front camshaft cap, intake center camshaft cap, intake rear camshaft cap, exhaust center camshaft cap and exhaust rear camshaft cap.

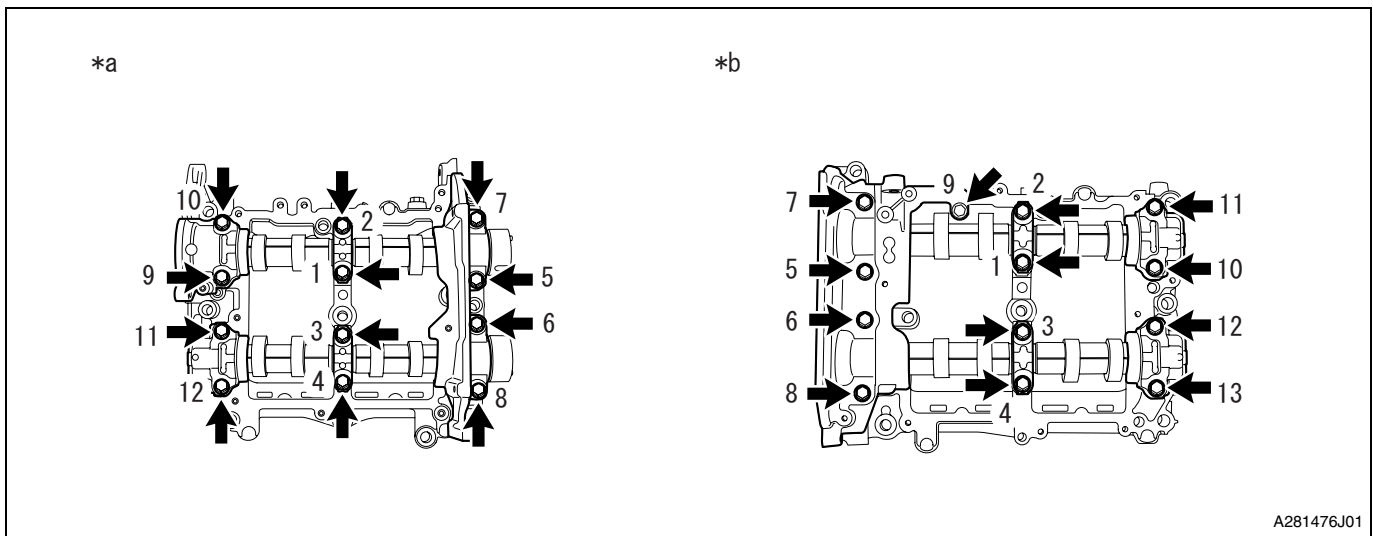

Captions in illustration

*a	Bank 1	*b	Bank 2
----	--------	----	--------

Standard value: $T=18\text{N}\cdot\text{m}$ {184kgf·cm} {13.3 ft·lbf}

- (6) Loosen each bolt equally and slowly in order as shown in the figure to remove the bolts of the front camshaft cap, intake center camshaft cap, intake rear camshaft cap, exhaust center camshaft cap and exhaust rear camshaft cap.

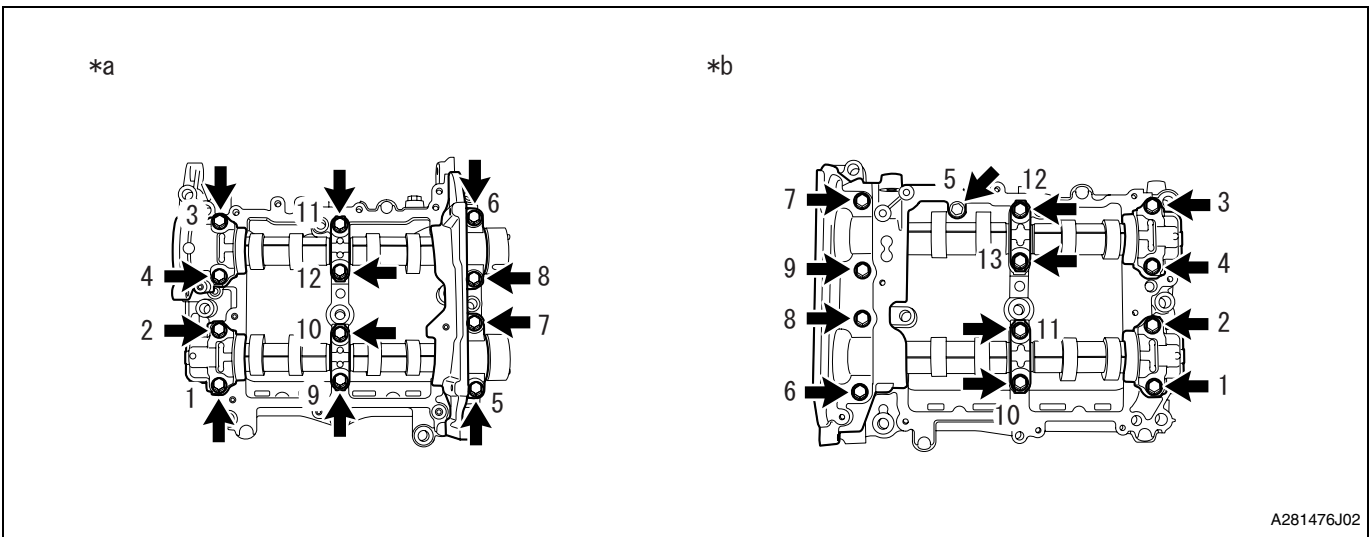

A281476J02

Captions in illustration

*a	Bank 1	*b	Bank 2
----	--------	----	--------

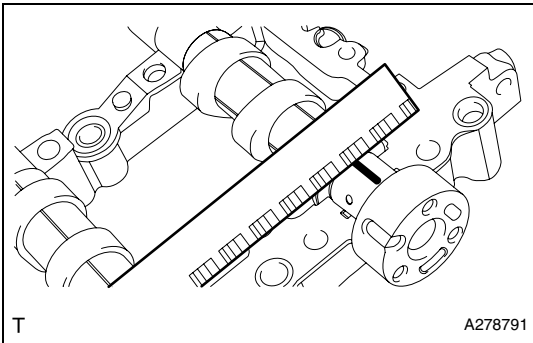

(8) Remove the plastigauge properly.

- (7) Obtain the camshaft oil clearance at the widest point of plastigauge on each journal.
 Standard value: 0.037 to 0.072 mm {0.00146 to 0.00283 in}
 <Reference>
 If it is not within the specified value, replace each camshaft cap and camshaft housing SUB-ASSY as a set. If necessary replace the camshaft.

ASSEMBLY

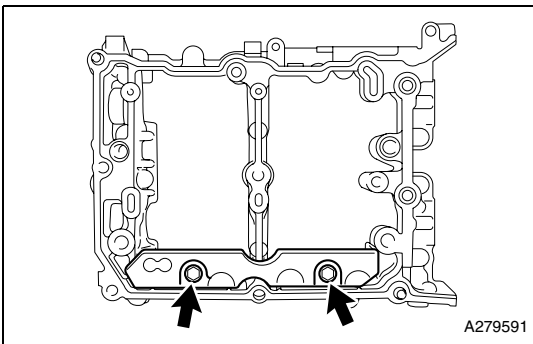

1. Installation of oil spacer LH
 - (1) Install the oil spacer LH with two bolts.
 Standard value: $T=6.4N \cdot m$ {65kgf·cm} {4.7 ft·lbf}

EM

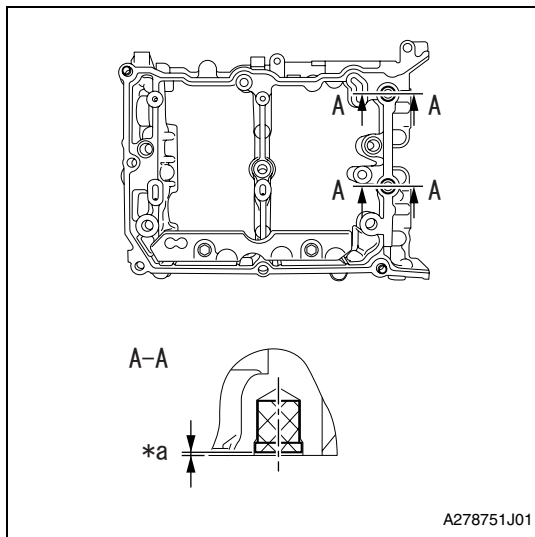

2. Installation of oil control valve filter LH

- (1) Install two new oil control valve filters LH to the camshaft housing SUB-ASSY LH.

Captions in illustration

*a	0 to 0.5 mm {0 to 0.0197 in} (from the end surface of camshaft housing SUB-ASSY LH)
----	---

3. Installation of camshaft (bank 2 side)

- (1) Apply engine oil to the camshaft housing SUB-ASSY LH journal.

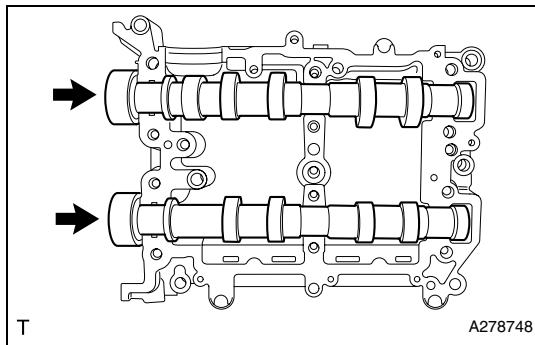

- (2) Install the intake camshaft LH and exhaust camshaft LH to the camshaft housing SUB-ASSY LH.

4. Installation of camshaft cap (bank 2 side)

- (1) Apply THREE BOND 1217G to the mating surface of front camshaft cap LH, intake rear camshaft cap LH and exhaust rear camshaft cap LH as shown in the figure.

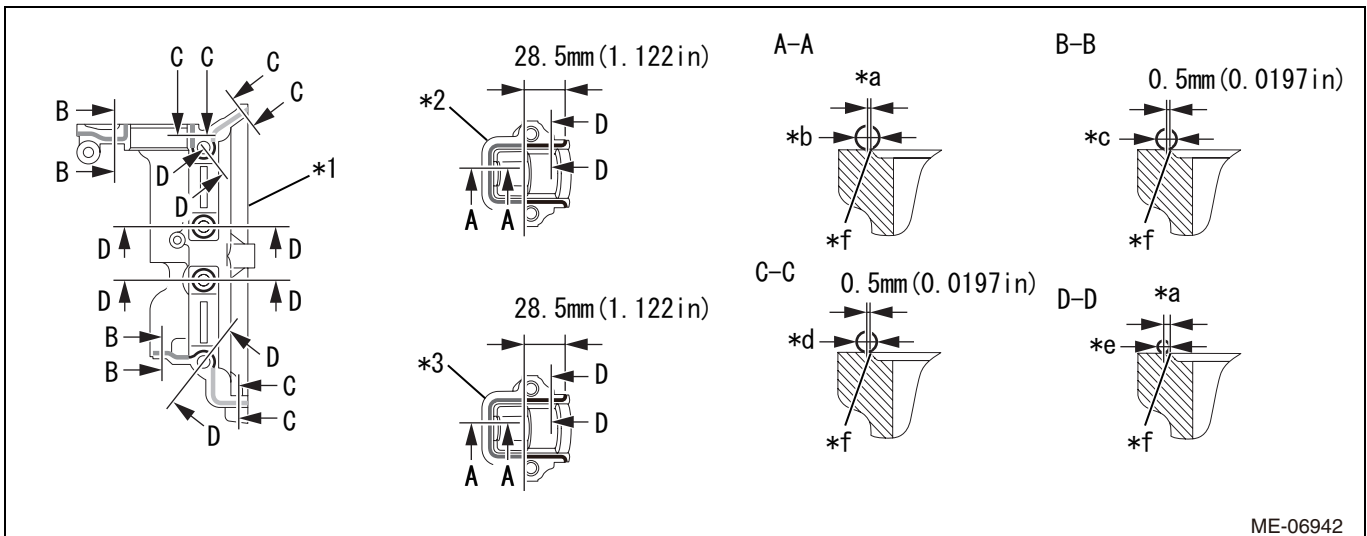

Captions in illustration

*1	Front camshaft cap LH	*2	Intake rear camshaft cap LH
*3	Exhaust rear camshaft cap LH	-	-
*a	1.0 mm {0.0394 in} or less	*b	3.0 to 4.0 mm {0.1181 to 0.1575 in} in dia.
*c	2.5 to 3.5 mm {0.0984 to 0.1378 in} in dia.	*d	2.5 to 4.0 mm {0.0984 to 0.1575 in} in dia.
*e	1.5 to 2.5 mm {0.0591 to 0.0984 in} in dia.	*f	Groove

<Caution>

- Clean and degrease the fitting surface.
- Do not apply liquid gasket excessively to avoid engine seizure.
- Do not apply liquid gasket to the intake center camshaft cap LH and exhaust center camshaft cap LH.
- Install within 5 min. after applying liquid gasket.

(2) Apply engine oil to the journals of each camshaft cap and set the camshaft housing SUB-ASSY LH.

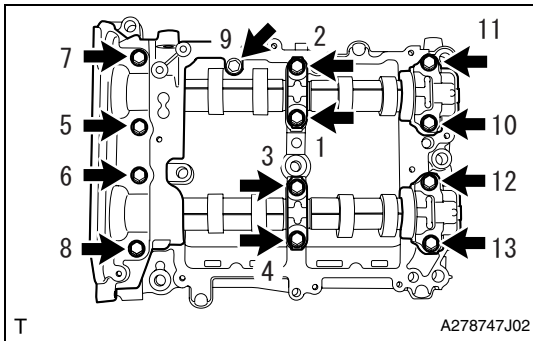

(3) Tighten 13 bolts in order as shown in the figure, install the front camshaft cap LH, intake center camshaft cap LH, intake rear camshaft cap LH, exhaust center camshaft cap LH and exhaust rear camshaft cap LH.

Standard value: $T=18N\cdot m$ {184kgf·cm} {13.3 ft·lbf}

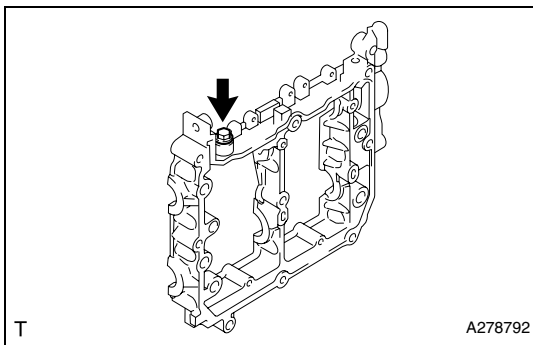

5. Installation of hole plug (transmission M/T)

(1) Using a new gasket, install the hole plug to the camshaft housing SUB-ASSY RH.

Standard value: $T=25N\cdot m$ {225kgf·cm} {18.4 ft·lbf}

6. Installation of camshaft oil field pipe SUB-ASSY (transmission A/T)

(1) Using two new gaskets, temporarily tighten the camshaft oil field pipe SUB-ASSY with the two union bolts and bolt.

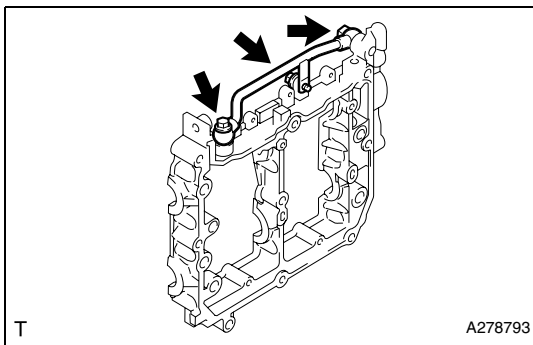

(2) Tighten the two union bolts to specified torque.

Standard value: $T=31N\cdot m$ {316kgf·cm} {22.9 ft·lbf}

(3) Tighten the bolt to specified torque.

Standard value: $T=6.4N\cdot m$ {65kgf·cm} {4.7 ft·lbf}

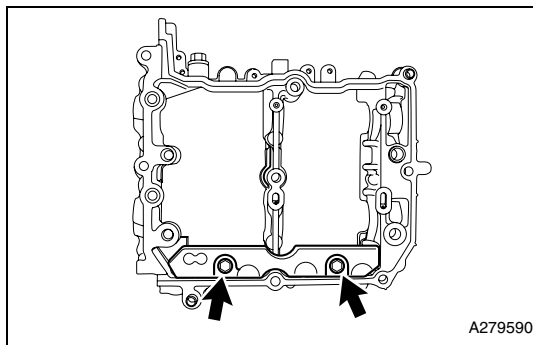

7. Installation of oil spacer RH

- (1) Install the oil spacer RH with two bolts.
Standard value: $T=6.4\text{N}\cdot\text{m}$ {65kgf•cm} {4.7 ft•lb}

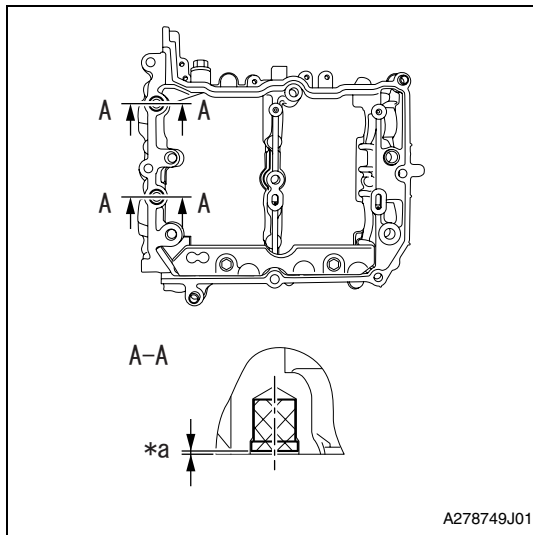

8. Installation of oil control valve filter RH

- (1) Install two new oil control valve filters RH to the camshaft housing SUB-ASSY RH as shown in the figure.

Captions in illustration

*a	0 to 0.5 mm {0 to 0.0197 in} (from the end surface of camshaft housing SUB-ASSY RH)
----	---

9. Installation of camshaft (bank 1 side)

- (1) Apply engine oil to the camshaft housing SUB-ASSY RH journal.

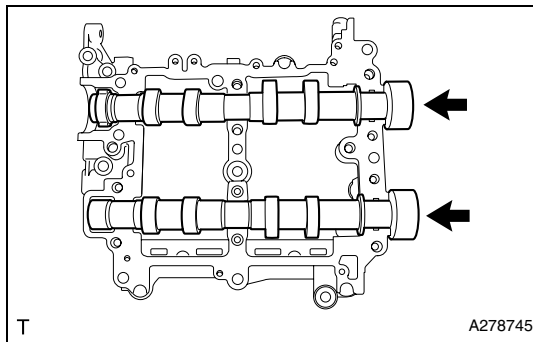

- (2) Install the intake camshaft RH and exhaust camshaft RH to the camshaft housing SUB-ASSY RH.

10. Installation of camshaft cap (bank 1 side)

- (1) Apply THREE BOND 1217G to the mating surface of front camshaft cap RH, intake rear camshaft cap RH and exhaust rear camshaft cap RH as shown in the figure.

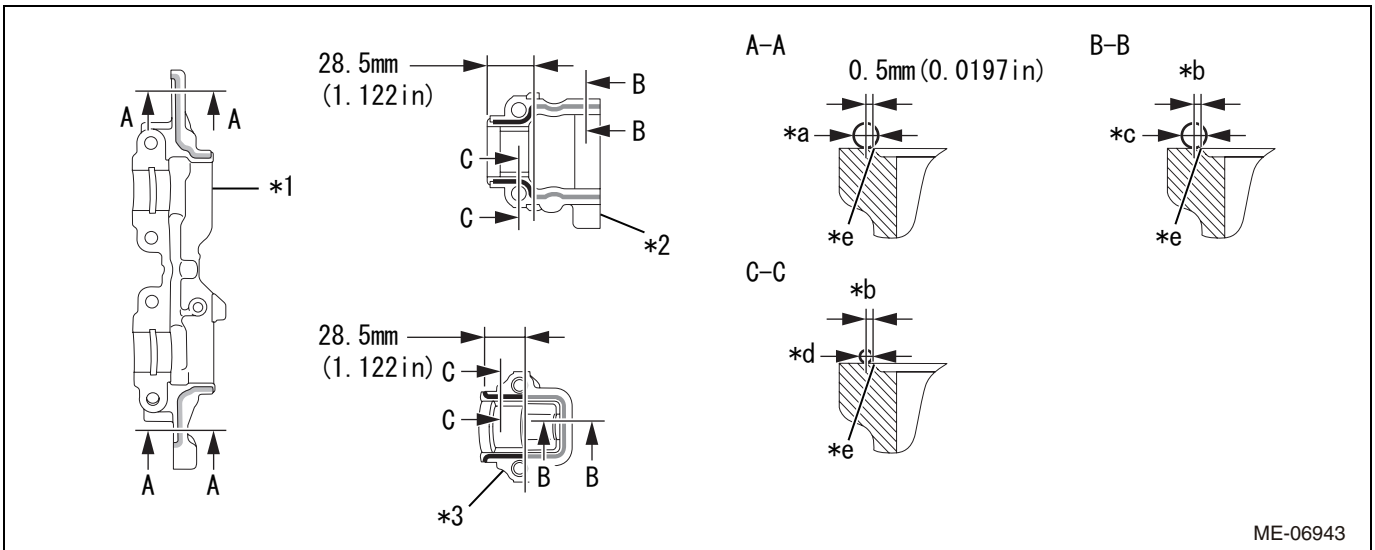

ME-06943

Captions in illustration

*1	Front camshaft cap RH	*2	Intake rear camshaft cap RH
*3	Exhaust rear camshaft cap RH	-	-
*a	2.5 to 4.0 mm {0.0984 to 0.1575 in} in diameter	*b	1.0 mm {0.0394 in} or less
*c	3.0 to 4.0 mm {0.1181 to 0.1575 in} in diameter	*d	1.5 to 2.5 mm {0.0591 to 0.0984 in} in diameter
*e	Groove	-	-

<Caution>

- Clean and degrease the fitting surface.
- Do not apply liquid gasket excessively to avoid engine seizure.
- Do not apply liquid gasket to the intake center camshaft cap RH and exhaust center camshaft cap RH.
- Install within 5 min. after applying liquid gasket.

(2) Apply engine oil to the journals of each camshaft cap and set to the camshaft housing SUB-ASSY RH.

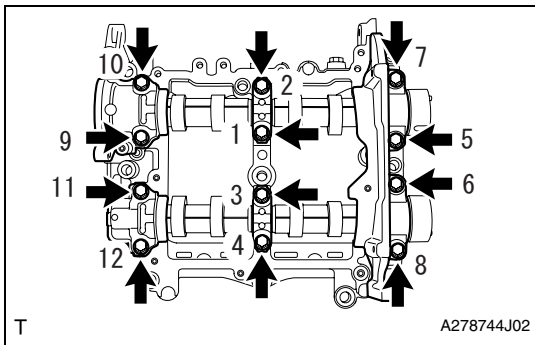

(3) Tighten 12 bolts in order as shown in the figure, install the front camshaft cap RH, intake center camshaft cap RH, intake rear camshaft cap RH, exhaust center camshaft cap RH and exhaust rear camshaft cap RH.

Standard value: $T=18N\cdot m$ {184kgf·cm} {13.3 ft·lbf}

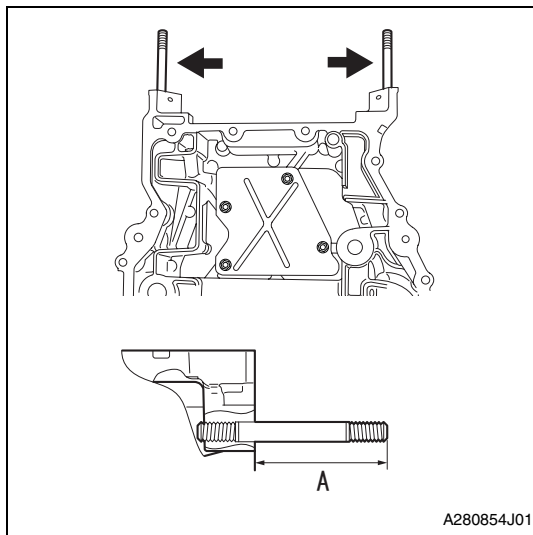

11. Installation of oil pan SUB-ASSY

- (1) Install the two stud bolts to the oil pan SUB-ASSY.
 Standard value: $T=10N\cdot m$ {102kgf·cm} {7.4 ft·lbf}
 Stud bolt height (A): 70.0 mm {2.756 in}

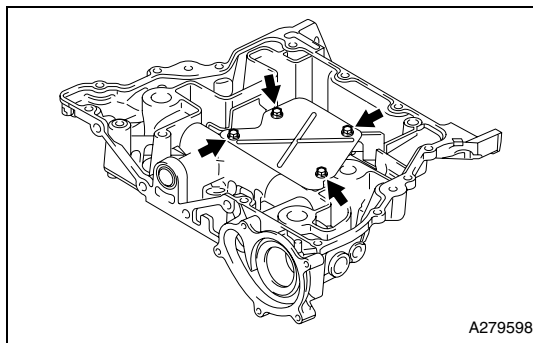

- (2) Install the baffle plate No. 1 to the oil pan SUB-ASSY with four bolts.
 Standard value: $T=6.4N\cdot m$ {65kgf·cm} {4.7 ft·lbf}

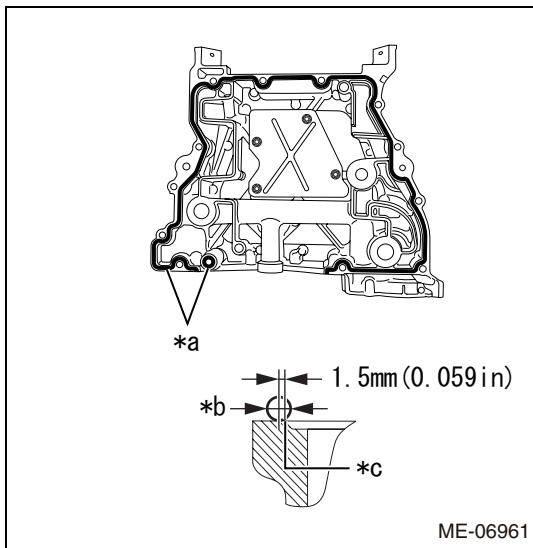

- (3) Apply THREE BOND 1217G to the mating surface of the oil pan SUB-ASSY as shown in the figure.

Captions in illustration

*a	THREE BOND 1217G
*b	4.0 to 6.0 mm {0.158 to 0.236 in} in diameter
*c	Groove

<Caution>

- Clean and degrease the fitting surface.
- Install within 5 min. after applying liquid gasket.
- Apply liquid gasket 1.5 mm {0.059 in} outside from the groove of the oil pan SUB-ASSY. However, application of liquid gasket around the bolt hole is allowed.

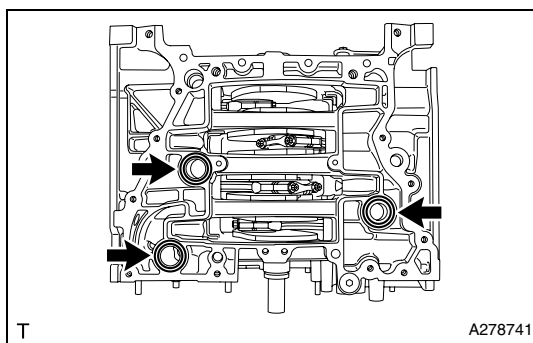

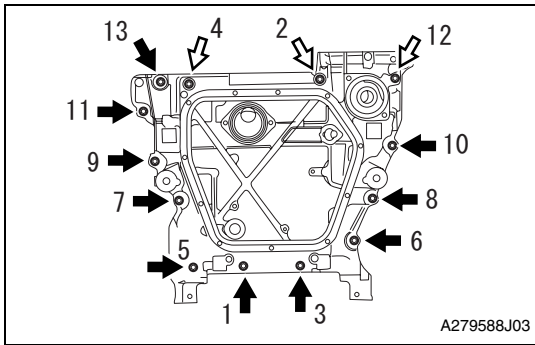

- (4) Install three new O-rings to the cylinder block.



- (5) Tighten 13 bolts (A and B) in order as shown in the figure, and install the oil pan SUB-ASSY to the cylinder block.

Standard value: $T=18N\cdot m$ {184kgf·cm} {13.3 ft·lbf}

Captions in illustration

	Bolt A
	Bolt B

Bolt type	Bolt length (except for head)
Bolt A	25 mm (0.984 in)
Bolt B	75 mm (2.953 in)



<Reference>

After tightening, if the liquid gasket is squeezed out in the seal surface area of the timing chain/belt cover SUB-ASSY, completely remove any liquid gasket that is squeezed out.

12. Installation of oil strainer SUB-ASSY

- (1) Install a new O-ring.

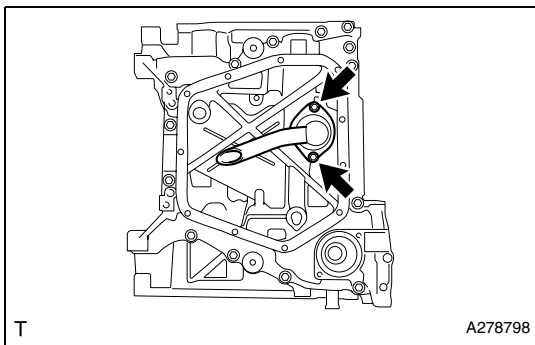

- (2) Install the oil strainer SUB-ASSY to the oil pan SUB-ASSY with two bolts.

Standard value: $T=6.4N\cdot m$ {65kgf·cm} {4.7 ft·lbf}

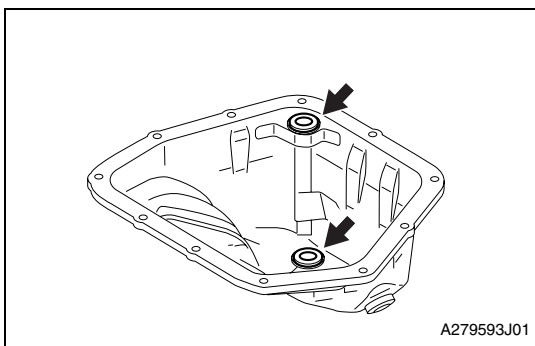

13. Installation of oil pan SUB-ASSY No. 2

- (1) Install the two new oil pan seal rings to the oil pan SUB-ASSY No. 2.

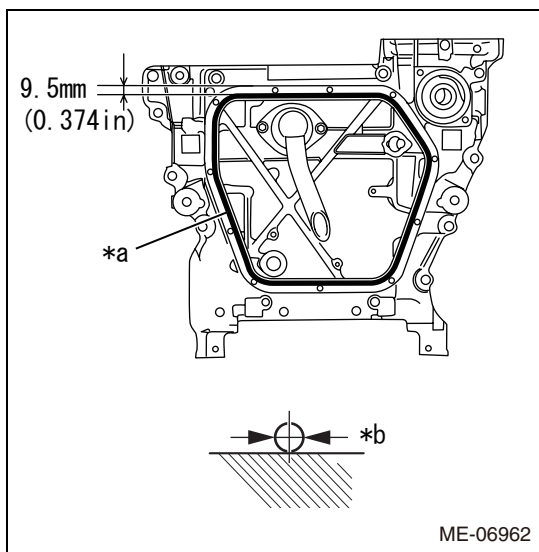

- (2) Apply THREE BOND 1217G to the mating surface of the oil pan SUB-ASSY No. 2 of the oil pan SUB-ASSY as shown in the figure.
Captions in illustration

*a	THREE BOND 1217G
*b	4.0 to 6.0 mm {0.158 to 0.236 in} in diameter

<Caution>

- Clean and degrease the fitting surface.
- Install within 5 min. after applying liquid gasket.

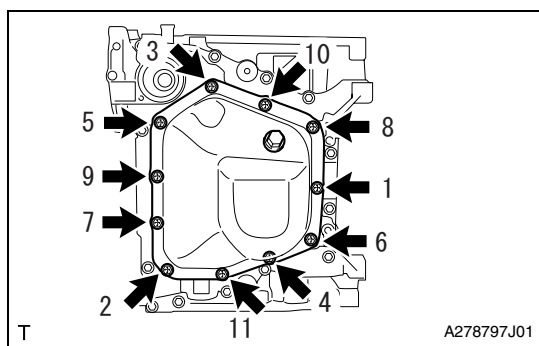

- (3) Tighten 11 bolts in order as shown in the figure, and install the oil pan SUB-ASSY No. 2.

Standard value: $T=6.4N\cdot m$ {65kgf·cm} {4.7 ft·lbf}

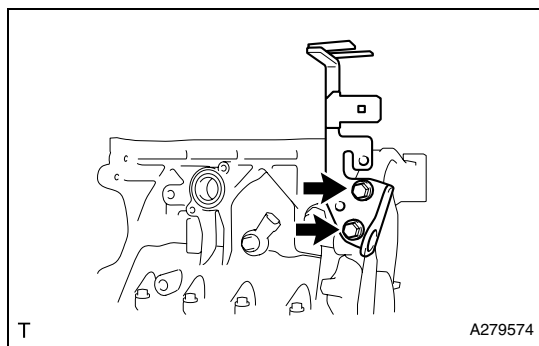

14. Installation of engine hanger No. 2

- (1) Install the engine hanger No. 2 to the cylinder block (bank 1 side) with two bolts.

Standard value: $T=21N\cdot m$ {214kgf·cm} {15.5 ft·lbf}

15. Installation of cylinder head gasket No. 2

- (1) Move the engine stand to face the bank 2 side upward.

- (2) Clean the bolt holes in the cylinder block (bank 2 side).

<Caution>

To avoid erroneous tightening of the bolts, clean out the bolt holes sufficiently by blowing with compressed air to eliminate engine coolant etc.

- (3) Apply THREE BOND 1217G to the mating surface of the new cylinder head gasket No. 2 as shown in the figure.

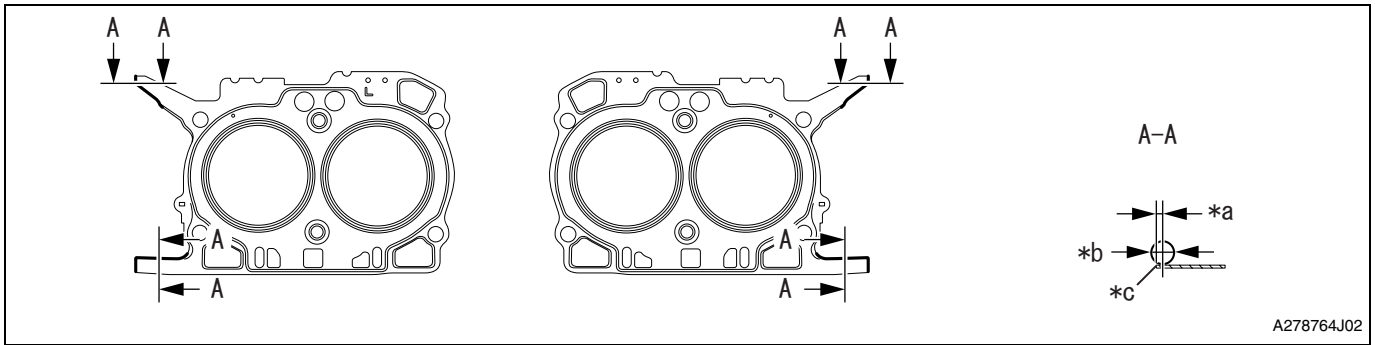

Captions in illustration

*a	0 to 1.0 mm {0 to 0.039 in}	*b	2.0 to 4.0 mm {0.079 to 0.158 in} in diameter
*c	Gasket end	-	-

<Caution>

- Clean and degrease the fitting surface.
- Install within 5 min. after applying liquid gasket.

(4) Install the cylinder head gasket No. 2.

16. Installation of cylinder head LH

- (1) Clean the cylinder head bolt threads and apply sufficient engine oil to the washer and cylinder head bolt threads.
- (2) Set the cylinder head LH to the cylinder block (bank 2 side).

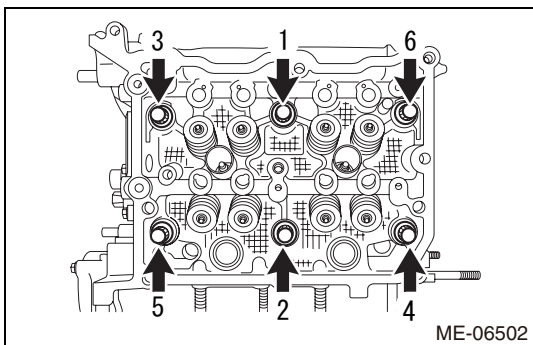

(3) Tighten the six cylinder head bolts in the order as shown in the figure.

Standard value: $T=20N \cdot m$ {204kgf·cm} {14.8 ft·lbf}

(4) Further-tighten the six cylinder head bolts in the same order.

Standard value: $T=100N \cdot m$ {102kgf·cm} {73.8 ft·lbf}

<Caution>

If the bolt makes stick-slip sound during tightening, clean the bolt holes and the fitting surface and wait until it dries, and then repeat the process from the procedure of application of gasket.

<Reference>

If the processes are resumed, the cylinder head gasket can be reused.

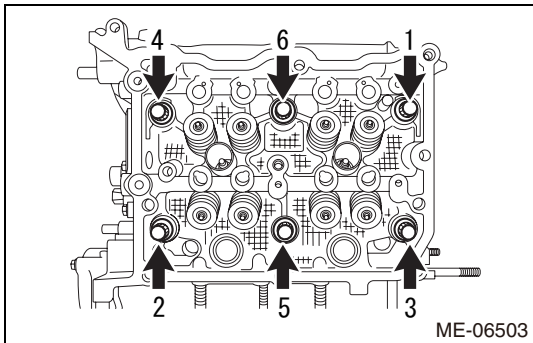

(5) Loosen the six cylinder head bolts by 360° in the order as shown in the figure.



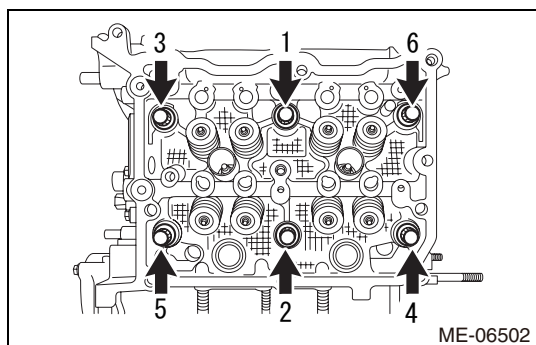

- (6) Tighten the six cylinder head bolts in the order as shown in the figure.

Standard value: $T=20N\cdot m$ {204kgf·cm} {14.8 ft·lbf}

- (7) Further-tighten the six cylinder head bolts in the same order.

Standard value: $T=42N\cdot m$ {428kgf·cm} {31.0 ft·lbf}

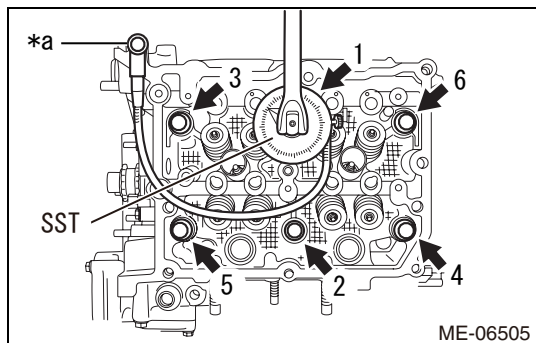

- (8) Further-tighten the six cylinder head bolts by 100° in the order as shown in the figure using SST.

SST 18854AA000

Captions in illustration

*a	Temporary bolt
----	----------------

<Reference>

As necessary, attach the temporary bolt to fix SST.

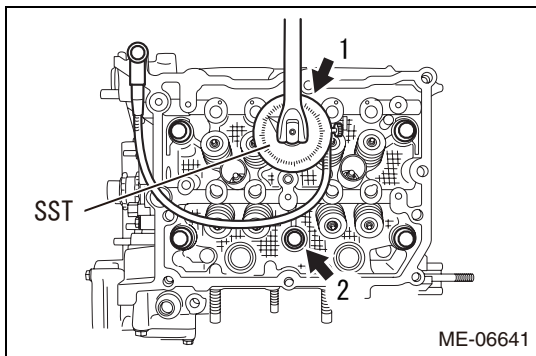

- (9) Further-tighten the two cylinder head bolts by 100° in the order as shown in the figure using SST.

SST 18854AA000

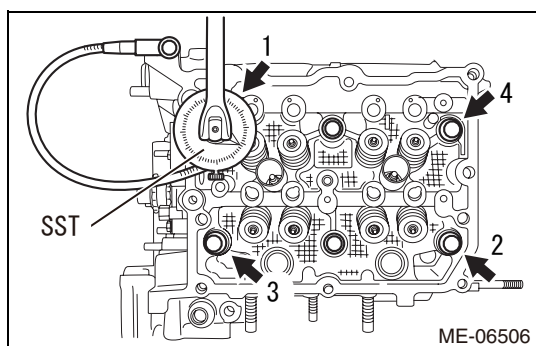

- (10) Further-tighten the four cylinder head bolts by 50° in the order as shown in the figure using SST.

SST 18854AA000

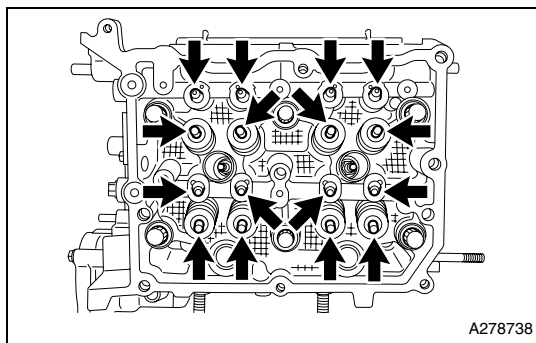

17. Installation of camshaft housing SUB-ASSY LH

- (1) Apply engine oil to the valve adjusting shim and the roller rocker arm pivot, and install to the cylinder head LH.

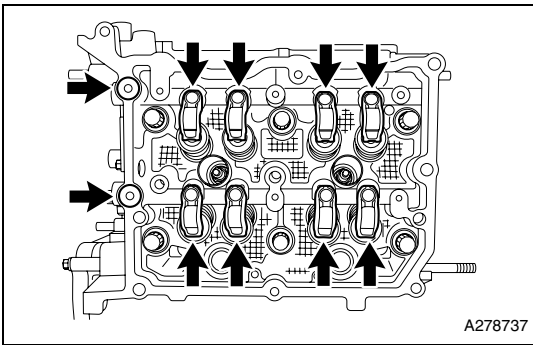

- (2) Apply engine oil to the eight sets of the valve rocker arm SUB-ASSY No. 1 and two new O-rings, and install to the cylinder head LH.
- (3) Apply THREE BOND 1217G to the mating surface of the camshaft housing SUB-ASSY LH as shown in the figure.

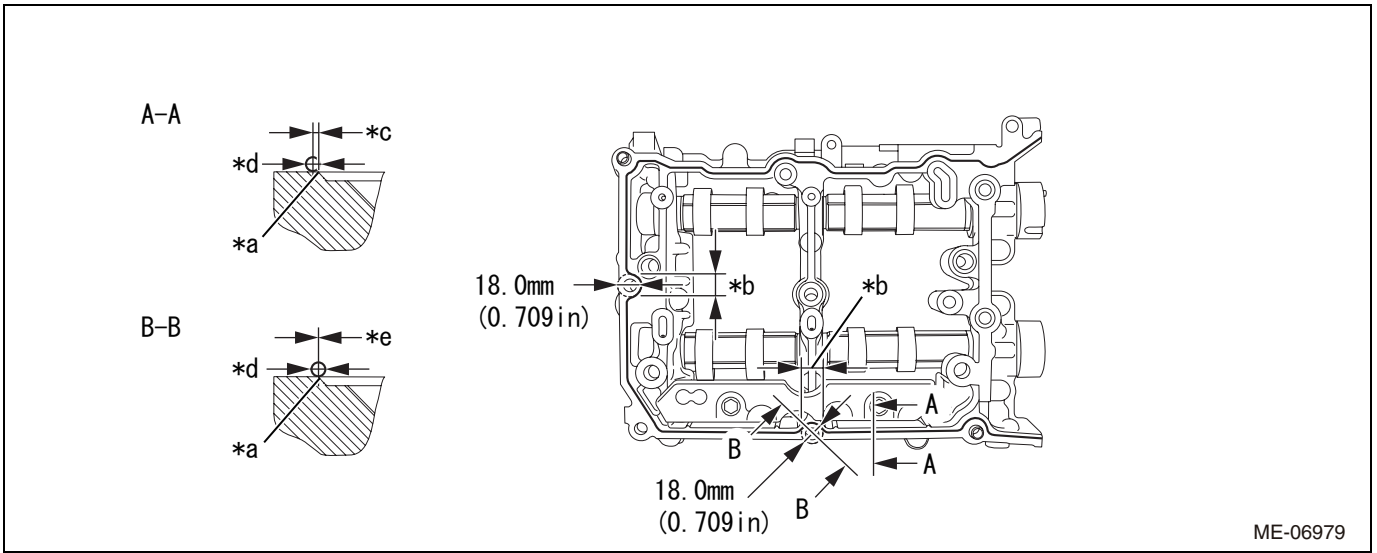

Captions in illustration

*a	Groove	*b	Range B-B
*c	1.0 mm {0.0394 in} or less	*d	2.5 to 3.5 mm {0.098 to 0.138 in} in diameter
*e	-0.5 to 0.5 mm {-0.0197 to 0.0197 in}	-	-

<Caution>

- Clean and degrease the fitting surface.
- Do not apply liquid gasket excessively.
- Install within 5 min. after applying liquid gasket.
- Completely remove any liquid gasket that is squeezed out on the fitting surface of the timing chain/belt cover SUB-ASSY.

- (4) Tighten nine bolts in order as shown in the figure, and install the camshaft housing SUB-ASSY LH.
Standard value: $T=18N \cdot m$ {184kgf·cm} {13.3 ft·lbf}

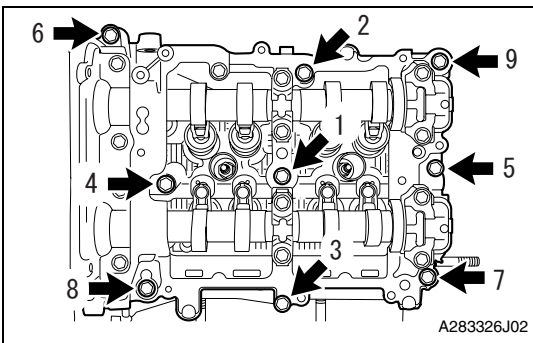

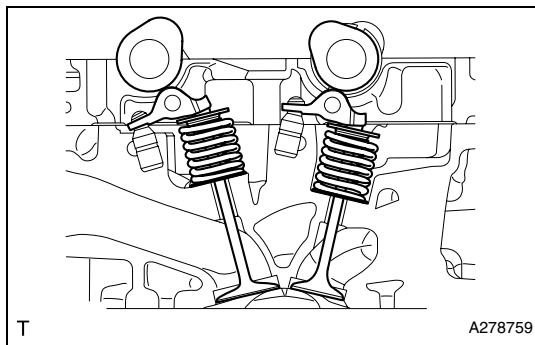

<Reference>

Set the intake camshaft LH and the exhaust camshaft LH to the zero-lift position.

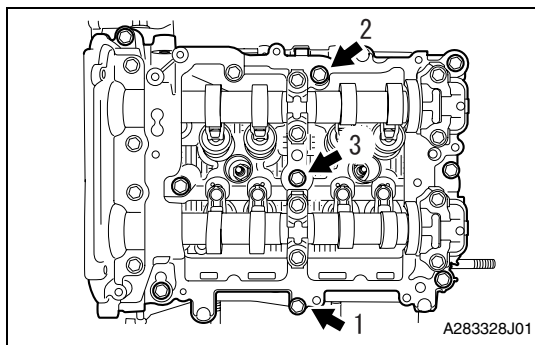

- (5) Loosen the three bolts by 180° in the order as shown in the figure.

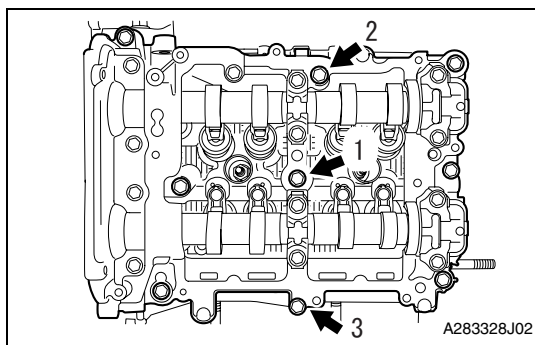

- (6) Tighten the three bolts in the order as shown in the figure.
Standard value: $T=18\text{N}\cdot\text{m}$ {184kgf·cm} {13.3 ft·lbf}

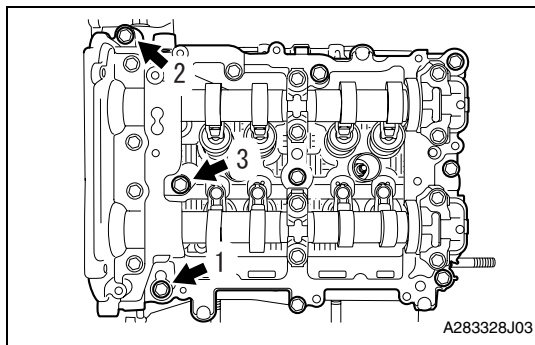

- (7) Loosen the three bolts by 180° in the order as shown in the figure.

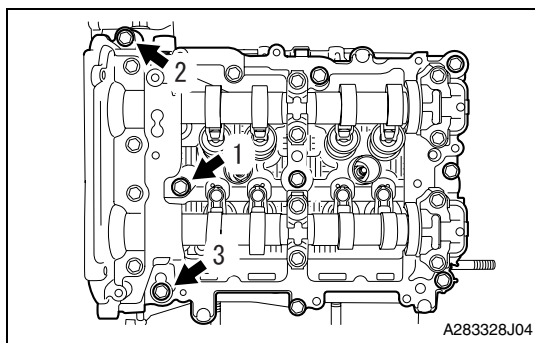

- (8) Tighten the three bolts in the order as shown in the figure.
Standard value: $T=18\text{N}\cdot\text{m}$ {184kgf·cm} {13.3 ft·lbf}

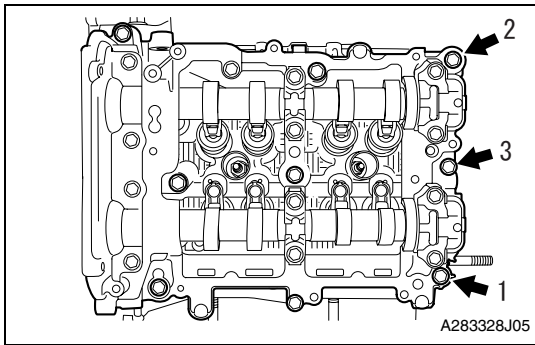

(9) Loosen the three bolts by 180° in the order as shown in the figure.

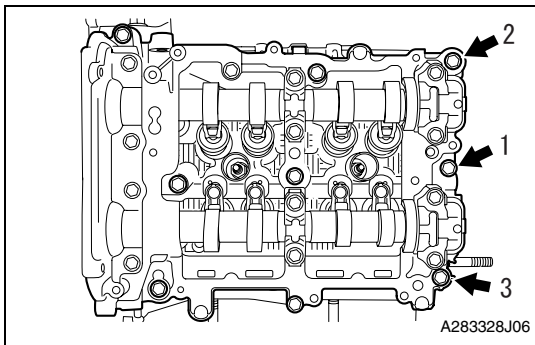

(10) Tighten the three bolts in the order as shown in the figure.

Standard value: $T=18N\cdot m$ {184kgf·cm} {13.3 ft·lbf}

<Reference>

After tightening, if the liquid gasket is squeezed out in the seal surface area of the timing chain/belt cover SUB-ASSY, completely remove any liquid gasket that is squeezed out.



18. Valve clearance check (bank 2 side)

<Caution>

Under the condition that the chain SUB-ASSY (bank 2 side) is detached, the valve heads contact each other and valve stem may bend. Do not turn the intake camshaft LH and exhaust camshaft LH to the outside of range of zero-lift (in range where it can be turned lightly by hand).

(1) Measure the roller surface of cam base circle and valve rocker arm SUB-ASSY No.1 using thickness gauge.

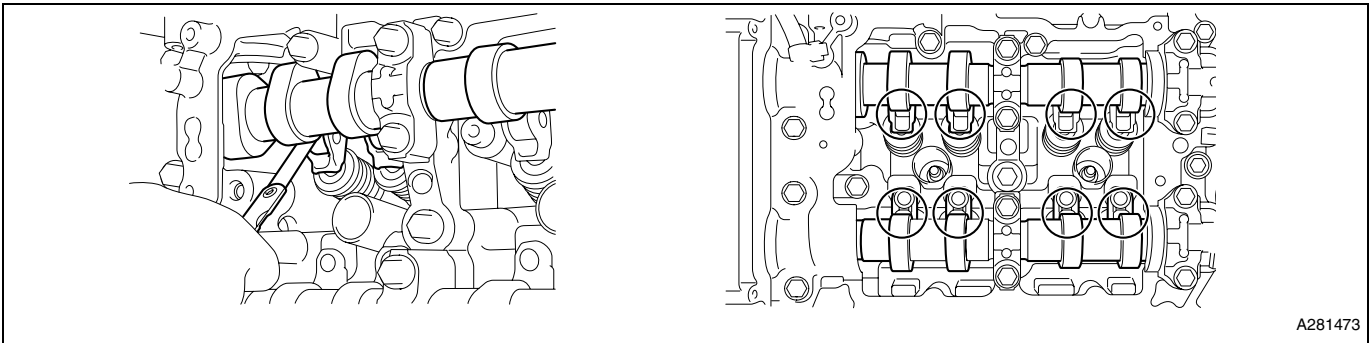

Standard value (when cold): 0.10 to 0.16 mm {0.0039 to 0.0063 in} (intake side)

0.21 to 0.27 mm {0.0083 to 0.0106 in} (exhaust side)

<Reference>

- For valve clearance inspection, adjust the cam base circle position so that the thickness gauge can be inserted easily by hand turning the camshaft to be measured.
- If the measured value is out of standard, take notes of the value in order to adjust the valve clearance later on.

19. Valve clearance adjustment (bank 2 side)

- (1) Remove the camshaft housing SUB-ASSY LH.
- (2) Remove the valve rocker arm SUB-ASSY No. 1.
- (3) Remove the valve adjusting shim.

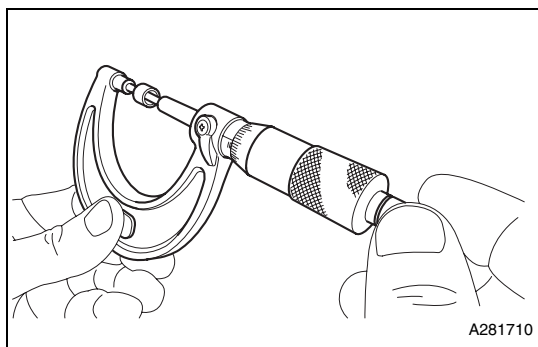

(4) Measure the thickness of the removed valve adjusting shim using micrometer.

- (5) Calculate the thickness of the valve adjusting shim so that the valve clearance is within the specified range.
 Standard value: Intake side: (Selected shim thickness) = (removed shim thickness) + [(measured clearance) - 0.13 mm {0.0051 in}] × 1.54
 Exhaust side: (Selected shim thickness) = (removed shim thickness) + [(measured clearance) - 0.24 mm {0.0094 in}] × 1.69
- (6) Apply engine oil to the inner circle area of the selected valve adjusting shim, and install to the valve.
 <Caution>
 Make sure that the valve adjusting shim turns smoothly after inserting.
- (7) Install the valve rocker arm SUB-ASSY No. 1.
- (8) Install the camshaft housing SUB-ASSY LH.

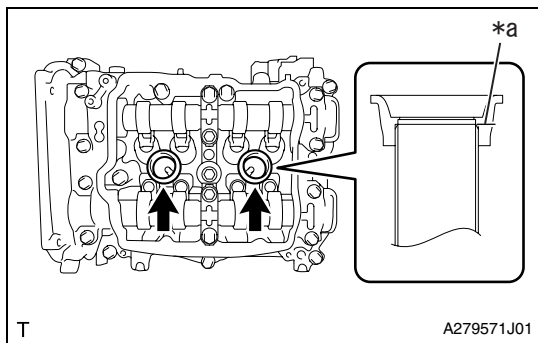

20. Installation of cylinder head cover SUB-ASSY LH

(1) Apply a light coat of engine oil to the two new spark plug tube gaskets, and insert them up to the spark plug tube end.

Captions in illustration

*a	Spark plug tube end
----	---------------------

(2) Install the new cylinder head cover gasket No. 2 to the cylinder head cover SUB-ASSY LH.

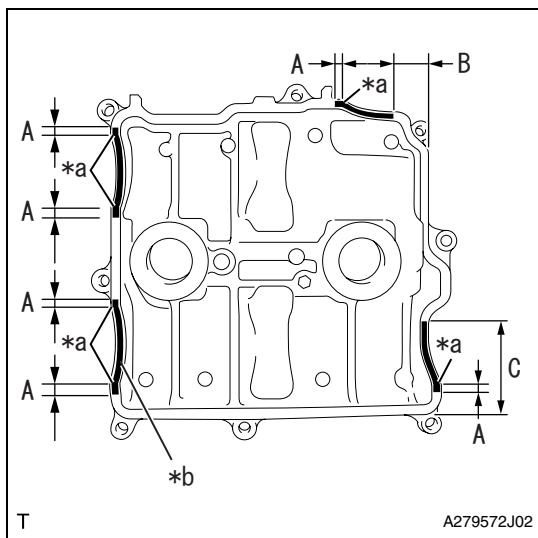

(3) Apply THREE BOND 1217G to the mating surface of the cylinder head cover SUB-ASSY LH as shown in the figure.

Application area	Application length
A	10.0 mm {0.394 in} or more
B	18.8 mm {0.740 in} or more
C	63.0 mm {2.480 in} or more

Captions in illustration

*a	Arch starting point
*b	2.0 to 4.0 mm {0.079 to 0.158 in} in diameter

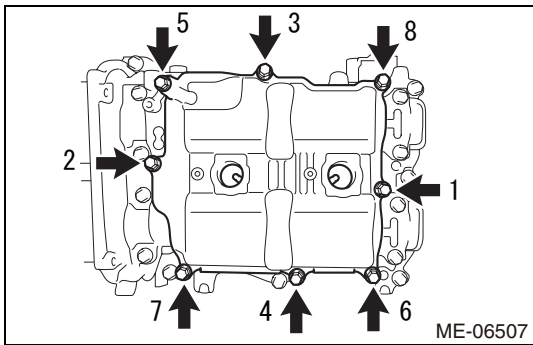

- (4) Set the cylinder head cover SUB-ASSY LH, and tighten the eight bolts in the order as shown in the figure.
Standard value: $T=6.4N\cdot m$ {65kgf·cm} {4.7 ft·lbf}

21. Installation of cylinder head gasket

- (1) Move the engine stand to face the bank 1 side upward.
(2) Clean the bolt holes in the cylinder block (bank 1 side).

<Caution>

To avoid erroneous tightening of the bolts, clean out the bolt holes sufficiently by blowing with compressed air to eliminate engine coolant etc.

- (3) Apply THREE BOND 1217G to the both surfaces of the cylinder head gasket as shown in the figure.

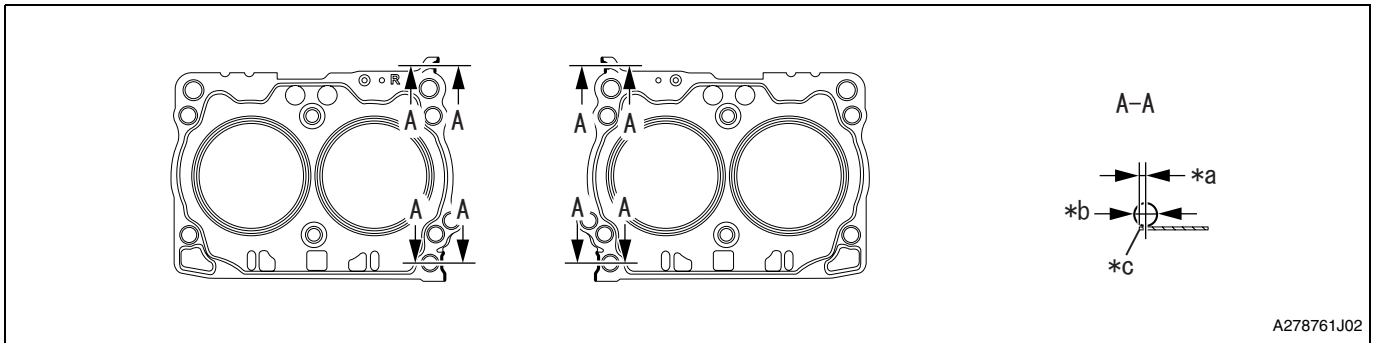

Captions in illustration

*a	0 to 1.0 mm {0 to 0.039 in}	*b	2.0 to 4.0 mm {0.79 to 0.158 in} in diameter
*c	Gasket end	-	-

<Caution>

- Clean and degrease the fitting surface.
- Install within 5 min. after applying liquid gasket.

- (4) Attach the cylinder head gasket.

22. Installation of cylinder head SUB-ASSY

- (1) Clean the cylinder head bolt threads and apply sufficient engine oil to the washer and cylinder head bolt threads.
(2) Set the cylinder head SUB-ASSY to the cylinder block (bank 1 side).

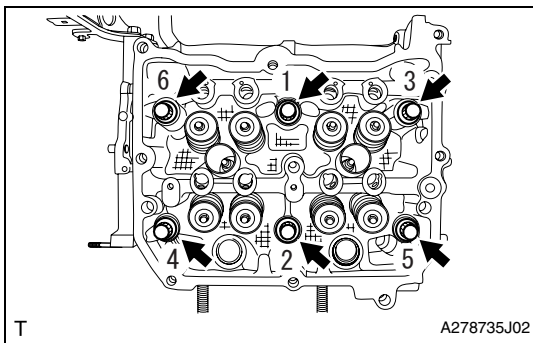

- (3) Tighten the six cylinder head bolts in the order as shown in the figure.

Standard value: $T=20N\cdot m$ {204kgf·cm} {14.8 ft·lbf}

- (4) Further-tighten the six cylinder head bolts in the same order.
Standard value: $T=100N\cdot m$ {102kgf·cm} {73.8 ft·lbf}



<Caution>

If the bolt makes stick-slip sound during tightening, clean the bolt holes and the fitting surface and wait until it dries, and then repeat the process from the procedure of application of gasket.

<Reference>

If the processes are resumed, the cylinder head gasket can be reused.

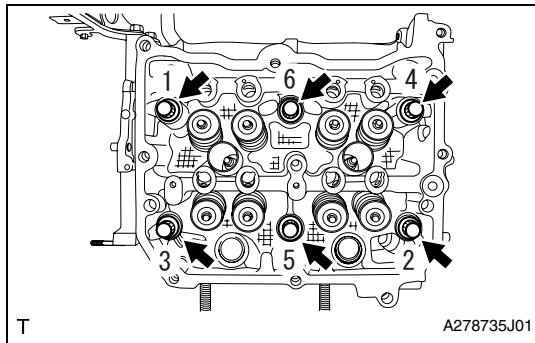

- (5) Loosen the six cylinder head bolts by 360° in the order as shown in the figure.

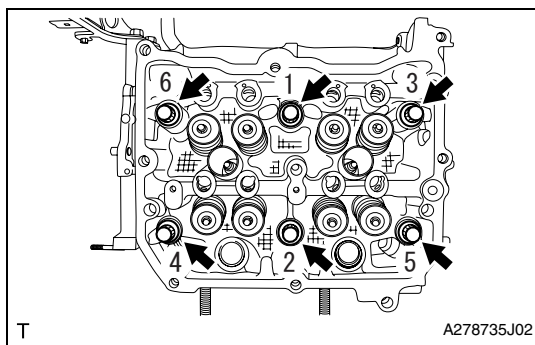

- (6) Tighten the six cylinder head bolts in the order as shown in the figure.

Standard value: $T=20N\cdot m$ {204kgf·cm} {14.8 ft·lbf}

- (7) Further-tighten the six cylinder head bolts in the same order.

Standard value: $T=42N\cdot m$ {428kgf·cm} {31.0 ft·lbf}

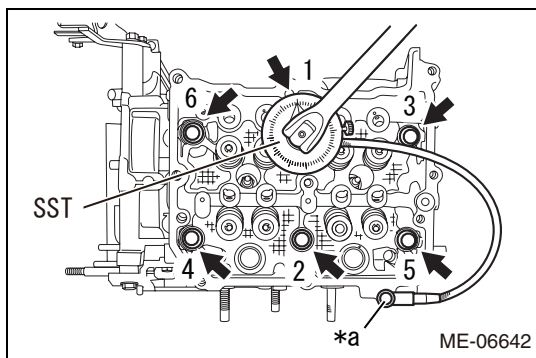

- (8) Further-tighten the six cylinder head bolts by 100° in the order as shown in the figure using SST.

SST 18854AA000

Captions in illustration

*a	Temporary bolt
----	----------------

<Reference>

As necessary, attach the temporary bolt to fix SST.

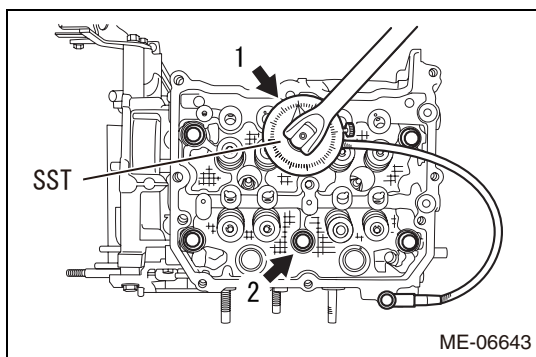

- (9) Further-tighten the two cylinder head bolts by 100° in the order as shown in the figure using SST.

SST 18854AA000

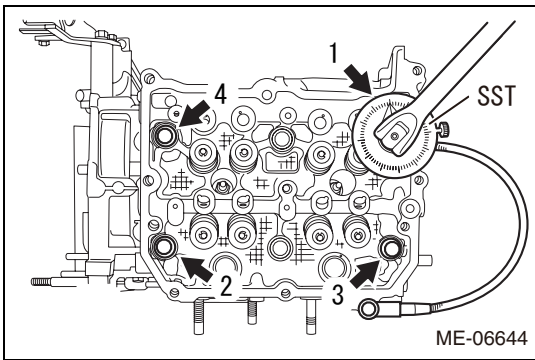

(10) Further-tighten the four cylinder head bolts by 50° in the order as shown in the figure using SST.

SST 18854AA000

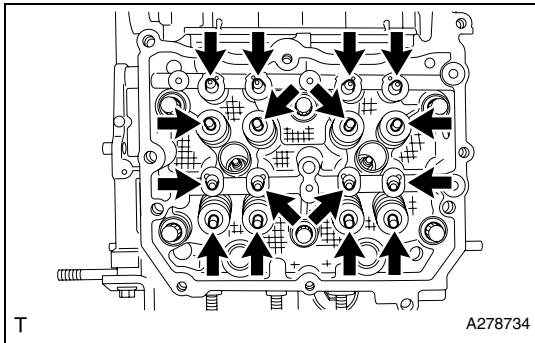

23. Installation of camshaft housing SUB-ASSY RH

(1) Apply engine oil to the valve adjusting shim and the roller rocker arm pivot, and install to the cylinder head SUB-ASSY.

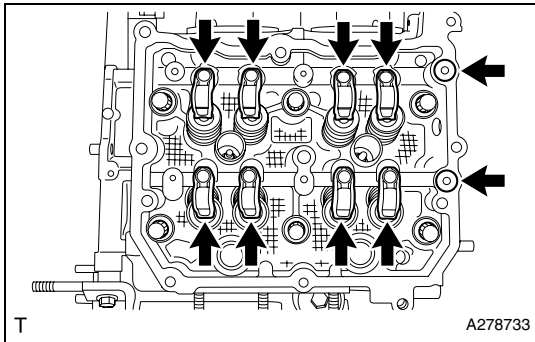

(2) Apply engine oil to the eight sets of the valve rocker arm SUB-ASSY No. 1 and two new O-rings, and install to the cylinder head SUB-ASSY.

(3) Apply THREE BOND 1217G to the mating surface of the camshaft housing SUB-ASSY RH as shown in the figure.

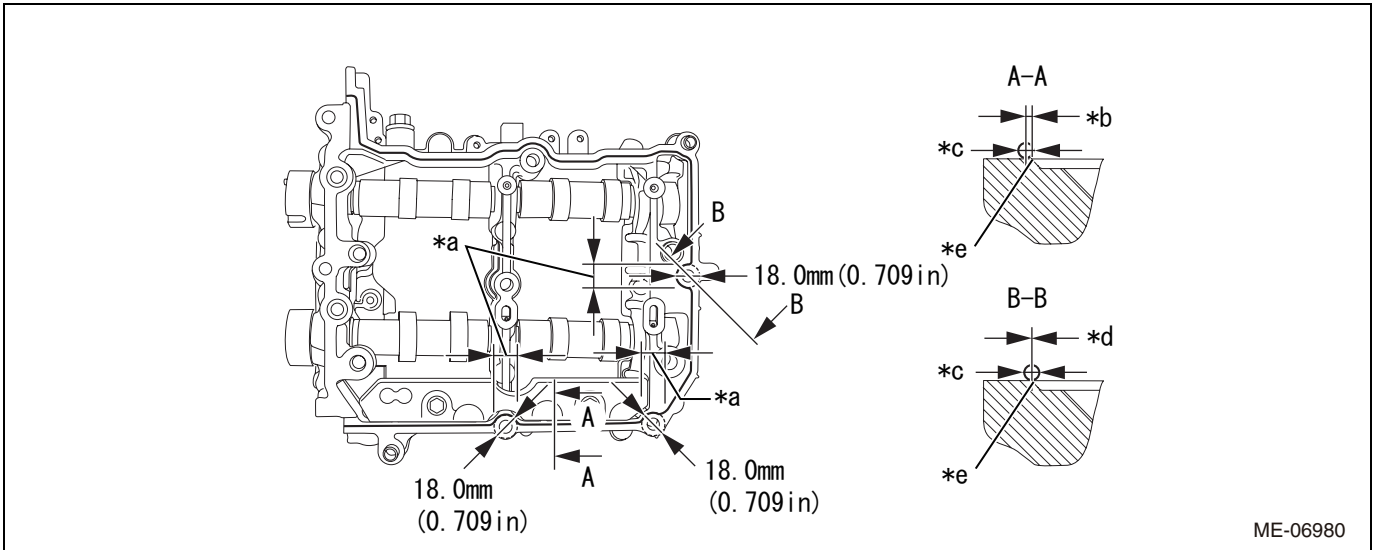

Captions in illustration

*a	Range B-B	*b	0 to 1.0 mm {0 to 0.0394 in}
*c	2.5 to 3.5 mm {0.098 to 0.138 in} in diameter	*d	-0.5 to 0.5 mm {-0.0197 to 0.0197 in}
*e	Groove end	-	-

<Caution>

- Clean and degrease the fitting surface.
- Do not apply liquid gasket excessively.
- Install within 5 min. after applying liquid gasket.
- Completely remove any liquid gasket that is squeezed out on the fitting surface of the timing chain/belt cover SUB-ASSY.

- (4) Tighten nine bolts in order as shown in the figure, and install the camshaft housing SUB-ASSY RH.

Standard value: $T=18\text{N}\cdot\text{m}$ {184kgf·cm} {13.3 ft·lbf}

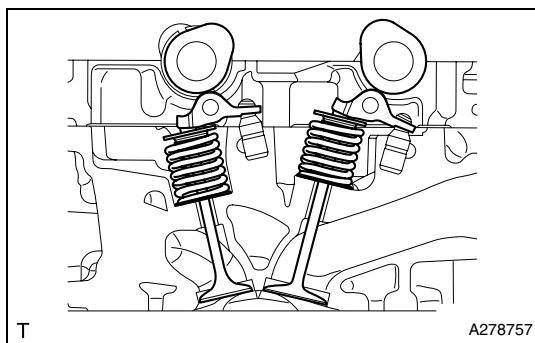
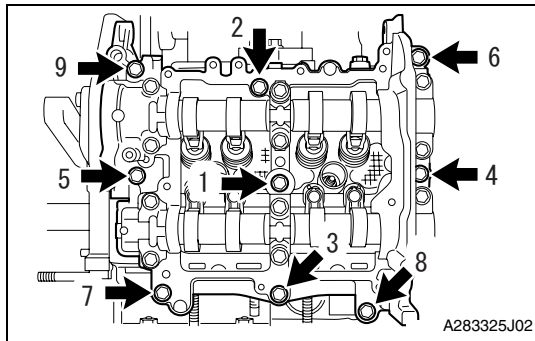

<Reference>

Set the intake camshaft RH and the exhaust camshaft RH to the zero-lift position.

- (5) Loosen the three bolts by 180° in the order as shown in the figure.

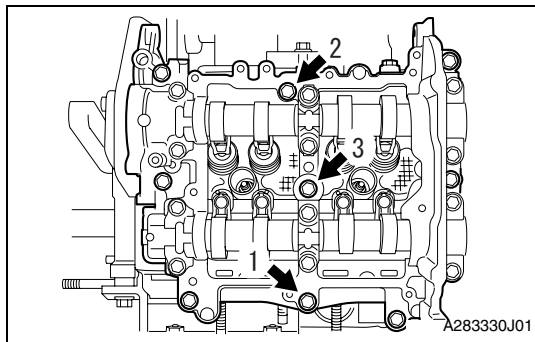

- (6) Tighten the three bolts in the order as shown in the figure.

Standard value: $T=18\text{N}\cdot\text{m}$ {184kgf·cm} {13.3 ft·lbf}

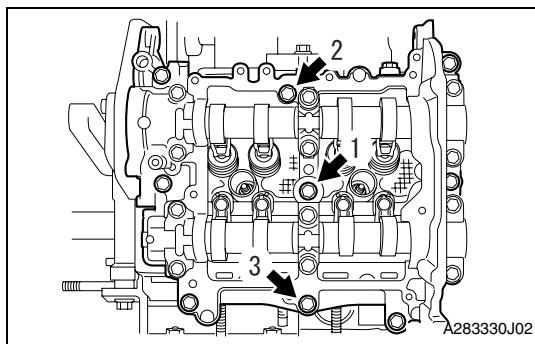

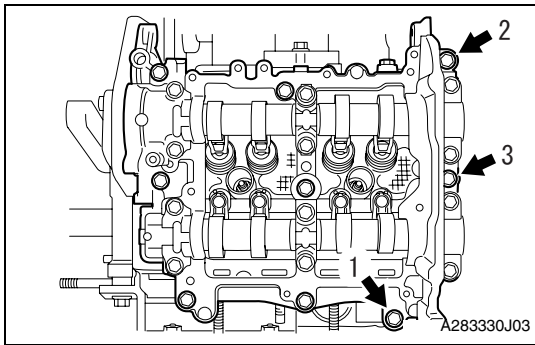

(7) Loosen the three bolts by 180° in the order as shown in the figure.

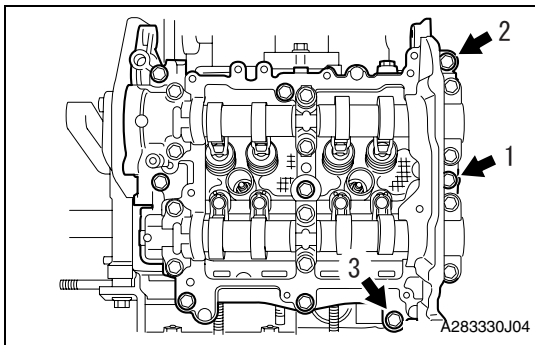

(8) Tighten the three bolts in the order as shown in the figure.
Standard value: $T=18N\cdot m$ {184kgf•cm} {13.3 ft•lbf}

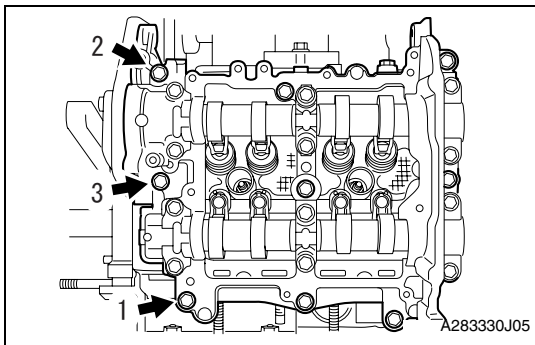

(9) Loosen the three bolts by 180° in the order as shown in the figure.

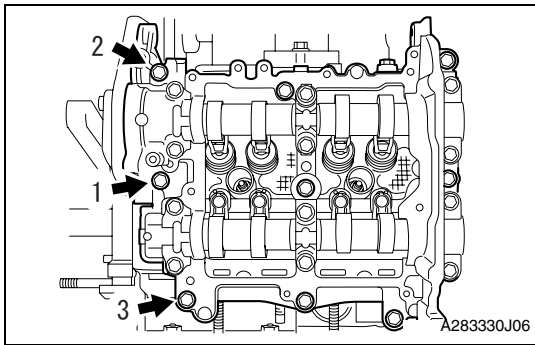

(10) Tighten the three bolts in the order as shown in the figure.

Standard value: $T=18N\cdot m$ {184kgf•cm} {13.3 ft•lbf}

<Reference>

After tightening, if the liquid gasket is squeezed out in the seal surface area of the timing chain/belt cover SUB-ASSY, completely remove any liquid gasket that is squeezed out.

24. Valve clearance check (bank 1 side)

<Caution>

Under the condition that the chain SUB-ASSY (bank 1 side) is detached, the valve heads contact each other and valve stem may bend. Do not turn the intake camshaft RH and exhaust camshaft RH to the outside of range of zero-lift (in range where it can be turned lightly by hand).

(1) Measure the roller surface of cam base circle and valve rocker arm SUB-ASSY No.1 using thickness gauge.

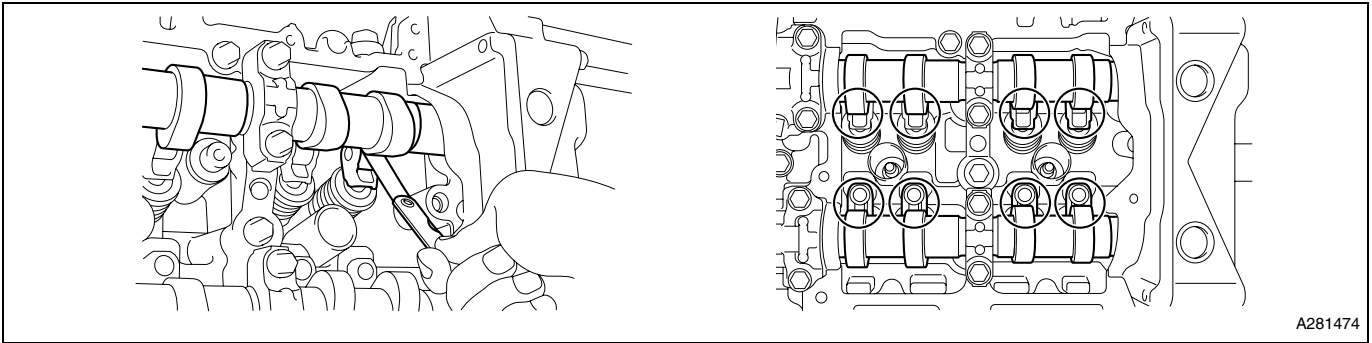

Standard value (when cold): 0.10 to 0.16 mm {0.0039 to 0.0063 in} (intake side)
0.21 to 0.27 mm {0.0083 to 0.0106 in} (exhaust side)

<Reference>

- For valve clearance inspection, adjust the cam base circle position so that the thickness gauge can be inserted easily by hand turning the camshaft to be measured.
- If the measured value is out of standard, take notes of the value in order to adjust the valve clearance later on.

25. Valve clearance adjustment (bank 1 side)

- (1) Remove the camshaft housing SUB-ASSY RH.
- (2) Remove the valve rocker arm SUB-ASSY No. 1.
- (3) Remove the valve adjusting shim.

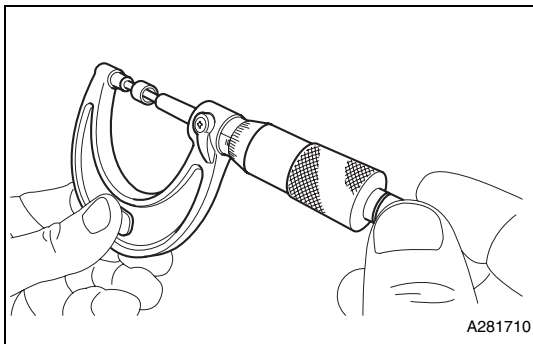

- (4) Measure the thickness of the removed valve adjusting shim using micrometer.

- (5) Calculate the thickness of the valve adjusting shim so that the valve clearance is within the specified range.

Standard value: Intake side: (Selected shim thickness) = (removed shim thickness) + [(measured clearance) - 0.13 mm {0.0051 in}] × 1.54
Exhaust side: (Selected shim thickness) = (removed shim thickness) + [(measured clearance) - 0.24 mm {0.0094 in}] × 1.69

- (6) Apply engine oil to the inner circle area of the selected valve adjusting shim, and install to the valve.

<Caution>

Make sure that the valve adjusting shim turns smoothly after inserting.

- (7) Install the valve rocker arm SUB-ASSY No. 1.
- (8) Install the camshaft housing SUB-ASSY RH.

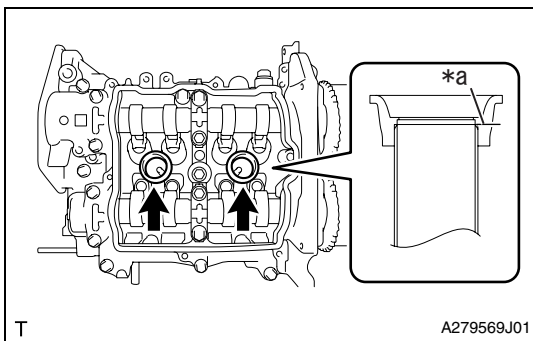

26. Installation of cylinder head cover SUB-ASSY

- (1) Apply a light coat of engine oil to the two new spark plug tube gaskets, and insert them up to the spark plug tube end.

Captions in illustration

*a	Spark plug tube end
----	---------------------

- (2) Install the cylinder head cover gasket to the cylinder head cover SUB-ASSY.

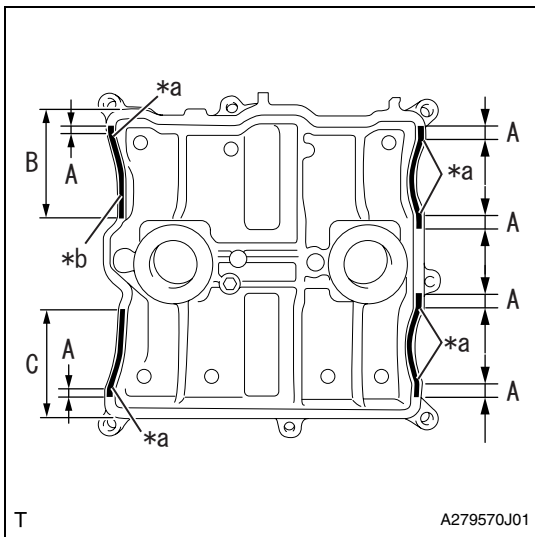

- (3) Apply THREE BOND 1217G to the mating surface of the cylinder head cover SUB-ASSY as shown in the figure.

Application area	Application length
A	10.0 mm {0.394 in} or more
B	68.0 mm {2.677 in} or more
C	70.7 mm {2.784 in} or more

Captions in illustration

*a	Arch starting point
*b	2.0 to 4.0 mm {0.079 to 0.158 in} in diameter

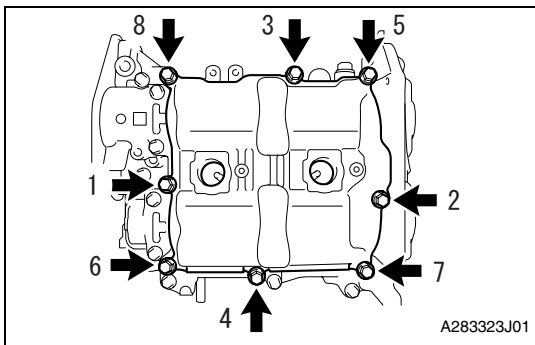

- (4) Set the cylinder head cover SUB-ASSY, and tighten the eight bolts in the order as shown in the figure.

Standard value: $T=6.4N\cdot m$ {65kgf·cm} {4.7 ft·lbf}

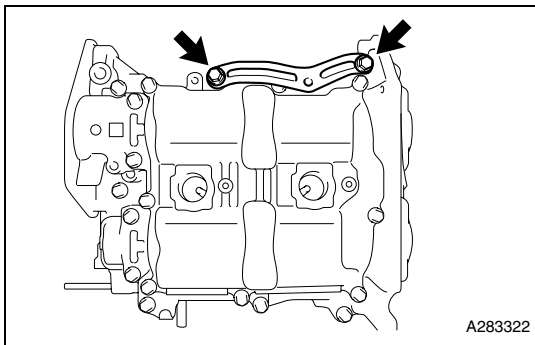

- (5) Install the injector driver bracket using two bolts.

Standard value: $T=6.4N\cdot m$ {65kgf·cm} {4.7 ft·lbf}

27. Installation of spark plug

- (1) Install the four spark plugs.

Standard value: $T=17N\cdot m$ {173kgf·cm} {12.5 ft·lbf}

28. Installation of camshaft timing exhaust gear ASSY LH

<Caution>

Before installation, check that there is no foreign matter on the camshaft timing exhaust gear ASSY LH and exhaust camshaft LH.

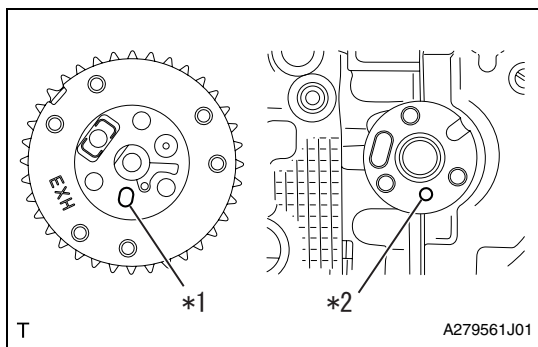

- (1) Install the camshaft timing exhaust gear ASSY LH by aligning the knock hole of the camshaft timing exhaust gear ASSY LH and the knock pin of the exhaust camshaft LH.

Captions in illustration

*1	Knock hole
*2	Knock pin

EM

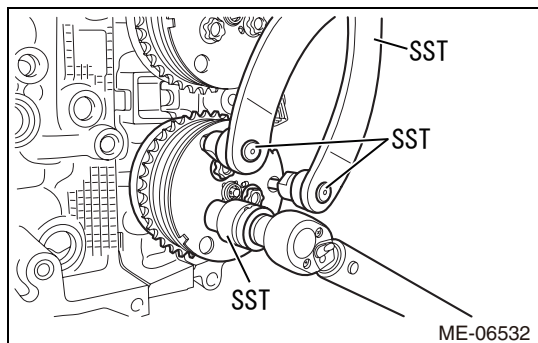

- (2) Fix the camshaft timing exhaust gear ASSY LH using SST and tighten the three bolts.

SST 18355AA000, 18334AA030, 18270KA010

Standard value: $T=18N\cdot m$ {184kgf·cm} {13.3 ft·lbf}

29. Installation of camshaft timing intake gear ASSY LH

<Caution>

Before installation, check that there is no foreign matter on the camshaft timing intake gear ASSY LH and intake camshaft LH.

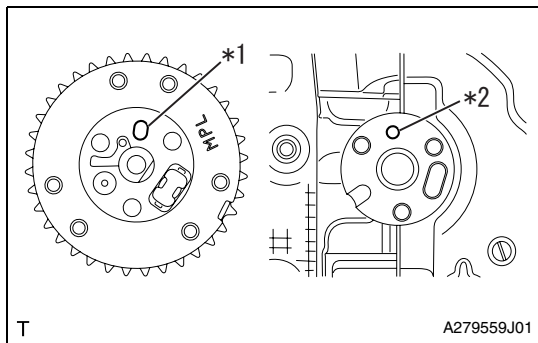

- (1) Install the camshaft timing intake gear ASSY LH by aligning the knock hole of the camshaft timing intake gear ASSY LH and the knock pin of the intake camshaft LH.

Captions in illustration

*1	Knock hole
*2	Knock pin

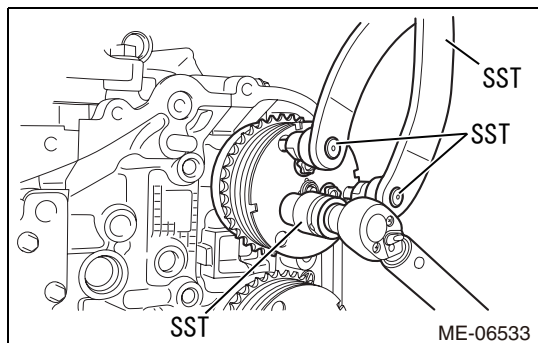

- (2) Fix the camshaft timing intake gear ASSY LH using SST and tighten the three bolts.

SST 18355AA000, 18334AA030, 18270KA010

Standard value: $T=18N\cdot m$ {184kgf·cm} {13.3 ft·lbf}

30. Installation of camshaft timing exhaust gear ASSY RH

<Caution>

Before installation, check that there is no foreign matter on the camshaft timing exhaust gear ASSY RH and exhaust camshaft RH.

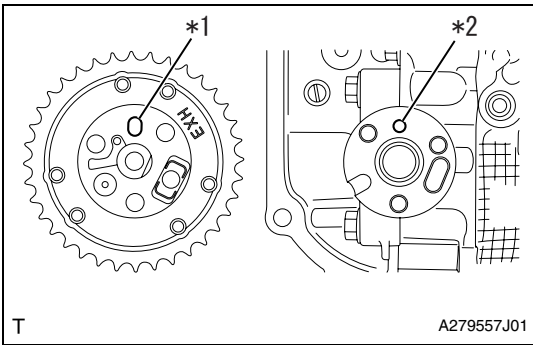

- (1) Install the camshaft timing exhaust gear ASSY RH by aligning the knock hole of the camshaft timing exhaust gear ASSY RH and the knock pin of the exhaust camshaft RH.

Captions in illustration

*1	Knock hole
*2	Knock pin

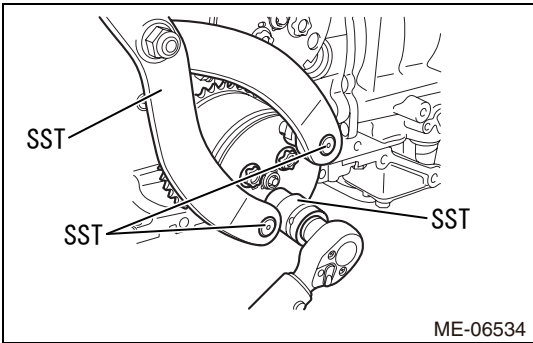

- (2) Fix the camshaft timing exhaust gear ASSY RH using SST and tighten the three bolts.

SST 18355AA000, 18334AA030, 18270KA010

Standard value: $T=18N\cdot m$ {184kgf·cm} {13.3 ft·lbf}



31. Installation of camshaft timing intake gear ASSY RH

<Caution>

Before installation, check that there is no foreign matter on the camshaft timing intake gear ASSY RH and intake camshaft RH.

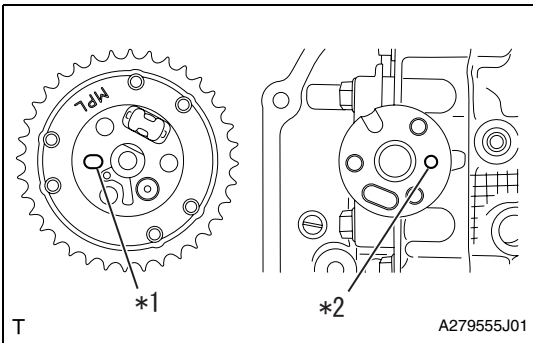

- (1) Install the camshaft timing intake gear ASSY RH by aligning the knock hole of the camshaft timing intake gear ASSY RH and the knock pin of the intake camshaft RH.

Captions in illustration

*1	Knock hole
*2	Knock pin

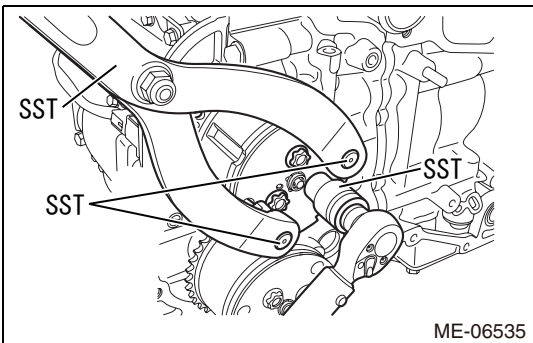

- (2) Fix the camshaft timing intake gear ASSY RH using SST and tighten the three bolts.

SST 18355AA000, 18334AA030, 18270KA010

Standard value: $T=18N\cdot m$ {184kgf·cm} {13.3 ft·lbf}

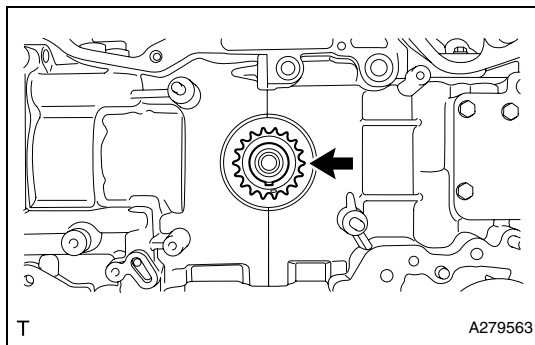

32. Installation of crankshaft timing gear/sprocket
 (1) Install the crankshaft timing gear/sprocket.

EM 33. Installation of chain SUB-ASSY (bank 2 side)

<Caution>

Be careful that the foreign matter is not into or onto the assembled component during installation.

<Reference>

Apply engine oil to all component parts of the chain SUB-ASSY.

- (1) Install the SST to the crankshaft.

SST 18252AA000

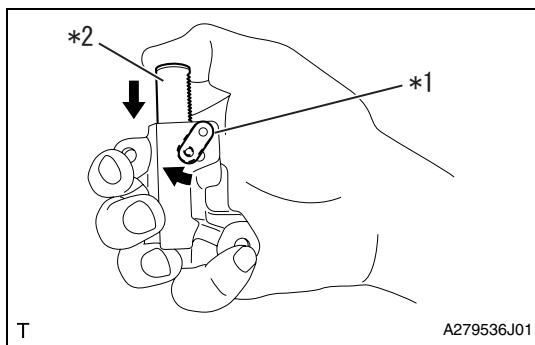

- (2) Move the link plate in the direction of arrow to press in the plunger.

Captions in illustration

*1	Link plate
*2	Plunger

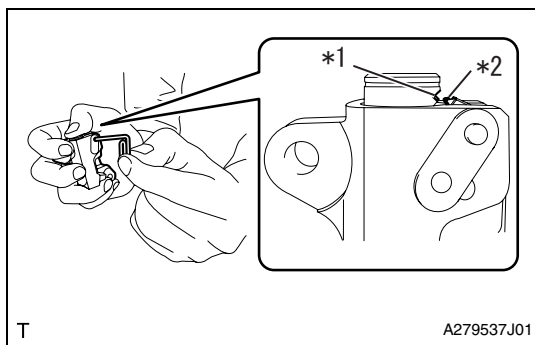

- (3) Insert a piece of metal wire (approx. 1 mm {0.0394 in} dia.) into the stopper pin hole to secure the plunger.

<Reference>

If the stopper pin hole on the link plate and the stopper pin hole on the chain tensioner ASSY are not aligned, check that the first notch of plunger rack is engaged with the stopper tooth. If not engaged, retract the plunger a little so that the first notch of plunger rack is engaged with the stopper tooth.

Captions in illustration

*1	First notch of rack
*2	Stopper tooth

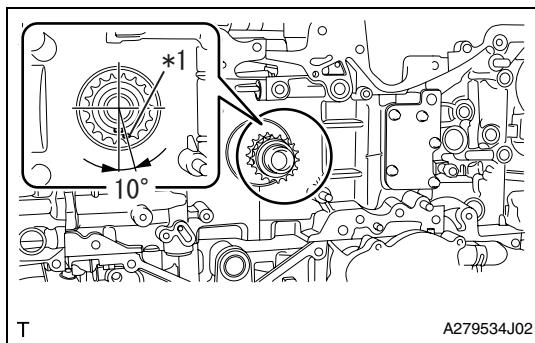

- (4) Check that the crankshaft timing gear/sprocket is located at the position shown in the figure. If not aligned, turn the crankshaft to align the crankshaft timing gear/sprocket alignment mark to the position shown in the figure.

Captions in illustration

*1	Alignment mark
----	----------------

<Caution>

Perform properly to avoid contact of the valve and piston.

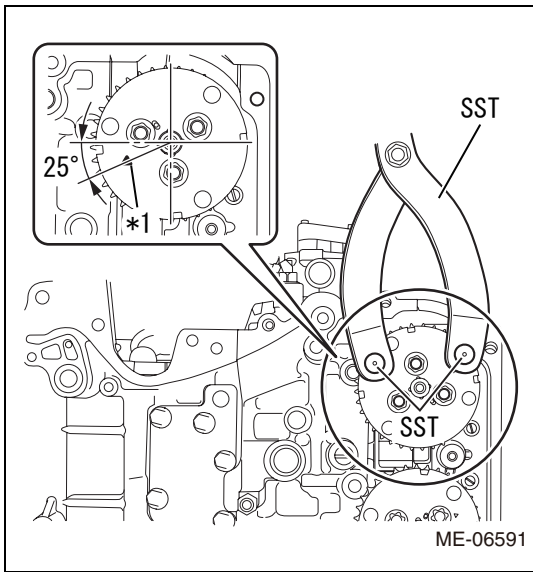

- (5) Using SST and by turning the camshaft timing intake gear ASSY LH, align the alignment mark to the position as shown in the figure.
 SST 18355AA000, 18334AA030
 <Caution>
 The intake valve and exhaust valve contact each other and valve stem may bend. Do not turn the exhaust camshaft LH.
 Captions in illustration

*1	Alignment mark
----	----------------

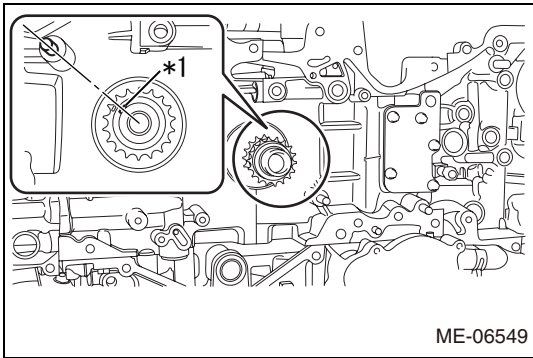

- (6) Using SST and by turning the crankshaft approximately 200° counterclockwise, align the crankshaft timing gear key to the position as shown in the figure.
 SST 18252AA000
 <Caution>
 Never turn clockwise because the valve and piston may contact. However, turning clockwise is allowed in case of fine adjustment after aligning the crankshaft timing gear key to the position shown in the figure.
 Captions in illustration

*1	Key
----	-----

(7) Remove SST.

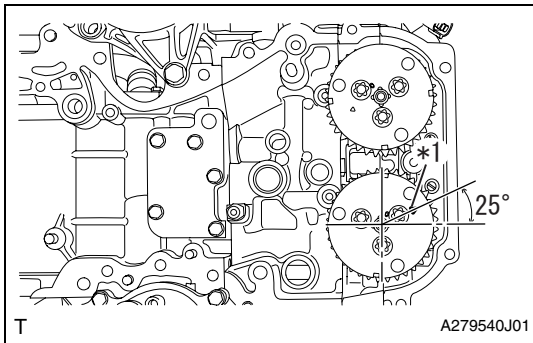

- (8) Using SST and by turning the camshaft timing exhaust gear ASSY LH, align the alignment mark to the position as shown in the figure.
 SST 18355AA000, 18334AA030
 <Caution>
 To prevent valve damage, turn the camshaft timing exhaust gear ASSY LH only within the range of zero-lift (in range where it can be turned lightly by hand).
 Captions in illustration

*1	Alignment mark
----	----------------

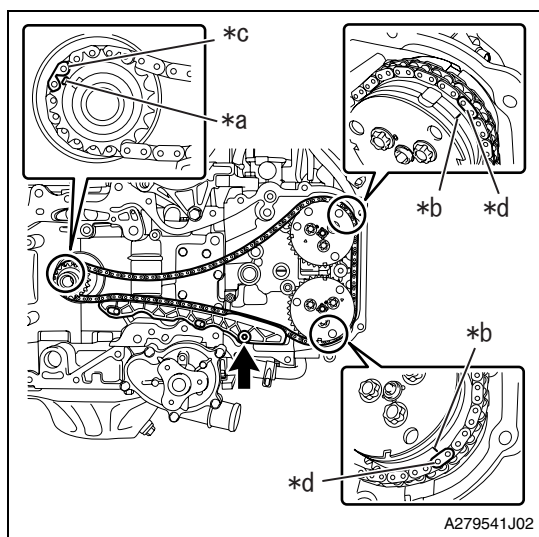

- (9) Align the mark plate (blue) of the chain SUB-ASSY to the alignment mark of the crankshaft timing gear/sprocket.

Captions in illustration

*a	Alignment mark
*b	Timing mark
*c	Mark plate (blue)
*d	Mark plate (pink)

- (10) Align the mark plate (pink) of the chain SUB-ASSY to the timing mark of the camshaft timing intake gear ASSY LH.

- (11) Align the mark (pink) of the chain SUB-ASSY to the timing mark of the camshaft timing exhaust gear ASSY LH.

- (12) Apply engine oil to the sliding surface of the chain vibration damper No. 1 bolt.

- (13) Install the chain vibration damper No. 1 with the bolt.

Standard value: $T=6.4\text{N}\cdot\text{m}$ {65kgf•cm} {4.7 ft•lbf}

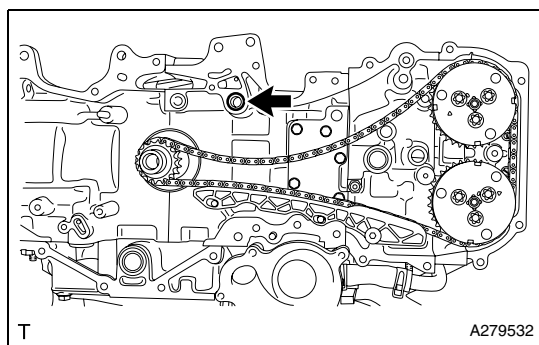

- (14) Install a new O-ring to the cylinder block (bank 2 side).

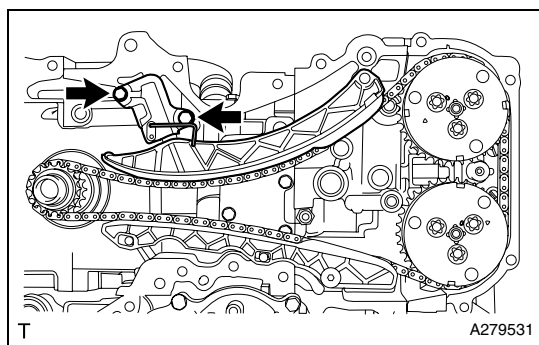

- (15) Install the chain tensioner slipper.

- (16) Tighten the two bolts to install the chain tensioner ASSY No. 2.

Standard value: $T=6.4\text{N}\cdot\text{m}$ {65kgf•cm} {4.7 ft•lbf}

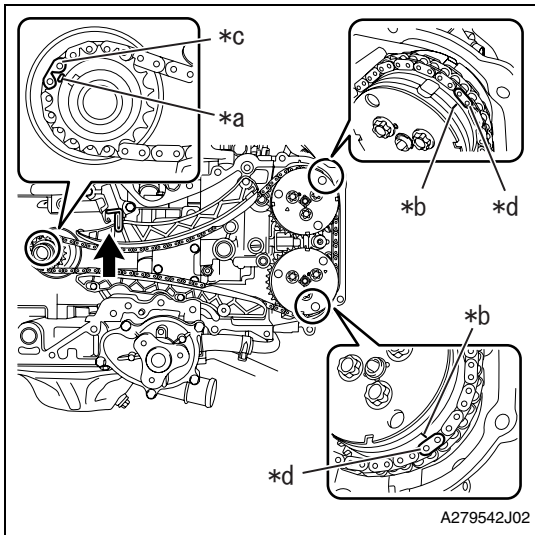

(17) Make sure that the chain SUB-ASSY is securely installed.

Captions in illustration

*a	Alignment mark
*b	Timing mark
*c	Mark plate (blue)
*d	Mark plate (pink)

- (a) Align the mark (blue) of the chain SUB-ASSY to the alignment mark of the crankshaft timing gear/sprocket.
- (b) Align the mark (pink) of the chain SUB-ASSY to the timing mark of the camshaft timing intake gear ASSY LH.
- (c) Align the mark (pink) of the chain SUB-ASSY to the timing mark of the camshaft timing exhaust gear ASSY LH.



(18) Pull out the wire from the chain tensioner ASSY No. 2.

<Reference>

Pull out the piece of metal wire, while pushing up the chain tensioner slipper to push in the plunger of the chain tensioner ASSY No. 2.

(19) Install the SST to the crankshaft.

SST 18252AA000

(20) Turn the crankshaft clockwise, and make sure that there is no abnormal condition.

<Caution>

Always perform this check.

34. Installation of chain SUB-ASSY (bank 1 side)

<Caution>

Be careful that the foreign matter is not into or onto the assembled component during installation.

<Reference>

Apply engine oil to all component parts of the chain SUB-ASSY.

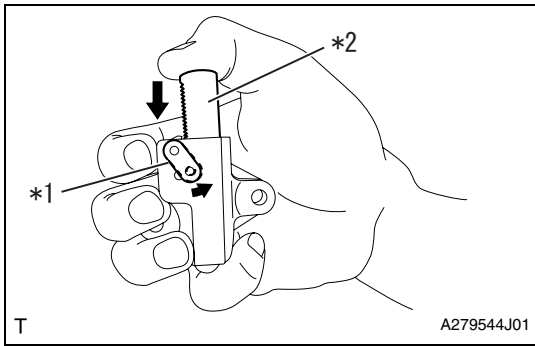

(1) Move the link plate in the direction of arrow to press in the plunger.

Captions in illustration

*1	Link plate
*2	Plunger

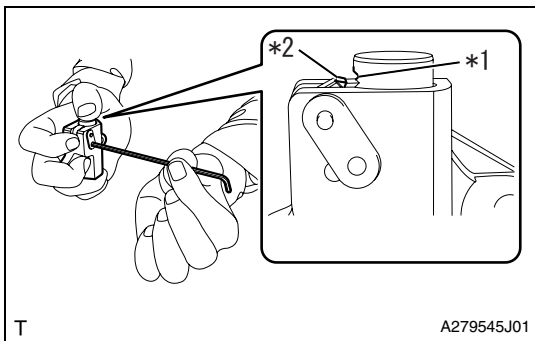

(2) Insert a dia. 2.5 mm {0.098 in} hex wrench into the stopper pin hole to fix the plunger.

Captions in illustration

*1	First notch of rack
*2	Stopper tooth

<Reference>

If the stopper pin hole on the link plate and the stopper pin hole on the chain tensioner ASSY are not aligned, check that the first notch of plunger rack is engaged with the stopper tooth. If not engaged, retract the plunger a little so that the first notch of plunger rack is engaged with the stopper tooth.

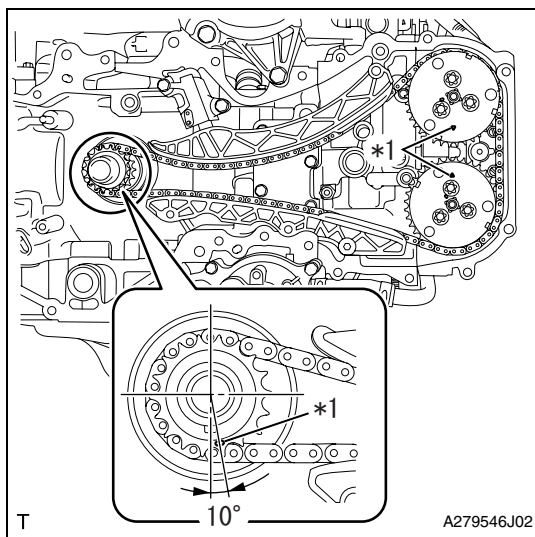

- (3) Using SST and by turning the crankshaft, align the alignment mark of the crankshaft timing gear/sprocket, camshaft timing intake gear ASSY LH and camshaft timing exhaust gear ASSY LH.

Captions in illustration

*1	Alignment mark
----	----------------

<Reference>

When the mark is aligned to the position shown in the figure, the crankshaft timing gear key points downward.

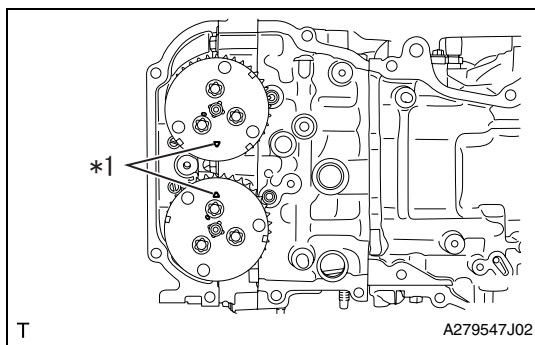

- (4) Using SST, align the alignment mark of the camshaft timing intake gear ASSY RH and camshaft timing exhaust gear ASSY RH to the position as shown in the figure.

SST 18355AA000, 18334AA030

<Caution>

To prevent valve damage, turn the camshaft timing intake gear ASSY RH and camshaft timing exhaust gear ASSY RH only within the range of zero-lift (in range where it can be turned lightly by hand).

Captions in illustration

*1	Alignment mark
----	----------------

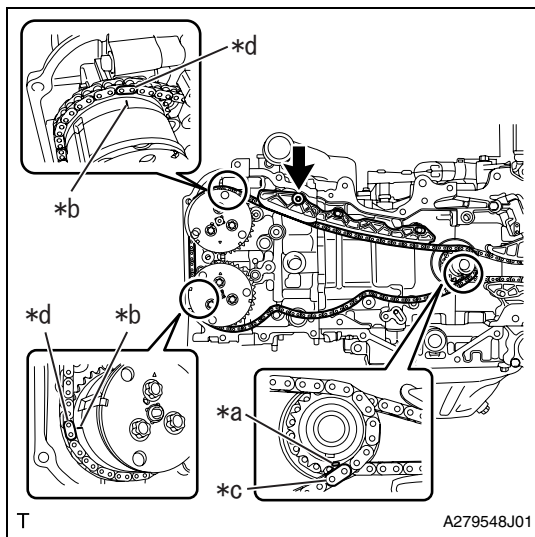

- (5) Align the mark plate (blue) of the chain SUB-ASSY to the alignment mark of the crankshaft timing gear/sprocket.

Captions in illustration

*a	Alignment mark
*b	Timing mark
*c	Mark plate (blue)
*d	Mark plate (pink)

- (6) Align the mark plate (pink) of the chain SUB-ASSY to the timing mark of the camshaft timing intake gear ASSY RH.
 (7) Align the mark plate (pink) of the chain SUB-ASSY to the timing mark of the camshaft timing exhaust gear ASSY RH.
 (8) Apply engine oil to the sliding surface of the chain vibration damper No. 1 bolt.
 (9) Install the chain vibration damper No. 1 with the bolt.

Standard value: $T=6.4\text{N}\cdot\text{m}$ {65kgf•cm} {4.7 ft•lbf}

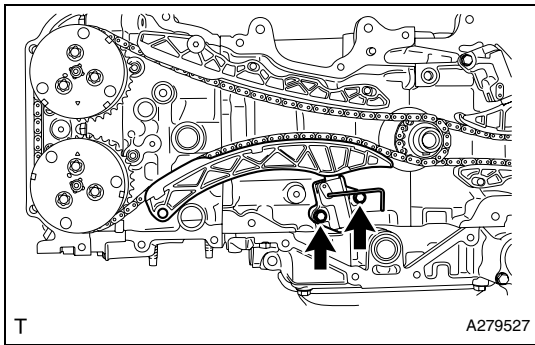

(10) Install the chain tensioner slipper.

(11) Tighten the two bolts to install the chain tensioner ASSY No. 1.

Standard value: $T=6.4N\cdot m$ {65kgf·cm} {4.7 ft·lbf}

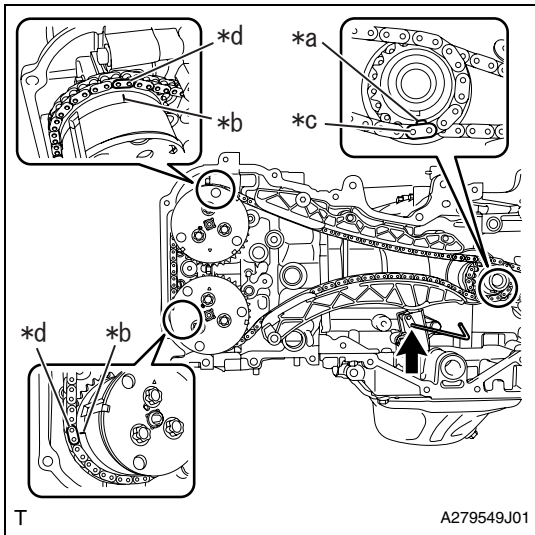

(12) Make sure that the chain SUB-ASSY is securely installed.

Captions in illustration

*a	Alignment mark
*b	Timing mark
*c	Mark plate (blue)
*d	Mark plate (pink)

(a) Align the mark plate (blue) of the chain SUB-ASSY to the alignment mark of the crankshaft timing gear/sprocket.

(b) Align the mark plate (pink) of the chain SUB-ASSY to the timing mark of the camshaft timing intake gear ASSY RH.

(c) Align the mark plate (pink) of the chain SUB-ASSY to the timing mark of the camshaft timing exhaust gear ASSY RH.

(13) Pull out the hex wrench from the chain tensioner ASSY No. 1.

(14) Turn the crankshaft clockwise, and make sure that there is no abnormal condition.

<Caution>

Always perform this check.

(15) Remove SST from the crankshaft.

35. Installation of timing chain/belt cover SUB-ASSY

- (1) Apply a little coat of engine oil to four new O-rings and install to the engine.
- (2) Before applying liquid gasket, completely remove the old sealing material attached to the sealing portion.
- (3) If there is a gap at the position shown in the figure, fill in the THREE BOND 1217G.

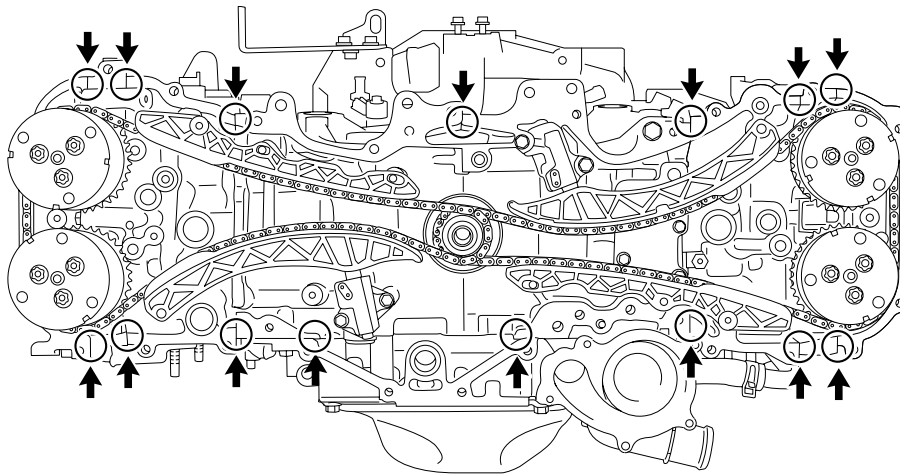

T

A281483

- (4) Apply THREE BOND 1217G to the timing chain/belt cover SUB-ASSY at the position shown in the figure.

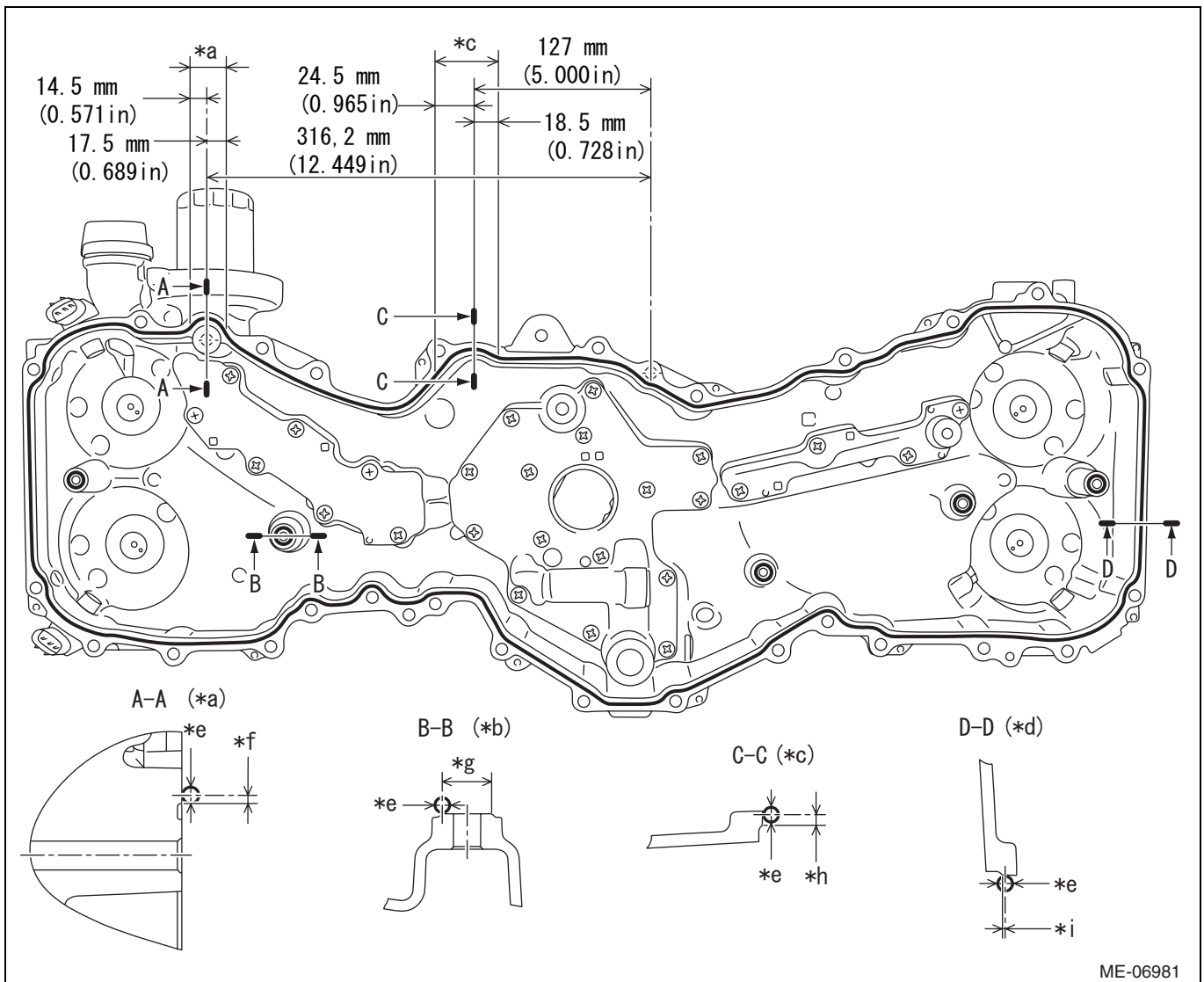

ME-06981

<Caution>

- Clean and degrease the fitting surface.
- Install within 5 min. after applying liquid gasket.

Captions in illustration

*a	Range A	*b	Boss (five locations)
*c	Range B	*d	Other than ranges A and B
*e	3.5 to 4.5 mm {0.138 to 0.177 in} in diameter	*f	2 mm {0.079 in}
*g	12 mm {0.472 in} in diameter	*h	2.5 mm {0.098 in}
*i	0.5 mm {0.0197 in}	-	-

(5) Temporarily install the timing chain/belt cover SUB-ASSY using 32 bolts.

(6) Tighten the 32 bolts in the order as shown in the figure.

EM

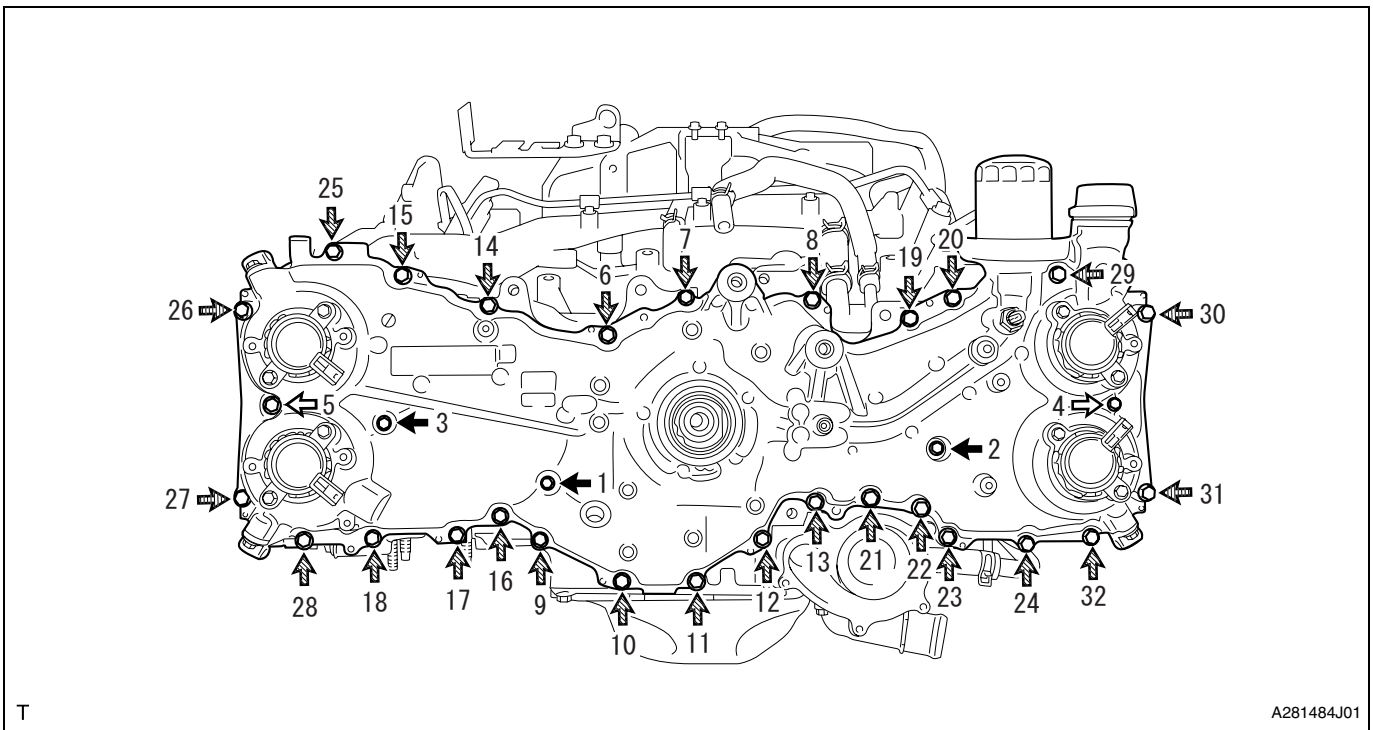

T

A281484J01

Captions in illustration

	Bolt A		Bolt B
	Bolt C		Bolt D

Standard value: Bolt A, B

$$T=10N\cdot m \{102kgf\cdot cm\} \{7.4 ft\cdot lbf\}$$

Bolt C, D

$$T=25N\cdot m \{255kgf\cdot cm\} \{18.4 ft\cdot lbf\}$$

<Reference>

Bolt type	Bolt length (except for head)	Bolt type	Bolt length (except for head)
Bolt A	20 mm {0.787 in}	Bolt B	25 mm {0.984 in}
Bolt C	60 mm {2.362 in}	Bolt D	50 mm {1.969 in}

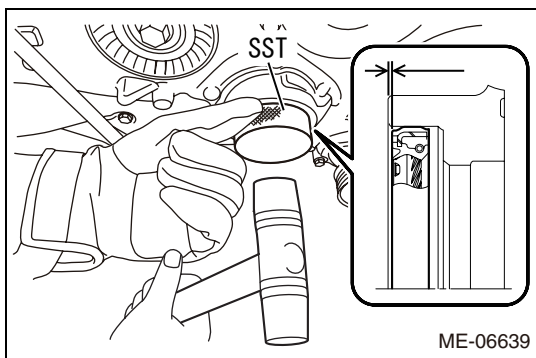

36. Installation of timing chain/belt cover oil seal

- (1) Apply a little coat of engine oil to the inside and outside of the new oil seal.

<Caution>

- Do not foul the lip.
- Do not attach engine oil to the dust seal portion.

- (2) Using SST, hammer in the timing chain/belt cover oil seal evenly so that it is aligned to the end surface of the timing chain/belt cover SUB-ASSY.

SST 398437700

<Caution>

- Do not hammer in the oil seal obliquely.
- Be careful not to deform the oil seal.

<Reference>

The depth at which the timing chain/belt cover oil seal is hammered in is allowed within 0 to -1.0 mm {0 to -0.0394 in} from the end surface of the timing chain/belt cover SUB-ASSY.

37. Installation of crankshaft pulley

- (1) Install the crankshaft pulley spacer.
- (2) Install a new O-ring to the crankshaft pulley spacer.

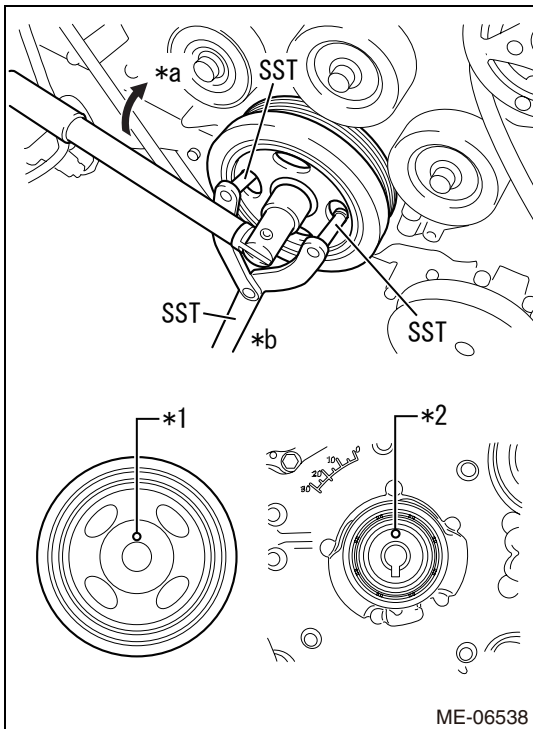

- (3) Install so that the knock hole of the crankshaft pulley and the knock pin of the crankshaft pulley spacer match.

Captions in illustration

*1	Knock hole
*2	Knock pin
*a	Rotate
*b	Hold

- (4) Apply engine oil to the washer and bolt threads of the crankshaft pulley set bolt.
- (5) Use the SST to lock the crankshaft pulley, and tighten the crankshaft pulley set bolt.

SST 18355AA000, 18334AA000

Standard value: $T=20N\cdot m$ {204kgf·cm} {14.8 ft·lbf}

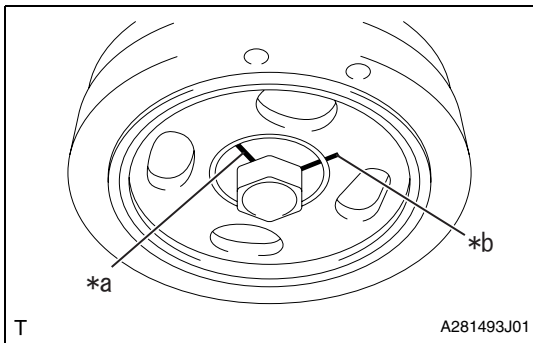

- (6) As shown in the figure, using a marker, draw a reference line (A) on the crankshaft pulley set bolt and end line (B) on the crank pulley at the same level of the line marked on the crankshaft pulley set bolt head portion.

Captions in illustration

*a	Reference line (A)
*b	End line (B)

<Reference>

Lines are marked at an interval of 90° on the crankshaft pulley set bolt head portion.

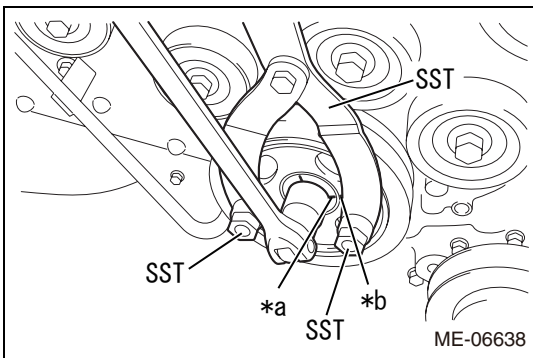

- (7) Use SST to lock the crankshaft pulley, and further-tighten the crankshaft pulley set bolt by 90° to the angle where reference line (A) and end line (B) are aligned.

SST 18355AA000, 18334AA000

Captions in illustration

*a	Reference line (A)
*b	End line (B)

38. Installation of thermostat

- (1) Install a new gasket to the thermostat.

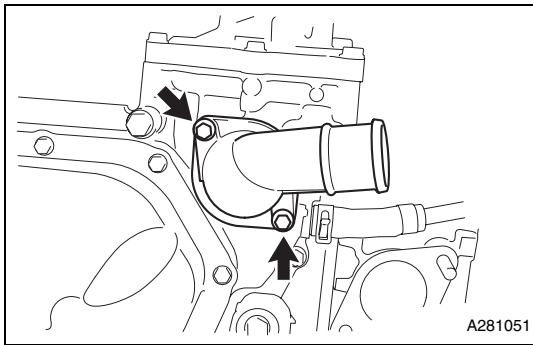

39. Installation of water outlet

- (1) Set the thermostat to the oil pan SUB-ASSY, and install the water outlet with two bolts.

Standard value: $T=6.4N\cdot m$ {65kgf·cm} {4.7 ft·lbf}

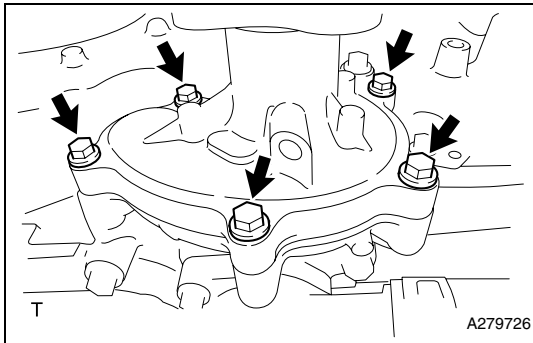

40. Installation of engine water pump ASSY

- (1) Using a new gasket, install the water pump ASSY with five bolts.

Standard value: $T=6.4N\cdot m$ {65kgf·cm} {4.7 ft·lbf}

41. Installation of water pump pulley

- (1) Temporarily- tighten the three bolts to the water pump pulley.

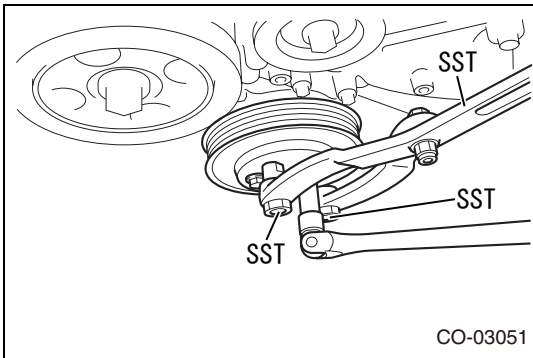

- (2) Fix the water pump pulley using SST.

SST 18355AA000, 18334AA030

- (3) Tighten the three bolts.

Standard value: $T=14N\cdot m$ {143kgf·cm} {10.3 ft·lbf}

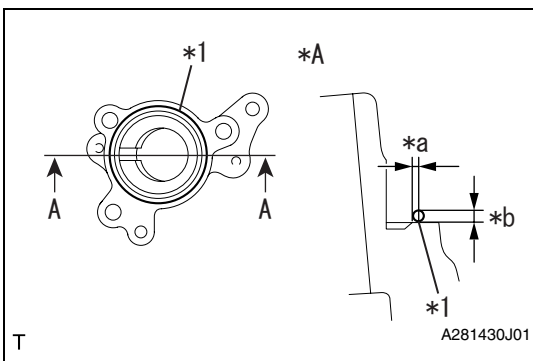

42. Installation of pump drive case ASSY

- (1) Apply THREE BOND 1217G to the pump drive case ASSY as shown in the figure.

Captions in illustration

*A	Cross section A - A
*1	THREE BOND 1217G
*a	Application area of liquid gasket: within 1 mm {0.039 in} from edge
*b	Diameter of liquid gasket: 2 to 4 mm {0.079 to 0.158 in}

<Caution>

- Clean and degrease the fitting surface.
- Install within 5 min. after applying liquid gasket.

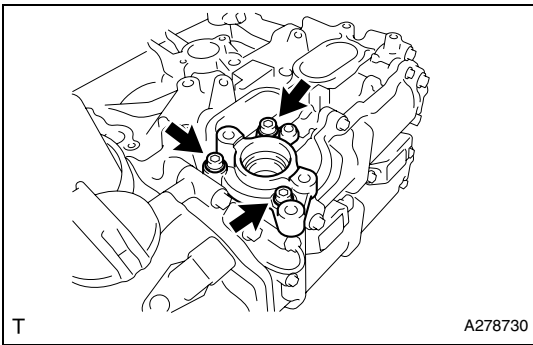

- (2) Tighten the three bolts to install the pump drive case ASSY.
Standard value: $T=19N\cdot m$ {194kgf·cm} {14.0 ft·lbf}

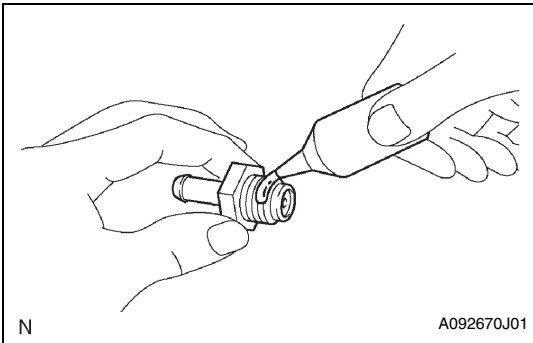

43. Installation of ventilation valve SUB-ASSY

- (1) Apply THREE BOND 1324 to the ventilation valve SUB-ASSY.

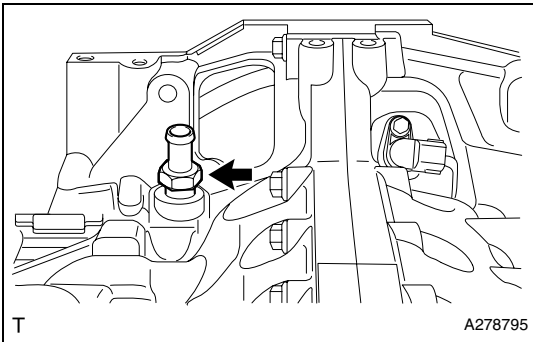

- (2) Install the ventilation valve SUB-ASSY to the cylinder head block.
Standard value: $T=23N\cdot m$ {235kgf·cm} {17.0 ft·lbf}

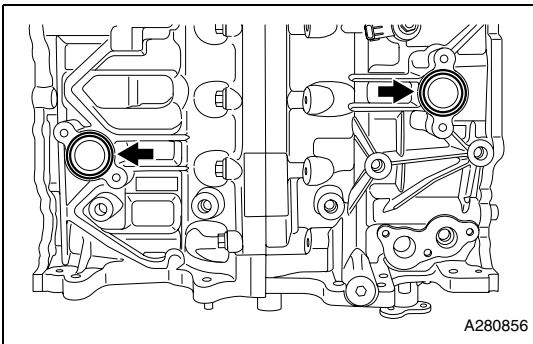

44. Installation of water inlet pipe

- (1) Install two new O-rings to the cylinder block.

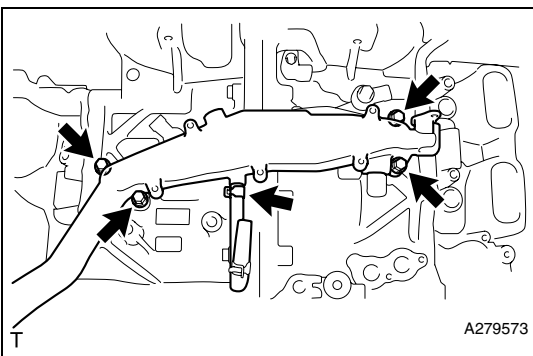

- (2) Install the water inlet pipe with four bolts.
Standard value: $T=6.4N\cdot m$ {65kgf·cm} {4.7 ft·lbf}

45. Installation of oil level gauge guide

- (1) Install a new O-ring to the oil level gauge guide.
- (2) Apply engine oil to the O-ring and install the oil level gauge guide with a bolt.
Standard value: $T=6.4\text{N}\cdot\text{m}$ {65kgf·cm} {4.7 ft·lbf}
- (3) Install the oil level gauge SUB-ASSY.

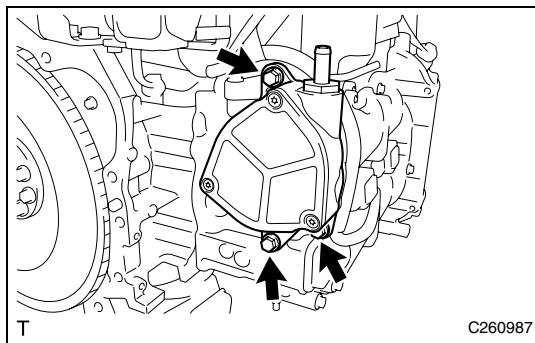
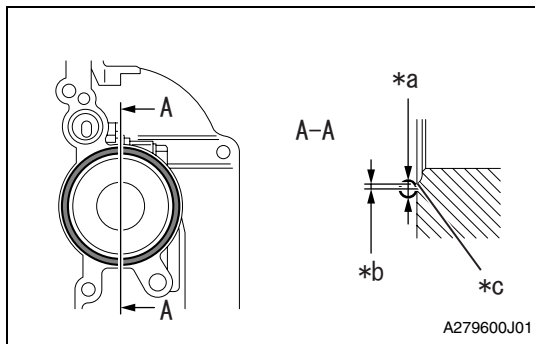
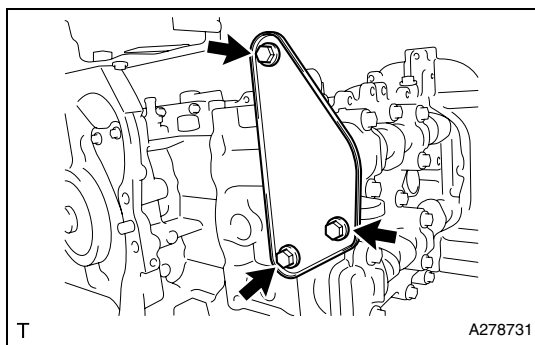
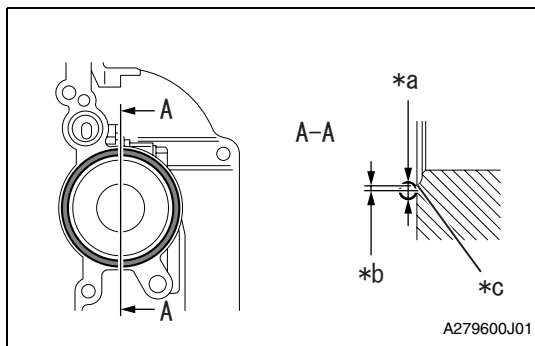

46. Installation of cylinder head plate RR (transmission M/T)

- (1) Apply THREE BOND 1217G to the camshaft housing SUB-ASSY RH as shown in the figure.

Captions in illustration

*a	2.0 to 4.0 mm {0.079 to 0.158 in} in diameter
*b	1.0 mm {0.0394 in} or less
*c	Groove

<Caution>

- Clean and degrease the fitting surface.
- Install within 5 min. after applying liquid gasket.

- (2) Install the cylinder head plate RR with three bolts.
Standard value: $T=16\text{N}\cdot\text{m}$ {163kgf·cm} {11.8 ft·lbf}

47. Installation of vacuum pump ASSY (transmission A/T).

- (1) Apply THREE BOND 1217G to the camshaft housing SUB-ASSY RH as shown in the figure.

Captions in illustration

*a	2.0 to 4.0 mm {0.079 to 0.158 in} in diameter
*b	1.0 mm {0.0394 in} or less
*c	Groove

<Caution>

- Clean and degrease the fitting surface.
- Install within 5 min. after applying liquid gasket.

- (2) Install a new O-ring.
- (3) Tighten the three bolts to install the vacuum pump ASSY.
Standard value: $T=16\text{N}\cdot\text{m}$ {163kgf·cm} {11.8 ft·lbf}

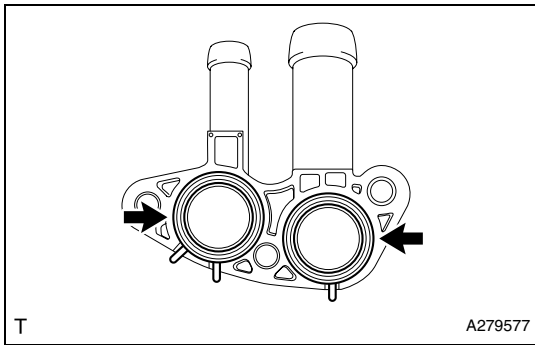

48. Installation of PCV hose connector
 (1) Install two new O-rings to the PCV hose connector.

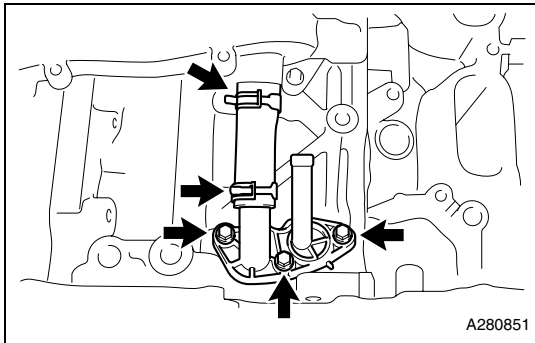

- (2) Connect the water by-pass hose No. 1 to the PCV hose connector and water inlet pipe using hose clamp.
 (3) Install the PCV hose connector with three bolts.
 Standard value: $T=6.4N\cdot m$ {65kgf·cm} {4.7 ft·lbf}



49. Installation of engine oil pressure switch ASSY

- (1) Degrease the threads of the engine oil pressure switch ASSY.

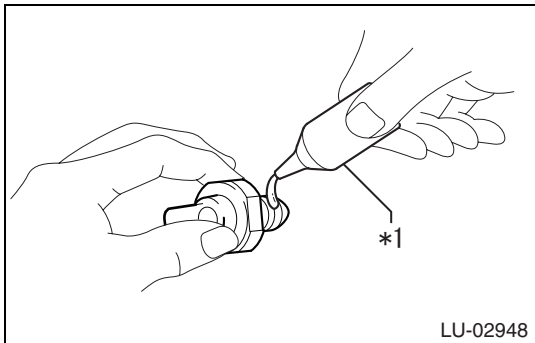

- (2) Apply THREE BOND 1324 to the threads.
 <Caution>
 Do not attach THREE BOND 1324 to the oil hole.
 Captions in illustration

*1	THREE BOND 1324
----	-----------------

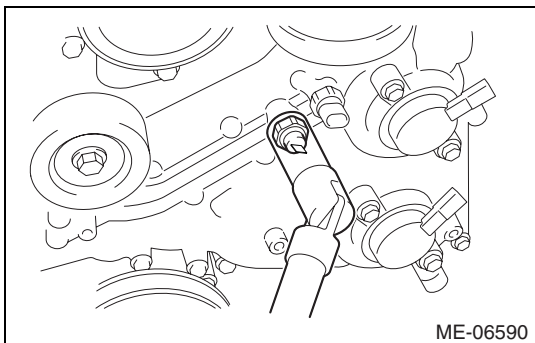

- (3) Install the engine oil pressure switch ASSY.
 Standard value: $T=18N\cdot m$ {184kgf·cm} {13.3 ft·lbf}
 <Caution>
 After assembly, do not start the engine within one hour.

50. Installation of engine oil temperature sensor

- (1) Install a new gasket to the engine oil temperature sensor.

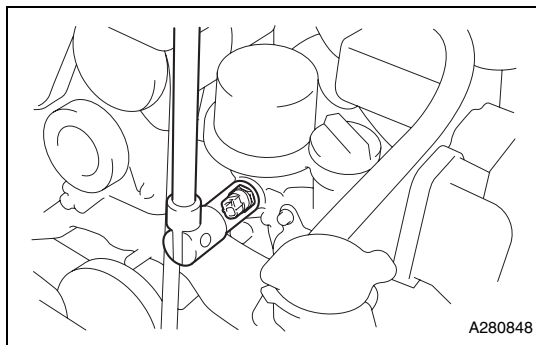

- (2) Install the engine oil temperature sensor.
Standard value: $T=18N\cdot m$ {184kgf·cm} {13.3 ft·lbf}

EM

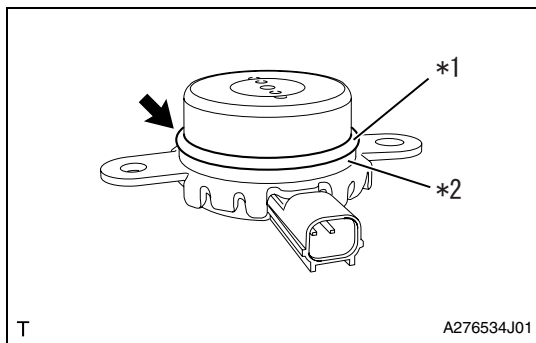

51. Installation of camshaft timing oil control valve ASSY

- (1) Install the back-up ring to the camshaft timing oil control valve ASSY (bank 2 exhaust side).

Captions in illustration

*1	O-ring
*2	Back-up ring

- (2) Install a new O-ring to the camshaft timing oil control valve ASSY (bank 2 exhaust side).
(3) Apply engine oil to O-ring.

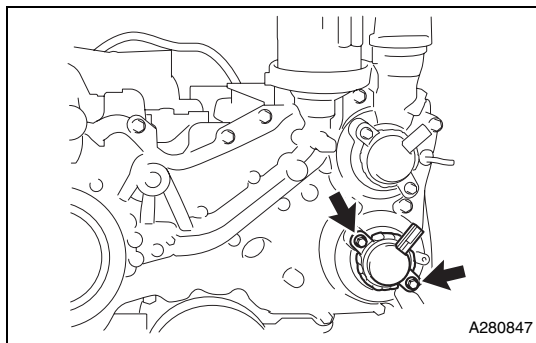

- (4) Install the camshaft timing oil control valve ASSY (bank 2 exhaust side) using two bolts.

Standard value: $T=6.4N\cdot m$ {65kgf·cm} {4.7 ft·lbf}

- (5) Install the back-up ring to the camshaft timing oil control valve ASSY (bank 2 intake side).
(6) Install a new O-ring to the camshaft timing oil control valve ASSY (bank 2 intake side).
(7) Apply engine oil to O-ring.

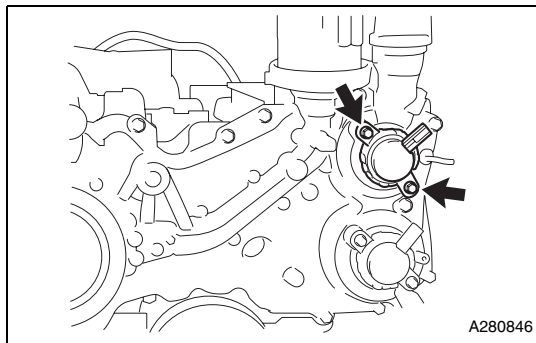

- (8) Install the camshaft timing oil control valve ASSY (bank 2 intake side) using two bolts.

Standard value: $T=6.4N\cdot m$ {65kgf·cm} {4.7 ft·lbf}

- (9) Install the back-up ring to the camshaft timing oil control valve ASSY (bank 1 exhaust side).
(10) Install a new O-ring to the camshaft timing oil control valve ASSY (bank 1 exhaust side).
(11) Apply engine oil to O-ring.

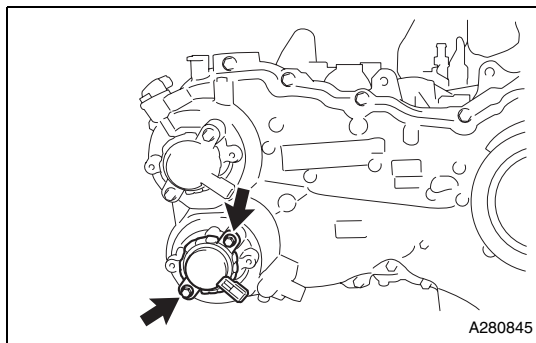

- (12) Install the camshaft timing oil control valve ASSY (bank 1 exhaust side) using two bolts.

Standard value: $T=6.4N\cdot m$ {65kgf·cm} {4.7 ft·lbf}

- (13) Install the back-up ring to the camshaft timing oil control valve ASSY (bank 1 intake side).
(14) Install a new O-ring to the camshaft timing oil control valve ASSY (bank 1 intake side).
(15) Apply engine oil to O-ring.

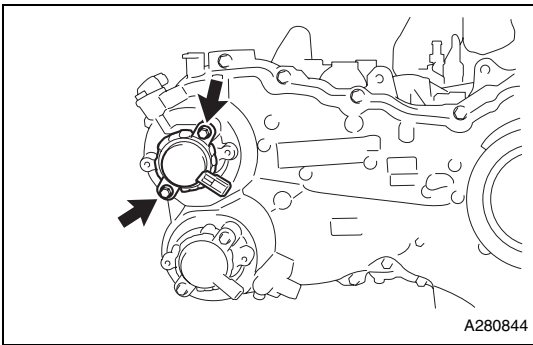

- (16) Install the camshaft timing oil control valve ASSY (bank 1 intake side) using two bolts.
Standard value: $T=6.4N\cdot m$ {65kgf \cdot cm} {4.7 ft \cdot lbf}

52. Installation of camshaft position sensor

- (1) Install a new O-ring to the camshaft position sensor (bank 2 exhaust side).
(2) Apply engine oil to O-ring.

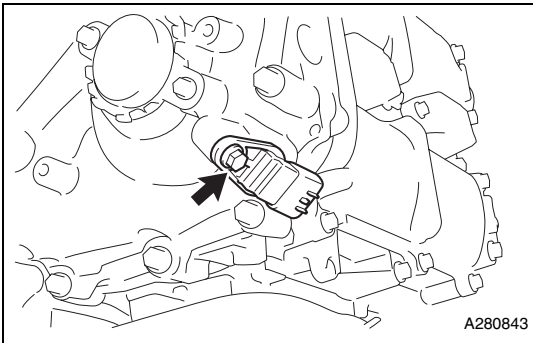

- (3) Install the camshaft position sensor (bank 2 exhaust side) using a bolt.
Standard value: $T=6.4N\cdot m$ {65kgf \cdot cm} {4.7 ft \cdot lbf}

- (4) Install a new O-ring to the camshaft position sensor (bank 2 intake side).
(5) Apply engine oil to O-ring.

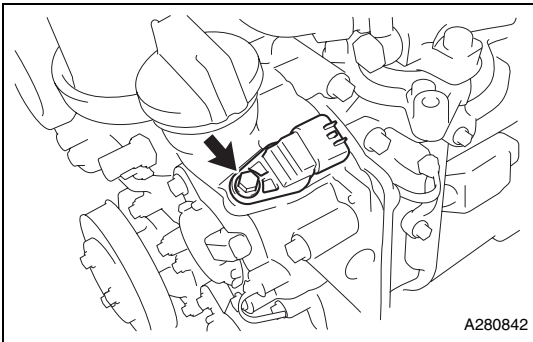

- (6) Install the camshaft position sensor (bank 2 intake side) using a bolt.
Standard value: $T=6.4N\cdot m$ {65kgf \cdot cm} {4.7 ft \cdot lbf}

- (7) Install a new O-ring to the camshaft position sensor (bank 1 exhaust side).
(8) Apply engine oil to O-ring.

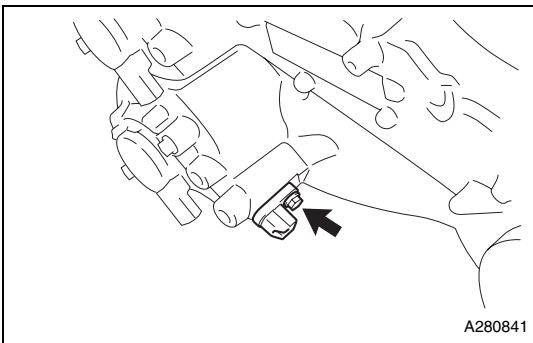

- (9) Install the camshaft position sensor (bank 1 exhaust side) using a bolt.
Standard value: $T=6.4N\cdot m$ {65kgf \cdot cm} {4.7 ft \cdot lbf}

- (10) Install a new O-ring to the camshaft position sensor (bank 1 intake side).
(11) Apply engine oil to O-ring.

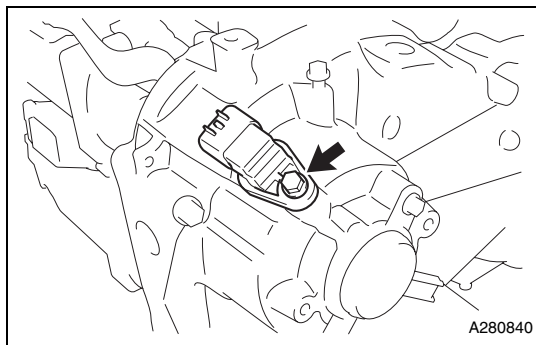

- (12) Install the camshaft position sensor (bank 1 intake side) using a bolt.

Standard value: $T=6.4\text{N}\cdot\text{m}$ {65kgf•cm} {4.7 ft•lbf}

EM

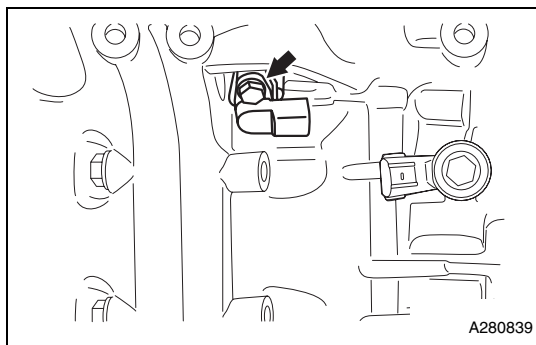

53. Installation of crank position sensor

- (1) Install the crank position sensor using a bolt.

Standard value: $T=6.4\text{N}\cdot\text{m}$ {65kgf•cm} {4.7 ft•lbf}

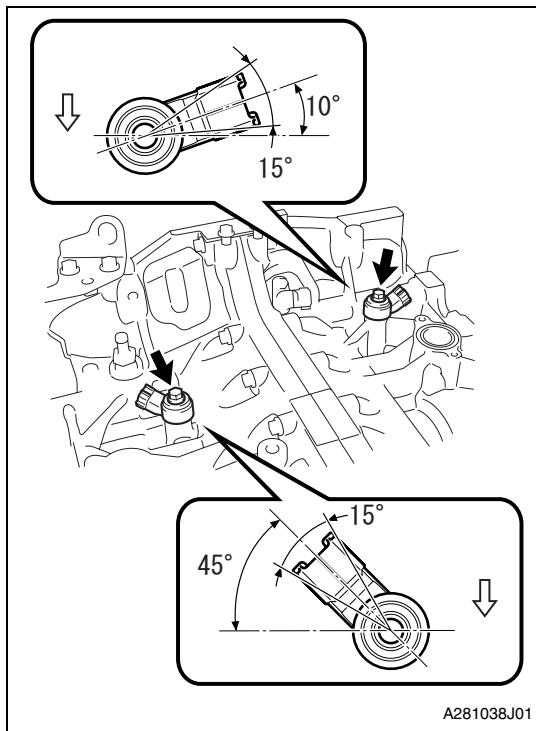

54. Installation of knock control sensor

- (1) Install the two knock control sensors in the direction shown in the figure using two bolts.

Standard value: $T=24\text{N}\cdot\text{m}$ {245kgf•cm} {17.7 ft•lbf}

Captions in illustration

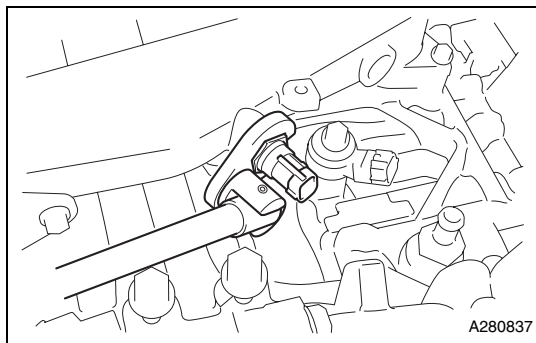

55. Installation of engine water temperature sensor

- (1) Install the engine water temperature sensor, using a new gasket.

Standard value: $T=18\text{N}\cdot\text{m}$ {184kgf•cm} {13.3 ft•lbf}

<Caution>

When a torque wrench extended with a union nut wrench is used, the actual tightening torque becomes over-torque if the part is tightened until the torque wrench reading reaches the specified tightening torque. (For the procedures, refer to IN?5.)

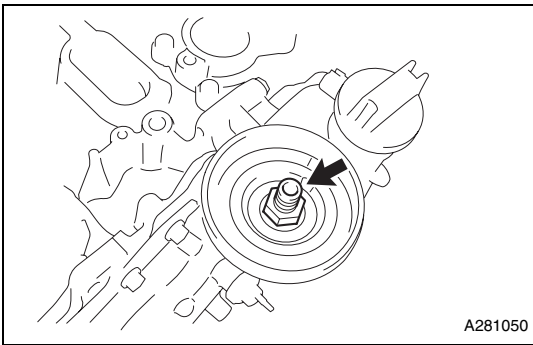

56. Installation of oil filter union

- (1) Install the oil filter union.

Standard value: $T=45\text{N}\cdot\text{m}$ {459kgf•cm} {33.2 ft•lbf}

57. Installation of oil filter SUB-ASSY

- (1) Apply a little coat of engine oil to the seal rubber portion of a new oil filter SUB-ASSY.
- (2) Tighten the oil filter SUB-ASSY by hand.

<Caution>

Be careful not to damage the seal rubber of the oil filter SUB-ASSY.

- (3) Using SST, tighten the oil filter SUB-ASSY.

SST 18332AA020

Standard value: Specified tightening torque

$$T=14\text{N}\cdot\text{m} \{143\text{kgf}\cdot\text{cm}\} \{10.3 \text{ft}\cdot\text{lbf}\}$$

When using SST, calculate the following formula.

$$\text{Calculation } T2 = L2/(L1 + L2) \times T1$$

T1	14 N•m {143 kgf•cm, 10.3 ft•lbf}
T2	Tightening torque
L1	SST length (0.080 m {3.150 in})
L2	Torque wrench length (m)

<Reference>

- This torque is valid when SST and a torque wrench are aligned.
- Install SST and a torque wrench so that they are aligned.

58. Installation of oil filler cap SUB-ASSY

- (1) Install the oil filler cap SUB-ASSY.

CYLINDER HEAD ASSY (FA20)

EXPLODED VIEW

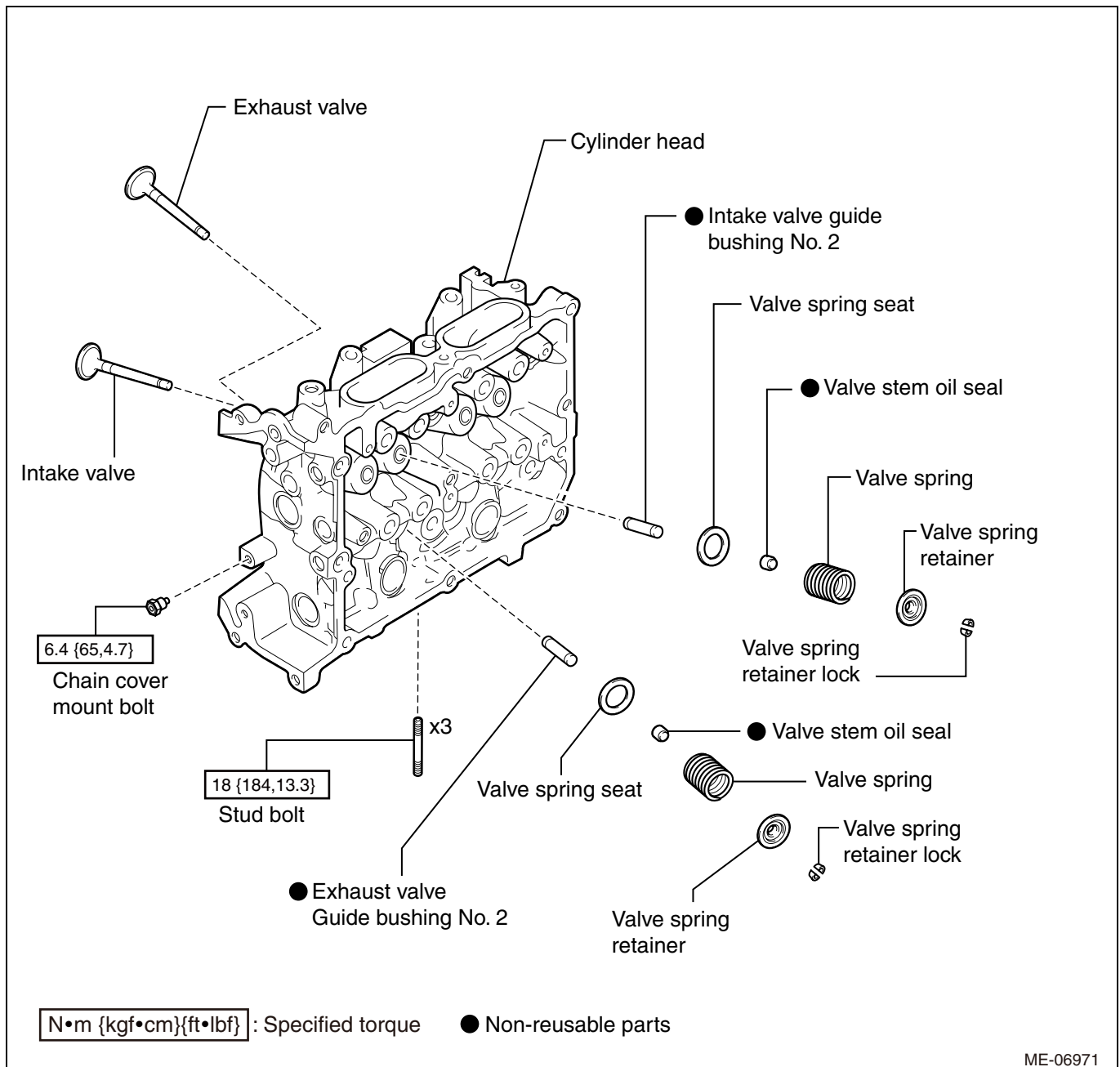

DISASSEMBLY

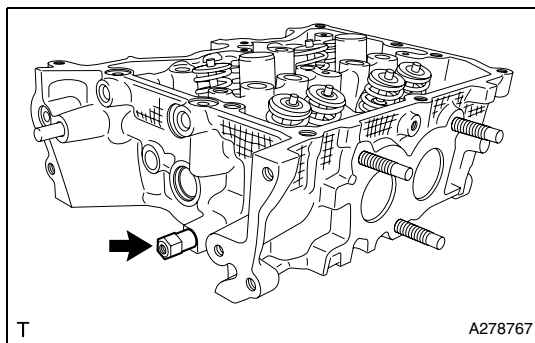

1. Removal of chain cover mount bolt
 - (1) Remove the chain cover mount bolt from the cylinder head.

2. Removal of stud bolt

<Reference>

Replace the stud bolt if deformed or damaged in the threaded portion.

(1) Remove the six stud bolts from the cylinder head.

Captions in illustration

*a	Bank 1
*b	Bank 2

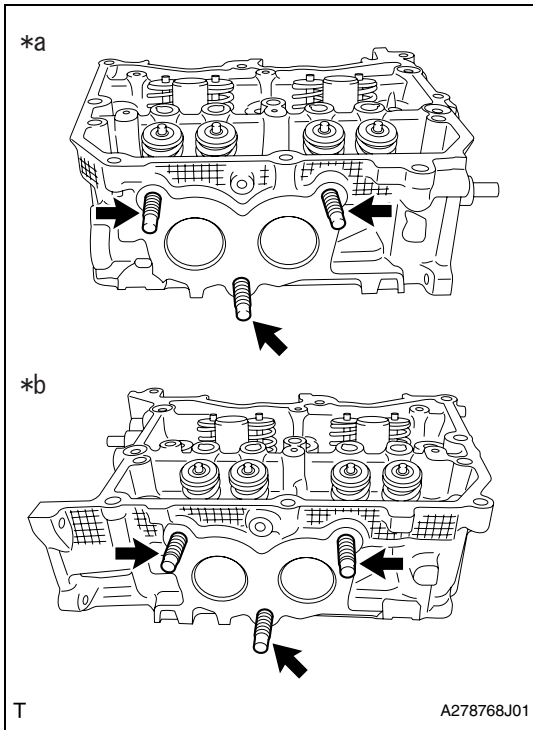

3. Removal of intake valve

<Caution>

During work, place a cloth, etc. to avoid scratching the mating surface of the cylinder head.

<Reference>

- Mark each part to prevent confusion.
- Organize disassembled parts by their installation positions.

(1) Compress the valve spring and remove the valve spring retainer lock using SST.

SST 0920287002000

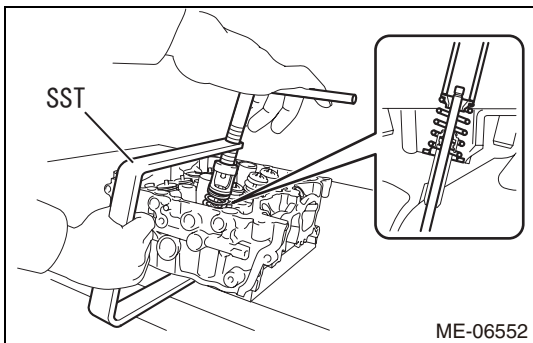

(2) Remove the valve, valve spring retainer, valve spring and valve spring seat.

4. Removal of exhaust valve

<WARNING>

- Metal sodium is included in the exhaust valve. Pay special attention to dealing and disposal of metal sodium because it is strong alkaline enough to cause a high chemical reaction.
- Do not disassemble because metal sodium may cause vision loss, burn and fire due to chemical reaction.
- It is safe as long as metal sodium is sealed in exhaust valve and not exposed to the air.
- If exhaust valve is broken, remove the exhaust valve and dispose of the metal sodium. (Perform the pre-disposal process and disposal process.)
- Do not break the exhaust valve intentionally to retrieve the metal sodium.

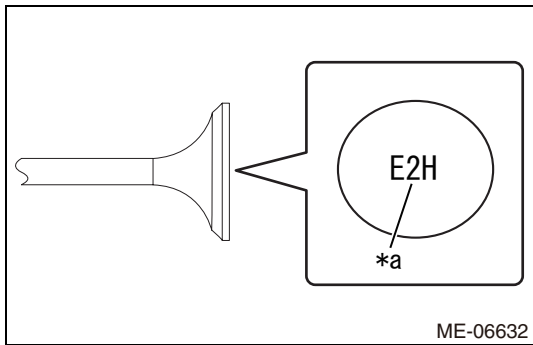

- To identify the exhaust valve including metal sodium, refer to its engraved mark.

Captions in illustration

*a	Engraved mark (identification: E2H•FA20 engine)
----	---

<Caution>

During work, place a cloth, etc. to avoid scratching the mating surface of the cylinder head.

<Reference>

- Mark each part to prevent confusion.
- Organize disassembled parts by their installation positions.

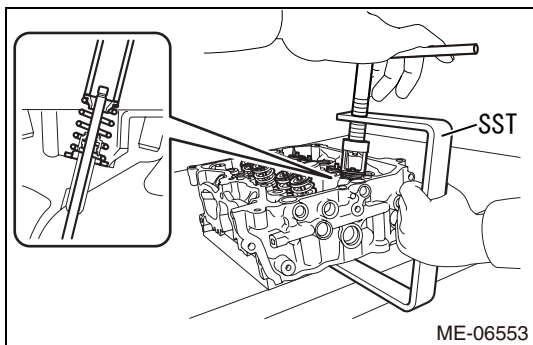

- Compress the valve spring and remove the valve spring retainer lock using SST.

SST 0920287002000

- Remove the valve, valve spring retainer, valve spring and valve spring seat.

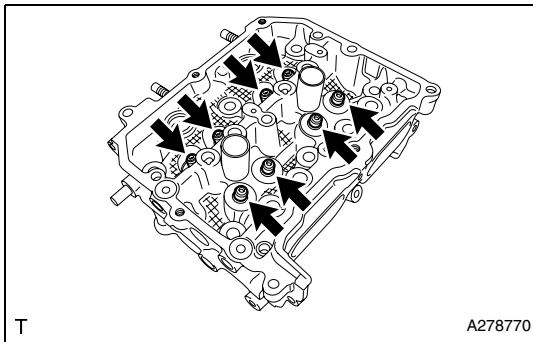

5. Removal of valve stem oil seal

- Remove the eight valve stem oil seals.

<Caution>

- During work, place a cloth, etc. to avoid scratching the mating surface of the cylinder head.
- Use special care not to damage the cylinder head and guide during work.

6. Removal of intake valve guide bushing No. 2

- Place the cylinder head on a wooden piece etc facing the combustion chamber upward.

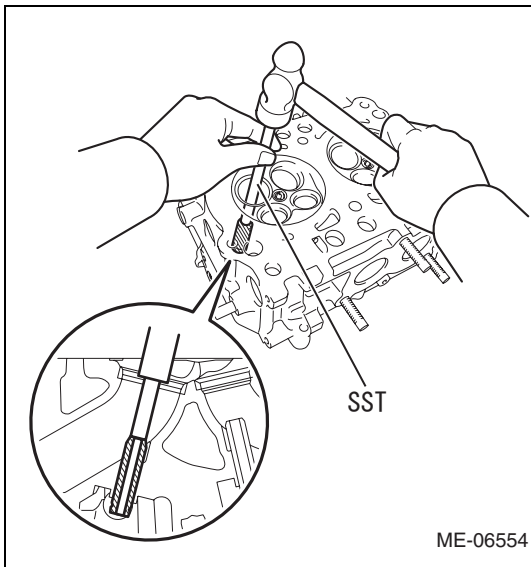

- (2) Using SST and a hammer, punch out intake valve guide bushing No. 2.

SST 499765700

<Caution>

- Place a wooden piece wrapped with a cloth to stabilize the cylinder head before work.
- Use special care not to damage the cylinder head during work.

7. Removal of exhaust valve guide bushing No. 2

- (1) Place the cylinder head on a wooden piece etc facing the combustion chamber upward.

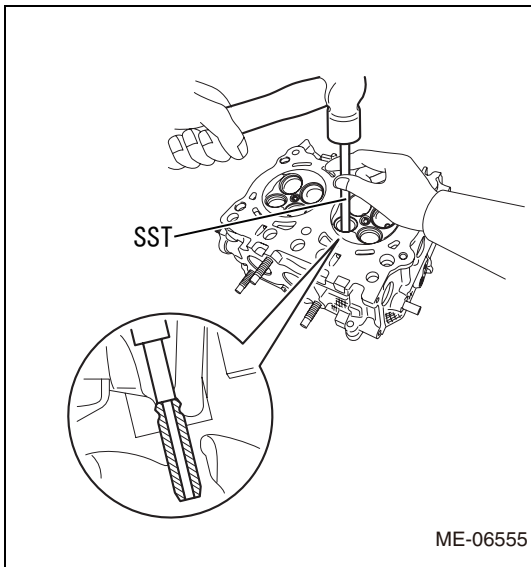

- (2) Using SST and a hammer, punch out exhaust valve guide bushing No. 2.

SST 499765700

<Caution>

- Place a wooden piece wrapped with a cloth to stabilize the cylinder head before work.
- Use special care not to damage the cylinder head during work.

8. Disposal of exhaust valve

<WARNING>

- Metal sodium is included in the exhaust valve. Pay special attention to dealing and disposal of metal sodium because it is strong alkaline enough to cause a high chemical reaction.
- Do not disassemble because metal sodium may cause vision loss, burn and fire due to chemical reaction.
- It is safe as long as metal sodium is sealed in exhaust valve and not exposed to the air.
- If exhaust valve is broken, remove the exhaust valve and dispose of the metal sodium. (Perform the pre-disposal process and disposal process.)
- Do not break the exhaust valve intentionally to retrieve the metal sodium.

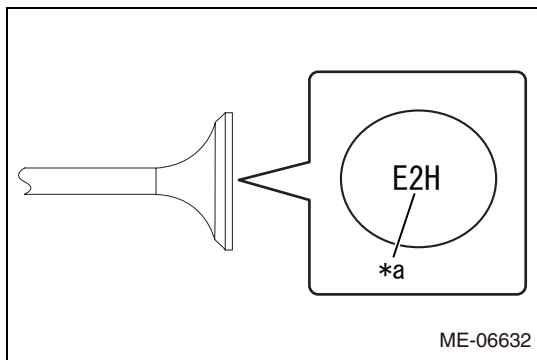

- To identify the exhaust valve including metal sodium, refer to its engraved mark.

Captions in illustration

*a	Engraved mark (identification: E2H•FA20 engine)
----	---

<Caution>

<Pre-disposal process>

- When industrial waste disposal process turns out to be dissolution, the process can be performed.
- If exhaust valve is broken, remove from the cylinder head and dispose in the same method of general steel after performing the process.
- When performing the process, observe the followings.
 - Prepare an extinguisher at hand.
 - Wear protective goggles.
 - Wear rubber gloves.

<Disposal process>

- Wearing rubber gloves, remove the broken exhaust valve from the cylinder head.
- Prepare a large container (bucket or oil tin etc.) in a well ventilated place, and fill the container with over 10 liter of water.
- Put in the broken exhaust valve longitudinally using a large tweezers or pliers.

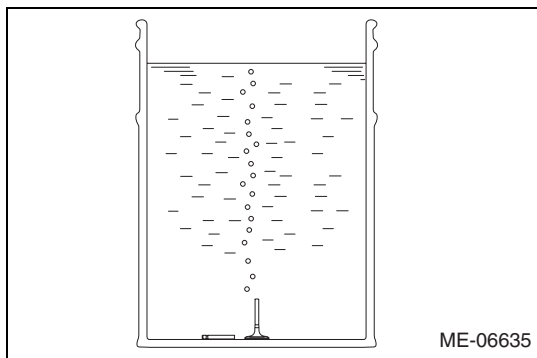

<Caution>

- Let the broken exhaust valve completely sunken.
- Keep fire away from the container because hydrogen gas generates due to chemical reaction.
- Stay away at least 2 to 3 m {6.6 to 9.8 ft} from the container because of an intense chemical reaction.

- After chemical reaction finishes (after the elapse of four to five hours), take out the exhaust valve using a large tweezers or pliers carefully, and dispose in the same disposal method as other parts.

<Caution>

- For disposal of chemically-reacted liquid waste (sodium hydroxide), follow all government and local regulations concerning disposal of liquid waste.
- If chemically-reacted liquid waste (sodium hydroxide) touches skin, wash it off immediately with a sufficient amount of water.

INSPECTION

1. Inspection of cylinder head

- Visually check that there are no cracks, scratches or other damage.
- Use liquid penetrant testing (red check) on the important sections to check for fissures.
- Check that there are no marks of gas leaking or water leaking on gasket attachment surface.
- Check the warping of the cylinder head mating surface that mates with cylinder block at the locations shown in the figure using a straight edge and thickness gauge.

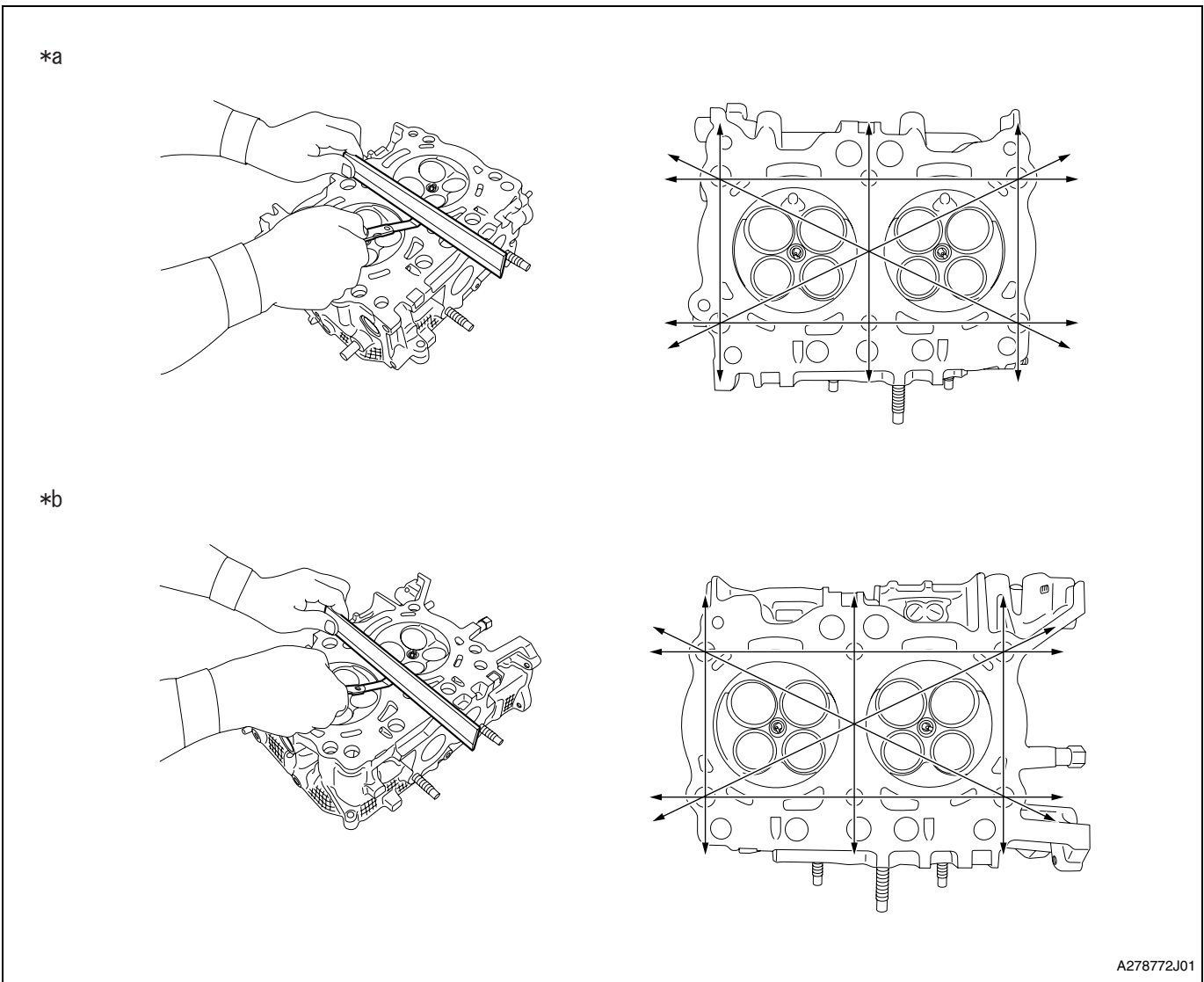

EM

A278772J01

Captions in illustration

*a	Bank 1	*b	Bank 2
----	--------	----	--------

Limit: 0.035 mm {0.00138 in}

Grinding limit of cylinder head: 98.4 mm {3.874 in} or less

Standard value for cylinder head height: 98.5 mm {3.878 in}

<Reference>

- Measurement should be performed at a temperature of 20°C {68°F}.
- If there is warpage on the cylinder head mating surface, the cylinder head bolt tightening torque and angle tightening may be improper. When installing the cylinder head, make sure that tightening to specified torque and angle tightening are performed precisely according to the operation procedures.
- If it exceeds the limit, correct the surface by grinding it with a surface grinder or replace the cylinder head.
- When the cylinder head is replaced, lap each valve.

2. Inspection of intake valve

- (1) Check the valve flange and stem for damage, wear or deformation.

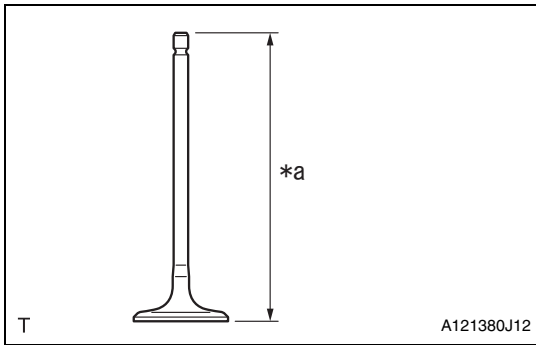

(2) Using a caliper, measure the whole length of the valve.

Captions in illustration

*a	Overall length
----	----------------

Standard value: 103.3 mm {4.067 in}

EM

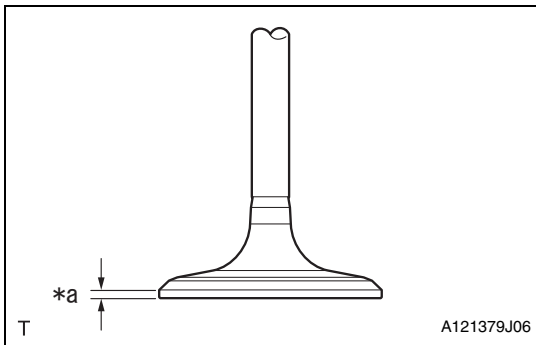

(3) Using a caliper, measure the thickness of the valve head.

Captions in illustration

*a	Thickness
----	-----------

Standard value: 0.8 to 1.2 mm {0.0315 to 0.0472 in}

<Reference>

- It is possible to differentiate between the intake valve and the exhaust valve by their overall length.
- If it is not within the specified value, replace the valve with a new part.
- When the valve is replaced, lap the valve.

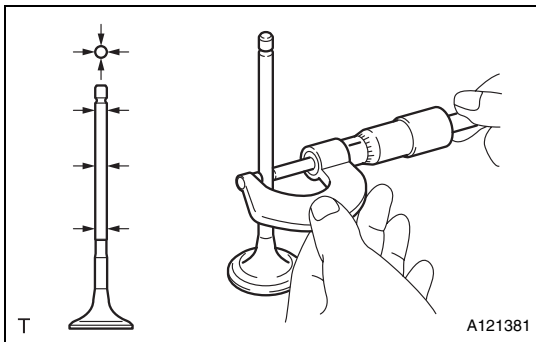

(4) Check the valve stem outer diameter using micrometer.

Standard value: 5.455 to 5.470 mm {0.2148 to 0.2154 in}

<Reference>

- Measurement should be performed at a temperature of 20°C {68°F}.
- Measure the outer diameter of the valve stem at the six locations as shown in the figure, and read the value of most worn location.
- If it is not within the specified value, replace the valve with a new part.
- When the valve is replaced, lap the valve.

3. Inspection of exhaust valve

(1) Check the valve flange and stem for damage, wear or deformation.

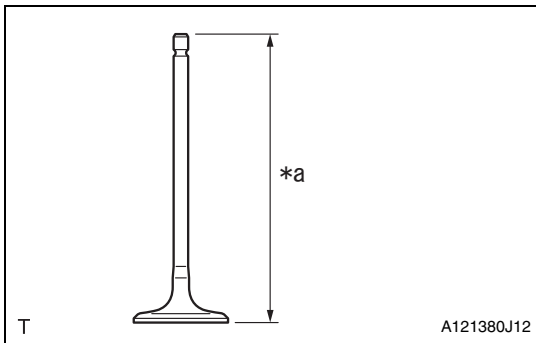

(2) Using a caliper, measure the whole length of the valve.

Captions in illustration

*a	Overall length
----	----------------

Standard value: 95.1 mm {3.744 in}

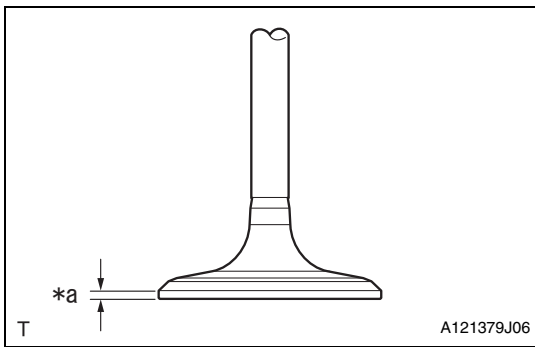

(3) Using a caliper, measure the thickness of the valve head.

Captions in illustration

*a	Thickness
----	-----------

Standard value: 1.0 to 1.4 mm {0.039 to 0.055 in}

<Reference>

- It is possible to differentiate between the intake valve and the exhaust valve by their overall length.
- If it is not within the specified value, replace the valve with a new part.
- When the valve is replaced, lap the valve.

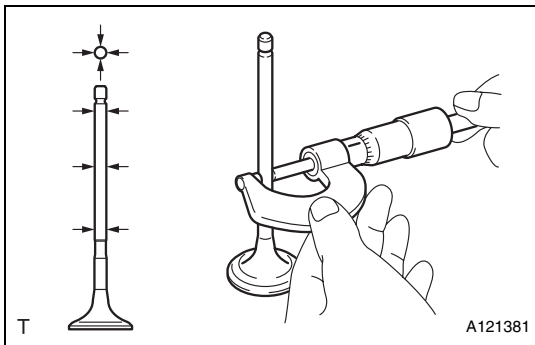

(4) Check the valve stem outer diameter using micrometer.

Standard value: 5.445 to 5.460 mm {0.21437 to 0.21496 in}

<Reference>

- Measurement should be performed at a temperature of 20°C {68°F}.
- Measure the outer diameter of the valve stem at the six locations as shown in the figure, and read the value of most worn location.
- If it is not within the specified value, replace the valve with a new part.
- When the valve is replaced, lap the valve.

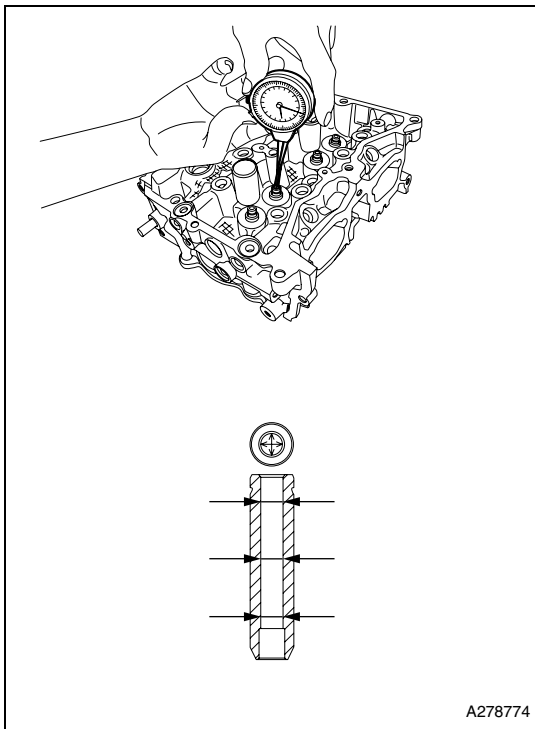

4. Inspection of valve guide bushing oil clearance

(1) Using a caliper gauge, measure the inner diameter of valve guide bushing.

Standard value: 5.500 to 5.512 mm {0.21654 to 0.21701 in}

<Reference>

- Measurement should be performed at a temperature of 20°C {68°F}.
- Measure the inner diameter of the valve guide bushing at the six locations as shown in the figure, and read the value of most worn location.
- If it is not within the standard value, replace the valve guide bushing.

(2) Calculate the oil clearance between valve and valve guide bushing.

Standard value (intake): 0.030 to 0.057 mm
{0.00118 to 0.00224 in}

Standard value (exhaust): 0.040 to 0.067 mm
{0.00157 to 0.00264 in}

<Reference>

- Oil clearance = valve guide bushing inner dia. - Valve stem outer dia.
- If the clearance between valve and valve guide bushing exceeds the standard, replace the valve or valve guide, whichever shows the greater amount of wear or damage.
- When the valve is replaced, lap the valve.

5. Inspection of valve adjusting shim clearance

(1) Visually check the valve adjusting shim for any damage.

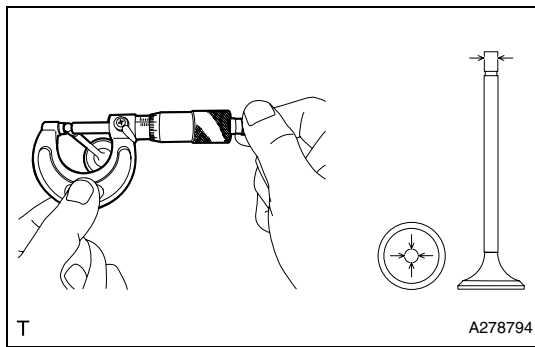

- (2) Measure the valve stem end outer diameter using micrometer.

Standard value (intake): 5.455 to 5.470 mm
{0.21476 to 0.21535 in}

Standard value (exhaust): 5.445 to 5.460 mm
{0.21437 to 0.21496 in}

<Reference>

- Measurement should be performed at a temperature of 20°C{68°F}.
- Measure the outer diameter of the valve stem end at the two locations as shown in the figure, and read the value of most worn location.
- If it is not within the specified value, replace the valve with a new part.
- When the valve is replaced, lap the valve.

- (3) Using a caliper gauge, measure the inner diameter of valve adjusting shim.

Standard value: 5.500 to 5.560 mm {0.21654 to 0.21890 in}

<Reference>

- Measurement should be performed at a temperature of 20°C {68°F}.
- Measure the inner diameter of the valve adjusting shim at the two locations as shown in the figure, and read the value of most worn location.
- If it is not within the standard value, replace the valve adjusting shim.
- If the valve adjusting shim has to be replaced, check the valve clearance and replace with the suitable valve adjusting shim.

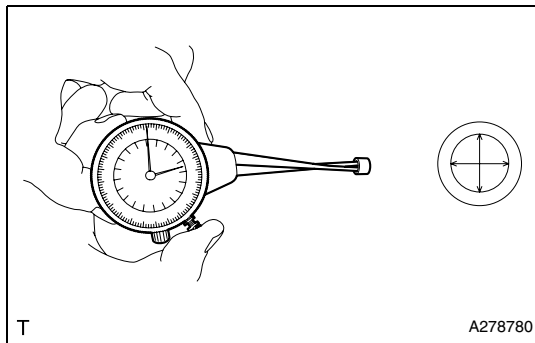

- (4) Calculate the clearance between valve and valve adjusting shim.

Standard value: 0.030 to 0.115 mm {0.00118 to 0.00453 in}

<Reference>

- Valve adjusting shim clearance = Valve adjusting shim inner dia. - Valve stem end outer dia.
- If it exceeds the standard, replace the valve or valve adjusting shim, whichever shows the greater amount of wear or damage.
- When the valve is replaced, lap the valve.
- If the valve adjusting shim has to be replaced, check the valve clearance and replace with the suitable valve adjusting shim.

6. Inspection of intake valve seat

- (1) Check the valve seat for damage and deformation.

- (2) Clean the valve and valve seat.

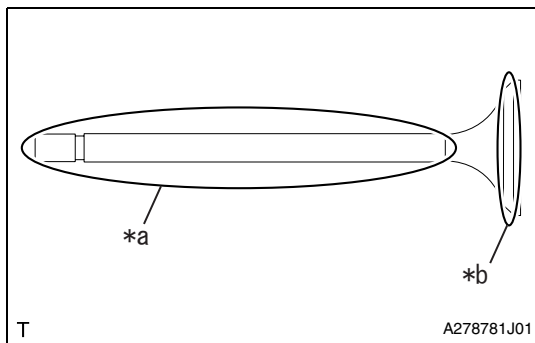

- (3) Apply a thin coat of engine oil to the valve stem, and apply red dye evenly on the valve face.

Captions in illustration

*a	Valve stem
*b	Valve face

- (4) Slowly insert the valve applied with red dye into the valve guide bushing, lightly press the valve against the valve seat without turning the valve, and then slowly pull out the valve.

- (5) Check the seating width of valve seat as shown in the figure, using a caliper gauge.

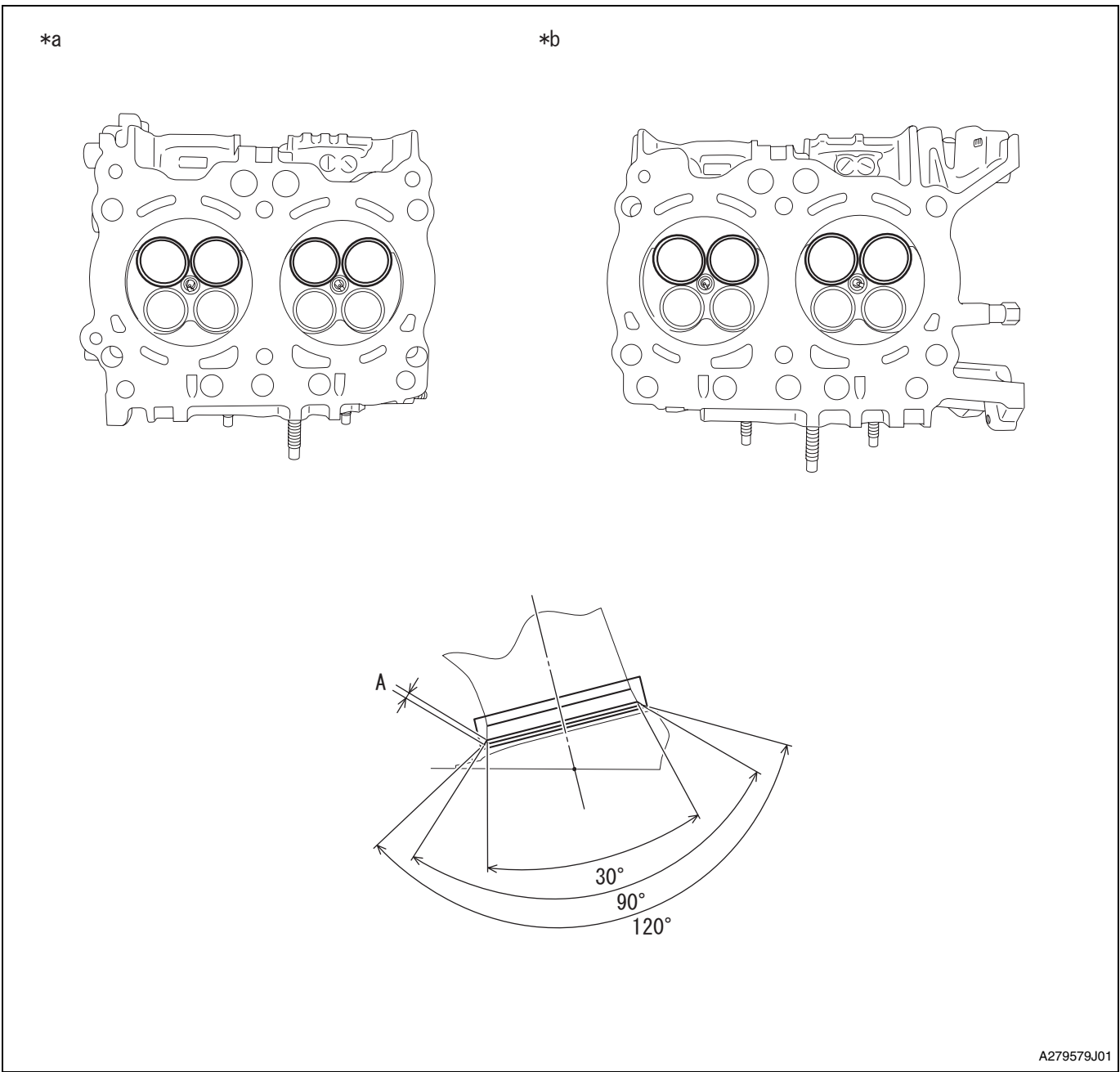

EM

A279579J01

Captions in illustration

*a	Bank 1	*b	Bank 2
----	--------	----	--------

Standard (A): 0.8 to 1.6 mm {0.032 to 0.063 in} (face at 90° in the figure)

<Reference>

- Check the seating width between valve and valve seat by measuring the width of red dye on the seating surface of valve seat.
- If the seating width between valve and valve seat is not within standard, correct the seating surface of valve seat using the valve seat cutter.
- When the red dye does not appear seamlessly on the valve seat seating surface, lap the valve.
- When the red dye does not appear seamlessly on the valve seat seating surface even after lapping the valve, correct the valve seat seating surface using the valve seat cutter.

(6) Wipe off the red dye on the valve and valve seat completely.

EM

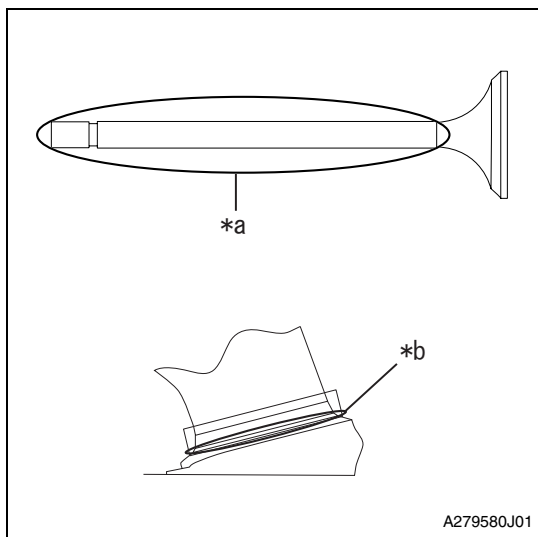

(7) Apply a thin coat of engine oil to the valve stem, and apply red dye evenly on the valve and valve seat seating surface.

Captions in illustration

*a	Valve stem
*b	Seating surface

(8) Slowly insert the valve into the valve guide bushing, lightly press the valve against the valve seat without turning the valve, and then slowly pull out the valve.

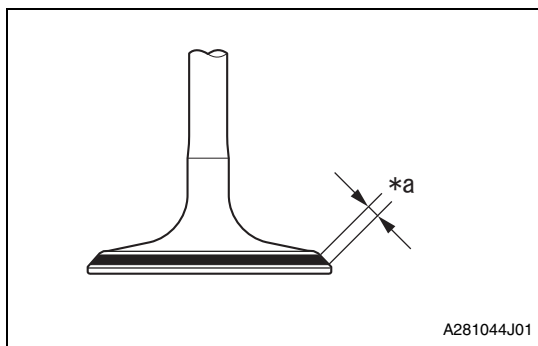

(9) Check the seating position between valve and valve seat.

Captions in illustration

*a	Seating position
----	------------------

Standard (Seating position between valve and valve seat):

Center all around the valve

<Reference>

- Check the seating position between valve and valve seat by checking the position of red dye on the valve face.
- If the seating position between valve and valve seat is not at the center of valve face, correct the seating surface of valve seat using the valve seat cutter.

(10) After inspection, wipe off the red dye completely.

7. Inspection of exhaust valve seat

- (1) Check the valve seat for damage and deformation.
- (2) Clean the valve and valve seat.

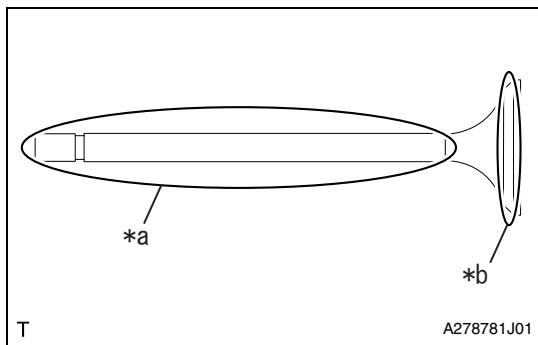

(3) Apply a thin coat of engine oil to the valve stem, and apply red dye evenly on the valve face.

Captions in illustration

*a	Valve stem
*b	Valve face

(4) Slowly insert the valve applied with red dye into the valve guide bushing, lightly press the valve against the valve seat without turning the valve, and then slowly pull out the valve.

(5) Check the seating width of valve seat as shown in the figure, using a caliper gauge.

*a

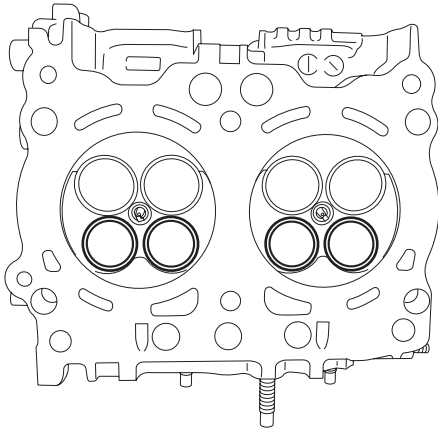

*b

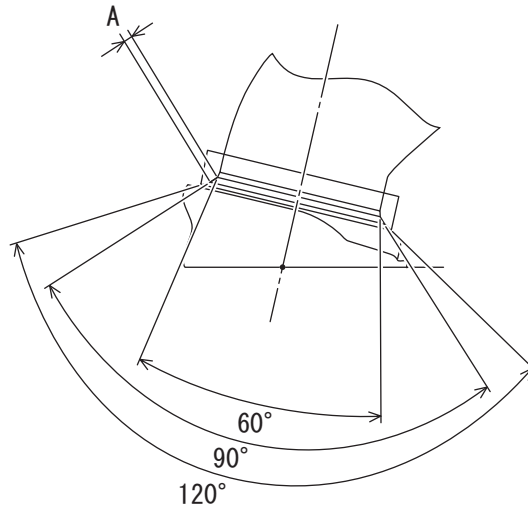
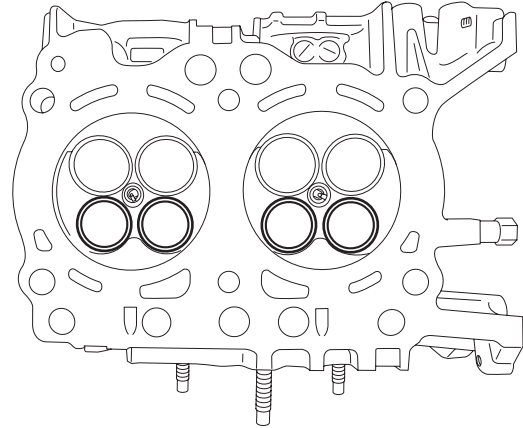

A279603J01

Captions in illustration

*a	Bank 1	*b	Bank 2
----	--------	----	--------

Standard (A): 1.1 to 1.7 mm {0.043 to 0.067 in} (face at 90° in the figure)

<Reference>

- Check the seating width between valve and valve seat by measuring the width of red dye on the seating surface of valve seat.
- If the seating width between valve and valve seat is not within standard, correct the seating surface of valve seat using the valve seat cutter.
- When the red dye does not appear seamlessly on the valve seat seating surface, lap the valve.
- When the red dye does not appear seamlessly on the valve seat seating surface even after lapping the valve, correct the valve seat seating surface using the valve seat cutter.

(6) Wipe off the red dye on the valve and valve seat completely.

EM

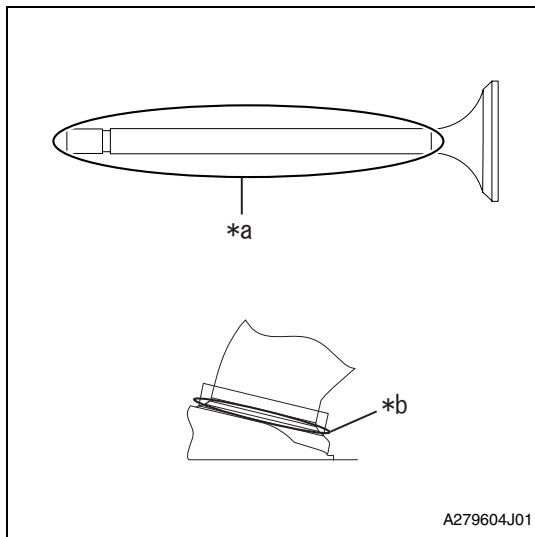

- (7) Apply a thin coat of engine oil to the valve stem, and apply red dye evenly on the valve and valve seat seating surface.

Captions in illustration

*a	Valve stem
*b	Seating surface

- (8) Slowly insert the valve into the valve guide bushing, lightly press the valve against the valve seat without turning the valve, and then slowly pull out the valve.

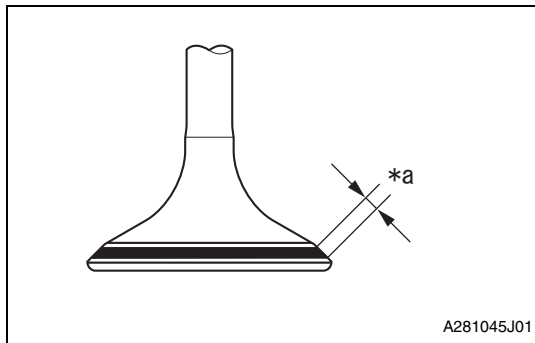

- (9) Check the seating position between valve and valve seat.

Captions in illustration

*a	Seating position
----	------------------

Standard (Seating position between valve and valve seat):

Center all around the valve

<Reference>

- Check the seating position between valve and valve seat by checking the position of red dye on the valve face.
- If the seating position between valve and valve seat is not at the center of valve face, correct the seating surface of valve seat using the valve seat cutter.

- (10) After inspection, wipe off the red dye completely.

8. Inspection of valve spring

- (1) Check the valve spring for damage and deformation.

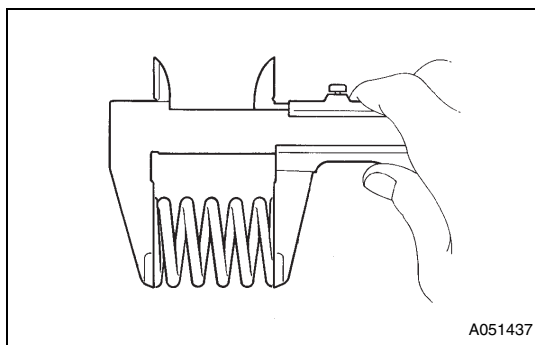

- (2) Using a caliper, measure the free length of the valve spring.

Standard value: 41.06 mm {1.617 in}

<Reference>

- Measurement should be performed at a temperature of 20°C {68°F}.
- If it is not within the specified value, replace the valve spring.

- (3) Using a valve spring tester, measure the load/length of the valve spring.

Standard value: 182 to 210N/33.0mm {1.299in}

552 to 610N/22.0mm {0.866in}

<Reference>

- Measurement should be performed at a temperature of 20°C {68°F}.
- If it is not within the specified value, replace the valve spring.

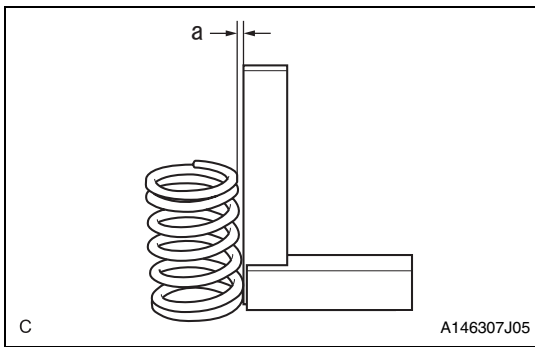

- (4) Using a right angle gauge and caliper, measure the squareness of the spring.

Limit (a): 2.5° (1.8 mm) {0.0710 in} or less

<Reference>

- Measurement should be performed at a temperature of 20°C {68°F}.
- To check the squareness of the valve spring, stand the valve spring on a flat table and check its deflection at the top of the valve spring using a right angle gauge.
- If it is not within the specified value, replace the valve spring.

ASSEMBLY

1. Installation of intake valve guide bushing No. 2

- (1) Before installing the valve guide bushing, make sure that neither scratches nor damages exist on the inner surface of valve guide bushing installation holes of cylinder head.

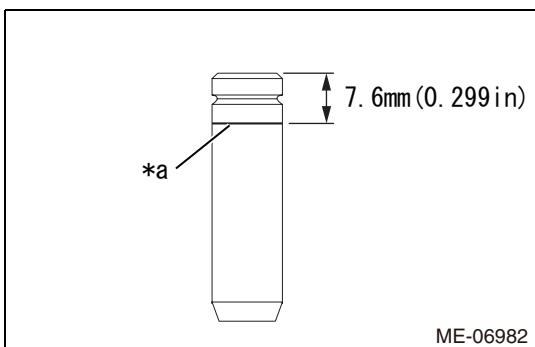

- (2) Draw a reference line for insert on the new valve guide bushing at the position shown in the figure using a marker.

Captions in illustration

*a	Reference line for insert
----	---------------------------

<Reference>

A reference line for insert is used as a guide when tapping-in the valve guide bushing.

- (3) Place the cylinder head on a wooden piece etc facing the combustion chamber downward.

- (4) Apply an enough coat of engine oil to the valve guide bushing, and set the valve guide bushing on the cylinder head.

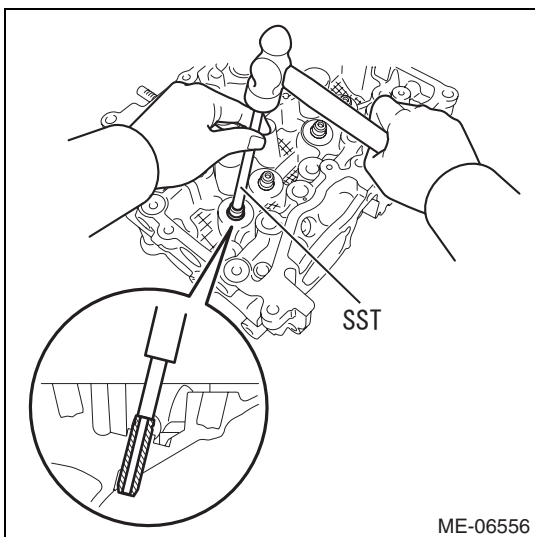

- (5) Using SST and a hammer, tap in the valve guide bushing down to the reference line for insert.

SST 499765700

<Caution>

- During work, place a cloth, etc. to avoid scratching the mating surface of the cylinder head.
- Use special care not to damage the cylinder head during work.

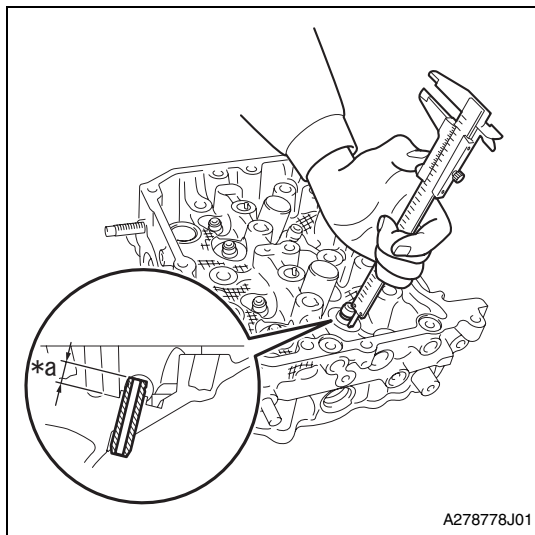

- (6) While measuring the protrusion amount shown in the figure using a caliper gauge, tap in the valve guide bushing within the range of the standard.

Captions in illustration

*a	Protrusion amount
----	-------------------

Specified protrusion amount: 11.4 to 11.8 mm {0.449 to 0.466 in}

<Caution>

- During work, place a cloth, etc. to avoid scratching the mating surface of the cylinder head.
- Use special care not to damage the cylinder head during work.

<Reference>

Be careful not to tap-in excessively by repeating the steps of Tapping-in several times → Measurement → Tapping-in several times → Measurement when installing the valve guide bushing.

- (7) Place the cylinder head on a wooden piece etc facing the combustion chamber upward.

<Caution>

- Place a wooden piece wrapped with a cloth to stabilize the cylinder head before work.
- Use special care not to damage the cylinder head during work.

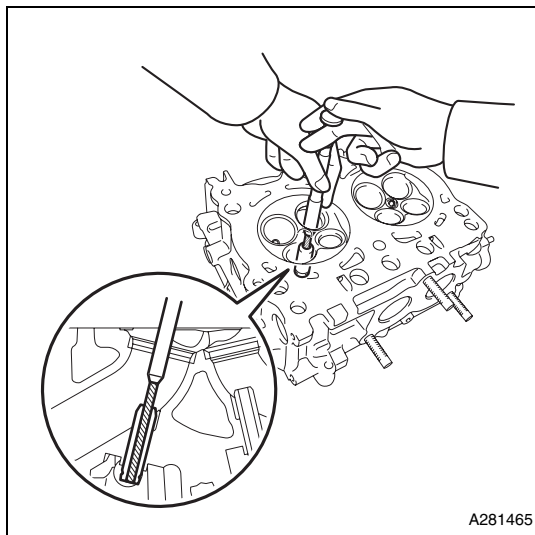

- (8) Using a hand reamer and pin vise, grind the inner surface of the valve guide bushing so that the oil clearance is within the specified value.

Standard value: 5.500 to 5.512 mm {0.21654 to 0.21701 in}
(20°C {68°F})

<Caution>

By widening the hole slowly and evenly using a hand reamer, grind so that it is within the specified value.

<Reference>

- Apply engine oil to a hand reamer.
- If the inner surface of valve guide bushing is damaged, the edge of the hand reamer should be slightly ground with an abrasive sheet (No. 400).
- If the inner surface of valve guide bushing becomes lustrous and the hand reamer does not chip, use a new hand reamer or remedy the hand reamer.

- (9) After reaming, clean the valve guide bushing to remove chips.

- (10) Using a caliper gauge, measure the inner diameter of valve guide bushing to calculate the oil clearance between the valve and valve guide bushing.

- (11) Check the seating width between valve and valve seat.

2. Installation of exhaust valve guide bushing No. 2

- (1) Before installing the valve guide bushing, make sure that neither scratches nor damages exist on the inner surface of valve guide bushing installation holes of cylinder head.

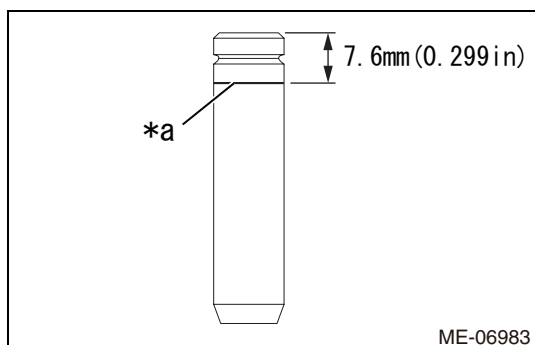

- (2) Draw a reference line for insert on the new valve guide bushing at the position shown in the figure using a marker.

Captions in illustration

*a	Reference line for insert
----	---------------------------

<Reference>

A reference line for insert is used as a guide when tapping-in the valve guide bushing.

- (3) Place the cylinder head on a wooden piece etc facing the combustion chamber downward.

(4) Apply an enough coat of engine oil to the valve guide bushing, and set the valve guide bushing on the cylinder head.

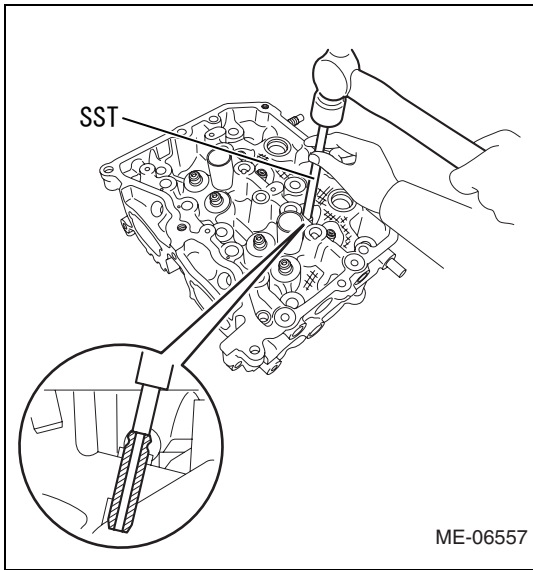

(5) Using SST and a hammer, tap in the valve guide bushing down to the reference line for insert.

SST 499765700

<Caution>

- During work, place a cloth, etc. to avoid scratching the mating surface of the cylinder head.
- Use special care not to damage the cylinder head during work.

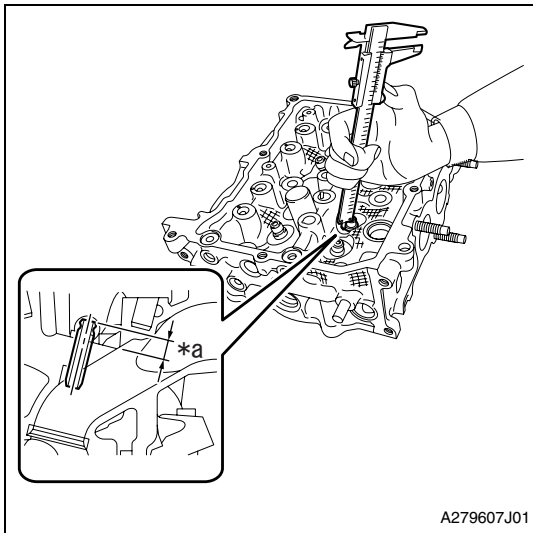

(6) While measuring the protrusion amount shown in the figure using a caliper gauge, tap in the valve guide bushing within the range of the standard.

Captions in illustration

*a	Protrusion amount
----	-------------------

Specified protrusion amount: 11.4 to 11.8 mm {0.449 to 0.466 in}

<Caution>

- During work, place a cloth, etc. to avoid scratching the mating surface of the cylinder head.
- Use special care not to damage the cylinder head during work.

<Reference>

Be careful not to tap-in excessively by repeating the steps of Tapping-in several times → Measurement → Tapping-in several times → Measurement when installing the valve guide bushing.

(7) Place the cylinder head on a wooden piece etc facing the combustion chamber upward.

<Caution>

- Place a wooden piece wrapped with a cloth to stabilize the cylinder head before work.
- Use special care not to damage the cylinder head during work.

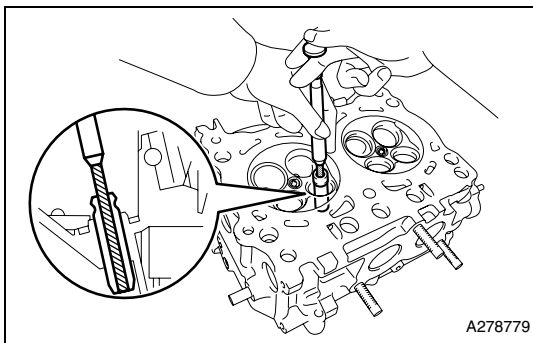

(8) Using a hand reamer and pin vise, grind the inner surface of the valve guide bushing so that the oil clearance is within the specified value.

Standard value: 5.500 to 5.512 mm {0.21654 to 0.21701 in}
(20°C {68°F})

<Caution>

By widening the hole slowly and evenly using a hand reamer, grind so that it is within the specified value.

<Reference>

- Apply engine oil to a hand reamer.
- If the inner surface of valve guide bushing is damaged, the edge of the hand reamer should be slightly ground with an abrasive sheet (No. 400).
- If the inner surface of valve guide bushing becomes lustrous and the hand reamer does not chip, use a new hand reamer or remedy the hand reamer.

(9) After reaming, clean the valve guide bushing to remove chips.

(10) Using a caliper gauge, measure the inner diameter of valve guide bushing to calculate the oil clearance between the valve and valve guide bushing.

(11) Check the seating width between valve and valve seat.

3. Correction of intake valve seat

<Caution>

- Always perform cutting while checking the valve seating position and width.
- Cut with a care to avoid any steps, and release force gradually towards end.

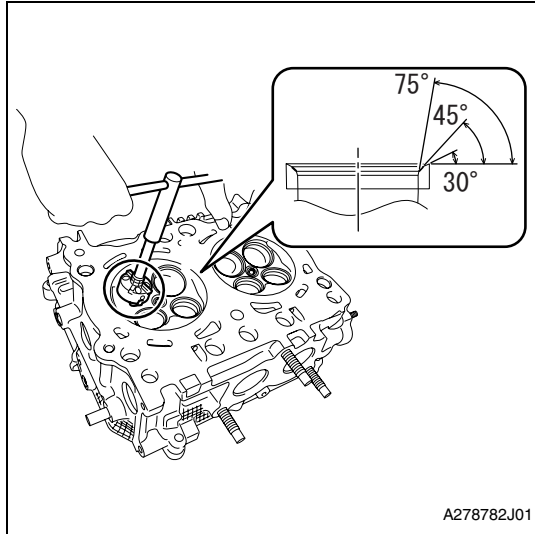

(1) Using a cutter with 45°, cut so that the seating width is wider than the specified value.

(2) Lap the valve.

(3) Check the seating position between valve and valve seat.

<Reference>

This procedure is necessary to select a seat cutter to be used in the following step.

(4) Using the 30° or 75° seat cutter, correct the valve seat so that the seating width between valve and valve seat becomes the standard value.

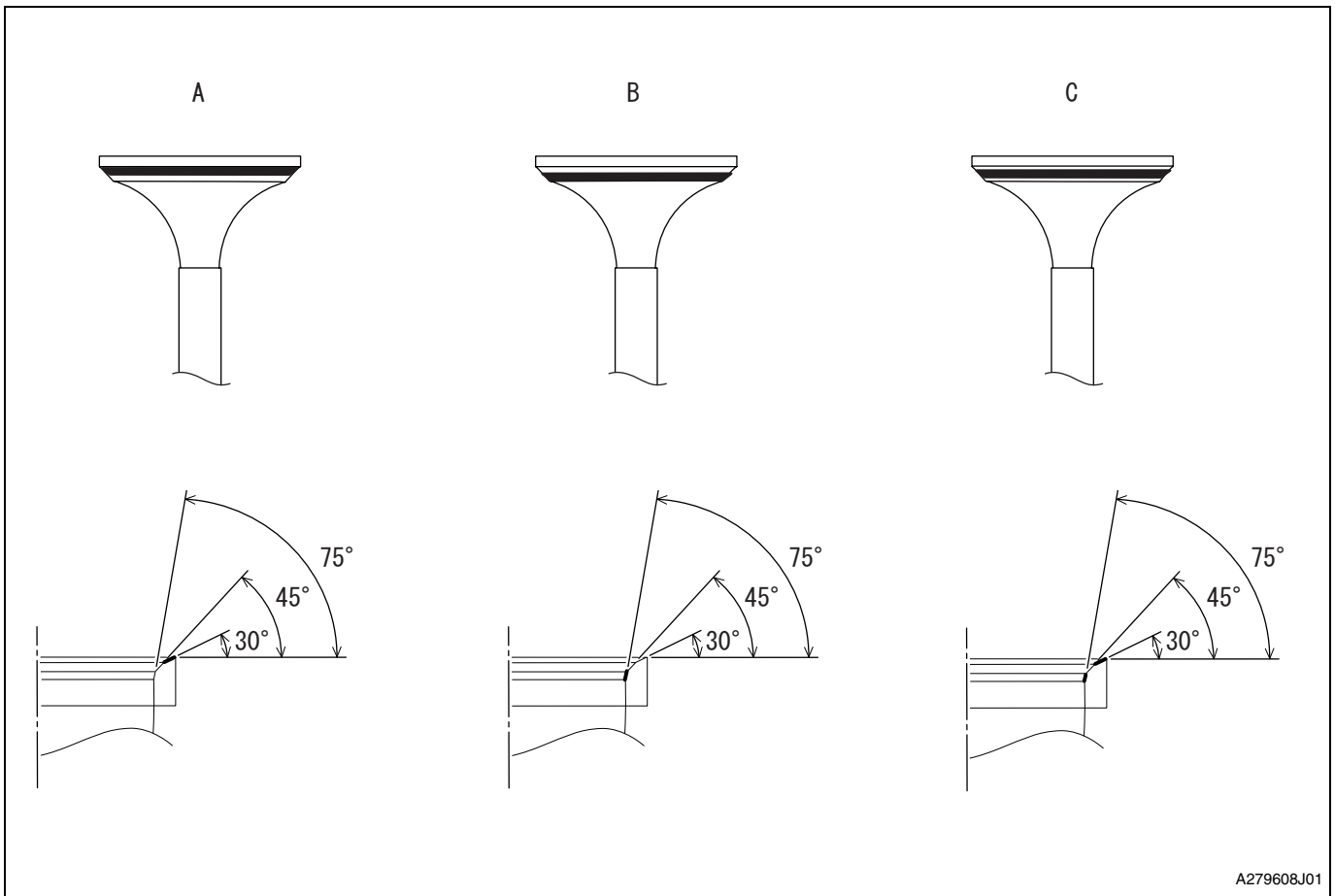

A279608J01

<Caution>

- Always perform cutting while checking the valve seating position and width.
- Cut with a care to avoid any steps, and release force gradually towards end.

<Reference>

Select a proper valve seat cutter according to the following table.

Seating position between valve and valve seat	Seat cutter selection
A in the figure	When the seating position of valve face is high, grind the surface using the 30° seat cutter until seating width between valve and valve seat becomes the standard value.
B in the figure	When the seating position of valve face is low, grind the surface using the 75° seat cutter until seating width between valve and valve seat becomes the standard value.
C in the figure	When the seating position of valve face is at center, grind the surface evenly using the 30° and 75° seat cutters until seating width between valve and valve seat becomes the standard value.

(5) Lap the valve.

4. Correction of exhaust valve seat

<Caution>

- Always perform cutting while checking the valve seating position and width.
- Cut with a care to avoid any steps, and release force gradually towards end.

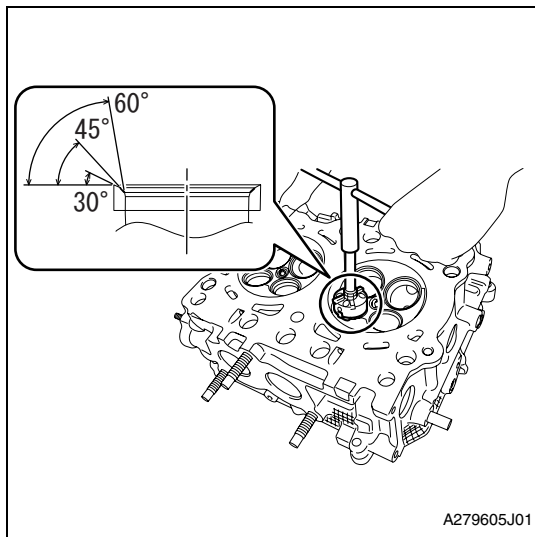

- (1) Using a cutter head with 45°, cut so that the seating width is wider than the specified value.

- (2) Lap the valve.
 (3) Check the seating position between valve and valve seat.

<Reference>

This procedure is necessary to select a seat cutter to be used in the following step.

- (4) Using the 30° or 60° seat cutter, correct the valve seat so that the seating width between valve and valve seat becomes the standard value.

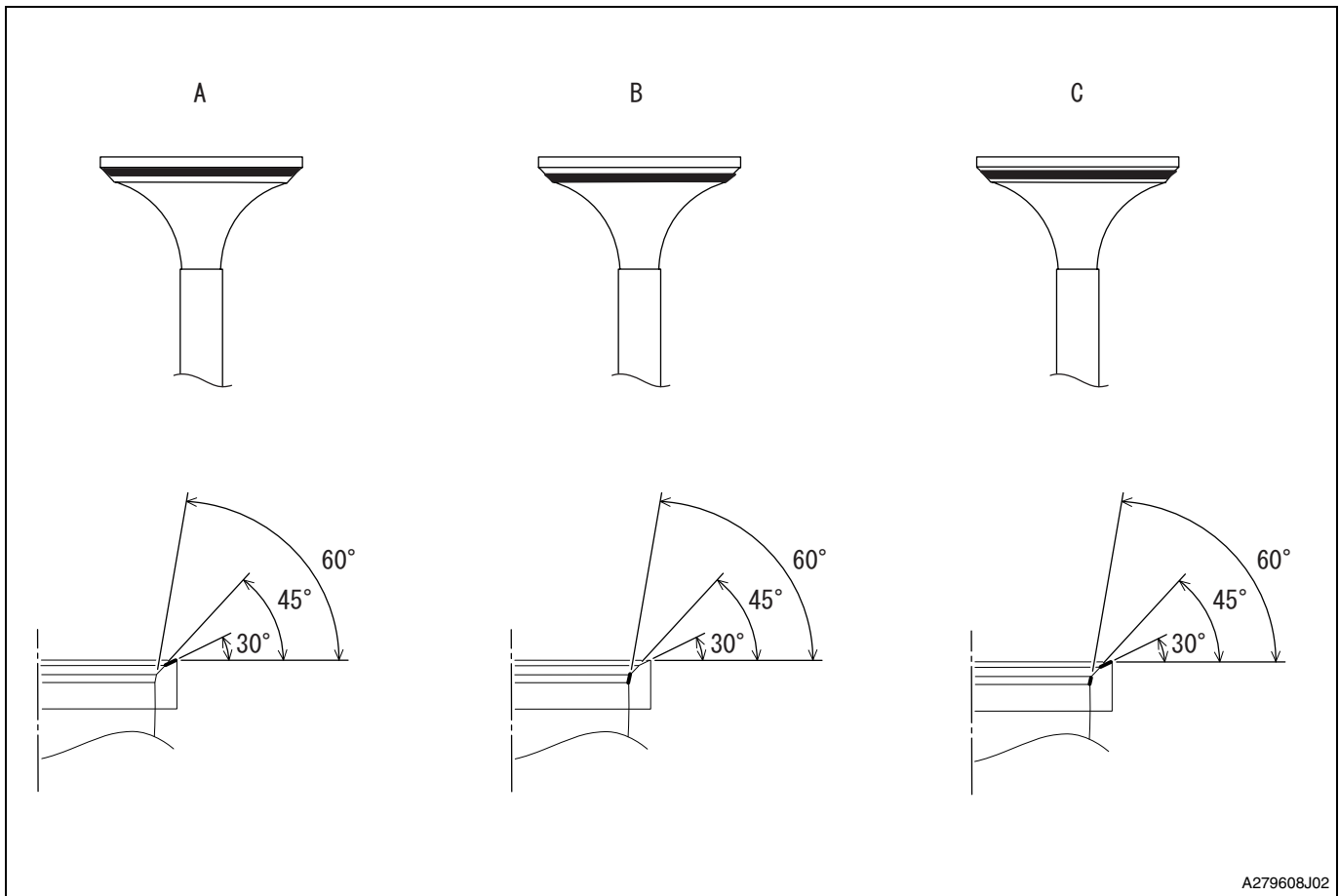

<Caution>

- Always perform cutting while checking the valve seating position and width.
- Cut with a care to avoid any steps, and release force gradually towards end.

<Reference>

Select a proper valve seat cutter according to the following table.

Seating position between valve and valve seat	Seat cutter selection
A in the figure	When the seating position of valve face is high, grind the surface using the 30° seat cutter until seating width between valve and valve seat becomes the standard value.
B in the figure	When the seating position of valve face is low, grind the surface using the 60° seat cutter until seating width between valve and valve seat becomes the standard value.
C in the figure	When the seating position of valve face is at center, grind the surface evenly using the 30° and 60° seat cutters until seating width between valve and valve seat becomes the standard value.

(5) Lap the valve.

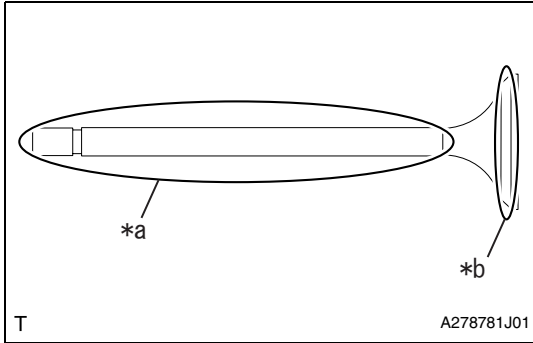

5. Lapping of valve

- (1) Apply a thin coat of engine oil to the valve stem, and apply a small amount of valve compound evenly on the valve face.

Captions in illustration

*a	Valve stem
*b	Valve face

<Reference>

- Be careful not to put the valve compound more than necessary.
- To avoid damaging the valve guide bushing and valve stem, be careful not to let the valve compound contact the valve stem.



- (2) Slowly insert the valve applied with the valve compound into the valve guide bushing, and lap the seating surface between valve and valve seat.

<Reference>

- First, lift the valve and strike it against the valve seat twice, and then slightly turn the valve once. Repeat these steps as one set.
- To prevent the seating width between valve and valve seat from exceeding the standard value, be careful not to keep turning the valve while pressing it against the valve seat during lapping.
- Be careful not to lift the valve too far during lapping in order to prevent the valve from coming off the valve guide bushing.

- (3) Wipe off the valve compound on the valve and valve seat completely after lapping.

<Caution>

Be careful not to leave any valve compound in order to avoid malfunction.

- (4) Check the seating width and seating position between valve and valve seat.

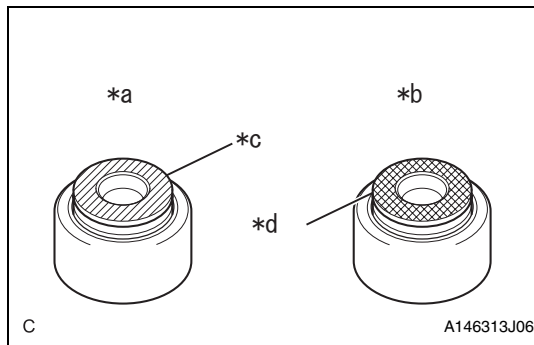

6. Installation of intake valve stem oil seal

- (1) Apply engine oil to the tip of the new intake valve stem oil seal.

Captions in illustration

*a	Intake side
*b	Exhaust side
*c	Grey
*d	Light green

<Caution>

- Be careful with the identification colors of valve stem oil seal.
- Wrong assembly between intake side and exhaust side will cause trouble.

- (2) Using SST, press in the intake valve stem oil seal fully into the valve guide bushing by hand.

SST 18261AA010

<Caution>

- During work, place a cloth, etc. to avoid scratching the mating surface of the cylinder head.
- When installing the valve oil seal, press the SST with hands to install it and never drive the SST with a plastic hammer, otherwise the valve oil seal can be damaged.
- Do not install the oil seal obliquely.

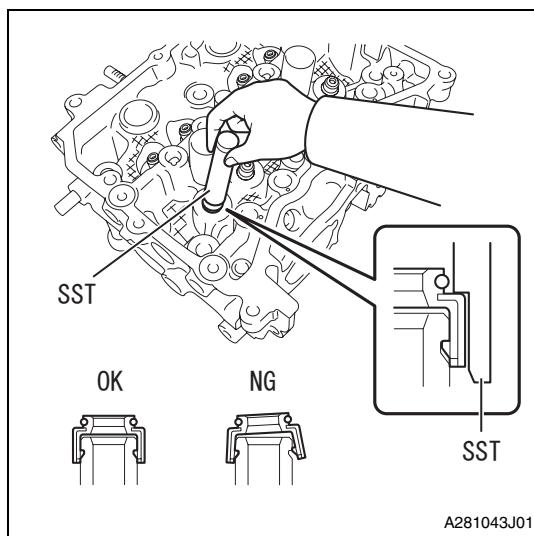

7. Installation of exhaust valve stem oil seal

- (1) Using SST, press in the exhaust valve stem oil seal fully into the valve guide bushing by hand.

SST 18261AA010

<Caution>

- During work, place a cloth, etc. to avoid scratching the mating surface of the cylinder head.
- When installing the valve oil seal, press the SST with hands to install it and never drive the SST with a plastic hammer, otherwise the valve oil seal can be damaged.
- Do not install the oil seal obliquely.

8. Installation of intake valve

<Caution>

During work, place a cloth, etc. to avoid scratching the mating surface of the cylinder head.

- (1) Set the valve spring seat, valve spring and valve spring retainer onto the cylinder head.
- (2) Apply engine oil to the valve stem of each valve and insert the valve into valve guide bushing.

<Caution>

When inserting the valve into valve guide bushing, use special care not to damage the oil seal lip.

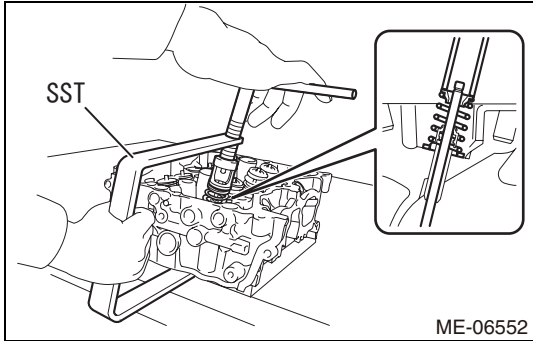

- (3) Using SST, compress the valve spring and install the valve spring retainer lock applied with engine oil.

SST 0920287002000

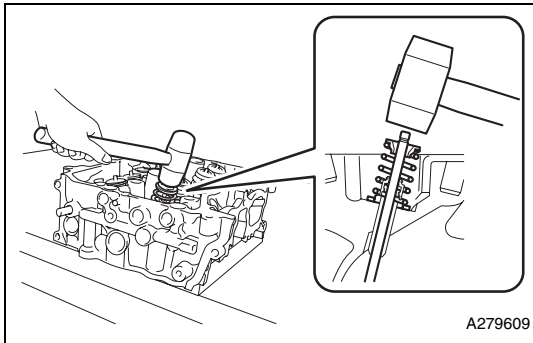

- (4) Using a plastic hammer, tap the tip of the valve stem slightly to settle the valve spring.

<Caution>

Do not strike the valve spring retainer.

9. Installation of exhaust valve

<Caution>

During work, place a cloth, etc. to avoid scratching the mating surface of the cylinder head.

- (1) Set the valve spring seat, valve spring and valve spring retainer onto the cylinder head.
- (2) Apply engine oil to the valve stem of each valve and insert the valve into valve guide bushing.

<Caution>

When inserting the valve into valve guide bushing, use special care not to damage the oil seal lip.

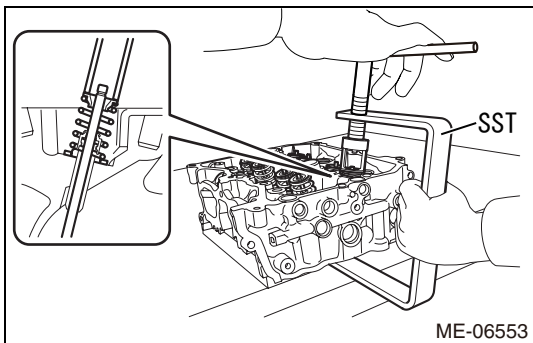

- (3) Using SST, compress the valve spring and install the valve spring retainer lock applied with engine oil.

SST 0920287002000

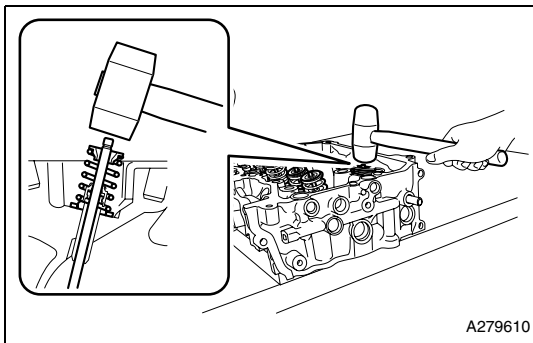

- (4) Using a plastic hammer, tap the tip of the valve stem slightly to settle the valve spring.

<Caution>

Do not strike the valve spring retainer.

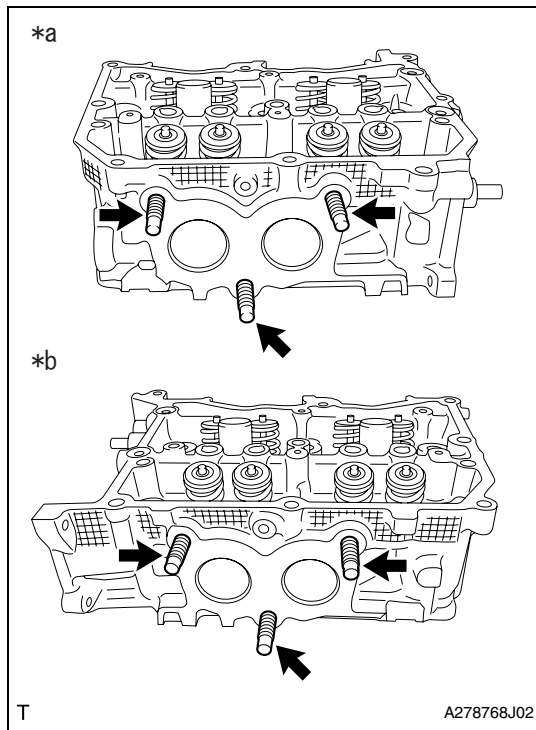

10. Installation of stud bolt

- (1) Install the six stud bolts onto the cylinder head.
Standard value: $T=18\text{N}\cdot\text{m}$ {184kgf·cm} {13.3 ft·lbf}

Captions in illustration

*a	Bank 1
*b	Bank 2

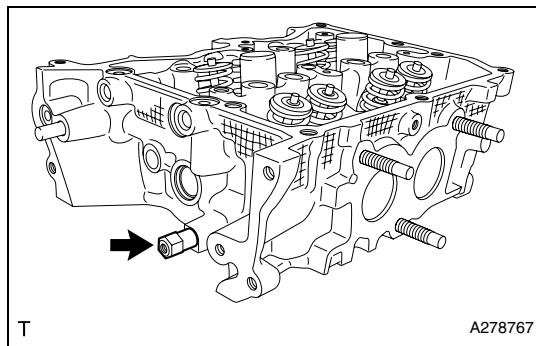

11. Installation of chain cover mount bolt

- (1) Install the chain cover mount bolt to the cylinder head LH.
Standard value: $T=6.4\text{N}\cdot\text{m}$ {65kgf·cm} {4.7 ft·lbf}

CYLINDER BLOCK ASSY (FA20)

EXPLODED VIEW

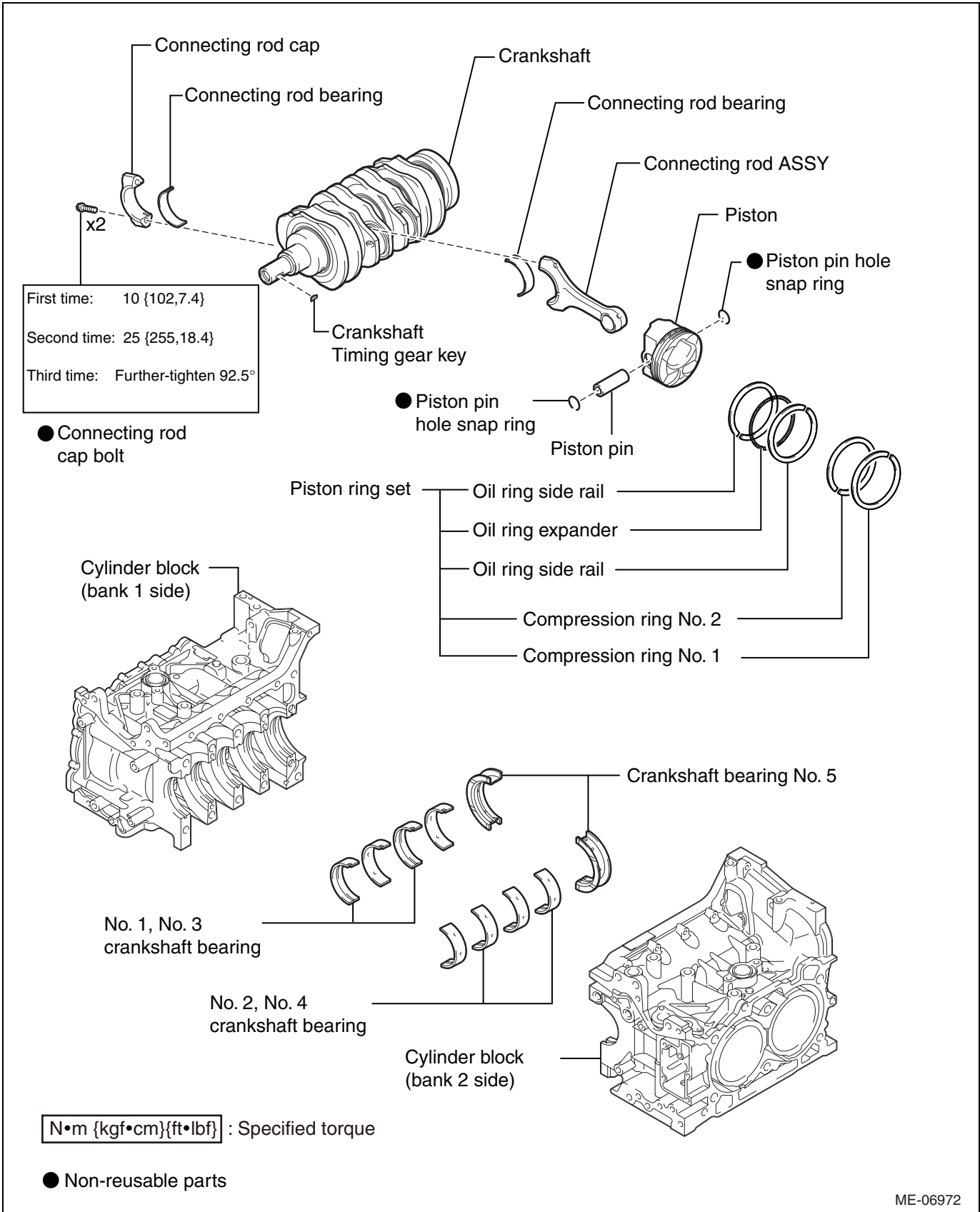

EM

- First time: 35 {357,25.8}
- Second time: Loosen 180°
- Third time: 35 {357,25.8}
- Fourth time: Loosen 180°
- Fifth time: 17 {173,12.5}
- Sixth time: Further-tighten 60°

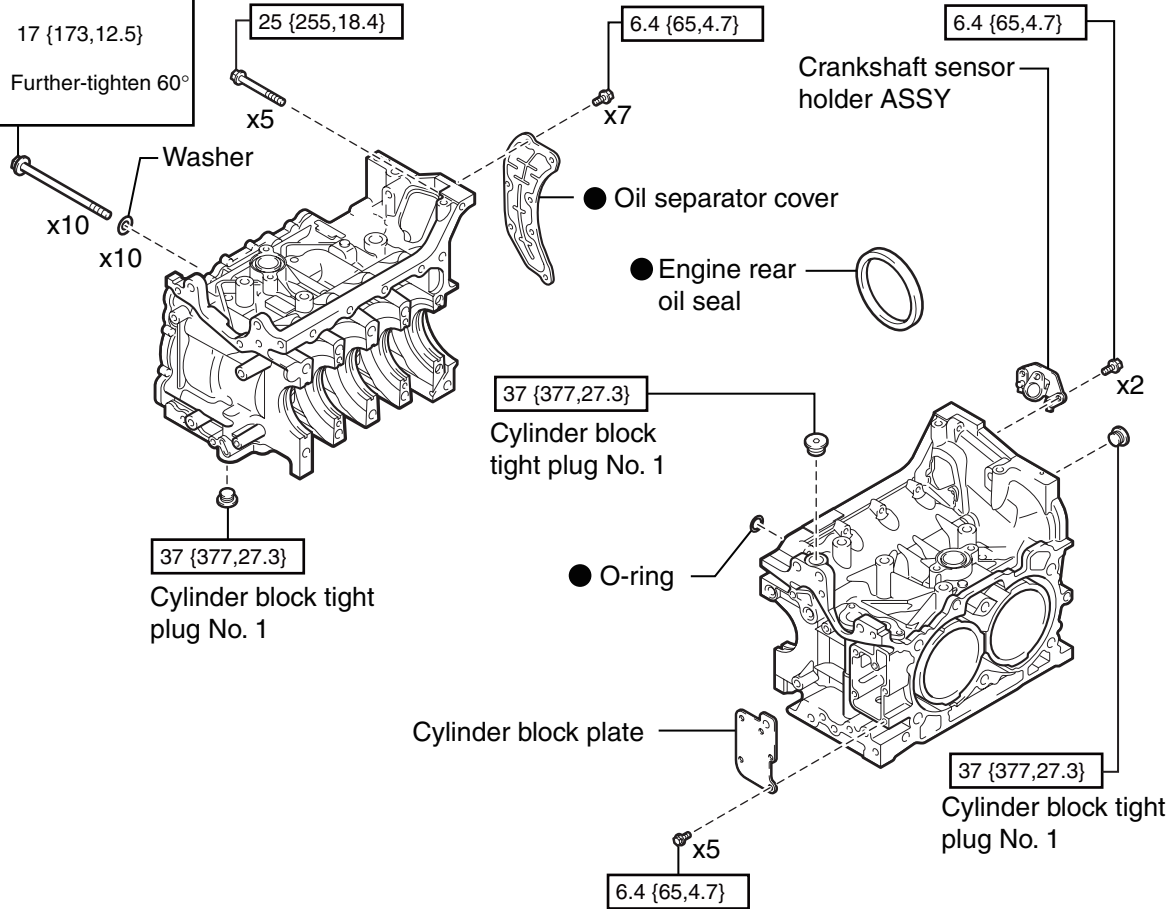

N·m {kgf·cm}{ft·lbf} : Specified torque

● Non-reusable parts

ME-06973

DISASSEMBLY

1. Removal of piston with connecting rod
 - (1) Mark each connecting rod cap and piston with a cylinder number.
 - (2) Turn the crankshaft to the position where the connecting rod cap bolt can be removed.

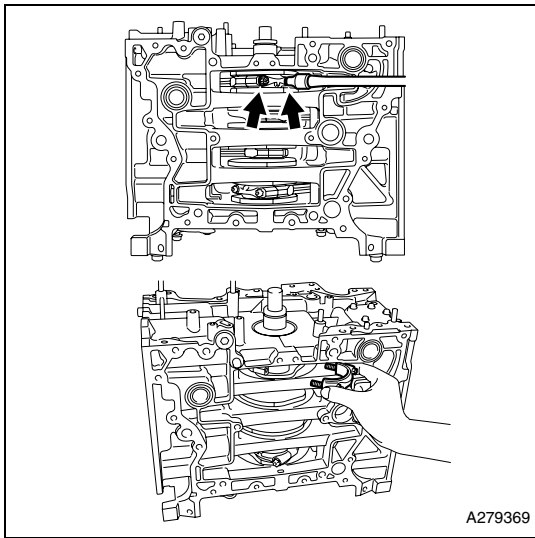

- (3) Using SST, remove the connecting rod cap bolt to remove the connecting rod cap.
SST 18270AA020

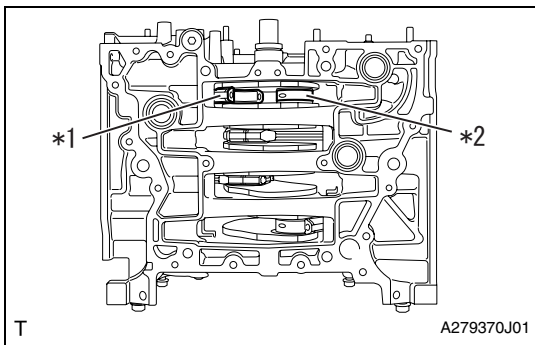

- (4) Turn the crankshaft to separate the crankshaft pin and connecting rod large end.

Captions in illustration

*1	Connecting rod
*2	Crankshaft pin

<Reference>

When removing the piston with connecting rod No. 1 and No. 3, turn the crankshaft clockwise, on the other hand, when removing the piston with connecting rod No. 2 and No. 4, turn the crankshaft counter clockwise.

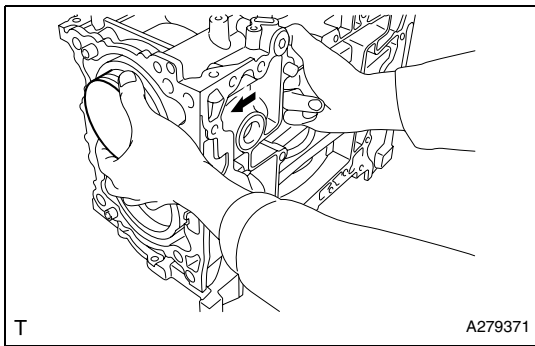

- (5) Push the connecting rod in the direction of the arrow, and remove the piston along with the connecting rod from the cylinder block.

2. Removal of cylinder block SUB-ASSY (bank 1 side)

<Caution>

Be careful not to scratch the mating surface of cylinder block during work.

- (1) Move the engine stand so that bank 1 side faces upward.

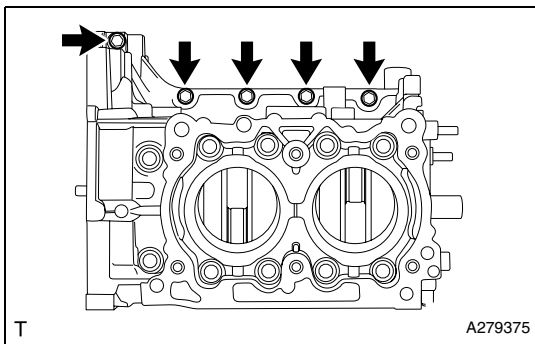

- (2) Remove the five bolts shown in the figure.



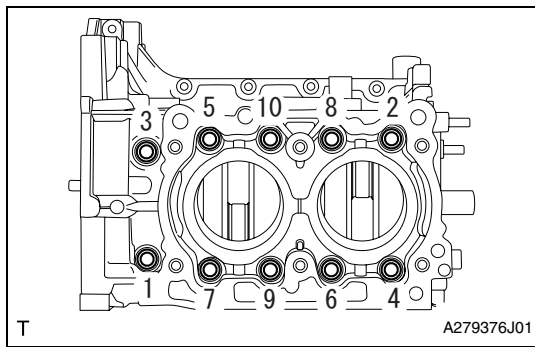

- (3) Loosen the ten cylinder block mounting bolts in the order as shown in the figure.

- (4) Remove the 10 bolts to remove the cylinder block (bank 1 side).

<Caution>

Lift the cylinder block (bank 1 side) slightly, and make sure that the crankshaft is remaining in the cylinder block (bank 2 side). If the cylinder block (bank 1 side) is lifted without care, the crankshaft may be lifted along and fall off from the cylinder block (bank 1 side).

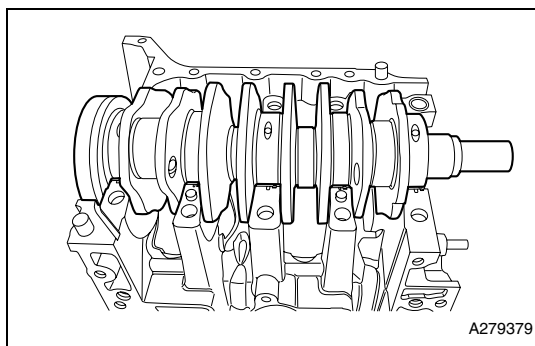

3. Removal of crankshaft

- (1) Remove the crankshaft from the cylinder block (bank 2 side).

4. Removal of engine rear oil seal

- (1) Remove the engine rear oil seal.

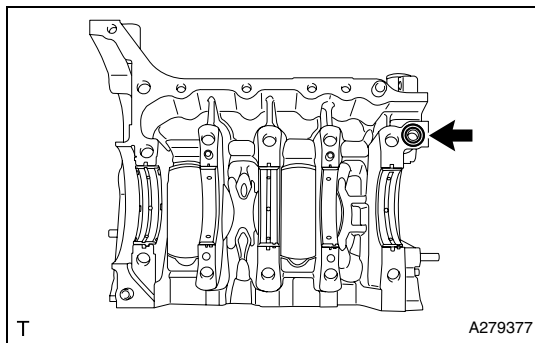

5. Removal of O-ring.

- (1) Remove the O-ring from the cylinder block (bank 2 side).

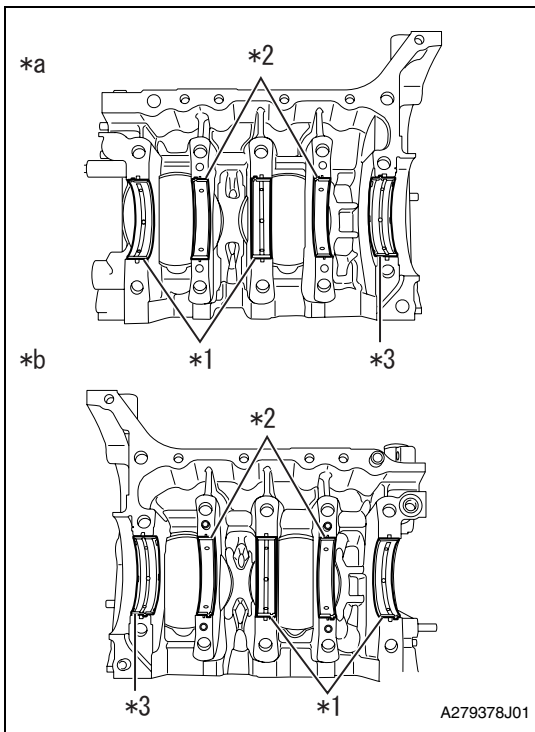

6. Removal of crankshaft bearing

- (1) Remove the 10 crankshaft bearings from the cylinder block (bank 1 side and bank 2 side).

Captions in illustration

*1	No. 1, No. 3 crankshaft bearing
*2	No. 2, No. 4 crankshaft bearing
*3	Crankshaft bearing No. 5
*a	Bank 1
*b	Bank 2

<Reference>

- Organize disassembled parts by their installation positions.
- Remove the bearing by pressing at the opposite side of the locking lip.

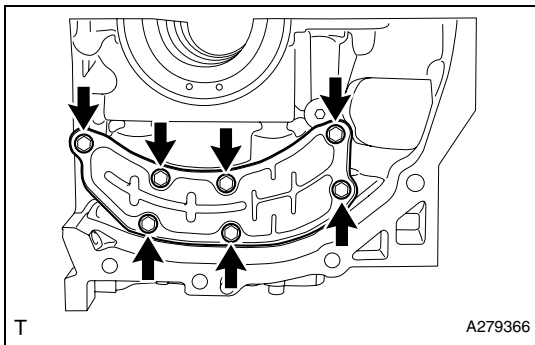

7. Removal of oil separator cover

- (1) Remove the 7 bolts to remove the oil separator cover from the cylinder block (bank 1 side).

8. Removal of cylinder block SUB-ASSY (bank 2 side)

- (1) Remove the bolt to remove the engine stand from the cylinder block (bank 2 side).

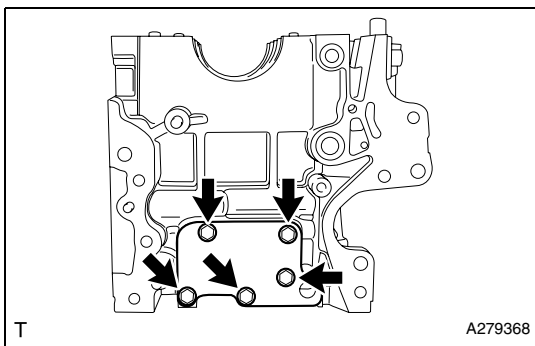

9. Removal of cylinder block plate

- (1) Remove the 5 bolts to remove the cylinder block plate from the cylinder block (bank 2 side).

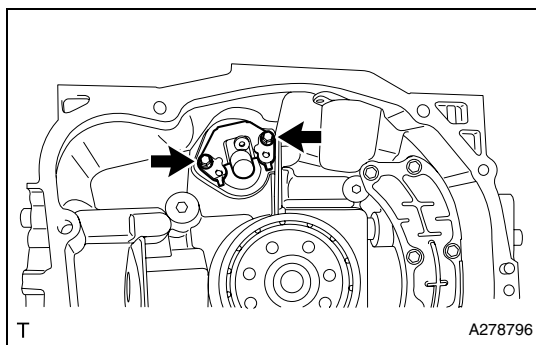

10. Removal of crankshaft sensor holder ASSY

- (1) Remove the two bolts to remove the crankshaft sensor holder ASSY from the cylinder block (bank 2 side).

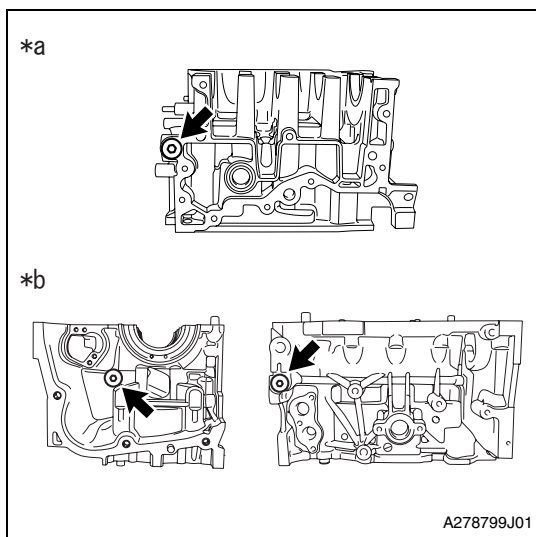

11. Removal of cylinder block tight plug No. 1

- (1) Remove the three cylinder tight plugs No. 1 from the cylinder block (bank 1 side and bank 2 side).

Captions in illustration

*a	Bank 1
*b	Bank 2

12. Removal of connecting rod bearing

- (1) Remove the connecting rod bearing from connecting rod and connecting rod cap.

<Reference>

Organize disassembled parts by their installation positions.

13. Removal of piston ring set

<Reference>

Organize disassembled parts by their installation positions.

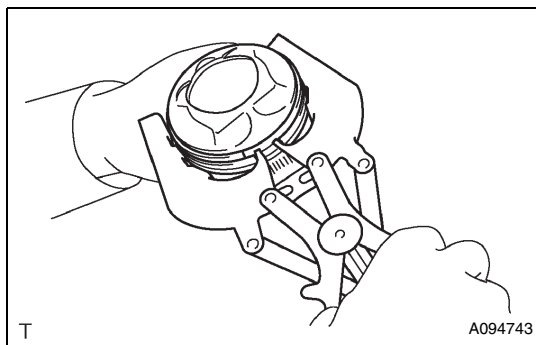

- (1) Remove compression ring No. 1 and then, compression ring No. 2 in numerical order, using piston ring tool.

- (2) Remove the oil rings in the order of oil ring side rail (upper), oil ring side rail (lower), oil ring expander by hand.

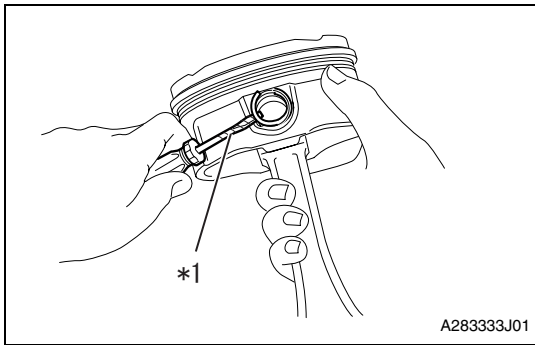

14. Removal of piston with pin

- (1) Remove either one of the piston pin hole snap rings from the piston using a flat tip screwdriver wrapped with protective tape.

Captions in illustration

*1	Protective tape
----	-----------------

<Reference>

Be careful not damage the piston and piston pin, by wrapping the tip of flat tip screwdriver with tape.

- (2) Remove the piston pin from the piston.

- (3) Remove the other piston pin hole snap ring from the piston using a flat tip screwdriver wrapped with protective tape.

<Reference>

Be careful not damage the piston and piston pin, by wrapping the tip of flat tip screwdriver with tape.

EM

INSPECTION

1. Inspection of cylinder block SUB-ASSY

- (1) Visually inspect to make sure that there are no cracks, scratches or other damage.
- (2) Use liquid penetrant testing (red check) on the important sections to check for fissures.
- (3) Check that there are no traces of gas leaking or water leaking on the gasket attachment surface.
- (4) Check the oil passages for clogging.

2. Inspection of cylinder block warpage

- (1) Check for warpage of mating surfaces of the cylinder block and cylinder head using a straight edge and thickness gauge.
Service limit: 0.025 mm {0.0098in}

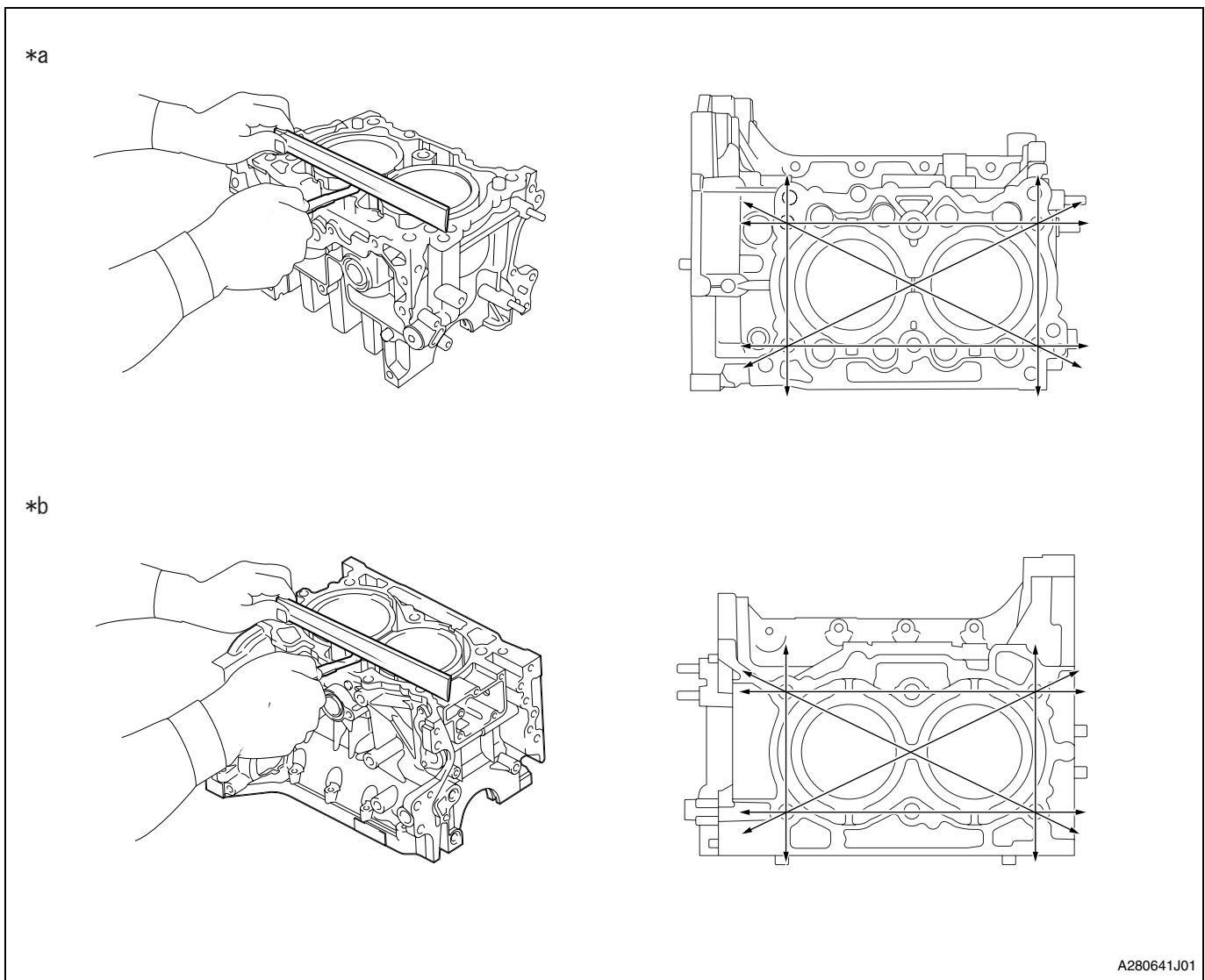

A280641J01

Captions in illustration

*a	Bank 1	*b	Bank 2
----	--------	----	--------

<Reference>

- Measurement should be performed at a temperature of 20°C {68°F}.
- If it exceeds the limit, correct the surface by grinding it with a surface grinder or replace the cylinder block.
Grinding limit of cylinder block: 204.9mm {8.067in}
Standard value for cylinder block height: 205.0mm {8.071in}

3. Inspection of cylinder liner

- (1) Measure the inner diameter of each cylinder at the positions shown in the figure, using a cylinder gauge to obtain the taper and out-of-roundness.

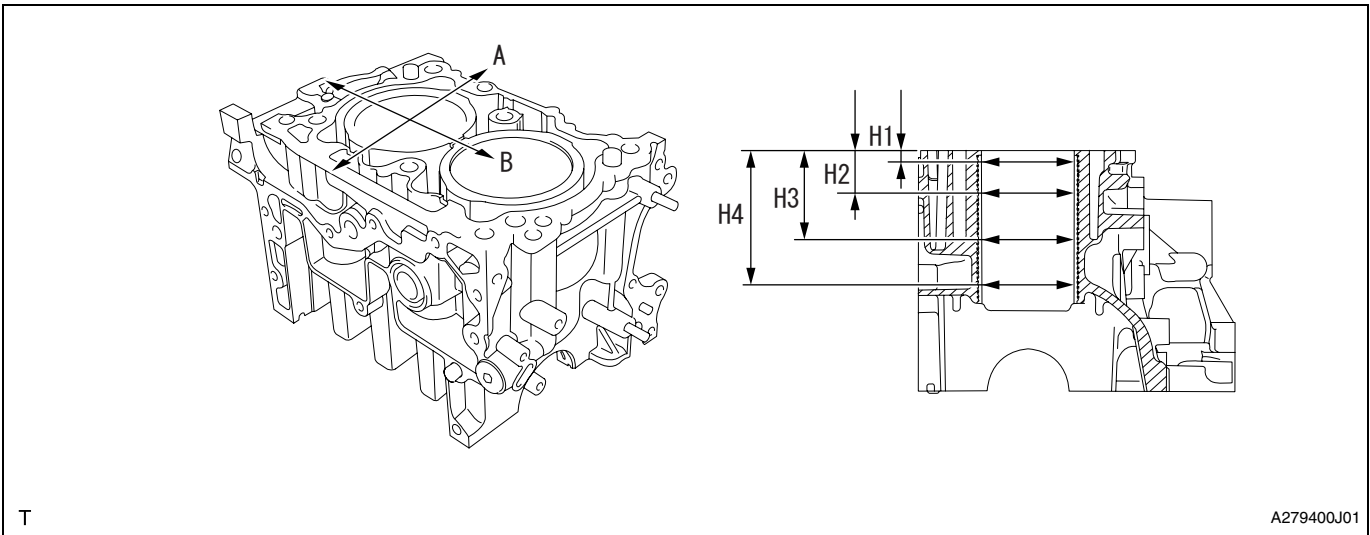

T

A279400J01

Standard value

Inner diameter A	86.005 to 86.015mm {3.38602 to 3.38641in}
Inner diameter B	85.995 to 86.005mm {3.38562 to 3.38602in}

Service limit

Taper	0.030mm {0.00118in}
Out-of-roundness	0.010mm {0.00039in}

Measuring point

H1	10.0mm {0.394in}
H2	45.0mm {1.772in}
H3	80.0mm {3.150in}
H4	115.0mm {4.528in}

<Reference>

- Measurement should be performed at a temperature of 20°C {68°F}.
- Measure the inner diameter of each cylinder liner in both the thrust and piston pin directions at the heights as shown in the figure.
- If it is not within the standard, perform boring and honing, or replace the cylinder block and piston as a set.
- The cylinder bore size mark is stamped on the upper face of the cylinder block.

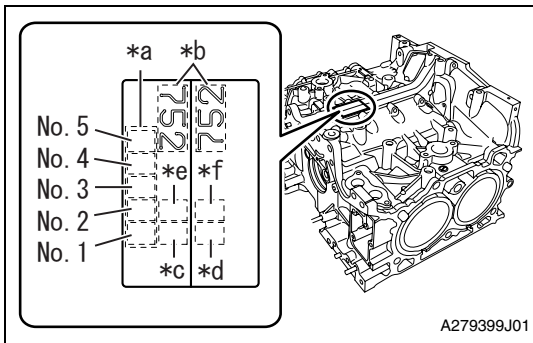

A279399J01

Captions in illustration

*a	Main journal size mark
*b	Cylinder block (bank 1/bank 2) combination mark
*c	Cylinder bore size mark No. 1
*d	Cylinder bore size mark No. 2
*e	Cylinder bore size mark No. 3
*f	Cylinder bore size mark No. 4

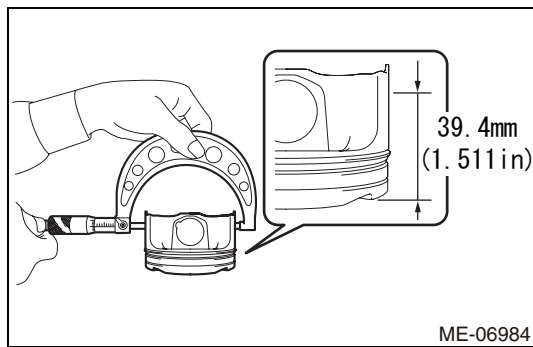

4. Inspection of piston outer diameter

- (1) Set a micrometer at 39.4 mm {1.551 in} from the upper face of piston skirt, and then measure the diameter at a right angle to the pin hole.

Standard value

Grade A	85.985 to 85.995mm {3.38523 to 3.38562in}
Grade B	85.975 to 85.985mm {3.38484 to 3.38523in}
0.25mm oversize	86.225 to 86.245mm {3.39468 to 3.39547in}
0.50mm oversize	86.475 to 86.495mm {3.40452 to 3.40531in}

<Reference>

- Measurement should be performed at a temperature of 20°C {68°F}.
- Measure the outer diameter of each piston in thrust direction at the height as shown in the figure.
- If it is not within the specified value, replace the piston.
- Standard sized pistons are classified into two grades, (A) and (B). These grades should be used as guide lines in selecting a standard piston.
- If the piston is replaced, check the clearance between cylinder liner and piston and select a suitable sized piston.

5. Inspection of piston oil clearance

- (1) Calculate the oil clearance from the inner diameter of cylinder liner and the outer diameter of piston.

Standard value: 0.010 to 0.030mm {0.00039 to 0.0018in}

<Reference>

- Oil clearance = Cylinder maximum inner dia. - Piston outer dia.
- If it is not within the standard, perform boring and honing, or replace the cylinder block and piston as a set.

6. Correction of cylinder liner

- (1) If any of the inner diameter, taper, out-of-roundness or clearance between cylinder liner and piston is out of standard or if there is any damage on the cylinder liner, rebores it to replace with an oversize piston.

Boring limit: 86.505 mm {3.40570in} (inner diameter of cylinder liner)

<Reference>

- When any of the cylinder liner needs reboring, all other cylinder liners must be bored at the same time, and replaced with oversize pistons.
- If the inner diameter of cylinder liner exceeds the limit after boring and honing, replace the cylinder block and piston as a set.
- Immediately after reboring, the inner diameter of cylinder liner may differ from its real diameter due to temperature rise. Thus, when measuring the inner diameter of cylinder liner, wait until it has cooled to a temperature of 20°C {68°F}.

7. Inspection of piston with pin

- (1) Check the piston and piston pin for wear or crack.
 (2) Check the piston hole snap ring for distortion or wear.
 (3) Check the piston ring groove for damage.

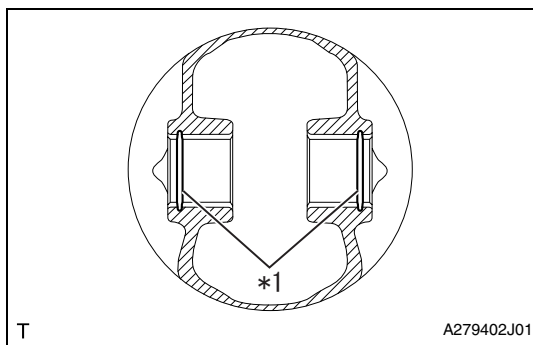

- (4) Check the groove for burr.

Captions in illustration

*1	Groove
----	--------

<Reference>

If the burr is found, remove the burr from groove.

- (5) Check that the piston pin can be inserted into the piston with a thumb.

<Reference>

Inspection should be performed at a temperature of 20°C {68°F}.

8. Inspection of connecting rod small end bushing

- (1) Check that the connecting rod small end bushing is not damaged.

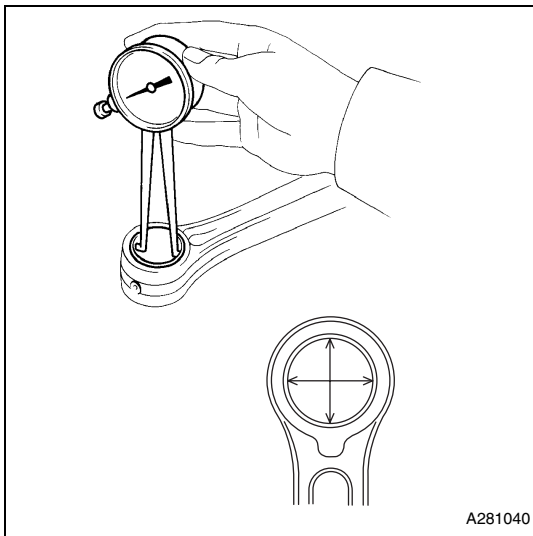
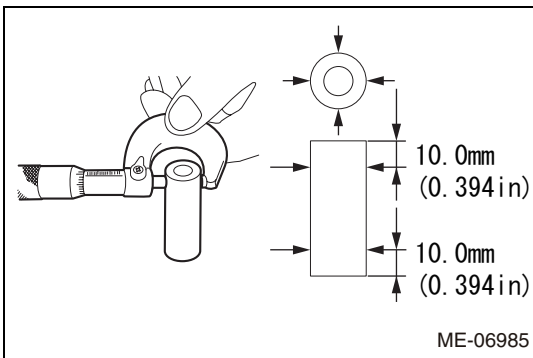
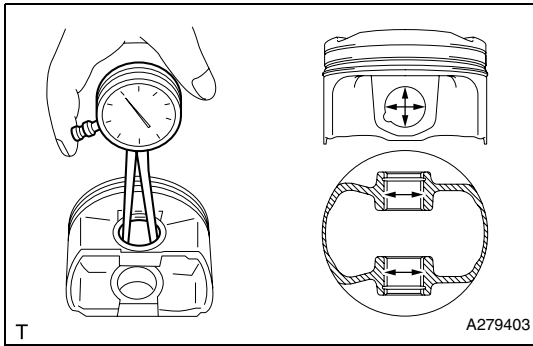

9. Inspection of piston pin oil clearance

- (1) Using a caliper gauge, measure the inner diameter of piston pin hole.

<Reference>

- Measurement should be performed at a temperature of 20°C {68°F}.
- Measure the inner diameter of the piston pin hole at the four locations as shown in the figure, and read the value of most worn location.
- Record the measured value.

- (2) Check the piston pin outer diameter at the position shown in the figure using a micrometer.

<Reference>

- Measurement should be performed at a temperature of 20°C {68°F}.
- Measure the outer diameter of the piston pin at the four locations as shown in the figure, and read the value of most worn location.
- Record the measured value.

- (3) Using a caliper gauge, measure the inner diameter of connecting rod bushing.

<Reference>

- Measurement should be performed at a temperature of 20°C {68°F}.
- Measure the inner diameter of the connecting rod bushing at the two locations as shown in the figure, and read the value of most worn location.
- Record the measured value.

- (4) Calculate the clearance between piston and piston pin.

Standard value: 0.004 to 0.008mm {0.00016 to 0.00031in}

<Reference>

- Oil clearance = Piston pin hole inner dia. - Piston pin outer dia.
- If it is not within the standard, replace the piston and piston pin as a set.

- (5) Calculate the clearance between piston pin and connecting rod bushing.

Standard value: 0.006 to 0.026mm {0.00024 to 0.00102in}

<Reference>

- Oil clearance = Connecting rod bushing inner dia. - Piston pin outer dia.
- If the clearance between piston pin and connecting rod bushing is not within the standard, replace the connecting rod and piston pin as a set.

10. Inspection of piston ring

- (1) Make sure the piston ring is not broken or damaged.

<Reference>

- If damaged, replace the piston ring.
- Use piston ring with same size as piston when replacing piston ring.



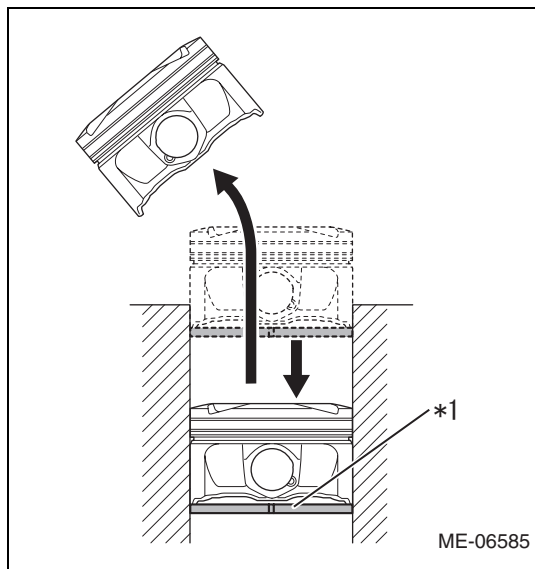

11. Inspection of ring closed gap

- (1) Using the piston, set the piston ring into cylinder liner at a right angle.

Captions in illustration

*1	Piston ring
----	-------------

<Reference>

Press down into the cylinder liner until the ring gets in down to the crown of the piston.

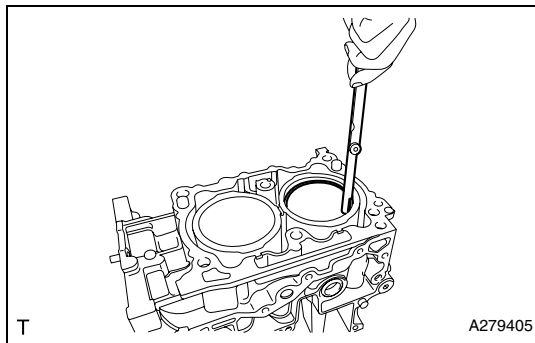

- (2) Measure the closed gap of the piston ring using a thickness gauge.
Standard value

No. 1	0.20 to 0.25mm {0.00784 to 0.00984in}
No. 2	0.60 to 0.70mm {0.02362 to 0.02756in}
Oil	0.10 to 0.35mm {0.00394 to 0.01378in}

<Reference>

- Measurement should be performed at a temperature of 20°C {68°F}.
- If it is not within the standard value, replace the piston ring.
- Use piston ring with same size as piston when replacing piston ring.

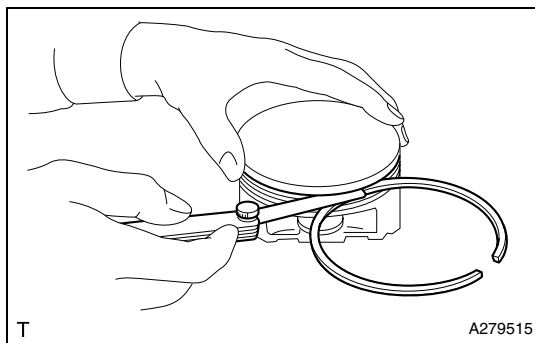

12. Inspection of clearance piston ring and ring groove

- (1) Fit the piston ring straight into the piston ring groove, then check the clearance between piston ring and piston using a thickness gauge.

Standard value

No. 1	0.030 to 0.080mm {0.00118 to 0.00315in}
No. 2	0.030 to 0.070mm {0.00118 to 0.00276in}

<Reference>

- Measurement should be performed at a temperature of 20°C {68°F}.
- Before inspecting the clearance, clean the piston ring groove and piston ring.
- If it is not within the standard value, replace the piston ring.
- Use piston ring with same size as piston when replacing piston ring.

13. Inspection of connecting rod ASSY

- (1) Check that the large or small end thrust surface of each connecting rod is not damaged.
(2) Check each connecting rod bearing for scar, peeling, seizure, melting or wear, etc.

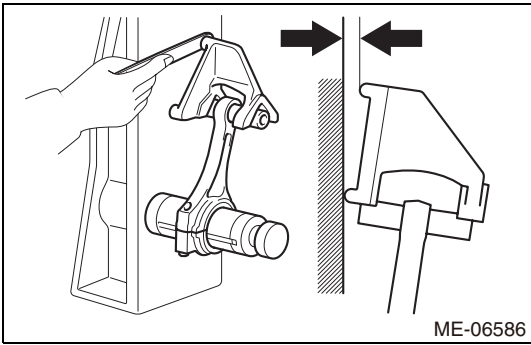

- (3) Check for bend using a connecting rod aligner.
 Limit (per a length of 100 mm {3.937 in}): 0.10mm {0.0039in}
 <Reference>
- Measurement should be performed at a temperature of 20°C {68°F}.
 - If it exceeds the limit, replace the connecting rod.

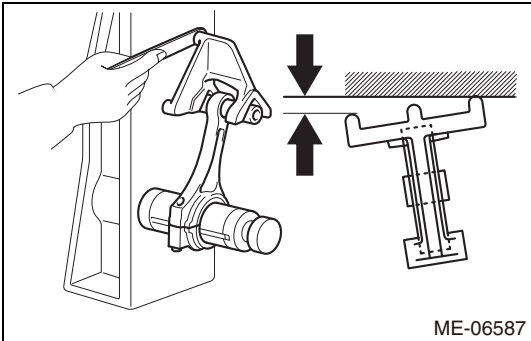

- (4) Check for twist using a connecting rod aligner.
 Limit (per a length of 100 mm {3.937 in}): 0.10mm {0.0039in}
 <Reference>
- Measurement should be performed at a temperature of 20°C {68°F}.
 - If it exceeds the limit, replace the connecting rod.



14. Inspection of connecting rod thrust clearance

- (1) Clean the connecting rod bearing and crank pin and apply engine oil to the crank pin.<*1>

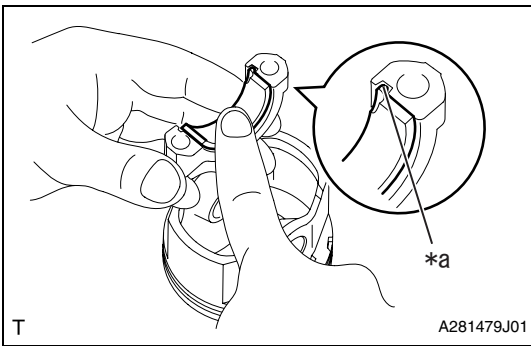

- (2) With the claw aligned in position, assemble the connecting rod bearing with the connecting rod and connecting rod cap.

Captions in illustration

*a	Claw position
----	---------------

T

A281479J01

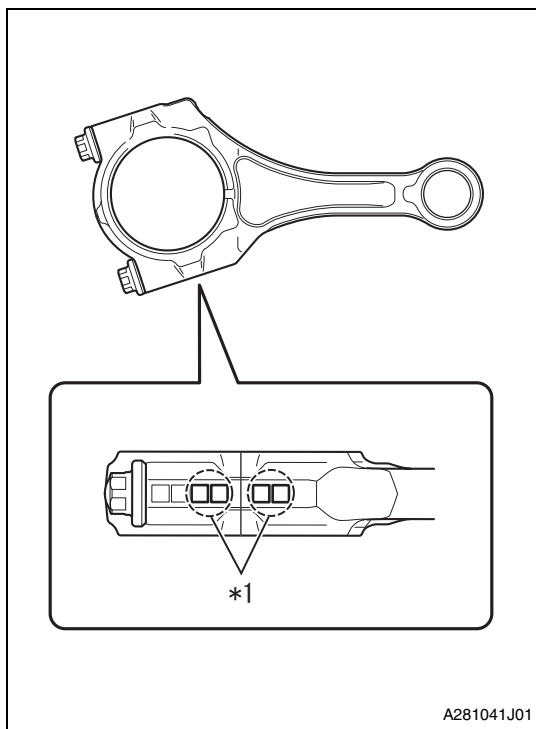

- (3) Check the identification symbol, and set the connecting rod, connecting rod cap and connecting rod cap bolt.

Captions in illustration

*1	Identification symbol
----	-----------------------

<Reference>

- Measurement should be performed at a temperature of 20°C {68°F}.
- Each connecting rod has its own mating cap.

- (4) Apply engine oil to the bolt threads.

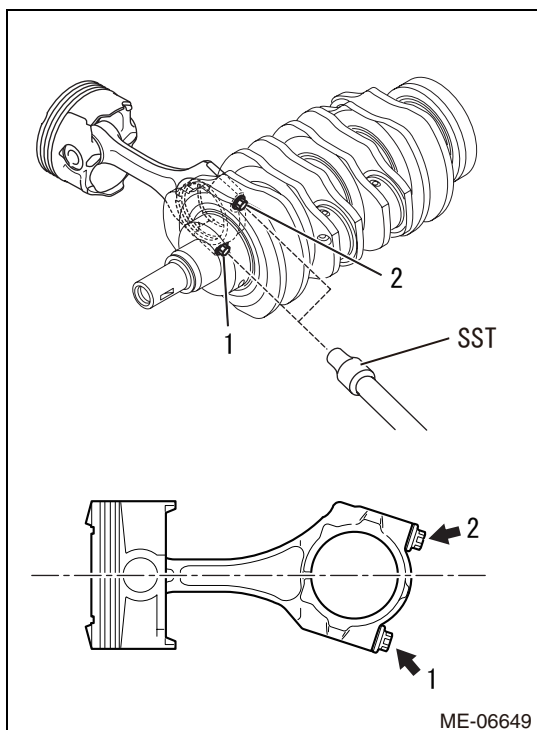

- (5) Using SST, tighten the connecting rod cap bolts in the order as shown in the figure.

SST 18270AA020

Standard value: $T=10N\cdot m$ {102kgf·cm} {7.4ft·lb}

<Caution>

- Make sure to hold the crankshaft securely during work.
- When holding the crankshaft, be careful not to damage the crankshaft.

- (6) Further tighten the connecting rod cap bolts.<*2>

Standard value: $T=25N\cdot m$ {255kgf·cm} {18.4ft·lb}

<Caution>

- Make sure to hold the crankshaft securely during work.
- When holding the crankshaft, be careful not to damage the crankshaft.

- (7) Using steps <*1> through <*2>, assemble the piston with connecting rod No. 2, No.3 and No. 4 as well as No. 1.

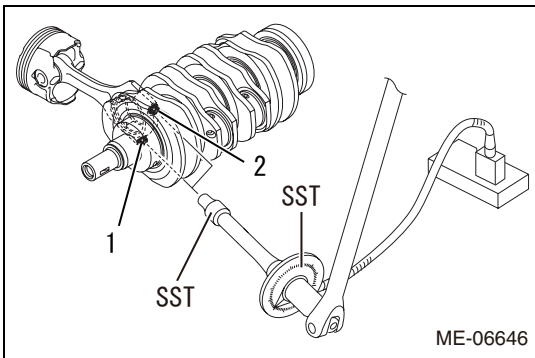

- (8) Further-tighten the connecting rod cap bolts No. 1 through No. 4 by 92.5° in the order as shown in the figure using SST.

SST 18270AA020, 18854AA000

<Caution>

- Make sure to hold the crankshaft securely during work.
- When holding the crankshaft, be careful not to damage the crankshaft.

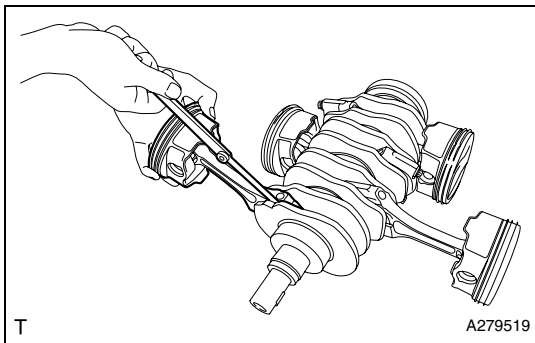

- (9) Check the thrust clearance of each connecting rod using a thickness gauge.

Standard value: 0.070 to 0.330mm {0.00276 to 0.01299in}

<Reference>

- If it is not within the standard value, replace the connecting rod.
- Measure the thrust clearance of each connecting rod at several points, and replace the connecting rod if there is uneven wear.

15. Inspection of connecting rod bearing oil clearance

- (1) Remove the connecting rod bearing.<*1>
- (2) Set the connecting rod bearing to the connecting rod and connecting rod cap.

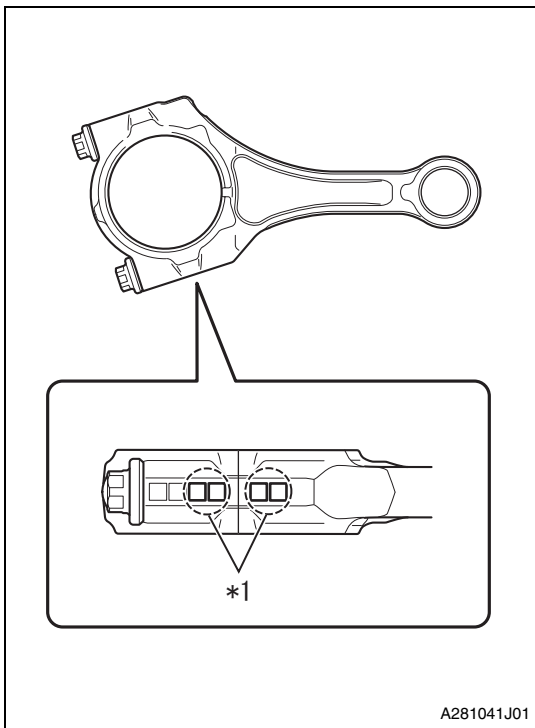

- (3) Place the plastigauge to the axial direction of crankshaft pin, and then, check the identification symbol, and set the connecting rod, connecting rod cap and connecting rod cap bolt.

Captions in illustration

*1	Identification symbol
----	-----------------------

<Reference>

- Measurement should be performed at a temperature of 20°C {68°F}.
- Each connecting rod has its own mating cap.

- (4) Apply engine oil to the bolt threads.

EM

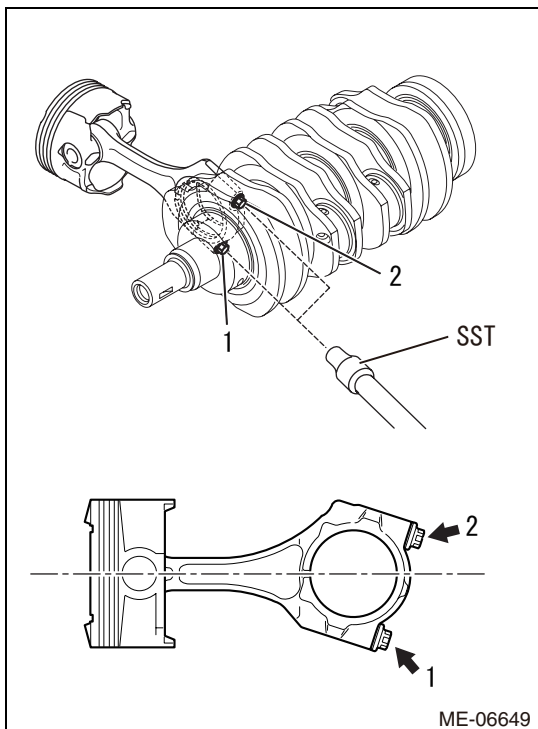

(5) Using SST, tighten the connecting rod cap bolts in the order as shown in the figure.

SST 18270AA020

Standard value: $T=10N\cdot m$ {102kgf·cm} {7.4ft·lbf}

<Caution>

- Do not turn the crankshaft during measuring.
- Make sure to hold the crankshaft securely during work.
- When holding the crankshaft, be careful not to damage the crankshaft.

(6) Further tighten the connecting rod cap bolts.<*2>

Standard value: $T=25N\cdot m$ {255kgf·cm} {18.4ft·lbf}

<Caution>

- Do not turn the crankshaft during measuring.
- Make sure to hold the crankshaft securely during work.
- When holding the crankshaft, be careful not to damage the crankshaft.

(7) Using steps <*1> through <*2>, assemble the piston with connecting rod No. 2, No.3 and No. 4 as well as No. 1.

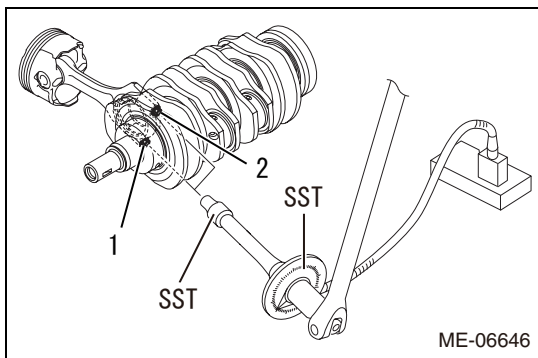

(8) Further-tighten the connecting rod cap bolts No. 1 through No. 4 by 92.5° in the order as shown in the figure using SST.

SST 18270AA020, 18854AA000

<Caution>

- Do not turn the crankshaft during measuring.
- Make sure to hold the crankshaft securely during work.
- When holding the crankshaft, be careful not to damage the crankshaft.

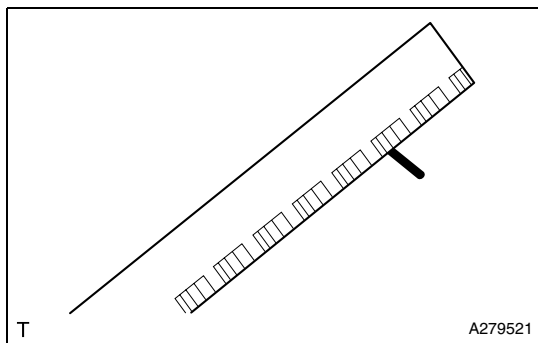

(9) Remove the bearing cap to measure the widest point of the plastigauge.

Standard value: 0.025 to 0.055mm {0.00098 to 0.00217in}

<Caution>

Completely remove the plastigauge after measuring.

<Reference>

- If it is not within the standard value, replace the connecting rod bearing.
- Measure the outer diameter of crank pin using micrometer, and select the suitable size connecting rod bearing when replacing the connecting rod bearing.

Standard value

Bearing	Bearing size (Thickness at center)	Outer diameter of crank pin
Standard	1.492 to 1.508 mm (0.05874 to 0.05937 in.)	49.976 to 50.000 mm (1.96756 to 1.96850 in.)
0.03 mm (0.0012 in.) Undersize	1.511 to 1.515 mm (0.05949 to 0.05965 in.)	49.946 to 49.970 mm (1.96637 to 1.96732 in.)
0.05 mm (0.0020 in.) Undersize	1.521 to 1.525 mm (0.05988 to 0.06004 in.)	49.926 to 49.950 mm (1.96559 to 1.96653 in.)

Bearing	Bearing size (Thickness at center)	Outer diameter of crank pin
0.25 mm (0.0098 in.) Undersize	1.621 to 1.625 mm (0.06382 to 0.06398 in.)	49.726 to 49.750 mm (1.95771 to 1.95866 in.)

16. Inspection of crankshaft

(1) Clean the crankshaft completely, and check it for cracks using liquid penetrant testing (red check).

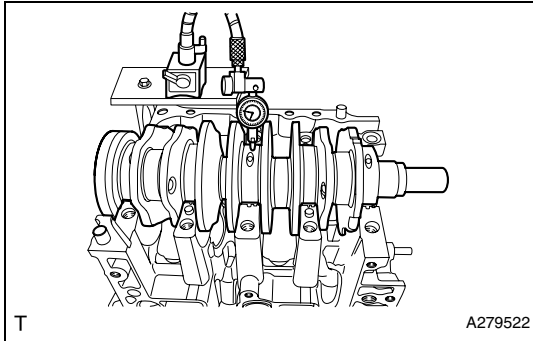

(2) Using a dial gauge, check the crankshaft bend.

Service limit: 0.035mm {0.00138in}

<Reference>

- Measurement should be performed at a temperature of 20°C {68°F}.
- If a suitable V-block is not available, using just crankshaft bearings No. 1 and No. 5, position the crankshaft on cylinder block. Then, measure the crankshaft bend using a dial gauge.
- If it exceeds the limit, grind to correct the crankshaft journal or replace the crankshaft.

(3) Measure the outer diameter of the crank pin and journal using a micrometer to calculate the taper and out-of-roundness.

Limit (pin)

Taper	0.006mm {0.00024in}
Out-of-roundness	0.005mm {0.00020in}

Limit (journal)

Taper	0.006mm {0.00024in}
Out-of-roundness	0.005mm {0.00020in}

Grinding limit

Pin	47.726mm {1.87897in}
Journal	67.735mm {2.6673in}

<Reference>

- Measurement should be performed at a temperature of 20°C {68°F}.
- If it is not within the standard, replace the connecting rod bearing or crankshaft bearing, and grind to correct the crank pin or journal, or replace the crankshaft as required.
- Select the suitable size connecting rod bearing or crankshaft bearing when replacing the connecting rod bearing or crankshaft bearing.
- When grinding to correct the crank journal or crank pin, finish them to the suitable dimensions as shown in the table below according to the undersize bearing to be used.

Standard value

Bearing	Connecting rod bearing thickness (at center)	Crank pin outer diameter	Crank shaft bearing thickness (at center)		Crankshaft journal diameter
			No. 1 to No. 4	No. 5	
Standard	1.492 to 1.508 mm (0.05874 to 0.05937 in.)	49.976 to 50.000 mm (1.96756 to 1.96850 in.)	2.495 to 2.513 mm (0.09823 to 0.09894 in.)	2.493 to 2.511 mm (0.09815 to 0.09886 in.)	67.985 to 68.009 mm (2.67657 to 2.67751 in.)
0.03 mm (0.0012 in.) Undersize	1.511 to 1.515 mm (0.05949 to 0.05965 in.)	49.946 to 49.970 mm (1.96637 to 1.96734 in.)	2.519 to 2.522 mm (0.09917 to 0.09929 in.)	2.517 to 2.520 mm (0.09909 to 0.09921 in.)	67.955 to 67.979 mm (2.67539 to 2.67633 in.)
0.05 mm (0.0020 in.) Undersize	1.521 to 1.525 mm (0.05988 to 0.06004 in.)	49.926 to 49.950 mm (1.96559 to 1.96653 in.)	2.529 to 2.532 mm (0.09957 to 0.09968 in.)	2.527 to 2.530 mm (0.09949 to 0.09961 in.)	67.935 to 67.959 mm (2.67460 to 2.67555 in.)
0.25 mm (0.0098 in.) Undersize	1.621 to 1.625 mm (0.06382 to 0.06398 in.)	49.726 to 49.750 mm (1.95771 to 1.95866 in.)	2.629 to 2.632 mm (0.10350 to 0.10362 in.)	2.627 to 2.630 mm (0.10342 to 0.10354 in.)	67.735 to 67.759 mm (2.66673 to 2.66767 in.)

17. Inspection of crankshaft bearing

- (1) Check the crankshaft bearing for scar, peeling, seizure, melting or wear, etc.

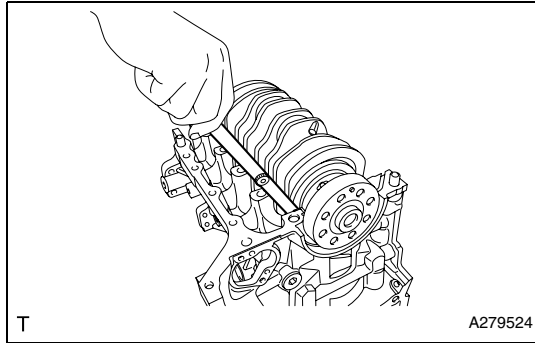

18. Inspection of crankshaft thrust clearance

- (1) Use a thickness gauge to check the thrust clearance of crankshaft at crankshaft bearing No. 5.

Standard value: 0.130 to 0.308mm {0.00512 to 0.01213in}

<Reference>

If it is not within the standard value, replace crankshaft bearing No. 5.

19. Inspection of crankshaft oil clearance

- (1) Remove the gasket from cylinder block.
- (2) Clean each crankshaft bearing and crankshaft journal.

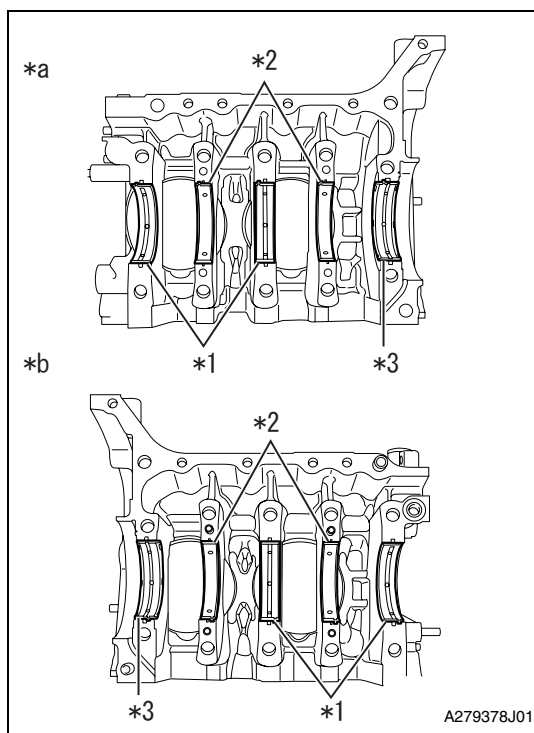

- (3) Set each crankshaft bearing to the cylinder block.

Captions in illustration

*1	Crankshaft bearing No. 1, No. 3 (with groove)
*2	Crankshaft bearing No. 2, No. 4 (without groove)
*3	Crankshaft bearing No. 5
*a	Bank 1
*b	Bank 2

<Caution>

- Be careful not to scratch the mating surface of cylinder block during work.
- Because journal bearings No. 1 and No. 3 differ from No. 2 and No. 4, confirm at assembly.

- (4) Set the crankshaft to the cylinder block (bank 2 side).
- (5) Set a plastigauge to the axial direction of the crankshaft journal.
- (6) Set the cylinder block (bank 1 side) to the cylinder block (bank 2 side).
- (7) Apply engine oil to the washers and cylinder block mounting bolt threads.

<Caution>

To prevent mixture of engine oil into the water jacket, do not apply a large amount.

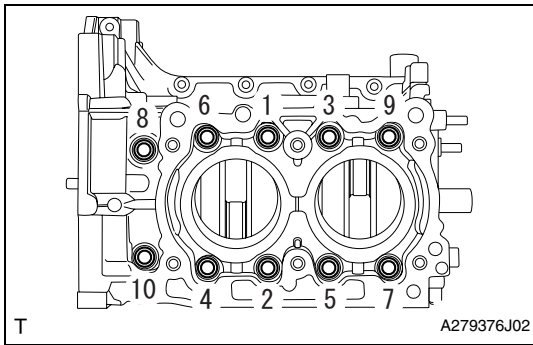

- (8) Tighten the ten mounting bolts in the order as shown in the figure.
 Standard value: $T=35\text{N}\cdot\text{m}$ {357kgf•cm} {25.8ft•lbf}
- <Caution>
 When tightening the mounting bolts, hold the cylinder block (bank 2 side) while not holding the cylinder block (bank 1 side) to ensure the joint accuracy of the cylinder block.

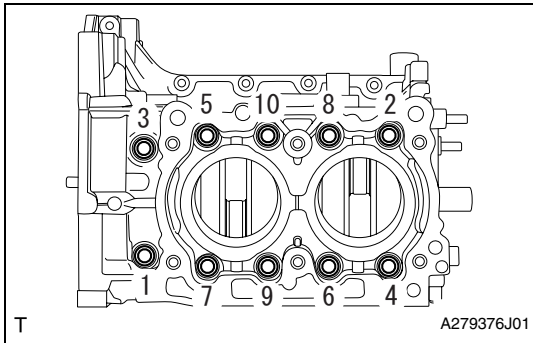

- (9) Loosen the ten mounting bolts by 180° in the order as shown in the figure.
 <Caution>
 When loosening the mounting bolts, hold the cylinder block (bank 2 side) while not holding the cylinder block (bank 1 side) to ensure the joint accuracy of the cylinder block.

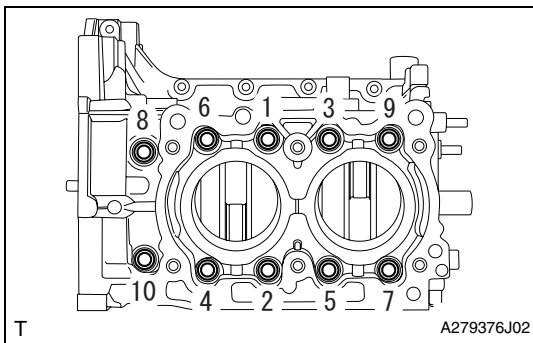

- (10) Tighten the ten mounting bolts in the order as shown in the figure.
 Standard value: $T=35\text{N}\cdot\text{m}$ {357kgf•cm} {25.8ft•lbf}
- <Caution>
 When tightening the mounting bolts, hold the cylinder block (bank 2 side) while not holding the cylinder block (bank 1 side) to ensure the joint accuracy of the cylinder block.

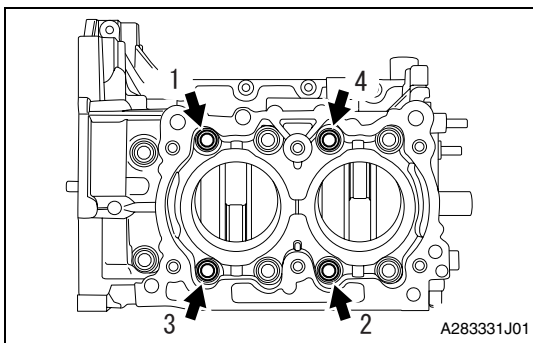

- (11) Loosen the four mounting bolts by 180° in the order as shown in the figure.
 <Caution>
 When loosening the mounting bolts, hold the cylinder block (bank 2 side) while not holding the cylinder block (bank 1 side) to ensure the joint accuracy of the cylinder block.

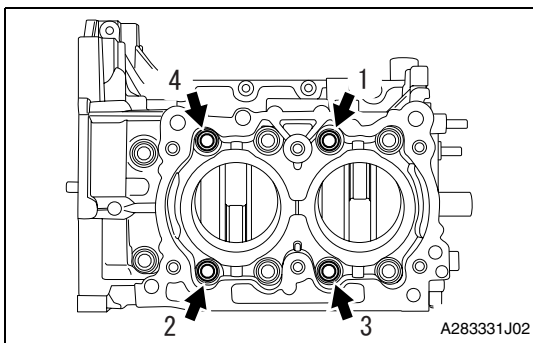

- (12) Tighten the four mounting bolts in the order as shown in the figure.
 Standard value: $T=17\text{N}\cdot\text{m}$ {173kgf•cm} {12.5ft•lbf}
- <Caution>
 When tightening the mounting bolts, hold the cylinder block (bank 2 side) while not holding the cylinder block (bank 1 side) to ensure the joint accuracy of the cylinder block.



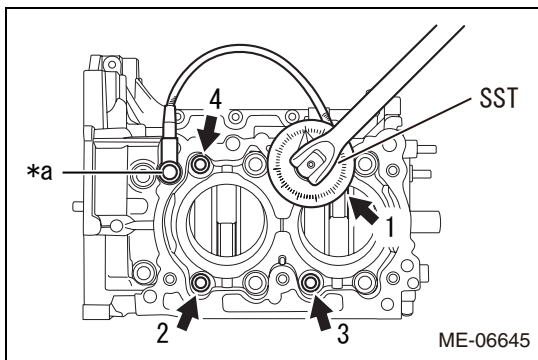

(13) Further-tighten the four mounting bolts by 60° in the order as shown in the figure using SST.

SST 18854AA000

Captions in illustration

*a	temporary bolt
----	----------------

<Caution>

When tightening the mounting bolts, hold the cylinder block (bank 2 side) while not holding the cylinder block (bank 1 side) to ensure the joint accuracy of the cylinder block.

<Reference>

As necessary, attach the temporary bolt to fix SST.

(14) Loosen the six mounting bolts by 180° in the order as shown in the figure.

<Caution>

When loosening the mounting bolts, hold the cylinder block (bank 2 side) while not holding the cylinder block (bank 1 side) to ensure the joint accuracy of the cylinder block.

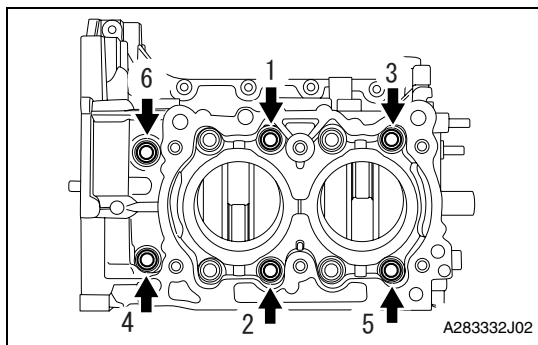
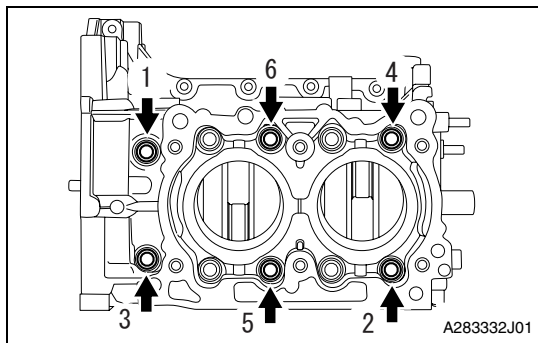

(15) Tighten the six mounting bolts in the order as shown in the figure.

Standard value: $T=17N\cdot m$ {173kgf·cm} {12.5ft·lbf}

<Caution>

When tightening the mounting bolts, hold the cylinder block (bank 2 side) while not holding the cylinder block (bank 1 side) to ensure the joint accuracy of the cylinder block.

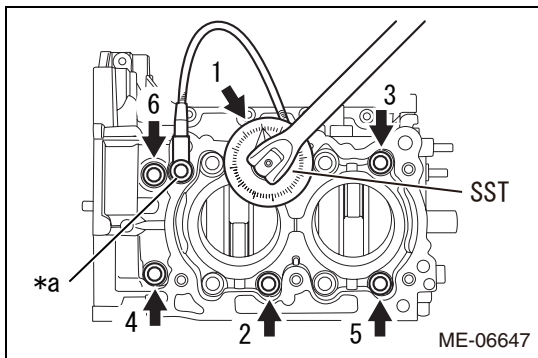

(16) Further-tighten the six mounting bolts by 60° in the order as shown in the figure using SST.

SST 18854AA000

Captions in illustration

*a	temporary bolt
----	----------------

<Caution>

When tightening the mounting bolts, hold the cylinder block (bank 2 side) while not holding the cylinder block (bank 1 side) to ensure the joint accuracy of the cylinder block.

<Reference>

As necessary, attach the temporary bolt to fix SST.

(17) Loosen the ten cylinder block mounting bolts in the order as shown in the figure.

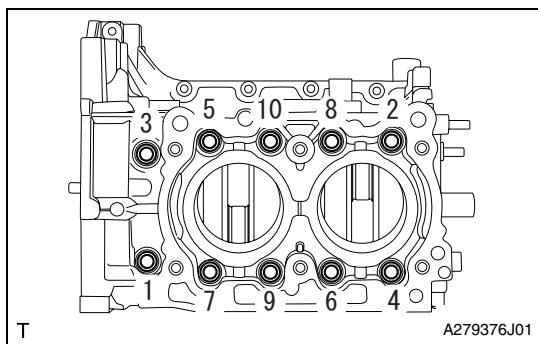

(18) Remove the 10 bolts to remove the cylinder block (bank 1 side).

<Caution>

Lift the cylinder block (bank 1 side) slightly, and make sure that the crankshaft is remaining in the cylinder block (bank 2 side). If the cylinder block (bank 1 side) is lifted without care, the crankshaft may be lifted along and fall off from the cylinder block (bank 1 side).

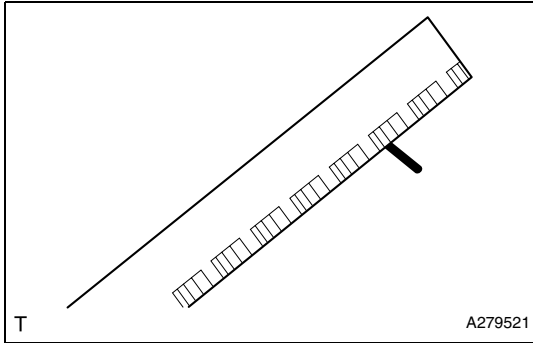

(19) Measure the widest point of the plastigauge.

Standard value: 0.013 to 0.031mm {0.00051 to 0.00122 in}

<Caution>

Completely remove the plastigauge after measuring.

<Reference>

- If it is not within the standard, replace the crankshaft bearing, and grind to correct the crankshaft journal or replace the crankshaft as required.
- Select the crankshaft bearing of suitable size according to the table below when replacing crankshaft bearing.
- When grinding to correct the crankshaft journal, finish them to the suitable dimensions as shown in the table below according to the undersize bearing to be used.



Standard value

Bearing	Connecting rod bearing thickness (at center)	Crank pin outer diameter	Crank shaft bearing thickness (at center)		Crankshaft journal diameter
			No. 1 to No. 4	No. 5	
Standard	1.492 to 1.508 mm (0.05874 to 0.05937 in.)	49.976 to 50.000 mm (1.96756 to 1.96850 in.)	2.495 to 2.513 mm (0.09823 to 0.09894 in.)	2.493 to 2.511 mm (0.09815 to 0.09886 in.)	67.985 to 68.009 mm (2.67657 to 2.67751 in.)
0.03 mm (0.0012 in.) Undersize	1.511 to 1.515 mm (0.05949 to 0.05965 in.)	49.946 to 49.970 mm (1.96637 to 1.96734 in.)	2.519 to 2.522 mm (0.09917 to 0.09929 in.)	2.517 to 2.520 mm (0.09909 to 0.09921 in.)	67.955 to 67.979 mm (2.67539 to 2.67633 in.)
0.05 mm (0.0020 in.) Undersize	1.521 to 1.525 mm (0.05988 to 0.06004 in.)	49.926 to 49.950 mm (1.96559 to 1.96653 in.)	2.529 to 2.532 mm (0.09957 to 0.09968 in.)	2.527 to 2.530 mm (0.09949 to 0.09961 in.)	67.935 to 67.959 mm (2.67460 to 2.67555 in.)
0.25 mm (0.0098 in.) Undersize	1.621 to 1.625 mm (0.06382 to 0.06398 in.)	49.726 to 49.750 mm (1.95771 to 1.95866 in.)	2.629 to 2.632 mm (0.10350 to 0.10362 in.)	2.627 to 2.630 mm (0.10342 to 0.10354 in.)	67.735 to 67.759 mm (2.66673 to 2.66767 in.)

ASSEMBLY

1. Installation of cylinder block tight plug No. 1

<Caution>

- During the work, stabilize the cylinder block by placing it on a wooden piece wrapped with cloth etc, in this case be careful not to contact the knock pin with the wooden piece.
- Be careful not to scratch the mating surface of cylinder block during work.

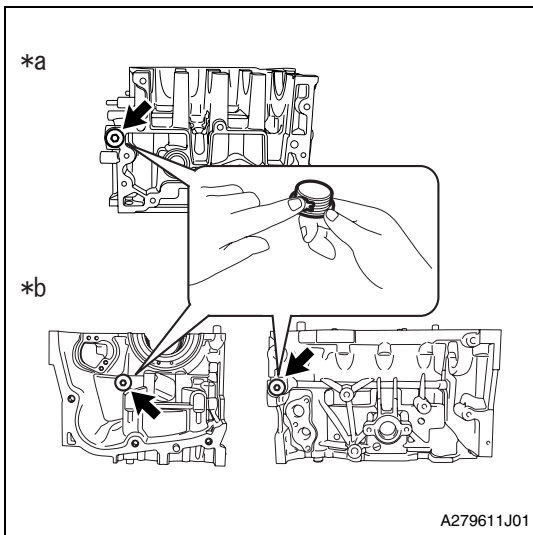

(1) Apply THREE BOND 1105 to the threaded portions of three cylinder block tight plug No. 1s and install to cylinder block (bank 1 side and bank 2 side).

Captions in illustration

*a	Bank 1
*b	Bank 2

Standard value: T=37N•m {377kgf•cm} {27.3ft•lbf}

<Caution>

Before applying liquid gasket, degrease the thread holes of the cylinder block and main gallery plug.

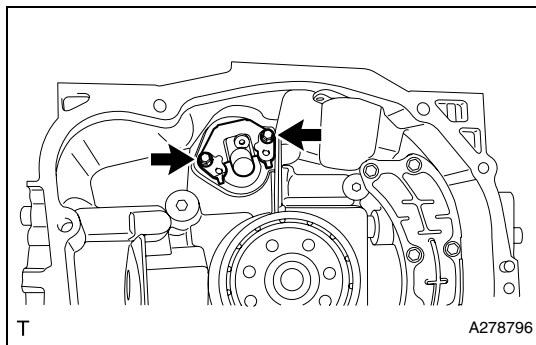

2. Installation of crankshaft sensor holder ASSY

- (1) Install the crankshaft sensor holder ASSY to the cylinder block (bank 2 side) with two bolts.

Standard value: $T=6.4\text{N}\cdot\text{m}$ {65kgf·cm} {4.7ft·lbf}

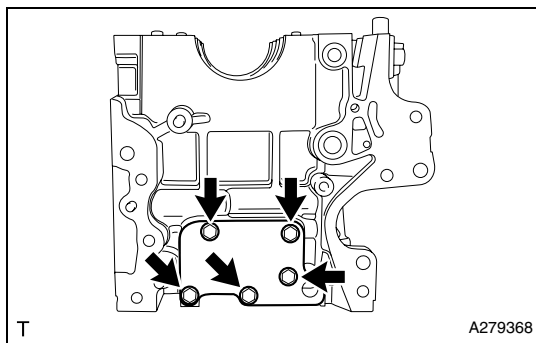

3. Installation of cylinder block plate

- (1) Install the cylinder block plate to the cylinder block (bank 2 side) with five bolts.

Standard value: $T=6.4\text{N}\cdot\text{m}$ {65kgf·cm} {4.7ft·lbf}

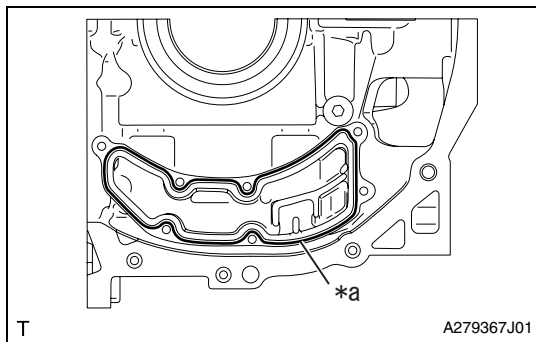

4. Installation of oil separator cover

- (1) Apply THREE BOND 1217G to the mating surface of the new oil separator cover.

Captions in illustration

*a	Dia. 3.0 to 5.0mm {0.138 to 0.197in}
----	--------------------------------------

<Caution>

- Clean and degrease the fitting surface.
- Install within 5 min. after applying liquid gasket.

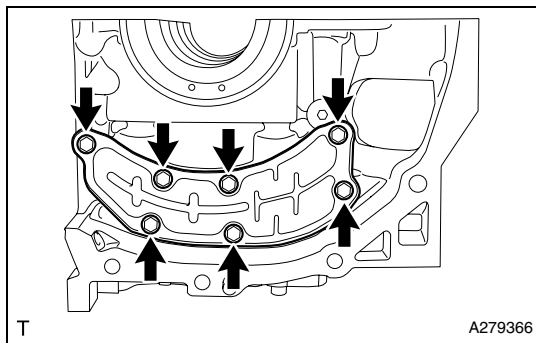

- (2) Tighten seven bolts in order as shown in the figure, and install the oil separator cover to the cylinder block (bank 1 side).

Standard value: $T=6.4\text{N}\cdot\text{m}$ {65kgf·cm} {4.7ft·lbf}

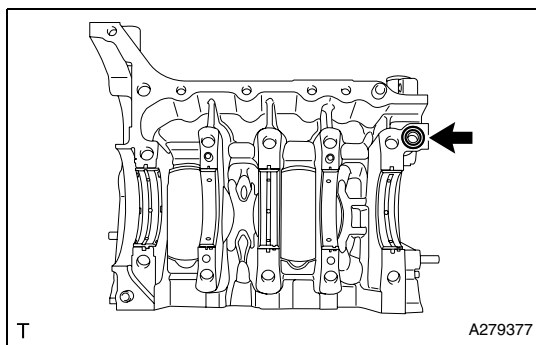

5. Installation of O-ring

- (1) Install a new O-ring to the cylinder block (bank 2 side).

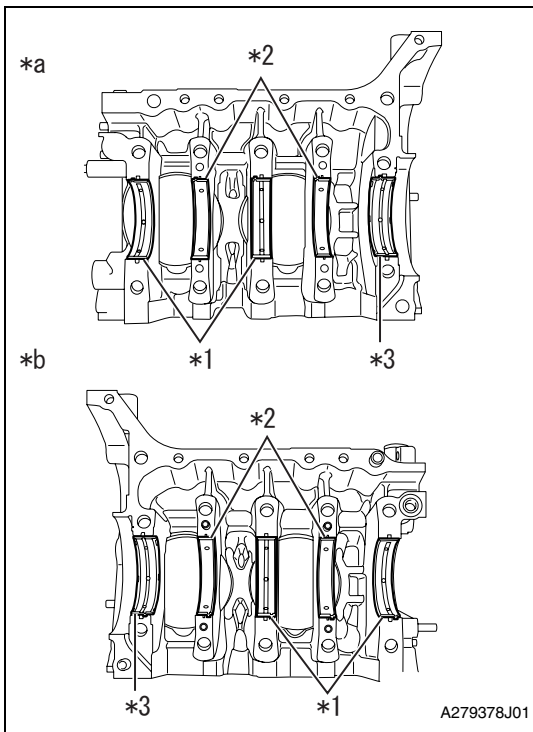

6. Installation of crankshaft bearing

- (1) Apply engine oil to the ten crankshaft bearing and install to cylinder block (bank 1 side and bank 2 side).

Captions in illustration

*1	Crankshaft bearing No. 1, No. 3 (with groove)
*2	Crankshaft bearing No. 2, No. 4 (without groove)
*3	Crankshaft bearing No. 5
*a	Bank 1
*b	Bank 2

<Caution>

- Be careful not to scratch the mating surface of cylinder block during work.
- Because journal bearings No. 1 and No. 3 differ from No. 2 and No. 4, confirm at assembly.

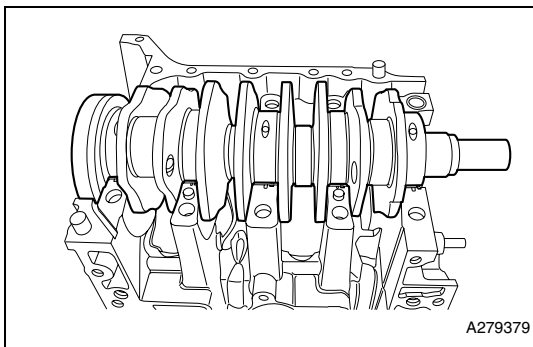

7. Installation of crankshaft

- (1) Apply engine oil to the crankshaft journal, and set to the cylinder block (bank 2 side).

8. Installation of cylinder block SUB-ASSY (bank 1 side)

- (1) Apply THREE BOND 1217G to the mating surface of the cylinder block (bank 1 side) as shown in the figure.

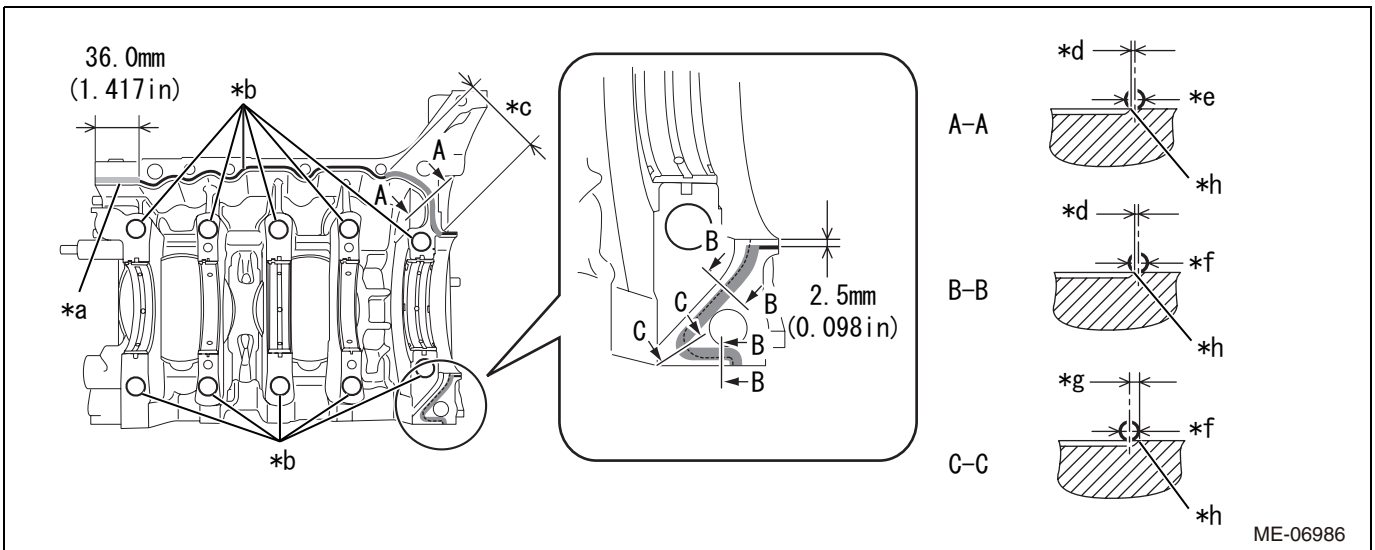

Captions in illustration

*a	Dia. 3.5 to 4.5mm {0.138 to 0.177in}	*b	Dia. 0.5 to 1.5mm {0.0197 to 0.0591in}
*c	Range A-A	*d	Within 1.0mm {0.039in}
*e	Dia. 2.7 to 3.7mm {0.106 to 0.146in}	*f	Dia. 3.5 to 4.5mm {0.138 to 0.177in}

*g	2.0mm {0.079in}	*h	Groove
----	-----------------	----	--------

<Caution>

- Do not let the gasket overflow to the oil passage and crankshaft bearing portions, because the engine seizure may result.
- Clean and degrease the fitting surface.
- Install within 5 min. after applying liquid gasket.

- (2) Install the cylinder block (bank 1 side) to the cylinder block (bank 2 side).
- (3) Apply engine oil to the washers and cylinder block mounting bolt threads.

<Caution>

To prevent mixture of engine oil into the water jacket, do not apply a large amount.

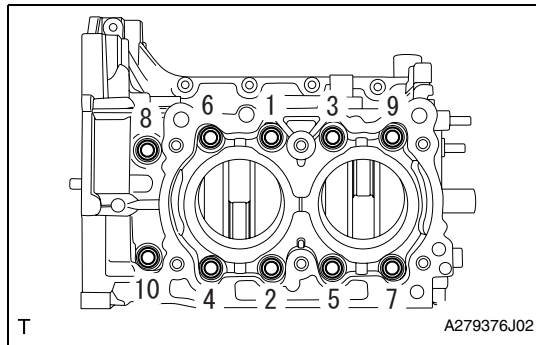

- (4) Tighten the ten mounting bolts in the order as shown in the figure.
Standard value: $T=35\text{N}\cdot\text{m}$ {357kgf·cm} {25.8ft·lbf}

<Caution>

When tightening the mounting bolts, hold the cylinder block (bank 2 side) while not holding the cylinder block (bank 1 side) to ensure the joint accuracy of the cylinder block.

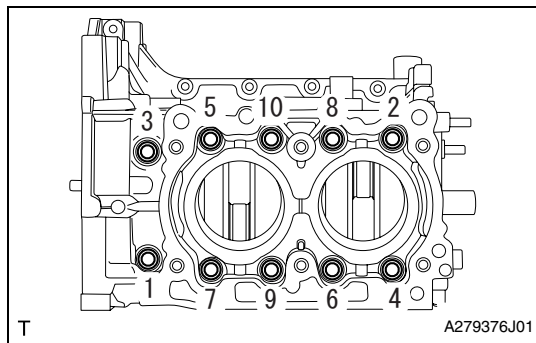

- (5) Loosen the ten mounting bolts by 180° in the order as shown in the figure.

<Caution>

When loosening the mounting bolts, hold the cylinder block (bank 2 side) while not holding the cylinder block (bank 1 side) to ensure the joint accuracy of the cylinder block.

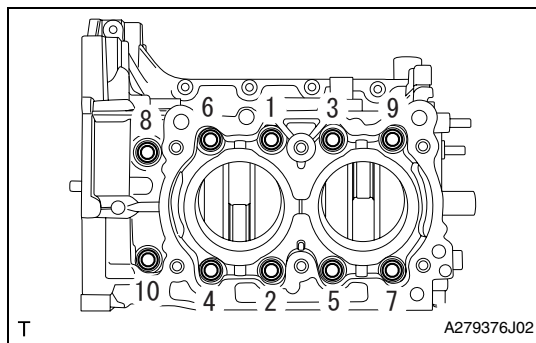

- (6) Tighten the ten mounting bolts in the order as shown in the figure.
Standard value: $T=35\text{N}\cdot\text{m}$ {357kgf·cm} {25.8ft·lbf}

<Caution>

When tightening the mounting bolts, hold the cylinder block (bank 2 side) while not holding the cylinder block (bank 1 side) to ensure the joint accuracy of the cylinder block.

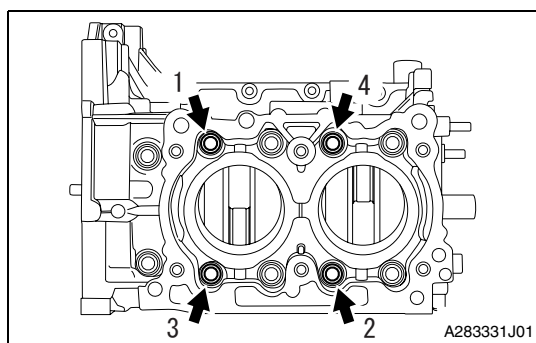

- (7) Loosen the four bolts by 180° in the order as shown in the figure.

<Caution>

When loosening the mounting bolts, hold the cylinder block (bank 2 side) while not holding the cylinder block (bank 1 side) to ensure the joint accuracy of the cylinder block.

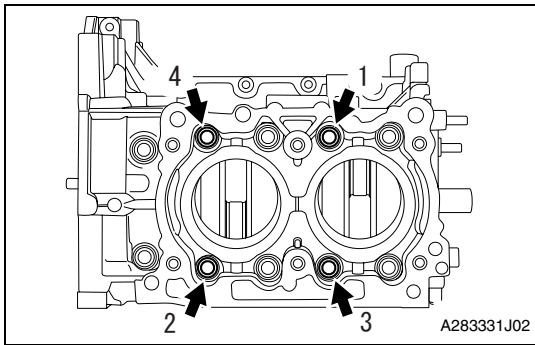

- (8) Tighten the four mounting bolts in the order as shown in the figure.
Standard value: $T=17N\cdot m$ {173kgf·cm} {12.5ft·lbf}

<Caution>

When tightening the mounting bolts, hold the cylinder block (bank 2 side) while not holding the cylinder block (bank 1 side) to ensure the joint accuracy of the cylinder block.

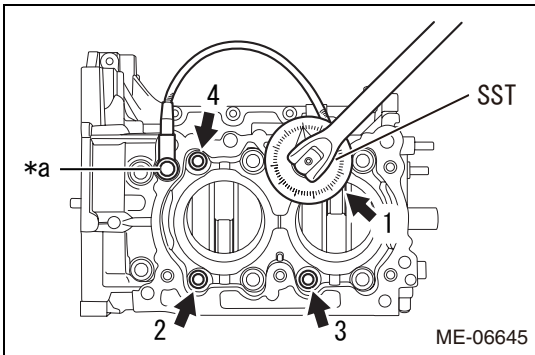

- (9) Further-tighten the four mounting bolts by 60° in the order as shown in the figure using SST.

SST 18854AA000

Captions in illustration

*a	temporary bolt
----	----------------

<Caution>

When tightening the mounting bolts, hold the cylinder block (bank 2 side) while not holding the cylinder block (bank 1 side) to ensure the joint accuracy of the cylinder block.

<Reference>

As necessary, attach the temporary bolt to fix SST.

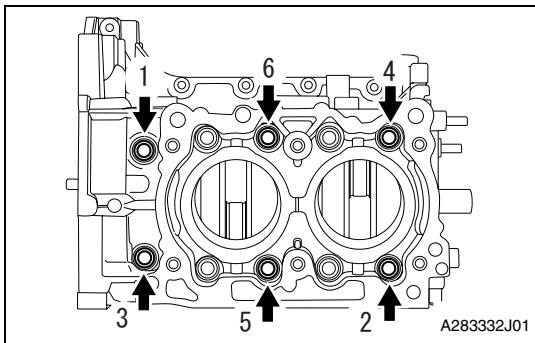

- (10) Loosen the six mounting bolts by 180° in the order as shown in the figure.

<Caution>

When loosening the mounting bolts, hold the cylinder block (bank 2 side) while not holding the cylinder block (bank 1 side) to ensure the joint accuracy of the cylinder block.

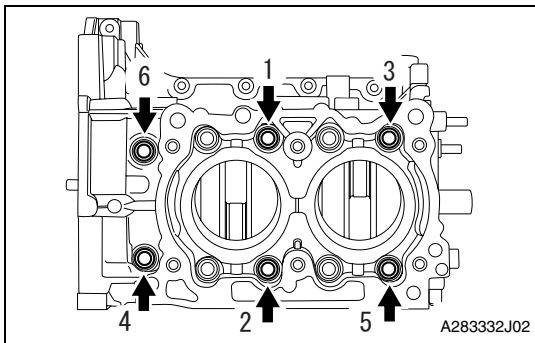

- (11) Tighten the six mounting bolts in the order as shown in the figure.

Standard value: $T=17N\cdot m$ {173kgf·cm} {12.5ft·lbf}

<Caution>

When tightening the mounting bolts, hold the cylinder block (bank 2 side) while not holding the cylinder block (bank 1 side) to ensure the joint accuracy of the cylinder block.

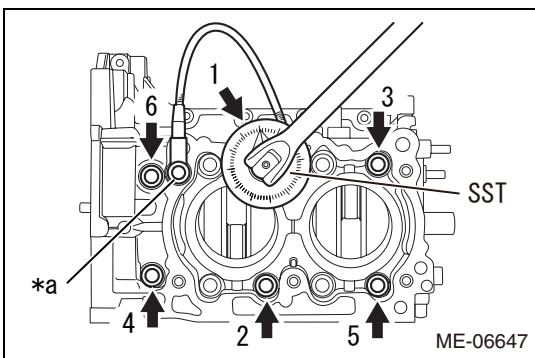

- (12) Further-tighten the six mounting bolts by 60° in the order as shown in the figure using SST.

SST 18854AA000

Captions in illustration

*a	temporary bolt
----	----------------

<Caution>

When tightening the mounting bolts, hold the cylinder block (bank 2 side) while not holding the cylinder block (bank 1 side) to ensure the joint accuracy of the cylinder block.

<Reference>

As necessary, attach the temporary bolt to fix SST.



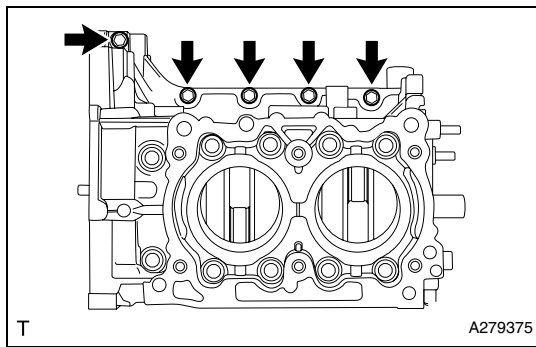

(13) Install the five bolts shown in the figure.

Standard value: $T=25\text{N}\cdot\text{m}$ {255kgf·cm} {18.4ft·lbf}

<Reference>

After tightening, if the gasket is squeezed out in the seal surface area of the oil pan upper, completely remove any gasket that is squeezed out. However, gasket in the groove should not be removed.



9. Installation of engine rear oil seal

(1) Apply a little coat of engine oil to the inside and outside of the new engine rear oil seal.

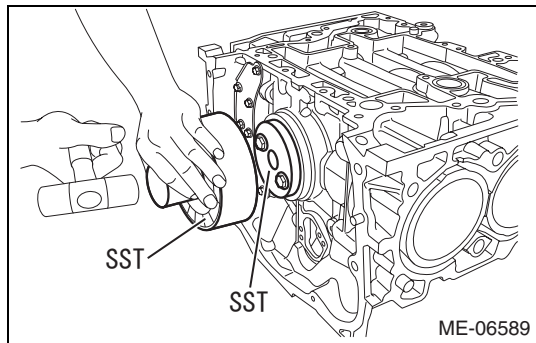

(2) Using SST, strike in the engine rear oil seal equally flush with the end surface of the cylinder block.

SST 18671AA020, 18657AA030

<Caution>

- Do not hammer in the engine rear oil seal obliquely.
- Wipe off the oil attached to the crankshaft.
- Do not hammer in the engine rear oil seal too deep.

<Reference>

The strike amount of the engine rear oil seal is allowed within 0 to -1 mm {0 to -0.039 in} from the end surface of the cylinder block.

10. Installation of cylinder block SUB-ASSY

(1) Mount the cylinder block SUB-ASSY onto the engine stand.

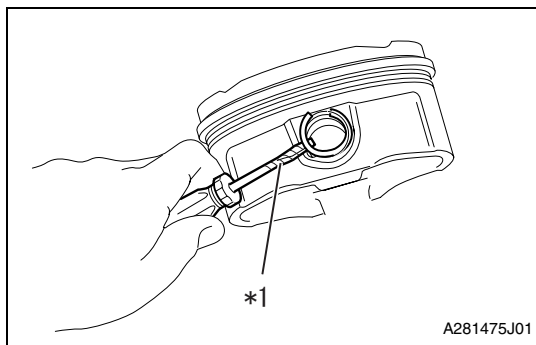

11. Installation of piston with pin

(1) Install the piston pin hole snap ring to one side of the piston using a screwdriver wrapped with protective tape.

Captions in illustration

*1	Protective tape
----	-----------------

<Reference>

- Make sure the piston pin hole snap ring is firmly inserted into the groove.
- After installing the piston pin hole snap ring, turn the piston pin hole snap ring so that the end and cutout portion of the hole snap ring do not match.

Captions in illustration

*1	Piston pin hole snap ring
*a	OK
*b	NG

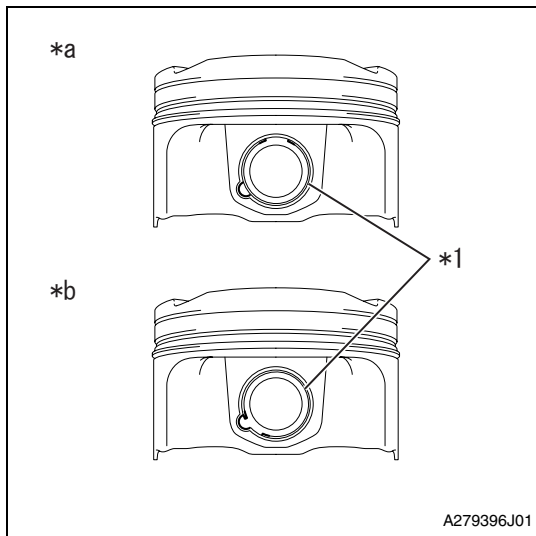

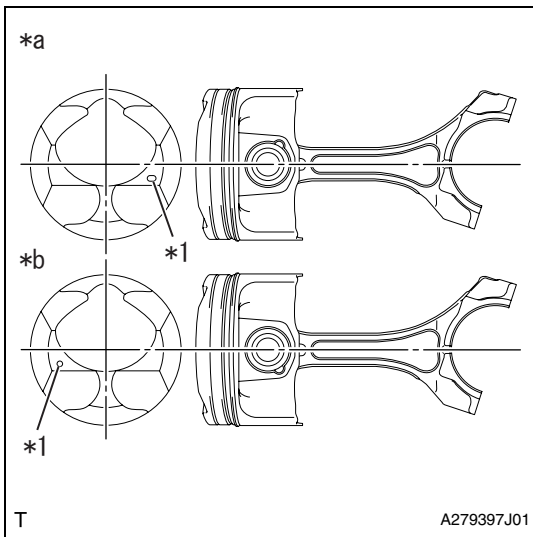

(2) Set the piston to the connecting rod.

Captions in illustration

*1	Front mark
*a	Bank 1
*b	Bank 2

<Reference>

Align the front mark of piston and the connecting rod direction correctly as shown in the figure.

(3) Apply engine oil to the piston pin, and attach the piston pin.

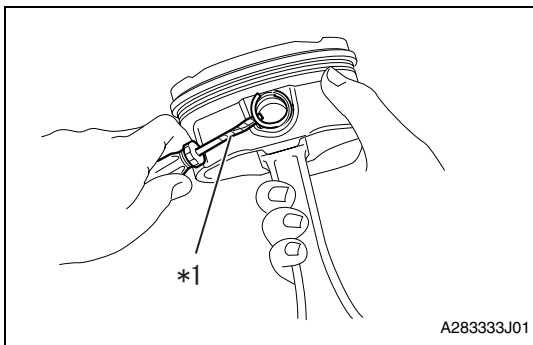

(4) Install the piston pin hole snap ring to the piston using a screwdriver wrapped with protective tape.

Captions in illustration

*1	Protective tape
----	-----------------

<Reference>

- Make sure the piston pin hole snap ring is firmly inserted into the groove.
- After installing the piston pin hole snap ring, turn the piston pin hole snap ring so that the end and cutout portion of the hole snap ring do not match.

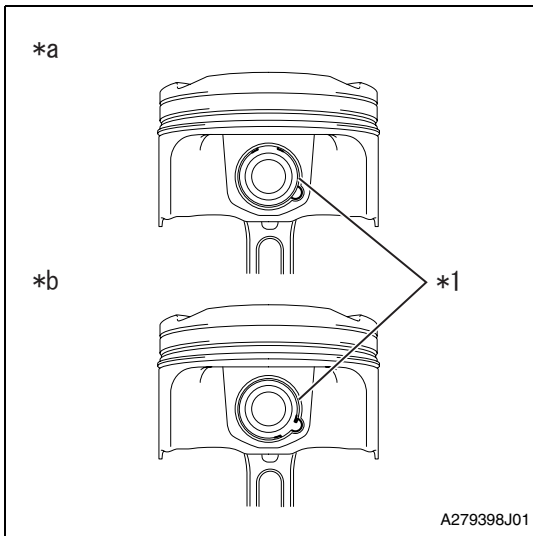

Captions in illustration

*1	Piston pin hole snap ring
*a	OK
*b	NG

12. Installation of piston ring set

(1) Install the oil ring in the order of oil ring expander, side rail (lower) and oil ring side rail (upper) by hand.

<Reference>

Oil ring consists of oil ring side rail (upper), oil ring expander and oil ring side rail (lower).

(2) Set the oil ring expander gap to the position (B) in the figure.



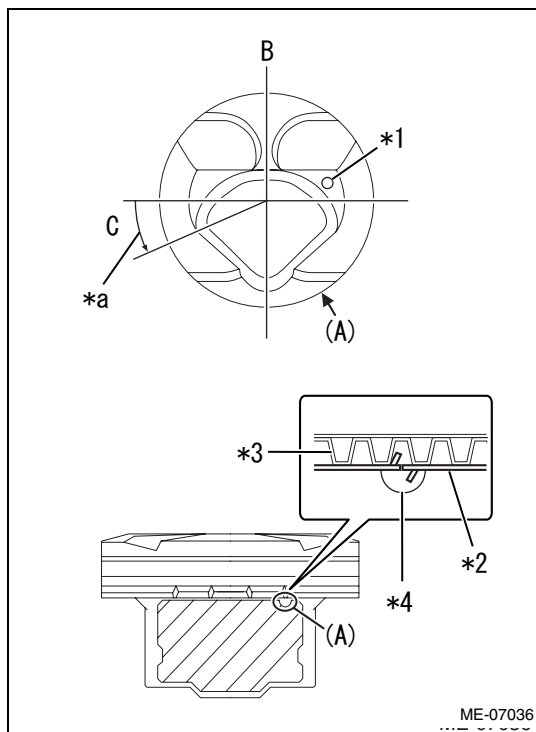

- (3) Engage the lower turn stopper of the oil ring side rail (lower) in the oil notch of the coated piston skirt cutout at the position (A) in the figure and engage the upper turn stopper to the oil ring expander.

Captions in illustration

*1	Front mark
*2	Oil ring side rail (lower)
*3	Oil ring expander
*4	Cutout portion
*a	0 to 20°

- (4) Align the oil ring side rail (upper) gap to position (C) (0 to 20°) in the figure and engage the upper turn stopper to the oil ring expander.
- (5) Using a piston ring tool, install compression ring No. 2 and then, compression ring No. 1 in numerical order with a stamped mark upward.

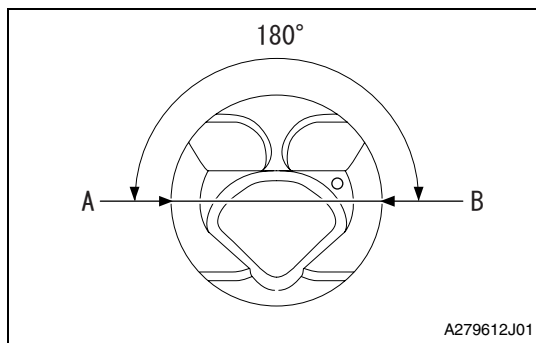

- (6) Set the gap of compression ring No. 1 to the position (A) or (B) in the figure.

<Reference>

Either (A) or (B) is good for compression ring No. 1 if it points in the piston pin direction.

- (7) Set the gap of compression ring No. 2 to the position (A) or (B), 180° opposite side of compression ring No. 1, in the figure.
- (8) Check that the positions of piston ring and oil ring gap are properly adjusted.

13. Installation of piston with connecting rod

- (1) Move the engine stand to face the oil pan side of the cylinder block upward.

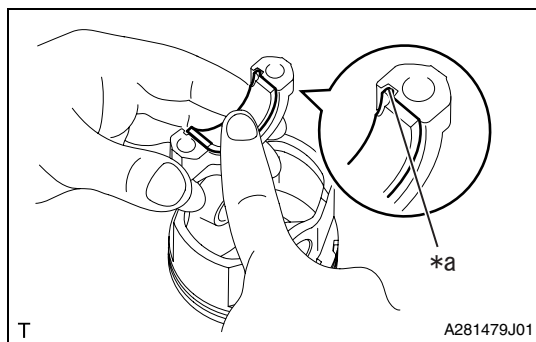

- (2) With the claw aligned in position, assemble the connecting rod bearing with the connecting rod and connecting rod cap.<*1>

Captions in illustration

*a	Claw position
----	---------------

- (3) Check that the positions of piston ring and oil ring gap are properly adjusted.
- (4) Apply engine oil to the outer circumference of each piston, crank pin, and in the cylinder block.

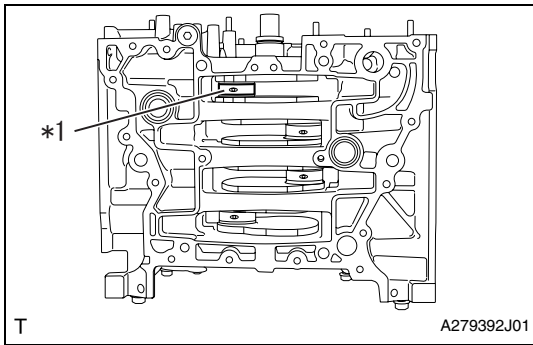

- (5) Turn the crankshaft so that the crankshaft pin position comes to TDC.

Captions in illustration

*1	Crankshaft pin
----	----------------

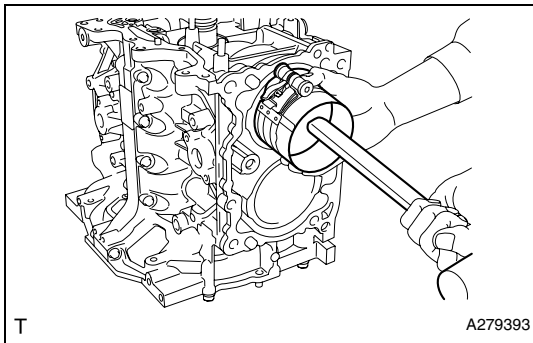

- (6) Compress the piston ring using piston ring compressor, and insert the piston with connecting rod into the cylinder block by tapping the piston crown using the handle of a plastic hammer etc.

<Caution>

- Be careful not to damage the cylinder liner and crankshaft pin by the connecting rod large end.
- Do not apply strong impact when inserting the piston with connecting rod to prevent connecting rod bearing from falling off.

<Reference>

Face the piston front mark towards the front of the engine.

- (7) Apply engine oil to the connecting rod cap seat and the connecting rod cap bolt threads.

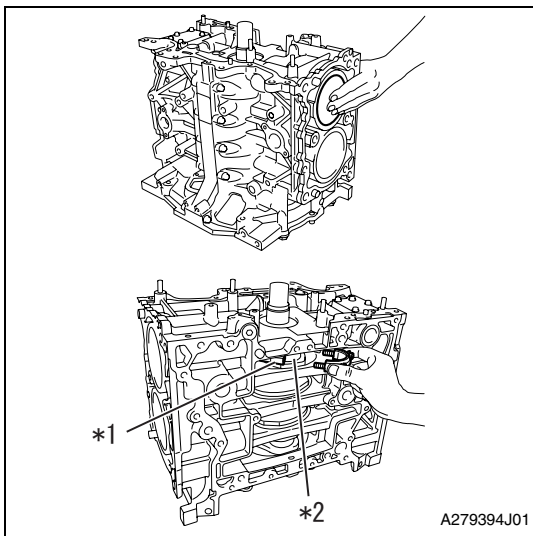

- (8) Turn the crankshaft so that the crank pin and the large end of connecting rod are positioned as shown in the figure, while pressing the piston crown, and then install the connecting rod cap using the connecting rod cap bolt.

Captions in illustration

*1	Connecting rod
*2	Crankshaft pin

EM

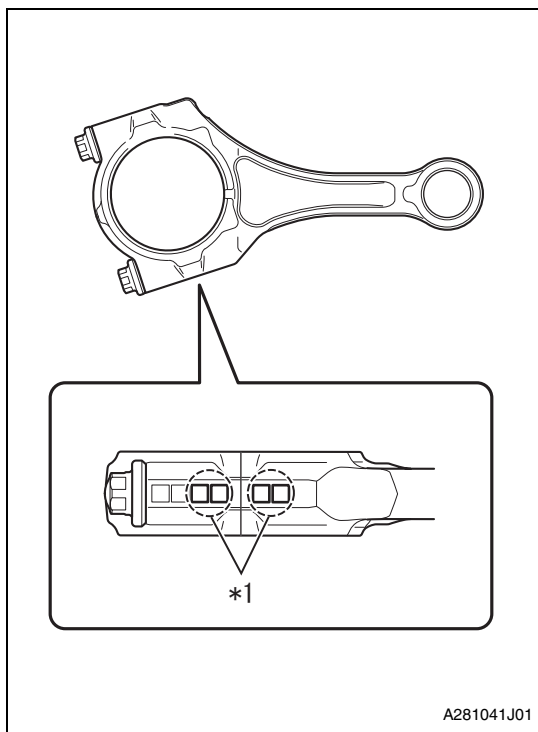

<Reference>

- Each connecting rod has its own mating cap. Make sure that they are assembled correctly by checking their identification symbols.

Captions in illustration

*1	Identification symbol
----	-----------------------

- Use a new connecting rod cap bolt.
- When installing piston with connecting rod No. 1 and No. 3, turn the crankshaft counter-clockwise, on the other hand, when installing the piston with connecting rod No. 2 and No. 4, turn the crankshaft clockwise.

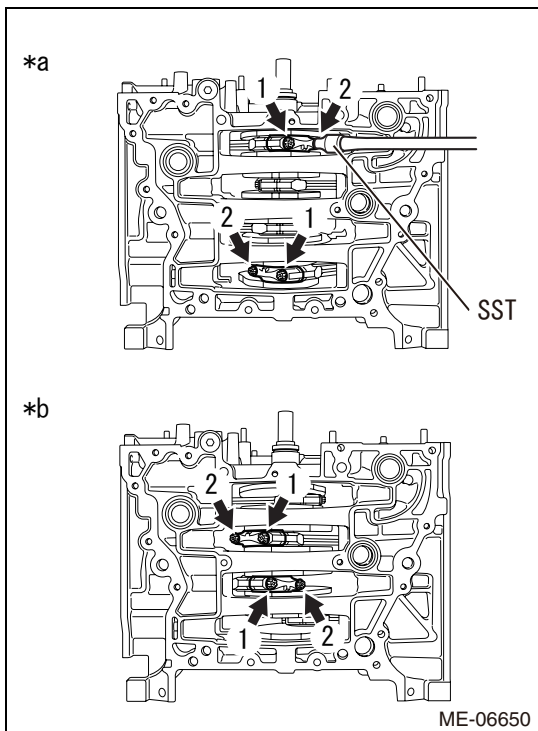

- (9) Using SST, tighten the two connecting rod cap bolts in the order as shown in the figure.

SST 18270AA020

Captions in illustration

*a	Cylinder No. 1, No. 4
*b	Cylinder No. 2, No. 3

Standard value: T=10N•m {102kgf•cm} {7.4ft•lbf}

- (10) Further-tighten the two bolts in the same order.<*2>

Standard value: T=25N•m {255kgf•cm} {18.4ft•lbf}

- (11) Using steps <*1> through <*2>, assemble the piston with connecting rod No. 2, No.3 and No. 4 as well as No. 1.

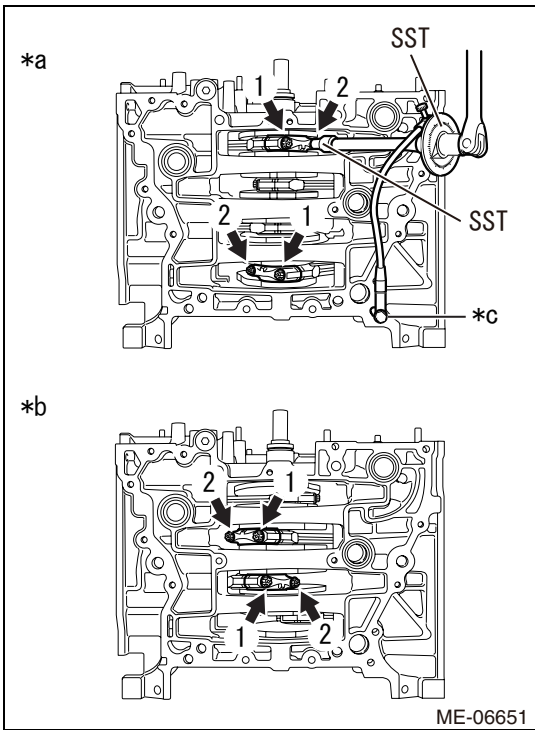

(12) Further-tighten the connecting rod cap bolts No. 1 through No. 4 by 92.5° in the order as shown in the figure using SST.

SST 18270AA020, 18854AA000

Captions in illustration

*a	Cylinder No. 1, No. 4
*b	Cylinder No. 2, No. 3
*c	temporary bolt

<Reference>

As necessary, attach the temporary bolt to fix SST.



(13) Make sure that the crankshaft turns smoothly.

EM

COOLING

WATER PUMP (FA20)

INSPECTION.....

CO-1

CO

WATER PUMP (FA20)

INSPECTION

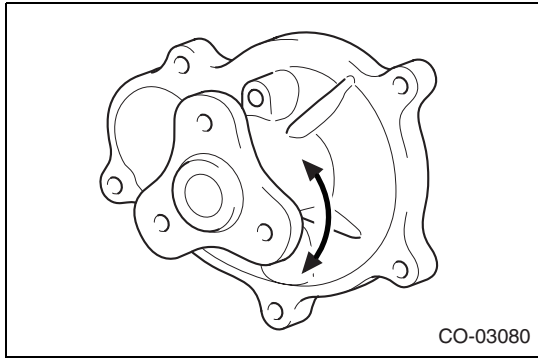

1. Inspection of engine water pump ASSY
 - (1) Make sure that the bearing has no noise and catch.
<Reference>
If noise or catch is noted, replace the engine water pump ASSY.
 - (2) Make sure the impeller is not abnormally deformed or damaged.
<Reference>
If the impeller is abnormally deformed or damaged, replace the engine water pump ASSY.