

PREPARATION MATERIALS

PREPARATION MATERIALS

PP

DRIVE TRAIN

MANUAL TRANSMISSION/TRANSAXLE

MT

PREPARATION MATERIALS

MANUAL TRANSMISSION/TRANSAXLE

SST	PP-2
GENERAL TOOL	PP-8
GREASE · OTHER	PP-8

PP-2
PP-8
PP-8



MANUAL TRANSMISSION/TRANSAXLE

SST

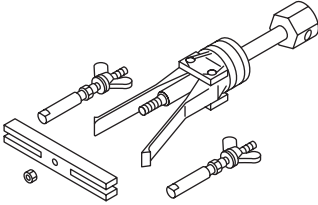
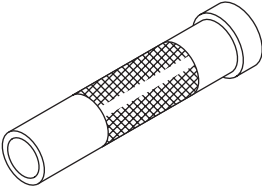
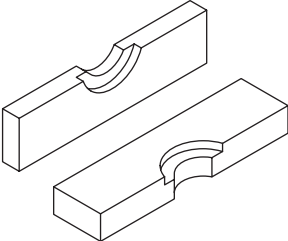
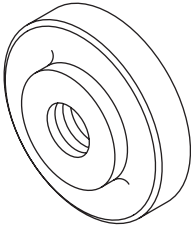
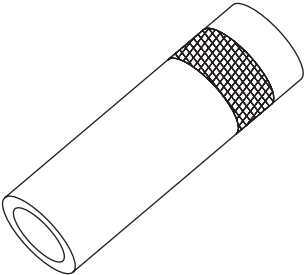
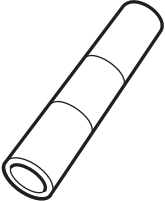

Illustration	Tool number	Description	Remarks
 <p data-bbox="309 625 443 646">ST-39852770</p>	39852770	Puller ASSY	Used for removing the transmission extension housing oil seal.
 <p data-bbox="309 1003 443 1024">ST-499277100</p>	499277100	Bushing 1-2 installer	<ul style="list-style-type: none"> • Used for installing the transmission clutch hub No. 3. • Used for installing the transmission clutch hub No. 1. • Used for installing the output shaft bearing RR. • Used for installing the sixth gear.
 <p data-bbox="309 1381 443 1402">ST-899714110</p>	899714110	Remover	<ul style="list-style-type: none"> • Used for removing the input shaft bearing FR. • Used for removing the counter drive gear. • Used for removing the counter shaft third gear. • Used for removing and installing the transmission clutch hub No. 3. • Used for installing the transmission clutch hub No. 1. • Used for installing the output shaft bearing RR. • Used for installing the sixth gear.
 <p data-bbox="309 1766 443 1787">ST-398477703</p>	398477703	Drift 2	<ul style="list-style-type: none"> • Used for installing the input shaft bearing FR. • Used for installing the transmission clutch hub No. 3. • Used for installing the transmission clutch hub No. 1. • Used for installing the output shaft bearing RR. • Used for installing the sixth gear. • Used for installing the transmission clutch hub No. 2. • Used for installing the counter drive gear.

Illustration	Tool number	Description	Remarks
 <p>ST-499277000</p>	499277000	Installer	<ul style="list-style-type: none"> • Used for installing the input shaft bearing FR. • Used for installing the transmission clutch hub No. 1. • Used for installing the output shaft bearing RR. • Used for installing the sixth gear. • Used for installing the counter drive gear.
 <p>ST18654AA000</p>	18654AA000	Installer	Used for installing the transmission clutch hub No. 2.
 <p>ST0932520010</p>	09325-20010	Transmission oil plug	<ul style="list-style-type: none"> • Used for installing the transmission extension housing oil seal (MTM). • Used for installing the transmission extension housing oil seal.
 <p>ST-498057300</p>	498057300	Installer	Used for installing the counter gear front bearing.

PP



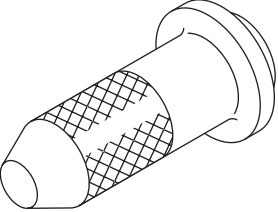
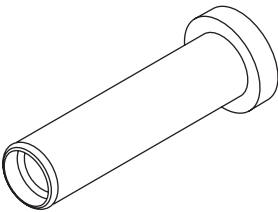
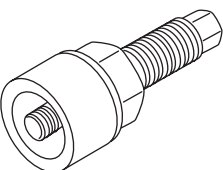
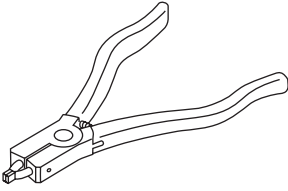
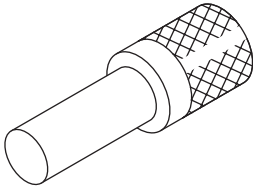
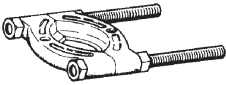

Illustration	Tool number	Description	Remarks
 <p data-bbox="301 514 440 537">ST0935020015</p>	<p data-bbox="496 174 609 197">09350-20015</p>	<p data-bbox="660 174 967 222">TOYOTA automatic transmission tool set</p>	<p data-bbox="1010 174 1449 222">Used for inspecting the counter shaft 6th gear thrust clearance.</p>
 <p data-bbox="301 892 440 915">ST0935006120</p>	<p data-bbox="491 552 620 575">(09350-06120)</p>	<p data-bbox="660 552 863 575">Terminal No. 2 measure</p>	<p data-bbox="1010 552 1457 600">Used for inspecting the counter shaft 6th gear thrust clearance.</p>
 <p data-bbox="296 1270 443 1293">ST18657AA040</p>	<p data-bbox="499 930 612 953">18657AA040</p>	<p data-bbox="660 930 735 953">Installer</p>	<p data-bbox="1010 930 1457 953">Used for installing the extension housing rear oil seal.</p>
 <p data-bbox="296 1648 443 1671">ST18682AA000</p>	<p data-bbox="499 1308 612 1331">18682AA000</p>	<p data-bbox="660 1308 735 1331">Installer</p>	<p data-bbox="1010 1308 1457 1331">Used for installing the transmission clutch hub No. 4.</p>

Illustration	Tool number	Description	Remarks
 <p data-bbox="336 514 470 537">ST-499895400</p>	499895400	Expander	Used for removing and installing the shaft snap ring.
 <p data-bbox="336 894 470 917">ST-899864100</p>	899864100	Remover	<ul style="list-style-type: none"> <li data-bbox="1042 556 1469 604">• Used for removing the transmission clutch hub No. 3. <li data-bbox="1042 611 1422 659">• Used for removing the counter gear front bearing. <li data-bbox="1042 665 1426 693">• Used for removing the counter drive gear.
 <p data-bbox="331 1272 470 1295">ST0995000020</p>	09950-00020	Remover	<ul style="list-style-type: none"> <li data-bbox="1042 934 1358 961">• Used for removing the sixth gear. <li data-bbox="1042 968 1422 1016">• Used for removing the counter gear front bearing.
 <p data-bbox="328 1656 470 1680">ST18722AA000</p>	18722AA000	Remover	Used for removing the first gear.

PP

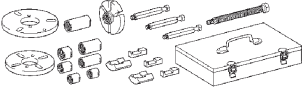



Illustration	Tool number	Description	Remarks
 <p data-bbox="300 514 440 537">ST0995030012</p>	<p data-bbox="496 176 609 199">09950-30012</p>	<p data-bbox="660 176 762 199">Puller A set</p>	<p data-bbox="1010 176 1458 199">Used for removing the transmission clutch hub No. 4.</p>
 <p data-bbox="300 894 440 917">ST0995103010</p>	<p data-bbox="491 554 614 577">(09951-03010)</p>	<p data-bbox="660 554 762 577">Upper plate</p>	<p data-bbox="1010 554 1458 577">Used for removing the transmission clutch hub No. 4.</p>
 <p data-bbox="300 1272 440 1295">ST0995303010</p>	<p data-bbox="491 932 614 955">(09953-03010)</p>	<p data-bbox="660 932 762 955">Center bolt</p>	<p data-bbox="1010 932 1458 955">Used for removing the transmission clutch hub No. 4.</p>
 <p data-bbox="300 1650 440 1673">ST0995603010</p>	<p data-bbox="491 1310 614 1333">(09956-03010)</p>	<p data-bbox="660 1310 762 1333">Adapter 16</p>	<p data-bbox="1010 1310 1458 1333">Used for removing the transmission clutch hub No. 4.</p>

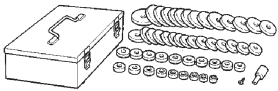

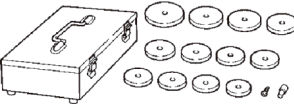
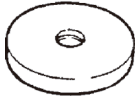
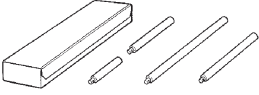

Illustration	Tool number	Description	Remarks
 <p>ST0995060010</p>	09950-60010	Replacer set	Used for installing the transmission front bearing retainer oil seal.
 <p>ST0995100420</p>	(09951-00420)	Replacer 42	Used for installing the transmission front bearing retainer oil seal.
 <p>ST0995060020</p>	09950-60020	Replacer set No. 2	Used for installing the extension housing dust deflector.
 <p>ST0995100750</p>	(09951-00750)	Replacer 75	Used for installing the extension housing dust deflector.

Illustration	Tool number	Description	Remarks
 <p>ST0995070010</p>	09950-70010	Handle set	<ul style="list-style-type: none"> Used for installing the transmission front bearing retainer oil seal. Used for installing the extension housing dust deflector.
 <p>ST0995107100</p>	09951-07100	Handle 100	<ul style="list-style-type: none"> Used for installing the transmission front bearing retainer oil seal. Used for installing the extension housing dust deflector.

GENERAL TOOL

Tool name	Remarks
Socket hexagon	Used for removing and installing the lock ball pin.
TORX® socket wrench T40	Used for removing and installing the head straight screw plug.
TORX® socket wrench T45	Used for removing and installing the TORX bolt.
Brass bar 16φ	<ul style="list-style-type: none"> Used for disassembling and assembling the manual transmission ASSY. Used for disassembling and assembling the input shaft ASSY. Used for disassembling and assembling the output shaft ASSY.
Thickness gauge	Used for measuring clearance.
Caliper	Used for measuring clearance.
Dial gauge (10 mm)	Used for measuring clearance.
Micrometer	Used for measuring outer diameter.
V-block	<ul style="list-style-type: none"> Used for inspecting the output shaft runout. Used for inspecting the counter shaft runout.
Cylinder gauge	Used for measuring inner diameter.
Magnetic base	Used for measuring clearance.

GREASE·OTHER

Description	Part number	Used location	
MG Gear Oil Special II	—	<ul style="list-style-type: none"> Manual transmission ASSY Input shaft ASSY Output shaft ASSY Counter gear ASSY 	GL-3 or more (75W-90) <Caution> <ul style="list-style-type: none"> The function or the performance of the substitute oil might be inferior to the genuine transmission gear oil. Do not mix different types of oil.
Nichimoly N-130 or equivalent	—	Input shaft	—
Permalub ECN-9 or equivalent	—	<ul style="list-style-type: none"> Floor shift control shaft Control shaft 	—
Nightight LYW No. 2 or equivalent	—	<ul style="list-style-type: none"> Shift lever cap Shift lever pin Control shift lever retainer 	—

MANUAL TRANSMISSION/TRANSAXLE

MANUAL TRANSMISSION ASSY

EXPLODED VIEW	MT-2
DISASSEMBLY	MT-8
INSPECTION	MT-23
ASSEMBLY	MT-26

MT

INPUT SHAFT ASSY

EXPLODED VIEW	MT-44
DISASSEMBLY	MT-44
INSPECTION	MT-46
ASSEMBLY	MT-46

OUTPUT SHAFT ASSY

EXPLODED VIEW	MT-48
DISASSEMBLY	MT-50
INSPECTION	MT-52
ASSEMBLY	MT-57

COUNTER GEAR ASSY

EXPLODED VIEW	MT-61
DISASSEMBLY	MT-62
INSPECTION	MT-65
ASSEMBLY	MT-68

MANUAL TRANSMISSION ASSY

EXPLODED VIEW

MT

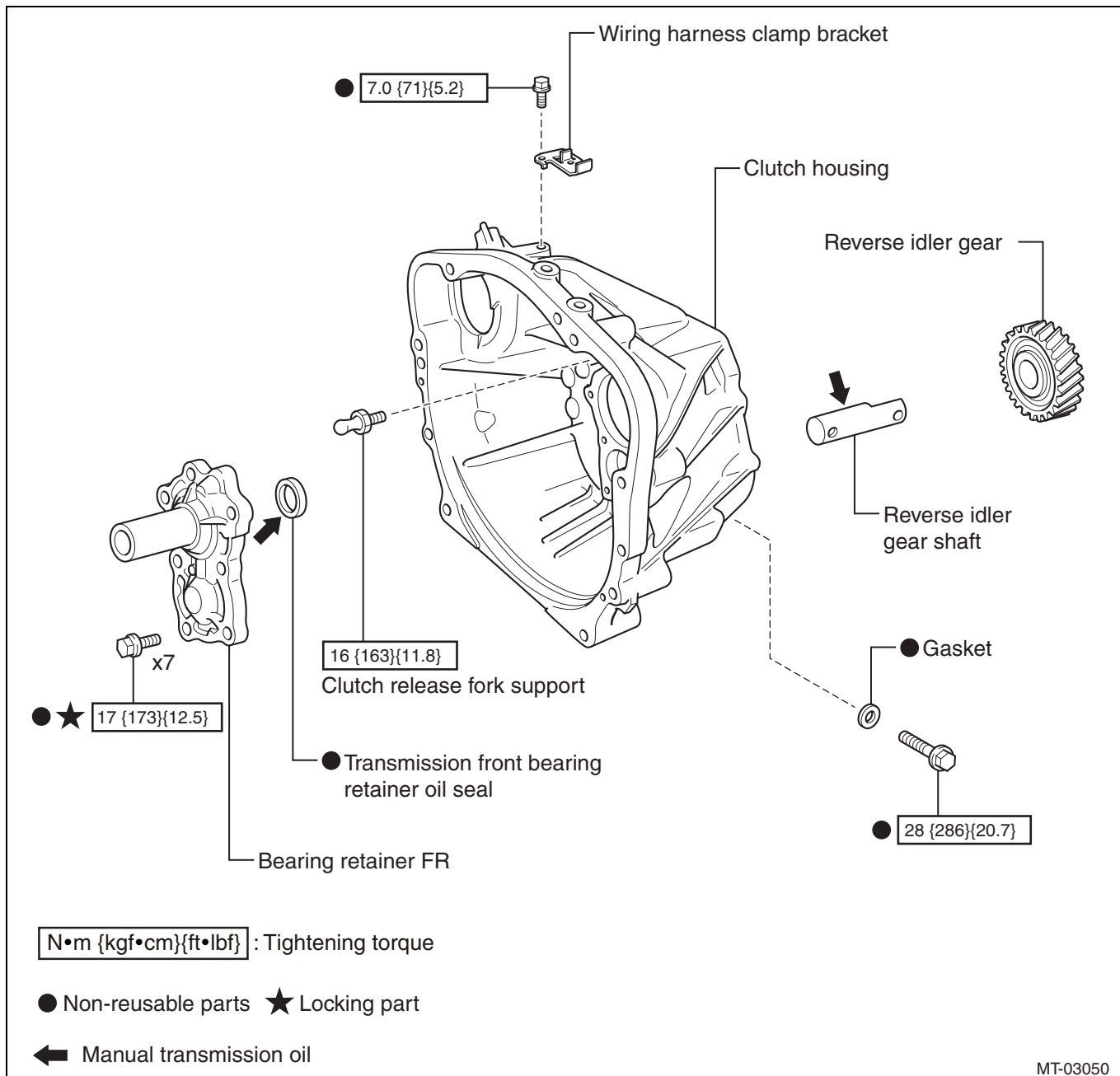

MT-03050

<Reference>

Use recommended or substitute products for manual transmission oil. (Refer to PP-8)

MT

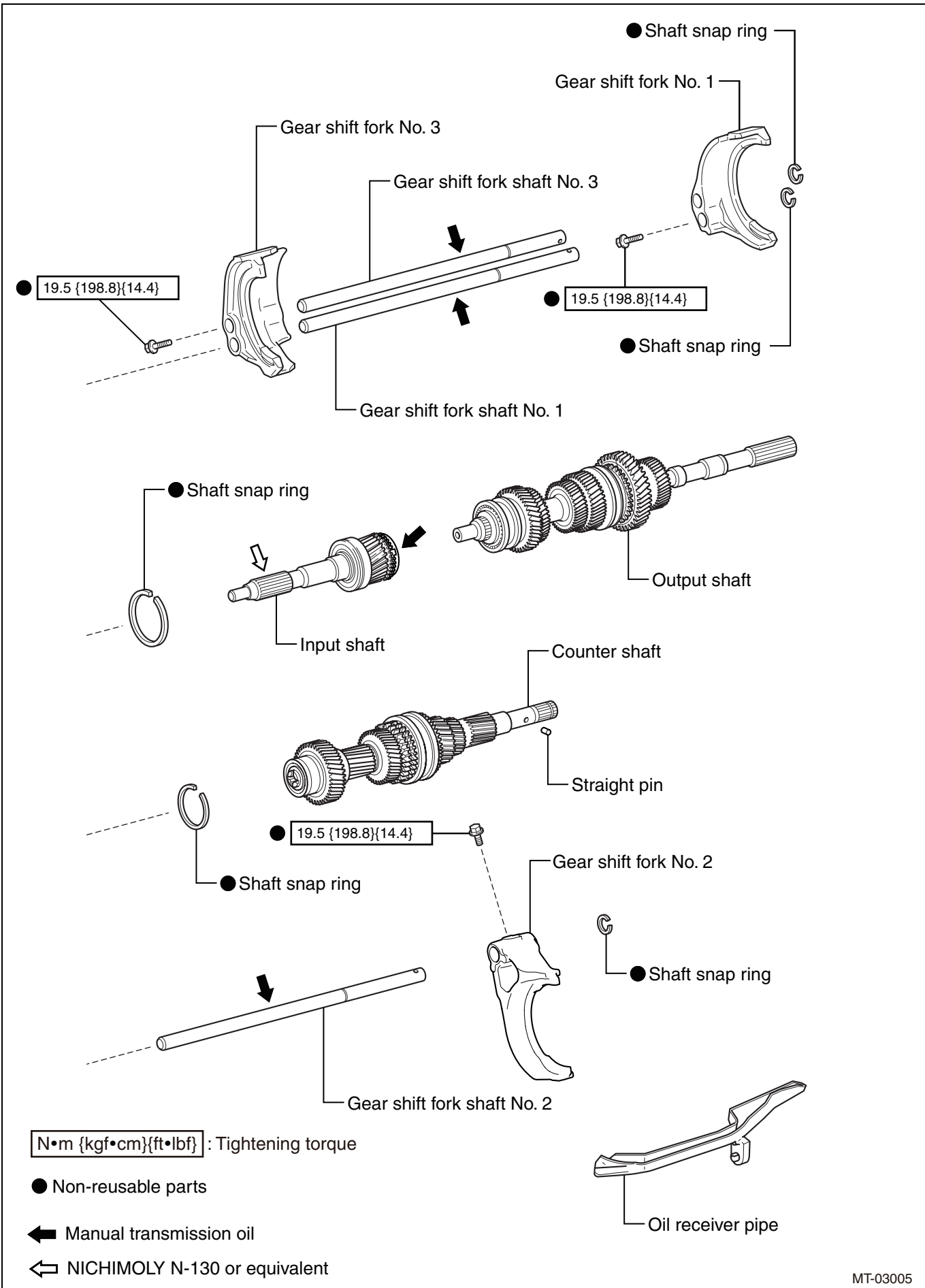

<Reference>

Use recommended or substitute products for manual transmission oil. (Refer to PP-8)

MT

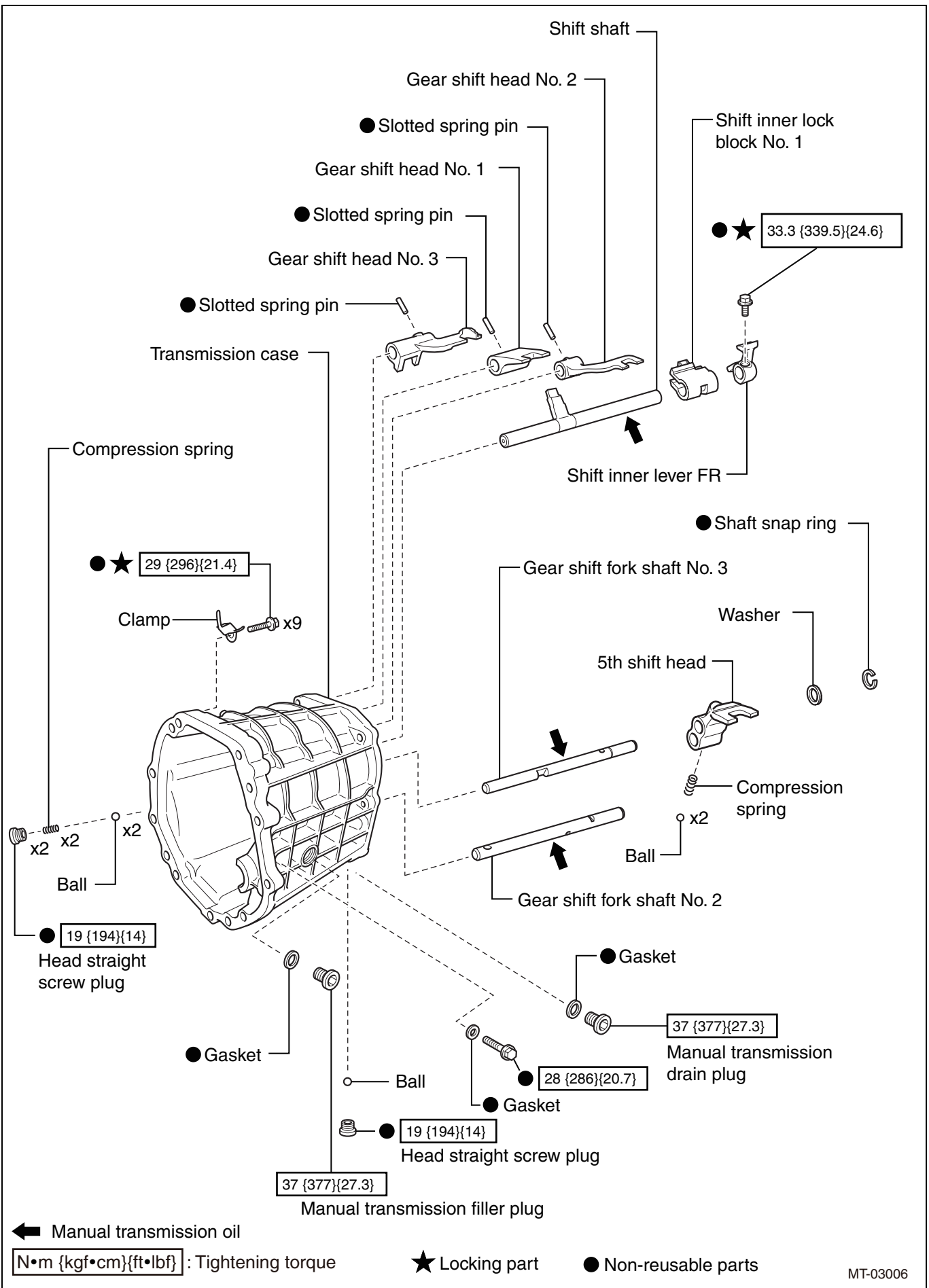

MT

<Reference>

Use recommended or substitute products for manual transmission oil. (Refer to PP-8)

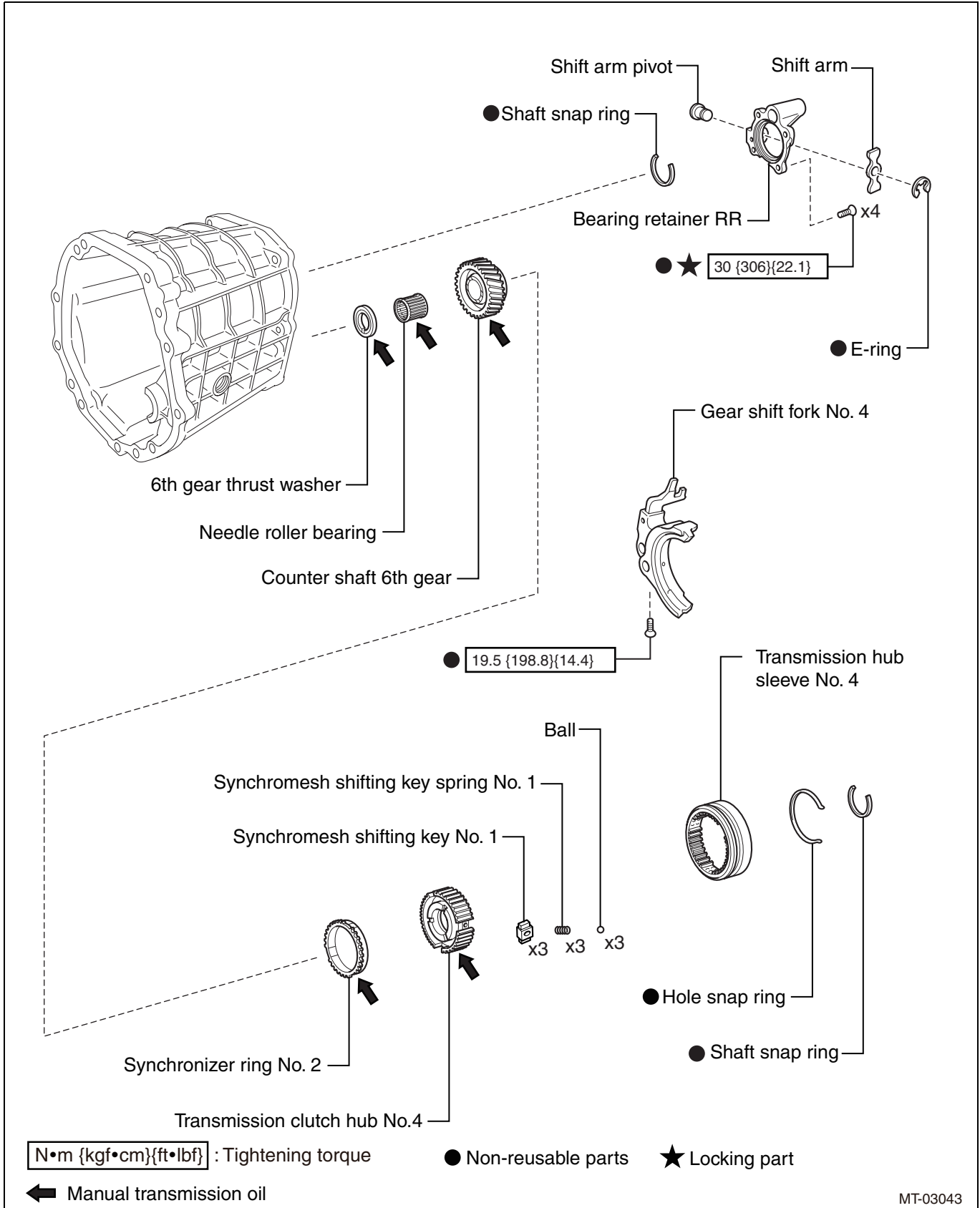

MT-03043

<Reference>

Use recommended or substitute products for manual transmission oil. (Refer to PP-8)

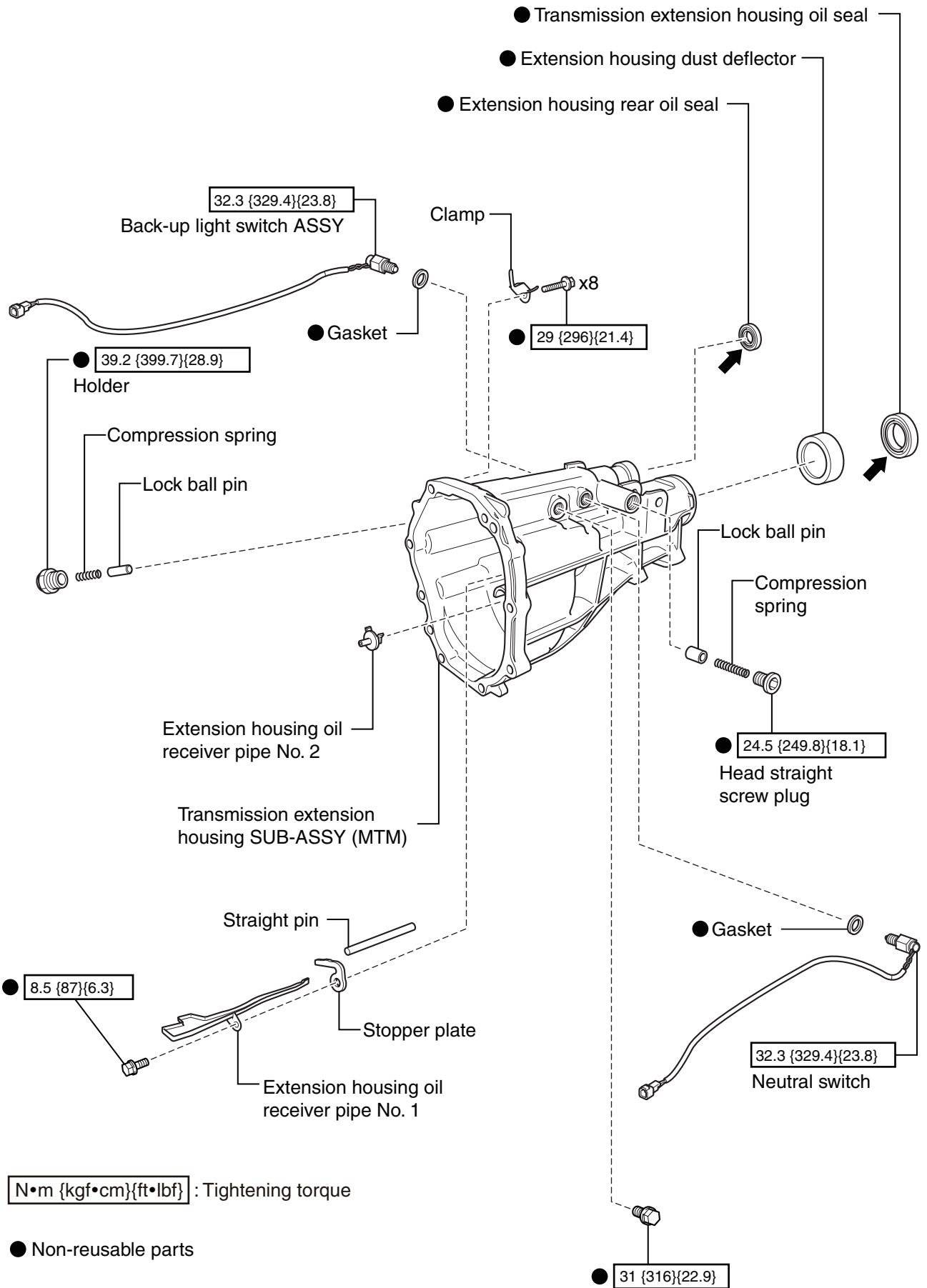

N·m {kgf·cm}{ft·lbf} : Tightening torque

● Non-reusable parts

← Manual transmission oil

<Reference>

Use recommended or substitute products for manual transmission oil. (Refer to PP-8)

DISASSEMBLY

MT

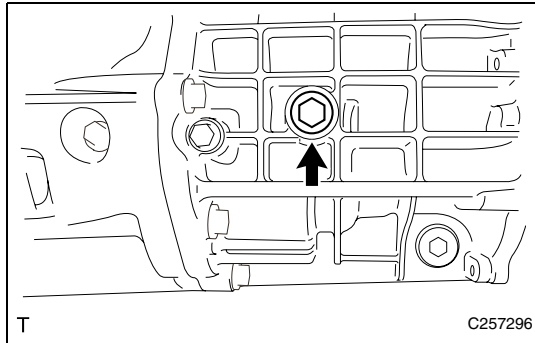

1. Remove the manual transmission filler plug.
 - (1) Remove the manual transmission filler plug and gasket.

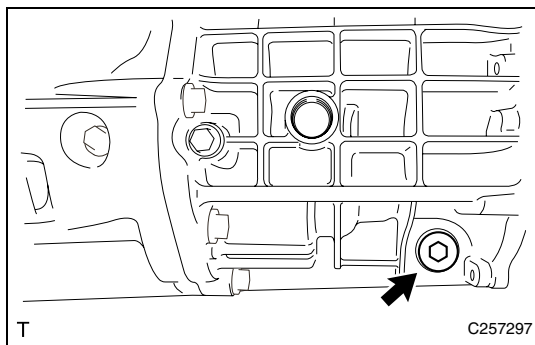

2. Remove the manual transmission drain plug.
 - (1) Remove the manual transmission drain plug and gasket.

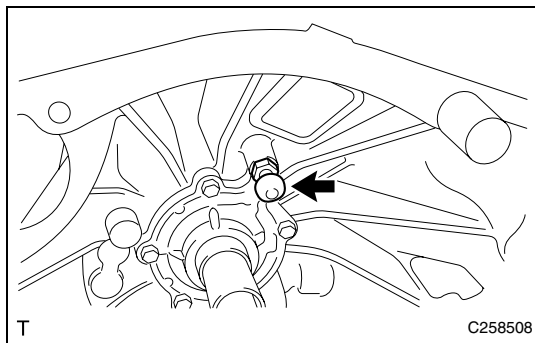

3. Remove the clutch release fork support.
 - (1) Remove the clutch release fork support from the clutch housing.

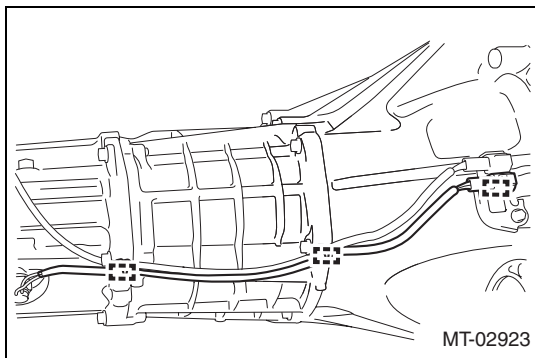

4. Remove the back-up light switch ASSY.
 - (1) Release the engagement of the three clamps.

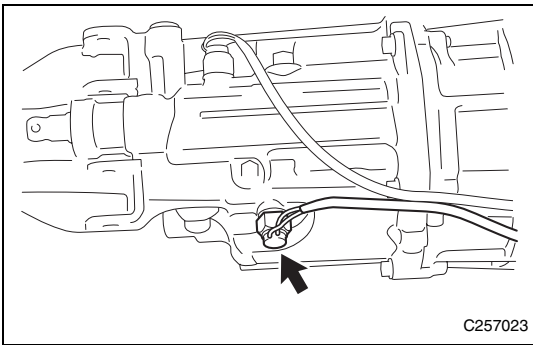

- (2) Remove the back-up light switch ASSY and gasket.

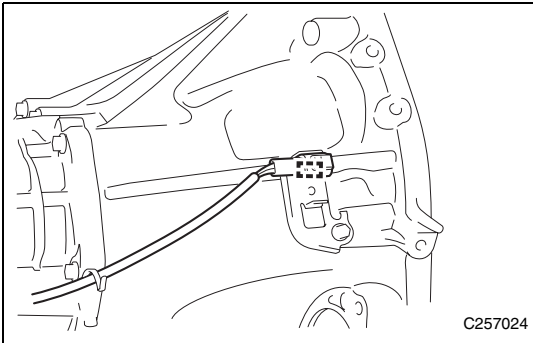

5. Remove the neutral switch.
(1) Release the engagement of the clamp.

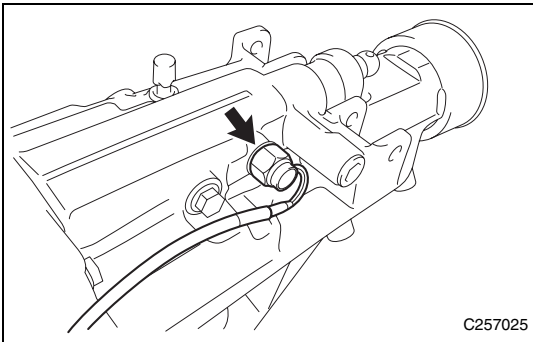

- (2) Remove the neutral switch and gasket.

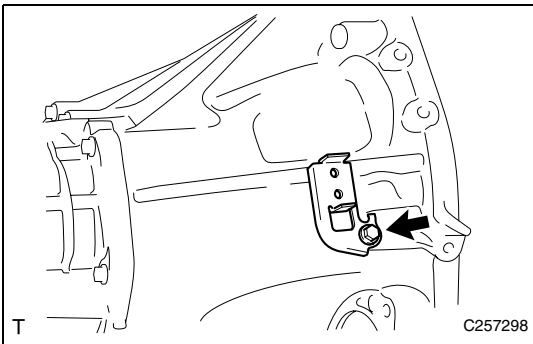

6. Remove the wiring harness clamp bracket.
(1) Remove the bolt, and remove the wiring harness clamp bracket.

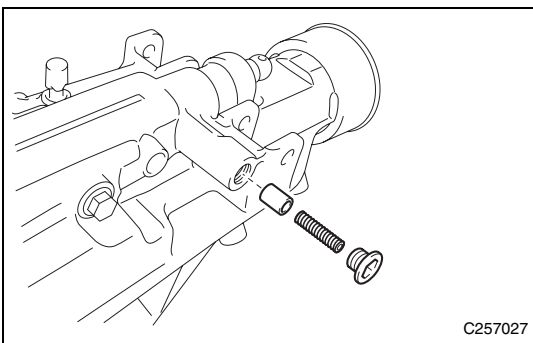

7. Remove the lock ball pin.
(1) Remove the head straight screw plug, compression spring and lock ball pin.

MT

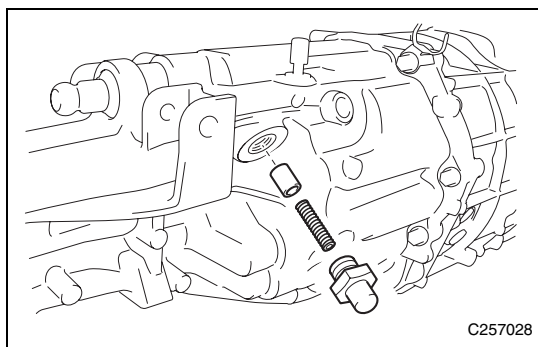

8. Remove the holder.
 - (1) Remove the holder, compression spring and lock ball pin.

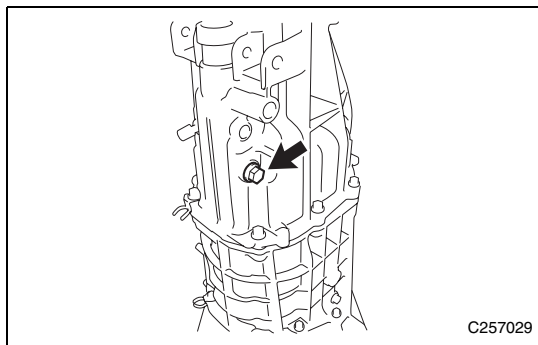

9. Remove the transmission extension housing SUB-ASSY (MTM).
 - (1) Remove the bolt.

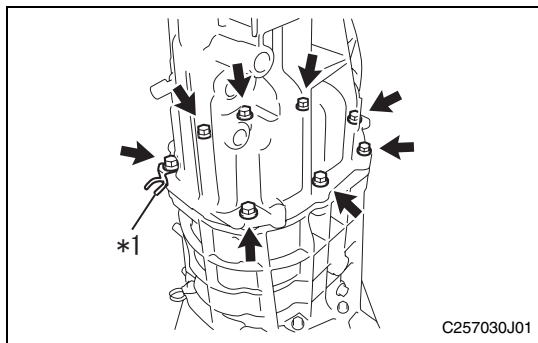

- (2) Remove the eight bolts and clamp.

Captions in illustration

*1	Clamp
----	-------

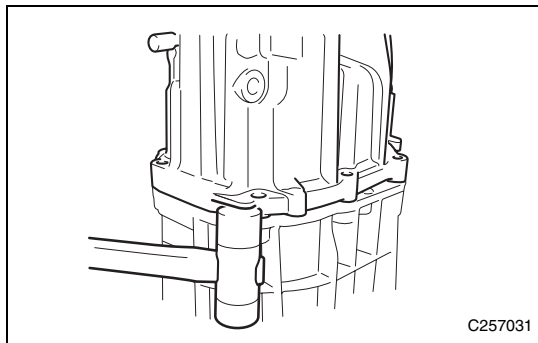

- (3) Remove the transmission extension housing SUB-ASSY (MTM).

<Caution>

 - Be careful not to damage the transmission extension housing SUB-ASSY (MTM).
 - Make sure to remove the transmission extension housing SUB-ASSY (MTM) with the shift position in neutral.

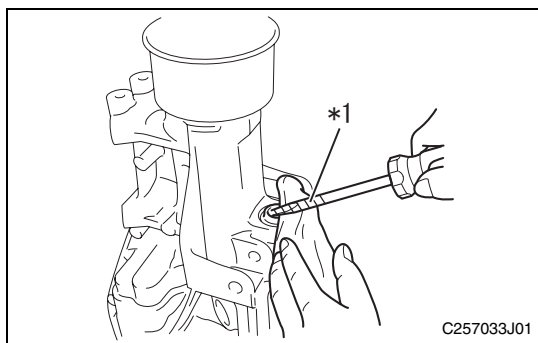

10. Remove the extension housing rear oil seal.
 - (1) Remove the extension housing rear oil seal.

Captions in illustration

*1	Protective tape
----	-----------------

- <Caution>
Be careful not to damage the transmission extension housing SUB-ASSY (MTM).
- <Reference>
When removing the part, apply a cloth to avoid damaging the transmission extension housing SUB-ASSY (MTM).

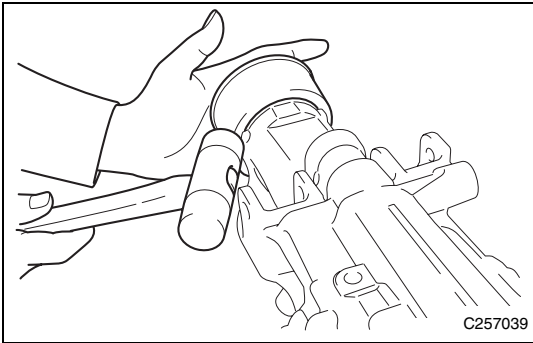

11. Remove the extension housing dust deflector.
 (1) Remove the extension housing dust deflector.

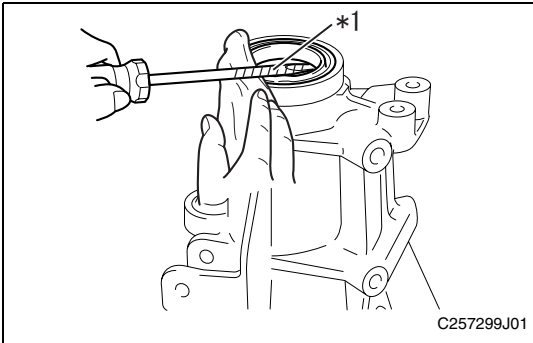

12. Remove the transmission extension housing oil seal.
 (1) Remove the transmission extension housing oil seal.

Captions in illustration

*1	Protective tape
----	-----------------

<Caution>

Be careful not to damage the transmission extension housing SUB-ASSY (MTM).

<Reference>

When removing the part, apply a cloth to avoid damaging the transmission extension housing SUB-ASSY (MTM).

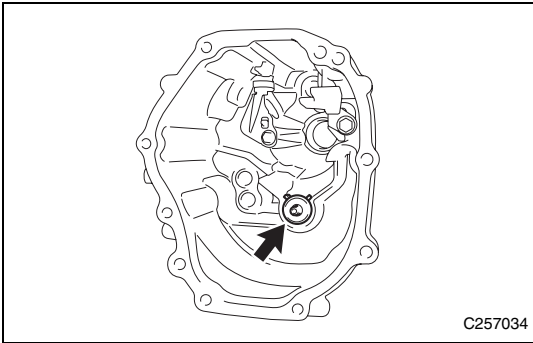

13. Remove the extension housing oil receiver pipe No. 2.
 (1) Remove the extension housing oil receiver pipe No. 2.

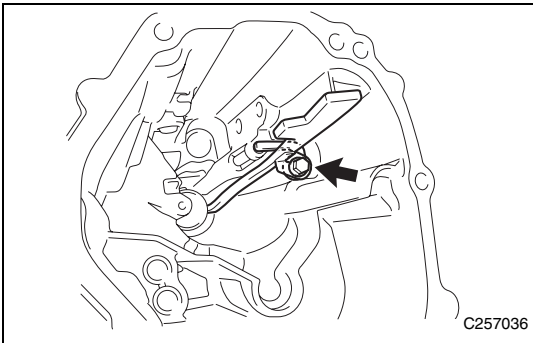

14. Remove the extension housing oil receiver pipe No. 1.
 (1) Remove the bolt, and remove the extension housing oil receiver pipe No. 1 and stopper plate.

MT

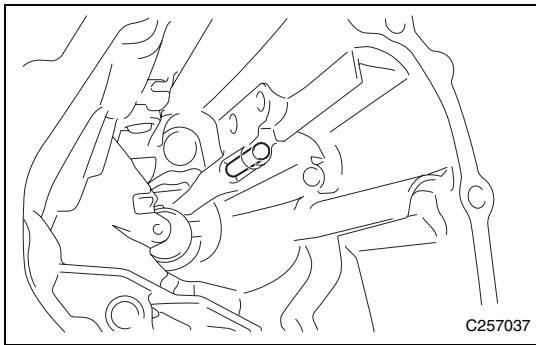

(2) Remove the straight pin.

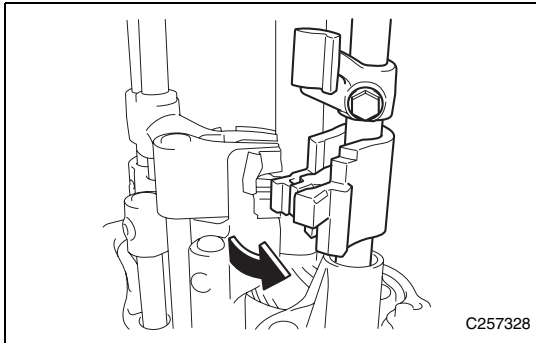

15. Remove the shift shaft.
 (1) Slide the shift shaft and shift inner lock block No. 1 to remove.

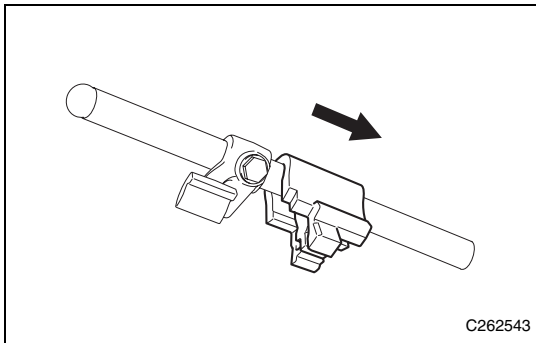

16. Remove the shift inner lock block No. 1.
 (1) Remove the shift inner lock block No. 1 from the shift shaft.

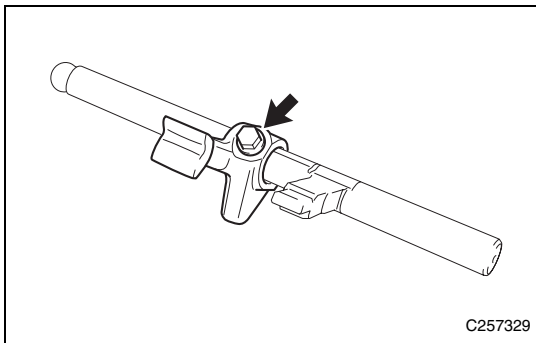

17. Remove the shift inner lever FR.
 (1) Remove the bolt, and remove the shift inner lever FR from the shift shaft.
 <Caution>
 Check the direction of the part.

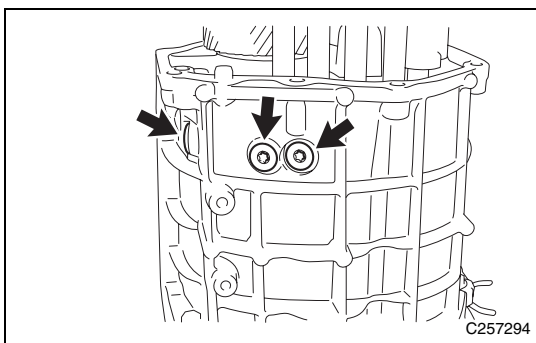

18. Remove the head straight screw plug.
 (1) Remove the three head straight screw plugs.

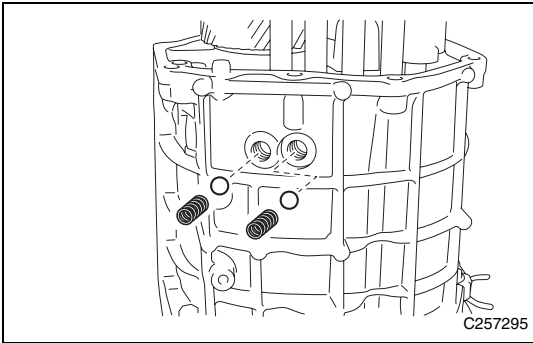

- (2) Remove the two compression springs and two balls.

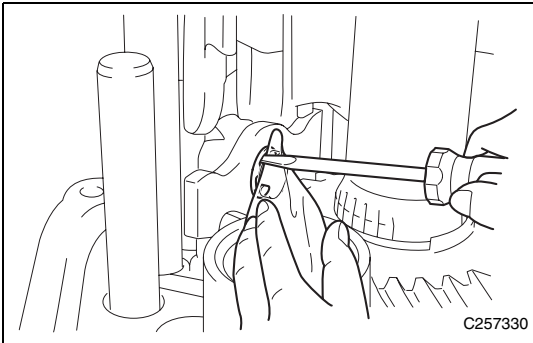

19. Remove the shift arm.

- (1) Remove the E-ring.

<Caution>

Hold with a cloth to prevent the E-ring from flying out.

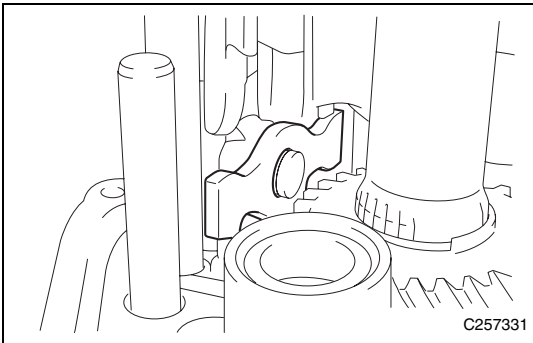

- (2) Remove the shift arm.

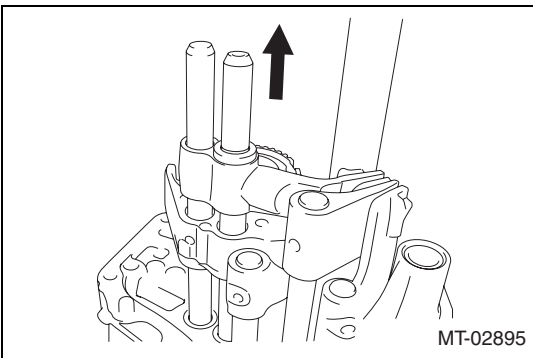

20. Remove the gear shift fork shaft No. 3.

- (1) Remove the gear shift fork shaft No. 3.

<Caution>

- Be careful that the ball may fall off from the 5th shift head portion.
- The ball in the transmission case portion may fall into the transmission case. In this case, remove the ball when the transmission case is detached.

- (2) Remove the ball from the 5th shift head portion.

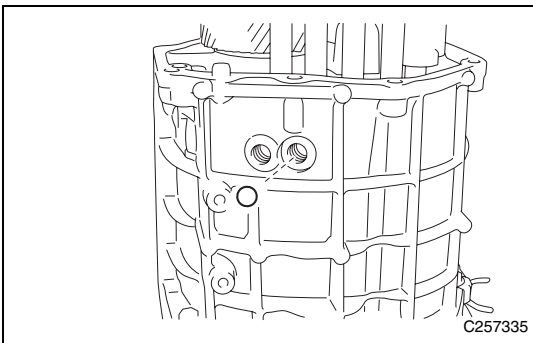

- (3) Remove the ball.

MT

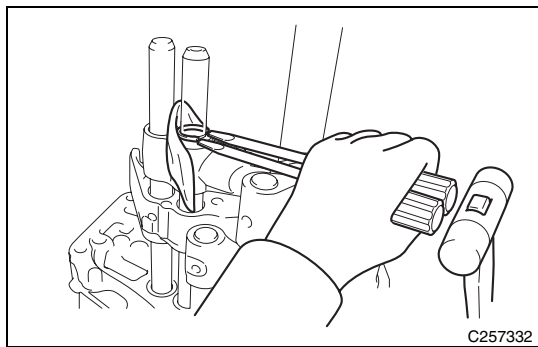

21. Remove the 5th shift head.

(1) Remove the shaft snap ring.

<Caution>

Hold with a cloth to prevent the shaft snap ring from flying out.

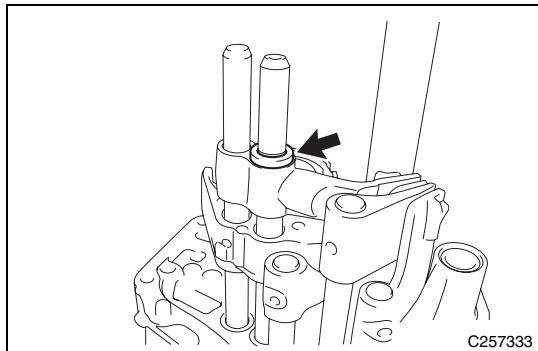

(2) Remove the washer.

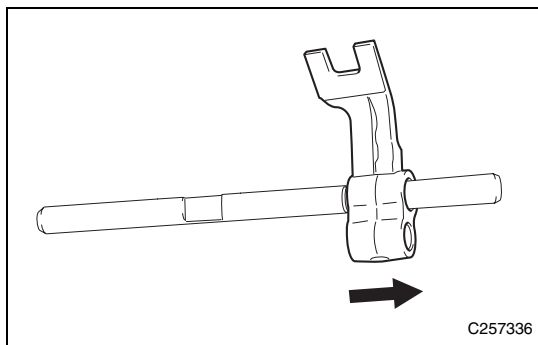

(3) Remove the 5th shift head, and remove the ball and compression spring.

<Caution>

Be careful that sliding the 5th shift head may cause fall of the ball and compression spring.

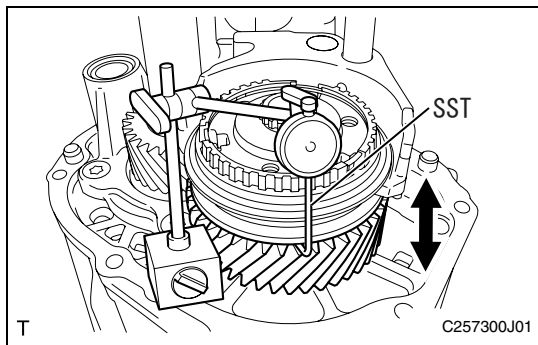

22. Check the counter shaft 6th gear thrust clearance.

(1) Using the SST, check the thrust clearance.

SST 09350-20015 (09350-06120), 498255400

Standard value: 0.10 to 0.40 mm {0.00394 to 0.0157 in}

Limit: 0.40 mm {0.0157 in}

<Reference>

When the result exceeds the limit, replace the counter shaft 6th gear, transmission clutch hub No. 4, 6th gear thrust washer, needle roller bearing, and counter shaft.

T

C257300J01

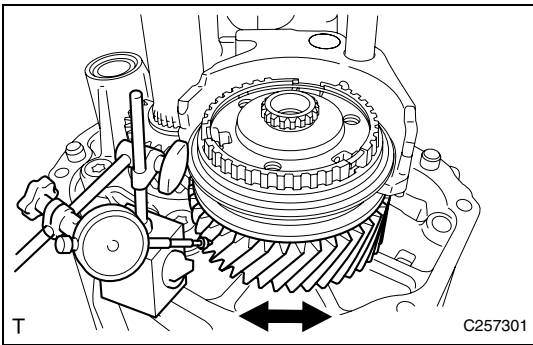

23. Check the counter shaft 6th gear radial clearance.

(1) Check the radial clearance.

Standard value: 0.015 to 0.068 mm {0.000590 to 0.00268 in}

Limit: 0.068 mm {0.00268 in}

<Reference>

When the result exceeds the limit, replace the counter shaft 6th gear, needle roller bearing, and counter shaft.

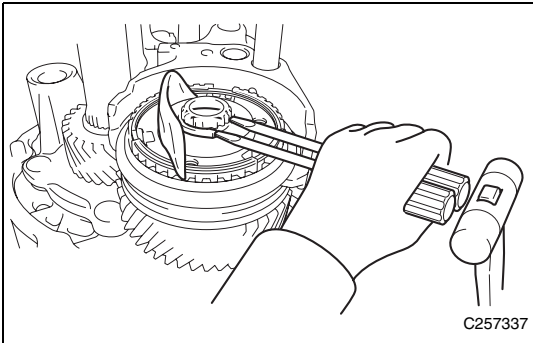

24. Remove the transmission clutch hub No. 4.

(1) Remove the shaft snap ring.

<Caution>

Hold with a cloth to prevent the shaft snap ring from flying out.

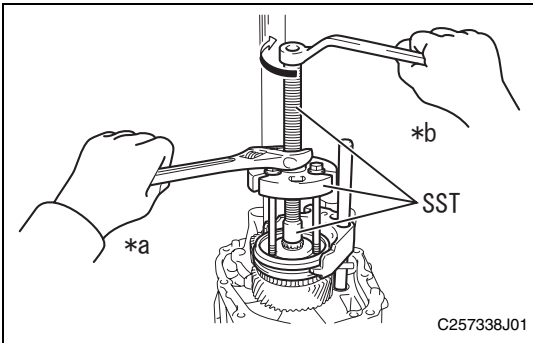

(2) Using the SST, remove the transmission clutch hub No. 4 with the transmission hub sleeve No. 4, gear shift fork No. 4 and gear shift fork shaft No. 2 as a unit.

Captions in illustration

*a	Hold
*b	Rotate

SST 09950-30012 (09951-03010, 09953-03010, 09956-03010)

<Caution>

Check the direction of the part.

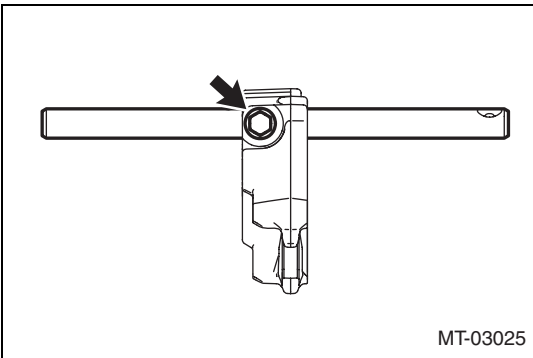

25. Remove the gear shift fork No. 4.

(1) Remove a bolt, and remove the gear shift fork No.4 from the gear shift fork shaft No.2.

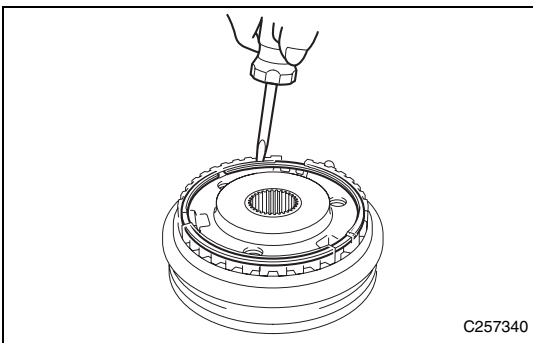

26. Remove the transmission hub sleeve No. 4.

(1) Remove the hole snap ring.

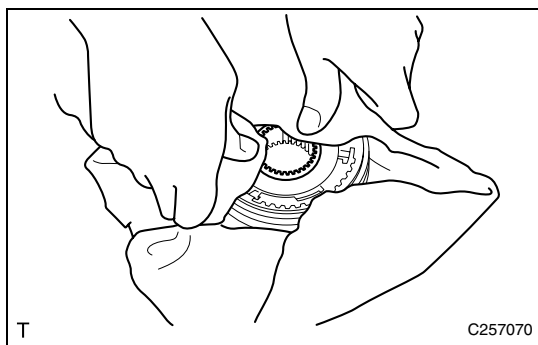

- (2) Remove the transmission hub sleeve No. 4, and remove the three synchronesh shifting key No. 1s, three synchronesh shifting key spring No. 1s, and three balls from the transmission clutch hub No. 4.

<Caution>

- Use a cloth to prevent the synchronesh shifting key No. 1s, synchronesh shifting key spring No. 1s, and balls from flying out.
- Do not deform the synchronesh shifting key spring No. 1s.
- Check the direction of the part.

<Reference>

Perform the procedure without moving the positions of the transmission clutch hub No. 4 and synchronesh shifting key No. 1s.

27. Remove the synchronizer ring No. 2.

- (1) Remove the synchronizer ring No. 2.

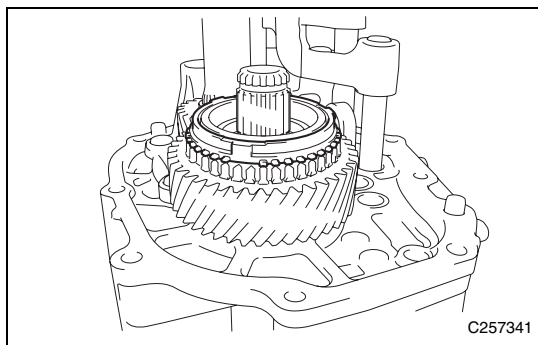

28. Remove the counter shaft 6th gear.

- (1) Remove the counter shaft 6th gear.

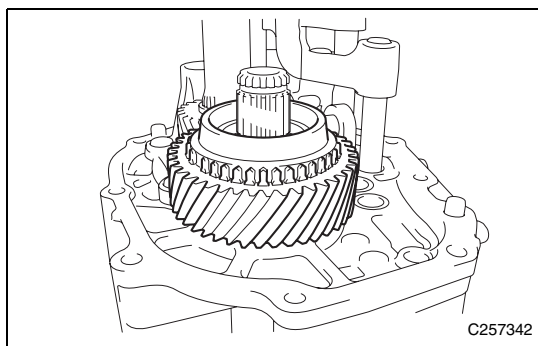

29. Remove the needle roller bearing.

- (1) Remove the needle roller bearing.

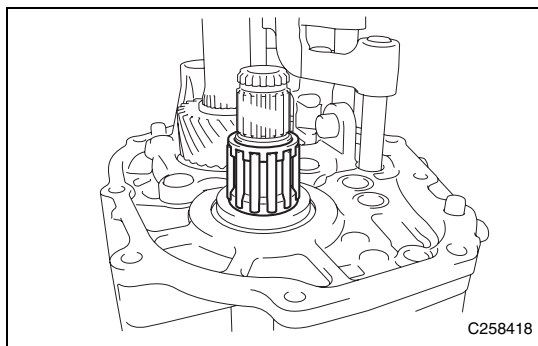

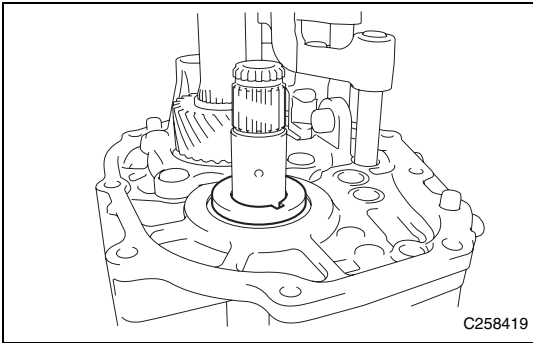

30. Remove the 6th gear thrust washer.
- (1) Remove the 6th gear thrust washer.
- <Caution>
Check the direction of the part.

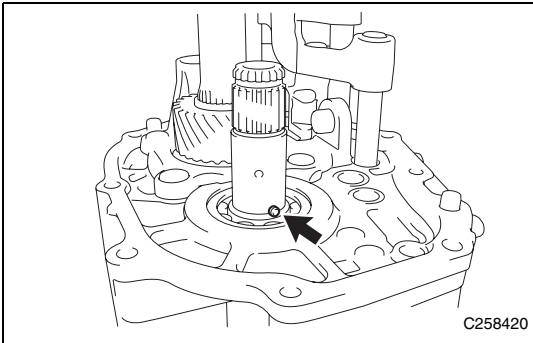

- (2) Remove the straight pin.

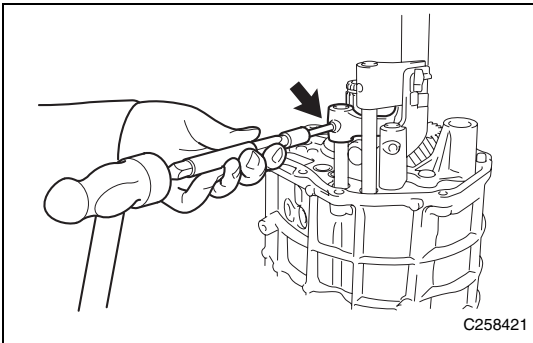

31. Remove the gear shift head No. 2.
- (1) Remove the slotted spring pin.
 - (2) Remove the gear shift head No. 2 from the gear shift fork shaft No. 2.
- <Caution>
- Hold with a cloth to prevent the slotted spring pin from flying out.
 - Be careful not to let the slotted spring pin fall inside from the fork shaft hole.
 - Check the direction of the part.

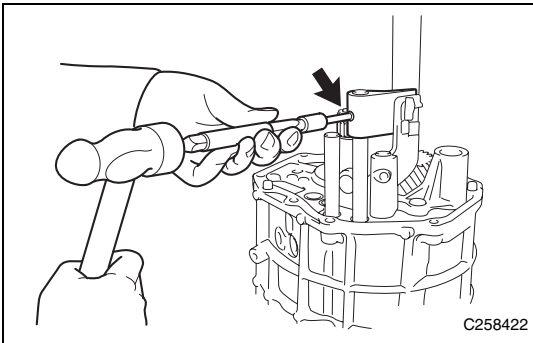

32. Remove the gear shift head No. 1.
- (1) Remove the slotted spring pin.
 - (2) Remove the gear shift head No. 1 from the gear shift fork shaft No. 1.

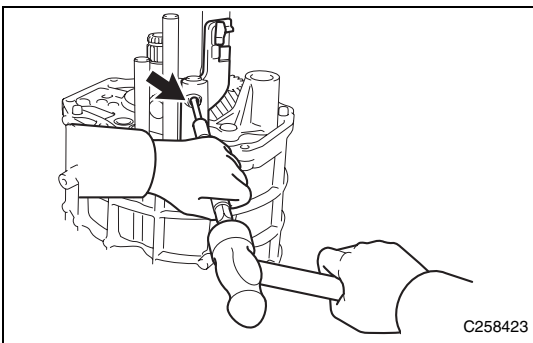

33. Remove the gear shift head No. 3.
- (1) Remove the slotted spring pin.
 - (2) Remove the gear shift head No. 3 from the gear shift fork shaft No. 3.

MT

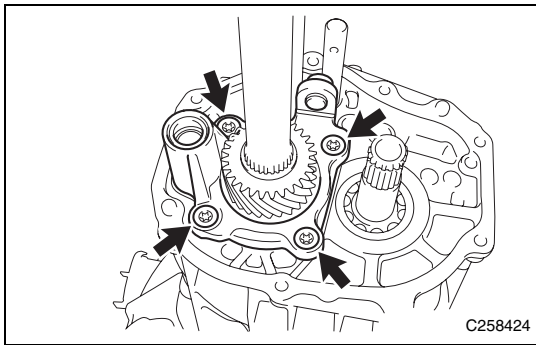

34. Remove the bearing retainer RR.
 (1) Remove the four TORX bolts, and remove the bearing retainer RR.

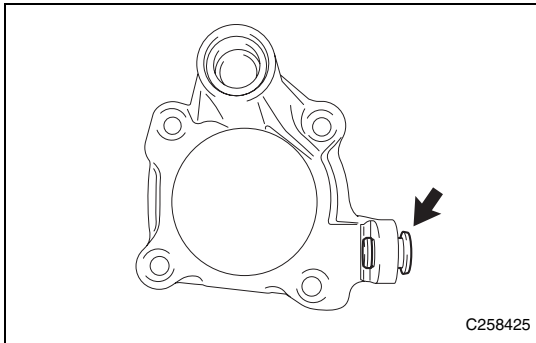

- (2) Remove the shift arm pivot.

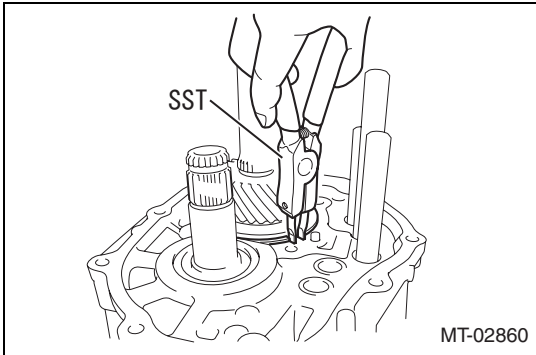

35. Remove the transmission case.
 (1) Using the SST, remove the shaft snap ring.
 SST 499895400

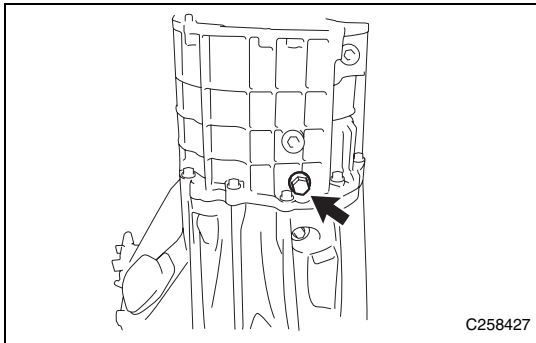

- (2) Remove the reverse idler gear shaft mounting bolt and gasket.
 (The transmission case side)

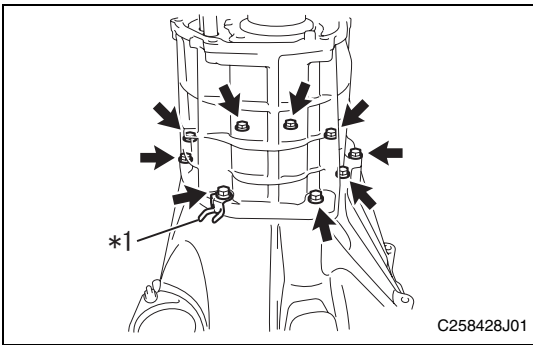

(3) Remove the nine bolts and clamp.

Captions in illustration

*1	Clamp
----	-------

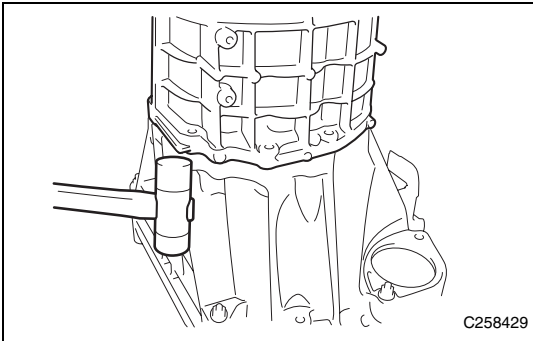

(4) Remove the transmission case.

<Caution>

Be careful not to damage the transmission case.

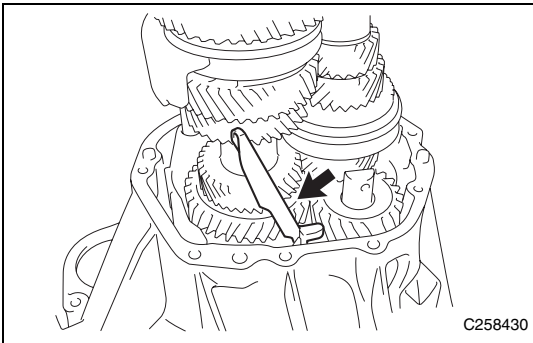

36. Remove the oil receiver pipe.

(1) Remove the oil receiver pipe.

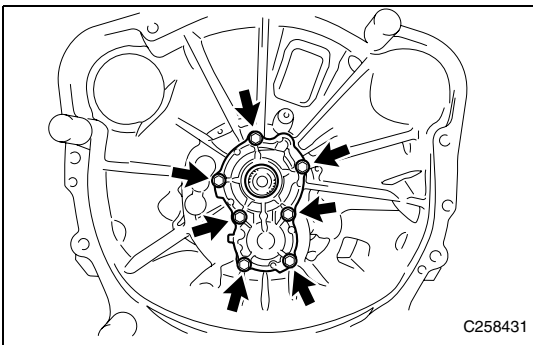

37. Remove the bearing retainer FR.

(1) Remove the seven bolts, and remove the bearing retainer FR.

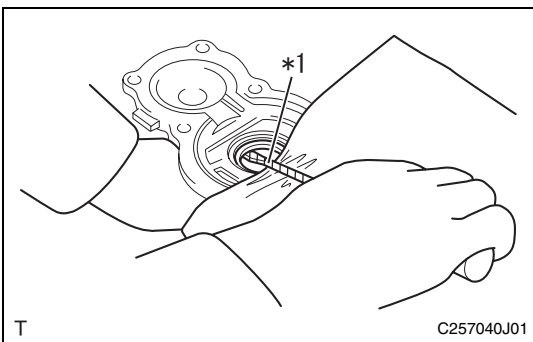

38. Remove the transmission front bearing retainer oil seal.

(1) Remove the transmission front bearing retainer oil seal.

Captions in illustration

*1	Protective tape
----	-----------------

<Caution>

Be careful not to damage the bearing retainer FR.

<Reference>

When removing the part, apply a cloth to avoid damaging the bearing retainer FR.

MT

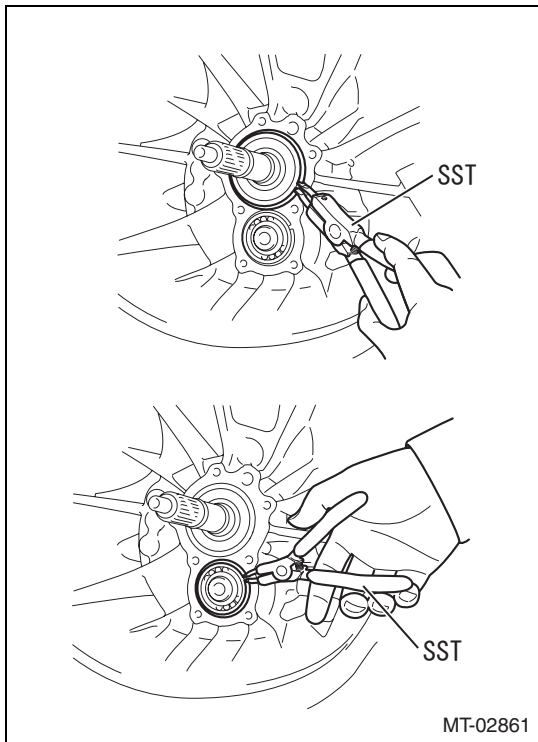

39. Remove the counter shaft.

(1) Using the SST, remove the two shaft snap rings.

SST 499895400

<Reference>

Remove the shaft snap rings on the input shaft side and counter shaft side both.

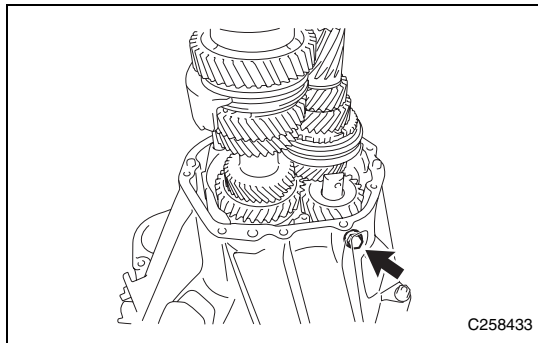

(2) Remove the bolt and gasket to free the reverse idler gear and reverse idler gear shaft. (The clutch housing side)

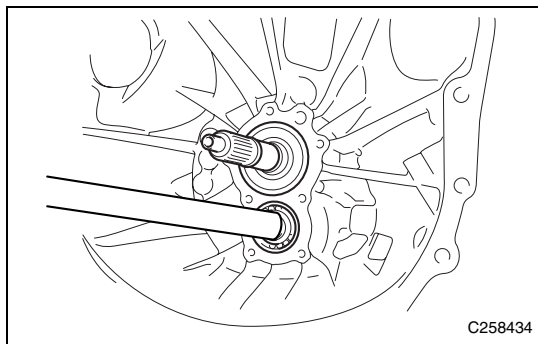

(3) While tapping with a hammer handle from the clutch housing side, remove the input shaft, output shaft, counter shaft, reverse idler gear, reverse idler gear shaft, gear shift fork shaft No. 1, gear shift fork shaft No. 2, and gear shift fork shaft No. 3 as a unit.

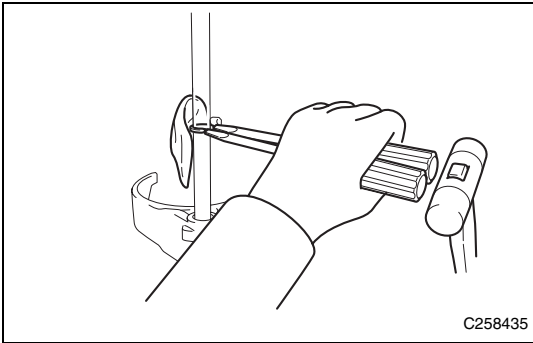

40. Remove the gear shift fork shaft No. 2.

(1) Remove the shaft snap ring.

<Caution>

Hold with a cloth to prevent the shaft snap ring from flying out.

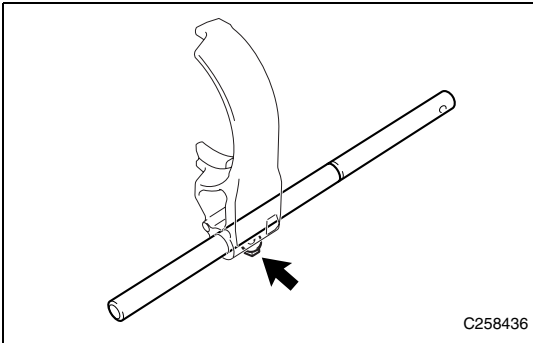

(2) Remove the bolt, and remove the gear shift fork shaft No. 2.

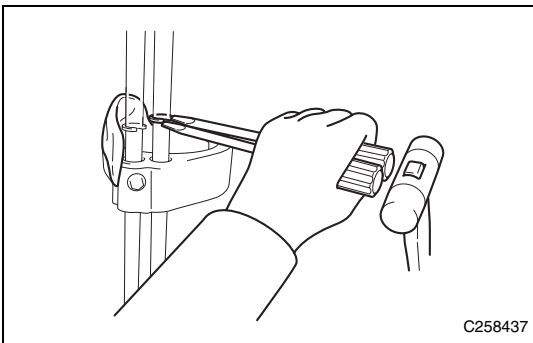

41. Remove the gear shift fork shaft No. 1.

(1) Remove the shaft snap ring.

<Caution>

Hold with a cloth to prevent the shaft snap ring from flying out.

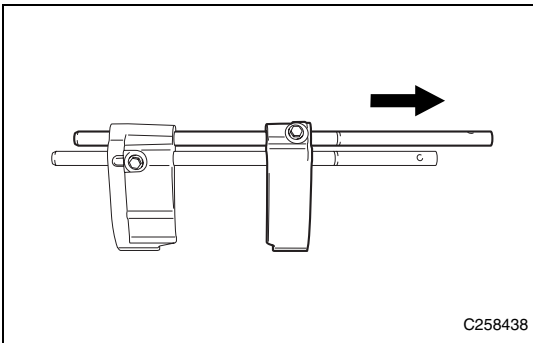

(2) Remove the gear shift fork shaft No. 1 and gear shift fork No. 1 as a unit.

MT

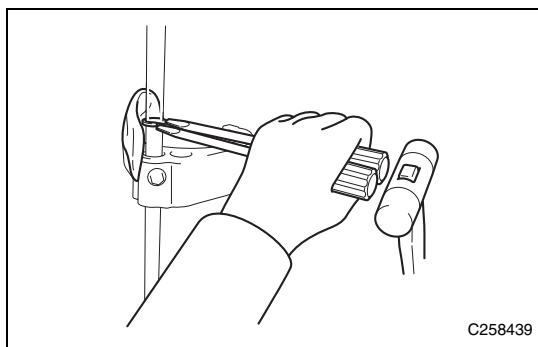

- (3) Remove the shaft snap ring.
<Caution>
Hold with a cloth to prevent the shaft snap ring from flying out.

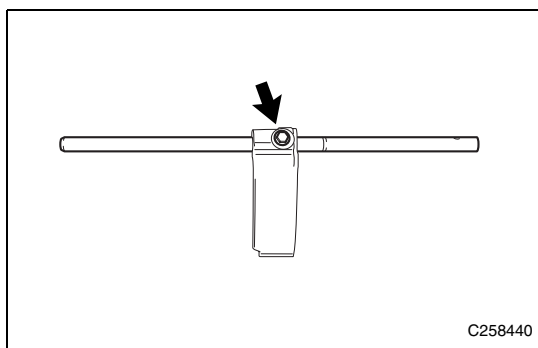

- (4) Remove the bolt, and remove the gear shift fork shaft No. 1.

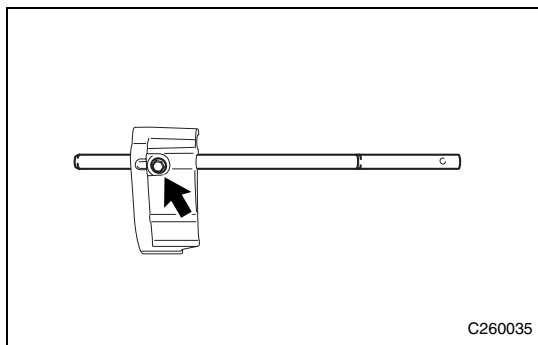

- 42. Remove the gear shift fork shaft No. 3.
(1) Remove the bolt, and remove the gear shift fork shaft No. 3.

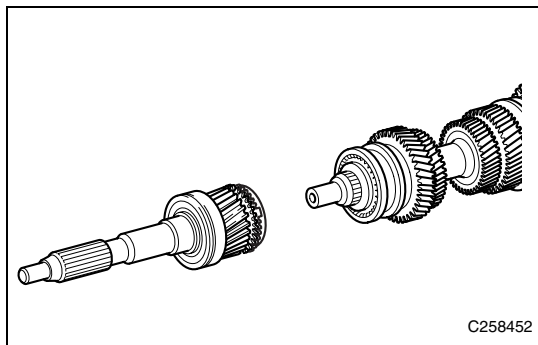

- 43. Remove the input shaft.
(1) Remove the input shaft from the output shaft.

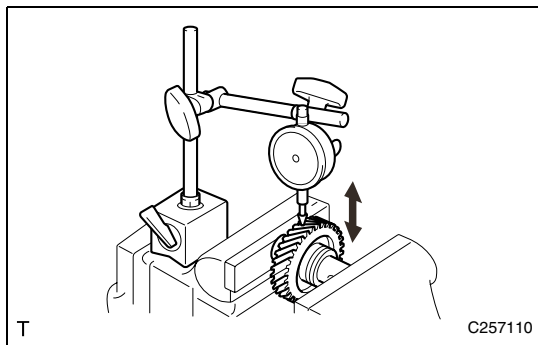

- 44. Check the reverse idler gear radial clearance.
(1) Fix the reverse idler gear shaft on a vise, and then check the radial clearance.
Standard value: 0.040 to 0.082 mm {0.00157 to 0.00323 in}
Limit: 0.082 mm {0.00323 in}
<Reference>
When the result exceeds the limit, replace the reverse idler gear and reverse idler gear shaft.

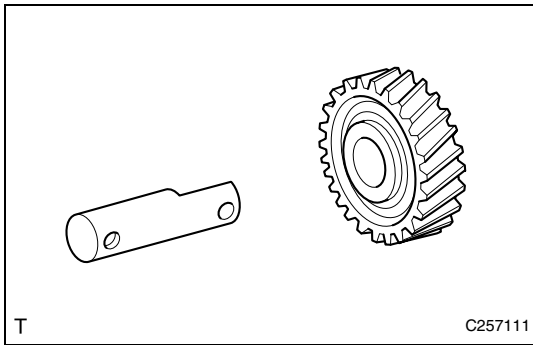

45. Remove the reverse idler gear shaft.

- (1) Remove the reverse idler gear shaft from the reverse idler gear.

INSPECTION

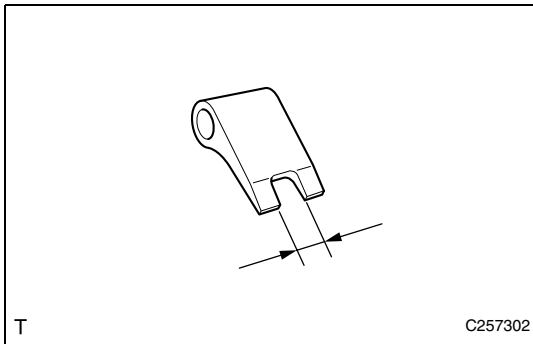

1. Check the gear shift head No. 1.

- (1) Measure the groove of the gear shift head No. 1.

Standard value: 15.2 to 15.4 mm {0.59843 to 0.60630 in}

Limit: 15.4 mm {0.60630 in}

<Reference>

When the result exceeds the limit, replace the gear shift head No. 1.

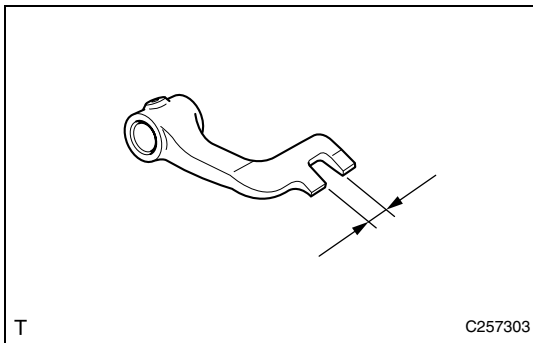

2. Check the gear shift head No. 2.

- (1) Measure the groove of the gear shift head No. 2.

Standard value: 15.2 to 15.4 mm {0.59843 to 0.60630 in}

Limit: 15.4 mm {0.60630 in}

<Reference>

When the result exceeds the limit, replace the gear shift head No. 2.

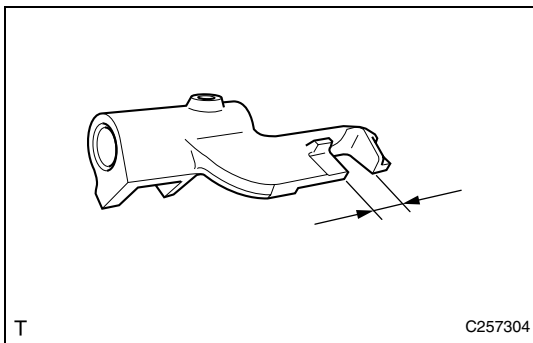

3. Check the gear shift head No. 3.

- (1) Measure the groove of the gear shift head No. 3.

Standard value: 15.2 to 15.4 mm {0.59843 to 0.60630 in}

Limit: 15.4 mm {0.60630 in}

<Reference>

When the result exceeds the limit, replace the gear shift head No. 3.

MT

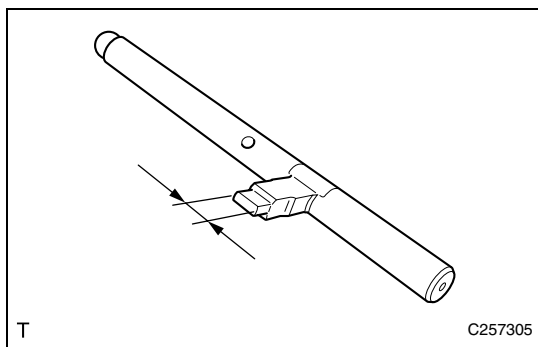

4. Check the shift shaft.
 - (1) Measure the thickness of the claw of shift shaft.

Standard value:	14.8 to 15.0 mm {0.583 to 0.591 in}
Limit:	14.8 mm {0.583 in}

<Reference>
When the result is below the limit, replace the shift shaft.

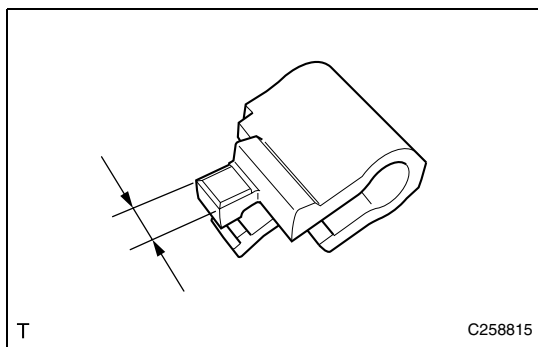

5. Check the shift inner lock block No. 1.
 - (1) Measure the thickness of the claw of shift inner lock block No. 1.

Standard value:	14.8 to 15.0 mm {0.583 to 0.591 in}
Limit:	14.8 mm {0.583 in}

<Reference>
When the result is below the limit, replace the shift inner lock block No. 1.

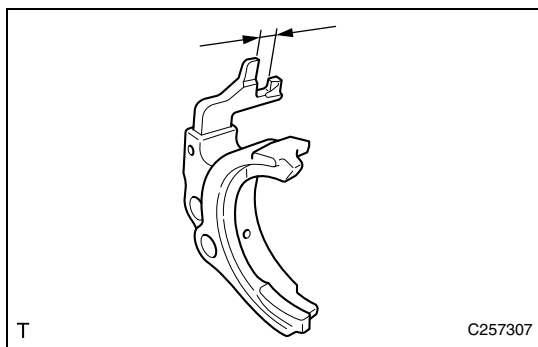

6. Check the gear shift fork No. 4.
 - (1) Measure the groove of the gear shift fork No. 4.

Standard value:	15.2 to 15.4 mm {0.59843 to 0.60630 in}
Limit:	15.4 mm {0.60630 in}

<Reference>
When the result exceeds the limit, replace the gear shift fork No. 4.

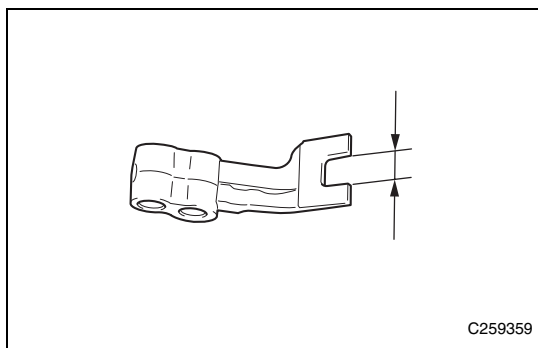

7. Check the 5th shift head.
 - (1) Measure the groove of the 5th shift head.

Standard value:	15.2 to 15.4 mm {0.59843 to 0.60630 in}
Limit:	15.4 mm {0.60630 in}

<Reference>
When the result exceeds the limit, replace the 5th shift head.

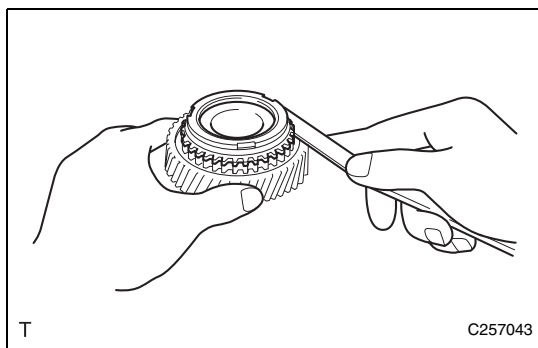

8. Check the synchronizer ring No. 2.
 - (1) Apply manual transmission oil to the taper cone portion of the counter shaft 6th gear, and with the synchronizer ring No. 2 tightly fit by pressing by hand, check the clearance between the synchronizer ring No. 2 and counter shaft 6th gear.

Standard value:	0.88 to 1.52 mm {0.0346 to 0.0598 in}
Limit:	0.88 mm {0.0346 in}

<Caution>
Check for the entire circumference of the gear.

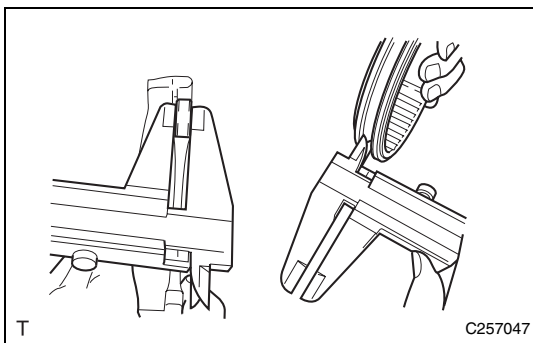
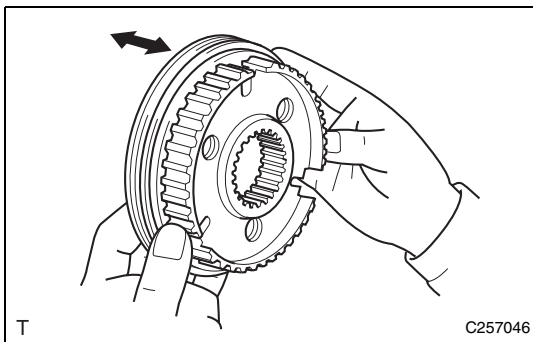
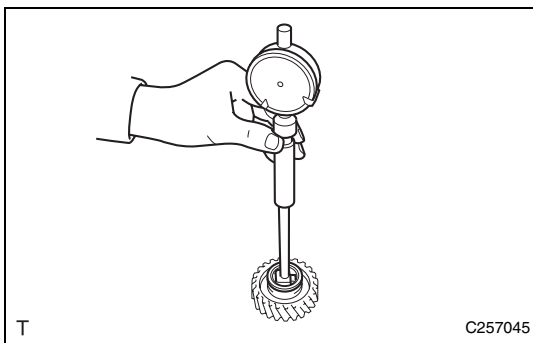
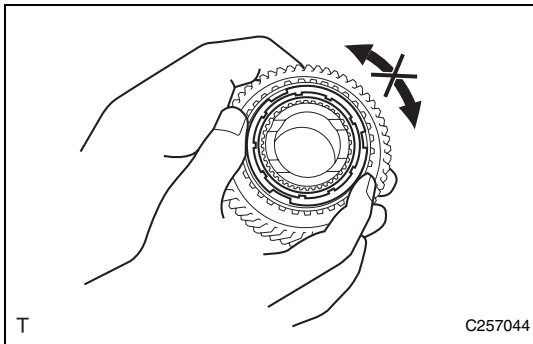

<Reference>

- When the result is below the limit, replace the synchronizer ring No. 2 and counter shaft 6th gear.
- Use recommended or substitute products for manual transmission oil. (Refer to PP-8)

- (2) Apply manual transmission oil to the taper cone portion of the counter shaft 6th gear, and with the synchronizer ring No. 2 tightly fit by pressing by hand, check there is no slippage in the circumferential direction.

<Reference>

- When slippage occurs, replace the synchronizer ring No. 2 and counter shaft 6th gear.
- Use recommended or substitute products for manual transmission oil. (Refer to PP-8)

9. Check the counter shaft 6th gear.

- (1) Measure the inner diameter of counter shaft 6th gear.

Standard value: 34.015 to 34.040 mm {1.33917 to 1.34016 in}

Limit: 34.040 mm {1.34016 in}

<Reference>

When the result exceeds the limit, replace the counter shaft 6th gear.

10. Check the transmission hub sleeve No. 4.

- (1) Check the spline gear edge of the transmission hub sleeve No. 4 for wear.

<Reference>

When wear is present, replace the transmission hub sleeve No. 4.

- (2) Install the transmission hub sleeve No. 4 to the transmission clutch hub No. 4, and check for smooth sliding.

<Reference>

When sliding is not smooth, replace the transmission hub sleeve No. 4 and transmission clutch hub No. 4.

11. Check the transmission hub sleeve No. 4 clearance.

- (1) Measure the thickness of the claw of gear shift fork No. 4.

Standard value: 7.9 to 8.0 mm {0.311 to 0.315 in}

Limit: 7.9 mm {0.311 in}

<Reference>

When the result is below the limit, replace the gear shift fork No. 4.

- (2) Measure the groove of transmission hub sleeve No. 4, and calculate the clearance between the gear shift fork No. 4.

Standard value: 0.15 to 0.35 mm {0.00590 to 0.0138 in}

Limit: 0.35 mm {0.0138 in}

<Reference>

When the result exceeds the limit, replace the gear shift fork No. 4 and transmission hub sleeve No. 4 as a set.

MT

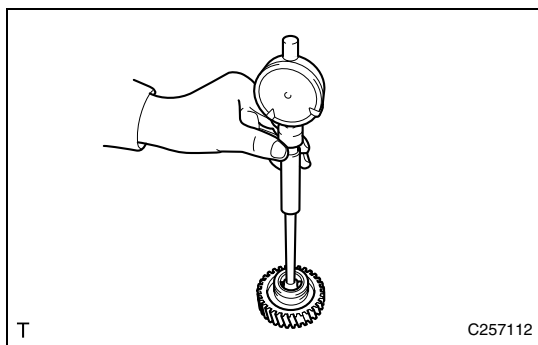

12. Check the reverse idler gear.

- (1) Measure the inner diameter of reverse idler gear.
 Standard value: 22.04 to 22.061 mm {0.86771 to 0.86854 in}
 Limit: 22.061 mm {0.86854 in}
 <Reference>
 When the result exceeds the limit, replace the reverse idler gear.

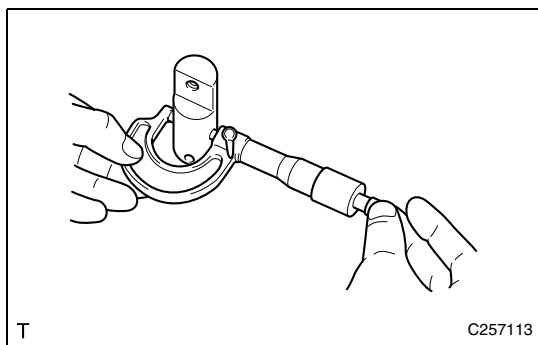

13. Check the reverse idler gear shaft.

- (1) Check the outer diameter of reverse idler gear shaft.
 Standard value: 21.979 to 22.000 mm {0.86531 to 0.86614 in}
 Limit: 21.979 mm {0.86531 in}
 <Reference>
 When the result is below the limit, replace the reverse idler gear shaft.

ASSEMBLY

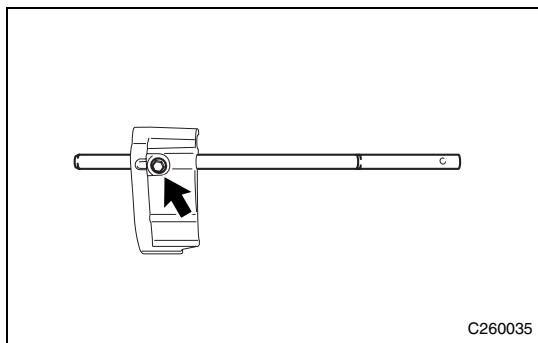

1. Install the gear shift fork shaft No. 3.

- (1) Install the gear shift fork shaft No. 3 to the gear shift fork No. 3, using a new bolt.
 Standard value: $T=19.5N\cdot m$ {198.8kgf·cm} {14.4ft·lbf}

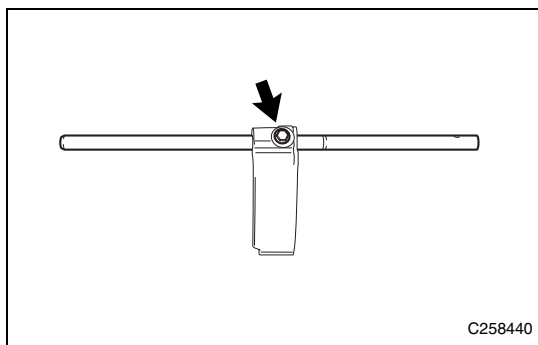

2. Install the gear shift fork shaft No. 1.

- (1) Install the gear shift fork shaft No. 1 to the gear shift fork No. 1, using a new bolt.
 Standard value: $T=19.5N\cdot m$ {198.8kgf·cm} {14.4ft·lbf}

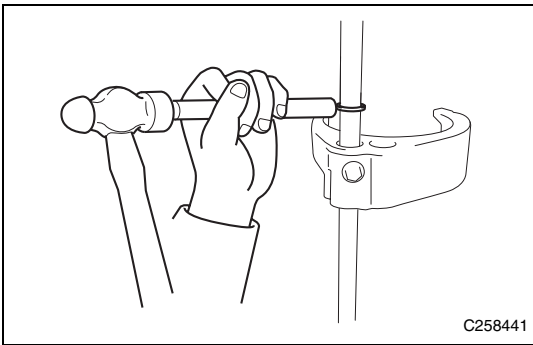

(2) Install a new shaft snap ring.

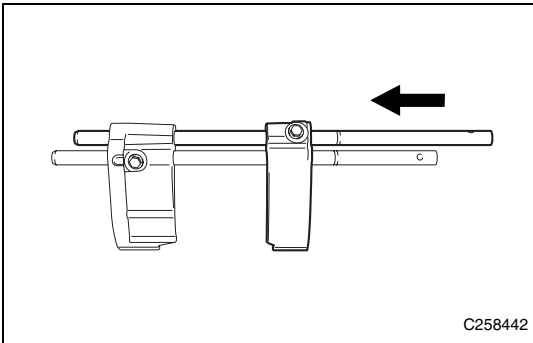

(3) Install the gear shift fork shaft No. 1 and gear shift fork No. 1 as a unit to the gear shift fork shaft No. 3 and gear shift fork No. 3.

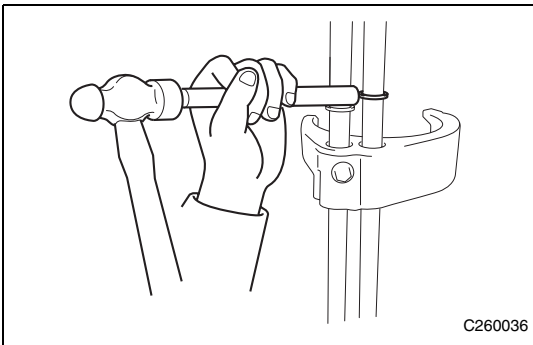

(4) Install a new shaft snap ring.

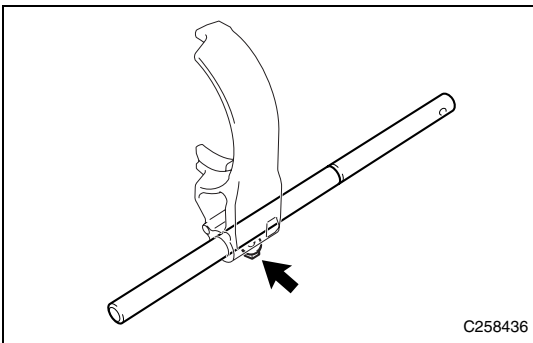

3. Install the gear shift fork shaft No. 2.

(1) Install the gear shift fork shaft No. 2 to the gear shift fork No. 2, using a new bolt.

Standard value: $T=19.5\text{N}\cdot\text{m}$ {198.8kgf·cm} {14.4ft·lbf}

MT

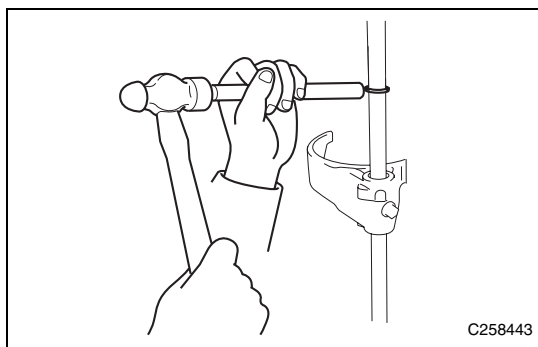

(2) Install a new shaft snap ring.

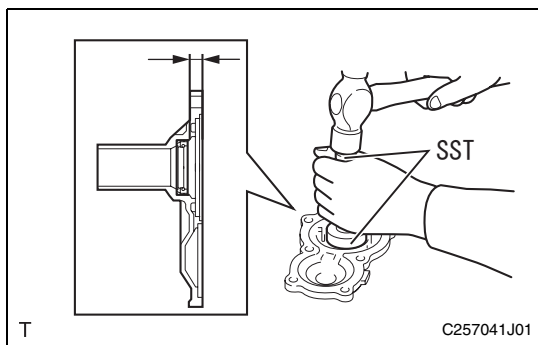

4. Install the transmission front bearing retainer oil seal.
- (1) Using the SST, install a new transmission front bearing retainer oil seal.
- SST 09950-60010 (09951-00420), 09950-70010 (09951-07100)
- Standard value: 11.1 to 11.9 mm {0.437 to 0.469 in}
(From the bearing retainer FR end face)

<Caution>

- Be careful not to damage the lip face of the transmission front bearing retainer oil seal.
- Be careful not to damage the bearing retainer FR.

(2) Apply manual transmission oil to the lip face of the transmission front bearing retainer oil seal.

<Reference>

Use recommended or substitute products for manual transmission oil. (Refer to PP-8)

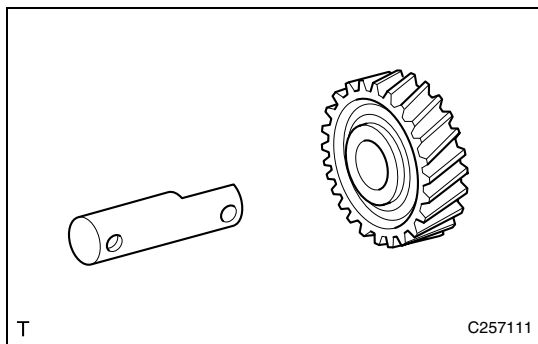

5. Install the reverse idler gear shaft.
- (1) Apply manual transmission oil to the reverse idler gear shaft, and install it to the reverse idler gear.
- <Reference>
- Use recommended or substitute products for manual transmission oil. (Refer to PP-8)

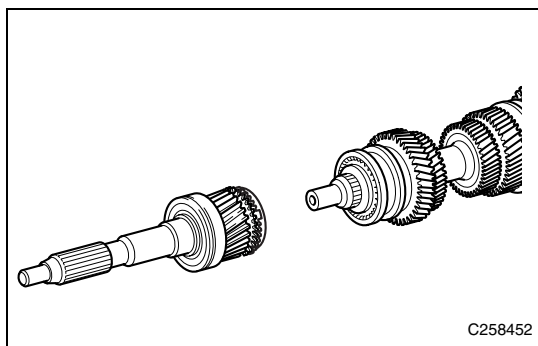

6. Install the input shaft.
- (1) Apply manual transmission oil to the needle roller bearing of input shaft, and install the input shaft to the output shaft.
- <Reference>
- Use recommended or substitute products for manual transmission oil. (Refer to PP-8)

7. Install the counter shaft.
- (1) Install the input shaft, output shaft, counter shaft, reverse idler gear, reverse idler gear shaft, gear shift fork shaft No. 1, gear shift fork shaft No. 2, and gear shift fork shaft No. 3 as a unit to the clutch housing.

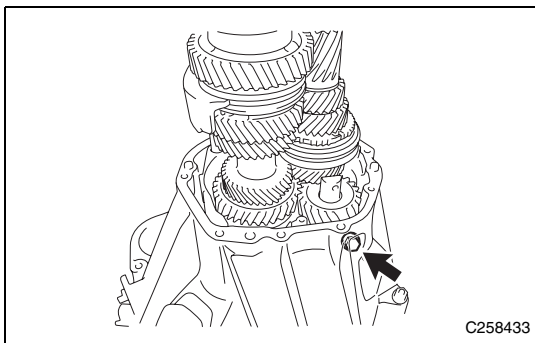
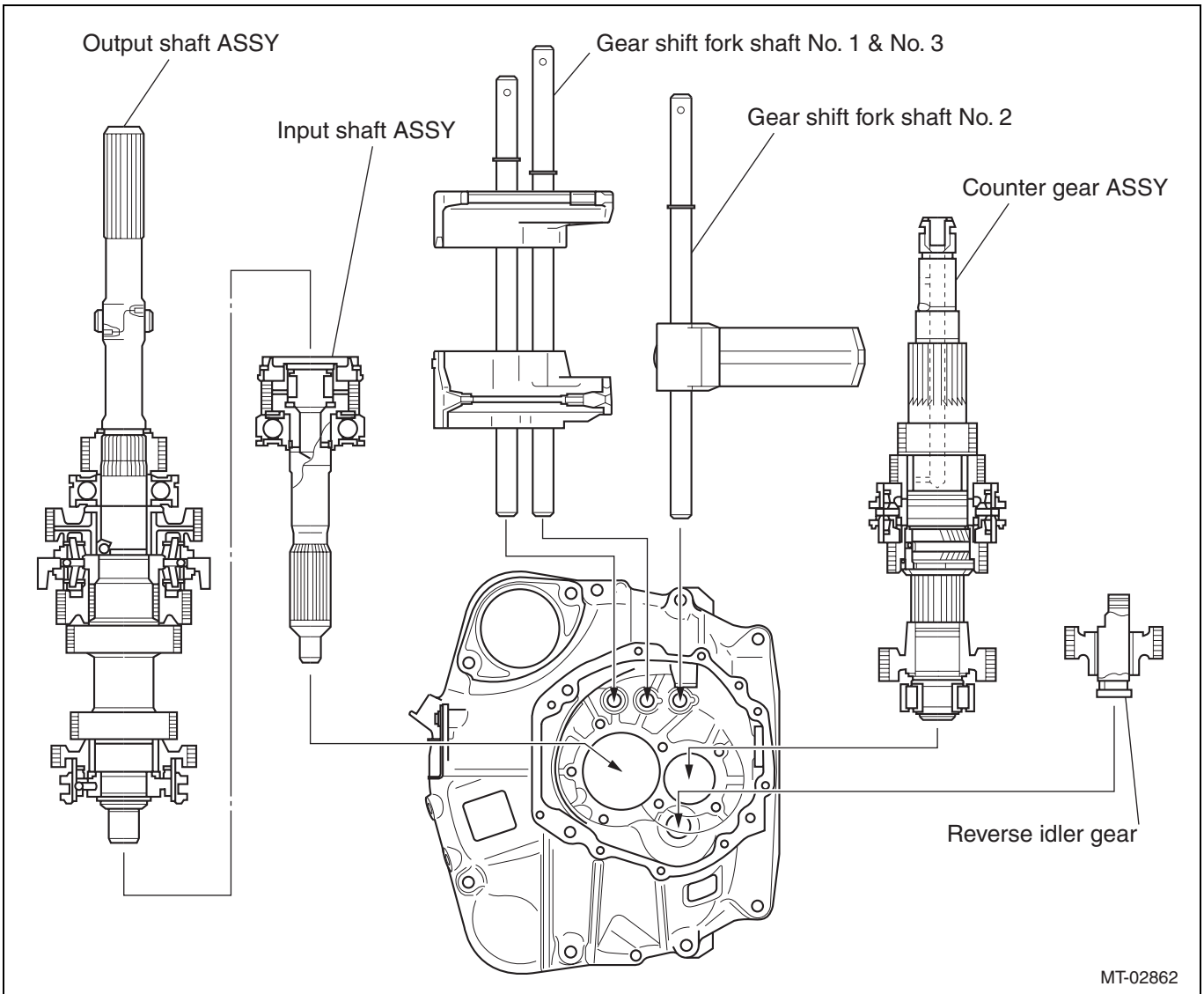

- (2) Using a new gasket, temporarily tighten a new bolt for the reverse idler gear shaft. (The clutch housing side)

MT

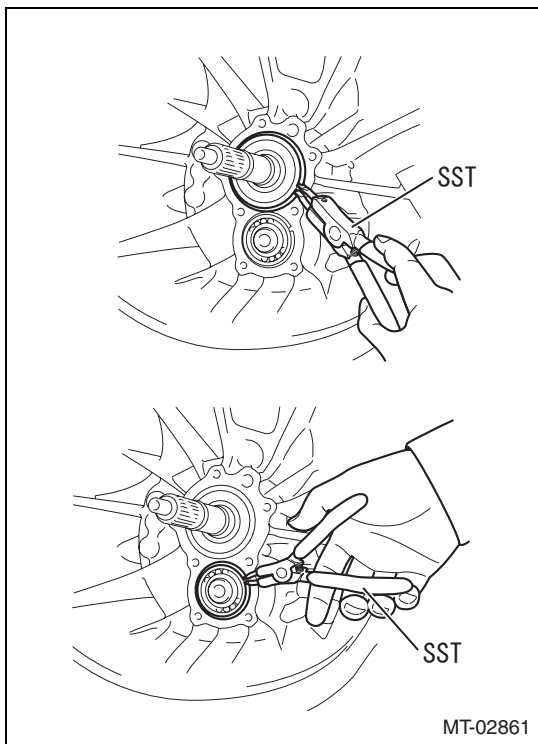

MT-02861

- (3) Using the SST, install two new shaft snap rings.
 SST 499895400
 <Reference>
 Install the shaft snap rings on the input shaft side and counter shaft side both.

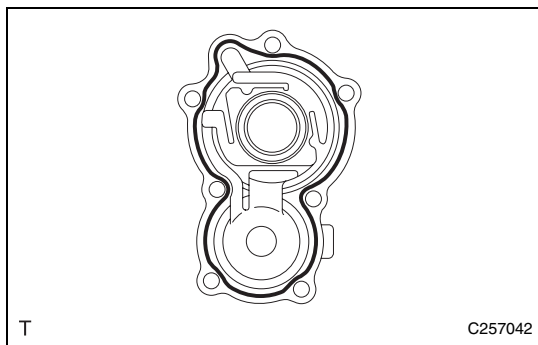

T

C257042

- 8. Install the bearing retainer FR.
 - (1) Apply three bond 1281 or equivalent to the bearing retainer FR continuously in a bead form as shown in the figure.
 Captions in illustration

	Three bond 1281 or equivalent
--	-------------------------------

<Caution>
 Install within 10 min. after applying the seal gasket.

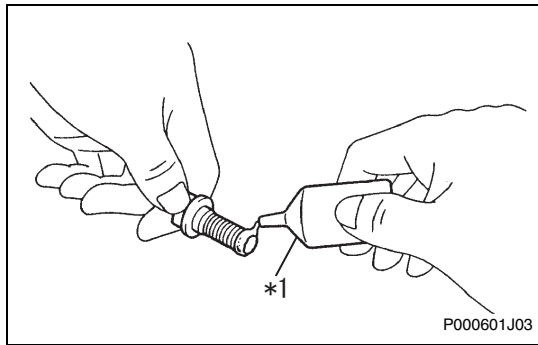

P000601J03

- (2) Apply ADHESIVE 1344 or equivalent to two to three pitches from the end of a new bolt.
 Captions in illustration

*1	ADHESIVE 1344 or equivalent
----	-----------------------------

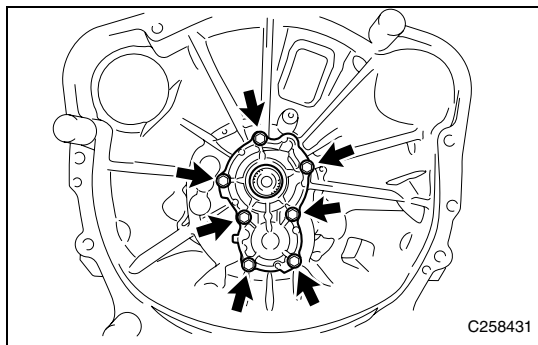

C258431

- (3) Install the bearing retainer FR using the seven bolts.
 Standard value: $T=17N \cdot m$ {173kgf·cm} {12.5ft·lbf}
 <Caution>
 Be careful not to damage the lip face of the bearing retainer FR oil seal.

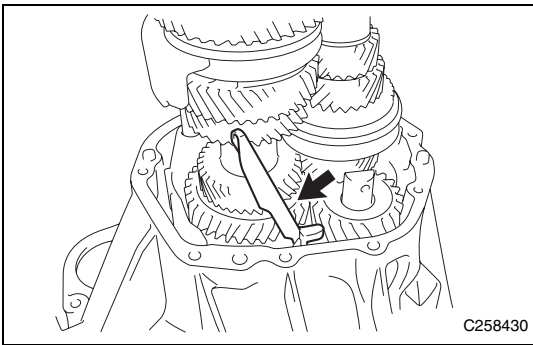

9. Install the oil receiver pipe.

(1) Install the oil receiver pipe.

<Caution>

Make sure that the oil receiver pipe end is not loosely fitted, or coming off.

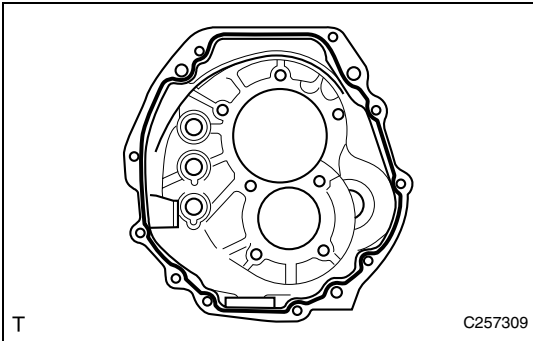

10. Install the transmission case.

(1) Apply three bond 1281 or equivalent to the transmission case continuously in a bead form as shown in the figure.

Captions in illustration

	Three bond 1281 or equivalent
--	-------------------------------

<Caution>

Install within 10 min. after applying the seal gasket.

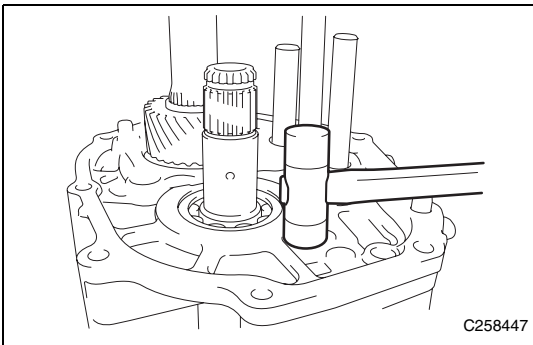

(2) Check the position of knock pin, and install the transmission case.

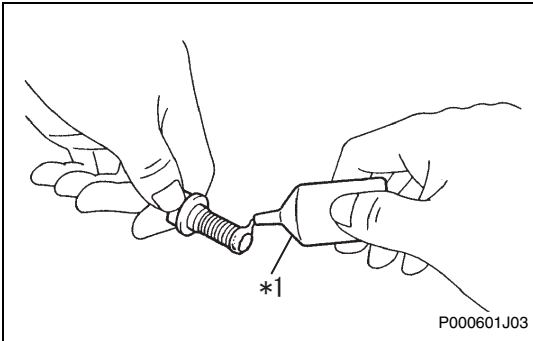

(3) Apply ADHESIVE 1324 or equivalent to two to three pitches from the end of a new bolt.

Captions in illustration

*1	ADHESIVE 1324 or equivalent
----	-----------------------------

MT

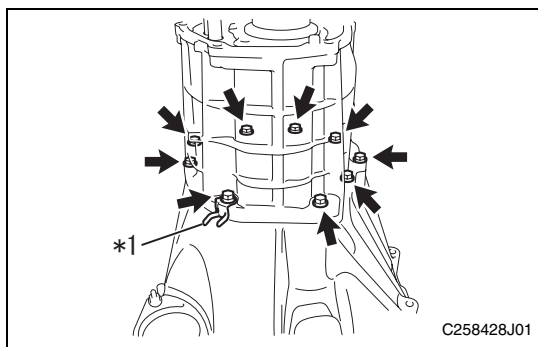

(4) Install the transmission case and clamp using the nine bolts.

Captions in illustration

*1	Clamp
----	-------

Standard value: $T=29N\cdot m$ {296kgf·cm} {21.4ft·lbf}

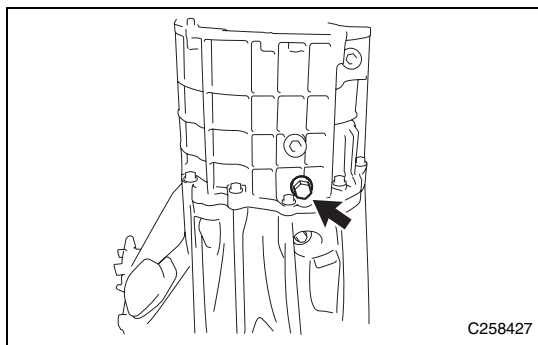

(5) Using a new gasket, tighten a new securing bolt for the reverse idler gear shaft. (The transmission case side)

Standard value: $T=28N\cdot m$ {286kgf·cm} {20.7ft·lbf}

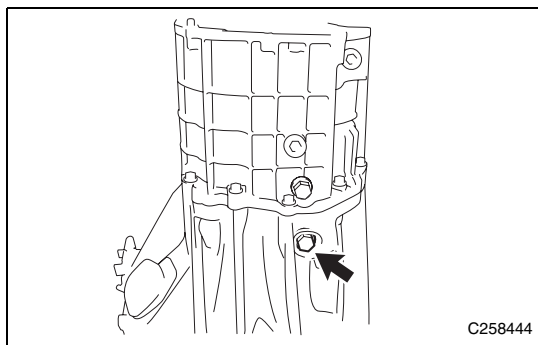

(6) Fully tighten the securing bolt for the reverse idler gear shaft. (The clutch housing side)

Standard value: $T=28N\cdot m$ {286kgf·cm} {20.7ft·lbf}

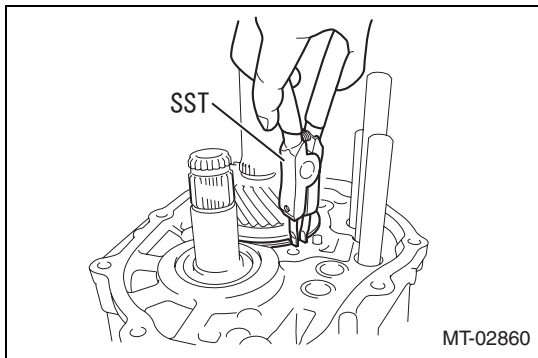

(7) Using the SST, install a new shaft snap ring.

SST 499895400

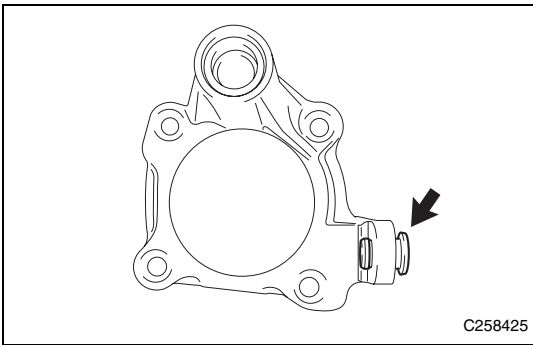

11. Install the bearing retainer RR.

- (1) Install the shift arm pivot to the bearing retainer RR.

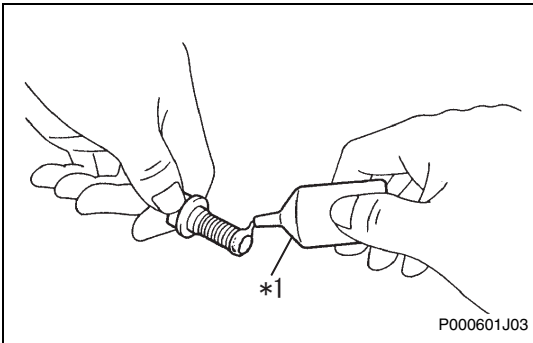

- (2) Apply ADHESIVE 1324 or equivalent to two to three pitches from the end of a new bolt.

Captions in illustration

*1	ADHESIVE 1324 or equivalent
----	-----------------------------

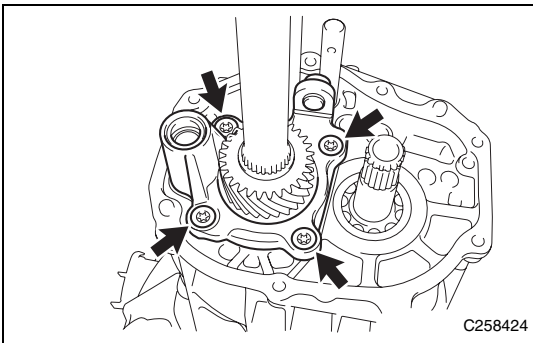

- (3) Install the bearing retainer RR using the four TORX bolts.

Standard value: $T=30N\cdot m$ {306kgf \cdot cm} {22.1ft \cdot lbf}

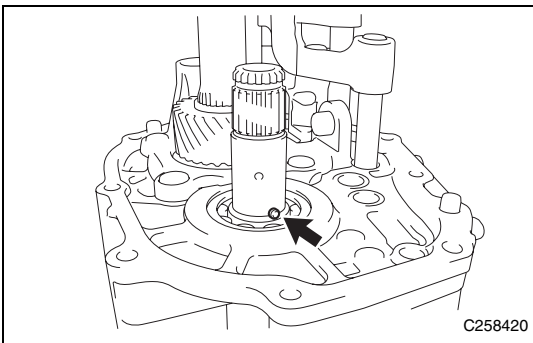

12. Install the 6th gear thrust washer.

- (1) Install the straight pin to the counter shaft.

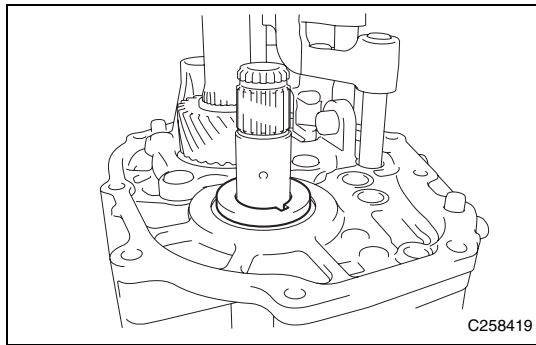

- (2) Apply manual transmission oil to the 6th gear thrust washer, and install it to the counter shaft.

<Reference>

Use recommended or substitute products for manual transmission oil. (Refer to PP-8)

MT

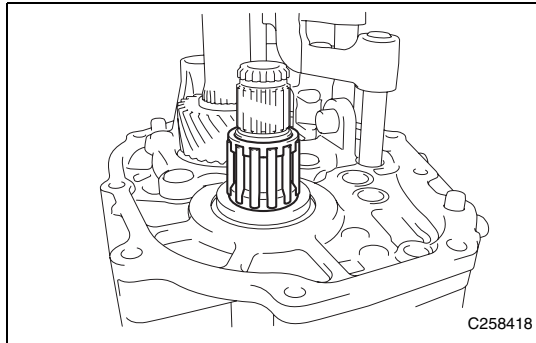

13. Install the needle roller bearing.

- (1) Apply manual transmission oil to the needle roller bearing, and install it to the counter shaft.

<Reference>

Use recommended or substitute products for manual transmission oil. (Refer to PP-8)

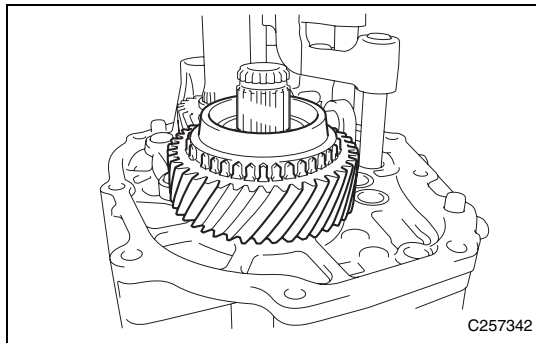

14. Install the counter shaft 6th gear.

- (1) Apply manual transmission oil to the counter shaft 6th gear, and install it to the counter shaft.

<Reference>

Use recommended or substitute products for manual transmission oil. (Refer to PP-8)

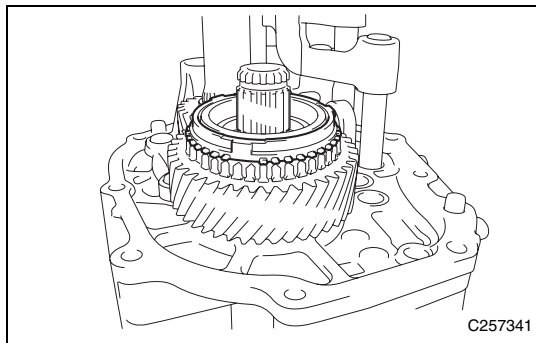

15. Install the synchronizer ring No. 2.

- (1) Apply manual transmission oil to the synchronizer ring No. 2, and install it to the counter shaft.

<Reference>

Use recommended or substitute products for manual transmission oil. (Refer to PP-8)

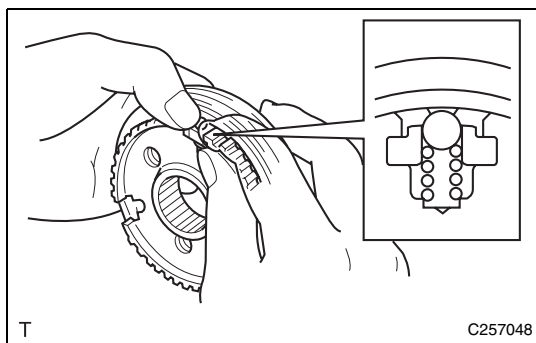

16. Install the transmission hub sleeve No. 4.

- (1) Apply manual transmission oil to the sliding surface of transmission clutch hub No. 4.

<Reference>

Use recommended or substitute products for manual transmission oil. (Refer to PP-8)

- (2) First install the transmission hub sleeve No. 4 to the transmission clutch hub No. 4, then install the three synchromesh shifting key No. 1s and the three synchromesh shifting key spring No. 1s as a unit, and lastly install the three balls.

T

C257048

<Reference>

- Install the balls, while compressing the synchromesh shifting key spring No. 1s.
- After finishing the installation, let the synchromesh shifting key spring No. 1s sit for a while.

(3) Install a new hole snap ring.

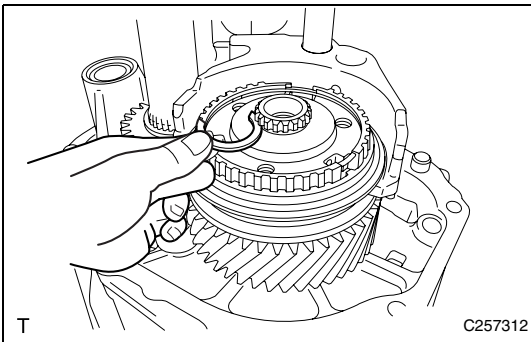
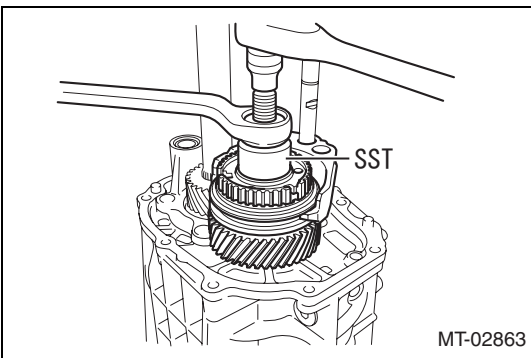
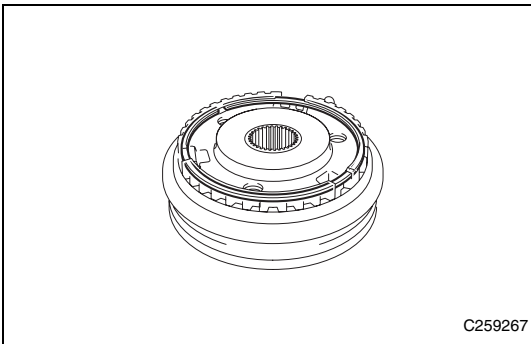

17. Install the transmission clutch hub No. 4.

- (1) Using the SST, install the transmission clutch hub No. 4, transmission hub sleeve No. 4, and gear shift fork No. 4 as a unit.
SST 18682AA000

18. Install the shaft snap ring.

- (1) Select a shaft snap ring so that the thrust gap between the transmission clutch hub No. 4 and snap ring is within the standard value.

Standard value: 0 to 0.1 mm {0 to 0.00394 in}

<Reference>

Select a shaft snap ring with the maximum thickness possible.

Shaft snap ring type

Item number	Thickness (mm {in})	Identification
17005AA230	2.80 {0.110}	A
17005AA240	2.85 {0.11220}	B
17005AA250	2.90 {0.11417}	C
17005AA260	2.95 {0.11614}	D
17005AA270	3.00 {0.11811}	E
17005AA280	3.05 {0.12007}	F

- (2) Install a new shaft snap ring to the counter shaft.

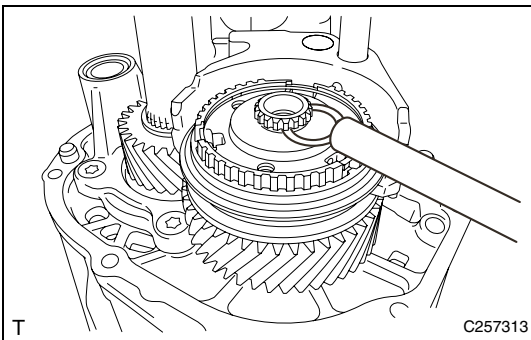

MT

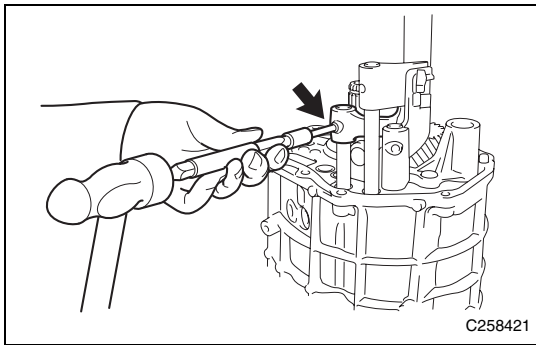

19. Install the gear shift head No. 2.

- (1) Install the gear shift head No. 2 to the gear shift fork shaft No. 2.
- (2) Install a new slotted spring pin to the gear shift fork shaft No. 2.

<Caution>

Be careful not to hammer in the pin excessively.

Standard value: 0 mm {0 in}

(From the gear shift head No. 2 end face)

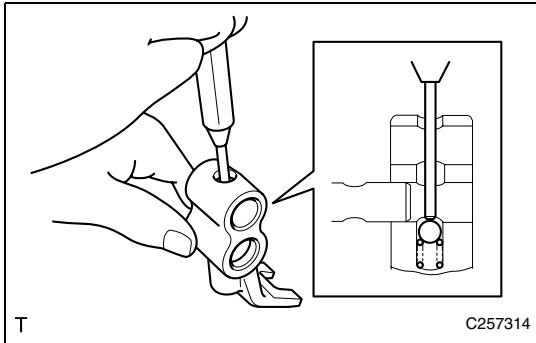

20. Install the 5th shift head.

- (1) Install the compression spring to the 5th shift head, and while pushing the ball with a pin punch 5, install the 5th shift head to the gear shift fork shaft No. 3.

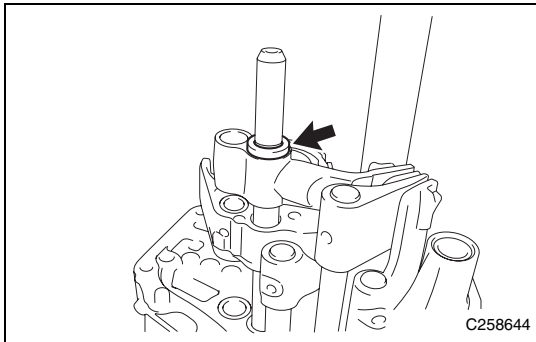

- (2) Install the washer.

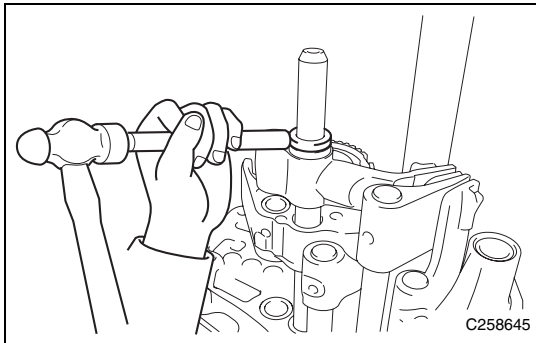

- (3) Install a new shaft snap ring to the gear shift fork shaft No. 3.

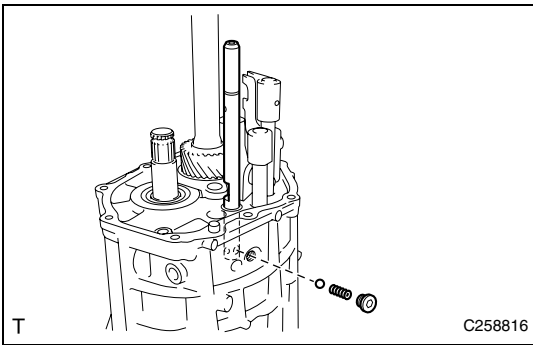

21. Install the gear shift fork shaft No. 3.

- (1) Insert the gear shift fork shaft No. 3 in the direction shown in the figure, install the ball and compression spring, and then tighten a new head straight screw plug.

Standard value: $T=19\text{N}\cdot\text{m}$ {194kgf·cm} {14ft·lb}

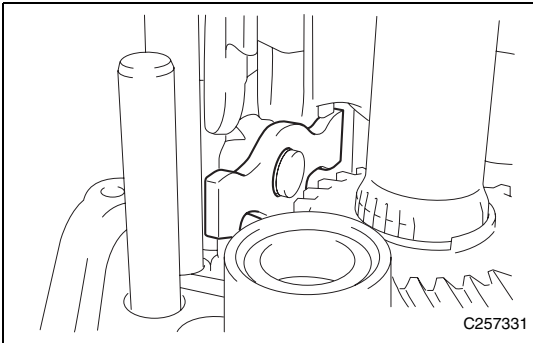

22. Install the shift arm.

- (1) Install the shift arm to the shift arm pivot.

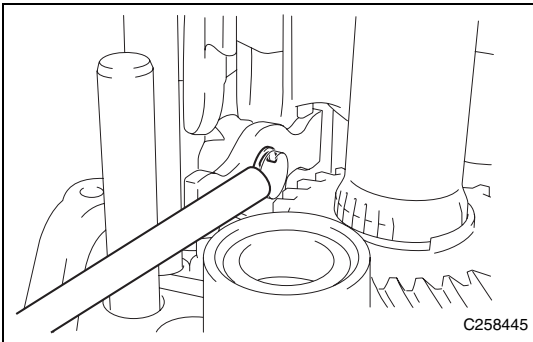

- (2) Install a new E-ring to the shift arm pivot.

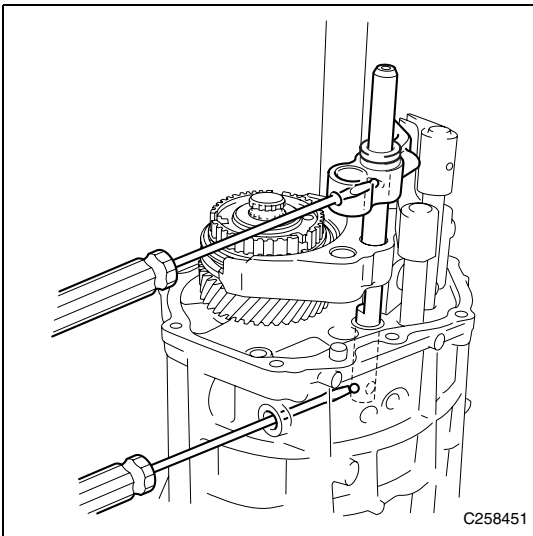

23. Install the gear shift fork shaft No. 2.

- (1) Install the two balls to the gear shift fork shaft No. 3.

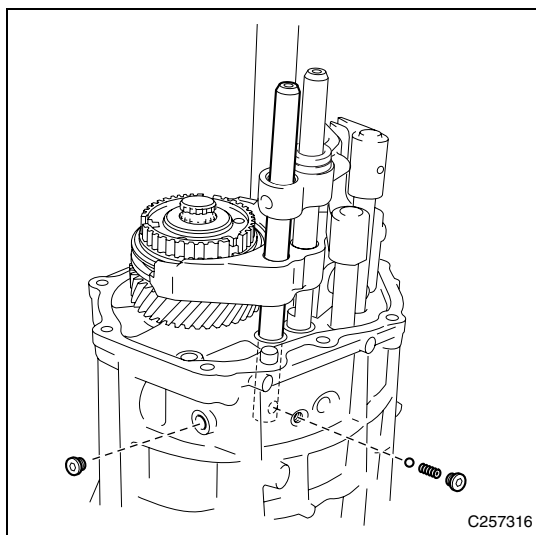

- (2) Insert the gear shift fork shaft No. 2 in the direction shown in the figure, install the ball and compression spring, and then tighten two new head straight screw plugs.

Standard value: $T=19N\cdot m$ {194kgf·cm} {14ft·lbf}

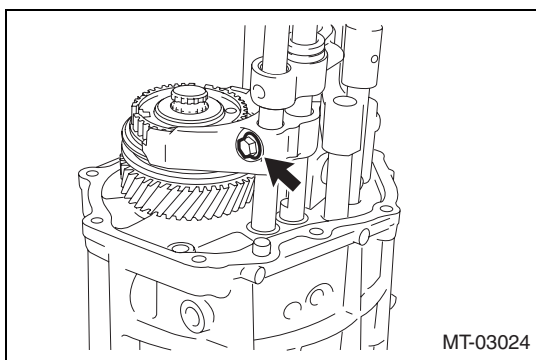

- (3) Install a new bolt to the gear shift fork shaft No. 2.

Standard value: $T=19.5N\cdot m$ {198.8kgf·cm} {14.4ft·lbf}

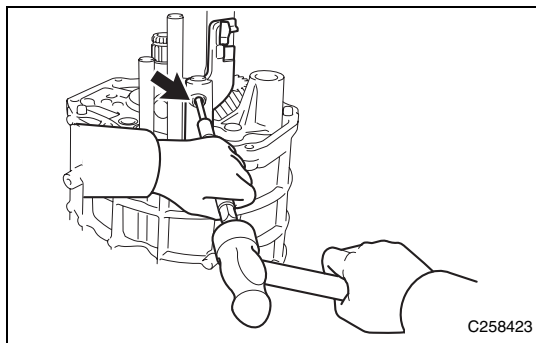

24. Install the gear shift head No. 3.

- (1) Install the gear shift head No. 3 to the gear shift fork shaft No. 3.

<Reference>

Install the gear shift head No. 3 while rotating so that the shift arm fits in the groove.

- (2) Install a new slotted spring pin to the gear shift fork shaft No. 3.

<Caution>

Be careful not to hammer in the pin excessively.

Standard value: 0 mm {0 in}

(From the gear shift head No. 3 end face)

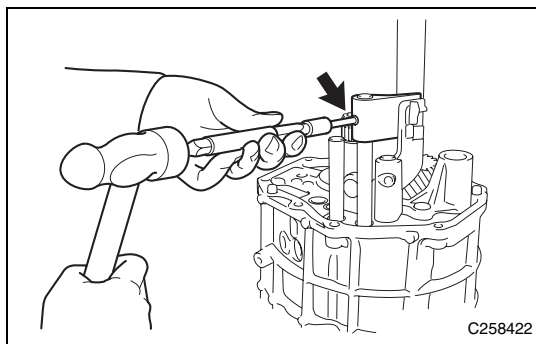

25. Install the gear shift head No. 1.

- (1) Install the gear shift head No. 1 to the gear shift fork shaft No. 1.

- (2) Install a new slotted spring pin to the gear shift fork shaft No. 1.

<Caution>

Be careful not to hammer in the pin excessively.

Standard value: 0 mm {0 in}

(From the gear shift head No. 1 end face)

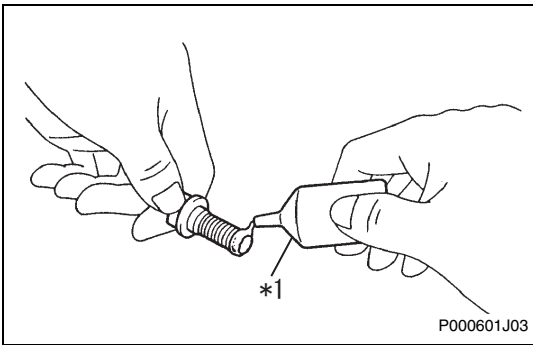

26. Install the shift inner lever FR.

- (1) Apply ADHESIVE 1324 or equivalent to two to three pitches from the end of a new bolt.

Captions in illustration

*1	ADHESIVE 1324 or equivalent
----	-----------------------------

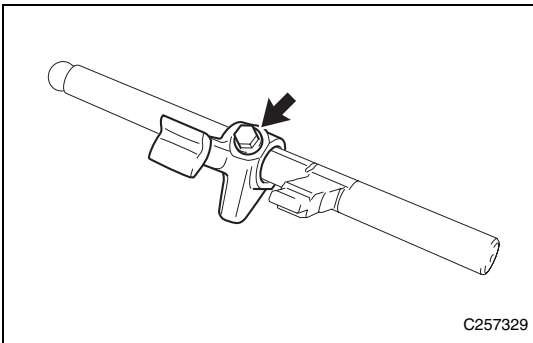

- (2) Install the shift inner lever FR to the shift shaft, using a new bolt.
Standard value: $T=33.3\text{N}\cdot\text{m}$ {339.5kgf·cm} {24.6ft·lbf}

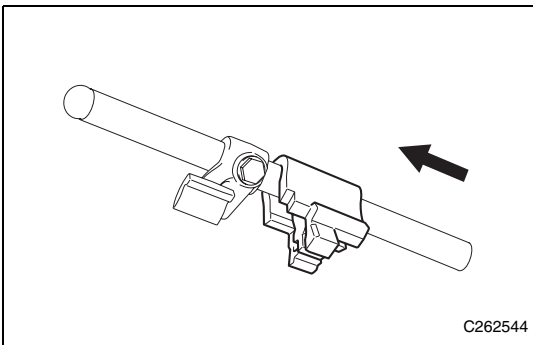

27. Install the shift inner lock block No. 1.

- (1) Install the shift inner lock block No. 1 to the shift shaft.

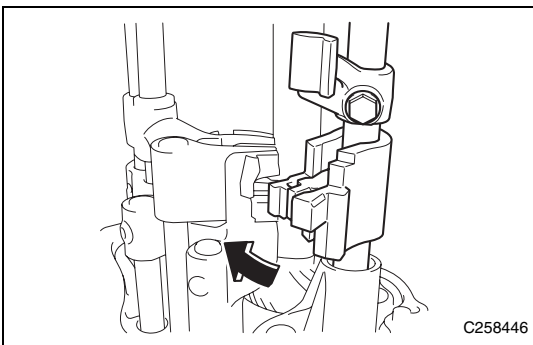

28. Install the shift shaft.

- (1) Slide the shift shaft and shift inner lock block No. 1 to install.

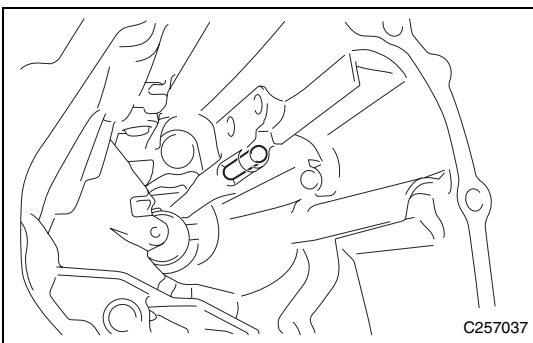

29. Install the extension housing oil receiver pipe No. 1.

- (1) Install the straight pin.

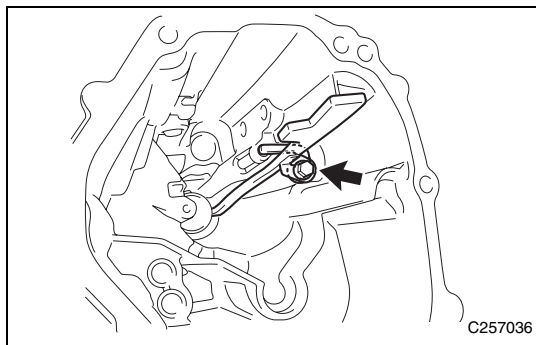

- (2) Install the extension housing oil receiver pipe No. 1 and stopper plate, using a new bolt.
 Standard value: $T=8.5N\cdot m$ {87kgf•cm} {6.3ft•lbf}
 <Reference>
 Check that the end of oil receiver pipe No. 1 is inserted into the groove.

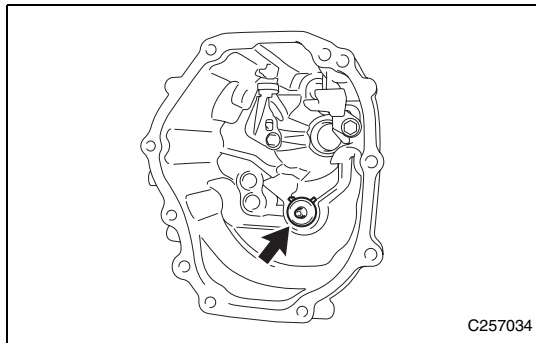

30. Install the extension housing oil receiver pipe No. 2.
 (1) Install the extension housing oil receiver pipe No. 2.

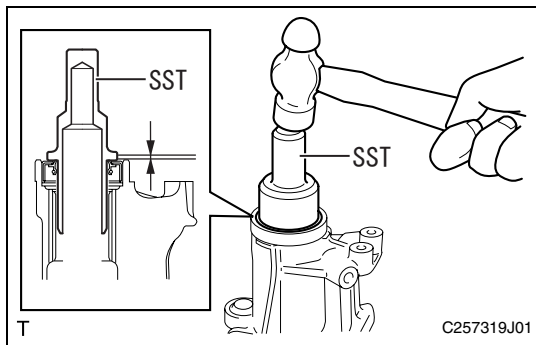

31. Install the transmission extension housing oil seal.
 (1) Apply manual transmission oil to the lip face of a new transmission extension housing oil seal.
 <Reference>
 Use recommended or substitute products for manual transmission oil. (Refer to PP-8)
 (2) Using the SST, install a new transmission extension housing oil seal.
 SST 09325-20010
 Standard value: 0.1 to 1.1 mm {0.00394 to 0.0433 in}
 (From the transmission extension housing SUB-ASSY (MTM) end face)

<Caution>

Be careful not to damage the lip face of the transmission extension housing oil seal.

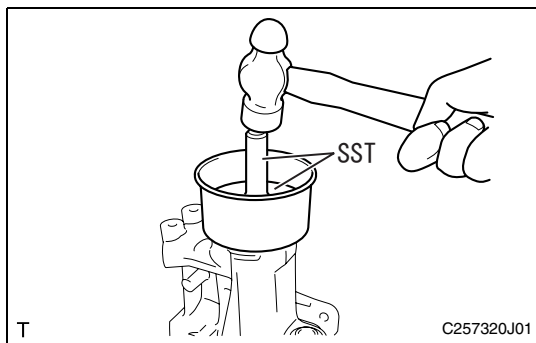

32. Install the extension housing dust deflector.
 (1) Using the SST, install a new extension housing dust deflector.
 SST 09950-60020 (09951-00750), 09950-70010 (09951-07100)
 <Reference>
 Make sure to hammer in until the end contacts the transmission extension housing SUB-ASSY (MTM).

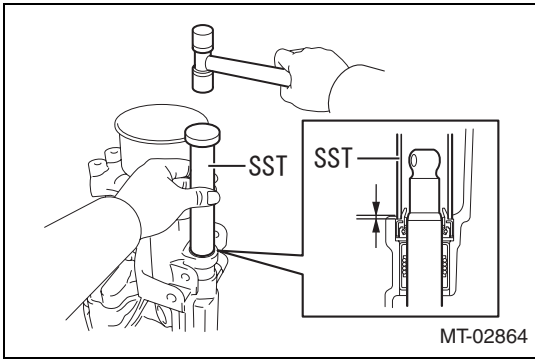

33. Install the extension housing rear oil seal.

- (1) Using the SST, install a new extension housing rear oil seal.
 SST 18657AA040
 Standard value: 1.0 to 2.0 mm {0.0394 to 0.0787 in}
 (From the transmission extension housing SUB-ASSY (MTM) end face)

<Caution>

Be careful not to damage the lip face of the extension housing rear oil seal.

- (2) Apply manual transmission oil to the lip face of the extension housing rear oil seal.

<Reference>

Use recommended or substitute products for manual transmission oil. (Refer to PP-8)

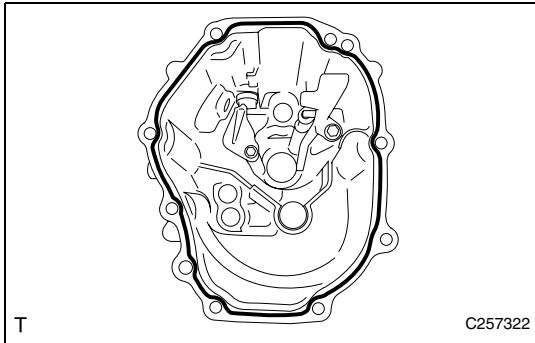

34. Install the transmission extension housing SUB-ASSY (MTM).

- (1) Apply three bond 1281 or equivalent to the transmission extension housing SUB-ASSY (MTM) continuously in a bead form as shown in the figure.

Captions in illustration

	Three bond 1281 or equivalent
--	-------------------------------

<Caution>

- Install within 10 min. after applying the seal gasket.
- Make sure to install the transmission extension housing SUB-ASSY (MTM) with the shift position in neutral.

- (2) Install the transmission extension housing SUB-ASSY (MTM) and clamp, using eight new bolts.

Captions in illustration

	*1 Clamp
--	----------

Standard value: T=29N•m {296kgf•cm} {21.4ft•lbf}

<Caution>

Make sure to align the knock pin with the knock pin hole.

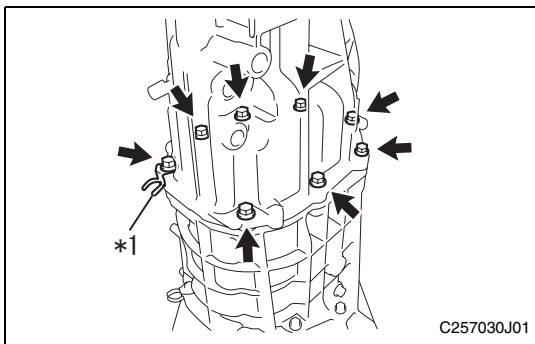

- (3) Install a new bolt.

Standard value: T=31N•m {316kgf•cm} {22.9ft•lbf}

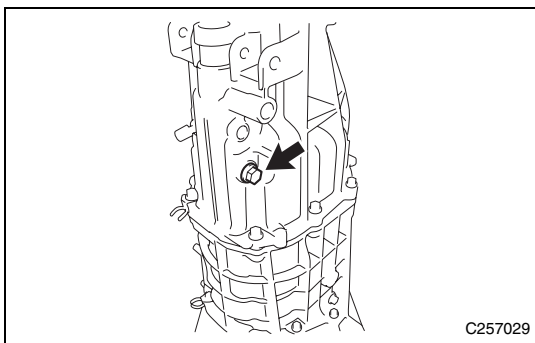

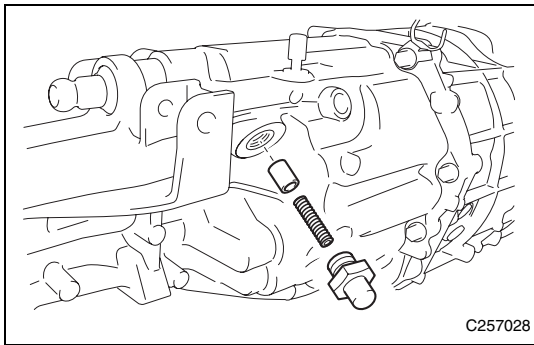

35. Install the holder.

- (1) Install a new holder, compression spring and lock ball pin.
Standard value: $T=39.2\text{N}\cdot\text{m}$ {399.7kgf·cm} {28.9ft·lbf}

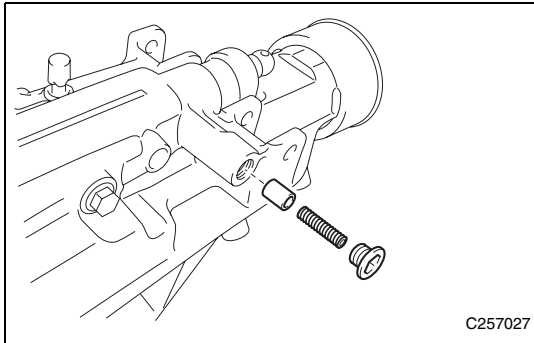

36. Install the lock ball pin.

- (1) Install a new head straight screw plug, compression spring and lock ball pin.
Standard value: $T=24.5\text{N}\cdot\text{m}$ {249.8kgf·cm} {18.1ft·lbf}

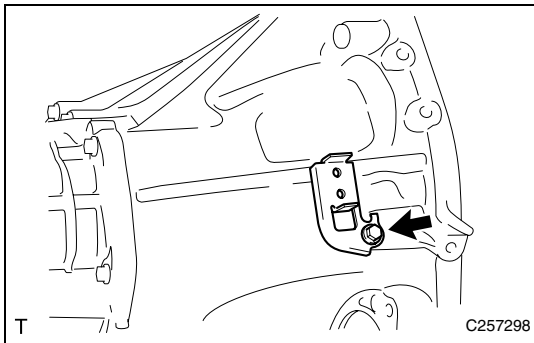

37. Install the wiring harness clamp bracket.

- (1) Install the wiring harness clamp bracket using a new bolt.
Standard value: $T=7.0\text{N}\cdot\text{m}$ {71kgf·cm} {5.2ft·lbf}

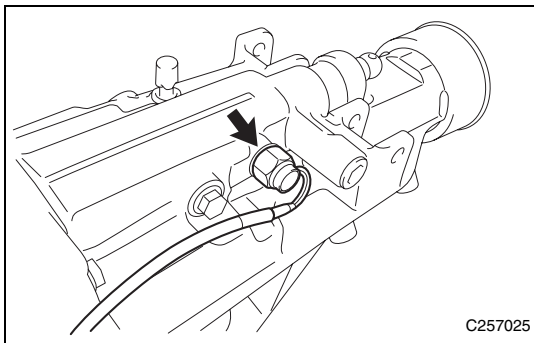

38. Install the neutral switch.

- (1) Install the neutral switch and a new gasket.
Standard value: $T=32.3\text{N}\cdot\text{m}$ {329.4kgf·cm} {23.8ft·lbf}

<Caution>

When a torque wrench extended with a union nut wrench is used, the actual tightening torque becomes over-torque if the part is tightened until the torque wrench reading reaches the specified tightening torque.

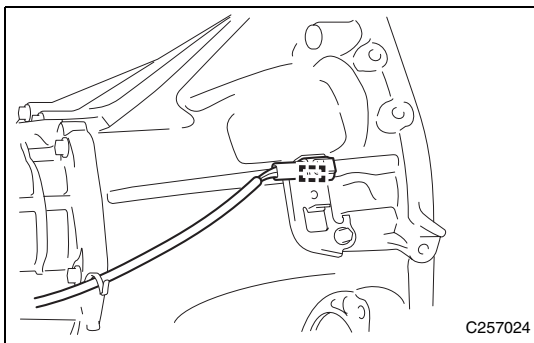

- (2) Engage the clamp and connect the neutral switch wire.

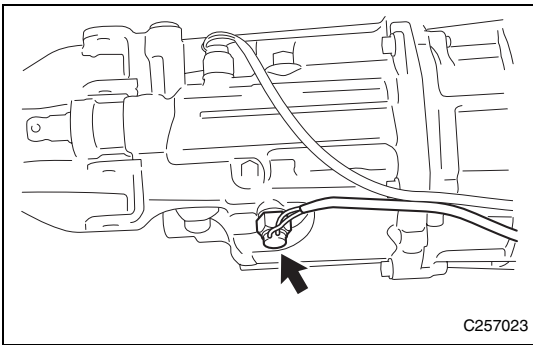

39. Install the back-up light switch ASSY.

- (1) Install the back-up light switch ASSY and a new gasket.
Standard value: $T=32.3\text{N}\cdot\text{m}$ {329.4kgf·cm} {23.8ft·lbf}

<Caution>

When a torque wrench extended with a union nut wrench is used, the actual tightening torque becomes over-torque if the part is tightened until the torque wrench reading reaches the specified tightening torque.

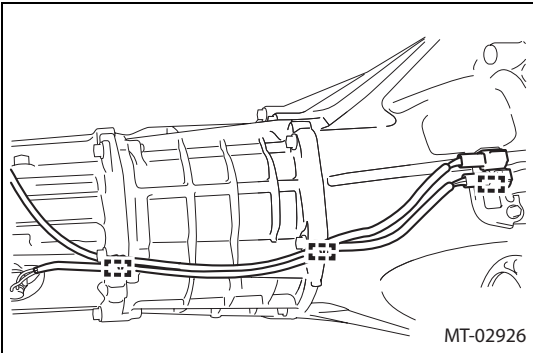

- (2) With the slack of the harness kept only in the front, engage the three clamps in order from the rearmost, and connect the back-up light switch ASSY wire and neutral switch wire.

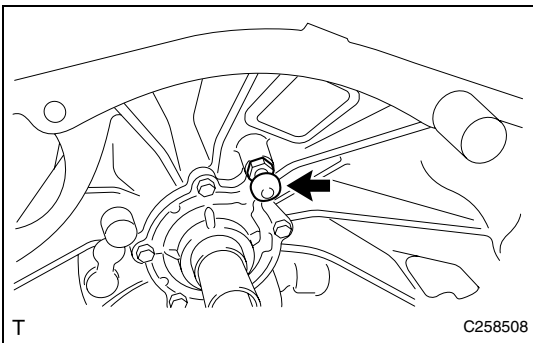

40. Install the clutch release fork support.

- (1) Install the clutch release fork support to the clutch housing.
Standard value: $T=16\text{N}\cdot\text{m}$ {163kgf·cm} {11.8ft·lbf}

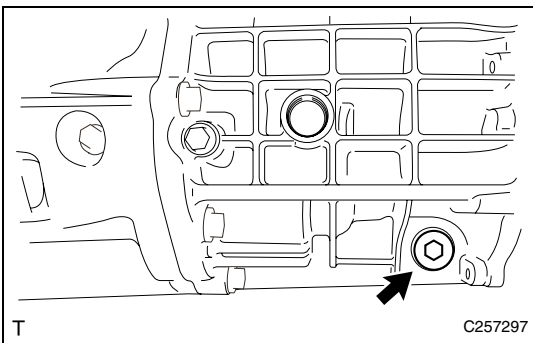

41. Install the manual transmission drain plug.

- (1) Install the manual transmission drain plug to the transmission case, using a new gasket.
Standard value: $T=37\text{N}\cdot\text{m}$ {377kgf·cm} {27.3ft·lbf}

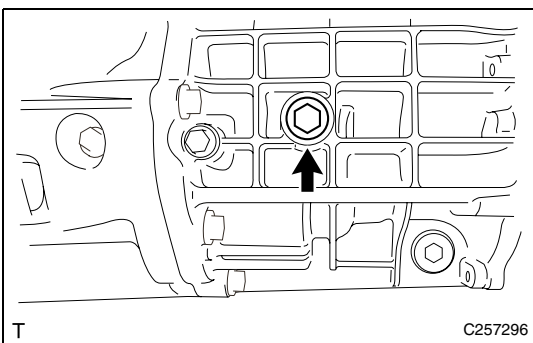

42. Install the manual transmission filler plug.

- (1) Install the manual transmission filler plug to the transmission case, using a new gasket.
Standard value: $T=37\text{N}\cdot\text{m}$ {377kgf·cm} {27.3ft·lbf}

INPUT SHAFT ASSY

EXPLODED VIEW

MT

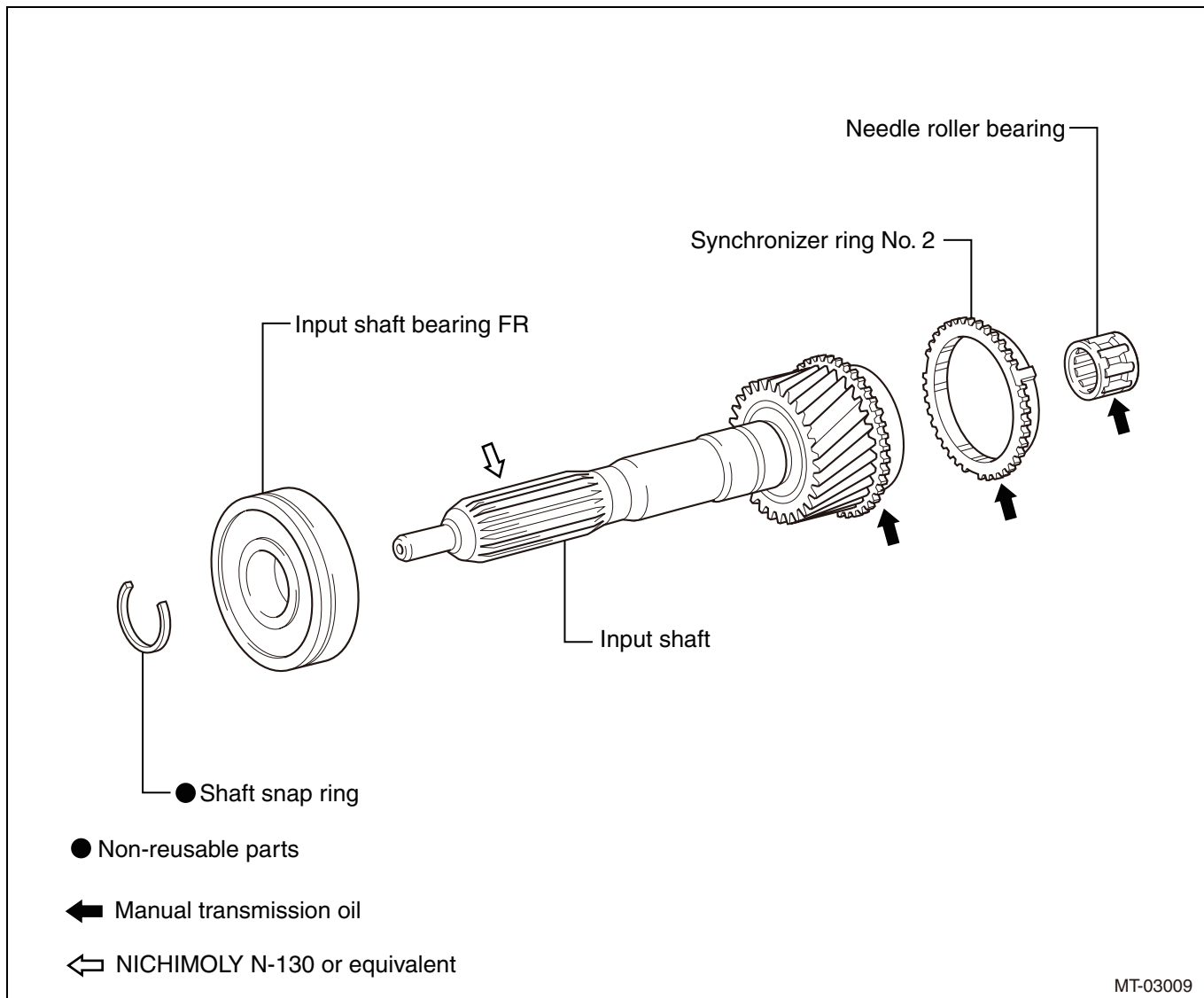

<Reference>

Use recommended or substitute products for manual transmission oil. (Refer to PP-8)

DISASSEMBLY

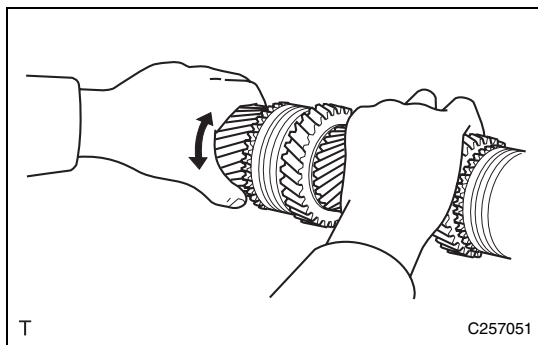

1. Check the needle roller bearing.
 - (1) Install the input shaft to the output shaft, and check the needle roller bearing.
 Specification: There is no abnormal feel in the part movement, binds, abnormal noise or loose fit.

<Reference>
 If defective, replace the needle roller bearing.

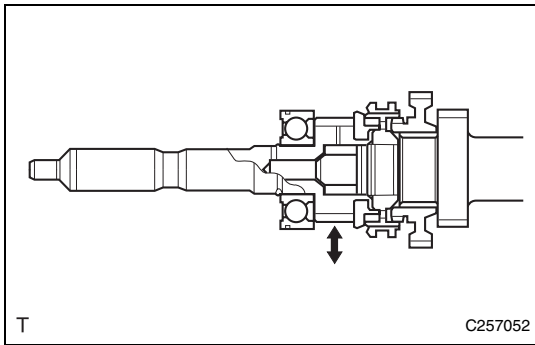

2. Check the radial clearance.

- (1) Install the input shaft to the output shaft, and check the radial clearance.

Standard value: 0.029 to 0.072 mm {0.00114 to 0.00283 in}

Limit: 0.072 mm {0.00283 in}

<Reference>

When the result exceeds the limit, replace the input shaft, needle roller bearing, and output shaft.

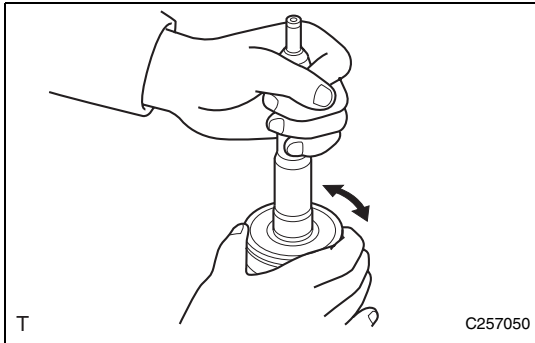

3. Check the input shaft bearing FR.

- (1) Check the input shaft bearing FR.

Specification: There is no abnormal feel in the part movement, binds, abnormal noise or loose fit.

<Reference>

If defective, replace the input shaft bearing FR.

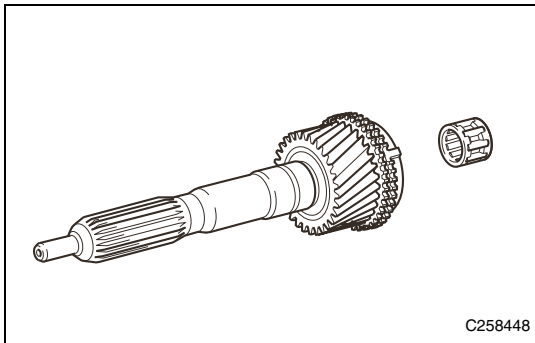

4. Remove the needle roller bearing.

- (1) Remove the needle roller bearing from the input shaft.

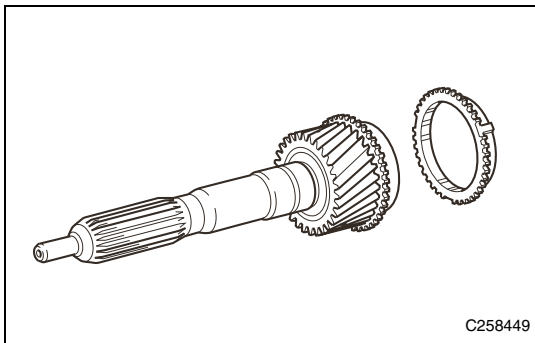

5. Remove the synchronizer ring No. 2.

- (1) Remove the synchronizer ring No. 2 from the input shaft.

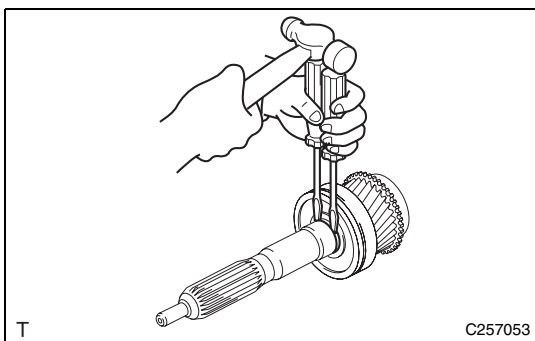

6. Remove the input shaft bearing FR.

- (1) Remove the shaft snap ring from the input shaft.

<Caution>

- Use a cloth to prevent the shaft snap ring from flying out.
- Check the direction of the part.

MT

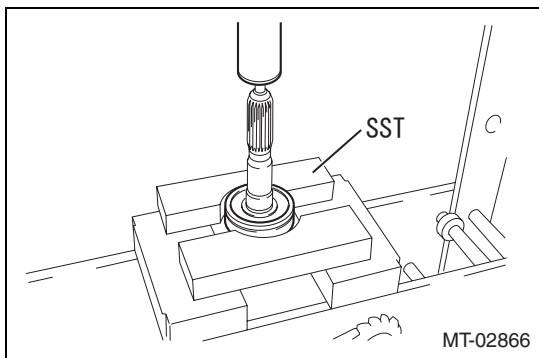

- (2) Using the SST, remove the input shaft bearing FR from the input shaft.
 SST 899714110
 <Caution>
 Apply press pressure to the inner race of input shaft bearing FR to remove the input shaft and bearing FR.

INSPECTION

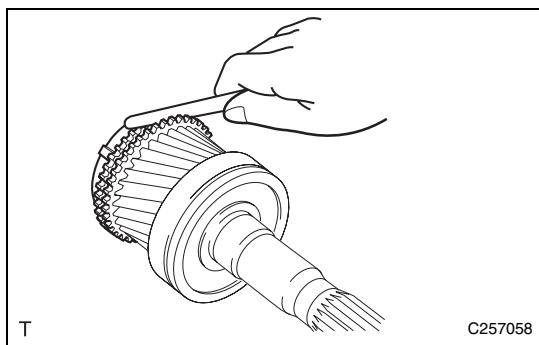

1. Check the synchronizer ring No. 2.
 - (1) Apply manual transmission oil to the cone portion of the third gear, and with the synchronizer ring No. 2 tightly fit by pressing by hand, check the clearance between the synchronizer ring No. 2 and third gear.
 Standard value: 0.8 to 1.6 mm {0.0314 to 0.0629 in}
 Limit: 0.8 mm {0.0314 in}
 <Caution>
 Check for the entire circumference of the gear.

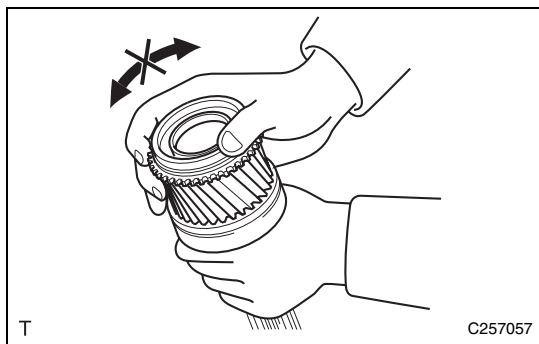

- <Reference>
 - When the result is below the limit, replace the synchronizer ring No. 2.
 - Use recommended or substitute products for manual transmission oil. (Refer to PP-8)
 - (2) Apply manual transmission oil to the cone portion of the third gear, and with the synchronizer ring No. 2 tightly fit by pressing by hand, check there is no slippage in the circumferential direction.
 <Reference>
 - When slippage occurs, replace the synchronizer ring No. 2.
 - Use recommended or substitute products for manual transmission oil. (Refer to PP-8)

ASSEMBLY

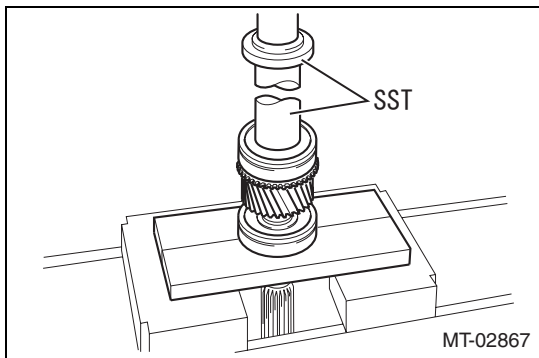

1. Install the input shaft bearing FR.
 - (1) Using the SST, install the input shaft bearing FR to the input shaft.
 SST 499277000, 398477703
 <Caution>
 Hold and press-fit the inner race of the input shaft bearing FR.

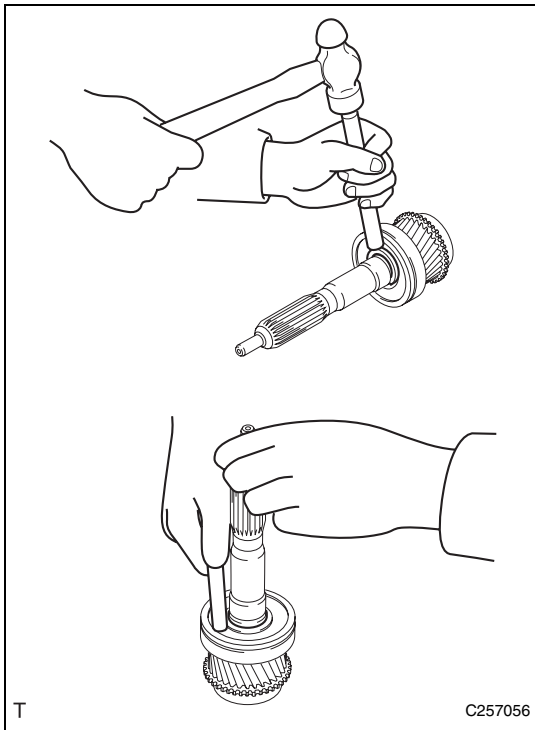

- (2) Select a shaft snap ring so that the thrust gap between the input shaft bearing FR and shaft snap ring is within the standard value.

Standard value: 0 mm {0 in}

Limit: 0.1 mm {0.00394 in}

Shaft snap ring type

Item number	Thickness (mm {in})	Identification mark
17005AA460	1.95 {0.07677}	0
17005AA470	2.00 {0.07874}	1
17005AA480	2.05 {0.08070}	2
17005AA490	2.10 {0.08267}	3
17005AA500	2.15 {0.08464}	4
17005AA510	2.20 {0.08661}	5

- (3) Install a new shaft snap ring to the input shaft.

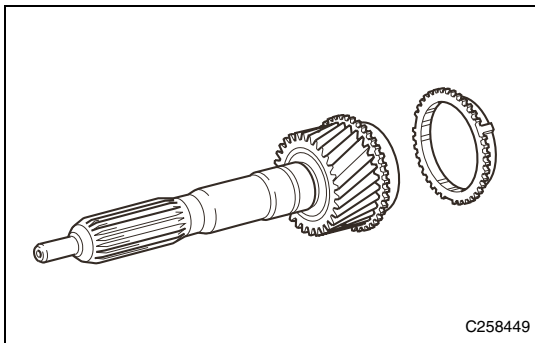

2. Install the synchronizer ring No. 2.

- (1) Apply manual transmission oil to the synchronizer ring No. 2, and install it to the input shaft.

<Reference>

Use recommended or substitute products for manual transmission oil. (Refer to PP-8)

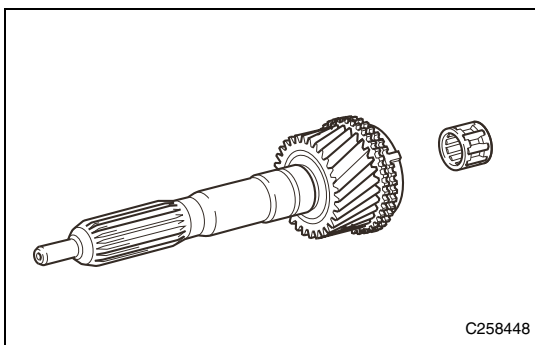

3. Install the needle roller bearing.

- (1) Apply manual transmission oil to the needle roller bearing, and install it to the input shaft.

<Reference>

Use recommended or substitute products for manual transmission oil. (Refer to PP-8)

OUTPUT SHAFT ASSY

EXPLODED VIEW

MT

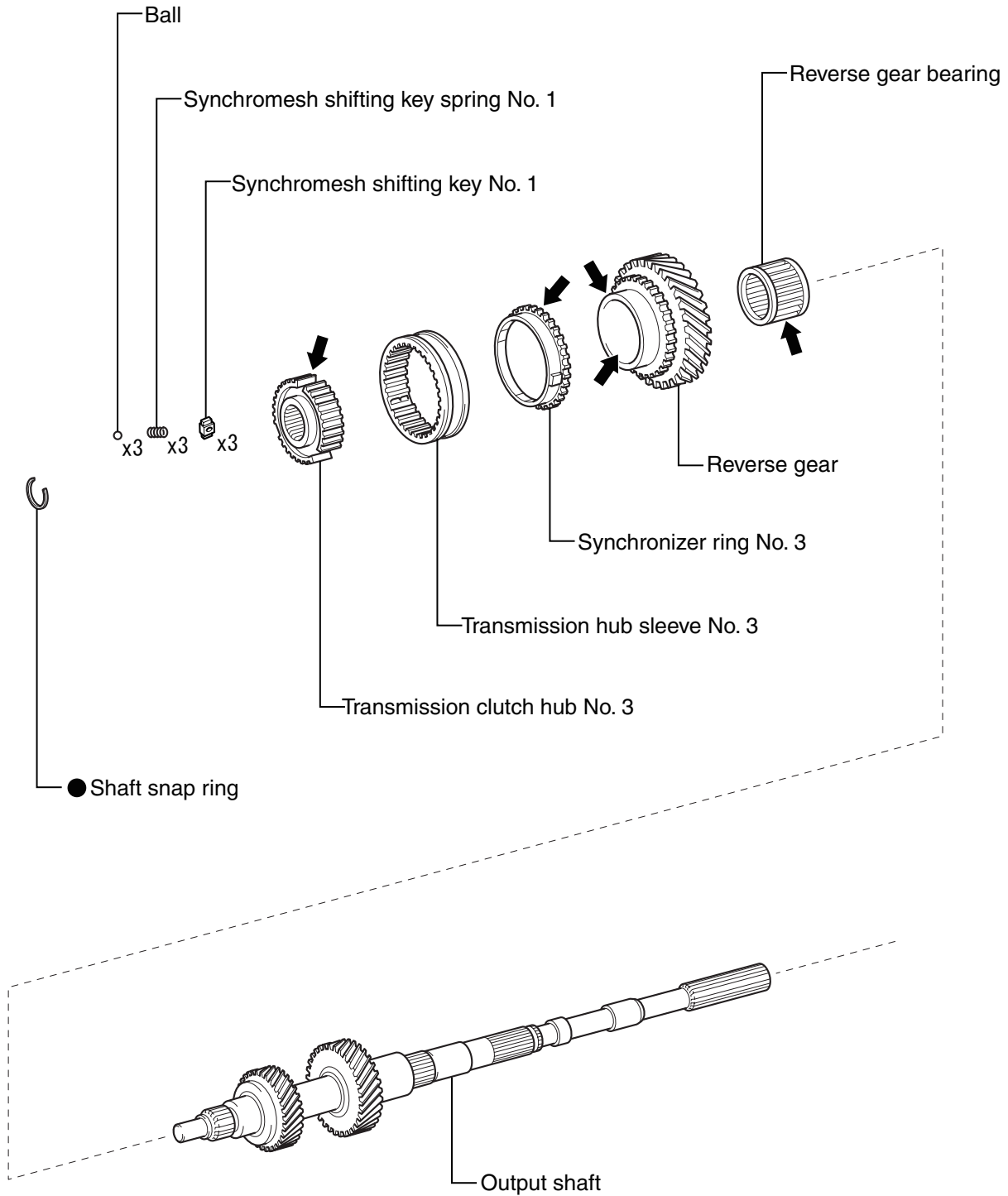

● Non-reusable parts

← Manual transmission oil

MT-03010

<Reference>

Use recommended or substitute products for manual transmission oil. (Refer to PP-8)

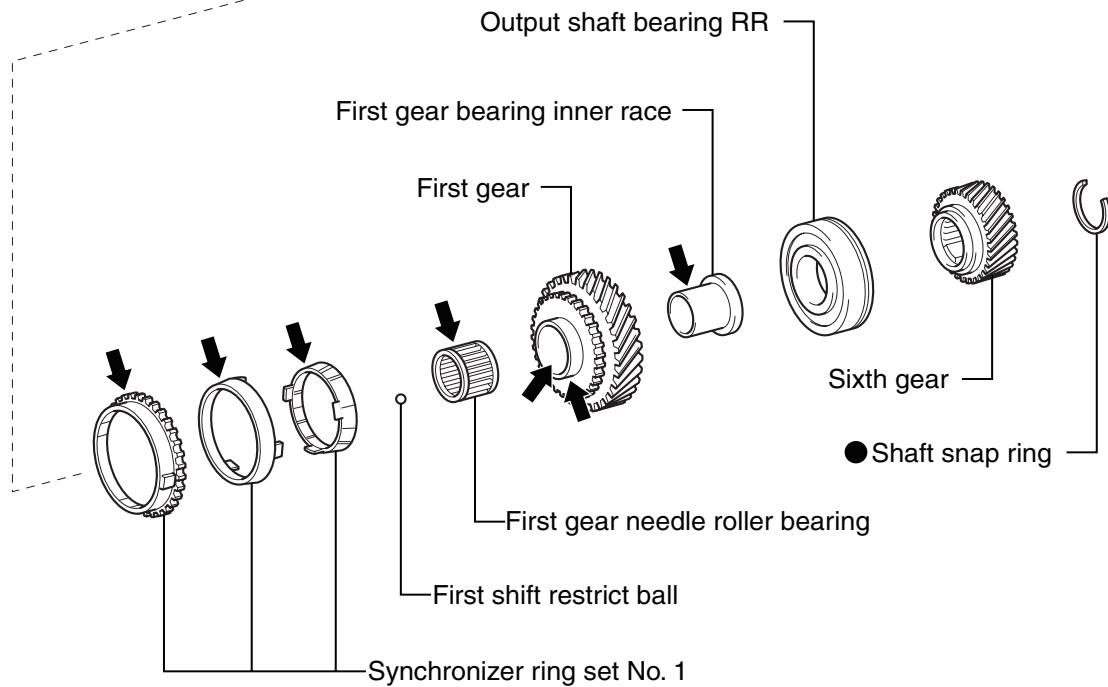
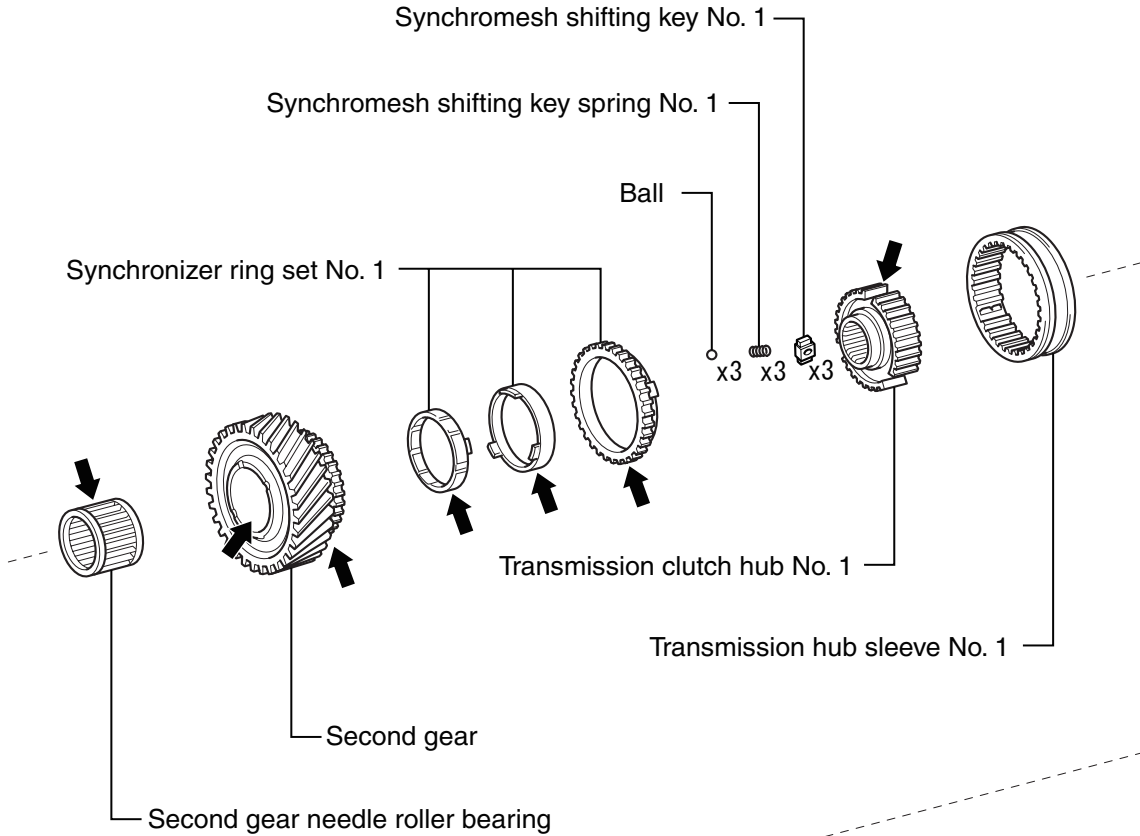

● Non-reusable parts

← Manual transmission oil

<Reference>

Use recommended or substitute products for manual transmission oil. (Refer to PP-8)

DISASSEMBLY

MT

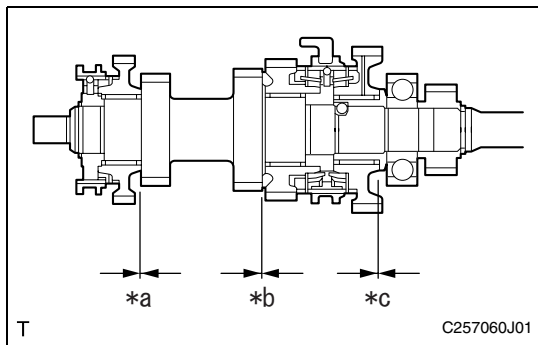

1. Check the thrust clearance.
 - (1) Check the thrust clearance of the first gear, second gear and reverse gear.

Captions in illustration

*a	Reverse gear thrust clearance
*b	Second gear thrust clearance
*c	First gear thrust clearance

Standard value

Gear	Standard value (mm {in})	Limit (mm {in})
First gear	0.15 to 0.40 {0.00590 to 0.0157}	0.40 {0.0157}
Second gear	0.10 to 0.45 {0.00394 to 0.0177}	0.45 {0.0177}
Reverse gear	0.10 to 0.45 {0.00394 to 0.0177}	0.45 {0.0177}

<Reference>

When the result exceeds the limit, replace the respective gear, transmission clutch hub, needle roller bearing, and output shaft.

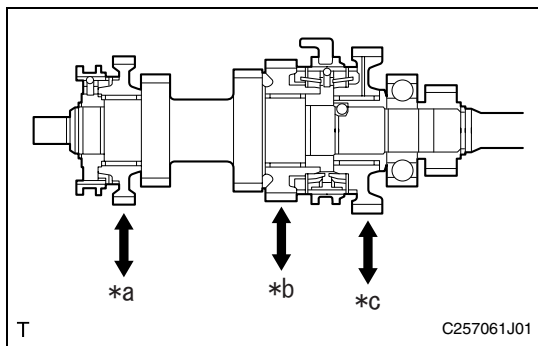

2. Check the radial clearance.
 - (1) Check the radial clearance of the first gear, second gear and reverse gear.

Captions in illustration

*a	Reverse gear radial clearance
*b	Second gear radial clearance
*c	First gear radial clearance

Standard value

Gear	Standard value (mm {in})	Limit (mm {in})
First gear	0.015 to 0.066 {0.000590 to 0.00260}	0.066 {0.00260}
Second gear	0.015 to 0.066 {0.000590 to 0.00260}	0.066 {0.00260}
Reverse gear	0.015 to 0.066 {0.000590 to 0.00260}	0.066 {0.00260}

<Reference>

When the result exceeds the limit, replace the respective gear, needle roller bearing, and output shaft.

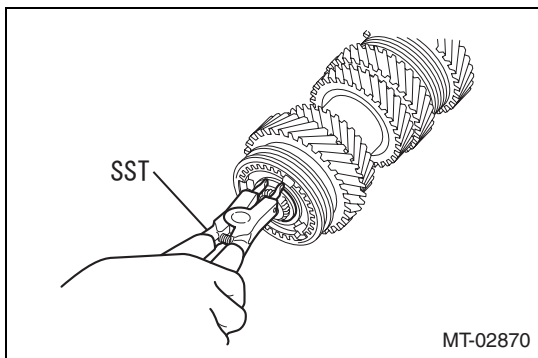

3. Remove the reverse gear.
 - (1) Using the SST, remove the shaft snap ring.
SST 499895400

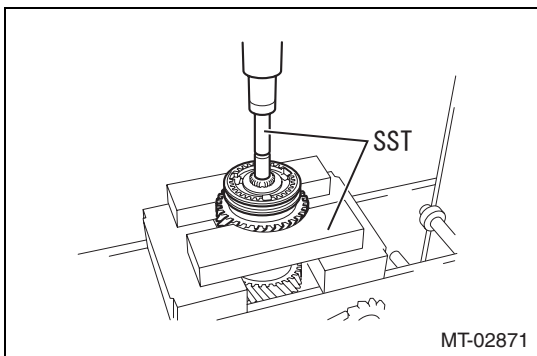

- (2) Using the SST, remove the transmission clutch hub No. 3, transmission hub sleeve No. 3, reverse gear, synchronizer ring No. 3, and reverse gear bearing from the output shaft.

SST 899714110, 899864100

<Caution>

Check the direction of the part.

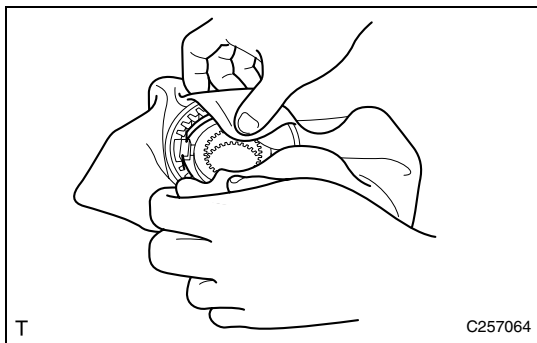

4. Remove the transmission hub sleeve No. 3.

- (1) Remove the transmission hub sleeve No. 3, and remove the three synchromesh shifting key No. 1s, three synchromesh shifting key spring No. 1s, and three balls from the transmission clutch hub No. 3.

<Caution>

- Use a cloth to prevent the synchromesh shifting key No. 1s, synchromesh shifting key spring No. 1s, and balls from flying out.
- Do not deform the synchromesh shifting key spring No. 1s.

<Reference>

Perform the procedure without moving the positions of the transmission clutch hub No. 3 and synchromesh shifting key No. 1s.

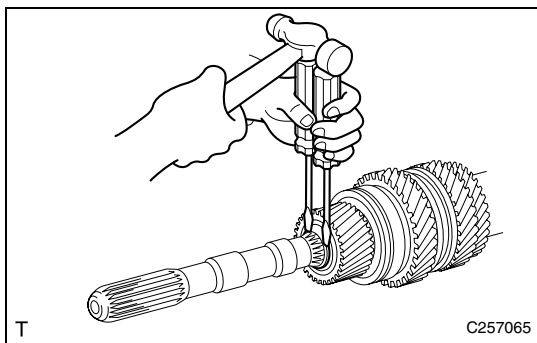

5. Remove the sixth gear.

- (1) Remove the shaft snap ring.

<Caution>

Use a cloth to prevent the shaft snap ring from flying out.

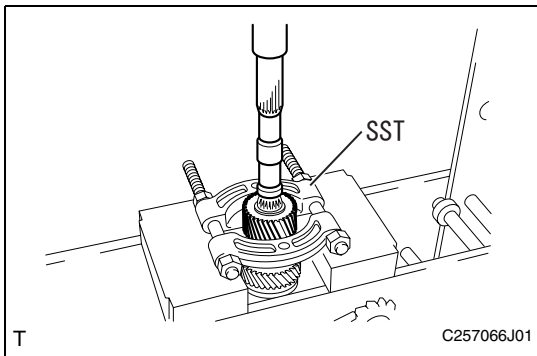

- (2) Using the SST, remove the sixth gear.

SST 09950-00020

MT

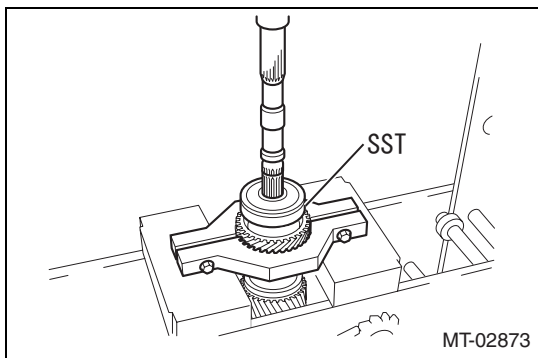

6. Remove the first gear.
 - (1) Using the SST, remove the output shaft bearing RR, first gear, first bearing inner race, first gear needle roller bearing, and first shift restrict ball.

SST 18722AA000

<Caution>
Check the direction of the part.

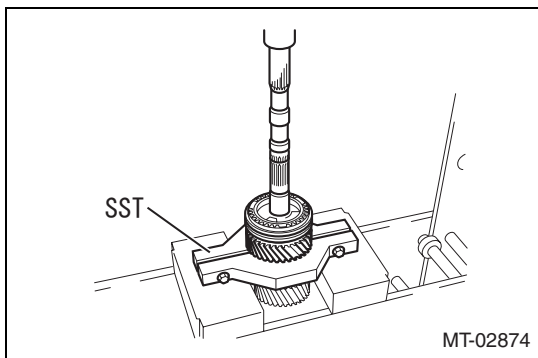

7. Remove the second gear.
 - (1) Using the SST, remove the second gear, transmission clutch hub No. 1, transmission hub sleeve No. 1, and second gear needle roller bearing from the output shaft.

SST 18722AA000

<Caution>
Check the direction of the part.

8. Remove the synchronizer ring set No. 1.
 - (1) Remove the two sets of the synchronizer ring set No. 1.

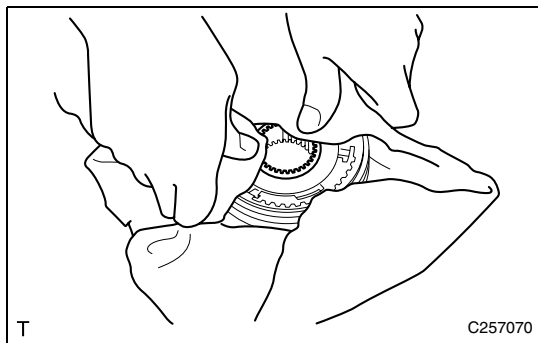

9. Remove the transmission hub sleeve No. 1.
 - (1) Remove the transmission hub sleeve No. 1, and remove the three synchromesh shifting key No. 1s, three synchromesh shifting key spring No. 1s, and three balls from the transmission clutch hub No. 1.

<Caution>

 - Use a cloth to prevent the synchromesh shifting key No. 1s, synchromesh shifting key spring No. 1s, and balls from flying out.
 - Do not deform the synchromesh shifting key spring No. 1s.

<Reference>
Perform the procedure without moving the positions of the transmission clutch hub No. 1 and synchromesh shifting key No. 1s.

INSPECTION

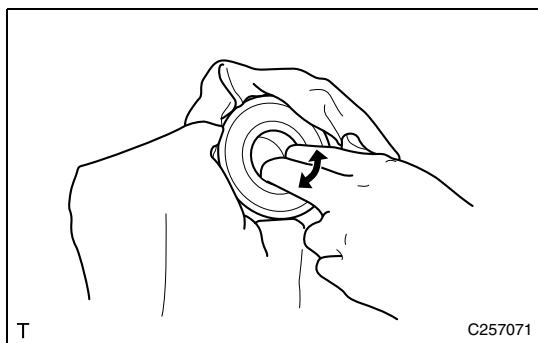

1. Check the output shaft bearing RR.
 - (1) Check the output shaft bearing RR.

Specification: There is no abnormal feel in the part movement, binds, abnormal noise or loose fit.

<Reference>
If defective, replace the output shaft bearing RR.

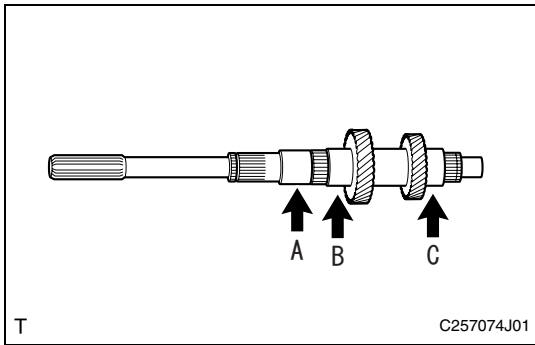

2. Check the output shaft.

- (1) Check the outer diameter of each portion.

Standard value

Check position	Standard value (mm {in})	Limit (mm {in})
A	31.984 to 32.000 {1.25921 to 1.25984}	31.984 {1.25921}
B	42.984 to 43.000 {1.69228 to 1.69291}	42.984 {1.69228}
C	40.984 to 41.000 {1.61354 to 1.61417}	40.984 {1.61354}

<Reference>

When the result is below the limit, replace the output shaft.

- (2) Check the runout at the positions shown in the figure.

Standard value: 0.03 mm {0.00118 in} or less

<Reference>

When the result is not within the standard value, replace the output shaft.

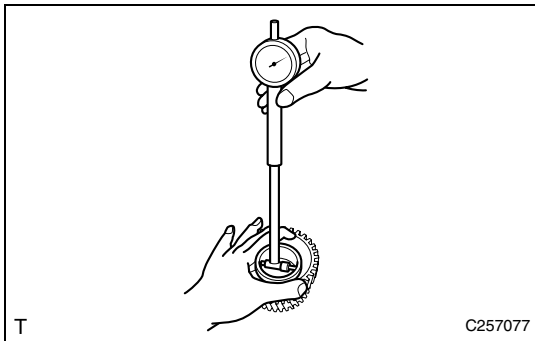
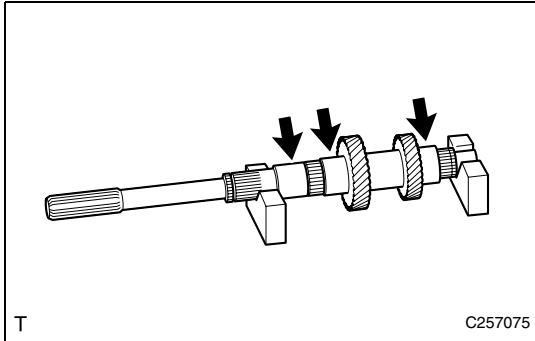

3. Check the reverse gear.

- (1) Measure the inner diameter of reverse gear.

Standard value: 47.015 to 47.040 mm {1.85098 to 1.85197 in}

Limit: 47.040 mm {1.85197 in}

<Reference>

When the result exceeds the limit, replace the reverse gear.

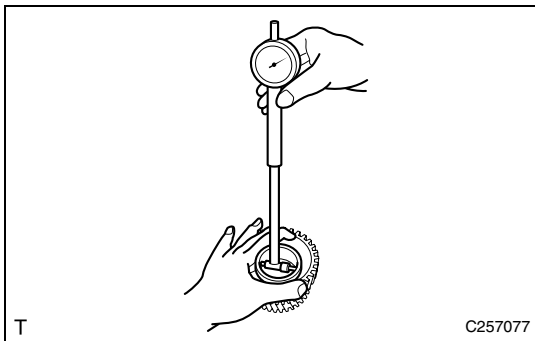

4. Check the first gear.

- (1) Measure the inner diameter of first gear.

Standard value: 46.315 to 46.340 mm {1.82425 to 1.82441 in}

Limit: 46.340 mm {1.82441 in}

<Reference>

When the result exceeds the limit, replace the first gear.

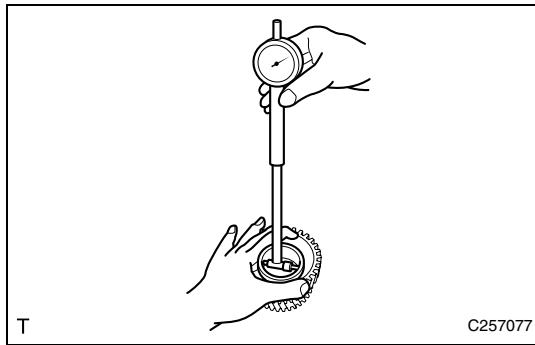

5. Check the second gear.
- (1) Measure the inner diameter of second gear.
Standard value: 49.015 to 49.040 mm {1.92972 to 1.93071 in}
Limit: 49.040 mm {1.93071 in}
<Reference>
When the result exceeds the limit, replace the second gear.

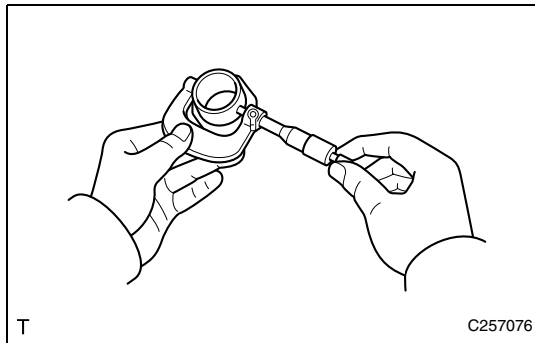

6. Check the first gear bearing inner race.
- (1) Check the outer diameter of first gear bearing inner race.
Standard value: 40.284 to 40.300 mm {1.58598 to 1.58661 in}
Limit: 40.284 mm {1.58598 in}
<Reference>
When the result is below the limit, replace the first gear bearing inner race.

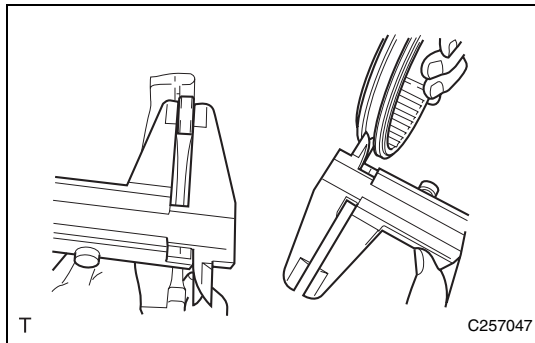

7. Check the transmission hub sleeve No. 1 clearance.
- (1) Measure the thickness of the claw of gear shift fork No. 1.
Standard value: 7.9 to 8.0 mm {0.311 to 0.315 in}
Limit: 7.9 mm {0.311 in}
<Reference>
When the result is below the limit, replace the gear shift fork No. 1.
 - (2) Measure the groove of transmission hub sleeve No. 1, and calculate the clearance between the gear shift fork No. 1.
Standard value: 0.15 to 0.35 mm {0.00590 to 0.0138 in}
Limit: 0.35 mm {0.0138 in}
<Reference>
When the result exceeds the limit, replace the gear shift fork No. 1 and transmission hub sleeve No. 1 as a set.

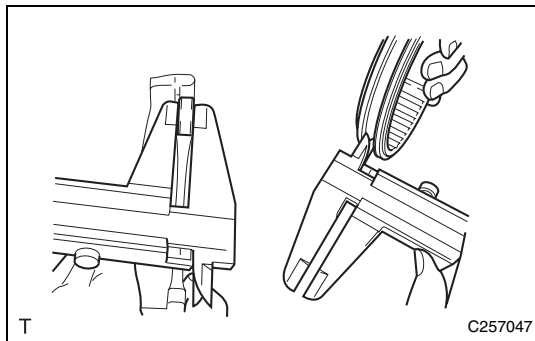

8. Check the transmission hub sleeve No. 3 clearance.
- (1) Measure the thickness of the claw of gear shift fork No. 3.
Standard value: 7.9 to 8.0 mm {0.311 to 0.315 in}
Limit: 7.9 mm {0.311 in}
<Reference>
When the result is below the limit, replace the gear shift fork No. 3.
 - (2) Measure the groove of transmission hub sleeve No. 3, and calculate the clearance between the gear shift fork No. 3.
Standard value: 0.15 to 0.35 mm {0.00590 to 0.0138 in}
Limit: 0.35 mm {0.0138 in}
<Reference>
When the result exceeds the limit, replace the gear shift fork No. 3 and transmission hub sleeve No. 3 as a set.

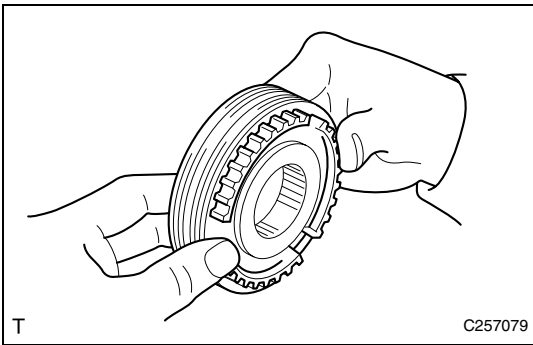

9. Check the transmission hub sleeve No. 1.
 - (1) Check the spline gear edge of the transmission hub sleeve No. 1 for wear.

<Reference>
When wear is present, replace the transmission hub sleeve No. 1.
 - (2) Install the transmission hub sleeve No. 1 to the transmission clutch hub No. 1, and check for smooth sliding.

<Reference>
When sliding is not smooth, replace the transmission hub sleeve No. 1 and transmission clutch hub No. 1.

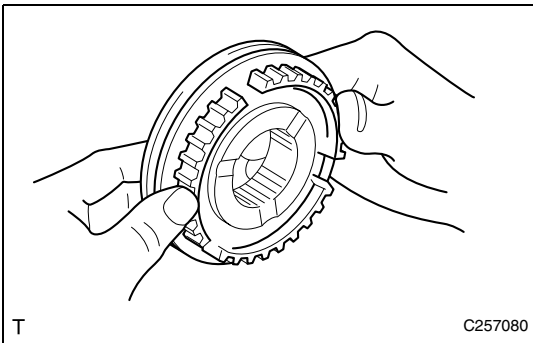

10. Check the transmission hub sleeve No. 3.
 - (1) Check the spline gear edge of the transmission hub sleeve No. 3 for wear.

<Reference>
When wear is present, replace the transmission hub sleeve No. 3.
 - (2) Install the transmission hub sleeve No. 3 to the transmission clutch hub No. 3, and check for smooth sliding.

<Reference>
When sliding is not smooth, replace the transmission hub sleeve No. 3 and transmission clutch hub No. 3.

11. Check the synchronizer ring set No. 1. (For the first gear)

- (1) Apply manual transmission oil to the taper cone portion of the first gear and synchronizer ring set No. 1, and with the synchronizer ring set No. 1 tightly fit by pressing by hand, check the clearance between the synchronizer ring set No. 1 and first gear.

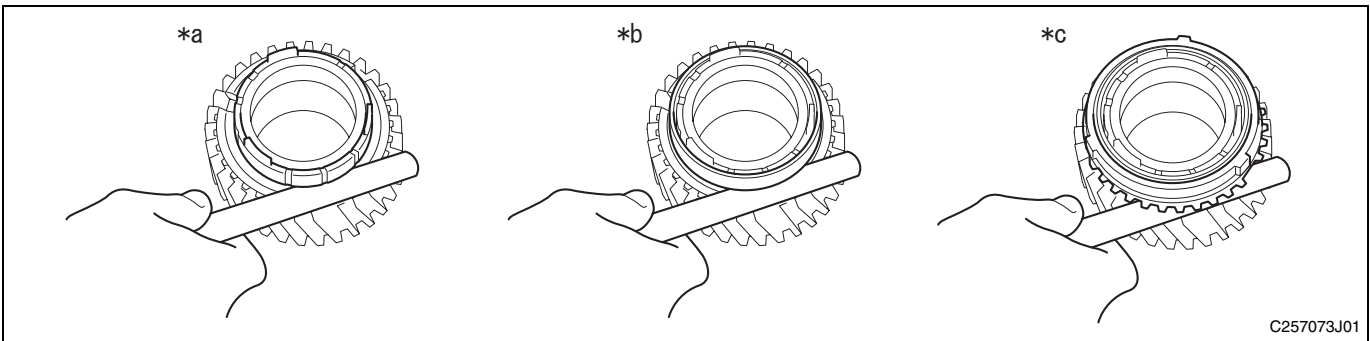

Captions in illustration

*a	Inner	*b	Middle
*c	Outer	-	-

Standard value

Measurement position	Standard value (mm {in})
Inner	0.48 to 1.12 {0.0189 to 0.0441}
Middle	0.38 to 1.22 {0.0150 to 0.0480}
Outer	0.8 to 1.8 {0.0315 to 0.0709}

<Caution>

Check for the entire circumference of the gear.

<Reference>

- When the result is not within the standard value, replace the synchronizer ring set No. 1.
- Use recommended or substitute products for manual transmission oil. (Refer to PP-8)



MT

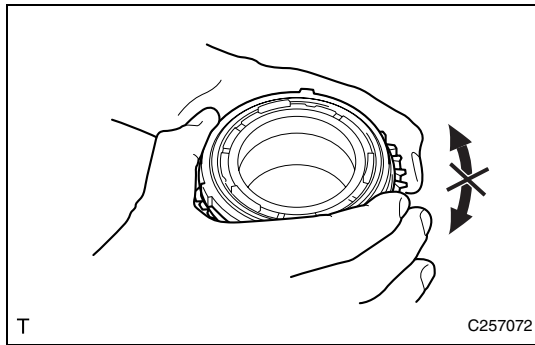

- (2) Apply manual transmission oil to the taper cone portion of the first gear, and with the synchronizer ring set No. 1 tightly fit by pressing by hand, check there is no slippage in the circumferential direction.
- <Reference>
- When slippage occurs, replace the synchronizer ring set No. 1.
 - Use recommended or substitute products for manual transmission oil. (Refer to PP-8)

12. Check the synchronizer ring set No. 1. (For the second gear)

- (1) Apply manual transmission oil to the taper cone portion of the second gear and synchronizer ring set No. 1, and with the synchronizer ring set No. 1 tightly fit by pressing by hand, check the clearance between the synchronizer ring set No. 1 and second gear.

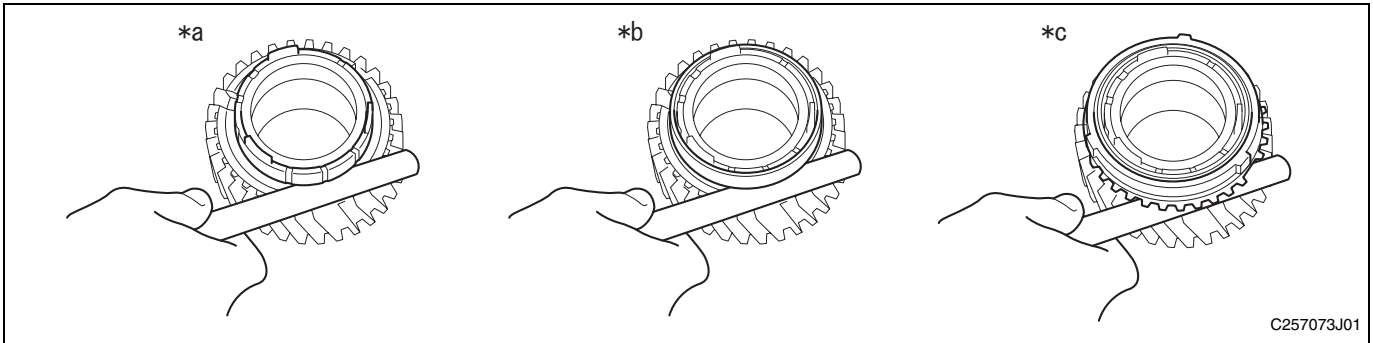

Captions in illustration

*a	Inner	*b	Middle
*c	Outer	-	-

Standard value

Measurement position	Standard value (mm {in})
Inner	0.48 to 1.12 {0.0189 to 0.0441}
Middle	0.38 to 1.22 {0.0150 to 0.0480}
Outer	0.8 to 1.8 {0.0315 to 0.0709}

<Caution>

Check for the entire circumference of the gear.

<Reference>

- When the result is not within the standard value, replace the synchronizer ring set No. 1.
- Use recommended or substitute products for manual transmission oil. (Refer to PP-8)

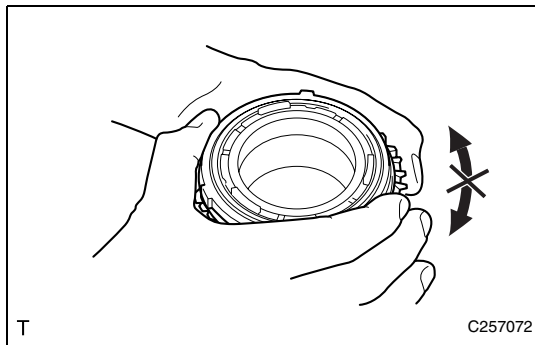

- (2) Apply manual transmission oil to the taper cone portion of the second gear, and with the synchronizer ring set No. 1 tightly fit by pressing by hand, check there is no slippage in the circumferential direction.
- <Reference>
- When slippage occurs, replace the synchronizer ring set No. 1.
 - Use recommended or substitute products for manual transmission oil. (Refer to PP-8)

ASSEMBLY

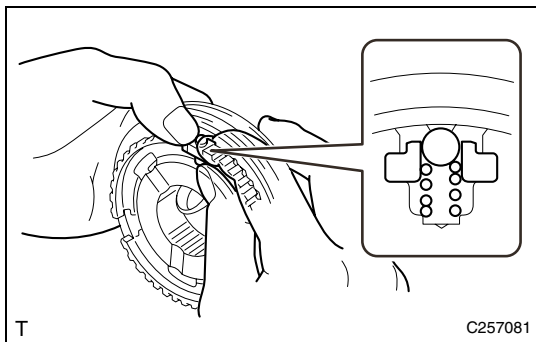

1. Install the transmission hub sleeve No. 1.
 - (1) Apply manual transmission oil to the sliding surface of transmission clutch hub No. 1.

<Reference>
Use recommended or substitute products for manual transmission oil. (Refer to PP-8)
 - (2) First install the transmission hub sleeve No. 1 to the transmission clutch hub No. 1, then install the three synchronesh shifting key No. 1s and the three synchronesh shifting key spring No. 1s as a unit, and lastly install the three balls.

<Reference>

 - Install the balls, while compressing the synchronesh shifting key spring No. 1s.
 - After finishing the installation, let the synchronesh shifting key spring No. 1s sit for a while.

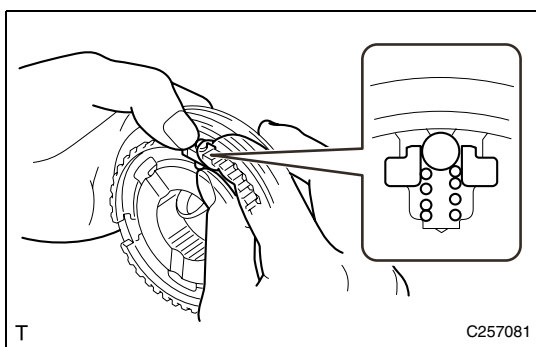

2. Install the transmission hub sleeve No. 3.
 - (1) Apply manual transmission oil to the sliding surface of transmission clutch hub No. 3.

<Reference>
Use recommended or substitute products for manual transmission oil. (Refer to PP-8)
 - (2) First install the transmission hub sleeve No. 3 to the transmission clutch hub No. 3, then install the three synchronesh shifting key No. 1s and the three synchronesh shifting key spring No. 1s as a unit, and lastly install the three balls.

<Reference>

 - Install the balls, while compressing the synchronesh shifting key spring No. 1s.
 - After finishing the installation, let the synchronesh shifting key spring No. 1s sit for a while.

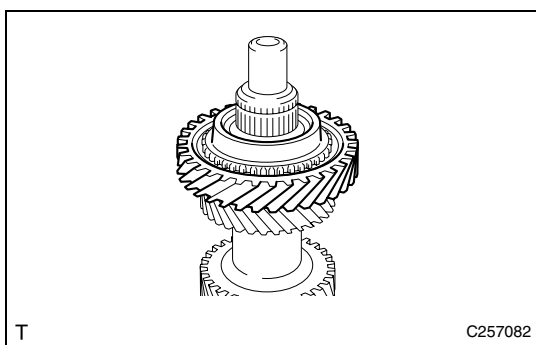

3. Install the reverse gear.
 - (1) Apply manual transmission oil to the installation portion of the output shaft, reverse gear bearing, and inner surface and taper cone portion of reverse gear.

<Reference>
Use recommended or substitute products for manual transmission oil. (Refer to PP-8)
 - (2) Install the reverse gear bearing and reverse gear to the output shaft.

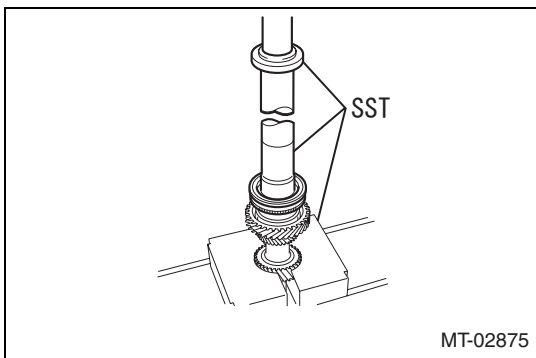

4. Install the transmission clutch hub No. 3.
 - (1) Install the synchronizer ring No. 3 to the reverse gear.
 - (2) Using the SST, install the transmission clutch hub No. 3.

SST 499277100, 398477703, 899714110

<Reference>

 - After installing the transmission clutch hub No. 3, make sure that the synchronizer ring moves in the thrust direction.
 - Press the transmission clutch hub No. 3 until it contacts the output shaft.
 - Align the transmission clutch hub No. 3 and synchronizer ring No. 3.

MT

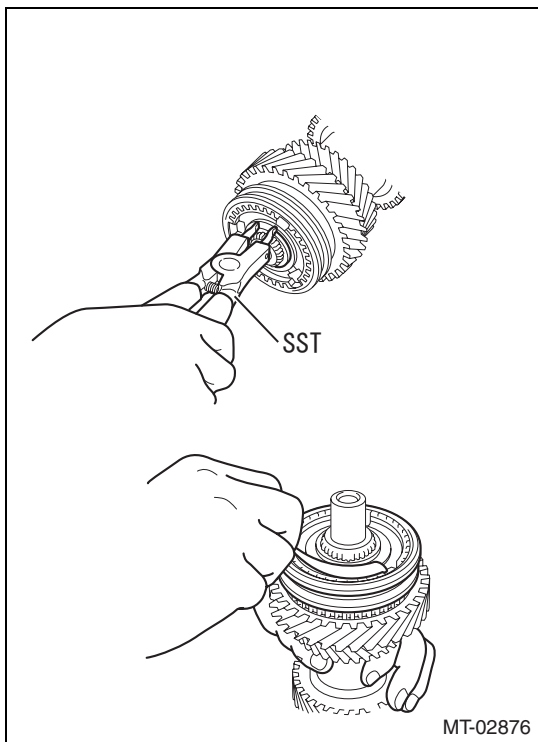

5. Install the shaft snap ring. (Transmission clutch hub No. 3)
 - (1) Select a shaft snap ring so that the thrust gap between the transmission clutch hub No. 3 and shaft snap ring is within the standard value.
 Standard value: 0 to 0.1 mm {0 to 0.00394 in}
 <Reference>
 Select a shaft snap ring with the maximum thickness possible.
 Shaft snap ring type

Item number	Thickness (mm {in})	Identification mark
17005AA520	1.80 {0.07086}	A
17005AA530	1.85 {0.07283}	B
17005AA540	1.90 {0.07480}	C
17005AA550	1.95 {0.07677}	D
17005AA560	2.00 {0.07874}	E
17005AA570	2.05 {0.08070}	F

- (2) Using the SST, install a new shaft snap ring to the output shaft.
 SST 499895400

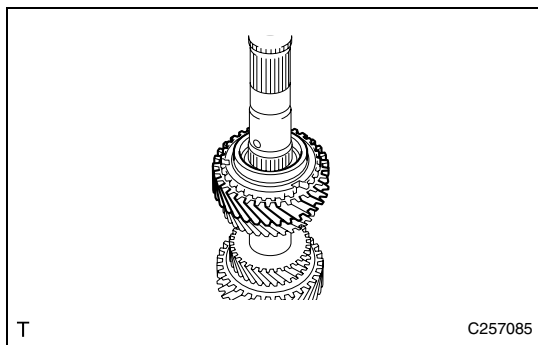

6. Install the second gear.
 - (1) Apply manual transmission oil to the installation portion of the output shaft, second gear needle roller bearing, and inner surface and taper cone portion of second gear.
 <Reference>
 Use recommended or substitute products for manual transmission oil. (Refer to PP-8)
 - (2) Install the second gear needle roller bearing and second gear to the output shaft.

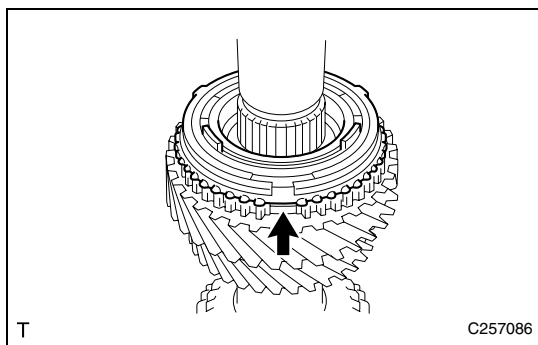

7. Install the transmission clutch hub No. 1.
 - (1) Install the synchronizer ring set No. 1 (for the second gear) in the position shown in the figure.
 <Caution>
 - Align the claw of middle ring with the gear groove.
 - Align the claw of inner ring with the outer ring groove.

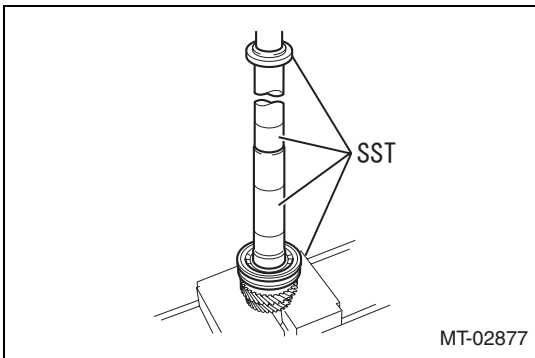

- (2) Using the SST, install the transmission clutch hub No. 1.
SST 499277100, 899714110, 398477703,
499277000

<Reference>

- After installing the transmission clutch hub No. 1, make sure that the synchronizer ring set No. 1 (for the second gear) moves in the thrust direction.
- Press the transmission clutch hub No. 1 until it contacts the output shaft.

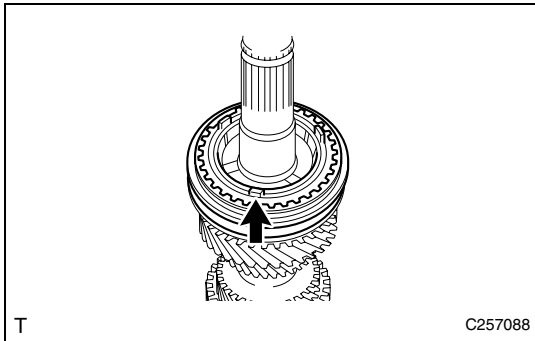

- (3) Install the synchronizer ring set No. 1 (for the first gear) in the position shown in the figure.

<Caution>

- Align the protruded section of outer ring with the hub groove.
- Align the claw of inner ring with the outer ring groove.

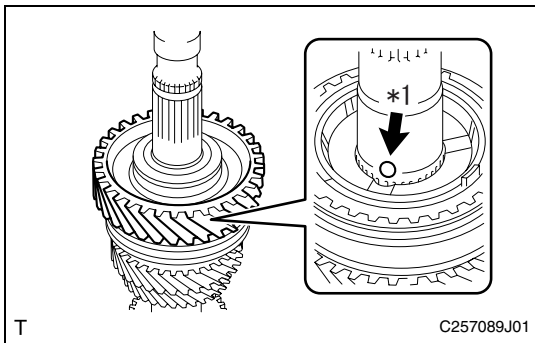

8. Install the first gear.

- (1) Apply manual transmission oil to the installation portion of the output shaft, needle roller bearing, bearing inner race, and inner surface and taper cone portion of first gear.

<Reference>

Use recommended or substitute products for manual transmission oil. (Refer to PP-8)

- (2) Install the first shift restrict ball, first gear, first gear needle roller bearing, and first gear bearing inner race to the output shaft.

<Caution>

Align the claw of middle ring with the gear groove.

Captions in illustration

*1	First shift restrict ball
----	---------------------------

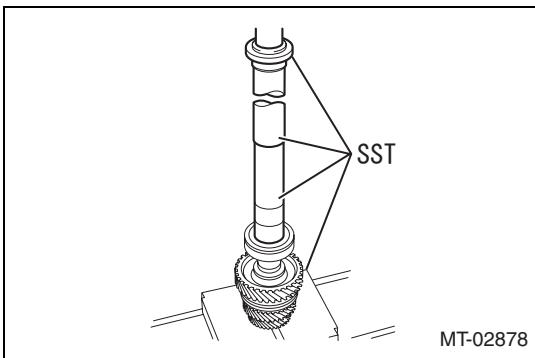

9. Install the output shaft bearing RR.

- (1) Using the SST, install the output shaft bearing RR.
SST 499277100, 899714110, 398477703,
499277000

<Reference>

Press the output shaft bearing RR until it contacts the first gear bearing inner race.

MT

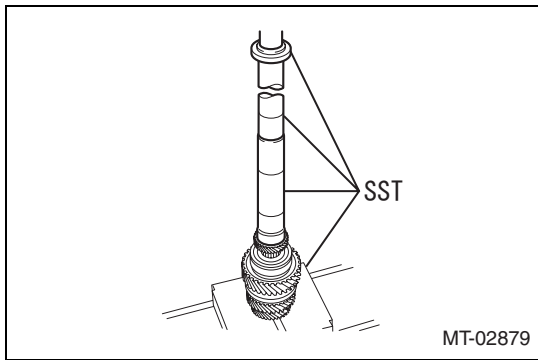

10. Install the sixth gear.

- (1) Using the SST, install the sixth gear.
SST 499277100, 899714110, 398477703,
499277000

<Reference>

Press the sixth gear until it contacts the output shaft bearing RR.

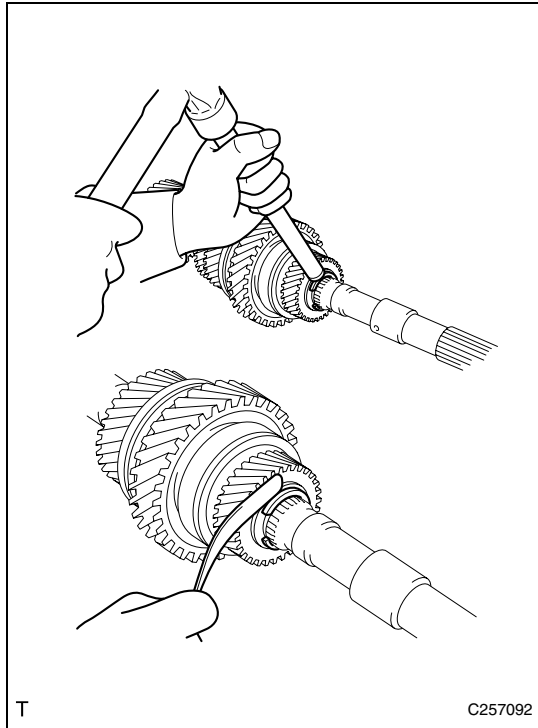

11. Install the shaft snap ring. (Sixth gear)

- (1) Select a shaft snap ring so that the thrust gap between the sixth gear and shaft snap ring is within the standard value.

Standard value: 0.1 to 0.11 mm {0.00394 to 0.00433 in}

<Reference>

Select a shaft snap ring with the maximum thickness possible.

Shaft snap ring type

Item number	Thickness (mm {in})	Identification mark
17005AA350	2.67 {0.10511}	A
17005AA360	2.73 {0.10748}	B
17005AA370	2.79 {0.10984}	C
17005AA380	2.85 {0.11220}	D
17005AA390	2.91 {0.11456}	E
17005AA400	2.97 {0.11692}	F
17005AA410	3.03 {0.11929}	G
17005AA420	3.09 {0.12165}	H
17005AA430	3.15 {0.12401}	J
17005AA440	3.21 {0.12638}	K
17005AA450	3.27 {0.12874}	L

- (2) Using a brass bar, install a new shaft snap ring to the output shaft.

COUNTER GEAR ASSY

EXPLODED VIEW

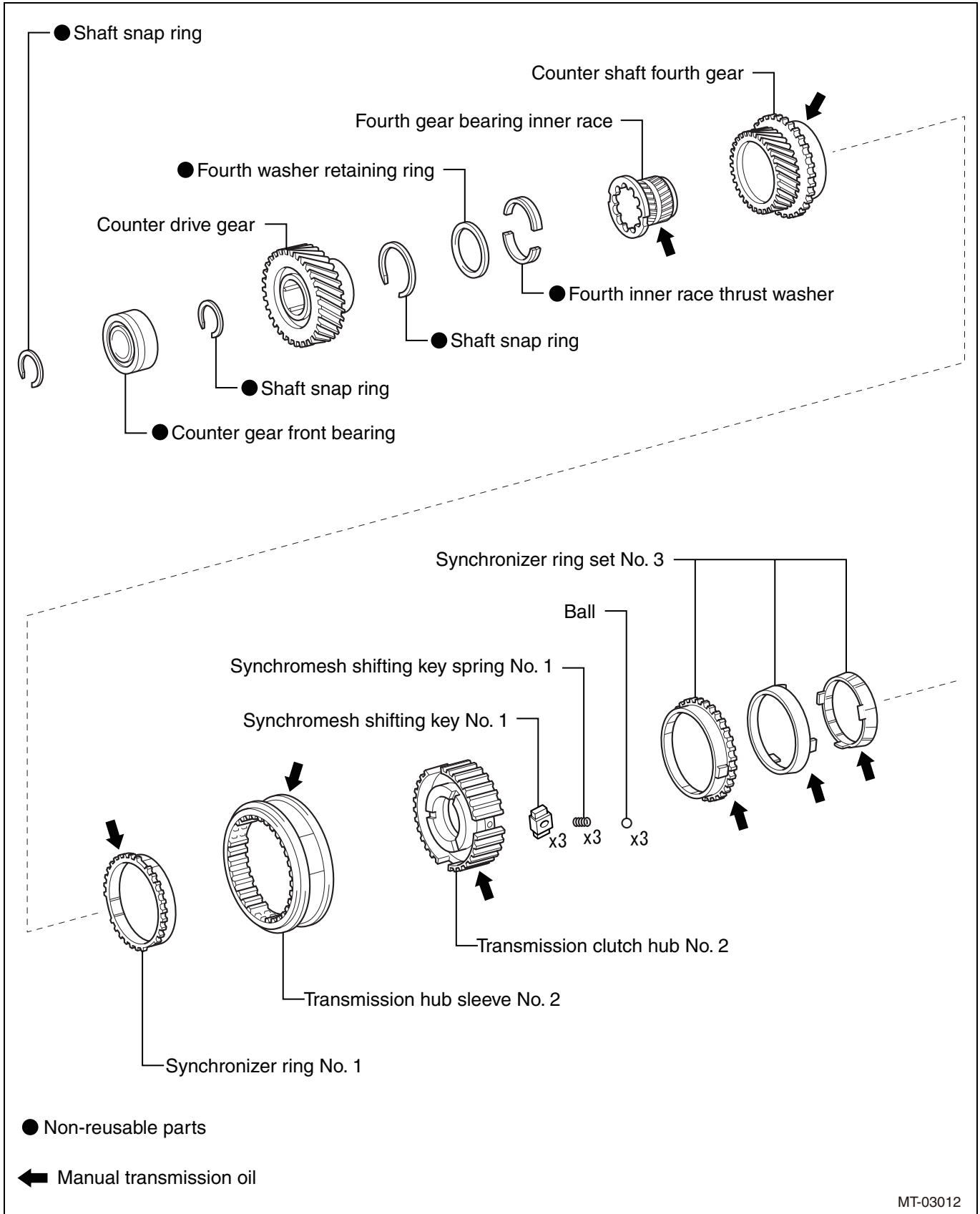

MT

<Reference>

Use recommended or substitute products for manual transmission oil. (Refer to PP-8)

MT

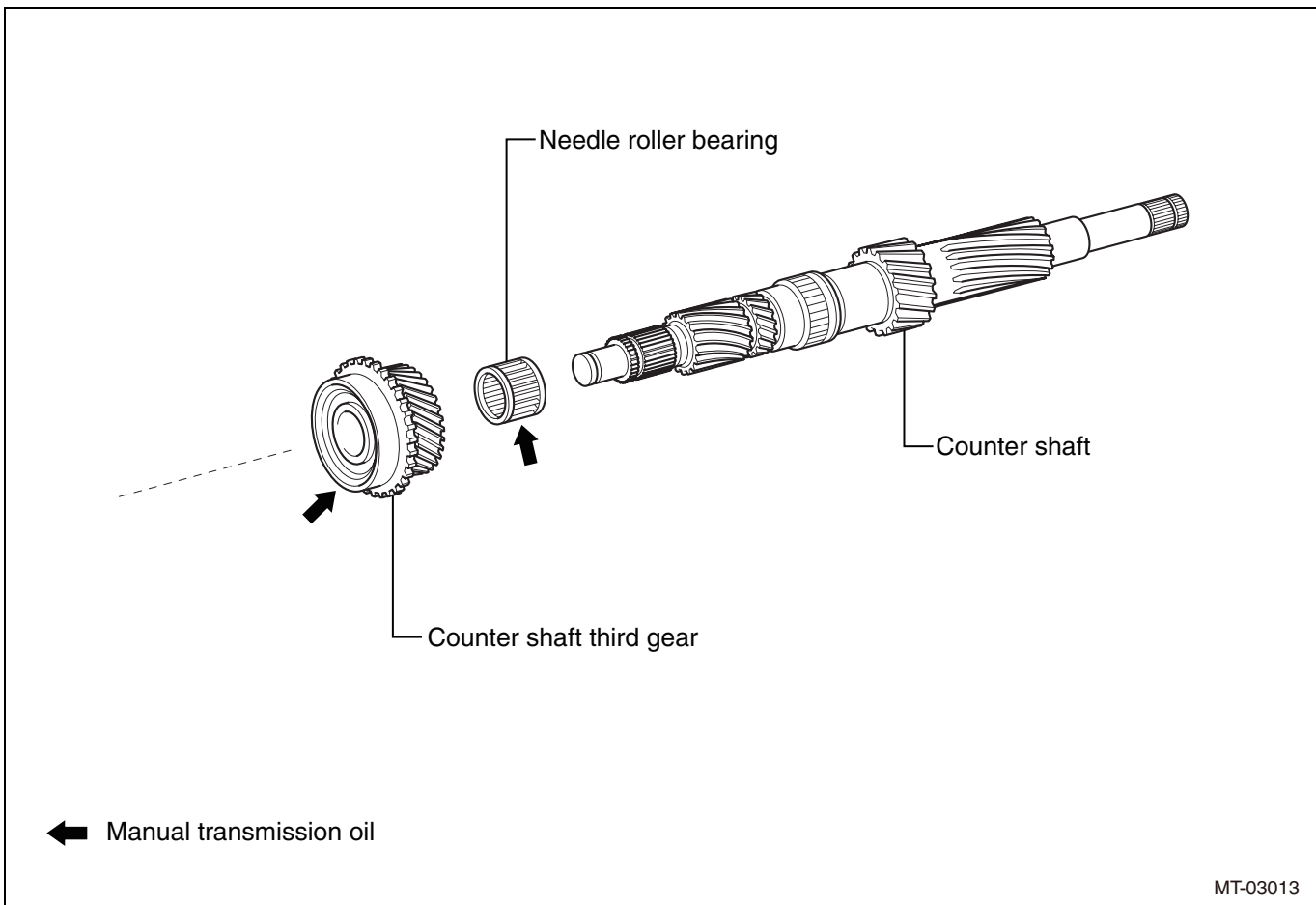

MT-03013

<Reference>

Use recommended or substitute products for manual transmission oil. (Refer to PP-8)

DISASSEMBLY

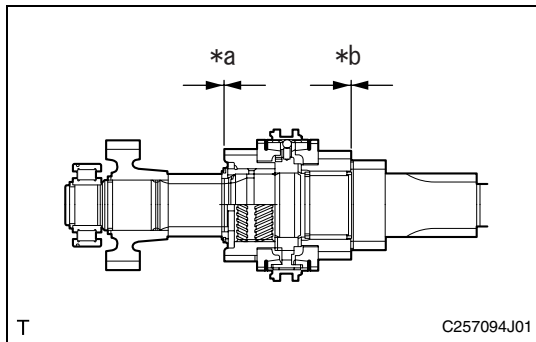

1. Check the thrust clearance.
 - (1) Check the thrust clearance of the counter shaft third gear and counter shaft fourth gear.

Captions in illustration

*a	Counter shaft fourth gear thrust clearance
*b	Counter shaft third gear thrust clearance

Standard value

Gear	Standard value (mm {in})	Limit (mm {in})
Counter shaft third gear	0.10 to 0.35 {0.00394 to 0.0138}	0.35 {0.0138}
Counter shaft fourth gear	0.10 to 0.35 {0.00394 to 0.0138}	0.35 {0.0138}

<Reference>

When the result exceeds the limit, adjust with the fourth inner race thrust washer.

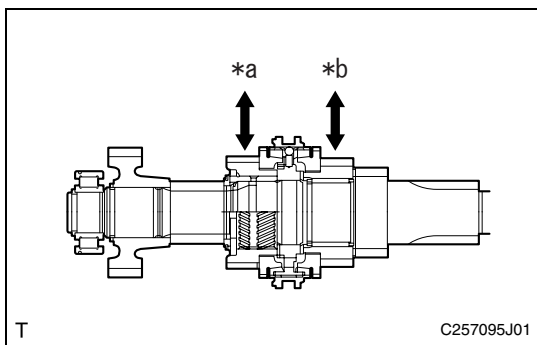

2. Check the radial clearance.
 - (1) Check the radial clearance of the counter shaft third gear and counter shaft fourth gear.

Captions in illustration

*a	Counter shaft fourth gear radial clearance
*b	Counter shaft third gear radial clearance

Standard value

Gear	Standard value (mm {in})	Limit (mm {in})
Counter shaft third gear	0.015 to 0.068 {0.000590 to 0.00268}	0.068 {0.00268}
Counter shaft fourth gear	0.065 to 0.115 {0.002559 to 0.00453}	0.115 {0.00453}

<Reference>

When the result exceeds the limit, replace the respective gear and needle roller bearing or fourth gear bearing inner race as a set.

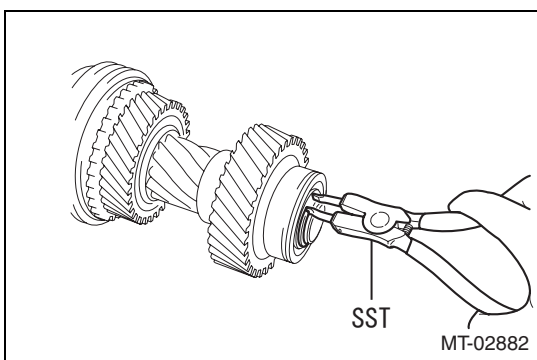

3. Remove the counter gear front bearing.
 - (1) Using the SST, remove the shaft snap ring.
SST 499895400

<Caution>

Check the direction of the part.

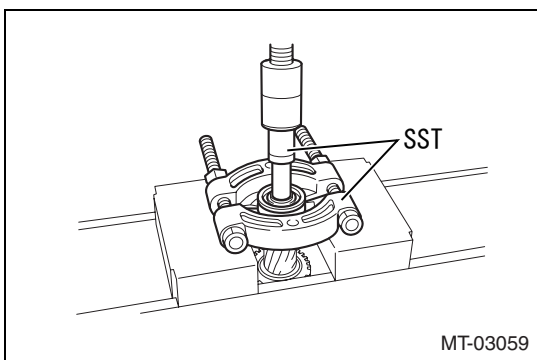

- (2) Using the SST, remove the counter gear front bearing.
SST 09950-00020, 899864100

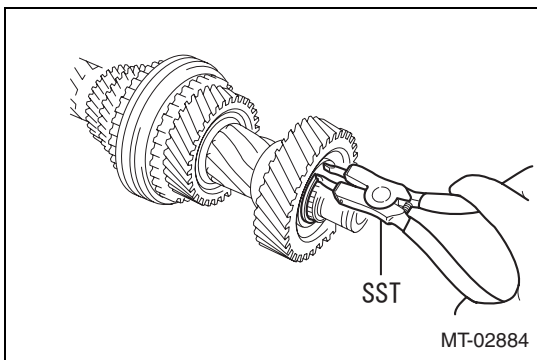

4. Remove the counter drive gear.
 - (1) Using the SST, remove the shaft snap ring.
SST 499895400

MT

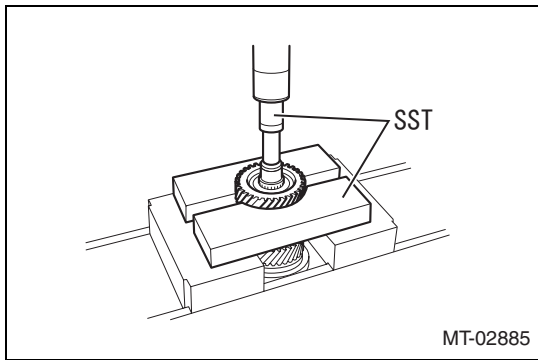

- (2) Using the SST, remove the counter drive gear.
SST 899714110, 899864100

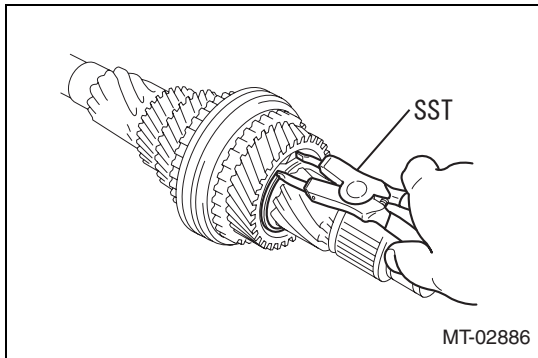

- 5. Remove the counter shaft fourth gear.
 - (1) Using the SST, remove the shaft snap ring, then the fourth washer retaining ring, and lastly fourth inner race thrust washer.
SST 499895400
<Caution>
Check the direction of the part.

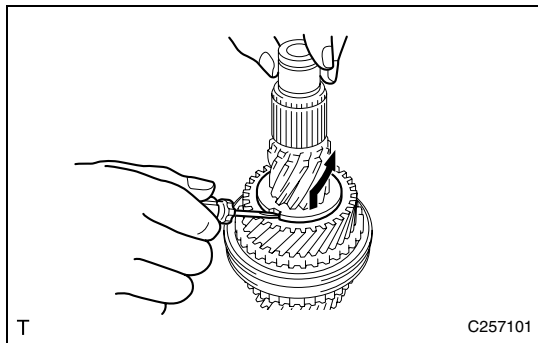

- (2) Remove the fourth gear bearing inner race, while prying with a flat tip screwdriver and rotating counterclockwise along the gear.

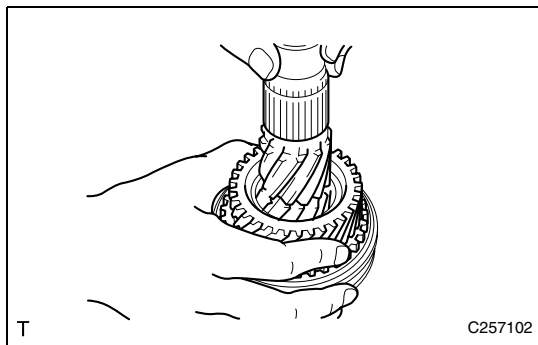

- (3) Remove the counter shaft fourth gear and synchronizer ring No. 1.

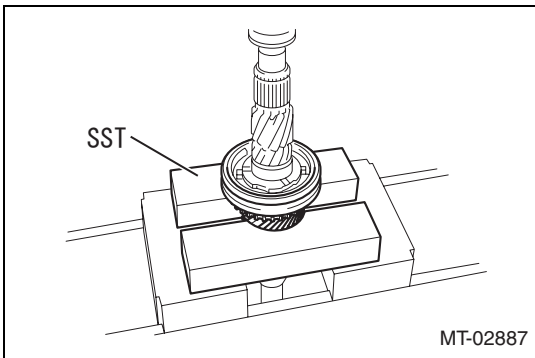

6. Remove the counter shaft third gear.

- (1) Using the SST, remove the transmission clutch hub No. 2, counter shaft third gear, synchronizer ring set No. 3, and needle roller bearing.

SST 899714110

<Caution>

Check the direction of the part.

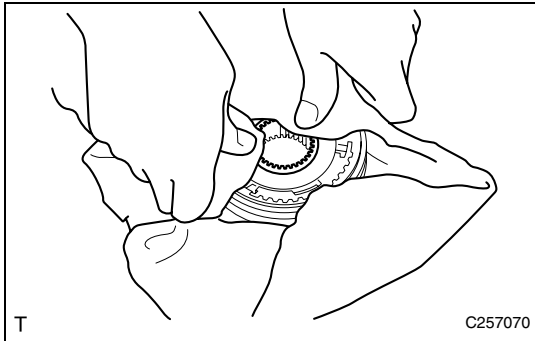

7. Remove the transmission hub sleeve No. 2.

- (1) Remove the transmission hub sleeve No. 2, and remove the three synchromesh shifting key No. 1s, three synchromesh shifting key spring No. 1s, and three balls from the transmission clutch hub No. 2.

<Caution>

- Use a cloth to prevent the synchromesh shifting key No. 1s, synchromesh shifting key spring No. 1s, and balls from flying out.
- Do not deform the synchromesh shifting key spring No. 1s.
- Check the direction of the part.

<Reference>

Perform the procedure without moving the positions of the transmission clutch hub No. 2 and synchromesh shifting key No. 1s.

INSPECTION

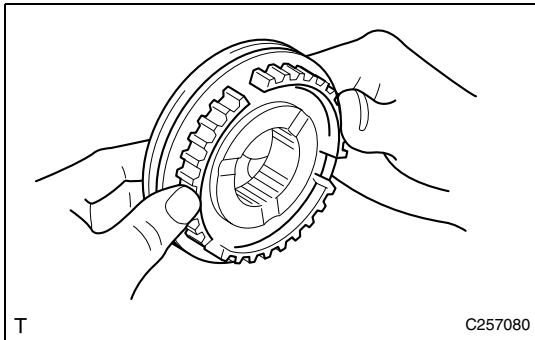

1. Check the transmission hub sleeve No. 2.

- (1) Check the spline gear edge of the transmission hub sleeve No. 2 for wear.

<Reference>

When wear is present, replace the transmission hub sleeve No. 2.

- (2) Install the transmission hub sleeve No. 2 to the transmission clutch hub No. 2, and check for smooth sliding.

<Reference>

When sliding is not smooth, replace the transmission hub sleeve No. 2 and transmission clutch hub No. 2.

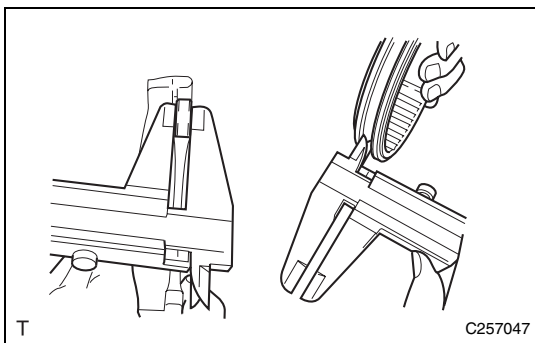

2. Check the transmission hub sleeve No. 2 clearance.

- (1) Measure the thickness of the claw of gear shift fork No. 2.

Standard value: 7.9 to 8.0 mm {0.311 to 0.315 in}

Limit: 7.9 mm {0.311 in}

<Reference>

When the result is below the limit, replace the gear shift fork No. 2.

- (2) Measure the groove of transmission hub sleeve No. 2, and calculate the clearance between the gear shift fork No. 2.

Standard value: 0.15 to 0.35 mm {0.00590 to 0.0138 in}

Limit: 0.35 mm {0.0138 in}

<Reference>

When the result exceeds the limit, replace the gear shift fork No. 2 and transmission hub sleeve No. 2 as a set.

MT

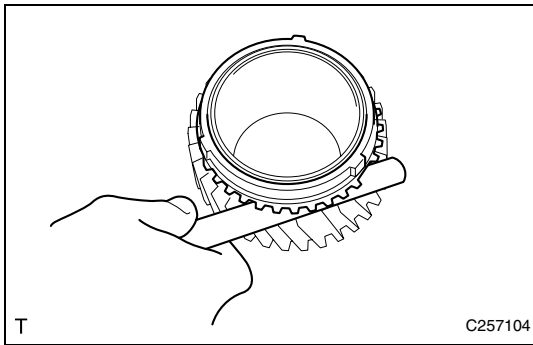

3. Check the synchronizer ring No. 1.
 - (1) Apply manual transmission oil to the taper cone portion of the counter shaft fourth gear, and with the synchronizer ring No. 1 tightly fit by pressing by hand, check the clearance between the synchronizer ring No. 1 and counter shaft fourth gear.
Standard value: 0.8 to 1.6 mm {0.0314 to 0.0629 in}
Limit: 0.8 mm {0.0314 in}

<Caution>

Check for the entire circumference of the gear.

<Reference>

- When the result is below the limit, replace the synchronizer ring No. 1 and counter shaft fourth gear.
- Use recommended or substitute products for manual transmission oil. (Refer to PP-8)

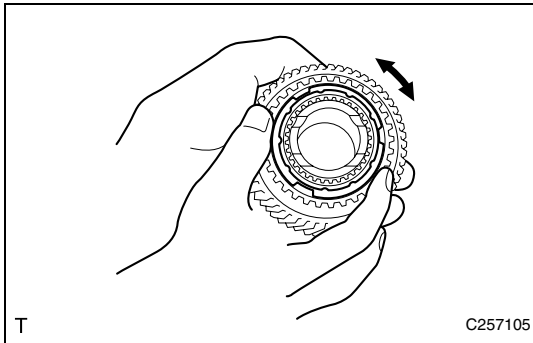

- (2) Apply manual transmission oil to the taper cone portion of the counter shaft fourth gear, and with the synchronizer ring No. 1 tightly fit by pressing by hand, check there is no slippage in the circumferential direction.

<Reference>

- When slippage occurs, replace the synchronizer ring No. 1 and counter shaft fourth gear.
- Use recommended or substitute products for manual transmission oil. (Refer to PP-8)

4. Check the synchronizer ring set No. 3.

- (1) Apply manual transmission oil to the taper cone portion of the counter shaft third gear and synchronizer ring set No. 3, and with the synchronizer ring set No. 3 tightly fit by pressing by hand, check the clearance between the synchronizer ring set No. 3 and counter shaft third gear.

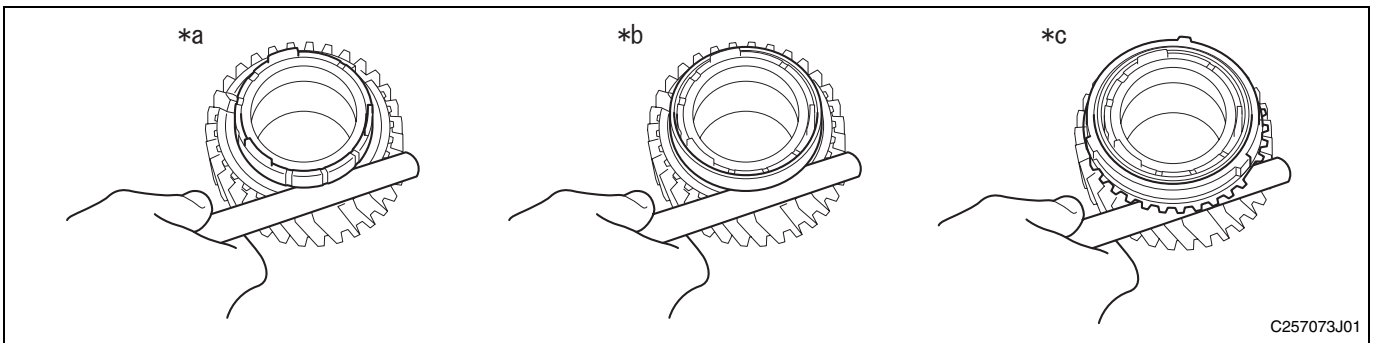

Captions in illustration

*a	Inner	*b	Middle
*c	Outer	-	-

Standard value

Measurement position	Standard value (mm {in})
Inner	0.4 to 1.2 {0.0157 to 0.0472}
Middle	0.3 to 1.3 {0.0118 to 0.0512}
Outer	0.8 to 1.8 {0.0315 to 0.0709}

<Caution>

Check for the entire circumference of the gear.

<Reference>

- When the result exceeds the limit, replace the synchronizer ring set No. 3.
- Use recommended or substitute products for manual transmission oil. (Refer to PP-8)

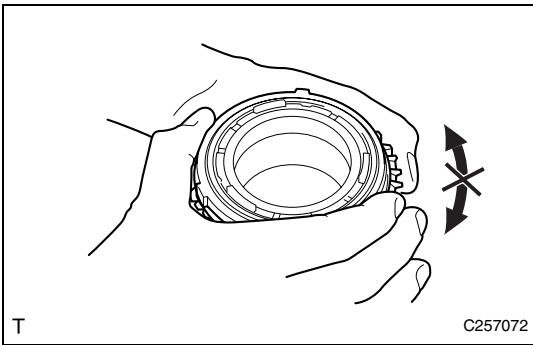

- (2) Apply manual transmission oil to the taper cone portion of the counter shaft third gear, and with the synchronizer ring set No. 3 tightly fit by pressing by hand, check there is no slippage in the circumferential direction.

<Reference>

- When slippage occurs, replace the synchronizer ring set No. 3.
- Use recommended or substitute products for manual transmission oil. (Refer to PP-8)

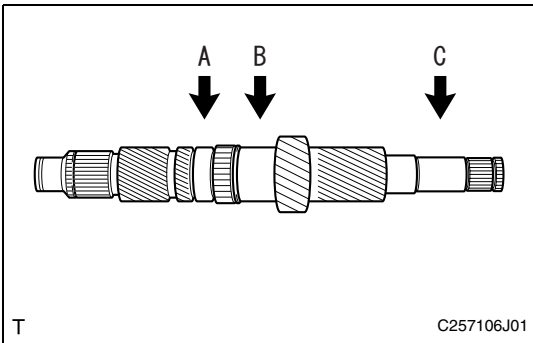

5. Check the counter shaft.

- (1) Check the outer diameter of each portion.

Standard value

Check position	Standard value (mm {in})	Limit (mm {in})
A	39.284 to 39.300 {1.54661 to 1.54721}	39.284 {1.54661}
B	37.984 to 38.000 {1.49543 to 1.49606}	37.984 {1.49543}
C	24.987 to 25.000 {0.98374 to 0.98425}	24.987 {0.98374}

<Reference>

When the result is below the limit, replace the counter shaft.

- (2) Check the runout at the positions shown in the figure.

Standard value: 0.03 mm {0.00118 in} or less

<Reference>

When the result is not within the standard value, replace the counter shaft.

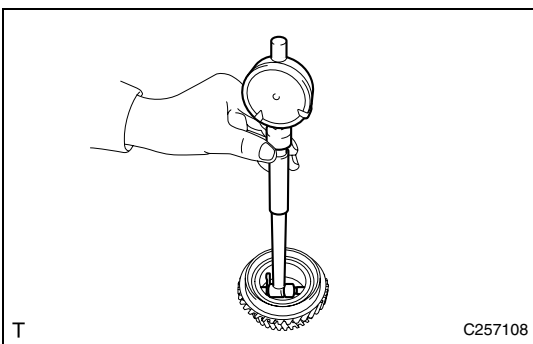
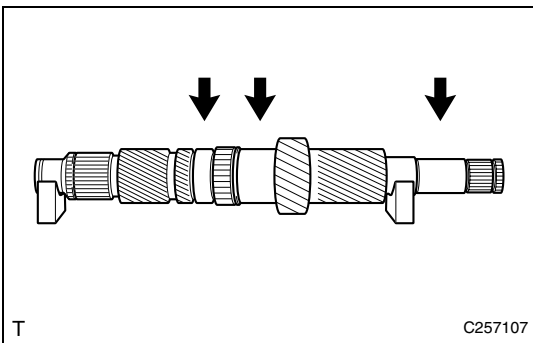

6. Check the counter shaft third gear.

- (1) Measure the inner diameter of counter shaft third gear.

Standard value: 43.015 to 43.040 mm {1.69350 to 1.69448 in}

Limit: 43.040 mm {1.69448 in}

<Reference>

When the result exceeds the limit, replace the counter shaft third gear.

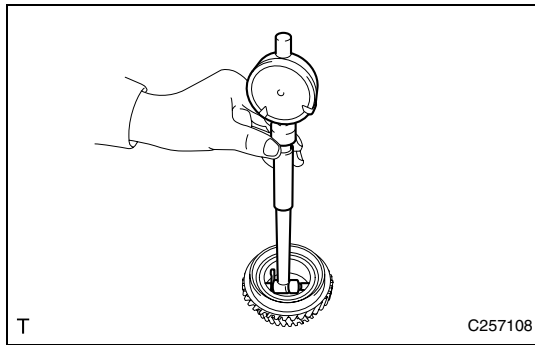

7. Check the counter shaft fourth gear.
 - (1) Measure the inner diameter of counter shaft fourth gear.
 Standard value: 46.315 to 46.340 mm {1.82425 to 1.82441 in}
 Limit: 46.340 mm {1.82441 in}
 <Reference>
 When the result exceeds the limit, replace the counter shaft fourth gear.

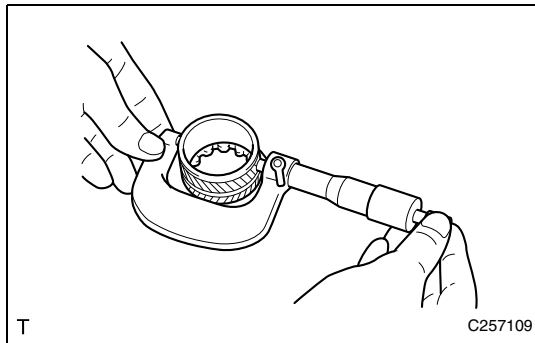

8. Check the fourth gear bearing inner race.
 - (1) Check the outer diameter of fourth gear bearing inner race.
 Standard value: 46.225 to 46.250 mm {1.81988 to 1.82087 in}
 Limit: 46.225 mm {1.81988 in}
 <Caution>
 Do not measure the oil groove.
 <Reference>
 When the result is below the limit, replace the fourth gear bearing inner race.

ASSEMBLY

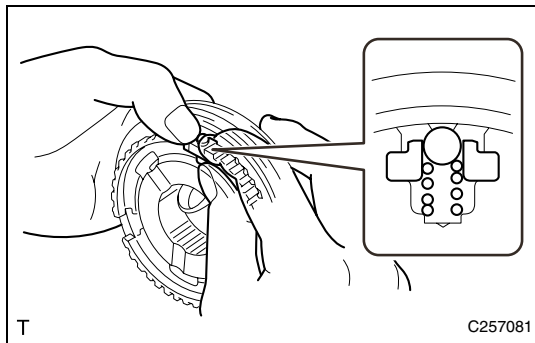

1. Install the transmission hub sleeve No. 2.
 - (1) Apply manual transmission oil to the sliding surface of transmission clutch hub No. 2.
 <Reference>
 Use recommended or substitute products for manual transmission oil. (Refer to PP-8)
 - (2) First install the transmission hub sleeve No. 2 to the transmission clutch hub No. 2, then install the three synchromesh shifting key No. 1s and the three synchromesh shifting key spring No. 1s as a unit, and lastly install the three balls.
 <Reference>
 - Install the shifting key pole, while compressing the shifting key spring. Install the balls, while compressing the synchromesh shifting key spring No. 1s.
 - After finishing the installation, let the synchromesh shifting key spring No. 1s sit for a while.

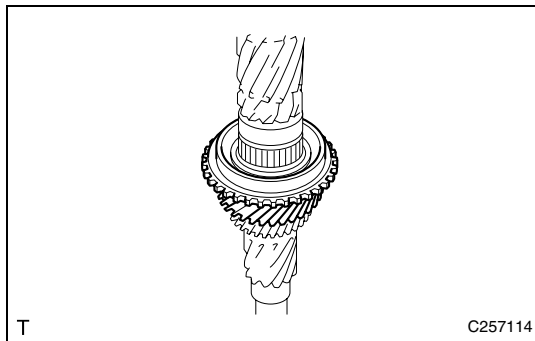

2. Install the counter shaft third gear.
 - (1) Apply manual transmission oil to the installation portion of the counter shaft, needle roller bearing, and inner surface and taper cone portion of counter shaft third gear.
 <Reference>
 Use recommended or substitute products for manual transmission oil. (Refer to PP-8)
 - (2) Install the needle roller bearing and counter shaft third gear.

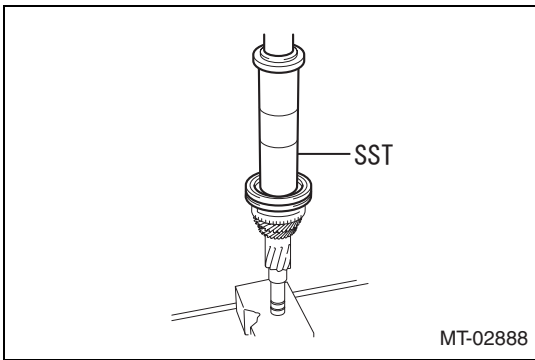

3. Install the transmission clutch hub No. 2.

(1) Install the synchronizer ring set No. 3 to the counter shaft third gear.

- Align the claw of middle ring with the gear groove.
- Align the claw of inner ring with the outer ring groove.

(2) Using the SST, install the transmission clutch hub No. 2.

SST 18654AA000, 398477703

<Caution>

Check the position of the synchronizer ring set No. 3.

<Reference>

- Press-fit the transmission clutch hub No. 2 until it contacts the counter shaft.
- After press-fitting, make sure that the synchronizer ring set No. 3 moves in the thrust direction.

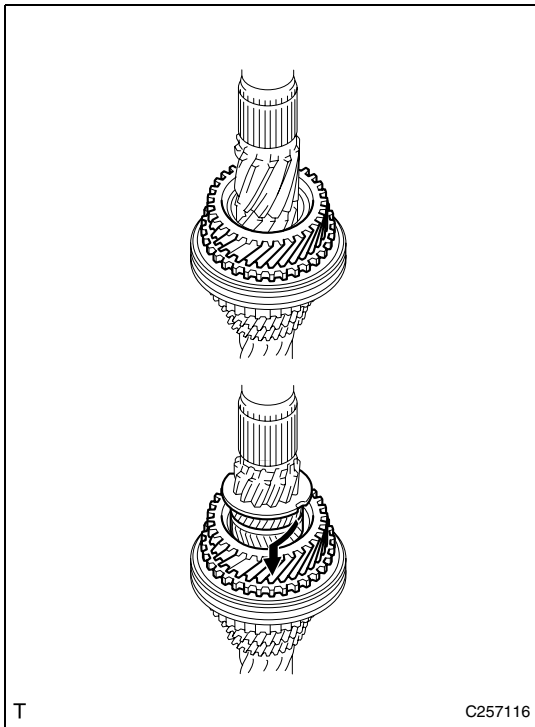

4. Install the counter shaft fourth gear.

(1) Install the synchronizer ring No. 1 to the transmission clutch hub No. 2.

(2) Apply manual transmission oil to the fourth gear bearing inner race, and inner surface and taper cone portion of counter shaft fourth gear.

<Reference>

Use recommended or substitute products for manual transmission oil. (Refer to PP-8)

(3) Install the counter shaft fourth gear and fourth gear bearing inner race.

<Reference>

Install the fourth gear bearing inner race, while rotating clockwise along the gear.

MT

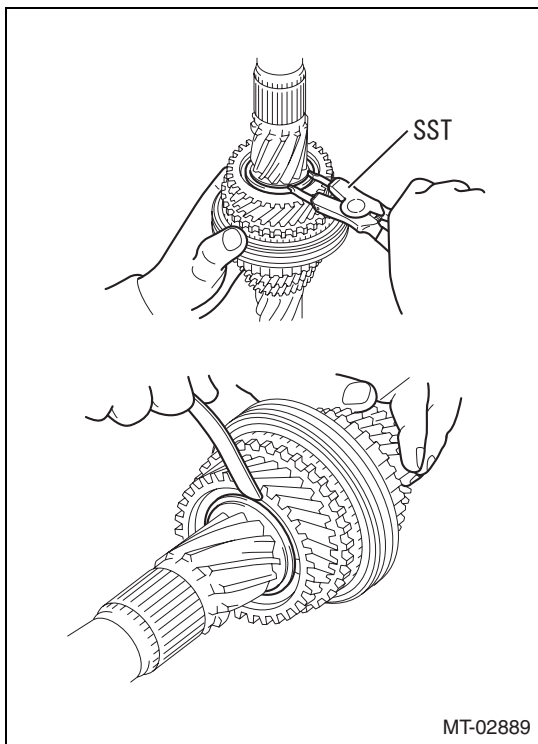

MT-02889

5. Install the fourth inner race thrust washer.
 - (1) Select a fourth inner race thrust washer so that the thrust gap between the fourth gear bearing inner race and fourth inner race thrust washer is within the standard value.

Standard value: 0 to 0.1 mm {0 to 0.00394 in}

<Reference>

Select a fourth inner race thrust washer with the maximum thickness possible.

Type of fourth inner race thrust washer

Item number	Thickness (mm {in})	Identification mark
17002AA090	3.75 {0.14763}	A
17002AA100	3.80 {0.14960}	B
17002AA110	3.85 {0.15157}	C
17002AA120	3.90 {0.15354}	D
17002AA130	3.95 {0.15551}	E
17002AA140	4.00 {0.15748}	F
17002AA150	4.05 {0.15944}	G
17002AA160	4.10 {0.16141}	H

- (2) Using the SST, install a new fourth inner race thrust washer, a new fourth washer retaining ring, and a new shaft snap ring to the counter shaft.

SST 499895400

6. Install the counter drive gear.

- (1) Using the SST, install the counter drive gear.

SST 499277000, 398477703

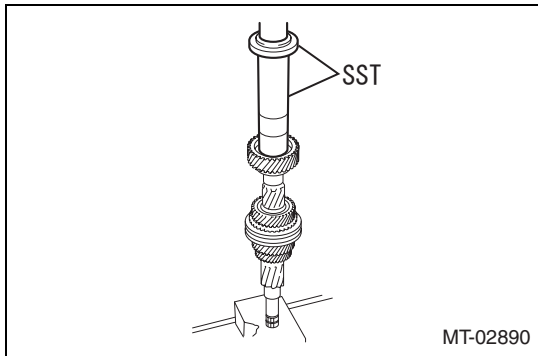

MT-02890

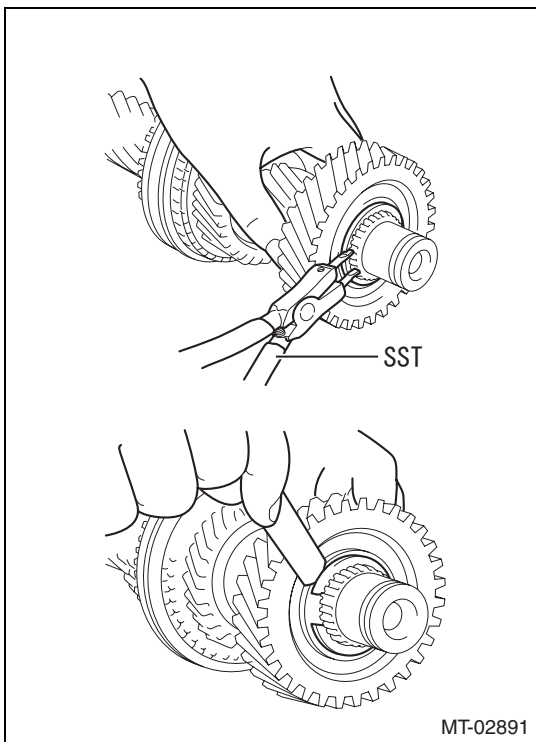

7. Install the shaft snap ring. (Transmission clutch hub No. 3)
 (1) Select a shaft snap ring so that the thrust gap between the counter drive gear and shaft snap ring is within the standard value.

Standard value: 0 to 0.1 mm {0 to 0.00394 in}

<Reference>

Select a shaft snap ring with the maximum thickness possible.

Shaft snap ring type

Item number	Thickness (mm {in})	Identification mark
17005AA520	1.80 {0.07086}	A
17005AA530	1.85 {0.07283}	B
17005AA540	1.90 {0.07480}	C
17005AA550	1.95 {0.07677}	D
17005AA560	2.00 {0.07874}	E
17005AA570	2.05 {0.08070}	F

- (2) Using the SST, install a new shaft snap ring to the counter shaft.
 SST 499895400

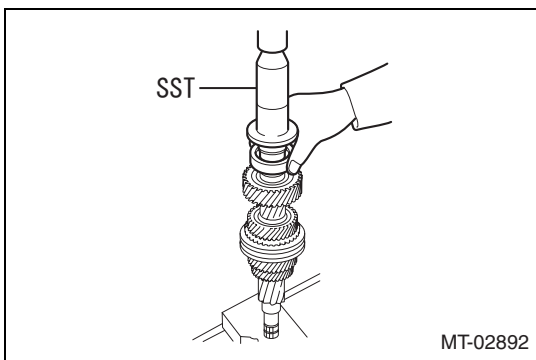

8. Install the counter gear front bearing.
 (1) Using the SST, install a new counter gear front bearing while holding down by hand.
 SST 498057300

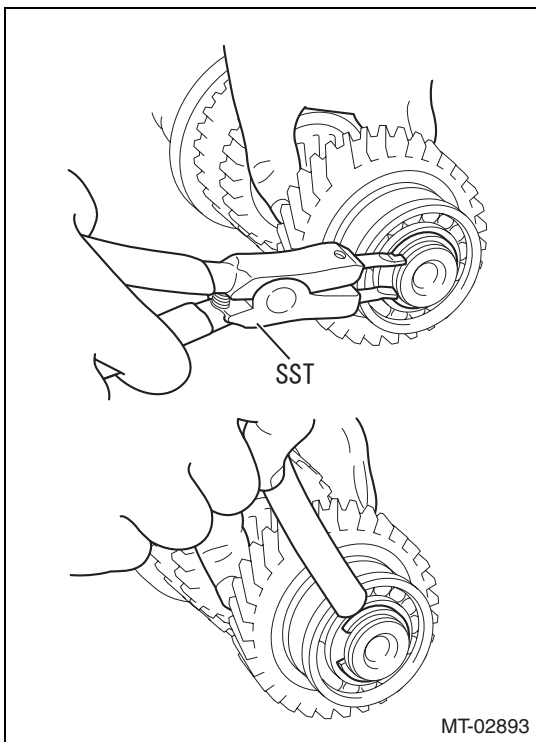

9. Install the shaft snap ring. (Counter gear front bearing)
 (1) Select a shaft snap ring so that the thrust gap between the counter gear front bearing and shaft snap ring is within the standard value.

Standard value: 0 to 0.1 mm {0 to 0.00394 in}

<Reference>

Select a shaft snap ring with the maximum thickness possible.

Shaft snap ring type

Item number	Thickness (mm {in})	Identification mark
17005AA310	2.05 {0.08070}	1
17005AA290	2.10 {0.08267}	2
17005AA320	2.15 {0.08464}	3
17005AA300	2.20 {0.08661}	4
17005AA330	2.25 {0.08858}	5
17005AA340	2.30 {0.09055}	6

- (2) Using the SST, install a new shaft snap ring to the counter shaft.
 SST 499895400

MT