

WHEEL AND TIRE SYSTEM

WT

	Page
1. General Description	2
2. Tire	6
3. Steel Wheel	7
4. Aluminum Wheel	8
5. Wheel Balancing	9
6. "T-type" Tire	11
7. Spare Tire Hoist	12
8. General Diagnostic Table.....	13

GENERAL DESCRIPTION

WHEEL AND TIRE SYSTEM

1. General Description

A: SPECIFICATIONS

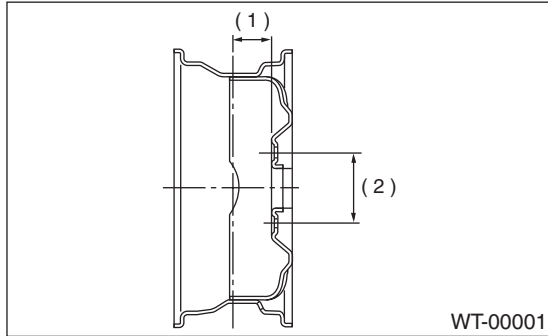

- (1) Offset
(2) P.C.D.

		Tire size	Rim size	Rim offset mm (in)	P.C.D. mm (in)
PICKUP	Front and Rear	P225/60R16 97H	16 × 6 1/2JJ	48 (1.89)	100 (3.94) dia.
	T-type tire	T145/80R16	16 × 4T	50 (1.97)	

		Tire size	Tire inflation pressure kPa (kg/cm ² , psi)	
			Light load	Trailer towing
PICKUP	Front and Rear	P225/60R16 97H	Ft: 230 (2.3, 33) Rr: 230 (2.3, 33)	Ft: 230 (2.3, 33) Rr: 230 (2.3, 33)
	T-type tire	T145/80R16	420 (4.2, 60)	—

NOTE:
"T-type" tire for temporary use is supplied as a spare tire.

GENERAL DESCRIPTION

WHEEL AND TIRE SYSTEM

1. SERVICE DATA

Item	Axial runout	Radial runout
Steel wheel	1.5 mm (0.059 in)	
Aluminum wheel	1.0 mm (0.039 in)	

2. ADJUSTING PARTS

Wheel balancing	Standard	Service limit
Dynamic unbalance	Less than 5 g (0.18 oz)	

Balance weight part number (For steel wheel)	Weight
28101AA001	5 g (0.18 oz)
28101AA011	10 g (0.35 oz)
28101AA021	15 g (0.53 oz)
28101AA031	20 g (0.71 oz)
28101AA041	25 g (0.88 oz)
28101AA051	30 g (1.06 oz)
28101AA061	35 g (1.23 oz)
28101AA071	40 g (1.41 oz)
28101AA081	45 g (1.59 oz)
28101AA091	50 g (1.76 oz)
—	55 g (1.94 oz)
28101AA111	60 g (2.12 oz)

Balance weight part number (Stick-on type for aluminum wheel)	Weight
23141GA462	5 g (0.18 oz)
23141GA472	10 g (0.35 oz)
23141GA482	15 g (0.53 oz)
23141GA492	20 g (0.71 oz)
23141GA502	25 g (0.88 oz)
23141GA512	30 g (1.06 oz)
23141GA522	35 g (1.23 oz)
23141GA532	40 g (1.41 oz)
23141GA542	45 g (1.59 oz)
23141GA552	50 g (1.76 oz)
—	55 g (1.94 oz)
23141GA572	60 g (2.12 oz)

Balance weight part number (Paste-on type for aluminum wheel)	Weight
28101AE00B	5 g (0.18 oz)
28101AE01B	7.5 g (0.26 oz)
28101AE02B	10 g (0.35 oz)
28101AE03B	12.5 g (0.44 oz)
28101AE04B	15 g (0.53 oz)
28101AE05B	17.5 g (0.62 oz)
28101AE06B	20 g (0.71 oz)
28101AE07B	22.5 g (0.79 oz)
28101AE08B	25 g (0.88 oz)
28101AE09B	27.5 g (0.97 oz)
28101AE10B	30 g (1.06 oz)
28101AE11B	32.5 g (1.15 oz)
28101AE12B	35 g (1.23 oz)
28101AE13B	37.5 g (1.32 oz)
28101AE14B	40 g (1.41 oz)
28101AE15B	42.5 g (1.50 oz)
28101AE16B	45 g (1.59 oz)
28101AE17B	47.5 g (1.68 oz)
28101AE18B	50 g (1.76 oz)
28101AE19B	52.5 g (1.85 oz)
28101AE20B	55 g (1.94 oz)
28101AE21B	57.5 g (2.03 oz)
28101AE22B	60 g (2.12 oz)
28101AE23B	62.5 g (2.20 oz)
28101AE24B	65 g (2.29 oz)
28101AE25B	67.5 g (2.38 oz)
28101AE26B	70 g (2.47 oz)
28101AE27B	72.5 g (2.56 oz)
28101AE28B	75 g (2.65 oz)
28101AE29B	77.5 g (2.73 oz)
28101AE30B	80 g (2.82 oz)
28101AE31B	82.5 g (2.91 oz)
28101AE32B	85 g (3.00 oz)
28101AE33B	87.5 g (3.09 oz)
28101AE34B	90 g (3.17 oz)
28101AE35B	92.5 g (3.26 oz)
28101AE36B	95 g (3.35 oz)
28101AE37B	97.5 g (3.44 oz)
28101AE38B	100 g (3.53 oz)

GENERAL DESCRIPTION

WHEEL AND TIRE SYSTEM

B: COMPONENT

1. SPARE TIRE HOIST

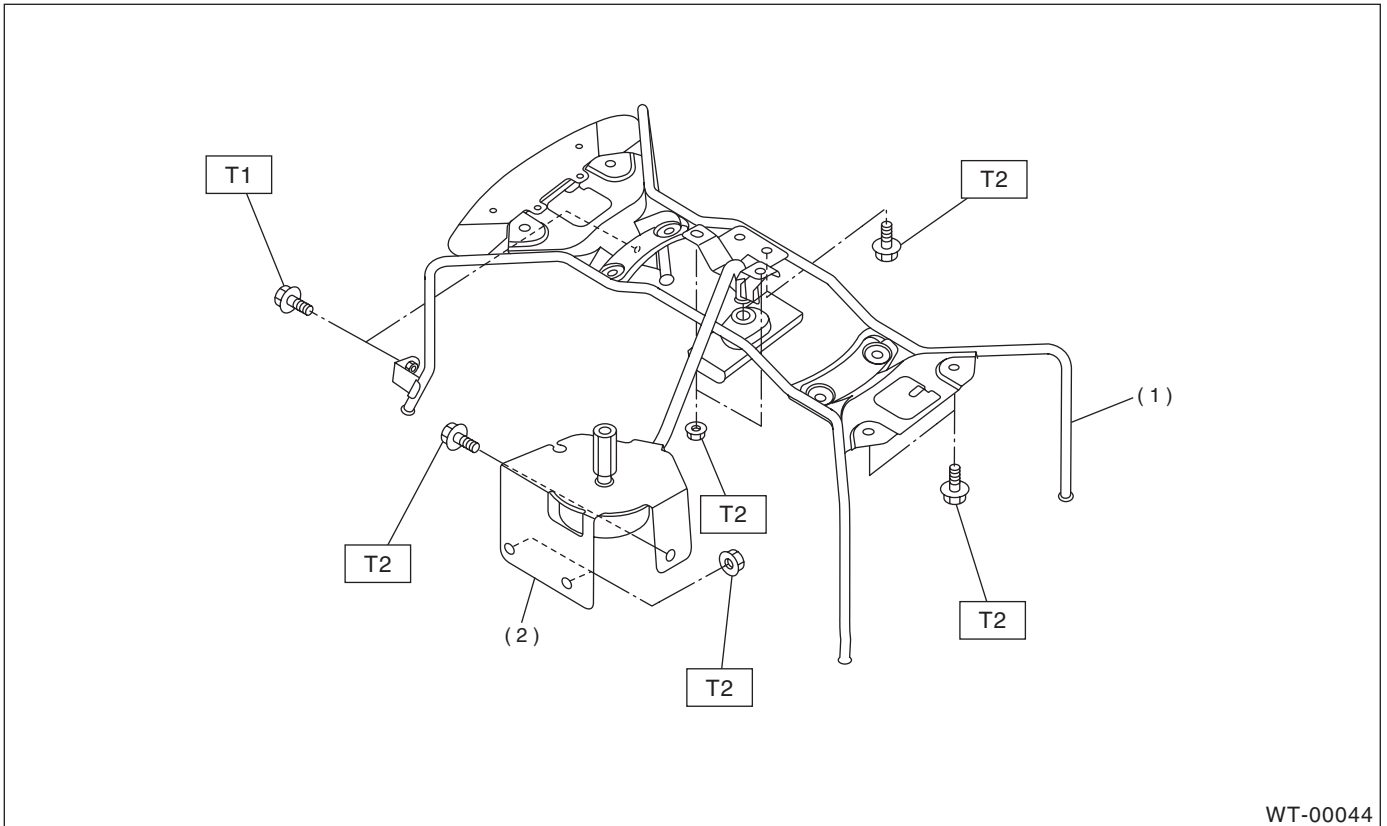

WT-00044

- (1) Spare tire guide
- (2) Spare tire hoist

Tightening torque: N·m (kgf·m, ft·lb)

T1: 13 (1.3, 9.4)

T2: 18 (1.8, 13.0)

C: PREPARATION TOOL

1. GENERAL PURPOSE TOOLS

TOOL NAME	REMARKS
Air Pressure Gauge	Used for measuring tire air pressure.
Dial Gauge	Used for measuring wheel runout.

2. Tire

A: INSPECTION

- 1) Take stone, glass, nail etc. off the tread groove.
- 2) Replace tire:

CAUTION:

- When replacing a tire, make sure to use only the same size, construction and load range as originally installed.
- Avoid mixing radial, belted bias or bias tires on the vehicle.

- (1) When large crack on side wall, damage or crack on tread is found.
- (2) When the "tread wear indicator" appears as a solid band across the tread.

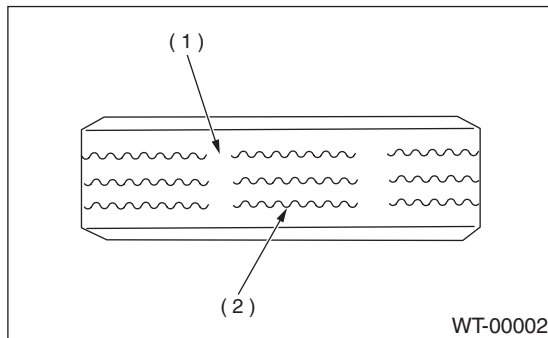

- (1) Tread wear indicator
- (2) Tire tread

- 3) When extremely biased wear on tire tread can be seen, after replacing tire, check wheel alignment. <Ref. to FS-8, Wheel Alignment.>

1. TIRE ROTATION

If tires are maintained at the same positions for a long period of time, uneven wear results. Therefore, they should be periodically rotated. This lengthens service life of tires.

CAUTION:

When rotating tires, replace unevenly worn or damaged tires with new ones.

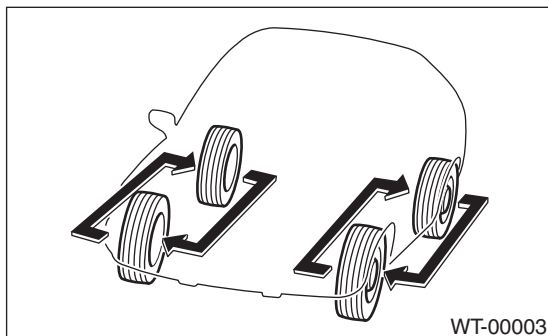

3. Steel Wheel

A: REMOVAL

- 1) Apply parking brake, and position select lever to "P" or "LOW".
- 2) Set shop jacks or a lift to the specified point, and support the vehicle with its wheels slightly contacting the floor.
- 3) Loosen wheel nuts.
- 4) Raise the vehicle until its wheels take off the ground using a jack or a lift.
- 5) Remove wheel nuts and wheels.

NOTE:

- While removing wheels, prevent hub bolts from damage.

NOTE:

- Place wheels with their outer sides facing upward to prevent wheels from damage.

B: INSTALLATION

- 1) Attach the wheel to the hub by aligning the wheel bolt hole with the hub bolt.
- 2) Temporarily attach the wheel nuts to the hub bolts. (In the case of aluminum wheel, use SUBARU genuine wheel nut for aluminum wheel.)
- 3) Manually tighten the nuts making sure the wheel hub hole is aligned correctly to the guide portion of hub.
- 4) Tighten the wheel nuts in a diagonal selection to the specified torque. Use a wheel nut wrench.

Wheel nut tightening torque:

110 N·m (11.2 kgf·m, 81.0 ft·lb)

CAUTION:

- Tighten the wheel nuts in two or three steps by gradually increasing the torque and working diagonally, until the specified torque is reached. For drum brake models, excess tightening of wheel nuts may cause wheels to "judder".
- Do not depress the wrench with a foot; Always use both hands when tightening.
- Make sure the bolt, nut and the nut seating surface of the wheel are free from oils.

- 5) If a wheel is removed for replacement or for repair of a puncture, retighten the wheel nuts to the specified torque after running 1,000 km (600 miles).

C: INSPECTION

- 1) Deformation or damage on the rim can cause air leakage. Check the rim flange for deformation, crack, or damage, and repair or replace as necessary.
- 2) Jack-up vehicle until wheels clear the floor.
- 3) Slowly rotate wheel to check rim "runout" using a dial gauge.

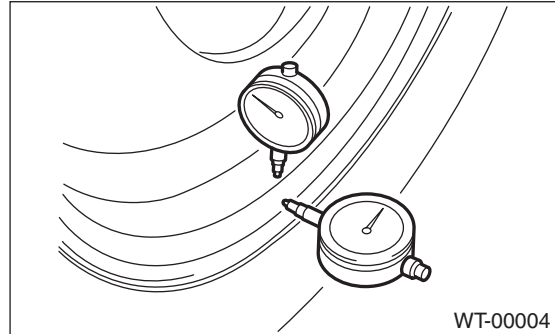

Axial runout limit	Radial runout limit
1.5 mm (0.059 in)	

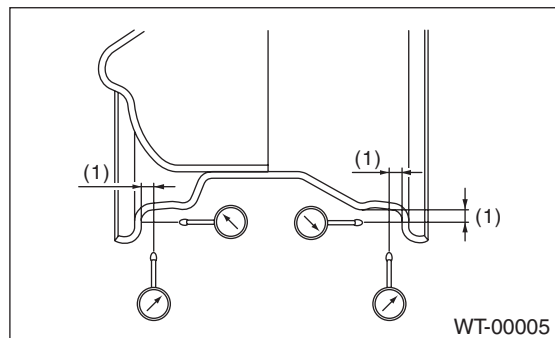

(1) Approx. 7 mm (0.28 in)

- 4) If rim runout exceeds the limit, remove tire from rim and check runout while attaching dial gauge to positions shown in figure.
- 5) If measured runout still exceeds the limit, replace the wheel.

4. Aluminum Wheel

A: REMOVAL

Refer to Steel Wheel for removal procedure of aluminum wheels.

<Ref. to WT-7, REMOVAL, Steel Wheel.>

B: INSTALLATION

Refer to Steel Wheel for installation procedure of aluminum wheels.

<Ref. to WT-7, INSTALLATION, Steel Wheel.>

C: INSPECTION

Refer to Steel Wheel for inspection procedure of aluminum wheels.

<Ref. to WT-7, INSPECTION, Steel Wheel.>

Rim runout:

Axial runout limit	Radial runout limit
1.0 mm (0.039 in)	

D: CAUTION

Aluminum wheels are easily scratched. To maintain their appearance and safety, do the following:

- 1) Do not damage aluminum wheels during removal, disassembly, installation, wheel balancing, etc. After removing aluminum wheels, place them on a rubber mat, etc.
- 2) While vehicle is being driven, be careful not to ride over sharp obstacles or allow aluminum wheels to contact the shoulder of the road.
- 3) When washing aluminum wheel, use neutral synthetic detergent and water. Avoid using the cleanser including abrasive, hard brushes or an automatic car washer.

5. Wheel Balancing

A: REPLACEMENT

1. STICK-ON TYPE BALANCE WEIGHT

- 1) Remove balance weights.
- 2) Using dynamic balancing, measure wheel balance.
- 3) Select a weight close to the value measured by dynamic balancing.

Balance weight part number (For steel wheel)	Weight
28101AA001	5 g (0.18 oz)
28101AA011	10 g (0.35 oz)
28101AA021	15 g (0.53 oz)
28101AA031	20 g (0.71 oz)
28101AA041	25 g (0.88 oz)
28101AA051	30 g (1.06 oz)
28101AA061	35 g (1.23 oz)
28101AA071	40 g (1.41 oz)
28101AA081	45 g (1.59 oz)
28101AA091	50 g (1.76 oz)
—	55 g (1.94 oz)
28101AA111	60 g (2.12 oz)

Balance weight part number (For aluminum wheel)	Weight
23141GA462	5 g (0.18 oz)
23141GA472	10 g (0.35 oz)
23141GA482	15 g (0.53 oz)
23141GA492	20 g (0.71 oz)
23141GA502	25 g (0.88 oz)
23141GA512	30 g (1.06 oz)
23141GA522	35 g (1.23 oz)
23141GA532	40 g (1.41 oz)
23141GA542	45 g (1.59 oz)
23141GA552	50 g (1.76 oz)
—	55 g (1.94 oz)
23141GA572	60 g (2.12 oz)

- 4) Install the selected weight to the point designated by dynamic balancing.
- 5) Using dynamic balancing, measure wheel balance again. Check that wheel balance is correctly adjusted.

Service limit: A

**Balance weight for steel wheel;
2.16 mm (0.085 in)**

**Balance weight for aluminum wheel;
4.5 mm (0.177 in)**

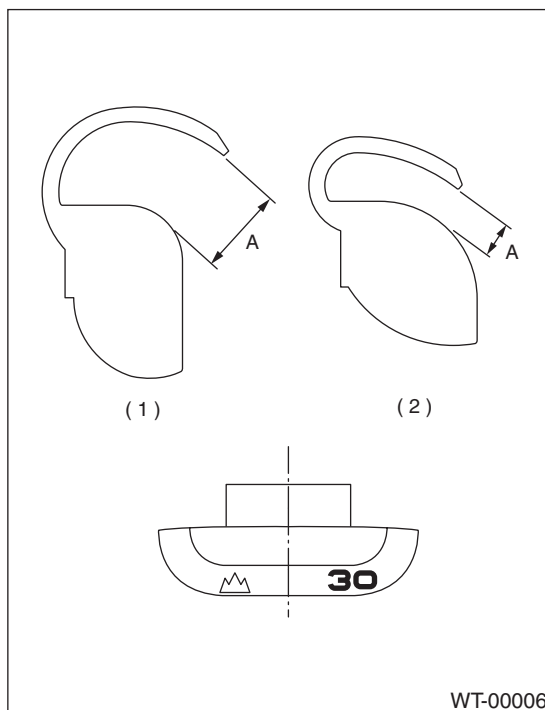

- (1) Balance weight for aluminum wheel
- (2) Balance weight for steel wheel

CAUTION:

- Use genuine balance weights.
- Balance weights are available for use with any of 14- to 16-inch wheels.

2. PASTE-ON TYPE BALANCE WEIGHT

- 1) Remove balance weights.
- 2) Remove traces of two-sided tape on wheel and clean adhesive layer.
- 3) Set balancing (dynamic balancing for stick-on balance weight is available) and measure wheel balance.
- 4) Multiply the measured weight by 1.6 to select a weight.
- 5) Select a weight close to the calculated value, clean the point designated by balancing and paste on the weight there.

WHEEL BALANCING

WHEEL AND TIRE SYSTEM

Example of selecting balance weight:

Measured wheel balance: 34 g

$$34 \text{ g} \times 1.6 = 54.4$$

Weight to be selected: 55g

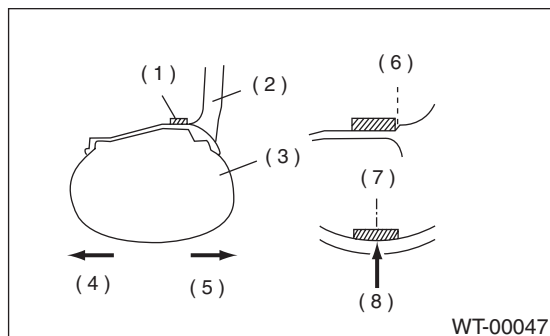

- (1) Paste-on type balance weight
- (2) Wheel
- (3) Tire
- (4) Inside
- (5) Outside
- (6) Clamp the balance on the step
- (7) Center of balance weight
- (8) Point designated by balancing

CAUTION:

- Press on the weight for more than 2 seconds with a force of 25 N·m (2.6 kgf·m, 18 ft·lb) or more per 5 g to paste on.
- Adjust weight balance from outside first and then inside.
- The weight to be pasted on must be under 100 g.

B: INSPECTION

- 1) Proper wheel balance may be lost if the tire is repaired or if it wears. Check the tire for dynamic balance, and repair as necessary.
- 2) To check for dynamic balance, use a dynamic balancer. Drive in the balance weight on both the top and rear sides of the rim.
- 3) Some types of balancer can cause damage to the wheel. Use an appropriate balancer when adjusting the wheel balance.

Service limit: A

Balance weight for steel wheel;

2.16 mm (0.085 in)

Balance weight for aluminum wheel;

4.5 mm (0.177 in)

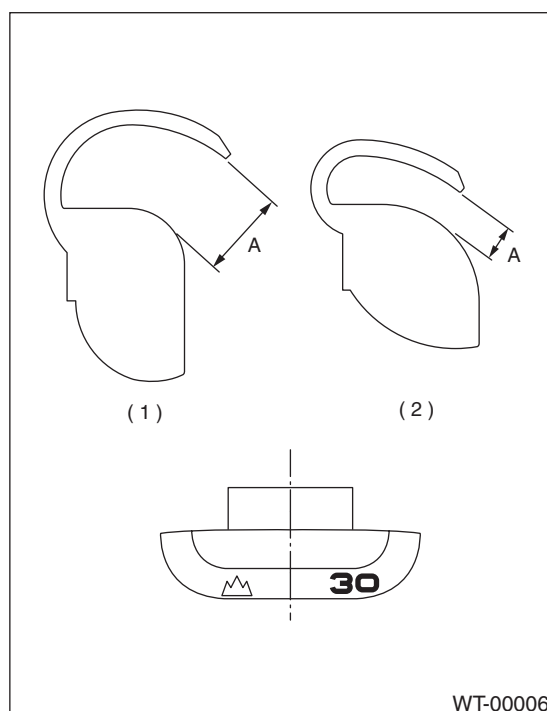

- (1) Balance weight for aluminum wheel
- (2) Balance weight for steel wheel

CAUTION:

- Use genuine balance weights.
- Balance weights are available for use with any of 14- to 16-inch wheels.

6. “T-type” Tire

A: NOTE

“T-type” tire for temporary use is prepared as a spare tire.

CAUTION:

- Do not use a tire chain with the “T-type” tire. Because of the smaller tire size, a tire chain will not fit properly and will result in damage to the vehicle and the tire.
- Do not drive at a speed greater than 80 km/h (50 MPH).
- Drive as slowly as possible and avoid passing over bumps.

B: REPLACEMENT

Refer to Removal and Installation of Steel Wheel for removal/installation of “T-type” tires. <Ref. to WT-7, Steel Wheel.>

CAUTION:

Replace with a conventional tire as soon as possible since the “T-type” tire is only for temporary use.

C: INSPECTION

- 1) Check tire inflation pressure.

Specification:

420 kPa (4.2 kg/cm², 60 psi)

- 2) Take stones, glass, nails, etc. out of the tread groove.
- 3) Check tires for deformation, cracks, partial wear, or wear.

CAUTION:

Replace the tire with a new one.

7. Spare Tire Hoist

A: REMOVAL

- 1) Remove spare tire from the vehicle.
- 2) Lift up the vehicle.
- 3) Remove spare tire guide.

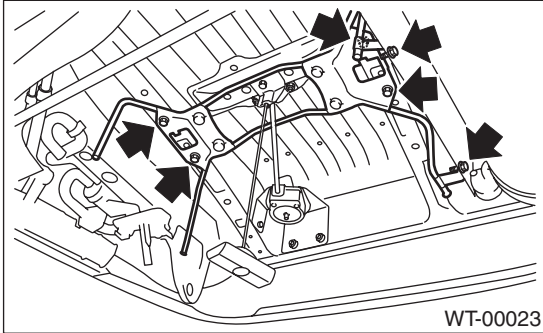

- 4) Remove spare tire hoist.

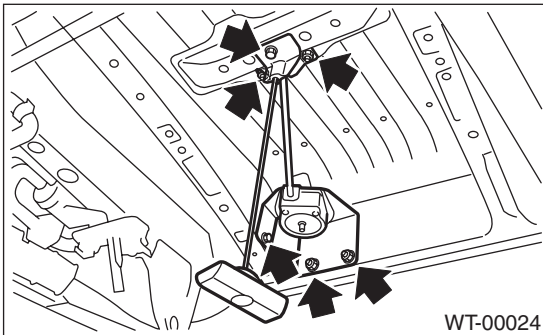

B: INSTALLATION

Install in the reverse order of removal.

Tightening torque:

Spare guide to body;

18 N·m (1.8 kgf·m, 13.0 ft·lb)

Spare guide to heat shield plate;

13 N·m (1.3 kgf·m, 9.4 ft·lb)

8. General Diagnostic Table

A: INSPECTION

Symptom	Possible cause	Remedy
Front wheel shimmy	• Worn or improperly inflated of tire.	Replace
	• Wheel is out of balance.	Adjustment
Abnormal tire wear	• Improperly inflated of tire.	Replace
Sways/pitches	• Worn or improperly inflated of tire.	Replace
Wander/pulls	• Worn or improperly inflated of tire.	Replace

GENERAL DIAGNOSTIC TABLE

WHEEL AND TIRE SYSTEM

MEMO: