

COOLING

CO(H4SO)

	Page
1. General Description	2
2. Radiator Main Fan System.....	6
3. Radiator Sub Fan System	9
4. Engine Coolant.....	12
5. Water Pump	14
6. Thermostat	19
7. Radiator.....	20
8. Radiator Cap	24
9. Radiator Main Fan and Fan Motor	25
10. Radiator Sub Fan and Fan Motor.....	27
11. Reservoir Tank.....	29
12. Engine Cooling System Trouble in General	30

GENERAL DESCRIPTION

COOLING

1. General Description

A: SPECIFICATIONS

Cooling system		Electric fan + Forced engine coolant circulation system	
Total engine coolant capacity		ℓ (US qt, Imp qt) MT: Approx. 6.8 (7.2, 6.0) AT: Approx. 6.7 (7.1, 5.9)	
Water pump	Type	Centrifugal impeller type	
	Discharge performance I	Discharge	18 ℓ (4.8 US gal, 4.0 Imp gal)/min.
		Pump speed—pressure leak	1,000 rpm — 7 kPa (0.7 mAq, 2.3 ftAq)
		Engine coolant temperature	80°C (176°F)
	Discharge performance II	Discharge	70 ℓ (18.5 US gal, 15.4 Imp gal)/min.
		Pump speed—pressure leak	3,000 rpm — 55 kPa (5.6 mAq, 18.4 ftAq)
		Engine coolant temperature	80°C (176°F)
	Discharge performance III	Discharge	153 ℓ (40.4 US gal, 33.7 Imp gal)/min.
		Pump speed—pressure leak	6,000 rpm — 217 kPa (22.1 mAq, 72.5 ftAq)
		Engine coolant temperature	80°C (176°F)
	Impeller diameter		74 mm (2.91 in)
Number of impeller vanes		8	
Pump pulley diameter		60 mm (2.36 in)	
Clearance between impeller and case	Standard	0.4 — 1.6 mm (0.016 — 0.063 in)	
Thermostat	Type	Wax pellet type	
	Starts to open	76 — 80°C (169 — 176°F)	
	Fully opened	91°C (196°F)	
	Valve lift	9.0 mm (0.354 in) or more	
	Valve opening bore	35 mm (1.38 in)	
Radiator fan	Motor	75 W (main fan) 75 W (sub fan)	
	Fan diameter × Blade	300 mm (11.81 in) × 5 (main fan) 300 mm (11.81 in) × 4 (sub fan)	
Radiator	Type	Down flow, pressure type	
	Core dimensions	691.5 × 340 × 16 mm (27.22 × 13.39 × 0.63 in)	
	Cap valve opening pressure	Above: 108±15 kPa (1.1±0.15 kg/cm ² , 16±2 psi) Below: -1.0 to -4.9 kPa (-0.01 to -0.05 kg/cm ² , -0.1 to -0.7 psi)	
	Fins	Corrugated fin type	
Reservoir tank	Capacity	0.5 ℓ (0.5 US qt, 0.4 Imp qt)	

B: COMPONENT

1. WATER PUMP

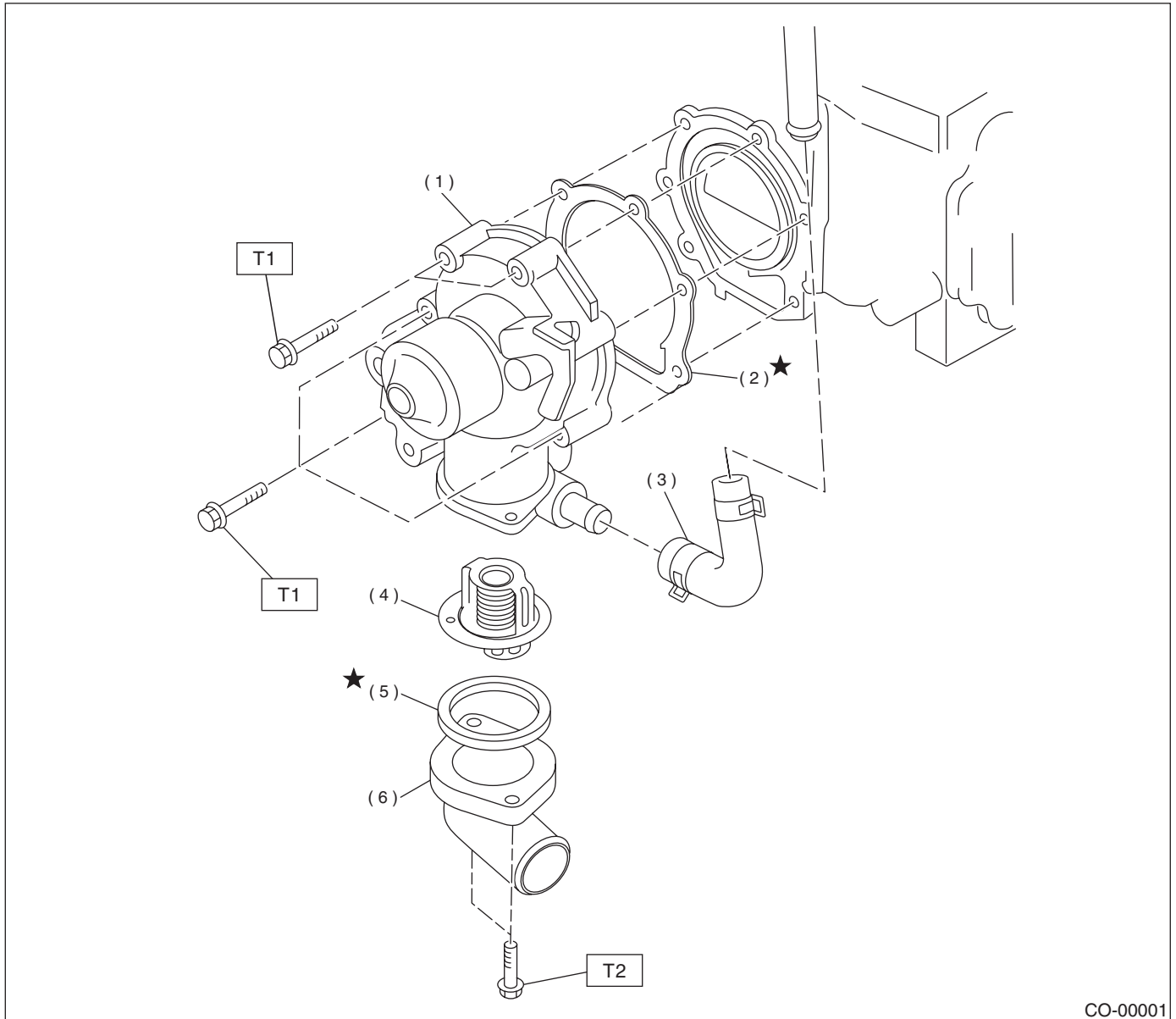

CO-00001

- | | |
|-------------------------|----------------------|
| (1) Water pump ASSY | (5) Gasket |
| (2) Gasket | (6) Thermostat cover |
| (3) Heater by-pass hose | |
| (4) Thermostat | |

Tightening torque: N·m (kgf·m, ft·lb)

**T1: First 12 (1.2, 8.7)
Second 12 (1.2, 8.7)**

T2: 6.5 (0.66, 4.8)

GENERAL DESCRIPTION

COOLING

2. RADIATOR AND RADIATOR FAN

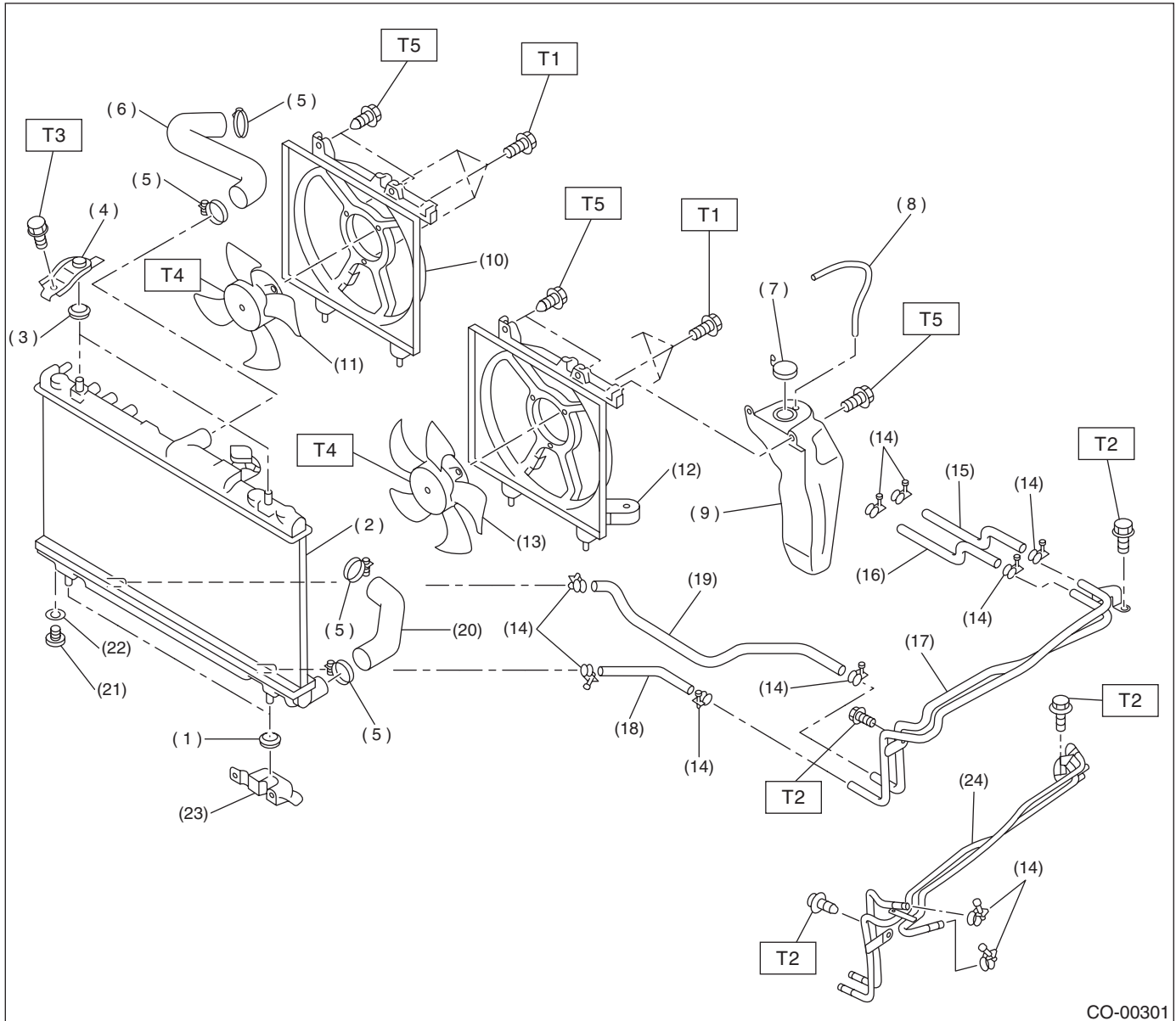

CO-00301

- | | | |
|--|--|----------------------------------|
| (1) Radiator lower cushion | (13) Radiator main fan and main fan motor ASSY | (22) O-ring |
| (2) Radiator | (14) ATF hose clamp (AT vehicles only) | (23) Radiator lower bracket |
| (3) Radiator upper cushion | (15) ATF inlet hose (AT vehicles only) | (24) ATF pipe (AT vehicles only) |
| (4) Radiator upper bracket | (16) ATF outlet hose (AT vehicles only) | |
| (5) Clamp | (17) ATF pipe (AT vehicles only) | |
| (6) Radiator inlet hose | (18) ATF outlet hose B (AT vehicles only) | |
| (7) Engine coolant reservoir tank cap | (19) ATF inlet hose B (AT vehicles only) | |
| (8) Overflow hose | (20) Radiator outlet hose | |
| (9) Engine coolant reservoir tank | (21) Radiator drain plug | |
| (10) Sub fan shroud | | |
| (11) Radiator sub fan and sub fan motor ASSY | | |
| (12) Main fan shroud | | |

Tightening torque: N·m (kgf·m, ft·lb)

T1: 4.4 (0.45, 3.3)

T2: 12 (1.2, 8.7)

T3: 18 (1.8, 13.0)

T4: 3.4 (0.35, 2.5)

T5: 4.9 (0.50, 3.6)

GENERAL DESCRIPTION

COOLING

C: CAUTION

- Wear working clothing, including a cap, protective goggles, and protective shoes during operation.
- Remove contamination including dirt and corrosion before removal, installation or disassembly.
- Keep the disassembled parts in order and protect them from dust or dirt.
- Before removal, installation or disassembly, be sure to clarify the failure. Avoid unnecessary removal, installation, disassembly, and replacement.

- Be careful not to burn your hands, because each part in the vehicle is hot after running.
- Be sure to tighten fasteners including bolts and nuts to the specified torque.
- Place shop jacks or safety stands at the specified points.
- Before disconnecting electrical connectors of sensors or units, be sure to disconnect ground cable from battery.

D: PREPARATION TOOL

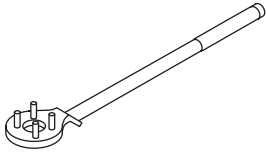
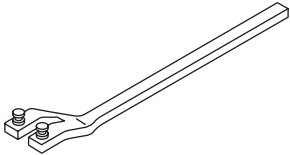
ILLUSTRATION	TOOL NUMBER	DESCRIPTION	REMARKS
 <p>ST-499977100</p>	499977100	CRANK PULLEY WRENCH	Used for fixing crankshaft pulley when loosening and tightening crankshaft pulley bolts.
 <p>ST18231AA010</p>	18231AA010	CAMSHAFT SPROCKET WRENCH	<ul style="list-style-type: none"> • Used for removing and installing camshaft sprocket. • Camshaft sprocket wrench (499207100) is also available.

RADIATOR MAIN FAN SYSTEM

COOLING

2. Radiator Main Fan System

A: SCHEMATIC

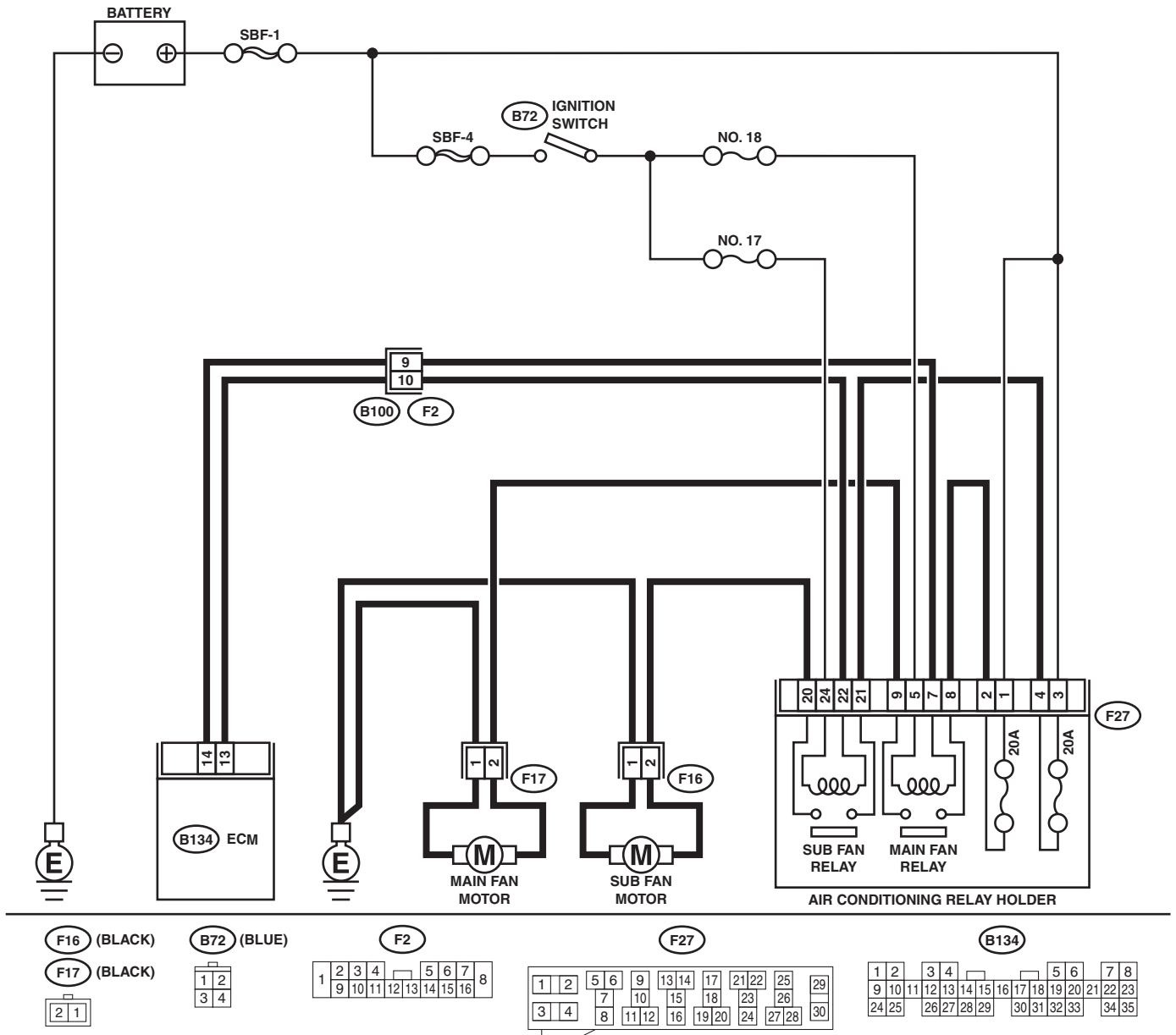

EN-03183

B: INSPECTION

DETECTING CONDITION:

Condition:

- Engine coolant temperature is above 95°C (203°F).
- Vehicle speed is below 19 km/h (12 MPH).

TROUBLE SYMPTOM:

- Radiator main fan does not rotate under the above conditions.

Step	Check	Yes	No
1 CHECK POWER SUPPLY TO MAIN FAN MOTOR. CAUTION: Be careful not to overheat engine during repair. 1) Turn ignition switch to OFF. 2) Disconnect connector from main fan motor. 3) Start the engine, and warm it up until engine coolant temperature increases over 95°C (203°F). 4) Stop the engine and turn ignition switch to ON. 5) Measure voltage between main fan motor connector and chassis ground. Connector & terminal (F17) No. 2 (+) — Chassis ground (-):	Is the measured value more than 10 V?	Go to step 2.	Go to step 5.
2 CHECK GROUND CIRCUIT OF MAIN FAN MOTOR. 1) Turn ignition switch to OFF. 2) Measure resistance between main fan motor connector and chassis ground. Connector & terminal (F17) No. 1 — Chassis ground:	Is the measured value less than 5 Ω?	Go to step 3.	Repair open circuit in harness between main fan motor connector and chassis ground.
3 CHECK POOR CONTACT. Check poor contact in main fan motor connector.	Is there poor contact in main fan motor connector?	Repair poor contact in main fan motor connector.	Go to step 4.
4 CHECK MAIN FAN MOTOR. Connect battery positive (+) terminal to terminal No. 2, and negative (-) terminal to terminal No. 1 of main fan motor connector.	Does the main fan rotate?	Repair poor contact in main fan motor connector.	Replace main fan motor with a new one.
5 CHECK POWER SUPPLY TO MAIN FAN RELAY. 1) Turn ignition switch to OFF. 2) Remove main fan relay from A/C relay holder. 3) Measure voltage between main fan relay terminal and chassis ground. Connector & terminal (F27) No. 8 (+) — Chassis ground (-):	Is the measured value more than 10 V?	Go to step 6.	Go to step 7.
6 CHECK POWER SUPPLY TO MAIN FAN RELAY. 1) Turn ignition switch to ON. 2) Measure voltage between main fan relay terminal and chassis ground. Connector & terminal (F27) No. 5 (+) — Chassis ground (-):	Is the measured value more than 10 V?	Go to step 10.	Go to step 9.
7 CHECK 20 A FUSE. 1) Remove 20 A fuse from A/C relay holder. 2) Check condition of fuse.	Is the fuse blown out?	Replace fuse.	Go to step 8.

RADIATOR MAIN FAN SYSTEM

COOLING

Step	Check	Yes	No
8 CHECK POWER SUPPLY TO A/C RELAY HOLDER 20 A FUSE TERMINAL. Measure voltage of harness between A/C relay holder 20 A fuse terminal and chassis ground. Connector & terminal (F27) No. 1 (+) — Chassis ground (-):	Is the measured value more than 10 V?	Repair open circuit in harness between 20 A fuse and main fan relay terminal.	Repair open circuit in harness between main fuse box connector and 20 A fuse terminal.
9 CHECK FUSE. 1) Turn ignition switch to OFF. 2) Remove fuse No. 18 from joint box. 3) Check fuse.	Is the fuse blown out?	Replace fuse.	Repair open circuit in harness between main fan relay and ignition switch.
10 CHECK MAIN FAN RELAY. 1) Turn ignition switch to OFF. 2) Measure resistance of main fan relay. Terminal No. 8 — No. 9:	Is the measured value more than 1 MΩ?	Go to step 11.	Replace main fan relay.
11 CHECK MAIN FAN RELAY. 1) Connect battery to terminals No. 5 and No. 7 of main fan relay. 2) Measure resistance of main fan relay. Terminal No. 8 — No. 9:	Is the measured value less than 1 Ω?	Go to step 12.	Replace main fan relay.
12 CHECK HARNESS BETWEEN MAIN FAN RELAY TERMINAL AND MAIN FAN MOTOR CONNECTOR. Measure resistance of harness between main fan motor connector and main fan relay terminal. Connector & terminal (F17) No. 2 — (F27) No. 9:	Is the measured value less than 1 Ω?	Go to step 13.	Repair open circuit in harness between main fan motor connector and main fan relay terminal.
13 CHECK HARNESS BETWEEN MAIN FAN RELAY AND ECM. 1) Turn ignition switch to OFF. 2) Disconnect connector from ECM. 3) Measure resistance of harness between main fan relay connector and ECM connector. Connector & terminal (F27) No. 7 — (B134) No. 14:	Is the measured value less than 1 Ω?	Go to step 14.	Repair open circuit in harness between main fan relay and ECM.
14 CHECK POOR CONTACT. Check poor contact in connector between main fan and ECM.	Is there poor contact?	Repair poor contact connector.	Contact with SOA (distributor) service.

3. Radiator Sub Fan System

A: SCHEMATIC

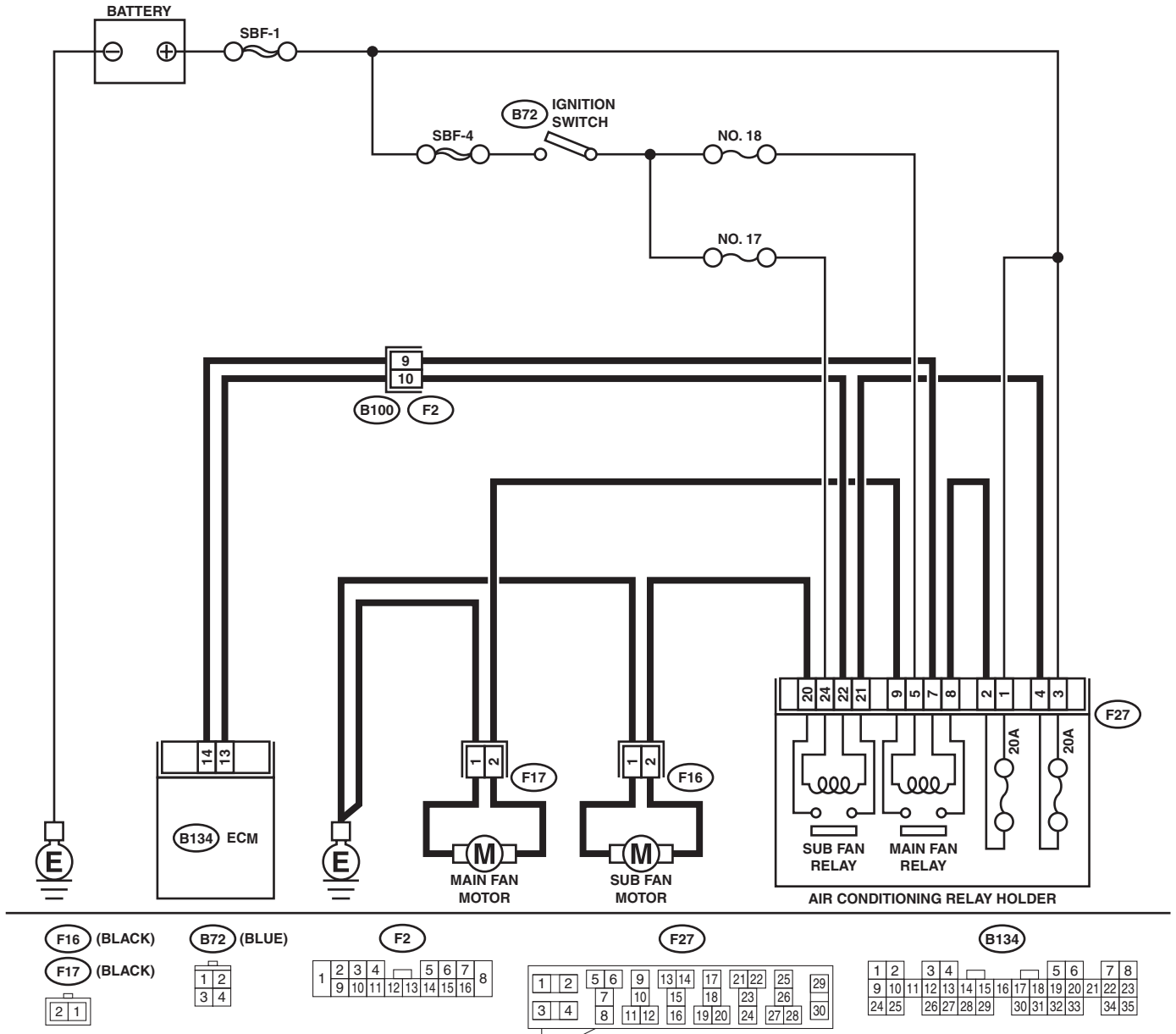

RADIATOR SUB FAN SYSTEM

COOLING

B: INSPECTION

NOTE:

Radiator sub fan system is for model with A/C.

DETECTING CONDITION:

Condition (1):

- Engine coolant temperature is below 95°C (203°F).
- A/C switch is turned ON.
- Vehicle speed is below 19 km/h (12 MPH).

Condition (2):

- Engine coolant temperature is above 100°C (212°F).
- A/C switch is turned OFF.
- Vehicle speed is below 19 km/h (12 MPH).

TROUBLE SYMPTOM:

- Radiator sub fan does not rotate under conditions (1) and (2) above.

Step	Check	Yes	No
1 CHECK POWER SUPPLY TO SUB FAN MOTOR. CAUTION: Be careful not to overheat engine during repair. 1) Turn ignition switch to OFF. 2) Disconnect connector from sub fan motor and main fan motor. 3) Start the engine, and warm it up until engine coolant temperature increases over 100°C (212°F). 4) Stop the engine and turn ignition switch to ON. 5) Measure voltage between sub fan motor connector and chassis ground. Connector & terminal (F16) No. 2 (+) — Chassis ground (-):	Is the measured value more than 10 V?	Go to step 2.	Go to step 5.
2 CHECK GROUND CIRCUIT OF SUB FAN MOTOR. 1) Turn ignition switch to OFF. 2) Measure resistance between sub fan motor connector and chassis ground. Connector & terminal (F16) No. 1 — Chassis ground:	Is the measured value less than 5 Ω?	Go to step 3.	Repair open circuit in harness between sub fan motor connector and chassis ground.
3 CHECK POOR CONTACT. Check poor contact in sub fan motor connector.	Is there poor contact in sub fan motor connector?	Repair poor contact in sub fan motor connector.	Go to step 4.
4 CHECK SUB FAN MOTOR. Connect battery positive (+) terminal to terminal No. 2, and negative (-) terminal to terminal No. 1 of sub fan motor connector.	Does the sub fan rotate?	Repair poor contact in sub fan motor connector.	Replace sub fan motor with a new one.
5 CHECK POWER SUPPLY TO SUB FAN RELAY. 1) Turn ignition switch to OFF. 2) Remove sub fan relay from A/C relay holder. 3) Measure voltage between sub fan relay terminal and chassis ground. Connector & terminal (F27) No. 21 (+) — Chassis ground (-):	Is the measured value more than 10 V?	Go to step 6.	Go to step 7.

RADIATOR SUB FAN SYSTEM

COOLING

Step	Check	Yes	No
6 CHECK POWER SUPPLY TO SUB FAN RELAY. 1) Turn ignition switch to ON. 2) Measure voltage between sub fan relay terminal and chassis ground. <i>Connector & terminal</i> <i>(F27) No. 24 (+) — Chassis ground (-):</i>	Is the measured value more than 10 V?	Go to step 10.	Go to step 9.
7 CHECK 20 A FUSE. 1) Remove 20 A fuse from A/C relay holder. 2) Check condition of fuse.	Is the fuse blown-out?	Replace fuse.	Go to step 8.
8 CHECK POWER SUPPLY TO A/C RELAY HOLDER 20 A FUSE TERMINAL. Measure voltage of harness between A/C relay holder 20 A fuse terminal and chassis ground. <i>Connector & terminal</i> <i>(F27) No. 3 (+) — Chassis ground (-):</i>	Is the measured value more than 10 V?	Repair open circuit in harness between 20 A fuse and sub fan relay terminal.	Repair open circuit in harness between main fuse box connector and 20 A fuse terminal.
9 CHECK FUSE. 1) Turn ignition switch to OFF. 2) Remove fuse No. 17 from joint box. 3) Check condition of fuse.	Is the fuse blown-out?	Replace fuse.	Repair open circuit in harness between sub fan relay and ignition switch.
10 CHECK SUB FAN RELAY. 1) Turn ignition switch to OFF. 2) Measure resistance of sub fan relay. <i>Terminal</i> <i>No. 20 — No. 21:</i>	Is the measured value more than 1 MΩ?	Go to step 11.	Replace sub fan relay.
11 CHECK SUB FAN RELAY. 1) Connect battery to terminals No. 22 and No. 24 of sub fan relay. 2) Measure resistance of sub fan relay. <i>Terminal</i> <i>No. 20 — No. 21:</i>	Is the measured value less than 1 Ω?	Go to step 12.	Replace sub fan relay.
12 CHECK HARNESS BETWEEN SUB FAN RELAY TERMINAL AND SUB FAN MOTOR CONNECTOR. Measure resistance of harness between sub fan motor connector and sub fan relay terminal. <i>Connector & terminal</i> <i>(F16) No. 2 — (F27) No. 20:</i>	Is the measured value less than 1 Ω?	Go to step 13.	Repair open circuit in harness between sub fan motor and sub fan relay connector.
13 CHECK HARNESS BETWEEN SUB FAN RELAY AND ECM. 1) Turn ignition switch to OFF. 2) Disconnect connector from ECM. 3) Measure resistance of harness between sub fan relay connector and ECM connector. <i>Connector & terminal</i> <i>(F27) No. 22 — (B134) No. 13:</i>	Is the measured value less than 1 Ω?	Go to step 14.	Repair open circuit in harness between sub fan relay and ECM.
14 CHECK POOR CONTACT. Check poor contact in connector between sub fan and ECM.	Is there poor contact in connector between sub fan motor and ECM?	Repair poor contact connector.	Contact with SOA (distributor) service.

ENGINE COOLANT

COOLING

4. Engine Coolant

A: REPLACEMENT

1. DRAINING OF ENGINE COOLANT

- 1) Lift-up the vehicle.
- 2) Remove under cover.

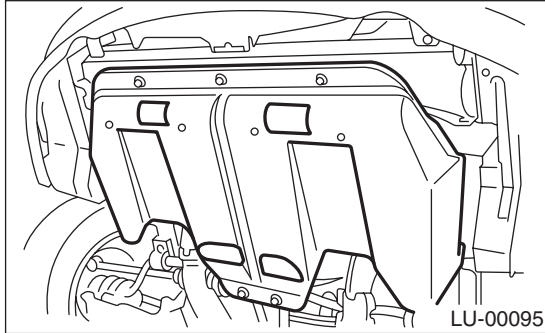

- 3) Remove drain cock to drain engine coolant from radiator.

NOTE:

Remove radiator cap so that engine coolant will drain faster.

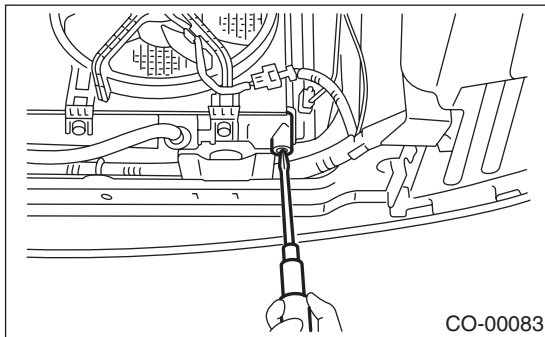

2. FILLING OF ENGINE COOLANT

- 1) Fill cooling system conditioner from filling port.

Cooling system protecting agent:
COOLING SYSTEM CONDITIONER (Part No. SOA635071)

- 2) Fill engine coolant into radiator up to filler neck position.

Engine coolant amount for refill:

MT model;

Approx. 6.8 ℓ (7.2 US qt, 6.0 Imp qt)

AT model;

Approx. 6.7 ℓ (7.1 US qt, 5.9 Imp qt)

CAUTION:

The SUBARU Genuine Coolant containing anti-freeze and anti-rust agents is especially made for SUBARU engine, which has an aluminum crankcase. Always use SUBARU Genuine Coolant, since other coolant may cause corrosion.

- 3) Fill engine coolant into reservoir tank up to upper level.

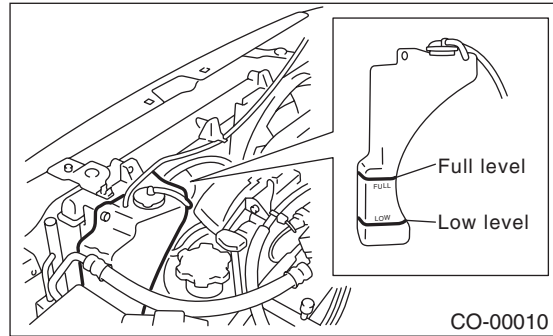

- 4) Attach radiator cap and reservoir tank cap properly.
- 5) Warm-up engine completely for more than five minutes at 2,000 to 3,000 rpm.
- 6) If engine coolant level drops in radiator, add engine coolant to filler neck position.
- 7) If engine coolant level drops from upper level of reservoir tank, add engine coolant to upper level.
- 8) Attach radiator cap and reservoir tank cap properly.

B: INSPECTION

1. RELATIONSHIP OF SUBARU COOLANT CONCENTRATION AND FREEZING TEMPERATURE

The concentration and safe operating temperature of the SUBARU coolant is shown in the diagram. Measuring the temperature and specific gravity of the coolant will provide this information.

[Example]

If the coolant temperature is 25°C (77°F) and its specific gravity is 1.054, the concentration is 35% (point A), the safe operating temperature is -14°C (7°F) (point B), and the freezing temperature is -20°C (-4°F) (point C).

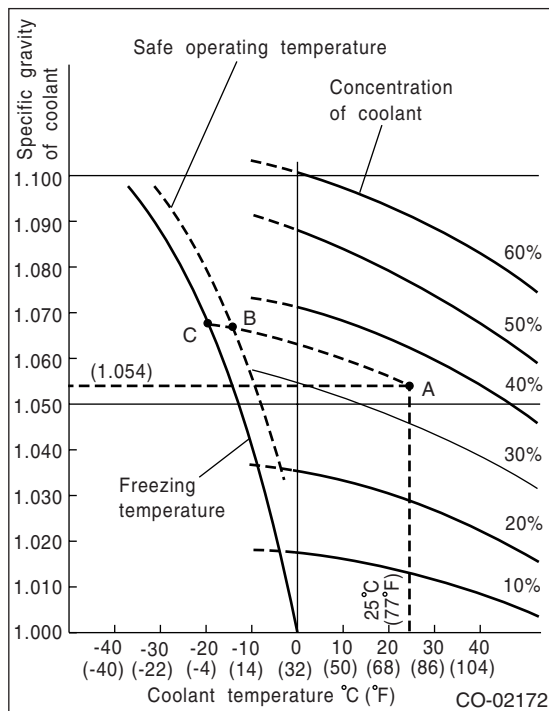

2. PROCEDURE TO ADJUST THE CONCENTRATION OF THE COOLANT

To adjust the concentration of the coolant according to temperature, find the proper fluid concentration in the above diagram and replace the necessary amount of coolant with an undiluted solution of SUBARU genuine coolant (concentration 50).

The amount of coolant that should be replaced can be determined using the diagram.

[Example]

Assume that the coolant concentration must be increased from 25% to 40%. Find point A, where the 25% line of coolant concentration intersects with the 40% curve of the necessary coolant concentration, and read the scale on the vertical axis of the graph at height A. The quantity of coolant to be drained is 2.1 liters (2.2 US qt, 1.8 Imp qt). Drain 2.1 liters (2.2 US qt, 1.8 Imp qt) of coolant from the cooling system and add 2.1 liters (2.2 US qt, 1.8 Imp qt) of the undiluted solution of SUBARU coolant.

If a coolant concentration of 50% is needed, drain all the coolant and refill with the undiluted solution only.

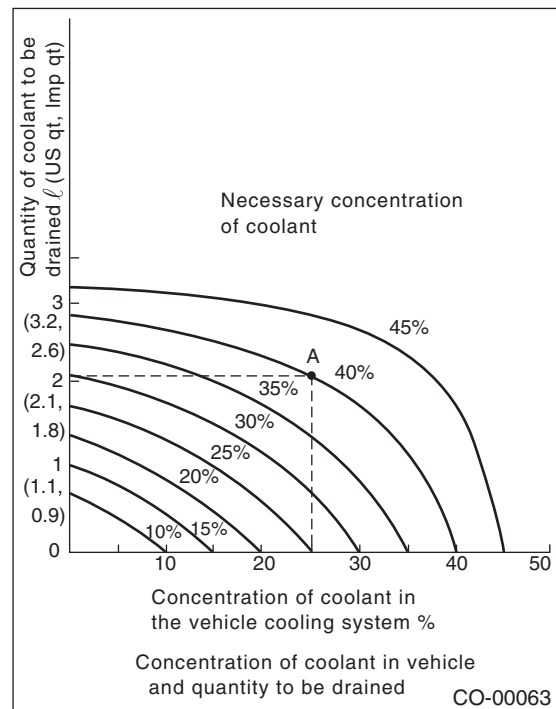

WATER PUMP

COOLING

5. Water Pump

A: REMOVAL

1) Disconnect ground cable from battery.

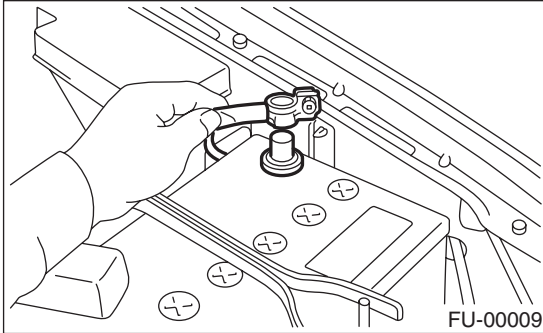

2) Lift-up the vehicle.

3) Remove under cover.

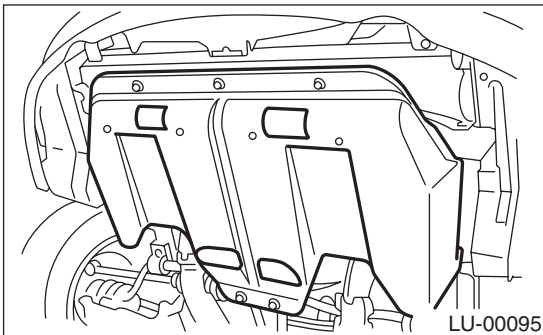

4) Drain engine coolant completely.

<Ref. to CO(H4SO)-12, DRAINING OF ENGINE COOLANT, REPLACEMENT, Engine Coolant.>

5) Disconnect connectors from radiator main fan (A) and sub fan (B) motors.

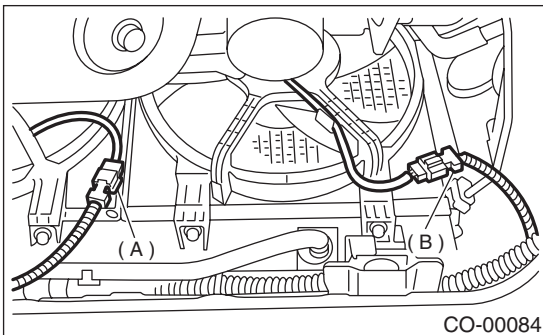

6) Disconnect radiator outlet hose and heater by-pass hose from water pump.

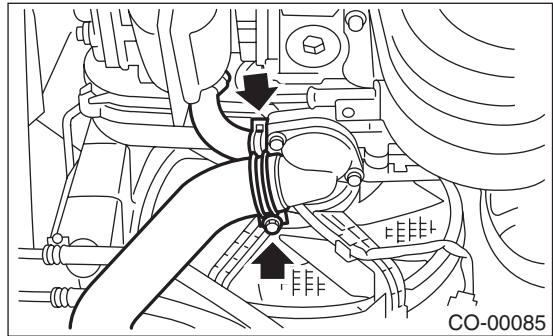

7) Lower the vehicle.

8) Remove air intake duct.

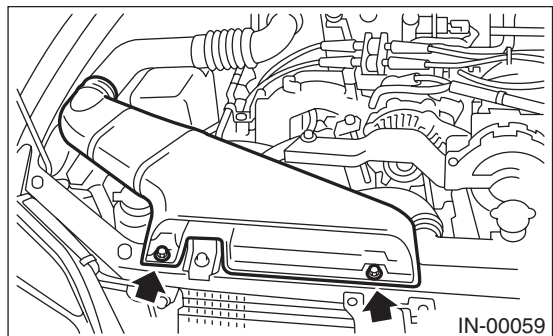

9) Disconnect overflow hose.

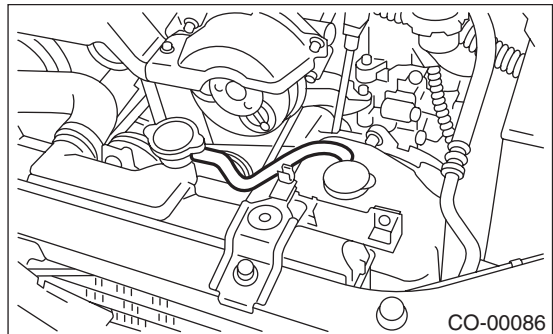

10) Remove reservoir tank.

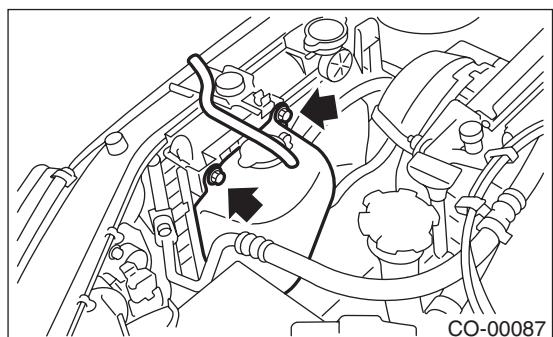

11) Remove radiator main fan and sub fan assemblies. <Ref. to CO(H4SO)-25, REMOVAL, Radiator Main Fan and Fan Motor.> and <Ref. to CO(H4SO)-27, REMOVAL, Radiator Sub Fan and Fan Motor.>

WATER PUMP

COOLING

12) Remove V-belts.

<Ref. to ME(H4SO)-40, REMOVAL, V-belt.>

13) Remove timing belt.

<Ref. to ME(H4SO)-44, TIMING BELT, REMOVAL, Timing Belt.>

14) Remove automatic belt tension adjuster.

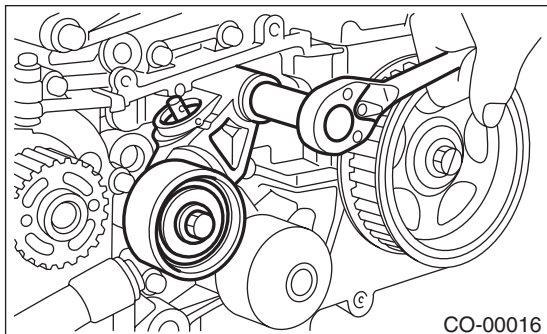

15) Remove belt idler No. 2.

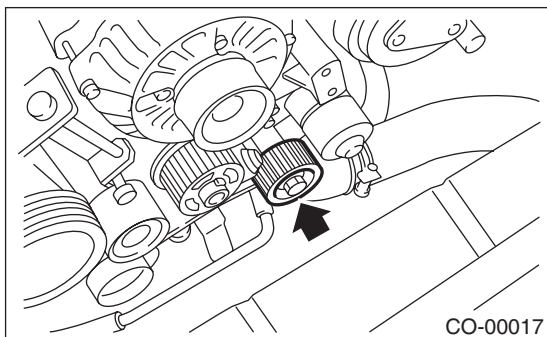

16) Remove left-hand camshaft sprocket by using ST.

ST 18231AA010 CAMSHAFT SPROCKET WRENCH

NOTE:

Camshaft sprocket wrench (499207100) is also available.

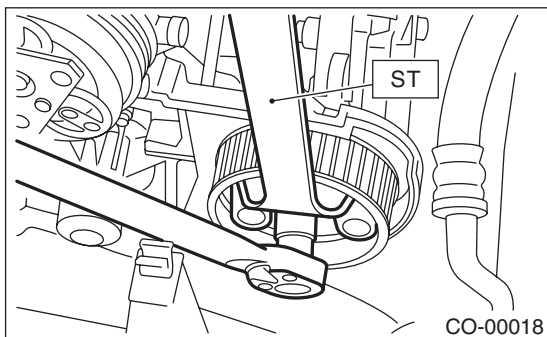

17) Remove left-hand belt cover No. 2.

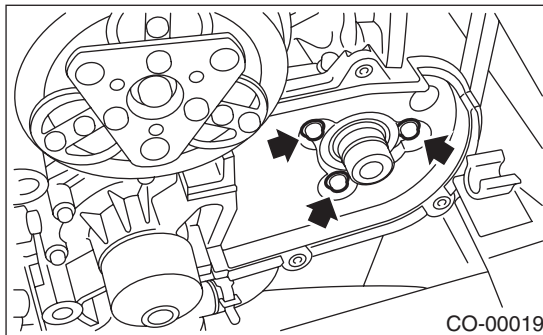

18) Remove tensioner bracket.

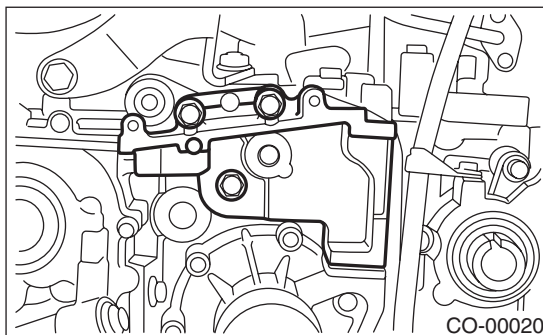

19) Remove water pump.

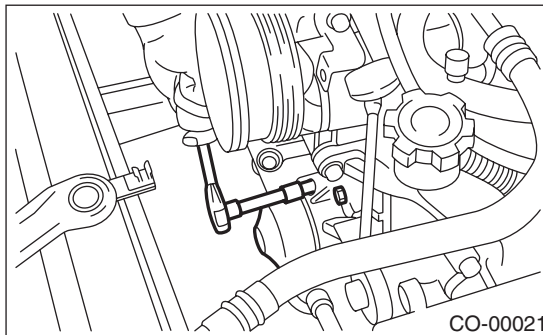

WATER PUMP

COOLING

B: INSTALLATION

1) Install water pump onto left-hand cylinder block.

NOTE:

- Replace gasket with a new one.
- When installing water pump, tighten bolts in two stages in alphabetical sequence as shown in figure.

Tightening torque:

First:

12 N·m (1.2 kgf-m, 8.7 ft-lb)

Second:

12 N·m (1.2 kgf-m, 8.7 ft-lb)

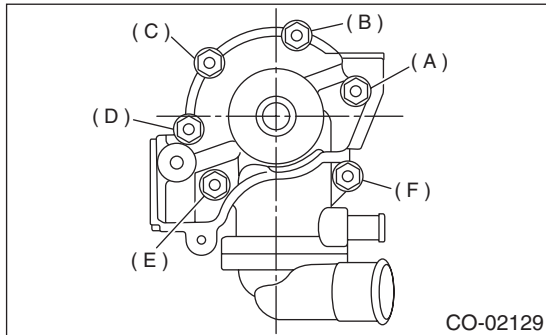

2) Install tensioner bracket.

Tightening torque:

24.5 N·m (2.5 kgf-m, 18.1 ft-lb)

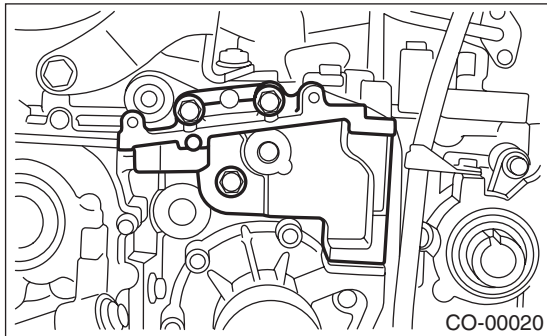

3) Install left-hand belt cover No. 2.

Tightening torque:

5 N·m (0.5 kgf-m, 3.6 ft-lb)

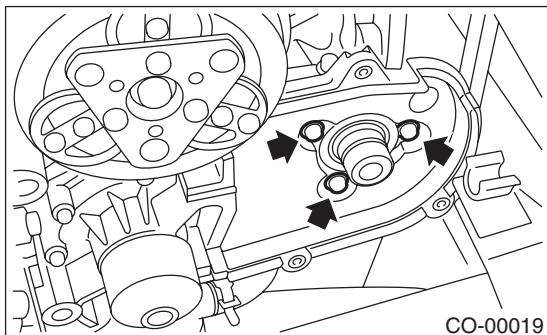

4) Install left-hand camshaft sprockets by using ST. ST 18231AA010 CAMSHAFT SPROCKET WRENCH

NOTE:

Camshaft sprocket wrench (499207100) is also available.

Tightening torque:

78 N·m (8.0 kgf-m, 57.9 ft-lb)

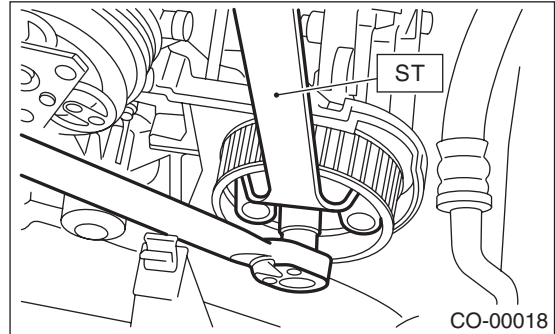

5) Install belt idler No. 2.

Tightening torque:

39 N·m (4.0 kgf-m, 28.9 ft-lb)

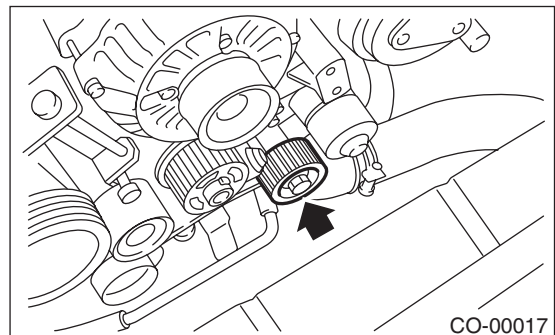

6) Install automatic belt tension adjuster which tension rod is held with pin. <Ref. to ME(H4SO)-45, INSTALLATION, Timing Belt.>

7) Install timing belt. <Ref. to ME(H4SO)-46, TIMING BELT, INSTALLATION, Timing Belt.>

8) Install V-belts. <Ref. to ME(H4SO)-40, INSTALLATION, V-belt.>

9) Install radiator main fan and sub fan motor assemblies. <Ref. to CO(H4SO)-25, INSTALLATION, Radiator Main Fan and Fan Motor.> and <Ref. to CO(H4SO)-27, INSTALLATION, Radiator Sub Fan and Fan Motor.>

10) Install reservoir tank.

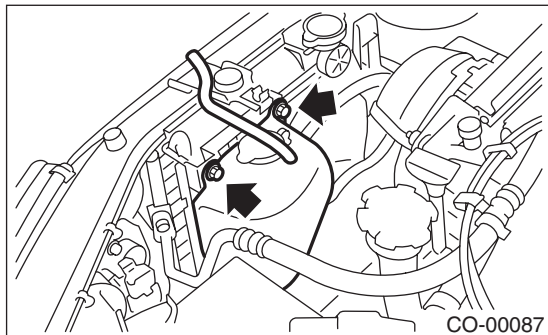

11) Connect overflow hose.

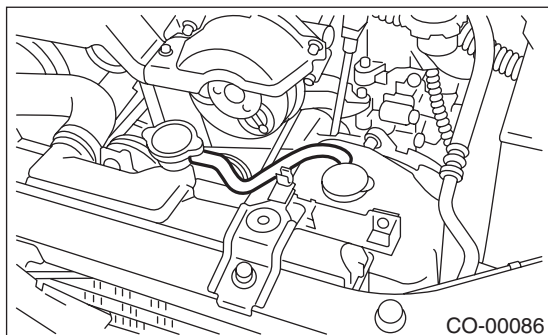

12) Install air intake duct.

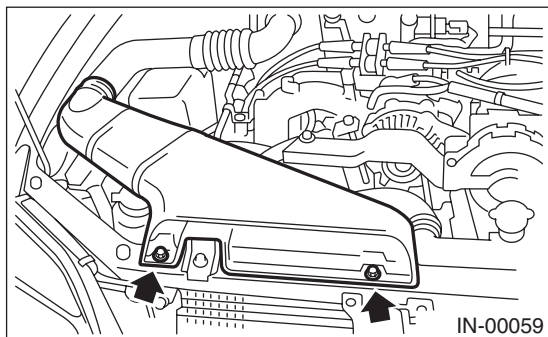

13) Lift-up the vehicle.

14) Connect radiator outlet hose and heater bypass hose to water pump.

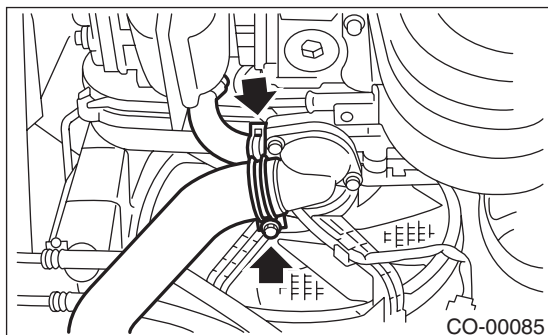

15) Connect connectors to radiator main fan (A) and sub fan (B) motors.

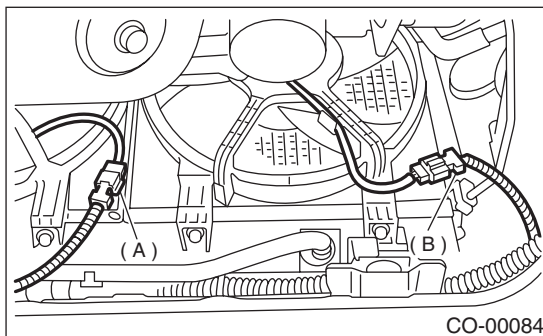

16) Install under cover.

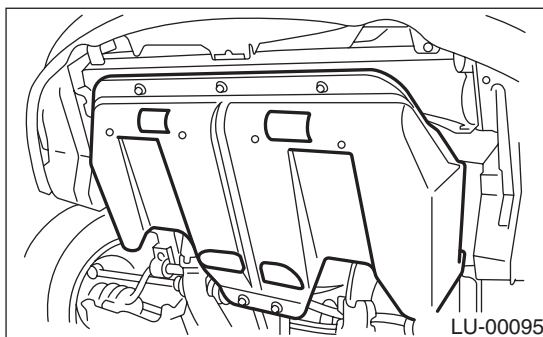

17) Lower the vehicle.

18) Connect battery ground cable.

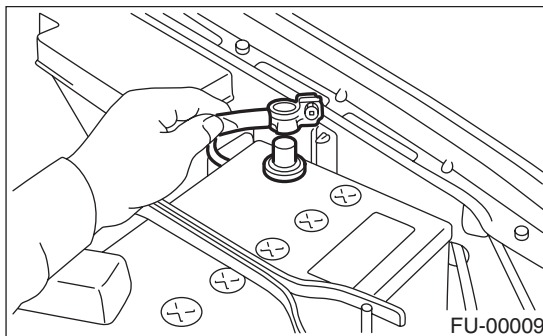

19) Fill coolant. <Ref. to CO(H4SO)-12, FILLING OF ENGINE COOLANT, REPLACEMENT, Engine Coolant.>

C: INSPECTION

- 1) Check water pump bearing for smooth rotation.
- 2) Check water pump pulley for abnormalities.
- 3) Inspect the impeller for crack or deformation.
- 4) Check clearance between impeller and pump case.

Clearance between impeller and pump case:

Standard

0.4 — 1.6 mm (0.016 — 0.063 in)

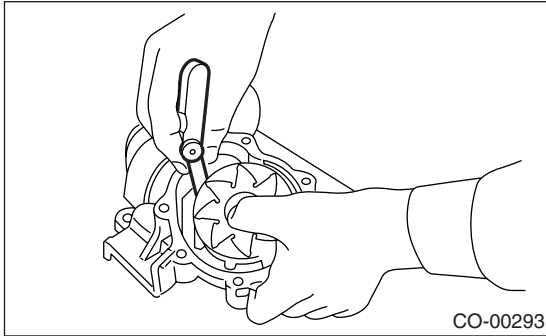

- 5) After water pump installation, check pulley shaft for engine coolant leaks. If leaks are noted, replace water pump assembly.

6. Thermostat

A: REMOVAL

- 1) Lift-up the vehicle.
- 2) Remove under cover.

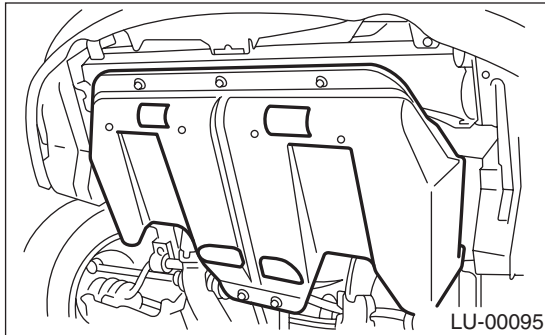

- 3) Drain engine coolant completely. <Ref. to CO(H4SO)-12, DRAINING OF ENGINE COOLANT, REPLACEMENT, Engine Coolant.>

- 4) Disconnect radiator outlet hose from thermostat cover.

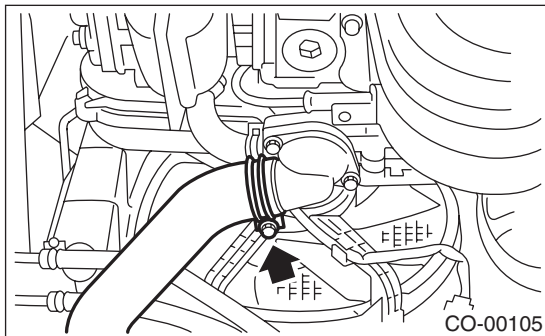

- 5) Remove thermostat cover and gasket, and pull out the thermostat.

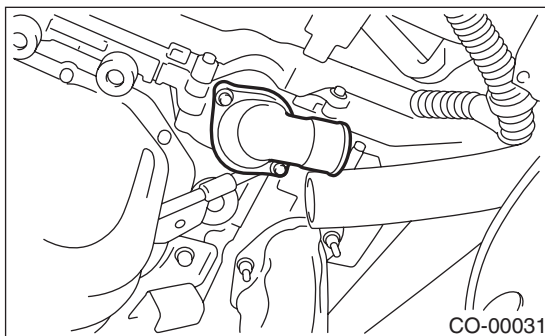

B: INSTALLATION

- 1) Install the thermostat in the water pump, and install the thermostat cover together with a gasket.

NOTE:

- Replace gasket with a new one.
- Thermostat must be installed with jiggle pin (A) facing the front side.

Tightening torque:

6.5 N·m (0.66 kgf·m, 4.8 ft·lb)

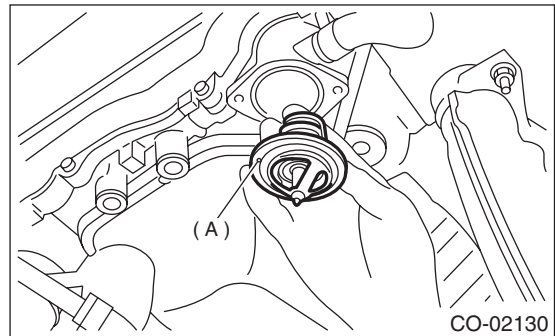

- 2) Fill coolant. <Ref. to CO(H4SO)-12, FILLING OF ENGINE COOLANT, REPLACEMENT, Engine Coolant.>

C: INSPECTION

Replace the thermostat if the valve does not close completely at an ambient temperature or if the following test shows unsatisfactory results.

• Inspection Method

Immerse the thermostat and a thermometer in water. Raise water temperature gradually, and measure the temperature and valve lift when the valve begins to open and when the valve is fully opened. During the test, agitate the water for even temperature distribution. If the measured temperature is within the specified range, the condition of thermostat is normal.

NOTE:

- When measuring amount of valve lift, leave the valve for 5 minutes or more in boiled water.
- Hold the thermostat wire so as not to contact the base of container.

Specified value:

Starts to open:

76.0 — 80.0°C (169 — 176°F)

Fully opens:

91°C (196°F)

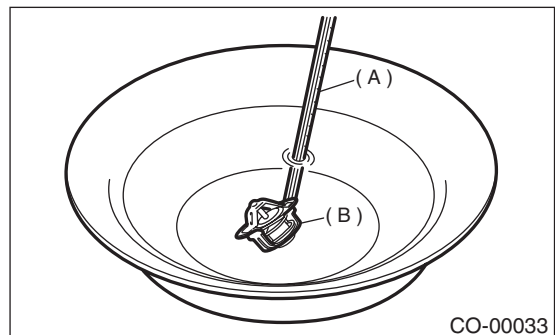

- (A) Thermometer
- (B) Thermostat

RADIATOR

COOLING

7. Radiator

A: REMOVAL

1) Disconnect battery ground cable.

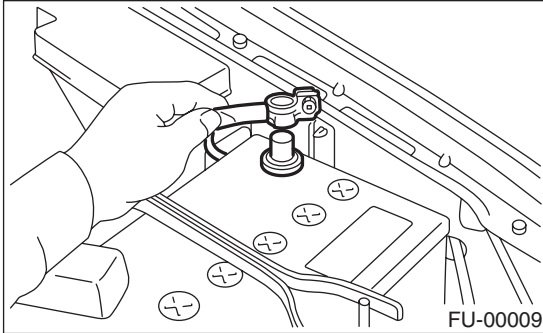

2) Lift-up the vehicle.

3) Remove under cover.

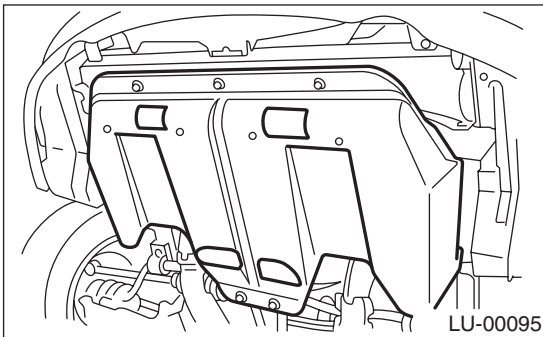

4) Drain engine coolant completely. <Ref. to CO(H4SO)-12, DRAINING OF ENGINE COOLANT, REPLACEMENT, Engine Coolant.>

5) Disconnect connectors of radiator main fan (A) and sub fan (B) motor.

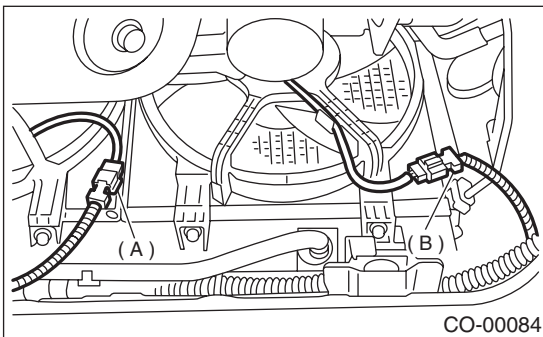

6) Disconnect radiator outlet hose from thermostat cover.

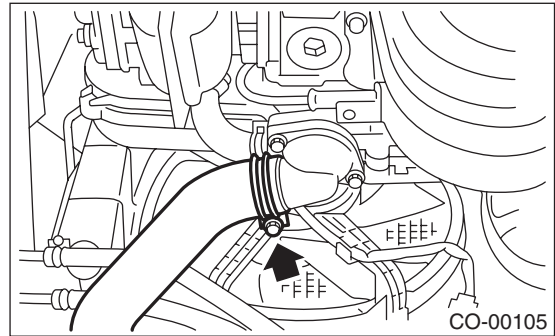

7) Disconnect ATF cooler hoses from radiator. (AT vehicles only)

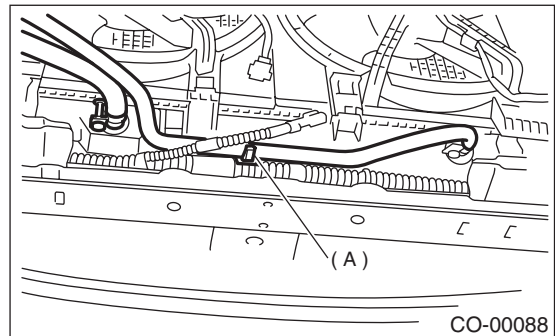

(A) Clip

8) Lower the vehicle.

9) Remove air intake duct.

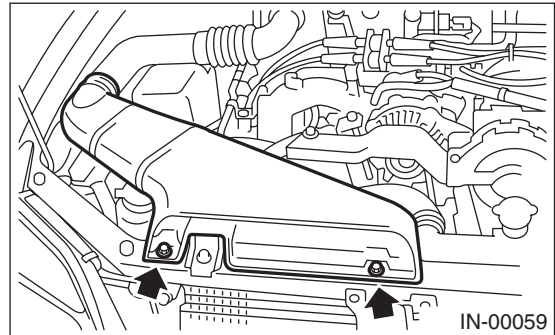

10) Disconnect overflow hose.

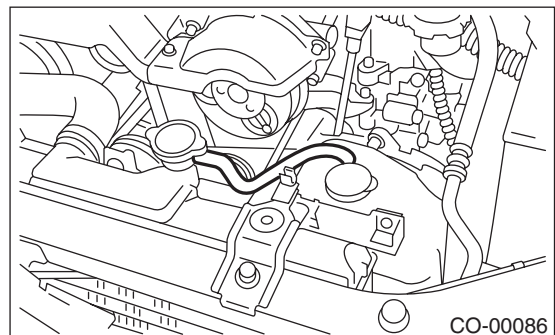

11) Remove reservoir tank.

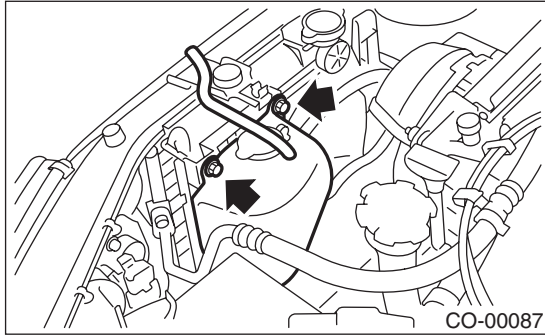

12) Disconnect radiator inlet hose from engine.

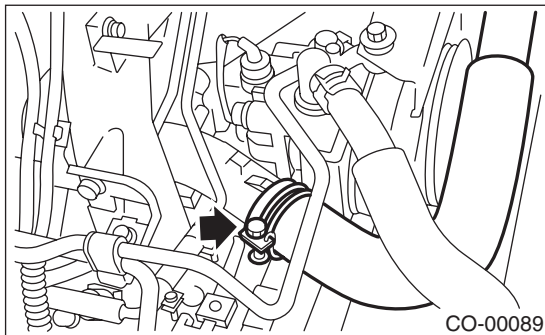

13) Remove radiator upper brackets.

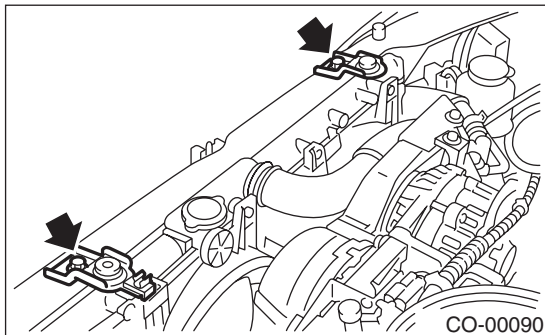

14) Detach power steering hose from the clip on the radiator.

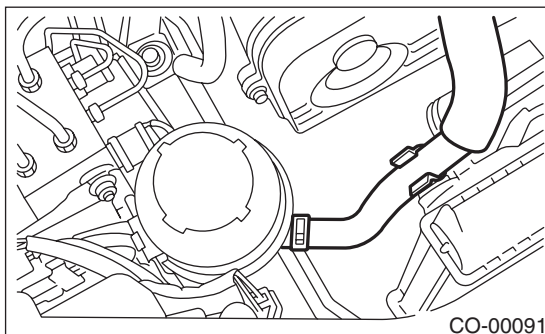

15) While slightly lifting radiator, slide it to left.

16) Lift radiator up and away from vehicle.

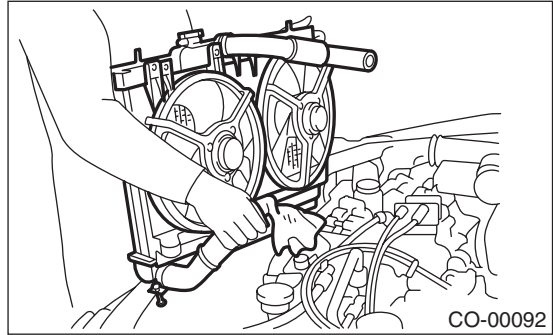

B: INSTALLATION

1) Attach radiator mounting cushions to holes on the vehicle.

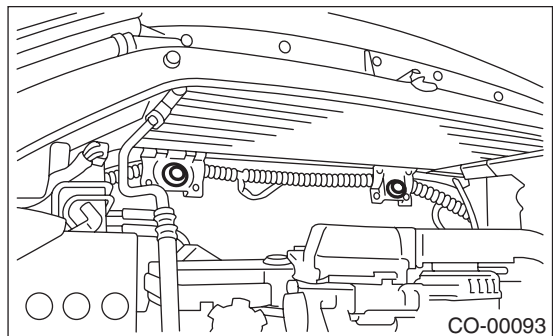

2) Install radiator while fitting radiator pins to cushions.

NOTE:

Fit pins on lower side of radiator into cushions on body side.

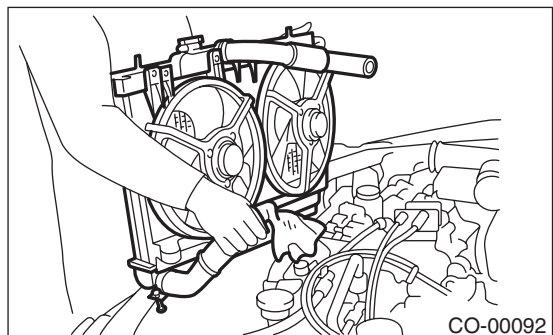

RADIATOR

COOLING

3) Install radiator brackets and tighten bolts.

Tightening torque:

18 N·m (1.8 kgf·m, 13.0 ft·lb)

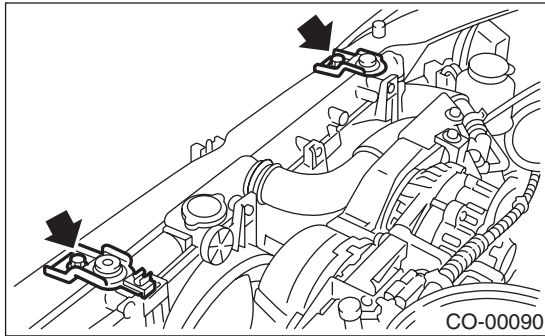

4) Attach power steering hose to the radiator.

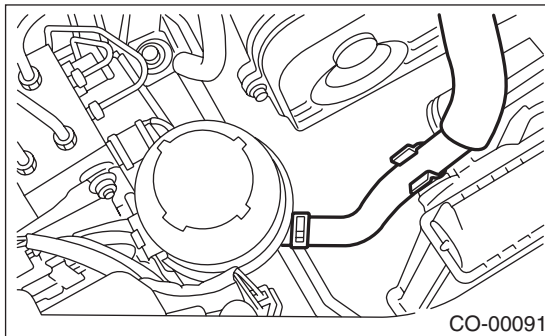

5) Connect radiator inlet hose.

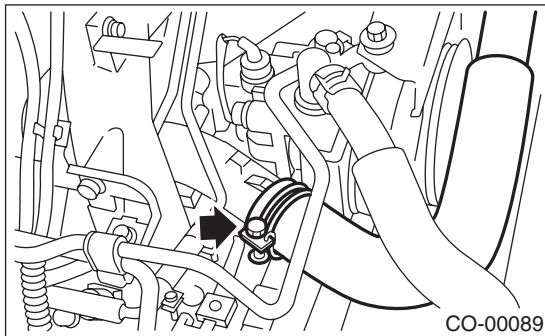

6) Install reservoir tank.

Tightening torque:

4.9 N·m (0.50 kgf·m, 3.6 ft·lb)

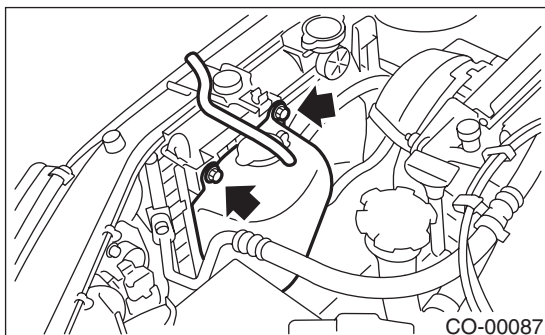

7) Install air intake duct.

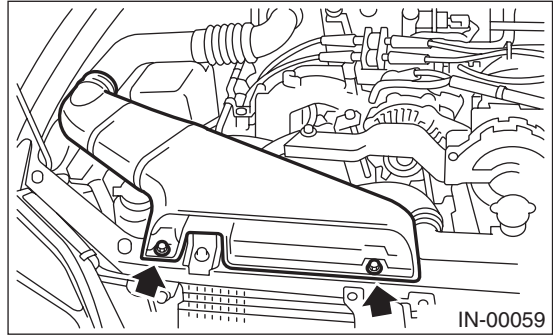

8) Lift-up the vehicle.

9) Connect ATF cooler hoses. (AT vehicles only)

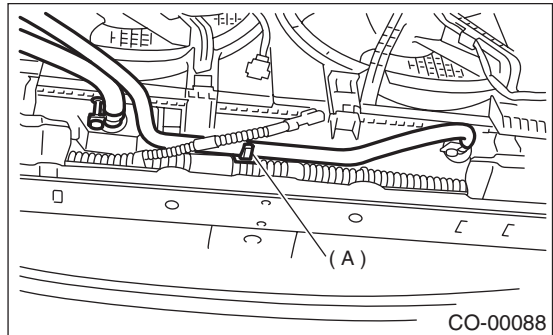

(A) Clip

10) Connect connectors to radiator main fan motor (A) and sub fan motor (B).

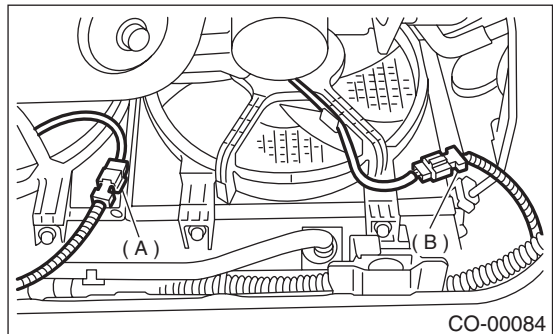

11) Connect radiator outlet hose.

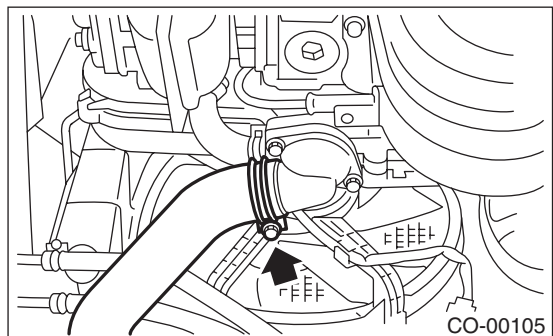

12) Install under cover.

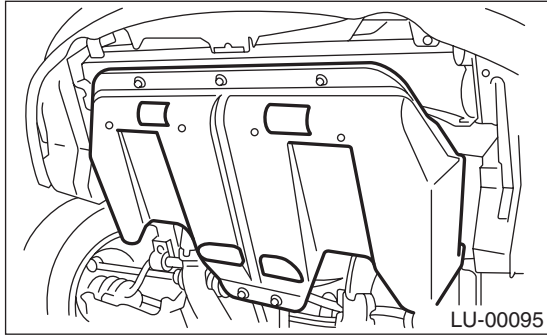

- Be careful to prevent engine coolant from spurting out when removing tester.
- Be careful not to deform filler neck of radiator when installing or removing tester.

13) Lower the vehicle.

14) Connect battery ground cable.

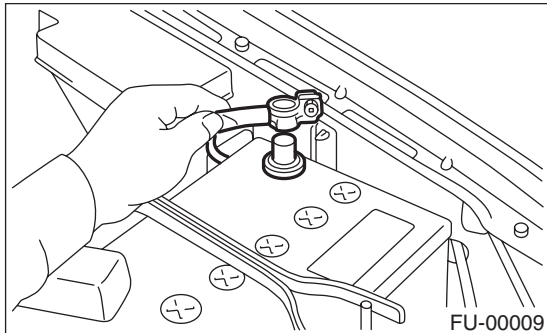

15) Fill coolant. <Ref. to CO(H4SO)-12, FILLING OF ENGINE COOLANT, REPLACEMENT, Engine Coolant.>

16) Check ATF level. <Ref. to 4AT-31, INSPECTION, Automatic Transmission Fluid.>

C: INSPECTION

1) Remove radiator cap, top off radiator, and attach tester to radiator in place of cap.

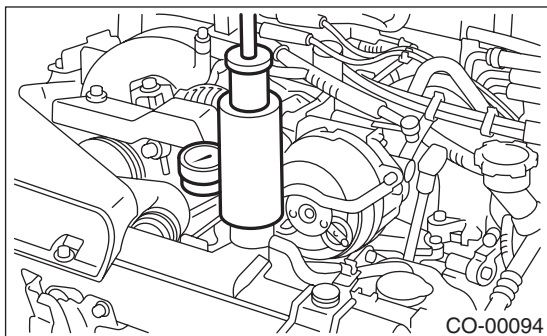

2) Apply a pressure of 157 kPa (1.6 kg/cm², 23 psi) to radiator to check if:

- (1) Engine coolant leaks at/around radiator.
- (2) Engine coolant leaks at/around hoses or connections.

CAUTION:

- Engine should be off.
- Wipe engine coolant from check points in advance.

8. Radiator Cap

A: INSPECTION

1) Attach radiator cap to tester.

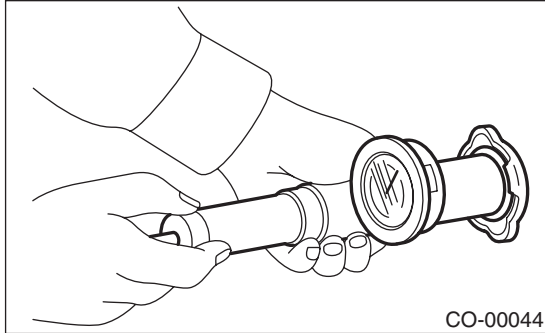

2) Increase pressure until tester gauge pointer stops. Radiator cap is functioning properly if it holds the service limit pressure for five to six seconds.

Standard pressure:

93 — 123 kPa (0.95 — 1.25 kg/cm², 14 — 18 psi)

Service limit pressure:

83 kPa (0.85 kg/cm², 12 psi)

CAUTION:

Be sure to remove foreign matter and rust from the cap before installing tester. Otherwise, results of pressure test will be incorrect.

9. Radiator Main Fan and Fan Motor

A: REMOVAL

1) Disconnect battery ground cable.

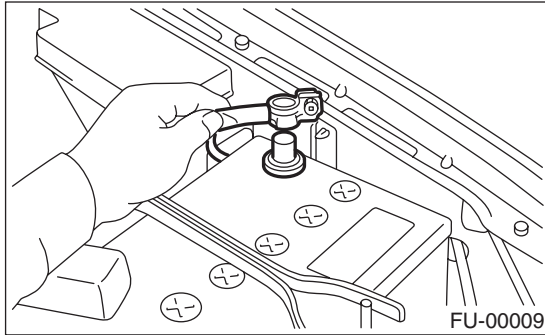

2) Lift-up the vehicle.

3) Remove under cover.

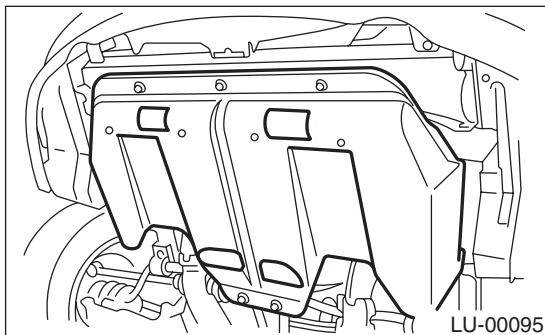

4) Disconnect connector of main fan motor.

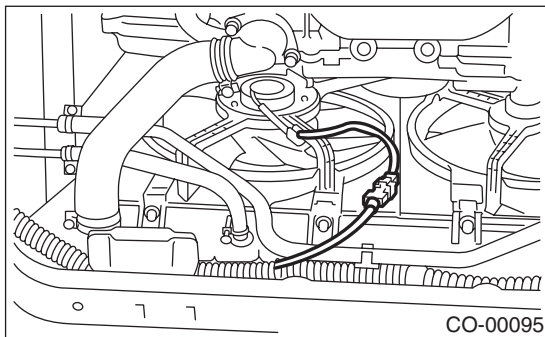

5) Lower the vehicle.

6) Remove air intake duct.

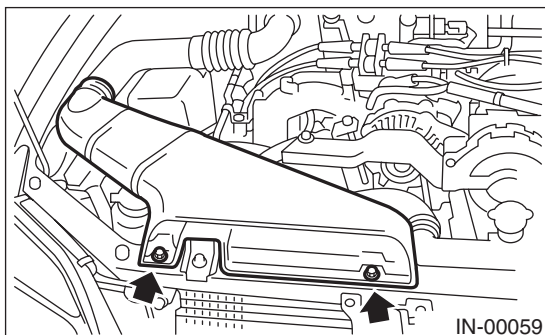

7) Disconnect overflow hose.

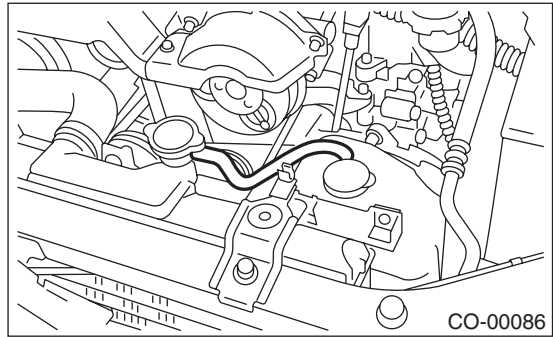

8) Remove reservoir tank.

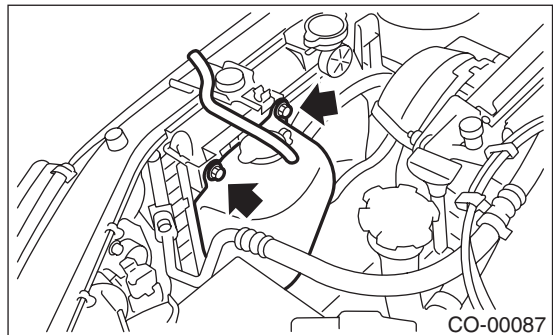

9) Remove radiator main fan motor assembly.

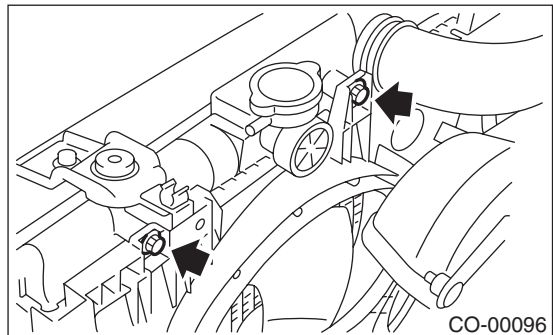

B: INSTALLATION

Install in the reverse order of removal.

NOTE:

When the main fan motor assembly cannot be installed as is, loosen the sub fan motor assembly securing bolts to install it.

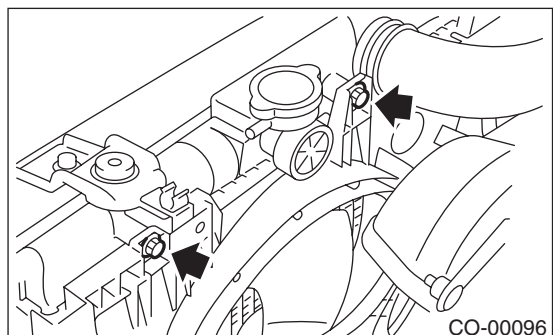

RADIATOR MAIN FAN AND FAN MOTOR

COOLING

Tightening torque:

4.9 N-m (0.50 kgf-m, 3.6 ft-lb)

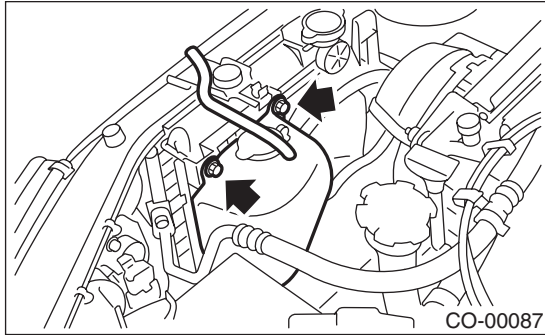

C: DISASSEMBLY

1) Remove clip which holds motor connector onto shroud.

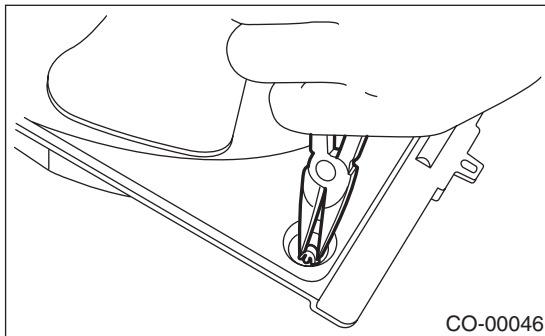

2) Remove nut which holds fan itself onto fan motor and shroud assembly.

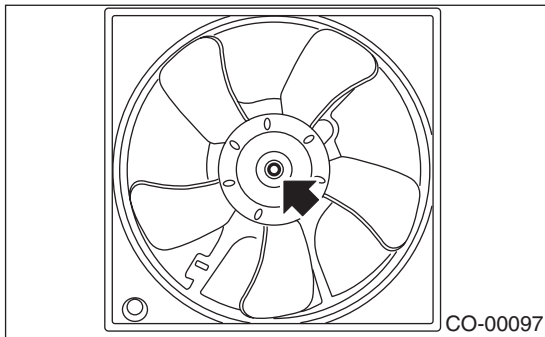

3) Remove bolts which install fan motor onto shroud.

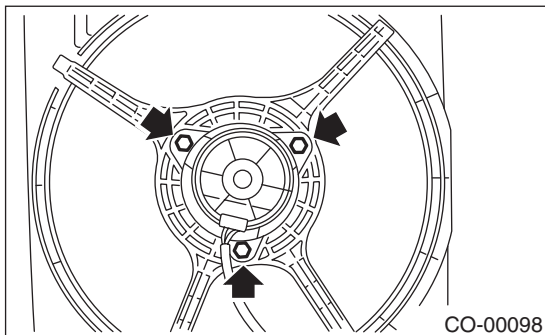

D: ASSEMBLY

Assemble in the reverse order of disassembly.

Tightening torque:

4.4 N-m (0.45 kgf-m, 3.3 ft-lb)

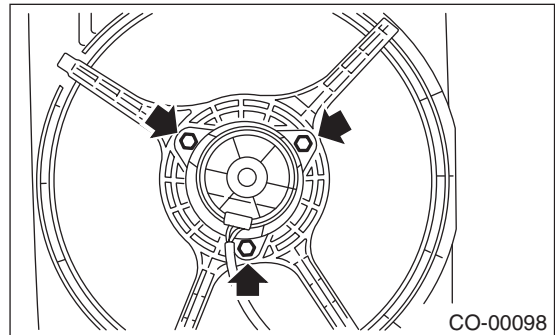

Tightening torque:

3.4 N-m (0.35 kgf-m, 2.5 ft-lb)

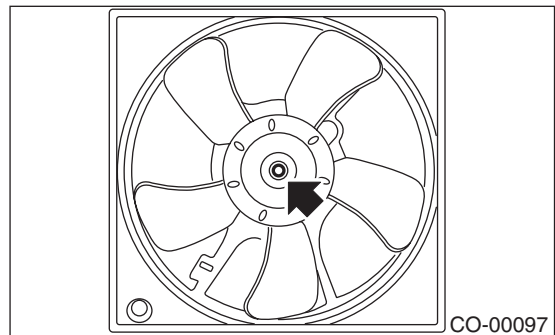

E: INSPECTION

- 1) Connect battery positive (+) terminal to terminal No. 2, and negative (-) terminal to terminal No. 1 of main fan motor connector.
- 2) Make sure the main fan motor operates properly. Replace it if it doesn't.

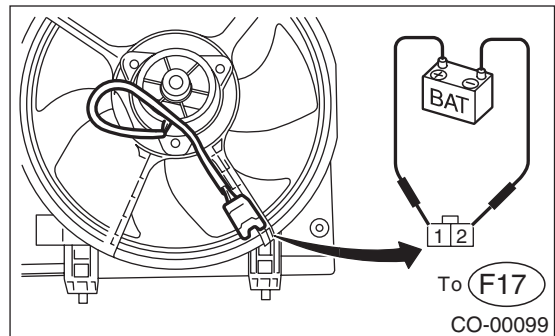

10. Radiator Sub Fan and Fan Motor

A: REMOVAL

- 1) Disconnect battery ground cable.

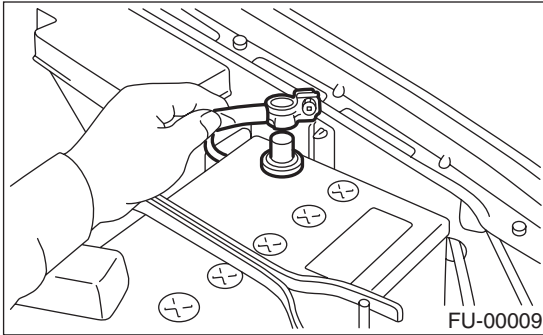

- 2) Lift-up the vehicle.
- 3) Remove under cover.

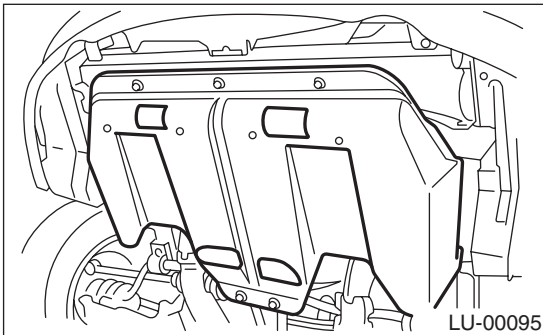

- 4) Disconnect connector of sub fan motor.

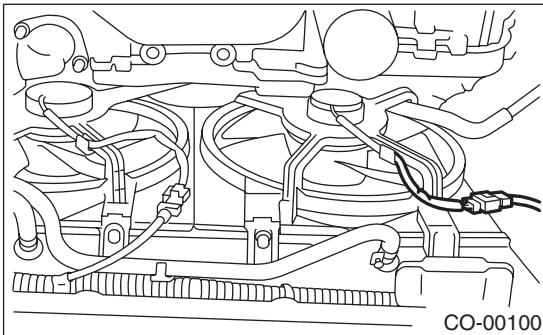

- 5) Lower the vehicle.
- 6) Remove air intake duct.

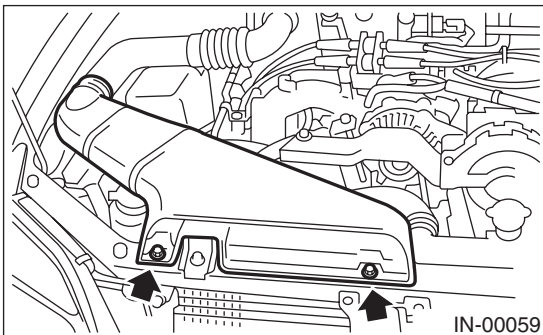

- 7) Remove bolts which hold sub fan shroud to radiator.
- 8) Remove radiator sub fan shroud through the under side of vehicle.

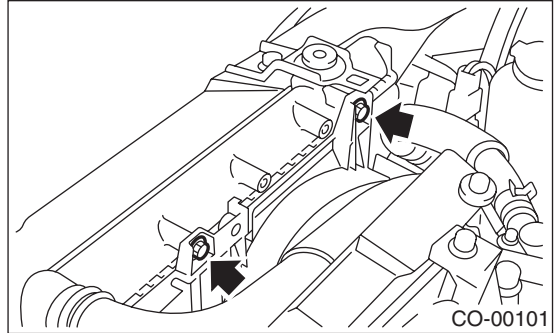

B: INSTALLATION

Install in the reverse order of removal.

Tightening torque:

4.9 N·m (0.50 kgf·m, 3.6 ft·lb)

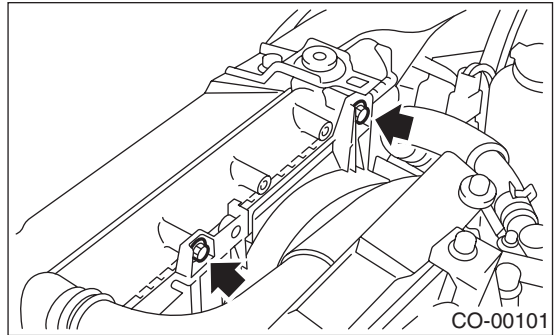

C: DISASSEMBLY

- 1) Remove clip which holds motor harness onto shroud.

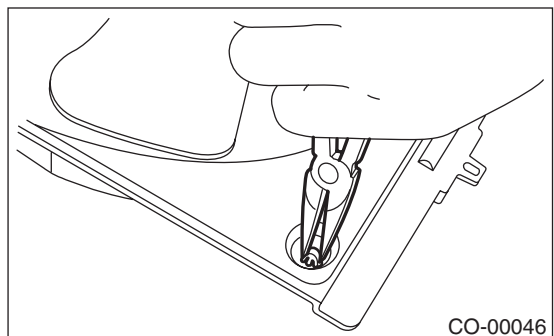

RADIATOR SUB FAN AND FAN MOTOR

COOLING

2) Remove nut which holds fan itself onto fan motor and shroud assembly.

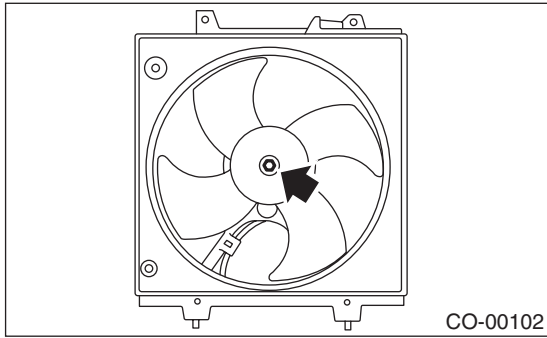

3) Remove bolts which install fan motor onto shroud.

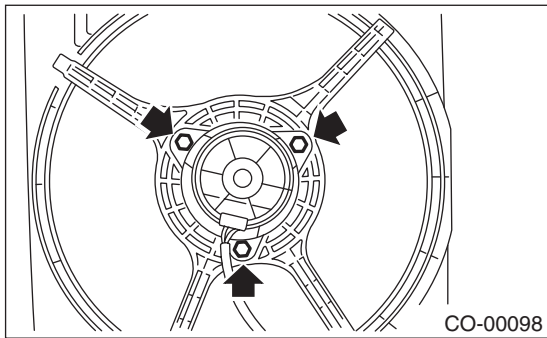

D: ASSEMBLY

Assemble in the reverse order of disassembly.

Tightening torque:

4.4 N·m (0.45 kgf·m, 3.3 ft·lb)

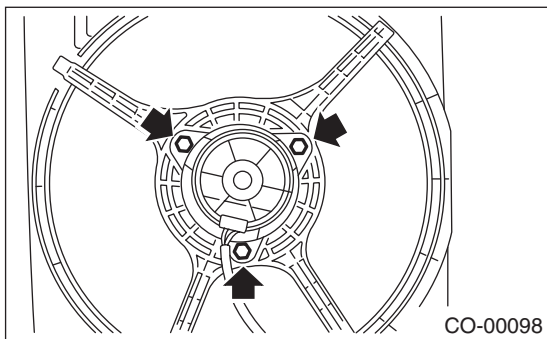

Tightening torque:

3.4 N·m (0.35 kgf·m, 2.5 ft·lb)

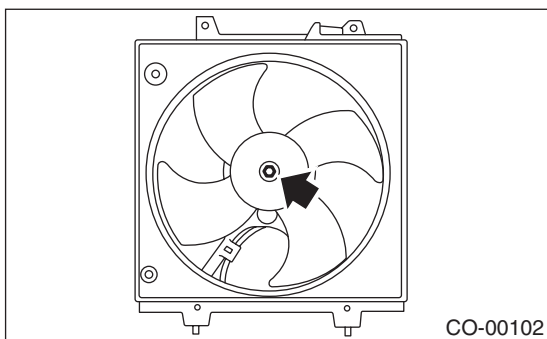

E: INSPECTION

1) Connect battery positive (+) terminal to terminal No. 2, and negative (-) terminal to terminal No. 1 of sub fan motor connector.

2) Make sure the sub-fan motor operates properly. Replace it if it doesn't.

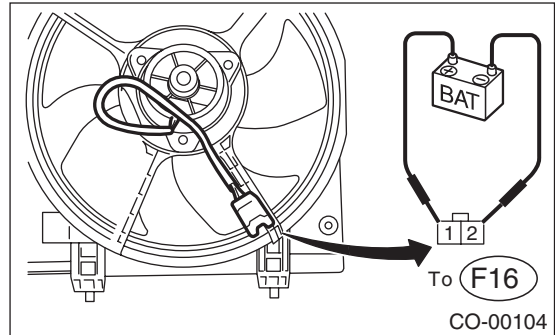

11. Reservoir Tank

A: REMOVAL

- 1) Disconnect overflow hose from radiator filler neck position.
- 2) Remove bolts which install reservoir tank onto radiator main fan shroud.
- 3) Remove reservoir tank.

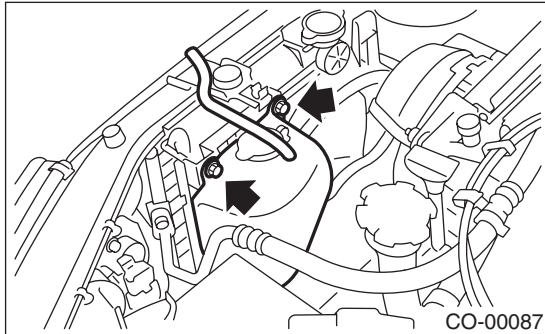

B: INSTALLATION

Install in the reverse order of removal.

Tightening torque:

4.9N-m (0.50 kgf-m, 3.6 ft-lb)

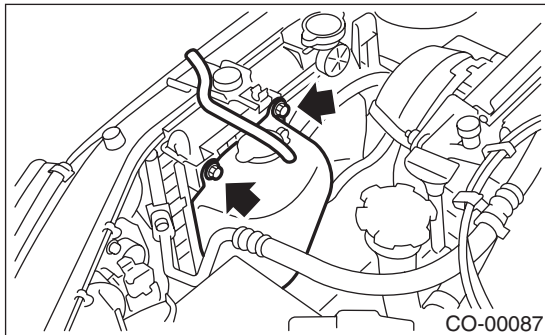

C: INSPECTION

Make sure the engine coolant level is between full and low.

ENGINE COOLING SYSTEM TROUBLE IN GENERAL

COOLING

12.Engine Cooling System Trouble in General

A: INSPECTION

Trouble		Corrective action
Over-heating	a. Insufficient engine coolant	Replenish engine coolant, inspect for leakage, and repair.
	b. Loosness of timing belt	Repair or replace timing belt tensioner.
	c. Oil on timing belt	Replace.
	d. Malfunction of thermostat	Replace.
	e. Malfunction of water pump	Replace.
	f. Clogged engine coolant passage	Clean.
	g. Improper ignition timing	Inspect and repair ignition control system. <Ref. to EN(H4SO)-2, ENGINE, PROCEDURE, Basic Diagnostic Procedure.>
	h. Clogged or leaking radiator	Clean or repair, or replace.
	i. Engine oil mixed in engine coolant	Replace engine coolant.
	j. Air/fuel mixture ratio too lean	Inspect and repair fuel injection system. <Ref. to EN(H4SO)-2, ENGINE, PROCEDURE, Basic Diagnostic Procedure.>
	k. Excessive back pressure in exhaust system	Clean or replace.
	l. Insufficient clearance between piston and cylinder	Adjust or replace.
	m. Slipping clutch	Repair or replace.
	n. Dragging brake	Adjust.
	o. Improper transmission oil	Replace.
p. Malfunction of electric fan	Inspect radiator fan relay, engine coolant temperature sensor or radiator motor and replace there.	
Over-cooling	a. Atmospheric temperature extremely low	Partly cover radiator front area.
	b. Malfunction of thermostat	Replace.
Engine coolant leaks.	a. Loosened or damaged connecting units on hoses	Repair or replace.
	b. Leakage from water pump	Replace.
	c. Leakage from water pipe	Repair or replace.
	d. Leakage around cylinder head gasket	Retighten cylinder head bolts or replace gasket.
	e. Damaged or cracked cylinder head and cylinder block	Repair or replace.
	f. Damaged or cracked thermostat cover	Repair or replace.
	g. Leakage from radiator	Repair or replace.
Noise	a. Defective drive belt	Replace.
	b. Defective radiator fan	Replace.
	c. Defective water pump bearing	Replace water pump.
	d. Defective water pump mechanical seal	Replace water pump.