

# FUEL INJECTION (FUEL SYSTEMS)

# *FU(H4SO)*

---

	<b>Page</b>
1. General Description .....	2
2. Throttle Body .....	14
3. Intake Manifold .....	15
4. Engine Coolant Temperature Sensor.....	27
5. Crankshaft Position Sensor.....	28
6. Camshaft Position Sensor.....	29
7. Knock Sensor .....	30
8. Throttle Position Sensor .....	31
9. Pressure Sensor .....	33
10. Intake Air Temperature Sensor .....	34
11. Idle Air Control Solenoid Valve .....	35
12. Air Assist Injector Solenoid Valve .....	36
13. EGR Valve .....	37
14. Fuel Injector .....	38
15. Front Oxygen (A/F) Sensor .....	43
16. Rear Oxygen Sensor.....	44
17. Engine Control Module.....	45
18. Main Relay .....	46
19. Fuel Pump Relay.....	47
20. Fuel .....	48
21. Fuel Tank .....	51
22. Fuel Filler Pipe .....	59
23. Fuel Pump.....	66
24. Fuel Level Sensor .....	68
25. Fuel Sub Level Sensor .....	69
26. Fuel Filter .....	70
27. Fuel Cut Valve.....	71
28. Fuel Delivery, Return and Evaporation Lines.....	72
29. Fuel System Trouble in General .....	75

# GENERAL DESCRIPTION

## FUEL INJECTION (FUEL SYSTEMS)

---

### 1. General Description

#### A: SPECIFICATIONS

Model		
Fuel tank	Capacity	64 ℓ (16.9 US gal, 14.1 Imp gal)
	Location	Under rear seat
Fuel pump	Type	Impeller
	Shutoff discharge pressure	370 — 677 kPa (3.77 — 6.9 kg/cm <sup>2</sup> , 53.6 — 98 psi)
	Discharge flow	More than 65 ℓ (17.2 US gal, 14.3 Imp gal)/h [12 V at 300 kPa (3.06 kg/cm <sup>2</sup> , 43.5 psi)]
Fuel filter		Cartridge type

# GENERAL DESCRIPTION

FUEL INJECTION (FUEL SYSTEMS)

---

MEMO:

# GENERAL DESCRIPTION

FUEL INJECTION (FUEL SYSTEMS)

## B: COMPONENT

### 1. INTAKE MANIFOLD

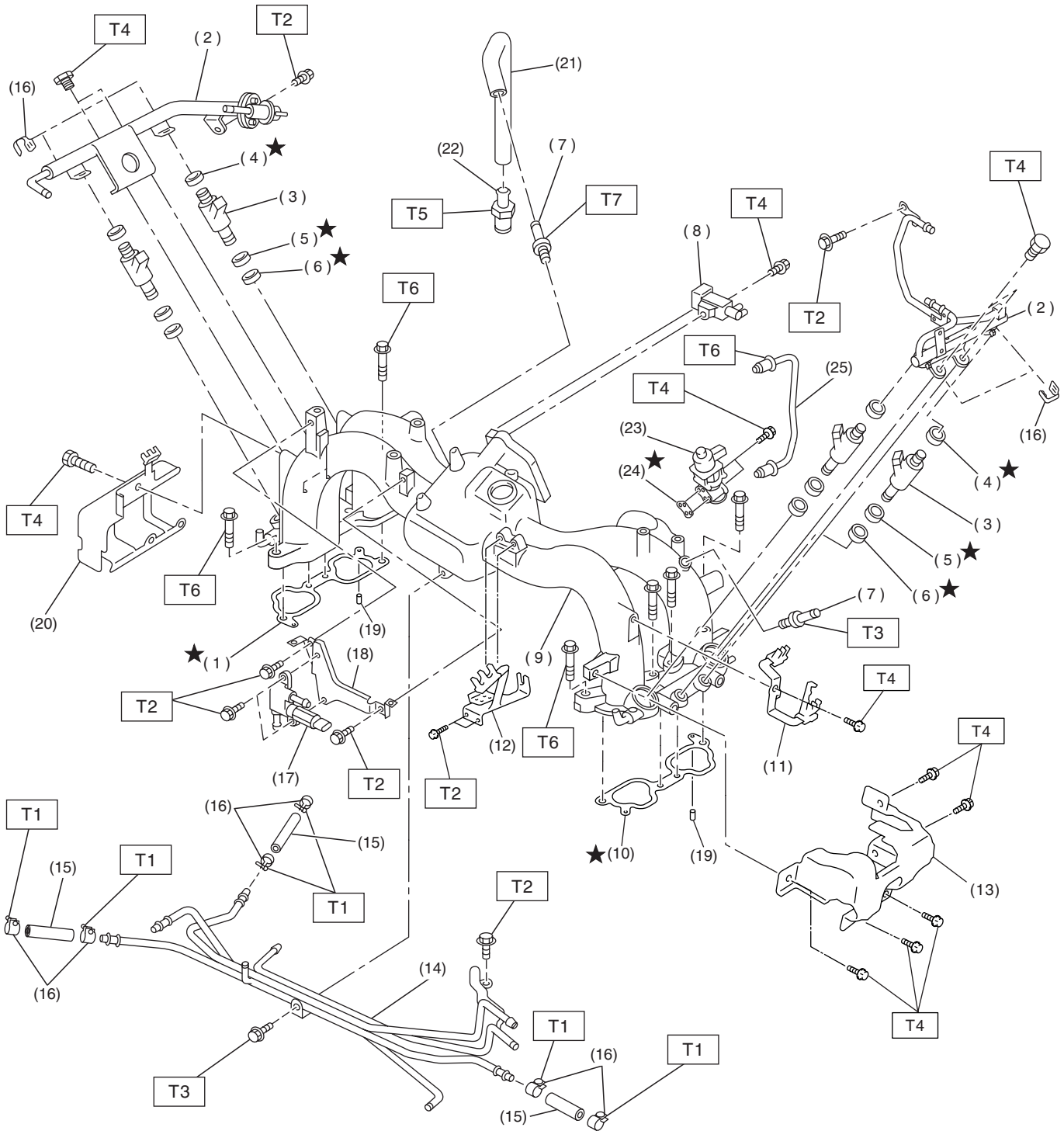

FU-02549

FU(H4SO)-4

# GENERAL DESCRIPTION

## FUEL INJECTION (FUEL SYSTEMS)

- (1) Intake manifold gasket RH
- (2) Fuel injector pipe
- (3) Fuel injector
- (4) O-ring
- (5) O-ring
- (6) O-ring
- (7) Nipple
- (8) Purge control solenoid valve
- (9) Intake manifold
- (10) Intake manifold gasket LH
- (11) Plug cord holder LH
- (12) Accelerator cable bracket
- (13) Fuel pipe protector LH

- (14) Fuel pipe ASSY
- (15) Fuel hose
- (16) Clip
- (17) Air assist injector solenoid valve
- (18) Air assist injector solenoid valve bracket
- (19) Guide pin
- (20) Fuel pipe protector RH
- (21) PCV hose
- (22) PCV valve
- (23) EGR valve
- (24) EGR valve gasket
- (25) EGR pipe

---

**Tightening torque: N·m (kgf-m, ft-lb)**

**T1: 1.5 (0.15, 1.1)**

**T2: 5.0 (0.51, 3.7)**

**T3: 17 (1.7, 12)**

**T4: 19 (1.9, 13.7)**

**T5: 23 (2.3, 17)**

**T6: 25 (2.6, 18.8)**

**T7: 22.5 (2.29, 16.6)**

---

# GENERAL DESCRIPTION

FUEL INJECTION (FUEL SYSTEMS)

## 2. AIR INTAKE SYSTEM

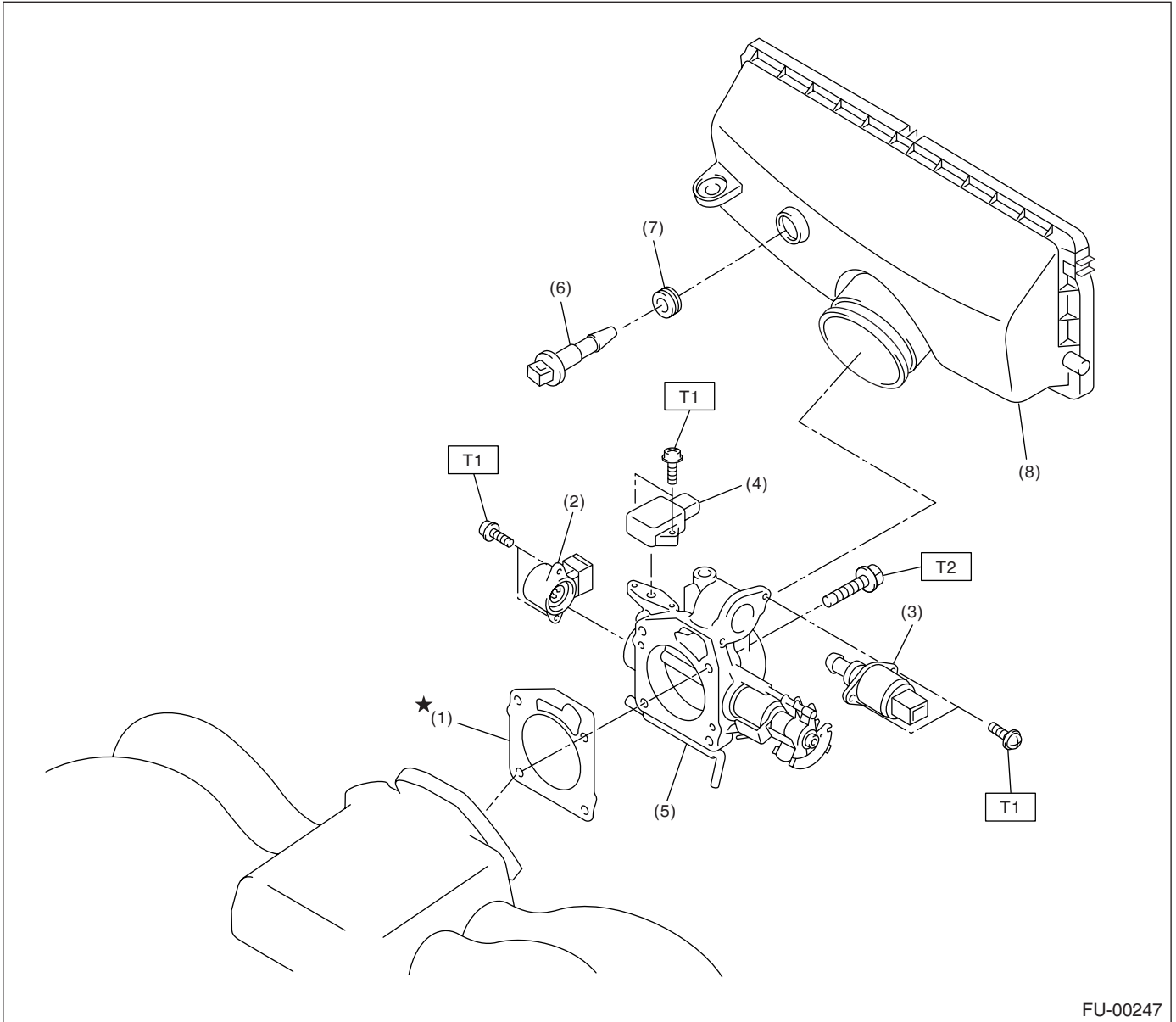

- (1) Gasket
- (2) Throttle position sensor
- (3) Idle air control solenoid valve
- (4) Pressure sensor

- (5) Throttle body
- (6) Intake air temperature sensor
- (7) Grommet
- (8) Air cleaner case

**Tightening torque: N-m (kgf-m, ft-lb)**

**T1: 2.4 (0.24, 1.7)**

**T2: 22 (2.2, 16)**

# GENERAL DESCRIPTION

FUEL INJECTION (FUEL SYSTEMS)

## 3. CRANKSHAFT POSITION, CAMSHAFT POSITION AND KNOCK SENSORS

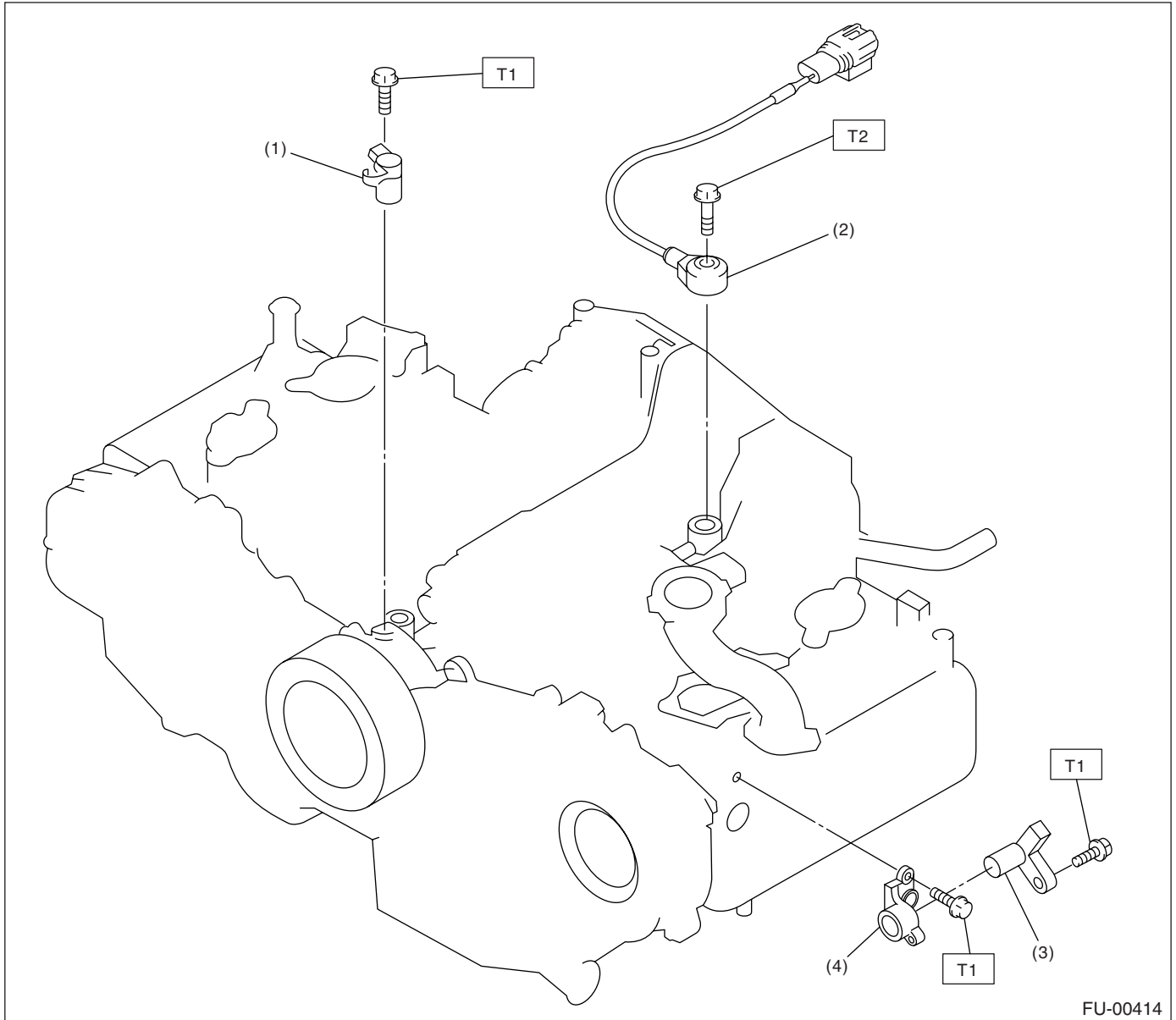

- (1) Crankshaft position sensor
- (2) Knock sensor

- (3) Camshaft position sensor
- (4) Camshaft position sensor support

**Tightening torque: N·m (kgf·m, ft·lb)**

**T1: 6.4 (0.65, 4.7)**

**T2: 24 (2.4, 17.4)**

# GENERAL DESCRIPTION

## FUEL INJECTION (FUEL SYSTEMS)

### 4. FUEL TANK

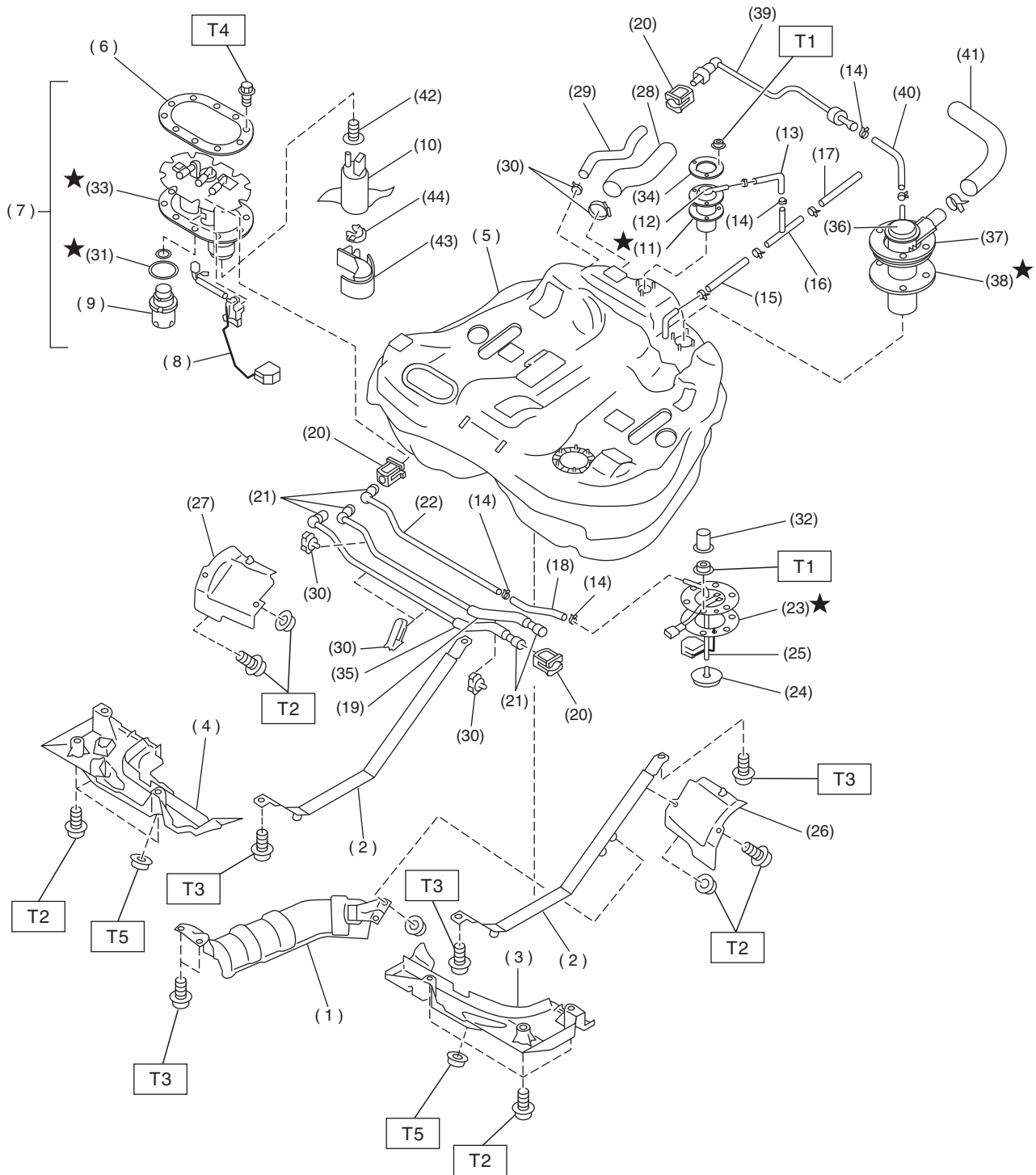

FU-05547



# GENERAL DESCRIPTION

## FUEL INJECTION (FUEL SYSTEMS)

---

(1) Heat sealed cover	(18) Jet pump hose A	(35) Fuel delivery tube
(2) Fuel tank band	(19) Fuel return tube	(36) Vent valve
(3) Protector LH (Front)	(20) Retainer	(37) Vent valve plate
(4) Protector RH (Front)	(21) Quick connector	(38) Vent valve gasket
(5) Fuel tank	(22) Jet pump tube B	(39) Evaporation tube
(6) Fuel pump plate	(23) Fuel sub level sensor gasket	(40) Evaporation hose D
(7) Fuel pump ASSY	(24) Jet pump filter	(41) Air vent hose
(8) Fuel level sensor	(25) Fuel sub level sensor	(42) Seal
(9) Fuel filter	(26) Protector LH (Rear)	(43) Fuel pump holder
(10) Fuel pump	(27) Protector RH (Rear)	(44) Grommet
(11) Fuel cut valve gasket	(28) Fuel filler hose	
(12) Fuel cut valve	(29) Fuel tank pressure sensor hose	
(13) Evaporation hose A	(30) Clamp	
(14) Clip	(31) Gasket	
(15) Evaporation hose C	(32) Cap	
(16) Joint pipe	(33) Gasket	
(17) Evaporation hose B	(34) Fuel cut valve plate	

---

**Tightening torque: N·m (kgf-m, ft-lb)**

**T1: 4.4 (0.45, 3.3)**

**T2: 18 (1.8, 13.0)**

**T3: 33 (3.4, 25)**

**T4: 5.9 (0.6, 4.3)**

**T5: 9 (0.9, 6.5)**

---

# GENERAL DESCRIPTION

## FUEL INJECTION (FUEL SYSTEMS)

### 5. FUEL LINE

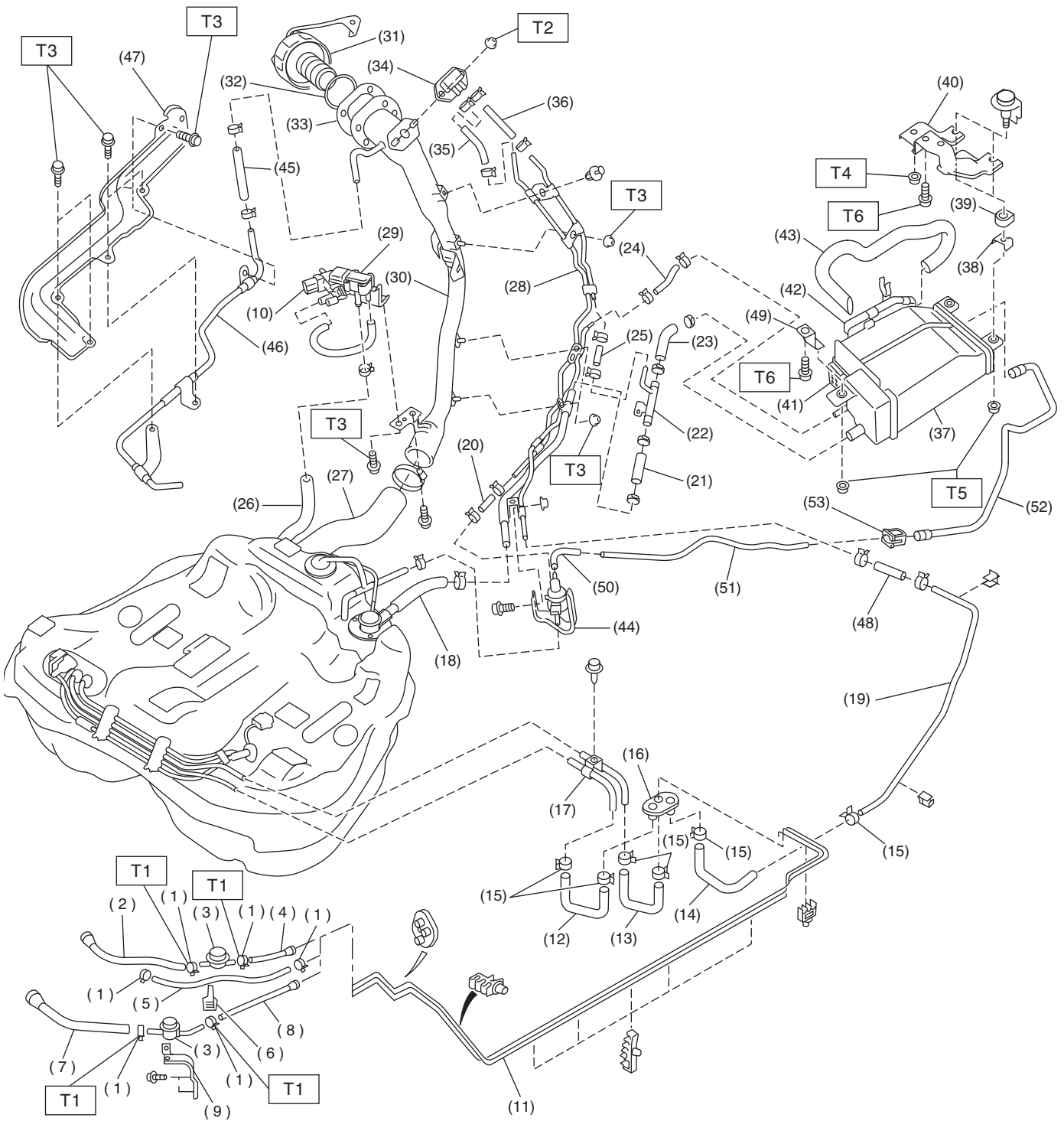

FU-05548

# GENERAL DESCRIPTION

## FUEL INJECTION (FUEL SYSTEMS)

- |                                     |                                      |                               |
|-------------------------------------|--------------------------------------|-------------------------------|
| (1) Clamp                           | (23) Air vent hose C                 | (45) Evaporation hose H       |
| (2) Fuel return hose A              | (24) Evaporation hose D              | (46) Evaporation pipe C       |
| (3) Fuel damper valve               | (25) Evaporation hose E              | (47) Pipe protector           |
| (4) Fuel return hose B              | (26) Fuel tank pressure sensor hose  | (48) Evaporation hose I       |
| (5) Evaporation hose A              | (27) Fuel filler hose                | (49) Canister bracket (front) |
| (6) Clip                            | (28) Evaporation pipe B              | (50) PCV hose                 |
| (7) Fuel delivery hose A            | (29) Fuel tank pressure sensor       | (51) PCV pipe                 |
| (8) Fuel delivery hose B            | (30) Fuel filler pipe                | (52) PCV tube                 |
| (9) Fuel damper valve bracket       | (31) Fuel filler cap                 | (53) Retainer                 |
| (10) Fuel tank sensor control valve | (32) Ring                            |                               |
| (11) Fuel pipe ASSY                 | (33) Packing                         |                               |
| (12) Fuel delivery hose C           | (34) Shut valve                      |                               |
| (13) Fuel return hose C             | (35) Evaporation hose F              |                               |
| (14) Evaporation hose B             | (36) Evaporation hose G              |                               |
| (15) Clamp                          | (37) Canister                        |                               |
| (16) Grommet                        | (38) Canister lower bracket          |                               |
| (17) Fuel pipe ASSY                 | (39) Cushion rubber                  |                               |
| (18) Air vent hose A                | (40) Canister upper bracket          |                               |
| (19) Evaporation pipe A             | (41) Drain valve                     |                               |
| (20) Evaporation hose C             | (42) Drain filter                    |                               |
| (21) Air vent hose B                | (43) Drain hose                      |                               |
| (22) Air vent pipe                  | (44) Pressure control solenoid valve |                               |

---

**Tightening torque: N·m (kgf-m, ft-lb)****T1: 1.5 (0.15, 1.1)****T2: 4.5 (0.46, 3.3)****T3: 7.5 (0.76, 5.5)****T4: 18 (1.8, 13.0)****T5: 23 (2.3, 16.6)****T6: 33 (3.4, 25)**

---

# GENERAL DESCRIPTION

## FUEL INJECTION (FUEL SYSTEMS)

### 6. FUEL FILLER PIPE

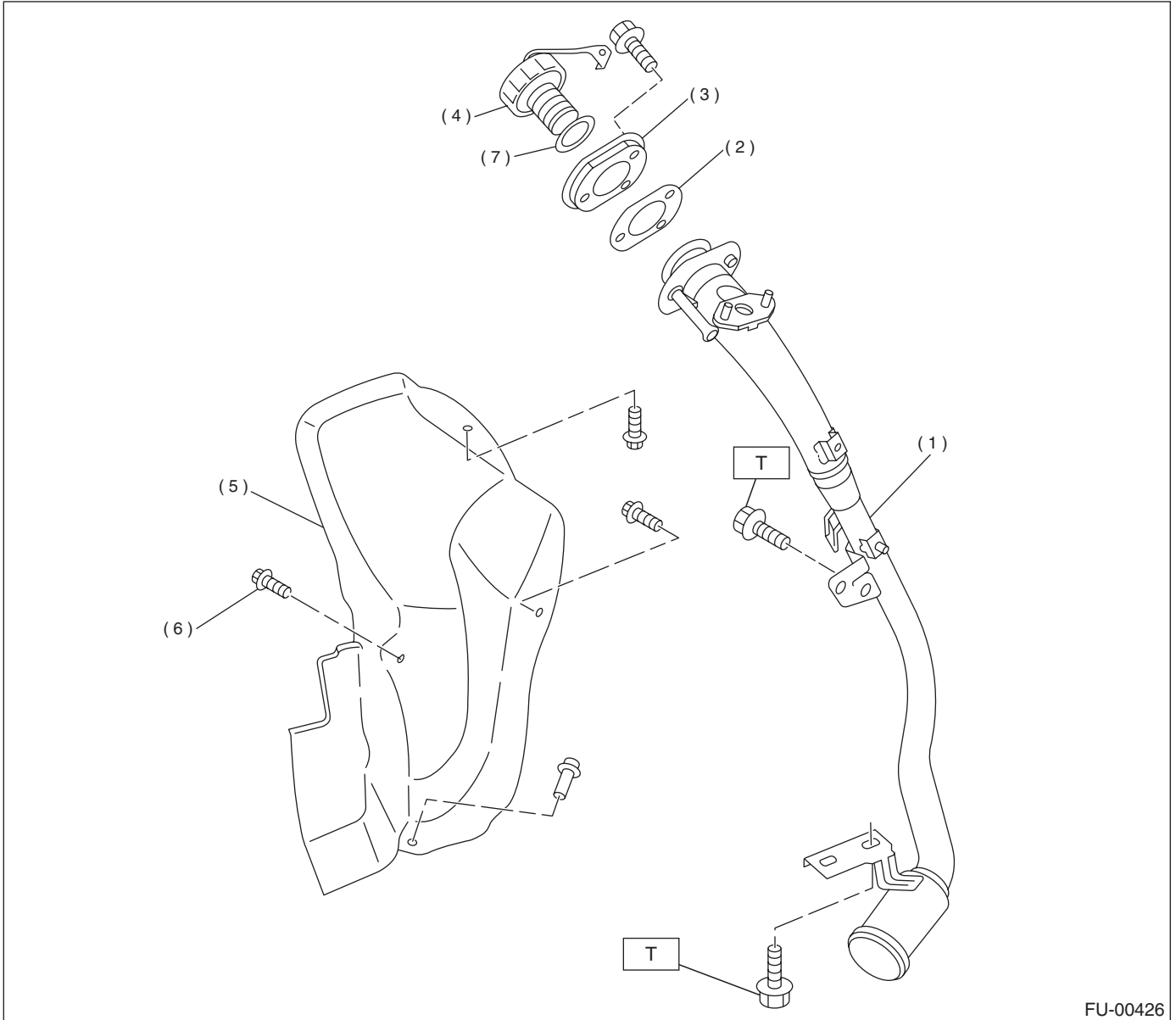

FU-00426

- |                           |                           |
|---------------------------|---------------------------|
| (1) Fuel filler pipe ASSY | (5) Filler pipe protector |
| (2) Filler pipe packing   | (6) Clip                  |
| (3) Filler ring           | (7) Ring B                |
| (4) Filler cap            |                           |

**Tightening torque: N·m (kgf·m, ft·lb)**

**T: 7.5 (0.75, 5.4)**

# GENERAL DESCRIPTION



## FUEL INJECTION (FUEL SYSTEMS)

### C: CAUTION

- Wear working clothing, including a cap, protective goggles, and protective shoes during operation.
- Remove contamination including dirt and corrosion before removal, installation or disassembly.
- Keep the disassembled parts in order and protect them from dust or dirt.
- Before removal, installation or disassembly, be sure to clarify the failure. Avoid unnecessary removal, installation, disassembly, and replacement.

- Be careful not to burn your hands, because each part on the vehicle is hot after running.
- Be sure to tighten fasteners including bolts and nuts to the specified torque.
- Place shop jacks or safety stands at the specified points.
- Before disconnecting electrical connectors of sensors or units, be sure to disconnect negative terminal from battery.
- Place "NO FIRE" signs near the working area.
- Be careful not to spill fuel on the floor.

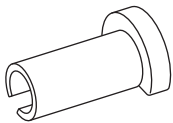
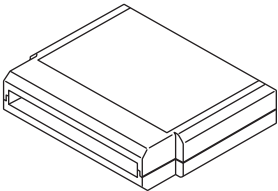
### D: PREPARATION TOOL

ILLUSTRATION	TOOL NUMBER	DESCRIPTION	REMARKS
 <p>ST42099AE000</p>	42099AE000	CONNECTOR REMOVER	Used for removing quick connector.
 <p>ST18482AA010</p>	18482AA010	CARTRIDGE	Troubleshooting for electrical systems.
 <p>ST22771AA030</p>	22771AA030	SELECT MONITOR KIT	Troubleshooting for electrical systems.

# THROTTLE BODY

## FUEL INJECTION (FUEL SYSTEMS)

### 2. Throttle Body

#### A: REMOVAL

1) Disconnect ground cable from battery.

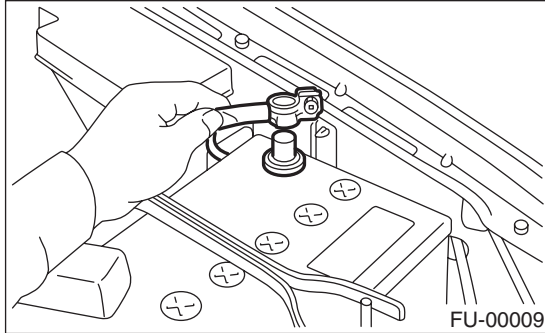

- 2) Remove air cleaner case.  
<Ref. to IN(H4SO)-5, REMOVAL, Air Cleaner.>
- 3) Disconnect accelerator cable (A).
- 4) Disconnect cruise control cable (B). (With cruise control model)

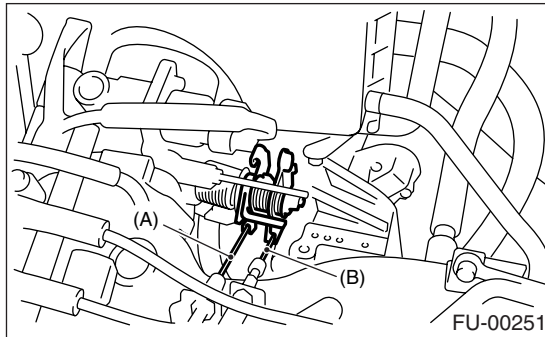

- 5) Disconnect connectors from idle air control solenoid valve, throttle position sensor and pressure sensor.
- 6) Disconnect air by-pass hose from throttle body.

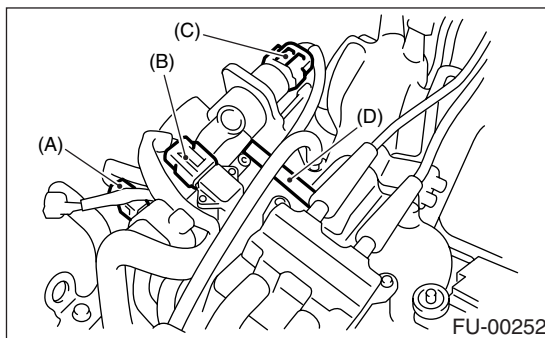

- (A) Throttle position sensor
- (B) Pressure sensor
- (C) Idle air control solenoid valve
- (D) Air by-pass hose

7) Disconnect engine coolant hoses (A) from throttle body.

8) Remove bolts (B) which install throttle body to intake manifold.

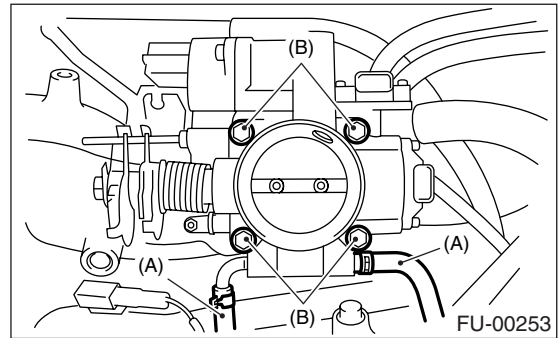

#### B: INSTALLATION

- 1) Install in the reverse order of removal.
- 2) Install accelerator cable.  
<Ref. to SP(H4SO)-6, INSTALLATION, Accelerator Control Cable.>

#### NOTE:

Always use a new gasket.

#### **Tightening torque:**

#### **Throttle body;**

**22 N·m (2.2 kgf-m, 15.9 ft-lb)**

## 3. Intake Manifold

### A: REMOVAL

- 1) Release fuel pressure. <Ref. to FU(H4SO)-48, RELEASING OF FUEL PRESSURE, OPERATION, Fuel.>
- 2) Open fuel flap lid, and remove fuel filler cap.
- 3) Disconnect battery ground cable.

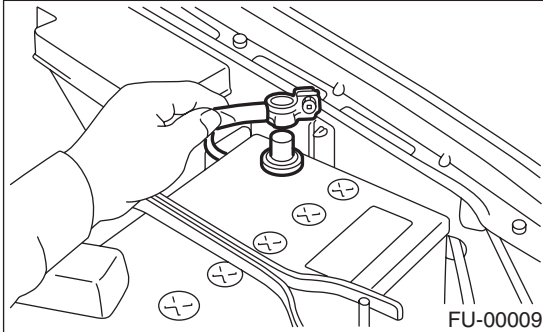

- 4) Remove air intake duct and air cleaner case. <Ref. to IN(H4SO)-7, REMOVAL, Air Intake Duct.> and <Ref. to IN(H4SO)-6, REMOVAL, Air Cleaner Case.>
- 5) Disconnect accelerator cable (A).
- 6) Disconnect cruise control cable (B). (With cruise control model)

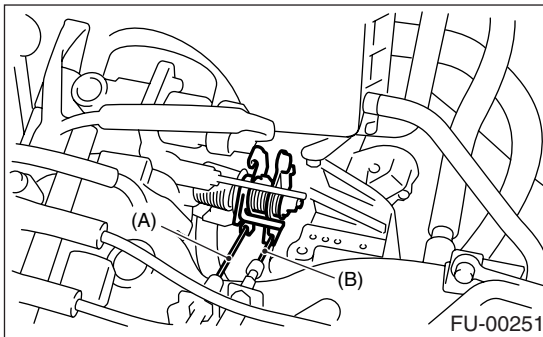

- 7) Remove power steering pump and tank from brackets.
  - (1) Remove resonator chamber. <Ref. to IN(H4SO)-8, REMOVAL, Resonator Chamber.>
  - (2) Remove front V-belt. <Ref. to ME(H4SO)-40, REMOVAL, V-belt.>
  - (3) Remove bolts which hold power steering pipes onto intake manifold protector.

**NOTE:**

Do not disconnect power steering hose.

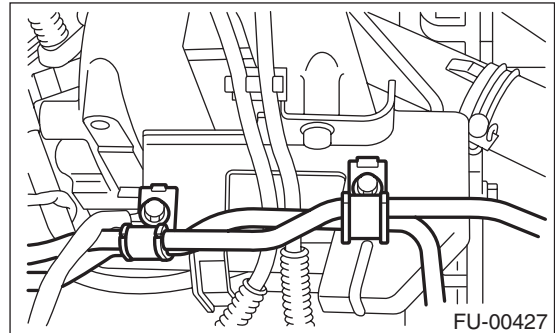

- (4) Remove bolts which install power steering pump bracket.

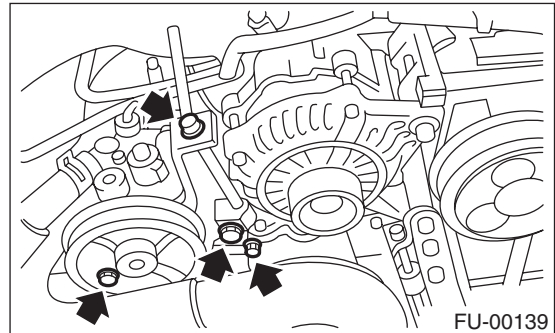

- (5) Disconnect connector from power steering pump switch.

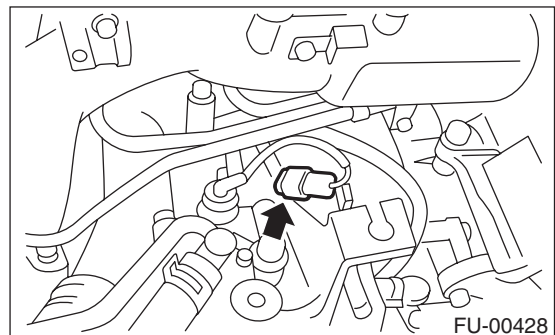

# INTAKE MANIFOLD

## FUEL INJECTION (FUEL SYSTEMS)

(6) Remove power steering tank from the bracket by pulling it upwards.

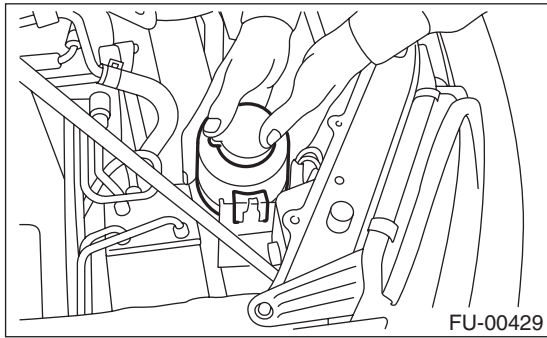

(7) Place power steering pump and tank on the right side wheel apron.

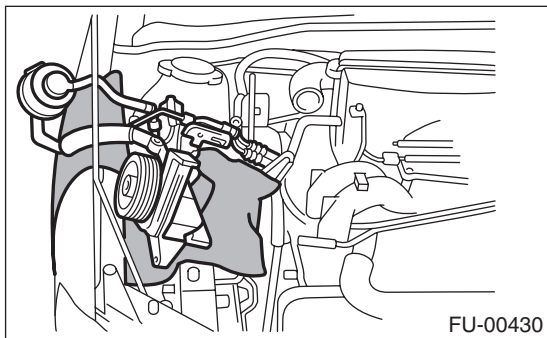

8) Disconnect spark plug cords from spark plugs.  
9) Disconnect PCV hose from intake manifold.

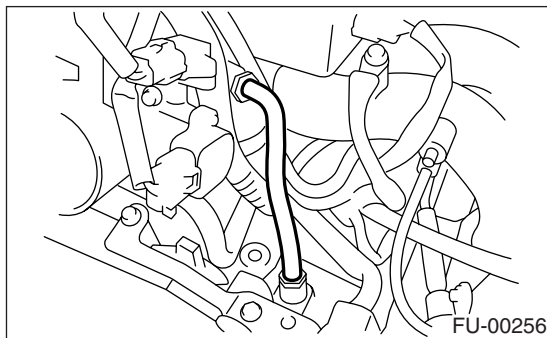

10) Disconnect engine coolant hose (A) from throttle body.

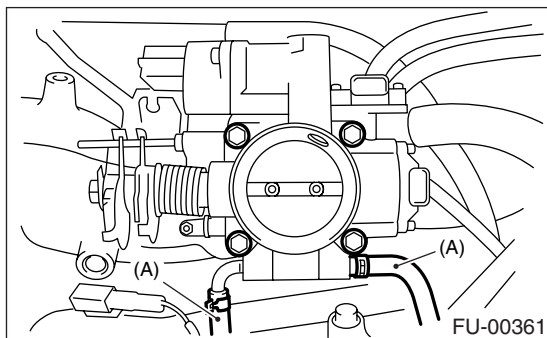

11) Disconnect brake booster hose.

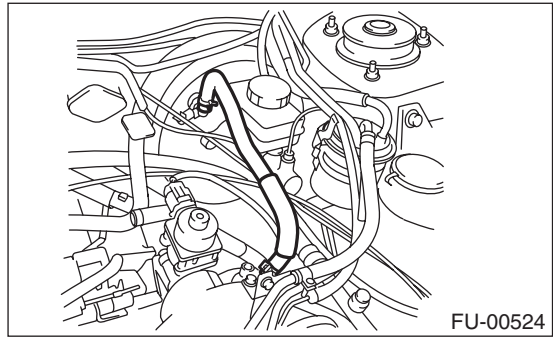

12) Remove air cleaner case stay RH and engine harness bracket, and disconnect engine harness connectors from bulkhead harness connectors.

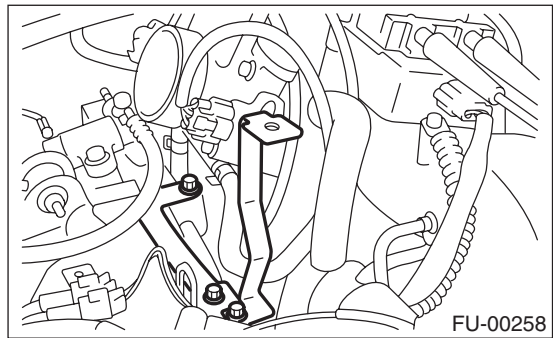

13) Disconnect connectors from engine coolant temperature sensor.

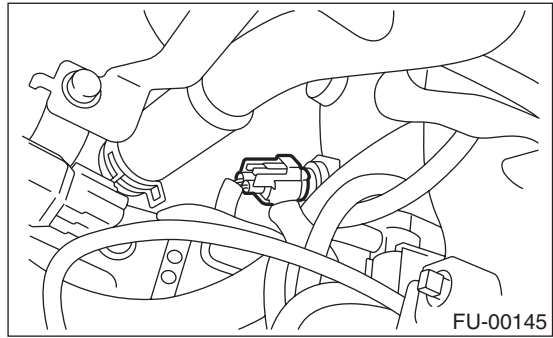

14) Disconnect knock sensor harness connector from connector bracket.  
15) Disconnect knock sensor connector.

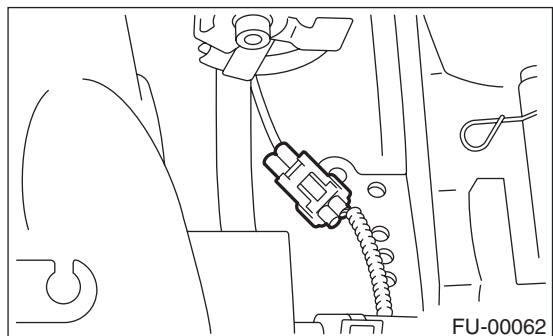



# INTAKE MANIFOLD

## FUEL INJECTION (FUEL SYSTEMS)

16) Disconnect connector from crankshaft position sensor.

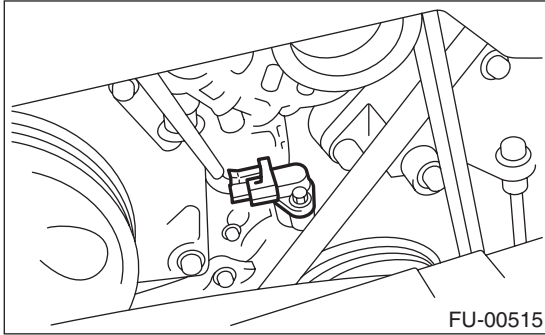

17) Disconnect connector from oil pressure switch.

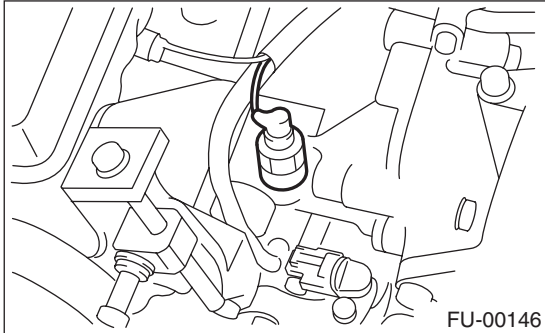

18) Disconnect connector from camshaft position sensor.

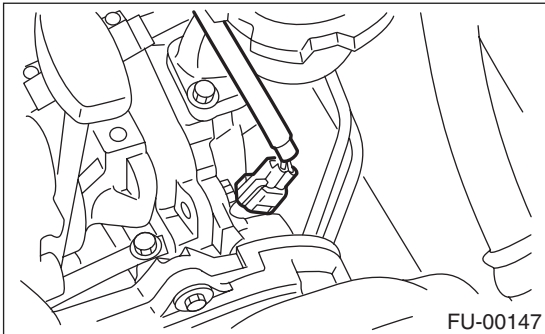

19) Remove EGR pipe from intake manifold and cylinder head.

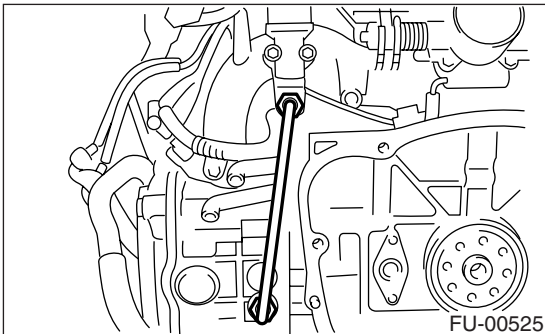

20) Using ST, disconnect fuel hoses from fuel pipes. <Ref. to FU(H4SO)-72, REMOVAL, Fuel Delivery, Return and Evaporation Lines.>

### WARNING:

- Do not spill fuel.
- Catch fuel from hoses in a container or cloth.

ST 42099AE000 CONNECTOR REMOVER

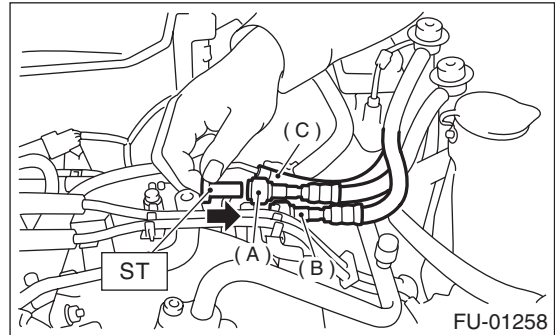

- (A) Fuel delivery hose
- (B) Return hose
- (C) Evaporation hose

21) Remove bolts which hold intake manifold onto cylinder heads, and remove intake manifold.

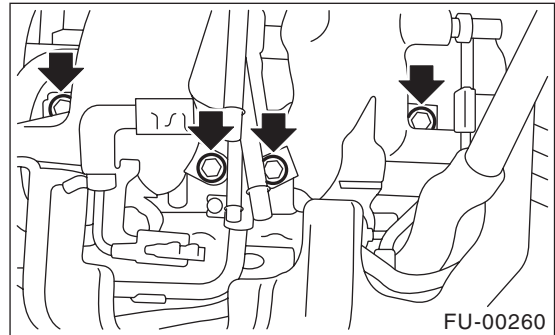

# INTAKE MANIFOLD

## FUEL INJECTION (FUEL SYSTEMS)

### B: INSTALLATION

1) Install intake manifold onto cylinder heads.

NOTE:

Always use new gaskets.

**Tightening torque:**

**25 N·m (2.5 kgf-m, 18.1 ft-lb)**

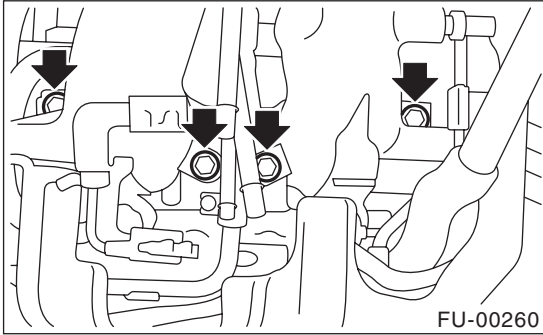

2) Connect fuel hoses.

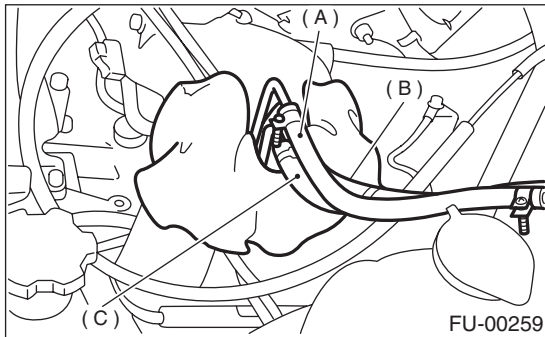

- (A) Fuel delivery hose
- (B) Return hose
- (C) Evaporation hose

3) Install EGR pipe to intake manifold and cylinder head.

**Tightening torque:**

**33 N·m (3.4 kgf-m, 24.6 ft-lb)**

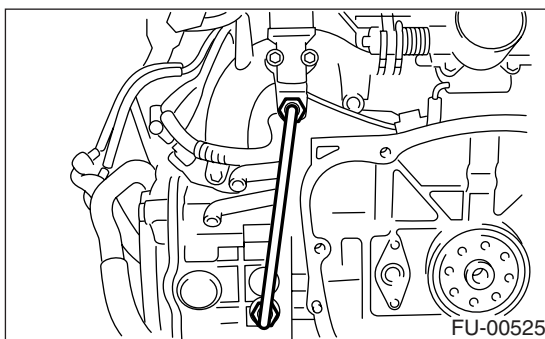

4) Connect connector to camshaft position sensor.

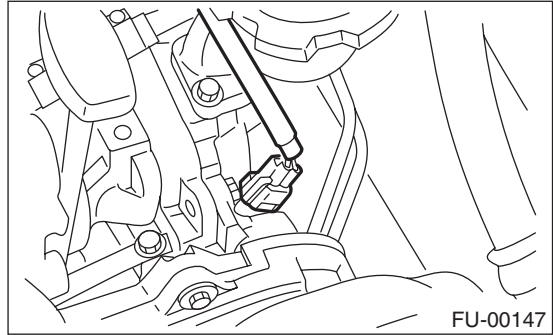

5) Connect connector to oil pressure switch.

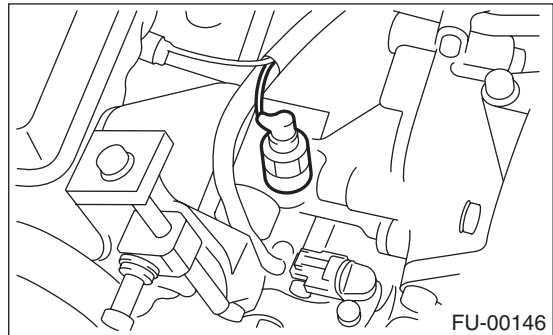

6) Connect connector to crankshaft position sensor.

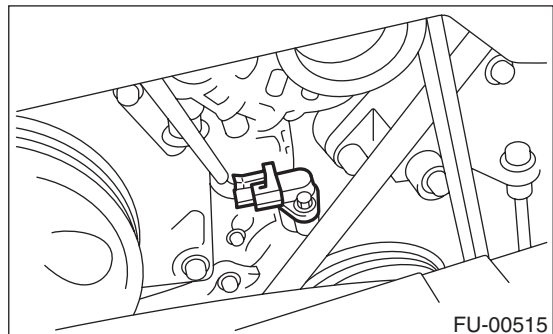

7) Connect knock sensor connector.

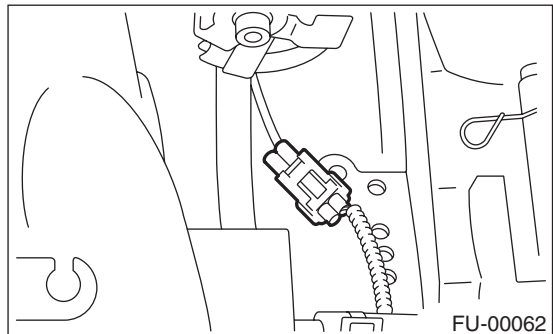

8) Install knock sensor harness connector to connector bracket.

# INTAKE MANIFOLD

## FUEL INJECTION (FUEL SYSTEMS)

9) Connect connectors to engine coolant temperature sensor.

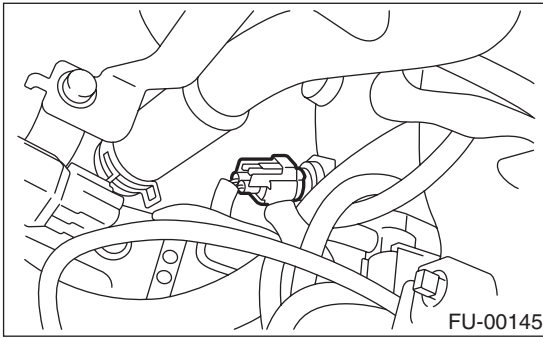

10) Install air cleaner case stay RH and engine harness bracket, and connect engine harness connectors to bulkhead connectors.

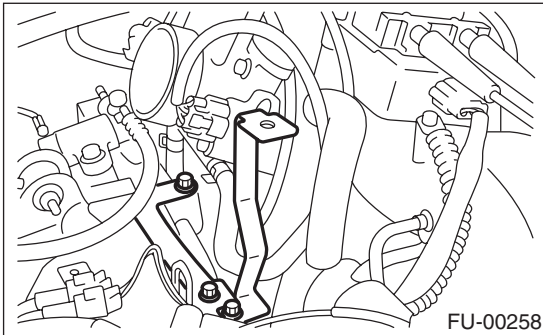

11) Connect brake booster hose.

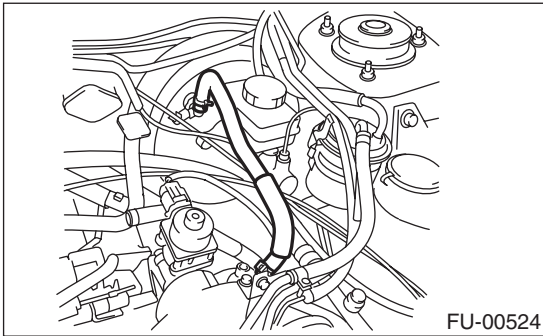

12) Connect engine coolant hose (A) to throttle body.

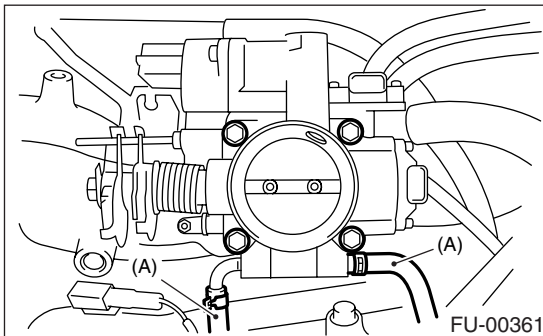

13) Connect PCV hose to intake manifold.

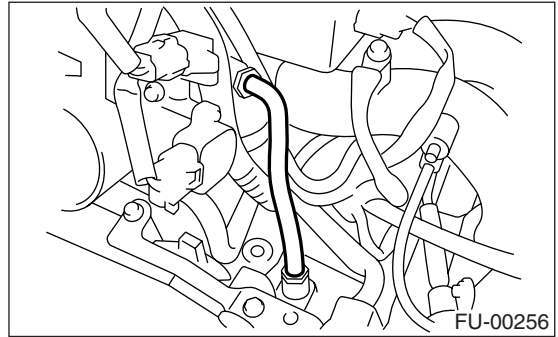

14) Connect spark plug cords to spark plugs.

15) Install power steering pump and tank on brackets.

(1) Install power steering tank on bracket.

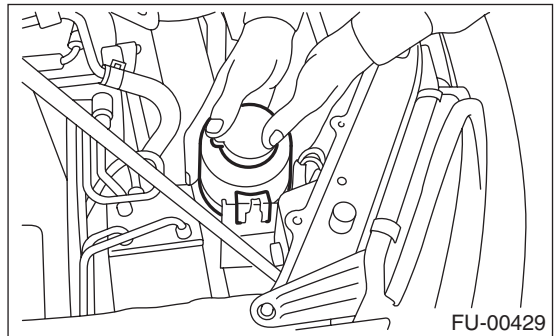

(2) Connect connector to power steering pump switch.

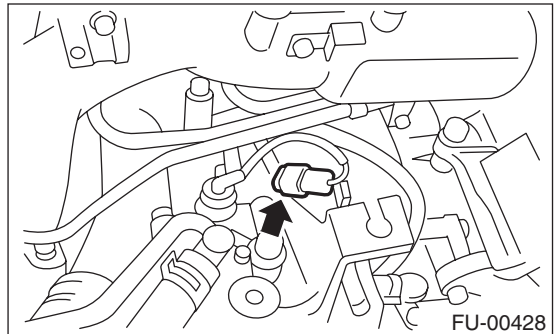

(3) Tighten bolts which install power steering pump on bracket.

**Tightening torque:**

**22 N·m (2.2 kgf·m, 15.9 ft·lb)**

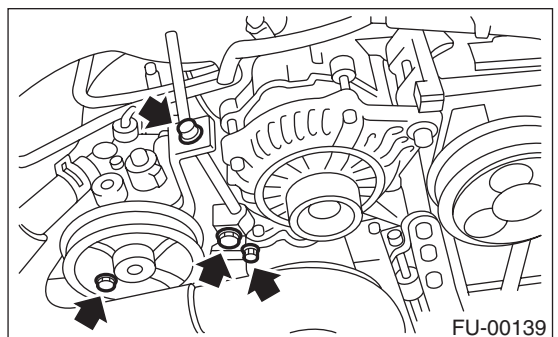

# INTAKE MANIFOLD

## FUEL INJECTION (FUEL SYSTEMS)

- (4) Install power steering pipes onto right side intake manifold protector.

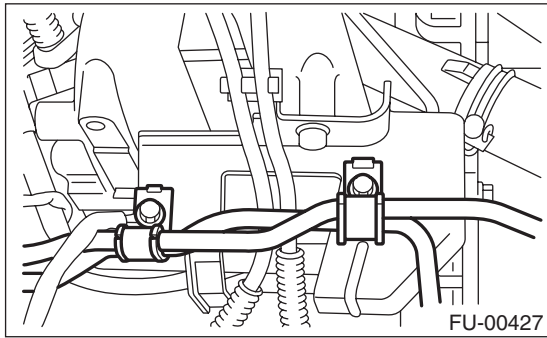

- (5) Install front V-belt.  
<Ref. to ME(H4SO)-40, INSTALLATION, V-belt.>  
(6) Install resonator chamber.

### **Tightening torque:**

**33 N·m (3.4 kgf·m, 24.6 ft·lb)**

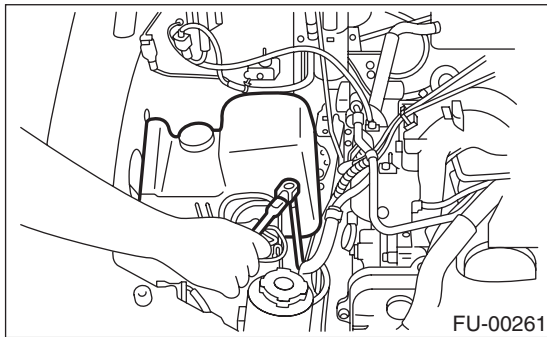

- 16) Connect accelerator control cable (A).  
<Ref. to SP(H4SO)-6, INSTALLATION, Accelerator Control Cable.>  
17) Connect cruise control cable (B). (With cruise control models)

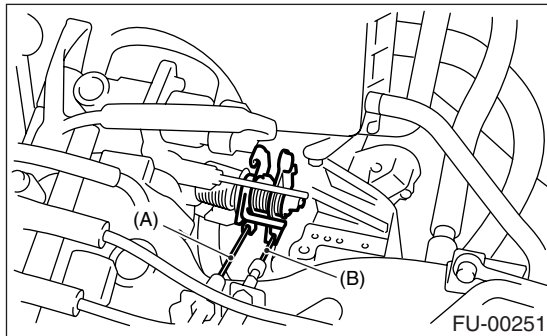

- 18) Install air intake duct and air cleaner case.  
<Ref. to IN(H4SO)-7, INSTALLATION, Air Intake Duct.> and <Ref. to IN(H4SO)-5, INSTALLATION, Air Cleaner.>

- 19) Connect connector to fuel pump relay.

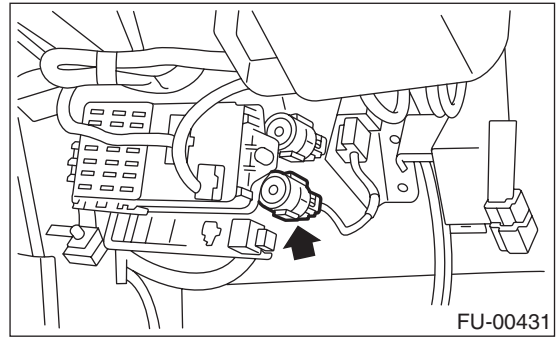

- 20) Connect battery ground cable.

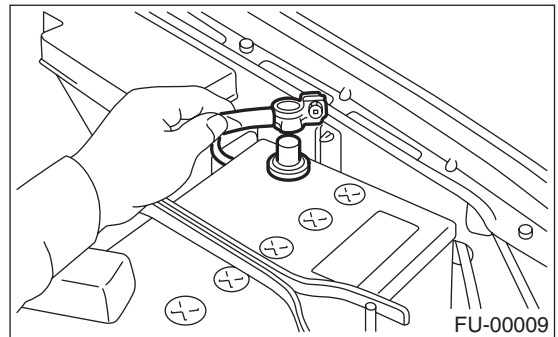

# INTAKE MANIFOLD

FUEL INJECTION (FUEL SYSTEMS)

## C: DISASSEMBLY

1) Disconnect engine ground terminal from intake manifold.

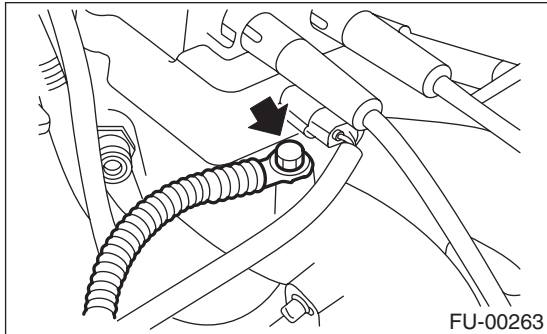

2) Disconnect connector from ignition coil and ignitor assembly.

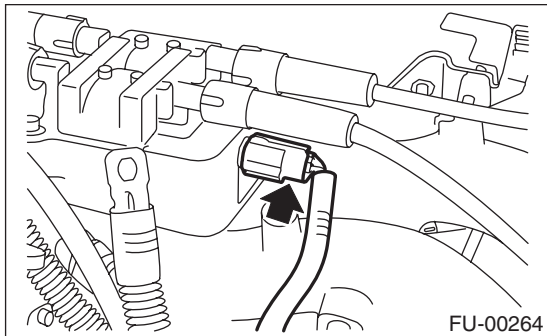

3) Remove ignition coil and ignitor assembly.

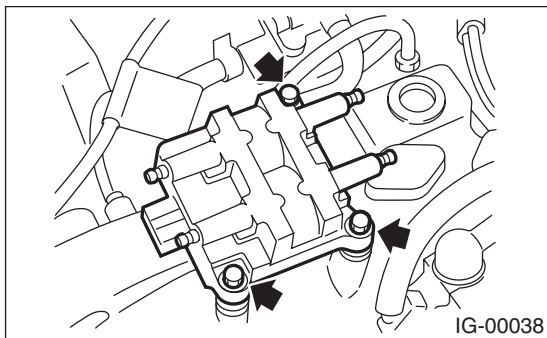

4) Remove throttle body.  
<Ref. to FU(H4SO)-14, REMOVAL, Throttle Body.>

5) Remove air assist injector solenoid valve.  
<Ref. to FU(H4SO)-36, REMOVAL, Air Assist Injector Solenoid Valve.>

6) Remove EGR valve.  
<Ref. to FU(H4SO)-37, REMOVAL, EGR Valve.>

7) Disconnect pressure regulator vacuum hose from intake manifold.

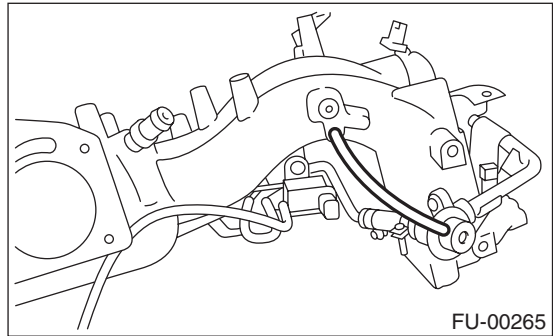

8) Remove fuel pipe protector LH.

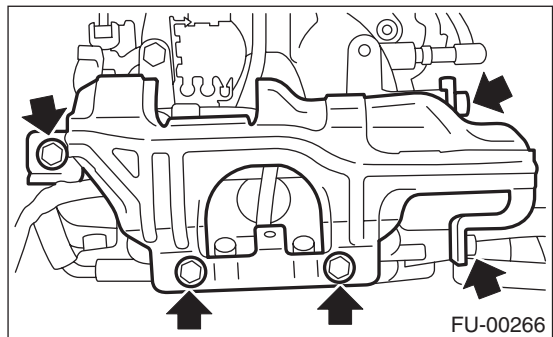

9) Remove fuel pipe protector RH.

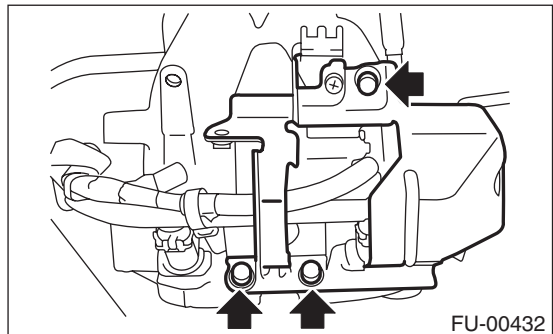

10) Disconnect connectors from fuel injectors.

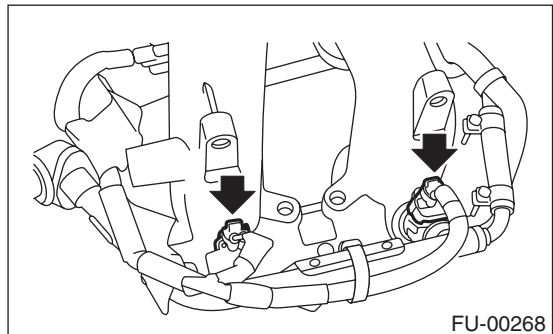

# INTAKE MANIFOLD

## FUEL INJECTION (FUEL SYSTEMS)

11) Disconnect connector from purge control solenoid valve.

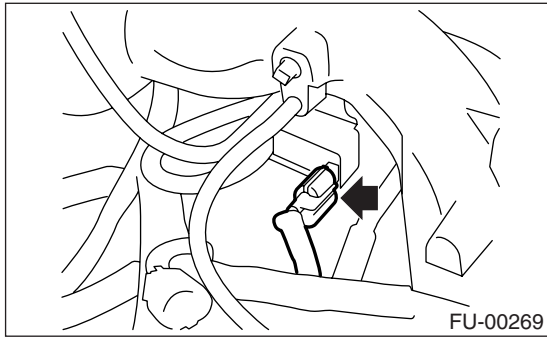

12) Disconnect air by-pass hose from purge control solenoid valve.

13) Remove harness bands (A) which hold engine harness onto intake manifold.

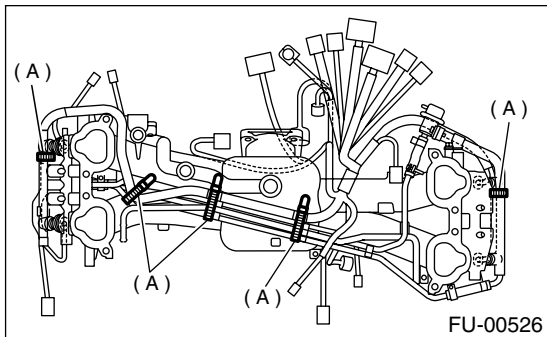

14) Remove engine harness from intake manifold.

15) Remove purge control solenoid valve.

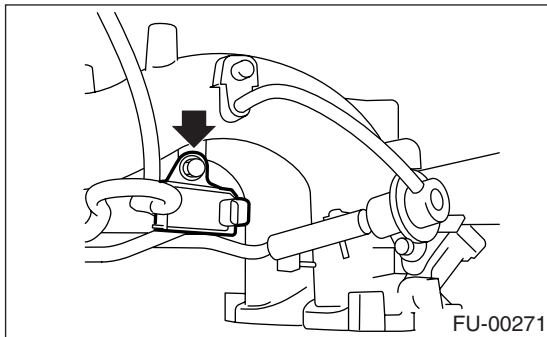

16) Remove bolt which installs injector pipe on intake manifold as shown in figure.

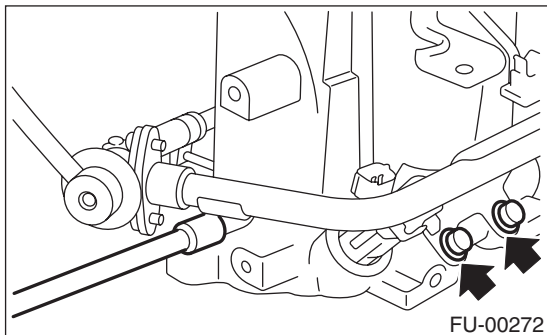

17) Remove two bolts which hold fuel pipes on the left side of intake manifold.

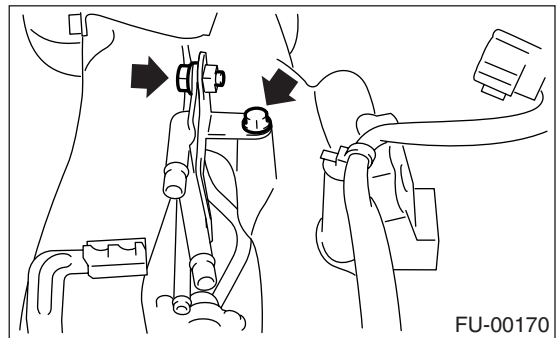

18) Remove fuel injectors.

(1) Remove fuel injector securing clip.

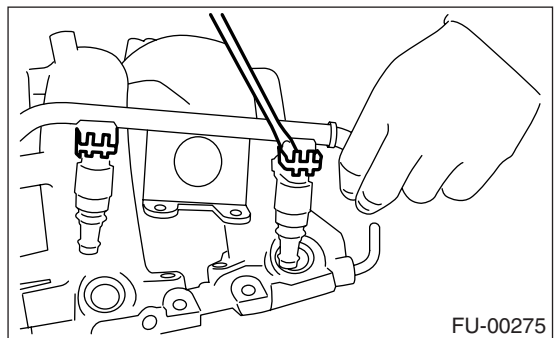

(2) Remove fuel injector while lifting up fuel injector pipe.

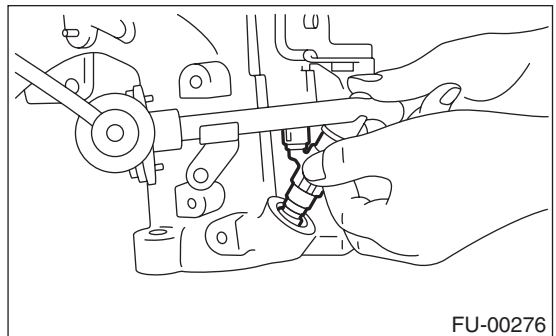

19) Disconnect air by-pass hoses from intake manifold.

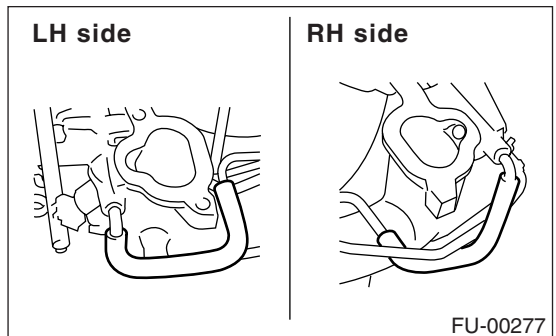

# INTAKE MANIFOLD

FUEL INJECTION (FUEL SYSTEMS)

20) Loosen clamp which holds front left side fuel hose to injector pipe and remove the pipe from clamp.

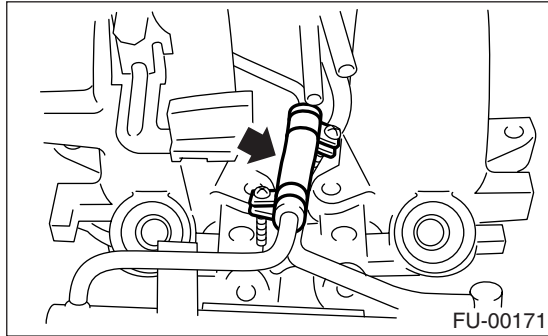

21) Loosen clamp which holds front right side fuel hose to injector pipe and remove the pipe from clamp.

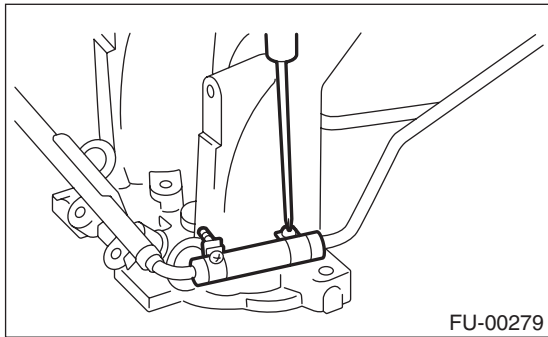

22) Remove fuel injector pipe.

23) Remove bolt which installs fuel pipes on intake manifold.

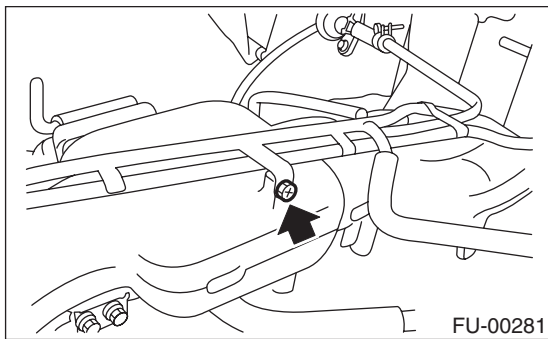

24) Remove fuel pipe assembly and pressure regulator, from intake manifold.

## D: ASSEMBLY

1) Install fuel pipe assembly and pressure regulator, etc. to intake manifold.

2) Tighten bolt which installs fuel pipes on intake manifold.

**Tightening torque:**

**5.0 N·m (0.5 kgf-m, 3.6 ft-lb)**

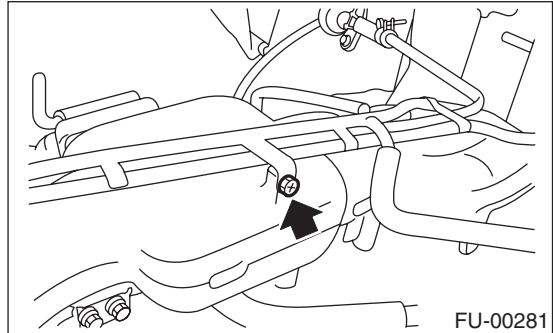

3) Connect right side fuel hose to injector pipe, and tighten clamp screw.

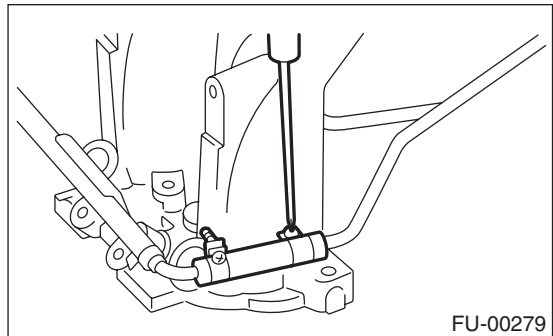

4) Install fuel injector pipe.

5) Connect left side fuel hose to injector pipe, and tighten clamp screw.

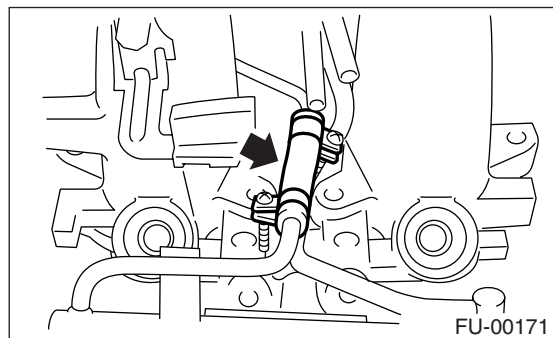

# INTAKE MANIFOLD

## FUEL INJECTION (FUEL SYSTEMS)

6) Connect air assist hoses.

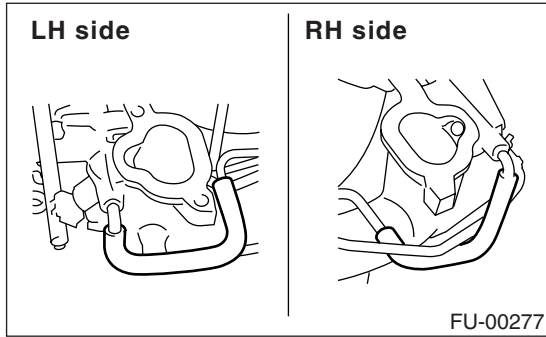

7) Install fuel injectors.

NOTE:

Always use new o-rings.

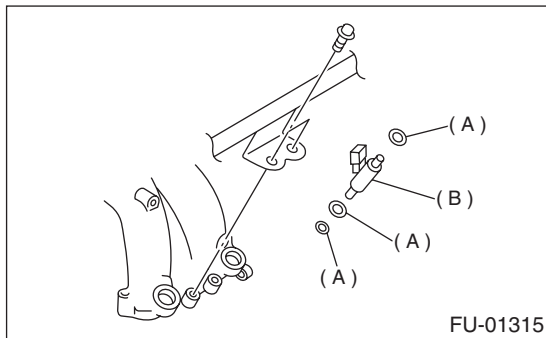

(A) O-ring

(B) Fuel injector

8) Do not forget to install the fuel injector securing clip.

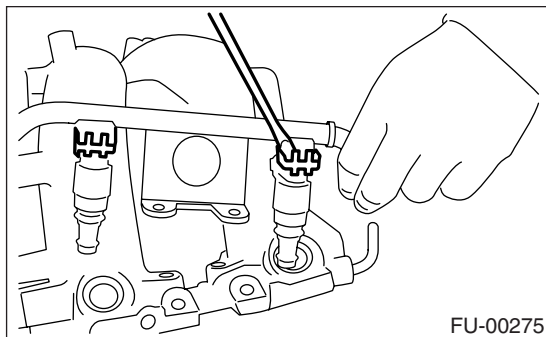

9) Tighten bolt which installs injector pipe on intake manifold.

**Tightening torque:**

**5.0 N·m (0.51 kgf-m, 3.7 ft-lb)**

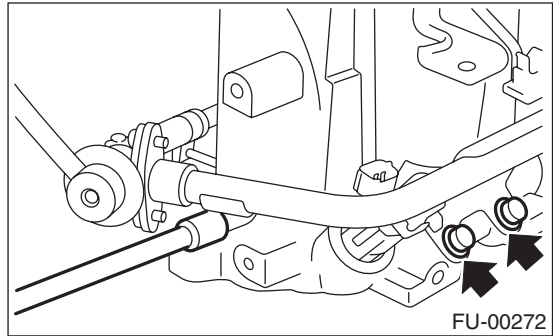

**Tightening torque:**

**19 N·m (1.9 kgf-m, 13.7 ft-lb)**

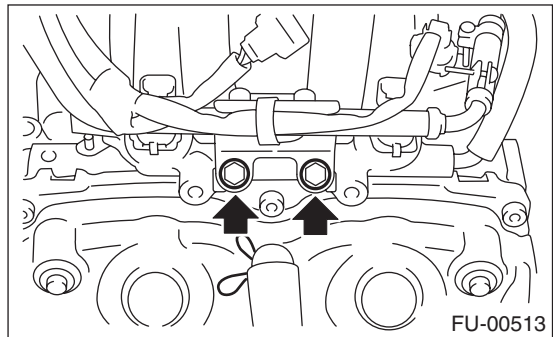

10) Tighten two bolts which install fuel pipes on the left side of intake manifold.

**Tightening torque:**

**5.0 N·m (0.51 kgf-m, 3.7 ft-lb)**

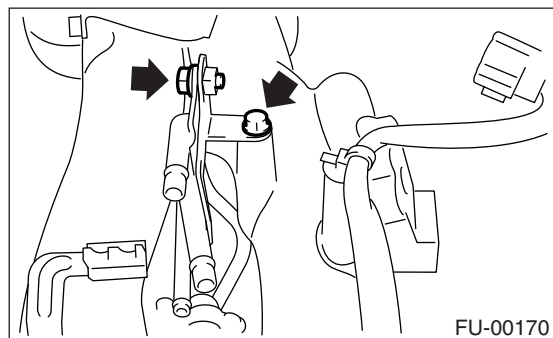



# INTAKE MANIFOLD

FUEL INJECTION (FUEL SYSTEMS)

11) Install purge control solenoid valve.

**Tightening torque:**

**19 N·m (1.9 kgf-m, 14.1 ft-lb)**

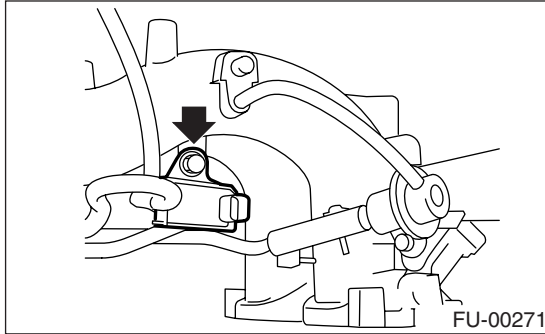

16) Install fuel pipe protector RH.

**Tightening torque:**

**19 N·m (1.9 kgf-m, 13.7 ft-lb)**

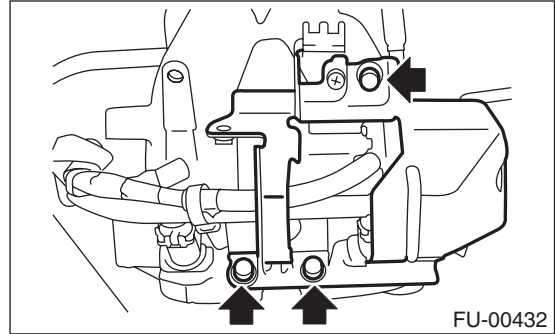

12) Connect hoses to purge control solenoid valve.

**CAUTION:**

**Connect evaporation hoses as shown in the figure.**

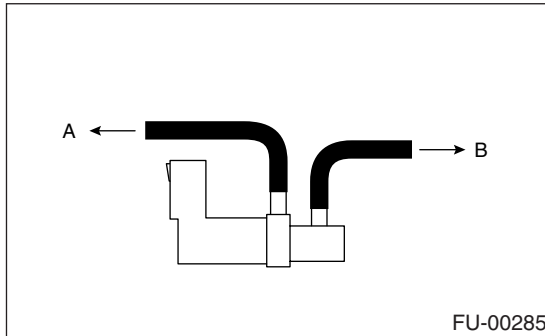

(A) To fuel pipe

(B) To intake manifold

17) Install fuel pipe protector LH.

**Tightening torque:**

**19 N·m (1.9 kgf-m, 13.7 ft-lb)**

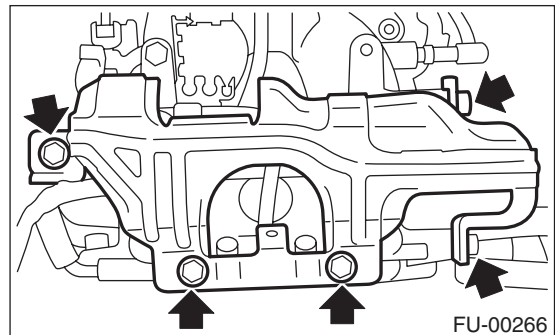

13) Install engine harness onto intake manifold.

14) Connect connectors to fuel injectors and purge control solenoid valve.

15) Hold engine harness by harness bands (A).

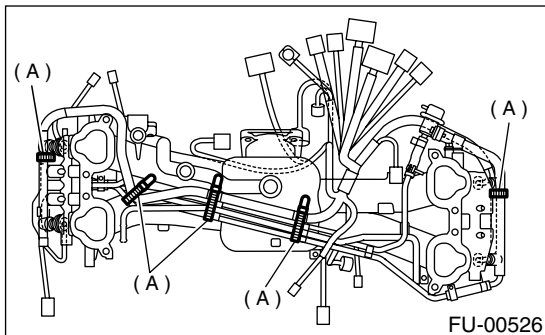

18) Connect pressure regulator vacuum hose to intake manifold.

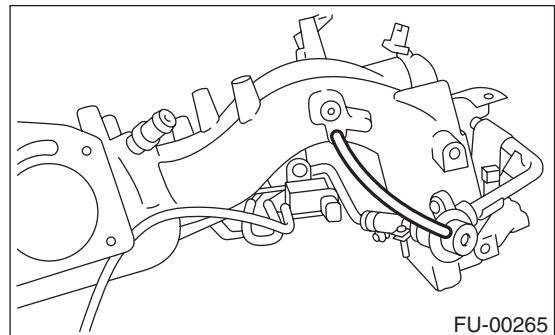

**NOTE:**

Do not use harness band on harnesses where they are supposed to be protected by the fuel pipe protector.

# INTAKE MANIFOLD

## FUEL INJECTION (FUEL SYSTEMS)

---

19) Install air assist injector solenoid valve to bracket.

<Ref. to FU(H4SO)-36, INSTALLATION, Air Assist Injector Solenoid Valve.>

20) Install EGR valve.

<Ref. to FU(H4SO)-37, INSTALLATION, EGR Valve.>

21) Install throttle body to intake manifold.

<Ref. to FU(H4SO)-14, INSTALLATION, Throttle Body.>

22) Install ignition coil and ignitor assembly.

### **Tightening torque:**

**8.0 N·m (0.8 kgf-m, 5.8 ft-lb)**

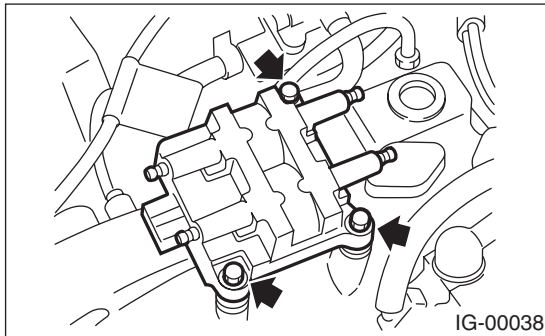

23) Connect connector to ignition coil and ignitor assembly.

24) Install engine ground terminal to intake manifold.

### **Tightening torque:**

**19 N·m (1.9 kgf-m, 13.7 ft-lb)**

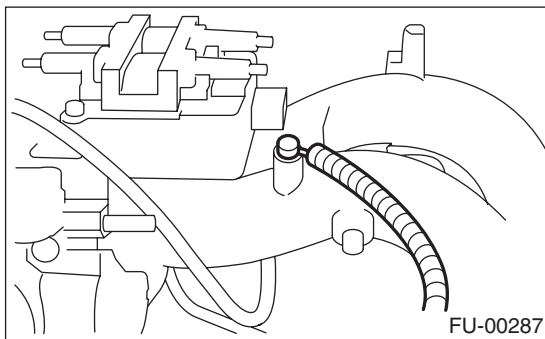

## **E: INSPECTION**

Make sure the fuel pipe and fuel hoses are not cracked and that connections are tight.

# ENGINE COOLANT TEMPERATURE SENSOR

FUEL INJECTION (FUEL SYSTEMS)

## 4. Engine Coolant Temperature Sensor

### A: REMOVAL

1) Disconnect ground cable from battery.

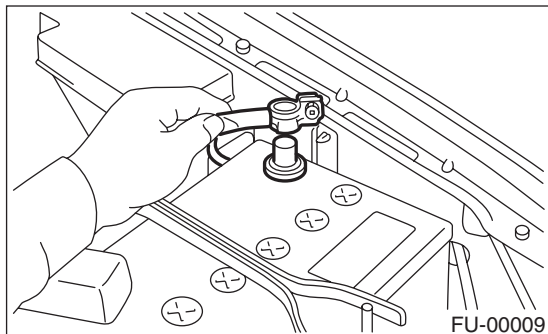

2) Remove air intake duct and air cleaner case.  
<Ref. to IN(H4SO)-7, REMOVAL, Air Intake Duct.>  
and <Ref. to IN(H4SO)-6, REMOVAL, Air Cleaner Case.>

3) Disconnect connector from engine coolant temperature sensor.

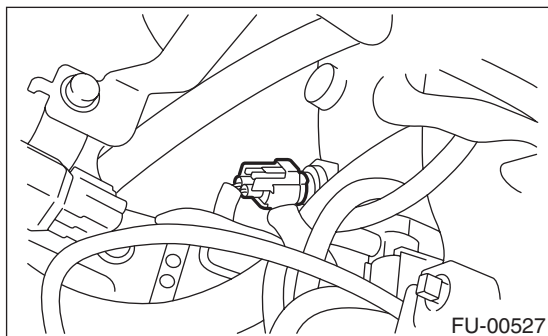

4) Remove engine coolant temperature sensor.

### B: INSTALLATION

Install in the reverse order of removal.

**Tightening torque:**

**18 N·m (1.8 kgf-m, 1.3 ft-lb)**

# CRANKSHAFT POSITION SENSOR

FUEL INJECTION (FUEL SYSTEMS)

## 5. Crankshaft Position Sensor

### A: REMOVAL

1) Disconnect ground cable from battery.

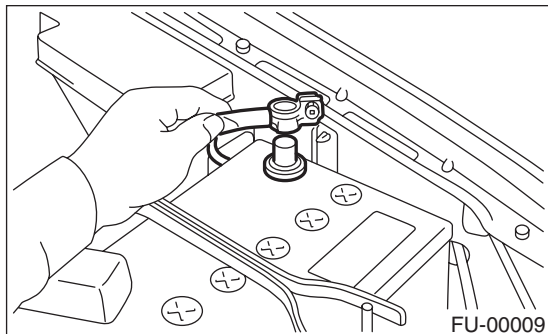

2) Remove bolt which installs crankshaft position sensor to cylinder block.

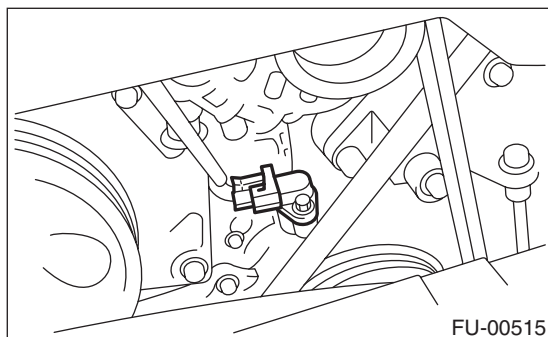

3) Remove crankshaft position sensor, and disconnect connector from it.

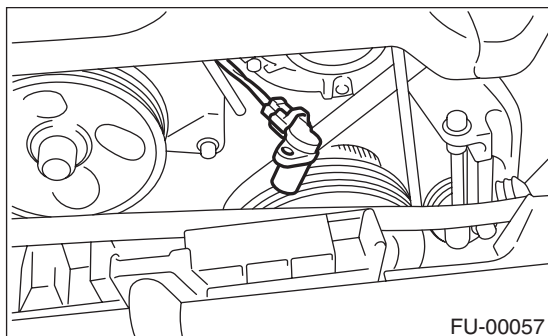

### B: INSTALLATION

Install in the reverse order of removal.

**Tightening torque:**

**T: 6.4 N·m (0.65 kgf-m, 4.7 ft-lb)**

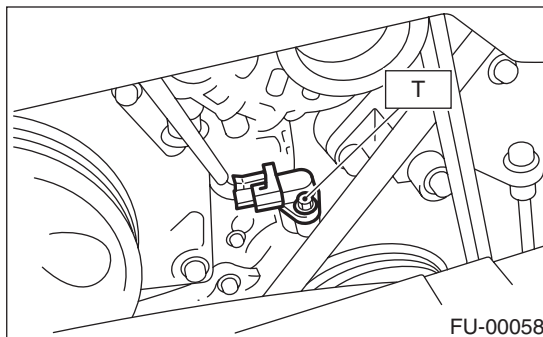

# CAMSHAFT POSITION SENSOR

FUEL INJECTION (FUEL SYSTEMS)

## 6. Camshaft Position Sensor

### A: REMOVAL

1) Disconnect ground cable from battery.

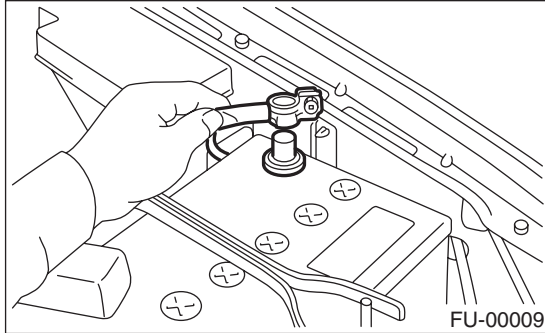

2) Disconnect connector from camshaft position sensor.

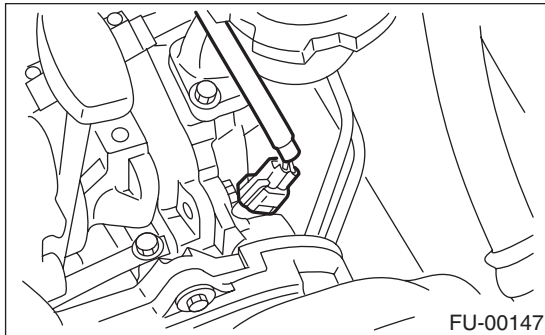

3) Remove bolt which installs camshaft position sensor to camshaft position sensor support.

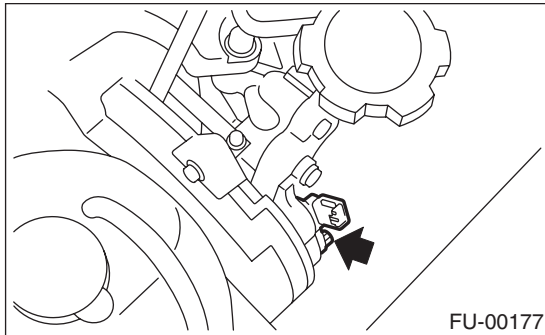

4) Remove bolt which installs camshaft position sensor support to camshaft cap LH.

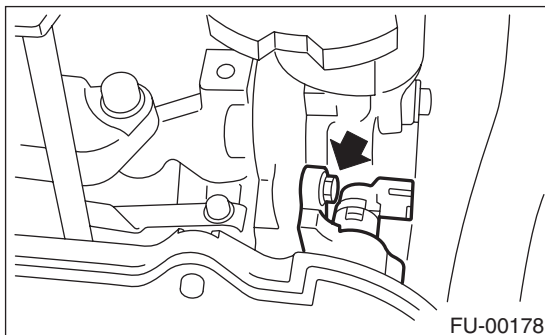

5) Remove camshaft position sensor and camshaft position sensor support as a unit.

6) Remove camshaft position sensor itself.

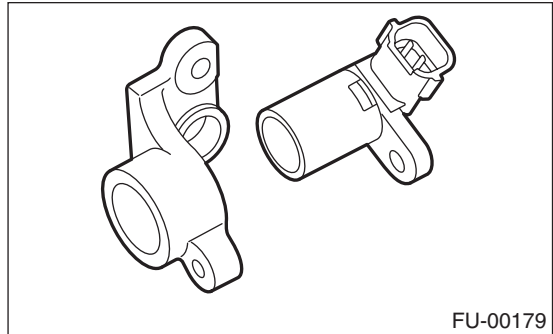

### B: INSTALLATION

Install in the reverse order of removal.

#### Tightening torque:

- **Camshaft position sensor support;**  
**6.4 N·m (0.65 kgf-m, 4.7 ft-lb)**
- **Camshaft position sensor;**  
**6.4 N·m (0.65 kgf-m, 4.7 ft-lb)**

# KNOCK SENSOR

FUEL INJECTION (FUEL SYSTEMS)

## 7. Knock Sensor

### A: REMOVAL

- 1) Disconnect ground cable from battery.

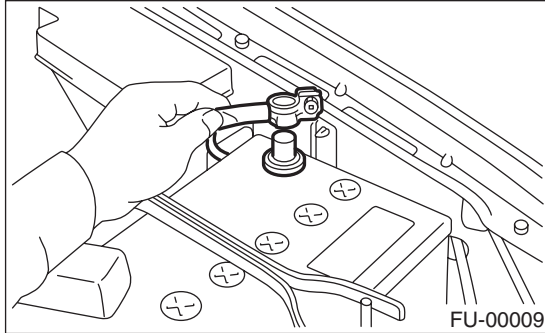

- 2) Remove air cleaner case.  
<Ref. to IN(H4SO)-6, REMOVAL, Air Cleaner Case.>
- 3) Disconnect knock sensor connector.

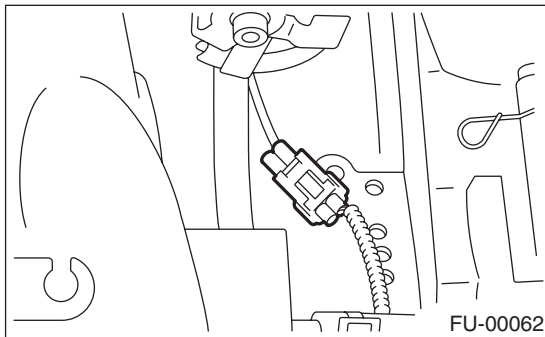

- 4) Remove knock sensor from cylinder block.

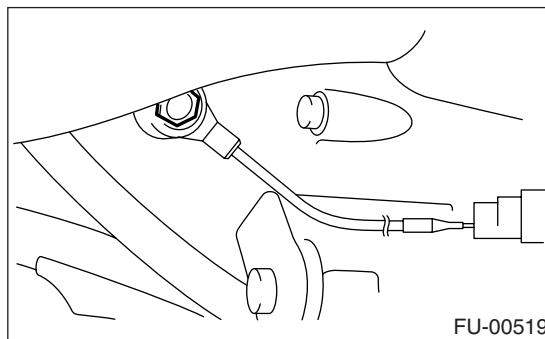

### B: INSTALLATION

- 1) Install knock sensor to cylinder block.

#### Tightening torque:

**24 N·m (2.4 kgf-m, 17.4 ft-lb)**

#### NOTE:

The extraction area of the knock sensor cord must be positioned at a 60° angle relative to the engine rear.

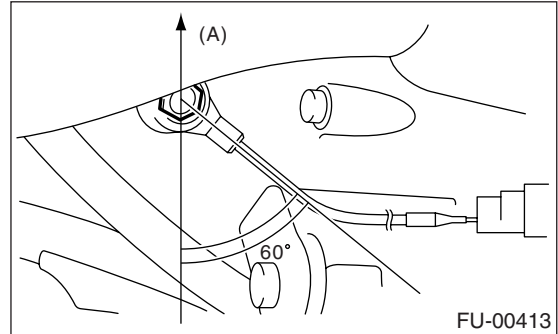

(A) Front side

- 2) Connect knock sensor connector.

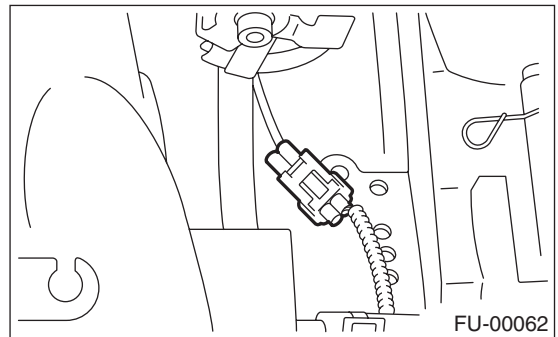

- 3) Install knock sensor harness connector to connector bracket.
- 4) Install air cleaner case.  
<Ref. to IN(H4SO)-6, INSTALLATION, Air Cleaner Case.>
- 5) Connect battery ground cable.

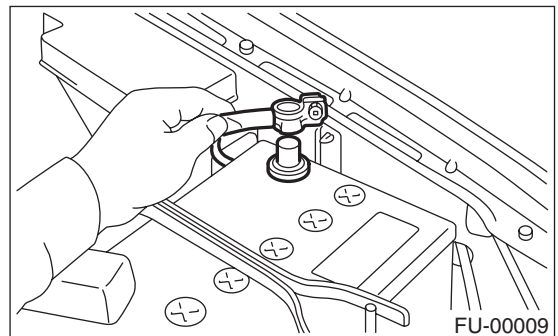

# THROTTLE POSITION SENSOR

FUEL INJECTION (FUEL SYSTEMS)

## 8. Throttle Position Sensor

### A: REMOVAL

- 1) Disconnect ground cable from battery.

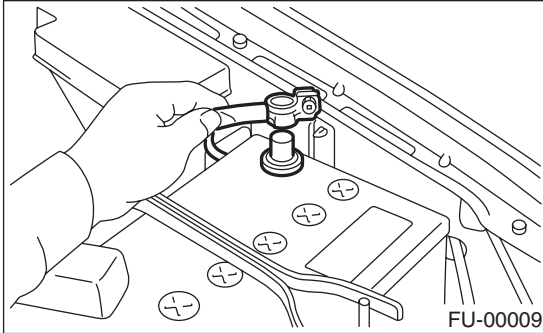

- 2) Disconnect connector from throttle position sensor.

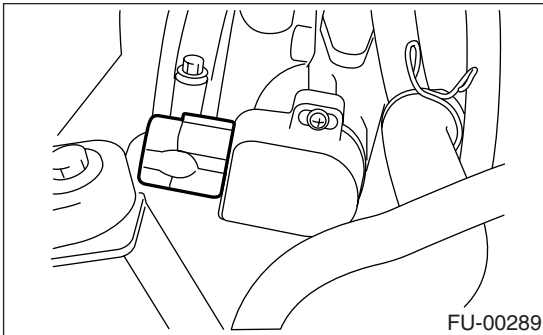

- 3) Remove throttle position sensor holding screws, and remove it.

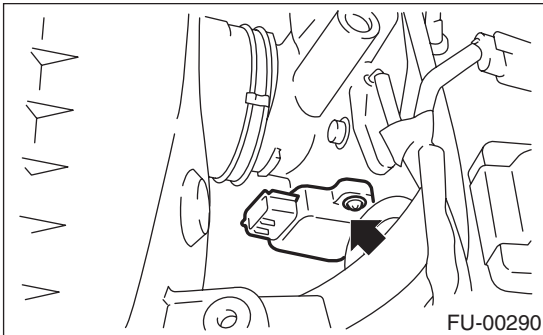

### B: INSTALLATION

Install in the reverse order of removal.

**Tightening torque:**

**2.4 N·m (0.24 kgf·m, 1.7 ft·lb)**

**CAUTION:**

**When installing throttle position sensor, adjust to the specified data.**

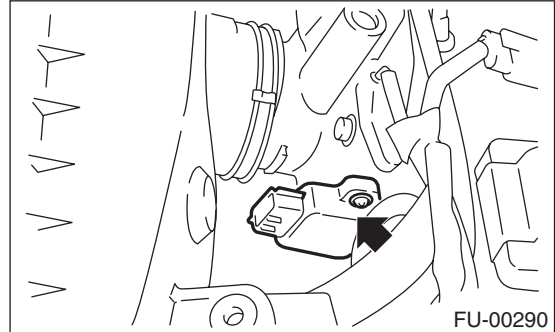

### C: ADJUSTMENT

- 1) Turn ignition switch to OFF.
- 2) Loosen throttle position sensor holding screws.

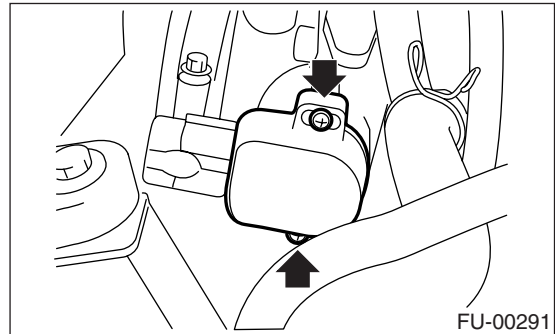

- 3) When using voltage meter;
  - (1) Take out ECM.
  - (2) Turn ignition switch to ON.
  - (3) Adjust throttle position sensor to the proper position to allow the voltage signal to ECM to be in specification.

**Connector & terminal / Specified voltage**

**(B135) No. 13 — (B135) No. 19 / 0.45 — 0.55 V**

**[Fully closed.]**

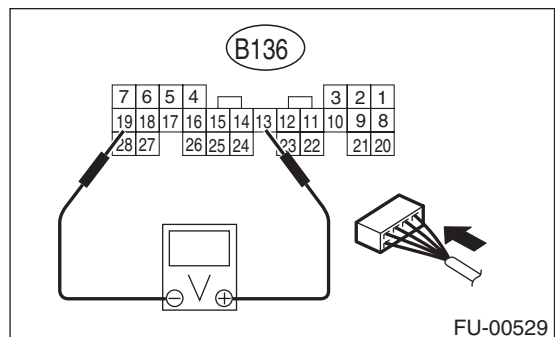

# THROTTLE POSITION SENSOR

## FUEL INJECTION (FUEL SYSTEMS)

- (4) Tighten throttle position sensor holding screws.

### **Tightening torque:**

**2.4 N·m (0.24 kgf-m, 1.7 ft-lb)**

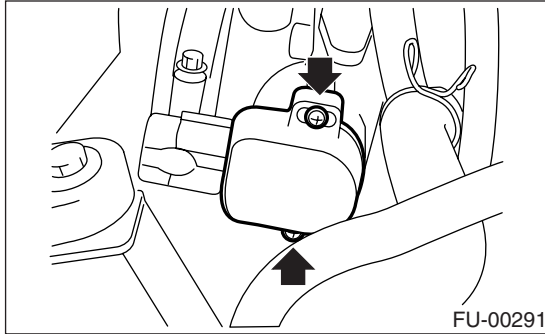

- 4) When using Subaru Select Monitor;
  - (1) Turn ignition switch to OFF.
  - (2) Loosen throttle position sensor holding screws.

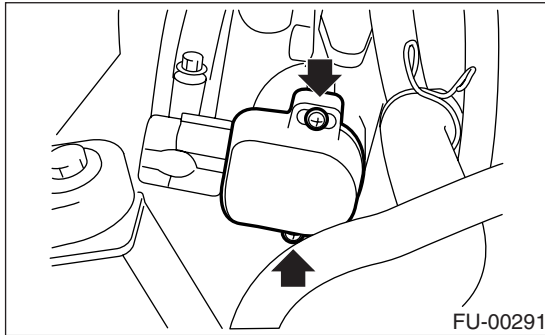

### **NOTE:**

For detailed operation procedures, refer to the Subaru Select Monitor Operation Manual.

- (3) Insert the cartridge to Subaru Select Monitor. <Ref. to FU(H4SO)-13, PREPARATION TOOL, General Description.>
- (4) Connect Subaru Select Monitor to the data link connector (A).

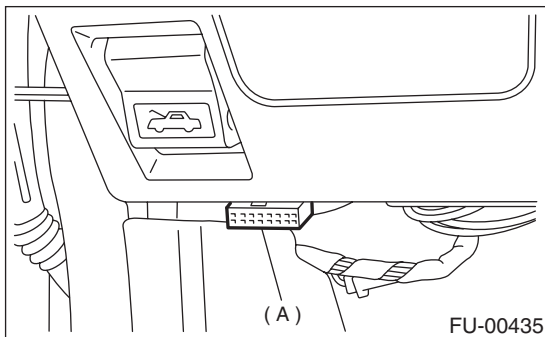

- 5) Turn ignition switch to ON, and Subaru Select Monitor switch to ON.

- 6) Select {2. Each System Check} in Main Menu.
- 7) Select {Engine Control System} in Selection Menu.

- 8) Select {1. Current Data Display & Save} in Engine Control System Diagnosis.

- 9) Select {1.12 Data Display} in Data Display Menu.

- 10) Adjust throttle position sensor to the proper position to match with the following specifications.

### **Condition: Throttle fully closed**

**Throttle opening angle 0.00%**

**Throttle sensor voltage 0.50 V**

- 11) Tighten throttle position sensor holding screws.

### **Tightening torque:**

**2.4 N·m (0.24 kgf-m, 1.7 ft-lb)**

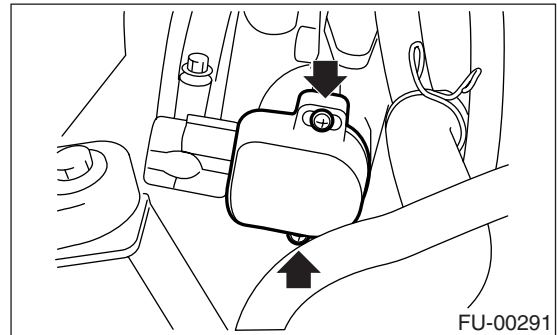



## 9. Pressure Sensor

### A: REMOVAL

- 1) Disconnect ground cable from battery.

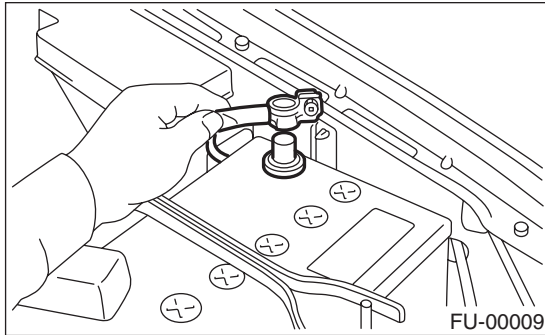

- 2) Disconnect connector from pressure sensor.

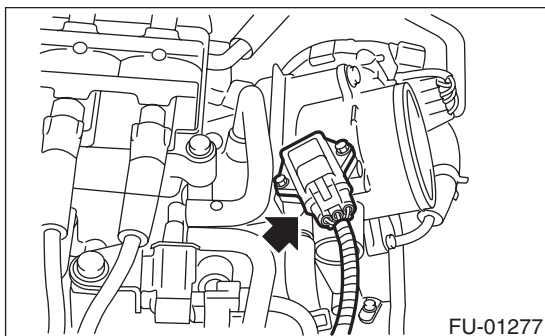

- 3) Remove pressure sensor from throttle body.

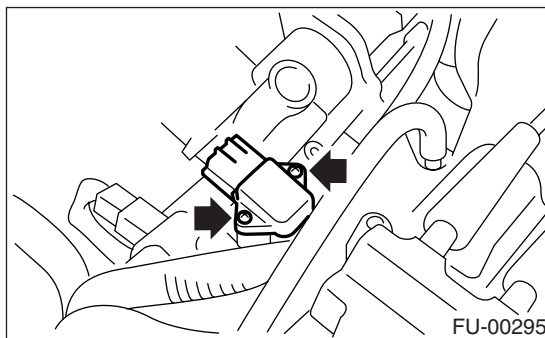

### B: INSTALLATION

Install in the reverse order of removal.

NOTE:

Replace O-ring with a new one.

**Tightening torque:**

**1.6 N·m (0.16 kgf-m, 1.2 ft-lb)**

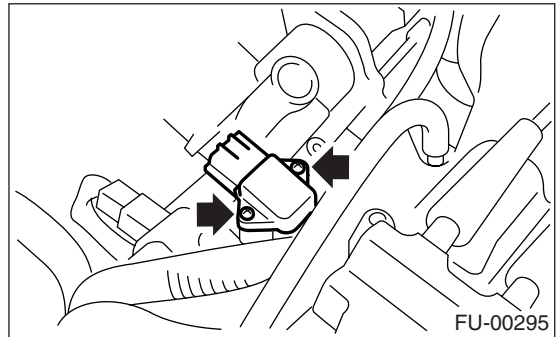

# INTAKE AIR TEMPERATURE SENSOR

FUEL INJECTION (FUEL SYSTEMS)

---

## 10. Intake Air Temperature Sensor

### A: REMOVAL

1) Disconnect ground cable from battery.

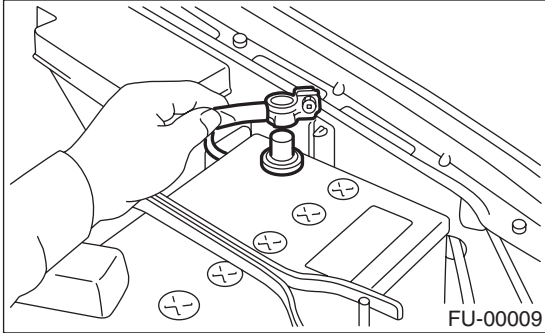

2) Disconnect the connector from the intake air temperature sensor.

3) Remove the intake air temperature sensor from air cleaner case.

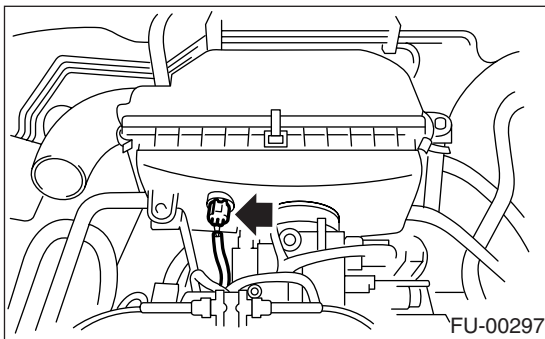

### B: INSTALLATION

Install in the reverse order of removal.

# IDLE AIR CONTROL SOLENOID VALVE

FUEL INJECTION (FUEL SYSTEMS)

## 11. Idle Air Control Solenoid Valve

### A: REMOVAL

- 1) Disconnect ground cable from battery.

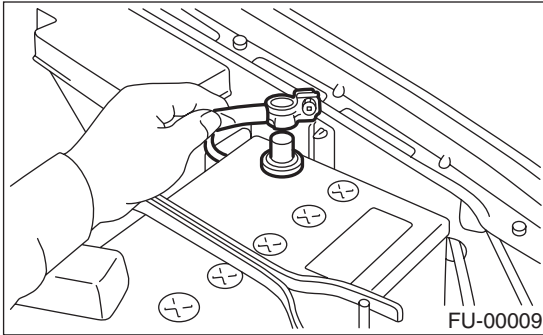

- 2) Disconnect connector from idle air control solenoid valve.

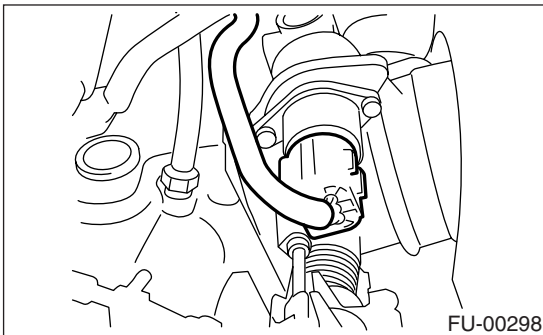

- 3) Remove idle air control solenoid valve from throttle body.

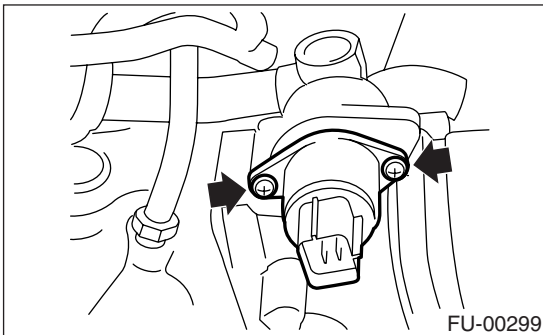

### B: INSTALLATION

Install in the reverse order of removal.

#### NOTE:

Always use a new gasket.

#### *Tightening torque:*

**2.4 N·m (0.24 kgf-m, 1.7 ft-lb)**

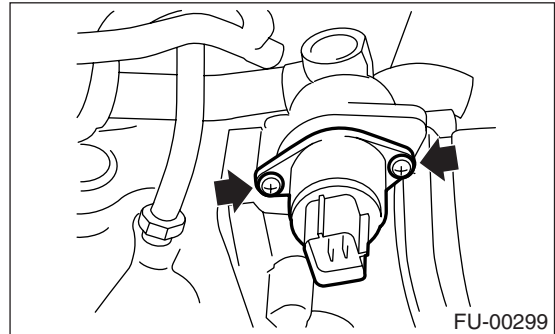

# AIR ASSIST INJECTOR SOLENOID VALVE

FUEL INJECTION (FUEL SYSTEMS)

## 12. Air Assist Injector Solenoid Valve

### A: REMOVAL

1) Disconnect ground cable from battery.

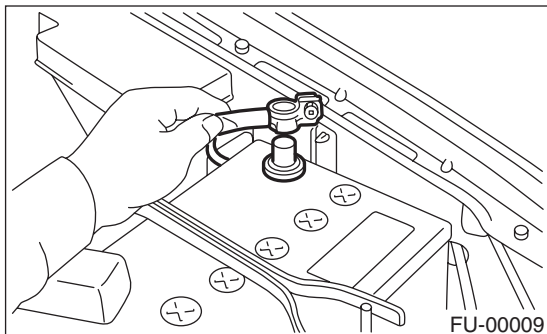

2) Disconnect connector from air assist injector solenoid valve and disconnect air by-pass hoses.

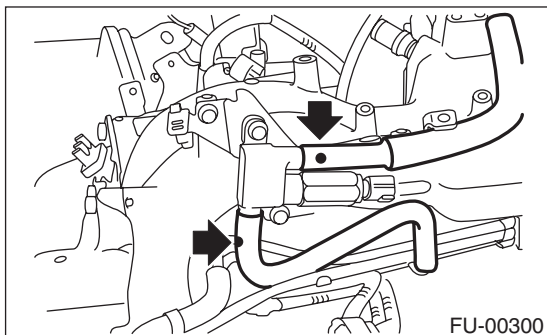

3) Remove air assist injector solenoid valve from intake manifold.

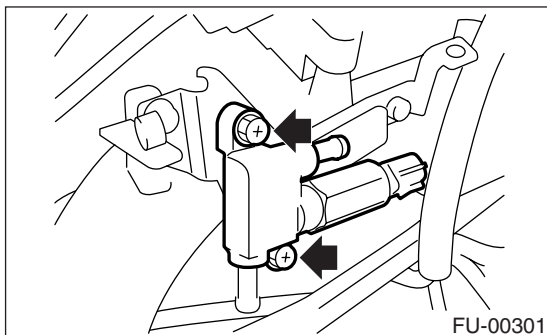

### B: INSTALLATION

Install in the reverse order of removal.

**Tightening torque:**

**5.0 N·m (0.51 kgf·m, 3.7 ft·lb)**

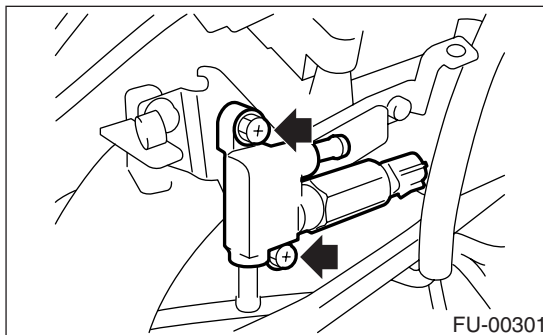

## 13.EGR Valve

### A: REMOVAL

1) Disconnect ground cable from battery.

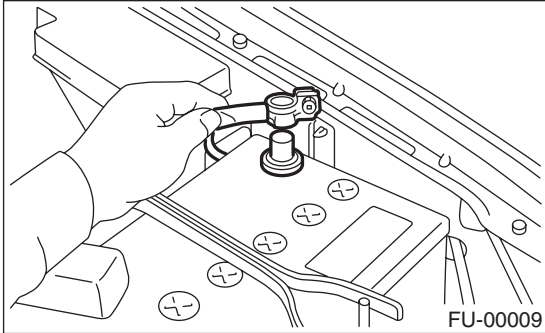

2) Disconnect connector from EGR valve.

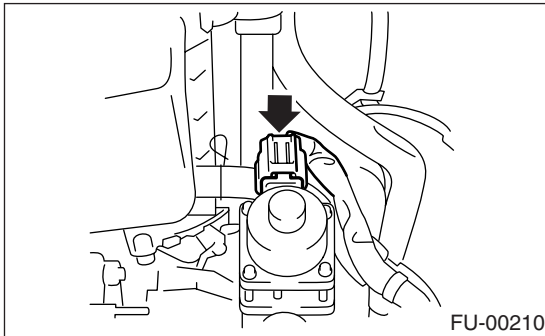

3) Remove EGR valve from intake manifold.

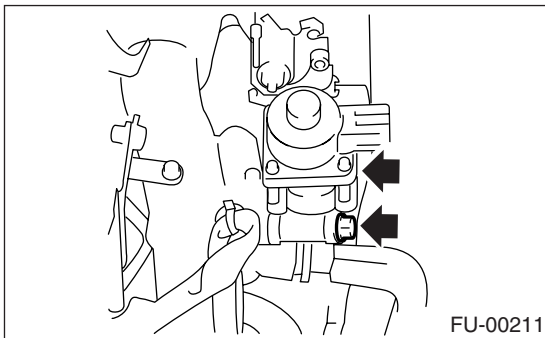

### B: INSTALLATION

Install in the reverse order of removal.

**Tightening torque:**

**19 N·m (1.9 kgf-m, 14.0 ft-lb)**

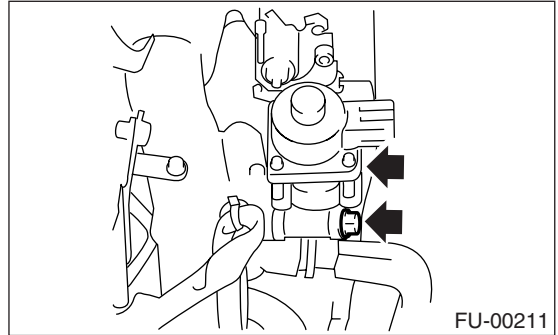

# FUEL INJECTOR

## FUEL INJECTION (FUEL SYSTEMS)

### 14. Fuel Injector

#### A: REMOVAL

##### 1. RH SIDE

- 1) Release fuel pressure.  
<Ref. to FU(H4SO)-48, RELEASING OF FUEL PRESSURE, OPERATION, Fuel.>
- 2) Open fuel flap lid, and remove fuel filler cap.
- 3) Disconnect battery ground cable.

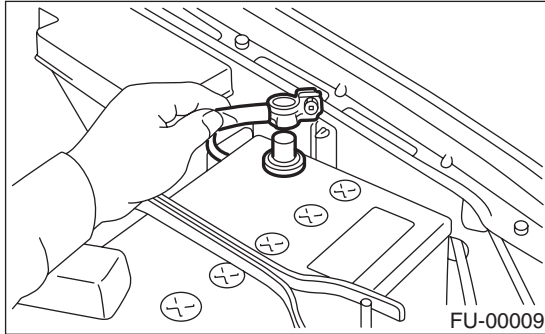

- 4) Remove resonator chamber.  
<Ref. to IN(H4SO)-8, REMOVAL, Resonator Chamber.>
- 5) Remove spark plug cords from spark plugs (#1 and #3 cylinders).

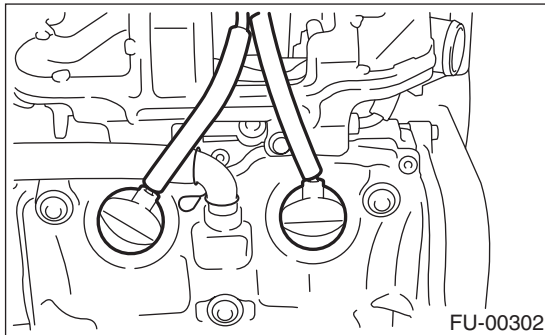

- 6) Remove power steering pump and tank from brackets.

(1) Remove front V-belt.  
<Ref. to ME(H4SO)-40, REMOVAL, V-belt.>

(2) Remove bolts which hold power steering pipes onto intake manifold protector.

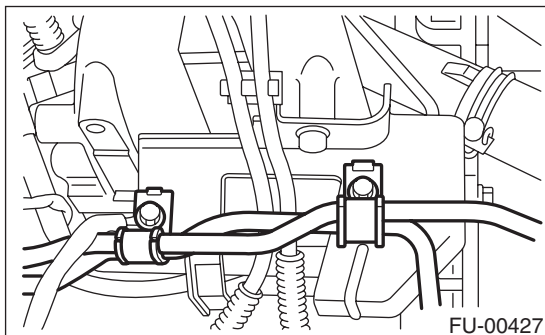

(3) Remove bolts which install power steering pump to bracket.

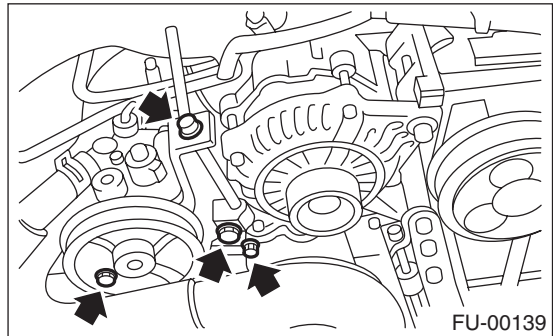

(4) Disconnect connector from power steering pump switch.

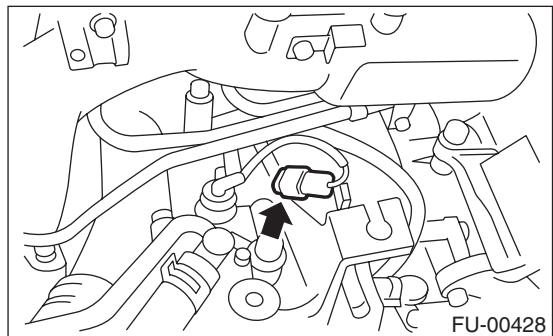

(5) Remove power steering tank from the bracket by pulling it upwards.

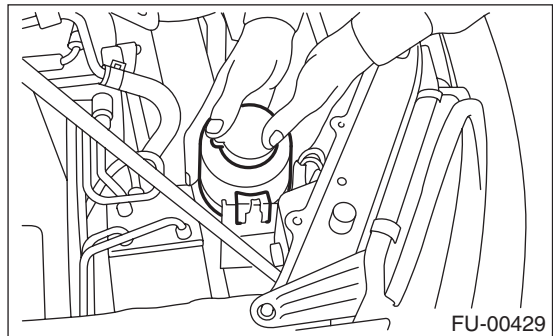

(6) Place power steering pump and tank on the right side wheel apron.

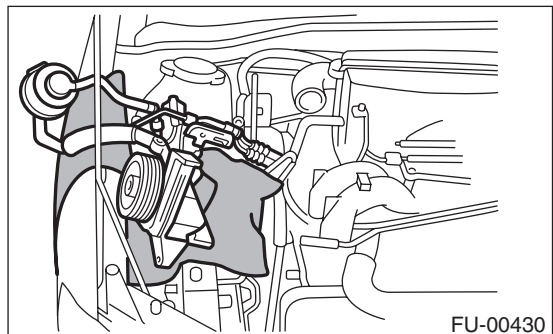

# FUEL INJECTOR

## FUEL INJECTION (FUEL SYSTEMS)

7) Remove fuel pipe protector RH.

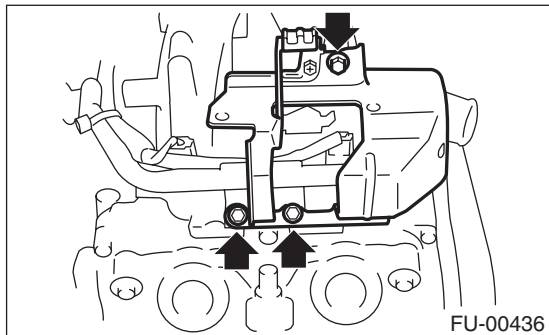

8) Disconnect connector from fuel injector.

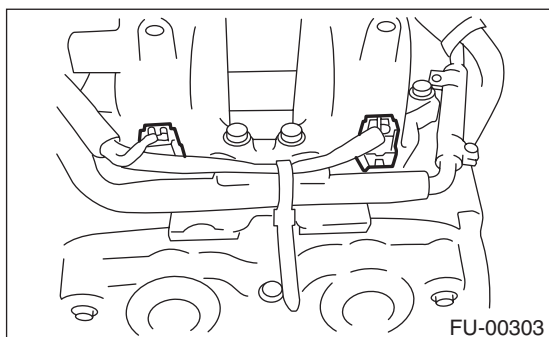

9) Remove bolts which hold injector pipe to intake manifold.

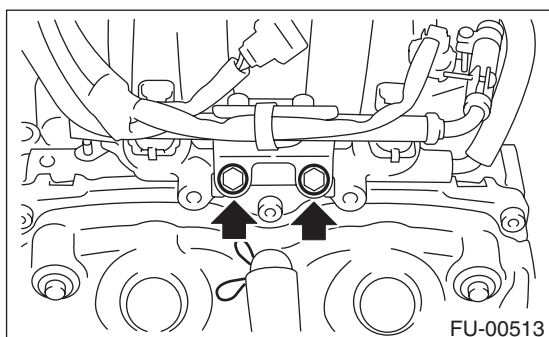

10) Remove bolt which install injector pipe to intake manifold.

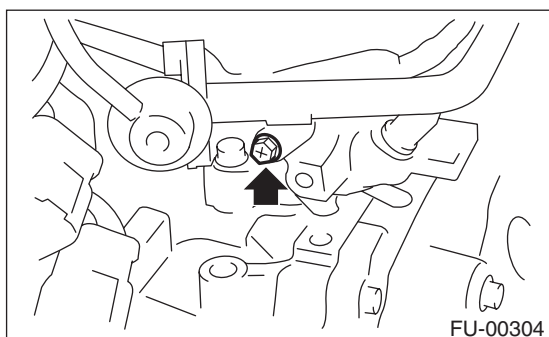

11) Remove fuel injector from intake manifold.

(1) Remove fuel injector securing clip.

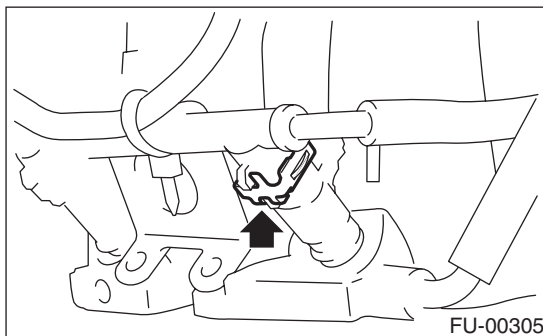

(2) Remove fuel injector while lifting up fuel injector pipe.

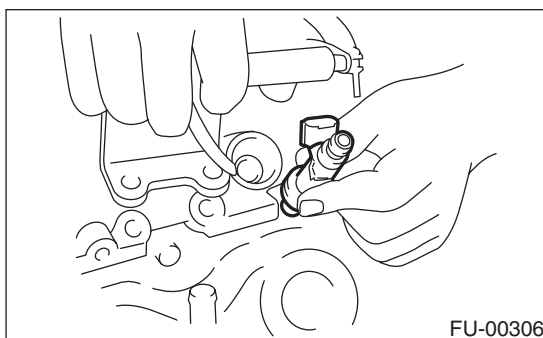

# FUEL INJECTOR

## FUEL INJECTION (FUEL SYSTEMS)

### 2. LH SIDE

- 1) Release fuel pressure. <Ref. to FU(H4SO)-48, RELEASING OF FUEL PRESSURE, OPERATION, Fuel.>
- 2) Open fuel flap lid, and remove fuel filler cap.
- 3) Disconnect battery ground cable.

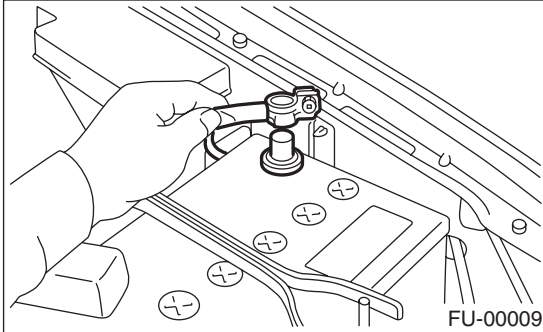

- 4) Remove two bolts which install washer tank on body.

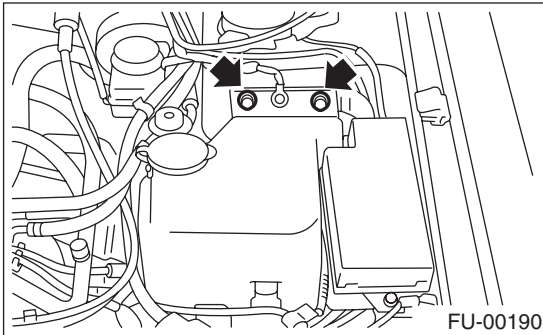

- 5) Disconnect connector from front window washer motor.
- 6) Disconnect connector from rear gate glass washer motor.

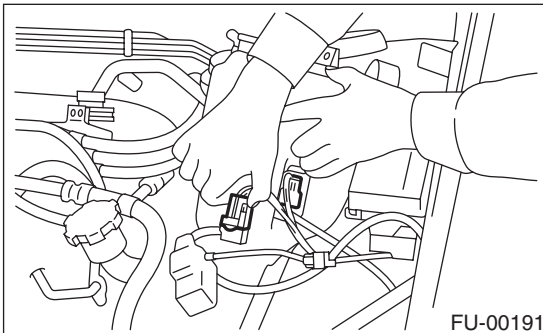

- 7) Disconnect rear window glass washer hose from washer motor, then plug connection with a suitable cap.

- 8) Move washer tank, and secure it away from working area.

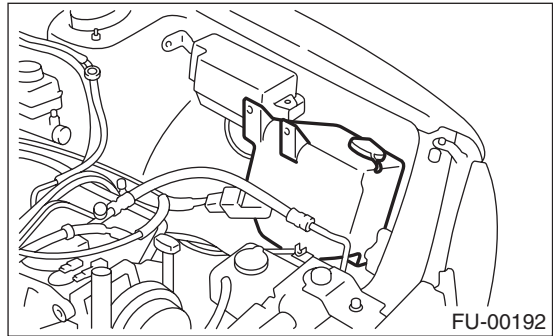

- 9) Remove spark plug cords from spark plugs (#2 and #4 cylinders).

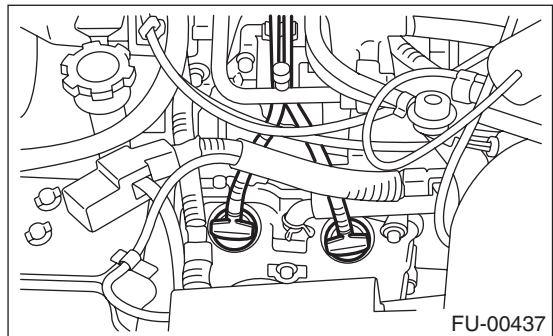

- 10) Remove fuel pipe protector LH.

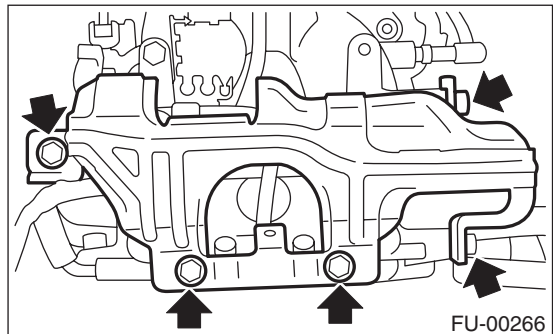

- 11) Disconnect connector from fuel injector.

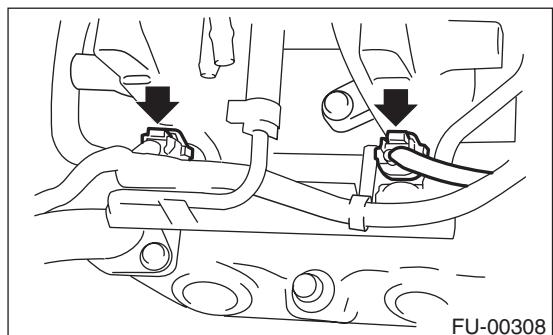



# FUEL INJECTOR

FUEL INJECTION (FUEL SYSTEMS)

12) Remove bolt which holds injector pipe to intake manifold.

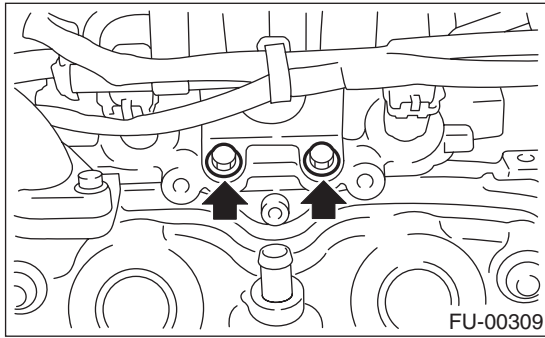

13) Remove bolt which holds fuel pipe on the left side intake manifold.

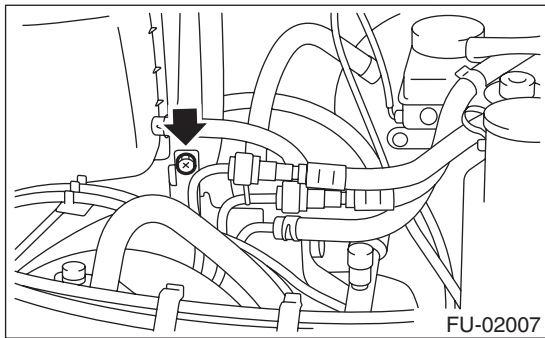

14) Remove fuel injector from intake manifold.  
(1) Remove fuel injector securing clip.

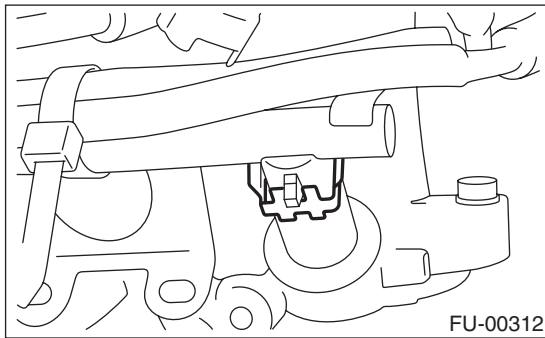

(2) Remove fuel injector while lifting up fuel injector pipe.

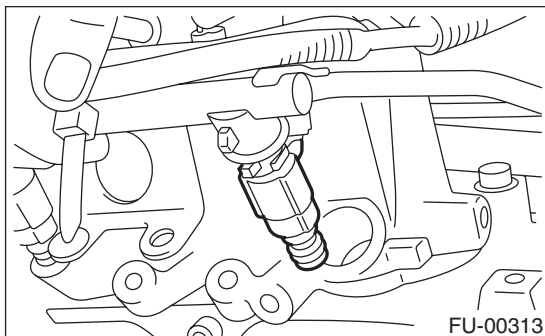

## B: INSTALLATION

### 1. RH SIDE

Install in the reverse order of removal.

NOTE:

Replace O-rings with new ones.

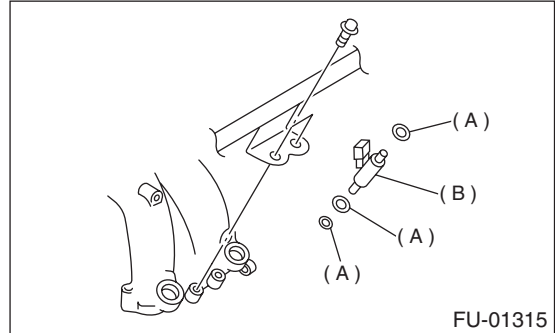

- (A) O-ring
- (B) Fuel injector

**Tightening torque:**

**5.0 N-m (0.51 kgf-m, 3.7 ft-lb)**

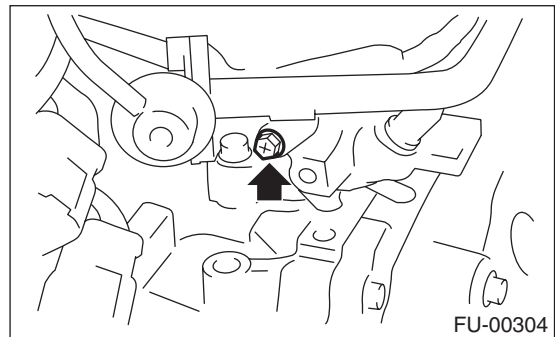

**Tightening torque:**

**19 N-m (0.19 kgf-m, 1.4 ft-lb)**

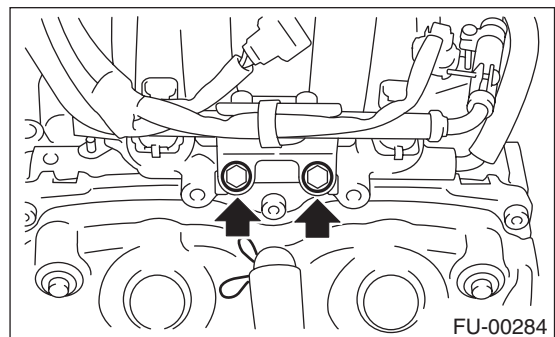

# FUEL INJECTOR

## FUEL INJECTION (FUEL SYSTEMS)

**Tightening torque:**  
**19 N·m (0.19 kgf-m, 1.4 ft-lb)**

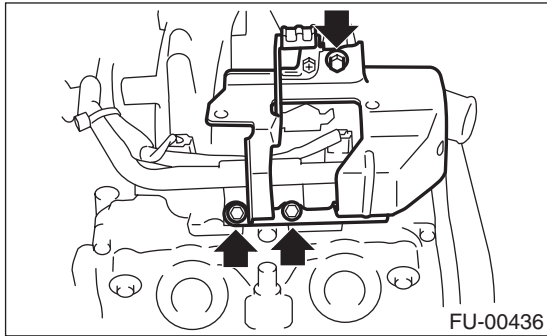

**Tightening torque:**  
**19 N·m (1.9 kgf-m, 13.7 ft-lb)**

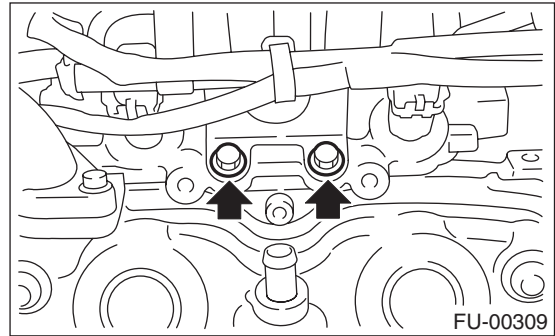

## 2. LH SIDE

Install in the reverse order of removal.

**NOTE:**

Replace O-rings with new ones.

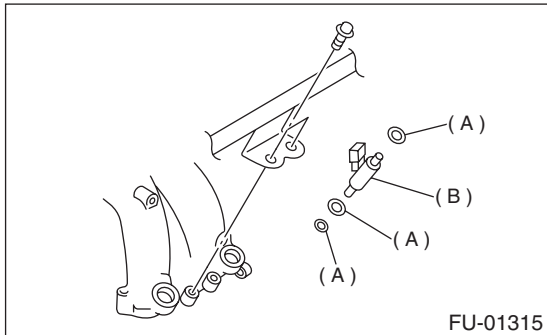

- (A) O-ring
- (B) Fuel injector

**Tightening torque:**  
**19 N·m (1.9 kgf-m, 13.7 ft-lb)**

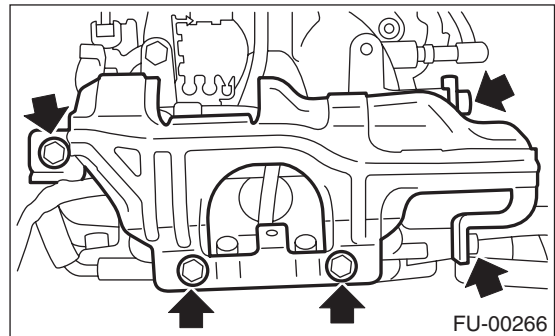

**Tightening torque:**  
**5.0 N·m (0.51 kgf-m, 3.7 ft-lb)**

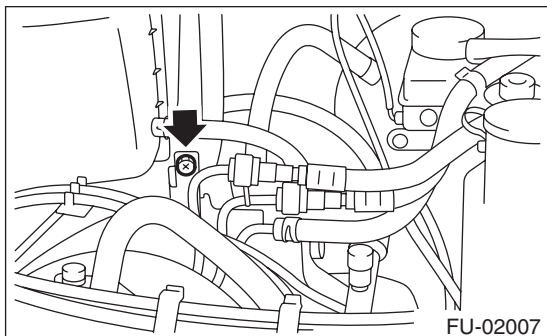

# FRONT OXYGEN (A/F) SENSOR

FUEL INJECTION (FUEL SYSTEMS)

## 15. Front Oxygen (A/F) Sensor

### A: REMOVAL

- 1) Disconnect ground cable from battery.

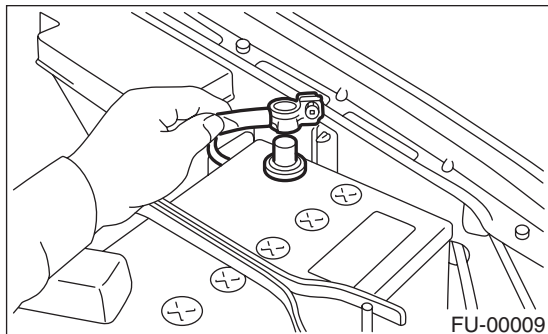

- 2) Disconnect connectors from engine hanger and front oxygen (A/F) sensor.

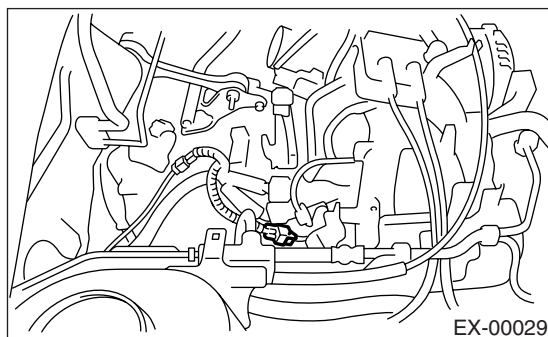

- 3) Lift-up the vehicle.
- 4) Apply SUBARU CRC or its equivalent to threaded portion of front oxygen (A/F) sensor, and leave it for one minute or more.

**SUBARU CRC (Part No. 004301003)**

- 5) Remove front oxygen (A/F) sensor.

### CAUTION:

**When removing the oxygen (A/F) sensor, wait until exhaust pipe cools, otherwise it will damage exhaust pipe.**

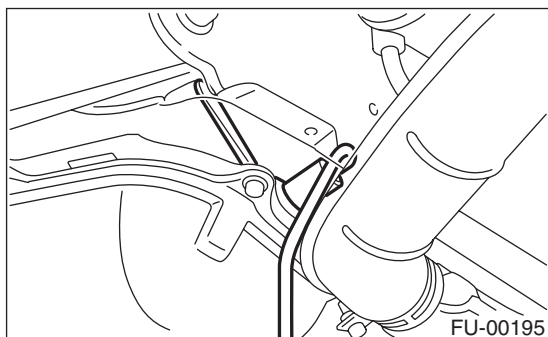

### B: INSTALLATION

- 1) Before installing front oxygen (A/F) sensor, apply anti-seize compound only to threaded portion of front oxygen (A/F) sensor to make the next removal easier.

**Anti-seize compound:**  
**SS-30 by JET LUBE**

### CAUTION:

**Never apply anti-seize compound to protector of front oxygen (A/F) sensor.**

- 2) Install front oxygen (A/F) sensor.

### Tightening torque:

**21 N·m (2.1 kgf-m, 15.2 ft-lb)**

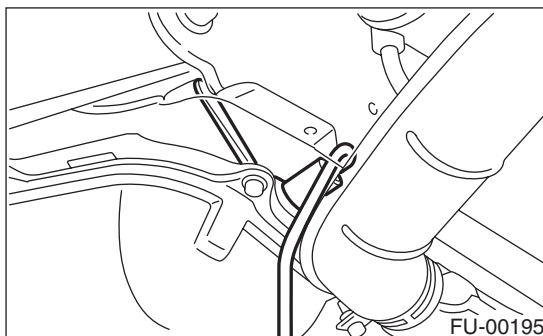

- 3) Lower the vehicle.
- 4) Connect connector of front oxygen (A/F) sensor.

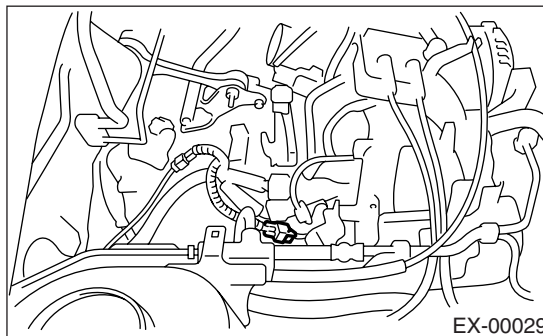

- 5) Connect battery ground cable.

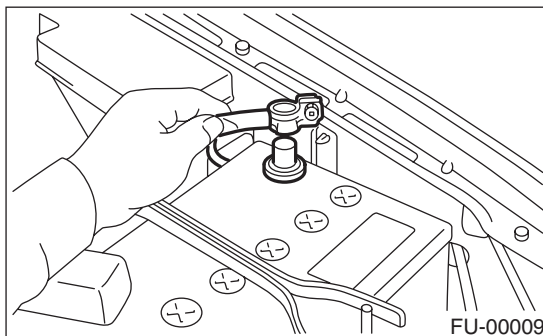

# REAR OXYGEN SENSOR

FUEL INJECTION (FUEL SYSTEMS)

## 16.Rear Oxygen Sensor

### A: REMOVAL

- 1) Disconnect ground cable from battery.

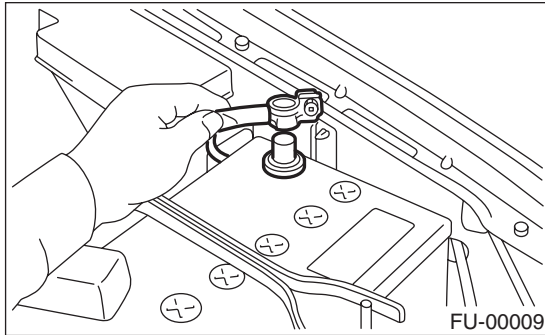

- 2) Disconnect connector from rear oxygen sensor.

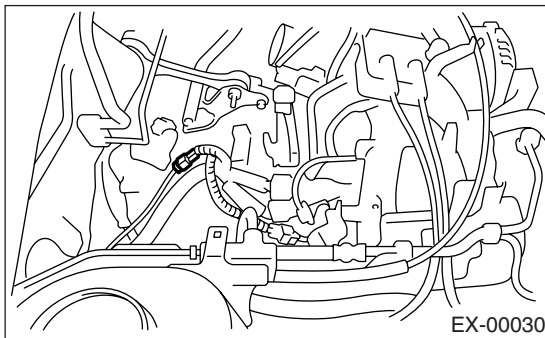

- 3) Lift-up the vehicle.
- 4) Apply SUBARU CRC or its equivalent to threaded portion of rear oxygen sensor, and leave it for one minute or more.

**SUBARU CRC (Part No. 004301003)**

- 5) Remove rear oxygen sensor.

### CAUTION:

**When removing the oxygen sensor, wait until exhaust pipe cools, otherwise it will damage exhaust pipe.**

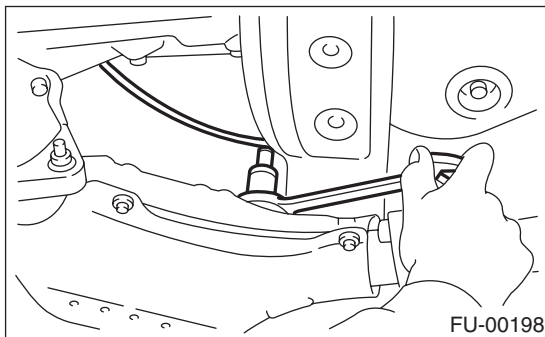

### B: INSTALLATION

- 1) Before installing rear oxygen sensor, apply anti-seize compound only to threaded portion of rear oxygen sensor to make the next removal easier.

### CAUTION:

**Never apply anti-seize compound to protector of rear oxygen sensor.**

**Anti-seize compound:**

**SS-30 by JET LUBE**

- 2) Install rear oxygen sensor.

**Tightening torque:**

**21 N·m (2.1 kgf-m, 15.2 ft-lb)**

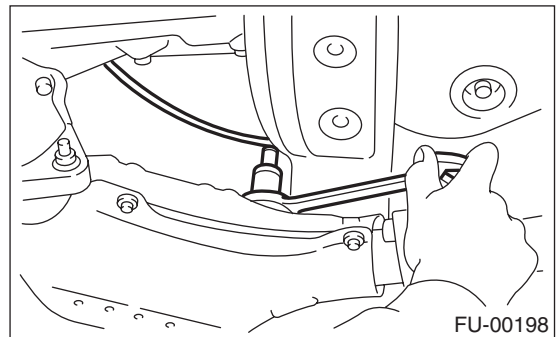

- 3) Lower the vehicle.
- 4) Connect connector to rear oxygen sensor.

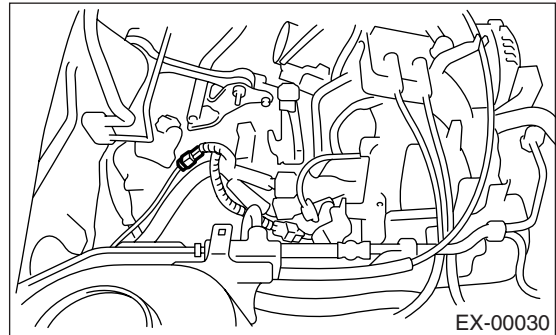

- 5) Connect battery ground cable.

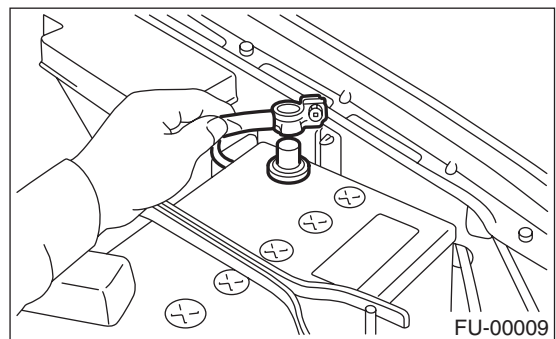

## 17.Engine Control Module

### A: REMOVAL

- 1) Disconnect ground cable from battery.

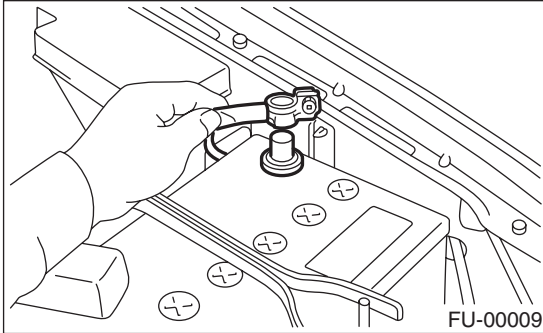

- 2) Remove lower inner trim of passenger side.  
<Ref. to EI-42, REMOVAL, Lower Inner Trim.>
- 3) Detach floor mat of passenger seat.
- 4) Remove protect cover.

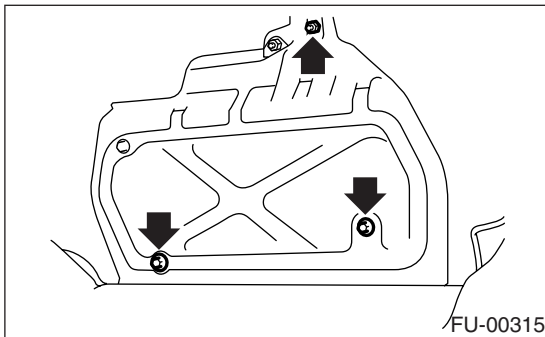

- 5) Remove nuts (A) which hold ECM to bracket.
- 6) Remove clip (B) from bracket.

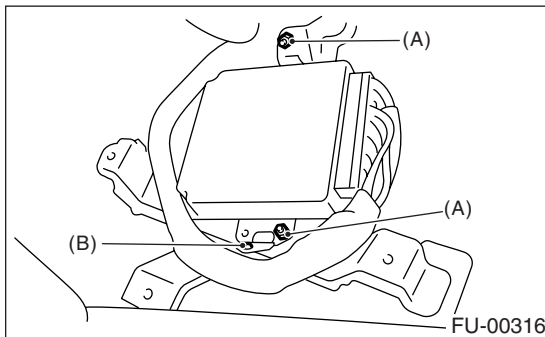

- 7) Disconnect ECM connectors and take out ECM.

### B: INSTALLATION

Install in the reverse order of removal.

#### CAUTION:

When replacing ECM, be careful not to use the wrong spec. ECM to avoid any damage to the fuel injection system.

#### Tightening torque:

**5 N·m (0.51 kgf-m, 3.7 ft-lb)**

# MAIN RELAY

FUEL INJECTION (FUEL SYSTEMS)

---

## 18.Main Relay

### A: REMOVAL

1) Disconnect ground cable from battery.

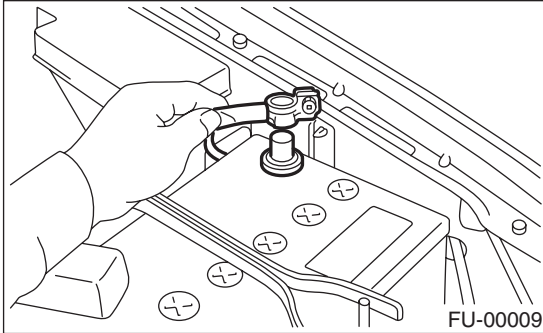

2) Remove lower inner trim of passenger side.

<Ref. to EI-42, REMOVAL, Lower Inner Trim.>

3) Disconnect connectors from main relay.

4) Remove bolt which holds main relay bracket on body.

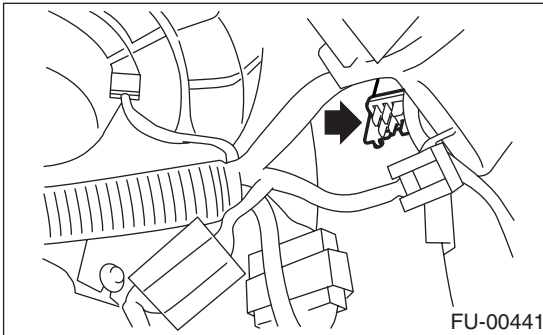

### B: INSTALLATION

Install in the reverse order of removal.

## 19. Fuel Pump Relay

### A: REMOVAL

1) Disconnect ground cable from battery.

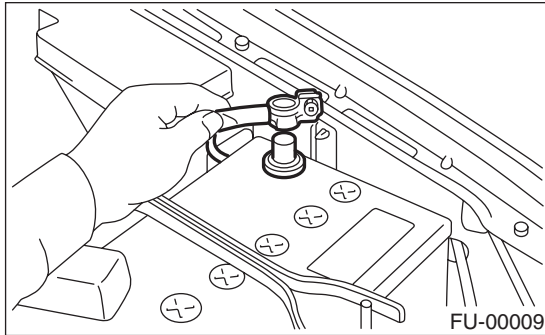

2) Remove lower cover. <Ref. to EI-37, REMOVAL, Instrument Panel Assembly.>

3) Disconnect connector from fuel pump relay.

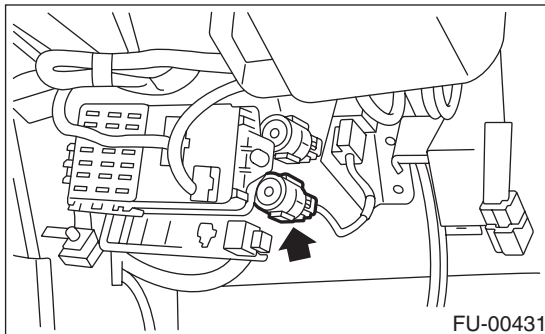

4) Remove fuel pump relay from mounting bracket.

### B: INSTALLATION

Install in the reverse order of removal.

### 20. Fuel

#### A: OPERATION

##### 1. RELEASING OF FUEL PRESSURE

###### WARNING:

- Place “NO FIRE” signs near the working area.
- Be careful not to spill fuel on the floor.

1) Disconnect connector from fuel pump relay.

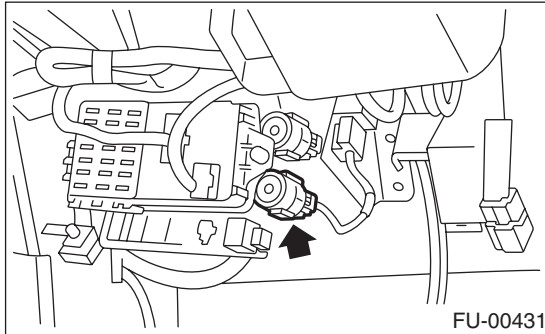

- 2) Start the engine and run it until it stalls.
- 3) After the engine stalls, crank it for five more seconds.
- 4) Turn ignition switch to OFF.

##### 2. DRAINING FUEL

###### WARNING:

- Place “NO FIRE” signs near the working area.
- Be careful not to spill fuel on the floor.

- 1) Set vehicle on the lift.
- 2) Disconnect battery ground cable.

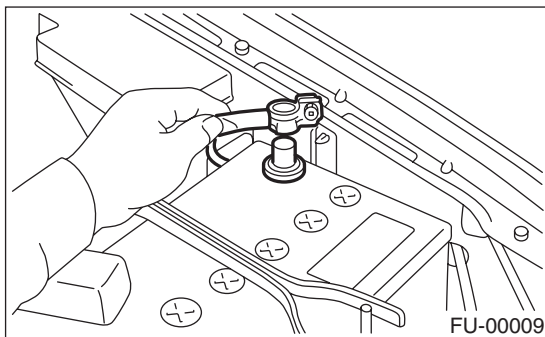

- 3) Lift-up the vehicle.
- 4) Remove front right side fuel tank cover.

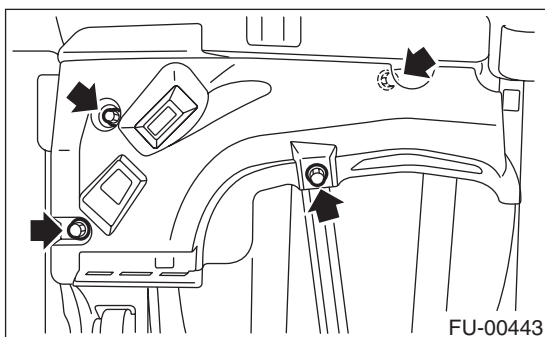

- 5) Drain fuel from fuel tank.  
Set a container under the vehicle and remove drain plug from fuel tank.

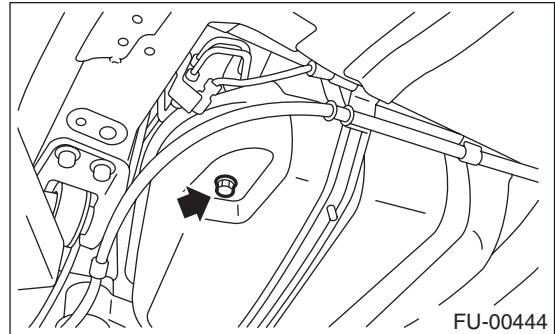

- 6) Tighten fuel drain plug and install front right side tank cover.

###### NOTE:

Replace a gasket with a new one.

###### Tightening torque:

**26 N·m (2.65 kgf·m, 19.2 ft·lb)**

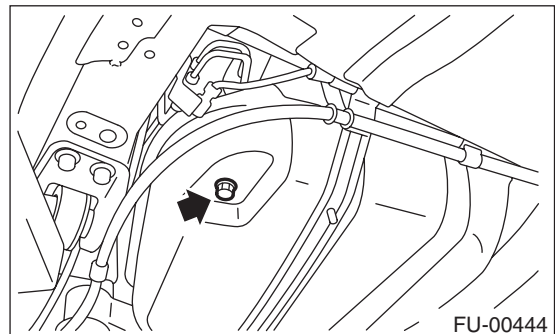

###### Tightening torque:

**18 N·m (1.8 kgf·m, 13.0 ft·lb)**

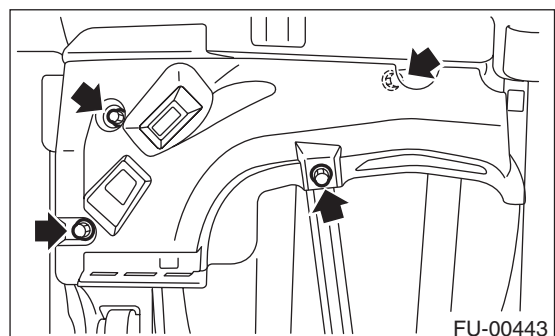

- 7) Lower the vehicle.



# FUEL

## FUEL INJECTION (FUEL SYSTEMS)

8) Remove sub service hole cover.

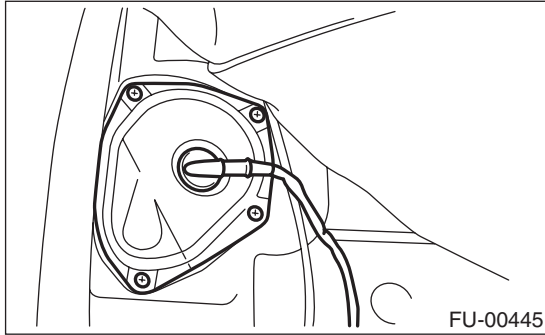

9) Disconnect connector from fuel sub level sensor.

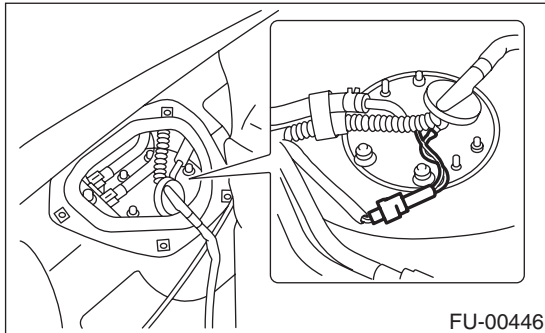

10) Disconnect fuel jet pump hose.

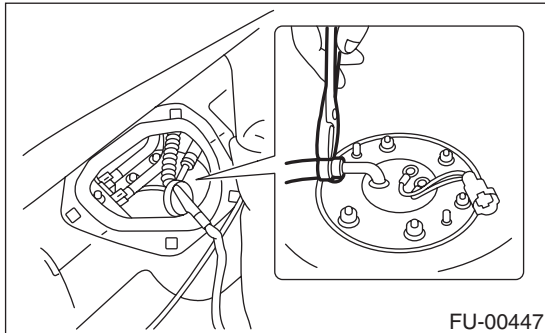

11) Remove fuel sub level sensor.

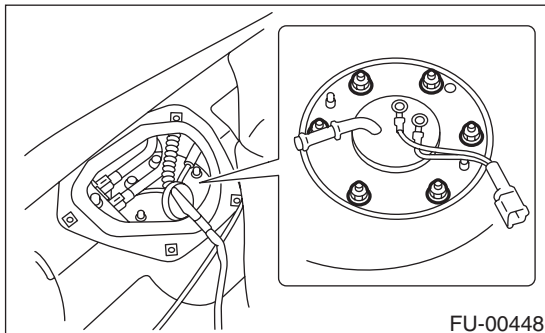

12) Drain fuel from fuel tank by using hand pump.

### WARNING:

**Do not use a motor pump when draining fuel.**

13) After draining fuel, reinstall fuel sub level sensor.

### Tightening torque:

**T: 4.4 N·m (0.45 kgf-m, 3.3 ft-lb)**

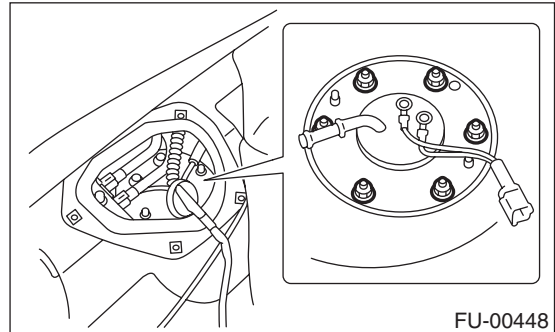

### NOTE:

If you have not removed fuel tank yet, proceed with the procedure below for installation.

(1) Connect fuel jet pump hose.

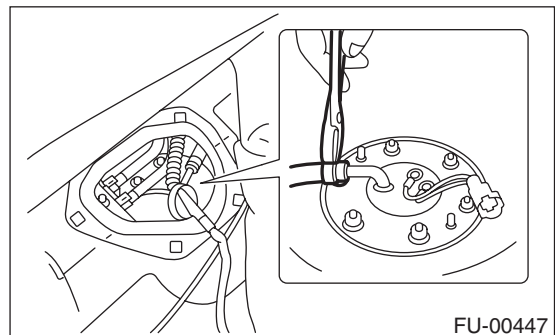

(2) Connect connector from fuel sub level sensor.

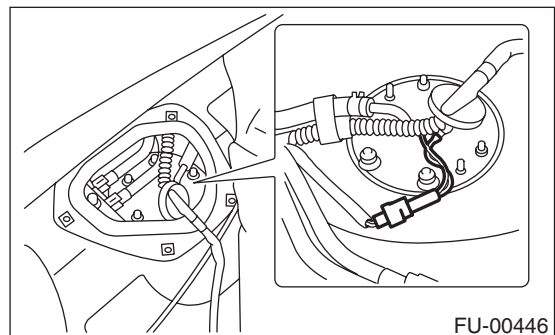

- (3) Install sub service hole cover.

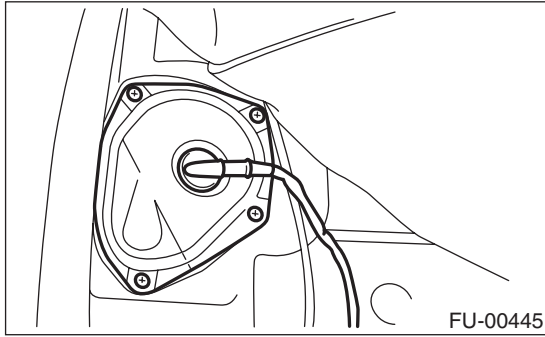

- (4) Set rear seat and floor mat.

### 21. Fuel Tank

#### A: REMOVAL

- 1) Set vehicle on the lift.
- 2) Release fuel pressure. <Ref. to FU(H4SO)-48, RELEASING OF FUEL PRESSURE, OPERATION, Fuel.>
- 3) Drain fuel from fuel tank. <Ref. to FU(H4SO)-48, DRAINING FUEL, OPERATION, Fuel.>
- 4) Remove holder clip which secures fuel tank cord on bracket.

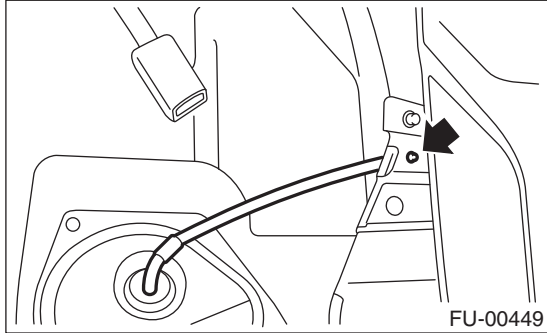

- 5) Disconnect connector of fuel tank cord to rear harness.

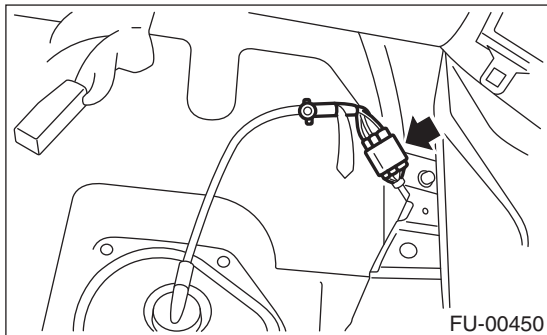

- 6) Push grommet which holds fuel tank cord on service hole cover into body side.

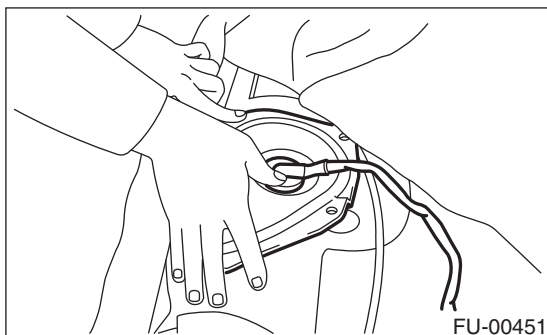

- 7) Separate quick connector of fuel delivery (A) and return hose (B). <Ref. to FU(H4SO)-72, REMOVAL, REMOVAL, Fuel Delivery, Return and Evaporation Lines.>

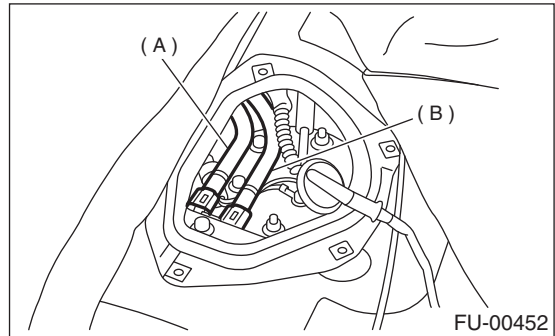

- 8) Remove parking brake cable.
  - (1) Remove console box. <Ref. to EI-36, REMOVAL, Console Box.>
  - (2) Remove parking brake bracket and disconnect parking brake cable from equalizer. <Ref. to PB-6, REMOVAL, Parking Brake Cable.>
- 9) Remove pipe protector.

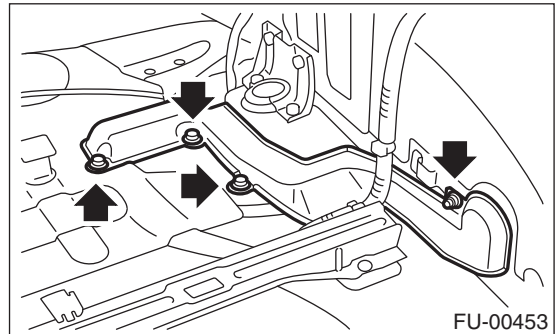

- 10) Separate quick connector of evaporation pipe.

#### NOTE:

To separate the quick connector, refer to the fuel delivery tube removal. <Ref. to FU(H4SO)-72, REMOVAL, Fuel Delivery, Return and Evaporation Lines.>

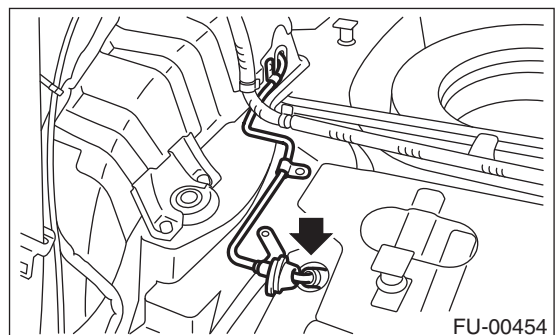

- 11) Remove wheel nuts from rear wheels.
- 12) Lift-up the vehicle.
- 13) Remove rear wheel.

# FUEL TANK

## FUEL INJECTION (FUEL SYSTEMS)

14) Remove front side fuel tank cover.

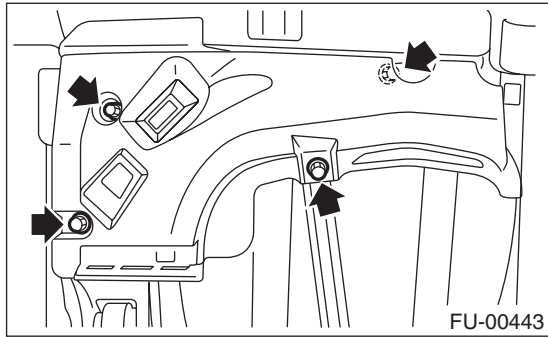

15) Remove rear exhaust pipe and muffler.

**NOTE:**

To facilitate removal, apply a coat of SUBARU CRC to matching area of rubber cushions in advance.

**SUBARU CRC (Part No. 004301003)**

(1) Separate rear exhaust pipe and center exhaust pipe.

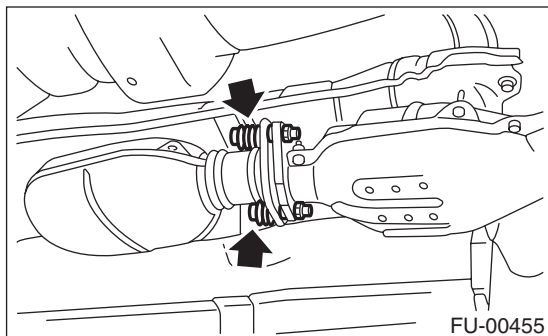

(2) Remove left and right rubber cushions.

**CAUTION:**

Be careful not to pull down muffler.

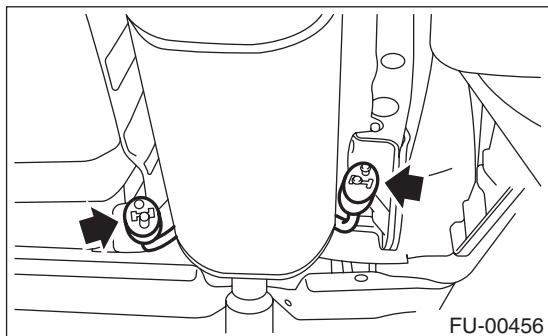

(3) Remove front rubber cushion and detach muffler assembly.

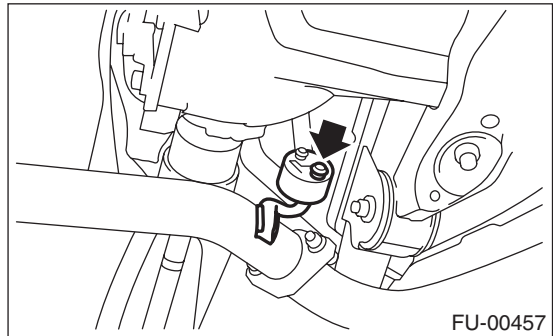

16) Remove propeller shaft. <Ref. to DS-15, REMOVAL, Propeller Shaft.>

17) Disconnect connector from ABS sensor.

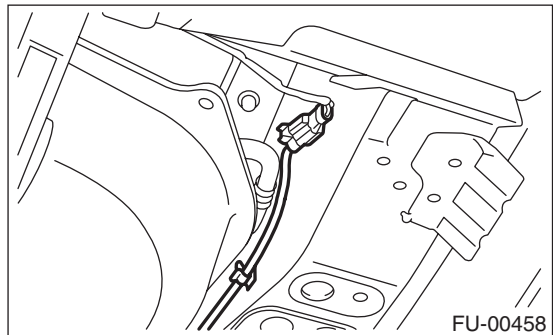

18) Remove bolts which hold parking brake cable holding bracket.

19) Remove parking brake cable from cabin by forcibly pulling it backward.

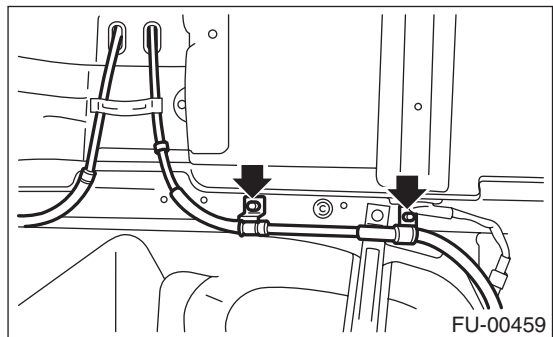

20) Remove bolts which hold parking brake cable holding bracket.

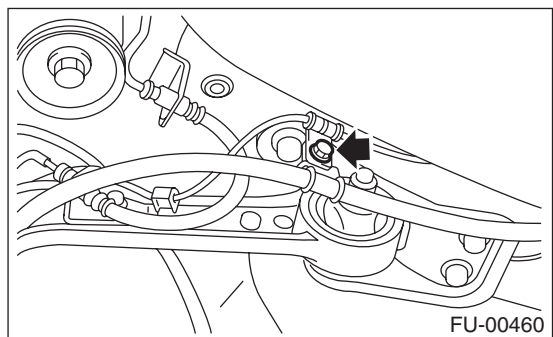

# FUEL TANK

## FUEL INJECTION (FUEL SYSTEMS)

21) Remove bolts which hold rear brake hoses holding bracket.

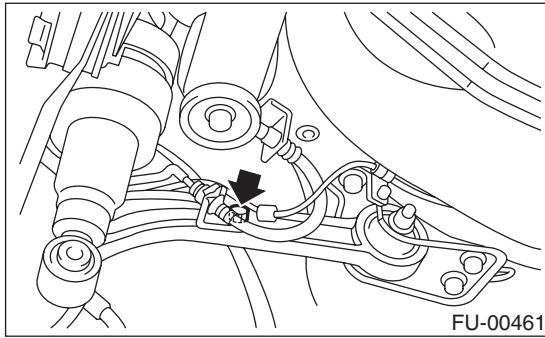

22) Remove rear brake caliper, then tie it up to the body side of the vehicle as shown in figure.

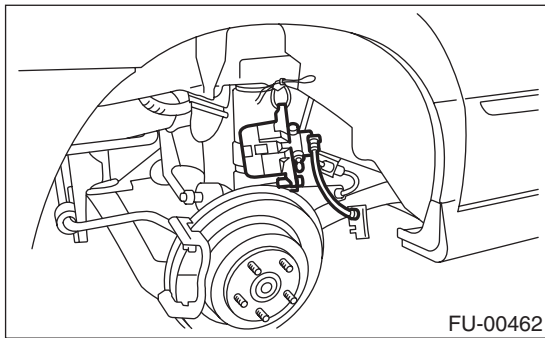

23) Remove rear suspension assembly.

### WARNING:

**A helper is required to perform this work.**

- (1) Support rear differential with transmission jack.
- (2) Remove bolt which holds rear shock absorber to rear suspension arm.

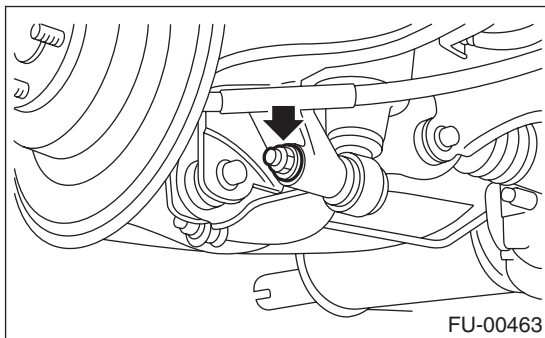

(3) Remove bolts which secure rear suspension assembly to body.

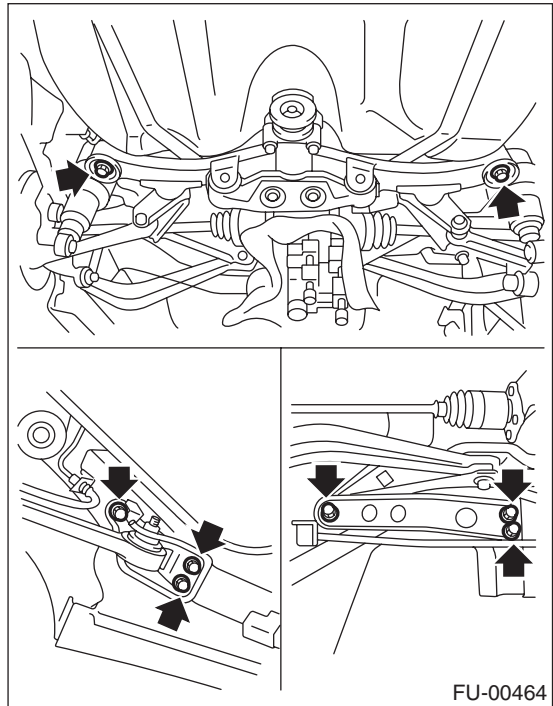

- (4) Remove rear suspension assembly.
- 24) Remove rear side fuel tank cover.

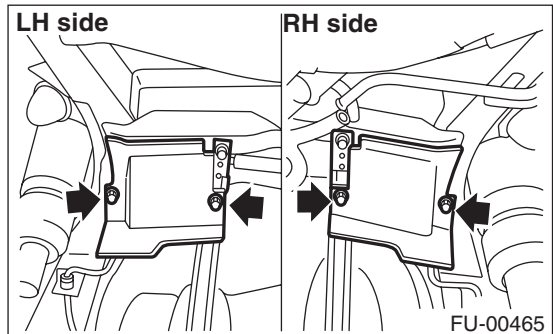

25) Disconnect fuel filler hose (A) and fuel tank pressure sensor hose (B).

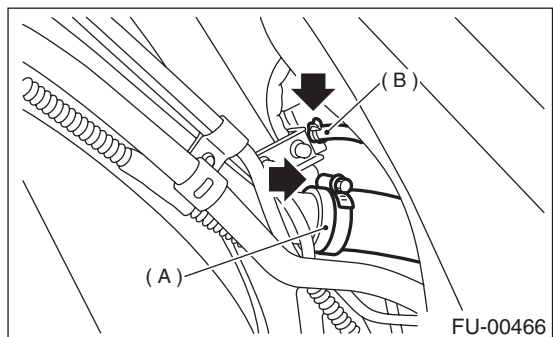

# FUEL TANK

## FUEL INJECTION (FUEL SYSTEMS)

26) Disconnect air vent hose (A) from evaporation pipe assembly and disconnect evaporation hose (B) from pressure control solenoid valve.

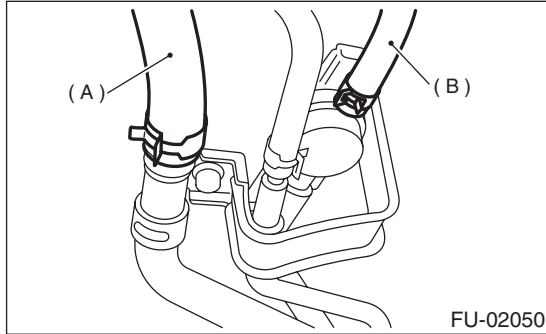

27) Support fuel tank with transmission jack, remove bolts from bands and dismount fuel tank from the vehicle.

**WARNING:**  
A helper is required to perform this work.

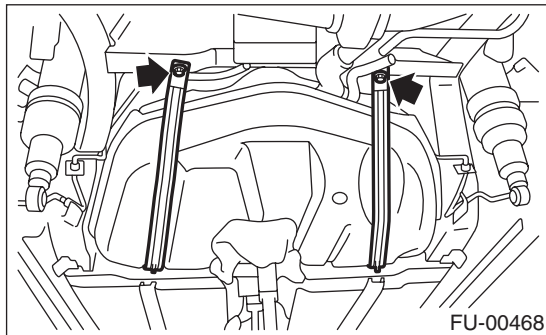

## B: INSTALLATION

1) Support fuel tank with transmission jack and push fuel tank harness into access hole with grommet.

2) Set fuel tank and temporarily tighten bolts of fuel tank bands.

**WARNING:**  
A helper is required to perform this work.

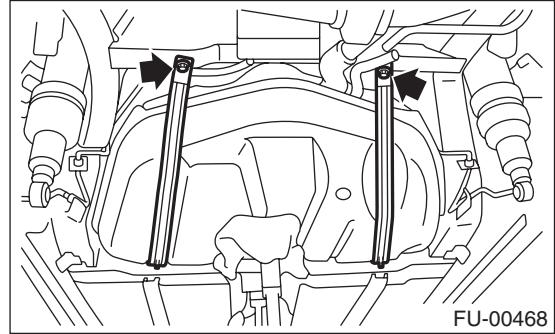

3) Connect air vent hose (A) to evaporation pipe assembly and connect evaporation hose (B) to pressure control solenoid valve.

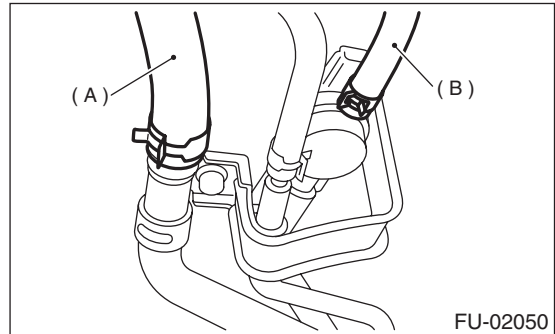

4) Connect fuel filler hose (A) and fuel tank pressure sensor hose (B).

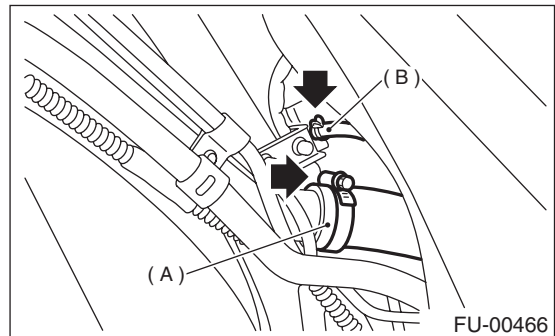

# FUEL TANK

## FUEL INJECTION (FUEL SYSTEMS)

5) Tighten band mounting bolts.

**Tightening torque:**

**33 N·m (3.4 kgf-m, 25 ft-lb)**

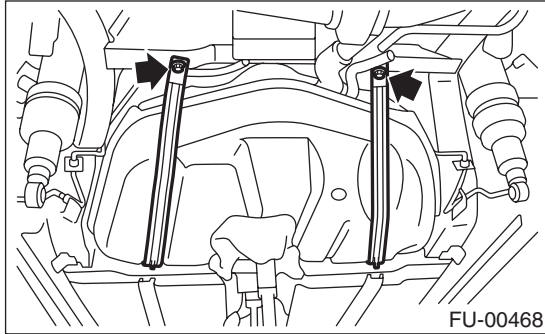

6) Install rear side fuel tank cover.

**Tightening torque:**

**18 N·m (1.8 kgf-m, 13.0 ft-lb)**

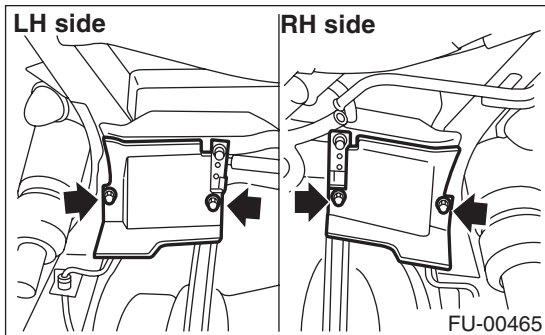

7) Install rear suspension assembly.

**WARNING:**

**A helper is required to perform this work.**

(1) Support rear suspension assembly and then tighten bolts which secure rear suspension assembly.

**Tightening torque:**

**T1: 172 N·m (17.5 kgf-m, 127 ft-lb)**

**T2: 108 N·m (11.0 kgf-m, 80 ft-lb)**

**T3: 66 N·m (6.7 kgf-m, 48 ft-lb)**

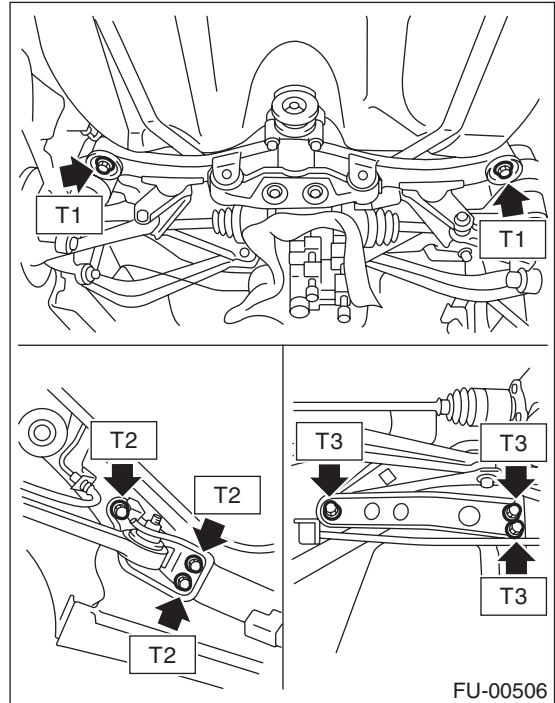

(2) Tighten bolt which holds rear shock absorber to rear suspension arm. <Ref. to RS-14, INSTALLATION, Link Upper.>

**Tightening torque:**

**157 N·m (16 kgf-m, 116 ft-lb)**

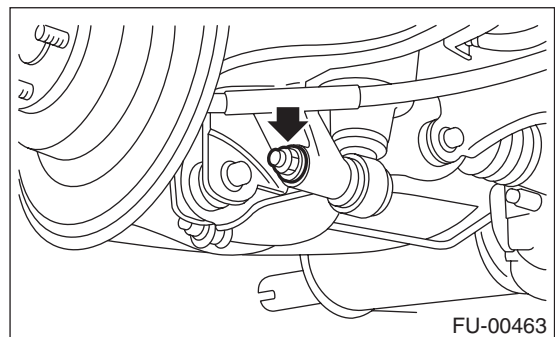

# FUEL TANK

## FUEL INJECTION (FUEL SYSTEMS)

8) Install rear brake caliper. <Ref. to BR-21, INSTALLATION, Rear Disc Brake Assembly.>

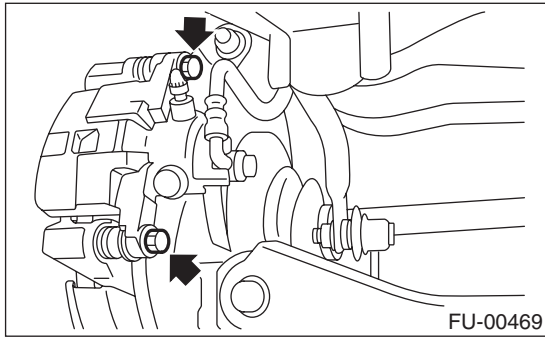

9) Tighten bolts which hold rear brake hoses holding bracket.

**Tightening torque:**

**33 N·m (3.4 kgf·m, 25 ft·lb)**

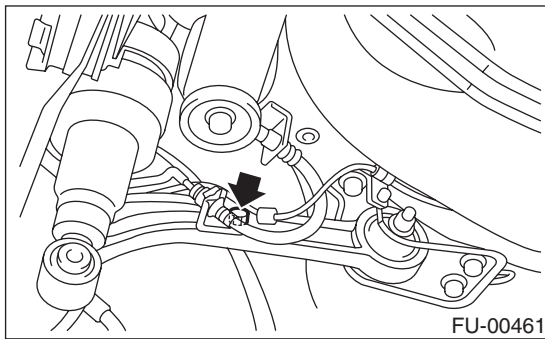

10) Install parking brake cable to cabin by forcibly pushing it forward.

11) Tighten bolts which hold parking brake cable holding bracket.

**Tightening torque:**

**18 N·m (1.8 kgf·m, 13.0 ft·lb)**

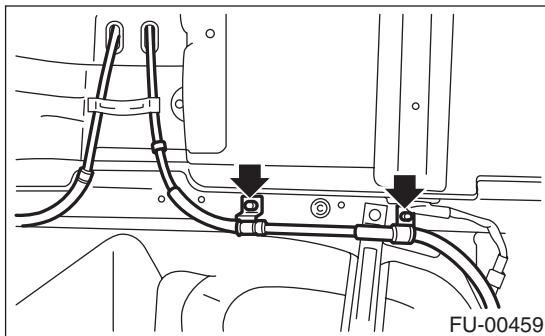

**Tightening torque:**

**32 N·m (3.3 kgf·m, 23.9 ft·lb)**

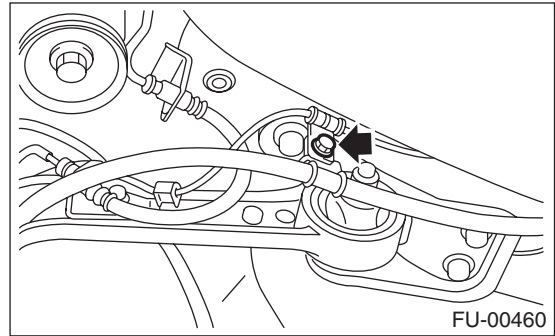

12) Connect connector to ABS sensor.

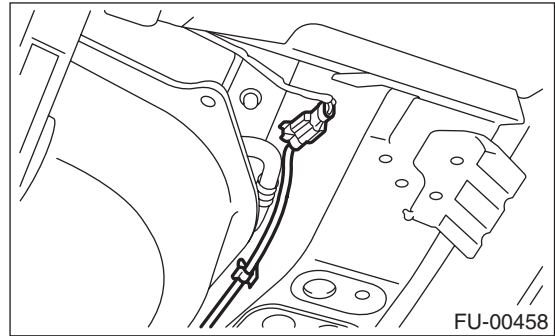

13) Install propeller shaft. <Ref. to DS-16, INSTALLATION, Propeller Shaft.>

14) Install rear exhaust pipe and muffler.

**NOTE:**

To facilitate the procedure, apply a coat of SUBARU CRC to matching area of rubber cushions in advance.

**SUBARU CRC (Part No. 004301003)**

(1) Install left and right rubber cushions.

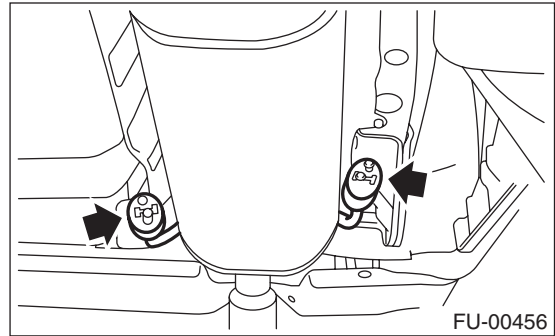



# FUEL TANK

## FUEL INJECTION (FUEL SYSTEMS)

- (2) Install front rubber cushion and attach muffler assembly.

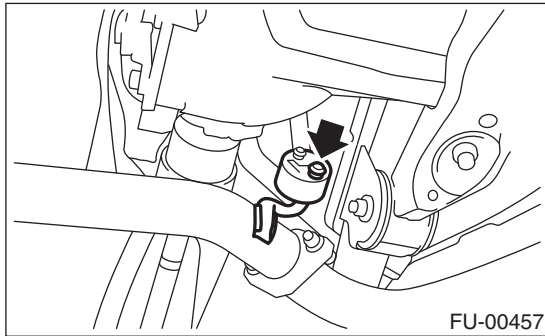

- (3) Install rear exhaust pipe to center exhaust pipe.

**Tightening torque:**

**18 N·m (1.8 kgf·m, 13.0 ft·lb)**

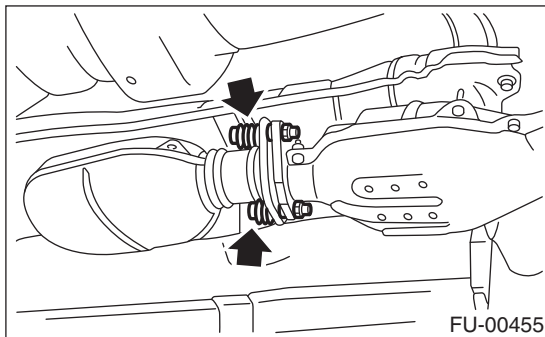

- 15) Install front side fuel tank cover.

**Tightening torque:**

**18 N·m (1.8 kgf·m, 13.0 ft·lb)**

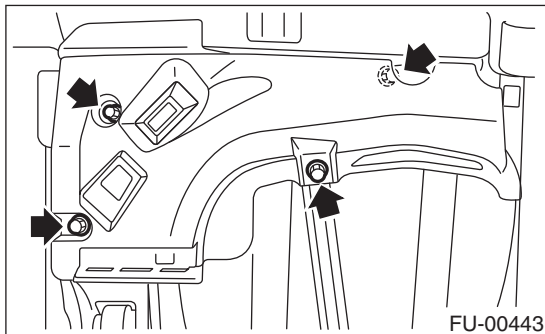

- 16) Install rear wheel.  
17) Lower the vehicle.  
18) Tighten wheel nuts to rear wheel.  
19) Install parking brake cable. <Ref. to PB-5, INSTALLATION, Parking Brake Lever.>  
20) Install console box. <Ref. to EI-36, INSTALLATION, Console Box.>

- 21) Connect fuel hoses and hold them with quick connector. <Ref. to FU(H4SO)-73, INSTALLATION, Fuel Delivery, Return and Evaporation Lines.>

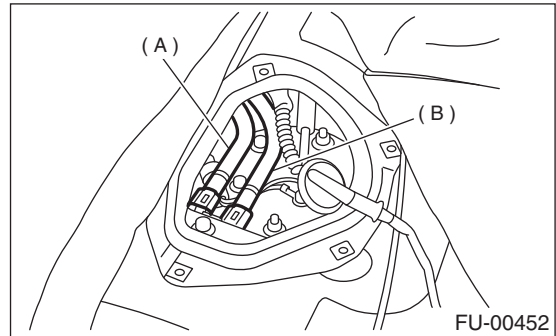

- (A) Delivery hose  
(B) Return hose

- 22) Connect evaporation pipe and hold it with quick connector.

**NOTE:**

To connect the quick connector, refer to the connection of the fuel line quick connector. <Ref. to FU(H4SO)-73, INSTALLATION, Fuel Delivery, Return and Evaporation Lines.>

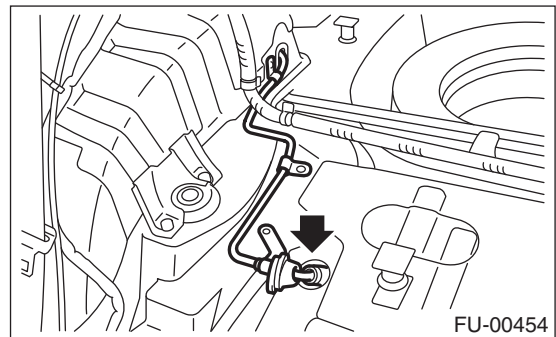

- 23) Install pipe protector.

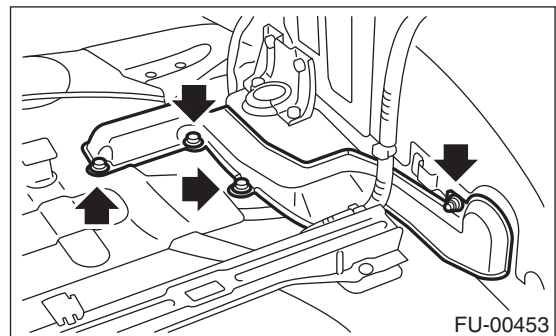

# FUEL TANK

## FUEL INJECTION (FUEL SYSTEMS)

24) Connect fuel jet pump hose.

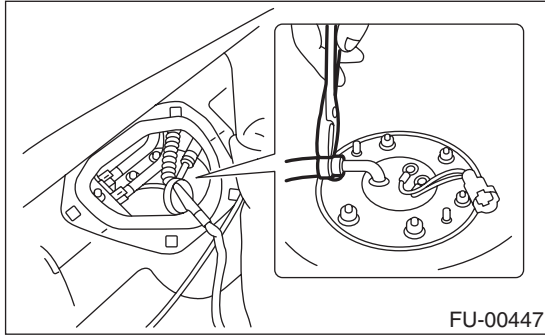

25) Connect connector to fuel sub level sensor.

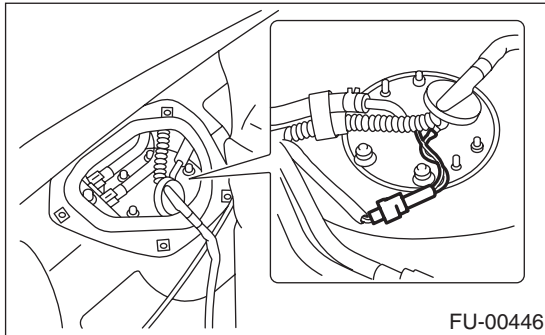

26) Install sub service hole cover.

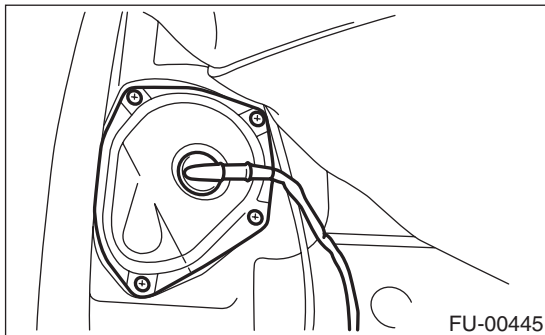

27) Connect connectors to fuel tank cord and plug service hole with grommet.

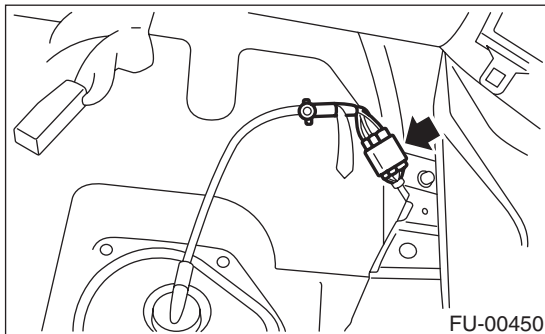

28) Install holder clip which secures fuel tank cord on bracket.

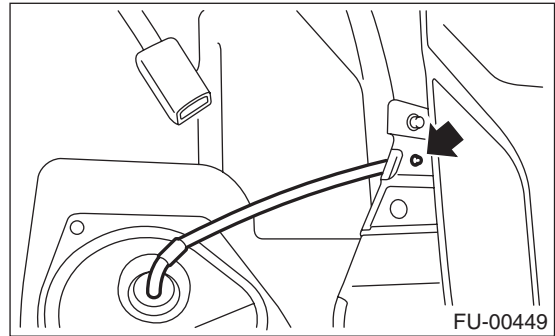

29) Set rear seat and floor mat.

30) Connect connector to fuel pump relay.

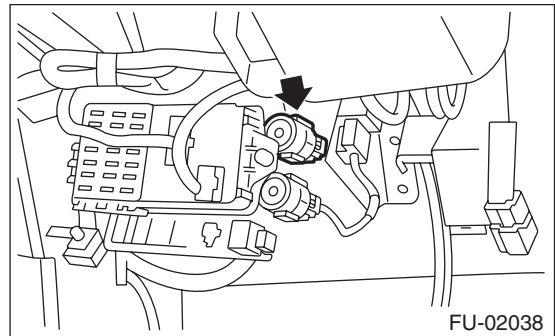

31) Adjust parking brake lever stroke. <Ref. to PB-5, ADJUSTMENT, Parking Brake Lever.>

32) Check wheel alignment and adjust if necessary. <Ref. to FS-8, INSPECTION, Wheel Alignment.>

### C: INSPECTION

1) Make sure there are no cracks, holes, or other damage on the fuel tank.

2) Make sure that the fuel hoses and fuel pipes are not cracked and that connections are tight.

## 22. Fuel Filler Pipe

### A: REMOVAL

**WARNING:**

- Place "NO FIRE" signs near the working area.
- Be careful not to spill fuel on the floor.

- 1) Drain fuel from fuel tank.  
<Ref. to FU(H4SO)-48, DRAINING FUEL, OPERATION, Fuel.>
- 2) Remove rear exhaust pipe and muffler.

**NOTE:**

To facilitate removal, apply a coat of SUBARU CRC to matching area of rubber cushions in advance.

**SUBARU CRC (Part No. 004301003)**

- (1) Separate rear exhaust pipe from center exhaust pipe.

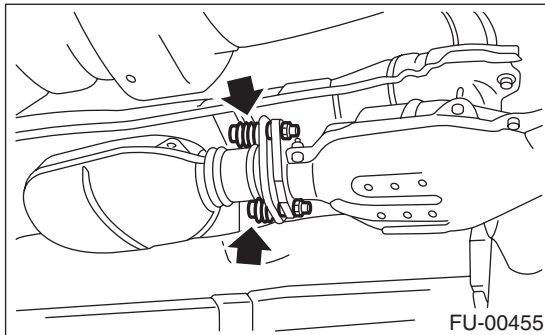

- (2) Remove left and right rubber cushions.

**CAUTION:**

Be careful not to pull down muffler.

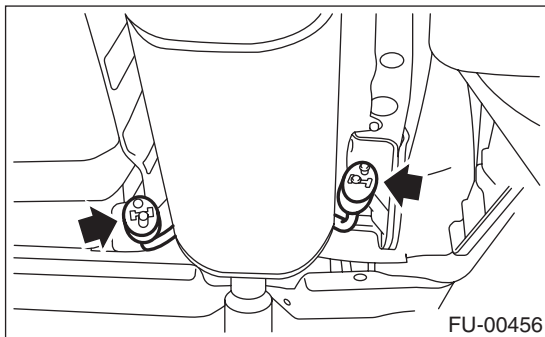

- (3) Remove front rubber cushion and detach muffler assembly.

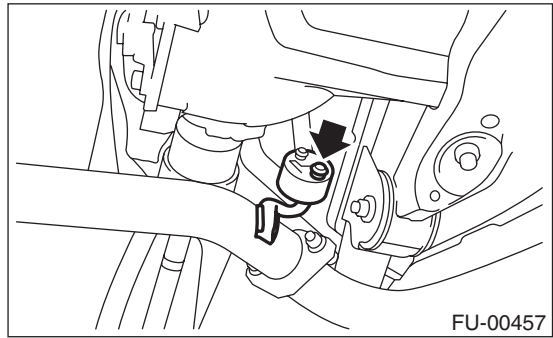

- 3) Remove heat sealed cover.

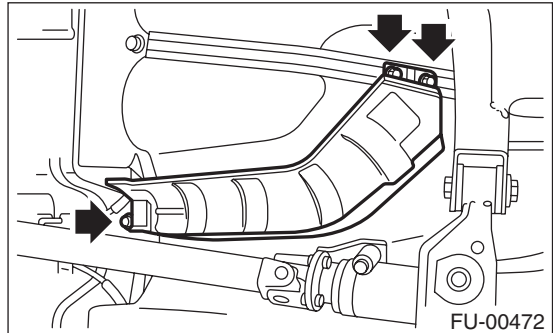

- 4) Place transmission jack under sub frame.

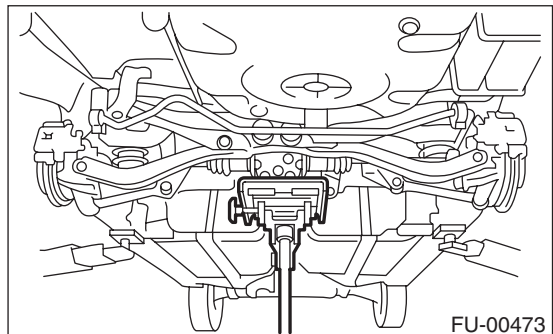

- 5) Remove bolt which holds rear shock absorber to rear suspension arm.

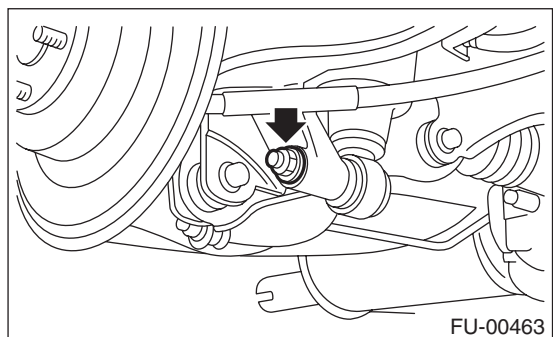

# FUEL FILLER PIPE

## FUEL INJECTION (FUEL SYSTEMS)

6) Remove bolts which hold rear sub frame on body.

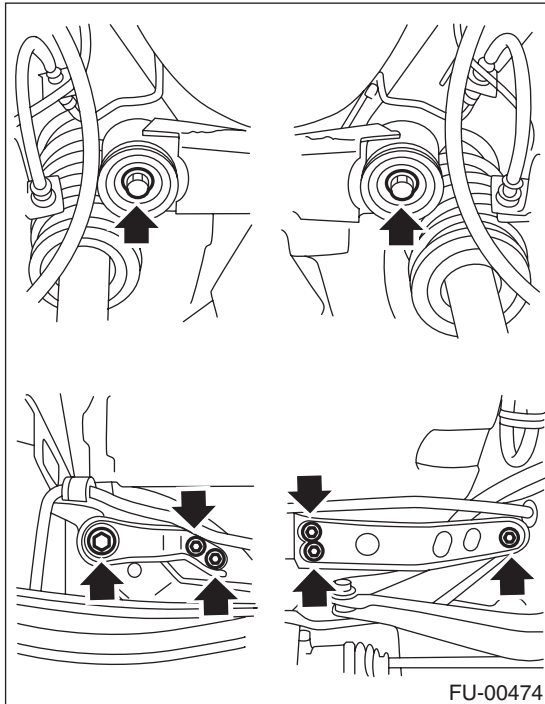

7) Lower the rear sub frame.

**CAUTION:**  
Be sure to lower sub frame slowly.

**A = 150 mm (5.91 in)**

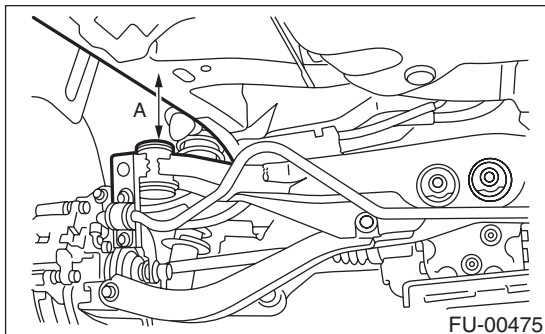

8) Remove fuel filler pipe protector.

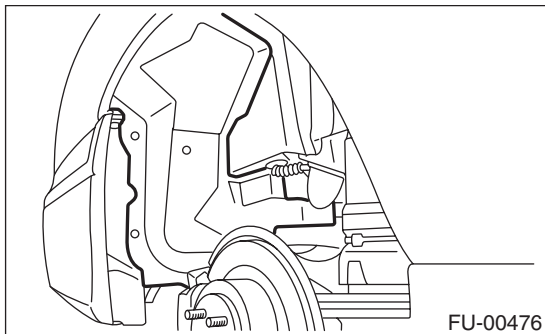

9) Disconnect air vent hose (A) and evaporation hose (B) from evaporation pipe assembly.

10) Disconnect evaporation hose (C) from pressure control solenoid valve.

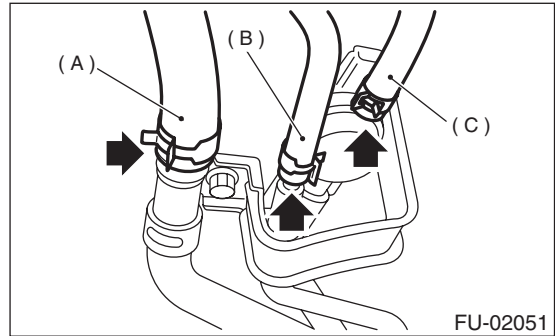

11) Remove bolt which holds evaporation pipe assembly on body.

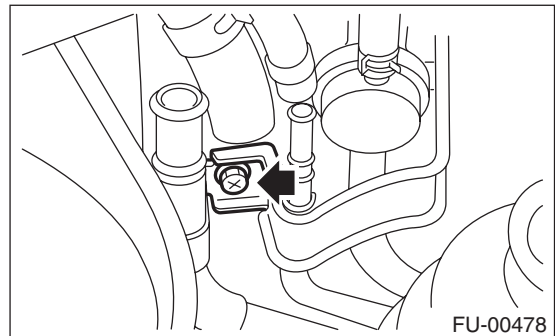

12) Disconnect fuel filler hose.

13) Remove bolt which holds fuel pressure sensor on fuel filler pipe and remove bolt which holds fuel filler pipe on body.

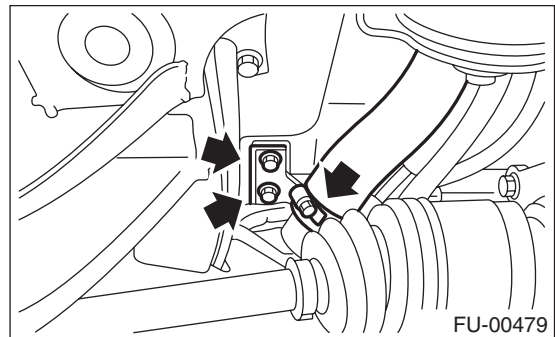

14) Disconnect canister hose from evaporation pipe assembly.

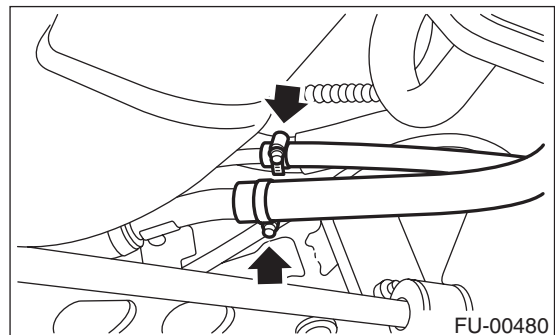

# FUEL FILLER PIPE

FUEL INJECTION (FUEL SYSTEMS)

15) Disconnect evaporation hose (O) from fuel filler pipe.

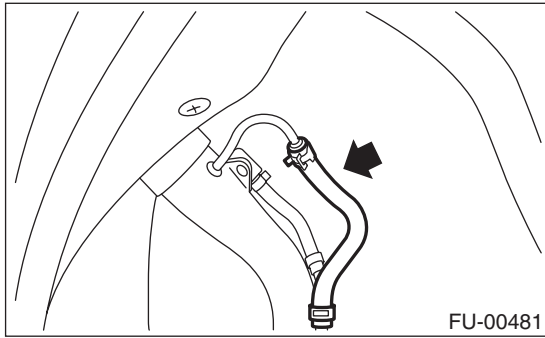

16) Remove bolt which holds fuel filler pipe to body.

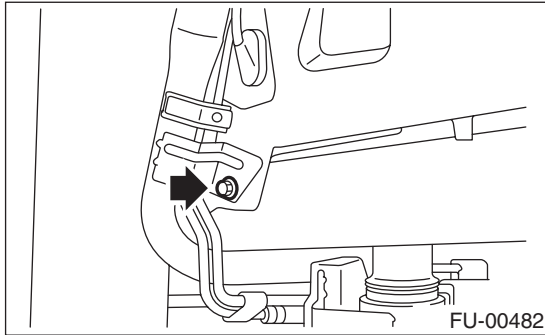

17) Remove fuel filler pipe from under side of the vehicle.

## B: INSTALLATION

1) Hold fuel filler flap open.

2) Set fuel saucer (A) with rubber packing (C) and insert fuel filler pipe into hole from the inner side of apron.

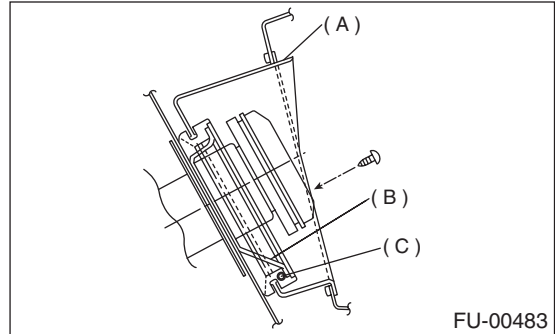

3) Align holes in fuel filler pipe neck and set cup (B), and tighten screws.

### NOTE:

If edges of rubber packing are folded toward the inside, straighten it with a screwdriver.

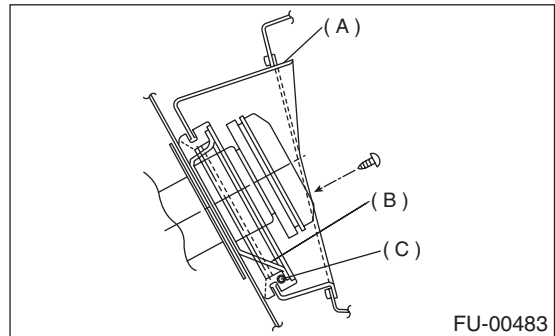

4) Tighten bolt which holds fuel filler pipe on body.

### Tightening torque:

**7.5 N·m (0.75 kgf-m, 5.4 ft-lb)**

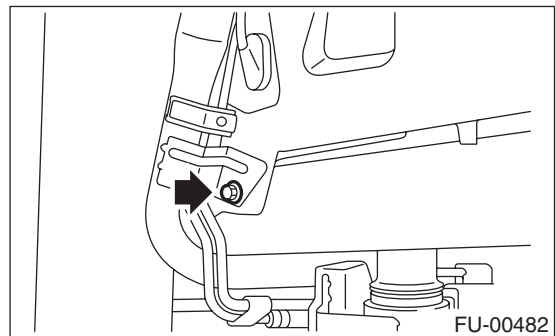

# FUEL FILLER PIPE

## FUEL INJECTION (FUEL SYSTEMS)

5) Insert evaporation hose approximately 25 to 30 mm (0.98 to 1.18 in) into the lower end of evaporation pipe and hold clip.

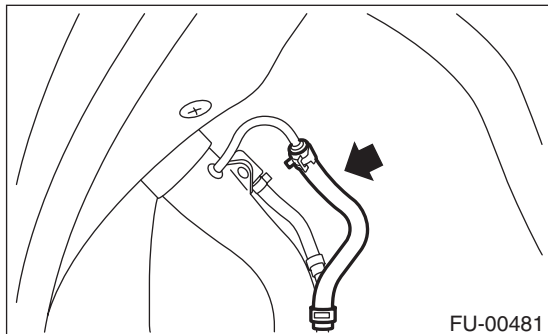

**$L = 27.5 \pm 2.5 \text{ mm (1.083 \pm 0.098 in)}$**

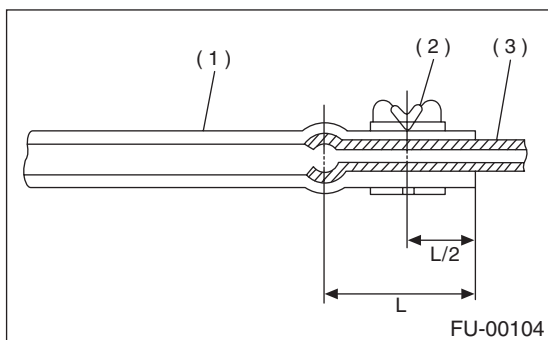

- (1) Hose
- (2) Clip
- (3) Pipe

6) Insert canister hoses approximately 25 to 30 mm (0.98 to 1.18 in) into the lower end of evaporation pipe assembly and tighten clamp.

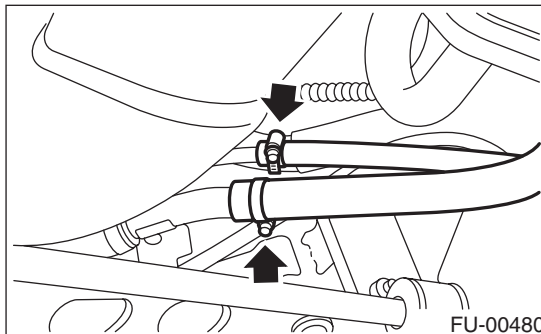

**$L = 27.5 \pm 2.5 \text{ mm (1.083 \pm 0.098 in)}$**

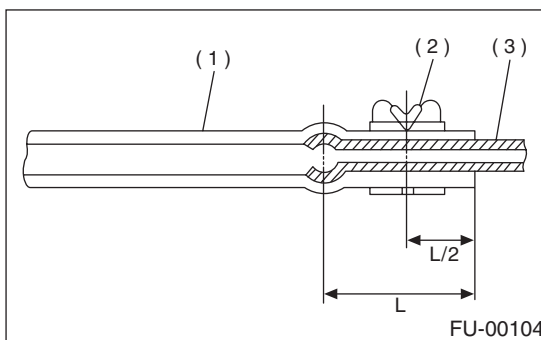

- (1) Hose
- (2) Clip
- (3) Pipe

7) Tighten bolt which holds evaporation pipe assembly on body.

**Tightening torque:**

**$7.5 \text{ N}\cdot\text{m (0.75 kgf}\cdot\text{m, 5.4 ft}\cdot\text{lb)}$**

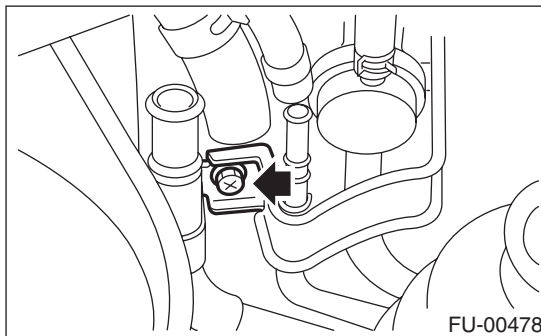

# FUEL FILLER PIPE

FUEL INJECTION (FUEL SYSTEMS)

8) Insert air vent hose (A), evaporation hose (B) approximately 25 to 30 mm (0.98 to 1.18 in) into the lower end of evaporation pipe assembly and hold clip.

9) Insert evaporation hose (C) to pressure control solenoid valve and hold clip.

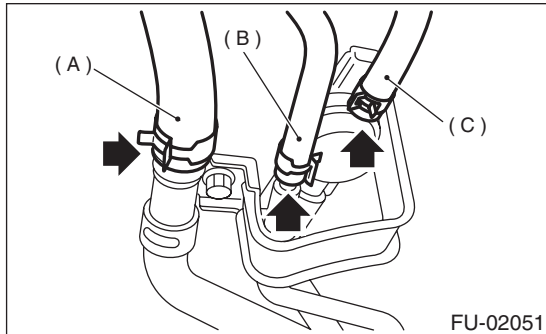

$L = 27.5 \pm 2.5 \text{ mm (1.083} \pm 0.098 \text{ in)}$

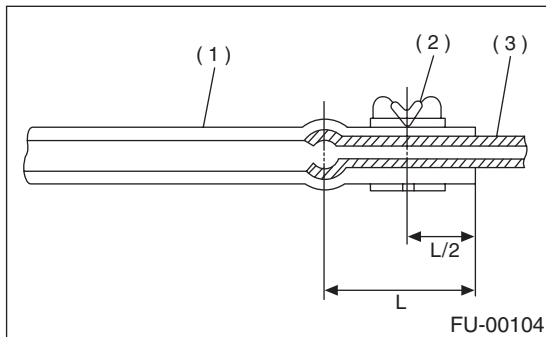

- (1) Hose
- (2) Clip
- (3) Pipe

10) Tighten bolt which holds fuel filler pipe on body and tighten bolt which holds fuel pressure sensor on fuel filler pipe.

**Tightening torque:**

**7.5 N·m (0.75 kgf-m, 5.4 ft-lb)**

11) Insert fuel filler hose approximately 35 to 40 mm (1.38 to 1.57 in) over the lower end of fuel filler pipe and tighten clamp.

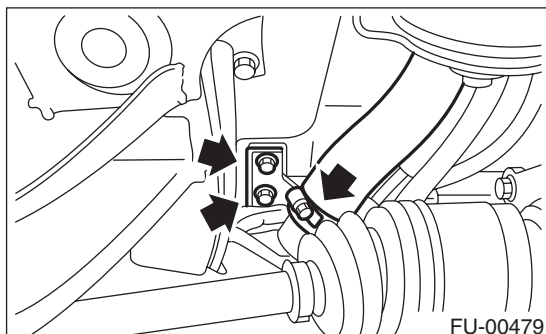

12) Jack-up the rear sub frame and tighten bolts which hold rear sub frame on body.

**Tightening torque:**

**T1: 66 N·m (6.7 kgf-m, 48.5 ft-lb)**

**T2: 172 N·m (17.5 kgf-m, 127 ft-lb)**

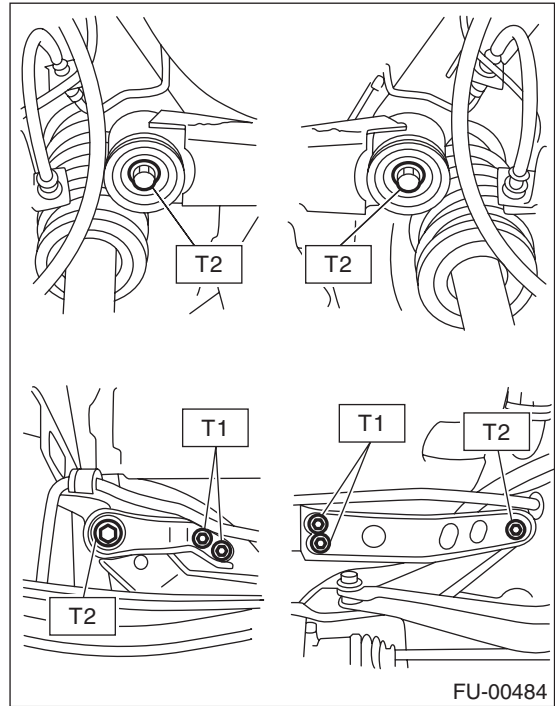

13) Tighten bolt which holds rear shock absorber to rear suspension arm. <Ref. to RS-16, INSTALLATION, Rear Shock Absorber.>

**Tightening torque:**

**157 N·m (16 kgf-m, 116 ft-lb)**

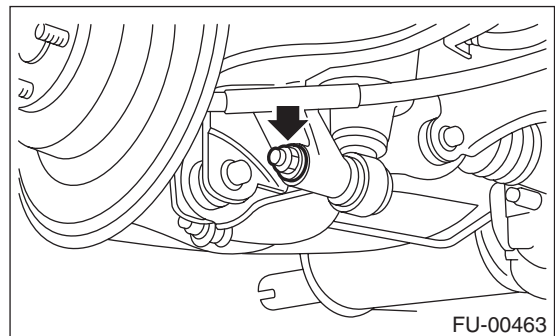

# FUEL FILLER PIPE

## FUEL INJECTION (FUEL SYSTEMS)

14) Install heat shield cover.

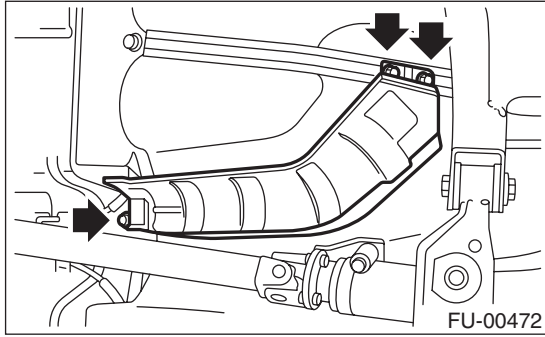

15) Install rear exhaust pipe and muffler.

### NOTE:

To facilitate the procedure, apply a coat of SUBARU CRC to matching area of rubber cushions in advance.

### **SUBARU CRC (Part No. 004301003)**

(1) Install left and right rubber cushions.

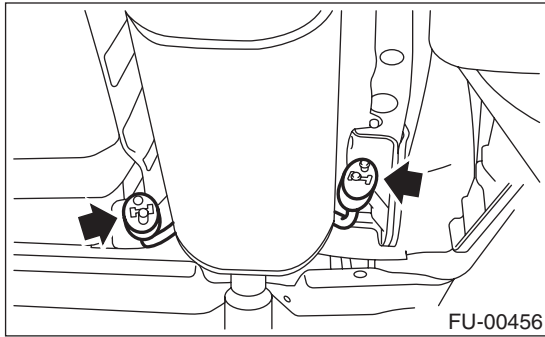

(2) Install front rubber cushion and attach muffler assembly.

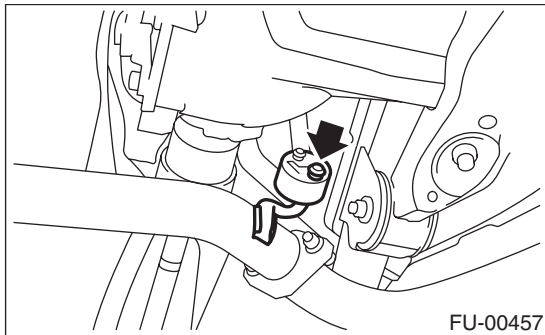

(3) Install rear exhaust pipe to center exhaust pipe.

### **Tightening torque:**

**18 N·m (1.8 kgf·m, 13.0 ft·lb)**

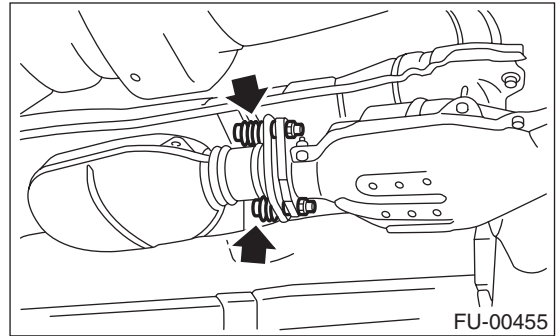

16) Install fuel filler pipe protector.

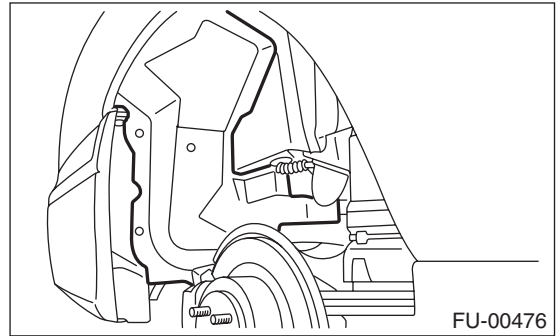

17) Install rear right wheel.

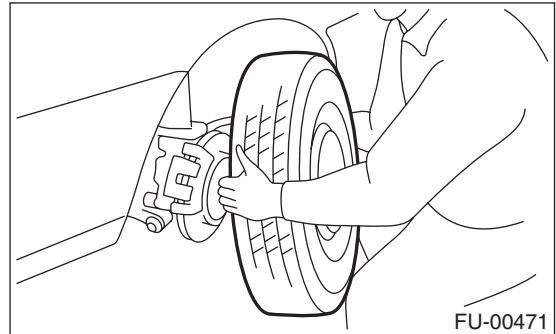

18) Lower the vehicle.

19) Tighten wheel nuts.

20) Connect battery ground cable.

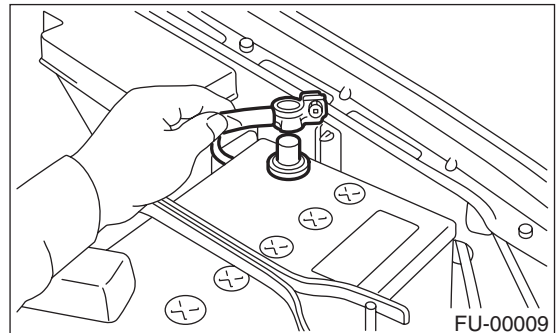



21) Remove fuel filler pipe to under side of the vehicle.

### C: DISASSEMBLY

1) Disconnect evaporation hose from evaporation pipe assembly.

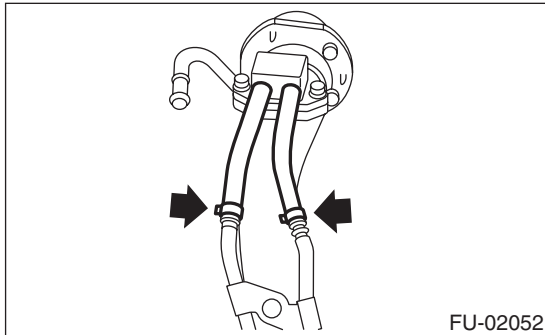

2) Remove shut valve from fuel filler pipe.

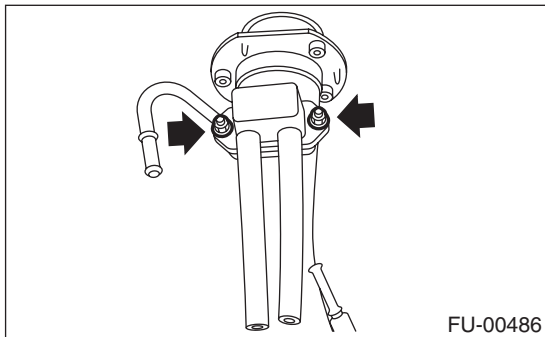

3) Remove nut which holds evaporation pipe assembly on fuel filler pipe.

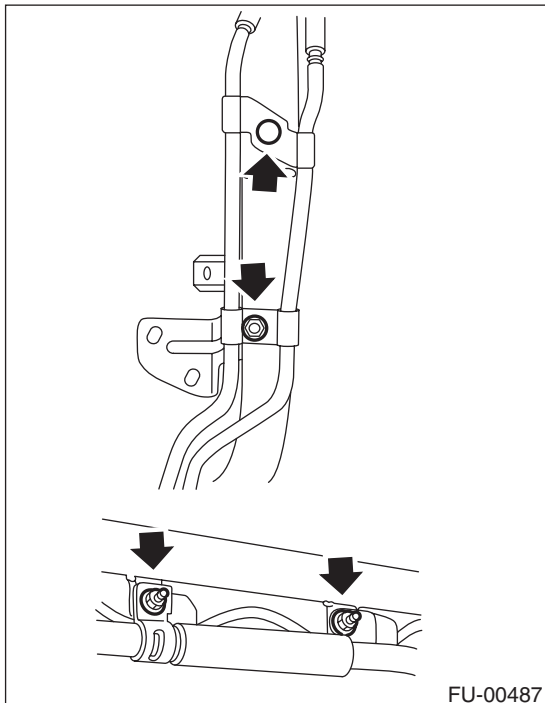

### D: ASSEMBLY

Assemble in the reverse order of disassembly.

# FUEL PUMP

## FUEL INJECTION (FUEL SYSTEMS)

### 23. Fuel Pump

#### A: REMOVAL

##### WARNING:

- Place “NO FIRE” signs near the working area.
- Be careful not to spill fuel on the floor.

##### NOTE:

Fuel pump assembly consists of fuel pump and fuel level sensor.

- 1) Release fuel pressure. <Ref. to FU(H4SO)-48, RELEASING OF FUEL PRESSURE, OPERATION, Fuel.>
- 2) Drain fuel from fuel tank. <Ref. to FU(H4SO)-48, DRAINING FUEL, OPERATION, Fuel.>
- 3) Raise rear seat and turn floor mat up.
- 4) Remove access hole lid.

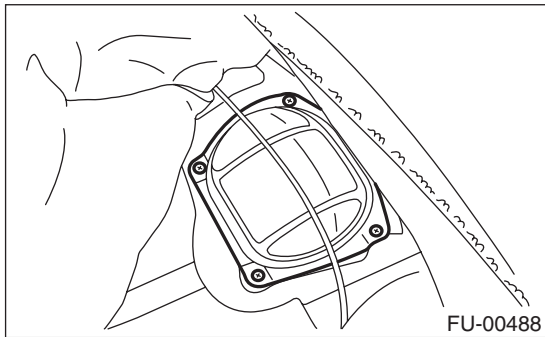

- 5) Disconnect connector from fuel pump.

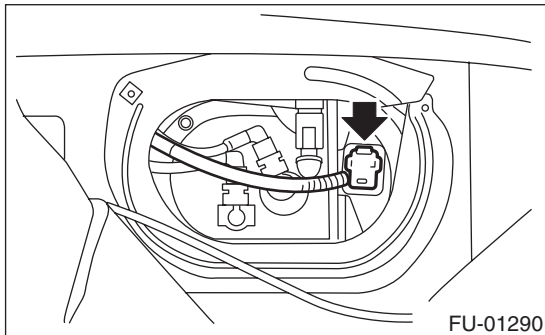

- 6) Disconnect quick connector and then disconnect fuel delivery hose (A) and return hose (B). <Ref. to FU(H4SO)-72, REMOVAL, Fuel Delivery, Return and Evaporation Lines.>

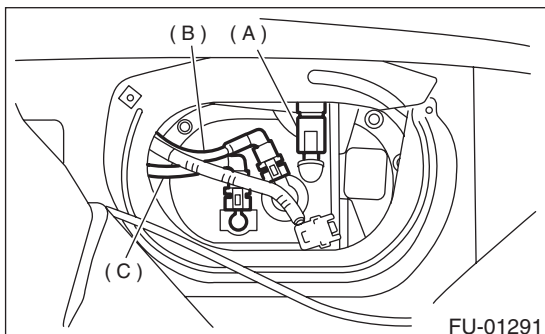

- 7) Remove nuts which install fuel pump assembly onto fuel tank.

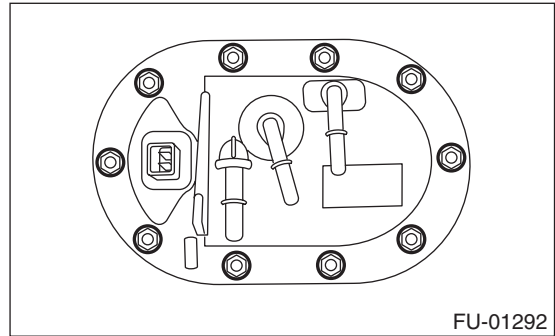

- 8) Take off fuel pump assembly from fuel tank.

#### B: INSTALLATION

Install in the reverse order of removal. Do the following:

- (1) Always use new gaskets.
- (2) Ensure sealing portion is free from fuel or foreign particles before installation.
- (3) Tighten nuts in alphabetical sequence shown in figure to specified torque.

##### Tightening torque:

**5.9 N·m (0.6 kgf·m, 4.3 ft·lb)**

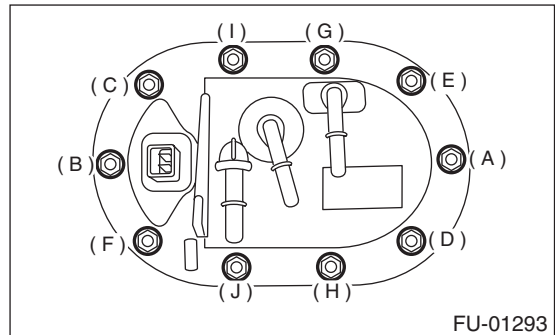

### C: DISASSEMBLY

1) Remove fuel pump and pump holder.

NOTE:

When disassembling pump holder, be careful as it is installed with two pawls.

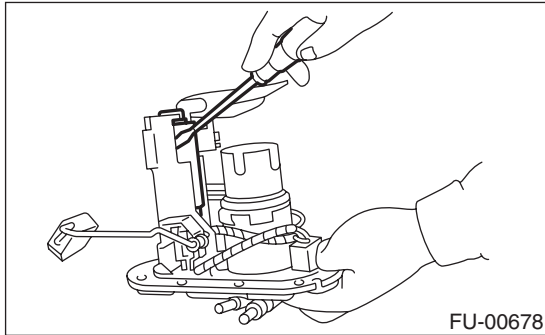

2) Disconnect connector from fuel pump.

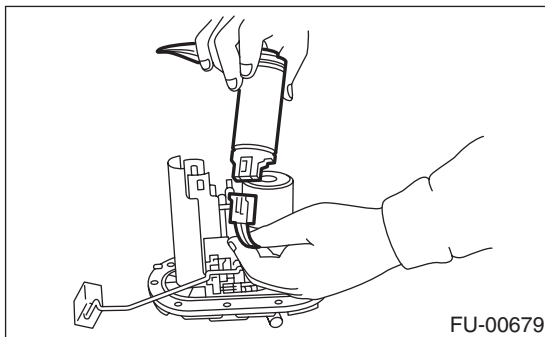

### D: ASSEMBLY

Assemble in the reverse order of disassembly.

### E: INSPECTION

Connect lead harness to connector terminal of fuel pump and apply battery power supply to check whether the pump operate.

**WARNING:**

- Wipe off the fuel completely.
- Keep battery as far apart from fuel pump as possible.
- Be sure to turn the battery supply ON and OFF on the battery side.
- Do not run fuel pump for a long time under non-load condition.

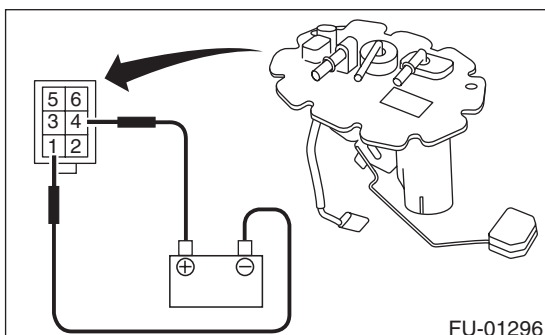

# FUEL LEVEL SENSOR

FUEL INJECTION (FUEL SYSTEMS)

## 24. Fuel Level Sensor

### A: REMOVAL

#### WARNING:

- Place “NO FIRE” signs near the working area.
- Be careful not to spill fuel on the floor.

#### NOTE:

Fuel level sensor is built in fuel pump assembly.

- 1) Remove fuel pump assembly. <Ref. to FU(H4SO)-66, REMOVAL, Fuel Pump.>
- 2) Disconnect connector from fuel pump bracket.

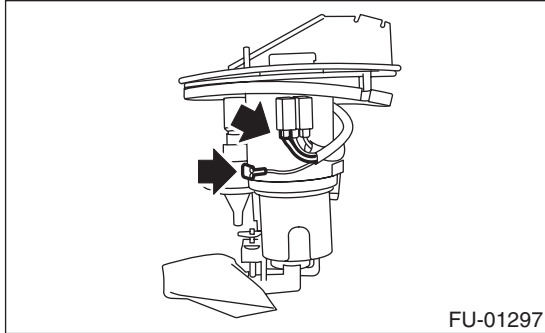

- 3) Pushing the pawls with a screwdriver, remove fuel level sensor by pulling it downwards.

#### NOTE:

If the retainer pawls are broken during removal, the fuel level sensor must be replaced with a new one.

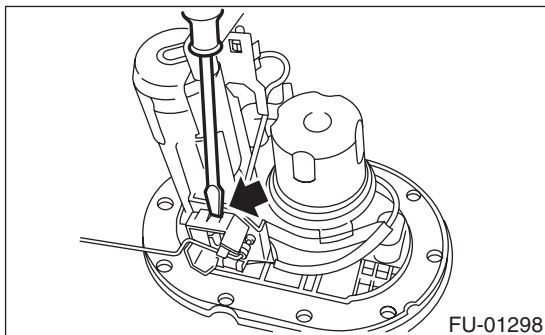

### B: INSTALLATION

Install in the reverse order of removal.

#### WARNING:

- Ground cable must be connected.
- Spark may occur and ignite if fuel is nearby.

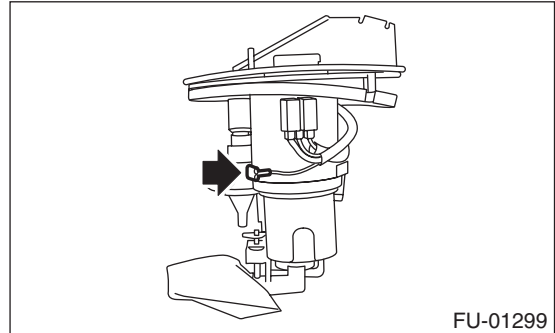

## 25. Fuel Sub Level Sensor

### A: REMOVAL

**WARNING:**

- Place “NO FIRE” signs near the working area.
- Be careful not to spill fuel on the floor.
- During work procedures, if fuel tank is more than 3/4 full, be careful because fuel may spill.

- 1) Drain fuel from fuel tank.  
<Ref. to FU(H4SO)-48, DRAINING FUEL, OPERATION, Fuel.>
- 2) Remove rear seat.
- 3) Remove service hole cover.

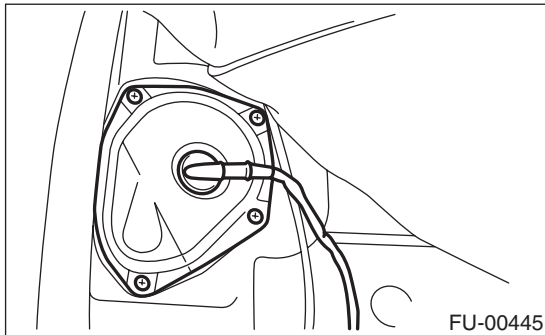

- 4) Disconnect connector from fuel sub level sensor.

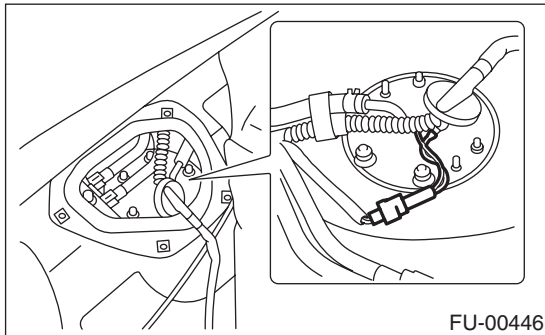

- 5) Disconnect fuel jet pump hose.

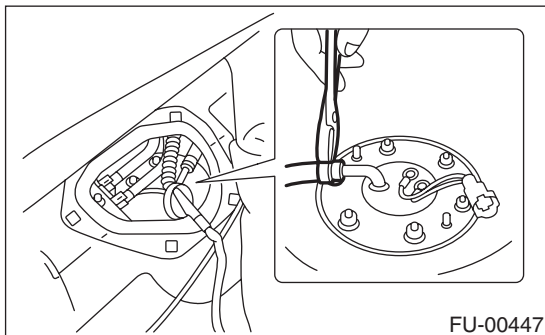

- 6) Remove bolts which install fuel sub level sensor on fuel tank.

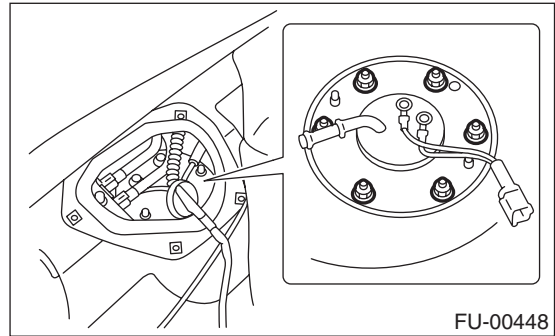

- 7) Remove fuel sub level sensor.

### B: INSTALLATION

Install in the reverse order of removal.

**NOTE:**

Replace a gasket with a new one.

**Tightening torque:**

**4.4 N·m (0.45 kgf·m, 3.3 ft·lb)**

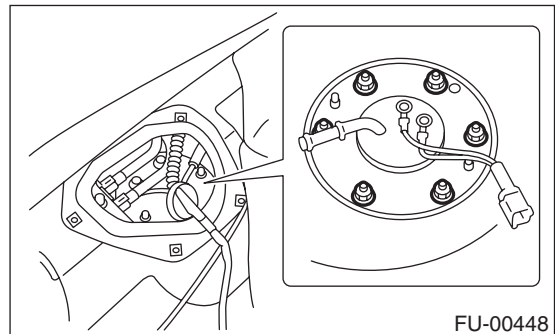

# FUEL FILTER

FUEL INJECTION (FUEL SYSTEMS)

## 26. Fuel Filter

### A: REMOVAL

#### WARNING:

- Place “NO FIRE” signs near the working area.
- Be careful not to spill fuel on the floor.

#### NOTE:

The fuel filter is built in fuel pump assembly.

- 1) Release the fuel pressure. <Ref. to FU(H4SO)-48, RELEASING OF FUEL PRESSURE, OPERATION, Fuel.>
- 2) Remove the fuel pump assembly. <Ref. to FU(H4SO)-66, REMOVAL, Fuel Pump.>
- 3) Disconnect the ground cable from filter holder.

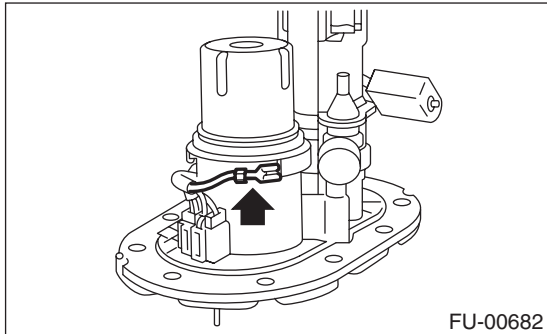

- 4) Remove the filter holder by turning it to the left from the body pawls, and then take out the filter.

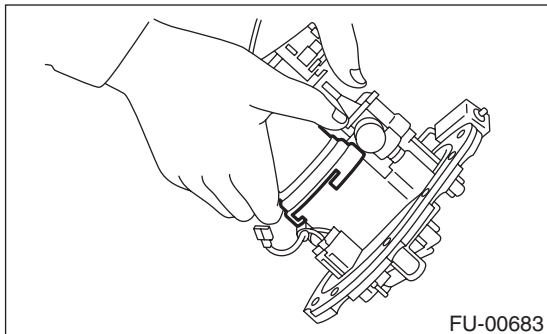

### B: INSTALLATION

#### NOTE:

- If the fuel hoses are damaged at the connecting portion, replace it with a new one.
  - If the clamps are badly damaged, replace with new ones.
  - Replace the o-ring with new ones.
- 1) Set the O-ring on the filter holder, and then install by turning to the right.

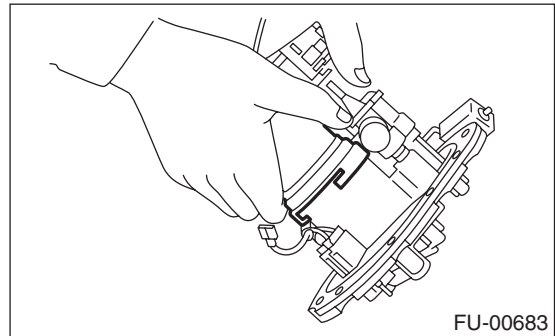

- 2) Connect the ground cable to filter holder.

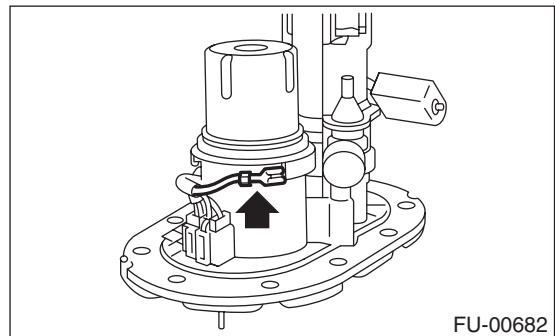

- 3) Install the fuel pump assembly. <Ref. to FU(H4SO)-66, INSTALLATION, Fuel Pump.>

### C: INSPECTION

- 1) Check the inside of fuel filter for dirt and water sediment.
- 2) If it is clogged, or if replacement interval has been reached, replace it.

## 27. Fuel Cut Valve

### A: REMOVAL

- 1) Remove fuel tank. <Ref. to FU(H4SO)-51, REMOVAL, Fuel Tank.>
- 2) Move clip and disconnect evaporation hose from fuel cut valve.

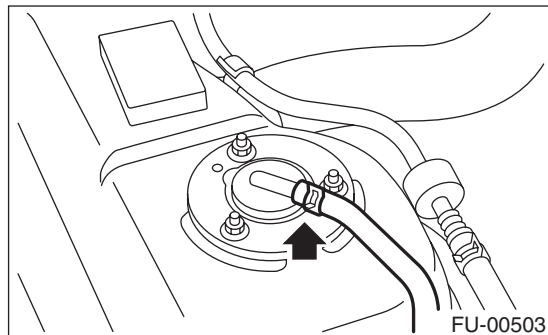

- 3) Remove bolts which install fuel cut valve.

### B: INSTALLATION

Install in the reverse order of removal.

NOTE:

Replace a gasket with a new one.

**Tightening torque:**

**4.4 N·m (0.45 kgf·m, 3.3 ft·lb)**

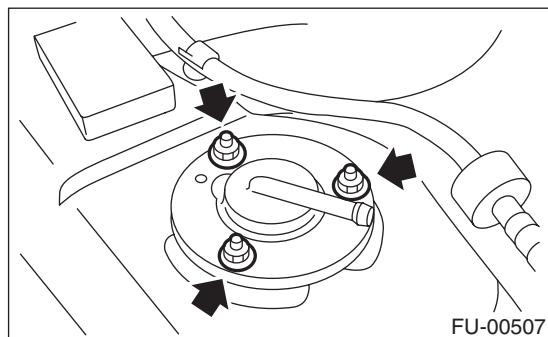

# FUEL DELIVERY, RETURN AND EVAPORATION LINES

FUEL INJECTION (FUEL SYSTEMS)

## 28. Fuel Delivery, Return and Evaporation Lines

### A: REMOVAL

#### WARNING:

Place a “Warning of flammability” sign in the work area.

#### CAUTION:

Do not cause the fuel to spray.

- 1) Place vehicle on the lift.
- 2) Release fuel pressure. <Ref. to FU(H4SO)-48, RELEASING OF FUEL PRESSURE, OPERATION, Fuel.>

- 3) Open fuel filler flap lid and remove fuel filler cap.
- 4) Remove the fuel tank. <Ref. to FU(H4SO)-51, REMOVAL, Fuel Tank.>
- 5) Remove fuel filler pipe. <Ref. to FU(H4SO)-59, REMOVAL, Fuel Filler Pipe.>
- 6) Remove floor mat. <Ref. to EI-45, REMOVAL, Floor Mat.>
- 7) Detach fuel delivery pipes and hoses, fuel return pipes and hoses, and evaporation pipes and hoses.

#### CAUTION:

- Do not cause the fuel to spray.
- Collect the fuel from the hose in a container or with a shop cloth.

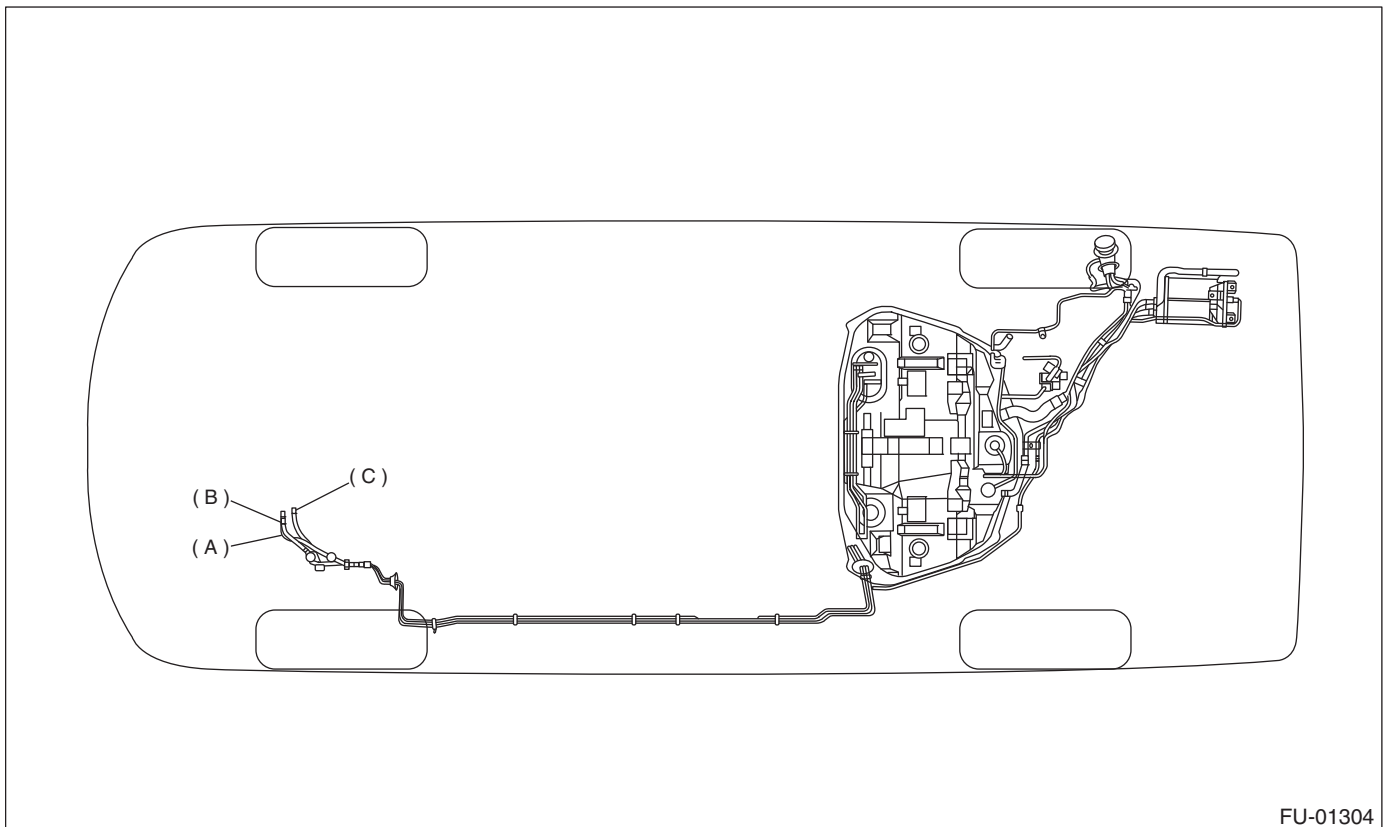

FU-01304

(A) Fuel delivery line

(B) Fuel return line

(C) Evaporation line

8) In the engine room, detach the fuel delivery hoses, fuel return hoses and evaporation hose.

#### CAUTION:

- Do not cause the fuel to spray.
- Collect the fuel from the hose in a container or with a shop cloth.

- (1) Attach ST to fuel pipe.

ST 42099AE000 Quick connector release

- (2) Detach the fuel delivery hose and the quick connector of the fuel return hose according to the direction of the indicator that the ST is pushed.



# FUEL DELIVERY, RETURN AND EVAPORATION LINES

FUEL INJECTION (FUEL SYSTEMS)

(3) Remove the clip, and then detach the evaporation hose from the fuel pipe.

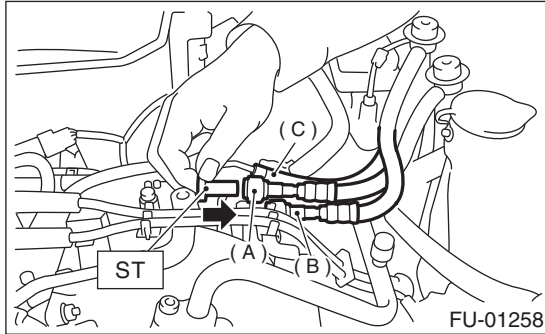

- (A) Fuel delivery hose
- (B) Fuel return hose
- (C) Evaporation hose

9) Remove the fuel pipe assembly from the vehicle.  
10) Remove the evaporation tube from the fuel tank.

11) Detach the quick connector, and remove the fuel delivery tube, fuel return tube and jet pump tube from the fuel tank.

- When using a special tool
  - (1) Attach ST to the pipe, and detach the quick connector according to the direction of the indicator that the ST is pushed.

ST 42099AE000 Quick connector release

### CAUTION:

- Do not cause the fuel to spray.
- Collect the fuel from the hose in a container or with a shop cloth.
- Pull out the connector in an axial direction as indicated in the illustration (C).
- If the connector and pipe are adhered together, with a special tool pushed in, push and pull until you can move freely, then pull out.
- When removing the connector, do not bend or twist the tube to the point of potential damage. If the tube was bent back and forth, replace it with a new part.

### NOTE:

If there is dust, clean the pipe and quick connector.

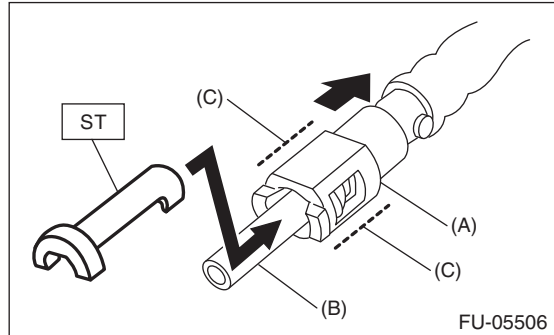

- (A) Quick connector
- (B) Pipe
- (C) Location that grips connector

(2) Cover the pipe and quick connector with a plastic bag, and make sure that it is not damaged and foreign matter does not enter.

### CAUTION:

When reusing the retainer, do not remove it from the connector.

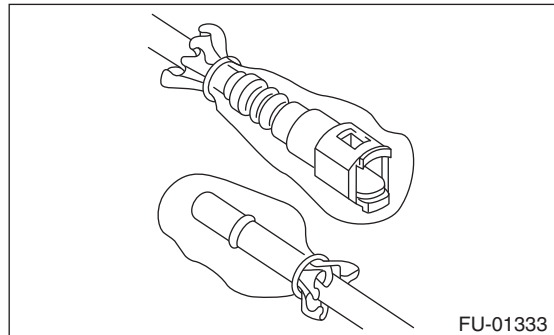

# FUEL DELIVERY, RETURN AND EVAPORATION LINES

## FUEL INJECTION (FUEL SYSTEMS)

- When not using a special tool  
(1) Push the retainer in the direction of the indicator, and detach the quick connector from the pipe.

### CAUTION:

- Be careful not to let the fuel spray.
- Collect fuel from hoses in a container or with a shop cloth.
- Pull out the connector in an axial direction as indicated in the illustration (D).
- If the connector and pipe are adhered together, with the retainer pushed in the direction of the arrow, push and pull until you can move freely, then pull out.
- When removing the connector, do not bend or twist the tube to the point of potential damage. If the tube was bent back and forth, replace it with a new part.

### NOTE:

If there is dust, clean the pipe and quick connector.

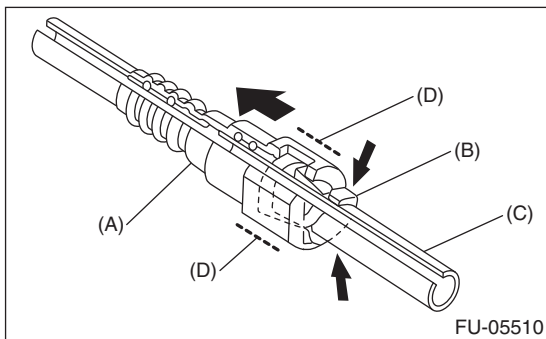

- (A) Quick connector
- (B) Retainer
- (C) Pipe
- (D) Location that grips connector

- (2) Cover the pipe and quick connector with a plastic bag, and make sure that it is not damaged and foreign matter does not enter.

### CAUTION:

When using the retainer for the second time, do not remove the retainer from the pipe.

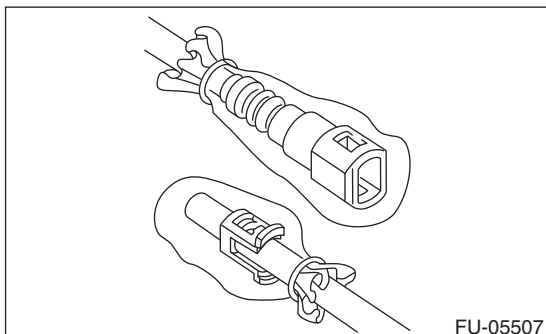

## B: INSTALLATION

Be careful of the following points and perform in the opposite order of removal.

### 1. CONNECTION OF THE FUEL LINE QUICK CONNECTOR

#### CAUTION:

- Make sure that there is no damage to or dust on the connected part. Clean the surface of the pipe seal if necessary.

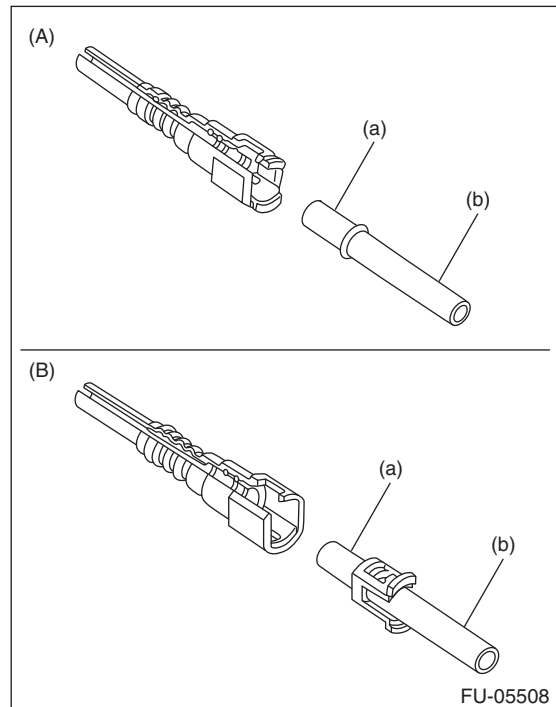

- (A) When removing with a special tool
- (B) When removing without a special tool
- (a) Seal surface
- (b) Pipe

- When using the retainer for the second time, make sure that there is no damage or deformation, and if the retainer has a defect, use a new one.

# FUEL DELIVERY, RETURN AND EVAPORATION LINES

FUEL INJECTION (FUEL SYSTEMS)

1) Connect the quick connector to the pipe.

## CAUTION:

- Make sure that the quick connector is securely connected.

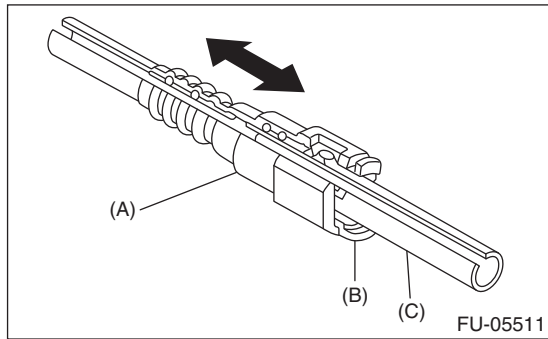

- (A) Quick connector
- (B) Retainer
- (C) Pipe

- Make sure that the 2 retainer poles are engaged to the connecting portion of the quick connector.
- Check that fuel does not overflow on the tube and connecting portion.
- Push in the connector in an axial direction as indicated in the illustration (d).
- When connecting the connector, do not bend or twist the tube to the point of potential damage. If the tube was bent back and forth, replace it with a new part.

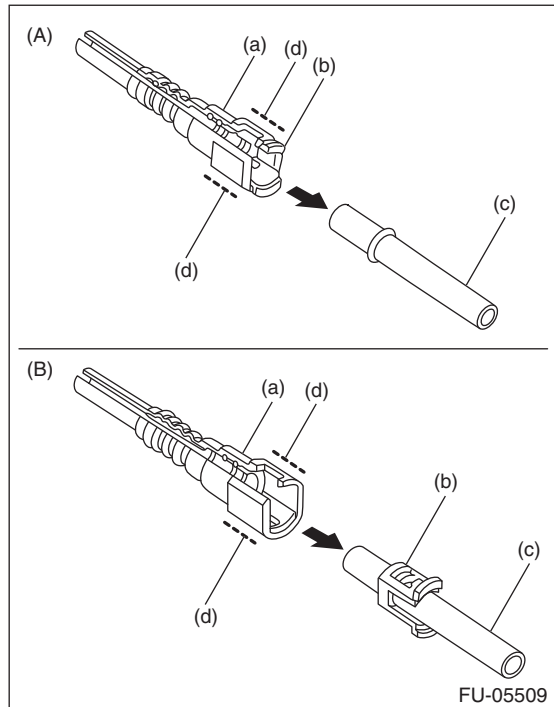

- (A) When removing with a special tool
- (B) When removing without a special tool
- (a) Quick connector
- (b) Retainer
- (c) Pipe
- (d) Location that grips connector

# FUEL DELIVERY, RETURN AND EVAPORATION LINES

## FUEL INJECTION (FUEL SYSTEMS)

### 2. CONNECT THE FUEL DELIVERY HOSE AND FUEL RETURN HOSE

Connect the fuel delivery hose and fuel return hose as shown in the illustration.

#### CAUTION:

- If there is a spool or a connection point, be careful not to over insert the hose and cause the end of it to crease, or perform an improper installation.
- Check that fuel does not overflow on the tube and connecting portion.

#### Tightening torque:

**1.25 N·m (0.1 kgf·m, 0.9 ft·lb)**

**L1: 2.5±1.5 mm (0.098±0.059 in)**

**L2: 22.5±2.5 mm (0.886±0.098 in)**

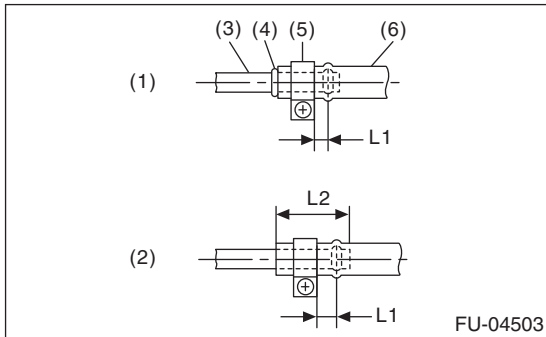

- (1) When there is a spool or connection point
- (2) When there is no spool or connection point
- (3) Pipe
- (4) Spool and connection point
- (5) Clamp
- (6) Hose

### 3. CONNECTING THE EVAPORATION HOSE

Insert the evaporation hose 15 to 20 mm (0.59 to 0.79 in) into the pipe and connect.

**L1: 17.5±2.5 mm (0.689±0.098 in)**

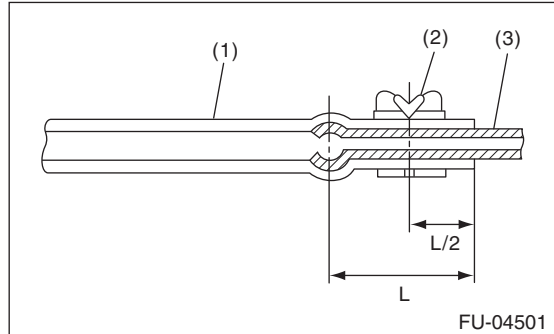

- (A) Hose
- (B) Clip
- (C) Pipe

### C: INSPECTION

- 1) Check that the fuel pipe is not deformed, has no cracks or other damage.
- 2) Check that the hose and tube do not have any cracks or damage, and check that they are not loose.

# FUEL SYSTEM TROUBLE IN GENERAL

FUEL INJECTION (FUEL SYSTEMS)

## 29. Fuel System Trouble in General

### A: INSPECTION

Trouble and possible cause		Corrective action
<b>1. Insufficient fuel supply to the injector</b>		
1)	Fuel pump will not operate.	
	○ Defective terminal contact.	Inspect connections, especially ground, and tighten securely.
	○ Trouble in electromagnetic or electronic circuit parts.	Replace fuel pump.
2)	Lowering of fuel pump function.	Replace fuel pump.
3)	Clogged dust or water in the fuel filter.	Replace fuel filter, clean or replace fuel tank.
4)	Clogged or bent fuel pipe or hose.	Clean, correct or replace fuel pipe or hose.
5)	Air is mixed in the fuel system.	Inspect or retighten each connection part.
6)	Clogged or bent breather tube or pipe.	Clean, correct or replace air breather tube or pipe.
7)	Damaged diaphragm of pressure regulator.	Replace.
<b>2. Leakage or blow out fuel</b>		
1)	Loosened joints of the fuel pipe.	Retightening.
2)	Cracked fuel pipe, hose and fuel tank.	Replace.
3)	Defective welding part on the fuel tank.	Replace.
4)	Defective drain packing of the fuel tank.	Replace.
5)	Clogged or bent air breather tube or air vent tube.	Clean, correct or replace air breather tube or air vent tube.
<b>3. Gasoline smell inside of compartment</b>		
1)	Loose joints at air breather tube, air vent tube and fuel filler pipe.	Retightening.
2)	Defective packing air tightness on the fuel saucer.	Correct or replace packing.
3)	Cracked fuel separator.	Replace separator.
4)	Inoperative fuel pump modulator or circuit.	Replace.
<b>4. Defective fuel level indicator</b>		
1)	Defective operation of fuel level sensor.	Replace.
<b>5. Noise</b>		
1)	Large operation noise or vibration of fuel pump.	Replace.

#### NOTE:

- When the vehicle is left unattended for an extended period of time, water may accumulate in the fuel tank. To prevent water condensation.

- Top off the fuel tank or drain the fuel completely.

- Drain water condensation from the fuel filter.

- Refilling the fuel tank.

Refill the fuel tank while there is still some fuel left in the tank.

- Protecting the fuel system against freezing and water condensation.

- Cold areas

In snow-covered areas, mountainous areas, skiing areas, etc. where ambient temperatures drop below 0°C (32°F) throughout the winter season, use an anti-freeze solution in the fuel tank. Refueling will also complement the effect of anti-freeze solution each time the fuel level drops to about one-half. After the winter season, drain water which may have accumulated in the fuel filter and fuel tank in the manner same as that described under damaged areas below.

- Damaged areas

If water accumulated in the fuel filter, drain water from both the fuel filter and fuel tank or use a water removing agent (or anti-freeze solution) in the fuel tank.

- Observe the instructions, notes, etc., indicated on the label affixed to the anti-freeze solution (water removing agent) container before use.

# FUEL SYSTEM TROUBLE IN GENERAL

FUEL INJECTION (FUEL SYSTEMS)

---

**MEMO:**