

IGNITION

IG(H4SO)

	Page
1. General Description	2
2. Spark Plug.....	4
3. Ignition Coil and Ignitor Assembly.....	7
4. Spark Plug Cord.....	8



GENERAL DESCRIPTION

IGNITION

1. General Description

A: SPECIFICATIONS

Item		Designation
Ignition coil and ignitor assembly	Model	FH0137
	Manufacturer	DEMCO
	Secondary coil resistance	12.8 k Ω ±15%
Spark plug	Type and manufacturer	RC10YC4 CHAMPION
	Alternate	BKR5E-11 NGK
	Thread size mm	14, P = 1.25
	Spark gap mm (in)	1.0 — 1.1 (0.039 — 0.043)

B: COMPONENT

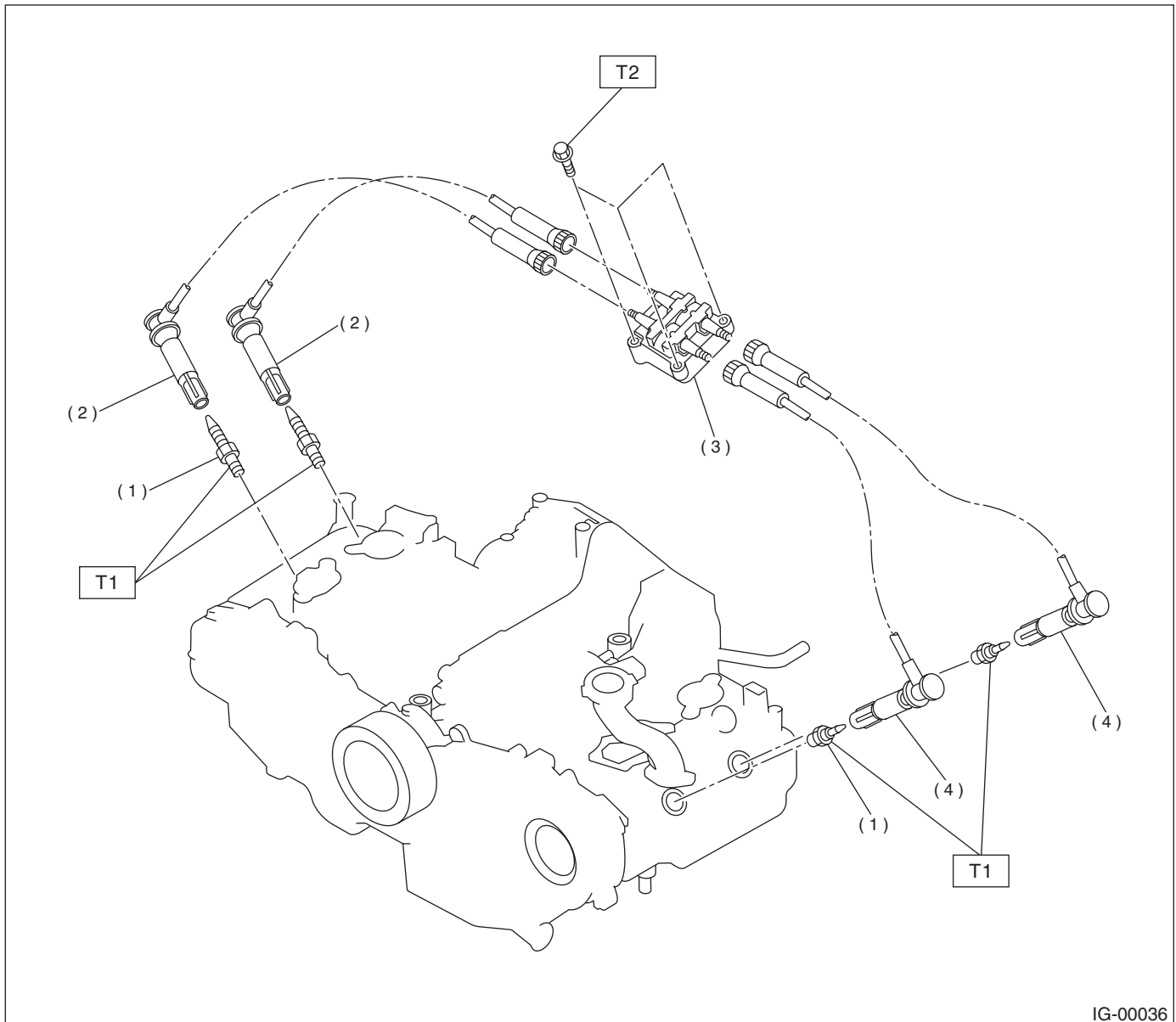

IG-00036

- (1) Spark plug
- (2) Spark plug cord (#1, #3)
- (3) Ignition coil and ignitor ASSY
- (4) Spark plug cord (#2, #4)

Tightening torque: N·m (kgf·m, ft·lb)

T1: 21 (2.1, 15)

T2: 8 (0.8, 5.8)

C: CAUTION

- Wear working clothing, including a cap, protective goggles, and protective shoes during operation.
- Remove contamination including dirt and corrosion before removal, installation or disassembly.
- Keep the disassembled parts in order and protect them from dust or dirt.
- Before removal, installation or disassembly, be sure to clarify the failure. Avoid unnecessary removal, installation, disassembly, and replacement.

- Be careful not to burn your hands, because each part on the vehicle is hot after running.
- Be sure to tighten fasteners including bolts and nuts to the specified torque.
- Place shop jacks or safety stands at the specified points.
- Before disconnecting electrical connectors of sensors or units, be sure to disconnect ground cable from battery.

SPARK PLUG

IGNITION

2. Spark Plug

A: REMOVAL

CAUTION:

All spark plugs installed on an engine, must be of the same heat range.

Spark plug:

Spark plug	
CHAMPION : RC10YC4	
Alternate	NGK : BKR5E-11

1. RH SIDE

1) Disconnect ground cable from battery.

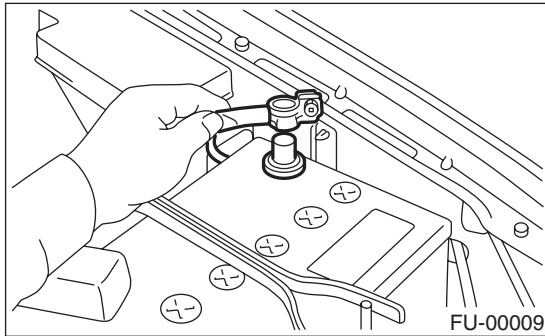

2) Remove spark plug cords by pulling boot, not cord itself.

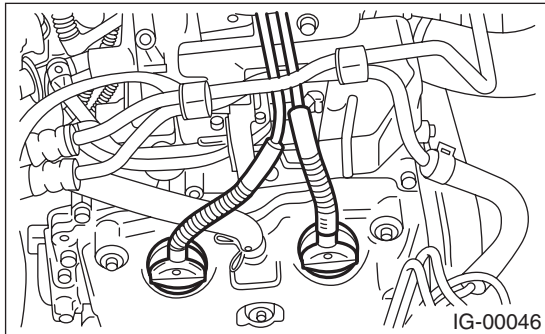

3) Remove spark plugs with the spark plug socket.

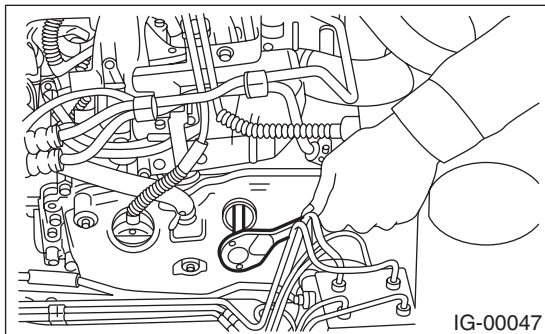

2. LH SIDE

1) Disconnect battery ground cable.

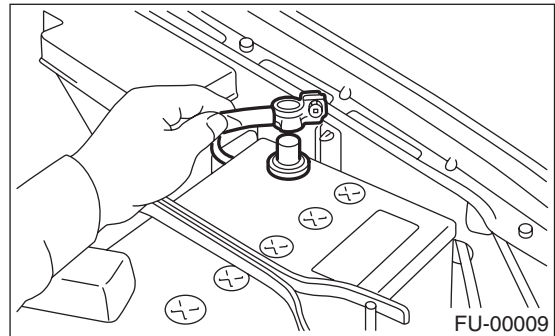

2) Disconnect washer motor connector.

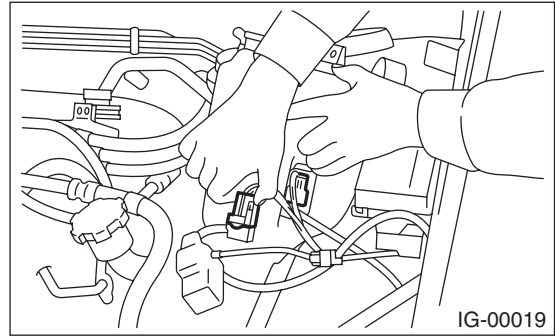

3) Disconnect rear window glass washer hose from washer motor, then plug connection with a suitable cap.

4) Remove the two bolts which hold the washer tank, then take the tank away from the working area.

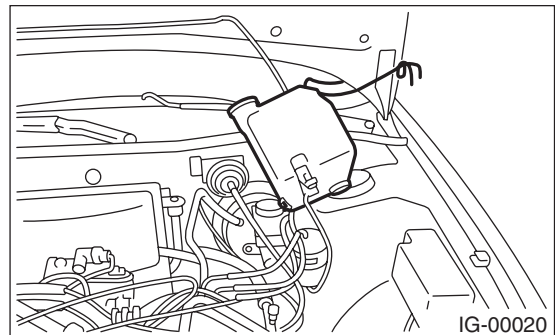

5) Remove spark plugs cord by pulling boot, not cord itself.

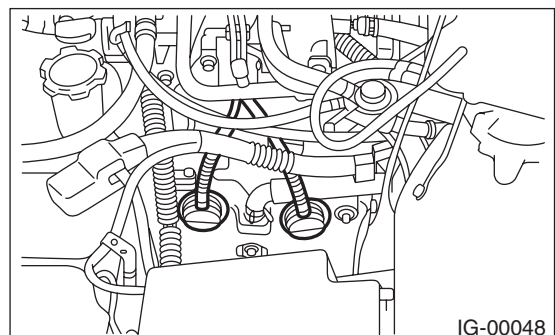

6) Remove spark plug with the spark plugs socket.

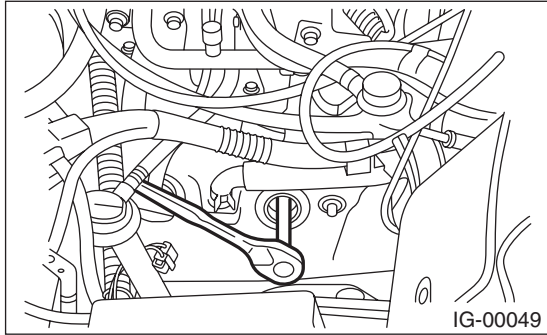

B: INSTALLATION

1. RH SIDE

1) Install in the reverse order of removal.

Tightening torque (Spark plug):
21 N·m (2.1 kgf-m, 15 ft-lb)

CAUTION:

The above torque should be only applied to new spark plugs without oil on their threads. In case their threads are lubricated, the torque should be reduced by approximately 1/3 of the specified torque in order to avoid over-stressing.

Tightening torque (Air cleaner case):
33 N·m (3.4 kgf-m, 24.6 ft-lb)

2. LH SIDE

1) Install in the reverse order of removal.

Tightening torque (Spark plug):
21 N·m (2.1 kgf-m, 15 ft-lb)

CAUTION:

The above torque should be only applied to new spark plugs without oil on their threads. In case their threads are lubricated, the torque should be reduced by approximately 1/3 of the specified torque in order to avoid over-stressing.

C: INSPECTION

Check electrodes and inner and outer porcelain of plugs, noting the type of deposits and the degree of electrode erosion.

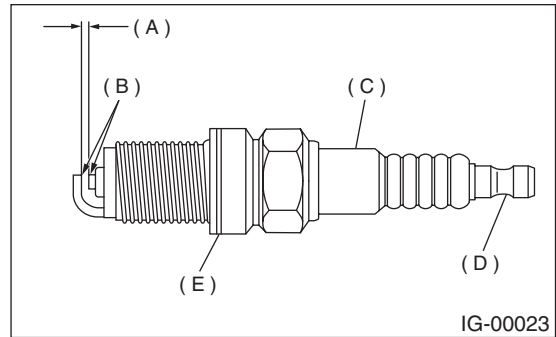

- (A) Spark plug gap
- (B) Carbon accumulation or wear
- (C) Cracks
- (D) Damage
- (E) Damaged gasket

1) Normal:

Brown to grayish-tan deposits and slight electrode wear indicate correct spark plug heat range.

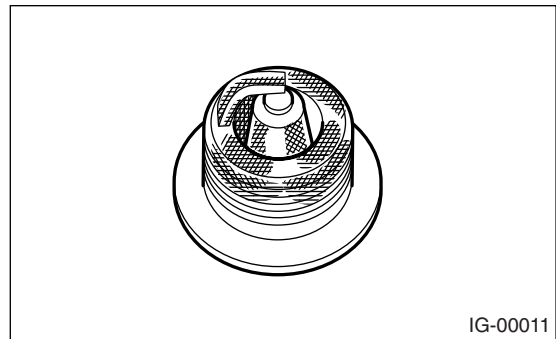

2) Carbon fouled:

Dry fluffy carbon deposits on insulator and electrode are mostly caused by slow speed driving in city, weak ignition, too rich fuel mixture, dirty air cleaner, etc.

It is advisable to replace with plugs having hotter heat range.

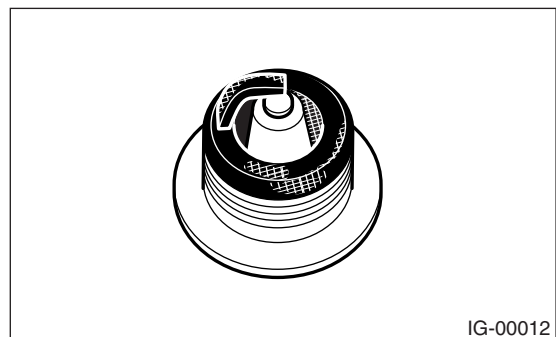

SPARK PLUG

IGNITION

3) Oil fouled:

Wet black deposits show excessive oil entrance into combustion chamber through worn rings and pistons or excessive clearance between valve guides and stems.

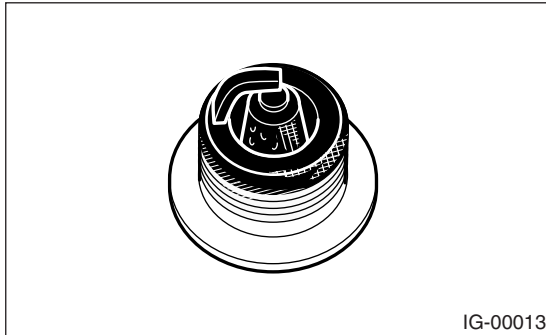

4) Overheating:

White or light gray insulator with black or gray brown spots and bluish burnt electrodes indicate engine overheating. Moreover, the appearance results from incorrect ignition timing, loose spark plugs, wrong selection of fuel, hotter range plug, etc. It is advisable to replace with plugs having colder heat range.

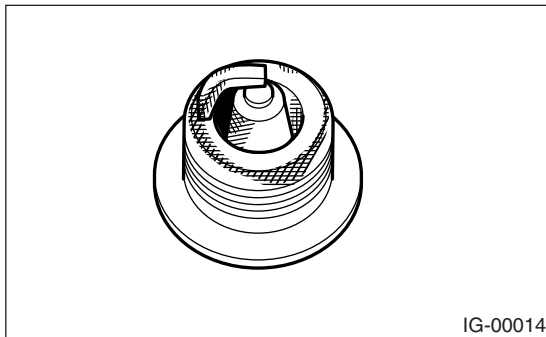

D: CLEANING

Clean spark plugs in a sand blast type cleaner. Avoid excessive blasting. Clean and remove carbon or oxide deposits, but do not wear away porcelain.

If deposits are too stubborn, replace plugs.

E: ADJUSTMENT

Correct it if the spark plug gap is measured with a gap gauge, and it is necessary.

Spark plug gap: L

1.0 — 1.1 mm (0.039 — 0.043 in)

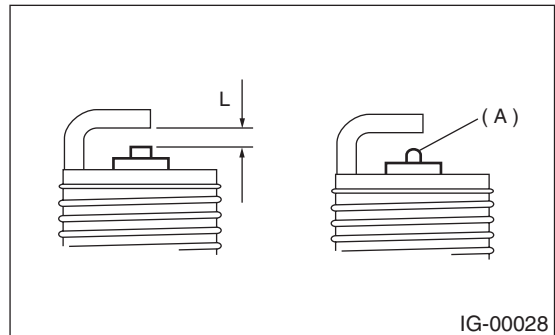

NOTE:

Replace with new spark plug if this area is worn to "ball" (A) shape.

3. Ignition Coil and Ignitor Assembly

A: REMOVAL

- 1) Disconnect ground cable from battery.

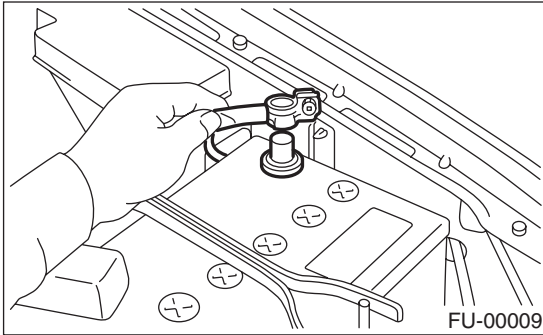

- 2) Disconnect spark plug cords from ignition coil and ignitor assembly.
- 3) Disconnect connector from ignition coil and ignitor assembly.

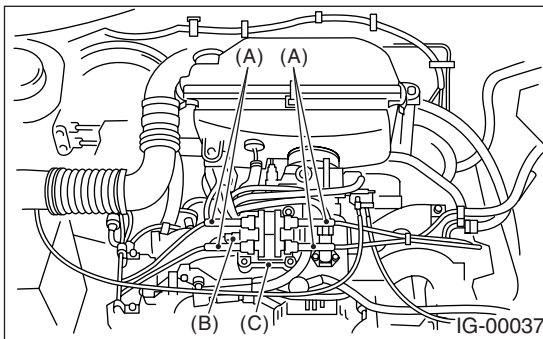

- (A) Spark plug cord
- (B) Connector
- (C) Ignition coil and ignitor ASSY

- 4) Remove ignition coil and ignitor assembly.

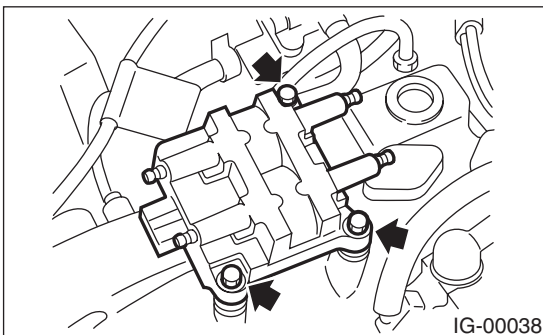

B: INSTALLATION

- 1) Install in the reverse order of removal.

Tightening torque:

8 N·m (0.8 kgf-m, 5.8 ft-lb)

CAUTION:

Be sure to connect spark plug cords to their proper positions. Failure to do so will damage unit.

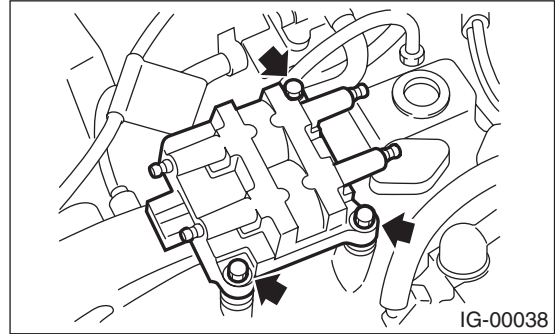

C: INSPECTION

Using tester, inspect the following items, and replace if defective.

- Secondary coil resistance

CAUTION:

- If the resistance is extremely low, there is a short circuit.
- Ignitor is built-in the coil. Therefore, the resistance of the primary coil cannot be measured.

Specified resistance:

[Secondary side]

Between (A) and (B)

12.8 kΩ±15%

Between (C) and (D)

12.8 kΩ±15%

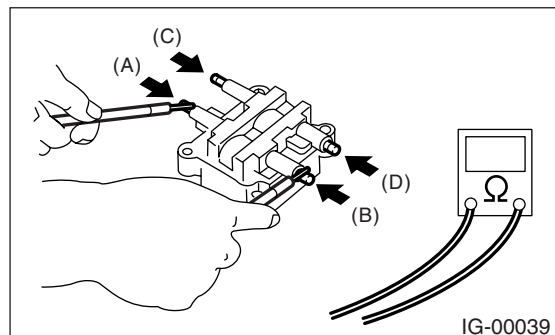

4. Spark Plug Cord

A: INSPECTION

Check for:

- 1) Damage to cords, deformation, burning or rust formation of terminals
- 2) Resistance values of cords

Resistance value:

#1 cord: 5.6 — 10.6 k Ω

#2 cord: 7.3 — 13.7 k Ω

#3 cord: 5.9 — 11.1 k Ω

#4 cord: 7.3 — 13.7 k Ω

