

General Description

HVAC SYSTEM (HEATER, VENTILATOR AND A/C)

1. General Description

A: SPECIFICATION

1. HEATER SYSTEM

Item		Specifications	Condition
Heating capacity		5.0 kW (4,300 kcal/h, 17,062 BTU/h) or more	<ul style="list-style-type: none"> Mode selector switch: HEAT Temperature control switch: FULL HOT Temperature difference between hot water and inlet air: 65°C (149°F) Hot water flow rate: 360 ℓ (95.1 US gal, 79.2 Imp gal)/h
Air flow rate		280 m ³ (9,888 cu ft)/h	Heat mode (FRESH), FULL HOT at 12.5 V
Max air flow rate		480 m ³ (16,951 cu ft)/h	<ul style="list-style-type: none"> Temperature control switch: FULL COLD Blower fan speed: 4th position Mode selector lever: Recirculation
Heater core size (height × length × width)		134.1 × 224.3 × 32 mm (5.28 × 8.83 × 1.26 in)	—
Blower motor	Type	Auto A/C (Brushless motor) 230 W or less	12.5 V
		Manual A/C (Cylinder motor) 260 W or less	12.5 V
	Fan type and size (diameter × width)	Sirocco fan type 150 × 75 mm (5.91 × 2.95 in)	—

2. A/C SYSTEM

- Auto A/C model

Item		Specifications
Type of air conditioner		Reheat air-mix type
Cooling capacity		5.0 kW (4,300 kcal/h, 17,064 BTU/h)
Refrigerant		HFC-134a (CH ₂ FCF ₃) [600±50 g (1.32±0.11 lb)]
Compressor	Type	Vane rotary, fix volume (DKV-14G)
	Discharge	140 cm ³ (8.54 cu in)/rev
	Max. permissible speed	7,000 rpm
Magnet clutch	Type	Dry, single-disc type
	Power consumption	38 W (DC12 V-25°C)
	Type of belt	V-belt 4 PK
	Pulley dia. (effective dia.)	125 mm (4.92 in)
	Pulley ratio	1.064
Condenser	Type	Corrugated fin (Sub cool type)
	Core face area	0.247 m ² (2.69 sq ft)
	Core thickness	16 mm (0.63 in)
	Radiation area	5.9 m ² (63.51 sq ft)
Receiver drier	Effective inner capacity	220 cm ³ (13.42 cu in)
Expansion valve	Type	External average pressure equation
Evaporator	Type	Single tank
	Dimension (height × length × width)	176.5 × 266 × 60 mm (6.95 × 10.47 × 2.36 in)
Blower fan	Fan type	Sirocco fan
	Outer diameter × width	150 × 75 mm (5.91 × 2.95 in)
	Power consumption	230 W or less at 12.5 V

General Description

HVAC SYSTEM (HEATER, VENTILATOR AND A/C)

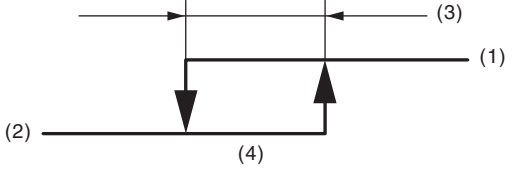
Item		Specifications	
Condenser fan (Sub fan)	Motor type	Magnet	
	Power consumption	120 W at 12 V	
	Fan outer diameter	320 mm (12.6 in)	
Radiator fan (Main fan)	Motor type	Magnet	
	Power consumption	120 W at 12 V	
	Fan outer diameter	320 mm (12.6 in)	
Idling speed (A/C ON)		800±100 rpm	
Triple switch (Pressure switch)	Low-pressure switch working pressure	ON → OFF	177±25 kPa (1.80±0.25 kg/cm ² , 25.60±3.56 psi)
		OFF → ON	206±30 kPa (2.10±0.31 kg/cm ² , 29.86±4.41 psi)
	High-pressure switch working pressure	ON → OFF	2,940±200 kPa (29.98±2.03 kg/cm ² , 426.32±28.87 psi)
		Difference	590±200 kPa (6.02±2.03 kg/cm ² , 85.6±28.87 psi)
	Middle-pressure switch operating pressure	ON → OFF	1,370±120 kPa (13.97±1.22 kg/cm ² , 198.65±17.35 psi)
		OFF → ON	1,770±100 kPa (18.05±1.02 kg/cm ² , 256.81±14.50 psi)
Thermo-control amplifier working temperature (Evaporator outlet air)		 <p style="text-align: right;">AC-00601</p>	
		(1) ON (2) OFF (3) 1.5±0.3°C (37±0.4°F) (4) 1.0±0.5°C (35±0.9°F)	

- Manual A/C model

Item		Specifications	
Type of air conditioner		Reheat air-mix type	
Cooling capacity		5.0 kW (4,300 kcal/h, 17,064 BTU/h)	
Refrigerant		HFC-134a (CH ₂ FCF ₃) [600±50 g (1.32±0.11 lb)]	
Compressor	Type	Vane rotary, fix volume (DKV-14G)	
	Discharge	140 cm ³ (8.54 cu in) per rotation	
	Max. permissible speed	7,000 rpm	
Magnet clutch	Type	Dry, single-disc type	
	Power consumption	38 W (DC12 V-25°C)	
	Type of belt	V-belt 4 PK	
	Pulley dia. (effective dia.)	125 mm (4.92 in)	
	Pulley ratio	1.064	
Condenser	Type	Corrugated fin (Sub cool type)	
	Core face area	0.247 m ² (2.69 sq ft)	
	Core thickness	16 mm (0.63 in)	
	Radiation area	5.9 m ² (63.51 sq ft)	

General Description

HVAC SYSTEM (HEATER, VENTILATOR AND A/C)

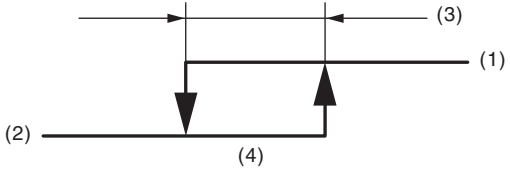
Item		Specifications	
Receiver drier		Effective inner capacity	220 cm ³ (13.42 cu in)
Expansion valve		Type	External average pressure equation
Evaporator		Type	Single tank
		Dimensions (W × H × T)	176.5 × 266 × 60 mm (6.95 × 10.47 × 2.36 in)
Blower fan		Fan type	Sirocco fan
		Outer diameter × width	150 × 75 mm (5.91 × 2.95 in)
		Power consumption	260 W or less at 12.5 V
Condenser fan (Sub fan)		Motor type	Magnet
		Power consumption	120 W at 12 V
		Fan outer diameter	320 mm (12.6 in)
Radiator fan (Main fan)		Motor type	Magnet
		Power consumption	120 W at 12 V
		Fan outer diameter	320 mm (12.6 in)
Idling speed (A/C ON)		MPFI model	800±100 rpm
Triple switch (Pressure switch)	Low-pressure switch working pressure	ON → OFF	177±25 kPa (1.80±0.25 kg/cm ² , 25.60±3.56 psi)
		OFF → ON	206±30 kPa (2.10±0.31 kg/cm ² , 29.86±4.41 psi)
	High-pressure switch working pressure	ON → OFF	2,940±200 kPa (29.98±2.03 kg/cm ² , 426.32±28.87 psi)
		Difference	590±200 kPa (6.02±2.03 kg/cm ² , 85.6±28.87 psi)
	Middle-pressure switch operating pressure	ON → OFF	1,370±120 kPa (13.97±1.22 kg/cm ² , 198.65±17.35 psi)
		OFF → ON	1,770±100 kPa (18.05±1.02 kg/cm ² , 256.81±14.50 psi)
Thermo control amplifier working temperature (Evaporator outlet air)		 <p style="text-align: right;">AC-00601</p>	
		(1) ON (2) OFF (3) 1.5±0.3°C (37±0.4°F) (4) 1.0±0.5°C (35±0.9°F)	

General Description

HVAC SYSTEM (HEATER, VENTILATOR AND A/C)

B: COMPONENT

1. HEATER COOLING UNIT

- Auto A/C model

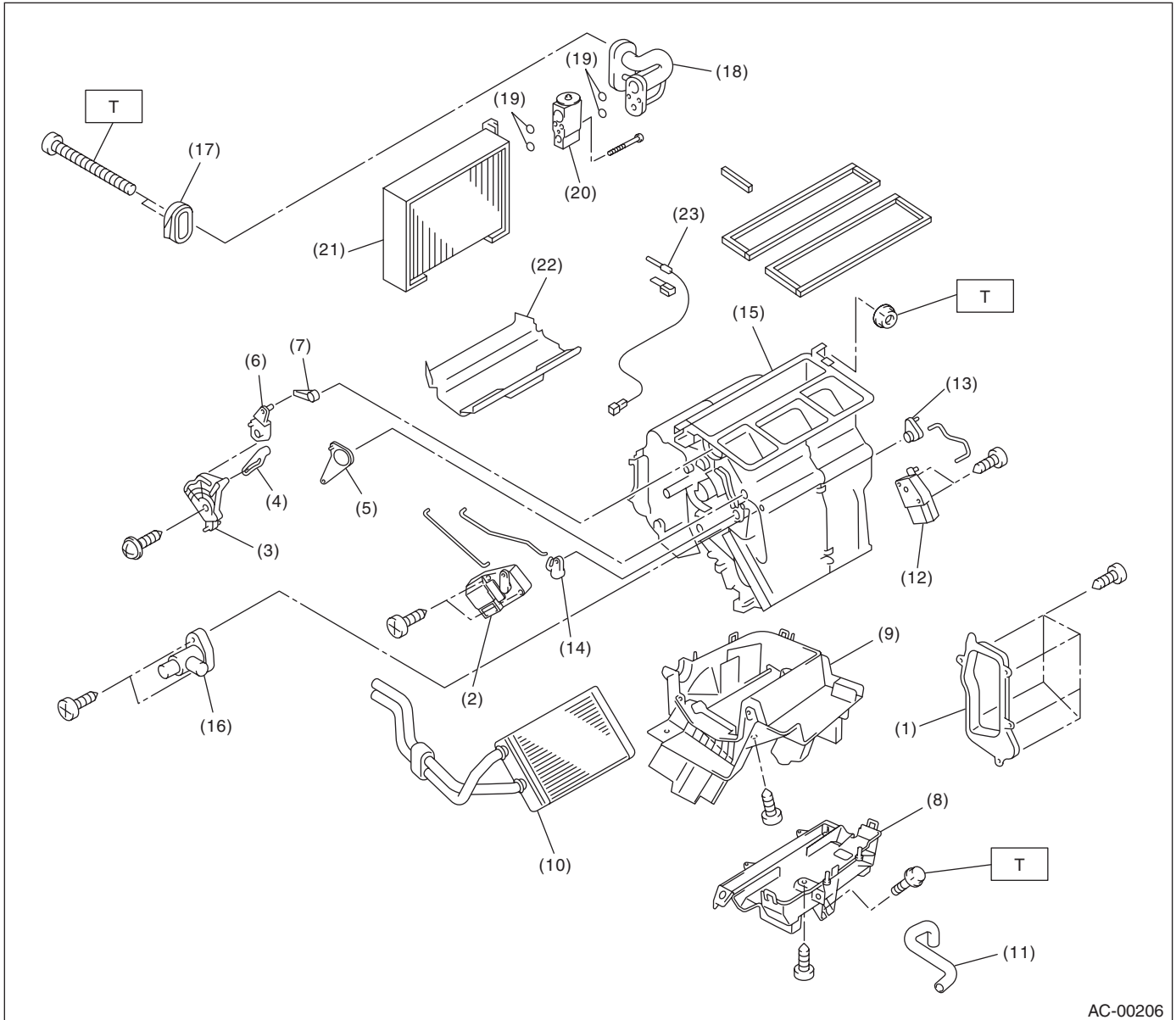

AC-00206

- | | | |
|------------------------|--------------------------|------------------------|
| (1) Evaporator cover | (10) Heater core | (19) O-ring |
| (2) Mode actuator | (11) Drain hose | (20) Expansion valve |
| (3) Mode main lever | (12) Mix actuator | (21) Evaporator |
| (4) Vent door lever | (13) Mix door lever | (22) Evaporator lining |
| (5) Foot door lever | (14) Foot door lever (B) | (23) Evaporator sensor |
| (6) Mode actuator link | (15) Upper case | |
| (7) Defroster lever | (16) Aspirator | |
| (8) Foot duct | (17) Packing | |
| (9) Lower case | (18) Cooling unit pipe | |

Tightening torque: N·m (kgf·m, ft·lb)

T: 7.5 (0.76, 5.5)

General Description

HVAC SYSTEM (HEATER, VENTILATOR AND A/C)

- Manual A/C model

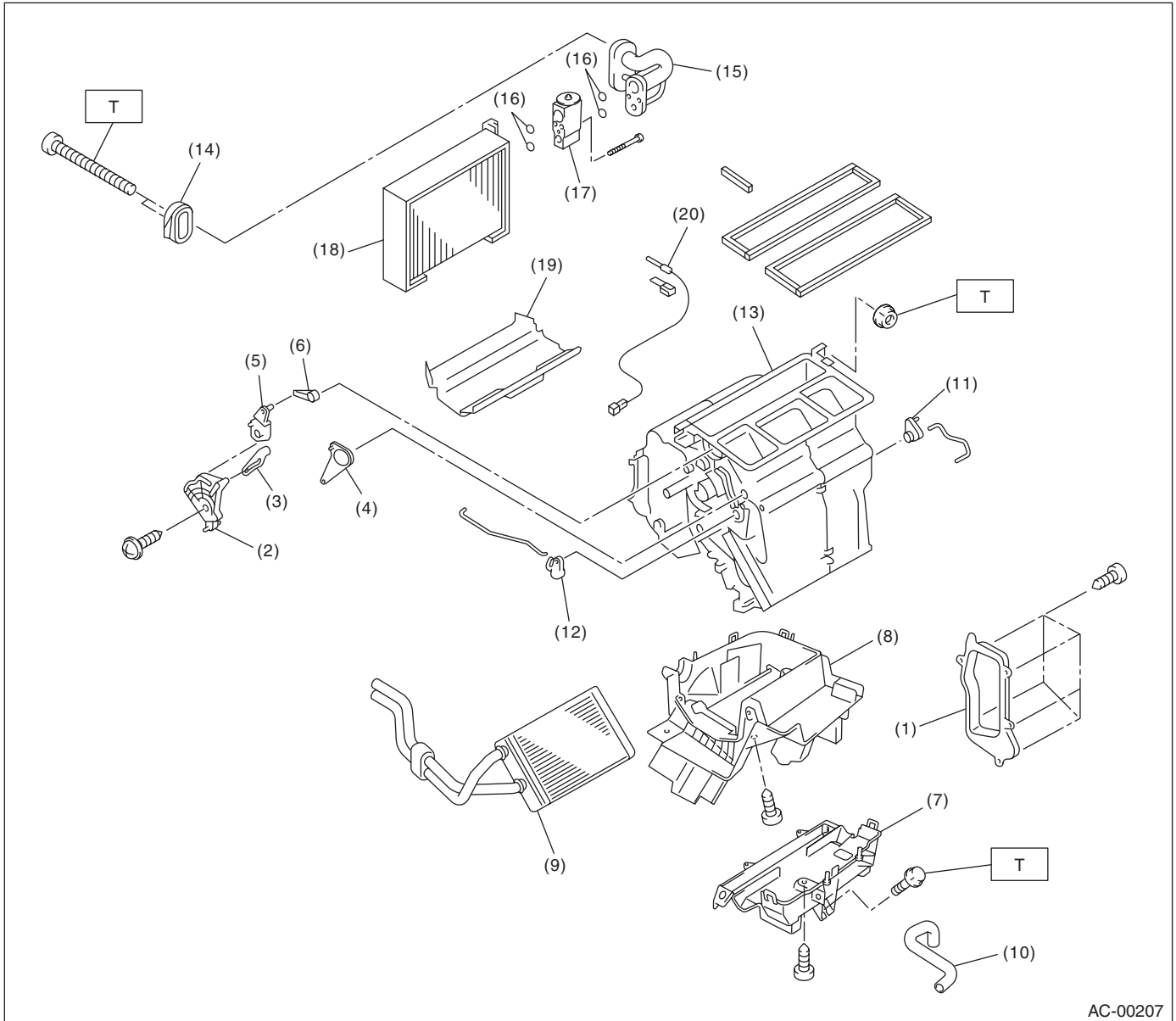

AC-00207

- | | | |
|------------------------|-------------------------|------------------------|
| (1) Evaporator cover | (9) Heater core | (17) Expansion valve |
| (2) Mode main lever | (10) Drain hose | (18) Evaporator |
| (3) Vent door lever | (11) Mix actuator lever | (19) Evaporator lining |
| (4) Foot door lever | (12) Foot door lever | (20) Evaporator sensor |
| (5) Mode actuator link | (13) Upper case | |
| (6) Defroster lever | (14) Packing | |
| (7) Foot duct | (15) Cooling unit pipe | |
| (8) Lower case | (16) O-ring | |

Tightening torque: N·m (kgf·m, ft·lb)

T: 7.5 (0.76, 5.5)

General Description

HVAC SYSTEM (HEATER, VENTILATOR AND A/C)

2. BLOWER MOTOR UNIT

- Auto A/C model

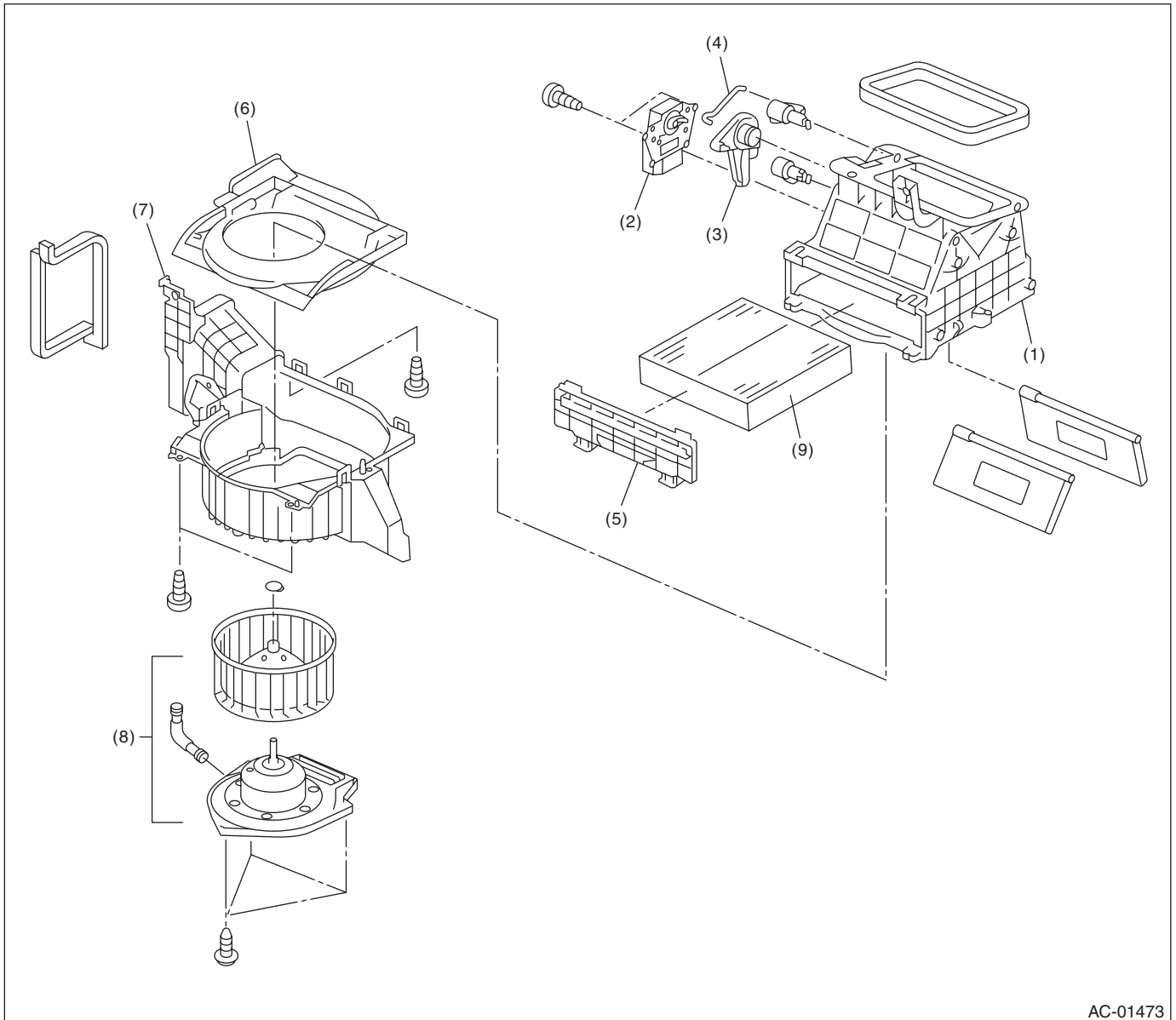

AC-01473

- | | | |
|--------------------------|------------------|----------------------------|
| (1) Upper case | (4) Link lever | (7) Lower case |
| (2) Intake door actuator | (5) Filter cover | (8) Blower motor ASSY |
| (3) FRESH/RECIRC link | (6) Cover | (9) Air conditioner filter |

General Description

HVAC SYSTEM (HEATER, VENTILATOR AND A/C)

- Manual A/C model

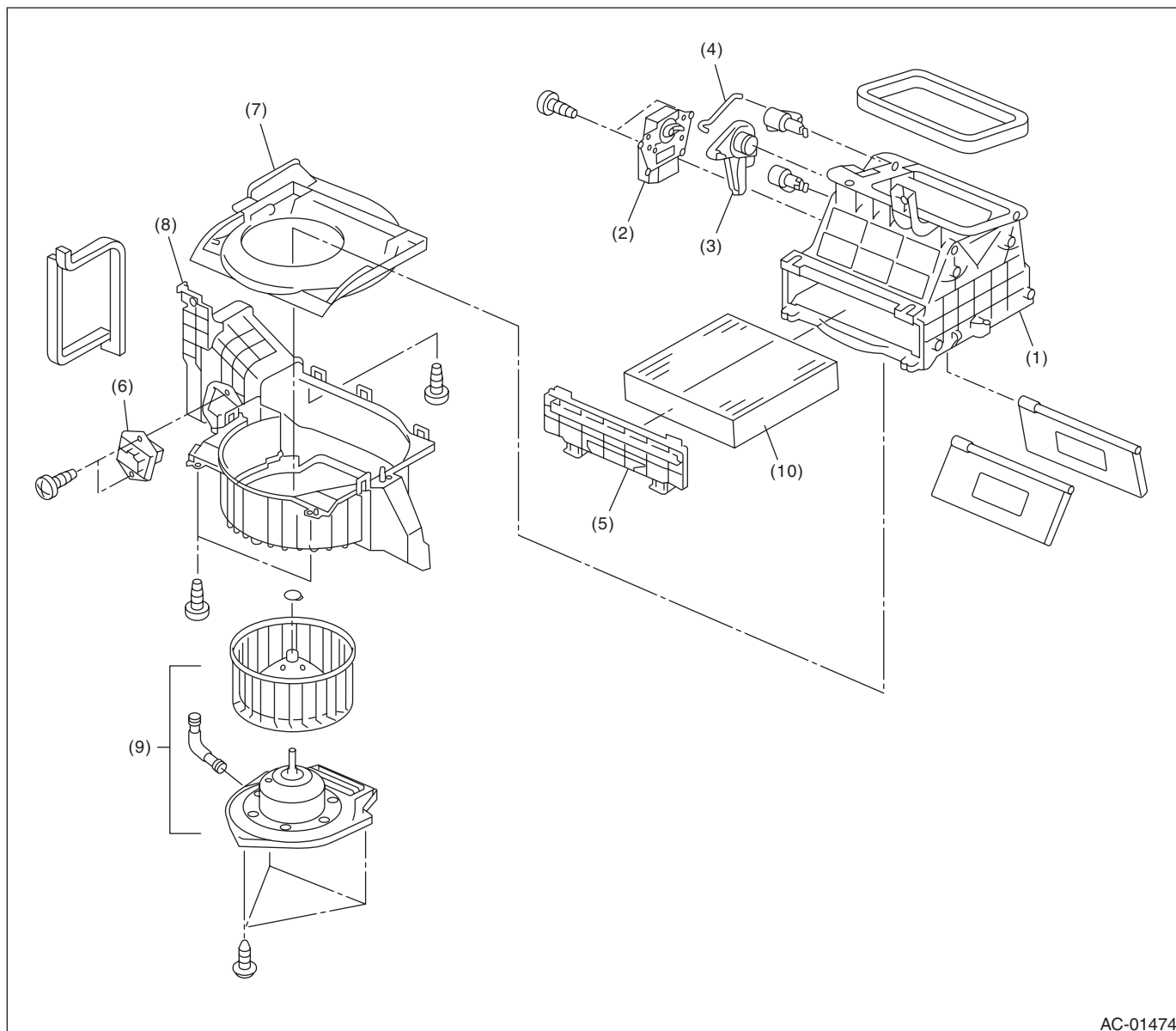

AC-01474

- | | | |
|--------------------------|---------------------|-----------------------------|
| (1) Upper case | (5) Filter cover | (8) Lower case |
| (2) Intake door actuator | (6) Blower resistor | (9) Blower motor ASSY |
| (3) FRESH/RECIRC link | (7) Cover | (10) Air conditioner filter |
| (4) Link rod | | |

General Description

HVAC SYSTEM (HEATER, VENTILATOR AND A/C)

3. CONTROL UNIT

- Auto A/C model

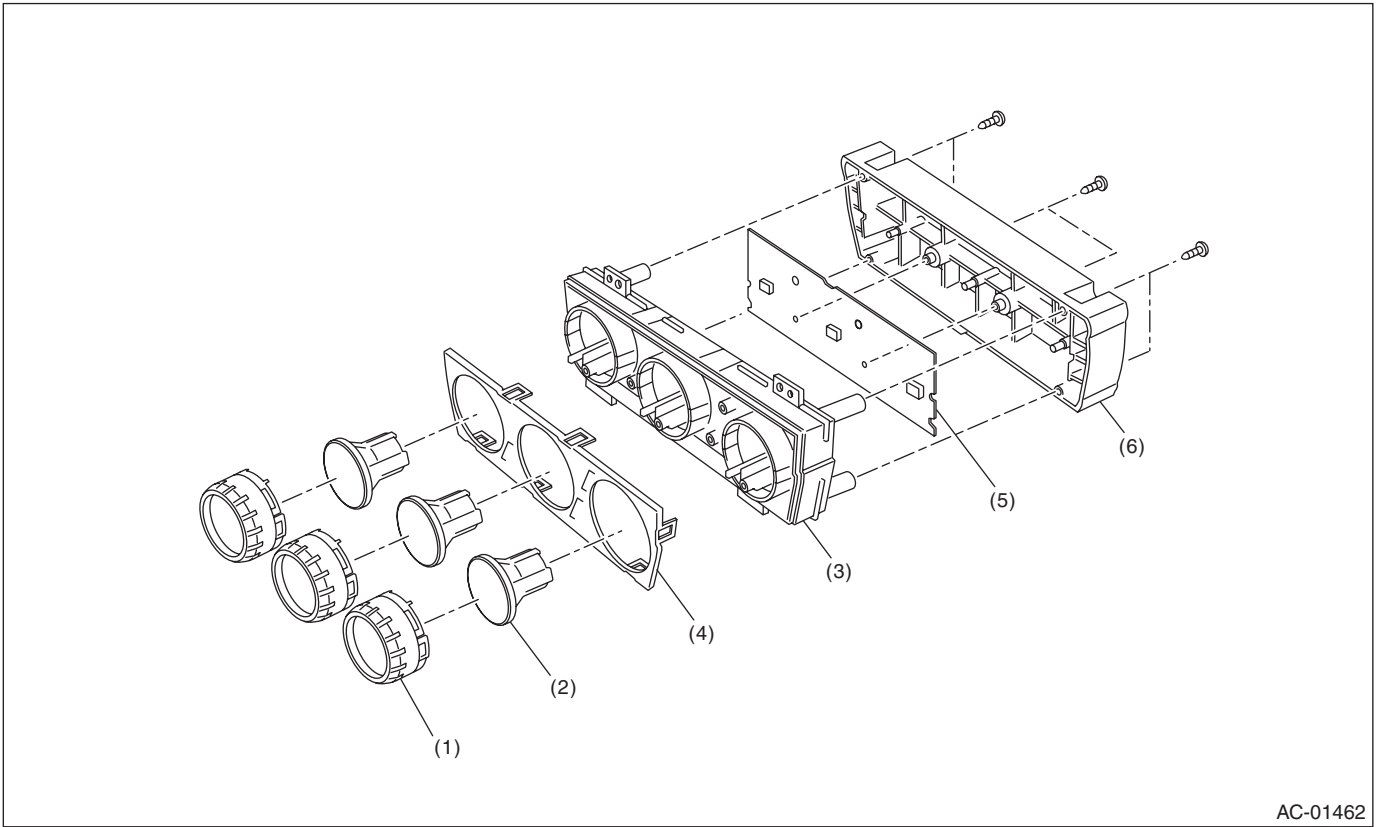

AC-01462

(1) Control dial
(2) Switch

(3) Control case (front)
(4) Front cover

(5) Control unit circuit
(6) Control case (rear)

General Description

HVAC SYSTEM (HEATER, VENTILATOR AND A/C)

- Manual A/C model

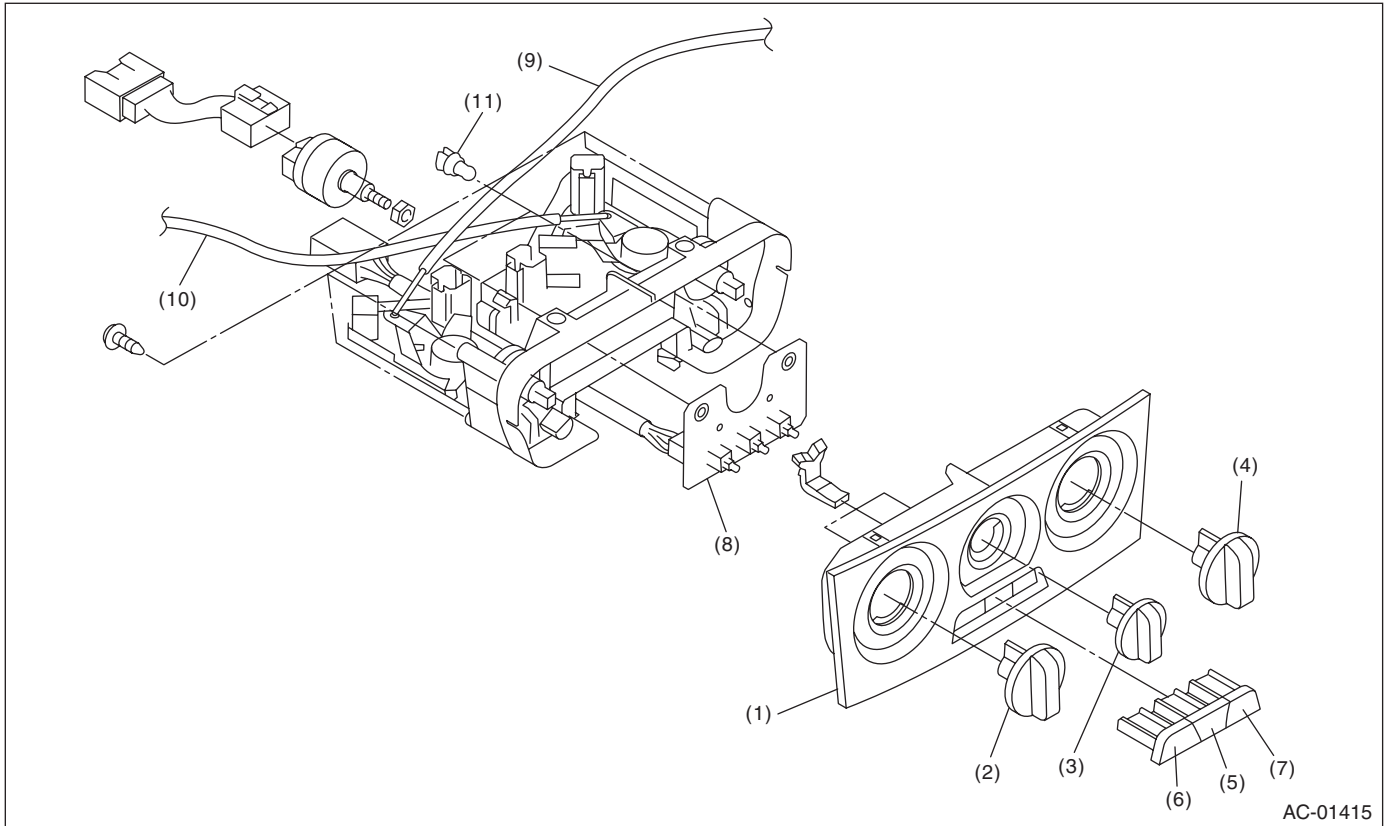

- | | | |
|---------------------------------|--------------------------|-----------------------------------|
| (1) Panel | (5) A/C switch | (9) Mode switch cable |
| (2) Temperature adjustment dial | (6) FRESH/RECIRC switch | (10) Temperature adjustment cable |
| (3) Fan speed control dial | (7) Rear defogger switch | (11) Valve |
| (4) Mode switch dial | (8) Switch board | |

General Description

HVAC SYSTEM (HEATER, VENTILATOR AND A/C)

4. AIR CONDITIONING UNIT

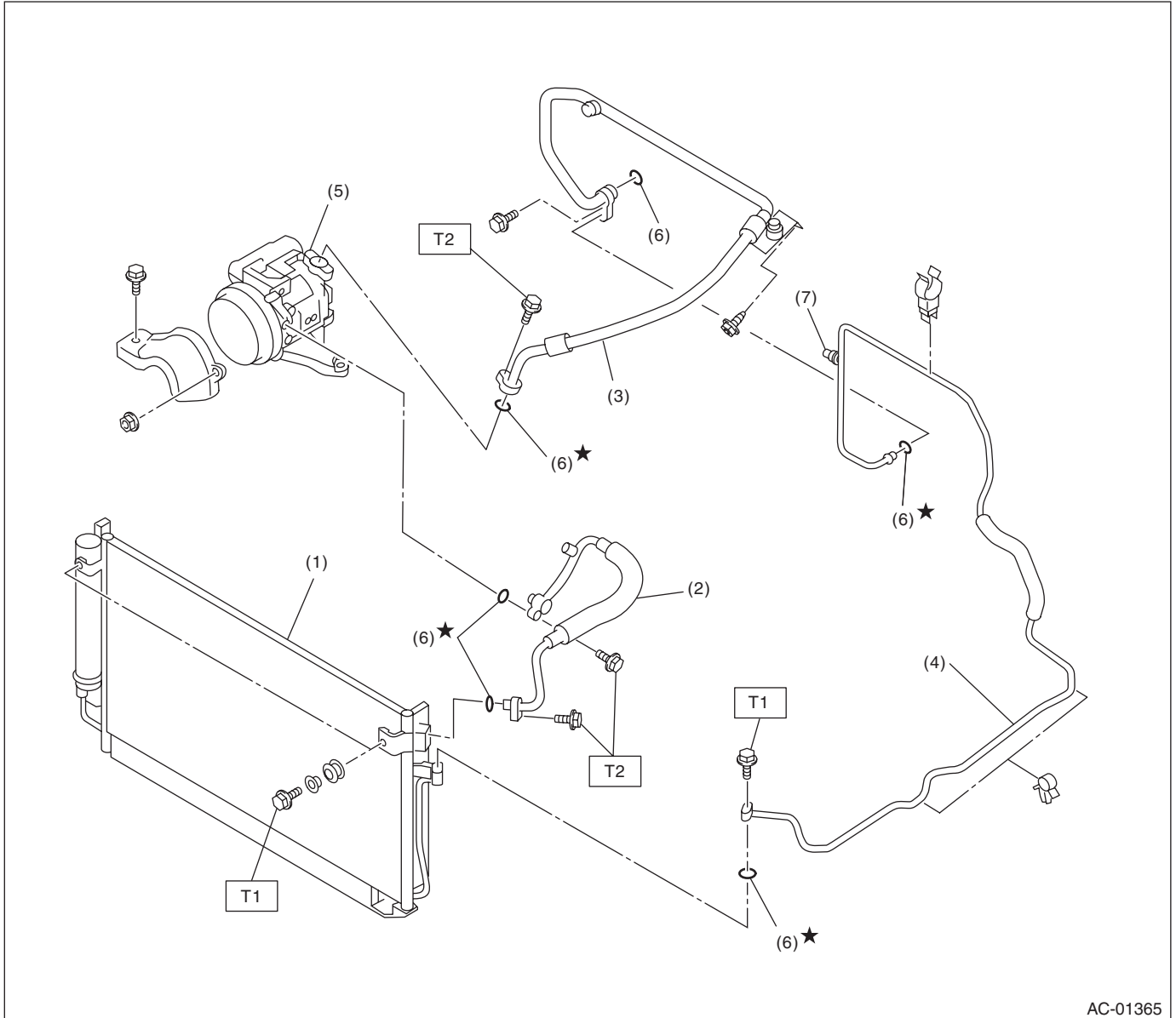

AC-01365

- | | |
|------------------------|----------------------------|
| (1) Condenser | (5) Compressor |
| (2) High-pressure hose | (6) O-ring |
| (3) Low-pressure hose | (7) Triple pressure switch |
| (4) Pipe | |

Tightening torque: N·m (kgf·m, ft·lb)

T1: 7.4 (0.75, 5.4)

T2: 15 (1.5, 10.8)

General Description

HVAC SYSTEM (HEATER, VENTILATOR AND A/C)

5. COMPRESSOR

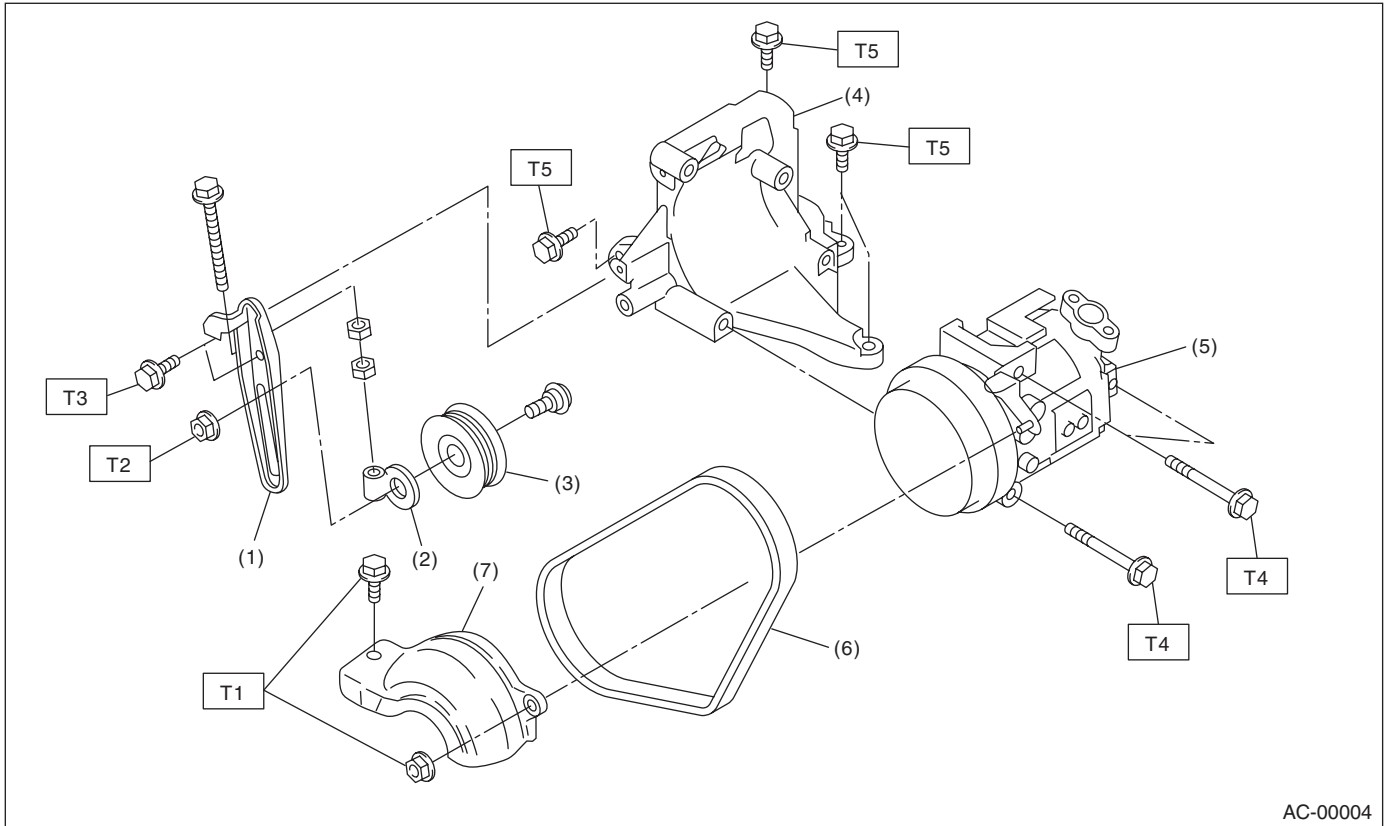

AC-00004

- (1) Idler pulley bracket
- (2) Idler pulley adjuster
- (3) Idler pulley
- (4) Compressor bracket
- (5) Compressor
- (6) V-belt

- (7) Compressor belt cover (Non-turbo model)

Tightening torque: N-m (kgf-m, ft-lb)

T1: 4.0 (0.40, 2.95)

T2: 22.6 (2.3, 16.6)

T3: 23.0 (2.35, 17.0)

T4: 28.9 (2.95, 21.3)

T5: 35 (3.6, 26)

General Description

HVAC SYSTEM (HEATER, VENTILATOR AND A/C)

6. HEATER DUCT

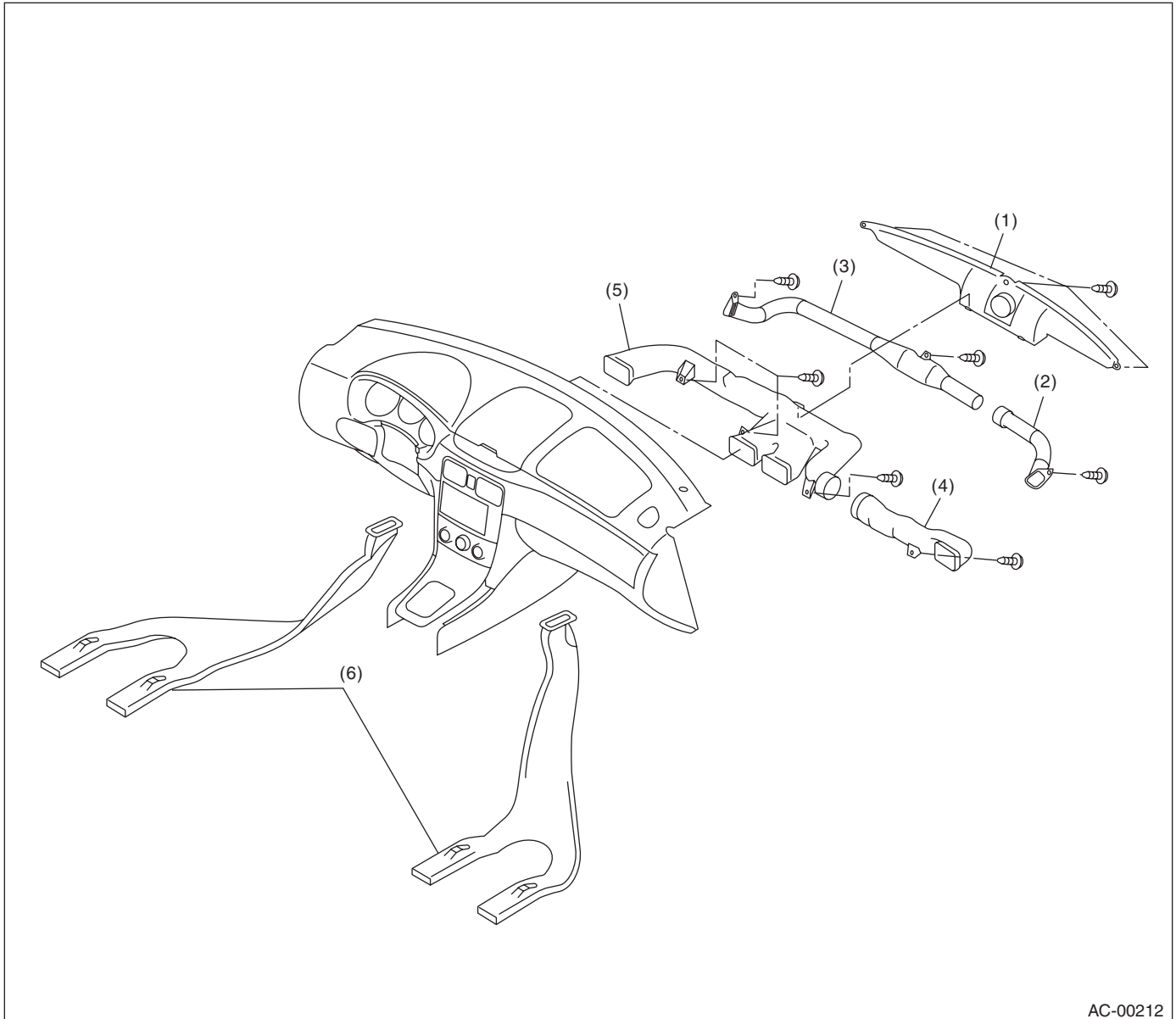

(1) Front defroster nozzle

(2) Side defroster duct (LH)

(3) Side defroster duct (RH)

(4) Side ventilation duct (LH)

(5) Side ventilation duct (RH)

(6) Rear heater duct

C: CAUTION

1. HFC-134A A/C SYSTEM

- The cooling system components for the HFC-134a system such as the refrigerant and compressor oil are different from the conventional CFC-12 system components and they are incompatible with each other.

- Vehicles with the HFC-134a system can be identified by the label (A) attached to the vehicle. Before maintenance, check which A/C system is installed to the vehicle.

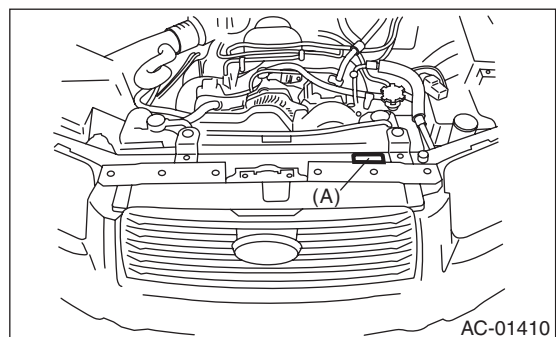

General Description

HVAC SYSTEM (HEATER, VENTILATOR AND A/C)

2. COMPRESSOR OIL

- HFC-134a compressor oil has no compatibility with that for CFC-12 system.
- Use only the manufacturer-authorized compressor oil for the HFC-134a system; only use ZXL200PG.
- Do not mix multiple compressor oils.

If CFC-12 compressor oil is used in the HFC-134a A/C system, the compressor may become stuck due to poor lubrication, or the refrigerant may leak due to swelling of rubber parts.

On the other hand, if HFC-134a compressor oil is used in a CFC-12 A/C system, the durability of the A/C system will be lowered.

- HFC-134a compressor oil is very hygroscopic. When replacing or installing/removing A/C parts, immediately isolate the oil from atmosphere using a plug or tape. In order to avoid moisture, store the oil in a container with its cap tightly closed.

3. REFRIGERANT

- The CFC-12 refrigerant cannot be used in the HFC-134a A/C system. The HFC-134a refrigerant also cannot be used in the CFC-12 A/C system.
- If an incorrect or no refrigerant is used, it will result in poor lubrication and the compressor itself may be damaged.

4. HANDLING OF REFRIGERANT

- The refrigerant boils at approx. -30°C (-22°F). When handling it, be sure to wear protective goggles and protective gloves. Direct contact of the refrigerant with skin may cause frostbite.

If the refrigerant gets into your eye, avoid rubbing your eyes with your hands. Wash your eye with plenty of water, and receive medical treatment from an eye doctor.

- Do not heat a service can. If a service can is directly heated, or put into boiling water, the inside pressure will become extremely high. This may cause the can to explode. If a service can must be warmed up, use hot water in 40°C (104°F) max.
- Do not drop or impact a service can. (Observe the precautions and operation procedure described on the refrigerant can.)
- When the engine is running, do not open the high-pressure valve of manifold gauge. The high-pressure gas will back-flow resulting in an explosion of the can.
- Provide good ventilation and do not work in a closed area.
- In order to prevent from global warming, avoid releasing HFC-134a into the atmosphere. Using a refrigerant recovery system, discharge and reuse it.

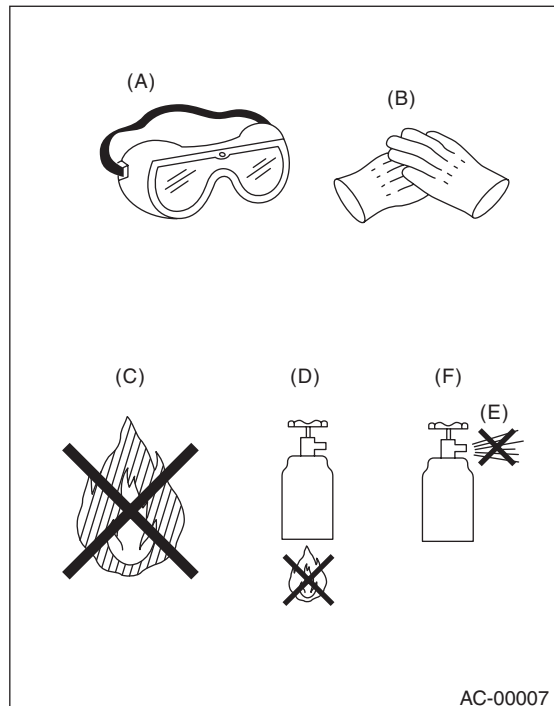

- (A) Goggles
- (B) Gloves
- (C) Avoid open flame
- (D) No direct heat on container
- (E) Do not discharge
- (F) Loosen

General Description

HVAC SYSTEM (HEATER, VENTILATOR AND A/C)

5. O-RING CONNECTIONS

- Always use a new O-ring.
- In order to keep the O-rings free of lint which will cause a refrigerant gas leak, perform operations without gloves and cloth.
- Apply compressor oil to O-rings to avoid sticking, before installation.
- Use a torque wrench to tighten the O-ring fittings. Over-tightening will damage the O-ring and tube end distortion.
- If the operation is interrupted before completing a pipe connection; recap the tubes, components and fittings with a plug or tape to prevent dirt from entering.

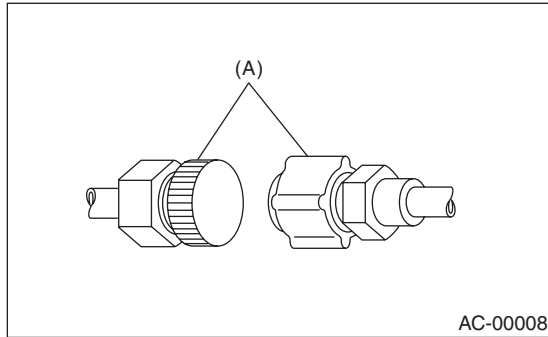

(A) Seal

- Visually check the surfaces and mating surfaces of O-rings, threads and connecting points. If a failure is found, replace the applicable parts.
- Install the O-rings straight against the groove of the tube.

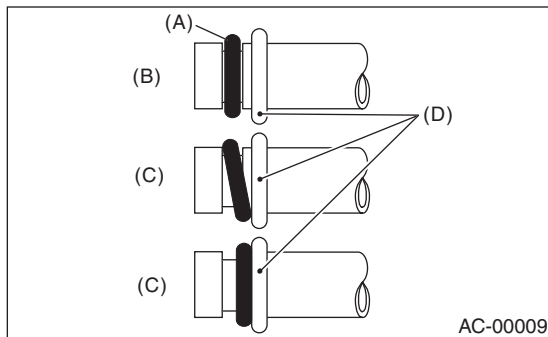

- (A) O-ring
- (B) OK
- (C) NG
- (D) Groove

- Use oil specified in the service manual to lubricate the O-rings. Apply oil to the top and sides of O-rings before installation. Apply the oil to the area including the O-rings and tube beads.

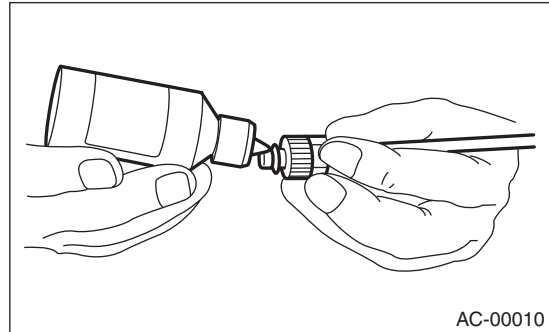

- After tightening, use a clean cloth to remove the excess oil from the connections and any oil which may have run on the vehicle body or other parts.
- If any leakage is suspected after tightening, do not further tighten the connections, but disconnect the connections, remove the O-rings, and check the O-rings, threads, and connections.

D: PREPARATION TOOL

CAUTION:

When working on vehicles with HFC-134a system, only use HFC-134a specified tools and parts. Do not mix with those of CFC-12. If HFC-134a and CFC-12 refrigerant or compressor oil is mixed, it will result in poor lubrication and the compressor itself may be destroyed.

In order to prevent the mixture of HFC-134a and CFC-12 parts and liquid, the tool and screw type and the type of service valves used are different. The gas leak detectors for the HFC-134a and CFC-12 systems must also not be interchanged.

	HFC-134a	CFC-12
Tool & screw type	Millimeter size	Inch size
Valve type	Quick joint type	Screw-in type

General Description

HVAC SYSTEM (HEATER, VENTILATOR AND A/C)

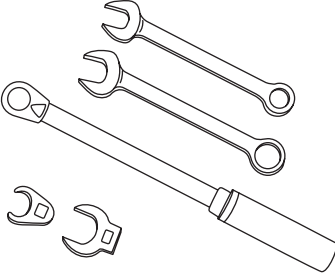
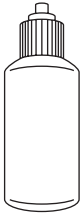
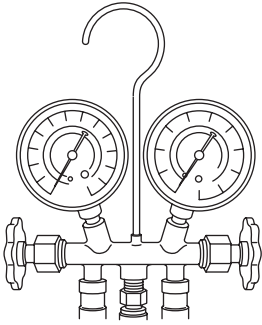
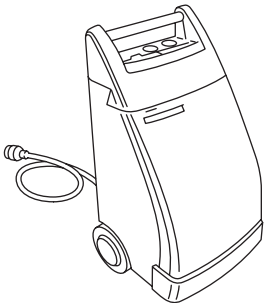
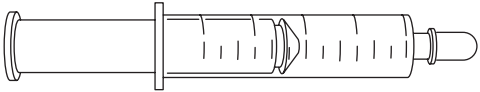
Description	Tools and Equipment
 <p style="text-align: right;">AC-00213</p>	<p>Wrench</p> <p>Various WRENCHES will be required to service any A/C system. A 7 to 40 N-m (0.7 to 4.1 kg-m, 5 to 30 ft-lb) torque wrench and various crow-foot wrenches will be needed. Open end or flare nut wrenches will be needed to hold the tube and hose fittings.</p>
 <p style="text-align: right;">AC-00012</p>	<p>Applicator bottle</p> <p>A small APPLICATOR BOTTLE is recommended to apply refrigerant oil to the various parts. It can be available at a hardware or drug store.</p>
 <p style="text-align: right;">AC-00013</p>	<p>Manifold gauge set</p> <p>A MANIFOLD GAUGE SET (with hoses) can be obtained at either a refrigerant supplier or an automotive equipment supplier.</p>
 <p style="text-align: right;">AC-00014</p>	<p>Refrigerant recovery system</p> <p>A REFRIGERANT RECOVERY SYSTEM is used for the recovery and reuse of A/C system refrigerant after contaminants and moisture have been removed from the refrigerant.</p>
 <p style="text-align: right;">AC-00015</p>	<p>Syringe</p> <p>A graduated plastic SYRINGE will be needed to add oil into the system again. A syringe can be available at a pharmacy or drug store.</p>

General Description

HVAC SYSTEM (HEATER, VENTILATOR AND A/C)

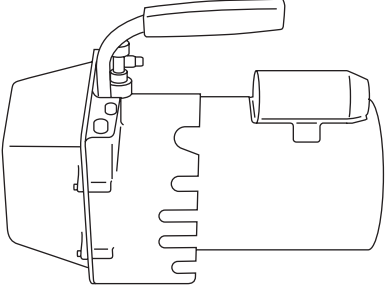
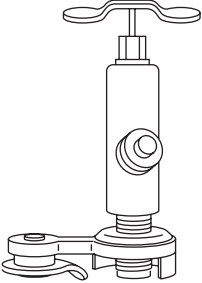
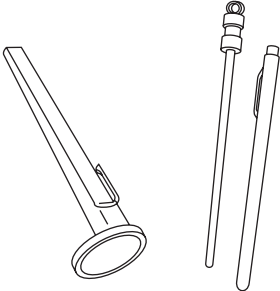
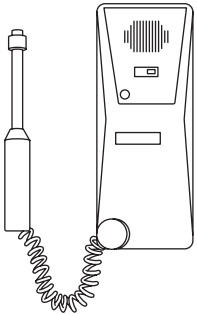
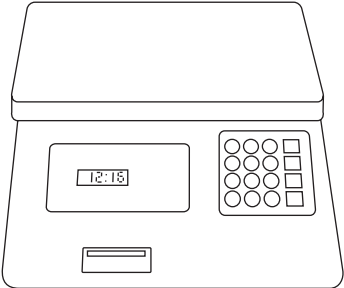
Description	Tools and Equipment
 <p data-bbox="602 512 698 533">AC-00016</p>	<p data-bbox="745 201 899 222">Vacuum pump</p> <p data-bbox="745 233 1484 317">A VACUUM PUMP (in good working condition) is necessary, and may be obtained from either a refrigerant supplier or an automotive equipment supplier.</p>
 <p data-bbox="602 863 698 884">AC-00017</p>	<p data-bbox="745 552 834 573">Can tap</p> <p data-bbox="745 583 1455 642">A CAN TAP for the 397 g (14 oz.) can is available at an automotive equipment supplier.</p>
 <p data-bbox="602 1213 698 1234">AC-00018</p>	<p data-bbox="745 903 891 924">Thermometer</p> <p data-bbox="745 934 1455 993">Pocket THERMOMETERS are available from either industrial hardware stores or commercial refrigeration supply houses.</p>
 <p data-bbox="602 1564 698 1585">AC-00019</p>	<p data-bbox="745 1253 997 1274">Electronic leak detector</p> <p data-bbox="745 1285 1490 1344">An ELECTRONIC LEAK DETECTOR can be available at either a specialty tool supplier or an A/C equipment supplier.</p>
 <p data-bbox="602 1919 698 1940">AC-00020</p>	<p data-bbox="745 1604 883 1625">Weight scale</p> <p data-bbox="745 1635 1490 1724">A WEIGHT SCALE such as an electronic charging scale or a bathroom scale with digital display will be needed, if a 13.6 kg (30 lb) refrigerant container is used.</p>