

Hose and Tube

HVAC SYSTEM (HEATER, VENTILATOR AND A/C)

16.Hose and Tube

A: REMOVAL

CAUTION:

- When disconnecting/connecting hoses, do not apply an excessive force to them. Confirm that no torsion and excessive tension is charged after installing.

- Seal the disconnected hose with a plug or vinyl tape to prevent dirt from entering.

- 1) Disconnect the ground cable from the battery.
- 2) Using the refrigerant recovery system, discharge refrigerant. <Ref. to AC-19, PROCEDURE, Refrigerant Recovery Procedure.>
- 3) Remove the evaporator unit attaching bolts (A).
- 4) Remove the low-pressure hose attaching bolts (B).
- 5) Disconnect the low-pressure hose from evaporator unit.
- 6) Disconnect the low-pressure hose from compressor.
- 7) Remove the low-pressure hose from vehicle.
- 8) Remove the high-pressure hose attaching bolts (C).
- 9) Disconnect the high-pressure hose from compressor.
- 10) Disconnect the high-pressure hose from condenser.
- 11) Remove the high-pressure hose from vehicle.
- 12) Remove the high-pressure tube attaching bolt (D).
- 13) Remove the high-pressure tube from vehicle.

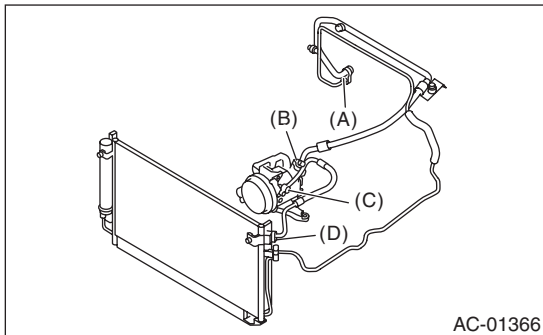

B: INSTALLATION

CAUTION:

- When disconnecting/connecting hoses, do not apply an excessive force to them. Confirm that no torsion and excessive tension is charged after installing.

- Seal the disconnected hose with a plug or vinyl tape to prevent dirt from entering.

- Replace the O-rings on the hoses or pipes with new parts, and then apply compressor oil.

- 1) Install in the reverse order of removal.
- 2) Charge refrigerant. <Ref. to AC-20, PROCEDURE, Refrigerant Charging Procedure.>

Tightening torque:

Refer to “COMPONENT” of “General Description”. <Ref. to AC-11, AIR CONDITIONING UNIT, COMPONENT, General Description.>

C: INSPECTION

NOTE:

If any cracks, damage, or expansion are found in the hose, replace it with new parts.