

**GENERAL INFORMATION
SECTION**

This service manual has been prepared to provide SUBARU service personnel with the necessary information and data for the correct maintenance and repair of SUBARU vehicles.

This manual includes the procedures for maintenance, disassembling, reassembling, inspection and adjustment of components and diagnostics for guidance of experienced mechanics.

Please peruse and utilize this manual fully to ensure complete repair work for satisfying our customers by keeping their vehicle in optimum condition. When replacement of parts during repair work is needed, be sure to use SUBARU genuine parts.

All information, illustration and specifications contained in this manual are based on the latest product information available at the time of publication approval.

FOREWORD**FW****HOW TO USE THIS MANUALS****HU****SPECIFICATIONS****SPC****PRECAUTION****PC****NOTE****NT****IDENTIFICATION****ID****RECOMMENDED MATERIALS****RM****PRE-DELIVERY INSPECTION****PI****PERIODIC MAINTENANCE SERVICES****PM**

FOREWORD

FW

	Page
1. Foreword	2

1. Foreword

A: FOREWORD

These manuals are used when performing maintenance, repair or diagnosis of Subaru Forester.

Applicable model: 2009 MY SH*****

The manuals contain the latest information at the time of publication. Changes in the specifications, methods, etc. may be made without notice.

HOW TO USE THIS MANUALS

HU

	Page
1. How to Use This Manuals	2

How to Use This Manuals

HOW TO USE THIS MANUALS

1. How to Use This Manuals

A: HOW TO USE THIS MANUALS

1. STRUCTURE

Each section consists of SCT that are broken down into SC that are divided into sections for each component. The specification, maintenance and other information for the components are included, and the diagnostic information has also been added where necessary.

2. CONTENTS

The first page has an index with tabs.

3. COMPONENT

Illustrations are provided for each component. The information necessary for repair work (tightening torque, grease up points, etc.) is described on these illustrations. Information is described using symbol.

To order parts, refer to parts catalogue.

Example:

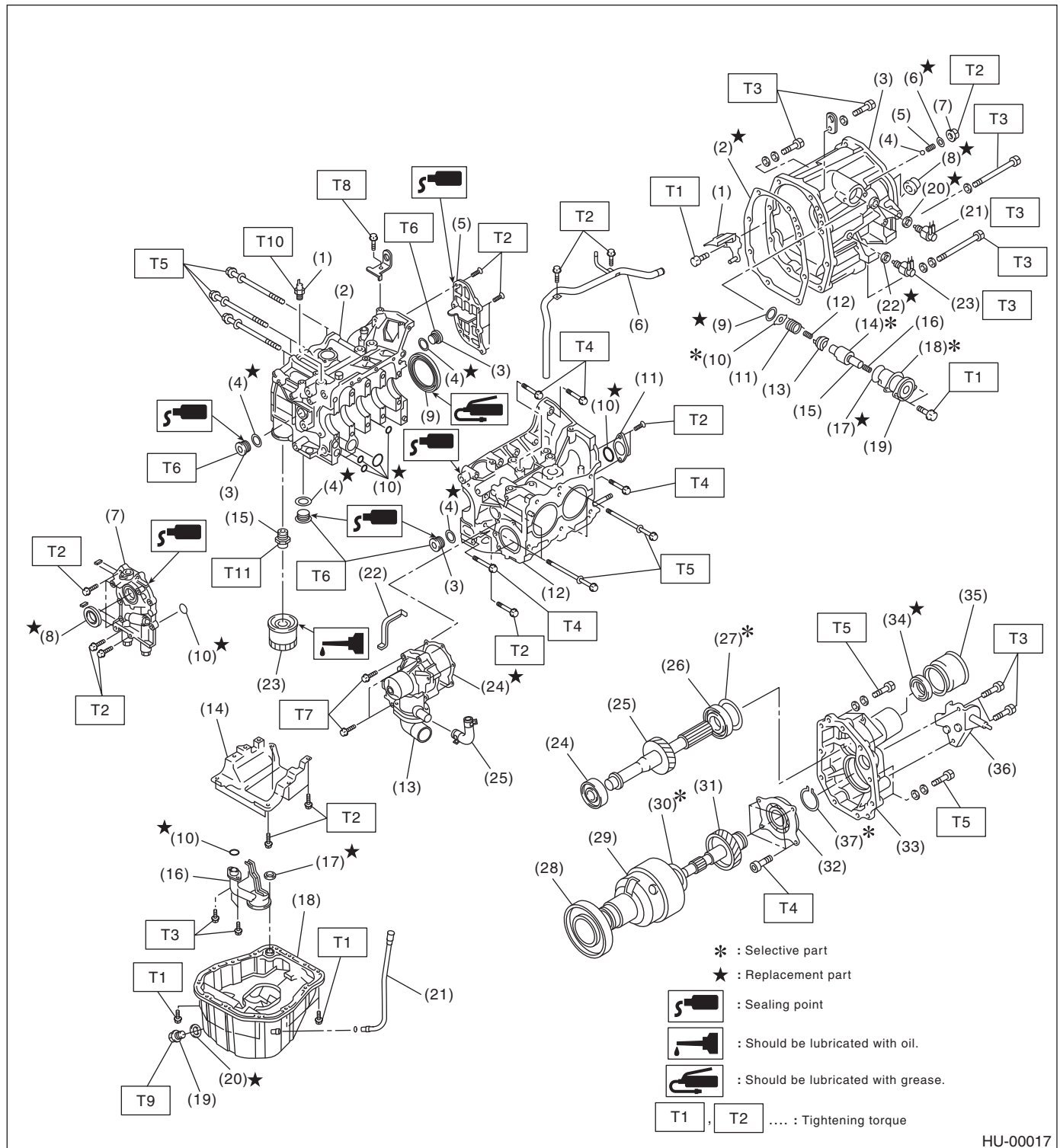

HU-00017

How to Use This Manuals

HOW TO USE THIS MANUALS

4. SPECIFICATION

If necessary, specifications are also included.

5. INSPECTION

Inspections to be carried out before and after maintenance are included.

6. MAINTENANCE

- Maintenance instructions for serviceable parts describe work area and detailed step with illustration. It also describes the use of special tool, tightening torque, caution for each procedure.
- If many serviceable parts are included in one service procedure, appropriate reference is provided for each parts.

Example:

15. Main Shaft Assembly for Single-Range ← (A)

A: REMOVAL ← (B)

1) Remove the manual transmission assembly from vehicle. <Ref. to MT-33, REMOVAL, Manual Transmission Assembly.> ← (C)

11) Tighten the lock nuts to the specified torque using ST1 and ST2.

NOTE: ← (D)

Secure the lock nuts in two places after tightening.

ST1 498937000 TRANSMISSION HOLDER

ST2 499987003 SOCKET WRENCH (35) ← (E) (F)

Tightening torque:

118 N·m (12.0 kgf-m, 86.8 ft-lb) ← (G)

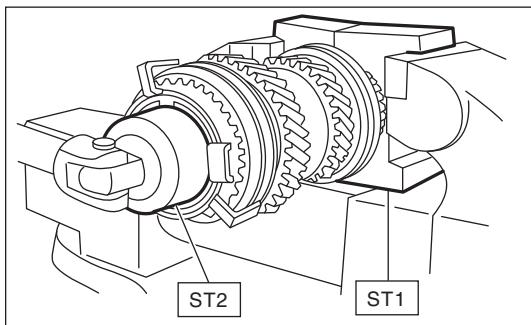

HU-00020

(A) Component

(B) Process

(C) Reference

(D) Cautions

(E) Tool number of special tool

(F) Name of special tool

(G) Tightening torque

(H) Illustration

7. DIAGNOSIS

Tables showing a step-by-step process make it easy to conduct diagnosis.

8. SI UNITS

Measurements in these manuals are according to the SI units. Metric and yard/pound measurements are also included.

Example:

Tightening torque:

44 N·m (4.5 kgf-m, 33 ft-lb)

How to Use This Manuals

HOW TO USE THIS MANUALS

9. EXPLANATION OF TERMINOLOGY

List

2ndr	: Secondary	INT	: Intermittent
AAI	: Air Assist Injection	I/O	: Input / Output
AAR	: Angular Adjusted Roller	ISC	: Idle Speed Control
A/B	: Airbag	LED	: Light Emitting Diode
ABS	: Anti-lock Brake System	LH	: LH (Left Hand)
A/C	: Air Conditioner	LSD	: Limited Slip Differential
AC	: Angular Contact	M/B	: Main Fuse & Relay Box
ACC	: Accessory	MD	: Mini Disc
A/F	: Air Fuel Ratio	MFI	: Multi Point Injection
ALT	: Generator	MP-T	: Multi-Plate Transfer
ASSY	: Assembly	MT	: Manual Transmission
AT	: Automatic Transmission	NA	: Natural Aspiration
ATF	: Automatic Transmission Fluid	NC	: Normal Close (Relay)
AVCS	: Active Valve Control System	NO	: Normal Open (Relay)
AWD	: All Wheel Drive	OP	: Option Parts
BATT	: Battery	OBD	: On-Board Diagnosis
BJ	: Bell Joint	P/S	: Power Steering
CAN	: Controller Area Network	P/W	: Power Window
CD-R/RW	: CD Recordable/Rewritable	PCD	: Pitch Circle Diameter
COMPL	: Complete	PCV	: Positive Crankcase Ventilation
CPU	: Central Processing Unit	PID	: Parameter Identification
DCCD	: Driver's Control Center Differential	Pr	: Primary
DOHC	: Double Overhead Camshaft	PTJ	: Pillow Tripod Joint
DTC	: Diagnosis Trouble Code	RAM	: Random Access Memory
DOJ	: Double Offset Joint	RH	: RH (Right Hand)
DVD	: Digital Versatile Disc or Digital Video Disc	ROM	: Read Only Memory
EBD	: Electric Brake Distribution	rpm	: Revolution Per Minute
EBJ	: High-Efficiency Compact Ball Fixed Joint	SOHC	: Single Overhead Camshaft
EDJ	: High-Efficiency Compact Double Offset Joint	SRS	: Supplemental Restraint System
ECM	: Engine Control Module	SSM	: Subaru Select Monitor
EGI	: Electronic Gasoline Injection	ST	: Special Tool
E/G	: Engine	STD	: Standard
EGR	: Exhaust Gas Recirculation	SW	: Switch
ELR	: Emergency Locking Retractor	T/B	: Turbocharger
EX	: Exhaust	TGV	: Tumble Generator Valve
ETC	: Electronic Throttle Control	T/M	: Transmission
F/B	: Fuse & Joint Box	UV	: Ultraviolet
FL	: Fusible Link	VDC	: Vehicle Dynamics Control
FWD	: Front Wheel Drive	VIN	: Vehicle Identification Number
GPS	: Global Positioning System	ViS-C	: Viscous Coupling
HID	: High-Intensity Discharge	VSV	: Vacuum Switching Valve
H/U	: Hydraulic Unit	VTD	: Variable Torque Distribution
IG	: Ignition	W/H	: Wiring Harness
IN	: Intake		

SPECIFICATIONS

SPC

	Page
1. Forester	2

Forester

SPECIFICATIONS

1. Forester

A: DIMENSION

Model		2.5 L	
		AWD	
		Non-turbo	Turbo
Overall length	mm (in)	4,560 (179.5)	
Overall width	mm (in)	1,780 (70.1)	
Total height (at C.W.)	mm (in)	Models without roof rail: 1,675 (65.9)	1,700 (66.9)
		Models with roof rail: 1,700 (66.9)	
Compartment	Head-room	Front mm (in)	1,012 (39.8) 992 (39.0)*1
		Rear mm (in)	998 (39.3) 938 (36.9)*1
	Leg room	Front mm (in)	1,108 (43.6)
		Rear mm (in)	856 (33.7)
	Shoulder room	Front mm (in)	1,356 (53.4)
		Rear mm (in)	1,361 (53.6)
Wheelbase	mm (in)	2,615 (103.0)	
Tread	Front mm (in)	1,530 (60.2)	
	Rear mm (in)	1,530 (60.2)	
Minimum road clearance	mm (in)	220 (8.7)	225 (8.9)

*1: Model with sunroof

B: ENGINE

Model		2.5 L Non-turbo	2.5 L Turbo
Engine type		Horizontally opposed, liquid cooled, 4-cylinder, 4-stroke gasoline engine	
Valve system mechanism	Method	SOHC	DOHC
	Number of valves	Intake 2/Exhaust 2	
Bore × stroke	mm (in)	99.5 × 79 (3.92 × 3.11)	
Displacement	cm ³ (cu in)	2,457 (149.94)	
Compression ratio		10.0	8.4
Ignition order		1 — 3 — 2 — 4	
Idling speed [at neutral position on MT, or "P" or "N" position on AT]	rpm	MT: 650 AT: 700	700
Maximum output	kW (HP)/rpm	126 (170)/6,000	167 (224)/5,200
Maximum torque	N·m (kgf·m, ft·lb)/rpm	229 (23.4, 169) /4,400	307 (31.3, 226) /2,800

C: ELECTRICAL

Model		2.5 L Non-turbo	2.5 L Turbo
Ignition timing/Idle speed	BTDC/rpm	MT: 10°/650 AT: 15°/700	17°/700
Spark plug		NGK: FR5AP-11	NGK: SILFR6A
Generator		12 V — 90 A	12 V — 110 A
Battery		MT: 12 V — 48 AH (55D23L) AT: 12 V — 52 AH (75D23L)	

D: TRANSMISSION**1. MT**

Model		2.5 L Non-turbo	
Transmission		5MT	
Clutch type		DSPD	
Gear ratio		1st	3.454
		2nd	2.062
		3rd	1.448
		4th	1.088
		5th	0.780
		Rev.	3.333
Reduction gear (Front)	Final deceleration	Type	Hypoid
		Gear ratio	4.111
Reduction gear (Rear)	Transfer reduction	Type	Helical
		Gear ratio	1.000
	Final deceleration	Type	Hypoid
		Gear ratio	4.111

5MT: 5-forward speeds with synchromesh and 1-reverse

DSPD: Dry Single Plate Diaphragm

2. AT

Model		2.5 L Non-turbo	2.5 L Turbo
Transmission		4AT	4AT
Clutch type		TCC	TCC
Gear ratio		1st	2.785
		2nd	1.545
		3rd	1.000
		4th	0.694
		Rev.	2.272
Reduction gear (Front)	First deceleration	Type	Helical
		Gear ratio	1.000
	Final deceleration	Type	Hypoid
		Gear ratio	4.444
Reduction gear (Rear)	Final deceleration	Type	Hypoid
		Gear ratio	4.444

4AT: Electronically controlled fully-automatic, 4-forward speeds and 1-reverse

TCC: Torque Converter Clutch

Forester

SPECIFICATIONS

E: STEERING

Type	Rack and Pinion, Integral		
Turns, lock to lock	3.2		
Minimum turning diameter	m (ft)	Curb to curb	10.6 (34.8)
		Wall to wall	11.4 (37.4)

F: SUSPENSION

Front	Macpherson strut type independent suspension
Rear	Double-wishbone type independent suspension

G: BRAKE

Service brake system	Dual circuit hydraulic with vacuum suspended power unit
Front	Ventilated disc brake
Rear	Disc brake
Parking brake	Mechanical on rear brakes

H: TIRE

Model	2.5X, 2.5XS, 2.5X PLUS	2.5X LTD, 2.5XT, 2.5XT LTD
Wheel size	16 × 6 ¹ / ₂ JJ, 16 × 6 ¹ / ₂ J	17 × 7JJ
Tire size	P215/65R16 96H P225/55R17 95H	P225/55R17 95H
Type	Steel belted radial, tubeless	

I: CAPACITY

Model	2.5 L Non-turbo		2.5 L Turbo	
Transmission	5MT	4AT	4AT	
Fuel tank	ℓ (US gal, Imp gal)		64 (16.9, 14.1)	
Engine oil	Total capacity (at overhaul)		5.0 (5.3, 4.4)	
	ℓ (US qt, Imp qt)	Filling amount of engine oil	When replacing engine oil and oil filter	4.2 (4.4, 3.7)
			When replacing only engine oil	4.0 (4.2, 3.5)
Transmission oil	ℓ (US qt, Imp qt)	3.5 (3.7, 3.1)	—	
ATF	ℓ (US qt, Imp qt)	—	9.3 (9.8, 8.2)	
Front differential gear oil	ℓ (US qt, Imp qt)	—	1.2 (1.3, 1.1)	
Rear differential gear oil	ℓ (US qt, Imp qt)	0.8 (0.8, 0.7)		
Power steering fluid	ℓ (US qt, Imp qt)	0.7 (0.7, 0.6)		
Engine coolant	ℓ (US qt, Imp qt)	6.8 (7.2, 6.0)	6.7 (7.1, 5.9)	8.0 (8.5, 7.0)

J: WEIGHT**1. NON-TURBO MODEL**

Option code		LK		YL, YB		3M	IM	
Engine type		2.5 L Non-turbo						
Grade		2.5 X		2.5X PLUS		2.5X LTD		
Transmission		5MT	4AT	5MT	4AT	4AT		
Destination code		U5, U6						
Vehicle weight (C.W.)	Front axle	kg (lb)	810 (1,785)	820 (1,810)	820 (1,810)	830 (1,830)	835 (1,840)	835 (1,840)
	Rear axle	kg (lb)	665 (1,465)	675 (1,490)	675 (1,490)	685 (1,510)	690 (1,520)	690 (1,520)
	Total	kg (lb)	1,475 (3,250)	1,495 (3,300)	1,495 (3,300)	1,515 (3,340)	1,525 (3,360)	1,525 (3,360)
Total axle weight (G.A.W.)	Front axle	kg (lb)	1,050 (2,310)	1,050 (2,310)	1,050 (2,310)	1,050 (2,310)	1,050 (2,310)	1,050 (2,310)
	Rear axle	kg (lb)	1,095 (2,410)	1,095 (2,410)	1,095 (2,410)	1,095 (2,410)	1,095 (2,410)	1,095 (2,410)
Total vehicle weight (G.V.W.)		kg (lb)	2,035 (4,480)	2,035 (4,480)	2,035 (4,480)	2,035 (4,480)	2,035 (4,480)	2,035 (4,480)
Option	Sunroof		—	—	○	○	○	○
	Leather and power seat		—	—	—	—	○	○

For option codes, refer to the ID section. <Ref. to ID-4, MODEL NUMBER PLATE, IDENTIFICATION, Identification.>

Option code		TA		NB, 5B		UM	
Engine type		2.5 L Non-turbo					
Grade		2.5 XS		2.5X PLUS		2.5X LTD	
Transmission		5MT	4AT	5MT	4AT	4AT	
Destination code		CO					
Vehicle weight (C.W.)	Front axle	kg (lb)	810 (1,785)	820 (1,810)	815 (1,795)	825 (1,820)	835 (1,840)
	Rear axle	kg (lb)	670 (1,465)	680 (1,490)	675 (1,490)	685 (1,510)	690 (1,520)
	Total	kg (lb)	1,480 (3,250)	1,500 (3,300)	1,490 (3,285)	1,510 (3,330)	1,525 (3,360)
Total axle weight (G.A.W.)	Front axle	kg (lb)	1,050 (2,310)	1,050 (2,310)	1,050 (2,310)	1,050 (2,310)	1,050 (2,310)
	Rear axle	kg (lb)	1,095 (2,410)	1,095 (2,410)	1,095 (2,410)	1,095 (2,410)	1,095 (2,410)
Total vehicle weight (G.V.W.)		kg (lb)	2,035 (4,480)	2,035 (4,480)	2,035 (4,480)	2,035 (4,480)	2,035 (4,480)
Option	Sunroof		—	—	○	○	○
	Leather and power seat		—	—	—	—	○

For option codes, refer to the ID section. <Ref. to ID-4, MODEL NUMBER PLATE, IDENTIFICATION, Identification.>

Forester

SPECIFICATIONS

Option code		TD		NC		3M	
Engine type		2.5 L Non-turbo					
Grade		2.5 XS		2.5X PLUS		2.5X LTD	
Transmission		5MT	4AT	5MT	4AT	4AT	
Destination code		C4					
Vehicle weight (C.W.)	Front axle	kg (lb)	810 (1,785)	820 (1,810)	815 (1,795)	825 (1,820)	835 (1,840)
	Rear axle	kg (lb)	670 (1,475)	680 (1,500)	675 (1,490)	685 (1,510)	690 (1,520)
	Total	kg (lb)	1,480 (3,260)	1,500 (3,310)	1,490 (3,285)	1,510 (3,330)	1,525 (3,360)
Total axle weight (G.A.W.)	Front axle	kg (lb)	1,050 (2,310)	1,050 (2,310)	1,050 (2,310)	1,050 (2,310)	1,050 (2,310)
	Rear axle	kg (lb)	1,095 (2,410)	1,095 (2,410)	1,095 (2,410)	1,095 (2,410)	1,095 (2,410)
Total vehicle weight (G.V.W.)		kg (lb)	2,035 (4,480)	2,035 (4,480)	2,035 (4,480)	2,035 (4,480)	2,035 (4,480)
Option	Sunroof		—	—	○	○	○
	Leather and power seat		—	—	—	—	○

For option codes, refer to the ID section. <Ref. to ID-4, MODEL NUMBER PLATE, IDENTIFICATION, Identification.>

2. TURBO MODEL

Option code		PL	EM	MM	QM	EM	
Engine type		2.5 L Turbo					
Grade		2.5 XT	2.5XT LTD				
Transmission		4AT	4AT				
Destination code		U4			CO	C4	
Vehicle weight (C.W.)	Front axle	kg (lb)	855 (1,885)	860 (1,895)	865 (1,905)	865 (1,895)	860 (1,895)
	Rear axle	kg (lb)	705 (1,555)	710 (1,565)	705 (1,555)	705 (1,565)	710 (1,565)
	Total	kg (lb)	1,560 (3,440)	1,570 (3,460)	1,570 (3,460)	1,570 (3,460)	1,570 (3,460)
Total axle weight (G.A.W.)	Front axle	kg (lb)	1,050 (2,310)	1,050 (2,310)	1,050 (2,310)	1,050 (2,310)	1,050 (2,310)
	Rear axle	kg (lb)	1,095 (2,410)	1,095 (2,410)	1,095 (2,410)	1,095 (2,410)	1,095 (2,410)
Total vehicle weight (G.V.W.)		kg (lb)	2,055 (4,525)	2,055 (4,525)	2,055 (4,525)	2,055 (4,525)	2,055 (4,525)
Option	Sunroof		○	○	○	○	○
	Leather and power seat		—	○	○	○	○

For option codes, refer to the ID section. <Ref. to ID-4, MODEL NUMBER PLATE, IDENTIFICATION, Identification.>

PRECAUTION

PC

	Page
1. Precaution	2



Precaution

PRECAUTION

1. Precaution

A: CAUTION

Please clearly understand and adhere to the following. They must be strictly followed to avoid minor or serious injury to the person doing the work or people in the area.

1. VEHICLE DYNAMICS CONTROL (VDC)

Handle the VDC as a total system. Do not disassemble or attempt to repair individual parts. Doing so could prevent the VDC system from operating when needed, or the system may operate incorrectly and result in injury.

2. BRAKE FLUID

If brake fluid gets in your eyes or on your skin, do the following:

- Wash eyes and seek immediate medical attention.
- Wash your skin with soap and then rinse thoroughly with water.

3. RADIATOR FAN

The radiator fan may rotate without warning, even when the engine is not ON. Do not place your hand, cloth, tools or other items near the fan at any time.

4. ROAD TEST

Always conduct road tests in accordance with traffic rules and regulations to avoid bodily injury and interrupting traffic.

5. AIRBAG

To prevent bodily injury from unexpected deployment of airbags and unnecessary maintenance, follow the instructions in this manual when performing maintenance on the airbag components or nearby, around front of the vehicle (radiator panel, front wheel apron, front side frame, front bumper, front hood panel, front fender panel), around side of the vehicle (front door panel, center pillar, side sill), rear door panel, C pillar, rear seat and the airbag wiring harnesses or nearby.

To prevent unexpected deployment, turn the ignition switch to OFF and disconnect the ground cable from battery, then wait at least 20 seconds to discharge electricity before starting work.

6. AIRBAG MODULE AND SEAT BELT PRETENSIONER DISPOSAL

To prevent bodily injury from unexpected airbag deployment, do not dispose the airbag modules and seat belt pretensioner in the same way as other waste. Follow all government regulations concerning disposal of refuse.

7. AIRBAG MODULE

Adhere to the following when handling and storing the airbag module to prevent bodily injury from unexpected deployment:

- Do not hold the harnesses or connectors to carry the module.
- Do not face the bag in the direction that it opens towards yourself or other people.
- Do not face the bag in the direction that it opens towards the floor or walls.

8. AIRBAG SPECIAL TOOL

To prevent unexpected deployment, only use special tools.

9. WINDOW

Always wear safety glasses when working around any glass to prevent glass fragments from damaging your eyes.

10. WINDOW ADHESIVE

Always use the recommended or equivalent adhesive when attaching glass to prevent it from coming loose and falling, resulting in accidents and injury.

11. OIL

When handling oil, adhere to the following to prevent from unexpected accident.

- Prepare a container and cloth when performing work which oil possibly spills. If oil spills, wipe it off immediately to prevent from penetrating into floor or flowing out for environmental protection.
- Follow all government and local regulations concerning disposal of refuse when disposing.

12. FUEL

When handling and storing fuel, adhere to the following to prevent from unexpected accident.

- Be careful with fire.
- Prepare a container and cloth to prevent scattering of fuels when performing work where fuels can be spilled. If the fuel spills, wipe it off immediately to prevent from penetrating into floor or flowing out for environmental protection.
- Follow all government and local regulations concerning disposal of refuse when disposing.

13. ENGINE COOLANT

When handling engine coolant, adhere to the following to prevent from unexpected accident.

- Never remove the radiator cap since engine coolant may blow out when it is hot.
- Prepare a container and cloth to prevent scattering of engine coolant when performing work where engine coolant can be spilled. If the fuel spills, wipe it off immediately to prevent from penetrating into floor or flowing out for environmental protection.
- Follow all government and local regulations concerning disposal of refuse when disposing.

14. AIR CONDITIONER REFRIGERANT

In order to prevent from global warming, avoid releasing air conditioner refrigerant into the atmosphere. Using a refrigerant recovery system, discharge and recycle it.

15. HOSE REMOVAL/INSTALLATION PROCEDURES

1. Hose Removal/Installation Pre-Procedures

- Be careful to inspect hoses so as not to use damaged or deformed hoses. Using such hoses could cause leakage or loss of oil, with leaked oil splashing on exhaust pipes or other hot parts, resulting in smoke or fire.
- Always remove hoses when performing work. Not removing the hoses and moving parts out of the way when performing procedures may damage the inside of hoses and cause other negative affects.

2. Hose Removal/Installation Procedures and Inspection

- Remove hoses according to the following instructions.
 - If using the hose remover (general tool), do not use the sharp-pointed hose remover (hose plucker) as it may damage pipe surfaces or hoses.

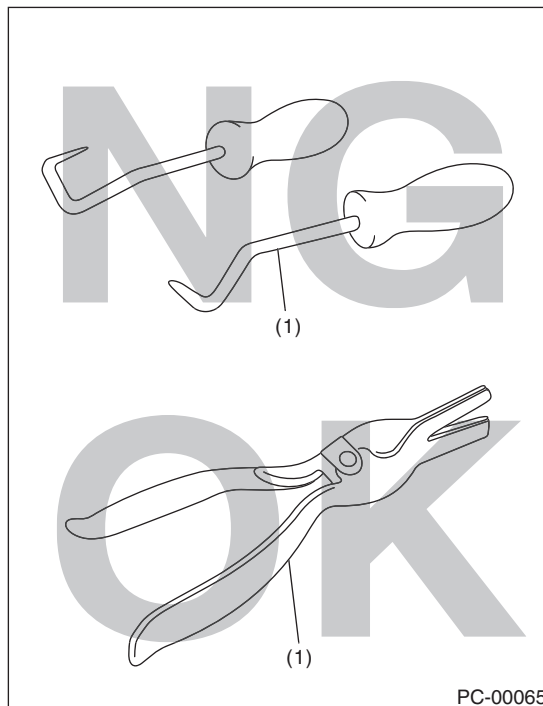

(1) Hose remover

- When using pliers to make hose removal easier, always be sure to use a cloth to protect the hose, slightly rotate the hose, and then pull straight out by hand.

Precaution

PRECAUTION

- **Inspect the following points in continuous use, and replace any hoses that are damaged or defective with new parts.**

- Replace any hoses that are riding over the stay or spool with new parts.

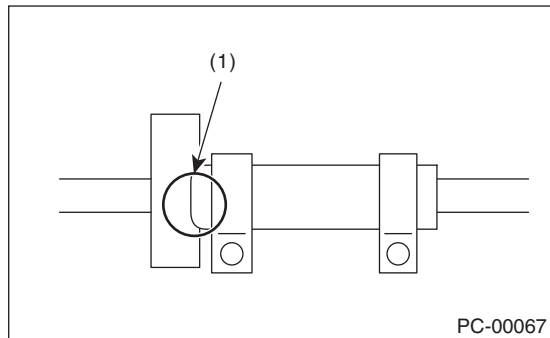

(1) Hose riding over a stay

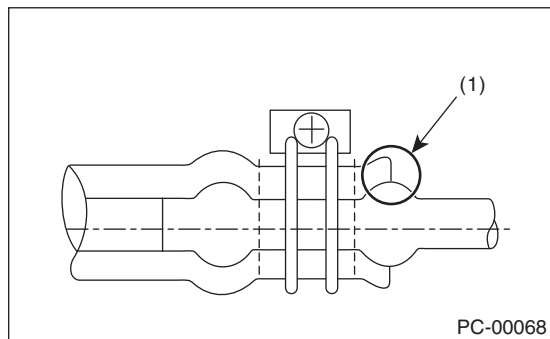

(1) Hose riding over a spool

- Check the inner and outer surfaces of the hose for damage, cracks, breakage, hardening/softening/swelling of rubber, internal peeling, and that there are no deformations caused by infiltration/adhesion of foreign matter, and no twisted hoses. Replace any defective hoses with new parts.

- **Install hoses according to the following instructions.**

- Carefully check the installation positions.
- Do not use any lubricants.
- Securely insert until the specified positions (until contacting spool).

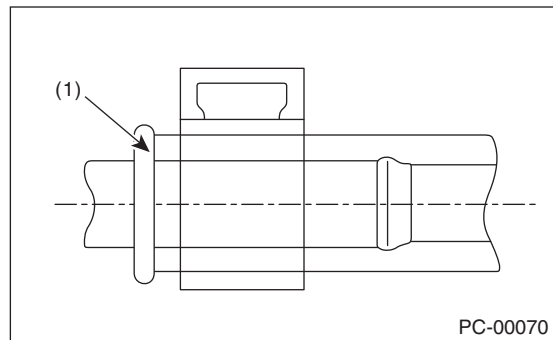
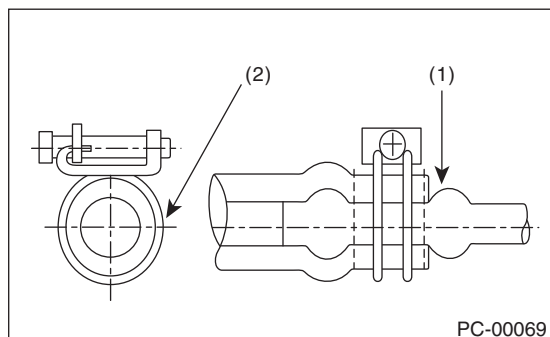

- (1) Contacting the spool. (Do not excessively insert the hose to prevent the hose from becoming wrinkled up.)
- (2) Apply an equal clamping force all around the hose periphery.

- Check that the position and orientation of hose clamps, and the hose layout are correct. (Check that the position and orientation are matching, they are not excessively short/long, there are no differences with before performing the procedures, and that there is clearance between hoses and surrounding parts.)
- After installing, check that there are no disconnection of hoses or leakage from hoses. (Check that hoses are securely fixed by the clamps.)
- **Inspect the hose clips and clamps according to the following points, and replace any parts that are damaged or defective with new parts.**
 - Check for deformations, rust, damage, and adhering of foreign matter.
 - For clips, check that the spring functions and has clamping force.
 - For clamps, check that the screw can clinch, the clamp has not become oval shaped, and the screw is not damaged.
- **Inspect the pipes according to the following points, and replace any parts that are damaged or defective with new parts.**

Check that the pipes do not have any damage, rust, peeling (including peeling plating), foreign matter adhering, twisting, crushing, bending, or cracks.
- **Replace the following parts with new parts if the hoses have been removed or their installation positions have been changed.**

ATF cooler hose, engine oil cooler hose, MT oil cooler hose, power steering suction hose, and power steering return hose.

NOTE

NT

	Page
1. Note	2



1. Note

A: NOTE

This information will improve the efficiency of maintenance and assure the sound work.

1. FASTENERS NOTICE

Replace the nonreusable parts with new parts. Check the tightening torque and tighten to the specified torque.

Do not apply paint, lubricant, rust retardant or other substance to the surface around bolts, nuts, etc. Doing so will make it difficult to obtain the correct torque and result in looseness and other problem.

2. STATIC ELECTRICITY DAMAGE

Do not touch the control modules, connectors, logic boards and other such parts when there is a risk of static electricity. Always use a static electricity prevention cord or touch grounded metal for the elimination of static electricity before conducting work.

3. BATTERY

When removing the battery cables, always be sure to turn the ignition switch to OFF to prevent electrical damage to the control module from overcurrent.

4. SERVICE PARTS

Use genuine parts for maximum performance and maintenance when conducting repairs. Subaru/FHI will not be responsible for poor performance resulting from the use of parts except for genuine parts.

5. PROTECTING VEHICLE UNDER MAINTENANCE

Make sure to attach the fender cover, seat covers, etc. before work.

6. ENSURING SECURITY DURING WORK

When working in a group of two or more, perform the work with calling each other to ensure mutual safety.

7. LIFT AND JACK

When using a lift or shop jack to raise a vehicle or using rigid rack to support a vehicle, always follow instructions concerning jack-up points and weight limits to prevent the vehicle from falling, which could result in injury. Be especially careful that the vehicle is balanced before raising it. Be sure to set the wheel stoppers when jacking-up only the front or rear side of the vehicle.

SUPPORT LOCATIONS

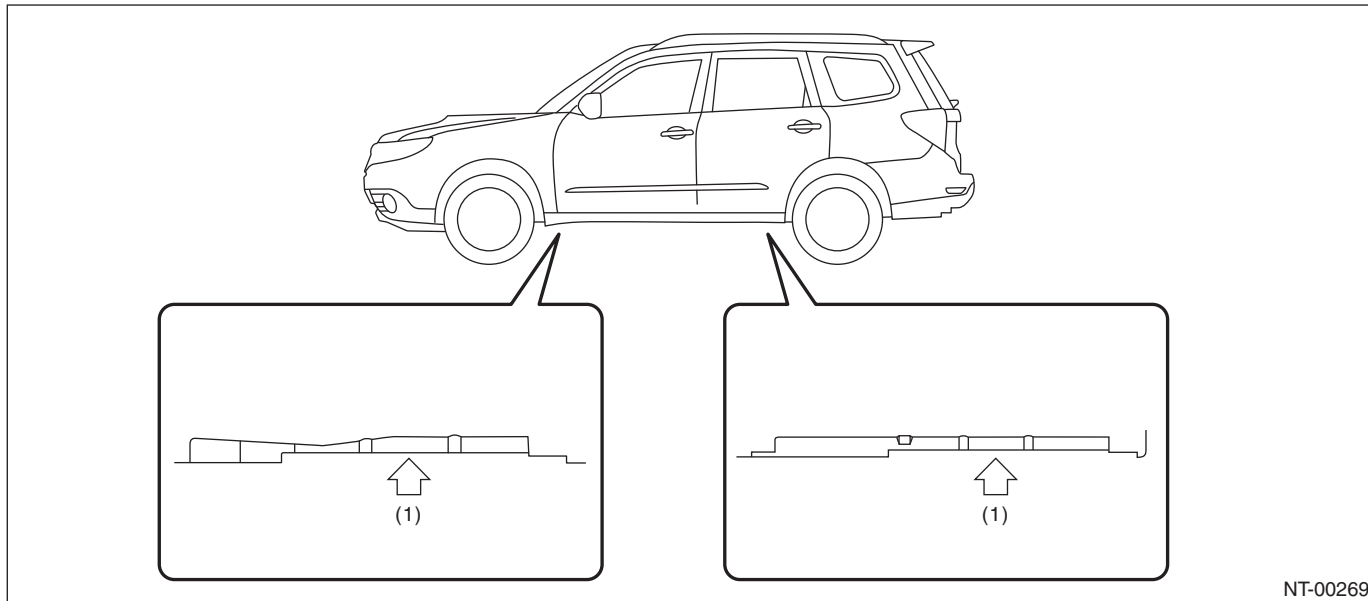

(1) Jack-up point

PANTOGRAPH JACK

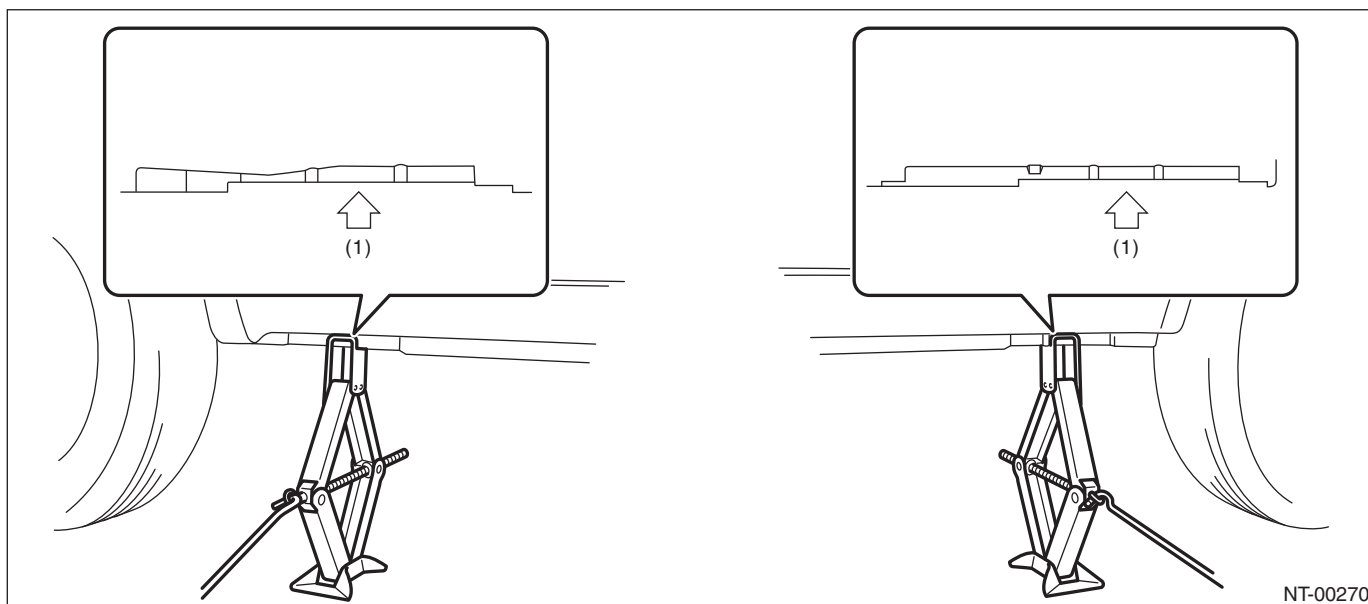

(1) Jack-up point

Note

NOTE

LIFT

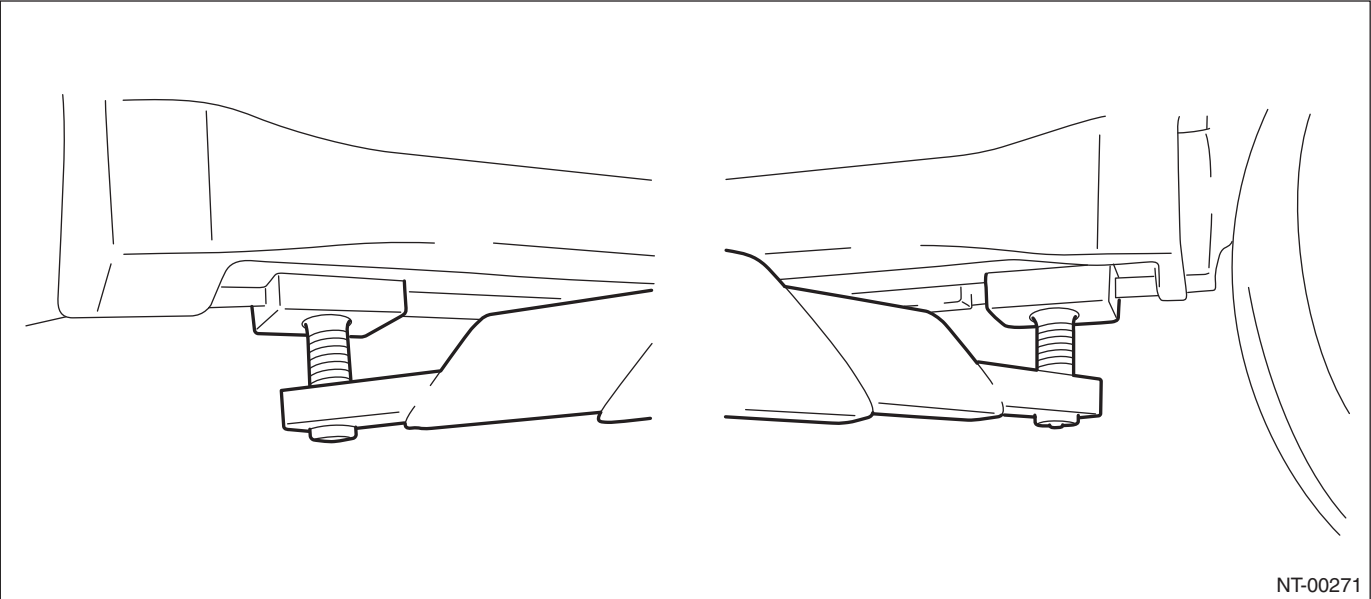

RIGID RACK

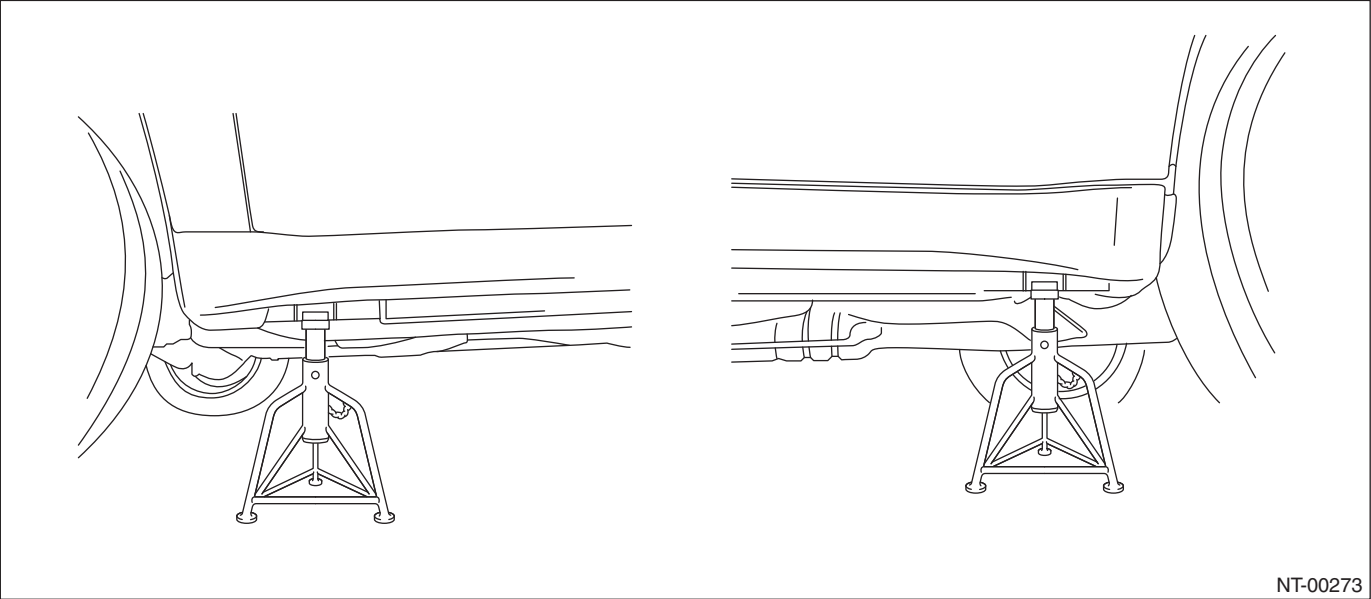

JACK-UP POINT

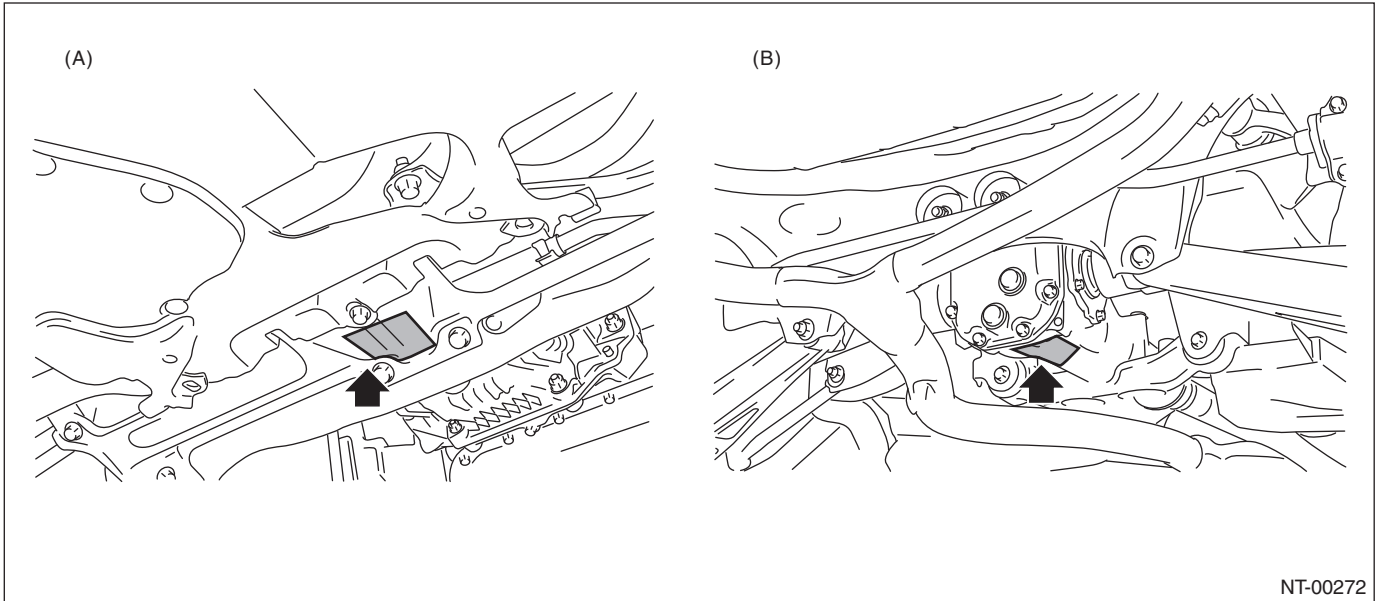

(A) Front

(B) Rear

CAUTION:

If jacking up the front side of the vehicle, make sure that the jack is attached at the center of the jack-up plate not at the sides.

Note

NOTE

8. TIE-DOWNS

Tie-downs are used when transporting vehicles and when using the chassis dynamo. Attach tie-down only to the specified locations on the vehicle.

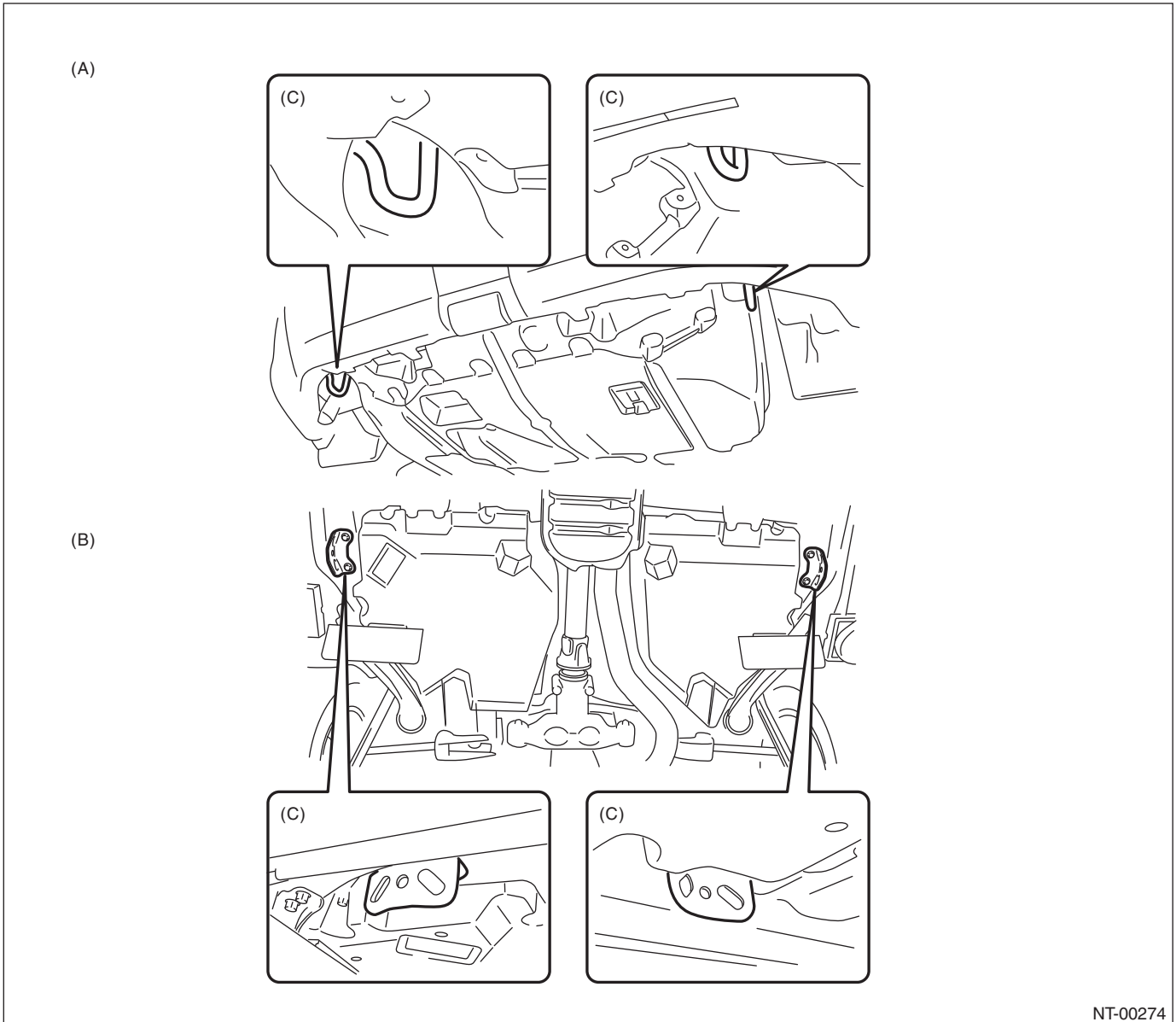

NT-00274

(A) Front

(B) Rear

(C) Hook for tie-down

CHAIN DIRECTION AT TIE-DOWN CONDITION

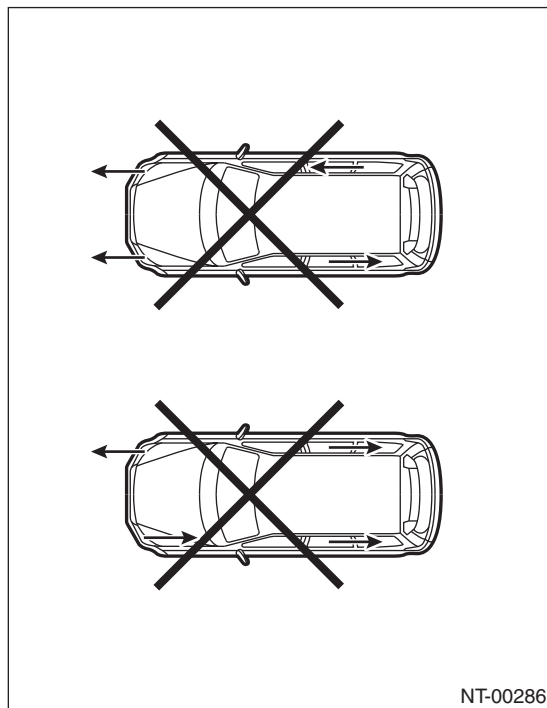
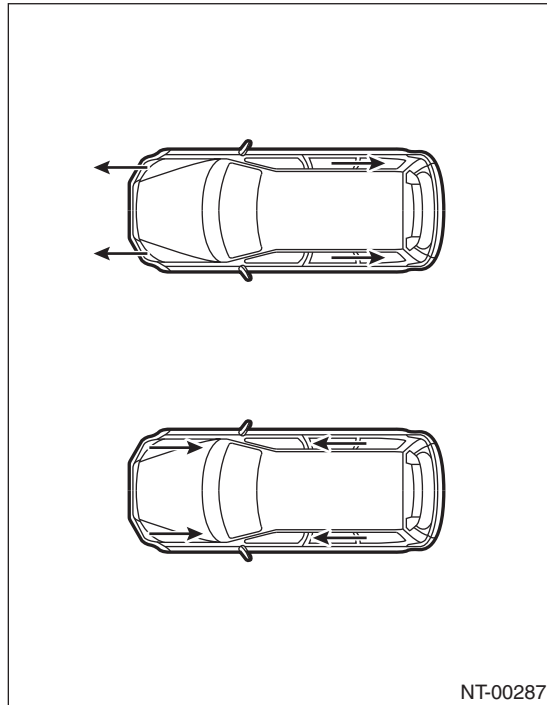

CHAIN PULLING RANGE AT TIE-DOWN CONDITION

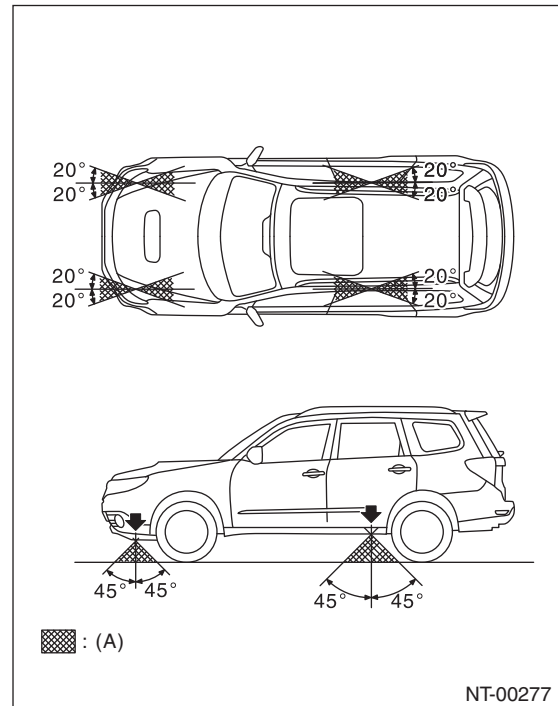

(A) Chain pulling range at tie-down condition

VEHICLE SINKING VOLUME AT TIE-DOWN CONDITION

Measure the distance between the highest tire point and highest arch point before and after tie-down. Difference of measured values (sinking volume) should be within 50 mm (1.97 in) and make sure to fix the vehicle securely.

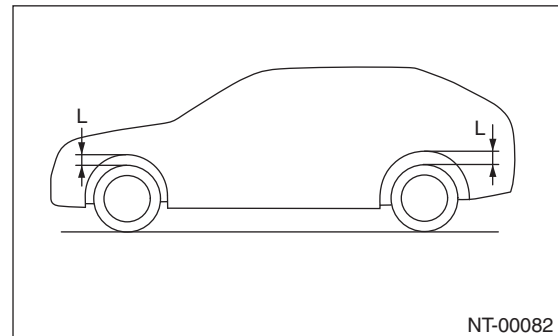

Note

NOTE

9. TOWING

Avoid towing vehicles except when the vehicle cannot be driven. For models with AWD or AT, use a loader instead of towing. When towing other vehicles, pay attention to the following to prevent hook or vehicle damage resulting from excessive weight.

- Do not tow other vehicles with a front tie-down hook.
- Make sure the vehicle towing is heavier than the vehicle being towed.
- When towing the vehicle, install the towing hook (eye bolt).

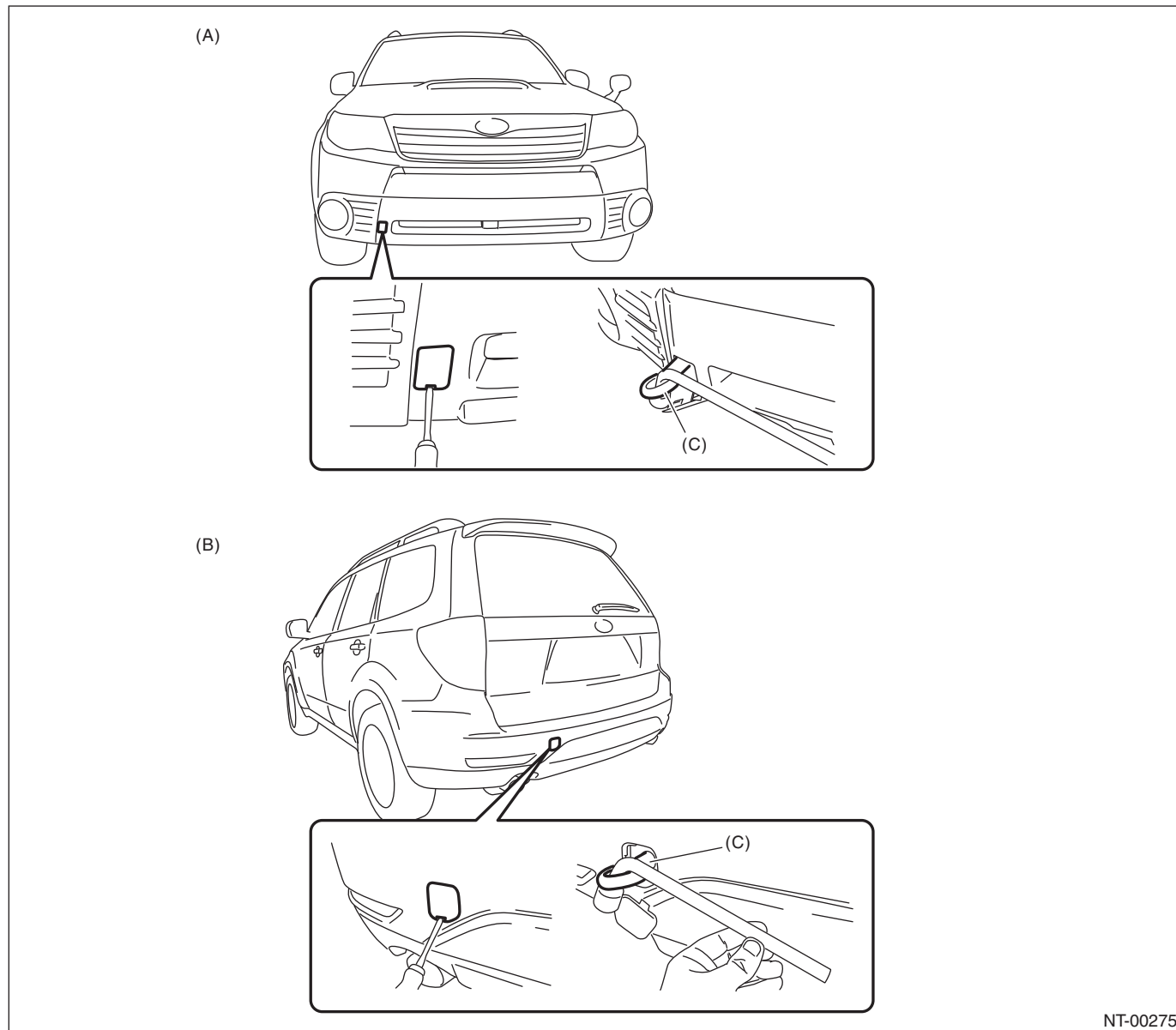

NT-00275

(A) Front

(B) Rear

(C) Towing hooks (eye bolt)

10.FRONT HOOD DAMPER STAY INSTALLATION

CAUTION:

- Do not leave one side of damper stay removed.
- Always perform works such as inspections and maintenance with both damper stays attached.

AT THE CHECK AND GENERAL MAINTENANCE

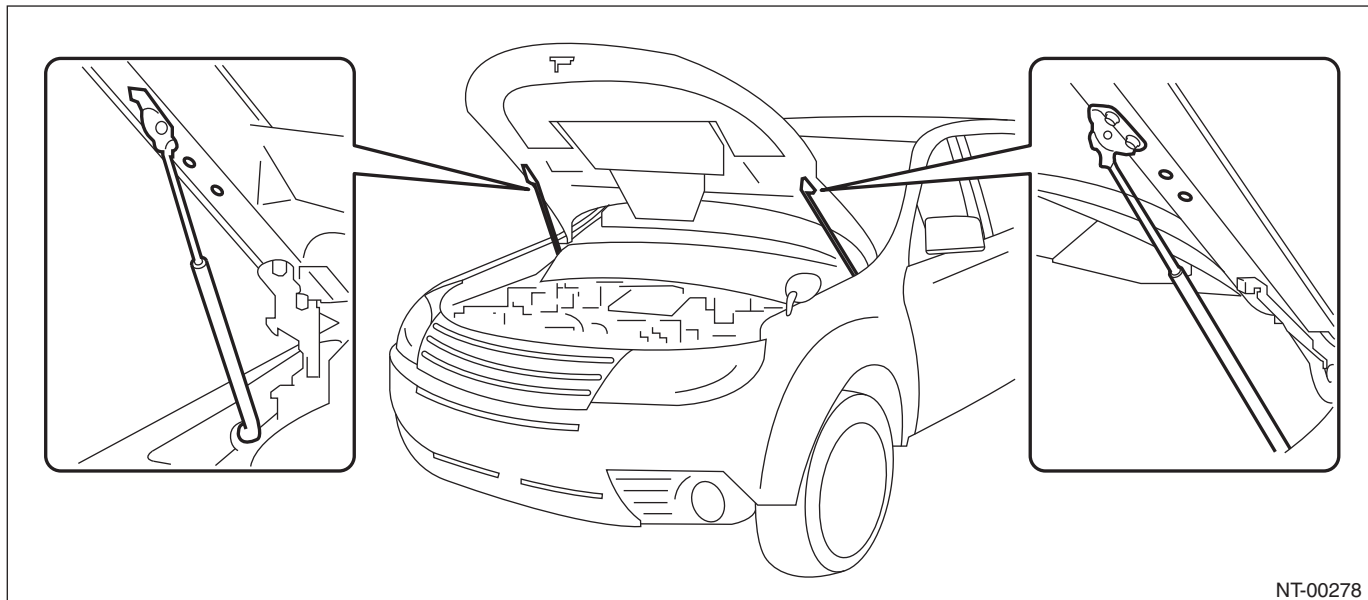

NT-00278

WHEN WIDER HOOD OPENING IS NECESSARY

CAUTION:

The hood cannot be closed with the hood damper on the full open side. When it is necessary to close, tie the hood striker and the radiator panel with a string etc. to fix them.

Set the damper stay below as shown in the figure.

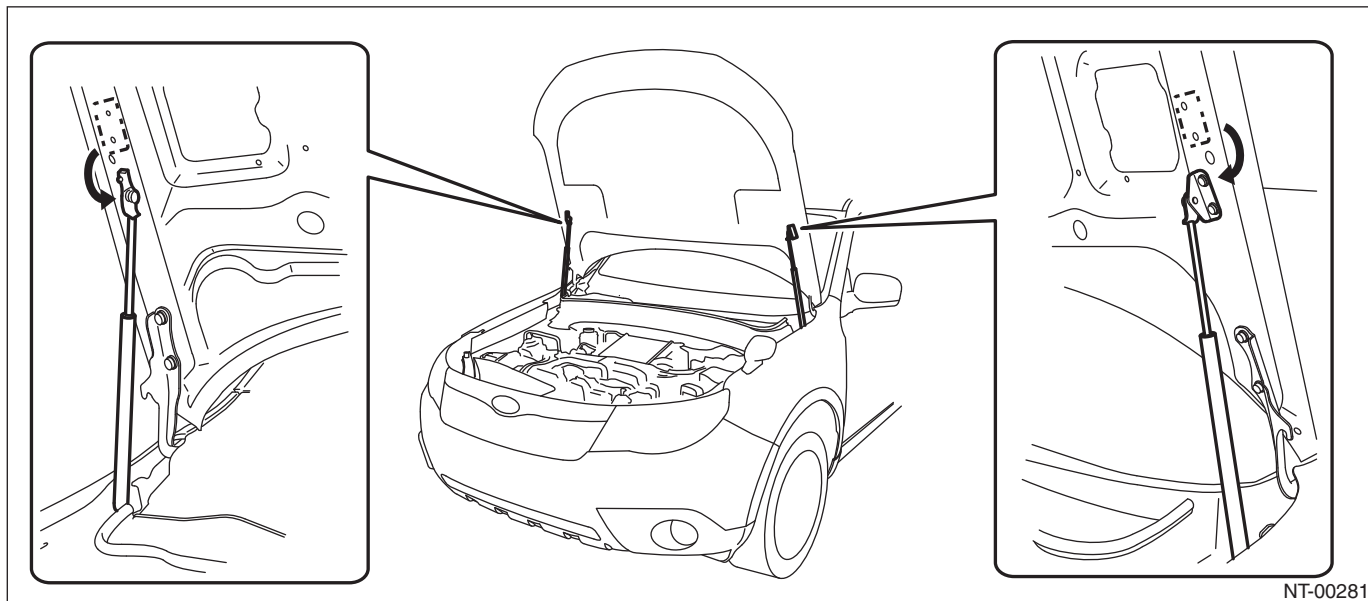

NT-00281

NOTE

11.TRAINING

For an information about training, contact a dealer or agent.

12.GENERAL SCAN TOOL

Using general scan tools will greatly improve the efficiency of repairing engine electronic controls. Subaru Select Monitor can be used to diagnose the engine, VDC, air conditioner and other electronically controlled parts.

IDENTIFICATION

ID

	Page
1. Identification	2



Identification

IDENTIFICATION

1. Identification

A: IDENTIFICATION

1. IDENTIFICATION NUMBER AND LABEL LOCATIONS

The V.I.N. (Vehicle Identification Numbers) is used to classify the vehicle.

- POSITIONING OF THE PLATE LABEL FOR IDENTIFICATION

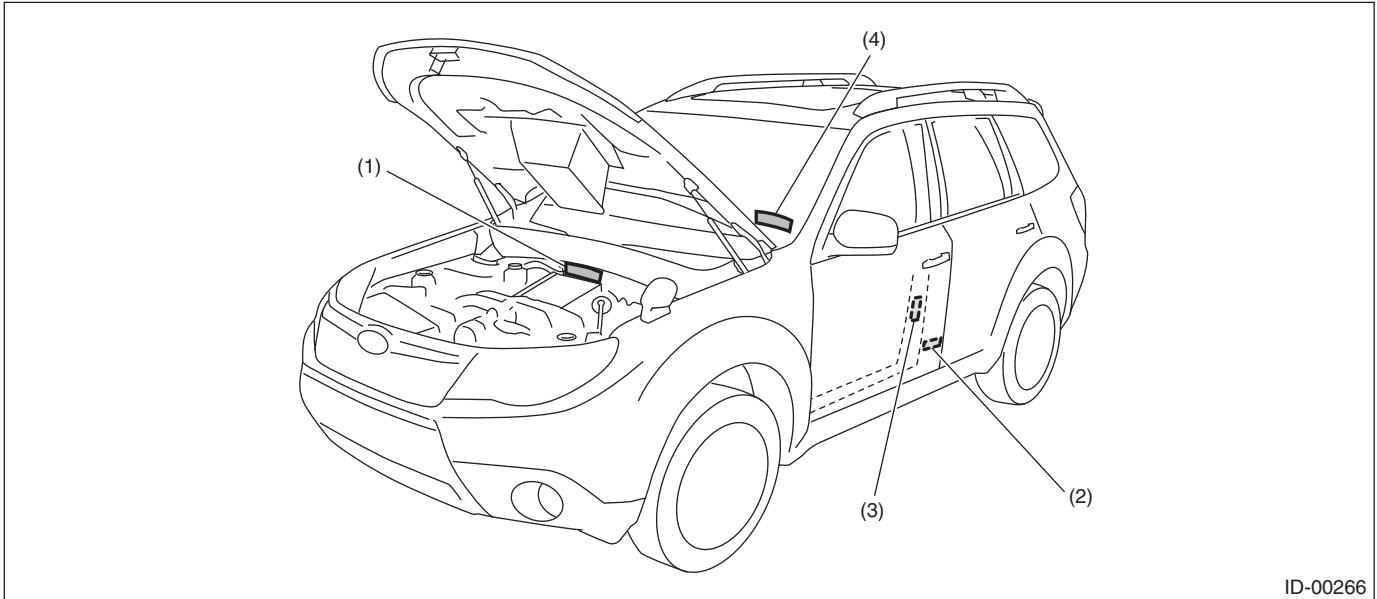

ID-00266

(1) Vehicle identification number
(V.I.N.)

(2) Label MVSS
(3) Tire inflation pressure label

(4) ID number plate

• LABEL MVSS



• REAR DIFFERENTIAL

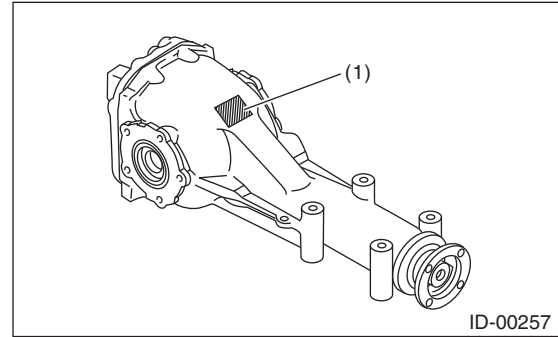

(1) Type (white paint)

• ENGINE

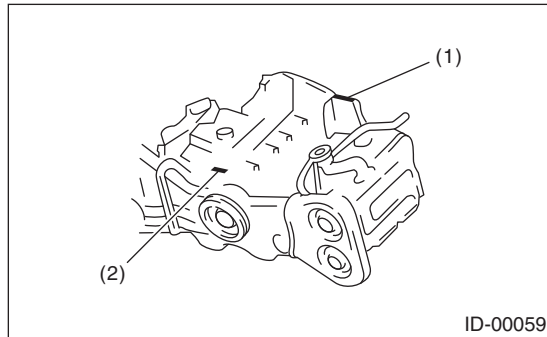

- (1) Engine serial number (punch mark)
- (2) Engine type (crankcase upper side)

• AUTOMATIC TRANSMISSION

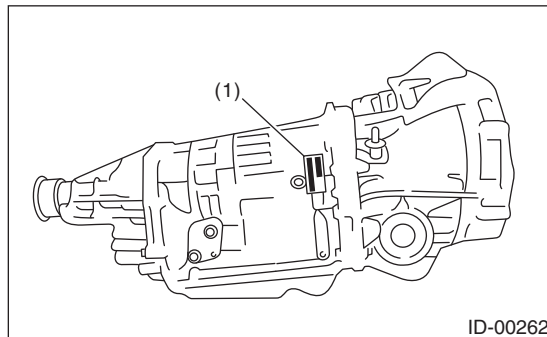

(1) AT type and transmission serial number label

• MANUAL TRANSMISSION

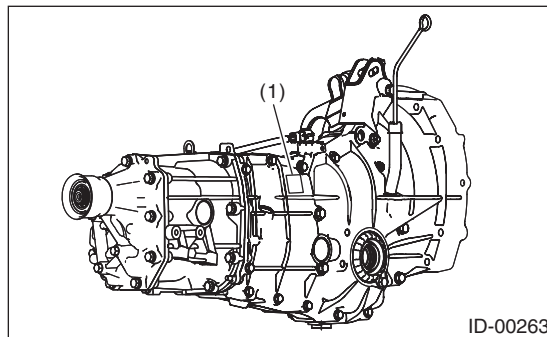

(1) MT type and transmission serial number label

Identification

IDENTIFICATION

2. MEANING OF V.I.N.

The meaning of the V.I.N. is as follows:

JF2SH636X9G700001

The large parentheses ([]) located in front and back are stop marks.

Digits	Code	Meaning	Details
1 — 3	JF2	Manufacture body area	JF2: Passenger car, FHI made
4	S	Car line	S: Forester
5	H	Body type	H: Wagon
6	6	Displacement	6: 2.5 L AWD
7	3	Grade	1: 2.5X 2: 2.5XS 3: 2.5X PLUS 4: 2.5X LTD 5: 2.5XT 6: 2.5XT LTD
8	6	Restraint	6: Manual belts, dual airbag, side airbag
9	X	Check numbers	X or 0 — 9
10	9	Model year	9: 2009MY
11	G	Transmission type	G: Full-time AWD 5 speed MT S/R H: Full-time AWD 4 speed AT
12 — 17	700001	Serial number	700001 —

3. MODEL NUMBER PLATE

The model number plate indicates: the applied model, the option code, the trim code, the engine type, the transmission type, and the exterior color code. This information is helpful when placing orders for parts.

SH9AY4J

Digits	Code	Meaning	Details
1	S	Series	S: Forester
2	H	Body type	H: Wagon
3	9	Total engine displacement Drive system	9: 2.5 L AWD
4	A	Model year	A: 2009MY
5	Y	Destination	Y: U.S., Canada
6	4	Grade	4: 2.5 X 5: 2.5 XS 6: 2.5X PLUS 7: 2.5X LTD 9: 2.5 XT A: 2.5XT LTD
7	J	Transmission, fuel feed system	J: SOHC MFI 5 speed MT L: SOHC MFI sport shift 4 speed AT T: DOHC MFI turbo sport shift 4 speed AT

Identification

IDENTIFICATION

The engine and transmission type are as follows.

ENGINE

EJ253ASZFB

Digits	Code	Meaning	Details
1 and 2	EJ	Engine type symbol	EJ: 4 cylinder
3 and 4	25	Displacement	25: 2.5 L
5	3	Fuel feed system	3: MFI non-turbo (SOHC) 5: MFI DOHC turbo
6	A	Exhaust regulations	A: For states not using California emission standards B: For all states C: For states using California emission standards
7	S	Mounted transmission	P: 4AT S: 5MT
8	Z	Model change	Z: Start → Y, X...
9 — 10	FB	Detailed specifications	Used for ordering parts. See the parts catalog for details.

TRANSMISSION

1. MT

TY758VCZAA

Digits	Code	Meaning	Details
1	T	Transmission	T: Transmission
2	Y	Transmission system	Y: Full-time AWD MT center differential
3 and 4	75	Classification	75: 5MT
5	8	Series	8: 5MT
6	V	Transmission basic specifications	V: Full-time AWD 5 speed MT single range with viscous coupling center differential
7	C	Mounted engine	C: 2.5 L SOHC
8	Z	Model change	Z: Start → Y, X...
9 — 10	AA	Detailed specifications	Used for ordering parts. See the parts catalog for details.

2. AT

TZ1B8LCZAA

Digits	Code	Meaning	Details
1	T	Transmission	T: Transmission
2	Z	Transmission system	Z: Full-time AWD AT MPT
3 and 4	1B	Classification	1B: 4AT
5	8	Series	8: 4AT
6	L	Transmission basic specifications	L: MP-T full-time AWD direct 4 speed AT
7	C	Mounted engine	B: 2.5 L DOHC turbo C: 2.5 L SOHC
8	Z	Model change	Z: Start → Y, X...
9 — 10	AA	Detailed specifications	Used for ordering parts. See the parts catalog for details.

REAR DIFFERENTIAL

T2

Code	Reduction gear ratio	LSD
B1	4.111	None
T2	4.111	None
TP	4.444	None

Identification

IDENTIFICATION

OPTION CODE

LK

- 1st digit

OP code	E	I	L	M	N	P	Q	T	U	Y	3
Aluminum wheel (16-inch)	—	—	—	—	○	—	—	—	—	—	—
Aluminum wheel (17-inch)	○	○	—	○	—	○	○	—	○	○	○
Leather seats and leather door trim center decoration	○	○	—	○	—	—	○	—	○	—	○
High grade audio	○	—	—	—	○	○	○	—	○	—	○
Navigation system	—	○	—	○	—	—	—	—	—	—	—
Front fog light	○	○	—	○	○	○	○	—	○	—	○
Cruise control	○	○	○	○	○	○	○	○	○	○	○
HID headlight	—	—	—	—	—	—	○	—	○	—	—
Dark colored glass	○	○	—	○	○	○	○	○	○	○	○
Roof spoiler	○	—	—	○	—	○	○	—	—	—	—
Leather package base*1	○	○	—	○	—	—	○	—	○	—	○

*1: Leather-wrapped MT shift knob or leather-wrapped AT selector grip, leather-wrapped steering wheel

- 2nd digit

OP code	A	B	C	D	K	L	M
Sunroof	—	○	○	—	—	○	○
VDC	○	○	○	○	○	○	○
Power seat	—	—	—	—	—	—	○
Seat heater	○	○	—	—	—	—	○
Fully automatic air conditioner	—	—	—	—	—	—	○
Manual air conditioner	○	○	○	○	○	○	—
Front wiper deicer	—	○	○	—	—	—	○
Heated mirror	○	○	○	○	—	—	○
Side airbag	○	○	○	○	○	○	○
Curtain airbag	○	○	○	○	○	○	○

RECOMMENDED MATERIALS

RM

	Page
1. Recommended Materials	2



Recommended Materials

RECOMMENDED MATERIALS

1. Recommended Materials

A: RECOMMENDED MATERIALS

1. GENERAL



To insure the best performance, always use the specified oil, gasoline, adhesive, sealant, etc. or a substitute of equivalent quality.

2. FUEL

- Use unleaded gasoline to reduce air pollution, because using leaded gasoline will damage the catalytic converter.
- Do not use the low quality gasoline, or improper fuel such as diesel fuel, fuel alcohol, or gasoline additive because they will adversely affect on engine components.
- Always use gasoline that is equivalent to that prescribed in the instruction manual or that of high octane value. There is the possibility of damaging or improper operation of the engine and fuel injection system if the specifications are not observed. Use the prescribed gasoline type to maintain proper vehicle performance.

3. LUBRICANTS

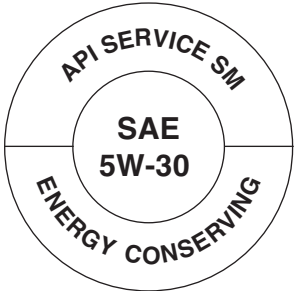
Use the lubricants shown in the table below, or equivalent. See the table below to choose the correct SAE viscosity.

Lubricants	Recommended materials	
	API spec.	ILSAC spec.
Engine oil Choose oil suitable for the standard from the right.	SM grade "Energy conservation"  RM-00049	GF-4  RM-00002
Manual transmission oil	GL-5	—
Front differential oil	GL-5	—
Rear differential oil	GL-5	—

Recommended Materials

RECOMMENDED MATERIALS

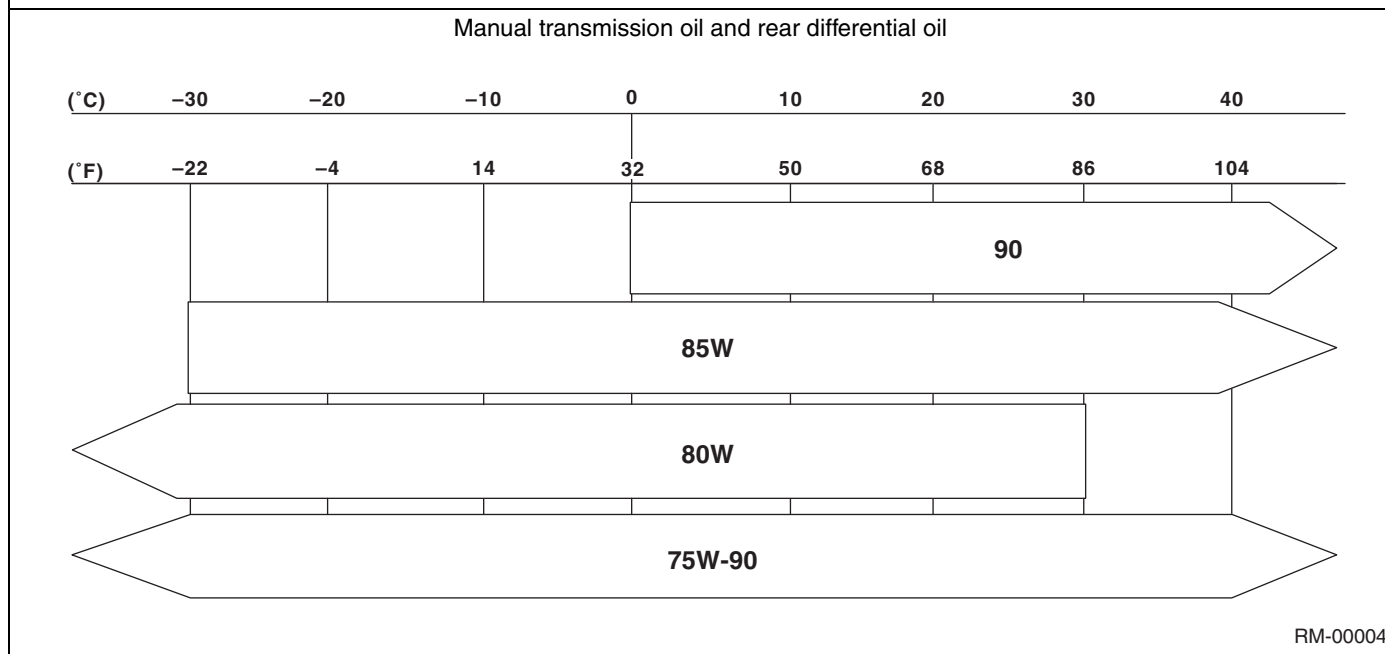
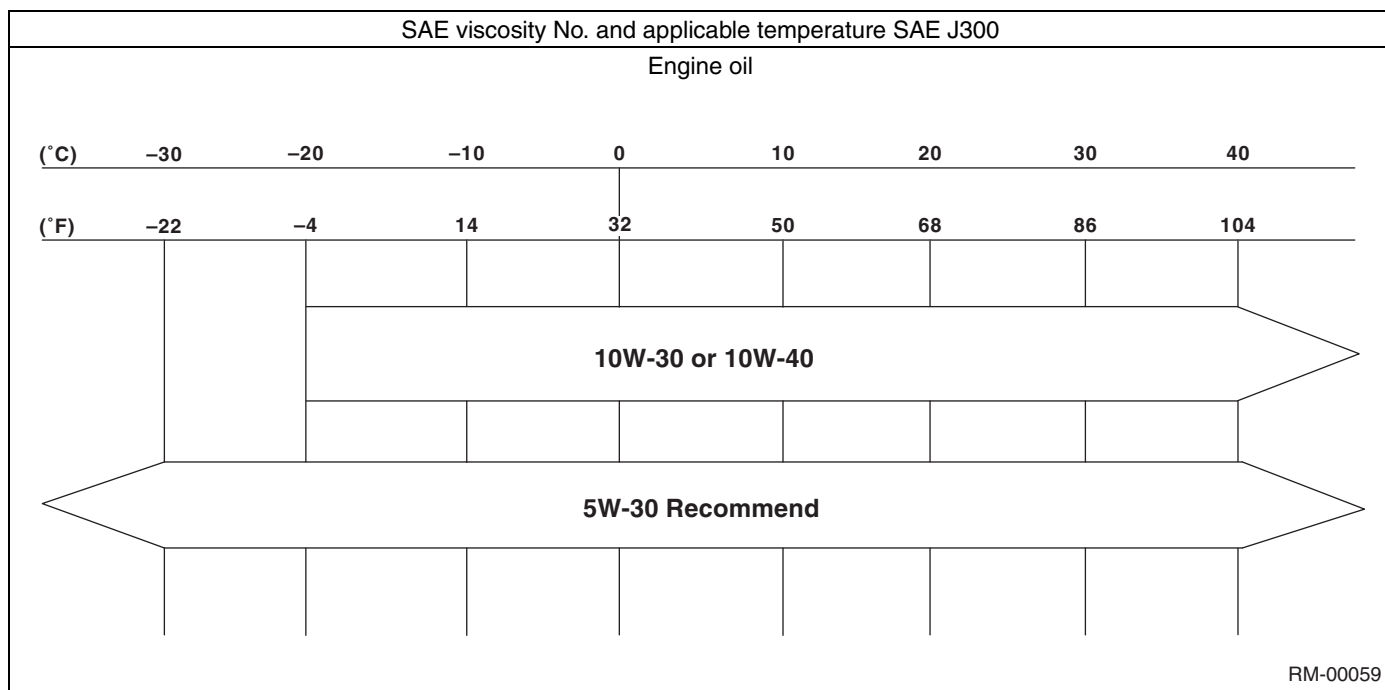

Recommended Materials

RECOMMENDED MATERIALS

SAE viscosity No. and applicable temperature SAE J300								
Front differential (AT)								
(°C)	-30	-20	-10	0	10	20	30	40
(°F)	-22	-4	14	32	50	68	86	104
								90
								85W
								80W
								75W-90

RM-00029

4. FLUID

Use the fluids specified in the table below. Do not mix two different kinds or makes of fluid.

CAUTION:

For AT model, be sure to use the recommended ATF or equivalent. Otherwise it will cause trouble.

Fluid	Recommended materials	Item number	Alternative
Automatic transmission fluid	SUBARU ATF HP	—	Idemitsu: ATF HP
Power steering fluid	SUBARU ATF HP	—	DEXRON III
Brake fluid	FMVSS No. 116 DOT3	—	—
Clutch fluid	FMVSS No. 116 DOT3	—	FMVSS No. 116 DOT4

5. ENGINE COOLANT

Use genuine engine coolant to protect the engine.

Engine coolant	Recommended materials	Item number	Alternative
Coolant	SUBARU SUPER COOLANT (Concentrated type)	—	—
	SUBARU SUPER COOLANT (Diluted type)	K0670Y0000	
Water for dilution	Distilled water	—	Soft water or tap water
Cooling system protective agent	Cooling system conditioner	SOA345001	—

6. REFRIGERANT

Standard air conditioners on Subaru vehicles use HFC134a refrigerant. Do not mix it with other refrigerants. Also, do not use any air compressor oil except for DH-PR.

Air conditioner	Recommended materials	Item number	Alternative
Refrigerant	HFC134a	—	—
Compressor oil	DH-PR	—	—

Recommended Materials

RECOMMENDED MATERIALS

7. GREASE

Use grease and supplementary lubricants shown in the table below.

Grease	Application point	Recommended materials	Item number	Alternative
Supplementary lubricants	Oxygen sensor	Spray type lubricant	—	—
Grease	MT main shaft (spline parts)	NICHIMOLY N-130	—	—
	Clutch master cylinder push rod	SILICONE GREASE G-40M	004404003	—
	<ul style="list-style-type: none"> • Gear shift lever • Drive select lever (dual-range model) • Select lever (except for shift lock parts) 	NIGHTIGHT LYW No. 2 grease	—	KOPR-KOTE
	<ul style="list-style-type: none"> • Clutch operating cylinder • Clutch pedal • Brake pedal • Clutch release bearing • MT main shaft (oil seal lip) • Clutch release lever 	KOPR-KOTE	003603001	—
	Select lever (shift lock parts)	Suncall GLO-224	002948040	—
	<ul style="list-style-type: none"> • Door latch • Door striker 	SILICONE GREASE G-30M	004404002	—
	Steering gearbox	VALIANT GREASE M2	003608001	ONE LUBER SG
	Disc brake (lock pin, guide pin, piston boot)	Brake grease (NIGLUBE RX-2)	000041000	—
	Between brake pad and shim	Molykote AS-880N	K0777YA010	—
	Brake shoe (parking brake)	Molykote M7439	K0770YA000	—
	Front axle PTJ	NKG302	—	—
	Rear axle EBJ	NKG106	—	—
	Rear axle DOJ	NKG205	—	—

8. ADHESIVE

Use the adhesives shown in the table below, or equivalent.

Adhesive	Application point	Recommended materials	Item number	Alternative
Adhesive	Windshield glass, rear quarter glass, rear gate glass and body	Dow Automotive's Adhesive: ESSEX U-400 HV or equivalent Glass primer: U-401 and No. U-402 Paint surface primer: U-413	—	—
	Lower end of rear gate molding	Cemedine 3000 (jelly type)	—	—
	Rearview mirror base	REPAIR KIT IN MR	65029FC000	—

Recommended Materials

RECOMMENDED MATERIALS

9. SEAL MATERIAL

Use the seal material shown in the table below, or equivalent.

Seal material	Application point	Recommended materials	Item number	Alternative
Seal material	<ul style="list-style-type: none"> • Torque converter clutch case • Transmission case 	THREE BOND 1215	004403007	DOW CORNING No. 7038
	Transmission oil pan (AT model)	THREE BOND 1217B	K0877YA020	—
	<ul style="list-style-type: none"> • Rear differential • Oil pressure switch 	THREE BOND 1324	004403042	—
	<ul style="list-style-type: none"> • Rear differential • Service hole plug 	THREE BOND 1105	004403010	DOW CORNING No. 7038
	Steering adjusting screw	THREE BOND 1141	004403006	—
	<ul style="list-style-type: none"> • Front sealing cover • Rear sealing cover 	3M Butyl Rubber 8626	—	—
	<ul style="list-style-type: none"> • Engine oil pan • Separator cover • Camshaft cap • Cylinder block • Oil pump • DOHC rocker cover 	THREE BOND 1217G	K0877Y0100	—
	Rear differential	THREE BOND 1110B	K0879Y0020	—

PRE-DELIVERY INSPECTION

PI

	Page
1. Pre-delivery Inspection	2



1. Pre-delivery Inspection

A: GENERAL DESCRIPTION

The purposes of the pre-delivery inspection (PDI) are as follows.

- Remove the additional parts used for ensuring the vehicle quality during transportation and restore the vehicle to its normal condition.
- Check the vehicle before delivery is in normal condition.
- Check that there are no scratches on the vehicle and that none of the vehicle protective parts are missing when shipping or in storage.
- Make sure to provide a complete vehicle to customer.

For above reasons, all SOA service centers must carry out the PDIs before delivery of vehicle.

Furthermore, all SOA service centers and PDI centers must inspect the status of all vehicles and clarify the responsible party.

B: PRE-DELIVERY INSPECTION (PDI) PROCEDURE

Perform the procedures indicated in the table below.

Static Checks Just After Vehicle Receipt

Step	Check point
1. Appearance	<ol style="list-style-type: none"> 1. If the vehicle is covered with protective coating, visually check the vehicle body for damage and dents. If the protective coating has been removed, visually inspect the body paints for small areas of damage or rust. 2. Visually check the glass and light lenses for any damage, cracks or excessive gaps between body sheet metal. 3. Visually check the plated parts for any damage.
2. Tire	<ol style="list-style-type: none"> 1. Check the tires for damage, defective, and dents on wheels. 2. Check the tire air pressure.
3. Fuse	If the vehicle is about to be shipped to the customer, attach a room light fuse.
4. Door Lock/Unlock and open/close operations	<ol style="list-style-type: none"> 1. Using the key, check the trunk lid can be locked or unlocked normally. 2. Open and close all doors to check that there are no defective. 3. Operate the power door lock switch to check that all doors and the rear gate lock and unlock normally.
5. Child safety lock	Check the child safety lock system operates normally.
6. Rear gate Lock/Unlock and open/close operations	<ol style="list-style-type: none"> 1. Open and close the rear gate to see that there are no abnormal conditions. 2. Check if the rear gate can be unlocked normally through the emergency hole. 3. Operate the power door lock switch to check that all doors and the rear gate lock and unlock normally.
7. Fuel filler lid opener lock release lever	Operate the fuel filler lid opener to check that the fuel filler lid unlocks normally.
8. Accessory	<p>Check that the following accessories are provided.</p> <ul style="list-style-type: none"> • Owner's manual • Warranty booklet • Maintenance note • Spare key • Key number plate • Jack • Tool set • Spare tire • Towing hook (Eye bolt)
9. Front hood lock release system	Operate the front hood lock release lever to check that the front hood opens normally.
10. Battery	Check the battery for any abnormal conditions such as rust and trace of battery fluid leaks.
11. Brake fluid	Check the fluid amount.
12. Engine oil	Check the oil amount.
13. Transmission gear oil	Check that the transmission gear oil level is correct.
14. AT front differential oil	Check the AT front differential oil amount.
15. Engine coolant	Check the engine coolant amount.
16. Clutch fluid	Check the clutch fluid amount.
17. Window washer fluid	Check the window washer fluid amount.
18. Front hood latch	Check that the hood is closed and latched completely.
19. Keyless entry system	Check that the keyless entry system operates normally.
20. Security system (Alarm system)	Check that the security system (alarm system) operates normally.
21. Seat	<ol style="list-style-type: none"> 1. Check the seat surfaces for stains or dirt. 2. Check the seat installation conditions and functionality. 3. Check that the passenger's seat occupant detection system operates normally.
22. Seat belt	<ol style="list-style-type: none"> 1. Check the seat belt installation conditions and functionality. 2. Check the seat belt warning functionality for normal operations.
23. TPMS	<ol style="list-style-type: none"> 1. Turn the transmitter power of TPMS to ON. 2. When the display of the TPMS warning light does not operate normally, perform the diagnosis while referring to TPMS(diag).
24. ECM protector	Check that the ECM protector is installed for vehicles destined for Canada.

Pre-delivery Inspection

PRE-DELIVERY INSPECTION

Checks with the Engine Running

Step	Check point
25. Test mode connector	Check that the test mode connector is disconnected.
26. Immobilizer system	1. Check that the engine starts with all keys that are equipped on vehicle. 2. 60 seconds after turning ignition switch from ON to ACC or OFF, or immediately after removing the key, check that the security indicator light is blinking.
27. Starting condition	Start the engine and check that the engine starts smoothly.
28. Exhaust system	Check that the exhaust noise is normal and no leaks are found.
29. Indicator and warning lights	Check that all indicator lights and warning lights operate normally.
30. Heater & ventilation	Check that the heater & ventilation system operates normally.
31. Air conditioner	Check that the air conditioner operates normally.
32. Clock	Check that the clock operates normally.
33. Antenna	Install the antenna.
34. Radio	Check that the radio system operates normally.
35. Accessory power supply socket	Check that the accessory power supply socket operates normally.
36. Lighting system	Check that the lighting system operates normally.
37. Window washer	Check that the window washer system operates normally.
38. Headlight washer	Check the headlight washer operation.
39. Wiper	Check that the wiper system operates normally.
40. Power window operation check	Check the power window for normal operations.

Dynamic Test with the Vehicle Running

Step	Check point
41. Brake test	Check the foot brake for normal operations.
42. Parking brake	Check the parking brake for normal operations.
43. AT shift control	Check that the AT shifts normally.
44. Cruise control	Check that the cruise control system operates normally.

Checks after Dynamic Test

Step	Check point
45. ATF level	Check that the ATF level is correct.
46. Power steering fluid level	Check that the power steering fluid level is normal.
47. Fluid leakage	Check for fluid/oil leaks.
48. Water leakage	Spray the vehicle with water and check for water leaks.
49. Appearance 2	1. Remove the protective coat. (If attached) 2. Check the body paints for damage and stain. 3. Check the plated parts for damage and rust.

1. APPEARANCE

- 1) If the vehicle is covered with protective coating, visually check the vehicle body for damage and dents.
- 2) If there is no protective coat, check the body paints for damage or stains in detail and repair as necessary.
- 3) Check the window glass, door glass, and lights for any cracks or damage and replace the parts as necessary.
- 4) Check the plated parts, such as the grilles and door knobs, for damage or loss of gloss and replace the parts as necessary.

2. TIRE

- Check the outer side surface of the tire damage.
- Check the tire air pressure by referring to the following table.

Tire size	Tire inflation pressure kPa (kg/cm ² , psi)	
	Front	Rear
P215/65R16	210 (2.1, 30)	200 (2.0, 29)
P225/55R17	220 (2.2, 32)	210 (2.1, 30)

3. FUSE

Fuses for the room light circuit on initially delivered vehicles are removed to prevent battery discharge. Attach the 20 A fuse (A) as shown in the figure.

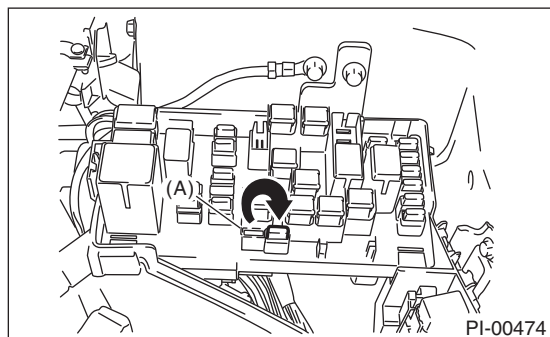

4. DOOR LOCK/UNLOCK AND OPEN/CLOSE OPERATIONS

- 1) Using the key, lock and unlock the door several times to check for normal operation. Open and close the door several times for smooth movement.

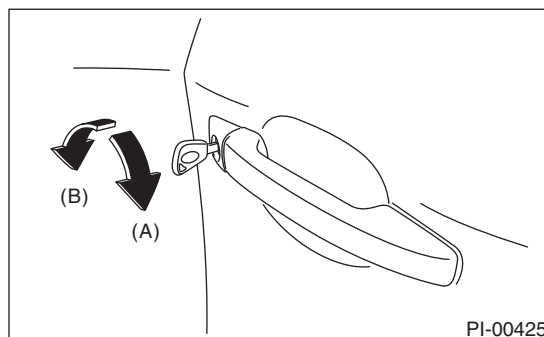

- (A) Unlock
- (B) Lock

- 2) Close the door of driver seat completely, and place the door lock knob (A) to the lock position. Then pull the inner remote (B) to ensure that doors will not open.

For other doors, place the door lock knob (A) to lock position and then pull the inner remote (B) to ensure that doors will not open.

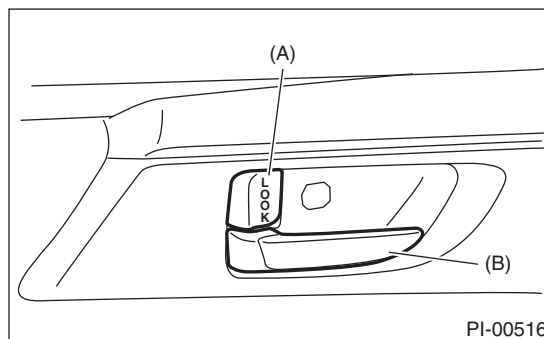

- (A) Door lock knob
- (B) Inner remote

- 3) Press the driver's power door lock switch to the lock side. Check that all doors (including the rear gate) lock.

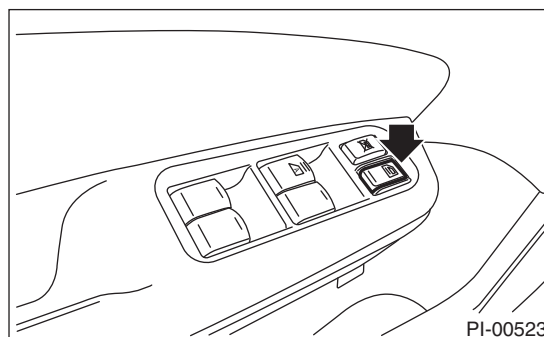

Pre-delivery Inspection

PRE-DELIVERY INSPECTION

4) Press the driver's power door lock switch to the unlock side. Check that all doors (including the rear gate) unlock.

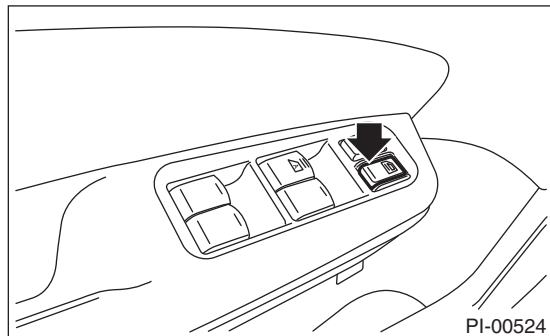

5. CHILD SAFETY LOCK

- 1) Set the child safety lock on both rear doors to the lock position.
- 2) Close the rear doors completely.
- 3) Check that the lock levers of the rear doors are in the unlock position. Then, pull inner remote of rear doors to ensure that doors will not open.
- 4) Pull the outer handles of the rear doors to ensure that doors will open.

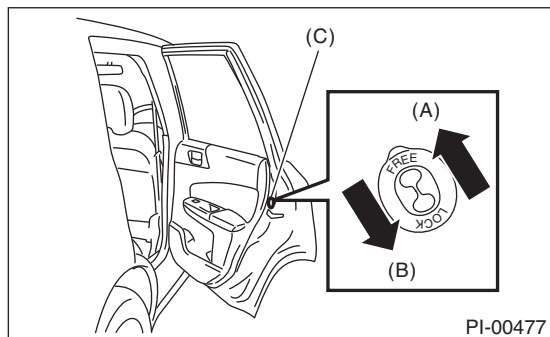

- (A) Unlock
- (B) Lock
- (C) Child safety lock

6. REAR GATE LOCK/UNLOCK AND OPEN/CLOSE OPERATIONS

- 1) Open and close the rear gate several times for smooth movement.
- 2) Operate the rear gate emergency lever to check that the rear gate unlocks normally.

(1) Remove the cover inside the rear gate.

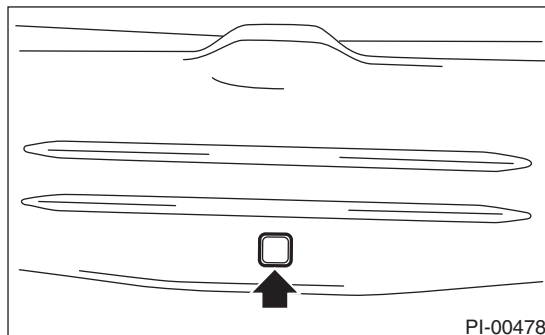

(2) Using a screwdriver, check that the rear gate is unlocked normally.

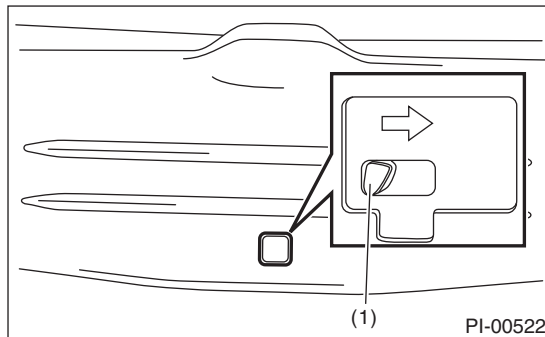

3) Press the driver's power door lock switch to the lock side. Check that all doors (including the rear gate) lock.

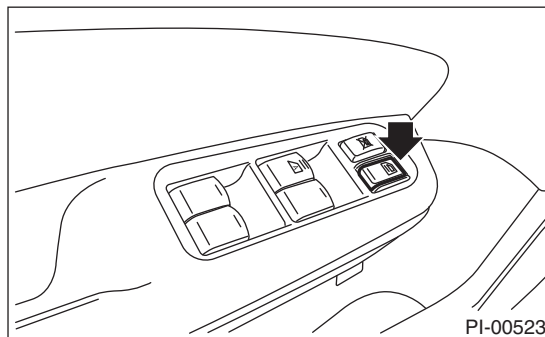

4) Press the driver's power door lock switch to the unlock side. Check that all doors (including the rear gate) unlock.

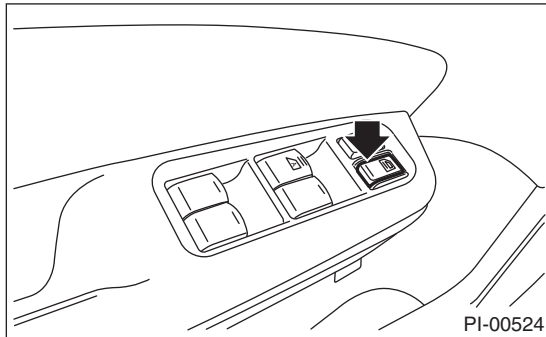

5) Lock all the doors including rear gate. Press the rear gate unlock button and the rear gate unlocks. Press the release button and open the rear gate. Check that the buzzer sounds twice and the hazard lights flash twice.

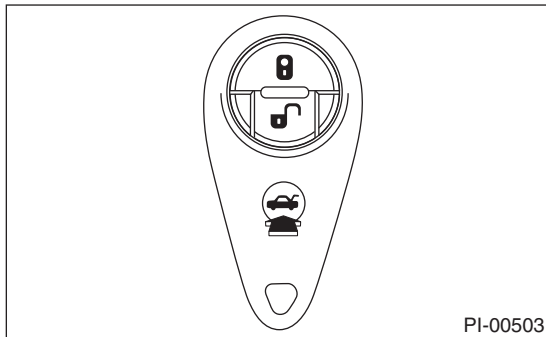

7. FUEL FILLER FLAP LID OPENER LOCK RELEASE LEVER

Operate the fuel filler lid opener to check that the fuel filler lid opens normally. Check that the fuel filler cap is closes securely.

8. ACCESSORY

Check that the following accessories are provided.

- Owner's manual
- Warranty booklet
- Maintenance note
- Spare key
- Key number plate
- Jack
- Tool set
- Spare tire
- Towing hook (Eye bolt)

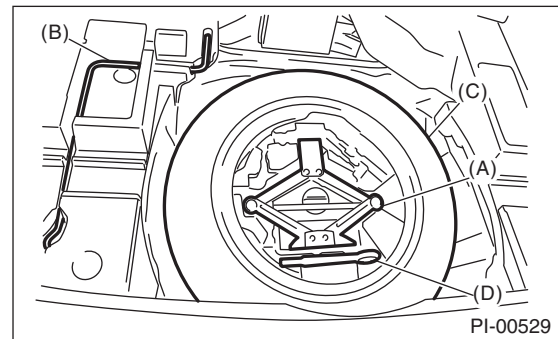

- (A) Jack
- (B) Jack handle
- (C) Spare tire
- (D) Towing hook (Eye bolt)

Pre-delivery Inspection

PRE-DELIVERY INSPECTION

9. FRONT HOOD LOCK RELEASE SYSTEM

Operate the front hood release knob to check that the front hood will unlock properly.

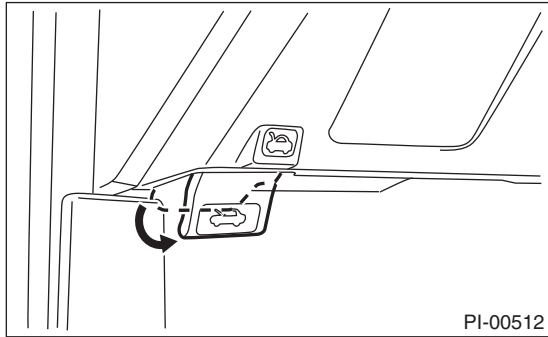

Operate the lever (A) and check that the front hood is opened normally.

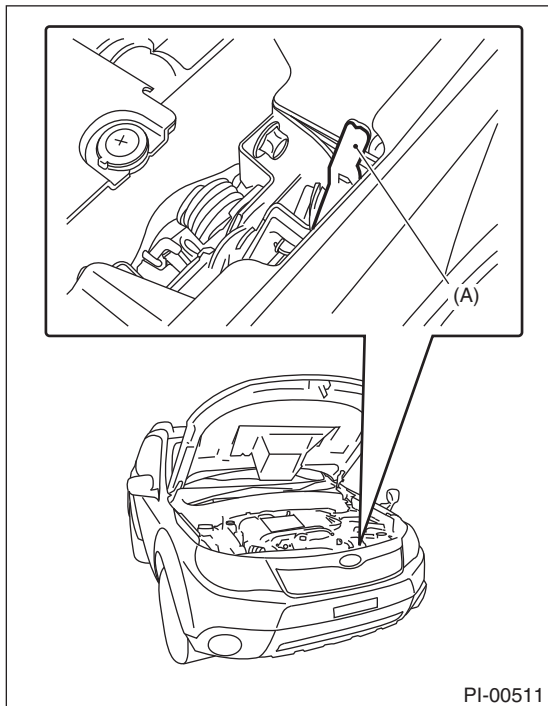

10. BATTERY

Check the battery terminals to make sure that no rust or corruptions due to fluid leaks. Check that the battery caps are securely tightened.

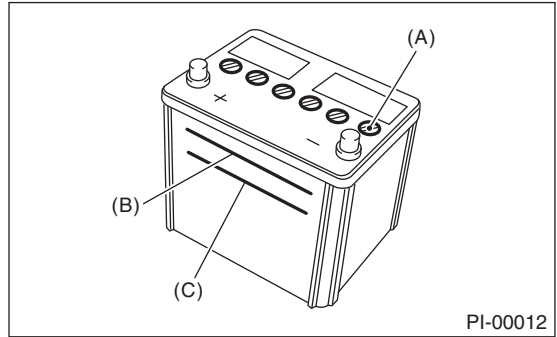

- (A) Cap
- (B) Upper level
- (C) Lower level

11. BRAKE FLUID

Check the brake fluid amount. If the amount is insufficient, carry out a brake line test to identify brake fluid leaks and check the brake operation. After that, refill the brake fluid tank with the specified type of fluid.

12. ENGINE OIL

Check the engine oil amount. If the amount of oil is insufficient, check that no leaks are found. Then, add the necessary amount of the specified engine oil.

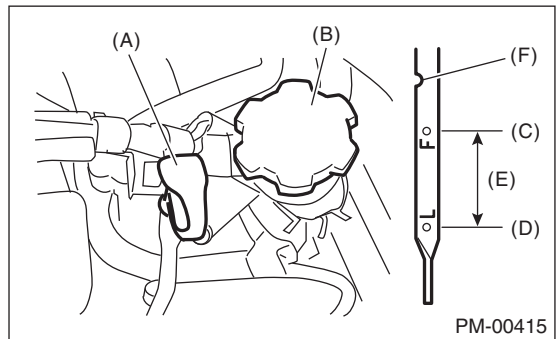

- (A) Engine oil level gauge
- (B) Engine oil filler cap
- (C) "F" line
- (D) "L" line
- (E) Approx. 1 \emptyset (1.1 US qt, 0.9 Imp qt)
- (F) Notch mark

13. TRANSMISSION GEAR OIL

Check the transmission gear oil amount. If the amount of gear oil is inappropriate, check that no leaks are found. Then, add the necessary amount of the specified gear oil.

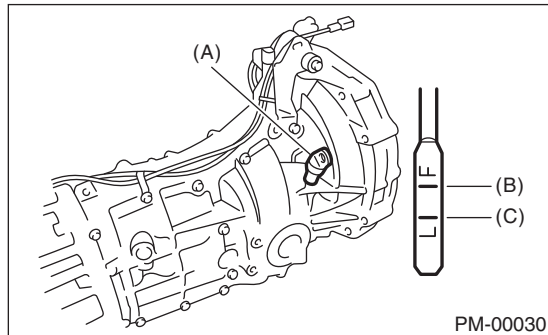

- (A) Oil level gauge
- (B) Upper level
- (C) Lower level

14. AT FRONT DIFFERENTIAL OIL

Check the AT front differential oil amount. If the amount of oil is inappropriate, check that no leaks are found. Then, add the necessary amount of the specified AT front differential oil.

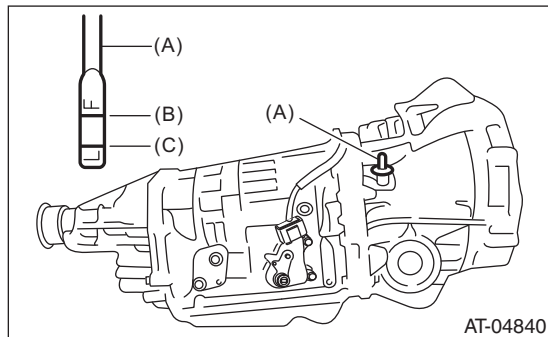

- (A) Oil level gauge
- (B) Upper level
- (C) Lower level

15. ENGINE COOLANT

Check the coolant amount on the reservoir. If the amount of engine coolant is insufficient, check that no leaks are found. Then, add the necessary amount of coolant with the specified concentration.

16. CLUTCH FLUID

Check the clutch fluid amount. If the amount of fluid is insufficient, check that no leaks are found. Then, add the necessary amount of specified fluid.

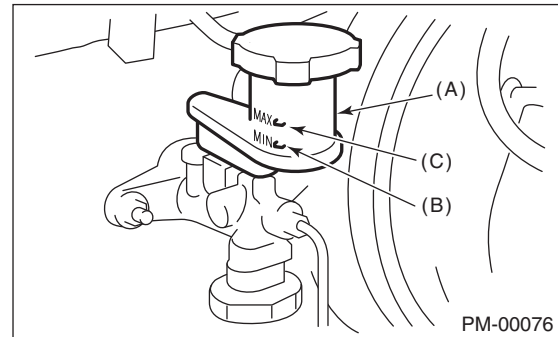

- (A) Reservoir tank
- (B) MIN. level
- (C) MAX. level

CAUTION:

If any clutch fluid is spilt on the exhaust pipe, wipe off completely to avoid emitting smoke or causing a fire.

17. WINDOW WASHER FLUID

Check the window washer fluid amount. If the amount is insufficient, check that no leaks are found. Then, add the necessary amount of washer fluid.

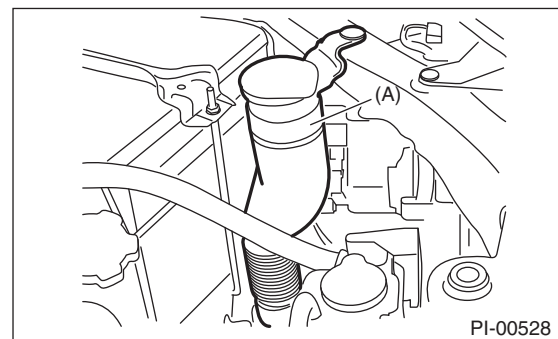

- (A) Window washer tank

18. FRONT HOOD LATCH

Close the front hood. Check that the front hood is completely latched.

Pre-delivery Inspection

PRE-DELIVERY INSPECTION

19. KEYLESS ENTRY SYSTEM

Check the keyless entry system operations as follows:

- Fully open all the door windows.
- Remove the key from the ignition switch and close all the doors including rear gate.
- Press the “” button momentarily on the keyless transmitter. Check if all the doors are locked, the buzzer sounds once and hazard light blinks once.

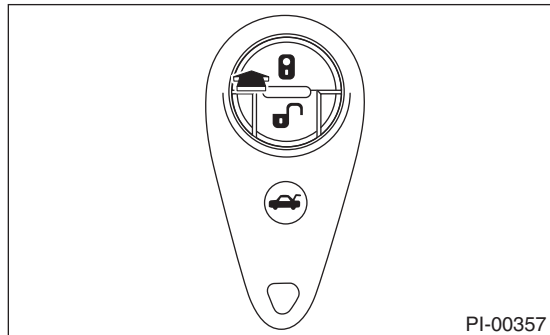

- Press the “” button momentarily on the keyless transmitter. Check if the driver’s side door is unlocked, the buzzer sounds twice and hazard light blinks twice.

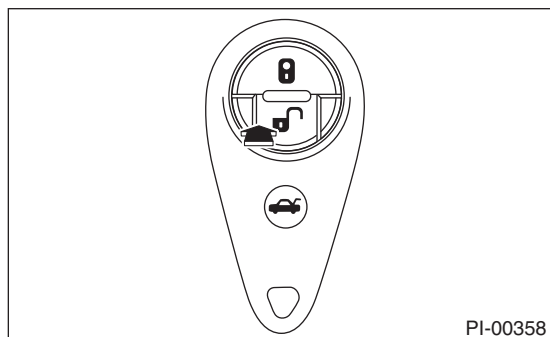

- Within five seconds, briefly press the “” button momentarily on the keyless transmitter. Check that all doors (including rear gate) are unlocked.
- Lock all the doors including rear gate. Press the rear gate unlock button and the rear gate unlocks. Press the release button and open the rear gate. Check that the buzzer sounds twice and the hazard lights flash twice.

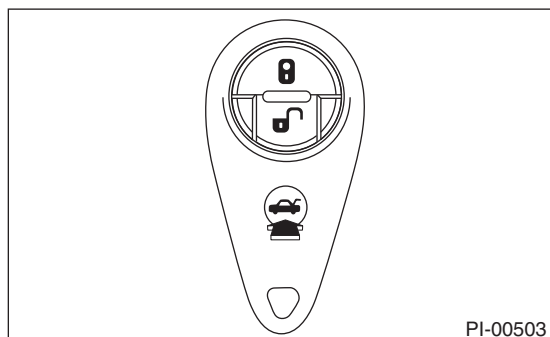

- Press the panic button of the keyless transmitter. Check whether a panic state (horn continuously honks) occurs. Also, check whether that state continues for 30 seconds or until the keyless transmitter button is pressed.

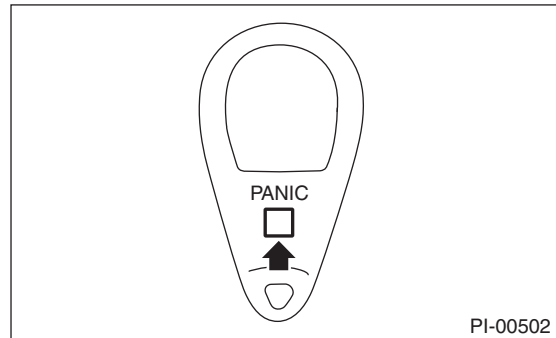

- Press the “” button once momentarily on the keyless transmitter with one door (including the rear gate) open. Check that the buzzer sounds five times and the door open warning is issued. Next, close all the doors including rear gate. Check if all the doors are locked, the buzzer sounds once and hazard light blinks once.
- Press the “LOCK” side of the power door switch with one door (including the rear gate) open. Next, close all the doors including rear gate. Check if all the doors are locked, the buzzer sounds once and hazard light blinks once.

- Driver’s side

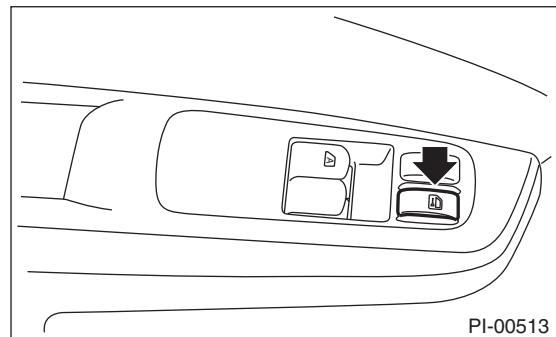

- Passenger’s side

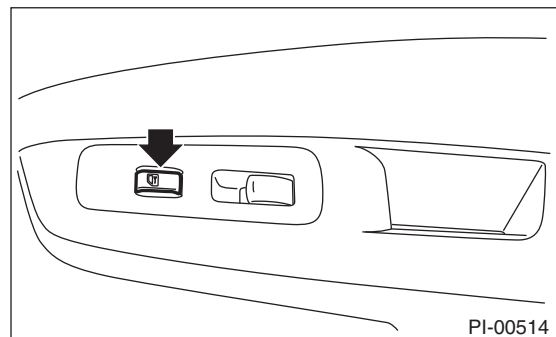

CHECK ANSWER BACK SOUND OPERATION

• The system uses a buzzer to sound an answer back when the doors are locked or unlocked. The answer back sound can be turned OFF if desired. To turn the answer back sound from ON to OFF, with all doors closed (the key is not in the key cylinder), insert the key into the key cylinder while pressing the “UNLOCK” side of the power door lock switch. Within 10 seconds after inserting/removing the key five times within or more 10 seconds, open/close the driver’s door. After the door is closed, the hazard lights flash three times indicating that the answer back sound is now OFF. Perform this same procedure to turn the answer back sound from OFF to ON. The hazard lights flash three times indicating that the answer back sound is now ON.

20.SECURITY SYSTEM

Check that the security system operates as indicated below.

- 1) Fully open all the door windows.
- 2) Remove the key from the ignition switch and close all the doors including rear gate.
- 3) Press the “” button on the keyless transmitter once.

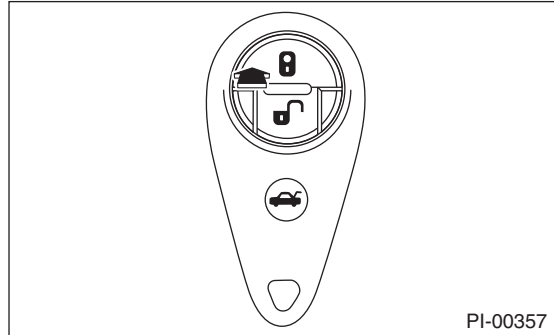

- 4) If all doors are locked, the buzzer sounds once, the hazard light blinks once and security indicator light flashes as shown in the figure, the alarm system is in the arming preparatory state.



- Alarm system arming preparatory state

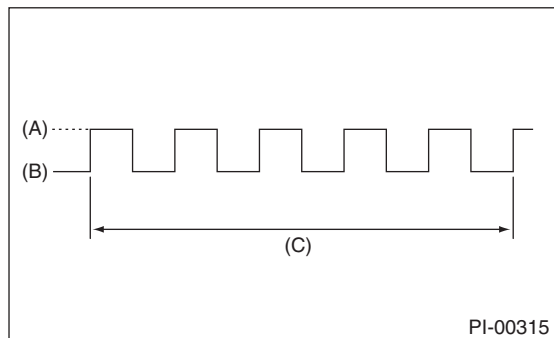

- (A) Light ON
- (B) Light OFF
- (C) 2 seconds

Pre-delivery Inspection

PRE-DELIVERY INSPECTION

5) Check that the system enters monitoring condition 30 seconds after the condition in 4).

- Alarm system monitoring condition (all models)

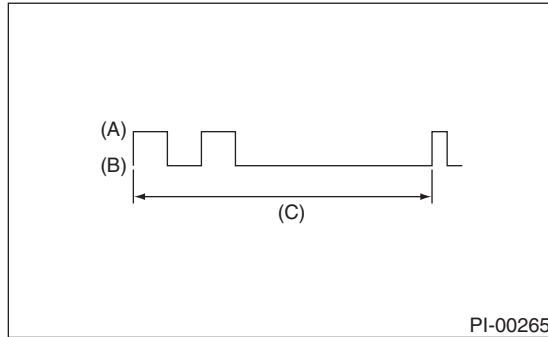

- (A) Light ON
- (B) Light OFF
- (C) 2 seconds

6) Press the “” button on the keyless transmitter once.

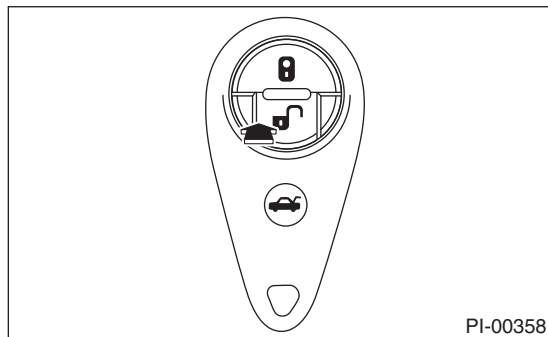

7) The driver’s side door is unlocked, the buzzer sounds twice and hazard light blinks twice, the room light lights up, and if the security indicator light flashes as shown in the figure below, the alarm system has been disarmed.



- Alarm system disarmed

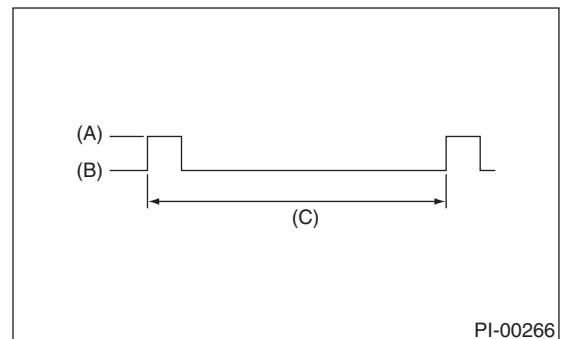

- (A) Light ON
- (B) Light OFF
- (C) 3 seconds

8) Press the “” button once on the keyless transmitter with one door (including the rear gate) open.

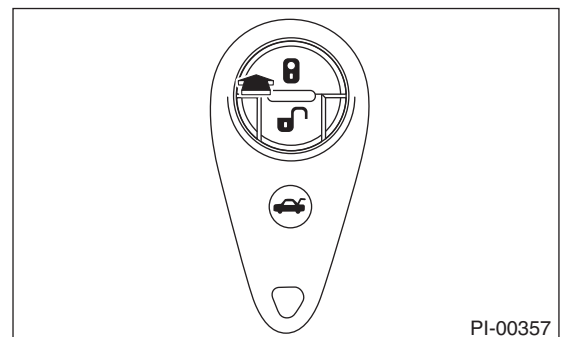

9) Check that the buzzer sounds five times and the door not fully closed warning.

10) Close all the doors including rear gate.

11) Check that it is in the monitoring condition (all the doors are locked, the buzzer sounds once and hazard light blinks once).

- Alarm system monitoring prepared condition

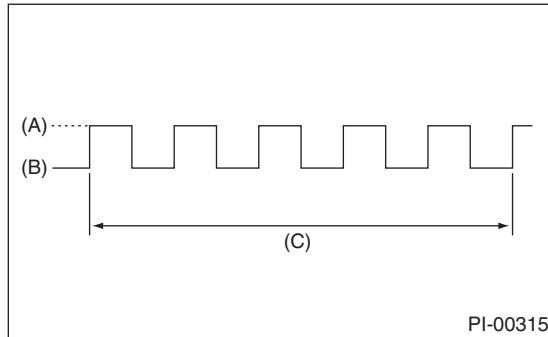

- (A) Light ON
- (B) Light OFF
- (C) 2 seconds

12) Check that the system enters monitoring condition 30 seconds after the condition 11).

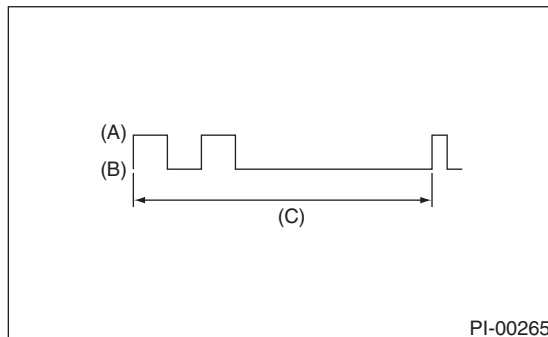

- (A) Light ON
- (B) Light OFF
- (C) 2 seconds

13) Press the “” button on the keyless transmitter once to disarm the system.

14) Press the “LOCK” side of the power door switch with one door (including the rear gate) open.

- Driver’s side

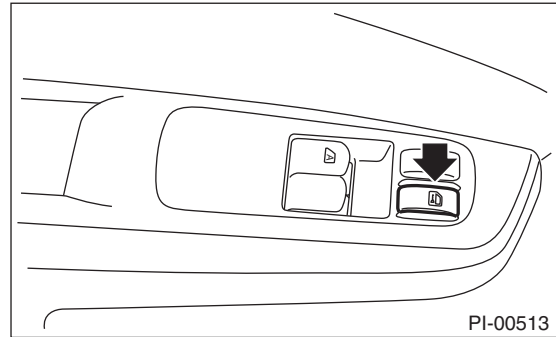

- Passenger’s side

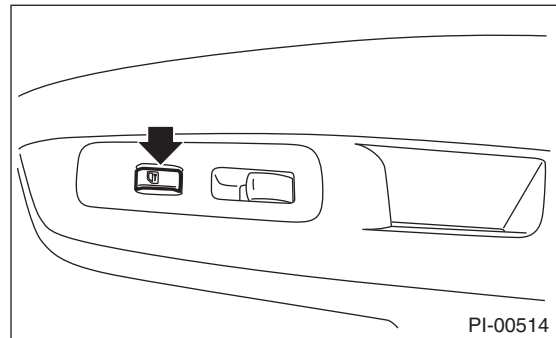

15) Close all the doors including rear gate.

16) If all the doors are locked, the buzzer sounds once and hazard light blinks once, the alarm system is in the monitoring prepared condition.

- Alarm system arming preparatory state

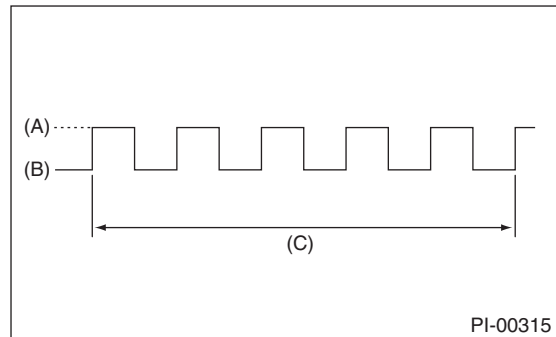

- (A) Light ON
- (B) Light OFF
- (C) 2 seconds

Pre-delivery Inspection

PRE-DELIVERY INSPECTION

17) Check that the system enters monitoring condition 30 seconds after the condition 15).

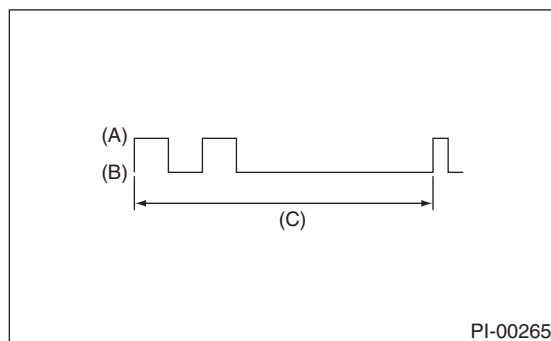

- (A) Light ON
- (B) Light OFF
- (C) 2 seconds

18) When the alarm system is in the monitoring condition, use the inner lock knob or key to unlock the door, and open the door.

19) Check that the alarm state (horn continuously honks, hazard light blinks, and security indicator light illuminates) has occurred.

20) Check that the state described in 18) continues either for 30 seconds or more, or until “” button of keyless transmitter is pressed, or until the ignition switch is turned to ON using the proper ignition key.

21) For model with impact sensor, manually tap on the windshield glass to cause an alarm to occur while the alarm system is in the monitoring condition.

22) Perform troubleshooting on the security system if the above does not apply. <Ref. to SL-22, INSPECTION, Security System.>

21. SEAT

1) Check that each seat provides full functionality in sliding and reclining. Check all of the functions of the rear seat.

2) Check the passenger's seat occupant detection system.

(1) Empty the passenger's seat and turn the ignition switch to ON.

(2) Check the ON and OFF of passenger's airbag indicator light come on simultaneously for about six seconds and go off for two seconds, and then only OFF comes on again.

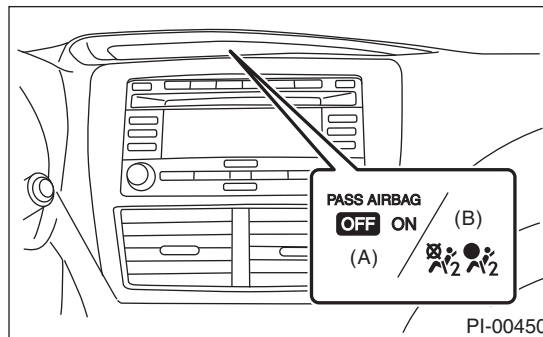

- (A) Airbag ON/OFF indicator light (U.S. model)
- (B) Airbag ON/OFF indicator light (Canada model)

(3) With a person sitting in the passenger's seat, and check if the passenger's airbag indicator lights in about four seconds.

(4) Empty the passenger's seat and check if the OFF of passenger's airbag indicator light comes on in about two seconds.

22. SEAT BELT

1) Pull out the seat belt and then release it. Check that the belt retracts smoothly.

2) Check seat belt warning system

(1) Turn the ignition switch to ON without fastening driver's and passenger's seat belts.

(2) Check if the seat belt warning lights of driver's and passenger's side blink for about six seconds and the buzzer beeps intermittently.

(3) Then, check that the seat belt warning light comes on and blinks in approximately 15 second cycles. (If the passengers seat is empty, seat belt warning light for passengers side does not operate.)

23.TPMS

1) Turn the ignition switch to ON, and confirm that the TPMS warning light operates normally.

- Normal operation (at IG ON (light check))

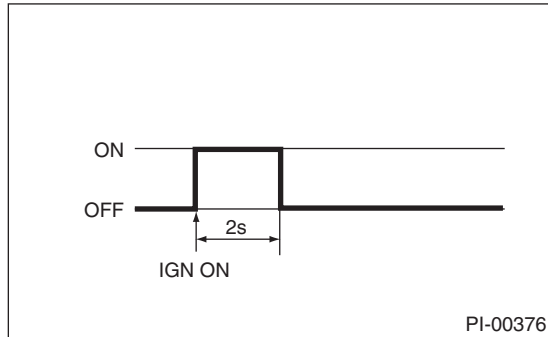

2) If the display of TPMS warning light does not operate normally, check and repair according to the procedures in the following table.

- All wheel transmitter power supplies OFF *1

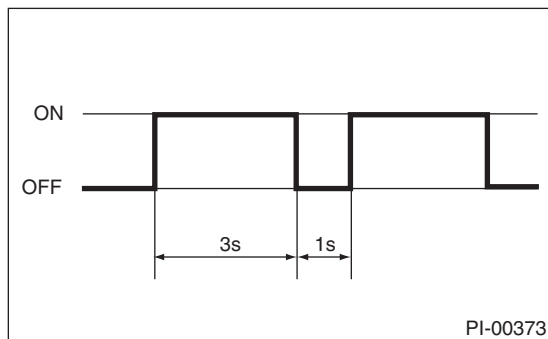

- No. 1 — 3 wheel transmitter power supplies OFF *2

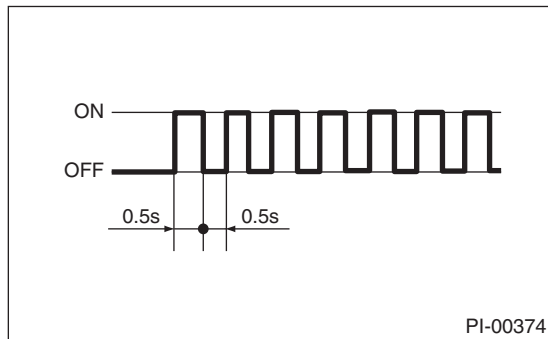

- Normal operation (at normal condition) *3

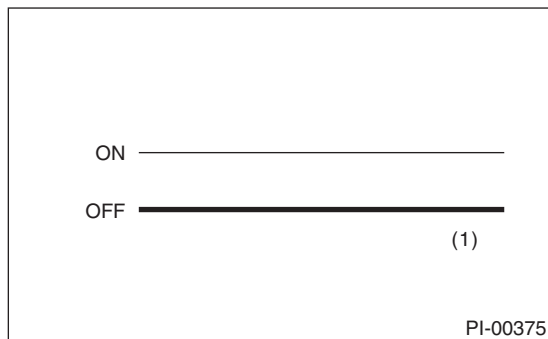

(1) Light OFF

- System failure (at normal condition)

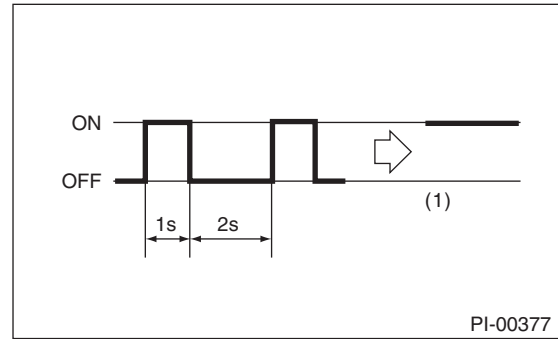

(1) Lights after blinking 25 times

- System failure (at IG ON)

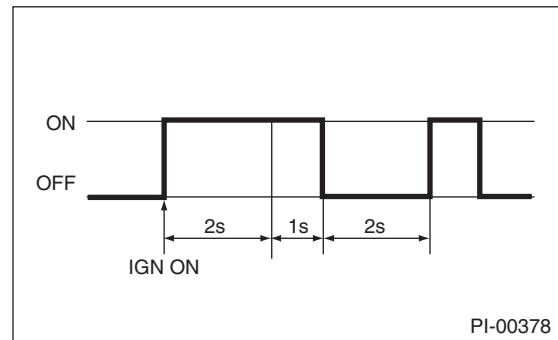

- At the tire air pressure decrease warning or ID unregistered

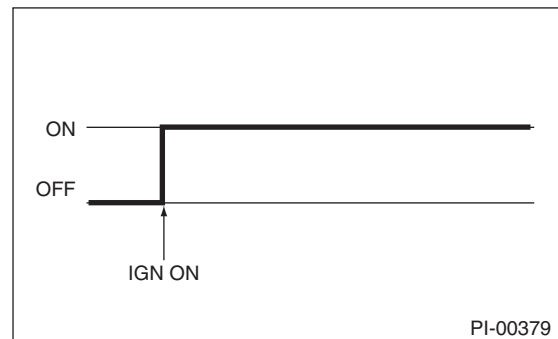

Pre-delivery Inspection

PRE-DELIVERY INSPECTION

Step	Check	Yes	No
1 CHECK TPMS WARNING LIGHT. 1) IG ON 2) Check the state of the TPMS warning light.	Does the state of the TPMS warning light become *1?	Go to step 2.	Go to step 3.
2 TURN THE VALVE POWER SUPPLY TO ON. 1) Contact the transmitter registration tool to the side wall near the air valve of the tire. 2) Press and hold the switch for 4 seconds or more. 3) Perform the same procedures for all wheels.	Does the state of the TPMS warning light become *3?	Go to step 10.	Go to step 9.
3 CHECK ID. 1) While checking the display of the Subaru Select Monitor, transmit the transmitter ID by using the transmitter registration tool.	Does the ID of the installed transmitter match the registered ID?	Go to step 6.	Go to step 4.
4 RE ID REGISTRATION. 1) Register the transmitter. 2) After the ID registration, check if the state of the TPMS warning light becomes *3.	Does the state of the TPMS warning light become *3?	Go to step 11.	Go to step 6.
5 CHECK TIRE PRESSURE. 1) Check the tire pressure for all tires. 2) Adjust the tire pressure. 3) Check the state of the TPMS warning light.	Does the state of the TPMS warning light become *3?	Go to step 7.	Go to step 6.
6 DIAGNOSIS. 1) Using the Subaru Select Monitor, check the diagnostic history.	Is DTC displayed on the Subaru Select Monitor?	Repair the trouble cause. <Ref. to TPM(diag)-2, PROCEDURE, Basic Diagnostic Procedure.>	Go to step 7.
7 CLEAR TROUBLE HISTORY. 1) Using the Subaru Select Monitor, perform the Clear Memory.	Is DTC displayed on the Subaru Select Monitor?	Repair the trouble cause. <Ref. to TPM(diag)-2, PROCEDURE, Basic Diagnostic Procedure.>	Go to step 8.
8 CHECK TPMS WARNING LIGHT. 1) IG OFF 2) IG ON 3) Check the state of the TPMS warning light.	Does the TPMS warning light display show *3?	Finish the procedures.	Perform the diagnosis again. <Ref. to TPM(diag)-2, PROCEDURE, Basic Diagnostic Procedure.>
9 CHECK TPMS WARNING LIGHT.	Does the state of the TPMS warning light become *1 or *2?	Go to step 3.	Go to step 5.
10 TRANSMIT DATA FORCIBLY. 1) Contact the transmitter registration tool to the side wall near the air valve of the tire. 2) Press and hold the switch for 4 seconds or more. 3) Perform the same procedures for all wheels.	Does the state of the TPMS warning light become *3?	Finish the procedures.	Go to step 5.
11 TRANSMIT DATA FORCIBLY. 1) Contact the transmitter registration tool to the side wall near the air valve of the tire. 2) Press and hold the switch for 4 seconds or more. 3) Perform the same procedures for all wheels.	Does the state of the TPMS warning light become *3?	Go to step 7.	Go to step 5.

24. ECM PROTECTOR

Check the install condition of the ECM protector is installed for vehicles for Canada models. Check the special nuts and plastic cover of the ECM protector are firmly installed.

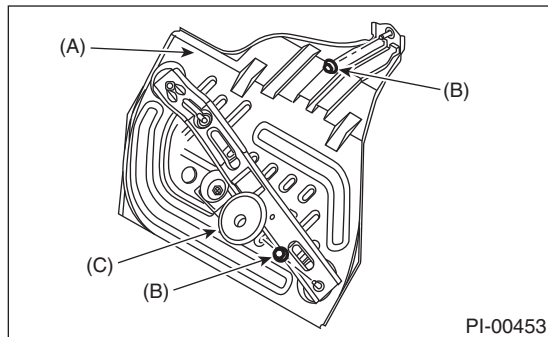

- (A) ECM protector
- (B) Special nut
- (C) Plastic cover

25. TEST MODE CONNECTOR

- 1) Turn the ignition switch to ON and check that the malfunction indicator light starts blinking.
- 2) If the light blinks, return the ignition key to LOCK.

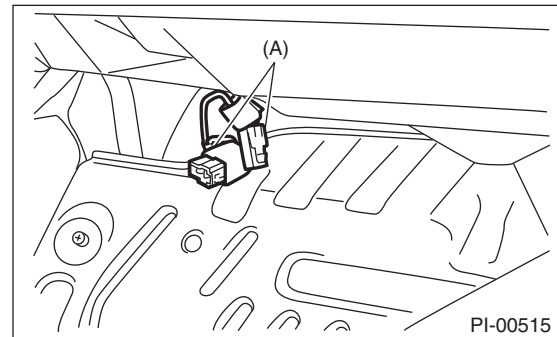

- (A) Test mode connector (Green)

- 3) Disconnect the test mode connector from under the feet of the passenger's seat.
- 4) Then, turn the ignition key to ON again.
- 5) If the malfunction indicator light blinks at that time in spite of the disconnected test mode connector, carry out an engine diagnosis.
- 6) Insert the disconnected test mode connector into the backside of the ECM protector.

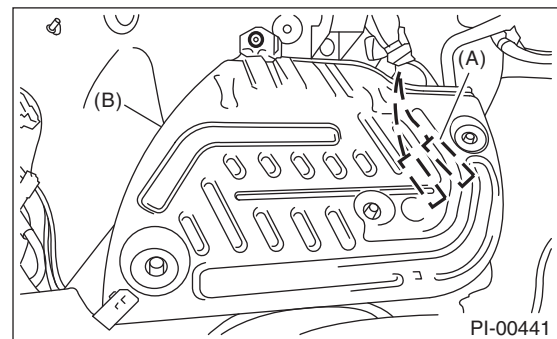

- (A) Test mode connector
- (B) ECM protector

26. IMMOBILIZER SYSTEM

- 1) Check if all keys of the vehicle can start the engine.
- 2) 60 seconds after turning the ignition switch from ON to ACC or OFF, or immediately after removing the key, check if the security indicator light blinks.

NOTE:

If malfunctions occur, refer to "IMMOBILIZER (diag)".

27. STARTING CONDITION

Start the engine and check that the engine starts smoothly. If the battery voltage is low, recharge or replace the battery. If any noises are observed, immediately stop the engine and check and repair the abnormal components.

Pre-delivery Inspection

PRE-DELIVERY INSPECTION

28. EXHAUST SYSTEM

Listen to the exhaust noise to see if no noises are observed.

29. INDICATOR AND WARNING LIGHTS

Check that all indicator lights and warning lights operate normally.

30. HEATER & VENTILATION

Operate the heater & ventilation system to check for normal airflow outlet control, air inlet control, airflow capacity and heating performance.

31. AIR CONDITIONER

Operate the air conditioner. Check that the A/C compressor operates normally and enough cooling is provided.

NOTE:

To prevent the insufficient lubrication of the air conditioner, operate the air conditioner for five minutes at idling.

32. CLOCK

Check the clock for normal operations and enough accuracy.

33. ANTENNA

Install the antenna.

- 1) Remove the cap from the antenna base.
- 2) Tighten the antenna rod on the rear seat by hand in the direction indicated by the arrow to install.

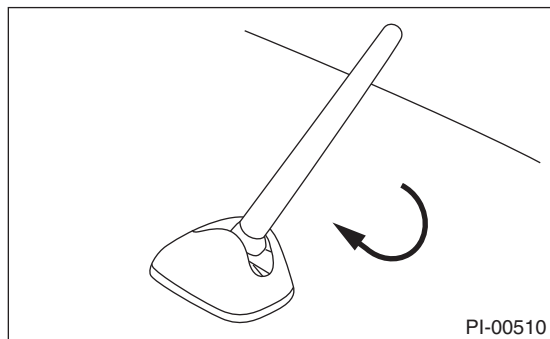

- 3) Make sure that radio reception operates correctly after installation.

34. RADIO

Check the radio for full functionality and normal noise level. Also check the CD unit operations.

35. ACCESSORY POWER SUPPLY SOCKET

- 1) Check operation of the accessory power supply socket in console box.
- 2) Check operation of the accessory power supply socket in luggage room.

36. LIGHTING SYSTEM

- 1) Check the headlight operations.
- 2) Check the stop light operation.
- 3) For model with manual headlight beam levelizer, check the operation of headlight beam levelizer.
- 4) Check other lights for normal operations.

37. WINDOW WASHER

Check that the window washer system injects washer fluid to the specified area of the windshield and rear window glass shown in the figure.

Front injection position:

A: 250 mm (9.84 in)

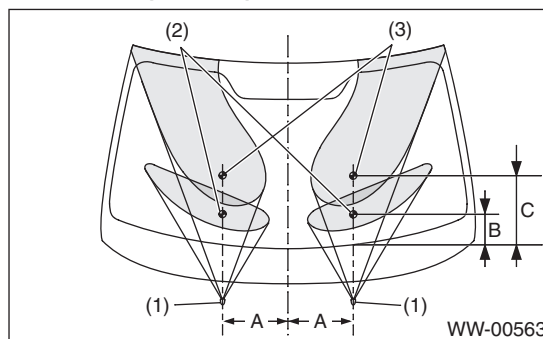

- (1) Nozzle
- (2) Center of upper nozzle
- (3) Center of lower nozzle

Rear injection position:

A: 72°

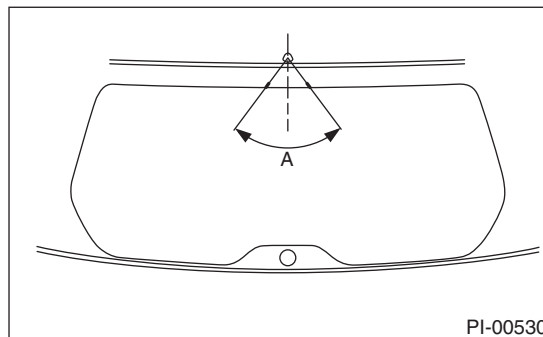

38. HEADLIGHT WASHER

For models with headlight washers, turn the ignition switch and the headlights ON. Check that the headlight washers operate when the front wiper washer switch has been ON for 0.6 seconds (approximately 1 second).

NOTE:

The headlight washers stop operation within 0.6 seconds of the front wiper washer switch being turned OFF.

39. WIPER

Check the front and rear wipers for normal operations.

40. POWER WINDOW

Operate the power window switches one by one to check that each of the power windows goes up and down without noises.

41. BRAKE TEST

Check the foot brake for normal operations.

42. PARKING BRAKE

Check the parking brake for normal operations. When pulling the parking brake lever with a force of 196 N (20 kgf, 44 lb), check that the lever stroke of parking brake lever is 7 to 8 notches.

43. AT SHIFT CONTROL

- 1) Turn the ignition switch to ON.
- 2) While brake pedal is not depressed, check if the select lever does not move from "P" range.
- 3) While brake pedal is depressed, check if the select lever moves from "P" range.
- 4) Set the select lever to other than "P" range.
- 5) When the ignition switch is turned OFF, check if the ignition key switch cannot be removed.
- 6) Set the AT selector lever to each gear position while checking that the demanded gear position is correctly attained.

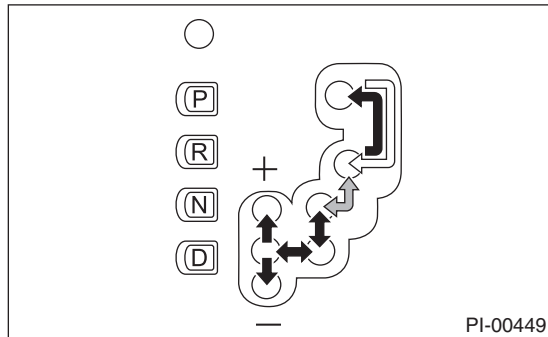

Selector position	Gear position			
	1st	2nd	3rd	4th
D	OK	OK	OK	OK
Manual mode	OK	OK	OK	OK

44. CRUISE CONTROL

Operate the cruise control system. Check that the system is activated and deactivated correctly.

45. ATF LEVEL

After selecting all positions (P, R, N, D), set the select lever in P range. Measure the ATF level with engine idling for one or two minutes. If the amount of ATF is insufficient, check that no leaks are found. Then, add the necessary amount of the specified ATF.

CAUTION:

Fill completely with the specified ATF. <Ref. to RM-4, FLUID, RECOMMENDED MATERIALS, Recommended Materials.>

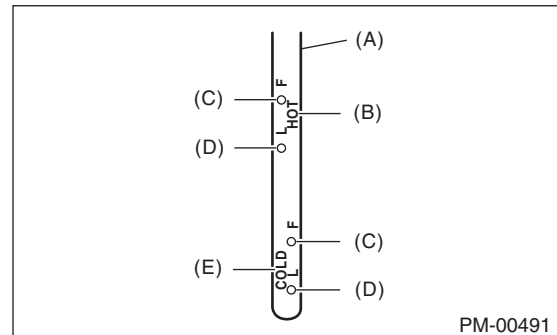

- (A) Level gauge
- (B) Inspection position when "HOT"
(70 — 80°C (158 — 176°F))
- (C) Upper level
- (D) Lower level
- (E) Inspection position when "COLD"
(20 — 30°C (68 — 86°F))

46. POWER STEERING FLUID LEVEL

Check that the power steering fluid level is normal. If insufficient, check for leaks. Then add the necessary amount of the specified power steering fluid.

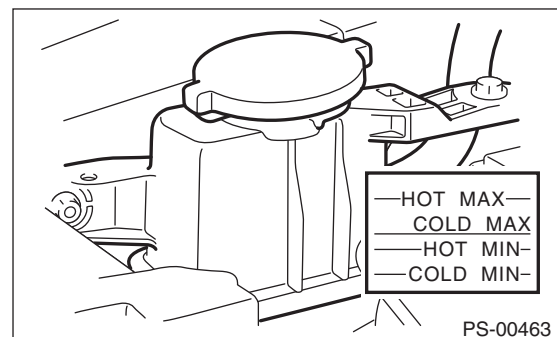

47. FLUID LEAKAGE

Check entire areas of the vehicle for any trace of coolant/oil/fluid leaks.

Pre-delivery Inspection

PRE-DELIVERY INSPECTION

48. WATER LEAKAGE

Spray the vehicle with water using a hose and check that no water enters the passenger compartment.

- Before performing the water leakage test, remove anything that may obstruct the operation or which must be kept dry.
- Close all the windows and doors securely. Close the front hood before starting the test.
- Connect a hose to a tap, and spray water on the vehicle. The rate of water spray must be approx. 20 to 25 ℓ (5.3 — 6.6 US gal, 4.4 — 5.5 Imp gal) per minute.

When spraying water on areas adjacent to the floor and wheel house, increase the pressure. When spraying water on areas other than the floor and wheel house, decrease the pressure. But the force of water must be made strong occasionally by pressing the end of the hose.

NOTE:

Be sure to keep the hose at least 10 cm (3.9 in) away from vehicle.

Check the following areas.

- Front window and body framework mating portion
- Door mating portions
- Glass mating portions
- Rear quarter window mating portions
- Rear window and body framework mating portion
- Around roof drips

If any dampness in the compartments is discovered after the water has been applied, carefully check all the areas that may have possibly contributed to the leak.

49. APPEARANCE 2

1) When vehicle body is covered with protective film (wrap guard), peel it off.

NOTE:

- It is easier to remove the wrap guard using steam.
 - For the vehicle left for a long time or at low temperature, sprinkle some water heated 50 — 60°C (122 — 140°F) over the vehicle to raise its surface temperature before peeling off the wrap guard. Do not use the water heated to over 60°C (140°F).
 - If the adhesive remains exists on the coated surface, soak a flannel rag, etc. with a small amount of coating wax or solvent such as oil benzene and IPA, put the soaked cloth on the remains lightly, and then wipe them off with a flannel rag etc.
 - Keep solvent from touching the resin or rubber parts. Do not use coating wax or solvent while the component surface temperature is high due to hot weather etc.
 - If the coated surface is swollen out due to seams or moisture, expose the vehicle to the sunlight for a few hours or heat the seam and swollen portions using a dryer etc.
 - Dispose of the peeled wrap guard as burnable industrial garbage.
 - If a yellow label is attached to the fog light lens, remove it.
- 2) Check the whole vehicle body for flaking paint, damage by transportation, corrosion, dirt, cracks or blisters.

NOTE:

- It is better to determine an inspection pattern in order to avoid missing an area, since the total inspection area is wide.
 - Do not repair the body paint unless absolutely necessary. Also, if the vehicle is in need of repair to remove scratches or corroded paint, the repair area must be limited to the minimum. Re-painting and spray painting must be avoided as much as possible.
- 3) Check each window glass for scratches carefully. Slight damage may be removed by polishing with cerium oxide. (Fill a cup half with cerium oxide, and add warm water to it. Then agitate the content until it turns to wax. Apply this wax to a soft cloth, and polish the glass with it.)
- 4) Check each portion of the vehicle body and underside components for the formation of rust. If rust is discovered, remove it with sandpaper of #80 to #180 and treat the surface with rust preventive. After this treatment is completed, flush the portion thoroughly, and prepare the surface for repair painting.
- 5) Check each portion of body and all of the exterior parts for deformation or distortion. Also, check each light lens for cracks.

PERIODIC MAINTENANCE SERVICES

PM

	Page
1. General Description	2
2. Schedule	3
3. Engine Oil	7
4. Engine Oil Filter	9
5. Spark Plug	10
6. V-belt	12
7. Timing Belt	14
8. Fuel Line	17
9. Fuel Filter	18
10. Air Cleaner Element	19
11. Cooling System	20
12. Engine Coolant	22
13. Clutch System	24
14. Transmission Gear Oil	25
15. Automatic Transmission Fluid	26
16. Front & Rear Differential Gear Oil	28
17. Brake Line	30
18. Brake Fluid	33
19. Disc Brake Pad and Disc	34
20. Parking Brake	35
21. Suspension	36
22. Wheel Bearing	38
23. Axle Boots & Joints	39
24. Tire Rotation	40
25. Steering System (Power Steering)	41

General Description

PERIODIC MAINTENANCE SERVICES

1. General Description

A: GENERAL DESCRIPTION

Be sure to perform periodic maintenance in order to maintain vehicle performance and find problems before they occur.

Schedule

PERIODIC MAINTENANCE SERVICES

2. Schedule

A: MAINTENANCE SCHEDULE

1. FOR U.S. MODEL

		MAINTENANCE INTERVAL [Number of months or km (miles), whichever occurs first]																	Remarks
Months		3	7.5	15	22.5	30	37.5	45	52.5	60	67.5	75	82.5	90	97.5	105	112.5	120	
× 1,000 km		4.8	12	24	36	48	60	72	81.4	96	108	120	132	144	156	168	180	192	
× 1,000 miles		3	7.5	15	22.5	30	37.5	45	52.5	60	67.5	75	82.5	90	97.5	105	112.5	120	
1	Engine oil	R	R	R	R	R	R	R	R	R	R	R	R	R	R	R	R	R	Non-turbo Model
		Replace every 3 ³ / ₄ months or 6,000 km (3,750 miles)																	Turbo Model
2	Engine oil filter	R	R	R	R	R	R	R	R	R	R	R	R	R	R	R	R	R	Non-turbo Model
		Replace every 3 ³ / ₄ months or 6,000 km (3,750 miles)																	Turbo Model
3	Spark plug					R				R					R			R	Non-turbo Model
										R									R
4	Drive belt					I				I				I			R		
5	Timing belt					I				I				I			R		
6	Fuel line					(I)				(I)				(I)				I	Note (1)
7	Fuel filter									R								R	Note (1)
8	Air cleaner element					R				R				R				R	Note (2)
9	Cooling system					I				I				I				I	
10	Engine coolant	Replace after the first 11 years or 220,000 km (137,500 miles), and every six years or 120,000 km (75,000 miles) thereafter																	
11	Clutch system			I		I		I		I		I		I		I		I	
12	Transmission oil					I				I				I				I	
13	ATF					I				I				I				I	
14	Front & rear differential gear oil					I				I				I				I	
15	Brake line			I		I		I		I		I		I		I		I	
16	Brake fluid					R				R				R				R	
17	Disc brake pads and discs					I				I				I				I	
18	Brake linings and drums					I				I				I				I	
19	Parking brake			I		I		I		I		I		I		I		I	
20	Suspension			I		I		I		I		I		I		I		I	
21	Wheel bearing									(I)								(I)	
22	Axle boots and joints			I		I		I		I		I		I		I		I	
23	Tire rotation		I	I	I	I	I	I	I	I	I	I	I	I	I	I	I	I	Note (3)
24	Steering system (Power steering)			I		I		I		I		I		I		I		I	
25	Air conditioner filter	Replace every 12 months or 12,000 km (7,500 miles)																	

Symbol

R: Replace

I: Inspect

(R) or (I): Inspections recommended for vehicle safety

Schedule

PERIODIC MAINTENANCE SERVICES

NOTE:

1. This inspection is not necessary to observe exhaust gas regulations or is the responsibility of the manufacturer under the current basic EPA regulations that must be observed by law.
2. Replace the air cleaner element more frequently than the periodic replacement if the vehicle is being used in an excessively dusty environment.
3. Replace the tires if the tread-wear indicator has caused a bar-shaped cut across the tread. The indicator will appear when the remaining amount of tread is less than 1.6 (0.063 in).

2. FOR CANADA MODEL

		MAINTENANCE INTERVAL																	Remarks
		[Number of months or km (miles), whichever occurs first]																	
Months		3	7.5	15	22.5	30	37.5	45	52.5	60	67.5	75	82.5	90	97.5	105	112.5	120	
× 1,000 km		4.8	12	24	36	48	60	72	81.4	96	108	120	132	144	156	168	180	192	
× 1,000 miles		3	7.5	15	22.5	30	37.5	45	52.5	60	67.5	75	82.5	90	97.5	105	112.5	120	
1	Engine oil	R	R	R	R	R	R	R	R	R	R	R	R	R	R	R	R	R	Non-turbo Model
	Replace every 3 ³ / ₄ months or 6,000 km (3,750 miles)																	Turbo Model	
2	Engine oil filter	R	R	R	R	R	R	R	R	R	R	R	R	R	R	R	R	R	Non-turbo Model
	Replace every 3 ³ / ₄ months or 6,000 km (3,750 miles)																	Turbo Model	
3	Spark plug					R				R				R				R	Non-turbo Model
										R								R	Turbo Model
4	Drive belt					I				I				I			R		
5	Timing belt					I				I				I			R		
6	Fuel line					(I)				(I)				(I)				I	Note (1)
7	Fuel filter									R								R	Note (1)
8	Air cleaner element					R				R				R				R	Note (2)
9	Cooling system					I				I				I				I	
10	Engine coolant	Replace after the first 11 years or 220,000 km (137,500 miles), and every six years or 120,000 km (75,000 miles) thereafter																	
11	Clutch system			I		I		I		I		I		I		I		I	
12	Transmission oil					I				I				I				I	
13	ATF					I				I				I				I	
14	Front & rear differential gear oil					I				I				I				I	
15	Brake line			I		I		I		I		I		I		I		I	
16	Brake fluid					R				R				R				R	
17	Disc brake pads and discs					I				I				I				I	
18	Brake linings and drums					I				I				I				I	
19	Parking brake			I		I		I		I		I		I		I		I	
20	Suspension			I		I		I		I		I		I		I		I	
21	Wheel bearing									(I)								(I)	
22	Axle boots and joints			I		I		I		I		I		I		I		I	
23	Tire rotation		I	I	I	I	I	I	I	I	I	I	I	I	I	I	I	I	Note (3)
24	Steering system (Power steering)			I		I		I		I		I		I		I		I	
25	Air conditioner filter	Replace every 12 months or 12,000 km (7,500 miles)																	

Schedule

PERIODIC MAINTENANCE SERVICES

Symbol

R: Replace

I: Inspect

(R) or (I): Inspections recommended for vehicle safety

NOTE:

1. This inspection is not necessary to observe exhaust gas regulations or is the responsibility of the manufacturer under the current basic EPA regulations that must be observed by law.
2. Replace the air cleaner element more frequently than the periodic replacement if the vehicle is being used in an excessively dusty environment.
3. Replace the tires if the tread-wear indicator has caused a bar-shaped cut across the tread. The indicator will appear when the remaining amount of tread is less than 1.6 (0.063 in).

Schedule

PERIODIC MAINTENANCE SERVICES

B: PERIODIC REPLACEMENT PARTS

Item	Every	Repeat short distance drive	Repeat rough muddy road drives	Extremely cold weather area	Salt or other corrosive used or coastal area	High humidity or mountain area	Repeat towing trailer
Engine oil	3.75 months	R		R			R
	6,000 km						
	3,750 miles						
Engine oil filter	3.75 months	R		R			R
	6,000 km						
	3,750 miles						
Fuel filter	15 months				I		
	24,000 km						
	15,000 miles						
Fuel line	15 months				I		
	24,000 km						
	15,000 miles						
Transmission oil	15 months						R
	24,000 km						
	15,000 miles						
ATF	15 months						R
	24,000 km						
	15,000 miles						
Front & rear differential gear oil	15 months						R
	24,000 km						
	15,000 miles						
Brake line	15 months	I	I		I		I
	24,000 km						
	15,000 miles						
Brake fluid	15 months					R	
	24,000 km						
	15,000 miles						
Disc brake pads and discs	15 months	I	I		I		I
	24,000 km						
	15,000 miles						
Brake linings and drums	15 months	I	I		I		I
	24,000 km						
	15,000 miles						
Parking brake	15 months	I	I		I		I
	24,000 km						
	15,000 miles						
Suspension	7.5 months		I	I	I		I
	12,000 km						
	7,500 miles						
Axle boots and joints	7.5 months	I	I	I	I		I
	12,000 km						
	7,500 miles						
Steering system (Power steering)	7.5 months	I	I	I	I		I
	12,000 km						
	7,500 miles						

3. Engine Oil

A: REPLACEMENT

- 1) Set the vehicle on a lift.
- 2) Open the engine oil filter cap for quick draining of engine oil.

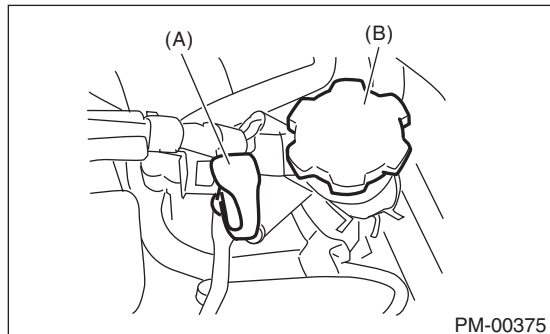

- (A) Oil level gauge
- (B) Oil filler cap

- 3) Lift up the vehicle.
- 4) Drain engine oil by loosening the engine oil drain plug.

- Non-turbo model

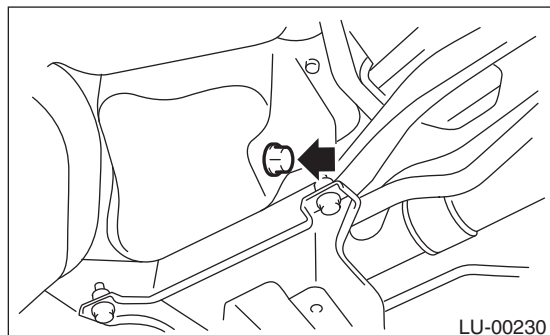

- Turbo model

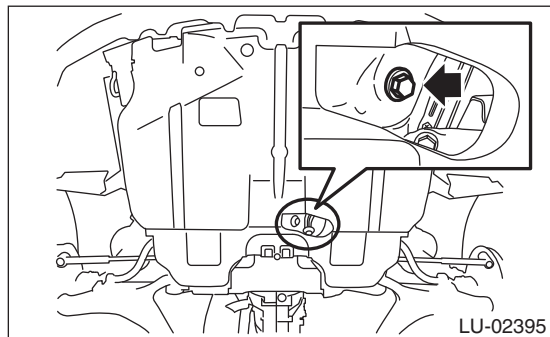

- 5) Replace the drain plug gasket.

NOTE:

Use a new drain plug gasket.

- 6) Tighten the engine oil drain plug after draining engine oil.

Tightening torque:

44 N·m (4.5 kgf-m, 32.5 ft-lb)

- Non-turbo model

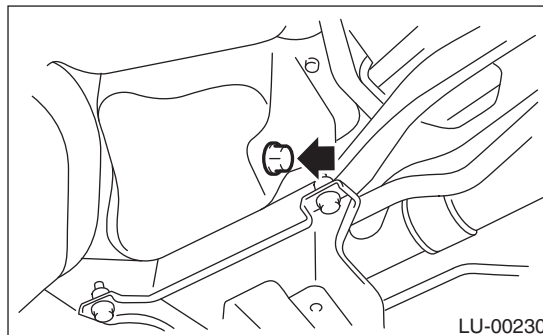

- Turbo model

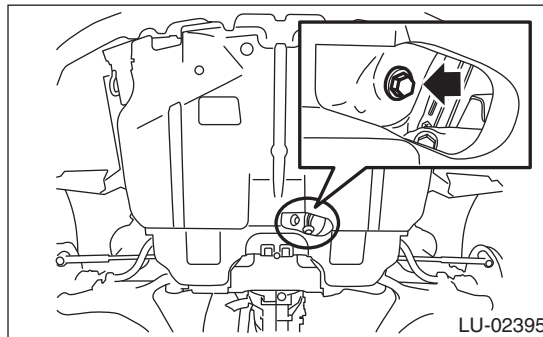

NOTE:

Prepare the container for draining of engine oil.

CAUTION:

If any engine oil is spilled on the exhaust pipe, wipe off completely to prevent fires or emission of smoke.

Engine Oil

PERIODIC MAINTENANCE SERVICES

7) Using engine oil of proper quality and viscosity, fill engine oil through the oil filler duct to the “F” line on oil level gauge. Place the vehicle on a level surface when checking oil level.

Recommended oil

For engine oil viscosity, refer to RM section. <Ref. to RM-2, LUBRICANTS, RECOMMENDED MATERIALS, Recommended Materials.>

Engine oil capacity

Refer to “SPC” section for the engine oil capacity. <Ref. to SPC-4, CAPACITY, Forester.>

NOTE:

- The vehicle will start well even when temperatures are low or high by increasing the cranking speed by reducing viscous friction for the appropriate viscosity.
- When replacing the oil, it is acceptable to use oil from a different manufacturer than the oil previously used. However, you must use an oil that matches the API standards and SAE viscosity specified by Subaru.
- It is acceptable to use oil having the viscosities described below if the vehicle is being used in desert locations or in excessive environments where temperatures are extremely high.

API standard: SM or SL

ILSAC standard: GF-4

SAE viscosity No.: 30, 40, 10W-50, 20W-40, 20W-50

8) Close the engine oil filler cap.

9) Start the engine and warm it up for a time.

10) Stop the engine to inspect the oil level again.

<Ref. to PM-8, INSPECTION, Engine Oil.>

B: INSPECTION

CAUTION:

If any engine oil is spilled on the exhaust pipe, wipe off completely to prevent fires or emission of smoke.

- 1) Park the vehicle on a level surface.
- 2) Remove the oil level gauge and wipe it clean.
- 3) Reinsert the oil level gauge all the way. Be sure that the oil level gauge is correctly inserted and properly orientated.
- 4) Remove the level gauge again and record the oil level. If the engine oil level is below “L” line, add oil to bring the level up to “F” line.
- 5) Start the engine and warm it up for a time.
- 6) After turning off the engine, wait a few minutes for the oil to return to the oil pan before checking the level.

CAUTION:

To prevent overfilling of engine oil, do not add oil above “F” line when the engine is cold.

NOTE:

- Just after driving or while the engine is still warm, engine oil level shows in the range between “F” line and cutout portion. This is caused by thermal expansion of engine oil.
- As the oil level gauge is used for daily maintenance, the “F” line and “L” line is set assuming that the engine is cold.

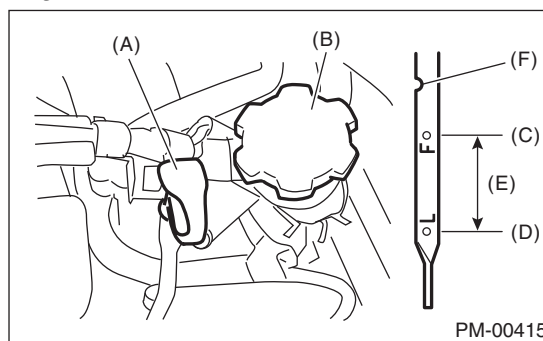

- (A) Oil level gauge
- (B) Oil filler cap
- (C) “F” line
- (D) “L” line
- (E) Approx. 1 ℓ (1.1 US qt, 0.9 Imp qt)
- (F) Notch mark

4. Engine Oil Filter

A: REPLACEMENT

1) Remove the clips (A) fastening the under cover service hole and turn the service hole cover in the direction indicated by the arrow. (Turbo model)

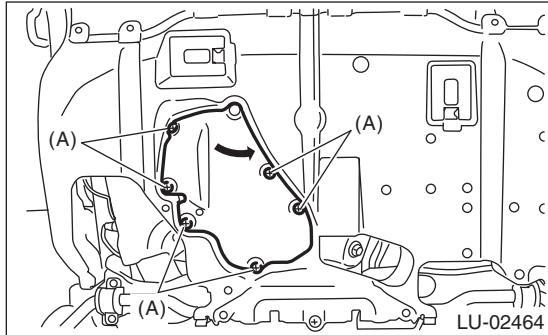

2) Remove the oil filter.

- Black oil filter

Remove using the ST.

ST 18332AA000 OIL FILTER WRENCH (OUTER DIAMETER: 68 MM (2.68 IN) FOR OIL FILTER)

- Blue oil filter

Remove using general tools (65/67 mm 14 Flutes).

CAUTION:

If any engine oil is spilled on the exhaust pipe, wipe off completely to prevent fires or emission of smoke.

- Non-turbo model

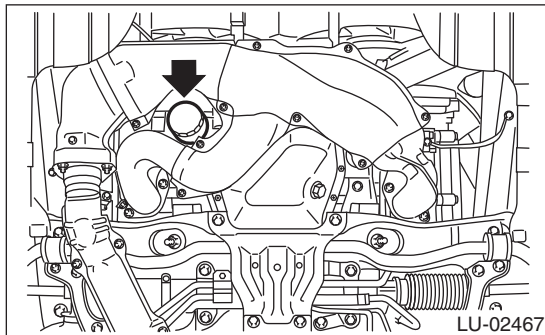

- Turbo model

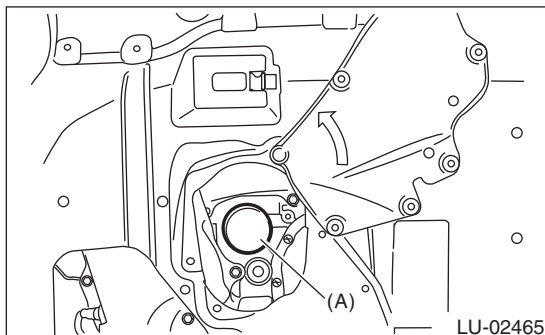

(A) Oil filter

3) Clean the oil filter installation surface on cylinder block.

4) Obtain a new engine oil filter and apply a thin coat of engine oil to the seal rubber.

5) Install the oil filter turning it by hand, being careful not to damage the seal rubber of the oil filter.

CAUTION:

Do not tighten excessively, or oil may leak.

- Tighten the black oil filter (outer diameter: 68 mm (2.68 in)) (approx. one rotation) after the seal rubber of the oil filter comes in contact with cylinder block. When using a torque wrench, tighten to 14 N·m (1.4 kgf-m, 10.3 ft-lb).

- Tighten the blue oil filter (outer diameter: 67.4 mm (2.65 in)) (approx. 7/8 rotations) after the seal rubber of the oil filter comes in contact with cylinder block. When using a torque wrench, tighten to 12 N·m (1.2 kgf-m, 8.9 ft-lb).

6) After installing the oil filter, run the engine and make sure that no oil is leaking around seal rubber.

NOTE:

The filter element and filter case are permanently jointed, therefore, interior cleaning is not necessary.

7) Return the service hole cover to its original position. (Turbo model)

8) Check the engine oil level. <Ref. to PM-8, INSPECTION, Engine Oil.>

Spark Plug

PERIODIC MAINTENANCE SERVICES

5. Spark Plug

A: REPLACEMENT

1. SOHC MODEL

- 1) Disconnect the battery cable, and then remove the battery and battery carrier.
- 2) Remove the air cleaner lower case.
- 3) Disconnect the spark plug cord.

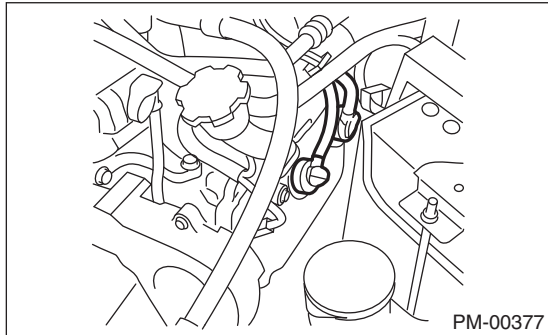

- 4) Remove the spark plug with a plug-wrench.
- 5) Install a new spark plug.

Recommended spark plug:

<Ref. to SPC-2, ELECTRICAL, Forester.>

- 6) Tighten the spark plug lightly with hand, and then secure with a plug-wrench to the specified torque.

Tightening torque:

21 N·m (2.1 kgf-m, 15.5 ft-lb)

NOTE:

- Be sure to place the gasket between the cylinder head and spark plug.
- If the torque wrench is not available, tighten the spark plug until gasket contacts cylinder head, then tighten further 1/4 to 1/2 turns.

2. DOHC MODEL

Recommended spark plug:

<Ref. to SPC-2, ELECTRICAL, Forester.>

1) RH side

- (1) Remove the collector cover.
- (2) Disconnect the ground cable from the battery.

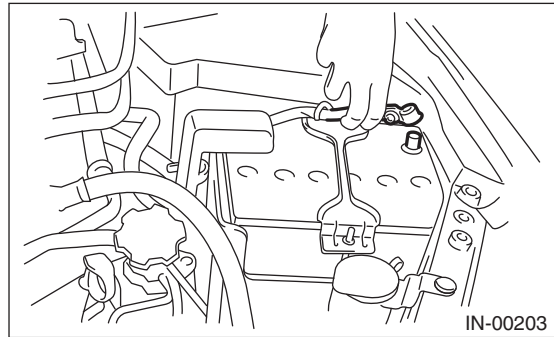

- (3) Remove the air cleaner case. **<Ref. to IN(H4DOTC)-8, REMOVAL, Air Cleaner Case.>**
- (4) Disconnect the connector from ignition coil.
- (5) Remove the ignition coil.

NOTE:

Turn #3 ignition coil by 180 degrees to remove it.

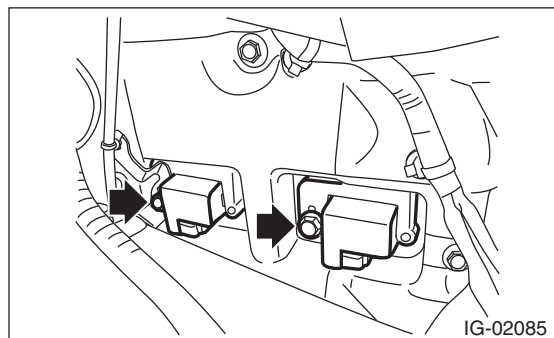

- (6) Remove the spark plug with a spark plug socket.
- (7) Install in the reverse order of removal.

Tightening torque (Spark plug):

21 N·m (2.1 kgf-m, 15.5 ft-lb)

Tightening torque (Ignition coil):

16 N·m (1.6 kgf-m, 11.8 ft-lb)

2) LH side

- (1) Remove the collector cover.
- (2) Remove the battery and battery carrier.
- (3) Disconnect the air duct from the secondary air pump.
- (4) Remove the bolts that attach the air pump duct to the rocker cover (LH), and raise the air pump duct.

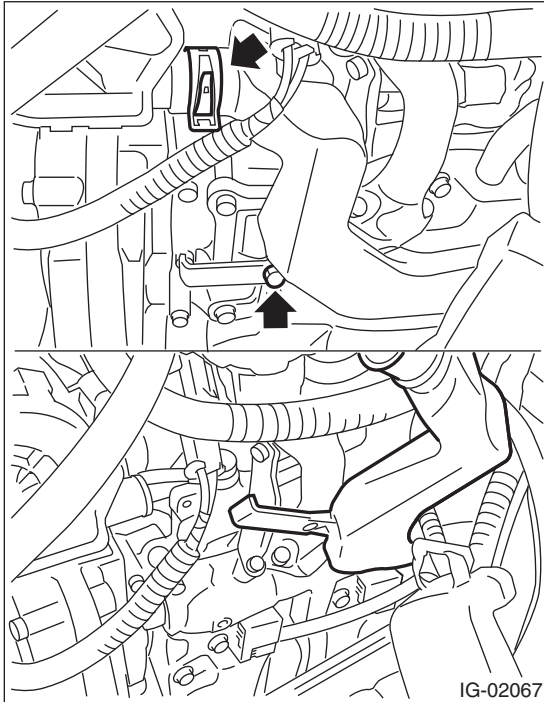

- (5) Disconnect the connector from ignition coil.
- (6) Remove the ignition coil.

NOTE:

Turn #4 ignition coil by 180 degrees to remove it.

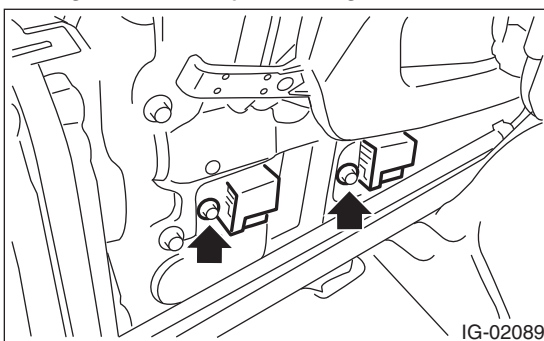

- (7) Remove the spark plug with a spark plug socket.
- (8) Install in the reverse order of removal.

Tightening torque (Spark plug):

21 N·m (2.1 kgf·m, 15.5 ft·lb)

Tightening torque (Ignition coil):

16 N·m (1.6 kgf·m, 11.8 ft·lb)

Tightening torque (Air pump duct):

9 N·m (0.9 kgf·m, 6.6 ft·lb)

6. V-belt

A: INSPECTION

NOTE:

The rear belt does not require tension adjustment because it is a stretch-type belt.

1. PROCEDURE NOT USING BELT A TENSION GAUGE

- 1) Replace the belts, if crack, fraying or wear is found.
- 2) Check the V-belt tension and adjust it if necessary by changing the generator installing position or idler pulley installing position. <Ref. to PM-13, REPLACEMENT, V-belt.>

Belt tension (when pressed with 98 N (10 kgf, 22 lbf))

When replacing: 7 — 9 mm (0.276 — 0.354 in)

When reusing: 9 — 11 mm (0.354 — 0.433 in)

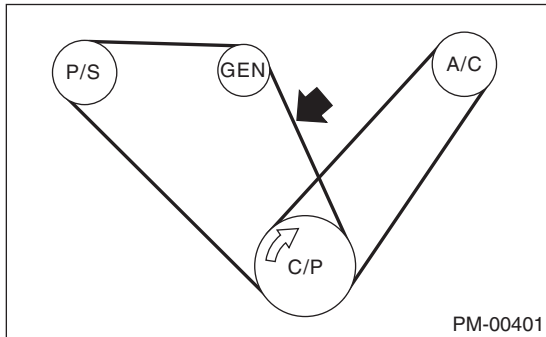

- C/P Crank pulley
- GEN Generator
- P/S Power steering oil pump pulley
- A/C A/C compressor pulley

2. PROCEDURE WITH BELT TENSION GAUGE

- 1) Replace the belts, if crack, fraying or wear is found.
- 2) Remove the V-belt cover and radiator reservoir tank.
- 3) Check the tension of the V-belt using the belt tension gauge. Adjust the tension if necessary by adjusting the installation position of the generator or idler pulley.

Belt tension (Non-turbo model)

When installing new parts:

640 — 780 N (65 — 80 kgf, 144 — 175 lbf)

At inspection:

490 — 640 N (50 — 65 kgf, 110 — 144 lbf)

Belt tension (Turbo model)

When installing new parts:

640 — 780 N (65 — 80 kgf, 144 — 175 lbf)

At inspection:

490 — 640 N (50 — 65 kgf, 110 — 144 lbf)

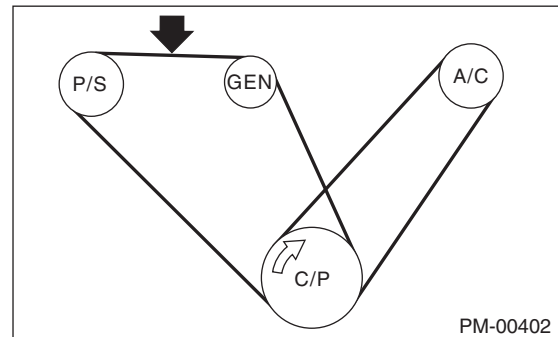

- C/P Crank pulley
- GEN Generator
- P/S Power steering oil pump pulley
- A/C A/C compressor pulley

B: REPLACEMENT**1. V-BELT COVER**

Remove the V-belt covers. (Non-turbo model)

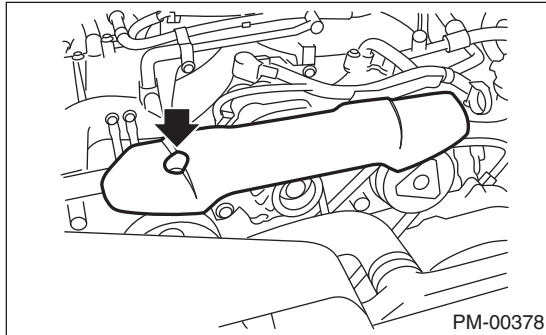
**2. FRONT SIDE BELT (FOR POWER STEERING OIL PUMP AND GENERATOR)****NOTE:**

Wipe off any oil or water on the belt and pulley.

- 1) Loosen the lock bolt (A).
- 2) Loosen the slider bolt (B).
- 3) Remove the front side belt (C).
- 4) Install a new belt, and tighten the slider bolt so as to obtain the specified belt tension.
- 5) Tighten the lock bolt (A).
- 6) Tighten the slider bolt (B).

Tightening torque:**Lock bolt**

25 N·m (2.5 kgf·m, 18.4 ft·lb)

Slider bolt

8 N·m (0.8 kgf·m, 5.9 ft·lb)

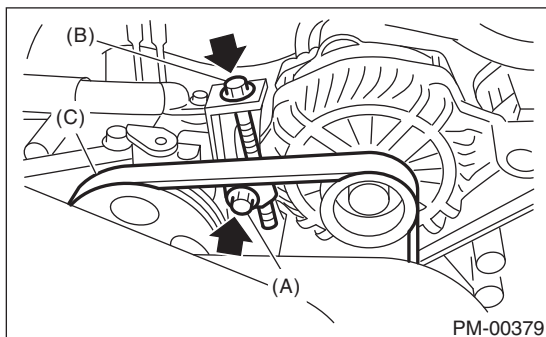

- 7) Start and run the engine for approximately five minutes to allow the V-belt to become fitted. (When using the gauge)
- 8) Stop the engine, check the belt tension and adjust as necessary. (When using the gauge)
- 9) Start and run the engine for approximately one minute to allow the V-belt to become fitted. (When using the gauge)
- 10) Stop the engine and check that the belt tension is within the specification. (When using the gauge)
- 11) Adjust until the specified belt tension is obtained. (When using the gauge)

3. REAR SIDE BELT (FOR AIR CONDITIONER)**CAUTION:**

Always use a new rear side belt.

- 1) Remove the front side belts.
- 2) Cut the rear side belt.
- 3) Install a new belt using an installation jig. <Ref. to ME(H4SO)-43, REAR SIDE BELT, INSTALLATION, V-belt.> <Ref. to ME(H4DOTC)-40, REAR SIDE BELT, INSTALLATION, V-belt.>
- 4) Install the front side belt. <Ref. to ME(H4SO)-42, FRONT SIDE BELT, INSTALLATION, V-belt.>

Timing Belt

PERIODIC MAINTENANCE SERVICES

7. Timing Belt

A: REPLACEMENT

1. NON-TURBO MODEL

- 1) Remove the radiator fan and air conditioner fan. <Ref. to CO(H4SO)-24, REMOVAL, Radiator Main Fan and Fan Motor.> <Ref. to CO(H4SO)-26, REMOVAL, Radiator Sub Fan and Fan Motor.>
- 2) Protect the radiator with cardboard and blanket.
- 3) Remove the V-belt covers.

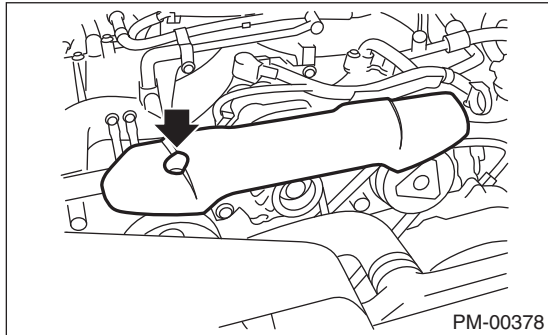

- 4) Remove the V-belts. <Ref. to ME(H4SO)-42, REMOVAL, V-belt.>

- 5) Remove the A/C compressor V-belt tensioner.

- 6) Using the ST, lock the crankshaft and remove pulley bolt.

- MT model

ST 499977100 CRANK PULLEY WRENCH

- AT model

ST 499977400 CRANK PULLEY WRENCH

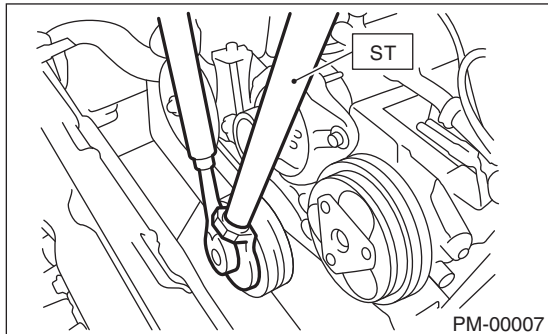

- 7) Remove the crank pulley.

- 8) Remove the belt cover LH.

- 9) Remove the front timing belt cover.

- 10) Remove the timing belt guide. (MT model)

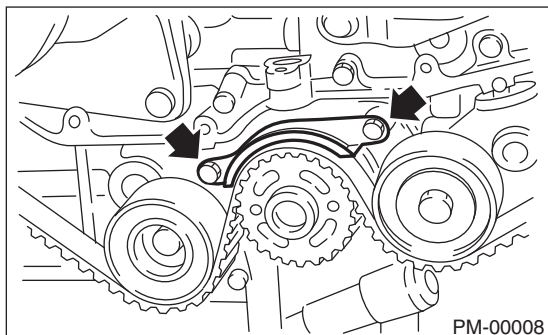

- 11) Turn the crankshaft and align the alignment marks on crankshaft, and left and right cam sprockets with notches of belt cover and cylinder block.

ST 499987500 CRANKSHAFT SOCKET

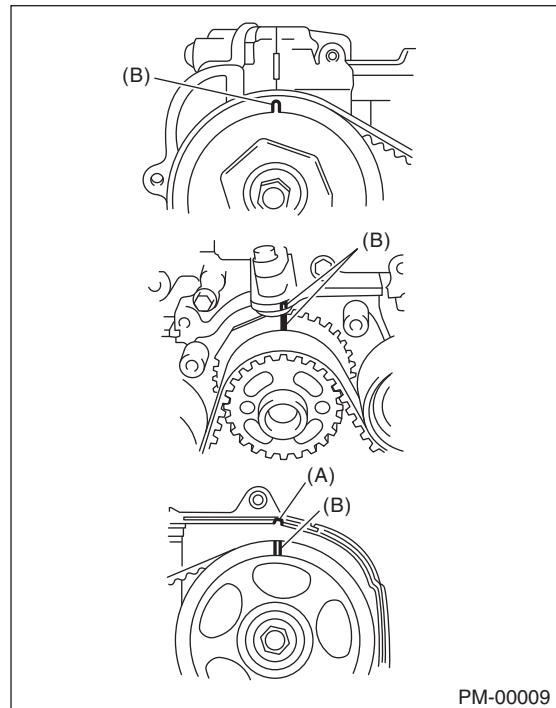

(A) Notch

(B) Alignment mark

- 12) Remove the belt idler.

- 13) Remove the belt idler (No. 2).

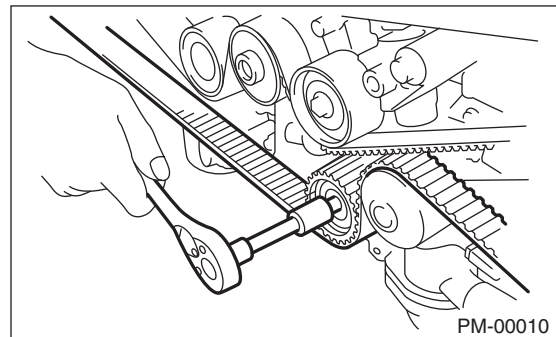

- 14) Remove the timing belt.

- 15) Remove the automatic belt tensioner assembly.

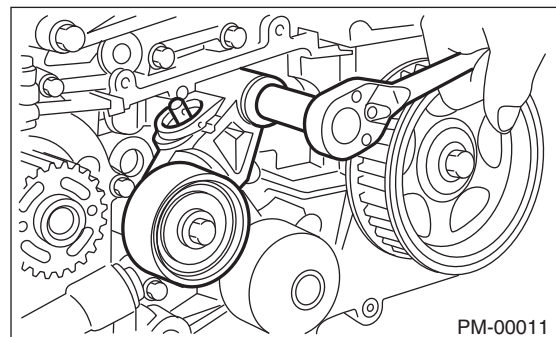

Timing Belt

16) Install in the reverse order of removal. <Ref. to ME(H4SO)-55, INSTALLATION, Timing Belt.>

2. TURBO MODEL

1) Remove the radiator fan and air conditioner fan. <Ref. to CO(H4DOTC)-24, REMOVAL, Radiator Main Fan and Fan Motor.> <Ref. to CO(H4DOTC)-26, REMOVAL, Radiator Sub Fan and Fan Motor.>

2) Protect the radiator with cardboard and blanket.

3) Remove the V-belts. <Ref. to ME(H4DOTC)-39, REMOVAL, V-belt.>

4) Remove the A/C compressor V-belt tensioner.

5) Remove the pulley bolt. Using the ST, lock the crankshaft.

ST 499977400 CRANK PULLEY WRENCH

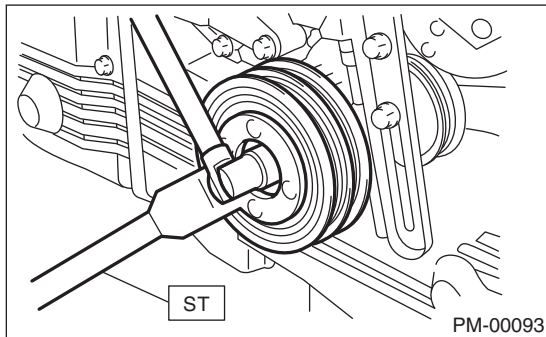

- 6) Remove the crank pulley.
- 7) Remove the A/C compressor V-belt tensioner.
- 8) Remove the belt cover (LH).
- 9) Remove the belt cover (RH).
- 10) Remove the front belt cover.
- 11) Turn the crankshaft and align the alignment marks on crankshaft, and left and right cam sprockets with notches of belt cover and cylinder block. Use the ST to turn crankshaft.

ST 499987500 CRANKSHAFT SOCKET

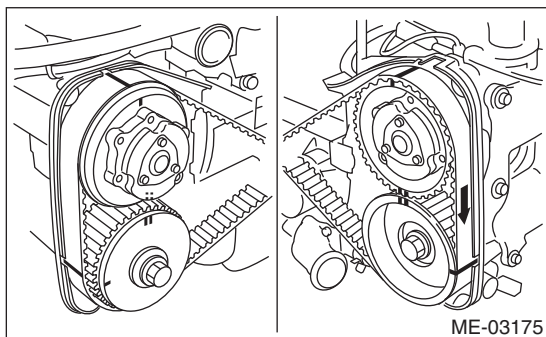
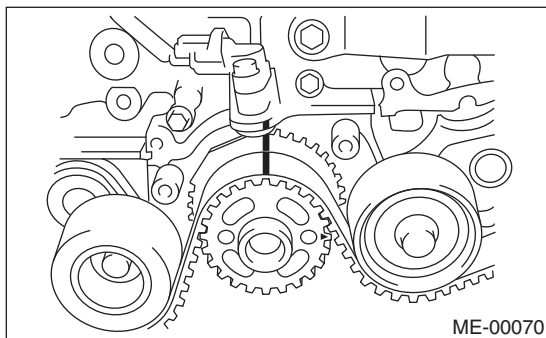

12) Remove the belt idler.

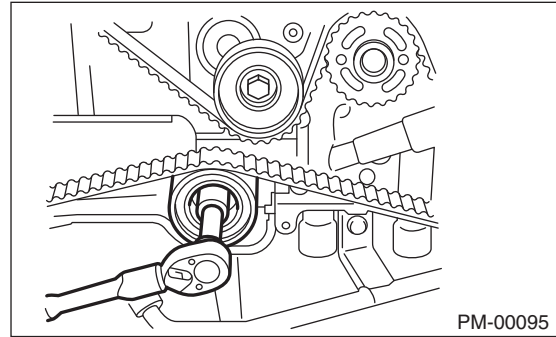

13) Remove the timing belt.

14) Remove the automatic belt tension adjuster assembly.

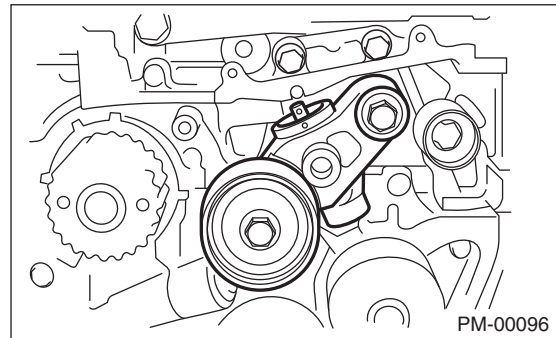

15) Install in the reverse order of removal. <Ref. to ME(H4DOTC)-51, INSTALLATION, Timing Belt.>

CAUTION:

When installing the timing belt, be sure to align all alignment marks on the belt with corresponding marks on the sprockets. If incorrectly installed, interference between pistons and valves may occur.

B: INSPECTION

1. NON-TURBO MODEL

- 1) Remove the timing belt cover (LH).
- 2) While cranking engine at least four rotations, check the timing belt back surface for cracks or damage. Replace the faulty timing belt as needed.
- 3) If the surface of timing belt (surface indicated by the arrow in the figure) is worn abnormally (scuffing and coming out of core) or damaged, inspect the idlers, tensioner, water pump pulley and cam sprocket and check the idler alignment for squareness. Replace the worn or damaged timing belt.

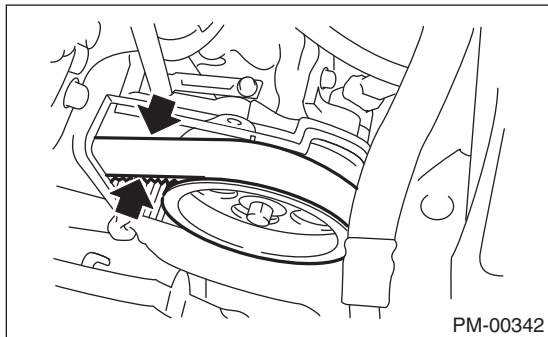

- 4) Install the timing belt cover (LH).

2. TURBO MODEL

- 1) Remove the timing belt cover (LH).
- 2) While cranking engine at least four rotations, check the timing belt back surface for cracks or damage. Replace the faulty timing belt as needed.
- 3) If the surface of timing belt (surface indicated by the arrow in the figure) is worn abnormally (scuffing and coming out of core) or damaged, inspect the idlers, tensioner, water pump pulley and cam sprocket and check the idler alignment for squareness. Replace the worn or damaged timing belt.
- 4) Install the timing belt cover (LH).

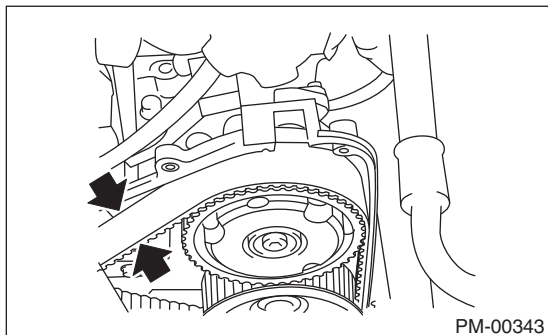

8. Fuel Line

A: INSPECTION

Check the pipes and for rust around the pipe, damage to the hose, and for looseness of the band. If faulty parts are found, repair or replace them.

- Non-turbo model

<Ref. to FU(H4SO)-65, Fuel Delivery and Evaporation Lines.>

- Turbo model

<Ref. to FU(H4DOTC)-72, Fuel Delivery, Return and Evaporation Lines.>

9. Fuel Filter

A: REPLACEMENT

For fuel filter replacement procedure, refer to FU section.

- Non-turbo model
<Ref. to FU(H4SO)-62, Fuel Filter.>
- Turbo model
<Ref. to FU(H4DOTC)-69, Fuel Filter.>

B: INSPECTION

If the filter is clogged, or if the replacement interval has been reached, replace it.

10. Air Cleaner Element

A: REPLACEMENT

- 1) Disconnect the ground cable from the battery.
- 2) Remove the air intake duct (rear).

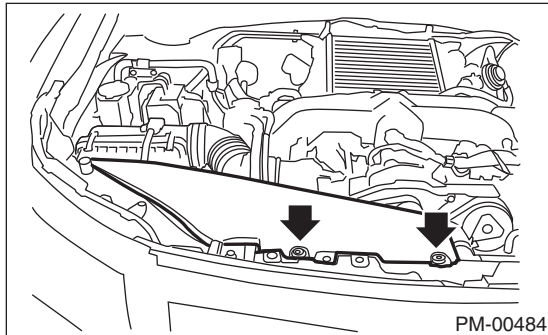

- 3) Disconnect the connector from the mass air flow and intake air temperature sensor.

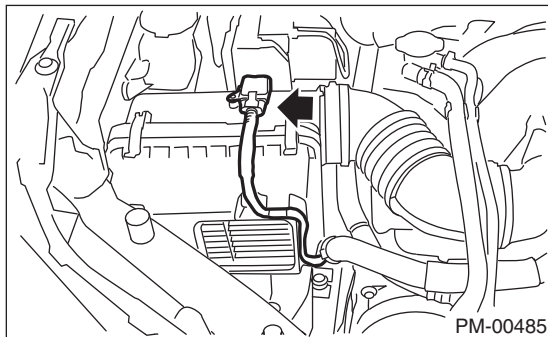

- 4) Remove the clips on the upper side of the air cleaner case.

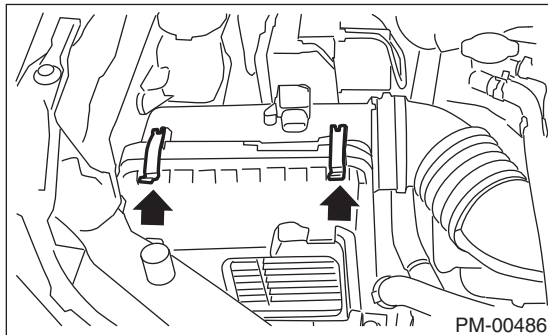

- 5) Separate the intake duct boot from the air cleaner case. (Non-turbo model)
- 6) Pull the air cleaner case (rear) towards the back of the vehicle and remove the element.

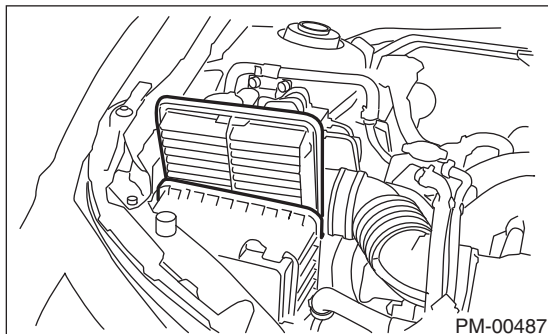

- 7) Check that there is no foreign matter on the clean side and install in the reverse order of removal.

CAUTION:

Be sure to use SUBARU genuine air cleaner element depending on the engine type when replacing the air cleaner elements. Otherwise engine performance may be damaged.

11. Cooling System

A: INSPECTION

1) To check the radiator for leakage, fill it with engine coolant, and attach the radiator cap tester (A) to the filler neck, and apply pressure.

Pressure:

Non-turbo model

157 kPa (1.6 kg/cm², 23 psi)

Turbo model

122 kPa (1.2 kg/cm², 18 psi)

Check the following points:

- Leak from radiator
- Hose joints and other connections for leakage

CAUTION:

- For Turbo model, inspection must be carried out at the side of coolant filler tank, not at the side of radiator.
- Be particularly careful not to deform the filler neck of radiator when installing and removing the tester and after testing.
- When performing this check, be sure to keep the engine stationary and fill radiator with coolant.
- Wipe off check points before applying pressure.
- Use care not to spill coolant when detaching tester from radiator.
- Do not remove the radiator cap. (Turbo model)
- Non-turbo model

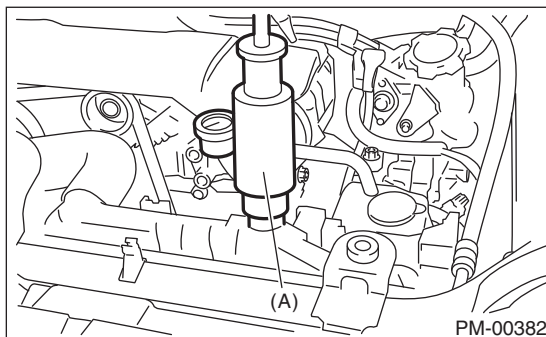

- Turbo model

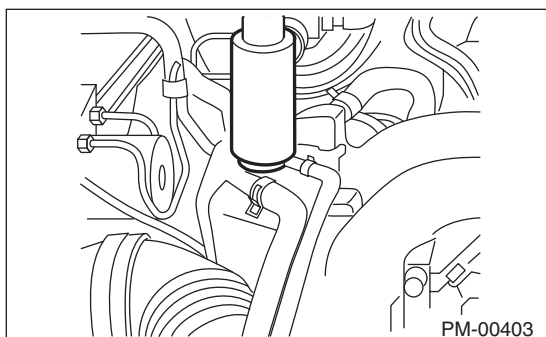

2) Check the radiator cap valve open pressure using radiator cap tester.

Raise the pressure until the needle of gauge stops and see if the pressure can be retained for five to six seconds. The radiator cap is normal if a pressure above the limit value has been maintained for this period. If the valve opened at the service limit or less, replace the radiator cap.

CAUTION:

Rust or dirt on the cap may prevent valve from functioning normally: be sure to clean the cap before testing.

Non-turbo model radiator side and turbo model coolant filler tank side

Specification:

93 — 123 kPa

(0.95 — 1.25 kg/cm², 14 — 18 psi)

Service limit:

83 kPa (0.85 kg/cm², 12 psi)

Radiator side on turbo models

Specification:

122 — 152 kPa

(1.24 — 1.55 kg/cm², 18 — 22 psi)

Service limit:

112 kPa (1.14 kg/cm², 16 psi)

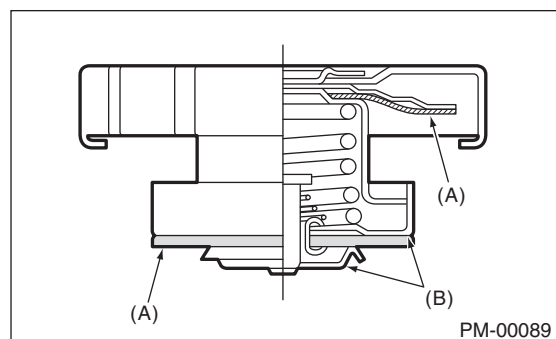
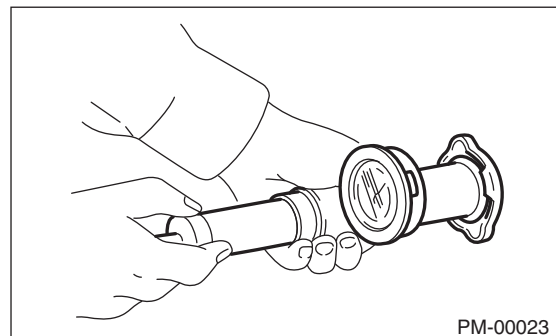

- (A) Check points for deformation
- (B) Check points for deformation, damage, rust

3) Start the engine, and then inspect that it does not overheat or it is cooled excessively. If it overheats or it is cooled excessively, check the cooling system. <Ref. to CO(H4SO)-16, INSPECTION, Water Pump.> <Ref. to CO(H4SO)-18, INSPECTION, Thermostat.> <Ref. to CO(H4SO)-19, Radiator.> <Ref. to CO(H4SO)-23, Radiator Cap.>

4) Check the radiator fan operates using Subaru Select Monitor, when the coolant temperature exceeds 95°C (203°F). If it does not operate, check the radiator fan system. <Ref. to CO(H4SO)-7, Radiator Fan System.>

12.Engine Coolant

A: REPLACEMENT

1. REPLACEMENT OF ENGINE COOLANT

WARNING:

The radiator is of the pressurized type. Do not attempt to remove the radiator cap immediately after the engine has been stopped.

- 1) Lift up the vehicle.
- 2) Remove the under cover.
- 3) Place a container under drain pipe.
- 4) Loosen and remove the drain cock to drain engine coolant into container.

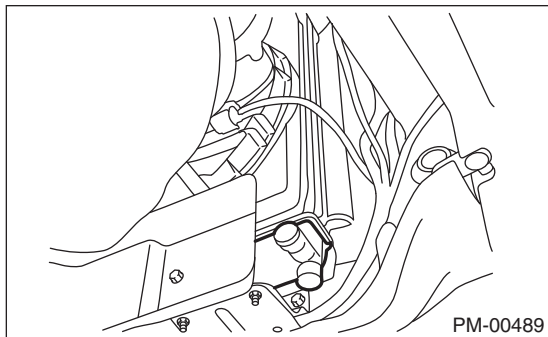

- 5) For quick draining, remove the radiator cap.

CAUTION:

- Be careful not to spill coolant on the floor.
- For turbo model, always open the radiator cap on the filler tank side.

- 6) Drain the coolant from reservoir tank.
- 7) Tighten the drain cock securely after draining coolant.
- 8) Pour cooling system conditioner through the filler neck.

Cooling system protecting agent:

**Cooling system conditioner
(Part No. SOA635071)**

- 9) Slowly pour the coolant from radiator filler port to neck of filler. Then, pour the coolant into reservoir tank up to "FULL" level.

Coolant level:

<Ref. to SPC-4, CAPACITY, Forester.>

NOTE:

The SUBARU Super Coolant containing anti-freeze and anti-rust agents is especially made for SUBARU engine, which has an aluminum crankcase. Always use SUBARU Super Coolant since other coolant may cause corrosion.

CAUTION:

Be careful not to spill engine coolant on the exhaust pipe to prevent it from emitting smoke or causing a fire. If engine coolant spilled, wipe it off completely with a clean rag.

- 10) Close the radiator cap (on non-turbo models) or the coolant filler tank cap (on turbo models), start the engine and race 5 to 6 times at less than 3,000 rpm, then stop the engine. (Complete this operation within 40 seconds.)

- 11) Wait for one minute after the engine stops, then open the radiator cap (on non-turbo models) or the coolant filler tank cap (on turbo models). If the engine coolant level drops, add engine coolant into the radiator filler neck (on non-turbo models) or the coolant filler tank filler neck (on turbo models) up to the filler neck position.

- 12) Perform the procedures 10) and 11) again.

- 13) Close the radiator cap (on non-turbo models) or the coolant filler tank cap (on turbo models), and the reservoir tank cap.

- 14) Start the engine and operate the heater at maximum hot position and the blower speed setting to "LO".

- 15) Run the engine at 2,000 rpm or less until radiator fan starts and stops.

NOTE:

Be careful with the engine coolant temperature gauge to prevent overheating.

- 16) Stop the engine and wait until the engine coolant temperature lowers to 30°C (86°F).

- 17) Open the radiator cap (on non-turbo models) or the coolant filler tank cap (on turbo models). If the engine coolant level drops, add engine coolant into the radiator filler neck (on non-turbo models) or the coolant filler tank filler neck (on turbo models) up to the filler neck position.

Then, pour the coolant into reservoir tank up to "FULL" level.

- 18) Close the radiator cap (on non-turbo models) or the coolant filler tank cap (on turbo models), and the reservoir tank cap.

- 19) Set the heater setting to maximum hot position and the blower speed setting to "LO" and start the engine. Perform racing at less than 3,000 rpm. If the flowing sound is heard from heater core, repeat the procedures from step 15) again.

B: ADJUSTMENT

1. PROCEDURE TO ADJUST THE SUPER COOLANT CONCENTRATION

CAUTION:

Use the Subaru Super Coolant with a 50 — 60% concentration in order to obtain maximum anti-freeze and anti-rust performance.

To adjust the concentration of Subaru Super Coolant according to temperature, find the proper Subaru Super Coolant concentration in the table, and add diluting water to the Subaru Super Coolant (undiluted type) until it reaches the proper dilution.

RELATIONSHIP OF SUBARU SUPER COOLANT CONCENTRATION AND FREEZING TEMPERATURE			
Subaru Super Coolant concentration	50%	55%	60%
Freezing temperature	-36°C (-33°F)	-41°C (-42°F)	-50°C (-58°F)

Recommended engine coolant and dilution water:

For the recommended engine coolant and dilution water, refer to “RM” section. <Ref. to RM-4, ENGINE COOLANT, RECOMMENDED MATERIALS, Recommended Materials.>

Clutch System

PERIODIC MAINTENANCE SERVICES

13. Clutch System

A: INSPECTION AND ADJUSTMENT

1) Push the release lever to retract the push rod of the operating cylinder and check if the fluid level in the clutch reservoir tank rises.

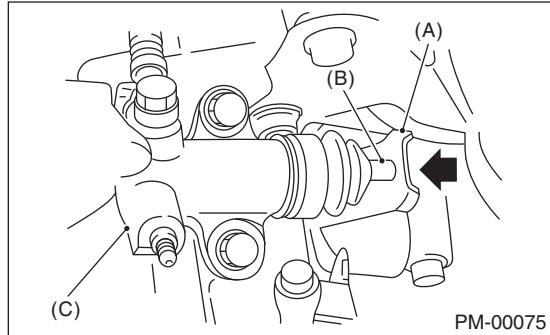

- (A) Release lever
- (B) Push rod
- (C) Operating cylinder

2) If the fluid level rises, pedal free play is correct.
3) If the fluid level does not rise, or the push rod cannot be retracted, adjust the clutch pedal. <Ref. to CL-22, Clutch Pedal.>

4) Check the fluid level using the scale on the outside of the clutch reservoir tank (A). If the level is below "MIN" (B), inspect the clutch master cylinder, operating cylinder and hydraulic line for fluid leaks. If fluid leaks are found, repair or replace. If fluid leaks are not found, add clutch fluid to bring it up to "MAX" (C) of clutch reservoir tank. <Ref. to RM-4, FLUID, RECOMMENDED MATERIALS, Recommended Materials.>

CAUTION:

- Prevent the clutch fluid from being splashed over vehicle body. If the clutch fluid is splashed over vehicle body, flush it, and then wipe it up.
- If any clutch fluid is spilled on exhaust pipe, wipe off completely to prevent fires or emission of smoke.
- Avoid mixing different brands of brake fluid to prevent degradation of the fluid.
- Be careful not to allow dirt or dust to get into the reservoir tank.

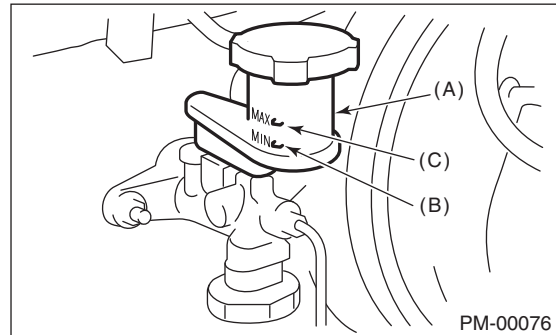

- (A) Reservoir tank
- (B) MIN. level
- (C) MAX. level

14. Transmission Gear Oil

A: REPLACEMENT

1. MANUAL TRANSMISSION

1) Remove the drain plug using TORX® bit T70, and then drain gear oil.

NOTE:

Before starting work, cool off the transmission gear oil well.

CAUTION:

If transmission gear oil is spilled on the exhaust pipe, wipe off to prevent fires or emission of smoke.

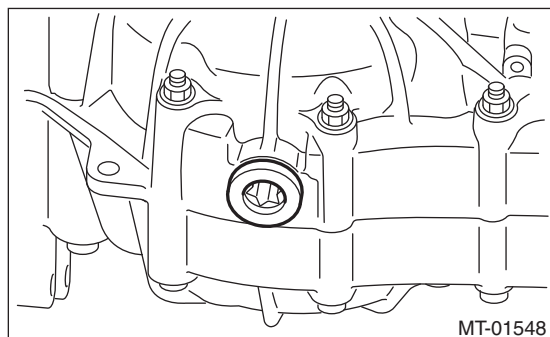

2) Replace the gasket with new part, and then tighten the drain plug to specified torque.

Tightening torque:

Copper gasket

70 N·m (7.1 kgf·m, 51.6 ft·lb)

Aluminum gasket

44 N·m (4.5 kgf·m, 32.5 ft·lb)

3) Fill the transmission gear oil through the oil level gauge hole up to the upper point of level gauge.

Recommended gear oil:

Refer to the RM section. <Ref. to RM-2, LUBRICANTS, RECOMMENDED MATERIALS, Recommended Materials.>

NOTE:

Each oil manufacturer has its base oil and additives. Thus, do not mix two or more brands.

Gear oil capacity:

<Ref. to SPC-4, CAPACITY, Forester.>

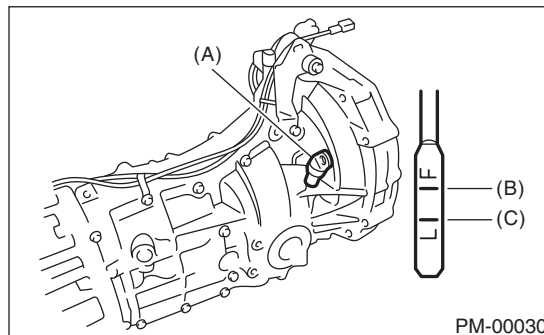

- (A) Oil level gauge
- (B) Upper level
- (C) Lower level

Automatic Transmission Fluid

PERIODIC MAINTENANCE SERVICES

15. Automatic Transmission Fluid

A: INSPECTION

CAUTION:

The level of ATF varies with fluid temperature. Pay attention to the ATF temperature when checking ATF level.

1) Raise the ATF temperature by driving a distance of 5 — 10 km (3 — 6 miles). Otherwise, idle the engine to raise ATF temperature to 70 — 80°C (158 — 176°F) on Subaru Select Monitor. <Ref. to 4AT(diag)-16, OPERATION, Read Current Data.>

2) Make sure the vehicle is level.

3) After selecting all positions (P, R, N, D), set the select lever in “P” range. Idle the engine for 1 or 2 minutes, and measure the ATF level.

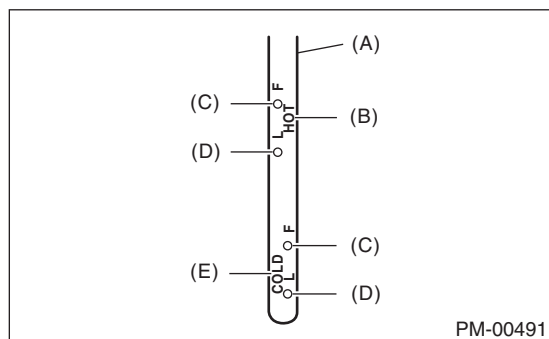

- (A) Level gauge
- (B) Inspection position when “HOT” (70 — 80°C (158 — 176°F))
- (C) Upper level
- (D) Lower level
- (E) Inspection position when “COLD” (20 — 30°C (68 — 86°F))

4) Make sure that ATF level is between the upper level and lower level on the “HOT” side.

5) If the ATF level is below the mid level between upper and lower marks, add the recommended ATF until the fluid level is above mid level.

CAUTION:

- Be careful not to exceed the upper level.
- Do not fill up to the upper level on the “HOT” side when the ATF temperature is less than 70° C (158° F) as overfilling can cause problems.

6) Check the ATF level after raising ATF temperature to 70 — 80°C (158 — 176°F) by driving the vehicle another 5 — 10 km (3 — 6 miles) or by idling the engine again.

7) Check that there are no ATF leaks.

If there are leaks, it is necessary to repair or replace gaskets, oil seals, plugs or other parts.

B: REPLACEMENT

- 1) Lift up the vehicle.
- 2) Remove the drain plug to drain the automatic transmission fluid (ATF).

CAUTION:

If any ATF is spilt on the exhaust pipe, wipe it off completely with a clean cloth.

NOTE:

Before starting work, allow the ATF to cool completely.

3) Check the condition of the drained ATF. <Ref. to 4AT-27, CONDITION CHECK, Automatic Transmission Fluid.>

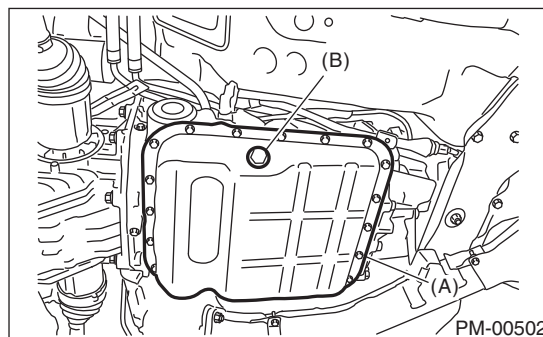

- (A) Oil pan
- (B) Drain plug (ATF)

4) Replace the gasket with new part, and then tighten the drain plug to specified torque.

Tightening torque:

25 N·m (2.5 kgf-m, 18.4 ft-lb)

- 5) Lower the vehicle.
- 6) Pour ATF from the oil charge pipe.

Recommended fluid:

<Ref. to RM-4, FLUID, RECOMMENDED MATERIALS, Recommended Materials.>

Fluid capacity:

Refill with the same amount of ATF drained from the ATF drain hole.

Automatic Transmission Fluid

7) Check the level and leaks of the ATF. <Ref. to PM-26, INSPECTION, Automatic Transmission Fluid.>

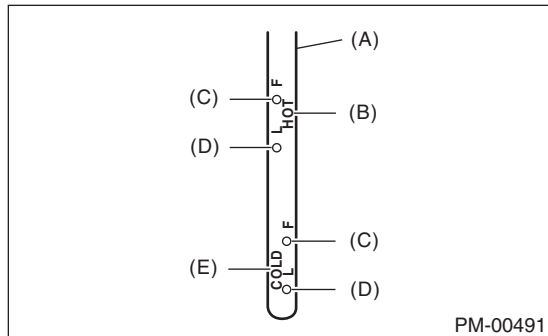

- (A) Level gauge
- (B) Inspection position when "HOT"
(70 — 80°C (158 — 176°F))
- (C) Upper level
- (D) Lower level
- (E) Inspection position when "COLD"
(20 — 30°C (68 — 86°F))

Front & Rear Differential Gear Oil

PERIODIC MAINTENANCE SERVICES

16. Front & Rear Differential Gear Oil

A: REPLACEMENT

1. FRONT DIFFERENTIAL (MT MODEL)

For MT model, differential oil works as manual transmission oil to lubricate differential. Refer to "Transmission Oil". <Ref. to PM-25, Transmission Gear Oil.>

2. FRONT DIFFERENTIAL (AT MODEL)

- 1) Lift up the vehicle.
- 2) Remove the drain plug using TORX® bit T70, and then drain differential gear oil.

CAUTION:

If any differential gear oil is spilt on the exhaust pipe, wipe it off with a cloth to avoid emitting smoke or causing a fire.

NOTE:

Before starting work, allow the differential gear oil to cool completely.

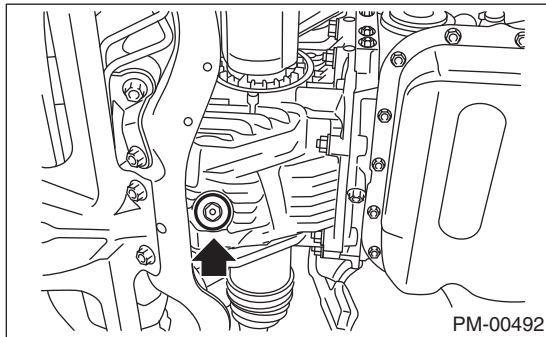

- 3) Replace the gasket with a new part and tighten the differential gear oil drain plug to the specified torque using the TORX® bit T70.

Tightening torque:

44 N·m (4.5 kgf·m, 32.5 ft·lb)

(Aluminum gasket)

70 N·m (7.1 kgf·m, 51.6 ft·lb) (Copper gasket)

- 4) Lower the vehicle.

- 5) Fill differential gear oil from the oil level gauge hole.

Recommended fluid:

<Ref. to RM-2, LUBRICANTS, RECOMMENDED MATERIALS, Recommended Materials.>

NOTE:

Each oil manufacturer has its base oil and additives. Thus, do not mix two or more brands.

Gear oil capacity:

1.1 — 1.3 ℓ (1.2 — 1.4 US qt, 1.0 — 1.1 Imp qt)

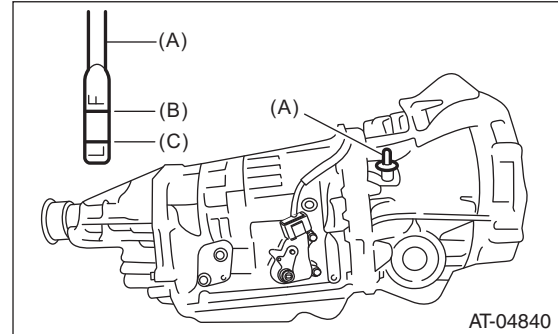

(A) Oil level gauge

(B) Upper level

(C) Lower level

- 6) Check the level of differential gear oil.

<Ref. to 4AT-28, INSPECTION, Differential Gear Oil.>

3. REAR DIFFERENTIAL

- 1) Remove the oil drain plug and drain the oil.
- 2) Remove the filler plug for quick draining oil.
- 3) Install the drain plug after draining oil.

NOTE:

Apply liquid gasket to the drain plug threads.

Liquid gasket:

THREE BOND 1105 (Part No. 004403010)

Tightening torque:

49 N·m (5.0 kgf·m, 36.2 ft·lb)

- 4) After installing drain plug onto rear differential gear case firmly, fill oil up fully to the mouth of filler plug.

Recommended gear oil:

GL-5 (75W-90) or equivalent

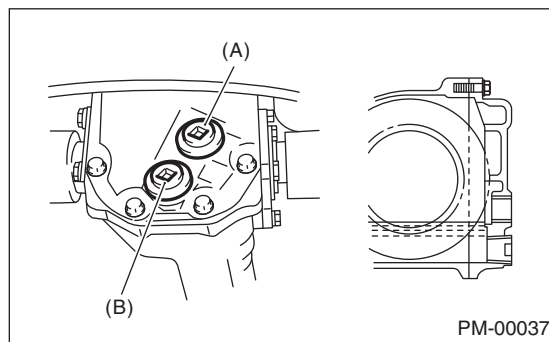

- (A) Filler plug
(B) Drain plug

Oil capacity:

0.8 ℓ (0.8 US qt, 0.7 Imp qt)

NOTE:

Each oil manufacturer has its base oil and additives. Thus, do not mix two or more brands.

CAUTION:

If any gear oil is spilt on the exhaust pipe, wipe it off with a clean cloth to avoid emitting smoke or causing a fire.

- 5) Install the filler plug onto rear differential gear case firmly.

NOTE:

Apply liquid gasket to the threads of the filler plug screws.

Liquid gasket:

THREE BOND 1105 (Part No. 004403010)

Tightening torque:

49 N·m (5.0 kgf·m, 36.2 ft·lb)

Brake Line

PERIODIC MAINTENANCE SERVICES

17. Brake Line

A: INSPECTION

1. BRAKE LINE

- 1) Check for scratches, swelling, corrosion, traces of fluid leakage on the brake hoses or pipe joints.
- 2) Check the possibility of adjacent parts interfering with brake pipes/hoses during driving, and loose connections/clamps.
- 3) Check any trace of fluid leakage, scratches, etc. on master cylinder and wheel cylinder.

NOTE:

- When the brake fluid level in the reservoir tank is lower than specified limit, the brake warning light on the combination meter will come on.
- Visually check the brake hose for damage. (Use a mirror where it is difficult to see)

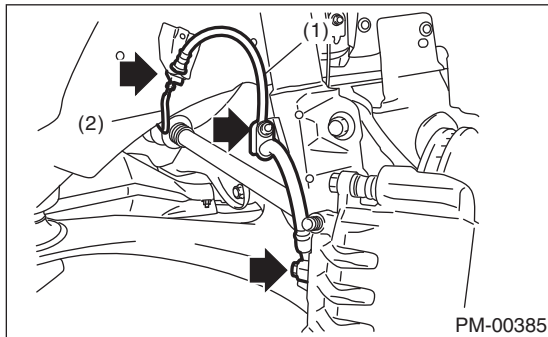

- (1) Front brake hose
- (2) Front brake pipe

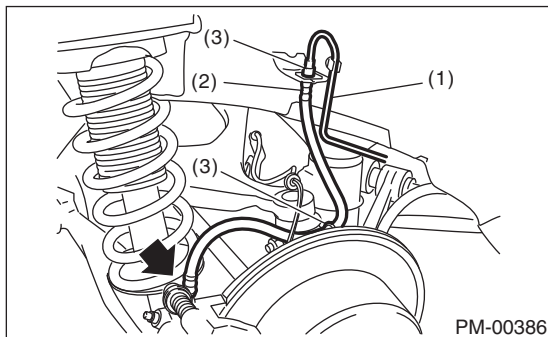

- (1) Rear brake pipe
- (2) Rear brake hose
- (3) Clamp

2. SERVICE BRAKE

- 1) Check the free play of brake pedal with a force of less than 10 N (1 kgf, 2 lbf).

Brake pedal play

0.5 — 2.0 mm (0.02 — 0.08 in)

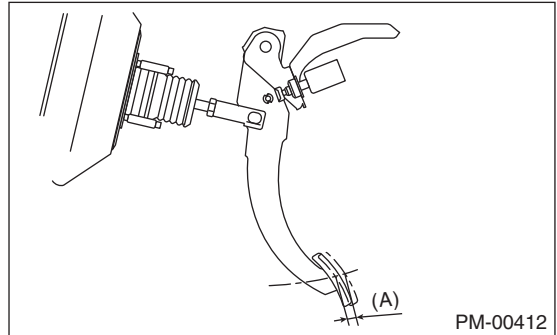

(A) Pedal free play

2) If the free play is out of the specifications values indicated above, adjust the brake pedal as follows.

(1) Make sure the engine is off. (No vacuum is applied to brake booster.)

(2) Inspect that there is play between brake booster clevis and pin at brake pedal installing portion. [Depress brake pedal pad with a force of less than 10 N (1 kgf, 2 lbf) to a stroke of 0.5 to 2.0 mm (0.02 to 0.08 in).]

(3) Pull the brake pedal by hand.

(4) If there is no play between the clevis pin and the clevis, rotate the brake switch to the left.

(5) Loosen the operating rod locknut, rotate the operating rod, adjust the pedal to the specified height and tighten the locknut.

Locknut tightening torque:

22 N·m (2.2 kgf·m, 16 ft·lb)

Pedal height L:

150 — 160 mm (5.91 — 6.30 in)

Brake pedal free play A:

0.5 — 2 mm (0.020 — 0.079 in) [When pulling the brake pedal upward with a force of less than 10 N (1 kgf, 2 lbf).]

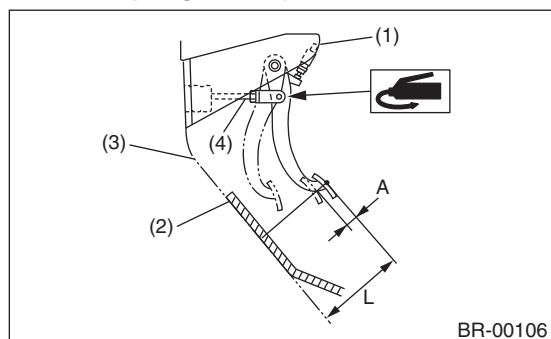

- (1) Stop light switch
- (2) Mat
- (3) Toe board
- (4) Brake booster operating rod

(6) While pulling up the brake pedal, insert the brake switch until the end of the brake switch screw contacts the stopper.

(7) With the end of the brake switch screw pushed against the stopper, turn the switch to the right and secure the switch.

(8) Check that gap C between the stopper and the end of the brake switch screw is within the specification.

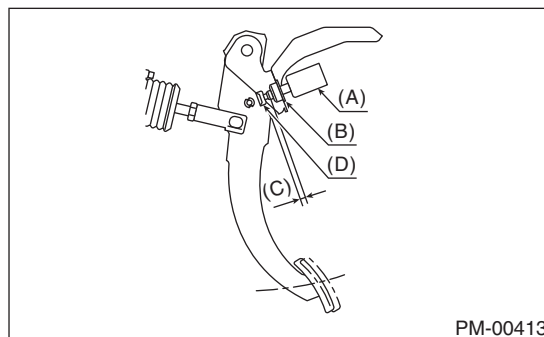

- (A) Brake switch
- (B) Switch clip
- (C) 1.35±0.61 mm (0.05±0.02 in)
- (D) Stopper

(9) Pull up the pedal pad and check the play. Check that the stop light goes out when the pedal is not pressed.

3) Check the pedal stroke.

While the engine is idling, depress the brake pedal with a 490 N (50 kgf, 110 lbf) load and measure the distance between the brake pedal and steering wheel. With the brake pedal released, measure the distance between pedal and steering wheel again. The difference between the two measured values must be less than specified value. If the measured value is more than specification, there is possibility of entering air in hydraulic unit.

Brake pedal stroke A:

95 mm (3.74 in) / 490 N (50 kgf, 110 lbf) or less

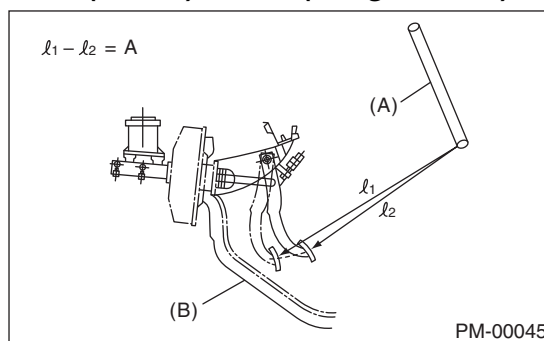

- (A) Steering wheel
- (B) Toe board

4) Check to see if air is in the hydraulic brake line by the feel of pedal operation. If air appears to exist in the line, bleed it from the system.

5) Check for even operation of all brakes, using a brake tester or by driving the vehicle for a short distance on a straight road.

3. BRAKE SERVO SYSTEM

1) With the engine off, depress the brake pedal several times applying the same pedal force. Make sure the travel distance should not change.

2) With the brake pedal depressed, start the engine. Check that the pedal moves slightly toward the floor.

3) With the brake pedal depressed, stop the engine and keep the pedal depressed for 30 seconds. Check that the pedal height does not change.

4) A check valve is built into the vacuum hose. Disconnect the vacuum hose to inspect function of the check valve.

Blow air into vacuum hose from the end of the brake booster side. Check that the air flows out from the engine side end of the air hose. Next blow air into hose from engine side: Check that the air does not flow out from the hose.

Replace the both check valve and vacuum hose if the check valve is faulty. Engine side of vacuum hose is indicated by marking "ENG" as shown.

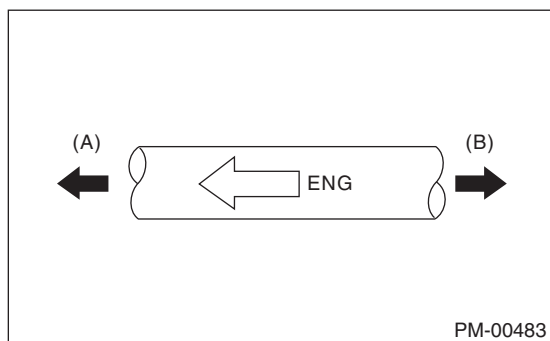
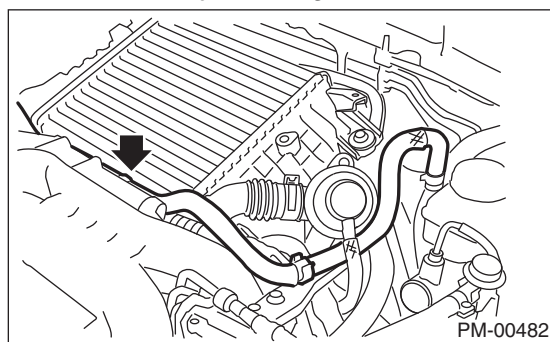

(A) Engine side

(B) Brake booster side

5) Check the vacuum hose for cracks or other damage.

CAUTION:

When installing the vacuum hose on the engine and brake booster, do not use soapy water or lubricating oil on their connections.

6) Check that the vacuum hose is securely mounted.

18.Brake Fluid

A: INSPECTION

1) Check that the brake fluid level remains between MIN and MAX. If out of the specified range, refill or drain fluid. If the fluid level becomes close to MIN, check the brake pad for wear and refill fluid.

2) Check the fluid for discoloration. If the fluid color has excessively changed, drain the fluid and refill with new fluid.

B: REPLACEMENT

CAUTION:

- Do not let brake fluid come into contact with the painted surface of the vehicle body. Wash away with water immediately and wipe off if it is spilled by accident.
- Avoid mixing brake fluid of different brands to prevent fluid performance from degrading.
- Be careful not to allow dirt or dust to enter into reservoir tank.
- If any brake fluid is spilled on the exhaust pipe, wipe off to prevent fires or emission of smoke.

NOTE:

- While working, keep the reservoir tank filled with brake fluid to eliminate entry of air.
 - Operate the brake pedal slowly.
 - For convenience and safety, perform work with 2 people.
 - The required amount of brake fluid is approximately 500 ml (16.9 US fl oz, 17.6 Imp fl oz) for entire brake system.
- 1) Jack up the vehicle and set rigid racks at the specified locations, or keep the vehicle lifted.
 - 2) Remove all the wheels.
 - 3) Drain the brake fluid from the reservoir tank.
 - 4) Refill the reservoir tank with Subaru genuine brake fluid.

Recommended brake fluid:

Refer to the "RM section". <Ref. to RM-4, FLUID, RECOMMENDED MATERIALS, Recommended Materials.>

Repeat the same procedure as for bleeding air from the brake line, until new brake fluid comes out from vinyl tube. <Ref. to BR-32, PROCEDURE, Air Bleeding.>

NOTE:

Perform brake fluid replacement in the order from the farthest wheel cylinder from the master cylinder.

5) Attach one end of the vinyl tube to the air bleeder and insert the other end into a container suitable for collecting brake fluid.

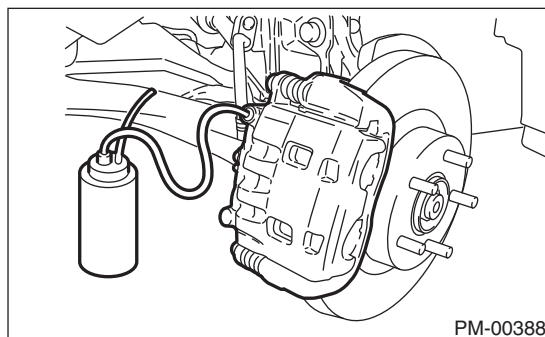

6) One person slowly pumps the brake pedal a few times and then holds it down.

7) Loosen the bleeder screw approximately a 1/4 rotation until a small amount of brake fluid comes out of the tube, and then quickly tighten the screw.

8) Continue to pour new fluid into the tube and repeat steps 6) and 7) until the bled off brake fluid does not contain any bubbles.

NOTE:

Be sure to always add the necessary amount of brake fluid while bleeding the air so that the tank is always full of fluid.

9) When air bleeding is completed, continue to hold the brake pedal down, tighten the screw and attach the bleeder cap.

Tightening torque:

8 N·m (0.8 kgf-m, 5.9 ft-lb)

10) Bleed air from each of the wheel cylinders according to steps 5) — 9).

11) Start the engine and depress the brake pedal with a pedal force of approximately 294 N (30 kgf, 66 lbf) and maintain for approximately 20 seconds. During this time, check the brake pedal for irregular operation. Visually inspect the bleeder screws and brake pipe joints for fluid leakage.

Disc Brake Pad and Disc

PERIODIC MAINTENANCE SERVICES

19. Disc Brake Pad and Disc

A: INSPECTION

1. DISC BRAKE PAD AND DISC

1) Jack up the vehicle and support it with rigid racks. Remove the wheels.

2) Visually check the pad thickness through inspection hole of disc brake assembly. Replace the pad if necessary.

NOTE:

When replacing a pad, always replace the pads for both the left and right wheels at the same time. Also replace the pad clips if they are twisted or worn.

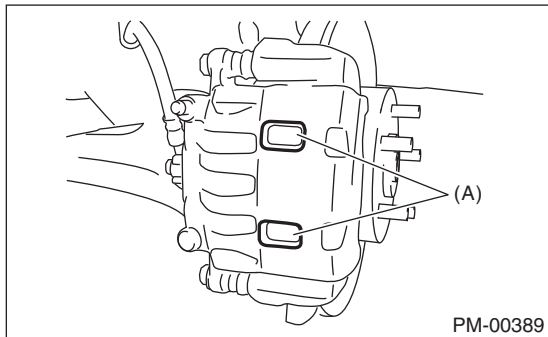

(A) Inspection hole

• Front (except for back metal)

Pad thickness	mm (in)
Standard	11 (0.43)
Wear limit	1.5 (0.059)

• Rear (except for back metal)

Pad thickness	mm (in)
Standard	9.0 (0.354)
Wear limit	1.5 (0.059)

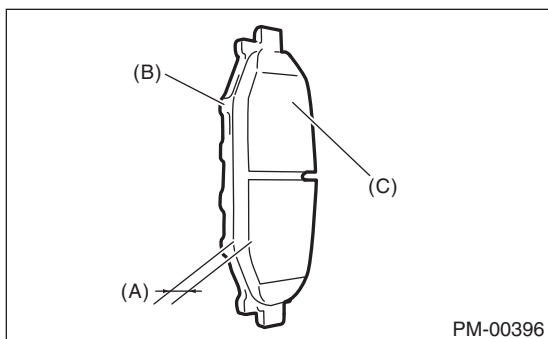

- (A) Pad thickness
- (B) Back metal
- (C) Lining

3) Check the disc rotor, and correct or replace if it is damaged or worn.

• Front

Disc rotor thickness	mm (in)
Standard	24 (0.94)
Wear limit	22 (0.87)

• Rear

Disc rotor thickness	mm (in)
Standard	10 (0.39)
Wear limit	8.5 (0.33)

4) Remove the caliper body. <Ref. to BR-14, Front Disc Brake Assembly.> <Ref. to BR-21, Rear Disc Brake Assembly.>

5) Tighten the wheel nuts to secure disc rotor.

6) Set a dial gauge at a point less than 10 mm (0.39 in) from outer periphery of the rotor, and then measure the disc rotor runout.

Disc rotor runout limit:

Front: 0.050 mm (0.0020 in)

Rear: 0.050 mm (0.0020 in)

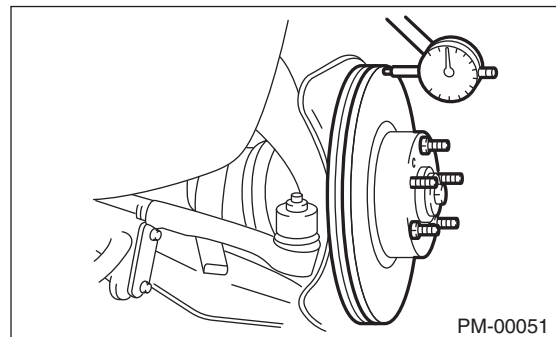

20. Parking Brake

A: INSPECTION

1) Measure the brake disc rotor inside diameter. If the disc is scored or worn, replace the brake disc rotor.

Disc rotor inside diameter:

Standard:

190 mm (7.48 in)

Service limit:

191 mm (7.52 in)

2) Measure the lining thickness. If it exceeds the limit, replace the brake shoes.

Lining thickness:

Standard:

2.8 mm (0.11 in)

Service limit:

1.5 mm (0.059 in)

CAUTION:

Replace the right and left brake shoe as a set.

B: ADJUSTMENT

Adjust the parking brake after bleeding air.

1) Remove the rear cover (rubber) installed to the rear disc rotor.

2) Turn the adjusting screw toward arrow mark (downward) until it is locked slightly, by using flat-tip screwdriver as shown in the figure.

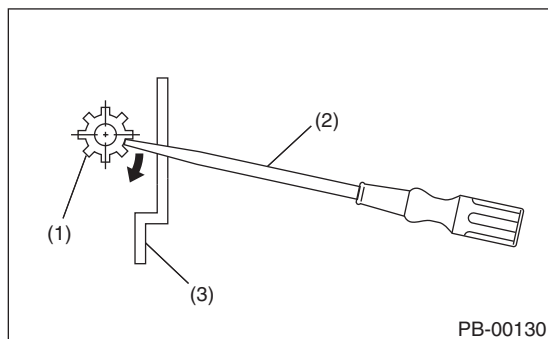

- (1) Adjusting screw
- (2) Flat tip screwdriver
- (3) Disc rotor

3) Turn the adjusting screw back (upward) three to four notches.

4) Install the cover (rubber) in original position correctly.

5) Check there is no brake drag.

Suspension

PERIODIC MAINTENANCE SERVICES

21. Suspension

A: INSPECTION

1. SUSPENSION BALL JOINT

- 1) Jack up the vehicle until front wheels are off ground.
- 2) Grasp the bottom of tire and move it in and out. If relative movement (B) is observed between the brake disc cover (A) and end of front arm (D), ball joint (C) may be excessively worn.

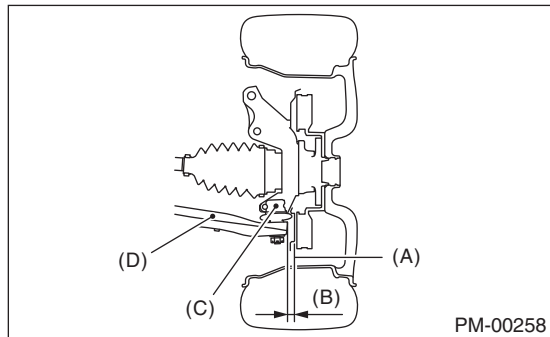

- 3) Hold the end of the front arm and move it up and down. Relative movement (A) between the housing (D) and front arm (C) boss indicates ball joint (B) may be excessively worn.

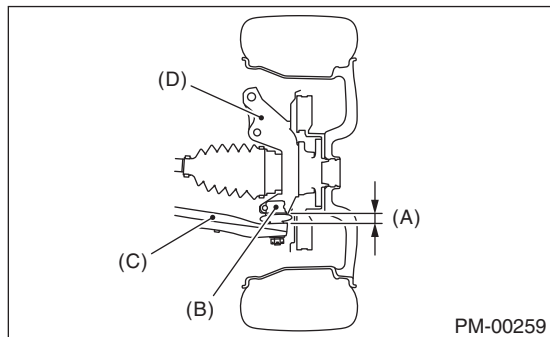

- 4) If the relative movement is observed in the preceding two steps, remove and inspect the ball joint. If the free play exceeds standard value, replace the ball joint. <Ref. to FS-17, Front Ball Joint.>

- 5) Damage of dust seal
Visually inspect the ball joint dust seal. If damaged, remove the front arm. <Ref. to FS-19, Front Arm.> Measure the play of the ball point. <Ref. to FS-17, Front Ball Joint.>

- (1) Replace the ball joint if the looseness exceeds the standard value.
- (2) If the dust seal is damaged, replace with a new ball joint.

NOTE:

When the front arm ball joint has been removed or replaced, check the toe of front wheel. If the front wheel toe is not within the specified value, adjust the toe-in. <Ref. to FS-7, Wheel Alignment.>

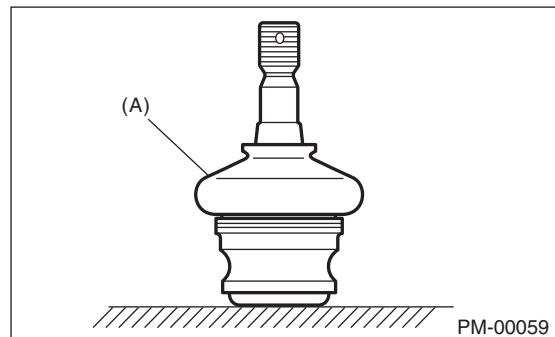

(A) Dust seal

2. FRONT/REAR SUSPENSION BUSHING

Apply pressure using the tire lever, and check the bushing for abnormal fatigue or damage. Replace the bushing if there is any damage.

3. WHEEL ARCH HEIGHT

- 1) Unload the cargoes and set the vehicle in curb weight (empty) condition.
- 2) Then, check the wheel arch height of front and rear suspensions to ensure that they are within specified values. <Ref. to FS-7, Wheel Alignment.>
- 3) When the wheel arch height is out of the tolerance value, visually inspect the following components and replace deformed parts.
 - Suspension components [Front strut assembly and rear shock absorber assembly]
 - Parts connecting suspension and body
- 4) When no components are deformed, adjust wheel arch height by replacing coil spring in the suspension whose wheel arch height is out of standard. <Ref. to FS-7, Wheel Alignment.>

4. WHEEL ALIGNMENT OF FRONT SUSPENSION

1) Check the alignment of front suspension to make sure the following items are within tolerance.

- Toe-in
- Camber
- Caster
- Steering angle

<Ref. to FS-7, Wheel Alignment.>

2) When the caster angle does not conform to the reference value obviously, visually inspect the following components and replace deformed parts.

- Suspension components [Strut assembly, cross-member, front arm, etc.]
- Parts connecting suspension and body

3) When the toe-in and camber are outside of the tolerance value, adjust each one so that they conform to the specified value.

4) When the rotating angles of the right and left tires are out of the specified value, adjust them so that they conform to the specified value.

5. WHEEL ALIGNMENT OF REAR SUSPENSION

1) Check the alignment of rear suspension to make sure the following items are within tolerance.

- Toe-in
- Camber
- Thrust angle

<Ref. to RS-7, Wheel Alignment.>

2) When the camber is out of the tolerance value, visually inspect the components listed below. Replace any deformed or damaged parts.

- Suspension components [Shock absorber, front lateral link, rear lateral link, upper arm, trailing link, sub frame, etc.]
- Parts connecting suspension and body

3) When the toe-in and thrust are outside of the tolerance value, adjust each one so that they conform to the specified value.

6. OIL LEAKAGE OF STRUT AND SHOCK ABSORBER

Visually inspect the front strut and rear shock absorber for oil leakage. If there is a bad oil leak, replace the front strut and rear shock absorber.

7. TIGHTNESS OF BOLTS AND NUTS

Check the bolts and nuts for looseness. Retighten the bolts and nuts to specified torque. If the self-locking nuts and bolts are removed, replace them with new parts.

Front suspension: <Ref. to FS-2, General Description.>

Rear suspension: <Ref. to RS-2, General Description.>

8. DAMAGE TO SUSPENSION PARTS

Check the following parts and the fastening portion of the vehicle body for deformation or excessive rusting which impairs the suspension. If necessary, replace the damaged parts with new parts. If minor rust, pitting, etc. are noted, remove the rust and take rust prevention measure.

- Front suspension
 - Front arm
 - Crossmember
 - Strut
- Rear suspension
 - Sub frame
 - Front lateral link
 - Rear lateral link
 - Upper arm
 - Trailing link
 - Shock absorber
- In the area where salt is sprayed to melt snow on a road in winter, check suspension parts for damage caused by rust every 12 months after lapse of 60 months. Take rust prevention measures as necessary.

Wheel Bearing

PERIODIC MAINTENANCE SERVICES

22. Wheel Bearing

A: INSPECTION

1. FRONT HUB UNIT

- 1) Jack-up the front of the vehicle.
- 2) While holding the front wheel by hand, swing it in and out to check if there is any bearing free play.
- 3) Loosen the wheel nuts, and remove the front wheel.
- 4) If the bearing free play exists in step 2) above, attach a dial gauge to hub and measure the looseness in the axial direction.

Service limit:

From the straight-ahead position: Max. of 0.05 mm (0.0020 in)

- 5) Remove the bolts and self-locking nuts, and extract transverse link from the front crossmember.
 - 6) Remove the PTJ of the front drive shaft from the transmission. <Ref. to DS-13, Front Axle.>
 - 7) While supporting the front drive shaft horizontally with one hand, turn the hub with the other hand to check for noise or binding.
- Replace the front hub unit if there is any abnormal noise from the hub or if it drags.

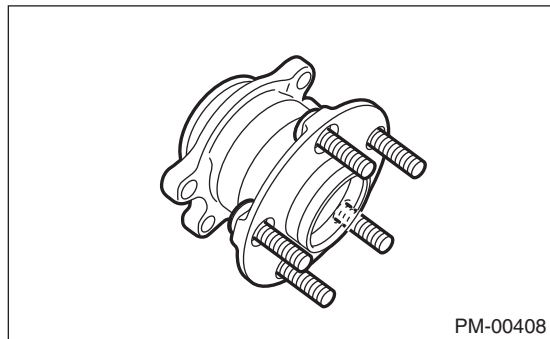

2. REAR HUB UNIT

- 1) Jack-up the rear of the vehicle.
- 2) While holding the rear wheel by hand, swing it in and out to check if there is any bearing free play.
- 3) Loosen the wheel nuts, and remove the rear wheel.
- 4) If the bearing free play exists in step 2) above, attach a dial gauge to hub and measure the looseness in the axial direction.

Service limit:

From the straight-ahead position: Max. of 0.05 mm (0.0020 in)

- 5) Remove the DOJ of the rear drive shaft from the rear differential. <Ref. to DS-33, Rear Drive Shaft.>
 - 6) While supporting the rear drive shaft horizontally with one hand, turn the hub with the other hand to check for noise or dragging/catching.
- Replace the front hub unit if there is any abnormal noise from the hub or dragging/catching.

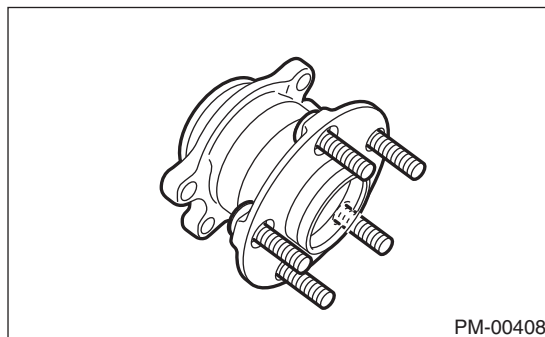

23. Axle Boots & Joints

A: INSPECTION

1. FRONT AND REAR AXLE BOOTS

Inspect the front axle boots (A) and rear axle boots (B) for deformation, damage or failure. If faulty, replace with new part. <Ref. to DS-27, Front Drive Shaft.> <Ref. to DS-33, Rear Drive Shaft.>

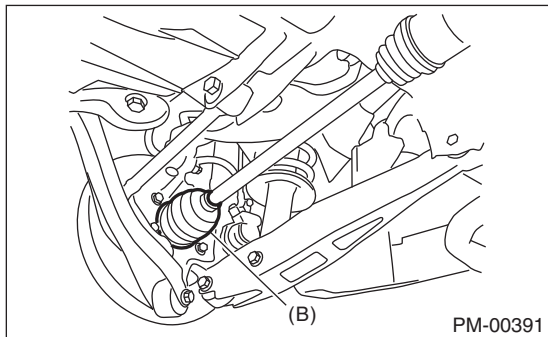
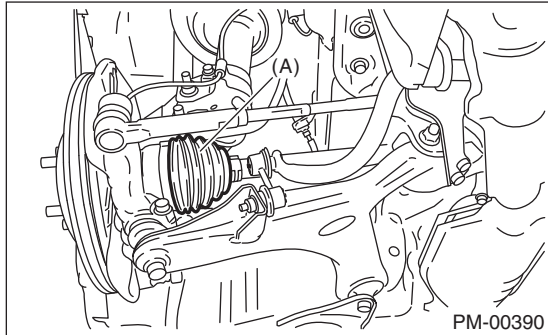

2. PROPELLER SHAFT

Inspect the propeller shaft for damage or failure. If faulty, replace with new part. <Ref. to DS-10, Propeller Shaft.>

24. Tire Rotation

A: INSPECTION

1) When the tread has worn down to less than 1.6 mm (0.063 in) or the wear indicator appears across the tread, replace the tire. (Replace the right and left tire as a set.)

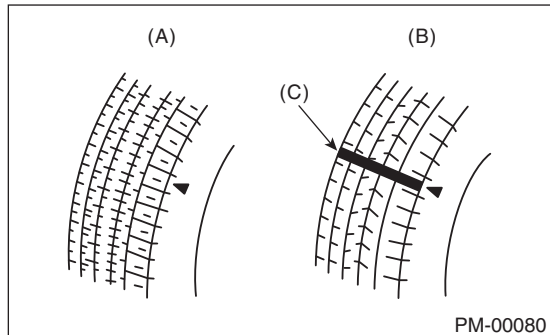

- (A) New tread
- (B) Damaged tread
- (C) Tread wear indicator

2) If the tire appears to be worn unevenly, adjust the wheel alignment.

3) Next, make a tire rotation between front and rear as shown in the figure, to make sure that tires are worn evenly.

- When the direction of tire rotation is not specified

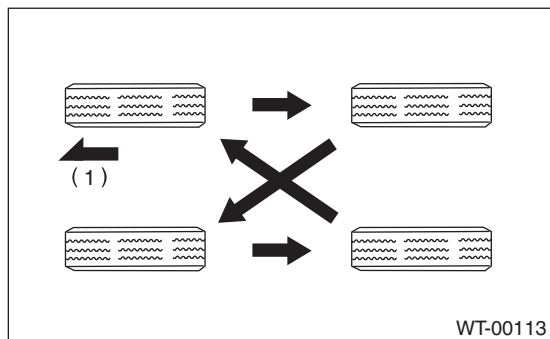

(1) Front

- When the direction of tire rotation is specified

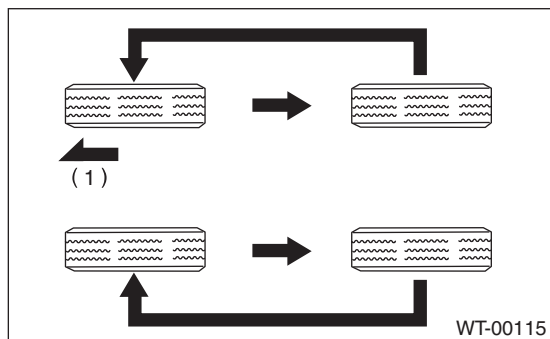

(1) Front

25. Steering System (Power Steering)

A: INSPECTION

1. STEERING WHEEL

1) Set the steering wheel in a straight-ahead position, and check the wheel spokes to make sure they are correctly set in their specified positions.

2) Lightly turn the steering wheel to the left and right to determine the point where front wheels start to move.

Measure the distance of the movement of steering wheel (outer periphery).

Steering wheel free play:

0 — 17 mm (0 — 0.67 in)

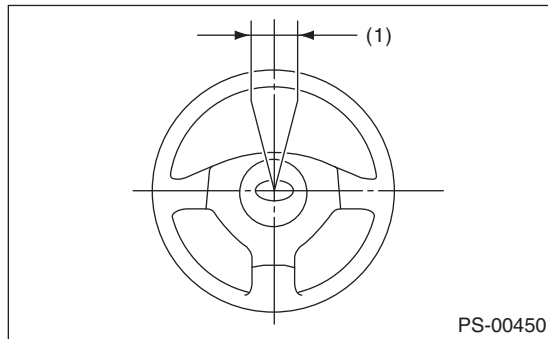

(1) Steering wheel free play

Move the steering wheel vertically toward the shaft to check if there is play in the direction.

Limit of play:

0.5 mm (0.020 in)

3) Drive the vehicle and check the following items.

(1) Steering force:

The effort required for steering should be smooth and even at all points, and should not vary.

(2) Pulled to one side:

Steering wheel should not be pulled to either side while driving on a level surface.

(3) Wheel runout:

Steering wheel should not show any sign of runout.

(4) Return shape:

The steering wheel should return to its original position after it has been turned by hand and then released.

2. STEERING SHAFT JOINT

When the steering wheel free play is excessive, disconnect the universal joint of steering shaft and check it for any play and yawing torque (at the point of the crossing direction). Also inspect for any damage to sealing or worn serrations. If the joint is loose, retighten the mounting bolts to the specified torque.

Tightening torque:

24 N·m (2.4 kgf-m, 17.4 ft-lb)

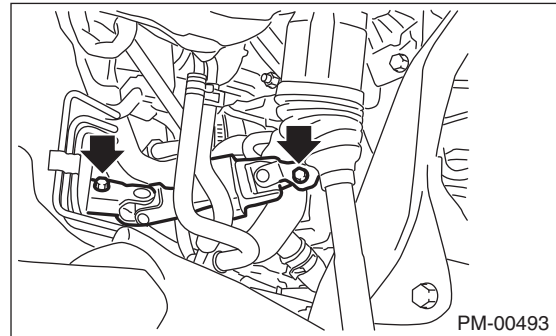

PM-00493

3. GEARBOX

1) Set the steering wheel in the straight position, then rotate it 90° in both the left and right directions. While steering wheel is being rotated, check the looseness of the gear box.

Tightening torque:

60 N·m (6.1 kgf-m, 44.3 ft-lb)

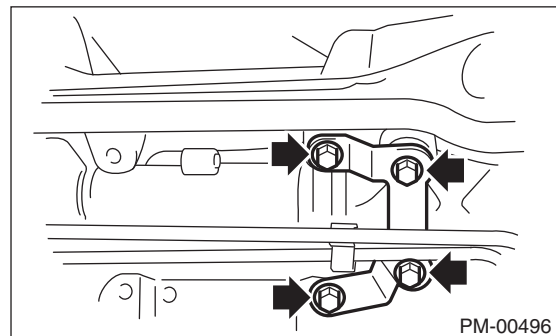

PM-00496

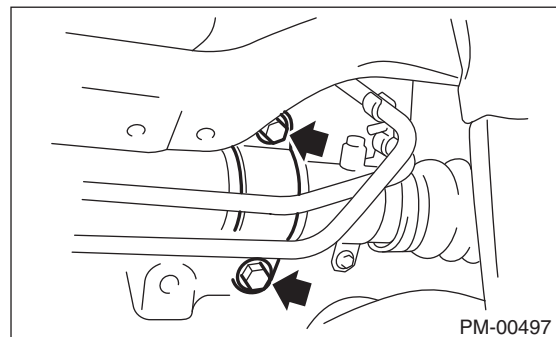

PM-00497

2) Check the boot for damage, cracks or deterioration.

Steering System (Power Steering)

PERIODIC MAINTENANCE SERVICES

3) With the vehicle stopped on a level surface, quickly turn the steering wheel to the left and right. While steering wheel is being rotated, check the gear backlash. If any noise is noticed, adjust the gear backlash in the following manner.

- (1) Tighten the adjusting screw to 9.8 N·m (0.99 kgf-m, 7.2 ft-lb) and then loosen.
- (2) Tighten the adjusting screw to 4.9 N·m (0.49 kgf-m, 3.6 ft-lb) and then loosen.
- (3) Tighten the adjusting screw to 4.9 N·m (0.49 kgf-m, 3.6 ft-lb) and then loosen 37°.
- (4) Apply liquid gasket to at least 1/3 of entire perimeter of adjusting screw thread.

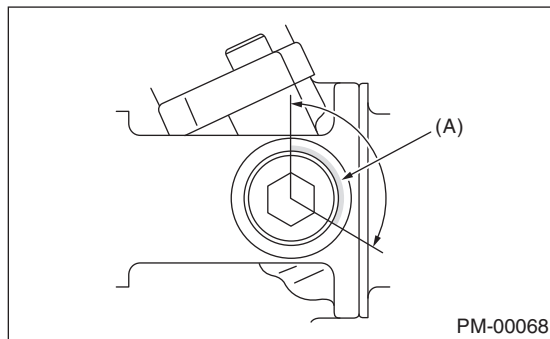

(A) Apply liquid gasket to at least 1/3 of entire thread.

(5) Install the lock nut. While holding the adjusting screw with a wrench, tighten the lock nut using ST.

ST 926230000 SPANNER

Tightening torque (lock nut):

39 N·m (4.0 kgf-m, 29 ft-lb)

Hold the adjusting screw with a wrench to prevent it from turning while tightening the lock nut.

4. TIE-ROD

1) Check the tie-rod and tie-rod ends for bends, scratches or other damage.

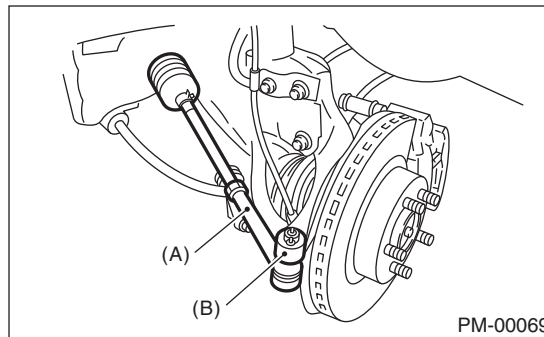

(A) Tie-rod end
(B) Knuckle arm

2) Check the connections of the knuckle ball joints for play, inspect for damage on dust seals, and check that there is no free play in the ball studs. If castle nut is loose, retighten it to the specified torque, then tighten further up to a maximum of 60° until the cotter pin hole is aligned.

Tightening torque:

27 N·m (2.75 kgf-m, 19.9 ft-lb)

3) Check the lock nut on the tie-rod end for tightness. If it is loose, retighten it to the specified value.

Tightening torque:

85 N·m (8.7 kgf-m, 62.7 ft-lb)

5. POWER STEERING FLUID LEVEL

NOTE:

- When power steering fluid temperature is 20°C (68°F), read the fluid level on the “COLD” side.
- When power steering fluid temperature is 80°C (176°F), read the fluid level on the “HOT” side.

1) Stop the engine to park the vehicle on a level surface.

2) Check the fluid level using the scale on the outside of the reservoir tank. If the level is below “MIN”, fill fluid up to “MAX” level.

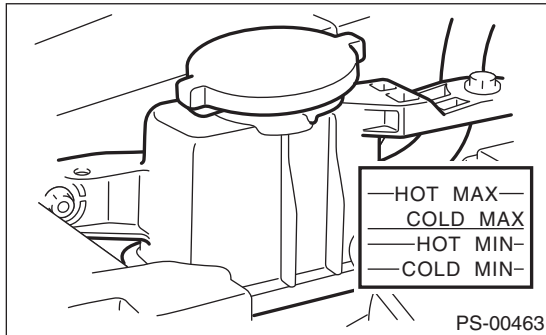

CAUTION:

If any power steering fluid is spilled on the exhaust pipe, wipe it off with a clean cloth to avoid emitting smoke or causing a fire.

NOTE:

If fluid level is at “MAX” level or above, drain fluid to keep the level in the specified range of indicator by using a syringe or the like.

Recommended fluid:

<Ref. to RM-4, FLUID, RECOMMENDED MATERIALS, Recommended Materials.>

Fluid capacity:

<Ref. to SPC-4, CAPACITY, Forester.>

6. POWER STEERING FLUID FOR LEAKS

Inspect the underside of oil pump and gearbox of power steering system, hoses, pipes and their couplings for fluid leaks.

If the fluid leaks are found, retighten their fitting bolts (or nuts) and/or replace their parts.

CAUTION:

Also pay attention to interference between hoses or pipes and other parts when inspecting fluid leaks.

7. HOSES OF OIL PUMP FOR DAMAGES

For the hydraulic power steering model, check the pressure hose and return hose of oil pump for crack, swell or damage. Replace the hose with a new part if necessary.

CAUTION:

Prevent hoses from turning and/or bending when installing hoses.

8. POWER STEERING PIPES FOR DAMAGES

Check the power steering pipes for corrosion and damage.

Replace the pipes with new parts if necessary.

9. GEARBOX BOOTS

For the hydraulic power steering model, inspect both sides of the gearbox boot as follows, and correct the defects if necessary.

- 1) The (A) and (B) positions of the gearbox boot are fitted in (A) and (C) grooves of gearbox and the rod.
- 2) Clips are fitted outside of positions (A) and (B) of boot.
- 3) Check that there is no cracks or holes in the boot.

NOTE:

Rotate (B) position of gearbox boot against the torsion produced by the adjustment of toe-in etc. Apply grease to the groove (C).

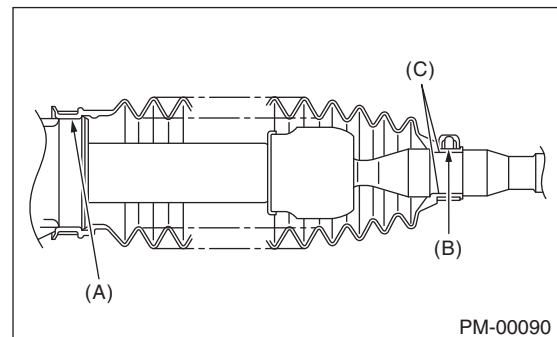

10. FITTING BOLTS AND NUTS

Inspect the installation bolts and nuts of the oil pump and bracket for looseness, and retighten them if necessary.

NOTE:

Inspect and/or retighten the bolts and nuts when the engine is cold.

Steering System (Power Steering)

PERIODIC MAINTENANCE SERVICES

ENGINE 1 SECTION

This service manual has been prepared to provide SUBARU service personnel with the necessary information and data for the correct maintenance and repair of SUBARU vehicles.

This manual includes the procedures for maintenance, disassembling, reassembling, inspection and adjustment of components and diagnostics for guidance of experienced mechanics.

Please peruse and utilize this manual fully to ensure complete repair work for satisfying our customers by keeping their vehicle in optimum condition. When replacement of parts during repair work is needed, be sure to use SUBARU genuine parts.

All information, illustration and specifications contained in this manual are based on the latest product information available at the time of publication approval.

FUEL INJECTION (FUEL SYSTEMS) FU(H4SO)

EMISSION CONTROL (AUX. EMISSION CONTROL DEVICES) EC(H4SO)

INTAKE (INDUCTION) IN(H4SO)

MECHANICAL ME(H4SO)

EXHAUST EX(H4SO)

COOLING CO(H4SO)

LUBRICATION LU(H4SO)

SPEED CONTROL SYSTEMS SP(H4SO)

IGNITION IG(H4SO)

STARTING/CHARGING SYSTEMS SC(H4SO)

ENGINE (DIAGNOSTICS) EN(H4SO)(diag)

GENERAL DESCRIPTION GD(H4SO)

FUEL INJECTION (FUEL SYSTEMS)

FU(H4SO)

	Page
1. General Description	2
2. Throttle Body	13
3. Intake Manifold	14
4. Engine Coolant Temperature Sensor	22
5. Crankshaft Position Sensor	23
6. Camshaft Position Sensor	24
7. Knock Sensor	25
8. Throttle Position Sensor	26
9. Manifold Absolute Pressure Sensor	27
10. Mass Air Flow and Intake Air Temperature Sensor	28
11. EGR Valve	29
12. Fuel Injector	30
13. Variable Valve Lift Diagnosis Oil Pressure Switch	33
14. Oil Temperature Sensor	34
15. Front Oxygen (A/F) Sensor	35
16. Rear Oxygen Sensor	37
17. Engine Control Module (ECM)	39
18. Main Relay	40
19. Fuel Pump Relay	41
20. Electronic Throttle Control Relay	42
21. Fuel	43
22. Fuel Tank	45
23. Fuel Filler Pipe	52
24. Fuel Pump	56
25. Fuel Level Sensor	58
26. Fuel Sub Level Sensor	60
27. Fuel Filter	62
28. Fuel Damper	63
29. Purge Damper	64
30. Fuel Delivery and Evaporation Lines	65
31. Fuel System Trouble in General	69

General Description

FUEL INJECTION (FUEL SYSTEMS)

1. General Description

A: SPECIFICATION

Fuel tank	Capacity	64 ℓ (16.9 US gal, 14.1 Imp gal)
	Install locations	Under rear seat
Fuel pump	Type	Impeller
	Shutoff discharge pressure	550 — 850 kPa (5.6 — 8.7 kg/cm ² , 79.7 — 123.2 psi)
	Discharge rate	125 ℓ (33 US gal, 27.5 Imp gal)/h or more. [12 V at 300 kPa (3.06 kg/cm ² , 43.5 psi)]
Fuel filter		Intank type

General Description

FUEL INJECTION (FUEL SYSTEMS)

- | | |
|----------------------------|-----------------------------------|
| (1) Intake manifold | (9) Fuel injector pipe RH |
| (2) Gasket | (10) Fuel injector |
| (3) Nipple | (11) O-ring |
| (4) Guide pin | (12) Purge control solenoid valve |
| (5) Plug cord stay | (13) Plug cord holder |
| (6) EGR valve | (14) Fuel pipe ASSY |
| (7) Fuel pipe protector RH | (15) Fuel injector pipe LH |
| (8) Fuel pipe protector LH | (16) Gasket |

Tightening torque:N·m (kgf-m, ft-lb)

T1: 6.4 (0.7, 4.7)

T2: 17 (1.7, 12.5)

T3: 19 (1.9, 14.0)

T4: 25 (2.5, 18.4)

T5: <Ref. to EC(H4SO)-9, INSTALLATION, Purge Control Solenoid Valve.>

*: Refer to "Purge Control Solenoid Valve, INSTALLATION" for the mounting hole of the purge control solenoid valve. <Ref. to EC(H4SO)-9, INSTALLATION, Purge Control Solenoid Valve.>

2. AIR INTAKE SYSTEM

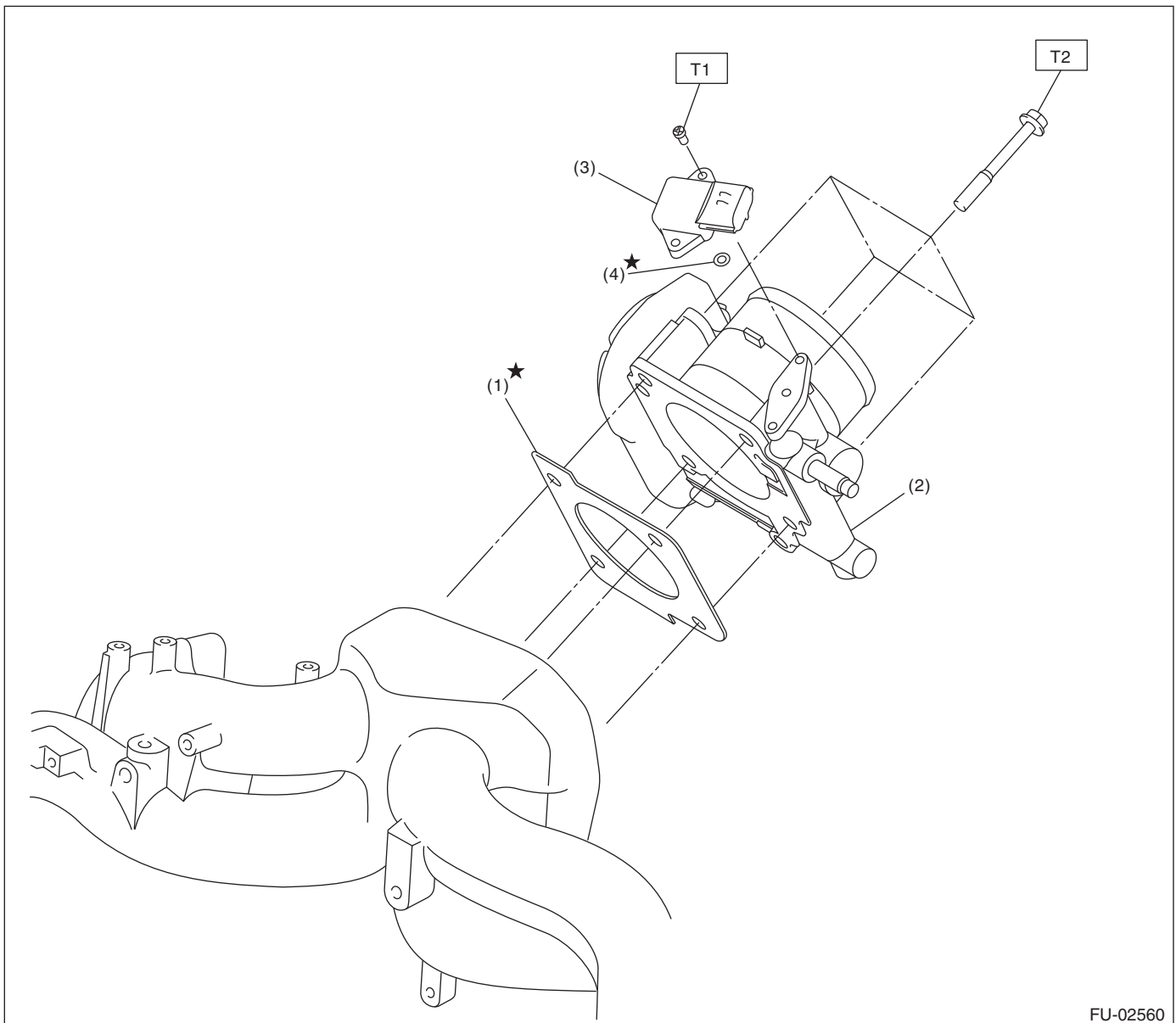

FU-02560

- | | |
|-------------------|---------------------------------------|
| (1) Gasket | (3) Manifold absolute pressure sensor |
| (2) Throttle body | (4) O-ring |

Tightening torque:N·m (kgf-m, ft-lb)

T1: 2 (0.2, 1.5)

T2: 8 (0.8, 5.9)

General Description

FUEL INJECTION (FUEL SYSTEMS)

3. CRANKSHAFT POSITION, CAMSHAFT POSITION AND KNOCK SENSORS

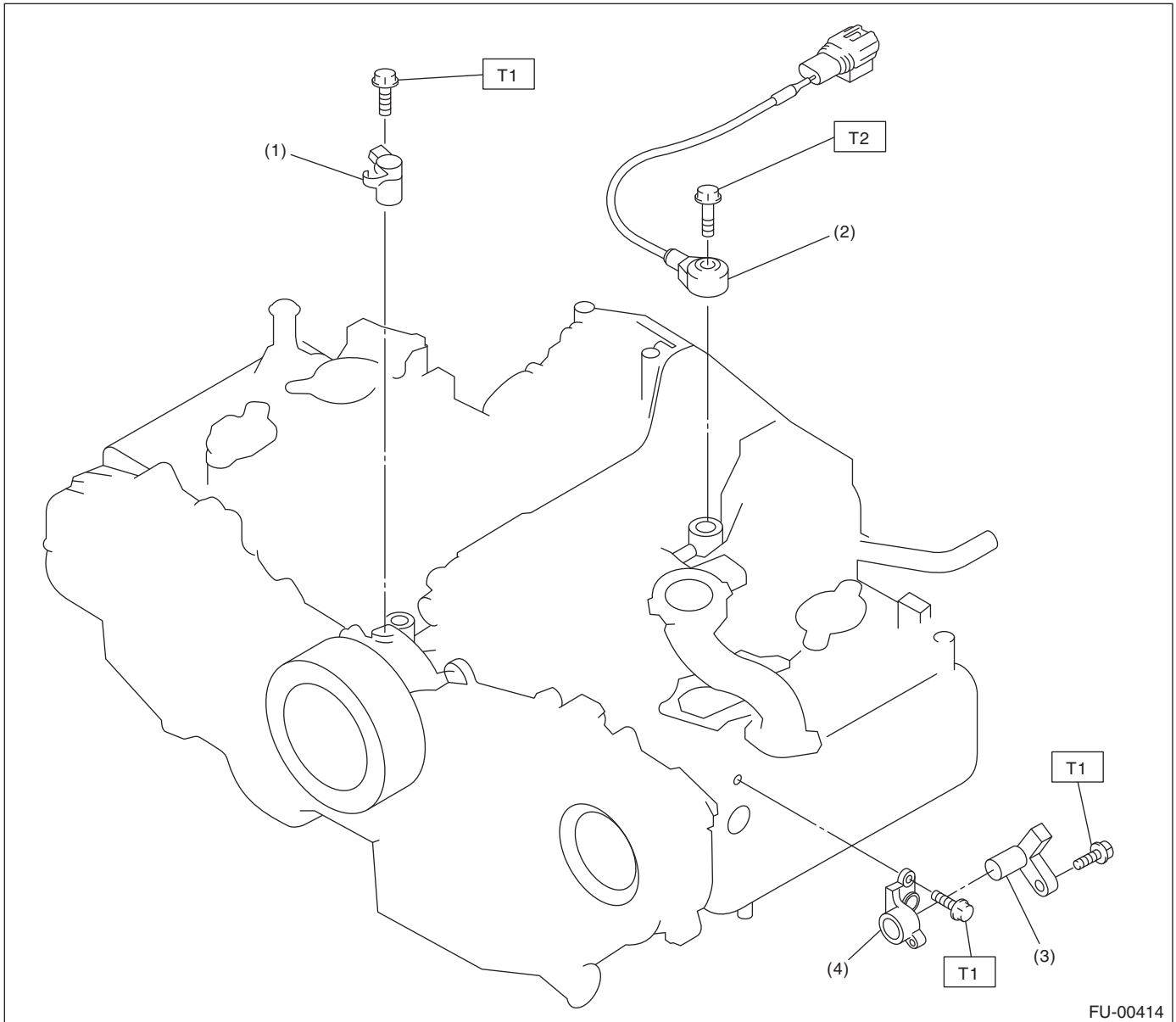

FU-00414

(1) Crankshaft position sensor

(3) Camshaft position sensor

Tightening torque: N·m (kgf·m, ft·lb)

(2) Knock sensor

(4) Camshaft position sensor support

T1: 6.4 (0.7, 4.7)

T2: 24 (2.4, 17.7)

General Description

FUEL INJECTION (FUEL SYSTEMS)

4. FUEL TANK

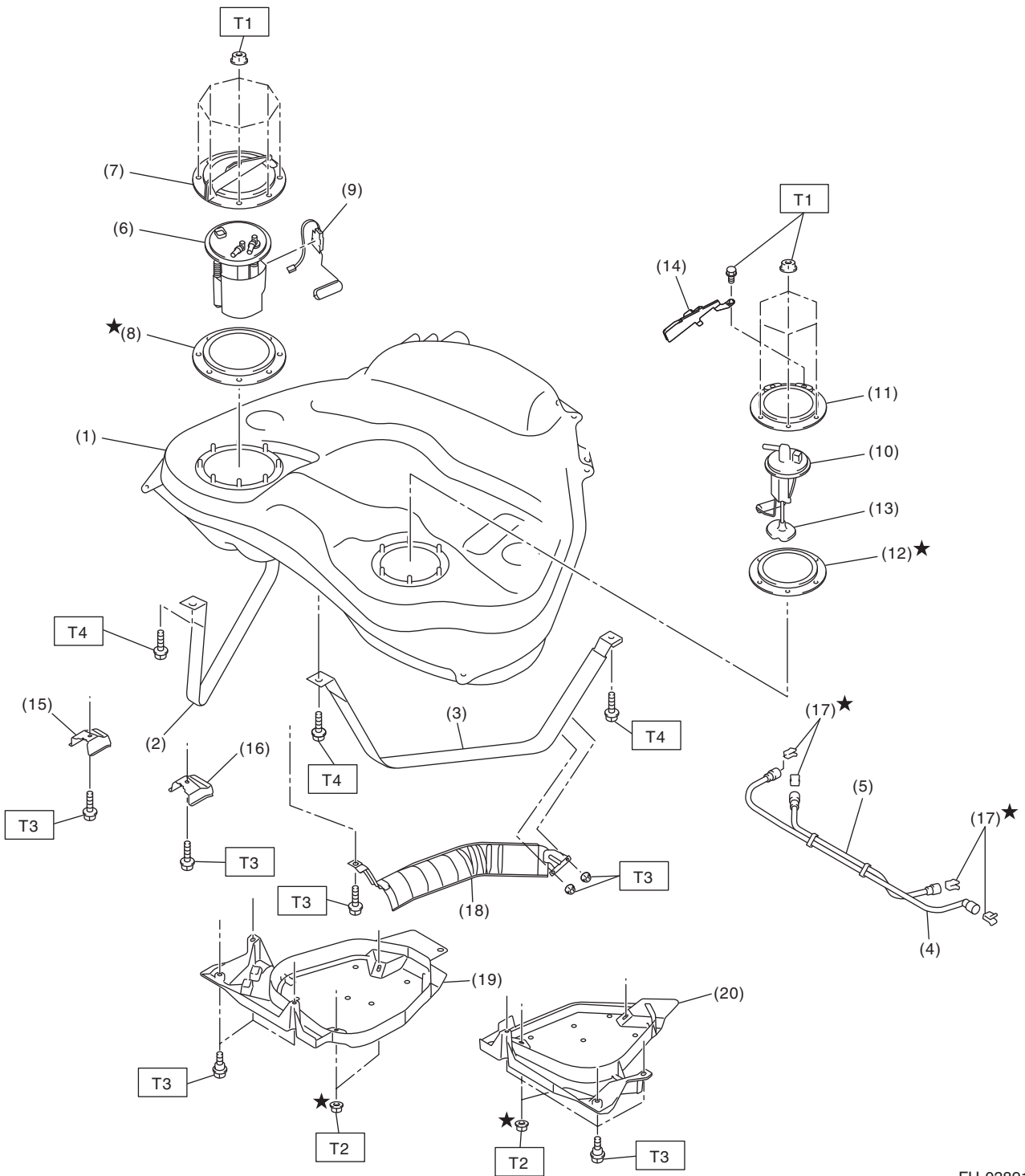

FU-03891

General Description

FUEL INJECTION (FUEL SYSTEMS)

- | | | |
|---------------------------|--|-----------------------------|
| (1) Fuel tank | (10) Fuel sub level sensor | (19) Fuel tank protector RH |
| (2) Fuel tank band RH | (11) Fuel sub level sensor upper plate | (20) Fuel tank protector LH |
| (3) Fuel tank band LH | (12) Fuel sub level sensor gasket | |
| (4) Delivery tube | (13) Fuel sub level sensor filter | |
| (5) Jet pump tube | (14) Fuel sub level sensor protector | |
| (6) Fuel pump ASSY | (15) Stopper RH | |
| (7) Fuel pump upper plate | (16) Stopper LH | |
| (8) Fuel pump gasket | (17) Retainer | |
| (9) Fuel level sensor | (18) Heat shield cover | |

Tightening torque:N·m (kgf-m, ft-lb)**T1: 4.4 (0.4, 3.2)****T2: 9 (0.9, 6.6)****T3: 18 (1.8, 13.3)****T4: 33 (3.4, 24.3)**

General Description

FUEL INJECTION (FUEL SYSTEMS)

5. FUEL LINE

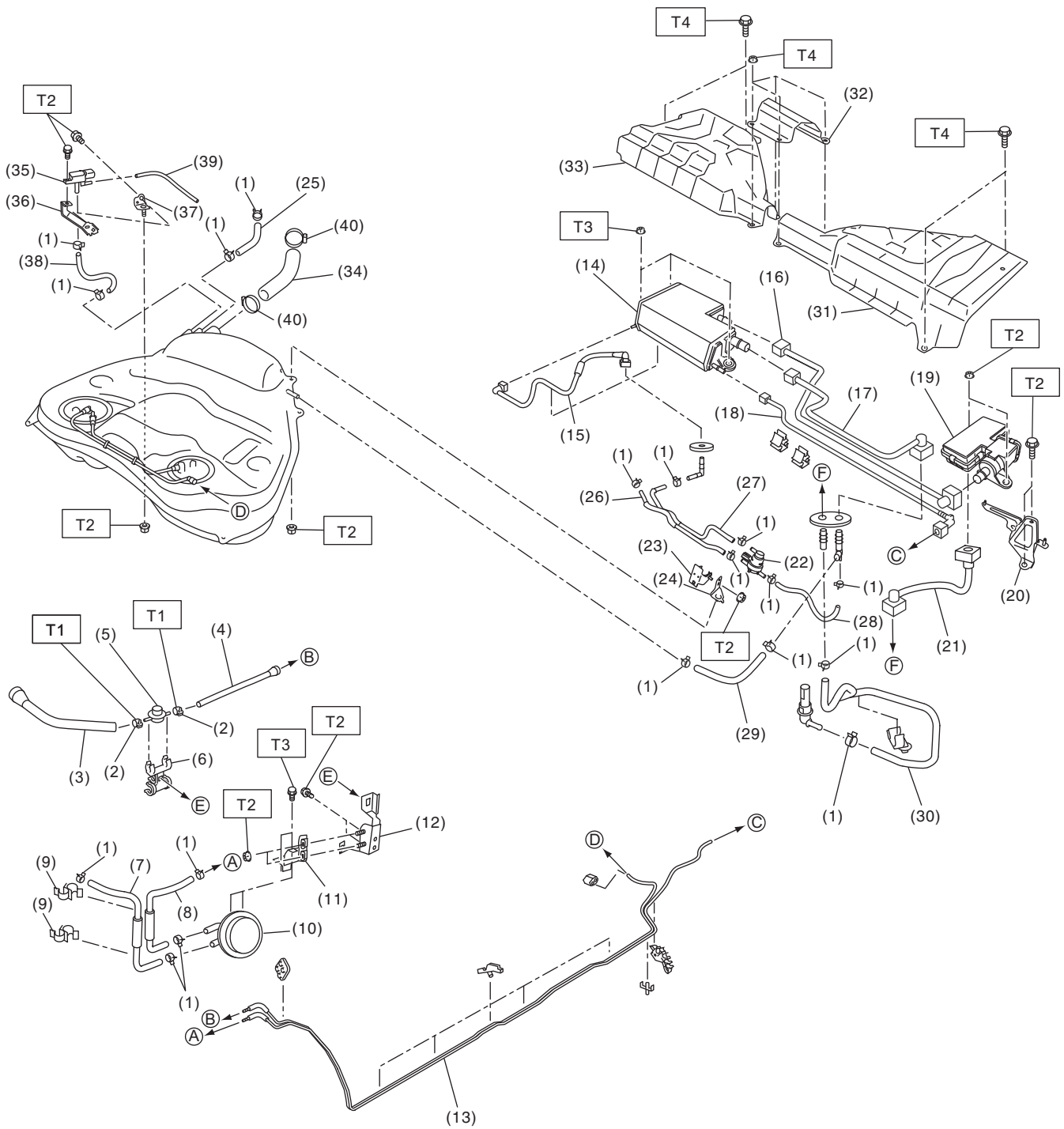

FU-03433

General Description

FUEL INJECTION (FUEL SYSTEMS)

(1) Clip	(17) Vent tube	(31) Canister cover LH
(2) Clamp	(18) Purge tube	(32) Center canister cover
(3) Fuel delivery hose A	(19) Drain valve	(33) Canister cover RH
(4) Fuel delivery hose B	(20) Drain valve bracket	(34) Fuel filler hose
(5) Fuel damper	(21) Drain tube B	(35) Fuel tank pressure sensor
(6) Fuel damper holder	(22) Pressure control solenoid valve	(36) Fuel tank pressure sensor bracket A
(7) Evaporation hose A	(23) Pressure control solenoid valve bracket A	(37) Fuel tank pressure sensor bracket B
(8) Evaporation hose B	(24) Pressure control solenoid valve bracket B	(38) Pressure hose
(9) Clamp	(25) Evaporation hose A	(39) Vacuum hose
(10) Purge damper valve	(26) Evaporation hose B	(40) Clamp
(11) Purge damper valve bracket A	(27) Evaporation hose C	
(12) Purge damper valve bracket B	(28) Evaporation hose D	
(13) Fuel pipe ASSY	(29) Evaporation hose E	
(14) Canister	(30) Canister drain hose	
(15) PCV drain tube		
(16) Drain tube A		

Tightening torque:N·m (kgf-m, ft-lb)

T1: 1.25 (0.1, 0.9)

T2: 7.5 (0.8, 5.5)

T3: 8 (0.8, 5.9)

T4: 18 (1.8, 13.3)

General Description

FUEL INJECTION (FUEL SYSTEMS)

6. FUEL PIPE

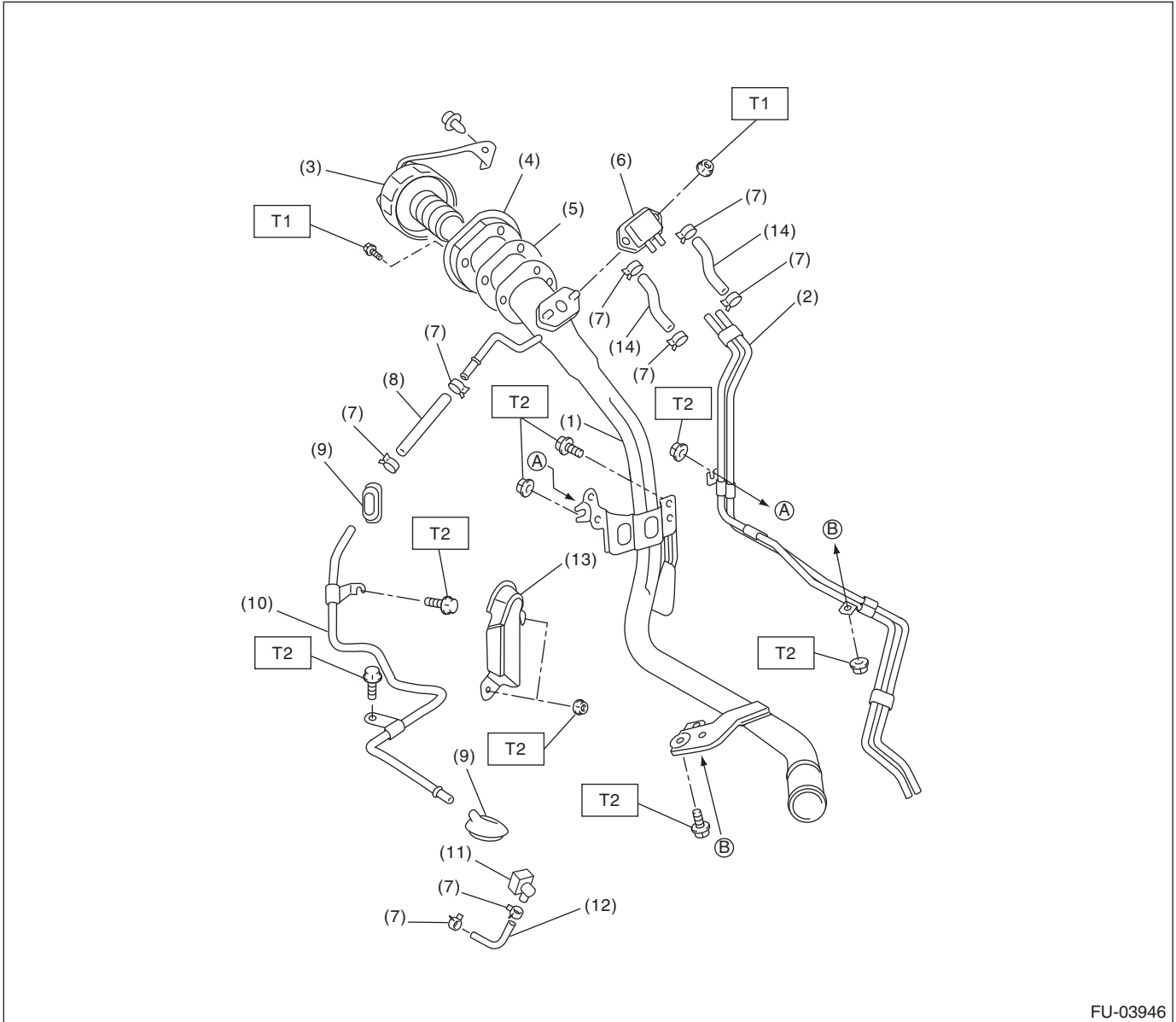

FU-03946

- (1) Fuel filler pipe ASSY
- (2) Evaporation pipe A
- (3) Fuel filler cap
- (4) Filler ring
- (5) Filler pipe gasket
- (6) Shut valve

- (7) Clip
- (8) Evaporation hose A
- (9) Grommet
- (10) Evaporation pipe B
- (11) Quick connector
- (12) Evaporation hose B

- (13) Evaporation pipe protector
- (14) Evaporation hose C

Tightening torque: N·m (kgf-m, ft-lb)

T1: 4.4 (0.4, 3.2)

T2: 7.5 (0.8, 5.5)

General Description

FUEL INJECTION (FUEL SYSTEMS)

7. FUEL PUMP

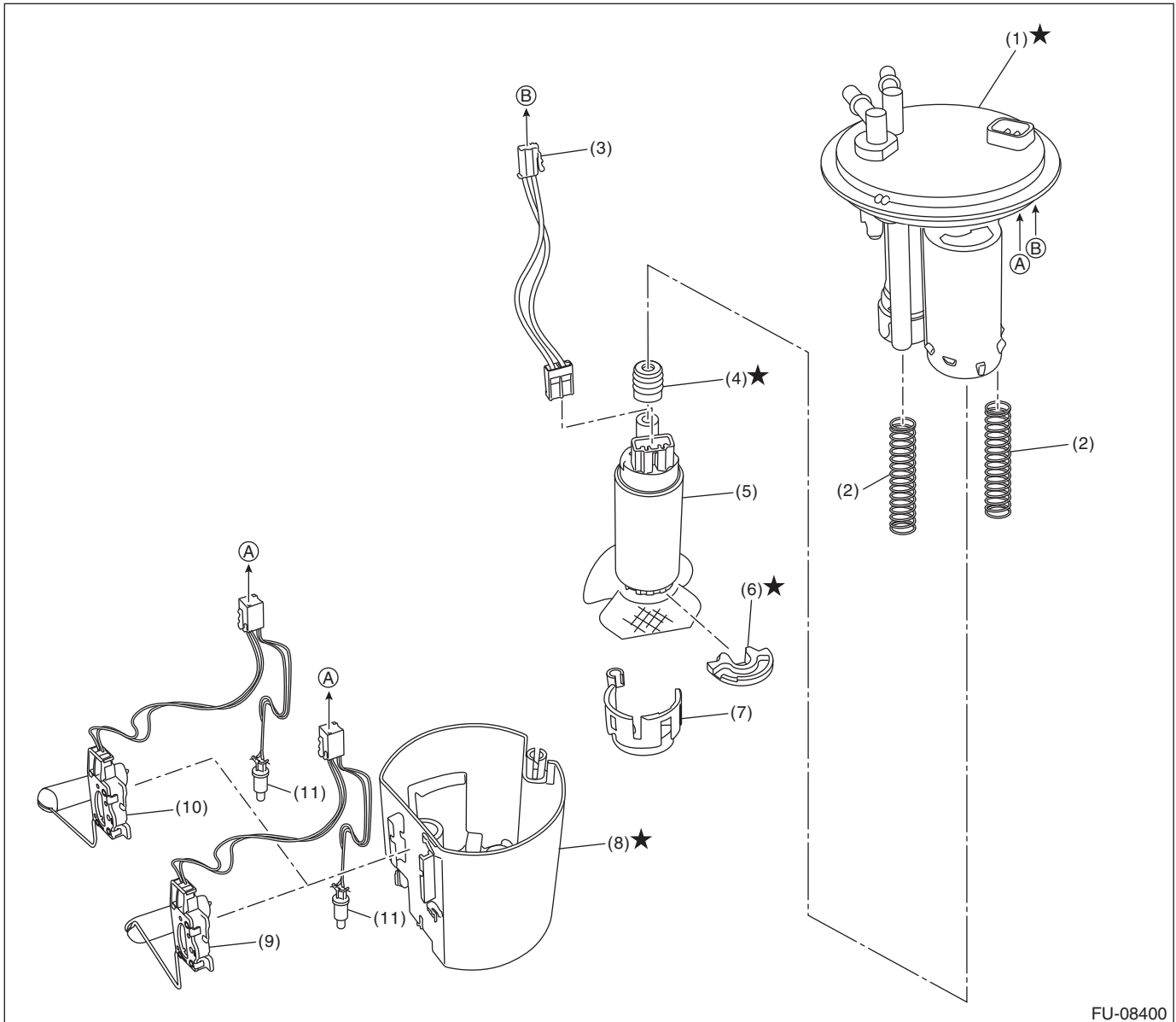

FU-08400

- | | | |
|--------------------------|----------------------------|---|
| (1) Fuel filter assembly | (5) Fuel pump | (9) Fuel level sensor (model with fuel level sensor bent in 3 locations) |
| (2) Pump module spring | (6) Support rubber cushion | (10) Fuel level sensor (model with fuel level sensor bent in 2 locations) |
| (3) Fuel pump harness | (7) Fuel pump holder | (11) Fuel temperature sensor |
| (4) Gasket spacer | (8) Fuel chamber ASSY | |

General Description

FUEL INJECTION (FUEL SYSTEMS)

C: CAUTION

- Wear appropriate work clothing, including a cap, protective goggles and protective shoes when performing any work.
- Remove contamination including dirt and corrosion before removal, installation or disassembly.
- Keep the disassembled parts in order and protect them from dust and dirt.
- Before removal, installation or disassembly, be sure to clarify the failure. Avoid unnecessary removal, installation, disassembly and replacement.
- Vehicle components are extremely hot after driving. Be wary of receiving burns from heated parts.
- Be sure to tighten fasteners including bolts and nuts to the specified torque.
- Place shop jacks or rigid racks at the specified points.
- Before disconnecting connectors of sensors or units, be sure to disconnect the ground cable from the battery.
- Place “NO OPEN FLAMES” signs near the working area.
- Prepare a container and cloth to prevent scattering of fuels when performing work where fuels can be spilled. If the fuel spills, wipe it off immediately to prevent from penetrating into floor or flowing out for environmental protection.
- Follow all government and local regulations concerning disposal of refuse when disposing fuel.

D: PREPARATION TOOL

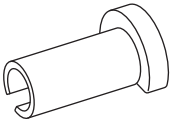
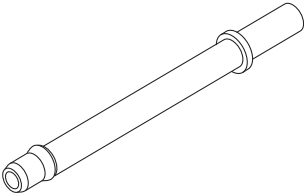
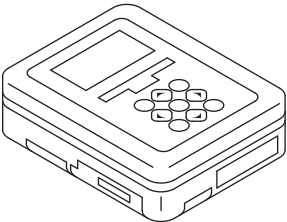
ILLUSTRATION	TOOL NUMBER	DESCRIPTION	REMARKS
 ST42099AE000	42099AE000	QUICK CONNECTOR RELEASE	Used for removing the quick connector.
 ST18471AA000	18471AA000 (Newly adopted tool)	FUEL PIPE ADAPTER	Used for draining fuel.
 ST1B022XU0	1B022XU0 (Newly adopted tool)	SUBARU SELECT MONITOR III KIT	Used for extracting fuel.

2. Throttle Body

A: REMOVAL

1) Disconnect the ground cable from the battery.

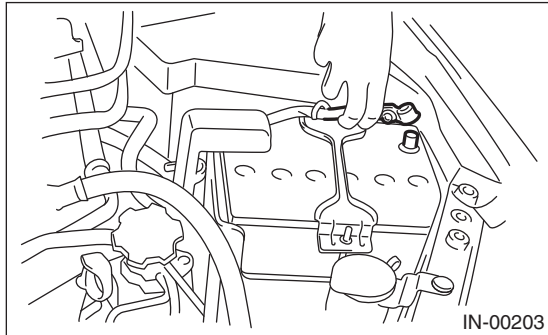

2) Remove the air intake chamber. <Ref. to IN(H4SO)-7, REMOVAL, Air Intake Chamber.>

3) Disconnect the throttle position sensor connector (A) and manifold pressure sensor connector (B).

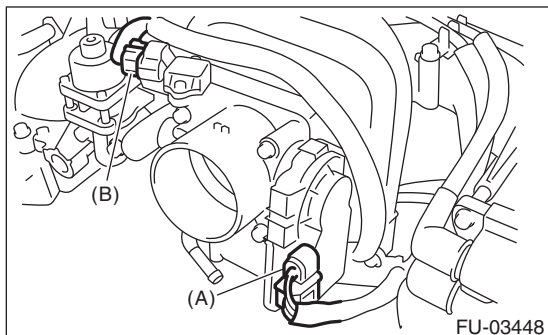

4) Disconnect the engine coolant hoses (A) from the throttle body.

5) Remove the bolts (B) which secure the throttle body to the intake manifold, and remove the throttle body.

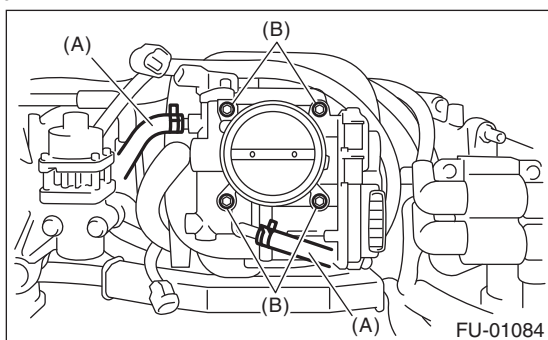

B: INSTALLATION

Install in the reverse order of removal.

NOTE:

Use a new gasket.

Tightening torque:

8 N·m (0.8 kgf·m, 5.9 ft·lb)

Intake Manifold

FUEL INJECTION (FUEL SYSTEMS)

3. Intake Manifold

A: REMOVAL

- 1) Release the fuel pressure.
<Ref. to FU(H4SO)-43, RELEASING OF FUEL PRESSURE, PROCEDURE, Fuel.>
- 2) Disconnect the ground cable from the battery.

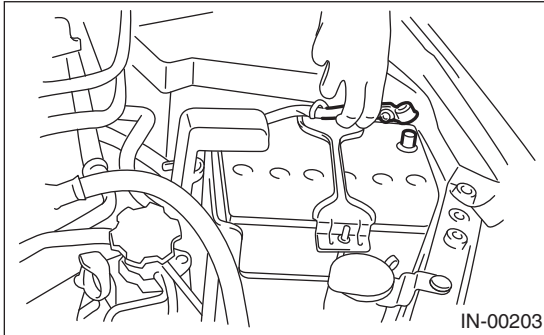

- 3) Remove the air cleaner case and air intake chamber. <Ref. to IN(H4SO)-5, REMOVAL, Air Cleaner Case.> <Ref. to IN(H4SO)-7, REMOVAL, Air Intake Chamber.>

- 4) Remove the generator. <Ref. to SC(H4SO)-15, REMOVAL, Generator.>

- 5) Disconnect the spark plug cord from the spark plug.

- 6) Disconnect the engine coolant hoses (A) from throttle body.

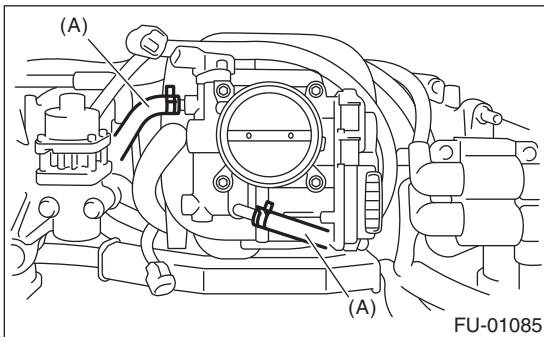

- 7) Disconnect brake booster vacuum hose (A).

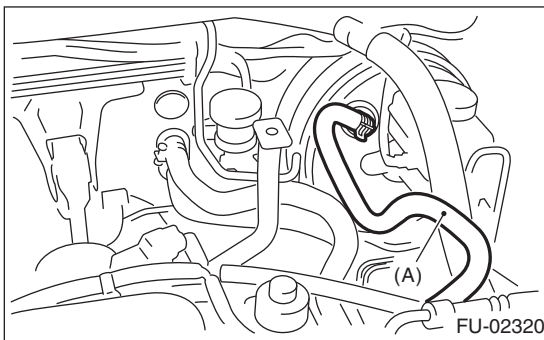

- 8) Disconnect the PCV hose (A) from intake manifold.

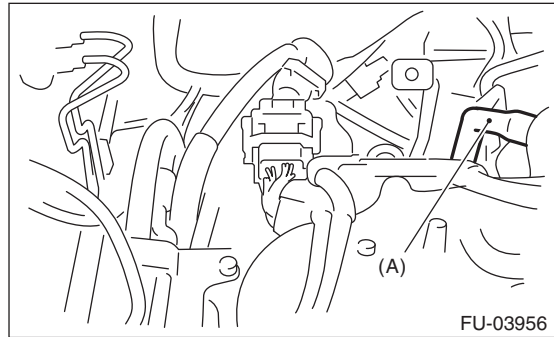

- 9) Remove the bolt and disconnect the engine harness connector from the bulkhead harness connector and rear engine hanger.

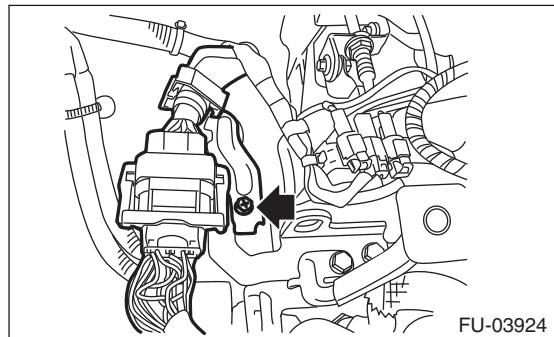

- 10) Slide the bulkhead harness connector in the direction of the arrow and remove the rear engine hanger.

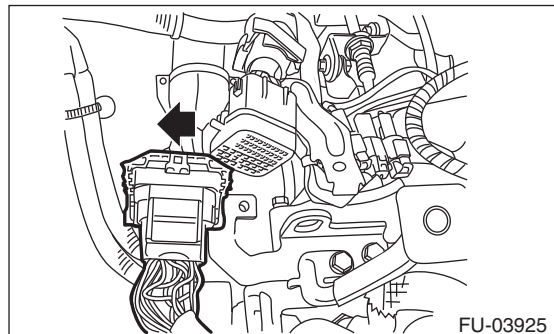

- 11) Disconnect the connectors from the engine coolant temperature sensor.

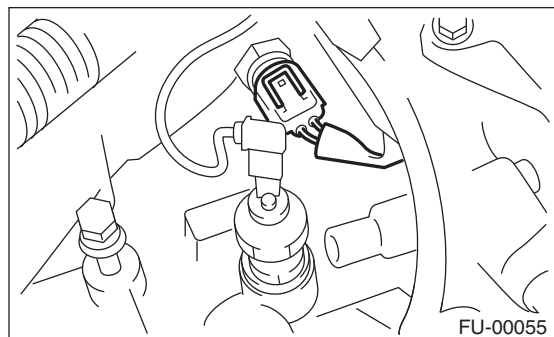

Intake Manifold

FUEL INJECTION (FUEL SYSTEMS)

12) Disconnect the knock sensor connector.

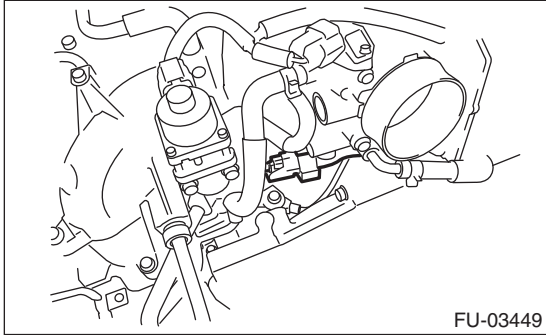

13) Disconnect the connector from crankshaft position sensor.

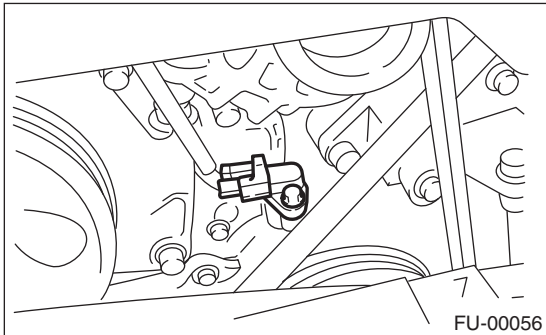

14) Disconnect the connector from power steering pump switch (A).

15) Disconnect the connector from the oil pressure switch (B).

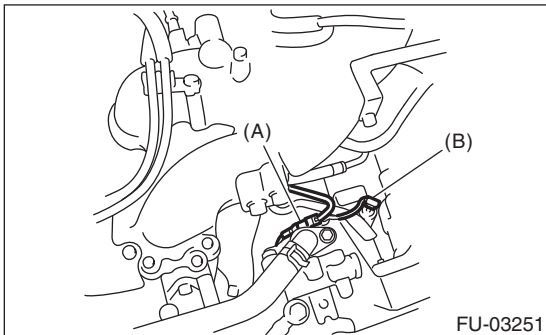

16) Disconnect the connector from the camshaft position sensor.

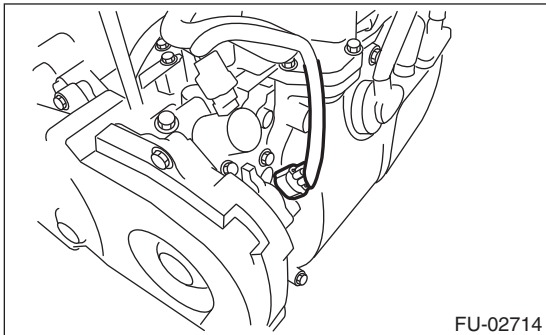

17) Disconnect the front oxygen (A/F) sensor connector (A) and rear oxygen sensor connector (B) and remove the clip (C) fastening the harness.

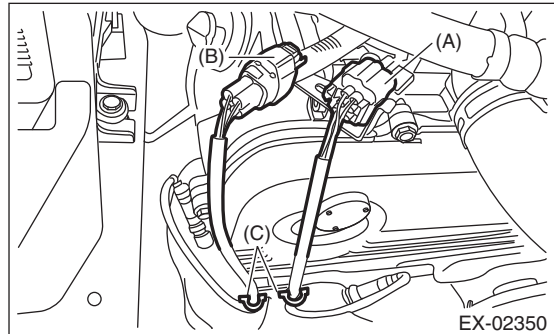

18) Remove the EGR pipe from intake manifold.

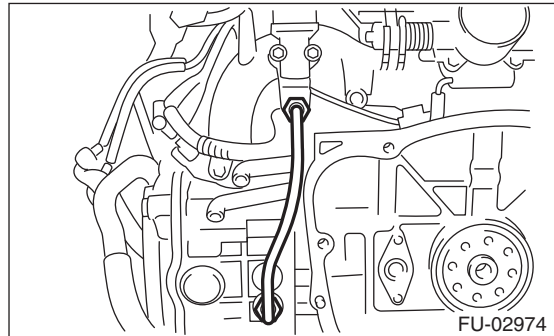

19) Disconnect the fuel hoses from fuel pipe.

(1) Disconnect the quick connector on the fuel delivery line by pushing the ST in the direction of the arrow.

ST 42099AE000 QUICK CONNECTOR RELEASE

(2) Remove the clip and disconnect the evaporation hose from the pipe.

CAUTION:

- Be careful not to spill fuel.
- Catch the fuel from hoses using a container or cloth.

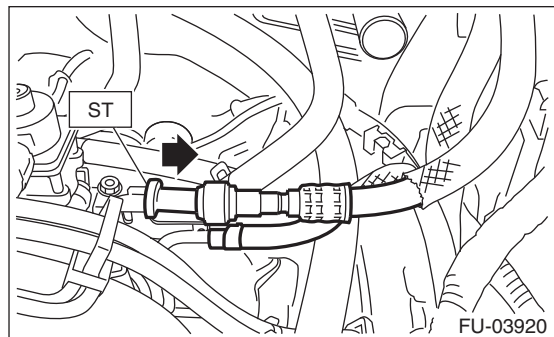

Intake Manifold

FUEL INJECTION (FUEL SYSTEMS)

20) Remove the bolts which secure intake manifold to cylinder head.

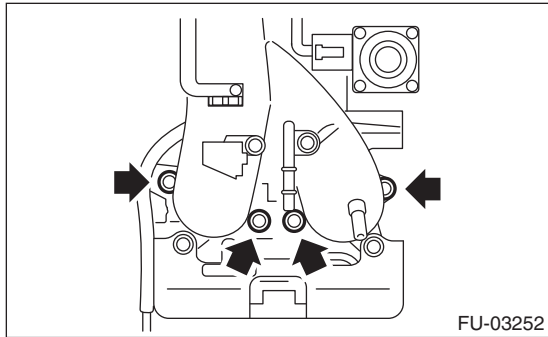

21) Remove the intake manifold.

B: INSTALLATION

1) Install the intake manifold onto cylinder heads.

NOTE:

Use a new gasket.

Tightening torque:

25 N·m (2.5 kgf·m, 18.4 ft·lb)

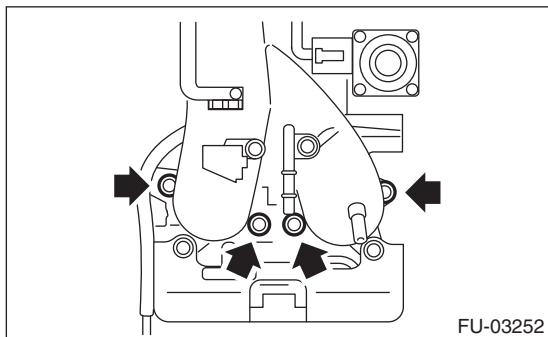

2) Connect the fuel delivery hose and evaporation hose to the fuel pipe. <Ref. to FU(H4SO)-67, INSTALLATION, Fuel Delivery and Evaporation Lines.>

NOTE:

If fuel hoses or clamps are damaged, replace them with new parts.

3) Install the EGR pipe to intake manifold.

Tightening torque:

34 N·m (3.5 kgf·m, 25.1 ft·lb)

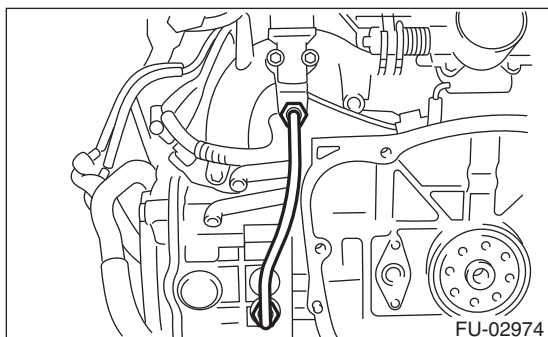

4) Connect the following connector and fasten the harness with clips.

- (1) Front oxygen (A/F) sensor connector
- (2) Rear oxygen sensor connector

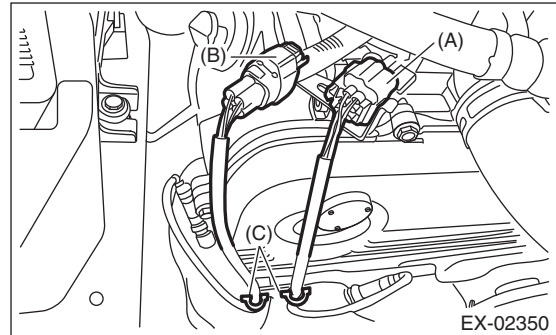

- (A) Front oxygen (A/F) sensor connector
- (B) Rear oxygen sensor connector
- (C) Clip

5) Connect the connectors to camshaft position sensor.

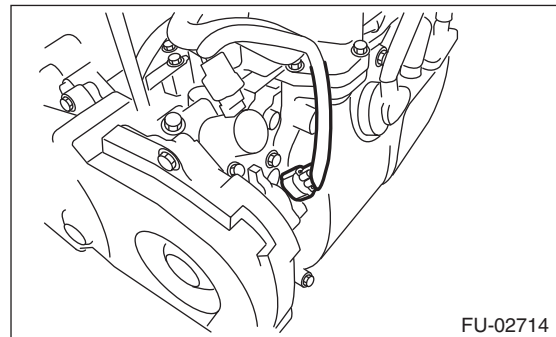

6) Connect the connector to the power steering pump switch (A).

7) Connect the connector to the oil pressure switch (B).

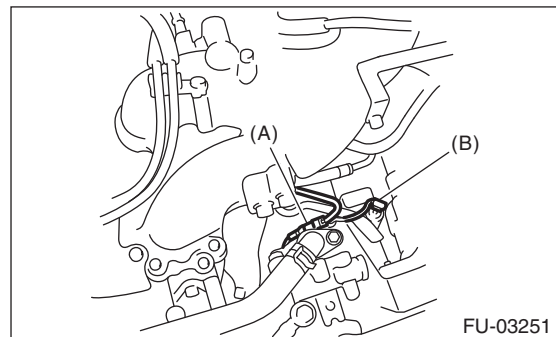

Intake Manifold

FUEL INJECTION (FUEL SYSTEMS)

- 8) Connect the connector to crankshaft position sensor.

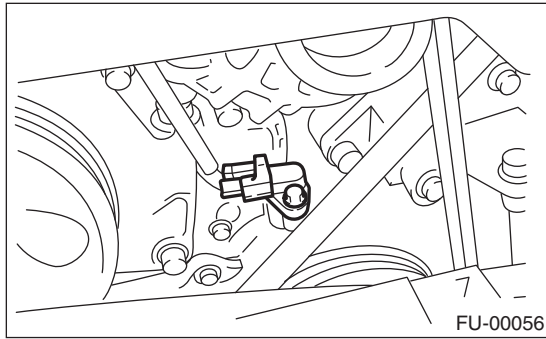

- 9) Connect the knock sensor connector.

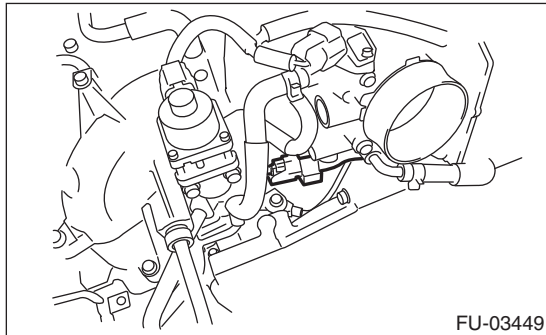

- 10) Connect the connector to engine coolant temperature sensor.

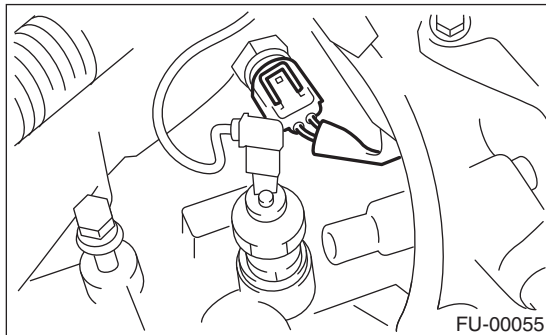

- 11) Connect the PCV hose (A) to intake manifold.

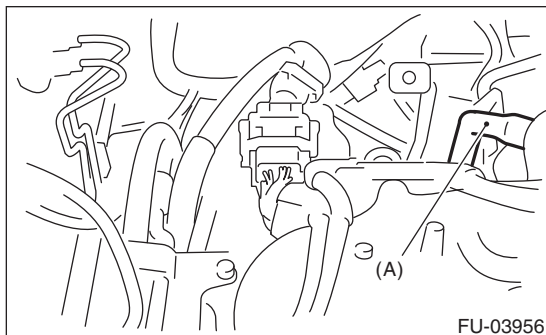

- 12) Connect the engine harness connector to the bulkhead harness connector and fasten to the rear engine hanger with bolt.

Tightening torque:

6.4 N·m (0.7 kgf·m, 4.7 ft·lb)

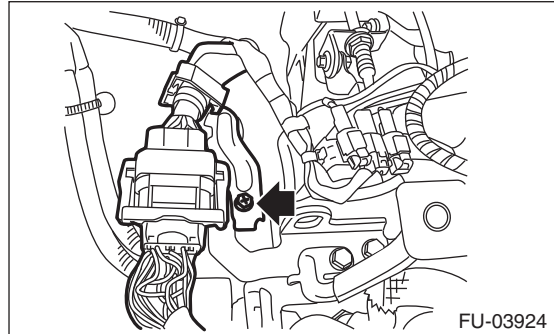

- 13) Connect the brake booster vacuum hose (A).

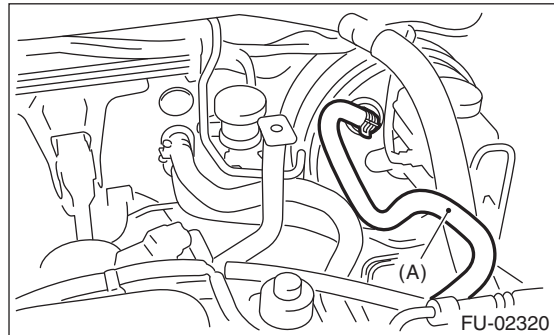

- 14) Connect the engine coolant hoses (A) to throttle body.

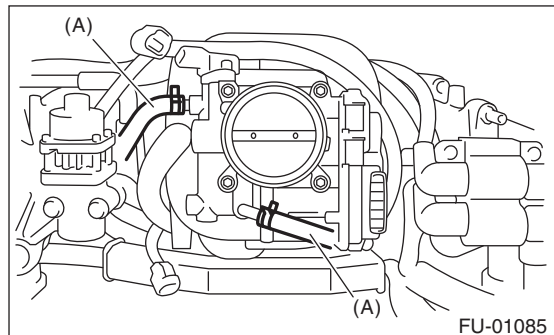

- 15) Connect the spark plug cords to spark plugs.
16) Install the generator. <Ref. to SC(H4SO)-16, INSTALLATION, Generator.>
17) Install the air cleaner case and air intake chamber. <Ref. to IN(H4SO)-6, INSTALLATION, Air Cleaner Case.> <Ref. to IN(H4SO)-7, INSTALLATION, Air Intake Chamber.>
18) Install the fuse of fuel pump relay to the main fuse box.

Intake Manifold

FUEL INJECTION (FUEL SYSTEMS)

19) Connect the battery ground cable to battery.

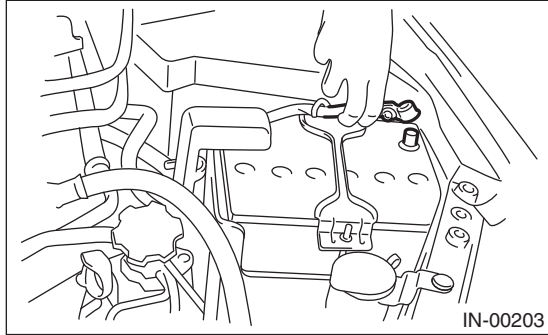

C: DISASSEMBLY

1) Disconnect the engine ground terminal from intake manifold.

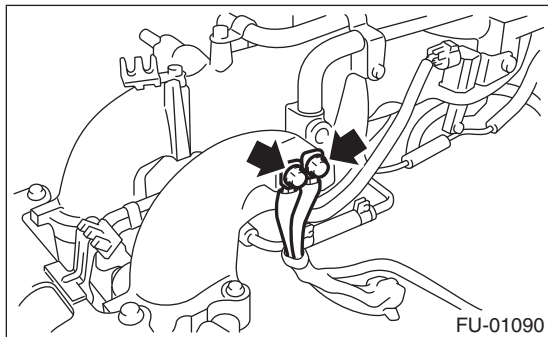

2) Remove the ignition coil and ignitor assembly. <Ref. to IG(H4SO)-6, REMOVAL, Ignition Coil and Ignitor Assembly.>

3) Remove the throttle body. <Ref. to FU(H4SO)-13, REMOVAL, Throttle Body.>

4) Remove the EGR valve. <Ref. to FU(H4SO)-29, REMOVAL, EGR Valve.>

5) Remove the plug cord stay.

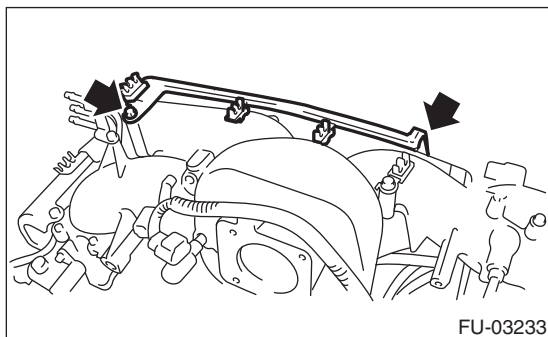

6) Remove the fuel pipe protector LH.

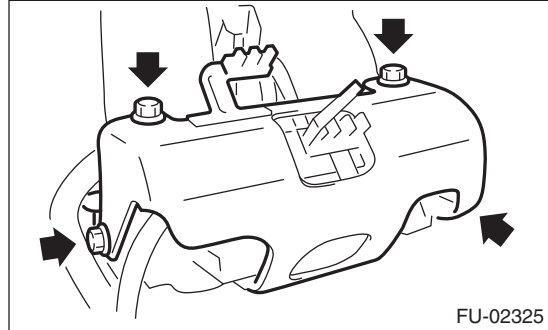

7) Remove the fuel pipe protector RH.

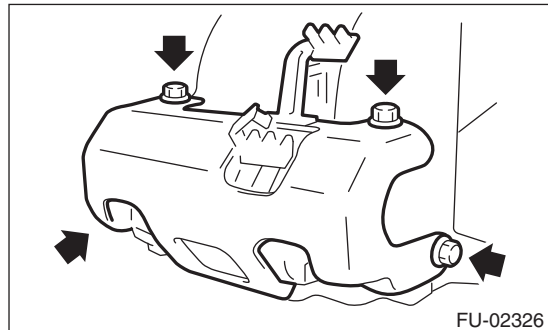

8) Disconnect the connectors (A) from fuel injector.

9) Remove the harness band (B) which holds the engine harness to injector pipe.

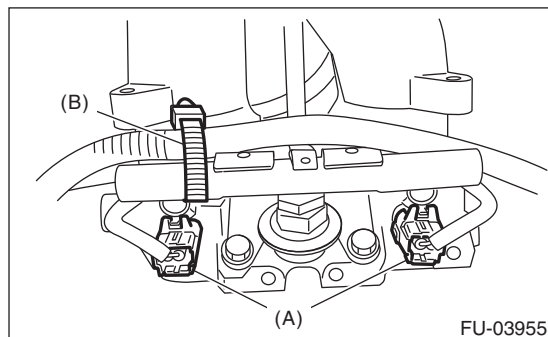

10) Remove the purge control solenoid valve. <Ref. to EC(H4SO)-9, REMOVAL, Purge Control Solenoid Valve.>

11) Remove the bolts which hold engine harness to intake manifold.

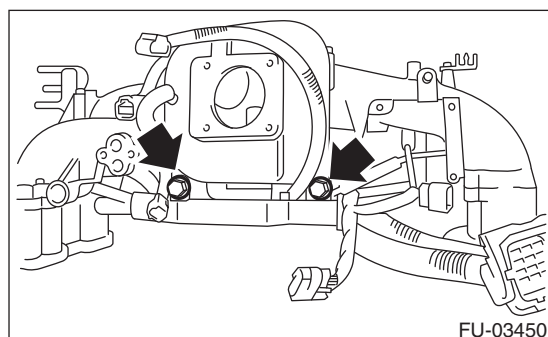

12) Remove the engine harness from intake manifold.

Intake Manifold

FUEL INJECTION (FUEL SYSTEMS)

13) Remove the bolts which install fuel injector pipe on the intake manifold as shown in the figure

- RH side

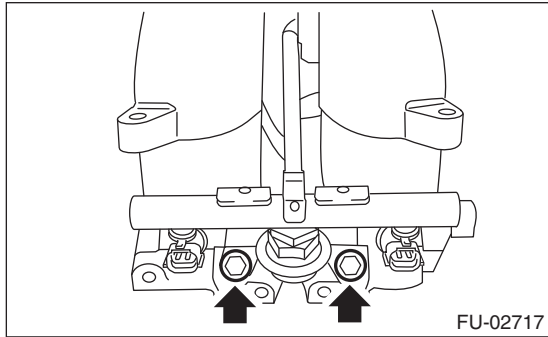

- LH side

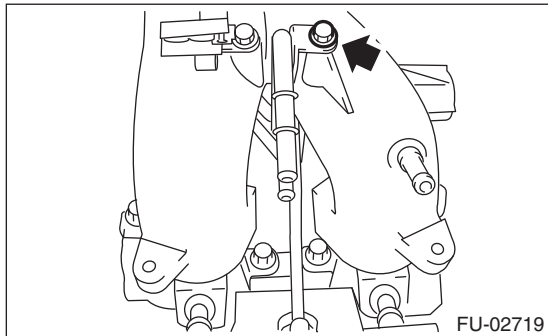
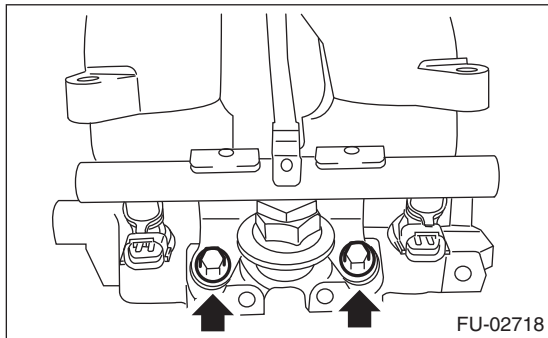

14) Remove the fuel injectors from the fuel injector pipe.

15) Disconnect the quick connector that fastens the fuel injector pipe RH to the fuel pipe.

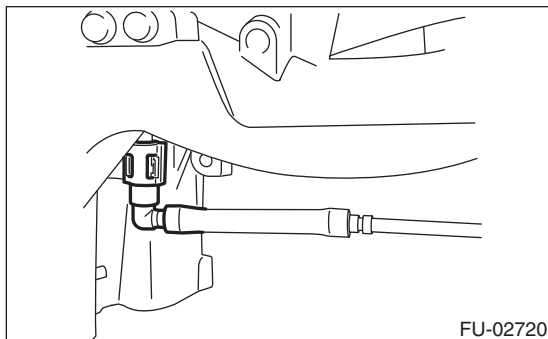

16) Disconnect the quick connector that fastens the fuel injector pipe LH to the fuel pipe.

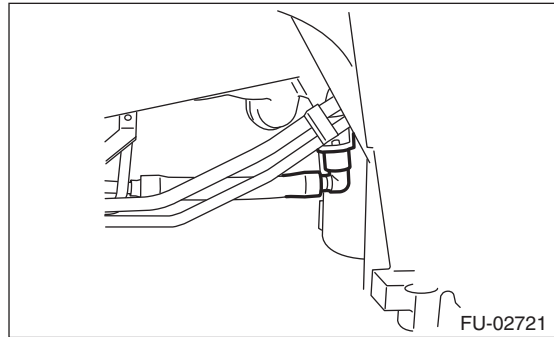

17) Remove the fuel injector pipe RH and LH.

18) Remove the bolts which install fuel pipes on intake manifold.

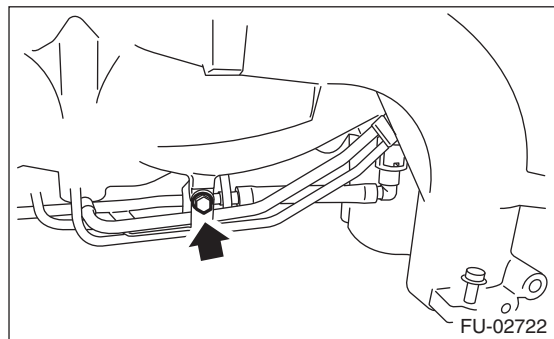

19) Remove the fuel pipe from intake manifold.

D: ASSEMBLY

NOTE:

When assembling the nipple, apply liquid gasket.

Liquid gasket:

THREE BOND 1105 (Part No. 004403010) or equivalent

1) Tighten the bolts which install fuel pipes on intake manifold.

Tightening torque:

6.4 N·m (0.7 kgf-m, 4.7 ft-lb)

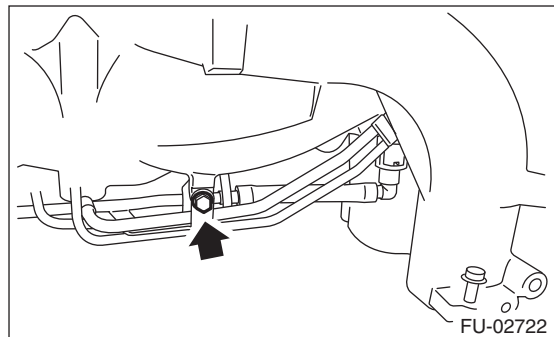

Intake Manifold

FUEL INJECTION (FUEL SYSTEMS)

2) Connect the fuel injector pipe LH to the fuel pipe.

NOTE:

Connect the quick connector securely.

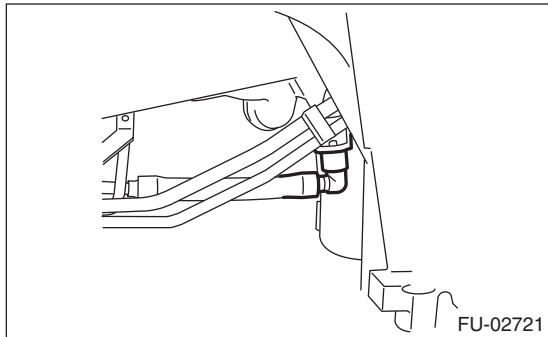

3) Connect the fuel injector pipe RH to the fuel pipe.

NOTE:

Connect the quick connector securely.

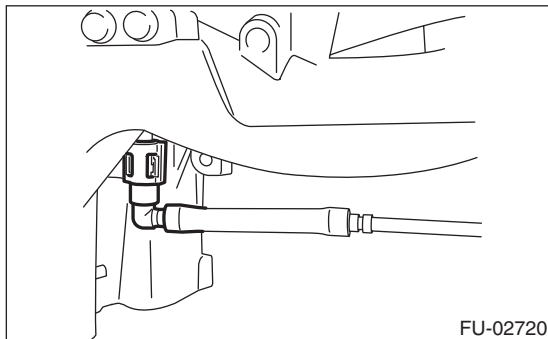

4) Install the fuel injector.

5) Tighten the bolts which install fuel injector pipes on intake manifold.

- RH side

Tightening torque:

19 N·m (1.9 kgf-m, 14.0 ft-lb)

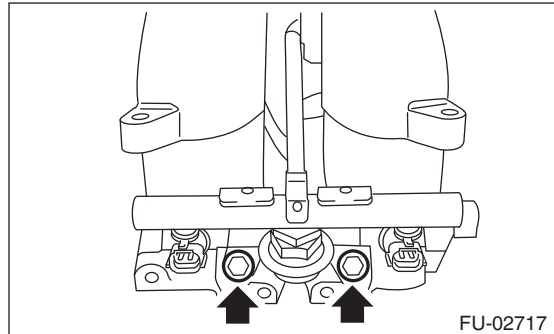

- LH side

Tightening torque:

19 N·m (1.9 kgf-m, 14.0 ft-lb)

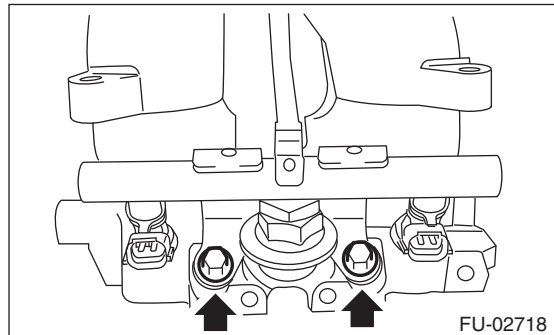

Tightening torque:

6.4 N·m (0.7 kgf-m, 4.7 ft-lb)

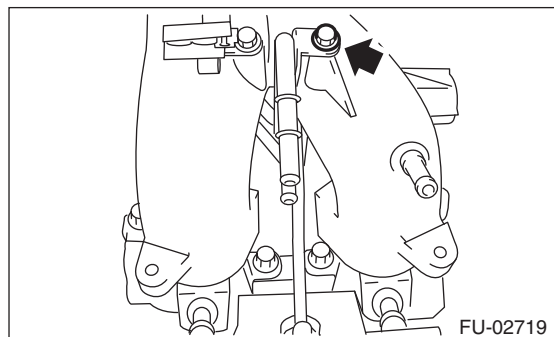

6) Install the engine harness to the intake manifold.

Intake Manifold

FUEL INJECTION (FUEL SYSTEMS)

7) Tighten the bolts which install engine harness on intake manifold.

Tightening torque:

19 N·m (1.9 kgf·m, 14.0 ft·lb)

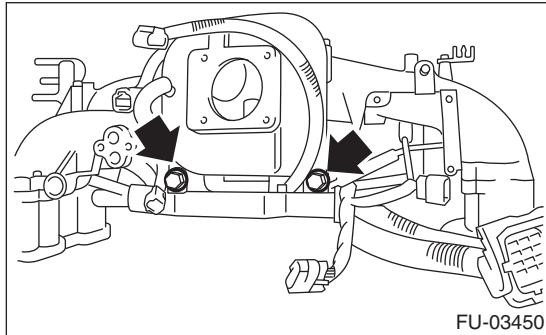

8) Install the purge control solenoid valve. <Ref. to EC(H4SO)-9, INSTALLATION, Purge Control Solenoid Valve.>

9) Connect the connectors (A) to fuel injector.

10) Hold the engine harness to injector pipe by harness band (B).

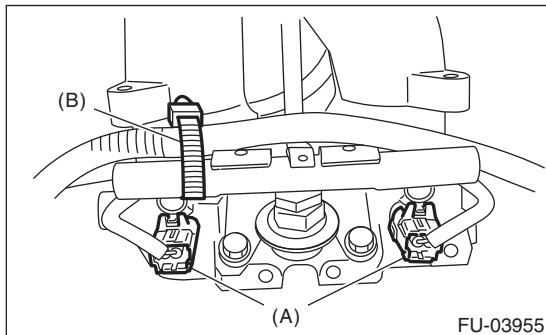

11) Install the fuel pipe protector RH.

Tightening torque:

19 N·m (1.9 kgf·m, 14.0 ft·lb)

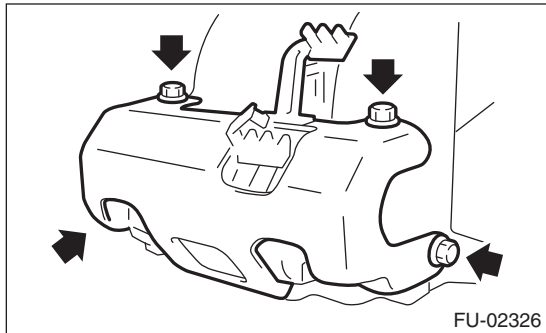

12) Install the fuel pipe protector LH.

Tightening torque:

19 N·m (1.9 kgf·m, 14.0 ft·lb)

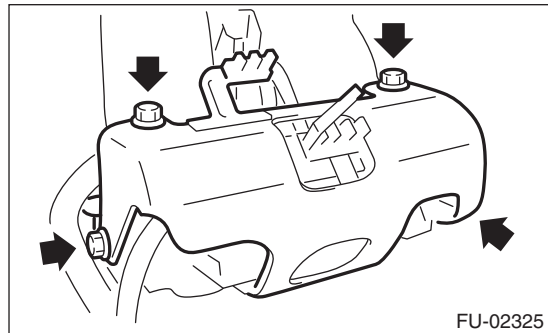

13) Install the plug cord stay.

Tightening torque:

6.4 N·m (0.7 kgf·m, 4.7 ft·lb)

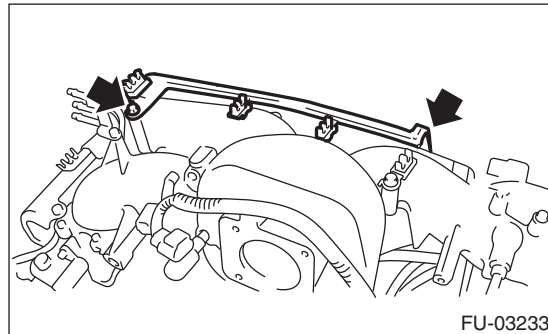

14) Install the EGR valve. <Ref. to FU(H4SO)-29, INSTALLATION, EGR Valve.>

15) Install the throttle body to intake manifold. <Ref. to FU(H4SO)-13, INSTALLATION, Throttle Body.>

16) Install the ignition coil and ignitor assembly. <Ref. to IG(H4SO)-6, INSTALLATION, Ignition Coil and Ignitor Assembly.>

17) Install the engine ground terminal to intake manifold.

Tightening torque:

19 N·m (1.9 kgf·m, 14.0 ft·lb)

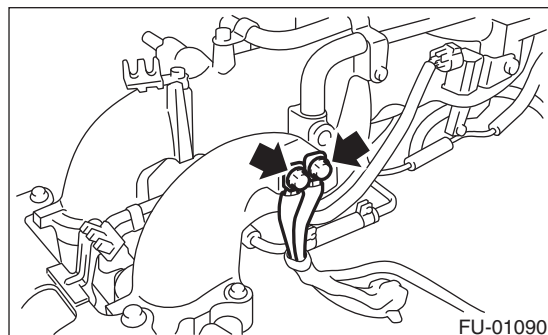

E: INSPECTION

Make sure the fuel pipe and fuel hoses are not damaged and the connections are tightened firmly.

Engine Coolant Temperature Sensor

FUEL INJECTION (FUEL SYSTEMS)

4. Engine Coolant Temperature Sensor

A: REMOVAL

1) Disconnect the ground cable from the battery.

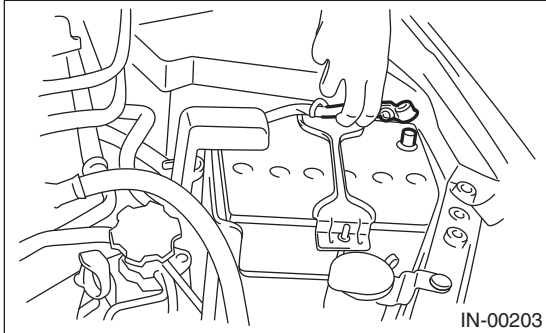

2) Remove the generator. <Ref. to SC(H4SO)-15, REMOVAL, Generator.>

3) Drain engine coolant. <Ref. to CO(H4SO)-13, DRAINING OF ENGINE COOLANT, REPLACEMENT, Engine Coolant.>

4) Disconnect the connectors from the engine coolant temperature sensor.

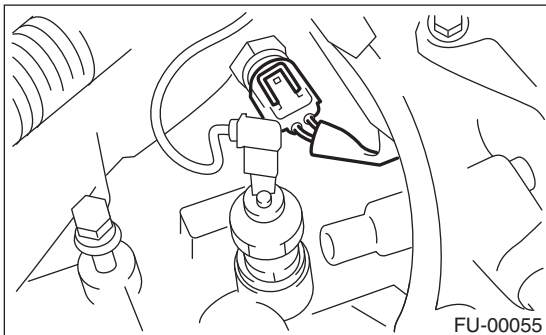

5) Remove the engine coolant temperature sensor.

B: INSTALLATION

Install in the reverse order of removal.

NOTE:

Use a new gasket.

Tightening torque:

18 N·m (1.8 kgf·m, 13.3 ft·lb)

5. Crankshaft Position Sensor

A: REMOVAL

1) Disconnect the ground cable from the battery.

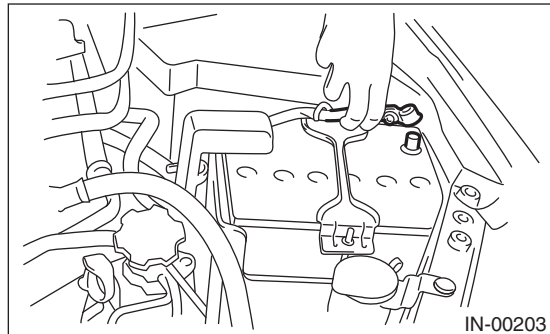

2) Remove the bolt which installs crankshaft position sensor to cylinder block.

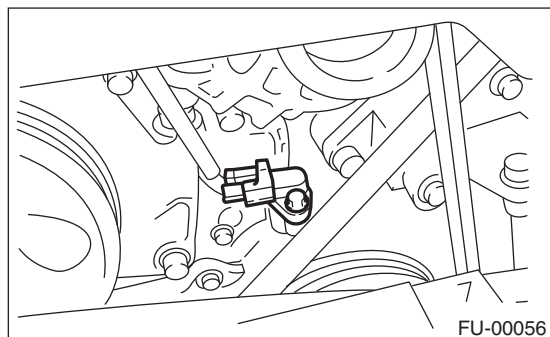

3) Remove the crankshaft position sensor, and then disconnect the connector from it.

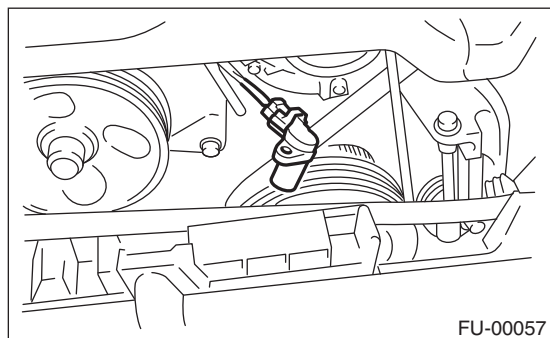

B: INSTALLATION

Install in the reverse order of removal.

Tightening torque:

T: 6.4 N·m (0.7 kgf-m, 4.7 ft-lb)

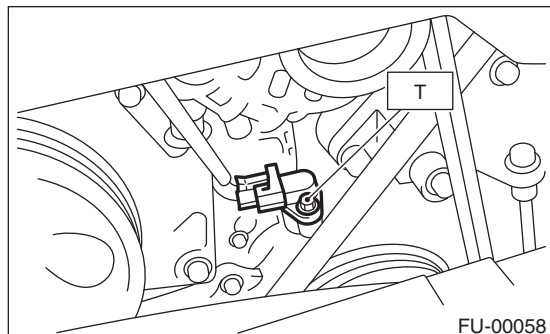

Camshaft Position Sensor

FUEL INJECTION (FUEL SYSTEMS)

6. Camshaft Position Sensor

A: REMOVAL

1) Disconnect the ground cable from the battery.

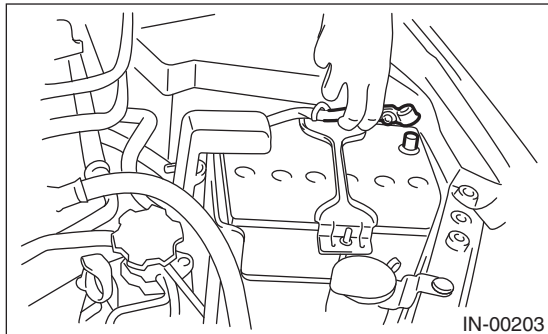

2) Disconnect the connector from the camshaft position sensor.

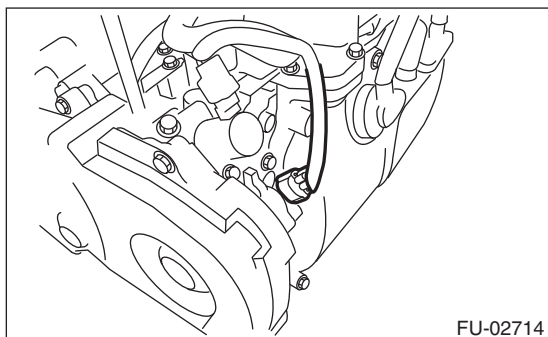

3) Remove the bolt which installs camshaft position sensor to support.

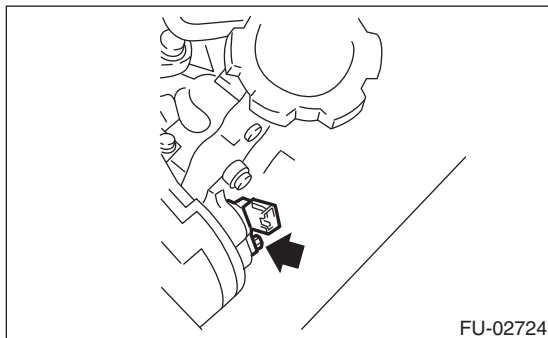

4) Remove the bolt which installs camshaft position sensor support to camshaft cap LH.

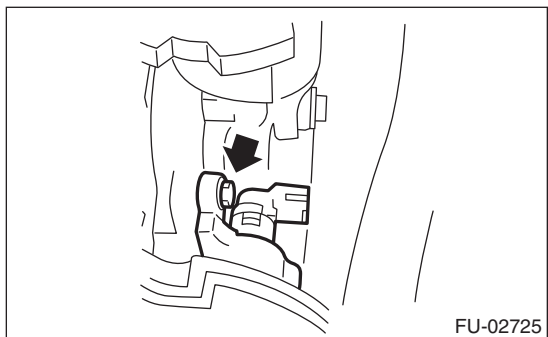

5) Remove the camshaft position sensor and the support as a unit.

6) Remove the camshaft position sensor from the camshaft position sensor support.

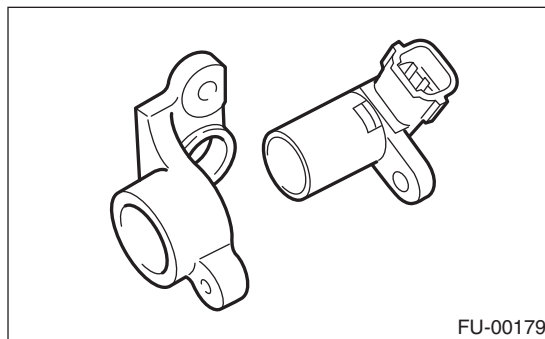

B: INSTALLATION

Install in the reverse order of removal.

Tightening torque:

Camshaft position sensor support

6.4 N·m (0.7 kgf-m, 4.7 ft-lb)

Camshaft position sensor

6.4 N·m (0.7 kgf-m, 4.7 ft-lb)

7. Knock Sensor

A: REMOVAL

- 1) Disconnect the ground cable from the battery.

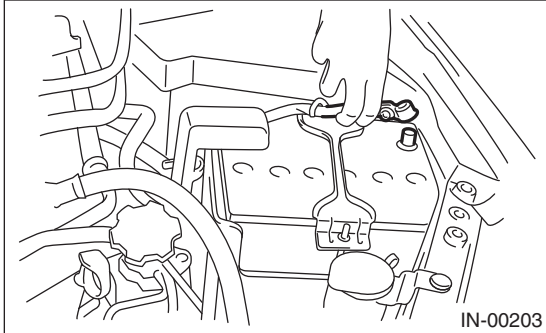

- 2) Remove the air intake chamber. <Ref. to IN(H4SO)-7, REMOVAL, Air Intake Chamber.>
- 3) Disconnect the knock sensor connector.

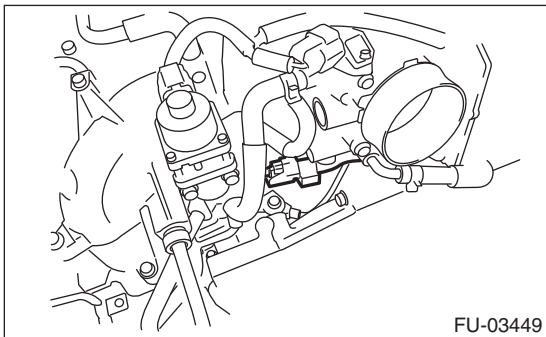

- 4) Remove the knock sensor from the cylinder block.

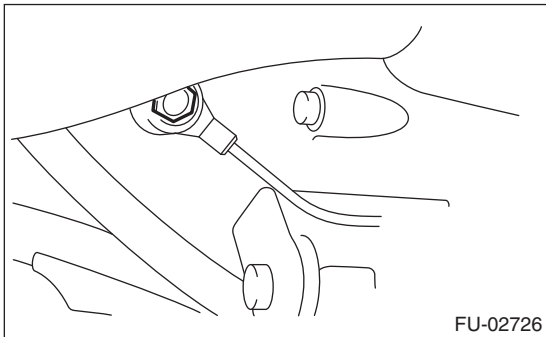

B: INSTALLATION

- 1) Install the knock sensor to the cylinder block.

NOTE:

Extraction area of knock sensor cord must be positioned at a 60° angle relative to the engine rear.

Tightening torque:

24 N·m (2.4 kgf·m, 17.7 ft·lb)

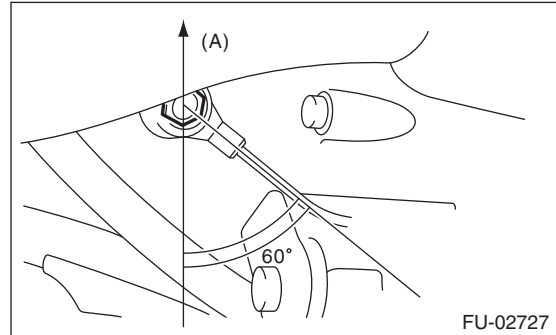

(A) Front side

- 2) Connect the knock sensor connector.

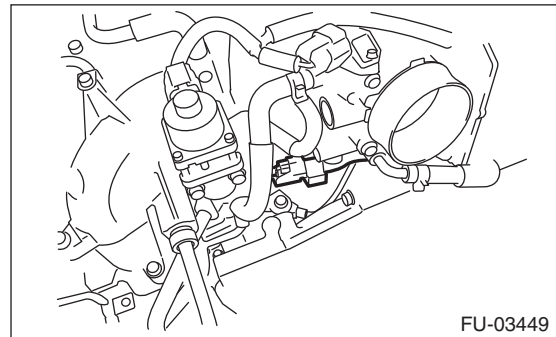

- 3) Install the air intake chamber. <Ref. to IN(H4SO)-7, INSTALLATION, Air Intake Chamber.>
- 4) Connect the battery ground cable to battery.

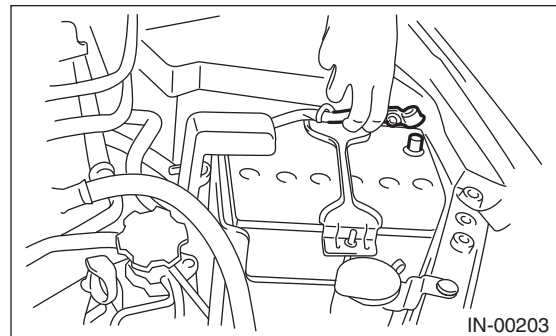

Throttle Position Sensor

FUEL INJECTION (FUEL SYSTEMS)

8. Throttle Position Sensor

A: SPECIFICATION

Throttle body is a non-disassembled part, so do not remove the throttle position sensor from throttle body.

Refer to “Throttle Body” for removal and installation procedure. <Ref. to FU(H4SO)-13, REMOVAL, Throttle Body.> <Ref. to FU(H4SO)-13, INSTALLATION, Throttle Body.>

9. Manifold Absolute Pressure Sensor

A: REMOVAL

1) Disconnect the ground cable from the battery.

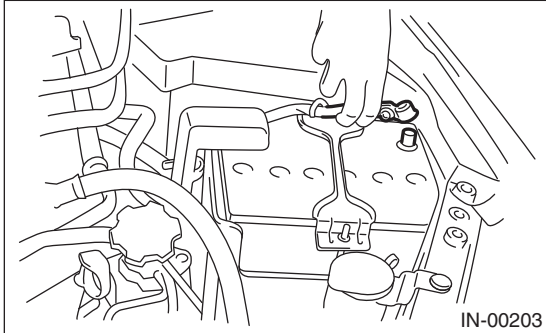

2) Disconnect the connector from manifold absolute pressure sensor.

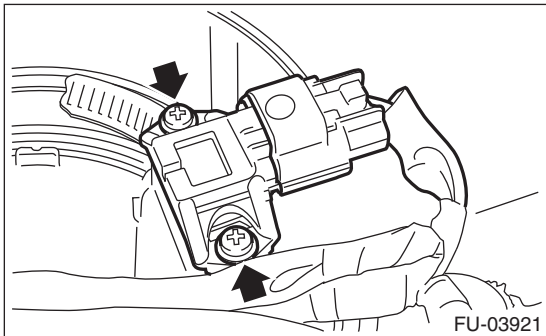

3) Remove the manifold absolute pressure sensor from throttle body.

B: INSTALLATION

Install in the reverse order of removal.

NOTE:

Use new O-rings.

Tightening torque:

2 N·m (0.2 kgf·m, 1.5 ft·lb)

Mass Air Flow and Intake Air Temperature Sensor

FUEL INJECTION (FUEL SYSTEMS)

10. Mass Air Flow and Intake Air Temperature Sensor

A: REMOVAL

- 1) Disconnect the ground cable from the battery.

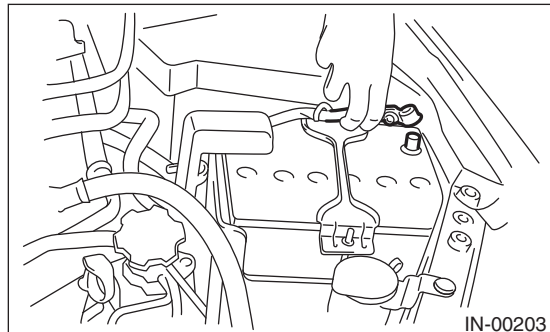

- 2) Disconnect the connectors from the mass air flow and intake air temperature sensor.
- 3) Remove the mass air flow and intake air temperature sensor.

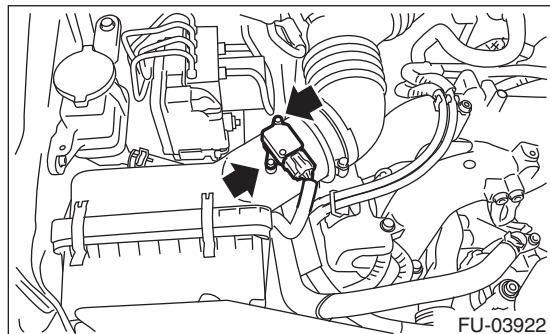

B: INSTALLATION

Install in the reverse order of removal.

Tightening torque:

1 N·m (0.1 kgf·m, 0.7 ft·lb)

11.EGR Valve

A: REMOVAL

- 1) Disconnect the ground cable from the battery.

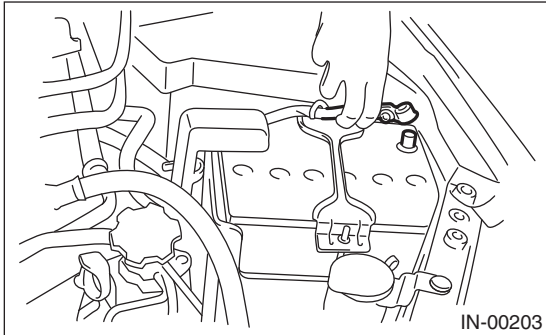

- 2) Disconnect the connector from the EGR valve.

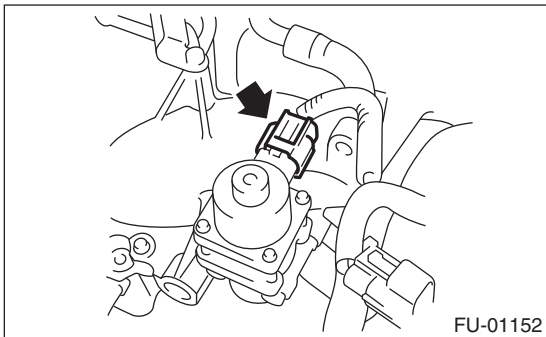

- 3) Remove the EGR valve from intake manifold.

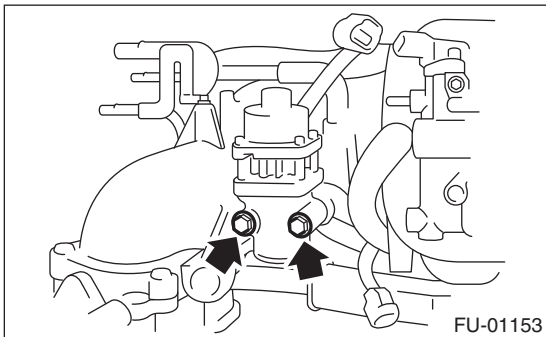

B: INSTALLATION

Install in the reverse order of removal.

NOTE:

Use a new gasket.

Tightening torque:

19 N·m (1.9 kgf·m, 14.0 ft·lb)

Fuel Injector

FUEL INJECTION (FUEL SYSTEMS)

12. Fuel Injector

A: REMOVAL

1. RH SIDE

- 1) Release the fuel pressure. <Ref. to FU(H4SO)-43, RELEASING OF FUEL PRESSURE, PROCEDURE, Fuel.>
- 2) Disconnect the ground cable from the battery.

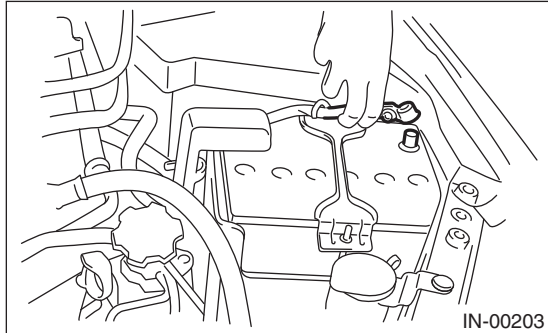

- 3) Open the fuel filler lid, and remove the fuel filler cap.
- 4) Remove the air intake duct and air cleaner case. <Ref. to IN(H4SO)-8, REMOVAL, Air Intake Duct.> <Ref. to IN(H4SO)-5, REMOVAL, Air Cleaner Case.>
- 5) Remove the spark plug cords from spark plugs (#1 and #3 cylinders).
- 6) Remove the fuel pipe protector RH.

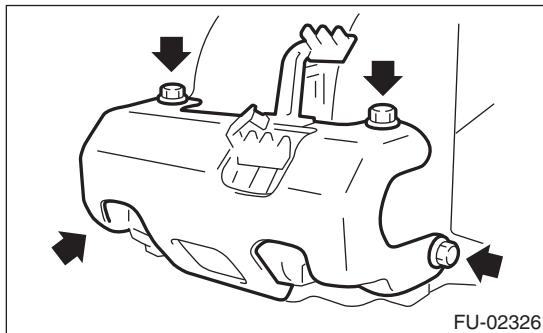

- 7) Disconnect the connectors (A) from fuel injector.
- 8) Remove the harness band (B) which holds the engine harness to injector pipe.

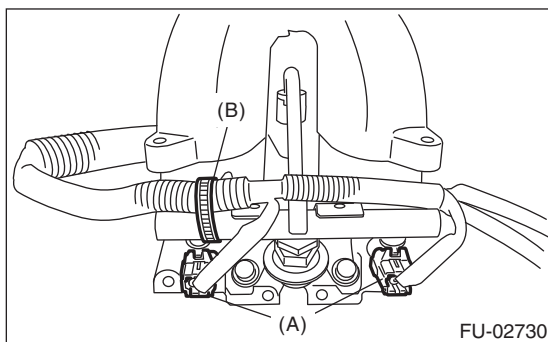

- 9) Remove the bolt which holds fuel injector pipe onto intake manifold.

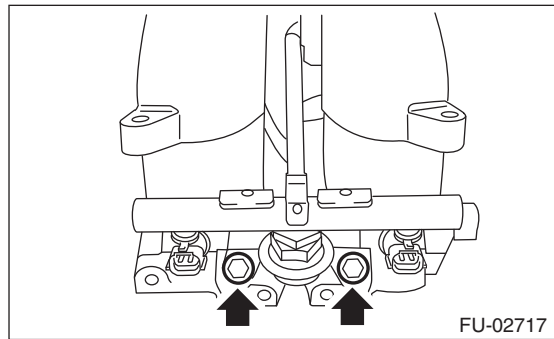

- 10) Remove the fuel injector while lifting up the fuel injector pipe.

2. LH SIDE

- 1) Release the fuel pressure. <Ref. to FU(H4SO)-43, RELEASING OF FUEL PRESSURE, PROCEDURE, Fuel.>
- 2) Remove the battery. <Ref. to SC(H4SO)-22, REMOVAL, Battery.>
- 3) Open the fuel filler lid, and remove the fuel filler cap.
- 4) Remove the spark plug cords from spark plugs (#2 and #4 cylinders).
- 5) Remove the fuel pipe protector LH.

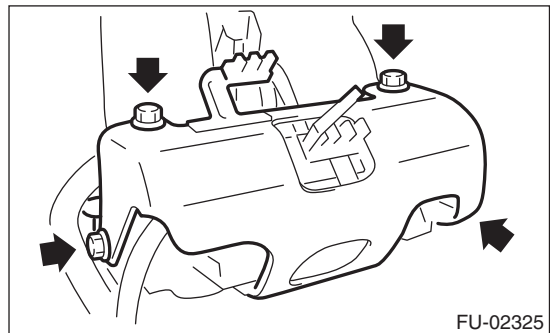

- 6) Disconnect the connectors (A) from fuel injector.
- 7) Remove the harness band (B) which holds the engine harness to injector pipe.

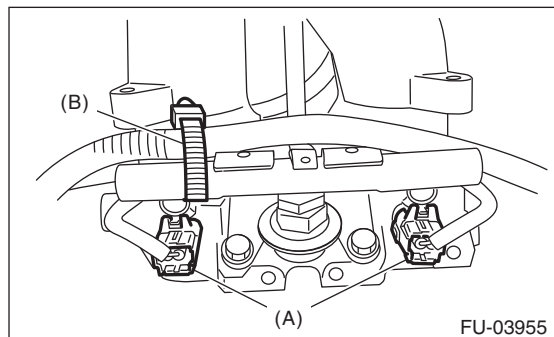

8) Remove the bolt which holds fuel injector pipe onto intake manifold.

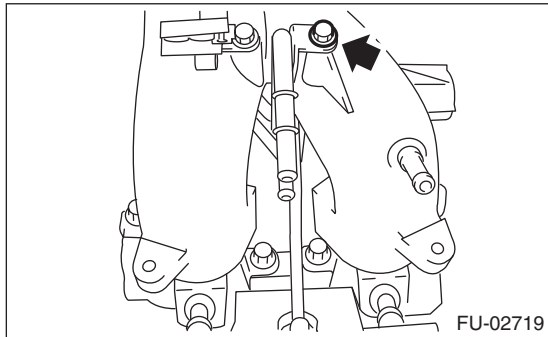
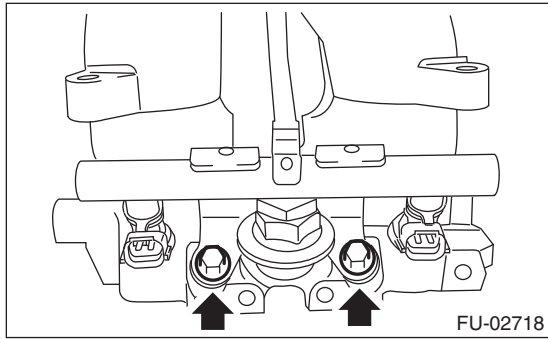

9) Remove the fuel injector while lifting up the fuel injector pipe.

B: INSTALLATION

1. RH SIDE

Install in the reverse order of removal.

NOTE:

Use new O-rings.

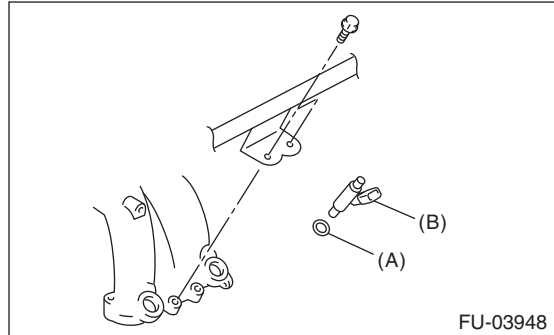

(A) O-ring

(B) Fuel injector

Tightening torque:

19 N·m (1.9 kgf-m, 14.0 ft-lb)

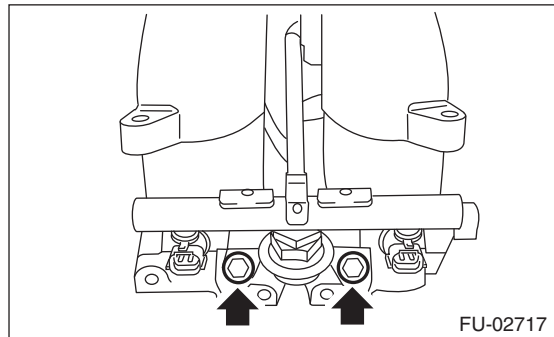

Tightening torque:

19 N·m (1.9 kgf-m, 14.0 ft-lb)

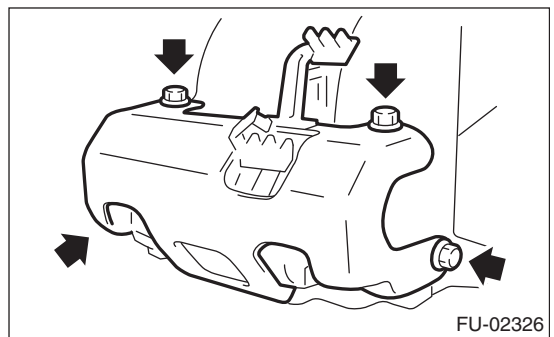

Fuel Injector

FUEL INJECTION (FUEL SYSTEMS)

2. LH SIDE

Install in the reverse order of removal.

NOTE:

Use new O-rings.

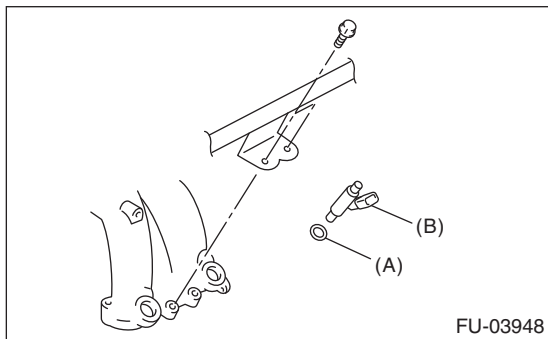

(A) O-ring

(B) Fuel injector

Tightening torque:

19 N·m (1.9 kgf-m, 14.0 ft-lb)

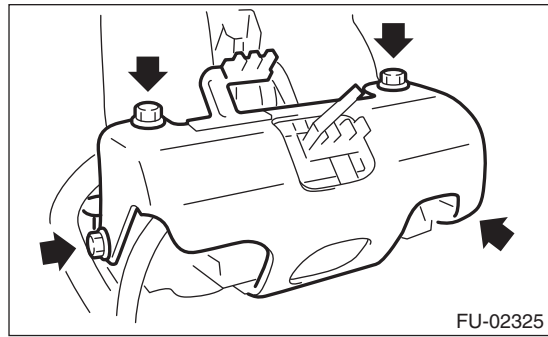

Tightening torque:

6.4 N·m (0.7 kgf-m, 4.7 ft-lb)

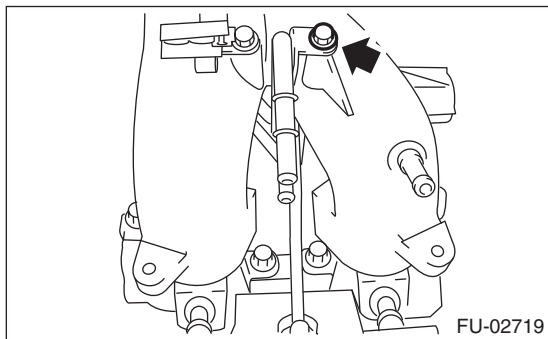

Tightening torque:

19 N·m (1.9 kgf-m, 14.0 ft-lb)

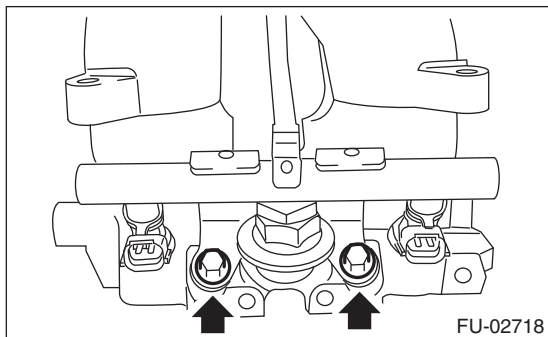

13. Variable Valve Lift Diagnosis Oil Pressure Switch

A: REMOVAL

- 1) Disconnect the ground cable from the battery.

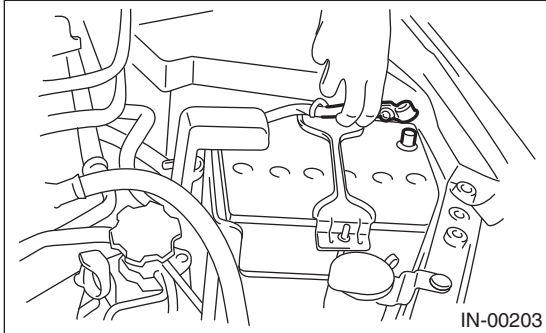

- 2) Remove the air intake chamber. <Ref. to IN(H4SO)-7, REMOVAL, Air Intake Chamber.>
- 3) Remove the engine harness connector from the bracket.
- 4) Disconnect the connector from the variable valve lift diagnosis oil pressure switch.
- 5) Remove the variable valve lift diagnosis oil pressure switch.

- LH side

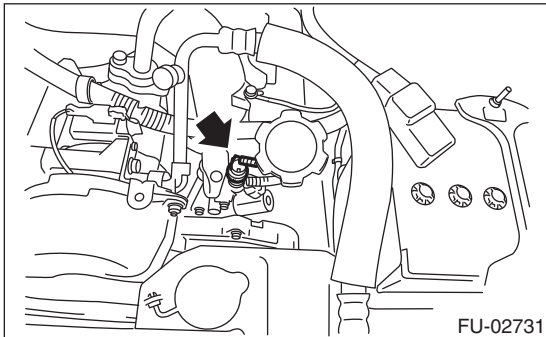

- RH side

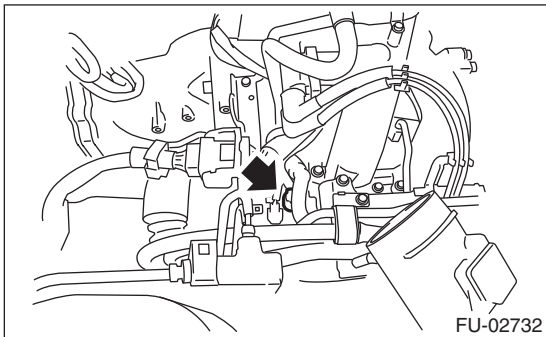

B: INSTALLATION

Install in the reverse order of removal.

NOTE:

Apply liquid gasket to the variable valve lift diagnosis oil pressure switch threads.

Liquid gasket:

THREE BOND 1324 (Part No. 004403042) or equivalent

Tightening torque:

17 N·m (1.7 kgf·m, 12.5 ft·lb)

Oil Temperature Sensor

FUEL INJECTION (FUEL SYSTEMS)

14. Oil Temperature Sensor

A: REMOVAL

1) Disconnect the ground cable from the battery.

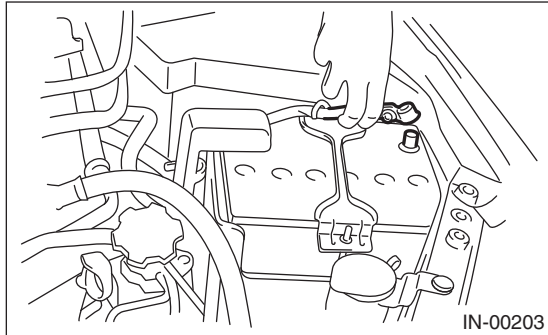

2) Remove the air intake chamber. <Ref. to IN(H4SO)-7, REMOVAL, Air Intake Chamber.>

3) Remove the engine harness connector from the bracket.

4) Disconnect the connector from the oil temperature sensor.

5) Remove the oil temperature sensor.

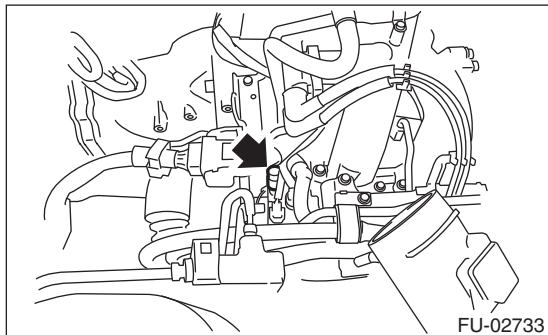

B: INSTALLATION

Install in the reverse order of removal.

NOTE:

Apply liquid gasket to the oil temperature sensor threads.

Liquid gasket:

THREE BOND 1324 (Part No. 004403042) or equivalent

Tightening torque:

18 N·m (1.8 kgf·m, 13.3 ft·lb)

Front Oxygen (A/F) Sensor

FUEL INJECTION (FUEL SYSTEMS)

15. Front Oxygen (A/F) Sensor

A: REMOVAL

- 1) Set the vehicle on a lift.
- 2) Disconnect the ground cable from the battery.

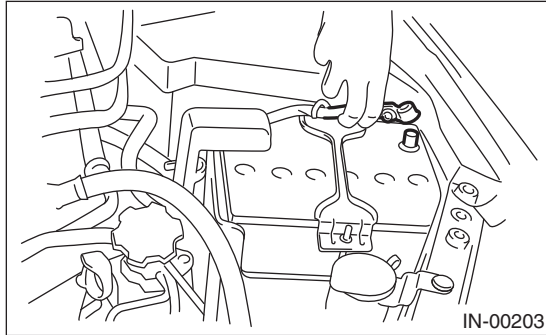

- 3) Remove the air intake duct. <Ref. to IN(H4SO)-8, REMOVAL, Air Intake Duct.>
- 4) Remove the clip fastening the harness and disconnect the front oxygen (A/F) sensor connector.

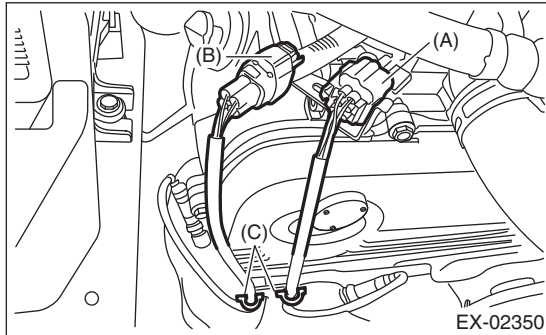

- (A) Front oxygen (A/F) sensor connector
- (B) Rear oxygen sensor connector
- (C) Clip

- 5) Lift up the vehicle.
- 6) Remove the under cover.
- 7) Apply spray-type lubricant to the threaded portion of front oxygen (A/F) sensor, and leave it for one minute or more.

- 8) Remove the front oxygen (A/F) sensor.

CAUTION:

When removing the front oxygen (A/F) sensor, wait until exhaust pipe cools, otherwise it will damage the exhaust pipe.

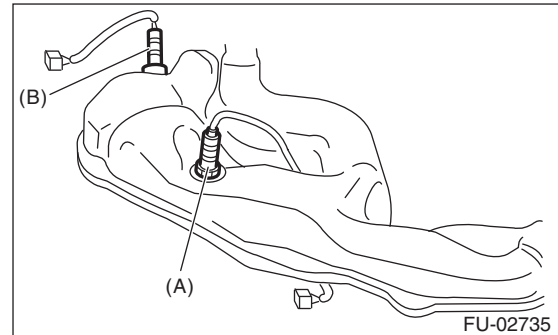

- (A) Front oxygen (A/F) sensor
- (B) Rear oxygen sensor

Front Oxygen (A/F) Sensor

FUEL INJECTION (FUEL SYSTEMS)

B: INSTALLATION

1) Before installing front oxygen (A/F) sensor, apply anti-seize compound only to the threaded portion of front oxygen (A/F) sensor to make the next removal easier.

CAUTION:

Never apply anti-seize compound to the protector of front oxygen (A/F) sensor.

Anti-seize compound:

NEVER-SEEZ NSN, JET LUBE SS-30 or equivalent

2) Install the front oxygen (A/F) sensor.

Tightening torque:

21 N·m (2.1 kgf·m, 15.5 ft·lb)

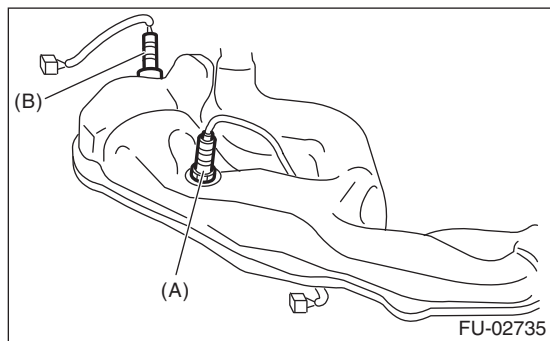

- (A) Front oxygen (A/F) sensor
- (B) Rear oxygen sensor

3) Install the under cover.

4) Lower the vehicle.

5) Connect the connector of front oxygen (A/F) sensor connector and fasten the harness with clips.

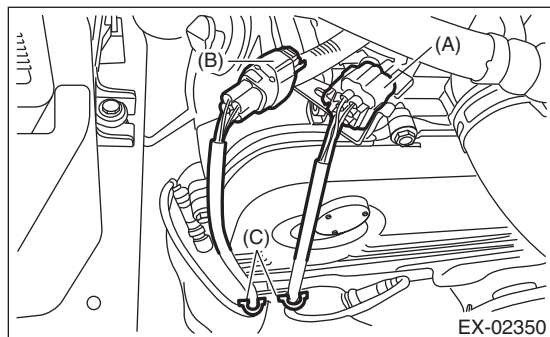

- (A) Front oxygen (A/F) sensor connector
- (B) Rear oxygen sensor connector
- (C) Clip

6) Connect the battery ground cable to battery.

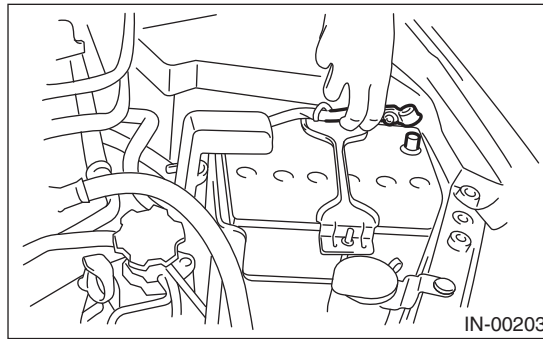

16.Rear Oxygen Sensor

A: REMOVAL

- 1) Set the vehicle on a lift.
- 2) Disconnect the ground cable from the battery.

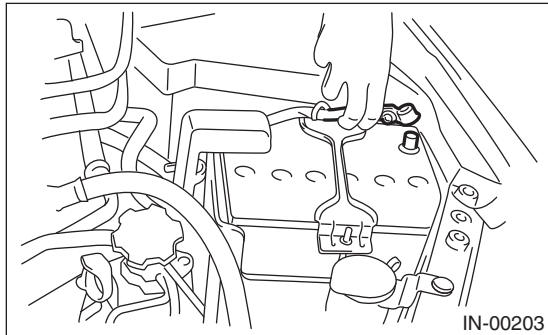

- 3) Remove the air intake duct. <Ref. to IN(H4SO)-8, REMOVAL, Air Intake Duct.>
- 4) Remove the clip fastening the harness and disconnect the rear oxygen (A/F) sensor connector.

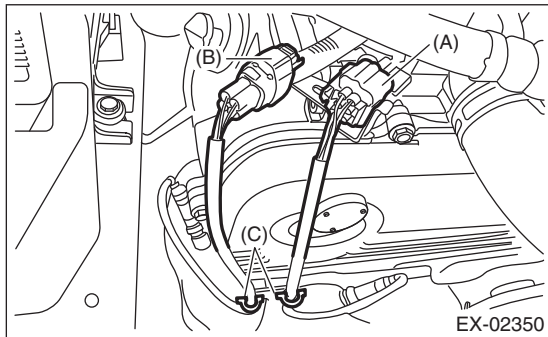

- (A) Front oxygen (A/F) sensor connector
- (B) Rear oxygen sensor connector
- (C) Clip

- 5) Lift up the vehicle.
- 6) Remove the under cover.
- 7) Apply spray-type lubricant to the threaded portion of rear oxygen sensor, and leave it for one minute or more.

- 8) Remove the rear oxygen sensor.

CAUTION:

When removing the rear oxygen sensor, wait until exhaust pipe cools, otherwise it will damage the exhaust pipe.

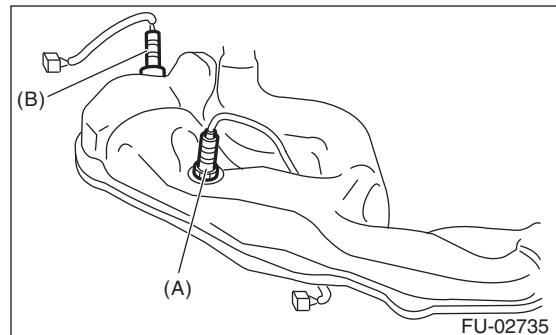

- (A) Front oxygen (A/F) sensor
- (B) Rear oxygen sensor

Rear Oxygen Sensor

FUEL INJECTION (FUEL SYSTEMS)

B: INSTALLATION

1) Before installing rear oxygen sensor, apply the anti-seize compound only to the threaded portion of rear oxygen sensor to make the next removal easier.

CAUTION:

Never apply anti-seize compound to the protector of rear oxygen sensor.

Anti-seize compound:

NEVER-SEEZ NSN, JET LUBE SS-30 or equivalent

2) Install the rear oxygen sensor.

Tightening torque:

21 N·m (2.1 kgf·m, 15.5 ft·lb)

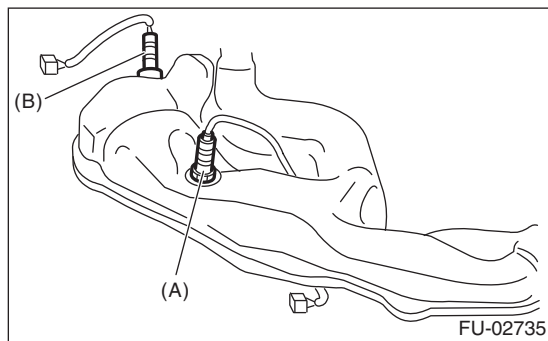

- (A) Front oxygen (A/F) sensor
- (B) Rear oxygen sensor

3) Install the under cover.

4) Lower the vehicle.

5) Connect the connector to rear oxygen sensor and mount the harness clips to the bracket for fastening.

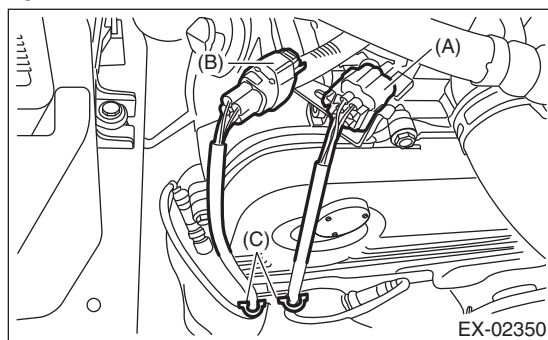

- (A) Front oxygen (A/F) sensor connector
- (B) Rear oxygen sensor connector
- (C) Clip

6) Connect the battery ground cable to battery.

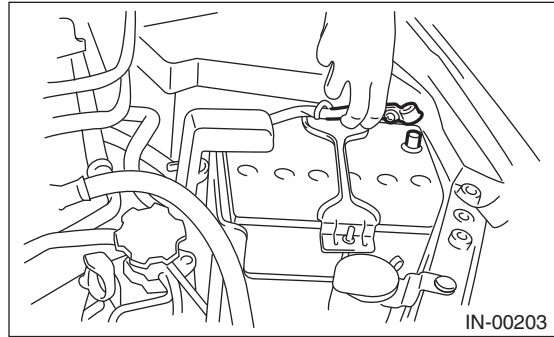

17.Engine Control Module (ECM)

A: REMOVAL

- 1) Disconnect the ground cable from the battery.

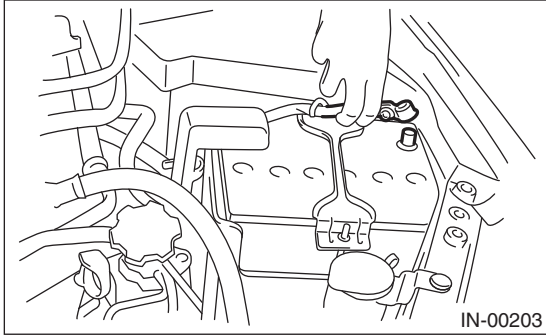

- 2) Remove the glove box lower cover. <Ref. to EI-45, REMOVAL, Glove Box.>
- 3) Remove the lower inner trim of passenger's side. <Ref. to EI-52, REMOVAL, Lower Inner Trim.>
- 4) Detach the floor mat of passenger's seat.
- 5) Remove the protect cover.

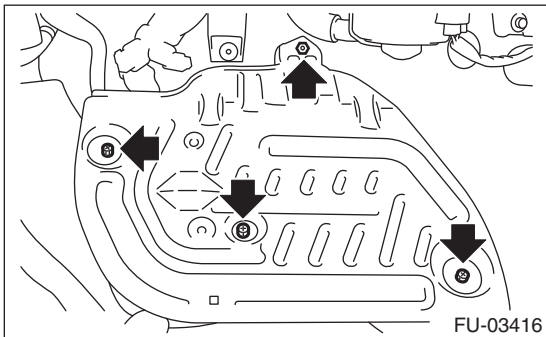

- 6) Remove the bolts and nuts which hold the ECM to the bracket.

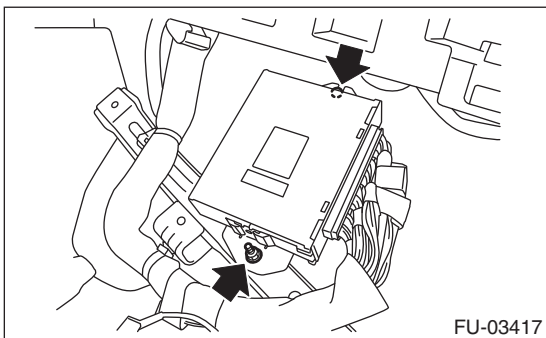

- 7) Disconnect the ECM connectors, and take out the ECM.

B: INSTALLATION

Install in the reverse order of removal.

CAUTION:

When the ECM on a model with immobilizer has been replaced, be sure to perform registration of the immobilizer. (Refer to the "PC application help for Subaru Select Monitor")

NOTE:

When replacing the ECM, be careful not to use the wrong spec. ECM to avoid any damage on the fuel injection system.

Tightening torque:

7.5 N·m (0.8 kgf-m, 5.5 ft-lb)

Main Relay

FUEL INJECTION (FUEL SYSTEMS)

18.Main Relay

A: REMOVAL

1) Disconnect the ground cable from the battery.

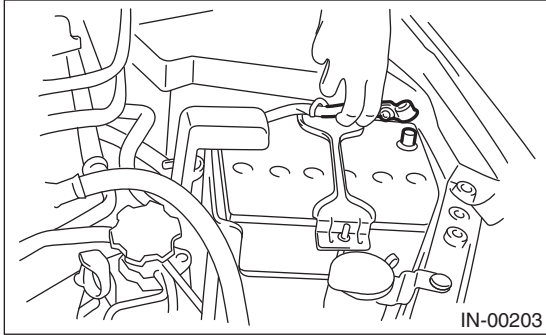

2) Remove the glove box lower cover. <Ref. to EI-45, REMOVAL, Glove Box.>

3) Remove the main relay from the relay block on the back side of the glove box.



B: INSTALLATION

Install in the reverse order of removal.

19. Fuel Pump Relay

A: REMOVAL

1) Disconnect the ground cable from the battery.

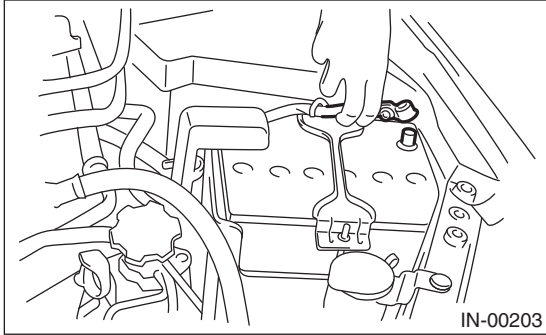

2) Remove the glove box lower cover. <Ref. to EI-45, REMOVAL, Glove Box.>

3) Remove the fuel pump relay from the relay block on the back side of the glove box.



B: INSTALLATION

Install in the reverse order of removal.

Electronic Throttle Control Relay

FUEL INJECTION (FUEL SYSTEMS)

20. Electronic Throttle Control Relay

A: REMOVAL

1) Disconnect the ground cable from the battery.

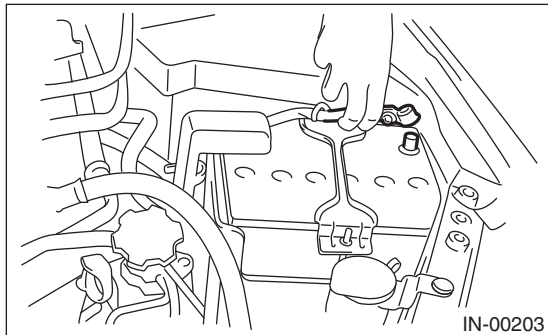

2) Remove the glove box lower cover. <Ref. to EI-45, REMOVAL, Glove Box.>

3) Remove the electronic throttle control relay from the relay block on the back side of the glove box.



B: INSTALLATION

Install in the reverse order of removal.

21. Fuel

A: PROCEDURE

1. RELEASING OF FUEL PRESSURE

WARNING:

Place “NO OPEN FLAMES” signs near the working area.

CAUTION:

Be careful not to spill fuel.

1) Remove the fuse of fuel pump from main fuse box.

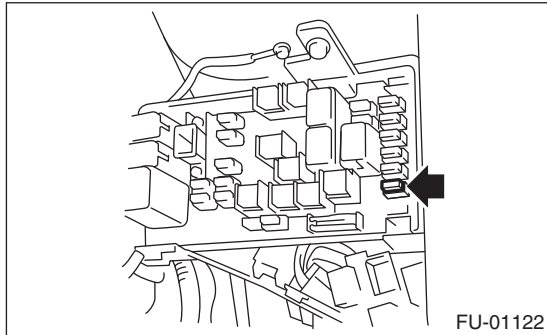

- 2) Start the engine and run it until it stalls.
- 3) After the engine stalls, crank it for five more seconds.
- 4) Turn the ignition switch to OFF.

2. DRAINING FUEL (WITH SUBARU SELECT MONITOR)

WARNING:

Place “NO OPEN FLAMES” signs near the working area.

CAUTION:

Be careful not to spill fuel.

NOTE:

- If the fuel pump cannot be actuated, refer to DRAINING FUEL (THROUGH THE FUEL FILLER HOSE). <Ref. to FU(H4SO)-44, DRAINING FUEL (THROUGH THE FUEL FILLER HOSE), PROCEDURE, Fuel.>
- Be careful not to let the battery run-out.

- 1) Release the fuel pressure. <Ref. to FU(H4SO)-43, RELEASING OF FUEL PRESSURE, PROCEDURE, Fuel.>

- 2) Attach ST to the fuel delivery pipe and push ST in the direction of arrow mark to disconnect the fuel delivery hose.

ST 42099AE000 QUICK CONNECTOR RELEASE

CAUTION:

- **Be careful not to spill fuel.**
- **Catch the fuel from hoses using a container or cloth.**

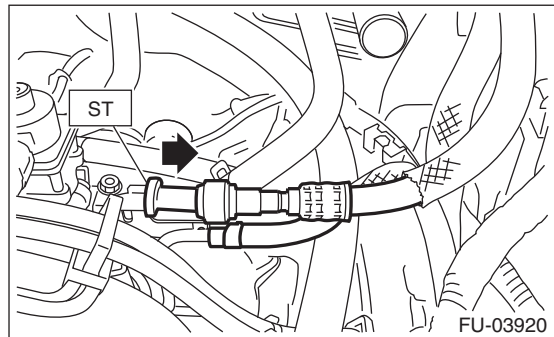

- 3) Connect ST to the fuel delivery hose.
ST 18471AA000 FUEL PIPE ADAPTER
- 4) Connect the gasoline proof hose to ST and put the end of the hose in the container.
- 5) Drive the fuel pump and drain the fuel using Subaru Select Monitor. <Ref. to EN(H4SO)(diag)-54, FUEL PUMP CONTROL (ON/OFF DRIVE), OPERATION, System Operation Check Mode.>

CAUTION:

Be careful not to spill fuel.

3. DRAINING FUEL (THROUGH THE FUEL FILLER HOSE)

WARNING:

Place “NO OPEN FLAMES” signs near the working area.

CAUTION:

- Be careful not to spill fuel.
- Fuel may remain in the fuel filler pipe. Drain the fuel from the fuel filler pipe through the fill opening using the gasoline proof pump and the gasoline proof hose (ø10 or less) before the operation.

- 1) Set the vehicle on a lift.
- 2) Lift up the vehicle.
- 3) Remove the rear exhaust pipe and muffler. <Ref. to EX(H4SO)-8, REMOVAL, Rear Exhaust Pipe.> <Ref. to EX(H4SO)-10, REMOVAL, Muffler.>
- 4) Open the fuel filler lid, and remove the fuel filler cap.
- 5) Drain the fuel from the fuel filler pipe through the fill opening using the gasoline proof pump and the gasoline proof hose (ø10 or less).
- 6) Disconnect the fuel filler hose from the fuel filler pipe assembly.

CAUTION:

- Be careful not to spill fuel.
- Catch the fuel from hoses using a container or cloth.

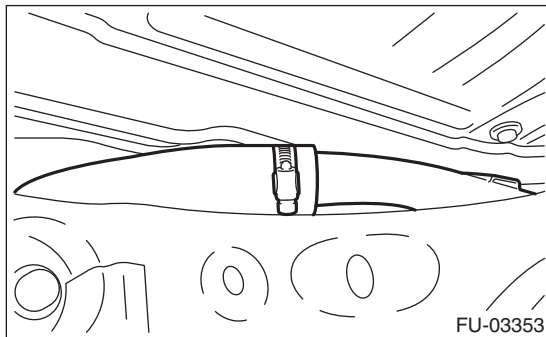

- 7) Set the container under the vehicle and insert the gasoline proof hose (ø10 or less) into the fuel filler hose to drain the fuel.

CAUTION:

Be careful not to spill fuel.

22. Fuel Tank

A: REMOVAL

WARNING:

Place "NO OPEN FLAMES" signs near the working area.

CAUTION:

Be careful not to spill fuel.

- 1) Set the vehicle on a lift.
- 2) Release the fuel pressure. <Ref. to FU(H4SO)-43, RELEASING OF FUEL PRESSURE, PROCEDURE, Fuel.>
- 3) Drain fuel from fuel tank. <Ref. to FU(H4SO)-43, DRAINING FUEL (WITH SUBARU SELECT MONITOR), PROCEDURE, Fuel.>
- 4) Disconnect the ground cable from the battery.

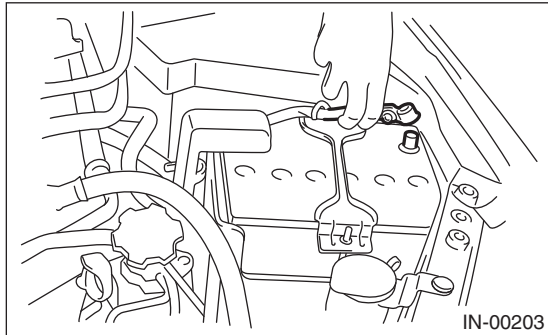

5) Remove the rear seat cushion. <Ref. to SE-15, REMOVAL, Rear Seat.>

6) Remove the service hole cover of fuel pump.

- (1) Disconnect fuel pump connector (A), and remove clip (B).
- (2) Remove the bolt (C).
- (3) Push the grommet (D) down and remove the service hole cover.

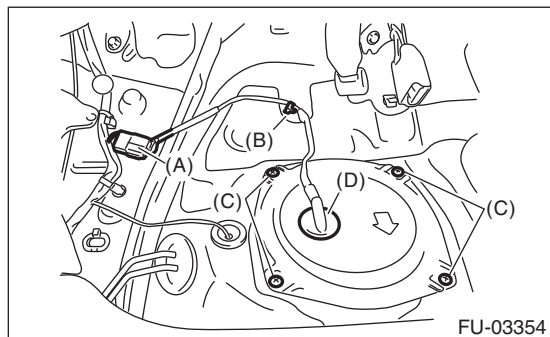

7) Remove the service hole cover of fuel sub level sensor.

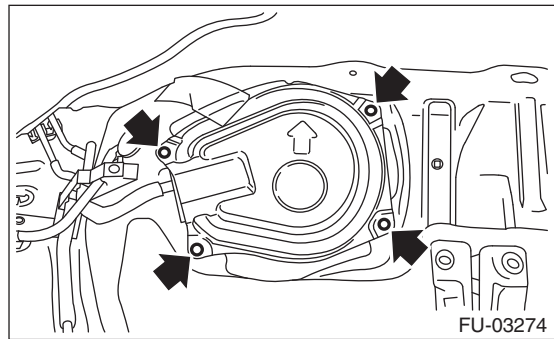

8) Disconnect the quick connector on the fuel delivery tube (A). <Ref. to FU(H4SO)-65, REMOVAL, Fuel Delivery and Evaporation Lines.>

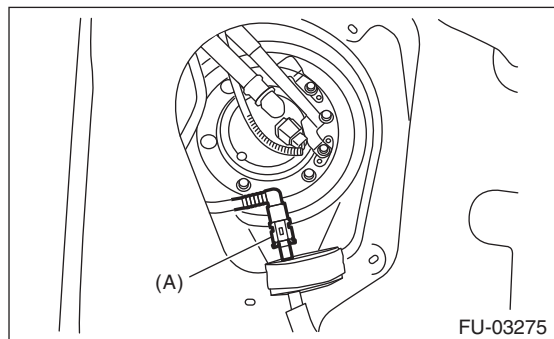

9) Remove the rear wheels.

10) Lift up the vehicle.

11) Remove the rear ABS wheel speed sensor from the rear housing.

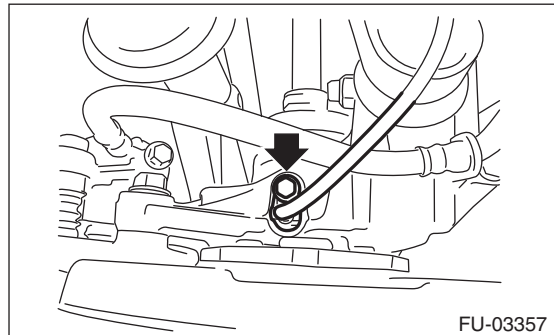

12) Remove the bolt holding the rear brake hose bracket.

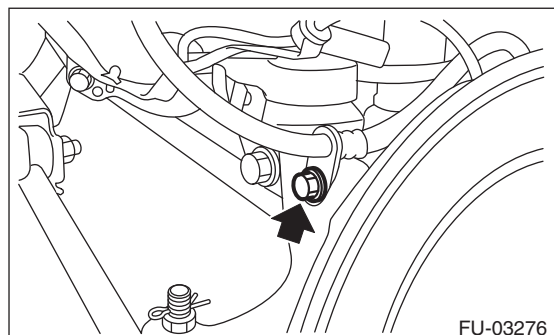

Fuel Tank

FUEL INJECTION (FUEL SYSTEMS)

13) Remove the rear brake caliper and tie it to the body side of the vehicle.

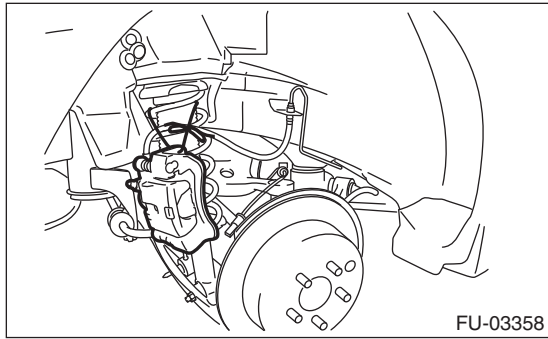

14) Remove the parking brake cable from the parking brake assembly. <Ref. to PB-6, REMOVAL, Parking Brake Assembly (Rear Disc Brake).>

15) Remove the rear exhaust pipe.

<Ref. to EX(H4SO)-8, REMOVAL, Rear Exhaust Pipe.>

16) Remove the propeller shaft. <Ref. to DS-10, REMOVAL, Propeller Shaft.>

17) Remove the heat shield cover and fuel tank protector.

18) Disconnect the connector from the rear ABS wheel speed sensor.

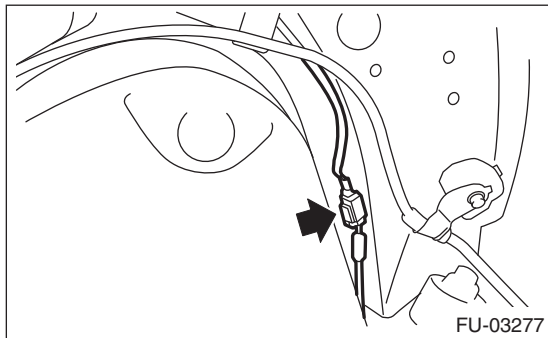

19) Remove the bolts securing the parking brake cable clamp.

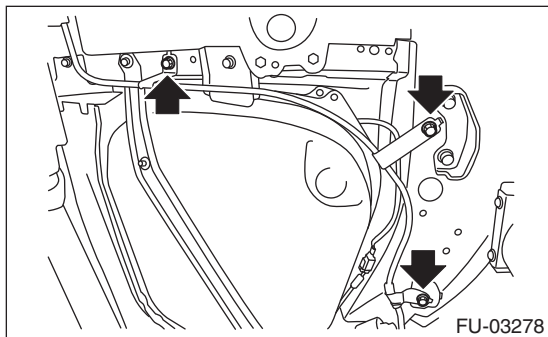

20) Disconnect drain hose (B) from the canister drain connector (A).

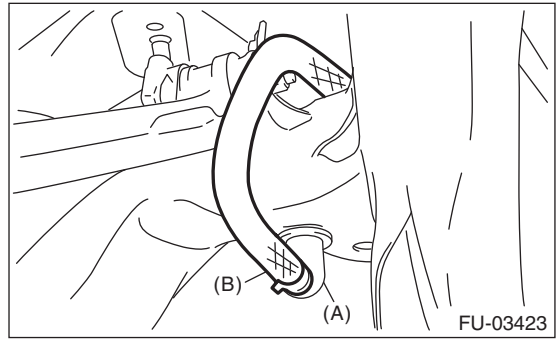

21) Disconnect the connector, remove the nuts, and then remove the rear vehicle height sensor. (models with auto headlight beam leveler, left side only)

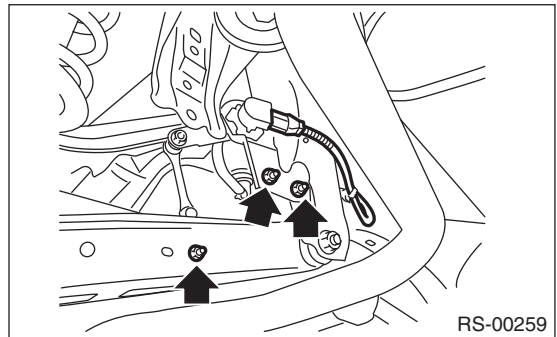

22) Remove the rear suspension assembly.

WARNING:

A helper is required to perform this work.

- (1) Support the rear differential with the transmission jack.
- (2) Remove the bolts which hold the rear shock absorber to the rear suspension arm.

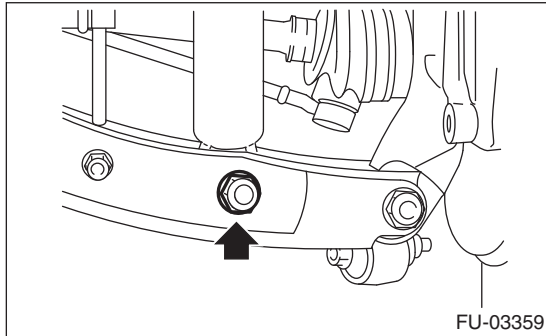

- (3) Remove the bolts which secure the rear suspension assembly to the body.

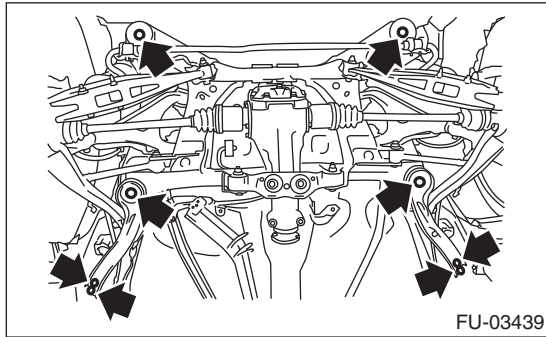

- (4) Remove the rear suspension assembly.

23) Disconnect evaporation hose (B) from connector (A).

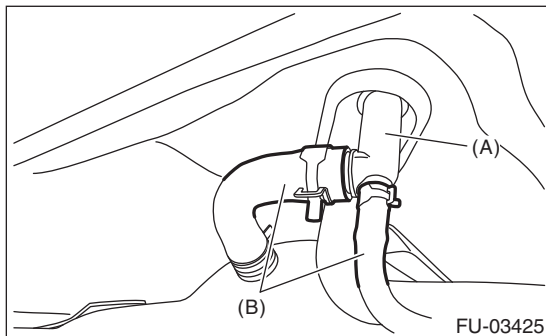

24) Disconnect the quick connector of the evaporation hose from the evaporation pipe as shown in the figure.

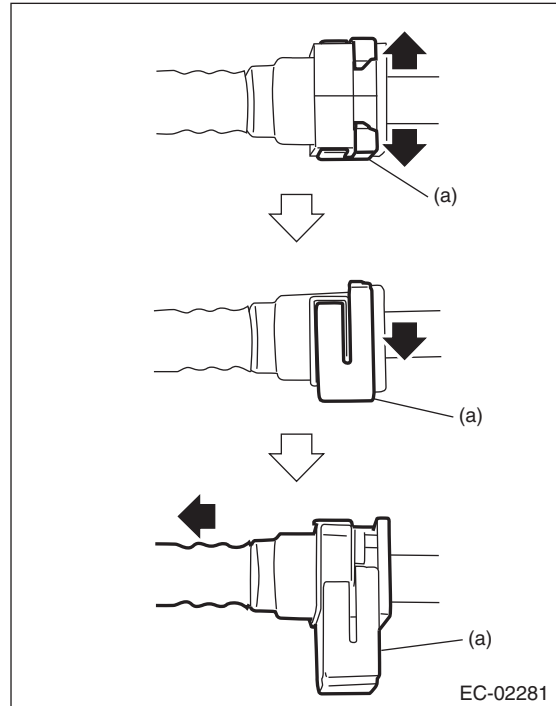

(a) Retainer

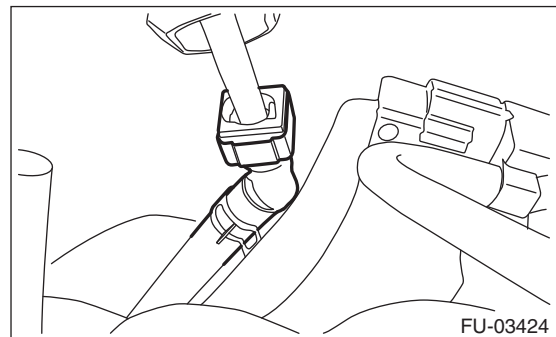

25) Disconnect the fuel filler hose (A) and evaporation hose (B) from the fuel filler pipe assembly.

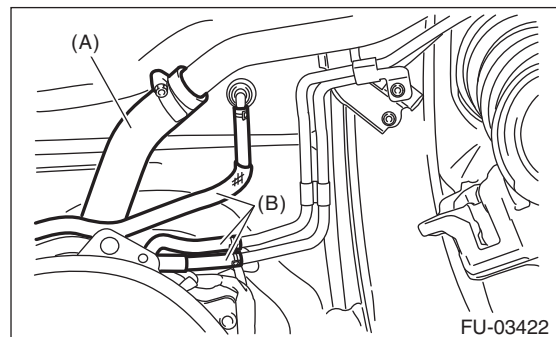

Fuel Tank

FUEL INJECTION (FUEL SYSTEMS)

26) Support the fuel tank with a transmission jack, remove the bolts from the fuel tank band, and remove the fuel tank from the vehicle.

WARNING:

- A helper is required to perform this work.
- Fuel may remain in the fuel tank. This will cause the left and right sides to be unbalanced. Be careful not to drop the fuel tank when removing.

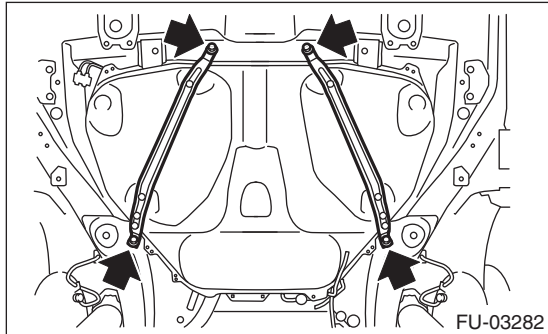

B: INSTALLATION

1) Support the fuel tank with a transmission jack, set the fuel tank in place, and temporarily tighten the bolts of the fuel tank band.

WARNING:

A helper is required to perform this work.

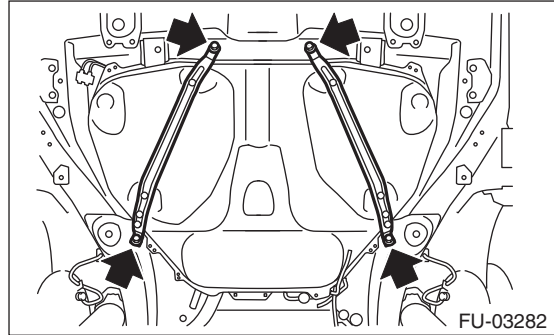

2) Securely insert the fuel filler hose (A) and evaporation hose (B) into the specified position, then attach the clamp and clip as shown in the figure.

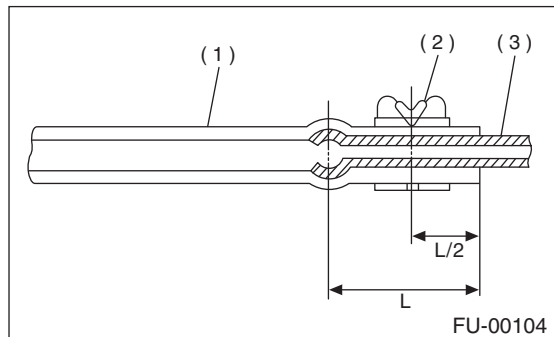
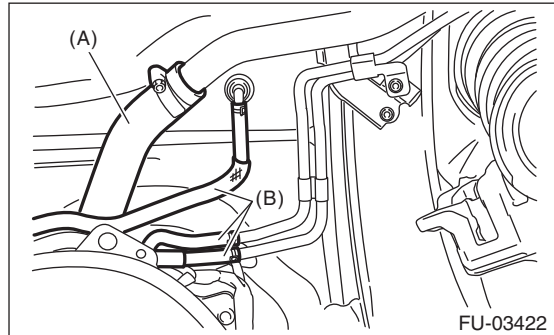

- (1) Hose
- (2) Clip or clamp
- (3) Pipe

3) Connect the quick connector of the evaporation hose to the evaporation pipe.

CAUTION:

- Check that there is no damage or dust on the quick connector. If necessary, clean seal surface of pipe.
- When connecting the quick connector, insert the pipe all the way in securely, then operate the push lock.
- If it is not possible to perform the push lock operation of the retainer, recheck whether the pipe is securely inserted.
- Confirm that the quick connector is securely connected.

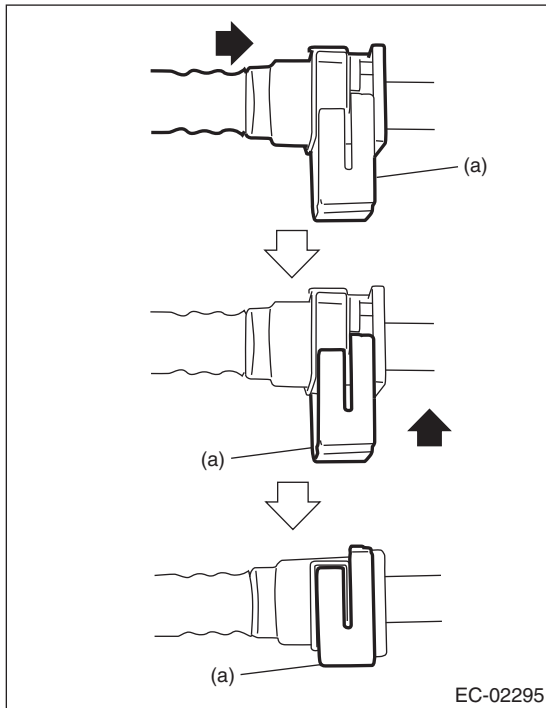

(a) Retainer

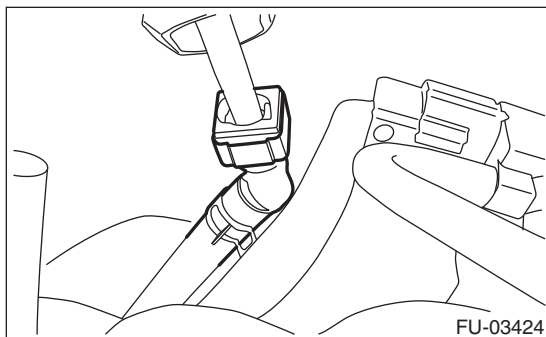

4) Connect evaporation hose (B) to connector (A).

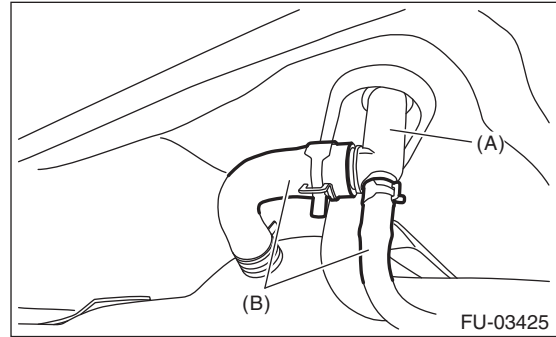

5) Tighten the fuel tank band bolts in the order shown in the figure.

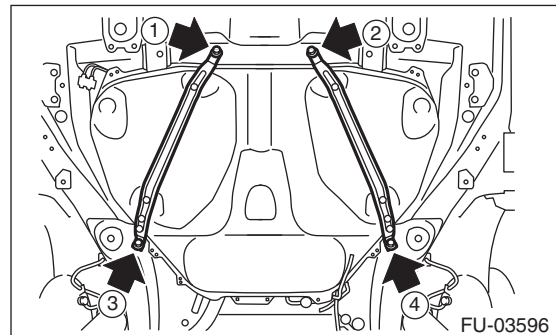

Tightening torque:

33 N·m (3.4 kgf-m, 24.3 ft-lb)

6) Install the rear suspension assembly.

WARNING:

A helper is required to perform this work.

- (1) Support the rear differential with the transmission jack.
- (2) Support the rear suspension assembly, and tighten the bolts which secure the rear suspension assembly to the body.

Tightening torque:

T1: 70 N·m (7.1 kgf-m, 51.6 ft-lb)

T2: 145 N·m (14.8 kgf-m, 106.9 ft-lb)

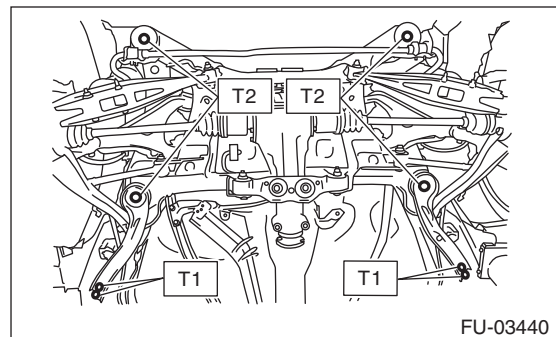

Fuel Tank

FUEL INJECTION (FUEL SYSTEMS)

- (3) Tighten the bolts which hold the rear shock absorber to the rear suspension arm.

Tightening torque:

120 N·m (12.2 kgf-m, 88.5 ft-lb)

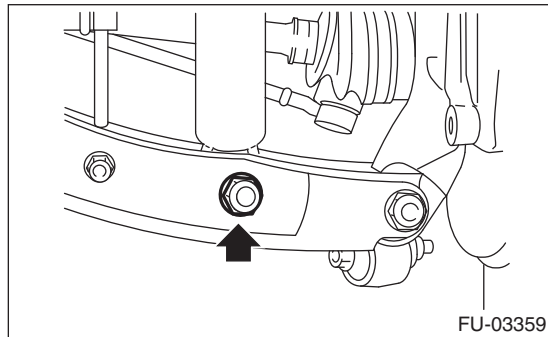

- 7) Install the rear vehicle height sensor. (models with auto headlight beam leveler, left side only)

Tightening torque:

7.5 N·m (0.8 kgf-m, 5.5 ft-lb)

- 8) Install the rear vehicle height sensor connector. (models with auto headlight beam leveler, left side only)

- 9) Connect drain hose (B) to canister drain connector (A).

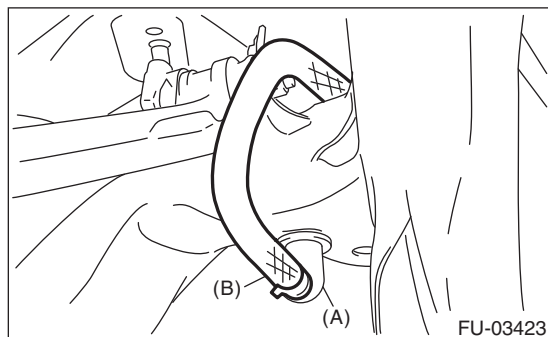

- 10) Tighten the bolts holding the parking brake cable clamp.

Tightening torque:

18 N·m (1.8 kgf-m, 13.3 ft-lb)

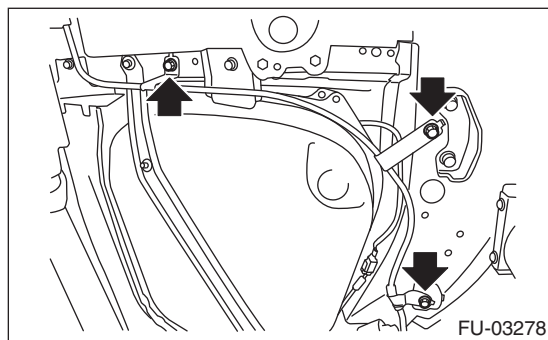

- 11) Connect the connector to the rear ABS wheel speed sensor.

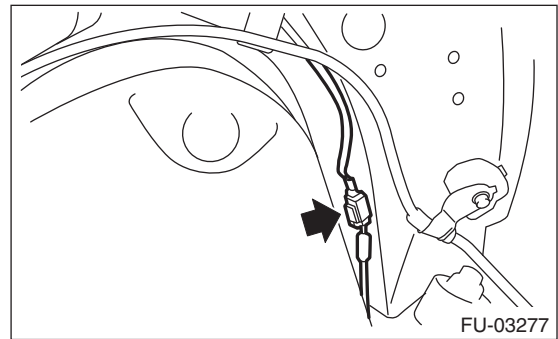

- 12) Install the heat shield cover.

Tightening torque:

18 N·m (1.8 kgf-m, 13.3 ft-lb)

- 13) Install the fuel tank protector.

Tightening torque:

Nut: 9 N·m (0.9 kgf-m, 6.6 ft-lb)

Bolt: 18 N·m (1.8 kgf-m, 13.3 ft-lb)

- 14) Install the propeller shaft. <Ref. to DS-11, INSTALLATION, Propeller Shaft.>

- 15) Install the rear exhaust pipe.

<Ref. to EX(H4SO)-8, INSTALLATION, Rear Exhaust Pipe.>

- 16) Lower the vehicle.

- 17) Connect the parking brake cable to the parking brake assembly. <Ref. to PB-7, INSTALLATION, Parking Brake Assembly (Rear Disc Brake).>

- 18) Install the rear brake caliper.

- 19) Tighten the bolts which hold the rear brake hose bracket.

Tightening torque:

33 N·m (3.4 kgf-m, 24.3 ft-lb)

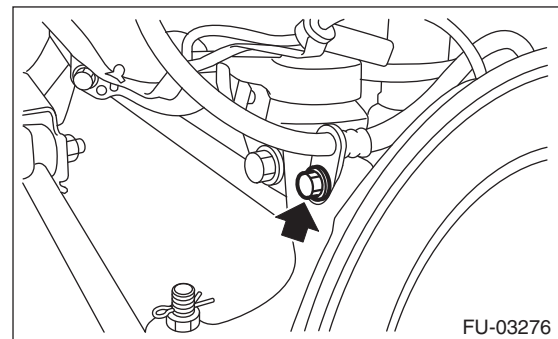

Fuel Tank

FUEL INJECTION (FUEL SYSTEMS)

20) Attach the rear ABS vehicle speed sensor to the rear housing.

Tightening torque:

7.5 N·m (0.8 kgf-m, 5.5 ft-lb)

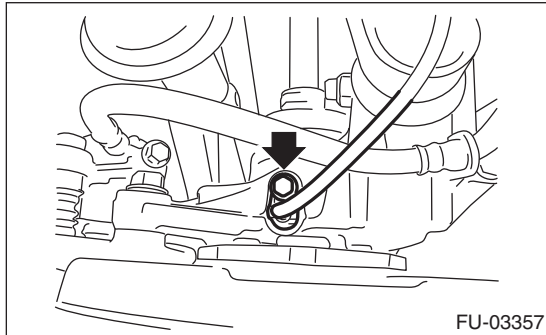

21) Install the rear wheels.

Tightening torque:

100 N·m (10.2 kgf-m, 73.8 ft-lb)

22) Connect quick connector of the fuel delivery tube (A).

<Ref. to FU(H4SO)-67, INSTALLATION, Fuel Delivery and Evaporation Lines.>

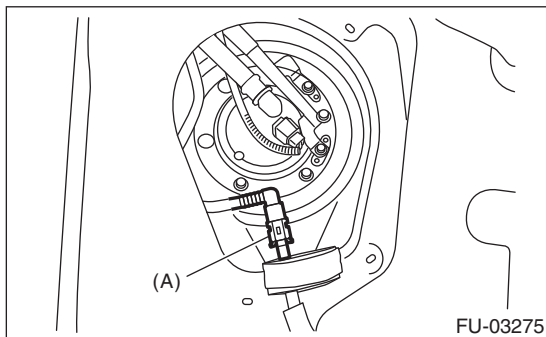

23) Install the service hole cover of fuel sub level sensor.

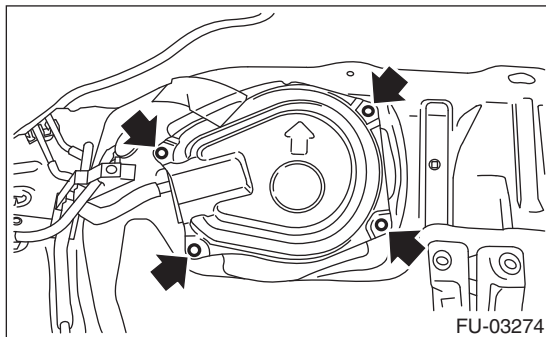

24) Attach the service hole cover of the fuel pump, and secure the connector and clip.

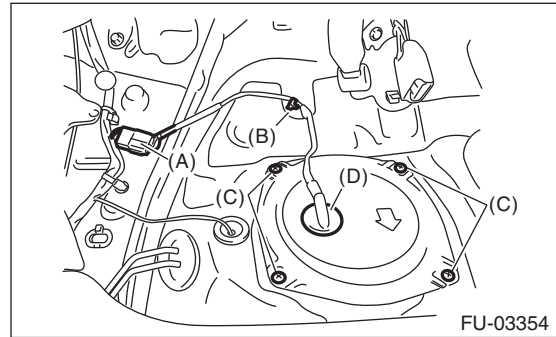

(A) Connector

(B) Clip

(C) Bolt

(D) Grommet

25) Install the rear seat cushion. <Ref. to SE-16, INSTALLATION, Rear Seat.>

26) Install the fuse of fuel pump to main fuse box.

27) Connect the ground cable to the battery.

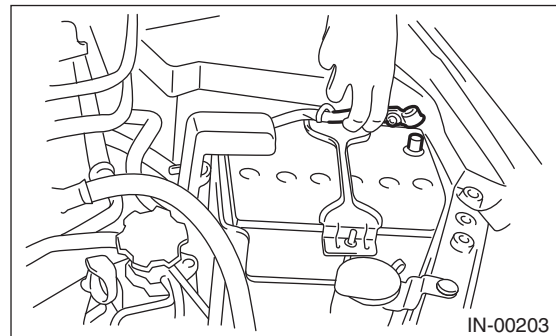

28) Inspect the wheel alignment and adjust if necessary.

29) Re-initialize the auto headlight beam leveler system. <Ref. to LI-15, PROCEDURE, Auto Headlight Beam Leveler System.>

C: INSPECTION

1) Check that the fuel tank does not have holes, cracks or is damaged in any way.

2) Make sure that the fuel pipe and fuel hose are not cracked and that the connections are tight.

Fuel Filler Pipe

FUEL INJECTION (FUEL SYSTEMS)

23. Fuel Filler Pipe

A: REMOVAL

WARNING:

Place "NO OPEN FLAMES" signs near the working area.

CAUTION:

Be careful not to spill fuel.

- 1) Set the vehicle on a lift.
- 2) Release the fuel pressure. <Ref. to FU(H4SO)-43, RELEASING OF FUEL PRESSURE, PROCEDURE, Fuel.>
- 3) Drain fuel from fuel tank. <Ref. to FU(H4SO)-43, DRAINING FUEL (WITH SUBARU SELECT MONITOR), PROCEDURE, Fuel.>
- 4) Disconnect the ground cable from the battery.

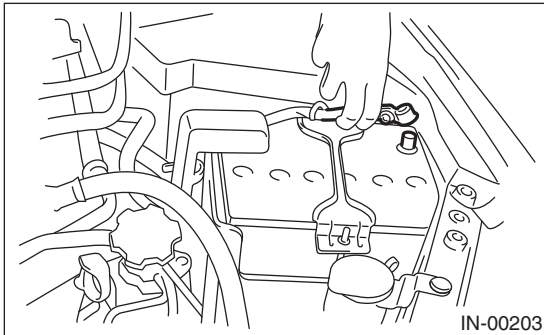

- 5) Open the fuel filler lid, and remove the filler cap.
- 6) Remove the screws which secure gasket.

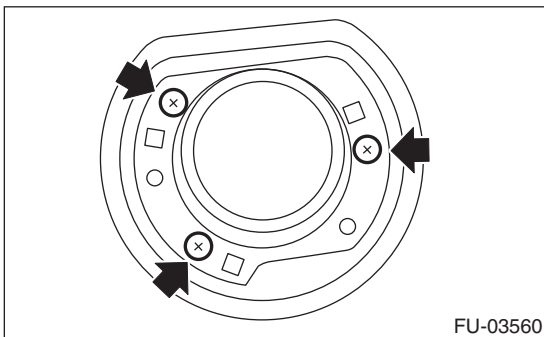

- 7) Remove the rear wheel RH.
- 8) Lift up the vehicle.
- 9) Remove the mud guard. <Ref. to EI-27, REMOVAL, Mud Guard.>
- 10) Remove the rear sub frame. <Ref. to RS-15, REMOVAL, Rear Sub Frame.>

- 11) Remove the bolts which hold fuel filler pipe bracket on the body.

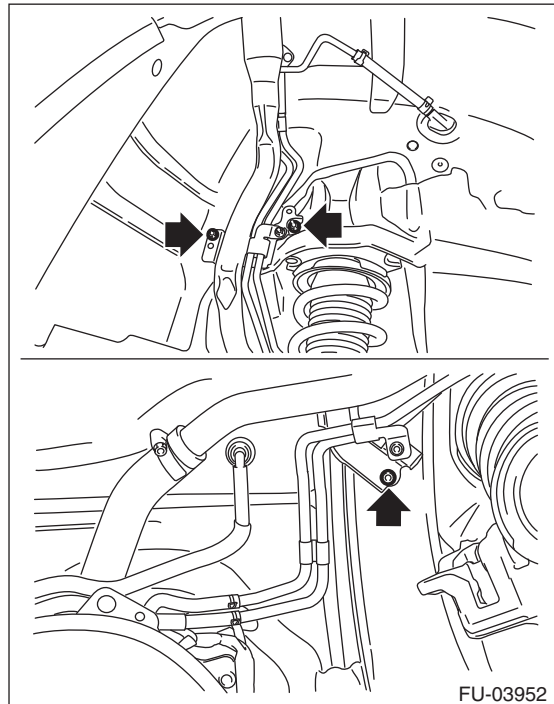

- 12) Loosen the clamp, and disconnect the fuel filler hose (A) and evaporation hose (B).

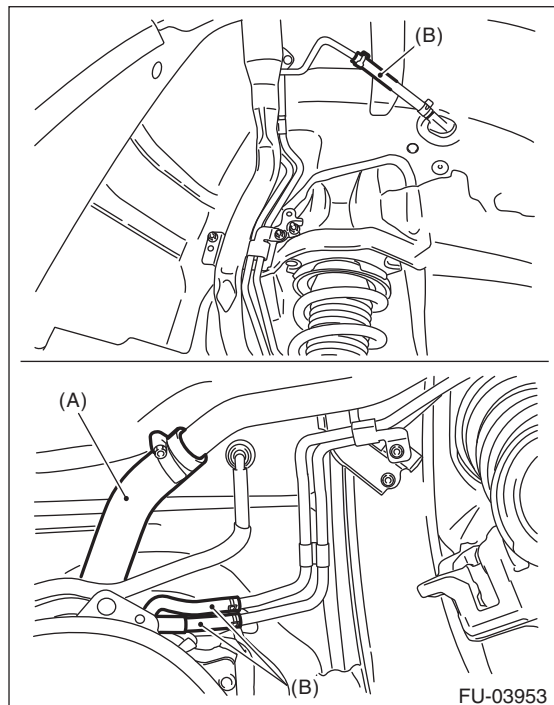

- 13) Remove the fuel filler pipe to the underside of the vehicle.

Fuel Filler Pipe

B: INSTALLATION

- 1) Open the fuel filler lid.
- 2) Set the fuel saucer (A) with rubber seal (C), and insert the fuel filler pipe into hole from the inner side of apron.
- 3) Align the holes in fuel filler pipe neck and set the cup (B), and tighten the screws.

NOTE:

If the edges of rubber seal are folded toward inside, straighten it with a flat tip screwdriver.

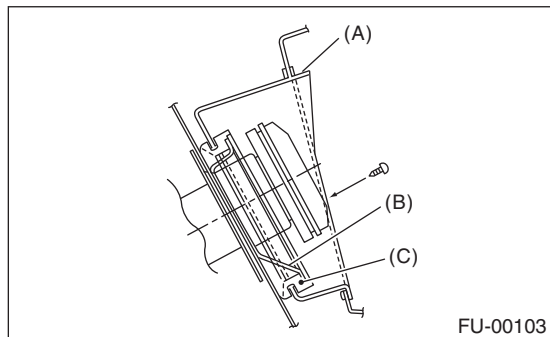

- 4) Securely insert the fuel filler hose (A) and evaporation hose (B) into the specified position, then attach the clamp or clip as shown in the figure.

Tightening torque:

2.5 N·m (0.3 kgf·m, 1.8 ft·lb)

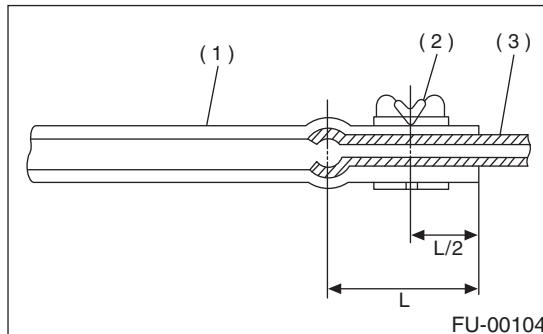
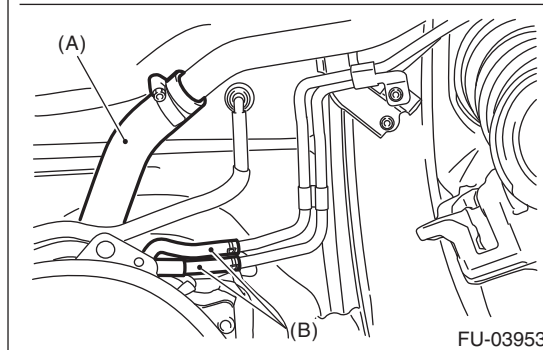
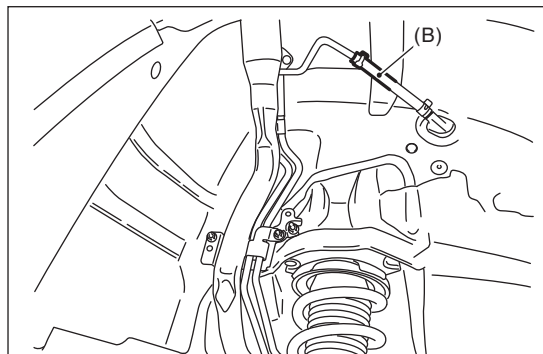

- (1) Hose
- (2) Clip or clamp
- (3) Pipe

Fuel Filler Pipe

FUEL INJECTION (FUEL SYSTEMS)

5) Tighten the bolts which hold fuel filler pipe bracket on the body.

Tightening torque:

7.5 N·m (0.8 kgf·m, 5.5 ft·lb)

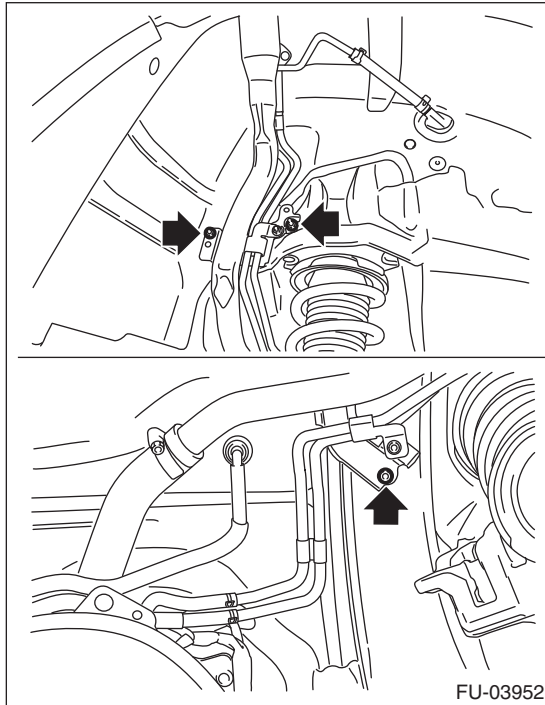

6) Install the rear sub frame. <Ref. to RS-16, INSTALLATION, Rear Sub Frame.>

7) Install the mud guard. <Ref. to EI-27, INSTALLATION, Mud Guard.>

8) Lower the vehicle.

9) Install the rear wheel RH.

Tightening torque:

100 N·m (10.2 kgf·m, 73.8 ft·lb)

10) Connect the battery ground cable to battery.

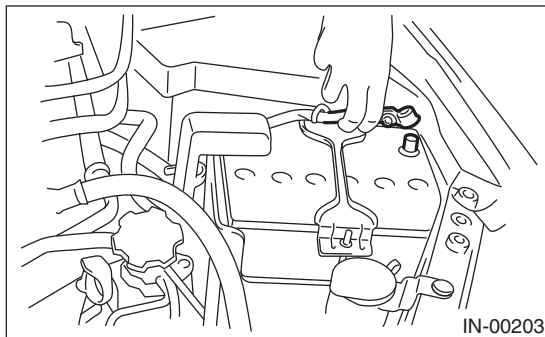

11) Inspect the wheel alignment and adjust if necessary.

12) Re-initialize the auto headlight beam leveler system. <Ref. to LI-15, PROCEDURE, Auto Headlight Beam Leveler System.>

C: INSPECTION

1) Check that the fuel tank does not have holes, cracks or is damaged in any way.

2) Make sure that the fuel hose is not cracked and that the connections are tight.

D: DISASSEMBLY

1) Remove the shut valve from the fuel filler pipe. <Ref. to EC(H4SO)-17, REMOVAL, Shut Valve.>

2) Remove the nut which holds the evaporation pipe assembly to the fuel filler pipe.

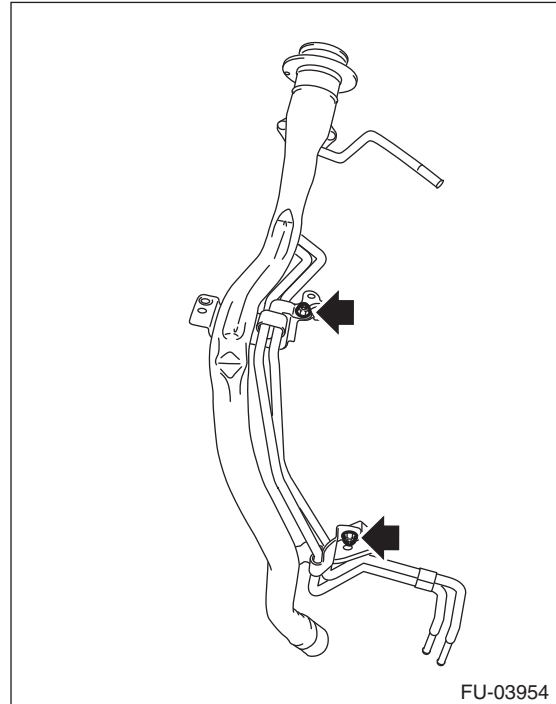

E: ASSEMBLY

1) Tighten the nuts which secure the evaporation pipe assembly to the fuel filler pipe.

Tightening torque:

7.5 N·m (0.8 kgf-m, 5.5 ft-lb)

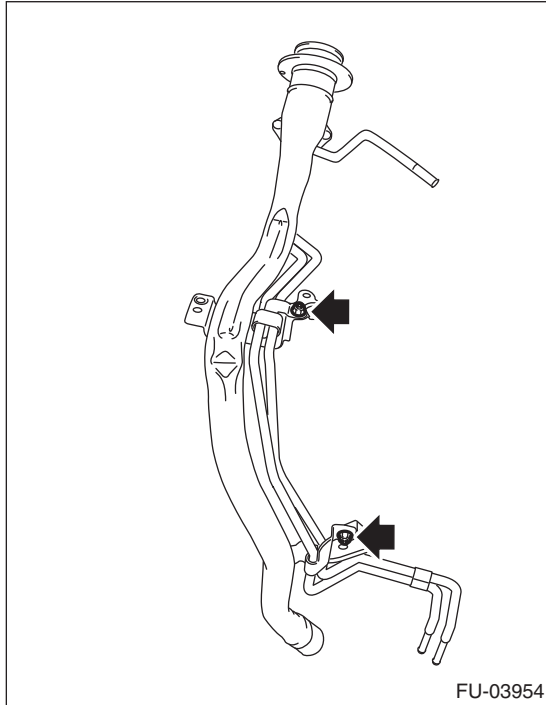

2) Install the shut valve to the fuel filler pipe. <Ref. to EC(H4SO)-17, INSTALLATION, Shut Valve.>

Fuel Pump

FUEL INJECTION (FUEL SYSTEMS)

24. Fuel Pump

A: REMOVAL

WARNING:

Place "NO OPEN FLAMES" signs near the working area.

CAUTION:

- Be careful not to spill fuel.
- When the fuel gauge pointer is at two third or more, the fuel may spill out. Be sure to drain the fuel before the operation.

NOTE:

Fuel pump assembly consists of fuel pump, fuel filter and fuel level sensor.

- 1) Release the fuel pressure. <Ref. to FU(H4SO)-43, RELEASING OF FUEL PRESSURE, PROCEDURE, Fuel.>
- 2) Drain fuel. <Ref. to FU(H4SO)-43, DRAINING FUEL (WITH SUBARU SELECT MONITOR), PROCEDURE, Fuel.>
- 3) Disconnect the ground cable from the battery.

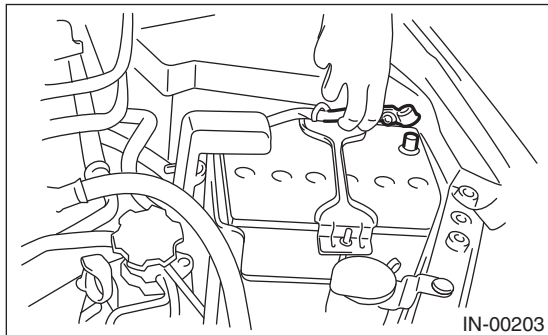

- 4) Remove the rear seat.
- 5) Remove the service hole cover.
 - (1) Remove the bolt (A).
 - (2) Push the grommet (B) down and remove the service hole cover.

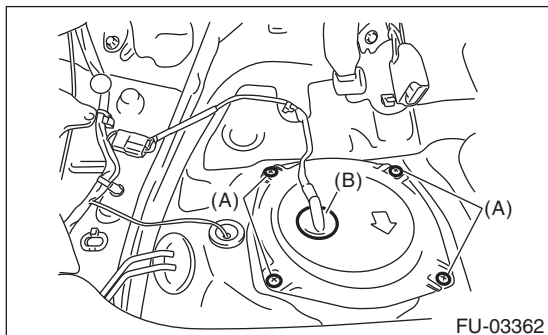

- 6) Disconnect the connector from fuel pump.

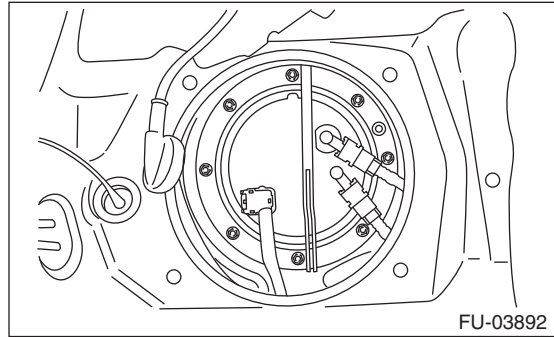

- 7) Disconnect the quick connector, then disconnect the fuel delivery tube and jet pump tube. <Ref. to FU(H4SO)-65, REMOVAL, Fuel Delivery and Evaporation Lines.>
- 8) Remove the nuts which install fuel pump assembly onto fuel tank.

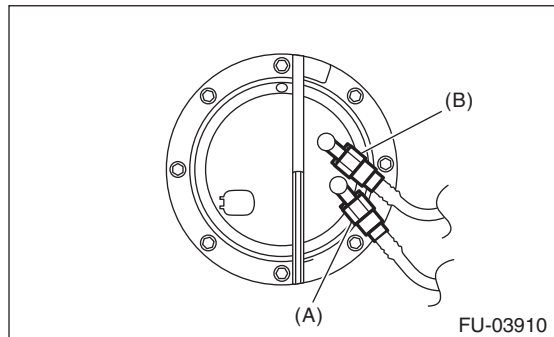

- (A) Fuel delivery tube
(B) Jet pump tube

- 9) Remove the fuel pump assembly from the fuel tank.

B: INSTALLATION

Install in the reverse order of removal while being careful of the following.

- Make sure the sealing portion is free from fuel or foreign matter before installation.
- When assembling, point the protrusion of the gasket (A) towards the front of the vehicle.
- Insert the protrusion (B) of the gasket into the upper plate. (3 locations)
- Align the protrusion (C) of the fuel pump assembly to the cut out in the upper plate.
- Tighten the nuts to the specified torque in the order as shown in the figure.

NOTE:

Use a new gasket and retainer.

Tightening torque:

4.4 N·m (0.4 kgf·m, 3.2 ft·lb)

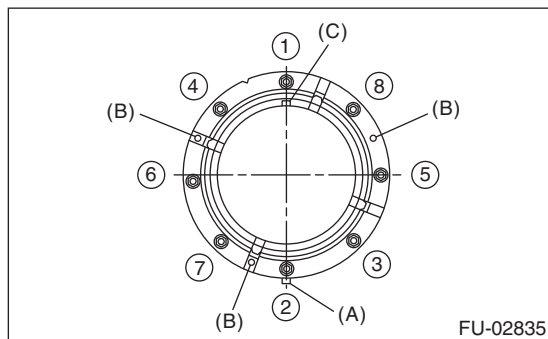

C: INSPECTION

Connect the lead harness to the connector terminal of fuel pump, and apply the battery power supply to check whether the pump operates.

WARNING:

- **Wipe off fuel completely.**
- **Keep the battery as far apart from fuel pump as possible.**
- **Be sure to perform the ON/OFF operation on the battery side.**
- **Do not run the fuel pump for a long time under non-load condition.**

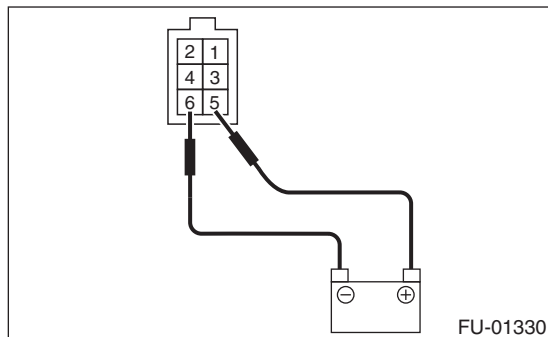

Fuel Level Sensor

FUEL INJECTION (FUEL SYSTEMS)

25. Fuel Level Sensor

A: REMOVAL

WARNING:

Place "NO OPEN FLAMES" signs near the working area.

CAUTION:

- Be careful not to spill fuel.
- When the fuel meter indication is higher than two third of the total, perform the work after draining the fuel not to spill the fuel.

NOTE:

The fuel level sensor is built in fuel pump assembly.
<Ref. to FU(H4SO)-56, REMOVAL, Fuel Pump.>

- 1) Remove the fuel pump assembly.
- 2) Disconnect the connector from fuel pump bracket.
- 3) Remove the fuel level sensor and fuel temperature sensor.

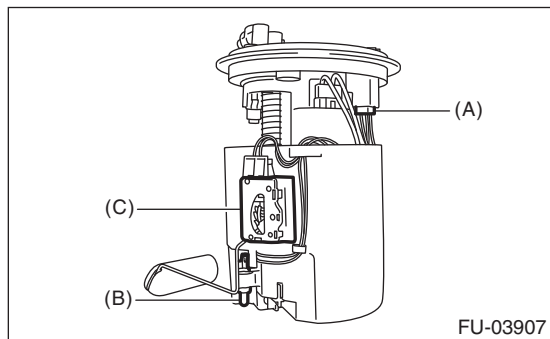

- (A) Connector
- (B) Fuel temperature sensor
- (C) Fuel level sensor

B: INSTALLATION

Install in the reverse order of removal.

Tightening torque:

4.4 N·m (0.4 kgf·m, 3.2 ft·lb)

C: INSPECTION

- 1) Check that the fuel level sensor has no damage.
- 2) Measure the fuel level sensor float position.

NOTE:

When inspecting the fuel level sensor, perform the work with the sensor installed to the fuel pump.

- Model with fuel level sensor bent in 3 locations

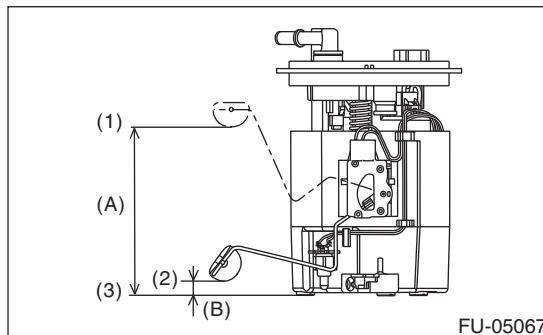

- (1) FULL
- (2) EMPTY
- (3) Fuel tank seating surface

Float position	Standard
FULL to Fuel tank seating surface (A)	126.4±4 mm (4.976±0.157 in)
EMPTY to Fuel tank seating surface (B)	11.0±4 mm (0.433±0.157 in)

- Model with fuel level sensor bent in 2 locations

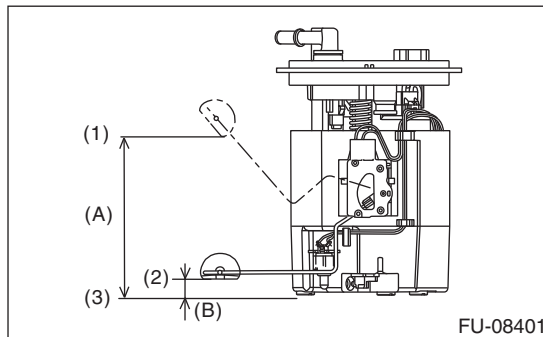

- (1) FULL
- (2) EMPTY
- (3) Fuel tank seating surface

Float position	Standard
FULL to Fuel tank seating surface (A)	120.9±4 mm (4.759±0.157 in)
EMPTY to Fuel tank seating surface (B)	14.8±4 mm (0.583±0.157 in)

Fuel Level Sensor

3) Measure the resistance between fuel level sensor terminals.

- Model with fuel level sensor bent in 3 locations

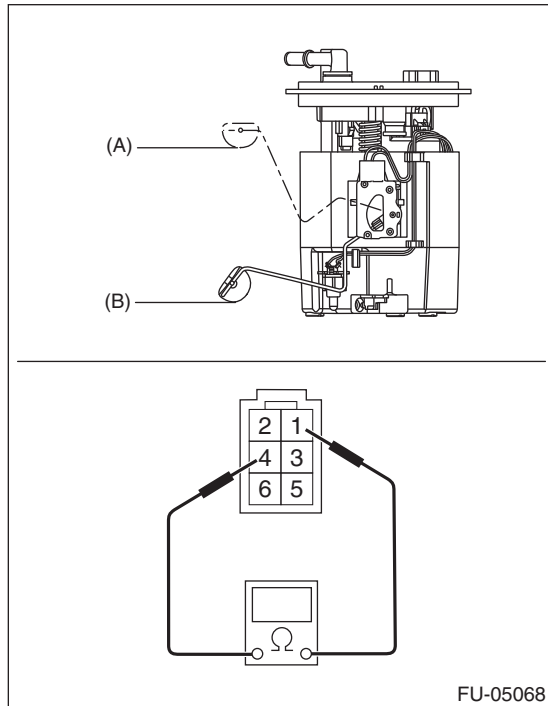

- Model with fuel level sensor bent in 2 locations

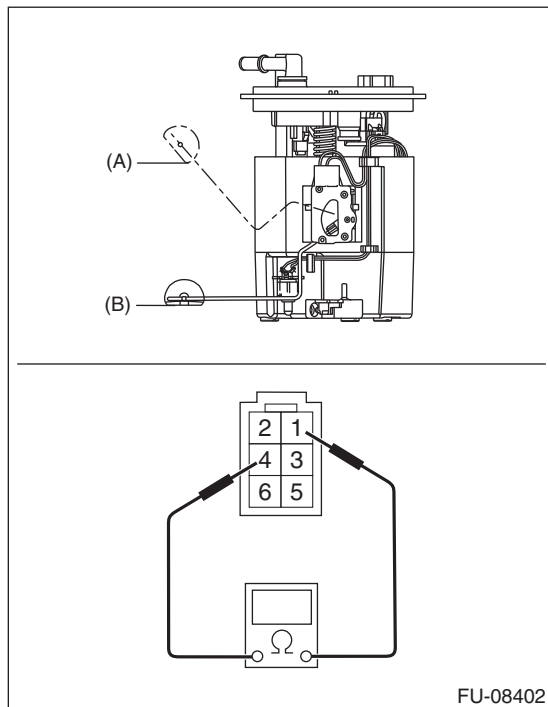

Float position	Terminal No.	Standard
FULL (A)	1 and 4	$8.7 \pm 1.0 \Omega$
EMPTY (B)		$139.1 \pm 2.0 \Omega$

Fuel Sub Level Sensor

FUEL INJECTION (FUEL SYSTEMS)

26. Fuel Sub Level Sensor

A: REMOVAL

WARNING:

Place "NO OPEN FLAMES" signs near the working area.

CAUTION:

- Be careful not to spill fuel.
- When the fuel gauge pointer is at two third or more, the fuel may spill out. Be sure to drain the fuel before the operation.

1) Release the fuel pressure. <Ref. to FU(H4SO)-43, RELEASING OF FUEL PRESSURE, PROCEDURE, Fuel.>

2) Drain fuel from fuel tank. <Ref. to FU(H4SO)-43, DRAINING FUEL (WITH SUBARU SELECT MONITOR), PROCEDURE, Fuel.>

3) Disconnect the ground cable from the battery.

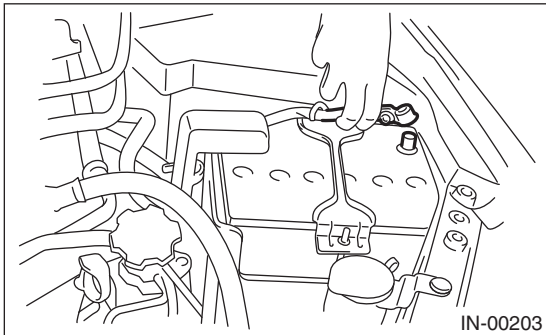

4) Remove the rear seat.

5) Remove the service hole cover.

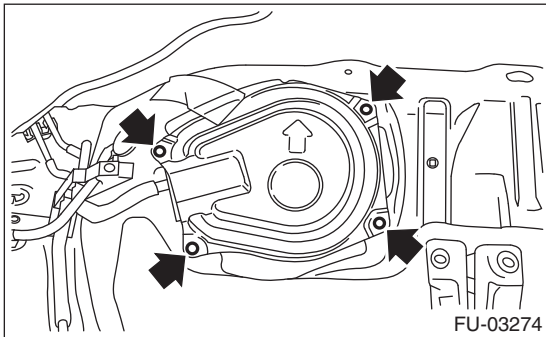

6) Disconnect the connector from the fuel sub level sensor.

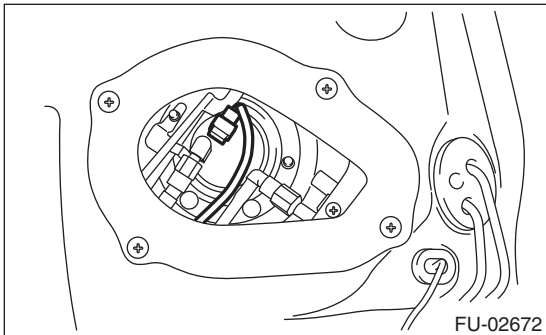

7) Disconnect the quick connector, then disconnect the fuel delivery tube and jet pump tube. <Ref. to FU(H4SO)-65, REMOVAL, Fuel Delivery and Evaporation Lines.>

8) Remove the nuts and bolts which install fuel sub level sensor on fuel tank.

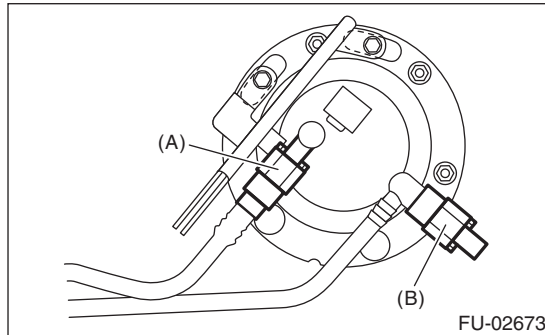

(A) Jet pump tube

(B) Fuel delivery tube

9) Remove the fuel sub level sensor.

B: INSTALLATION

Install in the reverse order of removal while being careful of the following.

- Make sure the sealing portion is free from fuel or foreign matter before installation.
- Align protrusion (A) of the gasket to the position shown in the following figure.
- Align protrusion (B) of the fuel sub level sensor to the cut out in the fuel sublevel sensor upper plate.
- Tighten the nuts and bolts to the specified torque in the order as shown in the figure.

NOTE:

Use a new gasket and retainer.

Tightening torque:

4.4 N·m (0.4 kgf·m, 3.2 ft·lb)

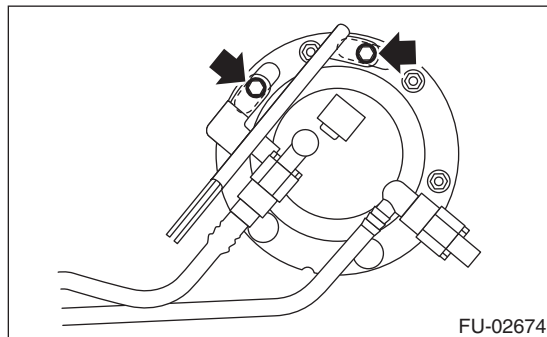
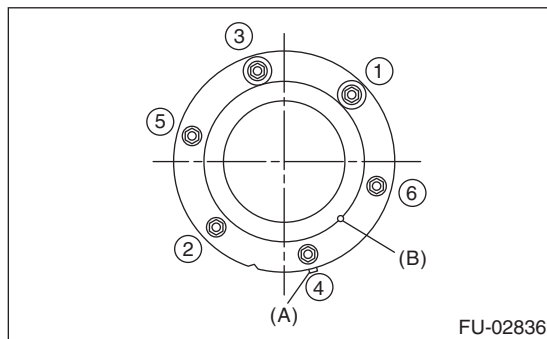

27. Fuel Filter

A: SPECIFICATION

Fuel filter forms a single unit with fuel pump.

Refer to "Fuel Pump" for removal and installation.

<Ref. to FU(H4SO)-56, REMOVAL, Fuel Pump.>

<Ref. to FU(H4SO)-57, INSTALLATION, Fuel Pump.>

28. Fuel Damper

A: REMOVAL

WARNING:

Place "NO OPEN FLAMES" signs near the working area.

CAUTION:

- Be careful not to spill fuel.
- Catch the fuel from hoses using a container or cloth.

1) Release the fuel pressure. <Ref. to FU(H4SO)-43, RELEASING OF FUEL PRESSURE, PROCEDURE, Fuel.>

2) Remove the fuel damper valve from the fuel delivery hose.

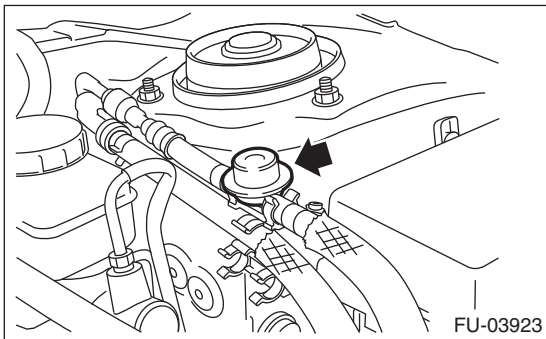

B: INSTALLATION

Install in the reverse order of removal.

Tightening torque:

1.25 N·m (0.1 kgf-m, 0.9 ft-lb)

Purge Damper

FUEL INJECTION (FUEL SYSTEMS)

29.Purge Damper

A: REMOVAL

WARNING:

Place “NO OPEN FLAMES” signs near the working area.

1) Remove the purge damper valve from the purge damper valve stay.

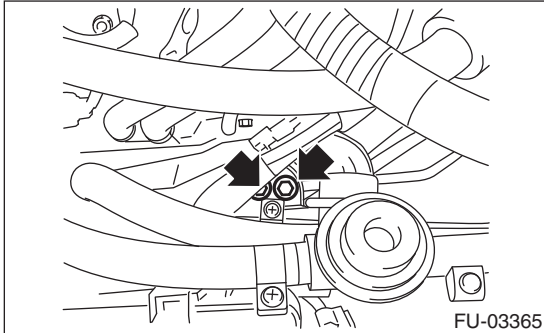

2) Disconnect the evaporation hose from the purge damper valve.

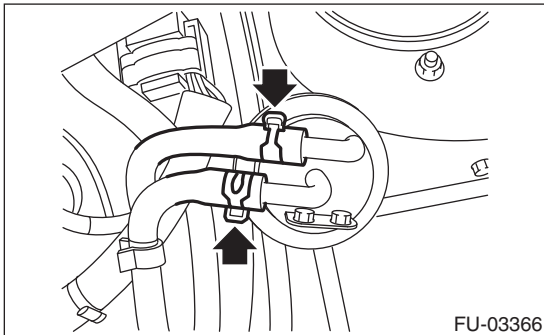

B: INSTALLATION

CAUTION:

If there is damage on the evaporation hose, replace with a new hose.

Install in the reverse order of removal.

Tightening torque:

8 N·m (0.8 kgf·m, 5.9 ft·lb)

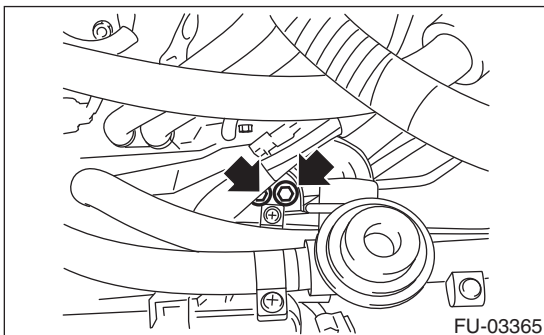

30. Fuel Delivery and Evaporation Lines

A: REMOVAL

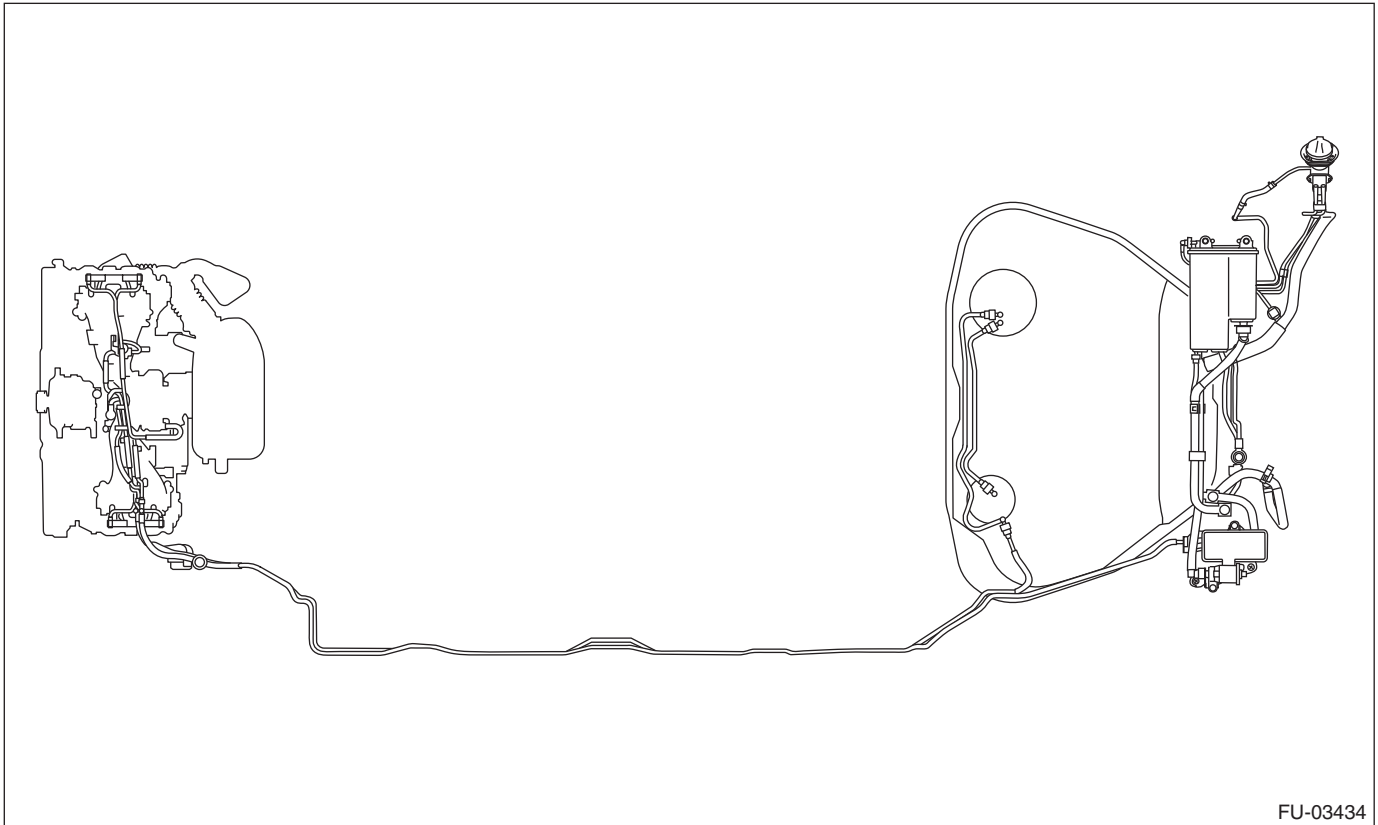

WARNING:
Place "NO OPEN FLAMES" signs near the working area.

CAUTION:
Be careful not to spill fuel.

Fuel Delivery and Evaporation Lines

FUEL INJECTION (FUEL SYSTEMS)

- 1) Set the vehicle on a lift.
- 2) Release the fuel pressure. <Ref. to FU(H4SO)-43, RELEASING OF FUEL PRESSURE, PROCEDURE, Fuel.>
- 3) Open the fuel filler lid, and remove the fuel filler cap.
- 4) Remove the floor mat. <Ref. to EI-61, REMOVAL, Floor Mat.>
- 5) In the engine compartment, disconnect the fuel delivery hoses and evaporation hose.

(1) Disconnect the quick connector of the fuel delivery line by pushing the ST in the direction of the arrow.

ST 42099FE000 QUICK CONNECTOR
RELEASE

(2) Remove the clip and disconnect the evaporation hose from the pipe.

CAUTION:

- Be careful not to spill fuel.
- Catch the fuel from hoses using a container or cloth.

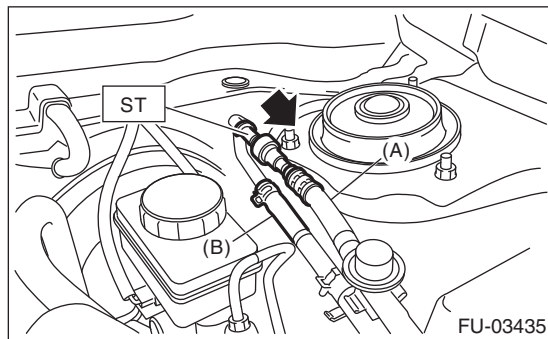

- (A) Fuel delivery hose
(B) Evaporation hose

- 6) Remove the canister. <Ref. to EC(H4SO)-5, REMOVAL, Canister.>
- 7) Remove the fuel tank. <Ref. to FU(H4SO)-45, REMOVAL, Fuel Tank.>
- 8) Remove the fuel pipe assembly.

9) Disconnect the quick connector, then disconnect the fuel delivery tube and jet pump tube.

(1) Clean the pipe and connector, if they are covered with dust.

(2) To prevent from damaging or entering foreign matter, wrap the pipes and connectors with plastic bag etc.

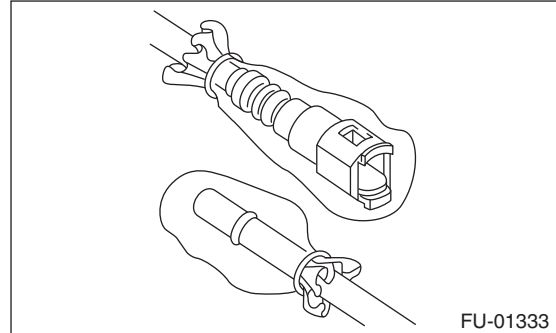

(3) Hold the connector (A) and push the retainer (B) down.

(4) Pull out the connector (A) from the retainer (B).

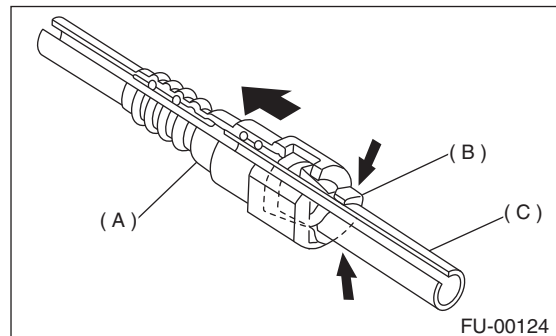

- (A) Connector
(B) Retainer
(C) Pipe

Fuel Delivery and Evaporation Lines

FUEL INJECTION (FUEL SYSTEMS)

B: INSTALLATION

Install in the reverse order of removal while being careful of the following.

1. CONNECTING THE FUEL LINE QUICK CONNECTOR

CAUTION:

Make sure there is no damage or dust on the connections. If necessary, clean seal surface of pipe.

NOTE:

Use a new retainer.

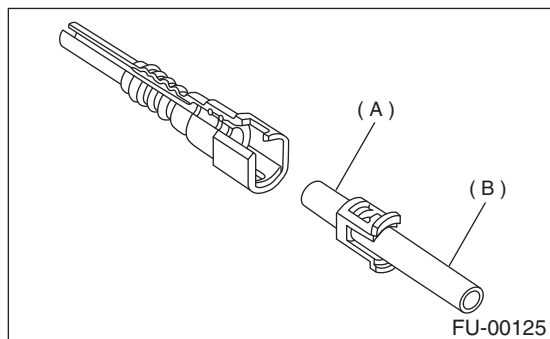

- (A) Seal surface
- (B) Pipe

1) Set the new retainer (B) to connector (A).

2) Push the pipe into the connector completely.

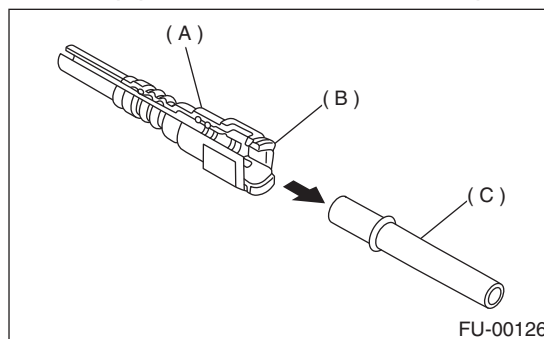

- (A) Connector
- (B) Retainer
- (C) Pipe

CAUTION:

- Pull the connector to ensure it is connected securely.
- Make sure the two retainer claws are engaged in their mating positions in the connector.
- Be sure to inspect hoses and their connections for any leakage of fuel.

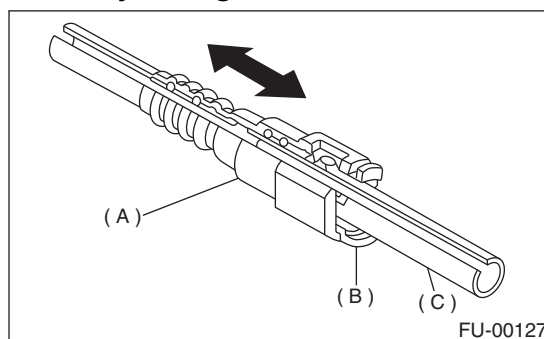

- (A) Connector
- (B) Retainer
- (C) Pipe

Fuel Delivery and Evaporation Lines

FUEL INJECTION (FUEL SYSTEMS)

2. CONNECTING THE FUEL DELIVERY HOSE

Connect the fuel delivery hose to the pipe with an overlap of 20 to 25 mm (0.79 to 0.98 in).

Type A: When the amount to be inserted is specified.

Type B: When the amount to be inserted is not specified.

L1: 2.5 ± 1.5 mm (0.098 ± 0.059 in)

L2: 22.5 ± 2.5 mm (0.886 ± 0.098 in)

CAUTION:

Be sure to inspect hoses and their connections for any leakage of fuel.

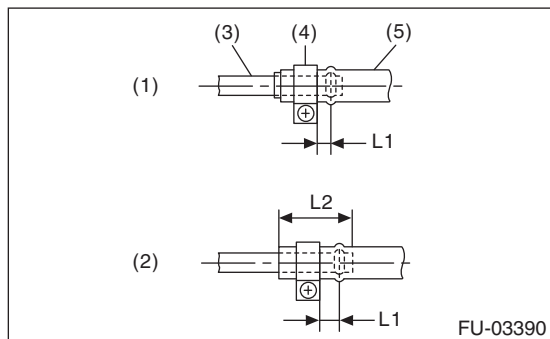

- (1) Type A
- (2) Type B
- (3) Pipe
- (4) Clamp
- (5) Hose

3. EVAPORATION HOSE CONNECTION

Insert the evaporation hose 15 to 20 mm (0.59 to 0.79 in) when connecting to the pipe.

L = 17.5 ± 2.5 mm (0.689 ± 0.098 in)

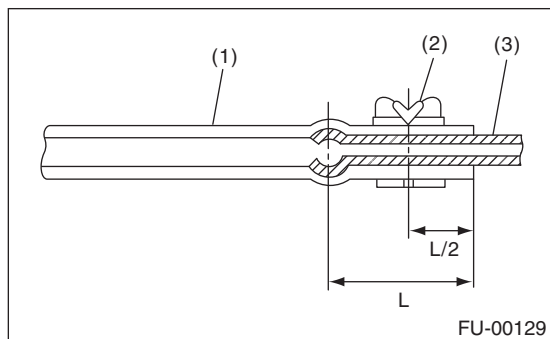

- (1) Hose
- (2) Clip
- (3) Pipe

C: INSPECTION

- 1) Make sure that there are no cracks on the fuel pipes and fuel hoses.
- 2) Make sure the fuel pipe and fuel hose connections are tightened firmly.

Fuel System Trouble in General

FUEL INJECTION (FUEL SYSTEMS)

31. Fuel System Trouble in General

A: INSPECTION

Trouble and possible cause		Corrective action
1. Insufficient fuel supply to injector		
1)	Fuel pump does not operate.	
	○ Defective terminal contact	Inspect contact, especially ground, and tighten it securely.
	○ Trouble in electromagnetic or electronic circuit parts	Replace the faulty parts.
2)	Decline of fuel pump function	Replace the fuel pump.
3)	Clogged fuel filter	Replace the fuel filter.
4)	Clogged or bent fuel pipe or hose	Clean, correct or replace the fuel pipe or hose.
5)	Air is mixed in the fuel system.	Inspect or retighten each connection part.
6)	Clogged or bent air breather tube or pipe.	Clean, correct or replace the air breather tube or pipe.
7)	Damaged diaphragm of pressure regulator	Replace.
2. Leakage or blow out of fuel		
1)	Loose joints of the fuel pipe	Retighten.
2)	Cracked fuel pipe, hose and fuel tank	Replace.
3)	Defective welding part on the fuel tank	Replace.
4)	Clogged or bent air breather tube or air vent tube	Clean, correct or replace the air breather tube or air vent tube.
3. Gasoline smell inside of compartment		
1)	Loose joints at air breather tube, air vent tube and fuel filler pipe	Retighten.
2)	Fuel saucer gasket air tightness fault	Correct or replace the gasket.
3)	Inoperative fuel pump modulator or circuit	Replace.
4. Defective fuel meter indicator		
1)	Defective operation of fuel level sensor	Replace.
2)	Defective operation of fuel meter	Replace.
5. Noise		
1)	Large operation noise or vibration of fuel pump	Replace.

NOTE:

- When the vehicle is left unattended for an extended period of time, water may accumulate in the fuel tank. Fill the fuel tank fully to prevent this.
- In snow-covered areas, mountainous areas, skiing areas, etc. where ambient temperatures drop below 0°C (32°F) throughout the winter season, use a water removing agent in the fuel system to prevent freezing fuel system and accumulating water.
- When water is accumulated in fuel filter, fill the water removing agent in the fuel tank.
- Before using water removing agent, follow the cautions noted on the bottle.

Fuel System Trouble in General

FUEL INJECTION (FUEL SYSTEMS)

EMISSION CONTROL (AUX. EMISSION CONTROL DEVICES) *EC(H4SO)*

	Page
1. General Description	2
2. Front Catalytic Converter	3
3. Rear Catalytic Converter	4
4. Canister	5
5. Purge Control Solenoid Valve	9
6. EGR Valve	10
7. Fuel Level Sensor	11
8. Fuel Temperature Sensor	12
9. Fuel Sub Level Sensor	13
10. Fuel Tank Pressure Sensor	14
11. Pressure Control Solenoid Valve	15
12. Drain Filter	16
13. Shut Valve	17
14. Drain Valve	18
15. PCV Hose Assembly	19

General Description

EMISSION CONTROL (AUX. EMISSION CONTROL DEVICES)

1. General Description

A: CAUTION

- Wear appropriate work clothing, including a cap, protective goggles and protective shoes when performing any work.
- Remove contamination including dirt and corrosion before removal, installation or disassembly.
- Keep the disassembled parts in order and protect them from dust and dirt.
- Before removal, installation or disassembly, be sure to clarify the failure. Avoid unnecessary removal, installation, disassembly and replacement.
- Vehicle components are extremely hot after driving. Be wary of receiving burns from heated parts.
- Be sure to tighten fasteners including bolts and nuts to the specified torque.
- Place shop jacks or rigid racks at the specified points.
- Before disconnecting connectors of sensors or units, be sure to disconnect the ground cable from battery.

B: PREPARATION TOOL

1. SPECIAL TOOL

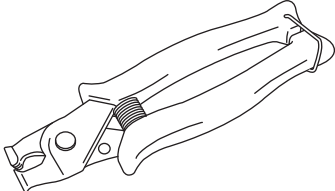
ILLUSTRATION	TOOL NUMBER	DESCRIPTION	REMARKS
 ST18353AA000	18353AA000	CLAMP PLIERS	<ul style="list-style-type: none">• Used for removing and installing the PCV hose.• This is a general tool made by the French company CAILLAU. (code) 54.0.000.205 To make this easier to obtain in the same way as genuine Subaru parts, it has been provided with a tool number as an ST.

Front Catalytic Converter

EMISSION CONTROL (AUX. EMISSION CONTROL DEVICES)

2. Front Catalytic Converter

A: REMOVAL

The front catalytic converter is integrated into the front exhaust pipe; therefore, refer to “Front Exhaust Pipe” for the removal procedure. <Ref. to EX(H4SO)-4, REMOVAL, Front Exhaust Pipe.>

B: INSTALLATION

The front catalytic converter is integrated into the front exhaust pipe; therefore, refer to “Front Exhaust Pipe” for the installation procedure. <Ref. to EX(H4SO)-5, INSTALLATION, Front Exhaust Pipe.>

C: INSPECTION

- 1) Check the connections and welds for exhaust leaks.
- 2) Check for hole or rust.

Rear Catalytic Converter

EMISSION CONTROL (AUX. EMISSION CONTROL DEVICES)

3. Rear Catalytic Converter

A: REMOVAL

The rear catalytic converter is integrated into the center exhaust pipe; therefore, refer to “Center Exhaust Pipe” for the removal procedure. <Ref. to EX(H4SO)-7, REMOVAL, Center Exhaust Pipe.>

B: INSTALLATION

The rear catalytic converter is integrated into the center exhaust pipe; therefore, refer to “Center Exhaust Pipe” for the installation procedure. <Ref. to EX(H4SO)-7, INSTALLATION, Center Exhaust Pipe.>

C: INSPECTION

- 1) Check the connections and welds for exhaust leaks.
- 2) Check for hole or rust.

Canister

EMISSION CONTROL (AUX. EMISSION CONTROL DEVICES)

4. Canister

A: REMOVAL

1) Disconnect the ground cable from the battery.

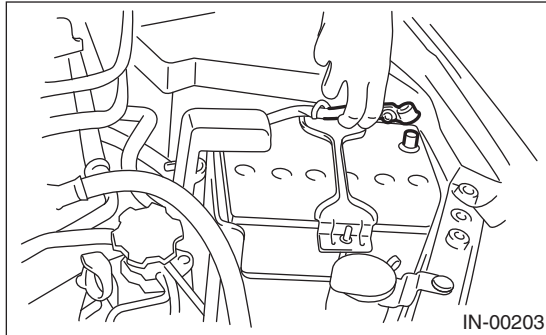

2) Open the rear gate, and remove the luggage floor mat.

3) Remove the center sub trunk (A) (model with center sub trunk), and remove the sub trunk RH (B) and sub trunk LH (C) fixed by clips.

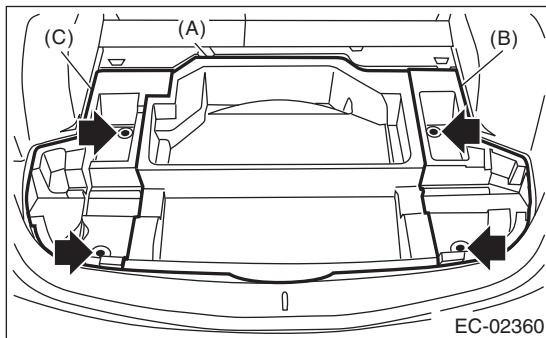

4) Tilt the rear seat backrest forward.

5) Remove the clips that is holding the rear seat backrest cover on the canister cover, and turn over the rear seat backrest cover toward the front side of the vehicle.

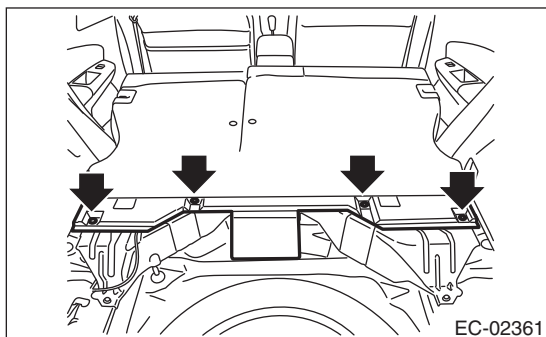

6) Remove the center canister cover.

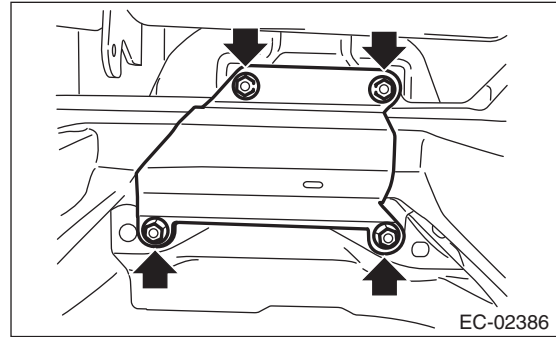

7) Remove the canister cover RH.

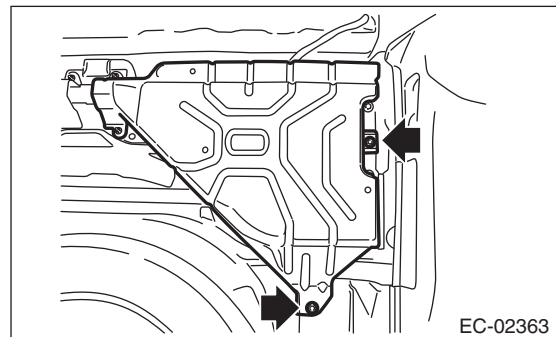

Canister

EMISSION CONTROL (AUX. EMISSION CONTROL DEVICES)

8) Disconnect the purge tube (A), vent tube (B), drain tube A (C) and PCV drain tube (D).

NOTE:

Disconnect the quick connector as shown in the figure.

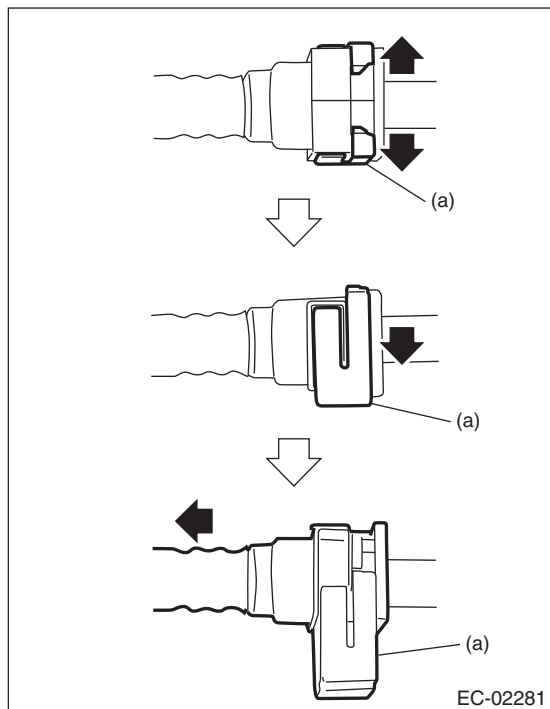

(a) Retainer

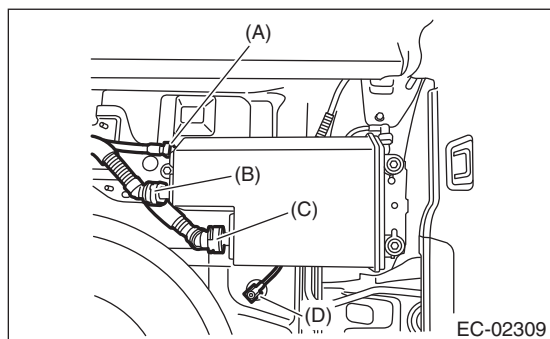

9) Remove the canister.

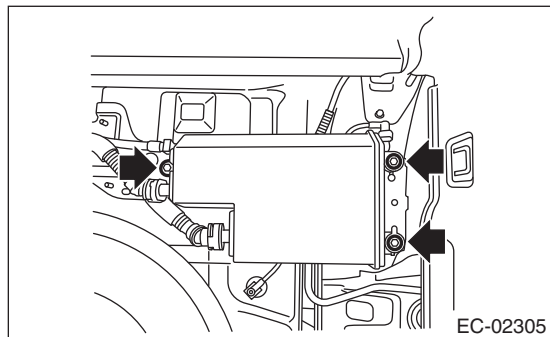

10) Remove the canister cover LH.

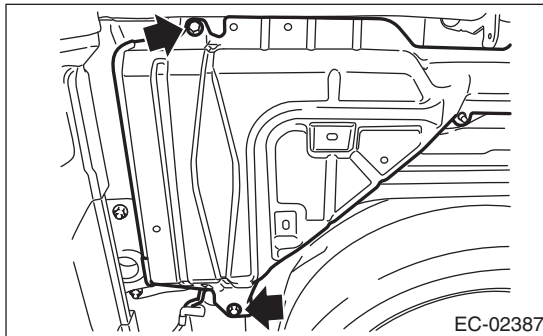

11) Disconnect drain tube A (A) and drain tube B (B).

NOTE:

Disconnect the quick connector as shown in the figure.

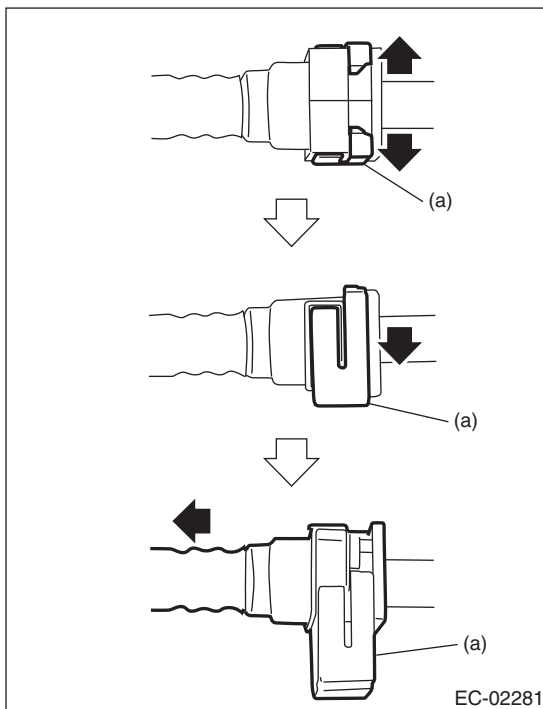

(a) Retainer

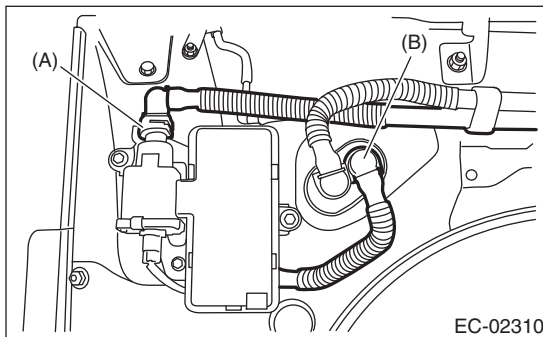

Canister

EMISSION CONTROL (AUX. EMISSION CONTROL DEVICES)

12) Disconnect connector (C) from the drain valve, and remove the drain valve.

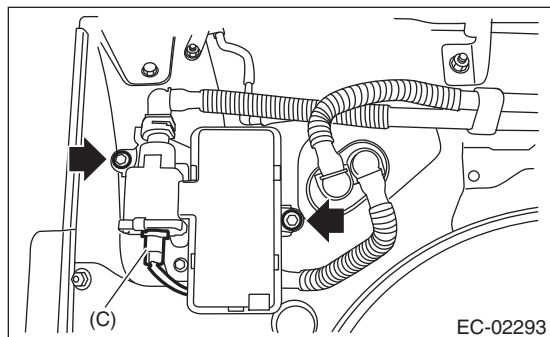

14) Remove purge tube (A), vent tube (B), and drain tube A (C).

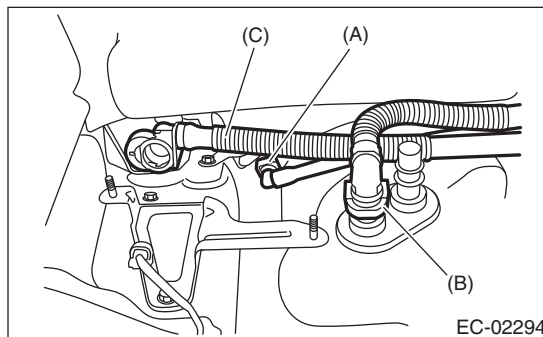

13) Disconnect purge tube (A) and vent tube (B).

NOTE:

Disconnect the quick connector as shown in the figure.

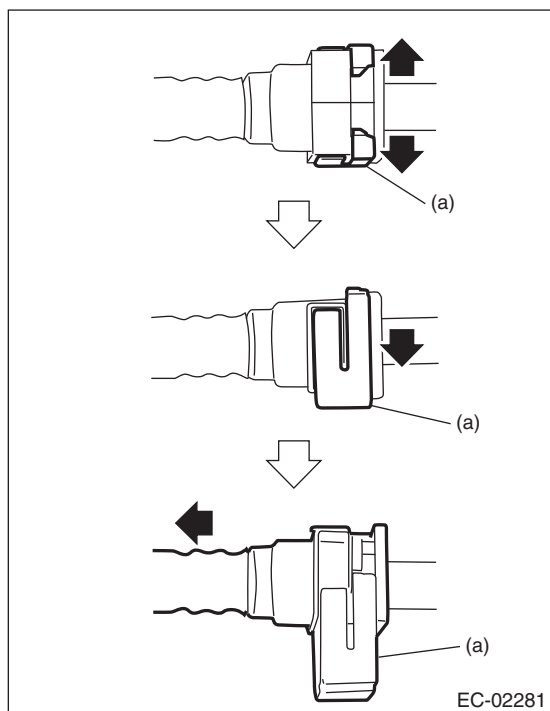

(a) Retainer

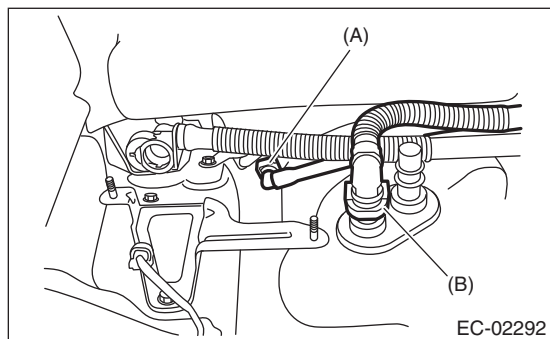

Canister

EMISSION CONTROL (AUX. EMISSION CONTROL DEVICES)

B: INSTALLATION

Install in the reverse order of removal while being careful of the following.

- Connect the quick connector as shown in the figure.

CAUTION:

- Check that there is no damage or dust on the quick connector. If necessary, clean seal surface of pipe.
- When connecting the quick connector, insert the pipe all the way in securely, then operate the push lock.
- If it is not possible to perform the push lock operation of the retainer, recheck whether the pipe is securely inserted.
- Confirm that the quick connector is securely connected.

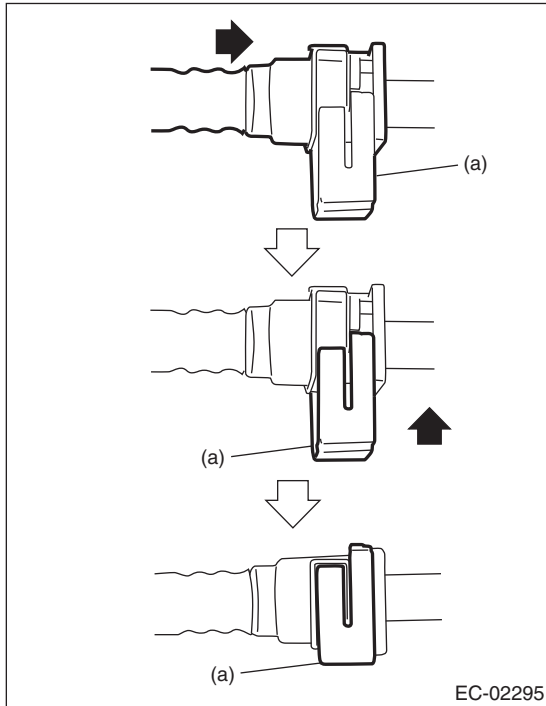

(a) Retainer

Tightening torque:

18 N·m (1.8 kgf·m, 13.3 ft·lb)

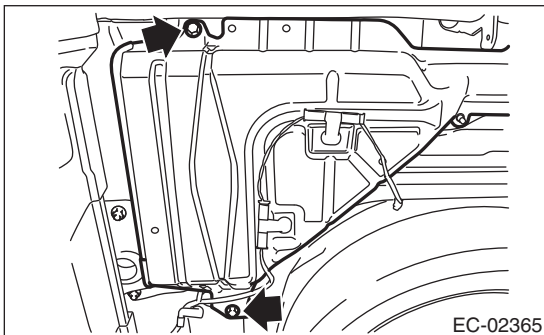

Tightening torque:

8 N·m (0.8 kgf·m, 5.9 ft·lb)

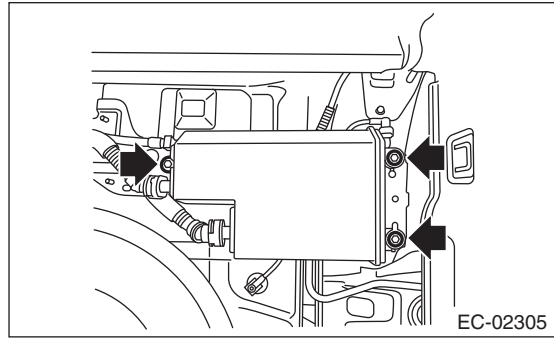

Tightening torque:

7.5 N·m (0.8 kgf·m, 5.5 ft·lb)

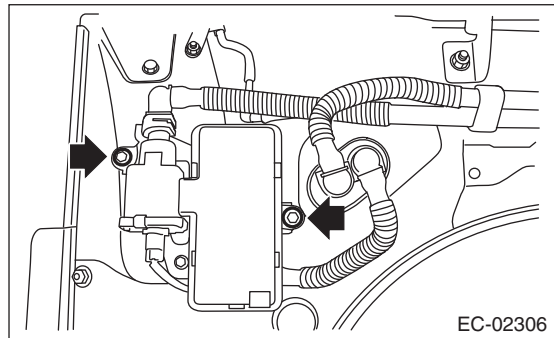

Tightening torque:

18 N·m (1.8 kgf·m, 13.3 ft·lb)

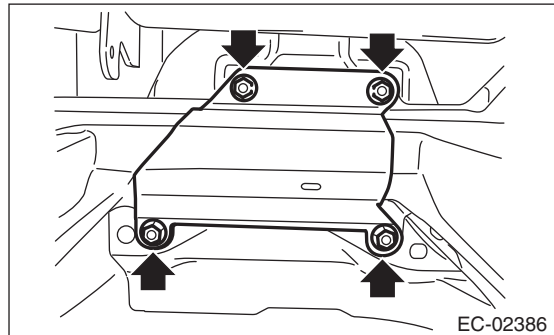
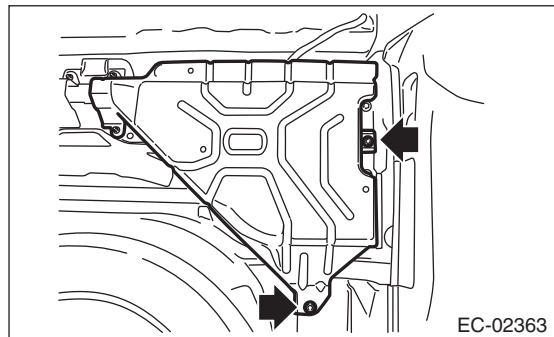

C: INSPECTION

Make sure that the canister, drain valve and tube are not cracked or loose.

Purge Control Solenoid Valve

EMISSION CONTROL (AUX. EMISSION CONTROL DEVICES)

5. Purge Control Solenoid Valve

A: REMOVAL

1) Disconnect the ground cable from battery.

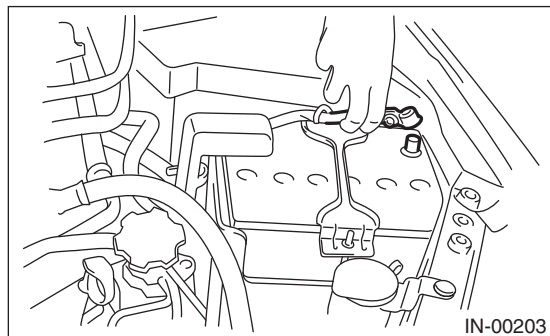

2) Disconnect the connector and evaporation hoses of purge control solenoid valve, and then remove the purge control solenoid valve.

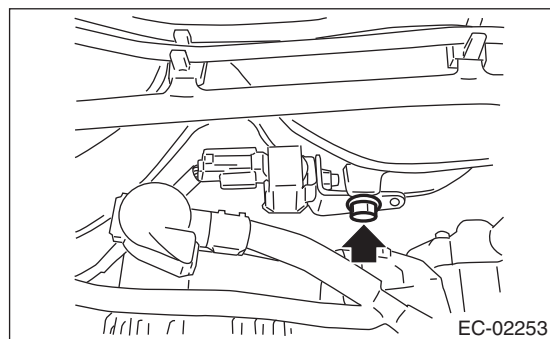

B: INSTALLATION

Install in the reverse order of removal.

NOTE:

• Connect the evaporation hose as shown in the figure.

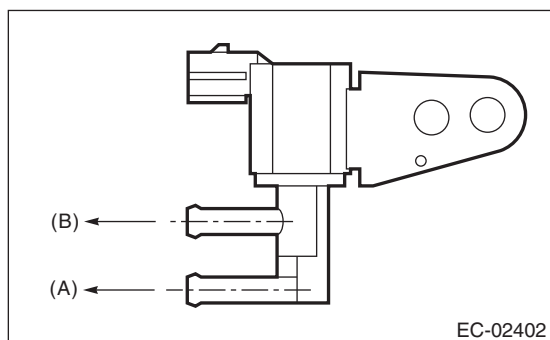

- (A) To fuel pipe (intake manifold)
- (B) To fuel pipe (evaporation line)

• Refer to the following figure for the mounting hole of the purge control solenoid valve because the location differs according to intake manifold specification.

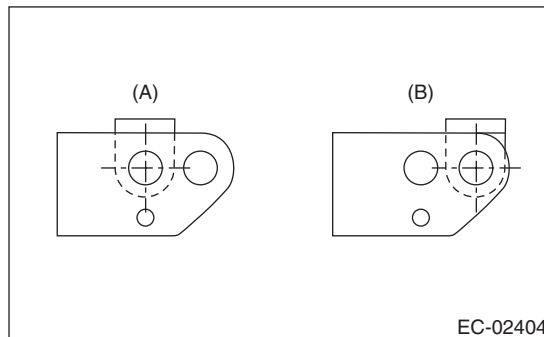

- (A) Without model number
- (B) With model number

• See the following figure to check if the intake manifold has a model number.

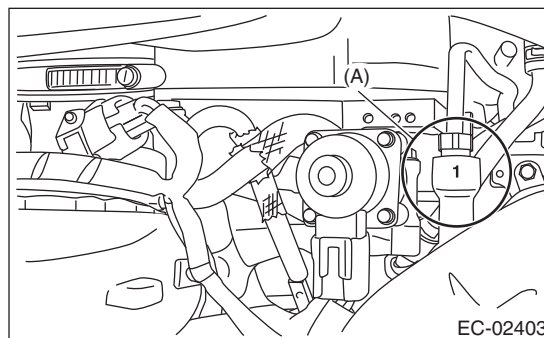

- (A) Model number (single digit number)

Tightening torque (Purge control solenoid valve attachment bolt):

19 N·m (1.9 kgf-m, 14.0 ft-lb)

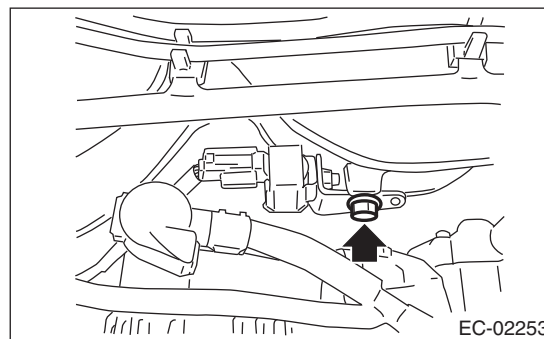

C: INSPECTION

Make sure the hoses are not cracked or loose.

EGR Valve

EMISSION CONTROL (AUX. EMISSION CONTROL DEVICES)

6. EGR Valve

A: REMOVAL

For removal procedures, refer to "FU" section.
<Ref. to FU(H4SO)-29, REMOVAL, EGR Valve.>

B: INSTALLATION

For installation procedures, refer to "FU" section. <Ref. to FU(H4SO)-29, INSTALLATION, EGR Valve.>

Fuel Level Sensor

EMISSION CONTROL (AUX. EMISSION CONTROL DEVICES)

7. Fuel Level Sensor

A: REMOVAL

For removal procedures, refer to "FU" section. <Ref. to FU(H4SO)-58, REMOVAL, Fuel Level Sensor.>

B: INSTALLATION

For installation procedures, refer to "FU" section. <Ref. to FU(H4SO)-58, INSTALLATION, Fuel Level Sensor.>

Fuel Temperature Sensor

EMISSION CONTROL (AUX. EMISSION CONTROL DEVICES)

8. Fuel Temperature Sensor

A: REMOVAL

The fuel temperature sensor is integrated into the fuel level sensor as one unit; therefore, refer to “Fuel Level Sensor” for removal procedures. <Ref. to FU(H4SO)-58, REMOVAL, Fuel Level Sensor.>

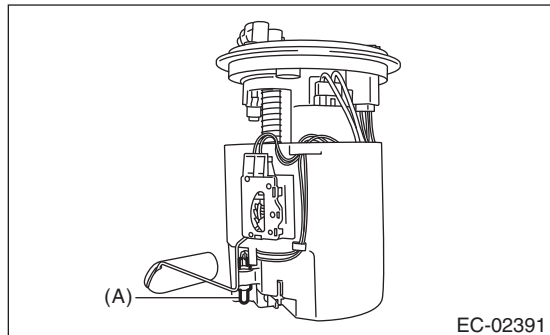

(A) Fuel temperature sensor

B: INSTALLATION

The fuel temperature sensor and fuel level sensor are integrated into one unit; therefore, refer to “Fuel Level Sensor” for installation procedure. <Ref. to FU(H4SO)-58, INSTALLATION, Fuel Level Sensor.>

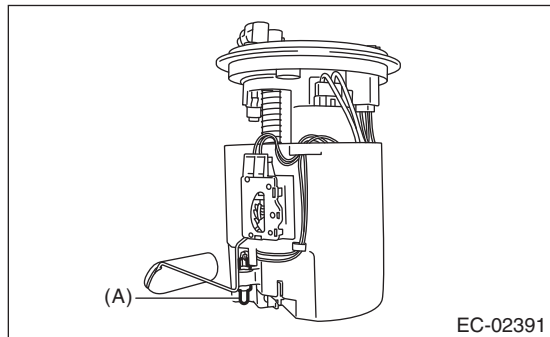

(A) Fuel temperature sensor

Fuel Sub Level Sensor

EMISSION CONTROL (AUX. EMISSION CONTROL DEVICES)

9. Fuel Sub Level Sensor

A: REMOVAL

For removal procedures, refer to "FU" section.
<Ref. to FU(H4SO)-60, REMOVAL, Fuel Sub Level Sensor.>

B: INSTALLATION

For installation procedures, refer to "FU" section.
<Ref. to FU(H4SO)-61, INSTALLATION, Fuel Sub Level Sensor.>

Fuel Tank Pressure Sensor

EMISSION CONTROL (AUX. EMISSION CONTROL DEVICES)

10. Fuel Tank Pressure Sensor

A: REMOVAL

WARNING:

Place "NO OPEN FLAMES" signs near the working area.

- 1) Set the vehicle on a lift.
- 2) Disconnect the ground cable from battery.

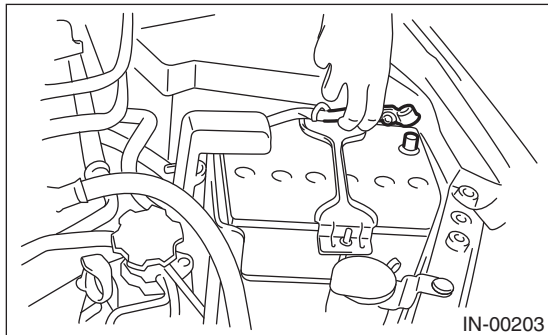

- 3) Open the fuel filler lid, and remove the fuel filler cap.
- 4) Lift up the vehicle.
- 5) Disconnect the connector from the fuel tank pressure sensor (A).
- 6) Disconnect the pressure hose from the fuel tank pressure sensor (B).
- 7) Remove the fuel tank pressure sensor along with the bracket.

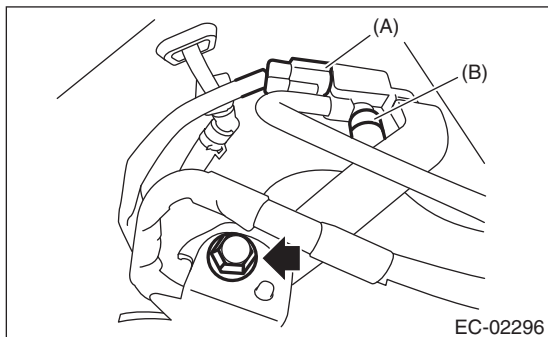

- 8) Remove the fuel tank pressure sensor from the bracket cover.

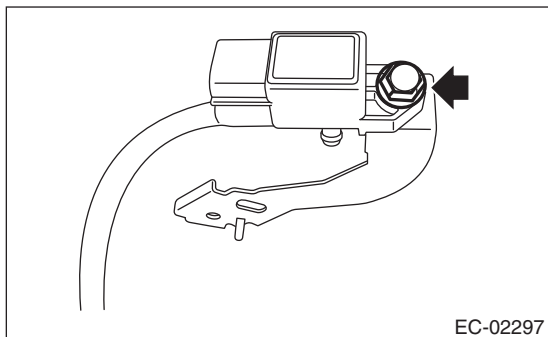

B: INSTALLATION

Install in the reverse order of removal.

Tightening torque:

7.35 N·m (0.7 kgf-m, 5.5 ft-lb)

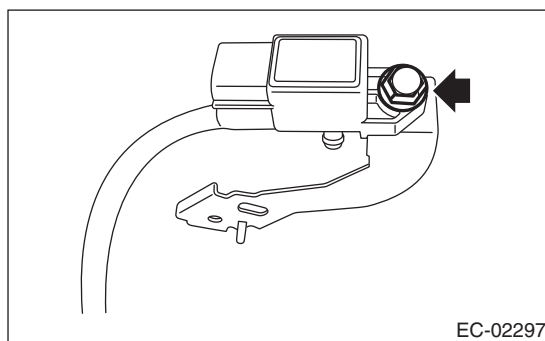
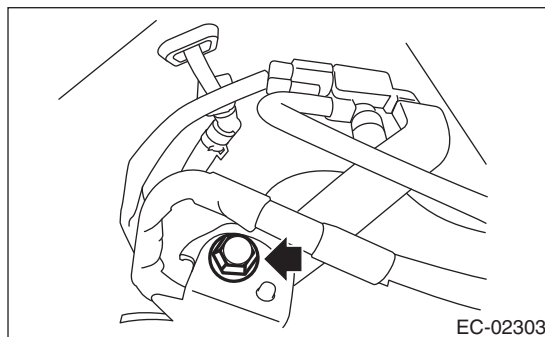

C: INSPECTION

Make sure the hoses are not cracked or loose.

Pressure Control Solenoid Valve

EMISSION CONTROL (AUX. EMISSION CONTROL DEVICES)

11. Pressure Control Solenoid Valve

A: REMOVAL

- 1) Set the vehicle on a lift.
- 2) Disconnect the ground cable from battery.

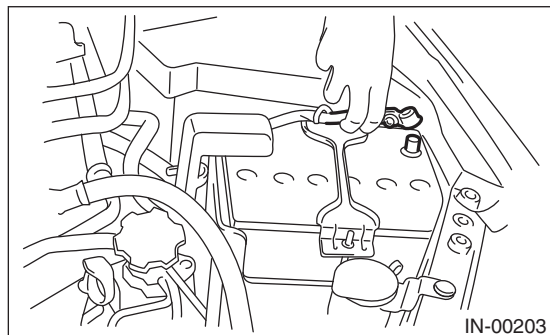

- 3) Lift up the vehicle.
- 4) Disconnect connector (A) from the pressure control solenoid valve.
- 5) Disconnect the evaporation hose (B) from the pressure control solenoid valve.
- 6) Remove the bolts (C) which secure the bracket to the fuel tank.

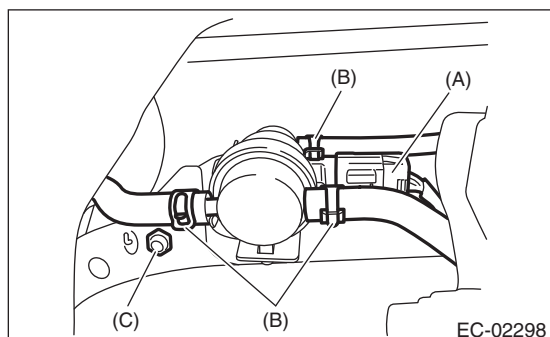

- 7) Remove the pressure control solenoid valve and bracket as a unit.
- 8) Remove the pressure control solenoid valve from the bracket.

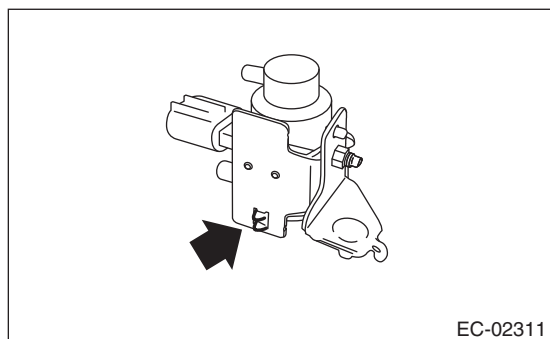

B: INSTALLATION

Install in the reverse order of removal.

Tightening torque:

7.35 N·m (0.7 kgf-m, 5.5 ft-lb)

C: INSPECTION

1. PRESSURE CONTROL SOLENOID VALVE

- 1) Check that the pressure control solenoid valve has no deformation, cracks or other damages.
- 2) Check the resistance between the pressure control solenoid valve terminals.

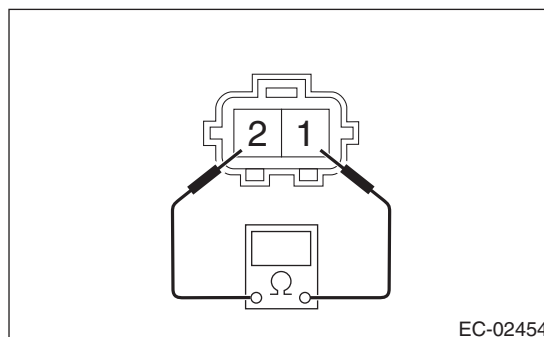

Terminal No.	Standard
1 and 2	20 — 30 Ω

- 3) Connect the Mighty Vac to fuel tank side of the pressure control solenoid valve.

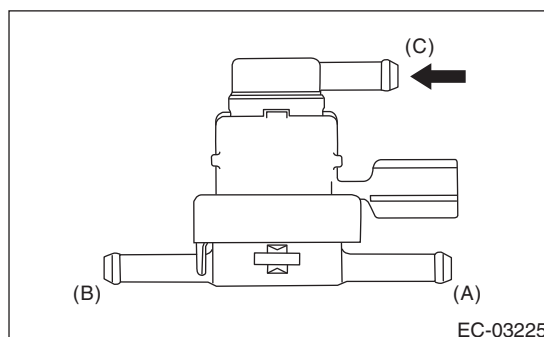

- (A) Fuel tank side
- (B) Canister side
- (C) Barometric pressure

- 4) Using the Mighty Vac, generate the positive pressure. Check that the Mighty Vac gauge needle rises at the pressure (0.55 — 1.55 kPa (0.006 — 0.016 kgf/cm², 0.08 — 0.23 psi)) then lowers.
- 5) Using the Mighty Vac, generate the negative pressure. Check that the Mighty Vac gauge needle does not rise.

2. OTHER INSPECTIONS

Check that the evaporation hose has no cracks, damage or loose part.

Drain Filter

EMISSION CONTROL (AUX. EMISSION CONTROL DEVICES)

12.Drain Filter

A: SPECIFICATION

The drain valve is a non-disassembled part, so do not remove the drain filter from drain valve.

Refer to “Canister” for removal and installation procedures. <Ref. to EC(H4SO)-5, REMOVAL, Canister.>

<Ref. to EC(H4SO)-8, INSTALLATION, Canister.>

Shut Valve

EMISSION CONTROL (AUX. EMISSION CONTROL DEVICES)

13. Shut Valve

A: REMOVAL

WARNING:

Place "NO OPEN FLAMES" signs near the working area.

CAUTION:

Be careful not to spill fuel.

- 1) Remove the fuel filler pipe.
<Ref. to FU(H4SO)-52, REMOVAL, Fuel Filler Pipe.>
- 2) Disconnect the evaporation hose from the shut valve.

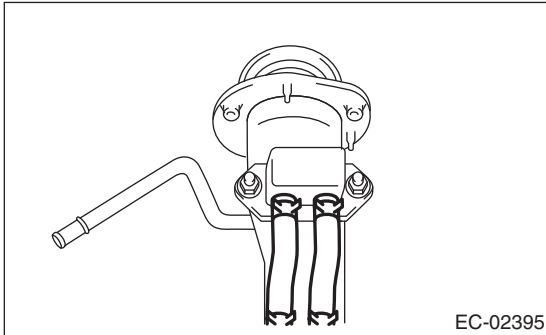

- 3) Remove the shut valve from the fuel filler pipe.

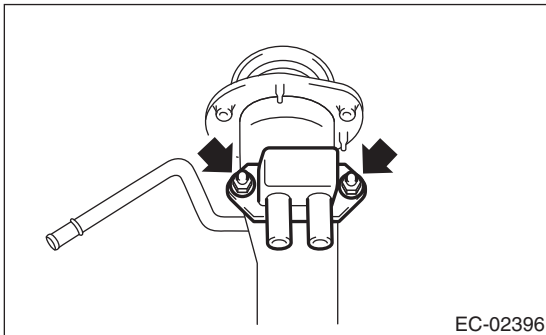

B: INSTALLATION

Install in the reverse order of removal.

Tightening torque:

4.5 N·m (0.5 kgf-m, 3.3 ft-lb)

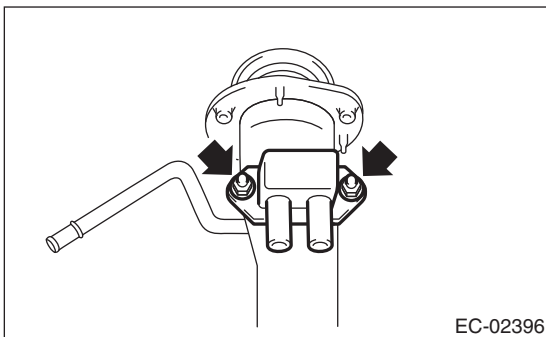

C: INSPECTION

Make sure the hoses are not cracked or loose.

Drain Valve

EMISSION CONTROL (AUX. EMISSION CONTROL DEVICES)

14.Drain Valve

A: REMOVAL

Refer to “Canister“ for removal procedures. <Ref. to EC(H4SO)-5, REMOVAL, Canister.>

B: INSTALLATION

Refer to “Canister” for installation procedures. <Ref. to EC(H4SO)-8, INSTALLATION, Canister.>

PCV Hose Assembly

EMISSION CONTROL (AUX. EMISSION CONTROL DEVICES)

15.PCV Hose Assembly

A: REMOVAL

CAUTION:

Do not remove unless the PCV hose, diagnostics connector and PCV valve are damaged.

- 1) Remove the air intake chamber. <Ref. to IN(H4SO)-7, REMOVAL, Air Intake Chamber.>
- 2) Fit the depression in the ST with the protrusion on the clamp to unlock.
- 3) Remove the PCV hose assembly.

ST 18353AA000 CLAMP PLIERS

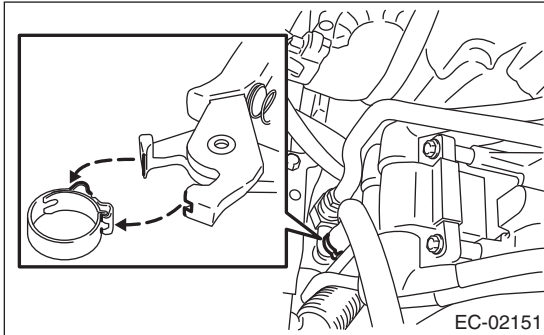

B: INSTALLATION

NOTE:

Use a new clamp.

- 1) Install the PCV hose assembly, then lock by fitting the ST on the clamp protrusion.

ST 18353AA000 CLAMP PLIERS

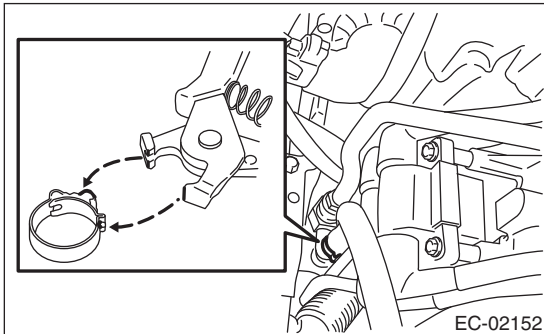

- 2) Install the air intake chamber. <Ref. to IN(H4SO)-7, INSTALLATION, Air Intake Chamber.>

PCV Hose Assembly

EMISSION CONTROL (AUX. EMISSION CONTROL DEVICES)

EC(H4SO)-20

INTAKE (INDUCTION)

IN(H4SO)

	Page
1. General Description	2
2. Air Cleaner Element	4
3. Air Cleaner Case	5
4. Air Intake Chamber	7
5. Air Intake Duct	8
6. Resonator Chamber	9

General Description

INTAKE (INDUCTION)

1. General Description

A: COMPONENT

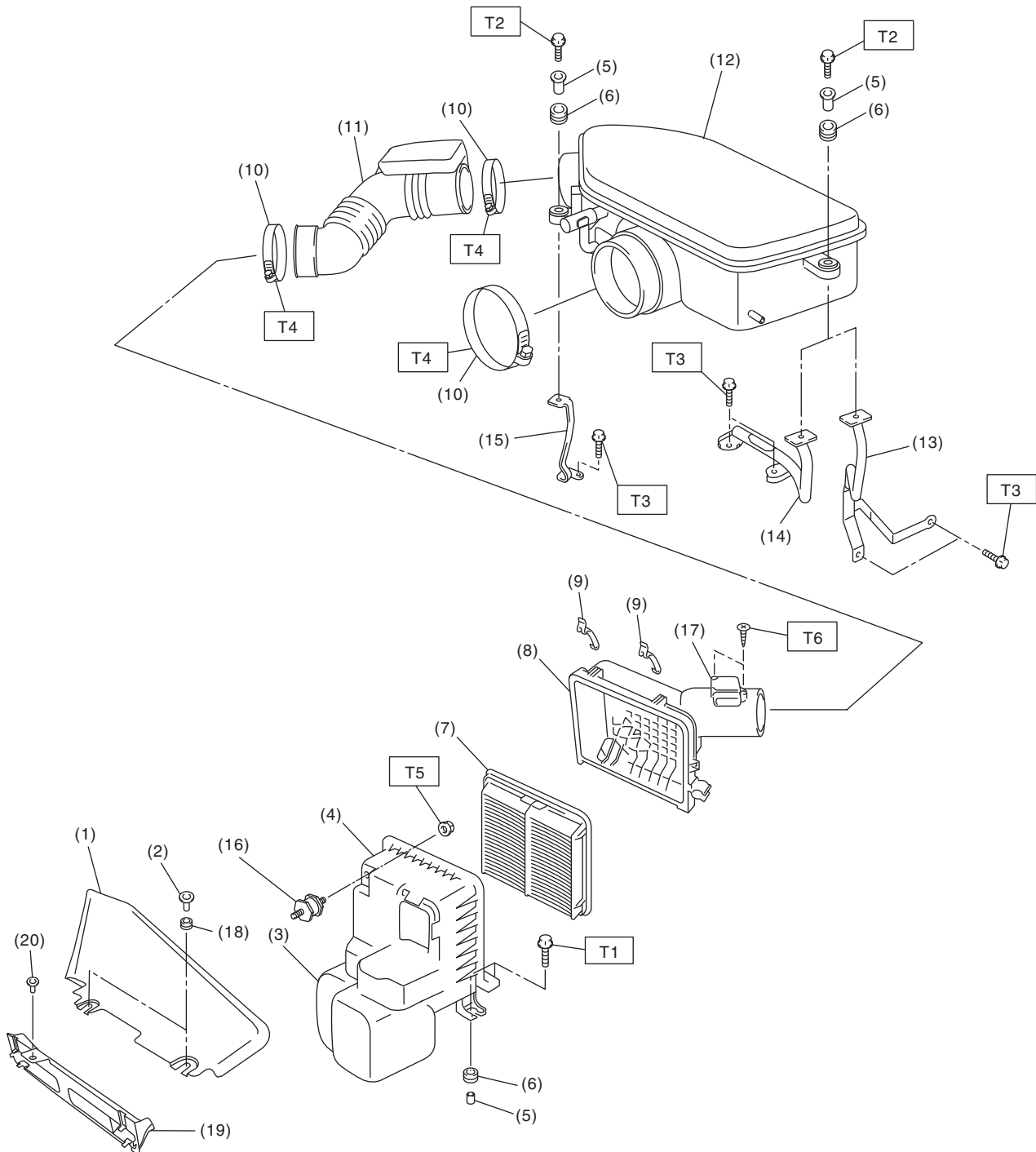

IN-02469

IN(H4SO)-2

General Description

INTAKE (INDUCTION)

(1) Air intake duct (rear)	(11) Intake boot	(20) Clip
(2) Clip	(12) Air intake chamber	
(3) Resonator chamber	(13) Stay LH (MT model)	
(4) Air cleaner case (front)	(14) Stay LH (AT model)	
(5) Spacer	(15) Stay RH	
(6) Cushion	(16) Cushion	
(7) Air cleaner element	(17) Mass air flow and intake air temperature sensor	
(8) Air cleaner case (rear)	(18) Cushion	
(9) Clip	(19) Air intake duct (front)	
(10) Clamp		

Tightening torque:N·m (kgf·m, ft·lb)

T1: 6 (0.6, 4.4)

T2: 6.5 (0.7, 4.8)

T3: 16 (1.6, 11.8)

T4: 3 (0.3, 2.2)

T5: 7.5 (0.8, 5.5)

T6: 1 (0.1, 0.7)

B: CAUTION

- Wear appropriate work clothing, including a cap, protective goggles and protective shoes when performing any work.
- Remove contamination including dirt and corrosion before removal, installation or disassembly.
- Keep the disassembled parts in order and protect them from dust and dirt.
- Before removal, installation or disassembly, be sure to clarify the failure. Avoid unnecessary removal, installation, disassembly and replacement.
- Vehicle components are extremely hot after driving. Be wary of receiving burns from heated parts.
- Be sure to tighten fasteners including bolts and nuts to the specified torque.
- Place shop jacks or rigid racks at the specified points.
- Before disconnecting connectors of sensors or units, be sure to disconnect the ground cable from the battery.

Air Cleaner Element

INTAKE (INDUCTION)

2. Air Cleaner Element

A: REMOVAL

1) Disconnect the ground cable from battery.

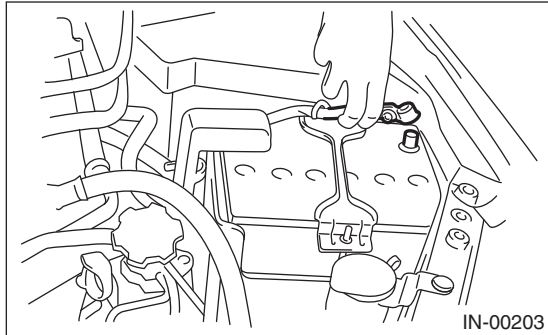

2) Disconnect the connector (A) from the mass air flow and intake air temperature sensor and remove the clip (B).

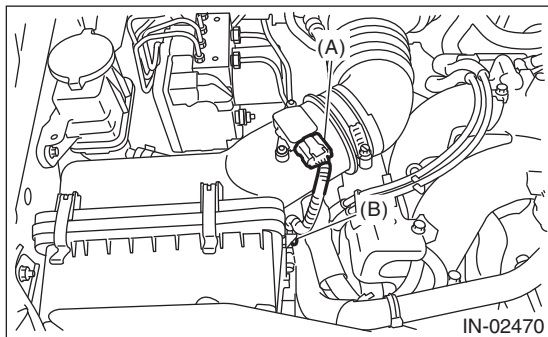

3) Loosen the clamps (A) which connect the air cleaner case and the intake boot.

4) Remove the clip (B) securing the upper side of air cleaner case.

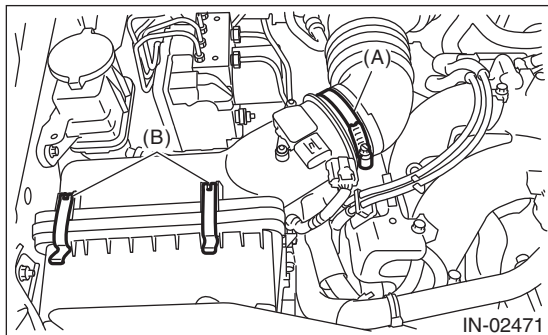

5) Remove the air cleaner case (rear) and air cleaner element.

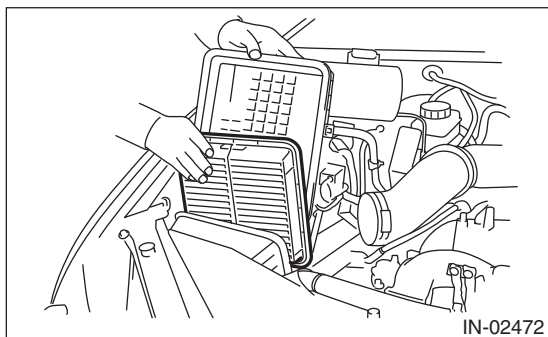

B: INSTALLATION

Install in the reverse order of removal.

CAUTION:

Be sure to use **SUBARU** genuine air cleaner element depending on the engine type when replacing the air cleaner elements. Otherwise engine performance may be damaged.

NOTE:

- Make sure there is no foreign material in the air cleaner case.
- When installing the air cleaner case (rear), align the protrusion of the air cleaner case (rear) to the hole on the air cleaner case (front) to install.

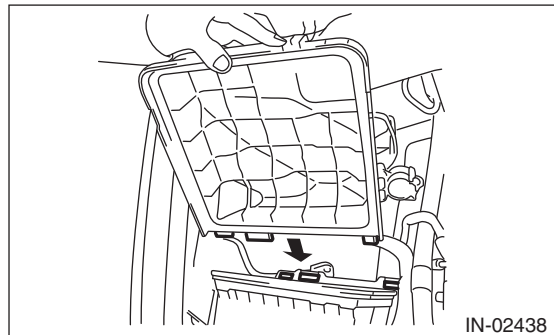

Tightening torque:

Clamp (A)

3 N·m (0.3 kgf-m, 2.2 ft-lb)

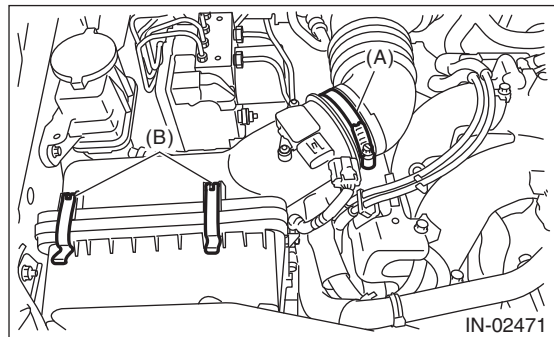

C: INSPECTION

- 1) Replace if excessively damaged or dirty.
- 2) Replace the air cleaner case (rear) when the HC adsorption filter is damaged. (U5 model)

3. Air Cleaner Case

A: REMOVAL

1) Disconnect the ground cable from the battery.

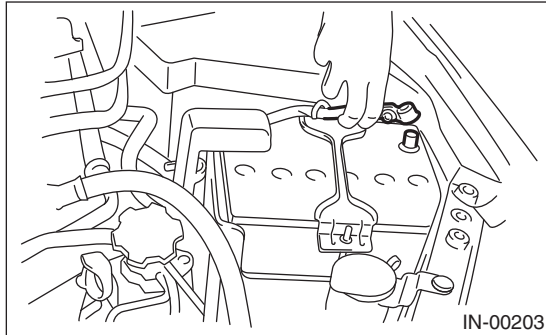

2) Disconnect the connector (A) from the mass air flow and intake air temperature sensor and remove the clip (B).

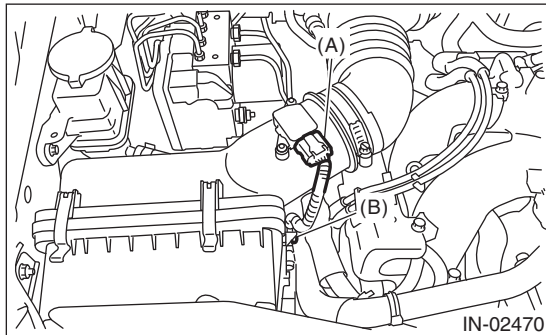

3) Loosen the clamps (A) which connect the air cleaner case and the intake boot.

4) Remove the clip (B) securing the upper side of air cleaner case.

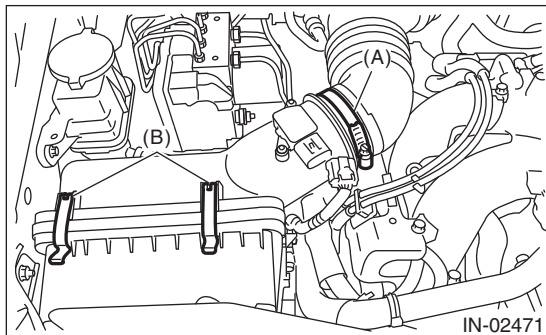

5) Remove the air cleaner case (rear) and air cleaner element.

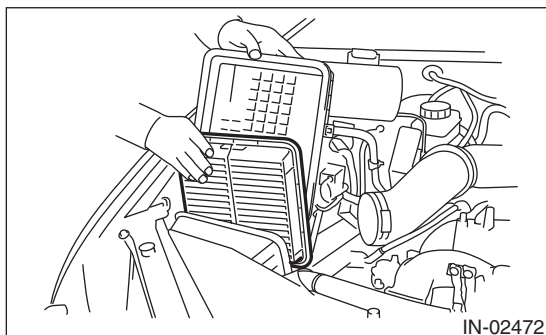

6) Remove the air intake duct (rear). <Ref. to IN(H4SO)-8, REMOVAL, Air Intake Duct.>

7) Remove the bolts (A) and nut (B) which secure the air cleaner case to body.

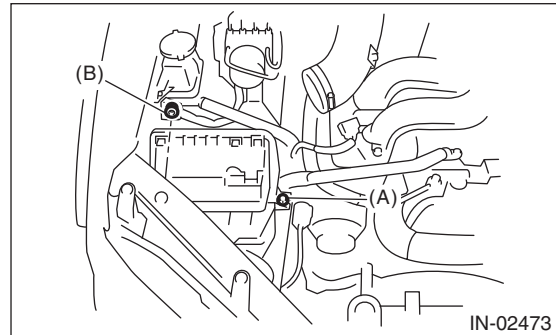

8) Remove the air cleaner case (front).

Air Cleaner Case

INTAKE (INDUCTION)

B: INSTALLATION

Install in the reverse order of removal.

Tightening torque:

Bolt (A)

6 N·m (0.6 kgf-m, 4.4 ft-lb)

NUT (B)

7.5 N·m (0.8 kgf-m, 5.5 ft-lb)

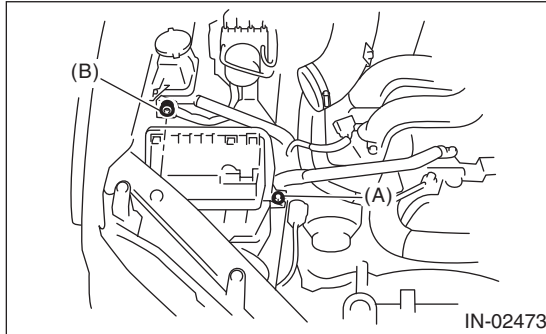

NOTE:

When installing the air cleaner case (rear), align the protrusion of the air cleaner case (rear) to the hole on the air cleaner case (front) to install.

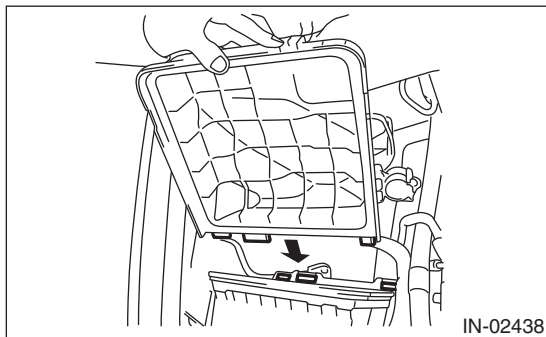

Tightening torque:

Clamp (A)

3 N·m (0.3 kgf-m, 2.2 ft-lb)

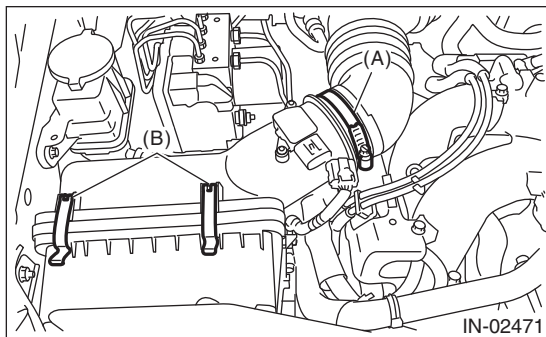

C: INSPECTION

Check for cracks or loose connections.

4. Air Intake Chamber

A: REMOVAL

- 1) Loosen the clamp (A) which connects air intake chamber to throttle body.
- 2) Loosen the clamp (B) which connects intake boot to air intake chamber.
- 3) Remove the bolt (C) which secures air intake chamber to the stay.
- 4) Disconnect the connector (D).

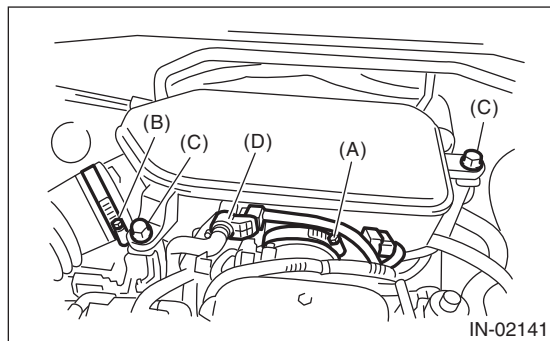

- 5) Disconnect the blow-by hoses, and then remove air intake chamber.

B: INSTALLATION

Install in the reverse order of removal.

Tightening torque:

Clamp (A), (B)

3 N·m (0.3 kgf·m, 2.2 ft·lb)

Bolt (C)

6.5 N·m (0.7 kgf·m, 4.8 ft·lb)

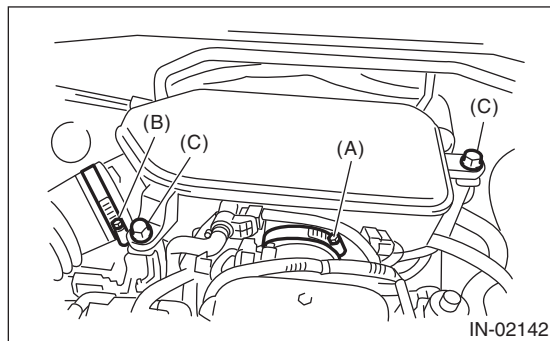

C: INSPECTION

- 1) Check for cracks or loose connections.
- 2) Inspect that no foreign objects are mixed in the air intake chamber.

Air Intake Duct

INTAKE (INDUCTION)

5. Air Intake Duct

A: REMOVAL

- 1) Remove the clip which installs the air intake duct (rear) on the front side of body.
- 2) Remove the air intake duct (rear).

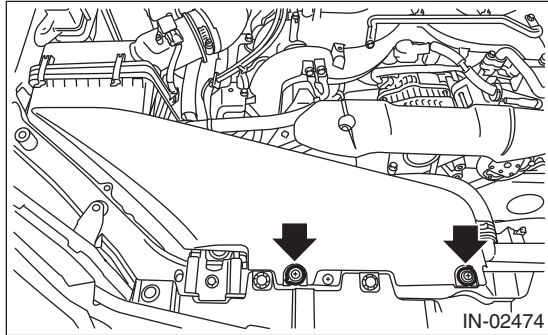

- 3) Remove the clip (A) and four claws and then remove the air intake duct (front).

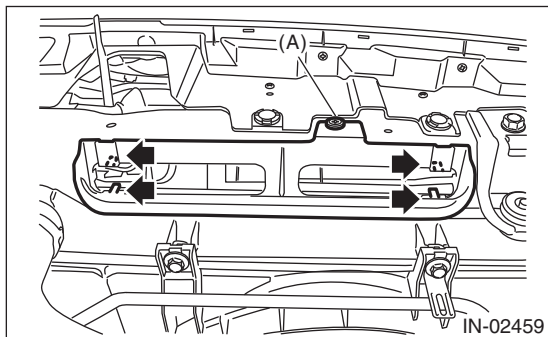

B: INSTALLATION

Install in the reverse order of removal.

C: INSPECTION

- 1) Check for cracks or clip damage.
- 2) Check that no foreign matter is mixed in air intake duct.

6. Resonator Chamber

A: REMOVAL

The resonator chamber and air cleaner case are integrated into one unit; therefore, refer to “Air Cleaner Case” for the removal procedure. <Ref. to IN(H4SO)-5, REMOVAL, Air Cleaner Case.>

B: INSTALLATION

The resonator chamber and air cleaner case are integrated into one unit; therefore, refer to “Air Cleaner Case” for installation procedure. <Ref. to IN(H4SO)-6, INSTALLATION, Air Cleaner Case.>

C: INSPECTION

Check for cracks or loose connections.

Resonator Chamber

INTAKE (INDUCTION)

IN(H4SO)-10

MECHANICAL

ME(H4SO)

	Page
1. General Description	2
2. Compression	23
3. Idle Speed	24
4. Ignition Timing	25
5. Intake Manifold Vacuum	26
6. Engine Oil Pressure	27
7. Fuel Pressure	28
8. Valve Clearance	29
9. Engine Assembly	32
10. Engine Mounting	40
11. Preparation for Overhaul	41
12. V-belt	42
13. Crank Pulley	50
14. Timing Belt Cover	52
15. Timing Belt	53
16. Cam Sprocket	59
17. Crank Sprocket	61
18. Valve Rocker Assembly	62
19. Camshaft	66
20. Cylinder Head	71
21. Cylinder Block	81
22. Oil Switching Solenoid Valve	104
23. Intake and Exhaust Valve	107
24. Piston	108
25. Connecting Rod	109
26. Crankshaft	110
27. Engine Trouble in General	111
28. Engine Noise	117

General Description

MECHANICAL

1. General Description

A: SPECIFICATION

Engine	Model		2.5 L		
	Cylinder arrangement		Horizontally opposed, liquid cooled, 4-cylinder, 4-stroke gasoline engine		
	Valve system mechanism		Belt driven Single overhead camshaft 4 valve/cylinder		
	Bore x Stroke		mm (in) 99.5 x 79.0 (3.917 x 3.110)		
	Piston displacement		cm ³ (cu in) 2,457 (150)		
	Compression ratio		10.0		
	Compression pressure (at 200 — 300 rpm)		kPa (kg/cm ² , psi) 1,020 — 1,275 (10.4 — 13.0, 148 — 185)		
	Number of piston rings		Pressure ring: 2, Oil ring: 1		
	Intake valve timing		Constant	Open	BTDC 0°
				Close	ABDC 58°
			Low speed	Open	BTDC 0°
				Close	ABDC -10°
			High speed	Open	BTDC 14°
				Close	ABDC 62°
	Exhaust valve timing		Open	BBDC 30°	
			Close	ATDC 14°	
	Valve clearance		mm (in)	Intake	0.20±0.04 (0.0079±0.0016)
				Exhaust	0.25±0.04 (0.0098±0.0016)
	Idling speed [at neutral position on MT, or "P" or "N" position on AT]		rpm	MT	650±100 (No load) 850±100 (A/C ON)
				AT	700±100 (No load) 850±100 (A/C ON)
Ignition order			1 → 3 → 2 → 4		
Ignition timing		BTDC/rpm	MT	10°±8°/650	
			AT	15°±10°/700	

General Description

MECHANICAL

NOTE:

US: Undersize OS: Oversize

Belt tension adjuster	Protrusion of adjuster rod		mm (in)	5.2 — 6.2 (0.205 — 0.244)		
Valve rocker arm	Clearance between shaft and arm	mm (in)	Standard	0.020 — 0.054 (0.0008 — 0.0021)		
Camshaft	Bending limit		mm (in)	0.025 (0.00098)		
	Thrust clearance		mm (in)	Standard	0.030 — 0.090 (0.0012 — 0.0035)	
	Cam lobe height	mm (in)	Intake	Constant	Standard	40.075 — 40.175 (1.5778 — 1.5817)
				Low speed	Standard	35.496 — 35.596 (1.3975 — 1.4014)
			High speed	Standard	40.315 — 40.415 (1.5872 — 1.5911)	
	Exhaust			Standard	39.289 — 39.389 (1.5468 — 1.5507)	
	Camshaft journal O.D.		mm (in)		31.928 — 31.945 (1.2570 — 1.2577)	
	Camshaft journal hole I.D.		mm (in)		32.000 — 32.018 (1.2598 — 1.2605)	
Oil clearance		mm (in)	Standard	0.055 — 0.090 (0.0022 — 0.0035)		
Cylinder head	Surface warpage limit (Mating surface with cylinder block)		mm (in)	0.035 (0.0014)		
	Grinding limit		mm (in)	0.1 (0.004)		
	Standard height		mm (in)	97.5 (3.84)		
Valve seat	Seating angle			90°		
	Contacting width	mm (in)	Intake	Standard	0.8 — 1.4 (0.03 — 0.055)	
Exhaust			Standard	1.2 — 1.8 (0.047 — 0.071)		
Valve guide	Inside diameter		mm (in)	6.000 — 6.012 (0.2362 — 0.2367)		
	Protrusion above head		mm (in)	Intake 20.0 — 21.0 (0.787 — 0.827) Exhaust 16.5 — 17.5 (0.650 — 0.689)		
Valve	Head edge thickness	mm (in)	Intake	Standard	0.8 — 1.2 (0.03 — 0.047)	
			Exhaust	Standard	1.0 — 1.4 (0.039 — 0.055)	
	Stem outer diameter	mm (in)	Intake		5.950 — 5.965 (0.2343 — 0.2348)	
			Exhaust		5.945 — 5.960 (0.2341 — 0.2346)	
	Valve stem gap	mm (in)	Standard	Intake		0.035 — 0.062 (0.0014 — 0.0024)
				Exhaust		0.040 — 0.067 (0.0016 — 0.0026)
Overall length		mm (in)	Intake 120.6 (4.75) Exhaust 121.7 (4.79)			
Valve spring	Free length		mm (in)	55.2 (2.173)		
	Squareness			2.5°, 2.4 (0.094) or less		
	Tension/spring height	N (kgf, lb)/mm (in)	Set		235.3 — 270.7 (24 — 27.6, 52.9 — 60.8)/45.0 (1.772)	
Lift				578.9 — 639.9 (59.1 — 65.3, 130.3 — 143.9)/34.7 (1.366)		
Cylinder block	Surface warpage limit (mating with cylinder head)		mm (in)	0.025 (0.00098)		
	Grinding limit		mm (in)	0.1 (0.004)		
	Standard height		mm (in)	201.0 (7.91)		
	Cylinder inner diameter	mm (in)	Standard	A	99.505 — 99.515 (3.9175 — 3.9179)	
				B	99.495 — 99.505 (3.9171 — 3.9175)	
	Taper		mm (in)	Standard	0.015 (0.0006)	
	Out-of-roundness		mm (in)	Standard	0.010 (0.0004)	
	Piston clearance		mm (in)	Standard	-0.010 — 0.010 (-0.00039 — 0.00039)	
Cylinder inner diameter boring limit (diameter)		mm (in)		To 100.005 (3.9372)		
Piston	Outer diameter	mm (in)	Standard	A	99.505 — 99.515 (3.9175 — 3.9179)	
				B	99.495 — 99.505 (3.9171 — 3.9175)	
			0.25 (0.0098) OS			99.745 — 99.765 (3.9270 — 3.9278)
			0.50 (0.0197) OS			99.995 — 100.015 (3.9368 — 3.9376)

General Description

MECHANICAL

Piston pin	Clearance between piston and piston pin:		mm (in)	Standard	0.004 — 0.008 (0.0002 — 0.0003)	
	Degree of fit				Piston pin can be fitted into position with thumb at 20°C (68°F).	
Piston ring	Ring closed gap	mm (in)	Top ring	Standard	0.20 — 0.35 (0.0079 — 0.0138)	
			Second ring	Standard	0.37 — 0.52 (0.0144 — 0.0203)	
			Oil ring	Standard	0.20 — 0.50 (0.0079 — 0.0197)	
	Ring groove gap	mm (in)	Top ring	Standard	0.040 — 0.080 (0.0016 — 0.0031)	
			Second ring	Standard	0.030 — 0.070 (0.0012 — 0.0028)	
Connecting rod	Bend or twist per 100 mm (3.94 in) in length		mm (in)	Limit	0.10 (0.0039)	
	Thrust clearance		mm (in)	Standard	0.070 — 0.330 (0.0028 — 0.0130)	
Bearing of large end	Oil clearance		mm (in)	Standard	0.016 — 0.044 (0.00063 — 0.0017)	
	Bearing size (Thickness at center)	mm (in)	Standard		1.492 — 1.501 (0.0587 — 0.0591)	
			0.03 (0.0012) US		1.510 — 1.513 (0.0594 — 0.0596)	
			0.05 (0.0020) US		1.520 — 1.523 (0.0598 — 0.0600)	
			0.25 (0.0098) US		1.620 — 1.623 (0.0638 — 0.0639)	
Bushing of small end	Clearance between piston pin and bushing		mm (in)	Standard	0 — 0.022 (0 — 0.0009)	
Crankshaft	Bend limit		mm (in)		0.035 (0.0014)	
	Crank pin	Out-of-roundness		mm (in)	0.003 (0.0001)	
		Cylindricity		mm (in)	0.004 (0.0002)	
		Grinding limit (dia.)		mm (in)	To 51.750 (2.0374)	
	Crank journal	Out-of-roundness		mm (in)	0.005 (0.0002)	
		Cylindricity		mm (in)	0.006 (0.0002)	
		Grinding limit (dia.)		mm (in)	To 59.758 (2.3527)	
	Crank pin outer diameter	mm (in)	Standard		51.984 — 52.000 (2.0466 — 2.0472)	
			0.03 (0.0012) US		51.954 — 51.970 (2.0454 — 2.0461)	
			0.05 (0.0020) US		51.934 — 51.950 (2.0446 — 2.0453)	
			0.25 (0.0098) US		51.734 — 51.750 (2.0368 — 2.0374)	
	Crank journal outer diameter	mm (in)	Standard		59.992 — 60.008 (2.3619 — 2.3625)	
			0.03 (0.0012) US		59.962 — 59.978 (2.3607 — 2.3613)	
			0.05 (0.0020) US		59.942 — 59.958 (2.3599 — 2.3605)	
0.25 (0.0098) US			59.742 — 59.758 (2.3520 — 2.3527)			
Thrust clearance		mm (in)	Standard	0.030 — 0.115 (0.0012 — 0.0045)		
Oil clearance		mm (in)	Standard	0.010 — 0.030 (0.0001 — 0.0012)		
Main bearing	Main bearing	mm (in)	#1, #3	Standard		1.998 — 2.011 (0.0787 — 0.0792)
				0.03 (0.0012) US		2.017 — 2.020 (0.0794 — 0.0795)
				0.05 (0.0020) US		2.027 — 2.030 (0.0798 — 0.0799)
				0.25 (0.0098) US		2.127 — 2.130 (0.0837 — 0.0839)
	#2, #4, #5	Standard		2.000 — 2.013 (0.0787 — 0.0793)		
		0.03 (0.0012) US		2.019 — 2.022 (0.0795 — 0.0796)		
		0.05 (0.0020) US		2.029 — 2.032 (0.0799 — 0.0800)		
		0.25 (0.0098) US		2.129 — 2.132 (0.0838 — 0.0839)		

B: COMPONENT

1. TIMING BELT

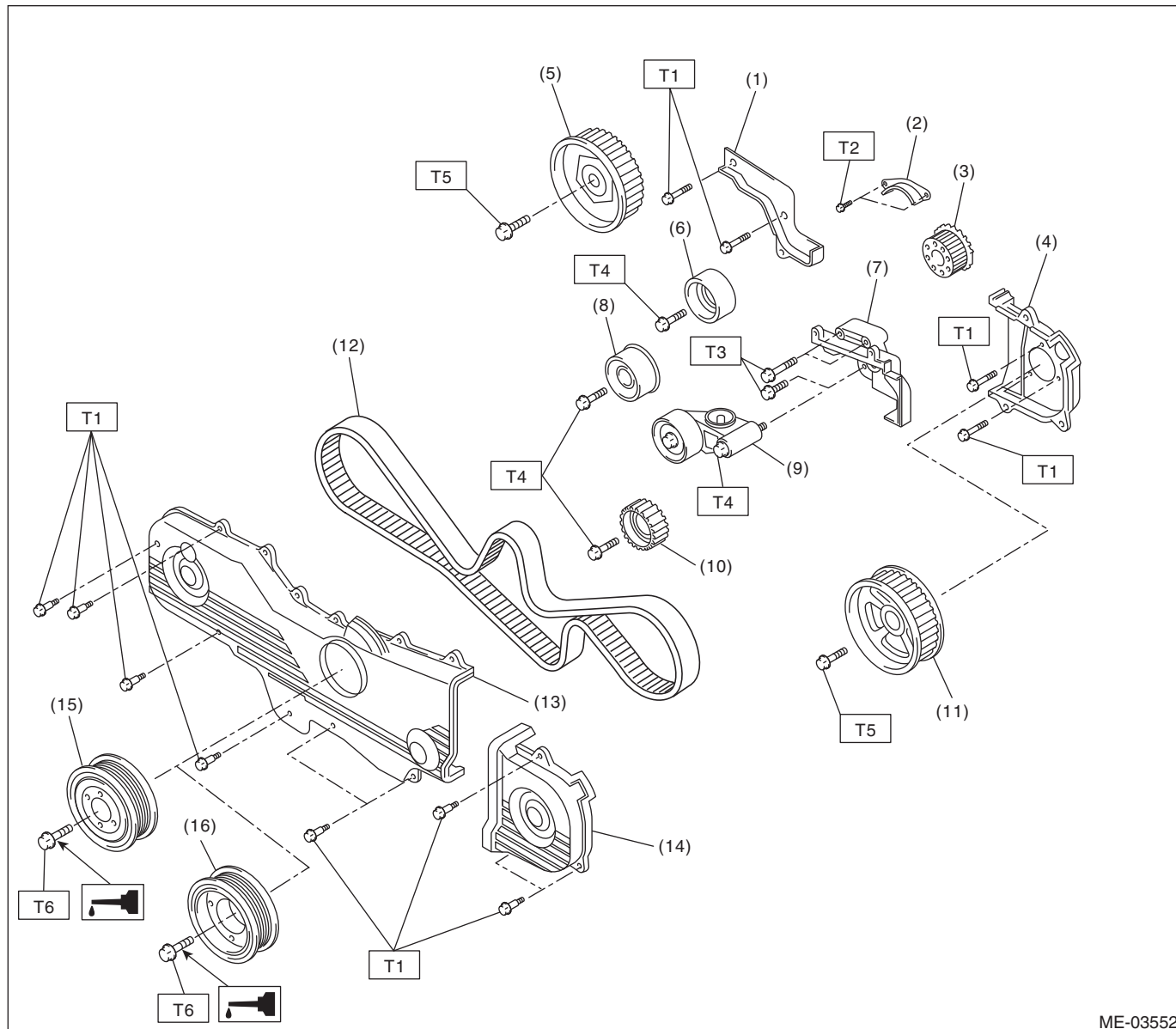

ME-03552

- | | |
|--|------------------------------|
| (1) Timing belt cover No. 2 RH | (10) Belt idler No. 2 |
| (2) Timing belt guide (MT model) | (11) Cam sprocket No. 2 |
| (3) Crank sprocket | (12) Timing belt |
| (4) Timing belt cover No. 2 LH | (13) Front timing belt cover |
| (5) Cam sprocket No. 1 | (14) Timing belt cover LH |
| (6) Belt idler (No. 1) | (15) Crank pulley (MT model) |
| (7) Tensioner bracket | (16) Crank pulley (AT model) |
| (8) Belt idler (No. 2) | |
| (9) Automatic belt tension adjuster ASSY | |

Tightening torque: N·m (kgf·m, ft·lb)

T1: 5 (0.5, 3.7)

T2: 9.75 (1.0, 7.2)

T3: 24.5 (2.5, 18.1)

T4: 39 (4.0, 28.8)

T5: 78 (8.0, 57.5)

T6: <Ref. to ME(H4SO)-50, INSTALLATION, Crank Pulley.>

General Description

MECHANICAL

2. CYLINDER HEAD AND CAMSHAFT

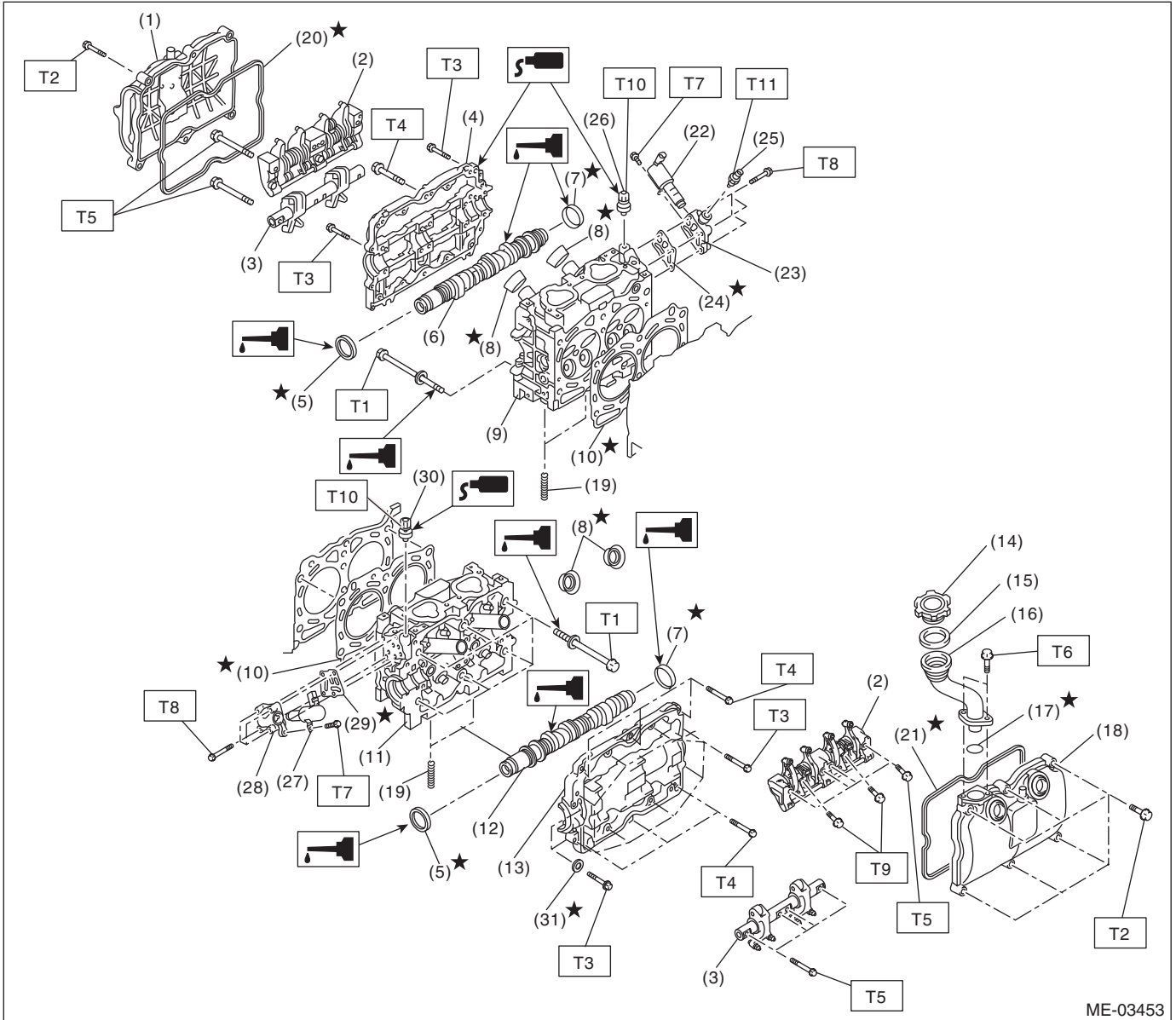

General Description

MECHANICAL

(1) Rocker cover RH	(18) Rocker cover LH	(31) Seal washer
(2) Intake valve rocker assembly	(19) Stud bolt	
(3) Exhaust valve rocker assembly	(20) Rocker cover gasket RH	<i>Tightening torque:N·m (kgf-m, ft-lb)</i>
(4) Camshaft cap RH	(21) Rocker cover gasket LH	<i>T1: <Ref. to ME(H4SO)-72, INSTALLATION, Cylinder Head.></i>
(5) Oil seal	(22) Oil switching solenoid valve RH	<i>T2: <Ref. to ME(H4SO)-63, INSTALLATION, Valve Rocker Assembly.></i>
(6) Camshaft RH	(23) Oil switching solenoid valve holder RH	<i>T3: 9.75 (1.0, 7.2)</i>
(7) Plug	(24) Gasket	<i>T4: 18 (1.8, 13.3)</i>
(8) Spark plug pipe gasket	(25) Oil temperature sensor	<i>T5: 25 (2.5, 18.4)</i>
(9) Cylinder head RH	(26) Variable valve lift diagnosis oil pressure switch RH	<i>T6: 6.4 (0.7, 4.7)</i>
(10) Cylinder head gasket	(27) Oil switching solenoid valve LH	<i>T7: 8 (0.8, 5.9)</i>
(11) Cylinder head LH	(28) Oil switching solenoid valve holder LH	<i>T8: 10 (1.0, 7.4)</i>
(12) Camshaft LH	(29) Gasket	<i>T9: 6 (0.6, 4.4)</i>
(13) Camshaft cap LH	(30) Variable valve lift diagnosis oil pressure switch LH	<i>T10: 17 (1.7, 12.5)</i>
(14) Oil filler cap		<i>T11: 18 (1.8, 13.3)</i>
(15) Gasket		
(16) Oil filler duct		
(17) O-ring		

General Description

MECHANICAL

3. VALVE ROCKER ASSEMBLY

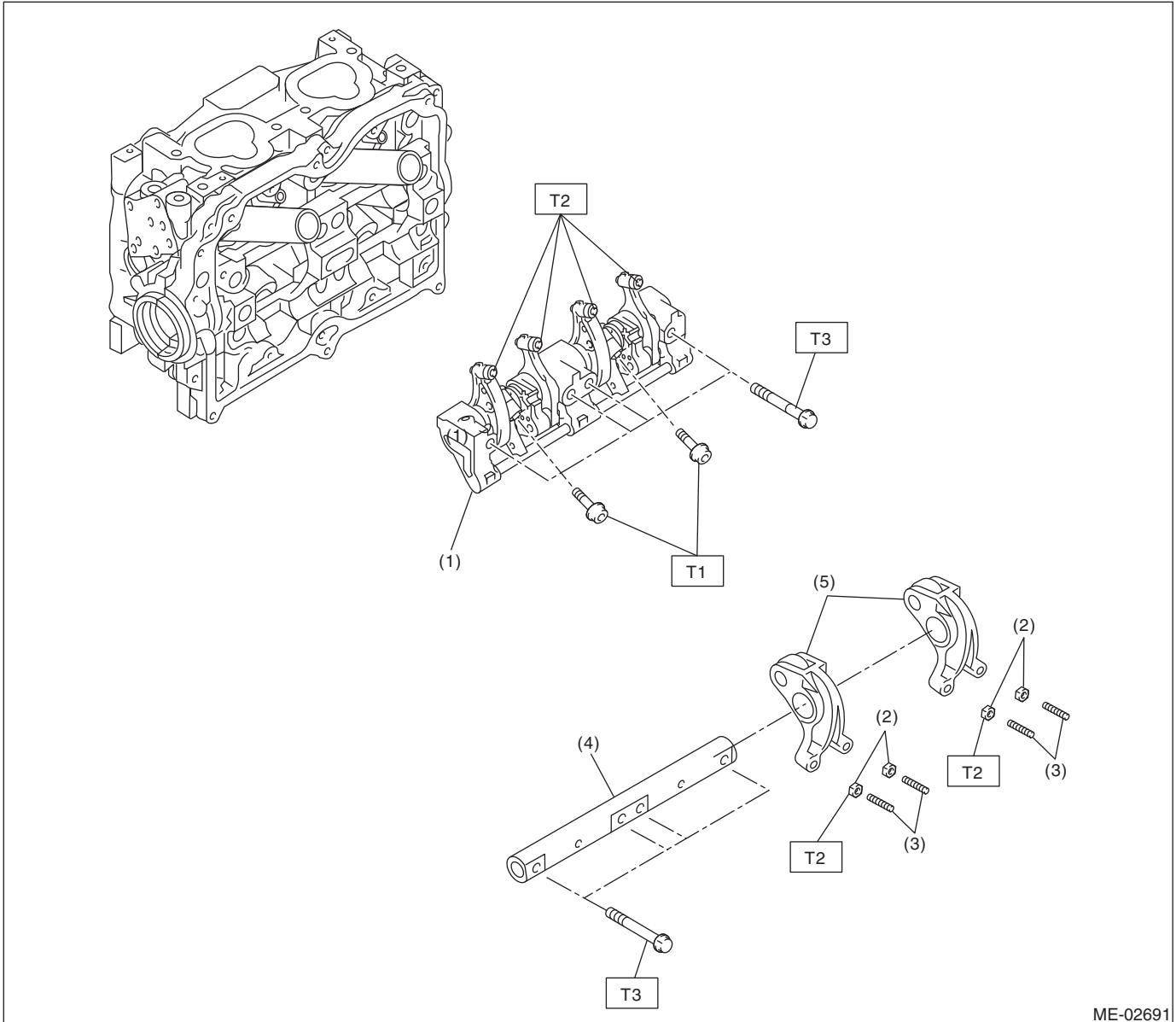

ME-02691

- | | |
|----------------------------------|------------------------------|
| (1) Intake valve rocker arm ASSY | (4) Exhaust rocker shaft |
| (2) Valve rocker nut | (5) Exhaust valve rocker arm |
| (3) Valve rocker adjusting screw | |

Tightening torque: N·m (kgf·m, ft·lb)

T1: 6 (0.6, 4.3)

T2: 9.75 (1.0, 7.2)

T3: 25 (2.5, 18.4)

4. CYLINDER HEAD AND VALVE ASSEMBLY

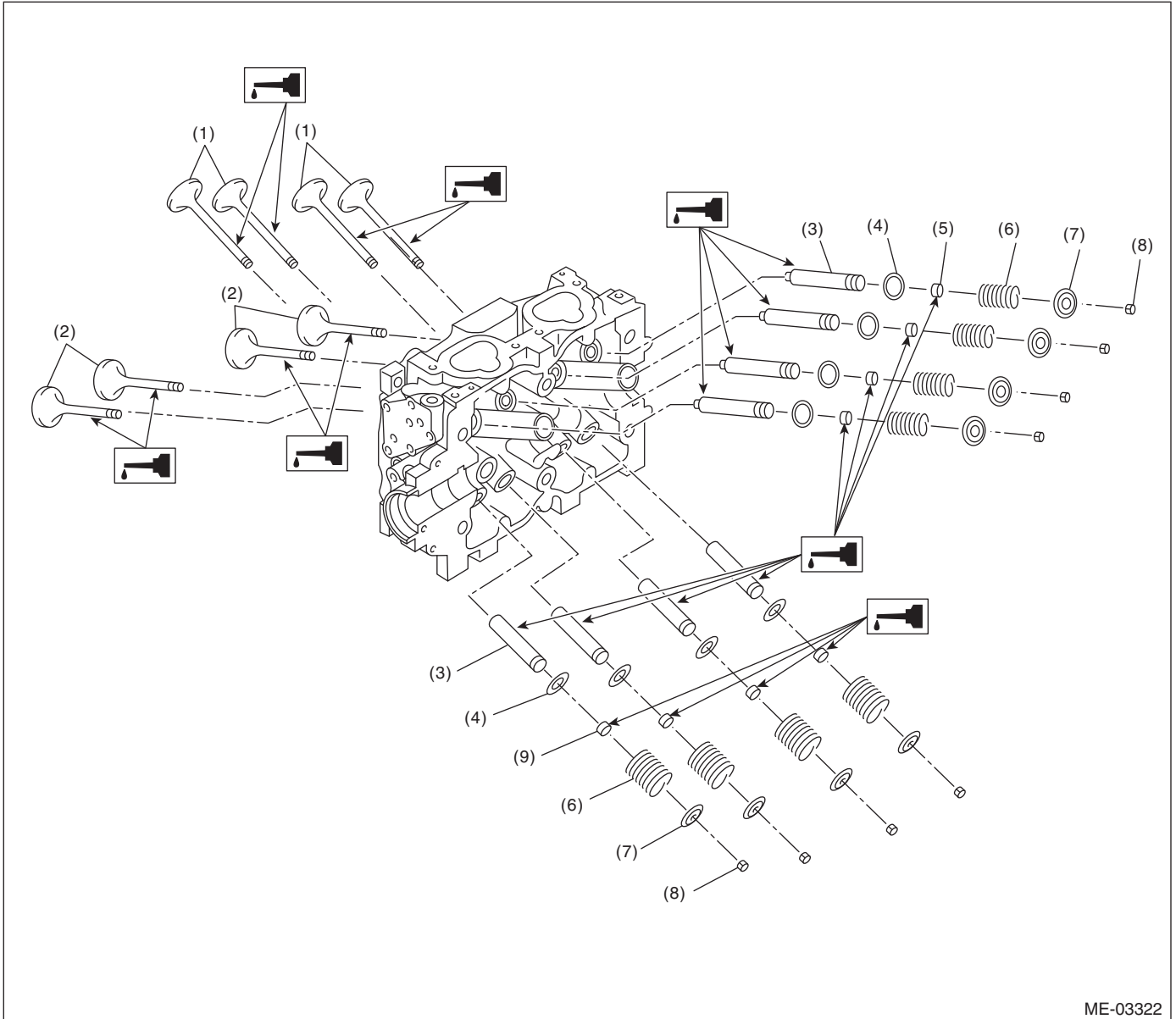

ME-03322

- | | | |
|-------------------|---------------------------|----------------------------|
| (1) Exhaust valve | (4) Valve spring seat | (7) Retainer |
| (2) Intake valve | (5) Intake valve oil seal | (8) Retainer key |
| (3) Valve guide | (6) Valve spring | (9) Exhaust valve oil seal |

General Description

MECHANICAL

5. CYLINDER BLOCK

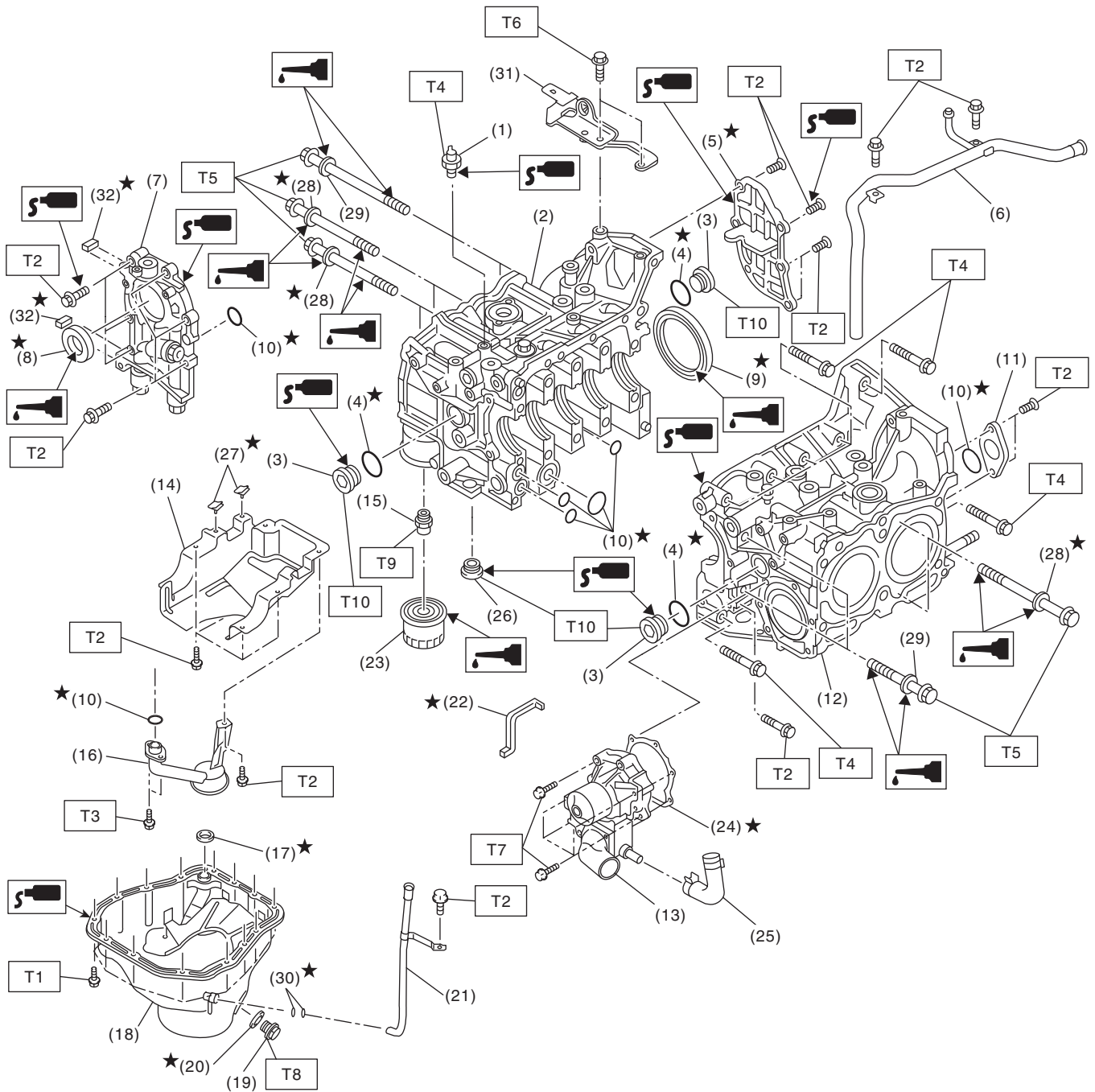

ME-03563

ME(H4SO)-10

General Description

MECHANICAL

(1) Oil pressure switch	(17) Gasket	(32) Oil pump seal
(2) Cylinder block RH	(18) Oil pan	
(3) Service hole plug	(19) Drain plug	
(4) Gasket	(20) Drain plug gasket	<hr/> Tightening torque:N·m (kgf-m, ft-lb)
(5) Oil separator cover	(21) Oil level gauge guide	T1: 5 (0.5, 3.7)
(6) Water by-pass pipe	(22) Water pump sealing	T2: 6.4 (0.7, 4.7)
(7) Oil pump	(23) Oil filter	T3: 10 (1.0, 7.4)
(8) Front oil seal	(24) Gasket	T4: 25 (2.5, 18.4)
(9) Rear oil seal	(25) Water pump hose	T5: <Ref. to ME(H4SO)-85, INSTAL-
(10) O-ring	(26) Plug	LATION, Cylinder Block.>
(11) Service hole cover	(27) Seal	T6: 16 (1.6, 11.8)
(12) Cylinder block LH	(28) Seal washer	T7: First 12 (1.2, 8.9)
(13) Water pump	(29) Washer	Second 12 (1.2, 8.9)
(14) Baffle plate	(30) O-ring	T8: 44 (4.5, 32.5)
(15) Oil filter connector	(31) Engine rear hanger	T9: 45 (4.6, 33.2)
(16) Oil strainer		<hr/> T10: 70 (7.1, 51.6)

General Description

MECHANICAL

6. CRANKSHAFT AND PISTON

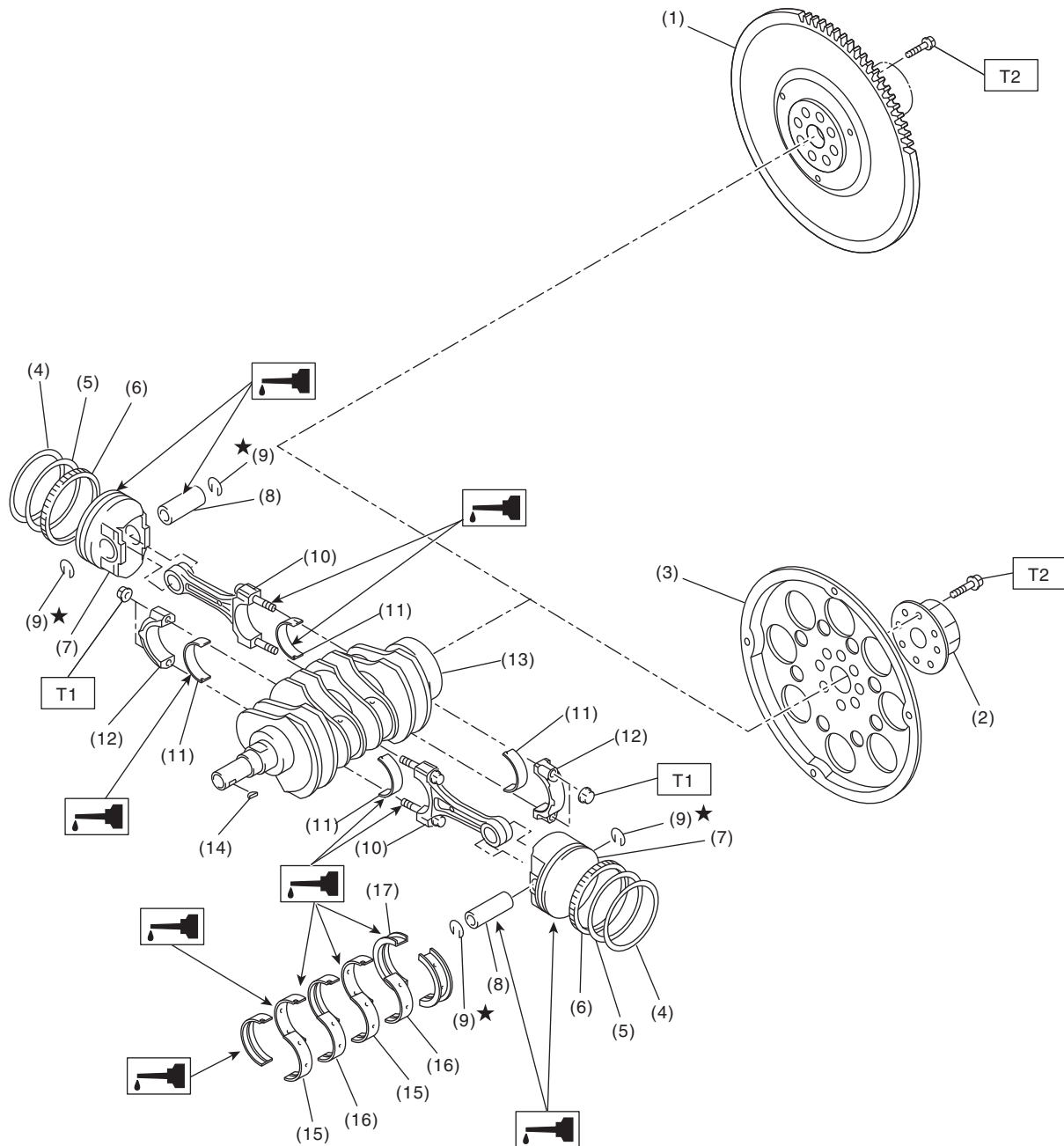

ME-03292

- | | | |
|------------------------------|-----------------------------|--------------------------------|
| (1) Flywheel (MT model) | (8) Piston pin | (15) Crankshaft bearing #1, #3 |
| (2) Reinforcement (AT model) | (9) Snap ring | (16) Crankshaft bearing #2, #4 |
| (3) Drive plate (AT model) | (10) Connecting rod | (17) Crankshaft bearing #5 |
| (4) Top ring | (11) Connecting rod bearing | |
| (5) Second ring | (12) Connecting rod cap | |
| (6) Oil ring | (13) Crankshaft | |
| (7) Piston | (14) Woodruff key | |

Tightening torque: N·m (kgf·m, ft·lb)

T1: 45 (4.6, 33.2)

T2: 72 (7.3, 53.1)

ME(H4SO)-12

7. ENGINE MOUNTING

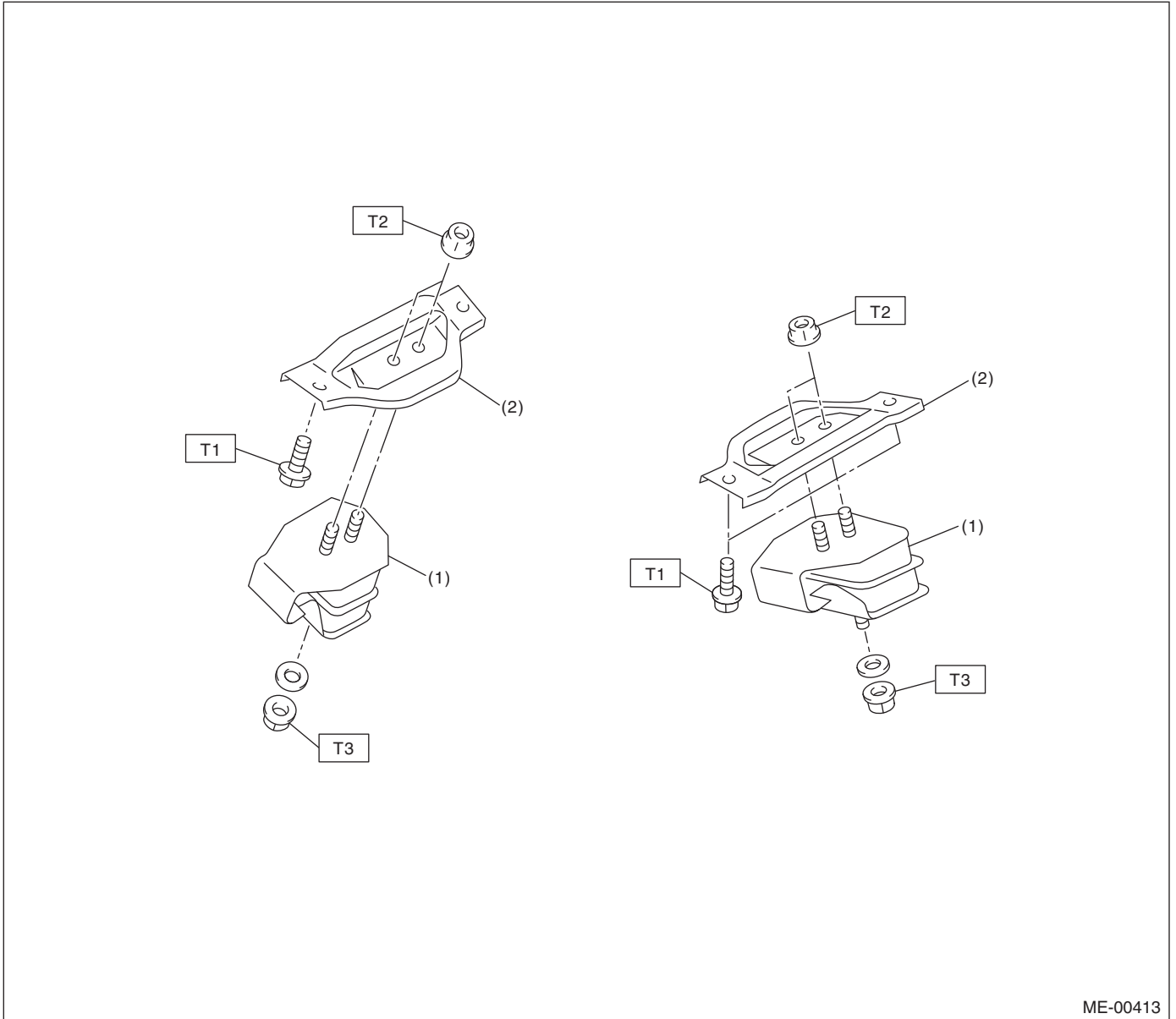

ME-00413

(1) Front cushion rubber

(2) Front engine mounting bracket

Tightening torque: N·m (kgf·m, ft·lb)

T1: 35 (3.6, 25.8)

T2: 42 (4.3, 31.0)

T3: 85 (8.7, 62.7)

General Description

MECHANICAL

C: CAUTION

- Wear appropriate work clothing, including a cap, protective goggles and protective shoes when performing any work.
- Remove contamination including dirt and corrosion before removal, installation or disassembly.
- Keep the disassembled parts in order and protect them from dust and dirt.
- Before removal, installation or disassembly, be sure to clarify the failure. Avoid unnecessary removal, installation, disassembly and replacement.
- Vehicle components are extremely hot after driving. Be wary of receiving burns from heated parts.
- Be sure to tighten fasteners including bolts and nuts to the specified torque.
- Place shop jacks or rigid racks at the specified points.
- Before disconnecting connectors of sensors or units, be sure to disconnect the ground cable from the battery.
- All parts should be thoroughly cleaned, paying special attention to engine oil passages, pistons and bearings.
- Rotating parts and sliding parts such as piston, bearing and gear should be coated with oil prior to assembly.
- Be careful not to let oil, grease or coolant contact the timing belt, clutch disc and flywheel.
- All removed parts, if to be reused, should be reinstalled in the original positions and directions.
- Bolts, nuts and washers should be replaced with new parts as required.
- Even if necessary inspections have been made in advance, proceed with assembly work while making rechecks.
- Remove or install the engine in an area where chain hoists, lifting devices, etc. are available for ready use.
- Be sure not to damage coated surfaces of body panels with tools, or not to stain seats and windows with coolant or oil. Place a cover over fender, as required, for protection.
- Prior to starting work, prepare the following:
Service tools, clean cloth, containers to catch coolant and oil, wire ropes, chain hoist, transmission jacks, etc.
- Lift up or lower the vehicle when necessary. Make sure to support the correct positions.

D: PREPARATION TOOL

1. SPECIAL TOOL

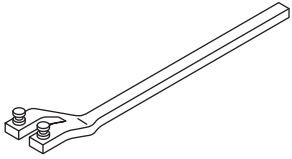
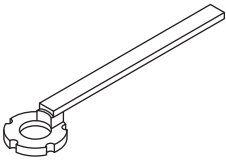
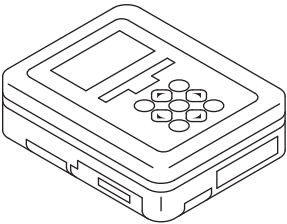
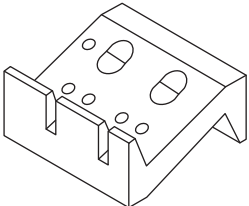
ILLUSTRATION	TOOL NUMBER	DESCRIPTION	REMARKS
 <p style="text-align: center;">ST18231AA010</p>	18231AA010	CAM SPROCKET WRENCH	<ul style="list-style-type: none"> • Used for removing and installing cam sprocket LH. • CAMSHAFT SPROCKET WRENCH (499207100) can also be used.
 <p style="text-align: center;">ST-499207400</p>	499207400	CAM SPROCKET WRENCH	Used for removing and installing cam sprocket RH.
 <p style="text-align: center;">ST1B022XU0</p>	1B022XU0 (Newly adopted tool)	SUBARU SELECT MONITOR III KIT	Used for troubleshooting for electrical system.
 <p style="text-align: center;">ST-498267800</p>	498267800	CYLINDER HEAD TABLE	<ul style="list-style-type: none"> • Used for replacing valve guides. • Used for removing and installing valve spring.

General Description

MECHANICAL

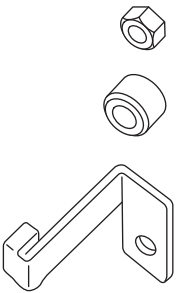
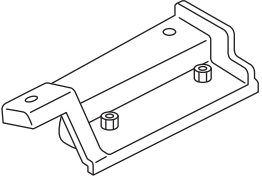
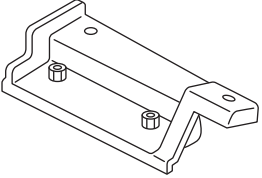
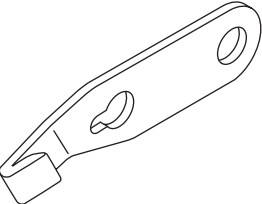
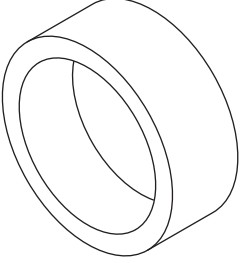
ILLUSTRATION	TOOL NUMBER	DESCRIPTION	REMARKS
 <p style="text-align: center;">ST-498277200</p>	498277200	STOPPER SET	Used for installing automatic transmission assembly to engine.
 <p style="text-align: center;">ST-498457000</p>	498457000	ENGINE STAND ADAPTER RH	Used together with the ENGINE STAND (499817100).
 <p style="text-align: center;">ST-498457100</p>	498457100	ENGINE STAND ADAPTER LH	Used together with the ENGINE STAND (499817100).
 <p style="text-align: center;">ST-498497100</p>	498497100	CRANKSHAFT STOPPER	Used for removing and installing the flywheel and the drive plate.
 <p style="text-align: center;">ST-498747300</p>	498747300	PISTON GUIDE	Used for installing piston in cylinder.

General Description

MECHANICAL

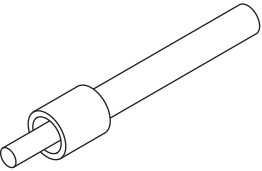
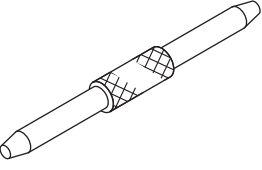
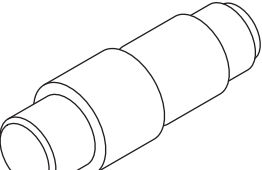
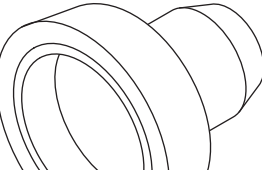
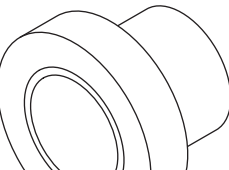
ILLUSTRATION	TOOL NUMBER	DESCRIPTION	REMARKS
 <p style="text-align: center;">ST-498857100</p>	498857100	VALVE OIL SEAL GUIDE	Used for press-fitting of intake and exhaust valve guide oil seals.
 <p style="text-align: center;">ST-499017100</p>	499017100	PISTON PIN GUIDE	Used for installing piston pin, piston and connecting rod.
 <p style="text-align: center;">ST-499037100</p>	499037100	CONNECTING ROD BUSHING REMOVER & INSTALLER	Used for removing and installing connecting rod bushing.
 <p style="text-align: center;">ST-499587200</p>	499587200	CRANKSHAFT OIL SEAL INSTALLER	<ul style="list-style-type: none"> • Used for installing crankshaft oil seal. • Used together with the CRANKSHAFT OIL SEAL GUIDE (499597100).
 <p style="text-align: center;">ST-499587500</p>	499587500	OIL SEAL INSTALLER	<ul style="list-style-type: none"> • Used for installing the camshaft oil seal. • Used together with the OIL SEAL GUIDE (499597000).

General Description

MECHANICAL

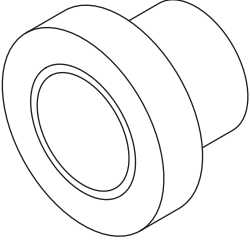
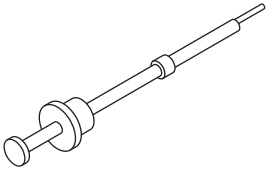
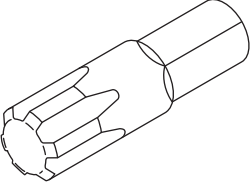
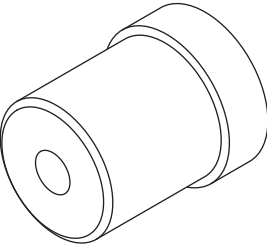
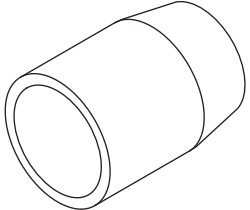
ILLUSTRATION	TOOL NUMBER	DESCRIPTION	REMARKS
 <p style="text-align: center;">ST-499587700</p>	499587700	CAMSHAFT OIL SEAL INSTALLER	Used for installing cylinder head plug.
 <p style="text-align: center;">ST-499097700</p>	499097700	PISTON PIN REMOVER ASSY	Used for removing piston pin.
 <p style="text-align: center;">ST-499497000</p>	499497000	TORX PLUS [®]	Used for removing and installing camshaft cap.
 <p style="text-align: center;">ST-499587100</p>	499587100	OIL SEAL INSTALLER	Used for installing oil pump oil seal.
 <p style="text-align: center;">ST-499597000</p>	499597000	OIL SEAL GUIDE	<ul style="list-style-type: none"> • Used for installing the camshaft oil seal. • Used together with the OIL SEAL INSTALLER (499587500).

General Description

MECHANICAL

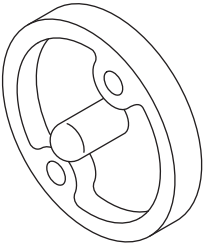
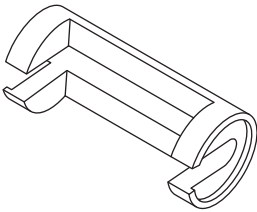
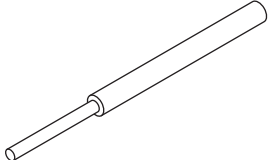
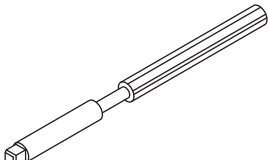
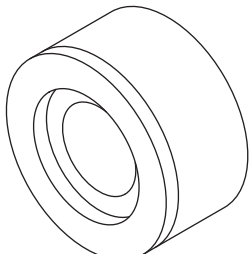
ILLUSTRATION	TOOL NUMBER	DESCRIPTION	REMARKS
 <p data-bbox="337 520 467 541">ST-499597100</p>	499597100	CRANKSHAFT OIL SEAL GUIDE	<ul style="list-style-type: none"> • Used for installing crankshaft oil seal. • Used together with the CRANKSHAFT OIL SEAL INSTALLER (499587200).
 <p data-bbox="337 871 467 892">ST-499718000</p>	499718000	VALVE SPRING REMOVER	Used for removing and installing valve spring.
 <p data-bbox="337 1222 467 1243">ST-499767200</p>	499767200	VALVE GUIDE REMOVER	Used for removing valve guides.
 <p data-bbox="337 1572 467 1593">ST-499767400</p>	499767400	VALVE GUIDE REAMER	Used for reaming valve guides.
 <p data-bbox="337 1923 467 1944">ST-499767700</p>	499767700	VALVE GUIDE ADJUSTER	Used for installing valve guides. (Intake side)

General Description

MECHANICAL

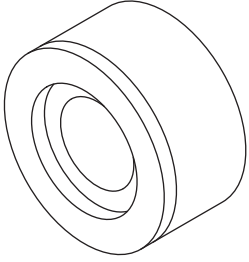
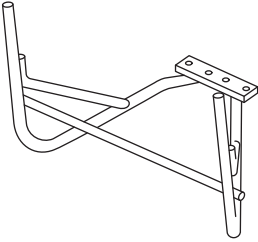
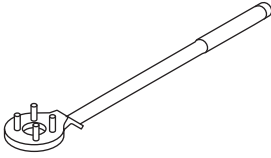
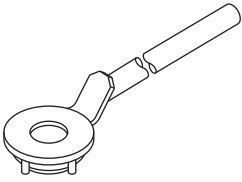
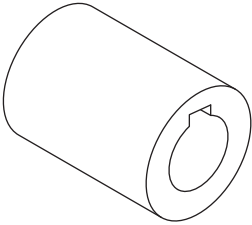
ILLUSTRATION	TOOL NUMBER	DESCRIPTION	REMARKS
 <p style="text-align: center;">ST-499767800</p>	499767800	VALVE GUIDE ADJUSTER	Used for installing valve guides. (Exhaust side)
 <p style="text-align: center;">ST-499817100</p>	499817100	ENGINE STAND	<ul style="list-style-type: none"> • Stand used for engine disassembly and assembly. • Used together with the ENGINE STAND ADAPTER RH (498457000) & LH (498457100).
 <p style="text-align: center;">ST-499977100</p>	499977100	CRANK PULLEY WRENCH	Used to stop rotation of the crank pulley when loosening or tightening crank pulley bolts. (MT model)
 <p style="text-align: center;">ST-499977400</p>	499977400	CRANK PULLEY WRENCH	Used to stop rotation of the crank pulley when loosening or tightening crank pulley bolts. (AT model)
 <p style="text-align: center;">ST-499987500</p>	499987500	CRANKSHAFT SOCKET	Used for rotating crankshaft.

General Description

MECHANICAL

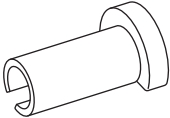
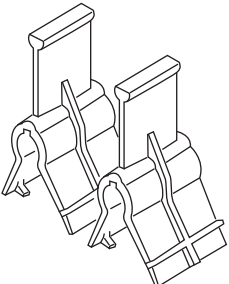
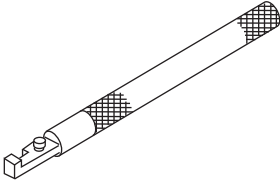
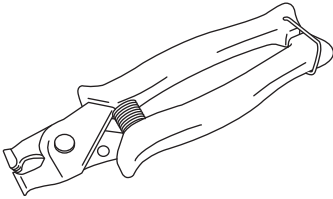
ILLUSTRATION	TOOL NUMBER	DESCRIPTION	REMARKS
 <p>ST42099AE000</p>	42099AE000	QUICK CONNECTOR RELEASE	Used for removing the quick connector.
 <p>ST18354AA000</p>	18354AA000	VALVE ROCKER HOLDER	Used for installing the valve rocker assembly (intake). (2-piece set)
 <p>ST18258AA000</p>	18258AA000	SPRING INSTALLER	Used for installing the valve rocker assembly (intake).
 <p>ST18353AA000</p>	18353AA000	CLAMP PLIERS	<ul style="list-style-type: none"> Used for removing and installing the PCV hose. This is a general tool made by the French company CAILLAU. (code) 54.0.000.205 To make this easier to obtain in the same way as genuine Subaru parts, it has been provided with a tool number as an ST.

2. GENERAL TOOL

TOOL NAME	REMARKS
Compression gauge	Used for measuring compression.
Vacuum gauge	Used for measuring vacuum pressure.
Oil pressure gauge	Used for measuring engine oil pressure.
Fuel pressure gauge	Used for measuring fuel pressure.
Timing light	Used for measuring ignition timing.

General Description

MECHANICAL

E: PROCEDURE

It is possible to conduct the following service procedures with engine on vehicle, however, the procedures described in this section are based on the condition that the engine is removed from vehicle.

- V-belt
- Timing belt
- Valve rocker assembly
- Camshaft
- Cylinder head

2. Compression

A: INSPECTION

CAUTION:

After warming-up, engine becomes very hot. Be careful not to burn yourself during measurement.

- 1) After warming-up the engine, turn the ignition switch to OFF.
- 2) Make sure that the battery is fully charged.
- 3) Release the fuel pressure.
<Ref. to FU(H4SO)-43, RELEASING OF FUEL PRESSURE, PROCEDURE, Fuel.>
- 4) Remove all the spark plugs. <Ref. to IG(H4SO)-4, REMOVAL, Spark Plug.>
- 5) Fully open the throttle valve.
- 6) Check the starter motor for satisfactory performance and operation.
- 7) Hold the compression gauge tightly against the spark plug hole.

NOTE:

When using a screw-in type compression gauge, the screw should be less than 18 mm (0.71 in) long.

- 8) Crank the engine by the starter motor, and read the maximum value on the gauge when the needle of gauge is steady.

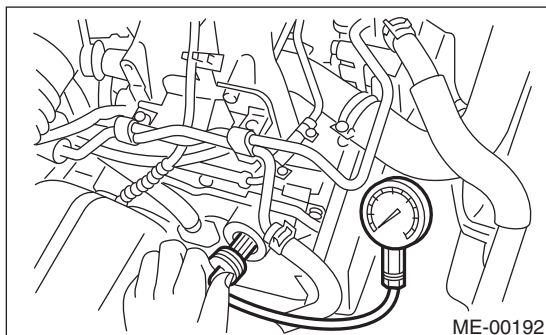

- 9) Perform at least two measurements per cylinder, and check that the values are correct.

Compression (Fully open throttle):

Standard

**1,020 — 1,275 kPa (10.4 — 13.0 kgf/cm²,
148 — 185 psi)**

Difference between cylinders

49 kPa (0.5 kgf/cm², 7 psi), or less

- 10) After inspection, install the related parts in the reverse order of removal.

3. Idle Speed

A: INSPECTION

1) Before checking the idle speed, check the following item:

(1) Check the air cleaner element is free from clogging, ignition timing is correct, spark plugs are in good condition, and hoses are connected properly.

(2) Check the malfunction indicator light does not illuminate.

2) Warm-up the engine.

3) Read the engine idle speed using Subaru Select Monitor. <Ref. to EN(H4SO)(diag)-34, READ CURRENT DATA FOR ENGINE (NORMAL MODE), OPERATION, Subaru Select Monitor.>

4) Check the idle speed when no-loaded. (Headlight, heater fan, rear defroster, radiator fan, A/C and etc. are OFF)

Idle speed [No load and gears in neutral, "P" or "N" range]:

650±100 rpm (MT model)

700±100 rpm (AT model)

5) Check the idle speed under load condition. (Turn the A/C switch to "ON" and operate the compressor for at least one minute before measurement.)

Idle speed [A/C ON and gears in neutral, "P" or "N" range]:

850±100 rpm

NOTE:

Idle speed cannot be adjusted manually, because the idle speed is automatically adjusted. If the specified idle speed cannot be maintained, refer to the General On-board Diagnosis Table under "Engine Control System". <Ref. to EN(H4SO)(diag)-2, Basic Diagnostic Procedure.>

4. Ignition Timing

A: INSPECTION

1) Before checking the ignition timing, check the following item:

(1) Check the air cleaner element is free from clogging, spark plugs are in good condition, and hoses are connected properly.

(2) Check the malfunction indicator light does not illuminate.

2) Warm-up the engine.

3) Stop the engine, and turn the ignition switch to OFF.

4) Connect the timing light to #1 cylinder spark plug cord, and then light the timing mark with the timing light.

5) Start the engine and check the ignition timing at idle speed as shown below.

Ignition timing [BTDC/rpm]:

$10^{\circ} \pm 8^{\circ} / 650$ (MT Model)

$15^{\circ} \pm 10^{\circ} / 700$ (AT Model)

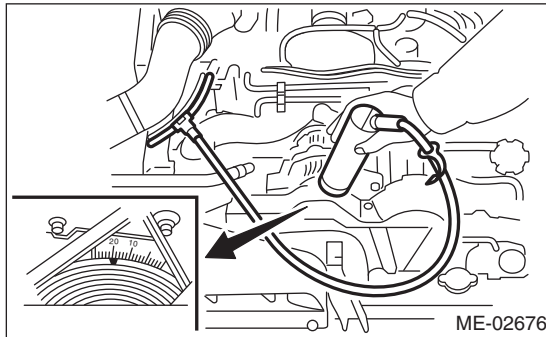

If the timing is not correct, check the ignition control system. <Ref. to EN(H4SO)(diag)-2, Basic Diagnostic Procedure.>

Intake Manifold Vacuum

MECHANICAL

5. Intake Manifold Vacuum

A: INSPECTION

- 1) Warm-up the engine.
- 2) Disconnect the brake vacuum hose from intake manifold, and then install the vacuum gauge.
- 3) Keep the engine at idle speed and read the vacuum gauge indication.

By observing the gauge needle movement, the internal condition of the engine can be diagnosed as described below.

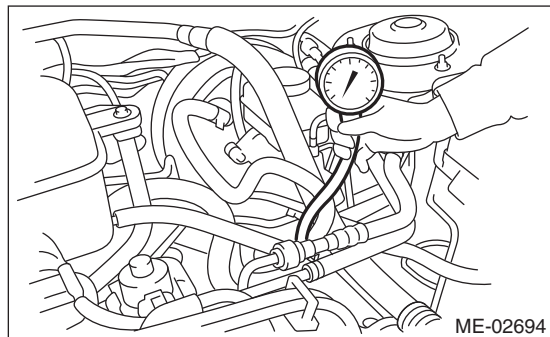

Vacuum pressure (at idling, A/C "OFF"):
-60.0 kPa (-450 mmHg, -17.72 inHg) or more

Diagnosis of engine condition by measurement of intake manifold vacuum	
Vacuum gauge indication	Possible engine condition
1. Needle is steady but lower than normal position. This tendency becomes more evident as engine temperature rises.	Air leakage around intake manifold gasket, disconnection or damage of vacuum hose
2. Needle intermittently drops to position lower than normal position.	Leakage around cylinder
3. Needle drops suddenly and intermittently from normal position.	Sticky valve
4. When engine speed is gradually increased, needle begins to vibrate rapidly at certain speed, and then vibration increases as engine speed increases.	Weak or broken valve springs
5. Needle vibrates above and below normal position in narrow range.	Defective ignition system

6. Engine Oil Pressure

A: INSPECTION

- 1) Disconnect the ground cable from the battery.

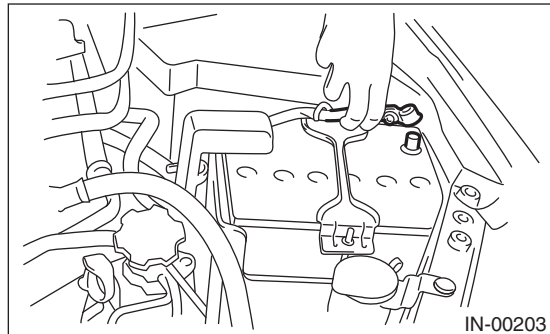

- 2) Remove the oil pressure switch. <Ref. to LU(H4SO)-18, REMOVAL, Oil Pressure Switch.>
- 3) Connect the oil pressure gauge to cylinder block.
- 4) Connect the ground cable to battery.

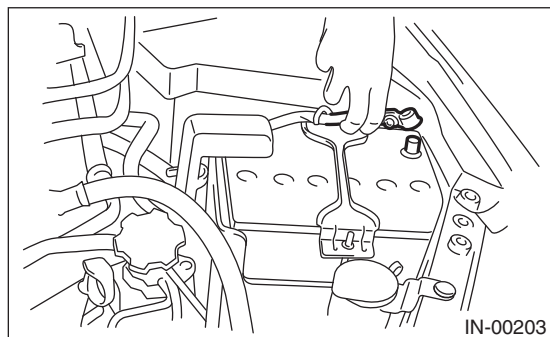

- 5) Start the engine, and measure the oil pressure.

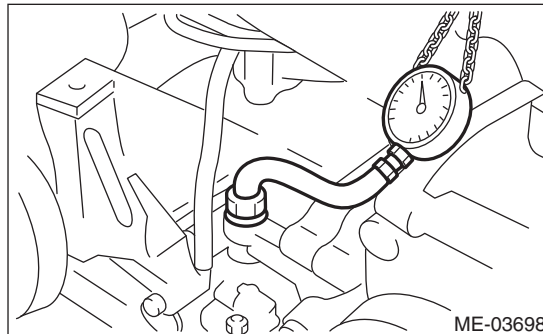

Oil pressure:

Standard

98 kPa (1.0 kg/cm², 14 psi) or more at 600 rpm
294 kPa (3.0 kg/cm², 43 psi) or more at 5,000 rpm

- If the oil pressure is out of specification, check oil pump, oil filter and lubrication line. <Ref. to LU(H4SO)-20, INSPECTION, Engine Lubrication System Trouble in General.>
- If the oil pressure warning light is ON and oil pressure is within specification, check the oil pressure switch. <Ref. to LU(H4SO)-20, INSPECTION, Engine Lubrication System Trouble in General.>

NOTE:

Standard value is based on an engine oil temperature of 80°C (176°F).

- 6) After measuring the oil pressure, install the oil pressure switch. <Ref. to LU(H4SO)-18, INSTALLATION, Oil Pressure Switch.>

7. Fuel Pressure

A: INSPECTION

CAUTION:

- Before removing the fuel pressure gauge, release the fuel pressure.
- Be careful not to spill fuel.
- Catch the fuel from hoses using a container or cloth.

NOTE:

Check or replace the fuel pump and fuel delivery line if the fuel pressure is out of the standard.

1) Release the fuel pressure.

<Ref. to FU(H4SO)-43, RELEASING OF FUEL PRESSURE, PROCEDURE, Fuel.>

2) Disconnect the fuel delivery hose from the fuel damper, and connect the fuel pressure gauge.

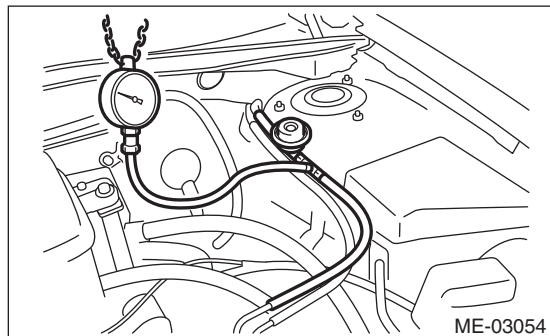

3) Install the fuse of fuel pump to main fuse box.

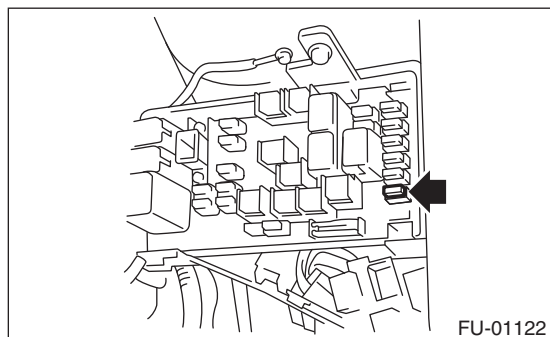

4) Start the engine.

5) Measure the fuel pressure after warming up the engine.

NOTE:

The fuel pressure gauge registers 10 to 20 kPa (0.1 to 0.2 kg/cm², 1 to 3 psi) higher than standard values during high-altitude operations.

Fuel pressure:

Standard:

338 — 348 kPa (3.4 — 3.5 kg/cm², 49 — 50 psi)

8. Valve Clearance

A: INSPECTION

NOTE:

Inspection and adjustment of valve clearance should be performed while engine is cold.

- 1) Set the vehicle on a lift.
- 2) Lift up the vehicle.
- 3) Remove the under cover.
- 4) Lower the vehicle.
- 5) Disconnect the ground cable from the battery.

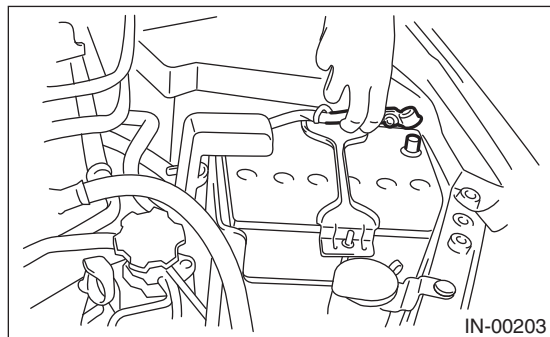

- 6) Remove the timing belt cover LH.

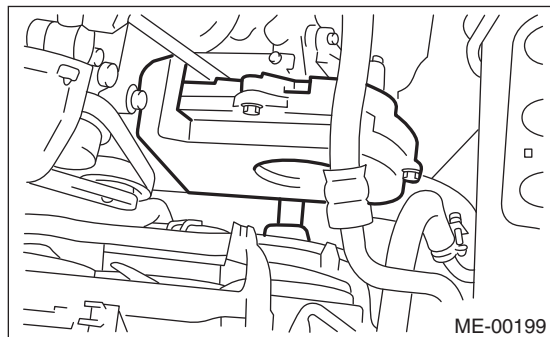

- 7) Remove the fuel injector. <Ref. to FU(H4SO)-30, REMOVAL, Fuel Injector.>

- 8) When inspecting #1 and #3 cylinders
 - (1) Disconnect the spark plug cords from spark plugs RH side. <Ref. to IG(H4SO)-4, RH SIDE, REMOVAL, Spark Plug.>
 - (2) Place a suitable container under the vehicle.
 - (3) Disconnect the PCV hose from the rocker cover RH.

NOTE:

Fit the depression in the ST with the protrusion of the clamp as shown in the figure below, and unlock the clamp.

ST 18353AA000 CLAMP PLIERS

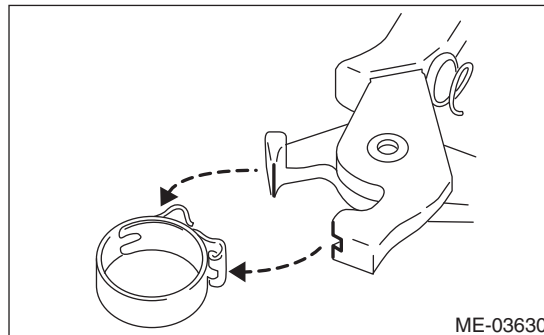

- (4) Remove the bolts, then remove the rocker cover RH.

- 9) When inspecting #2 and #4 cylinders
 - (1) Disconnect the spark plug cords from spark plugs LH side. <Ref. to IG(H4SO)-4, LH SIDE, REMOVAL, Spark Plug.>
 - (2) Place a suitable container under the vehicle.
 - (3) Disconnect the PCV hose from the rocker cover LH.

NOTE:

Fit the depression in the ST with the protrusion of the clamp as shown in the figure below, and unlock the clamp.

ST 18353AA000 CLAMP PLIERS

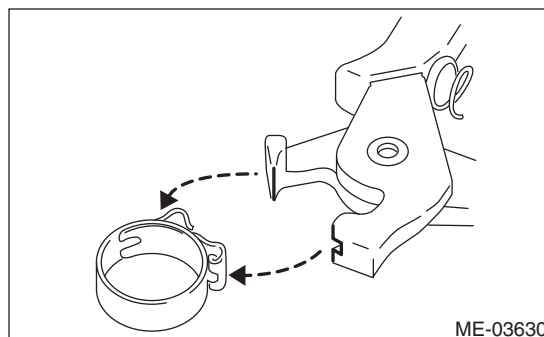

- (4) Remove the bolts, then remove the rocker cover LH.

Valve Clearance

MECHANICAL

10) Set #1 cylinder piston to top dead center of compression stroke by rotating the crank pulley clockwise using the socket wrench.

NOTE:

When the arrow mark (A) on cam sprocket LH is at the top position, the #1 cylinder piston is at top dead center of the compression stroke.

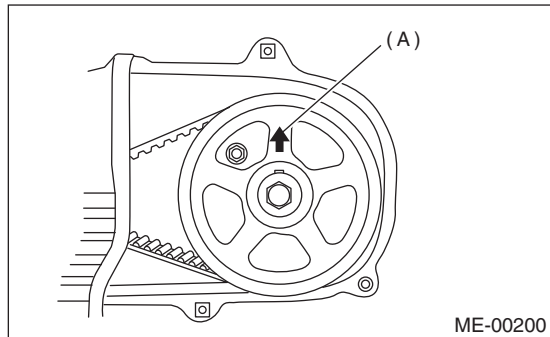

11) Measure #1 cylinder valve clearance by using thickness gauge (A).

NOTE:

- Insert the thickness gauge (A) in as horizontally as possible with respect to the valve stem end face.
- Lift up the vehicle and measure the exhaust valve clearances.

Valve clearance:

Intake

0.20 ± 0.04 mm (0.0079 ± 0.0016 in)

Exhaust

0.25 ± 0.04 mm (0.0098 ± 0.0016 in)

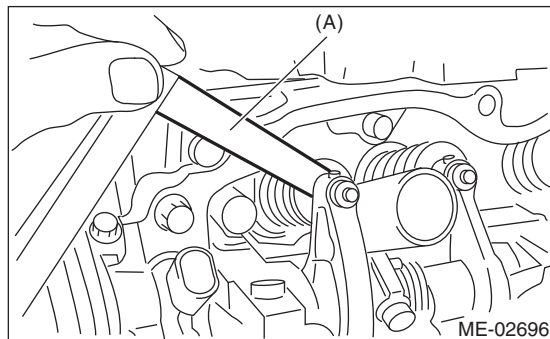

12) If necessary, adjust the valve clearance. <Ref. to ME(H4SO)-31, ADJUSTMENT, Valve Clearance.>

13) Measure the valve clearance in #3, #2 and #4 cylinder in the same measurement procedure as #1 cylinder in this order.

NOTE:

- Be sure to set the cylinder pistons to their respective top dead centers on compression stroke before measuring valve clearances.
- By rotating the crank pulley clockwise every 180° from the state that #1 cylinder piston is on the top dead center of compression stroke, #3, #2 and #4 cylinder pistons come to the top dead center of compression stroke in this order.

14) After inspection, install the related parts in the reverse order of removal.

NOTE:

- Use a new rocker cover gasket.
- For the PVC hose clamp, use a new clamp. Sandwich the protruding part of the clamp with the ST and lock the clamp.

ST 18353AA000 CLAMP PLIERS

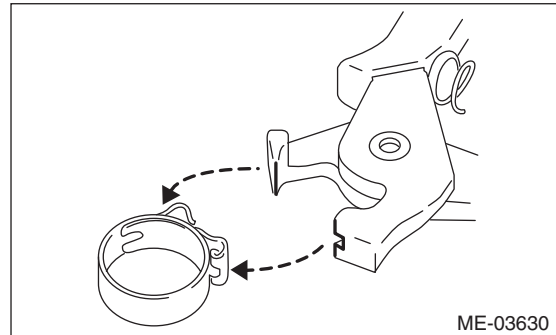

B: ADJUSTMENT

NOTE:

Adjustment of valve clearance should be performed while engine is cold.

1) Set #1 cylinder piston to top dead center of compression stroke by rotating the crank pulley clockwise using the socket wrench.

NOTE:

When the arrow mark (A) on cam sprocket LH is at the top position, the #1 cylinder piston is at top dead center of the compression stroke.

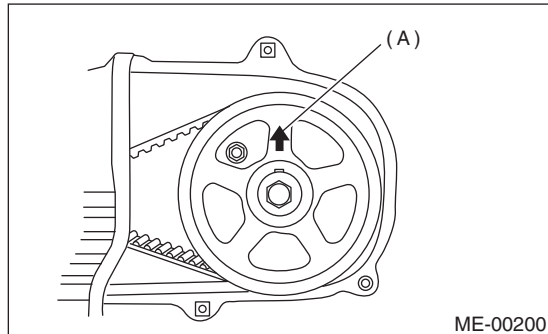

2) Adjust the #1 cylinder valve clearance.

- (1) Loosen the valve rocker nut and screw.
- (2) Set a suitable thickness gauge.
- (3) While noting the valve clearance, tighten the valve rocker adjusting screw.
- (4) When the specified valve clearance is obtained, tighten the valve rocker nut.

NOTE:

- Insert a thickness gauge in a direction as horizontal as possible with respect to the valve stem end face.
- Lift up the vehicle and adjust the exhaust valve clearances.

Valve clearance:

Intake

0.20 ± 0.04 mm (0.0079 ± 0.0016 in)

Exhaust

0.25 ± 0.04 mm (0.0098 ± 0.0016 in)

Tightening torque:

9.75 N·m (1.0 kgf·m, 7.2 ft·lb)

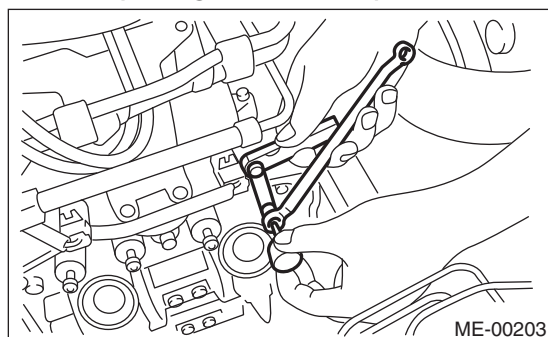

3) Adjust the valve clearance in #3, #2 and #4 cylinder in the same adjustment procedure as #1 cylinder in this order.

NOTE:

- Be sure to set the cylinder pistons to their respective top dead centers on compression stroke before adjusting valve clearances.
 - By rotating the crank pulley clockwise every 180° from the state that #1 cylinder piston is on the top dead center of compression stroke, #3, #2 and #4 cylinder pistons come to the top dead center of compression stroke in this order.
- 4) Ensure the valve clearances of each cylinder are within specifications. If necessary, readjust the valve clearances.

Engine Assembly

MECHANICAL

9. Engine Assembly

A: REMOVAL

- 1) Set the vehicle on a lift.
- 2) Change the bolt mounting position from (A) to (B), and completely open the front hood.

Tightening torque:

7.5 N·m (0.8 kgf-m, 5.5 ft-lb)

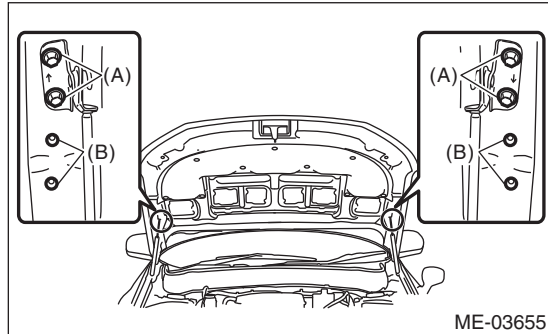

- 3) Remove the V-belt cover.

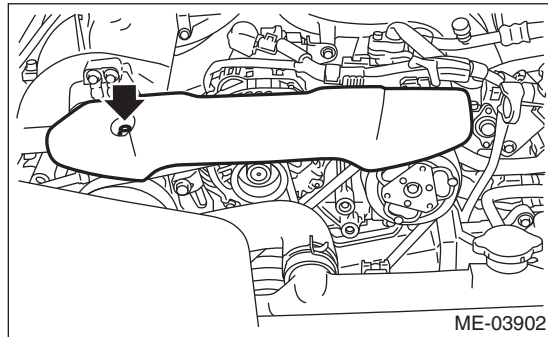

- 4) Collect the refrigerant from the A/C system. <Ref. to AC-17, PROCEDURE, Refrigerant Recovery Procedure.>
- 5) Release the fuel pressure. <Ref. to FU(H4SO)-43, RELEASING OF FUEL PRESSURE, PROCEDURE, Fuel.>
- 6) Disconnect the battery cable, and then remove the battery from the vehicle body.
- 7) Remove the air intake duct (rear), air cleaner case and air intake chamber. <Ref. to IN(H4SO)-8, REMOVAL, Air Intake Duct.> <Ref. to IN(H4SO)-5, REMOVAL, Air Cleaner Case.> <Ref. to IN(H4SO)-7, REMOVAL, Air Intake Chamber.>
- 8) Remove the under cover.
- 9) Remove the radiator from the vehicle. <Ref. to CO(H4SO)-19, REMOVAL, Radiator.>
- 10) Disconnect the A/C pressure hoses from A/C compressor.

- 11) Remove the air intake chamber stay.

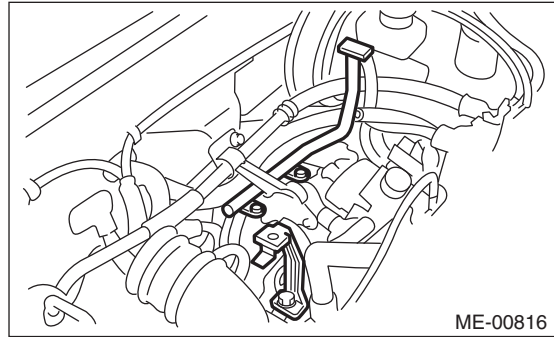

- 12) Disconnect the following connectors and cables.

- (1) Front oxygen (A/F) sensor connector
- (2) Rear oxygen sensor connector

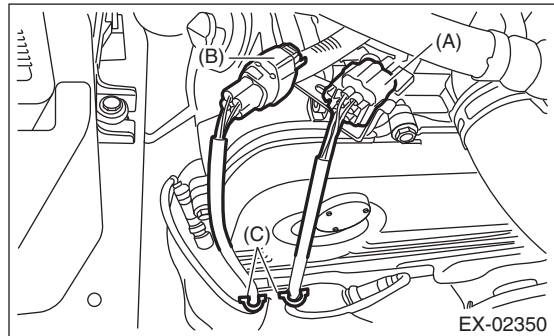

- (A) Front oxygen (A/F) sensor connector
- (B) Rear oxygen sensor connector
- (C) Clip

- (3) Engine ground terminal

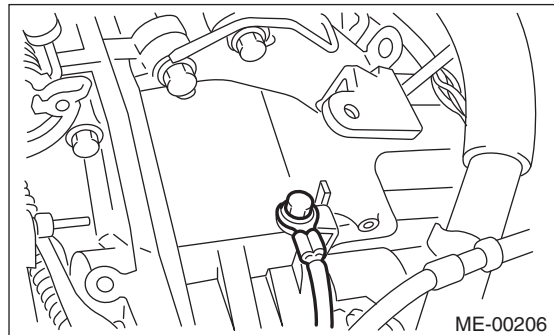

- (4) Remove the bolt, and disconnect the engine harness connector from the bulk head harness connector and rear engine hanger.

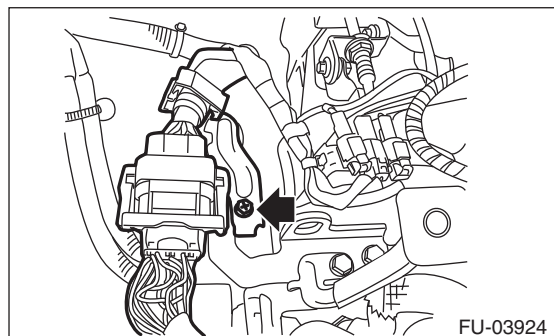

(5) Generator connector and terminal

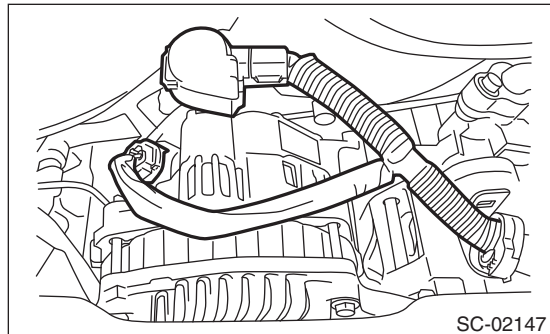

(6) A/C compressor connector

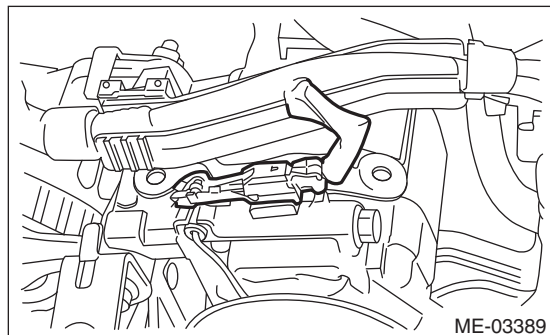

(7) Power steering switch connector

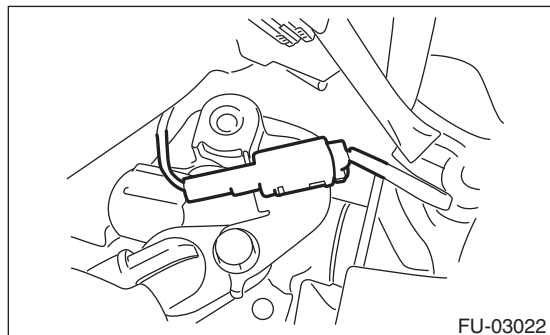

13) Disconnect the following hoses.

(1) Brake booster vacuum hose

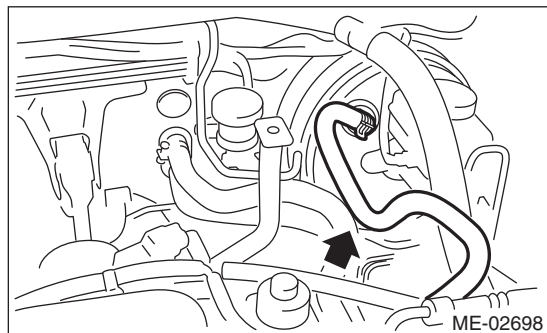

(2) Heater inlet and outlet hoses

14) Remove the power steering pump.

(1) Remove the front side belts. <Ref. to ME(H4SO)-42, FRONT SIDE BELT, REMOVAL, V-belt.>

(2) Remove the bolts which secure the power steering pump to the bracket.

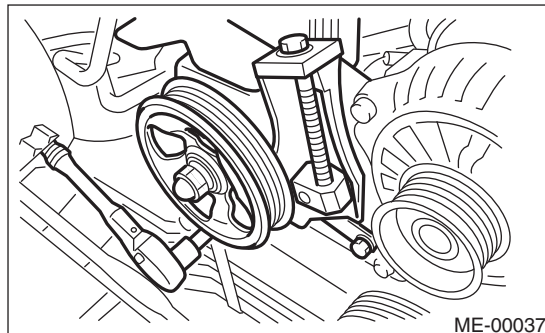

(3) Place the power steering pump on the right side wheel apron.

15) Lift up the vehicle.

16) Remove the front and center exhaust pipes. <Ref. to EX(H4SO)-4, REMOVAL, Front Exhaust Pipe.>

17) Disconnect the engine ground terminal from the cylinder head.

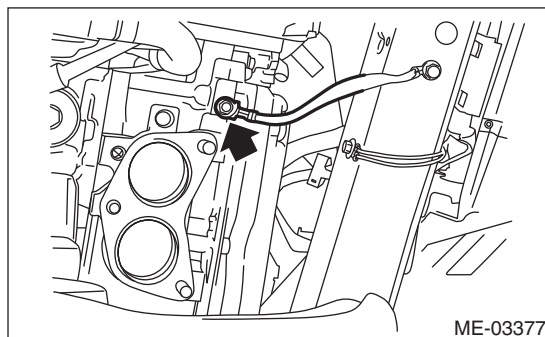
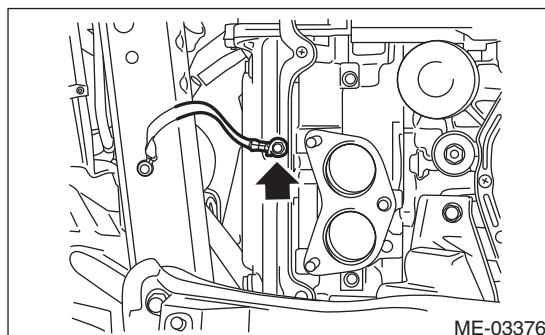

Engine Assembly

MECHANICAL

18) Remove the bolts and nuts which hold lower side of transmission to engine.

- AT model

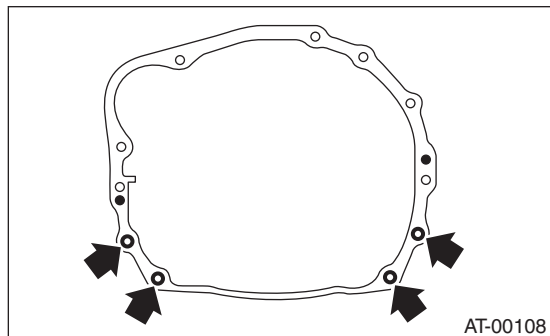

- MT model

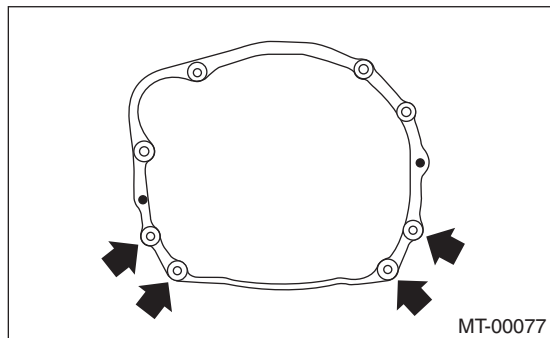

19) Remove the nuts which hold the engine mount to the front crossmember.

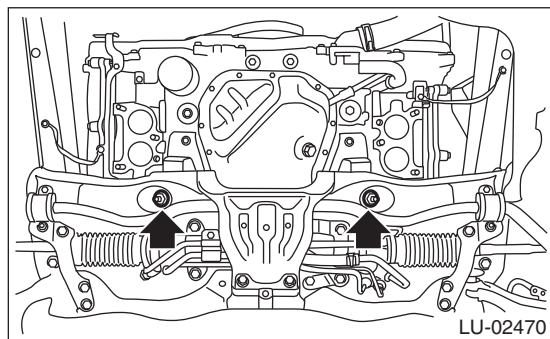

20) Separate the torque converter clutch from drive plate. (AT model)

- (1) Lower the vehicle.
- (2) Remove the service hole plug.
- (3) Remove the bolts which hold torque converter clutch to drive plate.
- (4) Remove all bolts while turning the crankshaft with a socket wrench.

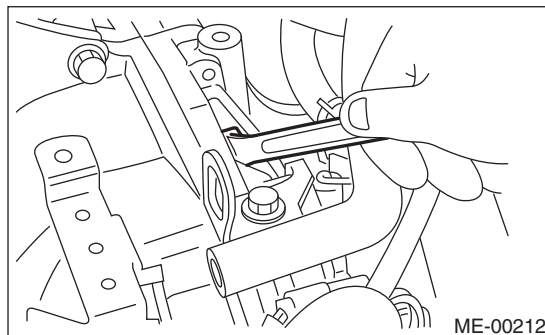

21) Remove the pitching stopper.

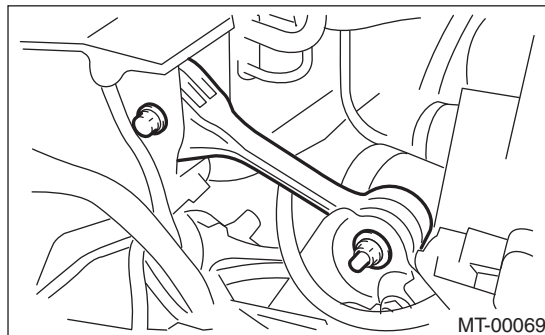

22) Disconnect the fuel hoses from fuel pipe.

- (1) Disconnect the quick connector on the fuel delivery line by pushing the ST in the direction of the arrow.

ST 42099AE000 QUICK CONNECTOR RELEASE

- (2) Remove the clip and disconnect the evaporation hose from the pipe.

CAUTION:

- Be careful not to spill fuel.
- Catch the fuel from hoses using a container or cloth.

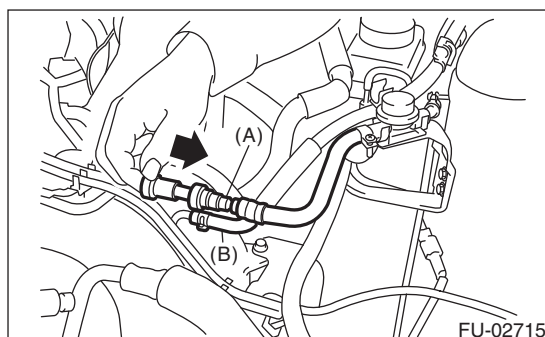

- (A) Fuel delivery hose
(B) Evaporation hose

23) Support the engine with a lifting device and wire ropes.

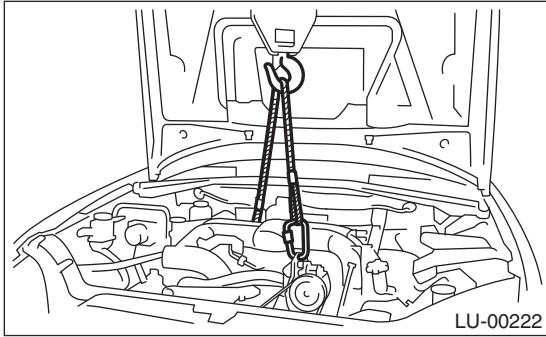

24) Support the transmission with a garage jack.

CAUTION:

Doing this is very important to prevent the transmission from lowering due to its own weight.

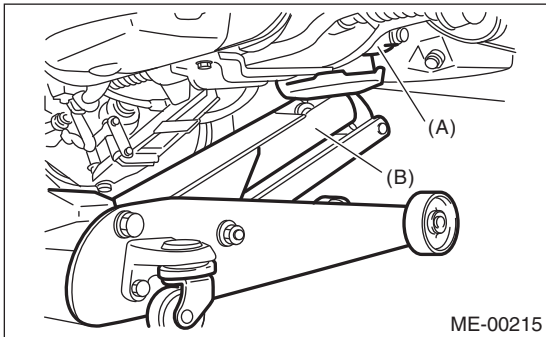

- (A) Transmission
- (B) Garage jack

25) Separation of engine and transmission.

CAUTION:

Before removing the engine away from transmission, check to be sure no work has been overlooked.

- (1) Remove the starter. <Ref. to SC(H4SO)-6, REMOVAL, Starter.>
- (2) Set the ST to torque converter clutch case. (AT model)

ST 498277200 STOPPER SET

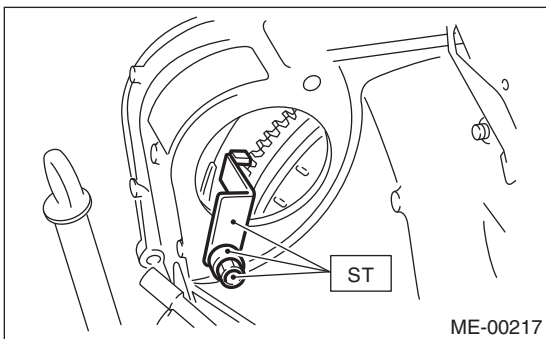

(3) Remove the bolts which hold upper side of transmission to engine.

- AT model

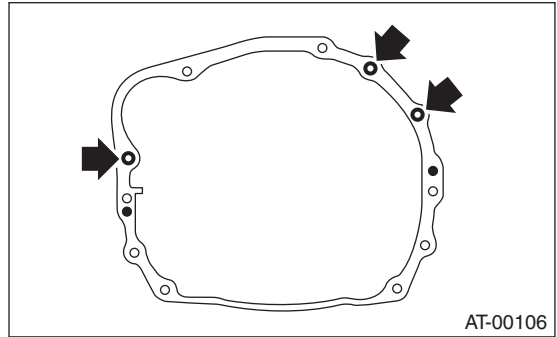

- MT model

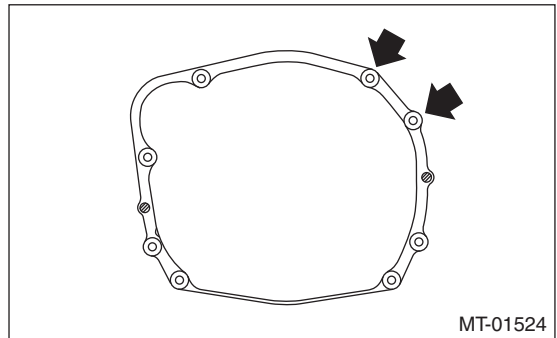

26) Remove the engine from vehicle.

- (1) Slightly raise the engine.
- (2) Raise the transmission with garage jack.
- (3) Move the engine horizontally until main shaft is withdrawn from clutch cover.
- (4) Slowly move the engine away from engine compartment.

NOTE:

Be careful not to damage adjacent parts or body panels with crank pulley, oil level gauge, etc.

27) Remove the engine mount.

Engine Assembly

MECHANICAL

B: INSTALLATION

1) Install the engine mount onto the engine.

Tightening torque:

35 N·m (3.6 kgf-m, 25.8 ft-lb)

2) Apply a small amount of grease to splines of main shaft. (MT model)

3) Position the engine in engine compartment and align it with transmission.

NOTE:

Be careful not to damage adjacent parts or body panels with crank pulley, oil level gauge, etc.

4) Tighten the bolts which hold upper side of transmission to engine.

Tightening torque:

50 N·m (5.1 kgf-m, 36.9 ft-lb)

- AT model

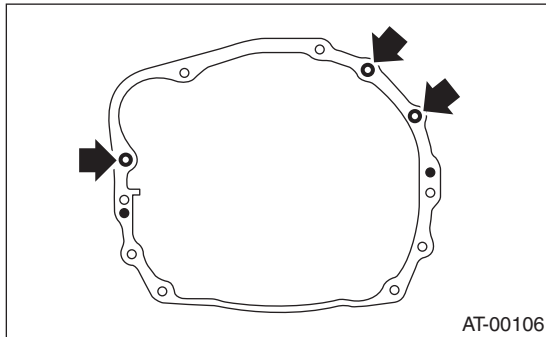

- MT model

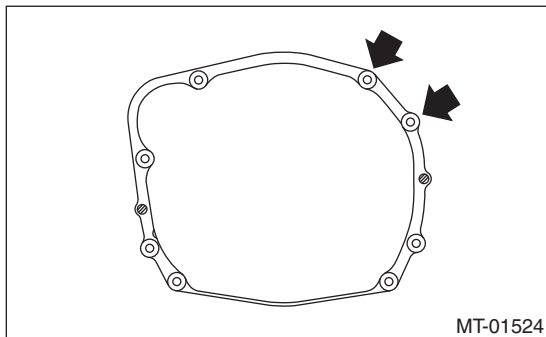

5) Remove the lifting device and wire ropes.

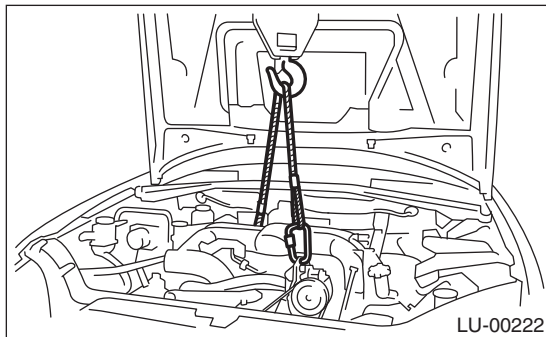

6) Remove the garage jack.

7) Install the pitching stopper.

Tightening torque:

T1: 50 N·m (5.1 kgf-m, 36.9 ft-lb)

T2: 58 N·m (5.9 kgf-m, 42.8 ft-lb)

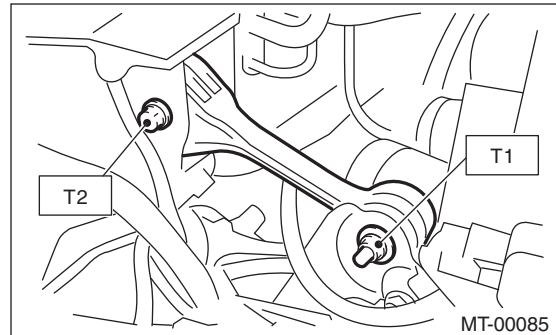

8) Remove the ST from the torque converter clutch case. (AT model)

NOTE:

Be careful not to drop the ST into the torque converter clutch case when removing the ST.

ST 498277200 STOPPER SET

9) Install the starter. <Ref. to SC(H4SO)-6, INSTALLATION, Starter.>

10) Install the torque converter clutch to drive plate. (AT model)

(1) Tighten the bolts which hold torque converter clutch to drive plate.

(2) Tighten other bolts while rotating the crankshaft using socket wrench.

NOTE:

Be careful not to drop bolts into the torque converter clutch housing.

Tightening torque:

25 N·m (2.5 kgf-m, 18.4 ft-lb)

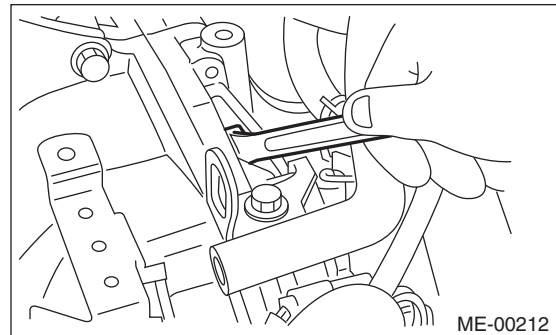

(3) Install the service hole plug.

- 11) Install the power steering pump.
 (1) Install the power steering pump to the bracket.

Tightening torque:
 Refer to "COMPONENT" of "Power Steering" for the tightening torque. <Ref. to PS-3, COMPONENT, General Description.>

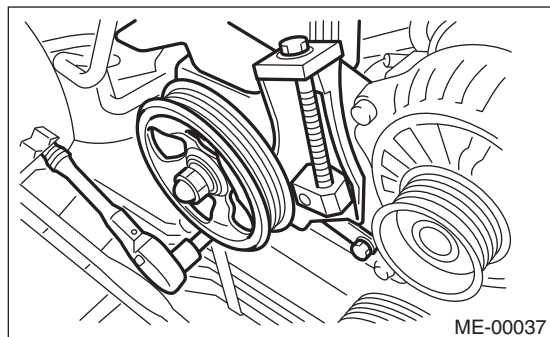

- (2) Connect the power steering switch connector.

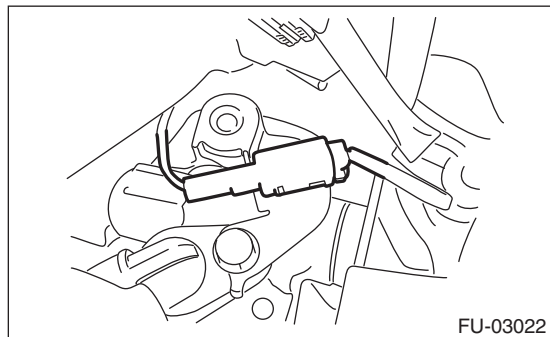

- (3) Install and adjust the front side belt. <Ref. to ME(H4SO)-42, FRONT SIDE BELT, INSTALLATION, V-belt.>

- 12) Lift up the vehicle.

- 13) Tighten the bolts and nuts which hold lower side of the transmission to engine.

Tightening torque:
 50 N·m (5.1 kgf-m, 36.9 ft-lb)

- AT model

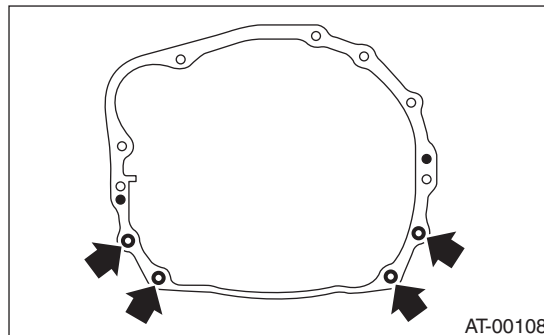

- MT model

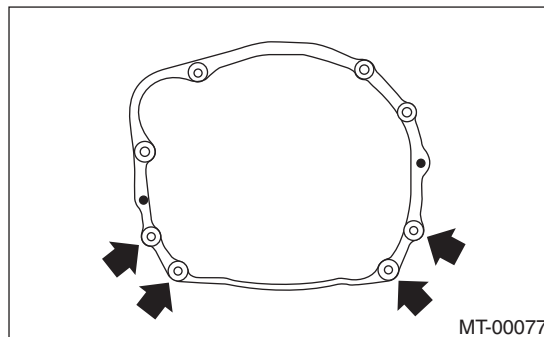

- 14) Tighten the nuts which hold the engine mount to the crossmember.

Tightening torque:
 85 N·m (8.7 kgf-m, 62.7 ft-lb)

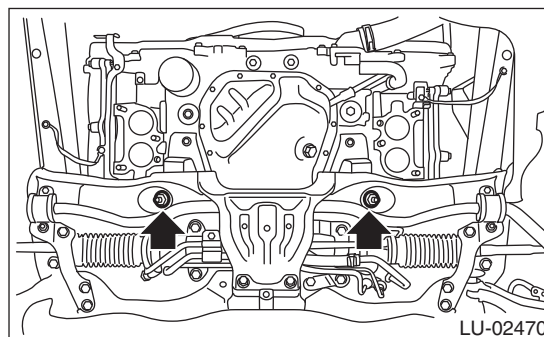

Engine Assembly

MECHANICAL

15) Install the engine ground terminal to the cylinder head.

Tightening torque:

7.5 N·m (0.8 kgf·m, 5.5 ft·lb)

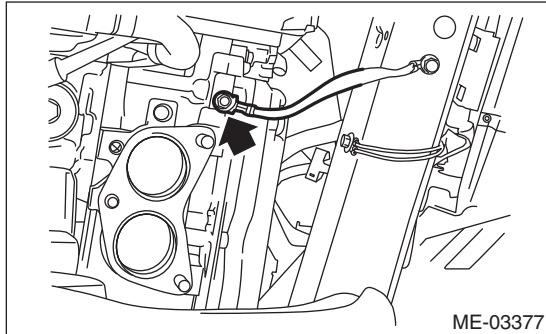
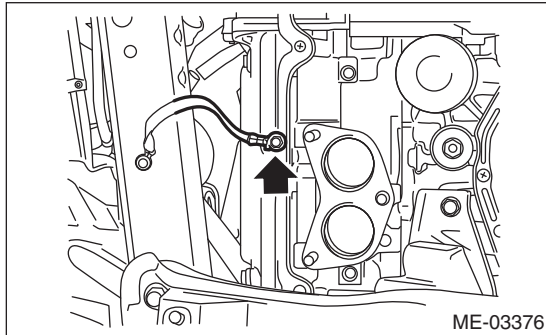

16) Install the front and center exhaust pipe. <Ref. to EX(H4SO)-5, INSTALLATION, Front Exhaust Pipe.>

17) Lower the vehicle.

18) Connect the following hoses.

- (1) Fuel delivery hose and evaporation hose
- (2) Heater inlet and outlet hoses
- (3) Brake booster vacuum hose

19) Connect the following connectors and terminals.

- (1) Front oxygen (A/F) sensor connector
- (2) Rear oxygen sensor connector
- (3) Engine harness connectors

Tightening torque:

6.4 N·m (0.7 kgf·m, 4.7 ft·lb)

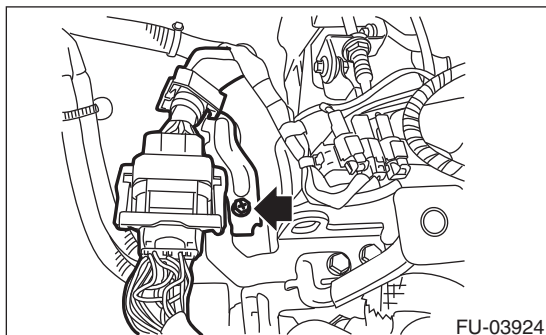

(4) Generator connector and terminal

Tightening torque:

15 N·m (1.5 kgf·m, 11.1 ft·lb)

(5) A/C compressor connector

20) Install the air intake chamber stay.

Tightening torque:

16 N·m (1.6 kgf·m, 11.8 ft·lb)

21) Tighten the engine ground cable.

Tightening torque:

14 N·m (1.4 kgf·m, 10.3 ft·lb)

22) Install the A/C pressure hoses.

<Ref. to AC-35, INSTALLATION, Hose and Pipe.>

23) Install the radiator to the vehicle. <Ref. to CO(H4SO)-20, INSTALLATION, Radiator.>

24) Install the air intake duct (rear), air cleaner case and air intake chamber. <Ref. to IN(H4SO)-8, INSTALLATION, Air Intake Duct.> <Ref. to IN(H4SO)-6, INSTALLATION, Air Cleaner Case.> <Ref. to IN(H4SO)-7, INSTALLATION, Air Intake Chamber.>

25) Install the under cover.

26) Install the battery in the vehicle, and connect cables.

27) Fill engine coolant.

<Ref. to CO(H4SO)-13, FILLING OF ENGINE COOLANT, REPLACEMENT, Engine Coolant.>

28) Check the ATF level and replenish it if necessary.

<Ref. to 4AT-26, INSPECTION, Automatic Transmission Fluid.>

29) Charge the A/C system with refrigerant. <Ref. to AC-18, PROCEDURE, Refrigerant Charging Procedure.>

30) Install the V-belt cover.

Tightening torque:

13 N·m (1.3 kgf·m, 9.6 ft·lb)

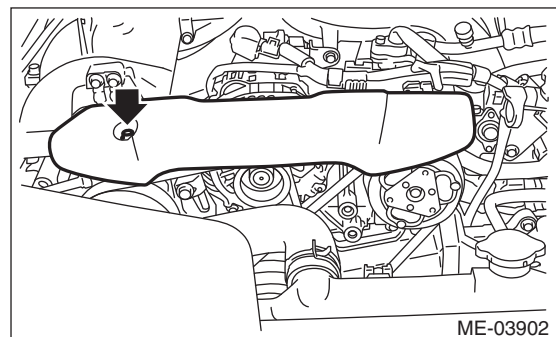

31) Change the bolt mounting position from (B) to (A), and close the front hood.

Tightening torque:

7.5 N·m (0.8 kgf-m, 5.5 ft-lb)

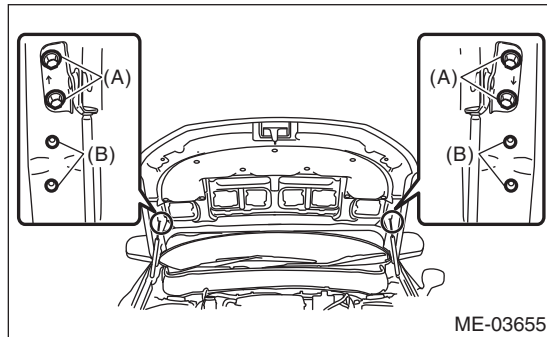

32) Lower the vehicle from the lift.

C: INSPECTION

- 1) Check that pipes, hoses, connectors and clamps are installed firmly.
- 2) Check the engine coolant is at specified level.
- 3) Check that the ATF is at specified level. (AT model)
- 4) Start the engine and check for exhaust gas, engine coolant, leaks of fuel, etc. Also check for noise and vibrations.

10.Engine Mounting

A: REMOVAL

- 1) Remove the engine unit. <Ref. to ME(H4SO)-32, REMOVAL, Engine Assembly.>
- 2) Remove the engine mounting from engine assembly.

B: INSTALLATION

Install in the reverse order of removal.

Tightening torque:

Engine mounting

35 N·m (3.6 kgf·m, 25.8 ft-lb)

C: INSPECTION

Make sure that no crack or other damages do not exist.

11. Preparation for Overhaul

A: PROCEDURE

1) After removing the engine from body, secure it to ST in the following procedure.

ST1	498457000	ENGINE STAND ADAPTER RH
ST2	498457100	ENGINE STAND ADAPTER LH
ST3	499817100	ENGINE STAND

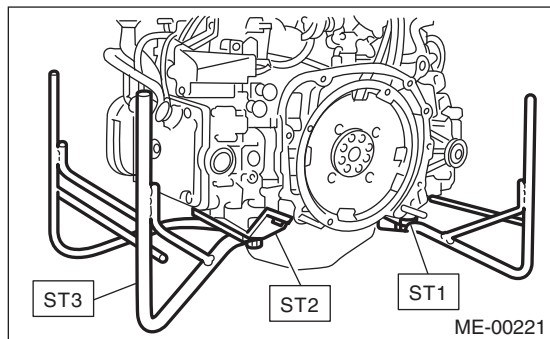

2) In this section the procedures described under each index are all connected and stated in order. The procedure for overhauling of the engine will be completed when you go through all steps in the process.

Therefore, in this section, to conduct the particular procedure within the flow of a section, you need to go back and conduct the procedure described previously in order to do that particular procedure.

12.V-belt

A: REMOVAL

NOTE:

Perform the work with the engine installed to body when replacing a single part.

1. FRONT SIDE BELT

- 1) Remove the V-belt cover.

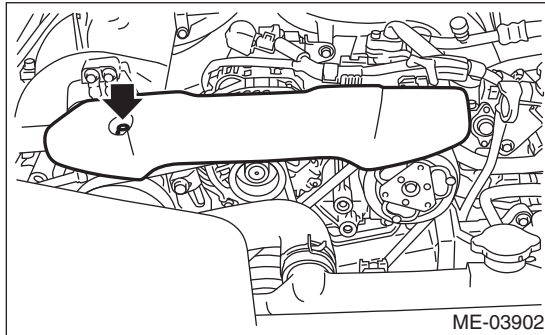

- 2) Remove the air intake duct (rear). <Ref. to IN(H4SO)-8, REMOVAL, Air Intake Duct.>
- 3) Loosen the bolt (A).
- 4) Loosen the slider bolt (B).
- 5) Remove the front side belt (C).

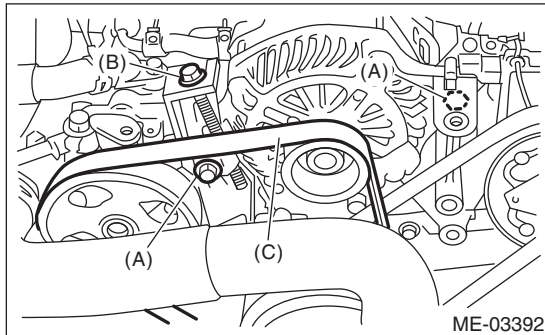

2. REAR SIDE BELT

- 1) Remove the front side belts. <Ref. to ME(H4SO)-42, FRONT SIDE BELT, REMOVAL, V-belt.>
- 2) Cut the rear side belt with a wire cutter, etc., and discard.

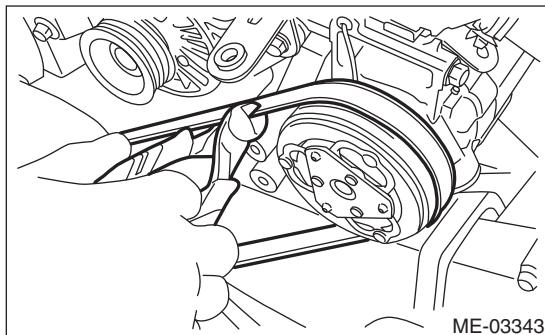

B: INSTALLATION

1. FRONT SIDE BELT

CAUTION:

- When reusing the front side belt, wipe off any sand or water with a cloth.
- Do not use the front side belt if there is any oil, grease or coolant on the belt.
- Be careful when touching the belt. If the end face of the belt is rubbed by hand, you may receive injury from bared wires.

- 1) Wipe off any sand, dust, oil or water from the pulley grooves with a cloth.
- 2) Install the front side belt (C), and adjust the slider bolt (B) so as to obtain the specified belt tension. <Ref. to ME(H4SO)-48, INSPECTION, V-belt.>
- 3) Tighten the bolt (A).
- 4) Tighten the slider bolt (B).

Tightening torque:

Bolt (A)

25 N·m (2.5 kgf·m, 18.4 ft·lb)

Slider bolt (B)

8 N·m (0.8 kgf·m, 5.9 ft·lb)

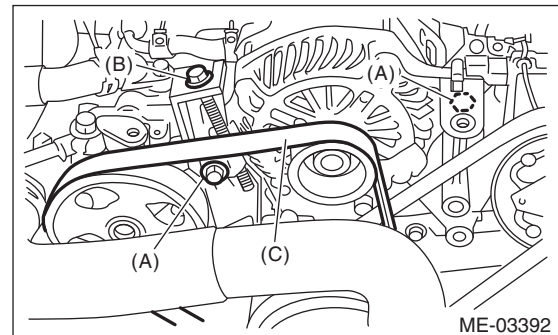

- 5) Install the air intake duct (rear). <Ref. to IN(H4SO)-8, INSTALLATION, Air Intake Duct.>
- 6) Install the V-belt cover.

Tightening torque:

13 N·m (1.3 kgf·m, 9.6 ft·lb)

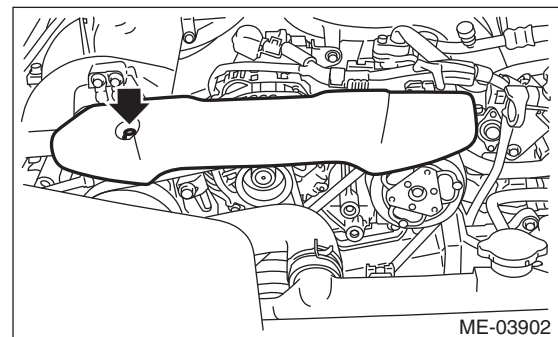

2. REAR SIDE BELT

CAUTION:

- Always use new rear side belt.
- Be careful that the new rear side belt does not come into contact with any oil, grease or coolant.
- Be careful when touching the belt. If the end face of the belt is rubbed by hand, you may receive injury from bared wires.
- When installing the rear side belt, always use the provided tools (belt stopper, belt guide, belt guide holder and bolt).

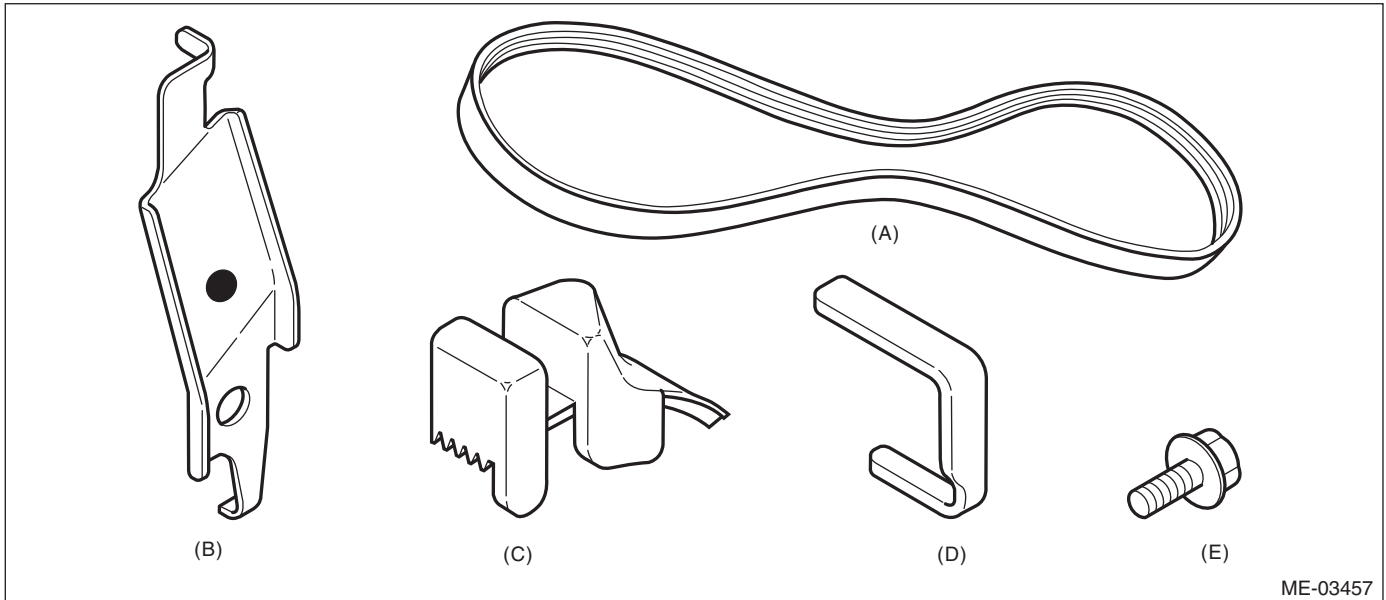

ME-03457

(A) Rear side belt
(B) Belt stopper

(C) Belt guide
(D) Belt guide holder

(E) Bolt

V-belt

MECHANICAL

- 1) Wipe off any sand, dust, oil or water from the pulley grooves with a cloth.
- 2) Wipe off any oil, water, mud or rust attached to the front side of the crank pulley with a cloth.
- 3) Turn the crank pulley to the right slowly, until the crank pulley service hole near the top.

CAUTION:

Never turn the crank pulley to the left.

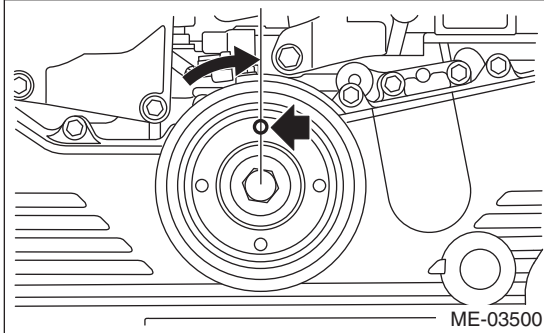

- 4) Attach a new rear side belt on the A/C compressor pulley.

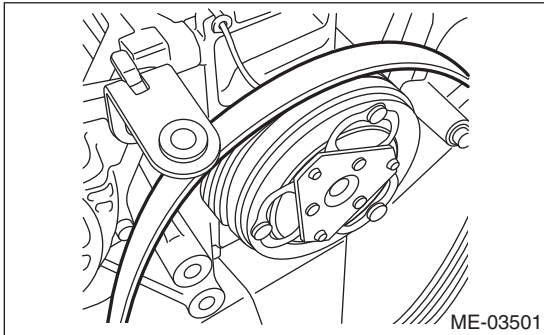

- 5) Insert the claw of the belt stopper (A) into the lower hole (B) on the compressor bracket as shown in the figure, and attach using bolt (C).

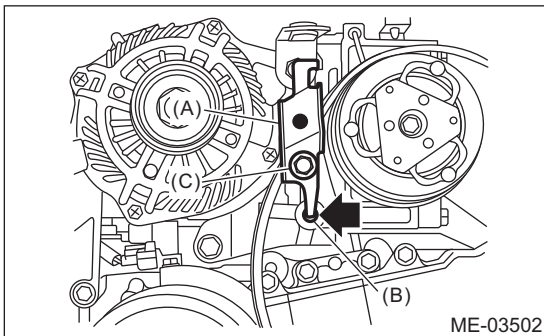

- 6) Mount the belt guide by matching to the belt line on the front side belt of the crank pulley.

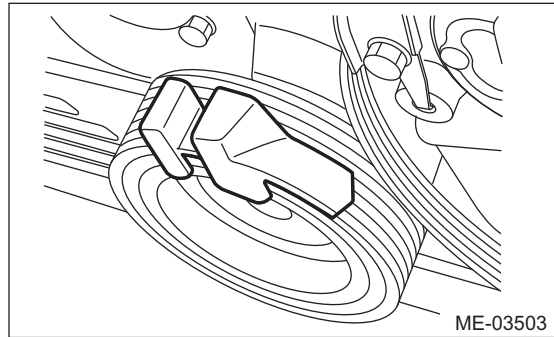

- 7) Insert the belt guide holder into the crank pulley service hole so as to clamp the belt guide.

NOTE:

The longer side of the belt guide holder is the upper side.

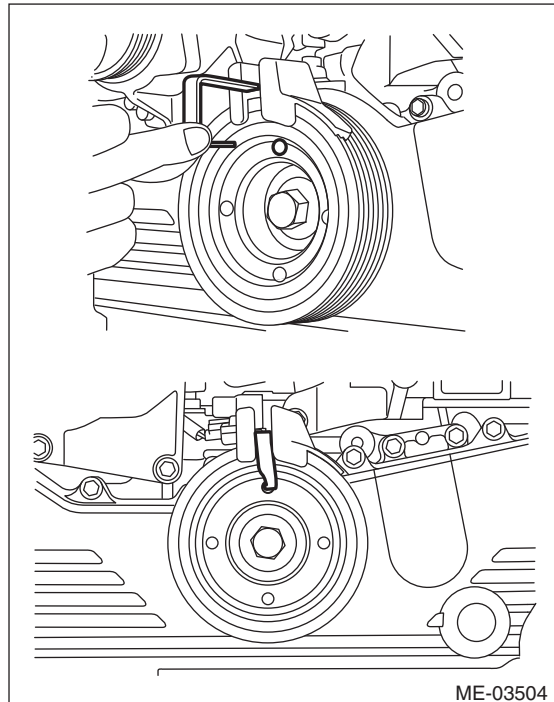

- 8) Turn the crank pulley slowly to the right, and set the belt guide at an approximately 45° position.

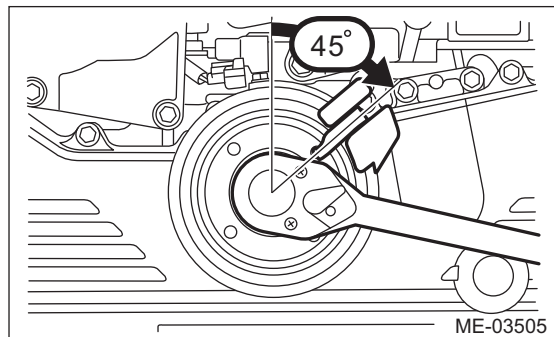

9) Place the rib face of the rear side belt onto the grooves of the crank pulley, and sandwich the rear side belt with the belt guide holder.

CAUTION:

If the rear side belt does not fit onto the groove of the crank pulley easily, pull out the belt guide holder halfway, then insert the rear side belt into the groove, and sandwich it with the belt guide holder.

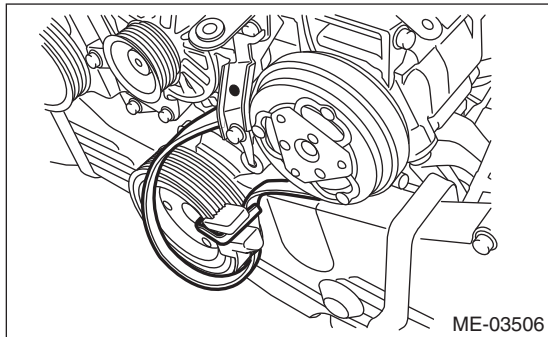

10) Place the tool through the loop of the rear side belt, and set on the crank pulley bolt.

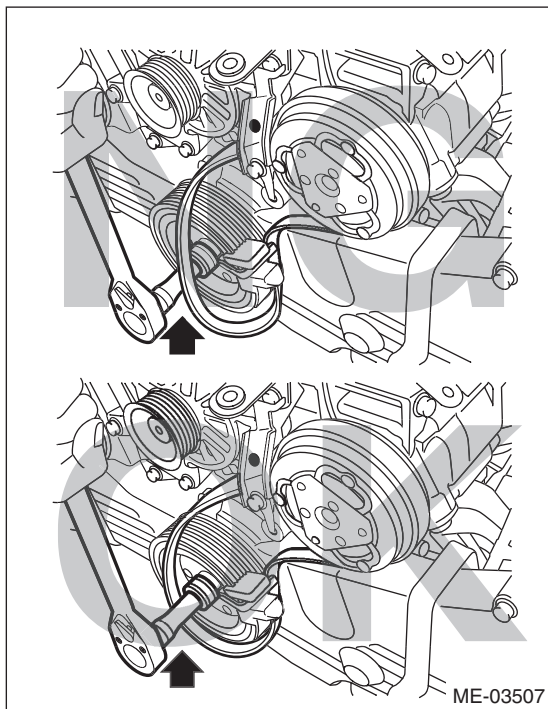

11) While checking for the following, turn the crank pulley slowly to the right by approximately 90° and set the belt guide to the position shown in the figure.

CAUTION:

When rotating the crank pulley, be careful that the belt guide does not slip off the groove of the crank pulley.

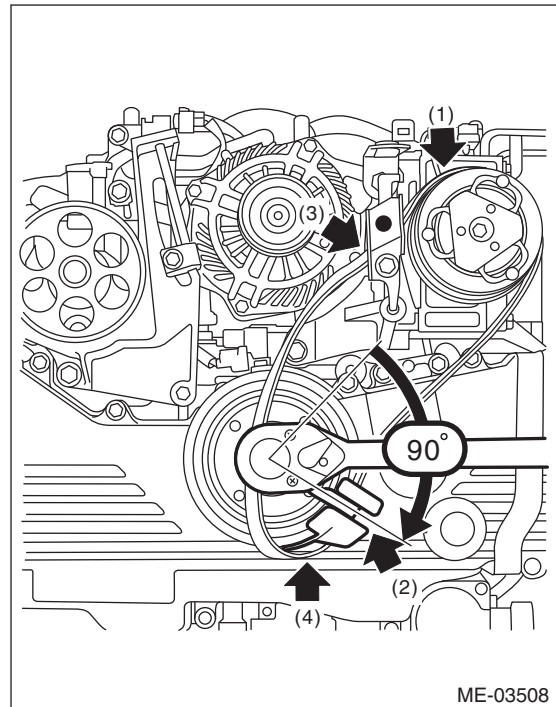

(1) The ribs of the rear side belt are properly riding on the grooves of the A/C compressor pulley.

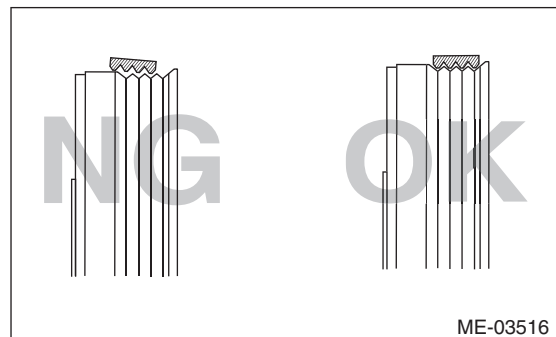

(2) The ribs of the rear side belt are properly riding on the grooves of the crank pulley.

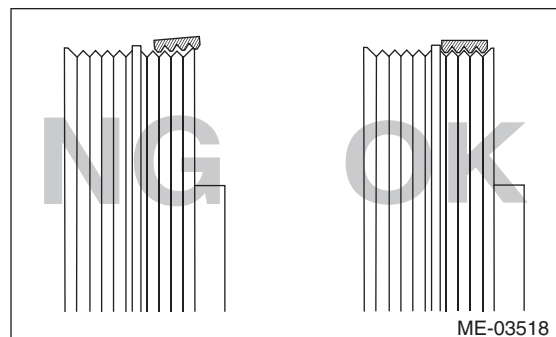

V-belt

MECHANICAL

(3) The surface of the rear side belt is being pressed by the belt stopper.

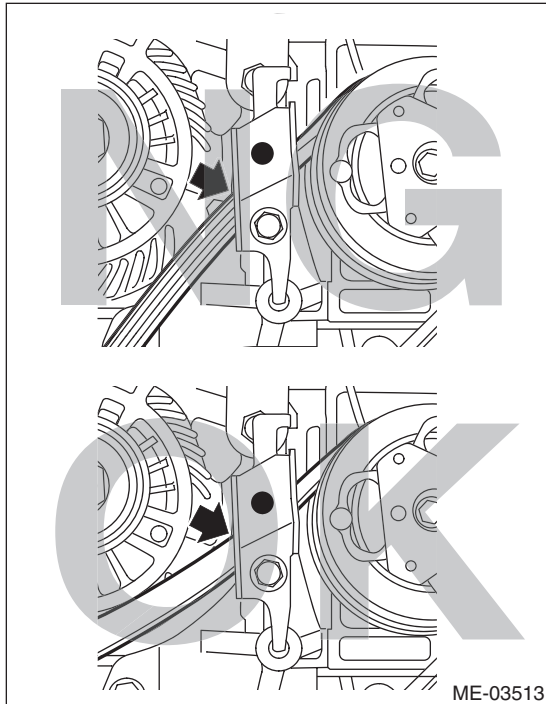

(4) The rear side belt is riding properly on the belt guide.

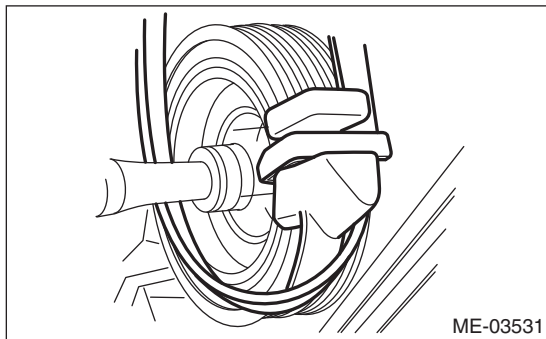

12) While checking for the following, turn the crank pulley slowly to the right by approximately 90° and set the belt guide to the position shown in the figure.

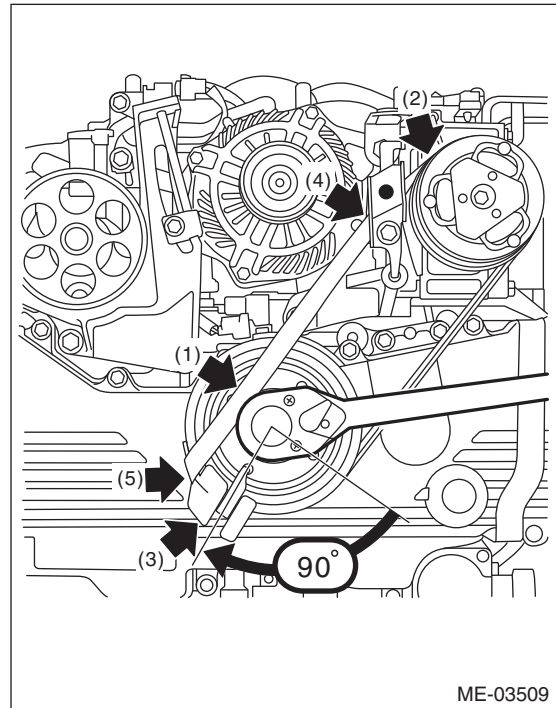

(1) The rear side belt is not twisted.

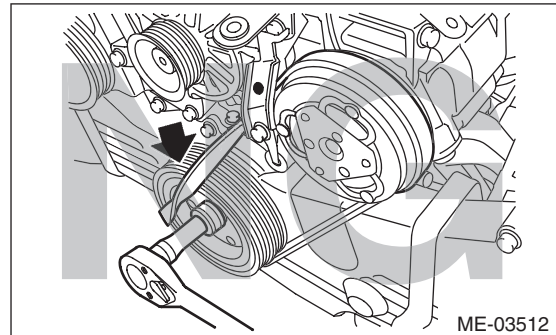

(2) The ribs of the rear side belt are properly riding on the grooves of the A/C compressor pulley.

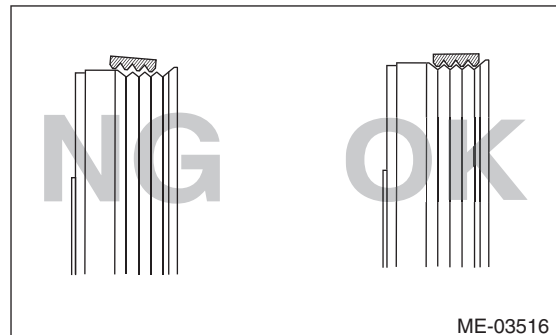

(3) The ribs of the rear side belt are properly riding on the grooves of the crank pulley.

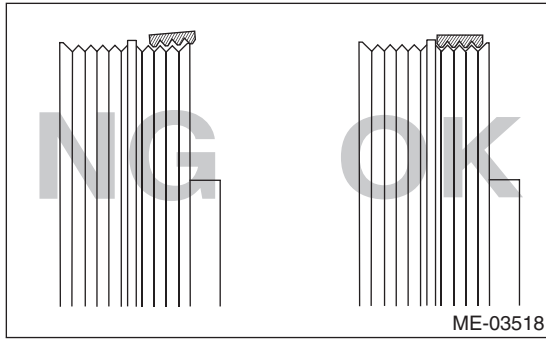

(4) The surface of the rear side belt is being pressed by the belt stopper.

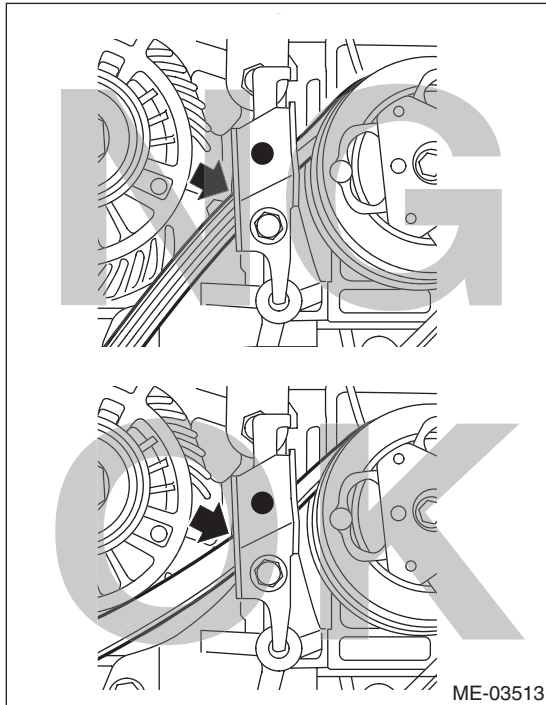

(5) The rear side belt is riding properly on the belt guide.

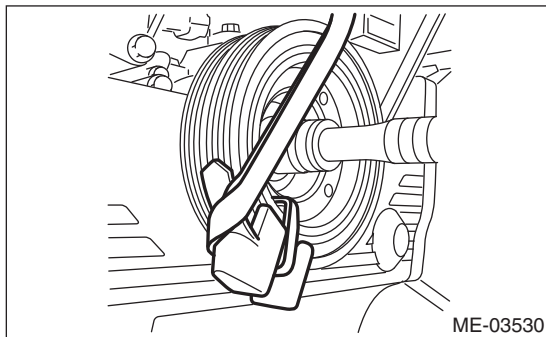

13) Turn the crank pulley slowly to the right, and attach the rear side belt.

CAUTION:

Because there is a possibility of damage to the rear side belt, and the belt guide holder falling off, care must be taken to make sure that the total of steps 8), 11), 12), and 13) does not exceed 330°.

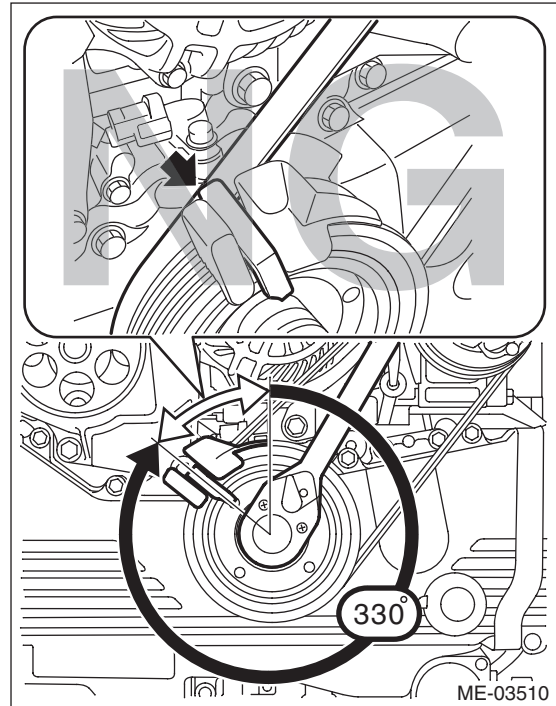

14) Remove the belt guide and belt guide holder from the crank pulley.

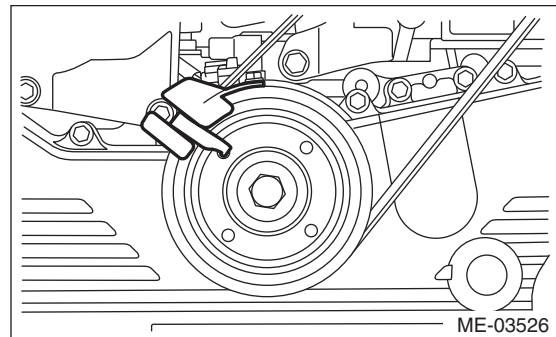

V-belt

MECHANICAL

15) Remove the belt stopper from the compressor bracket.

CAUTION:

Make sure to remove the belt stopper, as leaving it on can cause smoke, flames or belt breakage.

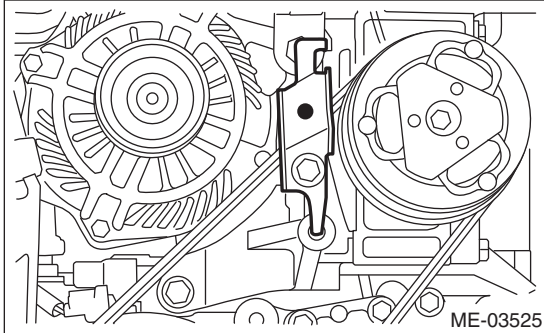

16) Make sure that the belt ribs are properly riding on the grooves of the pulleys, and turn the crank pulley slowly to the right twice to break in the rear side belt.

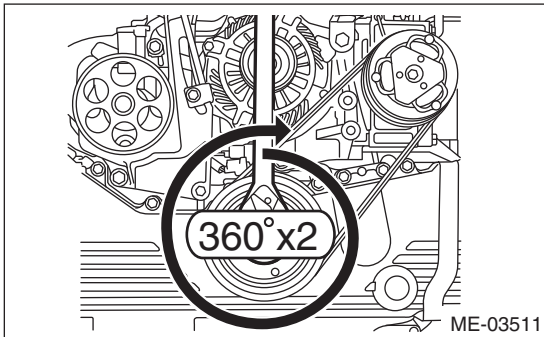

17) Discard the provided tools (belt stopper, belt guide, belt guide holder, bolt).

18) Install the front side belt. <Ref. to ME(H4SO)-42, FRONT SIDE BELT, INSTALLATION, V-belt.>

C: INSPECTION

1. FRONT SIDE BELT

- 1) Replace the front side belt, if cracking, fraying or wear is found.
- 2) Check the front side belt tension and adjust it if necessary by changing the generator installing position.

Front side belt tension (when using a belt tension gauge):

When installing new parts

640 — 780 N (65 — 80 kgf, 144 — 175 lbf)

At inspection

490 — 640 N (50 — 65 kgf, 110 — 144 lbf)

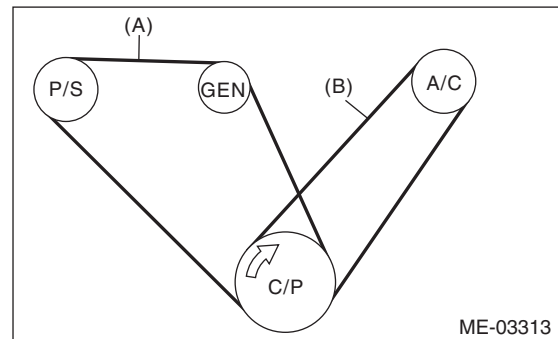

(A) Front side belt

(B) Rear side belt

C/P Crank pulley

GEN Generator

P/S Power steering oil pump pulley

A/C Air conditioning compressor pulley

Front side belt tension (when not using a belt tension gauge):

When installing new parts:

7 — 9 mm (0.276 — 0.354 in)

At inspection

9 — 11 mm (0.354 — 0.433 in)

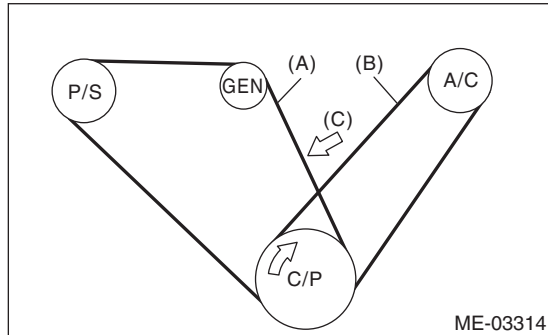

- (A) Front side belt
- (B) Rear side belt
- (C) 98 N (10 kgf, 22 lbf)
- C/P Crank pulley
- GEN Generator
- P/S Power steering oil pump pulley
- A/C Air conditioning compressor pulley

2. REAR SIDE BELT

If cracks, fraying or wear is found, and when abnormal noise is produced, replace the rear side belt.

NOTE:

Because the rear side belt is a stretch type belt, it is not necessary to check deflection and tension.

Crank Pulley

MECHANICAL

13.Crank Pulley

A: REMOVAL

NOTE:

Perform the work with the engine installed to body when replacing a single part.

1) Remove the V-belts. <Ref. to ME(H4SO)-42, REMOVAL, V-belt.>

2) Use the ST to lock the crank pulley, and remove the crank pulley bolts.

ST 499977100 CRANK PULLEY WRENCH (MT model)

ST 499977400 CRANK PULLEY WRENCH (AT model)

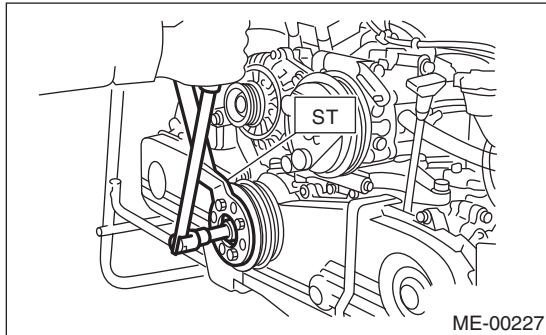

3) Remove the crank pulley.

B: INSTALLATION

1. AT MODEL

1) Install the crank pulley.

2) Use the ST to lock the crank pulley, and attach the crank pulley bolts.

ST 499977400 CRANK PULLEY WRENCH

(1) Clean the crankshaft thread using compressed air.

(2) Apply engine oil to the crank pulley bolt seat and thread.

(3) Tighten the bolts temporarily with tightening torque of 44 N·m (4.5 kgf·m, 32.5 ft·lb).

(4) Tighten the crank pulley bolts.

Tightening torque:

130 N·m (13.3 kgf·m, 95.9 ft·lb)

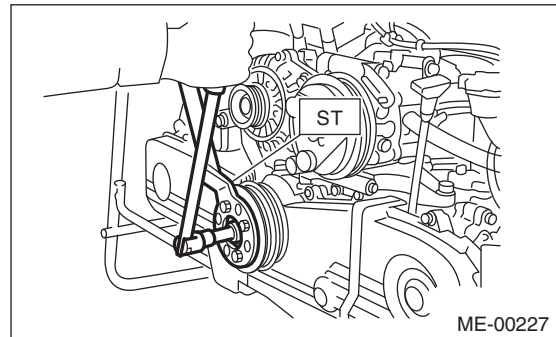

3) Check that the tightening angle of the crank pulley bolt is 45° or more. Perform the following procedure when less than 45°.

CAUTION:

If the tightening angle of crank pulley bolt is less than 45°, the bolt is damaged. In this case, the bolt must be replaced.

(1) Replace the crank pulley bolts and clean them.

Crank pulley bolt:

Part No. 12369AA011

(2) Clean the crankshaft thread using compressed air.

(3) Apply engine oil to the crank pulley bolt seat and thread.

(4) Tighten the bolts temporarily with tightening torque of 44 N·m (4.5 kgf·m, 32.5 ft·lb).

(5) Tighten the crank pulley bolts 45° to 60°.

NOTE:

Conduct the tightening procedures by confirming the turning angle of crank pulley bolt referring to the gauge indicated on timing belt cover.

4) Install the V-belts. <Ref. to ME(H4SO)-42, INSTALLATION, V-belt.>

2. MT MODEL

- 1) Install the crank pulley.
- 2) Use the ST to lock the crank pulley, and attach the crank pulley bolts.

ST 499977100 CRANK PULLEY WRENCH

- (1) Clean the crankshaft thread using compressed air.
- (2) Apply engine oil to the crank pulley bolt seat and thread.
- (3) Tighten the bolts temporarily with tightening torque of 44 N·m (4.5 kgf-m, 32.5 ft-lb).
- (4) Tighten the crank pulley bolts.

Tightening torque:

180 N·m (18.4 kgf-m, 132.8 ft-lb)

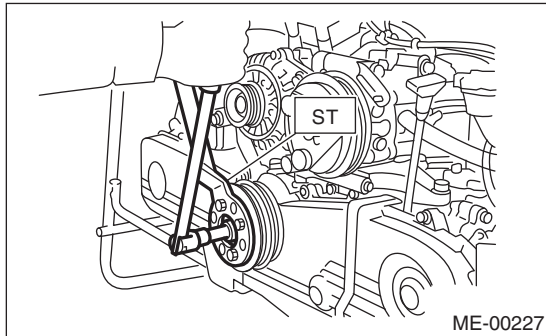

- 3) Check that the tightening angle of the crank pulley bolt is 65° or more. Perform the following procedure when less than 65°.

CAUTION:

If the tightening angle of crank pulley bolt is less than 65°, the bolt is damaged. In this case, the bolt must be replaced.

- (1) Replace the crank pulley bolts and clean them.

Crank pulley bolt:

Part No. 12369AA011

- (2) Clean the crankshaft thread using compressed air.
- (3) Apply engine oil to the crank pulley bolt seat and thread.
- (4) Tighten the bolts temporarily with tightening torque of 44 N·m (4.5 kgf-m, 32.5 ft-lb).
- (5) Tighten the crank pulley bolts 65° to 75°.

NOTE:

Conduct the tightening procedures by confirming the turning angle of crank pulley bolt referring to the gauge indicated on timing belt cover.

- 4) Install the V-belts. <Ref. to ME(H4SO)-42, INSTALLATION, V-belt.>

C: INSPECTION

- 1) Make sure the V-belts are not worn or otherwise damaged.
- 2) Check the tension of the front side belt. <Ref. to ME(H4SO)-48, INSPECTION, V-belt.>

14. Timing Belt Cover

A: REMOVAL

NOTE:

Perform the work with the engine installed to body when replacing a single part.

- 1) Remove the V-belts. <Ref. to ME(H4SO)-42, REMOVAL, V-belt.>
- 2) Remove the crank pulley. <Ref. to ME(H4SO)-50, REMOVAL, Crank Pulley.>
- 3) Remove the timing belt cover LH.
- 4) Remove the front timing belt cover.

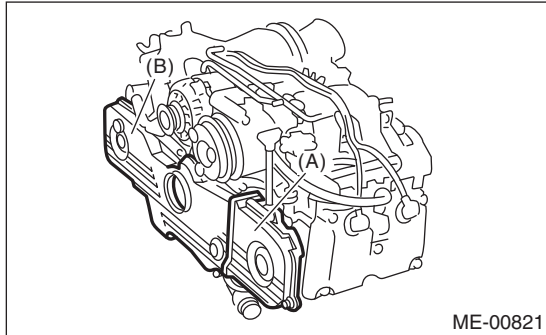

- (A) Timing belt cover LH
- (B) Front timing belt cover

B: INSTALLATION

- 1) Install the front timing belt cover.

Tightening torque:

5 N·m (0.5 kgf-m, 3.7 ft-lb)

- 2) Install the timing belt cover LH.

Tightening torque:

5 N·m (0.5 kgf-m, 3.7 ft-lb)

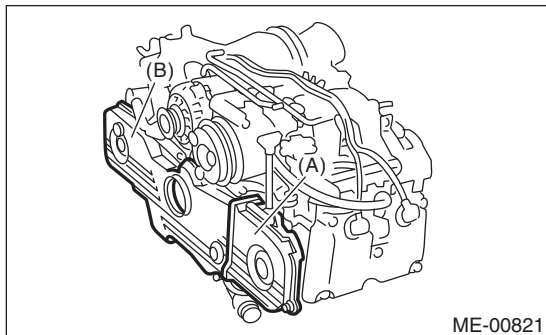

- (A) Timing belt cover LH
- (B) Front timing belt cover

- 3) Install the crank pulley. <Ref. to ME(H4SO)-50, INSTALLATION, Crank Pulley.>
- 4) Install the V-belts. <Ref. to ME(H4SO)-42, INSTALLATION, V-belt.>

C: INSPECTION

Check the timing belt cover for damage.

15. Timing Belt

A: REMOVAL

NOTE:

Perform the work with the engine installed to body when replacing a single part. For operation procedures, refer to "Timing Belt" in the PM section. <Ref. to PM-14, Timing Belt.>

1. TIMING BELT

- 1) Remove the V-belts. <Ref. to ME(H4SO)-42, REMOVAL, V-belt.>
- 2) Remove the crank pulley. <Ref. to ME(H4SO)-50, REMOVAL, Crank Pulley.>
- 3) Remove the timing belt cover. <Ref. to ME(H4SO)-52, REMOVAL, Timing Belt Cover.>
- 4) Remove the timing belt guide. (MT model)

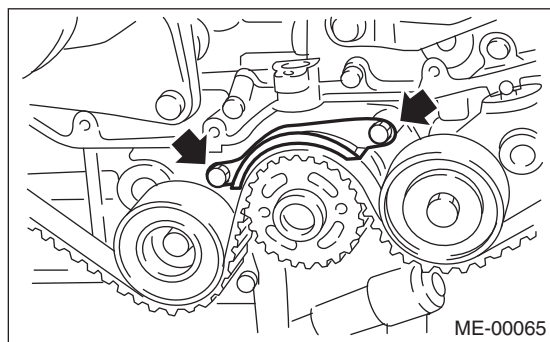

5) If the alignment mark or arrow mark (which indicates the direction of rotation) on timing belt fade away, put new marks before removing the timing belt as shown in procedures below.

- (1) Use the ST to turn crankshaft. Align the mark (a) of sprocket to the cylinder block notch (b), and then ensure the right side cam sprocket mark (c), cam cap and cylinder head matching surface (d) or left side cam sprocket mark (e), timing belt cover notch (f) are properly adjusted.

ST 499987500 CRANKSHAFT SOCKET

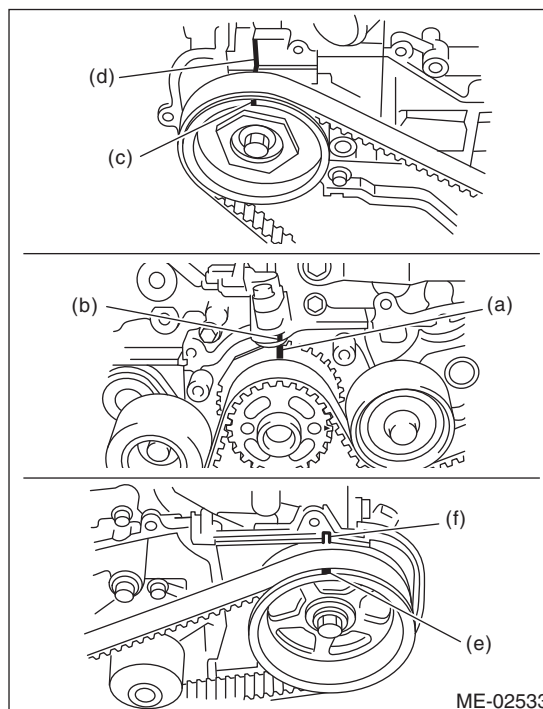
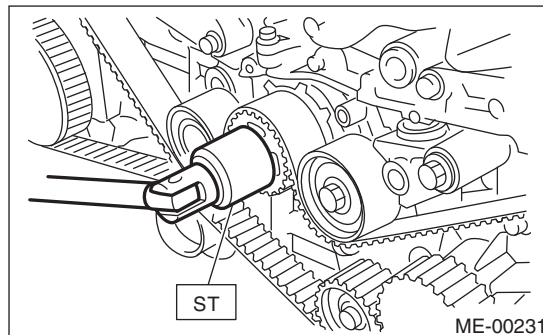

Timing Belt

MECHANICAL

(2) Using white paint, put an alignment mark or an arrow mark on timing belts in relation to the crank sprocket and cam sprockets.

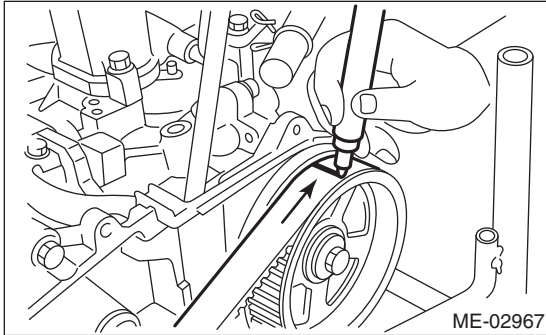

Z_1 : 46.8 teeth

Z_2 : 43.7 teeth

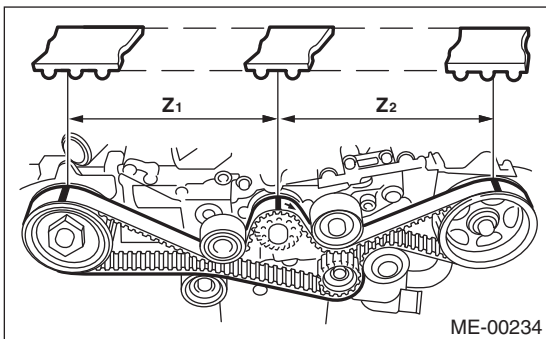

6) Remove the belt idler (A).

7) Remove the belt idler (B).

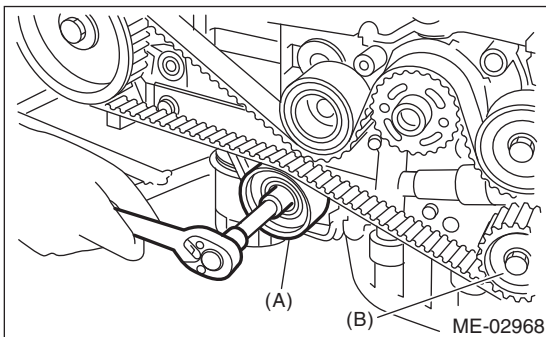

8) Remove the timing belt.

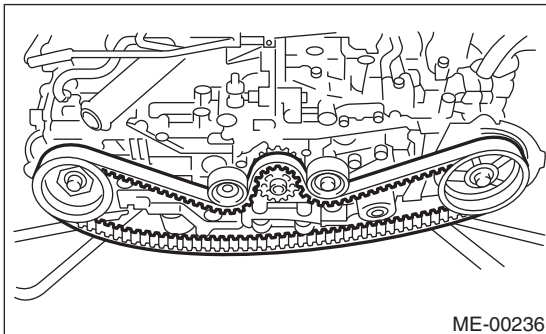

2. BELT IDLER AND AUTOMATIC BELT TENSION ADJUSTER ASSEMBLY

1) Remove the belt idler No. 1.

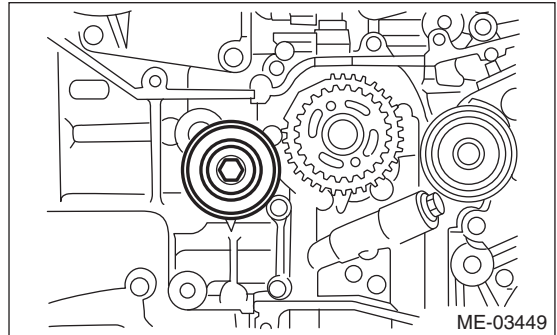

2) Remove the automatic belt tension adjuster assembly.

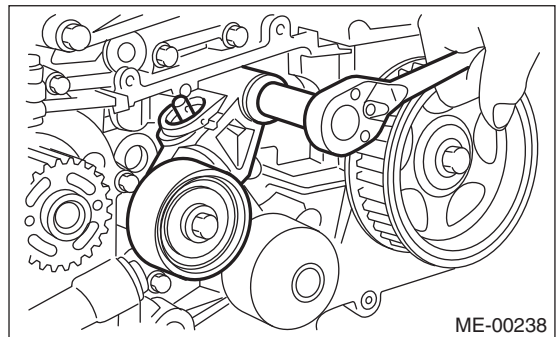

B: INSTALLATION

1. AUTOMATIC BELT TENSION ADJUSTER ASSEMBLY AND BELT IDLER

1) Prepare for installation of the automatic belt tension adjuster assembly.

CAUTION:

- Always use a vertical type pressing tool to move the adjuster rod down.
- Do not use a lateral type vise.
- Push the adjuster rod vertically.
- Press-in the push adjuster rod gradually taking three minutes or more.
- Do not allow press pressure to exceed 9,807 N (1,000 kgf, 2,205 lb).
- Push in the adjuster rod to the end face of the cylinder. However, do not push in the adjuster rod below the end face of the cylinder. Doing so may damage the cylinder.
- Do not release the press pressure until stopper pin is completely inserted.

(1) Attach the automatic belt tension adjuster assembly to vertical pressing tool.

(2) Slowly push in the adjuster rod with a pressure of 165 N (16.8 kgf, 37.1 lb) or more until the adjuster rod is aligned with the stopper pin hole in the cylinder.

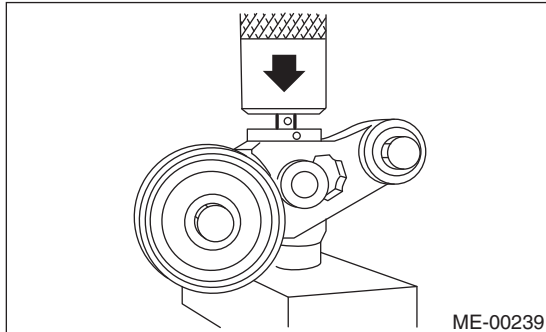

(3) With a 2 mm (0.08 in) dia. stopper pin or a 2 mm (nominal) dia. hex wrench inserted into the stopper pin hole in cylinder, secure the adjuster rod.

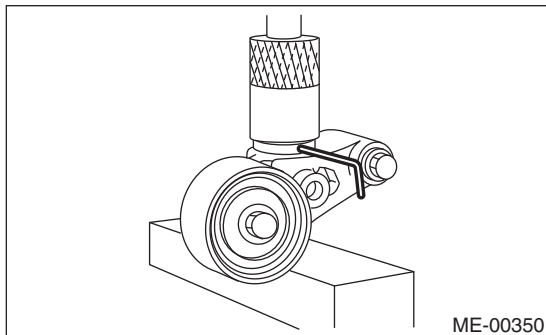

2) Install the automatic belt tension adjuster assembly.

Tightening torque:

39 N·m (4.0 kgf·m, 28.8 ft·lb)

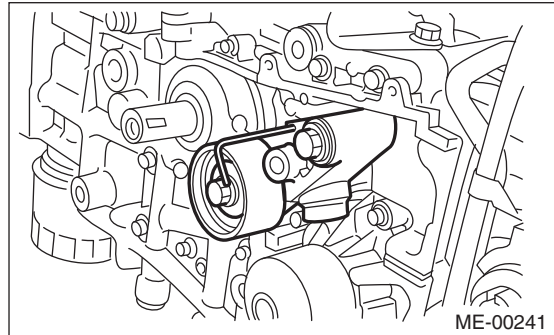

3) Install the belt idler No. 1.

Tightening torque:

39 N·m (4.0 kgf·m, 28.8 ft·lb)

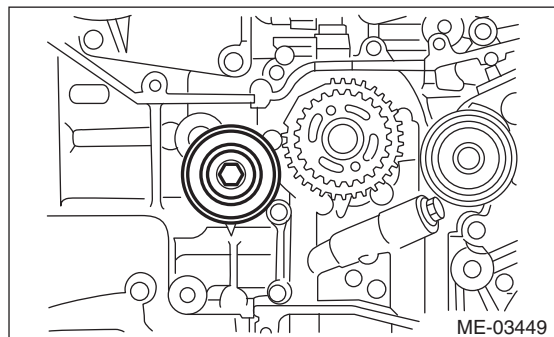

Timing Belt

MECHANICAL

2. TIMING BELT

1) Prepare for installation of the automatic belt tension adjuster assembly. <Ref. to ME(H4SO)-55, AUTOMATIC BELT TENSION ADJUSTER ASSEMBLY AND BELT IDLER, INSTALLATION, Timing Belt.>

2) Align the mark (A) on crank sprocket with the mark on oil pump cover at cylinder block.

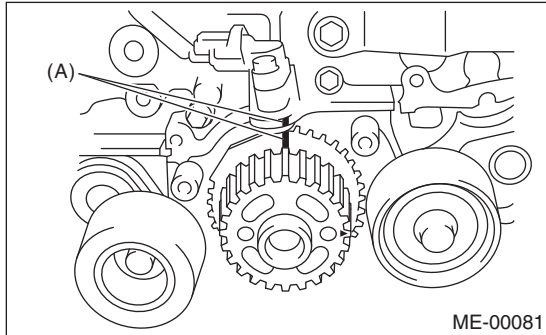

3) Turn the camshaft sprocket No. 2 using ST1, and turn the camshaft sprocket No. 1 using ST2 so that their alignment marks (A) come to top positions.

ST1 18231AA010 CAM SPROCKET WRENCH

NOTE:

CAM SPROCKET WRENCH (499207100) can also be used.

ST2 499207400 CAM SPROCKET WRENCH

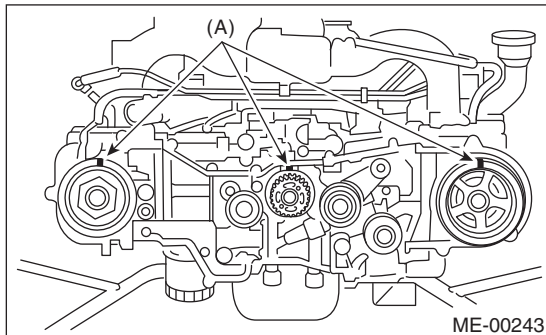

4) While aligning the alignment mark (B) on timing belt with the mark (A) on sprockets, position the timing belt properly.

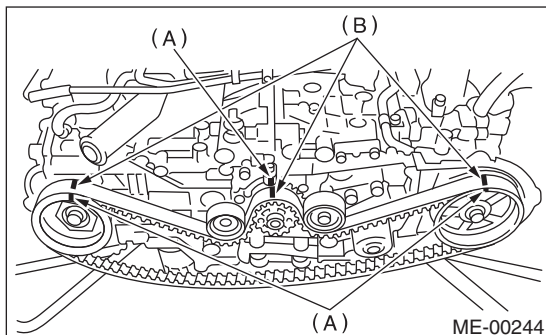

5) Install the belt idler (B).

Tightening torque:

39 N·m (4.0 kgf·m, 28.8 ft·lb)

6) Install the belt idler (A).

Tightening torque:

39 N·m (4.0 kgf·m, 28.8 ft·lb)

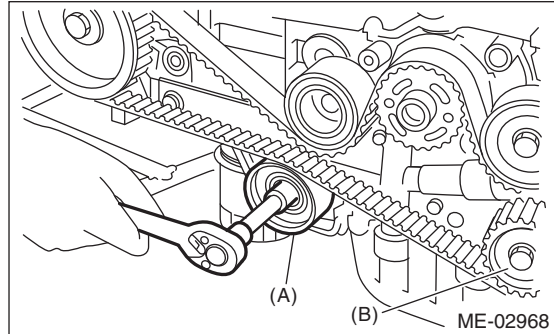

7) After ensuring the marks on timing belt and camshaft sprockets are aligned, remove the stopper pin from belt tension adjuster.

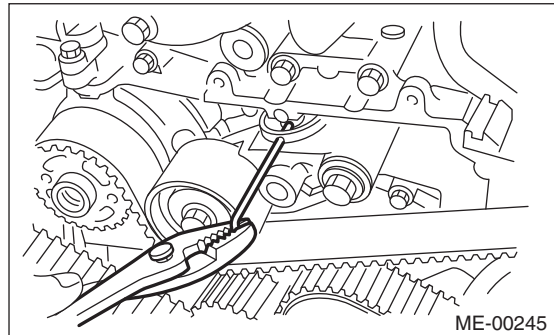

8) Install the timing belt guide. (MT model)

(1) Temporarily tighten the bolts mounting the timing belt guide.

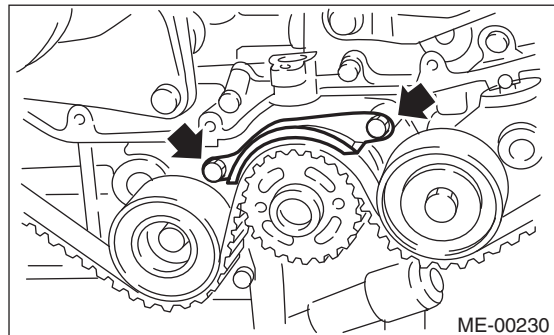

(2) Check and adjust the clearance between timing belt and timing belt guide by using thickness gauge.

Clearance:

1.0 ± 0.5 mm (0.039 ± 0.020 in)

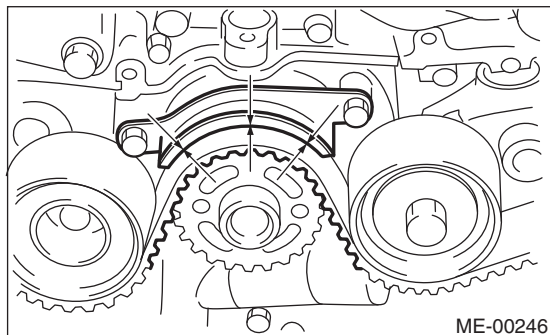

(3) Tighten the bolts mounting the timing belt guide.

Tightening torque:

9.75 N·m (1.0 kgf·m, 7.2 ft·lb)

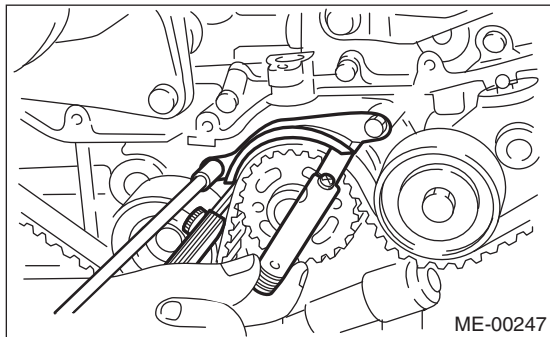

- 9) Install the timing belt cover. <Ref. to ME(H4SO)-52, INSTALLATION, Timing Belt Cover.>
- 10) Install the crank pulley. <Ref. to ME(H4SO)-50, INSTALLATION, Crank Pulley.>
- 11) Install the V-belts. <Ref. to ME(H4SO)-42, INSTALLATION, V-belt.>

C: INSPECTION

1. TIMING BELT

- 1) Check the timing belt teeth for breaks, cracks or wear. If any fault is found, replace the timing belt.
- 2) Check the condition on the back surface of the timing belt. If cracks are found, replace the timing belt.

CAUTION:

- Be careful not to let oil, grease or coolant contact the timing belt. Remove quickly and thoroughly if this happens.
- Do not bend the timing belt sharply.

In radial diameter h:

60 mm (2.36 in) or more

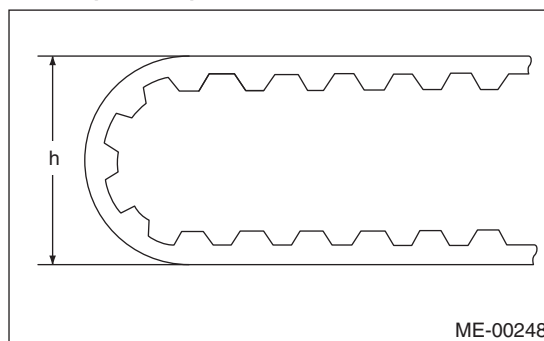

Timing Belt

MECHANICAL

2. AUTOMATIC BELT TENSION ADJUSTER

1) Visually check the oil seals for leaks, and rod ends for abnormal wear and scratches. If necessary, replace the automatic belt tension adjuster assembly.

NOTE:

Slight traces of oil at rod's oil seal does not indicate a problem.

2) Check that the adjuster rod does not move when a pressure of 165 N (16.8 kgf, 37.1 lb) is applied to it. This is to check adjuster rod stiffness.

3) If the adjuster rod is not stiff and moves freely when applying 165 N (16.8 kgf, 37.1 lb), check it using the following procedures:

(1) Slowly press the adjuster rod down to the end surface of cylinder. Repeat this operation two to three times.

(2) With the adjuster rod moved all the way up, apply a pressure of 165 N (16.8 kgf, 37.1 lb) to it. Check the adjuster rod stiffness.

(3) If the adjuster rod is not stiff and moves down, replace the automatic belt tension adjuster assembly with a new part.

CAUTION:

- Always use a vertical type pressing tool to move the adjuster rod down.
- Do not use a lateral type vise.
- Push the adjuster rod vertically.
- Press the adjuster rod gradually taking three minutes or more.
- Do not allow press pressure to exceed 9,807 N (1,000 kgf, 2,205 lb).
- Push in the adjuster rod to the end face of the cylinder. However, do not push in the adjuster rod below the end face of the cylinder. Doing so may damage the cylinder.

4) Measure the amount of rod protrusion "H" from the end surface of the body. If it is not within specified range, replace with new part.

Amount of rod protrusion H:

5.2 — 6.2 mm (0.204 — 0.244 in)

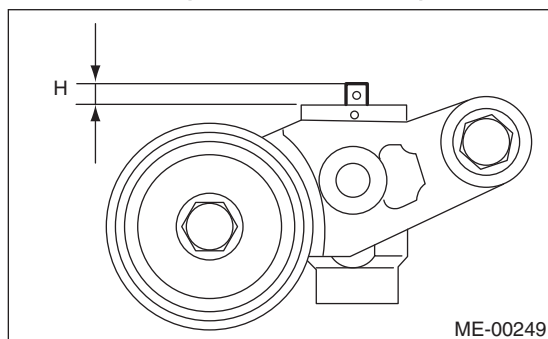

3. BELT TENSION PULLEY

1) Check the mating surfaces of timing belt and contact point of adjuster rod for abnormal wear or scratches. Replace the automatic belt tension adjuster assembly with a new part if faulty.

2) Check the belt tension pulley for smooth rotation. Replace if noise or excessive play occurs.

3) Check the belt tension pulley for grease leakage.

4. BELT IDLER

1) Check the belt idler for smooth rotation. Replace if noise or excessive play occurs.

2) Check the outer contacting surfaces of idler pulley for abnormal wear and scratches.

3) Check the belt idler for grease leakage.

16. Cam Sprocket

A: REMOVAL

NOTE:

Perform the work with the engine installed to body when replacing a single part.

- 1) Remove the V-belts. <Ref. to ME(H4SO)-42, REMOVAL, V-belt.>
- 2) Remove the crank pulley. <Ref. to ME(H4SO)-50, REMOVAL, Crank Pulley.>
- 3) Remove the timing belt cover. <Ref. to ME(H4SO)-52, REMOVAL, Timing Belt Cover.>
- 4) Remove the timing belt. <Ref. to ME(H4SO)-53, REMOVAL, Timing Belt.>
- 5) Remove the camshaft position sensor. <Ref. to FU(H4SO)-24, REMOVAL, Camshaft Position Sensor.>

6) Fasten the cam sprocket and remove from the cam shaft using ST.

ST 18231AA010 CAM SPROCKET WRENCH

NOTE:

CAM SPROCKET WRENCH (499207100) can also be used.

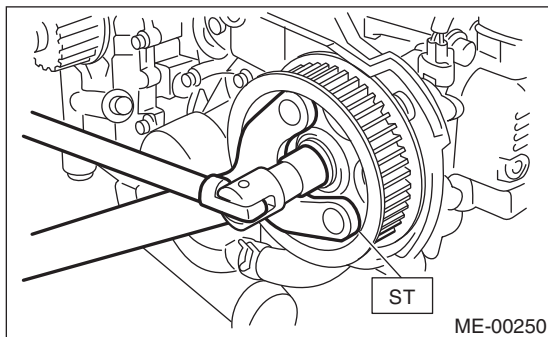

ST 499207400 CAM SPROCKET WRENCH

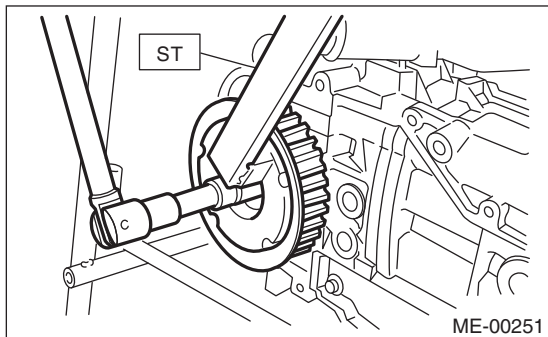

B: INSTALLATION

1) Fasten the cam sprocket and install to the cam shaft using ST.

NOTE:

Do not confuse left and right side cam sprockets during installation. They should be distinguished by the L or R indication.

ST 18231AA010 CAM SPROCKET WRENCH

NOTE:

CAM SPROCKET WRENCH (499207100) can also be used.

Tightening torque:

78 N·m (8.0 kgf-m, 57.5 ft-lb)

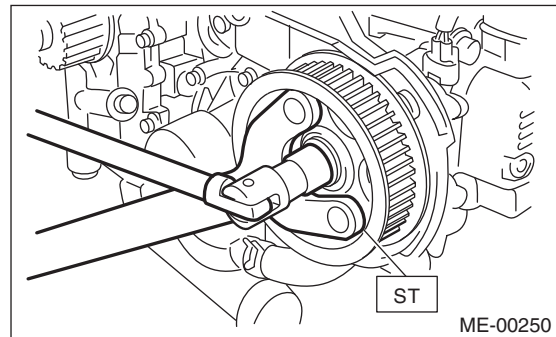

ST 499207400 CAM SPROCKET WRENCH

Tightening torque:

78 N·m (8.0 kgf-m, 57.5 ft-lb)

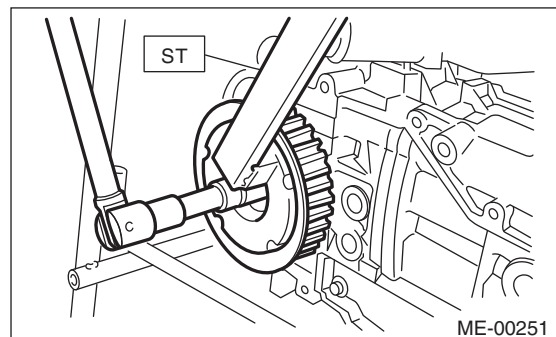

2) Install the camshaft position sensor. <Ref. to FU(H4SO)-24, INSTALLATION, Camshaft Position Sensor.>

3) Install the timing belt. <Ref. to ME(H4SO)-55, INSTALLATION, Timing Belt.>

4) Install the timing belt cover.

<Ref. to ME(H4SO)-52, INSTALLATION, Timing Belt Cover.>

5) Install the crank pulley. <Ref. to ME(H4SO)-50, INSTALLATION, Crank Pulley.>

6) Install the V-belts. <Ref. to ME(H4SO)-42, INSTALLATION, V-belt.>

Cam Sprocket

MECHANICAL

C: INSPECTION

- 1) Check the cam sprocket teeth for abnormal wear and scratches.
- 2) Make sure there is no free play between cam sprocket and key.
- 3) Check the cam sprocket protrusion used for sensor for damage and contamination of foreign matter.

17. Crank Sprocket

A: REMOVAL

NOTE:

Perform the work with the engine installed to body when replacing a single part.

- 1) Remove the V-belts. <Ref. to ME(H4SO)-42, REMOVAL, V-belt.>
- 2) Remove the crank pulley. <Ref. to ME(H4SO)-50, REMOVAL, Crank Pulley.>
- 3) Remove the timing belt cover. <Ref. to ME(H4SO)-52, REMOVAL, Timing Belt Cover.>
- 4) Remove the timing belt. <Ref. to ME(H4SO)-53, REMOVAL, Timing Belt.>
- 5) Remove the crank sprocket.

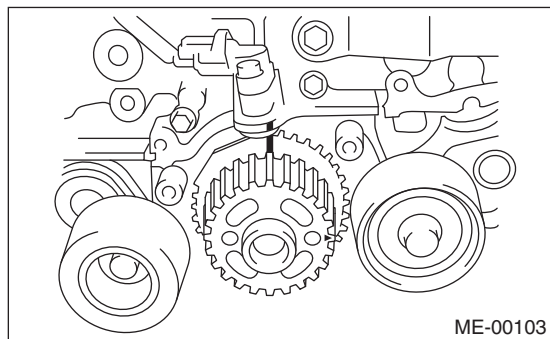

B: INSTALLATION

- 1) Install the crank sprocket.

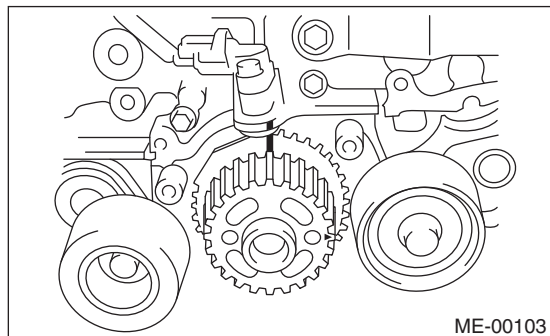

- 2) Install the timing belt. <Ref. to ME(H4SO)-55, INSTALLATION, Timing Belt.>
- 3) Install the timing belt cover. <Ref. to ME(H4SO)-52, INSTALLATION, Timing Belt Cover.>
- 4) Install the crank pulley. <Ref. to ME(H4SO)-50, INSTALLATION, Crank Pulley.>
- 5) Install the V-belts. <Ref. to ME(H4SO)-42, INSTALLATION, V-belt.>

C: INSPECTION

- 1) Check the crank sprocket teeth for abnormal wear and scratches.
- 2) Make sure there is no free play between crank sprocket and key.
- 3) Check the crank sprocket protrusion used for sensor for damage and contamination of foreign matter.

Valve Rocker Assembly

MECHANICAL

18. Valve Rocker Assembly

A: REMOVAL

NOTE:

Perform the work with the engine installed to body when replacing a single part. Refer to "Valve Clearance" for preparation procedures. <Ref. to ME(H4SO)-29, Valve Clearance.>

- 1) Remove the high tension cord.
- 2) Disconnect the PCV hose and remove the rocker cover.

NOTE:

Fit the depression in the ST with the protrusion of the clamp as shown in the figure below, and unlock the clamp.

ST 18353AA000 CLAMP PLIERS

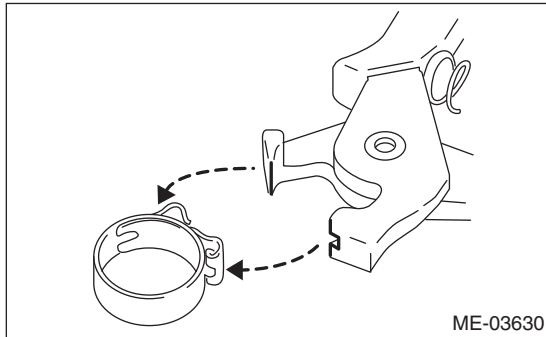

- 3) Remove the valve rocker assembly.

(1) Use the ST to rotate the spring stopper in the direction of the arrow to remove it from adjuster pin.

ST 18258AA000 SPRING INSTALLER

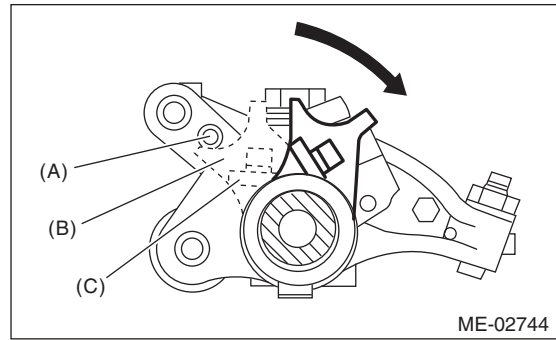
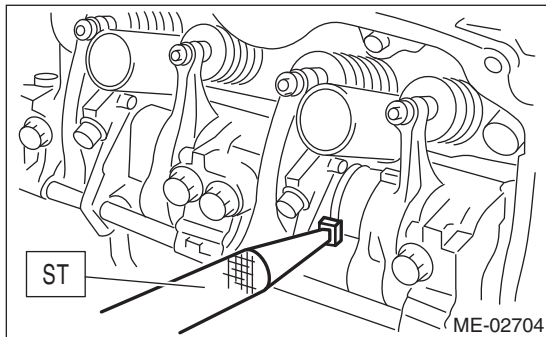

- (A) Adjuster pin
- (B) Spring stopper
- (C) Spring

- (2) Remove the bolts (a) through (j) in alphabetical sequence.

NOTE:

Leave two or three threads of bolts (i) and (j) engaged in order to retain the valve rocker assembly.

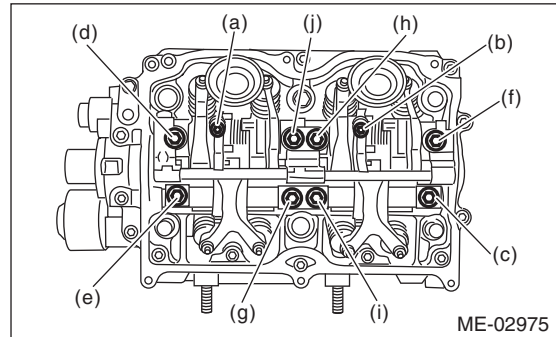

- (3) Remove the valve rocker assembly.

NOTE:

Set the ST in the position shown in the drawing to remove the intake valve rocker assembly.

ST 18354AA000 VALVE ROCKER HOLDER

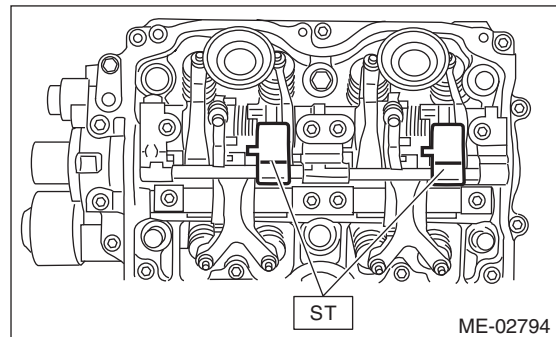

B: INSTALLATION

1) Install the valve rocker assembly.

(1) Temporarily tighten the bolts equally in alphabetical order as shown in the figure.

NOTE:

- Do not temporarily tighten the bolts (i) and (j).
- Set the ST in the position shown in the drawing to mount the intake valve rocker assembly.

ST 18354AA000 VALVE ROCKER HOLDER

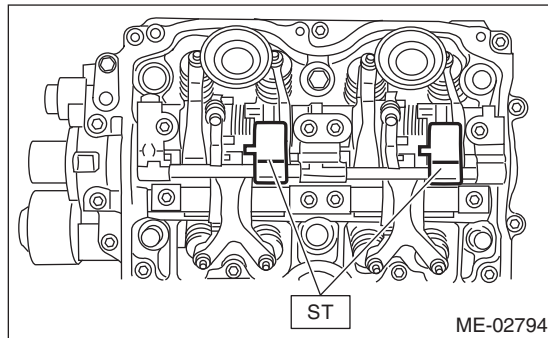

(2) Tighten the bolts (a) through (h) to specified torque.

Tightening torque:

25 N·m (2.5 kgf·m, 18.4 ft·lb)

(3) Tighten the bolts (i) through (j) to specified torque.

Tightening torque:

6 N·m (0.6 kgf·m, 4.4 ft·lb)

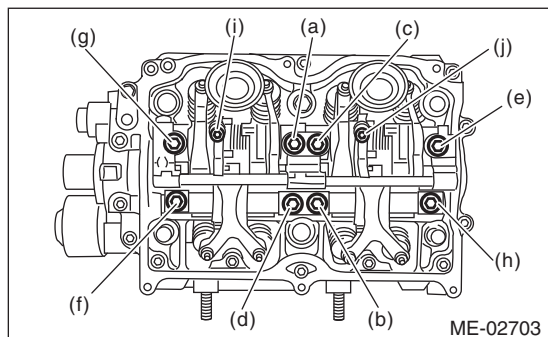

(4) Use the ST to rotate the spring stopper in the direction of the arrow to fasten the adjuster pin.

ST 18258AA000 SPRING INSTALLER

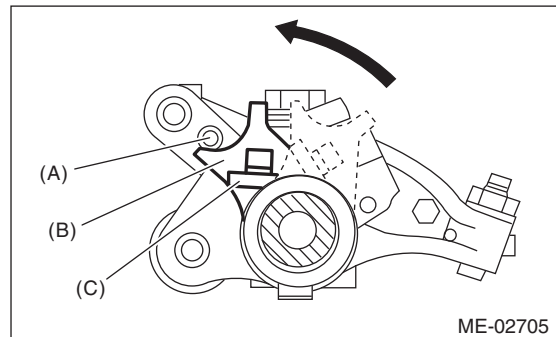
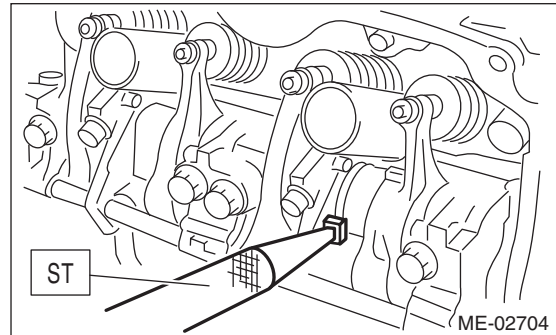

- (A) Adjuster pin
- (B) Spring stopper
- (C) Spring

2) Adjust the valve clearance. <Ref. to ME(H4SO)-31, ADJUSTMENT, Valve Clearance.>

Valve Rocker Assembly

MECHANICAL

- 3) Install the rocker cover.
(1) Install the rocker cover gasket to the rocker cover.

NOTE:

Use a new rocker cover gasket.

- (2) Temporarily tighten the bolts in alphabetical sequence as shown in figure, then tighten the bolt in 2 steps.

Tightening torque:

1st

6.4 N·m (0.7 kgf·m, 4.7 ft·lb)

2nd (only (a) and (b) are tightened)

6.4 N·m (0.7 kgf·m, 4.7 ft·lb)

RH side

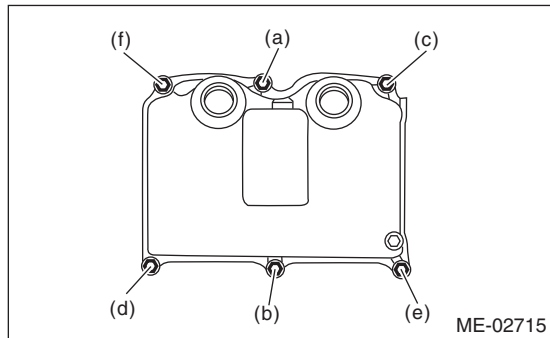

LH side

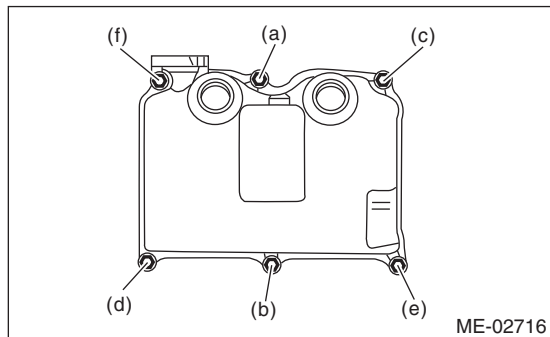

- 4) Connect the PCV hose.

NOTE:

For the PVC hose clamp, use a new clamp. Sandwich the protruding part of the clamp with the ST and lock the clamp.

ST 18353AA000 CLAMP PLIERS

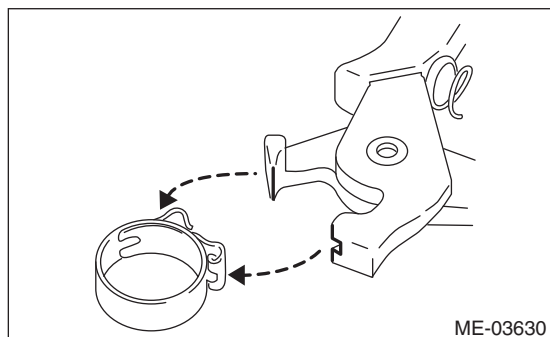

- 5) Install the high tension cord.

- 6) Install the timing belt cover.

<Ref. to ME(H4SO)-52, INSTALLATION, Timing Belt Cover.>

C: DISASSEMBLY

NOTE:

Intake valve rocker assembly cannot be disassembled.

- 1) Remove the exhaust valve rocker arm from the rocker shaft.

NOTE:

Keep all the removed parts in order for re-installing in their original positions.

- 2) Remove the nut and adjusting screw from exhaust valve rocker.

D: ASSEMBLY

NOTE:

Intake valve rocker assembly cannot be disassembled.

- 1) Install the adjusting screw and nut to the exhaust valve rocker.

- 2) Insert the exhaust valve rocker arm to rocker shaft.

NOTE:

Valve rocker arms, and rocker shaft have identification marks. Make sure the parts with same markings are properly assembled.

E: INSPECTION

1. INTAKE VALVE ROCKER ASSEMBLY

- 1) If the roller or valve contact surface of valve rocker arm is worn or dented excessively, replace the valve rocker assembly.
- 2) Check that the valve rocker arm roller rotates smoothly. If not, replace the valve rocker assembly.

2. EXHAUST VALVE ROCKER ASSEMBLY

- 1) Measure the inner diameter of valve rocker arm and outer diameter of valve rocker shaft, and confirm the difference (oil clearance) between the two values.

Clearance between arm and shaft:

Standard

0.020 — 0.054 mm (0.0008 — 0.0021 in)

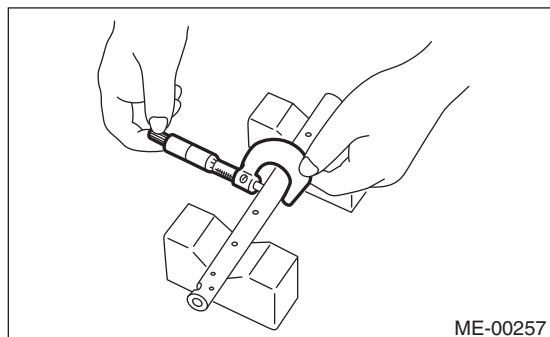
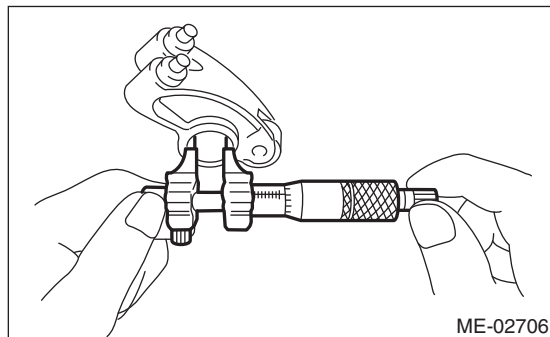

- 2) If the oil clearance exceeds the limit, replace the valve rocker arm or shaft, whichever shows the greater amount of wear.

Rocker arm inside diameter:

22.020 — 22.041 mm (0.8669 — 0.8678 in)

Rocker shaft diameter:

21.987 — 22.000 mm (0.8656 — 0.8661 in)

- 3) If the roller or valve contact surface of valve rocker arm is worn or dented excessively, replace the valve rocker arm.
- 4) Check that the valve rocker arm roller rotates smoothly. If not, replace the valve rocker arm.

19. Camshaft

A: REMOVAL

NOTE:

Perform the work with the engine installed to body when replacing a single part. Refer to "Valve Clearance" for preparation procedures. <Ref. to ME(H4SO)-29, Valve Clearance.>

- 1) Remove the V-belts. <Ref. to ME(H4SO)-42, REMOVAL, V-belt.>
- 2) Remove the crank pulley. <Ref. to ME(H4SO)-50, REMOVAL, Crank Pulley.>
- 3) Remove the timing belt cover. <Ref. to ME(H4SO)-52, REMOVAL, Timing Belt Cover.>
- 4) Remove the timing belt. <Ref. to ME(H4SO)-53, REMOVAL, Timing Belt.>
- 5) Remove the cam sprocket. <Ref. to ME(H4SO)-59, REMOVAL, Cam Sprocket.>
- 6) Remove the timing belt cover No. 2 LH.
- 7) Remove the timing belt cover No. 2 RH.

NOTE:

Do not damage or lose the seal rubber when removing the timing belt covers.

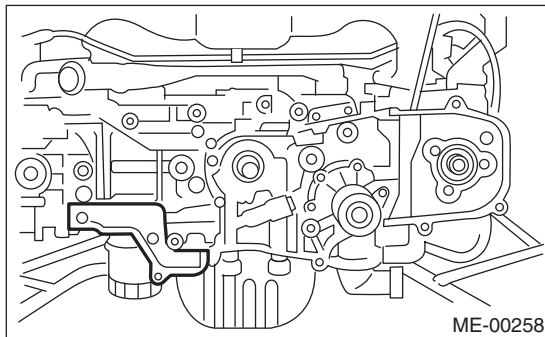

- 8) Remove the tensioner bracket.

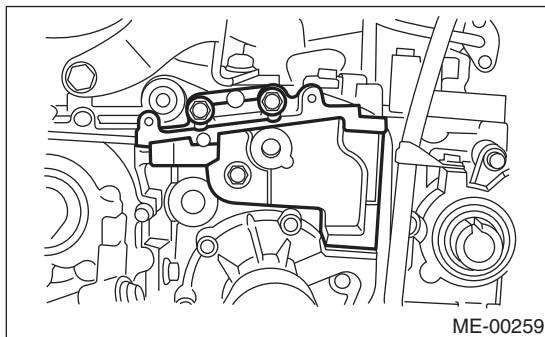

- 9) Remove the camshaft position sensor support. (LH side only)
- 10) Remove the valve rocker assembly. <Ref. to ME(H4SO)-62, REMOVAL, Valve Rocker Assembly.>

- 11) Remove the camshaft cap.

(1) Remove the bolts (a) and (b) in alphabetical sequence.

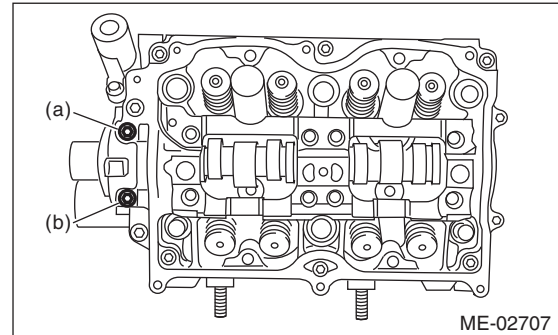

(2) Equally loosen the bolts (c) through (j) all the way in alphabetical sequence.

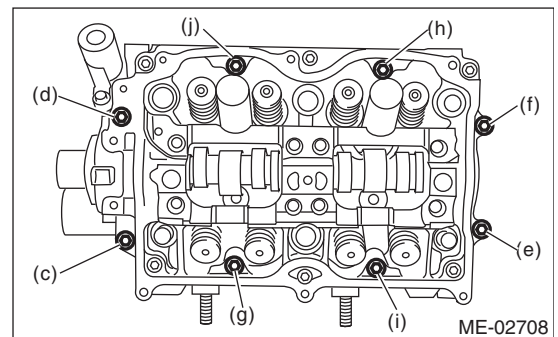

(3) Remove the bolts (k) through (p) in alphabetical sequence using ST.

ST 499497000 TORX PLUS®

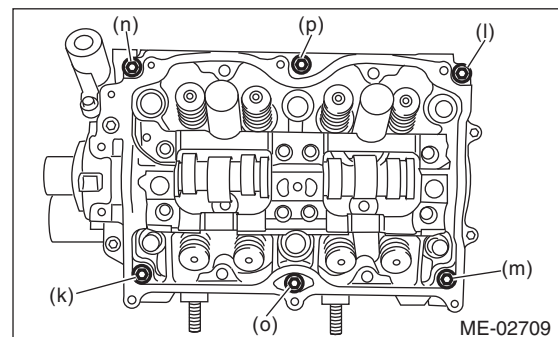

(4) Remove the camshaft cap.

12) Remove the camshaft.

13) Remove the oil seal.

14) Remove the plug from rear side of camshaft.

CAUTION:

Do not scratch the journal surface when removing the oil seal.

15) Similarly, remove the camshaft RH and related parts.

B: INSTALLATION

- 1) Apply a thin coat of engine oil to camshaft journals, and install the camshaft.
- 2) Install the camshaft cap.
 - (1) Apply liquid gasket to the mating surfaces of camshaft cap.

NOTE:

Install within 5 min. after applying liquid gasket.

Liquid gasket:

**THREE BOND 1217G (Part No. K0877Y0100)
or equivalent**

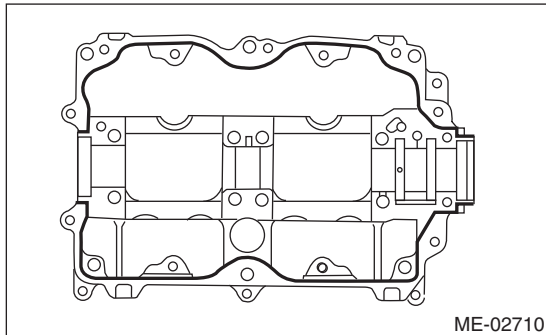

NOTE:

Apply a coat of liquid gasket of 3 mm (0.12 in) in diameter (A) along the edge (B) of camshaft cap (C) mating surface.

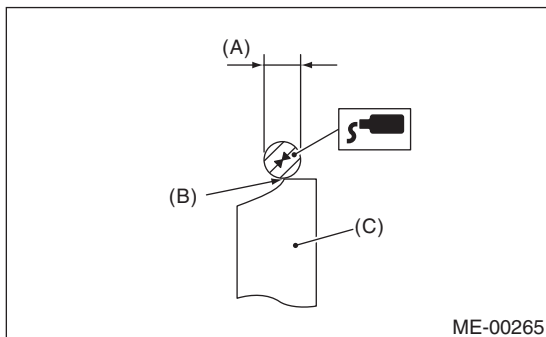

- (2) Temporarily tighten the bolts (a) through (d) in alphabetical sequence.

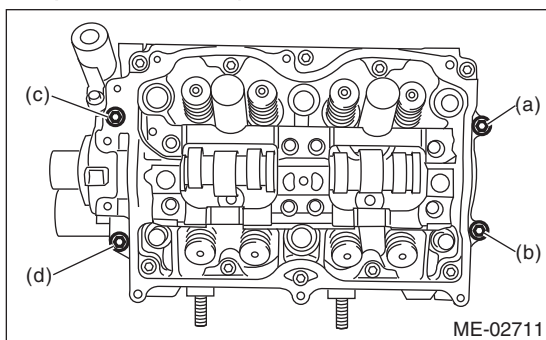

- (3) Install the valve rocker assembly.
<Ref. to ME(H4SO)-63, INSTALLATION, Valve Rocker Assembly.>

- (4) Tighten the TORX® bolts (e) through (j) in alphabetical sequence using the ST. ST 499497000 TORX PLUS®

Tightening torque:

18 N·m (1.8 kgf·m, 13.3 ft·lb)

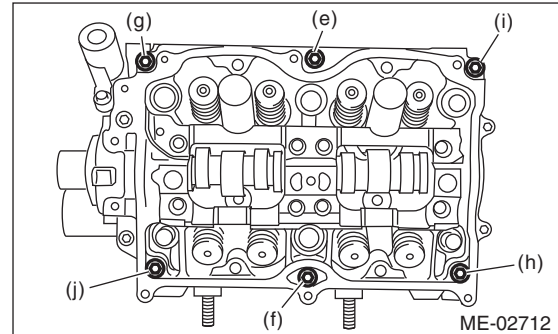

- (5) Tighten the bolts (k) through (r) in alphabetical sequence.

Tightening torque:

9.75 N·m (1.0 kgf·m, 7.2 ft·lb)

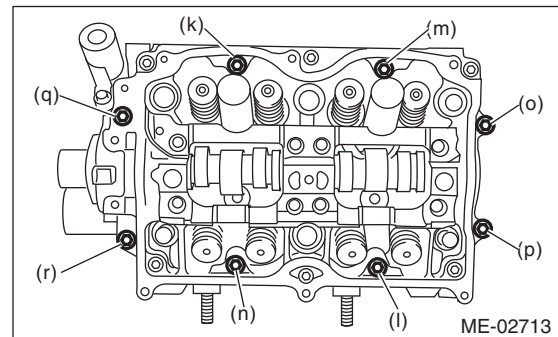

- (6) Tighten the bolts (s) and (t) in alphabetical sequence.

NOTE:

- Use a new seal washer.
- Install and tighten the seal washer to the bolt.

Tightening torque:

9.75 N·m (1.0 kgf·m, 7.2 ft·lb)

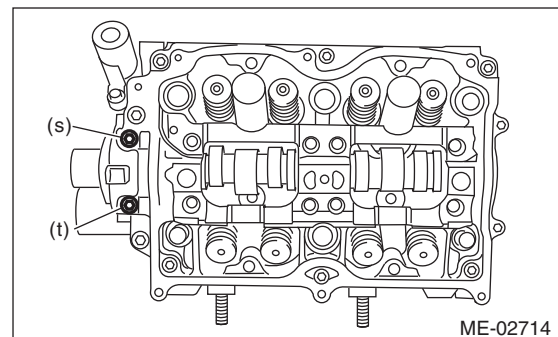

Camshaft

MECHANICAL

3) Apply a coat of engine oil to camshaft oil seal periphery and oil seal lips and install the oil seal (A) on camshaft using ST1 and ST2.

NOTE:

Use a new oil seal.

ST1	499597000	OIL SEAL GUIDE
ST2	499587500	OIL SEAL INSTALLER

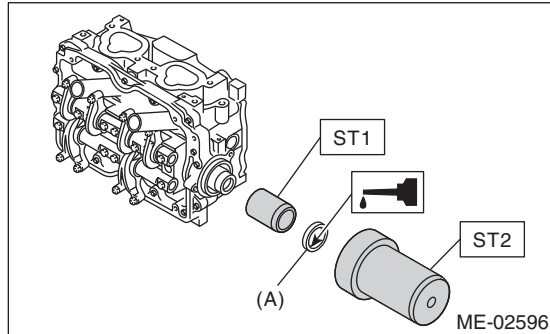

4) Apply a coat of engine oil to plug periphery and install the plug (A) using ST.

ST	499587700	CAMSHAFT OIL SEAL INSTALLER
----	-----------	-----------------------------

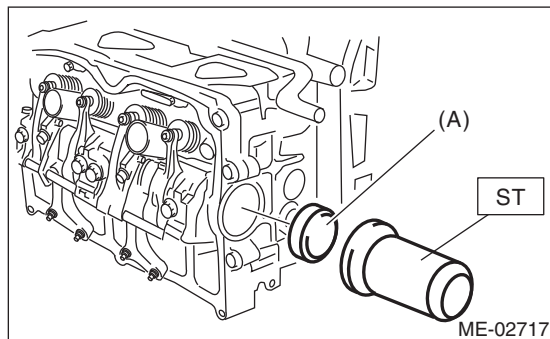

5) Install the camshaft position sensor support. (LH side only)

Tightening torque:

6.4 N·m (0.7 kgf-m, 4.7 ft-lb)

6) Similarly, install the parts on right-hand side.

7) Install the tensioner bracket.

Tightening torque:

24.5 N·m (2.5 kgf-m, 18.1 ft-lb)

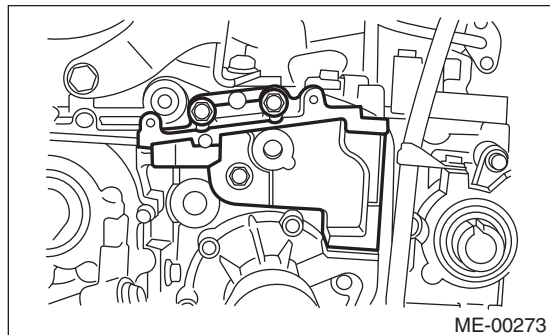

8) Install the timing belt cover No. 2 RH.

Tightening torque:

5 N·m (0.5 kgf-m, 3.7 ft-lb)

9) Install the timing belt cover No. 2 (LH).

Tightening torque:

5 N·m (0.5 kgf-m, 3.7 ft-lb)

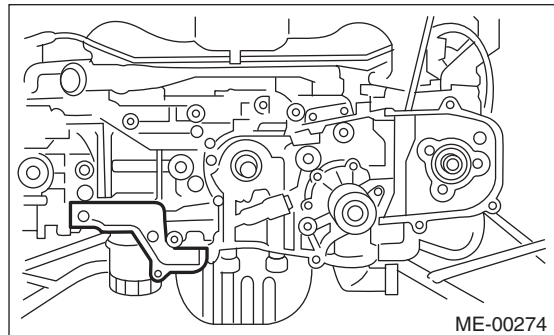

10) Install the cam sprocket. <Ref. to ME(H4SO)-59, INSTALLATION, Cam Sprocket.>

11) Install the timing belt. <Ref. to ME(H4SO)-55, INSTALLATION, Timing Belt.>

12) Adjust the valve clearance. <Ref. to ME(H4SO)-31, ADJUSTMENT, Valve Clearance.>

13) Install the rocker cover.

(1) Install the rocker cover gasket to the rocker cover.

NOTE:

Use a new rocker cover gasket.

(2) Temporarily tighten the bolts in alphabetical sequence as shown in figure, then tighten the bolt in 2 steps.

Tightening torque:

1st

6.4 N·m (0.7 kgf·m, 4.7 ft·lb)

2nd (only (a) and (b) are tightened)

6.4 N·m (0.7 kgf·m, 4.7 ft·lb)

RH side

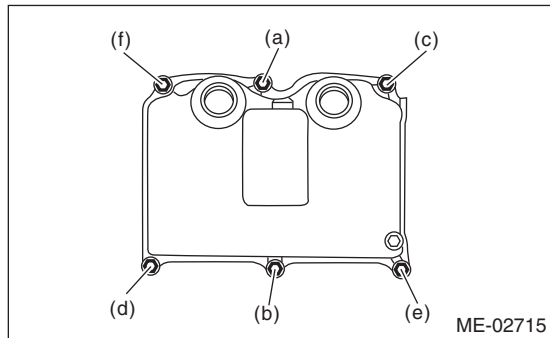

LH side

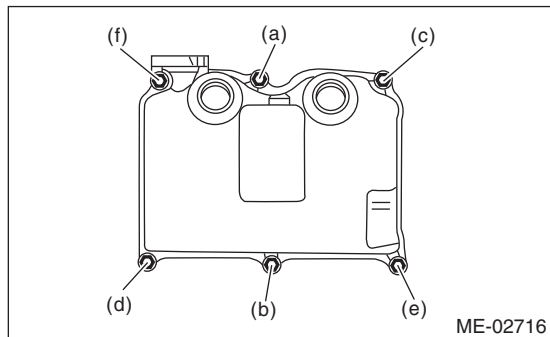

14) Connect the PCV hose.

NOTE:

For the PVC hose clamp, use a new clamp. Sandwich the protruding part of the clamp with the ST and lock the clamp.

ST 18353AA000 CLAMP PLIERS

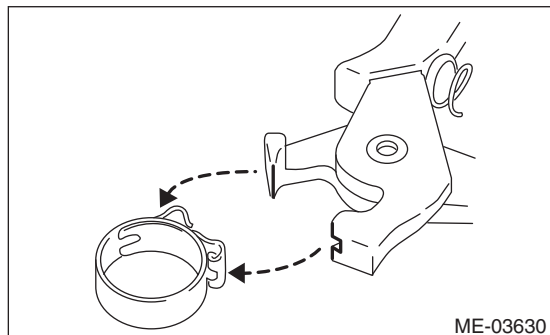

15) Install the high tension cord.

16) Install the timing belt cover.

<Ref. to ME(H4SO)-52, INSTALLATION, Timing Belt Cover.>

17) Install the crank pulley. <Ref. to ME(H4SO)-50, INSTALLATION, Crank Pulley.>

18) Install the V-belts. <Ref. to ME(H4SO)-42, INSTALLATION, V-belt.>

Camshaft

MECHANICAL

C: INSPECTION

1. CAMSHAFT

1) Measure the bend, and repair or replace if necessary.

Service limit:

0.025 mm (0.00098 in)

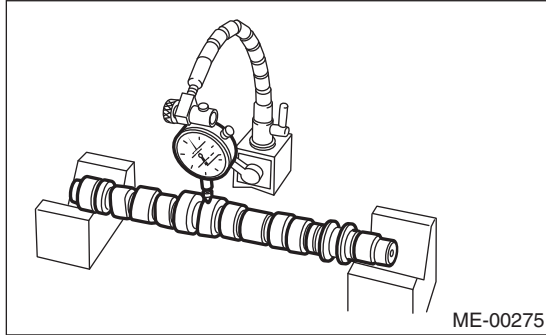

2) Check the journal for damage and wear. Replace if faulty.

3) Measure the outer diameter of camshaft journal and inner diameter of cylinder head journal, and check the difference (oil clearance) between the two values. If the oil clearance is not within the standard, replace the camshaft or cylinder head as necessary.

Unit: mm (in)		
Oil clearance	Standard	0.055 — 0.090 (0.0022 — 0.0035)
Camshaft journal O.D.		31.928 — 31.945 (1.2570 — 1.2577)
Journal hole I.D.		32.000 — 32.018 (1.2598 — 1.2605)

4) Check the cam face condition, and remove the minor faults by grinding with oil stone. Measure the cam height H. If it is not within the standard or offset wear occurs, replace it.

Cam height H:

Unit: mm (in)			
Intake	Constant	Standard	40.075 — 40.175 (1.5778 — 1.5817)
	Low speed	Standard	35.496 — 35.596 (1.3975 — 1.4014)
	High speed	Standard	40.315 — 40.415 (1.5872 — 1.5911)
Exhaust		Standard	39.289 — 39.389 (1.5468 — 1.5507)

Cam base circle diameter A:

Intake

34.00 mm (1.3386 in)

Exhaust

34.00 mm (1.3386 in)

Base circle step of adjacent intake cams (low speed and high speed):

0.03 mm (0.001 in) or less

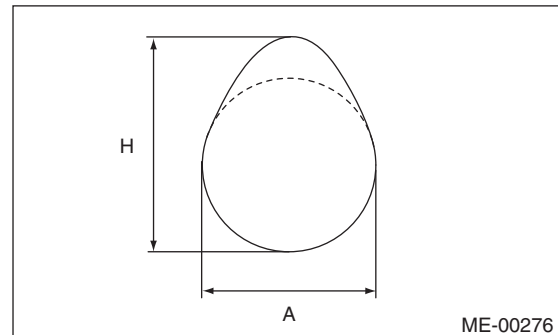

5) Measure the thrust clearance of camshaft with setting the dial gauge at end of camshaft. If the thrust clearance is not within the standard or there is offset wear, replace the camshaft caps and cylinder head as a set. If necessary, replace the camshaft.

Standard:

0.030 — 0.090 mm (0.0012 — 0.0035 in)

20. Cylinder Head

A: REMOVAL

NOTE:

Perform the work with the engine installed to body when replacing a single part. Refer to "Valve Clearance" for preparation procedures. <Ref. to ME(H4SO)-29, Valve Clearance.>

- 1) Remove the V-belts. <Ref. to ME(H4SO)-42, REMOVAL, V-belt.>
- 2) Remove the intake manifold. <Ref. to FU(H4SO)-14, REMOVAL, Intake Manifold.>
- 3) Remove the crank pulley. <Ref. to ME(H4SO)-50, REMOVAL, Crank Pulley.>
- 4) Remove the timing belt cover. <Ref. to ME(H4SO)-52, REMOVAL, Timing Belt Cover.>
- 5) Remove the timing belt. <Ref. to ME(H4SO)-53, REMOVAL, Timing Belt.>
- 6) Remove the cam sprocket. <Ref. to ME(H4SO)-59, REMOVAL, Cam Sprocket.>
- 7) Remove the bolt which installs the A/C compressor bracket on cylinder head.
- 8) Remove the valve rocker assembly. <Ref. to ME(H4SO)-62, REMOVAL, Valve Rocker Assembly.>
- 9) Remove the camshaft. <Ref. to ME(H4SO)-66, REMOVAL, Camshaft.>
- 10) Remove the oil level gauge guide. (LH side)
- 11) Remove the cylinder head bolts in alphabetical sequence as shown in the figure.

NOTE:

Leave bolts (a) and (c) engaged by three or four threads to prevent the cylinder head from falling.

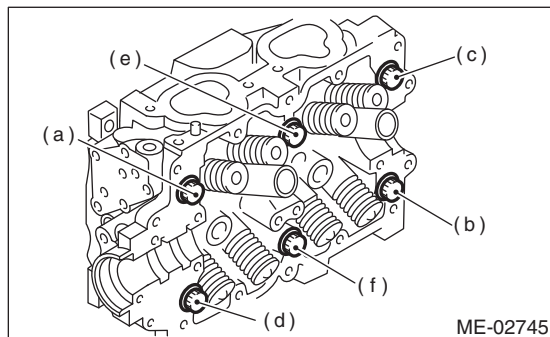

- 12) While tapping the cylinder head with a plastic hammer, separate it from cylinder block. Remove the bolts (a) and (c) to remove cylinder head.

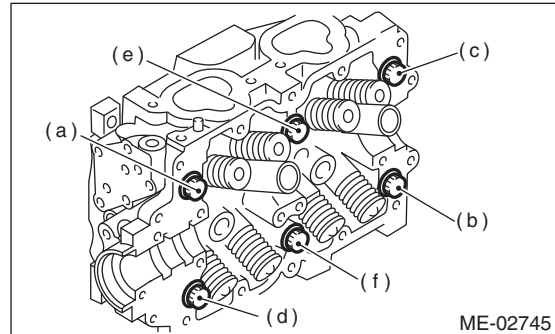

- 13) Remove the cylinder head gasket.

CAUTION:

Be careful not to scratch the mating surface of cylinder head and cylinder block.

- 14) Similarly, remove the right side cylinder head.

Cylinder Head

MECHANICAL

B: INSTALLATION

1) Install the cylinder head to the cylinder block.

CAUTION:

- Be careful not to scratch the mating surface of cylinder head and cylinder block.
- Be aware that the center bolts and corner bolts are different.

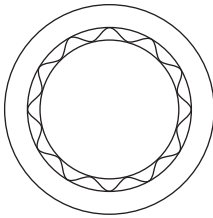
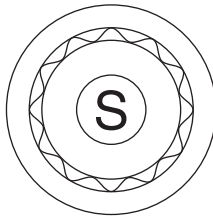
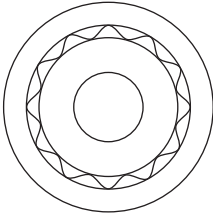
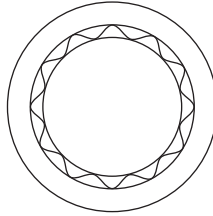
Bolt type	Center bolt	Corner bolt
Silver bolt	 <p style="text-align: center;">FU-05486 Flat</p>	 <p style="text-align: center;">FU-05487 Indent + S</p>
Black bolt	 <p style="text-align: center;">FU-05488 φ7 indent</p>	 <p style="text-align: center;">FU-05486 Flat</p>

NOTE:

Use a new cylinder head gasket.

- (1) Clean the bolt threads and the bolt holes in the cylinder block.

CAUTION:

To avoid erroneous tightening of the bolts, clean out the bolt holes sufficiently by blowing with compressed air to eliminate engine coolant etc.

- (2) Apply a sufficient coat of engine oil to the washer and bolt thread.
- (3) Tighten all bolts to 40 N·m (4.1 kgf-m, 29.5 ft-lb) in alphabetical order.
- (4) Retighten all bolts to 95 N·m (9.7 kgf-m, 70.1 ft-lb) in alphabetical order.

CAUTION:

If the bolt makes stick-slip sound during tightening, repeat the procedure from step (1). In this case, the cylinder head gasket can be re-used.

- (5) Loosen all the bolts by 180° in the reverse order of installing, and loosen them further by 180°.

- (6) Tighten all bolts to 10 N·m (1.0 kgf-m, 7.4 ft-lb) in alphabetical order.

- (7) Retighten all bolts to 30 N·m (3.1 kgf-m, 22.1 ft-lb) in alphabetical order.

- (8) Retighten all bolts to 60 N·m (6.1 kgf-m, 44.3 ft-lb) in alphabetical order.

- (9) Retighten all bolts by 80 — 90° in alphabetical order.

- (10) Retighten all bolts by 40 — 45° in alphabetical order.

CAUTION:

The tightening angle of the bolt should not exceed 45°.

(11) Retighten bolts (a) and (b) by 40 — 45°.

CAUTION:

Make sure the total “tightening angle” of steps (10) and (11) does not exceed 90°.

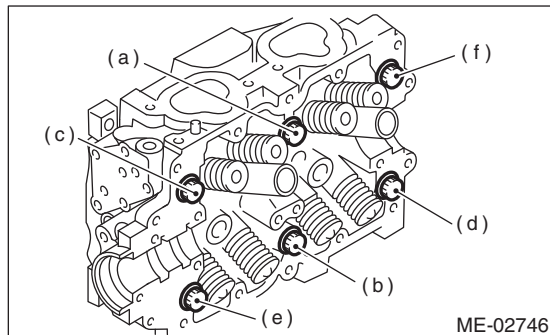

2) Install the oil level gauge guide. (LH side)

Tightening torque:

6.4 N·m (0.7 kgf-m, 4.7 ft-lb)

3) Install the camshaft. <Ref. to ME(H4SO)-67, INSTALLATION, Camshaft.>

4) Install the valve rocker assembly. <Ref. to ME(H4SO)-63, INSTALLATION, Valve Rocker Assembly.>

5) Install the A/C compressor bracket on cylinder head.

Tightening torque:

36 N·m (3.7 kgf-m, 26.6 ft-lb)

6) Install the cam sprocket. <Ref. to ME(H4SO)-59, INSTALLATION, Cam Sprocket.>

7) Install the timing belt. <Ref. to ME(H4SO)-55, INSTALLATION, Timing Belt.>

8) Adjust the valve clearance. <Ref. to ME(H4SO)-31, ADJUSTMENT, Valve Clearance.>

9) Install the rocker cover.

(1) Install the rocker cover gasket to the rocker cover.

NOTE:

Use a new rocker cover gasket.

(2) Temporarily tighten the bolts in alphabetical sequence as shown in figure, then tighten the bolt in 2 steps.

Tightening torque:

1st

6.4 N·m (0.7 kgf-m, 4.7 ft-lb)

2nd (only (a) and (b) are tightened)

6.4 N·m (0.7 kgf-m, 4.7 ft-lb)

RH side

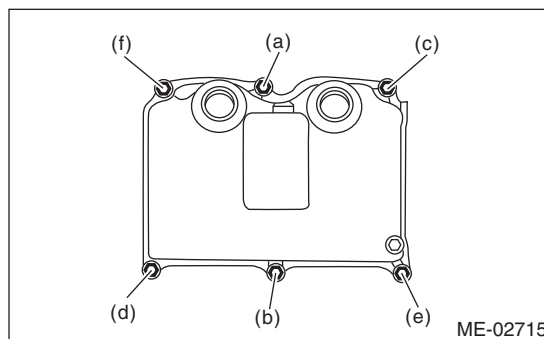

LH side

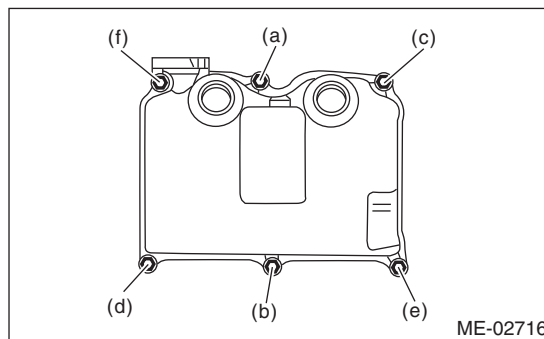

10) Install the timing belt cover. <Ref. to ME(H4SO)-52, INSTALLATION, Timing Belt Cover.>

11) Install the crank pulley. <Ref. to ME(H4SO)-50, INSTALLATION, Crank Pulley.>

12) Install the intake manifold. <Ref. to FU(H4SO)-16, INSTALLATION, Intake Manifold.>

13) Install the V-belts. <Ref. to ME(H4SO)-42, INSTALLATION, V-belt.>

Cylinder Head

MECHANICAL

C: DISASSEMBLY

1) Place the cylinder head on the ST.

ST 498267800 CYLINDER HEAD TABLE

2) Compress the valve spring and remove the valve spring retainer key using ST. Remove each valve and valve spring.

ST 499718000 VALVE SPRING REMOVER

NOTE:

- Keep all the removed parts in order for re-installing in their original positions.
- Mark each valve to prevent confusion.
- Pay careful attention not to damage the lips of intake valve oil seals and exhaust valve oil seals.
- For removal and installation procedures of the valve guide, intake valve oil seal and exhaust valve oil seal, refer to "Inspection". <Ref. to ME(H4SO)-77, VALVE GUIDE, INSPECTION, Cylinder Head.>
<Ref. to ME(H4SO)-80, INTAKE AND EXHAUST VALVE OIL SEAL, INSPECTION, Cylinder Head.>

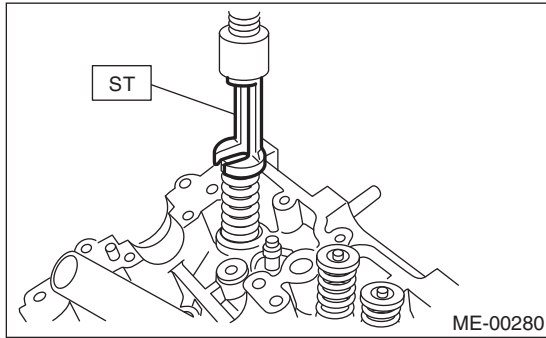

D: ASSEMBLY

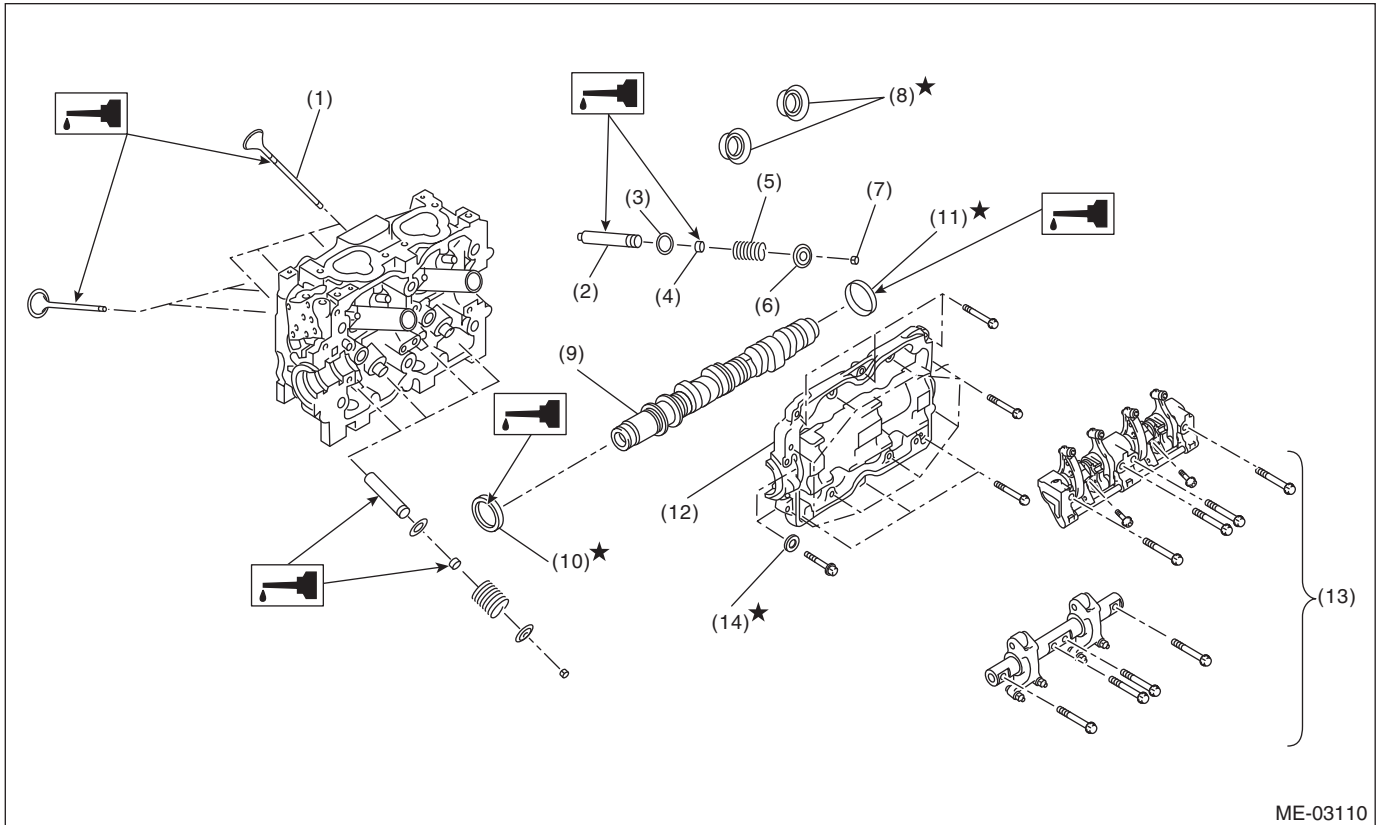

ME-03110

- | | | |
|-----------------------|-----------------------|------------------------|
| (1) Valve | (6) Retainer | (11) Plug |
| (2) Valve guide | (7) Retainer key | (12) Camshaft cap |
| (3) Valve spring seat | (8) Spark plug gasket | (13) Valve rocker ASSY |
| (4) Oil seal | (9) Camshaft | (14) Seal washer |
| (5) Valve spring | (10) Oil seal | |

Cylinder Head

MECHANICAL

- 1) Install the valve spring and valve.
 - (1) Coat the stem of each valve with engine oil and insert the valve into the valve guide.

NOTE:

When inserting the valve into valve guide, use special care not to damage the oil seal lip.

- (2) Set the cylinder head on ST.

ST 498267800 CYLINDER HEAD TABLE

- (3) Install the valve spring and retainer.

NOTE:

Be sure to install the valve spring with its close-coiled end facing the seat on cylinder head.

- (4) Set the ST on valve spring.

ST 499718000 VALVE SPRING REMOVER

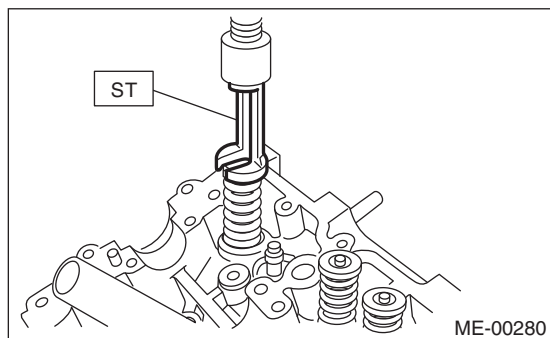

- (5) Compress the valve spring and fit the valve spring retainer key.

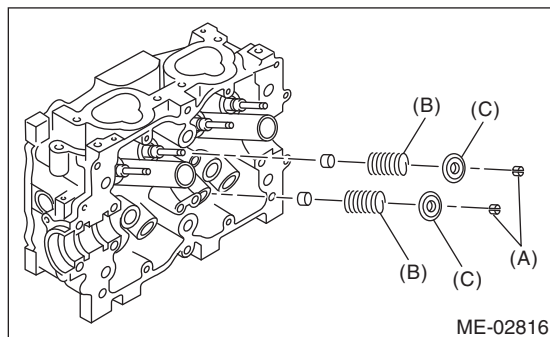

- (A) Retainer key
- (B) Valve spring
- (C) Retainer

- (6) After installing, tap the valve spring retainers lightly with a plastic hammer for better seating.

E: INSPECTION

1. CYLINDER HEAD

1) Check for cracks or damage. Use liquid penetrant tester on the important sections to check for fissures. Check that there are no marks of gas leaking or water leaking on gasket installing surface.

- 2) Place the cylinder head on the ST.

ST 498267800 CYLINDER HEAD TABLE

3) Measure the warping of the cylinder head surface that mates with cylinder block using a straight edge (A) and thickness gauge (B).

If the warping exceeds the limit, correct the surface by grinding it with a surface grinder.

Warping limit:

0.035 mm (0.0014 in)

Grinding limit:

0.1 mm (0.004 in)

Standard height of cylinder head:

97.5 mm (3.839 in)

NOTE:

Uneven torque for the cylinder head bolts can cause warping. When reassembling, pay special attention to the torque so as to tighten evenly.

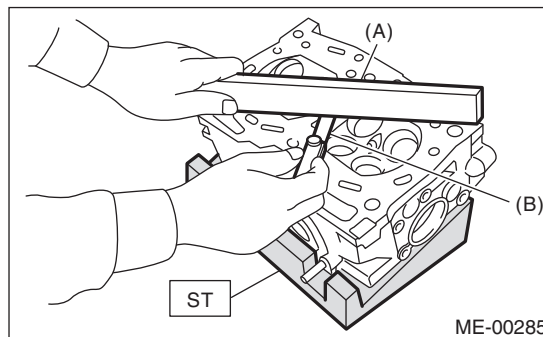

2. VALVE SEAT

Inspect the intake and exhaust valve seats, and correct the contact surfaces with a valve seat cutter if they are defective or when valve guides are replaced.

Valve seat width *W*:

Standard:

Intake (A)

0.8 — 1.4 mm (0.03 — 0.055 in)

Exhaust (B)

1.2 — 1.8 mm (0.047 — 0.071 in)

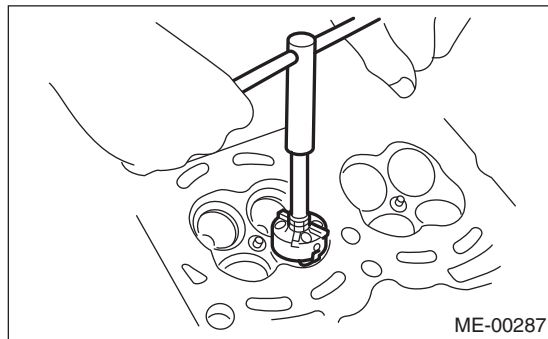
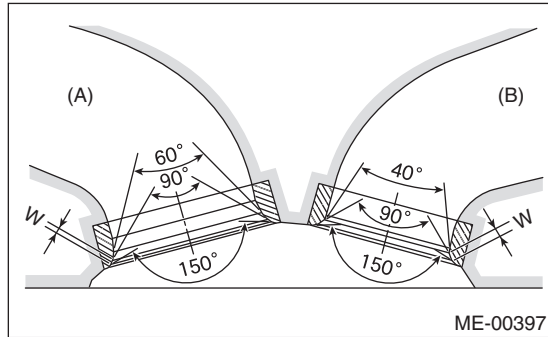

3. VALVE GUIDE

1) Check the clearance between valve guide and valve stem. The clearance can be checked by measuring respectively the outer diameter of valve stem with a micrometer and the inner diameter of valve guide with a caliper gauge.

Clearance between the valve guide and valve stem:

Standard:

Intake

0.035 — 0.062 mm (0.0014 — 0.0024 in)

Exhaust

0.040 — 0.067 mm (0.0016 — 0.0026 in)

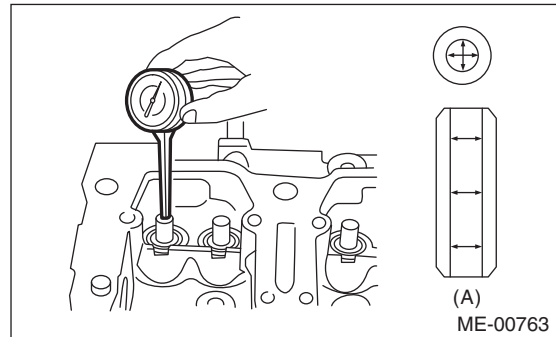

(A) Valve guide

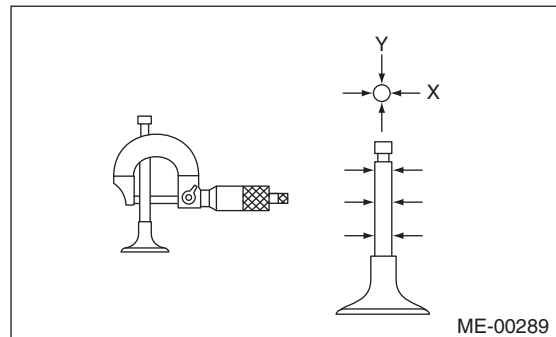

Cylinder Head

MECHANICAL

2) If the clearance between the valve guide and valve stem exceeds the standard, replace the valve guide or valve itself, whichever shows greater amount of wear or damage. See the following procedure for valve guide replacement.

Valve guide inner diameter:

6.000 — 6.012 mm (0.2362 — 0.2367 in)

Valve stem outer diameters:

Intake

5.950 — 5.965 mm (0.2343 — 0.2348 in)

Exhaust

5.945 — 5.960 mm (0.2341 — 0.2346 in)

(1) Place the cylinder head on ST1 with the combustion chamber upward so that valve guides fit the holes in ST1.

(2) Insert the ST2 into valve guide and press it down to remove the valve guide.

ST1 498267800 CYLINDER HEAD TABLE
ST2 499767200 VALVE GUIDE REMOVER

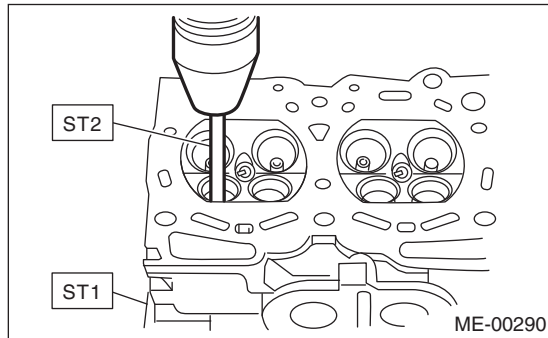

(3) Turn the cylinder head upside down and place the ST as shown in the figure.

Intake side

ST 499767700 VALVE GUIDE ADJUSTER

Exhaust side

ST 499767800 VALVE GUIDE ADJUSTER

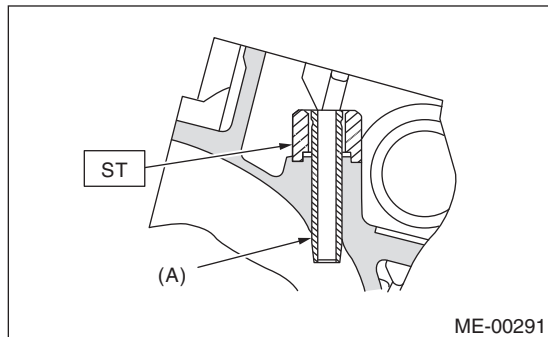

(A) Valve guide

(4) Before installing a new valve guide, make sure that neither scratches nor damages exist on the inner surface of valve guide holes in cylinder head.

(5) Put a new valve guide, coated with sufficient oil, in cylinder, and insert the ST1 into valve guide. Press in until the valve guide upper end is flush with the upper surface of ST2.

ST1 499767200 VALVE GUIDE REMOVER
Intake side

ST2 499767700 VALVE GUIDE ADJUSTER
Exhaust side

ST2 499767800 VALVE GUIDE ADJUSTER

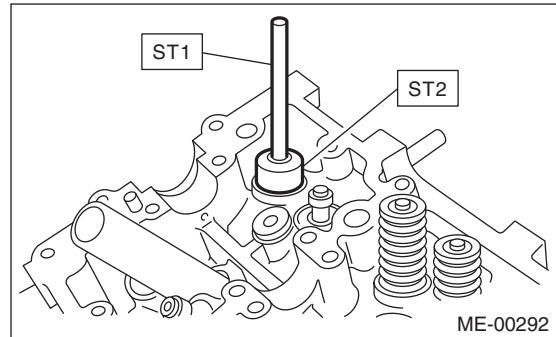

(6) Check the valve guide protrusion.

Valve guide protrusion L:

Intake

20.0 — 21.0 mm (0.787 — 0.827 in)

Exhaust

16.5 — 17.5 mm (0.650 — 0.689 in)

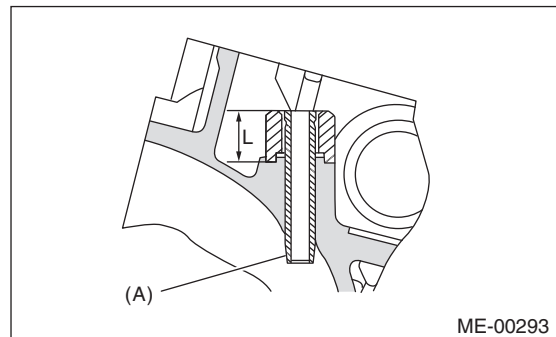

(A) Valve guide

(7) Ream the inside of valve guide using ST. Put the ST in valve guide, and rotate the ST slowly clockwise while pushing it lightly. Bring the ST back while rotating it clockwise.

NOTE:

- Apply engine oil to the ST when reaming.
- If the inner surface of valve guide is damaged, the edge of ST should be slightly ground with oil stone.
- If the inner surface of valve guide becomes lustrous and the ST does not chip, use a new ST or remedy the ST.

ST 499767400 VALVE GUIDE REAMER

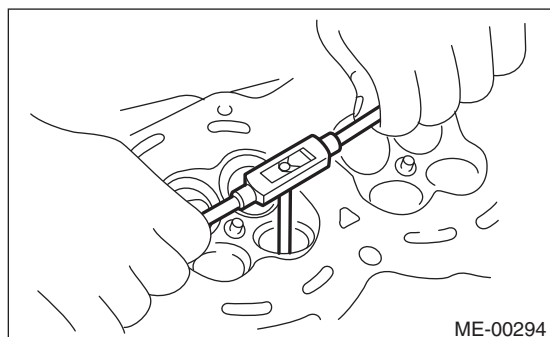

(8) After reaming, clean the valve guide to remove chips.

(9) Recheck the contact condition between valve and valve seat after replacing the valve guide.

4. INTAKE AND EXHAUST VALVE

1) Inspect the flange and stem of valve, and replace the valve with a new part if damaged, worn, deformed, or if dimension "H" in the figure is outside of the specified limit.

Head edge thickness H:

Intake (A)

Standard:

0.8 — 1.2 mm (0.03 — 0.047 in)

Exhaust (B)

Standard:

1.0 — 1.4 mm (0.039 — 0.055 in)

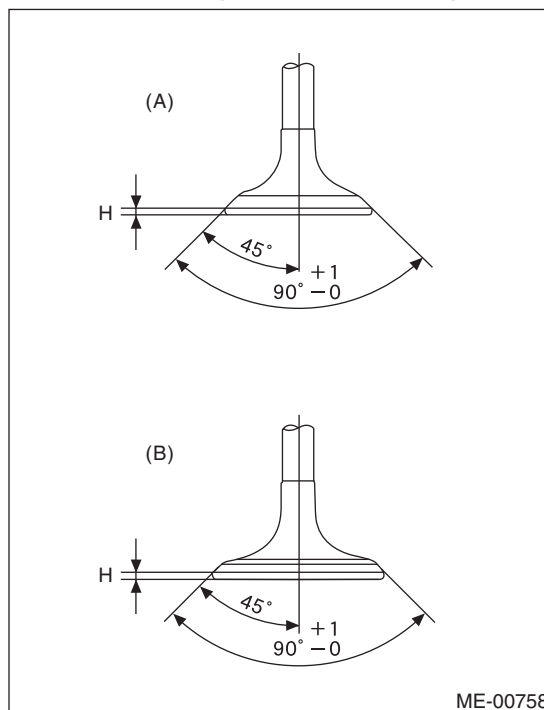

2) Put a small amount of grinding compound on the seat surface, and lap the valve and seat surface. Replace with a new valve oil seal after lapping.

NOTE:

It is possible to differentiate between the intake valve and the exhaust valve by their overall length.

Valve overall length:

Intake

120.6 mm (4.75 in)

Exhaust

121.7 mm (4.79 in)

Cylinder Head

MECHANICAL

5. VALVE SPRING

- 1) Check the valve springs for damage, free length, and tension. Replace the valve spring if it is not within the standard value presented in the table.
- 2) To measure the squareness of the valve spring, stand the spring on a surface plate and measure its deflection at the top of spring using a try square.

Free length	mm (in)	55.2 (2.173)
Tension/spring height N (kgf, lbf)/mm (in)	Set	235.3 — 270.7 (24 — 27.6, 52.9 — 60.8)/45.0 (1.772)
	Lift	578.9 — 639.9 (59.1 — 65.3, 130.3 — 143.9)/34.7 (1.366)
Squareness	2.5°, 2.4 mm (0.094 in) or less	

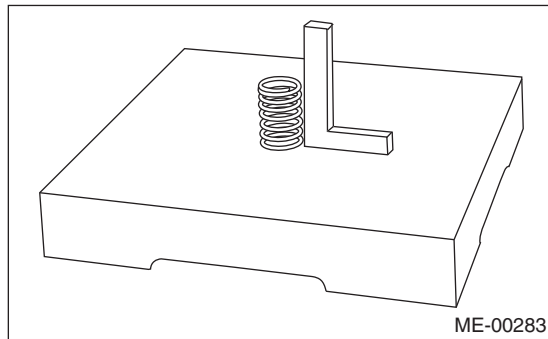

6. INTAKE AND EXHAUST VALVE OIL SEAL

- 1) For the following, replace the oil seal with a new part. See the procedure 2) and subsequent for replacement procedures.

- When the lip is damaged.
- When the spring is out of the specified position.
- When readjusting the surfaces of valve and valve seat.
- When replacing the valve guide.

- 2) Place the cylinder head on ST1, and use ST2 to press-fit the oil seal.

ST1 498267800 CYLINDER HEAD TABLE
ST2 498857100 VALVE OIL SEAL GUIDE

NOTE:

- Apply engine oil to oil seal before press-fitting.
- When press-fitting the oil seal, do not use a hammer or strike in.
- The intake valve oil seal and exhaust valve oil seal can be distinguished by colors.

Color of rubber part:

Intake [Gray]

Exhaust [Green]

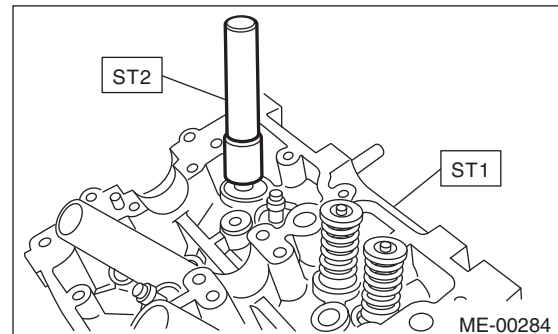

21. Cylinder Block

A: REMOVAL

NOTE:

Before conducting this procedure, drain the engine oil completely.

- 1) Remove the V-belts. <Ref. to ME(H4SO)-42, REMOVAL, V-belt.>
- 2) Remove the intake manifold. <Ref. to FU(H4SO)-14, REMOVAL, Intake Manifold.>
- 3) Remove the crank pulley. <Ref. to ME(H4SO)-50, REMOVAL, Crank Pulley.>
- 4) Remove the timing belt cover. <Ref. to ME(H4SO)-52, REMOVAL, Timing Belt Cover.>
- 5) Remove the timing belt. <Ref. to ME(H4SO)-53, REMOVAL, Timing Belt.>
- 6) Remove the cam sprocket. <Ref. to ME(H4SO)-59, REMOVAL, Cam Sprocket.>
- 7) Remove the crank sprocket. <Ref. to ME(H4SO)-61, REMOVAL, Crank Sprocket.>
- 8) Remove the generator and A/C compressor with their brackets.
- 9) Remove the cylinder head. <Ref. to ME(H4SO)-71, REMOVAL, Cylinder Head.>
- 10) Remove the clutch disc and cover. (MT model) <Ref. to CL-9, REMOVAL, Clutch Disc and Cover.>
- 11) Remove the flywheel. (MT model) <Ref. to CL-12, REMOVAL, Flywheel.>
- 12) Remove the drive plate. (AT model)

Using the ST, lock the crankshaft.

ST 498497100 CRANKSHAFT STOPPER

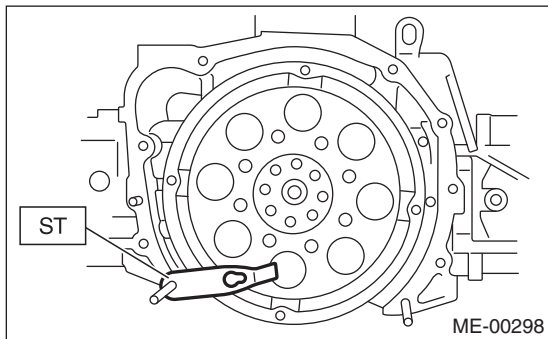

- 13) Remove the oil separator cover.
- 14) Remove the water by-pass pipe for heater.
- 15) Remove the water pump. <Ref. to CO(H4SO)-15, REMOVAL, Water Pump.>

- 16) Remove the bolts which install oil pump onto cylinder block.

NOTE:

When disassembling and checking the oil pump, loosen the relief valve plug before removing the oil pump.

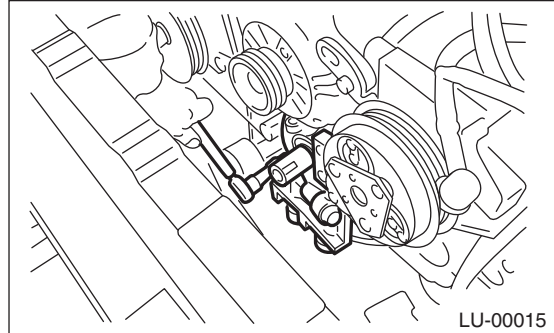

- 17) Remove the oil pump from cylinder block using a flat tip screwdriver.

CAUTION:

Be careful not to scratch the mating surface of cylinder block and oil pump.

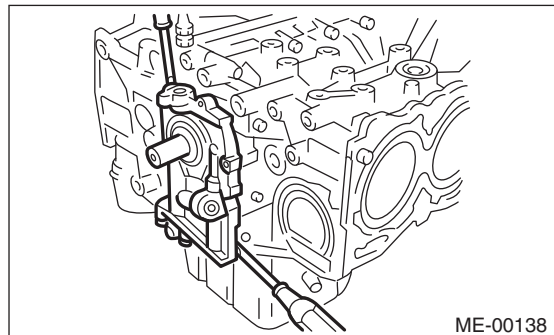

- 18) Remove the front oil seal from the oil pump.
- 19) Remove the oil pan.
 - (1) Set the part so that the cylinder block LH is on the upper side.
 - (2) Remove the bolts which secure oil pan to cylinder block.
 - (3) Insert an oil pan cutter blade between cylinder block-to-oil pan clearance and remove the oil pan.

CAUTION:

Do not use a screwdriver or similar tools in place of oil pan cutter.

- 20) Remove the oil strainer.
- 21) Remove the baffle plate.
- 22) Remove the oil filter. <Ref. to LU(H4SO)-19, REMOVAL, Engine Oil Filter.>

Cylinder Block

MECHANICAL

23) Remove the water pipe assembly.

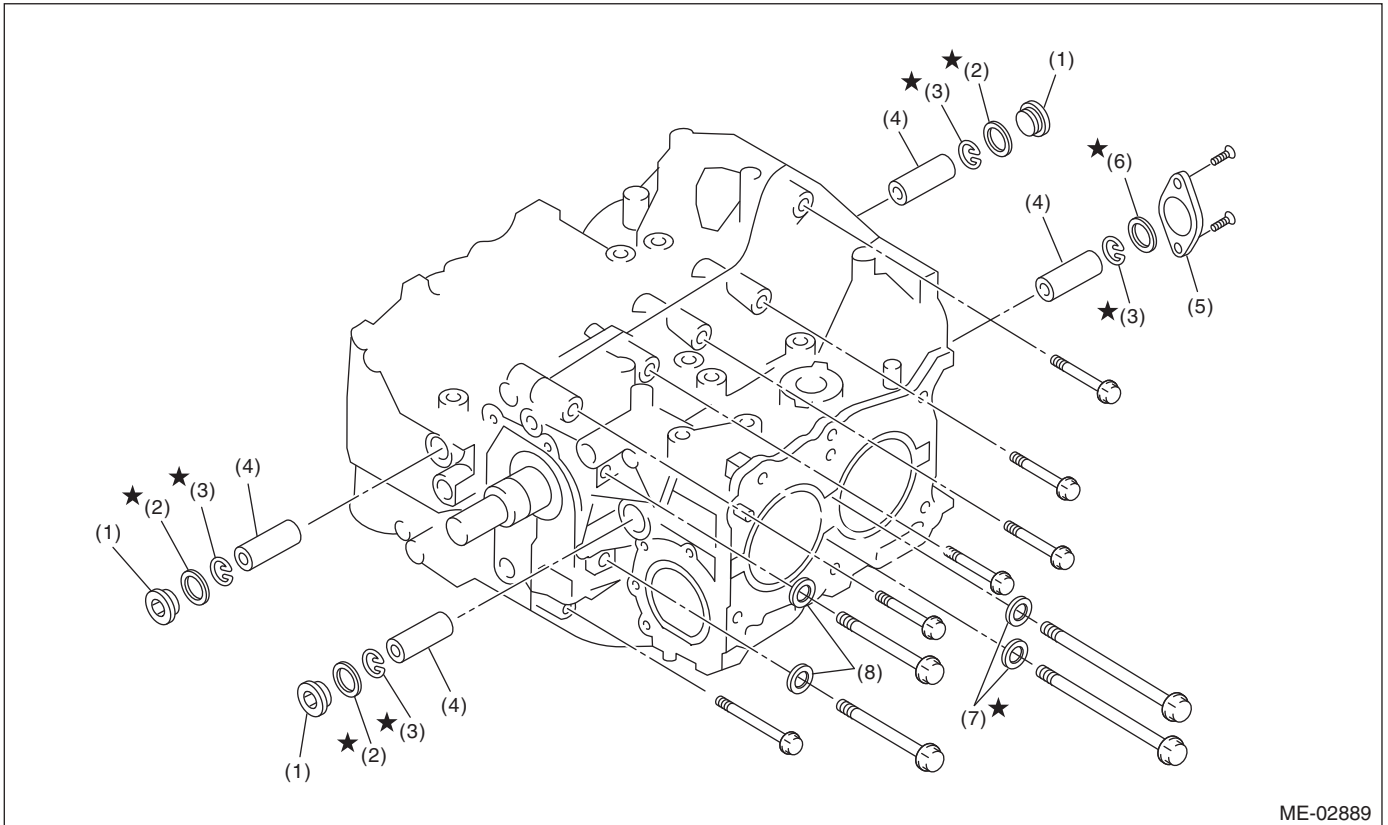
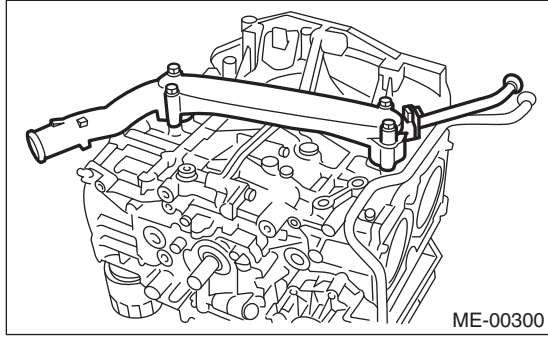

- (1) Service hole plug
- (2) Gasket
- (3) Snap ring

- (4) Piston pin
- (5) Service hole cover
- (6) O-ring

- (7) Seal washer
- (8) Washer

24) Remove the service hole plugs using a hexagon wrench [14 mm].

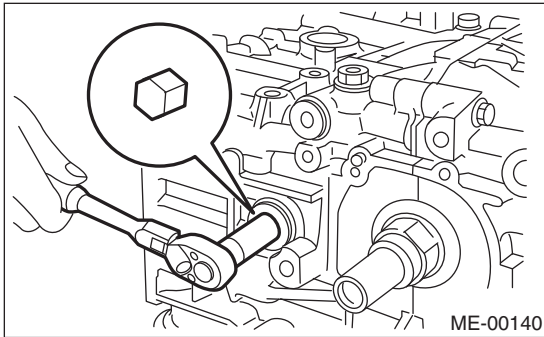

25) Remove the service hole cover.

26) Rotate the crankshaft to bring #1 and #2 pistons to bottom dead center position, then remove the piston snap ring through service hole of #1 and #2 cylinders.

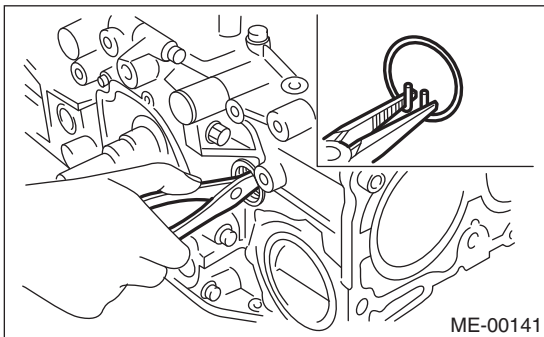

27) Draw out the piston pin from #1 and #2 pistons using ST.

ST 499097700 PISTON PIN REMOVER

NOTE:

Be careful not to confuse the original combination of piston, piston pin and cylinder.

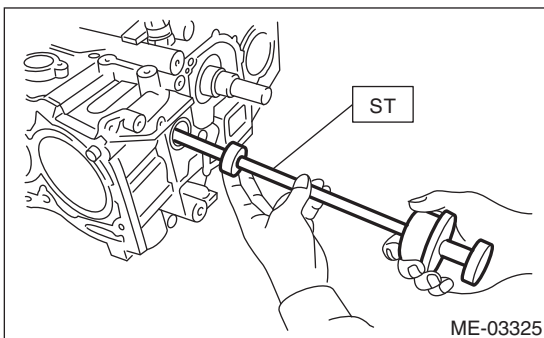

28) Similarly draw out the piston pins from #3 and #4 pistons.

29) Remove the cylinder block connecting bolt on the RH side.

30) Loosen the cylinder block connecting bolt on the LH side by 2-3 turns.

31) Set the part so that the cylinder block LH is on the upper side, and remove the cylinder block connecting bolt.

Cylinder Block

MECHANICAL

32) Separate the cylinder block LH and RH.

NOTE:

When separating the cylinder block, do not allow the connecting rod to fall and damage the cylinder block.

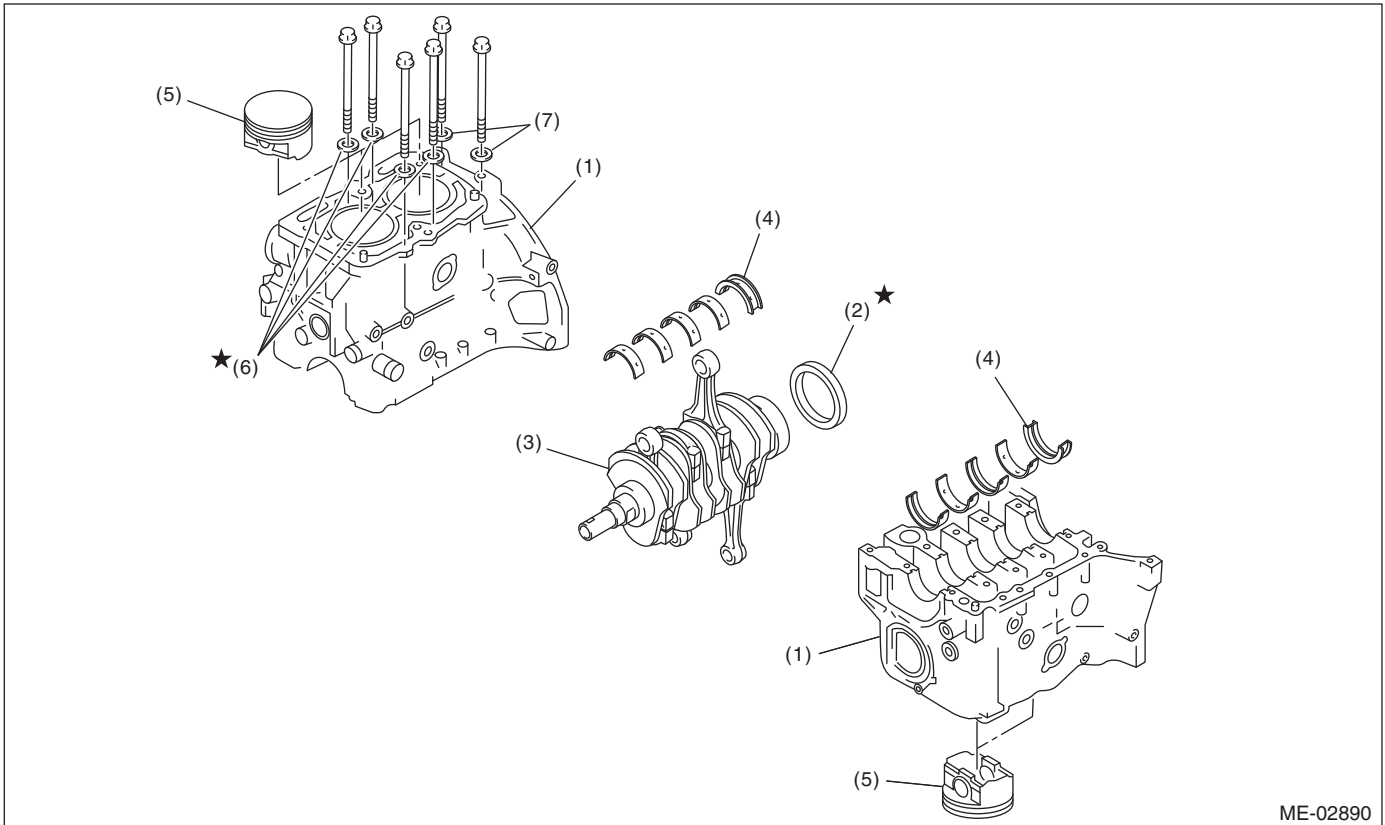

ME-02890

- | | | |
|--------------------|------------------------|-----------------|
| (1) Cylinder block | (4) Crankshaft bearing | (6) Seal washer |
| (2) Rear oil seal | (5) Piston | (7) Washer |
| (3) Crankshaft | | |

33) Remove the rear oil seal.

34) Remove the crankshaft together with connecting rod.

35) Remove the crankshaft bearings from cylinder block using a hammer handle.

NOTE:

- Push the opposite side of the crank shaft bearing locking lip to remove.
- Be careful not to confuse the crankshaft bearing combination.

36) Remove each piston from cylinder block using wooden bar or hammer handle.

NOTE:

Be careful not to confuse the original combination of piston and cylinder.

B: INSTALLATION

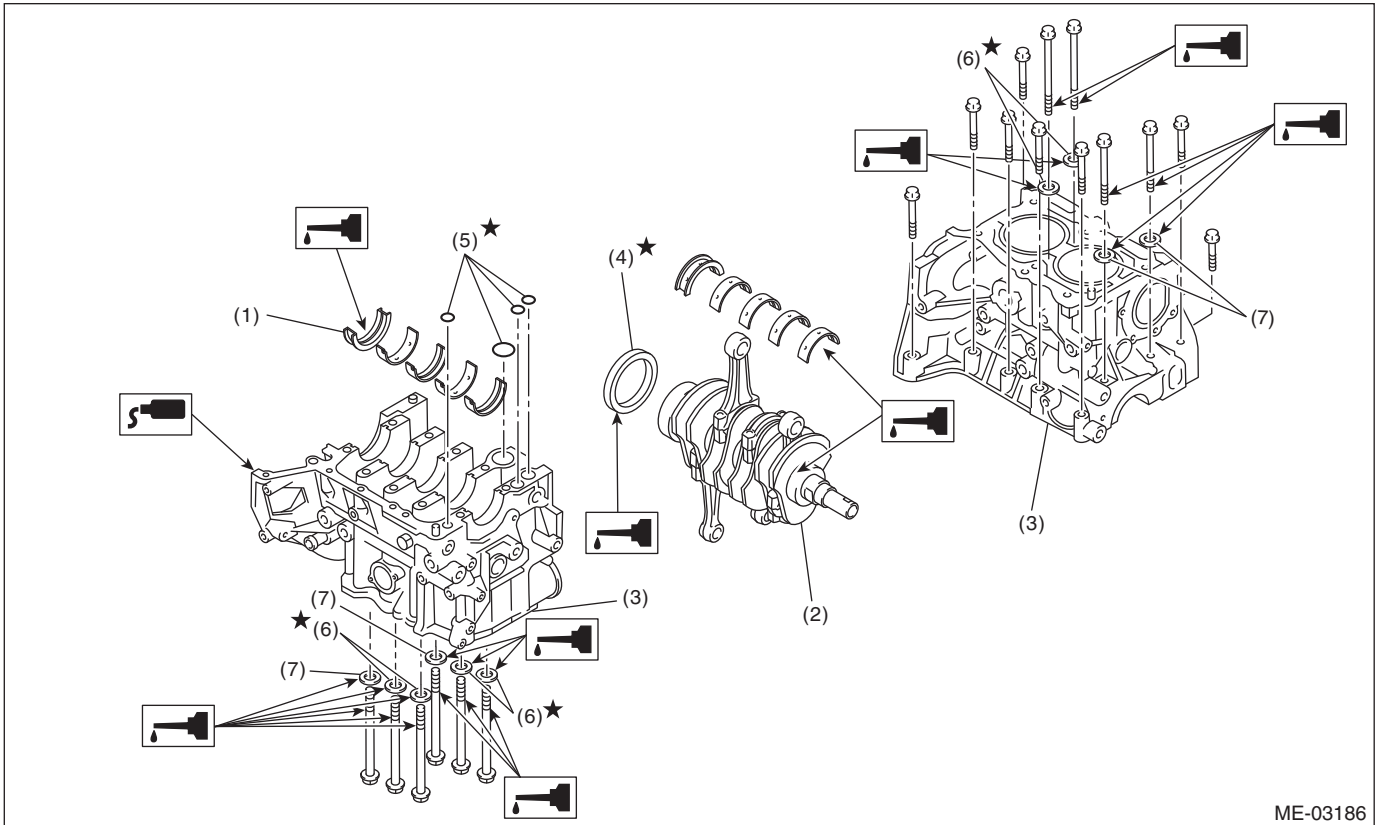

ME-03186

- (1) Crankshaft bearing
- (2) Crankshaft
- (3) Cylinder block

- (4) Rear oil seal
- (5) O-ring

- (6) Seal washer
- (7) Washer

Cylinder Block

MECHANICAL

- 1) Remove oil on the mating surface of cylinder block before installation. Apply a coat of engine oil to the bearing and crankshaft journal.
- 2) Position the crankshaft and O-ring on cylinder block RH.

NOTE:

Use new O-rings.

- 3) Apply liquid gasket to the mating surfaces of cylinder block RH, and position cylinder block LH.

NOTE:

- Install within 5 min. after applying liquid gasket.
- Do not allow liquid gasket to jut into O-ring grooves, oil passages, bearing grooves, etc.

Liquid gasket:

**THREE BOND 1217G (Part No. K0877Y0100)
or equivalent**

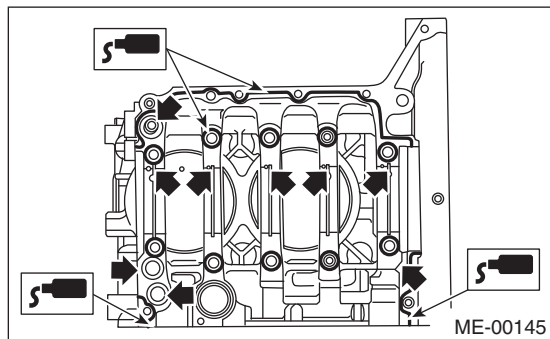

- 4) Apply a coat of engine oil to the washer and bolt thread.

NOTE:

Use a new seal washer.

- 5) Tighten the 10 mm cylinder block connecting bolts on the LH side (A — D) in alphabetical order.

Tightening torque:

10 N·m (1.0 kgf-m, 7.4 ft-lb)

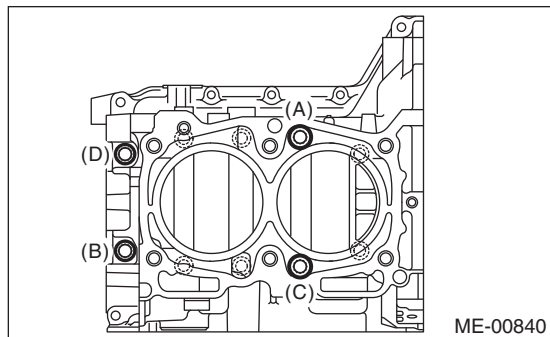

- 6) Tighten the 10 mm cylinder block connecting bolts on the RH side (E — J) in alphabetical order.

Tightening torque:

10 N·m (1.0 kgf-m, 7.4 ft-lb)

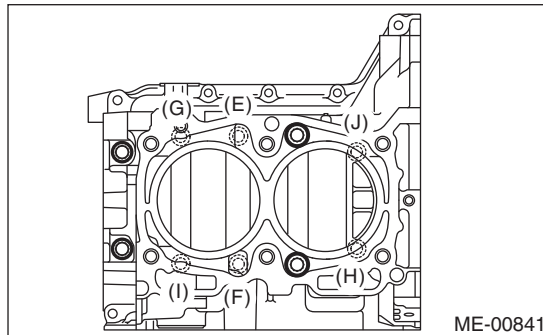

- 7) Tighten the LH side cylinder block connecting bolts (A — D) further in alphabetical order.

Tightening torque:

18 N·m (1.8 kgf-m, 13.3 ft-lb)

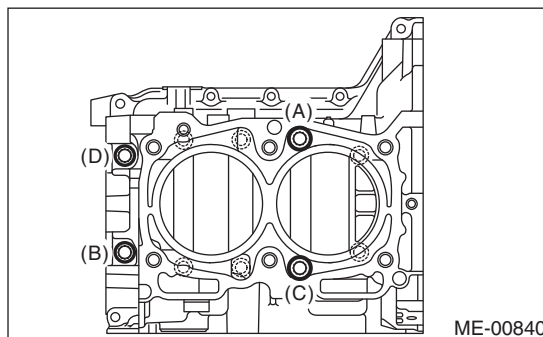

- 8) Tighten the RH side cylinder block connecting bolts (E — J) further in alphabetical order.

Tightening torque:

18 N·m (1.8 kgf-m, 13.3 ft-lb)

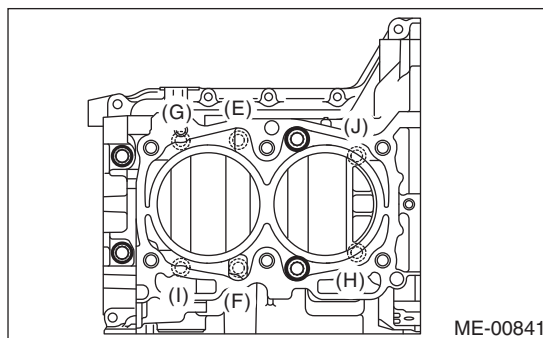

9) Tighten the LH side cylinder block connecting bolts (A — D) further in alphabetical order.

- (A), (C): Angle tightening

Tightening angle:

90°

- (B), (D): Torque tightening

Tightening torque:

40 N·m (4.1 kgf·m, 29.5 ft·lb)

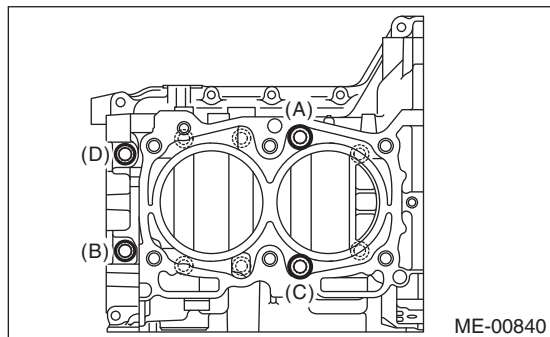

10) Tighten the RH side cylinder block connecting bolts (E — J) further in alphabetical order.

Tightening angle:

90°

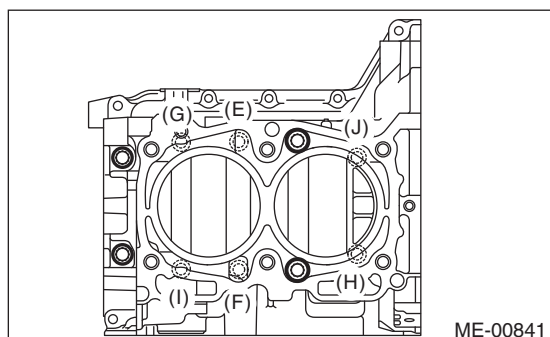

11) Tighten the 8 mm and 6 mm cylinder block connecting bolts on LH side (A — H) in alphabetical sequence.

Tightening torque:

(A) — (G): 25 N·m (2.5 kgf·m, 18.4 ft·lb)

(H): 6.4 N·m (0.7 kgf·m, 4.7 ft·lb)

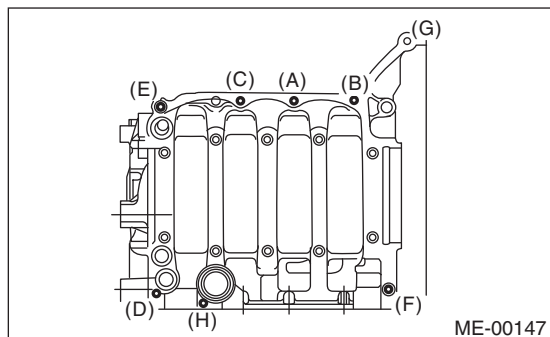

12) Apply a coat of engine oil to the oil seal periphery, then install the rear oil seal using ST1 and ST2.

NOTE:

Use a new rear oil seal.

ST1 499597100 CRANKSHAFT OIL SEAL GUIDE

ST2 499587200 CRANKSHAFT OIL SEAL INSTALLER

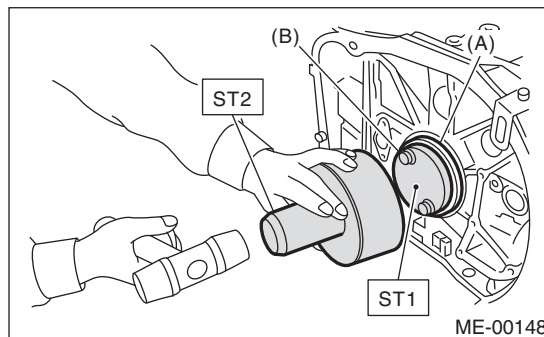

- (A) Rear oil seal
- (B) Flywheel attaching bolt

13) Position the top ring gap at (A) or (B) in the figure.

14) Position the second ring gap at 180° on the reverse side the top ring gap.

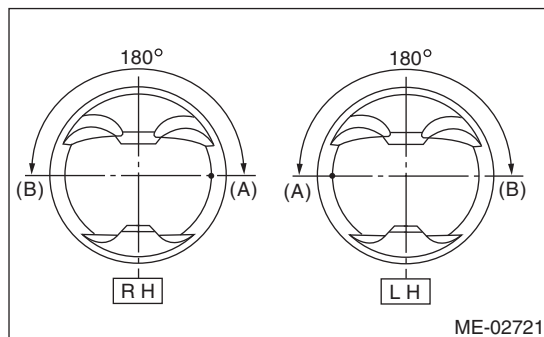

15) Position the upper rail gap at (C) in the figure.

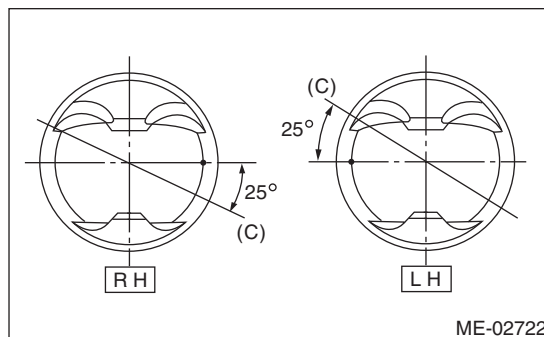

Cylinder Block

MECHANICAL

16) Align the upper rail spin stopper (E) to the side hole (D) on the piston.

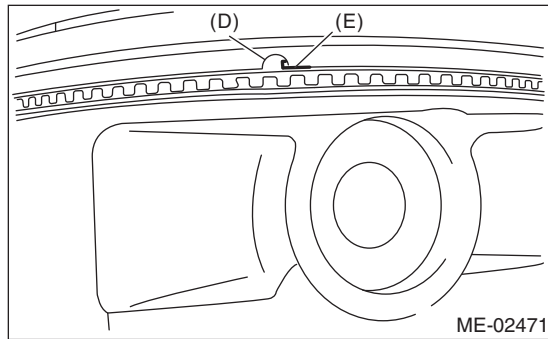

17) Position the expander gap at (F) on the 180° opposite direction of (C) in the figure.

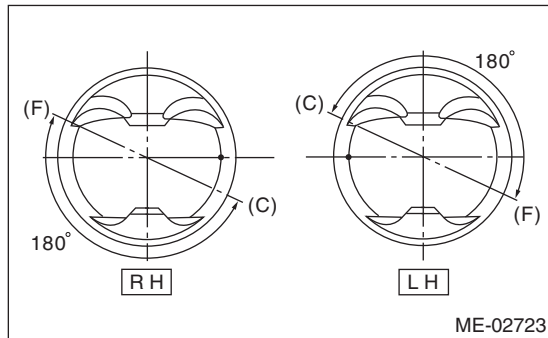

18) Set the lower rail gap at position (G), located 120° clockwise from (C) in the figure.

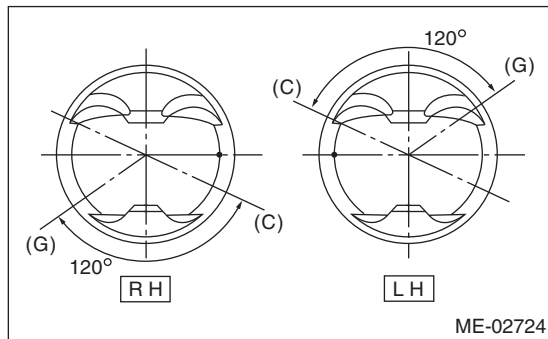

NOTE:

- Make sure ring gaps do not face the same direction.
- Make sure ring gaps are not within the piston skirt area.

Cylinder Block

MECHANICAL

19) Install the snap ring.
 Before positioning the piston on the cylinder block, attach the snap ring in the service hole of the cylinder ring in the cylinder block, and the piston hole on the opposite side.

NOTE:

Use new snap rings.

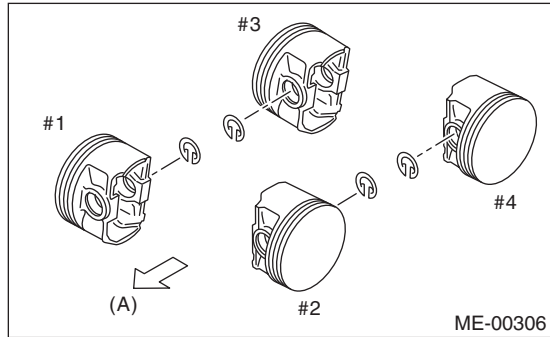

(A) Front side

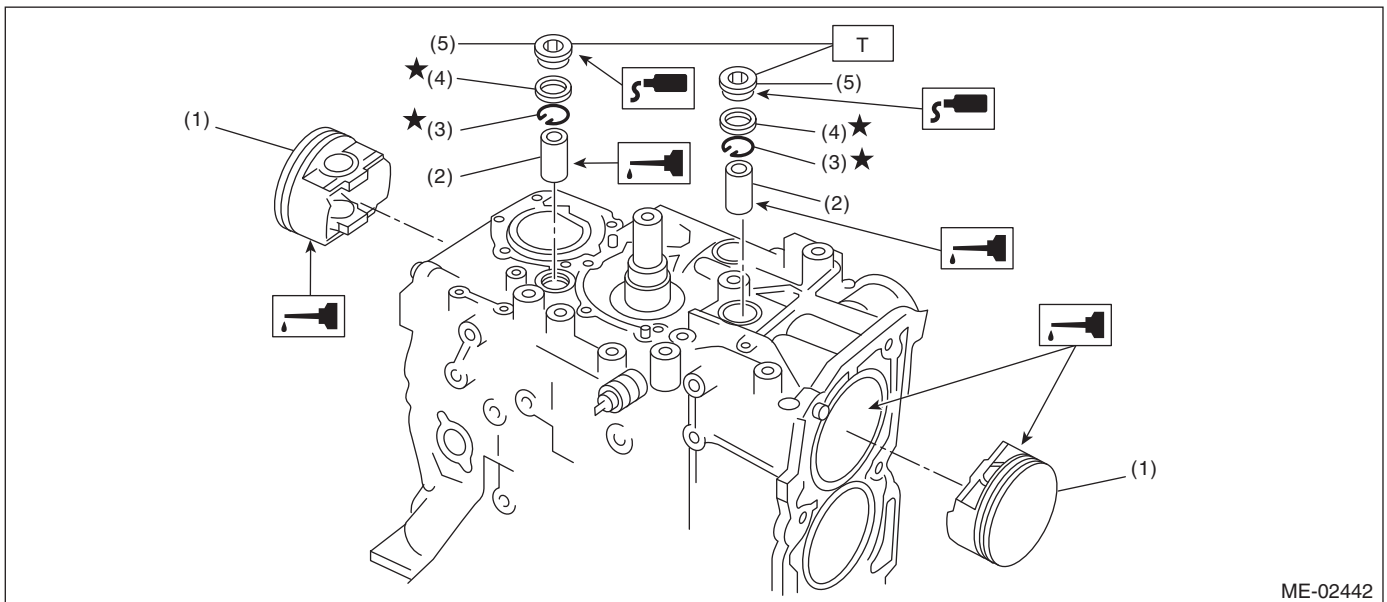

- | | |
|----------------|-----------------------|
| (1) Piston | (4) Gasket |
| (2) Piston pin | (5) Service hole plug |
| (3) Snap ring | |

Tightening torque: N·m (kgf·m, ft·lb)
T: 70 (7.1, 51.6)

Cylinder Block

MECHANICAL

20) Install the piston.

- (1) Set the parts so that the #1 and #2 cylinders are on the upper side.
- (2) Using the ST1, turn the crankshaft so that #1 and #2 connecting rods are set at bottom dead center.

ST1 499987500 CRANKSHAFT SOCKET

- (3) Apply a coat of engine oil to the pistons and cylinders and insert pistons in their cylinders using ST2.

ST2 498747300 PISTON GUIDE

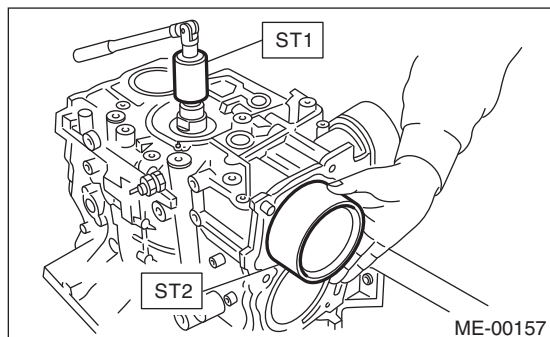

NOTE:

Face the piston front mark towards the front of the engine.

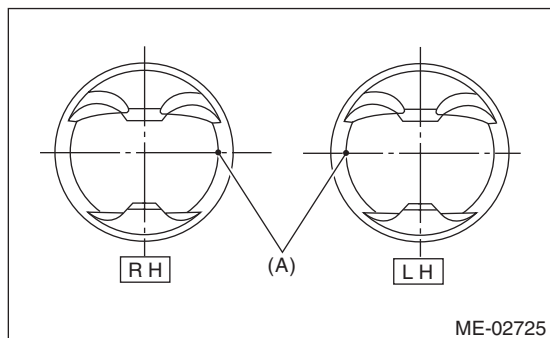

(A) Front mark

21) Install piston pin.

- (1) Apply a coat of engine oil to ST3.
- (2) Insert ST3 into the service hole to align piston pin hole with connecting rod small end.

ST3 499017100 PISTON PIN GUIDE

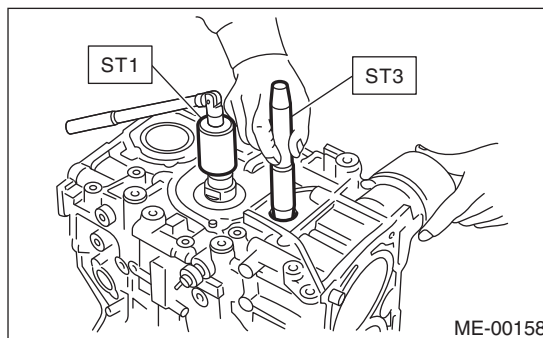

- (3) Apply a coat of engine oil to piston pin, and insert the piston pin into piston and connecting rod through service hole.
- (4) Install the snap ring.

NOTE:

Use new snap rings.

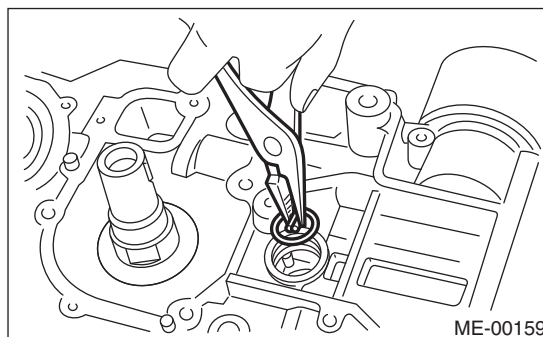

- (5) Apply liquid gasket to the threaded portion of the service hole plug.

Liquid gasket:

THREE BOND 1105 (Part No. 004403010) or equivalent

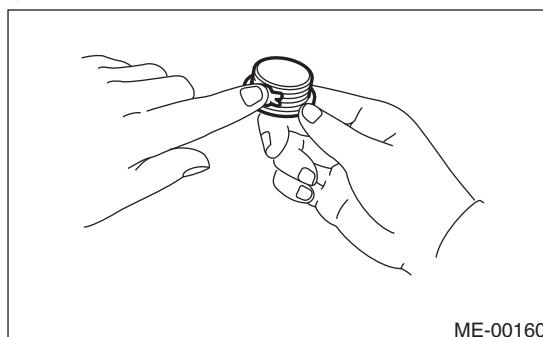

Cylinder Block

MECHANICAL

(6) Install the water pump and gasket.

NOTE:

Use a new gasket.

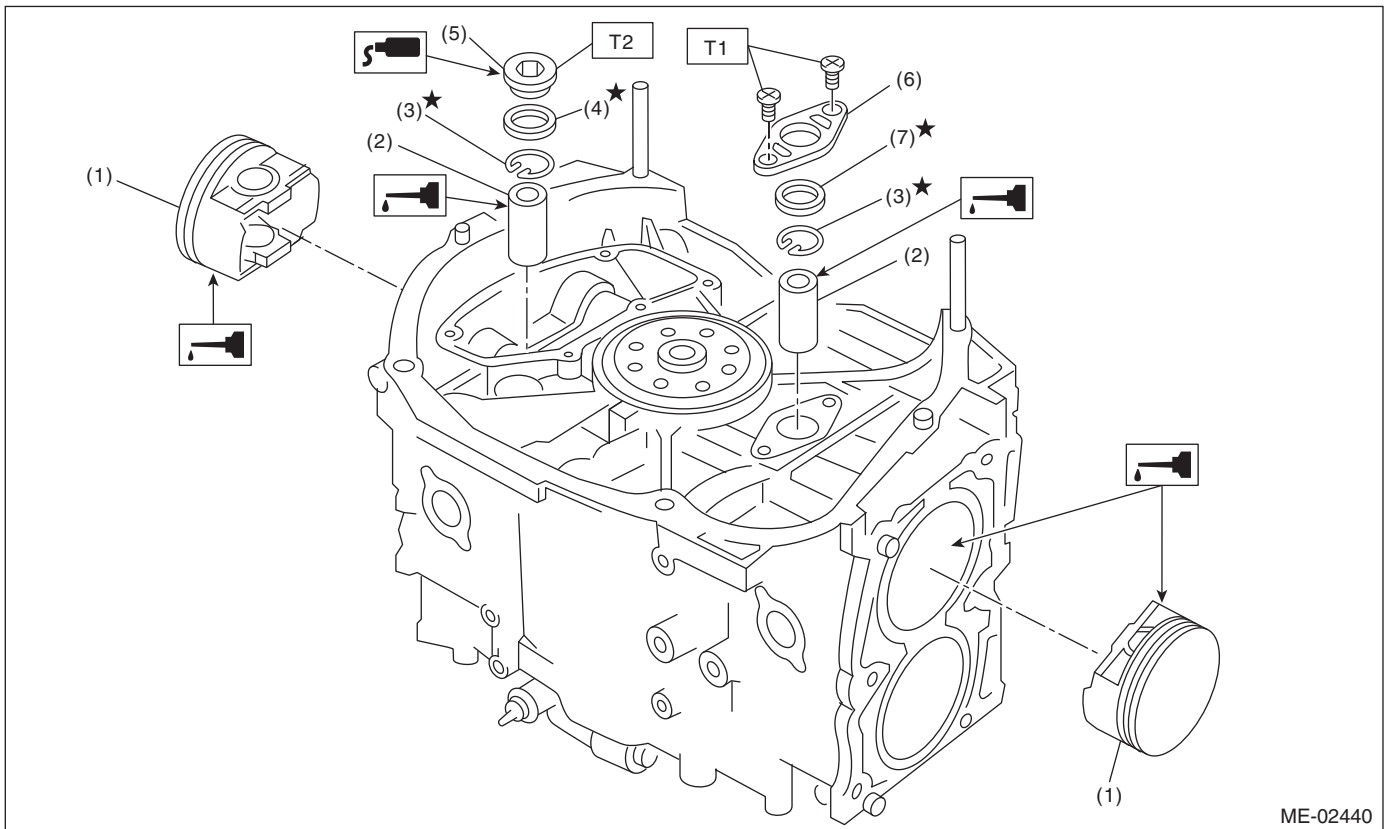
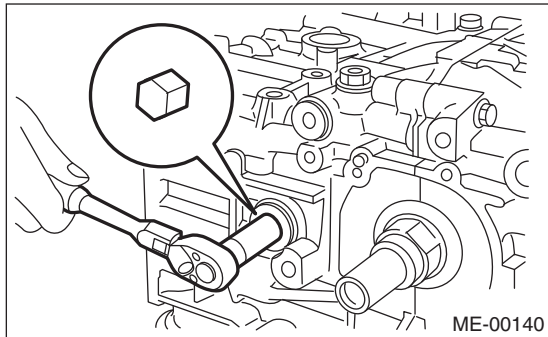

- | | |
|----------------|------------------------|
| (1) Piston | (5) Service hole plug |
| (2) Piston pin | (6) Service hole cover |
| (3) Snap ring | (7) O-ring |
| (4) Gasket | |

Tightening torque: N·m (kgf·m, ft·lb)

T1: 6.4 (0.7, 4.7)

T2: 70 (7.1, 51.6)

(7) Set the parts so that the #3 and #4 cylinders are on the upper side. Following the same procedures as used for #1 and #2 cylinders, install the pistons and piston pins.

(8) Install the service hole cover.

NOTE:

Use new O-rings.

Cylinder Block

MECHANICAL

22) Install the water pipe assembly.

NOTE:

Use new O-rings.

Tightening torque:

6.4 N·m (0.7 kgf·m, 4.7 ft·lb)

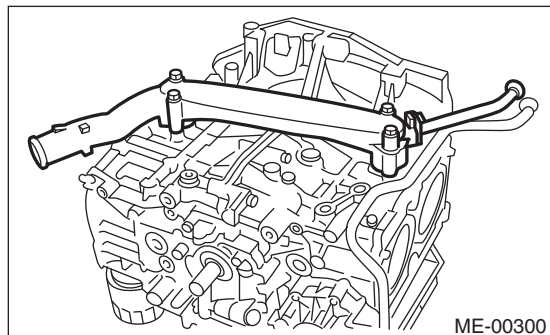

23) Install the baffle plate.

Tightening torque:

6.4 N·m (0.7 kgf·m, 4.7 ft·lb)

24) Install the oil strainer.

NOTE:

Use new O-rings.

Tightening torque:

10 N·m (1.0 kgf·m, 7.4 ft·lb)

25) Tighten the oil strainer stay together with the baffle plate.

Tightening torque:

6.4 N·m (0.7 kgf·m, 4.7 ft·lb)

26) Apply liquid gasket to the mating surfaces of the oil pan, and install the oil pan.

NOTE:

Install within 5 min. after applying liquid gasket.

Liquid gasket:

**THREE BOND 1217G (Part No. K0877Y0100)
or equivalent**

Tightening torque:

5 N·m (0.5 kgf·m, 3.7 ft·lb)

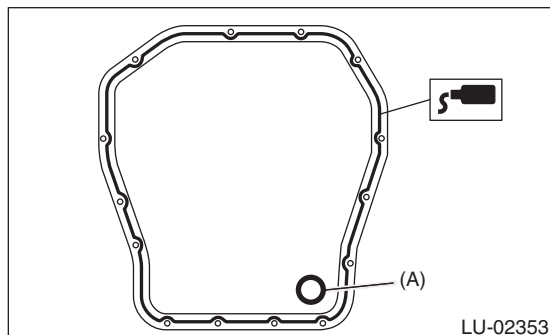

(A) Gasket

27) Apply liquid gasket to the mating surfaces of the oil separator cover and the threaded portion of bolt (A) shown in the figure (when reusing the bolt), and then install the oil separator cover.

NOTE:

- Install within 5 min. after applying liquid gasket.
- Use a new separator cover.

Liquid gasket:

• **Mating surface**

THREE BOND 1217G (Part No. K0877Y0100) or equivalent

• **Bolt thread area (A) (when reusing the bolt)**

THREE BOND 1324 (Part No. 004403042) or equivalent

Tightening torque:

6.4 N·m (0.7 kgf·m, 4.7 ft·lb)

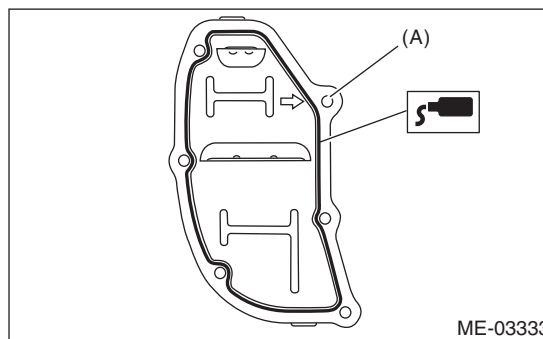

28) Install the flywheel. (MT model)

<Ref. to CL-12, INSTALLATION, Flywheel.>

29) Install the clutch disc and cover. (MT model)

<Ref. to CL-9, INSTALLATION, Clutch Disc and Cover.>

30) Install the drive plate. (AT model)

To lock the crankshaft, use the ST.

ST 498497100 CRANKSHAFT STOPPER

Tightening torque:

72 N·m (7.3 kgf·m, 53.1 ft·lb)

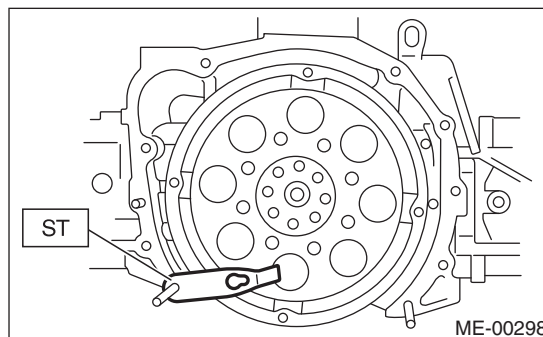

31) Install the oil pump.

(1) Using the ST, install the front oil seal.
ST 499587100 OIL SEAL INSTALLER

NOTE:

Use a new front oil seal.

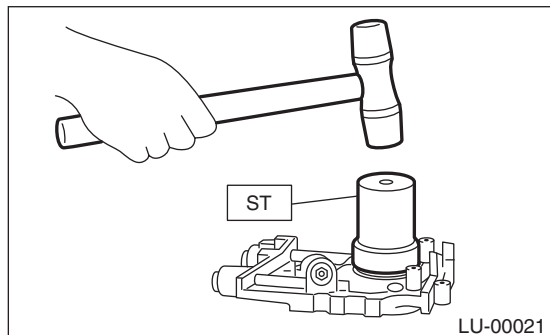

(2) Apply liquid gasket to the matching surface of oil pump.

NOTE:

Install within 5 min. after applying liquid gasket.

Liquid gasket:

THREE BOND 1217G (Part No. K0877Y0100) or equivalent

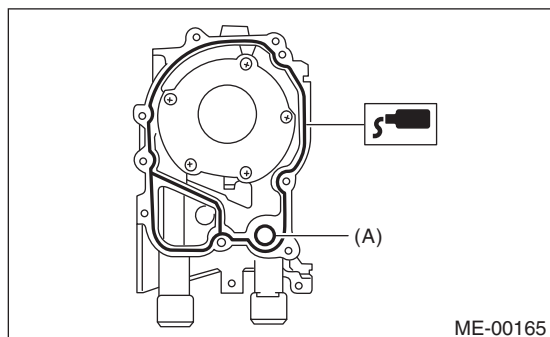

(A) O-ring

(3) Apply a coat of engine oil to the inside of oil seal.

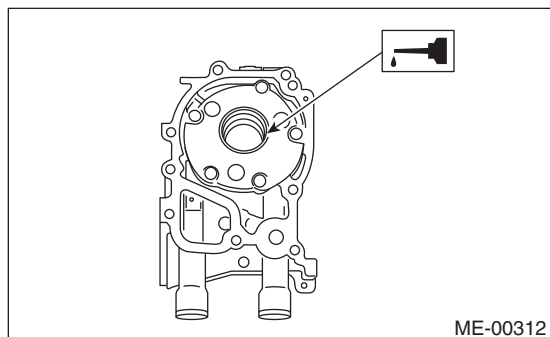

(4) Install the oil pump to cylinder block. Be careful not to damage the oil seal during installation.

NOTE:

- Make sure the oil seal lip is not folded.
- Align the flat surface of oil pump's inner rotor with crankshaft before installation.
- Use new O-rings and oil seals.
- Do not forget to assemble O-rings.

(5) Apply liquid gasket to the three bolts thread shown in figure. (when reusing bolts)

Liquid gasket:

THREE BOND 1324 (Part No. 004403042) or equivalent

Tightening torque:

T: 6.4 N·m (0.7 kgf·m, 4.7 ft·lb)

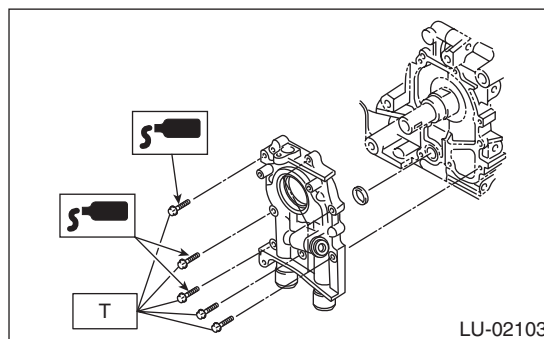

32) Install the water pump and gasket.

NOTE:

- When installing the water pump, tighten bolts in two stages in alphabetical order as shown in the figure.
- Use a new gasket.

Tightening torque:

First: 12 N·m (1.2 kgf·m, 8.9 ft·lb)

Second: 12 N·m (1.2 kgf·m, 8.9 ft·lb)

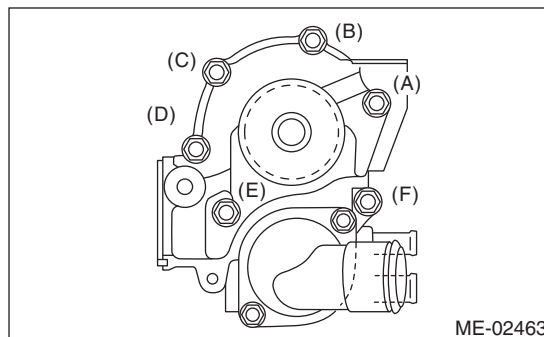

33) Install the water by-pass pipe for heater.

Tightening torque:

6.4 N·m (0.7 kgf·m, 4.7 ft·lb)

34) Install the oil filter. <Ref. to LU(H4SO)-19, INSTALLATION, Engine Oil Filter.>

35) Install the cylinder head. <Ref. to ME(H4SO)-72, INSTALLATION, Cylinder Head.>

Cylinder Block

MECHANICAL

36) Install the generator and A/C compressor with their brackets.

Tightening torque:

36 N·m (3.7 kgf-m, 26.6 ft-lb)

37) Install the crank sprocket. <Ref. to ME(H4SO)-61, INSTALLATION, Crank Sprocket.>

38) Install the cam sprocket. <Ref. to ME(H4SO)-59, INSTALLATION, Cam Sprocket.>

39) Install the timing belt. <Ref. to ME(H4SO)-55, INSTALLATION, Timing Belt.>

40) Adjust the valve clearance. <Ref. to ME(H4SO)-31, ADJUSTMENT, Valve Clearance.>

41) Install the rocker cover.

(1) Install the rocker cover gasket to the rocker cover.

NOTE:

Use a new rocker cover gasket.

(2) Temporarily tighten the bolts in alphabetical sequence as shown in figure, then tighten the bolt in 2 steps.

Tightening torque:

1st

6.4 N·m (0.7 kgf-m, 4.7 ft-lb)

2nd (only (a) and (b) are tightened)

6.4 N·m (0.7 kgf-m, 4.7 ft-lb)

RH side

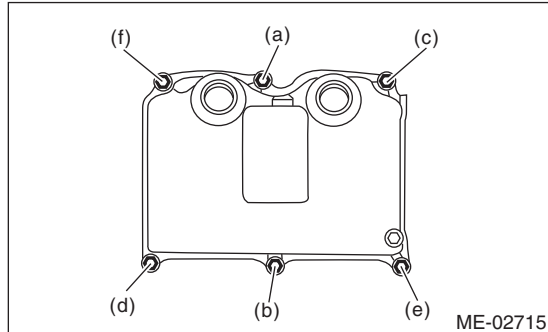

LH side

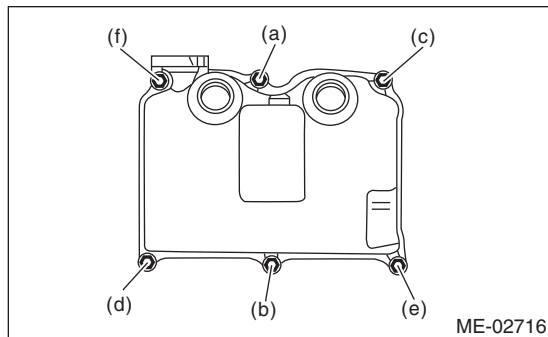

42) Install the timing belt cover. <Ref. to ME(H4SO)-52, INSTALLATION, Timing Belt Cover.>

43) Install the crank pulley. <Ref. to ME(H4SO)-50, INSTALLATION, Crank Pulley.>

44) Install the intake manifold. <Ref. to FU(H4SO)-16, INSTALLATION, Intake Manifold.>

45) Install the V-belts. <Ref. to ME(H4SO)-42, INSTALLATION, V-belt.>

C: DISASSEMBLY

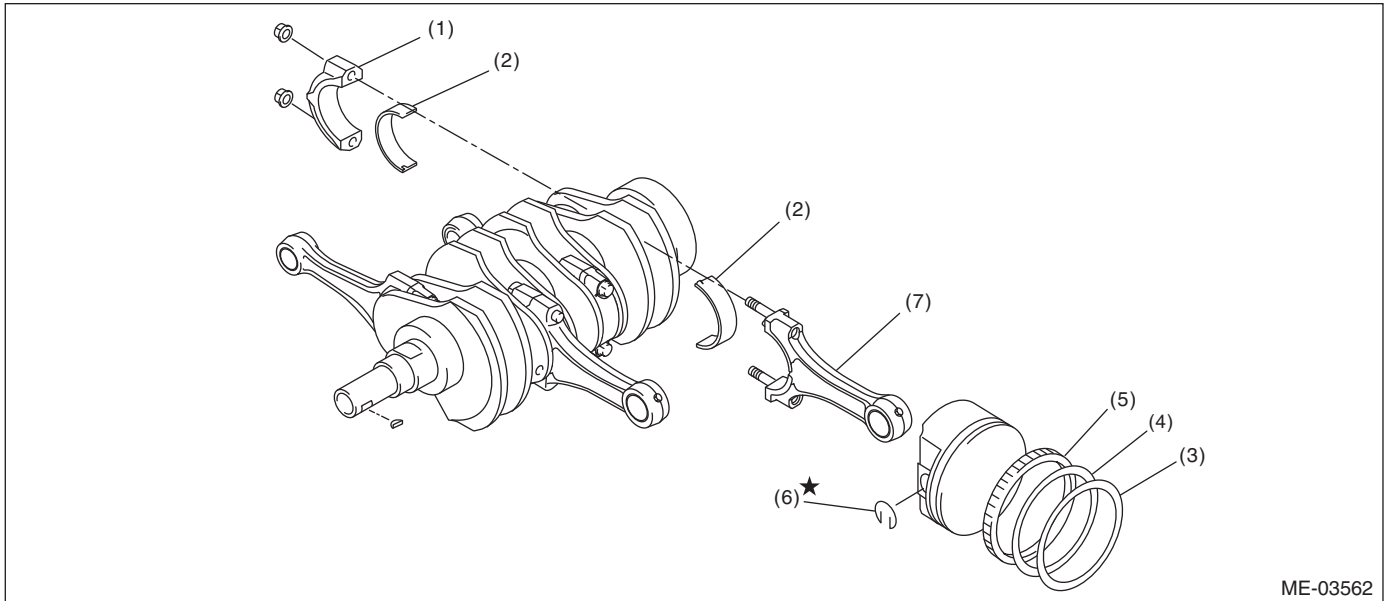

- | | | |
|----------------------------|-----------------|--------------------|
| (1) Connecting rod cap | (4) Second ring | (6) Snap ring |
| (2) Connecting rod bearing | (5) Oil ring | (7) Connecting rod |
| (3) Top ring | | |

- 1) Remove the connecting rod cap.
- 2) Remove the connecting rod bearing.

NOTE:

Keep the removed connecting rods, connecting rod caps and bearings in order so that they are kept in their original combinations/groups, and not mixed together.

- 3) Remove the piston rings using piston ring expander.
- 4) Remove the oil ring by hand.

NOTE:

Arrange the removed piston rings in proper order, to prevent confusion.

- 5) Remove the snap ring.

Cylinder Block

MECHANICAL

D: ASSEMBLY

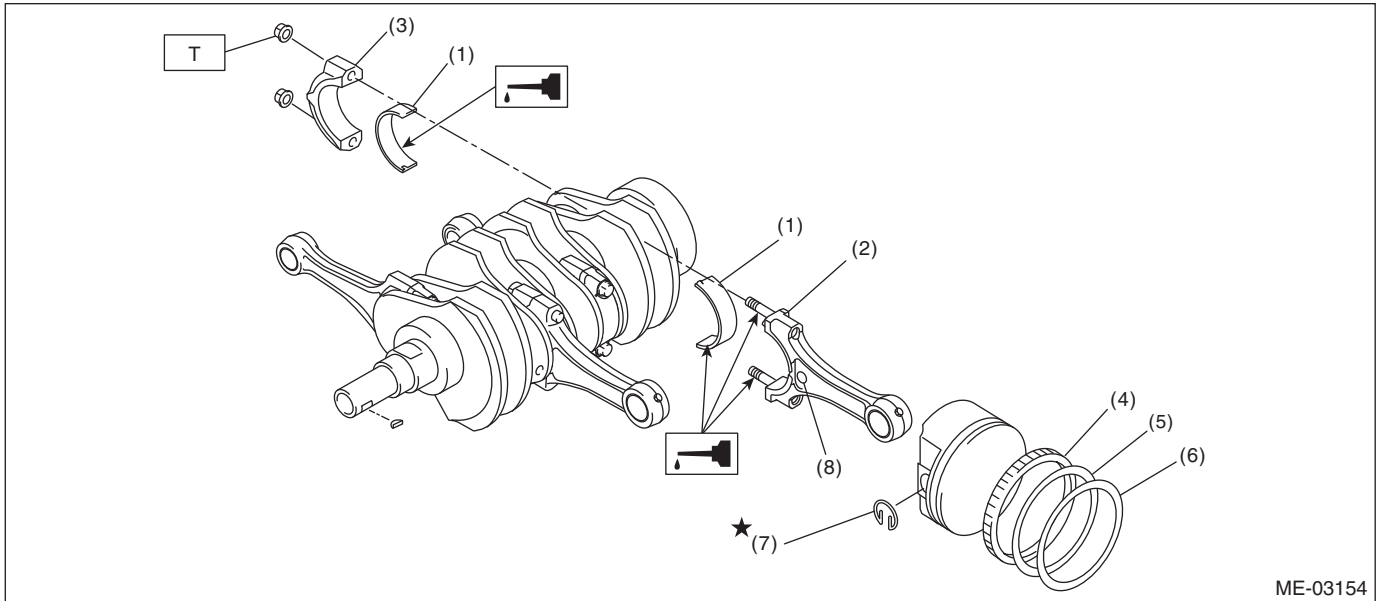

ME-03154

- | | |
|----------------------------|-----------------|
| (1) Connecting rod bearing | (5) Second ring |
| (2) Connecting rod | (6) Top ring |
| (3) Connecting rod cap | (7) Snap ring |
| (4) Oil ring | (8) Side mark |

Tightening torque: N·m (kgf·m, ft·lb)

T: 45 (4.6, 33.2)

1) Apply oil to the surface of the connecting rod bearings, and install the connecting rod bearings on connecting rods and connecting rod caps.

2) Position each connecting rod with the side with a side mark facing forward, and install it.

3) Attach the connecting rod cap, and tighten with connecting rod nut. Make sure the arrow mark on connecting rod cap facing front during installation.

NOTE:

- Each connecting rod has its own mating cap. Make sure that they are assembled correctly by checking their matching number.
- When tightening the connecting rod nuts, apply oil on the threads.

Tightening torque:

45 N·m (4.6 kgf·m, 33.2 ft·lb)

4) Install the oil ring upper rail, expander and lower rail by hand.

5) Install the second ring and top ring using piston ring expander.

NOTE:

Assemble so that the piston ring mark "R" faces the top side of the piston.

E: INSPECTION

1. CYLINDER BLOCK

- 1) Check for cracks or damage. Use liquid penetrant tester on the important sections to check for fissures. Check that there are no marks of gas leaking or water leaking on gasket installing surface.
- 2) Check the oil passages for clogging.
- 3) Inspect the cylinder head to cylinder block mating surface for warpage by using a straight edge, and correct by grinding if necessary.

Warping limit:
0.025 mm (0.00098 in)

Grinding limit:
0.1 mm (0.004 in)

Standard height of cylinder block:
201.0 mm (7.91 in)

2. CYLINDER AND PISTON

- 1) The cylinder bore size is stamped on the front upper face of the cylinder block.

NOTE:

- Measurement should be performed at a temperature of 20°C (68°F).
- Standard sized pistons are classified into two grades, "A" and "B". These grades should be used as guide lines in selecting a standard piston.

Standard diameter:

- A: 99.505 — 99.515 mm (3.9175 — 3.9179 in)**
B: 99.495 — 99.505 mm (3.9171 — 3.9175 in)

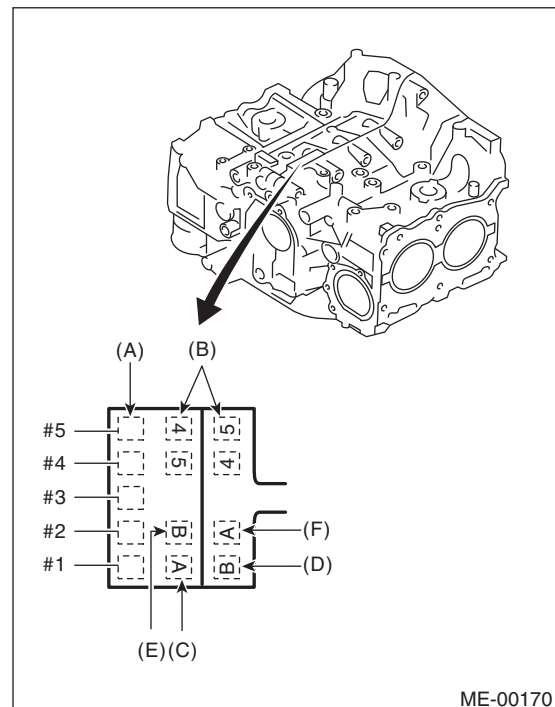

- (A) Main journal size mark
- (B) Cylinder block (RH) — (LH) combination mark
- (C) #1 cylinder bore size mark
- (D) #2 cylinder bore size mark
- (E) #3 cylinder bore size mark
- (F) #4 cylinder bore size mark

Cylinder Block

MECHANICAL

2) Measure the inner diameters of the cylinders. Measure the inner diameter of each cylinder in both the thrust and piston pin directions at the heights as shown in the figure, using a cylinder bore gauge.

NOTE:

Measurement should be performed at a temperature of 20°C (68°F).

Taper:

Standard:

0.015 mm (0.0006 in)

Out-of-roundness:

Standard:

0.010 mm (0.0004 in)

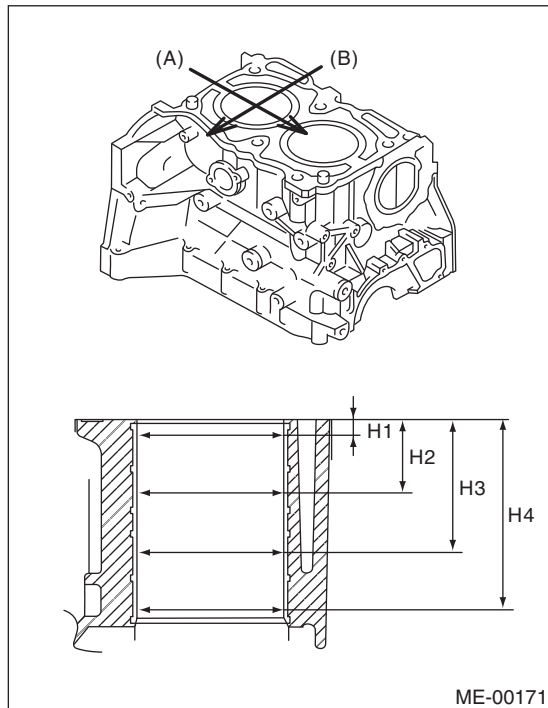

- (A) Piston pin direction
- (B) Thrust direction
- H1 10 mm (0.39 in)
- H2 45 mm (1.77 in)
- H3 80 mm (3.15 in)
- H4 115 mm (4.53 in)

3) When the piston is to be replaced due to general or cylinder wear, determine a suitable sized piston by measuring the piston clearance.

4) Measure the outer diameters of the pistons. Measure the outer diameter of each piston at the height as shown in the figure. (Thrust direction)

NOTE:

Measurement should be performed at a temperature of 20°C (68°F).

Piston grade point H:

38.2 mm (1.504 in)

Piston outer diameter:

Standard

A: 99.505 — 99.515 mm (3.9175 — 3.9179 in)

B: 99.495 — 99.505 mm (3.9171 — 3.9175 in)

0.25 mm (0.0098 in) oversize:

99.745 — 99.765 mm (3.9270 — 3.9278 in)

0.50 mm (0.0197 in) oversize:

99.995 — 100.015 mm (3.9368 — 3.9376 in)

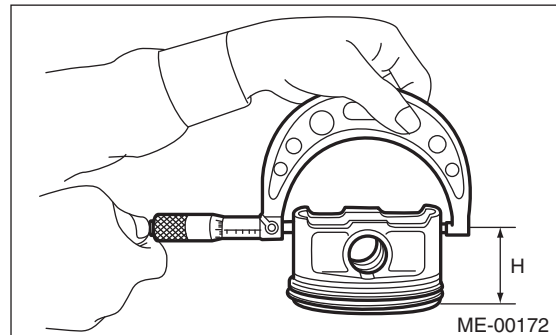

5) Calculate the clearance between cylinder and piston.

NOTE:

Measurement should be performed at a temperature of 20°C (68°F).

Cylinder to piston clearance at 20°C (68°F):

Standard:

-0.010 — 0.010 mm (-0.00039 — 0.00039 in)

6) Boring and honing

(1) If any of the measured value of taper, out-of-roundness or cylinder-to-piston clearance is out of standard or if there is any damage on the cylinder wall, rebores it to replace with an oversize piston.

CAUTION:

When any of the cylinders needs reboring, other cylinders must be bored at the same time, and replaced with oversize pistons.

(2) If the cylinder inner diameter exceeds the limit after boring and honing, replace the cylinder block.

NOTE:

Immediately after reboring, the cylinder diameter may differ from its real diameter due to temperature rise. Thus, when measuring the cylinder diameter, wait until it has cooled to room temperature.

**Cylinder inner diameter boring limit (diameter):
To 100.005 mm (3.9372 in)**

3. PISTON AND PISTON PIN

1) Check the piston and piston pin for breaks, cracks or wear. Replace if faulty.

2) Check the piston ring groove for wear and damage. Replace if faulty.

3) Make sure that the piston pin can be inserted into the piston pin hole with a thumb at 20°C (68°F). Replace if faulty.

**Clearance between piston hole and piston pin:
Standard**

0.004 — 0.008 mm (0.0002 — 0.0003 in)

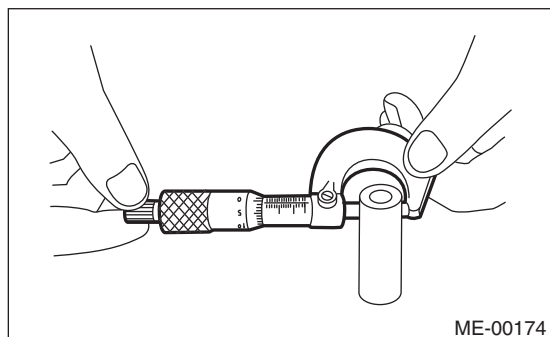
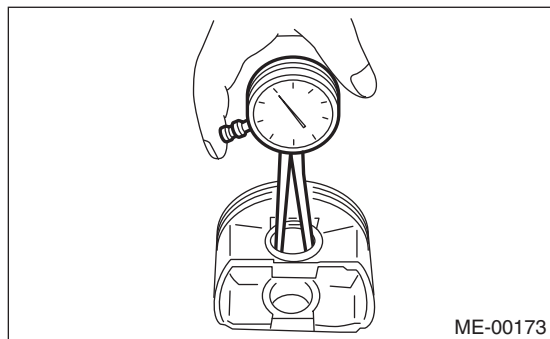

4) Check the snap ring installation groove (A) on the piston for burr. If necessary, remove burr from the groove so that the piston pin can lightly move.

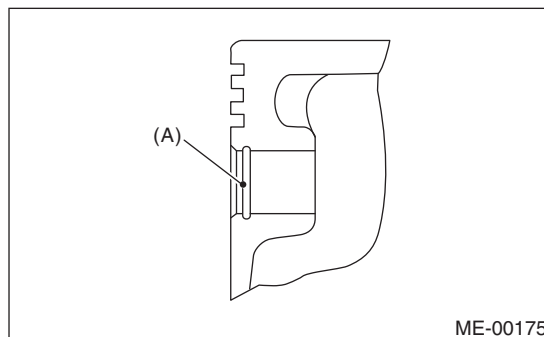

5) Check the piston pin snap ring for distortion, cracks and wear.

4. PISTON RING

1) If the piston ring is broken, damaged, worn, its tension is insufficient, or when replacing the piston, replace with a new piston ring of the same size as the piston.

NOTE:

- The top ring and second ring have the mark to determine the direction to install on them. When installing them to piston, face this mark to the top side.

- Oil ring consists of the upper rail, expander and lower rail. Be careful about the direction of rail when installing the oil ring to piston.

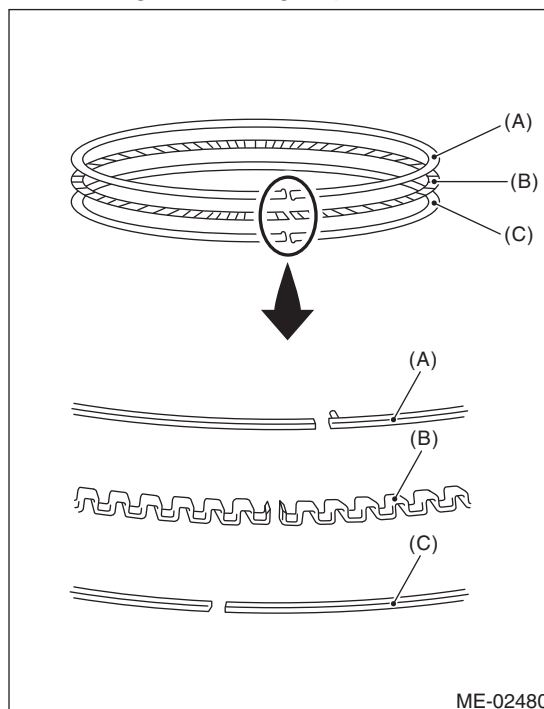

- (A) Upper rail
- (B) Expander
- (C) Lower rail

Cylinder Block

MECHANICAL

2) Squarely place the piston ring and oil ring in cylinder using the piston, and measure the piston ring gap with a thickness gauge.

		Standard mm (in)
Piston ring gap	Top ring	0.20 — 0.35 (0.0079 — 0.0138)
	Second ring	0.37 — 0.52 (0.0144 — 0.0203)
	Oil ring rail	0.20 — 0.50 (0.0079 — 0.0197)

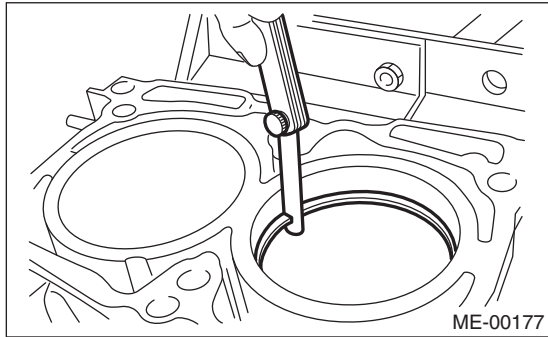

3) Fit the piston ring straight into the piston ring groove, then measure the clearance between piston ring and piston ring groove with a thickness gauge.

NOTE:

Before measuring the clearance, clean the piston ring groove and piston ring.

		Standard mm (in)
Clearance between piston ring and piston ring groove	Top ring	0.040 — 0.080 (0.0016 — 0.0031)
	Second ring	0.030 — 0.070 (0.0012 — 0.0028)

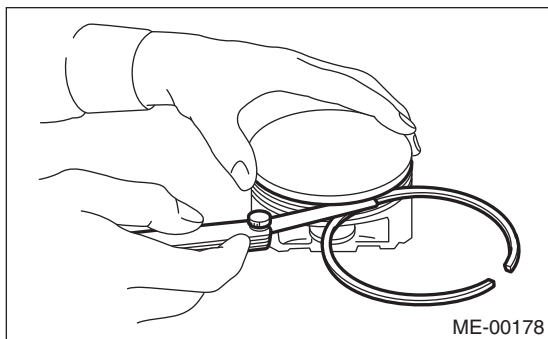

5. CONNECTING ROD

1) Replace the connecting rod, if the large or small end thrust surface is damaged.

2) Check for bend or twist using a connecting rod aligner. Replace the connecting rod if the bend or twist exceeds the limit.

Limit of bend or twist per 100 mm (3.94 in) in length:

0.10 mm (0.0039 in)

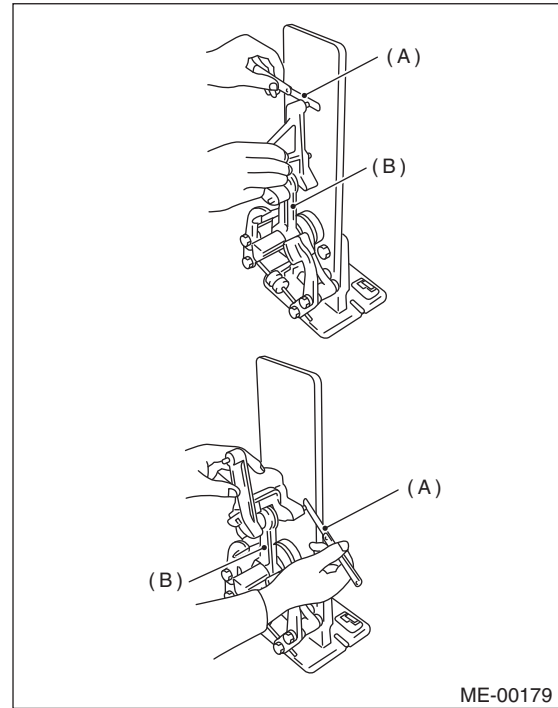

(A) Thickness gauge

(B) Connecting rod

3) Install the connecting rod fitted with bearing to the crankshaft, and measure the thrust clearance using a thickness gauge. If the thrust clearance exceeds the standard or uneven wear is found, replace the connecting rod.

Connecting rod thrust clearance:

Standard

0.070 — 0.330 mm (0.0028 — 0.0130 in)

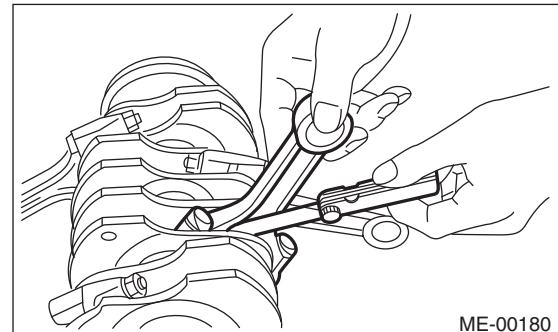

4) Inspect the connecting rod bearing for scar, peeling, seizure, melting, wear, etc.

5) Measure the oil clearance on each connecting rod bearing using plastigauge. If any oil clearance is not within the standard, replace the defective bearing with a new part of standard size or under-size as necessary.

**Connecting rod oil clearance:
Standard**

0.016 — 0.044 mm (0.00063 — 0.0017 in)

Unit: mm (in)		
Bearing	Bearing size (Thickness at center)	Outer diameter of crank pin
Standard	1.492 — 1.501 (0.0587 — 0.0591)	51.984 — 52.000 (2.0466 — 2.0472)
0.03 (0.0012) Undersize	1.510 — 1.513 (0.0594 — 0.0596)	51.954 — 51.970 (2.0454 — 2.0461)
0.05 (0.0020) Undersize	1.520 — 1.523 (0.0598 — 0.0600)	51.934 — 51.950 (2.0446 — 2.0453)
0.25 (0.0098) Undersize	1.620 — 1.623 (0.0638 — 0.0639)	51.734 — 51.750 (2.0368 — 2.0374)

6) Inspect the bushing at connecting rod small end, and replace with a new part if worn or damaged.

7) Measure the piston pin clearance at connecting rod small end. If the measured value is not within the standard, replace it with a new part.

**Clearance between piston pin and bushing:
Standard**

0 — 0.022 mm (0 — 0.0009 in)

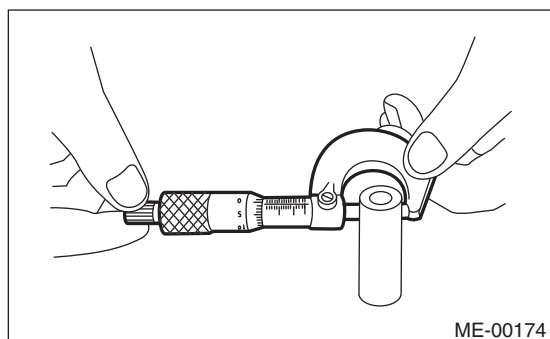
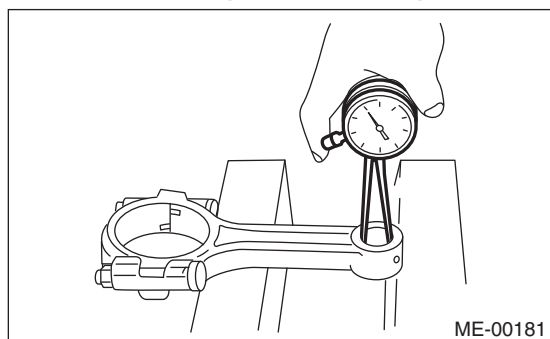

8) The replacement procedure for the connecting rod small end bushing is as follows.

(1) Remove the bushing from connecting rod with ST and press.

(2) Press the bushing with the ST after applying oil on the periphery of new bushing.

ST 499037100 CONNECTING ROD
BUSHING REMOVER AND
INSTALLER

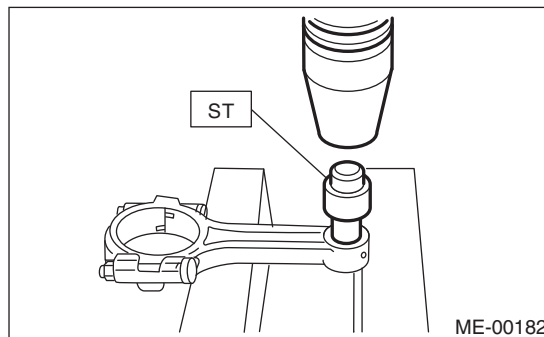

(3) Make two 3 mm (0.12 in) holes in the pressed bushing by aligning with the pre-manufactured holes on the connecting rod, and ream the inside of the bushing.

(4) After completion of reaming, clean the bushing to remove chips.

Cylinder Block

MECHANICAL

6. CRANKSHAFT AND CRANKSHAFT BEARING

- 1) Clean the crankshaft completely, and check it for cracks using liquid penetrant tester. If defective, replace the crankshaft.
- 2) Measure the bend of crankshaft. If it exceeds the limit, correct or replace it.

NOTE:

If a suitable V-block is not available, using just the #1 and #5 crankshaft bearings on cylinder block, position the crankshaft on cylinder block. Then, measure the crankshaft bend using a dial gauge.

Crankshaft bend limit:
0.035 mm (0.0014 in)

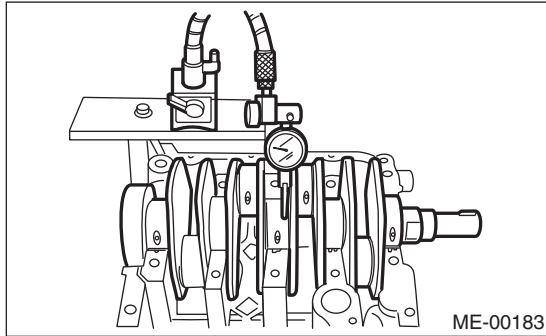

- 3) Inspect the crank journal and crank pin for wear. If they are not within the specification, replace the bearing with a suitable (undersize) one, and replace or grind to correct the crankshaft as necessary. When grinding the crank journal or crank pin, finish them to the specified dimensions according to the undersize bearing to be used.

Crank pin:

Out-of-roundness

0.003 mm (0.0001 in)

Cylindricality

0.004 mm (0.0002 in)

Grinding limit (dia.)

To 51.750 mm (2.0374 in)

Crank journal:

Out-of-roundness

0.005 mm (0.0002 in)

Cylindricality

0.006 mm (0.0002 in)

Grinding limit (dia.)

To 59.758 mm (2.3527 in)

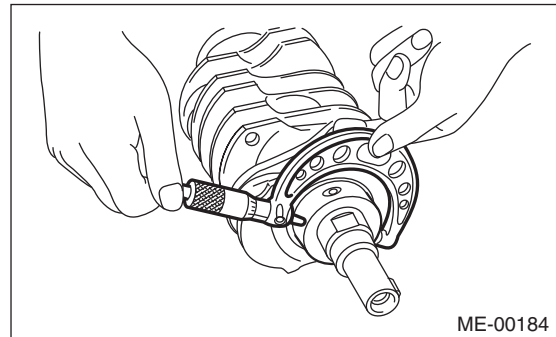

Cylinder Block

MECHANICAL

		Unit: mm (in)		
		Crank journal outer diameter		Crank pin outer diameter
		#1, #3	#2, #4, #5	
Standard	Journal O.D.	59.992 — 60.008 (2.3619 — 2.3625)	59.992 — 60.008 (2.3619 — 2.3625)	51.984 — 52.000 (2.0466 — 2.0472)
	Bearing size (Thickness at center)	1.998 — 2.011 (0.0787 — 0.0792)	2.000 — 2.013 (0.0787 — 0.0793)	1.492 — 1.501 (0.0587 — 0.0591)
0.03 (0.0012) Undersize	Journal O.D.	59.962 — 59.978 (2.3607 — 2.3613)	59.962 — 59.978 (2.3607 — 2.3613)	51.954 — 51.970 (2.0454 — 2.0461)
	Bearing size (Thickness at center)	2.017 — 2.020 (0.0794 — 0.0795)	2.019 — 2.022 (0.0795 — 0.0796)	1.510 — 1.513 (0.0594 — 0.0596)
0.05 (0.0020) Undersize	Journal O.D.	59.942 — 59.958 (2.3599 — 2.3605)	59.942 — 59.958 (2.3599 — 2.3605)	51.934 — 51.950 (2.0446 — 2.0453)
	Bearing size (Thickness at center)	2.027 — 2.030 (0.0798 — 0.0799)	2.029 — 2.032 (0.0799 — 0.0800)	1.520 — 1.523 (0.0598 — 0.0600)
0.25 (0.0098) Undersize	Journal O.D.	59.742 — 59.758 (2.3520 — 2.3527)	59.742 — 59.758 (2.3520 — 2.3527)	51.734 — 51.750 (2.0368 — 2.0374)
	Bearing size (Thickness at center)	2.127 — 2.130 (0.0837 — 0.0839)	2.129 — 2.132 (0.0838 — 0.0839)	1.620 — 1.623 (0.0638 — 0.0639)

4) Use a thickness gauge to measure the thrust clearance of the crankshaft at the #5 crank journal bearing. If the thrust clearance is not within the standard, replace the bearing.

Crankshaft thrust clearance:

Standard

0.030 — 0.115 mm (0.0012 — 0.0045 in)

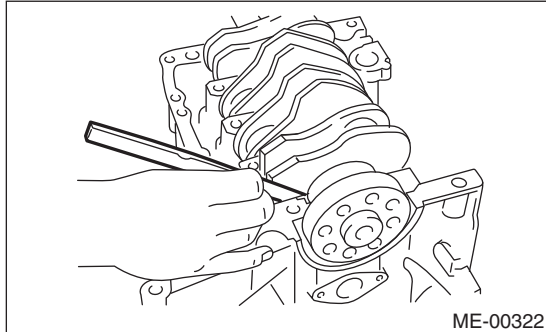

5) Inspect individual crankshaft bearings for signs of flaking, seizure, melting and wear.

6) Measure the oil clearance on each crankshaft bearing using plastigauge. If the measured value is out of standard, replace the defective bearing with an undersize one, and replace or grind to correct the crankshaft as necessary.

Crankshaft oil clearance:

Standard

0.010 — 0.030 mm (0.0004 — 0.0012 in)

Oil Switching Solenoid Valve

MECHANICAL

22.Oil Switching Solenoid Valve

A: REMOVAL

1. RH SIDE

1) Disconnect the ground cable from the battery.

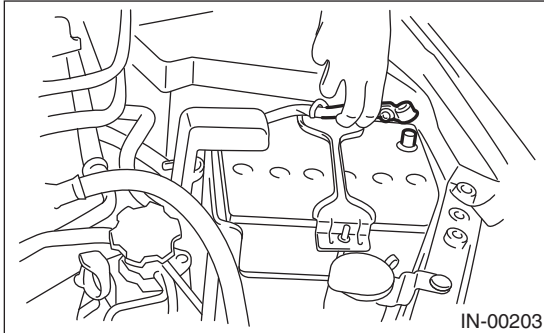

2) Remove the air intake chamber.

<Ref. to IN(H4SO)-7, REMOVAL, Air Intake Chamber.>

3) Remove the bolt, and disconnect the engine harness connector from the bulk head harness connector and rear engine hanger.

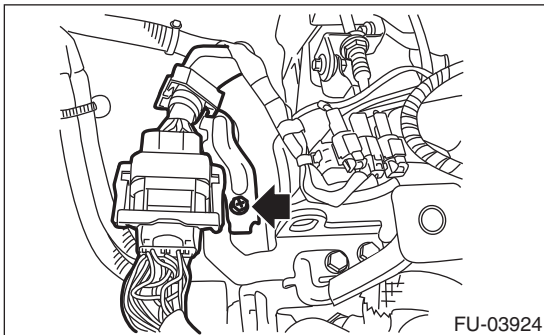

4) Slide the bulk head harness connector in the direction of the arrow, and remove from the rear engine cover.

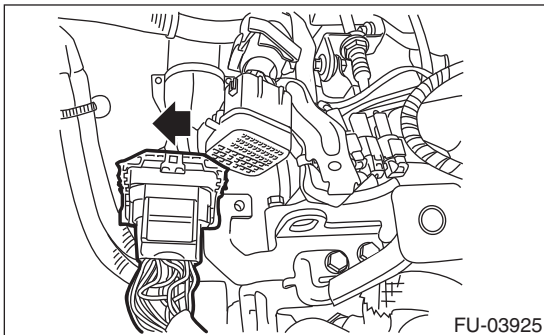

5) Disconnect the connector from the oil switching solenoid valve.

6) Remove the oil switching solenoid valve.

7) Remove the variable valve lift diagnosis oil pressure switch.

<Ref. to FU(H4SO)-33, REMOVAL, Variable Valve Lift Diagnosis Oil Pressure Switch.>

8) Remove the oil temperature sensor.

<Ref. to FU(H4SO)-34, REMOVAL, Oil Temperature Sensor.>

9) Remove the oil switching solenoid valve holder from the cylinder head.

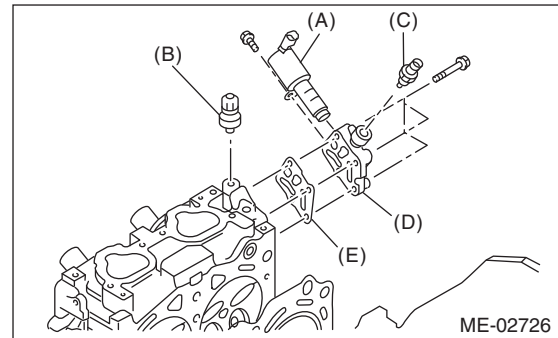

- (A) Oil switching solenoid valve
- (B) Variable valve lift diagnosis oil pressure switch
- (C) Oil temperature sensor
- (D) Oil switching solenoid valve holder
- (E) Gasket

2. LH SIDE

1) Disconnect the ground cable from the battery.

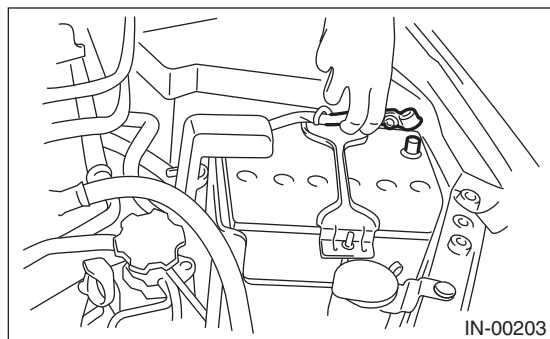

2) Remove the V-belts.

<Ref. to ME(H4SO)-42, REMOVAL, V-belt.>

3) Remove the crank pulley.

<Ref. to ME(H4SO)-50, REMOVAL, Crank Pulley.>

4) Remove the timing belt cover.

<Ref. to ME(H4SO)-52, REMOVAL, Timing Belt Cover.>

5) Remove the timing belt.

<Ref. to ME(H4SO)-53, REMOVAL, Timing Belt.>

6) Remove the cam sprocket.

<Ref. to ME(H4SO)-59, REMOVAL, Cam Sprocket.>

7) Remove the timing belt cover No. 2 (LH).

8) Disconnect the connector from the oil switching solenoid valve.

9) Remove the oil switching solenoid valve.

10) Remove the variable valve lift diagnosis oil pressure switch.

<Ref. to FU(H4SO)-33, REMOVAL, Variable Valve Lift Diagnosis Oil Pressure Switch.>

11) Remove the oil switching solenoid valve holder from the cylinder head.

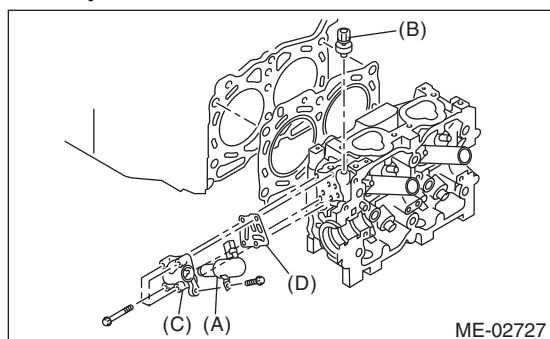

- (A) Oil switching solenoid valve
- (B) Variable valve lift diagnosis oil pressure switch
- (C) Oil switching solenoid valve holder
- (D) Gasket

B: INSTALLATION

1. RH SIDE

Install in the reverse order of removal.

NOTE:

- Use a new gasket.
- Apply liquid gasket to variable valve lift diagnosis oil pressure switch threads.
- Install the oil switching solenoid valve to the holder, then install it to the cylinder head.

Tightening torque:

T1: 8 N·m (0.8 kgf-m, 5.9 ft-lb)

T2: 10 N·m (1.0 kgf-m, 7.4 ft-lb)

T3: 17 N·m (1.7 kgf-m, 12.5 ft-lb)

T4: 18 N·m (1.8 kgf-m, 13.3 ft-lb)

Liquid gasket

THREE BOND 1324 (Part No. 004403042) or equivalent

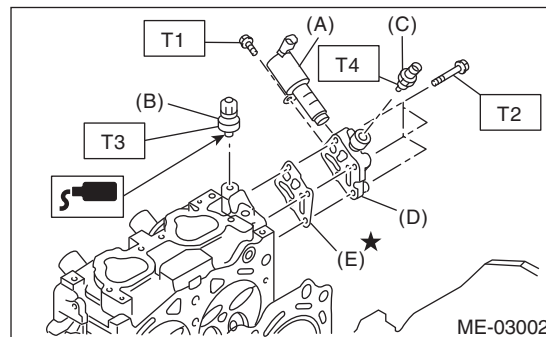

- (A) Oil switching solenoid valve
- (B) Variable valve lift diagnosis oil pressure switch
- (C) Oil temperature sensor
- (D) Oil switching solenoid valve holder
- (E) Gasket

Tightening torque:

6.4 N·m (0.7 kgf-m, 4.7 ft-lb)

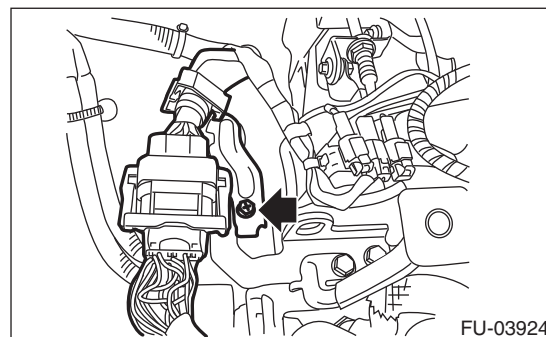

Oil Switching Solenoid Valve

MECHANICAL

2. LH SIDE

Install in the reverse order of removal.

NOTE:

- Use a new gasket.
- Apply liquid gasket to variable valve lift diagnosis oil pressure switch threads.
- Install the oil switching solenoid valve to the holder, then install it to the cylinder head.

Tightening torque:

T1: 8 N·m (0.8 kgf-m, 5.9 ft-lb)

T2: 10 N·m (1.0 kgf-m, 7.4 ft-lb)

T3: 17 N·m (1.7 kgf-m, 12.5 ft-lb)

Liquid gasket

THREE BOND 1324 (Part No. 004403042) or equivalent

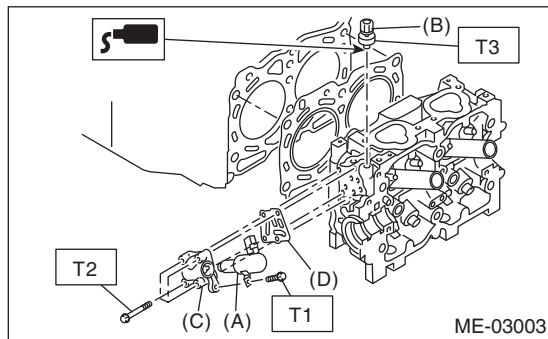

- (A) Oil switching solenoid valve
- (B) Variable valve lift diagnosis oil pressure switch
- (C) Oil switching solenoid valve holder
- (D) Gasket

23. Intake and Exhaust Valve

A: SPECIFICATION

Refer to "Cylinder Head" for removal and installation procedures of the intake and exhaust valves. <Ref. to ME(H4SO)-71, REMOVAL, Cylinder Head.> <Ref. to ME(H4SO)-72, INSTALLATION, Cylinder Head.>

24.Piston

A: SPECIFICATION

Refer to "Cylinder Block" for removal and installation procedures of pistons. <Ref. to ME(H4SO)-81, REMOVAL, Cylinder Block.> <Ref. to ME(H4SO)-85, INSTALLATION, Cylinder Block.>

25. Connecting Rod

A: SPECIFICATION

Refer to "Cylinder Block" for removal and installation procedures of connecting rod.

<Ref. to ME(H4SO)-81, REMOVAL, Cylinder Block.> <Ref. to ME(H4SO)-85, INSTALLATION, Cylinder Block.>

26.Crankshaft

A: SPECIFICATION

Refer to "Cylinder Block" for removal and installation procedures of the crankshaft. <Ref. to ME(H4SO)-81, REMOVAL, Cylinder Block.> <Ref. to ME(H4SO)-85, INSTALLATION, Cylinder Block.>

27.Engine Trouble in General

A: INSPECTION

NOTE:

The "RANK" shown in the chart shows the possibilities of the cause of trouble in order from "Very often" to "Rarely".

A — Very often

B — Sometimes

C — Rarely

Symptoms	Problem parts etc.	Possible cause	RANK
1. Engine does not start.			
1) Starter does not turn.	Starter	Defective battery-to-starter harness	B
		Defective starter switch	C
		Defective inhibitor switch	C
		Defective starter	B
	Battery	Improper connection of the terminal	A
		Run-down battery	A
		Defective charging system	B
	Friction	Seizure of crankshaft and connecting rod bearing	C
		Seized camshaft	C
Seized or stuck piston and cylinder		C	
2) Initial combustion does not occur.	Starter	Defective starter	C
	Engine control system <Ref. to EN(H4SO)(diag)-2, Basic Diagnostic Procedure.>		A
	Fuel line	Defective fuel pump and relay	A
		Clogged fuel line	B
		Lack of or insufficient fuel	B
	Timing belt	Degradation, etc.	B
		Defective timing	B
	Compression	Incorrect valve clearance	C
		Loosened spark plug or defective gasket	C
		Loosened cylinder head bolt or defective gasket	C
		Improper valve sealing	C
		Defective valve stem	C
		Worn or broken valve spring	B
Worn or stuck piston rings, cylinder and piston		C	
Incorrect valve timing		B	
Improper engine oil (low viscosity)	B		

Engine Trouble in General

MECHANICAL

Symptoms	Problem parts etc.	Possible cause	RANK
3) Initial combustion occurs.	Engine control system <Ref. to EN(H4SO)(diag)-2, Basic Diagnostic Procedure.>		A
	Intake system	Defective intake manifold gasket	B
		Defective throttle body gasket	B
	Fuel line	Defective fuel pump and relay	C
		Clogged fuel line	C
		Lack of or insufficient fuel	B
	Timing belt	Degradation, etc.	B
		Defective timing	B
	Compression	Incorrect valve clearance	C
		Loosened spark plug or defective gasket	C
		Loosened cylinder head bolt or defective gasket	C
		Improper valve sealing	C
		Defective valve stem	C
		Worn or broken valve spring	B
Worn or stuck piston rings, cylinder and piston		C	
Incorrect valve timing		B	
Improper engine oil (low viscosity)	B		
4) Engine stalls after initial combustion.	Engine control system <Ref. to EN(H4SO)(diag)-2, Basic Diagnostic Procedure.>		A
	Intake system	Loosened or cracked intake duct	B
		Loosened or cracked PCV hose	C
		Loosened or cracked vacuum hose	C
		Defective intake manifold gasket	B
		Defective throttle body gasket	B
		Dirty air cleaner element	C
	Fuel line	Clogged fuel line	C
		Lack of or insufficient fuel	B
	Timing belt	Degradation, etc.	B
		Defective timing	B
	Compression	Incorrect valve clearance	C
		Loosened spark plug or defective gasket	C
		Loosened cylinder head bolt or defective gasket	C
Improper valve sealing		C	
Defective valve stem		C	
Worn or broken valve spring		B	
Worn or stuck piston rings, cylinder and piston		C	
Incorrect valve timing		B	
Improper engine oil (low viscosity)	B		

Engine Trouble in General

MECHANICAL

Symptoms	Problem parts etc.	Possible cause	RANK
2. Rough idle and engine stall	Engine control system <Ref. to EN(H4SO)(diag)-2, Basic Diagnostic Procedure.>		A
	Intake system	Loosened or cracked intake duct	A
		Loosened or cracked PCV hose	A
		Loosened or cracked vacuum hose	A
		Defective intake manifold gasket	B
		Defective throttle body gasket	B
		Defective PCV valve	C
		Loosened oil filler cap	B
		Dirty air cleaner element	C
	Fuel line	Defective fuel pump and relay	C
		Clogged fuel line	C
		Lack of or insufficient fuel	B
	Timing belt	Defective timing	C
	Compression	Incorrect valve clearance	B
		Loosened spark plug or defective gasket	B
		Loosened cylinder head bolt or defective gasket	B
		Improper valve sealing	B
		Defective valve stem	C
		Worn or broken valve spring	B
		Worn or stuck piston rings, cylinder and piston	B
		Incorrect valve timing	A
	Lubrication system	Improper engine oil (low viscosity)	B
		Incorrect oil pressure	B
Cooling system	Defective rocker cover gasket	C	
	Overheating	C	
Others	Evaporative emission control system malfunction	A	
	Stuck or damaged throttle valve	B	

Engine Trouble in General

MECHANICAL

Symptoms	Problem parts etc.	Possible cause	RANK
3. Low output, hesitation and poor acceleration	Engine control system <Ref. to EN(H4SO)(diag)-2, Basic Diagnostic Procedure.>		A
	Intake system	Loosened or cracked intake duct	A
		Loosened or cracked PCV hose	A
		Loosened or cracked vacuum hose	B
		Defective intake manifold gasket	B
		Defective throttle body gasket	B
		Defective PCV valve	B
		Loosened oil filler cap	B
		Dirty air cleaner element	A
	Fuel line	Defective fuel pump and relay	B
		Clogged fuel line	B
		Lack of or insufficient fuel	C
	Timing belt	Defective timing	B
	Compression	Incorrect valve clearance	B
		Loosened spark plug or defective gasket	B
		Loosened cylinder head bolt or defective gasket	B
		Improper valve sealing	B
		Defective valve stem	C
		Worn or broken valve spring	B
		Worn or stuck piston rings, cylinder and piston	C
		Incorrect valve timing	A
	Improper engine oil (low viscosity)	B	
	Lubrication system	Incorrect oil pressure	B
	Cooling system	Overheating	C
		Over-cooling	C
	Others	Evaporative emission control system malfunction	A
4. Surging	Engine control system <Ref. to EN(H4SO)(diag)-2, Basic Diagnostic Procedure.>		A
	Intake system	Loosened or cracked intake duct	A
		Loosened or cracked PCV hose	A
		Loosened or cracked vacuum hose	A
		Defective intake manifold gasket	B
		Defective throttle body gasket	B
		Defective PCV valve	B
		Loosened oil filler cap	B
		Dirty air cleaner element	B
	Fuel line	Defective fuel pump and relay	B
		Clogged fuel line	B
		Lack of or insufficient fuel	C
	Timing belt	Defective timing	B
	Compression	Incorrect valve clearance	B
		Loosened spark plug or defective gasket	C
		Loosened cylinder head bolt or defective gasket	C
		Improper valve sealing	C
		Defective valve stem	C
		Worn or broken valve spring	C
		Worn or stuck piston rings, cylinder and piston	C
		Incorrect valve timing	A
	Improper engine oil (low viscosity)	B	
	Cooling system	Overheating	B
	Others	Evaporative emission control system malfunction	C

Engine Trouble in General

MECHANICAL

Symptoms	Problem parts etc.	Possible cause	RANK
5. Engine does not return to idle.	Engine control system <Ref. to EN(H4SO)(diag)-2, Basic Diagnostic Procedure.>		A
	Intake system	Loosened or cracked vacuum hose	A
	Others	Stuck or damaged throttle valve	A
6. Dieseling (Run-on)	Engine control system <Ref. to EN(H4SO)(diag)-2, Basic Diagnostic Procedure.>		A
	Cooling system	Overheating	B
	Others	Evaporative emission control system malfunction	B
7. After burning in exhaust system	Engine control system <Ref. to EN(H4SO)(diag)-2, Basic Diagnostic Procedure.>		A
	Intake system	Loosened or cracked intake duct	C
		Loosened or cracked PCV hose	C
		Loosened or cracked vacuum hose	B
		Defective PCV valve	B
		Loosened oil filler cap	C
	Timing belt	Defective timing	B
	Compression	Incorrect valve clearance	B
		Loosened spark plug or defective gasket	C
		Loosened cylinder head bolt or defective gasket	C
		Improper valve sealing	B
		Defective valve stem	C
		Worn or broken valve spring	C
		Worn or stuck piston rings, cylinder and piston	C
		Incorrect valve timing	A
	Lubrication system	Incorrect oil pressure	C
Cooling system	Over-cooling	C	
Others	Evaporative emission control system malfunction	C	
8. Knocking	Engine control system <Ref. to EN(H4SO)(diag)-2, Basic Diagnostic Procedure.>		A
	Intake system	Loosened oil filler cap	B
	Timing belt	Defective timing	B
	Compression	Incorrect valve clearance	C
		Incorrect valve timing	B
	Cooling system	Overheating	A
9. Excessive engine oil consumption	Intake system	Loosened or cracked PCV hose	A
		Defective PCV valve	B
		Loosened oil filler cap	C
	Compression	Defective valve stem	A
		Worn or stuck piston rings, cylinder and piston	A
	Lubrication system	Loosened oil pump attaching bolts and defective gasket	B
		Defective oil filter gasket	B
		Defective crankshaft oil seal	B
		Defective rocker cover gasket	B
		Loosened oil drain plug or defective gasket	B
	Loosened oil pan fitting bolts or defective oil pan	B	

Engine Trouble in General

MECHANICAL

Symptoms	Problem parts etc.	Possible cause	RANK	
10. Excessive fuel consumption	Engine control system <Ref. to EN(H4SO)(diag)-2, Basic Diagnostic Procedure.>		A	
	Intake system	Dirty air cleaner element	A	
	Timing belt	Defective timing	B	
	Compression	Incorrect valve clearance		B
		Loosened spark plug or defective gasket		C
		Loosened cylinder head bolt or defective gasket		C
		Improper valve sealing		B
		Defective valve stem		C
		Worn or broken valve spring		C
		Worn or stuck piston rings, cylinder and piston		B
		Incorrect valve timing		B
	Lubrication system	Incorrect oil pressure	C	
	Cooling system	Over-cooling	C	

28.Engine Noise

A: INSPECTION

Type of sound	Condition	Possible cause
Regular clicking sound	Sound increases as engine speed increases.	<ul style="list-style-type: none"> • Valve mechanism is defective. • Incorrect valve clearance • Worn valve rocker • Worn camshaft • Broken valve spring
Heavy and dull clank	Oil pressure is low.	<ul style="list-style-type: none"> • Worn crankshaft main bearing • Worn connecting rod bearing (large end)
	Oil pressure is normal.	<ul style="list-style-type: none"> • Damaged engine mounting • Loosened flywheel mounting bolt
High-pitched clank (Spark knock)	Sound is noticeable when accelerating with an overload condition.	<ul style="list-style-type: none"> • Ignition timing advanced • Accumulation of carbon inside combustion chamber • Wrong spark plug • Improper gasoline
Clank when engine speed is 1,000 to 2,000 rpm	Sound is reduced when fuel injector connector of noisy cylinder is disconnected. (NOTE*)	<ul style="list-style-type: none"> • Worn crankshaft main bearing • Worn connecting rod bearing (large end)
Knocking sound when engine is operating under idling speed and engine is warm	Sound is reduced when fuel injector connector of noisy cylinder is disconnected. (NOTE*)	<ul style="list-style-type: none"> • Worn cylinder liner and piston ring • Broken or stuck piston ring • Worn piston pin and hole at piston end of connecting rod
	Sound is not reduced if each fuel injector connector is disconnected in turn. (NOTE*)	<ul style="list-style-type: none"> • Worn cam sprocket • Worn camshaft journal bore in cylinder head
Squeaky sound	—	Insufficient generator lubrication
Rubbing sound	—	Poor contact of generator brush and rotor
Gear scream when starting engine	—	<ul style="list-style-type: none"> • Defective ignition starter switch • Worn gear and starter pinion
Sound like polishing glass with a dry cloth	—	<ul style="list-style-type: none"> • Loose V belt • Defective water pump shaft
Hissing sound	—	<ul style="list-style-type: none"> • Insufficient compression • Air leakage in air intake system, hose, connection or manifold
Timing belt noise	—	<ul style="list-style-type: none"> • Loose timing belt • Belt contacting with case/adjacent part
Valve noise	—	Incorrect valve clearance

NOTE*)

When disconnecting the fuel injector connector, the malfunction indicator light illuminates and DTC is stored in ECM memory. Therefore, after connecting the fuel injector connector, perform the clear memory mode <Ref. to EN(H4SO)(diag)-51, OPERATION, Clear Memory Mode.> and inspection mode <Ref. to EN(H4SO)(diag)-41, PROCEDURE, Inspection Mode.>.

Engine Noise

MECHANICAL

EXHAUST

EX(H4SO)

	Page
1. General Description	2
2. Front Exhaust Pipe	4
3. Center Exhaust Pipe	7
4. Rear Exhaust Pipe	8
5. Muffler	10

General Description

EXHAUST

1. General Description

A: COMPONENT

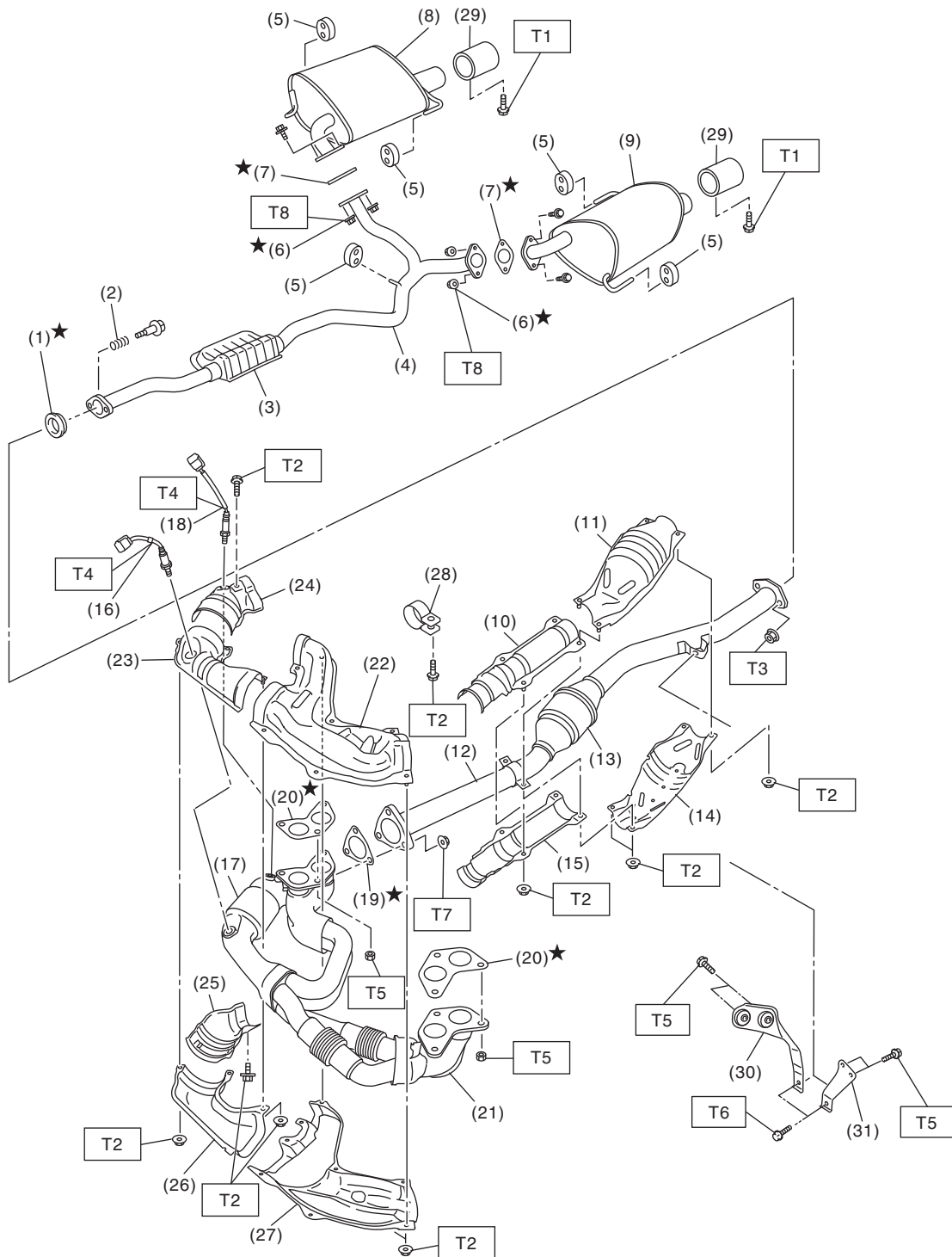

EX-02352

EX(H4SO)-2

General Description

EXHAUST

(1) Gasket	(15) Center exhaust pipe front lower cover	(27) Front exhaust pipe lower cover LH
(2) Spring	(16) Front oxygen (A/F) sensor	(28) Band
(3) Chamber	(17) Front catalytic converter	(29) Ornamental muffler tip (Models with ornamental muffler tips)
(4) Rear exhaust pipe	(18) Rear oxygen sensor	(30) Hanger bracket (MT model)
(5) Cushion rubber	(19) Gasket	(31) Hanger bracket (AT model)
(6) Self-locking nut	(20) Gasket	
(7) Gasket	(21) Front exhaust pipe	
(8) Muffler (RH)	(22) Front exhaust pipe upper cover LH	Tightening torque:N·m (kgf-m, ft-lb)
(9) Muffler (LH)	(23) Front exhaust pipe upper cover RH	T1: 7.5 (0.8, 5.5)
(10) Center exhaust pipe front upper cover	(24) Front catalytic converter upper cover	T2: 13 (1.3, 9.6)
(11) Rear catalytic converter upper cover	(25) Front catalytic converter lower cover	T3: 18 (1.8, 13.3)
(12) Center exhaust pipe	(26) Front exhaust pipe lower cover RH	T4: 21 (2.1, 15.5)
(13) Rear catalytic converter		T5: 30 (3.1, 22.1)
(14) Rear catalytic converter lower cover		T6: 35 (3.6, 25.8)
		T7: 40 (4.1, 29.5)
		T8: 48 (4.9, 35.4)

B: CAUTION

- Wear appropriate work clothing, including a cap, protective goggles and protective shoes when performing any work.
- Remove contamination including dirt and corrosion before removal, installation or disassembly.
- Keep the disassembled parts in order and protect them from dust and dirt.
- Before removal, installation or disassembly, be sure to clarify the failure. Avoid unnecessary removal, installation, disassembly and replacement.
- Vehicle components are extremely hot after driving. Be wary of receiving burns from heated parts.
- Be sure to tighten fasteners including bolts and nuts to the specified torque.
- Place shop jacks or rigid racks at the specified points.
- Before disconnecting connectors of sensors or units, be sure to disconnect the ground cable from the battery.
- If any fat adheres to the exhaust pipe, wipe it off. Otherwise a fire may happen.

Front Exhaust Pipe

EXHAUST

2. Front Exhaust Pipe

A: REMOVAL

CAUTION:

Be careful not to burn yourself, because the exhaust pipe becomes extremely hot after running.

- 1) Set the vehicle on a lift.
- 2) Remove the air intake duct (rear). <Ref. to IN(H4SO)-8, REMOVAL, Air Intake Duct.>
- 3) Disconnect the ground cable from the battery.

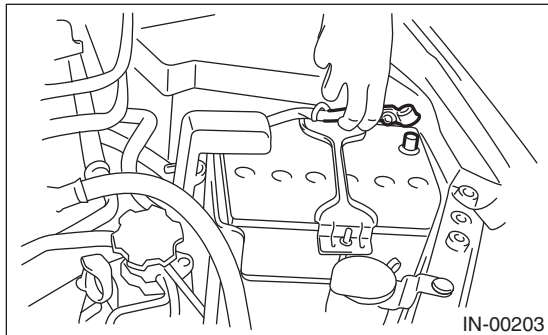

- 4) Unclip the clip fastening the harness and disconnect the following connectors.

- (1) Front oxygen (A/F) sensor connector
- (2) Rear oxygen sensor connector

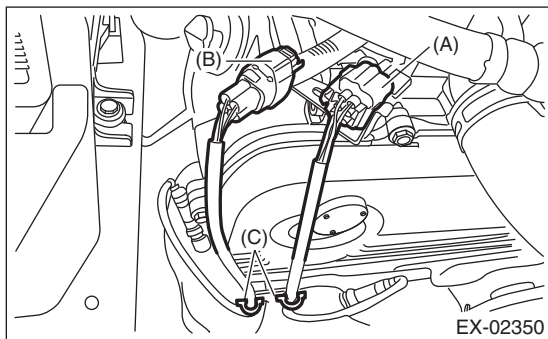

- (A) Front oxygen (A/F) sensor connector
(B) Rear oxygen sensor connector
(C) Clip

- 5) Lift up the vehicle.
- 6) Remove the under cover RH.
- 7) Separate the center exhaust pipe from rear exhaust pipe.

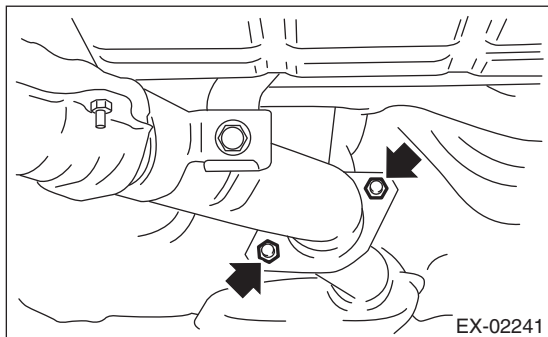

- 8) Remove the nuts which hold front exhaust pipe onto cylinder heads.

CAUTION:

Be careful not to pull down the front and center exhaust pipe assembly.

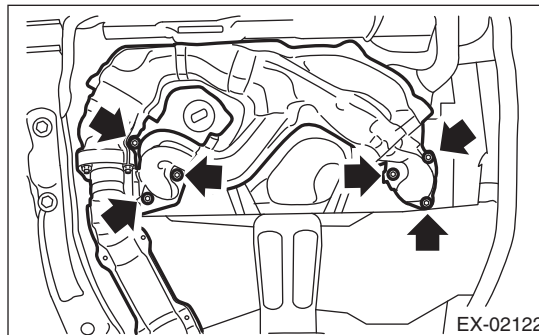

- 9) Remove the bolt which holds center exhaust pipe to hanger bracket.

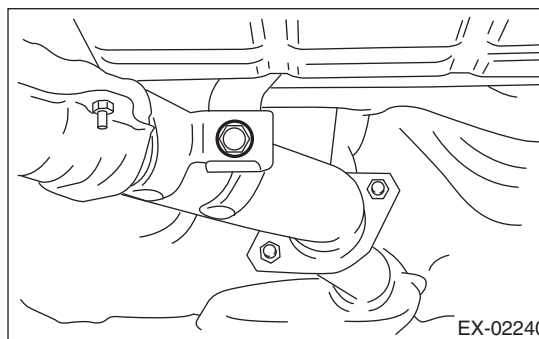

- 10) Remove the front and center exhaust pipe assembly from the vehicle.

CAUTION:

- The front and center exhaust pipe assemblies are very heavy. Be careful not to drop the exhaust pipes when removing.
- After removing the front and center exhaust pipe assemblies, do not pull on the rear exhaust pipe with excessive force.

- 11) Separate the front exhaust pipe from center exhaust pipe.

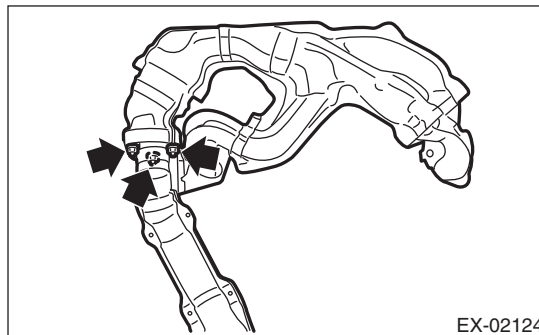

- 12) Remove the front oxygen (A/F) sensor and rear oxygen sensor. <Ref. to FU(H4SO)-35, REMOVAL, Front Oxygen (A/F) Sensor.> <Ref. to FU(H4SO)-37, REMOVAL, Rear Oxygen Sensor.>

B: INSTALLATION

1) Install the front oxygen (A/F) sensor and rear oxygen sensor to the front exhaust pipe. <Ref. to FU(H4SO)-36, INSTALLATION, Front Oxygen (A/F) Sensor.> <Ref. to FU(H4SO)-38, INSTALLATION, Rear Oxygen Sensor.>

2) Install the front exhaust pipe to center exhaust pipe.

NOTE:

Use a new gasket.

Tightening torque:

40 N·m (4.1 kgf-m, 29.5 ft-lb)

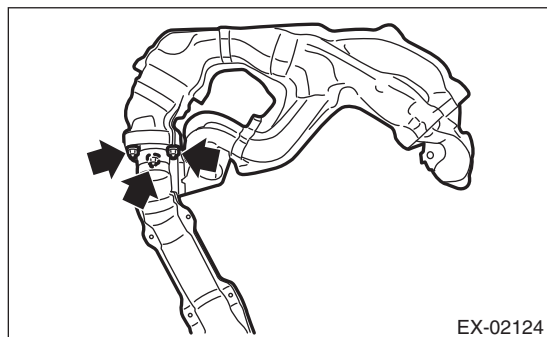

3) Install the front and center exhaust pipe assembly to the vehicle.

NOTE:

Use a new gasket.

4) Temporarily tighten the nuts which hold front exhaust pipe to cylinder heads.

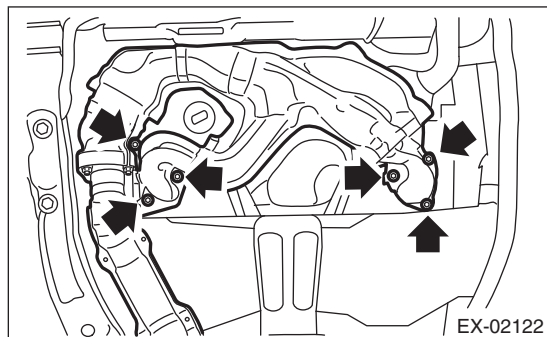

5) Tighten the bolt which holds the center exhaust pipe to exhaust pipe.

NOTE:

Use a new gasket.

Tightening torque:

18 N·m (1.8 kgf-m, 13.3 ft-lb)

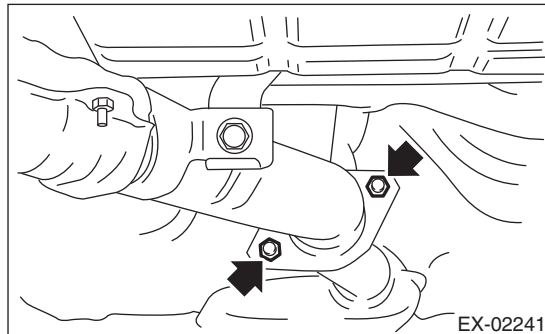

6) Tighten the bolt which holds center exhaust pipe to hanger bracket.

Tightening torque:

35 N·m (3.6 kgf-m, 25.8 ft-lb)

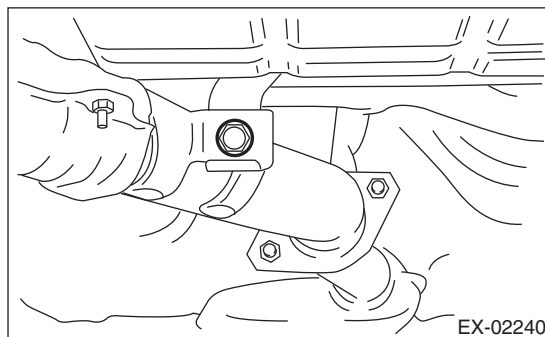

7) Tighten the nuts which hold front exhaust pipe to cylinder heads.

Tightening torque:

30 N·m (3.1 kgf-m, 22.1 ft-lb)

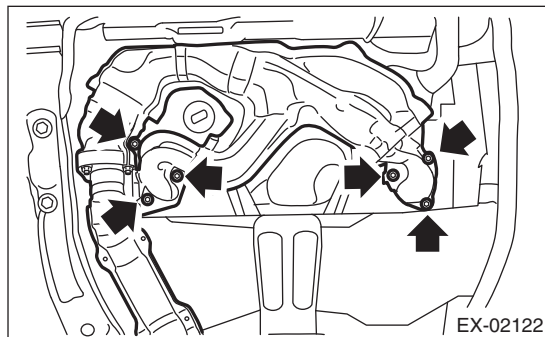

8) Install the under cover RH.

9) Lower the vehicle.

Front Exhaust Pipe

EXHAUST

10) Connect the following connector and fasten the harness with clips.

- (1) Front oxygen (A/F) sensor connector
- (2) Rear oxygen sensor connector

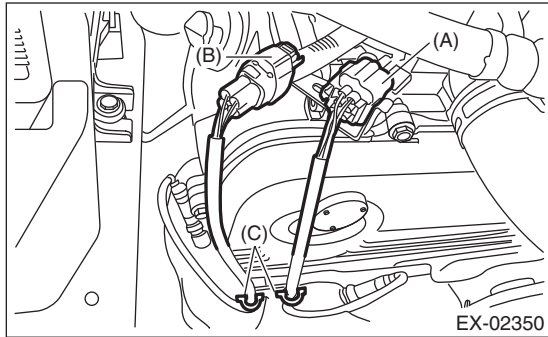

- (A) Front oxygen (A/F) sensor connector
- (B) Rear oxygen sensor connector
- (C) Clip

- 11) Install the air intake duct (rear). <Ref. to IN(H4SO)-8, INSTALLATION, Air Intake Duct.>
- 12) Connect the battery ground cable to battery.

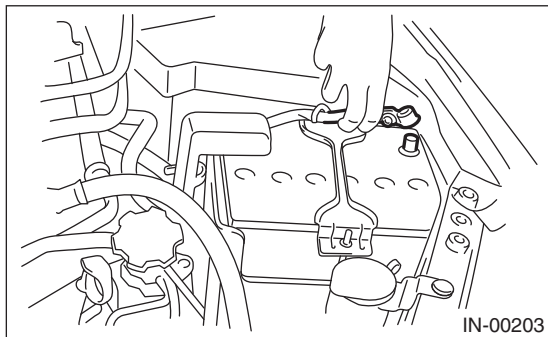

C: INSPECTION

- 1) Check the connections and welds for exhaust leaks.
- 2) Make sure there are no holes or rusting.

3. Center Exhaust Pipe

A: REMOVAL

After removing the center and front exhaust pipes as one unit, separate them. Refer to “Front Exhaust Pipe” for the removal procedure. <Ref. to EX(H4SO)-4, REMOVAL, Front Exhaust Pipe.>

B: INSTALLATION

Install the center exhaust pipe and front exhaust pipe as one unit. Refer to “Front Exhaust Pipe” for the installation procedure. <Ref. to EX(H4SO)-5, INSTALLATION, Front Exhaust Pipe.>

C: INSPECTION

- 1) Check the connections and welds for exhaust leaks.
- 2) Make sure there are no holes or rusting.

Rear Exhaust Pipe

EXHAUST

4. Rear Exhaust Pipe

A: REMOVAL

CAUTION:

Be careful not to burn yourself, because the exhaust pipe becomes extremely hot after running.

- 1) Set the vehicle on a lift.
- 2) Lift up the vehicle.
- 3) Separate the rear exhaust pipe from center exhaust pipe.

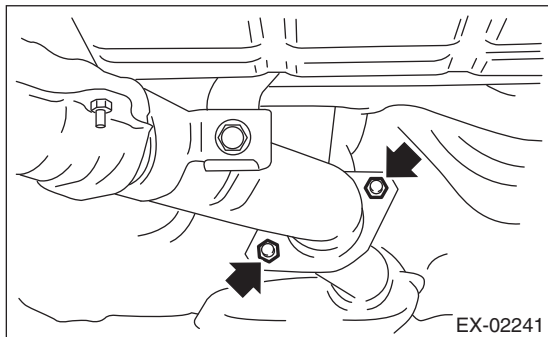

- 4) Separate the rear exhaust pipe from muffler.

CAUTION:

Be careful not to pull down the rear exhaust pipe.

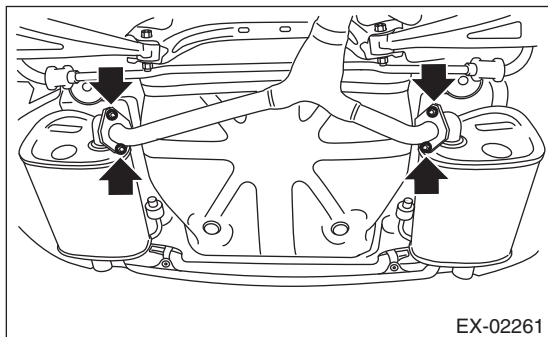

- 5) Apply a coat of spray type lubricant to the mating area of cushion rubber.
- 6) Remove the rear exhaust pipe bracket from cushion rubber.

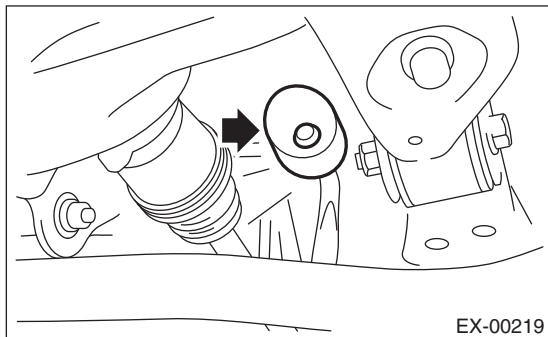

- 7) Remove the rear exhaust pipe.

B: INSTALLATION

- 1) Apply a coat of spray type lubricant to the mating area of cushion rubber.
- 2) Install the rear exhaust pipe bracket to cushion rubber.

NOTE:

After assembling, degrease the lubricant which was applied to the cushion rubber while removing/installing.

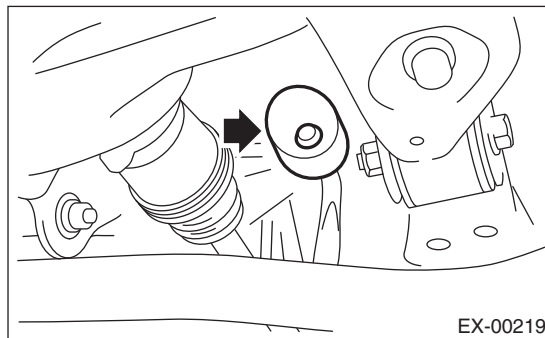

- 3) Install the rear exhaust pipe to muffler.

NOTE:

Use a new gasket and self-locking nut.

Tightening torque:

48 N·m (4.9 kgf-m, 35.4 ft-lb)

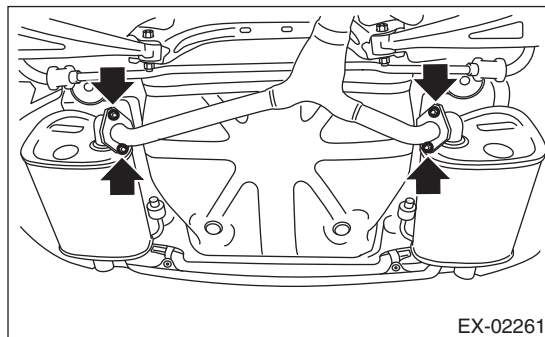

- 4) Install the rear exhaust pipe to center exhaust pipe.

NOTE:

Use a new gasket.

Tightening torque:

18 N·m (1.8 kgf-m, 13.3 ft-lb)

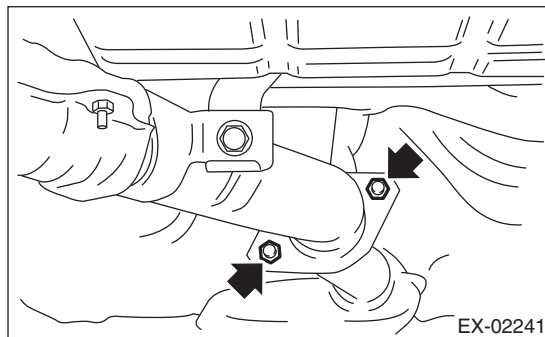

- 5) Lower the vehicle.

C: INSPECTION

- 1) Check the connections and welds for exhaust leaks.
- 2) Make sure there are no holes or rusting.
- 3) Check the cushion rubber for wear or crack.

Muffler

EXHAUST

5. Muffler

A: REMOVAL

CAUTION:

Be careful not to burn yourself, because the exhaust pipe becomes extremely hot after running.

- 1) Set the vehicle on a lift.
- 2) Lift up the vehicle.
- 3) Separate the muffler from rear exhaust pipe.

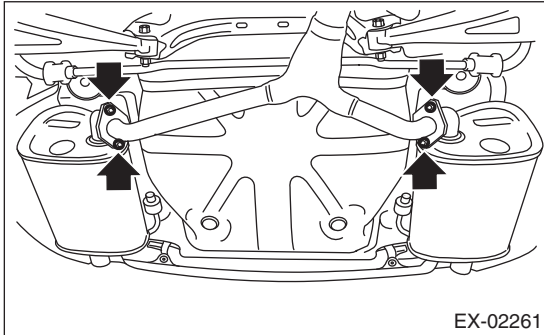

- 4) Apply a coat of spray type lubricant to the mating area of cushion rubber.
- 5) Remove the front and rear cushion rubber, and then remove the muffler.

CAUTION:

Be careful not to drop the muffler during removal.

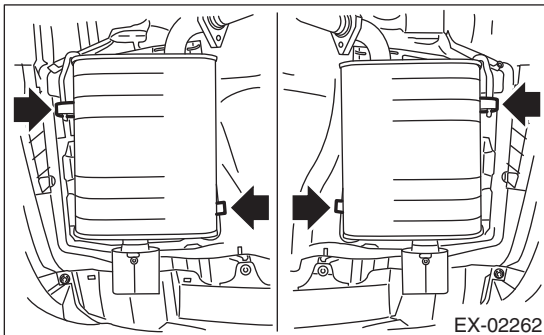

B: INSTALLATION

Install in the reverse order of removal.

NOTE:

- Use a new gasket and self-locking nut.
- After assembling, degrease the lubricant which was applied to the cushion rubber while removing/installing.

Tightening torque:

48 N·m (4.9 kgf-m, 35.4 ft-lb)

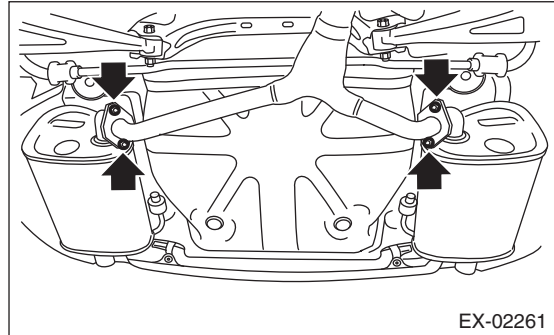

C: INSPECTION

- 1) Check the connections and welds for exhaust leaks.
- 2) Make sure there are no holes or rusting.
- 3) Check the cushion rubber for wear or crack.

COOLING

CO(H4SO)

	Page
1. General Description	2
2. Radiator Fan System	7
3. Engine Coolant	13
4. Water Pump	15
5. Thermostat	17
6. Radiator	19
7. Radiator Cap	23
8. Radiator Main Fan and Fan Motor	24
9. Radiator Sub Fan and Fan Motor	26
10. Reservoir Tank	28
11. Engine Cooling System Trouble in General	29

General Description

COOLING

1. General Description

A: SPECIFICATION

Cooling system			Electric fan + Forced engine coolant circulation system	
Total engine coolant capacity		ℓ (US qt, Imp qt)	Non-turbo model	
			Turbo model	
			MT: approx. 6.8 (7.2, 6.0) AT: approx. 6.7 (7.1, 5.9)	
			Approx. 7.5 (7.9, 6.6)	
Water pump	Type		Centrifugal impeller type	
	Discharge performance I	Discharge rate ℓ (US gal, Imp gal) /min	20 (5.3, 4.4)	
		Pump speed — Discharge pressure	760 rpm — 2.9 kPa (0.3 mAq)	
		Engine coolant temperature	80°C (176°F)	
	Discharge performance II	Discharge rate ℓ (US gal, Imp gal) /min	100 (26.4, 22.0)	
		Pump speed — Discharge pressure	3,000 rpm — 49 kPa (5.0 mAq)	
		Engine coolant temperature	80°C (176°F)	
	Discharge performance III	Discharge rate ℓ (US gal, Imp gal) /min	200 (52.8, 44.0)	
		Pump speed — Discharge pressure	6,000 rpm — 225.4 kPa (23 mAq)	
		Engine coolant temperature	80°C (176°F)	
	Impeller diameter		mm (in)	76 (2.99)
Number of impeller vanes			8	
Pump pulley diameter		mm (in)	60 (2.36)	
Clearance between impeller and case		Standard mm (in)	0.5 — 1.5 (0.020 — 0.060)	
Thermostat	Type		Wax pellet type	
	Starting temperature to open		80 — 84°C (176 — 183°F)	
	Fully opens		95°C (203°F)	
	Valve lift		mm (in)	9.0 (0.354) or more
	Valve bore		mm (in)	35 (1.38)
Radiator fan	Motor input	Main fan	90 W	
		Sub fan	90 W	
	Fan diameter / Blade	Main fan	300 mm (11.81 in)/4	
		Sub fan	300 mm (11.81 in)/5	
Radiator	Type		Down flow, pressure type	
	Core dimensions	Width × Height × Thickness mm (in)	687.4 × 340 × 16 (27.06 × 13.39 × 0.63)	
	Pressure range in which cap valve is open kPa (kg/cm ² , psi)		Above: 108±15 or more (1.1±0.15, 16±2) Below: -1.0 to -4.9 or less (-0.01 — -0.05, -0.1 — -0.7)	
	Fins		Corrugated fin type	
Reservoir tank	Capacity ℓ (US qt, Imp qt)		0.45 (0.48, 0.40)	

	Recommended materials	Item number	Alternative
Coolant	SUBARU SUPER COOLANT (concentrated type)	—	—
	SUBARU SUPER COOLANT (dilution type)	K0670Y0000	
Water for dilution	Distilled water	—	Soft water or tap water
Cooling system protective agent	Cooling system conditioner	SOA345001	—

B: COMPONENT

1. WATER PUMP

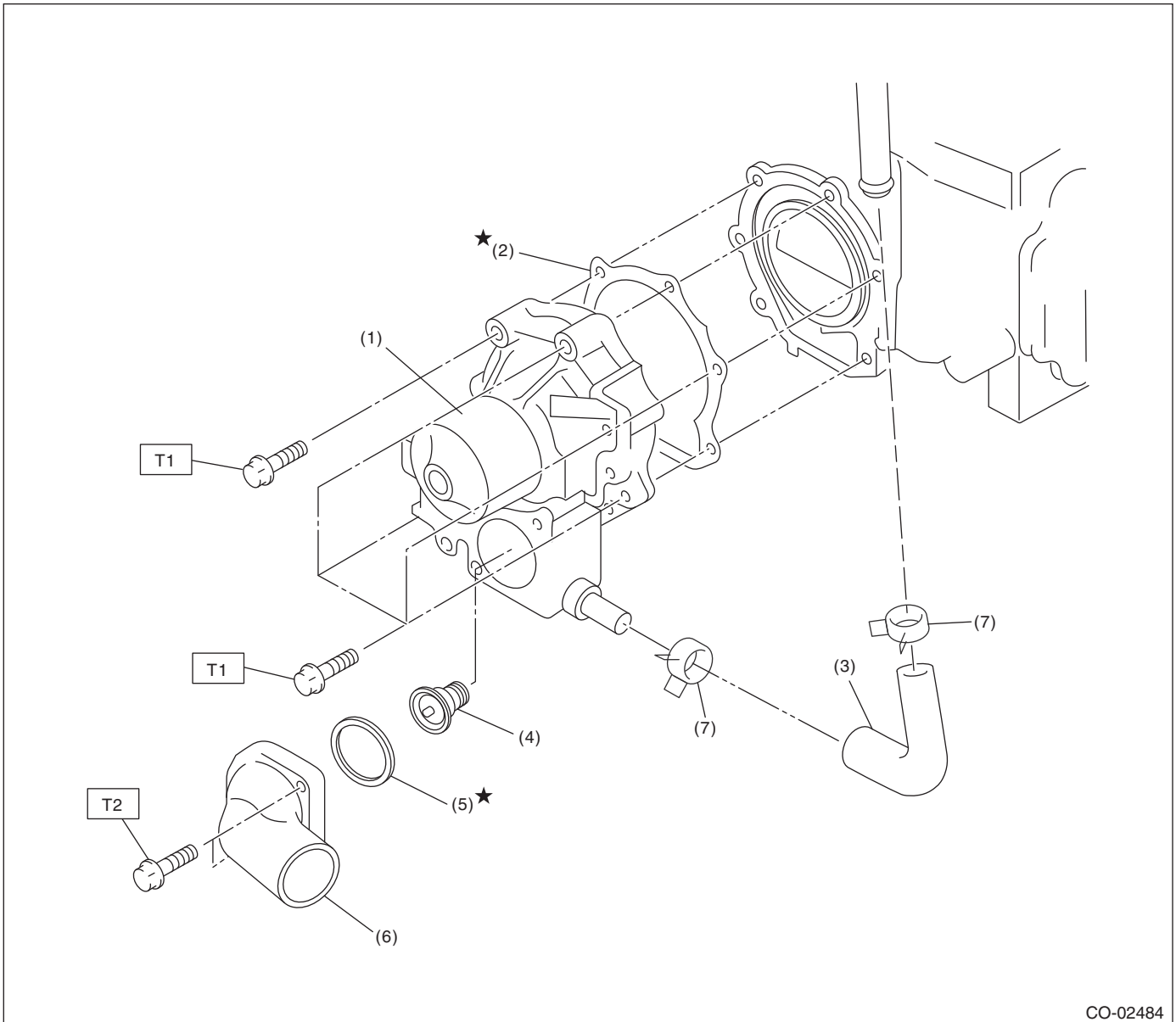

CO-02484

- | | |
|-------------------------|----------------------|
| (1) Water pump ASSY | (5) Gasket |
| (2) Gasket | (6) Thermostat cover |
| (3) Heater by-pass hose | (7) Clip |
| (4) Thermostat | |

Tightening torque: N·m (kgf·m, ft·lb)

T1: First 12 (1.2, 8.9)

Second 12 (1.2, 8.9)

T2: 12 (1.2, 8.9)

General Description

COOLING

2. RADIATOR & RADIATOR FAN

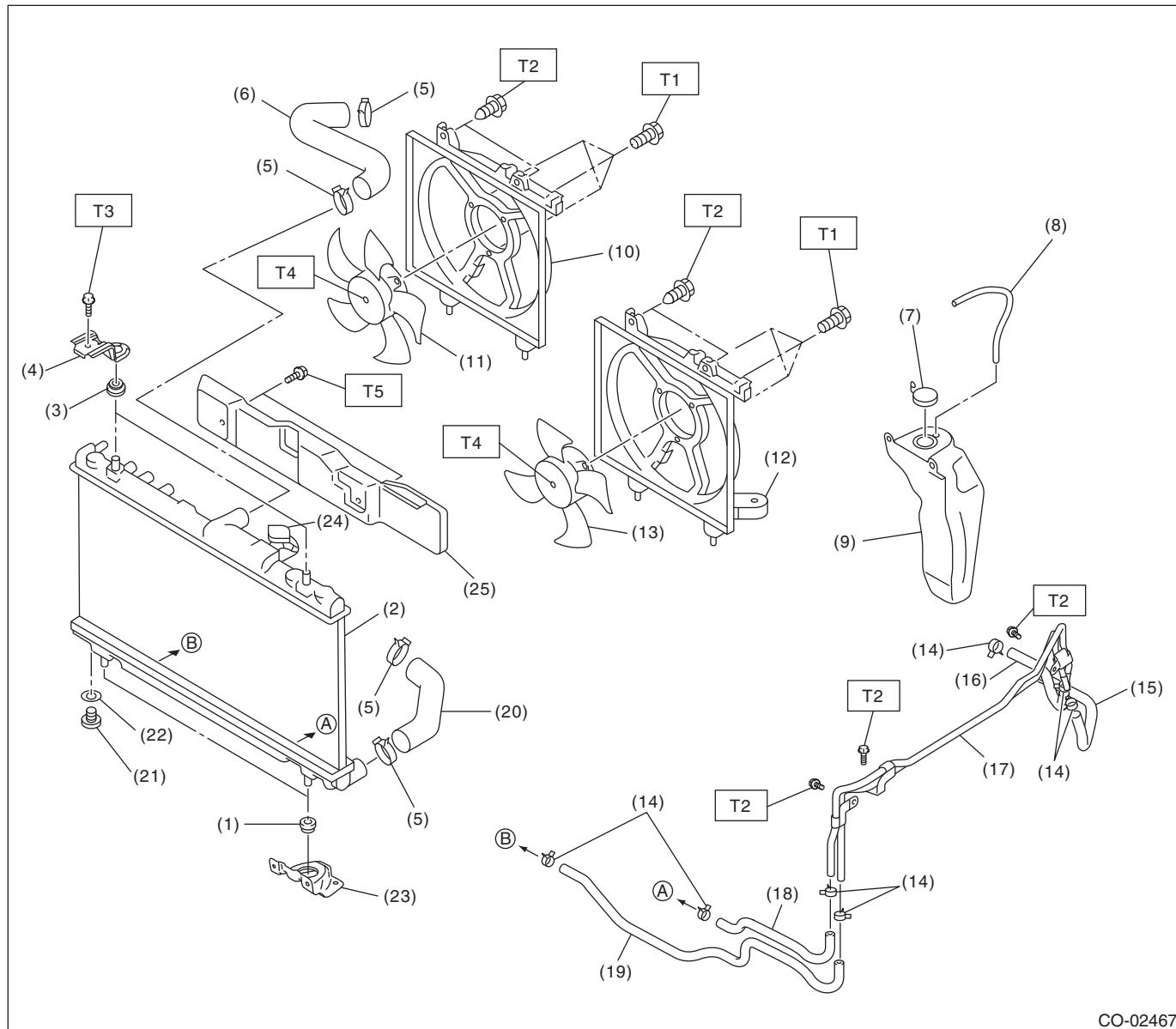

CO-02467

- | | | |
|--|--|-----------------------------------|
| (1) Radiator lower cushion | (12) Radiator main fan shroud | (22) O-ring |
| (2) Radiator | (13) Radiator main fan, radiator main fan motor ASSY | (23) Radiator lower bracket |
| (3) Radiator upper cushion | (14) ATF hose clamp (AT model) | (24) Radiator cap |
| (4) Radiator upper bracket | (15) ATF hose A (AT model) | (25) Heat shield cover (AT model) |
| (5) Clamp | (16) ATF hose B (AT model) | |
| (6) Radiator inlet hose | (17) ATF pipe (AT model) | |
| (7) Engine coolant reservoir tank cap | (18) ATF hose C (AT model) | |
| (8) Over flow hose | (19) ATF hose D (AT model) | |
| (9) Engine coolant reservoir tank | (20) Radiator outlet hose | |
| (10) Radiator sub fan shroud | (21) Radiator drain plug | |
| (11) Radiator sub fan, radiator sub fan motor ASSY | | |

Tightening torque: N·m (kgf·m, ft·lb)

T1: 5 (0.5, 3.7)

T2: 7.5 (0.8, 5.5)

T3: 12 (1.2, 8.9)

T4: 3.4 (0.3, 2.5)

T5: 3 (0.3, 2.2)

C: CAUTION

- Wear appropriate work clothing, including a cap, protective goggles and protective shoes when performing any work.
- Remove contamination including dirt and corrosion before removal, installation or disassembly.
- Keep the disassembled parts in order and protect them from dust and dirt.
- Before removal, installation or disassembly, be sure to clarify the failure. Avoid unnecessary removal, installation, disassembly and replacement.
- Vehicle components are extremely hot after driving. Be wary of receiving burns from heated parts.
- Be sure to tighten fasteners including bolts and nuts to the specified torque.
- Place shop jacks or rigid racks at the specified points.
- Before disconnecting connectors of sensors or units, be sure to disconnect the ground cable from the battery.
- Prepare a container and cloth to prevent scattering of engine coolant when performing work where engine coolant can be spilled. If the fuel spills, wipe it off immediately to prevent from penetrating into floor or flowing out for environmental protection.
- Follow all government and local regulations concerning disposal of refuse when disposing engine coolant.

General Description

COOLING

D: PREPARATION TOOL

1. SPECIAL TOOL

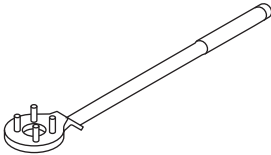
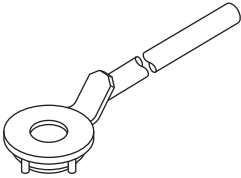
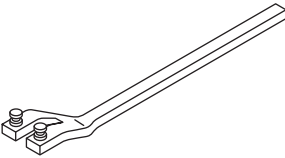
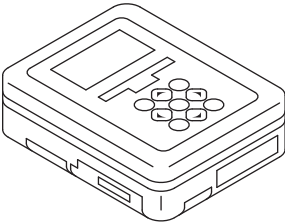
ILLUSTRATION	TOOL NUMBER	DESCRIPTION	REMARKS
 <p>ST-499977100</p>	499977100	CRANK PULLEY WRENCH	Used to stop rotation of the crank pulley when loosening or tightening crank pulley bolts. (MT model)
 <p>ST-499977400</p>	499977400	CRANK PULLEY WRENCH	Used to stop rotation of the crank pulley when loosening or tightening crank pulley bolts. (AT model)
 <p>ST18231AA010</p>	18231AA010	CAM SPROCKET WRENCH	<ul style="list-style-type: none"> Used for removing and installing cam sprocket. CAM SPROCKET WRENCH (499207100) can also be used.
 <p>ST1B022XU0</p>	1B022XU0 (Newly adopted tool)	SUBARU SELECT MONITOR III KIT	Used for troubleshooting for electrical system.

2. Radiator Fan System

A: WIRING DIAGRAM

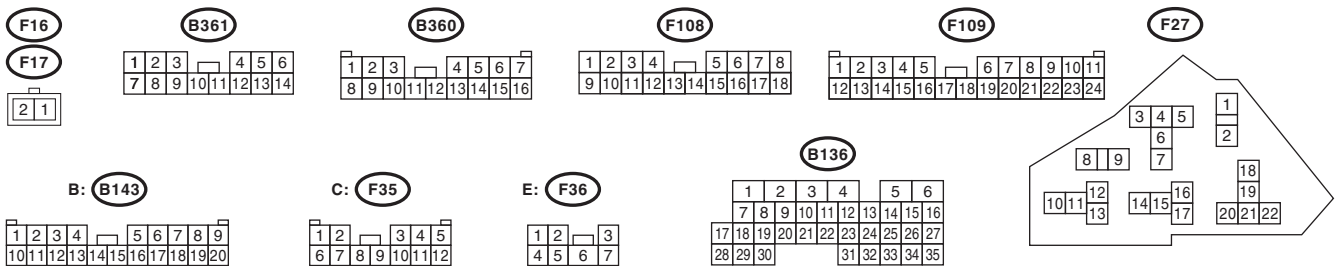
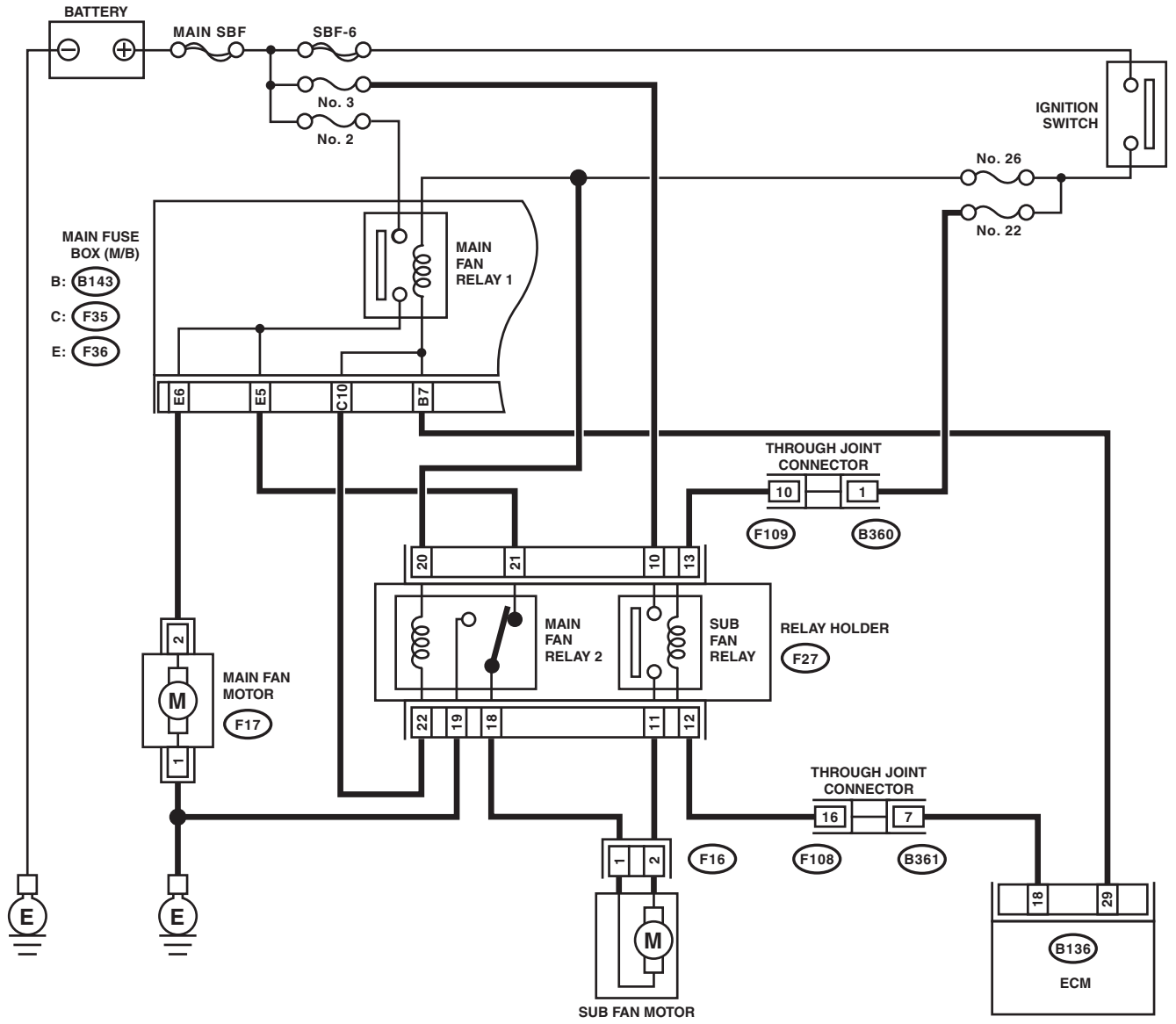

CO-02473

Radiator Fan System

COOLING

B: INSPECTION

Operating condition:

Vehicle speed	A/C compressor load	Engine coolant temperature		
		Increase: 94°C (201°F) or less Decrease: 92°C (198°F) or less	Increase: 95 — 99°C (203 — 210°F) Decrease: 93 — 94°C (199 — 201°F)	Increase: 100°C (212°F) or more Decrease: 95°C (203°F) or more
		Radiator fan operation	Radiator fan operation	Radiator fan operation
During acceleration: 19 km/h (12 MPH) or less During deceleration: 10 km/h (6 MPH) or less	OFF	OFF	Low-Speed	High-Speed
	Low	Low-Speed	Low-Speed	High-Speed
	High	High-Speed	High-Speed	High-Speed
During acceleration: 20 — 69 km/h (12 — 43 MPH) During deceleration: 11 — 64 km/h (7 — 40 MPH)	OFF	OFF	Low-Speed	High-Speed
	Low	High-Speed	High-Speed	High-Speed
	High	High-Speed	High-Speed	High-Speed
During acceleration: 70 — 134 km/h (43 — 83 MPH) During deceleration: 65 — 129 km/h (40 — 80 MPH)	OFF	OFF	Low-Speed	High-Speed
	Low	OFF	Low-Speed	High-Speed
	High	Low-Speed	High-Speed	High-Speed
During acceleration: 135 km/h (84 MPH) or more During deceleration: 130 km/h (81 MPH) or more	OFF	OFF	OFF	High-Speed
	Low	OFF	Low-Speed	High-Speed
	High	OFF	Low-Speed	High-Speed

Radiator Fan System

COOLING

DIAGNOSIS:

Radiator main fan and radiator sub fans do not rotate under the above operating conditions.

Step	Check	Yes	No
1 CHECK OPERATION OF RADIATOR FAN. 1) Connect the test mode connector. 2) Turn the ignition switch to ON. 3) Using the Subaru Select Monitor, check the forced operation of the radiator fan relay. NOTE: <ul style="list-style-type: none"> When performing a forced operation radiator fan relay check using the Subaru Select Monitor, the radiator main fan and radiator sub fan will repeat low speed revolution → high speed revolution → OFF in this order. Subaru Select Monitor Refer to Compulsory Valve Operation Check Mode for detailed procedures. <Ref. to EN(H4SO)(diag)-52, Compulsory Valve Operation Check Mode.>	Do the radiator main fans and radiator sub fans rotate at low speed?	Go to step 2.	Go to step 3.
2 CHECK OPERATION OF RADIATOR FAN. 1) Connect the test mode connector. 2) Turn the ignition switch to ON. 3) Using the Subaru Select Monitor, check the forced operation of the radiator fan relay. NOTE: <ul style="list-style-type: none"> When performing a forced operation radiator fan relay check using the Subaru Select Monitor, the radiator main fan and radiator sub fan will repeat low speed revolution → high speed revolution → OFF in this order. Subaru Select Monitor Refer to Compulsory Valve Operation Check Mode for detailed procedures. <Ref. to EN(H4SO)(diag)-52, Compulsory Valve Operation Check Mode.>	Do the radiator main fans and radiator sub fans rotate at high speed?	Radiator main fan system is normal.	Go to step 27.
3 CHECK POWER SUPPLY TO SUB FAN RELAY. 1) Turn the ignition switch to OFF. 2) Remove the sub fan relay from the relay holder. 3) Measure the voltage between the sub fan relay terminal and chassis ground. Connector & terminal (F27) No. 10 (+) — Chassis ground (-):	Is the voltage 10 V or more?	Go to step 4.	Go to step 5.
4 CHECK POWER SUPPLY TO SUB FAN RELAY. 1) Turn the ignition switch to ON. 2) Measure the voltage between the sub fan relay terminal and chassis ground. Connector & terminal (F27) No. 13 (+) — Chassis ground (-):	Is the voltage 10 V or more?	Go to step 7.	Go to step 6.
5 CHECK FUSE. 1) Turn the ignition switch to OFF. 2) Remove the fuse No. 3. 3) Check the condition of fuse.	Is the fuse blown out?	Replace the fuse.	Repair the power supply line.
6 CHECK FUSE. 1) Turn the ignition switch to OFF. 2) Remove the fuse No. 22. 3) Check the condition of fuse.	Is the fuse blown out?	Replace the fuse.	Repair the power supply line.

Radiator Fan System

COOLING

Step	Check	Yes	No
7 CHECK SUB FAN RELAY. 1) Turn the ignition switch to OFF. 2) Measure the resistance between sub fan relay terminals. <i>Terminals</i> <i>No. 10 — No. 11:</i>	Is the resistance 1 M Ω or more?	Go to step 8.	Replace the sub fan relay. <Ref. to AC-36, Relay and Fuse.>
8 CHECK SUB FAN RELAY. 1) Connect the battery to terminals No. 13 and No. 12 of the sub fan relay. 2) Measure the resistance between sub fan relay terminals. <i>Terminals</i> <i>No. 10 — No. 11:</i>	Is the resistance less than 1 Ω ?	Go to step 9.	Replace the sub fan relay. <Ref. to AC-36, Relay and Fuse.>
9 CHECK HARNESS BETWEEN SUB FAN RELAY TERMINAL AND SUB FAN MOTOR CONNECTOR. 1) Disconnect the connector from the sub fan motor. 2) Measure the resistance of harness between the sub fan relay terminal and sub fan motor connector. <i>Connector & terminal</i> <i>(F16) No. 2 — (F27) No. 11:</i>	Is the resistance less than 1 Ω ?	Go to step 10.	Repair the open circuit of harness between sub fan relay terminal and sub fan motor connector.
10 CHECK HARNESS BETWEEN SUB FAN MOTOR CONNECTOR AND MAIN FAN RELAY 2 CONNECTOR. 1) Remove the main fan relay 2 from the relay holder. 2) Measure the resistance of harness between sub fan motor connector and main fan relay 2 connector. <i>Connector & terminal</i> <i>(F16) No. 1 — (F27) No. 18:</i>	Is the resistance less than 1 Ω ?	Go to step 11.	Repair the open circuit of the harness between sub fan motor connector and main fan relay 2 connector.
11 CHECK POOR CONTACT. Check poor contact of sub fan motor connector.	Is there poor contact in the sub fan motor connector?	Repair the poor contact of sub fan motor connector.	Go to step 12.
12 CHECK SUB FAN MOTOR. Connect the battery positive (+) terminal to terminal No. 2 of the sub fan motor, and the ground (-) terminal to terminal No. 1.	Does the radiator sub fan rotate?	Go to step 13.	Replace the sub fan motor. <Ref. to CO(H4SO)-26, Radiator Sub Fan and Fan Motor.>
13 CHECK MAIN FAN RELAY 2. Measure the resistance of main fan relay 2. <i>Terminals</i> <i>No. 21 — No. 18:</i>	Is the resistance less than 1 Ω ?	Go to step 14.	Replace the main fan relay 2. <Ref. to AC-36, Relay and Fuse.>
14 CHECK HARNESS BETWEEN MAIN FAN RELAY 2 AND MAIN FAN MOTOR CONNECTOR. 1) Disconnect the connector from the main fan motor. 2) Measure the resistance of the harness between main fan relay 2 terminal and main fan motor connector. <i>Connector & terminal</i> <i>(F17) No. 2 — (F27) No. 21:</i>	Is the resistance less than 1 Ω ?	Go to step 15.	Repair the open circuit of the harness between main fan relay 2 terminal and main fan motor connector.

Radiator Fan System

COOLING

Step	Check	Yes	No
15 CHECK MAIN FAN MOTOR AND GROUND CIRCUIT. Measure the resistance between main fan motor connector and chassis ground. Connector & terminal (F17) No. 1 — Chassis ground:	Is the resistance less than 5 Ω ?	Go to step 16.	Repair the open circuit of the harness between main fan motor connector and chassis ground.
16 CHECK POOR CONTACT. Check poor contact of main fan motor connector.	Is there poor contact in the main fan motor connector?	Repair the poor contact of main fan motor connector.	Go to step 17.
17 CHECK MAIN FAN MOTOR. Connect the battery positive (+) terminal to terminal No. 2 of the main fan motor, and the ground (-) terminal to terminal No. 1.	Does the radiator main fan rotate?	Go to step 18.	Replace the main fan motor. <Ref. to CO(H4SO)-24, Radiator Main Fan and Fan Motor.>
18 CHECK HARNESS BETWEEN SUB FAN RELAY AND ECM. 1) Disconnect the connectors from the ECM. 2) Measure the resistance between the sub fan relay terminal and ECM connector. Connector & terminal (B136) No. 18 — (F27) No. 12:	Is the resistance less than 1 Ω ?	Go to step 19.	Repair the open circuit of harness between sub fan relay terminal and ECM.
19 CHECK POOR CONTACT. Check for poor contact of the ECM connector.	Is there poor contact in ECM connector?	Repair poor contact in ECM connector.	Check the DTC. Repair the trouble cause. <Ref. to EN(H4SO)(diag)-40, Read Diagnostic Trouble Code (DTC).>
20 CHECK MAIN FAN RELAY 1. 1) Turn the ignition switch to OFF. 2) Remove main fan relay 1 from the main fuse box. 3) Measure the resistance of terminal in main fan relay 1 switch.	Is the resistance 1 M Ω or more?	Go to step 21.	Replace the main fan relay 1. <Ref. to AC-36, Relay and Fuse.>
21 CHECK MAIN FAN RELAY 1. 1) Connect the main fan relay 1 coil side terminal to the battery. 2) Measure the resistance between terminals of main fan relay 1 switch.	Is the resistance less than 1 Ω ?	Go to step 22.	Replace the main fan relay 1. <Ref. to AC-36, Relay and Fuse.>
22 CHECK HARNESS BETWEEN MAIN FAN RELAY 1 AND MAIN FAN MOTOR CONNECTOR. 1) Disconnect the connector from the main fan motor. 2) Measure the resistance of the harness between main fan relay 1 terminal and main fan motor connector. Connector & terminal (F17) No. 2 — (F36) No. 6:	Is the resistance less than 1 Ω ?	Go to step 23.	Repair the open circuit of the harness between main fan relay 1 terminal and main fan motor connector.
23 CHECK HARNESS BETWEEN MAIN FAN RELAY 1 AND ECM. 1) Disconnect the connectors from the ECM. 2) Measure the resistance between main fan relay 1 terminal and ECM connector. Connector & terminal (B136) No. 29 — (B143) No. 7:	Is the resistance less than 1 Ω ?	Go to step 24.	Repair the open circuit of the harness between main fan relay 1 terminal and ECM.

Radiator Fan System

COOLING

Step	Check	Yes	No
24 CHECK HARNESS BETWEEN MAIN FAN RELAY 2 AND ECM. Measure the resistance between main fan relay 2 terminal and ECM connector. Connector & terminal (B136) No. 29 — (F27) No. 22:	Is the resistance less than 1 Ω ?	Go to step 25.	Repair the open circuit of the harness between main fan relay 2 terminal and ECM.
25 CHECK FUSE. 1) Turn the ignition switch to OFF. 2) Remove the fuse No. 2 and 26. 3) Check the condition of fuse.	Is the fuse blown out?	Replace the fuse.	Go to step 26.
26 CHECK POOR CONTACT. Check for poor contact of the ECM connector.	Is there poor contact in ECM connector?	Repair the poor contact of the ECM connector.	Repair the power supply circuit to the main fuse box.
27 CHECK OPERATION OF RADIATOR FAN. If the both fans do not rotate at high speed in the condition of step 2, check whether the radiator sub fan is rotating.	Does the radiator sub fan rotate?	Go to step 20.	Go to step 28.
28 CHECK GROUND CIRCUIT OF MAIN FAN RELAY 2. 1) Remove the main fan relay 2 from A/C relay holder. 2) Measure the resistance between main fan relay 2 terminal and chassis ground. Connector & terminal (F27) No. 19 — Chassis ground:	Is the resistance less than 1 Ω ?	Go to step 29.	Repair the open circuit of harness between main fan relay 2 and chassis ground.
29 CHECK POWER SUPPLY TO MAIN FAN RELAY 2. 1) Turn the ignition switch to ON. 2) Measure the voltage between main fan relay 2 terminal and chassis ground. Connector & terminal (F27) No. 20 (+) — Chassis ground (-):	Is the voltage 10 V or more?	Go to step 30.	Repair the power supply line.
30 CHECK MAIN FAN RELAY 2. 1) Turn the ignition switch to OFF. 2) Remove the main fan relay 2. 3) Measure the resistance of main fan relay 2. Terminals (F27) No. 18 — (F27) No. 19:	Is the resistance 1 M Ω or more?	Go to step 31.	Replace the main fan relay 2. <Ref. to AC-36, Relay and Fuse.>
31 CHECK MAIN FAN RELAY 2. 1) Connect the battery to main fan relay 2 terminals No. 20 and No. 22. 2) Measure the resistance of main fan relay 2. Terminals (F27) No. 18 — (F27) No. 19:	Is the resistance less than 1 Ω ?	Go to step 23.	Replace the main fan relay 2. <Ref. to AC-36, Relay and Fuse.>

3. Engine Coolant

A: REPLACEMENT

1. DRAINING OF ENGINE COOLANT

- 1) Set the vehicle on a lift.
- 2) Lift up the vehicle.
- 3) Remove the under cover RH.
- 4) Remove the drain plug (A) to drain engine coolant into container.

NOTE:

Remove the radiator cap so that engine coolant will drain faster.

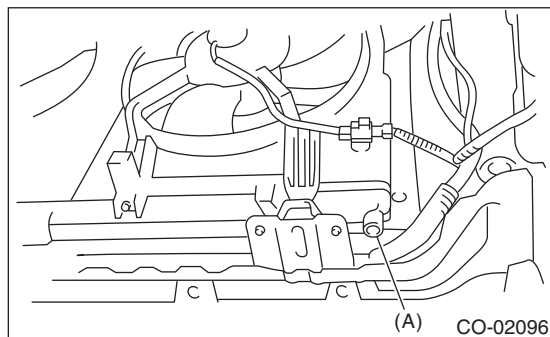

- 5) Install the drain plug.
- 6) Install the under cover RH.

2. FILLING OF ENGINE COOLANT

- 1) Pour cooling system conditioner through the filler neck.

Cooling system protective agent:

Refer to "SPECIFICATION" for the cooling system protective agent. <Ref. to CO(H4SO)-2, SPECIFICATION, General Description.>

- 2) Pour engine coolant into the radiator up to the filler neck position.

Recommended engine coolant:

Refer to "SPECIFICATION" for the recommended engine coolant. <Ref. to CO(H4SO)-2, SPECIFICATION, General Description.>

Coolant level:

Refer to "SPECIFICATION" for the coolant level. <Ref. to CO(H4SO)-2, SPECIFICATION, General Description.>

Concentration of coolant:

Refer to "ADJUSTMENT" for the concentration of the coolant. <Ref. to CO(H4SO)-14, ADJUSTMENT, Engine Coolant.>

NOTE:

The SUBARU Super Coolant containing anti-freeze and anti-rust agents is especially made for SUBARU engine, which has an aluminum cylinder block. Always use SUBARU Super Coolant, since other coolant may cause corrosion.

- 3) Fill engine coolant into the reservoir tank up to "FULL" level.

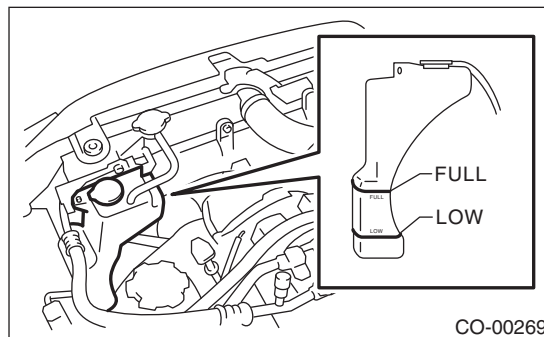

- 4) Close the radiator cap and start the engine. Race 5 to 6 times at 3,000 rpm or less, then stop the engine. (Complete this operation within 40 seconds.)
- 5) Wait for one minute after the engine stops, open the radiator cap. If the engine coolant level drops, add engine coolant into radiator up to the filler neck position.
- 6) Perform the procedures 4) and 5) again.
- 7) Attach the radiator cap and reservoir tank cap properly.
- 8) Start the engine and operate the heater at maximum hot position and the blower speed setting at "LO"
- 9) Run the engine at 2,000 rpm or less until radiator fan starts and stops.

NOTE:

Be careful with the engine coolant temperature gauge to prevent overheating.

- 10) Stop the engine and wait until the engine coolant temperature drops to 30°C (86°F) or less.
- 11) Open the radiator cap. If the engine coolant level drops, add engine coolant into radiator up to the filler neck position.
- 12) Attach the radiator cap correctly.
- 13) Set the heater setting to maximum hot position and the blower speed setting to "LO" and start the engine. Perform racing at 3,000 rpm or less. If the flowing sound is heard at this time, perform the procedures from 9) again.

Engine Coolant

COOLING

B: ADJUSTMENT

1. PROCEDURE TO ADJUST THE CONCENTRATION OF THE SUBARU SUPER COOLANT

CAUTION:

SUBARU Super Coolant concentration must be used from 50 to 60 % to assure the best performance of the anti-freeze and anti-rust agents.

To adjust the concentration of SUBARU Super Coolant according to temperature, find the proper SUBARU Super Coolant concentration from the table and adjust SUBARU Super Coolant (concentrated type) to the concentration with water for dilution.

RELATIONSHIP OF SUBARU SUPER COOLANT CONCENTRATION AND FREEZING TEMPERATURE			
Concentration of SUBARU Super Coolant	50%	55%	60%
Freezing temperature	-36°C (-33°F)	-41°C (-42°F)	-50°C (-58°F)

Recommended Engine Coolant and Water for Dilution:

Refer to "SPECIFICATION" for the recommended engine coolant and water for dilution. <Ref. to CO(H4SO)-2, SPECIFICATION, General Description.>

4. Water Pump

A: REMOVAL

- 1) Remove the radiator. <Ref. to CO(H4SO)-19, REMOVAL, Radiator.>
- 2) Remove the V-belts. <Ref. to ME(H4SO)-42, REMOVAL, V-belt.>
- 3) Remove the crank pulley. <Ref. to ME(H4SO)-50, REMOVAL, Crank Pulley.>
- 4) Remove the timing belt cover. <Ref. to ME(H4SO)-52, REMOVAL, Timing Belt Cover.>
- 5) Remove the timing belt. <Ref. to ME(H4SO)-53, TIMING BELT, REMOVAL, Timing Belt.>
- 6) Remove the automatic belt tension adjuster.

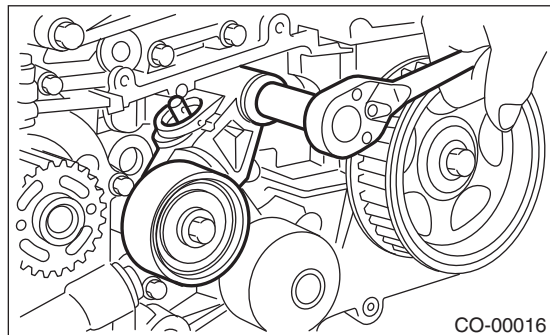

- 7) Remove the camshaft position sensor. <Ref. to FU(H4SO)-24, REMOVAL, Camshaft Position Sensor.>
- 8) Remove the cam sprocket LH. <Ref. to ME(H4SO)-59, REMOVAL, Cam Sprocket.>
- 9) Remove the belt cover LH No. 2.

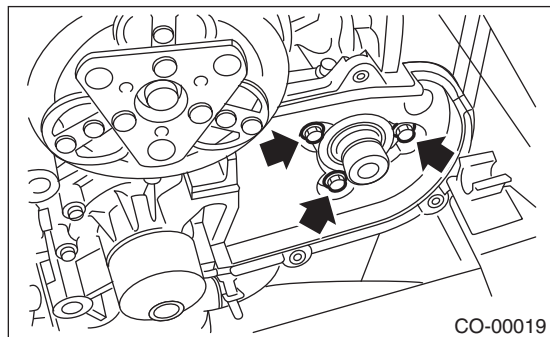

- 10) Remove the tensioner bracket.

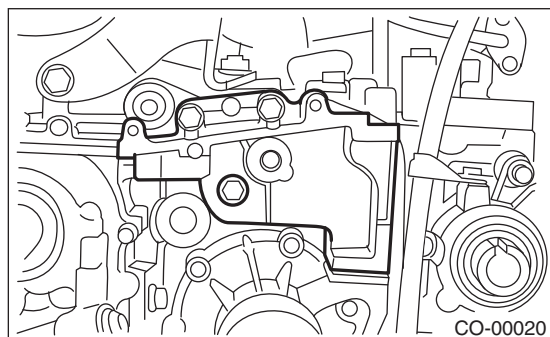

- 11) Disconnect the hose from water pump.

- 12) Remove the water pump.

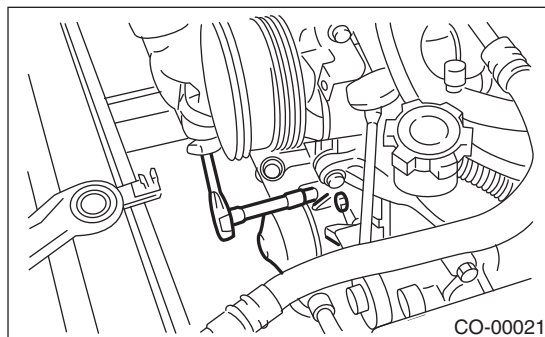

B: INSTALLATION

- 1) Install the water pump onto cylinder block LH.

NOTE:

- Use a new gasket.
- When installing the water pump, tighten the bolts in two stages in alphabetical sequence as shown in figure.

Tightening torque:

1st

12 N·m (1.2 kgf-m, 8.9 ft-lb)

2nd

12 N·m (1.2 kgf-m, 8.9 ft-lb)

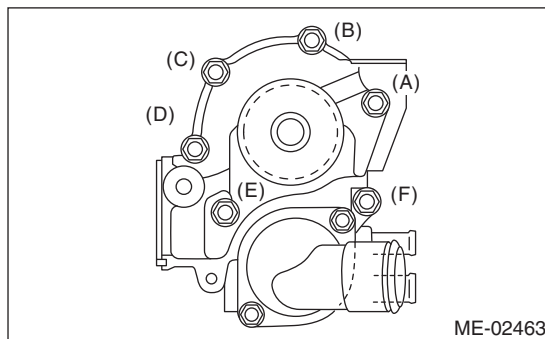

- 2) Install the hose to water pump.
- 3) Install the tensioner bracket.

Tightening torque:

24.5 N·m (2.5 kgf-m, 18.1 ft-lb)

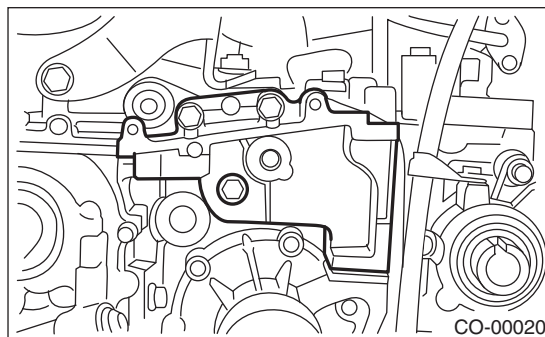

Water Pump

COOLING

4) Install the belt cover No. 2 LH.

Tightening torque:

5 N·m (0.5 kgf·m, 3.7 ft·lb)

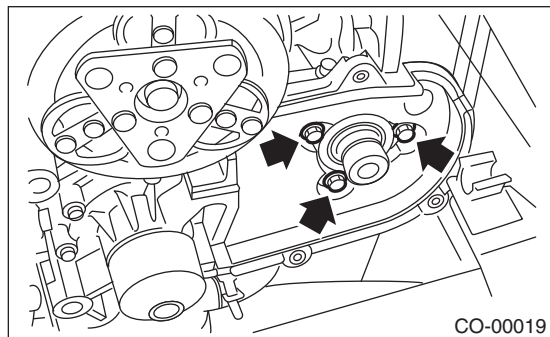

5) Install the cam sprocket LH. <Ref. to ME(H4SO)-59, INSTALLATION, Cam Sprocket.>

6) Install the camshaft position sensor. <Ref. to FU(H4SO)-24, INSTALLATION, Camshaft Position Sensor.>

7) Install an automatic belt tension adjuster with the tension rod held by a pin. <Ref. to ME(H4SO)-55, AUTOMATIC BELT TENSION ADJUSTER ASSEMBLY AND BELT IDLER, INSTALLATION, Timing Belt.>

8) Install the timing belt. <Ref. to ME(H4SO)-56, TIMING BELT, INSTALLATION, Timing Belt.>

9) Install the timing belt cover. <Ref. to ME(H4SO)-52, INSTALLATION, Timing Belt Cover.>

10) Install the crank pulley. <Ref. to ME(H4SO)-50, INSTALLATION, Crank Pulley.>

11) Install the V-belts. <Ref. to ME(H4SO)-42, INSTALLATION, V-belt.>

12) Install the radiator. <Ref. to CO(H4SO)-20, INSTALLATION, Radiator.>

C: INSPECTION

- 1) Check the water pump bearing for smooth rotation.
- 2) Check the water pump pulley for abnormalities.
- 3) Make sure the impeller is not deformed or damaged.
- 4) Inspect the clearance between impeller and pump case.

Clearance between impeller and pump case:

Standard

0.5 — 1.5 mm (0.020 — 0.060 in)

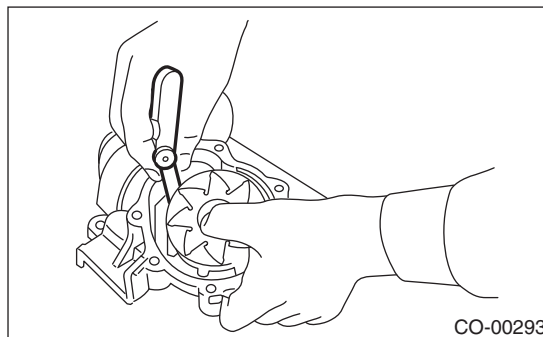

- 5) After water pump installation, check pulley shaft for engine coolant leaks or noise. If leaks or noise are noted, replace the water pump assembly.

5. Thermostat

A: REMOVAL

- 1) Set the vehicle on a lift.
- 2) Lift up the vehicle.
- 3) Remove the under cover LH.
- 4) Drain engine coolant completely. <Ref. to CO(H4SO)-13, DRAINING OF ENGINE COOLANT, REPLACEMENT, Engine Coolant.>
- 5) Remove the front exhaust pipe. <Ref. to EX(H4SO)-4, REMOVAL, Front Exhaust Pipe.>
- 6) Disconnect the radiator outlet hose from thermostat cover.

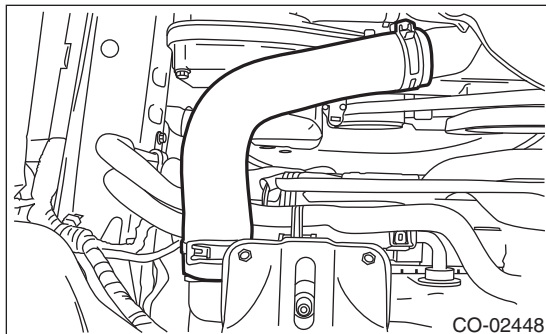

- 7) Remove the thermostat cover, and then remove the gasket and thermostat.

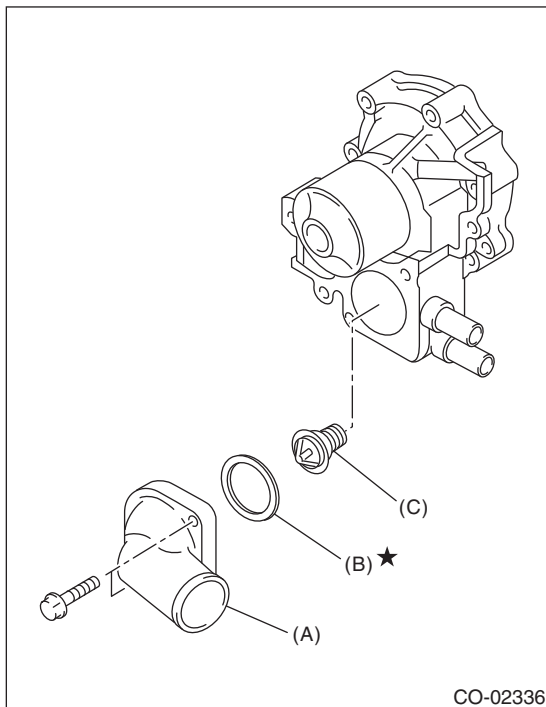

- (A) Thermostat cover
- (B) Gasket
- (C) Thermostat

B: INSTALLATION

- 1) Install a gasket to thermostat.

NOTE:

Use a new gasket.

- 2) Install the thermostat and thermostat cover.

NOTE:

The thermostat must be installed with the jiggle pin facing upward.

Tightening torque:

12 N·m (1.2 kgf·m, 8.9 ft·lb)

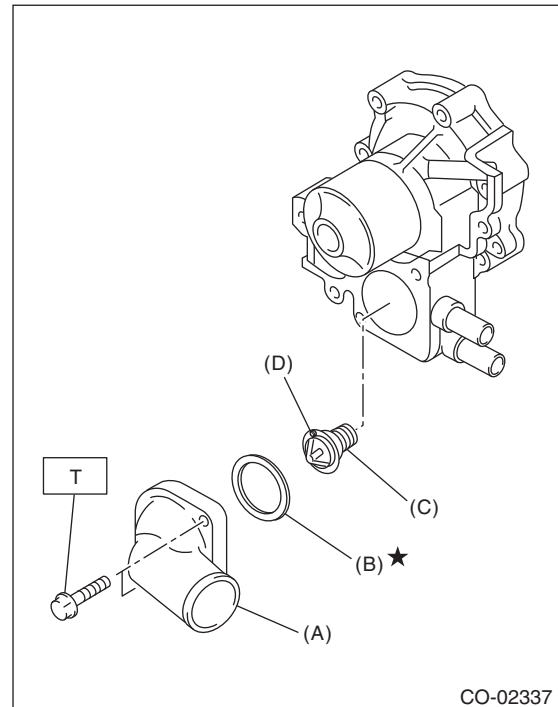

- (A) Thermostat cover
- (B) Gasket
- (C) Thermostat
- (D) Jiggle pin

- 3) Connect the radiator outlet hose to thermostat cover.
- 4) Install the front exhaust pipe. <Ref. to EX(H4SO)-5, INSTALLATION, Front Exhaust Pipe.>
- 5) Install the under cover LH.
- 6) Lower the vehicle.
- 7) Fill engine coolant. <Ref. to CO(H4SO)-13, FILLING OF ENGINE COOLANT, REPLACEMENT, Engine Coolant.>

C: INSPECTION

Replace the thermostat if the valve does not close completely at an ambient temperature or if the following test shows unsatisfactory results.

- Inspection method

Immerse the thermostat and a thermometer in water. Raise water temperature gradually, and measure the temperature and valve lift when the valve begins to open and when the valve is fully opened. During the test, agitate the water for even temperature distribution. The measured value should meet the specification.

NOTE:

- Leave the thermostat in the boiling water for five minutes or more before measuring valve lift.
- Hold the thermostat with a wire or the like to avoid contacting with container bottom.

Opening start temperature:

80 — 84°C (176 — 183°F)

Full open temperature:

95°C (203°F)

Valve lift:

9.0 mm (0.354 in) or more

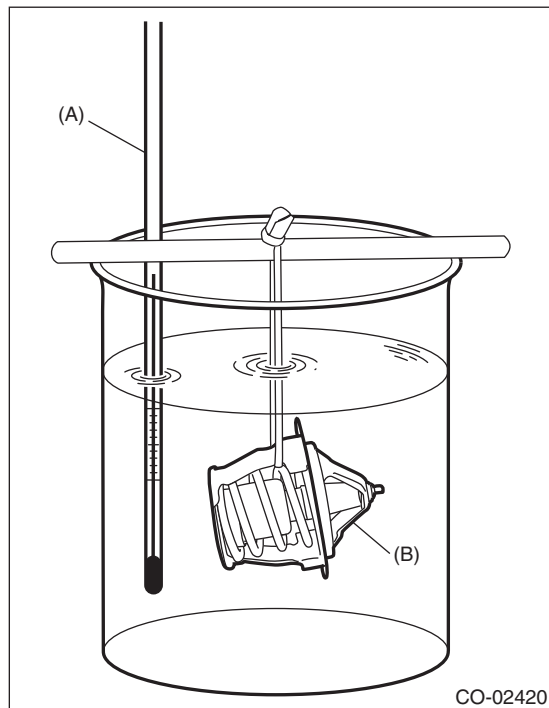

(A) Thermometer

(B) Thermostat

6. Radiator

A: REMOVAL

CAUTION:

The radiator is pressurized. Wait until engine cools down before working on the radiator.

- 1) Set the vehicle on a lift.
- 2) Disconnect the ground cable from the battery.

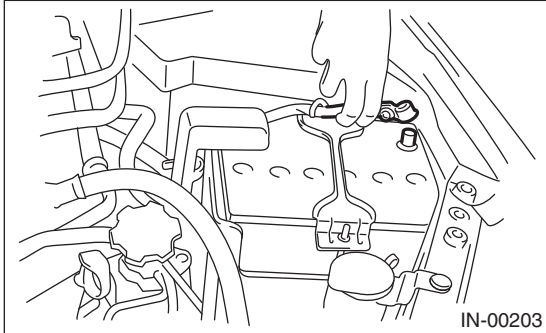

- 3) Lift up the vehicle.
- 4) Remove the under cover.
- 5) Remove the heat shield cover from radiator. (AT model)

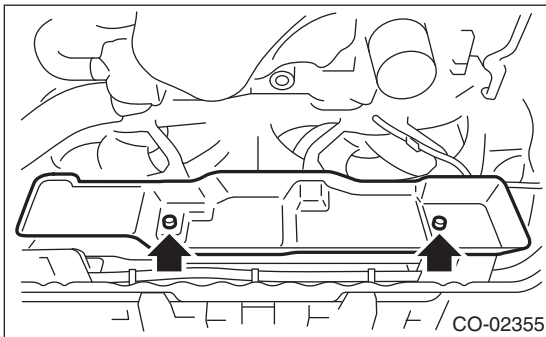

- 6) Drain engine coolant completely.
<Ref. to CO(H4SO)-13, DRAINING OF ENGINE COOLANT, REPLACEMENT, Engine Coolant.>

- 7) Disconnect the connectors of radiator main fan motor connector (A) and sub fan motor connector (B).

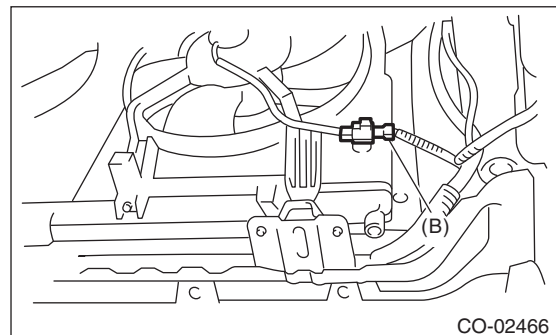
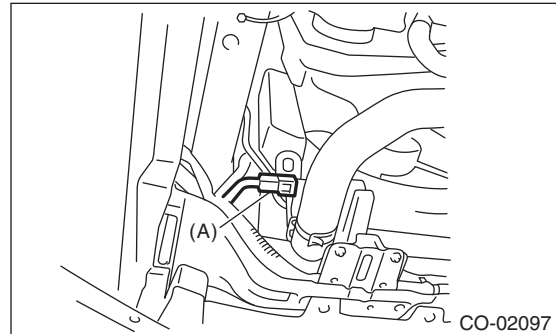

- 8) Disconnect the radiator outlet hose from thermostat cover.

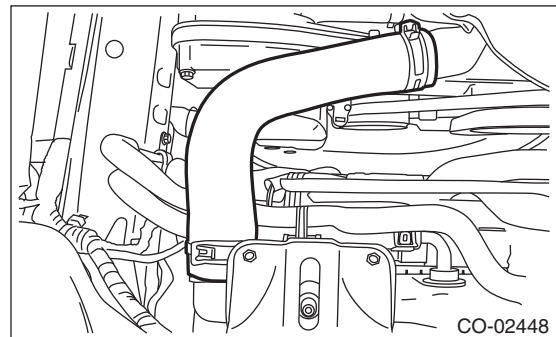

- 9) Disconnect the ATF cooler hoses from ATF pipes. (AT model)

NOTE:

Plug the ATF pipe to prevent ATF from leaking.

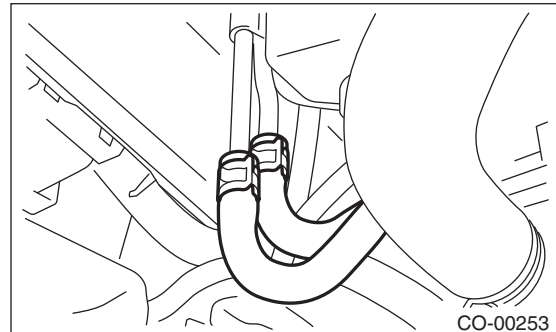

Radiator

COOLING

- 10) Lower the vehicle.
- 11) Disconnect the over flow hose.
- 12) Remove the reservoir tank. <Ref. to CO(H4SO)-28, REMOVAL, Reservoir Tank.>
- 13) Remove the air intake duct. <Ref. to IN(H4SO)-8, REMOVAL, Air Intake Duct.>
- 14) Disconnect the radiator inlet hoses from the engine.

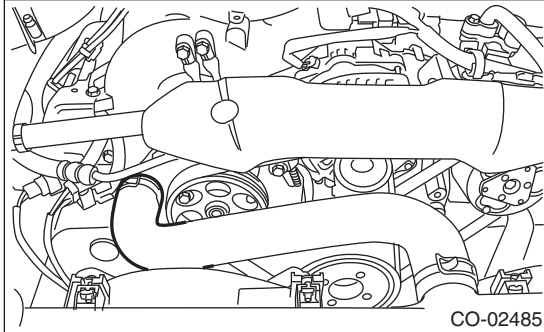

- 15) Remove the radiator upper brackets.

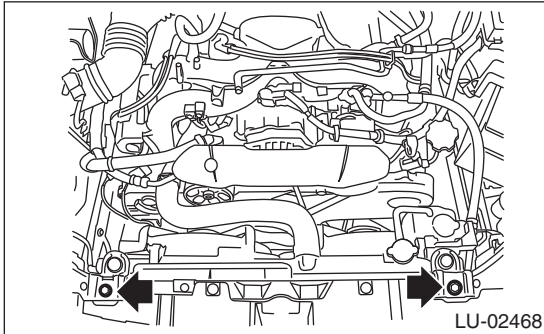

- 16) Lift the radiator up and away from vehicle.

B: INSTALLATION

- 1) Attach the radiator lower cushion to the hole on the radiator lower bracket.

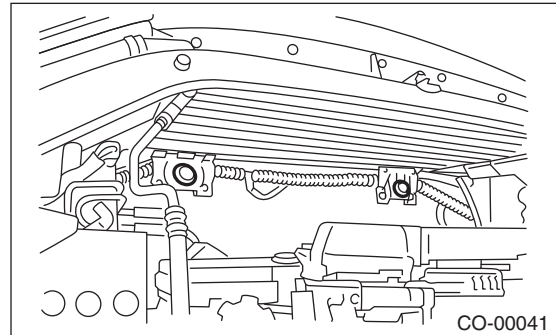

- 2) Install the radiator to vehicle.

NOTE:

Make pins on the lower side of radiator be fitted into the radiator lower cushions on body side.

- 3) Install the radiator upper brackets and tighten the bolts.

Tightening torque:

12 N·m (1.2 kgf·m, 8.9 ft·lb)

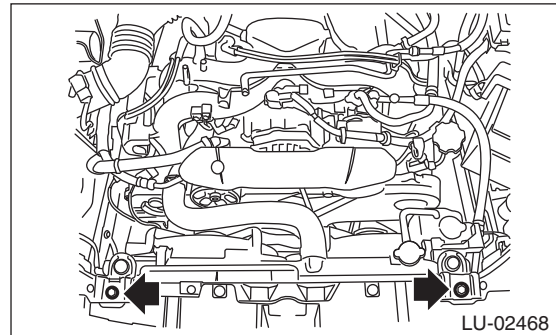

- 4) Connect the radiator inlet hose.

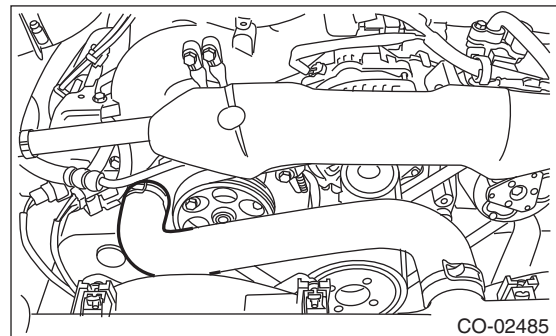

- 5) Install the air intake duct. <Ref. to IN(H4SO)-8, INSTALLATION, Air Intake Duct.>
- 6) Install the reservoir tank. <Ref. to CO(H4SO)-28, INSTALLATION, Reservoir Tank.>
- 7) Connect the over flow hose.
- 8) Lift up the vehicle.

9) Connect the ATF cooler hoses. (AT model)

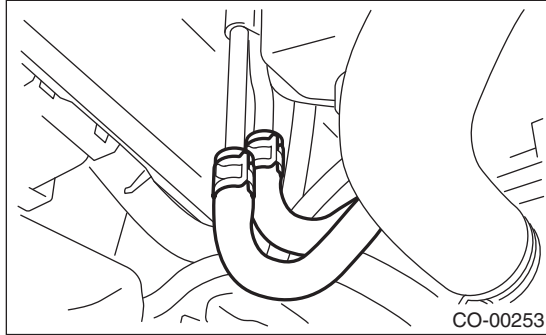

10) Connect the radiator outlet hose.

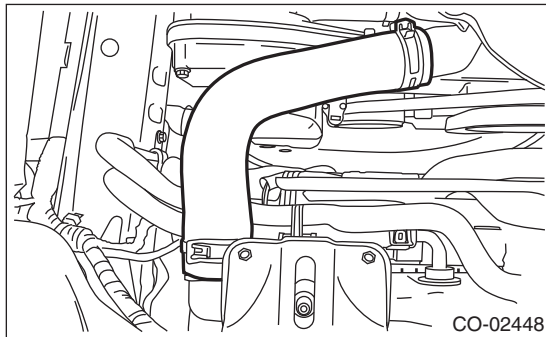

11) Connect the connectors of radiator main fan motor connector (A) and sub fan motor connector (B).

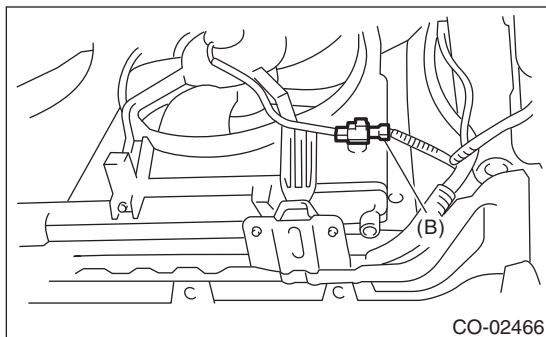
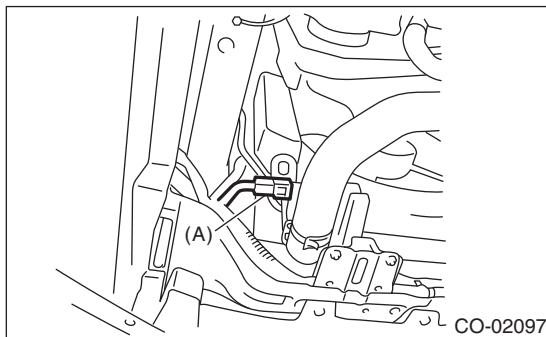

12) Install the heat shield cover. (AT model)

Tightening torque:
3 N·m (0.3 kgf·m, 2.2 ft·lb)

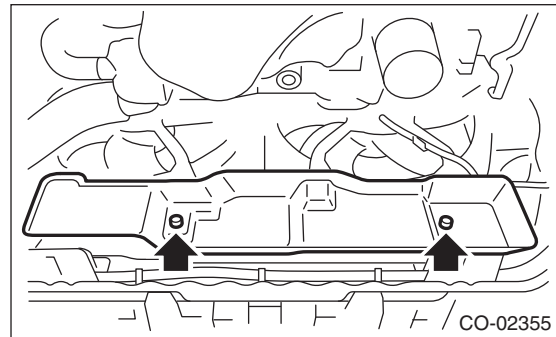

13) Install the under cover.

14) Lower the vehicle.

15) Connect the battery ground cable to battery.

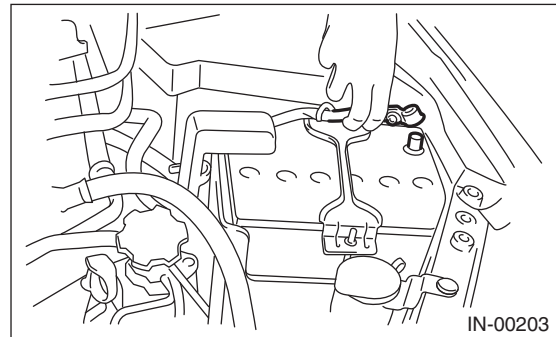

16) Fill engine coolant. <Ref. to CO(H4SO)-13, FILLING OF ENGINE COOLANT, REPLACEMENT, Engine Coolant.>

17) Check the ATF level. <Ref. to 4AT-26, INSPECTION, Automatic Transmission Fluid.>

C: INSPECTION

1) Remove the radiator cap, fill the radiator with engine coolant, and then install the tester to the installation position of cap.

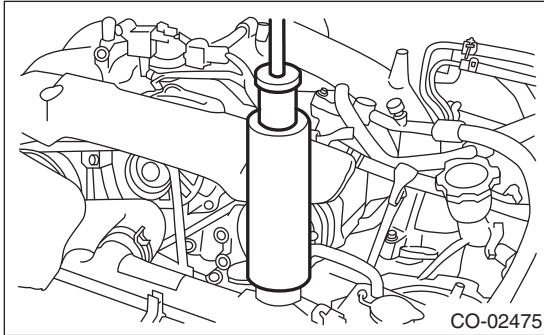

2) Apply a pressure of 157 kPa (1.6 kg/cm², 23 psi) to the radiator and check the following points:

- Leakage from the radiator or its vicinity
- Leakage from the hose or its connections

CAUTION:

- **Engine should be turned off.**
- **Wipe engine coolant from check points in advance.**
- **Be careful of engine coolant from spurting out when removing the tester.**
- **Be careful not to deform the filler neck of radiator when installing and removing the tester.**

7. Radiator Cap

A: INSPECTION

1) Attach the radiator cap to tester.

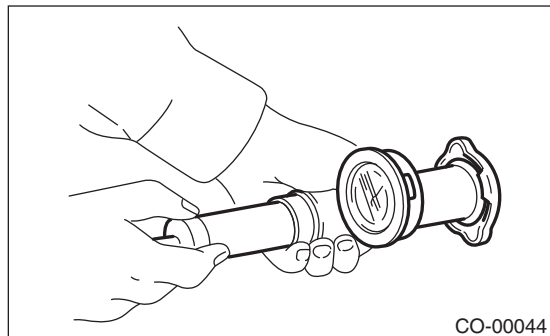

2) Increase pressure until the tester gauge pointer stops. Radiator cap is functioning properly if it holds the service limit pressure for five to six seconds. Replace the cap if it is opened under a pressure less than the service limit value.

Standard:

93 — 123 kPa (0.95 — 1.25 kg/cm², 14 — 18 psi)

Service limit:

83 kPa (0.85 kg/cm², 12 psi)

CAUTION:

Be sure to remove foreign matter and rust from the cap in advance. Otherwise, results of pressure test will be incorrect.

Radiator Main Fan and Fan Motor

COOLING

8. Radiator Main Fan and Fan Motor

A: REMOVAL

- 1) Set the vehicle on a lift.
- 2) Disconnect the ground cable from the battery.

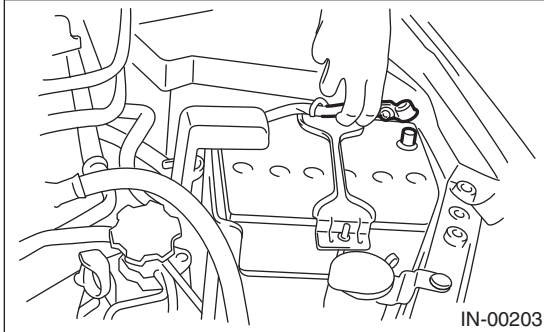

- 3) Lift up the vehicle.
- 4) Remove the under cover.
- 5) Disconnect the connector (A) of the main fan motor.

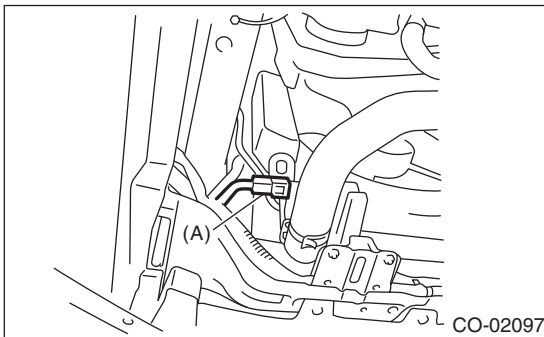

- 6) Remove the heat shield cover. (AT model)

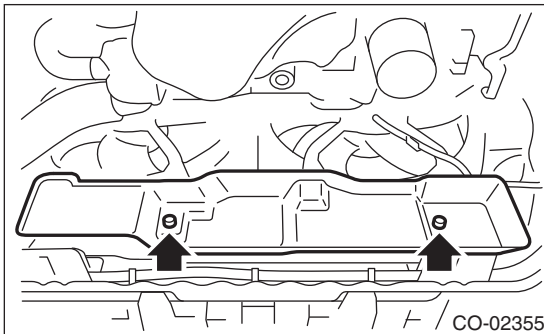

- 7) Remove the ATF hose from the clip of the radiator main fan motor assembly. (AT model)
- 8) Lower the vehicle.
- 9) Disconnect the over flow hose.
- 10) Remove the reservoir tank. <Ref. to CO(H4SO)-28, REMOVAL, Reservoir Tank.>
- 11) Drain approximately 2.0 ℓ of coolant. <Ref. to CO(H4SO)-13, DRAINING OF ENGINE COOLANT, REPLACEMENT, Engine Coolant.>

- 12) Disconnect the radiator inlet hoses from the engine.

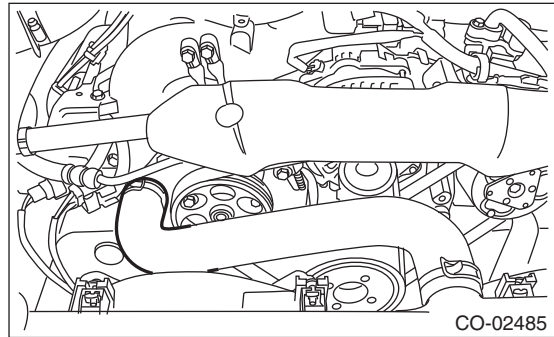

- 13) Remove the bolts which hold the radiator main fan shroud to the radiator.

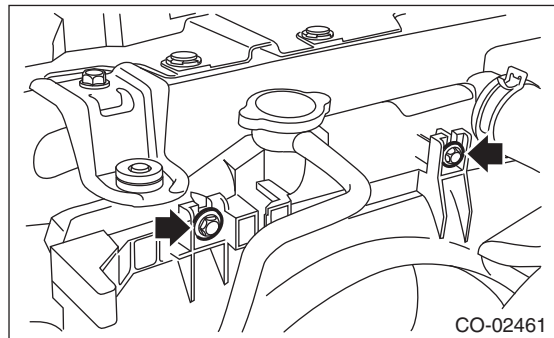

- 14) Remove the radiator main fan motor assembly.

B: INSTALLATION

Install in the reverse order of removal.

NOTE:

If the installation of the radiator main fan motor assembly is difficult, attempt installation after loosening the bolts which hold the radiator sub fan motor assembly.

Tightening torque:

7.5 N·m (0.8 kgf-m, 5.5 ft-lb)

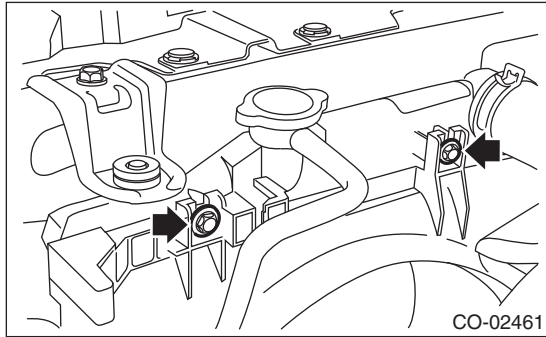

Tightening torque:

3 N·m (0.3 kgf-m, 2.2 ft-lb)

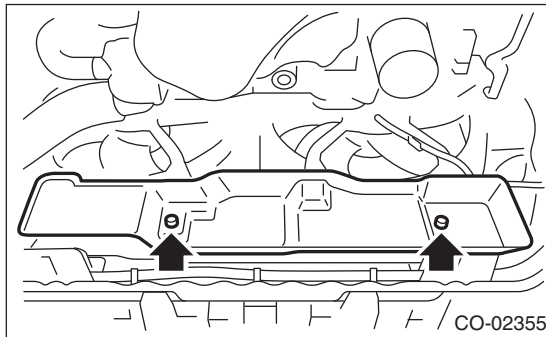

C: DISASSEMBLY

- 1) Remove the clip which holds motor connector onto the shroud.
- 2) Remove the nuts which hold the fan to the fan motor.

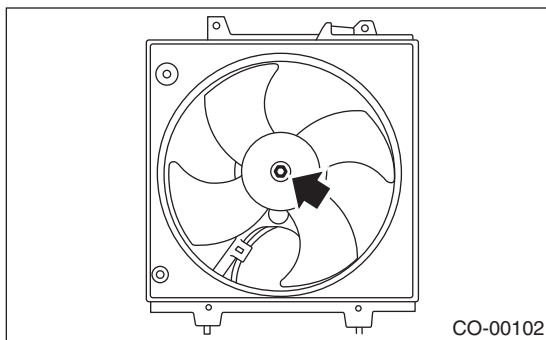

- 3) Remove the bolts which hold fan motor onto shroud.

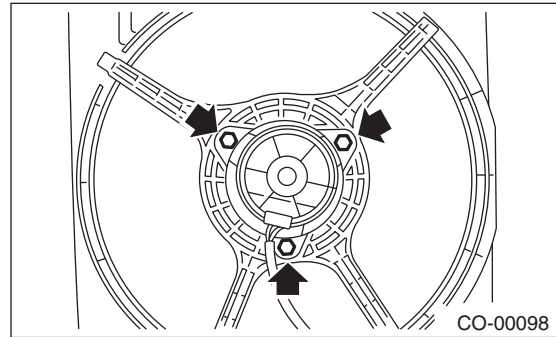

D: ASSEMBLY

Assemble in the reverse order of disassembly.

Tightening torque:

5 N·m (0.5 kgf-m, 3.7 ft-lb)

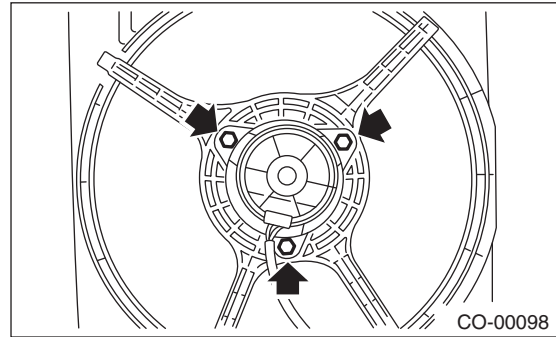

Tightening torque:

3.4 N·m (0.3 kgf-m, 2.5 ft-lb)

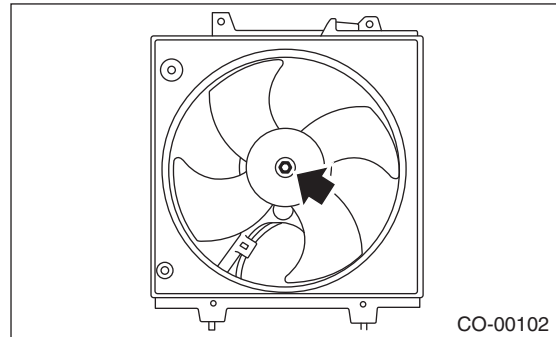

Radiator Sub Fan and Fan Motor

COOLING

9. Radiator Sub Fan and Fan Motor

A: REMOVAL

- 1) Set the vehicle on a lift.
- 2) Disconnect the ground cable from the battery.

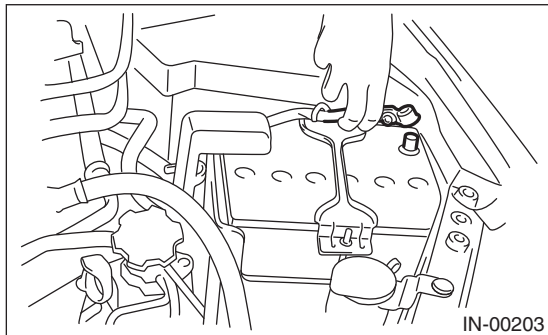

- 3) Lift up the vehicle.
- 4) Remove the under cover.
- 5) Remove the connector (B) of sub fan motor.

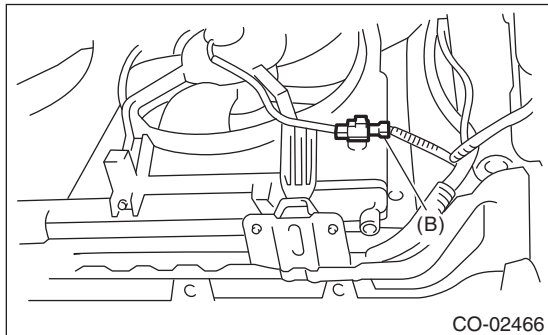

- 6) Remove the heat shield cover. (AT model)

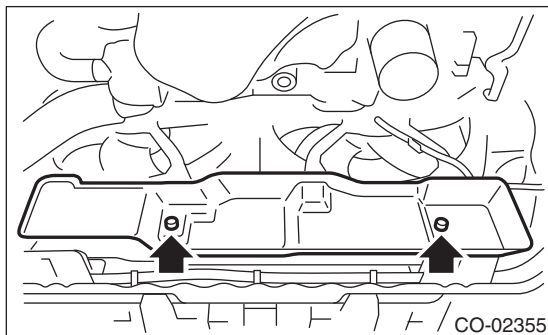

- 7) Remove the ATF hose from the clip of the radiator sub fan motor assembly. (AT model)
- 8) Lower the vehicle.
- 9) Remove the air intake duct (rear). <Ref. to IN(H4SO)-8, REMOVAL, Air Intake Duct.>
- 10) Drain approximately 2.0 ℓ of coolant. <Ref. to CO(H4SO)-13, DRAINING OF ENGINE COOLANT, REPLACEMENT, Engine Coolant.>

- 11) Disconnect the radiator inlet hoses from the engine.

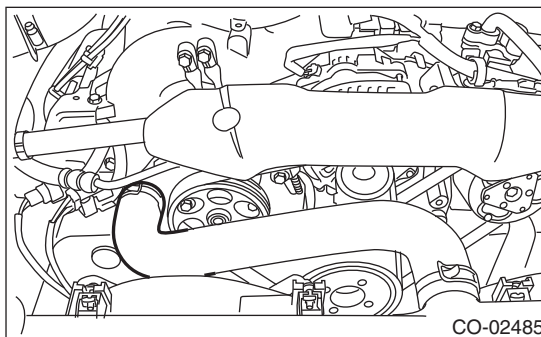

- 12) Remove the bolts which hold the radiator sub fan shroud to the radiator.

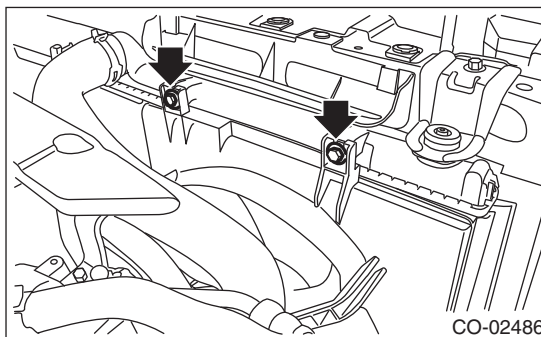

- 13) Remove the radiator sub fan motor assembly from underneath the vehicle.

B: INSTALLATION

Install in the reverse order of removal.

Tightening torque:

7.5 N·m (0.8 kgf·m, 5.5 ft·lb)

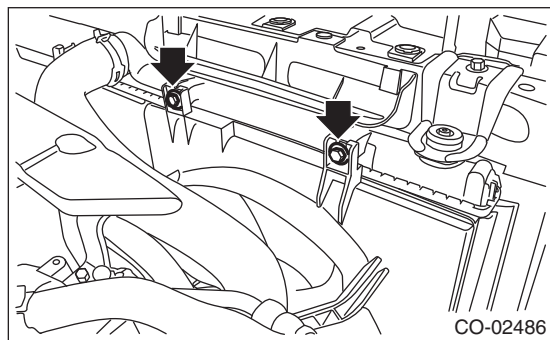

Tightening torque:

3 N·m (0.3 kgf·m, 2.2 ft·lb)

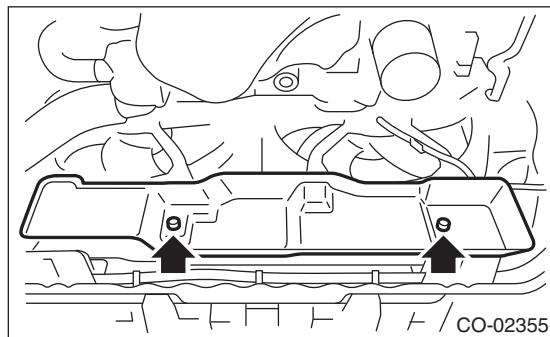

C: DISASSEMBLY

1) Remove the clip which holds the fan motor connector to the shroud.

2) Remove the nuts which hold the fan to the fan motor.

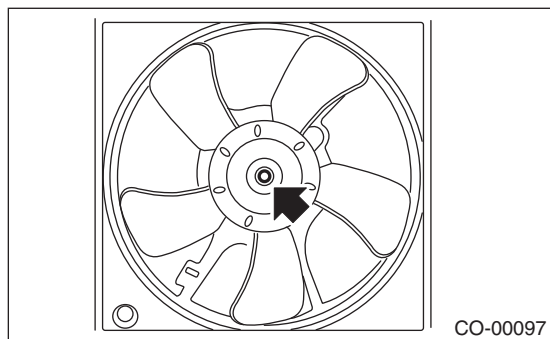

3) Remove the bolts which hold fan motor onto shroud.

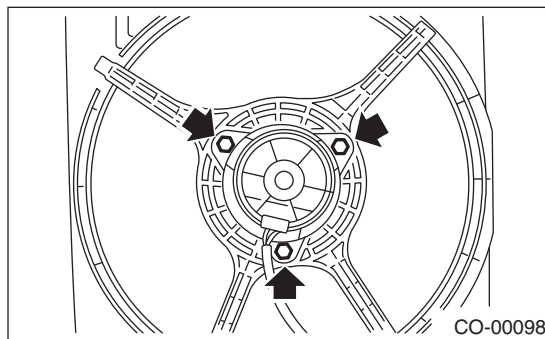

D: ASSEMBLY

Assemble in the reverse order of disassembly.

Tightening torque:

5 N·m (0.5 kgf·m, 3.7 ft·lb)

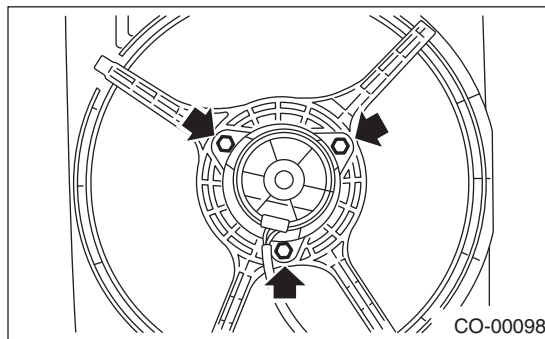

Tightening torque:

3.4 N·m (0.35 kgf·m, 2.5 ft·lb)

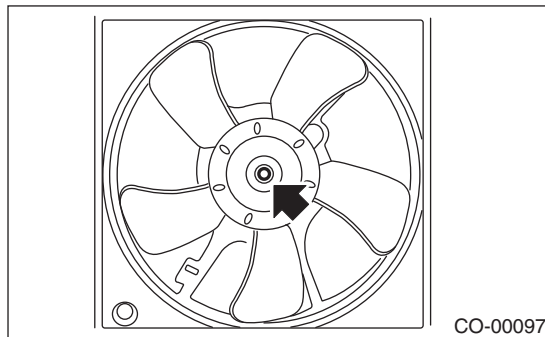

10. Reservoir Tank

A: REMOVAL

- 1) Drain the over flow hose connecting to the radiator from the reservoir tank.
- 2) Push in the hook (A), and pull the reserve tank in the direction of the arrow to remove.

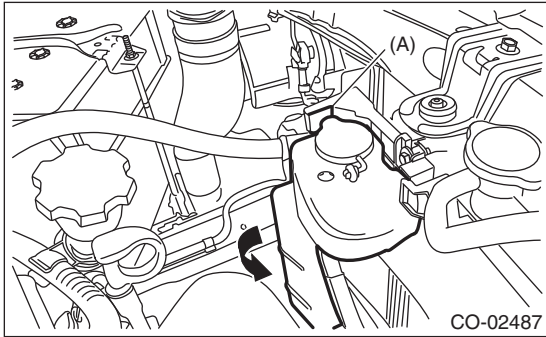

B: INSTALLATION

Install in the reverse order of removal.

C: INSPECTION

Make sure the engine coolant level is between "FULL" and "LOW".

11.Engine Cooling System Trouble in General

A: INSPECTION

Trouble	Possible cause	Corrective action
Overheat	a. Insufficient engine coolant	Replenish engine coolant, inspect for leakage, and repair it if necessary.
	b. Loose timing belt	Repair or replace timing belt tensioner.
	c. Oil on timing belt	Replace.
	d. Malfunction of thermostat	Replace.
	e. Malfunction of water pump	Replace.
	f. Clogged engine coolant passage	Clean.
	g. Improper ignition timing	Inspect and repair ignition control system. <Ref. to EN(H4SO)(diag)-2, Basic Diagnostic Procedure.>
	h. Clogged or leaking radiator	Clean, repair or replace.
	i. Engine oil mixed in engine coolant	Replace the engine coolant. If defective is not improved, check, repair and replace the engine parts.
	j. Air/fuel mixture ratio too lean	Inspect and repair the fuel injection system. <Ref. to EN(H4SO)(diag)-2, Basic Diagnostic Procedure.>
	k. Excessive back pressure in exhaust system	Clean or replace.
	l. Insufficient clearance between piston and cylinder	Adjust or replace.
	m. Slipping clutch	Correct or replace.
	n. Dragging brake	Adjust.
	o. Defective radiator fan	Inspect the radiator fan relay, engine coolant temperature sensor or fan motor and replace them.
Over-cooling	a. Ambient temperature extremely low	Partly cover radiator front area.
	b. Defective thermostat	Replace.
Engine coolant leaks	a. Loosened or damaged connecting units on hoses	Correct or replace.
	b. Leakage from water pump	Replace.
	c. Leakage from water pipe	Correct or replace.
	d. Leakage around cylinder head gasket	Retighten cylinder head bolts or replace gasket.
	e. Cylinder head and block damaged or cracked	Correct or replace.
	f. Damaged or cracked thermostat cover	Correct or replace.
	g. Leakage from radiator	Correct or replace.
Abnormal noise	a. Timing belt problem	Replace.
	b. Defective radiator fan	Replace.
	c. Defective water pump bearing	Replace water pump.
	d. Defective water pump mechanical seal	Replace water pump.

Engine Cooling System Trouble in General

COOLING

LUBRICATION

LU(H4SO)

	Page
1. General Description	2
2. Oil Pressure System	6
3. Engine Oil	8
4. Oil Pump	10
5. Oil Pan and Strainer	14
6. Oil Pressure Switch	18
7. Engine Oil Filter	19
8. Engine Lubrication System Trouble in General	20

General Description

LUBRICATION

1. General Description

A: SPECIFICATION

Lubrication method			Forced lubrication	
Oil pump	Pump type		Trochoid type	
	Number of teeth	Inner rotor	9	
		Outer rotor	10	
	Outer rotor diameter × thickness		mm (in) 76 × 10 (2.99 × 0.47)	
	Tip clearance between inner and outer rotors		mm (in) 0.04 — 0.14 (0.0016 — 0.0055)	
	Side clearance between inner rotor and pump case		mm (in) 0.02 — 0.07 (0.0008 — 0.0028)	
	Case clearance between outer rotor and pump case	Standard	mm (in) 0.10 — 0.175 (0.0039 — 0.0069)	
	Performance (Oil temperature 80°C (176°F))	600 rpm	Discharge pressure	kPa (kg/cm ² , psi) 98 (1.0, 14)
			Discharge rate	ℓ (US qt, Imp qt)/min. 4.6 (4.9, 4.0) or more
		5,000 rpm	Discharge pressure	kPa (kg/cm ² , psi) 294 (3.0, 43)
Discharge rate			ℓ (US qt, Imp qt)/min. 47.0 (49.7, 41.4) or more	
Relief valve working pressure		kPa (kg/cm ² , psi) 588 (6.0, 85)		
Oil filter	Filter type		Full-flow filter type	
	Filtration area		cm ² (sq in) 800 (124)	
	By-pass valve opening pressure		kPa (kg/cm ² , psi) 160 (1.63, 23.2)	
	Outer diameter × width		mm (in) 68 × 65 (2.68 × 2.56)	
	Installation screw specifications		M 20 × 1.5	
Oil pressure switch	Type		Immersed contact point type	
	Operating voltage — power consumption		12 V — 3.4 W or less	
	Warning light operating pressure		kPa (kg/cm ² , psi) 14.7 (0.15, 2.1)	
	Proof pressure		kPa (kg/cm ² , psi) 981 (10, 142) or more	
Engine oil	Total capacity (Overhaul)		ℓ (US qt, Imp qt) 5.0 (5.3, 4.4)	
	When replacing engine oil and oil filter		ℓ (US qt, Imp qt) 4.2 (4.4, 3.7)	
	When replacing engine oil only		ℓ (US qt, Imp qt) 4.0 (4.2, 3.5)	

Recommended oil:

Oil suitable for the standard from the followings.

- **For API standard, oil with SM “Energy Conserving” logo**
- **For ILSAC standard, oil with GF-4 “Star burst mark” label on the container**

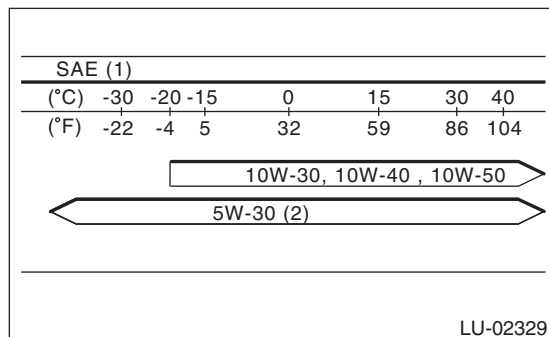

- (1) SAE viscosity No. and applicable temperature
- (2) Recommended

CAUTION:

It is acceptable to fill an engine with oil of another brand when replacing the oil, but make sure to use an oil with an API standard and SAE viscosity number specified by Subaru.

NOTE:

- The proper viscosity oil helps the engine maintain its ideal temperature, and cranking speed increased by reducing viscosity friction in hot condition.
- If the vehicle is used in regions with high temperatures or in other severe environments, use oil with the viscosities shown below.

API standard: SM or SL

SAE Viscosity No.: 30, 40, 10W-50, 20W-40, 20W-50

General Description

LUBRICATION

B: COMPONENT

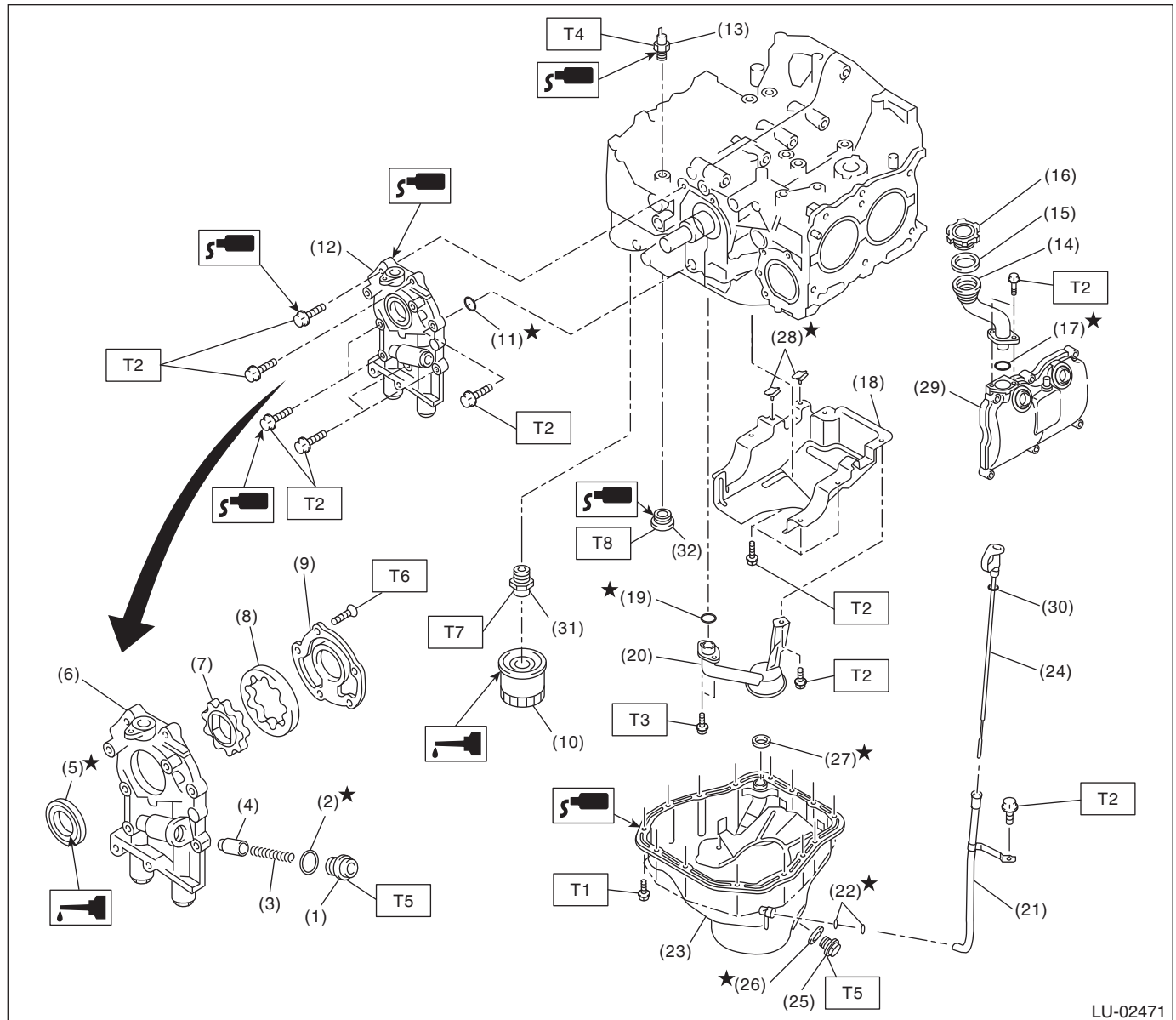

LU-02471

- | | | |
|--------------------------|----------------------------|---------------------------|
| (1) Plug | (15) Gasket | (29) Rocker cover |
| (2) Gasket | (16) Oil filler cap | (30) O-ring |
| (3) Relief valve spring | (17) O-ring | (31) Oil filter connector |
| (4) Relief valve | (18) Baffle plate | (32) Plug |
| (5) Front oil seal | (19) O-ring | |
| (6) Oil pump case | (20) Oil strainer | |
| (7) Inner rotor | (21) Oil level gauge guide | |
| (8) Outer rotor | (22) O-ring | |
| (9) Oil pump cover | (23) Oil pan | |
| (10) Oil filter | (24) Oil level gauge | |
| (11) O-ring | (25) Drain plug | |
| (12) Oil pump ASSY | (26) Drain plug gasket | |
| (13) Oil pressure switch | (27) Gasket | |
| (14) Oil filler duct | (28) Seal | |

Tightening torque: N·m (kgf·m, ft·lb)

- | | |
|------------|-----------------------|
| T1: | 5 (0.5, 3.7) |
| T2: | 6.4 (0.7, 4.7) |
| T3: | 10 (1.0, 7.4) |
| T4: | 25 (2.5, 18.4) |
| T5: | 44 (4.5, 32.5) |
| T6: | 5.4 (0.6, 4.0) |
| T7: | 45 (4.6, 33.2) |
| T8: | 70 (7.1, 51.6) |

LU(H4SO)-4

C: CAUTION

- Wear appropriate work clothing, including a cap, protective goggles and protective shoes when performing any work.
- Remove contamination including dirt and corrosion before removal, installation or disassembly.
- Keep the disassembled parts in order and protect them from dust and dirt.
- Before removal, installation or disassembly, be sure to clarify the failure. Avoid unnecessary removal, installation, disassembly and replacement.
- Vehicle components are extremely hot after driving. Be wary of receiving burns from heated parts.
- Be sure to tighten fasteners including bolts and nuts to the specified torque.
- Place shop jacks or rigid racks at the specified points.
- Before disconnecting connectors of sensors or units, be sure to disconnect the ground cable from the battery.
- If the engine oil is spilt over exhaust pipe or the under cover, wipe it off with cloth to avoid emitting smoke or causing a fire.
- Prepare a container and cloth when performing work which oil possibly spills. If oil spills, wipe it off immediately to prevent from penetrating into floor or flowing out for environmental protection.
- Follow all government and local regulations concerning disposal of refuse when disposing oil.

D: PREPARATION TOOL

1. SPECIAL TOOL

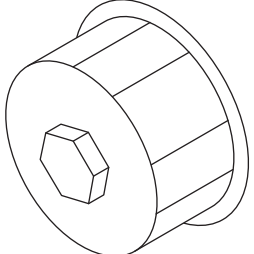
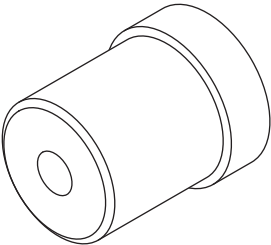
ILLUSTRATION	TOOL NUMBER	DESCRIPTION	REMARKS
 ST18332AA000	18332AA000	OIL FILTER WRENCH	Used for removing and installing the black oil filter (outer diameter: 68 mm (2.68 in)).
 ST-499587100	499587100	OIL SEAL INSTALLER	Used for installing oil seal into oil pump.

2. GENERAL TOOL

TOOL NAME	REMARKS
Oil filter wrench (65/67 mm 14 Flutes)	Used for removing and installing the blue oil filter (outer diameter: 67.4 mm (2.65 in)).

Oil Pressure System

LUBRICATION

2. Oil Pressure System

A: WIRING DIAGRAM

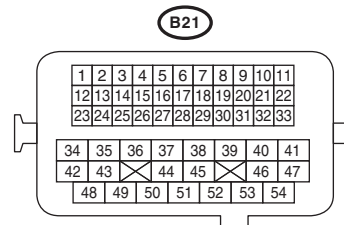
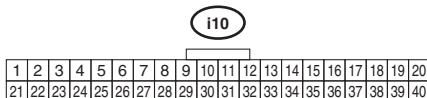
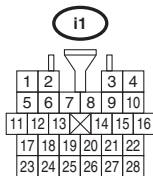
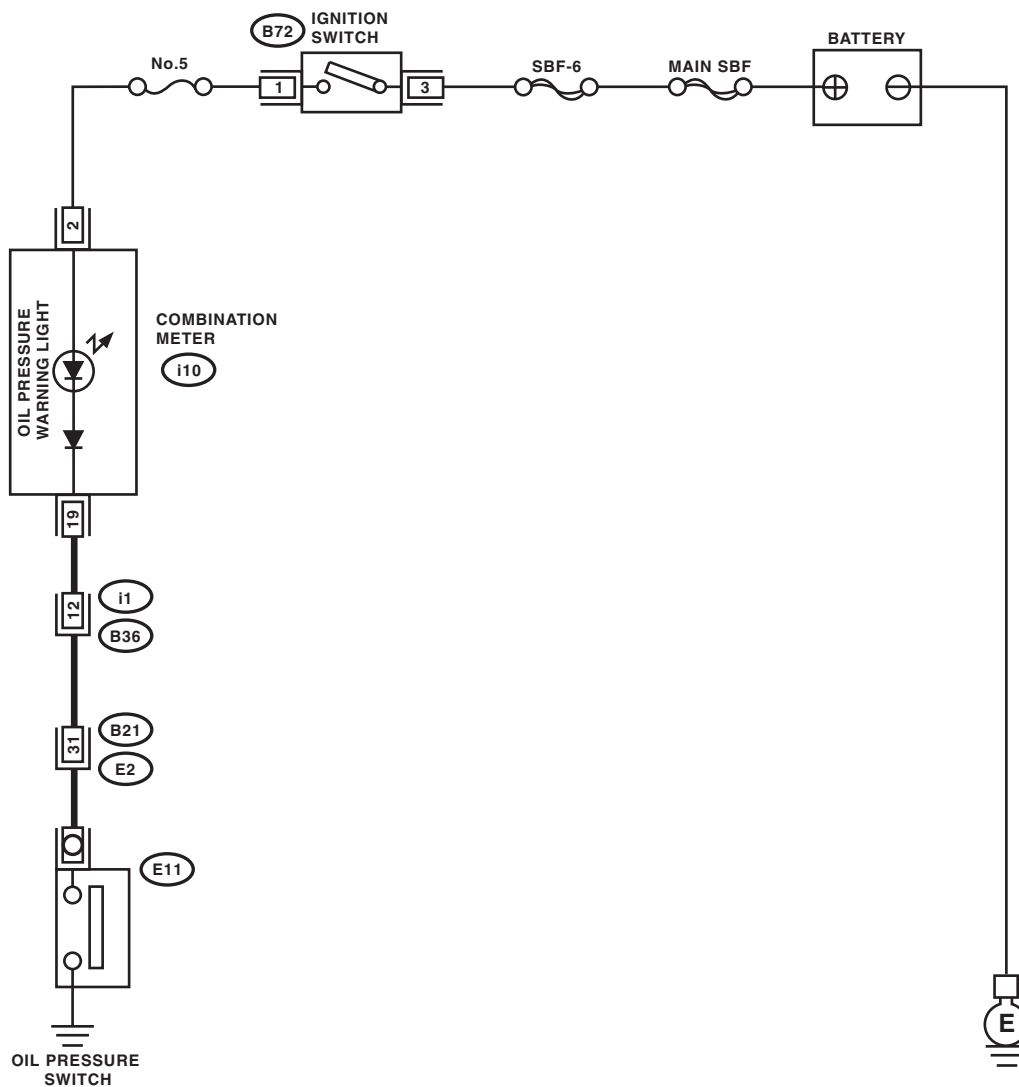

LU-02387

B: INSPECTION

Step	Check	Yes	No
1 CHECK COMBINATION METER. 1) Turn the ignition switch to ON. (engine OFF) 2) Check other warning lights.	Does the warning light illuminate?	Go to step 2.	Repair or replace the combination meter. <Ref. to IDI-4, INSPECTION, Combination Meter System.>
2 CHECK THE HARNESS CONNECTOR BETWEEN THE COMBINATION METER AND THE OIL PRESSURE SWITCH. 1) Turn the ignition switch to OFF. 2) Disconnect the connector from oil pressure switch. 3) Turn the ignition switch to ON. 4) Measure the voltage of harness between oil pressure switch connector and chassis ground. Connector & terminal (E11) No. 1 (+) — Chassis ground (-):	Is the voltage 10 V or more?	Replace the oil pressure switch. <Ref. to LU(H4SO)-18, Oil Pressure Switch.>	Go to step 3.
3 CHECK COMBINATION METER. 1) Turn the ignition switch to OFF. 2) Remove the combination meter. 3) Measure the resistance of combination meter. Terminals (i10) No. 2 — No. 19:	Is the resistance less than 10 Ω?	Repair the harness and connector. NOTE: In this case, repair the following item: • Open circuit of harness between combination meter and oil pressure switch • Poor contact in combination meter connector • Poor contact in oil pressure switch connector • Poor contact in coupling connector	Repair or replace the combination meter. <Ref. to IDI-4, INSPECTION, Combination Meter System.>

3. Engine Oil

A: INSPECTION

CAUTION:

If the engine oil is spilt over exhaust pipe or the under cover, wipe it off with cloth to avoid emitting smoke or causing a fire.

- 1) Park the vehicle on a level surface.
- 2) Remove the oil level gauge and wipe away all of the oil.
- 3) Reinsert the oil level gauge all the way. Be sure that the oil level gauge is correctly inserted and properly orientated.
- 4) Remove the oil level gauge again and check the reading. If the engine oil level is below "L" line, check for oil leakage from engine and add oil to bring the level up to "F" line.
- 5) Start the engine and warm it up for a time.
- 6) After turning off the engine, wait a few minutes for the oil to return to the oil pan before checking the level.

NOTE:

- Just after driving or while the engine is warm, engine oil level shows in the range between "F" line and cutout portion. This is caused by thermal expansion of engine oil.
- To prevent overfilling of engine oil, do not add oil above "F" line when the engine is cold.
- As the oil level gauge is used for daily maintenance, "F" line and "L" line is set assuming that the engine is cold.

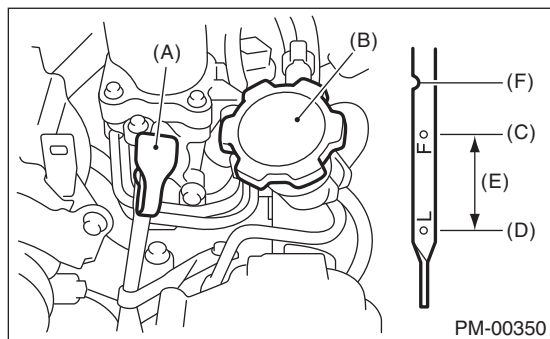

- (A) Oil level gauge
- (B) Engine oil filler cap
- (C) "F" line
- (D) "L" line
- (E) Approx. 1.0 ℓ (1.1 US qt, 0.9 Imp qt)
- (F) Notch mark

B: REPLACEMENT

CAUTION:

If the engine oil is spilt over exhaust pipe or the under cover, wipe it off with cloth to avoid emitting smoke or causing a fire.

- 1) Set the vehicle on a lift.
- 2) Open the engine oil filler cap for quick draining of engine oil.
- 3) Lift up the vehicle.
- 4) Drain engine oil by loosening the engine oil drain plug.

NOTE:

Prepare the container for draining of engine oil.

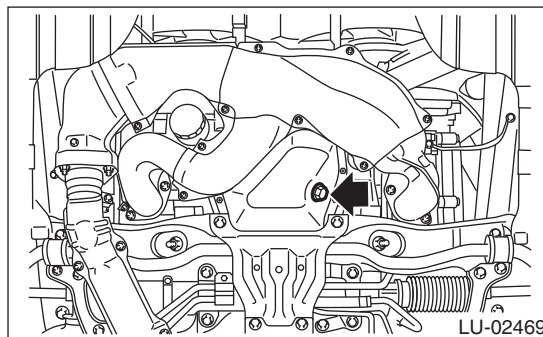

- 5) Tighten the engine oil drain plug after draining engine oil.

NOTE:

Use a new drain plug gasket.

Tightening torque:

44 N·m (4.5 kgf-m, 32.5 ft-lb)

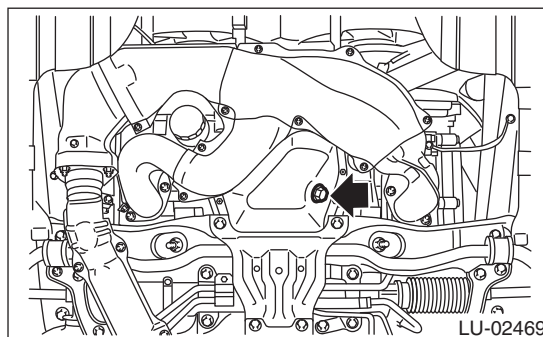

- 6) Lower the vehicle.
- 7) Using engine oil of proper quality and viscosity, fill engine oil through the filler duct to the "F" line on the oil level gauge. Make sure that the vehicle is parked on a level surface when checking oil level.

Recommended oil:

Refer to "SPECIFICATION" for the recommended oil. <Ref. to LU(H4SO)-2, SPECIFICATION, General Description.>

Engine oil capacity:

Refer to "SPECIFICATION" for the engine oil capacity. <Ref. to LU(H4SO)-2, SPECIFICATION, General Description.>

- 8) Close the engine oil filler cap.
- 9) Start the engine, and spreads the oil in engine room.
- 10) After stopping the engine, recheck the oil level.
If necessary, add engine oil up to the "F" line on the oil level gauge.

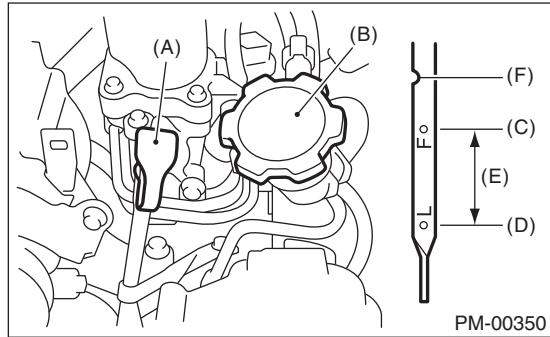

- (A) Oil level gauge
- (B) Engine oil filler cap
- (C) "F" line
- (D) "L" line
- (E) Approx. 1.0 ℓ (1.1 US qt, 0.9 Imp qt)
- (F) Notch mark

Oil Pump

LUBRICATION

4. Oil Pump

A: REMOVAL

- 1) Disconnect the ground cable from the battery.

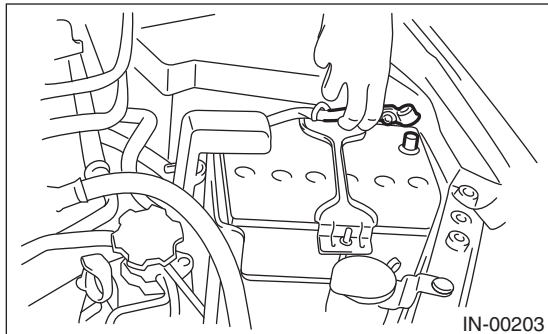

- 2) Remove the radiator. <Ref. to CO(H4SO)-19, REMOVAL, Radiator.>
- 3) Remove the crankshaft position sensor. <Ref. to FU(H4SO)-23, REMOVAL, Crankshaft Position Sensor.>
- 4) Remove the water pump. <Ref. to CO(H4SO)-15, REMOVAL, Water Pump.>
- 5) Remove the crank sprocket. <Ref. to ME(H4SO)-61, REMOVAL, Crank Sprocket.>
- 6) Remove the bolts which install oil pump onto cylinder block.

NOTE:

When disassembling and checking the oil pump, loosen the relief valve plug before removing the oil pump.

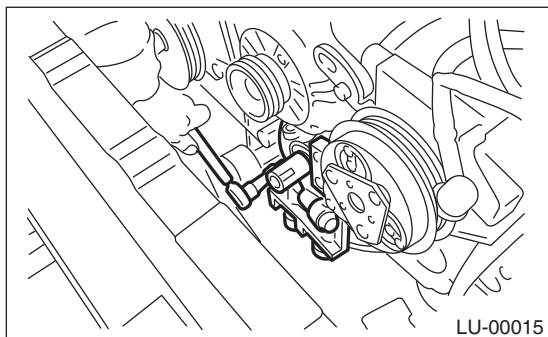

- 7) Remove the oil pump by using flat tip screwdriver.

CAUTION:

Be careful not to scratch mating surfaces of cylinder block and oil pump.

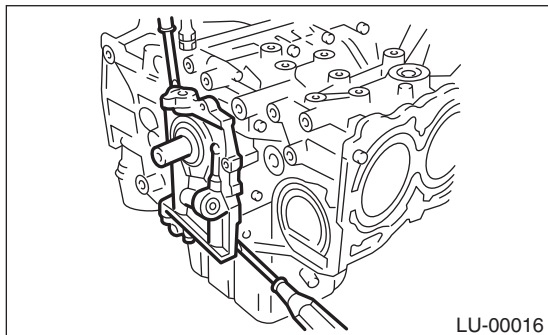

- 8) Remove the front oil seal from the oil pump.

B: INSTALLATION

- 1) Using the ST, install the front oil seal.
ST 499587100 OIL SEAL INSTALLER

NOTE:

Use a new front oil seal.

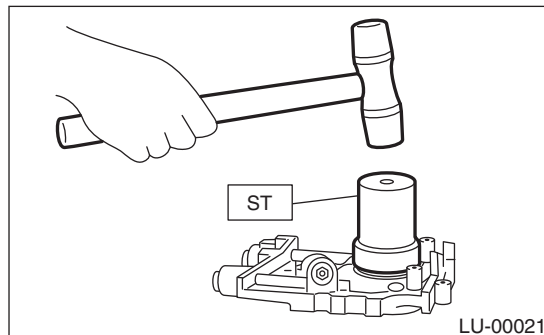

- 2) Apply liquid gasket to the mating surfaces of oil pump.

NOTE:

Install within 5 min. after applying liquid gasket.

Liquid gasket:

THREE BOND 1217G (Part No. K0877Y0100) or equivalent

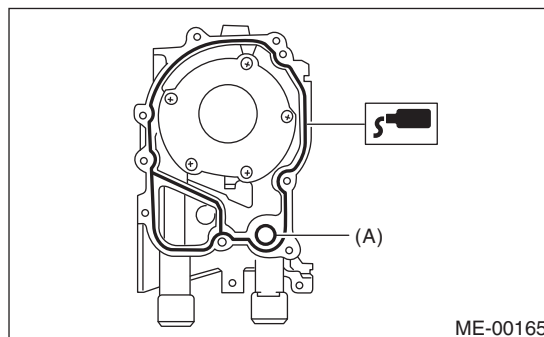

(A) O-ring

- 3) Apply a coat of engine oil to the inside of front oil seal.

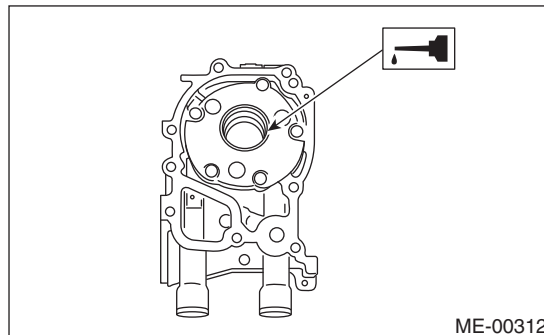

4) Install the oil pump to cylinder block. Be careful not to damage the front oil seal during installation.

NOTE:

- Make sure the front oil seal lip is not folded.
- Align the flat surface of oil pump's inner rotor with crankshaft before installation.
- Use new O-rings.
- Do not forget to assemble O-rings.

5) Apply liquid gasket to the three bolts thread shown in figure. (when reuse the bolts)

Liquid gasket:

THREE BOND 1324 (Part No. 004403042) or equivalent

Tightening torque:

6.4 N·m (0.7 kgf·m, 4.7 ft·lb)

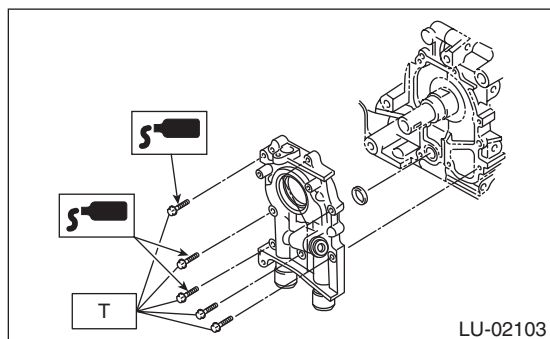

6) Install the crank sprocket. <Ref. to ME(H4SO)-61, INSTALLATION, Crank Sprocket.>

7) Install the water pump. <Ref. to CO(H4SO)-15, INSTALLATION, Water Pump.>

8) Install the crankshaft position sensor. <Ref. to FU(H4SO)-23, INSTALLATION, Crankshaft Position Sensor.>

9) Install the radiator. <Ref. to CO(H4SO)-20, INSTALLATION, Radiator.>

10) Connect the ground cable to the battery.

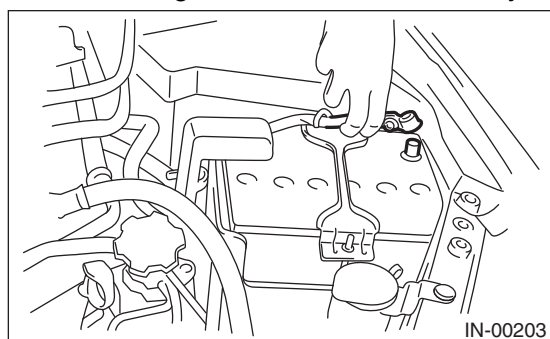

C: DISASSEMBLY

Remove the screw which secures oil pump cover and then disassemble oil pump. Inscribe alignment marks on the inner and outer rotors so that they can be replaced in their original positions during reassembly.

NOTE:

Before disassembling the oil pump, remove the relief valve.

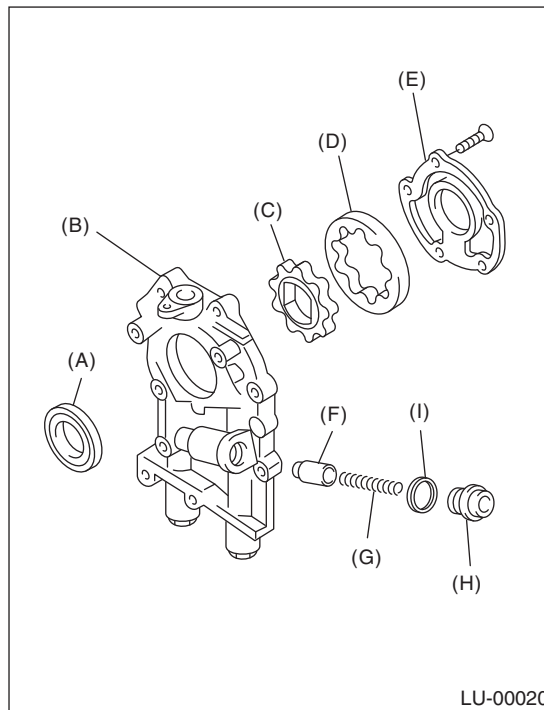

- (A) Front oil seal
- (B) Oil pump case
- (C) Inner rotor
- (D) Outer rotor
- (E) Oil pump cover
- (F) Relief valve
- (G) Relief valve spring
- (H) Plug
- (I) Gasket

Oil Pump

LUBRICATION

D: ASSEMBLY

1) Assemble the front oil seal by using ST.
ST 499587100 OIL SEAL INSTALLER

NOTE:

Use a new front oil seal.

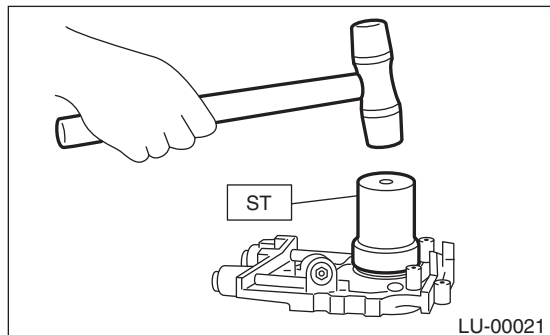

2) Apply a coat of engine oil to inner and outer rotors.

3) Assemble the inner and outer rotors in their original positions.

4) Assemble the oil relief valve and install relief valve spring and plug.

NOTE:

Use a new gasket.

5) Assemble the oil pump cover.

Tightening torque:

T1: 5.4 N·m (0.6 kgf·m, 4.0 ft·lb)

T2: 44 N·m (4.5 kgf·m, 32.5 ft·lb)

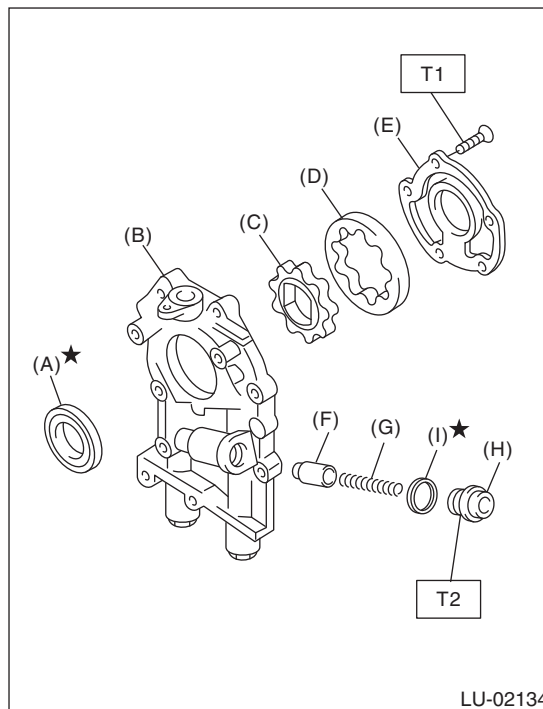

- (A) Front oil seal
- (B) Oil pump case
- (C) Inner rotor
- (D) Outer rotor
- (E) Oil pump cover
- (F) Relief valve
- (G) Relief valve spring
- (H) Plug
- (I) Gasket

E: INSPECTION

1. TIP CLEARANCE

Measure the tip clearance of rotors. If the clearance is out of specification, replace the rotors as a set.

Tip clearance:

Standard:

0.04 — 0.14 mm (0.0016 — 0.0055 in)

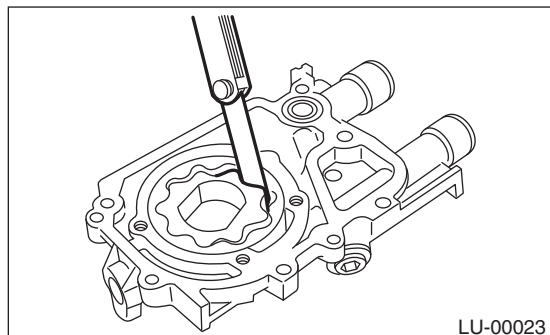

2. CASE CLEARANCE

Measure the clearance between the outer rotor and the oil pump case. If clearance is out of standard, replace the oil pump case.

Case clearance:

Standard:

0.10 — 0.175 mm (0.0039 — 0.0069 in)

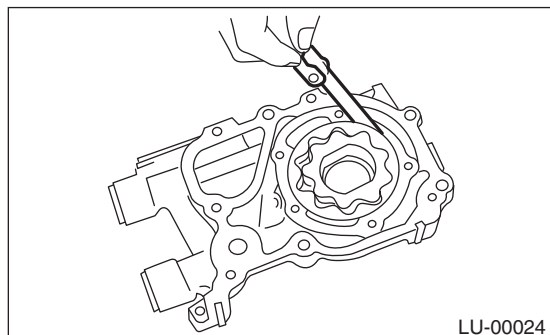

3. SIDE CLEARANCE

Measure the gap between the inner rotor and the oil pump to measure the clearance between the oil pump inner rotor and the oil pump cover as shown in the figure. If the clearance is not within the limit, replace the rotor or the oil pump case.

Side clearance:

Standard:

0.02 — 0.07 mm (0.0008 — 0.0028 in)

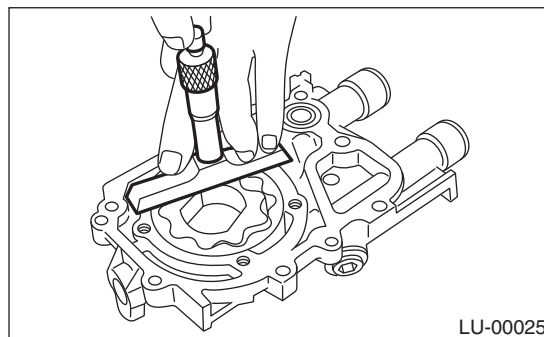

4. OIL RELIEF VALVE

Check the valve for assembly condition and damage, and the relief valve spring for damage and deterioration.

Replace the parts if defective.

Relief valve spring:

Free length

73.7 mm (2.902 in)

Installed length

54.7 mm (2.154 in)

Load when installed

93.1 N (9.49 kgf, 20.88 lbf)

5. OIL PUMP CASE

Check oil pump case for worn shaft holes, clogged oil passages, worn rotor chambers, cracks and other faults.

6. FRONT OIL SEAL

Check the front oil seal lips for deformation and hardening, wear.

5. Oil Pan and Strainer

A: REMOVAL

- 1) Set the vehicle on a lift.
- 2) Disconnect the ground cable from the battery.

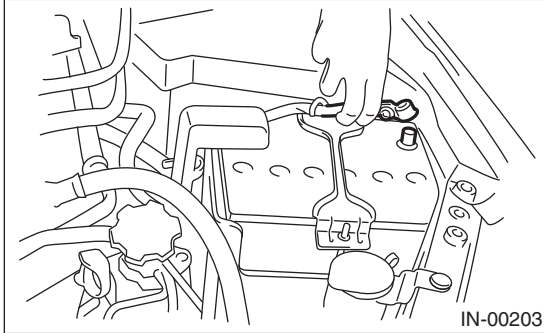

- 3) Remove the air intake duct (rear). <Ref. to IN(H4SO)-8, REMOVAL, Air Intake Duct.>

- 4) Remove the air intake chamber. <Ref. to IN(H4SO)-7, REMOVAL, Air Intake Chamber.>

- 5) Remove the pitching stopper.

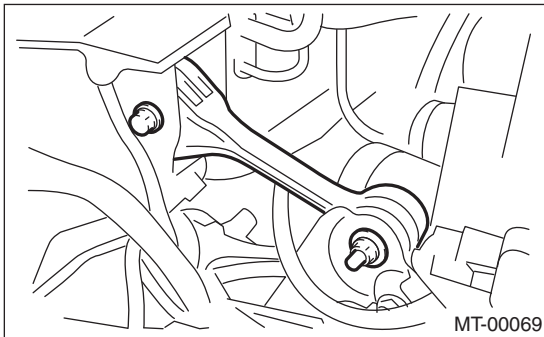

- 6) Remove the radiator upper brackets.

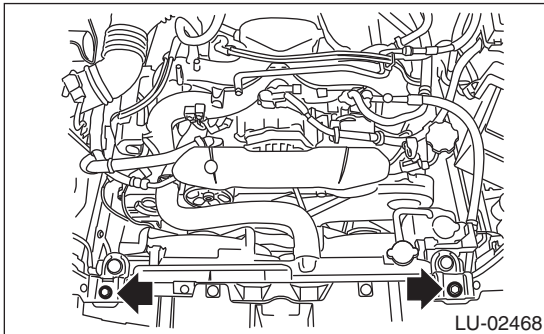

- 7) Support the engine with a lifting device and wire ropes.

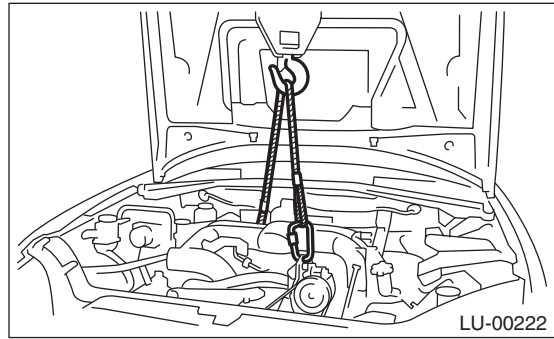

- 8) Lift up the vehicle.

CAUTION:

When lifting up the vehicle, raise up wire ropes at the same time.

- 9) Drain the engine oil. <Ref. to LU(H4SO)-8, REPLACEMENT, Engine Oil.>

- 10) Remove the front and center exhaust pipes. <Ref. to EX(H4SO)-4, REMOVAL, Front Exhaust Pipe.>

- 11) Remove the nuts which install front cushion rubber onto front crossmember.

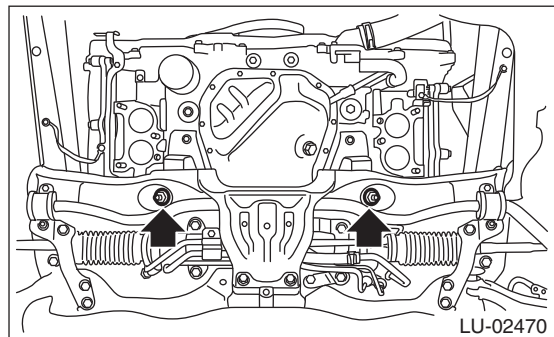

12) Remove the bolts which install oil pan on cylinder block with the engine raised up.

13) Insert an oil pan cutter blade between cylinder block-to-oil pan clearance and remove the oil pan.

CAUTION:

Do not use a screwdriver or similar tool in place of oil pan cutter.

14) Remove the oil strainer.

15) Remove the baffle plate.

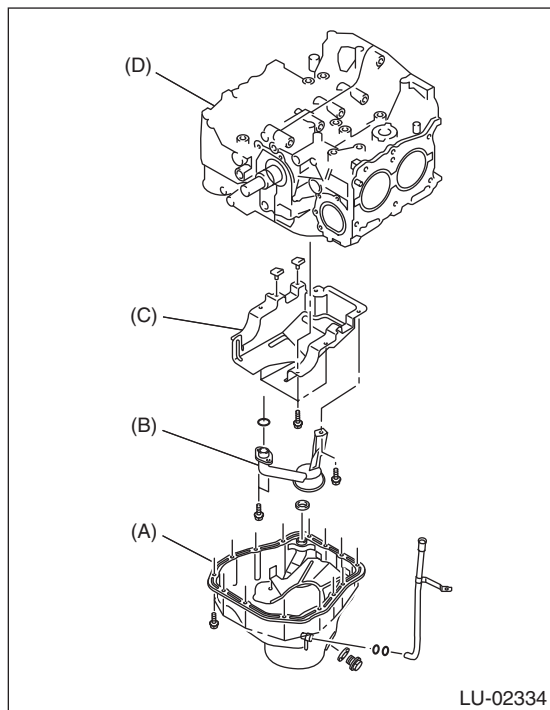

- (A) Oil pan
- (B) Oil strainer
- (C) Baffle plate
- (D) Cylinder block

B: INSTALLATION

NOTE:

Before installing the oil pan, clean the mating surface of oil pan and engine block.

1) Make sure that the seals (A) are installed securely on the baffle plate in a direction as shown in the figure below.

NOTE:

Use new seals.

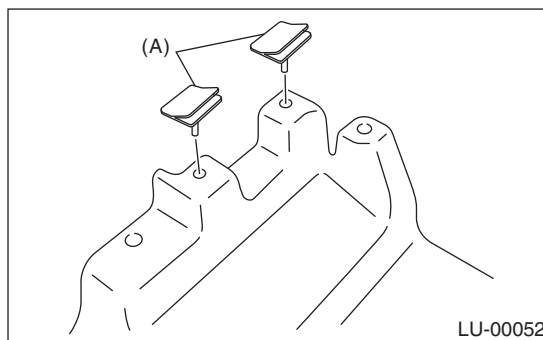

2) Install the baffle plate.

Tightening torque:

6.4 N·m (0.7 kgf·m, 4.7 ft·lb)

3) Install the oil strainer to the cylinder block.

NOTE:

Use new O-rings.

Tightening torque:

10 N·m (1.0 kgf·m, 7.4 ft·lb)

4) Tighten the oil strainer stay together with the baffle plate.

Tightening torque:

6.4 N·m (0.7 kgf·m, 4.7 ft·lb)

5) Apply liquid gasket to the mating surfaces of the oil pan, and install the oil pan.

NOTE:

- Use a new gasket.
- Install within 5 min. after applying liquid gasket.

Liquid gasket:

THREE BOND 1217G (Part No. K0877Y0100) or equivalent

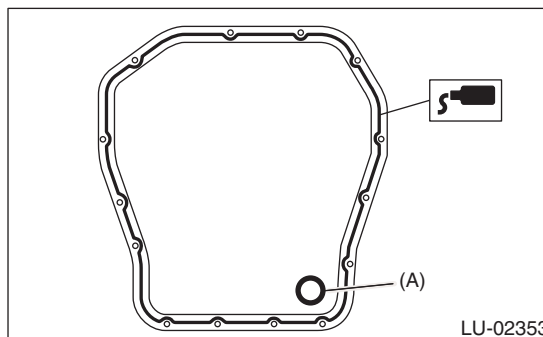

- (A) Gasket

Oil Pan and Strainer

LUBRICATION

6) Tighten the bolts which install the oil pan to the cylinder block.

Tightening torque:

T1: 5 N·m (0.5 kgf-m, 3.7 ft-lb)

T2: 6.4 N·m (0.7 kgf-m, 4.7 ft-lb)

T3: 10 N·m (1.0 kgf-m, 7.4 ft-lb)

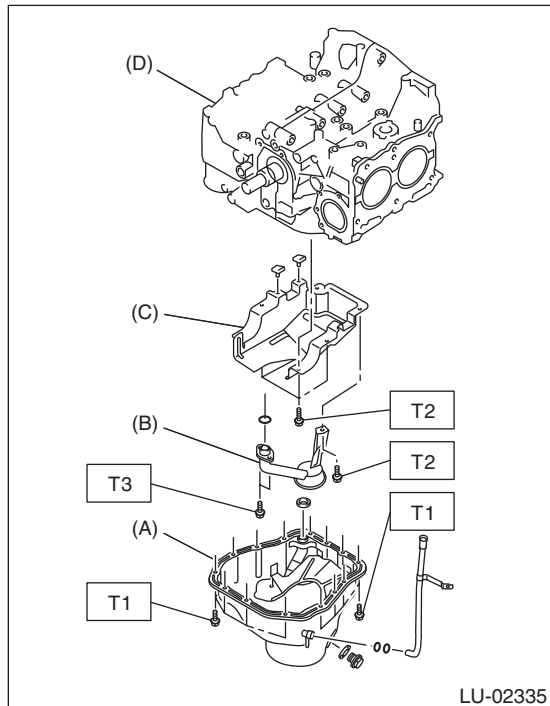

- (A) Oil pan
- (B) Oil strainer
- (C) Baffle plate
- (D) Cylinder block

7) Lower the engine onto front crossmember.

8) Tighten the nuts which install front cushion rubber onto front crossmember.

Tightening torque:

85 N·m (8.7 kgf-m, 62.7 ft-lb)

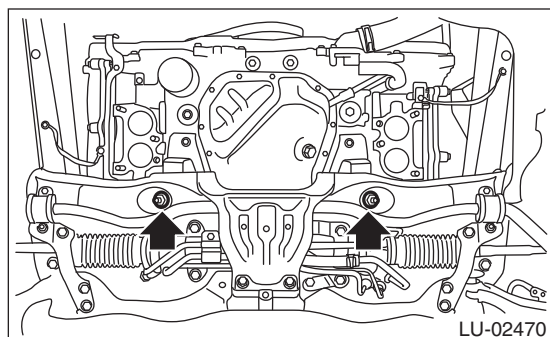

9) Install the front and center exhaust pipe. <Ref. to EX(H4SO)-5, INSTALLATION, Front Exhaust Pipe.>

10) Lower the vehicle.

CAUTION:

When lowering the vehicle, lower the lift-up device and wire ropes at the same time.

11) Remove the lifting device and wire ropes.

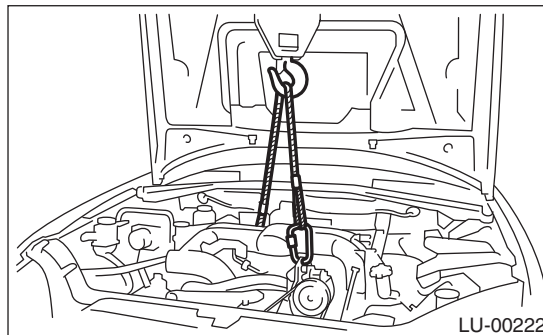

12) Install the pitching stopper.

Tightening torque:

T1: 50 N·m (5.1 kgf-m, 36.9 ft-lb)

T2: 58 N·m (5.9 kgf-m, 42.8 ft-lb)

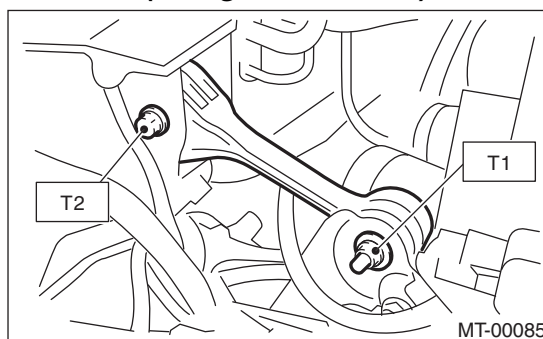

13) Install the radiator upper brackets.

Tightening torque:

12 N·m (1.2 kgf-m, 8.9 ft-lb)

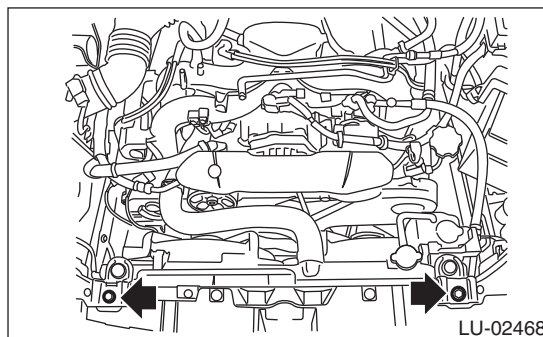

14) Install the air intake chamber.

<Ref. to IN(H4SO)-7, INSTALLATION, Air Intake Chamber.>

15) Install the air intake duct (rear). <Ref. to IN(H4SO)-8, INSTALLATION, Air Intake Duct.>

16) Connect the battery ground cable to battery.

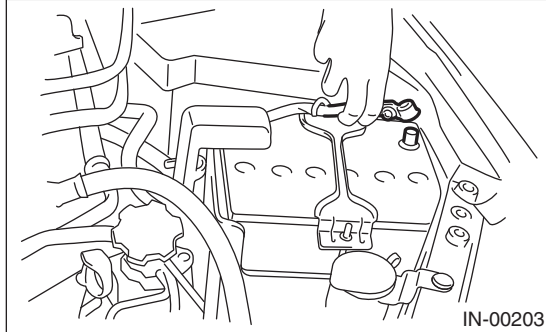

17) Refill the engine oil. <Ref. to LU(H4SO)-8, INSPECTION, Engine Oil.>

C: INSPECTION

Visually check that the oil pan, oil strainer, oil strainer stay and baffle plate are not damaged.

Oil Pressure Switch

LUBRICATION

6. Oil Pressure Switch

A: REMOVAL

- 1) Disconnect the ground cable from the battery.

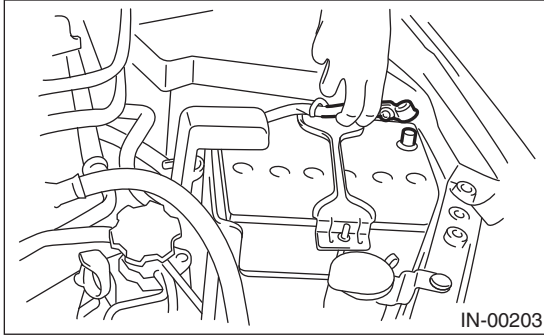

- 2) Remove the generator from the bracket. <Ref. to SC(H4SO)-15, REMOVAL, Generator.>
- 3) Disconnect the terminal from oil pressure switch.

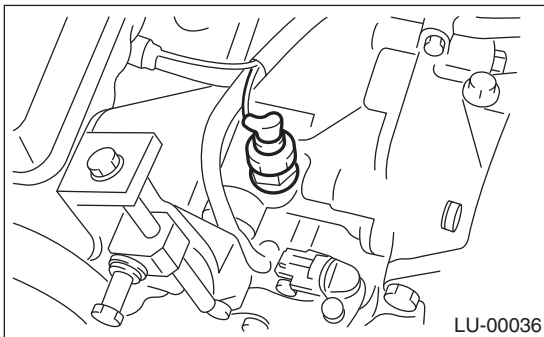

- 4) Remove the oil pressure switch.

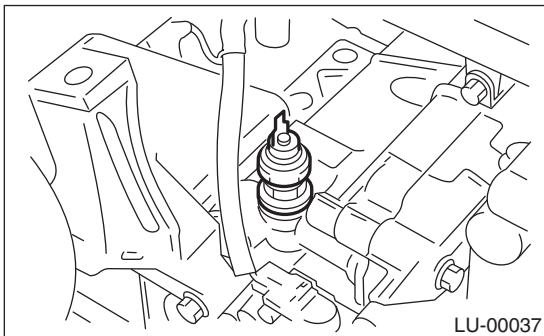

B: INSTALLATION

- 1) Apply liquid gasket to the oil pressure switch threads.

Liquid gasket:

THREE BOND 1324 (Part No. 004403042) or equivalent

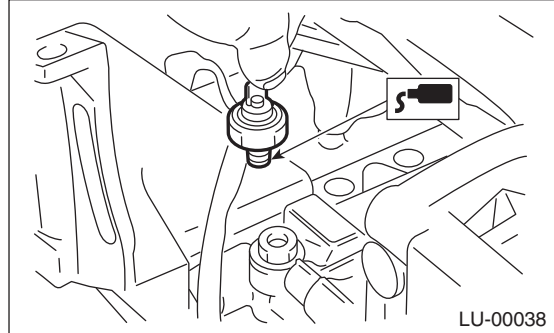

- 2) Install the oil pressure switch to the cylinder block.

Tightening torque:

25 N·m (2.5 kgf·m, 18.4 ft·lb)

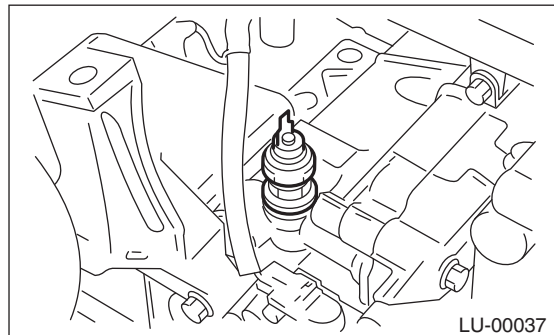

- 3) Connect the terminal to the oil pressure switch.

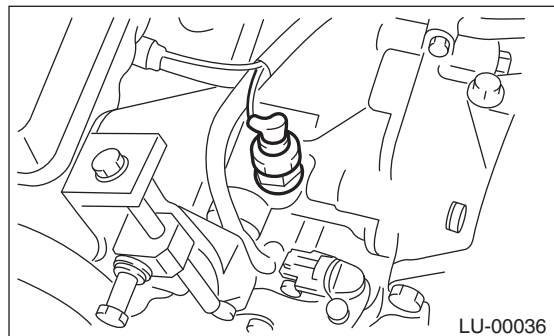

- 4) Install the generator to the bracket. <Ref. to SC(H4SO)-16, INSTALLATION, Generator.>

C: INSPECTION

Check the oil pressure switch installation portion for oil leakage and oil seepage.

7. Engine Oil Filter

A: REMOVAL

CAUTION:

If the engine oil is spilt over exhaust pipe or the under cover, wipe it off with cloth to avoid emitting smoke or causing a fire.

- 1) Set the vehicle on a lift.
- 2) Lift up the vehicle.
- 3) Remove the oil filter.

- Black oil filter

Remove using the ST.

ST 18332AA000 OIL FILTER WRENCH (OUTER DIAMETER: 68 MM (2.68 IN) FOR OIL FILTER)

- Blue oil filter

Remove using the general tool (65/67 mm 14 Flutes).

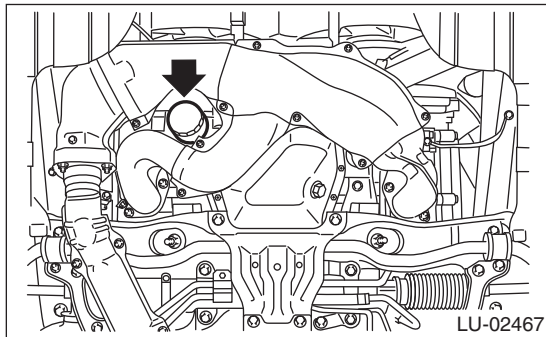

B: INSTALLATION

CAUTION:

Do not tighten excessively, or oil may leak.

- 1) Clean the oil filter installing surface of cylinder block.
- 2) Obtain a new oil filter and apply a thin coat of engine oil to the seal rubber.
- 3) Install the oil filter turning it by hand, being careful not to damage the seal rubber of the oil filter.
 - Tighten the black oil filter (outer diameter: 68 mm (2.68 in)) (approx. one rotation) after the seal rubber of the oil filter comes in contact with cylinder block. When using a torque wrench, tighten to 14 N·m (1.4 kgf-m, 10.3 ft-lb).
 - Tighten the blue oil filter (outer diameter: 67.4 mm (2.65 in)) (approx. 7/8 rotations) after the seal rubber of the oil filter comes in contact with cylinder block. When using a torque wrench, tighten to 12 N·m (1.2 kgf-m, 8.9 ft-lb).
- 4) Lower the vehicle.

C: INSPECTION

- 1) After installing the oil filter, run the engine and make sure that no oil is leaking around seal rubber.

NOTE:

The filter element and filter case are permanently jointed; therefore, interior cleaning is not necessary.

- 2) Check the engine oil level. <Ref. to LU(H4SO)-8, INSPECTION, Engine Oil.>

Engine Lubrication System Trouble in General

LUBRICATION

8. Engine Lubrication System Trouble in General

A: INSPECTION

Before performing diagnostics, make sure that the engine oil level is correct and no oil leakage exists.

Trouble	Possible cause	Corrective action	
1. Warning light remains ON.	1) Oil pressure switch failure	Cracked diaphragm or oil leakage within switch	Replace.
		Broken spring or seized contacts	Replace.
	2) Low oil pressure	Clogging of oil filter	Replace.
		Malfunction of oil by-pass valve in oil filter	Clean or replace.
		Malfunction of oil relief valve in oil pump	Clean or replace.
		Clogged oil passage	Clean.
		Excessive tip clearance and side clearance of oil pump rotor	Replace.
		Clogged oil strainer or broken pipe	Clean or replace.
	3) No oil pressure	Insufficient engine oil (including deterioration)	Replace.
		Broken pipe of oil strainer	Replace.
Stuck oil pump rotor		Replace.	
2. Warning light does not illuminate.	1) Malfunction of combination meter	Replace.	
	2) Poor contact of switch contact points	Replace.	
	3) Disconnection of wiring	Repair.	
3. Warning light flickers momentarily.	1) Poor contact of terminals	Repair.	
	2) Defective wiring harness	Repair.	
	3) Low oil pressure	Check for the same possible causes as listed 1. — 2.	

SPEED CONTROL SYSTEMS

SP(H4SO)

	Page
1. General Description	2
2. Accelerator Pedal	3

General Description

SPEED CONTROL SYSTEMS

1. General Description

A: SPECIFICATION

Accelerator pedal	Stroke	At pedal pad	50 — 59 mm (1.97 — 2.32 in)
-------------------	--------	--------------	-----------------------------

B: COMPONENT

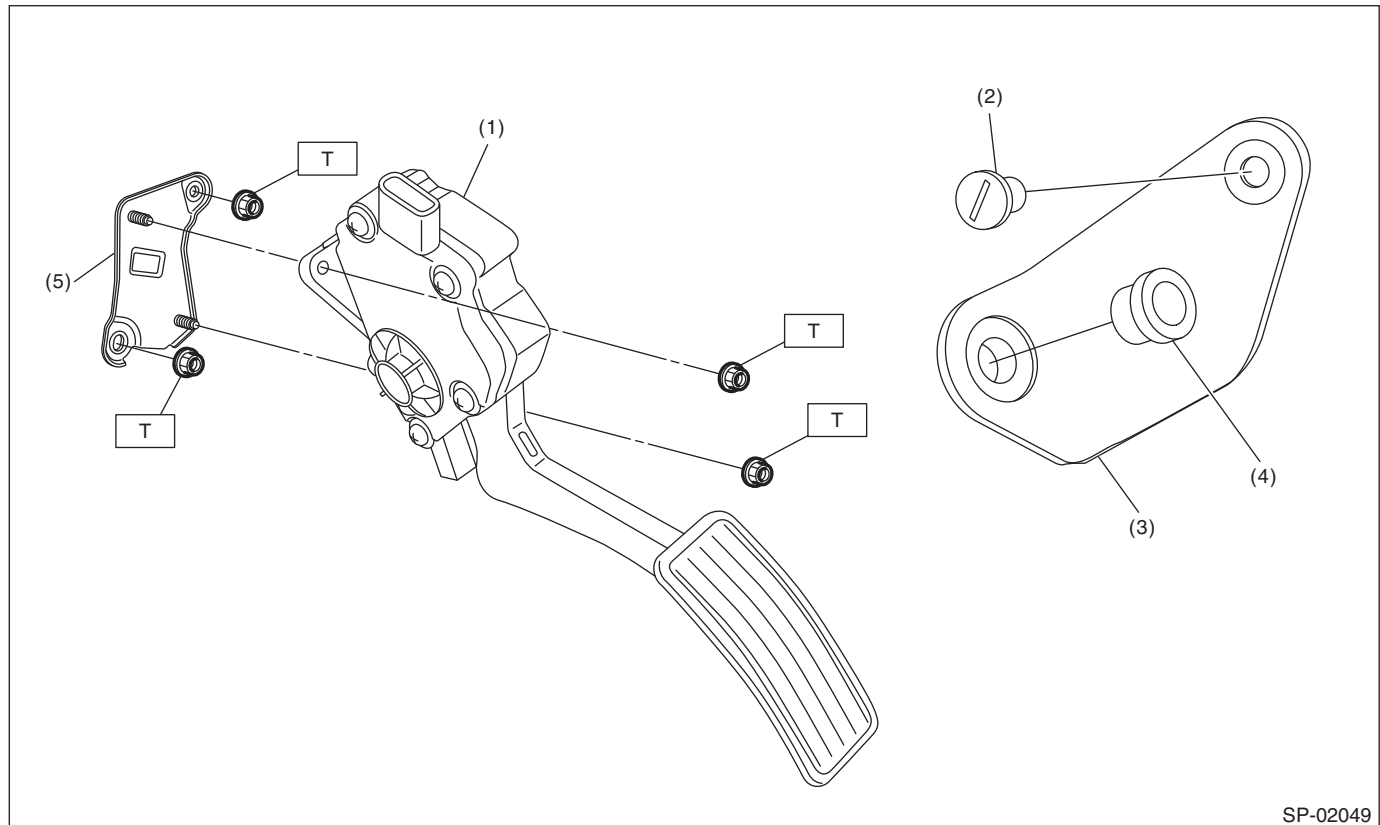

- | | |
|----------------------------|-------------------------------|
| (1) Accelerator pedal ASSY | (4) Accelerator stopper |
| (2) Clip | (5) Accelerator pedal bracket |
| (3) Accelerator plate | |

Tightening torque: N·m (kgf·m, ft·lb)
T: 18 (1.8, 13.3)

C: CAUTION

- Wear appropriate work clothing, including a cap, protective goggles and protective shoes when performing any work.
- Remove contamination including dirt and corrosion before removal or installation.
- Keep the parts in order and protect them from dust and dirt.
- Before removal or installation, be sure to clarify the failure. Avoid unnecessary removal, installation, disassembly and replacement.
- Vehicle components are extremely hot after driving. Be wary of receiving burns from heated parts.
- Be sure to tighten fasteners including bolts and nuts to the specified torque.
- Place shop jacks or rigid racks at the specified points.
- Before disconnecting connectors of sensors or units, be sure to disconnect the ground cable from the battery.

2. Accelerator Pedal

A: REMOVAL

- 1) Disconnect the ground cable from battery.

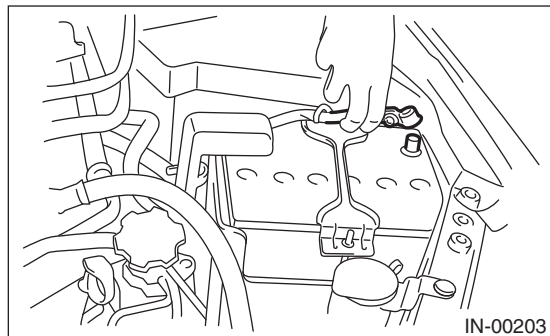

- 2) Disconnect the connector (A).
- 3) Remove the nut (B) securing accelerator pedal assembly.

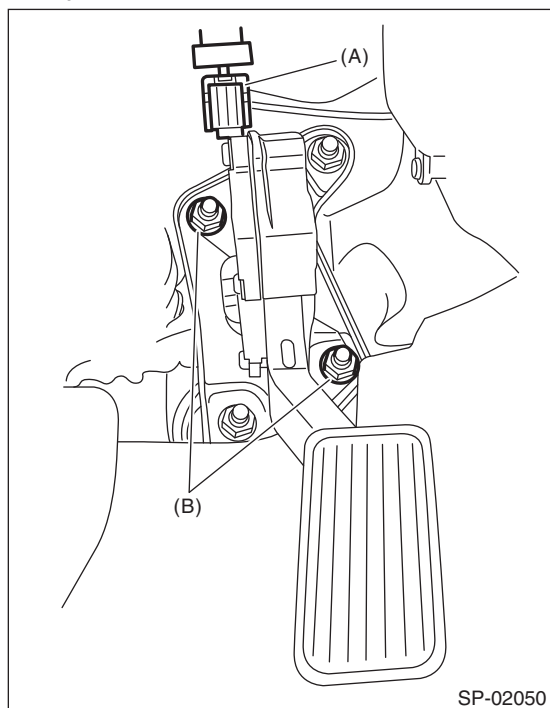

B: INSTALLATION

Install in the reverse order of removal.

Tightening torque:

18 N·m (1.8 kgf·m, 13.3 ft·lb)

C: DISASSEMBLY

NOTE:

The accelerator pedal cannot be disassembled.

D: INSPECTION

- 1) Check for smooth operation when the accelerator pedal is depressed.
- 2) Check if the accelerator pedal returns to its original position smoothly when the pedal is released.

Accelerator Pedal

SPEED CONTROL SYSTEMS

IGNITION

IG(H4SO)

	Page
1. General Description	2
2. Spark Plug	4
3. Ignition Coil and Ignitor Assembly	6
4. Spark Plug Cord	7

General Description

IGNITION

1. General Description

A: SPECIFICATION

Item		Specification
Engine	Model	2.5 L SOHC Non-turbo
Ignition coil & ignitor assembly	Type	FH 0359
	Manufacturer	Diamond Electric
	Secondary coil resistance	11.2 kΩ±15%
Spark plug	Manufacturer and type	NGK: FR5AP-11
	Thread size (diameter, pitch, length)	mm 14, 1.25, 19
	Spark plug gap	mm (in) 1.0 — 1.1 (0.039 — 0.043)
	Electrode	Platinum

B: COMPONENT

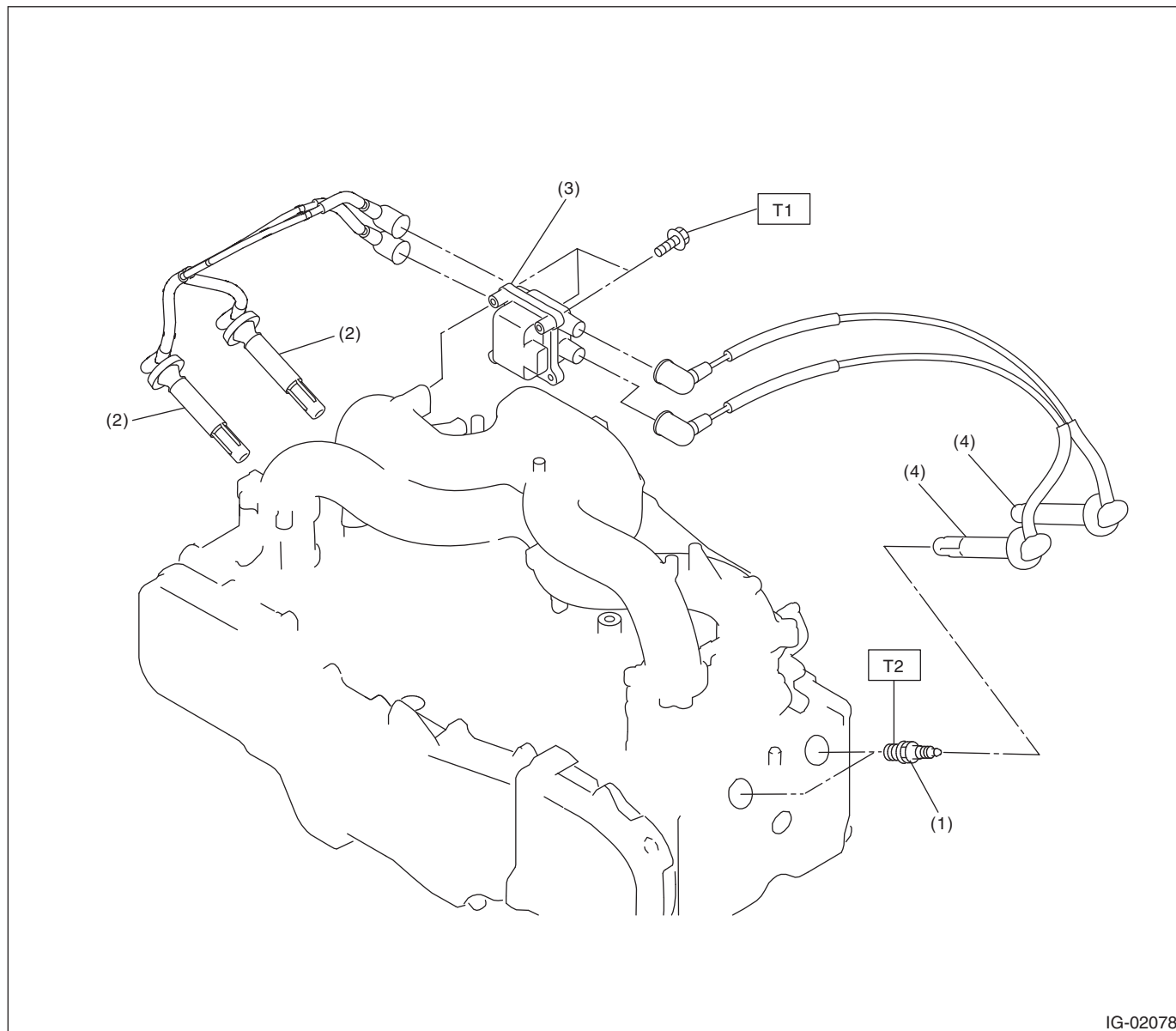

IG-02078

- | | |
|------------------------------|------------------------------------|
| (1) Spark plug | (3) Ignition coil and ignitor ASSY |
| (2) Spark plug cord (#1, #3) | (4) Spark plug cord (#2, #4) |

Tightening torque: N·m (kgf·m, ft·lb)

T1: 6.4(0.7, 4.7)

T2: 21 (2.1, 15.5)

IG(H4SO)-2

C: CAUTION

- Wear appropriate work clothing, including a cap, protective goggles and protective shoes when performing any work.
- Remove contamination including dirt and corrosion before removal, installation or disassembly.
- Keep the disassembled parts in order and protect them from dust and dirt.
- Before removal, installation or disassembly, be sure to clarify the failure. Avoid unnecessary removal, installation, disassembly and replacement.
- Vehicle components are extremely hot after driving. Be wary of receiving burns from heated parts.
- Be sure to tighten fasteners including bolts and nuts to the specified torque.
- Place shop jacks or rigid racks at the specified points.
- Before disconnecting connectors of sensors or units, be sure to disconnect the ground cable from the battery.

Spark Plug

IGNITION

2. Spark Plug

A: REMOVAL

Spark plug:

Refer to "SPECIFICATION" for the spark plug. <Ref. to IG(H4SO)-2, SPECIFICATION, General Description.>

1. RH SIDE

- 1) Disconnect the ground cable from the battery.

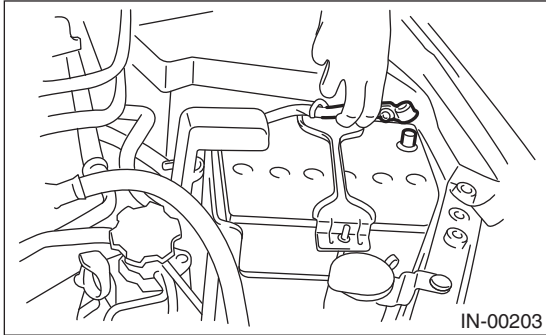

- 2) Remove the air cleaner case. <Ref. to IN(H4SO)-5, REMOVAL, Air Cleaner Case.>
- 3) Remove the spark plug cords by pulling the boot. (Do not pull the cord itself.)

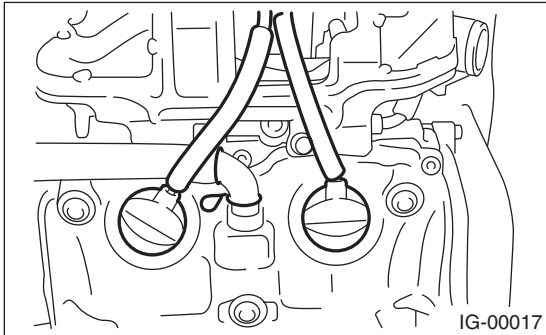

- 4) Remove the spark plug with a spark plug socket.

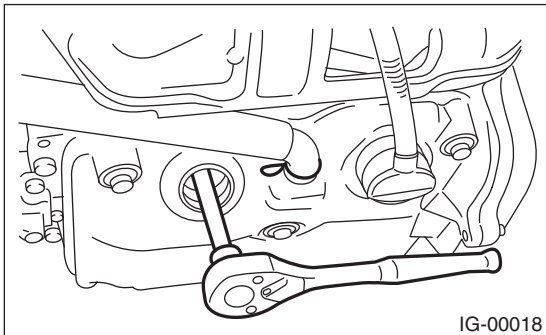

2. LH SIDE

- 1) Remove the battery. <Ref. to SC(H4SO)-22, REMOVAL, Battery.>
- 2) Remove the spark plug cords by pulling the boot. (Do not pull the cord itself.)

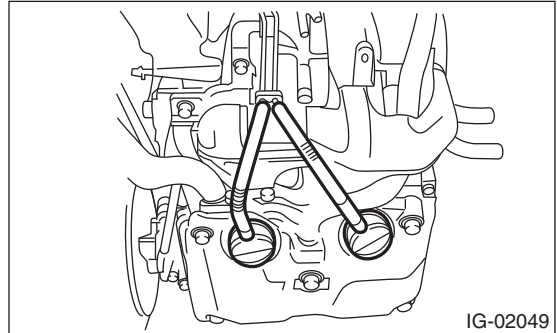

- 3) Remove the spark plug with a spark plug socket.

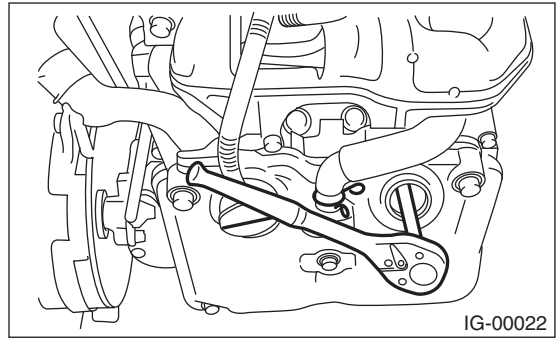

B: INSTALLATION

1. RH SIDE

Install in the reverse order of removal.

Tightening torque:

21 N·m (2.1 kgf-m, 15.5 ft-lb)

2. LH SIDE

Install in the reverse order of removal.

Tightening torque:

21 N·m (2.1 kgf-m, 15.5 ft-lb)

C: INSPECTION

Check the electrodes and inner and outer ceramic insulator of plugs, noting the type of deposits and the degree of electrode erosion.

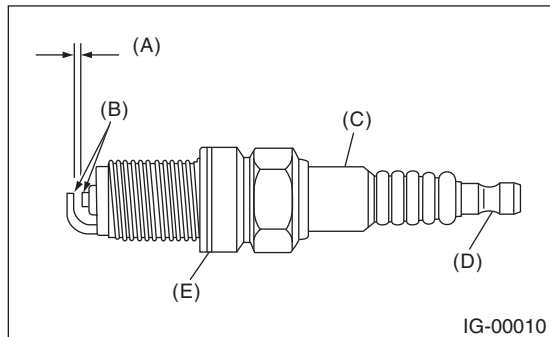

- (A) Spark plug gap
- (B) Carbon accumulation or wear
- (C) Cracks
- (D) Damage
- (E) Damaged gasket

1) Normal:

Brown to grayish-tan deposits and slight electrode wear indicate correct spark plug heat range.

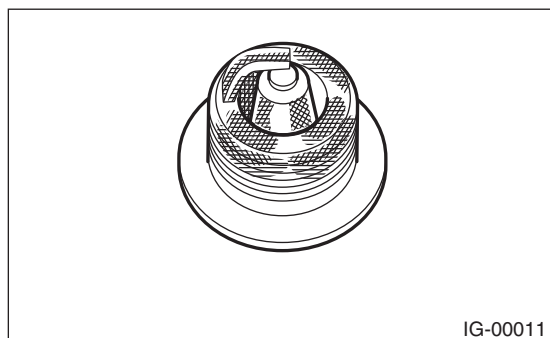

2) Carbon fouled:

Dry fluffy carbon deposits on insulator and electrode are mostly caused by slow speed driving in the city, weak ignition, too rich fuel mixture and dirty air cleaner.

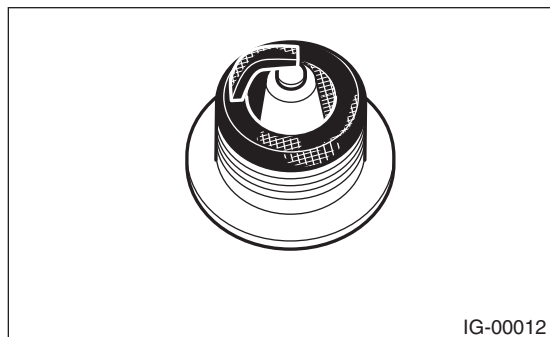

3) Oil fouled:

Wet black deposits show oil entrance into the combustion chamber through worn rings or pistons, or excessive clearance between valve guides and stems.

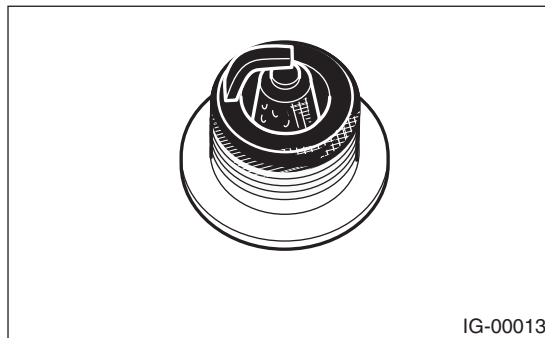

4) Overheating:

White or light gray insulator with black or brown spots and bluish burnt electrodes indicate engine overheating, incorrect ignition timing, wrong selection of fuel, and loose spark plugs.

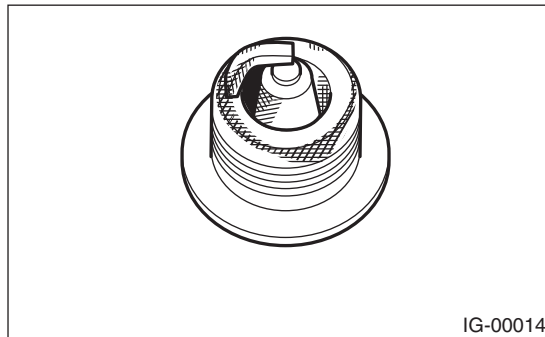

D: ADJUSTMENT

Clean spark plugs with a nylon brush, etc. Clean and remove the carbon or oxide deposits. If deposits are too stubborn, replace the spark plugs. After cleaning the spark plugs, measure the spark plug gap using a gap gauge.

NOTE:

- Never use plug cleaner.
- Do not use metal brush or it will wear insulator.

Spark plug gap L:

1.0 — 1.1 mm (0.039 — 0.043 in)

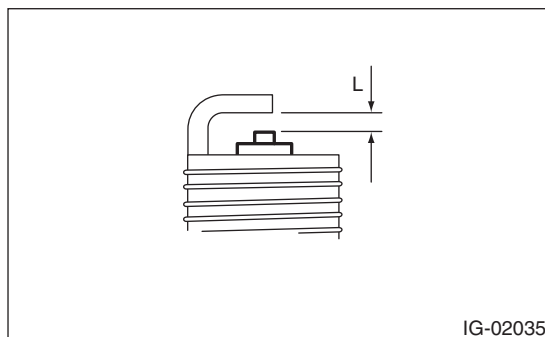

Ignition Coil and Ignitor Assembly

IGNITION

3. Ignition Coil and Ignitor Assembly

A: REMOVAL

1) Disconnect the ground cable from the battery.

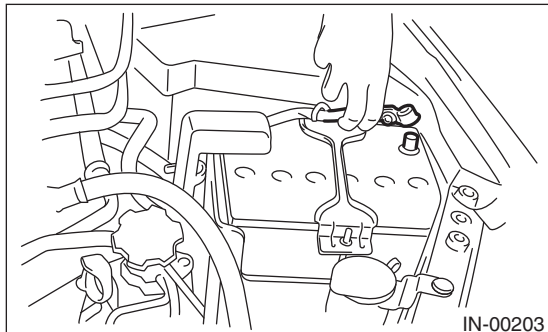

2) Disconnect the spark plug cords from ignition coil and ignitor assembly.

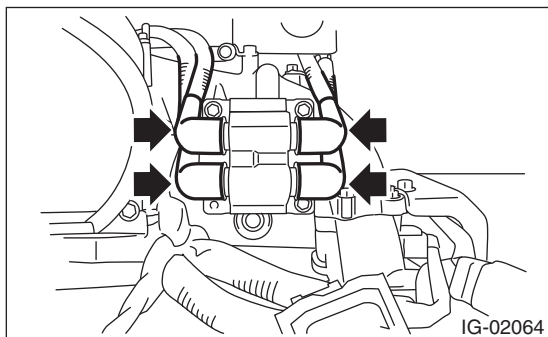

3) Disconnect the connector (A) from the ignition coil and ignitor assembly.

4) Remove the bolt (B) which secures the ignition coil and ignitor assembly to the intake manifold.

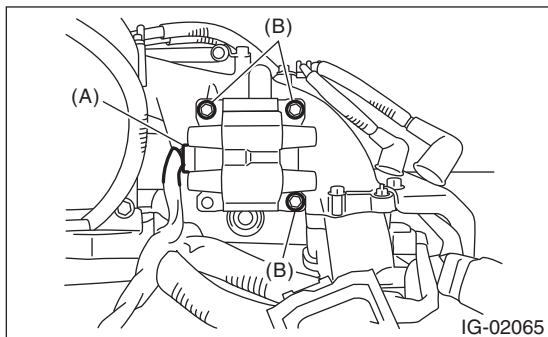

B: INSTALLATION

Install in the reverse order of removal.

Tightening torque:

6.4 N·m (0.7 kgf·m, 4.7 ft·lb)

CAUTION:

Connect the spark plug cords to correct positions. Failure to do so will damage the unit.

C: INSPECTION

Check the secondary coil resistance using a tester. Replace if defective.

CAUTION:

- If the resistance is extremely low, it indicates the presence of a short-circuit.
- Ignitor is integrated with the coil. Therefore the resistance of primary side coil cannot be measured.

Specified resistance:

[Secondary side]

Between (A) and (B)

11.2 kΩ±15%

Between (C) and (D)

11.2 kΩ±15%

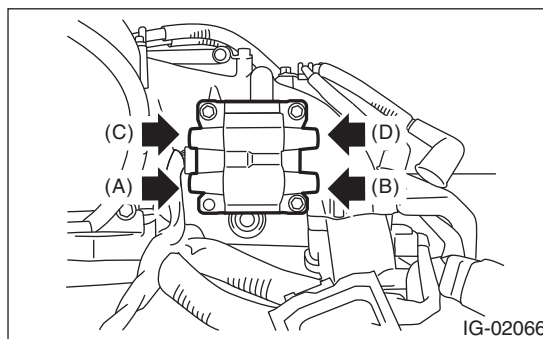

4. Spark Plug Cord

A: INSPECTION

Check the following items.

- Damage to cords, deformation, burning or rust formation of terminals
- Resistance value of cords

Specified resistance:

#1 cord: 7.1 — 12.1 k Ω

#2 cord: 12.1 — 19.9 k Ω

#3 cord: 7.7 — 13.0 k Ω

#4 cord: 12.3 — 20.2 k Ω

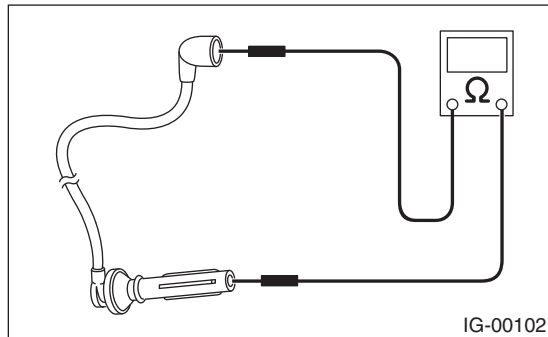

Spark Plug Cord

IGNITION

IG(H4SO)-8

STARTING/CHARGING SYSTEMS

SC(H4SO)

	Page
1. General Description	2
2. Starter	6
3. Generator	15
4. Battery	22

General Description

STARTING/CHARGING SYSTEMS

1. General Description

A: SPECIFICATION

1. NON-TURBO MODEL

Item		Specification		
Starter	Type	Reduction type		
	Vehicle model	MT	AT	
	Model	M000T30475	M000T20175	
	Manufacturer	Mitsubishi Electric		
	Voltage and output	12 V — 1.0 kW	12 V — 1.4 kW	
	Direction of rotation	Counterclockwise (when observed from pinion)		
	Number of pinion teeth	8	9	
	No-load characteristics	Voltage	11 V	
		Current	95 A or less	90 A or less
		Rotating speed	2,500 rpm or more	2,000 rpm or more
	Load characteristics	Voltage	7.5 V	7.7 V
		Current	300 A	400 A
		Torque	8.84 N·m (0.9 kgf·m, 6.5 ft·lb) or more	16.7 N·m (1.7 kgf·m, 12.3 ft·lb) or more
		Rotating speed	870 rpm or more	710 rpm or more
	Lock characteristics	Voltage	4 V	3.5 V
Current		680 A or less	960 A or less	
Torque		17 N·m (1.7 kgf·m, 12.5 ft·lb) or more	31 N·m (3.2 kgf·m, 22.9 ft·lb) or more	
Generator	Type	Rotating-field three-phase type, voltage regulator built-in type, with load response control system		
	Model	A2TG0391		
	Manufacturer	Mitsubishi Electric		
	Voltage and output	12 V — 90 A		
	Polarity on ground side	Negative		
	Direction of rotation	Clockwise (when observed from pulley side)		
	Armature connection	3-phase Y-type		
	Output current	1,500 rpm — 40 A or more		
		2,500 rpm — 74 A or more		
5,000 rpm — 84 A or more				
Regulated voltage	14.1 — 14.8 V [20°C (68°F)]			
Battery	Type and capacity	12 V — 48 AH (55D 23L)	12 V — 52 AH (75D 23L)	

General Description

STARTING/CHARGING SYSTEMS

2. TURBO MODEL

Item		Specification	
Starter	Type	Reduction type	
	Vehicle model	AT	
	Model	M000T20175	
	Manufacturer	Mitsubishi Electric	
	Voltage and output	12 V — 1.4 kW	
	Direction of rotation	Counterclockwise (when observed from pinion)	
	Number of pinion teeth	9	
	No-load characteristics	Voltage	11 V
		Current	90 A or less
		Direction of rotation	2,000 rpm or more
	Load characteristics	Voltage	7.7 V
		Current	400 A
		Torque	16.7 N·m (1.7 kgf-m, 12.3 ft-lb) or more
		Rotating speed	710 rpm or more
	Lock characteristics	Voltage	3.5 V
Current		960 A or less	
Torque		31 N·m (3.2 kgf-m, 22.9 ft-lb) or more	
Generator	Type	Rotating-field three-phase type, voltage regulator built-in type, with load response control system	
	Model	A3TG0491	
	Manufacturer	Mitsubishi Electric	
	Voltage and output	12 V — 110 A	
	Polarity on ground side	Negative	
	Direction of rotation	Clockwise (when observed from pulley side)	
	Armature connection	3-phase Y-type	
	Output current	1,500 rpm — 50 A or more	
		2,500 rpm — 91 A or more 5,000 rpm — 105 A or more	
Regulated voltage	14.1 — 14.8 V [20°C (68°F)]		
Battery	Type and capacity	12 V — 52 AH (75D 23L)	

General Description

STARTING/CHARGING SYSTEMS

B: COMPONENT

1. STARTER

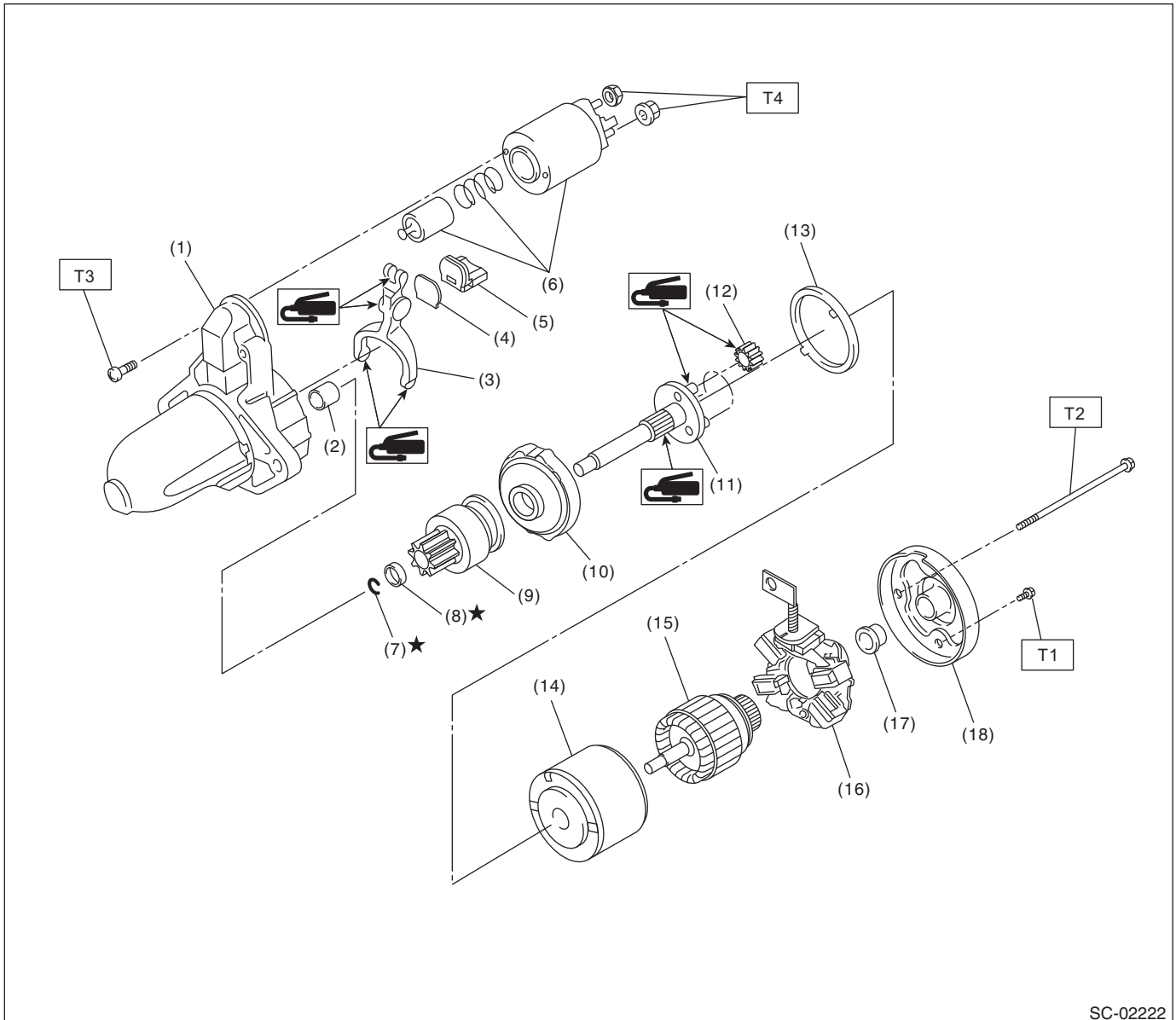

SC-02222

- | | | |
|--------------------------|-------------------------|-------------------------|
| (1) Starter housing ASSY | (9) Overrunning clutch | (17) Sleeve bearing |
| (2) Sleeve bearing | (10) Internal gear ASSY | (18) Starter cover ASSY |
| (3) Shift lever | (11) Shaft | |
| (4) Plate | (12) Pinion gear | |
| (5) Seal rubber | (13) Seal rubber | |
| (6) Magnet switch ASSY | (14) Yoke ASSY | |
| (7) Snap ring | (15) Armature ASSY | |
| (8) Stopper | (16) Brush holder ASSY | |

Tightening torque: N·m (kgf·m, ft·lb)

T1: 1.4 (0.1, 1.0)

T2: 6 (0.6, 4.4)

T3: 7.5 (0.8, 5.5)

T4: 10 (1.0, 7.4)

2. GENERATOR

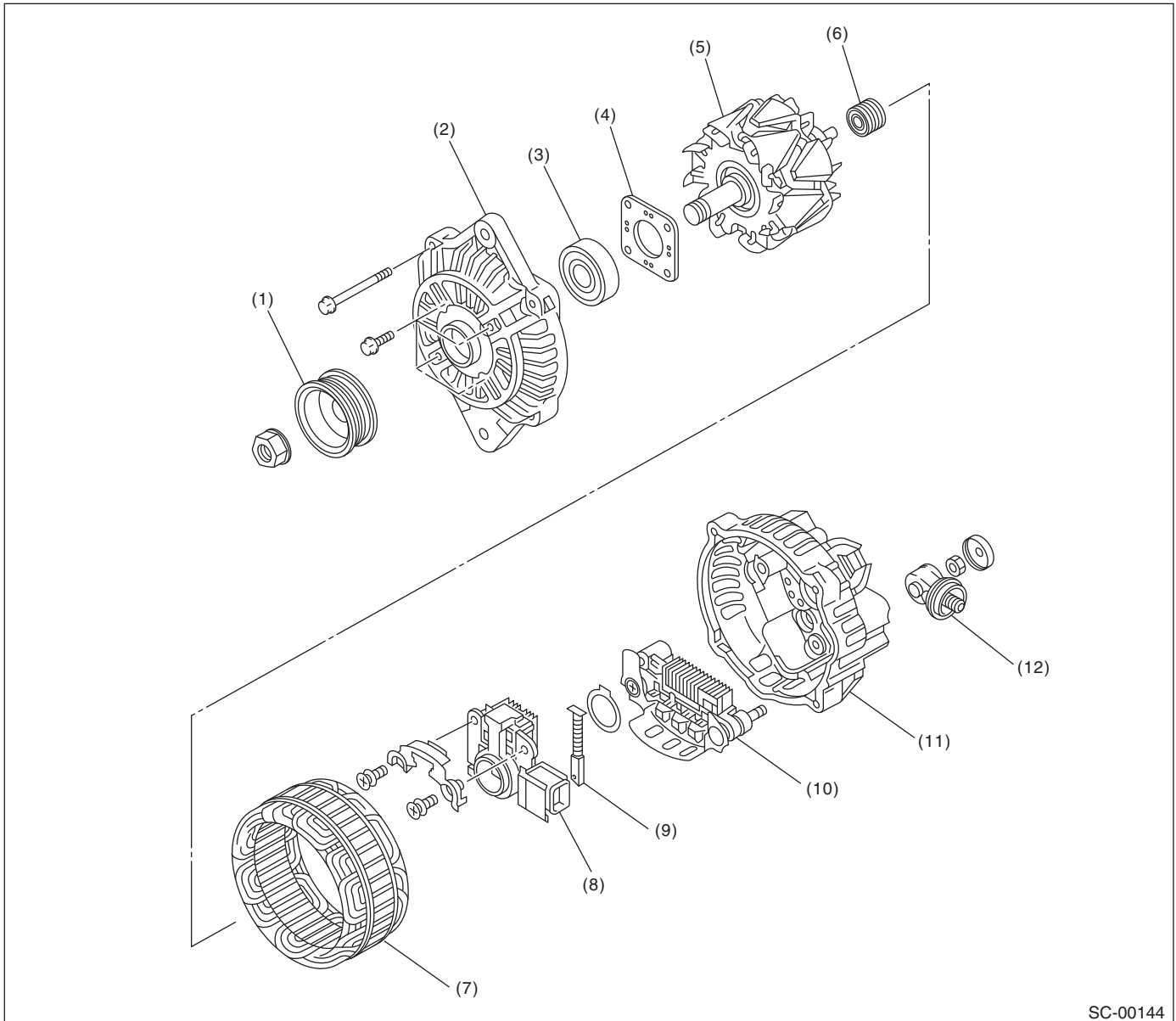

SC-00144

- | | | |
|----------------------|-----------------------------|-----------------|
| (1) Pulley | (5) Rotor | (9) Brush |
| (2) Front cover | (6) Bearing | (10) Rectifier |
| (3) Ball bearing | (7) Stator coil | (11) Rear cover |
| (4) Bearing retainer | (8) IC regulator with brush | (12) Terminal |

C: CAUTION

- Wear appropriate work clothing, including a cap, protective goggles and protective shoes when performing any work.
- Remove contamination including dirt and corrosion before removal, installation or disassembly.
- Keep the disassembled parts in order and protect them from dust and dirt.
- Before removal, installation or disassembly, be sure to clarify the failure. Avoid unnecessary removal, installation, disassembly and replacement.
- Vehicle components are extremely hot after driving. Be wary of receiving burns from heated parts.
- Be sure to tighten fasteners including bolts and nuts to the specified torque.
- Place shop jacks or rigid racks at the specified points.
- Before disconnecting connectors of sensors or units, be sure to disconnect the ground cable from the battery.

Starter

STARTING/CHARGING SYSTEMS

2. Starter

A: REMOVAL

1) Disconnect the ground cable from the battery.

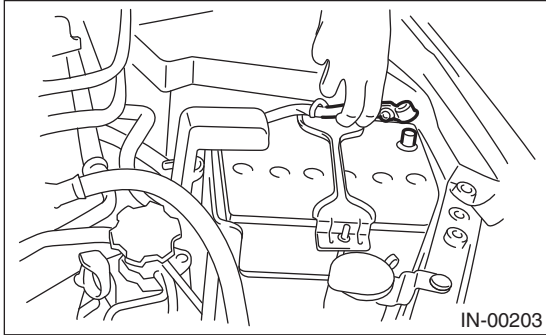

2) Remove the air intake chamber. (Non-turbo model) <Ref. to IN(H4SO)-7, REMOVAL, Air Intake Chamber.>

3) Remove the intercooler. (Turbo model) <Ref. to IN(H4DOTC)-11, REMOVAL, Intercooler.>

4) Remove the air intake chamber stay. (Non-turbo model)

- MT model

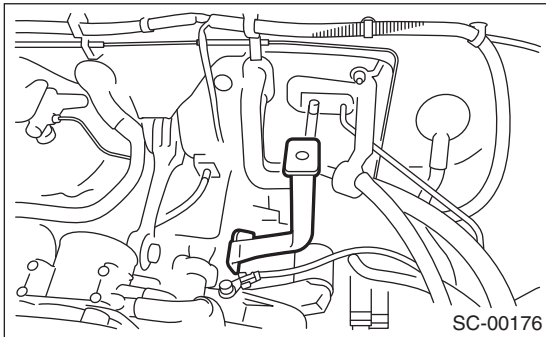

- AT model

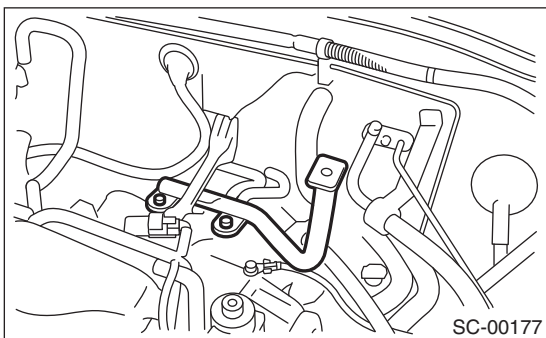

5) Disconnect the connector (B) and terminal (A) from starter.

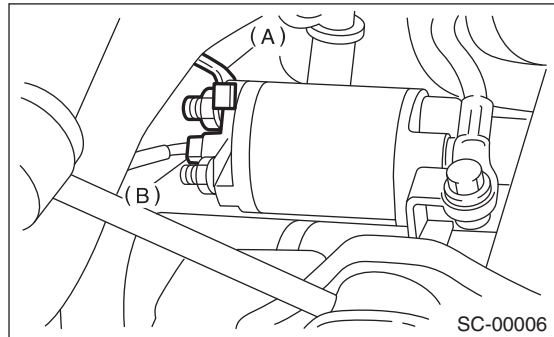

6) Remove the starter from transmission.

NOTE:

For the MT model, a bolt is used in place (A).

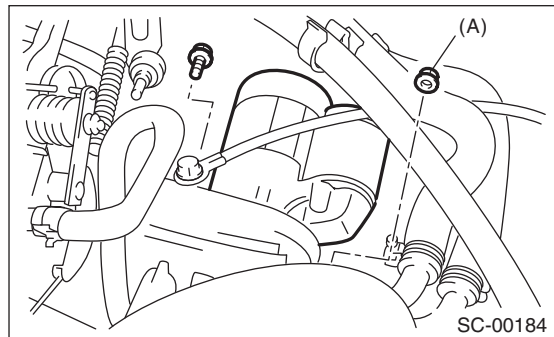

B: INSTALLATION

Install in the reverse order of removal.

NOTE:

For the MT model, a bolt is used in place (A).

Tightening torque:

50 N·m (5.1 kgf-m, 36.9 ft-lb)

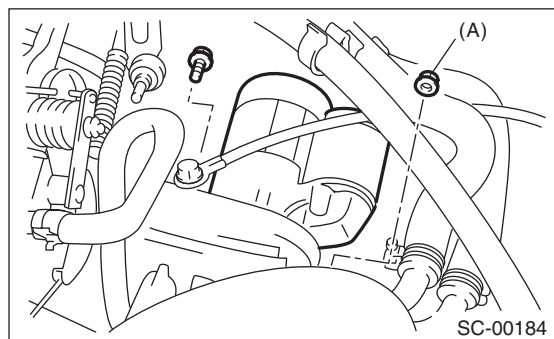

C: DISASSEMBLY

1) Loosen the nuts fastening the magnet switch assembly M terminal, then disconnect the harness from the terminal.

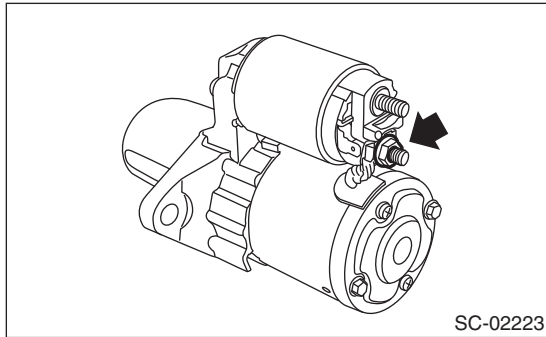

2) Remove the screws fastening the magnet switch assembly, then remove the magnet switch assembly from the starter housing assembly.

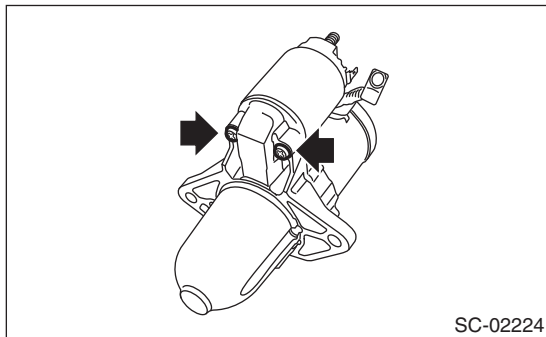

3) Remove screws (A) of the brush holder assembly, and through bolts (B) on both sides, and remove the starter cover assembly.

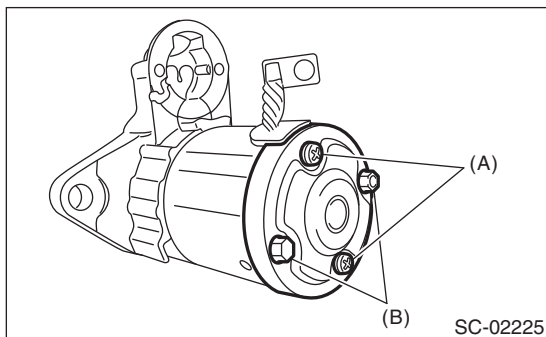

4) Remove the brush holder assembly from the armature assembly.

NOTE:

Hold the brush with your fingers so that the brush spring does not come flying out.

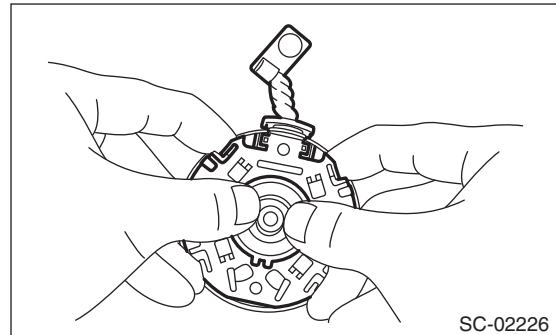

5) Remove the armature assembly and yoke assembly from the starter housing assembly together as a single unit.

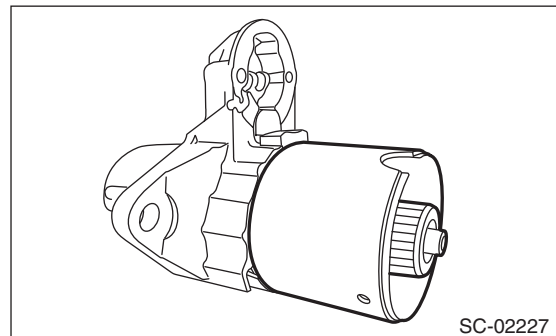

6) Separate the armature assembly and yoke assembly.

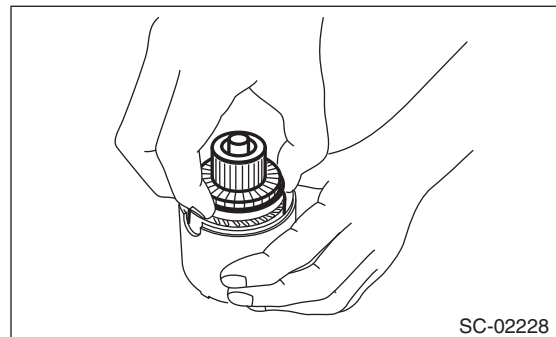

7) Remove the pinion gear from the internal gear assembly.

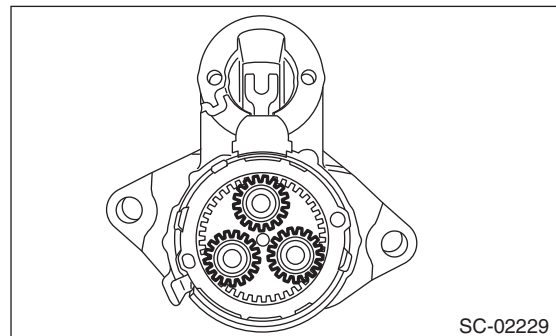

Starter

STARTING/CHARGING SYSTEMS

8) Remove the rubber seal (A), plate (B), and rubber seal (C).

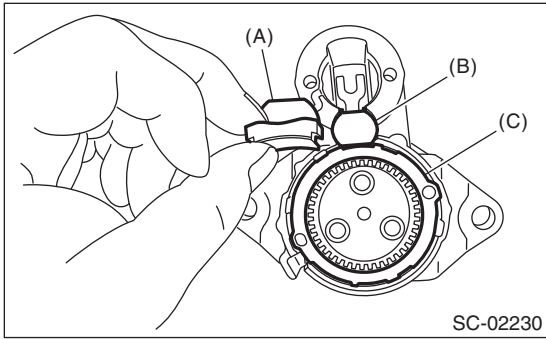

9) Lightly tap the starter housing assembly with a plastic hammer as shown in the figure, and remove the overrunning clutch, internal gear assembly, shaft and shift lever together as one piece.

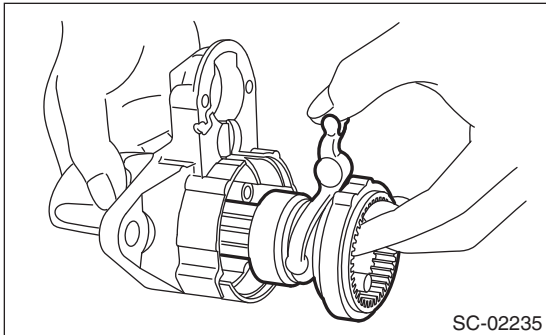
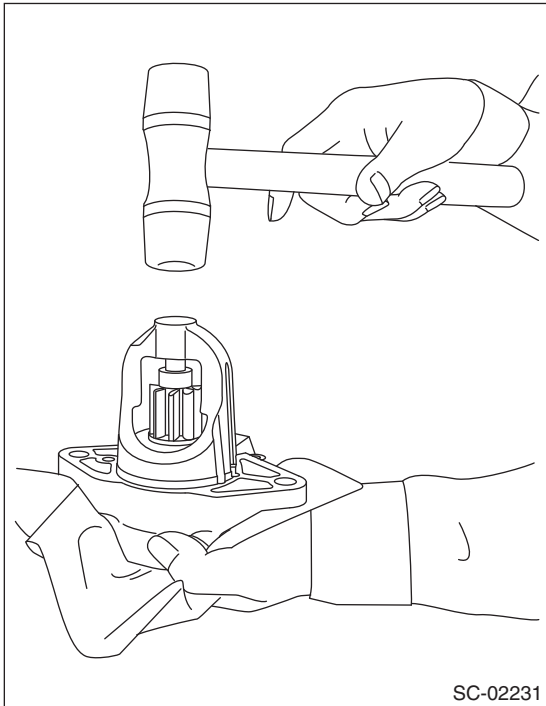

10) Use the following procedures to remove the overrunning clutch from the shaft.

(1) Use an appropriate tool (such as correctly sized socket wrenches) to lightly tap on the stopper to remove it from the snap ring.

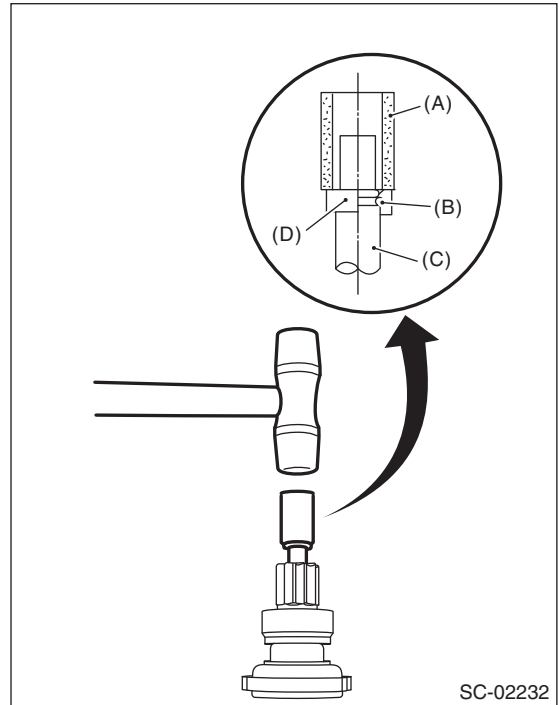

- (A) Appropriate tool
- (B) Snap ring
- (C) Shaft
- (D) Stopper

(2) Remove snap ring (A) from the shaft, and remove stopper (B).

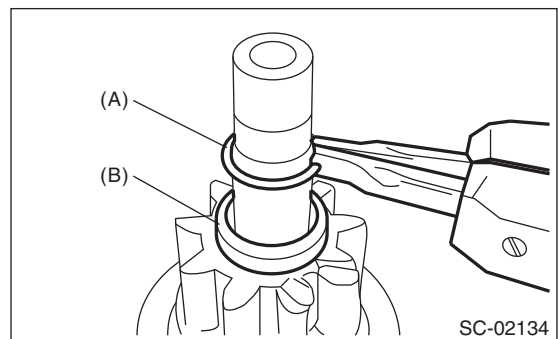

(3) Remove the overrunning clutch from the shaft.

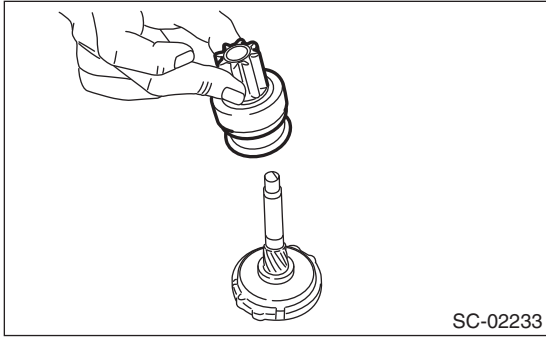

11) Separate the internal gear assembly and shaft.

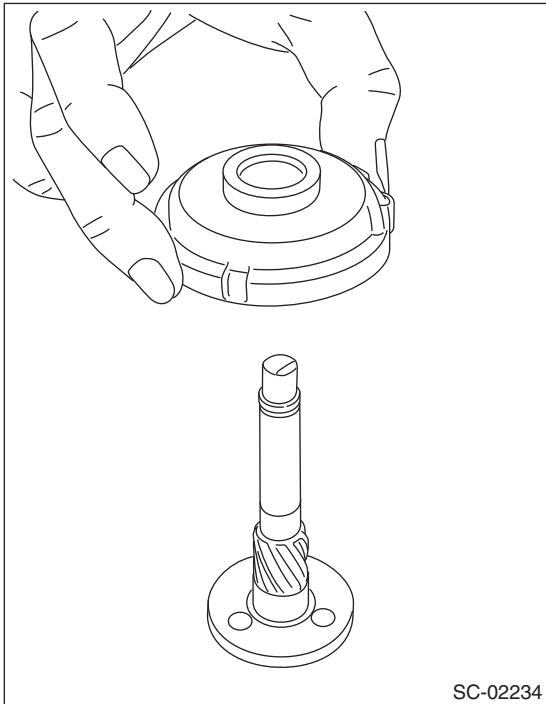

D: ASSEMBLY

1) Apply grease to the shaft sliding surfaces of the internal gear assembly.

Grease:

Marutemp #6129 or equivalent

2) Assemble the shaft to the internal gear assembly.

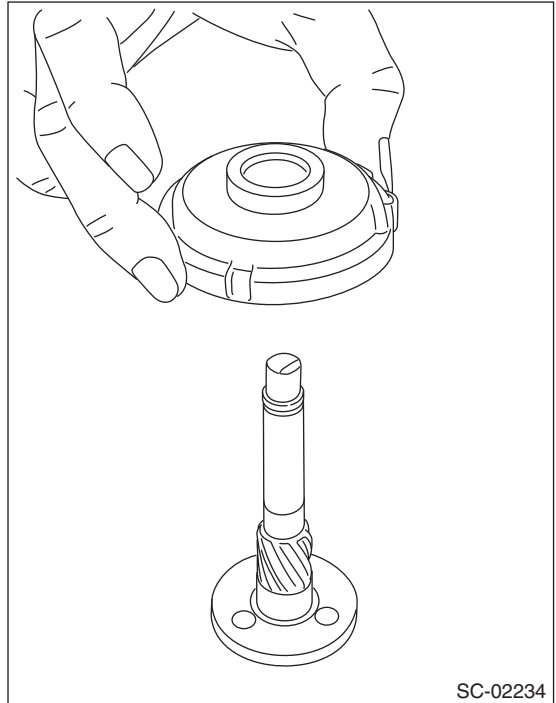

3) Use the procedures below to assemble the overrunning clutch.

(1) Apply grease to the splines of the shaft.

Grease:

Marutemp #6129 or equivalent

(2) Attach the overrunning clutch to the shaft.

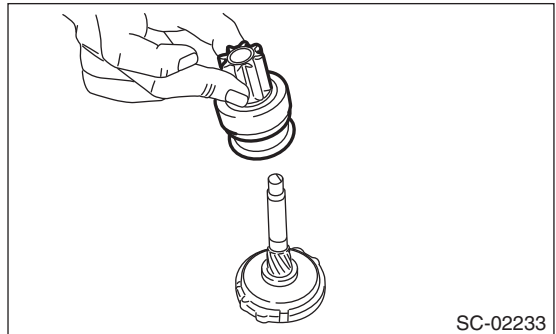

Starter

STARTING/CHARGING SYSTEMS

(3) Pass stopper (B) through the shaft assembly, and attach snap ring (A).

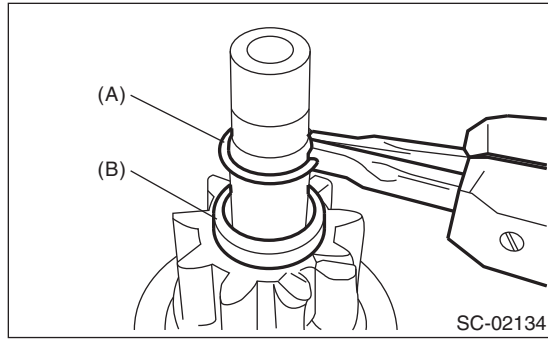

NOTE:

Use new stoppers and snap rings.

(4) Using a press, pressure fit stopper (B) into snap ring (A).

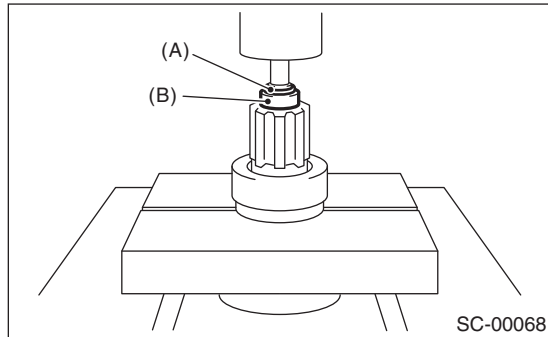

4) Assemble the overrunning clutch, internal gear assembly, shaft and shift lever as a single unit into the starter housing assembly.

NOTE:

Apply grease to the moving parts of the shift lever.

Grease:

Marutemp #6129 or equivalent

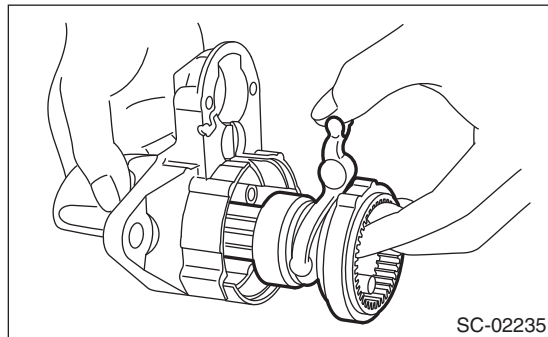

5) Apply grease to the inside of the internal gear assembly and pinion gear, and attach the pinion gear to the internal gear assembly.

NOTE:

- Apply grease evenly to the contact surfaces of each gear.
- Be careful that no debris becomes attached.

Grease:

Molykote® AG650 or equivalent

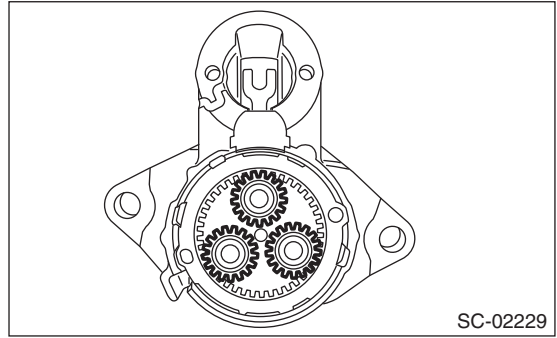

6) Attach rubber seal (A), plate (B), and rubber seal (C).

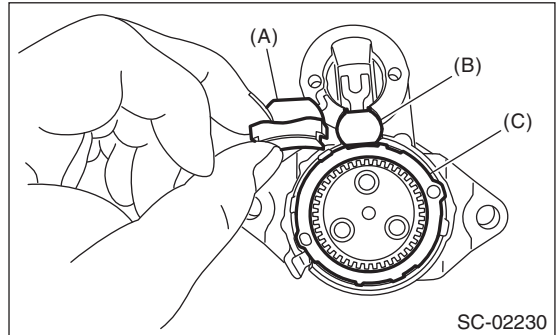

7) Assemble the armature assembly to the yoke assembly.

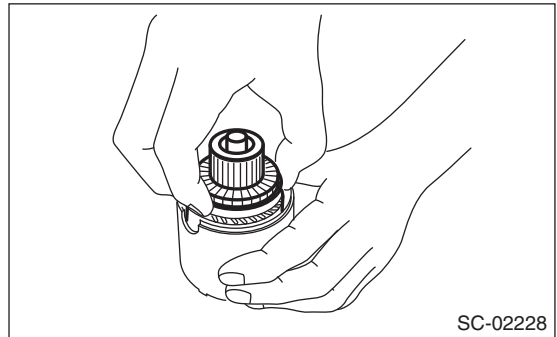

8) Attach the armature assembly and yoke assembly to the starter housing assembly together as a single unit.

NOTE:

As shown in the figure, match the protrusion of the yoke assembly to the cut out of the starter housing assembly.

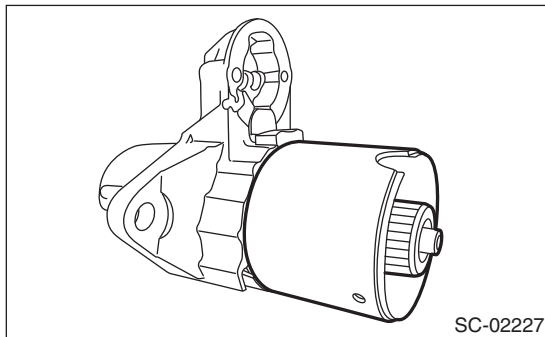
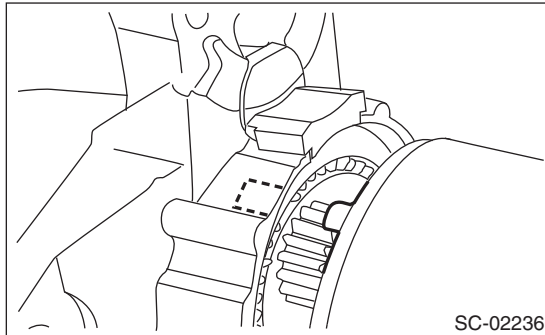

9) Use an appropriate tool (such as correctly sized socket wrenches) and attach the brush holder assembly to the armature assembly.

NOTE:

Be careful not to damage the brushes.

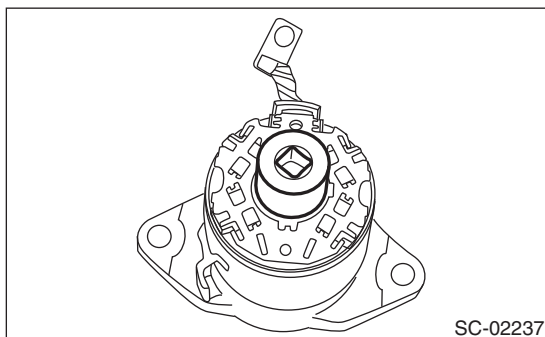

10) Attach the starter cover assembly, and affix to the brush holder assembly with screws (A).

Tightening torque:

1.4 N·m (0.1 kgf·m, 1.0 ft·lb)

11) Tighten through bolts (B) on both sides.

Tightening torque:

6 N·m (0.6 kgf·m, 4.4 ft·lb)

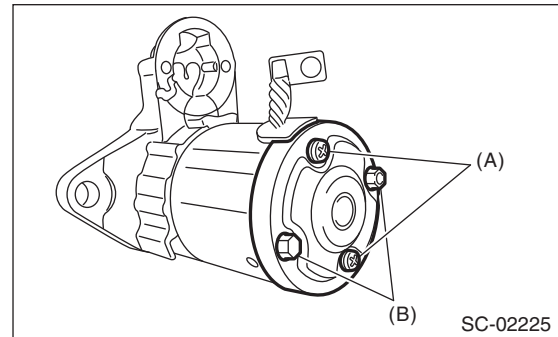

12) Attach the magnet switch assembly to the starter housing assembly, and tighten the screws.

Tightening torque:

7.5 N·m (0.8 kgf·m, 5.5 ft·lb)

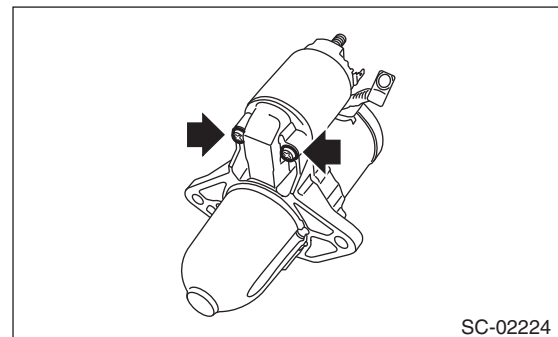

13) Attach the harness to the M terminal of the magnet switch assembly, and tighten the nuts.

Tightening torque:

10 N·m (1.0 kgf·m, 7.4 ft·lb)

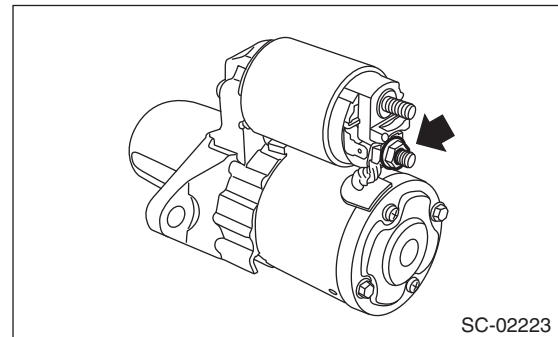

E: INSPECTION

1. ARMATURE

1) Check the commutator for signs of seizure or stepped wear caused by roughness of the surface. If there is light wear, use sandpaper to repair.

2) Run-out test

Check for run-out on the commutator. If excessive, replace it.

Commutator run-out:

Standard

0.05 mm (0.0020 in)

Service limit

0.10 mm (0.0039 in) or less

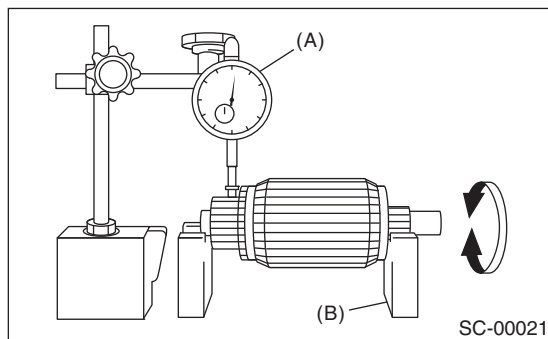

(A) Dial gauge

(B) V-block

3) Depth of segment mold

Check the depth of the segment mold.

Depth of segment mold:

0.5 mm (0.020 in)

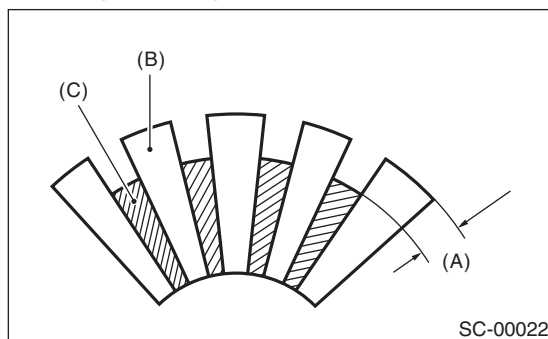

(A) Depth of mold

(B) Segment

(C) Mold

4) Armature short-circuit test

Place the armature on the growler tester to check for short circuits. While slowly turning the armature, support the steel seat for the armature core. If the circuit of the armature is shorted, the steel seat will vibrate, causing it to move towards the core. When the steel seat has moved or vibrated, replace or repair the armature with the shorted circuit.

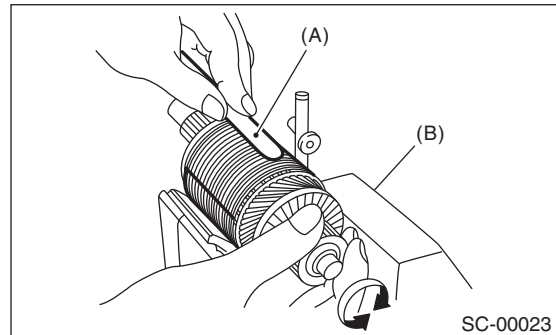

(A) Steel seat

(B) Growler tester

5) Armature ground test

Use a circuit tester to touch the probe of one side to the commutator segment, and the other probe to the shaft. If there is no continuity, it is normal. If there is continuity, the armature is grounded. If grounded, replace the armature.

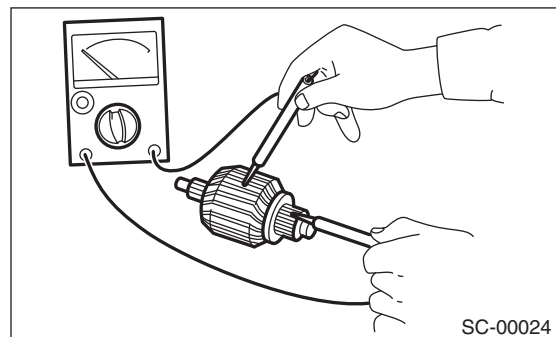

2. YOKE

Make sure that the pole is set at the predetermined position.

3. OVERRUNNING CLUTCH

Check that there is no wear or damage to the piston teeth. Replace if it is damaged. If it rotates smoothly when rotated in the correct direction (counter-clockwise) and does not return to the other direction, it is normal.

CAUTION:

To prevent spilling of grease, do not clean the overrunning clutch with oil.

4. BRUSH AND BRUSH HOLDER

1) Brush length

Measure the length of the brush. If it exceeds service limits, replace it.

Replace if there is abnormal wear or cracks.

Brush length:

Standard

12.3 mm (0.484 in)

Service limit

7.0 mm (0.276 in)

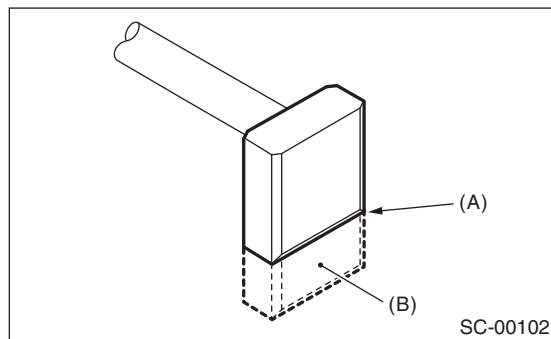

(A) Service limit line

(B) Brush

2) Brush movement

Check that the brush moves smoothly in the brush holder.

3) Brush spring force

Measure the brush spring force with a spring scale. Replace the brush holder if below the service limit.

Brush spring force:

Standard

15.9 — 19.5 N (1.62 — 1.99 kgf, 3.57 — 4.38 lbf)
(When new)

Service limit

2.5 N (0.25 kgf, 0.56 lbf)

5. SWITCH ASSEMBLY

Using a circuit tester (set to “ohm”), check that there is continuity between terminals S and M, and between terminal S and ground.

Also check to be sure there is no continuity between M terminal and B.

Terminal/Resistance:

S — M/1 Ω or less

S — Ground/1 Ω or less

M — B/1 M Ω or more

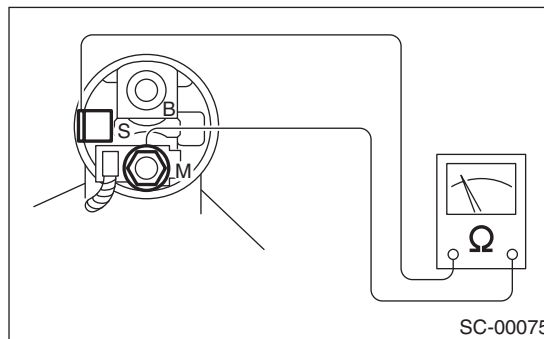

6. SWITCH ASSEMBLY OPERATION

1) Using a lead wire, connect the S terminal of switch assembly to positive terminal of battery, and starter body to ground terminal of battery. The pinion should be forced endwise on shaft.

NOTE:

With the pinion forced endwise on shaft, starter motor can sometimes rotate because current flows, through pull-in coil, to motor. This is not a problem.

2) Disconnect the connector from M terminal. Then using a lead wire, connect the positive terminal of battery and M terminal and ground terminal to starter body.

In this test set up, the pinion should return to its original position even when it is pulled out with a screwdriver.

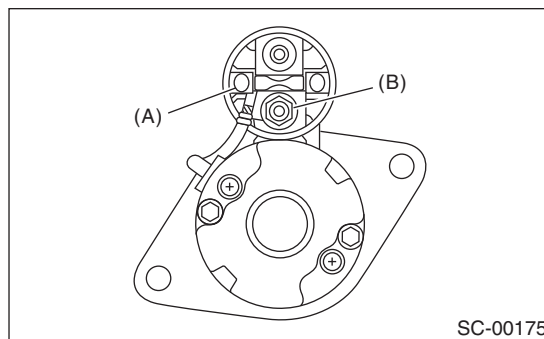

(A) S terminal

(B) M terminal

Starter

STARTING/CHARGING SYSTEMS

7. PERFORMANCE TEST

The starter should be submitted to performance tests whenever it has been overhauled, to assure its satisfactory performance when installed on the engine.

Three performance tests, no-load test, load test, and lock test, are presented here; however, if the load test and lock test cannot be performed, carry out at least the no-load test.

For these performance tests, use the circuit shown in figure.

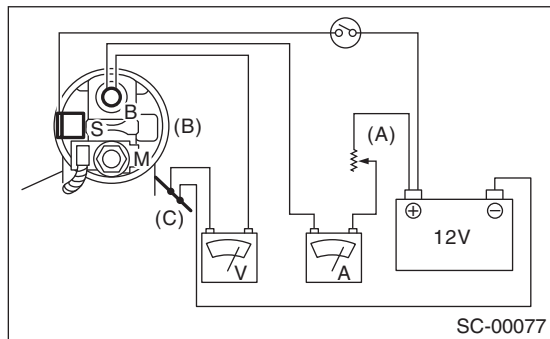

- (A) Variable resistance
- (B) Magnet switch
- (C) Starter body

1) No-load test

With switch on, adjust the variable resistance until the voltage is 11 V, read the value of ammeter to measure starter speed. Compare these values with the standard.

No-load test (standard):

Voltage/Current

MT model

Max. 11 V/95 A

AT model

Max. 11 V/90 A

Rotating speed

MT model

2,500 rpm or more

AT model

2,000 rpm or more

2) Load test

Apply the specified braking torque to starter. The condition is normal if the current draw and starter speed are within standard.

Load test (standard):

Voltage/Load

MT model

7.5 V/8.84 N·m (0.9 kgf-m, 6.5 ft-lb)

AT model

7.7 V/16.7 N·m (1.7 kgf-m, 12.3 ft-lb)

Current/Speed:

MT model

300 A/870 rpm or more

AT model

400 A/710 rpm or more

3) Lock test

With the starter stalled, or not rotating, measure the torque developed and current draw when the voltage is adjusted to standard voltage.

Lock test (standard):

Voltage/Current

MT model

4 V/680 A or less

AT model

3.5 V/960 A or less

Torque

MT model

17 N·m (1.7 kgf-m, 12.5 ft-lb) or more

AT model

31 N·m (3.2 kgf-m, 22.9 ft-lb) or more

3. Generator

A: REMOVAL

1) Disconnect the ground cable from the battery.

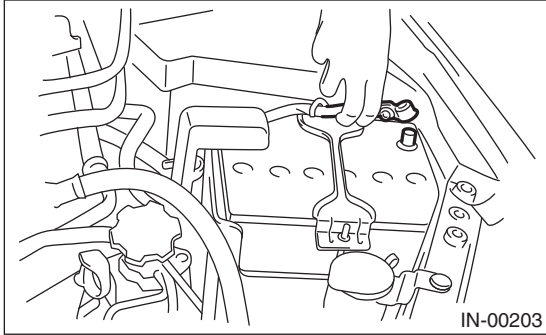

2) Remove the collector cover. (Turbo model)

3) Remove the collector cover cover bracket. (Turbo model)

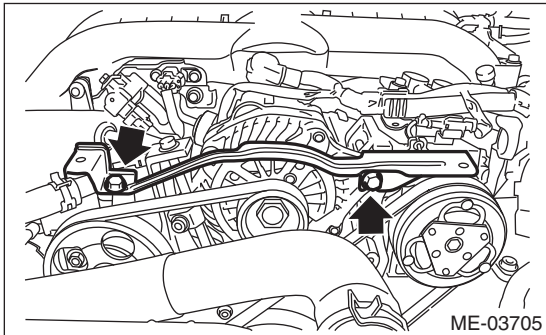

4) Remove the V-belt covers. (Non-turbo model)

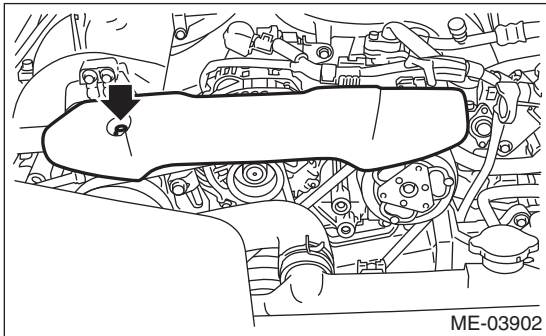

5) Disconnect the connector and terminal from generator.

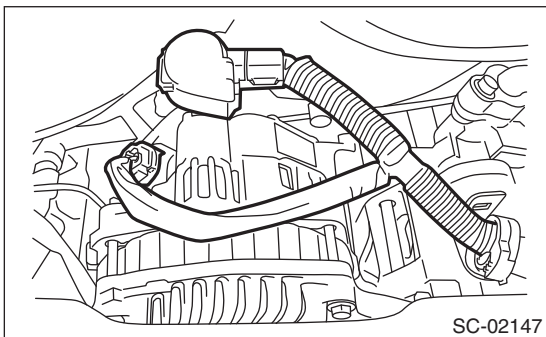

6) Remove the front side belts. <Ref. to ME(H4SO)-42, FRONT SIDE BELT, REMOVAL, V-belt.> <Ref. to ME(H4DOTC)-39, FRONT SIDE BELT, REMOVAL, V-belt.>

7) Remove the bolts which install the generator onto bracket.

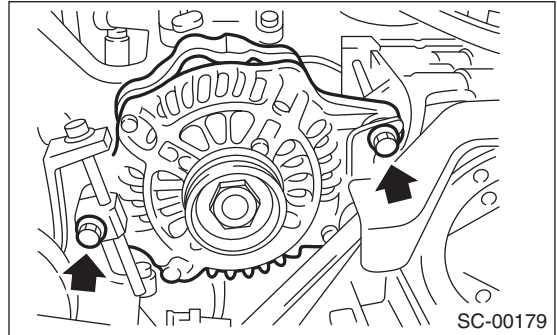

Generator

STARTING/CHARGING SYSTEMS

B: INSTALLATION

Install in the reverse order of removal.

Tightening torque:

25 N·m (2.5 kgf-m, 18.4 ft-lb)

CAUTION:

Check and adjust the front side belt tension.
<Ref. to ME(H4SO)-48, FRONT SIDE BELT, INSPECTION, V-belt.> <Ref. to ME(H4DOTC)-45, FRONT SIDE BELT, INSPECTION, V-belt.>

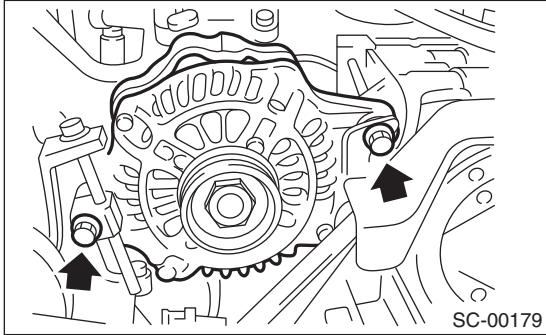

Tightening torque:

13 N·m (1.3 kgf-m, 9.6 ft-lb)

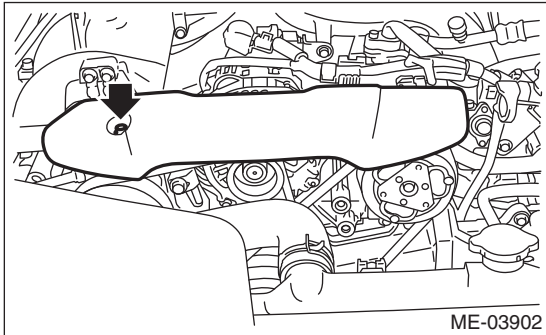

Tightening torque:

T1: 8.5 N·m (0.9 kgf-m, 6.3 ft-lb)

T2: 25 N·m (2.5 kgf-m, 18.4 ft-lb)

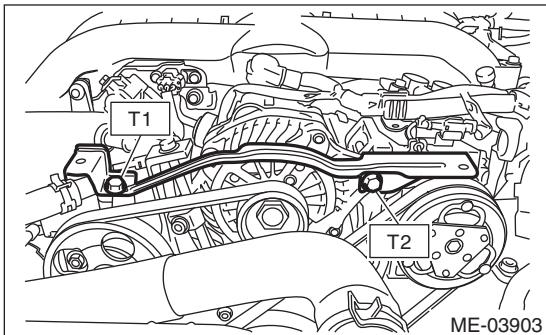

C: DISASSEMBLY

1) Remove the four through-bolts.

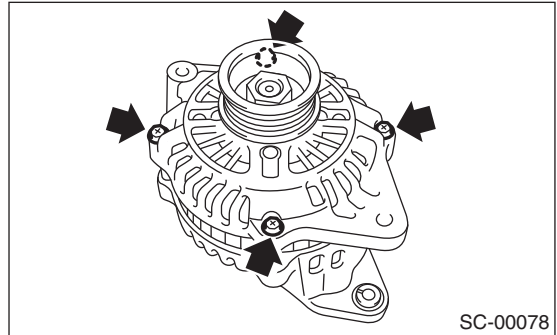

2) Use a drier to heat the rear cover (A) portion to 50°C (122°F).

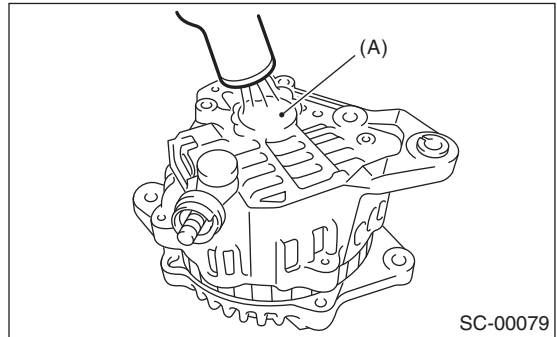

3) Insert the end of a flat tip screwdriver into the gap between stator core and front cover. Pry them apart to disassemble.

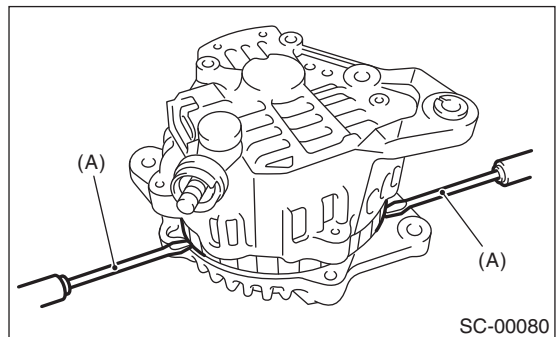

(A) Screwdriver

4) Using a vise, support the rotor and remove the pulley bolt.

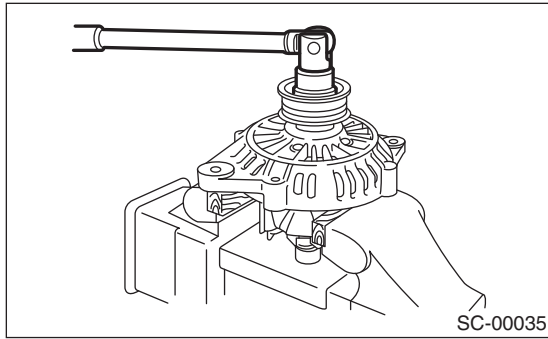

CAUTION:
When holding the rotor with a vise, place aluminum plates or wooden pieces on the vise jaws to prevent rotor from damage.

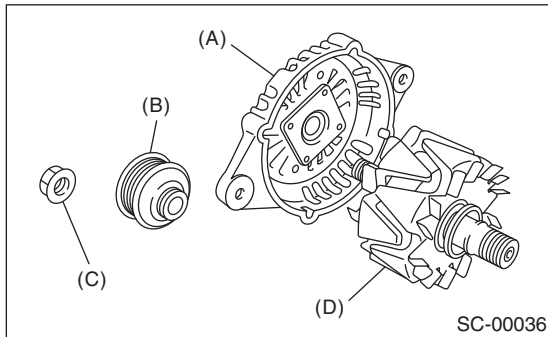

- (A) Front cover
- (B) Pulley
- (C) Nut
- (D) Rotor

5) Use the following procedures to remove the ball bearings.

(1) Remove the bolt, and then detach the bearing retainer.

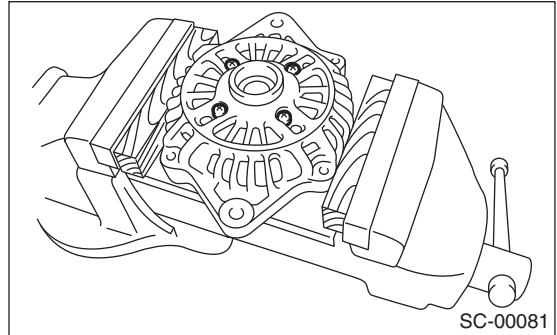

(2) Firmly attach an appropriate tool (such as a correct size socket wrench) to the bearing inner race.

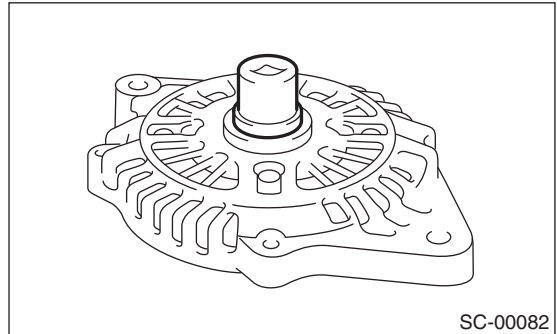

(3) Use the press to push the ball bearings out from the front cover.

6) Using the bearing puller, remove the bearings from the rotor.

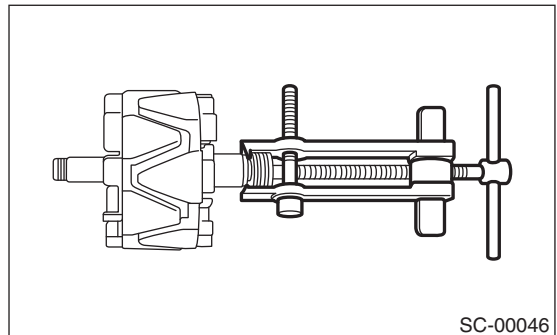

Generator

STARTING/CHARGING SYSTEMS

7) Disconnect the connection between the rectifier and stator coil, then remove the stator coil.

CAUTION:

The rectifier is easily damaged by heat. Do not allow a 180 — 270 W soldering iron to contact the terminals for 5 seconds or more at a time.

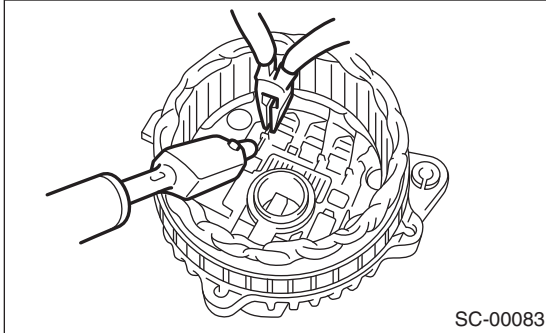

8) Use the following procedures to remove the IC regulator.

(1) Remove the screws which secure the IC regulator to the rear cover.

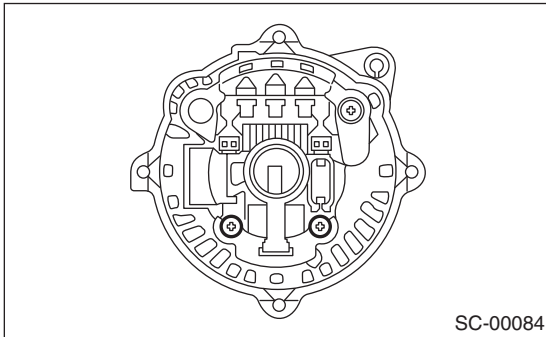

(2) Disconnect the connection between the IC regulator and rectifier, then remove the IC regulator.

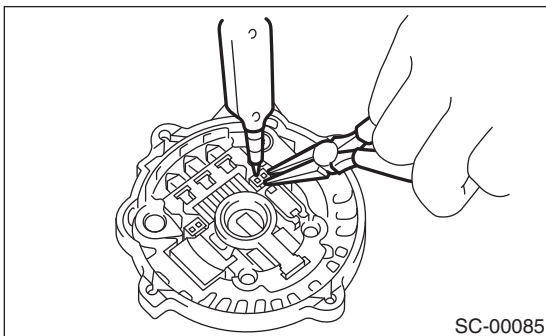

9) Use the following procedures to remove the brush.

(1) Remove the cover A.

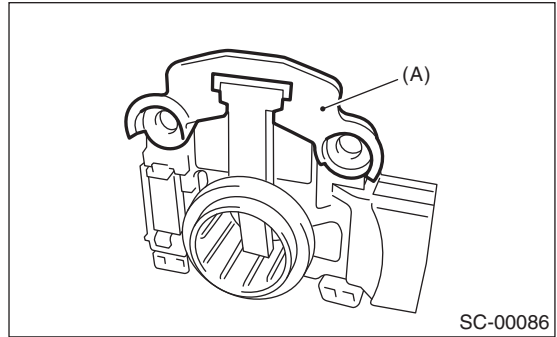

(A) Cover A

(2) Remove the cover B.

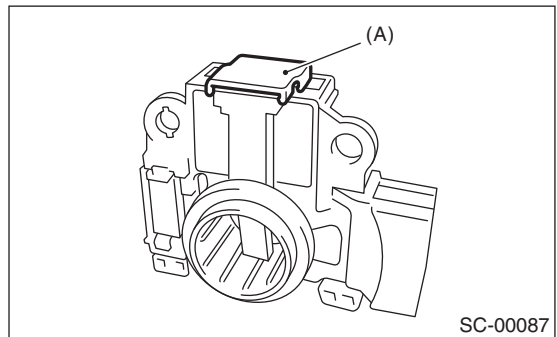

(A) Cover B

(3) Disconnect the connection and remove the brush.

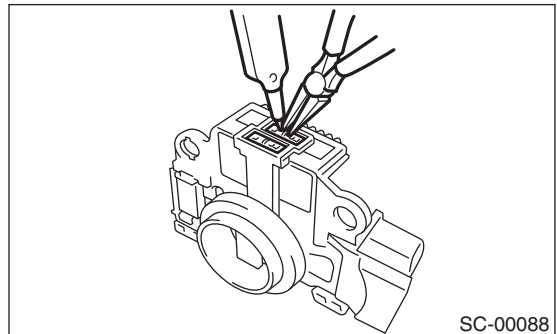

10) Remove the rectifier as follows.

(1) Remove the bolts which secure the rectifier.

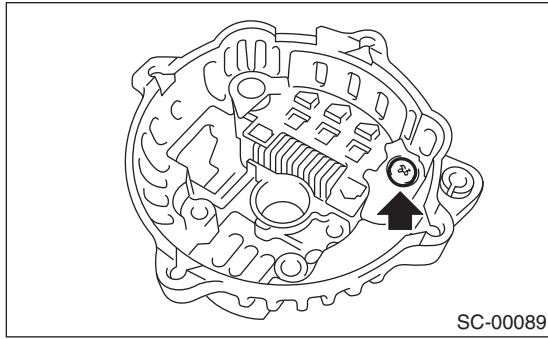

(2) Remove the cover on B terminal.

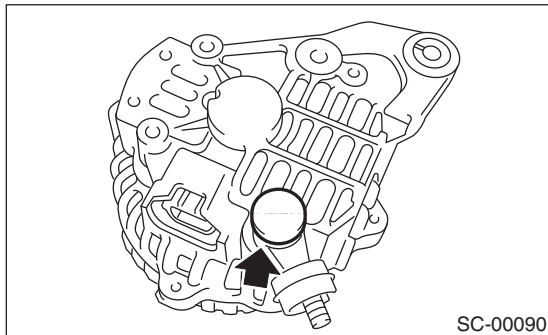

(3) Remove the nuts of B terminal, then remove the rectifier.

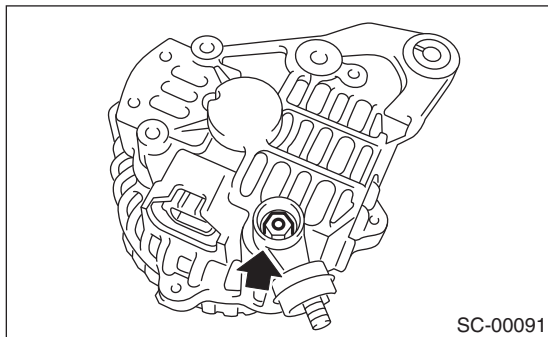

D: ASSEMBLY

Assemble in the reverse order of disassembly.

1) Pull-out of the brush

Before assembling, press the brush down into the brush holder, then fix the brush in that position by inserting a [1 mm (0.08 in) dia., 40 — 50 mm (1.6 — 2.0 in) long] wire through the hole as shown in the figure.

CAUTION:

After re-assembling, remove the wire.

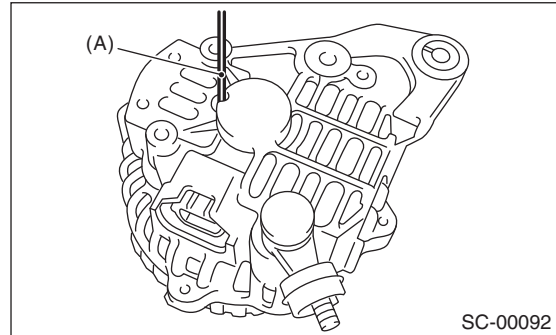

(A) Wire

2) Install the ball bearings.

(1) Set the ball bearings in the front cover, then securely install an appropriate tool (such as a socket wrench of proper size) to the bearing outer race.

(2) Using a press to press the ball bearings into the specified location.

(3) Install the bearing retainer.

3) Use a press to install the bearings (rear side) to the rotor shaft.

4) Heat the bearing box in rear cover [50 to 60°C (122 to 140°F)], and then press the rear bearing into rear cover.

CAUTION:

Do not apply grease to the rear bearings. If there is any oil on the bearing box, remove it completely.

5) After re-assembling, manually turn the pulley to check that the rotor rotates smoothly.

Generator

STARTING/CHARGING SYSTEMS

E: INSPECTION

1. DIODE

CAUTION:

There is the possibility of damaging the diodes if a mega-tester (used to measure high voltages) or a similar measuring instrument is used. Never use a mega tester or equivalent for this test.

1) Check the positive diode

Check for continuity between the diode lead and positive side heat sink. If resistance is 1Ω or less only in the direction from the diode lead to the heat sink, the positive diode is OK.

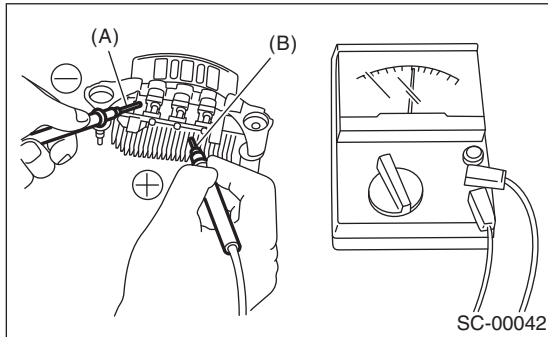

- (A) Diode lead
- (B) Heat sink (positive side)

2) Check negative diode

Check for continuity between the negative side heat sink and diode lead. If resistance is 1Ω or less only in the direction from the heat sink to the diode lead, the negative diode is OK.

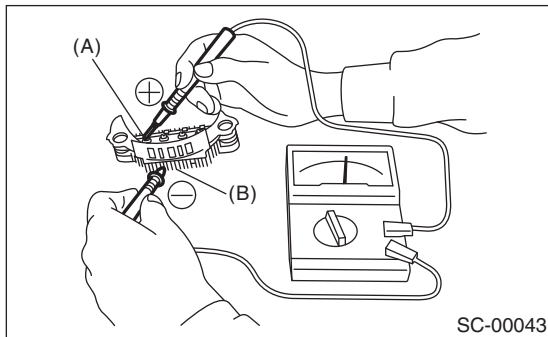

- (A) Diode lead
- (B) Heat sink (negative side)

2. ROTOR

1) Slip ring surface

Inspect the slip rings for contamination or any roughness on the sliding surface. Repair the slip ring surface using a lathe or sand paper.

2) Slip ring outer diameter

Measure the slip ring outer diameter. Replace the rotor assembly if the slip ring is worn.

Slip ring outer diameter:

Standard

22.7 mm (0.894 in)

Limit

22.1 mm (0.870 in)

3) Continuity test

Using a circuit tester, check the resistance between slip rings.

If the resistance is not within the standard, replace the rotor assembly.

Specified resistance:

Approximately 1.8 — 2.2 Ω

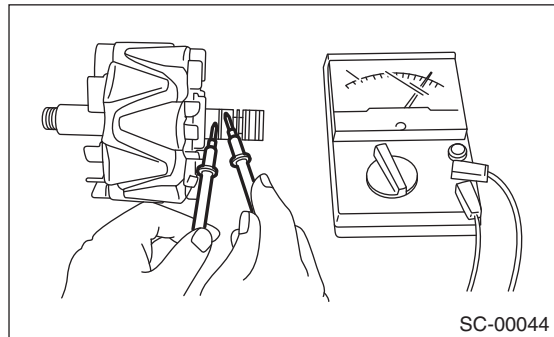

4) Insulation test

Check the continuity between slip ring and rotor core or shaft. If the resistance is 1Ω or less, replace the rotor assembly because the rotor coil is grounded.

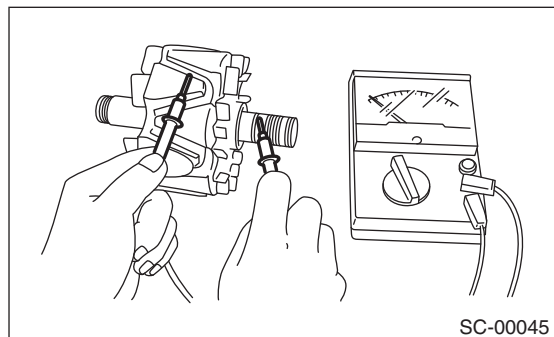

5) Ball bearings (rear side)

Check the rear ball bearing. If there is any noise, or the rotor does not rotate smoothly, replace the bearings.

3. STATOR

1) Continuity test

Inspect continuity between the stator coil lead wire terminals. If the resistance is 1 M Ω or more, the lead wire is damaged. Replace the stator assembly.

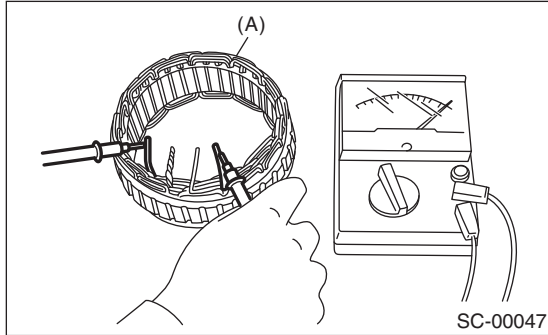

(A) Stator

2) Insulation test

Inspect the continuity between the stator coil stator core and lead wire terminals. If the resistance is 1 Ω or less, the stator coil is grounded. Replace the stator assembly.

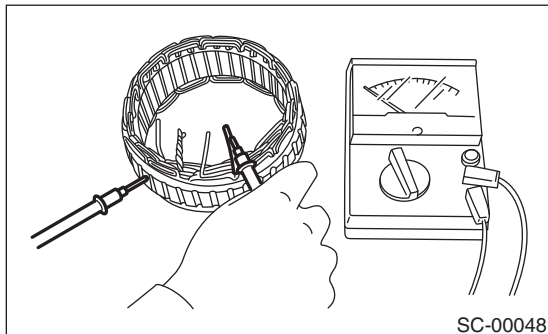

4. BRUSH

1) Measure the length of each brush. Replace the brush if wear exceeds service limits. There is a service limit mark (A) on each brush.

Brush length:

Standard

18.5 mm (0.728 in)

Service limit

5.0 mm (0.197 in)

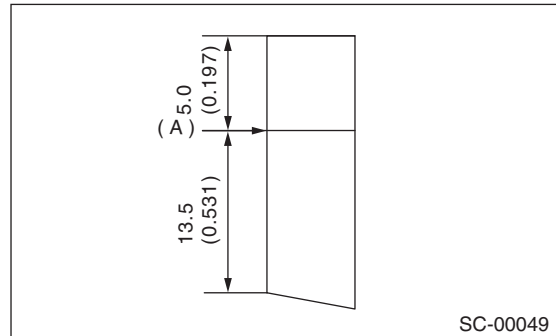

2) Check that there is appropriate pressure on the brush spring.

Using a spring pressure indicator, push the brush into the brush holder until its tip protrudes 2 mm (0.08 in). Then measure the pressure of brush spring. If the pressure is 2.648 N (270 g, 9.52 oz) or less, replace the brush spring with a new part. 4.609 — 5.786 N (470 — 590 g, 16.58 — 20.810 oz) pressure is required on the new spring.

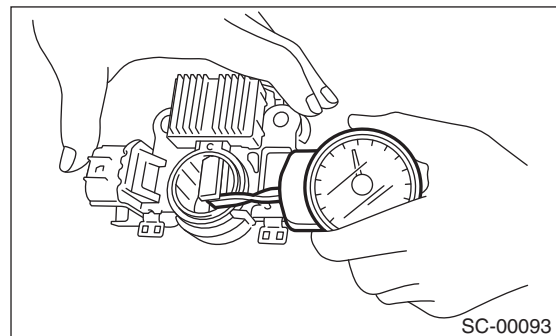

5. BEARING (FRONT SIDE)

Check the front ball bearing. Replace the ball bearings if there is resistance in the rotation, or if there is any abnormal noise.

4. Battery

A: REMOVAL

- 1) Disconnect the positive (+) terminal after disconnecting the negative (-) terminal of battery.
- 2) Remove the harness clip of the negative terminal from the battery rod.
- 3) Remove the flange nut from battery rod and remove battery holder.

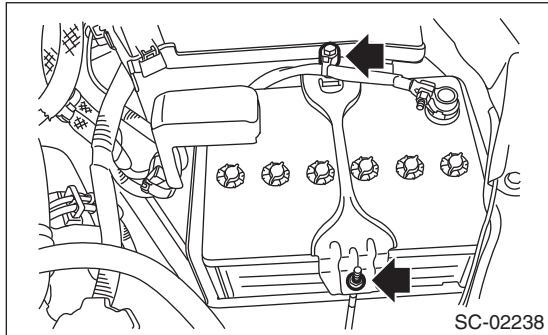

- 4) Remove the battery.

B: INSTALLATION

Install in the reverse order of removal.

Tightening torque:

3.5 N·m (0.4 kgf·m, 2.6 ft·lb)

NOTE:

- Clean the battery cable terminals and apply grease to retard the formation of corrosion.
- Connect the battery positive (+) terminal, and then connect the negative (-) terminal.
- After the battery is installed, initial diagnosis of the electronic throttle control is performed. Therefore, start the engine 10 seconds or more after have turning the ignition switch to ON.

C: INSPECTION

WARNING:

- Electrolyte is corrosive acid, and has toxicity; be careful of handling the fluid.
- Make sure the electrode does not come into contact with skin, eyes or clothing. Especially at contact with eyes, flush with water for 15 minutes and get prompt medical attention.
- In addition, be careful not to let the electrode contact with the coated parts.
- Be careful when handling the batteries because they produce explosive gases.
- Be sure to keep battery away from any fire.
- For safety, in case an explosion does occur, wear eye protection or shield your eyes when working near any battery. In addition, never lean over the battery.
- Ventilate sufficiently when using or charging battery in enclosed space.
- Before starting work, remove rings, metal watch-bands, and other metal jewelry.
- Never allow metal tools to contact the positive battery terminal and anything connected to it while you are at the same time in contact with any other metallic portion of the vehicle.

1. EXTERNAL PARTS

Check the battery case, top cover, vent plugs, and terminal posts for dirt or cracks. If necessary, clean with water and wipe with a dry cloth.

Apply a thin coat of grease on the terminal posts to prevent corrosion.

2. ELECTROLYTE LEVEL

Check the electrolyte level in each cell. If the level is below MIN level, bring the level to MAX level by pouring distilled water into the battery cell. Do not fill beyond MAX level.

3. SPECIFIC GRAVITY OF ELECTROLYTE

1) Measure specific gravity of electrolyte using a hydrometer and a thermometer.

Specific gravity varies with temperature of electrolyte so that it must be corrected at 20°C (68°F) using the following calculation:

$$S_{20} = St + 0.0007 \times (t - 20)$$

S₂₀: Specific gravity corrected at electrolyte temperature of 20°C

St: Measured specific gravity

t: Measured temperature (°C)

Determine whether or not battery must be charged, according to corrected specific gravity.

Standard specific gravity: 1.220 — 1.290 [20°C (68°F)]

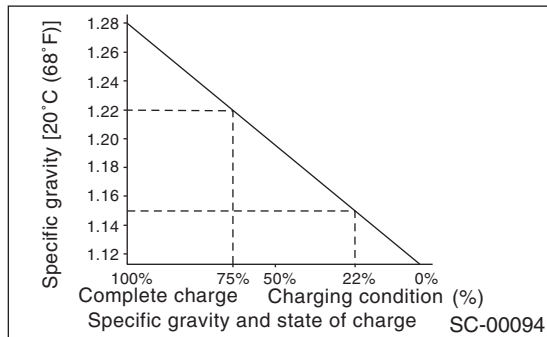

2) Measuring the specific gravity of the electrolyte in the battery will disclose the state of charge of the battery. The relation between specific gravity and state of charge is as shown in the figure.

D: MEASUREMENT

WARNING:

Do not bring an open flame close to the battery when working.

CAUTION:

- Prior to charging, corroded terminals should be cleaned with a brush and common caustic soda solution.
- Be careful since battery electrolyte overflows while charging the battery.
- Observe instructions when handling the battery charger.
- Before charging the battery on the vehicle, disconnect the battery ground terminal to prevent damage of generator diodes or other electrical units.

1. JUDGEMENT OF BATTERY IN CHARGED CONDITION

1) Specific gravity of electrolyte should be held within the specific range of 1.250 — 1.290 for one hour or more.

2) Voltage per battery cell should be held at a specific value in a range of 2.5 — 2.8 V for one hour or more.

2. CHECK CONDITION OF CHARGE WITH HYDROMETER

Hydrometer indicator	State of charge	Corrective action
Green dot	65% or more	Load test
Dark dot	65% or less	Charge battery
Clear dot	Low electrolyte	Replace the battery.* (If cranking is difficult)

* Check electrical system before replacement.

3. NORMAL CHARGING

Charge the battery at the current value specified by manufacturer or at approximately 1/10 of battery's ampere-hour rating.

4. QUICK CHARGING

Quick charging is a method that the battery is charged in a short period of time with a relatively large current by using a quick charger.

Since a large current flow raises electrolyte temperature, the battery is subject to damage if the large current is used for prolonged time. For this reason, the quick charging must be carried out within a current range that will not raise the electrolyte temperature to 40°C (104°F) or more.

Also the quick charging is a temporary mean to bring battery voltage up to some level, and battery should be charged slowly with low current as a rule.

CAUTION:

- **Observe the items in 3. NORMAL CHARGING.**
- **Never use 10 A or more when charging the battery because it will shorten the battery life.**

ENGINE (DIAGNOSTICS)

EN(H4SO)(diag)

	Page
1. Basic Diagnostic Procedure	2
2. Check List for Interview	3
3. General Description	5
4. Electrical Component Location	8
5. Engine Control Module (ECM) I/O Signal	17
6. Engine Condition Data	27
7. Data Link Connector	28
8. General Scan Tool	29
9. Subaru Select Monitor	33
10. Read Diagnostic Trouble Code (DTC)	40
11. Inspection Mode	41
12. Drive Cycle	46
13. Clear Memory Mode	51
14. Compulsory Valve Operation Check Mode	52
15. System Operation Check Mode	54
16. Malfunction Indicator Light	57
17. Diagnostics for Engine Starting Failure	66
18. Diagnostic Procedure for Subaru Select Monitor Communication	80
19. List of Diagnostic Trouble Code (DTC)	82
20. Diagnostic Procedure with Diagnostic Trouble Code (DTC)	89
21. General Diagnostic Table	304

Basic Diagnostic Procedure

ENGINE (DIAGNOSTICS)

1. Basic Diagnostic Procedure

A: PROCEDURE

1. ENGINE

	Step	Check	Yes	No
1	CHECK ENGINE START FAILURE. 1) Ask the customer when and how the trouble occurred using the interview check list. <Ref. to EN(H4SO)(diag)-3, CHECK, Check List for Interview.> 2) Start the engine.	Does the engine start?	Go to step 2.	Inspection using "Diagnostics for Engine Start Failure". <Ref. to EN(H4SO)(diag)-66, Diagnostics for Engine Starting Failure.>
2	CHECK ILLUMINATION OF MALFUNCTION INDICATOR LIGHT.	Does the malfunction indicator light illuminate?	Go to step 3.	Inspection using "General Diagnostic Table" <Ref. to EN(H4SO)(diag)-304, INSPECTION, General Diagnostic Table.>
3	CHECK THE COMMUNICATION STATUS. 1) Turn the ignition switch to OFF. 2) Connect the Subaru Select Monitor or general scan tool to data link connector. 3) Turn the ignition switch to ON, and run the Subaru Select Monitor or general scan tool. NOTE: <ul style="list-style-type: none"> Subaru Select Monitor For detailed procedures, refer to "Subaru Select Monitor". <Ref. to EN(H4SO)(diag)-33, Subaru Select Monitor.> <ul style="list-style-type: none"> General scan tool For detailed operation procedures, refer to the general scan tool operation manual.	Does Subaru select monitor or general scan tool communicate with vehicle normally?	Go to step 4.	Inspection using "Diagnostics Procedure for Subaru Select Monitor Communication". <Ref. to EN(H4SO)(diag)-80, Diagnostic Procedure for Subaru Select Monitor Communication.>
4	CHECK DTC. Read DTC using Subaru Select Monitor or general scan tool. NOTE: <ul style="list-style-type: none"> Subaru Select Monitor Refer to "Read Diagnostic Trouble Code" for detailed operation procedure. <Ref. to EN(H4SO)(diag)-40, Read Diagnostic Trouble Code (DTC).> <ul style="list-style-type: none"> General scan tool For detailed operation procedures, refer to the general scan tool operation manual.	Is DTC displayed on the Subaru Select Monitor or general scan tool?	Record the DTC. Repair the trouble cause. <Ref. to EN(H4SO)(diag)-82, List of Diagnostic Trouble Code (DTC).> Go to step 5.	Repair the related parts. NOTE: If DTC is not shown on display although the malfunction indicator light illuminates, perform the diagnosis of malfunction indicator light circuit or combination meter. <Ref. to EN(H4SO)(diag)-57, Malfunction Indicator Light.>
5	PERFORM DIAGNOSIS. 1) Perform the Clear Memory Mode. <Ref. to EN(H4SO)(diag)-51, Clear Memory Mode.> 2) Perform the Inspection Mode. <Ref. to EN(H4SO)(diag)-41, Inspection Mode.>	Is DTC displayed on the Subaru Select Monitor or general scan tool?	Inspect using "Diagnostic Procedure with Diagnostic Trouble Code (DTC)". <Ref. to EN(H4SO)(diag)-89, Diagnostic Procedure with Diagnostic Trouble Code (DTC).>	Finish the diagnosis.

Check List for Interview

ENGINE (DIAGNOSTICS)

2. Check List for Interview

A: CHECK

1. CHECK LIST NO. 1

Check the following item when problem has occurred.

NOTE:

Use copies of this page for interviewing customers.

Customer's name		Engine No.	
Date of purchase		Fuel type	
Date of repair		Odometer reading	km
V.I.N.			miles
Weather	<input type="checkbox"/> Fine <input type="checkbox"/> Cloudy <input type="checkbox"/> Rainy <input type="checkbox"/> Snowy <input type="checkbox"/> Various/Others:		
Ambient air temperature	°C (°F)		
	<input type="checkbox"/> Hot <input type="checkbox"/> Warm <input type="checkbox"/> Cool <input type="checkbox"/> Cold		
Place	<input type="checkbox"/> Highway <input type="checkbox"/> Suburbs <input type="checkbox"/> Inner city <input type="checkbox"/> Uphill <input type="checkbox"/> Downhill <input type="checkbox"/> Rough road <input type="checkbox"/> Others:		
	<input type="checkbox"/> Cold <input type="checkbox"/> Warming-up <input type="checkbox"/> After warming-up <input type="checkbox"/> Any temperature <input type="checkbox"/> Others:		
Engine speed	rpm		
Vehicle speed	km/h (MPH)		
Driving conditions	<input type="checkbox"/> Not affected <input type="checkbox"/> At starting <input type="checkbox"/> While idling <input type="checkbox"/> At racing <input type="checkbox"/> While accelerating <input type="checkbox"/> While cruising <input type="checkbox"/> While decelerating <input type="checkbox"/> While turning (RH/LH)		
Headlight	<input type="checkbox"/> ON/ <input type="checkbox"/> OFF	Rear defogger	<input type="checkbox"/> ON/ <input type="checkbox"/> OFF
Blower	<input type="checkbox"/> ON/ <input type="checkbox"/> OFF	Audio	<input type="checkbox"/> ON/ <input type="checkbox"/> OFF
A/C compressor	<input type="checkbox"/> ON/ <input type="checkbox"/> OFF	CD/Cassette	<input type="checkbox"/> ON/ <input type="checkbox"/> OFF
Radiator fan	<input type="checkbox"/> ON/ <input type="checkbox"/> OFF	Car phone	<input type="checkbox"/> ON/ <input type="checkbox"/> OFF
Front wiper	<input type="checkbox"/> ON/ <input type="checkbox"/> OFF	Wireless device	<input type="checkbox"/> ON/ <input type="checkbox"/> OFF
Rear wiper	<input type="checkbox"/> ON/ <input type="checkbox"/> OFF		

Check List for Interview

ENGINE (DIAGNOSTICS)

2. CHECK LIST NO. 2

Check the following item about the vehicle's state when malfunction indicator light illuminates.

NOTE:

Use copies of this page for interviewing customers.

a) Other warning lights or indicators illuminate. <input type="checkbox"/> Yes / <input type="checkbox"/> No
<input type="checkbox"/> Low fuel warning light <input type="checkbox"/> Charge indicator light <input type="checkbox"/> Coolant temperature indicator light <input type="checkbox"/> Oil pressure indicator light <input type="checkbox"/> ATF temperature indicator light or SPORT indicator light <input type="checkbox"/> Drivers control center differential indicator light <input type="checkbox"/> ABS warning light <input type="checkbox"/> VDC warning light <input type="checkbox"/> Cruise indicator light <input type="checkbox"/> SI-CRUISE indicator light <input type="checkbox"/> Immobilizer indicator light <input type="checkbox"/> STEERING indicator light <input type="checkbox"/> Others:
b) Fuel level
<ul style="list-style-type: none">• Lack of gasoline: <input type="checkbox"/> Yes / <input type="checkbox"/> No• Indicator position of fuel gauge:• Experienced running out of fuel: <input type="checkbox"/> Yes / <input type="checkbox"/> No
c) Intentional connecting or disconnecting of harness connectors or spark plug cords: <input type="checkbox"/> Yes / <input type="checkbox"/> No
<ul style="list-style-type: none">• What:
d) Intentional connecting or disconnecting of hoses: <input type="checkbox"/> Yes / <input type="checkbox"/> No
<ul style="list-style-type: none">• What:
e) Installing of parts other than genuine parts: <input type="checkbox"/> Yes / <input type="checkbox"/> No
<ul style="list-style-type: none">• What:• Where:
f) Occurrence of noise: <input type="checkbox"/> Yes / <input type="checkbox"/> No
<ul style="list-style-type: none">• From where:• What kind:
g) Occurrence of smell: <input type="checkbox"/> Yes / <input type="checkbox"/> No
<ul style="list-style-type: none">• From where:• What kind:
h) Intrusion of water into engine compartment or passenger compartment: <input type="checkbox"/> Yes / <input type="checkbox"/> No
i) Troubles occurred
<input type="checkbox"/> Engine does not start. <input type="checkbox"/> Engine stalls during idling. <input type="checkbox"/> Engine stalls while driving. <input type="checkbox"/> Engine speed decreases. <input type="checkbox"/> Engine speed does not decrease. <input type="checkbox"/> Rough idling <input type="checkbox"/> Poor acceleration <input type="checkbox"/> Back fire <input type="checkbox"/> After fire <input type="checkbox"/> Does not shift. <input type="checkbox"/> Excessive shift shock

3. General Description

A: CAUTION

1) Airbag system wiring harness is routed near the ECM, main relay and fuel pump relay.

CAUTION:

- Do not use the electrical test equipment on airbag system circuits.
- Be careful not to damage the airbag system wiring harness when servicing the ECM, TCM, main relay and fuel pump relay.

2) Never connect the battery in reverse polarity. Failure to do so will damage the ECM instantly, and other parts will also be damaged.

3) Do not disconnect the battery terminals while the engine is running. A large counter electromotive force will be generated in the generator, and this voltage may damage electronic parts such as ECM etc.

4) Before disconnecting the connectors of each sensor and ECM, be sure to turn the ignition switch to OFF. Perform the Clear Memory Mode after connecting the connectors. <Ref. to EN(H4SO)(diag)-51, Clear Memory Mode.>

5) Measure the voltage or resistance of individual sensor or all electrical control modules using a tapered pin with a diameter of less than 0.6 mm (0.024 in). Do not insert the pin 4 mm (0.16 in) or more into the part.

CAUTION:

When replacing the ECM, be careful not to use the wrong spec. ECM to avoid any damage on the fuel injection system.

NOTE:

When replacing the ECM of the models with Immobilizer, immobilizer system must be registered. To do so, all ignition keys and ID cards need to be prepared. For detailed operation procedure, refer to the "PC application help for Subaru Select Monitor".

6) Take care not to allow water to get into the connectors when servicing or washing the vehicle in rainy weather. Avoid exposure to water even if the connectors are waterproof.

7) Use ECM mounting stud bolts at the body side grounding point when measuring voltage and resistance inside the passenger compartment.

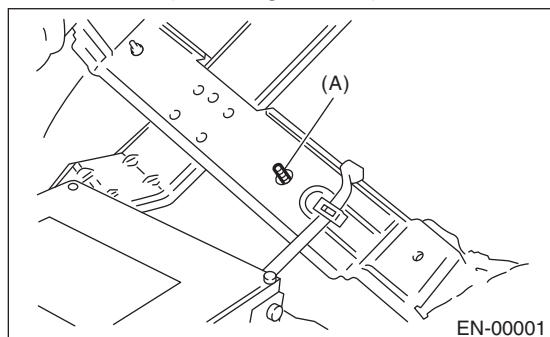

(A) Stud bolt

8) Use the engine ground terminal or engine assembly for the grounding point to chassis when measuring the voltage and resistance in engine compartment.

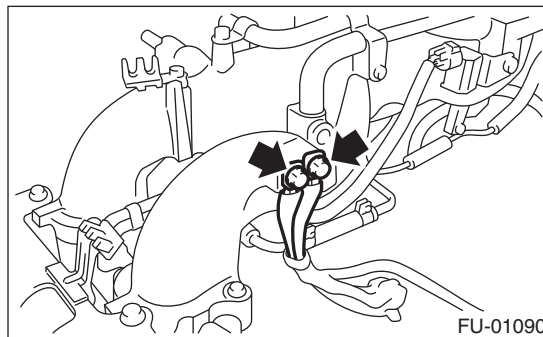

9) Every engine control system-related part is a precision part. Do not drop them.

10) Observe the following cautions when installing a radio in vehicle.

CAUTION:

- The antenna must be kept as far apart as possible from control unit. (ECM is installed under the passenger's side floor mat.)
- The antenna feeder must be placed as far apart as possible from the ECM and engine control system harness.
- Carefully adjust the antenna for correct matching.
- When mounting a large power type radio, pay special attention to the three items mentioned above.
- Incorrect installation of the radio may affect the operation of ECM.

11) When disconnecting the fuel hose, release the fuel pressure. <Ref. to FU(H4SO)-43, RELEASING OF FUEL PRESSURE, PROCEDURE, Fuel.>

12) ABS warning light may illuminate when performing driving test with jacked-up or lifted-up condition, but this is not a system malfunction. The reason for this is the speed difference between the front and rear wheels. After diagnosis of engine control system, perform the ABS memory clear procedure of self-diagnosis function.

General Description

ENGINE (DIAGNOSTICS)

B: INSPECTION

Before performing diagnostics, check the following item which might affect engine problems.

1. BATTERY

1) Measure the battery voltage and specific gravity of the electrolyte.

Standard voltage: 12 V

Specific gravity: 1.260 or more

2) Check the condition of the main and other fuses, and harnesses and connectors. Also check for proper grounding.

2. ENGINE GROUND

Check if the engine ground terminal is properly connected to engine.

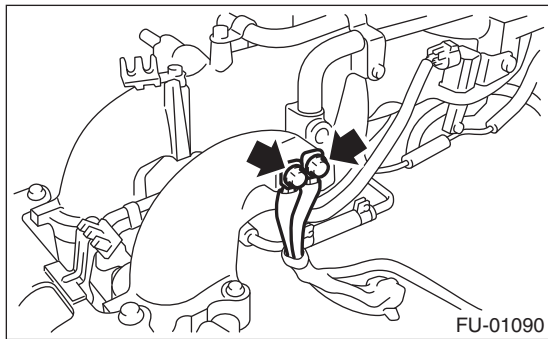

C: NOTE

- The on-board diagnostic (OBD) system detects and indicates a fault in various inputs and outputs of the complex electronic throttle control. Malfunction indicator light in the combination meter indicates occurrence of a fault or trouble.
- Further, against such a failure or sensors as may disable the drive, the fail-safe function is provided to ensure the minimal driveability.
- The OBD system incorporated with the vehicles within this type of engine complies with OBD-II regulations. The OBD system monitors the components and the system malfunction listed in "Engine Section" which affects on emissions.
- When the system decides that a malfunction occurs, malfunction indicator light illuminates. At the same time of the malfunction indicator light illumination or blinking, a DTC and a freeze frame engine conditions are stored into on-board computer.
- The OBD system stores freeze frame engine condition data (engine load, engine coolant temperature, fuel trim, engine speed and vehicle speed, etc.) into on-board computer when it detects a malfunction.
- The freeze frame engine condition data are stored until DTCs are cleared. However, if any faults concerning fuel trim or misfiring are detected while the freeze frame engine condition data are stored, these data are rewritten to those concerning fuel trim or misfiring.
- When the malfunction does not occur again for three consecutive driving cycles, malfunction indicator light is turned off, but DTC remains at on-board computer.
- When troubleshooting the vehicle which complies with OBD-II regulations, connect the Subaru Select Monitor or general scan tool to the vehicle.

General Description

ENGINE (DIAGNOSTICS)

D: PREPARATION TOOL

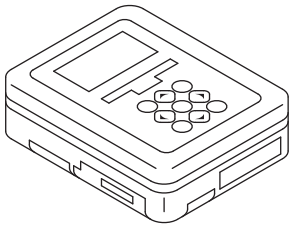
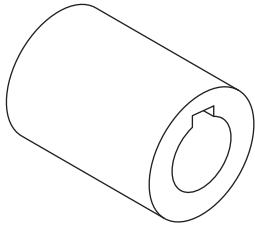
ILLUSTRATION	TOOL NUMBER	DESCRIPTION	REMARKS
 ST1B022XU0	1B022XU0 (Newly adopted tool)	SUBARU SELECT MONITOR III KIT	Used for troubleshooting the electrical system.
 ST-499987500	499987500	CRANKSHAFT SOCKET	Used for rotating crankshaft.

Electrical Component Location

ENGINE (DIAGNOSTICS)

4. Electrical Component Location

A: LOCATION

1. ENGINE

- Control module

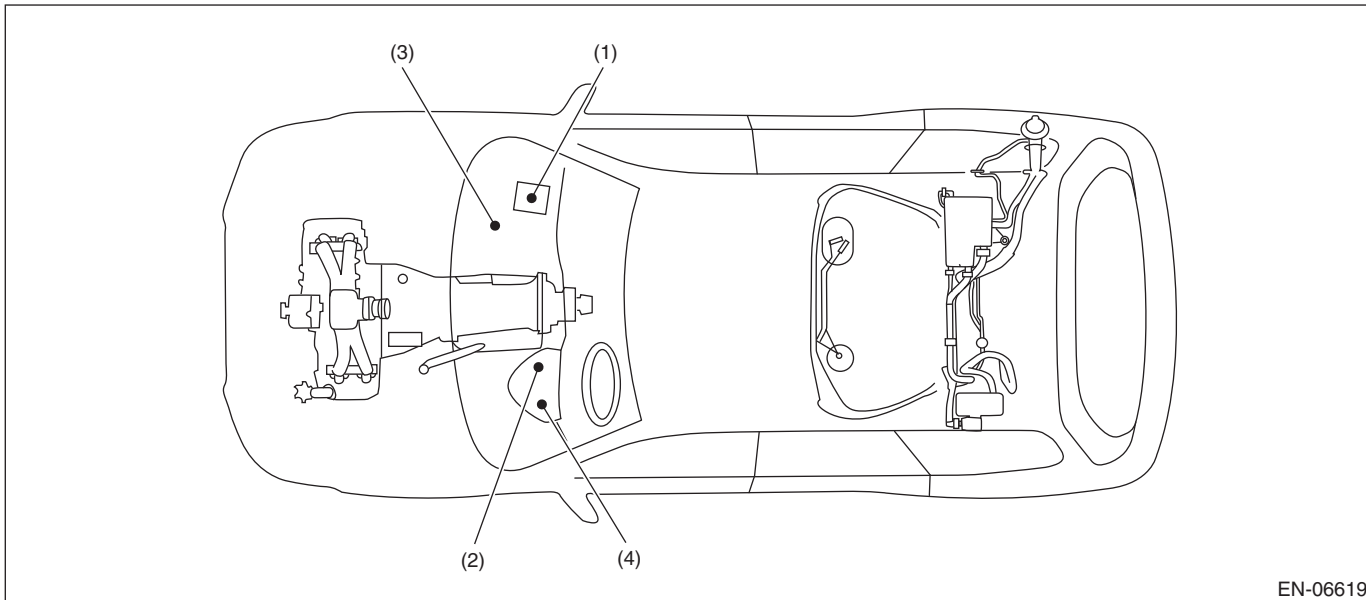

EN-06619

- (1) Engine control module (ECM) (3) Delivery (test) mode connector (4) Data link connector
(2) Malfunction indicator light

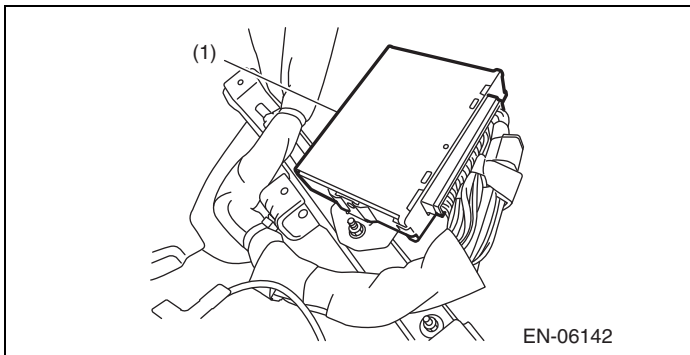

EN-06142

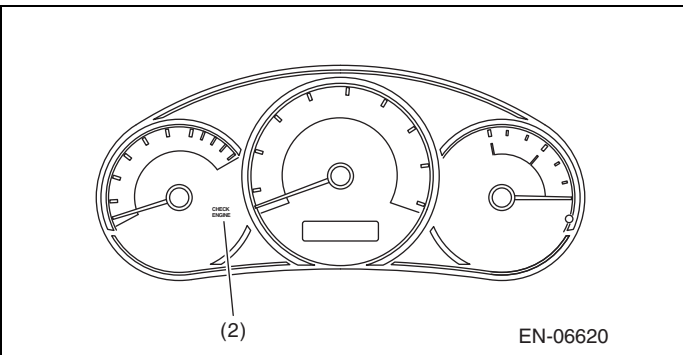

EN-06620

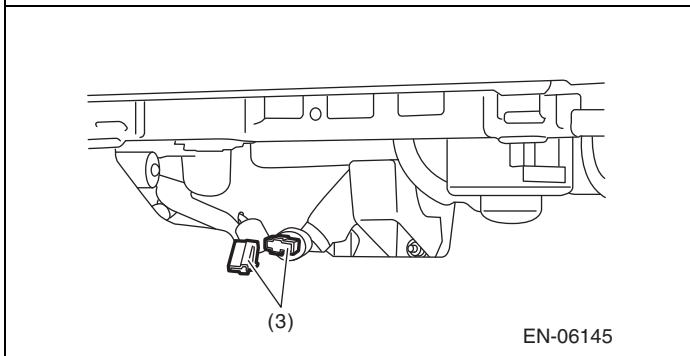

EN-06145

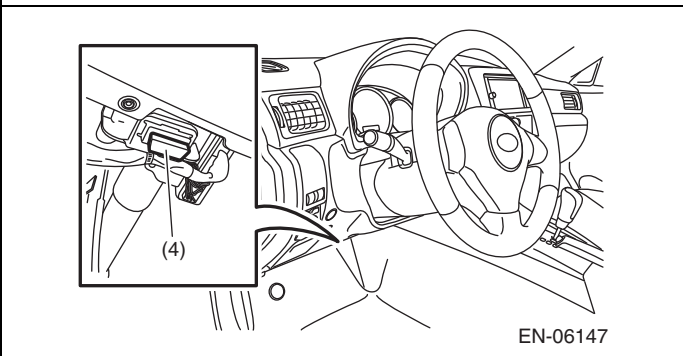

EN-06147

Electrical Component Location

ENGINE (DIAGNOSTICS)

- Sensor

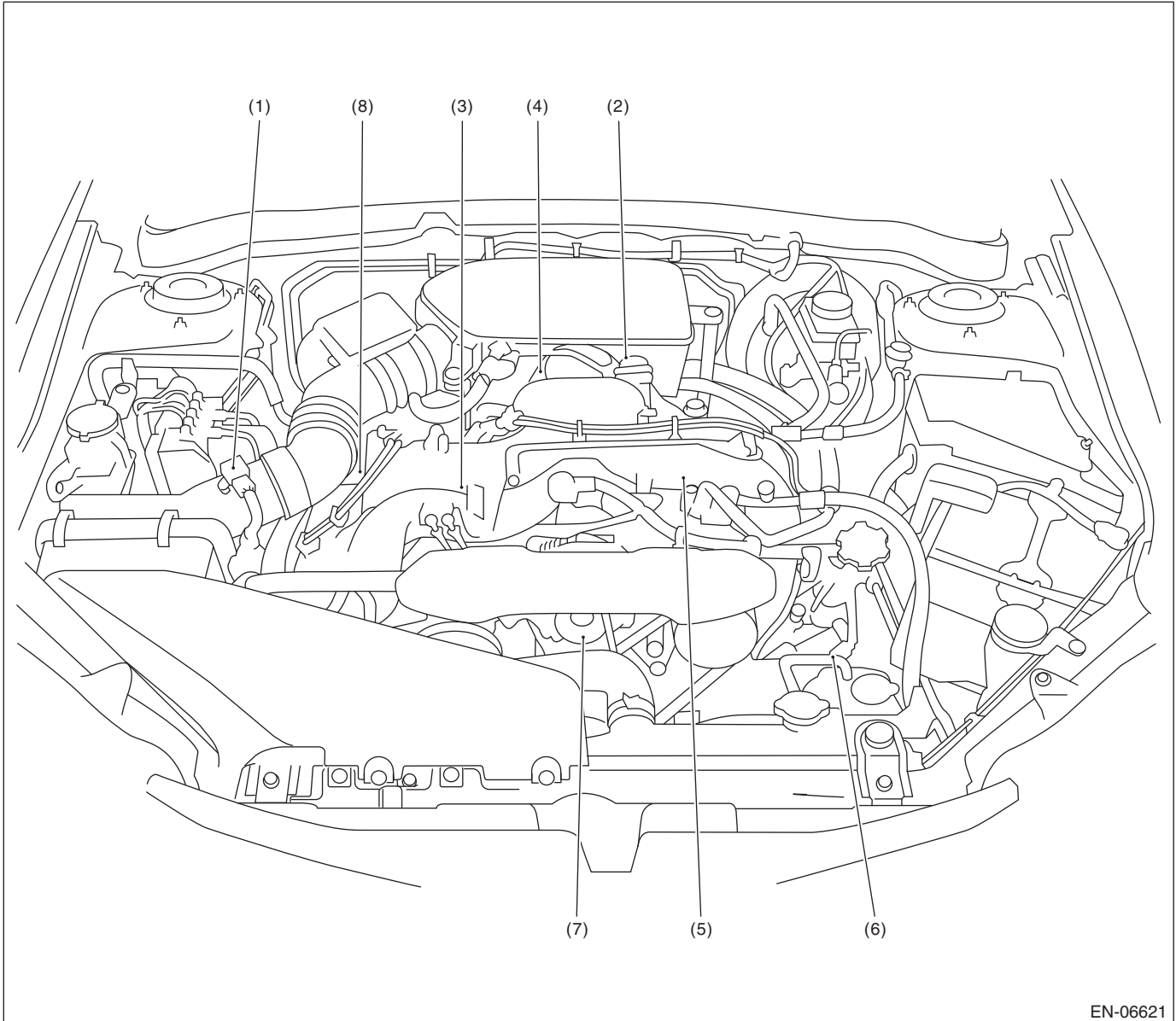

EN-06621

(1) Mass air flow and intake air temperature sensor

(3) Engine coolant temperature sensor

(6) Camshaft position sensor

(2) Manifold absolute pressure sensor

(4) Electronic throttle control

(7) Crankshaft position sensor

(5) Knock sensor

(8) Oil temperature sensor

Electrical Component Location

ENGINE (DIAGNOSTICS)

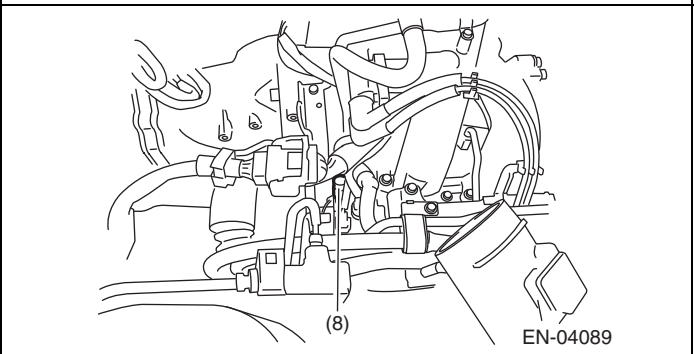
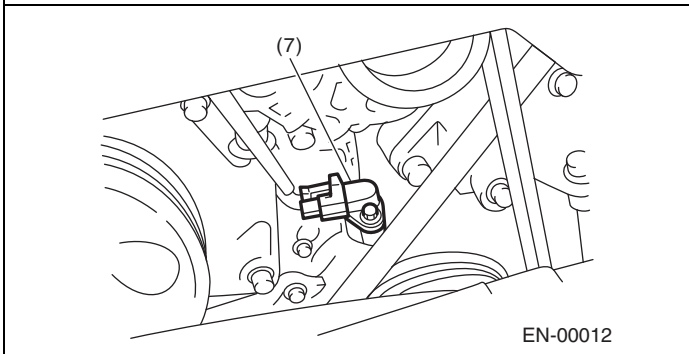
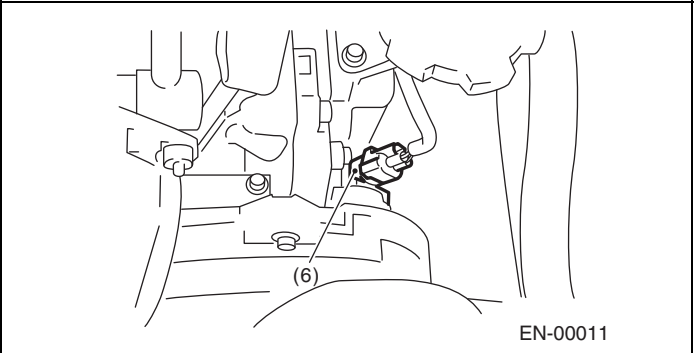
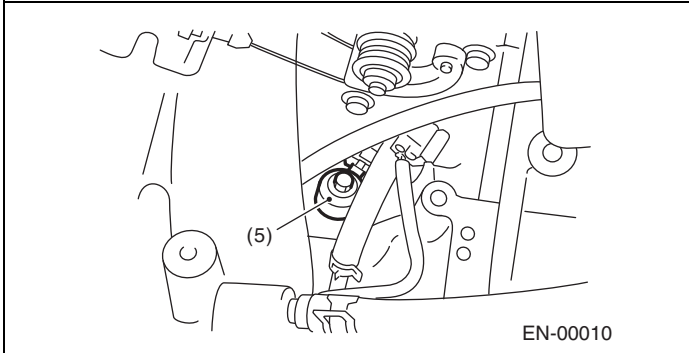
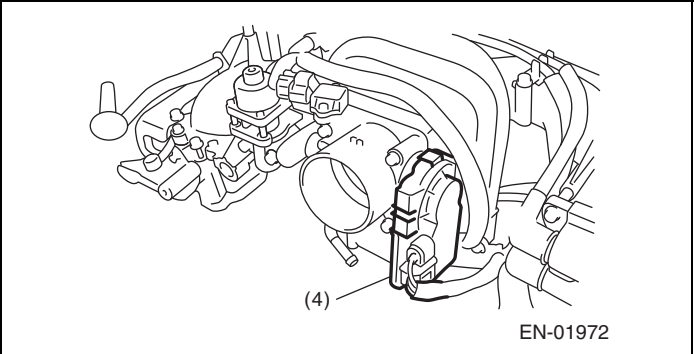
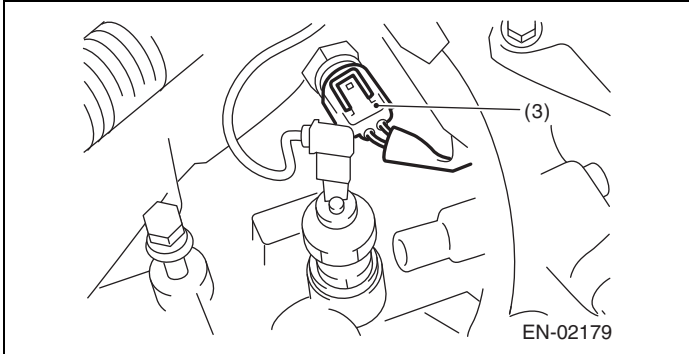
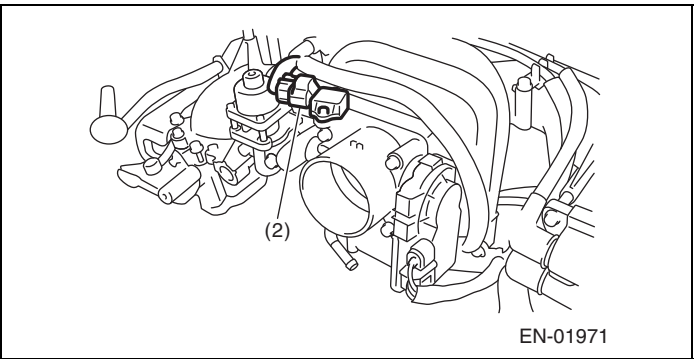
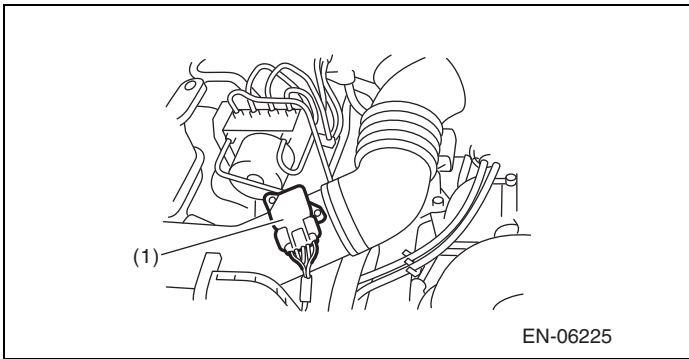

Electrical Component Location

ENGINE (DIAGNOSTICS)

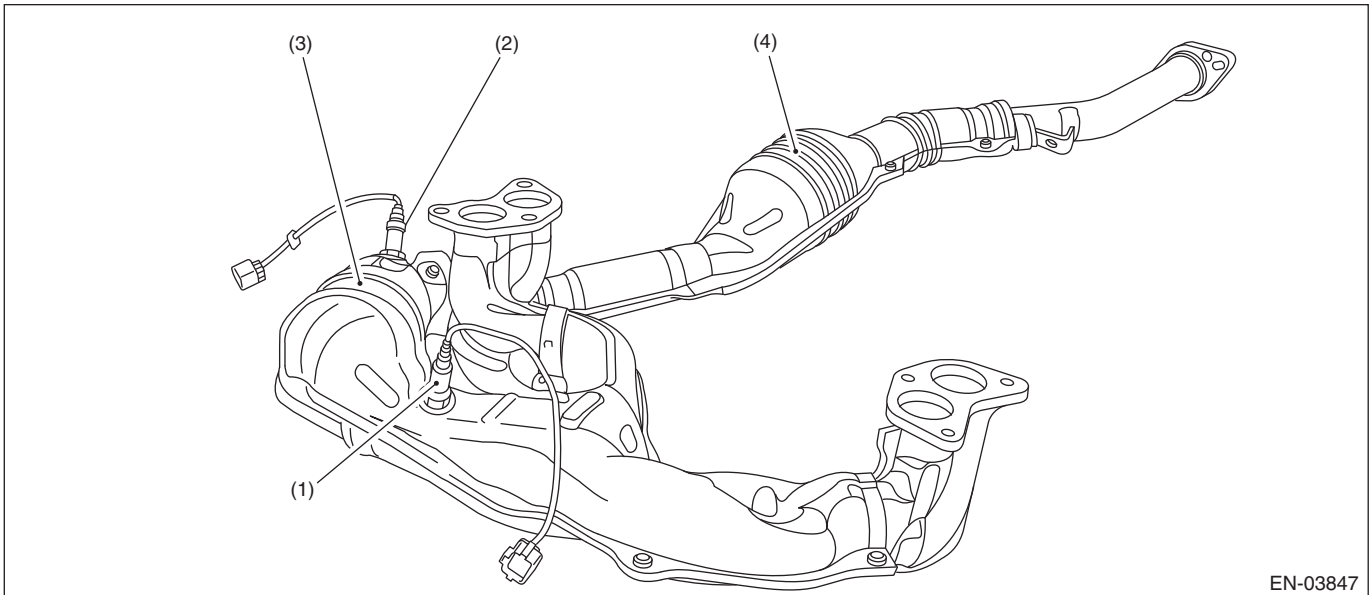

- (1) Front oxygen (A/F) sensor
- (2) Rear oxygen sensor
- (3) Front catalytic converter
- (4) Rear catalytic converter

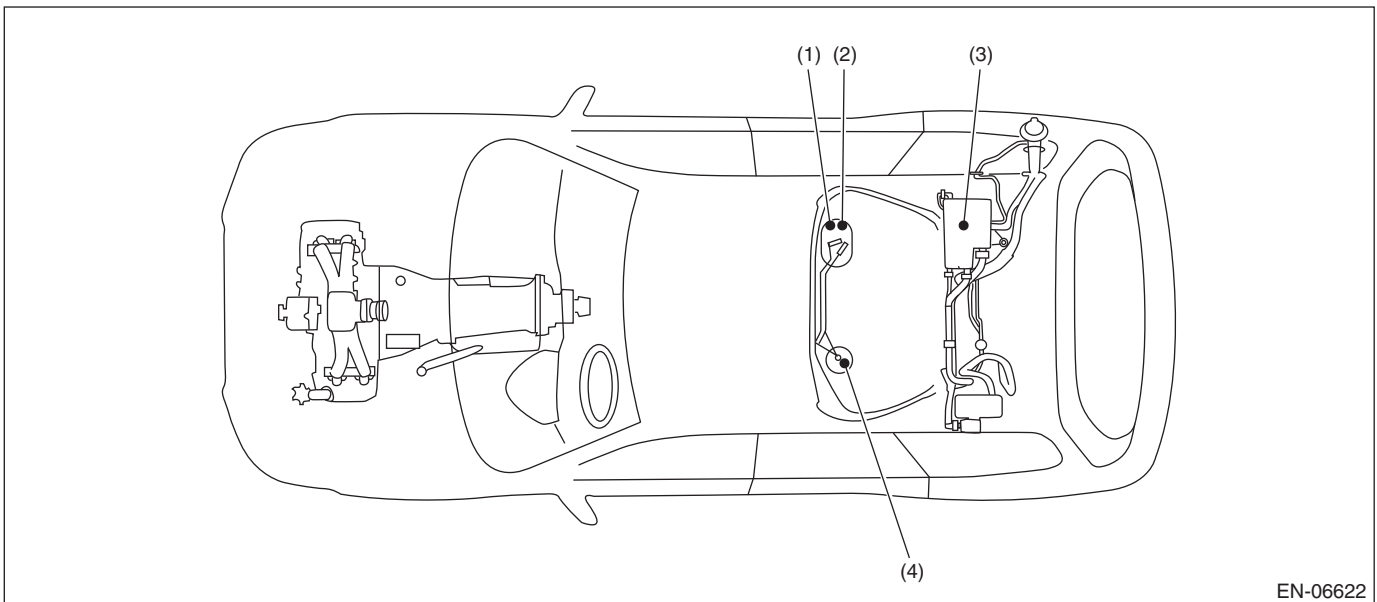

- (1) Fuel level sensor
- (2) Fuel temperature sensor
- (3) Fuel tank pressure sensor
- (4) Fuel sub level sensor

Electrical Component Location

ENGINE (DIAGNOSTICS)

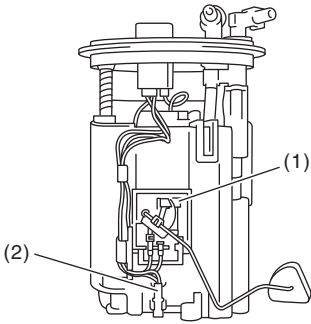
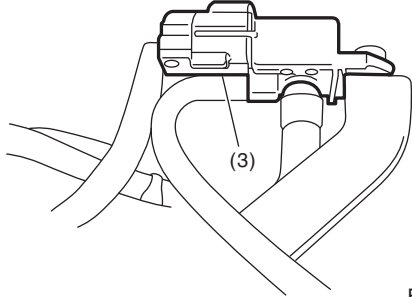
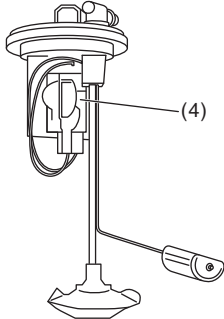
 <p>EN-05725</p>	 <p>EN-06168</p>
 <p>EN-03132</p>	<p>SUBARU.</p>

Electrical Component Location

ENGINE (DIAGNOSTICS)

- Solenoid valve, actuator, emission control system parts and ignition system parts

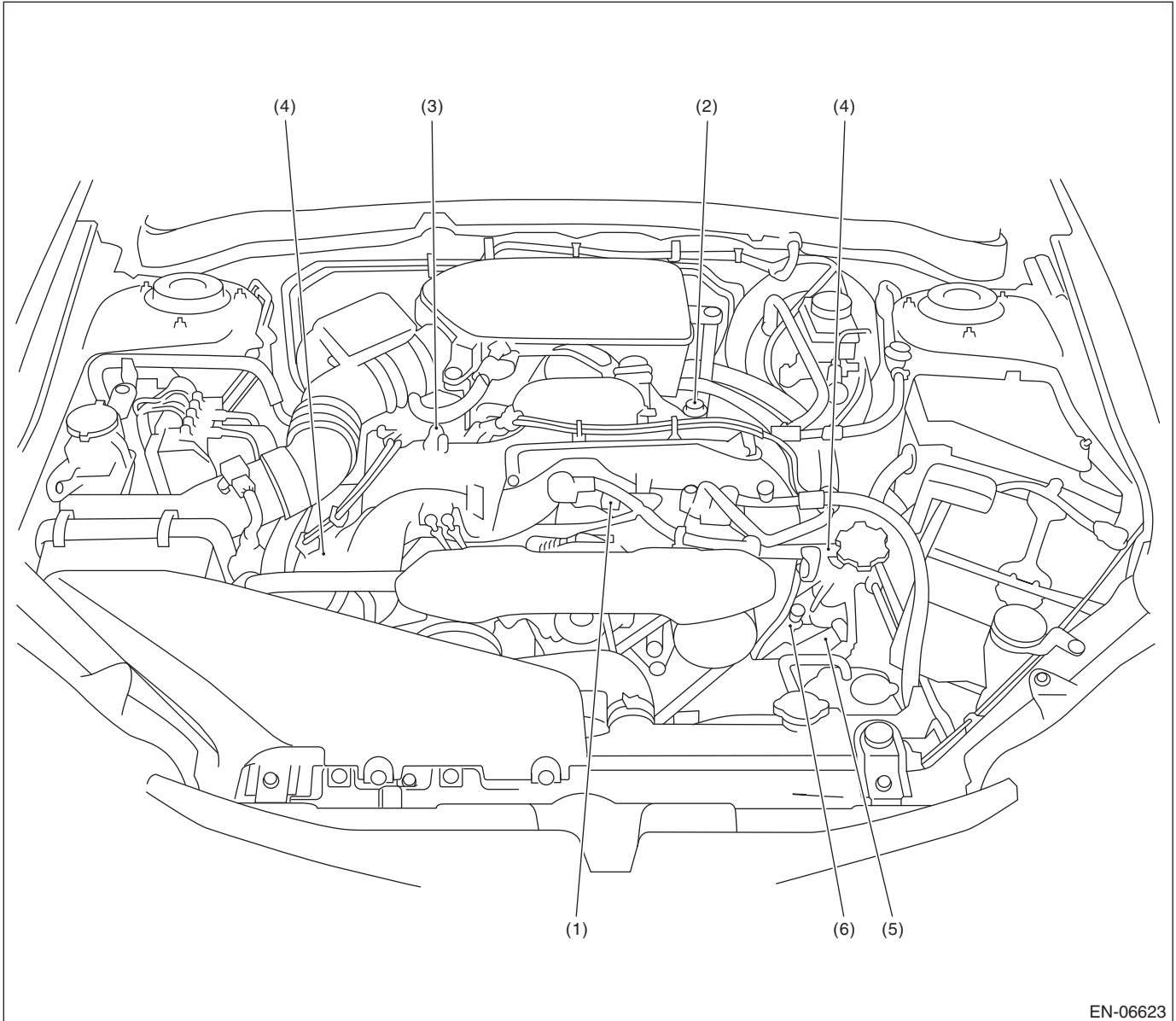

EN-06623

- (1) Purge control solenoid valve
- (2) EGR valve
- (3) Ignition coil and ignitor ASSY

- (4) Fuel injector
- (5) Oil switching solenoid valve

- (6) Variable valve lift diagnosis oil pressure switch

Electrical Component Location

ENGINE (DIAGNOSTICS)

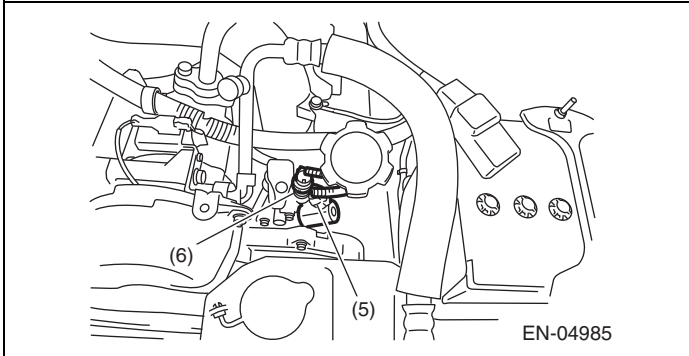
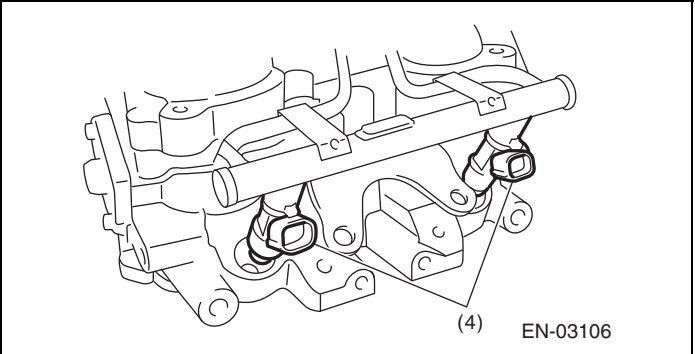
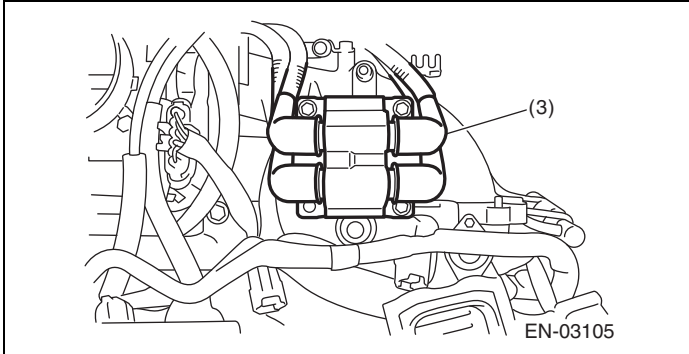
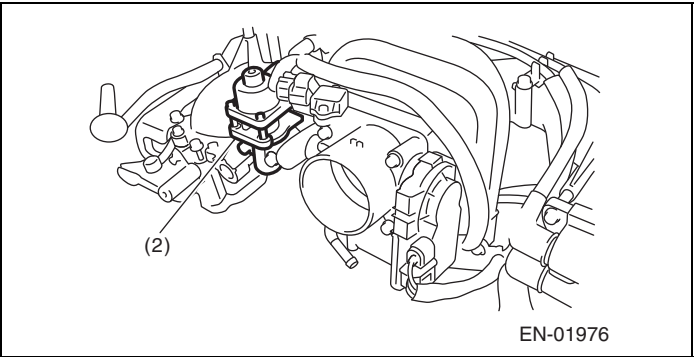
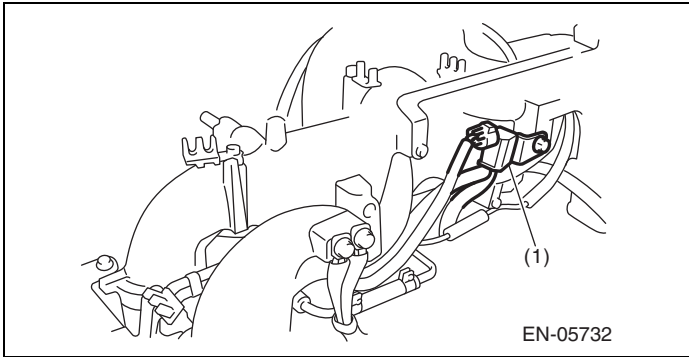

Electrical Component Location

ENGINE (DIAGNOSTICS)

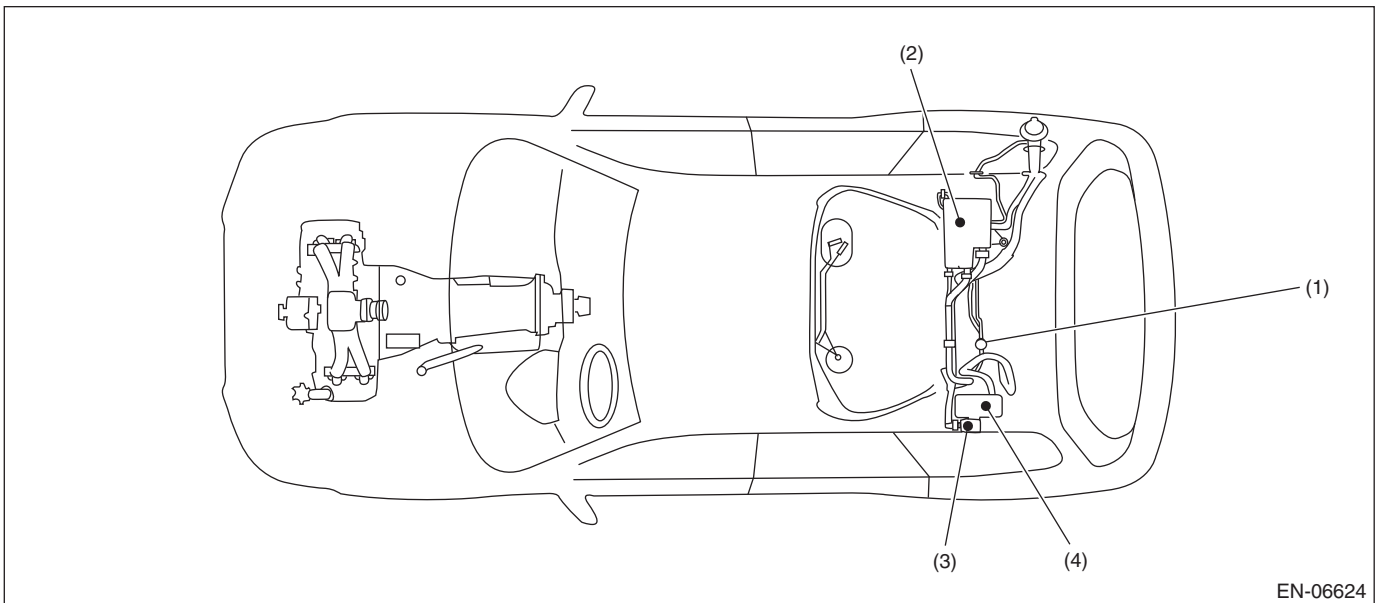

EN-06624

- (1) Pressure control solenoid valve
- (2) Canister
- (3) Drain valve
- (4) Drain filter

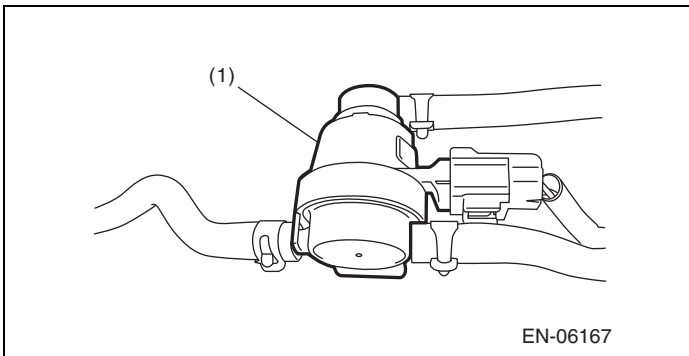

EN-06167

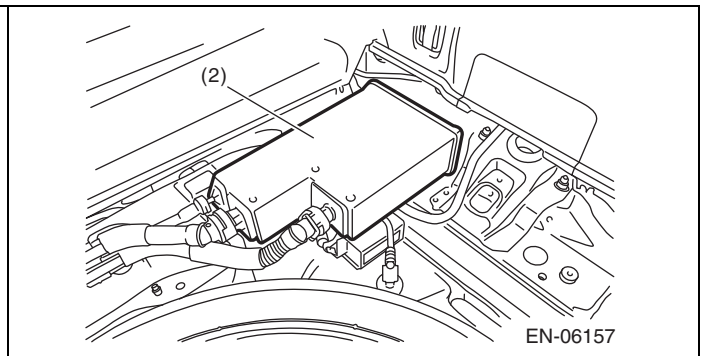

EN-06157

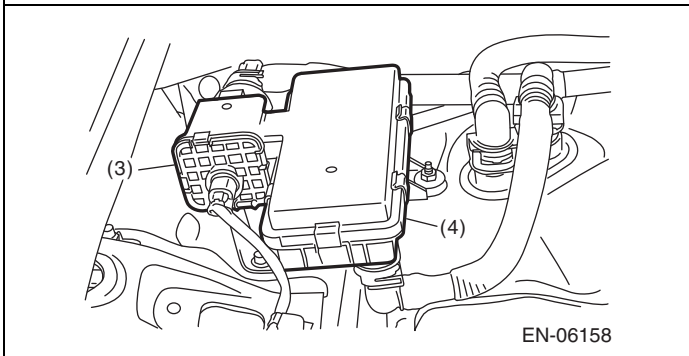

EN-06158

SUBARU.

Electrical Component Location

ENGINE (DIAGNOSTICS)

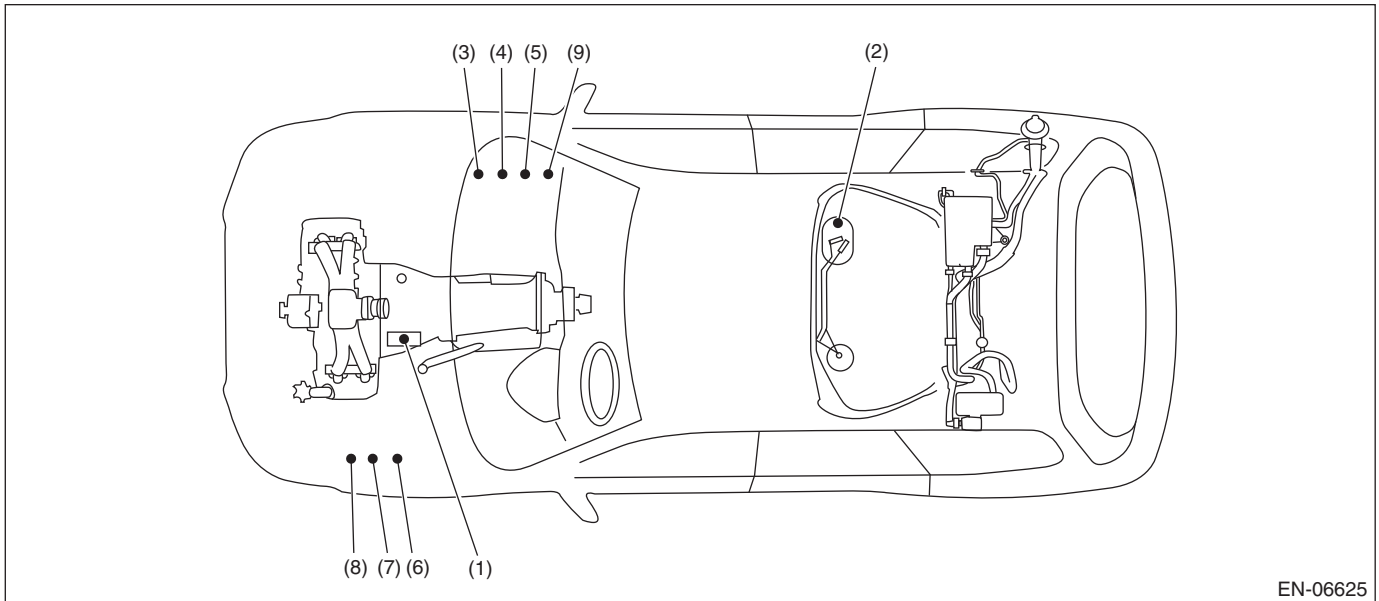

EN-06625

- | | | |
|----------------|---------------------------------------|-------------------------------|
| (1) Starter | (4) Fuel pump relay | (7) Radiator sub fan relay |
| (2) Fuel pump | (5) Electronic throttle control relay | (8) Radiator main fan relay 2 |
| (3) Main relay | (6) Radiator main fan relay 1 | (9) A/F, oxygen sensor relay |

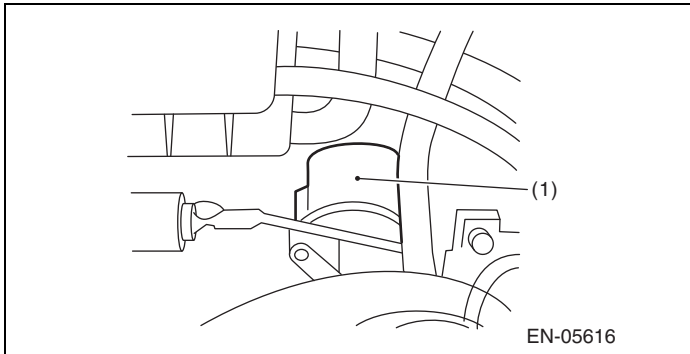

EN-05616

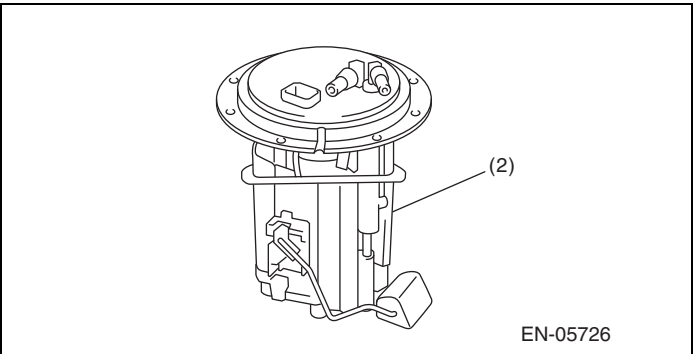

EN-05726

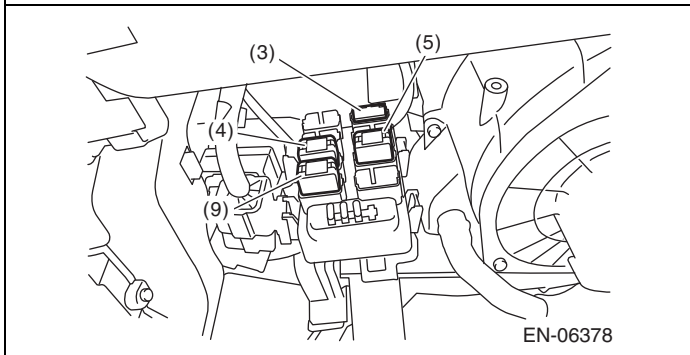

EN-06378

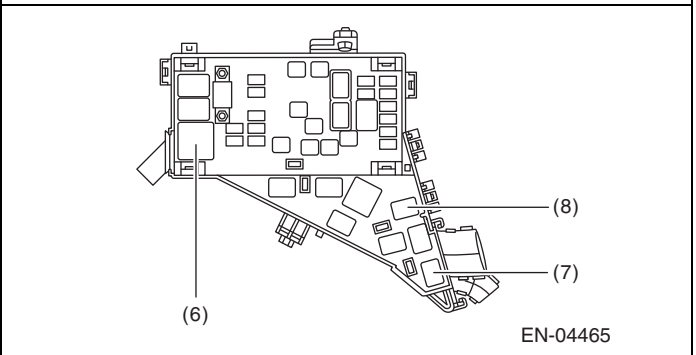

EN-04465

5. Engine Control Module (ECM) I/O Signal

A: ELECTRICAL SPECIFICATION

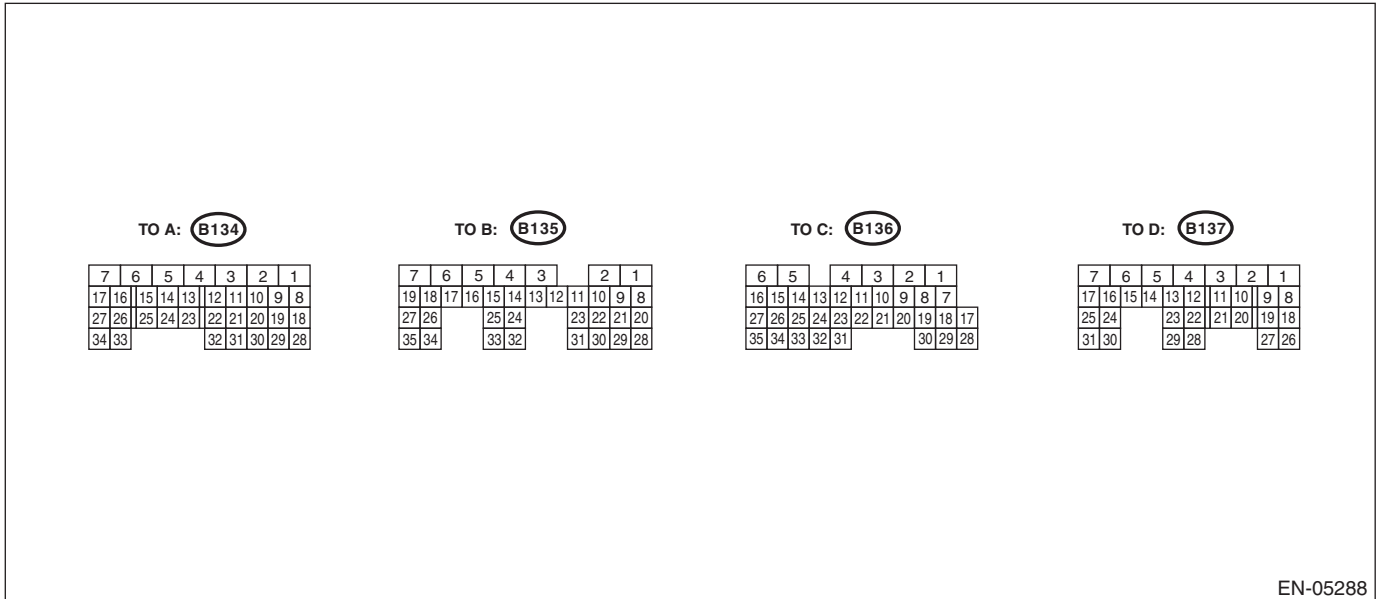

Contents	Connector No.	Terminal No.	Signal (V)		Note	
			Ignition SW ON (engine OFF)	Engine ON (idling)		
Crankshaft position sensor	Signal (+)	B134	13	0	-7 — +7	Waveform
	Signal (-)	B134	14	0	0	—
	Shield	B134	24	0	0	—
Camshaft position sensor	Signal (+)	B134	12	0	-7 — +7	Waveform
	Signal (-)	B134	22	0	0	—
	Shield	B134	24	0	0	—
Electronic throttle control	Main	B134	18	0.64 — 0.72 Fully opened: 3.96	0.64 — 0.72 (After engine is warmed up.)	Fully closed: 0.6 Fully opened: 3.96
	Sub	B134	28	1.51 — 1.58 Fully opened: 4.17	1.51 — 1.58 (After engine is warmed up.)	Fully closed: 1.48 Fully opened: 4.17
	Power supply	B134	19	5	5	—
	GND (sensor)	B134	29	0	0	—
Electronic throttle control motor (+)	B137	5		Duty waveform	Duty waveform	Drive frequency: 500 Hz
Electronic throttle control motor (-)	B137	4		Duty waveform	Duty waveform	Drive frequency: 500 Hz
Electronic throttle control motor power supply	B136	1		10 — 13	12 — 14	—
Electronic throttle control motor relay	B136	21		ON: 0 OFF: 10 — 13	ON: 0 OFF: 12 — 14	When ignition switch is turned to ON: ON

Engine Control Module (ECM) I/O Signal

ENGINE (DIAGNOSTICS)

Contents		Connector No.	Terminal No.	Signal (V)		Note
				Ignition SW ON (engine OFF)	Engine ON (idling)	
Accelerator pedal position sensor	Main sensor signal	B135	23	Fully closed: 1.0 Fully opened: 3.5	Fully closed: 1.0 Fully opened: 3.5	—
	Main power supply	B135	21	5	5	—
	GND (Main sensor)	B135	29	0	0	—
	Sub sensor signal	B135	31	Fully closed: 1.0 Fully opened: 3.5	Fully closed: 1.0 Fully opened: 3.5	—
	Sub power supply	B135	22	5	5	—
	GND (Sub sensor)	B135	30	0	0	—
Rear oxygen sensor	Signal	B135	4	0	0 — 0.9	—
	Shield	B135	1	0	0	—
Front oxygen (A/F) sensor heater	Signal 1	B136	3	10 — 13	1 — 14	Duty waveform
	Signal 2	B136	2	10 — 13	1 — 14	Duty waveform
Rear oxygen sensor heater signal		B136	4	10 — 13	1 — 14	Duty waveform
Engine coolant temperature sensor		B134	34	1.0 — 1.4	1.0 — 1.4	After engine is warmed up.
Starter switch		B136	32	0	0	AT model Cranking: 8 — 14 MT model Cranking with the clutch pedal pressed: 8 — 14
Starter relay control		B136	20	ON: 0.5 or less OFF: 10 — 13	ON: 0.5 or less OFF: 12 — 14	—
A/C switch		B136	24	ON: 10 — 13 OFF: 0	ON: 12 — 14 OFF: 0	—
Ignition switch		B135	19	10 — 13	12 — 14	—
Neutral position switch	AT	B136	31	ON: 0 OFF: 12±0.5		For AT model, switch is ON when select lever is shifted into "P" range or "N" range.
	MT			ON: 0 OFF: 12±0.5		For MT model, switch is ON when select lever is shifted into "N" range.
Delivery (test) mode connector		B135	27	10 — 13	13 — 14	When connected: 0
Knock sensor	Signal	B134	15	2.5	2.5	—
	Shield	B134	25	0	0	—
Back-up power supply		B135	5	10 — 13	12 — 14	Ignition switch "OFF": 10 — 13
Control module power supply		B134	7	10 — 13	12 — 14	—
		B135	2	10 — 13	12 — 14	—
Ignition control	#1, #2	B137	18	0	1 — 3.4	Waveform
	#3, #4	B137	19	0	1 — 3.4	Waveform
Fuel injector	#1	B137	8	10 — 13	1 — 14	Waveform
	#2	B137	9	10 — 13	1 — 14	Waveform
	#3	B137	10	10 — 13	1 — 14	Waveform
	#4	B137	11	10 — 13	1 — 14	Waveform
Fuel pump relay control		B136	12	ON: 0.5 or less OFF: 10 — 13	ON: 0.5 or less OFF: 12 — 14	—
A/C relay control		B136	9	ON: 0.5 or less OFF: 10 — 13	ON: 0.5 or less OFF: 12 — 14	—

Engine Control Module (ECM) I/O Signal

ENGINE (DIAGNOSTICS)

Contents	Connector No.	Terminal No.	Signal (V)		Note	
			Ignition SW ON (engine OFF)	Engine ON (idling)		
Radiator fan relay 1 control	B136	18	ON: 0.5 or less OFF: 10 — 13	ON: 0.5 or less OFF: 12 — 14	—	
Radiator fan relay 2 control	B136	29	ON: 0.5 or less OFF: 10 — 13	ON: 0.5 or less OFF: 12 — 14	—	
Self-shutoff control	B136	23	0.5 or less	0.5 or less	—	
Malfunction indicator light	B136	11	—	—	Light "ON": 1 or less Light "OFF": 10 — 14	
Engine speed output	B136	22	—	0 — 13 or more	Waveform	
Oil temperature sensor signal	B134	23	1.0 — 1.4	1.0 — 1.4	After engine is warmed up.	
Blow-by leak diagnosis	B134	30	0	0	—	
Purge control solenoid valve	B137	29	ON: 1 or less OFF: 10 — 13	ON: 1 or less OFF: 12 — 14	Duty waveform	
EGR valve	Signal 1	B134	8	0 or 10 — 13	0 or 12 — 14	Waveform
	Signal 2	B134	9	0 or 10 — 13	0 or 12 — 14	Waveform
	Signal 3	B134	10	0 or 10 — 13	0 or 12 — 14	Waveform
	Signal 4	B134	20	0 or 10 — 13	0 or 12 — 14	Waveform
Power steering oil pressure switch	B134	33	ON: 1 or less OFF: 10 — 13	ON: 1 or less OFF: 12 — 14	—	
Blower fan switch	B135	16	ON: 0 OFF: 10 — 13	ON: 0 OFF: 12 — 14	Manual A/C model	
A/C middle pressure switch	B136	33	ON: 0 OFF: 10 — 13	ON: 0 OFF: 12 — 14	—	
Oil switching solenoid valve RH	Signal (+)	B137	25	0	Duty waveform	Drive frequency: 300 Hz
	Signal (-)	B137	24	0	0	—
Oil switching solenoid valve LH	Signal (+)	B137	31	0	Duty waveform	Drive frequency: 300 Hz
	Signal (-)	B137	30	0	0	—
Variable valve lift diagnosis oil pressure switch RH	B134	31	0	0	—	
Variable valve lift diagnosis oil pressure switch LH	B134	32	0	0	—	
Front oxygen (A/F) sensor	Signal (+)	B135	9	—	2.7 — 2.9	—
	Signal (-)	B135	8	—	2.35 — 2.25	—
	Shield	B135	1	0	0	—
Manifold absolute pressure sensor	B134	6	3.4 — 3.8	1.4 — 1.8	—	
Air flow sensor	Signal	B135	26	—	0.3 — 4.5	—
	Shield	B135	35	0	0	—
	GND	B135	34	0	0	—
Intake air temperature sensor signal	B135	18	0.3 — 4.6	0.3 — 4.6	—	
Immobilizer communication 1	B136	26	1 or less ↔ 4 or more	1 or less ↔ 4 or more	—	
Immobilizer communication 2	B136	34	1 or less ↔ 4 or more	1 or less ↔ 4 or more	—	
SSM/GST communication line	B136	16	1 or less ↔ 4 or more	1 or less ↔ 4 or more	—	
Sensor power supply	B134	19	5	5	—	
	B135	22	5	5	—	
GND (sensor)	B134	29	0	0	—	
	B135	30	0	0	—	

Engine Control Module (ECM) I/O Signal

ENGINE (DIAGNOSTICS)

Contents		Connector No.	Terminal No.	Signal (V)		Note
				Ignition SW ON (engine OFF)	Engine ON (idling)	
GND	(Engine 1)	B134	5	0	0	—
	(Engine 2)	B137	7	0	0	—
	(Engine 3)	B137	2	0	0	—
	(Engine 4)	B137	1	0	0	—
	(Engine 5)	B137	3	0	0	—
	(Body)	B136	6	0	0	—
Clutch switch		B136	25	When clutch pedal is depressed: 0 When clutch pedal is released: 10 — 13	When clutch pedal is depressed: 0 When clutch pedal is released: 12 — 14	—
Brake switch 1		B135	20	When brake pedal is depressed: 0 When brake pedal is released: 10 — 13	When brake pedal is depressed: 0 When brake pedal is released: 12 — 14	—
Brake switch 2		B135	28	When brake pedal is depressed: 10 — 13 When brake pedal is released: 0	When brake pedal is depressed: 12 — 14 When brake pedal is released: 0	—
Cruise control main switch		B135	12	ON: 0 OFF: 5	ON: 0 OFF: 5	—
Cruise control command switch		B135	24	When operating nothing: 3.5 — 4.5 When operating RES/ACC: 2.5 — 3.5 When operating SET/COAST: 0.5 — 1.5 When operating cancel: 0 — 0.5	When operating nothing: 3.5 — 4.5 When operating RES/ACC: 2.5 — 3.5 When operating SET/COAST: 0.5 — 1.5 When operating cancel: 0 — 0.5	—
Fuel temperature sensor		B135	17	2.5 — 3.8	2.5 — 3.8	Ambient temperature: 25°C (77°F)
Fuel tank pressure sensor		B135	32	2.3 — 2.7	2.3 — 2.7	Value after removing fuel filler cap and installing again
Pressure control solenoid valve		B136	28	ON: 1 or less OFF: 10 — 13	ON: 1 or less OFF: 12 — 14	—
Drain valve		B136	17	ON: 1 or less OFF: 10 — 13	ON: 1 or less OFF: 12 — 14	—
CAN communication line (+)		B136	27	2.5 — 3.5	2.5 — 3.5	Waveform
CAN communication line (-)		B136	35	1.5 — 2.5	1.5 — 2.5	Waveform
AT/MT identification line		B136	15	—	—	MT model: 1 or less

Engine Control Module (ECM) I/O Signal

ENGINE (DIAGNOSTICS)

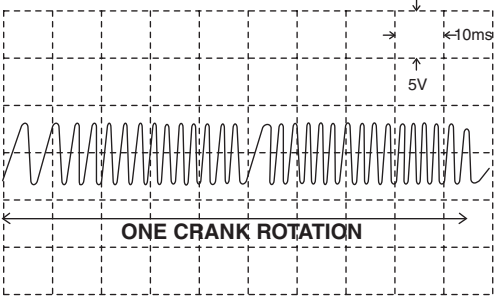
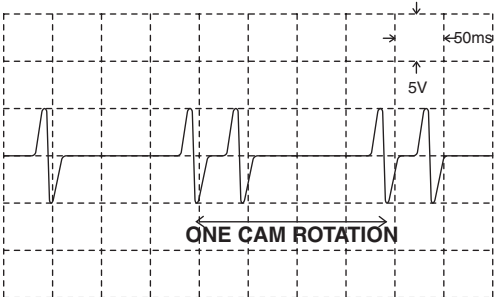
Input/output name	Measuring condition	Waveform
1. Crankshaft position sensor	At idling	 <p style="text-align: right;">EN-05322</p>
2. Camshaft position sensor	At idling	 <p style="text-align: right;">EN-05323</p>

Engine Control Module (ECM) I/O Signal

ENGINE (DIAGNOSTICS)

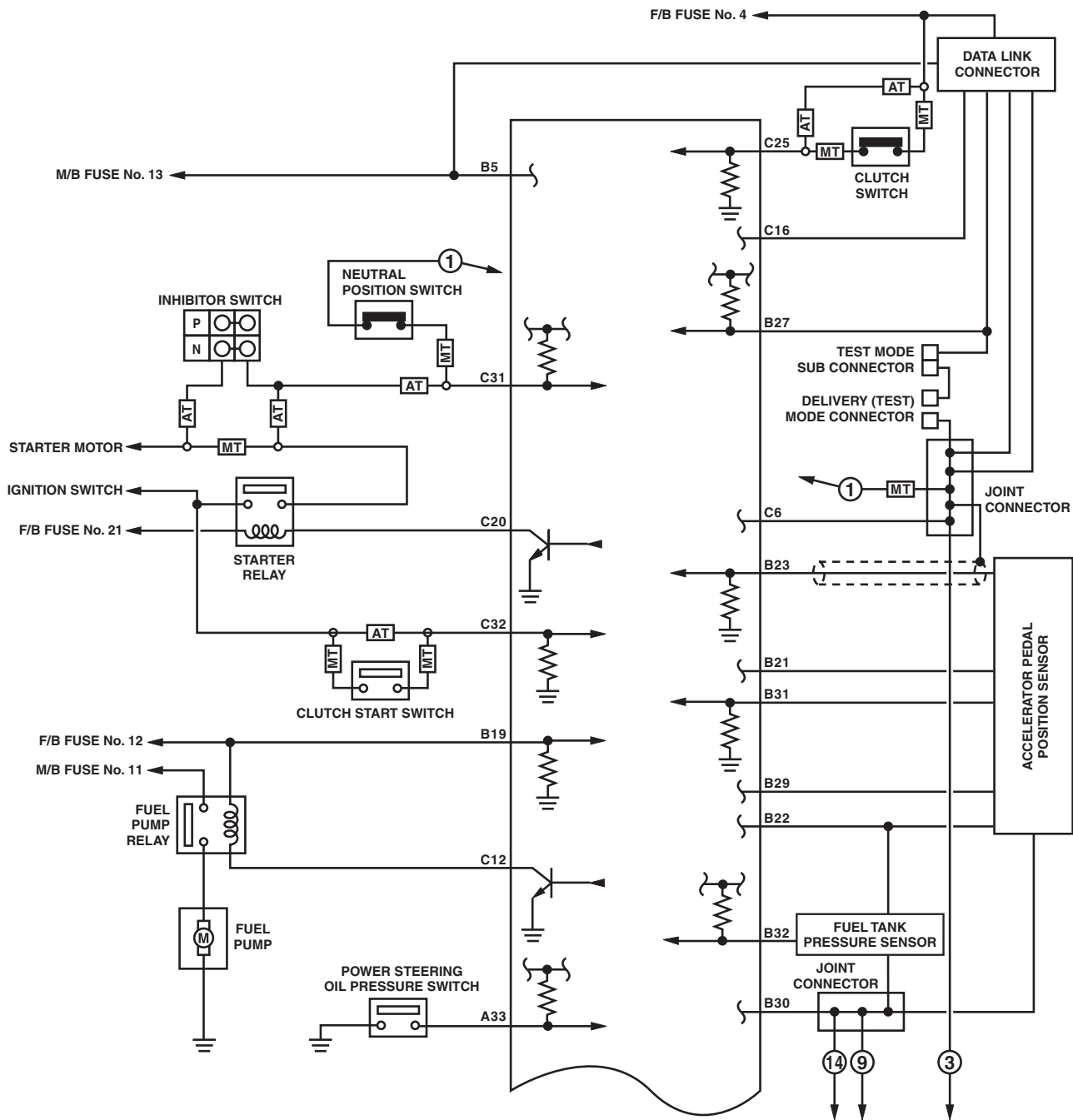

EN-06662

Engine Control Module (ECM) I/O Signal

ENGINE (DIAGNOSTICS)

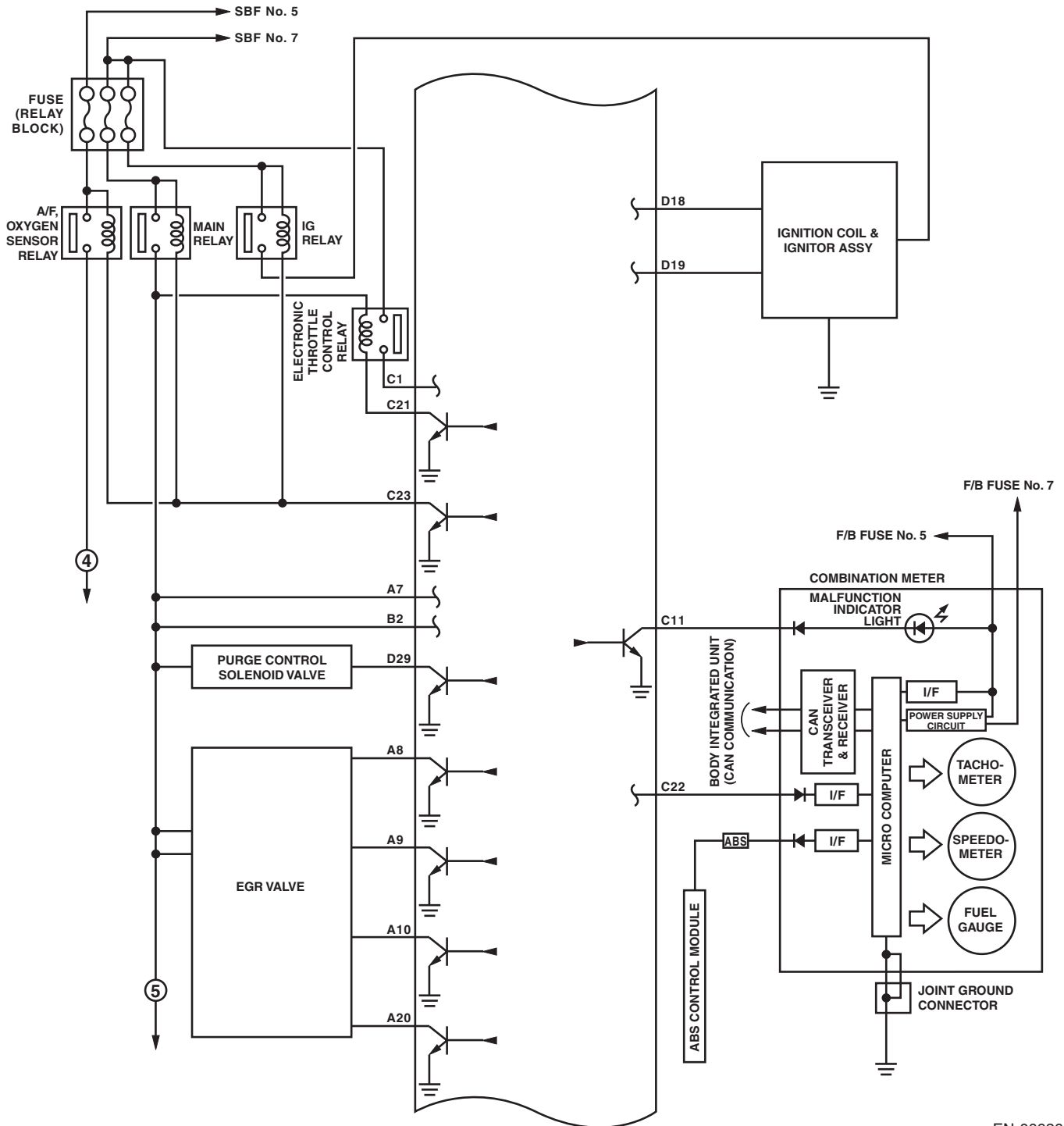

EN-06626

Engine Control Module (ECM) I/O Signal

ENGINE (DIAGNOSTICS)

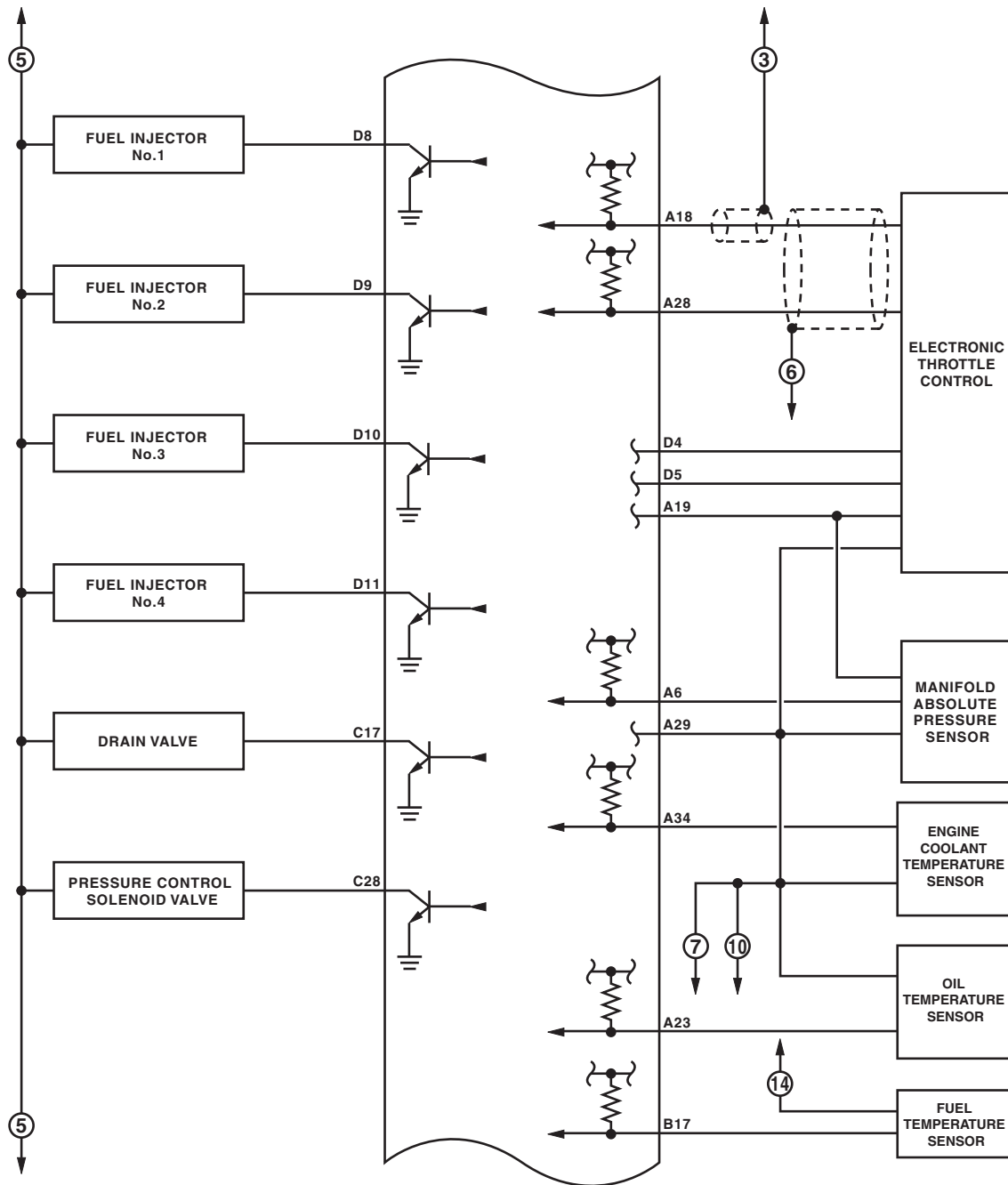

EN-06232

Engine Control Module (ECM) I/O Signal

ENGINE (DIAGNOSTICS)

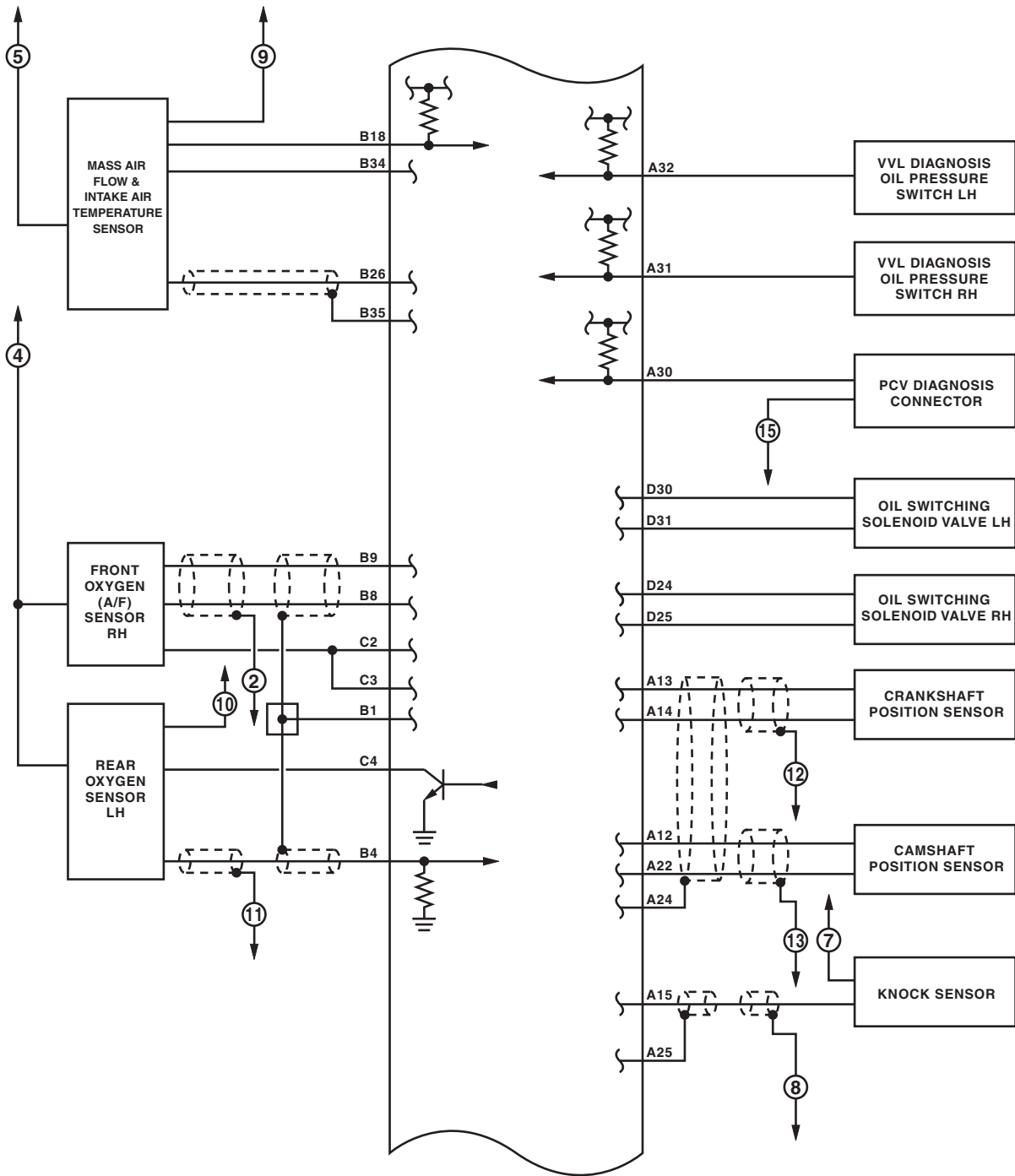

EN-06233

Engine Control Module (ECM) I/O Signal

ENGINE (DIAGNOSTICS)

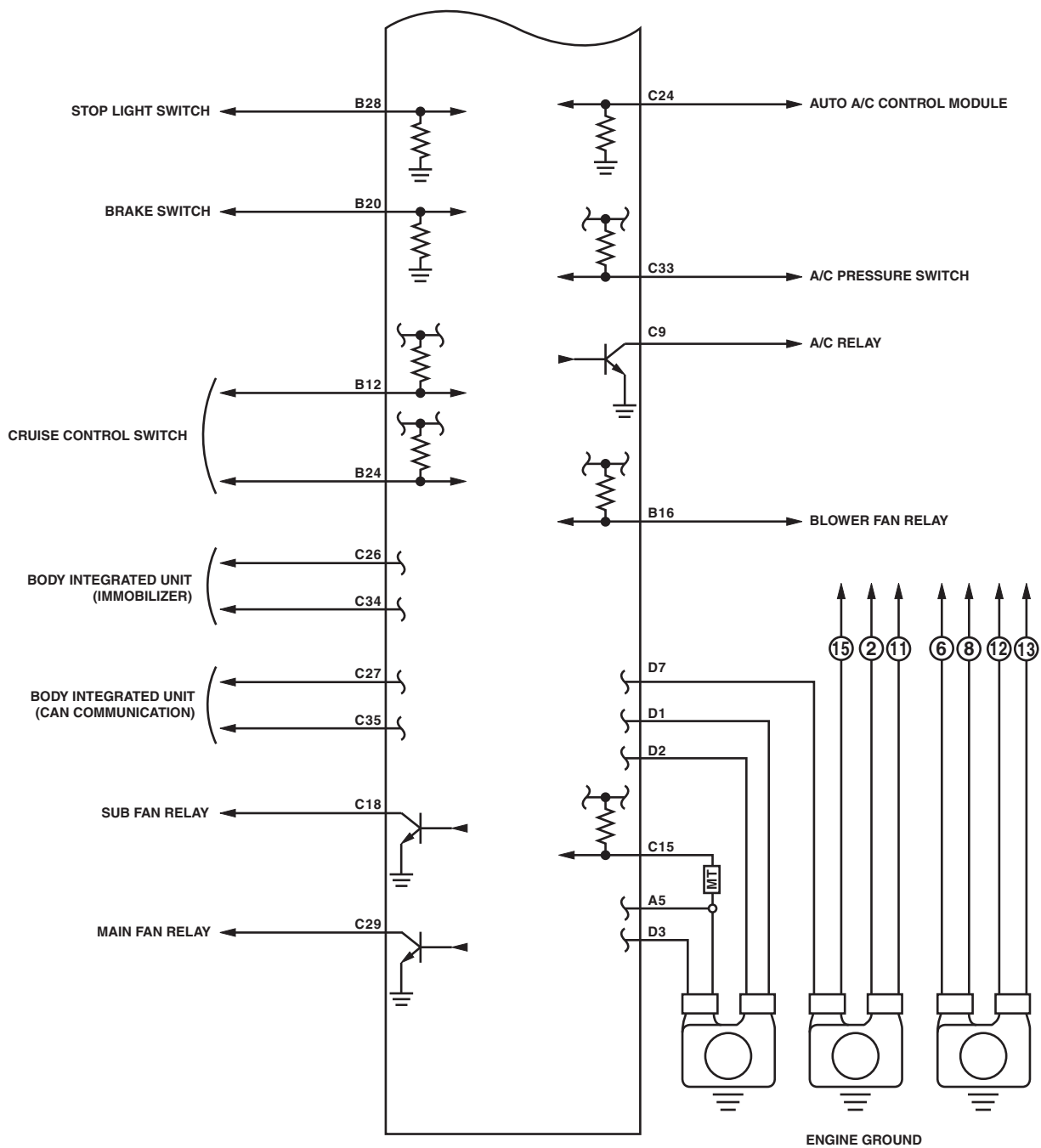

EN-06627

6. Engine Condition Data

A: ELECTRICAL SPECIFICATION

Remarks	Specification
Engine load	17.6 — 40.5 (%): Idling
	14.7 — 29.8 (%) 2,500 rpm racing

Measuring condition:

- After engine is warmed up.
- Set the select lever in “P” range or “N” range, or the shift lever in neutral.
- Turn the A/C to OFF.
- Turn all the accessory switches to OFF.

Data Link Connector

ENGINE (DIAGNOSTICS)

7. Data Link Connector

A: NOTE

This connector is used for Subaru Select Monitor.

CAUTION:

Do not connect any scan tools except Subaru Select Monitor or general scan tool because the circuit for Subaru Select Monitor may be damaged.

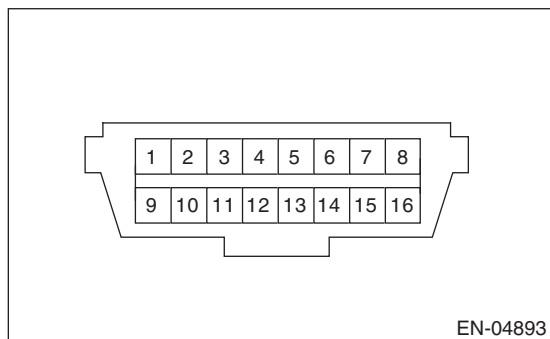

Terminal No.	Remarks	Terminal No.	Remarks
1	Empty	9	Empty
2	Empty	10	Empty
3	Empty	11	Empty
4	Ground	12	Empty
5	Ground	13	Empty
6	CAN communication (+)	14	CAN communication (-)
7	Subaru Select Monitor signal	15	Empty
8	Empty	16	Power supply

8. General Scan Tool

A: OPERATION

1. HOW TO USE GENERAL SCAN TOOL

- 1) Prepare a scan tool (general scan tool) required by SAE J1978.
- 2) Connect the general scan tool to data link connector located in the lower portion of the instrument panel (on the driver's side).

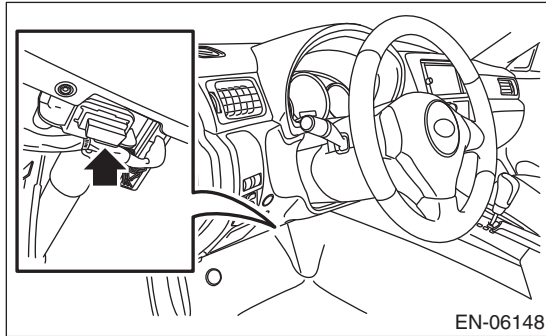

- 3) Using the general scan tool, call up DTC and freeze frame data. General scan tool functions consist of:

- (1) MODE \$01: Current powertrain diagnostic data
- (2) MODE \$02: Powertrain freeze frame data
- (3) MODE \$03: Emission-related powertrain DTC
- (4) MODE \$04: Clear/Reset emission-related diagnostic information
- (5) MODE \$06: Request on-board monitoring test results for intermittently monitored systems
- (6) MODE \$07: Request on-board monitoring test results for continuously monitored systems
- (7) MODE \$09: Request vehicle information

Read out the data according to repair procedures. (For detailed operation procedure, refer to the general scan tool instruction manual.)

NOTE:

For details concerning DTC, refer to "List of Diagnostic Trouble Code (DTC)". <Ref. to EN(H4SO)(diag)-82, List of Diagnostic Trouble Code (DTC).>

General Scan Tool

ENGINE (DIAGNOSTICS)

2. MODE \$01: (CURRENT POWERTRAIN DIAGNOSTIC DATA)

Refer to data denoting the current operating condition of analog input/output, digital input/output or the powertrain system.

A list of the support data and PID (Parameter Identification) codes are shown in the following table.

PID	Data	Unit of measure
\$01	Number of emission-related powertrain DTC, and malfunction indicator light status and diagnosis support information	—
\$03	Fuel system control status	—
\$04	Calculated engine load value	%
\$05	Engine coolant temperature	°C
\$06	Short term fuel trim	%
\$07	Long term fuel trim	%
\$0B	Intake manifold absolute pressure	kPa
\$0C	Engine speed	rpm
\$0D	Vehicle speed	MPH
\$0E	Ignition timing advance	°
\$0F	Intake air temperature	°C
\$10	Air flow rate from mass air flow sensor	g/sec
\$11	Throttle valve absolute opening angle	%
\$13	Check whether oxygen sensor is installed.	—
\$15	Oxygen sensor output voltage and short term fuel trim associated with oxygen sensor (Bank 1 Sensor 2)	V and %
\$1C	Supporting OBD system	—
\$1F	Elapsed time after starting the engine	sec
\$21	Travel distance after the malfunction indicator light illuminates	miles
\$24	A/F value and A/F sensor output voltage (Bank 1 Sensor 1)	— and V
\$2C	Target EGR	%
\$2D	EGR deviation	%
\$2E	Evaporative purge	%
\$2F	Fuel level	%
\$30	Number of warm ups after DTC clear	—
\$31	Travel distance after DTC clear	miles
\$32	Fuel tank pressure	Pa
\$33	Barometric pressure	kPa
\$34	A/F value and A/F sensor current (Bank 1 Sensor 1)	— and mA
\$3C	Catalyst temperature #1	°C
\$41	Diagnostic monitor of each drive cycle	—
\$42	ECM power voltage	V
\$43	Absolute load	%
\$44	A/F target lambda	—
\$45	Relative throttle opening angle	%
\$46	Ambient temperature	°C
\$47	Absolute throttle opening angle 2	%
\$49	Absolute accelerator opening angle 1	%
\$4A	Absolute accelerator opening angle 2	%
\$4C	Target throttle opening angle	%
\$4D	Engine operating time while malfunction indicator lit	min
\$4E	Elapsed time after DTC clear	min
\$51	Fuel used	—
\$5A	Relative accelerator opening angle	%

NOTE:

Refer to general scan tool manufacturer's instruction manual to access generic OBD-II PIDs (MODE \$01).

3. MODE \$02 (POWERTRAIN FREEZE FRAME DATA)

Refer to data denoting the operating condition when trouble is detected by on-board diagnosis system. A list of the support data and PID (Parameter Identification) codes are shown in the following table.

PID	Data	Unit of measure
\$02	DTC that caused the freeze frame data storage required by CARB	—
\$03	Fuel system control status	—
\$04	Calculated engine load value	%
\$05	Engine coolant temperature	°C
\$06	Short term fuel trim (Bank 1 Sensor 1)	%
\$07	Long term fuel trim (Bank 1 Sensor 1)	%
\$0B	Intake manifold absolute pressure	kPa
\$0C	Engine speed	rpm
\$0D	Vehicle speed	MPH
\$0E	Ignition timing advance	°
\$0F	Intake air temperature	°C
\$10	Air flow rate from mass air flow sensor	g/sec
\$11	Throttle valve absolute opening angle	%
\$13	Check whether oxygen sensor is installed.	—
\$15	Oxygen sensor output voltage and short term fuel trim associated with oxygen sensor (Bank 1 Sensor 2)	V and %
\$1C	Supporting OBD system	—
\$1F	Elapsed time after starting the engine	sec
\$2C	Target EGR	%
\$2D	EGR deviation	%
\$2E	Evaporative purge	%
\$2F	Fuel level	%
\$32	Fuel tank pressure	Pa
\$33	Barometric pressure	kPa
\$42	ECM power voltage	V
\$43	Absolute load	%
\$44	A/F target lambda	—
\$45	Relative throttle opening angle	%
\$46	Ambient temperature	°C
\$47	Absolute throttle opening angle 2	%
\$49	Absolute accelerator opening angle 1	%
\$4A	Absolute accelerator opening angle 2	%
\$4C	Target throttle opening angle	%

NOTE:

Refer to general scan tool manufacturer's instruction manual to access freeze frame data (MODE \$02).

4. MODE \$03 (EMISSION-RELATED POWERTRAIN DTC)

Refer to "List of Diagnostic Trouble Code (DTC)" for information about data denoting emission-related powertrain DTC. <Ref. to EN(H4SO)(diag)-82, List of Diagnostic Trouble Code (DTC).>

5. MODE \$04 (CLEAR/RESET EMISSION-RELATED DIAGNOSTIC INFORMATION)

Refer to the mode used to clear or reset emission-related diagnostic information (OBD-II trouble diagnostic information).

NOTE:

Refer to general scan tool manufacturer's instruction manual to clear the emission-related diagnostic information (MODE \$04).

General Scan Tool

ENGINE (DIAGNOSTICS)

6. MODE \$06

Refer to test value of troubleshooting and data of test limit indicated on the support data bit sequence table. A list of the support data is shown in the following table.

OBDMID	TID	SID	Diagnostic item
\$01	\$81	\$0A	A/F sensor continuity abnormal (Bank 1 Sensor 1)
	\$82	\$8D	
	\$83	\$14	
	\$84	\$1E	A/F sensor range abnormal (Bank 1 Sensor 1)
	\$85	\$1E	
	\$86	\$20	A/F sensor response abnormal (Bank 1 Sensor 1)
\$02	\$07	\$0B	Oxygen sensor drop abnormal (Bank 1 Sensor 2)
	\$08	\$0B	
	\$A5	\$0B	
	\$05	\$10	Oxygen sensor response abnormal (Bank 1 Sensor 2)
	\$06	\$10	
\$21	\$89	\$20	Catalyst deterioration diagnosis (Bank 1)
\$31	\$8A	\$FD	EGR system diagnosis
\$39	\$93	\$FE	Evaporative emission control system (Cap off)
\$3B	\$94	\$FE	Evaporative emission control system (0.04 inch leak)
	\$95	\$FE	
\$3C	\$96	\$FE	Evaporative emission control system (0.02 inch leak)
	\$97	\$FE	
\$3D	\$98	\$FE	Evaporative emission control system (Purge flow)
\$41	\$99	\$24	A/F sensor heater abnormal (Bank 1 Sensor 1)
	\$9A	\$24	
	\$9B	\$14	A/F sensor heater characteristics abnormal (Bank 1 Sensor 1)
\$42	\$9C	\$24	Oxygen sensor heater abnormal (Bank 1 Sensor 1)
	\$9D	\$24	
\$A1	\$0B	\$24	Misfire monitoring (All cylinders)
	\$0C	\$24	
\$A2	\$0B	\$24	Misfire monitoring (#1 cylinder)
	\$0C	\$24	
\$A3	\$0B	\$24	Misfire monitoring (#2 cylinder)
	\$0C	\$24	
\$A4	\$0B	\$24	Misfire monitoring (#3 cylinder)
	\$0C	\$24	
\$A5	\$0B	\$24	Misfire monitoring (#4 cylinder)
	\$0C	\$24	

7. MODE \$07

Refer to the data of DTC (pending code) for troubleshooting result about emission in the first time.

8. MODE \$09

Refer to data of vehicle specification (V.I.N., calibration ID, diagnosis frequency etc.).

9. Subaru Select Monitor

A: OPERATION

1. HOW TO USE THE SUBARU SELECT MONITOR

1) Prepare the Subaru Select Monitor kit. <Ref. to EN(H4SO)(diag)-7, PREPARATION TOOL, General Description.>

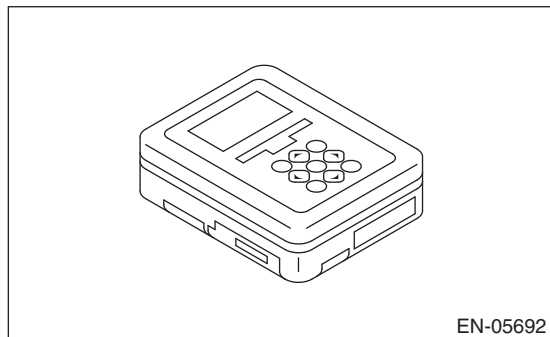

2) Prepare the personal computer which has been installed the Subaru Select Monitor.

3) Connect the USB cable between SDI (Subaru Diagnosis Interface) and USB port on the personal computer (dedicated port for the Subaru Select Monitor).

NOTE:

The dedicated port for the Subaru Select Monitor means the USB port which was used to install the Subaru Select Monitor.

4) Connect the diagnosis cable to the SDI.

5) Connect the SDI to data link connector located in the lower portion of the instrument panel (on the driver's side).

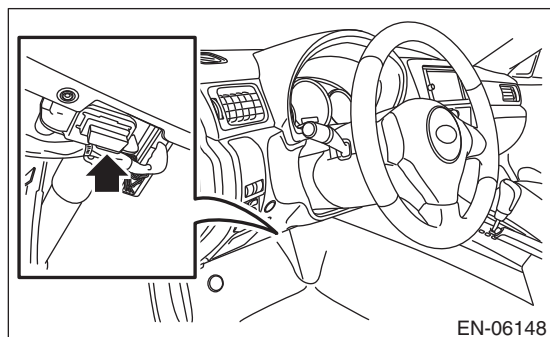

CAUTION:

Do not connect the scan tools except for Subaru Select Monitor and general scan tool.

6) Start up the personal computer.

7) Turn the ignition switch to ON (engine OFF), and run the "PC application for Subaru Select Monitor".

8) Call up DTC and data, then record them.

NOTE:

For detailed operation procedure, refer to the "PC application help for Subaru Select Monitor".

Subaru Select Monitor

ENGINE (DIAGNOSTICS)

2. READ CURRENT DATA FOR ENGINE (NORMAL MODE)

- 1) On the «Main Menu» display screen, select the {Each System Check}.
 - 2) On the «System Selection Menu» display screen, select the {Engine Control System}.
 - 3) Click the [OK] button after the information of engine type has been displayed.
 - 4) On the «Engine Diagnosis» display screen, select the {Current Data Display & Save}.
 - 5) On the «Current Data Display & Save» display screen, select the {Normal Sampling}.
 - 6) Using the scroll key, scroll the display screen up or down until the desired data is shown.
- A list of the support data is shown in the following table.

Remarks	Display	Unit of measure	Note (at idling)
Engine load	Engine Load	%	21.0%
Engine coolant temperature signal	Coolant Temp.	°C or °F	85°C or 185°F or more (after warm up)
A/F correction 1	A/F Correction #1	%	-0.8%
A/F learning 1	A/F Learning #1	%	0.0%
Intake manifold absolute pressure	Mani. Absolute Pressure	mmHg, kPa, inHg or psig	200 — 300 mmHg, 26.7 — 40 kPa, 7.8 — 11.8 inHg or 3.8 — 5.8 psig
Engine speed signal	Engine Speed	rpm	700 rpm (Agree with the tachometer indication)
Meter vehicle speed signal	Vehicle Speed	km/h or MPH	0 km/h or 0 MPH (at park- ing)
Ignition timing signal	Ignition Timing	deg	14 — 16 deg
Intake air temperature signal	Intake Air Temp.	°C or °F	(Ambient air temperature)
Amount of intake air	Mass Air Flow	g/s or lb/m	2.5 g/s or 0.33 lb/m
Throttle opening angle signal	Throttle Opening Angle	%	2.0%
Rear oxygen sensor voltage	Rear O2 Sensor	V	0.1 — 0.7 V
Battery voltage	Battery Voltage	V	12 — 14 V
Mass air flow voltage	Air Flow Sensor Voltage	V	1.26 V
Injection 1 pulse width	Fuel Injection #1 Pulse	ms	2.82 ms
Atmospheric pressure signal	Atmosphere Pressure	mmHg, kPa, inHg or psig	(Atmosphere pressure)
Intake manifold relative pressure	Mani. Relative Pressure	mmHg, kPa, inHg or psig	(Air intake absolute pres- sure – atmosphere pres- sure)
Ignition learning value	Learned Ignition Timing	deg	0 deg
Acceleration opening angle signal	Accel. Opening Angle	%	0.0%
Fuel temperature signal	Fuel Temp.	°C or °F	+20°C or +68°F
Purge control solenoid duty ratio	CPC Valve Duty Ratio	%	0 — 3%
No. of EGR steps	No. of EGR steps	STEP	0 STEP
A/F sensor current value 1	A/F Sensor #1 Current	mA	-0.2 — 0.2 mA
A/F sensor resistance value 1	A/F Sensor #1 Resistance	Ω	32 Ω
A/F sensor output lambda 1	A/F Sensor #1	—	1.0
A/F correction 3	A/F Correction #3	%	0.3%
A/F learning 3	A/F Learning #3	%	0.00%
Throttle motor duty	Throttle Motor Duty	%	-15%
Throttle power supply voltage	Throttle Motor Voltage	V	(Battery voltage)
Sub throttle sensor voltage	Sub-Throttle Sensor	V	1.52 V
Main throttle sensor voltage	Main-Throttle Sensor	V	0.66 V
Sub accelerator sensor voltage	Sub-Accelerator Sensor	V	0.68 V
Main accelerator sensor voltage	Main-Accelerator Sensor	V	0.68 V
Memory vehicle speed	Memorized Cruise Speed	km/h or MPH	0 km/h or 0 MPH
Fuel level sensor signal	Fuel level resistance	Ω	2 — 96 Ω

Subaru Select Monitor

ENGINE (DIAGNOSTICS)

Remarks	Display	Unit of measure	Note (at idling)
Engine oil temperature	Oil Temperature	°C	≥ 85°C (After engine is warmed up.)
Oil switching solenoid valve duty R	OSV Duty R	%	16.9%
Oil switching solenoid valve duty L	OSV Duty L	%	16.9%
Oil switching solenoid valve current R	OSV Current R	mA	192 mA
Oil switching solenoid valve current L	OSV Current L	mA	192 mA
Variable valve lift mode	VVL Lift Mode	—	1
#1 cylinder roughness monitor	Roughness Monitor #1	—	0
#2 cylinder roughness monitor	Roughness Monitor #2	—	0
#3 cylinder roughness monitor	Roughness Monitor #3	—	0
#4 cylinder roughness monitor	Roughness Monitor #4	—	0
Knock sensor compensation	Knocking Correction	deg	0.0 deg
Fuel tank pressure signal	Fuel Tank Pressure	mmHg, kPa, inHg or psig	+7.7 mmHg, +1.1 kPa, +0.31 inHg or +0.15 psig
AT/MT identification terminal	AT Vehicle ID Signal	—	AT/MT
Delivery (test) mode terminal	Test Mode Signal	—	OFF
D check request flag	D-check Require Flag	—	OFF
Delivery (test) mode terminal	Delivery Mode Connector (Test Mode Connector)	—	OFF
Neutral position switch signal	Neutral Position Switch	—	ON
Soft idle switch signal	Idle Switch Signal	—	ON
Ignition switch signal	Ignition Switch	—	ON
Power steering switch signal	P/S Switch	—	OFF (when OFF)
Air conditioning switch signal	A/C Switch	—	OFF (when OFF)
Starter switch signal	Starter Switch	—	OFF
Rear oxygen monitor	Rear O2 Rich Signal	—	ON/OFF
Knocking signal	Knocking Signal	—	OFF
Crankshaft position sensor signal	Crankshaft Position Sig.	—	ON
Camshaft position sensor signal	Camshaft Position Sig.	—	ON
Rear defogger switch signal	Rear Defogger SW	—	OFF (when OFF)
Blower fan switch signal	Blower Fan SW	—	OFF (when OFF)
Light switch signal	Light Switch	—	OFF (when OFF)
A/C middle pressure switch signal	A/C Mid Pressure Switch	—	OFF (when OFF)
Air conditioner compressor relay output signal	A/C Compressor Signal	—	OFF (when OFF)
Radiator fan relay 1 signal	Radiator Fan Relay #1	—	OFF (when OFF)
Radiator fan relay 2 signal	Radiator Fan Relay #2	—	OFF (when OFF)
Fuel pump relay signal	Fuel Pump Relay	—	ON
PCV hose assembly diagnosis signal	Blow-by leak Connector	—	ON
Pressure control solenoid valve signal	PCV Solenoid Valve	—	OFF
Drain valve signal	Vent. Solenoid Valve	—	OFF
Variable valve lift diagnosis oil pressure switch signal 1	Eng. Oil Press. SW 1	—	ON
Variable valve lift diagnosis oil pressure switch signal 2	Eng. Oil Press. SW 2	—	ON
AT coordinate retard angle demand signal	Retard Signal from AT	—	OFF
AT coordinate fuel cut demand signal	Fuel Cut signal from AT	—	OFF
Vehicle dynamics control (VDC) torque down prohibition output	Ban of Torque Down	—	ON
Vehicle dynamics control (VDC) torque down demand	Request Torque Down VDC	—	OFF
AT coordinate permission signal	Torque Permission Signal	—	ON (OFF on MT vehicles)
Electronic throttle control motor relay signal	ETC Motor Relay	—	ON
Clutch switch signal	Clutch Switch	—	OFF (when OFF)

Subaru Select Monitor

ENGINE (DIAGNOSTICS)

Remarks	Display	Unit of measure	Note (at idling)
Stop light switch signal	Stop Light Switch	—	OFF (when OFF)
SET/COAST switch signal	SET/COAST Switch	—	OFF (when OFF)
RES/ACC switch signal	RESUME/ACCEL Switch	—	OFF (when OFF)
Brake switch signal	Brake Switch	—	OFF (when OFF)
Main switch signal	Main Switch	—	OFF (when OFF)
Body integrated unit data reception	Body Int. Unit Data	—	ON
Body integrated unit counter update	Body Int. Unit Count	—	ON
Cruise control cancel switch signal	CC Cancel SW	—	OFF (when OFF)
Malfunction indicator light signal	MIL On Flag	—	OFF (when unlit)

NOTE:

For detailed operation procedure, refer to the “PC application help for Subaru Select Monitor”.

3. READ CURRENT DATA FOR ENGINE (OBD MODE)

- 1) On the «Main Menu» display screen, select the {Each System Check}.
 - 2) On the «System Selection Menu» display screen, select the {Engine Control System}.
 - 3) Click the [OK] button after the information of engine type has been displayed.
 - 4) On the «Engine Diagnosis» display screen, select the {OBD System}.
 - 5) On the «OBD Menu» display screen, select the {Current Data Display & Save}.
 - 6) On the «Current Data Display & Save» display screen, select the {All Data Display}.
 - 7) Using the scroll key, scroll the display screen up or down until the desired data is shown.
- A list of the support data is shown in the following table.

Remarks	Display	Referential value (at idling)	Unit of measure
Number of diagnosis code	Number of Diag. Code:	0	—
Condition of malfunction indicator light	MI(MIL)	OFF	—
Monitoring test of misfire	Misfire monitoring (Supp)	YES	—
Monitoring test of misfire	Misfire monitoring (Rdy)	YES	—
Monitoring test of fuel system	Fuel system monitoring (Supp)	YES	—
Monitoring test of fuel system	Fuel system monitoring (Rdy)	YES	—
Monitoring test of comprehensive component	Component monitoring (Supp)	YES	—
Monitoring test of comprehensive component	Component monitoring (Rdy)	YES	—
Test of catalyst	Catalyst Diagnosis (Supp)	YES	—
Test of catalyst	Catalyst Diagnosis (Rdy)	NO	—
Test of heating-type catalyst	Heated catalyst (Supp)	NO	—
Test of heating-type catalyst	Heated catalyst (Rdy)	N/A	—
Test of evaporative emission purge control system	Evaporative purge system (Supp)	YES	—
Test of evaporative emission purge control system	Evaporative purge system (Rdy)	NO	—
Secondary air system test	Secondary air system (Supp)	NO	—
Secondary air system test	Secondary air system (Rdy)	N/A	—
Test of air conditioning system refrigerant	A/C system refrigerant (Supp)	NO	—
Test of air conditioning system refrigerant	A/C system refrigerant (Rdy)	N/A	—
Test of oxygen sensor	Oxygen sensor (Supp)	YES	—

Subaru Select Monitor

ENGINE (DIAGNOSTICS)

Remarks	Display	Referential value (at idling)	Unit of measure
Test of oxygen sensor	Oxygen sensor (Rdy)	NO	—
Test of oxygen sensor heater	O2 Heater Diagnosis (Supp)	YES	—
Test of oxygen sensor heater	O2 Heater Diagnosis (Rdy)	NO	—
Test of EGR system	EGR system (Supp)	YES	—
Test of EGR system	EGR system (Rdy)	NO	—
Air fuel ratio control system for bank 1	Fuel system for Bank 1	Cl_normal	—
Engine load data	Calculated load value	23.0	%
Engine coolant temperature signal	Coolant Temp.	92	°C
Short term fuel trim by front oxygen (A/F) sensor (Bank 1)	Short term fuel trim B1	-0.8	%
Long term fuel trim by front oxygen (A/F) sensor (Bank 1)	Long term fuel trim B1	0.0	%
Intake manifold absolute pressure signal	Mani. Absolute Pressure	28	kPa
Engine speed signal	Engine Speed	700	rpm
Vehicle speed signal	Vehicle Speed	0	km/h
#1 Cylinder ignition timing	Ignition timing adv. #1	16.0	°
Intake air temperature signal	Intake Air Temp.	36	°C
Amount of intake air	Mass Air Flow	2.7	g/s
Throttle position signal	Throttle Opening Angle	13	%
Oxygen sensor (Bank 1 Sensor 2)	Oxygen sensor #12	0.7	V
A/F correction (Bank 1 Sensor 2)	Short term fuel trim #12	0.0	%
On-board diagnostic system	OBD System	OBD/OBD2	—
Front oxygen (A/F) sensor (Bank 1 Sensor 1)	Oxygen sensor #11	Supported	—
Oxygen sensor (Bank 1 Sensor 2)	Oxygen sensor #12	Supported	—
Time elapsed after engine start	Time Since Engine Start	—	sec
Driving distance after the malfunction indicator light illuminates	Lighted MI lamp history	—	km
A/F lambda signal (Bank 1 Sensor 1)	A/F Sensor #11	1.001	—
A/F sensor output signal (Bank 1 Sensor 1)	A/F Sensor #11	2.79	V
Target EGR	Commanded EGR	—	%
EGR error	EGR Error	—	%
Evaporative purge	Commanded Evap Purge	0	%
Fuel level signal	Fuel Level	—	%
Number of warm ups after DTC clear	Number of warm ups	—	—
Driving distance after DTC clear	Meter since DTC cleared	—	km
Fuel tank pressure signal	Fuel Tank Pressure	1	Pa
Atmospheric pressure signal	Atmosphere Pressure	Atmospheric pressure	kPa
A/F lambda signal (Bank 1 Sensor 1)	A/F Sensor #11	1.001	—
A/F sensor current (Bank 1 Sensor 1)	A/F Sensor #11	0.00	mA
Catalyst temperature #1	Catalyst Temperature #11	—	°C
Monitoring test of misfire	Misfire monitoring (Enable)	YES	—
Monitoring test of misfire	Misfire monitoring (Comp)	NO	—
Monitoring test of fuel system	Fuel system monitoring (Enable)	YES	—
Monitoring test of fuel system	Fuel system monitoring (Comp)	NO	—
Monitoring test of comprehensive component	Component monitoring (Enable)	YES	—
Monitoring test of comprehensive component	Component monitoring (Comp)	NO	—

Subaru Select Monitor

ENGINE (DIAGNOSTICS)

Remarks	Display	Referential value (at idling)	Unit of measure
Test of catalyst	Catalyst Diagnosis (Enable)	YES	—
Test of catalyst	Catalyst Diagnosis (Comp)	NO	—
Test of heating-type catalyst	Heated catalyst (Enable)	N/A	—
Test of heating-type catalyst	Heated catalyst (Comp)	N/A	—
Test of evaporative emission purge control system	Evaporative purge system (Enable)	NO	—
Test of evaporative emission purge control system	Evaporative purge system (Comp)	NO	—
Secondary air system test	Secondary air system (Enable)	N/A	—
Secondary air system test	Secondary air system (Comp)	N/A	—
Test of air conditioning system refrigerant	A/C system refrigerant (Enable)	N/A	—
Test of air conditioning system refrigerant	A/C system refrigerant (Comp)	N/A	—
Test of oxygen sensor	Oxygen sensor (Enable)	YES	—
Test of oxygen sensor	Oxygen sensor (Comp)	NO	—
Test of oxygen sensor heater	O2 Heater Diagnosis (Enable)	YES	—
Test of oxygen sensor heater	O2 Heater Diagnosis (Comp)	NO	—
Test of EGR system	EGR system (Enable)	YES	—
Test of EGR system	EGR system (Comp)	NO	—
ECM power voltage	Control module voltage	13.789	V
Absolute load	Absolute Load Value	22	%
A/F ratio target lambda	Target Equivalence Ratio	0.976	—
Relative throttle opening angle	Relative Throttle Pos.	2	%
Ambient temperature	Ambient Temperature	Ambient air temperature	°C
Absolute throttle opening angle 2	Absolute Throttle Pos.#2	32	%
Absolute accelerator opening angle 1	Accelerator Pedal Pos.#1	13	%
Absolute accelerator opening angle 2	Accelerator Pedal Pos.#2	13	%
Target throttle opening angle	Target Throt. Act. Cont.	0	%
Engine operating time while malfunction indicator lit	Time while MIL lighted	—	min
Time elapsed after DTC clear	Time since DTC cleared	—	min
Fuel used	Type of fuel	GAS	—
Relative accelerator opening angle	Relative Accelera. Pos.	0	%

NOTE:

For detailed operation procedure, refer to the “PC application help for Subaru Select Monitor”.

4. READ FREEZE FRAME DATA FOR ENGINE (OBD MODE)

- 1) On the «Main Menu» display screen, select the {Each System Check}.
 - 2) On the «System Selection Menu» display screen, select the {Engine Control System}.
 - 3) Click the [OK] button after the information of engine type has been displayed.
 - 4) On the «Engine Diagnosis» display screen, select the {OBD System}.
 - 5) On the «OBD Menu» display screen, select the {Freeze Frame Data Display}.
- A list of the support data is shown in the following table.

Remarks	Display	Unit of measure
Freeze frame data DTC code	Freeze frame data	DTC
Air fuel ratio control system for bank 1	Fuel system for Bank 1	Cl_normal or Op_init.
Engine load data	Calculated load value	%
Engine coolant temperature signal	Coolant Temp.	°C or °F
Short term fuel trim by front oxygen (A/F) sensor	Short term fuel trim B1	%
Long term fuel trim by front oxygen (A/F) sensor	Long term fuel trim B1	%
Intake manifold absolute pressure signal	Mani. Absolute Pressure	mmHg, kPa, inHg or psig
Engine speed signal	Engine Speed	rpm
Vehicle speed signal	Vehicle Speed	km/h or MPH
Ignition timing advance for #1 cylinder	Ignition timing adv. #1	°
Intake air temperature signal	Intake Air Temp.	°C or °F
Amount of intake air	Mass Air Flow	g/s or lb/m
Throttle position signal	Throttle Opening Angle	%
Oxygen sensor (Bank 1 Sensor 2)	Oxygen sensor #12	V
A/F correction (Bank 1 Sensor 2)	Short term fuel trim #12	%
On-board diagnostic system	OBD System	—
Front oxygen (A/F) sensor (Bank 1 Sensor 1)	Oxygen sensor #11	Supported
Oxygen sensor (Bank 1 Sensor 2)	Oxygen sensor #12	Supported
Time elapsed after engine start	Time Since Engine Start	sec
Target EGR	Commanded EGR	%
EGR error	EGR Error	%
Evaporative purge	Commanded Evap Purge	%
Fuel level signal	Fuel Level	%
Fuel tank pressure signal	Fuel Tank Pressure	mmHg, kPa, inHg or psig
Atmospheric pressure	Atmosphere Pressure	mmHg, kPa, inHg or psig
ECM power voltage	Control module voltage	V
Absolute load	Absolute Load Value	%
A/F ratio target lambda	Target Equivalence Ratio	—
Relative throttle opening angle	Relative Throttle Pos.	%
Ambient temperature	Ambient Temperature	°C or °F
Absolute throttle opening angle 2	Absolute Throttle Pos.#2	%
Absolute accelerator opening angle 1	Accelerator Pedal Pos.#1	%
Absolute accelerator opening angle 2	Accelerator Pedal Pos.#2	%
Target throttle opening angle	Target Throt. Act. Cont.	%

NOTE:

For detailed operation procedure, refer to the “PC application help for Subaru Select Monitor”.

5. V.I.N REGISTRATION

- 1) On the «Main Menu» display screen, select the {Each System Check}.
- 2) On the «System Selection Menu» display screen, select the {Engine Control System}.
- 3) Click the [OK] button after the information of engine type has been displayed.
- 4) On the «Engine Diagnosis» display screen, select the {Entry VIN}.
- 5) Perform the procedures shown on the display screen.

NOTE:

For detailed operation procedure, refer to the “PC application help for Subaru Select Monitor”.

Read Diagnostic Trouble Code (DTC)

ENGINE (DIAGNOSTICS)

10. Read Diagnostic Trouble Code (DTC)

A: OPERATION

1. SUBARU SELECT MONITOR (NORMAL MODE)

- 1) On the «Main Menu» display screen, select the {Each System Check}.
- 2) On the «System Selection Menu» display screen, select the {Engine Control System}.
- 3) Click the [OK] button after the information of engine type has been displayed.
- 4) On the «Engine Diagnosis» display screen, select the {Diagnostic Code(s) Display}.
- 5) On the «Diagnostic Code(s) Display» screen, select the {Temporary Diagnostic Code(s)} or {Memorized Diagnostic Code(s)}.

NOTE:

- For detailed operation procedure, refer to the “PC application help for Subaru Select Monitor”.
- For details concerning DTC, refer to “List of Diagnostic Trouble Code (DTC)”. <Ref. to EN(H4SO)(diag)-82, List of Diagnostic Trouble Code (DTC).>

2. SUBARU SELECT MONITOR (OBD MODE)

- 1) On the «Main Menu» display screen, select the {Each System Check}.
- 2) On the «System Selection Menu» display screen, select the {Engine Control System}.
- 3) Click the [OK] button after the information of engine type has been displayed.
- 4) On the «Engine Diagnosis» display screen, select the {OBD System}.
- 5) On the «OBD Menu» display screen, select the {Diagnostic Code(s) Display}.
- 6) Make sure DTC is shown on the screen.

NOTE:

- For detailed operation procedure, refer to the “PC application help for Subaru Select Monitor”.
- For details concerning DTC, refer to “List of Diagnostic Trouble Code (DTC)”. <Ref. to EN(H4SO)(diag)-82, List of Diagnostic Trouble Code (DTC).>

3. GENERAL SCAN TOOL

Refer to data denoting emission-related powertrain DTC.

For details concerning DTC, refer to “List of Diagnostic Trouble Code (DTC)”. <Ref. to EN(H4SO)(diag)-82, List of Diagnostic Trouble Code (DTC).>

NOTE:

Refer to general scan tool manufacturer’s instruction manual to access powertrain DTC (MODE \$03).

11. Inspection Mode

A: PROCEDURE

Perform the diagnosis shown in the following DTC table.

When performing the diagnosis not listed in “List of Diagnostic Trouble Code (DTC)”, refer to the item on the drive cycle. <Ref. to EN(H4SO)(diag)-46, Drive Cycle.>

DTC	Item	Condition
P0031	HO2S Heater Control Circuit Low (Bank 1 Sensor 1)	—
P0032	HO2S Heater Control Circuit High (Bank 1 Sensor 1)	—
P0037	HO2S Heater Control Circuit Low (Bank 1 Sensor 2)	—
P0038	HO2S Heater Control Circuit High (Bank 1 Sensor 2)	—
P0077	Intake Valve Control Solenoid Circuit High (Bank 1)	—
P0083	Intake Valve Control Solenoid Circuit High (Bank 2)	—
P0102	Mass or Volume Air Flow Circuit Low Input	—
P0103	Mass or Volume Air Flow Circuit High Input	—
P0107	Manifold Absolute Pressure/Barometric Pressure Circuit Low Input	—
P0108	Manifold Absolute Pressure/Barometric Pressure Circuit High Input	—
P0112	Intake Air Temperature Sensor 1 Circuit Low	—
P0113	Intake Air Temperature Sensor 1 Circuit High	—
P0117	Engine Coolant Temperature Circuit Low	—
P0118	Engine Coolant Temperature Circuit High	—
P0122	Throttle/Pedal Position Sensor/Switch “A” Circuit Low	—
P0123	Throttle/Pedal Position Sensor/Switch “A” Circuit High	—
P0131	O2 Sensor Circuit Low Voltage (Bank 1 Sensor 1)	—
P0132	O2 Sensor Circuit High Voltage (Bank 1 Sensor 1)	—
P0137	O2 Sensor Circuit Low Voltage (Bank 1 Sensor 2)	—
P0138	O2 Sensor Circuit High Voltage (Bank 1 Sensor 2)	—
P0140	O2 Sensor Circuit No Activity Detected (Bank 1 Sensor 2)	—
P0182	Fuel Temperature Sensor “A” Circuit Low Input	—
P0183	Fuel Temperature Sensor “A” Circuit High Input	—
P0197	Engine Oil Temperature Sensor Low	—
P0198	Engine Oil Temperature Sensor High	—
P0222	Throttle/Pedal Position Sensor/Switch “B” Circuit Low	—
P0223	Throttle/Pedal Position Sensor/Switch “B” Circuit High	—
P0327	Knock Sensor 1 Circuit Low (Bank 1 or Single Sensor)	—
P0328	Knock Sensor 1 Circuit High (Bank 1 or Single Sensor)	—
P0335	Crankshaft Position Sensor “A” Circuit	—
P0336	Crankshaft Position Sensor “A” Circuit Range/Performance	—
P0340	Camshaft Position Sensor “A” Circuit (Bank 1 or Single Sensor)	—
P0341	Camshaft Position Sensor “A” Circuit Range/Performance (Bank 1 or Single Sensor)	—
P0447	Evaporative Emission Control System Vent Control Circuit Open	—
P0448	Evaporative Emission Control System Vent Control Circuit Shorted	—
P0452	Evaporative Emission Control System Pressure Sensor Low Input	—
P0453	Evaporative Emission Control System Pressure Sensor High Input	—
P0458	Evaporative Emission System Purge Control Valve Circuit Low	—
P0462	Fuel Level Sensor “A” Circuit Low	—
P0463	Fuel Level Sensor “A” Circuit High	—
P0500	Vehicle Speed Sensor “A”	—
P0512	Starter Request Circuit	—
P0513	Incorrect Immobilizer Key	—

Inspection Mode

ENGINE (DIAGNOSTICS)

DTC	Item	Condition
P0600	Serial Communication Link	—
P0604	Internal Control Module Random Access Memory (RAM) Error	—
P0605	Internal Control Module Read Only Memory (ROM) Error	—
P0607	Throttle Control System Circuit Range/Performance	—
P0638	Throttle Actuator Control Range/Performance (Bank 1)	—
P0700	Transmission Control System (MIL Request)	—
P0851	Park/Neutral Switch Input Circuit Low	—
P0852	Park/Neutral Switch Input Circuit High	—
P1152	O2 Sensor Circuit Range/Performance (Low) (Bank 1 Sensor 1)	—
P1153	O2 Sensor Circuit Range/Performance (High) (Bank 1 Sensor 1)	—
P1160	Return Spring Failure	—
P1400	Fuel Tank Pressure Control Solenoid Valve Circuit Low	—
P1420	Fuel Tank Pressure Control Sol. Valve Circuit High	—
P1491	Positive Crankcase Ventilation (Blow-by) Function Problem	—
P1560	Back-up Voltage Circuit Malfunction	—
P1570	Antenna	—
P1571	Reference Code Incompatibility	—
P1572	IMM Circuit Failure (Except Antenna Circuit)	—
P1574	Key Communication Failure	—
P1576	EGI Control Module EEPROM	—
P1577	IMM Control Module EEPROM	—
P1578	Meter Failure	—
P2101	Throttle Actuator Control Motor Circuit Range/Performance	—
P2102	Throttle Actuator Control Motor Circuit Low	—
P2103	Throttle Actuator Control Motor Circuit High	—
P2109	Throttle/Pedal Position Sensor "A" Minimum Stop Performance	—
P2122	Throttle/Pedal Position Sensor/Switch "D" Circuit Low Input	—
P2123	Throttle/Pedal Position Sensor/Switch "D" Circuit High Input	—
P2127	Throttle/Pedal Position Sensor/Switch "E" Circuit Low Input	—
P2128	Throttle/Pedal Position Sensor/Switch "E" Circuit High Input	—
P2135	Throttle/Pedal Position Sensor/Switch "A"/"B" Voltage Correlation	—
P2138	Throttle/Pedal Position Sensor/Switch "D"/"E" Voltage Correlation	—
P2227	Barometric Pressure Circuit Range/Performance	—
P2228	Barometric Pressure Circuit Low	—
P2229	Barometric Pressure Circuit High	—

1. PREPARATION FOR THE INSPECTION MODE

1) Check that the battery voltage is 12 V or more and fuel remains approx. half [20 — 40 ℓ (5.3 — 10.6 US gal, 4.4 — 8.8 Imp gal)].

2) Lift up the vehicle using a garage jack and place it on rigid racks, or drive the vehicle onto free rollers.

WARNING:

- Before lifting up the vehicle, ensure parking brakes are applied.
- Do not use a pantograph jack in place of a rigid rack.
- Secure a rope or wire to the front or rear towing hooks to prevent the lateral runout of front wheels.
- Before rotating the wheels, make sure that there is no one in front of the vehicle. Besides while the wheels are rotating, make sure that no one approaches the vehicle front side.
- Make sure that there is nothing around the wheels. For AWD model, pay special attention to all four wheels.
- While servicing, do not depress or release the clutch pedal or accelerator pedal quickly regardless of the engine speed. Quick operation may cause the vehicle to drop off the free roller.
- To prevent the vehicle from slipping due to vibration, do not place anything between rigid rack and the vehicle.

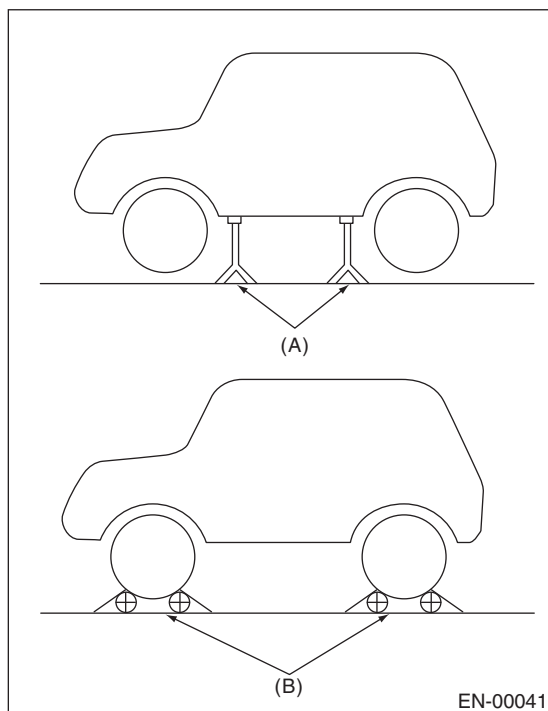

EN-00041

- (A) Rigid racks
- (B) Free rollers

2. SUBARU SELECT MONITOR

1) After clearing the memory, check for any remaining unresolved trouble data. <Ref. to EN(H4SO)(diag)-51, Clear Memory Mode.>

2) Warm up the engine.

3) Prepare the Subaru Select Monitor kit. <Ref. to EN(H4SO)(diag)-7, PREPARATION TOOL, General Description.>

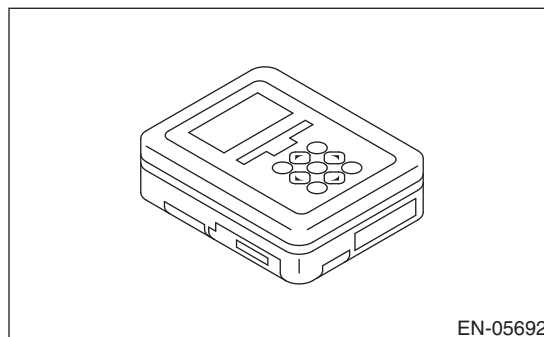

4) Prepare the personal computer which has been installed the Subaru Select Monitor.

5) Connect the USB cable between SDI (Subaru Diagnosis Interface) and USB port on the personal computer (dedicated port for the Subaru Select Monitor).

NOTE:

The dedicated port for the Subaru Select Monitor means the USB port which was used to install the Subaru Select Monitor.

6) Connect the diagnosis cable to the SDI.

7) Connect the delivery (test) mode connector (A) located under the glove box.

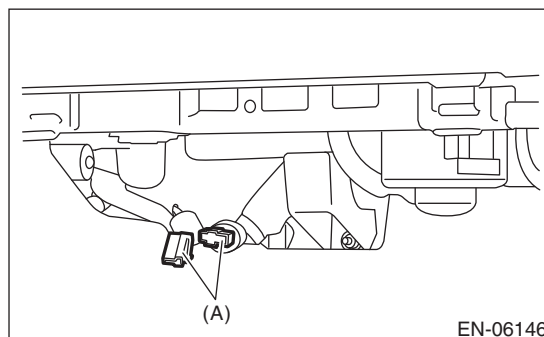

Inspection Mode

ENGINE (DIAGNOSTICS)

8) Connect the SDI to data link connector located in the lower portion of the instrument panel (on the driver's side).

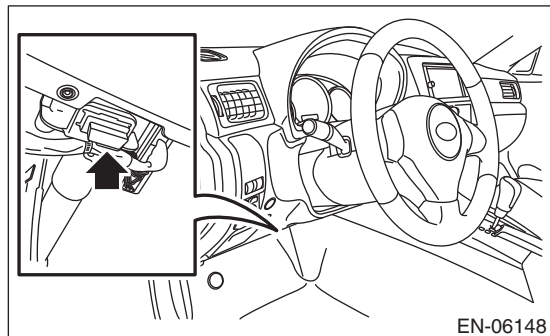

CAUTION:

Do not connect any scan tools except Subaru Select Monitor and general scan tool.

9) Start up the personal computer.

10) Turn the ignition switch to ON (engine OFF), and run the "PC application for Subaru Select Monitor".

11) On the «Main Menu» display screen, select the {Each System Check}.

12) On the «System Selection Menu» display screen, select the {Engine Control System}.

13) Click the [OK] button after the information of engine type has been displayed.

14) On the «Engine Diagnosis» display screen, select the {Dealer Check Mode Procedure}.

15) When the «Perform Inspection (Dealer Check Mode)» is shown on the screen, click the [Next] button.

16) Perform subsequent procedures as instructed on the display screen.

- If trouble still remains in the memory, the corresponding DTC appears on the display screen.

NOTE:

- For detailed operation procedure, refer to the "PC application help for Subaru Select Monitor".
- For details concerning DTC, refer to "List of Diagnostic Trouble Code (DTC)". <Ref. to EN(H4SO)(diag)-82, List of Diagnostic Trouble Code (DTC).>
- Release the parking brake.
- The speed difference between front and rear wheels may illuminate the ABS warning light, but this does not indicate a malfunction. When engine control diagnosis is finished, perform the ABS memory clearance procedure of self-diagnosis function. <Ref. to VDC(diag)-24, Clear Memory Mode.>

3. GENERAL SCAN TOOL

1) After performing the diagnostics and clearing the memory, check for any remaining unresolved trouble data. <Ref. to EN(H4SO)(diag)-51, Clear Memory Mode.>

2) Warm up the engine.

3) Connect the delivery (test) mode connector (A) located under the glove box.

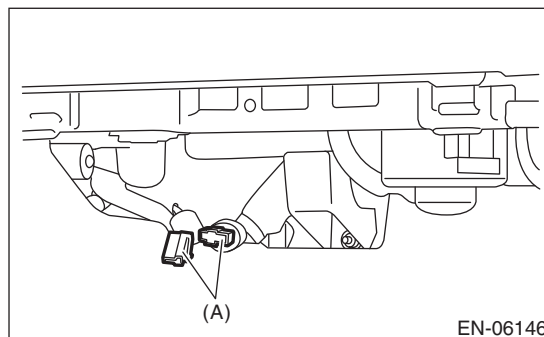

4) Connect the general scan tool to data link connector located in the lower portion of the instrument panel (on the driver's side).

CAUTION:

Do not connect any scan tools except Subaru Select Monitor and general scan tool.

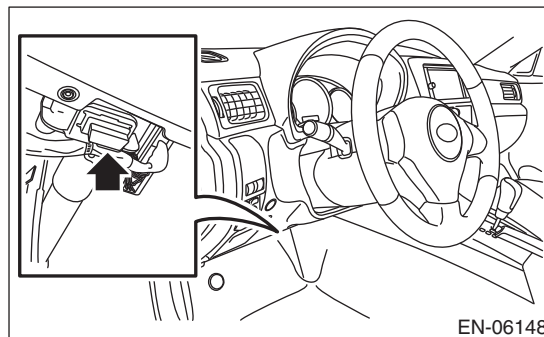

5) Start the engine.

NOTE:

- Ensure the select lever is placed in "P" range before starting. (AT model)
 - Depress the clutch pedal when starting engine. (MT model)
- 6) Turn the neutral position switch to ON using select lever or shift lever.
- 7) Depress the brake pedal to turn the brake switch ON. (AT model)
- 8) Keep the engine speed in 2,500 — 3,000 rpm range for 40 seconds.

9) Place the select lever or shift lever in D position (AT model) or 1st gear (MT model) and drive the vehicle at 5 to 10 km/h (3 to 6 MPH).

NOTE:

- For AWD model, release the parking brake.
- The speed difference between front and rear wheels may illuminate the ABS warning light, but this indicates no malfunctions. When engine control diagnosis is finished, perform the ABS memory clearance procedure of self-diagnosis system. <Ref. to VDC(diag)-24, Clear Memory Mode.>

10) Using the general scan tool, check DTC and record the result(s).

NOTE:

- For detailed operation procedures, refer to the general scan tool operation manual.
- For details concerning DTC, refer to “List of Diagnostic Trouble Code (DTC)”. <Ref. to EN(H4SO)(diag)-82, List of Diagnostic Trouble Code (DTC).>

Drive Cycle

ENGINE (DIAGNOSTICS)

12. Drive Cycle

A: PROCEDURE

For the troubleshooting, there are driving patterns described below. Driving in the specified pattern allows to diagnose malfunctioning items listed below. After the repair of the following trouble items, be sure to drive the vehicle with the specified drive patterns to check whether the function is resumed correctly.

1. PREPARATION FOR DRIVE CYCLE

- 1) Check that the battery voltage is 12 V or more and fuel remains approx. half [20 — 40 ℓ (5.3 — 10.6 US gal, 4.4 — 8.8 Imp gal)].
- 2) After performing the diagnostics and clearing the memory, check for any remaining unresolved trouble data. <Ref. to EN(H4SO)(diag)-51, Clear Memory Mode.>
- 3) Disconnect the delivery (test) mode connector.

NOTE:

- Perform the diagnosis after warming up the engine except when the engine coolant temperature at starting is specified.
- Perform the diagnosis twice if the DTC marked with *. After completing the first diagnosis, stop the engine and perform second diagnosis in same condition.

2. DRIVE CYCLE A — DRIVE THE VEHICLE WITH 80 KM/H (50 MPH) FOR 20 MINUTES, AND THEN IDLE THE ENGINE FOR A MINUTE

DTC	Item	Condition
*P0125	Insufficient Coolant Temperature for Closed Loop Fuel Control	Coolant temperature at start is less than 20°C (68°F).
*P0128	Coolant Thermostat	—
*P0133	O2 Sensor Circuit Slow Response (Bank 1 Sensor 1)	—
*P0171	System Too Lean (Bank 1)	Diagnosis completes in drive cycle B or C as well.
*P0172	System Too Rich (Bank 1)	Diagnosis completes in drive cycle B or C as well.
P0196	Oil Temp. Sensor Circuit Range/Performance Problem	—
*P0301	Cylinder 1 Misfire Detected	Diagnosis completes in drive cycle B or C as well.
*P0302	Cylinder 2 Misfire Detected	Diagnosis completes in drive cycle B or C as well.
*P0303	Cylinder 3 Misfire Detected	Diagnosis completes in drive cycle B or C as well.
*P0304	Cylinder 4 Misfire Detected	Diagnosis completes in drive cycle B or C as well.
*P0420	Catalyst System Efficiency Below Threshold	—
*P0442	Evaporative Emission Control System Leak Detected (Small Leak)	Engine coolant temperature at engine start is less than 30°C (86°F).
*P0451	Fuel Tank Pressure Sensor Performance Problem	—
*P0456	Evaporative Emission Control System Leak Detected (Very Small Leak)	Engine coolant temperature at engine start is less than 30°C (86°F).
*P0457	Evaporative Emission Control System Leak Detected (Fuel Cap Loose/Off)	Engine coolant temperature at engine start is less than 30°C (86°F).
*P0459	Evaporative Emission System Purge Control Valve Circuit High	—
P1443	Vent Control Solenoid Valve Function Problem	—
*P2096	Post Catalyst Fuel Trim System Too Lean (Bank 1)	Diagnosis completes in drive cycle B or C as well.
*P2097	Post Catalyst Fuel Trim System Too Rich (Bank 1)	Diagnosis completes in drive cycle B or C as well.

3. DRIVE CYCLE B — 10 MINUTES IDLING

NOTE:

Drive the vehicle at 10 km/h (6 MPH) or faster before diagnosis.

DTC	Item	Condition
*P0126	Insufficient Engine Coolant Temperature for Stable Operation	—
*P0171	System Too Lean (Bank 1)	Diagnosis completes in drive cycle A or C as well.
*P0172	System Too Rich (Bank 1)	Diagnosis completes in drive cycle A or C as well.
*P0301	Cylinder 1 Misfire Detected	Diagnosis completes in drive cycle A or C as well.
*P0302	Cylinder 2 Misfire Detected	Diagnosis completes in drive cycle A or C as well.
*P0303	Cylinder 3 Misfire Detected	Diagnosis completes in drive cycle A or C as well.
*P0304	Cylinder 4 Misfire Detected	Diagnosis completes in drive cycle A or C as well.
*P0464	Fuel Level Sensor Circuit Intermittent	—
*P0506	Idle Control System RPM Lower than Expected	—
*P0507	Idle Control System RPM Higher than Expected	—
*P2096	Post Catalyst Fuel Trim System Too Lean (Bank 1)	Diagnosis completes in drive cycle A or C as well.
*P2097	Post Catalyst Fuel Trim System Too Rich (Bank 1)	Diagnosis completes in drive cycle A or C as well.

Drive Cycle

ENGINE (DIAGNOSTICS)

4. DRIVE CYCLE C — DRIVE THE VEHICLE WITH FOLLOWING DRIVE PATTERNS

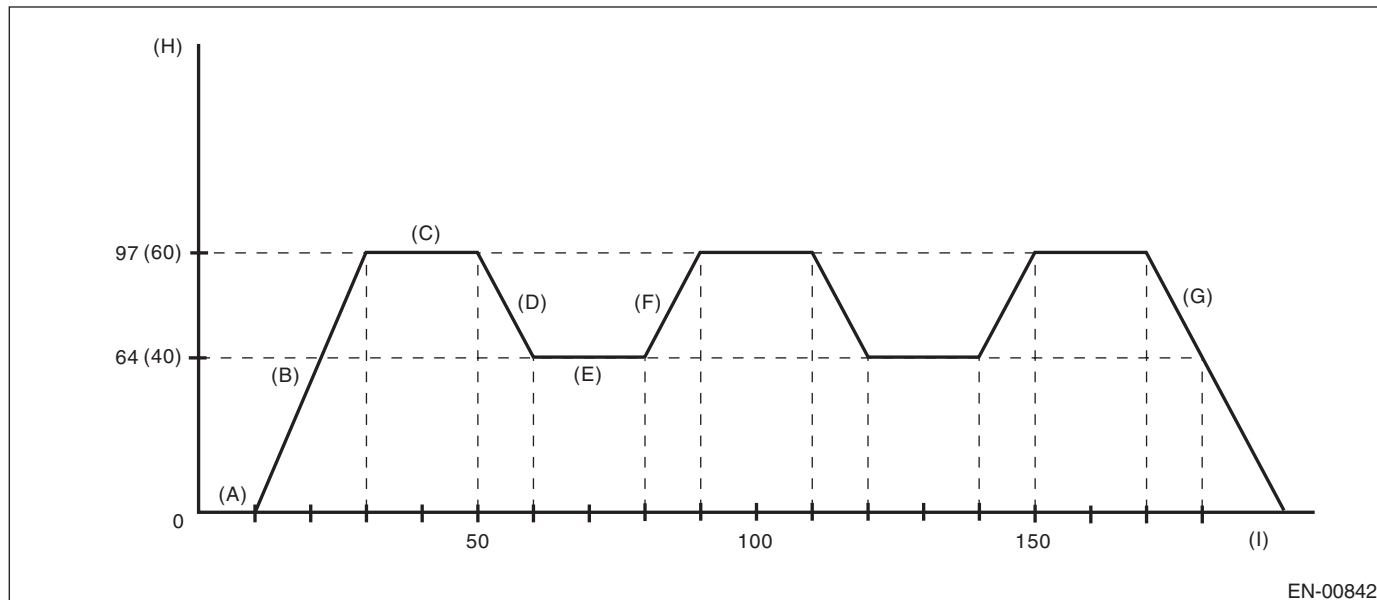

- | | | |
|---|--|--|
| (A) Idle the engine for 10 seconds or more. | (D) Decelerate with fully closed throttle to 64 km/h (40 MPH). | (G) Stop vehicle with the throttle fully closed. |
| (B) Accelerate to 97 km/h (60 MPH) within 20 seconds. | (E) Drive the vehicle at 64 km/h (40 MPH) for 20 seconds. | (H) Vehicle speed km/h (MPH) |
| (C) Drive the vehicle at 97 km/h (60 MPH) for 20 seconds. | (F) Accelerate to 97 km/h (60 MPH) within 10 seconds. | (I) Sec. |

DTC	Item	Condition
P0026	Intake Valve Control Solenoid Circuit Range/Performance (Bank 1)	—
P0028	Intake Valve Control Solenoid Circuit Range/Performance (Bank 2)	—
*P0030	HO2S Heater Control Circuit (Bank 1 Sensor 1)	—
*P0068	MAP/MAF - Throttle Position Correlation	—
P0076	Intake Valve Control Solenoid Circuit Low (Bank 1)	—
P0082	Intake Valve Control Solenoid Circuit Low (Bank 2)	—
*P0101	Mass or Volume Air Flow Circuit Range/Performance	—
*P0134	O2 Sensor Circuit No Activity Detected (Bank 1 Sensor 1)	—
*P0139	O2 Sensor Circuit Slow Response (Bank 1 Sensor 2)	—
*P0171	System Too Lean (Bank 1)	Diagnosis completes in drive cycle A or B as well.
*P0172	System Too Rich (Bank 1)	Diagnosis completes in drive cycle A or B as well.
*P0301	Cylinder 1 Misfire Detected	Diagnosis completes in drive cycle A or B as well.
*P0302	Cylinder 2 Misfire Detected	Diagnosis completes in drive cycle A or B as well.
*P0303	Cylinder 3 Misfire Detected	Diagnosis completes in drive cycle A or B as well.
*P0304	Cylinder 4 Misfire Detected	Diagnosis completes in drive cycle A or B as well.
*P0400	Exhaust Gas Recirculation Flow	—
P1492	EGR Solenoid Valve Signal #1 Circuit Malfunction (Low Input)	—
P1493	EGR Solenoid Valve Signal #1 Circuit Malfunction (High Input)	—
P1494	EGR Solenoid Valve Signal #2 Circuit Malfunction (Low Input)	—
P1495	EGR Solenoid Valve Signal #2 Circuit Malfunction (High Input)	—

Drive Cycle

ENGINE (DIAGNOSTICS)

DTC	Item	Condition
P1496	EGR Solenoid Valve Signal #3 Circuit Malfunction (Low Input)	—
P1497	EGR Solenoid Valve Signal #3 Circuit Malfunction (High Input)	—
P1498	EGR Solenoid Valve Signal #4 Circuit Malfunction (Low Input)	—
P1499	EGR Solenoid Valve Signal #4 Circuit Malfunction (High Input)	—
*P2096	Post Catalyst Fuel Trim System Too Lean (Bank 1)	Diagnosis completes in drive cycle A or B as well.
*P2097	Post Catalyst Fuel Trim System Too Rich (Bank 1)	Diagnosis completes in drive cycle A or B as well.

5. DRIVE CYCLE D

• DRIFT DIAGNOSIS

- 1) Check that the engine coolant temperature at engine start is less than 30°C (86°F).
- 2) Make sure that fuel remains 10 ℓ (2.6 US gal, 2.2 Imp gal) or more and the battery voltage is 10.9 V or more.
- 3) Start the engine, and check that the engine coolant temperature increases by 10°C (50°F) or more, and reaches 75°C (167°F) or more, when the engine is warmed up.
- 4) Idle the engine for 120 seconds or more in the condition of step 3.

• STUCK DIAGNOSIS

- 1) Make sure that the battery voltage is 10.9 V or more.
- 2) Perform the Clear Memory Mode. <Ref. to EN(H4SO)(diag)-51, Clear Memory Mode.>
- 3) Drive the vehicle for the distance equal to the fuel of 50 ℓ (13.2 US gal, 11 Imp gal).

NOTE:

- It is acceptable to drive the vehicle intermittently.
- Do not disconnect the battery terminals while diagnosing. (Data will be cleared by disconnecting the battery terminals.)

DTC	Item	Condition
P0181	Fuel Temperature Sensor "A" Circuit Range/Performance	—

6. DRIVE CYCLE E

- 1) Make sure that the battery voltage is 10.9 V or more.
- 2) Perform the Clear Memory Mode. <Ref. to EN(H4SO)(diag)-51, Clear Memory Mode.>
- 3) Drive the vehicle for the distance equal to the fuel of 30 ℓ (7.9 US gal, 6.6 Imp gal).

NOTE:

- It is acceptable to drive the vehicle intermittently.
- Do not disconnect the battery terminals while diagnosing. (Data will be cleared by disconnecting the battery terminals.)

DTC	Item	Condition
P0461	Fuel Level Sensor "A" Circuit Range/Performance	—

7. DRIVE CYCLE F

- 1) Check that the engine coolant temperature at engine start is less than 30°C (86°F).
- 2) Start the engine, and warm it up until engine coolant temperature increases over 95°C (203°F).
- 3) After the engine has reached the state of procedure 2), idle the engine for 10 minutes or more.

NOTE:

Do not disconnect the battery terminals while diagnosing. (Data will be cleared by disconnecting the battery terminals.)

DTC	Item	Condition
P0111	Intake Air Temperature Sensor 1 Circuit Range/Performance	—

Drive Cycle

ENGINE (DIAGNOSTICS)

8. DRIVE CYCLE H

- 1) Perform the Clear Memory Mode. <Ref. to EN(H4SO)(diag)-51, Clear Memory Mode.>
- 2) With the ignition switch ON, read the engine coolant temperature, intake air temperature and fuel temperature. <Ref. to EN(H4SO)(diag)-34, READ CURRENT DATA FOR ENGINE (NORMAL MODE), OPERATION, Subaru Select Monitor.>
- 3) If the values from step 2) satisfy the following two conditions, start the engine.

Condition:

|Engine coolant temperature — Intake air temperature | ≤ 5°C (41°F)

|Engine coolant temperature — Fuel temperature | ≤ 2°C (36°F)

NOTE:

- If the conditions are not satisfied, turn the ignition switch to OFF and wait until the parameters are satisfied.
 - Start AT vehicles in the P range, and MT vehicles in the neutral position.
- 4) Idle the engine for 1 minute under the conditions in step 3).

DTC	Item	Condition
*P1602	Control Module Programming Error	—

13. Clear Memory Mode

A: OPERATION

NOTE:

If the Clear Memory Mode is executed from Subaru Select Monitor OBD mode, only DTCs are cleared.

1. SUBARU SELECT MONITOR (NORMAL MODE)

- 1) On the «Main Menu» display screen, select the {Each System Check}.
- 2) On the «System Selection Menu» display screen, select the {Engine Control System}.
- 3) Click the [OK] button after the information of engine type has been displayed.
- 4) On the «Engine Diagnosis» display screen, select the {Clear Memory}.
- 5) When the “Clear Memory?” is shown on the screen, click the [Yes] button.
- 6) When “Done” and “Turn ignition switch to OFF” is shown on the display screen, turn the ignition switch to OFF.

NOTE:

- Initial diagnosis of electronic throttle control is performed after memory clearance. Therefore, start the engine 10 seconds or more after turning the ignition switch to ON.
- For detailed operation procedure, refer to the “PC application help for Subaru Select Monitor”.

2. SUBARU SELECT MONITOR (OBD MODE)

- 1) On the «Main Menu» display screen, select the {Each System Check}.
- 2) On the «System Selection Menu» display screen, select the {Engine Control System}.
- 3) Click the [OK] button after the information of engine type has been displayed.
- 4) On the «Engine Diagnosis» display screen, select the {OBD System}.
- 5) On the «OBD Menu» display screen, select the {Clear Diagnostic Code?}.
- 6) When the “Clear Diagnostic Code?” is shown on the screen, click the [Yes] button.
- 7) When “Done” and “Turn ignition switch to OFF” is shown on the display screen, turn the ignition switch to OFF.

NOTE:

- Initial diagnosis of electronic throttle control is performed after memory clearance. Therefore, start the engine 10 seconds or more after turning the ignition switch to ON.
- For detailed operation procedure, refer to the “PC application help for Subaru Select Monitor”.

3. GENERAL SCAN TOOL

For clear memory procedures using the general scan tool, refer to “General Scan Tool Instruction Manual”.

NOTE:

Initial diagnosis of electronic throttle control is performed after memory clearance. For this reason, start the engine after 10 seconds or more have elapsed since the ignition switch was turned to ON.

Compulsory Valve Operation Check Mode

ENGINE (DIAGNOSTICS)

14. Compulsory Valve Operation Check Mode

A: OPERATION

1) Prepare the Subaru Select Monitor kit. <Ref. to EN(H4SO)(diag)-7, PREPARATION TOOL, General Description.>

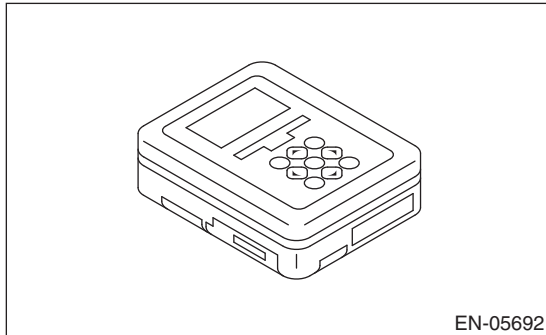

2) Prepare the personal computer which has been installed the Subaru Select Monitor.

3) Connect the USB cable between SDI (Subaru Diagnosis Interface) and USB port on the personal computer (dedicated port for the Subaru Select Monitor).

NOTE:

The dedicated port for the Subaru Select Monitor means the USB port which was used to install the Subaru Select Monitor.

4) Connect the diagnosis cable to the SDI.

5) Connect the delivery (test) mode connector (A) located under the glove box.

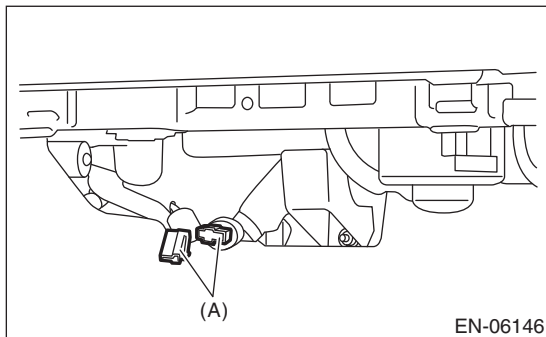

6) Connect the SDI to data link connector located in the lower portion of the instrument panel (on the driver's side).

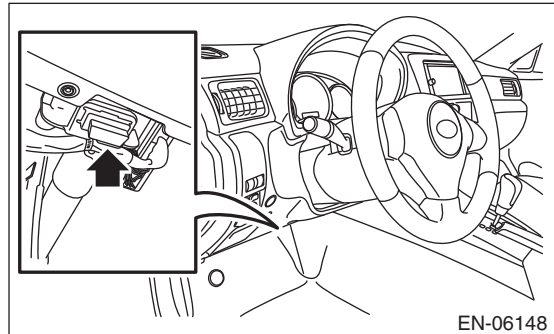

CAUTION:

Do not connect the scan tools except for Subaru Select Monitor and general scan tool.

7) Start up the personal computer.

8) Turn the ignition switch to ON (engine OFF), and run the "PC application for Subaru Select Monitor".

9) On the «Main Menu» display screen, select the {Each System Check}.

10) On the «System Selection Menu» display screen, select the {Engine Control System}.

11) Click the [OK] button after the information of engine type has been displayed.

12) On the «Engine Diagnosis» display screen, select the {System Operation Check Mode}.

13) On the «System Operation Check Mode» display screen, select the {Actuator ON/OFF Operation}.

14) Select the desired compulsory actuator on the «Actuator ON/OFF Operation» display screen and click the [Next] button.

Compulsory Valve Operation Check Mode

ENGINE (DIAGNOSTICS)

15) Clicking the [End] button completes the compulsory valve operation check mode. The display will then return to the «Actuator ON/OFF Operation» screen.

- A list of the support data is shown in the following table.

Description	Display
Compulsory fuel pump relay operation check	Fuel Pump Relay
Compulsory purge control solenoid valve operation check	CPC Solenoid Valve
Compulsory radiator fan relay operation check	Radiator Fan Relay
Compulsory air conditioning relay operation check	A/C Compressor Relay
Compulsory pressure control solenoid valve operation check	PCV Solenoid Valve
Compulsory drain valve operation check	Vent. Solenoid Valve

NOTE:

- The following parts will be displayed but not functional.

Display
EGR Solenoid Valve
ASV Solenoid Valve
FICD Solenoid
Pressure Switching Sol.1
Pressure Switching Sol.2
AAI Solenoid Valve
Fuel Tank Sensor Control Valve
Turbocharger Wastegate Solenoid
EXH. Bypass Control Permit Flag
Secondary Air Combi Valve 1

- For detailed operation procedure, refer to the “PC application help for Subaru Select Monitor”.

System Operation Check Mode

ENGINE (DIAGNOSTICS)

15. System Operation Check Mode

A: OPERATION

1) Prepare the Subaru Select Monitor kit. <Ref. to EN(H4SO)(diag)-7, PREPARATION TOOL, General Description.>

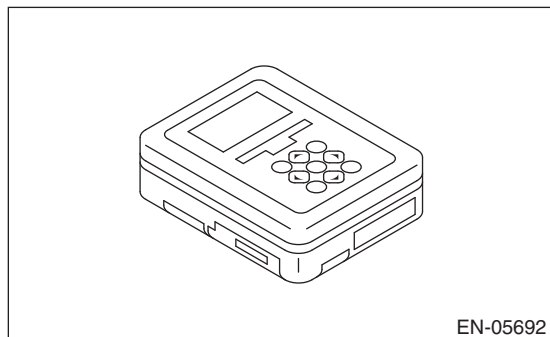

2) Prepare the personal computer which has been installed the Subaru Select Monitor.

3) Connect the USB cable between SDI (Subaru Diagnosis Interface) and USB port on the personal computer (dedicated port for the Subaru Select Monitor).

NOTE:

The dedicated port for the Subaru Select Monitor means the USB port which was used to install the Subaru Select Monitor.

4) Connect the diagnosis cable to the SDI.

5) Connect the SDI to data link connector located in the lower portion of the instrument panel (on the driver's side).

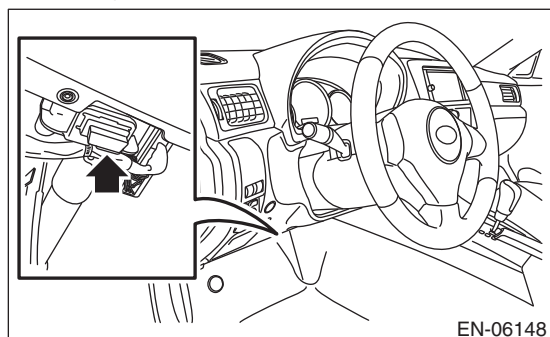

CAUTION:

Do not connect the scan tools except for Subaru Select Monitor and general scan tool.

6) Start up the personal computer.

7) Turn the ignition switch to ON (engine OFF), and run the "PC application for Subaru Select Monitor".

8) On the «Main Menu» display screen, select the {Each System Check}.

9) On the «System Selection Menu» display screen, select the {Engine Control System}.

10) Click the [OK] button after the information of engine type has been displayed.

11) On the «Engine Diagnosis» display screen, select the {System Operation Check Mode}.

12) The following items will be displayed on screen.

Display
Actuator ON/OFF Operation
Immobilizer System
Fuel Pump Control
Fixed Idle Ignition Timing
Idle Speed Control
Injector Control
EGR Valve Control

1. FUEL PUMP CONTROL (OFF DRIVE)

CAUTION:

After executing the operation check mode, execute the Clear Memory Mode. <Ref. to EN(H4SO)(diag)-51, OPERATION, Clear Memory Mode.>

1) On the «System Operation Check Mode» display, select the {Fuel Pump Control}.

2) On the «Fuel Pump Control» display screen, select the {OFF Drive}.

3) On the «Start the Engine» display screen, start the engine and click the [OK] button.

4) On the «OFF Drive» display screen, click the [Execution] button and execute OFF drive.

5) Click the [Cancel] button to stop the OFF drive.

6) Click the [Exit] button to end the OFF drive. The screen will return to the «Fuel Pump Control» screen.

NOTE:

For detailed operation procedure, refer to the "PC application help for Subaru Select Monitor".

2. FUEL PUMP CONTROL (ON/OFF DRIVE)

CAUTION:

After executing the operation check mode, execute the Clear Memory Mode. <Ref. to EN(H4SO)(diag)-51, OPERATION, Clear Memory Mode.>

1) On the «System Operation Check Mode» display, select the {Fuel Pump Control}.

2) On the «Fuel Pump Control» display screen, select the {ON/OFF Dr.}.

3) On the «Turn Ignition Switch ON with Engine OFF» display screen, turn the ignition switch to ON and click the [OK] button.

4) On the «ON/OFF Dr.» display screen, click the [Execution] button and execute ON/OFF drive.

5) Click the [Cancel] button to stop the ON/OFF drive.

6) Click the [Exit] button to end the ON/OFF drive. The screen will return to the «Fuel Pump Control» screen.

NOTE:

For detailed operation procedure, refer to the "PC application help for Subaru Select Monitor".

3. IDLING IGNITION TIMING FIXED

CAUTION:

After executing the operation check mode, execute the Clear Memory Mode. <Ref. to EN(H4SO)(diag)-51, OPERATION, Clear Memory Mode.>

- 1) On the «System Operation Check Mode» display screen, select the {Fixed Idle Ignition Timing}.
- 2) On the «Start the Engine» display screen, start the engine and click the [OK] button.
- 3) On the «Fixed Idle Ignition Timing» display screen, click the [Execution] button and execute idling ignition timing fixed.
- 4) Click the [Cancel] button to stop the idling ignition timing fixed.
- 5) Click the [Exit] button to end the idling ignition timing fixed. The screen will return to the «System Operation Check Mode» screen.

NOTE:

For detailed operation procedure, refer to the “PC application help for Subaru Select Monitor”.

4. IDLE SPEED CONTROL

CAUTION:

After executing the operation check mode, execute the Clear Memory Mode. <Ref. to EN(H4SO)(diag)-51, OPERATION, Clear Memory Mode.>

- 1) On the «System Operation Check Mode» display screen, select the {Idle Speed Control}.
- 2) On the «Start the Engine» display screen, start the engine and click the [OK] button.
- 3) In the «Idle Speed Control» display screen, click the [△] button or the [▽] button to change the setting values, then click the [OK] button. Setting is possible in a range from 500 rpm to 2,000 rpm, in increments of 50 rpm. However, the engine speed that can actually be controlled will vary depending on the vehicle.
- 4) Click the [Cancel] button to stop the idle speed control.
- 5) Click the [Exit] button to end the idle speed control. The screen will return to the «System Operation Check Mode» screen.

NOTE:

For detailed operation procedure, refer to the “PC application help for Subaru Select Monitor”.

5. INJECTOR CONTROL (INJECTION STOP MODE)

CAUTION:

After executing the operation check mode, execute the Clear Memory Mode. <Ref. to EN(H4SO)(diag)-51, OPERATION, Clear Memory Mode.>

- 1) On the «System Operation Check Mode» display, select the {Injector Control}.
- 2) On the «Injector Control» display screen, select the {Injection Stop Mode}.
- 3) On the «Injection Stop Mode» display screen, select a fuel injector to be stopped.
- 4) On the «Start the Engine» display screen, start the engine and click the [OK] button.
- 5) On the «Fuel Injector #» display screen, click the [Execution] button and execute injection stop mode.
- 6) Click the [Cancel] button to stop the injection stop mode.
- 7) Click the [Exit] button to return the «Injection Stop Mode» display screen.
- 8) On the «Injection Stop Mode» display screen, click the [Return] button to end the «Injection Stop Mode». The screen will return to the «Injector Control» screen.

NOTE:

For detailed operation procedure, refer to the “PC application help for Subaru Select Monitor”.

6. INJECTOR CONTROL (INJECTION QUANTITY CONTROL)

CAUTION:

After executing the operation check mode, execute the Clear Memory Mode. <Ref. to EN(H4SO)(diag)-51, OPERATION, Clear Memory Mode.>

- 1) On the «System Operation Check Mode» display, select the {Injector Control}.
- 2) On the «Injector Control» display screen, select the {Injection Quantity Control}.
- 3) On the «Start the Engine» display screen, start the engine and click the [OK] button.
- 4) In the «Injection Quantity Control» screen, click the [△] button or the [▽] button to change the setting values, then click the [OK] button. Setting is possible in a range from 0 to 20%, in increments of 1%.
- 5) Click the [Cancel] button to stop the injection quantity control.
- 6) Click the [Exit] button to end the injection quantity control. The screen will return to the «Injector Control» screen.

NOTE:

For detailed operation procedure, refer to the “PC application help for Subaru Select Monitor”.

System Operation Check Mode

ENGINE (DIAGNOSTICS)

7. EGR VALVE CONTROL

CAUTION:

After executing the operation check mode, execute the Clear Memory Mode. <Ref. to EN(H4SO)(diag)-51, OPERATION, Clear Memory Mode.>

1) On the «System Operation Check Mode» display, select the {EGR Valve Control}.

2) On the «Start the Engine» display screen, start the engine and click the [OK] button.

3) In the «EGR Valve Control» screen, click the [△] button or the [▽] button to change the setting values, then click the [OK] button.

Setting is possible in 1 STEP increments. However, the number of steps that can actually be controlled will vary depending on the vehicle.

4) Click the [Cancel] button to stop the EGR valve control.

5) Click the [F12 Exit] button to end the EGR valve control. The screen will return to the «System Operation Check Mode» screen.

NOTE:

For detailed operation procedure, refer to the “PC application help for Subaru Select Monitor”.

16. Malfunction Indicator Light

A: PROCEDURE

1. Activation of malfunction indicator light. <Ref. to EN(H4SO)(diag)-58, ACTIVATION OF MALFUNCTION INDICATOR LIGHT, Malfunction Indicator Light.>
↓
2. Malfunction indicator light does not come on. <Ref. to EN(H4SO)(diag)-59, MALFUNCTION INDICATOR LIGHT DOES NOT COME ON, Malfunction Indicator Light.>
↓
3. Malfunction indicator light does not go off. <Ref. to EN(H4SO)(diag)-61, MALFUNCTION INDICATOR LIGHT DOES NOT GO OFF, Malfunction Indicator Light.>
↓
4. Malfunction indicator light does not blink. <Ref. to EN(H4SO)(diag)-62, MALFUNCTION INDICATOR LIGHT DOES NOT BLINK, Malfunction Indicator Light.>
↓
5. Malfunction indicator light remains blinking. <Ref. to EN(H4SO)(diag)-64, MALFUNCTION INDICATOR LIGHT REMAINS BLINKING, Malfunction Indicator Light.>

Malfunction Indicator Light

ENGINE (DIAGNOSTICS)

B: ACTIVATION OF MALFUNCTION INDICATOR LIGHT

1) When the ignition switch is turned to ON (engine OFF), the malfunction indicator light (A) in the combination meter illuminates.

NOTE:

If the malfunction indicator light does not illuminate, perform diagnostics of the malfunction indicator light circuit or the combination meter circuit. <Ref. to EN(H4SO)(diag)-59, MALFUNCTION INDICATOR LIGHT DOES NOT COME ON, Malfunction Indicator Light.>

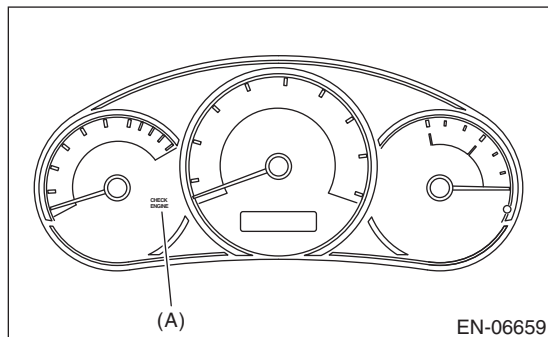

2) After starting the engine, the malfunction indicator light goes out. If it does not go off, either the engine or emission control system has malfunction.

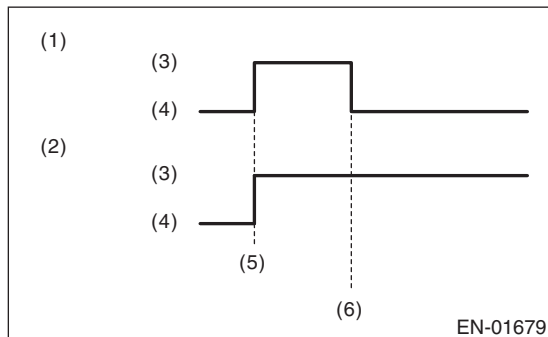

- (1) No faulty
- (2) Trouble occurs
- (3) ON
- (4) OFF
- (5) Ignition switch ON
- (6) Engine start

3) Turn the ignition switch to OFF and connect the delivery (test) mode connector.

(1) When the ignition switch is turned to ON (engine OFF), the malfunction indicator light illuminates.

(2) After the engine starts, malfunction indicator light blinks in a cycle of 0.5 Hz. (During diagnosis)

(3) Malfunction indicator light blinks at a cycle of 3 Hz after diagnosis if there is no trouble. Malfunction indicator light illuminates if faulty.

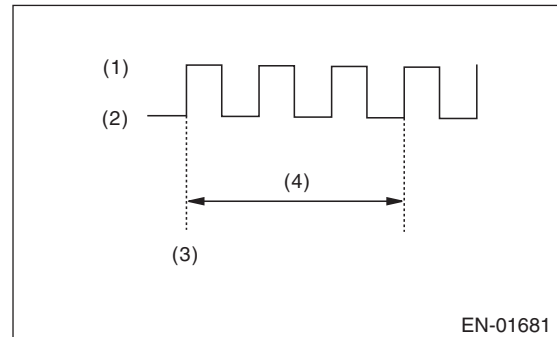

- (1) ON
- (2) OFF
- (3) Ignition switch ON
- (4) 1 second

Malfunction Indicator Light

ENGINE (DIAGNOSTICS)

C: MALFUNCTION INDICATOR LIGHT DOES NOT COME ON

DIAGNOSIS:

The malfunction indicator light circuit is open or shorted.

TROUBLE SYMPTOM:

When the ignition switch is turned to ON (engine OFF), malfunction indicator light does not come on.

WIRING DIAGRAM:

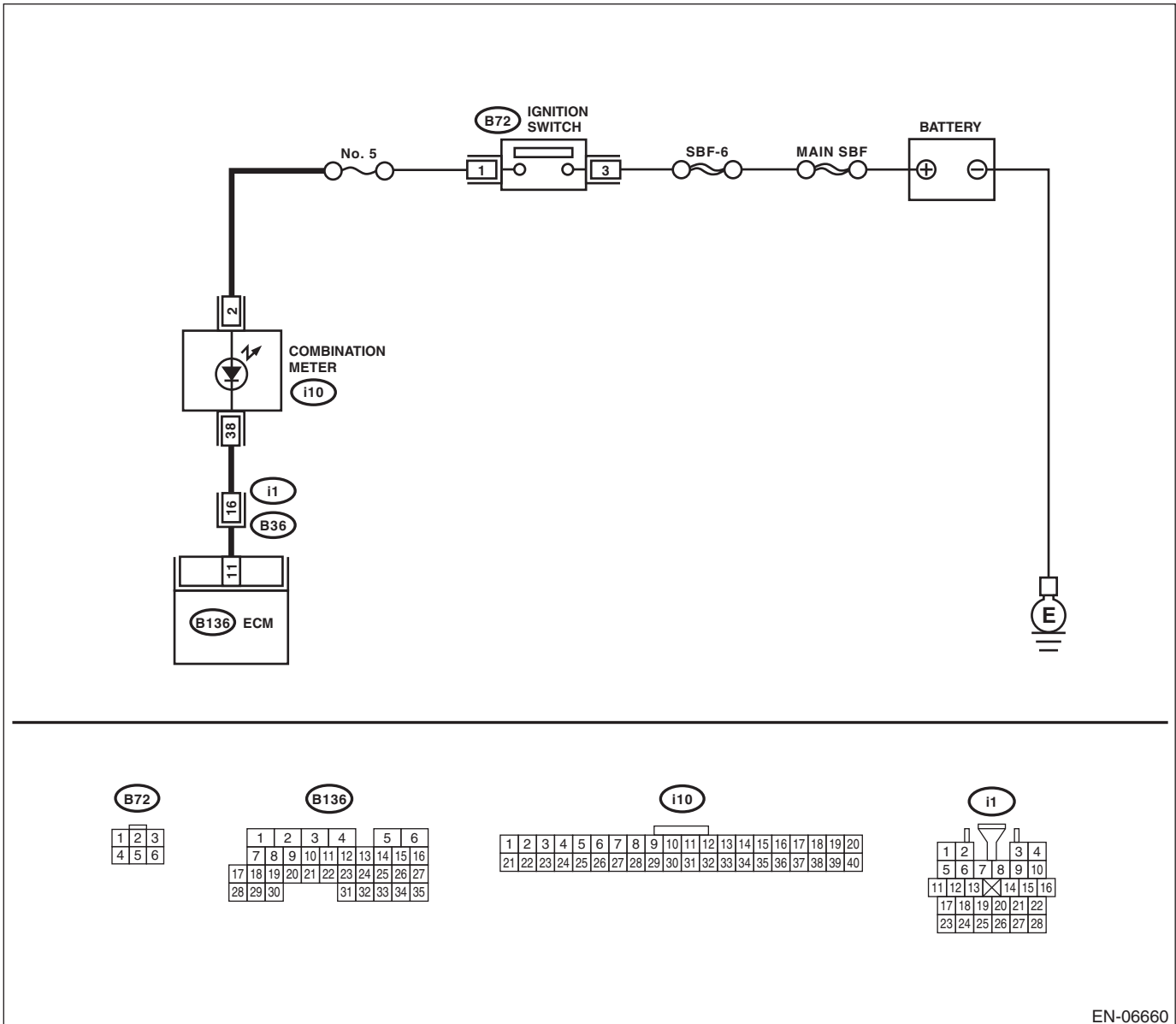

EN-06660

Malfunction Indicator Light

ENGINE (DIAGNOSTICS)

Step	Check	Yes	No
1 CHECK OUTPUT SIGNAL OF ECM. 1) Turn the ignition switch to ON. 2) Measure the voltage between ECM connector and chassis ground. Connector & terminal (B136) No. 11 (+) — Chassis ground (-):	Is the voltage less than 1 V?	Go to step 4.	Go to step 2.
2 CHECK POOR CONTACT. Check for poor connection by shaking or pulling ECM connector and harness.	Does the malfunction indicator light illuminate?	Repair poor contact of the ECM connector.	Go to step 3.
3 CHECK ECM CONNECTOR. Check the connection of ECM connector.	Is the ECM connector correctly connected?	Replace the ECM. <Ref. to FU(H4SO)-39, Engine Control Module (ECM).>	Repair the connection of ECM connector.
4 CHECK HARNESS BETWEEN COMBINATION METER AND ECM CONNECTOR. 1) Turn the ignition switch to OFF. 2) Remove the combination meter. <Ref. to IDI-16, Combination Meter.> 3) Disconnect the connector from ECM and combination meter. 4) Measure the resistance of harness between ECM and combination meter connector. Connector & terminal (B136) No. 11 — (i10) No. 38:	Is the resistance less than 1 Ω ?	Go to step 5.	Repair the harness and connector. NOTE: In this case, repair the following item: • Open circuit of harness between ECM and combination meter connector • Poor contact of coupling connector
5 CHECK POOR CONTACT. Check for poor contact of combination meter connector.	Is there poor contact in combination meter connector?	Repair the poor contact of combination meter connector.	Go to step 6.
6 CHECK HARNESS BETWEEN COMBINATION METER AND IGNITION SWITCH CONNECTOR. 1) Turn the ignition switch to ON. 2) Measure the voltage between combination meter connector and chassis ground. Connector & terminal (i10) No. 2 (+) — Chassis ground (-):	Is the voltage 10 V or more?	Replace the combination meter circuit board. <Ref. to IDI-16, Combination Meter.>	Check the following item and repair if necessary. NOTE: • Blown out of fuse (No. 5) • Open or short circuit in harness between fuse (No. 5) and battery terminal • Poor contact of ignition switch connector

Malfunction Indicator Light

ENGINE (DIAGNOSTICS)

Step	Check	Yes	No
1 CHECK STATUS OF MALFUNCTION INDICATOR LIGHT. 1) Turn the ignition switch to OFF. 2) Disconnect the delivery (test) mode connector. 3) Turn the ignition switch to ON. (engine OFF)	Does the malfunction indicator light illuminate?	Go to step 2.	Repair the malfunction indicator light circuit. <Ref. to EN(H4SO)(diag)-59, MALFUNCTION INDICATOR LIGHT DOES NOT COME ON, Malfunction Indicator Light.>
2 CHECK HARNESS BETWEEN COMBINATION METER AND ECM CONNECTOR. 1) Turn the ignition switch to OFF. 2) Disconnect the connectors from the ECM. 3) Turn the ignition switch to ON.	Does the malfunction indicator light illuminate?	Repair the ground short circuit of harness between ECM and combination meter connector.	Go to step 3.
3 CHECK HARNESS BETWEEN DELIVERY (TEST) MODE CONNECTOR AND ECM. 1) Turn the ignition switch to OFF. 2) Disconnect the connectors from the ECM. 3) Measure the resistance of harness between delivery (test) mode connector and ECM. Connector & terminal (B76) No. 1 — (B136) No. 6: (B75) No. 1 — (B135) No. 27:	Is the resistance less than 1 Ω?	Go to step 4.	Repair the harness and connector. NOTE: In this case, repair the following item: • Open circuit of harness between ECM and delivery (test) mode connector • Poor contact of joint connector
4 CHECK POOR CONTACT. Check for poor contact of the ECM connector.	Is there poor contact in ECM connector?	Repair poor contact of the ECM connector.	Replace the ECM. <Ref. to FU(H4SO)-39, Engine Control Module (ECM).>

Malfunction Indicator Light

ENGINE (DIAGNOSTICS)

F: MALFUNCTION INDICATOR LIGHT REMAINS BLINKING

DIAGNOSIS:

The delivery (test) mode connector circuit is shorted.

TROUBLE SYMPTOM:

Malfunction indicator light blinks when delivery (test) mode connector is not connected.

WIRING DIAGRAM:

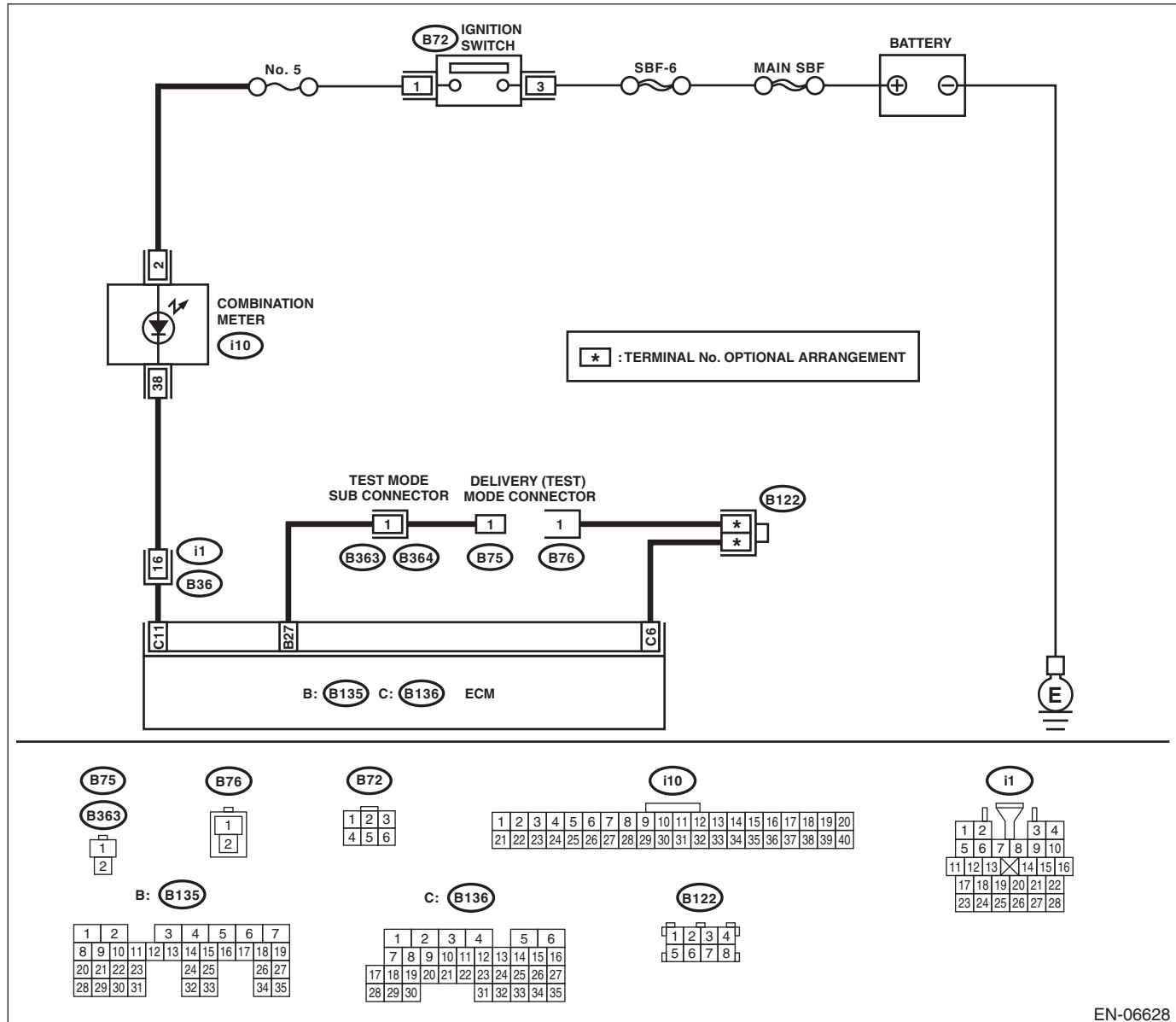

EN-06628

Malfunction Indicator Light

ENGINE (DIAGNOSTICS)

Step	Check	Yes	No
1 CHECK DELIVERY (TEST) MODE CONNECTOR. 1) Disconnect the delivery (test) mode connector. 2) Turn the ignition switch to ON.	Does the malfunction indicator light blink?	Go to step 2.	System is normal. NOTE: Malfunction indicator light blinks when delivery (test) mode connector is connected.
2 CHECK HARNESS BETWEEN ECM AND CHASSIS GROUND. 1) Turn the ignition switch to OFF. 2) Disconnect the connectors from the ECM. 3) Measure the resistance of harness between ECM connector and chassis ground. Connector & terminal (B135) No. 27 — Chassis ground:	Is the resistance less than 5 Ω?	Repair the short circuit to ground in harness between ECM and delivery (test) mode connector.	Replace the ECM. <Ref. to FU(H4SO)-39, Engine Control Module (ECM).>

Diagnostics for Engine Starting Failure

ENGINE (DIAGNOSTICS)

17. Diagnostics for Engine Starting Failure

A: PROCEDURE

1. Check of the fuel amount
↓
2. Inspection of starter motor circuit. <Ref. to EN(H4SO)(diag)-67, STARTER MOTOR CIRCUIT, Diagnostics for Engine Starting Failure.>
↓
3. Inspection of ECM power supply and ground line. <Ref. to EN(H4SO)(diag)-71, CHECK POWER SUPPLY AND GROUND LINE OF ENGINE CONTROL MODULE (ECM), Diagnostics for Engine Starting Failure.>
↓
4. Inspection of ignition control system. <Ref. to EN(H4SO)(diag)-73, IGNITION CONTROL SYSTEM, Diagnostics for Engine Starting Failure.>
↓
5. Inspection of fuel pump circuit. <Ref. to EN(H4SO)(diag)-76, FUEL PUMP CIRCUIT, Diagnostics for Engine Starting Failure.>
↓
6. Inspection of fuel injector circuit. <Ref. to EN(H4SO)(diag)-78, FUEL INJECTOR CIRCUIT, Diagnostics for Engine Starting Failure.>

B: STARTER MOTOR CIRCUIT

CAUTION:

After repair or replacement of faulty parts, perform Clear Memory Mode <Ref. to EN(H4SO)(diag)-51, Clear Memory Mode.> and Inspection Mode <Ref. to EN(H4SO)(diag)-41, Inspection Mode.>

WIRING DIAGRAM:

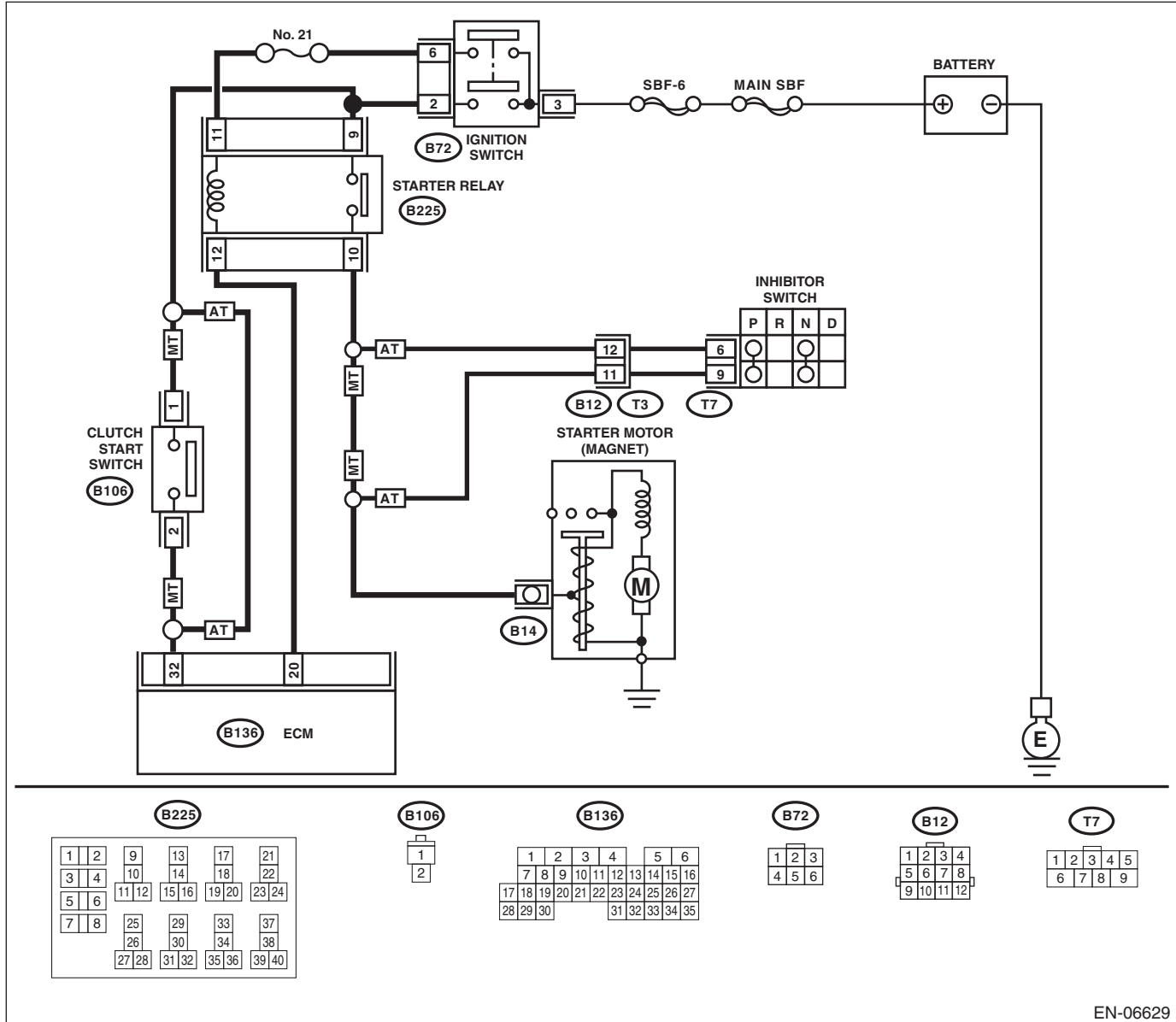

EN-06629

Diagnostics for Engine Starting Failure

ENGINE (DIAGNOSTICS)

Step	Check	Yes	No	
1	CHECK BATTERY. Check the battery voltage.	Is the voltage 12 V or more?	Go to step 2.	Charge or replace the battery.
2	CHECK OPERATION OF STARTER MOTOR.	Does the starter motor operate?	Go to step 3.	Go to step 4.
3	CHECK DTC.	Is DTC displayed? <Ref. to EN(H4SO)(diag)-40, OPERATION, Read Diagnostic Trouble Code (DTC).>	Check the appropriate DTC using the List of Diagnostic Trouble Code (DTC). <Ref. to EN(H4SO)(diag)-82, List of Diagnostic Trouble Code (DTC).>	The circuit has returned to a normal condition at this time. Reproduce the failure, and then perform the diagnosis again. NOTE: In this case, there may be a temporary connector contact failure.
4	CHECK INPUT SIGNAL FOR STARTER MOTOR. 1) Turn the ignition switch to OFF. 2) Disconnect the connector from starter motor. 3) On AT models, set the select lever to the "P" range or "N" range, and on MT models, depress the clutch pedal. 4) Turn the ignition switch to START. 5) Measure the voltage between the starter motor connector and the engine ground. Connector & terminal (B14) No. 1 (+) — Engine ground (-):	Is the voltage 10 V or more?	Check the starter motor. <Ref. to SC(H4SO)-6, Starter.>	Go to step 5.
5	CHECK HARNESS BETWEEN BATTERY AND IGNITION SWITCH CONNECTOR. 1) Turn the ignition switch to OFF. 2) Disconnect the connector from ignition switch. 3) Measure the voltage between ignition switch connector and chassis ground. Connector & terminal (B72) No. 3 (+) — Chassis ground (-):	Is the voltage 10 V or more?	Go to step 6.	Check the following item and repair if necessary. • Blown out of fuse • Open or ground short circuit of harness between ignition switch connector and battery
6	CHECK IGNITION SWITCH. Measure the resistance between ignition switch terminals after turning the ignition switch to START position. Terminals No. 3 — No. 2: No. 3 — No. 6:	Is the resistance less than 1 Ω ?	Go to step 7.	Replace the ignition switch. <Ref. to SL-36, REPLACEMENT, Ignition Key Lock.>
7	CHECK INPUT VOLTAGE OF STARTER RELAY. 1) Remove the starter relay. 2) Connect the connector to ignition switch. 3) Measure the voltage between starter relay connector and chassis ground after turning the ignition switch to START position. Connector & terminal (B225) No. 9 (+) — Chassis ground (-): (B225) No. 11 (+) — Chassis ground (-):	Is the voltage 10 V or more?	Go to step 8.	Repair open circuit or short circuit to ground in harness between starter relay connector and ignition switch connector.

Diagnostics for Engine Starting Failure

ENGINE (DIAGNOSTICS)

Step	Check	Yes	No
8 CHECK STARTER RELAY. 1) Connect the battery to starter relay terminals No. 11 and No. 12. 2) Measure the resistance between starter relay terminals. <i>Terminals</i> <i>No. 9 — No. 10:</i>	Is the resistance less than 1 Ω ?	Go to step 9.	Replace the starter relay.
9 CHECK HARNESS BETWEEN ECM AND STARTER RELAY. 1) Turn the ignition switch to OFF. 2) Disconnect the connectors from the ECM. 3) Measure the resistance of harness between ECM and starter relay connector. <i>Connector & terminal</i> <i>(B136) No. 20 — (B225) No. 12:</i>	Is the resistance less than 1 Ω ?	Go to step 10.	Repair the open circuit of harness between ECM and starter relay connector.
10 CHECK TRANSMISSION TYPE.	Is the transmission type AT?	Go to step 11.	Go to step 15.
11 CHECK ECM INPUT VOLTAGE. 1) Turn the ignition switch to START. 2) Measure the input voltage between ECM connector and chassis ground. <i>Connector & terminal</i> <i>(B136) No. 32 (+) — Chassis ground (-):</i>	Is the voltage 10 V or more?	Go to step 12.	Repair the open circuit in harness between ECM and ignition switch connector.
12 CHECK HARNESS BETWEEN STARTER RELAY AND INHIBITOR SWITCH. 1) Turn the ignition switch to OFF. 2) Disconnect the connector from inhibitor switch. 3) Measure the resistance of harness between starter relay connector and inhibitor relay connector. <i>Connector & terminal</i> <i>(B225) No. 10 — (T7) No. 6:</i>	Is the resistance less than 1 Ω ?	Go to step 13.	Repair the harness and connector. NOTE: In this case, repair the following item: • Open circuit in harness between starter relay connector and inhibitor switch connector • Poor contact of coupling connector
13 CHECK HARNESS BETWEEN INHIBITOR SWITCH AND STARTER MOTOR. Measure the resistance of harness between the inhibitor switch connector and starter motor. <i>Connector & terminal</i> <i>(T7) No. 9 — (B14) No. 1:</i>	Is the resistance less than 1 Ω ?	Go to step 14.	Repair the harness and connector. NOTE: In this case, repair the following item: • Open circuit in harness between inhibitor switch connector and starter motor • Poor contact of coupling connector
14 CHECK INHIBITOR SWITCH. 1) Place the select lever in other than "P" range and "N" range. 2) Measure the resistance between inhibitor switch terminals. <i>Terminals</i> <i>No. 6 — No. 9:</i>	Is the resistance 1 M Ω or more?	Check the ECM power supply and ground line. <Ref. to EN(H4SO)(diag)-71, CHECK POWER SUPPLY AND GROUND LINE OF ENGINE CONTROL MODULE (ECM), Diagnostics for Engine Starting Failure.>	Replace the inhibitor switch. <Ref. to 4AT-46, Inhibitor Switch.>

Diagnostics for Engine Starting Failure

ENGINE (DIAGNOSTICS)

Step	Check	Yes	No
15 CHECK HARNESS BETWEEN IGNITION SWITCH AND CLUTCH START SWITCH. 1) Turn the ignition switch to OFF. 2) Disconnect the connector from clutch start switch. 3) Turn the ignition switch to START. 4) Measure the voltage between the clutch start switch connector and chassis ground. Connector & terminal (B106) No. 1 (+) — Chassis ground (-):	Is the voltage 10 V or more?	Go to step 16.	Repair the open circuit in harness between ignition switch connector and clutch start switch connector.
16 CHECK CLUTCH START SWITCH. Measure the resistance between clutch start switch terminals while depressing the clutch pedal. Terminals No. 1 — No. 2:	Is the resistance less than 1 Ω ?	Go to step 17.	Replace the clutch start switch. <Ref. to CL-26, Clutch Switch.>
17 CHECK HARNESS BETWEEN ECM AND CLUTCH START SWITCH. Measure the resistance of harness between ECM and clutch start switch connector. Connector & terminal (B136) No. 32 — (B106) No. 2:	Is the resistance less than 1 Ω ?	Go to step 18.	Repair the open circuit of harness between ECM and clutch start switch connector.
18 CHECK HARNESS BETWEEN STARTER RELAY AND STARTER MOTOR. Measure the resistance of harness between starter relay connector and starter motor. Connector & terminal (B225) No. 10 — (B14) No. 1:	Is the resistance less than 1 Ω ?	Check the ECM power supply and ground line. <Ref. to EN(H4SO)(diag)-71, CHECK POWER SUPPLY AND GROUND LINE OF ENGINE CONTROL MODULE (ECM), Diagnostics for Engine Starting Failure.>	Repair the open circuit of the harness between starter relay connector and starter motor.

Diagnostics for Engine Starting Failure

ENGINE (DIAGNOSTICS)

C: CHECK POWER SUPPLY AND GROUND LINE OF ENGINE CONTROL MODULE (ECM)

CAUTION:

After repair or replacement of faulty parts, perform Clear Memory Mode <Ref. to EN(H4SO)(diag)-51, OPERATION, Clear Memory Mode.> and Inspection Mode <Ref. to EN(H4SO)(diag)-41, PROCEDURE, Inspection Mode.>.

WIRING DIAGRAM:

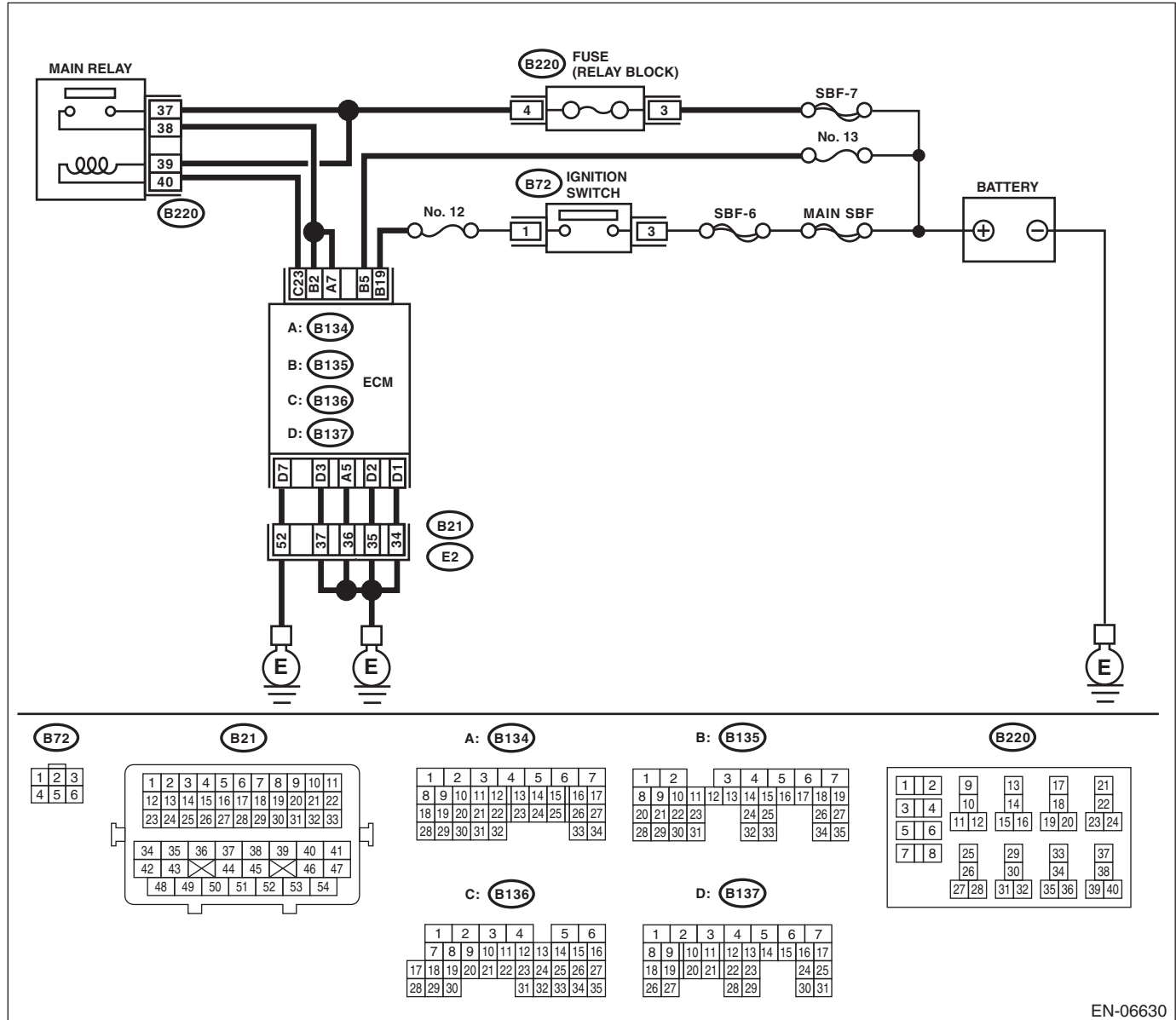

Diagnostics for Engine Starting Failure

ENGINE (DIAGNOSTICS)

Step	Check	Yes	No
1 CHECK MAIN RELAY. 1) Turn the ignition switch to OFF. 2) Remove the main relay. 3) Connect the battery to main relay terminals No. 39 and No. 40. 4) Measure the resistance between main relay terminals. Terminals No. 37 — No. 38:	Is the resistance less than 1 Ω ?	Go to step 2.	Replace the main relay.
2 CHECK GROUND CIRCUIT FOR ECM. 1) Disconnect the connectors from the ECM. 2) Measure the resistance of harness between ECM and chassis ground. Connector & terminal (B134) No. 5 — Chassis ground: (B137) No. 1 — Chassis ground: (B137) No. 2 — Chassis ground: (B137) No. 3 — Chassis ground: (B137) No. 7 — Chassis ground:	Is the resistance less than 5 Ω ?	Go to step 3.	Repair the harness and connector. NOTE: In this case, repair the following item: • Open circuit in harness between ECM connector and engine ground • Poor contact of coupling connector
3 CHECK INPUT VOLTAGE OF ECM. 1) Turn the ignition switch to ON. 2) Measure the voltage between ECM connector and chassis ground. Connector & terminal (B135) No. 5 (+) — Chassis ground (-): (B135) No. 19 (+) — Chassis ground (-):	Is the voltage 10 V or more?	Go to step 4.	Repair the open or ground short circuit of power supply circuit.
4 CHECK INPUT VOLTAGE OF MAIN RELAY. Measure the voltage between main relay connector and chassis ground. Connector & terminal (B220) No. 37 (+) — Chassis ground (-): (B220) No. 39 (+) — Chassis ground (-):	Is the voltage 10 V or more?	Go to step 5.	Repair the open or ground short circuit of harness of power supply circuit.
5 CHECK INPUT VOLTAGE OF ECM. 1) Turn the ignition switch to OFF. 2) Install the main relay. 3) Turn the ignition switch to ON. 4) Measure the voltage between ECM connector and chassis ground. Connector & terminal (B136) No. 23 (+) — Chassis ground (-):	Is the voltage 10 V or more?	Go to step 6.	Repair the open circuit of harness between ECM connector and main relay connector.
6 CHECK INPUT VOLTAGE OF ECM. 1) Turn the ignition switch to ON. 2) Measure the voltage between ECM connector and chassis ground. Connector & terminal (B134) No. 7 (+) — Chassis ground (-): (B135) No. 2 (+) — Chassis ground (-):	Is the voltage 10 V or more?	Check ignition control system. <Ref. to EN(H4SO)(diag)-73, IGNITION CONTROL SYSTEM, Diagnostics for Engine Starting Failure.>	Repair the open circuit of harness between ECM connector and main relay connector.

Diagnostics for Engine Starting Failure

D: IGNITION CONTROL SYSTEM

CAUTION:

After repair or replacement of faulty parts, perform Clear Memory Mode <Ref. to EN(H4SO)(diag)-51, Clear Memory Mode.> and Inspection Mode <Ref. to EN(H4SO)(diag)-41, Inspection Mode.>.

WIRING DIAGRAM:

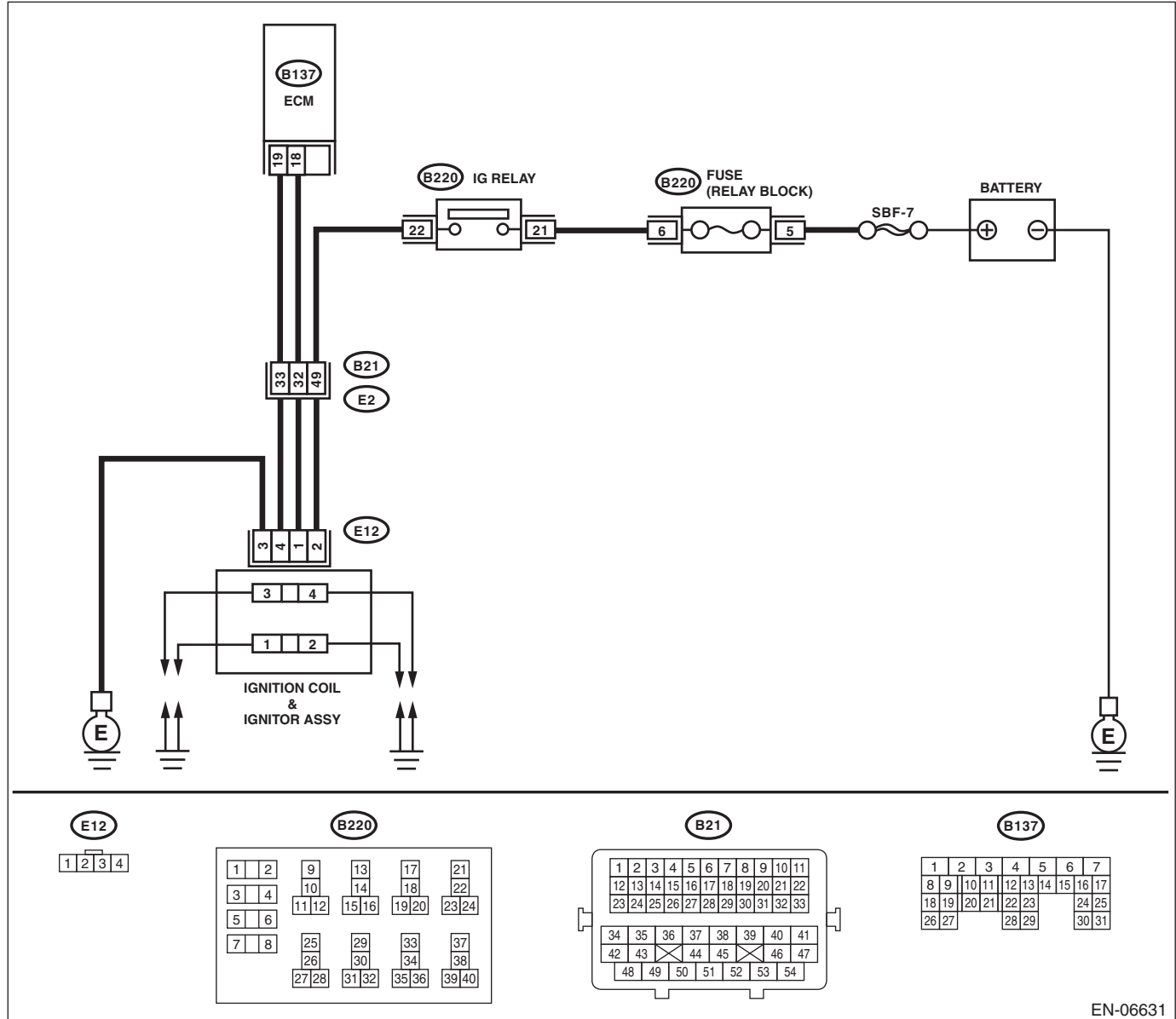

EN-06631

Diagnostics for Engine Starting Failure

ENGINE (DIAGNOSTICS)

Step	Check	Yes	No
<p>1</p> <p>CHECK IGNITION SYSTEM FOR SPARKS. 1) Remove the plug cord cap from each spark plug. 2) Install a new spark plug on plug cord cap.</p> <p>CAUTION: Do not remove the spark plug from engine. 3) Contact the spark plug thread portion to engine. 4) While opening the throttle valve fully, crank the engine to check that spark occurs at each cylinder.</p>	Does spark occur at each cylinder?	Check fuel pump system. <Ref. to EN(H4SO)(diag)-76, FUEL PUMP CIRCUIT, Diagnostics for Engine Starting Failure.>	Go to step 2.
<p>2</p> <p>CHECK POWER SUPPLY CIRCUIT FOR IGNITION COIL AND IGNITOR ASSEMBLY. 1) Turn the ignition switch to OFF. 2) Disconnect the connector from the ignition coil and ignitor assembly. 3) Turn the ignition switch to ON. 4) Measure the power supply voltage between ignition coil and ignitor assembly connector and engine ground.</p> <p>Connector & terminal (E12) No. 2 (+) — Engine ground (-):</p>	Is the voltage 10 V or more?	Go to step 3.	Repair the harness and connector. NOTE: In this case, repair the following item: • Open circuit in harness between ignition coil and ignitor assembly and IG relay connector • Poor contact of coupling connector • Blown out of fuse
<p>3</p> <p>CHECK HARNESS BETWEEN IGNITION COIL AND IGNITOR ASSEMBLY, AND ECM. 1) Turn the ignition switch to OFF. 2) Measure the resistance between the ignition coil and ignitor assembly connector, and engine ground.</p> <p>Connector & terminal (E12) No. 3 — Engine ground:</p>	Is the resistance less than 5 Ω?	Go to step 4.	Repair the open circuit in harness between ignitor assembly connector and engine ground.
<p>4</p> <p>CHECK IGNITION COIL AND IGNITOR ASSEMBLY. 1) Remove the spark plug cords. 2) Measure the resistance between spark plug cord contact portions to check secondary coil.</p> <p>Terminals No. 1 — No. 2: No. 3 — No. 4:</p>	Is the resistance between 10 and 15 kΩ?	Go to step 5.	Replace the ignition coil and ignitor assembly. <Ref. to IG(H4SO)-6, Ignition Coil and Ignitor Assembly.>
<p>5</p> <p>CHECK INPUT SIGNAL FOR IGNITION COIL AND IGNITOR ASSEMBLY. 1) Connect the connector to the Ignition coil and ignitor assembly. 2) Check if voltage varies synchronously with engine speed when cranking, while monitoring voltage between ignition coil and ignitor assembly connector and engine ground.</p> <p>Connector & terminal (E12) No. 1 (+) — Engine ground (-): (E12) No. 4 (+) — Engine ground (-):</p>	Does the voltage vary 10 V or more?	Go to step 6.	Replace the ignition coil and ignitor assembly. <Ref. to IG(H4SO)-6, Ignition Coil and Ignitor Assembly.>

Diagnostics for Engine Starting Failure

ENGINE (DIAGNOSTICS)

Step	Check	Yes	No
<p>6</p> <p>CHECK HARNESS BETWEEN ECM AND IGNITION COIL AND IGNITOR ASSEMBLY CONNECTOR.</p> <p>1) Turn the ignition switch to OFF. 2) Disconnect the connectors from the ECM. 3) Disconnect the connector from the ignition coil and ignitor assembly. 4) Measure the resistance of harness between ECM and ignition coil and ignitor assembly connector.</p> <p>Connector & terminal <i>(B137) No. 18 — (E12) No. 1:</i> <i>(B137) No. 19 — (E12) No. 4:</i></p>	<p>Is the resistance less than 1 Ω?</p>	<p>Go to step 7.</p>	<p>Repair the harness and connector.</p> <p>NOTE: In this case, repair the following item:</p> <ul style="list-style-type: none"> • Open circuit in harness between ECM and ignition coil and ignitor assembly connector • Poor contact of coupling connector
<p>7</p> <p>CHECK HARNESS BETWEEN ECM AND IGNITION COIL AND IGNITOR ASSEMBLY CONNECTOR.</p> <p>Measure the resistance of harness between ECM and engine ground.</p> <p>Connector & terminal: <i>(B137) No. 18 — Engine ground:</i> <i>(B137) No. 19 — Engine ground:</i></p>	<p>Is the resistance 1 MΩ or more?</p>	<p>Repair poor contact of the ECM connector.</p>	<p>Repair the ground short circuit of harness between ECM and ignition coil and ignitor assembly connector.</p>

Diagnostics for Engine Starting Failure

ENGINE (DIAGNOSTICS)

E: FUEL PUMP CIRCUIT

CAUTION:

After repair or replacement of faulty parts, perform Clear Memory Mode <Ref. to EN(H4SO)(diag)-51, OPERATION, Clear Memory Mode.> and Inspection Mode <Ref. to EN(H4SO)(diag)-41, PROCEDURE, Inspection Mode.>.

WIRING DIAGRAM:

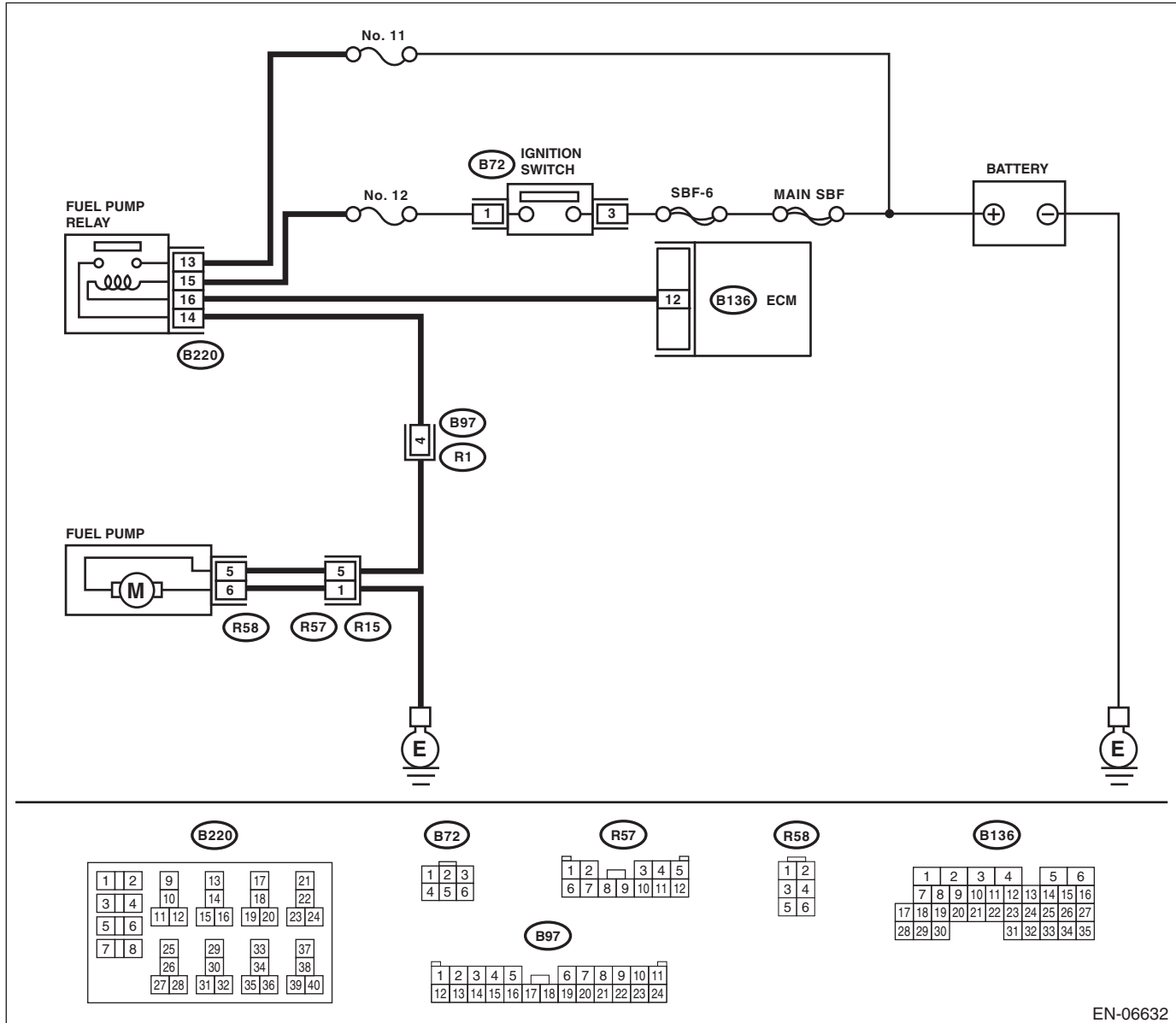

EN-06632

Step	Check	Yes	No	
1	<p>CHECK OPERATING SOUND OF FUEL PUMP.</p> <p>Make sure that the fuel pump operates for two seconds when turning the ignition switch to ON.</p> <p>NOTE: Fuel pump operation can be executed using the Subaru Select Monitor.</p> <p>For the procedures, refer to "Compulsory Valve Operation Check Mode". <Ref. to EN(H4SO)(diag)-52, Compulsory Valve Operation Check Mode.></p>	Does the fuel pump emit operating sound?	Check the fuel injector circuit. <Ref. to EN(H4SO)(diag)-78, FUEL INJECTOR CIRCUIT, Diagnostics for Engine Starting Failure.>	Go to step 2.

Diagnostics for Engine Starting Failure

ENGINE (DIAGNOSTICS)

Step	Check	Yes	No
<p>2 CHECK GROUND CIRCUIT OF FUEL PUMP. 1) Turn the ignition switch to OFF. 2) Remove the fuel pump access hole lid. 3) Disconnect the connector from fuel pump. 4) Measure the resistance of harness between fuel pump and chassis ground. Connector & terminal (R58) No. 6 — Chassis ground:</p>	Is the resistance less than 5 Ω?	Go to step 3.	Repair the harness and connector. NOTE: In this case, repair the following item: • Open circuit in harness between fuel pump connector and chassis grounding terminal • Poor contact of coupling connector
<p>3 CHECK POWER SUPPLY TO FUEL PUMP. 1) Turn the ignition switch to ON. 2) Measure the voltage between fuel pump connector and chassis ground. Connector & terminal (R58) No. 5 (+) — Chassis ground (-):</p>	Is the voltage 10 V or more?	Replace the fuel pump. <Ref. to FU(H4SO)-56, Fuel Pump.>	Go to step 4.
<p>4 CHECK HARNESS BETWEEN FUEL PUMP AND FUEL PUMP RELAY CONNECTOR. 1) Turn the ignition switch to OFF. 2) Remove the fuel pump relay. 3) Measure the resistance of harness between fuel pump connector and fuel pump relay connector. Connector & terminal (R58) No. 5 — (B220) No. 14:</p>	Is the resistance less than 1 Ω?	Go to step 5.	Repair the harness and connector. NOTE: In this case, repair the following item: • Open circuit in harness between fuel pump connector and fuel pump relay connector • Poor contact of coupling connector
<p>5 CHECK HARNESS BETWEEN FUEL PUMP AND FUEL PUMP RELAY CONNECTOR. Measure the resistance of harness between fuel pump connector and fuel pump relay connector. Connector & terminal (R58) No. 5 — Chassis ground:</p>	Is the resistance 1 MΩ or more?	Go to step 6.	Repair the short circuit to ground in harness between fuel pump connector and fuel pump relay connector.
<p>6 CHECK FUEL PUMP RELAY. 1) Connect the battery to fuel pump relay terminals No. 15 and No. 16. 2) Measure the resistance between terminals of fuel pump relay. Terminals No. 13 — No. 14:</p>	Is the resistance less than 1 Ω?	Go to step 7.	Replace the fuel pump relay. <Ref. to FU(H4SO)-41, Fuel Pump Relay.>
<p>7 CHECK HARNESS BETWEEN ECM AND FUEL PUMP RELAY CONNECTOR. 1) Disconnect the connectors from the ECM. 2) Measure the resistance of harness between ECM and fuel pump relay connector. Connector & terminal (B136) No. 12 — (B220) No. 16:</p>	Is the resistance less than 1 Ω?	Go to step 8.	Repair the open circuit of harness between ECM and fuel pump relay connector.
<p>8 CHECK POWER SUPPLY OF FUEL PUMP RELAY. 1) Turn the ignition switch to ON. 2) Measure the voltage between fuel pump relay connector and chassis ground. Connector & terminal (B220) No. 13 (+) — Chassis ground (-): (B220) No. 15 (+) — Chassis ground (-):</p>	Is the voltage 10 V or more?	Repair poor contact of the ECM connector.	Repair the open or ground short circuit of power supply circuit.

Diagnostics for Engine Starting Failure

ENGINE (DIAGNOSTICS)

F: FUEL INJECTOR CIRCUIT

CAUTION:

- Check or repair only faulty parts.
- After repair or replacement of faulty parts, perform Clear Memory Mode <Ref. to EN(H4SO)(diag)-51, OPERATION, Clear Memory Mode.> and Inspection Mode <Ref. to EN(H4SO)(diag)-41, PROCEDURE, Inspection Mode.>.

WIRING DIAGRAM:

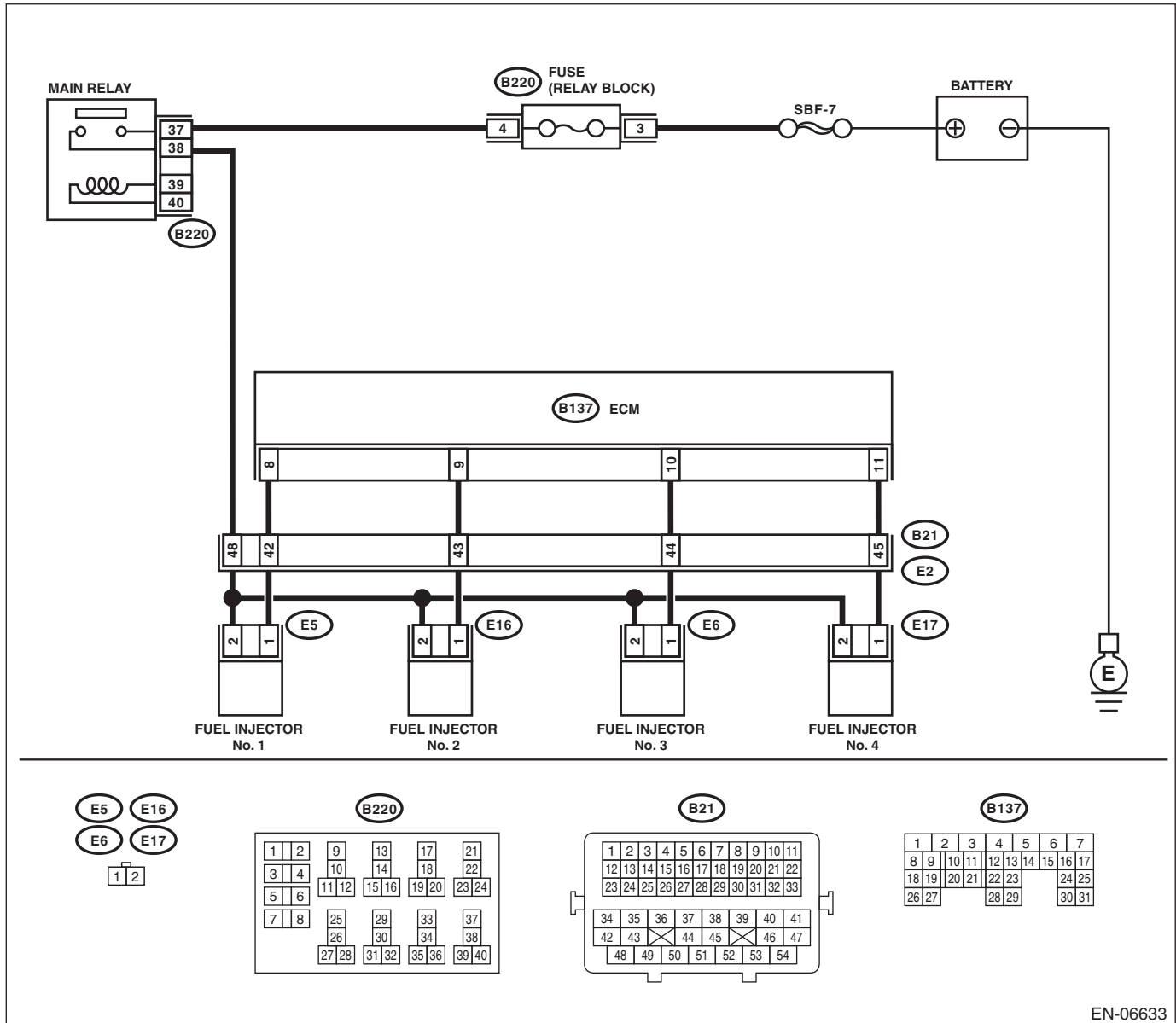

EN-06633

Diagnostics for Engine Starting Failure

ENGINE (DIAGNOSTICS)

Step	Check	Yes	No
<p>1 CHECK OPERATION OF EACH FUEL INJECTOR. While cranking the engine, check each fuel injector emits operating sound. Use a sound scope or attach a screwdriver to the injector to listen to sounds for this check.</p>	Does the fuel pump emit operating sound?	Check the fuel pressure. <Ref. to ME(H4SO)-28, INSPECTION, Fuel Pressure.>	Go to step 2.
<p>2 CHECK POWER SUPPLY TO EACH FUEL INJECTOR. 1) Turn the ignition switch to OFF. 2) Disconnect the connector from fuel injector. 3) Turn the ignition switch to ON. 4) Measure the power supply voltage between fuel injector terminal and engine ground. Connector & terminal #1 (E5) No. 2 (+) — Engine ground (-): #2 (E16) No. 2 (+) — Engine ground (-): #3 (E6) No. 2 (+) — Engine ground (-): #4 (E17) No. 2 (+) — Engine ground (-):</p>	Is the voltage 10 V or more?	Go to step 3.	Repair the harness and connector. NOTE: In this case, repair the following item: • Open circuit in harness between main relay connector and fuel injector connector • Poor contact of main relay connector • Poor contact of coupling connector
<p>3 CHECK HARNESS BETWEEN ECM AND FUEL INJECTOR CONNECTOR. 1) Disconnect the connectors from the ECM. 2) Measure the resistance of harness between ECM and fuel injector connector. Connector & terminal #1 (B137) No. 8 — (E5) No. 1: #2 (B137) No. 9 — (E16) No. 1: #3 (B137) No. 10 — (E6) No. 1: #4 (B137) No. 11 — (E17) No. 1:</p>	Is the resistance less than 1 Ω?	Go to step 4.	Repair the harness and connector. NOTE: In this case, repair the following item: • Open circuit of harness between ECM and fuel injector connector • Poor contact of coupling connector
<p>4 CHECK HARNESS BETWEEN ECM AND FUEL INJECTOR CONNECTOR. Measure the resistance of harness between ECM and fuel injector connector. Connector & terminal #1 (B137) No. 8 — Chassis ground: #2 (B137) No. 9 — Chassis ground: #3 (B137) No. 10 — Chassis ground: #4 (B137) No. 11 — Chassis ground:</p>	Is the resistance 1 MΩ or more?	Go to step 5.	Repair the ground short circuit of harness between ECM and fuel injector connector.
<p>5 CHECK EACH FUEL INJECTOR. 1) Turn the ignition switch to OFF. 2) Measure the resistance between each fuel injector terminals. Terminals No. 1 — No. 2:</p>	Is the resistance between 5 — 20 Ω?	Go to step 6.	Replace the faulty fuel injector. <Ref. to FU(H4SO)-30, Fuel Injector.>
<p>6 CHECK POOR CONTACT. Check for poor contact of the ECM connector.</p>	Is there poor contact in ECM connector?	Repair poor contact of the ECM connector.	Inspection using “General Diagnostic Table” <Ref. to EN(H4SO)(diag)-304, INSPECTION, General Diagnostic Table.>

Diagnostic Procedure for Subaru Select Monitor Communication

ENGINE (DIAGNOSTICS)

18. Diagnostic Procedure for Subaru Select Monitor Communication

A: COMMUNICATION FOR INITIALIZING IMPOSSIBLE

DIAGNOSIS:

Open or short circuit in data link connector

TROUBLE SYMPTOM:

Subaru Select Monitor communication failure

WIRING DIAGRAM:

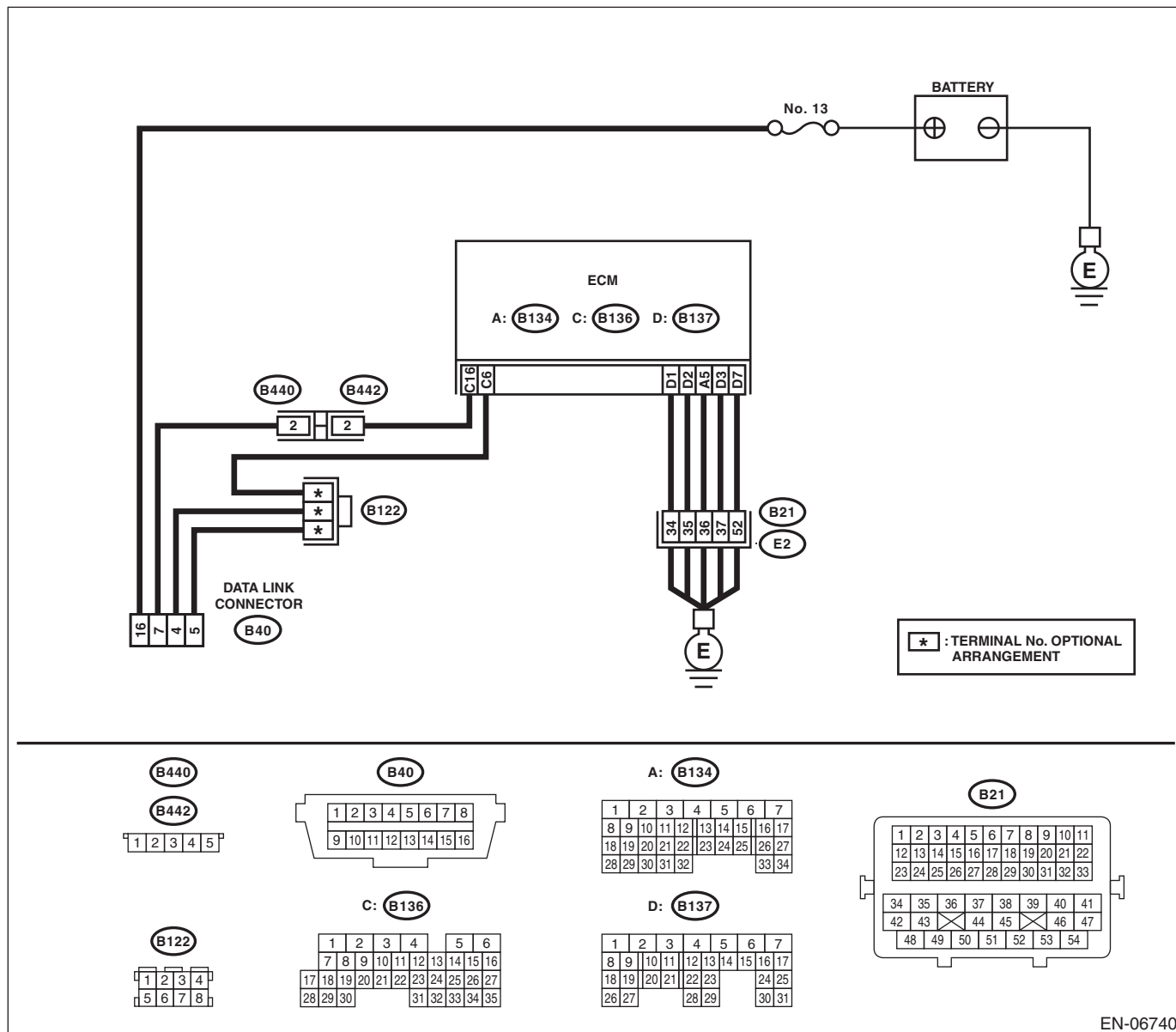

Diagnostic Procedure for Subaru Select Monitor Communication

ENGINE (DIAGNOSTICS)

	Step	Check	Yes	No
1	CHECK POWER SUPPLY CIRCUIT. Connect the SDI (Subaru Diagnosis Interface) or general scan tool to data link connector.	Does SDI or general scan tool turn ON?	Go to step 4.	Go to step 2.
2	CHECK POWER SUPPLY CIRCUIT. Measure the voltage between data link connector and chassis ground. Connector & terminal (B40) No. 16 (+) — Chassis ground (-):	Is the voltage 10 V or more?	Go to step 3.	Repair the power supply circuit. NOTE: In this case, repair the following item: <ul style="list-style-type: none"> • Open or ground short circuit of harness between battery and data link connector • Blown out of fuse (M/B No. 13)
3	CHECK HARNESS BETWEEN DATA LINK CONNECTOR AND CHASSIS GROUND. 1) Turn the ignition switch to OFF. 2) Measure the resistance of harness between data link connector and chassis ground. Connector & terminal (B40) No. 4 — Chassis ground: (B40) No. 5 — Chassis ground:	Is the resistance less than 5 Ω?	Repair the poor contact of data link connector.	Repair the harness and connector. NOTE: In this case, repair the following item: <ul style="list-style-type: none"> • Open circuit of harness between ECM and data link connector • Open circuit of harness between ECM and engine ground • Poor contact in ECM connector • Poor contact of coupling connector
4	CHECK HARNESS BETWEEN ECM AND DATA LINK CONNECTOR. 1) Disconnect the connector from ECM, TCM, VDC CU, airbag CM and body integrated unit. CAUTION: When disconnecting the connector from airbag control module, always follow the precautions on AB section. <Ref. to AB-5, CAUTION, General Description.> 2) Measure the resistance of harness between ECM and data link connector. Connector & terminal (B136) No. 16 — (B40) No. 7:	Is the resistance less than 1 Ω?	Go to step 5.	Repair the harness and connector. NOTE: In this case, repair the following item: <ul style="list-style-type: none"> • Open circuit of harness between ECM and data link connector • Poor contact of coupling connector
5	CHECK HARNESS BETWEEN ECM AND DATA LINK CONNECTOR. Measure the resistance between data link connector and chassis ground. Connector & terminal (B40) No. 7 — Chassis ground:	Is the resistance 1 MΩ or more?	Repair the poor contact in the ECM or data link connector.	Repair the ground short circuit of harness between ECM and data link connector.

List of Diagnostic Trouble Code (DTC)

ENGINE (DIAGNOSTICS)

19. List of Diagnostic Trouble Code (DTC)

A: LIST

DTC	Item	Reference
P0026	Intake Valve Control Solenoid Circuit Range/Performance (Bank 1)	<Ref. to EN(H4SO)(diag)-89, DTC P0026 INTAKE VALVE CONTROL SOLENOID CIRCUIT RANGE/PERFORMANCE (BANK 1), Diagnostic Procedure with Diagnostic Trouble Code (DTC).>
P0028	Intake Valve Control Solenoid Circuit Range/Performance (Bank 2)	<Ref. to EN(H4SO)(diag)-91, DTC P0028 INTAKE VALVE CONTROL SOLENOID CIRCUIT RANGE/PERFORMANCE (BANK 2), Diagnostic Procedure with Diagnostic Trouble Code (DTC).>
P0030	HO2S Heater Control Circuit (Bank 1 Sensor 1)	<Ref. to EN(H4SO)(diag)-93, DTC P0030 HO2S HEATER CONTROL CIRCUIT (BANK 1 SENSOR 1), Diagnostic Procedure with Diagnostic Trouble Code (DTC).>
P0031	HO2S Heater Control Circuit Low (Bank 1 Sensor 1)	<Ref. to EN(H4SO)(diag)-95, DTC P0031 HO2S HEATER CONTROL CIRCUIT LOW (BANK 1 SENSOR 1), Diagnostic Procedure with Diagnostic Trouble Code (DTC).>
P0032	HO2S Heater Control Circuit High (Bank 1 Sensor 1)	<Ref. to EN(H4SO)(diag)-97, DTC P0032 HO2S HEATER CONTROL CIRCUIT HIGH (BANK 1 SENSOR 1), Diagnostic Procedure with Diagnostic Trouble Code (DTC).>
P0037	HO2S Heater Control Circuit Low (Bank 1 Sensor 2)	<Ref. to EN(H4SO)(diag)-99, DTC P0037 HO2S HEATER CONTROL CIRCUIT LOW (BANK 1 SENSOR 2), Diagnostic Procedure with Diagnostic Trouble Code (DTC).>
P0038	HO2S Heater Control Circuit High (Bank 1 Sensor 2)	<Ref. to EN(H4SO)(diag)-101, DTC P0038 HO2S HEATER CONTROL CIRCUIT HIGH (BANK 1 SENSOR 2), Diagnostic Procedure with Diagnostic Trouble Code (DTC).>
P0068	MAP/MAF - Throttle Position Correlation	<Ref. to EN(H4SO)(diag)-103, DTC P0068 MAP/MAF - THROTTLE POSITION CORRELATION, Diagnostic Procedure with Diagnostic Trouble Code (DTC).>
P0076	Intake Valve Control Solenoid Circuit Low (Bank 1)	<Ref. to EN(H4SO)(diag)-105, DTC P0076 INTAKE VALVE CONTROL SOLENOID CIRCUIT LOW (BANK 1), Diagnostic Procedure with Diagnostic Trouble Code (DTC).>
P0077	Intake Valve Control Solenoid Circuit High (Bank 1)	<Ref. to EN(H4SO)(diag)-107, DTC P0077 INTAKE VALVE CONTROL SOLENOID CIRCUIT HIGH (BANK 1), Diagnostic Procedure with Diagnostic Trouble Code (DTC).>
P0082	Intake Valve Control Solenoid Circuit Low (Bank 2)	<Ref. to EN(H4SO)(diag)-109, DTC P0082 INTAKE VALVE CONTROL SOLENOID CIRCUIT LOW (BANK 2), Diagnostic Procedure with Diagnostic Trouble Code (DTC).>
P0083	Intake Valve Control Solenoid Circuit High (Bank 2)	<Ref. to EN(H4SO)(diag)-111, DTC P0083 INTAKE VALVE CONTROL SOLENOID CIRCUIT HIGH (BANK 2), Diagnostic Procedure with Diagnostic Trouble Code (DTC).>
P0101	Mass or Volume Air Flow Circuit Range/Performance	<Ref. to EN(H4SO)(diag)-113, DTC P0101 MASS OR VOLUME AIR FLOW CIRCUIT RANGE/PERFORMANCE, Diagnostic Procedure with Diagnostic Trouble Code (DTC).>
P0102	Mass or Volume Air Flow Circuit Low Input	<Ref. to EN(H4SO)(diag)-115, DTC P0102 MASS OR VOLUME AIR FLOW CIRCUIT LOW INPUT, Diagnostic Procedure with Diagnostic Trouble Code (DTC).>
P0103	Mass or Volume Air Flow Circuit High Input	<Ref. to EN(H4SO)(diag)-117, DTC P0103 MASS OR VOLUME AIR FLOW CIRCUIT HIGH INPUT, Diagnostic Procedure with Diagnostic Trouble Code (DTC).>
P0107	Manifold Absolute Pressure/Barometric Pressure Circuit Low Input	<Ref. to EN(H4SO)(diag)-119, DTC P0107 MANIFOLD ABSOLUTE PRESSURE/BAROMETRIC PRESSURE CIRCUIT LOW INPUT, Diagnostic Procedure with Diagnostic Trouble Code (DTC).>
P0108	Manifold Absolute Pressure/Barometric Pressure Circuit High Input	<Ref. to EN(H4SO)(diag)-121, DTC P0108 MANIFOLD ABSOLUTE PRESSURE/BAROMETRIC PRESSURE CIRCUIT HIGH INPUT, Diagnostic Procedure with Diagnostic Trouble Code (DTC).>

List of Diagnostic Trouble Code (DTC)

ENGINE (DIAGNOSTICS)

DTC	Item	Reference
P0111	Intake Air Temperature Sensor 1 Circuit Range/Performance	<Ref. to EN(H4SO)(diag)-123, DTC P0111 INTAKE AIR TEMPERATURE SENSOR 1 CIRCUIT RANGE/PERFORMANCE, Diagnostic Procedure with Diagnostic Trouble Code (DTC).>
P0112	Intake Air Temperature Sensor 1 Circuit Low	<Ref. to EN(H4SO)(diag)-125, DTC P0112 INTAKE AIR TEMPERATURE SENSOR 1 CIRCUIT LOW, Diagnostic Procedure with Diagnostic Trouble Code (DTC).>
P0113	Intake Air Temperature Sensor 1 Circuit High	<Ref. to EN(H4SO)(diag)-127, DTC P0113 INTAKE AIR TEMPERATURE SENSOR 1 CIRCUIT HIGH, Diagnostic Procedure with Diagnostic Trouble Code (DTC).>
P0117	Engine Coolant Temperature Circuit Low	<Ref. to EN(H4SO)(diag)-129, DTC P0117 ENGINE COOLANT TEMPERATURE CIRCUIT LOW, Diagnostic Procedure with Diagnostic Trouble Code (DTC).>
P0118	Engine Coolant Temperature Circuit High	<Ref. to EN(H4SO)(diag)-131, DTC P0118 ENGINE COOLANT TEMPERATURE CIRCUIT HIGH, Diagnostic Procedure with Diagnostic Trouble Code (DTC).>
P0122	Throttle/Pedal Position Sensor/Switch "A" Circuit Low	<Ref. to EN(H4SO)(diag)-133, DTC P0122 THROTTLE/PEDAL POSITION SENSOR/SWITCH "A" CIRCUIT LOW, Diagnostic Procedure with Diagnostic Trouble Code (DTC).>
P0123	Throttle/Pedal Position Sensor/Switch "A" Circuit High	<Ref. to EN(H4SO)(diag)-135, DTC P0123 THROTTLE/PEDAL POSITION SENSOR/SWITCH "A" CIRCUIT HIGH, Diagnostic Procedure with Diagnostic Trouble Code (DTC).>
P0125	Insufficient Coolant Temperature for Closed Loop Fuel Control	<Ref. to EN(H4SO)(diag)-137, DTC P0125 INSUFFICIENT COOLANT TEMPERATURE FOR CLOSED LOOP FUEL CONTROL, Diagnostic Procedure with Diagnostic Trouble Code (DTC).>
P0126	Insufficient Engine Coolant Temperature for Stable Operation	<Ref. to EN(H4SO)(diag)-138, DTC P0126 INSUFFICIENT ENGINE COOLANT TEMPERATURE FOR STABLE OPERATION, Diagnostic Procedure with Diagnostic Trouble Code (DTC).>
P0128	Coolant Thermostat (Engine Coolant Temperature Below Thermostat Regulating Temperature)	<Ref. to EN(H4SO)(diag)-140, DTC P0128 COOLANT THERMOSTAT (ENGINE COOLANT TEMPERATURE BELOW THERMOSTAT REGULATING TEMPERATURE), Diagnostic Procedure with Diagnostic Trouble Code (DTC).>
P0131	O2 Sensor Circuit Low Voltage (Bank 1 Sensor 1)	<Ref. to EN(H4SO)(diag)-141, DTC P0131 O2 SENSOR CIRCUIT LOW VOLTAGE (BANK 1 SENSOR 1), Diagnostic Procedure with Diagnostic Trouble Code (DTC).>
P0132	O2 Sensor Circuit High Voltage (Bank 1 Sensor 1)	<Ref. to EN(H4SO)(diag)-143, DTC P0132 O2 SENSOR CIRCUIT HIGH VOLTAGE (BANK 1 SENSOR 1), Diagnostic Procedure with Diagnostic Trouble Code (DTC).>
P0133	O2 Sensor Circuit Slow Response (Bank 1 Sensor 1)	<Ref. to EN(H4SO)(diag)-145, DTC P0133 O2 SENSOR CIRCUIT SLOW RESPONSE (BANK 1 SENSOR 1), Diagnostic Procedure with Diagnostic Trouble Code (DTC).>
P0134	O2 Sensor Circuit No Activity Detected (Bank 1 Sensor 1)	<Ref. to EN(H4SO)(diag)-147, DTC P0134 O2 SENSOR CIRCUIT NO ACTIVITY DETECTED (BANK 1 SENSOR 1), Diagnostic Procedure with Diagnostic Trouble Code (DTC).>
P0137	O2 Sensor Circuit Low Voltage (Bank 1 Sensor 2)	<Ref. to EN(H4SO)(diag)-149, DTC P0137 O2 SENSOR CIRCUIT LOW VOLTAGE (BANK 1 SENSOR 2), Diagnostic Procedure with Diagnostic Trouble Code (DTC).>
P0138	O2 Sensor Circuit High Voltage (Bank 1 Sensor 2)	<Ref. to EN(H4SO)(diag)-151, DTC P0138 O2 SENSOR CIRCUIT HIGH VOLTAGE (BANK 1 SENSOR 2), Diagnostic Procedure with Diagnostic Trouble Code (DTC).>
P0139	O2 Sensor Circuit Slow Response (Bank 1 Sensor 2)	<Ref. to EN(H4SO)(diag)-153, DTC P0139 O2 SENSOR CIRCUIT SLOW RESPONSE (BANK 1 SENSOR 2), Diagnostic Procedure with Diagnostic Trouble Code (DTC).>
P0140	O2 Sensor Circuit No Activity Detected (Bank 1 Sensor 2)	<Ref. to EN(H4SO)(diag)-155, DTC P0140 O2 SENSOR CIRCUIT NO ACTIVITY DETECTED (BANK 1 SENSOR 2), Diagnostic Procedure with Diagnostic Trouble Code (DTC).>
P0171	System Too Lean (Bank 1)	<Ref. to EN(H4SO)(diag)-157, DTC P0171 SYSTEM TOO LEAN (BANK 1), Diagnostic Procedure with Diagnostic Trouble Code (DTC).>

List of Diagnostic Trouble Code (DTC)

ENGINE (DIAGNOSTICS)

DTC	Item	Reference
P0172	System Too Rich (Bank 1)	<Ref. to EN(H4SO)(diag)-158, DTC P0172 SYSTEM TOO RICH (BANK 1), Diagnostic Procedure with Diagnostic Trouble Code (DTC).>
P0181	Fuel Temperature Sensor "A" Circuit Range/Performance	<Ref. to EN(H4SO)(diag)-160, DTC P0181 FUEL TEMPERATURE SENSOR "A" CIRCUIT RANGE/PERFORMANCE, Diagnostic Procedure with Diagnostic Trouble Code (DTC).>
P0182	Fuel Temperature Sensor "A" Circuit Low Input	<Ref. to EN(H4SO)(diag)-162, DTC P0182 FUEL TEMPERATURE SENSOR "A" CIRCUIT LOW INPUT, Diagnostic Procedure with Diagnostic Trouble Code (DTC).>
P0183	Fuel Temperature Sensor "A" Circuit High Input	<Ref. to EN(H4SO)(diag)-164, DTC P0183 FUEL TEMPERATURE SENSOR "A" CIRCUIT HIGH INPUT, Diagnostic Procedure with Diagnostic Trouble Code (DTC).>
P0196	Engine Oil Temperature Sensor Circuit Range/Performance	<Ref. to EN(H4SO)(diag)-166, DTC P0196 ENGINE OIL TEMPERATURE SENSOR CIRCUIT RANGE/PERFORMANCE, Diagnostic Procedure with Diagnostic Trouble Code (DTC).>
P0197	Engine Oil Temperature Sensor Low	<Ref. to EN(H4SO)(diag)-168, DTC P0197 ENGINE OIL TEMPERATURE SENSOR LOW, Diagnostic Procedure with Diagnostic Trouble Code (DTC).>
P0198	Engine Oil Temperature Sensor High	<Ref. to EN(H4SO)(diag)-170, DTC P0198 ENGINE OIL TEMPERATURE SENSOR HIGH, Diagnostic Procedure with Diagnostic Trouble Code (DTC).>
P0222	Throttle/Pedal Position Sensor/Switch "B" Circuit Low	<Ref. to EN(H4SO)(diag)-172, DTC P0222 THROTTLE/PEDAL POSITION SENSOR/SWITCH "B" CIRCUIT LOW, Diagnostic Procedure with Diagnostic Trouble Code (DTC).>
P0223	Throttle/Pedal Position Sensor/Switch "B" Circuit High	<Ref. to EN(H4SO)(diag)-174, DTC P0223 THROTTLE/PEDAL POSITION SENSOR/SWITCH "B" CIRCUIT HIGH, Diagnostic Procedure with Diagnostic Trouble Code (DTC).>
P0301	Cylinder 1 Misfire Detected	<Ref. to EN(H4SO)(diag)-175, DTC P0301 CYLINDER 1 MISFIRE DETECTED, Diagnostic Procedure with Diagnostic Trouble Code (DTC).>
P0302	Cylinder 2 Misfire Detected	<Ref. to EN(H4SO)(diag)-175, DTC P0302 CYLINDER 2 MISFIRE DETECTED, Diagnostic Procedure with Diagnostic Trouble Code (DTC).>
P0303	Cylinder 3 Misfire Detected	<Ref. to EN(H4SO)(diag)-175, DTC P0303 CYLINDER 3 MISFIRE DETECTED, Diagnostic Procedure with Diagnostic Trouble Code (DTC).>
P0304	Cylinder 4 Misfire Detected	<Ref. to EN(H4SO)(diag)-176, DTC P0304 CYLINDER 4 MISFIRE DETECTED, Diagnostic Procedure with Diagnostic Trouble Code (DTC).>
P0327	Knock Sensor 1 Circuit Low (Bank 1 or Single Sensor)	<Ref. to EN(H4SO)(diag)-182, DTC P0327 KNOCK SENSOR 1 CIRCUIT LOW (BANK 1 OR SINGLE SENSOR), Diagnostic Procedure with Diagnostic Trouble Code (DTC).>
P0328	Knock Sensor 1 Circuit High (Bank 1 or Single Sensor)	<Ref. to EN(H4SO)(diag)-184, DTC P0328 KNOCK SENSOR 1 CIRCUIT HIGH (BANK 1 OR SINGLE SENSOR), Diagnostic Procedure with Diagnostic Trouble Code (DTC).>
P0335	Crankshaft Position Sensor "A" Circuit	<Ref. to EN(H4SO)(diag)-186, DTC P0335 CRANKSHAFT POSITION SENSOR "A" CIRCUIT, Diagnostic Procedure with Diagnostic Trouble Code (DTC).>
P0336	Crankshaft Position Sensor "A" Circuit Range/Performance	<Ref. to EN(H4SO)(diag)-188, DTC P0336 CRANKSHAFT POSITION SENSOR "A" CIRCUIT RANGE/PERFORMANCE, Diagnostic Procedure with Diagnostic Trouble Code (DTC).>
P0340	Camshaft Position Sensor "A" Circuit (Bank 1 or Single Sensor)	<Ref. to EN(H4SO)(diag)-190, DTC P0340 CAMSHAFT POSITION SENSOR "A" CIRCUIT (BANK 1 OR SINGLE SENSOR), Diagnostic Procedure with Diagnostic Trouble Code (DTC).>
P0341	Camshaft Position Sensor "A" Circuit Range/Performance (Bank 1 or Single Sensor)	<Ref. to EN(H4SO)(diag)-192, DTC P0341 CAMSHAFT POSITION SENSOR "A" CIRCUIT RANGE/PERFORMANCE (BANK 1 OR SINGLE SENSOR), Diagnostic Procedure with Diagnostic Trouble Code (DTC).>
P0400	Exhaust Gas Recirculation Flow	<Ref. to EN(H4SO)(diag)-194, DTC P0400 EXHAUST GAS RECIRCULATION FLOW, Diagnostic Procedure with Diagnostic Trouble Code (DTC).>
P0420	Catalyst System Efficiency below Threshold (Bank 1)	<Ref. to EN(H4SO)(diag)-196, DTC P0420 CATALYST SYSTEM EFFICIENCY BELOW THRESHOLD (BANK 1), Diagnostic Procedure with Diagnostic Trouble Code (DTC).>

List of Diagnostic Trouble Code (DTC)

ENGINE (DIAGNOSTICS)

DTC	Item	Reference
P0442	Evaporative Emission Control System Leak Detected (Small Leak)	<Ref. to EN(H4SO)(diag)-200, DTC P0442 EVAPORATIVE EMISSION CONTROL SYSTEM LEAK DETECTED (SMALL LEAK), Diagnostic Procedure with Diagnostic Trouble Code (DTC).>
P0447	Evaporative Emission Control System Vent Control Circuit Open	<Ref. to EN(H4SO)(diag)-203, DTC P0447 EVAPORATIVE EMISSION CONTROL SYSTEM VENT CONTROL CIRCUIT OPEN, Diagnostic Procedure with Diagnostic Trouble Code (DTC).>
P0448	Evaporative Emission Control System Vent Control Circuit Shorted	<Ref. to EN(H4SO)(diag)-205, DTC P0448 EVAPORATIVE EMISSION CONTROL SYSTEM VENT CONTROL CIRCUIT SHORTED, Diagnostic Procedure with Diagnostic Trouble Code (DTC).>
P0451	Evaporative Emission Control System Pressure Sensor	<Ref. to EN(H4SO)(diag)-207, DTC P0451 EVAPORATIVE EMISSION CONTROL SYSTEM PRESSURE SENSOR, Diagnostic Procedure with Diagnostic Trouble Code (DTC).>
P0452	Evaporative Emission Control System Pressure Sensor Low Input	<Ref. to EN(H4SO)(diag)-209, DTC P0452 EVAPORATIVE EMISSION CONTROL SYSTEM PRESSURE SENSOR LOW INPUT, Diagnostic Procedure with Diagnostic Trouble Code (DTC).>
P0453	Evaporative Emission Control System Pressure Sensor High Input	<Ref. to EN(H4SO)(diag)-211, DTC P0453 EVAPORATIVE EMISSION CONTROL SYSTEM PRESSURE SENSOR HIGH INPUT, Diagnostic Procedure with Diagnostic Trouble Code (DTC).>
P0456	Evaporative Emission Control System Leak Detected (Very Small Leak)	<Ref. to EN(H4SO)(diag)-215, DTC P0456 EVAPORATIVE EMISSION CONTROL SYSTEM LEAK DETECTED (VERY SMALL LEAK), Diagnostic Procedure with Diagnostic Trouble Code (DTC).>
P0457	Evaporative Emission Control System Leak Detected (Fuel Cap Loose/Off)	<Ref. to EN(H4SO)(diag)-218, DTC P0457 EVAPORATIVE EMISSION CONTROL SYSTEM LEAK DETECTED (FUEL CAP LOOSE/OFF), Diagnostic Procedure with Diagnostic Trouble Code (DTC).>
P0458	Evaporative Emission System Purge Control Valve Circuit Low	<Ref. to EN(H4SO)(diag)-221, DTC P0458 EVAPORATIVE EMISSION SYSTEM PURGE CONTROL VALVE CIRCUIT LOW, Diagnostic Procedure with Diagnostic Trouble Code (DTC).>
P0459	Evaporative Emission System Purge Control Valve Circuit High	<Ref. to EN(H4SO)(diag)-223, DTC P0459 EVAPORATIVE EMISSION SYSTEM PURGE CONTROL VALVE CIRCUIT HIGH, Diagnostic Procedure with Diagnostic Trouble Code (DTC).>
P0461	Fuel Level Sensor "A" Circuit Range/Performance	<Ref. to EN(H4SO)(diag)-225, DTC P0461 FUEL LEVEL SENSOR "A" CIRCUIT RANGE/PERFORMANCE, Diagnostic Procedure with Diagnostic Trouble Code (DTC).>
P0462	Fuel Level Sensor "A" Circuit Low	<Ref. to EN(H4SO)(diag)-225, DTC P0462 FUEL LEVEL SENSOR "A" CIRCUIT LOW, Diagnostic Procedure with Diagnostic Trouble Code (DTC).>
P0463	Fuel Level Sensor "A" Circuit High	<Ref. to EN(H4SO)(diag)-225, DTC P0463 FUEL LEVEL SENSOR "A" CIRCUIT HIGH, Diagnostic Procedure with Diagnostic Trouble Code (DTC).>
P0464	Fuel Level Sensor Circuit Intermittent	<Ref. to EN(H4SO)(diag)-226, DTC P0464 FUEL LEVEL SENSOR CIRCUIT INTERMITTENT, Diagnostic Procedure with Diagnostic Trouble Code (DTC).>
P0500	Vehicle Speed Sensor "A"	<Ref. to EN(H4SO)(diag)-226, DTC P0500 VEHICLE SPEED SENSOR "A", Diagnostic Procedure with Diagnostic Trouble Code (DTC).>
P0506	Idle Air Control System RPM Lower Than Expected	<Ref. to EN(H4SO)(diag)-227, DTC P0506 IDLE AIR CONTROL SYSTEM RPM LOWER THAN EXPECTED, Diagnostic Procedure with Diagnostic Trouble Code (DTC).>
P0507	Idle Air Control System RPM Higher Than Expected	<Ref. to EN(H4SO)(diag)-229, DTC P0507 IDLE AIR CONTROL SYSTEM RPM HIGHER THAN EXPECTED, Diagnostic Procedure with Diagnostic Trouble Code (DTC).>
P0512	Starter Request Circuit	<Ref. to EN(H4SO)(diag)-231, DTC P0512 STARTER REQUEST CIRCUIT, Diagnostic Procedure with Diagnostic Trouble Code (DTC).>
P0513	Incorrect Immobilizer Key	<Ref. to IM(diag)-16, DTC P0513 INCORRECT IMMOBILIZER KEY, Diagnostic Procedure with Diagnostic Trouble Code (DTC).>
P0600	Serial Communication Link	<Ref. to EN(H4SO)(diag)-232, DTC P0600 SERIAL COMMUNICATION LINK, Diagnostic Procedure with Diagnostic Trouble Code (DTC).>
P0604	Internal Control Module Random Access Memory (RAM) Error	<Ref. to EN(H4SO)(diag)-233, DTC P0604 INTERNAL CONTROL MODULE RANDOM ACCESS MEMORY (RAM) ERROR, Diagnostic Procedure with Diagnostic Trouble Code (DTC).>

List of Diagnostic Trouble Code (DTC)

ENGINE (DIAGNOSTICS)

DTC	Item	Reference
P0605	Internal Control Module Read Only Memory (ROM) Error	<Ref. to EN(H4SO)(diag)-234, DTC P0605 INTERNAL CONTROL MODULE READ ONLY MEMORY (ROM) ERROR, Diagnostic Procedure with Diagnostic Trouble Code (DTC).>
P0607	Throttle Control System Circuit Range/Performance	<Ref. to EN(H4SO)(diag)-235, DTC P0607 THROTTLE CONTROL SYSTEM CIRCUIT RANGE/PERFORMANCE, Diagnostic Procedure with Diagnostic Trouble Code (DTC).>
P0638	Throttle Actuator Control Range/Performance (Bank 1)	<Ref. to EN(H4SO)(diag)-236, DTC P0638 THROTTLE ACTUATOR CONTROL RANGE/PERFORMANCE (BANK 1), Diagnostic Procedure with Diagnostic Trouble Code (DTC).>
P0700	Transmission Control System (MIL Request)	<Ref. to EN(H4SO)(diag)-236, DTC P0700 TRANSMISSION CONTROL SYSTEM (MIL REQUEST), Diagnostic Procedure with Diagnostic Trouble Code (DTC).>
P0851	Park/Neutral Switch Input Circuit Low (AT Model)	<Ref. to EN(H4SO)(diag)-237, DTC P0851 PARK/NEUTRAL SWITCH INPUT CIRCUIT LOW (AT MODEL), Diagnostic Procedure with Diagnostic Trouble Code (DTC).>
P0851	Neutral Switch Input Circuit Low (MT Model)	<Ref. to EN(H4SO)(diag)-239, DTC P0851 NEUTRAL SWITCH INPUT CIRCUIT LOW (MT MODEL), Diagnostic Procedure with Diagnostic Trouble Code (DTC).>
P0852	Park/Neutral Switch Input Circuit High (AT Model)	<Ref. to EN(H4SO)(diag)-241, DTC P0852 PARK/NEUTRAL SWITCH INPUT CIRCUIT HIGH (AT MODEL), Diagnostic Procedure with Diagnostic Trouble Code (DTC).>
P0852	Neutral Switch Input Circuit High (MT Model)	<Ref. to EN(H4SO)(diag)-243, DTC P0852 NEUTRAL SWITCH INPUT CIRCUIT HIGH (MT MODEL), Diagnostic Procedure with Diagnostic Trouble Code (DTC).>
P1152	O2 Sensor Circuit Range/Performance (Low) (Bank 1 Sensor 1)	<Ref. to EN(H4SO)(diag)-245, DTC P1152 O2 SENSOR CIRCUIT RANGE/PERFORMANCE (LOW) (BANK1 SENSOR1), Diagnostic Procedure with Diagnostic Trouble Code (DTC).>
P1153	O2 Sensor Circuit Range/Performance (High) (Bank 1 Sensor 1)	<Ref. to EN(H4SO)(diag)-247, DTC P1153 O2 SENSOR CIRCUIT RANGE/PERFORMANCE (HIGH) (BANK1 SENSOR1), Diagnostic Procedure with Diagnostic Trouble Code (DTC).>
P1160	Return Spring Failure	<Ref. to EN(H4SO)(diag)-248, DTC P1160 RETURN SPRING FAILURE, Diagnostic Procedure with Diagnostic Trouble Code (DTC).>
P1400	Fuel Tank Pressure Control Solenoid Valve Circuit Low	<Ref. to EN(H4SO)(diag)-249, DTC P1400 FUEL TANK PRESSURE CONTROL SOLENOID VALVE CIRCUIT LOW, Diagnostic Procedure with Diagnostic Trouble Code (DTC).>
P1420	Fuel Tank Pressure Control Sol. Valve Circuit High	<Ref. to EN(H4SO)(diag)-251, DTC P1420 FUEL TANK PRESSURE CONTROL SOL. VALVE CIRCUIT HIGH, Diagnostic Procedure with Diagnostic Trouble Code (DTC).>
P1443	Vent Control Solenoid Valve Function Problem	<Ref. to EN(H4SO)(diag)-253, DTC P1443 VENT CONTROL SOLENOID VALVE FUNCTION PROBLEM, Diagnostic Procedure with Diagnostic Trouble Code (DTC).>
P1491	Positive Crankcase Ventilation (Blow-by) Function Problem	<Ref. to EN(H4SO)(diag)-255, DTC P1491 POSITIVE CRANKCASE VENTILATION (BLOW-BY) FUNCTION PROBLEM, Diagnostic Procedure with Diagnostic Trouble Code (DTC).>
P1492	EGR Solenoid Valve Signal #1 Circuit Malfunction (Low Input)	<Ref. to EN(H4SO)(diag)-257, DTC P1492 EGR SOLENOID VALVE SIGNAL #1 CIRCUIT MALFUNCTION (LOW INPUT), Diagnostic Procedure with Diagnostic Trouble Code (DTC).>
P1493	EGR Solenoid Valve Signal #1 Circuit Malfunction (High Input)	<Ref. to EN(H4SO)(diag)-257, DTC P1493 EGR SOLENOID VALVE SIGNAL #1 CIRCUIT MALFUNCTION (HIGH INPUT), Diagnostic Procedure with Diagnostic Trouble Code (DTC).>
P1494	EGR Solenoid Valve Signal #2 Circuit Malfunction (Low Input)	<Ref. to EN(H4SO)(diag)-257, DTC P1494 EGR SOLENOID VALVE SIGNAL #2 CIRCUIT MALFUNCTION (LOW INPUT), Diagnostic Procedure with Diagnostic Trouble Code (DTC).>
P1495	EGR Solenoid Valve Signal #2 Circuit Malfunction (High Input)	<Ref. to EN(H4SO)(diag)-257, DTC P1495 EGR SOLENOID VALVE SIGNAL #2 CIRCUIT MALFUNCTION (HIGH INPUT), Diagnostic Procedure with Diagnostic Trouble Code (DTC).>

List of Diagnostic Trouble Code (DTC)

ENGINE (DIAGNOSTICS)

DTC	Item	Reference
P1496	EGR Solenoid Valve Signal #3 Circuit Malfunction (Low Input)	<Ref. to EN(H4SO)(diag)-257, DTC P1496 EGR SOLENOID VALVE SIGNAL #3 CIRCUIT MALFUNCTION (LOW INPUT), Diagnostic Procedure with Diagnostic Trouble Code (DTC).>
P1497	EGR Solenoid Valve Signal #3 Circuit Malfunction (High Input)	<Ref. to EN(H4SO)(diag)-257, DTC P1497 EGR SOLENOID VALVE SIGNAL #3 CIRCUIT MALFUNCTION (HIGH INPUT), Diagnostic Procedure with Diagnostic Trouble Code (DTC).>
P1498	EGR Solenoid Valve Signal #4 Circuit Malfunction (Low Input)	<Ref. to EN(H4SO)(diag)-258, DTC P1498 EGR SOLENOID VALVE SIGNAL #4 CIRCUIT MALFUNCTION (LOW INPUT), Diagnostic Procedure with Diagnostic Trouble Code (DTC).>
P1499	EGR Solenoid Valve Signal #4 Circuit Malfunction (High Input)	<Ref. to EN(H4SO)(diag)-261, DTC P1499 EGR SOLENOID VALVE SIGNAL #4 CIRCUIT MALFUNCTION (HIGH INPUT), Diagnostic Procedure with Diagnostic Trouble Code (DTC).>
P1560	Back-up Voltage Circuit Malfunction	<Ref. to EN(H4SO)(diag)-263, DTC P1560 BACK-UP VOLTAGE CIRCUIT MALFUNCTION, Diagnostic Procedure with Diagnostic Trouble Code (DTC).>
P1570	Antenna	<Ref. to IM(diag)-17, DTC P1570 ANTENNA, Diagnostic Procedure with Diagnostic Trouble Code (DTC).>
P1571	Reference Code Incompatibility	<Ref. to IM(diag)-19, DTC P1571 REFERENCE CODE INCOMPATIBILITY, Diagnostic Procedure with Diagnostic Trouble Code (DTC).>
P1572	IMM Circuit Failure (Except Antenna Circuit)	<Ref. to IM(diag)-20, DTC P1572 IMM CIRCUIT FAILURE (EXCEPT ANTENNA CIRCUIT), Diagnostic Procedure with Diagnostic Trouble Code (DTC).>
P1574	Key Communication Failure	<Ref. to IM(diag)-22, DTC P1574 KEY COMMUNICATION FAILURE, Diagnostic Procedure with Diagnostic Trouble Code (DTC).>
P1576	EGI Control Module EEPROM	<Ref. to IM(diag)-23, DTC P1576 EGI CONTROL MODULE EEPROM, Diagnostic Procedure with Diagnostic Trouble Code (DTC).>
P1577	IMM Control Module EEPROM	<Ref. to IM(diag)-23, DTC P1577 IMM CONTROL MODULE EEPROM, Diagnostic Procedure with Diagnostic Trouble Code (DTC).>
P1578	Meter Failure	<Ref. to IM(diag)-24, DTC P1578 METER FAILURE, Diagnostic Procedure with Diagnostic Trouble Code (DTC).>
P1602	Control Module Programming Error	<Ref. to EN(H4SO)(diag)-265, DTC P1602 CONTROL MODULE PROGRAMMING ERROR, Diagnostic Procedure with Diagnostic Trouble Code (DTC).>
P2096	Post Catalyst Fuel Trim System Too Lean (Bank 1)	<Ref. to EN(H4SO)(diag)-273, DTC P2096 POST CATALYST FUEL TRIM SYSTEM TOO LEAN (BANK 1), Diagnostic Procedure with Diagnostic Trouble Code (DTC).>
P2097	Post Catalyst Fuel Trim System Too Rich (Bank 1)	<Ref. to EN(H4SO)(diag)-274, DTC P2097 POST CATALYST FUEL TRIM SYSTEM TOO RICH (BANK 1), Diagnostic Procedure with Diagnostic Trouble Code (DTC).>
P2101	Throttle Actuator Control Motor Circuit Range/Performance	<Ref. to EN(H4SO)(diag)-280, DTC P2101 THROTTLE ACTUATOR CONTROL MOTOR CIRCUIT RANGE/PERFORMANCE, Diagnostic Procedure with Diagnostic Trouble Code (DTC).>
P2102	Throttle Actuator Control Motor Circuit Low	<Ref. to EN(H4SO)(diag)-285, DTC P2102 THROTTLE ACTUATOR CONTROL MOTOR CIRCUIT LOW, Diagnostic Procedure with Diagnostic Trouble Code (DTC).>
P2103	Post Catalyst Fuel Trim System Too Rich (Bank 1)	<Ref. to EN(H4SO)(diag)-287, DTC P2103 THROTTLE ACTUATOR CONTROL MOTOR CIRCUIT HIGH, Diagnostic Procedure with Diagnostic Trouble Code (DTC).>
P2109	Throttle/Pedal Position Sensor "A" Minimum Stop Performance	<Ref. to EN(H4SO)(diag)-288, DTC P2109 THROTTLE/PEDAL POSITION SENSOR "A" MINIMUM STOP PERFORMANCE, Diagnostic Procedure with Diagnostic Trouble Code (DTC).>
P2122	Throttle/Pedal Position Sensor/Switch "D" Circuit Low Input	<Ref. to EN(H4SO)(diag)-289, DTC P2122 THROTTLE/PEDAL POSITION SENSOR/SWITCH "D" CIRCUIT LOW INPUT, Diagnostic Procedure with Diagnostic Trouble Code (DTC).>
P2123	Throttle/Pedal Position Sensor/Switch "D" Circuit High Input	<Ref. to EN(H4SO)(diag)-291, DTC P2123 THROTTLE/PEDAL POSITION SENSOR/SWITCH "D" CIRCUIT HIGH INPUT, Diagnostic Procedure with Diagnostic Trouble Code (DTC).>

List of Diagnostic Trouble Code (DTC)

ENGINE (DIAGNOSTICS)

DTC	Item	Reference
P2127	Throttle/Pedal Position Sensor/Switch "E" Circuit Low Input	<Ref. to EN(H4SO)(diag)-293, DTC P2127 THROTTLE/PEDAL POSITION SENSOR/SWITCH "E" CIRCUIT LOW INPUT, Diagnostic Procedure with Diagnostic Trouble Code (DTC).>
P2128	Throttle/Pedal Position Sensor/Switch "E" Circuit High Input	<Ref. to EN(H4SO)(diag)-295, DTC P2128 THROTTLE/PEDAL POSITION SENSOR/SWITCH "E" CIRCUIT HIGH INPUT, Diagnostic Procedure with Diagnostic Trouble Code (DTC).>
P2135	Throttle/Pedal Position Sensor/Switch "A"/"B" Voltage Correlation	<Ref. to EN(H4SO)(diag)-297, DTC P2135 THROTTLE/PEDAL POSITION SENSOR/SWITCH "A"/"B" VOLTAGE CORRELATION, Diagnostic Procedure with Diagnostic Trouble Code (DTC).>
P2138	Throttle/Pedal Position Sensor/Switch "D"/"E" Voltage Correlation	<Ref. to EN(H4SO)(diag)-300, DTC P2138 THROTTLE/PEDAL POSITION SENSOR/SWITCH "D"/"E" VOLTAGE CORRELATION, Diagnostic Procedure with Diagnostic Trouble Code (DTC).>
P2227	Barometric Pressure Circuit Range/Performance	<Ref. to EN(H4SO)(diag)-302, DTC P2227 BAROMETRIC PRESSURE CIRCUIT RANGE/PERFORMANCE, Diagnostic Procedure with Diagnostic Trouble Code (DTC).>
P2228	Barometric Pressure Circuit Low	<Ref. to EN(H4SO)(diag)-302, DTC P2228 BAROMETRIC PRESSURE CIRCUIT LOW, Diagnostic Procedure with Diagnostic Trouble Code (DTC).>
P2229	Barometric Pressure Circuit High	<Ref. to EN(H4SO)(diag)-303, DTC P2229 BAROMETRIC PRESSURE CIRCUIT HIGH, Diagnostic Procedure with Diagnostic Trouble Code (DTC).>

20. Diagnostic Procedure with Diagnostic Trouble Code (DTC)

A: DTC P0026 INTAKE VALVE CONTROL SOLENOID CIRCUIT RANGE/ PERFORMANCE (BANK 1)

DTC DETECTING CONDITION:

- Immediately at fault recognition
- GENERAL DESCRIPTION <Ref. to GD(H4SO)-8, DTC P0026 INTAKE VALVE CONTROL SOLENOID CIRCUIT RANGE/PERFORMANCE (BANK 1), Diagnostic Trouble Code (DTC) Detecting Criteria.>

TROUBLE SYMPTOM:

Improper idling

CAUTION:

After repair or replacement of faulty parts, perform Clear Memory Mode <Ref. to EN(H4SO)(diag)-51, OPERATION, Clear Memory Mode.> and Inspection Mode <Ref. to EN(H4SO)(diag)-41, PROCEDURE, Inspection Mode.>.

WIRING DIAGRAM:

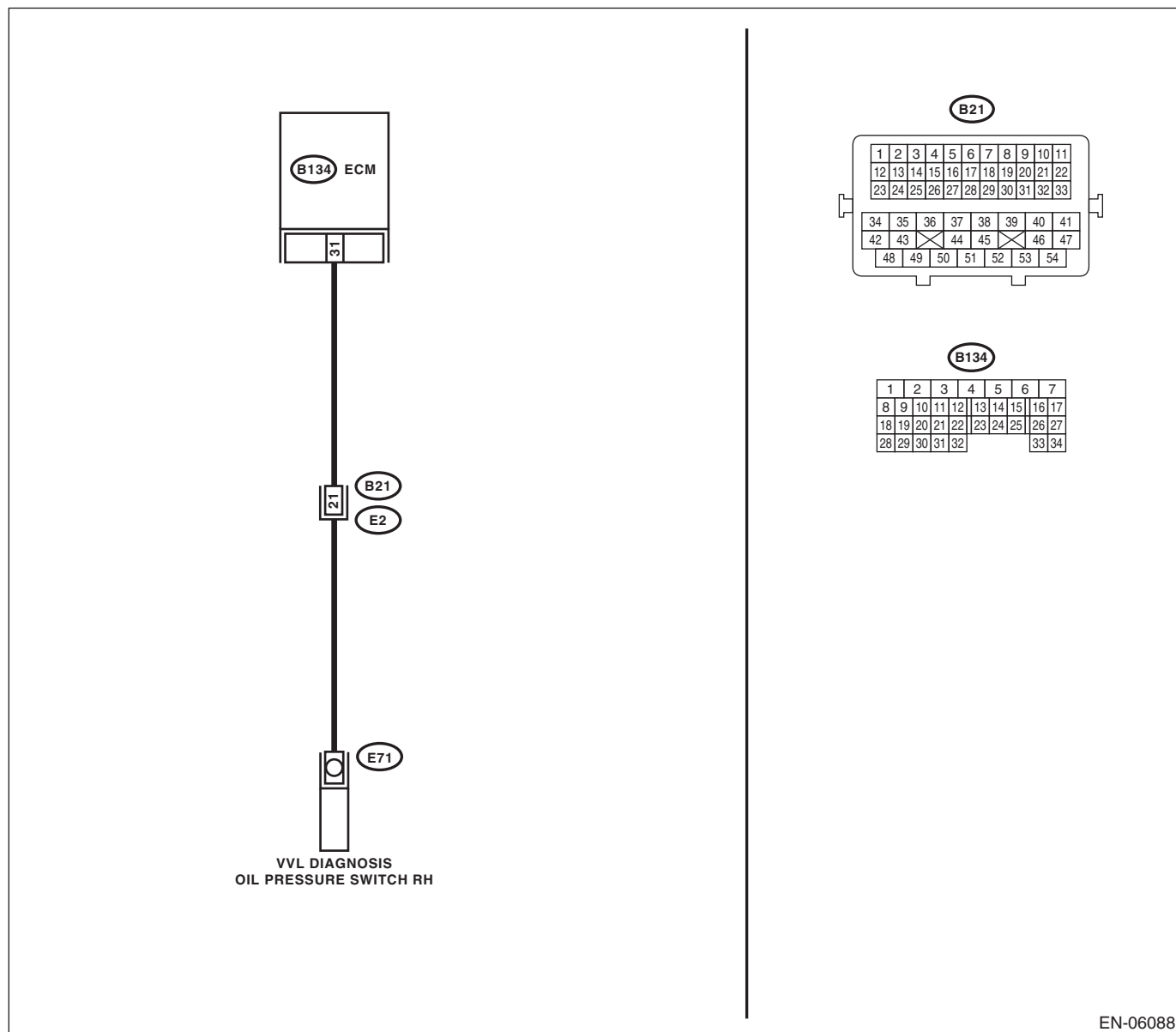

Diagnostic Procedure with Diagnostic Trouble Code (DTC)

ENGINE (DIAGNOSTICS)

Step	Check	Yes	No
1 CHECK HARNESS BETWEEN ECM AND VARIABLE VALVE LIFT DIAGNOSIS OIL PRESSURE SWITCH. 1) Warm up the engine. 2) Turn the ignition switch to OFF. 3) Disconnect the connectors from the ECM and variable valve lift diagnosis oil pressure switch. 4) Measure the resistance of harness between ECM and variable valve lift diagnosis oil pressure switch connector. Connector & terminal (B134) No. 31 — (E71) No. 1:	Is the resistance less than 1 Ω?	Go to step 2.	Repair the harness and connector. NOTE: In this case, repair the following item: • Open circuit in harness between ECM and variable valve lift diagnosis oil pressure switch connector • Poor contact of coupling connector
2 CHECK HARNESS BETWEEN ECM AND VARIABLE VALVE LIFT DIAGNOSIS OIL PRESSURE SWITCH. Measure the resistance between the variable valve lift diagnosis oil pressure switch connector and engine ground. Connector & terminal (E71) No. 1 — Engine ground:	Is the resistance 1 MΩ or more?	Go to step 3.	Repair the ground short circuit of harness between ECM and variable valve lift diagnosis oil pressure switch connector.
3 CHECK HARNESS BETWEEN ECM AND VARIABLE VALVE LIFT DIAGNOSIS OIL PRESSURE SWITCH. 1) Turn the ignition switch to ON. 2) Measure the voltage between the variable valve lift diagnosis oil pressure switch connector and engine ground. Connector & terminal (E71) No. 1 (+) — Engine ground (-):	Is the voltage 10 V or more?	Repair the short circuit to power of the harness between the ECM and variable valve lift diagnosis oil pressure switch connector.	Go to step 4.
4 CHECK DTC. 1) Perform the Clear Memory Mode. 2) After idling the engine, check the DTC. NOTE: For detailed procedures, refer to “Clear Memory Mode”. <Ref. to EN(H4SO)(diag)-51, Clear Memory Mode.>	Is DTC displayed?	Replace the oil switching solenoid valve. <Ref. to ME(H4SO)-104, Oil Switching Solenoid Valve.> Go to step 5.	END
5 CHECK DTC. 1) Perform the Clear Memory Mode. 2) After idling the engine, check the DTC. NOTE: For detailed procedures, refer to “Clear Memory Mode”. <Ref. to EN(H4SO)(diag)-51, Clear Memory Mode.>	Is DTC displayed?	Check for oil routing.	END.

Diagnostic Procedure with Diagnostic Trouble Code (DTC)

ENGINE (DIAGNOSTICS)

B: DTC P0028 INTAKE VALVE CONTROL SOLENOID CIRCUIT RANGE/ PERFORMANCE (BANK 2)

DTC DETECTING CONDITION:

- Immediately at fault recognition
- GENERAL DESCRIPTION <Ref. to GD(H4SO)-10, DTC P0028 INTAKE VALVE CONTROL SOLENOID CIRCUIT RANGE/PERFORMANCE (BANK 2), Diagnostic Trouble Code (DTC) Detecting Criteria.>

TROUBLE SYMPTOM:

Improper idling

CAUTION:

After repair or replacement of faulty parts, perform Clear Memory Mode <Ref. to EN(H4SO)(diag)-51, OPERATION, Clear Memory Mode.> and Inspection Mode <Ref. to EN(H4SO)(diag)-41, PROCEDURE, Inspection Mode.>.

WIRING DIAGRAM:

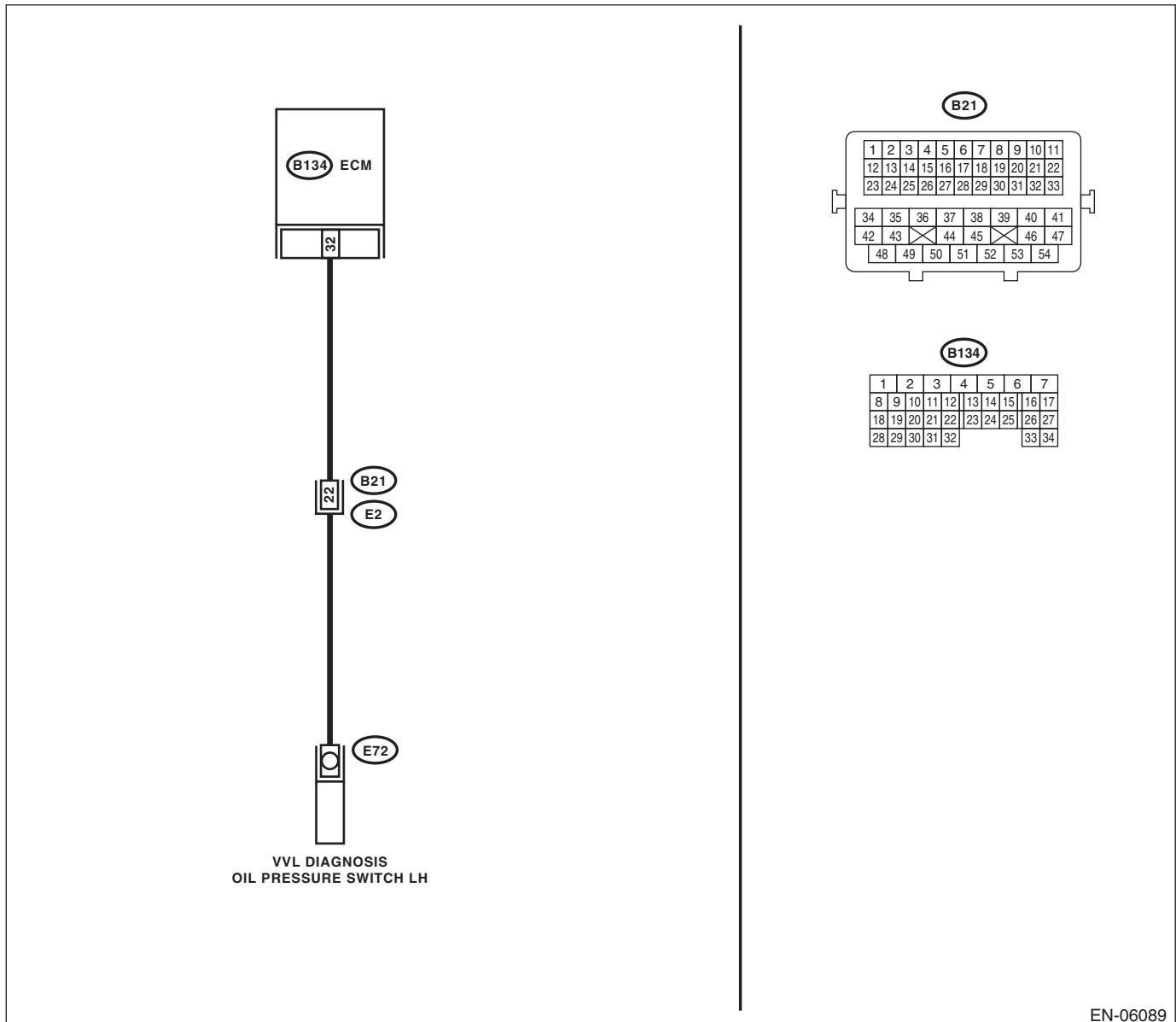

EN-06089

Diagnostic Procedure with Diagnostic Trouble Code (DTC)

ENGINE (DIAGNOSTICS)

Step	Check	Yes	No
1 CHECK HARNESS BETWEEN ECM AND VARIABLE VALVE LIFT DIAGNOSIS OIL PRESSURE SWITCH. 1) Warm up the engine. 2) Turn the ignition switch to OFF. 3) Disconnect the connectors from the ECM and variable valve lift diagnosis oil pressure switch. 4) Measure the resistance of harness between ECM and variable valve lift diagnosis oil pressure switch connector. Connector & terminal (B134) No. 32 — (E72) No. 1:	Is the resistance less than 1 Ω?	Go to step 2.	Repair the harness and connector. NOTE: In this case, repair the following item: • Open circuit in harness between ECM and variable valve lift diagnosis oil pressure switch connector • Poor contact of coupling connector
2 CHECK HARNESS BETWEEN ECM AND VARIABLE VALVE LIFT DIAGNOSIS OIL PRESSURE SWITCH. Measure the resistance between the variable valve lift diagnosis oil pressure switch connector and engine ground. Connector & terminal (E72) No. 1 — Engine ground:	Is the resistance 1 MΩ or more?	Go to step 3.	Repair the ground short circuit of harness between ECM and variable valve lift diagnosis oil pressure switch connector.
3 CHECK HARNESS BETWEEN ECM AND VARIABLE VALVE LIFT DIAGNOSIS OIL PRESSURE SWITCH. 1) Turn the ignition switch to ON. 2) Measure the voltage between the variable valve lift diagnosis oil pressure switch connector and engine ground. Connector & terminal (E72) No. 1 (+) — Engine ground (-):	Is the voltage 10 V or more?	Repair the short circuit to power of the harness between the ECM and variable valve lift diagnosis oil pressure switch connector.	Go to step 4.
4 CHECK DTC. 1) Perform the Clear Memory Mode. 2) After idling the engine, check the DTC. NOTE: For detailed procedures, refer to “Clear Memory Mode”. <Ref. to EN(H4SO)(diag)-51, Clear Memory Mode.>	Is DTC displayed?	Replace the oil switching solenoid valve. <Ref. to ME(H4SO)-104, Oil Switching Solenoid Valve.> Go to step 5.	END
5 CHECK DTC. 1) Perform the Clear Memory Mode. 2) After idling the engine, check the DTC. NOTE: For detailed procedures, refer to “Clear Memory Mode”. <Ref. to EN(H4SO)(diag)-51, Clear Memory Mode.>	Is DTC displayed?	Check for oil routing.	END.

Diagnostic Procedure with Diagnostic Trouble Code (DTC)

ENGINE (DIAGNOSTICS)

C: DTC P0030 HO2S HEATER CONTROL CIRCUIT (BANK 1 SENSOR 1)

DTC DETECTING CONDITION:

- Detected when two consecutive driving cycles with fault occur.
- GENERAL DESCRIPTION <Ref. to GD(H4SO)-10, DTC P0030 HO2S HEATER CONTROL CIRCUIT (BANK 1 SENSOR 1), Diagnostic Trouble Code (DTC) Detecting Criteria.>

CAUTION:

After repair or replacement of faulty parts, perform Clear Memory Mode <Ref. to EN(H4SO)(diag)-51, OPERATION, Clear Memory Mode.> and Inspection Mode <Ref. to EN(H4SO)(diag)-41, PROCEDURE, Inspection Mode.>.

WIRING DIAGRAM:

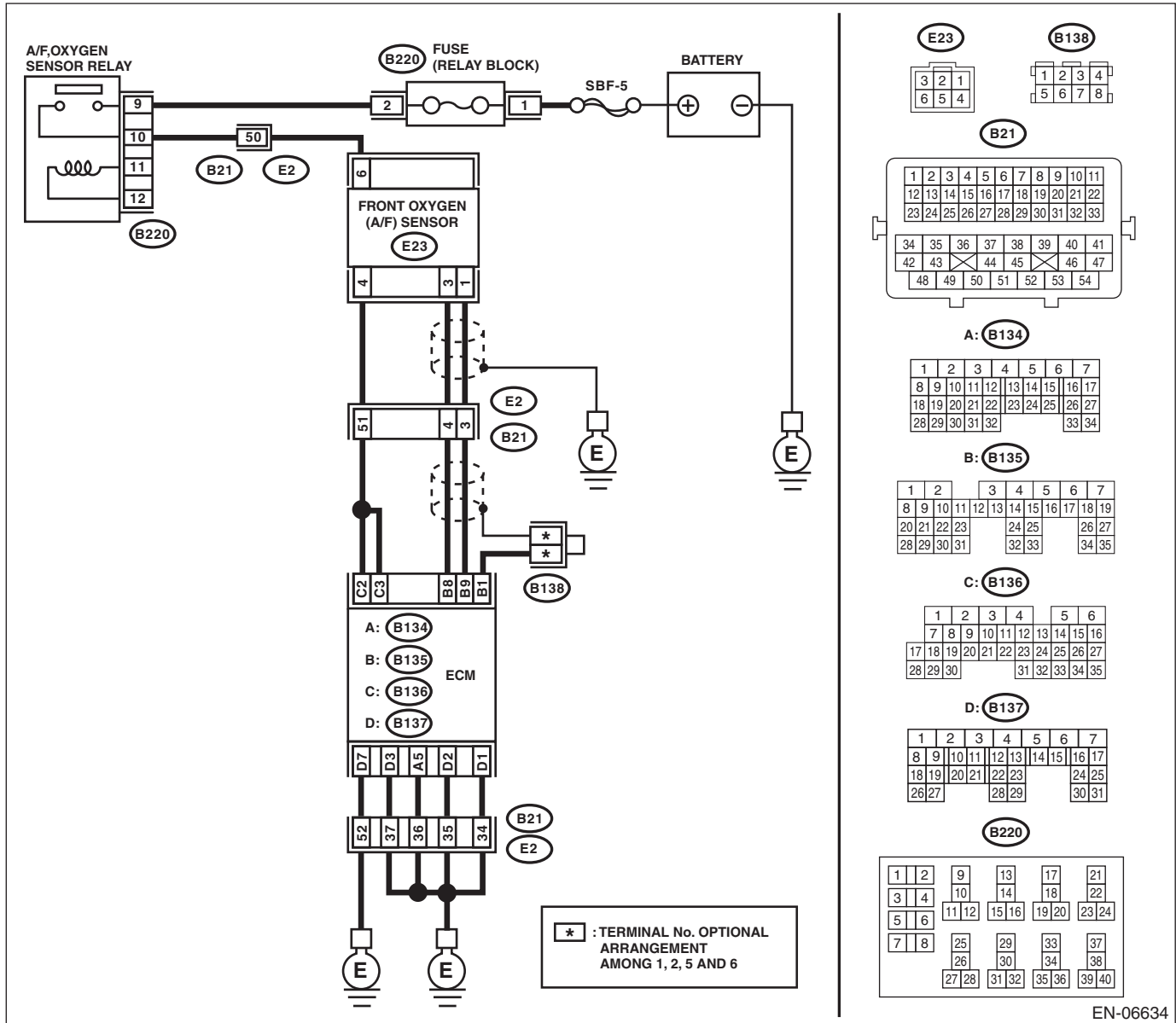

EN-06634

Diagnostic Procedure with Diagnostic Trouble Code (DTC)

ENGINE (DIAGNOSTICS)

Step	Check	Yes	No
1 CHECK HARNESS BETWEEN ECM AND FRONT OXYGEN (A/F) SENSOR CONNECTOR. 1) Start and warm up the engine. 2) Turn the ignition switch to OFF. 3) Disconnect the connectors from the ECM and front oxygen (A/F) sensor. 4) Measure the resistance of harness between ECM and front oxygen (A/F) sensor connector. <i>Connector & terminal</i> <i>(B136) No. 2 — (E23) No. 4:</i> <i>(B136) No. 3 — (E23) No. 4:</i>	Is the resistance less than 1 Ω ?	Go to step 2.	Repair the harness and connector. NOTE: In this case, repair the following item: <ul style="list-style-type: none"> • Open circuit in harness between ECM and front oxygen (A/F) sensor connector • Poor contact of coupling connector
2 CHECK HARNESS BETWEEN ECM AND FRONT OXYGEN (A/F) SENSOR CONNECTOR. Measure the resistance of harness between ECM and front oxygen (A/F) sensor connector. <i>Connector & terminal</i> <i>(B135) No. 9 — (E23) No. 1:</i> <i>(B135) No. 8 — (E23) No. 3:</i>	Is the resistance less than 1 Ω ?	Go to step 3.	Repair the harness and connector. NOTE: In this case, repair the following item: <ul style="list-style-type: none"> • Open circuit in harness between ECM and front oxygen (A/F) sensor connector • Poor contact of coupling connector
3 CHECK FRONT OXYGEN (A/F) SENSOR. Measure the resistance between front oxygen (A/F) sensor terminals. <i>Terminals</i> <i>No. 6 — No. 4:</i>	Is the resistance between 2 — 3 Ω ?	Go to step 4.	Replace the front oxygen (A/F) sensor. <Ref. to FU(H4SO)-35, Front Oxygen (A/F) Sensor.>
4 CHECK POOR CONTACT. Check poor contact of ECM and front oxygen (A/F) sensor connector.	Is there poor contact in ECM or front oxygen (A/F) sensor connector?	Repair the poor contact of ECM or front oxygen (A/F) sensor connector.	Replace the front oxygen (A/F) sensor. <Ref. to FU(H4SO)-35, Front Oxygen (A/F) Sensor.>

Diagnostic Procedure with Diagnostic Trouble Code (DTC)

ENGINE (DIAGNOSTICS)

D: DTC P0031 HO2S HEATER CONTROL CIRCUIT LOW (BANK 1 SENSOR 1)

DTC DETECTING CONDITION:

- Immediately at fault recognition
- GENERAL DESCRIPTION <Ref. to GD(H4SO)-12, DTC P0031 HO2S HEATER CONTROL CIRCUIT LOW (BANK 1 SENSOR 1), Diagnostic Trouble Code (DTC) Detecting Criteria.>

CAUTION:

After repair or replacement of faulty parts, perform Clear Memory Mode <Ref. to EN(H4SO)(diag)-51, OPERATION, Clear Memory Mode.> and Inspection Mode <Ref. to EN(H4SO)(diag)-41, PROCEDURE, Inspection Mode.>.

WIRING DIAGRAM:

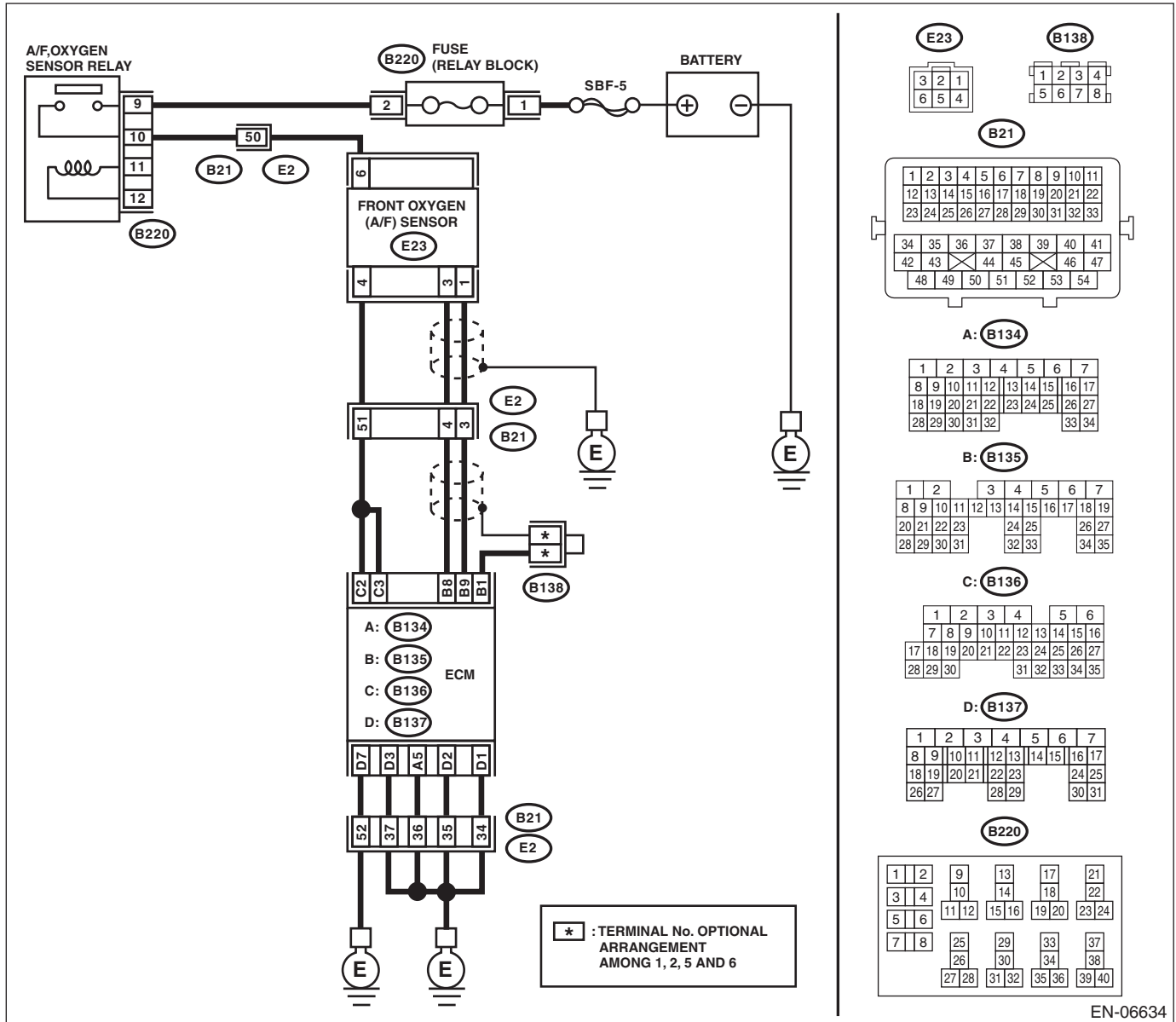

EN-06634

Diagnostic Procedure with Diagnostic Trouble Code (DTC)

ENGINE (DIAGNOSTICS)

Step	Check	Yes	No
<p>1 CHECK POWER SUPPLY TO FRONT OXYGEN (A/F) SENSOR.</p> <p>1) Turn the ignition switch to OFF. 2) Disconnect the connector from front oxygen (A/F) sensor. 3) Turn the ignition switch to ON. 4) Measure the voltage between front oxygen (A/F) sensor connector and engine ground.</p> <p>Connector & terminal (E23) No. 6 (+) — Engine ground (-):</p>	Is the voltage 10 V or more?	Go to step 2.	Repair the power supply line. Or replace the main relay. NOTE: In this case, repair the following item: • Open circuit in harness between A/F, oxygen sensor relay connector and front oxygen (A/F) sensor connector • Poor contact of A/F, oxygen sensor relay connector • Poor contact of coupling connector
<p>2 CHECK HARNESS BETWEEN ECM AND FRONT OXYGEN (A/F) SENSOR.</p> <p>1) Turn the ignition switch to OFF. 2) Disconnect the connectors from the ECM. 3) Measure the resistance between ECM and front oxygen (A/F) sensor connector.</p> <p>Connector & terminal (B136) No. 2 — (E23) No. 4: (B136) No. 3 — (E23) No. 4:</p>	Is the resistance less than 1 Ω?	Go to step 3.	Repair the harness and connector. NOTE: In this case, repair the following item: • Open circuit in harness between ECM and front oxygen (A/F) sensor connector • Poor contact of coupling connector
<p>3 CHECK GROUND CIRCUIT FOR ECM.</p> <p>Measure the resistance of harness between ECM and chassis ground.</p> <p>Connector & terminal (B134) No. 5 — Chassis ground: (B137) No. 1 — Chassis ground: (B137) No. 2 — Chassis ground: (B137) No. 3 — Chassis ground: (B137) No. 7 — Chassis ground:</p>	Is the resistance less than 5 Ω?	Go to step 4.	Repair the harness and connector. NOTE: In this case, repair the following item: • Open circuit of harness between ECM and engine ground • Poor contact of coupling connector
<p>4 CHECK FRONT OXYGEN (A/F) SENSOR.</p> <p>Measure the resistance between front oxygen (A/F) sensor terminals.</p> <p>Terminals No. 6 — No. 4:</p>	Is the resistance between 2 — 3 Ω?	Repair poor contact of the ECM connector.	Replace the front oxygen (A/F) sensor. <Ref. to FU(H4SO)-35, Front Oxygen (A/F) Sensor.>

Diagnostic Procedure with Diagnostic Trouble Code (DTC)

ENGINE (DIAGNOSTICS)

E: DTC P0032 HO2S HEATER CONTROL CIRCUIT HIGH (BANK 1 SENSOR 1)

DTC DETECTING CONDITION:

- Immediately at fault recognition
- GENERAL DESCRIPTION <Ref. to GD(H4SO)-14, DTC P0032 HO2S HEATER CONTROL CIRCUIT HIGH (BANK 1 SENSOR 1), Diagnostic Trouble Code (DTC) Detecting Criteria.>

CAUTION:

After repair or replacement of faulty parts, perform Clear Memory Mode <Ref. to EN(H4SO)(diag)-51, OPERATION, Clear Memory Mode.> and Inspection Mode <Ref. to EN(H4SO)(diag)-41, PROCEDURE, Inspection Mode.>.

WIRING DIAGRAM:

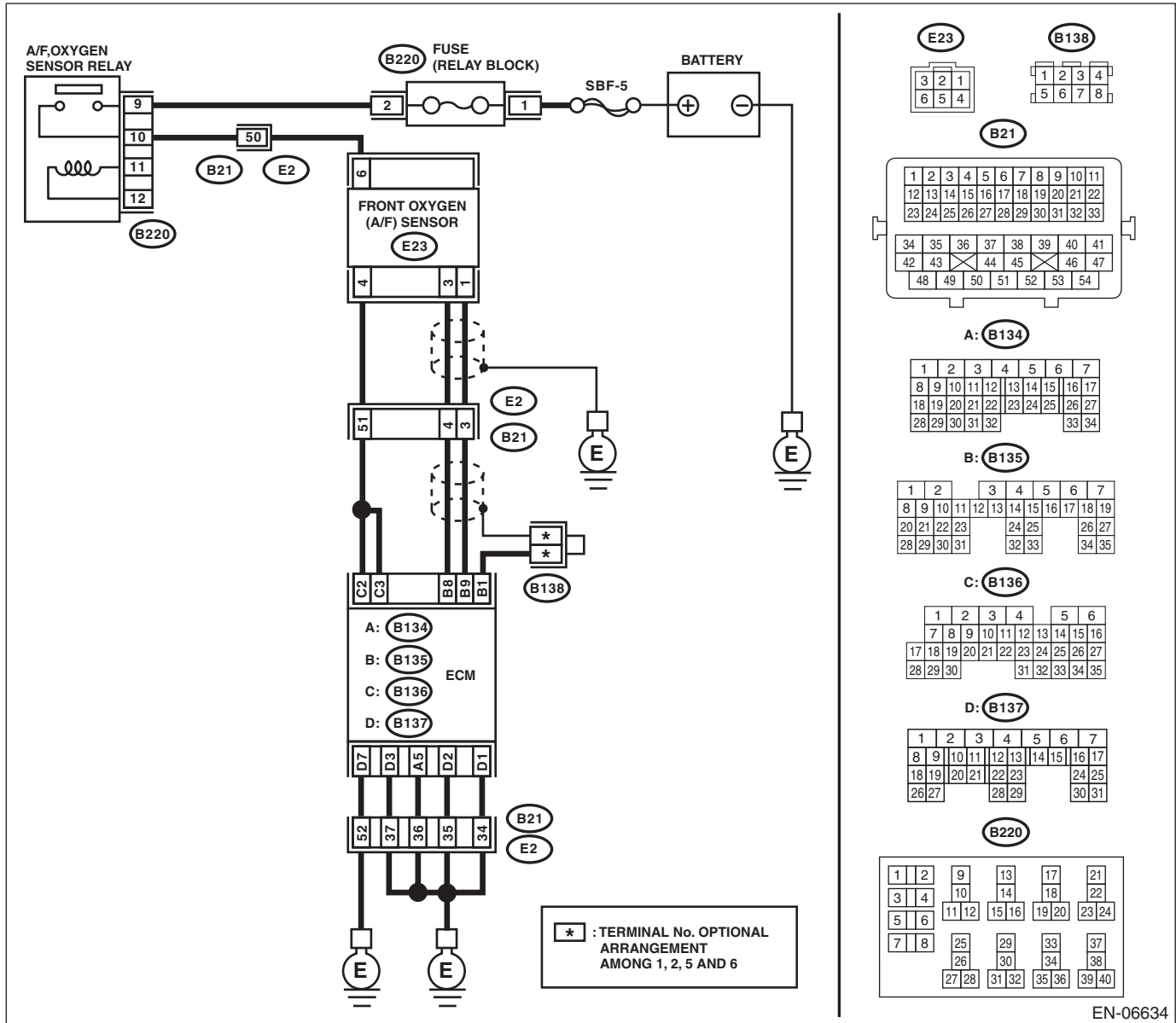

EN-06634

Diagnostic Procedure with Diagnostic Trouble Code (DTC)

ENGINE (DIAGNOSTICS)

Step	Check	Yes	No
1 CHECK HARNESS BETWEEN ECM AND FRONT OXYGEN (A/F) SENSOR. 1) Turn the ignition switch to OFF. 2) Measure the voltage between ECM and chassis ground. <i>Connector & terminal</i> <i>(B136) No. 2 (+) — Chassis ground (-):</i> <i>(B136) No. 3 (+) — Chassis ground (-):</i>	Is the voltage 10 V or more?	Repair the short circuit to power in the harness between the ECM and front oxygen (A/F) sensor connector.	Go to step 2.
2 CHECK GROUND CIRCUIT FOR ECM. 1) Disconnect the connectors from the ECM. 2) Measure the resistance between ECM and chassis ground. <i>Connector & terminal</i> <i>(B134) No. 5 — Chassis ground:</i> <i>(B137) No. 1 — Chassis ground:</i> <i>(B137) No. 2 — Chassis ground:</i> <i>(B137) No. 3 — Chassis ground:</i> <i>(B137) No. 7 — Chassis ground:</i>	Is the resistance less than 5 Ω ?	Repair the poor contact of the ECM connector.	Repair the harness and connector. NOTE: In this case, repair the following item: • Open circuit of harness between ECM and engine ground • Poor contact of coupling connector

Diagnostic Procedure with Diagnostic Trouble Code (DTC)

ENGINE (DIAGNOSTICS)

F: DTC P0037 HO2S HEATER CONTROL CIRCUIT LOW (BANK 1 SENSOR 2)

DTC DETECTING CONDITION:

- Detected when two consecutive driving cycles with fault occur.
- GENERAL DESCRIPTION <Ref. to GD(H4SO)-16, DTC P0037 HO2S HEATER CONTROL CIRCUIT LOW (BANK 1 SENSOR 2), Diagnostic Trouble Code (DTC) Detecting Criteria.>

CAUTION:

After repair or replacement of faulty parts, perform Clear Memory Mode <Ref. to EN(H4SO)(diag)-51, OPERATION, Clear Memory Mode.> and Inspection Mode <Ref. to EN(H4SO)(diag)-41, PROCEDURE, Inspection Mode.>.

WIRING DIAGRAM:

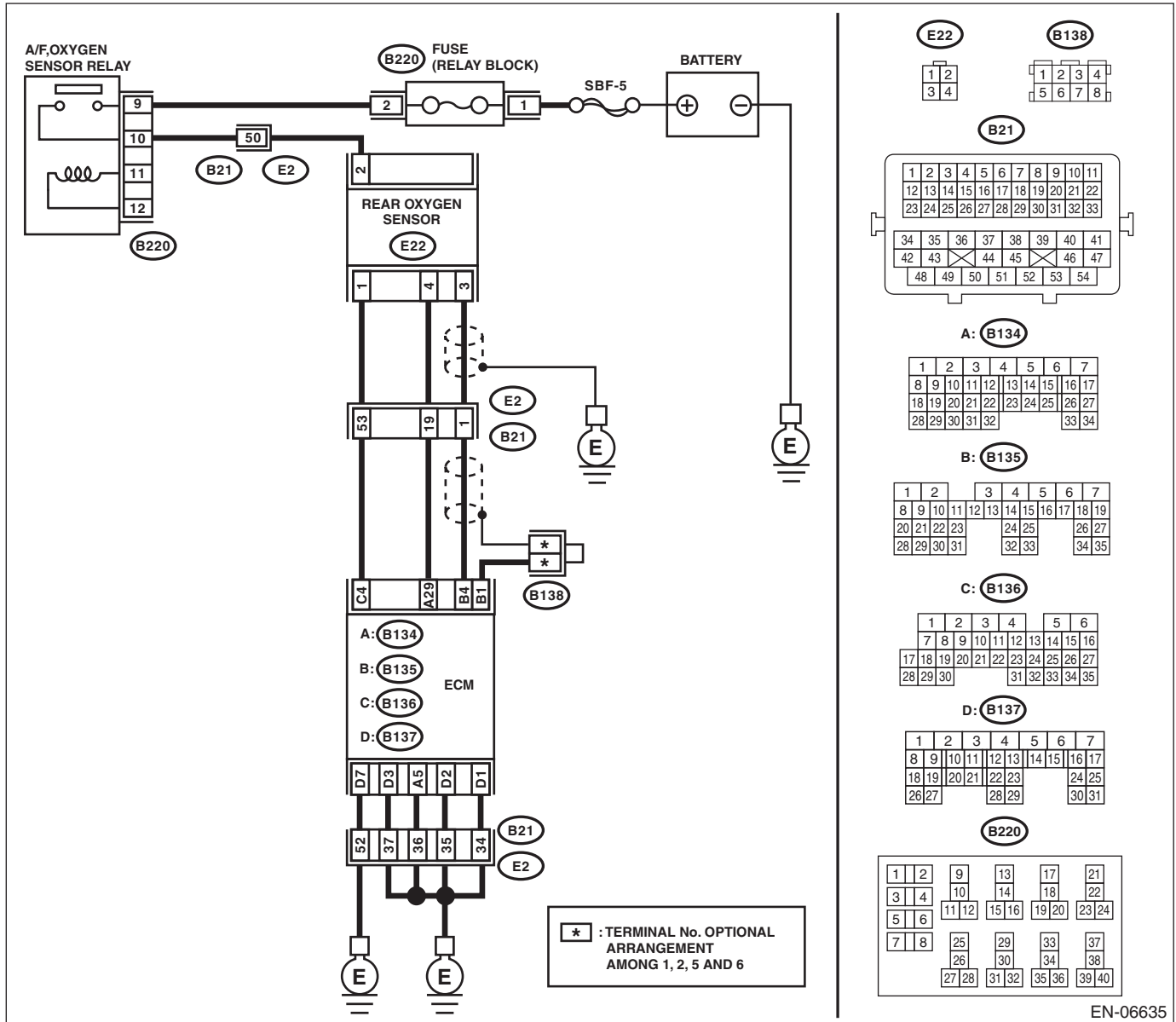

EN-06635

Diagnostic Procedure with Diagnostic Trouble Code (DTC)

ENGINE (DIAGNOSTICS)

Step	Check	Yes	No
<p>1 CHECK POWER SUPPLY TO REAR OXYGEN SENSOR. 1) Turn the ignition switch to OFF. 2) Disconnect the connector from the rear oxygen sensor. 3) Turn the ignition switch to ON. 4) Measure the voltage between rear oxygen sensor connector and engine ground. Connector & terminal (E22) No. 2 (+) — Engine ground (-):</p>	Is the voltage 10 V or more?	Go to step 2.	Repair the power supply line. Or replace the main relay. NOTE: In this case, repair the following item: • Open circuit in harness between A/F, oxygen sensor relay connector and rear oxygen sensor connector • Poor contact of A/F, oxygen sensor relay connector • Poor contact of coupling connector
<p>2 CHECK HARNESS BETWEEN ECM AND REAR OXYGEN SENSOR. 1) Turn the ignition switch to OFF. 2) Disconnect the connectors from the ECM. 3) Measure the resistance between ECM and oxygen sensor connector. Connector & terminal (B136) No. 4 — (E22) No. 1:</p>	Is the resistance less than 1 Ω ?	Go to step 3.	Repair the harness and connector. NOTE: In this case, repair the following item: • Open circuit in harness between ECM and rear oxygen sensor connector • Poor contact of coupling connector
<p>3 CHECK GROUND CIRCUIT FOR ECM. Measure the resistance of harness between ECM and chassis ground. Connector & terminal (B134) No. 5 — Chassis ground: (B137) No. 1 — Chassis ground: (B137) No. 2 — Chassis ground: (B137) No. 3 — Chassis ground: (B137) No. 7 — Chassis ground:</p>	Is the resistance less than 5 Ω ?	Go to step 4.	Repair the harness and connector. NOTE: In this case, repair the following item: • Open circuit of harness between ECM and engine ground • Poor contact of coupling connector
<p>4 CHECK REAR OXYGEN SENSOR. Measure the resistance between rear oxygen sensor terminals. Terminals No. 2 — No. 1:</p>	Is the resistance between 5 — 7 Ω ?	Repair poor contact of the ECM connector.	Replace the rear oxygen sensor. <Ref. to FU(H4SO)-37, Rear Oxygen Sensor.>

Diagnostic Procedure with Diagnostic Trouble Code (DTC)

ENGINE (DIAGNOSTICS)

G: DTC P0038 HO2S HEATER CONTROL CIRCUIT HIGH (BANK 1 SENSOR 2)

DTC DETECTING CONDITION:

- Detected when two consecutive driving cycles with fault occur.
- GENERAL DESCRIPTION <Ref. to GD(H4SO)-18, DTC P0038 HO2S HEATER CONTROL CIRCUIT HIGH (BANK 1 SENSOR 2), Diagnostic Trouble Code (DTC) Detecting Criteria.>

CAUTION:

After repair or replacement of faulty parts, perform Clear Memory Mode <Ref. to EN(H4SO)(diag)-51, OPERATION, Clear Memory Mode.> and Inspection Mode <Ref. to EN(H4SO)(diag)-41, PROCEDURE, Inspection Mode.>.

WIRING DIAGRAM:

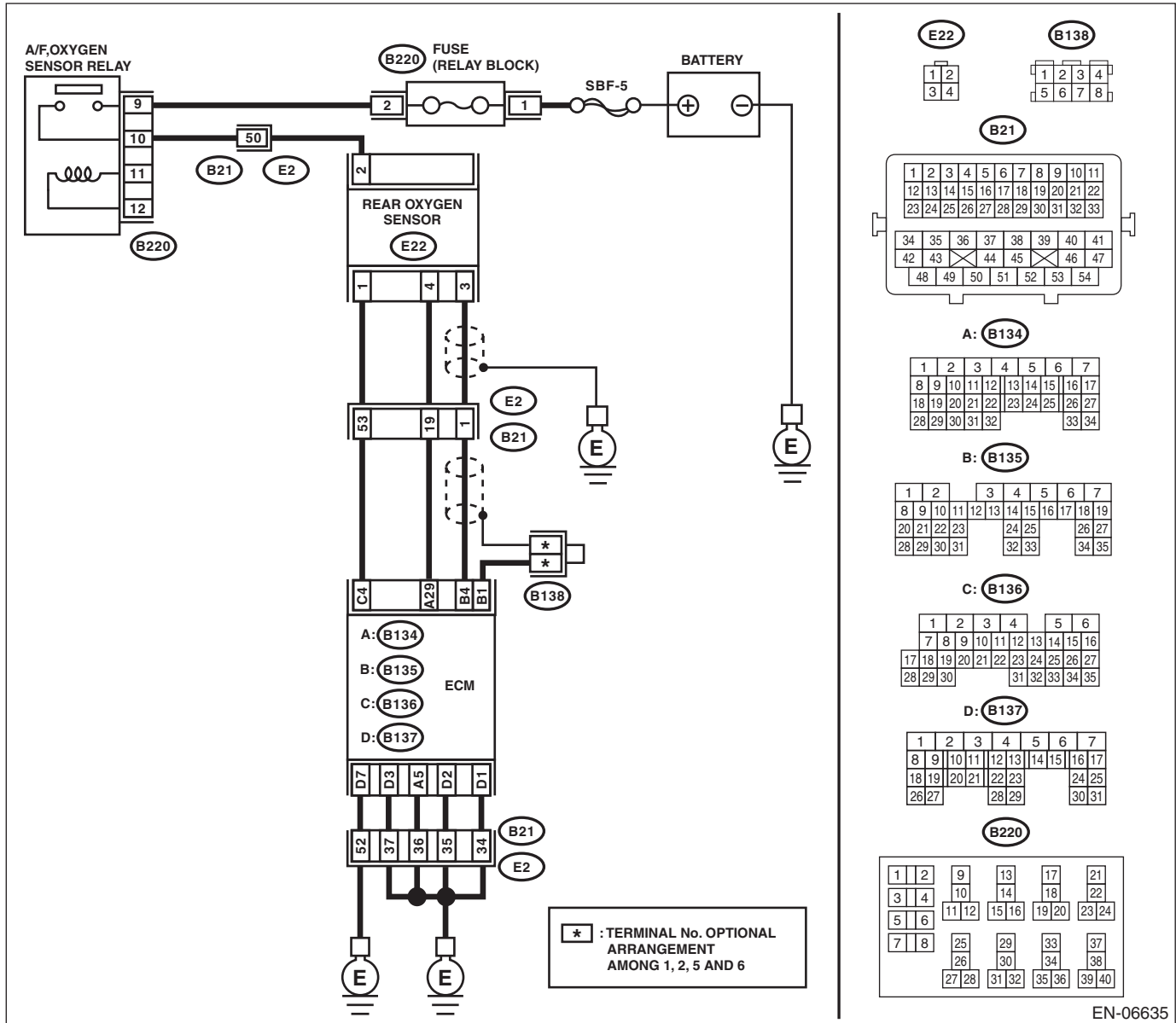

EN-06635

Diagnostic Procedure with Diagnostic Trouble Code (DTC)

ENGINE (DIAGNOSTICS)

Step	Check	Yes	No
1 CHECK HARNESS BETWEEN ECM AND REAR OXYGEN SENSOR. 1) Turn the ignition switch to OFF. 2) Measure the voltage between ECM and chassis ground. <i>Connector & terminal</i> <i>(B136) No. 4 (+) — Chassis ground (-):</i>	Is the voltage 10 V or more?	Repair the short circuit to power in the harness between ECM and rear oxygen sensor connector.	Go to step 2.
2 CHECK GROUND CIRCUIT FOR ECM. 1) Disconnect the connectors from the ECM. 2) Measure the resistance between ECM and chassis ground. <i>Connector & terminal</i> <i>(B134) No. 5 — Chassis ground:</i> <i>(B137) No. 1 — Chassis ground:</i> <i>(B137) No. 2 — Chassis ground:</i> <i>(B137) No. 3 — Chassis ground:</i> <i>(B137) No. 7 — Chassis ground:</i>	Is the resistance less than 5 Ω ?	Repair the poor contact of the ECM connector.	Repair the harness and connector. NOTE: In this case, repair the following item: <ul style="list-style-type: none"> • Open circuit of harness between ECM and engine ground • Poor contact of coupling connector

Diagnostic Procedure with Diagnostic Trouble Code (DTC)

ENGINE (DIAGNOSTICS)

H: DTC P0068 MAP/MAF - THROTTLE POSITION CORRELATION

DTC DETECTING CONDITION:

- Detected when two consecutive driving cycles with fault occur.
- GENERAL DESCRIPTION <Ref. to GD(H4SO)-20, DTC P0068 MAP/MAF - THROTTLE POSITION CORRELATION, Diagnostic Trouble Code (DTC) Detecting Criteria.>

CAUTION:

After repair or replacement of faulty parts, perform Clear Memory Mode <Ref. to EN(H4SO)(diag)-51, OPERATION, Clear Memory Mode.> and Inspection Mode <Ref. to EN(H4SO)(diag)-41, PROCEDURE, Inspection Mode.>.

WIRING DIAGRAM:

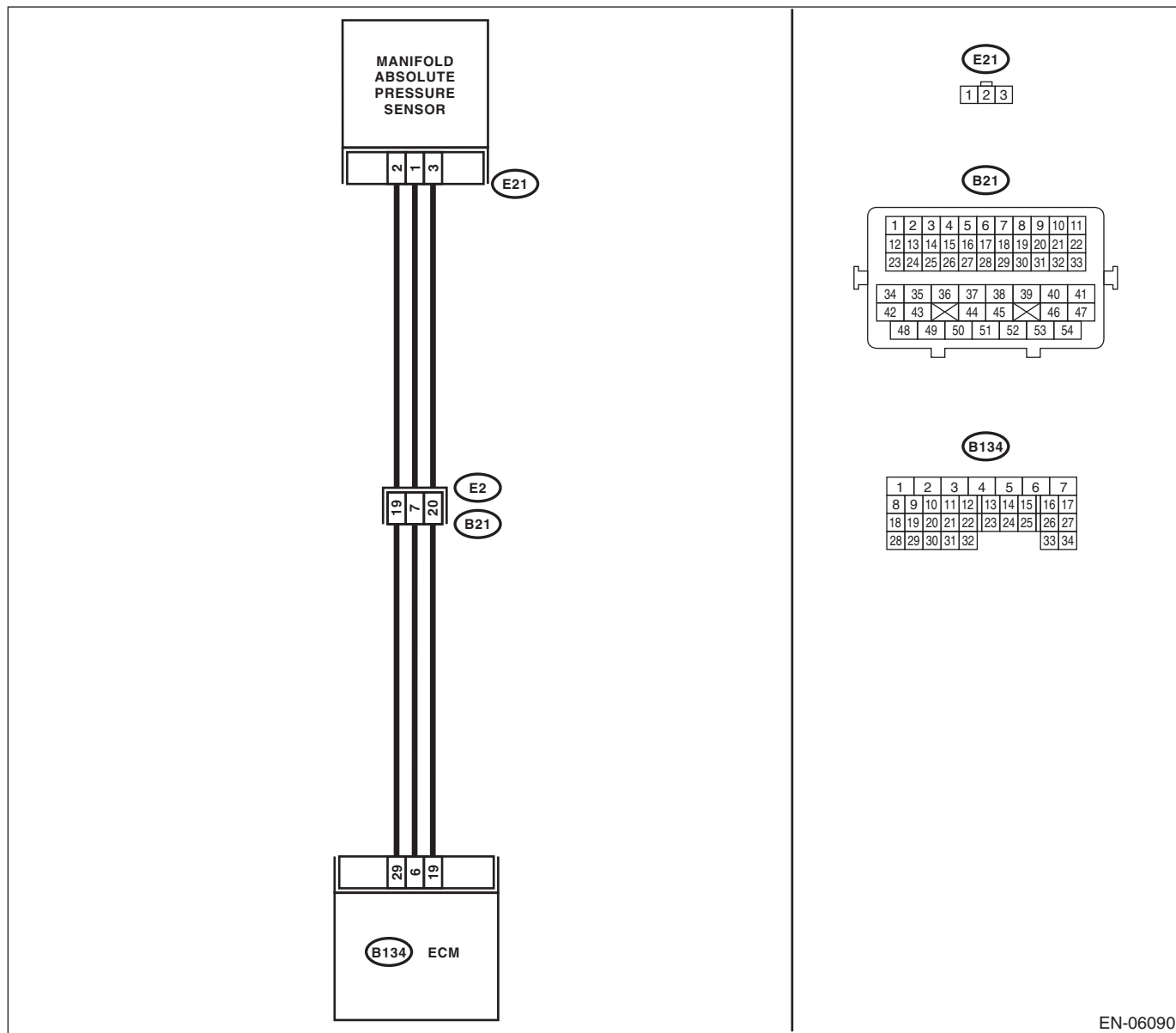

EN-06090

Diagnostic Procedure with Diagnostic Trouble Code (DTC)

ENGINE (DIAGNOSTICS)

	Step	Check	Yes	No
1	CHECK AIR INTAKE SYSTEM.	Are there holes, loose bolts or disconnection of hose on air intake system?	Repair the air intake system.	Go to step 2.
2	CHECK MANIFOLD ABSOLUTE PRESSURE SENSOR. 1) Start the engine and warm up engine until coolant temperature is higher than 75°C (167°F). 2) For AT models, set the select lever to "P" range or "N" range, and for MT models, place the shift lever in the neutral position. 3) Turn the A/C switch to OFF. 4) Turn all the accessory switches to OFF. 5) Read the data of intake manifold pressure sensor signal using Subaru Select Monitor or general scan tool. NOTE: • Subaru Select Monitor For detailed operation procedures, refer to "READ CURRENT DATA FOR ENGINE". <Ref. to EN(H4SO)(diag)-33, Subaru Select Monitor.> • General scan tool For detailed operation procedures, refer to the "General Scan Tool Instruction Manual".	Is the measured value 73.3 — 106.6 kPa (550 — 800 mmHg, 21.65 — 31.50 inHg) when the ignition is turned ON, and 20.0 — 46.7 kPa (150 — 350 mmHg, 5.91 — 13.78 inHg) during idling?	Go to step 3.	Replace the manifold absolute pressure sensor. <Ref. to FU(H4SO)-27, Manifold Absolute Pressure Sensor.>
3	CHECK THROTTLE OPENING ANGLE. Read the data of throttle position signal using Subaru Select Monitor or general scan tool. NOTE: • Subaru Select Monitor For detailed operation procedures, refer to "READ CURRENT DATA FOR ENGINE". <Ref. to EN(H4SO)(diag)-33, Subaru Select Monitor.> • General scan tool For detailed operation procedures, refer to the "General Scan Tool Instruction Manual".	Is the measured value less than 5% when throttle is fully closed?	Go to step 4.	Replace the electronic throttle control. <Ref. to FU(H4SO)-13, Throttle Body.>
4	CHECK THROTTLE OPENING ANGLE.	Is the measured value 85% or more when throttle is fully open?	Replace the manifold absolute pressure sensor. <Ref. to FU(H4SO)-27, Manifold Absolute Pressure Sensor.>	Replace the electronic throttle control. <Ref. to FU(H4SO)-13, Throttle Body.>

Diagnostic Procedure with Diagnostic Trouble Code (DTC)

ENGINE (DIAGNOSTICS)

I: DTC P0076 INTAKE VALVE CONTROL SOLENOID CIRCUIT LOW (BANK 1)

DTC DETECTING CONDITION:

- Immediately at fault recognition
- GENERAL DESCRIPTION <Ref. to GD(H4SO)-22, DTC P0076 INTAKE VALVE CONTROL SOLENOID CIRCUIT LOW (BANK 1), Diagnostic Trouble Code (DTC) Detecting Criteria.>

TROUBLE SYMPTOM:

Improper idling

CAUTION:

After repair or replacement of faulty parts, perform Clear Memory Mode <Ref. to EN(H4SO)(diag)-51, OPERATION, Clear Memory Mode.> and Inspection Mode <Ref. to EN(H4SO)(diag)-41, PROCEDURE, Inspection Mode.>.

WIRING DIAGRAM:

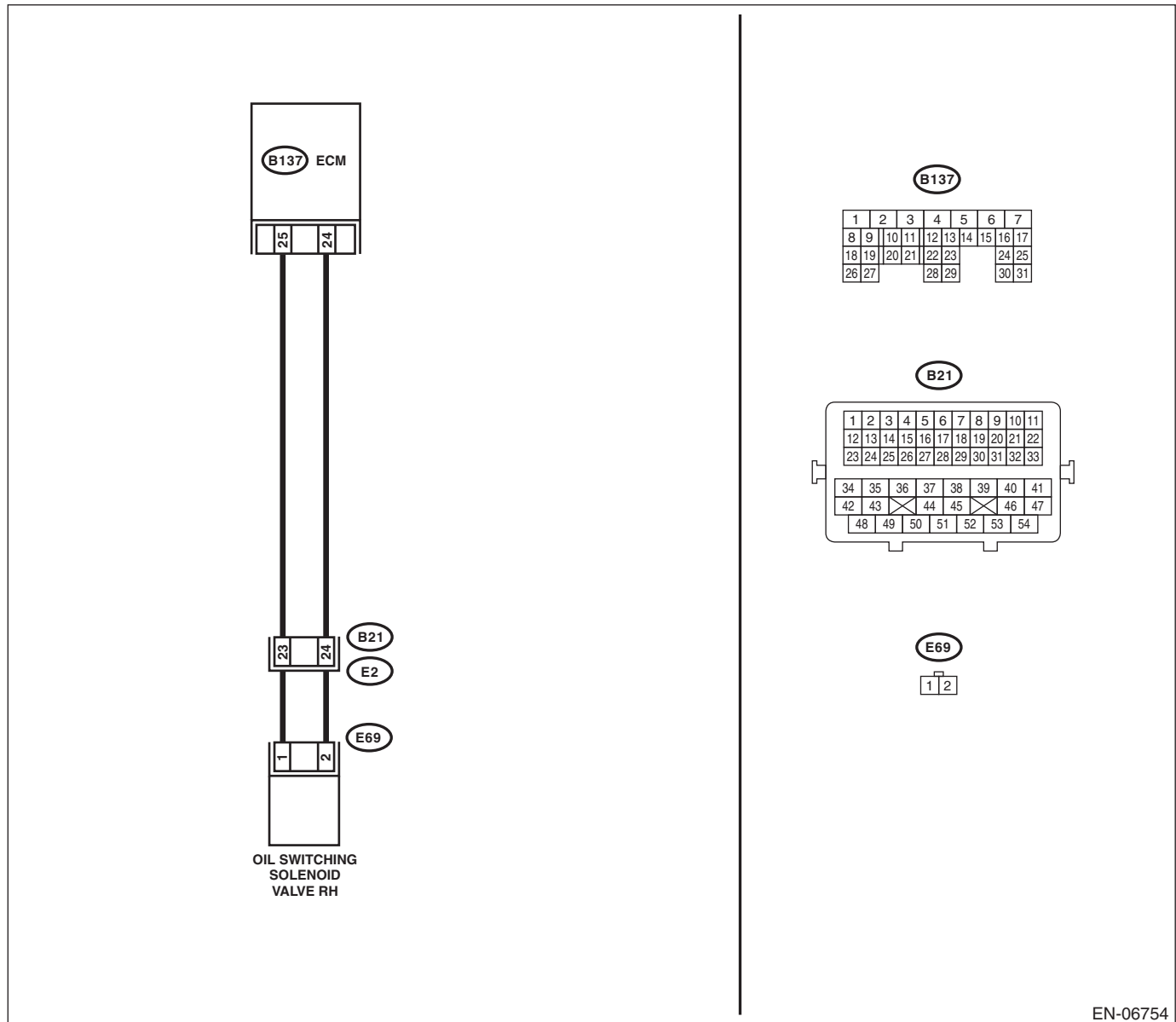

EN-06754

Diagnostic Procedure with Diagnostic Trouble Code (DTC)

ENGINE (DIAGNOSTICS)

Step	Check	Yes	No
<p>1 CHECK HARNESS BETWEEN ECM AND OIL SWITCHING SOLENOID VALVE. 1) Turn the ignition switch to OFF. 2) Disconnect the connectors from the ECM and oil switching solenoid valve. 3) Measure the resistance of harness between ECM and oil switching solenoid valve. Connector & terminal (B137) No. 25 — (E69) No. 1: (B137) No. 24 — (E69) No. 2:</p>	<p>Is the resistance less than 1 Ω?</p>	<p>Go to step 2.</p>	<p>Repair the harness and connector. NOTE: In this case, repair the following item: • Open circuit of harness between ECM and oil switching solenoid valve connector • Poor contact of coupling connector</p>
<p>2 CHECK HARNESS BETWEEN ECM AND OIL SWITCHING SOLENOID VALVE. Measure the resistance between ECM and chassis ground. Connector & terminal (B137) No. 25 — Chassis ground: (B137) No. 24 — Chassis ground:</p>	<p>Is the resistance 1 MΩ or more?</p>	<p>Go to step 3.</p>	<p>Repair the ground short circuit of harness between ECM and oil switching solenoid valve connector.</p>
<p>3 CHECK OIL SWITCHING SOLENOID VALVE. Measure the resistance between oil switching solenoid valve terminals. Terminals No. 1 — No. 2:</p>	<p>Is the resistance between 6 — 12 Ω?</p>	<p>Repair the poor contact of ECM and oil switching solenoid valve connector.</p>	<p>Replace the oil switching solenoid valve. <Ref. to ME(H4SO)-104, Oil Switching Solenoid Valve.></p>

Diagnostic Procedure with Diagnostic Trouble Code (DTC)

ENGINE (DIAGNOSTICS)

J: DTC P0077 INTAKE VALVE CONTROL SOLENOID CIRCUIT HIGH (BANK 1)

DTC DETECTING CONDITION:

- Immediately at fault recognition
- GENERAL DESCRIPTION <Ref. to GD(H4SO)-23, DTC P0077 INTAKE VALVE CONTROL SOLENOID CIRCUIT HIGH (BANK 1), Diagnostic Trouble Code (DTC) Detecting Criteria.>

TROUBLE SYMPTOM:

Improper idling

CAUTION:

After repair or replacement of faulty parts, perform Clear Memory Mode <Ref. to EN(H4SO)(diag)-51, OPERATION, Clear Memory Mode.> and Inspection Mode <Ref. to EN(H4SO)(diag)-41, PROCEDURE, Inspection Mode.>.

WIRING DIAGRAM:

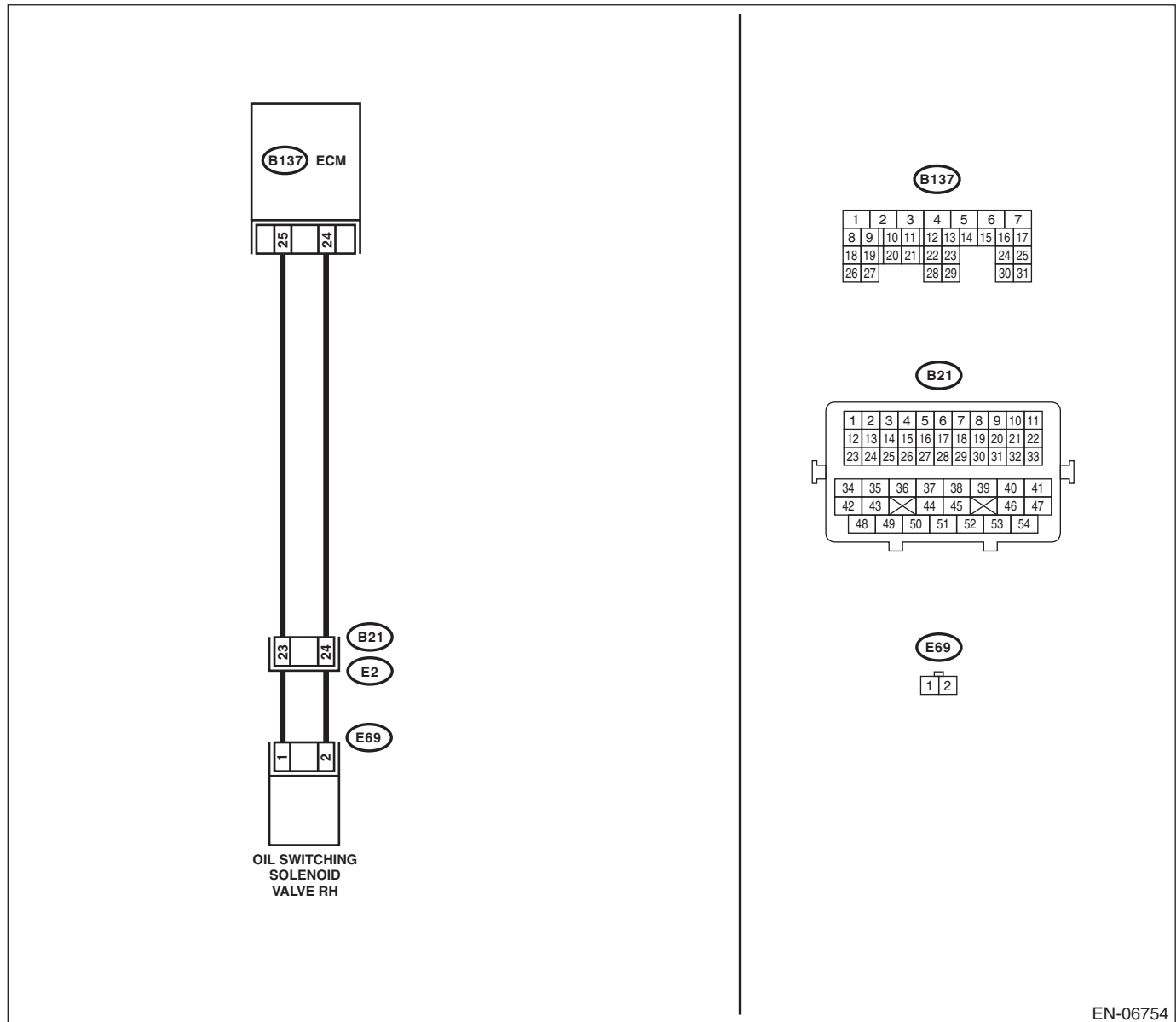

EN-06754

Diagnostic Procedure with Diagnostic Trouble Code (DTC)

ENGINE (DIAGNOSTICS)

Step	Check	Yes	No
<p>1 CHECK HARNESS BETWEEN ECM AND OIL SWITCHING SOLENOID VALVE. 1) Turn the ignition switch to OFF. 2) Disconnect the connectors from the ECM and oil switching solenoid valve. 3) Measure the voltage between ECM and chassis ground. Connector & terminal (B137) No. 25 (+) — Chassis ground (-): (B137) No. 24 (+) — Chassis ground (-):</p>	Is the voltage less than 1 V?	Go to step 2.	Repair the short circuit to power in the harness between ECM and oil switching solenoid valve connector.
<p>2 CHECK HARNESS BETWEEN ECM AND OIL SWITCHING SOLENOID VALVE. Measure the resistance of harness between ECM and oil switching solenoid valve connector. Connector & terminal (B137) No. 25 — (E69) No. 1: (B137) No. 24 — (E69) No. 2:</p>	Is the resistance less than 1 Ω?	Go to step 3.	Repair the harness and connector. NOTE: In this case, repair the following item: <ul style="list-style-type: none"> • Open circuit of harness between ECM and oil switching solenoid valve connector • Poor contact of coupling connector
<p>3 CHECK OIL SWITCHING SOLENOID VALVE. Measure the resistance between oil switching solenoid valve terminals. Terminals No. 1 — No. 2:</p>	Is the resistance between 6 — 12 Ω?	Repair the poor contact of ECM and oil switching solenoid valve connector.	Replace the oil switching solenoid valve. <Ref. to ME(H4SO)-104, Oil Switching Solenoid Valve.>

Diagnostic Procedure with Diagnostic Trouble Code (DTC)

ENGINE (DIAGNOSTICS)

Step	Check	Yes	No
<p>1 CHECK HARNESS BETWEEN ECM AND OIL SWITCHING SOLENOID VALVE. 1) Turn the ignition switch to OFF. 2) Disconnect the connectors from the ECM and oil switching solenoid valve. 3) Measure the resistance between ECM and oil switching solenoid valve. Connector & terminal (B137) No. 31 — (E70) No. 1: (B137) No. 30 — (E70) No. 2:</p>	<p>Is the resistance less than 1 Ω?</p>	<p>Go to step 2.</p>	<p>Repair the harness and connector. NOTE: In this case, repair the following item: • Open circuit of harness between ECM and oil switching solenoid valve connector • Poor contact of coupling connector</p>
<p>2 CHECK HARNESS BETWEEN ECM AND OIL SWITCHING SOLENOID VALVE. Measure the resistance between ECM and chassis ground. Connector & terminal (B137) No. 31 — Chassis ground: (B137) No. 30 — Chassis ground:</p>	<p>Is the resistance 1 MΩ or more?</p>	<p>Go to step 3.</p>	<p>Repair the ground short circuit of harness between ECM and oil switching solenoid valve connector.</p>
<p>3 CHECK OIL SWITCHING SOLENOID VALVE. Measure the resistance between oil switching solenoid valve terminals. Terminals No. 1 — No. 2:</p>	<p>Is the resistance between 6 — 12 Ω?</p>	<p>Repair the poor contact of ECM and oil switching solenoid valve connector.</p>	<p>Replace the oil switching solenoid valve. <Ref. to ME(H4SO)-104, Oil Switching Solenoid Valve.></p>

Diagnostic Procedure with Diagnostic Trouble Code (DTC)

ENGINE (DIAGNOSTICS)

L: DTC P0083 INTAKE VALVE CONTROL SOLENOID CIRCUIT HIGH (BANK 2)

DTC DETECTING CONDITION:

- Immediately at fault recognition
- GENERAL DESCRIPTION <Ref. to GD(H4SO)-24, DTC P0083 INTAKE VALVE CONTROL SOLENOID CIRCUIT HIGH (BANK 2), Diagnostic Trouble Code (DTC) Detecting Criteria.>

TROUBLE SYMPTOM:

Improper idling

CAUTION:

After repair or replacement of faulty parts, perform Clear Memory Mode <Ref. to EN(H4SO)(diag)-51, OPERATION, Clear Memory Mode.> and Inspection Mode <Ref. to EN(H4SO)(diag)-41, PROCEDURE, Inspection Mode.>.

WIRING DIAGRAM:

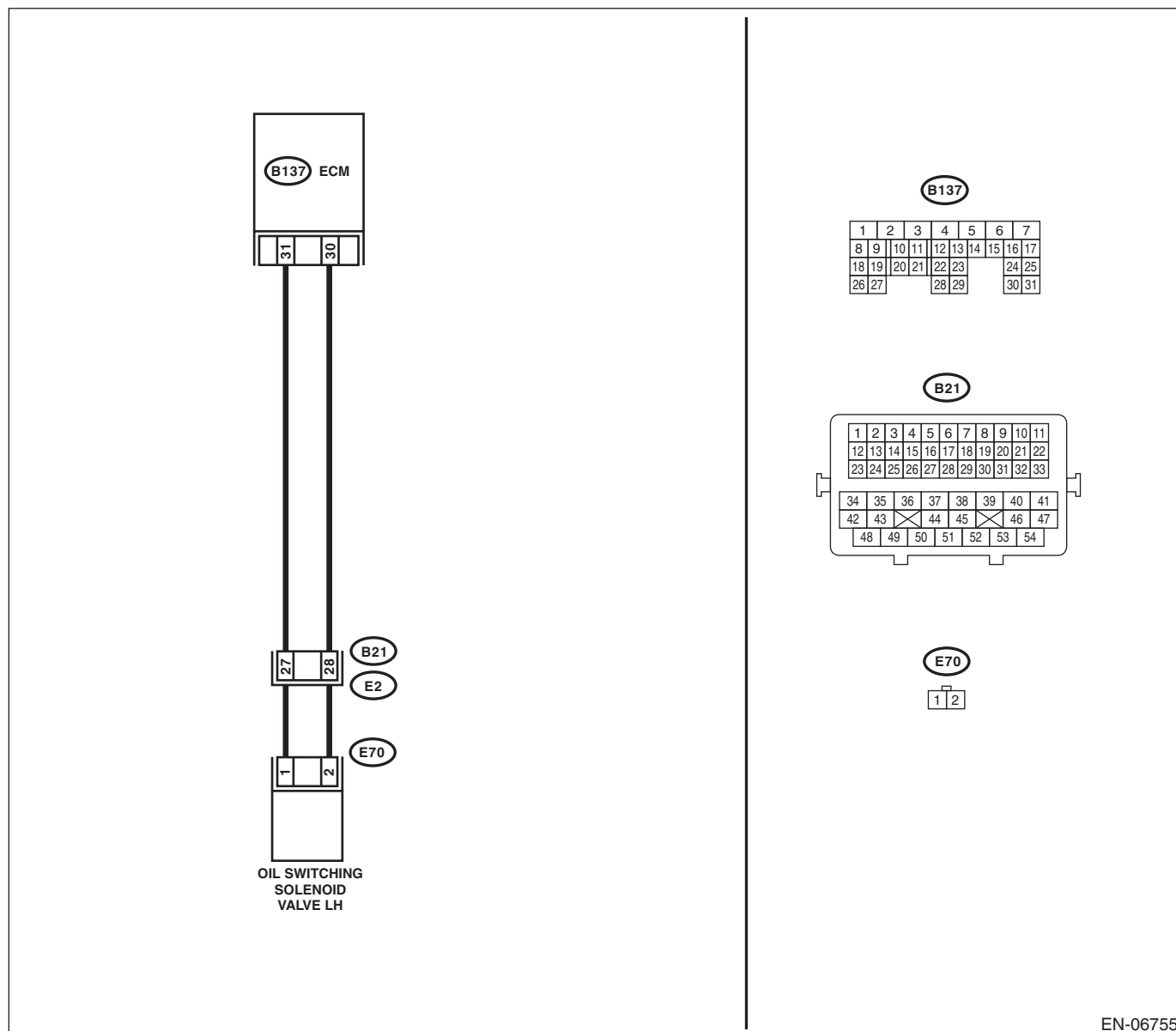

EN-06755

Diagnostic Procedure with Diagnostic Trouble Code (DTC)

ENGINE (DIAGNOSTICS)

Step	Check	Yes	No
<p>1 CHECK HARNESS BETWEEN ECM AND OIL SWITCHING SOLENOID VALVE. 1) Turn the ignition switch to OFF. 2) Disconnect the connectors from the ECM and oil switching solenoid valve. 3) Measure the voltage between ECM and chassis ground. Connector & terminal (B137) No. 31 (+) — Chassis ground (-): (B137) No. 30 (+) — Chassis ground (-):</p>	Is the voltage less than 1 V?	Go to step 2.	Repair the short circuit to power in the harness between ECM and oil switching solenoid valve connector.
<p>2 CHECK HARNESS BETWEEN ECM AND OIL SWITCHING SOLENOID VALVE. Measure the resistance between the ECM and oil switching solenoid valve connector. Connector & terminal (B137) No. 31 — (E70) No. 1: (B137) No. 30 — (E70) No. 2:</p>	Is the resistance less than 1 Ω?	Go to step 3.	Repair the harness and connector. NOTE: In this case, repair the following item: <ul style="list-style-type: none"> • Open circuit of harness between ECM and oil switching solenoid valve connector • Poor contact of coupling connector
<p>3 CHECK OIL SWITCHING SOLENOID VALVE. Measure the resistance between oil switching solenoid valve terminals. Terminals No. 1 — No. 2:</p>	Is the resistance between 6 — 12 Ω?	Repair the poor contact of ECM and oil switching solenoid valve connector.	Replace the oil switching solenoid valve. <Ref. to ME(H4SO)-104, Oil Switching Solenoid Valve.>

Diagnostic Procedure with Diagnostic Trouble Code (DTC)

ENGINE (DIAGNOSTICS)

M: DTC P0101 MASS OR VOLUME AIR FLOW CIRCUIT RANGE/PERFORMANCE

DTC DETECTING CONDITION:

- Detected when two consecutive driving cycles with fault occur.
- GENERAL DESCRIPTION <Ref. to GD(H4SO)-25, DTC P0101 MASS OR VOLUME AIR FLOW CIRCUIT RANGE/PERFORMANCE, Diagnostic Trouble Code (DTC) Detecting Criteria.>

TROUBLE SYMPTOM:

- Improper idling
- Engine stalls.
- Poor driving performance

CAUTION:

After repair or replacement of faulty parts, perform Clear Memory Mode <Ref. to EN(H4SO)(diag)-51, OPERATION, Clear Memory Mode.> and Inspection Mode <Ref. to EN(H4SO)(diag)-41, PROCEDURE, Inspection Mode.>.

WIRING DIAGRAM:

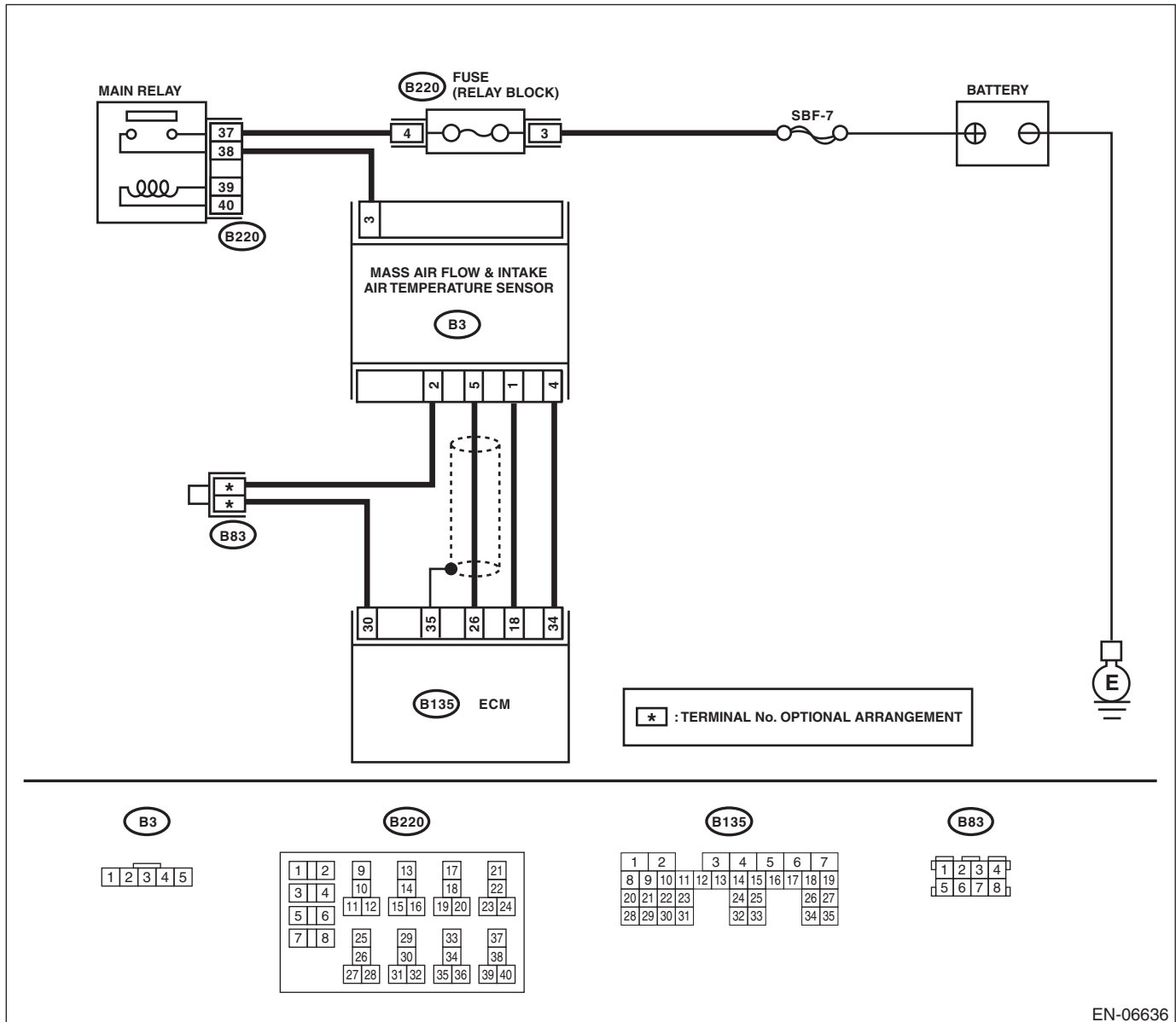

EN-06636

Diagnostic Procedure with Diagnostic Trouble Code (DTC)

ENGINE (DIAGNOSTICS)

Step	Check	Yes	No
1 CHECK FOR ANY OTHER DTC ON DISPLAY.	Is any other DTC displayed?	Check the appropriate DTC using the "List of Diagnostic Trouble Code (DTC)". <Ref. to EN(H4SO)(diag)-82, List of Diagnostic Trouble Code (DTC).>	Replace the mass air flow and intake air temperature sensor. <Ref. to FU(H4SO)-28, Mass Air Flow and Intake Air Temperature Sensor.>

N: DTC P0102 MASS OR VOLUME AIR FLOW CIRCUIT LOW INPUT

DTC DETECTING CONDITION:

- Immediately at fault recognition
- GENERAL DESCRIPTION <Ref. to GD(H4SO)-27, DTC P0102 MASS OR VOLUME AIR FLOW CIRCUIT LOW INPUT, Diagnostic Trouble Code (DTC) Detecting Criteria.>

TROUBLE SYMPTOM:

- Improper idling
- Engine stalls.
- Poor driving performance

CAUTION:

After repair or replacement of faulty parts, perform Clear Memory Mode <Ref. to EN(H4SO)(diag)-51, OPERATION, Clear Memory Mode.> and Inspection Mode <Ref. to EN(H4SO)(diag)-41, PROCEDURE, Inspection Mode.>.

WIRING DIAGRAM:

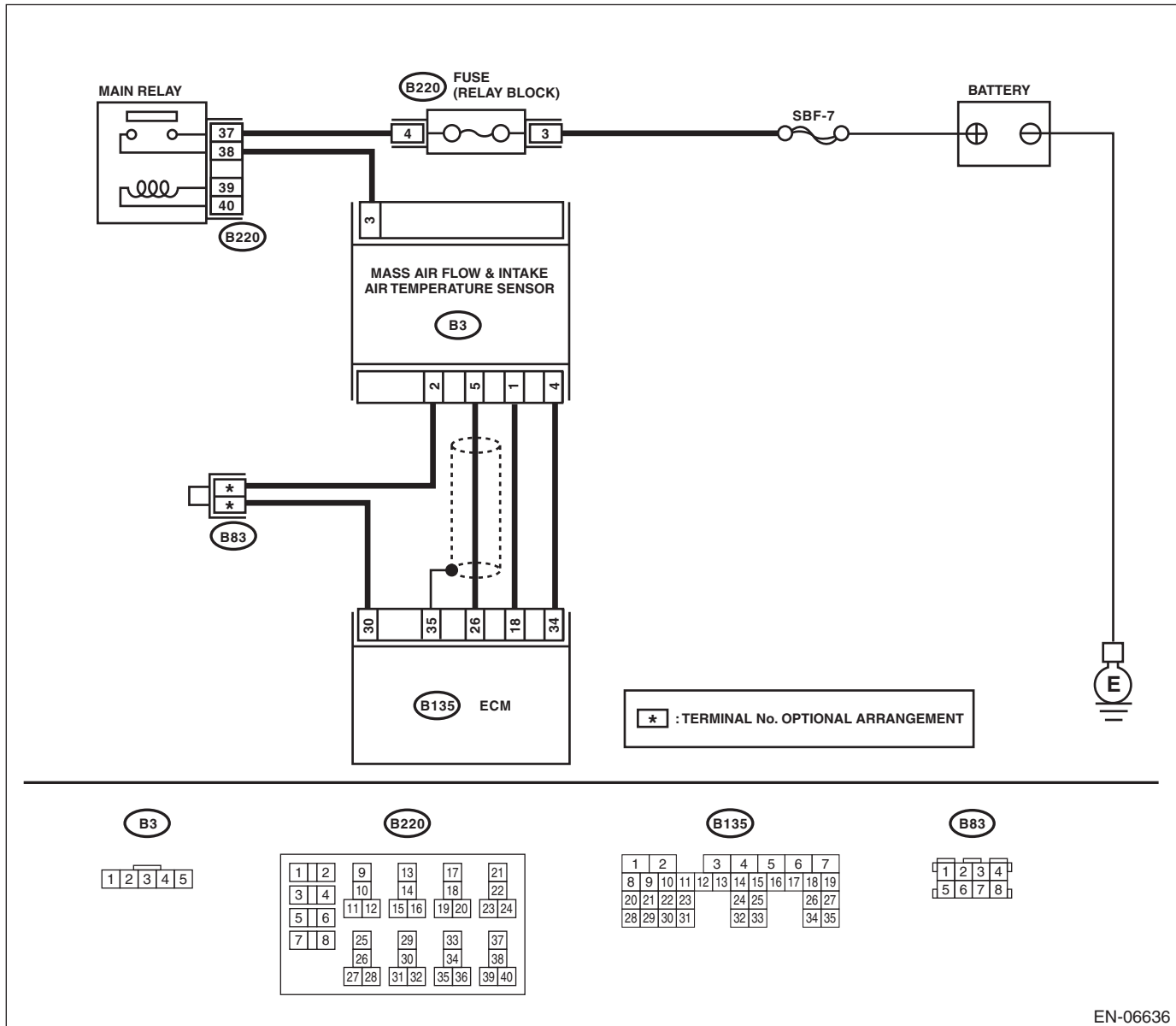

EN-06636

Diagnostic Procedure with Diagnostic Trouble Code (DTC)

ENGINE (DIAGNOSTICS)

Step	Check	Yes	No
<p>1 CHECK CURRENT DATA.</p> <p>1) Start the engine.</p> <p>2) Read the data of air flow sensor signal using the Subaru Select Monitor or general scan tool.</p> <p>NOTE:</p> <ul style="list-style-type: none"> • Subaru Select Monitor <p>For detailed operation procedures, refer to "READ CURRENT DATA FOR ENGINE". <Ref. to EN(H4SO)(diag)-33, Subaru Select Monitor.></p> <ul style="list-style-type: none"> • General scan tool <p>For detailed operation procedures, refer to the general scan tool operation manual.</p>	Is the voltage less than 0.2 V?	Go to step 2.	<p>Even if the malfunction indicator light illuminates, the circuit has returned to a normal condition at this time. Reproduce the failure, and then reperform the diagnosis again.</p> <p>NOTE:</p> <p>In this case, temporary poor contact of connector may be the cause.</p>
<p>2 CHECK POWER SUPPLY OF MASS AIR FLOW AND INTAKE AIR TEMPERATURE SENSOR.</p> <p>1) Turn the ignition switch to OFF.</p> <p>2) Disconnect the connector from the mass air flow and intake air temperature sensor.</p> <p>3) Turn the ignition switch to ON.</p> <p>4) Measure the voltage between mass air flow and intake air temperature sensor connector and engine ground.</p> <p>Connector & terminal (B3) No. 3 (+) — Engine ground (-):</p>	Is the voltage 10 V or more?	Go to step 3.	<p>Repair the harness and connector.</p> <p>NOTE:</p> <p>In this case, repair the following item:</p> <ul style="list-style-type: none"> • Open circuit of harness between the main relay and the mass air flow and intake air temperature sensor connector. • Poor contact of main relay connector
<p>3 CHECK HARNESS BETWEEN ECM, MASS AIR FLOW AND INTAKE AIR TEMPERATURE SENSOR CONNECTORS.</p> <p>1) Turn the ignition switch to OFF.</p> <p>2) Disconnect the connectors from the ECM.</p> <p>3) Measure the resistance of harness between ECM and the mass air flow and intake air temperature sensor connector.</p> <p>Connector & terminal (B135) No. 26 — (B3) No. 5:</p>	Is the resistance less than 1 Ω?	Go to step 4.	Repair the open circuit of harness between the ECM and the mass air flow and intake air temperature sensor connector.
<p>4 CHECK HARNESS BETWEEN ECM, MASS AIR FLOW AND INTAKE AIR TEMPERATURE SENSOR CONNECTORS.</p> <p>Measure the resistance between ECM and chassis ground.</p> <p>Connector & terminal (B135) No. 26 — Chassis ground:</p>	Is the resistance 1 MΩ or more?	Go to step 5.	Repair the ground short circuit of harness between the ECM and the mass air flow and intake air temperature sensor connector.
<p>5 CHECK POOR CONTACT.</p> <p>Check for any poor contact in the ECM or the mass air flow or intake air temperature sensor connector.</p>	Is there poor contact in the ECM or the mass air flow and intake air temperature sensor connector?	Repair any poor contact in the ECM or the mass air flow and intake air temperature sensor connector.	Replace the mass air flow and intake air temperature sensor. <Ref. to FU(H4SO)-28, Mass Air Flow and Intake Air Temperature Sensor.>

Diagnostic Procedure with Diagnostic Trouble Code (DTC)

ENGINE (DIAGNOSTICS)

Step	Check	Yes	No
<p>1 CHECK CURRENT DATA.</p> <p>1) Start the engine.</p> <p>2) Read the data of air flow sensor signal using the Subaru Select Monitor or general scan tool.</p> <p>NOTE:</p> <ul style="list-style-type: none"> • Subaru Select Monitor <p>For detailed operation procedures, refer to "READ CURRENT DATA FOR ENGINE". <Ref. to EN(H4SO)(diag)-33, Subaru Select Monitor.></p> <ul style="list-style-type: none"> • General scan tool <p>For detailed operation procedures, refer to the general scan tool operation manual.</p>	<p>Is the voltage 5 V or more?</p>	<p>Go to step 2.</p>	<p>Even if the malfunction indicator light illuminates, the circuit has returned to a normal condition at this time. Reproduce the fault condition, and reperform the check.</p> <p>NOTE:</p> <p>In this case, there may be a temporary connector contact failure.</p>
<p>2 CHECK HARNESS BETWEEN ECM, MASS AIR FLOW AND INTAKE AIR TEMPERATURE SENSOR CONNECTORS.</p> <p>1) Turn the ignition switch to OFF.</p> <p>2) Disconnect the connector from the mass air flow and intake air temperature sensor.</p> <p>3) Start the engine.</p> <p>4) Read the data of air flow sensor signal using the Subaru Select Monitor or general scan tool.</p> <p>NOTE:</p> <ul style="list-style-type: none"> • Subaru Select Monitor <p>For detailed operation procedures, refer to "READ CURRENT DATA FOR ENGINE". <Ref. to EN(H4SO)(diag)-33, Subaru Select Monitor.></p> <ul style="list-style-type: none"> • General scan tool <p>For detailed operation procedures, refer to the general scan tool operation manual.</p>	<p>Is the voltage 5 V or more?</p>	<p>Repair the short circuit to power in the harness between the ECM and the mass air flow and intake air temperature sensor connectors.</p>	<p>Go to step 3.</p>
<p>3 CHECK HARNESS BETWEEN ECM, MASS AIR FLOW AND INTAKE AIR TEMPERATURE SENSOR CONNECTORS.</p> <p>1) Turn the ignition switch to OFF.</p> <p>2) Measure the resistance of harness between mass air flow and intake air temperature sensor connector and engine ground.</p> <p>Connector & terminal (B3) No. 4 — Engine ground:</p>	<p>Is the resistance less than 5 Ω?</p>	<p>Go to step 4.</p>	<p>Repair the harness and connector.</p> <p>NOTE:</p> <p>In this case, repair the following item:</p> <ul style="list-style-type: none"> • Open circuit of harness between ECM, mass air flow and intake air temperature sensor connectors. • Poor contact in ECM connector
<p>4 CHECK POOR CONTACT.</p> <p>Check for any poor contact between the mass air flow and intake air temperature sensor connectors.</p>	<p>Is there poor contact in the mass air flow and intake air temperature sensor connectors?</p>	<p>Repair any poor contact of the mass air flow and intake air temperature sensor connectors.</p>	<p>Replace the mass air flow and intake air temperature sensor. <Ref. to FU(H4SO)-28, Mass Air Flow and Intake Air Temperature Sensor.></p>

Diagnostic Procedure with Diagnostic Trouble Code (DTC)

ENGINE (DIAGNOSTICS)

P: DTC P0107 MANIFOLD ABSOLUTE PRESSURE/BAROMETRIC PRESSURE CIRCUIT LOW INPUT

DTC DETECTING CONDITION:

- Immediately at fault recognition
- GENERAL DESCRIPTION <Ref. to GD(H4SO)-29, DTC P0107 MANIFOLD ABSOLUTE PRESSURE/BAROMETRIC PRESSURE CIRCUIT LOW INPUT, Diagnostic Trouble Code (DTC) Detecting Criteria.>

CAUTION:

After repair or replacement of faulty parts, perform Clear Memory Mode <Ref. to EN(H4SO)(diag)-51, OPERATION, Clear Memory Mode.> and Inspection Mode <Ref. to EN(H4SO)(diag)-41, PROCEDURE, Inspection Mode.>.

WIRING DIAGRAM:

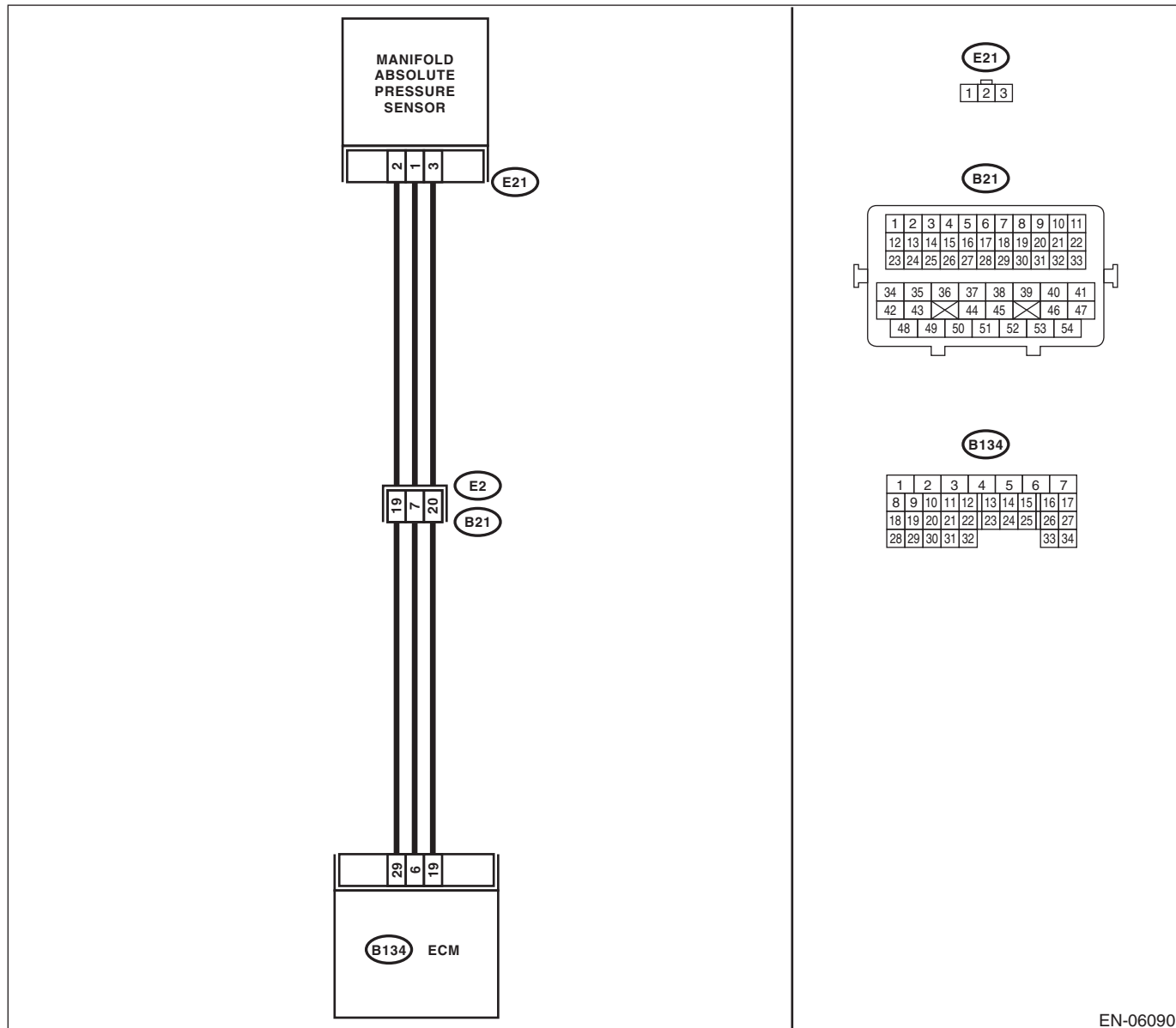

EN-06090

Diagnostic Procedure with Diagnostic Trouble Code (DTC)

ENGINE (DIAGNOSTICS)

	Step	Check	Yes	No
1	<p>CHECK CURRENT DATA.</p> <p>1) Start the engine.</p> <p>2) Read the data of intake manifold absolute pressure signal using Subaru Select Monitor or general scan tool.</p> <p>NOTE:</p> <ul style="list-style-type: none"> Subaru Select Monitor <p>For detailed operation procedures, refer to "READ CURRENT DATA FOR ENGINE". <Ref. to EN(H4SO)(diag)-33, Subaru Select Monitor.></p> <ul style="list-style-type: none"> General scan tool <p>For detailed operation procedures, refer to the general scan tool operation manual.</p>	Is the measured value less than 13.3 kPa (100 mmHg, 3.94 inHg)?	Go to step 2.	<p>Even if the malfunction indicator light illuminates, the circuit has returned to a normal condition at this time. Reproduce the fault condition, and reperform the check.</p> <p>NOTE:</p> <p>In this case, there may be a temporary connector contact failure.</p>
2	<p>CHECK POWER SUPPLY OF THE MANIFOLD ABSOLUTE PRESSURE SENSOR.</p> <p>1) Turn the ignition switch to OFF.</p> <p>2) Disconnect the connector from manifold absolute pressure sensor.</p> <p>3) Turn the ignition switch to ON.</p> <p>4) Measure the voltage between manifold absolute pressure sensor connector and engine ground.</p> <p>Connector & terminal (E21) No. 3 (+) — Engine ground (-):</p>	Is the voltage 4.5 V or more?	Go to step 3.	<p>Repair the harness and connector.</p> <p>NOTE:</p> <p>In this case, repair the following item:</p> <ul style="list-style-type: none"> Open circuit of harness between ECM and manifold absolute pressure sensor connector. Poor contact in ECM connector Poor contact of coupling connector
3	<p>CHECK HARNESS BETWEEN ECM AND MANIFOLD ABSOLUTE PRESSURE SENSOR CONNECTOR.</p> <p>1) Turn the ignition switch to OFF.</p> <p>2) Disconnect the connectors from the ECM.</p> <p>3) Measure the resistance of harness between ECM and manifold absolute pressure sensor connector.</p> <p>Connector & terminal (B134) No. 6 — (E21) No. 1:</p>	Is the resistance less than 1 Ω?	Go to step 4.	<p>Repair the harness and connector.</p> <p>NOTE:</p> <p>In this case, repair the following item:</p> <ul style="list-style-type: none"> Open circuit of harness between ECM and manifold absolute pressure sensor connector. Poor contact of coupling connector
4	<p>CHECK HARNESS BETWEEN ECM AND MANIFOLD ABSOLUTE PRESSURE SENSOR CONNECTOR.</p> <p>Measure the resistance between ECM and chassis ground.</p> <p>Connector & terminal (B134) No. 6 — Chassis ground:</p>	Is the resistance 1 MΩ or more?	Go to step 5.	<p>Repair ground short circuit of harness between ECM and manifold absolute pressure sensor connector.</p>
5	<p>CHECK POOR CONTACT.</p> <p>Check for poor contact between the ECM and manifold pressure sensor connector.</p>	Is there poor contact in the ECM or manifold absolute pressure sensor connector?	Repair the poor contact in the ECM or manifold absolute pressure sensor connector.	<p>Replace the manifold absolute pressure sensor. <Ref. to FU(H4SO)-27, Manifold Absolute Pressure Sensor.></p>

Diagnostic Procedure with Diagnostic Trouble Code (DTC)

ENGINE (DIAGNOSTICS)

Q: DTC P0108 MANIFOLD ABSOLUTE PRESSURE/BAROMETRIC PRESSURE CIRCUIT HIGH INPUT

DTC DETECTING CONDITION:

- Immediately at fault recognition
- GENERAL DESCRIPTION <Ref. to GD(H4SO)-30, DTC P0108 MANIFOLD ABSOLUTE PRESSURE/BAROMETRIC PRESSURE CIRCUIT HIGH INPUT, Diagnostic Trouble Code (DTC) Detecting Criteria.>

CAUTION:

After repair or replacement of faulty parts, perform Clear Memory Mode <Ref. to EN(H4SO)(diag)-51, OPERATION, Clear Memory Mode.> and Inspection Mode <Ref. to EN(H4SO)(diag)-41, PROCEDURE, Inspection Mode.>.

WIRING DIAGRAM:

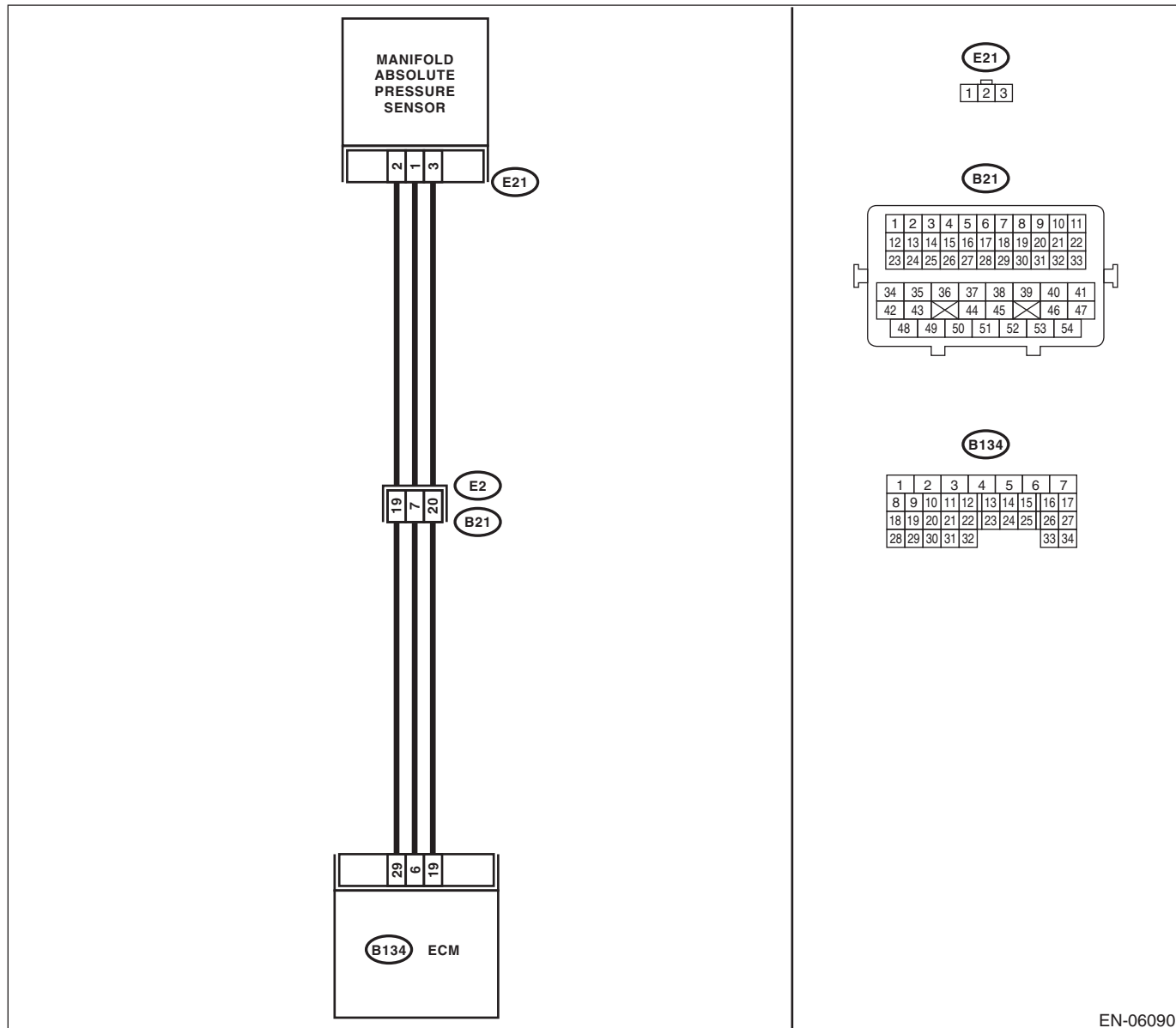

EN-06090

Diagnostic Procedure with Diagnostic Trouble Code (DTC)

ENGINE (DIAGNOSTICS)

Step	Check	Yes	No
<p>1 CHECK CURRENT DATA.</p> <p>1) Start the engine.</p> <p>2) Read the data of intake manifold absolute pressure signal using Subaru Select Monitor or general scan tool.</p> <p>NOTE:</p> <ul style="list-style-type: none"> • Subaru Select Monitor <p>For detailed operation procedures, refer to "READ CURRENT DATA FOR ENGINE". <Ref. to EN(H4SO)(diag)-33, Subaru Select Monitor.></p> <ul style="list-style-type: none"> • General scan tool <p>For detailed operation procedures, refer to the general scan tool operation manual.</p>	<p>Is the measured value 119.5 kPa (896.5 mmHg, 35.29 inHg) or more?</p>	<p>Go to step 2.</p>	<p>Even if the malfunction indicator light illuminates, the circuit has returned to a normal condition at this time. Reproduce the fault condition, and reperform the check.</p> <p>NOTE:</p> <p>In this case, there may be a temporary connector contact failure.</p>
<p>2 CHECK HARNESS BETWEEN ECM AND MANIFOLD ABSOLUTE PRESSURE SENSOR CONNECTOR.</p> <p>1) Turn the ignition switch to OFF.</p> <p>2) Disconnect the connector from manifold absolute pressure sensor.</p> <p>3) Start the engine.</p> <p>4) Read the data of intake manifold absolute pressure signal using Subaru Select Monitor or general scan tool.</p> <p>NOTE:</p> <ul style="list-style-type: none"> • Subaru Select Monitor <p>For detailed operation procedures, refer to "READ CURRENT DATA FOR ENGINE". <Ref. to EN(H4SO)(diag)-33, Subaru Select Monitor.></p> <ul style="list-style-type: none"> • General scan tool <p>For detailed operation procedures, refer to the general scan tool operation manual.</p>	<p>Is the measured value 119.5 kPa (896.5 mmHg, 35.29 inHg) or more?</p>	<p>Repair the short circuit to power in the harness between ECM and manifold absolute pressure sensor connector.</p>	<p>Go to step 3.</p>
<p>3 CHECK HARNESS BETWEEN ECM AND MANIFOLD ABSOLUTE PRESSURE SENSOR CONNECTOR.</p> <p>1) Turn the ignition switch to OFF.</p> <p>2) Measure the resistance of harness between manifold absolute pressure sensor connector and engine ground.</p> <p>Connector & terminal (E21) No. 2 — Engine ground:</p>	<p>Is the resistance less than 5 Ω?</p>	<p>Go to step 4.</p>	<p>Repair the harness and connector.</p> <p>NOTE:</p> <p>In this case, repair the following item:</p> <ul style="list-style-type: none"> • Open circuit of harness between ECM and manifold absolute pressure sensor connector. • Poor contact in ECM connector • Poor contact of coupling connector
<p>4 CHECK POOR CONTACT.</p> <p>Check for poor contact of the manifold absolute pressure sensor connector.</p>	<p>Is there poor contact in manifold absolute pressure sensor connector?</p>	<p>Repair the poor contact of manifold absolute pressure sensor connector.</p>	<p>Replace the manifold absolute pressure sensor. <Ref. to FU(H4SO)-27, Manifold Absolute Pressure Sensor.></p>

Diagnostic Procedure with Diagnostic Trouble Code (DTC)

ENGINE (DIAGNOSTICS)

	Step	Check	Yes	No
1	<p>CHECK ENGINE COOLANT TEMPERATURE.</p> <p>1) Start the engine and warm up completely. 2) Measure the engine coolant temperature using the Subaru Select Monitor or general scan tool.</p> <p>NOTE:</p> <ul style="list-style-type: none">• Subaru Select Monitor <p>For detailed operation procedures, refer to "READ CURRENT DATA FOR ENGINE". <Ref. to EN(H4SO)(diag)-33, Subaru Select Monitor.></p> <ul style="list-style-type: none">• General scan tool <p>For detailed operation procedures, refer to the general scan tool operation manual.</p>	Is the engine coolant temperature 75°C (167°F) or higher?	Replace the mass air flow and intake air temperature sensor. <Ref. to FU(H4SO)-28, Mass Air Flow and Intake Air Temperature Sensor.>	Check DTC P0125 using "List of Diagnostic Trouble Code (DTC)". <Ref. to EN(H4SO)(diag)-82, List of Diagnostic Trouble Code (DTC).>

S: DTC P0112 INTAKE AIR TEMPERATURE SENSOR 1 CIRCUIT LOW

DTC DETECTING CONDITION:

- Immediately at fault recognition
- GENERAL DESCRIPTION <Ref. to GD(H4SO)-33, DTC P0112 INTAKE AIR TEMPERATURE SENSOR 1 CIRCUIT LOW, Diagnostic Trouble Code (DTC) Detecting Criteria.>

TROUBLE SYMPTOM:

- Improper idling
- Poor driving performance

CAUTION:

After repair or replacement of faulty parts, perform Clear Memory Mode <Ref. to EN(H4SO)(diag)-51, OPERATION, Clear Memory Mode.> and Inspection Mode <Ref. to EN(H4SO)(diag)-41, PROCEDURE, Inspection Mode.>.

WIRING DIAGRAM:

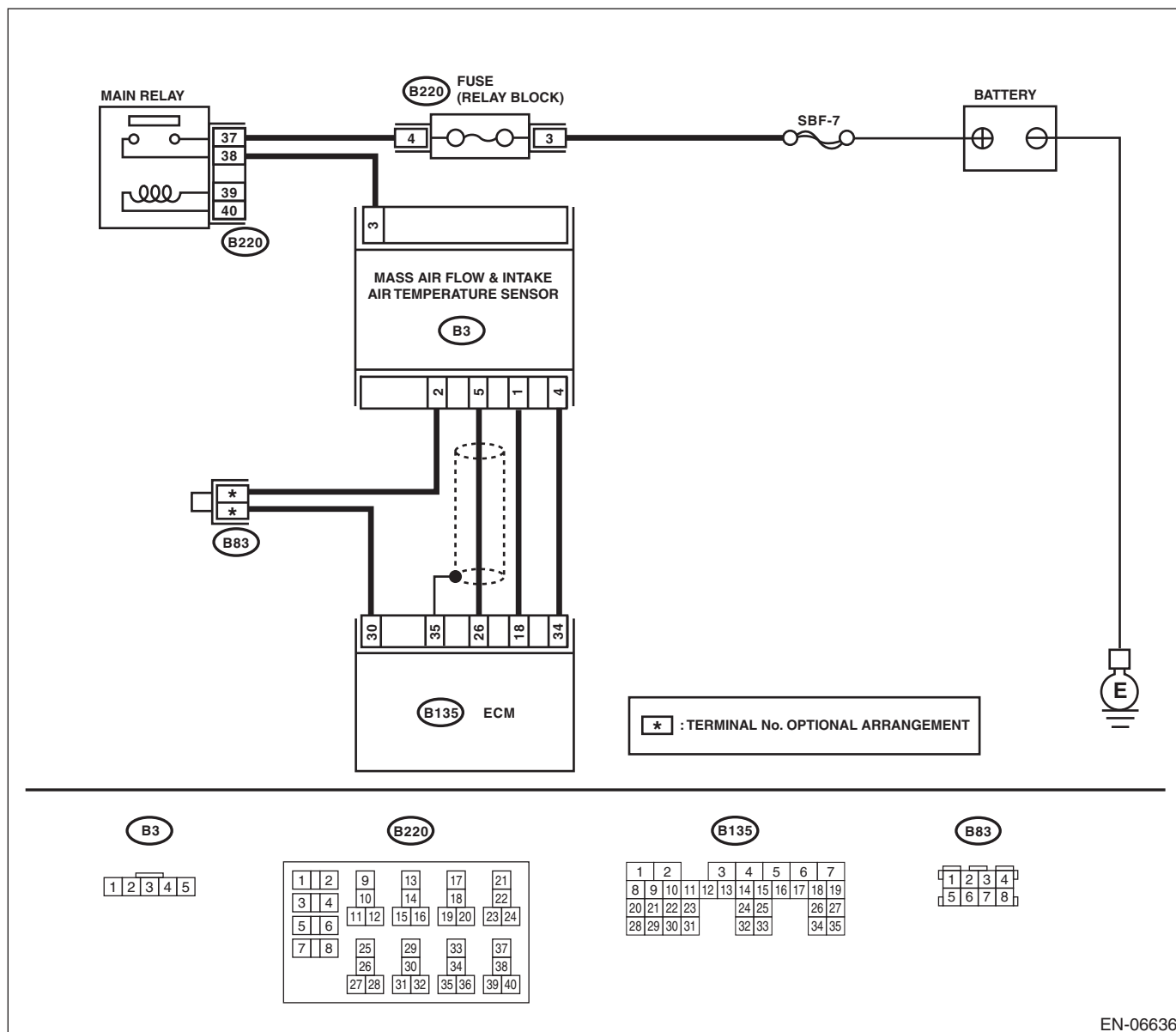

EN-06636

Diagnostic Procedure with Diagnostic Trouble Code (DTC)

ENGINE (DIAGNOSTICS)

	Step	Check	Yes	No
1	<p>CHECK CURRENT DATA.</p> <p>1) Start the engine.</p> <p>2) Read the data of intake air temperature sensor signal using Subaru Select Monitor or general scan tool.</p> <p>NOTE:</p> <ul style="list-style-type: none"> Subaru Select Monitor <p>For detailed operation procedures, refer to "READ CURRENT DATA FOR ENGINE". <Ref. to EN(H4SO)(diag)-33, Subaru Select Monitor.></p> <ul style="list-style-type: none"> General scan tool <p>For detailed operation procedures, refer to the general scan tool operation manual.</p>	Is the intake air temperature 120°C (248°F) or higher?	Go to step 2.	Even if the malfunction indicator light illuminates, the circuit has returned to a normal condition at this time. Reproduce the fault condition, and reperform the check. NOTE: In this case, there may be a temporary connector contact failure.
2	<p>CHECK HARNESS BETWEEN ECM, MASS AIR FLOW AND INTAKE AIR TEMPERATURE SENSOR CONNECTORS.</p> <p>1) Turn the ignition switch to OFF.</p> <p>2) Disconnect the connector from the ECM and the mass air flow & intake air temperature sensor.</p> <p>3) Measure the resistance between ECM and chassis ground.</p> <p>Connector & terminal (B135) No. 18 — Chassis ground:</p>	Is the resistance 1 MΩ or more?	Replace the mass air flow and intake air temperature sensor. <Ref. to FU(H4SO)-28, Mass Air Flow and Intake Air Temperature Sensor.>	Repair the ground short circuit of harness between the ECM and the mass air flow & intake air temperature sensor connectors.

Diagnostic Procedure with Diagnostic Trouble Code (DTC)

ENGINE (DIAGNOSTICS)

T: DTC P0113 INTAKE AIR TEMPERATURE SENSOR 1 CIRCUIT HIGH

DTC DETECTING CONDITION:

- Immediately at fault recognition
- GENERAL DESCRIPTION <Ref. to GD(H4SO)-34, DTC P0113 INTAKE AIR TEMPERATURE SENSOR 1 CIRCUIT HIGH, Diagnostic Trouble Code (DTC) Detecting Criteria.>

TROUBLE SYMPTOM:

- Improper idling
- Poor driving performance

CAUTION:

After repair or replacement of faulty parts, perform Clear Memory Mode <Ref. to EN(H4SO)(diag)-51, OPERATION, Clear Memory Mode.> and Inspection Mode <Ref. to EN(H4SO)(diag)-41, PROCEDURE, Inspection Mode.>.

WIRING DIAGRAM:

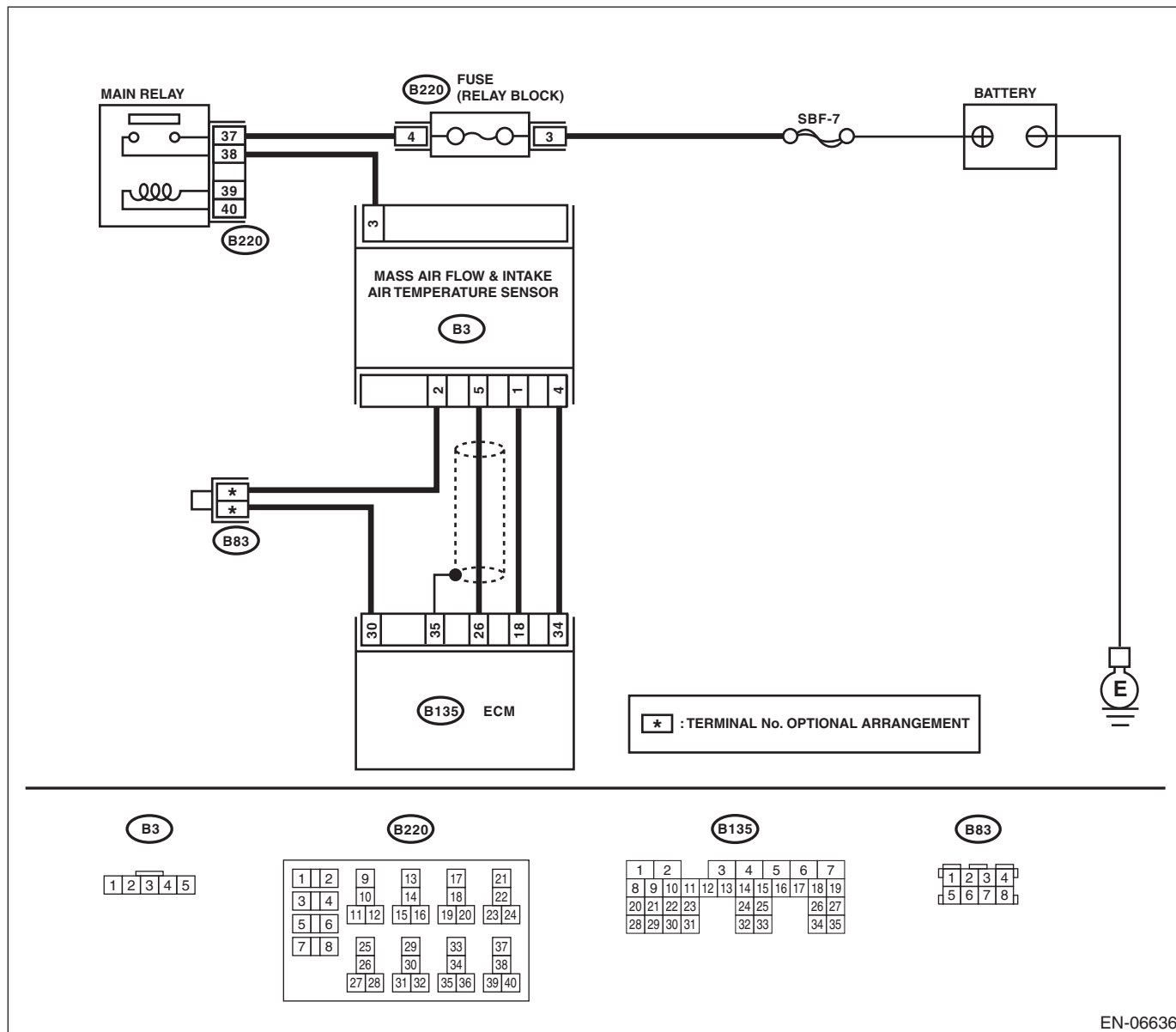

EN-06636

Diagnostic Procedure with Diagnostic Trouble Code (DTC)

ENGINE (DIAGNOSTICS)

	Step	Check	Yes	No
1	<p>CHECK CURRENT DATA.</p> <p>1) Start the engine.</p> <p>2) Read the data of intake air temperature sensor signal using Subaru Select Monitor or general scan tool.</p> <p>NOTE:</p> <ul style="list-style-type: none"> Subaru Select Monitor <p>For detailed operation procedures, refer to "READ CURRENT DATA FOR ENGINE". <Ref. to EN(H4SO)(diag)-33, Subaru Select Monitor.></p> <ul style="list-style-type: none"> General scan tool <p>For detailed operation procedures, refer to the general scan tool operation manual.</p>	Is the intake air temperature less than -40°C (-40°F) ?	Go to step 2.	<p>Even if the malfunction indicator light illuminates, the circuit has returned to a normal condition at this time. Reproduce the fault condition, and reperform the check.</p> <p>NOTE:</p> <p>In this case, there may be a temporary connector contact failure.</p>
2	<p>CHECK POOR CONTACT.</p> <p>Check the poor contact between the ECM and the mass air flow and intake air temperature sensor connectors.</p>	Is there poor contact in the ECM or the mass air flow and intake air temperature sensor connectors?	Repair any poor contact between the ECM and the mass air flow and intake air temperature sensor connectors.	Go to step 3.
3	<p>CHECK HARNESS BETWEEN ECM, MASS AIR FLOW AND INTAKE AIR TEMPERATURE SENSOR CONNECTORS.</p> <p>1) Turn the ignition switch to OFF.</p> <p>2) Disconnect the connector from the ECM and the mass air flow and intake air temperature sensor.</p> <p>3) Measure the resistance of harness between ECM and mass air flow and intake air temperature sensor connectors.</p> <p>Connector & terminal (B135) No. 18 — (B3) No. 1: (B135) No. 30 — (B3) No. 2:</p>	Is the resistance less than $1\ \Omega$?	Go to step 4.	Repair the open circuit of harness between the ECM and mass air flow and intake air temperature sensor connectors.
4	<p>CHECK HARNESS BETWEEN ECM, MASS AIR FLOW AND INTAKE AIR TEMPERATURE SENSOR CONNECTORS.</p> <p>1) Connect all connectors.</p> <p>2) Turn the ignition switch to ON.</p> <p>3) Measure the voltage between ECM and chassis ground.</p> <p>Connector & terminal (B135) No. 18 (+) — Chassis ground (-):</p>	Is the voltage 5 V or more?	Repair the short circuit to power in the harness between the ECM and the mass air flow & intake air temperature sensor connectors.	Replace the mass air flow and intake air temperature sensor. <Ref. to FU(H4SO)-28, Mass Air Flow and Intake Air Temperature Sensor.>

Diagnostic Procedure with Diagnostic Trouble Code (DTC)

ENGINE (DIAGNOSTICS)

U: DTC P0117 ENGINE COOLANT TEMPERATURE CIRCUIT LOW

DTC DETECTING CONDITION:

- Immediately at fault recognition
- GENERAL DESCRIPTION <Ref. to GD(H4SO)-35, DTC P0117 ENGINE COOLANT TEMPERATURE CIRCUIT LOW, Diagnostic Trouble Code (DTC) Detecting Criteria.>

TROUBLE SYMPTOM:

- Hard to start
- Improper idling
- Poor driving performance

CAUTION:

After repair or replacement of faulty parts, perform Clear Memory Mode <Ref. to EN(H4SO)(diag)-51, OPERATION, Clear Memory Mode.> and Inspection Mode <Ref. to EN(H4SO)(diag)-41, PROCEDURE, Inspection Mode.>.

WIRING DIAGRAM:

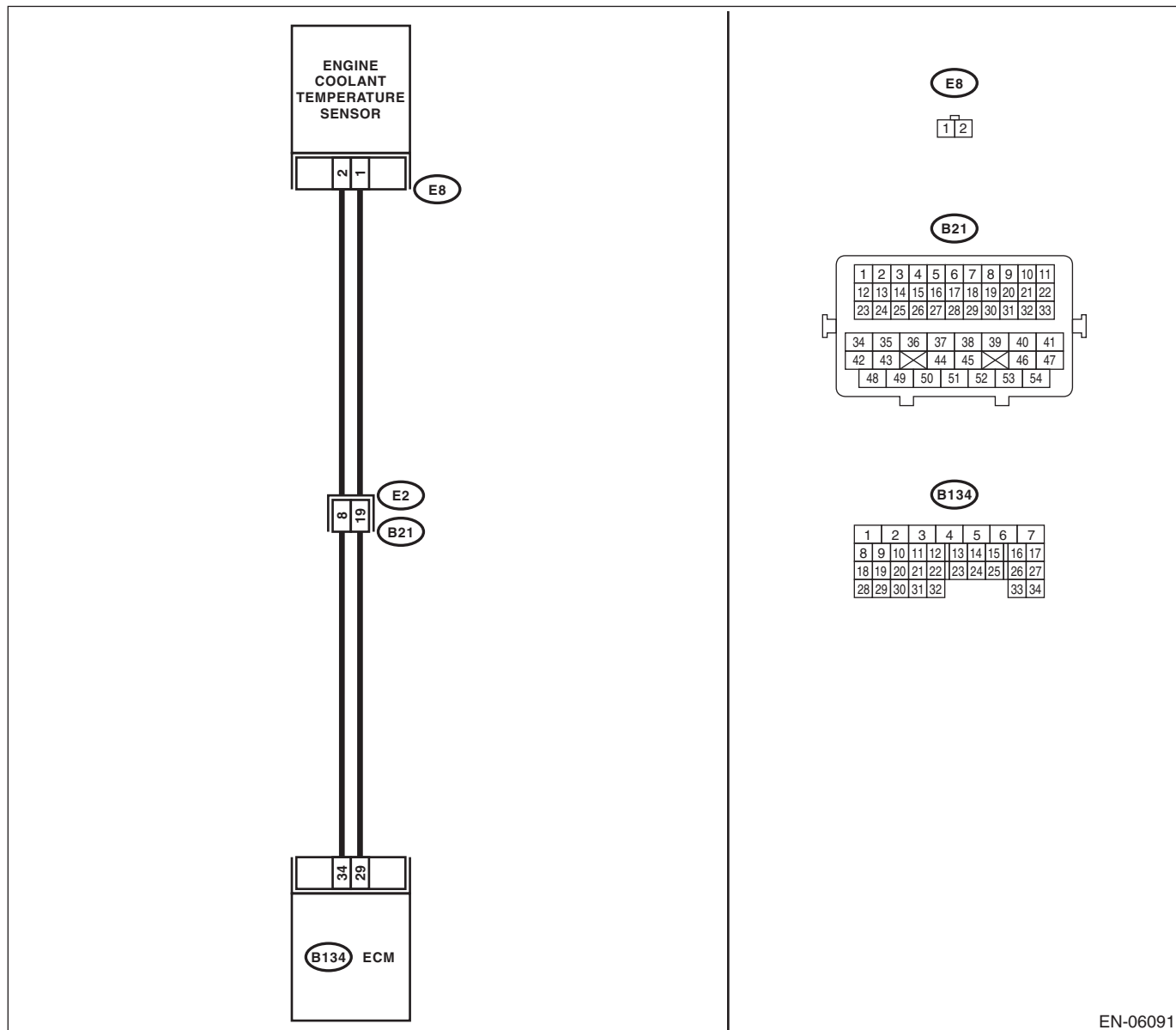

EN-06091

Diagnostic Procedure with Diagnostic Trouble Code (DTC)

ENGINE (DIAGNOSTICS)

	Step	Check	Yes	No
1	<p>CHECK CURRENT DATA.</p> <p>1) Start the engine.</p> <p>2) Read the data of engine coolant temperature sensor signal using Subaru Select Monitor or general scan tool.</p> <p>NOTE:</p> <ul style="list-style-type: none"> Subaru Select Monitor <p>For detailed operation procedures, refer to "READ CURRENT DATA FOR ENGINE". <Ref. to EN(H4SO)(diag)-33, Subaru Select Monitor.></p> <ul style="list-style-type: none"> General scan tool <p>For detailed operation procedures, refer to the general scan tool operation manual.</p>	Is the engine coolant temperature 150°C (302°F) or higher?	Go to step 2.	<p>Even if the malfunction indicator light illuminates, the circuit has returned to a normal condition at this time. Reproduce the fault condition, and reperform the check.</p> <p>NOTE:</p> <p>In this case, there may be a temporary connector contact failure.</p>
2	<p>CHECK HARNESS BETWEEN ECM AND ENGINE COOLANT TEMPERATURE SENSOR CONNECTOR.</p> <p>1) Turn the ignition switch to OFF.</p> <p>2) Disconnect the connectors from the ECM and engine coolant temperature sensor.</p> <p>3) Measure the resistance between ECM and chassis ground.</p> <p>Connector & terminal (B134) No. 34 — Chassis ground:</p>	Is the resistance 1 MΩ or more?	Replace the engine coolant temperature sensor. <Ref. to FU(H4SO)-22, Engine Coolant Temperature Sensor.>	Repair short circuit in harness to ground between ECM and engine coolant temperature sensor connector.

Diagnostic Procedure with Diagnostic Trouble Code (DTC)

ENGINE (DIAGNOSTICS)

V: DTC P0118 ENGINE COOLANT TEMPERATURE CIRCUIT HIGH

DTC DETECTING CONDITION:

- Immediately at fault recognition
- GENERAL DESCRIPTION <Ref. to GD(H4SO)-36, DTC P0118 ENGINE COOLANT TEMPERATURE CIRCUIT HIGH, Diagnostic Trouble Code (DTC) Detecting Criteria.>

TROUBLE SYMPTOM:

- Hard to start
- Improper idling
- Poor driving performance

CAUTION:

After repair or replacement of faulty parts, perform Clear Memory Mode <Ref. to EN(H4SO)(diag)-51, OPERATION, Clear Memory Mode.> and Inspection Mode <Ref. to EN(H4SO)(diag)-41, PROCEDURE, Inspection Mode.>.

WIRING DIAGRAM:

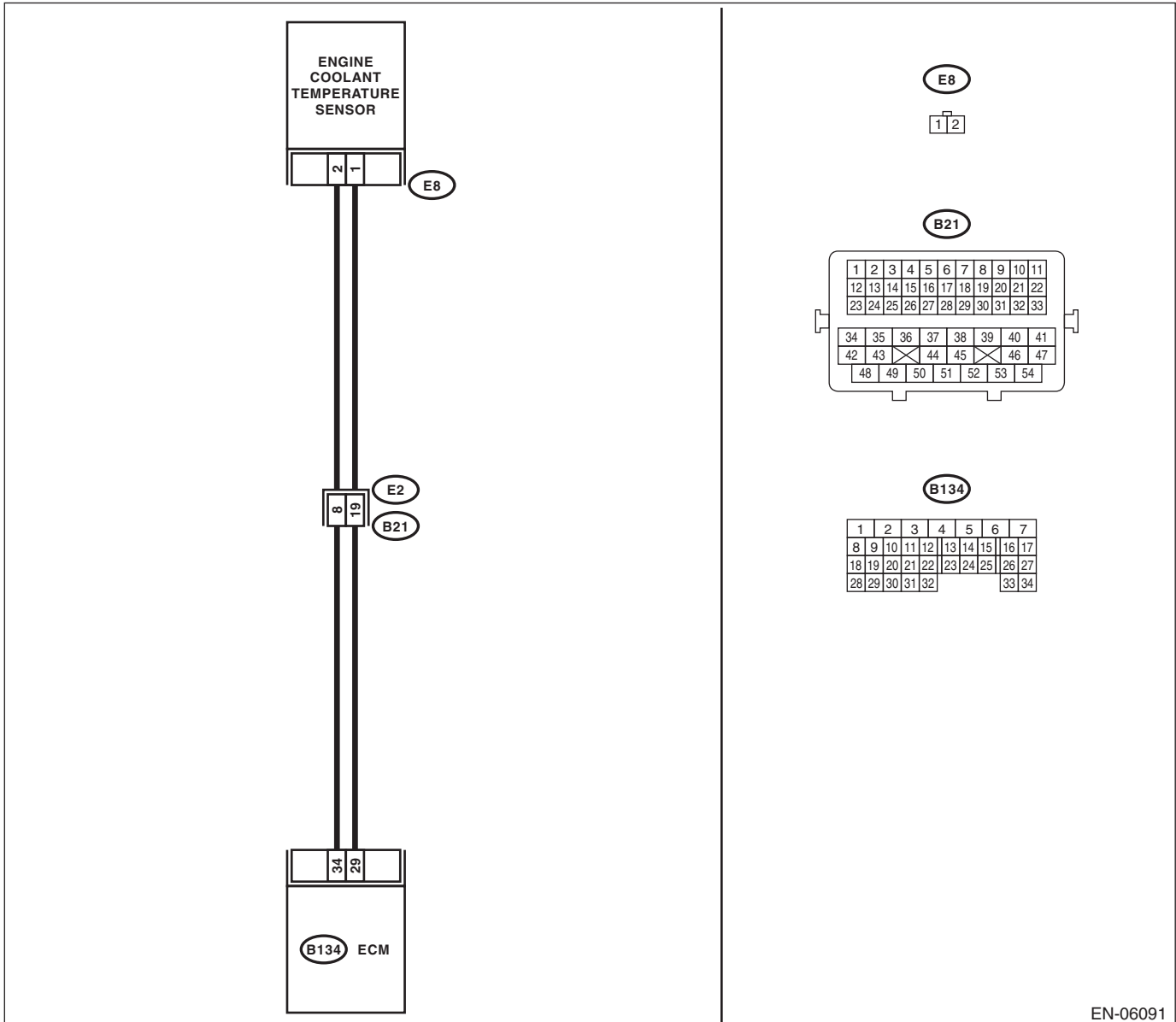

EN-06091

Diagnostic Procedure with Diagnostic Trouble Code (DTC)

ENGINE (DIAGNOSTICS)

Step	Check	Yes	No
<p>1 CHECK CURRENT DATA.</p> <p>1) Start the engine.</p> <p>2) Read the data of engine coolant temperature sensor signal using Subaru Select Monitor or general scan tool.</p> <p>NOTE:</p> <ul style="list-style-type: none"> Subaru Select Monitor <p>For detailed operation procedures, refer to "READ CURRENT DATA FOR ENGINE". <Ref. to EN(H4SO)(diag)-33, Subaru Select Monitor.></p> <ul style="list-style-type: none"> General scan tool <p>For detailed operation procedures, refer to the general scan tool operation manual.</p>	<p>Is the engine coolant temperature less than -40°C (-40°F) ?</p>	<p>Go to step 2.</p>	<p>Even if the malfunction indicator light illuminates, the circuit has returned to a normal condition at this time. Reproduce the fault condition, and reperform the check.</p> <p>NOTE:</p> <p>In this case, there may be a temporary connector contact failure.</p>
<p>2 CHECK POOR CONTACT.</p> <p>Check for poor contact between the ECM and engine coolant temperature sensor connectors.</p>	<p>Is there poor contact in the ECM or engine coolant temperature sensor connectors?</p>	<p>Repair any poor contact between the ECM and engine coolant temperature sensor connectors.</p>	<p>Go to step 3.</p>
<p>3 CHECK HARNESS BETWEEN ECM AND ENGINE COOLANT TEMPERATURE SENSOR CONNECTOR.</p> <p>1) Turn the ignition switch to OFF.</p> <p>2) Disconnect the connectors from the ECM and engine coolant temperature sensor.</p> <p>3) Measure the resistance of the harness between the ECM and engine coolant temperature sensor connector.</p> <p>Connector & terminal</p> <p>(B134) No. 34 — (E8) No. 2:</p> <p>(B134) No. 29 — (E8) No. 1:</p>	<p>Is the resistance less than $1\ \Omega$?</p>	<p>Go to step 4.</p>	<p>Repair the harness and connector.</p> <p>NOTE:</p> <p>In this case, repair the following item:</p> <ul style="list-style-type: none"> Open circuit in harness between ECM and engine coolant temperature sensor connector Poor contact of coupling connector
<p>4 CHECK HARNESS BETWEEN ECM AND ENGINE COOLANT TEMPERATURE SENSOR CONNECTOR.</p> <p>1) Connect all connectors.</p> <p>2) Turn the ignition switch to ON.</p> <p>3) Measure the voltage between ECM and chassis ground.</p> <p>Connector & terminal</p> <p>(B134) No. 34 (+) — Chassis ground (-):</p>	<p>Is the voltage 5 V or more?</p>	<p>Repair the short circuit to power in the harness between the ECM and engine coolant temperature sensor connector.</p>	<p>Replace the engine coolant temperature sensor. <Ref. to FU(H4SO)-22, Engine Coolant Temperature Sensor.></p>

Diagnostic Procedure with Diagnostic Trouble Code (DTC)

ENGINE (DIAGNOSTICS)

W: DTC P0122 THROTTLE/PEDAL POSITION SENSOR/SWITCH "A" CIRCUIT LOW

DTC DETECTING CONDITION:

- Immediately at fault recognition
- GENERAL DESCRIPTION <Ref. to GD(H4SO)-37, DTC P0122 THROTTLE/PEDAL POSITION SENSOR/SWITCH "A" CIRCUIT LOW, Diagnostic Trouble Code (DTC) Detecting Criteria.>

TROUBLE SYMPTOM:

- Improper idling
- Engine stalls.
- Poor driving performance

CAUTION:

After repair or replacement of faulty parts, perform Clear Memory Mode <Ref. to EN(H4SO)(diag)-51, OPERATION, Clear Memory Mode.> and Inspection Mode <Ref. to EN(H4SO)(diag)-41, PROCEDURE, Inspection Mode.>.

WIRING DIAGRAM:

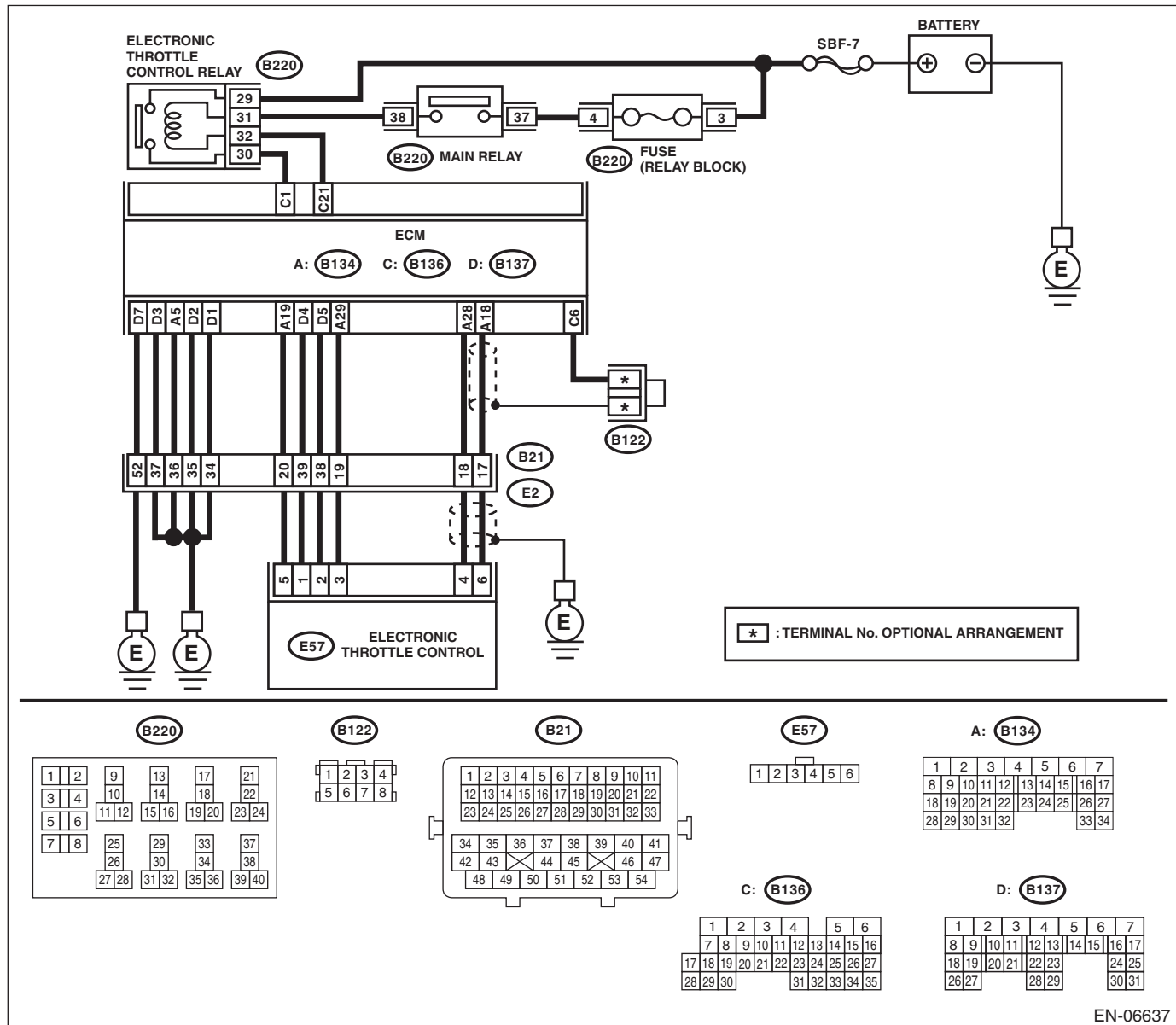

EN-06637

Diagnostic Procedure with Diagnostic Trouble Code (DTC)

ENGINE (DIAGNOSTICS)

Step	Check	Yes	No
<p>1</p> <p>CHECK HARNESS BETWEEN ECM AND ELECTRONIC THROTTLE CONTROL.</p> <p>1) Turn the ignition switch to OFF. 2) Disconnect the connectors from ECM and electronic throttle control. 3) Measure the resistance between ECM and chassis ground.</p> <p>Connector & terminal (B134) No. 19 — Chassis ground: (B134) No. 18 — Chassis ground: (B134) No. 18 — (B136) No. 6:</p>	<p>Is the resistance 1 MΩ or more?</p>	<p>Go to step 2.</p>	<p>Repair the ground short circuit of harness between ECM and electronic throttle control connector.</p>
<p>2</p> <p>CHECK SHORT CIRCUIT INSIDE THE ECM.</p> <p>1) Connect the connector to ECM. 2) Measure the resistance between electronic throttle control connector and engine ground.</p> <p>Connector & terminal (E57) No. 6 — Engine ground:</p>	<p>Is the resistance 1 MΩ or more?</p>	<p>Replace the electronic throttle control. <Ref. to FU(H4SO)-13, Throttle Body.></p>	<p>Repair the ground short circuit of harness between ECM and electronic throttle control connector. Replace the ECM if defective. <Ref. to FU(H4SO)-39, Engine Control Module (ECM).></p>

Diagnostic Procedure with Diagnostic Trouble Code (DTC)

ENGINE (DIAGNOSTICS)

X: DTC P0123 THROTTLE/PEDAL POSITION SENSOR/SWITCH "A" CIRCUIT HIGH

DTC DETECTING CONDITION:

- Immediately at fault recognition
- GENERAL DESCRIPTION <Ref. to GD(H4SO)-38, DTC P0123 THROTTLE/PEDAL POSITION SENSOR/SWITCH "A" CIRCUIT HIGH, Diagnostic Trouble Code (DTC) Detecting Criteria.>

TROUBLE SYMPTOM:

- Improper idling
- Engine stalls.
- Poor driving performance

CAUTION:

After repair or replacement of faulty parts, perform Clear Memory Mode <Ref. to EN(H4SO)(diag)-51, OPERATION, Clear Memory Mode.> and Inspection Mode <Ref. to EN(H4SO)(diag)-41, PROCEDURE, Inspection Mode.>.

WIRING DIAGRAM:

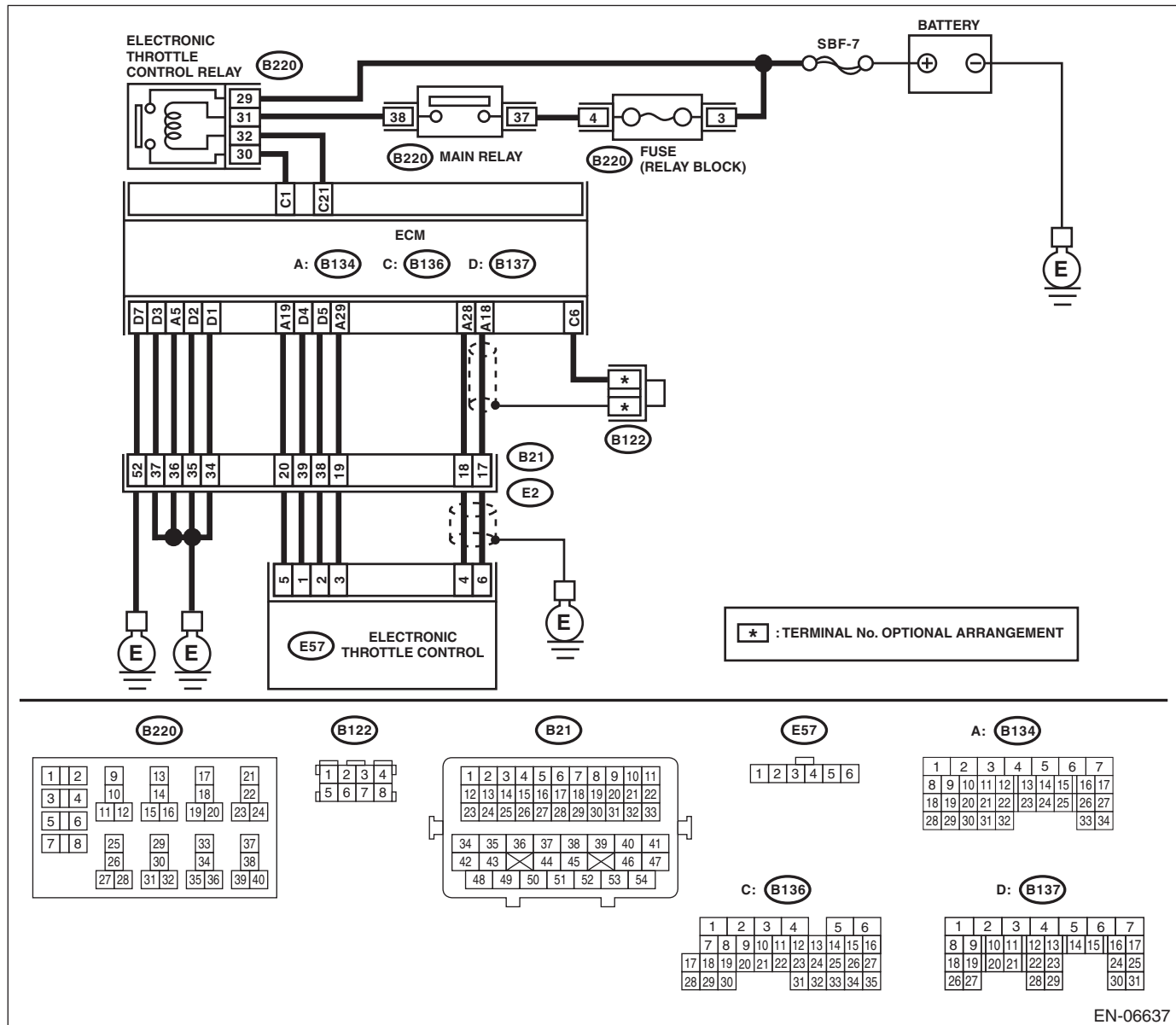

EN-06637

Diagnostic Procedure with Diagnostic Trouble Code (DTC)

ENGINE (DIAGNOSTICS)

Step	Check	Yes	No
<p>1</p> <p>CHECK HARNESS BETWEEN ECM AND ELECTRONIC THROTTLE CONTROL.</p> <p>1) Turn the ignition switch to OFF. 2) Disconnect the connectors from ECM and electronic throttle control. 3) Measure the resistance of harness between ECM and electronic throttle control connector.</p> <p>Connector & terminal (B134) No. 18 — (E57) No. 6: (B134) No. 29 — (E57) No. 3:</p>	Is the resistance less than 1 Ω ?	Go to step 2.	Repair the harness and connector. NOTE: In this case, repair the following item: • Open circuit in harness between ECM and electronic throttle control connector • Poor contact of coupling connector
<p>2</p> <p>CHECK HARNESS BETWEEN ECM AND ELECTRONIC THROTTLE CONTROL.</p> <p>1) Connect the connector to ECM. 2) Measure the resistance between electronic throttle control connector and engine ground.</p> <p>Connector & terminal (E57) No. 3 — Engine ground:</p>	Is the resistance less than 5 Ω ?	Go to step 3.	Repair the harness and connector. NOTE: In this case, repair the following item: • Open circuit of harness between ECM and engine ground • Poor contact in ECM connector • Poor contact of coupling connector
<p>3</p> <p>CHECK HARNESS BETWEEN ECM AND ELECTRONIC THROTTLE CONTROL.</p> <p>1) Turn the ignition switch to ON. 2) Measure the voltage between electronic throttle control connector and engine ground.</p> <p>Connector & terminal (E57) No. 6 (+) — Engine ground (-):</p>	Is the voltage 4.85 V or more?	Repair the short circuit to power in the harness between ECM and electronic throttle control connector.	Go to step 4.
<p>4</p> <p>CHECK HARNESS BETWEEN ECM AND ELECTRONIC THROTTLE CONTROL.</p> <p>1) Turn the ignition switch to OFF. 2) Disconnect the connectors from the ECM. 3) Measure the resistance between ECM connectors.</p> <p>Connector & terminal (B134) No. 19 — (B134) No. 18:</p>	Is the resistance 1 M Ω or more?	Repair poor contact of the electronic throttle control connector. Replace the electronic throttle control if defective. <Ref. to FU(H4SO)-13, Throttle Body.>	Repair the short circuit to power in the harness between ECM and electronic throttle control connector.

Diagnostic Procedure with Diagnostic Trouble Code (DTC)

ENGINE (DIAGNOSTICS)

Y: DTC P0125 INSUFFICIENT COOLANT TEMPERATURE FOR CLOSED LOOP FUEL CONTROL

DTC DETECTING CONDITION:

- Detected when two consecutive driving cycles with fault occur.
- GENERAL DESCRIPTION <Ref. to GD(H4SO)-39, DTC P0125 INSUFFICIENT COOLANT TEMPERATURE FOR CLOSED LOOP FUEL CONTROL, Diagnostic Trouble Code (DTC) Detecting Criteria.>

TROUBLE SYMPTOM:

Engine does not return to idle.

CAUTION:

After repair or replacement of faulty parts, perform Clear Memory Mode <Ref. to EN(H4SO)(diag)-51, OPERATION, Clear Memory Mode.> and Inspection Mode <Ref. to EN(H4SO)(diag)-41, PROCEDURE, Inspection Mode.>.

Step	Check	Yes	No
1 CHECK TIRE SIZE.	Is the tire size as specified? and the same size as other three wheels?	Go to step 2.	Replace the tire.
2 CHECK ENGINE COOLANT. Check the following items: <ul style="list-style-type: none">• Amount of engine coolant• Engine coolant freeze• Contamination of engine coolant	Is the engine coolant normal?	Go to step 3.	Fill or replace the engine coolant. <Ref. to CO(H4SO)-13, REPLACEMENT, Engine Coolant.>
3 CHECK THERMOSTAT.	Does the thermostat remain opened?	Replace the thermostat. <Ref. to CO(H4SO)-17, Thermostat.>	Replace the engine coolant temperature sensor. <Ref. to FU(H4SO)-22, Engine Coolant Temperature Sensor.>

Diagnostic Procedure with Diagnostic Trouble Code (DTC)

ENGINE (DIAGNOSTICS)

Z: DTC P0126 INSUFFICIENT ENGINE COOLANT TEMPERATURE FOR STABLE OPERATION

DTC DETECTING CONDITION:

- Detected when two consecutive driving cycles with fault occur.
- GENERAL DESCRIPTION <Ref. to GD(H4SO)-41, DTC P0126 INSUFFICIENT ENGINE COOLANT TEMPERATURE FOR STABLE OPERATION, Diagnostic Trouble Code (DTC) Detecting Criteria.>

TROUBLE SYMPTOM:

- Hard to start
- Improper idling
- Poor driving performance

CAUTION:

After repair or replacement of faulty parts, perform Clear Memory Mode <Ref. to EN(H4SO)(diag)-51, OPERATION, Clear Memory Mode.> and Inspection Mode <Ref. to EN(H4SO)(diag)-41, PROCEDURE, Inspection Mode.>.

WIRING DIAGRAM:

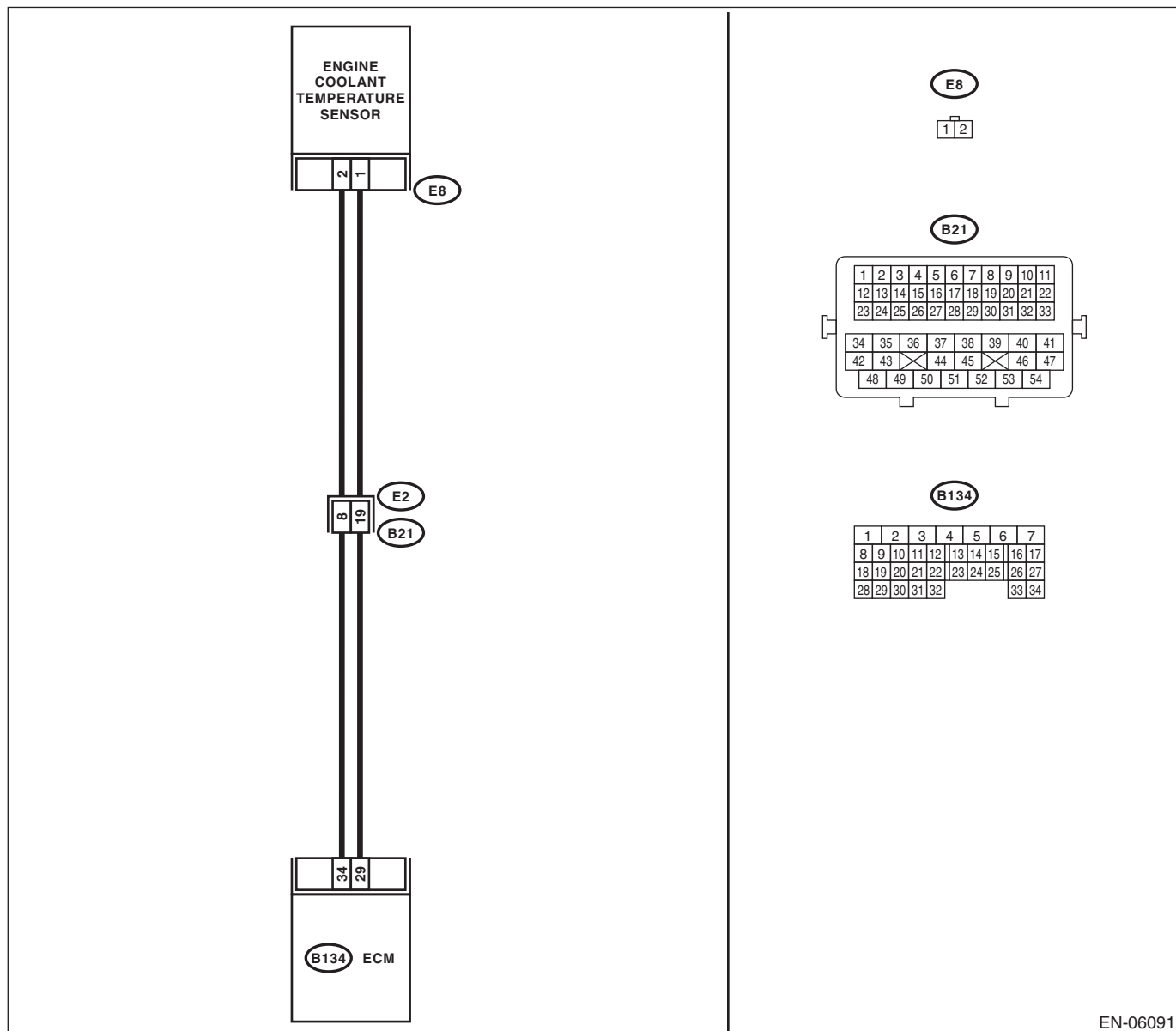

EN-06091

Diagnostic Procedure with Diagnostic Trouble Code (DTC)

ENGINE (DIAGNOSTICS)

	Step	Check	Yes	No
1 CHECK ENGINE COOLANT TEMPERATURE SENSOR. Measure the resistance between engine coolant temperature sensor terminals when the engine coolant is cold and after warmed up. <i>Terminals</i> <i>No. 1 — No. 2:</i>		Is the resistance of engine coolant temperature sensor different between when engine coolant is cold and after warmed up?	Repair the poor contact of the ECM connector.	Replace the engine coolant temperature sensor. <Ref. to FU(H4SO)-22, Engine Coolant Temperature Sensor.>

Diagnostic Procedure with Diagnostic Trouble Code (DTC)

ENGINE (DIAGNOSTICS)

AA:DTC P0128 COOLANT THERMOSTAT (ENGINE COOLANT TEMPERATURE BELOW THERMOSTAT REGULATING TEMPERATURE)

DTC DETECTING CONDITION:

- Detected when two consecutive driving cycles with fault occur.
- GENERAL DESCRIPTION <Ref. to GD(H4SO)-43, DTC P0128 COOLANT THERMOSTAT (ENGINE COOLANT TEMPERATURE BELOW THERMOSTAT REGULATING TEMPERATURE), Diagnostic Trouble Code (DTC) Detecting Criteria.>

TROUBLE SYMPTOM:

Thermostat remains open.

CAUTION:

After repair or replacement of faulty parts, perform Clear Memory Mode <Ref. to EN(H4SO)(diag)-51, OPERATION, Clear Memory Mode.> and Inspection Mode <Ref. to EN(H4SO)(diag)-41, PROCEDURE, Inspection Mode.>.

Step	Check	Yes	No
1 CHECK ENGINE COOLANT.	Are the coolant level and mixture ratio of engine coolant to anti-freeze solution correct?	Go to step 2.	Replace the engine coolant. <Ref. to CO(H4SO)-13, REPLACEMENT, Engine Coolant.>
2 CHECK RADIATOR FAN. 1) Start the engine. 2) Check the radiator fan operation.	Does the radiator fan continuously rotate for 3 minutes or more during idling?	Repair radiator fan circuit. <Ref. to CO(H4SO)-24, Radiator Main Fan and Fan Motor.> and <Ref. to CO(H4SO)-26, Radiator Sub Fan and Fan Motor.>	Replace the thermostat. <Ref. to CO(H4SO)-17, Thermostat.>

Diagnostic Procedure with Diagnostic Trouble Code (DTC)

ENGINE (DIAGNOSTICS)

AB:DTC P0131 O2 SENSOR CIRCUIT LOW VOLTAGE (BANK 1 SENSOR 1)

DTC DETECTING CONDITION:

- Immediately at fault recognition
- GENERAL DESCRIPTION <Ref. to GD(H4SO)-45, DTC P0131 O2 SENSOR CIRCUIT LOW VOLTAGE (BANK 1 SENSOR 1), Diagnostic Trouble Code (DTC) Detecting Criteria.>

CAUTION:

After repair or replacement of faulty parts, perform Clear Memory Mode <Ref. to EN(H4SO)(diag)-51, OPERATION, Clear Memory Mode.> and Inspection Mode <Ref. to EN(H4SO)(diag)-41, PROCEDURE, Inspection Mode.>.

WIRING DIAGRAM:

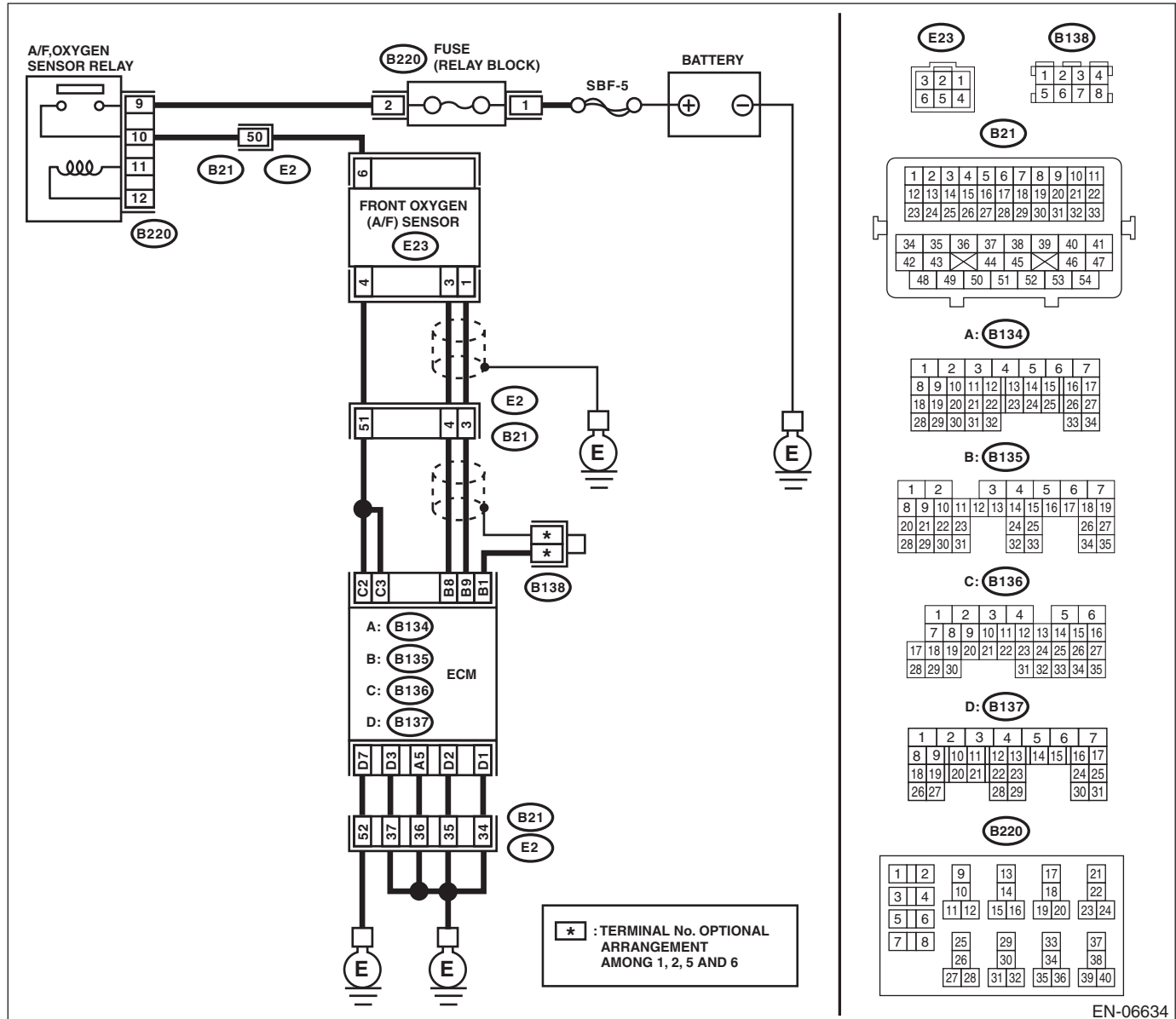

EN-06634

Diagnostic Procedure with Diagnostic Trouble Code (DTC)

ENGINE (DIAGNOSTICS)

Step	Check	Yes	No
1 CHECK FRONT OXYGEN (A/F) SENSOR CONNECTOR AND COUPLING CONNECTOR.	Has water entered the connector?	Completely remove any water inside.	Go to step 2.
2 CHECK HARNESS BETWEEN ECM AND FRONT OXYGEN (A/F) SENSOR CONNECTOR. 1) Turn the ignition switch to OFF. 2) Disconnect the connectors from the ECM and front oxygen (A/F) sensor. 3) Measure the resistance between ECM and chassis ground. Connector & terminal (B135) No. 9 — Chassis ground: (B135) No. 8 — Chassis ground:	Is the resistance 1 MΩ or more?	Go to step 3.	Repair the ground short circuit of harness between ECM and front oxygen (A/F) sensor connector.
3 CHECK POOR CONTACT. Check poor contact of front oxygen (A/F) sensor connector.	Is there poor contact in front oxygen (A/F) sensor connector?	Repair the poor contact of the front oxygen (A/F) sensor connector.	Replace the front oxygen (A/F) sensor. <Ref. to FU(H4SO)-35, Front Oxygen (A/F) Sensor.>

Diagnostic Procedure with Diagnostic Trouble Code (DTC)

ENGINE (DIAGNOSTICS)

AC:DTC P0132 O2 SENSOR CIRCUIT HIGH VOLTAGE (BANK 1 SENSOR 1)

DTC DETECTING CONDITION:

- Immediately at fault recognition
- GENERAL DESCRIPTION <Ref. to GD(H4SO)-47, DTC P0132 O2 SENSOR CIRCUIT HIGH VOLTAGE (BANK 1 SENSOR 1), Diagnostic Trouble Code (DTC) Detecting Criteria.>

CAUTION:

After repair or replacement of faulty parts, perform Clear Memory Mode <Ref. to EN(H4SO)(diag)-51, OPERATION, Clear Memory Mode.> and Inspection Mode <Ref. to EN(H4SO)(diag)-41, PROCEDURE, Inspection Mode.>.

WIRING DIAGRAM:

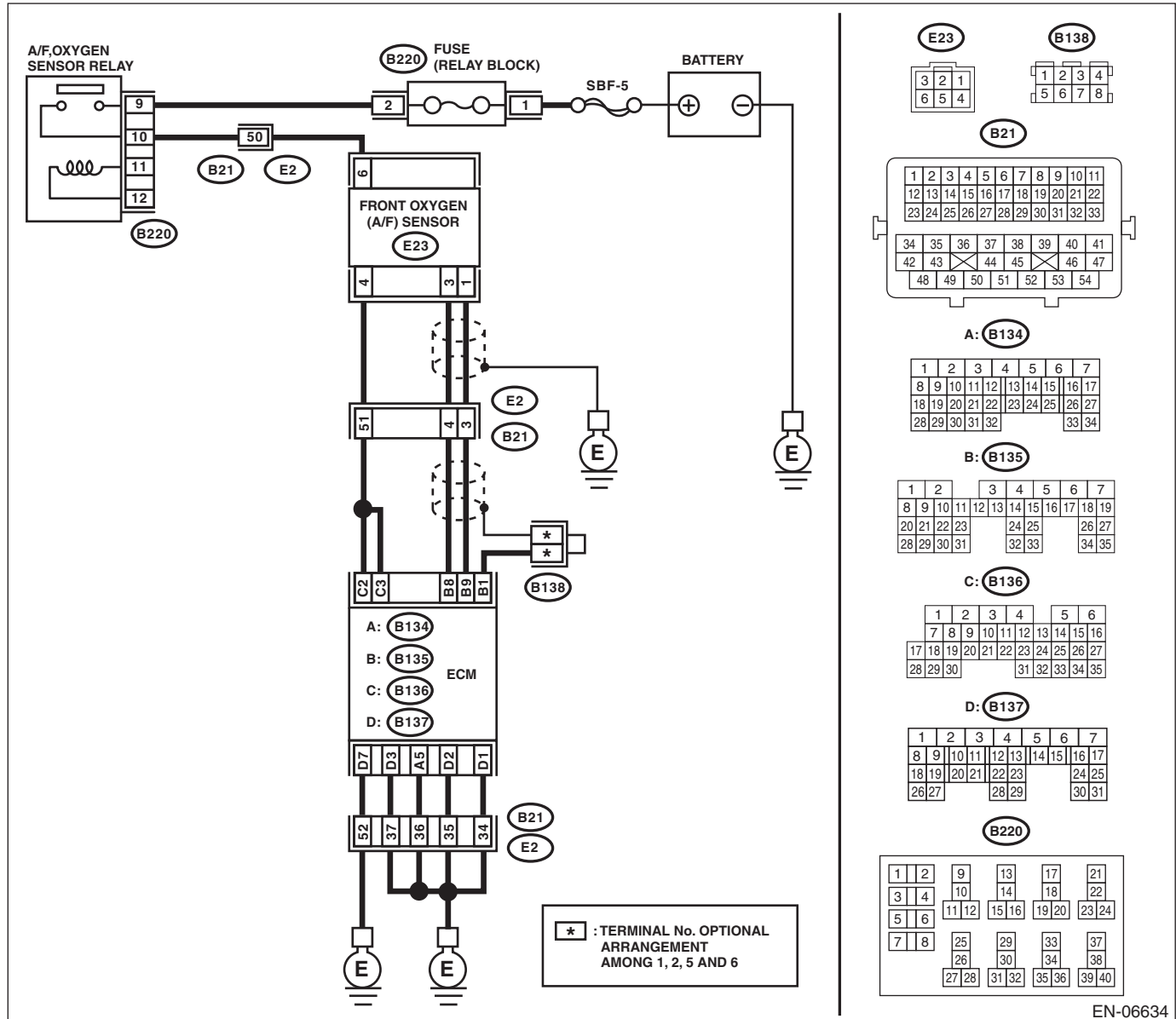

EN-06634

Diagnostic Procedure with Diagnostic Trouble Code (DTC)

ENGINE (DIAGNOSTICS)

Step	Check	Yes	No
1 CHECK FRONT OXYGEN (A/F) SENSOR CONNECTOR AND COUPLING CONNECTOR.	Has water entered the connector?	Completely remove any water inside.	Go to step 2.
2 CHECK HARNESS BETWEEN ECM AND FRONT OXYGEN (A/F) SENSOR CONNECTOR. 1) Turn the ignition switch to OFF. 2) Disconnect the connector from front oxygen (A/F) sensor. 3) Turn the ignition switch to ON. 4) Measure the voltage between ECM and chassis ground. Connector & terminal (B135) No. 9 (+) — Chassis ground (-): (B135) No. 8 (+) — Chassis ground (-):	Is the voltage 8 V or more?	Repair the short circuit to power in the harness between the ECM and front oxygen (A/F) sensor connector.	Replace the front oxygen (A/F) sensor. <Ref. to FU(H4SO)-35, Front Oxygen (A/F) Sensor.>

Diagnostic Procedure with Diagnostic Trouble Code (DTC)

ENGINE (DIAGNOSTICS)

AD:DTC P0133 O2 SENSOR CIRCUIT SLOW RESPONSE (BANK 1 SENSOR 1)

DTC DETECTING CONDITION:

- Detected when two consecutive driving cycles with fault occur.
- GENERAL DESCRIPTION <Ref. to GD(H4SO)-49, DTC P0133 O2 SENSOR CIRCUIT SLOW RESPONSE (BANK 1 SENSOR 1), Diagnostic Trouble Code (DTC) Detecting Criteria.>

CAUTION:

After repair or replacement of faulty parts, perform Clear Memory Mode <Ref. to EN(H4SO)(diag)-51, OPERATION, Clear Memory Mode.> and Inspection Mode <Ref. to EN(H4SO)(diag)-41, PROCEDURE, Inspection Mode.>.

WIRING DIAGRAM:

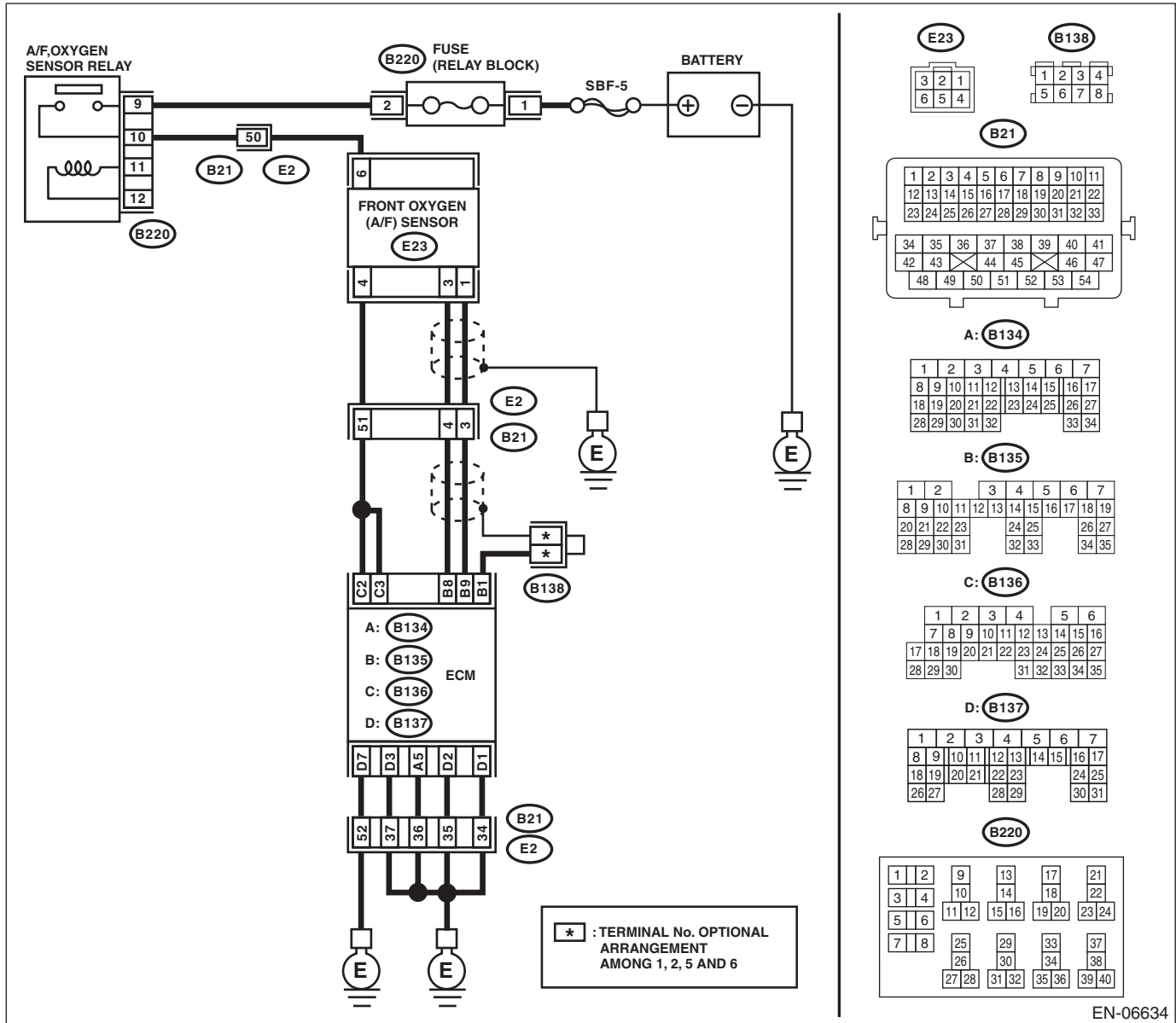

EN-06634

Diagnostic Procedure with Diagnostic Trouble Code (DTC)

ENGINE (DIAGNOSTICS)

Step	Check	Yes	No
1 CHECK EXHAUST SYSTEM. NOTE: Check the following items. <ul style="list-style-type: none">• Loose installation of front portion of exhaust pipe onto cylinder heads• Loose connection between front exhaust pipe and front catalytic converter• Damage of exhaust pipe resulting in a hole	Is there any fault in exhaust system?	Repair the exhaust system.	Replace the front oxygen (A/F) sensor. <Ref. to FU(H4SO)-35, Front Oxygen (A/F) Sensor.>

AE:DTC P0134 O2 SENSOR CIRCUIT NO ACTIVITY DETECTED (BANK 1 SENSOR 1)

DTC DETECTING CONDITION:

- Immediately at fault recognition
- GENERAL DESCRIPTION <Ref. to GD(H4SO)-52, DTC P0134 O2 SENSOR CIRCUIT NO ACTIVITY DETECTED (BANK 1 SENSOR 1), Diagnostic Trouble Code (DTC) Detecting Criteria.>

CAUTION:

After repair or replacement of faulty parts, perform Clear Memory Mode <Ref. to EN(H4SO)(diag)-51, OPERATION, Clear Memory Mode.> and Inspection Mode <Ref. to EN(H4SO)(diag)-41, PROCEDURE, Inspection Mode.>.

WIRING DIAGRAM:

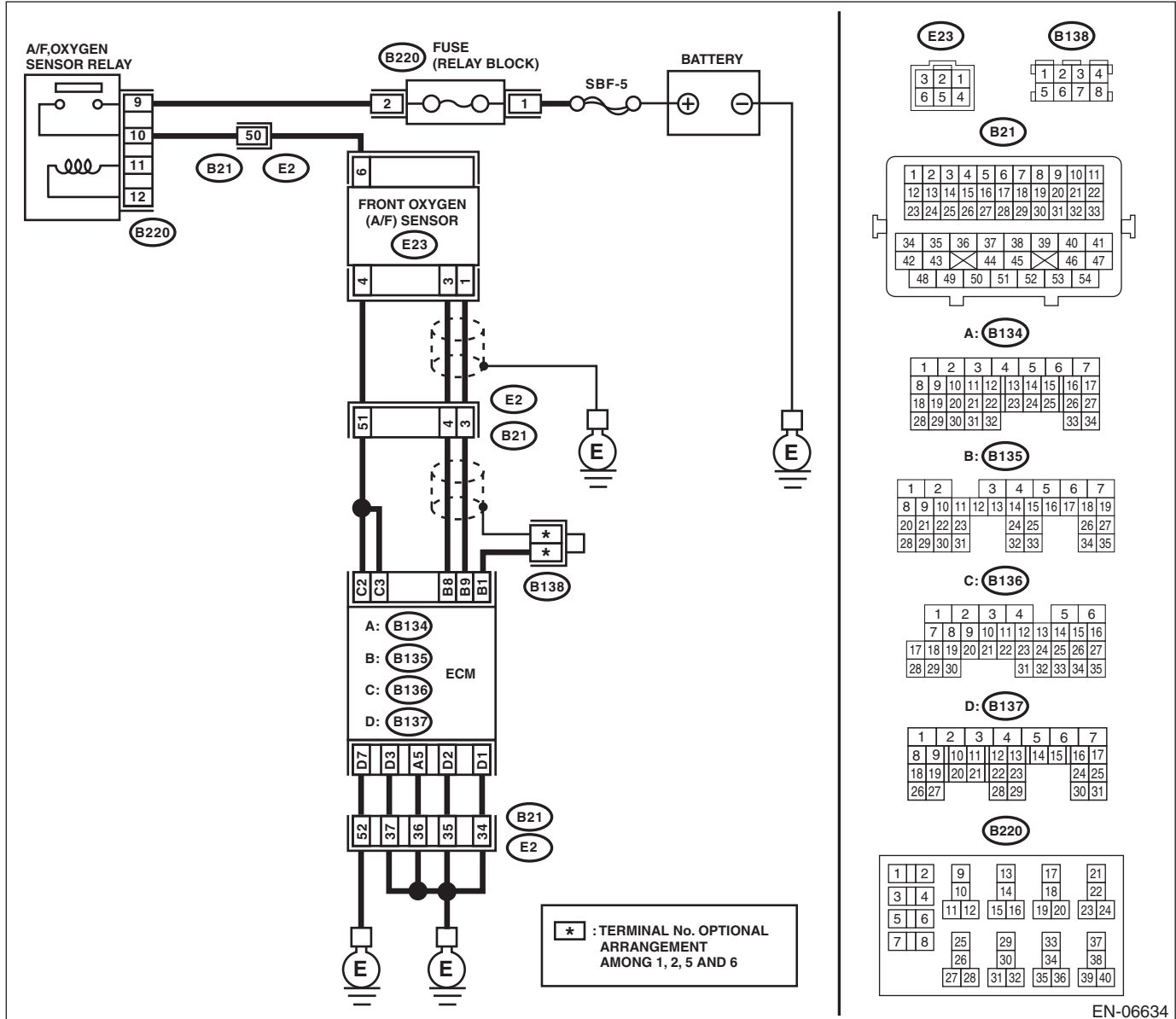

Diagnostic Procedure with Diagnostic Trouble Code (DTC)

ENGINE (DIAGNOSTICS)

Step	Check	Yes	No
<p>1 CHECK HARNESS BETWEEN ECM AND FRONT OXYGEN (A/F) SENSOR CONNECTOR.</p> <p>1) Turn the ignition switch to OFF. 2) Disconnect the connectors from the ECM and front oxygen (A/F) sensor. 3) Measure the resistance of harness between ECM and front oxygen (A/F) sensor connector.</p> <p>Connector & terminal (B135) No. 9 — (E23) No. 1: (B135) No. 8 — (E23) No. 3:</p>	<p>Is the resistance less than 1 Ω?</p>	<p>Go to step 2.</p>	<p>Repair the harness and connector.</p> <p>NOTE: In this case, repair the following item:</p> <ul style="list-style-type: none"> • Open circuit in harness between ECM and front oxygen (A/F) sensor connector • Poor contact of coupling connector
<p>2 CHECK POOR CONTACT. Check poor contact of ECM and front oxygen (A/F) sensor connector.</p>	<p>Is there poor contact in ECM or front oxygen (A/F) sensor connector?</p>	<p>Repair the poor contact of ECM or front oxygen (A/F) sensor connector.</p>	<p>Replace the front oxygen (A/F) sensor. <Ref. to FU(H4SO)-35, Front Oxygen (A/F) Sensor.></p>

Diagnostic Procedure with Diagnostic Trouble Code (DTC)

ENGINE (DIAGNOSTICS)

AF:DTC P0137 O2 SENSOR CIRCUIT LOW VOLTAGE (BANK 1 SENSOR 2)

DTC DETECTING CONDITION:

- Detected when two consecutive driving cycles with fault occur.
- GENERAL DESCRIPTION <Ref. to GD(H4SO)-54, DTC P0137 O2 SENSOR CIRCUIT LOW VOLTAGE (BANK 1 SENSOR 2), Diagnostic Trouble Code (DTC) Detecting Criteria.>

CAUTION:

After repair or replacement of faulty parts, perform Clear Memory Mode <Ref. to EN(H4SO)(diag)-51, OPERATION, Clear Memory Mode.> and Inspection Mode <Ref. to EN(H4SO)(diag)-41, PROCEDURE, Inspection Mode.>.

WIRING DIAGRAM:

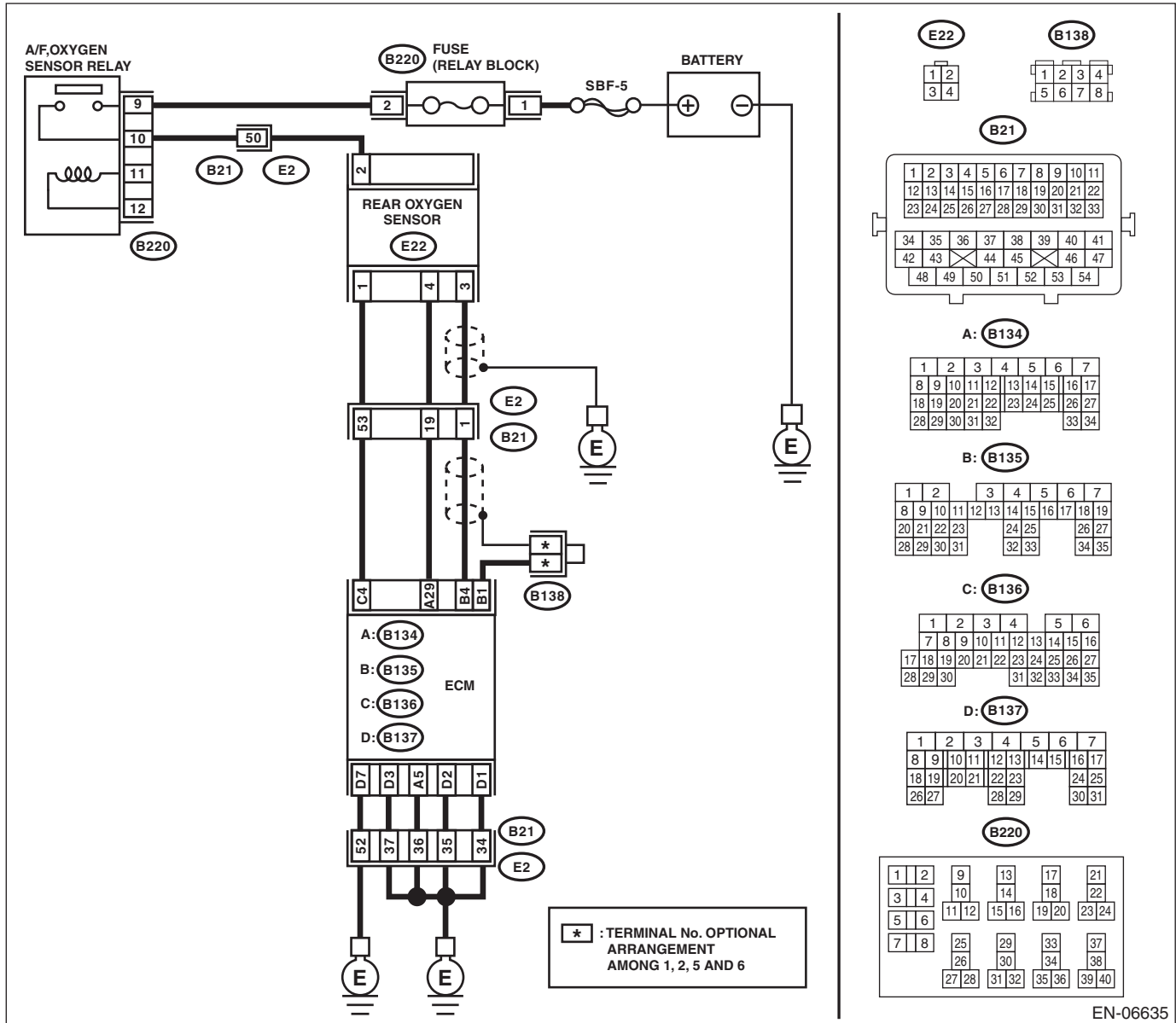

EN-06635

Diagnostic Procedure with Diagnostic Trouble Code (DTC)

ENGINE (DIAGNOSTICS)

Step	Check	Yes	No
<p>1 CHECK REAR OXYGEN SENSOR DATA. 1) Warm up the engine until engine coolant temperature is higher than 75°C (167°F), and keep the engine speed at 3,000 rpm. (2 minutes maximum) 2) Read the data of rear oxygen sensor signal using Subaru Select Monitor or general scan tool. NOTE: • Subaru Select Monitor For detailed operation procedures, refer to "READ CURRENT DATA FOR ENGINE". <Ref. to EN(H4SO)(diag)-33, Subaru Select Monitor.> • General scan tool For detailed operation procedures, refer to the general scan tool operation manual.</p>	Is the voltage 490 mV or more?	Go to step 5.	Go to step 2.
<p>2 CHECK REAR OXYGEN SENSOR CONNECTOR AND COUPLING CONNECTOR.</p>	Has water entered the connector?	Completely remove any water inside.	Go to step 3.
<p>3 CHECK HARNESS BETWEEN ECM AND REAR OXYGEN SENSOR CONNECTOR. 1) Turn the ignition switch to OFF. 2) Disconnect the connector from ECM and rear oxygen sensor. 3) Measure the resistance of harness between ECM and rear oxygen sensor connector. Connector & terminal (B135) No. 4 — (E22) No. 3: (B134) No. 29 — (E22) No. 4:</p>	Is the resistance less than 1 Ω?	Go to step 4.	Repair the harness and connector. NOTE: In this case, repair the following item: • Open circuit in harness between ECM and rear oxygen sensor connector • Poor contact of coupling connector
<p>4 CHECK HARNESS BETWEEN ECM AND REAR OXYGEN SENSOR. 1) Turn the ignition switch to OFF. 2) Disconnect the connector from rear oxygen sensor. 3) Turn the ignition switch to ON. 4) Measure the voltage between rear oxygen sensor connector and chassis ground. Connector & terminal (E22) No. 3 (+) — Chassis ground (-):</p>	Is the voltage 0.2 — 0.5 V?	Replace the rear oxygen sensor. <Ref. to FU(H4SO)-37, Rear Oxygen Sensor.>	Repair the harness and connector. NOTE: In this case, repair the following item: • Open circuit in harness between ECM and rear oxygen sensor connector • Poor contact in ECM connector • Poor contact of coupling connector
<p>5 CHECK EXHAUST SYSTEM. Check exhaust system parts. NOTE: Check the following items. • Loose part and incomplete installation of exhaust system • Damage (crack, hole etc.) of parts • Loose part and improper installation between front oxygen (A/F) sensor and rear oxygen sensor</p>	Is there any fault in exhaust system?	Repair or replace faulty parts.	Replace the rear oxygen sensor. <Ref. to FU(H4SO)-37, Rear Oxygen Sensor.>

Diagnostic Procedure with Diagnostic Trouble Code (DTC)

ENGINE (DIAGNOSTICS)

AG:DTC P0138 O2 SENSOR CIRCUIT HIGH VOLTAGE (BANK 1 SENSOR 2)

DTC DETECTING CONDITION:

- Detected when two consecutive driving cycles with fault occur.
- GENERAL DESCRIPTION <Ref. to GD(H4SO)-57, DTC P0138 O2 SENSOR CIRCUIT HIGH VOLTAGE (BANK 1 SENSOR 2), Diagnostic Trouble Code (DTC) Detecting Criteria.>

CAUTION:

After repair or replacement of faulty parts, perform Clear Memory Mode <Ref. to EN(H4SO)(diag)-51, OPERATION, Clear Memory Mode.> and Inspection Mode <Ref. to EN(H4SO)(diag)-41, PROCEDURE, Inspection Mode.>.

WIRING DIAGRAM:

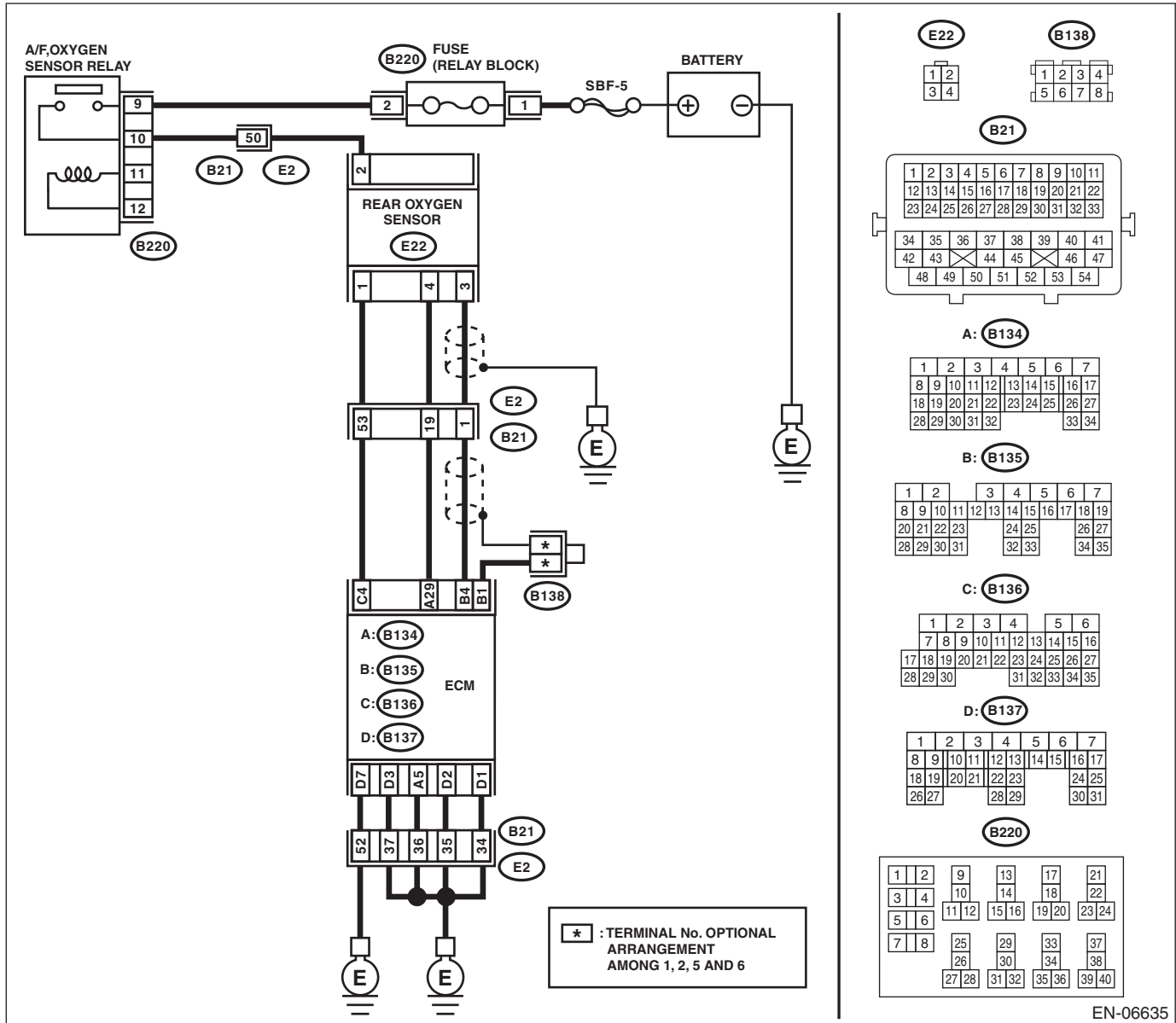

EN-06635

Diagnostic Procedure with Diagnostic Trouble Code (DTC)

ENGINE (DIAGNOSTICS)

Step	Check	Yes	No
<p>1 CHECK REAR OXYGEN SENSOR DATA. 1) Warm up the engine until engine coolant temperature is higher than 75°C (167°F), and rapidly reduce the engine speed from 3,000 rpm. 2) Read the data of rear oxygen sensor signal using Subaru Select Monitor or general scan tool.</p> <p>NOTE: • Subaru Select Monitor For detailed operation procedures, refer to "READ CURRENT DATA FOR ENGINE". <Ref. to EN(H4SO)(diag)-33, Subaru Select Monitor.> • General scan tool For detailed operation procedures, refer to the general scan tool operation manual.</p>	Is the voltage 250 mV or less?	Go to step 5.	Go to step 2.
<p>2 CHECK REAR OXYGEN SENSOR CONNECTOR AND COUPLING CONNECTOR.</p>	Has water entered the connector?	Completely remove any water inside.	Go to step 3.
<p>3 CHECK HARNESS BETWEEN ECM AND REAR OXYGEN SENSOR CONNECTOR. 1) Turn the ignition switch to OFF. 2) Disconnect the connector from ECM and rear oxygen sensor. 3) Measure the resistance of harness between ECM and rear oxygen sensor connector.</p> <p>Connector & terminal (B135) No. 4 — (E22) No. 3: (B134) No. 29 — (E22) No. 4:</p>	Is the resistance less than 1 Ω?	Go to step 4.	Repair the harness and connector. NOTE: In this case, repair the following item: • Open circuit in harness between ECM and rear oxygen sensor connector • Poor contact of coupling connector
<p>4 CHECK HARNESS BETWEEN ECM AND REAR OXYGEN SENSOR. 1) Turn the ignition switch to OFF. 2) Disconnect the connector from rear oxygen sensor. 3) Turn the ignition switch to ON. 4) Measure the voltage between rear oxygen sensor connector and chassis ground.</p> <p>Connector & terminal (E22) No. 3 (+) — Chassis ground (-):</p>	Is the voltage 0.2 — 0.5 V?	Replace the rear oxygen sensor. <Ref. to FU(H4SO)-37, Rear Oxygen Sensor.>	Repair the harness and connector. NOTE: In this case, repair the following item: • Open circuit in harness between ECM and rear oxygen sensor connector • Poor contact in ECM connector • Poor contact of coupling connector
<p>5 CHECK EXHAUST SYSTEM. Check exhaust system parts.</p> <p>NOTE: Check the following items. • Loose part and incomplete installation of exhaust system • Damage (crack, hole etc.) of parts • Loose part and improper installation between front oxygen (A/F) sensor and rear oxygen sensor</p>	Is there any fault in exhaust system?	Repair or replace faulty parts.	Replace the rear oxygen sensor. <Ref. to FU(H4SO)-37, Rear Oxygen Sensor.>

Diagnostic Procedure with Diagnostic Trouble Code (DTC)

ENGINE (DIAGNOSTICS)

AH:DTC P0139 O2 SENSOR CIRCUIT SLOW RESPONSE (BANK 1 SENSOR 2)

DTC DETECTING CONDITION:

- Detected when two consecutive driving cycles with fault occur.
- GENERAL DESCRIPTION <Ref. to GD(H4SO)-58, DTC P0139 O2 SENSOR CIRCUIT SLOW RESPONSE (BANK 1 SENSOR 2), Diagnostic Trouble Code (DTC) Detecting Criteria.>

CAUTION:

After repair or replacement of faulty parts, perform Clear Memory Mode <Ref. to EN(H4SO)(diag)-51, OPERATION, Clear Memory Mode.> and Inspection Mode <Ref. to EN(H4SO)(diag)-41, PROCEDURE, Inspection Mode.>.

WIRING DIAGRAM:

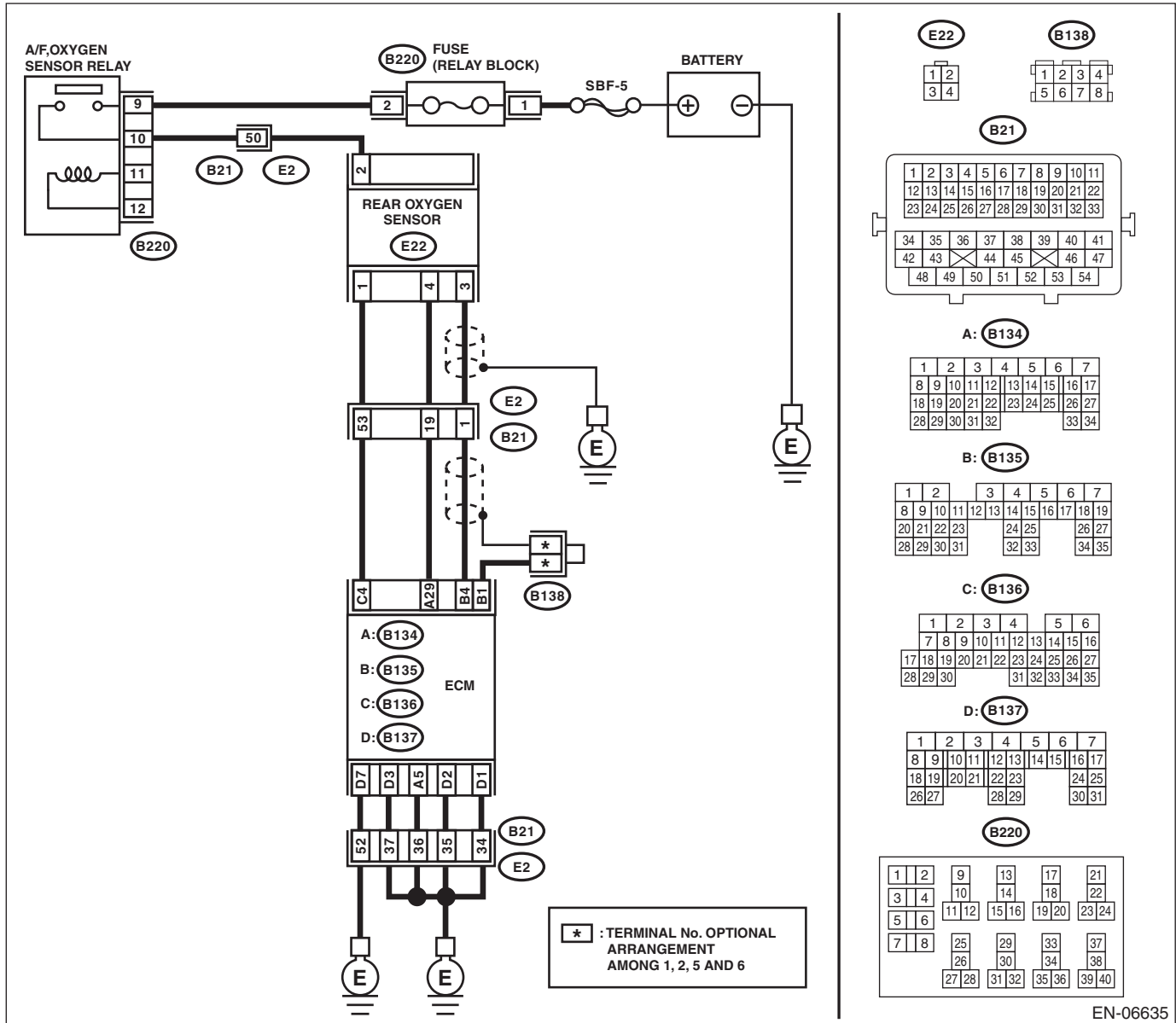

EN-06635

Diagnostic Procedure with Diagnostic Trouble Code (DTC)

ENGINE (DIAGNOSTICS)

Step	Check	Yes	No
<p>1</p> <p>CHECK HARNESS BETWEEN ECM AND REAR OXYGEN SENSOR CONNECTOR.</p> <p>1) Turn the ignition switch to OFF. 2) Disconnect the connector from ECM and rear oxygen sensor. 3) Measure the resistance of harness between ECM and rear oxygen sensor connector.</p> <p>Connector & terminal (B135) No. 4 — (E22) No. 3:</p>	<p>Is the resistance less than 1 Ω?</p>	<p>Go to step 2.</p>	<p>Repair the harness and connector.</p> <p>NOTE: In this case, repair the following item:</p> <ul style="list-style-type: none"> • Open circuit in harness between ECM and rear oxygen sensor connector • Poor contact of coupling connector
<p>2</p> <p>CHECK HARNESS BETWEEN ECM AND REAR OXYGEN SENSOR CONNECTOR.</p> <p>Measure the resistance between rear oxygen sensor connector and chassis ground.</p> <p>Connector & terminal (E22) No. 3 — Chassis ground:</p>	<p>Is the resistance 1 MΩ or more?</p>	<p>Go to step 3.</p>	<p>Repair the ground short circuit of harness between ECM and rear oxygen sensor connector.</p>
<p>3</p> <p>CHECK REAR OXYGEN SENSOR.</p> <p>Measure the resistance between rear oxygen sensor terminals.</p> <p>Terminals No. 3 — No. 4</p>	<p>Is the resistance less than 1 Ω?</p>	<p>Replace the rear oxygen sensor. <Ref. to FU(H4SO)-37, Rear Oxygen Sensor.></p>	<p>Even if the malfunction indicator light illuminates, the circuit has returned to a normal condition at this time. Reproduce the fault condition, and reperform the check.</p> <p>NOTE: In this case, there may be a temporary connector contact failure.</p>

Diagnostic Procedure with Diagnostic Trouble Code (DTC)

ENGINE (DIAGNOSTICS)

AI: DTC P0140 O2 SENSOR CIRCUIT NO ACTIVITY DETECTED (BANK 1 SENSOR 2)

DTC DETECTING CONDITION:

- Detected when two consecutive driving cycles with fault occur.
- GENERAL DESCRIPTION <Ref. to GD(H4SO)-63, DTC P0140 O2 SENSOR CIRCUIT NO ACTIVITY DETECTED (BANK 1 SENSOR 2), Diagnostic Trouble Code (DTC) Detecting Criteria.>

CAUTION:

After repair or replacement of faulty parts, perform Clear Memory Mode <Ref. to EN(H4SO)(diag)-51, OPERATION, Clear Memory Mode.> and Inspection Mode <Ref. to EN(H4SO)(diag)-41, PROCEDURE, Inspection Mode.>.

WIRING DIAGRAM:

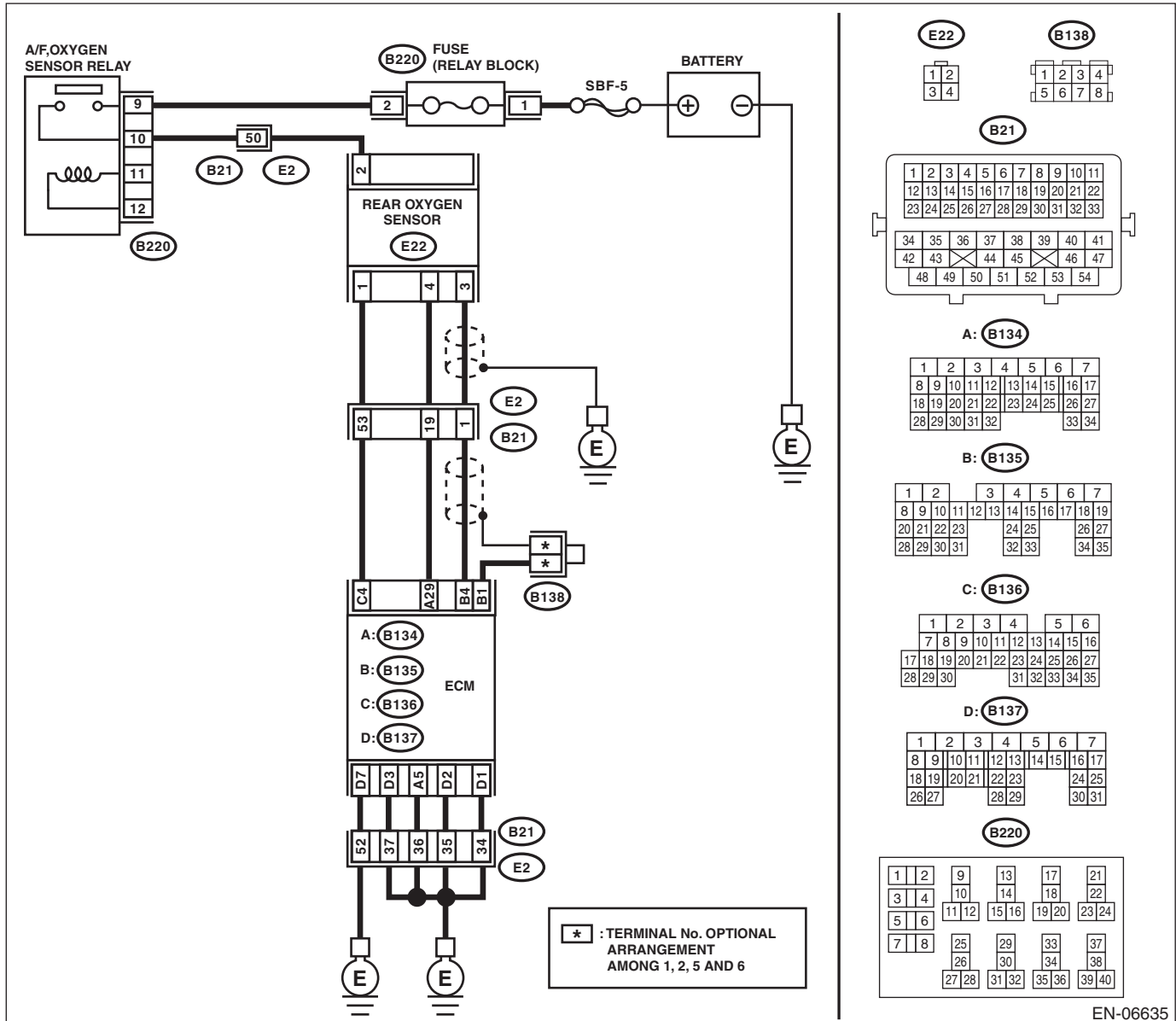

EN-06635

Diagnostic Procedure with Diagnostic Trouble Code (DTC)

ENGINE (DIAGNOSTICS)

Step	Check	Yes	No
1 CHECK REAR OXYGEN SENSOR DATA. 1) Warm up the engine until engine coolant temperature is higher than 75°C (167°F), and keep the engine speed at 3,000 rpm. (2 minutes maximum) 2) Read the data of rear oxygen sensor signal using Subaru Select Monitor or general scan tool. NOTE: • Subaru Select Monitor For detailed operation procedures, refer to "READ CURRENT DATA FOR ENGINE". <Ref. to EN(H4SO)(diag)-33, Subaru Select Monitor.> • General scan tool For detailed operation procedures, refer to the general scan tool operation manual.	Is the voltage 490 mV or more?	Go to step 6.	Go to step 2.
2 CHECK REAR OXYGEN SENSOR DATA. 1) Warm up the engine until engine coolant temperature is higher than 75°C (167°F), and rapidly reduce the engine speed from 3,000 rpm. 2) Read the data of rear oxygen sensor signal using Subaru Select Monitor or general scan tool. NOTE: • Subaru Select Monitor For detailed operation procedures, refer to "READ CURRENT DATA FOR ENGINE". <Ref. to EN(H4SO)(diag)-33, Subaru Select Monitor.> • General scan tool For detailed operation procedures, refer to the general scan tool operation manual.	Is the voltage 250 mV or less?	Go to step 6.	Go to step 3.
3 CHECK REAR OXYGEN SENSOR CONNECTOR AND COUPLING CONNECTOR.	Has water entered the connector?	Completely remove any water inside.	Go to step 4.
4 CHECK HARNESS BETWEEN ECM AND REAR OXYGEN SENSOR CONNECTOR. 1) Turn the ignition switch to OFF. 2) Disconnect the connector from ECM and rear oxygen sensor. 3) Measure the resistance of harness between ECM and rear oxygen sensor connector. Connector & terminal (B135) No. 4 — (E22) No. 3: (B134) No. 29 — (E22) No. 4:	Is the resistance less than 1 Ω?	Go to step 5.	Repair the harness and connector. NOTE: In this case, repair the following item: • Open circuit in harness between ECM and rear oxygen sensor connector • Poor contact of coupling connector

Diagnostic Procedure with Diagnostic Trouble Code (DTC)

ENGINE (DIAGNOSTICS)

Step	Check	Yes	No
5 CHECK HARNESS BETWEEN ECM AND REAR OXYGEN SENSOR. 1) Turn the ignition switch to OFF. 2) Disconnect the connector from the rear oxygen sensor. 3) Turn the ignition switch to ON. 4) Measure the voltage between rear oxygen sensor connector and chassis ground. Connector & terminal (E22) No. 3 (+) — Chassis ground (-):	Is the voltage 0.2 — 0.5 V?	Replace the rear oxygen sensor. <Ref. to FU(H4SO)-37, Rear Oxygen Sensor.>	Repair the harness and connector. NOTE: In this case, repair the following item: <ul style="list-style-type: none"> • Open circuit in harness between ECM and rear oxygen sensor connector • Poor contact in ECM connector • Poor contact of coupling connector
6 CHECK EXHAUST SYSTEM. Check exhaust system parts. NOTE: Check the following items. <ul style="list-style-type: none"> • Loose part and improper installation of exhaust system • Damage (crack, hole etc.) of parts • Loose part and improper installation between front oxygen (A/F) sensor and rear oxygen sensor 	Is there any fault in exhaust system?	Repair or replace faulty parts.	Replace the rear oxygen sensor. <Ref. to FU(H4SO)-37, Rear Oxygen Sensor.>

AJ:DTC P0171 SYSTEM TOO LEAN (BANK 1)

Refer to DTC P0172 for diagnostic procedure. <Ref. to EN(H4SO)(diag)-158, DTC P0172 SYSTEM TOO RICH (BANK 1), Diagnostic Procedure with Diagnostic Trouble Code (DTC).>

Diagnostic Procedure with Diagnostic Trouble Code (DTC)

ENGINE (DIAGNOSTICS)

AK:DTC P0172 SYSTEM TOO RICH (BANK 1)

DTC DETECTING CONDITION:

- Detected when two consecutive driving cycles with fault occur.
- GENERAL DESCRIPTION <Ref. to GD(H4SO)-66, DTC P0172 SYSTEM TOO RICH (BANK 1), Diagnostic Trouble Code (DTC) Detecting Criteria.>

TROUBLE SYMPTOM:

- Improper idling
- Engine stalls.
- Poor driving performance

CAUTION:

After repair or replacement of faulty parts, perform Clear Memory Mode <Ref. to EN(H4SO)(diag)-51, OPERATION, Clear Memory Mode.> and Inspection Mode <Ref. to EN(H4SO)(diag)-41, PROCEDURE, Inspection Mode.>.

Step	Check	Yes	No
1	CHECK EXHAUST SYSTEM.	Are there holes or loose bolts on exhaust system?	Repair the exhaust system. Go to step 2.
2	CHECK AIR INTAKE SYSTEM.	Are there holes, loose bolts or disconnection of hose on air intake system?	Repair the air intake system. Go to step 3.
3	CHECK FUEL PRESSURE. WARNING: Place "NO OPEN FLAMES" signs near the working area. CAUTION: Be careful not to spill fuel. Measure the fuel pressure. <Ref. to ME(H4SO)-28, INSPECTION, Fuel Pressure.> CAUTION: Release fuel pressure before removing the fuel pressure gauge.	Is the measured value 333.4 — 360.5 kPa (3.4 — 3.7 kg/cm ² , 48.4 — 52 psi)?	Go to step 4. Repair the following item. Fuel pressure is too high: • Clogged fuel line or bent hose Fuel pressure is too low: • Improper fuel pump discharge • Clogged fuel line
4	CHECK ENGINE COOLANT TEMPERATURE SENSOR. 1) Start the engine and warm up completely. 2) Read the data of engine coolant temperature sensor signal using Subaru Select Monitor or general scan tool. NOTE: • Subaru Select Monitor For detailed operation procedures, refer to "READ CURRENT DATA FOR ENGINE". <Ref. to EN(H4SO)(diag)-33, Subaru Select Monitor.> • General scan tool For detailed operation procedures, refer to the general scan tool operation manual.	Is the engine coolant temperature 75°C (167°F) or higher?	Go to step 5. Replace the engine coolant temperature sensor. <Ref. to FU(H4SO)-22, Engine Coolant Temperature Sensor.>

Diagnostic Procedure with Diagnostic Trouble Code (DTC)

ENGINE (DIAGNOSTICS)

Step	Check	Yes	No
<p>5</p> <p>CHECK MASS AIR FLOW AND INTAKE AIR TEMPERATURE SENSOR.</p> <ol style="list-style-type: none"> 1) Start the engine and warm up engine until coolant temperature is higher than 75°C (167°F). 2) For AT models, set the select lever to “P” range or “N” range, and for MT models, place the shift lever in the neutral position. 3) Turn the A/C switch to OFF. 4) Turn all the accessory switches to OFF. 5) Read the data of mass air flow and intake air temperature sensor signal using Subaru Select Monitor or general scan tool. <p>NOTE:</p> <ul style="list-style-type: none"> • Subaru Select Monitor <p>For detailed operation procedures, refer to “READ CURRENT DATA FOR ENGINE”. <Ref. to EN(H4SO)(diag)-33, Subaru Select Monitor.></p> <ul style="list-style-type: none"> • General scan tool <p>For detailed operation procedures, refer to the general scan tool operation manual.</p>	<p>Is the measured value 2.0 — 5.0 g/s (0.26 — 0.66 lb/m)?</p>	<p>Go to step 6.</p>	<p>Replace the mass air flow and intake air temperature sensor. <Ref. to FU(H4SO)-28, Mass Air Flow and Intake Air Temperature Sensor.></p>
<p>6</p> <p>CHECK MASS AIR FLOW AND INTAKE AIR TEMPERATURE SENSOR.</p> <ol style="list-style-type: none"> 1) Start the engine and warm up engine until coolant temperature is higher than 75°C (167°F). 2) For AT models, set the select lever to “P” range or “N” range, and for MT models, place the shift lever in the neutral position. 3) Turn the A/C switch to OFF. 4) Turn all the accessory switches to OFF. 5) Open the front hood. 6) Measure the ambient temperature. 7) Read the data of mass air flow and intake air temperature sensor signal using Subaru Select Monitor or general scan tool. <p>NOTE:</p> <ul style="list-style-type: none"> • Subaru Select Monitor <p>For detailed operation procedures, refer to “READ CURRENT DATA FOR ENGINE”. <Ref. to EN(H4SO)(diag)-33, Subaru Select Monitor.></p> <ul style="list-style-type: none"> • General scan tool <p>For detailed operation procedures, refer to the general scan tool operation manual.</p>	<p>Subtract ambient temperature from intake air temperature. Is the obtained value -10 — 50°C (-18 — 90°F)?</p>	<p>Repair the poor contact of the ECM connector.</p>	<p>Check the mass air flow and intake air temperature sensor. <Ref. to FU(H4SO)-28, Mass Air Flow and Intake Air Temperature Sensor.></p>

Diagnostic Procedure with Diagnostic Trouble Code (DTC)

ENGINE (DIAGNOSTICS)

AL:DTC P0181 FUEL TEMPERATURE SENSOR "A" CIRCUIT RANGE/ PERFORMANCE

DTC DETECTING CONDITION:

- Detected when two consecutive driving cycles with fault occur.
- GENERAL DESCRIPTION <Ref. to GD(H4SO)-67, DTC P0181 FUEL TEMPERATURE SENSOR "A" CIRCUIT RANGE/PERFORMANCE, Diagnostic Trouble Code (DTC) Detecting Criteria.>

CAUTION:

After repair or replacement of faulty parts, perform Clear Memory Mode <Ref. to EN(H4SO)(diag)-51, OPERATION, Clear Memory Mode.> and Inspection Mode <Ref. to EN(H4SO)(diag)-41, PROCEDURE, Inspection Mode.>.

WIRING DIAGRAM:

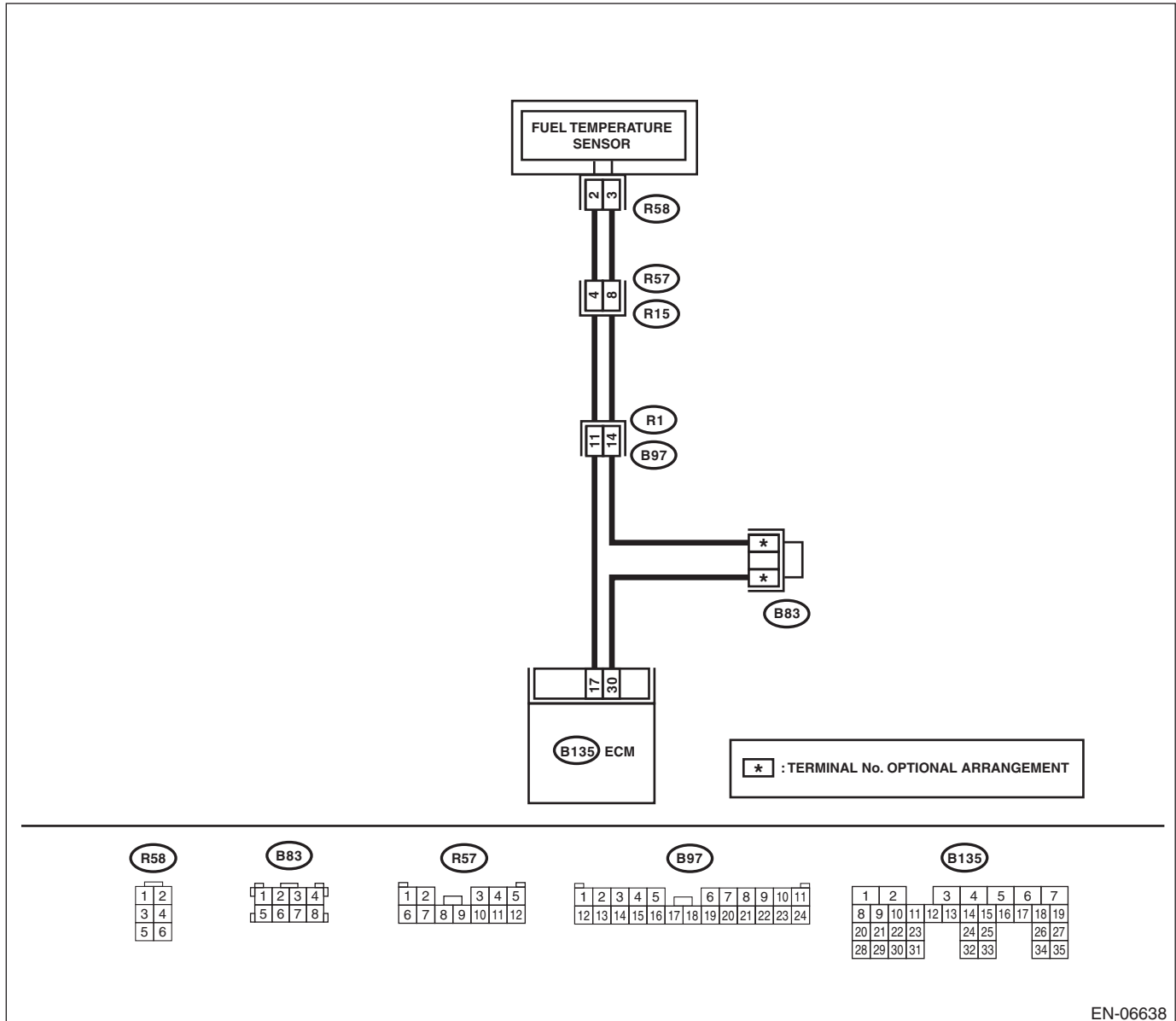

EN-06638

Diagnostic Procedure with Diagnostic Trouble Code (DTC)

ENGINE (DIAGNOSTICS)

	Step	Check	Yes	No
1	CHECK FOR ANY OTHER DTC ON DISPLAY.	Is any other DTC displayed?	Check the appropriate DTC using the "List of Diagnostic Trouble Code (DTC)". <Ref. to EN(H4SO)(diag)-82, List of Diagnostic Trouble Code (DTC).>	Replace the fuel temperature sensor. <Ref. to EC(H4SO)-12, Fuel Temperature Sensor.>

Diagnostic Procedure with Diagnostic Trouble Code (DTC)

ENGINE (DIAGNOSTICS)

	Step	Check	Yes	No
1	<p>CHECK CURRENT DATA.</p> <p>1) Start the engine.</p> <p>2) Read the data of fuel temperature sensor signal using Subaru Select Monitor.</p> <p>NOTE: For detailed operation procedures, refer to "READ CURRENT DATA FOR ENGINE". <Ref. to EN(H4SO)(diag)-33, Subaru Select Monitor.></p>	Is the temperature 120°C (248°F) or higher?	Go to step 2.	<p>Even if the malfunction indicator light illuminates, the circuit has returned to a normal condition at this time. Reproduce the fault condition, and reperform the check.</p> <p>NOTE: In this case, there may be a temporary connector contact failure.</p>
2	<p>CHECK HARNESS BETWEEN ECM AND FUEL TEMPERATURE SENSOR CONNECTOR.</p> <p>1) Turn the ignition switch to OFF.</p> <p>2) Disconnect the connectors from the ECM and fuel temperature sensor.</p> <p>3) Measure the resistance between ECM and chassis ground.</p> <p>Connector & terminal (B135) No. 17 — Chassis ground:</p>	Is the resistance 1 MΩ or more?	Replace the fuel temperature sensor. <Ref. to EC(H4SO)-12, Fuel Temperature Sensor.>	Repair the ground short circuit of harness between ECM and fuel pump connector.

Diagnostic Procedure with Diagnostic Trouble Code (DTC)

ENGINE (DIAGNOSTICS)

AN:DTC P0183 FUEL TEMPERATURE SENSOR "A" CIRCUIT HIGH INPUT

DTC DETECTING CONDITION:

- Immediately at fault recognition
- GENERAL DESCRIPTION <Ref. to GD(H4SO)-71, DTC P0183 FUEL TEMPERATURE SENSOR "A" CIRCUIT HIGH INPUT, Diagnostic Trouble Code (DTC) Detecting Criteria.>

CAUTION:

After repair or replacement of faulty parts, perform Clear Memory Mode <Ref. to EN(H4SO)(diag)-51, OPERATION, Clear Memory Mode.> and Inspection Mode <Ref. to EN(H4SO)(diag)-41, PROCEDURE, Inspection Mode.>.

WIRING DIAGRAM:

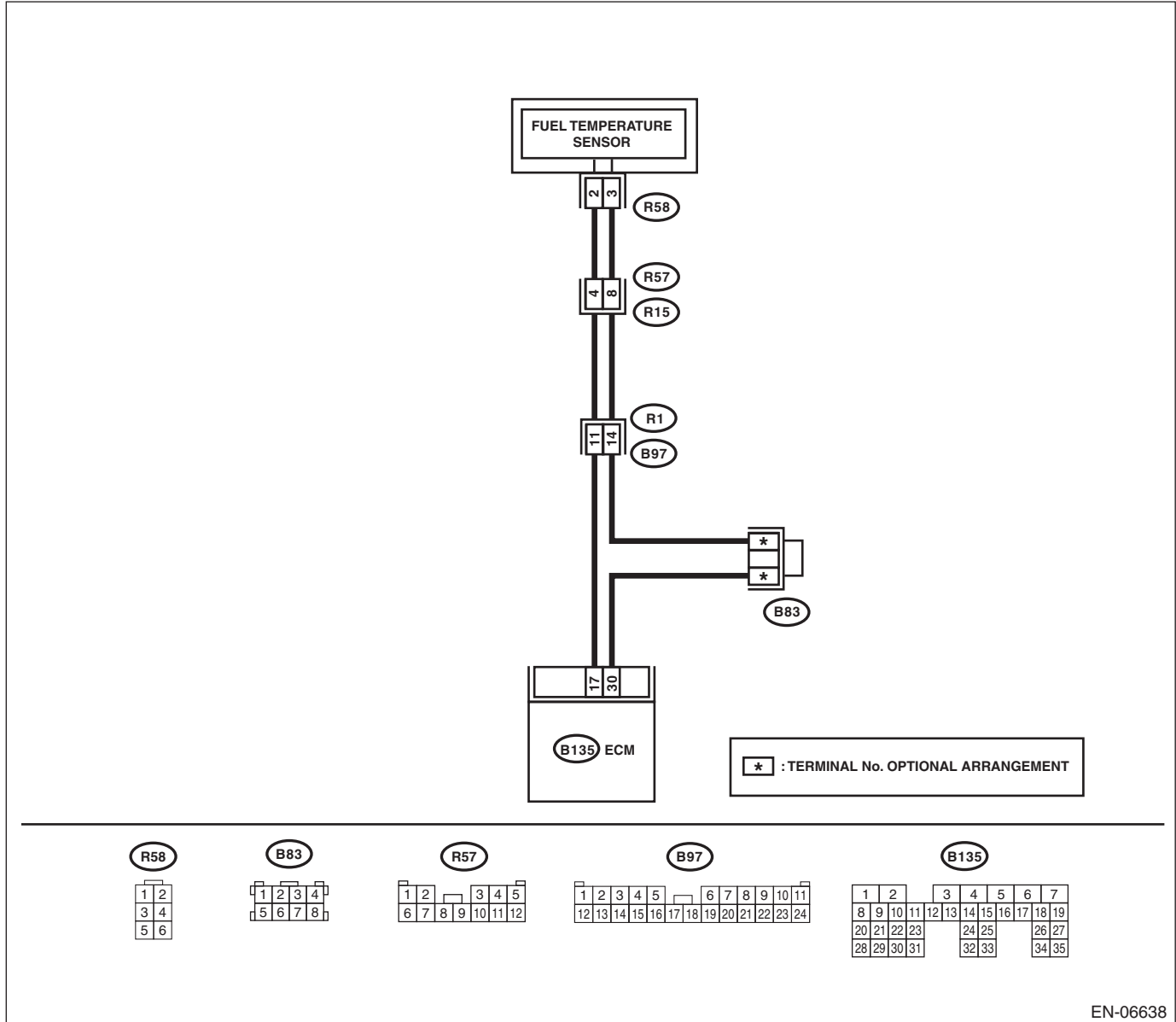

Diagnostic Procedure with Diagnostic Trouble Code (DTC)

ENGINE (DIAGNOSTICS)

	Step	Check	Yes	No
1	<p>CHECK CURRENT DATA.</p> <p>1) Start the engine.</p> <p>2) Read the data of fuel temperature sensor signal using Subaru Select Monitor.</p> <p>NOTE: For detailed operation procedures, refer to "READ CURRENT DATA FOR ENGINE". <Ref. to EN(H4SO)(diag)-33, Subaru Select Monitor.></p>	Is the temperature less than -40°C (-40°F)?	Go to step 2.	<p>Even if the malfunction indicator light illuminates, the circuit has returned to a normal condition at this time. Reproduce the fault condition, and reperform the check.</p> <p>NOTE: In this case, there may be a temporary connector contact failure.</p>
2	<p>CHECK POOR CONTACT.</p> <p>Repair any poor contact between the ECM and fuel temperature sensor connectors.</p>	Is there poor contact in the ECM or fuel temperature sensor connectors?	Repair any poor contact between the ECM and fuel temperature sensor connectors.	Go to step 3.
3	<p>CHECK HARNESS BETWEEN ECM AND FUEL TEMPERATURE SENSOR CONNECTOR.</p> <p>1) Turn the ignition switch to OFF.</p> <p>2) Disconnect the connectors from the ECM and fuel temperature sensor.</p> <p>3) Measure the resistance of the harness between the ECM and fuel temperature sensor connector.</p> <p>Connector & terminal (B135) No. 17 — (R58) No. 2: (B135) No. 30 — (R58) No. 3:</p>	Is the resistance less than $1\ \Omega$?	Go to step 4.	<p>Repair the harness and connector.</p> <p>NOTE: In this case, repair the following item:</p> <ul style="list-style-type: none"> • Open circuit in harness between ECM and fuel temperature sensor connector • Poor contact of coupling connector • Poor contact of joint connector
4	<p>CHECK HARNESS BETWEEN ECM AND FUEL TEMPERATURE SENSOR CONNECTOR.</p> <p>1) Connect all connectors.</p> <p>2) Turn the ignition switch to ON.</p> <p>3) Measure the voltage between ECM and chassis ground.</p> <p>Connector & terminal (B135) No. 17 (+) — Chassis ground (-):</p>	Is the voltage 5 V or more?	Repair the short circuit to power in the harness between the ECM and fuel temperature sensor connector.	Replace the fuel temperature sensor. <Ref. to EC(H4SO)-12, Fuel Temperature Sensor.>

Diagnostic Procedure with Diagnostic Trouble Code (DTC)

ENGINE (DIAGNOSTICS)

AO:DTC P0196 ENGINE OIL TEMPERATURE SENSOR CIRCUIT RANGE/ PERFORMANCE

DTC DETECTING CONDITION:

- Detected when two consecutive driving cycles with fault occur.
- GENERAL DESCRIPTION <Ref. to GD(H4SO)-72, DTC P0196 ENGINE OIL TEMPERATURE SENSOR CIRCUIT RANGE/PERFORMANCE, Diagnostic Trouble Code (DTC) Detecting Criteria.>

TROUBLE SYMPTOM:

- Hard to start
- Improper idling
- Poor driving performance

CAUTION:

After repair or replacement of faulty parts, perform Clear Memory Mode <Ref. to EN(H4SO)(diag)-51, OPERATION, Clear Memory Mode.> and Inspection Mode <Ref. to EN(H4SO)(diag)-41, PROCEDURE, Inspection Mode.>.

WIRING DIAGRAM:

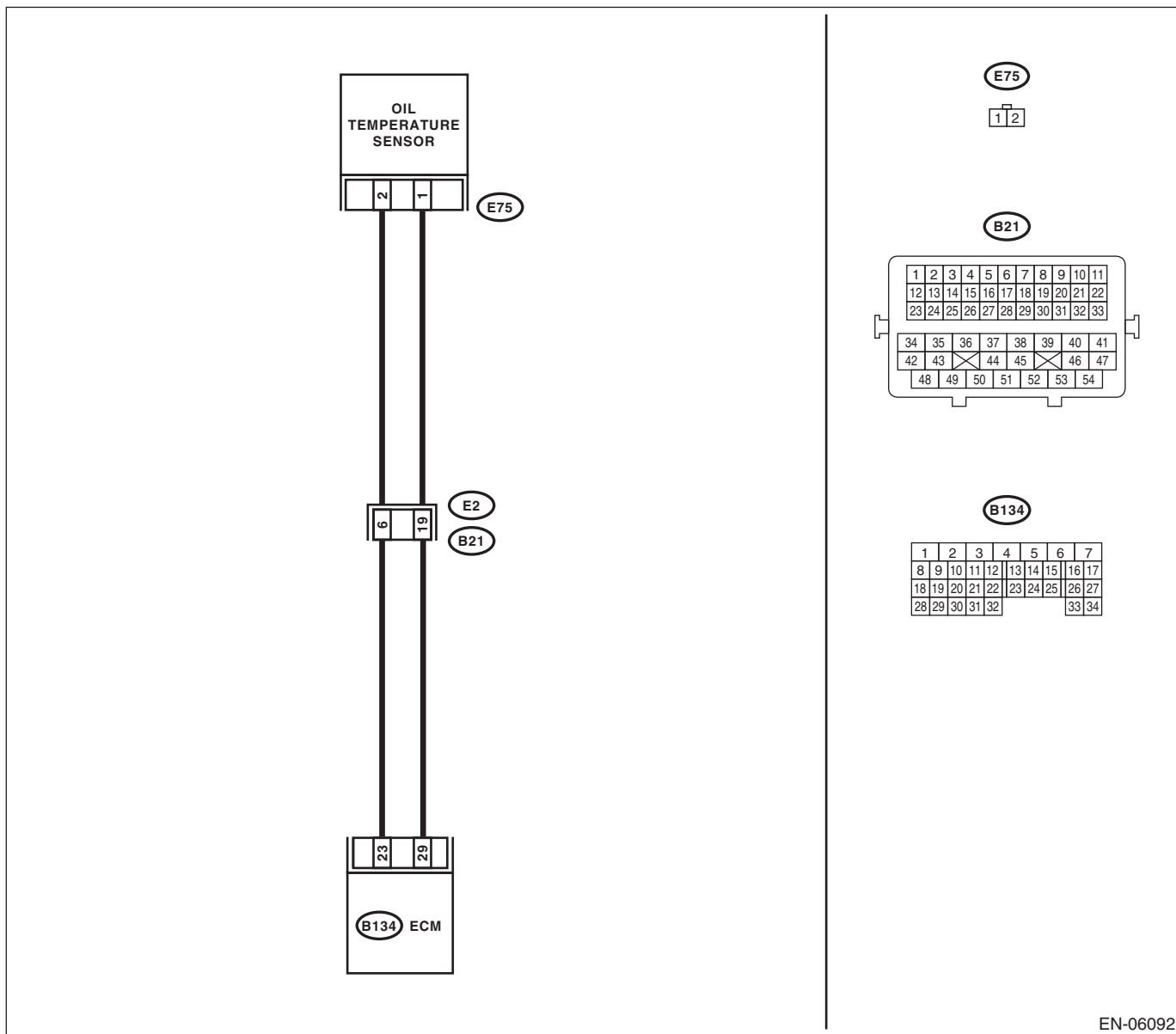

EN-06092

Diagnostic Procedure with Diagnostic Trouble Code (DTC)

ENGINE (DIAGNOSTICS)

	Step	Check	Yes	No
1	CHECK FOR ANY OTHER DTC ON DISPLAY.	Is any other DTC displayed?	Check the appropriate DTC using the "List of Diagnostic Trouble Code (DTC)". <Ref. to EN(H4SO)(diag)-82, List of Diagnostic Trouble Code (DTC).>	Replace the oil temperature sensor. <Ref. to FU(H4SO)-34, Oil Temperature Sensor.>

Diagnostic Procedure with Diagnostic Trouble Code (DTC)

ENGINE (DIAGNOSTICS)

	Step	Check	Yes	No
1	<p>CHECK CURRENT DATA.</p> <p>1) Start the engine.</p> <p>2) Read the data of the oil temperature sensor signal using the Subaru Select Monitor or general scan tool.</p> <p>NOTE:</p> <ul style="list-style-type: none"> Subaru Select Monitor <p>For detailed operation procedures, refer to "READ CURRENT DATA FOR ENGINE". <Ref. to EN(H4SO)(diag)-33, Subaru Select Monitor.></p> <ul style="list-style-type: none"> General scan tool <p>For detailed operation procedures, refer to the general scan tool operation manual.</p>	<p>Is the oil temperature 215°C (419°F) or more?</p>	<p>Go to step 2.</p>	<p>Even if the malfunction indicator light illuminates, the circuit has returned to a normal condition at this time. Reproduce the fault condition, and reperform the check.</p> <p>NOTE:</p> <p>In this case, there may be a temporary connector contact failure.</p>
2	<p>CHECK HARNESS BETWEEN ECM AND OIL TEMPERATURE SENSOR CONNECTOR.</p> <p>1) Turn the ignition switch to OFF.</p> <p>2) Disconnect the connector from the ECM and oil temperature sensor.</p> <p>3) Measure the resistance between ECM and chassis ground.</p> <p>Connector & terminal (B134) No. 23 — Chassis ground:</p>	<p>Is the resistance 1 MΩ or more?</p>	<p>Replace the oil temperature sensor. <Ref. to FU(H4SO)-34, Oil Temperature Sensor.></p>	<p>Repair the short circuit to ground in harness between ECM and oil temperature sensor connector.</p>

Diagnostic Procedure with Diagnostic Trouble Code (DTC)

ENGINE (DIAGNOSTICS)

AQ:DTC P0198 ENGINE OIL TEMPERATURE SENSOR HIGH

DTC DETECTING CONDITION:

- Immediately at fault recognition
- GENERAL DESCRIPTION <Ref. to GD(H4SO)-75, DTC P0198 ENGINE OIL TEMPERATURE SENSOR HIGH, Diagnostic Trouble Code (DTC) Detecting Criteria.>

TROUBLE SYMPTOM:

- Hard to start
- Improper idling
- Poor driving performance

CAUTION:

After repair or replacement of faulty parts, perform Clear Memory Mode <Ref. to EN(H4SO)(diag)-51, OPERATION, Clear Memory Mode.> and Inspection Mode <Ref. to EN(H4SO)(diag)-41, PROCEDURE, Inspection Mode.>.

WIRING DIAGRAM:

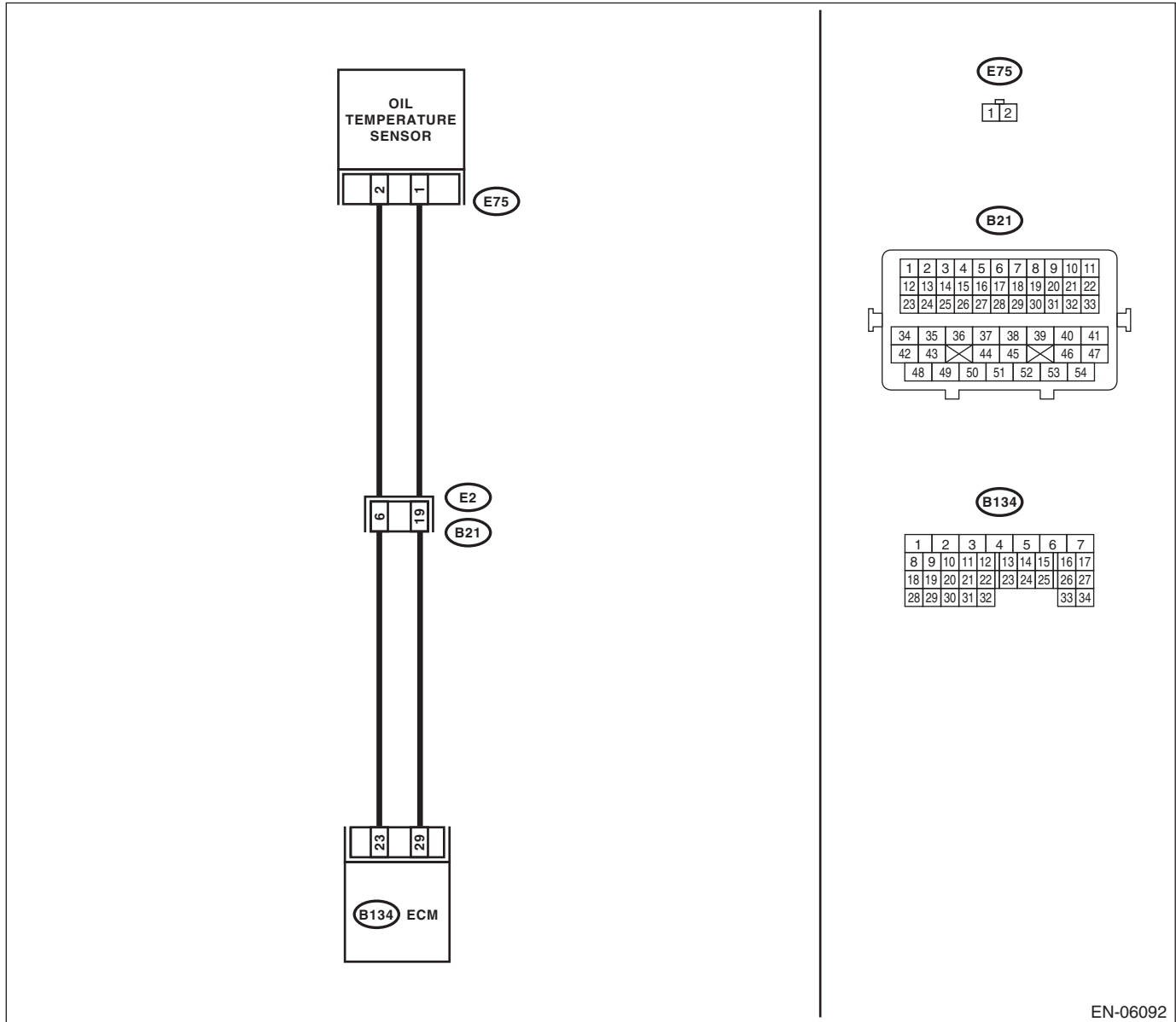

EN-06092

Diagnostic Procedure with Diagnostic Trouble Code (DTC)

ENGINE (DIAGNOSTICS)

	Step	Check	Yes	No
1	<p>CHECK CURRENT DATA.</p> <p>1) Start the engine.</p> <p>2) Read the data of the oil temperature sensor signal using the Subaru Select Monitor or general scan tool.</p> <p>NOTE:</p> <ul style="list-style-type: none"> Subaru Select Monitor <p>For detailed operation procedures, refer to "READ CURRENT DATA FOR ENGINE". <Ref. to EN(H4SO)(diag)-33, Subaru Select Monitor.></p> <ul style="list-style-type: none"> General scan tool <p>For detailed operation procedures, refer to the general scan tool operation manual.</p>	Is the oil temperature less than -40°C (-40°F)?	Go to step 2.	<p>Even if the malfunction indicator light illuminates, the circuit has returned to a normal condition at this time. Reproduce the fault condition, and reperform the check.</p> <p>NOTE:</p> <p>In this case, there may be a temporary connector contact failure.</p>
2	<p>CHECK POOR CONTACT.</p> <p>Check for poor contact of the ECM and oil temperature sensor connector.</p>	Is there poor contact in the ECM or oil temperature sensor connector?	Repair the poor contact in the ECM or the oil temperature sensor connector.	Go to step 3.
3	<p>CHECK HARNESS BETWEEN ECM AND OIL TEMPERATURE SENSOR CONNECTOR.</p> <p>1) Turn the ignition switch to OFF.</p> <p>2) Disconnect the connector from the ECM and oil temperature sensor.</p> <p>3) Measure the resistance of the harness between the ECM and oil temperature sensor connector.</p> <p>Connector & terminal (B134) No. 23 — (E75) No. 2: (B134) No. 29 — (E75) No. 1:</p>	Is the resistance less than 1 Ω?	Go to step 4.	<p>Repair the harness and connector.</p> <p>NOTE:</p> <p>In this case, repair the following item:</p> <ul style="list-style-type: none"> Open circuit in harness between ECM and oil temperature sensor connector Poor contact of coupling connector
4	<p>CHECK HARNESS BETWEEN ECM AND OIL TEMPERATURE SENSOR CONNECTOR.</p> <p>1) Connect all connectors.</p> <p>2) Turn the ignition switch to ON.</p> <p>3) Measure the voltage between ECM and chassis ground.</p> <p>Connector & terminal (B134) No. 23 (+) — Chassis ground (-):</p>	Is the voltage 5 V or more?	Repair the short circuit to power supply in the harness between the ECM and oil temperature sensor connector.	Replace the oil temperature sensor. <Ref. to FU(H4SO)-34, Oil Temperature Sensor.>

Diagnostic Procedure with Diagnostic Trouble Code (DTC)

ENGINE (DIAGNOSTICS)

AR:DTC P0222 THROTTLE/PEDAL POSITION SENSOR/SWITCH "B" CIRCUIT LOW

DTC DETECTING CONDITION:

- Immediately at fault recognition
- GENERAL DESCRIPTION <Ref. to GD(H4SO)-76, DTC P0222 THROTTLE/PEDAL POSITION SENSOR/SWITCH "B" CIRCUIT LOW, Diagnostic Trouble Code (DTC) Detecting Criteria.>

TROUBLE SYMPTOM:

- Improper idling
- Poor driving performance
- Engine stalls.

CAUTION:

After repair or replacement of faulty parts, perform Clear Memory Mode <Ref. to EN(H4SO)(diag)-51, OPERATION, Clear Memory Mode.> and Inspection Mode <Ref. to EN(H4SO)(diag)-41, PROCEDURE, Inspection Mode.>.

WIRING DIAGRAM:

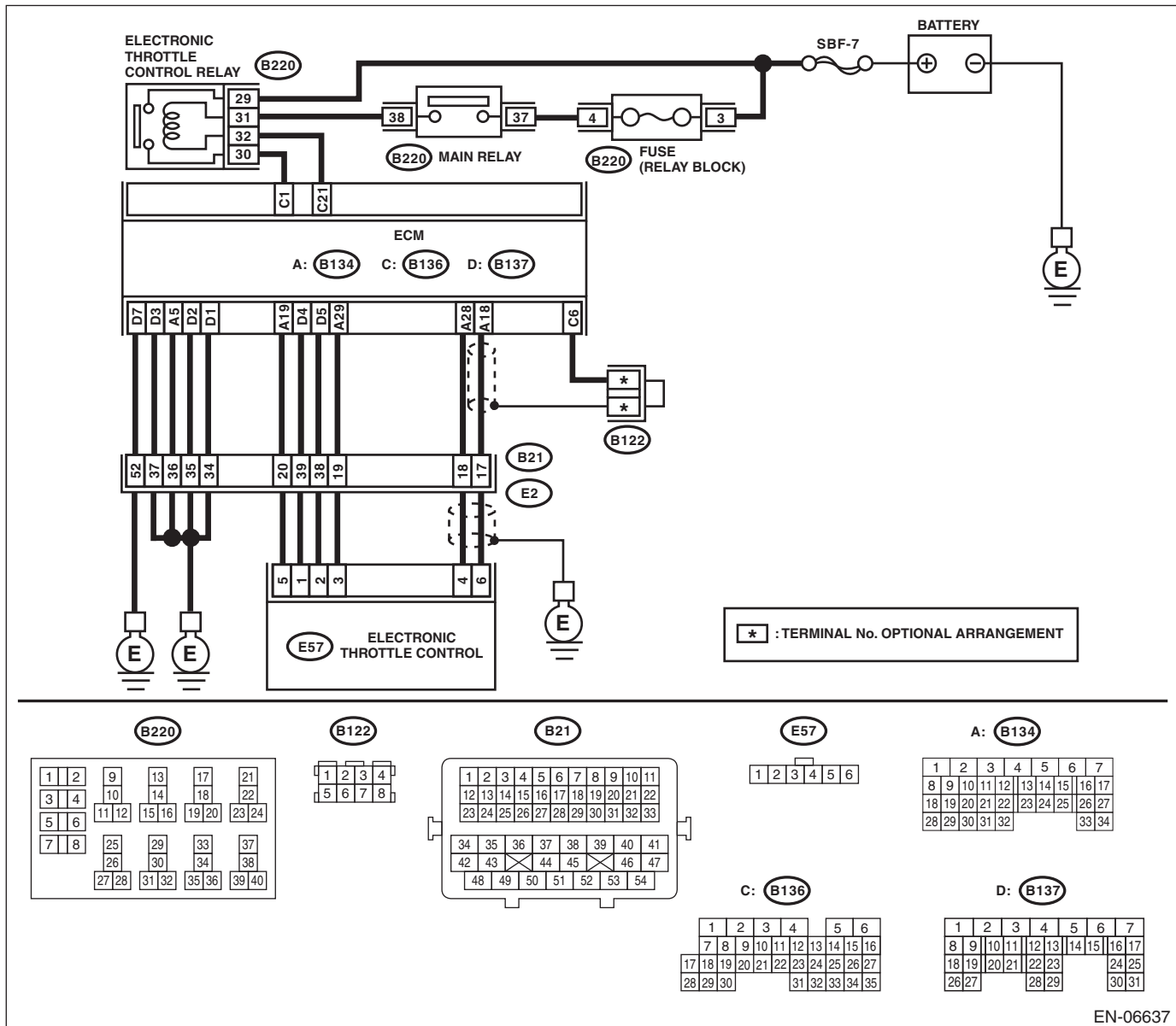

EN-06637

Diagnostic Procedure with Diagnostic Trouble Code (DTC)

ENGINE (DIAGNOSTICS)

Step	Check	Yes	No
<p>1</p> <p>CHECK HARNESS BETWEEN ECM AND ELECTRONIC THROTTLE CONTROL.</p> <p>1) Turn the ignition switch to OFF. 2) Disconnect the connectors from ECM and electronic throttle control. 3) Measure the resistance between ECM and chassis ground.</p> <p>Connector & terminal (B134) No. 19 — Chassis ground: (B134) No. 28 — Chassis ground:</p>	<p>Is the resistance 1 MΩ or more?</p>	<p>Go to step 2.</p>	<p>Repair the ground short circuit of harness between ECM and electronic throttle control connector.</p>
<p>2</p> <p>CHECK SHORT CIRCUIT INSIDE THE ECM.</p> <p>1) Connect the connector to ECM. 2) Measure the resistance between electronic throttle control connector and engine ground.</p> <p>Connector & terminal (E57) No. 4 — Engine ground:</p>	<p>Is the resistance 1 MΩ or more?</p>	<p>Replace the electronic throttle control. <Ref. to FU(H4SO)-13, Throttle Body.></p>	<p>Repair the ground short circuit of harness between ECM and electronic throttle control connector. Replace the ECM if defective. <Ref. to FU(H4SO)-39, Engine Control Module (ECM).></p>

Diagnostic Procedure with Diagnostic Trouble Code (DTC)

ENGINE (DIAGNOSTICS)

Step	Check	Yes	No
1 CHECK HARNESS BETWEEN ECM AND ELECTRONIC THROTTLE CONTROL. 1) Turn the ignition switch to OFF. 2) Disconnect the connectors from ECM and electronic throttle control. 3) Measure the resistance of harness between ECM and electronic throttle control connector. Connector & terminal (B134) No. 28 — (E57) No. 4: (B134) No. 29 — (E57) No. 3:	Is the resistance less than 1 Ω?	Go to step 2.	Repair the harness and connector. NOTE: In this case, repair the following item: • Open circuit in harness between ECM and electronic throttle control connector • Poor contact of coupling connector
2 CHECK HARNESS BETWEEN ECM AND ELECTRONIC THROTTLE CONTROL. 1) Connect the connector to ECM. 2) Measure the resistance between electronic throttle control connector and engine ground. Connector & terminal (E57) No. 3 — Engine ground:	Is the resistance less than 5 Ω?	Go to step 3.	Repair the harness and connector. NOTE: In this case, repair the following item: • Open circuit of harness between ECM and engine ground • Poor contact in ECM connector • Poor contact of coupling connector
3 CHECK HARNESS BETWEEN ECM AND ELECTRONIC THROTTLE CONTROL. 1) Turn the ignition switch to ON. 2) Measure the voltage between electronic throttle control connector and engine ground. Connector & terminal (E57) No. 4 (+) — Engine ground (-):	Is the voltage 4.85 V or more?	Repair the short circuit to power in the harness between ECM and electronic throttle control connector.	Go to step 4.
4 CHECK HARNESS BETWEEN ECM AND ELECTRONIC THROTTLE CONTROL. 1) Turn the ignition switch to OFF. 2) Disconnect the connectors from the ECM. 3) Measure the resistance between ECM connectors. Connector & terminal (B134) No. 19 — (B134) No. 28:	Is the resistance 1 MΩ or more?	Repair poor contact of the electronic throttle control connector. Replace the electronic throttle control if defective. <Ref. to FU(H4SO)-13, Throttle Body.>	Repair the short circuit to power in the harness between ECM and electronic throttle control connector.

AT:DTC P0301 CYLINDER 1 MISFIRE DETECTED

NOTE:

For the diagnostic procedure, refer to DTC P0304. <Ref. to EN(H4SO)(diag)-176, DTC P0304 CYLINDER 4 MISFIRE DETECTED, Diagnostic Procedure with Diagnostic Trouble Code (DTC).>

AU:DTC P0302 CYLINDER 2 MISFIRE DETECTED

NOTE:

For the diagnostic procedure, refer to DTC P0304. <Ref. to EN(H4SO)(diag)-176, DTC P0304 CYLINDER 4 MISFIRE DETECTED, Diagnostic Procedure with Diagnostic Trouble Code (DTC).>

AV:DTC P0303 CYLINDER 3 MISFIRE DETECTED

NOTE:

For the diagnostic procedure, refer to DTC P0304. <Ref. to EN(H4SO)(diag)-176, DTC P0304 CYLINDER 4 MISFIRE DETECTED, Diagnostic Procedure with Diagnostic Trouble Code (DTC).>

Diagnostic Procedure with Diagnostic Trouble Code (DTC)

ENGINE (DIAGNOSTICS)

AW:DTC P0304 CYLINDER 4 MISFIRE DETECTED

DTC DETECTING CONDITION:

- Detected when two consecutive driving cycles with fault occur.
- Immediately at fault recognition (A misfire which could damage catalyst occurs.)
- GENERAL DESCRIPTION <Ref. to GD(H4SO)-83, DTC P0304 CYLINDER 4 MISFIRE DETECTED, Diagnostic Trouble Code (DTC) Detecting Criteria.>

TROUBLE SYMPTOM:

- Engine stalls.
- Improper idling
- Rough driving

CAUTION:

After repair or replacement of faulty parts, perform Clear Memory Mode <Ref. to EN(H4SO)(diag)-51, OPERATION, Clear Memory Mode.> and Inspection Mode <Ref. to EN(H4SO)(diag)-41, PROCEDURE, Inspection Mode.>.

WIRING DIAGRAM:

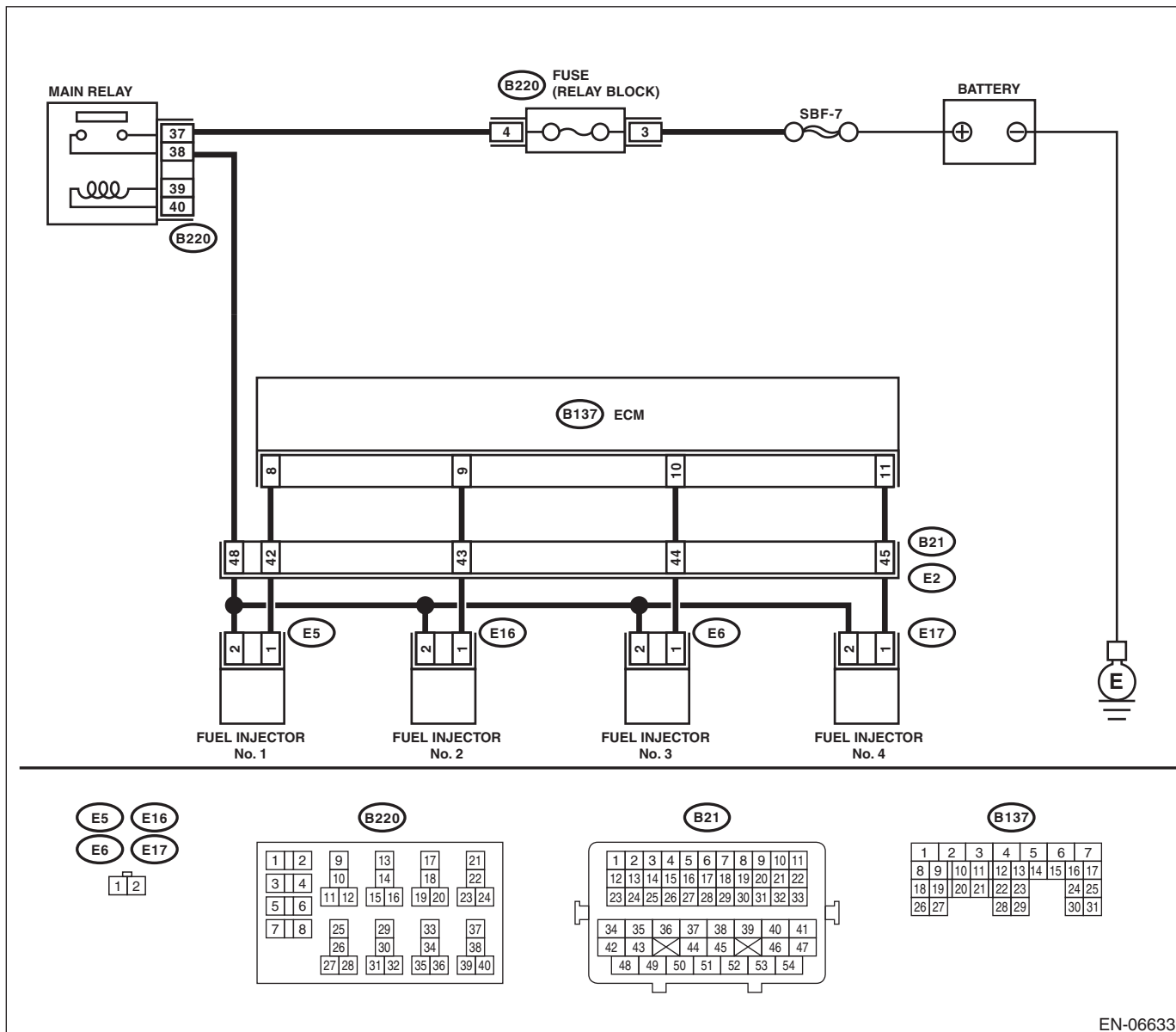

EN-06633

Diagnostic Procedure with Diagnostic Trouble Code (DTC)

ENGINE (DIAGNOSTICS)

Step	Check	Yes	No
1 CHECK OUTPUT SIGNAL OF ECM. 1) Turn the ignition switch to ON. 2) Measure the voltage between the ECM and chassis ground for faulty cylinders. Connector & terminal #1 (B137) No. 8 (+) — Chassis ground (-): #2 (B137) No. 9 (+) — Chassis ground (-): #3 (B137) No. 10 (+) — Chassis ground (-): #4 (B137) No. 11 (+) — Chassis ground (-):	Is the voltage 10 V or more?	Go to step 6.	Go to step 2.
2 CHECK HARNESS BETWEEN ECM AND FUEL INJECTOR. 1) Turn the ignition switch to OFF. 2) Disconnect the connector from fuel injector on faulty cylinders. 3) Measure the resistance between the fuel injector connector and engine ground on faulty cylinders. Connector & terminal #1 (E5) No. 1 — Engine ground: #2 (E16) No. 1 — Engine ground: #3 (E6) No. 1 — Engine ground: #4 (E17) No. 1 — Engine ground:	Is the resistance 1 MΩ or more?	Go to step 3.	Repair the short circuit to ground in harness between ECM and fuel injector connector.
3 CHECK HARNESS BETWEEN ECM AND FUEL INJECTOR. Measure the resistance of harness between the ECM and fuel injector on faulty cylinders. Connector & terminal #1 (B137) No. 8 — (E5) No. 1: #2 (B137) No. 9 — (E16) No. 1: #3 (B137) No. 10 — (E6) No. 1: #4 (B137) No. 11 — (E17) No. 1:	Is the resistance less than 1 Ω?	Go to step 4.	Repair the harness and connector. NOTE: In this case, repair the following item: • Open circuit of harness between ECM and fuel injector connector • Poor contact of coupling connector
4 CHECK FUEL INJECTOR. Measure the resistance between fuel injector terminals on faulty cylinder. Terminals No. 1 — No. 2:	Is the resistance between 5 — 20 Ω?	Go to step 5.	Replace the faulty fuel injector. <Ref. to FU(H4SO)-30, Fuel Injector.>
5 CHECK POWER SUPPLY LINE. 1) Turn the ignition switch to ON. 2) Measure the voltage between fuel injector and engine ground on faulty cylinders. Connector & terminal #1 (E5) No. 2 (+) — Engine ground (-): #2 (E16) No. 2 (+) — Engine ground (-): #3 (E6) No. 2 (+) — Engine ground (-): #4 (E17) No. 2 (+) — Engine ground (-):	Is the voltage 10 V or more?	Repair the poor contact of all connectors in fuel injector circuit.	Repair the harness and connector. NOTE: In this case, repair the following item: • Open circuit in harness between the main relay connector and fuel injector connector on faulty cylinders • Poor contact of coupling connector • Poor contact of main relay connector

Diagnostic Procedure with Diagnostic Trouble Code (DTC)

ENGINE (DIAGNOSTICS)

Step	Check	Yes	No
6 CHECK HARNESS BETWEEN ECM AND FUEL INJECTOR. 1) Turn the ignition switch to OFF. 2) Disconnect the connector from fuel injector on faulty cylinders. 3) Turn the ignition switch to ON. 4) Measure the voltage between the ECM and chassis ground for faulty cylinders. Connector & terminal #1 (B137) No. 8 (+) — Chassis ground (-): #2 (B137) No. 9 (+) — Chassis ground (-): #3 (B137) No. 10 (+) — Chassis ground (-): #4 (B137) No. 11 (+) — Chassis ground (-):	Is the voltage 10 V or more?	Repair the short circuit to power in harness between ECM and fuel injector connector.	Go to step 7.
7 CHECK FUEL INJECTOR. 1) Turn the ignition switch to OFF. 2) Measure the resistance between fuel injector terminals on faulty cylinder. Terminals No. 1 — No. 2:	Is the resistance less than 1 Ω ?	Replace the faulty fuel injector. <Ref. to FU(H4SO)-30, Fuel Injector.>	Go to step 8.
8 CHECK INSTALLATION CONDITION OF CAMSHAFT POSITION SENSOR/CRANKSHAFT POSITION SENSOR.	Is the camshaft position sensor or crankshaft position sensor loosely installed?	Tighten the camshaft position sensor or crankshaft position sensor.	Go to step 9.
9 CHECK CRANK SPROCKET. Remove the timing belt cover. <Ref. to ME(H4SO)-52, REMOVAL, Timing Belt Cover.>	Is the crank sprocket rusted or does it have damaged teeth?	Replace the crank sprocket. <Ref. to ME(H4SO)-61, Crank Sprocket.>	Go to step 10.
10 CHECK INSTALLATION CONDITION OF TIMING BELT. Turn the crankshaft using ST, and align alignment mark on crank sprocket with alignment mark on cylinder block. ST 499987500 CRANKSHAFT SOCKET	Is the timing belt dislocated from its proper position?	Repair the installation condition of timing belt. <Ref. to ME(H4SO)-53, Timing Belt.>	Go to step 11.
11 CHECK FUEL LEVEL.	Is the fuel meter indication higher than the "Lower" level?	Go to step 12.	Replenish fuel so that fuel meter indication is higher than the "Lower" level. After replenishing fuel, Go to step 12.
12 CHECK STATUS OF MALFUNCTION INDICATOR LIGHT. 1) Clear the memory using the Subaru Select Monitor or general scan tool. <Ref. to EN(H4SO)(diag)-51, Clear Memory Mode.> 2) Start the engine, and drive the vehicle 10 minutes or more.	Does the malfunction indicator light illuminate or blink?	Go to step 14.	Go to step 13.

Diagnostic Procedure with Diagnostic Trouble Code (DTC)

ENGINE (DIAGNOSTICS)

Step	Check	Yes	No
13	CHECK CAUSE OF MISFIRE.	Has the cause of misfire been detected with the engine running?	Finish diagnostics operation, if the engine has no abnormality.
			Repair the poor contact of connector. NOTE: In this case, repair the following item: <ul style="list-style-type: none"> • Poor contact of ignition coil connector • Poor contact of fuel injector connector on faulty cylinders • Poor contact in ECM connector • Poor contact of coupling connector
14	CHECK AIR INTAKE SYSTEM.	Is there any fault in air intake system?	Repair the air intake system. NOTE: Check the following items. <ul style="list-style-type: none"> • Are there air leaks or air suction caused by loose or dislocated nuts and bolts? • Are there cracks or any disconnection of hoses?
15	CHECK MISFIRE SYMPTOM. 1) Turn the ignition switch to ON. 2) Read DTC. NOTE: <ul style="list-style-type: none"> • Subaru Select Monitor For detailed operation procedures, refer to "READ CURRENT DATA FOR ENGINE". <Ref. to EN(H4SO)(diag)-33, Subaru Select Monitor.> <ul style="list-style-type: none"> • General scan tool For detailed operation procedures, refer to the general scan tool operation manual.	Does the Subaru Select Monitor or general scan tool indicate only one DTC?	Go to step 20.
			Go to step 16.
16	CHECK DTC.	Are DTCs P0301 and P0302 displayed on the Subaru Select Monitor or general scan tool?	Go to step 21.
			Go to step 17.
17	CHECK DTC.	Are DTCs P0303 and P0304 displayed on the Subaru Select Monitor or general scan tool?	Go to step 22.
			Go to step 18.
18	CHECK DTC.	Are DTCs P0301 and P0303 displayed on the Subaru Select Monitor or general scan tool?	Go to step 23.
			Go to step 19.
19	CHECK DTC.	Are DTCs P0302 and P0304 displayed on the Subaru Select Monitor or general scan tool?	Go to step 24.
			Go to step 25.

Diagnostic Procedure with Diagnostic Trouble Code (DTC)

ENGINE (DIAGNOSTICS)

Step	Check	Yes	No
20 ONLY ONE CYLINDER.	Is there any fault in the cylinder?	Repair or replace faulty parts. NOTE: Check the following items. <ul style="list-style-type: none"> • Spark plug • Spark plug cord • Fuel injector • Compression ratio 	Go to DTC P0171. <Ref. to EN(H4SO)(diag)-157, DTC P0171 SYSTEM TOO LEAN (BANK 1), Diagnostic Procedure with Diagnostic Trouble Code (DTC).>
21 GROUP OF #1 AND #2 CYLINDERS.	Are there any faults in #1 and #2 cylinders?	Repair or replace faulty parts. NOTE: • Check the following items. <ul style="list-style-type: none"> • Spark plug • Fuel injector • Ignition coil • Compression ratio • If any fault are not found, check the "IGNITION CONTROL SYSTEM" of #1 and #2 cylinders side. <Ref. to EN(H4SO)(diag)-73, IGNITION CONTROL SYSTEM, Diagnostics for Engine Starting Failure.>	Go to DTC P0171. <Ref. to EN(H4SO)(diag)-157, DTC P0171 SYSTEM TOO LEAN (BANK 1), Diagnostic Procedure with Diagnostic Trouble Code (DTC).>
22 GROUP OF #3 AND #4 CYLINDERS.	Are there any faults in #3 and #4 cylinders?	Repair or replace faulty parts. NOTE: • Check the following items. <ul style="list-style-type: none"> • Spark plug • Fuel injector • Ignition coil • Compression ratio • If any fault are not found, check the "IGNITION CONTROL SYSTEM" of #3 and #4 cylinders side. <Ref. to EN(H4SO)(diag)-73, IGNITION CONTROL SYSTEM, Diagnostics for Engine Starting Failure.>	Go to DTC P0171. <Ref. to EN(H4SO)(diag)-157, DTC P0171 SYSTEM TOO LEAN (BANK 1), Diagnostic Procedure with Diagnostic Trouble Code (DTC).>

Diagnostic Procedure with Diagnostic Trouble Code (DTC)

ENGINE (DIAGNOSTICS)

Step	Check	Yes	No
23 GROUP OF #1 AND #3 CYLINDERS.	Are there any faults in #1 and #3 cylinders?	Repair or replace faulty parts. NOTE: Check the following items. <ul style="list-style-type: none"> • Spark plug • Fuel injector • Compression ratio • Skipping timing belt teeth 	Go to DTC P0171. <Ref. to EN(H4SO)(diag)-157, DTC P0171 SYSTEM TOO LEAN (BANK 1), Diagnostic Procedure with Diagnostic Trouble Code (DTC).>
24 GROUP OF #2 AND #4 CYLINDERS.	Are there any faults in #2 and #4 cylinders?	Repair or replace faulty parts. NOTE: Check the following items. <ul style="list-style-type: none"> • Spark plug • Fuel injector • Compression ratio • Skipping timing belt teeth 	Go to DTC P0171. <Ref. to EN(H4SO)(diag)-157, DTC P0171 SYSTEM TOO LEAN (BANK 1), Diagnostic Procedure with Diagnostic Trouble Code (DTC).>
25 CYLINDER AT RANDOM.	Is the engine idle rough?	Go to DTC P0171. <Ref. to EN(H4SO)(diag)-157, DTC P0171 SYSTEM TOO LEAN (BANK 1), Diagnostic Procedure with Diagnostic Trouble Code (DTC).>	Repair or replace faulty parts. NOTE: Check the following items. <ul style="list-style-type: none"> • Spark plug • Fuel injector • Compression ratio

Diagnostic Procedure with Diagnostic Trouble Code (DTC)

ENGINE (DIAGNOSTICS)

AX:DTC P0327 KNOCK SENSOR 1 CIRCUIT LOW (BANK 1 OR SINGLE SENSOR)

DTC DETECTING CONDITION:

- Immediately at fault recognition
- GENERAL DESCRIPTION <Ref. to GD(H4SO)-84, DTC P0327 KNOCK SENSOR 1 CIRCUIT LOW (BANK 1 OR SINGLE SENSOR), Diagnostic Trouble Code (DTC) Detecting Criteria.>

TROUBLE SYMPTOM:

- Poor driving performance
- Knocking occurs.

CAUTION:

After repair or replacement of faulty parts, perform Clear Memory Mode <Ref. to EN(H4SO)(diag)-51, OPERATION, Clear Memory Mode.> and Inspection Mode <Ref. to EN(H4SO)(diag)-41, PROCEDURE, Inspection Mode.>.

WIRING DIAGRAM:

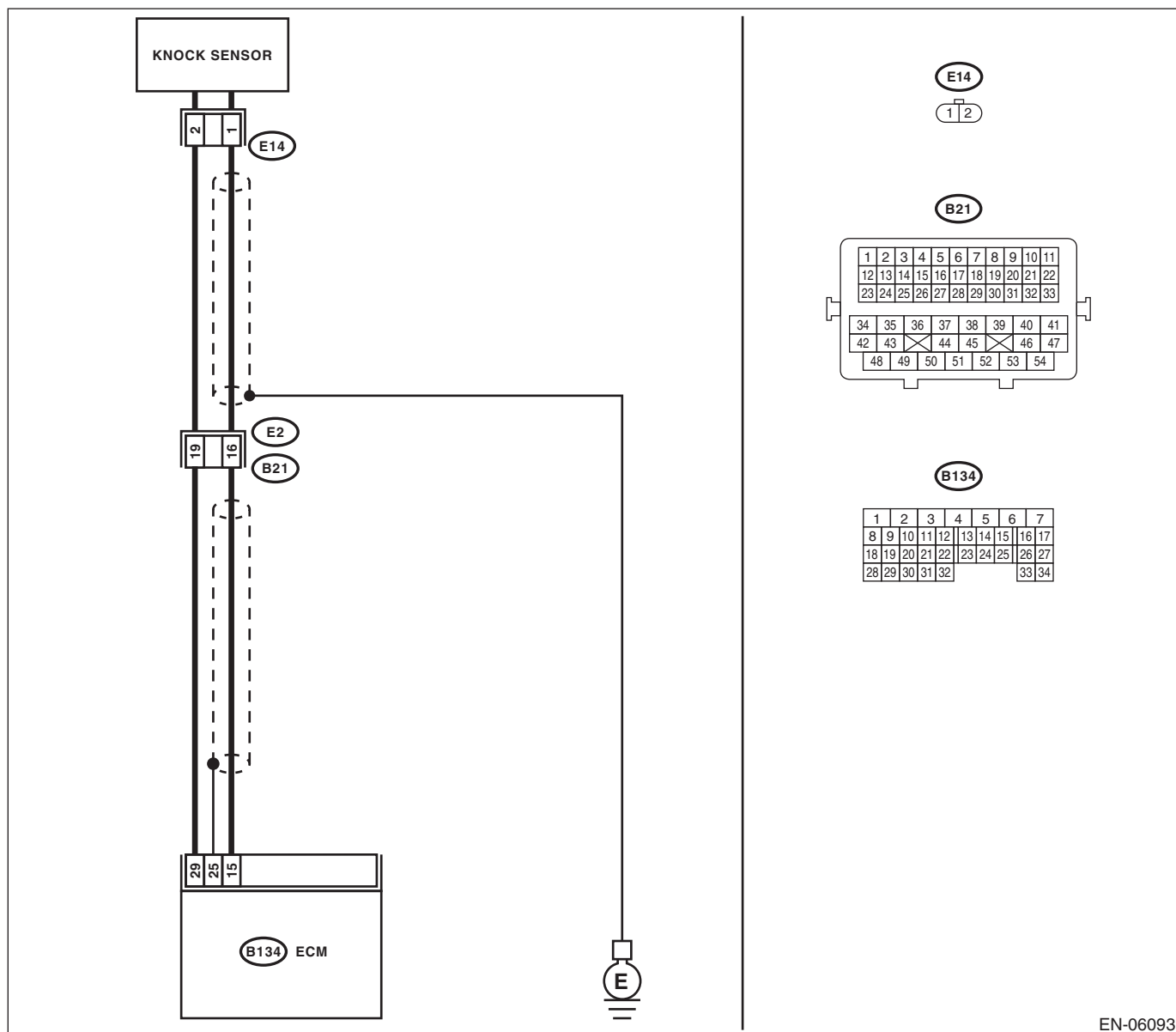

EN-06093

Diagnostic Procedure with Diagnostic Trouble Code (DTC)

ENGINE (DIAGNOSTICS)

Step	Check	Yes	No
<p>1 CHECK HARNESS BETWEEN ECM AND KNOCK SENSOR. 1) Turn the ignition switch to OFF. 2) Disconnect the connectors from the ECM. 3) Measure the resistance between ECM connectors. Connector & terminal (B134) No. 15 — (B134) No. 29:</p>	<p>Is the resistance 600 kΩ or more?</p>	<p>Go to step 2.</p>	<p>Repair poor contact of the ECM connector.</p>
<p>2 CHECK KNOCK SENSOR. 1) Disconnect the connector from knock sensor. 2) Measure the resistance between knock sensor terminals. Terminals No. 1 — No. 2:</p>	<p>Is the resistance 600 kΩ or more?</p>	<p>Replace the knock sensor. <Ref. to FU(H4SO)-25, Knock Sensor.></p>	<p>Repair the harness and connector. NOTE: In this case, repair the following item: • Open circuit in harness between ECM and knock sensor connector • Poor contact of the knock sensor connector • Poor contact of coupling connector</p>

Diagnostic Procedure with Diagnostic Trouble Code (DTC)

ENGINE (DIAGNOSTICS)

AY:DTC P0328 KNOCK SENSOR 1 CIRCUIT HIGH (BANK 1 OR SINGLE SENSOR)

DTC DETECTING CONDITION:

- Immediately at fault recognition
- GENERAL DESCRIPTION <Ref. to GD(H4SO)-86, DTC P0328 KNOCK SENSOR 1 CIRCUIT HIGH (BANK 1 OR SINGLE SENSOR), Diagnostic Trouble Code (DTC) Detecting Criteria.>

TROUBLE SYMPTOM:

- Poor driving performance
- Knocking occurs.

CAUTION:

After repair or replacement of faulty parts, perform Clear Memory Mode <Ref. to EN(H4SO)(diag)-51, OPERATION, Clear Memory Mode.> and Inspection Mode <Ref. to EN(H4SO)(diag)-41, PROCEDURE, Inspection Mode.>.

WIRING DIAGRAM:

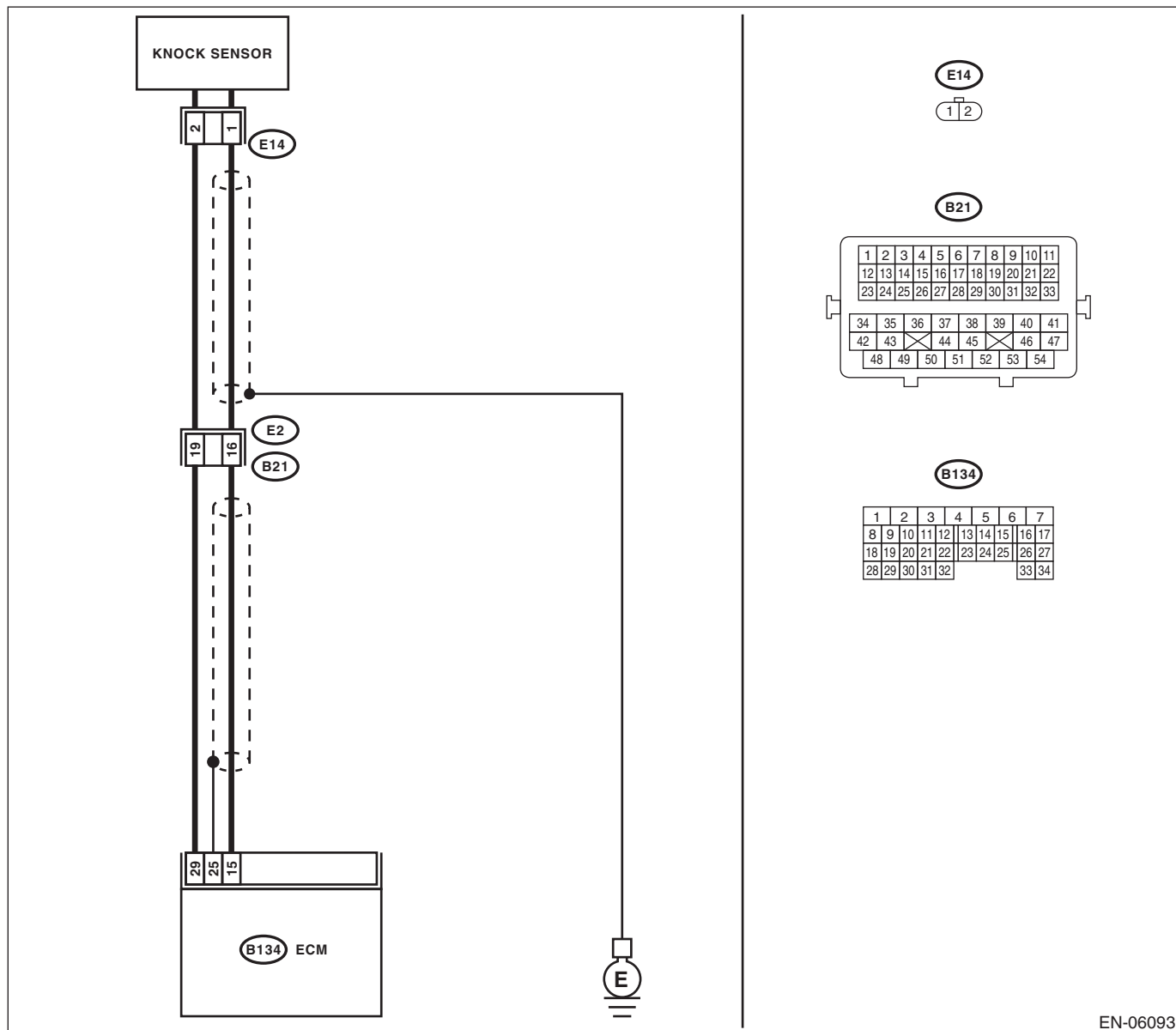

EN-06093

Diagnostic Procedure with Diagnostic Trouble Code (DTC)

ENGINE (DIAGNOSTICS)

	Step	Check	Yes	No
1	<p>CHECK HARNESS BETWEEN ECM AND KNOCK SENSOR.</p> <p>1) Turn the ignition switch to OFF. 2) Disconnect the connectors from the ECM. 3) Measure the resistance between ECM connectors.</p> <p>Connector & terminal (B134) No. 15 — (B134) No. 29:</p>	<p>Is the resistance less than 500 kΩ?</p>	<p>Go to step 2.</p>	<p>Go to step 3.</p>
2	<p>CHECK KNOCK SENSOR.</p> <p>1) Disconnect the connector from knock sensor. 2) Measure the resistance between knock sensor terminals.</p> <p>Terminals No. 1 — No. 2:</p>	<p>Is the resistance less than 500 kΩ?</p>	<p>Replace the knock sensor. <Ref. to FU(H4SO)-25, Knock Sensor.></p>	<p>Repair the ground short circuit of harness between the ECM and knock sensor connector.</p> <p>NOTE: The harness between both connectors are shielded. Remove the shield and repair the short circuit of the harness circuit.</p>
3	<p>CHECK INPUT SIGNAL OF ECM.</p> <p>1) Connect the ECM. 2) Turn the ignition switch to ON. 3) Measure the voltage between ECM and chassis ground.</p> <p>Connector & terminal (B134) No. 15 (+) — Chassis ground (-):</p>	<p>Is the voltage 2 V or more?</p>	<p>Even if the malfunction indicator light illuminates, the circuit has returned to a normal condition at this time. Reproduce the fault condition, and reperform the check.</p> <p>NOTE: In this case, there may be a temporary connector contact failure.</p>	<p>Repair poor contact of the ECM connector.</p>

Diagnostic Procedure with Diagnostic Trouble Code (DTC)

ENGINE (DIAGNOSTICS)

AZ:DTC P0335 CRANKSHAFT POSITION SENSOR "A" CIRCUIT

DTC DETECTING CONDITION:

- Immediately at fault recognition
- GENERAL DESCRIPTION <Ref. to GD(H4SO)-87, DTC P0335 CRANKSHAFT POSITION SENSOR "A" CIRCUIT, Diagnostic Trouble Code (DTC) Detecting Criteria.>

TROUBLE SYMPTOM:

- Engine stalls.
- Failure of engine to start

CAUTION:

After repair or replacement of faulty parts, perform Clear Memory Mode <Ref. to EN(H4SO)(diag)-51, OPERATION, Clear Memory Mode.> and Inspection Mode <Ref. to EN(H4SO)(diag)-41, PROCEDURE, Inspection Mode.>.

WIRING DIAGRAM:

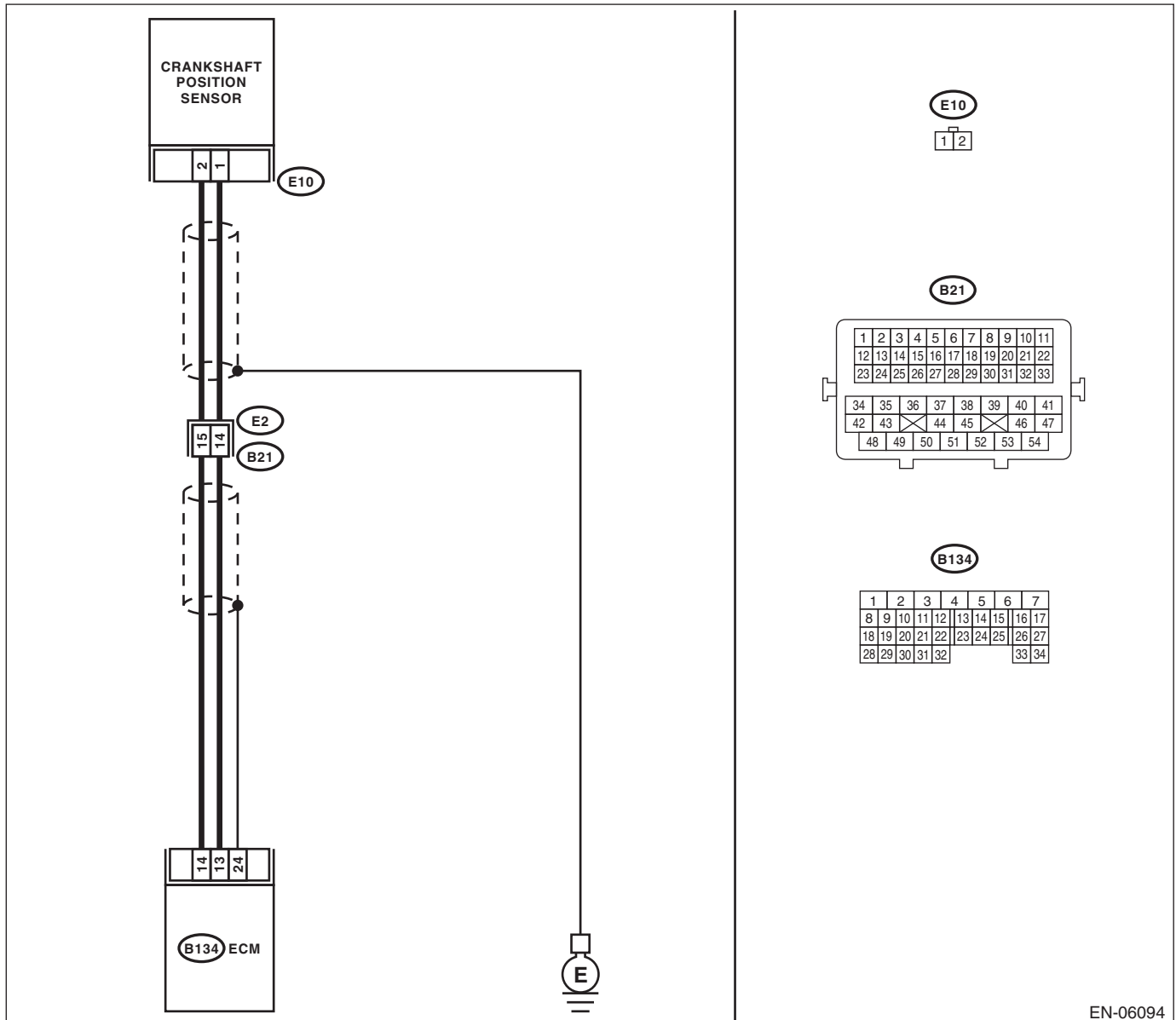

EN-06094

Diagnostic Procedure with Diagnostic Trouble Code (DTC)

ENGINE (DIAGNOSTICS)

Step	Check	Yes	No
1 CHECK INSTALLATION CONDITION OF CRANKSHAFT POSITION SENSOR.	Is the crankshaft position sensor installation bolt tightened securely?	Go to step 2.	Tighten the crankshaft position sensor installation bolt securely.
2 CHECK CRANKSHAFT POSITION SENSOR. 1) Turn the ignition switch to OFF. 2) Remove the crankshaft position sensor. 3) Measure the resistance between terminals of crankshaft position sensor. Terminals No. 1 — No. 2:	Is the resistance between 1 and 4 k Ω ?	Go to step 3.	Replace the crankshaft position sensor. <Ref. to FU(H4SO)-23, Crankshaft Position Sensor.>
3 CHECK HARNESS BETWEEN ECM AND CRANK SHAFT POSITION SENSOR. 1) Disconnect the connectors from the ECM. 2) Measure the resistance of harness between the ECM and crankshaft position sensor connector. Connector & terminal (B134) No. 13 — (E10) No. 1: (B134) No. 14 — (E10) No. 2:	Is the resistance less than 1 Ω ?	Repair the poor contact of the ECM and crankshaft position sensor connector.	Repair the harness and connector. NOTE: In this case, repair the following item: • Open circuit of harness between ECM and crankshaft position sensor connector • Poor contact of coupling connector

Diagnostic Procedure with Diagnostic Trouble Code (DTC)

ENGINE (DIAGNOSTICS)

BA:DTC P0336 CRANKSHAFT POSITION SENSOR "A" CIRCUIT RANGE/ PERFORMANCE

DTC DETECTING CONDITION:

- Detected when two consecutive driving cycles with fault occur.
- GENERAL DESCRIPTION <Ref. to GD(H4SO)-89, DTC P0336 CRANKSHAFT POSITION SENSOR "A" CIRCUIT RANGE/PERFORMANCE, Diagnostic Trouble Code (DTC) Detecting Criteria.>

TROUBLE SYMPTOM:

- Engine stalls.
- Failure of engine to start

CAUTION:

After repair or replacement of faulty parts, perform Clear Memory Mode <Ref. to EN(H4SO)(diag)-51, OPERATION, Clear Memory Mode.> and Inspection Mode <Ref. to EN(H4SO)(diag)-41, PROCEDURE, Inspection Mode.>.

WIRING DIAGRAM:

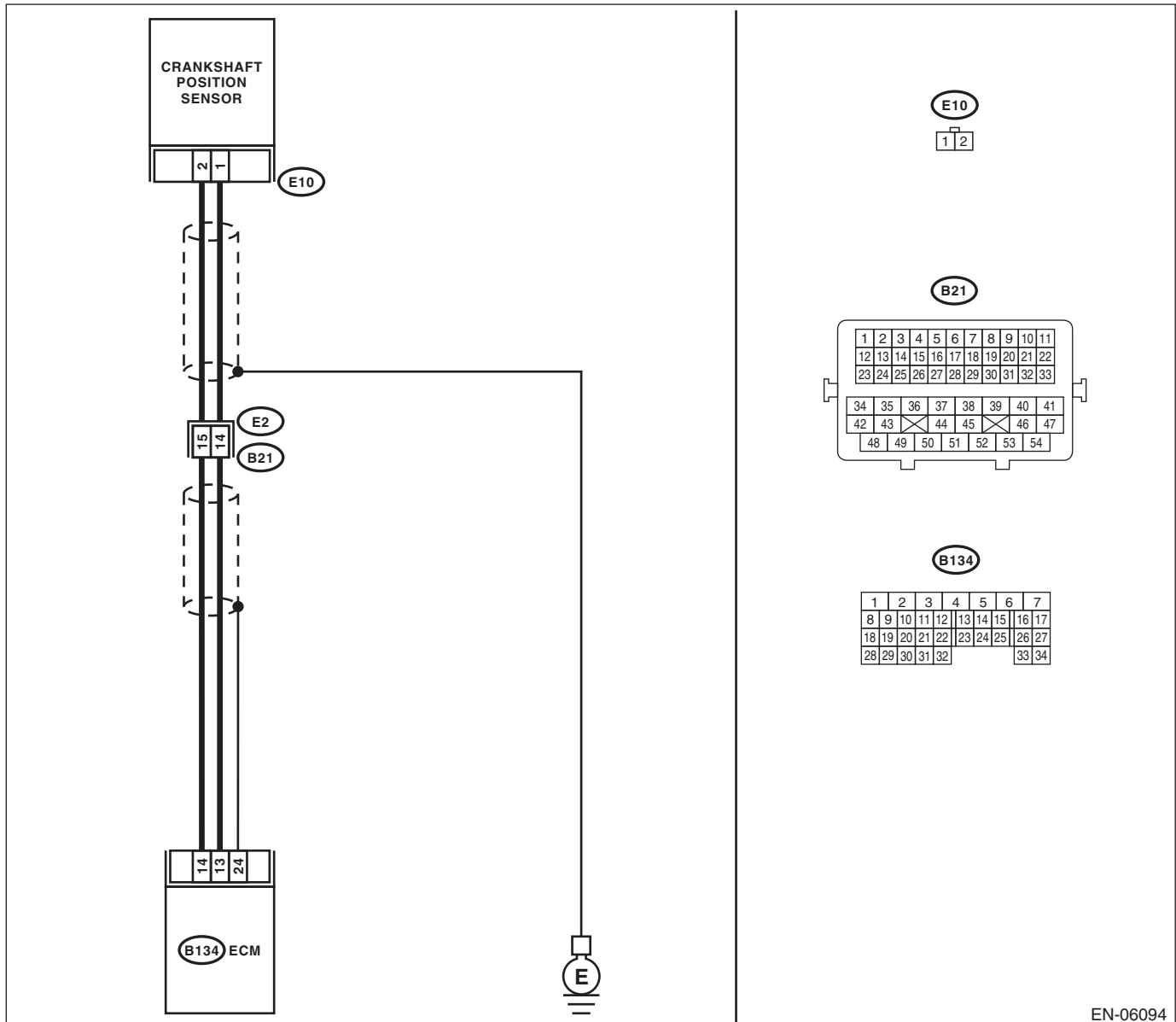

EN-06094

Diagnostic Procedure with Diagnostic Trouble Code (DTC)

ENGINE (DIAGNOSTICS)

	Step	Check	Yes	No
1	CHECK CONDITION OF CRANKSHAFT POSITION SENSOR. Turn the ignition switch to OFF.	Is the crankshaft position sensor installation bolt tightened securely?	Go to step 2.	Tighten the crankshaft position sensor installation bolt securely.
2	CHECK CRANK SPROCKET. Remove the timing belt cover.	Are crank sprocket teeth cracked or damaged?	Replace the crank sprocket. <Ref. to ME(H4SO)-61, Crank Sprocket.>	Go to step 3.
3	CHECK INSTALLATION CONDITION OF TIMING BELT. Turn the crankshaft, and align alignment mark on crank sprocket with alignment mark on cylinder block.	Is the timing belt dislocated from its proper position?	Repair the installation condition of timing belt. <Ref. to ME(H4SO)-53, Timing Belt.>	Replace the crankshaft position sensor. <Ref. to FU(H4SO)-23, Crankshaft Position Sensor.>

Diagnostic Procedure with Diagnostic Trouble Code (DTC)

ENGINE (DIAGNOSTICS)

BB:DTC P0340 CAMSHAFT POSITION SENSOR "A" CIRCUIT (BANK 1 OR SINGLE SENSOR)

DTC DETECTING CONDITION:

- Immediately at fault recognition
- GENERAL DESCRIPTION <Ref. to GD(H4SO)-91, DTC P0340 CAMSHAFT POSITION SENSOR "A" CIRCUIT (BANK 1 OR SINGLE SENSOR), Diagnostic Trouble Code (DTC) Detecting Criteria.>

TROUBLE SYMPTOM:

- Engine stalls.
- Failure of engine to start

CAUTION:

After repair or replacement of faulty parts, perform Clear Memory Mode <Ref. to EN(H4SO)(diag)-51, OPERATION, Clear Memory Mode.> and Inspection Mode <Ref. to EN(H4SO)(diag)-41, PROCEDURE, Inspection Mode.>.

WIRING DIAGRAM:

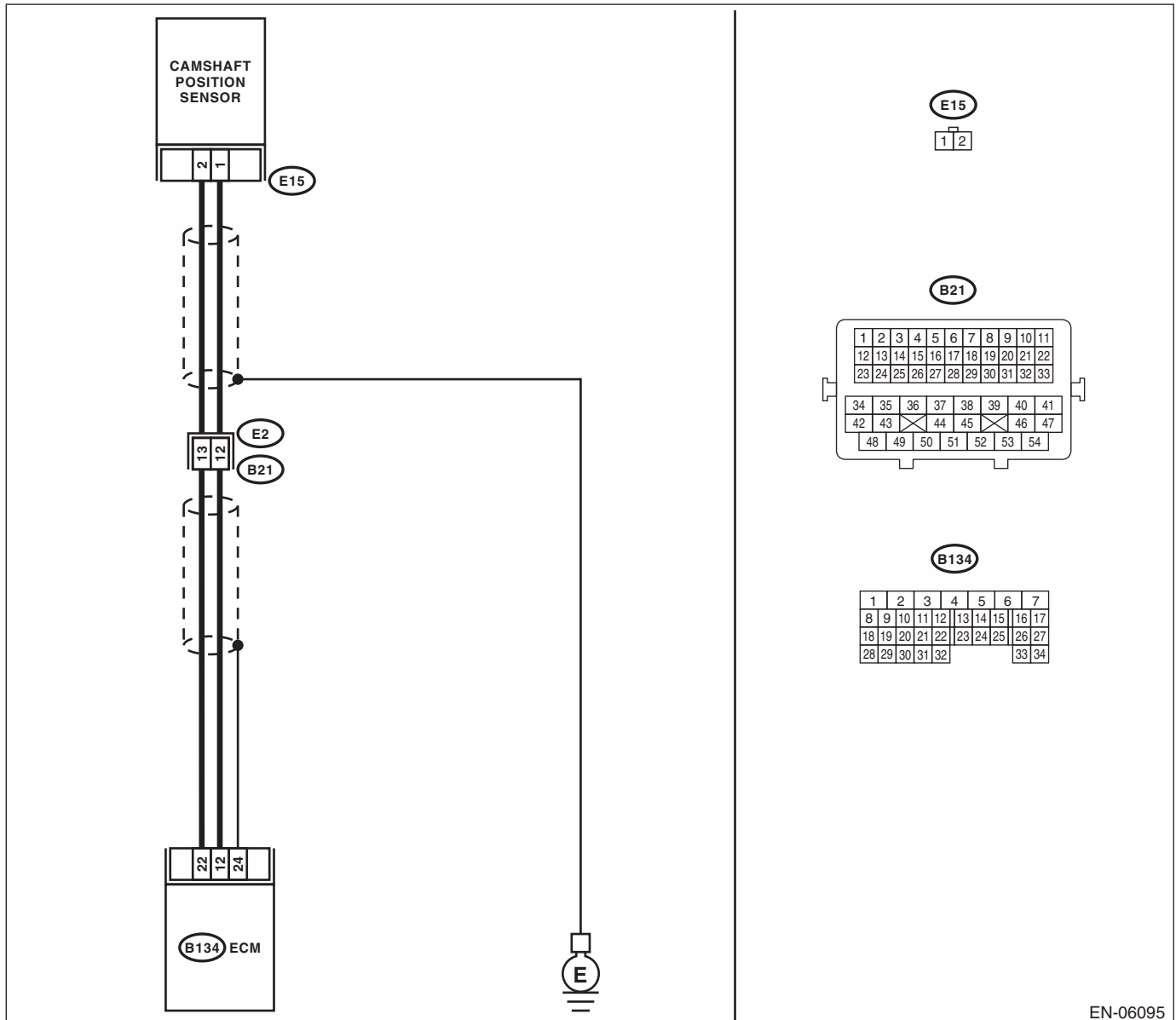

EN-06095

Diagnostic Procedure with Diagnostic Trouble Code (DTC)

ENGINE (DIAGNOSTICS)

	Step	Check	Yes	No
1	<p>CHECK HARNESS BETWEEN ECM AND CAMSHAFT POSITION SENSOR.</p> <p>1) Turn the ignition switch to OFF. 2) Disconnect the connectors from the ECM and camshaft position sensor. 3) Measure the resistance of harness between the ECM and camshaft position sensor connector.</p> <p>Connector & terminal (B134) No. 12 — (E15) No. 1: (B134) No. 22 — (E15) No. 2:</p>	Is the resistance less than 1 Ω?	Go to step 2.	<p>Repair the harness and connector.</p> <p>NOTE: In this case, repair the following item:</p> <ul style="list-style-type: none"> • Open circuit in harness between the ECM and camshaft position sensor connector • Poor contact of coupling connector
2	<p>CHECK HARNESS BETWEEN ECM AND CAMSHAFT POSITION SENSOR.</p> <p>Measure the resistance between camshaft position sensor connector and engine ground.</p> <p>Connector & terminal (E15) No. 1 — Engine ground:</p>	Is the resistance 1 MΩ or more?	Go to step 3.	<p>Repair the short circuit to ground of harness between the ECM and camshaft position sensor.</p> <p>NOTE: The harness between both connectors are shielded. Remove the shield and repair the ground short circuit of the harness circuit.</p>
3	<p>CHECK INSTALLATION CONDITION OF CAMSHAFT POSITION SENSOR.</p>	Is the camshaft position sensor installation bolt tightened securely?	Go to step 4.	Tighten the camshaft position sensor installation bolt securely.
4	<p>CHECK CAMSHAFT POSITION SENSOR.</p> <p>1) Remove the camshaft position sensor. 2) Measure the resistance between terminals of camshaft position sensor.</p> <p>Terminals No. 1 — No. 2:</p>	Is the resistance between 1 and 4 kΩ?	Repair the poor contact of the ECM or camshaft position sensor connector.	Replace the camshaft position sensor. <Ref. to FU(H4SO)-24, Camshaft Position Sensor.>

Diagnostic Procedure with Diagnostic Trouble Code (DTC)

ENGINE (DIAGNOSTICS)

BC:DTC P0341 CAMSHAFT POSITION SENSOR "A" CIRCUIT RANGE/ PERFORMANCE (BANK 1 OR SINGLE SENSOR)

DTC DETECTING CONDITION:

- Detected when two consecutive driving cycles with fault occur.
- GENERAL DESCRIPTION <Ref. to GD(H4SO)-92, DTC P0341 CAMSHAFT POSITION SENSOR "A" CIRCUIT RANGE/PERFORMANCE (BANK 1 OR SINGLE SENSOR), Diagnostic Trouble Code (DTC) Detecting Criteria.>

TROUBLE SYMPTOM:

- Engine stalls.
- Failure of engine to start

CAUTION:

After repair or replacement of faulty parts, perform Clear Memory Mode <Ref. to EN(H4SO)(diag)-51, OPERATION, Clear Memory Mode.> and Inspection Mode <Ref. to EN(H4SO)(diag)-41, PROCEDURE, Inspection Mode.>.

WIRING DIAGRAM:

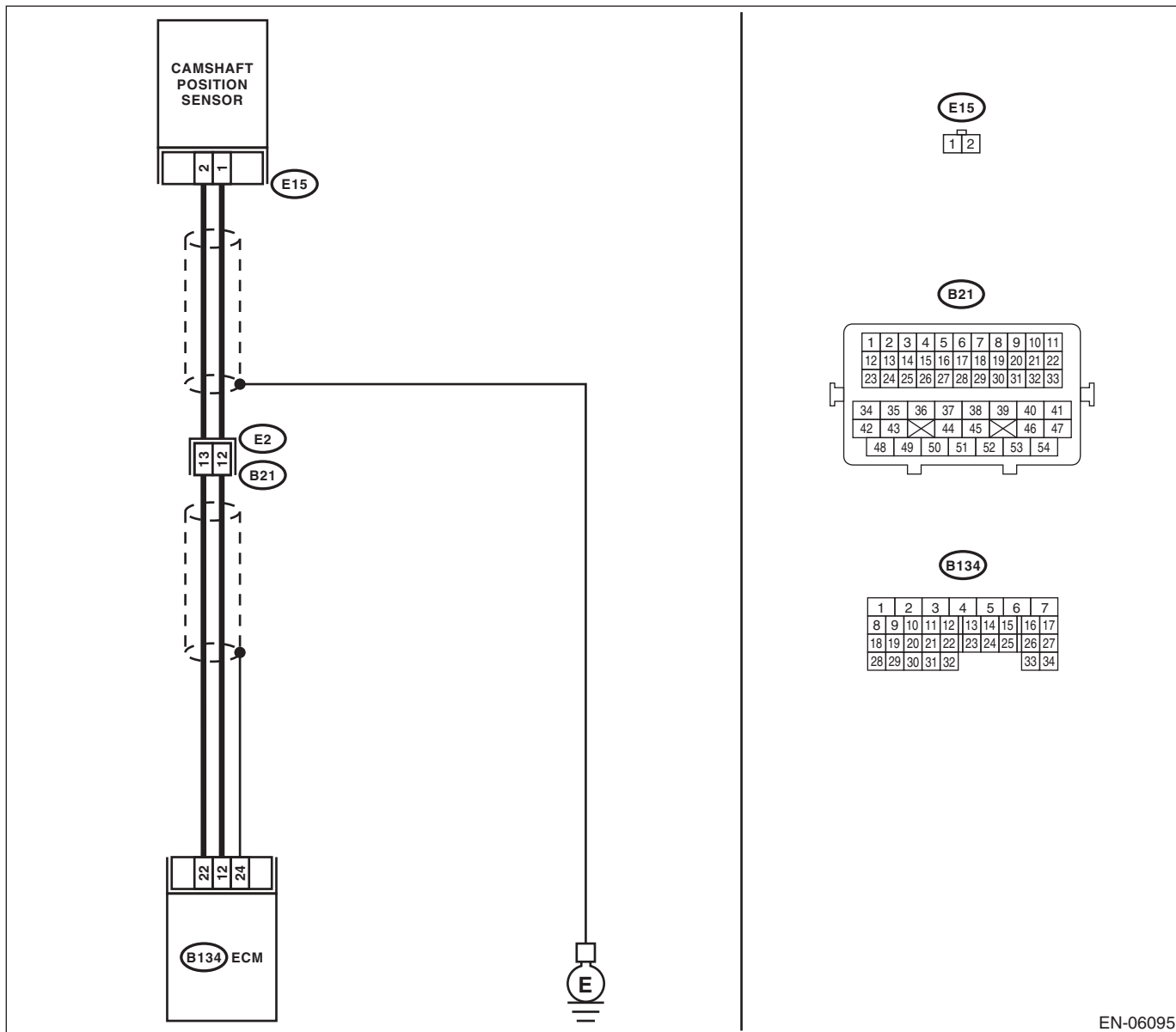

EN-06095

Diagnostic Procedure with Diagnostic Trouble Code (DTC)

ENGINE (DIAGNOSTICS)

Step	Check	Yes	No
<p>1 CHECK HARNESS BETWEEN ECM AND CAMSHAFT POSITION SENSOR.</p> <p>1) Turn the ignition switch to OFF. 2) Disconnect the connectors from the ECM and camshaft position sensor. 3) Measure the resistance of harness between the ECM and camshaft position sensor connector.</p> <p>Connector & terminal (B134) No. 12 — (E15) No. 1: (B134) No. 22 — (E15) No. 2:</p>	Is the resistance less than 1 Ω?	Go to step 2.	Repair the harness and connector. NOTE: In this case, repair the following item: • Open circuit in harness between the ECM and camshaft position sensor connector • Poor contact of coupling connector
<p>2 CHECK HARNESS BETWEEN ECM AND CAMSHAFT POSITION SENSOR.</p> <p>Measure the resistance between camshaft position sensor connector and engine ground.</p> <p>Connector & terminal (E15) No. 1 — Engine ground:</p>	Is the resistance 1 MΩ or more?	Go to step 3.	Repair the short circuit to ground of harness between the ECM and camshaft position sensor. NOTE: The harness between both connectors are shielded. Remove the shield and repair the ground short circuit of the harness circuit.
<p>3 CHECK INSTALLATION CONDITION OF CAMSHAFT POSITION SENSOR.</p>	Is the camshaft position sensor installation bolt tightened securely?	Go to step 4.	Tighten the camshaft position sensor installation bolt securely.
<p>4 CHECK CAMSHAFT POSITION SENSOR.</p> <p>1) Remove the camshaft position sensor. 2) Measure the resistance between terminals of camshaft position sensor.</p> <p>Terminals No. 1 — No. 2:</p>	Is the resistance between 1 and 4 kΩ?	Go to step 5.	Replace the camshaft position sensor. <Ref. to FU(H4SO)-24, Camshaft Position Sensor.>
<p>5 CHECK CAM SPROCKET.</p> <p>Remove the timing belt cover. <Ref. to ME(H4SO)-52, Timing Belt Cover.></p>	Are cam sprocket teeth cracked or damaged?	Replace the cam sprocket. <Ref. to ME(H4SO)-59, Cam Sprocket.>	Go to step 6.
<p>6 CHECK INSTALLATION CONDITION OF TIMING BELT.</p> <p>Turn the crankshaft using the ST, and align the alignment mark on the cam sprocket with the alignment mark on the timing belt cover LH.</p> <p>ST 499987500 CRANKSHAFT SOCKET</p>	Is the timing belt dislocated from its proper position?	Repair the installation condition of timing belt. <Ref. to ME(H4SO)-53, Timing Belt.>	Replace the camshaft position sensor. <Ref. to FU(H4SO)-24, Camshaft Position Sensor.>

Diagnostic Procedure with Diagnostic Trouble Code (DTC)

ENGINE (DIAGNOSTICS)

BD:DTC P0400 EXHAUST GAS RECIRCULATION FLOW

DTC DETECTING CONDITION:

- Detected when two consecutive driving cycles with fault occur.
- GENERAL DESCRIPTION <Ref. to GD(H4SO)-94, DTC P0400 EXHAUST GAS RECIRCULATION FLOW, Diagnostic Trouble Code (DTC) Detecting Criteria.>

TROUBLE SYMPTOM:

- Movement performance problem when engine is low speed.
- Improper idling
- Movement performance problem

CAUTION:

After repair or replacement of faulty parts, perform Clear Memory Mode <Ref. to EN(H4SO)(diag)-51, OPERATION, Clear Memory Mode.> and Inspection Mode <Ref. to EN(H4SO)(diag)-41, PROCEDURE, Inspection Mode.>.

WIRING DIAGRAM:

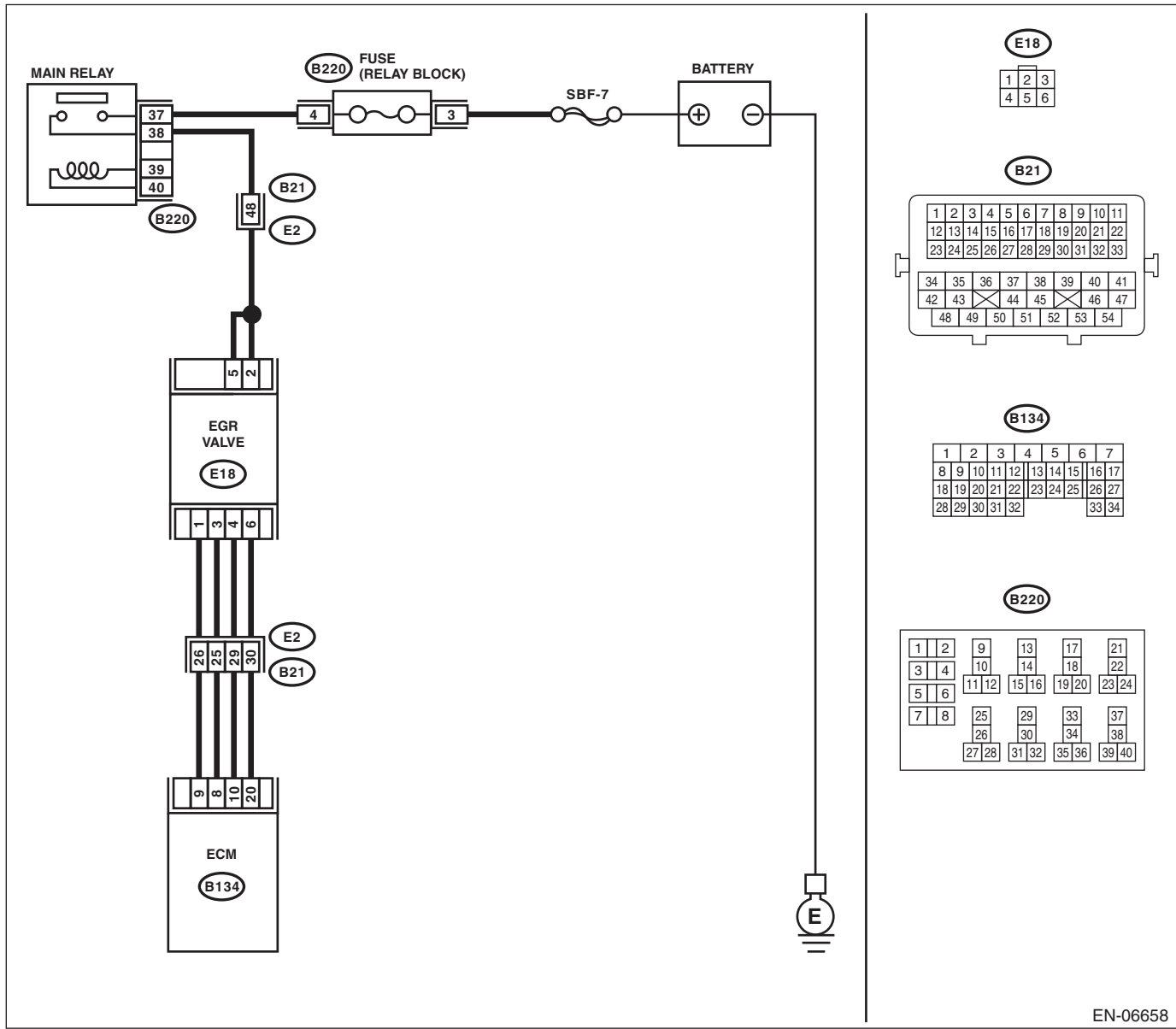

EN-06658

Diagnostic Procedure with Diagnostic Trouble Code (DTC)

ENGINE (DIAGNOSTICS)

	Step	Check	Yes	No
1	CHECK CURRENT DATA. 1) Start the engine. 2) Read data of intake manifold absolute pressure signal using Subaru Select Monitor or general scan tool. NOTE: • Subaru Select Monitor For detailed operation procedures, refer to "READ CURRENT DATA FOR ENGINE". <Ref. to EN(H4SO)(diag)-33, Subaru Select Monitor.> • General scan tool For detailed operation procedures, refer to the general scan tool operation manual.	Is the measured value 53.3 kPa (400 mmHg, 15.75 inHg) or more?	Make sure that the EGR valve, manifold absolute pressure sensor and throttle body are installed securely.	Go to step 2.
2	CHECK EGR SOLENOID VALVE. Remove the EGR valve.	Are there holes, plugged piping or foreign objects caught in the EGR system?	Repair the EGR system.	Replace the EGR valve. <Ref. to FU(H4SO)-29, EGR Valve.>

Diagnostic Procedure with Diagnostic Trouble Code (DTC)

ENGINE (DIAGNOSTICS)

BE:DTC P0420 CATALYST SYSTEM EFFICIENCY BELOW THRESHOLD (BANK 1)

DTC DETECTING CONDITION:

- Detected when two consecutive driving cycles with fault occur.
- GENERAL DESCRIPTION <Ref. to GD(H4SO)-97, DTC P0420 CATALYST SYSTEM EFFICIENCY BELOW THRESHOLD (BANK 1), Diagnostic Trouble Code (DTC) Detecting Criteria.>

TROUBLE SYMPTOM:

- Engine stalls.
- Idle mixture is out of specifications.

CAUTION:

After repair or replacement of faulty parts, perform Clear Memory Mode <Ref. to EN(H4SO)(diag)-51, OPERATION, Clear Memory Mode.> and Inspection Mode <Ref. to EN(H4SO)(diag)-41, PROCEDURE, Inspection Mode.>.

WIRING DIAGRAM:

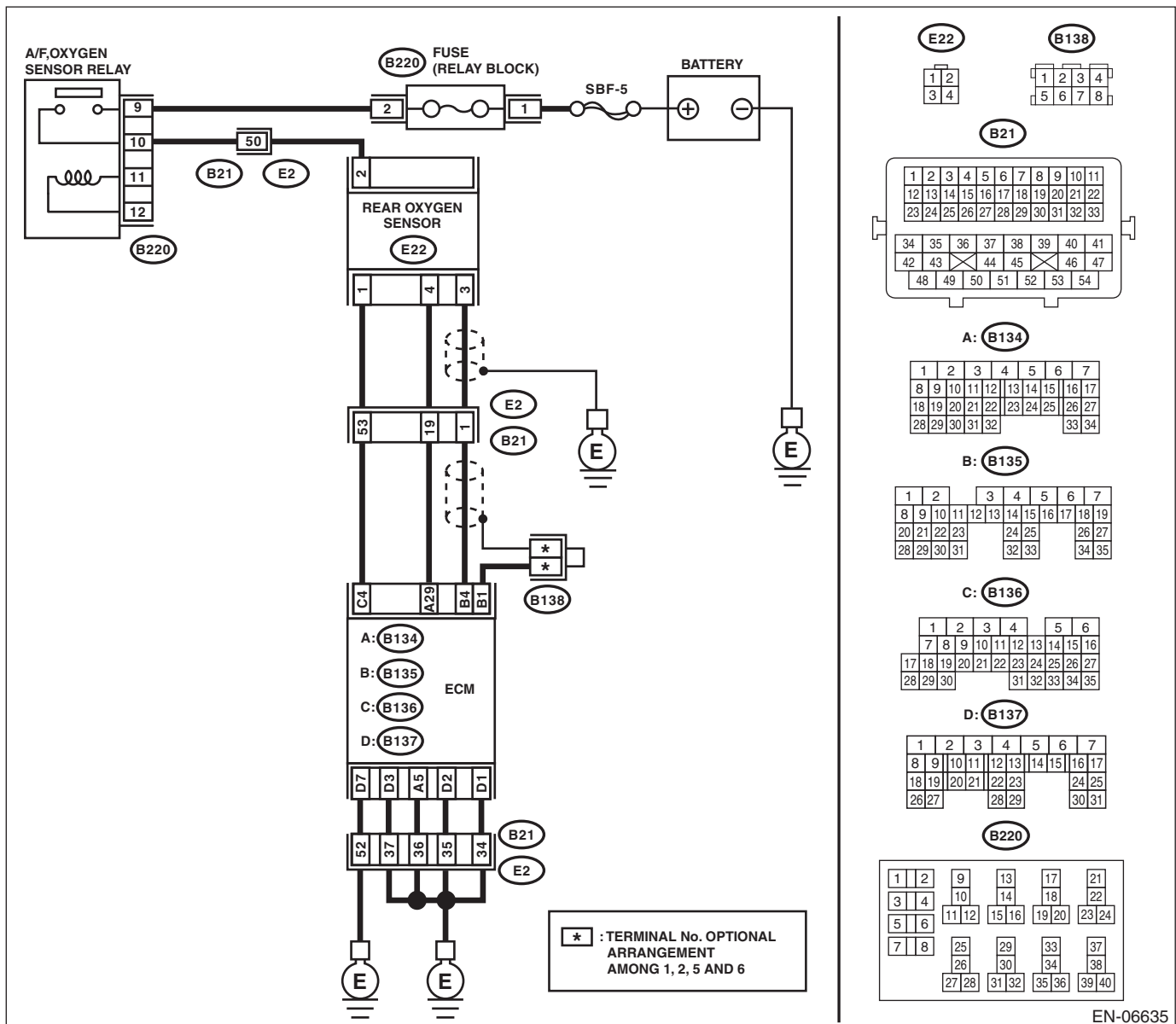

EN-06635

Diagnostic Procedure with Diagnostic Trouble Code (DTC)

ENGINE (DIAGNOSTICS)

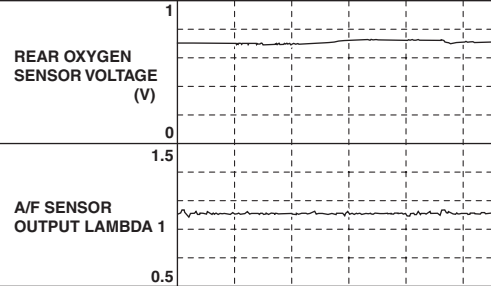
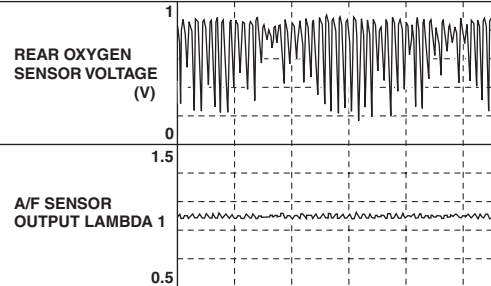
Step	Check	Yes	No
<p>1</p> <p>CHECK EXHAUST SYSTEM. Check for gas leaks or air suction caused by loose or dislocated nuts and bolts, and open hole at exhaust pipes.</p> <p>NOTE: Check the following positions.</p> <ul style="list-style-type: none"> • Between cylinder head and front exhaust pipe • Between front exhaust pipe and front catalytic converter • Between front catalytic converter and rear catalytic converter • Loose or improperly attached front oxygen (A/F) sensor or rear oxygen sensor 	<p>Is there any fault in exhaust system?</p>	<p>Repair or replace the exhaust system. <Ref. to EX(H4SO)-2, General Description.></p>	<p>Go to step 2.</p>
<p>2</p> <p>CHECK WAVEFORM DATA ON THE SUBARU SELECT MONITOR (WHILE DRIVING).</p> <p>1) Drive at a constant speed between 80 — 112 km/h (50 — 70 MPH).</p> <p>2) After 5 minutes have elapsed in the condition of step 1), use the Subaru Select Monitor while still driving to read the waveform data.</p> <ul style="list-style-type: none"> • At normal condition  <p>10 sec/div EN-06666</p> <ul style="list-style-type: none"> • At abnormal condition (numerous inversion)  <p>10 sec/div EN-06667</p>	<p>Is a normal waveform displayed?</p>	<p>Even if the malfunction indicator light illuminates, the circuit has returned to a normal condition at this time. Reproduce the failure, and then perform the diagnosis again.</p> <p>NOTE: In this case, temporary poor contact of connector may be the cause.</p>	<p>Go to step 3.</p>

Diagnostic Procedure with Diagnostic Trouble Code (DTC)

ENGINE (DIAGNOSTICS)

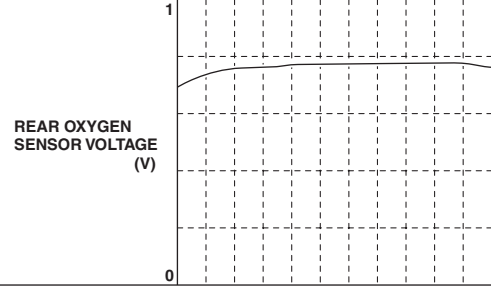
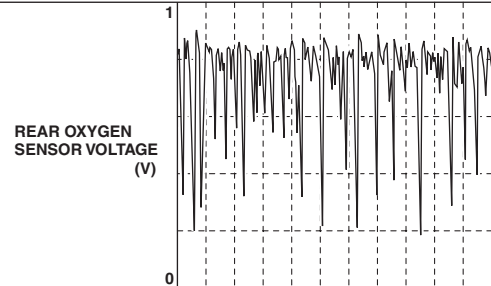
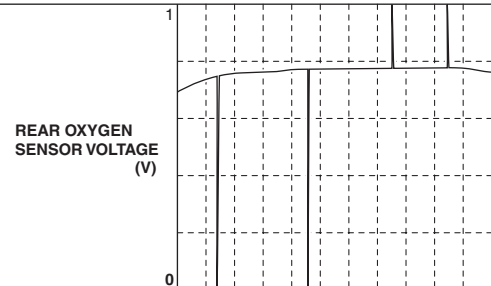
Step	Check	Yes	No
<p>3 CHECK WAVEFORM DATA ON THE SUBARU SELECT MONITOR (WHILE IDLING).</p> <p>1) Run the engine at idle. 2) In the condition of step 1), use the Subaru Select Monitor to read the waveform data.</p> <ul style="list-style-type: none"> At normal condition  <p>10 sec/div EN-06668</p> <ul style="list-style-type: none"> At abnormal condition 1 (numerous inversion)  <p>10 sec/div EN-06669</p> <ul style="list-style-type: none"> At abnormal condition 2 (noise input)  <p>10 sec/div EN-06670</p>	<p>Is a normal waveform displayed?</p>	<p>Go to step 4.</p>	<ul style="list-style-type: none"> The waveform is displayed at abnormal condition 1: Go to step 4. The waveform is displayed at abnormal condition 2: Go to step 5.
<p>4 CHECK CATALYTIC CONVERTER.</p>	<p>Is the catalytic converter damaged?</p>	<p>Replace the catalytic converter. <Ref. to EC(H4SO)-3, Front Catalytic Converter.></p>	<p>Go to step 5.</p>
<p>5 CHECK REAR OXYGEN SENSOR CONNECTOR AND COUPLING CONNECTOR.</p>	<p>Has water entered the connector?</p>	<p>Completely remove any water inside.</p>	<p>Go to step 6.</p>

Diagnostic Procedure with Diagnostic Trouble Code (DTC)

ENGINE (DIAGNOSTICS)

Step	Check	Yes	No
<p>6 CHECK HARNESS BETWEEN ECM AND REAR OXYGEN SENSOR CONNECTOR.</p> <p>1) Turn the ignition switch to OFF. 2) Disconnect the connector from ECM and rear oxygen sensor. 3) Measure the resistance of harness between ECM and rear oxygen sensor connector.</p> <p>Connector & terminal (B135) No. 4 — (E22) No. 3: (B134) No. 29 — (E22) No. 4:</p>	Is the resistance less than 1 Ω ?	Go to step 7.	Repair the harness and connector. NOTE: Repair the following locations. • Open circuit in harness between ECM and rear oxygen sensor connector • Poor contact of coupling connector
<p>7 CHECK HARNESS BETWEEN ECM AND REAR OXYGEN SENSOR CONNECTOR.</p> <p>1) Turn the ignition switch to ON. 2) Measure the voltage between rear oxygen sensor connector and chassis ground.</p> <p>Connector & terminal (E22) No. 3 (+) — Chassis ground (-):</p>	Is the voltage 0.2 — 0.5 V?	Go to step 8.	Repair the harness and connector. NOTE: Repair the following locations. • Open circuit in harness between ECM and rear oxygen sensor connector • Poor contact in ECM connector • Poor contact of coupling connector
<p>8 CHECK REAR OXYGEN SENSOR SHIELD.</p> <p>1) Turn the ignition switch to OFF. 2) Expose the rear oxygen sensor connector body side harness sensor shield. 3) Measure the resistance between the sensor shield and chassis ground.</p>	Is the resistance less than 1 Ω ?	Replace the rear oxygen sensor. <Ref. to FU(H4SO)-37, Rear Oxygen Sensor.>	Repair the open circuit in the rear oxygen sensor harness.

Diagnostic Procedure with Diagnostic Trouble Code (DTC)

ENGINE (DIAGNOSTICS)

BF:DTC P0442 EVAPORATIVE EMISSION CONTROL SYSTEM LEAK DETECTED (SMALL LEAK)

DTC DETECTING CONDITION:

- Detected when two consecutive driving cycles with fault occur.
- GENERAL DESCRIPTION <Ref. to GD(H4SO)-99, DTC P0442 EVAPORATIVE EMISSION CONTROL SYSTEM LEAK DETECTED (SMALL LEAK), Diagnostic Trouble Code (DTC) Detecting Criteria.>

TROUBLE SYMPTOM:

- Fuel odor
- There is a hole of more than 1.0 mm (0.04 in) dia. in evaporation system or fuel tank.

CAUTION:

After repair or replacement of faulty parts, perform Clear Memory Mode <Ref. to EN(H4SO)(diag)-51, OPERATION, Clear Memory Mode.> and Inspection Mode <Ref. to EN(H4SO)(diag)-41, PROCEDURE, Inspection Mode.>.

WIRING DIAGRAM:

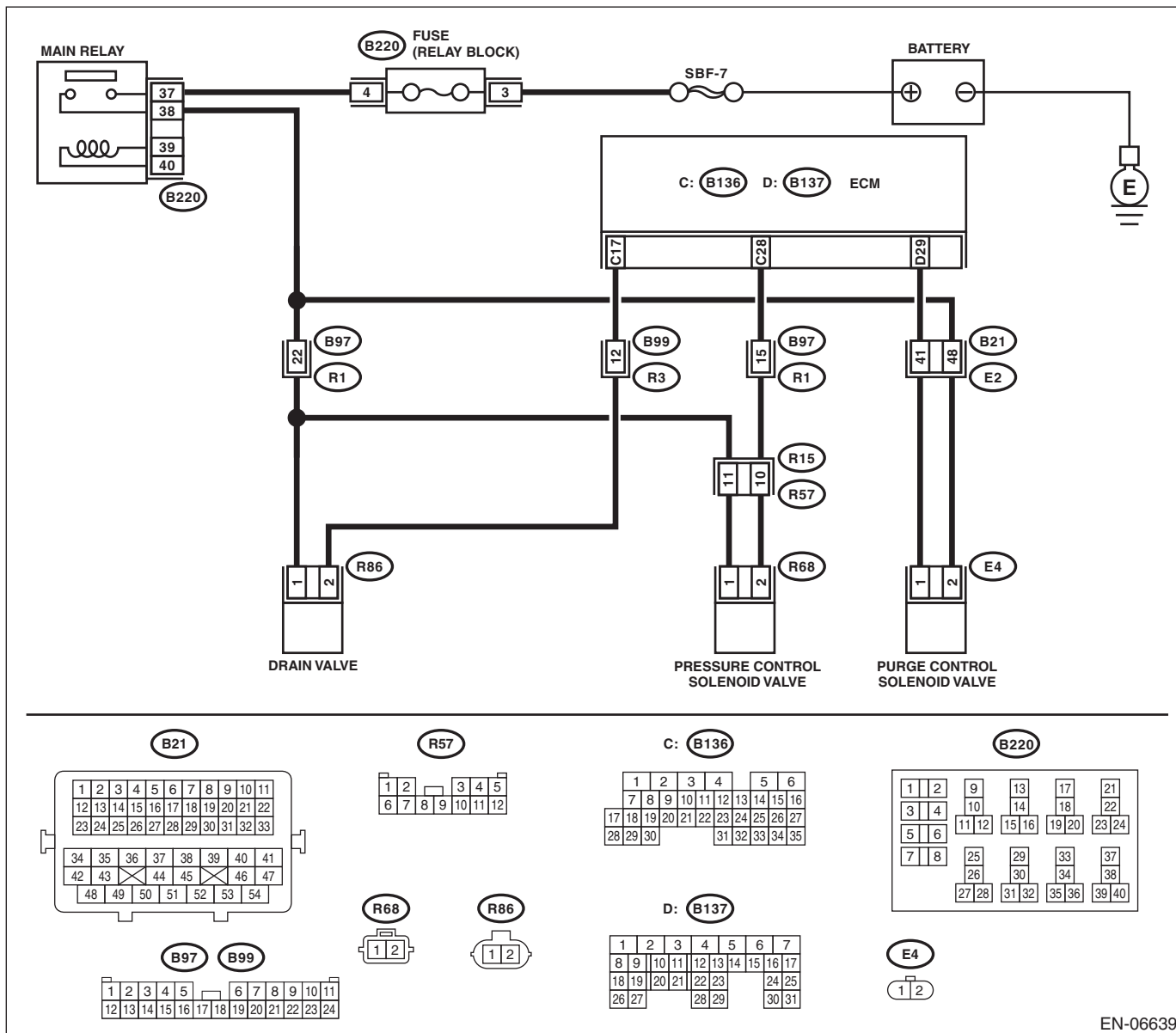

EN-06639

Diagnostic Procedure with Diagnostic Trouble Code (DTC)

ENGINE (DIAGNOSTICS)

Step	Check	Yes	No
1 CHECK FUEL FILLER CAP. 1) Turn the ignition switch to OFF. 2) Check the fuel filler cap. NOTE: The DTC is stored in memory if fuel filler cap is or was loose or if the cap chain has caught while tightening.	Is the fuel filler cap tightened securely?	Go to step 2.	Tighten fuel filler cap securely.
2 CHECK FUEL FILLER CAP.	Is the fuel filler cap genuine?	Go to step 3.	Replace with a genuine fuel filler cap.
3 CHECK FUEL FILLER PIPE GASKET.	Is there any damage to the seal between fuel filler cap and fuel filler pipe?	Repair or replace the fuel filler cap and fuel filler pipe. <Ref. to FU(H4SO)-52, Fuel Filler Pipe.>	Go to step 4.
4 CHECK DRAIN VALVE. 1) Connect the delivery (test) mode connector. 2) Turn the ignition switch to ON. 3) Operate the drain valve using the Subaru Select Monitor. NOTE: Drain valve operation can be executed using Subaru Select Monitor. Regarding the procedures, refer to "Compulsory Valve Operation Check Mode". <Ref. to EN(H4SO)(diag)-52, Compulsory Valve Operation Check Mode.>	Does the drain valve operate?	Go to step 5.	Replace the drain valve. <Ref. to EC(H4SO)-18, Drain Valve.>
5 CHECK PURGE CONTROL SOLENOID VALVE. Operate the purge control solenoid valve using the Subaru Select Monitor. NOTE: Purge control solenoid valve operation can be executed using Subaru Select Monitor. Regarding the procedures, refer to "Compulsory Valve Operation Check Mode". <Ref. to EN(H4SO)(diag)-52, Compulsory Valve Operation Check Mode.>	Does the purge control solenoid valve operate?	Go to step 6.	Replace the purge control solenoid valve. <Ref. to EC(H4SO)-9, Purge Control Solenoid Valve.>
6 CHECK PRESSURE CONTROL SOLENOID VALVE. Operate the pressure control solenoid valve using the Subaru Select Monitor. NOTE: The pressure control solenoid valve operation can be executed using the Subaru Select Monitor. Regarding the procedures, refer to "Compulsory Valve Operation Check Mode". <Ref. to EN(H4SO)(diag)-52, Compulsory Valve Operation Check Mode.>	Does the pressure control solenoid valve operate?	Go to step 7.	Replace the pressure control solenoid valve. <Ref. to EC(H4SO)-15, Pressure Control Solenoid Valve.>
7 CHECK EVAPORATIVE EMISSION CONTROL SYSTEM LINE. 1) Turn the ignition switch to OFF. 2) Disconnect the delivery (test) mode connector.	Is there any hole of more than 1.0 mm (0.04 in) dia. on evaporation line?	Repair or replace the evaporation line. <Ref. to FU(H4SO)-65, Fuel Delivery and Evaporation Lines.>	Go to step 8.

Diagnostic Procedure with Diagnostic Trouble Code (DTC)

ENGINE (DIAGNOSTICS)

	Step	Check	Yes	No
8	CHECK CANISTER.	Is the canister damaged or is there a hole of more than 1.0 mm (0.04 in) dia. in it?	Repair or replace the canister. <Ref. to EC(H4SO)-5, Canister.>	Go to step 9.
9	CHECK FUEL TANK. Remove the fuel tank. <Ref. to FU(H4SO)-45, Fuel Tank.>	Is the fuel tank damaged or is there any hole of more than 1.0 mm (0.04 in) dia. in it?	Repair or replace the fuel tank. <Ref. to FU(H4SO)-45, Fuel Tank.>	Go to step 10.
10	CHECK ANY OTHER MECHANICAL TROUBLE IN EVAPORATIVE EMISSION CONTROL SYSTEM.	Is there any hole of more than 1.0 mm (0.04 in) dia., crack, clogging, or disconnections, bend, misconnection of hoses or pipes in evaporative emission control system?	Repair or replace the hoses or pipes.	Repair the poor contact of the ECM connector.

Diagnostic Procedure with Diagnostic Trouble Code (DTC)

ENGINE (DIAGNOSTICS)

BG:DTC P0447 EVAPORATIVE EMISSION CONTROL SYSTEM VENT CONTROL CIRCUIT OPEN

DTC DETECTING CONDITION:

- Immediately at fault recognition
- GENERAL DESCRIPTION <Ref. to GD(H4SO)-115, DTC P0447 EVAPORATIVE EMISSION CONTROL SYSTEM VENT CONTROL CIRCUIT OPEN, Diagnostic Trouble Code (DTC) Detecting Criteria.>

CAUTION:

After repair or replacement of faulty parts, perform Clear Memory Mode <Ref. to EN(H4SO)(diag)-51, OPERATION, Clear Memory Mode.> and Inspection Mode <Ref. to EN(H4SO)(diag)-41, PROCEDURE, Inspection Mode.>.

WIRING DIAGRAM:

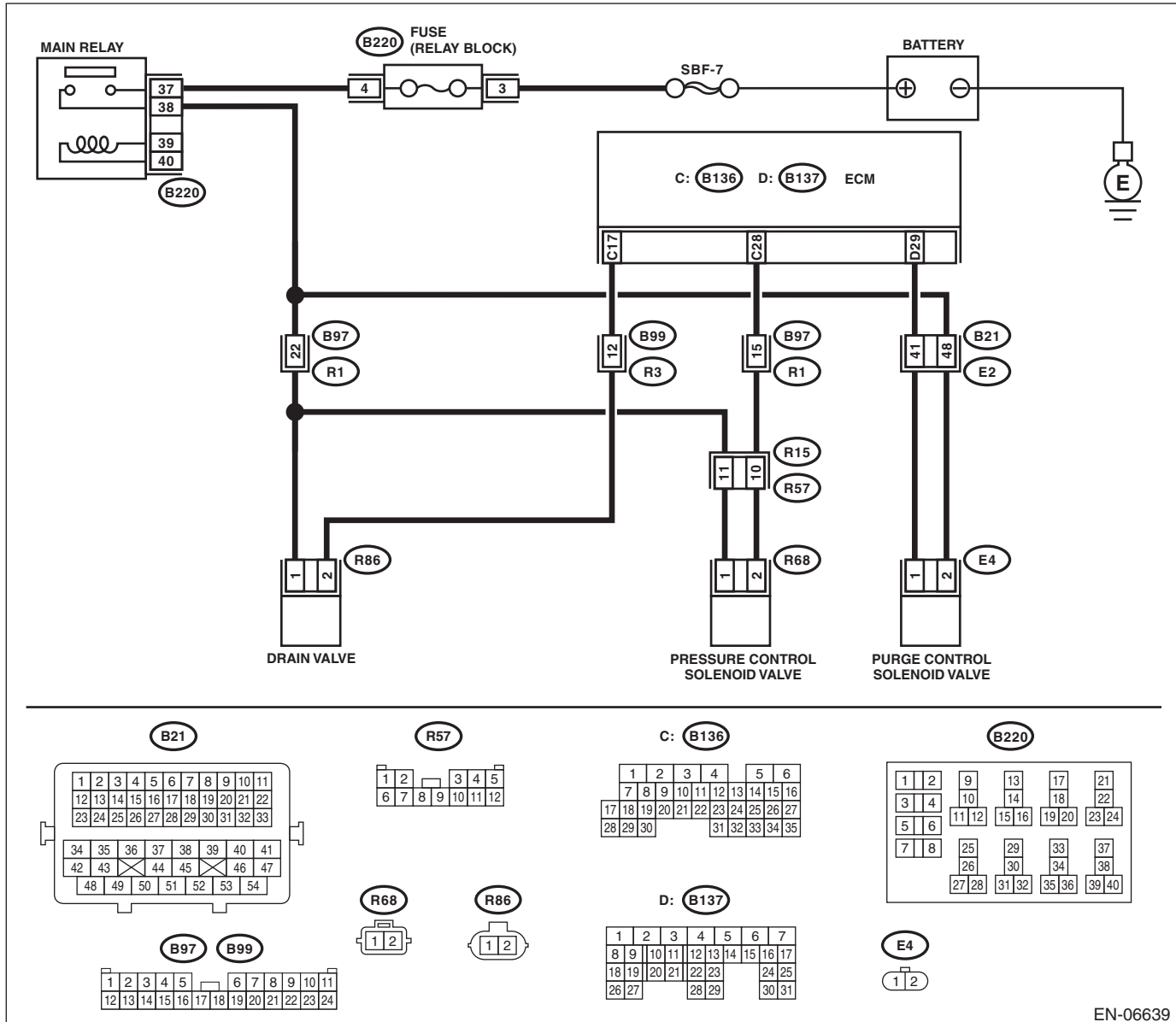

EN-06639

Diagnostic Procedure with Diagnostic Trouble Code (DTC)

ENGINE (DIAGNOSTICS)

Step	Check	Yes	No
1 CHECK OUTPUT SIGNAL OF ECM. 1) Turn the ignition switch to ON. 2) Measure the voltage between ECM and chassis ground. Connector & terminal (B136) No. 17 (+) — Chassis ground (-):	Is the voltage 10 V or more?	Go to step 2.	Go to step 3.
2 CHECK FOR POOR CONTACT. Check for poor contact of ECM connector.	Is there poor contact of ECM connector?	Repair the poor contact of ECM connector.	Even if DTC is detected, the circuit has returned to a normal condition at this time. Reproduce the failure, and then perform the diagnosis again. NOTE: In this case, temporary open or short circuit of harness or temporary poor contact of connector may be the cause.
3 CHECK POWER SUPPLY TO DRAIN VALVE. Measure the voltage between drain valve and chassis ground. Connector & terminal (R86) No. 1 (+) — Chassis ground (-):	Is the voltage 10 V or more?	Go to step 4.	Repair the power supply circuit.
4 CHECK HARNESS BETWEEN ECM AND DRAIN VALVE. 1) Turn the ignition switch to OFF. 2) Disconnect the connectors from the ECM and drain valve. 3) Measure the resistance between the drain valve connector and chassis ground. Connector & terminal (R86) No. 2 — Chassis ground:	Is the resistance 1 M Ω or more?	Go to step 5.	Repair the ground short circuit of harness between ECM and drain valve connector.
5 CHECK HARNESS BETWEEN ECM AND DRAIN VALVE. Measure the resistance of harness between ECM and drain valve connector. Connector & terminal (B136) No. 17 — (R86) No. 2:	Is the resistance less than 1 Ω ?	Go to step 6.	Repair the harness and connector. NOTE: In this case, repair the following item: <ul style="list-style-type: none"> • Open circuit of harness between ECM and drain valve connector • Poor contact of coupling connector
6 CHECK DRAIN VALVE. Measure the resistance between drain valve terminals. Terminals No. 1 — No. 2:	Is the resistance between 10 — 100 Ω ?	Repair poor contact of the drain valve connector.	Replace the drain valve. <Ref. to EC(H4SO)-18, Drain Valve.>

BH:DTC P0448 EVAPORATIVE EMISSION CONTROL SYSTEM VENT CONTROL CIRCUIT SHORTED

DTC DETECTING CONDITION:

- Immediately at fault recognition
- GENERAL DESCRIPTION <Ref. to GD(H4SO)-117, DTC P0448 EVAPORATIVE EMISSION CONTROL SYSTEM VENT CONTROL CIRCUIT SHORTED, Diagnostic Trouble Code (DTC) Detecting Criteria.>

CAUTION:

After repair or replacement of faulty parts, perform Clear Memory Mode <Ref. to EN(H4SO)(diag)-51, OPERATION, Clear Memory Mode.> and Inspection Mode <Ref. to EN(H4SO)(diag)-41, PROCEDURE, Inspection Mode.>.

WIRING DIAGRAM:

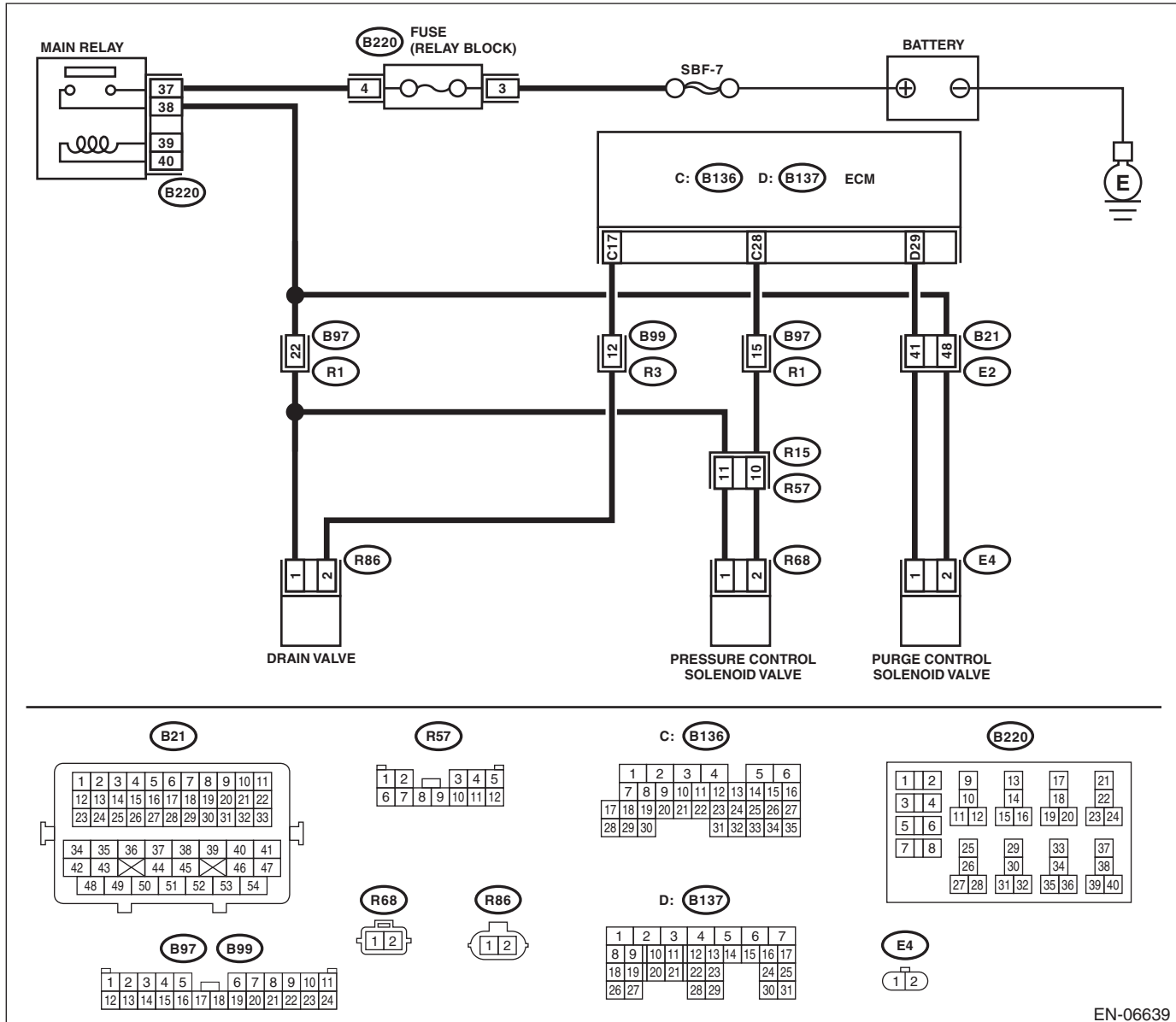

EN-06639

Diagnostic Procedure with Diagnostic Trouble Code (DTC)

ENGINE (DIAGNOSTICS)

Step	Check	Yes	No
1 CHECK HARNESS BETWEEN ECM AND DRAIN VALVE. 1) Turn the ignition switch to OFF. 2) Disconnect the connectors from the ECM and drain valve. 3) Turn the ignition switch to ON. 4) Measure the voltage between ECM and chassis ground. <i>Connector & terminal</i> <i>(B136) No. 17 (+) — Chassis ground (-):</i>	Is the voltage 10 V or more?	Repair the short circuit to power in the harness between ECM and drain valve connector.	Go to step 2.
2 CHECK DRAIN VALVE. 1) Turn the ignition switch to OFF. 2) Measure the resistance between drain valve terminals. <i>Terminals</i> <i>No. 1 — No. 2:</i>	Is the resistance less than 1 Ω ?	Replace the drain valve. <Ref. to EC(H4SO)-18, Drain Valve.>	Repair the poor contact of the ECM connector.

Diagnostic Procedure with Diagnostic Trouble Code (DTC)

ENGINE (DIAGNOSTICS)

BI: DTC P0451 EVAPORATIVE EMISSION CONTROL SYSTEM PRESSURE SENSOR

DTC DETECTING CONDITION:

- Detected when two consecutive driving cycles with fault occur.
- GENERAL DESCRIPTION <Ref. to GD(H4SO)-119, DTC P0451 EVAPORATIVE EMISSION CONTROL SYSTEM PRESSURE SENSOR, Diagnostic Trouble Code (DTC) Detecting Criteria.>

CAUTION:

After repair or replacement of faulty parts, perform Clear Memory Mode <Ref. to EN(H4SO)(diag)-51, OPERATION, Clear Memory Mode.> and Inspection Mode <Ref. to EN(H4SO)(diag)-41, PROCEDURE, Inspection Mode.>.

WIRING DIAGRAM:

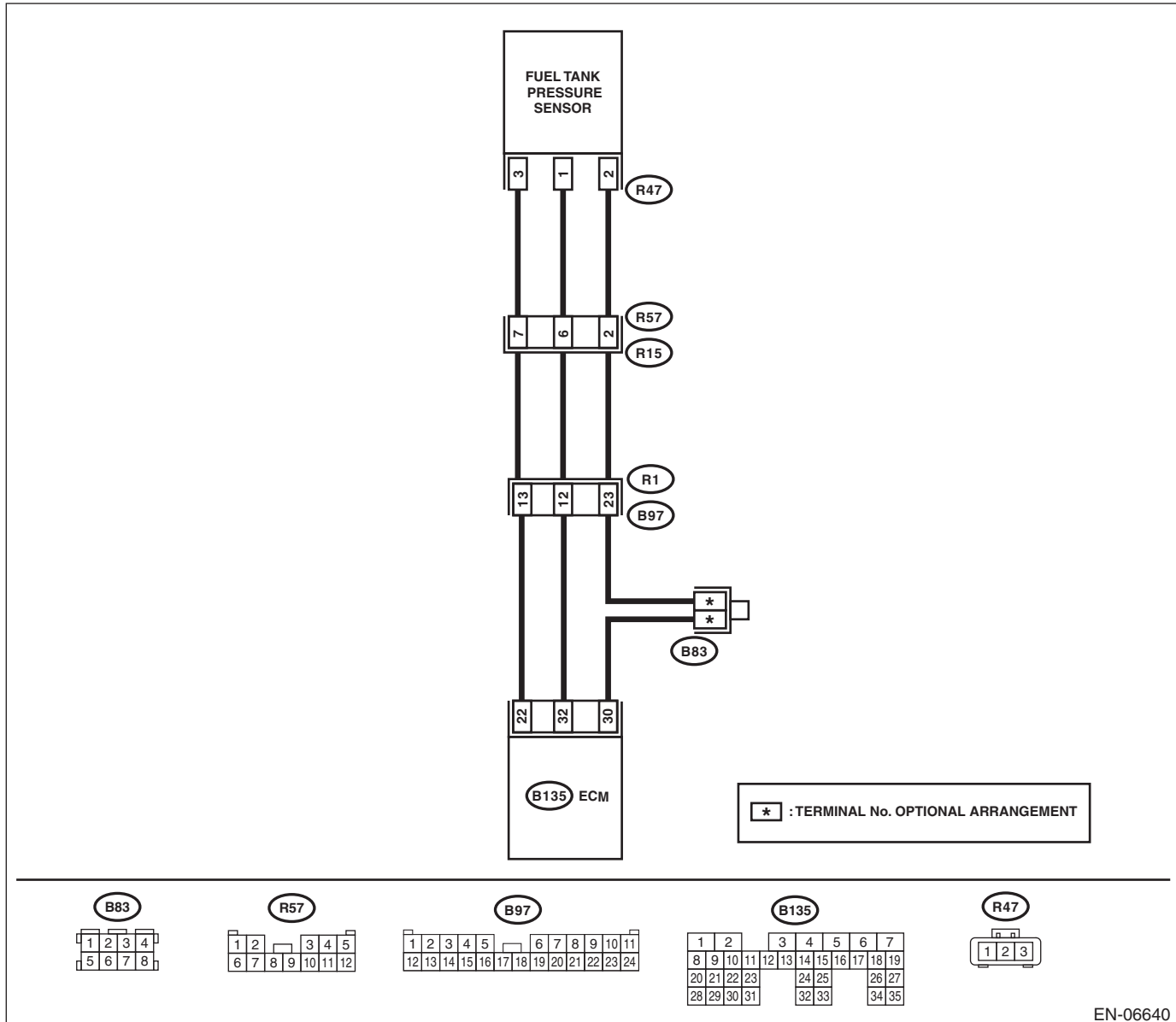

EN-06640

Diagnostic Procedure with Diagnostic Trouble Code (DTC)

ENGINE (DIAGNOSTICS)

Step	Check	Yes	No
1 CHECK FUEL FILLER CAP. 1) Turn the ignition switch to OFF. 2) Open the fuel flap.	Is the fuel filler cap tightened securely?	Go to step 2.	Tighten fuel filler cap securely.
2 CHECK PRESSURE VACUUM LINE. NOTE: Check the following items. <ul style="list-style-type: none">• Disconnection, leakage and clogging of the vacuum hoses and pipes between fuel tank pressure sensor and fuel tank• Disconnection, leakage and clogging of air ventilation hoses and pipes between fuel filler pipe and fuel tank	Is there any fault in pressure/vacuum line?	Repair or replace the hoses and pipes.	Replace the fuel tank pressure sensor. <Ref. to EC(H4SO)-14, Fuel Tank Pressure Sensor.>

BJ: DTC P0452 EVAPORATIVE EMISSION CONTROL SYSTEM PRESSURE SENSOR LOW INPUT

DTC DETECTING CONDITION:

- Immediately at fault recognition
- GENERAL DESCRIPTION <Ref. to GD(H4SO)-121, DTC P0452 EVAPORATIVE EMISSION CONTROL SYSTEM PRESSURE SENSOR LOW INPUT, Diagnostic Trouble Code (DTC) Detecting Criteria.>

CAUTION:

After repair or replacement of faulty parts, perform Clear Memory Mode <Ref. to EN(H4SO)(diag)-51, OPERATION, Clear Memory Mode.> and Inspection Mode <Ref. to EN(H4SO)(diag)-41, PROCEDURE, Inspection Mode.>.

WIRING DIAGRAM:

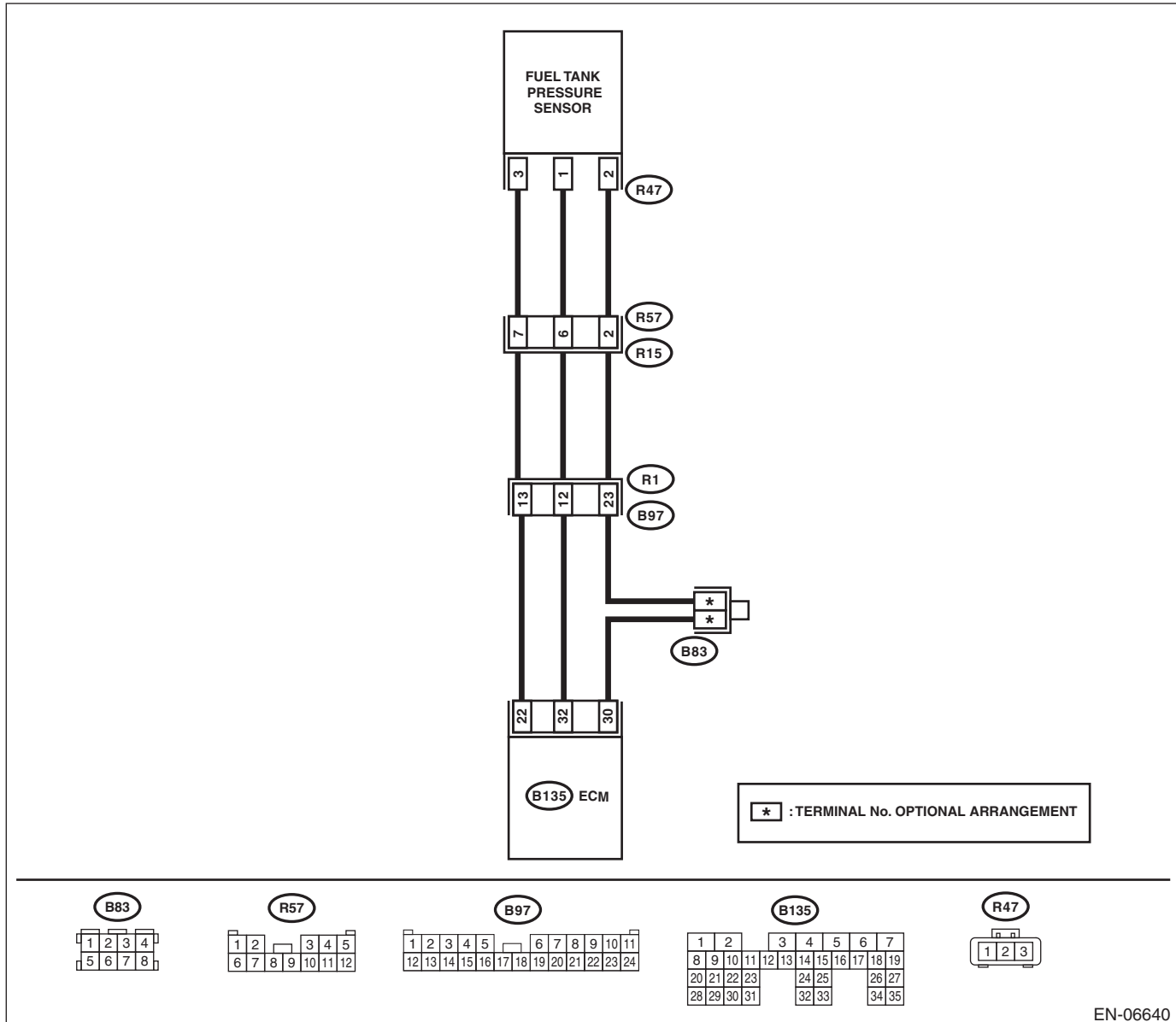

Diagnostic Procedure with Diagnostic Trouble Code (DTC)

ENGINE (DIAGNOSTICS)

	Step	Check	Yes	No
1	<p>CHECK CURRENT DATA.</p> <p>1) Turn the ignition switch to ON.</p> <p>2) Read the data of fuel tank pressure sensor signal using the Subaru Select Monitor or general scan tool.</p> <p>NOTE:</p> <ul style="list-style-type: none"> Subaru Select Monitor <p>For detailed operation procedures, refer to "READ CURRENT DATA FOR ENGINE". <Ref. to EN(H4SO)(diag)-33, Subaru Select Monitor.></p> <ul style="list-style-type: none"> General scan tool <p>For detailed operation procedures, refer to the general scan tool operation manual.</p>	Is the measured value less than -7.45 kPa (-55.9 mmHg, -2.2 inHg)?	Go to step 2.	<p>Even if the malfunction indicator light illuminates, the circuit has returned to a normal condition at this time. Reproduce the fault condition, and reperform the check.</p> <p>NOTE:</p> <p>In this case, there may be a temporary connector contact failure.</p>
2	<p>CHECK FUEL TANK PRESSURE SENSOR POWER SOURCE.</p> <p>1) Turn the ignition switch to OFF.</p> <p>2) Disconnect the connector from the fuel tank pressure sensor.</p> <p>3) Turn the ignition switch to ON.</p> <p>4) Measure the voltage between the fuel tank pressure sensor connector and chassis ground.</p> <p>Connector & terminal (R47) No. 3 (+) — Chassis ground (-):</p>	Is the voltage 4.5 V or more?	Go to step 3.	<p>Repair the harness and connector.</p> <p>NOTE:</p> <p>In this case, repair the following item:</p> <ul style="list-style-type: none"> Open circuit of harness between ECM and fuel tank pressure sensor connector Poor contact in ECM connector Poor contact of coupling connector
3	<p>CHECK HARNESS BETWEEN ECM AND FUEL TANK PRESSURE SENSOR CONNECTOR.</p> <p>1) Turn the ignition switch to OFF.</p> <p>2) Disconnect the connectors from the ECM.</p> <p>3) Measure the resistance of harness between the ECM and fuel tank pressure sensor connector.</p> <p>Connector & terminal (B135) No. 32 — (R47) No. 1:</p>	Is the resistance less than 1 Ω?	Go to step 4.	<p>Repair the harness and connector.</p> <p>NOTE:</p> <p>In this case, repair the following item:</p> <ul style="list-style-type: none"> Open circuit of harness between ECM and fuel tank pressure sensor connector Poor contact of coupling connector
4	<p>CHECK HARNESS BETWEEN ECM AND FUEL TANK PRESSURE SENSOR CONNECTOR.</p> <p>Measure the resistance between ECM and chassis ground.</p> <p>Connector & terminal (B135) No. 32 — Chassis ground:</p>	Is the resistance 1 MΩ or more?	Go to step 5.	<p>Repair the ground short circuit of harness between ECM and fuel tank pressure sensor connector.</p>
5	<p>CHECK POOR CONTACT.</p> <p>Check for poor contact between the ECM and fuel tank pressure sensor connector.</p>	Is there poor contact in the ECM or fuel tank pressure sensor connector?	Repair the poor contact in the ECM or fuel tank pressure sensor connector.	<p>Replace the fuel tank pressure sensor. <Ref. to EC(H4SO)-14, Fuel Tank Pressure Sensor.></p>

BK:DTC P0453 EVAPORATIVE EMISSION CONTROL SYSTEM PRESSURE SENSOR HIGH INPUT

DTC DETECTING CONDITION:

- Immediately at fault recognition
- GENERAL DESCRIPTION <Ref. to GD(H4SO)-123, DTC P0453 EVAPORATIVE EMISSION CONTROL SYSTEM PRESSURE SENSOR HIGH INPUT, Diagnostic Trouble Code (DTC) Detecting Criteria.>

CAUTION:

After repair or replacement of faulty parts, perform Clear Memory Mode <Ref. to EN(H4SO)(diag)-51, OPERATION, Clear Memory Mode.> and Inspection Mode <Ref. to EN(H4SO)(diag)-41, PROCEDURE, Inspection Mode.>.

WIRING DIAGRAM:

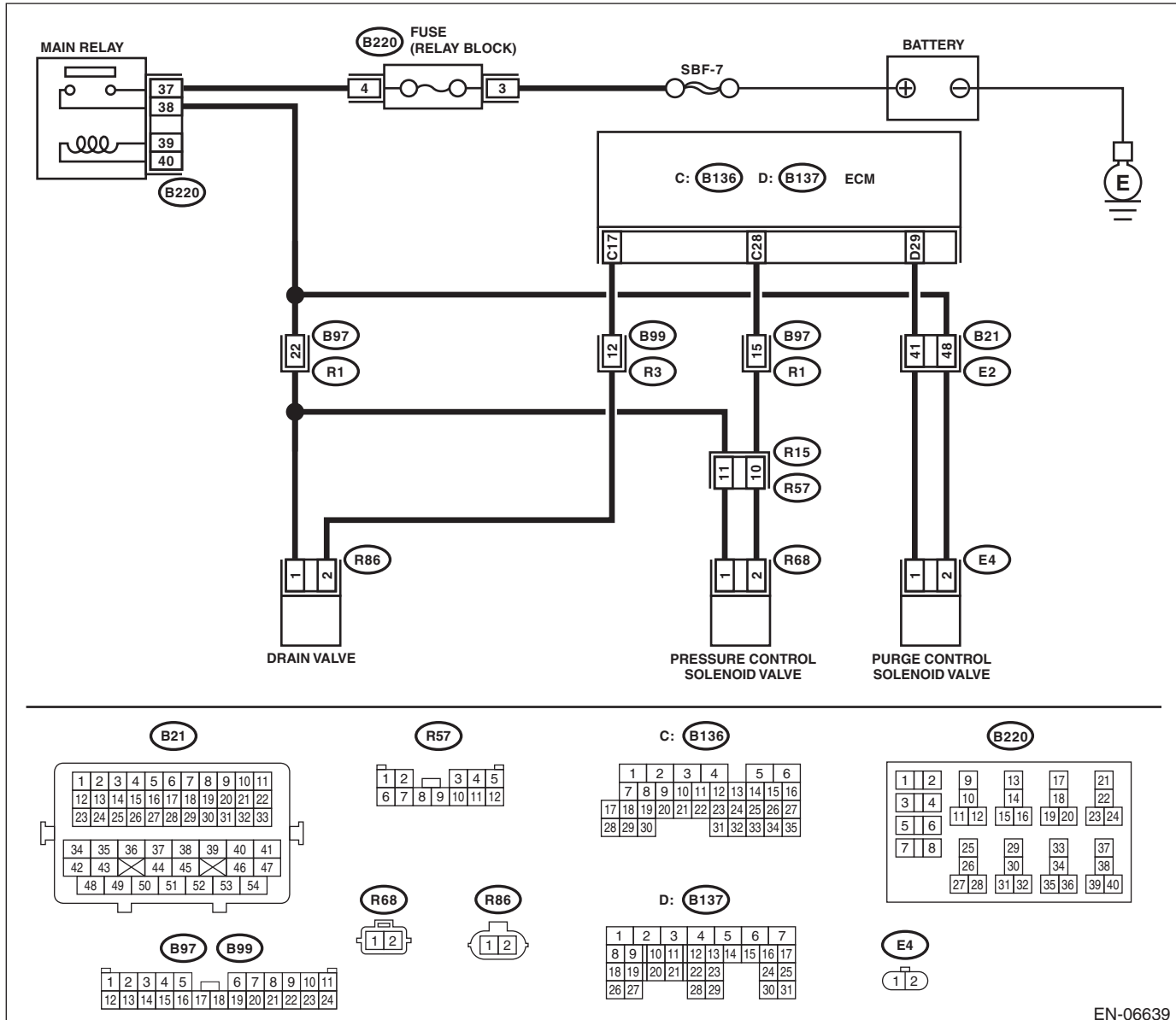

EN-06639

Diagnostic Procedure with Diagnostic Trouble Code (DTC)

ENGINE (DIAGNOSTICS)

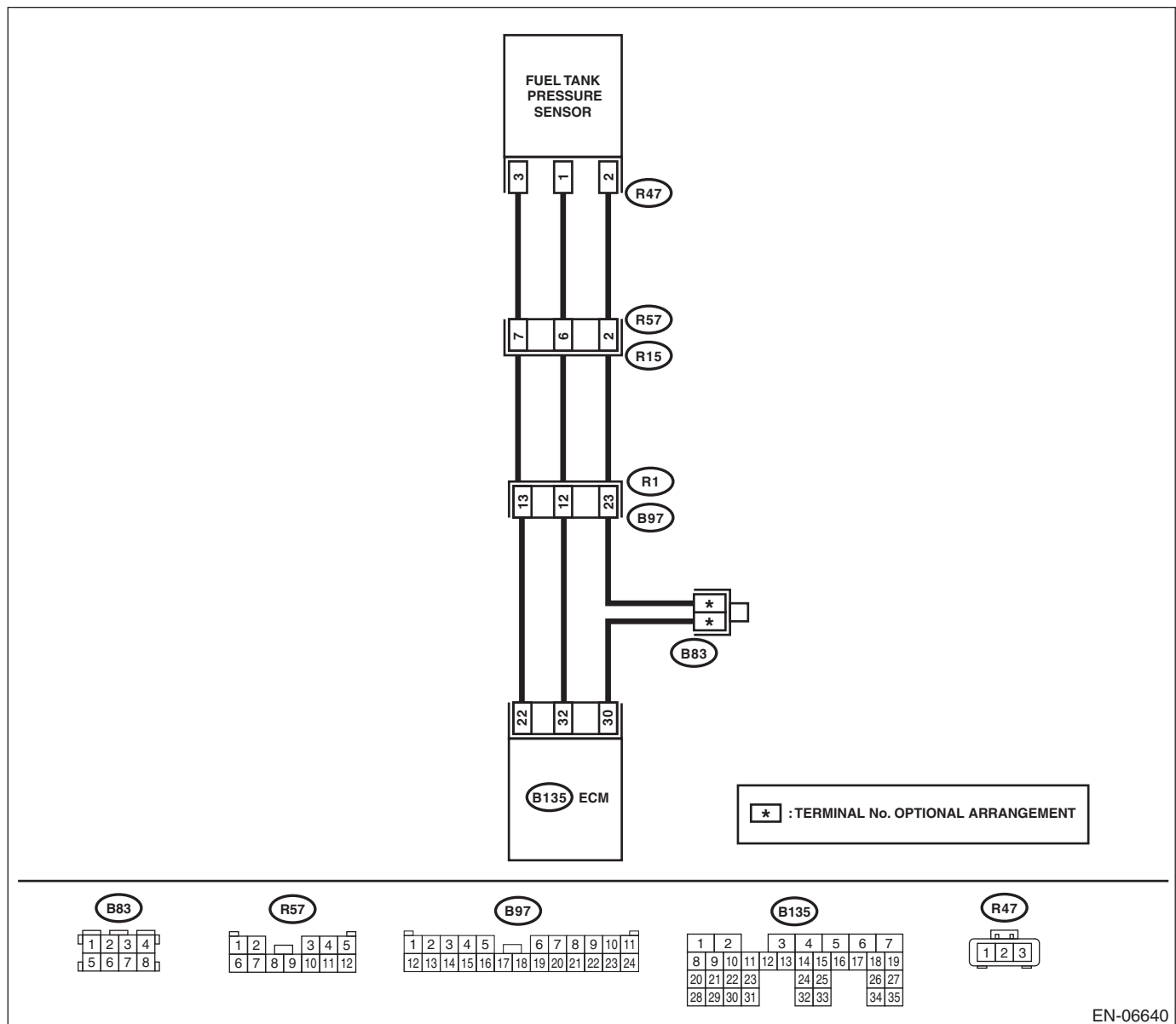

EN-06640

Step	Check	Yes	No
1 CHECK PRESSURE CONTROL SOLENOID VALVE AND EVAPORATION HOSE. Check the pressure control solenoid valve and the evaporation hose. <Ref. to EC(H4SO)-15, INSPECTION, Pressure Control Solenoid Valve.>	Is the pressure control solenoid valve and the evaporation hose normal?	Go to step 2.	Replace the pressure control solenoid valve or the evaporation hose. <Ref. to EC(H4SO)-15, Pressure Control Solenoid Valve.>
2 CHECK HARNESS BETWEEN ECM AND PRESSURE CONTROL SOLENOID VALVE. 1) Turn the ignition switch to OFF. 2) Disconnect the connector from the ECM and pressure control solenoid valve. 3) Turn the ignition switch to ON. 4) Measure the voltage between ECM and chassis ground. Connector & terminal (B136) No. 28 (+) — Chassis ground (-):	Is the voltage 10 V or more?	Repair the short circuit to power in the harness between ECM and pressure control solenoid valve connector.	Go to step 3.

Diagnostic Procedure with Diagnostic Trouble Code (DTC)

ENGINE (DIAGNOSTICS)

Step	Check	Yes	No
3 CHECK PRESSURE CONTROL SOLENOID VALVE. 1) Turn the ignition switch to OFF. 2) Measure the resistance between pressure control solenoid valve terminals. Terminals No. 1 — No. 2:	Is the resistance 20 — 30 Ω?	Go to step 4.	Replace the pressure control solenoid valve. <Ref. to EC(H4SO)-15, Pressure Control Solenoid Valve.>
4 CHECK FOR POOR CONTACT. Check for poor contact of ECM connector.	Is there poor contact of ECM connector?	Repair the poor contact of ECM connector.	Go to step 5.
5 CHECK CURRENT DATA. 1) Turn the ignition switch to ON. 2) Read the data of fuel tank pressure sensor signal using the Subaru Select Monitor or general scan tool. NOTE: <ul style="list-style-type: none"> Subaru Select Monitor For detailed operation procedures, refer to "READ CURRENT DATA FOR ENGINE". <Ref. to EN(H4SO)(diag)-33, Subaru Select Monitor.> <ul style="list-style-type: none"> General scan tool For detailed operation procedures, refer to the general scan tool operation manual.	Is the measured value 7.95 kPa (59.6 mmHg, 2.35 inHg) or more?	Go to step 6.	Even if the malfunction indicator light illuminates, the circuit has returned to a normal condition at this time. Reproduce the fault condition, and reperform the check. NOTE: In this case, there may be a temporary connector contact failure.
6 CHECK HARNESS BETWEEN ECM AND FUEL TANK PRESSURE SENSOR CONNECTOR. 1) Turn the ignition switch to OFF. 2) Disconnect the connector from the fuel tank pressure sensor. 3) Turn the ignition switch to ON. 4) Read the data of fuel tank pressure sensor signal using the Subaru Select Monitor or general scan tool. NOTE: <ul style="list-style-type: none"> Subaru Select Monitor For detailed operation procedures, refer to "READ CURRENT DATA FOR ENGINE". <Ref. to EN(H4SO)(diag)-33, Subaru Select Monitor.> <ul style="list-style-type: none"> General scan tool For detailed operation procedures, refer to the general scan tool operation manual.	Is the measured value 7.95 kPa (59.6 mmHg, 2.35 inHg) or more?	Repair the short circuit to power in the harness between ECM and fuel tank pressure sensor connector.	Go to step 7.
7 CHECK HARNESS BETWEEN ECM AND FUEL TANK PRESSURE SENSOR CONNECTOR. 1) Turn the ignition switch to OFF. 2) Measure the resistance of harness between fuel tank pressure sensor connector and engine ground. Connector & terminal (R47) No. 2 — Engine ground:	Is the resistance less than 5 Ω?	Go to step 8.	Repair the harness and connector. NOTE: In this case, repair the following item: <ul style="list-style-type: none"> Open circuit of harness between ECM and fuel tank pressure sensor connector Poor contact in ECM connector Poor contact of coupling connector

Diagnostic Procedure with Diagnostic Trouble Code (DTC)

ENGINE (DIAGNOSTICS)

	Step	Check	Yes	No
8	CHECK FOR POOR CONTACT. Check for poor contact of the fuel tank pressure sensor connector.	Is there poor contact in fuel tank pressure sensor connector?	Repair the poor contact in the fuel tank pressure sensor connector.	Replace the fuel tank pressure sensor. <Ref. to EC(H4SO)-14, Fuel Tank Pressure Sensor.>

Diagnostic Procedure with Diagnostic Trouble Code (DTC)

ENGINE (DIAGNOSTICS)

BL:DTC P0456 EVAPORATIVE EMISSION CONTROL SYSTEM LEAK DETECTED (VERY SMALL LEAK)

DTC DETECTING CONDITION:

- Detected when two consecutive driving cycles with fault occur.
- GENERAL DESCRIPTION <Ref. to GD(H4SO)-125, DTC P0456 EVAPORATIVE EMISSION CONTROL SYSTEM LEAK DETECTED (VERY SMALL LEAK), Diagnostic Trouble Code (DTC) Detecting Criteria.>

TROUBLE SYMPTOM:

- Fuel odor
- There is a hole of more than 0.5 mm (0.020 in) dia. in evaporation system or fuel tank.

CAUTION:

After repair or replacement of faulty parts, perform Clear Memory Mode <Ref. to EN(H4SO)(diag)-51, OPERATION, Clear Memory Mode.> and Inspection Mode <Ref. to EN(H4SO)(diag)-41, PROCEDURE, Inspection Mode.>.

WIRING DIAGRAM:

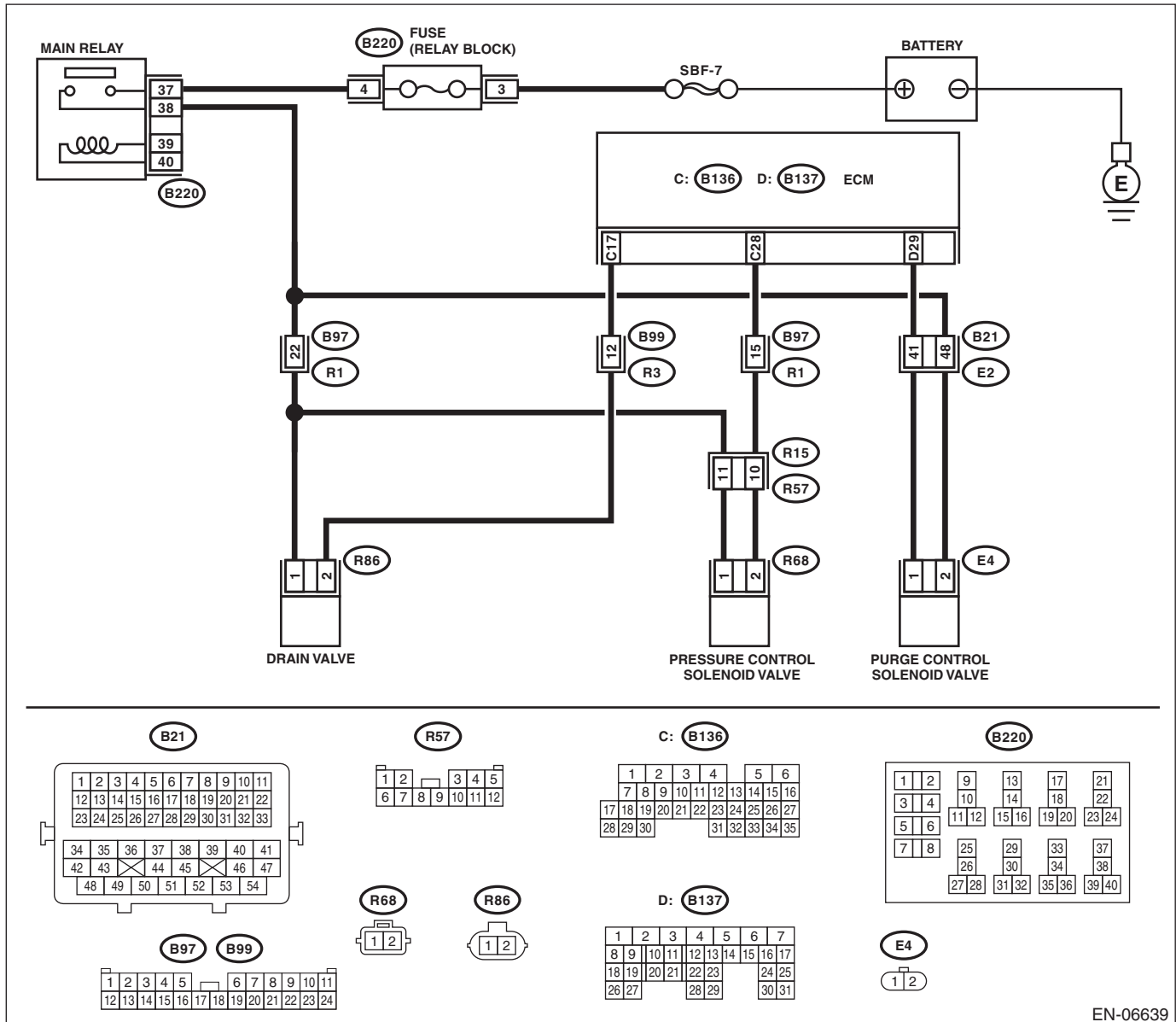

EN-06639

Diagnostic Procedure with Diagnostic Trouble Code (DTC)

ENGINE (DIAGNOSTICS)

Step	Check	Yes	No
1 CHECK FUEL FILLER CAP. 1) Turn the ignition switch to OFF. 2) Check the fuel filler cap. NOTE: The DTC is stored in memory if fuel filler cap is or was loose or if the cap chain has caught while tightening.	Is the fuel filler cap tightened securely?	Go to step 2.	Tighten fuel filler cap securely.
2 CHECK FUEL FILLER CAP.	Is the fuel filler cap genuine?	Go to step 3.	Replace with a genuine fuel filler cap.
3 CHECK FUEL FILLER PIPE GASKET.	Is there any damage to the seal between fuel filler cap and fuel filler pipe?	Repair or replace the fuel filler cap and fuel filler pipe. <Ref. to FU(H4SO)-52, Fuel Filler Pipe.>	Go to step 4.
4 CHECK DRAIN VALVE. 1) Connect the delivery (test) mode connector. 2) Turn the ignition switch to ON. 3) Operate the drain valve using the Subaru Select Monitor. NOTE: Drain valve operation can be executed using the Subaru Select Monitor. Regarding the procedures, refer to "Compulsory Valve Operation Check Mode". <Ref. to EN(H4SO)(diag)-52, Compulsory Valve Operation Check Mode.>	Does the drain valve operate?	Go to step 5.	Replace the drain valve. <Ref. to EC(H4SO)-18, Drain Valve.>
5 CHECK PURGE CONTROL SOLENOID VALVE. Operate the purge control solenoid valve using the Subaru Select Monitor. NOTE: Purge control solenoid valve operation can be executed using Subaru Select Monitor. Regarding the procedures, refer to "Compulsory Valve Operation Check Mode". <Ref. to EN(H4SO)(diag)-52, Compulsory Valve Operation Check Mode.>	Does the purge control solenoid valve operate?	Go to step 6.	Replace the purge control solenoid valve. <Ref. to EC(H4SO)-9, Purge Control Solenoid Valve.>
6 CHECK PRESSURE CONTROL SOLENOID VALVE. Operate the pressure control solenoid valve using the Subaru Select Monitor. NOTE: The pressure control solenoid valve operation can be executed using the Subaru Select Monitor. Regarding the procedures, refer to "Compulsory Valve Operation Check Mode". <Ref. to EN(H4SO)(diag)-52, Compulsory Valve Operation Check Mode.>	Does the pressure control solenoid valve operate?	Go to step 7.	Replace the pressure control solenoid valve. <Ref. to EC(H4SO)-15, Pressure Control Solenoid Valve.>
7 CHECK EVAPORATIVE EMISSION CONTROL SYSTEM LINE. 1) Turn the ignition switch to OFF. 2) Disconnect the delivery (test) mode connector.	Is there any hole of more than 0.5 mm (0.020 in) dia. on evaporation line?	Repair or replace the evaporation line. <Ref. to FU(H4SO)-65, Fuel Delivery and Evaporation Lines.>	Go to step 8.

Diagnostic Procedure with Diagnostic Trouble Code (DTC)

ENGINE (DIAGNOSTICS)

Step	Check	Yes	No
8 CHECK CANISTER.	Is the canister damaged or is there a hole of more than 0.5 mm (0.020 in) dia. in it?	Repair or replace the canister. <Ref. to EC(H4SO)-5, Canister.>	Go to step 9 .
9 CHECK FUEL TANK. Remove the fuel tank. <Ref. to FU(H4SO)-45, Fuel Tank.>	Is the fuel tank damaged or is there any hole of more than 0.5 mm (0.020 in) dia. in it?	Repair or replace the fuel tank. <Ref. to FU(H4SO)-45, Fuel Tank.>	Go to step 10 .
10 CHECK ANY OTHER MECHANICAL TROUBLE IN EVAPORATIVE EMISSION CONTROL SYSTEM.	Is there any hole of more than 0.5 mm (0.020 in) dia., crack, clogging, or disconnections, bend, misconnection of hoses or pipes in evaporative emission control system?	Repair or replace the hoses or pipes.	Repair the poor contact of the ECM connector.

Diagnostic Procedure with Diagnostic Trouble Code (DTC)

ENGINE (DIAGNOSTICS)

BM:DTC P0457 EVAPORATIVE EMISSION CONTROL SYSTEM LEAK DETECTED (FUEL CAP LOOSE/OFF)

DTC DETECTING CONDITION:

- Detected when two consecutive driving cycles with fault occur.
- GENERAL DESCRIPTION <Ref. to GD(H4SO)-125, DTC P0457 EVAPORATIVE EMISSION CONTROL SYSTEM LEAK DETECTED (FUEL CAP LOOSE/OFF), Diagnostic Trouble Code (DTC) Detecting Criteria.>

TROUBLE SYMPTOM:

- Fuel odor
- Fuel filler cap loose or lost

CAUTION:

After repair or replacement of faulty parts, perform Clear Memory Mode <Ref. to EN(H4SO)(diag)-51, OPERATION, Clear Memory Mode.> and Inspection Mode <Ref. to EN(H4SO)(diag)-41, PROCEDURE, Inspection Mode.>.

WIRING DIAGRAM:

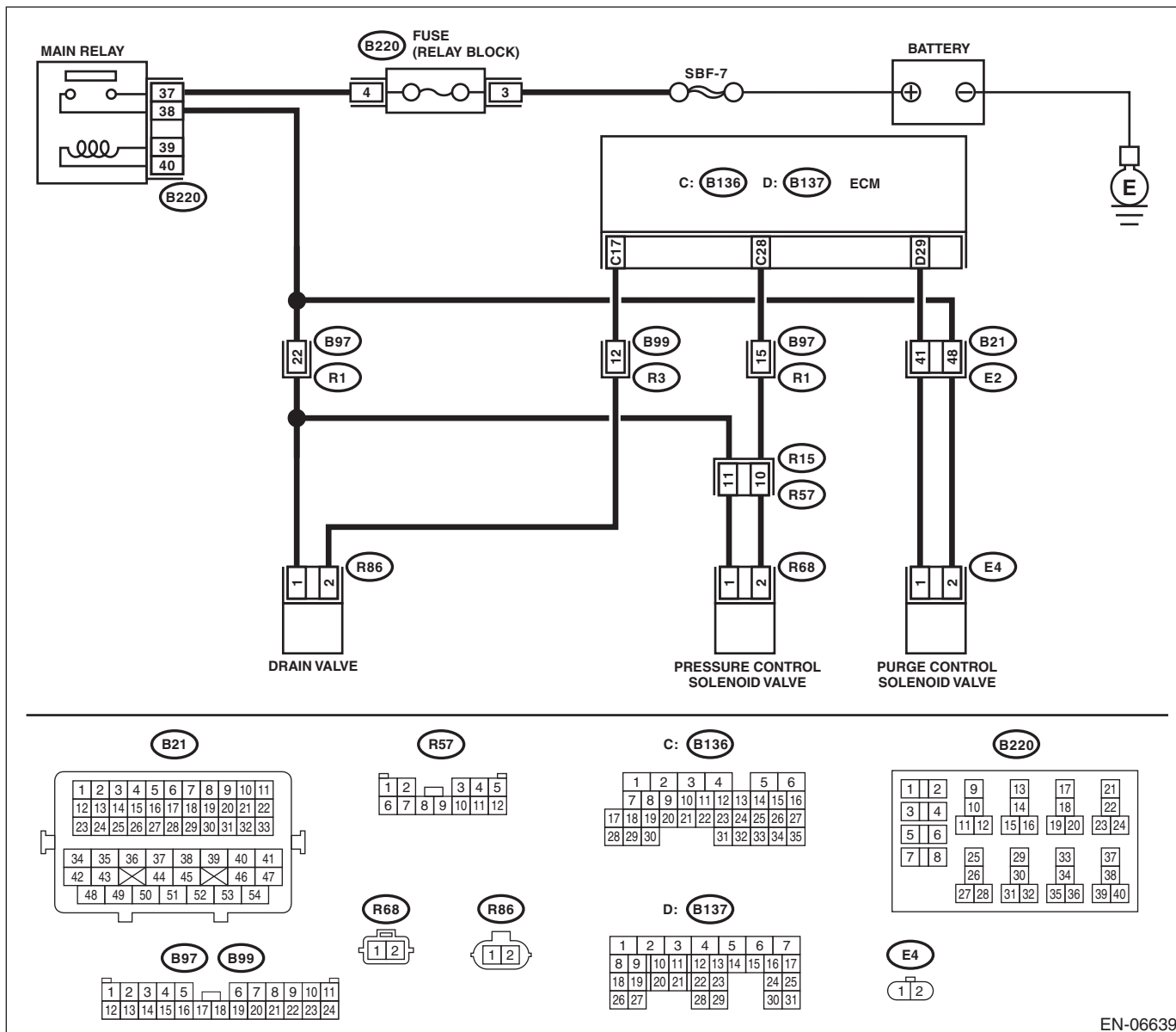

EN-06639

Diagnostic Procedure with Diagnostic Trouble Code (DTC)

ENGINE (DIAGNOSTICS)

Step	Check	Yes	No
1 CHECK FUEL FILLER CAP. 1) Turn the ignition switch to OFF. 2) Check the fuel filler cap. NOTE: The DTC is stored in memory if fuel filler cap is or was loose or if the cap chain has caught while tightening.	Is the fuel filler cap tightened securely?	Go to step 2.	Tighten fuel filler cap securely.
2 CHECK FUEL FILLER CAP.	Is the fuel filler cap genuine?	Go to step 3.	Replace with a genuine fuel filler cap.
3 CHECK FUEL FILLER PIPE GASKET.	Is there any damage to the seal between fuel filler cap and fuel filler pipe?	Repair or replace the fuel filler cap and fuel filler pipe. <Ref. to FU(H4SO)-52, Fuel Filler Pipe.>	Go to step 4.
4 CHECK DRAIN VALVE. 1) Connect the delivery (test) mode connector. 2) Turn the ignition switch to ON. 3) Operate the drain valve using the Subaru Select Monitor. NOTE: Drain valve operation can be executed using the Subaru Select Monitor. Regarding the procedures, refer to "Compulsory Valve Operation Check Mode". <Ref. to EN(H4SO)(diag)-52, Compulsory Valve Operation Check Mode.>	Does the drain valve operate?	Go to step 5.	Replace the drain valve. <Ref. to EC(H4SO)-18, Drain Valve.>
5 CHECK PURGE CONTROL SOLENOID VALVE. Operate the purge control solenoid valve using the Subaru Select Monitor. NOTE: Purge control solenoid valve operation can be executed using Subaru Select Monitor. Regarding the procedures, refer to "Compulsory Valve Operation Check Mode". <Ref. to EN(H4SO)(diag)-52, Compulsory Valve Operation Check Mode.>	Does the purge control solenoid valve operate?	Go to step 6.	Replace the purge control solenoid valve. <Ref. to EC(H4SO)-9, Purge Control Solenoid Valve.>
6 CHECK PRESSURE CONTROL SOLENOID VALVE. Operate the pressure control solenoid valve using the Subaru Select Monitor. NOTE: The pressure control solenoid valve operation can be executed using the Subaru Select Monitor. Regarding the procedures, refer to "Compulsory Valve Operation Check Mode". <Ref. to EN(H4SO)(diag)-52, Compulsory Valve Operation Check Mode.>	Does the pressure control solenoid valve operate?	Go to step 7.	Replace the pressure control solenoid valve. <Ref. to EC(H4SO)-15, Pressure Control Solenoid Valve.>
7 CHECK EVAPORATIVE EMISSION CONTROL SYSTEM LINE. 1) Turn the ignition switch to OFF. 2) Disconnect the delivery (test) mode connector.	Are there any disconnected, broken or clogged evaporation lines?	Repair or replace the evaporation line. <Ref. to FU(H4SO)-65, Fuel Delivery and Evaporation Lines.>	Go to step 8.

Diagnostic Procedure with Diagnostic Trouble Code (DTC)

ENGINE (DIAGNOSTICS)

	Step	Check	Yes	No
8	CHECK CANISTER.	Is the canister damaged?	Repair or replace the canister. <Ref. to EC(H4SO)-5, Canister.>	Go to step 9.
9	CHECK FUEL TANK. Remove the fuel tank. <Ref. to FU(H4SO)-45, Fuel Tank.>	Is the fuel tank damaged?	Repair or replace the fuel tank. <Ref. to FU(H4SO)-45, Fuel Tank.>	Go to step 10.
10	CHECK ANY OTHER MECHANICAL TROUBLE IN EVAPORATIVE EMISSION CONTROL SYSTEM.	Are there holes, cracks, clogging, or disconnections, misconnection of hoses or pipes in evaporative emission control system?	Repair or replace the hoses or pipes.	Repair the poor contact of the ECM connector.

Diagnostic Procedure with Diagnostic Trouble Code (DTC)

ENGINE (DIAGNOSTICS)

BN:DTC P0458 EVAPORATIVE EMISSION SYSTEM PURGE CONTROL VALVE CIRCUIT LOW

DTC DETECTING CONDITION:

- Detected when two consecutive driving cycles with fault occur.
- GENERAL DESCRIPTION <Ref. to GD(H4SO)-126, DTC P0458 EVAPORATIVE EMISSION SYSTEM PURGE CONTROL VALVE CIRCUIT LOW, Diagnostic Trouble Code (DTC) Detecting Criteria.>

TROUBLE SYMPTOM:

Improper idling

CAUTION:

After repair or replacement of faulty parts, perform Clear Memory Mode <Ref. to EN(H4SO)(diag)-51, OPERATION, Clear Memory Mode.> and Inspection Mode <Ref. to EN(H4SO)(diag)-41, PROCEDURE, Inspection Mode.>.

WIRING DIAGRAM:

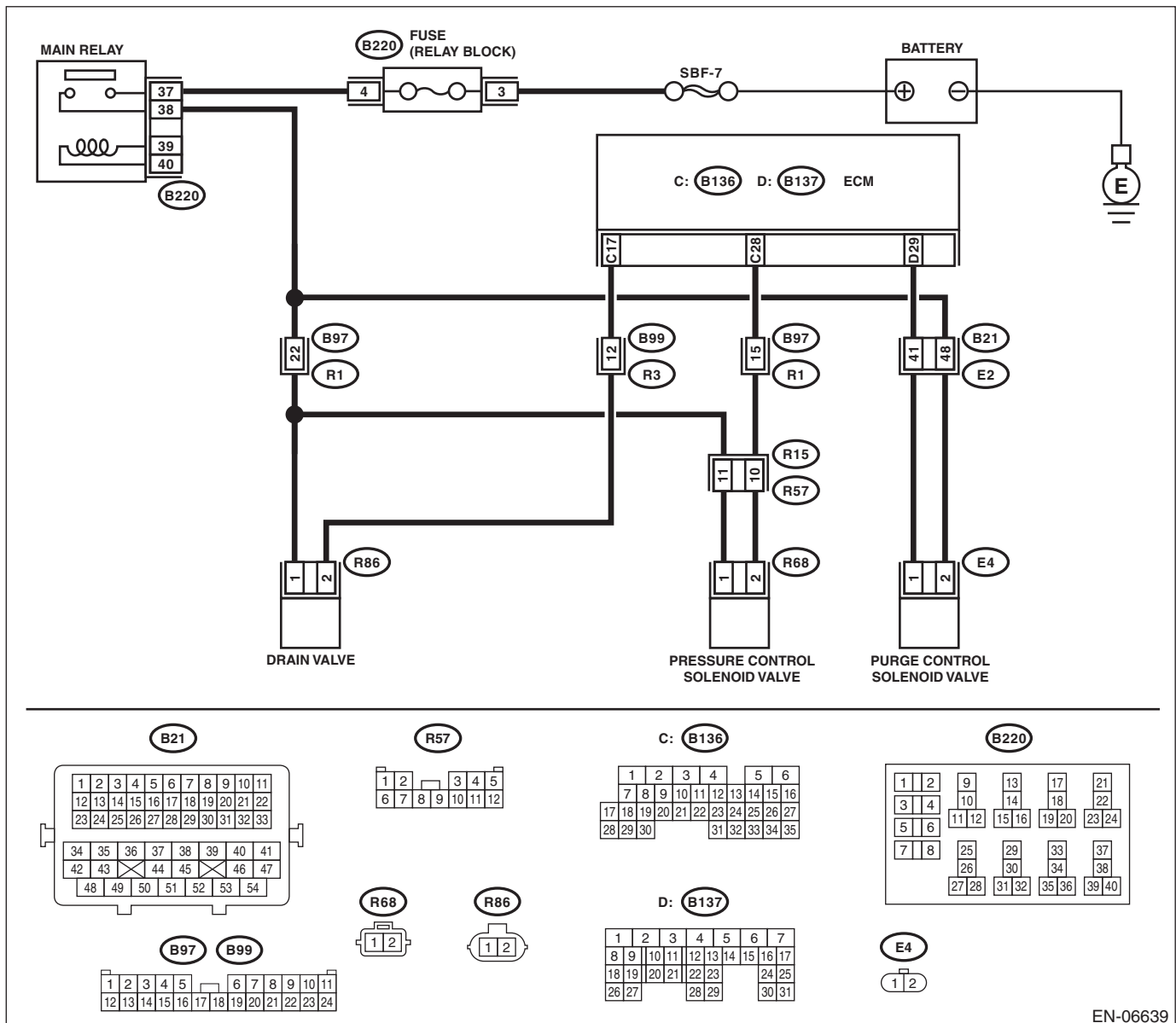

EN-06639

Diagnostic Procedure with Diagnostic Trouble Code (DTC)

ENGINE (DIAGNOSTICS)

Step	Check	Yes	No
1 CHECK OUTPUT SIGNAL OF ECM. 1) Turn the ignition switch to ON. 2) Measure the voltage between ECM and chassis ground. Connector & terminal (B137) No. 29 (+) — Chassis ground (-):	Is the voltage 10 V or more?	Go to step 2.	Go to step 3.
2 CHECK FOR POOR CONTACT. Check for poor contact of ECM connector.	Is there poor contact of ECM connector?	Repair the poor contact of ECM connector.	Even if DTC is detected, the circuit has returned to a normal condition at this time. Reproduce the failure, and then perform the diagnosis again. NOTE: In this case, temporary open or short circuit of harness or temporary poor contact of connector may be the cause.
3 CHECK POWER SUPPLY TO PURGE CONTROL SOLENOID VALVE. Measure the voltage between purge control solenoid valve and engine ground. Connector & terminal (E4) No. 2 (+) — Engine ground (-):	Is the voltage 10 V or more?	Go to step 4.	Repair the power supply circuit.
4 CHECK HARNESS BETWEEN ECM AND PURGE CONTROL SOLENOID VALVE. 1) Turn the ignition switch to OFF. 2) Disconnect the connectors from ECM and purge control solenoid valve. 3) Measure the resistance between the purge control solenoid valve connector and engine ground. Connector & terminal (E4) No. 1 — Engine ground:	Is the resistance 1 M Ω or more?	Go to step 5.	Repair the ground short circuit of harness between ECM and purge control solenoid valve connector.
5 CHECK HARNESS BETWEEN ECM AND PURGE CONTROL SOLENOID VALVE. Measure the resistance of harness between ECM and purge control solenoid valve. Connector & terminal (B137) No. 29 — (E4) No. 1:	Is the resistance less than 1 Ω ?	Go to step 6.	Repair the harness and connector. NOTE: In this case, repair the following item: <ul style="list-style-type: none"> • Open circuit of harness between ECM and purge control solenoid valve connector • Poor contact of coupling connector
6 CHECK PURGE CONTROL SOLENOID VALVE. 1) Remove the purge control solenoid valve. 2) Measure the resistance between purge control solenoid valve terminals. Terminals No. 1 — No. 2:	Is the resistance between 10 — 100 Ω ?	Repair the poor contact of purge control solenoid valve connector.	Replace the purge control solenoid valve. <Ref. to EC(H4SO)-9, Purge Control Solenoid Valve.>

Diagnostic Procedure with Diagnostic Trouble Code (DTC)

ENGINE (DIAGNOSTICS)

BO:DTC P0459 EVAPORATIVE EMISSION SYSTEM PURGE CONTROL VALVE CIRCUIT HIGH

DTC DETECTING CONDITION:

- Detected when two consecutive driving cycles with fault occur.
- GENERAL DESCRIPTION <Ref. to GD(H4SO)-127, DTC P0459 EVAPORATIVE EMISSION SYSTEM PURGE CONTROL VALVE CIRCUIT HIGH, Diagnostic Trouble Code (DTC) Detecting Criteria.>

TROUBLE SYMPTOM:

Improper idling

CAUTION:

After repair or replacement of faulty parts, perform Clear Memory Mode <Ref. to EN(H4SO)(diag)-51, OPERATION, Clear Memory Mode.> and Inspection Mode <Ref. to EN(H4SO)(diag)-41, PROCEDURE, Inspection Mode.>.

WIRING DIAGRAM:

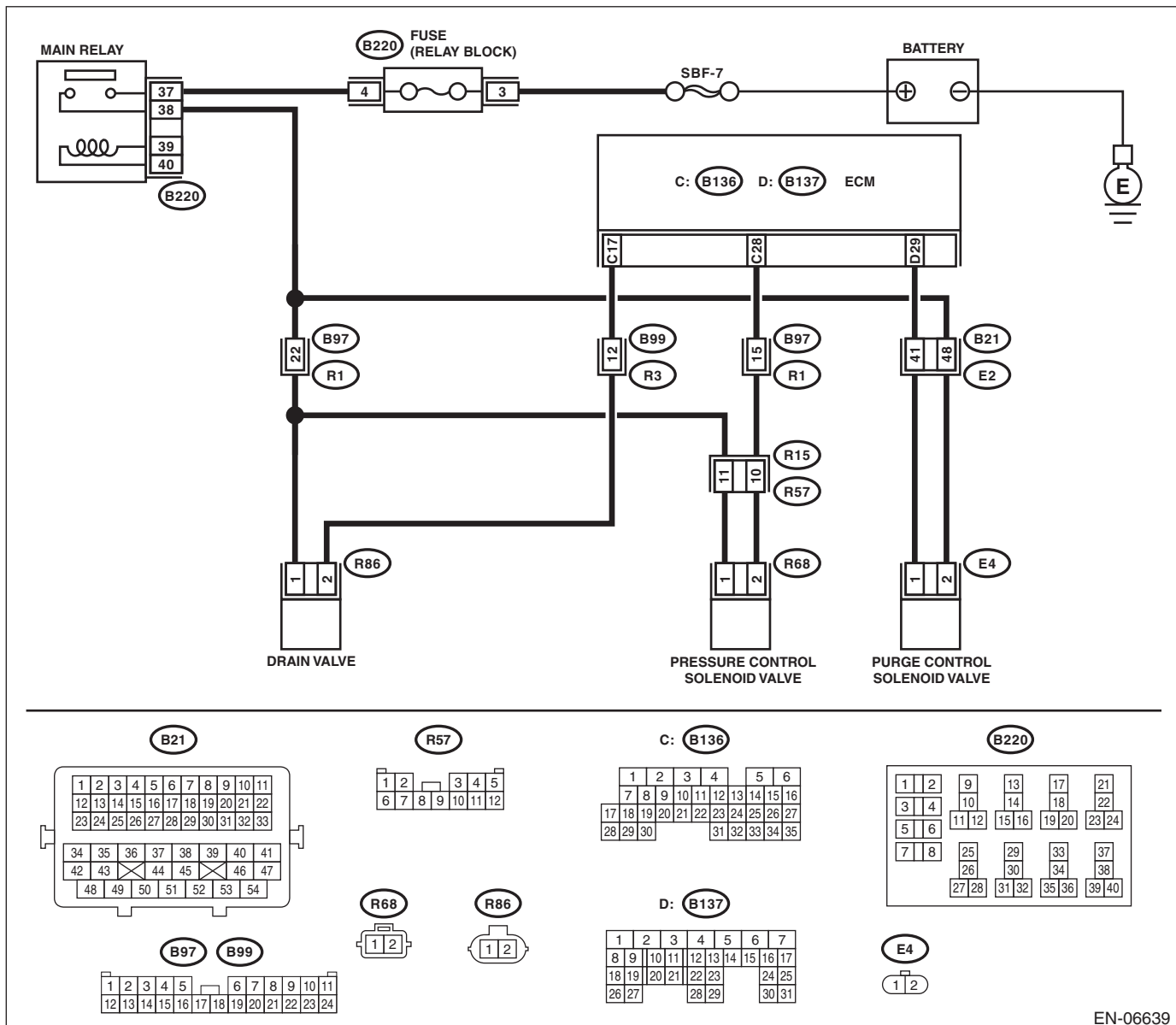

EN-06639

Diagnostic Procedure with Diagnostic Trouble Code (DTC)

ENGINE (DIAGNOSTICS)

Step	Check	Yes	No
1 CHECK HARNESS BETWEEN ECM AND PURGE CONTROL SOLENOID VALVE. 1) Turn the ignition switch to OFF. 2) Disconnect the connectors from ECM and purge control solenoid valve. 3) Turn the ignition switch to ON. 4) Measure the voltage between ECM and chassis ground. Connector & terminal (B137) No. 29 (+) — Chassis ground (-):	Is the voltage 10 V or more?	Repair the short circuit to power in the harness between the ECM and purge control solenoid valve connector.	Go to step 2.
2 CHECK PURGE CONTROL SOLENOID VALVE. 1) Turn the ignition switch to OFF. 2) Measure the resistance between purge control solenoid valve terminals. Terminals No. 1 — No. 2:	Is the resistance less than 1 Ω ?	Replace the purge control solenoid valve. <Ref. to EC(H4SO)-9, Purge Control Solenoid Valve.>	Repair the poor contact of the ECM connector.

Diagnostic Procedure with Diagnostic Trouble Code (DTC)

ENGINE (DIAGNOSTICS)

BP:DTC P0461 FUEL LEVEL SENSOR “A” CIRCUIT RANGE/PERFORMANCE

DTC DETECTING CONDITION:

- Detected when two consecutive driving cycles with fault occur.
- GENERAL DESCRIPTION <Ref. to GD(H4SO)-128, DTC P0461 FUEL LEVEL SENSOR “A” CIRCUIT RANGE/PERFORMANCE, Diagnostic Trouble Code (DTC) Detecting Criteria.>

CAUTION:

After repair or replacement of faulty parts, perform Clear Memory Mode <Ref. to EN(H4SO)(diag)-51, OPERATION, Clear Memory Mode.> and Inspection Mode <Ref. to EN(H4SO)(diag)-41, PROCEDURE, Inspection Mode.>.

Step	Check	Yes	No
1 CHECK FOR ANY OTHER DTC ON DISPLAY.	Is any other DTC displayed?	Check the appropriate DTC using the “List of Diagnostic Trouble Code (DTC)”. <Ref. to EN(H4SO)(diag)-82, List of Diagnostic Trouble Code (DTC).>	Replace the fuel level sensor and fuel sub level sensor. <Ref. to FU(H4SO)-58, Fuel Level Sensor.> <Ref. to FU(H4SO)-60, Fuel Sub Level Sensor.>

BQ:DTC P0462 FUEL LEVEL SENSOR “A” CIRCUIT LOW

NOTE:

For the diagnostic procedure, refer to DTC P0463. <Ref. to EN(H4SO)(diag)-225, DTC P0463 FUEL LEVEL SENSOR “A” CIRCUIT HIGH, Diagnostic Procedure with Diagnostic Trouble Code (DTC).>

BR:DTC P0463 FUEL LEVEL SENSOR “A” CIRCUIT HIGH

DTC DETECTING CONDITION:

- Detected when two consecutive driving cycles with fault occur.
- GENERAL DESCRIPTION <Ref. to GD(H4SO)-132, DTC P0463 FUEL LEVEL SENSOR “A” CIRCUIT HIGH, Diagnostic Trouble Code (DTC) Detecting Criteria.>

CAUTION:

After repair or replacement of faulty parts, perform Clear Memory Mode <Ref. to EN(H4SO)(diag)-51, OPERATION, Clear Memory Mode.> and Inspection Mode <Ref. to EN(H4SO)(diag)-41, PROCEDURE, Inspection Mode.>.

Step	Check	Yes	No
1 CHECK FOR ANY OTHER DTC ON DISPLAY.	Is DTC P0462 or P0463 displayed on the Subaru Select Monitor?	Check the combination meter. <Ref. to IDI-8, CHECK FUEL LEVEL SENSOR, INSPECTION, Combination Meter System.>	Even if the malfunction indicator light illuminates, the circuit has returned to a normal condition at this time. Reproduce the fault condition, and reperform the check. NOTE: In this case, there may be a temporary connector contact failure.

Diagnostic Procedure with Diagnostic Trouble Code (DTC)

ENGINE (DIAGNOSTICS)

BS:DTC P0464 FUEL LEVEL SENSOR CIRCUIT INTERMITTENT

DTC DETECTING CONDITION:

- Detected when two consecutive driving cycles with fault occur.
- GENERAL DESCRIPTION <Ref. to GD(H4SO)-134, DTC P0464 FUEL LEVEL SENSOR CIRCUIT INTERMITTENT, Diagnostic Trouble Code (DTC) Detecting Criteria.>

CAUTION:

After repair or replacement of faulty parts, perform Clear Memory Mode <Ref. to EN(H4SO)(diag)-51, OPERATION, Clear Memory Mode.> and Inspection Mode <Ref. to EN(H4SO)(diag)-41, PROCEDURE, Inspection Mode.>.

Step	Check	Yes	No
1	CHECK FOR ANY OTHER DTC ON DISPLAY. Is DTC P0464 displayed on the display?	Check the combination meter. <Ref. to IDI-8, CHECK FUEL LEVEL SENSOR, INSPECTION, Combination Meter System.>	Even if the malfunction indicator light illuminates, the circuit has returned to a normal condition at this time. Reproduce the fault condition, and reperform the check. NOTE: In this case, there may be a temporary connector contact failure.

BT:DTC P0500 VEHICLE SPEED SENSOR “A”

DTC DETECTING CONDITION:

- Immediately at fault recognition
- GENERAL DESCRIPTION <Ref. to GD(H4SO)-137, DTC P0500 VEHICLE SPEED SENSOR “A”, Diagnostic Trouble Code (DTC) Detecting Criteria.>

CAUTION:

After repair or replacement of faulty parts, perform Clear Memory Mode <Ref. to EN(H4SO)(diag)-51, OPERATION, Clear Memory Mode.> and Inspection Mode <Ref. to EN(H4SO)(diag)-41, PROCEDURE, Inspection Mode.>.

Step	Check	Yes	No
1	CHECK DTC OF VDC. Check DTC of VDC.	Perform the diagnosis according to DTC. <Ref. to VDC(diag)-32, List of Diagnostic Trouble Code (DTC).>	Repair poor contact of the ECM connector.

Diagnostic Procedure with Diagnostic Trouble Code (DTC)

ENGINE (DIAGNOSTICS)

BU:DTC P0506 IDLE AIR CONTROL SYSTEM RPM LOWER THAN EXPECTED

DTC DETECTING CONDITION:

- Detected when two consecutive driving cycles with fault occur.
- GENERAL DESCRIPTION <Ref. to GD(H4SO)-138, DTC P0506 IDLE AIR CONTROL SYSTEM RPM LOWER THAN EXPECTED, Diagnostic Trouble Code (DTC) Detecting Criteria.>

TROUBLE SYMPTOM:

- Hard to start the engine.
- Engine does not start.
- Improper idling
- Engine stalls.

CAUTION:

After repair or replacement of faulty parts, perform Clear Memory Mode <Ref. to EN(H4SO)(diag)-51, OPERATION, Clear Memory Mode.> and Inspection Mode <Ref. to EN(H4SO)(diag)-41, PROCEDURE, Inspection Mode.>.

WIRING DIAGRAM:

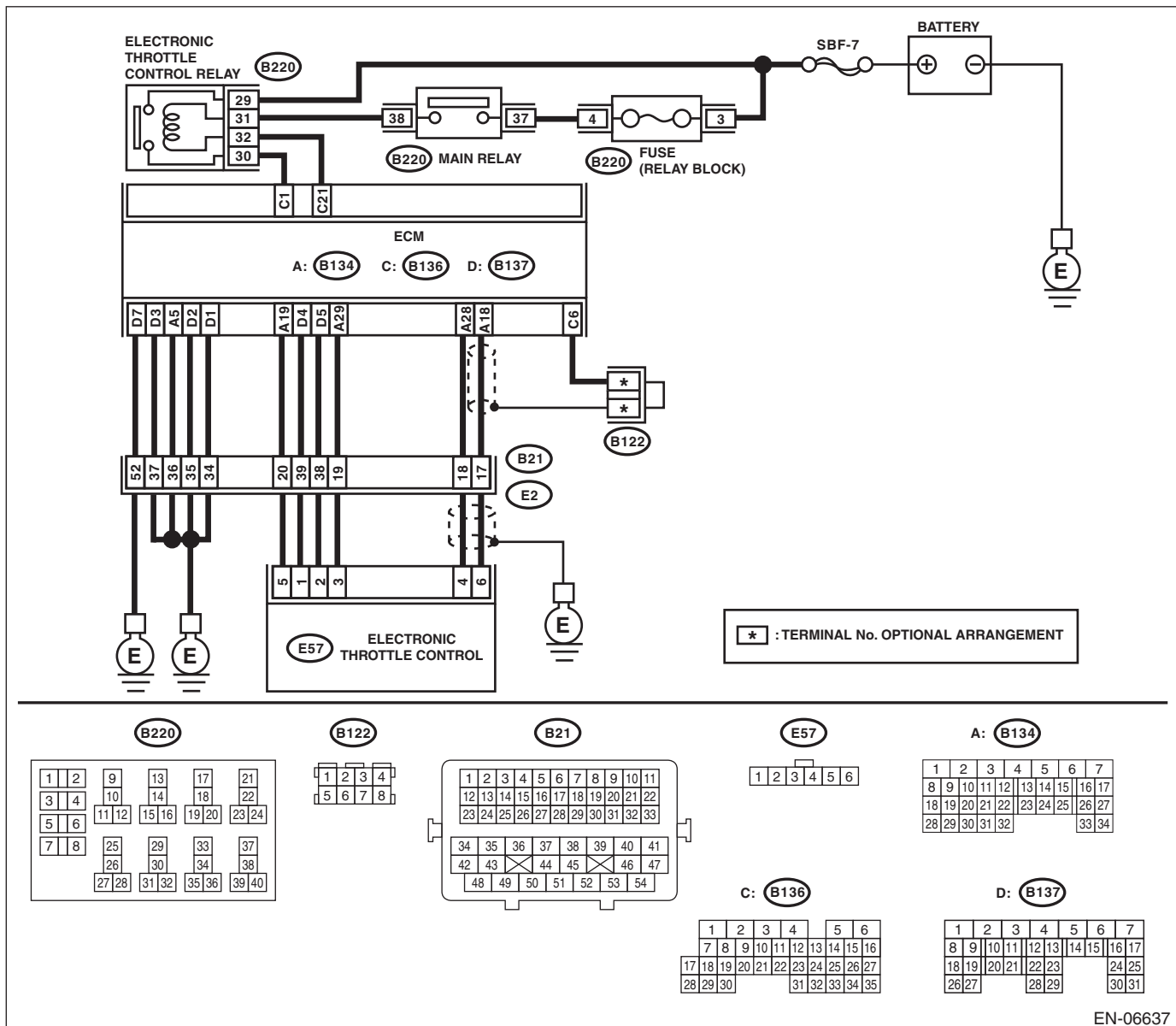

EN-06637

Diagnostic Procedure with Diagnostic Trouble Code (DTC)

ENGINE (DIAGNOSTICS)

Step	Check	Yes	No
1 CHECK FOR ANY OTHER DTC ON DISPLAY.	Is any other DTC displayed?	Check the appropriate DTC using the "List of Diagnostic Trouble Code (DTC)". <Ref. to EN(H4SO)(diag)-82, List of Diagnostic Trouble Code (DTC).>	Go to step 2.
2 CHECK AIR CLEANER ELEMENT. 1) Turn the ignition switch to OFF. 2) Check the air cleaner element.	Is there excessive clogging on air cleaner element?	Replace the air cleaner element. <Ref. to IN(H4SO)-4, Air Cleaner Element.>	Go to step 3.
3 CHECK ELECTRONIC THROTTLE CONTROL. 1) Remove the electronic throttle control. 2) Check the electronic throttle control.	Are foreign matter found inside electronic throttle control?	Remove foreign matter from electronic throttle control.	Perform the diagnosis of DTC P2101. <Ref. to EN(H4SO)(diag)-280, DTC P2101 THROTTLE ACTUATOR CONTROL MOTOR CIRCUIT RANGE/PERFORMANCE, Diagnostic Procedure with Diagnostic Trouble Code (DTC).>

Diagnostic Procedure with Diagnostic Trouble Code (DTC)

ENGINE (DIAGNOSTICS)

BV:DTC P0507 IDLE AIR CONTROL SYSTEM RPM HIGHER THAN EXPECTED

DTC DETECTING CONDITION:

- Detected when two consecutive driving cycles with fault occur.
- GENERAL DESCRIPTION <Ref. to GD(H4SO)-139, DTC P0507 IDLE AIR CONTROL SYSTEM RPM HIGHER THAN EXPECTED, Diagnostic Trouble Code (DTC) Detecting Criteria.>

TROUBLE SYMPTOM:

Engine keeps running at higher speed than specified idle speed.

CAUTION:

After repair or replacement of faulty parts, perform Clear Memory Mode <Ref. to EN(H4SO)(diag)-51, OPERATION, Clear Memory Mode.> and Inspection Mode <Ref. to EN(H4SO)(diag)-41, PROCEDURE, Inspection Mode.>.

WIRING DIAGRAM:

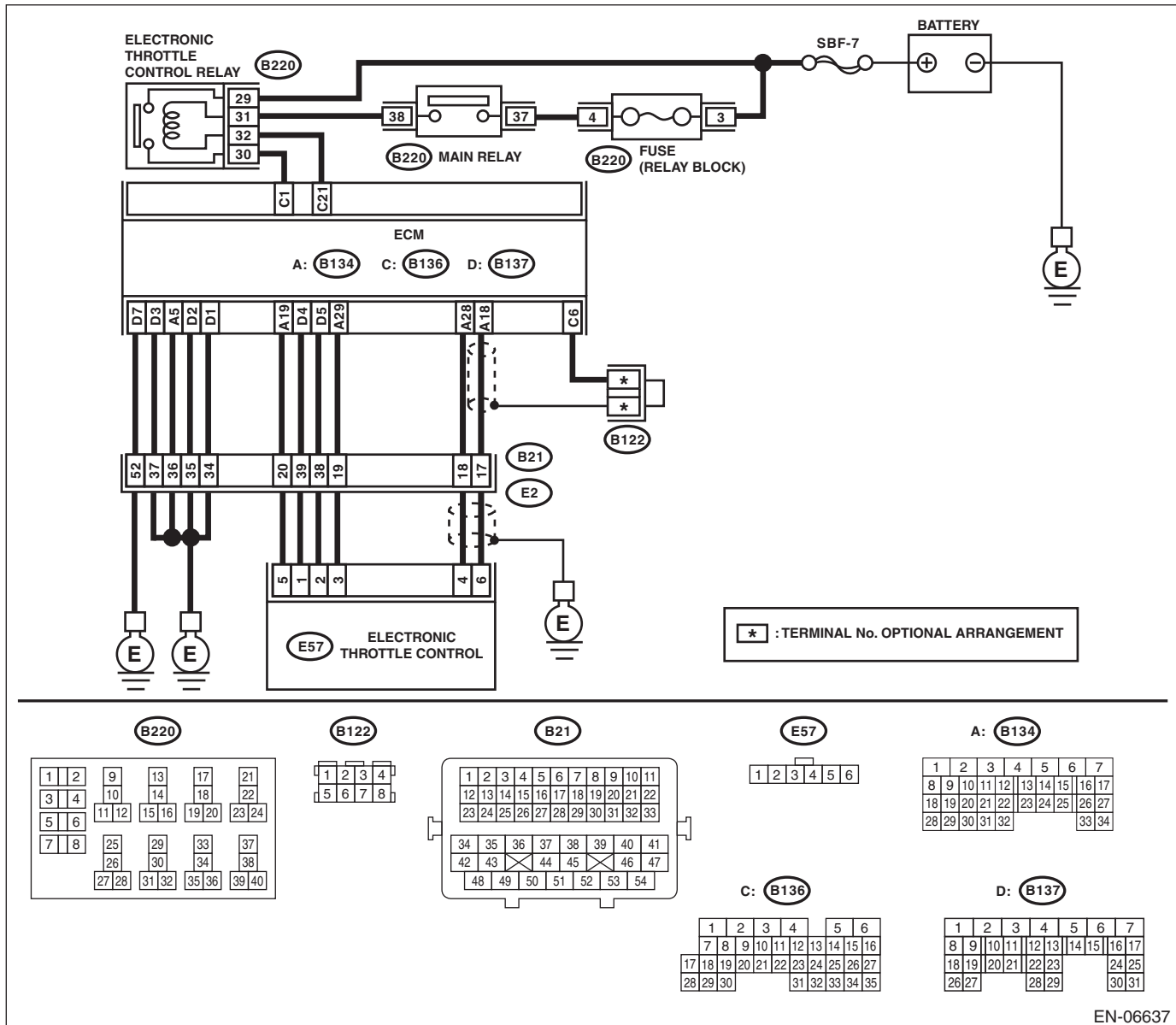

Diagnostic Procedure with Diagnostic Trouble Code (DTC)

ENGINE (DIAGNOSTICS)

Step	Check	Yes	No
1 CHECK FOR ANY OTHER DTC ON DISPLAY.	Is any other DTC displayed?	Check the appropriate DTC using the "List of Diagnostic Trouble Code (DTC)". <Ref. to EN(H4SO)(diag)-82, List of Diagnostic Trouble Code (DTC).>	Go to step 2.
2 CHECK AIR INTAKE SYSTEM. 1) Start and idle the engine. 2) Check the following items. <ul style="list-style-type: none"> • Loose installation of intake manifold and throttle body • Cracks of intake manifold gasket and throttle body gasket • Disconnection of vacuum hoses 	Is there any fault in air intake system?	Repair air suction and leaks.	Go to step 3.
3 CHECK ELECTRONIC THROTTLE CONTROL. 1) Turn the ignition switch to OFF. 2) Remove the electronic throttle control. 3) Check the electronic throttle control.	Are foreign matter found inside electronic throttle control?	Remove foreign matter from electronic throttle control.	Perform the diagnosis of DTC P2101. <Ref. to EN(H4SO)(diag)-280, DTC P2101 THROTTLE ACTUATOR CONTROL MOTOR CIRCUIT RANGE/PERFORMANCE, Diagnostic Procedure with Diagnostic Trouble Code (DTC).>

Diagnostic Procedure with Diagnostic Trouble Code (DTC)

ENGINE (DIAGNOSTICS)

BW:DTC P0512 STARTER REQUEST CIRCUIT

DTC DETECTING CONDITION:

- Immediately at fault recognition
- GENERAL DESCRIPTION <Ref. to GD(H4SO)-140, DTC P0512 STARTER REQUEST CIRCUIT, Diagnostic Trouble Code (DTC) Detecting Criteria.>

TROUBLE SYMPTOM:

Failure of engine to start

CAUTION:

After repair or replacement of faulty parts, perform Clear Memory Mode <Ref. to EN(H4SO)(diag)-51, OPERATION, Clear Memory Mode.> and Inspection Mode <Ref. to EN(H4SO)(diag)-41, PROCEDURE, Inspection Mode.>.

WIRING DIAGRAM:

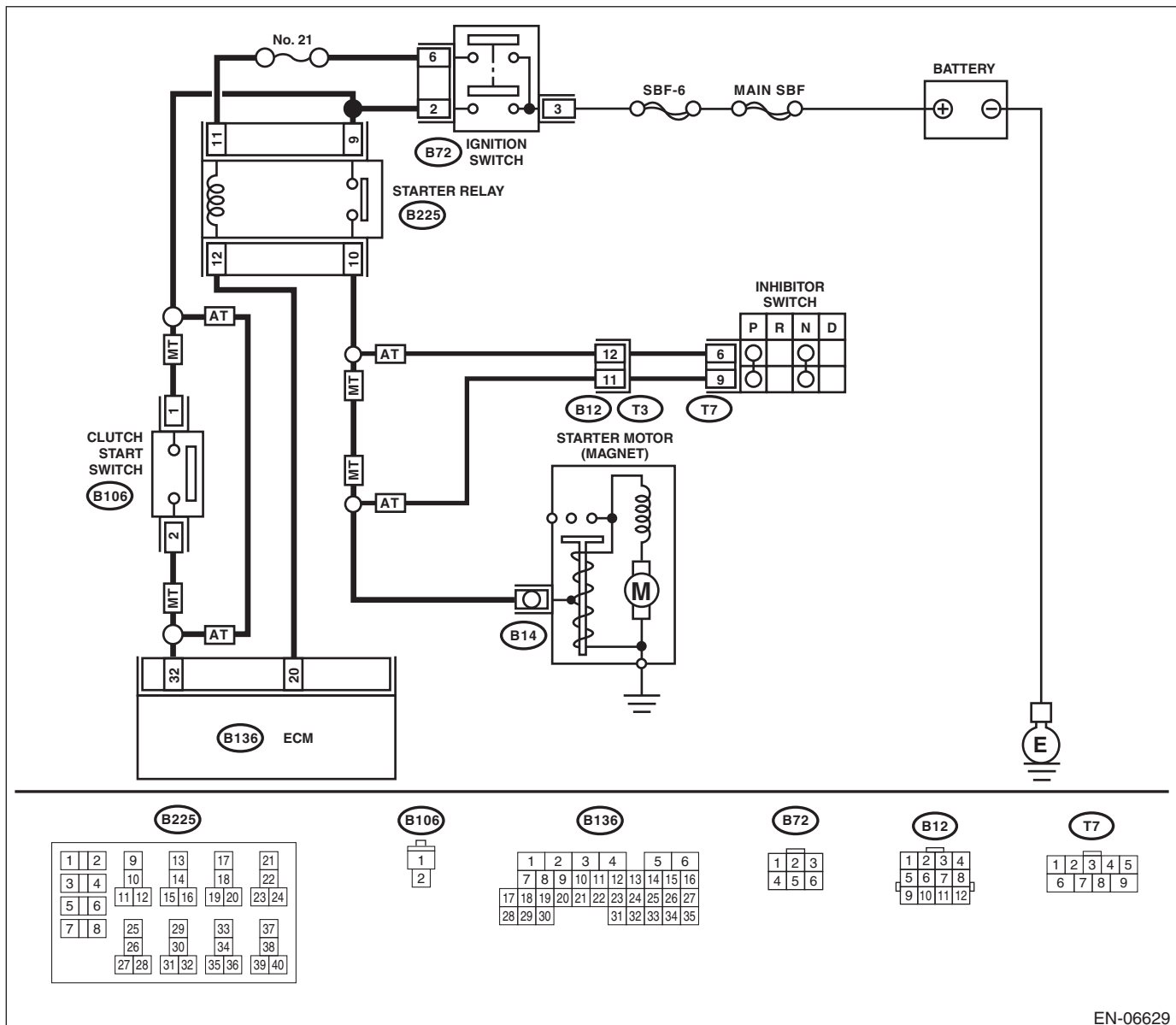

EN-06629

Diagnostic Procedure with Diagnostic Trouble Code (DTC)

ENGINE (DIAGNOSTICS)

Step	Check	Yes	No
1 CHECK FOR ANY OTHER DTC ON DISPLAY.	Is any other DTC displayed?	Check the appropriate DTC using the "List of Diagnostic Trouble Code (DTC)". <Ref. to EN(H4SO)(diag)-82, List of Diagnostic Trouble Code (DTC).>	Go to step 2.
2 CHECK HARNESS BETWEEN ECM AND IGNITION SWITCH. 1) Turn the ignition switch to OFF. 2) Disconnect the connectors from the ECM. 3) Turn the ignition switch to ON. 4) Measure the voltage between ECM and chassis ground. Connector & terminal (B136) No. 32 (+) — Chassis ground (-):	Is the voltage 10 V or more?	Repair the short circuit to power in harness between ECM and ignition switch connector.	Repair the poor contact of the ECM connector.

BX:DTC P0600 SERIAL COMMUNICATION LINK

NOTE:

For the diagnostic procedure, refer to LAN section. <Ref. to LAN(diag)-2, Basic Diagnostic Procedure.>

Diagnostic Procedure with Diagnostic Trouble Code (DTC)

ENGINE (DIAGNOSTICS)

BY:DTC P0604 INTERNAL CONTROL MODULE RANDOM ACCESS MEMORY (RAM) ERROR

DTC DETECTING CONDITION:

- Immediately at fault recognition
- GENERAL DESCRIPTION <Ref. to GD(H4SO)-143, DTC P0604 INTERNAL CONTROL MODULE RANDOM ACCESS MEMORY (RAM) ERROR, Diagnostic Trouble Code (DTC) Detecting Criteria.>

TROUBLE SYMPTOM:

- Engine does not start.
- Engine stalls.

CAUTION:

After repair or replacement of faulty parts, perform Clear Memory Mode <Ref. to EN(H4SO)(diag)-51, OPERATION, Clear Memory Mode.> and Inspection Mode <Ref. to EN(H4SO)(diag)-41, PROCEDURE, Inspection Mode.>.

WIRING DIAGRAM:

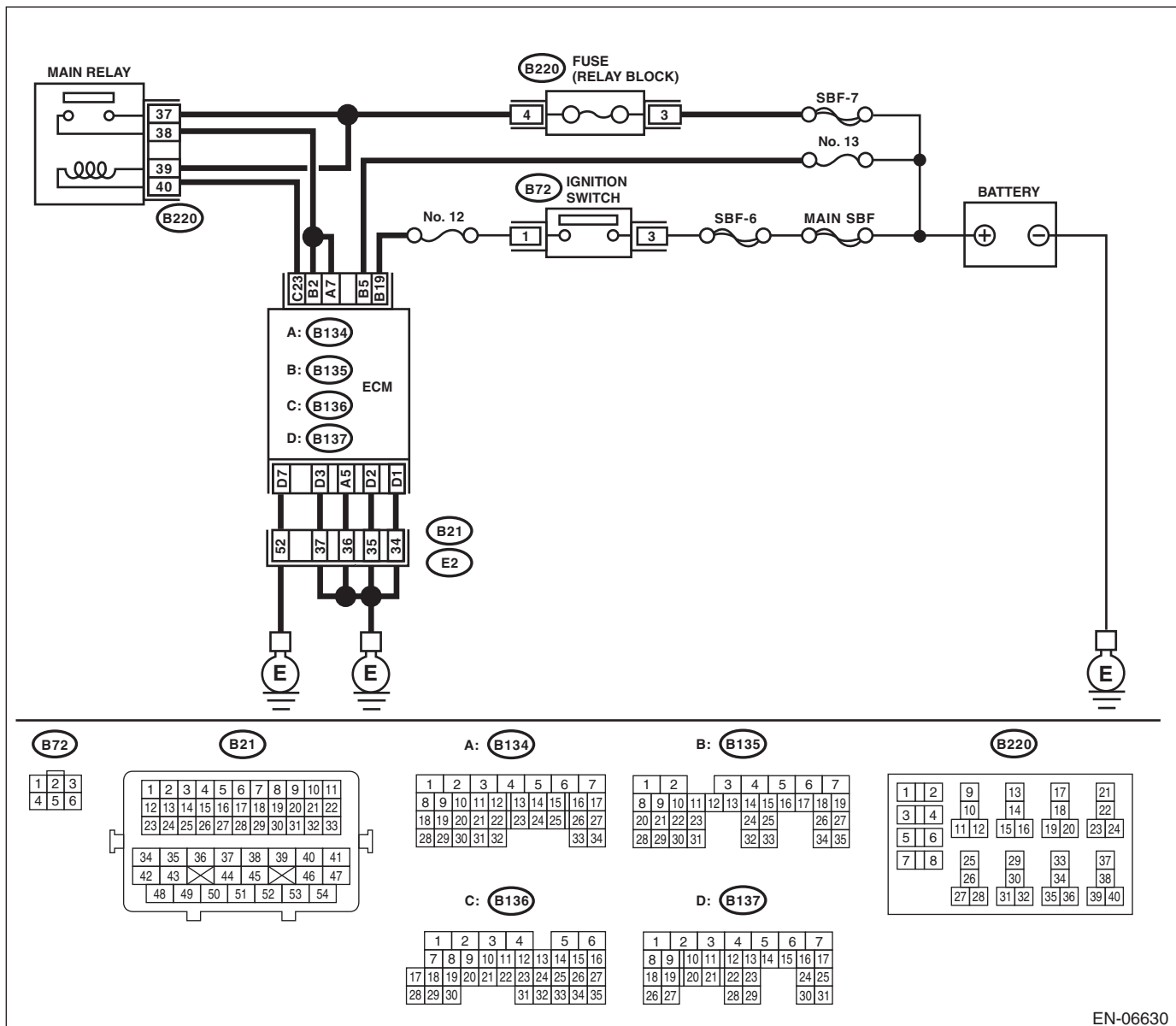

EN-06630

Diagnostic Procedure with Diagnostic Trouble Code (DTC)

ENGINE (DIAGNOSTICS)

Step	Check	Yes	No
1 CHECK FOR ANY OTHER DTC ON DISPLAY.	Is any other DTC displayed?	Check the appropriate DTC using the "List of Diagnostic Trouble Code (DTC)". <Ref. to EN(H4SO)(diag)-82, List of Diagnostic Trouble Code (DTC).>	Even if the malfunction indicator light illuminates, the circuit has returned to a normal condition at this time. Reproduce the fault condition, and reperform the check. NOTE: In this case, there may be a temporary connector contact failure.

BZ:DTC P0605 INTERNAL CONTROL MODULE READ ONLY MEMORY (ROM) ERROR

NOTE:

For the diagnostic procedure, refer to DTC P0607. <Ref. to EN(H4SO)(diag)-235, DTC P0607 THROTTLE CONTROL SYSTEM CIRCUIT RANGE/PERFORMANCE, Diagnostic Procedure with Diagnostic Trouble Code (DTC).>

Diagnostic Procedure with Diagnostic Trouble Code (DTC)

ENGINE (DIAGNOSTICS)

CA:DTC P0607 THROTTLE CONTROL SYSTEM CIRCUIT RANGE/PERFORMANCE

DTC DETECTING CONDITION:

- Depending on the content of malfunction, adapt either of the followings.
 - Immediately at fault recognition
 - Detected when two consecutive driving cycles with fault occur.
- GENERAL DESCRIPTION <Ref. to GD(H4SO)-145, DTC P0607 THROTTLE CONTROL SYSTEM CIRCUIT RANGE/PERFORMANCE, Diagnostic Trouble Code (DTC) Detecting Criteria.>

TROUBLE SYMPTOM:

- Improper idling
- Poor driving performance

CAUTION:

After repair or replacement of faulty parts, perform Clear Memory Mode <Ref. to EN(H4SO)(diag)-51, OPERATION, Clear Memory Mode.> and Inspection Mode <Ref. to EN(H4SO)(diag)-41, PROCEDURE, Inspection Mode.>.

WIRING DIAGRAM:

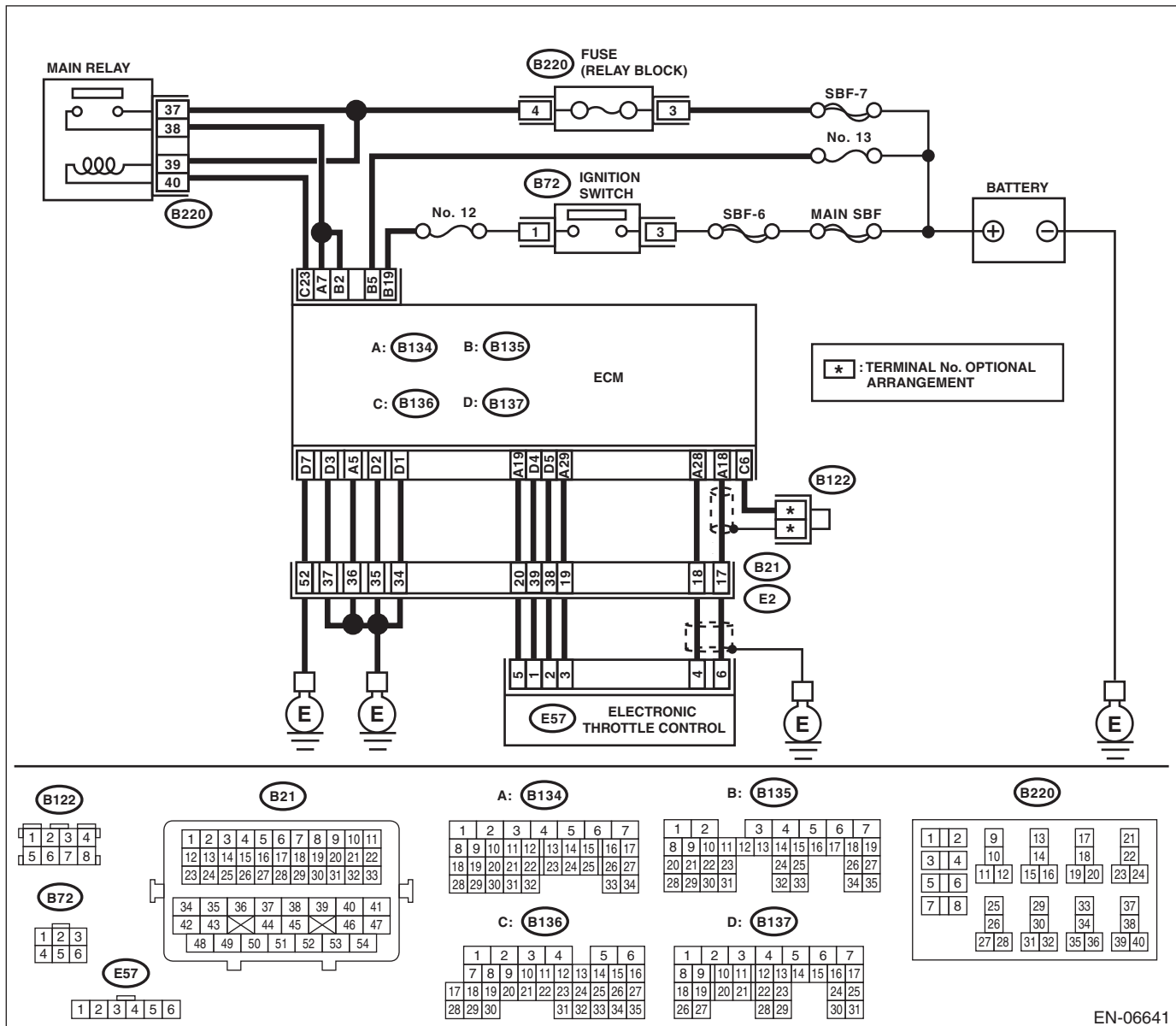

EN-06641

Diagnostic Procedure with Diagnostic Trouble Code (DTC)

ENGINE (DIAGNOSTICS)

Step	Check	Yes	No
1 CHECK INPUT VOLTAGE OF ECM. 1) Turn the ignition switch to ON. 2) Measure the voltage between ECM and chassis ground. <i>Connector & terminal</i> <i>(B134) No. 7 (+) — Chassis ground (-):</i> <i>(B135) No. 2 (+) — Chassis ground (-):</i>	Is the voltage 10 — 13 V?	Go to step 2.	Repair the open or ground short circuit of power supply circuit.
2 CHECK INPUT VOLTAGE OF ECM. 1) Start the engine. 2) Measure the voltage between ECM and chassis ground. <i>Connector & terminal</i> <i>(B134) No. 7 (+) — Chassis ground (-):</i> <i>(B135) No. 2 (+) — Chassis ground (-):</i>	Is the voltage 13 — 15 V?	Go to step 3.	Repair the open or ground short circuit of power supply circuit.
3 CHECK HARNESS BETWEEN ECM AND ELECTRONIC THROTTLE CONTROL. 1) Turn the ignition switch to OFF. 2) Disconnect the connectors from ECM and electronic throttle control. 3) Measure the resistance of harness between ECM and electronic throttle control connector. <i>Connector & terminal</i> <i>(B134) No. 19 — (E57) No. 5:</i> <i>(B134) No. 29 — (E57) No. 3:</i>	Is the resistance less than 1 Ω?	Go to step 4.	Repair the open circuit of harness between ECM and electronic throttle control connector.
4 CHECK ECM GROUND HARNESS. Measure the voltage between ECM and chassis ground. <i>Connector & terminal</i> <i>(B134) No. 5 (+) — Chassis ground (-):</i> <i>(B137) No. 1 (+) — Chassis ground (-):</i> <i>(B137) No. 2 (+) — Chassis ground (-):</i> <i>(B137) No. 3 (+) — Chassis ground (-):</i> <i>(B137) No. 7 (+) — Chassis ground (-):</i>	Is the voltage less than 1 V?	Repair the poor contact of the ECM connector.	Repair the following item. <ul style="list-style-type: none"> • Open circuit of ground circuit • Retightening of engine ground terminals • Poor contact in ECM connector • Poor contact of coupling connector

CB:DTC P0638 THROTTLE ACTUATOR CONTROL RANGE/PERFORMANCE (BANK 1)

NOTE:

For the diagnostic procedure, refer to DTC P2101. <Ref. to EN(H4SO)(diag)-280, DTC P2101 THROTTLE ACTUATOR CONTROL MOTOR CIRCUIT RANGE/PERFORMANCE, Diagnostic Procedure with Diagnostic Trouble Code (DTC).>

CC:DTC P0700 TRANSMISSION CONTROL SYSTEM (MIL REQUEST)

NOTE:

For the diagnostic procedure, refer to AT section. <Ref. to 4AT(diag)-2, Basic Diagnostic Procedure.>

Diagnostic Procedure with Diagnostic Trouble Code (DTC)

ENGINE (DIAGNOSTICS)

CD:DTC P0851 PARK/NEUTRAL SWITCH INPUT CIRCUIT LOW (AT MODEL)

DTC DETECTING CONDITION:

- Detected when two consecutive driving cycles with fault occur.
- GENERAL DESCRIPTION <Ref. to GD(H4SO)-150, DTC P0851 PARK/NEUTRAL SWITCH INPUT CIRCUIT LOW (AT MODEL), Diagnostic Trouble Code (DTC) Detecting Criteria.>

TROUBLE SYMPTOM:

Improper idling

CAUTION:

After repair or replacement of faulty parts, perform Clear Memory Mode <Ref. to EN(H4SO)(diag)-51, OPERATION, Clear Memory Mode.> and Inspection Mode <Ref. to EN(H4SO)(diag)-41, PROCEDURE, Inspection Mode.>.

WIRING DIAGRAM:

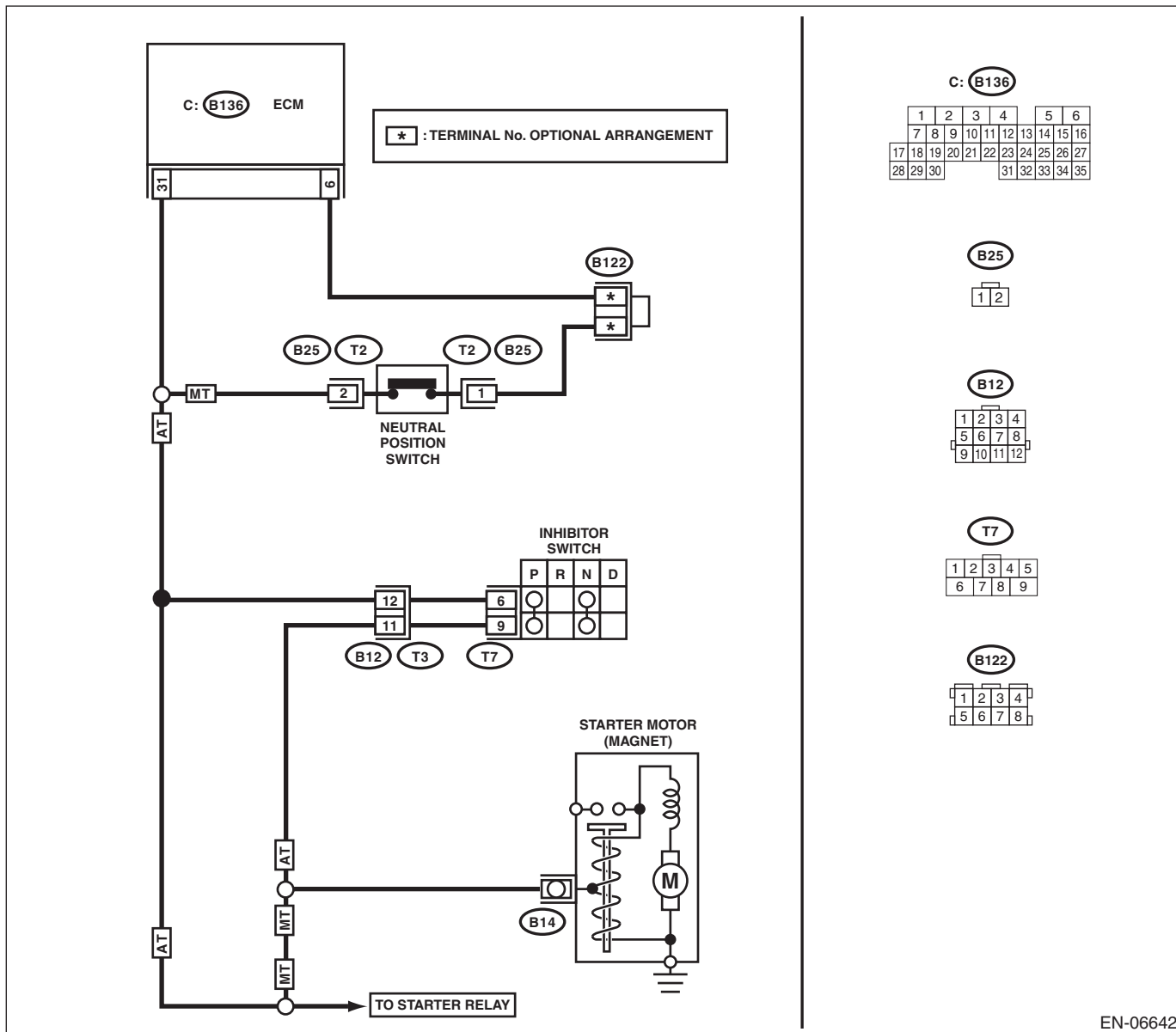

EN-06642

Diagnostic Procedure with Diagnostic Trouble Code (DTC)

ENGINE (DIAGNOSTICS)

Step	Check	Yes	No
1 CHECK SELECT CABLE.	Are there any faults in the select cable?	Repair or adjust the select cable. <Ref. to CS-25, Select Cable.>	Go to step 2.
2 CHECK INPUT SIGNAL OF ECM. 1) Turn the ignition switch to ON. 2) Place the select lever in other than "P" range and "N" range. 3) Measure the voltage between ECM and chassis ground. Connector & terminal (B136) No. 31 (+) — Chassis ground (-):	Is the voltage 10 V or more?	Repair the poor contact of the ECM connector.	Go to step 3.
3 CHECK HARNESS BETWEEN ECM AND TRANSMISSION HARNESS CONNECTOR. 1) Turn the ignition switch to OFF. 2) Disconnect the connectors from ECM and transmission harness connector (T3). 3) Measure the resistance between ECM and chassis ground. Connector & terminal (B136) No. 31 — Chassis ground:	Is the resistance 1 MΩ or more?	Go to step 4.	Repair the ground short circuit of harness between ECM and transmission harness connector.
4 CHECK TRANSMISSION HARNESS CONNECTOR. 1) Disconnect the connector from inhibitor switch. 2) Measure the resistance between the transmission harness connector and engine ground. Connector & terminal (T3) No. 12 — Engine ground:	Is the resistance 1 MΩ or more?	Replace the inhibitor switch. <Ref. to 4AT-46, Inhibitor Switch.>	Repair the ground short circuit of harness between transmission harness connector and inhibitor switch connector.

Diagnostic Procedure with Diagnostic Trouble Code (DTC)

ENGINE (DIAGNOSTICS)

CE:DTC P0851 NEUTRAL SWITCH INPUT CIRCUIT LOW (MT MODEL)

DTC DETECTING CONDITION:

- Detected when two consecutive driving cycles with fault occur.
- GENERAL DESCRIPTION <Ref. to GD(H4SO)-151, DTC P0851 NEUTRAL SWITCH INPUT CIRCUIT LOW (MT MODEL), Diagnostic Trouble Code (DTC) Detecting Criteria.>

TROUBLE SYMPTOM:

Improper idling

CAUTION:

After repair or replacement of faulty parts, perform Clear Memory Mode <Ref. to EN(H4SO)(diag)-51, OPERATION, Clear Memory Mode.> and Inspection Mode <Ref. to EN(H4SO)(diag)-41, PROCEDURE, Inspection Mode.>.

WIRING DIAGRAM:

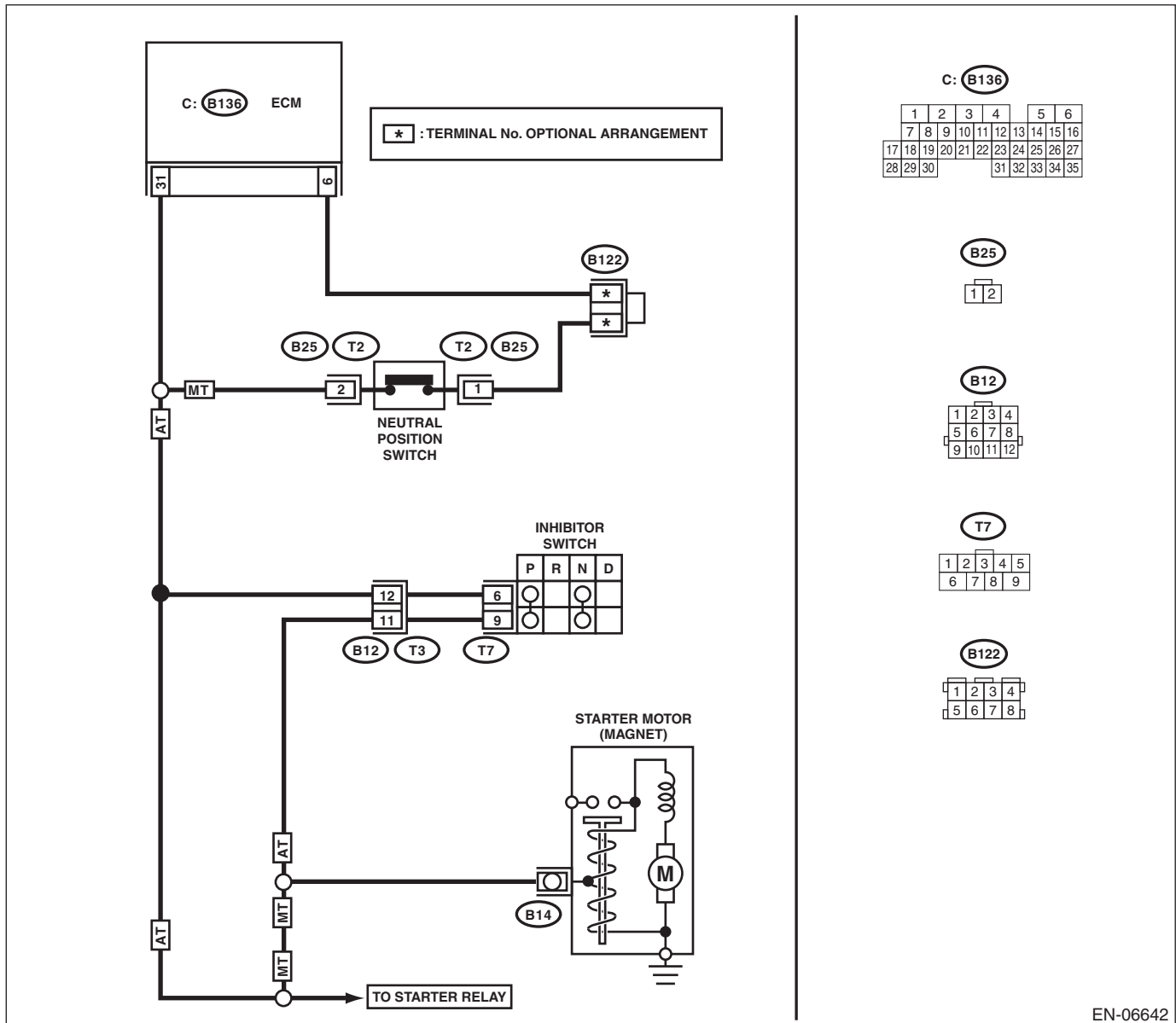

EN-06642

Diagnostic Procedure with Diagnostic Trouble Code (DTC)

ENGINE (DIAGNOSTICS)

Step	Check	Yes	No
1 CHECK INPUT SIGNAL OF ECM. 1) Turn the ignition switch to ON. 2) Place the shift lever in a position other than neutral. 3) Measure the voltage between ECM and chassis ground. Connector & terminal (B136) No. 31 (+) — Chassis ground (-):	Is the voltage 10 V or more?	Repair the poor contact of the ECM connector.	Go to step 2.
2 CHECK HARNESS BETWEEN ECM AND NEUTRAL POSITION SWITCH CONNECTOR. 1) Turn the ignition switch to OFF. 2) Disconnect the connectors from ECM and neutral position switch. 3) Measure the resistance between ECM and chassis ground. Connector & terminal (B136) No. 31 — Chassis ground:	Is the resistance 1 MΩ or more?	Replace the neutral position switch.	Repair the short circuit to ground harness between ECM and neutral position switch connector.

Diagnostic Procedure with Diagnostic Trouble Code (DTC)

ENGINE (DIAGNOSTICS)

CF:DTC P0852 PARK/NEUTRAL SWITCH INPUT CIRCUIT HIGH (AT MODEL)

DTC DETECTING CONDITION:

- Detected when two consecutive driving cycles with fault occur.
- GENERAL DESCRIPTION <Ref. to GD(H4SO)-152, DTC P0852 PARK/NEUTRAL SWITCH INPUT CIRCUIT HIGH (AT MODEL), Diagnostic Trouble Code (DTC) Detecting Criteria.>

TROUBLE SYMPTOM:

Improper idling

CAUTION:

After repair or replacement of faulty parts, perform Clear Memory Mode <Ref. to EN(H4SO)(diag)-51, OPERATION, Clear Memory Mode.> and Inspection Mode <Ref. to EN(H4SO)(diag)-41, PROCEDURE, Inspection Mode.>.

WIRING DIAGRAM:

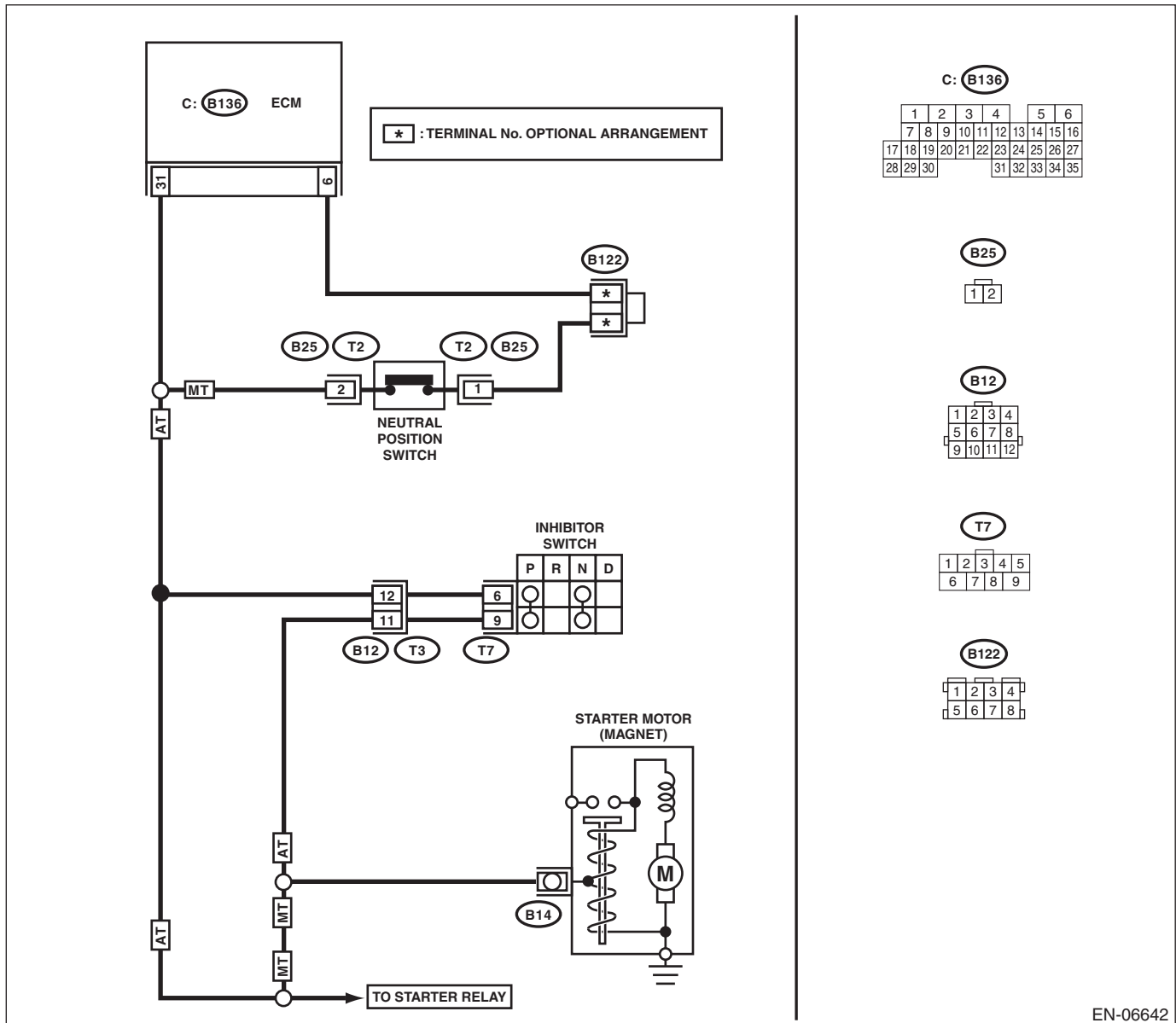

EN-06642

Diagnostic Procedure with Diagnostic Trouble Code (DTC)

ENGINE (DIAGNOSTICS)

Step	Check	Yes	No
1 CHECK SELECT CABLE.	Are there any faults in the select cable?	Repair or adjust the select cable. <Ref. to CS-25, Select Cable.>	Go to step 2.
2 CHECK INPUT SIGNAL OF ECM. 1) Turn the ignition switch to ON. 2) Measure the voltage between ECM and chassis ground with select lever at "P" range and "N" range. Connector & terminal (B136) No. 31 (+) — Chassis ground (-):	Is the voltage less than 1 V?	Repair the poor contact of the ECM connector.	Go to step 3.
3 CHECK HARNESS BETWEEN ECM AND INHIBITOR SWITCH CONNECTOR. 1) Turn the ignition switch to OFF. 2) Disconnect the connectors from ECM and inhibitor switch. 3) Measure the resistance of harness between ECM and inhibitor switch connector. Connector & terminal (B136) No. 31 — (T7) No. 6:	Is the resistance less than 1 Ω?	Go to step 4.	Repair the harness and connector. NOTE: In this case, repair the following item: • Open circuit in harness between ECM and inhibitor switch connector • Poor contact of coupling connector
4 CHECK INHIBITOR SWITCH GROUND LINE. Measure the resistance of harness between inhibitor switch connector and engine ground. Connector & terminal (T7) No. 9 — Engine ground:	Is the resistance less than 5 Ω?	Replace the inhibitor switch. <Ref. to 4AT-46, Inhibitor Switch.>	Repair the harness and connector. NOTE: In this case, repair the following item: • Open circuit in harness between inhibitor switch connector and starter motor ground line • Poor contact of coupling connector • Poor contact in starter motor connector • Poor contact in starter motor ground • Starter motor

Diagnostic Procedure with Diagnostic Trouble Code (DTC)

ENGINE (DIAGNOSTICS)

CG:DTC P0852 NEUTRAL SWITCH INPUT CIRCUIT HIGH (MT MODEL)

DTC DETECTING CONDITION:

- Detected when two consecutive driving cycles with fault occur.
- GENERAL DESCRIPTION <Ref. to GD(H4SO)-153, DTC P0852 NEUTRAL SWITCH INPUT CIRCUIT HIGH (MT MODEL), Diagnostic Trouble Code (DTC) Detecting Criteria.>

TROUBLE SYMPTOM:

Improper idling

CAUTION:

After repair or replacement of faulty parts, perform Clear Memory Mode <Ref. to EN(H4SO)(diag)-51, OPERATION, Clear Memory Mode.> and Inspection Mode <Ref. to EN(H4SO)(diag)-41, PROCEDURE, Inspection Mode.>.

WIRING DIAGRAM:

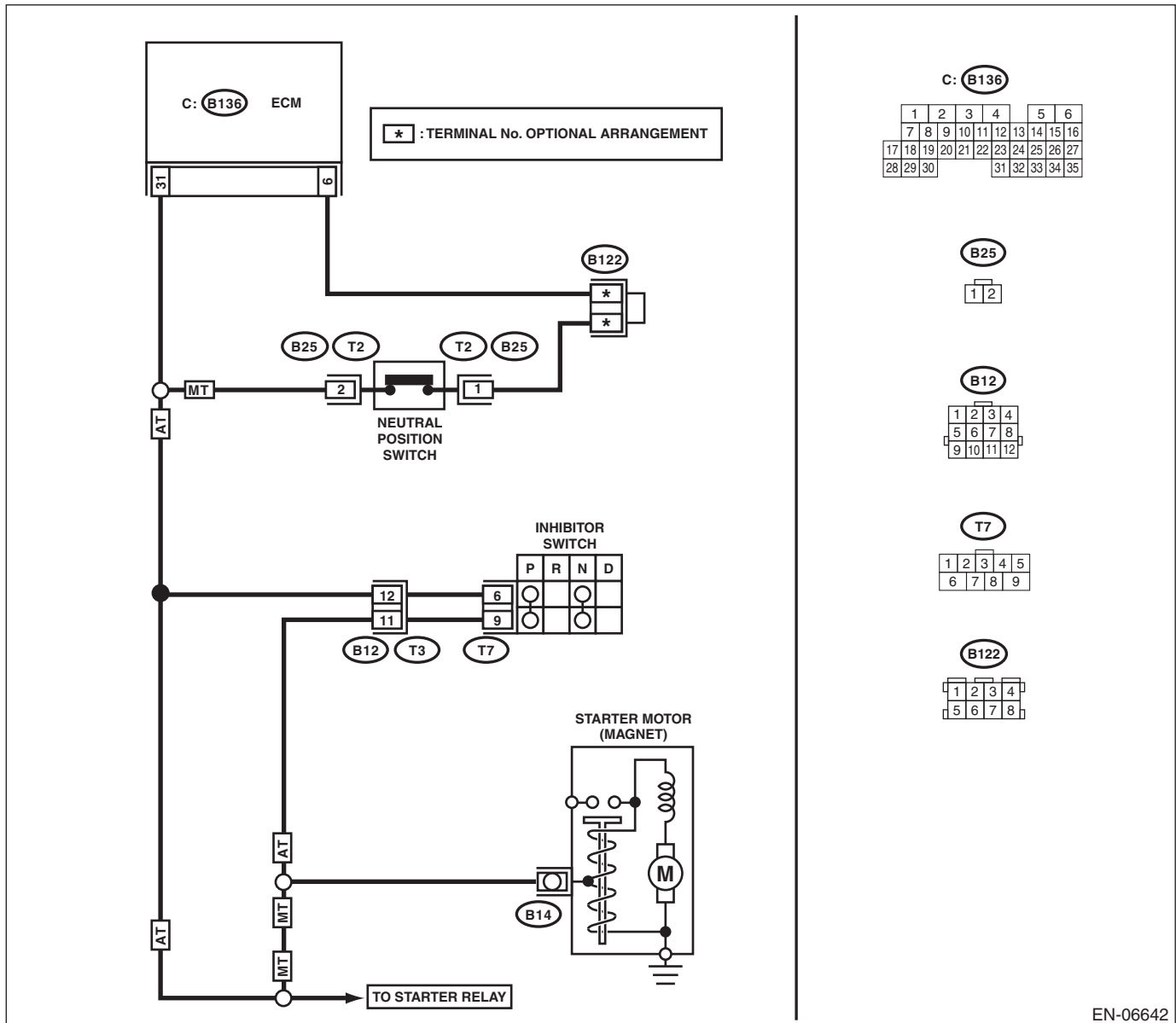

Diagnostic Procedure with Diagnostic Trouble Code (DTC)

ENGINE (DIAGNOSTICS)

Step	Check	Yes	No
1 CHECK INPUT SIGNAL OF ECM. 1) Turn the ignition switch to ON. 2) Place the shift lever in neutral. 3) Measure the voltage between ECM and chassis ground. Connector & terminal (B136) No. 31 (+) — Chassis ground (-):	Is the voltage less than 1 V?	Repair the poor contact of the ECM connector.	Go to step 2.
2 CHECK HARNESS BETWEEN ECM AND NEUTRAL POSITION SWITCH CONNECTOR. 1) Turn the ignition switch to OFF. 2) Disconnect the connectors from ECM and neutral position switch. 3) Measure the resistance of harness between ECM and neutral position switch connector. Connector & terminal (B136) No. 31 — (T2) No. 2: (B136) No. 6 — (T2) No. 1:	Is the resistance less than 1 Ω ?	Go to step 3.	Repair the harness and connector. NOTE: In this case, repair the following item: • Open circuit in harness between ECM and neutral position switch connector • Poor contact of coupling connector
3 CHECK NEUTRAL POSITION SWITCH. 1) Place the shift lever in neutral. 2) Measure the resistance between neutral position switch terminals. Terminals No. 1 — No. 2:	Is the resistance less than 1 Ω ?	Repair poor contact of the ECM connector.	Replace the neutral position switch.

CH:DTC P1152 O2 SENSOR CIRCUIT RANGE/PERFORMANCE (LOW) (BANK1 SENSOR1)

DTC DETECTING CONDITION:

- Detected when two consecutive driving cycles with fault occur.
- GENERAL DESCRIPTION <Ref. to GD(H4SO)-154, DTC P1152 O2 SENSOR CIRCUIT RANGE/PERFORMANCE (LOW) (BANK1 SENSOR1), Diagnostic Trouble Code (DTC) Detecting Criteria.>

CAUTION:

After repair or replacement of faulty parts, perform Clear Memory Mode <Ref. to EN(H4SO)(diag)-51, OPERATION, Clear Memory Mode.> and Inspection Mode <Ref. to EN(H4SO)(diag)-41, PROCEDURE, Inspection Mode.>.

WIRING DIAGRAM:

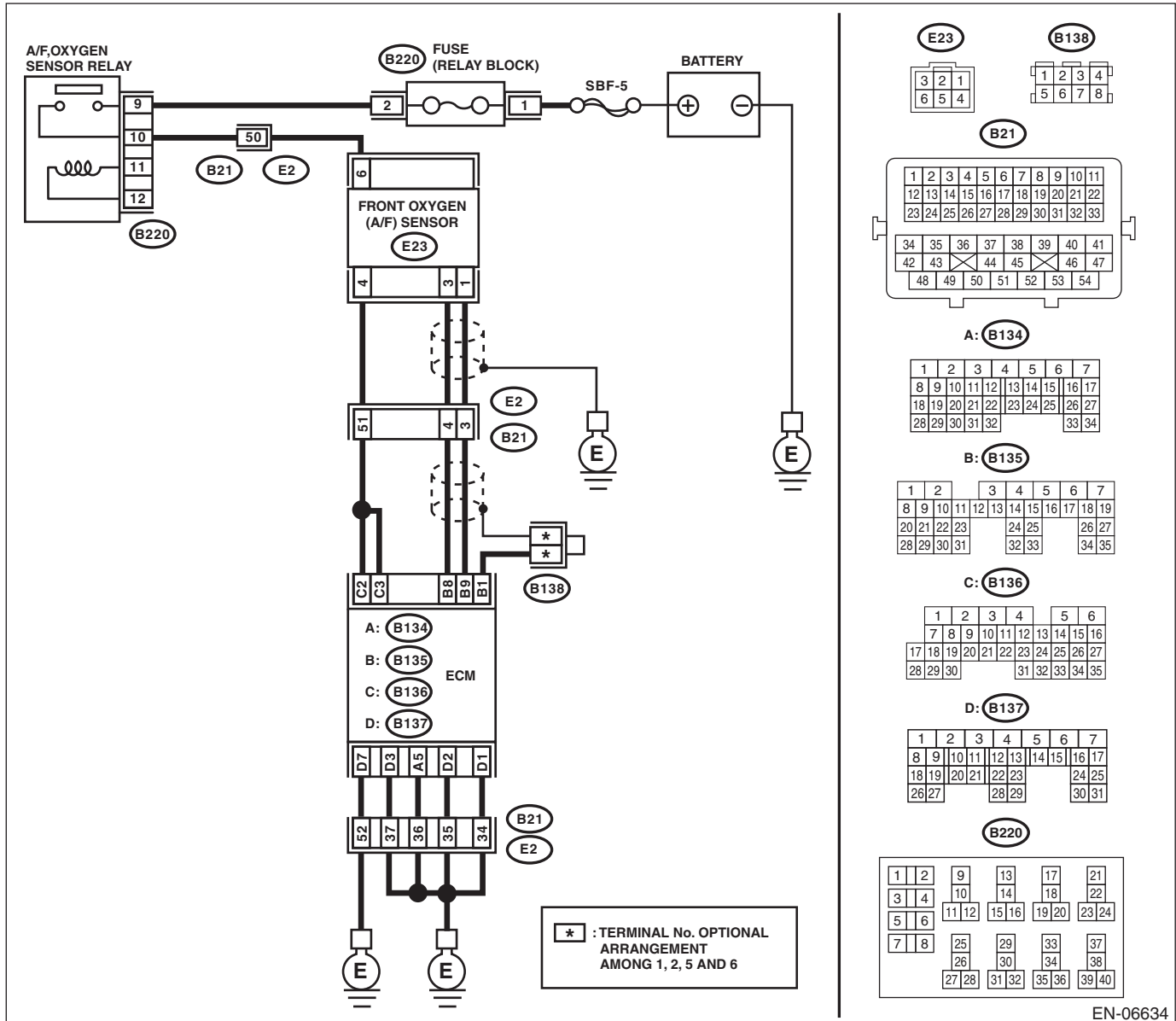

EN-06634

Diagnostic Procedure with Diagnostic Trouble Code (DTC)

ENGINE (DIAGNOSTICS)

Step	Check	Yes	No
1 CHECK FRONT OXYGEN (A/F) SENSOR CONNECTOR AND COUPLING CONNECTOR.	Has water entered the connector?	Completely remove any water inside.	Go to step 2.
2 CHECK HARNESS BETWEEN ECM AND FRONT OXYGEN (A/F) SENSOR CONNECTOR. 1) Turn the ignition switch to OFF. 2) Disconnect the connectors from the ECM and front oxygen (A/F) sensor. 3) Measure the resistance of harness between ECM and front oxygen (A/F) sensor connector. Connector & terminal (B135) No. 9 — (E23) No. 1: (B135) No. 8 — (E23) No. 3:	Is the resistance less than 1 Ω ?	Go to step 3.	Repair the harness and connector. NOTE: In this case, repair the following item: • Open circuit in harness between ECM and front oxygen (A/F) sensor connector • Poor contact of coupling connector
3 CHECK POOR CONTACT. Check poor contact of front oxygen (A/F) sensor connector.	Is there poor contact in front oxygen (A/F) sensor connector?	Repair the poor contact of the front oxygen (A/F) sensor connector.	Replace the front oxygen (A/F) sensor. <Ref. to FU(H4SO)-35, Front Oxygen (A/F) Sensor.>

Diagnostic Procedure with Diagnostic Trouble Code (DTC)

ENGINE (DIAGNOSTICS)

Step	Check	Yes	No
1 CHECK FRONT OXYGEN (A/F) SENSOR CONNECTOR AND COUPLING CONNECTOR.	Has water entered the connector?	Completely remove any water inside.	Go to step 2.
2 CHECK HARNESS BETWEEN ECM AND FRONT OXYGEN (A/F) SENSOR CONNECTOR. 1) Turn the ignition switch to OFF. 2) Disconnect the connectors from the ECM. 3) Measure the resistance between ECM and chassis ground. Connector & terminal (B135) No. 9 — Chassis ground: (B135) No. 8 — Chassis ground:	Is the resistance 1 MΩ or more?	Go to step 3.	Repair the ground short circuit of harness between ECM and front oxygen (A/F) sensor connector.
3 CHECK OUTPUT SIGNAL FOR ECM. 1) Connect the connector to ECM. 2) Turn the ignition switch to ON. 3) Measure the voltage between ECM and chassis ground. Connector & terminal (B135) No. 9 (+) — Chassis ground (-):	Is the voltage 4.5 V or more?	Go to step 5.	Go to step 4.
4 CHECK OUTPUT SIGNAL FOR ECM. Measure the voltage between ECM and chassis ground. Connector & terminal (B135) No. 8 (+) — Chassis ground (-):	Is the voltage 4.95 V or more?	Go to step 5.	Replace the front oxygen (A/F) sensor. <Ref. to FU(H4SO)-35, Front Oxygen (A/F) Sensor.>
5 CHECK OUTPUT SIGNAL FOR ECM. Measure the voltage between ECM and chassis ground. Connector & terminal (B135) No. 9 (+) — Chassis ground (-): (B135) No. 8 (+) — Chassis ground (-):	Is the voltage 8 V or more?	Repair the short circuit to power in the harness between the ECM and front oxygen (A/F) sensor connector. After repair, replace the ECM. <Ref. to FU(H4SO)-39, Engine Control Module (ECM).>	Repair the poor contact of the ECM connector.

CJ:DTC P1160 RETURN SPRING FAILURE

NOTE:

For the diagnostic procedure, refer to DTC P2101. <Ref. to EN(H4SO)(diag)-280, DTC P2101 THROTTLE ACTUATOR CONTROL MOTOR CIRCUIT RANGE/PERFORMANCE, Diagnostic Procedure with Diagnostic Trouble Code (DTC).>

Diagnostic Procedure with Diagnostic Trouble Code (DTC)

ENGINE (DIAGNOSTICS)

CK:DTC P1400 FUEL TANK PRESSURE CONTROL SOLENOID VALVE CIRCUIT LOW

DTC DETECTING CONDITION:

- Detected when two consecutive driving cycles with fault occur.
- GENERAL DESCRIPTION <Ref. to GD(H4SO)-159, DTC P1400 FUEL TANK PRESSURE CONTROL SOLENOID VALVE CIRCUIT LOW, Diagnostic Trouble Code (DTC) Detecting Criteria.>

CAUTION:

After repair or replacement of faulty parts, perform Clear Memory Mode <Ref. to EN(H4SO)(diag)-51, OPERATION, Clear Memory Mode.> and Inspection Mode <Ref. to EN(H4SO)(diag)-41, PROCEDURE, Inspection Mode.>.

WIRING DIAGRAM:

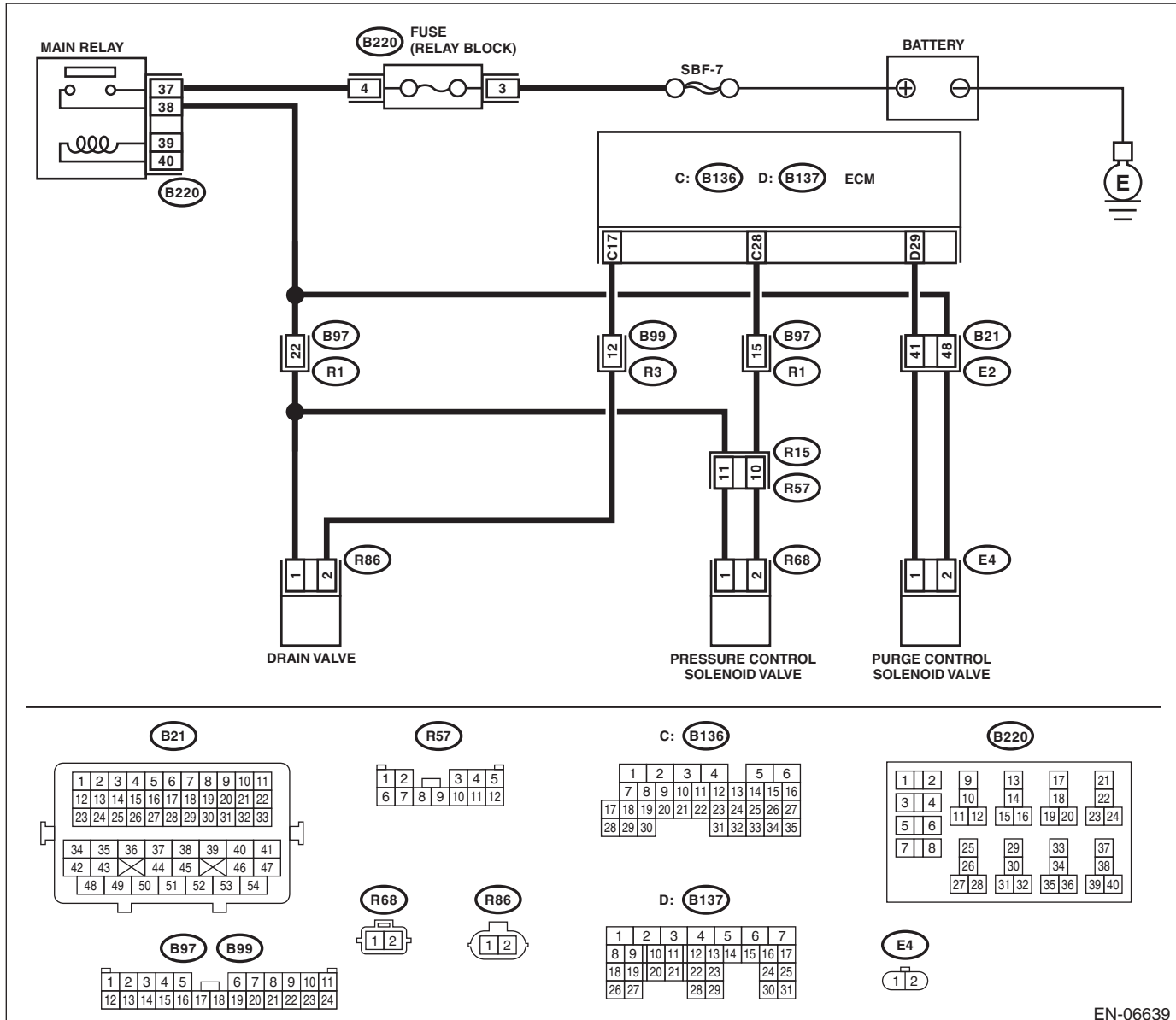

EN-06639

Diagnostic Procedure with Diagnostic Trouble Code (DTC)

ENGINE (DIAGNOSTICS)

Step	Check	Yes	No
1 CHECK OUTPUT SIGNAL OF ECM. 1) Turn the ignition switch to ON. 2) Measure the voltage between ECM and chassis ground. <i>Connector & terminal</i> <i>(B136) No. 28 (+) — Chassis ground (-):</i>	Is the voltage 10 V or more?	Go to step 2.	Go to step 3.
2 CHECK FOR POOR CONTACT. Check for poor contact of ECM connector.	Is there poor contact of ECM connector?	Repair the poor contact of ECM connector.	Even if DTC is detected, the circuit has returned to a normal condition at this time. Reproduce the failure, and then perform the diagnosis again. NOTE: In this case, temporary open or short circuit of harness or temporary poor contact of connector may be the cause.
3 CHECK POWER SUPPLY TO THE PRESSURE CONTROL SOLENOID VALVE. Measure the voltage between pressure control solenoid valve and chassis ground. <i>Connector & terminal</i> <i>(R68) No. 1 (+) — Chassis ground (-):</i>	Is the voltage 10 V or more?	Go to step 4.	Repair the power supply circuit.
4 CHECK HARNESS BETWEEN ECM AND PRESSURE CONTROL SOLENOID VALVE. 1) Turn the ignition switch to OFF. 2) Disconnect the connector from the ECM and pressure control solenoid valve. 3) Measure the resistance between pressure control solenoid valve and chassis ground. <i>Connector & terminal</i> <i>(R68) No. 2 — Chassis ground:</i>	Is the resistance 1 M Ω or more?	Go to step 5.	Repair the ground short circuit of harness between ECM and pressure control solenoid valve connector.
5 CHECK HARNESS BETWEEN ECM AND PRESSURE CONTROL SOLENOID VALVE. Measure the resistance of harness between ECM and pressure control solenoid valve connector. <i>Connector & terminal</i> <i>(B136) No. 28 — (R68) No. 2:</i>	Is the resistance less than 1 Ω ?	Go to step 6.	Repair the harness and connector. NOTE: In this case, repair the following item: <ul style="list-style-type: none"> • Open circuit in harness between ECM and pressure control solenoid valve connector • Poor contact of coupling connector
6 CHECK PRESSURE CONTROL SOLENOID VALVE. Measure the resistance between pressure control solenoid valve terminals. <i>Terminals</i> <i>No. 1 — No. 2:</i>	Is the resistance between 10 — 100 Ω ?	Repair the poor contact of pressure control solenoid valve connector.	Replace the pressure control solenoid valve. <Ref. to EC(H4SO)-15, Pressure Control Solenoid Valve.>

Diagnostic Procedure with Diagnostic Trouble Code (DTC)

ENGINE (DIAGNOSTICS)

CL:DTC P1420 FUEL TANK PRESSURE CONTROL SOL. VALVE CIRCUIT HIGH

DTC DETECTING CONDITION:

- Detected when two consecutive driving cycles with fault occur.
- GENERAL DESCRIPTION <Ref. to GD(H4SO)-161, DTC P1420 FUEL TANK PRESSURE CONTROL SOL. VALVE CIRCUIT HIGH, Diagnostic Trouble Code (DTC) Detecting Criteria.>

CAUTION:

After repair or replacement of faulty parts, perform Clear Memory Mode <Ref. to EN(H4SO)(diag)-51, OPERATION, Clear Memory Mode.> and Inspection Mode <Ref. to EN(H4SO)(diag)-41, PROCEDURE, Inspection Mode.>.

WIRING DIAGRAM:

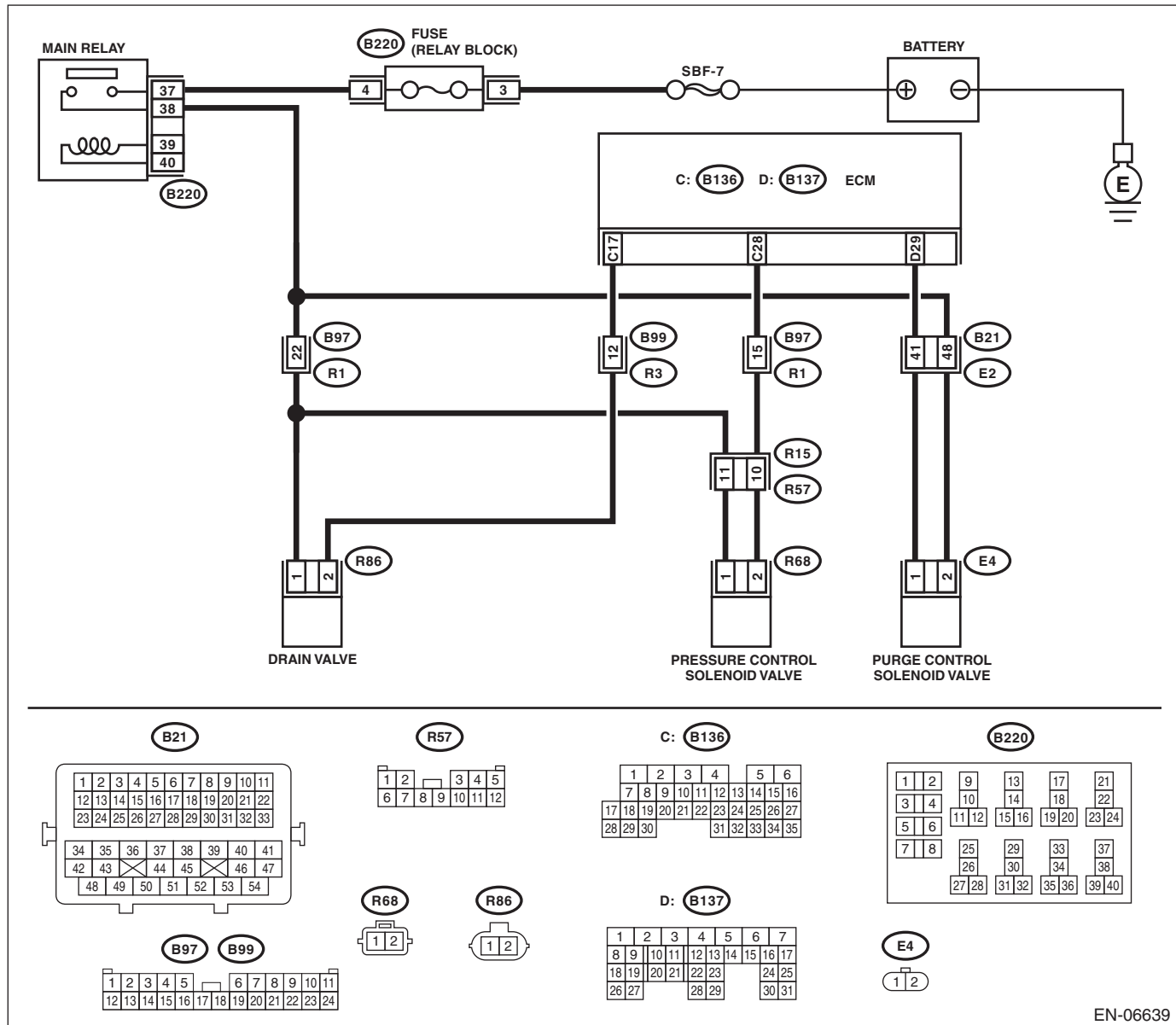

EN-06639

Diagnostic Procedure with Diagnostic Trouble Code (DTC)

ENGINE (DIAGNOSTICS)

Step	Check	Yes	No
1 CHECK HARNESS BETWEEN ECM AND PRESSURE CONTROL SOLENOID VALVE. 1) Turn the ignition switch to OFF. 2) Disconnect the connector from the ECM and pressure control solenoid valve. 3) Turn the ignition switch to ON. 4) Measure the voltage between ECM and chassis ground. <i>Connector & terminal</i> <i>(B136) No. 28 (+) — Chassis ground (-):</i>	Is the voltage 10 V or more?	Repair the short circuit to power in the harness between ECM and pressure control solenoid valve connector.	Go to step 2.
2 CHECK PRESSURE CONTROL SOLENOID VALVE. 1) Turn the ignition switch to OFF. 2) Measure the resistance between pressure control solenoid valve terminals. <i>Terminals</i> <i>No. 1 — No. 2:</i>	Is the resistance less than 1 Ω ?	Replace the pressure control solenoid valve. <Ref. to EC(H4SO)-15, Pressure Control Solenoid Valve.>	Repair the poor contact of the ECM connector.

Diagnostic Procedure with Diagnostic Trouble Code (DTC)

ENGINE (DIAGNOSTICS)

CM:DTC P1443 VENT CONTROL SOLENOID VALVE FUNCTION PROBLEM

DTC DETECTING CONDITION:

- Immediately at fault recognition
- GENERAL DESCRIPTION <Ref. to GD(H4SO)-163, DTC P1443 VENT CONTROL SOLENOID VALVE FUNCTION PROBLEM, Diagnostic Trouble Code (DTC) Detecting Criteria.>

TROUBLE SYMPTOM:

Improper fuel supply

CAUTION:

After repair or replacement of faulty parts, perform Clear Memory Mode <Ref. to EN(H4SO)(diag)-51, OPERATION, Clear Memory Mode.> and Inspection Mode <Ref. to EN(H4SO)(diag)-41, PROCEDURE, Inspection Mode.>.

WIRING DIAGRAM:

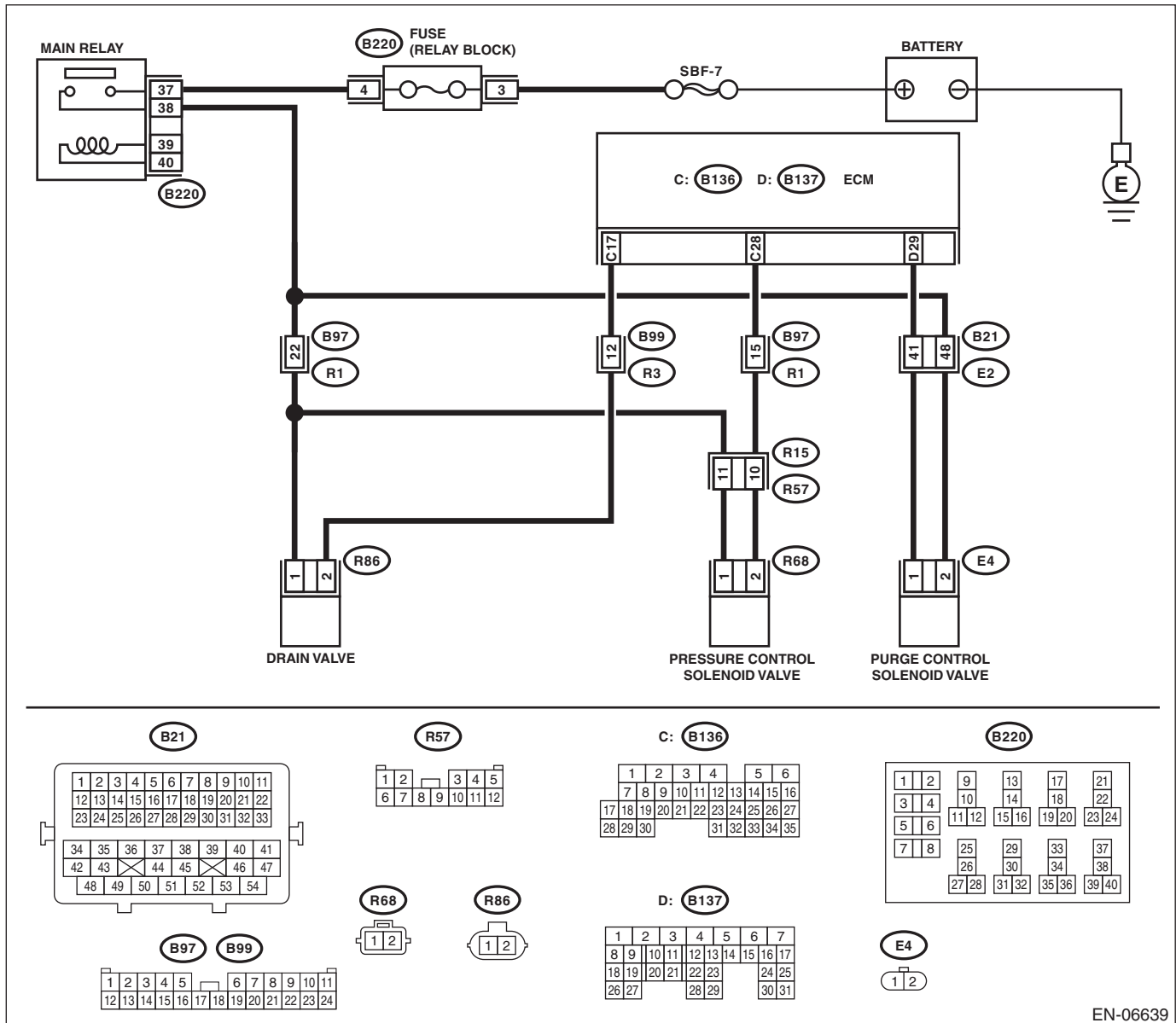

EN-06639

Diagnostic Procedure with Diagnostic Trouble Code (DTC)

ENGINE (DIAGNOSTICS)

	Step	Check	Yes	No
1	CHECK FOR ANY OTHER DTC ON DISPLAY.	Is any other DTC displayed?	Check the appropriate DTC using the "List of Diagnostic Trouble Code (DTC)". <Ref. to EN(H4SO)(diag)-82, List of Diagnostic Trouble Code (DTC).>	Go to step 2.
2	CHECK DRAIN HOSE. Check the drain hose for clogging.	Is there clogging in the drain hose?	Replace the drain hose.	Go to step 3.
3	CHECK DRAIN VALVE OPERATION. 1) Turn the ignition switch to OFF. 2) Connect the delivery (test) mode connector at the lower portion of instrument panel (on the driver's side). 3) Turn the ignition switch to ON. 4) Operate the drain valve. NOTE: Drain valve operation can be executed using the Subaru Select Monitor. Regarding the procedures, refer to "Compulsory Valve Operation Check Mode". <Ref. to EN(H4SO)(diag)-52, Compulsory Valve Operation Check Mode.>	Does the drain valve operate?	Repair the poor contact of the ECM connector.	Replace the drain valve. <Ref. to EC(H4SO)-18, Drain Valve.>

Diagnostic Procedure with Diagnostic Trouble Code (DTC)

ENGINE (DIAGNOSTICS)

CN:DTC P1491 POSITIVE CRANKCASE VENTILATION (BLOW-BY) FUNCTION PROBLEM

DTC DETECTING CONDITION:

- Immediately at fault recognition
- GENERAL DESCRIPTION <Ref. to GD(H4SO)-165, DTC P1491 POSITIVE CRANKCASE VENTILATION (BLOW-BY) FUNCTION PROBLEM, Diagnostic Trouble Code (DTC) Detecting Criteria.>

TROUBLE SYMPTOM:

Improper idling

CAUTION:

After repair or replacement of faulty parts, perform Clear Memory Mode <Ref. to EN(H4SO)(diag)-51, OPERATION, Clear Memory Mode.> and Inspection Mode <Ref. to EN(H4SO)(diag)-41, PROCEDURE, Inspection Mode.>.

WIRING DIAGRAM:

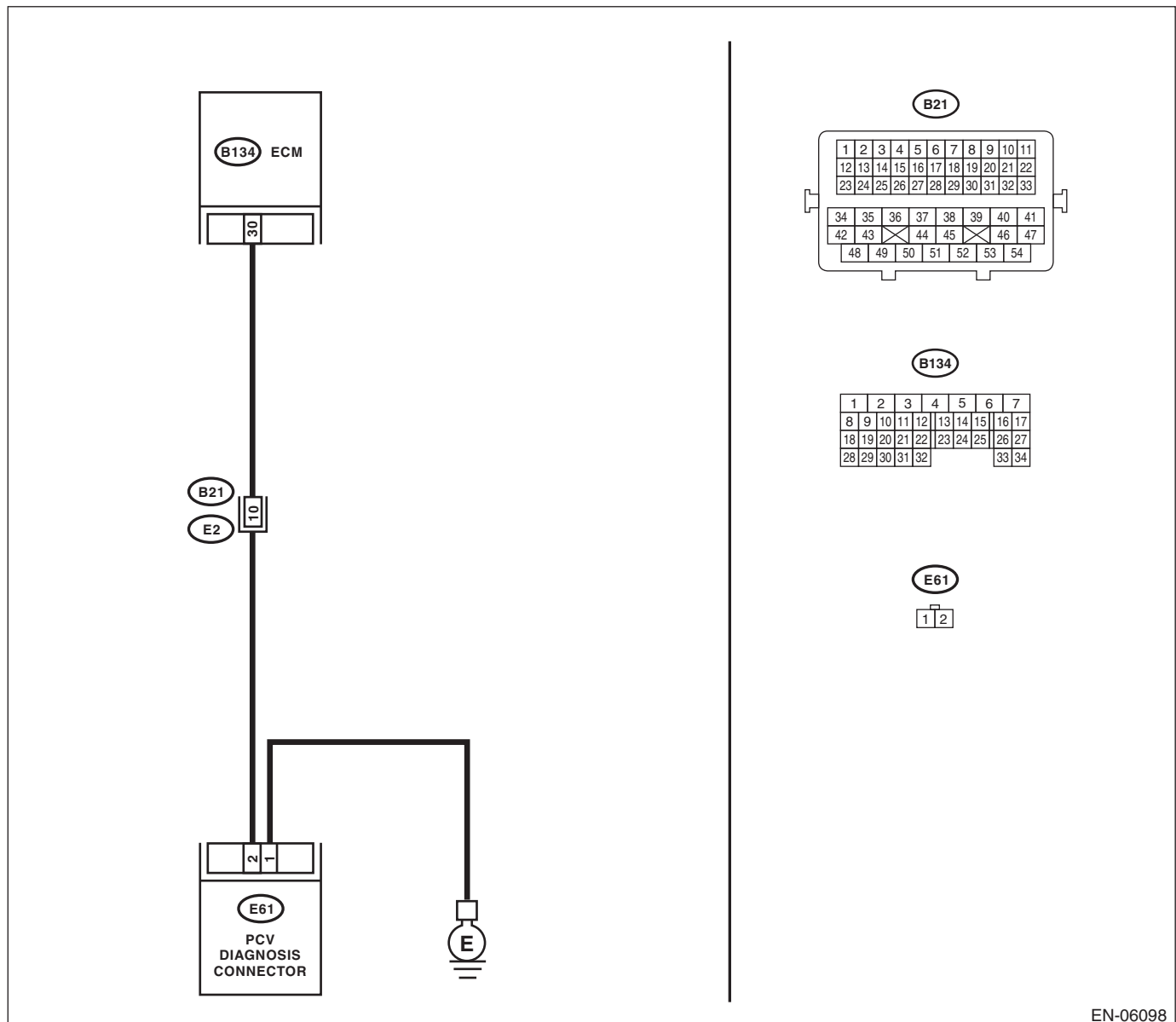

EN-06098

Diagnostic Procedure with Diagnostic Trouble Code (DTC)

ENGINE (DIAGNOSTICS)

Step	Check	Yes	No
1 CHECK BLOW-BY HOSE. Check the blow-by hose condition.	Is there any disconnection or crack in blow-by hose?	Repair or replace the blow-by hose.	Go to step 2.
2 CHECK HARNESS BETWEEN ECM AND PCV HOSE ASSEMBLY. 1) Turn the ignition switch to OFF. 2) Disconnect the connectors from the ECM and PCV hose assembly. 3) Measure the resistance of harness between ECM and PCV hose assembly connector. Connector & terminal (B134) No. 30 — (E61) No. 2:	Is the resistance less than 1 Ω ?	Go to step 3.	Repair the harness and connector. NOTE: In this case, repair the following item: • Open circuit in harness between ECM and PCV hose assembly connector • Poor contact of coupling connector
3 CHECK HARNESS BETWEEN ECM AND PCV HOSE ASSEMBLY. Measure the resistance between PCV hose assembly connector and chassis ground. Connector & terminal (B134) No. 30 — Chassis ground:	Is the resistance 1 M Ω or more?	Go to step 4.	Repair the short circuit to ground in harness between ECM and PCV hose assembly connector.
4 CHECK GROUND CIRCUIT OF PCV HOSE ASSEMBLY. Measure the resistance of harness between PCV hose assembly connector and engine ground. Connector & terminal (E61) No. 1 — Engine ground:	Is the resistance less than 5 Ω ?	Go to step 5.	Repair the open circuit of harness between PCV hose assembly and engine ground.
5 CHECK THE PCV HOSE ASSEMBLY. Measure the resistance between the PCV hose assembly terminals. Terminals No. 1 — No. 2:	Is the resistance less than 1 Ω ?	Repair the poor contact in ECM and PCV hose assembly connector.	Replace the PCV hose assembly.

CO:DTC P1492 EGR SOLENOID VALVE SIGNAL #1 CIRCUIT MALFUNCTION (LOW INPUT)

NOTE:

For the diagnostic procedure, refer to DTC P1498. <Ref. to EN(H4SO)(diag)-258, DTC P1498 EGR SOLENOID VALVE SIGNAL #4 CIRCUIT MALFUNCTION (LOW INPUT), Diagnostic Procedure with Diagnostic Trouble Code (DTC).>

CP:DTC P1493 EGR SOLENOID VALVE SIGNAL #1 CIRCUIT MALFUNCTION (HIGH INPUT)

NOTE:

For the diagnostic procedure, refer to DTC P1499. <Ref. to EN(H4SO)(diag)-261, DTC P1499 EGR SOLENOID VALVE SIGNAL #4 CIRCUIT MALFUNCTION (HIGH INPUT), Diagnostic Procedure with Diagnostic Trouble Code (DTC).>

CQ:DTC P1494 EGR SOLENOID VALVE SIGNAL #2 CIRCUIT MALFUNCTION (LOW INPUT)

NOTE:

For the diagnostic procedure, refer to DTC P1498. <Ref. to EN(H4SO)(diag)-258, DTC P1498 EGR SOLENOID VALVE SIGNAL #4 CIRCUIT MALFUNCTION (LOW INPUT), Diagnostic Procedure with Diagnostic Trouble Code (DTC).>

CR:DTC P1495 EGR SOLENOID VALVE SIGNAL #2 CIRCUIT MALFUNCTION (HIGH INPUT)

NOTE:

For the diagnostic procedure, refer to DTC P1499. <Ref. to EN(H4SO)(diag)-261, DTC P1499 EGR SOLENOID VALVE SIGNAL #4 CIRCUIT MALFUNCTION (HIGH INPUT), Diagnostic Procedure with Diagnostic Trouble Code (DTC).>

CS:DTC P1496 EGR SOLENOID VALVE SIGNAL #3 CIRCUIT MALFUNCTION (LOW INPUT)

NOTE:

For the diagnostic procedure, refer to DTC P1498. <Ref. to EN(H4SO)(diag)-258, DTC P1498 EGR SOLENOID VALVE SIGNAL #4 CIRCUIT MALFUNCTION (LOW INPUT), Diagnostic Procedure with Diagnostic Trouble Code (DTC).>

CT:DTC P1497 EGR SOLENOID VALVE SIGNAL #3 CIRCUIT MALFUNCTION (HIGH INPUT)

NOTE:

For the diagnostic procedure, refer to DTC P1499. <Ref. to EN(H4SO)(diag)-261, DTC P1499 EGR SOLENOID VALVE SIGNAL #4 CIRCUIT MALFUNCTION (HIGH INPUT), Diagnostic Procedure with Diagnostic Trouble Code (DTC).>

Diagnostic Procedure with Diagnostic Trouble Code (DTC)

ENGINE (DIAGNOSTICS)

CU:DTC P1498 EGR SOLENOID VALVE SIGNAL #4 CIRCUIT MALFUNCTION (LOW INPUT)

DTC DETECTING CONDITION:

- Immediately at fault recognition
- GENERAL DESCRIPTION <Ref. to GD(H4SO)-167, DTC P1492 EGR SOLENOID VALVE SIGNAL #1 CIRCUIT MALFUNCTION (LOW INPUT), Diagnostic Trouble Code (DTC) Detecting Criteria.> <Ref. to GD(H4SO)-171, DTC P1494 EGR SOLENOID VALVE SIGNAL #2 CIRCUIT MALFUNCTION (LOW INPUT), Diagnostic Trouble Code (DTC) Detecting Criteria.> <Ref. to GD(H4SO)-171, DTC P1496 EGR SOLENOID VALVE SIGNAL #3 CIRCUIT MALFUNCTION (LOW INPUT), Diagnostic Trouble Code (DTC) Detecting Criteria.> <Ref. to GD(H4SO)-171, DTC P1498 EGR SOLENOID VALVE SIGNAL #4 CIRCUIT MALFUNCTION (LOW INPUT), Diagnostic Trouble Code (DTC) Detecting Criteria.>

TROUBLE SYMPTOM:

- Improper idling
- Poor driving performance
- Engine breathing

CAUTION:

After repair or replacement of faulty parts, perform Clear Memory Mode <Ref. to EN(H4SO)(diag)-51, OPERATION, Clear Memory Mode.> and Inspection Mode <Ref. to EN(H4SO)(diag)-41, PROCEDURE, Inspection Mode.>.

Diagnostic Procedure with Diagnostic Trouble Code (DTC)

WIRING DIAGRAM:

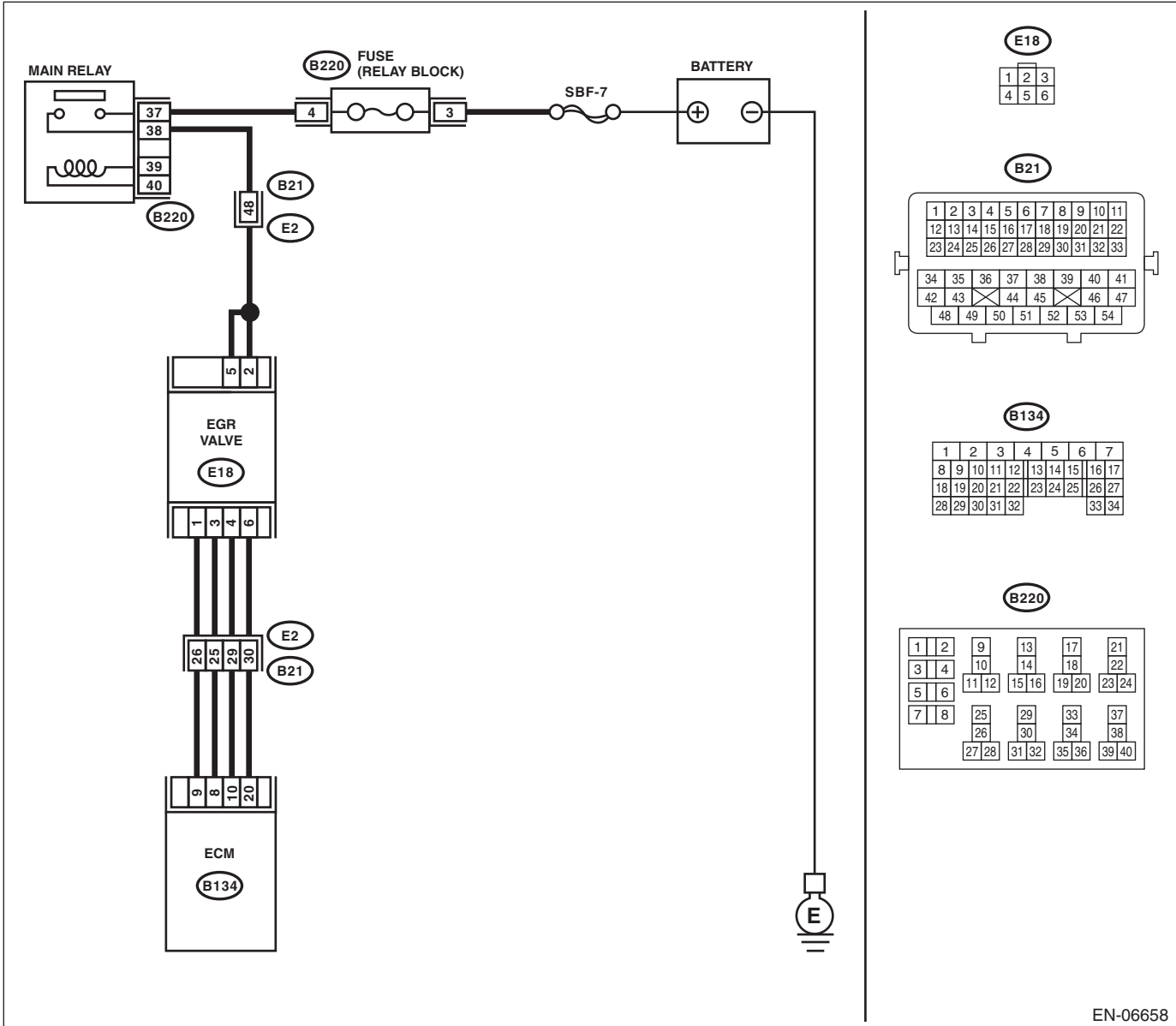

1	2	3
4	5	6

1	2	3	4	5	6	7	8	9	10	11
12	13	14	15	16	17	18	19	20	21	22
23	24	25	26	27	28	29	30	31	32	33
34	35	36	37	38	39	40	41			
42	43	44	45	46	47					
48	49	50	51	52	53	54				

1	2	3	4	5	6	7			
8	9	10	11	12	13	14	15	16	17
18	19	20	21	22	23	24	25	26	27
28	29	30	31	32				33	34

1	2	9	13	17	21				
3	4	10	14	18	22				
5	6	11	12	15	16	19	20	23	24
7	8	25	29	33	37				
		26	30	34	38				
		27	28	31	32	35	36	39	40

EN-06658

Diagnostic Procedure with Diagnostic Trouble Code (DTC)

ENGINE (DIAGNOSTICS)

Step	Check	Yes	No
1 CHECK POWER SUPPLY TO EGR VALVE. 1) Turn the ignition switch to OFF. 2) Disconnect the connector from the EGR valve. 3) Turn the ignition switch to ON. 4) Measure the voltage between EGR valve connector and engine ground. Connector & terminal (E18) No. 2 (+) — Engine ground (-): (E18) No. 5 (+) — Engine ground (-):	Is the voltage 10 V or more?	Go to step 2.	Repair the harness and connector. NOTE: In this case, repair the following item: • Open circuit in harness between EGR valve and main relay connector • Poor contact of coupling connector
2 CHECK HARNESS BETWEEN ECM AND EGR VALVE CONNECTOR. 1) Turn the ignition switch to OFF. 2) Disconnect the connectors from the ECM. 3) Measure the resistance between ECM and EGR valve connector. Connector & terminal DTC P1492; (B134) No. 8 — (E18) No. 3: DTC P1494; (B134) No. 9 — (E18) No. 1: DTC P1496; (B134) No. 10 — (E18) No. 4: DTC P1498; (B134) No. 20 — (E18) No. 6:	Is the resistance less than 1 Ω ?	Go to step 3.	Repair the harness and connector. NOTE: In this case, repair the following item: • Open circuit in harness between ECM and EGR valve connector • Poor contact of coupling connector
3 CHECK HARNESS BETWEEN ECM AND EGR VALVE CONNECTOR. 1) Disconnect the connectors from the ECM. 2) Measure the resistance between ECM and chassis ground. Connector & terminal DTC P1492; (B134) No. 8 — Chassis ground: DTC P1494; (B134) No. 9 — Chassis ground: DTC P1496; (B134) No. 10 — Chassis ground: DTC P1498; (B134) No. 20 — Chassis ground:	Is the resistance 1 M Ω or more?	Go to step 4.	Repair the ground short in harness between ECM and EGR valve connector.
4 CHECK POOR CONTACT. Check poor contact in ECM and EGR valve connector.	Is there poor contact in ECM or EGR valve connector?	Repair the poor contact in ECM or EGR valve connector.	Replace the EGR valve. <Ref. to FU(H4SO)-29, EGR Valve.>

CV:DTC P1499 EGR SOLENOID VALVE SIGNAL #4 CIRCUIT MALFUNCTION (HIGH INPUT)

DTC DETECTING CONDITION:

- Immediately at fault recognition
- GENERAL DESCRIPTION <Ref. to GD(H4SO)-169, DTC P1493 EGR SOLENOID VALVE SIGNAL #1 CIRCUIT MALFUNCTION (HIGH INPUT), Diagnostic Trouble Code (DTC) Detecting Criteria.> <Ref. to GD(H4SO)-171, DTC P1495 EGR SOLENOID VALVE SIGNAL #2 CIRCUIT MALFUNCTION (HIGH INPUT), Diagnostic Trouble Code (DTC) Detecting Criteria.> <Ref. to GD(H4SO)-171, DTC P1497 EGR SOLENOID VALVE SIGNAL #3 CIRCUIT MALFUNCTION (HIGH INPUT), Diagnostic Trouble Code (DTC) Detecting Criteria.> <Ref. to GD(H4SO)-171, DTC P1499 EGR SOLENOID VALVE SIGNAL #4 CIRCUIT MALFUNCTION (HIGH INPUT), Diagnostic Trouble Code (DTC) Detecting Criteria.>

TROUBLE SYMPTOM:

- Improper idling
- Poor driving performance
- Engine breathing

CAUTION:

After repair or replacement of faulty parts, perform Clear Memory Mode <Ref. to EN(H4SO)(diag)-51, OPERATION, Clear Memory Mode.> and Inspection Mode <Ref. to EN(H4SO)(diag)-41, PROCEDURE, Inspection Mode.>.

Diagnostic Procedure with Diagnostic Trouble Code (DTC)

ENGINE (DIAGNOSTICS)

WIRING DIAGRAM:

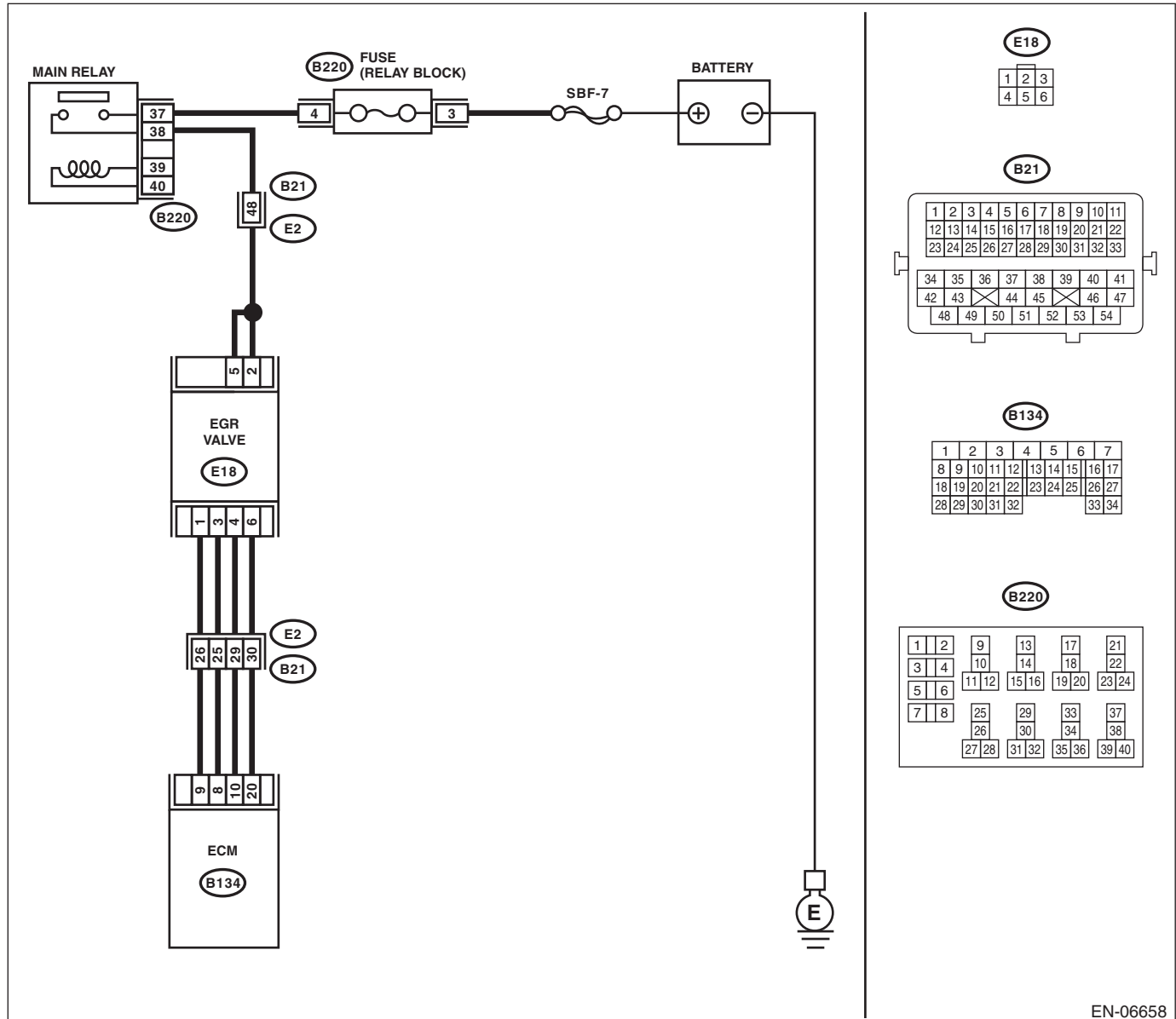

EN-06658

Step	Check	Yes	No
<p>1</p> <p>CHECK HARNESS BETWEEN ECM AND EGR VALVE CONNECTOR.</p> <p>1) Turn the ignition switch to OFF.</p> <p>2) Disconnect the connector from the EGR valve.</p> <p>3) Turn the ignition switch to ON.</p> <p>4) Measure the voltage between ECM and chassis ground.</p> <p>Connector & terminal</p> <p>DTC P1493; (B134) No. 8 (+) — Chassis ground (-):</p> <p>DTC P1495; (B134) No. 9 (+) — Chassis ground (-):</p> <p>DTC P1497; (B134) No. 10 (+) — Chassis ground (-):</p> <p>DTC P1499; (B134) No. 20 (+) — Chassis ground (-):</p>	<p>Is the voltage 10 V or more?</p>	<p>Repair the short circuit to power in the harness between the ECM and EGR valve connectors.</p>	<p>Repair the poor contact of the ECM connector.</p>

Diagnostic Procedure with Diagnostic Trouble Code (DTC)

ENGINE (DIAGNOSTICS)

CW:DTC P1560 BACK-UP VOLTAGE CIRCUIT MALFUNCTION

DTC DETECTING CONDITION:

- Immediately at fault recognition
- GENERAL DESCRIPTION <Ref. to GD(H4SO)-172, DTC P1560 BACK-UP VOLTAGE CIRCUIT MALFUNCTION, Diagnostic Trouble Code (DTC) Detecting Criteria.>

CAUTION:

After repair or replacement of faulty parts, perform Clear Memory Mode <Ref. to EN(H4SO)(diag)-51, OPERATION, Clear Memory Mode.> and Inspection Mode <Ref. to EN(H4SO)(diag)-41, PROCEDURE, Inspection Mode.>.

WIRING DIAGRAM:

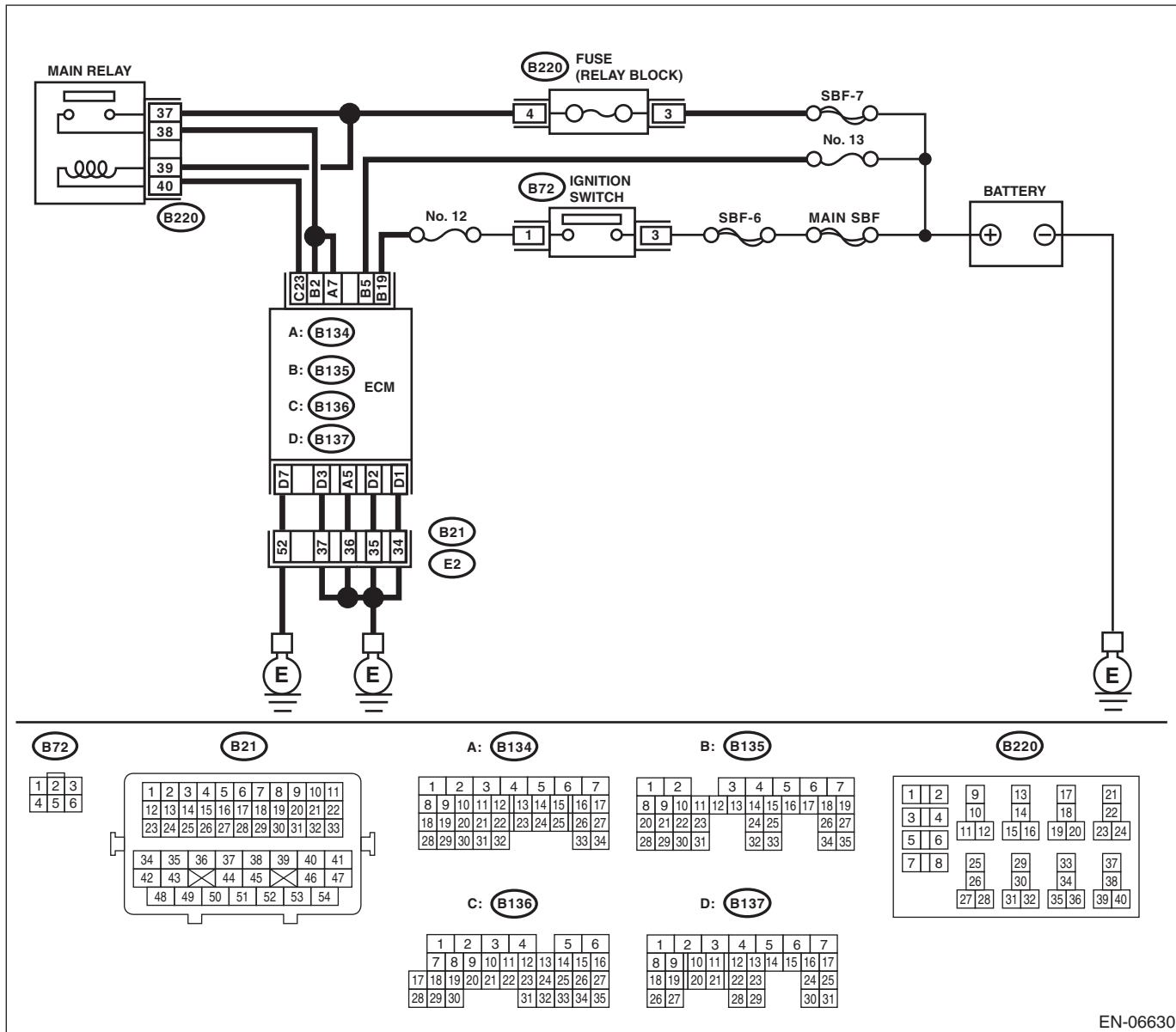

EN-06630

Diagnostic Procedure with Diagnostic Trouble Code (DTC)

ENGINE (DIAGNOSTICS)

Step	Check	Yes	No
1 CHECK INPUT SIGNAL OF ECM. 1) Turn the ignition switch to OFF. 2) Measure the voltage between ECM and chassis ground. <i>Connector & terminal</i> <i>(B135) No. 5 (+) — Chassis ground (-):</i>	Is the voltage 10 V or more?	Repair poor contact of the ECM connector.	Go to step 2.
2 CHECK HARNESS BETWEEN ECM AND MAIN FUSE BOX CONNECTOR. 1) Disconnect the connectors from the ECM. 2) Measure the resistance between ECM and chassis ground. <i>Connector & terminal</i> <i>(B135) No. 5 — Chassis ground:</i>	Is the resistance 1 MΩ or more?	Go to step 3.	Repair the ground short circuit of harness between ECM and battery terminal.
3 CHECK FUSE NO. 13 (IN MAIN FUSE BOX).	Is the fuse blown out?	Replace the fuse.	Repair the harness and connector. NOTE: In this case, repair the following item: <ul style="list-style-type: none"> • Open circuit of harness between ECM and battery • Poor contact in ECM connector • Poor contact of battery terminal

Diagnostic Procedure with Diagnostic Trouble Code (DTC)

ENGINE (DIAGNOSTICS)

CX:DTC P1602 CONTROL MODULE PROGRAMMING ERROR

DTC DETECTING CONDITION:

- Detected when two consecutive driving cycles with fault occur.
- GENERAL DESCRIPTION <Ref. to GD(H4SO)-174, DTC P1602 CONTROL MODULE PROGRAMMING ERROR, Diagnostic Trouble Code (DTC) Detecting Criteria.>

TROUBLE SYMPTOM:

- Engine keeps running at higher speed than specified idle speed.
- Engine keeps running at a lower speed than the specified idle speed.
- Engine stalls.

CAUTION:

After repair or replacement of faulty parts, perform Clear Memory Mode <Ref. to EN(H4SO)(diag)-51, OPERATION, Clear Memory Mode.> and Inspection Mode <Ref. to EN(H4SO)(diag)-41, PROCEDURE, Inspection Mode.>.

WIRING DIAGRAM:

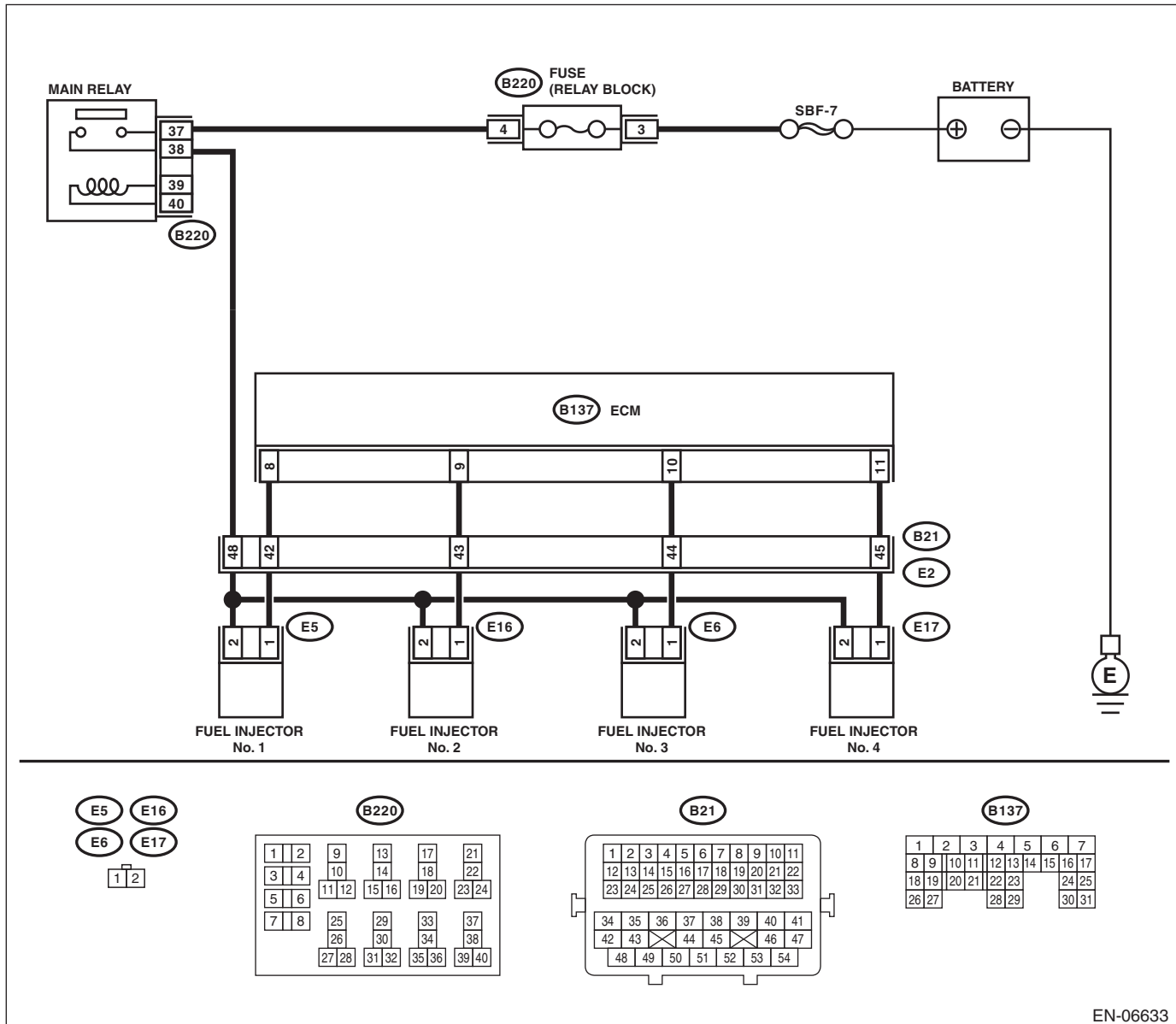

EN-06633

Diagnostic Procedure with Diagnostic Trouble Code (DTC)

ENGINE (DIAGNOSTICS)

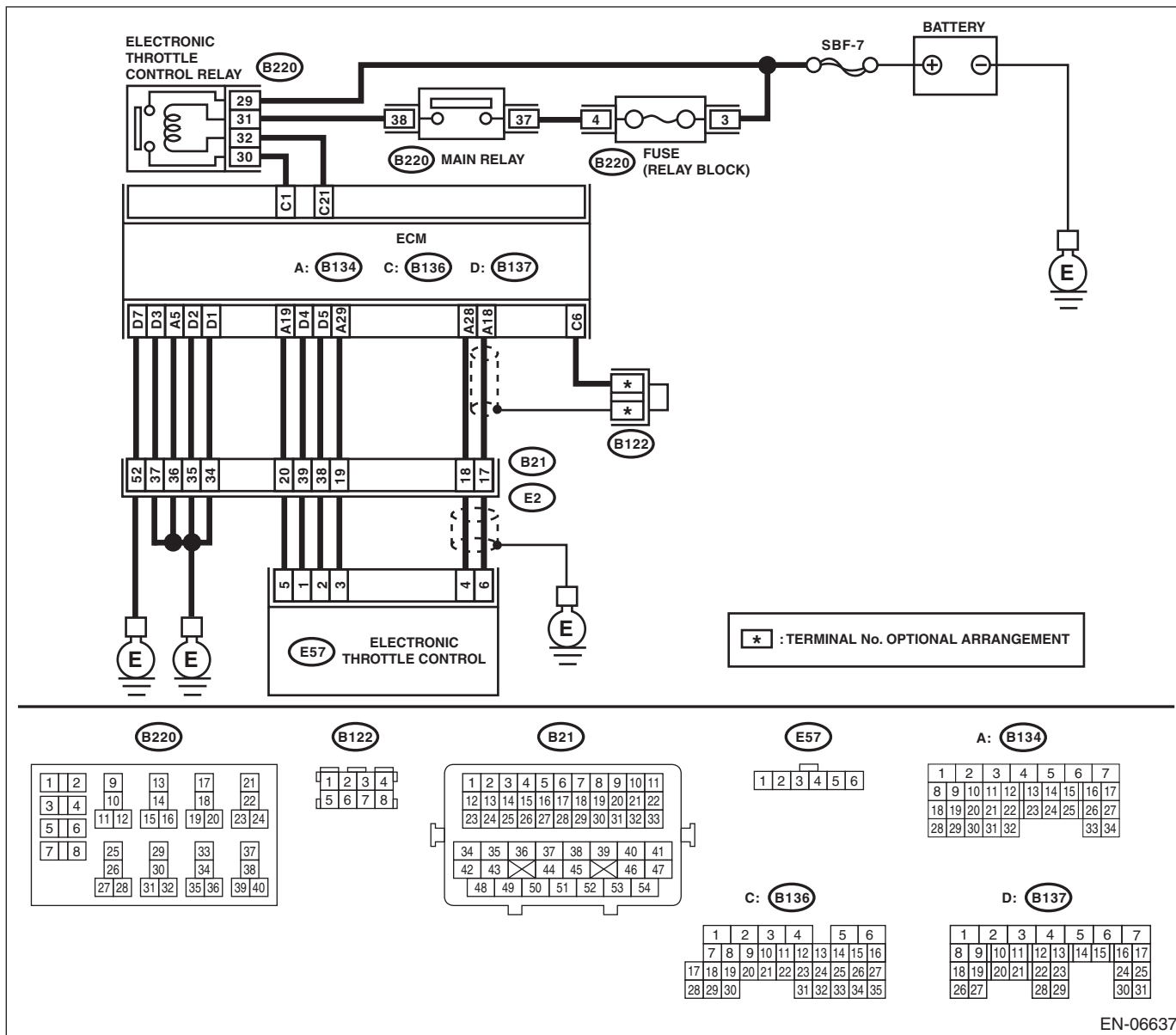

EN-06637

Diagnostic Procedure with Diagnostic Trouble Code (DTC)

ENGINE (DIAGNOSTICS)

Step	Check	Yes	No
1 CHECK FOR ANY OTHER DTC ON DISPLAY.	Is any other DTC displayed?	Check the appropriate DTC using the "List of Diagnostic Trouble Code (DTC)". <Ref. to EN(H4SO)(diag)-82, List of Diagnostic Trouble Code (DTC).>	Go to step 2.
2 CHECK ENGINE OIL.	Is there a proper amount of engine oil?	Go to step 3.	Replace engine oil. <Ref. to LU(H4SO)-8, REPLACEMENT, Engine Oil.>
3 CHECK EXHAUST SYSTEM.	Are there holes or loose bolts on exhaust system?	Repair the exhaust system.	Go to step 4.
4 CHECK AIR INTAKE SYSTEM.	Are there holes, loose bolts or disconnection of hose on air intake system?	Repair the air intake system.	Go to step 5.
5 CHECK FUEL PRESSURE. WARNING: Place "NO OPEN FLAMES" signs near the working area. CAUTION: Be careful not to spill fuel. Measure the fuel pressure. <Ref. to ME(H4SO)-28, INSPECTION, Fuel Pressure.> CAUTION: Release fuel pressure before removing the fuel pressure gauge.	Is the measured value 339.5 — 360.5 kPa (3.5 — 3.7 kg/cm ² , 49 — 52 psi)?	Go to step 6.	Repair the following item. Fuel pressure is too high: • Clogged fuel line or bent hose Fuel pressure is too low: • Improper fuel pump discharge • Clogged fuel line
6 CHECK ENGINE COOLANT TEMPERATURE SENSOR. 1) Start the engine and warm up completely. 2) Read the data of engine coolant temperature sensor signal using Subaru Select Monitor or general scan tool. NOTE: • Subaru Select Monitor For detailed operation procedures, refer to "READ CURRENT DATA FOR ENGINE". <Ref. to EN(H4SO)(diag)-33, Subaru Select Monitor.> • General scan tool For detailed operation procedures, refer to the general scan tool operation manual.	Is the engine coolant temperature 75°C (167°F) or higher?	Go to step 7.	Replace the engine coolant temperature sensor. <Ref. to FU(H4SO)-22, Engine Coolant Temperature Sensor.>

Diagnostic Procedure with Diagnostic Trouble Code (DTC)

ENGINE (DIAGNOSTICS)

Step	Check	Yes	No
<p>7</p> <p>CHECK MASS AIR FLOW AND INTAKE AIR TEMPERATURE SENSOR.</p> <p>1) Start the engine and warm up engine until coolant temperature is higher than 75°C (167°F).</p> <p>2) For AT models, set the select lever to “P” range or “N” range, and for MT models, place the shift lever in the neutral position.</p> <p>3) Turn the A/C switch to OFF.</p> <p>4) Turn all the accessory switches to OFF.</p> <p>5) Read the data of mass air flow and intake air temperature sensor signal using Subaru Select Monitor or general scan tool.</p> <p>NOTE:</p> <ul style="list-style-type: none"> • Subaru Select Monitor <p>For detailed operation procedures, refer to “READ CURRENT DATA FOR ENGINE”. <Ref. to EN(H4SO)(diag)-33, Subaru Select Monitor.></p> <ul style="list-style-type: none"> • General scan tool <p>For detailed operation procedures, refer to the general scan tool operation manual.</p>	<p>Is the measured value 2.0 — 5.0 g/s (0.26 — 0.66 lb/m)?</p>	<p>Go to step 8.</p>	<p>Replace the mass air flow and intake air temperature sensor. <Ref. to FU(H4SO)-28, Mass Air Flow and Intake Air Temperature Sensor.></p>
<p>8</p> <p>CHECK MASS AIR FLOW AND INTAKE AIR TEMPERATURE SENSOR.</p> <p>1) Start the engine and warm up engine until coolant temperature is higher than 75°C (167°F).</p> <p>2) For AT models, set the select lever to “P” range or “N” range, and for MT models, place the shift lever in the neutral position.</p> <p>3) Turn the A/C switch to OFF.</p> <p>4) Turn all the accessory switches to OFF.</p> <p>5) Open the front hood.</p> <p>6) Measure the ambient temperature.</p> <p>7) Read the data of mass air flow and intake air temperature sensor signal using Subaru Select Monitor or general scan tool.</p> <p>NOTE:</p> <ul style="list-style-type: none"> • Subaru Select Monitor <p>For detailed operation procedures, refer to “READ CURRENT DATA FOR ENGINE”. <Ref. to EN(H4SO)(diag)-33, Subaru Select Monitor.></p> <ul style="list-style-type: none"> • General scan tool <p>For detailed operation procedures, refer to the general scan tool operation manual.</p>	<p>Subtract ambient temperature from intake air temperature. Is the obtained value -10 — 50°C (-18 — 90°F)?</p>	<p>Go to step 9.</p>	<p>Check the mass air flow and intake air temperature sensor. <Ref. to FU(H4SO)-28, Mass Air Flow and Intake Air Temperature Sensor.></p>
<p>9</p> <p>CHECK OUTPUT SIGNAL OF ECM.</p> <p>1) Turn the ignition switch to ON.</p> <p>2) Measure the voltage between the ECM and chassis ground for faulty cylinders.</p> <p>Connector & terminal</p> <p>#1 (B137) No. 8 (+) — Chassis ground (-):</p> <p>#2 (B137) No. 9 (+) — Chassis ground (-):</p> <p>#3 (B137) No. 10 (+) — Chassis ground (-):</p> <p>#4 (B137) No. 11 (+) — Chassis ground (-):</p>	<p>Is the voltage 10 V or more?</p>	<p>Go to step 14.</p>	<p>Go to step 10.</p>

Diagnostic Procedure with Diagnostic Trouble Code (DTC)

ENGINE (DIAGNOSTICS)

Step	Check	Yes	No
<p>10 CHECK HARNESS BETWEEN ECM AND FUEL INJECTOR.</p> <p>1) Turn the ignition switch to OFF. 2) Disconnect the connector from fuel injector on faulty cylinders. 3) Measure the resistance between the fuel injector connector and engine ground on faulty cylinders.</p> <p>Connector & terminal #1 (E5) No. 1 — Engine ground: #2 (E16) No. 1 — Engine ground: #3 (E6) No. 1 — Engine ground: #4 (E17) No. 1 — Engine ground:</p>	Is the resistance 1 MΩ or more?	Go to step 11.	Repair the short circuit to ground in harness between ECM and fuel injector connector.
<p>11 CHECK HARNESS BETWEEN ECM AND FUEL INJECTOR.</p> <p>Measure the resistance of harness between the ECM and fuel injector on faulty cylinders.</p> <p>Connector & terminal #1 (B137) No. 8 — (E5) No. 1: #2 (B137) No. 9 — (E16) No. 1: #3 (B137) No. 10 — (E6) No. 1: #4 (B137) No. 11 — (E17) No. 1:</p>	Is the resistance less than 1 Ω?	Go to step 12.	Repair the harness and connector. NOTE: In this case, repair the following item: <ul style="list-style-type: none"> • Open circuit of harness between ECM and fuel injector connector • Poor contact of coupling connector
<p>12 CHECK FUEL INJECTOR.</p> <p>Measure the resistance between fuel injector terminals on faulty cylinder.</p> <p>Terminals No. 1 — No. 2:</p>	Is the resistance between 5 — 20 Ω?	Go to step 13.	Replace the faulty fuel injector. <Ref. to FU(H4SO)-30, Fuel Injector.>
<p>13 CHECK POWER SUPPLY LINE.</p> <p>1) Turn the ignition switch to ON. 2) Measure the voltage between fuel injector and engine ground on faulty cylinders.</p> <p>Connector & terminal #1 (E5) No. 2 (+) — Engine ground (-): #2 (E16) No. 2 (+) — Engine ground (-): #3 (E6) No. 2 (+) — Engine ground (-): #4 (E17) No. 2 (+) — Engine ground (-):</p>	Is the voltage 10 V or more?	Repair the poor contact of all connectors in fuel injector circuit.	Repair the harness and connector. NOTE: In this case, repair the following item: <ul style="list-style-type: none"> • Open circuit in harness between the main relay connector and fuel injector connector on faulty cylinders • Poor contact of coupling connector • Poor contact of main relay connector
<p>14 CHECK HARNESS BETWEEN ECM AND FUEL INJECTOR.</p> <p>1) Turn the ignition switch to OFF. 2) Disconnect the connector from fuel injector on faulty cylinders. 3) Turn the ignition switch to ON. 4) Measure the voltage between the ECM and chassis ground for faulty cylinders.</p> <p>Connector & terminal #1 (B137) No. 8 (+) — Chassis ground (-): #2 (B137) No. 9 (+) — Chassis ground (-): #3 (B137) No. 10 (+) — Chassis ground (-): #4 (B137) No. 11 (+) — Chassis ground (-):</p>	Is the voltage 10 V or more?	Repair the short circuit to power in harness between ECM and fuel injector connector.	Go to step 15.

Diagnostic Procedure with Diagnostic Trouble Code (DTC)

ENGINE (DIAGNOSTICS)

Step	Check	Yes	No
15 CHECK FUEL INJECTOR. 1) Turn the ignition switch to OFF. 2) Measure the resistance between fuel injector terminals on faulty cylinder. <i>Terminals</i> <i>No. 1 — No. 2:</i>	Is the resistance less than 1 Ω ?	Replace the faulty fuel injector. <Ref. to FU(H4SO)-30, Fuel Injector.>	Go to step 16.
16 CHECK INSTALLATION CONDITION OF CAMSHAFT POSITION SENSOR/CRANKSHAFT POSITION SENSOR.	Is the camshaft position sensor or crankshaft position sensor loosely installed?	Tighten the camshaft position sensor or crankshaft position sensor.	Go to step 17.
17 CHECK CRANK SPROCKET. Remove the timing belt cover. <Ref. to ME(H4SO)-52, REMOVAL, Timing Belt Cover.>	Is the crank sprocket rusted or does it have damaged teeth?	Replace the crank sprocket. <Ref. to ME(H4SO)-61, Crank Sprocket.>	Go to step 18.
18 CHECK INSTALLATION CONDITION OF TIMING BELT. Turn the crankshaft using ST, and align alignment mark on crank sprocket with alignment mark on cylinder block. ST 499987500 CRANKSHAFT SOCKET	Is the timing belt dislocated from its proper position?	Repair the installation condition of timing belt. <Ref. to ME(H4SO)-53, Timing Belt.>	Go to step 19.
19 CHECK ELECTRONIC THROTTLE CONTROL RELAY. 1) Turn the ignition switch to OFF. 2) Remove the electronic throttle control relay. 3) Connect the battery to terminals No. 31 and No. 32 of electronic throttle control relay. 4) Measure the resistance between electronic throttle control relay terminals. <i>Terminals</i> <i>No. 29 — No. 30:</i>	Is the resistance less than 1 Ω ?	Go to step 20.	Replace the electronic throttle control relay. <Ref. to FU(H4SO)-42, Electronic Throttle Control Relay.>
20 CHECK POWER SUPPLY OF ELECTRONIC THROTTLE CONTROL RELAY. Measure the voltage between electronic throttle control relay connector and chassis ground. <i>Connector & terminal</i> <i>(B220) No. 29 (+) — Chassis ground (-):</i>	Is the voltage 10 V or more?	Go to step 21.	Repair the open or ground short circuit of power supply circuit.
21 CHECK HARNESS BETWEEN ECM AND ELECTRONIC THROTTLE CONTROL RELAY. 1) Disconnect the connectors from the ECM. 2) Turn the ignition switch to ON. 3) Measure the voltage between electronic throttle control relay connector and chassis ground. <i>Connector & terminal</i> <i>(B220) No. 32 (+) — Chassis ground (-):</i>	Is the voltage 10 V or more?	Repair the short circuit to power in the harness between ECM and electronic throttle control relay connector.	Go to step 22.
22 CHECK HARNESS BETWEEN ECM AND ELECTRONIC THROTTLE CONTROL RELAY. 1) Turn the ignition switch to OFF. 2) Measure the resistance between electronic throttle control relay connector and chassis ground. <i>Connector & terminal</i> <i>(B220) No. 32 — Chassis ground:</i> <i>(B220) No. 30 — Chassis ground:</i>	Is the resistance 1 M Ω or more?	Go to step 23.	Repair the short circuit in harness to ground between ECM and electronic throttle control relay connector.

Diagnostic Procedure with Diagnostic Trouble Code (DTC)

ENGINE (DIAGNOSTICS)

Step	Check	Yes	No
<p>23 CHECK HARNESS BETWEEN ECM AND ELECTRONIC THROTTLE CONTROL RELAY. Measure the resistance between the ECM and electronic throttle control relay connector. Connector & terminal (B136) No. 21 — (B220) No. 32: (B136) No. 1 — (B220) No. 30:</p>	Is the resistance less than 1 Ω?	Go to step 24.	Repair the open circuit in harness between ECM and electronic throttle control relay connector.
<p>24 CHECK HARNESS BETWEEN ECM AND ELECTRONIC THROTTLE CONTROL. 1) Turn the ignition switch to OFF. 2) Disconnect the connectors from ECM and electronic throttle control. 3) Measure the resistance between ECM and chassis ground. Connector & terminal (B134) No. 19 — Chassis ground: (B134) No. 18 — Chassis ground: (B134) No. 18 — (B136) No. 6: (B134) No. 28 — Chassis ground:</p>	Is the resistance 1 MΩ or more?	Go to step 25.	Repair the ground short circuit of harness between ECM and electronic throttle control connector.
<p>25 CHECK SHORT CIRCUIT INSIDE THE ECM. 1) Connect the connector to ECM. 2) Measure the resistance between electronic throttle control connector and engine ground. Connector & terminal (E57) No. 6 — Engine ground: (E57) No. 4 — Engine ground:</p>	Is the resistance 1 MΩ or more?	Go to step 26.	Repair the ground short circuit of harness between ECM and electronic throttle control connector. Replace the ECM if defective. <Ref. to FU(H4SO)-39, Engine Control Module (ECM).>
<p>26 CHECK HARNESS BETWEEN ECM AND ELECTRONIC THROTTLE CONTROL. 1) Disconnect the connectors from the ECM. 2) Measure the resistance of harness between ECM and electronic throttle control connector. Connector & terminal (B134) No. 18 — (E57) No. 6: (B134) No. 28 — (E57) No. 4: (B134) No. 29 — (E57) No. 3:</p>	Is the resistance less than 1 Ω?	Go to step 27.	Repair the harness and connector. NOTE: In this case, repair the following item: • Open circuit in harness between ECM and electronic throttle control connector • Poor contact of coupling connector
<p>27 CHECK HARNESS BETWEEN ECM AND ELECTRONIC THROTTLE CONTROL. 1) Connect the connector to ECM. 2) Measure the resistance between electronic throttle control connector and engine ground. Connector & terminal (E57) No. 3 — Engine ground:</p>	Is the resistance less than 5 Ω?	Go to step 28.	Repair the harness and connector. NOTE: In this case, repair the following item: • Open circuit of harness between ECM and engine ground • Poor contact in ECM connector • Poor contact of coupling connector

Diagnostic Procedure with Diagnostic Trouble Code (DTC)

ENGINE (DIAGNOSTICS)

Step	Check	Yes	No
28 CHECK HARNESS BETWEEN ECM AND ELECTRONIC THROTTLE CONTROL. 1) Turn the ignition switch to ON. 2) Measure the voltage between electronic throttle control connector and engine ground. Connector & terminal <i>(E57) No. 6 (+) — Engine ground (-):</i> <i>(E57) No. 4 (+) — Engine ground (-):</i>	Is the voltage 4.85 V or more?	Repair the short circuit to power in the harness between ECM and electronic throttle control connector.	Go to step 29.
29 CHECK HARNESS BETWEEN ECM AND ELECTRONIC THROTTLE CONTROL. 1) Turn the ignition switch to OFF. 2) Disconnect the connectors from the ECM. 3) Measure the resistance between ECM connectors. Connector & terminal <i>(B134) No. 19 — (B134) No. 18:</i> <i>(B134) No. 19 — (B134) No. 28:</i>	Is the resistance 1 M Ω or more?	Go to step 30.	Repair the short circuit to power in the harness between ECM and electronic throttle control connector.
30 CHECK SENSOR OUTPUT. 1) Connect all connectors. 2) Turn the ignition switch to ON. 3) Read the data of main throttle sensor signal using Subaru Select Monitor. NOTE: For detailed operation procedures, refer to "READ CURRENT DATA FOR ENGINE". <Ref. to EN(H4SO)(diag)-33, Subaru Select Monitor.>	Is the voltage 0.81 — 0.87 V?	Go to step 31.	Repair poor contact of the electronic throttle control connector. Replace the electronic throttle control if defective. <Ref. to FU(H4SO)-13, Throttle Body.>
31 CHECK SENSOR OUTPUT. Read the data of sub throttle sensor signal using Subaru Select Monitor. NOTE: Subaru Select Monitor For detailed operation procedures, refer to "READ CURRENT DATA FOR ENGINE". <Ref. to EN(H4SO)(diag)-33, Subaru Select Monitor.>	Is the voltage 1.64 — 1.70 V?	Go to step 32.	Repair poor contact of the electronic throttle control connector. Replace the electronic throttle control if defective. <Ref. to FU(H4SO)-13, Throttle Body.>
32 CHECK HARNESS BETWEEN ECM AND ELECTRONIC THROTTLE CONTROL MOTOR. 1) Turn the ignition switch to OFF. 2) Disconnect the connectors from ECM and electronic throttle control. 3) Measure the resistance between ECM and electronic throttle control connector. Connector & terminal <i>(B137) No. 5 — (E57) No. 2:</i> <i>(B137) No. 4 — (E57) No. 1:</i>	Is the resistance less than 1 Ω ?	Go to step 33.	Repair the harness and connector. NOTE: In this case, repair the following item: • Open circuit in harness between ECM and electronic throttle control connector • Poor contact of coupling connector
33 CHECK HARNESS BETWEEN ECM AND ELECTRONIC THROTTLE CONTROL MOTOR. 1) Connect the connector to ECM. 2) Turn the ignition switch to ON. 3) Measure the voltage between electronic throttle control connector and engine ground. Connector & terminal <i>(E57) No. 2 (+) — Engine ground (-):</i> <i>(E57) No. 1 (+) — Engine ground (-):</i>	Is the voltage 5 V or more?	Repair the short circuit to power in the harness between ECM and electronic throttle control connector.	Go to step 34.

Diagnostic Procedure with Diagnostic Trouble Code (DTC)

ENGINE (DIAGNOSTICS)

Step	Check	Yes	No
34 CHECK HARNESS BETWEEN ECM AND ELECTRONIC THROTTLE CONTROL MOTOR. 1) Turn the ignition switch to OFF. 2) Disconnect the connectors from the ECM. 3) Measure the resistance between electronic throttle control connector and engine ground. <i>Connector & terminal</i> <i>(E57) No. 2 — Engine ground:</i> <i>(E57) No. 1 — Engine ground:</i>	Is the resistance 1 M Ω or more?	Go to step 35.	Repair the short circuit to ground in harness between ECM and electronic throttle control connector.
35 CHECK ELECTRONIC THROTTLE CONTROL MOTOR HARNESS. Measure the resistance between the electronic throttle control connector terminals. <i>Connector & terminal</i> <i>(E57) No. 2 — (E57) No. 1:</i>	Is the resistance 1 M Ω or more?	Go to step 36.	Repair the short circuit of harness between ECM and electronic throttle control connector.
36 CHECK ELECTRONIC THROTTLE CONTROL GROUND CIRCUIT. Measure the resistance between ECM and chassis ground. <i>Connector & terminal</i> <i>(B134) No. 5 — Chassis ground:</i> <i>(B137) No. 1 — Chassis ground:</i> <i>(B137) No. 2 — Chassis ground:</i> <i>(B137) No. 3 — Chassis ground:</i> <i>(B137) No. 7 — Chassis ground:</i>	Is the resistance less than 5 Ω ?	Go to step 37.	Repair the harness and connector. NOTE: In this case, repair the following item: • Open circuit of harness between ECM and engine ground • Poor contact of coupling connector
37 CHECK ELECTRONIC THROTTLE CONTROL. Measure the resistance between electronic throttle control terminals. <i>Terminals</i> <i>No. 2 — No. 1:</i>	Is the resistance 50 Ω or less?	Go to step 38.	Replace the electronic throttle control. <Ref. to FU(H4SO)-13, Throttle Body.>
38 CHECK ELECTRONIC THROTTLE CONTROL. Move the throttle valve to the fully open and fully closed positions with fingers. Check that the valve returns to the specified position when releasing fingers.	Does the valve return to the specified position? Standard value: 3 mm (0.12 in) from fully closed position	Repair the poor contact of the ECM connector.	Replace the electronic throttle control. <Ref. to FU(H4SO)-13, Throttle Body.>

CY:DTC P2096 POST CATALYST FUEL TRIM SYSTEM TOO LEAN (BANK 1)

Refer to DTC P2097 for diagnostic procedure. <Ref. to EN(H4SO)(diag)-274, DTC P2097 POST CATALYST FUEL TRIM SYSTEM TOO RICH (BANK 1), Diagnostic Procedure with Diagnostic Trouble Code (DTC).>

Diagnostic Procedure with Diagnostic Trouble Code (DTC)

ENGINE (DIAGNOSTICS)

CZ:DTC P2097 POST CATALYST FUEL TRIM SYSTEM TOO RICH (BANK 1)

DTC DETECTING CONDITION:

- Detected when two consecutive driving cycles with fault occur.
- GENERAL DESCRIPTION <Ref. to GD(H4SO)-178, DTC P2097 POST CATALYST FUEL TRIM SYSTEM TOO RICH (BANK 1), Diagnostic Trouble Code (DTC) Detecting Criteria.>

CAUTION:

After repair or replacement of faulty parts, perform Clear Memory Mode <Ref. to EN(H4SO)(diag)-51, OPERATION, Clear Memory Mode.> and Inspection Mode <Ref. to EN(H4SO)(diag)-41, PROCEDURE, Inspection Mode.>.

WIRING DIAGRAM:

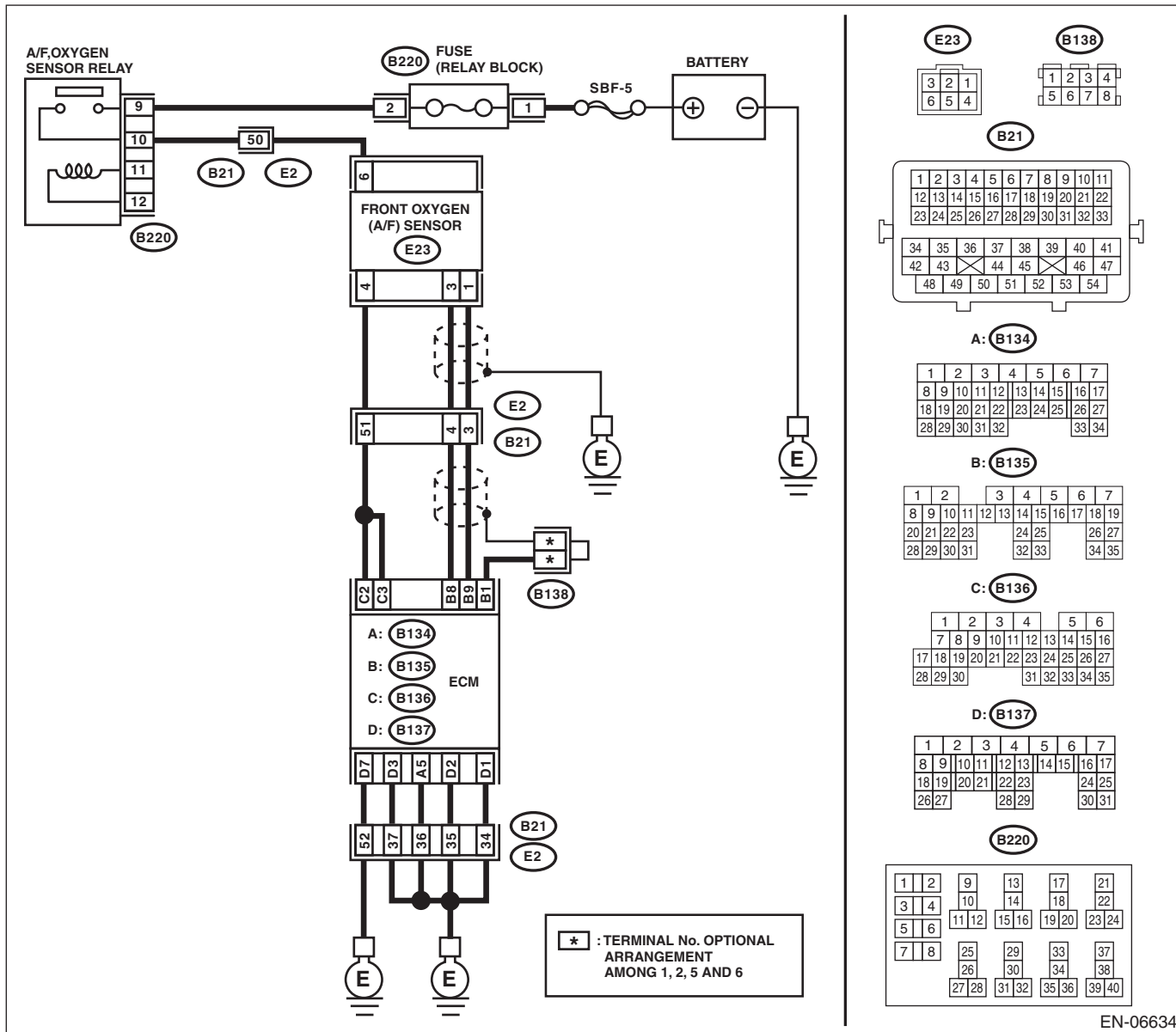

EN-06634

Diagnostic Procedure with Diagnostic Trouble Code (DTC)

ENGINE (DIAGNOSTICS)

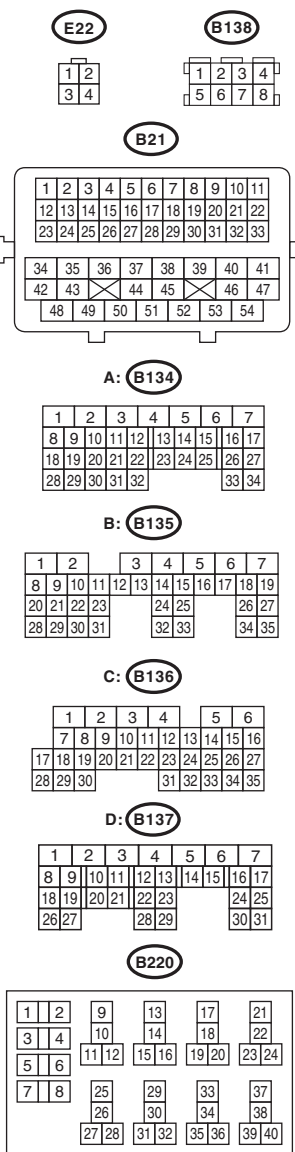
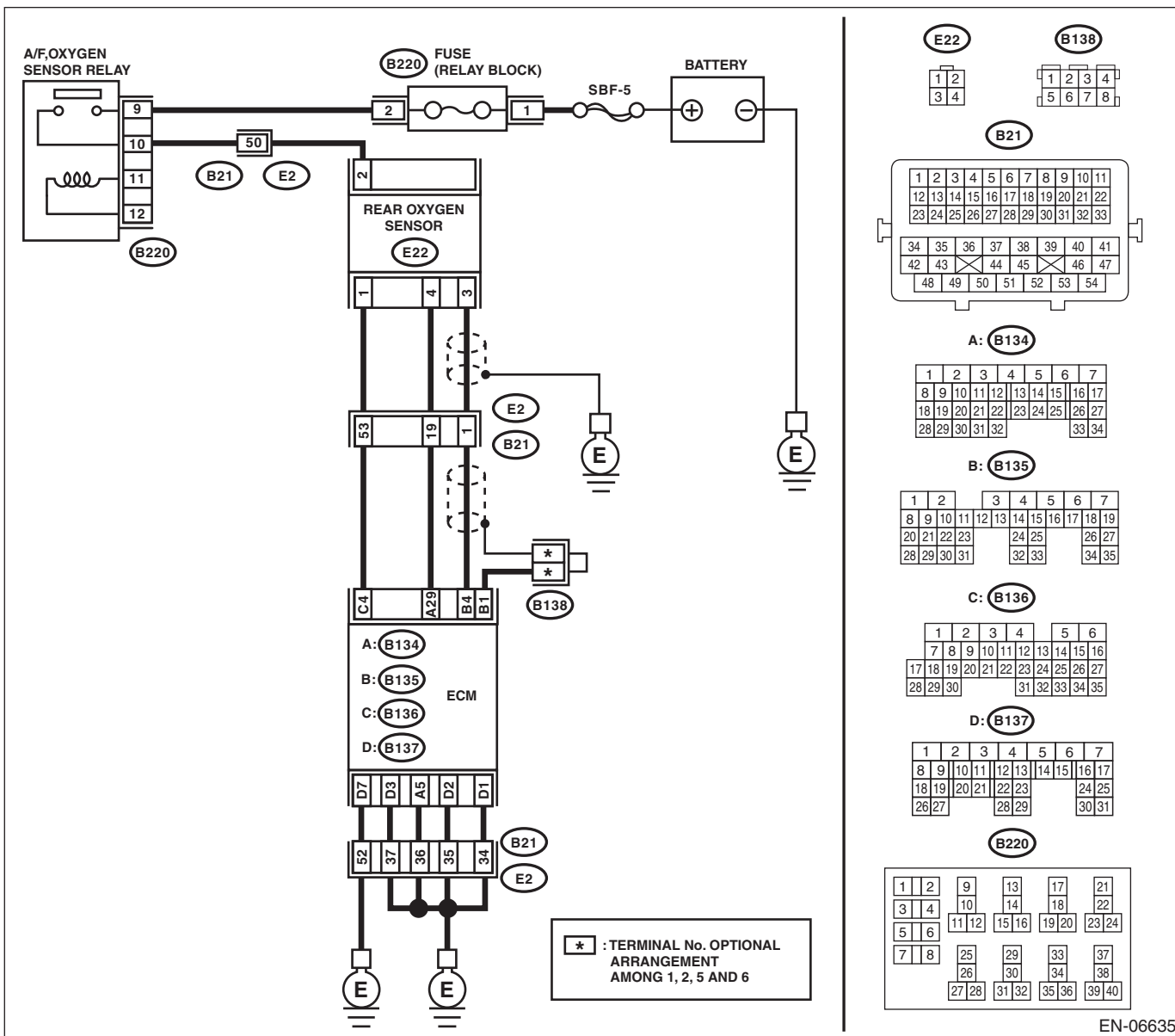

EN-06635

Diagnostic Procedure with Diagnostic Trouble Code (DTC)

ENGINE (DIAGNOSTICS)

Step	Check	Yes	No	
1	CHECK FOR ANY OTHER DTC ON DISPLAY.	Is any other DTC displayed?	Check DTC using "List of Diagnostic Trouble Code (DTC)". <Ref. to EN(H4SO)(diag)-82, List of Diagnostic Trouble Code (DTC).>	Go to step 2.
2	CHECK FRONT OXYGEN (A/F) SENSOR CONNECTOR AND COUPLING CONNECTOR.	Has water entered the connector?	Completely remove any water inside.	Go to step 3.
3	CHECK HARNESS BETWEEN ECM AND FRONT OXYGEN (A/F) SENSOR CONNECTOR. 1) Turn the ignition switch to OFF. 2) Disconnect the connectors from the ECM and front oxygen (A/F) sensor. 3) Measure the resistance of harness between ECM and front oxygen (A/F) sensor connector. Connector & terminal (B135) No. 9 — (E23) No. 1: (B135) No. 8 — (E23) No. 3:	Is the resistance less than 1 Ω?	Go to step 4.	Repair the harness and connector. NOTE: In this case, repair the following item: • Open circuit in harness between ECM and front oxygen (A/F) sensor connector • Poor contact of coupling connector
4	CHECK HARNESS BETWEEN ECM AND FRONT OXYGEN (A/F) SENSOR CONNECTOR. Measure the resistance between ECM and chassis ground. Connector & terminal (B135) No. 9 — Chassis ground: (B135) No. 8 — Chassis ground:	Is the resistance 1 MΩ or more?	Go to step 5.	Repair the ground short circuit of harness between ECM and front oxygen (A/F) sensor connector.
5	CHECK OUTPUT SIGNAL FOR ECM. 1) Connect the connector to ECM. 2) Turn the ignition switch to ON. 3) Measure the voltage between front oxygen (A/F) sensor connector and chassis ground. Connector & terminal (E23) No. 1 (+) — Chassis ground (-):	Is the voltage 4.5 V or more?	Go to step 7.	Go to step 6.
6	CHECK OUTPUT SIGNAL FOR ECM. Measure the voltage between front oxygen (A/F) sensor connector and chassis ground. Connector & terminal (E23) No. 3 (+) — Chassis ground (-):	Is the voltage 4.95 V or more?	Go to step 7.	Go to step 8.
7	CHECK OUTPUT SIGNAL FOR ECM. Measure the voltage between front oxygen (A/F) sensor connector and chassis ground. Connector & terminal (E23) No. 1 (+) — Chassis ground (-): (E23) No. 3 (+) — Chassis ground (-):	Is the voltage 8 V or more?	Repair the short circuit to power in the harness between the ECM and front oxygen (A/F) sensor connector. After repair, replace the ECM. <Ref. to FU(H4SO)-39, Engine Control Module (ECM).>	Repair poor contact of the ECM connector.
8	CHECK EXHAUST SYSTEM.	Are there holes or loose bolts on exhaust system?	Repair the exhaust system.	Go to step 9.

Diagnostic Procedure with Diagnostic Trouble Code (DTC)

ENGINE (DIAGNOSTICS)

Step	Check	Yes	No
9 CHECK AIR INTAKE SYSTEM.	Are there holes, loose bolts or disconnection of hose on air intake system?	Repair the air intake system.	Go to step 10.
10 CHECK FUEL PRESSURE. WARNING: Place “NO OPEN FLAMES” signs near the working area. CAUTION: Be careful not to spill fuel. 1) Connect the front oxygen (A/F) sensor connector. 2) Measure the fuel pressure. <Ref. to ME(H4SO)-28, INSPECTION, Fuel Pressure.> CAUTION: Release fuel pressure before removing the fuel pressure gauge.	Is the measured value 333.4 — 360.5 kPa (3.4 — 3.7 kg/cm ² , 48.4 — 52 psi)?	Go to step 11.	Repair the following item. Fuel pressure is too high: • Clogged fuel line or bent hose Fuel pressure is too low: • Improper fuel pump discharge • Clogged fuel line
11 CHECK ENGINE COOLANT TEMPERATURE SENSOR. 1) Start the engine and warm up completely. 2) Read the data of engine coolant temperature sensor signal using Subaru Select Monitor or general scan tool. NOTE: • Subaru Select Monitor For detailed operation procedures, refer to “READ CURRENT DATA FOR ENGINE”. <Ref. to EN(H4SO)(diag)-33, Subaru Select Monitor.> • General scan tool For detailed operation procedures, refer to the general scan tool operation manual.	Is the engine coolant temperature 75°C (167°F) or higher?	Go to step 12.	Replace the engine coolant temperature sensor. <Ref. to FU(H4SO)-22, Engine Coolant Temperature Sensor.>
12 CHECK MASS AIR FLOW AND INTAKE AIR TEMPERATURE SENSOR. 1) Start the engine and warm up engine until coolant temperature is higher than 75°C (167°F). 2) For AT models, set the select lever to “P” range or “N” range, and for MT models, place the shift lever in the neutral position. 3) Turn the A/C switch to OFF. 4) Turn all the accessory switches to OFF. 5) Read the data of mass air flow and intake air temperature sensor signal using Subaru Select Monitor or general scan tool. NOTE: • Subaru Select Monitor For detailed operation procedures, refer to “READ CURRENT DATA FOR ENGINE”. <Ref. to EN(H4SO)(diag)-33, Subaru Select Monitor.> • General scan tool For detailed operation procedures, refer to the general scan tool operation manual.	Is the measured value 2.0 — 5.0 g/s (0.26 — 0.66 lb/m)?	Go to step 13.	Replace the mass air flow and intake air temperature sensor. <Ref. to FU(H4SO)-28, Mass Air Flow and Intake Air Temperature Sensor.>

Diagnostic Procedure with Diagnostic Trouble Code (DTC)

ENGINE (DIAGNOSTICS)

Step	Check	Yes	No
<p>13 CHECK MASS AIR FLOW AND INTAKE AIR TEMPERATURE SENSOR.</p> <p>1) Start the engine and warm up engine until coolant temperature is higher than 75°C (167°F).</p> <p>2) For AT models, set the select lever to “P” range or “N” range, and for MT models, place the shift lever in the neutral position.</p> <p>3) Turn the A/C switch to OFF.</p> <p>4) Turn all the accessory switches to OFF.</p> <p>5) Open the front hood.</p> <p>6) Measure the ambient temperature.</p> <p>7) Read the data of mass air flow and intake air temperature sensor signal using Subaru Select Monitor or general scan tool.</p> <p>NOTE:</p> <ul style="list-style-type: none"> • Subaru Select Monitor <p>For detailed operation procedures, refer to “READ CURRENT DATA FOR ENGINE”. <Ref. to EN(H4SO)(diag)-33, Subaru Select Monitor.></p> <ul style="list-style-type: none"> • General scan tool <p>For detailed operation procedures, refer to the general scan tool operation manual.</p>	<p>Subtract ambient temperature from intake air temperature. Is the obtained value -10 — 50°C (-18 — 90°F)?</p>	<p>Go to step 14.</p>	<p>Check the mass air flow and intake air temperature sensor. <Ref. to FU(H4SO)-28, Mass Air Flow and Intake Air Temperature Sensor.></p>
<p>14 CHECK REAR OXYGEN SENSOR DATA.</p> <p>1) Warm up the engine until engine coolant temperature is higher than 75°C (167°F), and keep the engine speed at 3,000 rpm. (2 minutes maximum)</p> <p>2) Read the data of rear oxygen sensor signal using Subaru Select Monitor or general scan tool.</p> <p>NOTE:</p> <ul style="list-style-type: none"> • Depress the clutch pedal. (MT model) • Subaru Select Monitor <p>For detailed operation procedures, refer to “READ CURRENT DATA FOR ENGINE”. <Ref. to EN(H4SO)(diag)-33, Subaru Select Monitor.></p> <ul style="list-style-type: none"> • General scan tool <p>For detailed operation procedures, refer to the general scan tool operation manual.</p>	<p>Is the voltage 490 mV or more?</p>	<p>Go to step 15.</p>	<p>Go to step 16.</p>
<p>15 CHECK REAR OXYGEN SENSOR DATA.</p> <p>1) Warm up the engine until engine coolant temperature is higher than 75°C (167°F), and rapidly reduce the engine speed from 3,000 rpm.</p> <p>2) Read the data of rear oxygen sensor signal using Subaru Select Monitor or general scan tool.</p> <p>NOTE:</p> <ul style="list-style-type: none"> • Depress the clutch pedal. (MT model) • Subaru Select Monitor <p>For detailed operation procedures, refer to “READ CURRENT DATA FOR ENGINE”. <Ref. to EN(H4SO)(diag)-33, Subaru Select Monitor.></p> <ul style="list-style-type: none"> • General scan tool <p>For detailed operation procedures, refer to the general scan tool operation manual.</p>	<p>Is the voltage 250 mV or less?</p>	<p>Go to step 17.</p>	<p>Go to step 16.</p>

Diagnostic Procedure with Diagnostic Trouble Code (DTC)

ENGINE (DIAGNOSTICS)

Step	Check	Yes	No
16	CHECK REAR OXYGEN SENSOR CONNECTOR AND COUPLING CONNECTOR.	Has water entered the connector?	Completely remove any water inside.
17	CHECK FRONT OXYGEN (A/F) SENSOR AND REAR OXYGEN SENSOR DATA. 1) Warm up the engine until engine coolant temperature is higher than 75°C (167°F), then keep the engine idling for 5 minutes or more. 2) Read the data of rear oxygen sensor signal using Subaru Select Monitor or general scan tool. NOTE: • Subaru Select Monitor For detailed operation procedures, refer to "READ CURRENT DATA FOR ENGINE". <Ref. to EN(H4SO)(diag)-33, Subaru Select Monitor.> • General scan tool For detailed operation procedures, refer to the general scan tool operation manual.	Is a voltage of 0.8 V or more maintained for 5 minutes or more?	Replace the front oxygen (A/F) sensor. <Ref. to FU(H4SO)-35, Front Oxygen (A/F) Sensor.>
18	CHECK HARNESS BETWEEN ECM AND REAR OXYGEN SENSOR CONNECTOR. 1) Turn the ignition switch to OFF. 2) Disconnect the connector from ECM and rear oxygen sensor. 3) Measure the resistance of harness between ECM and rear oxygen sensor connector. Connector & terminal (B135) No. 4 — (E22) No. 3: (B134) No. 29 — (E22) No. 4:	Is the resistance less than 1 Ω?	Go to step 19. Repair the harness and connector. NOTE: In this case, repair the following item: • Open circuit in harness between ECM and rear oxygen sensor connector • Poor contact of coupling connector
19	CHECK HARNESS BETWEEN ECM AND REAR OXYGEN SENSOR CONNECTOR. 1) Connect the connector to ECM. 2) Turn the ignition switch to ON. 3) Measure the voltage between rear oxygen sensor connector and chassis ground. Connector & terminal (E22) No. 3 (+) — Chassis ground (-):	Is the voltage 0.2 — 0.5 V?	Replace the rear oxygen sensor. <Ref. to FU(H4SO)-37, Rear Oxygen Sensor.> Repair the harness and connector. NOTE: In this case, repair the following item: • Open circuit in harness between ECM and rear oxygen sensor connector • Poor contact in ECM connector • Poor contact of coupling connector

Diagnostic Procedure with Diagnostic Trouble Code (DTC)

ENGINE (DIAGNOSTICS)

DA:DTC P2101 THROTTLE ACTUATOR CONTROL MOTOR CIRCUIT RANGE/ PERFORMANCE

DTC DETECTING CONDITION:

- Immediately at fault recognition
- GENERAL DESCRIPTION <Ref. to GD(H4SO)-180, DTC P2101 THROTTLE ACTUATOR CONTROL MOTOR CIRCUIT RANGE/PERFORMANCE, Diagnostic Trouble Code (DTC) Detecting Criteria.>

TROUBLE SYMPTOM:

- Improper idling
- Poor driving performance
- Engine stalls.

CAUTION:

After repair or replacement of faulty parts, perform Clear Memory Mode <Ref. to EN(H4SO)(diag)-51, OPERATION, Clear Memory Mode.> and Inspection Mode <Ref. to EN(H4SO)(diag)-41, PROCEDURE, Inspection Mode.>.

WIRING DIAGRAM:

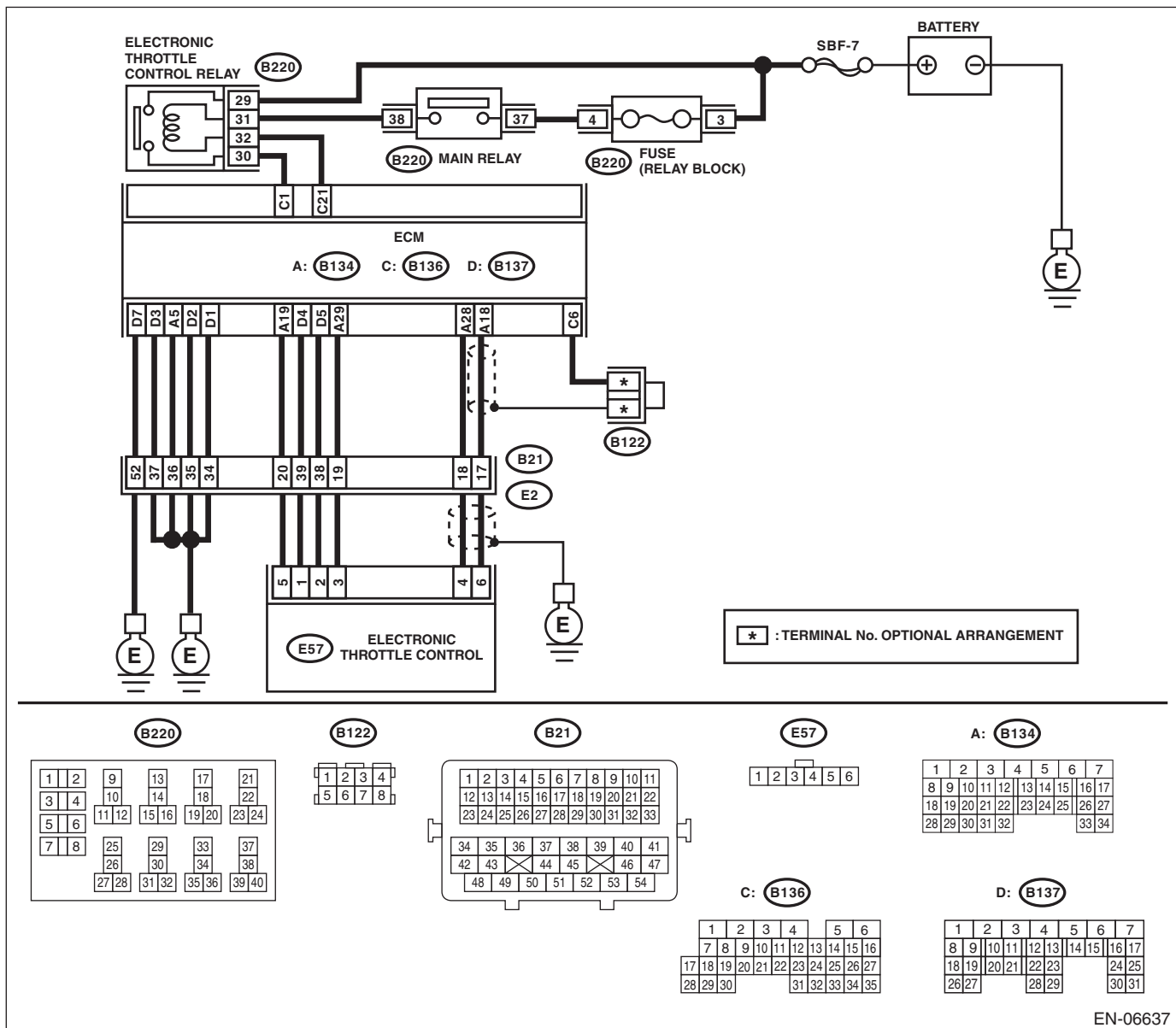

EN-06637

Diagnostic Procedure with Diagnostic Trouble Code (DTC)

ENGINE (DIAGNOSTICS)

Step	Check	Yes	No
<p>1 CHECK ELECTRONIC THROTTLE CONTROL RELAY.</p> <p>1) Turn the ignition switch to OFF. 2) Remove the electronic throttle control relay. 3) Connect the battery to terminals No. 31 and No. 32 of electronic throttle control relay. 4) Measure the resistance between electronic throttle control relay terminals.</p> <p>Terminals No. 29 — No. 30:</p>	Is the resistance less than 1 Ω ?	Go to step 2.	Replace the electronic throttle control relay.
<p>2 CHECK POWER SUPPLY OF ELECTRONIC THROTTLE CONTROL RELAY.</p> <p>Measure the voltage between electronic throttle control relay connector and chassis ground.</p> <p>Connector & terminal (B220) No. 29 (+) — Chassis ground (-):</p>	Is the voltage 10 V or more?	Go to step 3.	Repair the open or ground short circuit of power supply circuit.
<p>3 CHECK HARNESS BETWEEN ECM AND ELECTRONIC THROTTLE CONTROL RELAY.</p> <p>1) Disconnect the connectors from the ECM. 2) Turn the ignition switch to ON. 3) Measure the voltage between electronic throttle control relay connector and chassis ground.</p> <p>Connector & terminal (B220) No. 32 (+) — Chassis ground (-):</p>	Is the voltage 10 V or more?	Repair the short circuit to power in the harness between ECM and electronic throttle control relay connector.	Go to step 4.
<p>4 CHECK HARNESS BETWEEN ECM AND ELECTRONIC THROTTLE CONTROL RELAY.</p> <p>1) Turn the ignition switch to OFF. 2) Measure the resistance between electronic throttle control relay connector and chassis ground.</p> <p>Connector & terminal (B220) No. 32 — Chassis ground: (B220) No. 30 — Chassis ground:</p>	Is the resistance 1 M Ω or more?	Go to step 5.	Repair the short circuit in harness to ground between ECM and electronic throttle control relay connector.
<p>5 CHECK HARNESS BETWEEN ECM AND ELECTRONIC THROTTLE CONTROL RELAY.</p> <p>Measure the resistance between the ECM and electronic throttle control relay connector.</p> <p>Connector & terminal (B136) No. 21 — (B220) No. 32: (B136) No. 1 — (B220) No. 30:</p>	Is the resistance less than 1 Ω ?	Go to step 6.	Repair the open circuit in harness between ECM and electronic throttle control relay connector.
<p>6 CHECK HARNESS BETWEEN ECM AND ELECTRONIC THROTTLE CONTROL.</p> <p>1) Turn the ignition switch to OFF. 2) Disconnect the connectors from electronic throttle control. 3) Measure the resistance between ECM and chassis ground.</p> <p>Connector & terminal (B134) No. 19 — Chassis ground: (B134) No. 18 — Chassis ground: (B134) No. 18 — (B136) No. 6: (B134) No. 28 — Chassis ground:</p>	Is the resistance 1 M Ω or more?	Go to step 7.	Repair the ground short circuit of harness between ECM and electronic throttle control connector.

Diagnostic Procedure with Diagnostic Trouble Code (DTC)

ENGINE (DIAGNOSTICS)

Step	Check	Yes	No
7 CHECK SHORT CIRCUIT INSIDE THE ECM. 1) Connect the connector to ECM. 2) Measure the resistance between electronic throttle control connector and engine ground. Connector & terminal <i>(E57) No. 6 — Engine ground:</i> <i>(E57) No. 4 — Engine ground:</i>	Is the resistance 1 M Ω or more?	Go to step 8.	Repair the ground short circuit of harness between ECM and electronic throttle control connector. Replace the ECM if defective. <Ref. to FU(H4SO)-39, Engine Control Module (ECM).>
8 CHECK HARNESS BETWEEN ECM AND ELECTRONIC THROTTLE CONTROL. 1) Disconnect the connectors from the ECM. 2) Measure the resistance of harness between ECM and electronic throttle control connector. Connector & terminal <i>(B134) No. 18 — (E57) No. 6:</i> <i>(B134) No. 28 — (E57) No. 4:</i> <i>(B134) No. 29 — (E57) No. 3:</i>	Is the resistance less than 1 Ω ?	Go to step 9.	Repair the harness and connector. NOTE: In this case, repair the following item: <ul style="list-style-type: none"> • Open circuit in harness between ECM and electronic throttle control connector • Poor contact of coupling connector
9 CHECK HARNESS BETWEEN ECM AND ELECTRONIC THROTTLE CONTROL. 1) Connect the connector to ECM. 2) Measure the resistance between electronic throttle control connector and engine ground. Connector & terminal <i>(E57) No. 3 — Engine ground:</i>	Is the resistance less than 5 Ω ?	Go to step 10.	Repair the harness and connector. NOTE: In this case, repair the following item: <ul style="list-style-type: none"> • Open circuit of harness between ECM and engine ground • Poor contact in ECM connector • Poor contact of coupling connector
10 CHECK HARNESS BETWEEN ECM AND ELECTRONIC THROTTLE CONTROL. 1) Turn the ignition switch to ON. 2) Measure the voltage between electronic throttle control connector and engine ground. Connector & terminal <i>(E57) No. 6 (+) — Engine ground (-):</i> <i>(E57) No. 4 (+) — Engine ground (-):</i>	Is the voltage 4.85 V or more?	Repair the short circuit to power in the harness between ECM and electronic throttle control connector.	Go to step 11.
11 CHECK HARNESS BETWEEN ECM AND ELECTRONIC THROTTLE CONTROL. 1) Turn the ignition switch to OFF. 2) Disconnect the connectors from the ECM. 3) Measure the resistance between ECM connectors. Connector & terminal <i>(B134) No. 19 — (B134) No. 18:</i> <i>(B134) No. 19 — (B134) No. 28:</i>	Is the resistance 1 M Ω or more?	Go to step 12.	Repair the short circuit to power in the harness between ECM and electronic throttle control connector.

Diagnostic Procedure with Diagnostic Trouble Code (DTC)

ENGINE (DIAGNOSTICS)

Step	Check	Yes	No
<p>12 CHECK SENSOR OUTPUT. 1) Connect all connectors. 2) Turn the ignition switch to ON. 3) Read the data of main throttle sensor signal using Subaru Select Monitor. NOTE: For detailed operation procedures, refer to "READ CURRENT DATA FOR ENGINE". <Ref. to EN(H4SO)(diag)-33, Subaru Select Monitor.></p>	Is the voltage 0.81 — 0.87 V?	Go to step 13.	Repair poor contact of the electronic throttle control connector. Replace the electronic throttle control if defective. <Ref. to FU(H4SO)-13, Throttle Body.>
<p>13 CHECK SENSOR OUTPUT. Read the data of sub throttle sensor signal using Subaru Select Monitor. NOTE: Subaru Select Monitor For detailed operation procedures, refer to "READ CURRENT DATA FOR ENGINE". <Ref. to EN(H4SO)(diag)-33, Subaru Select Monitor.></p>	Is the voltage 1.64 — 1.70 V?	Go to step 14.	Repair poor contact of the electronic throttle control connector. Replace the electronic throttle control if defective. <Ref. to FU(H4SO)-13, Throttle Body.>
<p>14 CHECK HARNESS BETWEEN ECM AND ELECTRONIC THROTTLE CONTROL MOTOR. 1) Turn the ignition switch to OFF. 2) Disconnect the connectors from ECM and electronic throttle control. 3) Measure the resistance between ECM and electronic throttle control connector. <i>Connector & terminal</i> <i>(B137) No. 5 — (E57) No. 2:</i> <i>(B137) No. 4 — (E57) No. 1:</i></p>	Is the resistance less than 1 Ω?	Go to step 15.	Repair the harness and connector. NOTE: In this case, repair the following item: • Open circuit in harness between ECM and electronic throttle control connector • Poor contact of coupling connector
<p>15 CHECK HARNESS BETWEEN ECM AND ELECTRONIC THROTTLE CONTROL MOTOR. 1) Connect the connector to ECM. 2) Turn the ignition switch to ON. 3) Measure the voltage between electronic throttle control connector and engine ground. <i>Connector & terminal</i> <i>(E57) No. 2 (+) — Engine ground (-):</i> <i>(E57) No. 1 (+) — Engine ground (-):</i></p>	Is the voltage 5 V or more?	Repair the short circuit to power in the harness between ECM and electronic throttle control connector.	Go to step 16.
<p>16 CHECK HARNESS BETWEEN ECM AND ELECTRONIC THROTTLE CONTROL MOTOR. 1) Turn the ignition switch to OFF. 2) Disconnect the connectors from the ECM. 3) Measure the resistance between electronic throttle control connector and engine ground. <i>Connector & terminal</i> <i>(E57) No. 2 — Engine ground:</i> <i>(E57) No. 1 — Engine ground:</i></p>	Is the resistance 1 MΩ or more?	Go to step 17.	Repair the short circuit to ground in harness between ECM and electronic throttle control connector.
<p>17 CHECK ELECTRONIC THROTTLE CONTROL MOTOR HARNESS. Measure the resistance between the electronic throttle control connector terminals. <i>Connector & terminal</i> <i>(E57) No. 2 — (E57) No. 1:</i></p>	Is the resistance 1 MΩ or more?	Go to step 18.	Repair the short circuit of harness between ECM and electronic throttle control connector.

Diagnostic Procedure with Diagnostic Trouble Code (DTC)

ENGINE (DIAGNOSTICS)

Step	Check	Yes	No
18 CHECK ELECTRONIC THROTTLE CONTROL GROUND CIRCUIT. Measure the resistance between ECM and chassis ground. Connector & terminal <i>(B134) No. 5 — Chassis ground:</i> <i>(B137) No. 1 — Chassis ground:</i> <i>(B137) No. 2 — Chassis ground:</i> <i>(B137) No. 3 — Chassis ground:</i> <i>(B137) No. 7 — Chassis ground:</i>	Is the resistance less than 5 Ω ?	Go to step 19 .	Repair the harness and connector. NOTE: In this case, repair the following item: <ul style="list-style-type: none"> • Open circuit of harness between ECM and engine ground • Poor contact of coupling connector
19 CHECK ELECTRONIC THROTTLE CONTROL. Measure the resistance between electronic throttle control terminals. Terminals No. 2 — No. 1:	Is the resistance 50 Ω or less?	Go to step 20 .	Replace the electronic throttle control. <Ref. to FU(H4SO)-13, Throttle Body.>
20 CHECK ELECTRONIC THROTTLE CONTROL. Move the throttle valve to the fully open and fully closed positions with fingers. Check that the valve returns to the specified position when releasing fingers.	Does the valve return to the specified position? Standard value: 3 mm (0.12 in) from fully closed position	Repair the poor contact of the ECM connector.	Replace the electronic throttle control. <Ref. to FU(H4SO)-13, Throttle Body.>

Diagnostic Procedure with Diagnostic Trouble Code (DTC)

ENGINE (DIAGNOSTICS)

DB:DTC P2102 THROTTLE ACTUATOR CONTROL MOTOR CIRCUIT LOW

DTC DETECTING CONDITION:

- Immediately at fault recognition
- GENERAL DESCRIPTION <Ref. to GD(H4SO)-181, DTC P2102 THROTTLE ACTUATOR CONTROL MOTOR CIRCUIT LOW, Diagnostic Trouble Code (DTC) Detecting Criteria.>

TROUBLE SYMPTOM:

- Improper idling
- Poor driving performance
- Engine stalls.

CAUTION:

After repair or replacement of faulty parts, perform Clear Memory Mode <Ref. to EN(H4SO)(diag)-51, OPERATION, Clear Memory Mode.> and Inspection Mode <Ref. to EN(H4SO)(diag)-41, PROCEDURE, Inspection Mode.>.

WIRING DIAGRAM:

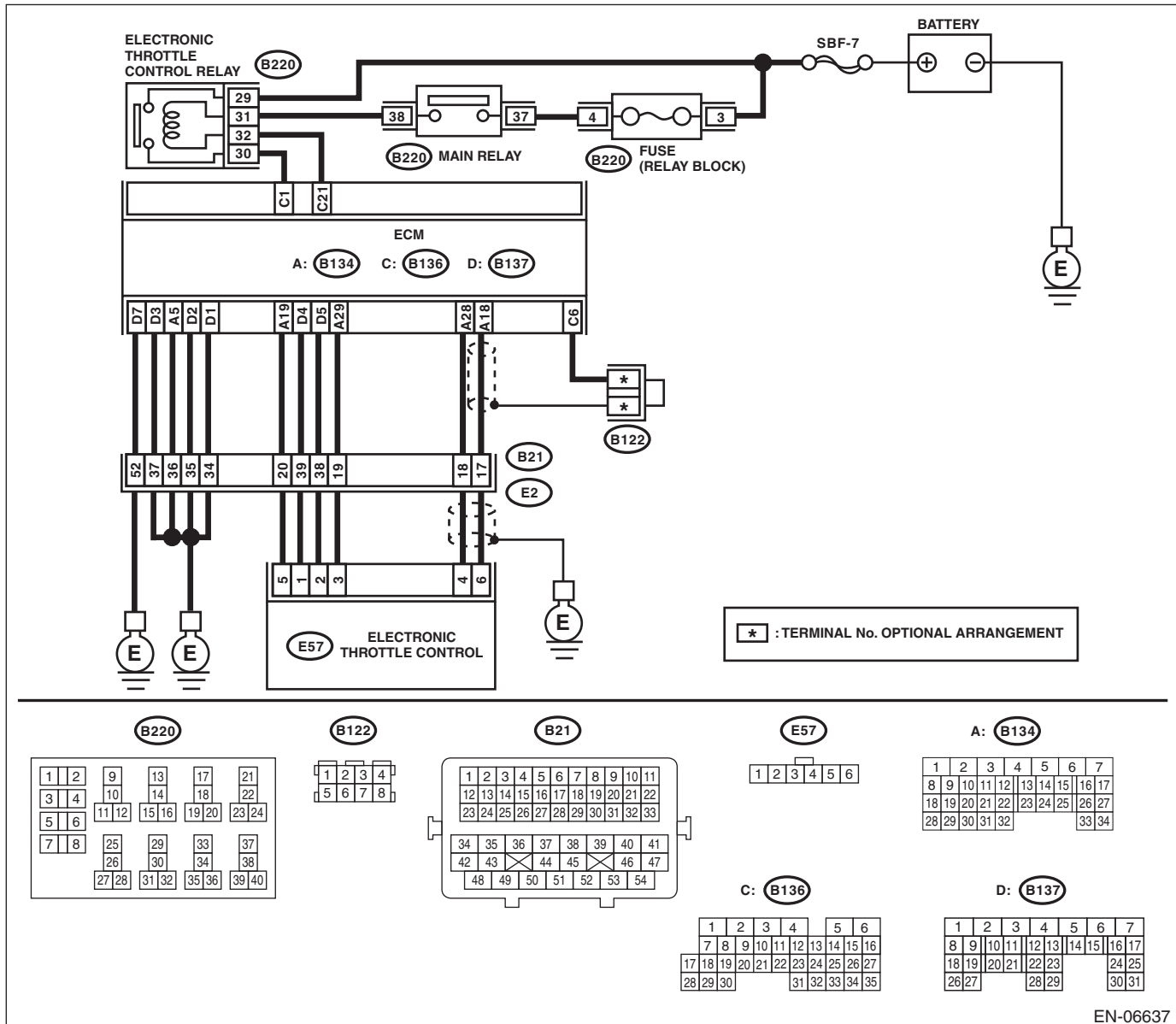

EN-06637

Diagnostic Procedure with Diagnostic Trouble Code (DTC)

ENGINE (DIAGNOSTICS)

Step	Check	Yes	No
1 CHECK ELECTRONIC THROTTLE CONTROL RELAY. 1) Turn the ignition switch to OFF. 2) Remove the electronic throttle control relay. 3) Connect the battery to terminals No. 31 and No. 32 of electronic throttle control relay. 4) Measure the resistance between electronic throttle control relay terminals. <i>Terminals</i> <i>No. 29 — No. 30:</i>	Is the resistance less than 1 Ω ?	Go to step 2.	Replace the electronic throttle control relay.
2 CHECK POWER SUPPLY OF ELECTRONIC THROTTLE CONTROL RELAY. Measure the voltage between electronic throttle control relay connector and chassis ground. <i>Connector & terminal</i> <i>(B220) No. 29 (+) — Chassis ground (-):</i>	Is the voltage 10 V or more?	Go to step 3.	Repair the open or ground short circuit of power supply circuit.
3 CHECK HARNESS BETWEEN ECM AND ELECTRONIC THROTTLE CONTROL RELAY. 1) Disconnect the connectors from the ECM. 2) Turn the ignition switch to ON. 3) Measure the voltage between electronic throttle control relay connector and chassis ground. <i>Connector & terminal</i> <i>(B220) No. 32 (+) — Chassis ground (-):</i>	Is the voltage 10 V or more?	Repair the short circuit to power in the harness between ECM and electronic throttle control relay connector.	Go to step 4.
4 CHECK HARNESS BETWEEN ECM AND ELECTRONIC THROTTLE CONTROL RELAY. 1) Turn the ignition switch to OFF. 2) Measure the resistance between electronic throttle control relay connector and chassis ground. <i>Connector & terminal</i> <i>(B220) No. 32 — Chassis ground:</i> <i>(B220) No. 30 — Chassis ground:</i>	Is the resistance 1 M Ω or more?	Go to step 5.	Repair the short circuit in harness to ground between ECM and electronic throttle control relay connector.
5 CHECK HARNESS BETWEEN ECM AND ELECTRONIC THROTTLE CONTROL RELAY. Measure the resistance between the ECM and electronic throttle control relay connector. <i>Connector & terminal</i> <i>(B136) No. 21 — (B220) No. 32:</i> <i>(B136) No. 1 — (B220) No. 30:</i>	Is the resistance less than 1 Ω ?	Repair the poor contact of the ECM connector.	Repair the open circuit in harness between ECM and electronic throttle control relay connector.

Diagnostic Procedure with Diagnostic Trouble Code (DTC)

ENGINE (DIAGNOSTICS)

DC:DTC P2103 THROTTLE ACTUATOR CONTROL MOTOR CIRCUIT HIGH

DTC DETECTING CONDITION:

- Immediately at fault recognition
- GENERAL DESCRIPTION <Ref. to GD(H4SO)-182, DTC P2103 THROTTLE ACTUATOR CONTROL MOTOR CIRCUIT HIGH, Diagnostic Trouble Code (DTC) Detecting Criteria.>

CAUTION:

After repair or replacement of faulty parts, perform Clear Memory Mode <Ref. to EN(H4SO)(diag)-51, OPERATION, Clear Memory Mode.> and Inspection Mode <Ref. to EN(H4SO)(diag)-41, PROCEDURE, Inspection Mode.>.

WIRING DIAGRAM:

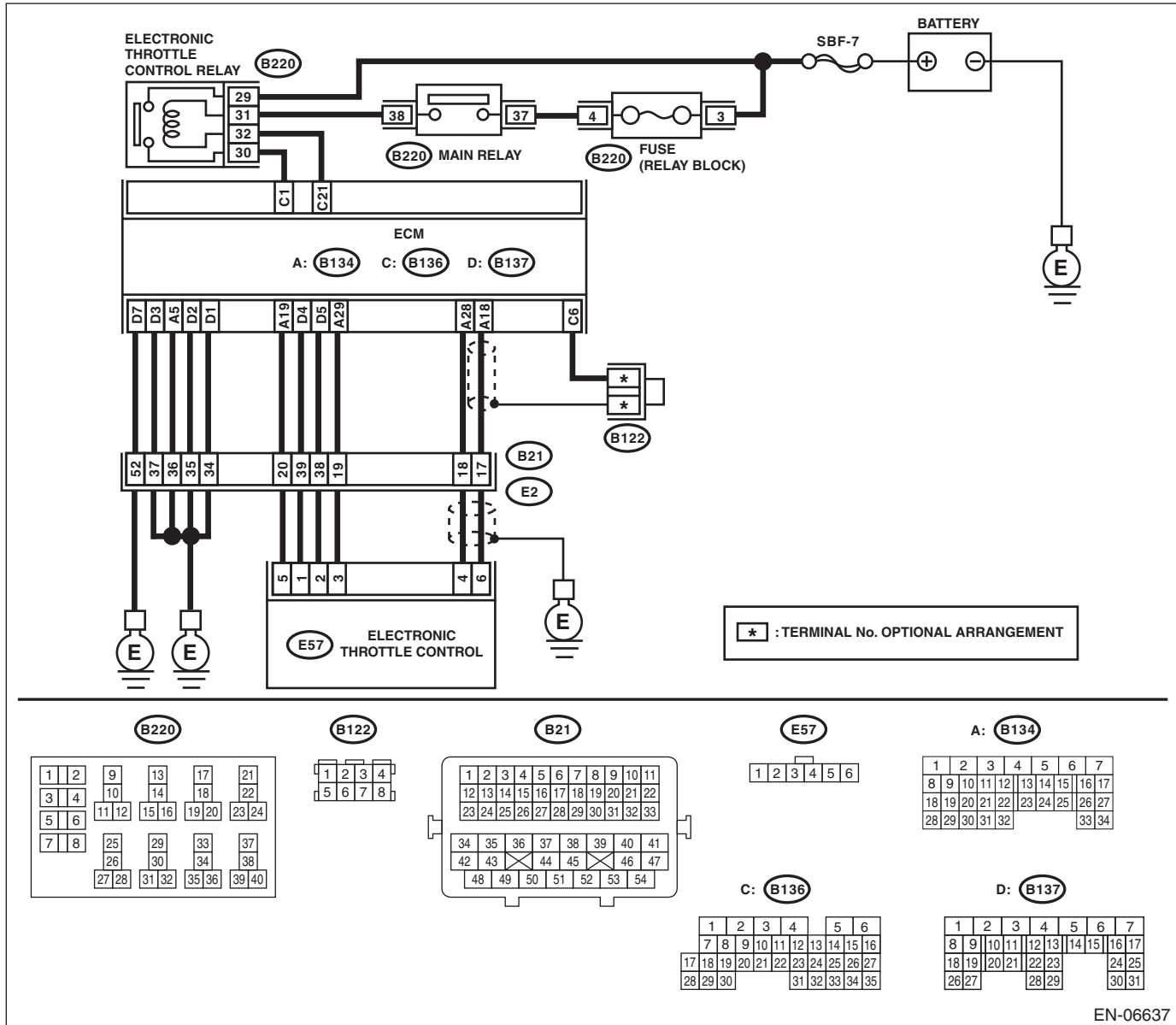

EN-06637

Diagnostic Procedure with Diagnostic Trouble Code (DTC)

ENGINE (DIAGNOSTICS)

Step	Check	Yes	No
1 CHECK ELECTRONIC THROTTLE CONTROL RELAY. 1) Turn the ignition switch to OFF. 2) Remove the electronic throttle control relay. 3) Measure the resistance between electronic throttle control relay terminals. <i>Terminals</i> <i>No. 29 — No. 30:</i>	Is the resistance 1 MΩ or more?	Go to step 2.	Replace the electronic throttle control relay.
2 CHECK SHORT CIRCUIT OF ELECTRONIC THROTTLE CONTROL RELAY POWER SUPPLY. 1) Turn the ignition switch to ON. 2) Measure the voltage between electronic throttle control relay connector and chassis ground. <i>Connector & terminal</i> <i>(B220) No. 30 (+) — Chassis ground (-):</i>	Is the voltage 10 V or more?	Repair the short circuit to power in the harness between ECM and electronic throttle control relay connector.	Go to step 3.
3 CHECK HARNESS BETWEEN ECM AND ELECTRONIC THROTTLE CONTROL RELAY. 1) Turn the ignition switch to OFF. 2) Disconnect the connectors from the ECM. 3) Measure the resistance between ECM and chassis ground. <i>Connector & terminal</i> <i>(B136) No. 21 — Chassis ground:</i>	Is the resistance 1 MΩ or more?	Repair the poor contact of the ECM connector.	Repair the short circuit in harness to ground between ECM and electronic throttle control relay connector.

DD:DTC P2109 THROTTLE/PEDAL POSITION SENSOR “A” MINIMUM STOP PERFORMANCE

NOTE:

For the diagnostic procedure, refer to DTC P2101. <Ref. to EN(H4SO)(diag)-280, DTC P2101 THROTTLE ACTUATOR CONTROL MOTOR CIRCUIT RANGE/PERFORMANCE, Diagnostic Procedure with Diagnostic Trouble Code (DTC).>

Diagnostic Procedure with Diagnostic Trouble Code (DTC)

ENGINE (DIAGNOSTICS)

DE:DTC P2122 THROTTLE/PEDAL POSITION SENSOR/SWITCH "D" CIRCUIT LOW INPUT

DTC DETECTING CONDITION:

- Immediately at fault recognition
- GENERAL DESCRIPTION <Ref. to GD(H4SO)-184, DTC P2122 THROTTLE/PEDAL POSITION SENSOR/SWITCH "D" CIRCUIT LOW INPUT, Diagnostic Trouble Code (DTC) Detecting Criteria.>

TROUBLE SYMPTOM:

- Improper idling
- Poor driving performance

CAUTION:

After repair or replacement of faulty parts, perform Clear Memory Mode <Ref. to EN(H4SO)(diag)-51, OPERATION, Clear Memory Mode.> and Inspection Mode <Ref. to EN(H4SO)(diag)-41, PROCEDURE, Inspection Mode.>.

WIRING DIAGRAM:

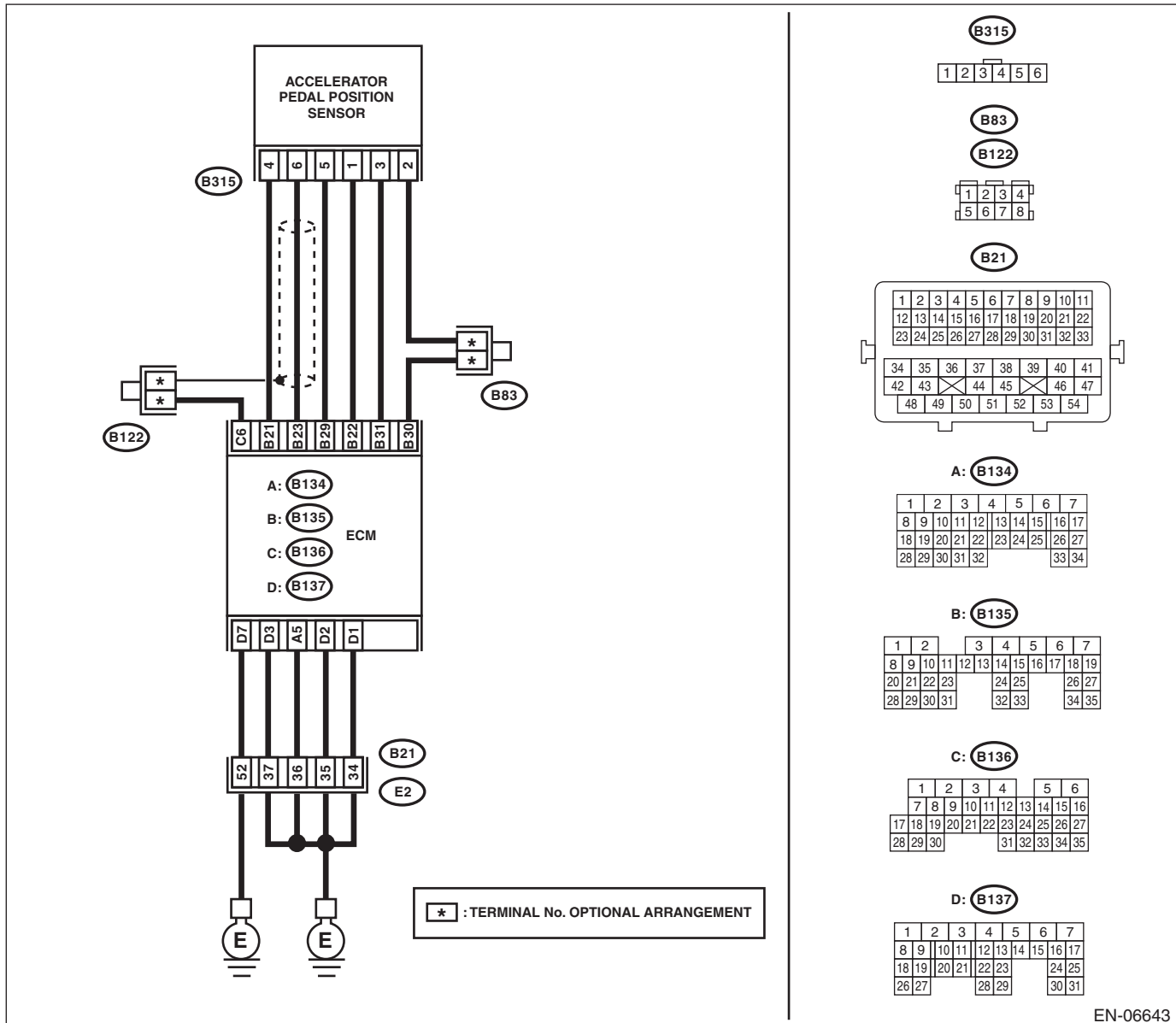

EN-06643

Diagnostic Procedure with Diagnostic Trouble Code (DTC)

ENGINE (DIAGNOSTICS)

Step	Check	Yes	No
<p>1</p> <p>CHECK HARNESS BETWEEN ECM AND ACCELERATOR PEDAL POSITION SENSOR.</p> <p>1) Turn the ignition switch to OFF. 2) Disconnect the connector from the ECM and accelerator pedal position sensor. 3) Measure the resistance between ECM and chassis ground.</p> <p>Connector & terminal (B135) No. 21 — Chassis ground: (B135) No. 23 — Chassis ground: (B135) No. 23 — (B136) No. 6:</p>	<p>Is the resistance 1 MΩ or more?</p>	<p>Go to step 2.</p>	<p>Repair the ground short of the harness between the ECM and accelerator pedal position sensor connector.</p>
<p>2</p> <p>CHECK SHORT CIRCUIT INSIDE THE ECM.</p> <p>1) Connect the connector to ECM. 2) Measure the resistance between accelerator pedal position sensor connector and chassis ground.</p> <p>Connector & terminal (B315) No. 6 — Chassis ground:</p>	<p>Is the resistance 1 MΩ or more?</p>	<p>Replace the accelerator pedal. <Ref. to SP(H4SO)-3, Accelerator Pedal.></p>	<p>Repair the short circuit to ground in harness between ECM and accelerator pedal position sensor connector. Replace the ECM if defective. <Ref. to FU(H4SO)-39, Engine Control Module (ECM).></p>

Diagnostic Procedure with Diagnostic Trouble Code (DTC)

ENGINE (DIAGNOSTICS)

DF:DTC P2123 THROTTLE/PEDAL POSITION SENSOR/SWITCH "D" CIRCUIT HIGH INPUT

DTC DETECTING CONDITION:

- Immediately at fault recognition
- GENERAL DESCRIPTION <Ref. to GD(H4SO)-186, DTC P2123 THROTTLE/PEDAL POSITION SENSOR/SWITCH "D" CIRCUIT HIGH INPUT, Diagnostic Trouble Code (DTC) Detecting Criteria.>

TROUBLE SYMPTOM:

- Improper idling
- Poor driving performance

CAUTION:

After repair or replacement of faulty parts, perform Clear Memory Mode <Ref. to EN(H4SO)(diag)-51, OPERATION, Clear Memory Mode.> and Inspection Mode <Ref. to EN(H4SO)(diag)-41, PROCEDURE, Inspection Mode.>.

WIRING DIAGRAM:

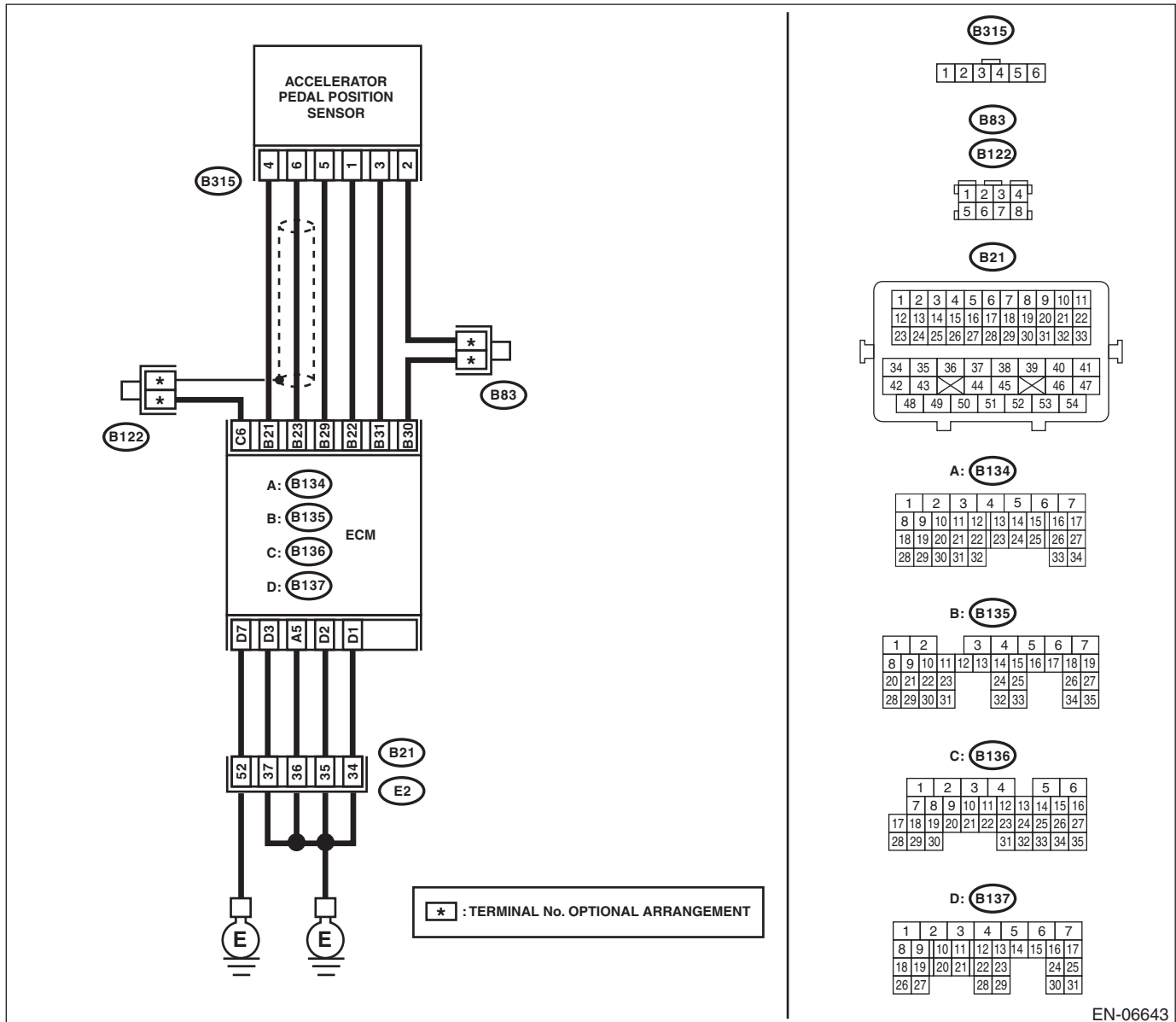

EN-06643

Diagnostic Procedure with Diagnostic Trouble Code (DTC)

ENGINE (DIAGNOSTICS)

Step	Check	Yes	No
<p>1 CHECK HARNESS BETWEEN ECM AND ACCELERATOR PEDAL POSITION SENSOR. 1) Turn the ignition switch to OFF. 2) Disconnect the connector from the ECM and accelerator pedal position sensor. 3) Measure the resistance of harness between ECM and accelerator pedal position sensor connector.</p> <p>Connector & terminal (B135) No. 23 — (B315) No. 6: (B135) No. 29 — (B315) No. 5:</p>	Is the resistance less than 1 Ω?	Go to step 2.	Repair the open circuit of the harness between the ECM and accelerator pedal position sensor connector.
<p>2 CHECK HARNESS BETWEEN ECM AND ACCELERATOR PEDAL POSITION SENSOR. 1) Connect the connector to ECM. 2) Measure the resistance between accelerator pedal position sensor connector and chassis ground.</p> <p>Connector & terminal (B315) No. 5 — Chassis ground:</p>	Is the resistance less than 5 Ω?	Go to step 3.	Repair the harness and connector. NOTE: In this case, repair the following item: • Open circuit of harness between ECM and engine ground • Poor contact in ECM connector • Poor contact of coupling connector
<p>3 CHECK HARNESS BETWEEN ECM AND ACCELERATOR PEDAL POSITION SENSOR. 1) Turn the ignition switch to ON. 2) Measure the voltage between accelerator pedal position sensor connector and chassis ground.</p> <p>Connector & terminal (B315) No. 6 (+) — Chassis ground (-):</p>	Is the voltage 4.85 V or more?	Repair the short circuit to power source in the harness between the ECM and accelerator pedal position sensor connector.	Go to step 4.
<p>4 CHECK HARNESS BETWEEN ECM AND ACCELERATOR PEDAL POSITION SENSOR. 1) Turn the ignition switch to OFF. 2) Disconnect the connectors from the ECM. 3) Measure the resistance between ECM connectors.</p> <p>Connector & terminal (B135) No. 21 — (B135) No. 23:</p>	Is the resistance 1 MΩ or more?	Repair the poor contact of accelerator pedal position sensor connector. Replace the accelerator pedal if defective. <Ref. to SP(H4SO)-3, Accelerator Pedal.>	Repair the short circuit to power source in the harness between the ECM and accelerator pedal position sensor connector.

Diagnostic Procedure with Diagnostic Trouble Code (DTC)

ENGINE (DIAGNOSTICS)

DG:DTC P2127 THROTTLE/PEDAL POSITION SENSOR/SWITCH "E" CIRCUIT LOW INPUT

DTC DETECTING CONDITION:

- Immediately at fault recognition
- GENERAL DESCRIPTION <Ref. to GD(H4SO)-188, DTC P2127 THROTTLE/PEDAL POSITION SENSOR/SWITCH "E" CIRCUIT LOW INPUT, Diagnostic Trouble Code (DTC) Detecting Criteria.>

TROUBLE SYMPTOM:

- Improper idling
- Poor driving performance

CAUTION:

After repair or replacement of faulty parts, perform Clear Memory Mode <Ref. to EN(H4SO)(diag)-51, OPERATION, Clear Memory Mode.> and Inspection Mode <Ref. to EN(H4SO)(diag)-41, PROCEDURE, Inspection Mode.>.

WIRING DIAGRAM:

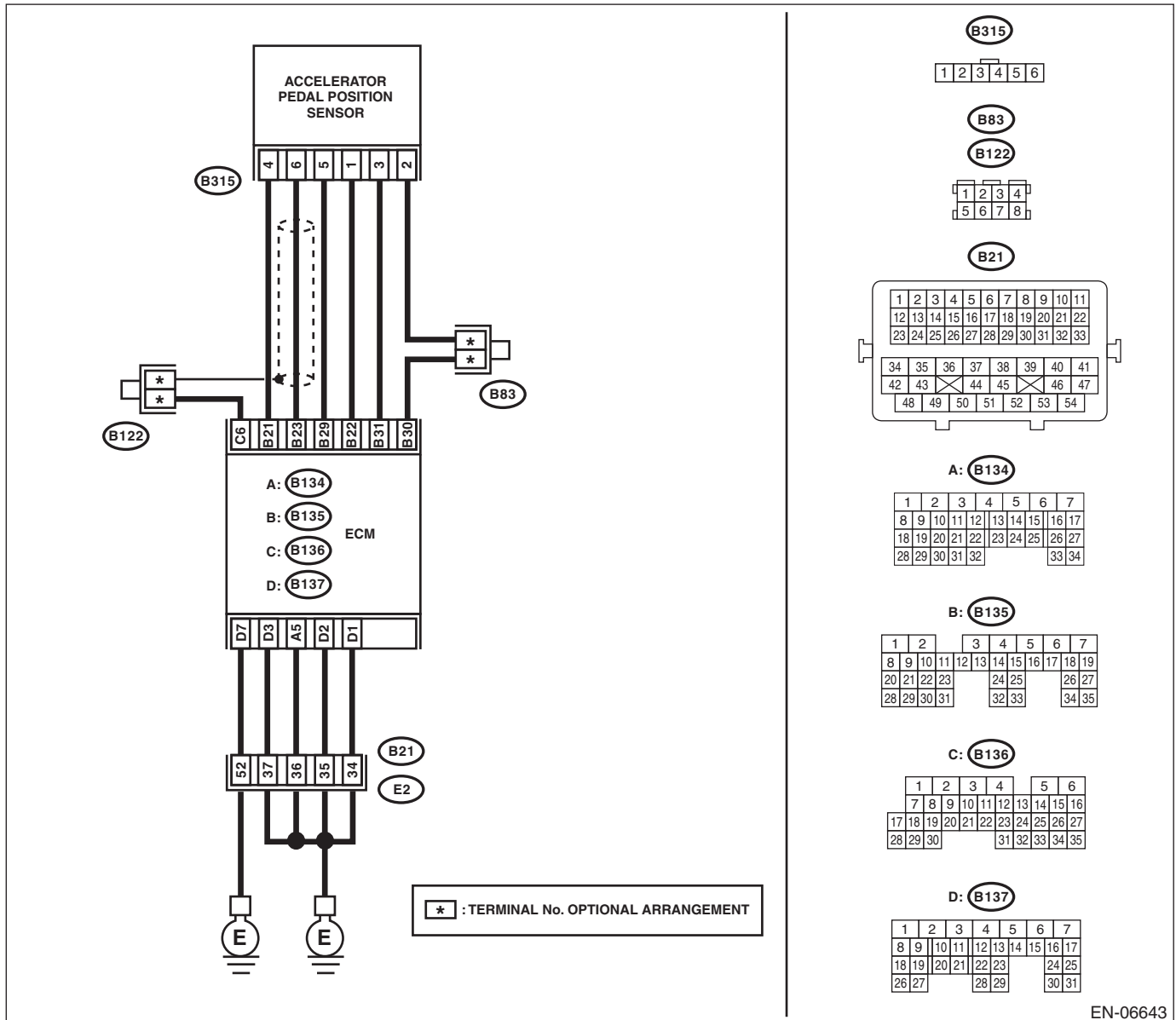

EN-06643

Diagnostic Procedure with Diagnostic Trouble Code (DTC)

ENGINE (DIAGNOSTICS)

Step	Check	Yes	No
<p>1</p> <p>CHECK HARNESS BETWEEN ECM AND ACCELERATOR PEDAL POSITION SENSOR.</p> <p>1) Turn the ignition switch to OFF. 2) Disconnect the connector from the ECM and accelerator pedal position sensor. 3) Measure the resistance between ECM and chassis ground.</p> <p>Connector & terminal (B135) No. 22 — Chassis ground: (B135) No. 31 — Chassis ground:</p>	<p>Is the resistance 1 MΩ or more?</p>	<p>Go to step 2.</p>	<p>Repair the ground short of the harness between the ECM and accelerator pedal position sensor connector.</p>
<p>2</p> <p>CHECK SHORT CIRCUIT INSIDE THE ECM.</p> <p>1) Connect the connector to ECM. 2) Measure the resistance between accelerator pedal position sensor connector and chassis ground.</p> <p>Connector & terminal (B315) No. 3 — Chassis ground:</p>	<p>Is the resistance 1 MΩ or more?</p>	<p>Replace the accelerator pedal. <Ref. to SP(H4SO)-3, Accelerator Pedal.></p>	<p>Repair the short circuit to ground in harness between ECM and accelerator pedal position sensor connector. Replace the ECM if defective. <Ref. to FU(H4SO)-39, Engine Control Module (ECM).></p>

Diagnostic Procedure with Diagnostic Trouble Code (DTC)

ENGINE (DIAGNOSTICS)

Step	Check	Yes	No
<p>1 CHECK HARNESS BETWEEN ECM AND ACCELERATOR PEDAL POSITION SENSOR.</p> <p>1) Turn the ignition switch to OFF. 2) Disconnect the connector from the ECM and accelerator pedal position sensor. 3) Measure the resistance of harness between ECM and accelerator pedal position sensor connector.</p> <p>Connector & terminal (B135) No. 31 — (B315) No. 3: (B135) No. 30 — (B315) No. 2:</p>	Is the resistance less than 1 Ω?	Go to step 2.	Repair the open circuit of the harness between the ECM and accelerator pedal position sensor connector.
<p>2 CHECK HARNESS BETWEEN ECM AND ACCELERATOR PEDAL POSITION SENSOR.</p> <p>1) Connect the connector to ECM. 2) Measure the resistance between accelerator pedal position sensor connector and chassis ground.</p> <p>Connector & terminal (B315) No. 2 — Chassis ground:</p>	Is the resistance less than 1 Ω?	Go to step 3.	Repair the harness and connector. NOTE: In this case, repair the following item: <ul style="list-style-type: none"> • Open circuit of harness between ECM and engine ground • Poor contact in ECM connector • Poor contact of coupling connector
<p>3 CHECK HARNESS BETWEEN ECM AND ACCELERATOR PEDAL POSITION SENSOR.</p> <p>1) Turn the ignition switch to ON. 2) Measure the voltage between accelerator pedal position sensor connector and chassis ground.</p> <p>Connector & terminal (B315) No. 3 (+) — Chassis ground (-):</p>	Is the voltage 4.85 V or more?	Repair the short circuit to power source in the harness between the ECM and accelerator pedal position sensor connector.	Go to step 4.
<p>4 CHECK HARNESS BETWEEN ECM AND ACCELERATOR PEDAL POSITION SENSOR.</p> <p>1) Turn the ignition switch to OFF. 2) Disconnect the connectors from the ECM. 3) Measure the resistance between ECM connectors.</p> <p>Connector & terminal (B135) No. 22 — (B135) No. 31:</p>	Is the resistance 1 MΩ or more?	Repair the poor contact of accelerator pedal position sensor connector. Replace the accelerator pedal if defective. <Ref. to SP(H4SO)-3, Accelerator Pedal.>	Repair the short circuit to power source in the harness between the ECM and accelerator pedal position sensor connector.

Diagnostic Procedure with Diagnostic Trouble Code (DTC)

ENGINE (DIAGNOSTICS)

DI: DTC P2135 THROTTLE/PEDAL POSITION SENSOR/SWITCH "A"/"B" VOLTAGE CORRELATION

DTC DETECTING CONDITION:

- Immediately at fault recognition
- GENERAL DESCRIPTION <Ref. to GD(H4SO)-192, DTC P2135 THROTTLE/PEDAL POSITION SENSOR/SWITCH "A"/"B" VOLTAGE CORRELATION, Diagnostic Trouble Code (DTC) Detecting Criteria.>

TROUBLE SYMPTOM:

- Improper idling
- Poor driving performance

CAUTION:

After repair or replacement of faulty parts, perform Clear Memory Mode <Ref. to EN(H4SO)(diag)-51, OPERATION, Clear Memory Mode.> and Inspection Mode <Ref. to EN(H4SO)(diag)-41, PROCEDURE, Inspection Mode.>.

WIRING DIAGRAM:

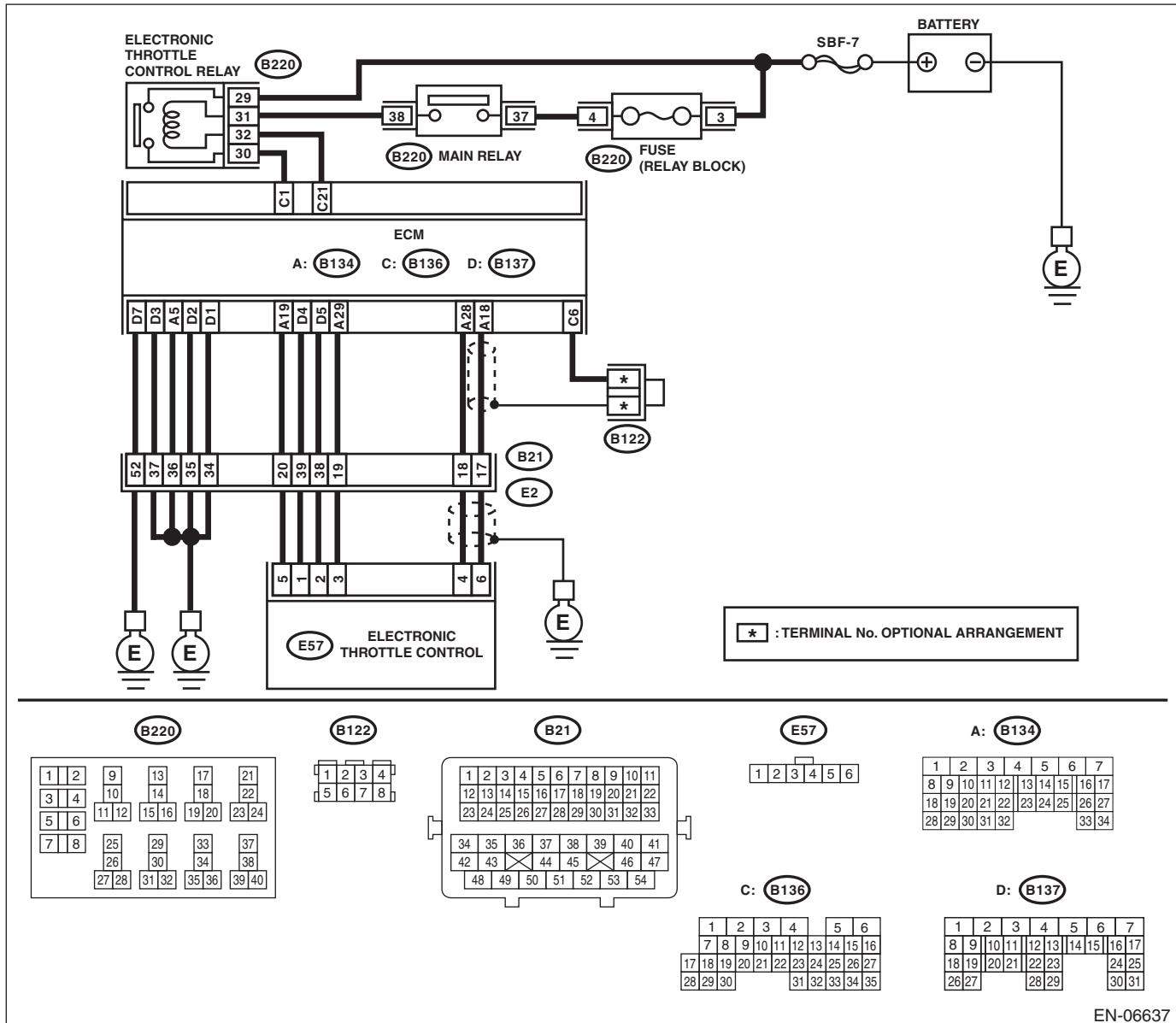

EN-06637

Diagnostic Procedure with Diagnostic Trouble Code (DTC)

ENGINE (DIAGNOSTICS)

Step	Check	Yes	No
<p>1 CHECK HARNESS BETWEEN ECM AND ELECTRONIC THROTTLE CONTROL.</p> <p>1) Turn the ignition switch to OFF. 2) Disconnect the connectors from ECM and electronic throttle control. 3) Measure the resistance between ECM and chassis ground.</p> <p>Connector & terminal (B134) No. 19 — Chassis ground: (B134) No. 18 — Chassis ground: (B134) No. 18 — (B136) No. 6: (B134) No. 28 — Chassis ground:</p>	Is the resistance 1 M Ω or more?	Go to step 2.	Repair the ground short circuit of harness between ECM and electronic throttle control connector.
<p>2 CHECK SHORT CIRCUIT INSIDE THE ECM.</p> <p>1) Connect the connector to ECM. 2) Measure the resistance between electronic throttle control connector and engine ground.</p> <p>Connector & terminal (E57) No. 6 — Engine ground: (E57) No. 4 — Engine ground:</p>	Is the resistance 1 M Ω or more?	Go to step 3.	Repair the ground short circuit of harness between ECM and electronic throttle control connector. Replace the ECM if defective. <Ref. to FU(H4SO)-39, Engine Control Module (ECM).>
<p>3 CHECK HARNESS BETWEEN ECM AND ELECTRONIC THROTTLE CONTROL.</p> <p>1) Disconnect the connectors from the ECM. 2) Measure the resistance of harness between ECM and electronic throttle control connector.</p> <p>Connector & terminal (B134) No. 18 — (E57) No. 6: (B134) No. 28 — (E57) No. 4: (B134) No. 29 — (E57) No. 3:</p>	Is the resistance less than 1 Ω ?	Go to step 4.	Repair the harness and connector. NOTE: In this case, repair the following item: • Open circuit in harness between ECM and electronic throttle control connector • Poor contact of coupling connector
<p>4 CHECK HARNESS BETWEEN ECM AND ELECTRONIC THROTTLE CONTROL.</p> <p>1) Connect the connector to ECM. 2) Measure the resistance between electronic throttle control connector and engine ground.</p> <p>Connector & terminal (E57) No. 3 — Engine ground:</p>	Is the resistance less than 5 Ω ?	Go to step 5.	Repair the harness and connector. NOTE: In this case, repair the following item: • Open circuit of harness between ECM and engine ground • Poor contact in ECM connector • Poor contact of coupling connector
<p>5 CHECK HARNESS BETWEEN ECM AND ELECTRONIC THROTTLE CONTROL.</p> <p>1) Turn the ignition switch to ON. 2) Measure the voltage between electronic throttle control connector and engine ground.</p> <p>Connector & terminal (E57) No. 6 (+) — Engine ground (-): (E57) No. 4 (+) — Engine ground (-):</p>	Is the voltage 4.85 V or more?	Repair the short circuit to power in the harness between ECM and electronic throttle control connector.	Go to step 6.

Diagnostic Procedure with Diagnostic Trouble Code (DTC)

ENGINE (DIAGNOSTICS)

Step	Check	Yes	No
<p>6</p> <p>CHECK HARNESS BETWEEN ECM AND ELECTRONIC THROTTLE CONTROL.</p> <p>1) Turn the ignition switch to OFF. 2) Disconnect the connectors from the ECM. 3) Measure the resistance between ECM connectors.</p> <p>Connector & terminal (B134) No. 19 — (B134) No. 18: (B134) No. 19 — (B134) No. 28:</p>	<p>Is the resistance 1 MΩ or more?</p>	<p>Repair poor contact of the electronic throttle control connector. Replace the electronic throttle control if defective. <Ref. to FU(H4SO)-13, Throttle Body.></p>	<p>Repair the short circuit to power in the harness between ECM and electronic throttle control connector.</p>

Diagnostic Procedure with Diagnostic Trouble Code (DTC)

ENGINE (DIAGNOSTICS)

Step	Check	Yes	No
<p>1 CHECK ACCELERATOR PEDAL POSITION SENSOR OUTPUT. 1) Turn the ignition switch to ON. 2) Measure the voltage between ECM and chassis ground. Connector & terminal Main accelerator pedal position sensor signal (B135) No. 23 (+) — Chassis ground (-): Sub accelerator pedal position sensor signal (B135) No. 31 (+) — Chassis ground (-):</p>	<p>Is the difference in measured values for the main accelerator pedal position sensor signal and the sub accelerator pedal position sensor signal 0 V?</p>	<p>Go to step 3.</p>	<p>Go to step 2.</p>
<p>2 CHECK ACCELERATOR PEDAL POSITION SENSOR OUTPUT. 1) Measure the voltage between accelerator pedal position sensor connector and chassis ground. Connector & terminal (B315) No. 6 (+) — Chassis ground (-): (B315) No. 3 (+) — Chassis ground (-):</p>	<p>Is the difference in measured values for the main accelerator pedal position sensor signal and the sub accelerator pedal position sensor signal 0 V?</p>	<p>Replace the accelerator pedal. <Ref. to SP(H4SO)-3, Accelerator Pedal.></p>	<p>Repair the harness and connector. NOTE: In this case, repair the following item: • Open circuit of harness between the ECM and accelerator pedal position sensor connector. • Ground short circuit of harness between the ECM and accelerator pedal position sensor connectors. • Poor contact of coupling connector</p>
<p>3 CHECK HARNESS BETWEEN ECM AND ACCELERATOR PEDAL POSITION SENSOR CONNECTOR. Measure the resistance of harness between accelerator pedal position sensor connector and chassis ground. Connector & terminal (B315) No. 5 — Chassis ground: (B315) No. 2 — Chassis ground:</p>	<p>Is the resistance less than 5 Ω?</p>	<p>Repair the poor contact of the ECM connector.</p>	<p>Repair the harness and connector. NOTE: In this case, repair the following item: • Open circuit of harness between the ECM and accelerator pedal position sensor connector. • Open circuit of harness between ECM and engine ground • Poor contact in ECM connector • Poor contact of coupling connector</p>

Diagnostic Procedure with Diagnostic Trouble Code (DTC)

ENGINE (DIAGNOSTICS)

DK:DTC P2227 BAROMETRIC PRESSURE CIRCUIT RANGE/PERFORMANCE

DTC DETECTING CONDITION:

- Detected when two consecutive driving cycles with fault occur.
- GENERAL DESCRIPTION <Ref. to GD(H4SO)-196, DTC P2227 BAROMETRIC PRESSURE CIRCUIT RANGE/PERFORMANCE, Diagnostic Trouble Code (DTC) Detecting Criteria.>

CAUTION:

After repair or replacement of faulty parts, perform Clear Memory Mode <Ref. to EN(H4SO)(diag)-51, OPERATION, Clear Memory Mode.> and Inspection Mode <Ref. to EN(H4SO)(diag)-41, PROCEDURE, Inspection Mode.>.

Step	Check	Yes	No
1 CHECK FOR ANY OTHER DTC ON DISPLAY.	Is any other DTC displayed?	Check DTC using "List of Diagnostic Trouble Code (DTC)". <Ref. to EN(H4SO)(diag)-82, List of Diagnostic Trouble Code (DTC).>	Replace the ECM. <Ref. to FU(H4SO)-39, Engine Control Module (ECM).> NOTE: The barometric pressure sensor is built into the ECM.

DL:DTC P2228 BAROMETRIC PRESSURE CIRCUIT LOW

DTC DETECTING CONDITION:

- Immediately at fault recognition
- GENERAL DESCRIPTION <Ref. to GD(H4SO)-197, DTC P2228 BAROMETRIC PRESSURE CIRCUIT LOW, Diagnostic Trouble Code (DTC) Detecting Criteria.>

CAUTION:

After repair or replacement of faulty parts, perform Clear Memory Mode <Ref. to EN(H4SO)(diag)-51, OPERATION, Clear Memory Mode.> and Inspection Mode <Ref. to EN(H4SO)(diag)-41, PROCEDURE, Inspection Mode.>.

Step	Check	Yes	No
1 CHECK FOR ANY OTHER DTC ON DISPLAY.	Is any other DTC displayed?	Check DTC using "List of Diagnostic Trouble Code (DTC)". <Ref. to EN(H4SO)(diag)-82, List of Diagnostic Trouble Code (DTC).>	Replace the ECM. <Ref. to FU(H4SO)-39, Engine Control Module (ECM).> NOTE: The barometric pressure sensor is built into the ECM.

Diagnostic Procedure with Diagnostic Trouble Code (DTC)

ENGINE (DIAGNOSTICS)

DM:DTC P2229 BAROMETRIC PRESSURE CIRCUIT HIGH

DTC DETECTING CONDITION:

- Immediately at fault recognition
- GENERAL DESCRIPTION <Ref. to GD(H4SO)-198, DTC P2229 BAROMETRIC PRESSURE CIRCUIT HIGH, Diagnostic Trouble Code (DTC) Detecting Criteria.>

CAUTION:

After repair or replacement of faulty parts, perform Clear Memory Mode <Ref. to EN(H4SO)(diag)-51, OPERATION, Clear Memory Mode.> and Inspection Mode <Ref. to EN(H4SO)(diag)-41, PROCEDURE, Inspection Mode.>.

Step	Check	Yes	No
1 CHECK FOR ANY OTHER DTC ON DISPLAY.	Is any other DTC displayed?	Check DTC using "List of Diagnostic Trouble Code (DTC)". <Ref. to EN(H4SO)(diag)-82, List of Diagnostic Trouble Code (DTC).>	Replace the ECM. <Ref. to FU(H4SO)-39, Engine Control Module (ECM).> NOTE: The barometric pressure sensor is built into the ECM.

General Diagnostic Table

ENGINE (DIAGNOSTICS)

21. General Diagnostic Table

A: INSPECTION

1. ENGINE

NOTE:

Malfunction of parts other than those listed is also possible. <Ref. to ME(H4SO)-111, Engine Trouble in General.>

Symptom	Problem parts
1. Engine stalls during idling.	1) Manifold absolute pressure sensor 2) Mass air flow and intake air temperature sensor 3) Ignition parts (*1) 4) Engine coolant temperature sensor (*2) 5) Crankshaft position sensor (*3) 6) Camshaft position sensor (*3) 7) Fuel injection parts (*4)
2. Rough idling	1) Manifold absolute pressure sensor 2) Mass air flow and intake air temperature sensor 3) Engine coolant temperature sensor (*2) 4) Ignition parts (*1) 5) Air intake system (*5) 6) Fuel injection parts (*4) 7) Electronic throttle control 8) Crankshaft position sensor (*3) 9) Camshaft position sensor (*3) 10) Oxygen sensor 11) Fuel pump and fuel pump relay 12) EGR valve
3. Engine does not return to idle.	1) Engine coolant temperature sensor 2) Electronic throttle control 3) Manifold absolute pressure sensor 4) Mass air flow and intake air temperature sensor 5) EGR valve
4. Poor acceleration	1) Manifold absolute pressure sensor 2) Mass air flow and intake air temperature sensor 3) Electronic throttle control 4) Fuel injection parts (*4) 5) Fuel pump and fuel pump relay 6) Engine coolant temperature sensor (*2) 7) Crankshaft position sensor (*3) 8) Camshaft position sensor (*3) 9) A/C switch and A/C cut relay 10) Engine torque control signal circuit 11) Ignition parts (*1) 12) EGR valve
5. Engine stalls, hesitates, or sputters at acceleration.	1) Manifold absolute pressure sensor 2) Mass air flow and intake air temperature sensor 3) Engine coolant temperature sensor (*2) 4) Crankshaft position sensor (*3) 5) Camshaft position sensor (*3) 6) Purge control solenoid valve 7) Fuel injection parts (*4) 8) Electronic throttle control 9) Fuel pump and fuel pump relay 10) EGR valve

General Diagnostic Table

ENGINE (DIAGNOSTICS)

Symptom	Problem parts
6. Surging	1) Mass air flow and intake air temperature sensor 2) Manifold absolute pressure sensor 3) Engine coolant temperature sensor (*2) 4) Crankshaft position sensor (*3) 5) Camshaft position sensor (*3) 6) Fuel injection parts (*4) 7) Electronic throttle control 8) Fuel pump and fuel pump relay 9) EGR valve
7. Spark knock	1) Mass air flow and intake air temperature sensor 2) Manifold absolute pressure sensor 3) Engine coolant temperature sensor 4) Knock sensor 5) Fuel injection parts (*4) 6) Fuel pump and fuel pump relay 7) EGR valve
8. After burning in exhaust system	1) Mass air flow and intake air temperature sensor 2) Manifold absolute pressure sensor 3) Engine coolant temperature sensor (*2) 4) Fuel injection parts (*4) 5) Fuel pump and fuel pump relay

*1: Check ignition coil and ignitor assembly and spark plug.

*2: Indicate the symptom occurring only in cold temperatures.

*3: Ensure the secure installation.

*4: Check fuel injector, fuel pressure regulator and fuel filter.

*5: Inspect air leak in air intake system.

General Diagnostic Table

ENGINE (DIAGNOSTICS)

GENERAL DESCRIPTION

GD(H4SO)

	Page
1. List of Diagnostic Trouble Code (DTC)	2
2. Diagnostic Trouble Code (DTC) Detecting Criteria	8

List of Diagnostic Trouble Code (DTC)

GENERAL DESCRIPTION

1. List of Diagnostic Trouble Code (DTC)

A: LIST

DTC	Item	Index
P0026	Intake Valve Control Solenoid Circuit Range/Performance (Bank 1)	<Ref. to GD(H4SO)-8, DTC P0026 INTAKE VALVE CONTROL SOLENOID CIRCUIT RANGE/PERFORMANCE (BANK 1), Diagnostic Trouble Code (DTC) Detecting Criteria.>
P0028	Intake Valve Control Solenoid Circuit Range/Performance (Bank 2)	<Ref. to GD(H4SO)-10, DTC P0028 INTAKE VALVE CONTROL SOLENOID CIRCUIT RANGE/PERFORMANCE (BANK 2), Diagnostic Trouble Code (DTC) Detecting Criteria.>
P0030	HO2S Heater Control Circuit (Bank 1 Sensor 1)	<Ref. to GD(H4SO)-10, DTC P0030 HO2S HEATER CONTROL CIRCUIT (BANK 1 SENSOR 1), Diagnostic Trouble Code (DTC) Detecting Criteria.>
P0031	HO2S Heater Control Circuit Low (Bank 1 Sensor 1)	<Ref. to GD(H4SO)-12, DTC P0031 HO2S HEATER CONTROL CIRCUIT LOW (BANK 1 SENSOR 1), Diagnostic Trouble Code (DTC) Detecting Criteria.>
P0032	HO2S Heater Control Circuit High (Bank 1 Sensor 1)	<Ref. to GD(H4SO)-14, DTC P0032 HO2S HEATER CONTROL CIRCUIT HIGH (BANK 1 SENSOR 1), Diagnostic Trouble Code (DTC) Detecting Criteria.>
P0037	HO2S Heater Control Circuit Low (Bank 1 Sensor 2)	<Ref. to GD(H4SO)-16, DTC P0037 HO2S HEATER CONTROL CIRCUIT LOW (BANK 1 SENSOR 2), Diagnostic Trouble Code (DTC) Detecting Criteria.>
P0038	HO2S Heater Control Circuit High (Bank 1 Sensor 2)	<Ref. to GD(H4SO)-18, DTC P0038 HO2S HEATER CONTROL CIRCUIT HIGH (BANK 1 SENSOR 2), Diagnostic Trouble Code (DTC) Detecting Criteria.>
P0068	MAP/MAF - Throttle Position Correlation	<Ref. to GD(H4SO)-20, DTC P0068 MAP/MAF - THROTTLE POSITION CORRELATION, Diagnostic Trouble Code (DTC) Detecting Criteria.>
P0076	Intake Valve Control Solenoid Circuit Low (Bank 1)	<Ref. to GD(H4SO)-22, DTC P0076 INTAKE VALVE CONTROL SOLENOID CIRCUIT LOW (BANK 1), Diagnostic Trouble Code (DTC) Detecting Criteria.>
P0077	Intake Valve Control Solenoid Circuit High (Bank 1)	<Ref. to GD(H4SO)-23, DTC P0077 INTAKE VALVE CONTROL SOLENOID CIRCUIT HIGH (BANK 1), Diagnostic Trouble Code (DTC) Detecting Criteria.>
P0082	Intake Valve Control Solenoid Circuit Low (Bank 2)	<Ref. to GD(H4SO)-24, DTC P0082 INTAKE VALVE CONTROL SOLENOID CIRCUIT LOW (BANK 2), Diagnostic Trouble Code (DTC) Detecting Criteria.>
P0083	Intake Valve Control Solenoid Circuit High (Bank 2)	<Ref. to GD(H4SO)-24, DTC P0083 INTAKE VALVE CONTROL SOLENOID CIRCUIT HIGH (BANK 2), Diagnostic Trouble Code (DTC) Detecting Criteria.>
P0101	Mass or Volume Air Flow Circuit Range/Performance	<Ref. to GD(H4SO)-25, DTC P0101 MASS OR VOLUME AIR FLOW CIRCUIT RANGE/PERFORMANCE, Diagnostic Trouble Code (DTC) Detecting Criteria.>
P0102	Mass or Volume Air Flow Circuit Low Input	<Ref. to GD(H4SO)-27, DTC P0102 MASS OR VOLUME AIR FLOW CIRCUIT LOW INPUT, Diagnostic Trouble Code (DTC) Detecting Criteria.>
P0103	Mass or Volume Air Flow Circuit High Input	<Ref. to GD(H4SO)-28, DTC P0103 MASS OR VOLUME AIR FLOW CIRCUIT HIGH INPUT, Diagnostic Trouble Code (DTC) Detecting Criteria.>
P0107	Manifold Absolute Pressure/Barometric Pressure Circuit Low Input	<Ref. to GD(H4SO)-29, DTC P0107 MANIFOLD ABSOLUTE PRESSURE/BAROMETRIC PRESSURE CIRCUIT LOW INPUT, Diagnostic Trouble Code (DTC) Detecting Criteria.>
P0108	Manifold Absolute Pressure/Barometric Pressure Circuit High Input	<Ref. to GD(H4SO)-30, DTC P0108 MANIFOLD ABSOLUTE PRESSURE/BAROMETRIC PRESSURE CIRCUIT HIGH INPUT, Diagnostic Trouble Code (DTC) Detecting Criteria.>
P0111	Intake Air Temperature Sensor 1 Circuit Range/Performance	<Ref. to GD(H4SO)-31, DTC P0111 INTAKE AIR TEMPERATURE SENSOR 1 CIRCUIT RANGE/PERFORMANCE, Diagnostic Trouble Code (DTC) Detecting Criteria.>
P0112	Intake Air Temperature Sensor 1 Circuit Low	<Ref. to GD(H4SO)-33, DTC P0112 INTAKE AIR TEMPERATURE SENSOR 1 CIRCUIT LOW, Diagnostic Trouble Code (DTC) Detecting Criteria.>
P0113	Intake Air Temperature Sensor 1 Circuit High	<Ref. to GD(H4SO)-34, DTC P0113 INTAKE AIR TEMPERATURE SENSOR 1 CIRCUIT HIGH, Diagnostic Trouble Code (DTC) Detecting Criteria.>
P0117	Engine Coolant Temperature Circuit Low	<Ref. to GD(H4SO)-35, DTC P0117 ENGINE COOLANT TEMPERATURE CIRCUIT LOW, Diagnostic Trouble Code (DTC) Detecting Criteria.>

List of Diagnostic Trouble Code (DTC)

GENERAL DESCRIPTION

DTC	Item	Index
P0118	Engine Coolant Temperature Circuit High	<Ref. to GD(H4SO)-36, DTC P0118 ENGINE COOLANT TEMPERATURE CIRCUIT HIGH, Diagnostic Trouble Code (DTC) Detecting Criteria.>
P0122	Throttle/Pedal Position Sensor/Switch "A" Circuit Low	<Ref. to GD(H4SO)-37, DTC P0122 THROTTLE/PEDAL POSITION SENSOR/SWITCH "A" CIRCUIT LOW, Diagnostic Trouble Code (DTC) Detecting Criteria.>
P0123	Throttle/Pedal Position Sensor/Switch "A" Circuit High	<Ref. to GD(H4SO)-38, DTC P0123 THROTTLE/PEDAL POSITION SENSOR/SWITCH "A" CIRCUIT HIGH, Diagnostic Trouble Code (DTC) Detecting Criteria.>
P0125	Insufficient Coolant Temperature for Closed Loop Fuel Control	<Ref. to GD(H4SO)-39, DTC P0125 INSUFFICIENT COOLANT TEMPERATURE FOR CLOSED LOOP FUEL CONTROL, Diagnostic Trouble Code (DTC) Detecting Criteria.>
P0126	Insufficient Engine Coolant Temperature for Stable Operation	<Ref. to GD(H4SO)-41, DTC P0126 INSUFFICIENT ENGINE COOLANT TEMPERATURE FOR STABLE OPERATION, Diagnostic Trouble Code (DTC) Detecting Criteria.>
P0128	Coolant Thermostat (Engine Coolant Temperature Below Thermostat Regulating Temperature)	<Ref. to GD(H4SO)-43, DTC P0128 COOLANT THERMOSTAT (ENGINE COOLANT TEMPERATURE BELOW THERMOSTAT REGULATING TEMPERATURE), Diagnostic Trouble Code (DTC) Detecting Criteria.>
P0131	O2 Sensor Circuit Low Voltage (Bank 1 Sensor 1)	<Ref. to GD(H4SO)-45, DTC P0131 O2 SENSOR CIRCUIT LOW VOLTAGE (BANK 1 SENSOR 1), Diagnostic Trouble Code (DTC) Detecting Criteria.>
P0132	O2 Sensor Circuit High Voltage (Bank 1 Sensor 1)	<Ref. to GD(H4SO)-47, DTC P0132 O2 SENSOR CIRCUIT HIGH VOLTAGE (BANK 1 SENSOR 1), Diagnostic Trouble Code (DTC) Detecting Criteria.>
P0133	O2 Sensor Circuit Slow Response (Bank 1 Sensor 1)	<Ref. to GD(H4SO)-49, DTC P0133 O2 SENSOR CIRCUIT SLOW RESPONSE (BANK 1 SENSOR 1), Diagnostic Trouble Code (DTC) Detecting Criteria.>
P0134	O2 Sensor Circuit No Activity Detected (Bank 1 Sensor 1)	<Ref. to GD(H4SO)-52, DTC P0134 O2 SENSOR CIRCUIT NO ACTIVITY DETECTED (BANK 1 SENSOR 1), Diagnostic Trouble Code (DTC) Detecting Criteria.>
P0137	O2 Sensor Circuit Low Voltage (Bank 1 Sensor 2)	<Ref. to GD(H4SO)-54, DTC P0137 O2 SENSOR CIRCUIT LOW VOLTAGE (BANK 1 SENSOR 2), Diagnostic Trouble Code (DTC) Detecting Criteria.>
P0138	O2 Sensor Circuit High Voltage (Bank 1 Sensor 2)	<Ref. to GD(H4SO)-57, DTC P0138 O2 SENSOR CIRCUIT HIGH VOLTAGE (BANK 1 SENSOR 2), Diagnostic Trouble Code (DTC) Detecting Criteria.>
P0139	O2 Sensor Circuit Slow Response (Bank 1 Sensor 2)	<Ref. to GD(H4SO)-58, DTC P0139 O2 SENSOR CIRCUIT SLOW RESPONSE (BANK 1 SENSOR 2), Diagnostic Trouble Code (DTC) Detecting Criteria.>
P0140	O2 Sensor Circuit No Activity Detected (Bank 1 Sensor 2)	<Ref. to GD(H4SO)-63, DTC P0140 O2 SENSOR CIRCUIT NO ACTIVITY DETECTED (BANK 1 SENSOR 2), Diagnostic Trouble Code (DTC) Detecting Criteria.>
P0171	System Too Lean (Bank 1)	<Ref. to GD(H4SO)-65, DTC P0171 SYSTEM TOO LEAN (BANK 1), Diagnostic Trouble Code (DTC) Detecting Criteria.>
P0172	System Too Rich (Bank 1)	<Ref. to GD(H4SO)-66, DTC P0172 SYSTEM TOO RICH (BANK 1), Diagnostic Trouble Code (DTC) Detecting Criteria.>
P0181	Fuel Temperature Sensor "A" Circuit Range/Performance	<Ref. to GD(H4SO)-67, DTC P0181 FUEL TEMPERATURE SENSOR "A" CIRCUIT RANGE/PERFORMANCE, Diagnostic Trouble Code (DTC) Detecting Criteria.>
P0182	Fuel Temperature Sensor "A" Circuit Low Input	<Ref. to GD(H4SO)-70, DTC P0182 FUEL TEMPERATURE SENSOR "A" CIRCUIT LOW INPUT, Diagnostic Trouble Code (DTC) Detecting Criteria.>
P0183	Fuel Temperature Sensor "A" Circuit High Input	<Ref. to GD(H4SO)-71, DTC P0183 FUEL TEMPERATURE SENSOR "A" CIRCUIT HIGH INPUT, Diagnostic Trouble Code (DTC) Detecting Criteria.>
P0196	Engine Oil Temperature Sensor Circuit Range/Performance	<Ref. to GD(H4SO)-72, DTC P0196 ENGINE OIL TEMPERATURE SENSOR CIRCUIT RANGE/PERFORMANCE, Diagnostic Trouble Code (DTC) Detecting Criteria.>
P0197	Engine Oil Temperature Sensor Low	<Ref. to GD(H4SO)-74, DTC P0197 ENGINE OIL TEMPERATURE SENSOR LOW, Diagnostic Trouble Code (DTC) Detecting Criteria.>
P0198	Engine Oil Temperature Sensor High	<Ref. to GD(H4SO)-75, DTC P0198 ENGINE OIL TEMPERATURE SENSOR HIGH, Diagnostic Trouble Code (DTC) Detecting Criteria.>

List of Diagnostic Trouble Code (DTC)

GENERAL DESCRIPTION

DTC	Item	Index
P0222	Throttle/Pedal Position Sensor/Switch "B" Circuit Low	<Ref. to GD(H4SO)-76, DTC P0222 THROTTLE/PEDAL POSITION SENSOR/SWITCH "B" CIRCUIT LOW, Diagnostic Trouble Code (DTC) Detecting Criteria.>
P0223	Throttle/Pedal Position Sensor/Switch "B" Circuit High	<Ref. to GD(H4SO)-77, DTC P0223 THROTTLE/PEDAL POSITION SENSOR/SWITCH "B" CIRCUIT HIGH, Diagnostic Trouble Code (DTC) Detecting Criteria.>
P0301	Cylinder 1 Misfire Detected	<Ref. to GD(H4SO)-78, DTC P0301 CYLINDER 1 MISFIRE DETECTED, Diagnostic Trouble Code (DTC) Detecting Criteria.>
P0302	Cylinder 2 Misfire Detected	<Ref. to GD(H4SO)-83, DTC P0302 CYLINDER 2 MISFIRE DETECTED, Diagnostic Trouble Code (DTC) Detecting Criteria.>
P0303	Cylinder 3 Misfire Detected	<Ref. to GD(H4SO)-83, DTC P0303 CYLINDER 3 MISFIRE DETECTED, Diagnostic Trouble Code (DTC) Detecting Criteria.>
P0304	Cylinder 4 Misfire Detected	<Ref. to GD(H4SO)-83, DTC P0304 CYLINDER 4 MISFIRE DETECTED, Diagnostic Trouble Code (DTC) Detecting Criteria.>
P0327	Knock Sensor 1 Circuit Low (Bank 1 or Single Sensor)	<Ref. to GD(H4SO)-84, DTC P0327 KNOCK SENSOR 1 CIRCUIT LOW (BANK 1 OR SINGLE SENSOR), Diagnostic Trouble Code (DTC) Detecting Criteria.>
P0328	Knock Sensor 1 Circuit High (Bank 1 or Single Sensor)	<Ref. to GD(H4SO)-86, DTC P0328 KNOCK SENSOR 1 CIRCUIT HIGH (BANK 1 OR SINGLE SENSOR), Diagnostic Trouble Code (DTC) Detecting Criteria.>
P0335	Crankshaft Position Sensor "A" Circuit	<Ref. to GD(H4SO)-87, DTC P0335 CRANKSHAFT POSITION SENSOR "A" CIRCUIT, Diagnostic Trouble Code (DTC) Detecting Criteria.>
P0336	Crankshaft Position Sensor "A" Circuit Range/Performance	<Ref. to GD(H4SO)-89, DTC P0336 CRANKSHAFT POSITION SENSOR "A" CIRCUIT RANGE/PERFORMANCE, Diagnostic Trouble Code (DTC) Detecting Criteria.>
P0340	Camshaft Position Sensor "A" Circuit (Bank 1 or Single Sensor)	<Ref. to GD(H4SO)-91, DTC P0340 CAMSHAFT POSITION SENSOR "A" CIRCUIT (BANK 1 OR SINGLE SENSOR), Diagnostic Trouble Code (DTC) Detecting Criteria.>
P0341	Camshaft Position Sensor "A" Circuit Range/Performance (Bank 1 or Single Sensor)	<Ref. to GD(H4SO)-92, DTC P0341 CAMSHAFT POSITION SENSOR "A" CIRCUIT RANGE/PERFORMANCE (BANK 1 OR SINGLE SENSOR), Diagnostic Trouble Code (DTC) Detecting Criteria.>
P0400	Exhaust Gas Recirculation Flow	<Ref. to GD(H4SO)-94, DTC P0400 EXHAUST GAS RECIRCULATION FLOW, Diagnostic Trouble Code (DTC) Detecting Criteria.>
P0420	Catalyst System Efficiency below Threshold (Bank 1)	<Ref. to GD(H4SO)-97, DTC P0420 CATALYST SYSTEM EFFICIENCY BELOW THRESHOLD (BANK 1), Diagnostic Trouble Code (DTC) Detecting Criteria.>
P0442	Evaporative Emission Control System Leak Detected (Small Leak)	<Ref. to GD(H4SO)-99, DTC P0442 EVAPORATIVE EMISSION CONTROL SYSTEM LEAK DETECTED (SMALL LEAK), Diagnostic Trouble Code (DTC) Detecting Criteria.>
P0447	Evaporative Emission Control System Vent Control Circuit Open	<Ref. to GD(H4SO)-115, DTC P0447 EVAPORATIVE EMISSION CONTROL SYSTEM VENT CONTROL CIRCUIT OPEN, Diagnostic Trouble Code (DTC) Detecting Criteria.>
P0448	Evaporative Emission Control System Vent Control Circuit Shorted	<Ref. to GD(H4SO)-117, DTC P0448 EVAPORATIVE EMISSION CONTROL SYSTEM VENT CONTROL CIRCUIT SHORTED, Diagnostic Trouble Code (DTC) Detecting Criteria.>
P0451	Evaporative Emission Control System Pressure Sensor	<Ref. to GD(H4SO)-119, DTC P0451 EVAPORATIVE EMISSION CONTROL SYSTEM PRESSURE SENSOR, Diagnostic Trouble Code (DTC) Detecting Criteria.>
P0452	Evaporative Emission Control System Pressure Sensor Low Input	<Ref. to GD(H4SO)-121, DTC P0452 EVAPORATIVE EMISSION CONTROL SYSTEM PRESSURE SENSOR LOW INPUT, Diagnostic Trouble Code (DTC) Detecting Criteria.>
P0453	Evaporative Emission Control System Pressure Sensor High Input	<Ref. to GD(H4SO)-123, DTC P0453 EVAPORATIVE EMISSION CONTROL SYSTEM PRESSURE SENSOR HIGH INPUT, Diagnostic Trouble Code (DTC) Detecting Criteria.>

List of Diagnostic Trouble Code (DTC)

GENERAL DESCRIPTION

DTC	Item	Index
P0456	Evaporative Emission Control System Leak Detected (Very Small Leak)	<Ref. to GD(H4SO)-125, DTC P0456 EVAPORATIVE EMISSION CONTROL SYSTEM LEAK DETECTED (VERY SMALL LEAK), Diagnostic Trouble Code (DTC) Detecting Criteria.>
P0457	Evaporative Emission Control System Leak Detected (Fuel Cap Loose/Off)	<Ref. to GD(H4SO)-125, DTC P0457 EVAPORATIVE EMISSION CONTROL SYSTEM LEAK DETECTED (FUEL CAP LOOSE/OFF), Diagnostic Trouble Code (DTC) Detecting Criteria.>
P0458	Evaporative Emission System Purge Control Valve Circuit Low	<Ref. to GD(H4SO)-126, DTC P0458 EVAPORATIVE EMISSION SYSTEM PURGE CONTROL VALVE CIRCUIT LOW, Diagnostic Trouble Code (DTC) Detecting Criteria.>
P0459	Evaporative Emission System Purge Control Valve Circuit High	<Ref. to GD(H4SO)-127, DTC P0459 EVAPORATIVE EMISSION SYSTEM PURGE CONTROL VALVE CIRCUIT HIGH, Diagnostic Trouble Code (DTC) Detecting Criteria.>
P0461	Fuel Level Sensor "A" Circuit Range/Performance	<Ref. to GD(H4SO)-128, DTC P0461 FUEL LEVEL SENSOR "A" CIRCUIT RANGE/PERFORMANCE, Diagnostic Trouble Code (DTC) Detecting Criteria.>
P0462	Fuel Level Sensor "A" Circuit Low	<Ref. to GD(H4SO)-130, DTC P0462 FUEL LEVEL SENSOR "A" CIRCUIT LOW, Diagnostic Trouble Code (DTC) Detecting Criteria.>
P0463	Fuel Level Sensor "A" Circuit High	<Ref. to GD(H4SO)-132, DTC P0463 FUEL LEVEL SENSOR "A" CIRCUIT HIGH, Diagnostic Trouble Code (DTC) Detecting Criteria.>
P0464	Fuel Level Sensor Circuit Intermittent	<Ref. to GD(H4SO)-134, DTC P0464 FUEL LEVEL SENSOR CIRCUIT INTERMITTENT, Diagnostic Trouble Code (DTC) Detecting Criteria.>
P0500	Vehicle Speed Sensor "A"	<Ref. to GD(H4SO)-137, DTC P0500 VEHICLE SPEED SENSOR "A", Diagnostic Trouble Code (DTC) Detecting Criteria.>
P0506	Idle Air Control System RPM Lower Than Expected	<Ref. to GD(H4SO)-138, DTC P0506 IDLE AIR CONTROL SYSTEM RPM LOWER THAN EXPECTED, Diagnostic Trouble Code (DTC) Detecting Criteria.>
P0507	Idle Air Control System RPM Higher Than Expected	<Ref. to GD(H4SO)-139, DTC P0507 IDLE AIR CONTROL SYSTEM RPM HIGHER THAN EXPECTED, Diagnostic Trouble Code (DTC) Detecting Criteria.>
P0512	Starter Request Circuit	<Ref. to GD(H4SO)-140, DTC P0512 STARTER REQUEST CIRCUIT, Diagnostic Trouble Code (DTC) Detecting Criteria.>
P0513	Incorrect Immobilizer Key	<Ref. to GD(H4SO)-141, DTC P0513 INCORRECT IMMOBILIZER KEY, Diagnostic Trouble Code (DTC) Detecting Criteria.>
P0600	Serial Communication Link	<Ref. to GD(H4SO)-142, DTC P0600 SERIAL COMMUNICATION LINK, Diagnostic Trouble Code (DTC) Detecting Criteria.>
P0604	Internal Control Module Random Access Memory (RAM) Error	<Ref. to GD(H4SO)-143, DTC P0604 INTERNAL CONTROL MODULE RANDOM ACCESS MEMORY (RAM) ERROR, Diagnostic Trouble Code (DTC) Detecting Criteria.>
P0605	Internal Control Module Read Only Memory (ROM) Error	<Ref. to GD(H4SO)-144, DTC P0605 INTERNAL CONTROL MODULE READ ONLY MEMORY (ROM) ERROR, Diagnostic Trouble Code (DTC) Detecting Criteria.>
P0607	Throttle Control System Circuit Range/Performance	<Ref. to GD(H4SO)-145, DTC P0607 THROTTLE CONTROL SYSTEM CIRCUIT RANGE/PERFORMANCE, Diagnostic Trouble Code (DTC) Detecting Criteria.>
P0638	Throttle Actuator Control Range/Performance (Bank 1)	<Ref. to GD(H4SO)-147, DTC P0638 THROTTLE ACTUATOR CONTROL RANGE/PERFORMANCE (BANK 1), Diagnostic Trouble Code (DTC) Detecting Criteria.>
P0700	Transmission Control System (MIL Request)	<Ref. to GD(H4SO)-149, DTC P0700 TRANSMISSION CONTROL SYSTEM (MIL REQUEST), Diagnostic Trouble Code (DTC) Detecting Criteria.>
P0851	Park/Neutral Switch Input Circuit Low (AT Model)	<Ref. to GD(H4SO)-150, DTC P0851 PARK/NEUTRAL SWITCH INPUT CIRCUIT LOW (AT MODEL), Diagnostic Trouble Code (DTC) Detecting Criteria.>
P0851	Neutral Switch Input Circuit Low (MT Model)	<Ref. to GD(H4SO)-151, DTC P0851 NEUTRAL SWITCH INPUT CIRCUIT LOW (MT MODEL), Diagnostic Trouble Code (DTC) Detecting Criteria.>
P0852	Park/Neutral Switch Input Circuit High (AT Model)	<Ref. to GD(H4SO)-152, DTC P0852 PARK/NEUTRAL SWITCH INPUT CIRCUIT HIGH (AT MODEL), Diagnostic Trouble Code (DTC) Detecting Criteria.>

List of Diagnostic Trouble Code (DTC)

GENERAL DESCRIPTION

DTC	Item	Index
P0852	Neutral Switch Input Circuit High (MT Model)	<Ref. to GD(H4SO)-153, DTC P0852 NEUTRAL SWITCH INPUT CIRCUIT HIGH (MT MODEL), Diagnostic Trouble Code (DTC) Detecting Criteria.>
P1152	O2 Sensor Circuit Range/Performance (Low) (Bank 1 Sensor 1)	<Ref. to GD(H4SO)-154, DTC P1152 O2 SENSOR CIRCUIT RANGE/PERFORMANCE (LOW) (BANK1 SENSOR1), Diagnostic Trouble Code (DTC) Detecting Criteria.>
P1153	O2 Sensor Circuit Range/Performance (High) (Bank 1 Sensor 1)	<Ref. to GD(H4SO)-156, DTC P1153 O2 SENSOR CIRCUIT RANGE/PERFORMANCE (HIGH) (BANK1 SENSOR1), Diagnostic Trouble Code (DTC) Detecting Criteria.>
P1160	Return Spring Failure	<Ref. to GD(H4SO)-158, DTC P1160 RETURN SPRING FAILURE, Diagnostic Trouble Code (DTC) Detecting Criteria.>
P1400	Fuel Tank Pressure Control Solenoid Valve Circuit Low	<Ref. to GD(H4SO)-159, DTC P1400 FUEL TANK PRESSURE CONTROL SOLENOID VALVE CIRCUIT LOW, Diagnostic Trouble Code (DTC) Detecting Criteria.>
P1420	Fuel Tank Pressure Control Sol. Valve Circuit High	<Ref. to GD(H4SO)-161, DTC P1420 FUEL TANK PRESSURE CONTROL SOL. VALVE CIRCUIT HIGH, Diagnostic Trouble Code (DTC) Detecting Criteria.>
P1443	Vent Control Solenoid Valve Function Problem	<Ref. to GD(H4SO)-163, DTC P1443 VENT CONTROL SOLENOID VALVE FUNCTION PROBLEM, Diagnostic Trouble Code (DTC) Detecting Criteria.>
P1491	Positive Crankcase Ventilation (Blow-by) Function Problem	<Ref. to GD(H4SO)-165, DTC P1491 POSITIVE CRANKCASE VENTILATION (BLOW-BY) FUNCTION PROBLEM, Diagnostic Trouble Code (DTC) Detecting Criteria.>
P1492	EGR Solenoid Valve Signal #1 Circuit Malfunction (Low Input)	<Ref. to GD(H4SO)-167, DTC P1492 EGR SOLENOID VALVE SIGNAL #1 CIRCUIT MALFUNCTION (LOW INPUT), Diagnostic Trouble Code (DTC) Detecting Criteria.>
P1493	EGR Solenoid Valve Signal #1 Circuit Malfunction (High Input)	<Ref. to GD(H4SO)-169, DTC P1493 EGR SOLENOID VALVE SIGNAL #1 CIRCUIT MALFUNCTION (HIGH INPUT), Diagnostic Trouble Code (DTC) Detecting Criteria.>
P1494	EGR Solenoid Valve Signal #2 Circuit Malfunction (Low Input)	<Ref. to GD(H4SO)-171, DTC P1494 EGR SOLENOID VALVE SIGNAL #2 CIRCUIT MALFUNCTION (LOW INPUT), Diagnostic Trouble Code (DTC) Detecting Criteria.>
P1495	EGR Solenoid Valve Signal #2 Circuit Malfunction (High Input)	<Ref. to GD(H4SO)-171, DTC P1495 EGR SOLENOID VALVE SIGNAL #2 CIRCUIT MALFUNCTION (HIGH INPUT), Diagnostic Trouble Code (DTC) Detecting Criteria.>
P1496	EGR Solenoid Valve Signal #3 Circuit Malfunction (Low Input)	<Ref. to GD(H4SO)-171, DTC P1496 EGR SOLENOID VALVE SIGNAL #3 CIRCUIT MALFUNCTION (LOW INPUT), Diagnostic Trouble Code (DTC) Detecting Criteria.>
P1497	EGR Solenoid Valve Signal #3 Circuit Malfunction (High Input)	<Ref. to GD(H4SO)-171, DTC P1497 EGR SOLENOID VALVE SIGNAL #3 CIRCUIT MALFUNCTION (HIGH INPUT), Diagnostic Trouble Code (DTC) Detecting Criteria.>
P1498	EGR Solenoid Valve Signal #4 Circuit Malfunction (Low Input)	<Ref. to GD(H4SO)-171, DTC P1498 EGR SOLENOID VALVE SIGNAL #4 CIRCUIT MALFUNCTION (LOW INPUT), Diagnostic Trouble Code (DTC) Detecting Criteria.>
P1499	EGR Solenoid Valve Signal #4 Circuit Malfunction (High Input)	<Ref. to GD(H4SO)-171, DTC P1499 EGR SOLENOID VALVE SIGNAL #4 CIRCUIT MALFUNCTION (HIGH INPUT), Diagnostic Trouble Code (DTC) Detecting Criteria.>
P1560	Back-up Voltage Circuit Malfunction	<Ref. to GD(H4SO)-172, DTC P1560 BACK-UP VOLTAGE CIRCUIT MALFUNCTION, Diagnostic Trouble Code (DTC) Detecting Criteria.>
P1570	Antenna	<Ref. to GD(H4SO)-173, DTC P1570 ANTENNA, Diagnostic Trouble Code (DTC) Detecting Criteria.>
P1571	Reference Code Incompatibility	<Ref. to GD(H4SO)-173, DTC P1571 REFERENCE CODE INCOMPATIBILITY, Diagnostic Trouble Code (DTC) Detecting Criteria.>
P1572	IMM Circuit Failure (Except Antenna Circuit)	<Ref. to GD(H4SO)-173, DTC P1572 IMM CIRCUIT FAILURE (EXCEPT ANTENNA CIRCUIT), Diagnostic Trouble Code (DTC) Detecting Criteria.>
P1574	Key Communication Failure	<Ref. to GD(H4SO)-173, DTC P1574 KEY COMMUNICATION FAILURE, Diagnostic Trouble Code (DTC) Detecting Criteria.>

List of Diagnostic Trouble Code (DTC)

GENERAL DESCRIPTION

DTC	Item	Index
P1576	EGI Control Module EEPROM	<Ref. to GD(H4SO)-173, DTC P1576 EGI CONTROL MODULE EEPROM, Diagnostic Trouble Code (DTC) Detecting Criteria.>
P1577	IMM Control Module EEPROM	<Ref. to GD(H4SO)-173, DTC P1577 IMM CONTROL MODULE EEPROM, Diagnostic Trouble Code (DTC) Detecting Criteria.>
P1578	Meter Failure	<Ref. to GD(H4SO)-173, DTC P1578 METER FAILURE, Diagnostic Trouble Code (DTC) Detecting Criteria.>
P1602	Control Module Programming Error	<Ref. to GD(H4SO)-174, DTC P1602 CONTROL MODULE PROGRAMMING ERROR, Diagnostic Trouble Code (DTC) Detecting Criteria.>
P2096	Post Catalyst Fuel Trim System Too Lean (Bank 1)	<Ref. to GD(H4SO)-176, DTC P2096 POST CATALYST FUEL TRIM SYSTEM TOO LEAN (BANK 1), Diagnostic Trouble Code (DTC) Detecting Criteria.>
P2097	Post Catalyst Fuel Trim System Too Rich (Bank 1)	<Ref. to GD(H4SO)-178, DTC P2097 POST CATALYST FUEL TRIM SYSTEM TOO RICH (BANK 1), Diagnostic Trouble Code (DTC) Detecting Criteria.>
P2101	Throttle Actuator Control Motor Circuit Range/Performance	<Ref. to GD(H4SO)-180, DTC P2101 THROTTLE ACTUATOR CONTROL MOTOR CIRCUIT RANGE/PERFORMANCE, Diagnostic Trouble Code (DTC) Detecting Criteria.>
P2102	Throttle Actuator Control Motor Circuit Low	<Ref. to GD(H4SO)-181, DTC P2102 THROTTLE ACTUATOR CONTROL MOTOR CIRCUIT LOW, Diagnostic Trouble Code (DTC) Detecting Criteria.>
P2103	Throttle Actuator Control Motor Circuit High	<Ref. to GD(H4SO)-182, DTC P2103 THROTTLE ACTUATOR CONTROL MOTOR CIRCUIT HIGH, Diagnostic Trouble Code (DTC) Detecting Criteria.>
P2109	Throttle/Pedal Position Sensor "A" Minimum Stop Performance	<Ref. to GD(H4SO)-183, DTC P2109 THROTTLE/PEDAL POSITION SENSOR "A" MINIMUM STOP PERFORMANCE, Diagnostic Trouble Code (DTC) Detecting Criteria.>
P2122	Throttle/Pedal Position Sensor/Switch "D" Circuit Low Input	<Ref. to GD(H4SO)-184, DTC P2122 THROTTLE/PEDAL POSITION SENSOR/SWITCH "D" CIRCUIT LOW INPUT, Diagnostic Trouble Code (DTC) Detecting Criteria.>
P2123	Throttle/Pedal Position Sensor/Switch "D" Circuit High Input	<Ref. to GD(H4SO)-186, DTC P2123 THROTTLE/PEDAL POSITION SENSOR/SWITCH "D" CIRCUIT HIGH INPUT, Diagnostic Trouble Code (DTC) Detecting Criteria.>
P2127	Throttle/Pedal Position Sensor/Switch "E" Circuit Low Input	<Ref. to GD(H4SO)-188, DTC P2127 THROTTLE/PEDAL POSITION SENSOR/SWITCH "E" CIRCUIT LOW INPUT, Diagnostic Trouble Code (DTC) Detecting Criteria.>
P2128	Throttle/Pedal Position Sensor/Switch "E" Circuit High Input	<Ref. to GD(H4SO)-190, DTC P2128 THROTTLE/PEDAL POSITION SENSOR/SWITCH "E" CIRCUIT HIGH INPUT, Diagnostic Trouble Code (DTC) Detecting Criteria.>
P2135	Throttle/Pedal Position Sensor/Switch "A"/"B" Voltage Correlation	<Ref. to GD(H4SO)-192, DTC P2135 THROTTLE/PEDAL POSITION SENSOR/SWITCH "A"/"B" VOLTAGE CORRELATION, Diagnostic Trouble Code (DTC) Detecting Criteria.>
P2138	Throttle/Pedal Position Sensor/Switch "D"/"E" Voltage Correlation	<Ref. to GD(H4SO)-194, DTC P2138 THROTTLE/PEDAL POSITION SENSOR/SWITCH "D"/"E" VOLTAGE CORRELATION, Diagnostic Trouble Code (DTC) Detecting Criteria.>
P2227	Barometric Pressure Circuit Range/Performance	<Ref. to GD(H4SO)-196, DTC P2227 BAROMETRIC PRESSURE CIRCUIT RANGE/PERFORMANCE, Diagnostic Trouble Code (DTC) Detecting Criteria.>
P2228	Barometric Pressure Circuit Low	<Ref. to GD(H4SO)-197, DTC P2228 BAROMETRIC PRESSURE CIRCUIT LOW, Diagnostic Trouble Code (DTC) Detecting Criteria.>
P2229	Barometric Pressure Circuit High	<Ref. to GD(H4SO)-198, DTC P2229 BAROMETRIC PRESSURE CIRCUIT HIGH, Diagnostic Trouble Code (DTC) Detecting Criteria.>

Diagnostic Trouble Code (DTC) Detecting Criteria

GENERAL DESCRIPTION

2. Diagnostic Trouble Code (DTC) Detecting Criteria

A: DTC P0026 INTAKE VALVE CONTROL SOLENOID CIRCUIT RANGE/ PERFORMANCE (BANK 1)

1. OUTLINE OF DIAGNOSIS

Judge as NG with either Low NG or High NG.

A variable valve lift diagnosis oil pressure switch is installed for diagnosis. It is possible to determine whether the intake valve is in high mode (increase the amount of lift) or in low mode (suppressing the amount of lift) when the variable valve lift diagnosis oil pressure switch is turned ON or OFF.

• Normal

Oil switching solenoid valve duty	Intake valve	Variable valve lift diagnosis oil pressure switch
Large	High mode	OFF
Minimum	Low mode	ON

• Low NG

When the variable valve lift diagnosis oil pressure switch remains ON even though the intake valve tried to enter high mode (oil switching solenoid valve duty is large), this is judged as a Low NG.

• High NG

When the variable valve lift diagnosis oil pressure switch remains OFF even though the intake valve tried to enter low mode (oil switching solenoid valve duty is small), this is judged as a High NG.

2. COMPONENT DESCRIPTION

The variable valve lift system optimizes the intake valve lift by switching between the low lift cam and the high lift cam according to the engine speed. The amount of intake valve lift is varied by controlling the oil switching solenoid valve duty according to signals from the ECM.

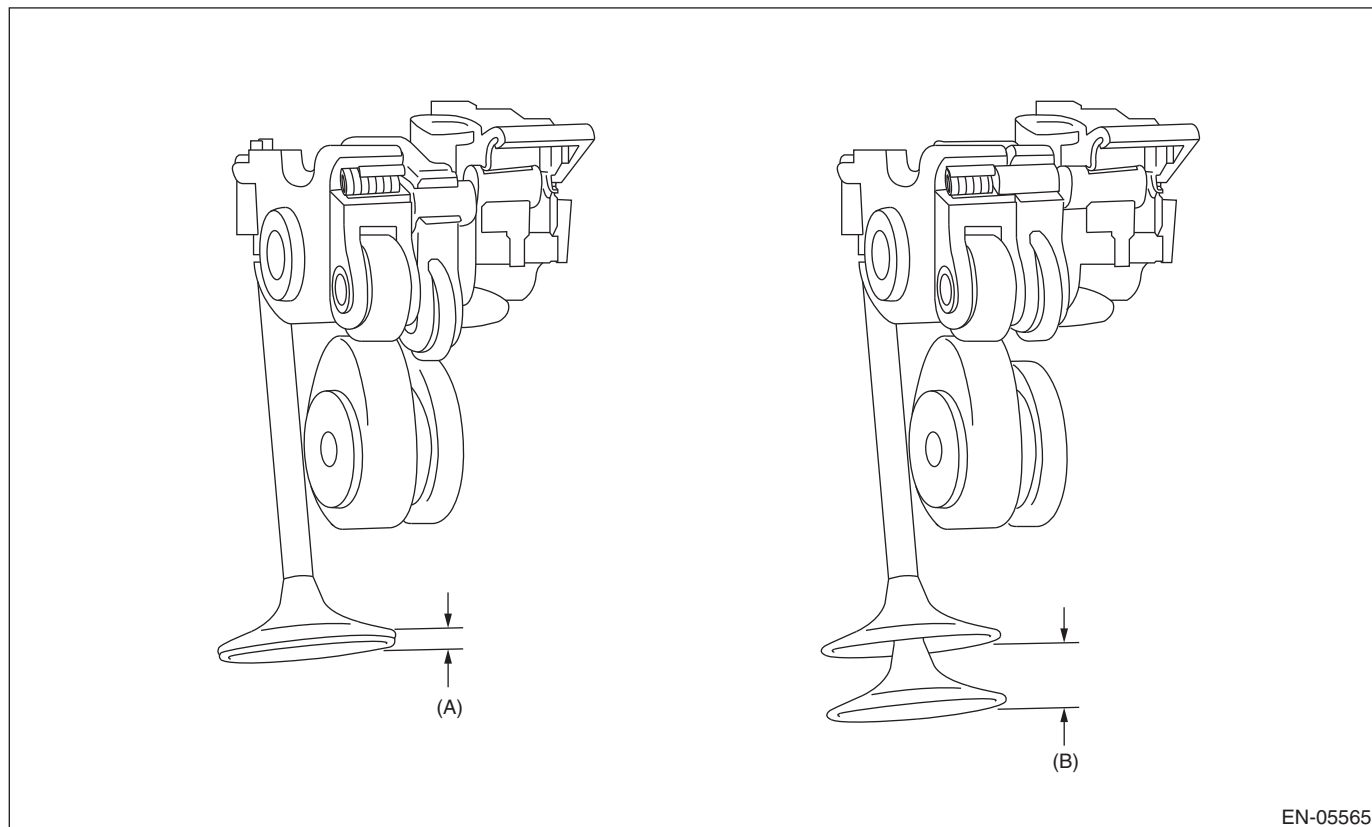

EN-05565

(A) Low lift

(B) High lift

Diagnostic Trouble Code (DTC) Detecting Criteria

GENERAL DESCRIPTION

3. ENABLE CONDITION

Secondary Parameters	Enable Conditions
Battery voltage	≥ 10.9 V
After engine starting	≥ 6000 ms
Engine oil temperature	≥ 15 °C (59 °F)
Variable valve lift control	Operation

4. GENERAL DRIVING CYCLE

Perform the diagnosis continuously 6 seconds after engine start while variable valve lift is being controlled.

5. DIAGNOSTIC METHOD

• Abnormality Judgement

If the duration of time while the following conditions are met is longer than the time indicated, judge as NG.

Judgement Value

Malfunction Criteria	Threshold Value
Low	
Duty ratio	≥ 62 %
Variable valve lift diagnosis oil pressure switch	ON
High	
Duty ratio	< 33 %
Variable valve lift diagnosis oil pressure switch	OFF

Time Needed for Diagnosis:

Low side: 784 ms

High side: 3000 ms

Malfunction Indicator Light Illumination: Illuminates as soon as a malfunction occurs.

• Normality Judgement

Judge as OK and clear the NG if the continuous time while the following conditions are established is more than the predetermined time.

Judgement Value

Malfunction Criteria	Threshold Value
Low	
Duty ratio	≥ 62 %
Variable valve lift diagnosis oil pressure switch	OFF
High	
Duty ratio	< 33 %
Variable valve lift diagnosis oil pressure switch	ON

Time Needed for Diagnosis:

Low side: 208 ms

High side: 3000 ms

Diagnostic Trouble Code (DTC) Detecting Criteria

GENERAL DESCRIPTION

B: DTC P0028 INTAKE VALVE CONTROL SOLENOID CIRCUIT RANGE/ PERFORMANCE (BANK 2)

1. OUTLINE OF DIAGNOSIS

NOTE:

For the detection standard, refer to DTC P0026. <Ref. to GD(H4SO)-8, DTC P0026 INTAKE VALVE CONTROL SOLENOID CIRCUIT RANGE/PERFORMANCE (BANK 1), Diagnostic Trouble Code (DTC) Detecting Criteria.>

C: DTC P0030 HO2S HEATER CONTROL CIRCUIT (BANK 1 SENSOR 1)

1. OUTLINE OF DIAGNOSIS

Detect functional errors of the front oxygen (A/F) sensor heater.

Judge as NG when it is determined that the front oxygen (A/F) sensor impedance is large when looking at engine status such as deceleration fuel cut.

2. COMPONENT DESCRIPTION

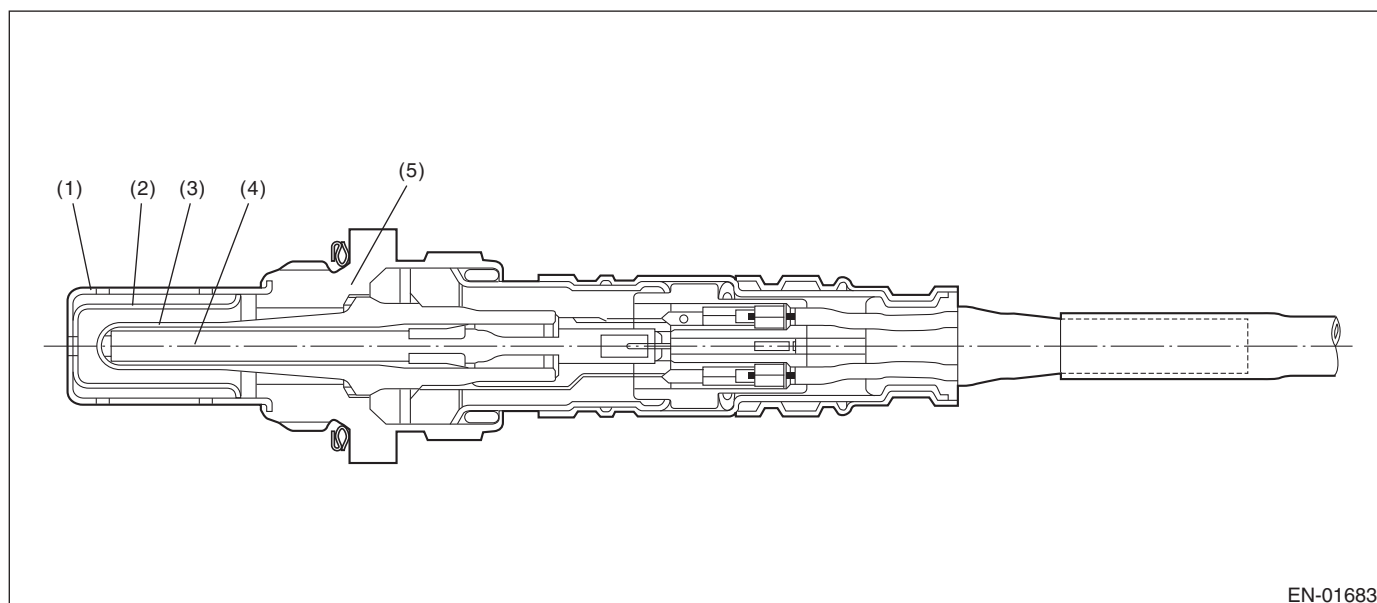

(1) Element cover (outer)

(2) Element cover (inner)

(3) Sensor element

(4) Ceramic heater

(5) Sensor housing

3. ENABLE CONDITION

Secondary Parameters	Enable Conditions
Condition established time	≥ 42000 ms
Battery voltage	≥ 10.9 V
Heater current	Permitted
Control duty ≥ 35 %	Experienced
After fuel cut	≥ 20000 ms

4. GENERAL DRIVING CYCLE

Perform the diagnosis continuously after 42000 ms seconds or more have passed since the engine started.

Diagnostic Trouble Code (DTC) Detecting Criteria

GENERAL DESCRIPTION

5. DIAGNOSTIC METHOD

• Abnormality Judgement

If the duration of time while the following conditions are met is longer than the time indicated, judge as NG.

Judgement Value

Malfunction Criteria	Threshold Value
Front oxygen (A/F) sensor impedance	> 50 Ω

Time Needed for Diagnosis:10000 ms

Malfunction Indicator Light Illumination: Illuminates when malfunction occurs in 2 continuous driving cycles.

• Normality Judgement

Judge as OK and clear the NG if the continuous time while the following conditions are established is more than the predetermined time.

Judgement Value

Malfunction Criteria	Threshold Value
Front oxygen (A/F) sensor impedance	\leq 50 Ω

Time Needed for Diagnosis:10000 ms

Diagnostic Trouble Code (DTC) Detecting Criteria

GENERAL DESCRIPTION

D: DTC P0031 HO2S HEATER CONTROL CIRCUIT LOW (BANK 1 SENSOR 1)

1. OUTLINE OF DIAGNOSIS

Detect front oxygen (A/F) sensor heater open or short circuit.

The front oxygen (A/F) sensor heater performs duty control, and the output terminal voltage at ON is 0 V, and the output terminal voltage at OFF is the battery voltage.

Judge as NG when the terminal voltage remains Low.

2. COMPONENT DESCRIPTION

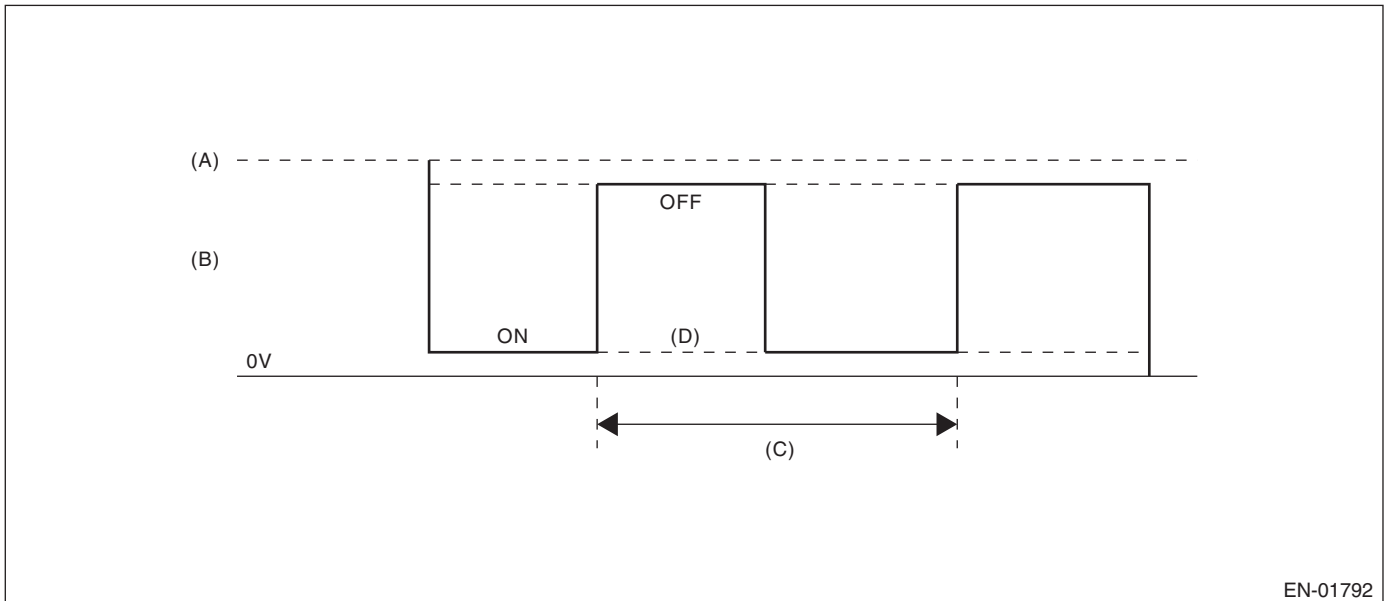

EN-01792

(A) Battery voltage

(B) Front oxygen (A/F) sensor heater
output voltage

(C) 128 milliseconds

(D) Low error

3. ENABLE CONDITION

Secondary Parameters	Enable Conditions
Battery voltage	$\geq 10.9 \text{ V}$

4. GENERAL DRIVING CYCLE

Always perform the diagnosis continuously.

Diagnostic Trouble Code (DTC) Detecting Criteria

GENERAL DESCRIPTION

5. DIAGNOSTIC METHOD

• Abnormality Judgement

If the duration of time while the following conditions are met is longer than the time indicated, judge as NG.

Judgement Value

Malfunction Criteria	Threshold Value
Output voltage level	Low
Front oxygen (A/F) sensor heater control duty	< 87.5 %

Time Needed for Diagnosis: 4 ms × 250 time(s)

Malfunction Indicator Light Illumination: Illuminates as soon as a malfunction occurs.

• Normality Judgement

Judge as OK and clear the NG if the continuous time while the following conditions are established is more than the predetermined time.

Judgement Value

Malfunction Criteria	Threshold Value
Output voltage level	High

Time Needed for Diagnosis: Less than 1 second

Diagnostic Trouble Code (DTC) Detecting Criteria

GENERAL DESCRIPTION

E: DTC P0032 HO2S HEATER CONTROL CIRCUIT HIGH (BANK 1 SENSOR 1)

1. OUTLINE OF DIAGNOSIS

Detect front oxygen (A/F) sensor heater open or short circuit.

The front oxygen (A/F) sensor heater performs duty control, and the output terminal voltage at ON is 0 V, and the output terminal voltage at OFF is the battery voltage.

Judge as NG when the terminal voltage remains High.

2. COMPONENT DESCRIPTION

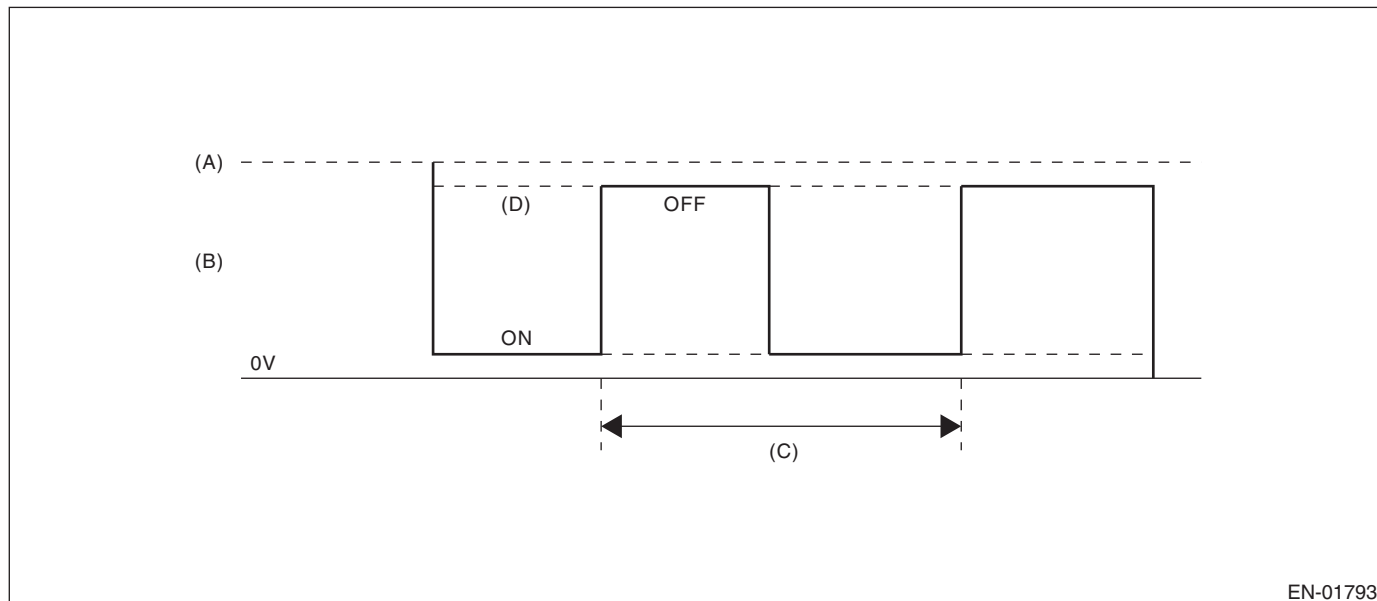

EN-01793

(A) Battery voltage

(B) Front oxygen (A/F) sensor heater
output voltage

(C) 128 milliseconds

(D) High error

3. ENABLE CONDITION

Secondary Parameters	Enable Conditions
Battery voltage	$\geq 10.9 \text{ V}$

4. GENERAL DRIVING CYCLE

Always perform the diagnosis continuously.

Diagnostic Trouble Code (DTC) Detecting Criteria

GENERAL DESCRIPTION

5. DIAGNOSTIC METHOD

• Abnormality Judgement

If the duration of time while the following conditions are met is longer than the time indicated, judge as NG.

Judgement Value

Malfunction Criteria	Threshold Value
Output voltage level	High
Front oxygen (A/F) sensor heater control duty	≥ 12.5 %

Time Needed for Diagnosis: 4 ms × 500 time(s)

Malfunction Indicator Light Illumination: Illuminates as soon as a malfunction occurs.

• Normality Judgement

Judge as OK and clear the NG if the continuous time while the following conditions are established is more than the predetermined time.

Judgement Value

Malfunction Criteria	Threshold Value
Output voltage level	Low

Time Needed for Diagnosis: Less than 1 second

Diagnostic Trouble Code (DTC) Detecting Criteria

GENERAL DESCRIPTION

F: DTC P0037 HO2S HEATER CONTROL CIRCUIT LOW (BANK 1 SENSOR 2)

1. OUTLINE OF DIAGNOSIS

Detect the rear oxygen sensor heater open or short circuit.

The rear oxygen sensor heater performs duty control, and the output terminal voltage at ON is 0 V, and the output terminal voltage at OFF is the battery voltage.

Judge as NG when the terminal voltage remains Low.

2. COMPONENT DESCRIPTION

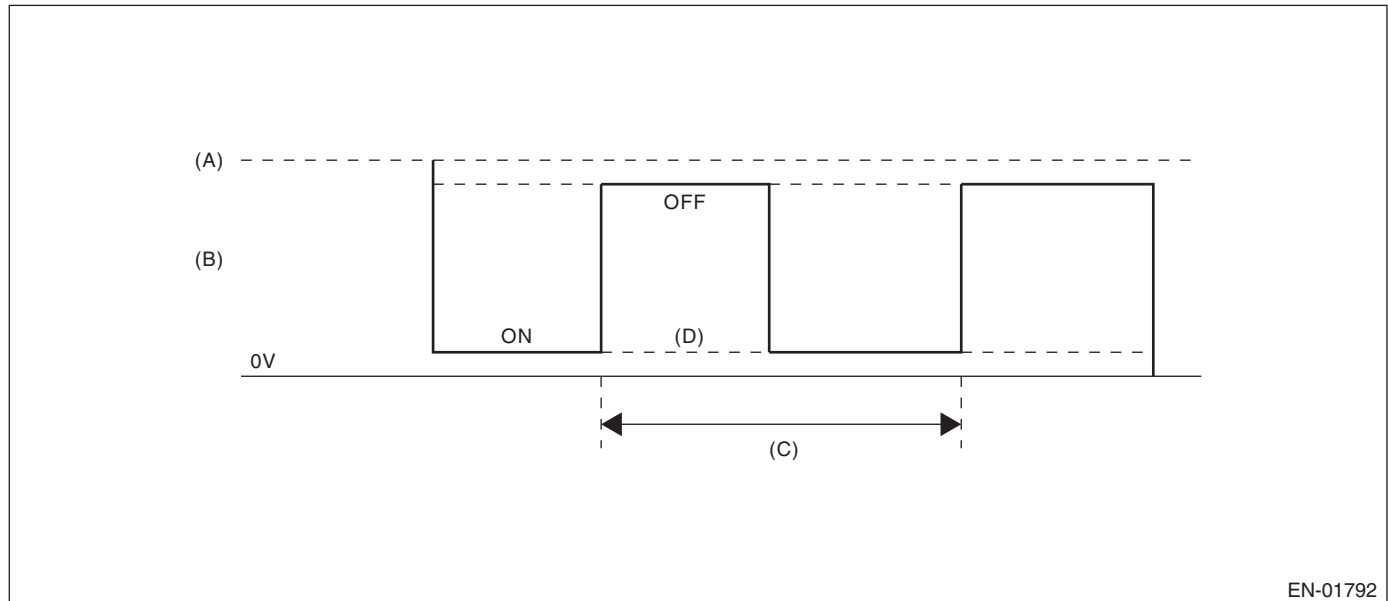

(A) Battery voltage

(B) Output voltage of the rear oxygen sensor heater

(C) 256 milliseconds (cycles)

(D) Low error

3. ENABLE CONDITION

Secondary Parameters	Enable Conditions
Battery voltage	$\geq 10.9 \text{ V}$
Elapsed time after engine starting	$\geq 1 \text{ second}$
Engine speed	$< 8000 \text{ rpm}$

4. GENERAL DRIVING CYCLE

After starting the engine, perform the diagnosis continuously when engine speed is low.

Diagnostic Trouble Code (DTC) Detecting Criteria

GENERAL DESCRIPTION

5. DIAGNOSTIC METHOD

• Abnormality Judgement

If the duration of time while the following conditions are met is longer than the time indicated, judge as NG.

Judgement Value

Malfunction Criteria	Threshold Value
Output voltage level	Low
Rear oxygen sensor heater control duty	< 75 %

Time Needed for Diagnosis: 8 ms × 320 time(s)

Malfunction Indicator Light Illumination: Illuminates when malfunction occurs in 2 continuous driving cycles.

• Normality Judgement

Judge as OK and clear the NG if the continuous time while the following conditions are established is more than the predetermined time.

Judgement Value

Malfunction Criteria	Threshold Value
Output voltage level	High

Time Needed for Diagnosis: Less than 1 second

Diagnostic Trouble Code (DTC) Detecting Criteria

GENERAL DESCRIPTION

G: DTC P0038 HO2S HEATER CONTROL CIRCUIT HIGH (BANK 1 SENSOR 2)

1. OUTLINE OF DIAGNOSIS

Detect the rear oxygen sensor heater open or short circuit.

The rear oxygen sensor heater performs duty control, and the output terminal voltage at ON is 0 V, and the output terminal voltage at OFF is the battery voltage.

Judge as NG when the terminal voltage remains High.

2. COMPONENT DESCRIPTION

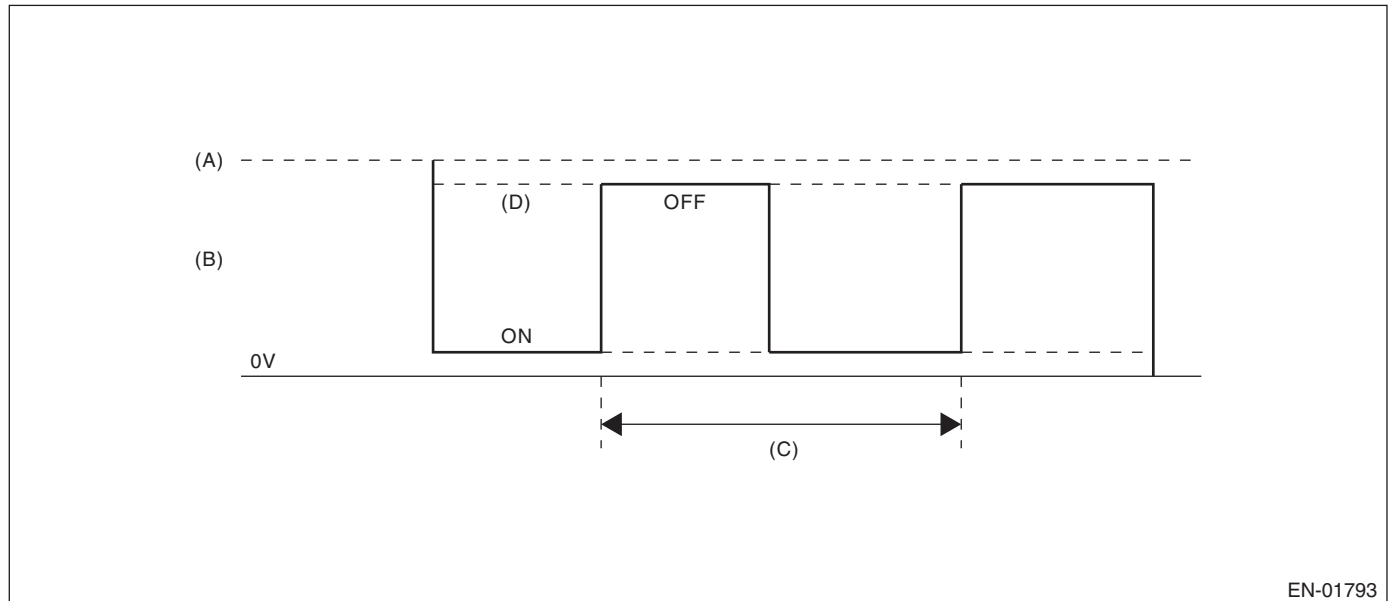

EN-01793

(A) Battery voltage

(B) Output voltage of the rear oxygen sensor heater

(C) 256 milliseconds (cycles)

(D) High error

3. ENABLE CONDITION

Secondary Parameters	Enable Conditions
Battery voltage	≥ 10.9 V
Elapsed time after engine starting	≥ 1 second
Engine speed	< 8000 rpm

4. GENERAL DRIVING CYCLE

After starting the engine, perform the diagnosis continuously when engine speed is low speed.

Diagnostic Trouble Code (DTC) Detecting Criteria

GENERAL DESCRIPTION

5. DIAGNOSTIC METHOD

• Abnormality Judgement

If the duration of time while the following conditions are met is longer than the time indicated, judge as NG.

Judgement Value

Malfunction Criteria	Threshold Value
Output voltage level	High
Rear oxygen sensor heater control duty	≥ 20 %

Time Needed for Diagnosis: 8 ms × 320 time(s)

Malfunction Indicator Light Illumination: Illuminates when malfunction occurs in 2 continuous driving cycles.

• Normality Judgement

Judge as OK and clear the NG if the continuous time while the following conditions are established is more than the predetermined time.

Judgement Value

Malfunction Criteria	Threshold Value
Output voltage level	Low

Time Needed for Diagnosis: Less than 1 second

Diagnostic Trouble Code (DTC) Detecting Criteria

GENERAL DESCRIPTION

H: DTC P0068 MAP/MAF - THROTTLE POSITION CORRELATION

1. OUTLINE OF DIAGNOSIS

Detect problems in the intake manifold pressure sensor output properties.

Judge as NG when the intake air pressure AD value is Low whereas it seemed to be High from the viewpoint of engine condition, or when it is High whereas it seemed to be Low from the engine condition.

2. COMPONENT DESCRIPTION

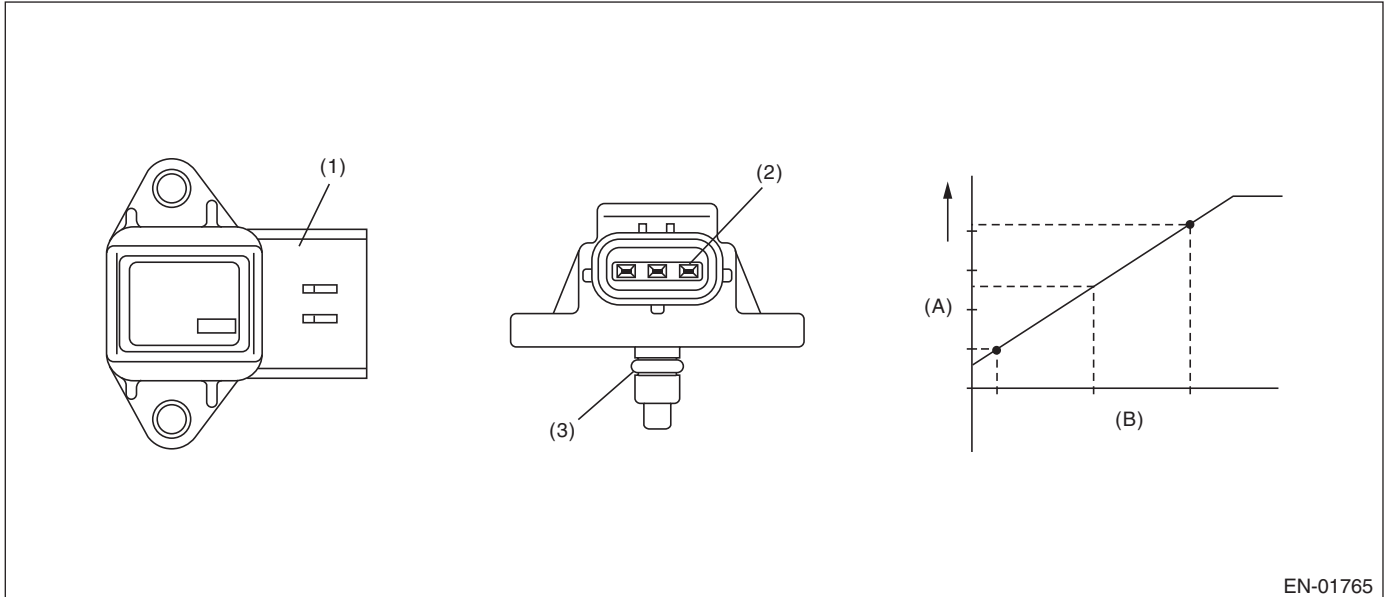

EN-01765

(A) Output voltage

(B) Absolute pressure

(1) Connector

(2) Terminals

(3) O-ring

3. ENABLE CONDITION

Secondary Parameters	Enable Conditions
Engine coolant temperature	$\geq 75\text{ }^{\circ}\text{C}$ (167 $^{\circ}\text{F}$)

4. GENERAL DRIVING CYCLE

Perform the diagnosis continuously after idling.

Diagnostic Trouble Code (DTC) Detecting Criteria

GENERAL DESCRIPTION

5. DIAGNOSTIC METHOD

• Abnormality Judgement

Judge as NG when Low side or High side becomes NG.

If the duration of time while the following conditions are met is longer than the time indicated, judge as NG.

Judgement Value

Malfunction Criteria	Threshold Value
Low	
Engine speed	< 2500 rpm
Throttle position	$\geq 12^\circ$
Output voltage	< 1.63 V
Engine load	> 0.6 g/rev (0.02 oz/rev)
High	
Engine speed	600 rpm — 900 rpm
Throttle position	< 2.44 °
Output voltage	≥ 3.4 V
Engine load	< 0.4 g/rev (0.01 oz/rev)

Time Needed for Diagnosis:

Low side: 3000 ms

High side: 7000 ms

Malfunction Indicator Light Illumination: Illuminates when malfunction occurs in 2 continuous driving cycles.

• Normality Judgement

Judge as OK and clear the NG when both Low side and High side become OK.

If the duration of time while the following conditions are met is longer than the time indicated, judge as OK.

Judgement Value

Malfunction Criteria	Threshold Value
Low	
Engine speed	< 2500 rpm
Throttle position	$\geq 12^\circ$
Output voltage	≥ 1.63 V
Engine load	> 0.6 g/rev (0.02 oz/rev)
High	
Engine speed	600 rpm — 900 rpm
Throttle position	< 2.44 °
Output voltage	< 3.4 V
Engine load	< 0.4 g/rev (0.01 oz/rev)

Time Needed for Diagnosis:

Low side: Less than 1 second

High side: Less than 1 second

Diagnostic Trouble Code (DTC) Detecting Criteria

GENERAL DESCRIPTION

I: DTC P0076 INTAKE VALVE CONTROL SOLENOID CIRCUIT LOW (BANK 1)

1. OUTLINE OF DIAGNOSIS

Detect the open circuit of the oil switching solenoid valve.

Judge as NG when the current is small even though the output duty is large.

2. ENABLE CONDITION

Secondary Parameters	Enable Conditions
Battery voltage	≥ 10.9 V

3. GENERAL DRIVING CYCLE

Always perform the diagnosis continuously.

4. DIAGNOSTIC METHOD

• Abnormality Judgement

If the duration of time while the following conditions are met is longer than the time indicated, judge as NG.

Judgement Value

Malfunction Criteria	Threshold Value
Duty ratio	≥ 30 %
Control current	< 0.026 A

Time Needed for Diagnosis:2000 ms

Malfunction Indicator Light Illumination: Illuminates as soon as a malfunction occurs.

• Normality Judgement

Judge as OK and clear the NG if the continuous time while the following conditions are established is more than the predetermined time.

Judgement Value

Malfunction Criteria	Threshold Value
Oil switching solenoid valve target current value – Oil switching solenoid valve current value	< 0.08 A
Target current	≥ 0.11 A

Time Needed for Diagnosis:2000 ms

Diagnostic Trouble Code (DTC) Detecting Criteria

GENERAL DESCRIPTION

J: DTC P0077 INTAKE VALVE CONTROL SOLENOID CIRCUIT HIGH (BANK 1)

1. OUTLINE OF DIAGNOSIS

Detect short circuits of the oil switching solenoid valve.

Judge as a short NG when the current is large even though the output duty is small.

2. ENABLE CONDITION

Secondary Parameters	Enable Conditions
Battery voltage	≥ 10.9 V

3. GENERAL DRIVING CYCLE

Always perform the diagnosis continuously.

4. DIAGNOSTIC METHOD

• Abnormality Judgement

If the duration of time while the following conditions are met is longer than the time indicated, judge as NG.

Judgement Value

Malfunction Criteria	Threshold Value
Duty ratio	< 7 %
Control current	≥ 0.465 A

Time Needed for Diagnosis:2000 ms

Malfunction Indicator Light Illumination: Illuminates as soon as a malfunction occurs.

• Normality Judgement

Judge as OK and clear the NG if the continuous time while the following conditions are established is more than the predetermined time.

Judgement Value

Malfunction Criteria	Threshold Value
Oil switching solenoid valve target current value – Oil switching solenoid valve current value	< 0.08 A

Time Needed for Diagnosis:2000 ms

Diagnostic Trouble Code (DTC) Detecting Criteria

GENERAL DESCRIPTION

K: DTC P0082 INTAKE VALVE CONTROL SOLENOID CIRCUIT LOW (BANK 2)

1. OUTLINE OF DIAGNOSIS

NOTE:

For the detection standard, refer to DTC P0076. <Ref. to GD(H4SO)-22, DTC P0076 INTAKE VALVE CONTROL SOLENOID CIRCUIT LOW (BANK 1), Diagnostic Trouble Code (DTC) Detecting Criteria.>

L: DTC P0083 INTAKE VALVE CONTROL SOLENOID CIRCUIT HIGH (BANK 2)

1. OUTLINE OF DIAGNOSIS

NOTE:

For the detection standard, refer to DTC P0077. <Ref. to GD(H4SO)-23, DTC P0077 INTAKE VALVE CONTROL SOLENOID CIRCUIT HIGH (BANK 1), Diagnostic Trouble Code (DTC) Detecting Criteria.>

Diagnostic Trouble Code (DTC) Detecting Criteria

GENERAL DESCRIPTION

M: DTC P0101 MASS OR VOLUME AIR FLOW CIRCUIT RANGE/PERFORMANCE

1. OUTLINE OF DIAGNOSIS

Detect the malfunction of air flow sensor output properties.

Judge as a low side NG when the air flow voltage indicates a small value regardless of running in a state where the air flow voltage increases. Judge as a high side NG when the air flow voltage indicates a large value regardless of running in a state where the air flow voltage decreases. Judge air flow sensor property NG when the Low side or High side becomes NG.

2. COMPONENT DESCRIPTION

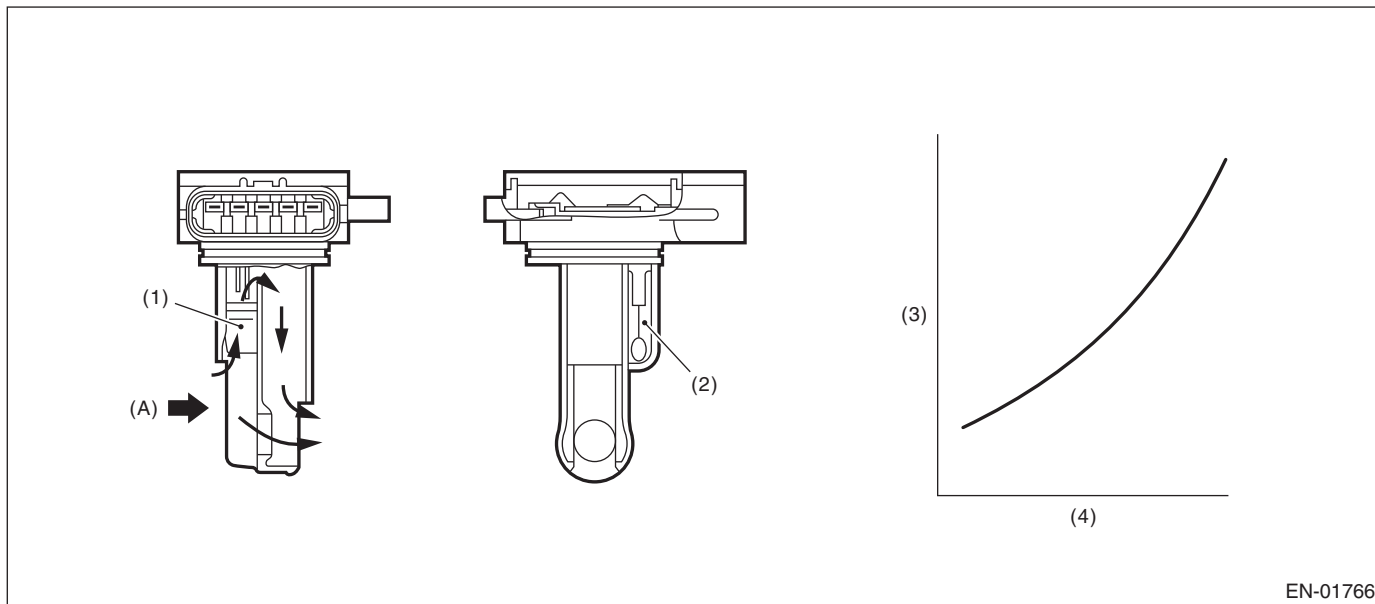

EN-01766

(A) Air

(1) Air flow sensor

(2) Intake air temperature sensor

(3) Voltage (V)

(4) Amount of intake air (kg (lb)/s)

3. ENABLE CONDITION

Secondary Parameters	Enable Conditions
Engine coolant temperature	$\geq 75\text{ }^{\circ}\text{C}$ (167 °F)

4. GENERAL DRIVING CYCLE

Perform the diagnosis continuously after idling.

Diagnostic Trouble Code (DTC) Detecting Criteria

GENERAL DESCRIPTION

5. DIAGNOSTIC METHOD

• Abnormality Judgement

Judge as NG when Low side or High side becomes NG.

If the duration of time while the following conditions are met is longer than the time indicated, judge as NG.

Judgement Value

Malfunction Criteria	Threshold Value
Low	
Output voltage	< 1.49 V
Engine speed	≥ 2000 rpm
Throttle opening angle	≥ 12 °
Intake manifold pressure	≥ 66.7 kPa (500 mmHg, 19.7 inHg)
High (1)	
Output voltage	≥ 2.66 V
Engine speed	600 rpm — 900 rpm
Throttle opening angle	< 2.44 °
Intake manifold pressure	< 40 kPa (300 mmHg, 11.8 inHg)
High (2)	
Output voltage	≥ 1.45 V
Engine speed	600 rpm — 900 rpm
Throttle opening angle	< 2.44 °
Intake manifold pressure	< 40 kPa (300 mmHg, 11.8 inHg)
Fuel system diagnosis	Rich side malfunction

Time Needed for Diagnosis:

Low: 5000 ms

High: 10000 ms

Malfunction Indicator Light Illumination: Illuminates when malfunction occurs in 2 continuous driving cycles.

• Normality Judgement

Judge as OK and clear the NG when both Low side and High side become OK.

Judge as OK and clear the NG if the continuous time while the following conditions are established is more than the predetermined time.

Judgement Value

Malfunction Criteria	Threshold Value
Low	
Output voltage	≥ 1.49 V
Engine speed	≥ 2000 rpm
Throttle opening angle	≥ 12 °
Intake manifold pressure	≥ 66.7 kPa (500 mmHg, 19.7 inHg)
High	
Output voltage	< 2.66 V
Engine speed	600 rpm — 900 rpm
Throttle opening angle	< 2.44 °
Intake manifold pressure	< 40 kPa (300 mmHg, 11.8 inHg)
Fuel system diagnosis	Rich side normal

Time Needed for Diagnosis:

Low: Less than 1 second

High: Less than 1 second

Diagnostic Trouble Code (DTC) Detecting Criteria

GENERAL DESCRIPTION

N: DTC P0102 MASS OR VOLUME AIR FLOW CIRCUIT LOW INPUT

1. OUTLINE OF DIAGNOSIS

Detect open or short circuits of the air flow sensor.

Judge as NG if out of specification.

2. COMPONENT DESCRIPTION

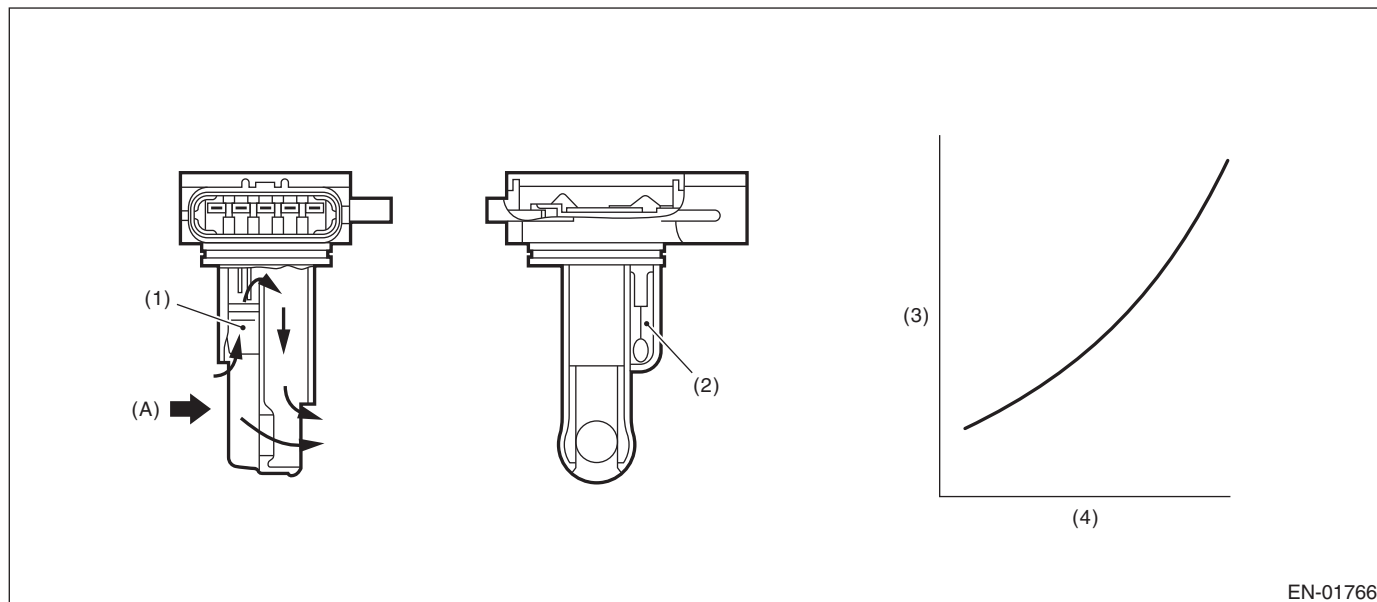

EN-01766

(A) Air

(1) Air flow sensor

(3) Voltage (V)

(4) Amount of intake air (kg (lb)/s)

(2) Intake air temperature sensor

3. ENABLE CONDITION

Secondary Parameters	Enable Conditions
None	

4. GENERAL DRIVING CYCLE

Always perform the diagnosis continuously.

5. DIAGNOSTIC METHOD

• Abnormality Judgement

If the duration of time while the following conditions are met is longer than the time indicated, judge as NG.

Judgement Value

Malfunction Criteria	Threshold Value
Output voltage	≤ 0.22 V

Time Needed for Diagnosis: 500 ms

Malfunction Indicator Light Illumination: Illuminates as soon as a malfunction occurs.

• Normality Judgement

Judge as OK and clear the NG if the continuous time while the following conditions are established is more than the predetermined time.

Judgement Value

Malfunction Criteria	Threshold Value
Output voltage	> 0.22 V

Time Needed for Diagnosis: Less than 1 second

Diagnostic Trouble Code (DTC) Detecting Criteria

GENERAL DESCRIPTION

O: DTC P0103 MASS OR VOLUME AIR FLOW CIRCUIT HIGH INPUT

1. OUTLINE OF DIAGNOSIS

Detect open or short circuits of the air flow sensor.
Judge as NG if out of specification.

2. COMPONENT DESCRIPTION

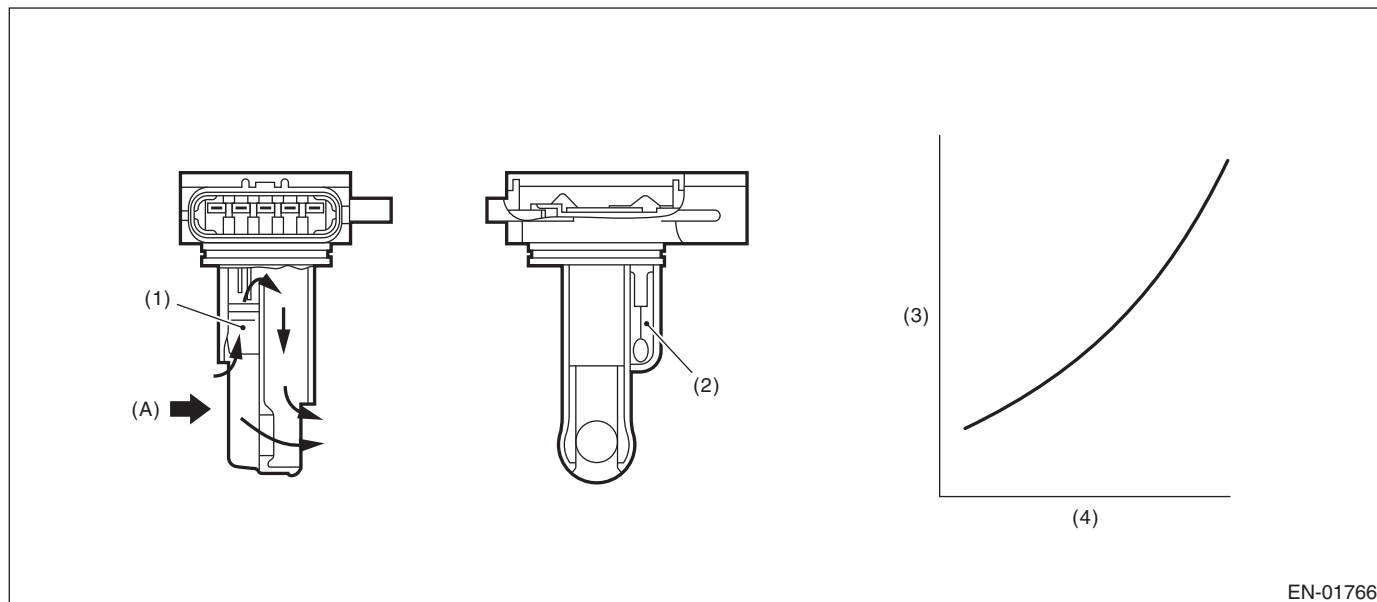

EN-01766

(A) Air

(1) Air flow sensor

(3) Voltage (V)

(4) Amount of intake air (kg (lb)/s)

(2) Intake air temperature sensor

3. ENABLE CONDITION

Secondary Parameters	Enable Conditions
None	

4. GENERAL DRIVING CYCLE

Always perform the diagnosis continuously.

5. DIAGNOSTIC METHOD

• Abnormality Judgement

If the duration of time while the following conditions are met is longer than the time indicated, judge as NG.

Judgement Value

Malfunction Criteria	Threshold Value
Output voltage	≥ 4.179943192 V

Time Needed for Diagnosis: 500 ms

Malfunction Indicator Light Illumination: Illuminates as soon as a malfunction occurs.

• Normality Judgement

Judge as OK and clear the NG if the continuous time while the following conditions are established is more than the predetermined time.

Judgement Value

Malfunction Criteria	Threshold Value
Output voltage	< 4.179943192 V

Time Needed for Diagnosis: Less than 1 second

Diagnostic Trouble Code (DTC) Detecting Criteria

GENERAL DESCRIPTION

P: DTC P0107 MANIFOLD ABSOLUTE PRESSURE/BAROMETRIC PRESSURE CIRCUIT LOW INPUT

1. OUTLINE OF DIAGNOSIS

Detect the open or short circuit of intake manifold pressure sensor.
Judge as NG if out of specification.

2. COMPONENT DESCRIPTION

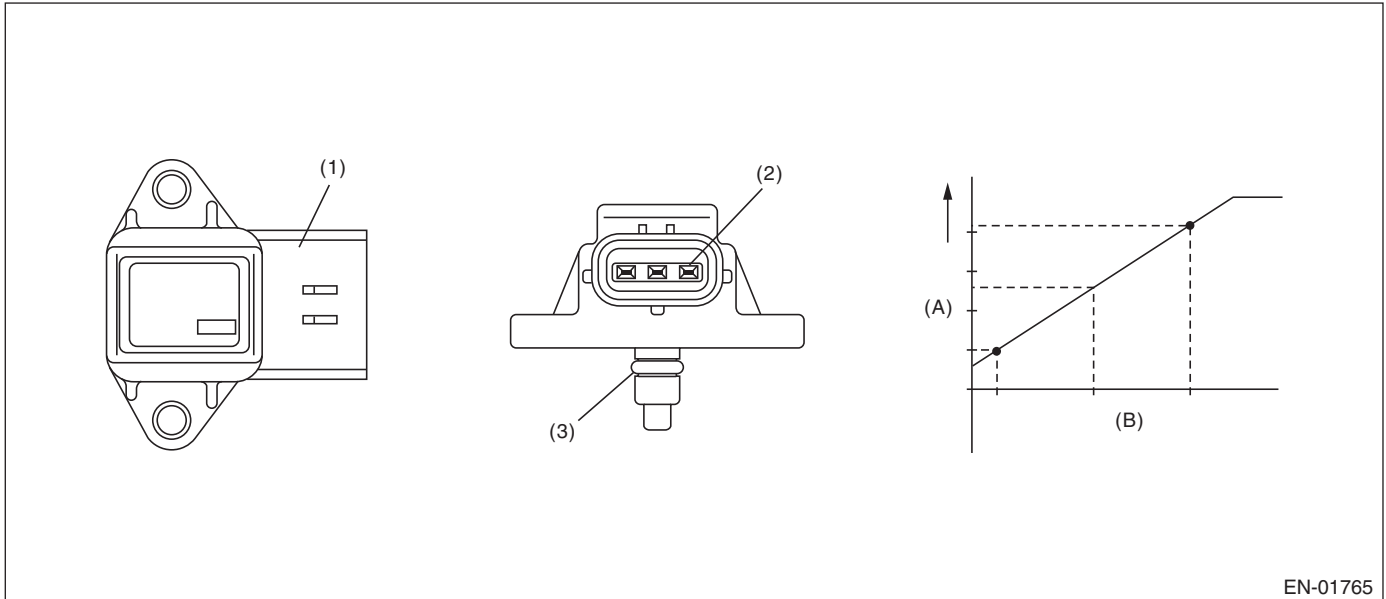

EN-01765

(A) Output voltage

(B) Absolute pressure

(1) Connector

(2) Terminals

(3) O-ring

3. ENABLE CONDITION

Secondary Parameters	Enable Conditions
None	

4. GENERAL DRIVING CYCLE

Always perform the diagnosis continuously.

5. DIAGNOSTIC METHOD

• Abnormality Judgement

If the duration of time while the following conditions are met is longer than the time indicated, judge as NG.

Judgement Value

Malfunction Criteria	Threshold Value
Output voltage	≤ 0.573 V

Time Needed for Diagnosis: 500 ms

Malfunction Indicator Light Illumination: Illuminates as soon as a malfunction occurs.

• Normality Judgement

Judge as OK and clear the NG if the continuous time while the following conditions are established is more than the predetermined time.

Judgement Value

Malfunction Criteria	Threshold Value
Output voltage	> 0.573 V

Time Needed for Diagnosis: Less than 1 second

Diagnostic Trouble Code (DTC) Detecting Criteria

GENERAL DESCRIPTION

Q: DTC P0108 MANIFOLD ABSOLUTE PRESSURE/BAROMETRIC PRESSURE CIRCUIT HIGH INPUT

1. OUTLINE OF DIAGNOSIS

Detect the open or short circuit of intake manifold pressure sensor.

Judge as NG if out of specification.

2. COMPONENT DESCRIPTION

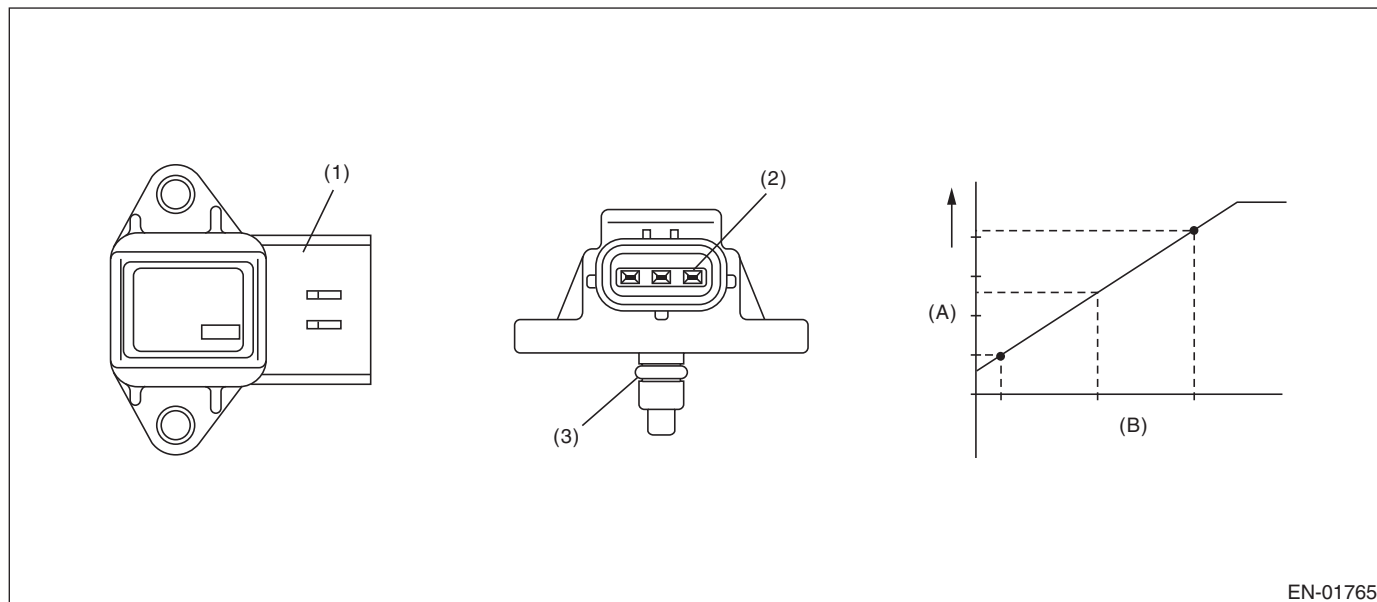

(A) Output voltage

(B) Absolute pressure

(1) Connector

(2) Terminals

(3) O-ring

EN-01765

3. ENABLE CONDITION

Secondary Parameters	Enable Conditions
None	

4. GENERAL DRIVING CYCLE

Always perform the diagnosis continuously.

5. DIAGNOSTIC METHOD

• Abnormality Judgement

If the duration of time while the following conditions are met is longer than the time indicated, judge as NG.

Judgement Value

Malfunction Criteria	Threshold Value
Output voltage	≥ 4.38757221 V

Time Needed for Diagnosis: 500 ms

Malfunction Indicator Light Illumination: Illuminates as soon as a malfunction occurs.

• Normality Judgement

Judge as OK and clear the NG if the continuous time while the following conditions are established is more than the predetermined time.

Judgement Value

Malfunction Criteria	Threshold Value
Output voltage	< 4.38757221 V

Time Needed for Diagnosis: Less than 1 second

Diagnostic Trouble Code (DTC) Detecting Criteria

GENERAL DESCRIPTION

R: DTC P0111 INTAKE AIR TEMPERATURE SENSOR 1 CIRCUIT RANGE/ PERFORMANCE

1. OUTLINE OF DIAGNOSIS

Detect the malfunction of intake air temperature sensor output property.

Judge as NG when the intake air temperature is not varied whereas it seemed to be varied from the viewpoint of engine condition.

2. COMPONENT DESCRIPTION

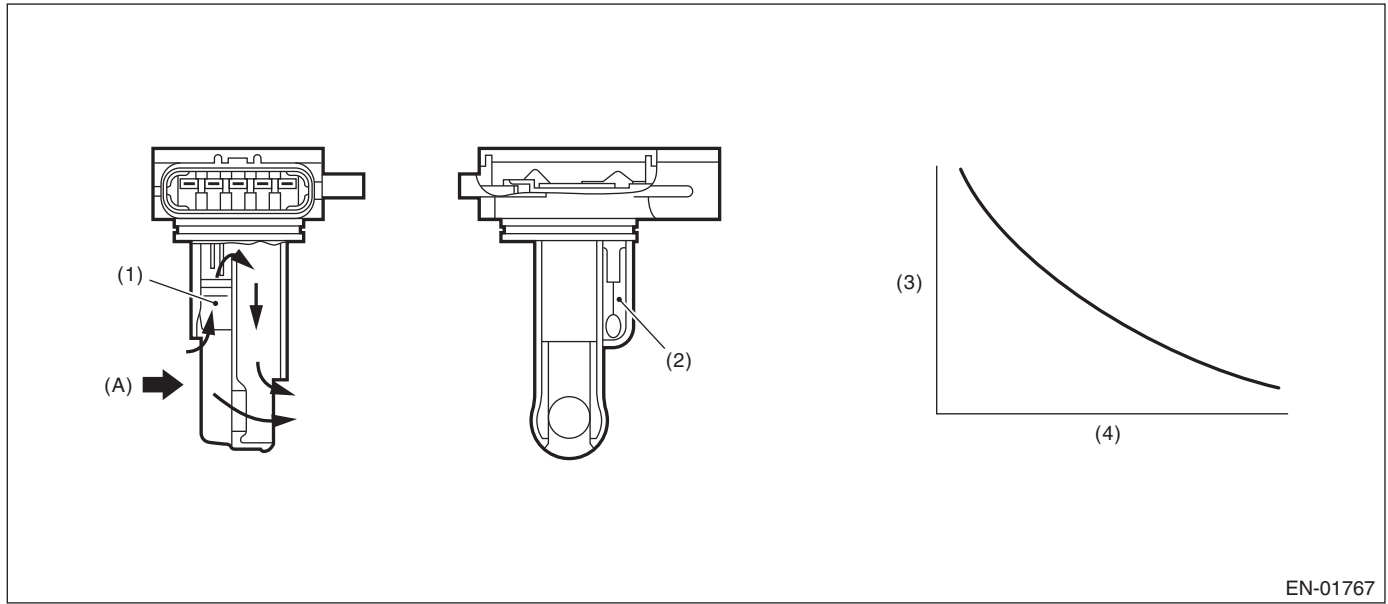

EN-01767

(A) Air

(1) Air flow sensor

(3) Resistance value (Ω)

(4) Intake air temperature $^{\circ}\text{C}$ ($^{\circ}\text{F}$)

(2) Intake air temperature sensor

3. ENABLE CONDITION

Secondary Parameters	Enable Conditions
Engine coolant temperature at engine starting	$< 30\text{ }^{\circ}\text{C}$ ($86\text{ }^{\circ}\text{F}$)
Engine coolant temperature	$\geq 100\text{ }^{\circ}\text{C}$ ($212\text{ }^{\circ}\text{F}$)
Battery voltage	$\geq 10.9\text{ V}$
Continuous time when the vehicle speed is less than 60 km/h (37.3 MPH)	$\geq 600\text{ s}$

4. GENERAL DRIVING CYCLE

Perform the diagnosis when the vehicle speed condition is met after warming up from a cold condition.

Diagnostic Trouble Code (DTC) Detecting Criteria

GENERAL DESCRIPTION

5. DIAGNOSTIC METHOD

• Abnormality Judgement

Judge as NG when the following conditions are established.

Judgement Value

Malfunction Criteria	Threshold Value
Output voltage difference between Max. and Min.	< 0.02 V (Equivalent to approximately 0.5°C (0.9°F) near 25°C)

Time Needed for Diagnosis: Less than 1 second

Malfunction Indicator Light Illumination: Illuminates when malfunction occurs in 2 continuous driving cycles.

• Normality Judgement

Judge as OK and clear the NG if the following conditions are established.

Judgement Value

Malfunction Criteria	Threshold Value
Output voltage difference between Max. and Min.	≥ 0.02 V

Time Needed for Diagnosis: Less than 1 second

S: DTC P0112 INTAKE AIR TEMPERATURE SENSOR 1 CIRCUIT LOW

1. OUTLINE OF DIAGNOSIS

Detect open or short circuit of the intake air temperature sensor.

Judge as NG if out of specification.

2. COMPONENT DESCRIPTION

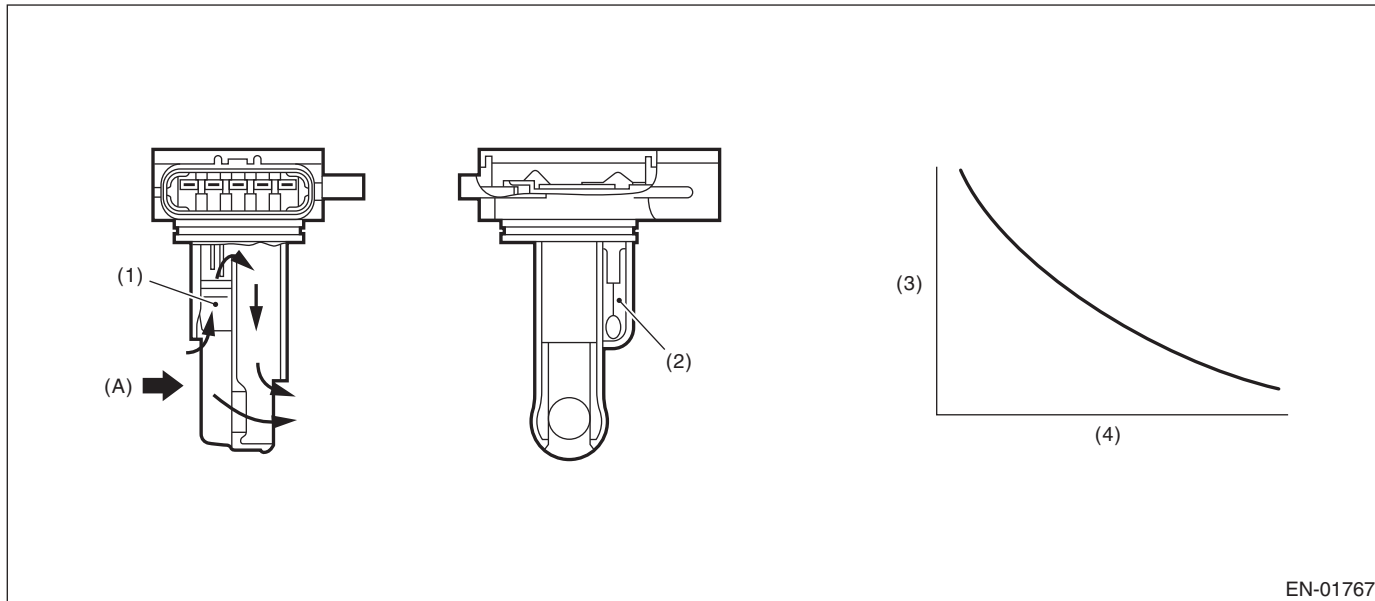

EN-01767

(A) Air

(1) Air flow sensor

(3) Resistance value (Ω)

(4) Intake air temperature °C (°F)

(2) Intake air temperature sensor

3. ENABLE CONDITION

Secondary Parameters	Enable Conditions
None	

4. GENERAL DRIVING CYCLE

Always perform the diagnosis continuously.

5. DIAGNOSTIC METHOD

• Abnormality Judgement

If the duration of time while the following conditions are met is longer than the time indicated, judge as NG.

Judgement Value

Malfunction Criteria	Threshold Value
Output voltage	< 0.230975449 V

Time Needed for Diagnosis: 500 ms

Malfunction Indicator Light Illumination: Illuminates as soon as a malfunction occurs.

• Normality Judgement

Judge as OK and clear the NG if the continuous time while the following conditions are established is more than the predetermined time.

Judgement Value

Malfunction Criteria	Threshold Value
Output voltage	≥ 0.230975449 V

Time Needed for Diagnosis: Less than 1 second

Diagnostic Trouble Code (DTC) Detecting Criteria

GENERAL DESCRIPTION

T: DTC P0113 INTAKE AIR TEMPERATURE SENSOR 1 CIRCUIT HIGH

1. OUTLINE OF DIAGNOSIS

Detect open or short circuit of the intake air temperature sensor.
Judge as NG if out of specification.

2. COMPONENT DESCRIPTION

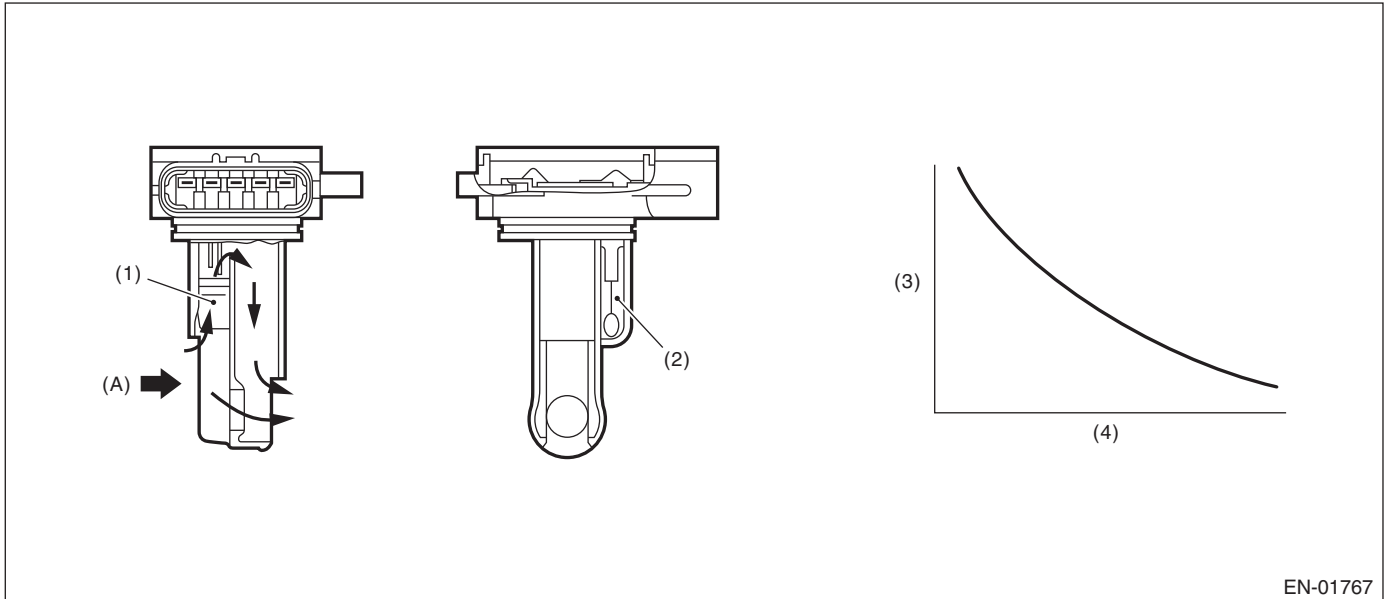

EN-01767

(A) Air

(1) Air flow sensor

(3) Resistance value (Ω)

(4) Intake air temperature °C (°F)

(2) Intake air temperature sensor

3. ENABLE CONDITION

Secondary Parameters	Enable Conditions
None	

4. GENERAL DRIVING CYCLE

Always perform the diagnosis continuously.

5. DIAGNOSTIC METHOD

• Abnormality Judgement

If the duration of time while the following conditions are met is longer than the time indicated, judge as NG.

Judgement Value

Malfunction Criteria	Threshold Value
Output voltage	≥ 4.716 V

Time Needed for Diagnosis: 500 ms

Malfunction Indicator Light Illumination: Illuminates as soon as a malfunction occurs.

• Normality Judgement

Judge as OK and clear the NG if the continuous time while the following conditions are established is more than the predetermined time.

Judgement Value

Malfunction Criteria	Threshold Value
Output voltage	< 4.716 V

Time Needed for Diagnosis: Less than 1 second

U: DTC P0117 ENGINE COOLANT TEMPERATURE CIRCUIT LOW

1. OUTLINE OF DIAGNOSIS

Detect the open or short circuit of the engine coolant temperature sensor.
Judge as NG if out of specification.

2. COMPONENT DESCRIPTION

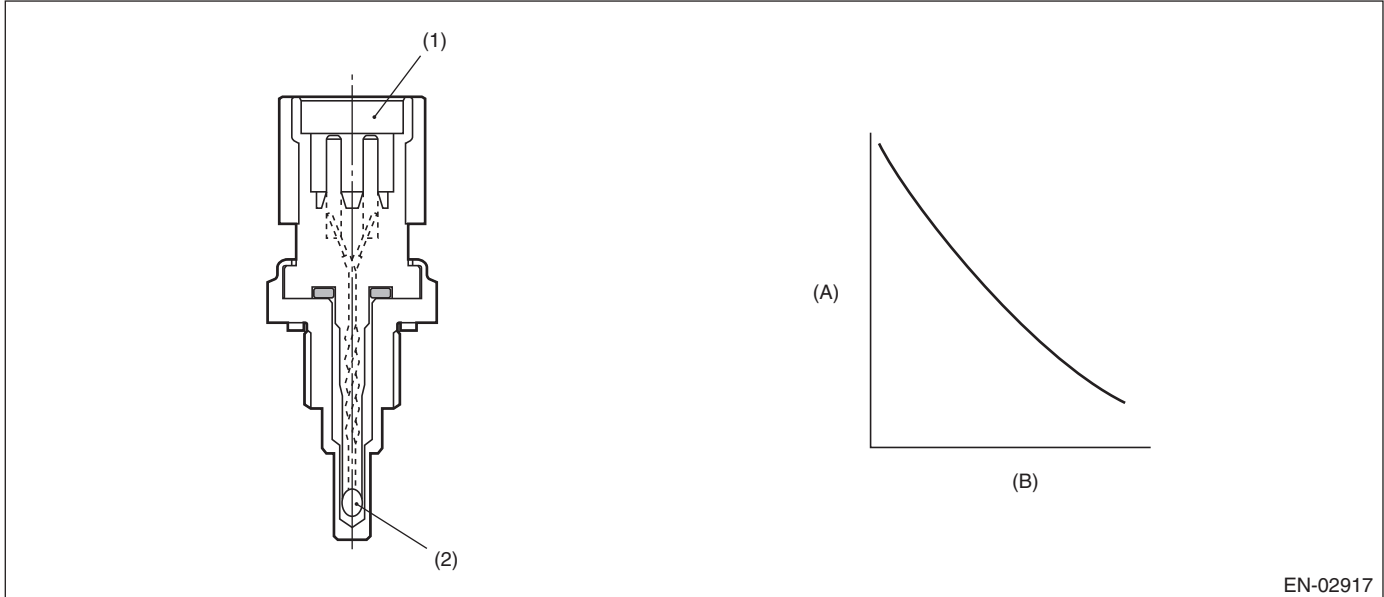

EN-02917

- (A) Resistance value (kΩ) (B) Temperature °C (°F)
- (1) Connector (2) Thermistor element

3. ENABLE CONDITION

Secondary Parameters	Enable Conditions
None	

4. GENERAL DRIVING CYCLE

Always perform the diagnosis continuously.

5. DIAGNOSTIC METHOD

• Abnormality Judgement

If the duration of time while the following conditions are met is longer than the time indicated, judge as NG.

Judgement Value

Malfunction Criteria	Threshold Value
Output voltage	< 0.264738528 V

Time Needed for Diagnosis: 500 ms

Malfunction Indicator Light Illumination: Illuminates as soon as a malfunction occurs.

• Normality Judgement

Judge as OK and clear the NG if the continuous time while the following conditions are established is more than the predetermined time.

Judgement Value

Malfunction Criteria	Threshold Value
Output voltage	≥ 0.264738528 V

Time Needed for Diagnosis: Less than 1 second

Diagnostic Trouble Code (DTC) Detecting Criteria

GENERAL DESCRIPTION

V: DTC P0118 ENGINE COOLANT TEMPERATURE CIRCUIT HIGH

1. OUTLINE OF DIAGNOSIS

Detect the open or short circuit of the engine coolant temperature sensor.
Judge as NG if out of specification.

2. COMPONENT DESCRIPTION

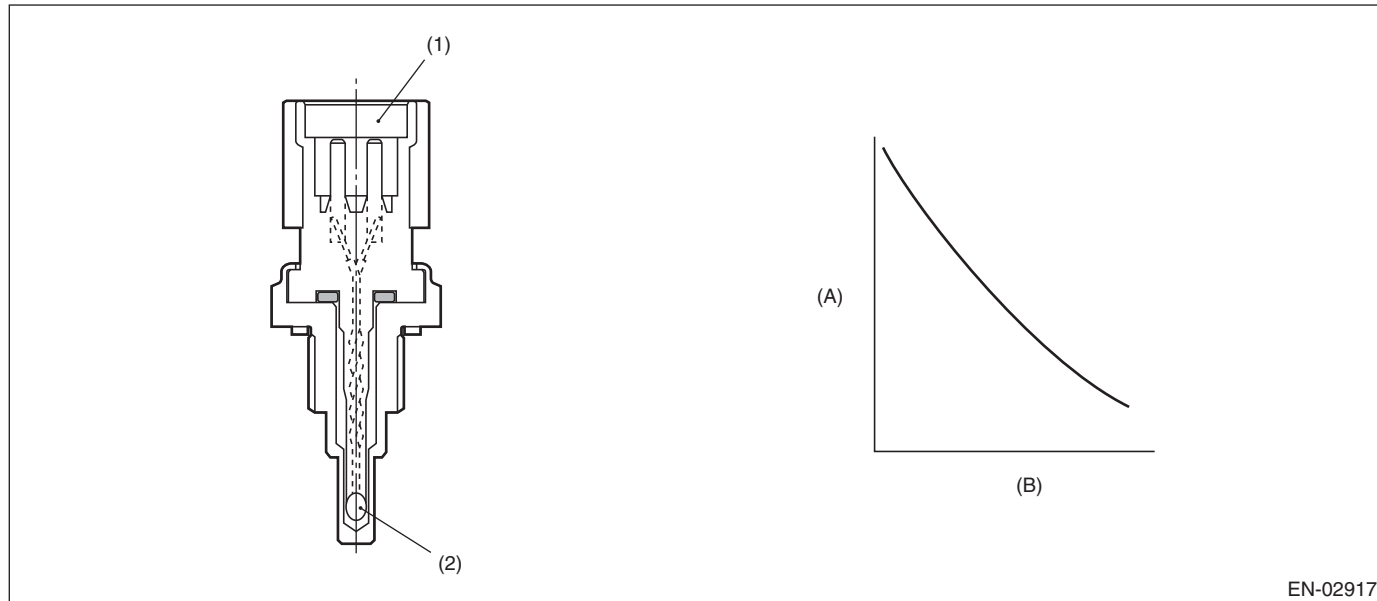

(A) Resistance value (kΩ)

(B) Temperature °C (°F)

(1) Connector

(2) Thermistor element

EN-02917

3. ENABLE CONDITION

Secondary Parameters	Enable Conditions
None	

4. GENERAL DRIVING CYCLE

Always perform the diagnosis continuously.

5. DIAGNOSTIC METHOD

• Abnormality Judgement

If the duration of time while the following conditions are met is longer than the time indicated, judge as NG.

Judgement Value

Malfunction Criteria	Threshold Value
Output voltage	≥ 4.716 V

Time Needed for Diagnosis: 500 ms

Malfunction Indicator Light Illumination: Illuminates as soon as a malfunction occurs.

• Normality Judgement

Judge as OK and clear the NG if the continuous time while the following conditions are established is more than the predetermined time.

Judgement Value

Malfunction Criteria	Threshold Value
Output voltage	< 4.716 V

Time Needed for Diagnosis: Less than 1 second

W: DTC P0122 THROTTLE/PEDAL POSITION SENSOR/SWITCH “A” CIRCUIT LOW

1. OUTLINE OF DIAGNOSIS

Detect the open or short circuit of throttle position sensor 1.
Judge as NG if out of specification.

2. COMPONENT DESCRIPTION

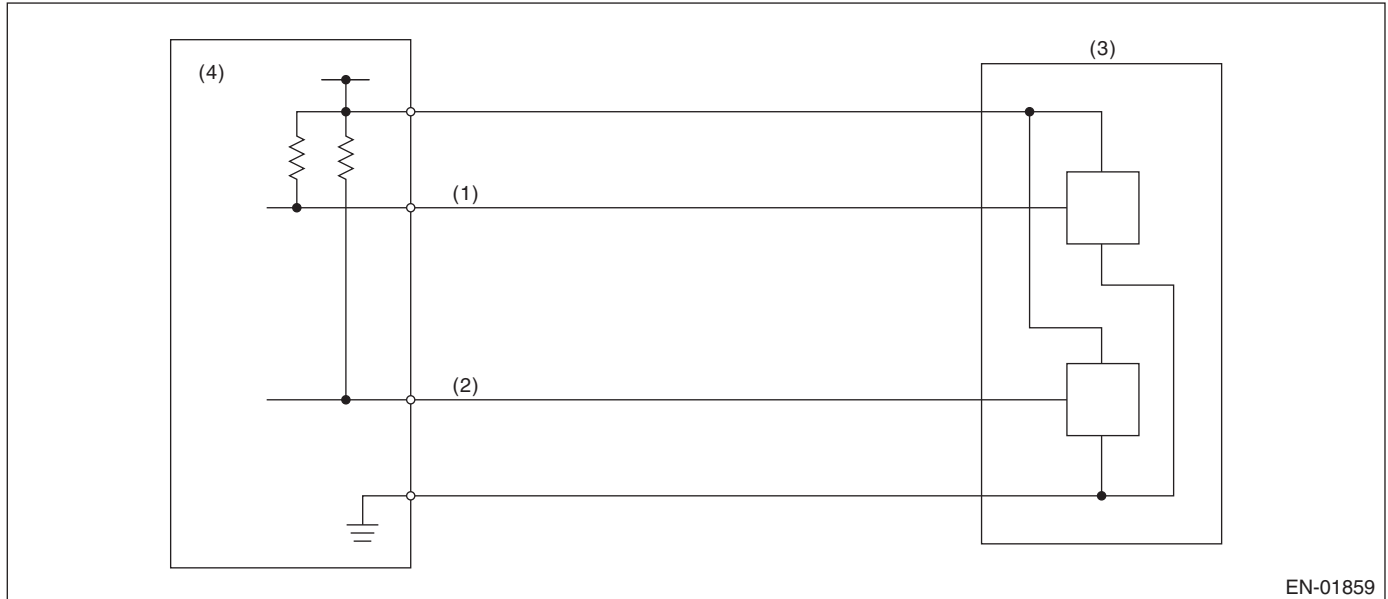

- (1) Throttle position sensor 1 signal (3) Throttle position sensor (4) Engine control module (ECM)
 (2) Throttle position sensor 2 signal

3. ENABLE CONDITION

Secondary Parameters	Enable Conditions
Ignition switch	ON
Battery voltage	≥ 6 V

4. GENERAL DRIVING CYCLE

Always perform the diagnosis continuously.

5. DIAGNOSTIC METHOD

• Abnormality Judgement

If the duration of time while the following conditions are met is longer than the time indicated, judge as NG.

Judgement Value

Malfunction Criteria	Threshold Value
Sensor 1 input voltage	≤ 0.217 V

Time Needed for Diagnosis:24 ms

Malfunction Indicator Light Illumination: Illuminates as soon as a malfunction occurs.

• Normality Judgement

Judge as OK and clear the NG if the continuous time while the following conditions are established is more than the predetermined time.

Judgement Value

Malfunction Criteria	Threshold Value
Sensor 1 input voltage	> 0.217 V

Time Needed for Diagnosis:24 ms

Diagnostic Trouble Code (DTC) Detecting Criteria

GENERAL DESCRIPTION

X: DTC P0123 THROTTLE/PEDAL POSITION SENSOR/SWITCH “A” CIRCUIT HIGH

1. OUTLINE OF DIAGNOSIS

Detect the open or short circuit of throttle position sensor 1.
Judge as NG if out of specification.

2. COMPONENT DESCRIPTION

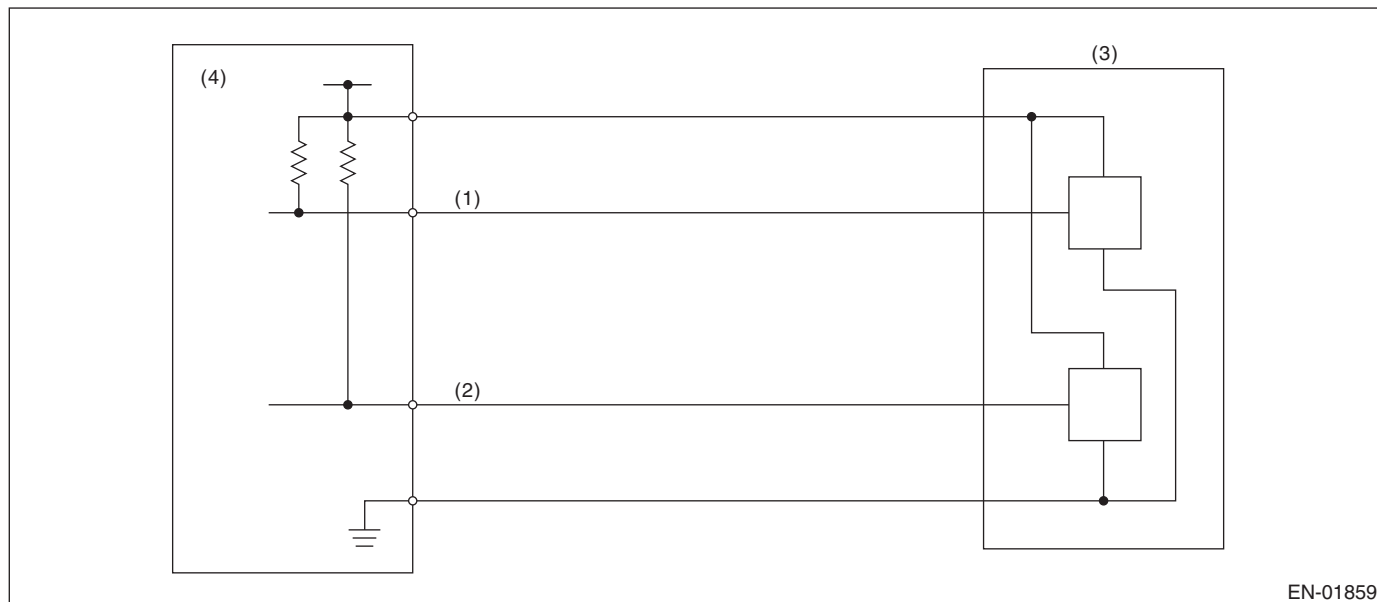

- (1) Throttle position sensor 1 signal (3) Throttle position sensor (4) Engine control module (ECM)
(2) Throttle position sensor 2 signal

3. ENABLE CONDITION

Secondary Parameters	Enable Conditions
Ignition switch	ON
Battery voltage	$\geq 6 \text{ V}$

4. GENERAL DRIVING CYCLE

Always perform the diagnosis continuously.

5. DIAGNOSTIC METHOD

• Abnormality Judgement

If the duration of time while the following conditions are met is longer than the time indicated, judge as NG.

Judgement Value

Malfunction Criteria	Threshold Value
Sensor 1 input voltage	$\geq 4.858 \text{ V}$

Time Needed for Diagnosis: 24 ms

Malfunction Indicator Light Illumination: Illuminates as soon as a malfunction occurs.

• Normality Judgement

Judge as OK and clear the NG if the continuous time while the following conditions are established is more than the predetermined time.

Judgement Value

Malfunction Criteria	Threshold Value
Sensor 1 input voltage	$< 4.858 \text{ V}$

Time Needed for Diagnosis: 24 ms

Y: DTC P0125 INSUFFICIENT COOLANT TEMPERATURE FOR CLOSED LOOP FUEL CONTROL

1. OUTLINE OF DIAGNOSIS

Detect the malfunction of engine coolant temperature output property.

Judge as NG when the engine coolant temperature does not rise in driving conditions where it should.

2. COMPONENT DESCRIPTION

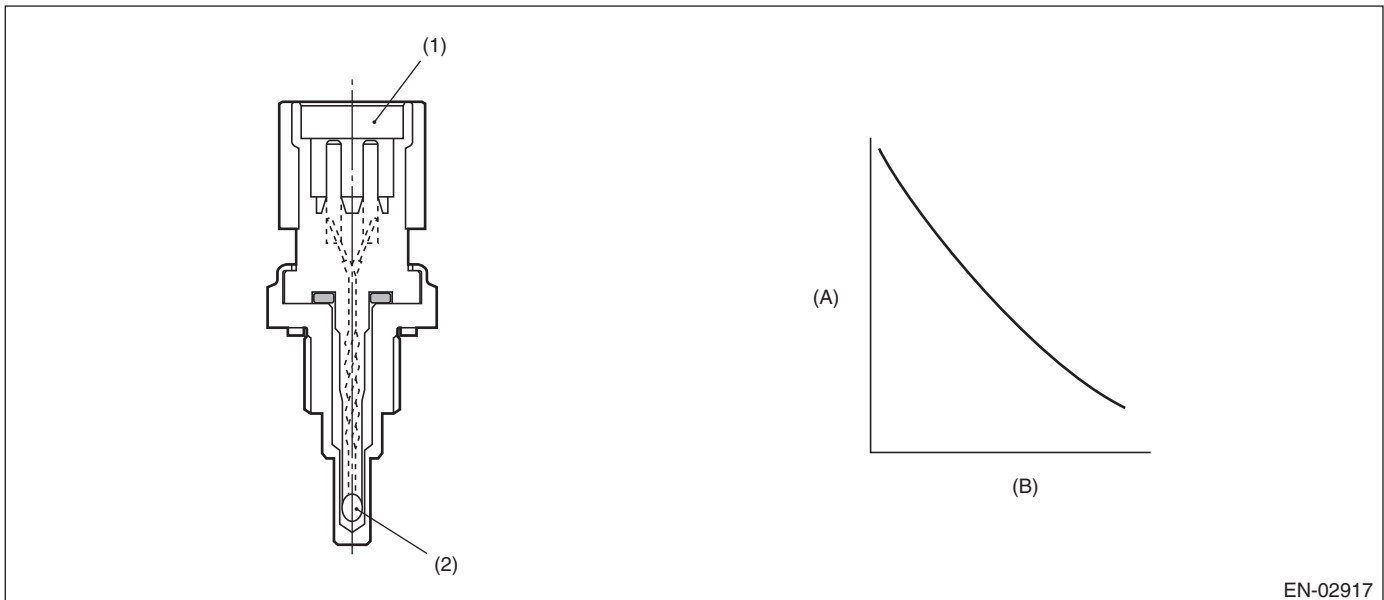

EN-02917

- (A) Resistance value (kΩ) (B) Temperature °C (°F)
- (1) Connector (2) Thermistor element

3. ENABLE CONDITION

Secondary Parameters	Enable Conditions
Engine speed	≥ Value from Map
Battery voltage	≥ 10.9 V

Map

Engine coolant temperature °C (°F)	-40 (-40)	-30 (-22)	-20 (-4)	-10 (14)	0 (32)	10 (50)	20 (68)	30 (86)
Engine speed rpm	500	500	500	500	500	500	500	500

Engine coolant temperature °C (°F)	40 (104)	50 (122)	60 (140)	70 (158)	80 (176)	90 (194)	100 (212)	110 (230)
Engine speed rpm	500	500	500	500	500	500	500	500

4. GENERAL DRIVING CYCLE

Perform the diagnosis only once after engine start.

Diagnostic Trouble Code (DTC) Detecting Criteria

GENERAL DESCRIPTION

5. DIAGNOSTIC METHOD

• Abnormality Judgement

Judge as NG if the criteria below are met.

Judgement Value

Malfunction Criteria	Threshold Value
Engine coolant temperature	< 20 °C (68 °F)
Timer for diagnosis after engine start	≥ Judgement value of timer after engine start

Timer for diagnosis after engine start

a. Timer stop at fuel cut

b. During the driving conditions except a) above, timer counts up as follows.

64 milliseconds + TWCNT milliseconds (at the time of 64 milliseconds)

TWCNT is defined as follows,

TWCNT = 0 at idle switch ON,

TWCNT show on the following table at idle switch OFF.

		Vehicle speed km/h (MPH)							
		0 (0)	8 (5)	16 (9.9)	24 (14.9)	32 (19.9)	40 (24.9)	48 (29.8)	56 (34.8)
Temper- ature °C (°F)	-20 (-4)	0 ms	32.076 ms	39.977 ms	47.879 ms	82.544 ms	117.209 ms	154.214 ms	185.26 ms
	-10 (14)	0 ms	25.704 ms	33.606 ms	41.508 ms	68.52 ms	95.532 ms	125.667 ms	155.802 ms
	0 (32)	0 ms	17.646 ms	25.548 ms	33.45 ms	53.652 ms	73.855 ms	97.12 ms	120.386 ms
	10 (50)	0 ms	7.901 ms	15.802 ms	23.704 ms	37.941 ms	52.177 ms	68.573 ms	82.538 ms
	20 (68)	0 ms	7.901 ms	15.802 ms	23.704 ms	37.941 ms	52.177 ms	68.573 ms	82.538 ms

Judgement value of timer after engine starting

$$t = 573669 \text{ ms} - 33924 \text{ ms} \times T_i$$

T_i : The lowest coolant temperature after engine start

Time Needed for Diagnosis: Less than 1 second

Malfunction Indicator Light Illumination: Illuminates when malfunction occurs in 2 continuous driving cycles.

• Normality Judgement

Judge as OK and clear the NG when the malfunction criteria below are met.

Judgement Value

Malfunction Criteria	Threshold Value
Engine coolant temperature	≥ 20 °C (68 °F)

Time Needed for Diagnosis: Less than 1 second

Diagnostic Trouble Code (DTC) Detecting Criteria

GENERAL DESCRIPTION

Z: DTC P0126 INSUFFICIENT ENGINE COOLANT TEMPERATURE FOR STABLE OPERATION

1. OUTLINE OF DIAGNOSIS

Detect the malfunction of the engine coolant temperature sensor characteristics.

Memorize the engine coolant temperature and fuel temperature at the last engine stop, and use them to judge as NG when the engine coolant temperature does not decrease when it should.

2. COMPONENT DESCRIPTION

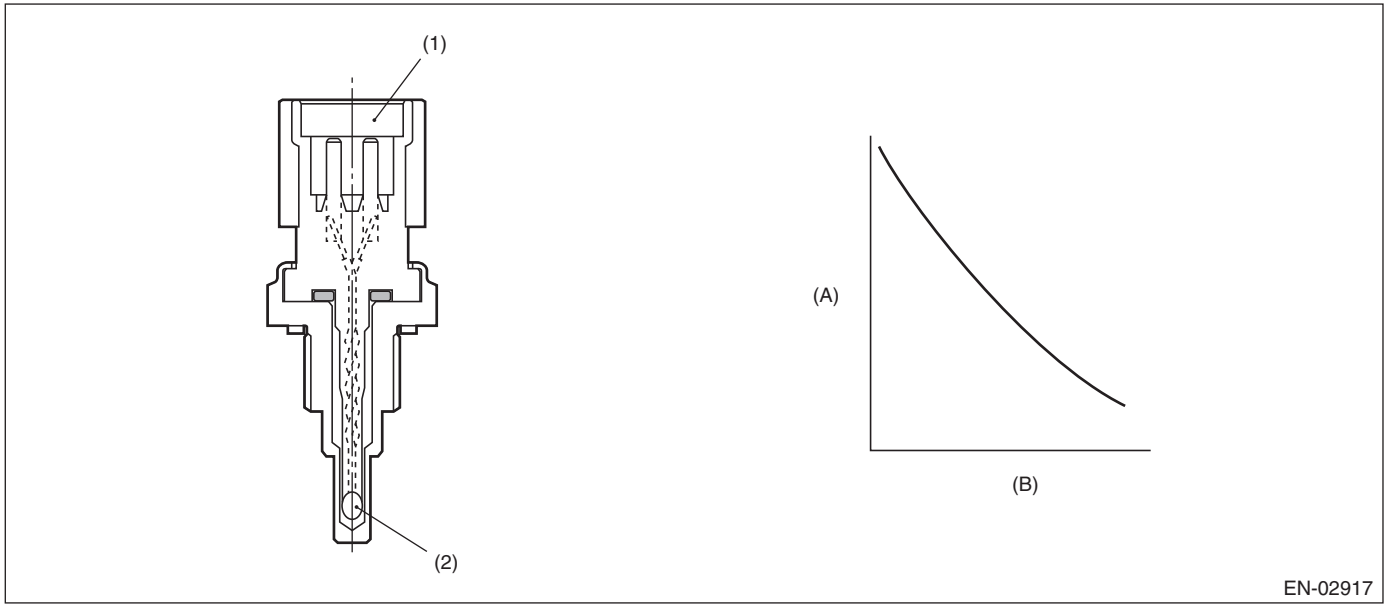

EN-02917

(A) Resistance value (k Ω)

(B) Temperature °C (°F)

(1) Connector

(2) Thermistor element

3. ENABLE CONDITION

Secondary Parameters	Enable Conditions
Battery voltage	≥ 10.9 V
Refueling from the last engine stop till the current engine start	None
Fuel level	≥ 15 ℓ (3.96 US gal, 3.3 Imp gal)
Engine coolant temperature at the last engine stop	≥ 75 °C (167 °F)

4. GENERAL DRIVING CYCLE

Perform the diagnosis only once after starting the engine.

Diagnostic Trouble Code (DTC) Detecting Criteria

GENERAL DESCRIPTION

5. DIAGNOSTIC METHOD

• Abnormality Judgement

If the duration of time while the following conditions are met is longer than the time indicated, judge as NG.

Judgement Value

Malfunction Criteria	Threshold Value
Engine coolant temperature at the last engine stop — Minimum engine coolant temperature after the engine start	< 2.5 °C (36.5 °F)
Fuel temperature at the last engine stop — Fuel temperature	≥ 5 °C (41 °F)
Intake air temperature — Fuel temperature	< 2.5 °C (36.5 °F)
Fuel temperature	< 35 °C (95 °F)

Time Needed for Diagnosis: 2500 ms

Malfunction Indicator Light Illumination: Illuminates when malfunction occurs in 2 continuous driving cycles.

• Normality Judgement

Judge as OK and clear the NG if the continuous time while the following conditions are established is more than the predetermined time.

Judgement Value

Malfunction Criteria	Threshold Value
Engine coolant temperature at the last engine stop — Minimum engine coolant temperature after the engine start	≥ 2.5 °C (36.5 °F)

Time Needed for Diagnosis: Less than 1 second

Diagnostic Trouble Code (DTC) Detecting Criteria

GENERAL DESCRIPTION

AA:DTC P0128 COOLANT THERMOSTAT (ENGINE COOLANT TEMPERATURE BELOW THERMOSTAT REGULATING TEMPERATURE)

1. OUTLINE OF DIAGNOSIS

Detect malfunctions of the thermostat function.

Judge as NG when the engine coolant temperature is lower than the estimated engine coolant temperature and the difference between them is large. Judge as OK when the engine coolant temperature becomes to 75°C (167°F), and the difference is small, before judging NG.

2. COMPONENT DESCRIPTION

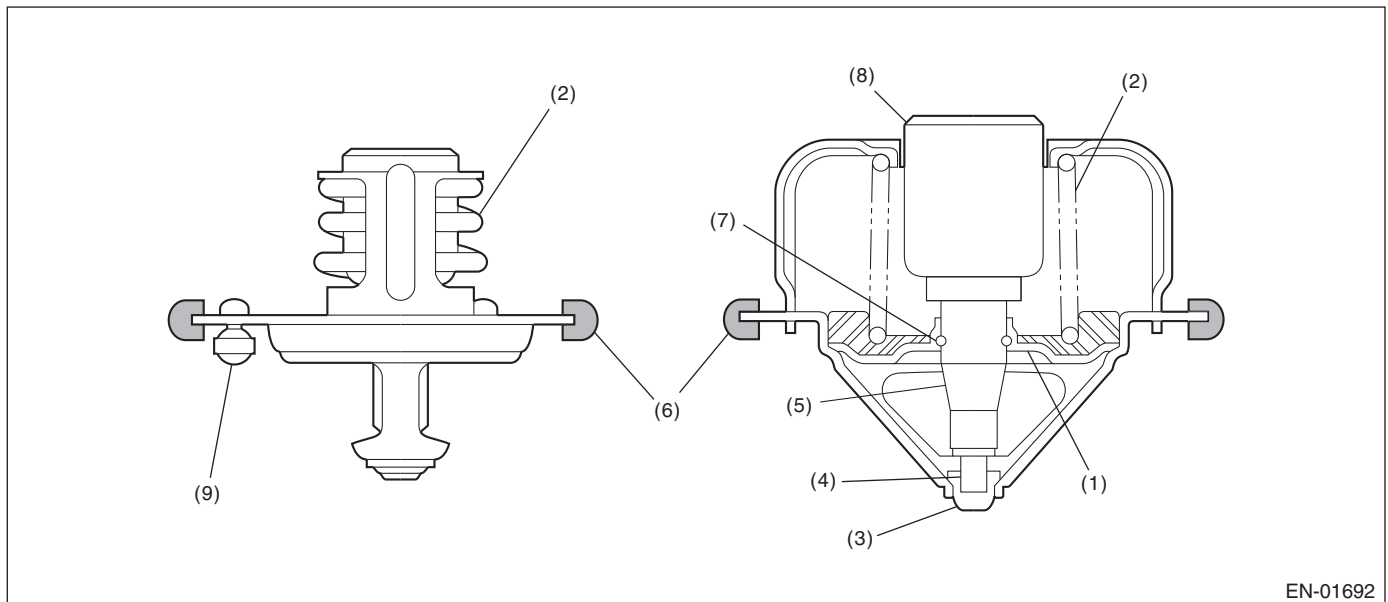

EN-01692

- | | | |
|-------------|-----------------|------------------|
| (1) Valve | (4) Piston | (7) Stop ring |
| (2) Spring | (5) Guide | (8) Wax element |
| (3) Stopper | (6) Rubber seal | (9) Jiggle valve |

3. ENABLE CONDITION

Secondary Parameters	Enable Conditions
None	

4. GENERAL DRIVING CYCLE

Always perform the diagnosis continuously.

Diagnostic Trouble Code (DTC) Detecting Criteria

GENERAL DESCRIPTION

5. DIAGNOSTIC METHOD

• Abnormality Judgement

If the duration of time while the following conditions are met is longer than the time indicated, judge as NG.

Judgement Value

Malfunction Criteria	Threshold Value
Battery voltage	≥ 10.9 V
Estimate ambient temperature	≥ -7 °C (19.4 °F)
Thermostat malfunction diagnosis	Incomplete
Engine coolant temperature at engine starting	< 55 °C (131 °F)
Estimated coolant temperature	≥ 75 °C (167 °F)
Engine coolant temperature	≤ 75 °C (167 °F)
(Estimated – measured) Engine coolant temperature	> 30 °C (86 °F)
Vehicle speed	≥ 30 km/h (18.6 MPH)

Time Needed for Diagnosis: 64 ms × 3 time(s) × 152 time(s)

Malfunction Indicator Light Illumination: Illuminates when malfunction occurs in 2 continuous driving cycles.

• Normality Judgement

Judge as OK and clear the NG if the continuous time while the following conditions are established is more than the predetermined time.

Judgement Value

Malfunction Criteria	Threshold Value
Battery voltage	≥ 10.9 V
Estimate ambient temperature	≥ -7 °C (19.4 °F)
Thermostat malfunction diagnosis	Incomplete
Engine coolant temperature at engine starting	< 55 °C (131 °F)
Engine coolant temperature	≥ 75 °C (167 °F)
(Estimated – measured) Engine coolant temperature	≤ 30 °C (86 °F)

Time Needed for Diagnosis: Less than 1 second

AB:DTC P0131 O2 SENSOR CIRCUIT LOW VOLTAGE (BANK 1 SENSOR 1)

1. OUTLINE OF DIAGNOSIS

Detect the open or short circuit of sensor.

Judge as NG, when the element voltage is out of the specified range.

2. COMPONENT DESCRIPTION

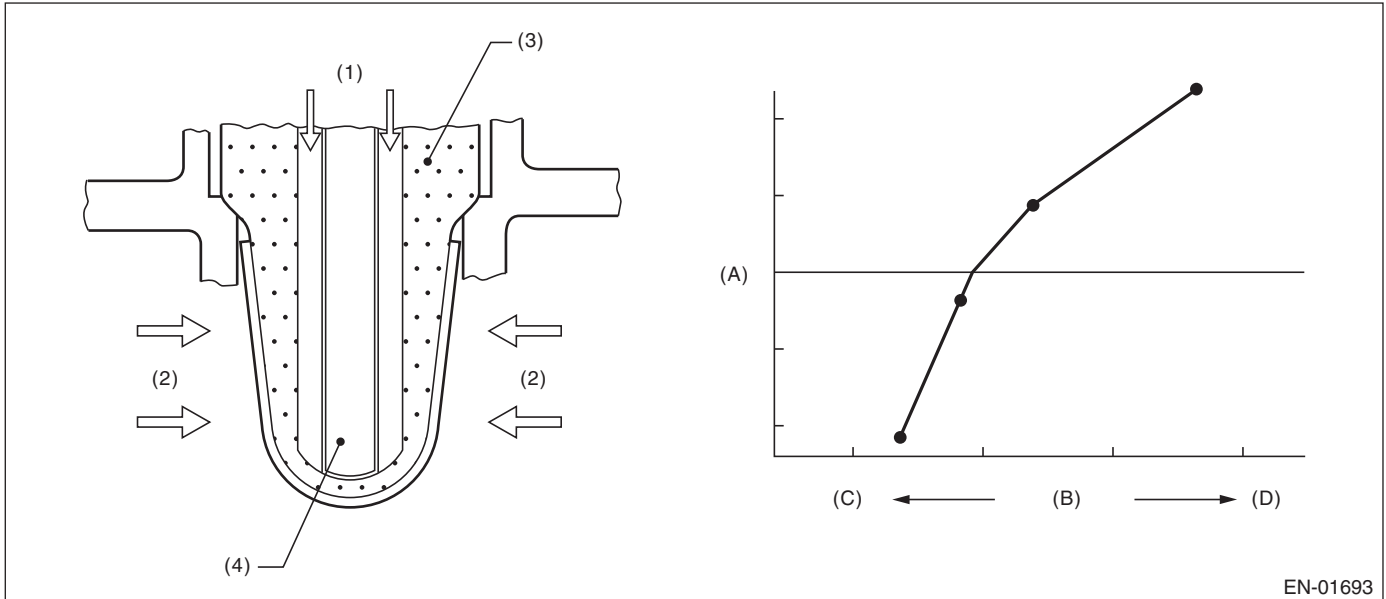

(A) Electromotive force

(B) Air fuel ratio

(C) Lean

(D) Rich

(1) Atmosphere

(3) ZrO₂

(4) Ceramic heater

(2) Exhaust gas

3. ENABLE CONDITION

Secondary Parameters	Enable Conditions
Battery voltage	≥ 10.9 V

4. GENERAL DRIVING CYCLE

Always perform the diagnosis continuously.

Diagnostic Trouble Code (DTC) Detecting Criteria

GENERAL DESCRIPTION

5. DIAGNOSTIC METHOD

• Abnormality Judgement

If the duration of time while the following conditions are met is longer than the time indicated, judge as NG.

Judgement Value

Malfunction Criteria	Threshold Value
Input voltage (+) or Input voltage (-)	< 1.128 V
or Input voltage (+) – Input voltage (-)	< 0.23 V
	< 0.644 V

Time Needed for Diagnosis:

Input voltage (+): 1000 ms

Input voltage (-): 1000 ms

|Input voltage (+) – Input voltage (-)|: 1000 ms

Malfunction Indicator Light Illumination: Illuminates as soon as a malfunction occurs.

• Normality Judgement

Judge as OK and clear the NG if the continuous time while the following conditions are established is more than the predetermined time.

Judgement Value

Malfunction Criteria	Threshold Value
Input voltage (+)	≥ 1.128 V
Input voltage (-)	≥ 0.23 V
Input voltage (+) – Input voltage (-)	≥ 0.644 V

Time Needed for Diagnosis: Less than 1 second

AC:DTC P0132 O2 SENSOR CIRCUIT HIGH VOLTAGE (BANK 1 SENSOR 1)

1. OUTLINE OF DIAGNOSIS

Detect the open or short circuit of sensor.

Judge as NG, when the element voltage is out of the specified range.

2. COMPONENT DESCRIPTION

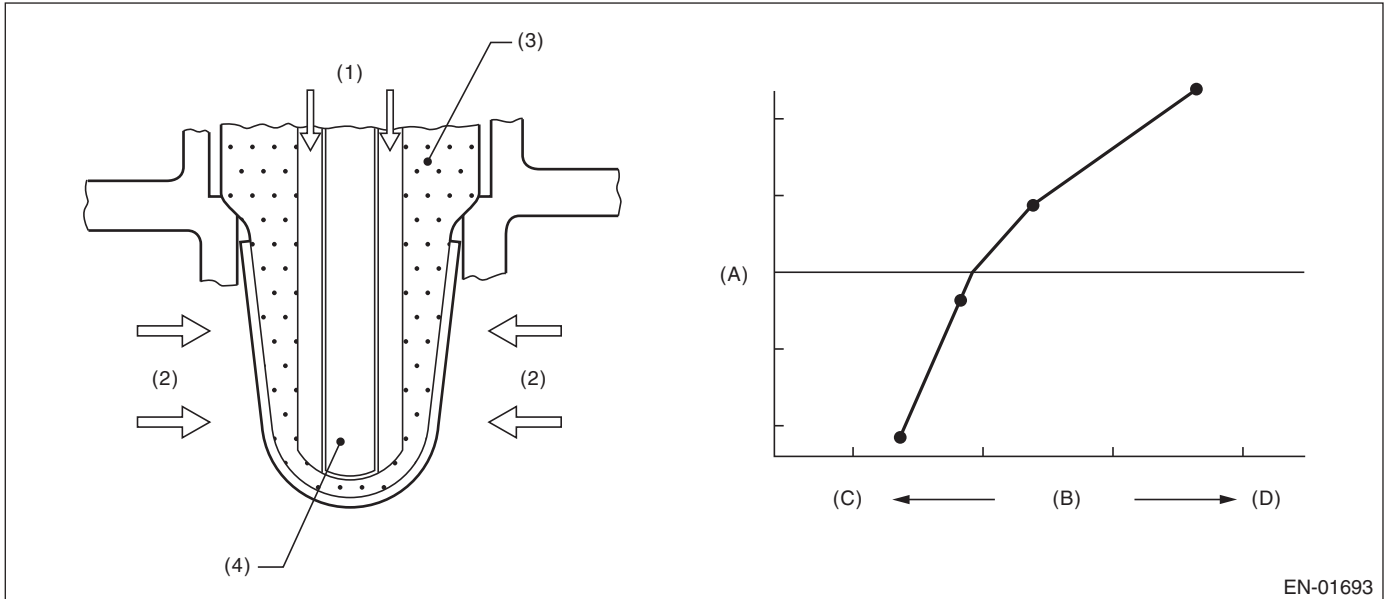

(A) Electromotive force

(B) Air fuel ratio

(C) Lean

(D) Rich

(1) Atmosphere

(3) ZrO₂

(4) Ceramic heater

(2) Exhaust gas

3. ENABLE CONDITION

Secondary Parameters	Enable Conditions
Battery voltage	≥ 10.9 V

4. GENERAL DRIVING CYCLE

Always perform the diagnosis continuously.

Diagnostic Trouble Code (DTC) Detecting Criteria

GENERAL DESCRIPTION

5. DIAGNOSTIC METHOD

• Abnormality Judgement

If the duration of time while the following conditions are met is longer than the time indicated, judge as NG.

Judgement Value

Malfunction Criteria	Threshold Value
Input voltage (+) or Input voltage (-)	> 3.589 V > 3.541 V

Time Needed for Diagnosis:

Input voltage (+): 1000 ms

Input voltage (-): 1000 ms

Malfunction Indicator Light Illumination: Illuminates as soon as a malfunction occurs.

• Normality Judgement

Judge as OK and clear the NG if the continuous time while the following conditions are established is more than the predetermined time.

Judgement Value

Malfunction Criteria	Threshold Value
Input voltage (+) Input voltage (-)	≤ 3.589 V ≤ 3.541 V

Time Needed for Diagnosis: Less than 1 second

AD:DTC P0133 O2 SENSOR CIRCUIT SLOW RESPONSE (BANK 1 SENSOR 1)

1. OUTLINE OF DIAGNOSIS

Detect the slow response of front oxygen (A/F) sensor.

Front oxygen (A/F) sensor cover has some ventilation holes for exhaust gas. Clogged ventilation holes are diagnosed.

When the holes are clogged, the A/F output variation becomes slow comparing with the actual A/F variation because oxygen which reaches the zirconia layer is insufficient. Therefore, if the sensor cover holes are clogged, the rich to lean judgement in the ECM is delayed when the actual change from rich to lean occurs. Judge as NG when the actual movement in comparison to the ECM control amount is slow.

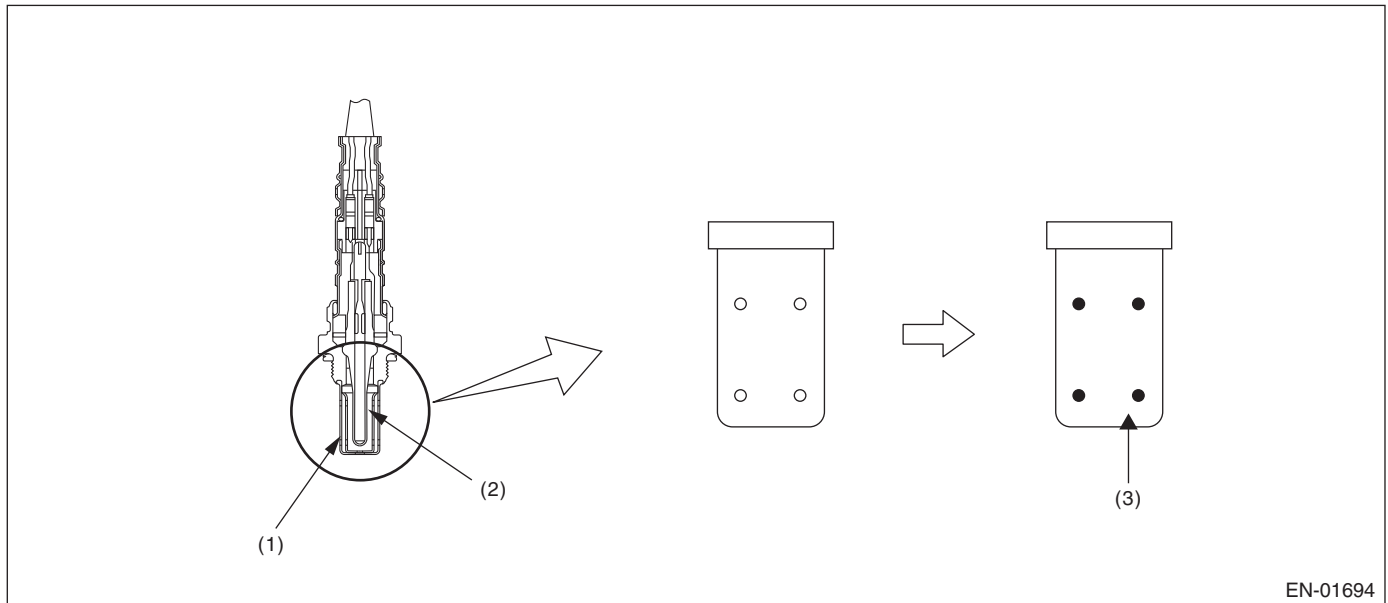

(1) Cover

(2) Zirconia

(3) Clogging

Diagnostic Trouble Code (DTC) Detecting Criteria

GENERAL DESCRIPTION

2. COMPONENT DESCRIPTION

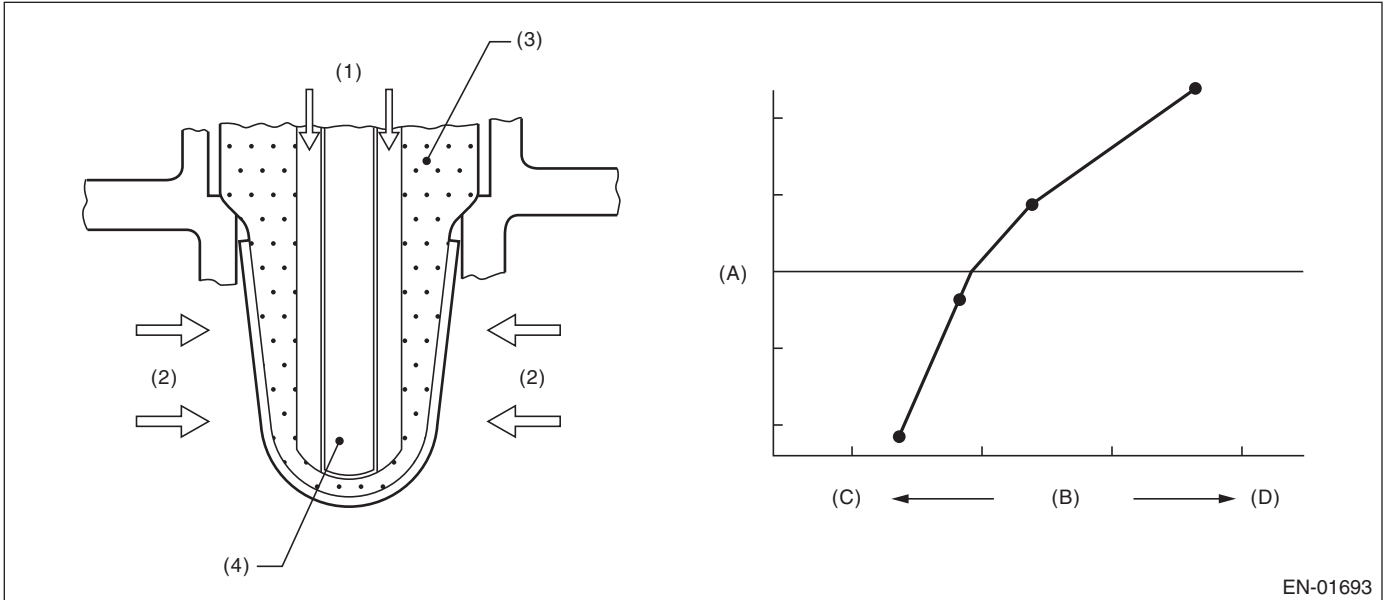

EN-01693

(A) Electromotive force

(B) Air fuel ratio

(C) Lean

(D) Rich

(1) Atmosphere

(3) ZrO_2

(4) Ceramic heater

(2) Exhaust gas

3. ENABLE CONDITION

Secondary Parameters	Enable Conditions
Time needed for all secondary parameters to be in enable conditions	≥ 1024 ms
Battery voltage	≥ 10.9 V
Barometric pressure	> 75 kPa (563 mmHg, 22.2 inHg)
Closed loop control with main feedback	Operation
Front oxygen (A/F) sensor impedance	$0 \Omega - 50 \Omega$
Elapsed time after starting the engine	≥ 120000 ms
Engine coolant temperature	≥ 75 °C (167 °F)
Engine speed	1000 rpm — 3200 rpm
Vehicle speed	10 km/h — 120 km/h (6.2 MPH — 74.6 MPH)
Amount of intake air	10 g/s — 40 g/s (0.35 oz/s — 1.41 oz/s)
Engine load	< 0.02 g/rev (0 oz/rev)
Learning value of EVAP conc. during purge	< 0.2
Total time of operating canister purge	≥ 19.9 s

4. GENERAL DRIVING CYCLE

Perform diagnosis only once at a constant speed of 10 km/h — 120 km/h (6.2 MPH — 74.6 MPH) 120000 ms or more after starting the engine.

5. DIAGNOSTIC METHOD

Calculate faf difference every $32\text{ms} \times 4$, and the λ value difference. Calculate the diagnosis value after calculating 1640 time(s).

Diagnostic Trouble Code (DTC) Detecting Criteria

GENERAL DESCRIPTION

• Abnormality Judgement

If the duration of time while the following conditions are met is longer than the time indicated, judge as NG.

Judgement Value

Malfunction Criteria	Threshold Value
$para_{fca} = td_{2faf}/td_{2lmd}$ where, $td_{2faf}(N) = td_{2faf}(n-1) + d_{2faf}(n) $ $td_{2lmd}(N) = td_{2lmd}(n-1) + d_{2lmd}(n) $ add up to $32\text{ ms} \times 4 \times 1640$ time(s). $d_{2faf}(n) = (faf(n) - faf(n-1)) - (faf(n-1) - faf(n-2))$ $d_{2lmd}(n) = (lmd(n) - lmd(n-1)) - (lmd(n-1) - lmd(n-2))$ faf = main feedback compensation coefficient every 128 milliseconds lmd = output lambda every 128 milliseconds	> 0.4 (U5 model) > 0.45 (Other than U5 model)

Time Needed for Diagnosis: $32\text{ ms} \times 4 \times 1640$ time(s)

Malfunction Indicator Light Illumination: Illuminates when malfunction occurs in 2 continuous driving cycles.

• Normality Judgement

Judge as OK and clear the NG if the continuous time while the following conditions are established is more than the predetermined time.

Judgement Value

Malfunction Criteria	Threshold Value
$para_{fca} = td_{2faf}/td_{2lmd}$ where, $td_{2faf}(N) = td_{2faf}(n-1) + d_{2faf}(n) $ $td_{2lmd}(N) = td_{2lmd}(n-1) + d_{2lmd}(n) $ add up to $32\text{ ms} \times 4 \times 1640$ time(s). $d_{2faf}(n) = (faf(n) - faf(n-1)) - (faf(n-1) - faf(n-2))$ $d_{2lmd}(n) = (lmd(n) - lmd(n-1)) - (lmd(n-1) - lmd(n-2))$ faf = main feedback compensation coefficient every 128 milliseconds lmd = output lambda every 128 milliseconds	≤ 0.4 (U5 model) ≤ 0.45 (Other than U5 model)

Time Needed for Diagnosis: $32\text{ ms} \times 4 \times 1640$ time(s)

Diagnostic Trouble Code (DTC) Detecting Criteria

GENERAL DESCRIPTION

AE:DTC P0134 O2 SENSOR CIRCUIT NO ACTIVITY DETECTED (BANK 1 SENSOR 1)

1. OUTLINE OF DIAGNOSIS

Detect open circuits of the sensor.

Judge as NG when the impedance of the element is large.

2. COMPONENT DESCRIPTION

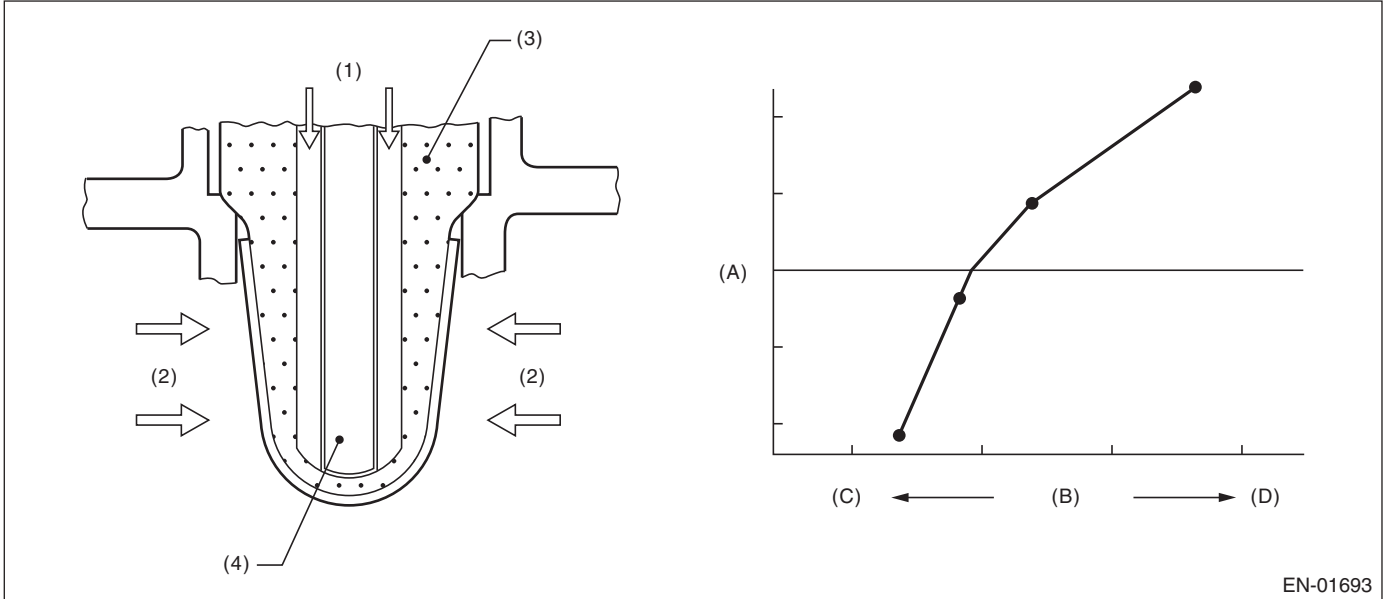

EN-01693

(A) Electromotive force

(B) Air fuel ratio

(C) Lean

(D) Rich

(1) Atmosphere

(3) ZrO₂

(4) Ceramic heater

(2) Exhaust gas

3. ENABLE CONDITION

Secondary Parameters	Enable Conditions
None	

4. GENERAL DRIVING CYCLE

Always perform the diagnosis continuously.

Diagnostic Trouble Code (DTC) Detecting Criteria

GENERAL DESCRIPTION

5. DIAGNOSTIC METHOD

• Abnormality Judgement

If the duration of time while the following conditions are met is longer than the time indicated, judge as NG.

Judgement Value

Malfunction Criteria	Threshold Value
Battery voltage	$\geq 10.9 \text{ V}$
Time of heater control duty at 70 % or more	$\geq 36000 \text{ ms}$
Front oxygen (A/F) sensor impedance.	$> 500 \Omega$

Time Needed for Diagnosis: 5000 ms

Malfunction Indicator Light Illumination: Illuminates as soon as a malfunction occurs.

• Normality Judgement

Judge as OK and clear the NG if the continuous time while the following conditions are established is more than the predetermined time.

Judgement Value

Malfunction Criteria	Threshold Value
Battery voltage	$\geq 10.9 \text{ V}$
Front oxygen (A/F) sensor impedance.	$\leq 500 \Omega$

Time Needed for Diagnosis: Less than 1 second

Diagnostic Trouble Code (DTC) Detecting Criteria

GENERAL DESCRIPTION

AF:DTC P0137 O2 SENSOR CIRCUIT LOW VOLTAGE (BANK 1 SENSOR 2)

1. OUTLINE OF DIAGNOSIS

Detect continuity NG of the oxygen sensor. If the oxygen sensor voltage reading is not within the probable range considering the operating conditions, judge as NG.

2. COMPONENT DESCRIPTION

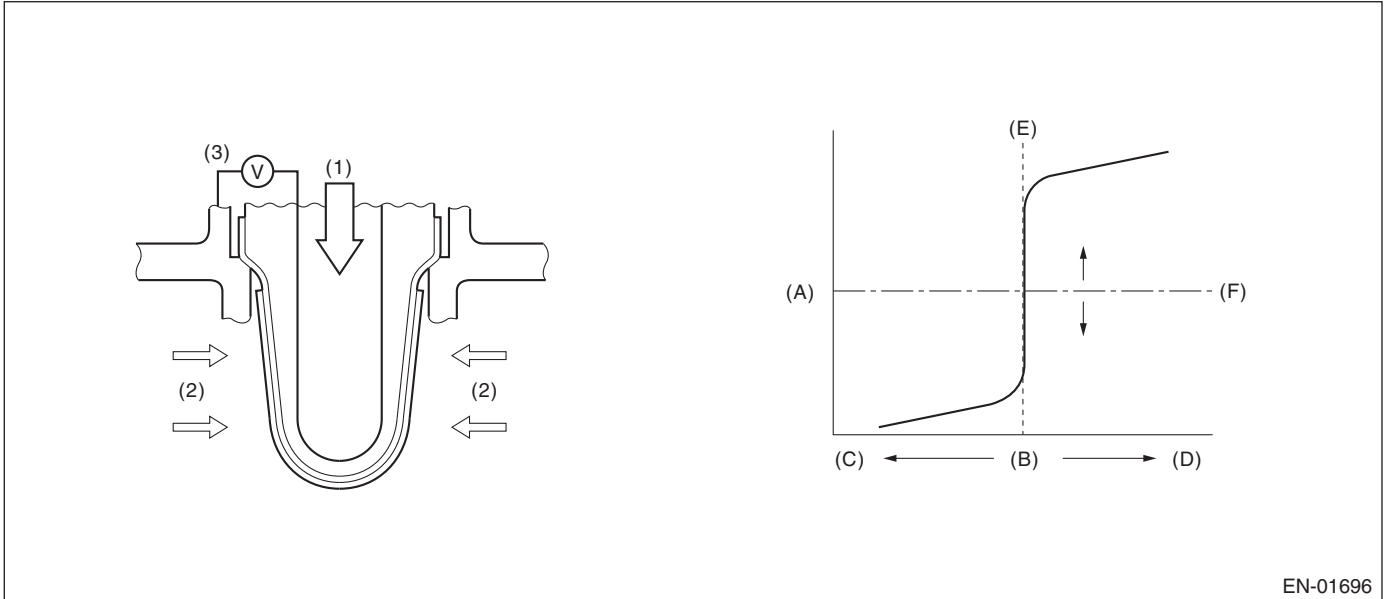

EN-01696

(A) Electromotive force

(D) Lean

(1) Atmosphere

(B) Air fuel ratio

(E) Theoretical air fuel ratio

(2) Exhaust gas

(C) Rich

(F) Comparative voltage

(3) Electromotive force

Diagnostic Trouble Code (DTC) Detecting Criteria

GENERAL DESCRIPTION

3. ENABLE CONDITION

Used for abnormality judgement

Secondary Parameters	Enable Conditions
High Secondary air system Closed loop control at the oxygen sensor Misfire detection every 200 rotations Front oxygen (A/F) sensor compensation coefficient Battery voltage Engine coolant temperature	Not in operation In operation < 5 time(s) Not in limit value ≥ 10.9 V ≥ 75 °C (167 °F)
Low (1) Secondary air system Closed loop control at the oxygen sensor Misfire detection every 200 rotations Front oxygen (A/F) sensor compensation coefficient Battery voltage Engine coolant temperature Amount of intake air	Not in operation In operation < 5 time(s) Not in limit value ≥ 10.9 V ≥ 75 °C (167 °F) ≥ 10 g/s (0.35 oz/s)
Low (2) Secondary air system Closed loop control at the oxygen sensor Misfire detection every 200 rotations Front oxygen (A/F) sensor compensation coefficient Battery voltage Engine coolant temperature Amount of intake air Current continuation time of the rear oxygen sensor heater	Not in operation In operation < 5 time(s) Not in limit value ≥ 10.9 V ≥ 75 °C (167 °F) < 10 g/s (0.35 oz/s) ≥ 30000 ms
Low (3) Secondary air system Closed loop control at the oxygen sensor Misfire detection every 200 rotations Front oxygen (A/F) sensor compensation coefficient Battery voltage Engine coolant temperature Amount of intake air Current continuation time of the rear oxygen sensor heater Fuel cut	Not in operation In operation < 5 time(s) Not in limit value ≥ 10.9 V ≥ 75 °C (167 °F) < 10 g/s (0.35 oz/s) ≥ 30000 ms Experienced

Used for normality judgement

Secondary Parameters	Enable Conditions
Secondary air system Closed loop control at the oxygen sensor Misfire detection every 200 rotations Front oxygen (A/F) sensor compensation coefficient Battery voltage Engine coolant temperature	Not in operation In operation < 5 time(s) Not in limit value ≥ 10.9 V ≥ 75 °C (167 °F)

4. GENERAL DRIVING CYCLE

After starting the engine, continuously perform the diagnosis with the same engine condition.

Diagnostic Trouble Code (DTC) Detecting Criteria

GENERAL DESCRIPTION

5. DIAGNOSTIC METHOD

• Abnormality Judgement

If the duration of time while the following conditions are met is longer than the time indicated, judge as NG.

Judgement Value

Malfunction Criteria	Threshold Value	DTC
High Sensor output voltage	> 1.2 V	P0138
Low Sensor output voltage	< 0.03 V	P0137

Time Needed for Diagnosis:

- High: 2500 ms
- Low (1): 20000 ms
- Low (2): 40000 ms
- Low (3): Value from Map

Map

Fuel Cut Time (second)	0	2000	10000
Time Needed for Diagnosis (second)	40000	40000	60000

Malfunction Indicator Light Illumination: Illuminates when malfunction occurs in 2 continuous driving cycles.

• Normality Judgement

Judge as OK and clear the NG if the continuous time while the following conditions are established is more than the predetermined time.

Judgement Value

Malfunction Criteria	Threshold Value	DTC
High Sensor output voltage	≤ 1.2 V	P0138
Low Sensor output voltage	≥ 0.03 V	P0137

Time Needed for Diagnosis:

- High: Less than 1 second
- Low (1): Less than 1 second
- Low (2): Less than 1 second
- Low (3): Less than 1 second

Diagnostic Trouble Code (DTC) Detecting Criteria

GENERAL DESCRIPTION

AG:DTC P0138 O2 SENSOR CIRCUIT HIGH VOLTAGE (BANK 1 SENSOR 2)

1. OUTLINE OF DIAGNOSIS

NOTE:

For the detection standard, refer to DTC P0137. <Ref. to GD(H4SO)-54, DTC P0137 O2 SENSOR CIRCUIT LOW VOLTAGE (BANK 1 SENSOR 2), Diagnostic Trouble Code (DTC) Detecting Criteria.>

Diagnostic Trouble Code (DTC) Detecting Criteria

GENERAL DESCRIPTION

AH:DTC P0139 O2 SENSOR CIRCUIT SLOW RESPONSE (BANK 1 SENSOR 2)

1. OUTLINE OF DIAGNOSIS

Detect the slow response of the oxygen sensor.

Judge as NG if either of the rich to lean response diagnosis or lean to rich response diagnosis is NG, and Judge as OK if both are OK.

[Rich → lean diagnosis response]

1. Measure the response time for oxygen sensor output changes when the A/F ratio changes to rich to lean. If the measured response time is larger than the threshold value, it is NG. If it is smaller, it is OK.

2. Judge as NG when the oxygen sensor voltage is large (rich) when recovering from a deceleration fuel cut.

[Lean → rich diagnosis response]

1. Measure the response time for oxygen sensor output changes when the A/F ratio changes to lean to rich. If the measured response time is larger than the threshold value, it is NG.

2. Judge as NG when the oxygen sensor voltage remains small when recovering from a deceleration fuel cut.

Diagnostic method

Measure the response time of the output change of the oxygen sensor when the A/F ratio changes to rich to lean. And Judge as NG when the measured response time is larger than the threshold value.

2. COMPONENT DESCRIPTION

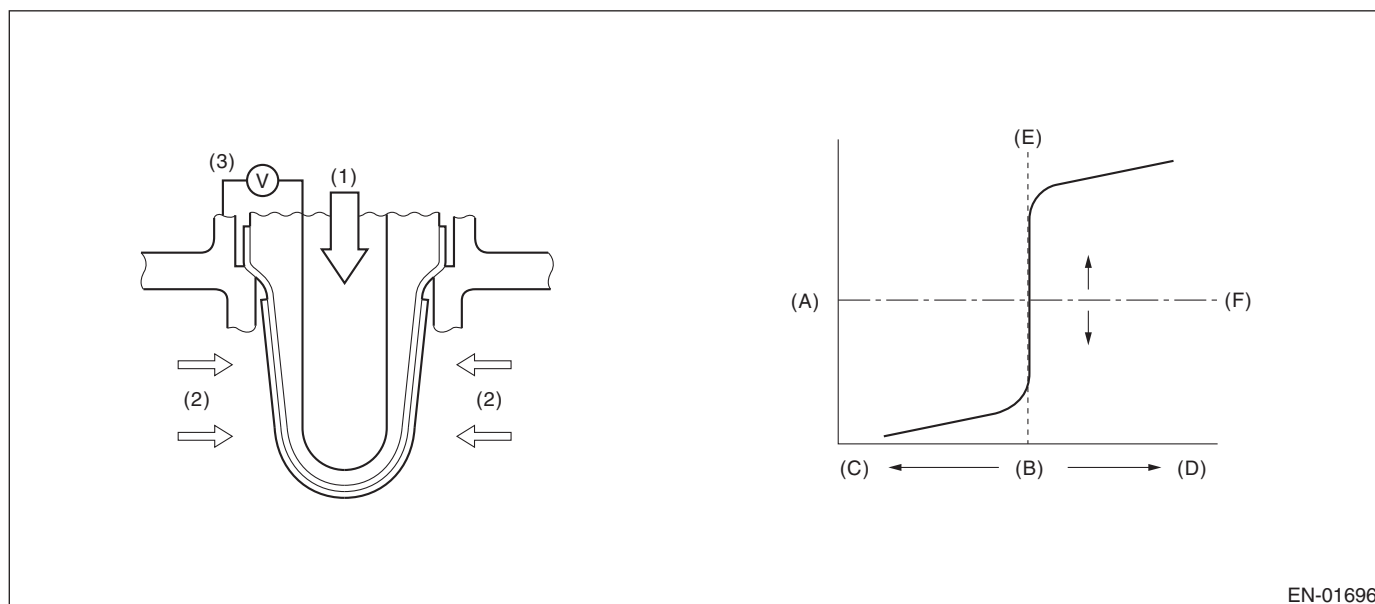

EN-01696

(A) Electromotive force

(B) Air fuel ratio

(C) Rich

(D) Lean

(E) Theoretical air fuel ratio

(F) Comparative voltage

(1) Atmosphere

(2) Exhaust gas

(3) Electromotive force

3. ENABLE CONDITION

Rich → lean diagnosis response

Secondary Parameters	Enable Conditions
Battery voltage	≥ 10.9 V
A/F main feedback control condition	Completed
Deceleration fuel cut time is 6000 ms or more.	Experienced
After fuel cut	≥ 2000 ms
Current calculation time of the rear oxygen sensor heater	≥ 55000 ms
Current continuation time of the rear oxygen sensor heater	≥ 29000 ms
Estimated catalyst temperature	≥ 480 °C (896 °F)
Number of deceleration fuel cut	≥ 1 time(s)

Diagnostic Trouble Code (DTC) Detecting Criteria

GENERAL DESCRIPTION

4. GENERAL DRIVING CYCLE

Perform the diagnosis only once when deceleration fuel cut occurs after rapid acceleration. (Pay attention to the oxygen sensor voltage for the timing of the deceleration.)

5. DIAGNOSTIC METHOD

When the oxygen sensor output voltage changes from 0.55 V (rich) to 0.15 V (lean), calculate the minimum response time for output change between 0.5 V and 0.2 V for the judgement criteria.

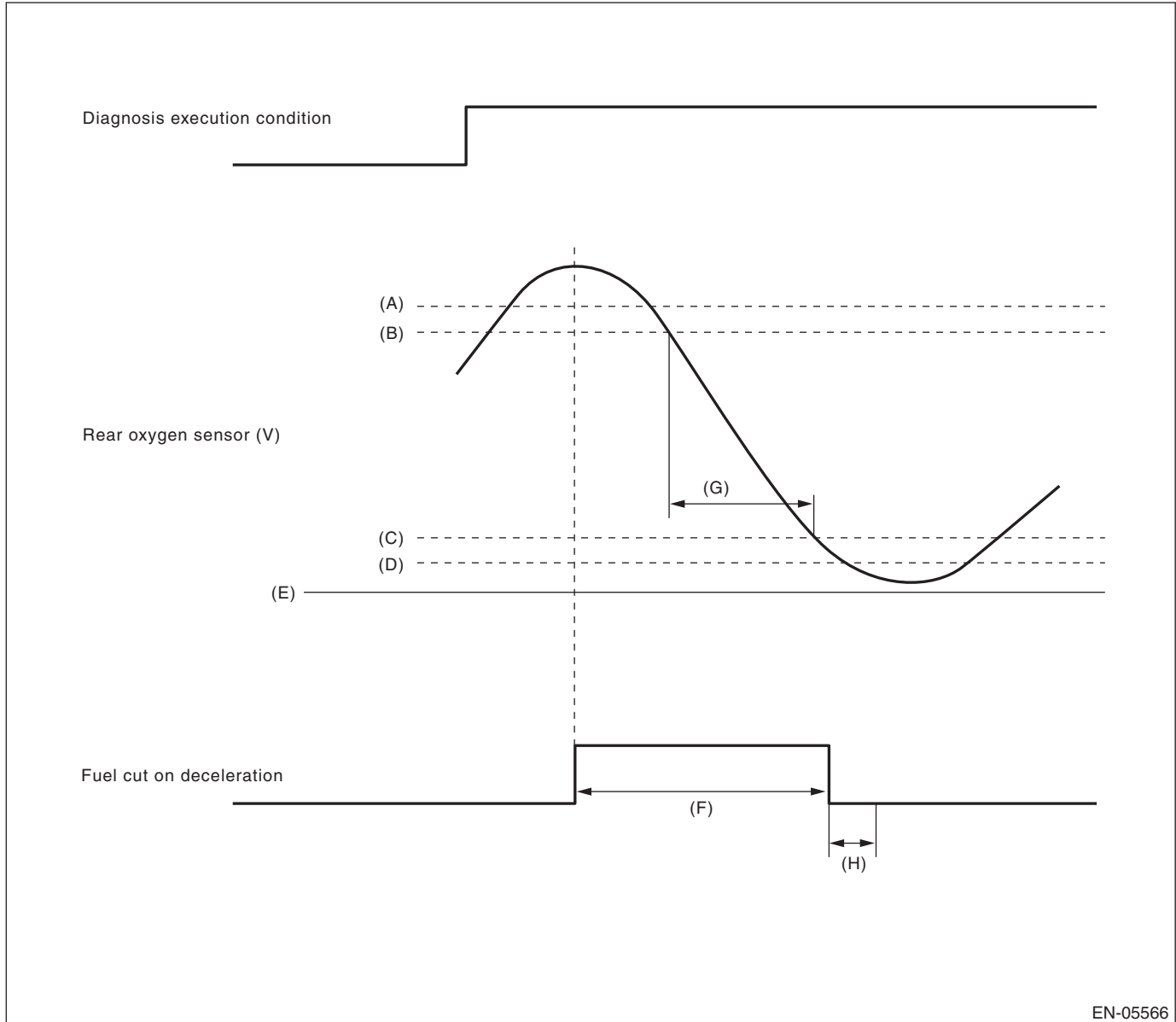

EN-05566

- (A) 0.55 V
- (B) 0.5 V
- (C) 0.2 V
- (D) 0.15 V

- (E) 0 V
- (F) More than 6000 ms
- (G) Measure the response time.

- (H) Execute the malfunction judgement in 2000 ms from the recovery of fuel cut on deceleration.

Diagnostic Trouble Code (DTC) Detecting Criteria

GENERAL DESCRIPTION

• Abnormality Judgement

1) Judge as NG when the judgement value is larger than the threshold value after deceleration fuel cut.
Response time (diagnosis value) > Threshold value → abnormal

NOTE:

Variation time of rear oxygen sensor output voltage is short during fuel cut in deceleration. NG judgement should be performed after deceleration fuel cut. Even without deceleration fuel cut, judge as OK if the value is below the threshold.

When the deceleration fuel cut time is 6000 ms or more, judge as NG if the following criteria are met 2000 ms after recovering from the deceleration fuel cut.

2) Judge as NG when the oxygen sensor voltage at recovery from a deceleration fuel cut is large.

If the fuel cut time in a deceleration fuel cut is long (6000 ms or more), and even after recovering from a deceleration fuel cut, the oxygen sensor voltage is high (0.55 V or more), judge as NG.

Judgement Value

Malfunction Criteria	Threshold Value
Shortest time change from rich (0.5 V O ₂ output) to lean (0.2 V) when voltage reduces from 0.55 V to 0.15 V or Longest time over 0.55 V	> 491 ms ≥ 2000 ms

Time Needed for Diagnosis: 1 time(s)

Malfunction Indicator Light Illumination: Illuminates when malfunction occurs in 2 continuous driving cycles.

• Normality Judgement

1) Regardless of a deceleration fuel cut, if the response time (diagnosis value) when the oxygen sensor voltage has changed from rich to lean is shorter than the threshold value (judgement value), judge as a normal condition.

Response time (diagnosis value) ≤ Threshold value → normal

2) Do not judge as a normal condition.

Judge as OK and clear the NG if the following conditions are established.

Judgement Value

Malfunction Criteria	Threshold Value
Shortest time change from rich (0.5 V O ₂ output) to lean (0.2 V) when voltage reduces from 0.55 V to 0.15 V	≤ 491 ms

Time Needed for Diagnosis: 1 time(s)

6. ENABLE CONDITION

Lean → rich response diagnosis

Secondary Parameters	Enable Conditions
Battery voltage	≥ 10.9 V
A/F main feedback control condition	Completed
Deceleration fuel cut time is 6000 ms or more.	Experienced
After fuel cut	≥ 2000 ms
Current calculation time of the rear oxygen sensor heater	≥ 55000 ms
Current continuation time of the rear oxygen sensor heater	≥ 29000 ms
Estimated catalyst temperature	≥ 450 °C (842 °F)
Number of deceleration fuel cut	≥ 1 time(s)

7. GENERAL DRIVING CYCLE

Perform the diagnosis only once when deceleration fuel cut occurs after rapid acceleration. (Pay attention to the oxygen sensor voltage for the timing of the deceleration.)

8. DIAGNOSTIC METHOD

When the oxygen sensor output voltage changes from 0.25 V (lean) to 0.55 V (rich), calculate the minimum response time for output change between 0.3 V and 0.5 V for the judgement criteria.

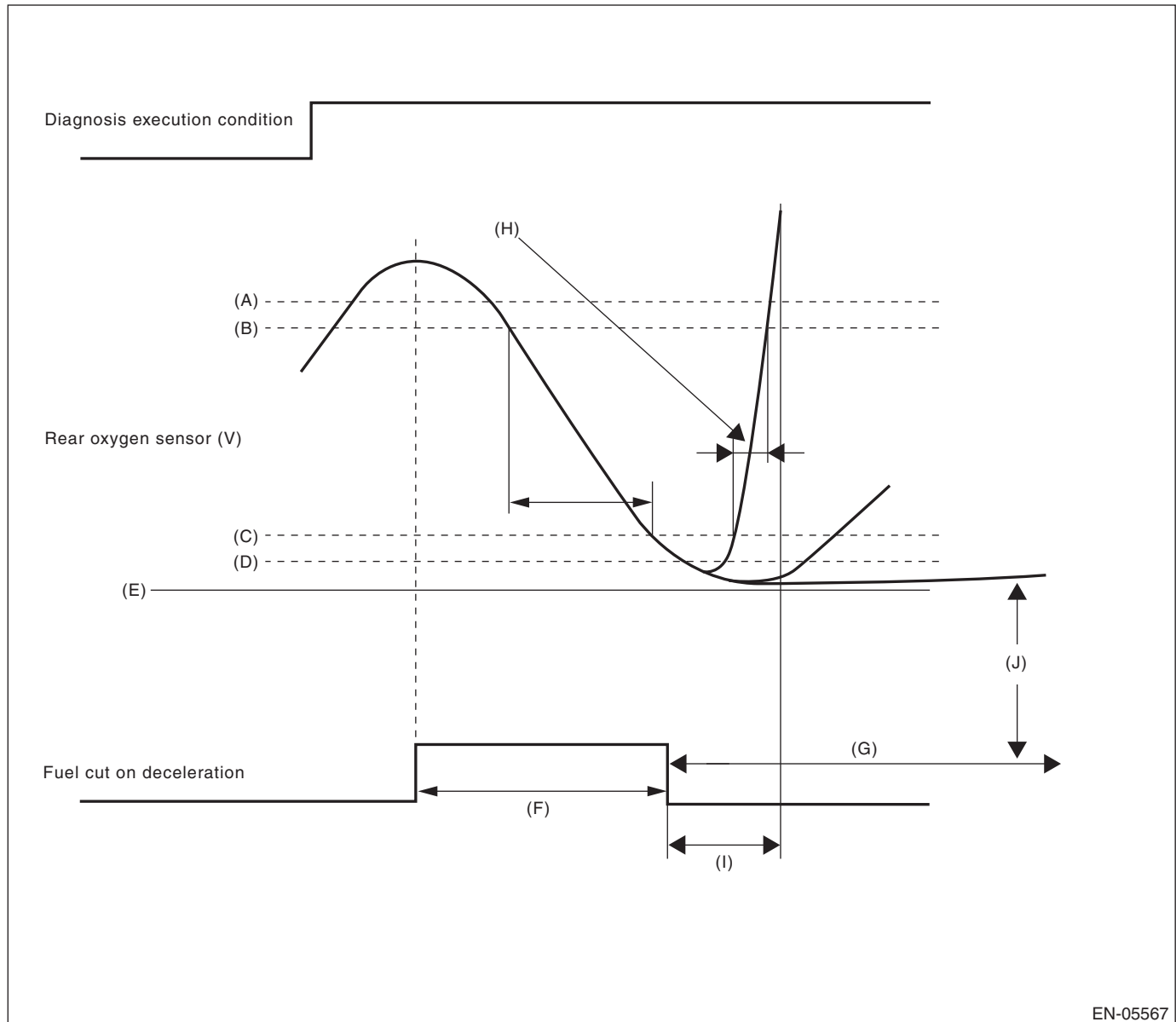

EN-05567

- (A) 0.55 V
- (B) 0.5 V
- (C) 0.3 V
- (D) 0.25 V
- (E) 0 V
- (F) More than 5 seconds

- (G) More than 120000 ms
- (H) Measure the response time (diagnostic value).
- (I) Execute the malfunction judgement in 2000 ms from the recovery of fuel cut on deceleration.

- (J) Judge NG when the voltage of rear oxygen sensor is 0.25 V or less for 120000 ms or more after recovery of fuel cut on deceleration.

Diagnostic Trouble Code (DTC) Detecting Criteria

GENERAL DESCRIPTION

• Abnormality Judgement

- 1) Judge as NG when the judgement value is larger than the threshold value after deceleration fuel cut.
Response time (diagnosis value) > Threshold value → abnormal
- 2) If the oxygen sensor voltage is small after recovering from a deceleration fuel cut, and remains small, judge as NG.

Judgement Value

Malfunction Criteria	Threshold Value
Shortest time change from lean (0.3 V O ₂ output) to rich (0.5 V) when voltage changes from 0.25 V to 0.55 V or Longest time under 0.25 V	> 2000 ms ≥ 120000 ms

Time Needed for Diagnosis: 1 time(s)

Malfunction Indicator Light Illumination: Illuminates when malfunction occurs in 2 continuous driving cycles.

• Normality Judgement

- 1) Regardless of a deceleration fuel cut, if the response time (diagnosis value) when the oxygen sensor voltage has changed from rich to lean is shorter than the threshold value (judgement value), judge as a normal condition.

Response time (diagnosis value) ≤ threshold value → normal

- 2) Do not judge as a normal condition.

Judge as OK and clear the NG if the following conditions are established.

Judgement Value

Malfunction Criteria	Threshold Value
Shortest time change from lean (0.3 V O ₂ output) to rich (0.5 V) when voltage changes from 0.25 V to 0.55 V	≤ 2000 ms

Time Needed for Diagnosis: 1 time(s)

AI: DTC P0140 O2 SENSOR CIRCUIT NO ACTIVITY DETECTED (BANK 1 SENSOR 2)

1. OUTLINE OF DIAGNOSIS

Detect the rear oxygen sensor open or short circuit. Judge as NG when the rear oxygen sensor voltage can be determined to be abnormal considering conditions such as intake air amount, engine coolant temperature, main feedback control and deceleration fuel cut.

2. COMPONENT DESCRIPTION

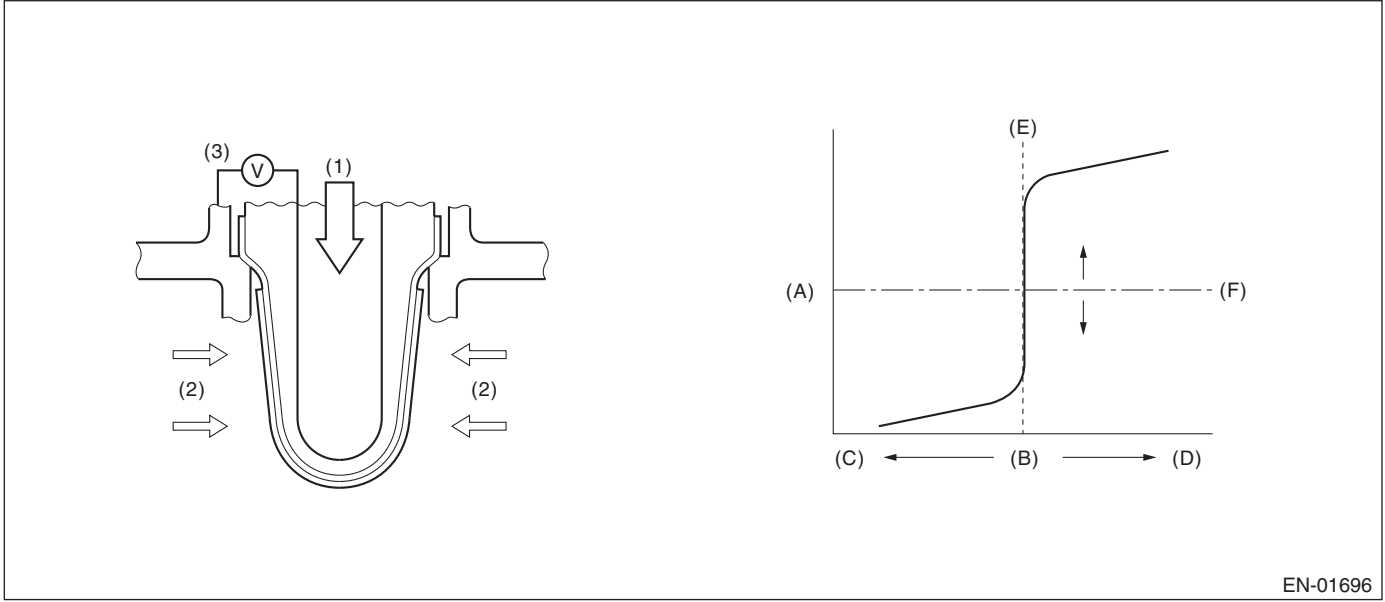

EN-01696

- | | | |
|-------------------------|--------------------------------|-------------------------|
| (A) Electromotive force | (B) Air fuel ratio | (C) Rich |
| (D) Lean | (E) Theoretical air fuel ratio | (F) Comparative voltage |
| (1) Atmosphere | (2) Exhaust gas | (3) Electromotive force |

3. ENABLE CONDITION (USED ONLY FOR MALFUNCTION JUDGEMENT)

Secondary Parameters	Enable Conditions
Closed loop control at the rear oxygen sensor	In operation
Target output voltage of rear oxygen sensor	$\geq 0.55 \text{ V} + 0.05 \text{ V}$
Amount of intake air	$\geq 10 \text{ g/s}$ (0.35 oz/s)
Engine coolant temperature	$\geq 75 \text{ }^\circ\text{C}$ (167 $^\circ\text{F}$)
Misfire detection every 200 rotations	$< 5 \text{ time(s)}$
Front oxygen (A/F) sensor compensation coefficient	Not in limit value
Battery voltage	$\geq 10.9 \text{ V}$
Deceleration fuel cut of 6000 ms or more.	Experienced

4. GENERAL DRIVING CYCLE

Perform the diagnosis once after starting the engine.

Diagnostic Trouble Code (DTC) Detecting Criteria

GENERAL DESCRIPTION

5. DIAGNOSTIC METHOD

• Abnormality Judgement

If the duration of time while the following conditions are met is longer than the time indicated, judge as NG.

Judgement Value

Malfunction Criteria	Threshold Value
Minimum output voltage or Maximum output voltage	> 0.15 V < 0.55 V

Time Needed for Diagnosis: 200000 ms

Malfunction Indicator Light Illumination: Illuminates when malfunction occurs in 2 continuous driving cycles.

• Normality Judgement

Judge as OK and clear the NG if the following conditions are established.

Judgement Value

Malfunction Criteria	Threshold Value
Diagnosis of the rear oxygen sensor voltage low side	Incomplete
Minimum output voltage	≤ 0.15 V
Maximum output voltage	≥ 0.55 V

Time Needed for Diagnosis: Less than 1 second

Diagnostic Trouble Code (DTC) Detecting Criteria

GENERAL DESCRIPTION

AJ:DTC P0171 SYSTEM TOO LEAN (BANK 1)

1. OUTLINE OF DIAGNOSIS

Detect fuel system malfunction by the amount of main feedback control.

Diagnostic method

Fuel system is diagnosed by comparing the target air fuel ratio calculated by ECM with the actual air fuel ratio measured by sensor.

2. ENABLE CONDITION

Secondary Parameters	Enable Conditions
A/F main learning system	In operation
Engine coolant temperature	≥ 75 °C (167 °F)
Engine load change	< 0.02 g/rev (0 oz/rev)
Engine load	≥ Value of Map 1

Map 1

Engine speed (rpm)	Idling	650	1000	1500	2000	2500	3000	3500	4000	4500
Measured value (g(oz)/rev)	na	0.208 (0.01)	0.201 (0.01)	0.185 (0.01)	0.183 (0.01)	0.193 (0.01)	0.206 (0.01)	0.206 (0.01)	0.225 (0.01)	0.245 (0.01)

3. GENERAL DRIVING CYCLE

Perform the diagnosis continuously at idling or at a constant speed after warming up the engine.

4. DIAGNOSTIC METHOD

• Abnormality Judgement

Compare the diagnosed value (fsobd) with the threshold value, and if a condition meeting the malfunction criteria below continues for 10 s × 5 time(s) or more, judge that there is a fault in the fuel system.

Judgement Value

Malfunction Criteria	Threshold Value
$fsobd = (sglmd - tglmda) + faf + flaf$ In this case: sglmd = measured lambda tglmda = target lambda faf = main feedback compensation coefficient every 64 milliseconds flaf = main feedback learning compensation coefficient	≥ Value of Map 2

Map 2 (U5 model)

Amount of air (g (oz)/s)	0 (0)	3.2 (0.11)	6.4 (0.23)	9.6 (0.34)	12.8 (0.45)	16 (0.56)	19.2 (0.68)
fsobdL1 (%)	1.4	1.4	1.332	1.25	1.25	1.25	1.25

Map 2 (Other than U5 model)

Amount of air (g (oz)/s)	0 (0)	3.2 (0.11)	6.4 (0.23)	9.6 (0.34)	12.8 (0.45)	16 (0.56)	19.2 (0.68)
fsobdL1 (%)	1.4	1.4	1.332	1.265	1.265	1.265	1.265

Time Needed for Diagnosis: 10 s × 5 time(s)

Malfunction Indicator Light Illumination: Illuminates when malfunction occurs in 2 continuous driving cycles.

• Normality Judgement

Judge as OK and clear the NG if the continuous time while the following conditions are established is more than the predetermined time.

Judgement Value

Malfunction Criteria	Threshold Value
$fsobd = (sglmd - tglmda) + faf + flaf$	< 1.2

Time Needed for Diagnosis: 10 s

Diagnostic Trouble Code (DTC) Detecting Criteria

GENERAL DESCRIPTION

AK:DTC P0172 SYSTEM TOO RICH (BANK 1)

1. OUTLINE OF DIAGNOSIS

Detect fuel system malfunction by the amount of main feedback control.

Diagnostic method

Fuel system is diagnosed by comparing the target air fuel ratio calculated by ECM with the actual air fuel ratio measured by sensor.

2. ENABLE CONDITION

Secondary Parameters	Enable Conditions
A/F main learning system	In operation
Engine coolant temperature	$\geq 75\text{ }^{\circ}\text{C}$ (167 $^{\circ}\text{F}$)
Engine load change	$\leq 0.02\text{ g/rev}$ (0 oz/rev)
Learning value of EVAP conc.	< 0.15
Cumulative time of canister purge after engine start	$\geq 20\text{ s}$
Continuous period after canister purge starting	$\geq 29884\text{ ms}$
Engine load	\geq Value of Map 1

Map 1

Engine speed (rpm)	Idling	650	1000	1500	2000	2500	3000	3500	4000	4500
Measured value (g(oz)/rev)	na	0.208 (0.01)	0.201 (0.01)	0.185 (0.01)	0.183 (0.01)	0.193 (0.01)	0.206 (0.01)	0.206 (0.01)	0.225 (0.01)	0.245 (0.01)

3. GENERAL DRIVING CYCLE

Perform the diagnosis continuously at idling or at a constant speed after warming up the engine.

4. DIAGNOSTIC METHOD

• Abnormality Judgement

Compare the diagnosed value (fsobd) with the threshold value, and if a condition meeting the malfunction criteria below continues for 10 s \times 5 time(s) or more, judge that there is a fault in the fuel system.

Judgement Value

Malfunction Criteria	Threshold Value
$\text{fsobd} = (\text{sglmd} - \text{tglm da}) + \text{faf} + \text{flaf}$ In this case: sglmd = measured lambda tglm da = target lambda faf = main feedback compensation coefficient every 64 milliseconds flaf = main feedback learning compensation coefficient	$<$ Value of Map 2

Map 2

Amount of air (g (oz)/s)	0 (0)	3.2 (0.11)	6.4 (0.23)	9.6 (0.34)	12.8 (0.45)	16 (0.56)	19.2 (0.68)
fsobdL1 (%)	0.6	0.6	0.668	0.735	0.735	0.735	0.735

Time Needed for Diagnosis: 10 s \times 5 time(s)

Malfunction Indicator Light Illumination: Illuminates when malfunction occurs in 2 continuous driving cycles.

• Normality Judgement

Judge as OK when the malfunction criteria below continues for 10 seconds.

Judgement Value

Malfunction Criteria	Threshold Value
$\text{fsobd} = (\text{sglmd} - \text{tglm da}) + \text{faf} + \text{flaf}$	≥ 0.8

Time Needed for Diagnosis: 10 s

AL:DTC P0181 FUEL TEMPERATURE SENSOR “A” CIRCUIT RANGE/ PERFORMANCE

1. OUTLINE OF DIAGNOSIS

Detect faults in the fuel temperature sensor output properties.

Diagnosis is performed in two methods (drift diagnosis and stuck diagnosis). If either is NG, judge as NG. If both are OK, Judge as OK and clear the NG.

DRIFT DIAGNOSIS

Normally fuel temperature is lower than engine coolant temperature. When the fuel temperature becomes higher than the engine coolant temperature, the range is considered to be shifted, and judged as NG.

STUCK DIAGNOSIS

As the engine warms up (cumulative amount of intake air after starting is large), if the fuel temperature which should rise does not, determine as being stuck and NG.

2. COMPONENT DESCRIPTION

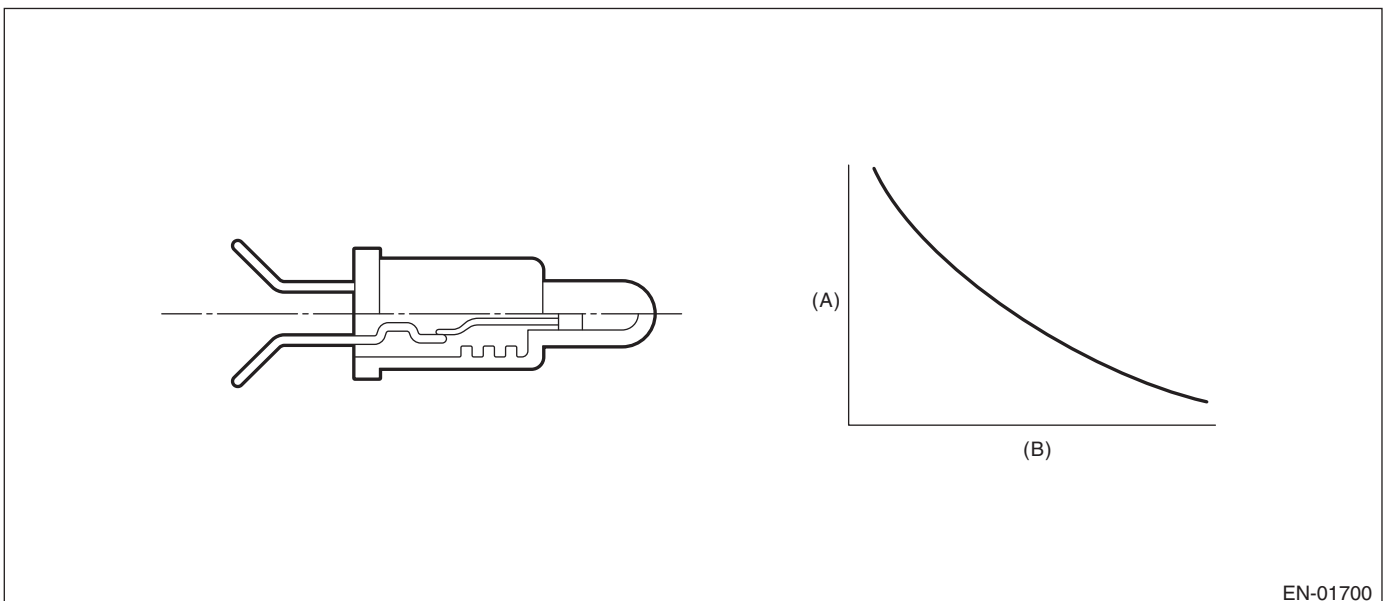

EN-01700

(A) Resistance value (Ω)

(B) Fuel temperature $^{\circ}\text{C}$ ($^{\circ}\text{F}$)

3. ENABLE CONDITION

DRIFT DIAGNOSIS

Secondary Parameters	Enable Conditions
None	

4. GENERAL DRIVING CYCLE

Always perform the diagnosis continuously.

Diagnostic Trouble Code (DTC) Detecting Criteria

GENERAL DESCRIPTION

5. DIAGNOSTIC METHOD

• Abnormality Judgement

If the duration of time while the following conditions are met is longer than the time indicated, judge as NG.

Judgement Value

Malfunction Criteria	Threshold Value
Fuel level	≥ 9.6 ℓ (2.54 US gal, 2.11 Imp gal)
Elapsed time after starting the engine	≥ 20 s
Engine coolant temperature – Engine coolant temperature at engine start	> 10 °C (50 °F)
Fuel temperature – Engine coolant temperature	≥ 10 °C (50 °F)
Battery voltage	≥ 10.9 V

Time Needed for Diagnosis: 120 s

Malfunction Indicator Light Illumination: Illuminates when malfunction occurs in 2 continuous driving cycles.

• Normality Judgement

Judge as OK and clear the NG if the continuous time while the following conditions are established is more than the predetermined time.

Judgement Value

Malfunction Criteria	Threshold Value
Fuel level	≥ 9.6 ℓ (2.54 US gal, 2.11 Imp gal)
Elapsed time after starting the engine	≥ 20 s
Engine coolant temperature – Engine coolant temperature at engine start	> 10 °C (50 °F)
Fuel temperature – Engine coolant temperature	< 10 °C (50 °F)
Battery voltage	≥ 10.9 V
Engine coolant temperature	< 75 °C (167 °F)

Time Needed for Diagnosis: Less than 1 second

6. ENABLE CONDITION

STUCK DIAGNOSIS

Secondary Parameters	Enable Conditions
Elapsed time after starting the engine	≥ 20000 ms
Battery voltage	≥ 10.9 V

7. GENERAL DRIVING CYCLE

Always perform diagnosis after 20 seconds have passed since the engine started.

Diagnostic Trouble Code (DTC) Detecting Criteria

GENERAL DESCRIPTION

8. DIAGNOSTIC METHOD

• Abnormality Judgement

Judge as NG when the following conditions are established.

Judgement Value

Malfunction Criteria	Threshold Value
Accumulated amount of intake air	≥ 551043 g (19435.29 oz)
Fuel temperature difference between Max. and Min.	< 2 °C (35.6 °F)

Time Needed for Diagnosis: Less than 1 second

Malfunction Indicator Light Illumination: Illuminates when malfunction occurs in 2 continuous driving cycles.

• Normality Judgement

Judge as OK and clear the NG if the following conditions are established.

Judgement Value

Malfunction Criteria	Threshold Value
Fuel temperature difference between Max. and Min.	≥ 2 °C (35.6 °F)

Time Needed for Diagnosis: Less than 1 second

Diagnostic Trouble Code (DTC) Detecting Criteria

GENERAL DESCRIPTION

AM:DTC P0182 FUEL TEMPERATURE SENSOR "A" CIRCUIT LOW INPUT

1. OUTLINE OF DIAGNOSIS

Detect the open or short circuit of fuel temperature sensor.
Judge as NG if out of specification.

2. COMPONENT DESCRIPTION

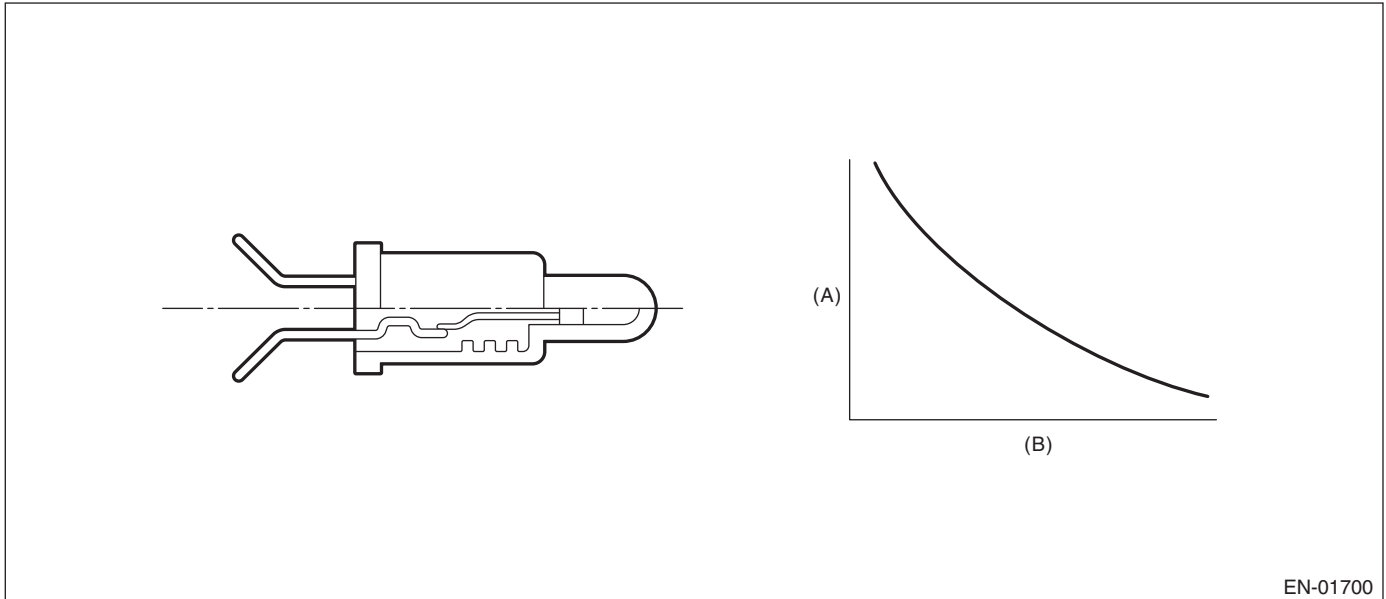

EN-01700

(A) Resistance value (Ω)

(B) Fuel temperature °C (°F)

3. ENABLE CONDITION

Secondary Parameters	Enable Conditions
None	

4. GENERAL DRIVING CYCLE

Always perform the diagnosis continuously.

5. DIAGNOSTIC METHOD

• Abnormality Judgement

If the duration of time while the following conditions are met is longer than the time indicated, judge as NG.

Judgement Value

Malfunction Criteria	Threshold Value
Output voltage	< 0.343951474 V
Battery voltage	≥ 10.9 V

Time Needed for Diagnosis:2500 ms

Malfunction Indicator Light Illumination: Illuminates as soon as a malfunction occurs.

• Normality Judgement

Judge as OK and clear the NG if the continuous time while the following conditions are established is more than the predetermined time.

Judgement Value

Malfunction Criteria	Threshold Value
Output voltage	≥ 0.343951474 V
Battery voltage	≥ 10.9 V

Time Needed for Diagnosis: Less than 1 second

Diagnostic Trouble Code (DTC) Detecting Criteria

GENERAL DESCRIPTION

AN:DTC P0183 FUEL TEMPERATURE SENSOR "A" CIRCUIT HIGH INPUT

1. OUTLINE OF DIAGNOSIS

Detect the open or short circuit of fuel temperature sensor.
Judge as NG if out of specification.

2. COMPONENT DESCRIPTION

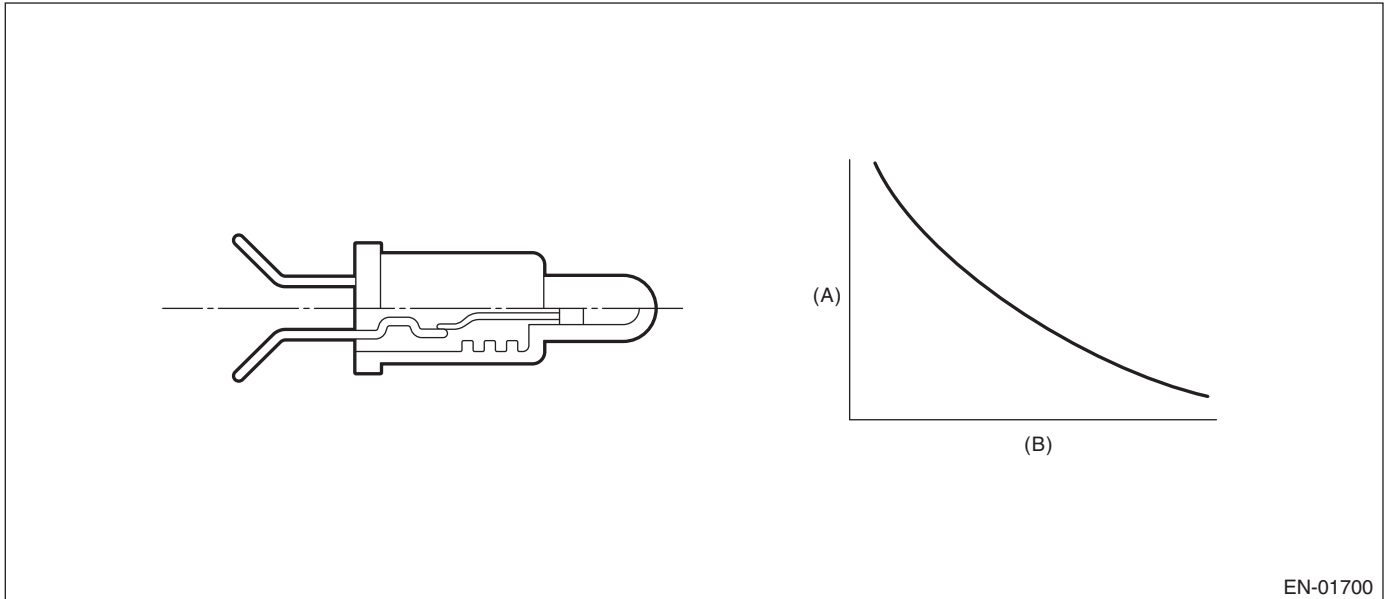

EN-01700

(A) Resistance value (Ω)

(B) Fuel temperature °C (°F)

3. ENABLE CONDITION

Secondary Parameters	Enable Conditions
None	

4. GENERAL DRIVING CYCLE

Always perform the diagnosis continuously.

5. DIAGNOSTIC METHOD

• Abnormality Judgement

If the duration of time while the following conditions are met is longer than the time indicated, judge as NG.

Judgement Value

Malfunction Criteria	Threshold Value
Output voltage	$\geq 4.716 \text{ V}$
Battery voltage	$\geq 10.9 \text{ V}$

Time Needed for Diagnosis: 2500 ms

Malfunction Indicator Light Illumination: Illuminates as soon as a malfunction occurs.

• Normality Judgement

Judge as OK and clear the NG if the continuous time while the following conditions are established is more than the predetermined time.

Judgement Value

Malfunction Criteria	Threshold Value
Output voltage	$< 4.716 \text{ V}$
Battery voltage	$\geq 10.9 \text{ V}$

Time Needed for Diagnosis: Less than 1 second

Diagnostic Trouble Code (DTC) Detecting Criteria

GENERAL DESCRIPTION

AO:DTC P0196 ENGINE OIL TEMPERATURE SENSOR CIRCUIT RANGE/ PERFORMANCE

1. OUTLINE OF DIAGNOSIS

Detect for abnormal values in the oil temperature sensor output properties.

Judge as NG when the oil temperature does not rise even though the engine is running under a condition where it should rise.

2. ENABLE CONDITION

Secondary Parameters	Enable Conditions
Battery voltage	≥ 10.9 V
Engine speed	≥ Value from Map

Map

Engine coolant temperature °C (°F)	-40 (-40)	-30 (-22)	-20 (-4)	-10 (14)	0 (32)	10 (50)	20 (68)	30 (86)
Engine speed rpm	500	500	500	500	500	500	500	500

Engine coolant temperature °C (°F)	40 (104)	50 (122)	60 (140)	70 (158)	80 (176)	90 (194)	100 (212)	110 (230)
Engine speed rpm	500	500	500	500	500	500	500	500

3. GENERAL DRIVING CYCLE

Perform the diagnosis continuously after starting the engine.

Diagnostic Trouble Code (DTC) Detecting Criteria

GENERAL DESCRIPTION

4. DIAGNOSTIC METHOD

• Abnormality Judgement

Judge as NG when the following conditions are established.

Judgement Value

Malfunction Criteria	Threshold Value
Engine oil temperature	< 15 °C (59 °F)
After engine start oil temperature sensor characteristic diagnosis timer.	≥ Judgement value for after engine start oil temperature sensor characteristic diagnosis timer

After engine start oil temperature sensor characteristic diagnosis timer (timer for diagnosis).

a. Timer stop at fuel cut

b. During the driving conditions except a) above, timer counts up as follows.

64 milliseconds + TOILCNT milliseconds (at the time of 64 milliseconds)

Where, TOILCNT is determined as follows,

TOILCNT = 0 at idle switch ON

For TOILCNT at Idle switch off, refer to the following table.

		Vehicle speed km/h (MPH)							
		0 (0)	8 (5)	16 (9.9)	24 (14.9)	32 (19.9)	40 (24.9)	48 (29.8)	56 (34.8)
Temperature °C (°F)	-30 (-22)	64 ms	73.2 ms	83.9 ms	96.3 ms	113.2 ms	133.9 ms	160.2 ms	194.6 ms
	-20 (-4)	64 ms	73.3 ms	84 ms	96.6 ms	113.7 ms	135 ms	162 ms	197.4 ms
	-10 (14)	64 ms	73.4 ms	84.2 ms	96.9 ms	114.5 ms	136.4 ms	164.4 ms	201.5 ms
	0 (32)	64 ms	73.5 ms	84.5 ms	97.4 ms	115.6 ms	138.5 ms	168 ms	207.6 ms
	10 (50)	102.2 ms	114.8 ms	129.4 ms	146.7 ms	171.7 ms	203.4 ms	245.1 ms	302.1 ms

After engine start oil temperature characteristic diagnosis timer judgement value (t).

$t = 1882940 \text{ ms} - 43302 \text{ ms} \times T_i$ ($t \geq 2400000$)

T_i = The lowest coolant temperature after starting the engine.

Time Needed for Diagnosis: Less than 1 second

Malfunction Indicator Light Illumination: Illuminates when malfunction occurs in 2 continuous driving cycles.

• Normality Judgement

Judge as OK and clear the NG if the following conditions are established.

Judgement Value

Malfunction Criteria	Threshold Value
Engine oil temperature	≥ 15 °C (59 °F)

Time Needed for Diagnosis: Less than 1 second

Diagnostic Trouble Code (DTC) Detecting Criteria

GENERAL DESCRIPTION

AP:DTC P0197 ENGINE OIL TEMPERATURE SENSOR LOW

1. OUTLINE OF DIAGNOSIS

Detect the open or short circuit of the oil temperature sensor.
Judge as NG when outside of the judgement value.

2. ENABLE CONDITION

Secondary Parameters	Enable Conditions
None	

3. GENERAL DRIVING CYCLE

Always perform the diagnosis continuously.

4. DIAGNOSTIC METHOD

• Abnormality Judgement

If the duration of time while the following conditions are met is longer than the time indicated, judge as NG.

Judgement Value

Malfunction Criteria	Threshold Value
Output voltage	< 0.166 V

Time Needed for Diagnosis: 500 ms

Malfunction Indicator Light Illumination: Illuminates as soon as a malfunction occurs.

• Normality Judgement

Judge as OK and clear the NG if the continuous time while the following conditions are established is more than the predetermined time.

Judgement Value

Malfunction Criteria	Threshold Value
Output voltage	≥ 0.166 V

Time Needed for Diagnosis: Less than 1 second

Diagnostic Trouble Code (DTC) Detecting Criteria

GENERAL DESCRIPTION

AQ:DTC P0198 ENGINE OIL TEMPERATURE SENSOR HIGH

1. OUTLINE OF DIAGNOSIS

Detect the open or short circuit of the oil temperature sensor.
Judge as NG when outside of the judgement value.

2. ENABLE CONDITION

Secondary Parameters	Enable Conditions
None	

3. GENERAL DRIVING CYCLE

Always perform the diagnosis continuously.

4. DIAGNOSTIC METHOD

• Abnormality Judgement

If the duration of time while the following conditions are met is longer than the time indicated, judge as NG.

Judgement Value

Malfunction Criteria	Threshold Value
Output voltage	≥ 4.716 V

Time Needed for Diagnosis: 500 ms

Malfunction Indicator Light Illumination: Illuminates as soon as a malfunction occurs.

• Normality Judgement

Judge as OK and clear the NG if the continuous time while the following conditions are established is more than the predetermined time.

Judgement Value

Malfunction Criteria	Threshold Value
Output voltage	< 4.716 V

Time Needed for Diagnosis: Less than 1 second

Diagnostic Trouble Code (DTC) Detecting Criteria

GENERAL DESCRIPTION

AR:DTC P0222 THROTTLE/PEDAL POSITION SENSOR/SWITCH “B” CIRCUIT LOW

1. OUTLINE OF DIAGNOSIS

Detect the open or short circuit of throttle position sensor 2.

Judge as NG if out of specification.

2. COMPONENT DESCRIPTION

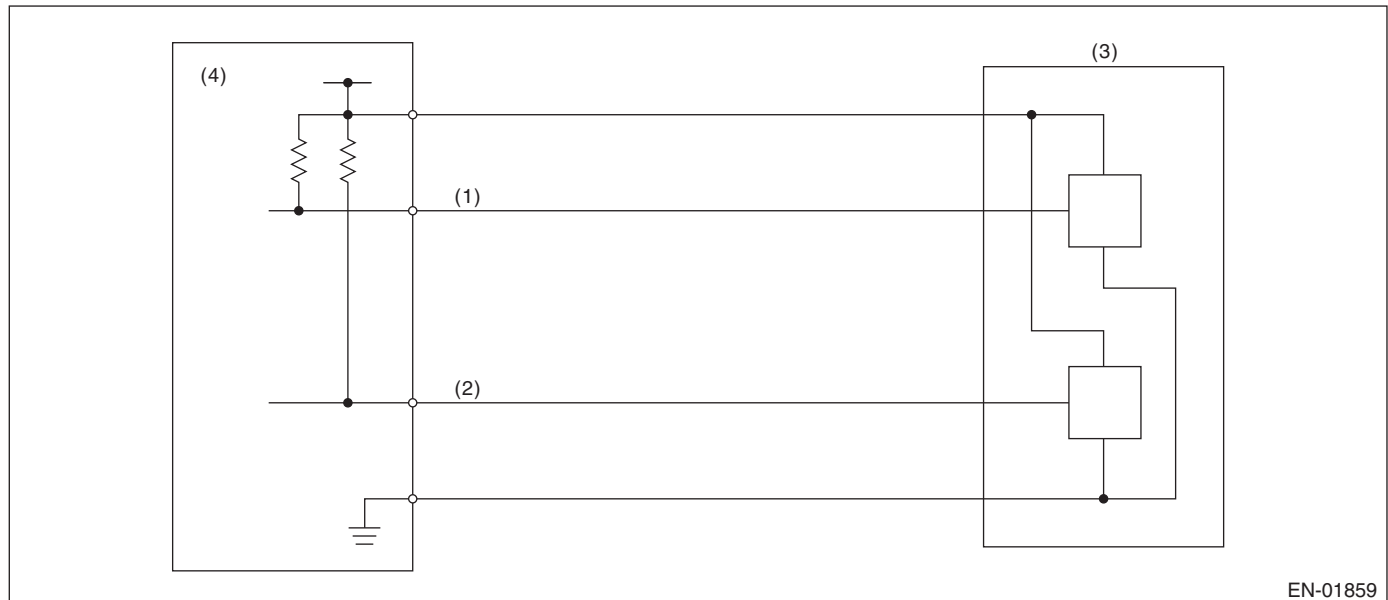

EN-01859

- (1) Throttle position sensor 1 signal (3) Throttle position sensor (4) Engine control module (ECM)
 (2) Throttle position sensor 2 signal

3. ENABLE CONDITION

Secondary Parameters	Enable Conditions
Ignition switch	ON
Battery voltage	$\geq 6 \text{ V}$

4. GENERAL DRIVING CYCLE

Always perform the diagnosis continuously.

5. DIAGNOSTIC METHOD

• Abnormality Judgement

If the duration of time while the following conditions are met is longer than the time indicated, judge as NG.

Judgement Value

Malfunction Criteria	Threshold Value
Sensor 2 input voltage	$\leq 0.926256 \text{ V}$

Time Needed for Diagnosis: 24 ms

Malfunction Indicator Light Illumination: Illuminates as soon as a malfunction occurs.

• Normality Judgement

Judge as OK and clear the NG if the continuous time while the following conditions are established is more than the predetermined time.

Judgement Value

Malfunction Criteria	Threshold Value
Sensor 2 input voltage	$> 0.926256 \text{ V}$

Time Needed for Diagnosis: 24 ms

AS:DTC P0223 THROTTLE/PEDAL POSITION SENSOR/SWITCH “B” CIRCUIT HIGH

1. OUTLINE OF DIAGNOSIS

Detect the open or short circuit of throttle position sensor 2.
Judge as NG if out of specification.

2. COMPONENT DESCRIPTION

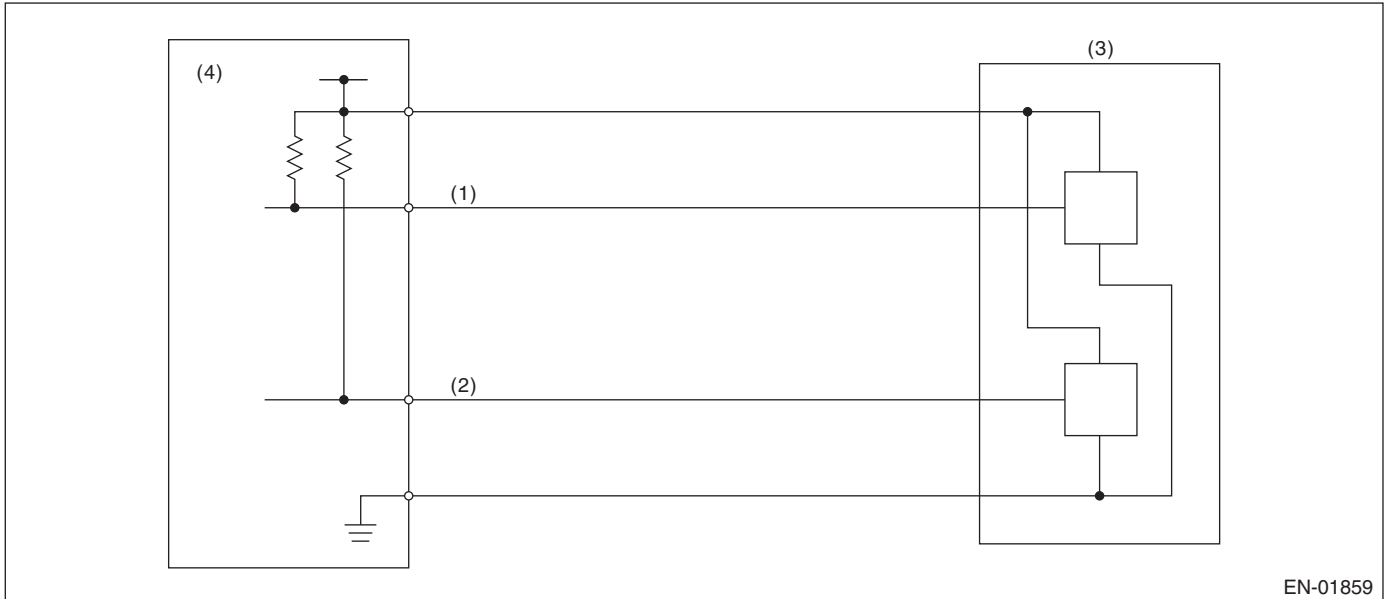

EN-01859

- (1) Throttle position sensor 1 signal (3) Throttle position sensor (4) Engine control module (ECM)
 (2) Throttle position sensor 2 signal

3. ENABLE CONDITION

Secondary Parameters	Enable Conditions
Ignition switch	ON
Battery voltage	≥ 6 V

4. GENERAL DRIVING CYCLE

Always perform the diagnosis continuously.

5. DIAGNOSTIC METHOD

• Abnormality Judgement

If the duration of time while the following conditions are met is longer than the time indicated, judge as NG.

Judgement Value

Malfunction Criteria	Threshold Value
Sensor 2 input voltage	≥ 4.858 V

Time Needed for Diagnosis:24 ms

Malfunction Indicator Light Illumination: Illuminates as soon as a malfunction occurs.

• Normality Judgement

Judge as OK and clear the NG if the continuous time while the following conditions are established is more than the predetermined time.

Judgement Value

Malfunction Criteria	Threshold Value
Sensor 2 input voltage	< 4.858 V

Time Needed for Diagnosis:24 ms

Diagnostic Trouble Code (DTC) Detecting Criteria

GENERAL DESCRIPTION

AT:DTC P0301 CYLINDER 1 MISFIRE DETECTED

1. OUTLINE OF DIAGNOSIS

Detect the presence of misfire occurrence. (Revolution fluctuation method)

Monitoring Misfire which influences exhaust deterioration (1.5 times of FTP) and catalyst damage is made obligatory by the law. Misfire affecting these two has two patterns below.:

- Intermittent misfire (The same cylinder misfires in random, or different cylinders misfire in random.): FTP 1.5 times misfire
- Every time misfire (The same cylinder misfires every time.): FTP 1.5 times misfire, Catalyst damage misfire

The following detecting methods are adopted for these detection.

1) Intermittent misfire: FTP 1.5 times misfire

- 180° Interval Difference Method (MT: 1,800 rpm or less; AT: None)
- 360° Interval Difference Method (whole range)
- 720° Interval Difference Method (3,000 rpm or more)

2) Misfire every time: FTP 1.5 times misfire, Catalyst damage misfire

- 360° Interval Difference Method

2. ENABLE CONDITION

Secondary Parameters	Enable Conditions
All secondary parameters enable conditions	≥ 1024 ms
Intake manifold pressure change at 180°CA	< Value of Map 1
Throttle position change during 16 milliseconds	< 21 °
Fuel shut-off function	Not in operation
Fuel level	≥ 9.6 ℓ (2.54 US gal, 2.11 Imp gal)
Vehicle dynamic control or AT torque control	Not in operation
Evaporative system leak check	Not in operation
Engine speed	460 rpm — 6300 rpm
Intake manifold pressure	≥ Value of Map 2
Battery voltage	≥ 8 V
Fuel parameter determination	Not extremely low volatility
Elapsed time after starting the engine	≥ 0 ms
Engine load change during 32 milliseconds	< 1000 rpm

Map 1

- AT model

rpm	700	1000	1500	2000	2500	3000	3500	4000	4500	5000	5500	6000	6300
kPa	13.3	13.3	13.3	13.3	13.3	13.3	13.3	13.3	13.3	13.3	13.3	13.3	13.3
(mmHg, inHg)	(100, 3.9)	(100, 3.9)	(100, 3.9)	(100, 3.9)	(100, 3.9)	(100, 3.9)	(100, 3.9)	(100, 3.9)	(100, 3.9)	(100, 3.9)	(100, 3.9)	(100, 3.9)	(100, 3.9)

- MT model

rpm	650	1000	1500	2000	2500	3000	3500	4000	4500	5000	5500	6000	6300
kPa	13.3	13.3	13.3	13.3	13.3	13.3	13.3	13.3	13.3	13.3	13.3	13.3	13.3
(mmHg, inHg)	(100, 3.9)	(100, 3.9)	(100, 3.9)	(100, 3.9)	(100, 3.9)	(100, 3.9)	(100, 3.9)	(100, 3.9)	(100, 3.9)	(100, 3.9)	(100, 3.9)	(100, 3.9)	(100, 3.9)

Map 2

- AT model

rpm	700	1000	1500	2000	2500	3000	3500	4000	4500	5000	5500	6000	6300
kPa	26	23.9	23.3	23.1	23.6	25.1	26.2	26.6	26.9	30	33.4	37.8	39.5
(mmHg, inHg)	(195.0, 7.7)	(179.5, 7.1)	(174.7, 6.9)	(173.2, 6.8)	(176.8, 7)	(188.0, 7.4)	(196.9, 7.8)	(199.6, 7.9)	(201.5, 7.9)	(225.0, 8.9)	(250.4, 9.9)	(283.5, 11.2)	(296.0, 11.7)

Diagnostic Trouble Code (DTC) Detecting Criteria

GENERAL DESCRIPTION

- MT model

Vehicle speed < 64 km/h (39.8 MPH)

rpm	650	1000	1500	2000	2500	3000	3500	4000	4500	5000	5500	6000	6300
kPa (mmHg, inHg)	24.5 (184, 7.2)	22.7 (170.3, 6.7)	21.4 (160.2, 6.3)	21.5 (161.6, 6.4)	21.5 (161.4, 6.4)	23.2 (174.4, 6.9)	24.7 (185.5, 7.3)	25.8 (193.3, 7.6)	27.1 (203.2, 8)	28.8 (216.3, 8.5)	32.3 (242.2, 9.5)	36.3 (272, 10.7)	37.9 (284.5, 11.2)

Vehicle speed ≥ 68 km/h (42.3 MPH)

rpm	650	1000	1500	2000	2500	3000	3500	4000	4500	5000	5500	6000	6300
kPa (mmHg, inHg)	31.6 (237, 9.3)	31.6 (237, 9.3)	31.6 (237, 9.3)	31.1 (233, 9.2)	31.3 (235, 9.3)	33.1 (248, 9.8)	33.9 (254, 10)	28.8 (216, 8.5)	30.1 (226, 8.9)	33.3 (250, 9.8)	36.9 (277, 10.9)	40.1 (301, 11.9)	43.2 (324, 12.8)

3. GENERAL DRIVING CYCLE

- If conditions are met, it is possible to detect the misfires from idling to high engine speed. However, in case any engine load or breakage occurs, perform with the engine at idle.
- Perform the diagnosis continuously.

4. DIAGNOSTIC METHOD

When a misfire occurs, the engine speed will decreased and the crankshaft position speed will change. Calculate the interval difference value (diagnostic value) from crankshaft position speed by the following formula, and judge whether a misfire is occurring or not comparing the calculated result with judgement value. While counting the number of misfires, if the misfire ratio is higher during 1000 revs. or 200 revs., judge corresponding cylinders as NG.

Diagnostic value calculation (Calculate from angle speed) →	Misfire detection every single ignition (Compare diagnostic value with judgement value) →	NG judgement (Misfire occurrence judgement required by the law) (Compare number of misfire with judgement)
	<ul style="list-style-type: none"> • 180° Interval Difference Method • 360° Interval Difference Method • 720° Interval Difference Method 	<ul style="list-style-type: none"> • FTP 1.5 times misfire NG judgement • Catalyst damage misfire NG judgement

As shown in the following figure, pick a cylinder as the standard and name it omg 0. And the former crankshaft position speed is named omg 1, the second former crankshaft position speed is named omg 2, the third is named omg 3, etc.

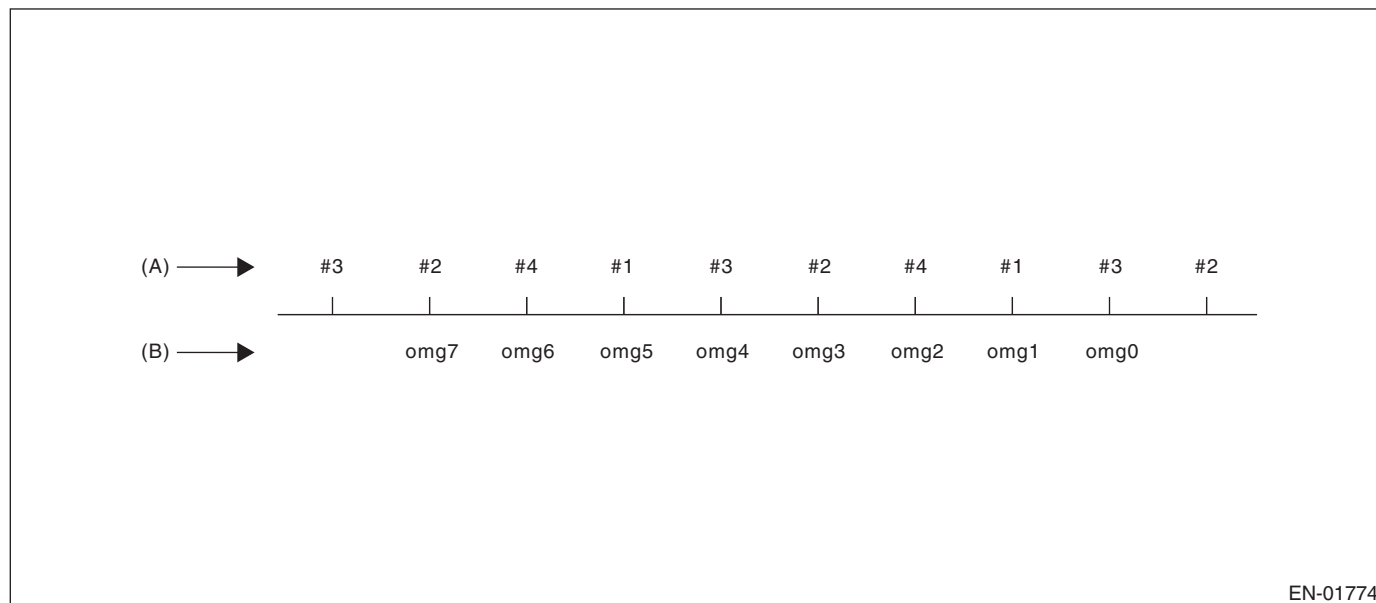

EN-01774

(A) Ignition order

(B) Crankshaft position speed

Diagnostic Trouble Code (DTC) Detecting Criteria

GENERAL DESCRIPTION

180° Interval Difference Method

Diagnostic value $domg\ 180 = (omg\ 1 - omg\ 0) - (omg\ 5 - omg\ 1)/4$

Judge as a misfire in the following cases.

- $domg\ 180 >$ judgement value of positive side
- $domg\ 180 \leq$ judgement value of negative side
(Judgement value before 180° CA)

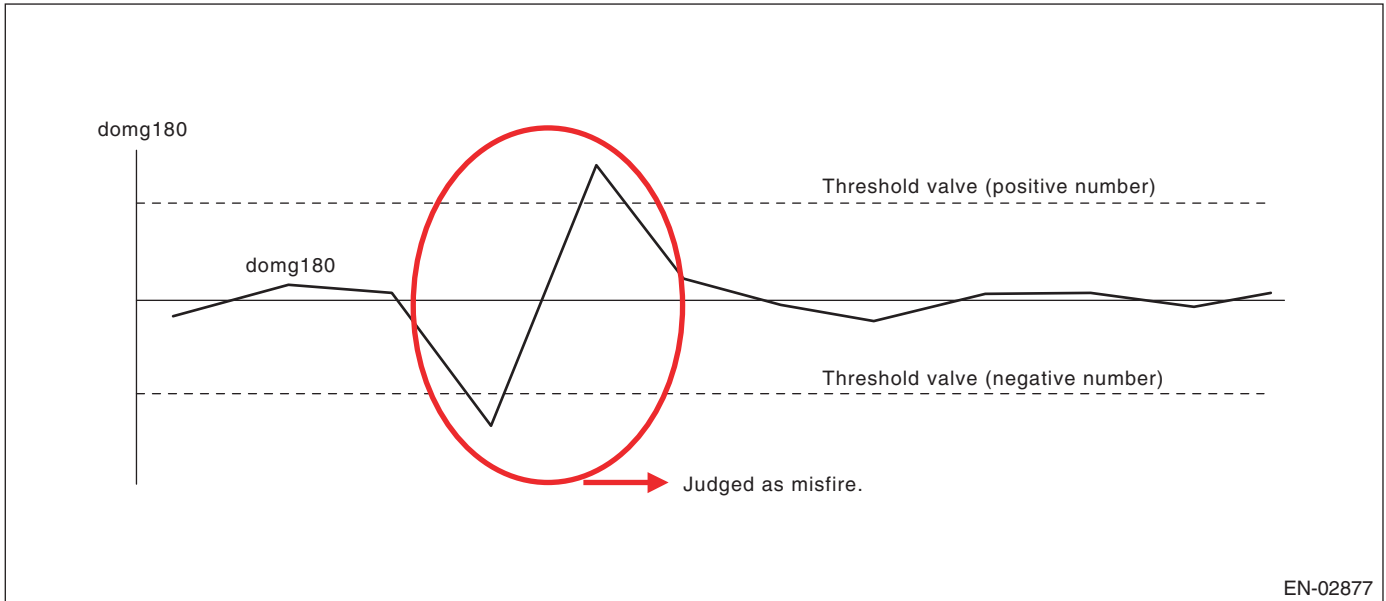

360° Interval Difference Method

Diagnostic value $domg\ 360 = (omg\ 1 - omg\ 0) - (omg\ 3 - omg\ 2)$

Misfire judgement $domg\ 360 >$ Judgement value \rightarrow Judge as misfire

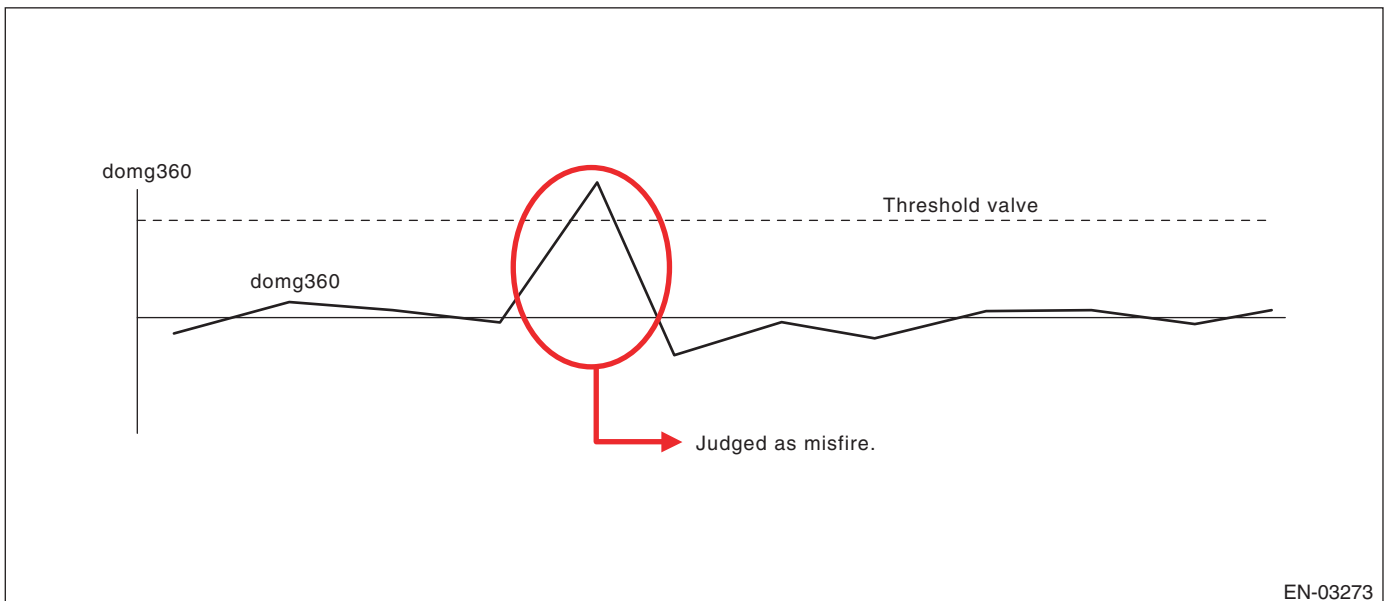

Diagnostic Trouble Code (DTC) Detecting Criteria

GENERAL DESCRIPTION

720° Interval Difference Method

Diagnostic value	$\text{domg 720} = (\text{omg 1} - \text{omg 0}) - (\text{omg 5} - \text{omg 4})$
Misfire judgement	$\text{domg 720} > \text{Judgement value} \rightarrow \text{Judge as misfire}$

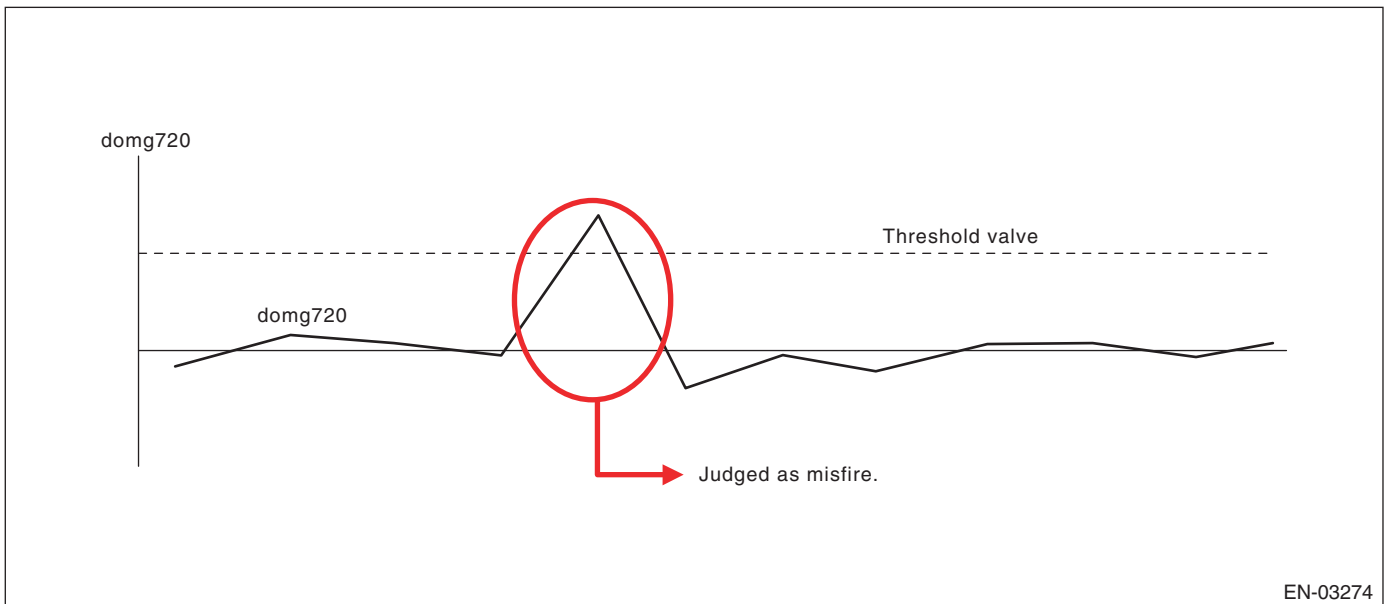

- FTP 1.5 times misfire (Misfire occurrence level which influences exhaust gas)

- Abnormality Judgement

Judgement Value (Judge that malfunction occurs when the misfire ratio is high in 1000 engine revs.)

Malfunction Criteria	Threshold Value
FTP emission judgement value	$\geq 18 \times 100/2000\%$ in 1000 revs. (U5 model)
	$\geq 20 \times 100/2000\%$ in 1000 revs. (Other than U5 model)

Time Needed for Diagnosis: 1000 engine revs.

Malfunction Indicator Light Illumination: Illuminates when malfunction occurs in 2 continuous driving cycles.

- Normality Judgement

Judgement Value

Malfunction Criteria	Threshold Value
FTP emission judgement value	$< 18 \times 100/2000\%$ in 1000 revs. (U5 model)
	$< 20 \times 100/2000\%$ in 1000 revs. (Other than U5 model)

Time Needed for Diagnosis: 1000 engine revs.

Diagnostic Trouble Code (DTC) Detecting Criteria

GENERAL DESCRIPTION

- Catalyst damage misfire (Misfire occurrence level damaging catalyst)
- Abnormality Judgement

Judgement Value

Malfunction Criteria	Threshold Value
Catalyst damage misfire judgement value	≥ Value of Map 3

Map 3 (U5 model)

		Intake air (g(oz)/rev)							
		0.16 (0.01)	0.28 (0.01)	0.4 (0.01)	0.52 (0.02)	0.64 (0.02)	0.76 (0.03)	0.92 (0.03)	1.1 (0.04)
Engine speed (rpm)	700	100	100	100	100	90	80	64	48
	1000	100	100	100	100	90	80	52	24
	1500	100	100	90	80	69	57	39	22
	2000	80	80	80	80	62	44	33	21
	2500	67	67	58	50	40	31	25	20
	3000	57	57	49	40	30	20	20	20
	3500	44	44	34	24	20	20	20	20
	4000	36	36	28	20	20	20	20	20
	4500	27	27	20	20	20	20	20	20
	5000	20	20	20	20	20	20	20	20
	5500	20	20	20	20	20	20	20	20
	6000	20	20	20	20	20	20	20	20
6300	20	20	20	20	20	20	20	20	

Map 3 (Other than U5 model)

		Intake air (g(oz)/rev)							
		0.16 (0.01)	0.28 (0.01)	0.4 (0.01)	0.52 (0.02)	0.64 (0.02)	0.76 (0.03)	0.92 (0.03)	1.1 (0.04)
Engine speed (rpm)	700	100	100	100	100	90	80	64	48
	1000	100	100	100	100	90	80	63	44
	1500	100	100	90	80	73	67	54	40
	2000	80	80	80	80	68	57	51	44
	2500	80	80	73	67	62	57	51	44
	3000	67	67	62	57	51	44	44	44
	3500	67	67	56	44	40	36	34	31
	4000	57	57	44	31	24	20	20	20
	4500	44	44	33	31	20	20	20	20
	5000	44	44	38	31	20	20	20	20
	5500	36	36	31	27	20	20	20	20
	6000	20	20	20	20	20	20	20	20
6300	20	20	20	20	20	20	20	20	

Time Needed for Diagnosis: 200 engine revs.

Malfunction Indicator Light Illumination: Illuminates as soon as a malfunction occurs.

- Normality Judgement

Judgement Value

Malfunction Criteria	Threshold Value
Catalyst damage misfire judgement value	< Value of Map 3

Time Needed for Diagnosis: 200 engine revs.

Diagnostic Trouble Code (DTC) Detecting Criteria

GENERAL DESCRIPTION

AU:DTC P0302 CYLINDER 2 MISFIRE DETECTED

1. OUTLINE OF DIAGNOSIS

NOTE:

For the detection standard, refer to DTC P0301. <Ref. to GD(H4SO)-78, DTC P0301 CYLINDER 1 MISFIRE DETECTED, Diagnostic Trouble Code (DTC) Detecting Criteria.>

AV:DTC P0303 CYLINDER 3 MISFIRE DETECTED

1. OUTLINE OF DIAGNOSIS

NOTE:

For the detection standard, refer to DTC P0301. <Ref. to GD(H4SO)-78, DTC P0301 CYLINDER 1 MISFIRE DETECTED, Diagnostic Trouble Code (DTC) Detecting Criteria.>

AW:DTC P0304 CYLINDER 4 MISFIRE DETECTED

1. OUTLINE OF DIAGNOSIS

NOTE:

For the detection standard, refer to DTC P0301. <Ref. to GD(H4SO)-78, DTC P0301 CYLINDER 1 MISFIRE DETECTED, Diagnostic Trouble Code (DTC) Detecting Criteria.>

Diagnostic Trouble Code (DTC) Detecting Criteria

GENERAL DESCRIPTION

AX:DTC P0327 KNOCK SENSOR 1 CIRCUIT LOW (BANK 1 OR SINGLE SENSOR)

1. OUTLINE OF DIAGNOSIS

Detect the open or short circuit of knock sensor.
Judge as NG if out of specification.

2. COMPONENT DESCRIPTION

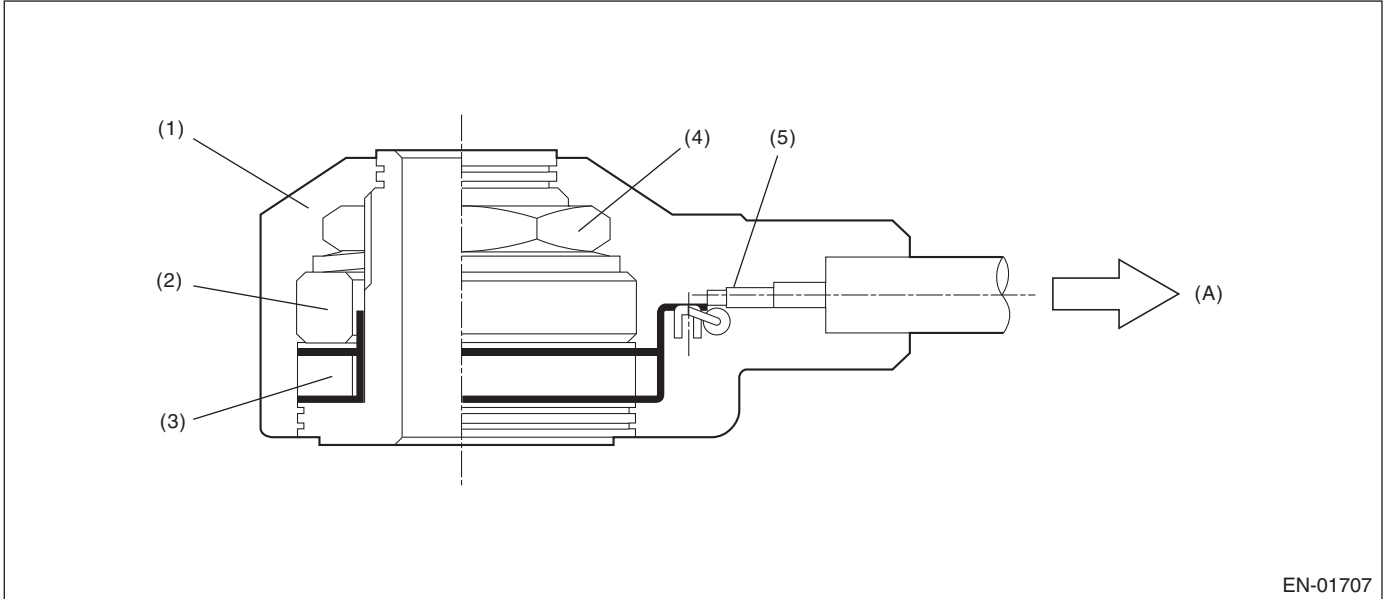

EN-01707

(A) To knock sensor harness

(1) Case

(3) Piezoelectric element

(5) Resistance

(2) Weight

(4) Nut

3. ENABLE CONDITION

Secondary Parameters	Enable Conditions
None	

4. GENERAL DRIVING CYCLE

Always perform the diagnosis continuously.

Diagnostic Trouble Code (DTC) Detecting Criteria

GENERAL DESCRIPTION

5. DIAGNOSTIC METHOD

• Abnormality Judgement

If the duration of time while the following conditions are met is longer than the time indicated, judge as NG.

Judgement Value

Malfunction Criteria	Threshold Value
Output voltage	< 0.243 V

Time Needed for Diagnosis: 1000 ms

Malfunction Indicator Light Illumination: Illuminates as soon as a malfunction occurs.

• Normality Judgement

Judge as OK and clear the NG if the continuous time while the following conditions are established is more than the predetermined time.

Judgement Value

Malfunction Criteria	Threshold Value
Output voltage	≥ 0.243 V

Time Needed for Diagnosis: Less than 1 second

Diagnostic Trouble Code (DTC) Detecting Criteria

GENERAL DESCRIPTION

AY:DTC P0328 KNOCK SENSOR 1 CIRCUIT HIGH (BANK 1 OR SINGLE SENSOR)

1. OUTLINE OF DIAGNOSIS

Detect the open or short circuit of knock sensor.

Judge as NG if out of specification.

2. COMPONENT DESCRIPTION

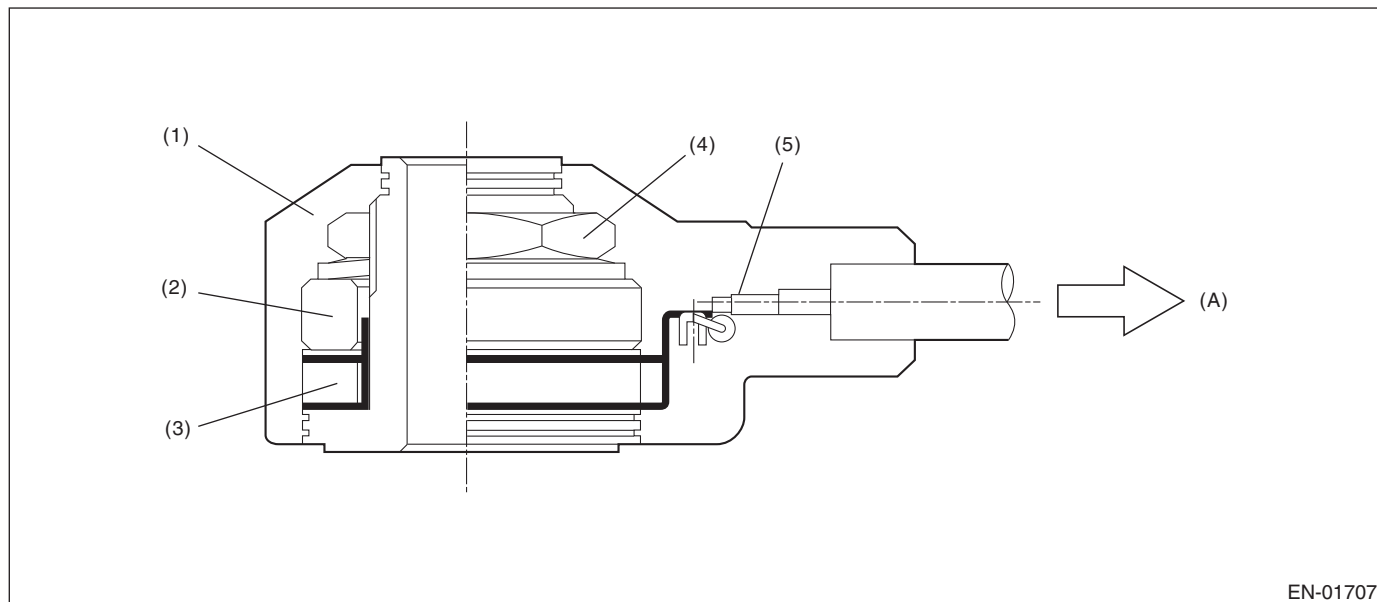

(A) To knock sensor harness

(1) Case

(2) Weight

(3) Piezoelectric element

(4) Nut

(5) Resistance

3. ENABLE CONDITION

Secondary Parameters	Enable Conditions
None	

4. GENERAL DRIVING CYCLE

Always perform the diagnosis continuously.

5. DIAGNOSTIC METHOD

• Abnormality Judgement

If the duration of time while the following conditions are met is longer than the time indicated, judge as NG.

Judgement Value

Malfunction Criteria	Threshold Value
Output voltage	≥ 4.709 V

Time Needed for Diagnosis: 1000 ms

Malfunction Indicator Light Illumination: Illuminates as soon as a malfunction occurs.

• Normality Judgement

Judge as OK and clear the NG if the continuous time while the following conditions are established is more than the predetermined time.

Judgement Value

Malfunction Criteria	Threshold Value
Output voltage	< 4.709 V

Time Needed for Diagnosis: Less than 1 second

AZ:DTC P0335 CRANKSHAFT POSITION SENSOR "A" CIRCUIT

1. OUTLINE OF DIAGNOSIS

Detect the open or short circuit of the crankshaft position sensor.

Judge as NG when the crank signal is not input even though the starter was rotated.

2. COMPONENT DESCRIPTION

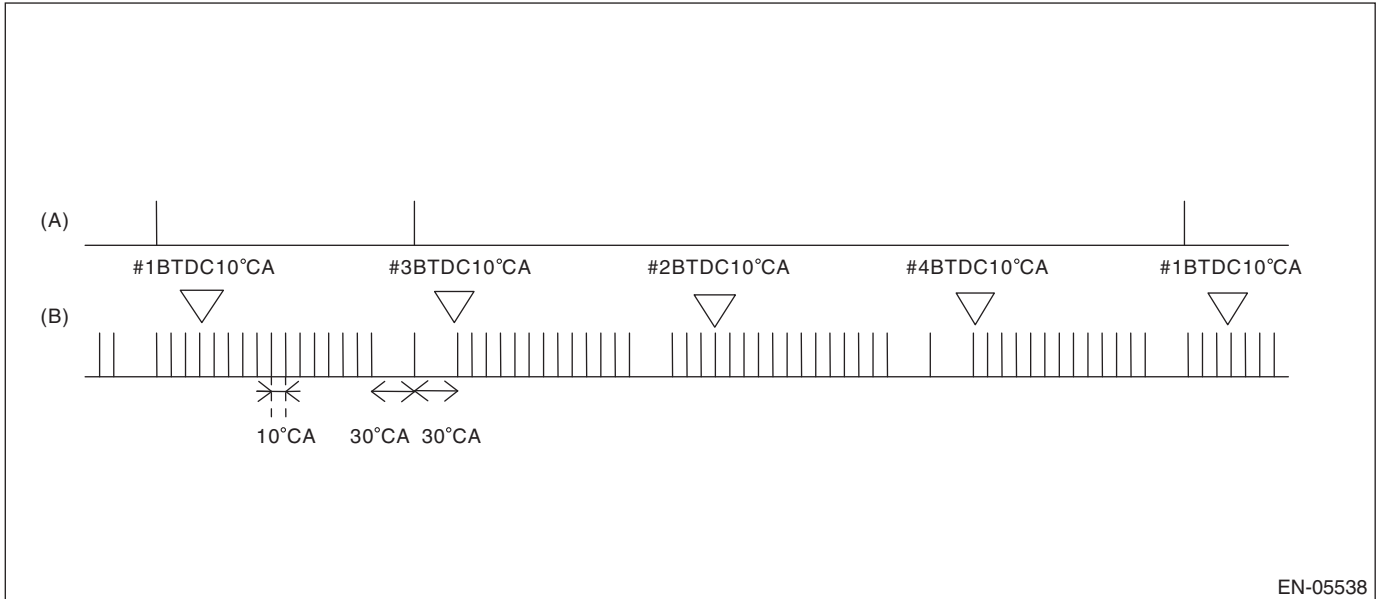

(A) Cam signal

(B) Crankshaft signal

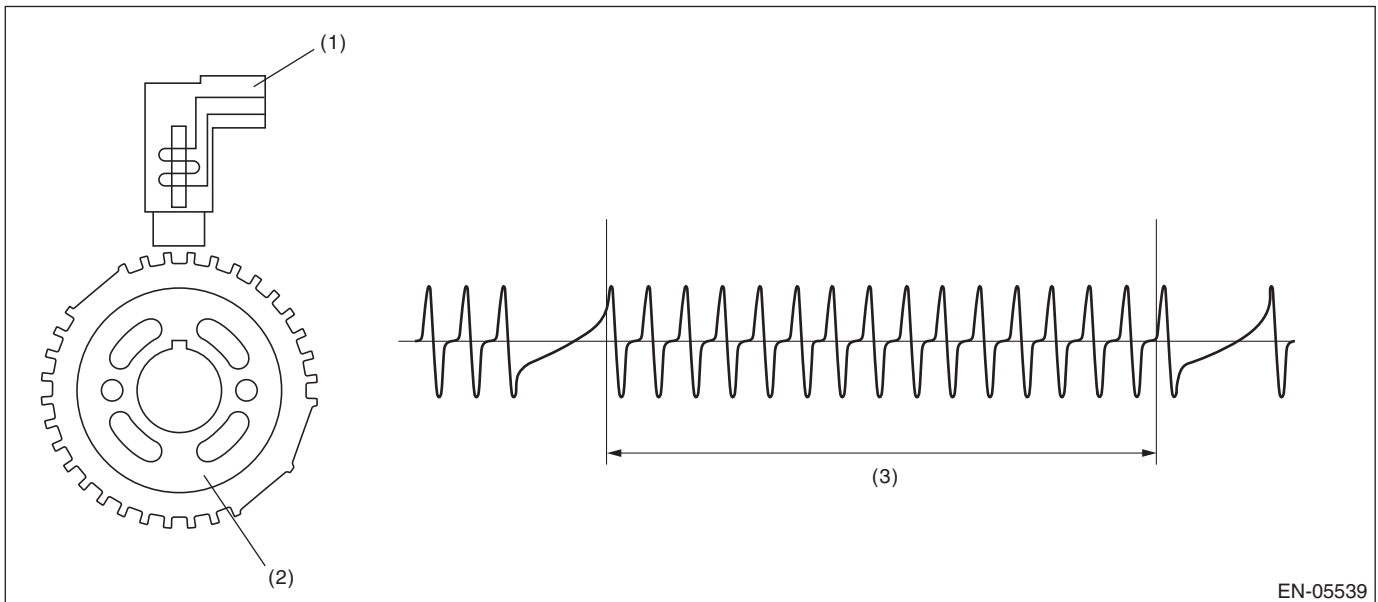

(1) Crankshaft position sensor

(2) Crank sprocket

(3) Crankshaft half-turn

3. ENABLE CONDITION

Secondary Parameters	Enable Conditions
None	

4. GENERAL DRIVING CYCLE

Always perform the diagnosis continuously.

Diagnostic Trouble Code (DTC) Detecting Criteria

GENERAL DESCRIPTION

5. DIAGNOSTIC METHOD

• Abnormality Judgement

If the duration of time while the following conditions are met is longer than the time indicated, judge as NG.

Judgement Value

Malfunction Criteria	Threshold Value
Starter switch	ON
Crankshaft position sensor signal	Not detected
Battery voltage	$\geq 8\text{ V}$

Time Needed for Diagnosis:3000 ms

Malfunction Indicator Light Illumination: Illuminates as soon as a malfunction occurs.

• Normality Judgement

Judge as OK and clear the NG if the continuous time while the following conditions are established is more than the predetermined time.

Judgement Value

Malfunction Criteria	Threshold Value
Crankshaft position sensor signal	Input exists
Battery voltage	$\geq 8\text{ V}$

Time Needed for Diagnosis: Less than 1 second

Diagnostic Trouble Code (DTC) Detecting Criteria

GENERAL DESCRIPTION

BA:DTC P0336 CRANKSHAFT POSITION SENSOR "A" CIRCUIT RANGE/ PERFORMANCE

1. OUTLINE OF DIAGNOSIS

Detect for faults in crankshaft position sensor output properties.

Judge as NG when there is a problem in the number of crankshaft signals for every revolution.

2. COMPONENT DESCRIPTION

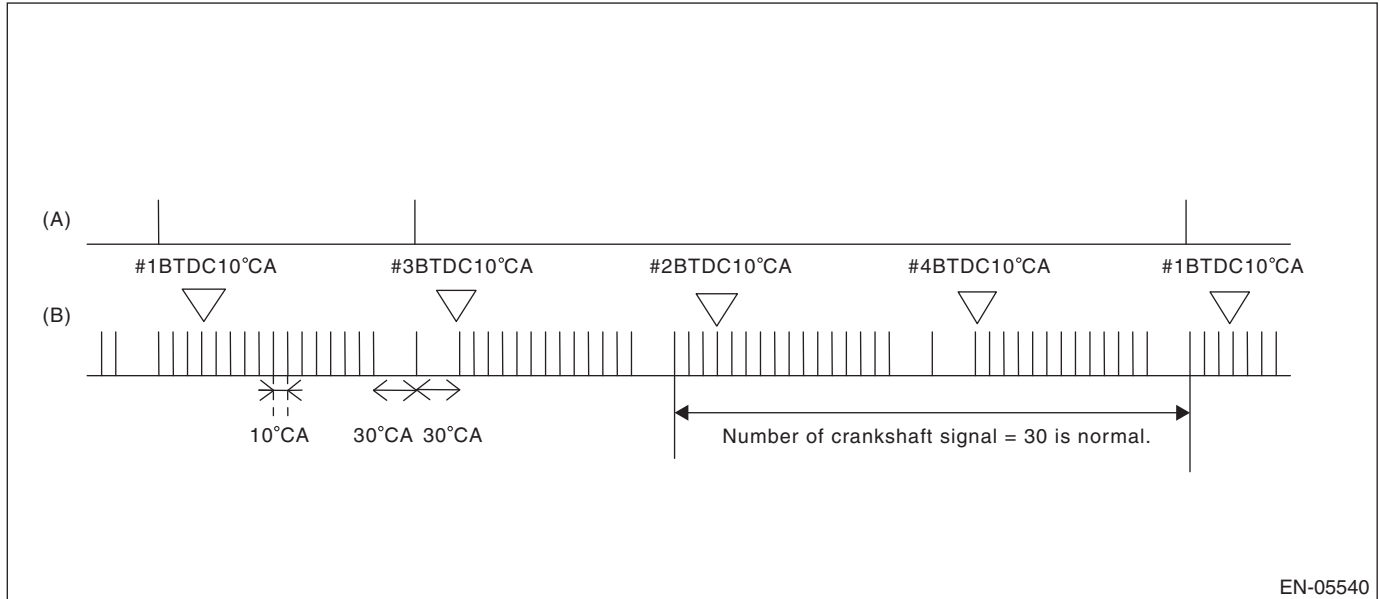

(A) Cam signal

(B) Crankshaft signal

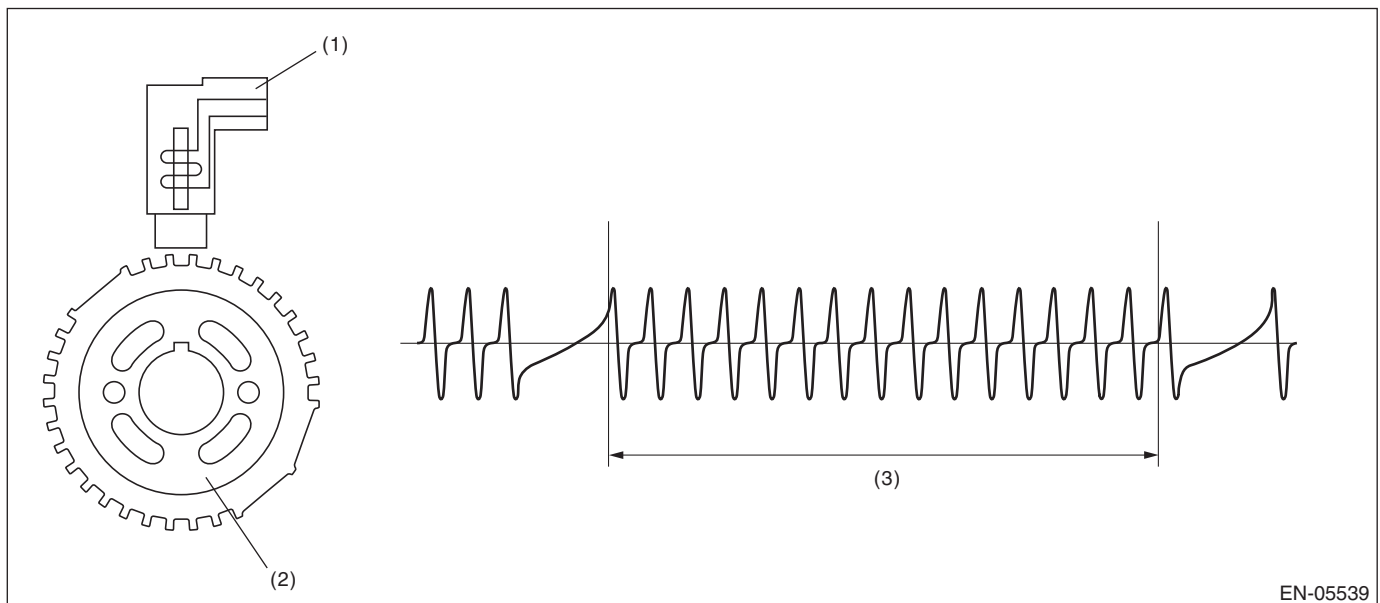

(1) Crankshaft position sensor

(2) Crank sprocket

(3) Crankshaft half-turn

3. ENABLE CONDITION

Secondary Parameters	Enable Conditions
Battery voltage	≥ 8 V
Engine speed	< 4000 rpm

Diagnostic Trouble Code (DTC) Detecting Criteria

GENERAL DESCRIPTION

4. GENERAL DRIVING CYCLE

Perform the diagnosis continuously under 3000 rpm engine revs.

5. DIAGNOSTIC METHOD

• Abnormality Judgement

Judge as NG when the following conditions are established.

Judgement Value

Malfunction Criteria	Threshold Value
Cylinder number identification	Completed
Amount of crank sensor signal during 1 rev.	Not = 30

Time Needed for Diagnosis: 10 engine revs.

Malfunction Indicator Light Illumination: Illuminates when malfunction occurs in 2 continuous driving cycles.

• Normality Judgement

Judge as OK and clear the NG if the continuous time while the following conditions are established is more than the predetermined time.

Judgement Value

Malfunction Criteria	Threshold Value
Cylinder number identification	Completed
Amount of crank sensor signal during 1 rev.	= 30

Time Needed for Diagnosis: Less than 1 second

BB:DTC P0340 CAMSHAFT POSITION SENSOR “A” CIRCUIT (BANK 1 OR SINGLE SENSOR)

1. OUTLINE OF DIAGNOSIS

Detect the open or short circuit of the camshaft position sensor.
Judge as NG when the number of camshaft signals remains abnormal.

2. COMPONENT DESCRIPTION

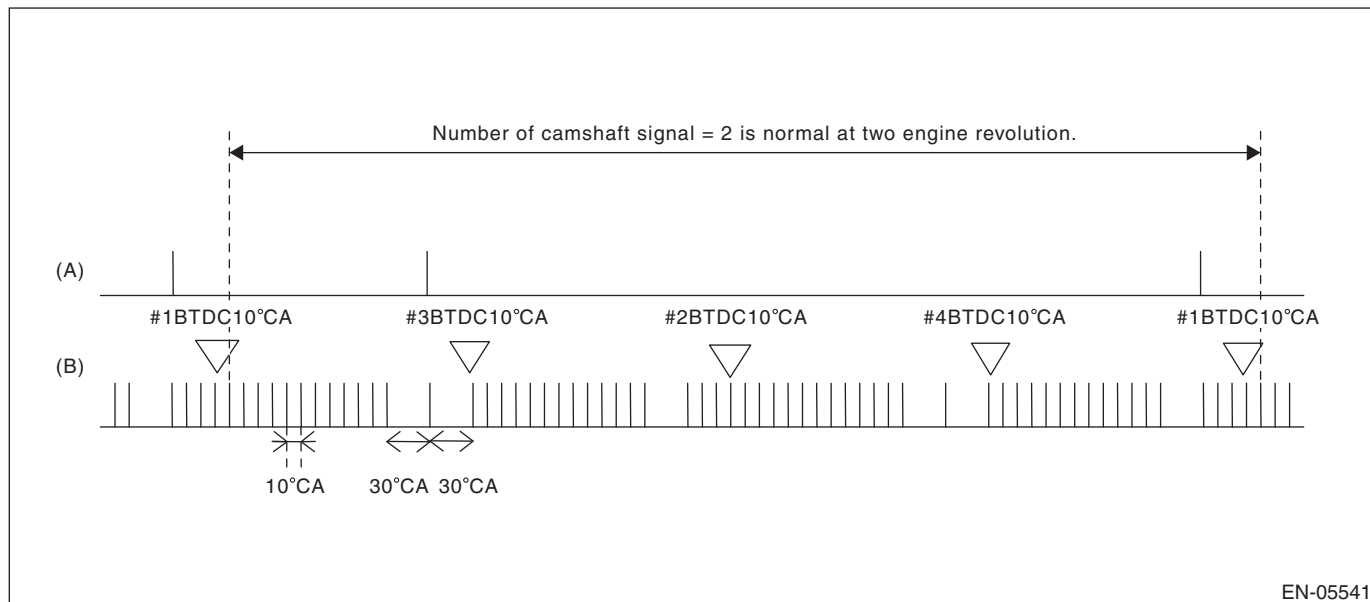

(A) Camshaft signal

(B) Crankshaft signal

3. ENABLE CONDITION

Secondary Parameters	Enable Conditions
None	

4. GENERAL DRIVING CYCLE

Always perform the diagnosis continuously.

5. DIAGNOSTIC METHOD

Abnormality Judgement

If the duration of time while the following conditions are met is longer than the time indicated, judge as NG.

Judgement Value

Malfunction Criteria	Threshold Value
Battery voltage	≥ 8 V
Amount of camshaft sensor signal during 2 revs.	Not = 2

Time Needed for Diagnosis: Two engine revs. × 4 time(s)

Malfunction Indicator Light Illumination: Illuminates as soon as a malfunction occurs.

Normality Judgement

Judge as OK and clear the NG if the continuous time while the following conditions are established is more than the predetermined time.

Judgement Value

Malfunction Criteria	Threshold Value
Voltage	≥ 8 V
Amount of camshaft sensor signal during 2 revs.	= 2

Time Needed for Diagnosis: Two engine revs.

Diagnostic Trouble Code (DTC) Detecting Criteria

GENERAL DESCRIPTION

BC:DTC P0341 CAMSHAFT POSITION SENSOR "A" CIRCUIT RANGE/ PERFORMANCE (BANK 1 OR SINGLE SENSOR)

1. OUTLINE OF DIAGNOSIS

Detect the malfunction of camshaft position sensor output property.

Judge as NG when the camshaft line signal input timing is shifted from the crankshaft signal because of timing belt tooth chip etc.

2. COMPONENT DESCRIPTION

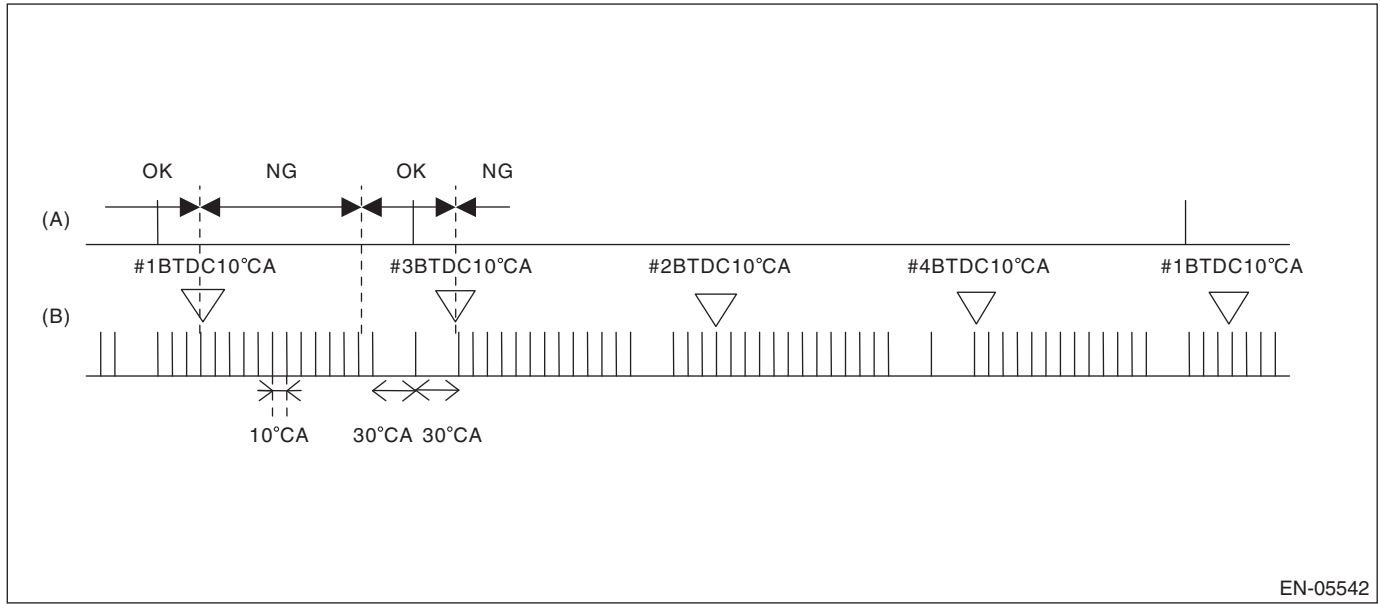

EN-05542

(A) Camshaft signal

(B) Crankshaft signal

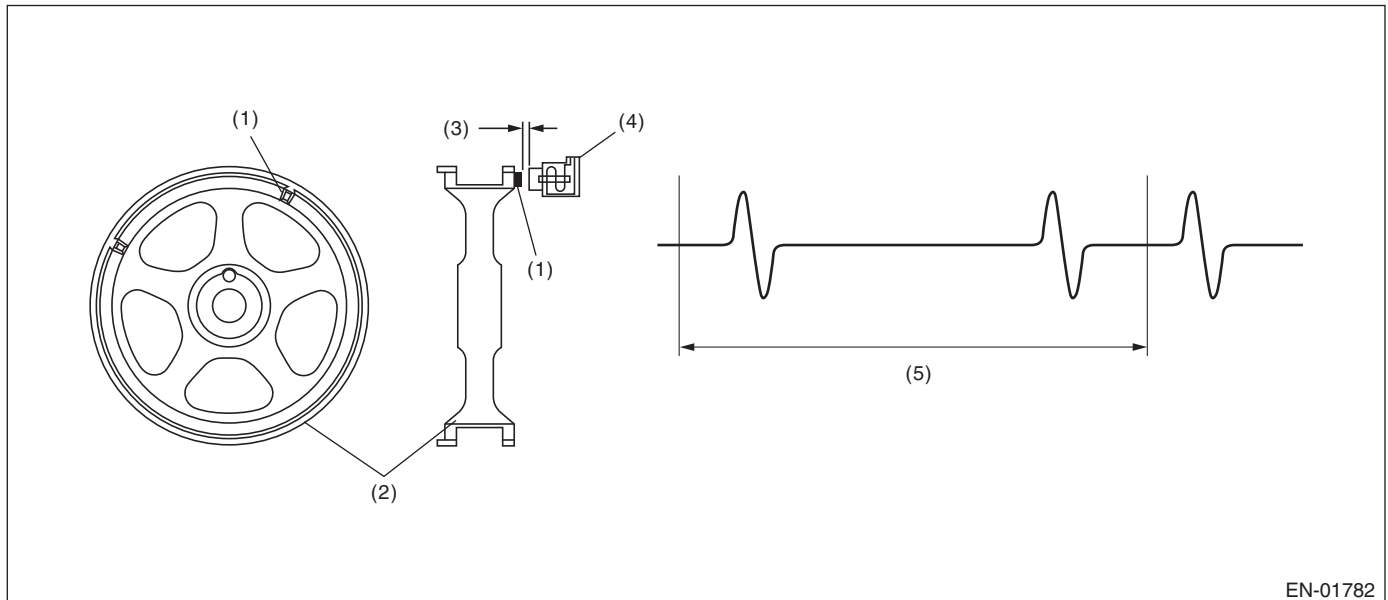

EN-01782

- (1) Boss
- (2) Cam sprocket

- (3) Air gap
- (4) Camshaft position sensor

- (5) One camshaft revolution (two engine revolutions)

Diagnostic Trouble Code (DTC) Detecting Criteria

GENERAL DESCRIPTION

3. ENABLE CONDITION

Secondary Parameters	Enable Conditions
Cylinder number identification	Completed
Battery voltage	$\geq 8 \text{ V}$
Engine speed	550 rpm — 1000 rpm
Engine operation	Idling
Misfire	Not detected
Engine load change during 4 milliseconds	$\leq 12799.8 \text{ rpm}$

4. GENERAL DRIVING CYCLE

Always perform the diagnosis continuously at idle speed.

5. DIAGNOSTIC METHOD

• Abnormality Judgement

If the duration of time while the following conditions are met is longer than the time indicated, judge as NG.

Judgement Value

Malfunction Criteria	Threshold Value
Position of camshaft position sensor signal	Not between BTDC 10°CA and BTDC 80°CA

Time Needed for Diagnosis: 10 engine revs.

Malfunction Indicator Light Illumination: Illuminates when malfunction occurs in 2 continuous driving cycles.

• Normality Judgement

Judge as OK and clear the NG if the continuous time while the following conditions are established is more than the predetermined time.

Judgement Value

Malfunction Criteria	Threshold Value
Position of camshaft position sensor signal	Between BTDC10°CA and BTDC80°CA

Time Needed for Diagnosis: Two engine revs.

Diagnostic Trouble Code (DTC) Detecting Criteria

GENERAL DESCRIPTION

BD:DTC P0400 EXHAUST GAS RECIRCULATION FLOW

1. OUTLINE OF DIAGNOSIS

Detect EGR system malfunction.

Intake manifold pressure (negative pressure) is constant because the throttle valve is fully closed during deceleration fuel cut. At this time, when the EGR valve is opened/closed, the intake manifold pressure will change. EGR System OK/NG is judged by the range of this change.

2. COMPONENT DESCRIPTION

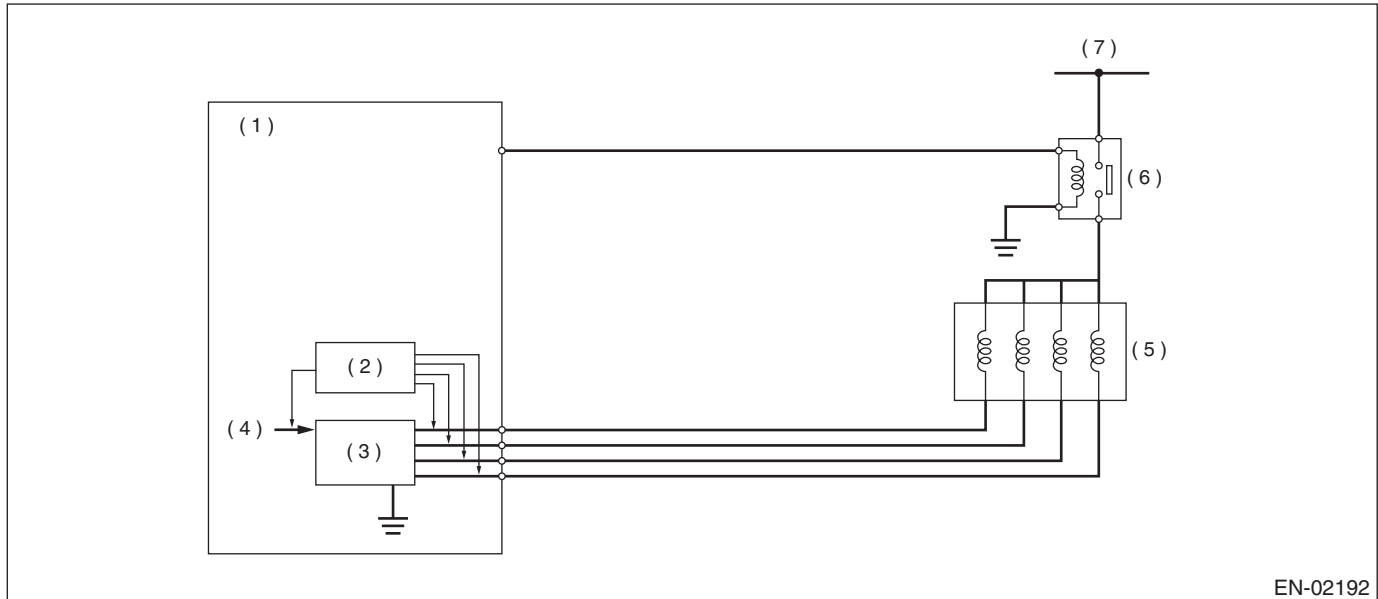

EN-02192

- | | | |
|-----------------------|---------------|--------------------------|
| (1) ECM | (4) CPU | (6) Main relay |
| (2) Detecting circuit | (5) EGR valve | (7) Battery power supply |
| (3) Switching circuit | | |

Diagnostic Trouble Code (DTC) Detecting Criteria

GENERAL DESCRIPTION

3. ENABLE CONDITION

Secondary Parameters	Enable Conditions
Elapsed time after starting the engine	≥ 40 s
Engine coolant temperature	≥ 75 °C(167 °F)
Engine speed	1200 rpm — 2950 rpm
Intake manifold pressure (absolute pressure)	< 44 kPa (330 mmHg, 13 inHg)
Ambient air temperature	≥ 5 °C(41 °F)
Throttle position	< 0.25 °
Battery voltage	≥ 10.9 V
Barometric pressure	≥ 75 kPa (563 mmHg, 22.2 inHg)
Vehicle speed	≥58 km/h (36 MPH)
Fuel shut-off function	In operation
Neutral switch	OFF
After neutral switch ON/OFF change	≥ Value from Map
No load change (A/C, power steering, lighting, rear defogger, heater fan and radiator fan)	≥ 5000 ms

Map

Engine coolant temperature °C (°F)	-40 (-40)	-30 (-22)	-20 (-4)	-10 (14)	0 (32)	10 (50)	20 (68)	30 (86)
After neutral switch change msec	0	0	0	0	0	0	0	0

Engine coolant temperature °C (°F)	40 (104)	50 (122)	60 (140)	70 (158)	80 (176)	90 (194)	100 (212)	110 (230)
After neutral switch change msec	0	0	0	0	0	0	0	0

4. GENERAL DRIVING CYCLE

During deceleration fuel cut from 53 km/h (approx. 33 MPH) or more, perform diagnosis once.

Be careful of vehicle speed and engine speed. (Diagnosis will not be completed if the vehicle speed and engine speed conditions become out of specification due to deceleration.)

5. DIAGNOSTIC METHOD

Measure the pressure values when the enable conditions are established, and perform diagnosis by calculating those results.

1. Label the intake manifold pressure value as PMOF1, which is observed when enable conditions are established, and set the EGR target step to 50 steps (nearly full open).
2. Label the intake manifold pressure value as PMON, which is observed after one second has passed since EGR target step was set to 50 steps (when the enable conditions were established), and set the EGR target step to 0.
3. Label the intake manifold pressure as PMOF2, which is observed after one second has passed since EGR target step was set to 0 (after two seconds have passed since the enable conditions were established).

Diagnostic Trouble Code (DTC) Detecting Criteria

GENERAL DESCRIPTION

• Abnormality Judgement

Judge as NG when the following conditions are established.

Judgement Value

Malfunction Criteria	Threshold Value
$PMON - (PMOF1 + PMOF2)/2$	< 2.5 kPa (18.63 mmHg, 0.7 inHg)

Time Needed for Diagnosis: 1 time

Malfunction Indicator Light Illumination: Illuminates when malfunction occurs in 2 continuous driving cycles.

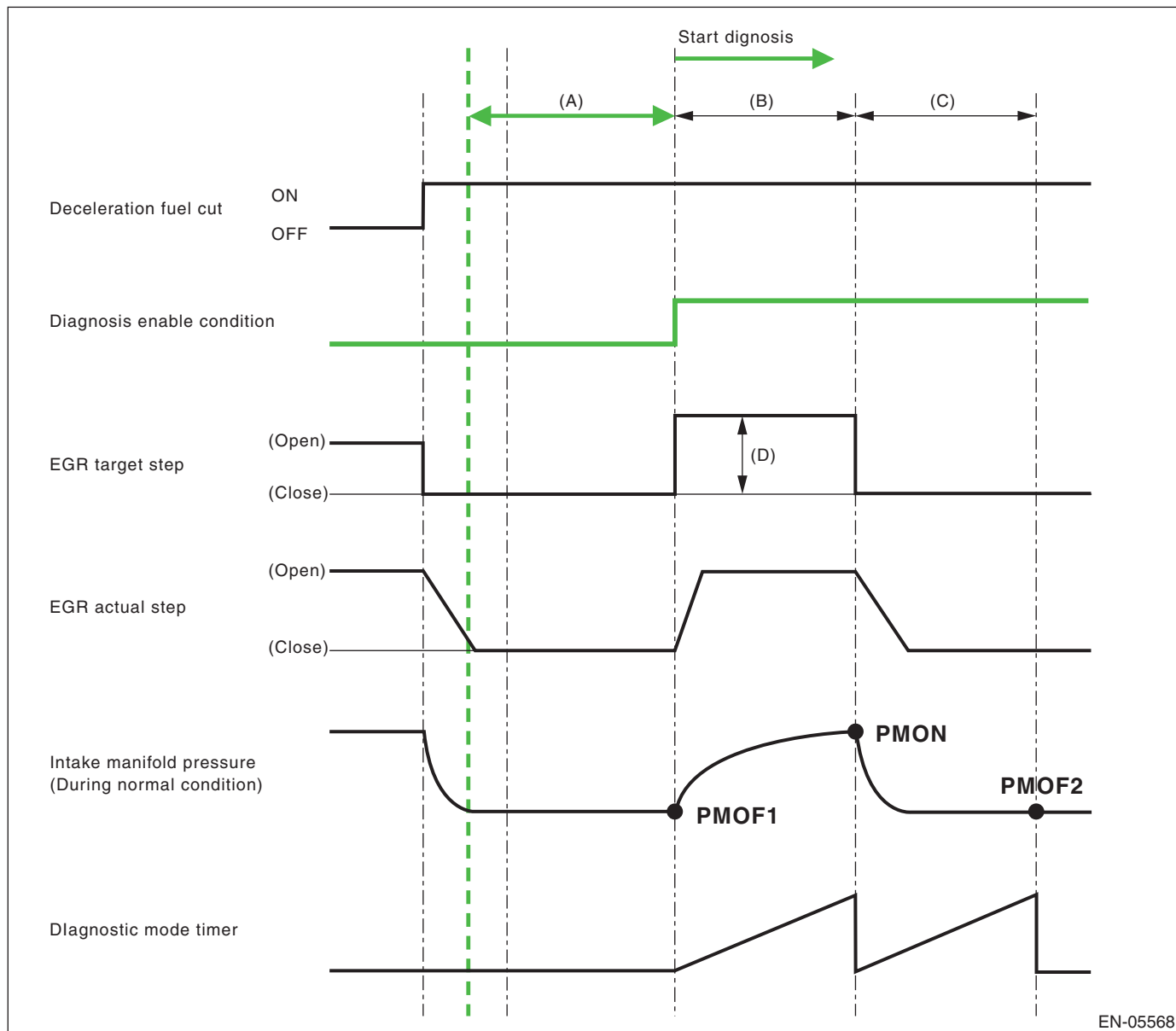

(A) 3000 ms
(B) 1000 ms

(C) 1000 ms

(D) 45 step (s)

EN-05568

• Normality Judgement

Judge as OK and clear the NG if the following conditions are established.

Judgement Value

Malfunction Criteria	Threshold Value
$PMON - (PMOF1 + PMOF2)/2$	≥ 2.5 kPa (18.63 mmHg, 0.7 inHg)

Time Needed for Diagnosis: 1 time

Diagnostic Trouble Code (DTC) Detecting Criteria

GENERAL DESCRIPTION

BE:DTC P0420 CATALYST SYSTEM EFFICIENCY BELOW THRESHOLD (BANK 1)

1. OUTLINE OF DIAGNOSIS

Detect the deterioration of the catalyst function.

Though the front oxygen sensor output would change slowly with a new catalyst, the sensor output with a deteriorated catalyst becomes high and the inversion time is shortened.

For this reason, the catalyst diagnosis is carried out by monitoring the front oxygen sensor output and comparing it with the front oxygen (A/F) sensor output.

2. COMPONENT DESCRIPTION

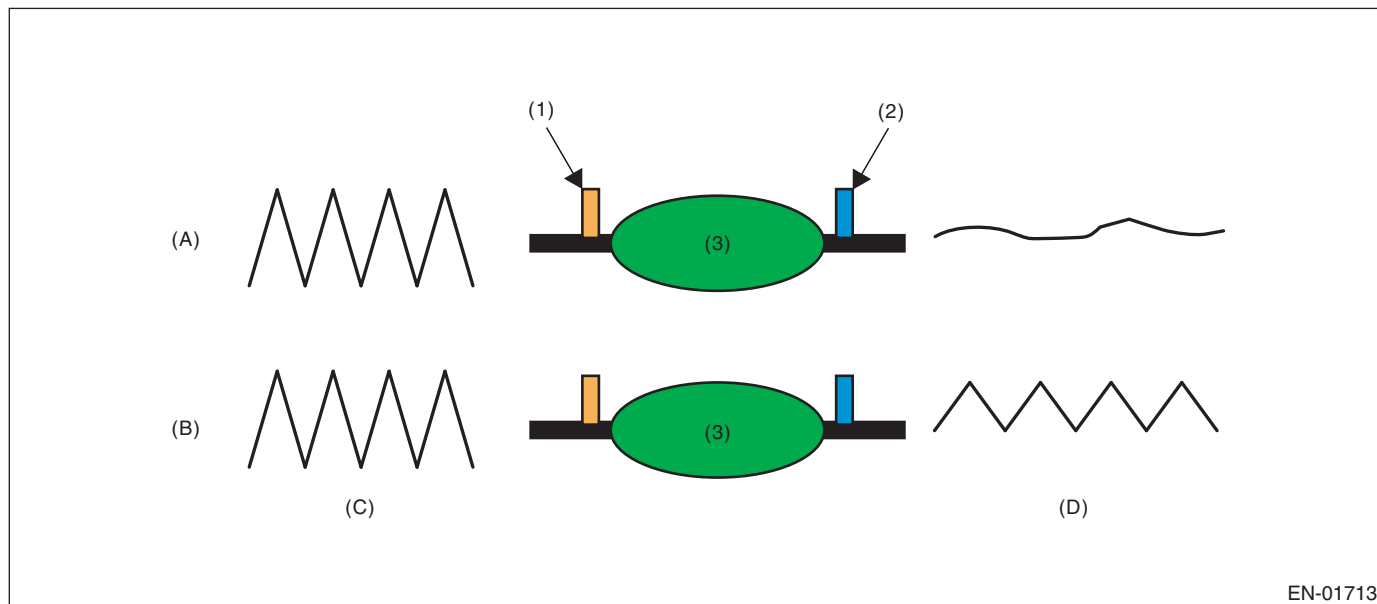

EN-01713

(A) Normal

(B) Deterioration

(C) Output waveform from the front oxygen (A/F) sensor

(D) Output waveform from the rear oxygen Sensor

(1) Front oxygen (A/F) sensor

(2) Front oxygen sensor

(3) Catalytic converter

3. ENABLE CONDITION

Secondary Parameters	Enable Conditions
Battery voltage	≥ 10.9 V
Barometric pressure	≥ 75 kPa (563 mmHg, 22.2 inHg)
Engine coolant temperature	≥ 70 °C (158 °F)
Estimated catalyst temperature	≥ 645 °C (1193 °F)
Misfire detection every 200 rotations	< 5 time(s)
Learning value of evaporation gas density	< 0.2
Sub feedback	In operation
Evaporative system diagnosis	Not in operation
Time of difference (< 0.10) between actual lambda and target lambda	≥ 1000 ms
Vehicle speed	> 70 km/h (43.5 MPH)
Amount of intake air	≥ 10 g/s (0.35 oz/s) and < 40 g/s (1.41 oz/s)
Engine load change every 0.5 engine revs.	< 0.02 g/rev (0 oz/rev)
Rear oxygen output change from 660 mV or less to 660 mV or more	Experienced after fuel cut
Elapsed time after starting the engine	≥ 205 s
Purge execution calculated time	≥ 0 s

Diagnostic Trouble Code (DTC) Detecting Criteria

GENERAL DESCRIPTION

4. GENERAL DRIVING CYCLE

Perform the diagnosis only once at a constant 70 km/h (43.5 MPH) or higher.

5. DIAGNOSTIC METHOD

After establishing the execution conditions, calculate the front oxygen (A/F) sensor lambda deviation cumulative value per 32 milliseconds $\times 4$ ($\sum |(sglmd_n - sglmd_{n-1})|$) and rear oxygen sensor output voltage deviation cumulative value ($\sum |(ro2sad_n - ro2sad_{n-1})|$), and when the front oxygen (A/F) sensor lambda deviation cumulative value ($\sum |(sglmd_n - sglmd_{n-1})|$) becomes the predetermined value or more, calculate the diagnostic value.

• Abnormality Judgement

If the duration of time while the following conditions are met is within the time indicated, judge as NG.

Judgement Value

Malfunction Criteria	Threshold Value
$\sum (ro2sad_n - ro2sad_{n-1}) / \sum (sglmd_n - sglmd_{n-1}) $	> 10 (U5 model) > 14 (Other than U5 model)

Time Needed for Diagnosis: 30 — 55 seconds

Malfunction Indicator Light Illumination: Illuminates when malfunction occurs in 2 continuous driving cycles.

• Normality Judgement

Judge as OK and clear the NG if the continuous time while the following conditions are established is within the predetermined time.

Judgement Value

Malfunction Criteria	Threshold Value
$\sum (ro2sad_n - ro2sad_{n-1}) / \sum (sglmd_n - sglmd_{n-1}) $	≤ 10 (U5 model) ≤ 14 (Other than U5 model)

Time Needed for Diagnosis: 30 — 55 seconds

BF:DTC P0442 EVAPORATIVE EMISSION CONTROL SYSTEM LEAK DETECTED (SMALL LEAK)

1. OUTLINE OF DIAGNOSIS

Check if there is a leakage in fuel system or not, and perform the function diagnosis of valve.

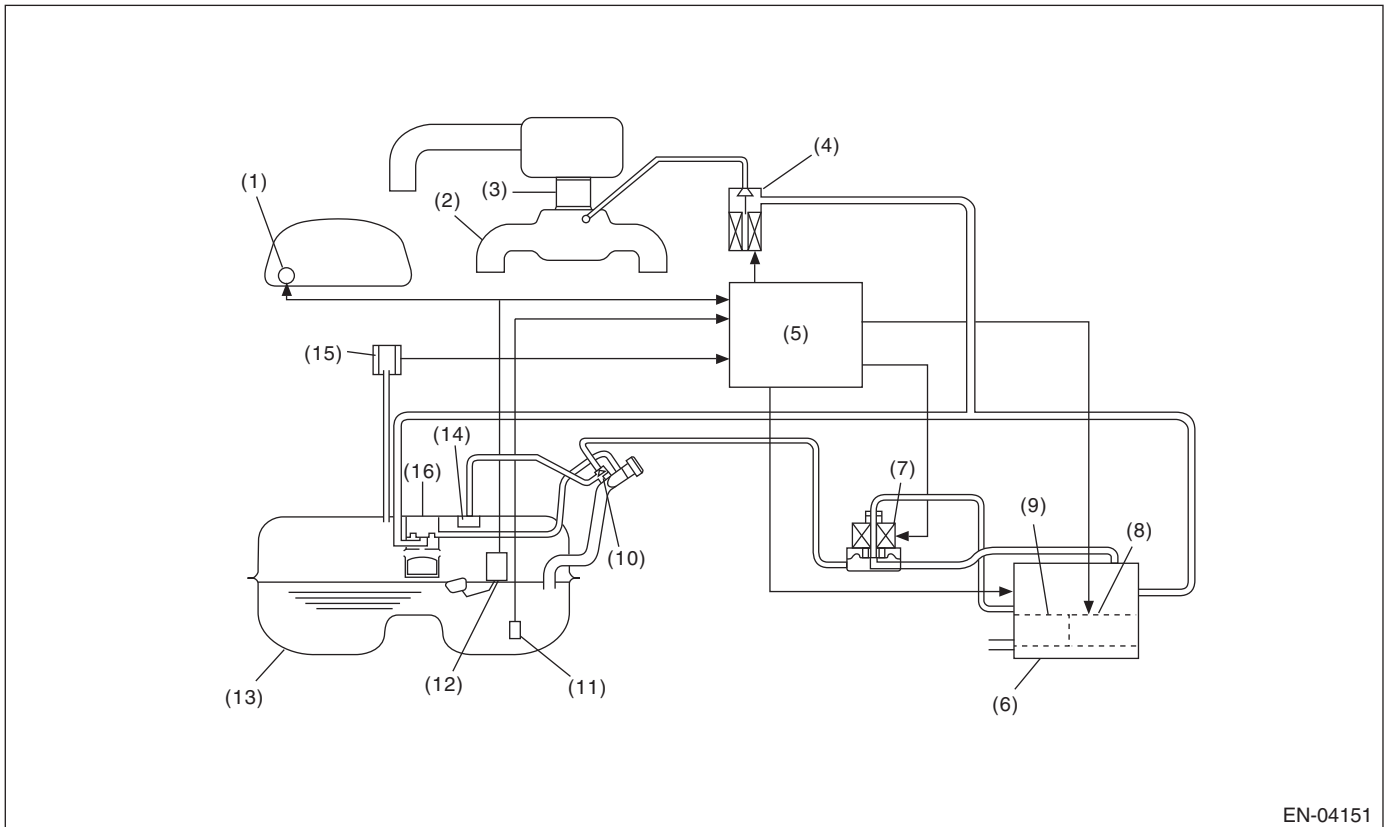

EN-04151

- | | | |
|----------------------------------|------------------------------|--------------------------------|
| (1) Fuel gauge | (7) Pressure control valve | (12) Fuel level sensor |
| (2) Intake manifold | (8) Drain valve | (13) Fuel tank |
| (3) Throttle body | (9) Drain filter | (14) Fuel cut valve |
| (4) Purge control solenoid valve | (10) Shut-off valve | (15) Fuel tank pressure sensor |
| (5) Engine control module (ECM) | (11) Fuel temperature sensor | (16) Vent valve |
| (6) Canister | | |

In this system diagnosis, check for leakage and valve function is conducted by changing the fuel tank pressure and monitoring the pressure change using the fuel tank pressure sensor. When in 0.04 inch diagnosis, perform in the order of mode Z → mode A → mode B → mode C and mode D; When in 0.02 inch diagnosis, perform in the order of mode A → mode B → mode C → mode D and mode E.

Diagnostic Trouble Code (DTC) Detecting Criteria

GENERAL DESCRIPTION

0.04-inch Diagnosis

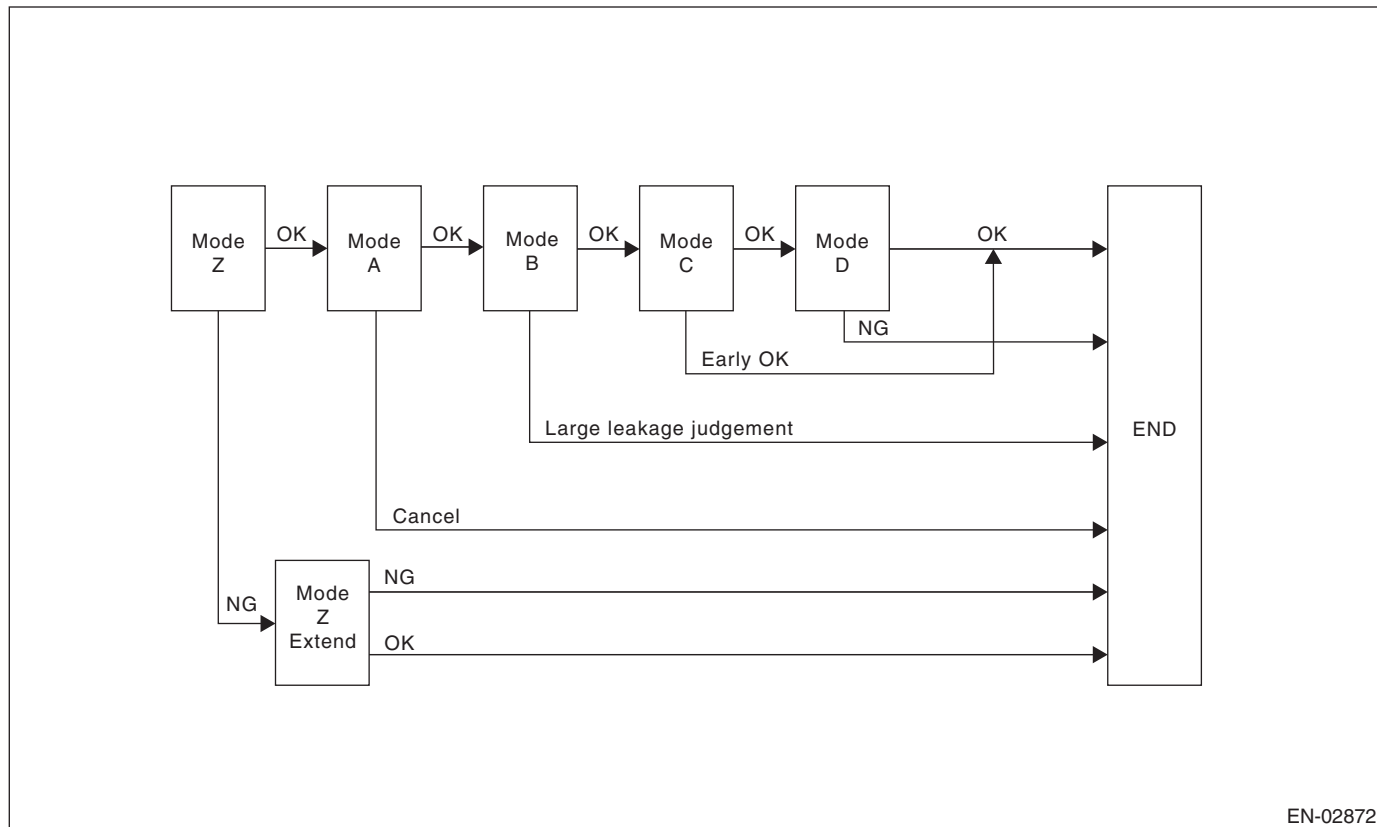

EN-02872

Mode	Mode Description	Diagnosis Period
Mode Z (Purge control solenoid valve opening failure diagnosis)	Perform purge control solenoid valve opening failure diagnosis from the size of tank pressure variation from diagnosis start.	0 ms + 3000 ms — 0 ms + 3000 ms + 13000 ms
Mode A (Estimated evaporation amount)	Calculate the tank pressure change amount (P1).	10000 ms
Mode B (Sealed negative pressure, large leakage judgement)	Decrease the pressure in the tank to the target value by introducing the intake manifold pressure to the fuel tank. If the tank pressure cannot be reduced, it is diagnosed as large leak.	0 — 10000 ms + 25000 ms
Mode C (Pressure increase check, advanced OK judgement)	Wait until the tank pressure returns to the target (start level of P2 calculation). If the tank pressure does not become the value, make advanced OK judgement.	0 — 18600 ms
Mode D (Negative pressure variation measurement, evaporation leakage diagnosis)	Calculate the tank pressure variation (P2), and obtain the diagnostic value using P1 found in Mode A. Perform the evaporation diagnosis using the diagnostic value.	0 ms + 10000 ms

Mode Table for Evaporative Emission Control System Diagnosis

Mode	Behavior of tank internal pressure under normal conditions	Diagnostic item	DTC
Mode Z	Roughly the same as barometric pressure (Same as 0 kPa (0 mmHg, 0 inHg))	Purge control solenoid valve is judged to be open.	P0457
Mode A	Pressure is in proportion to amount of evaporative emission.	—	None
Mode B	Negative pressure is formed due to intake manifold negative pressure	Large leak	P0457
Mode C	Reaches target pressure	—	None
Mode D	Pressure change is small.	EVAP system large leak determination [1.0 mm (0.04 in)]	P0442

Diagnostic Trouble Code (DTC) Detecting Criteria

GENERAL DESCRIPTION

0.02-inch Diagnosis

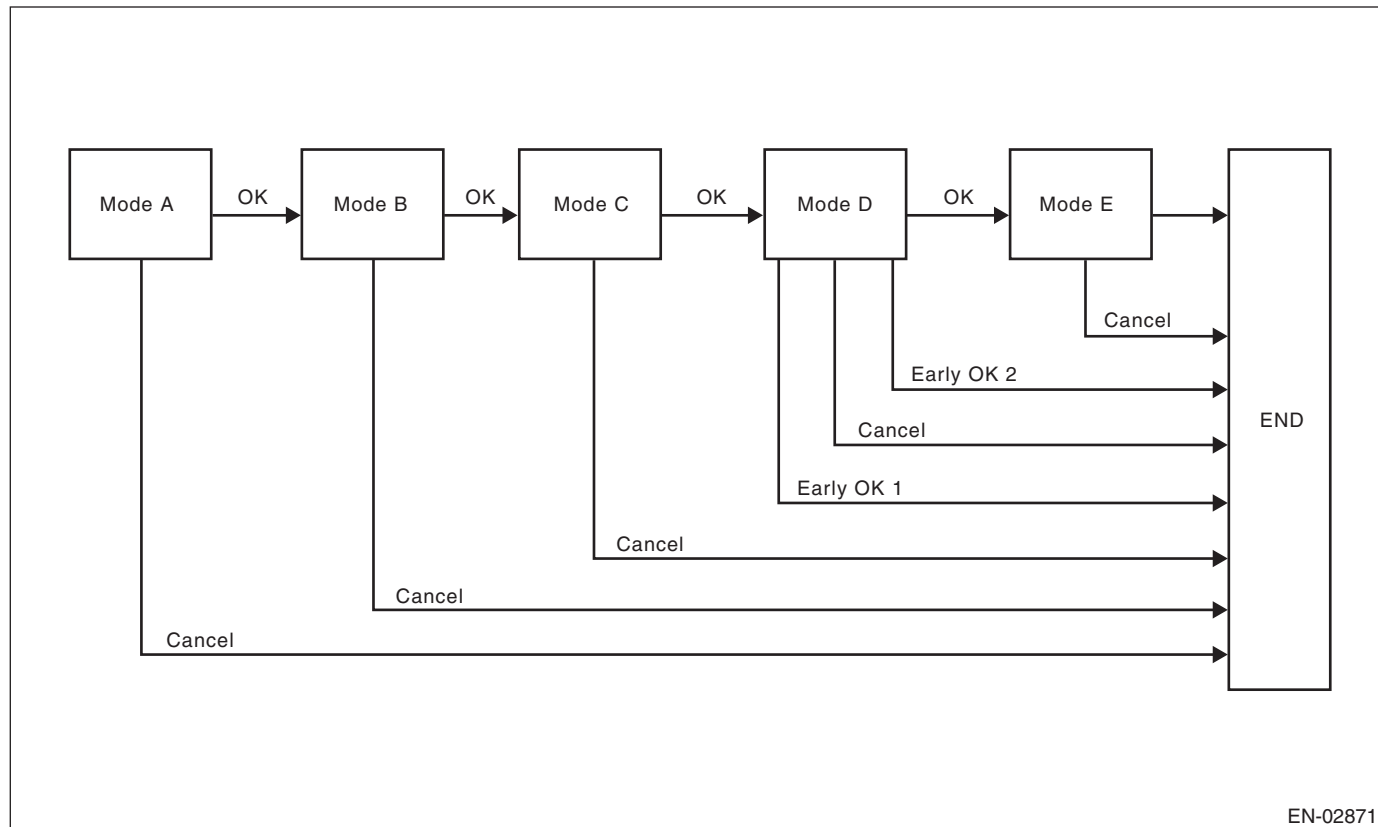

EN-02871

Mode	Mode Description	Diagnosis Period
Mode A (0 point compensation)	When the pressure in the tank is not near 0 mmHg, wait until it returns to 0 point (near 0 mmHg).	0 — Value of Map 1
Mode B (Negative pressure introduced)	Decrease the pressure in the tank to the target value by introducing the intake manifold pressure to the fuel tank.	0 — Value of Map 2
Mode C (Negative pressure maintained)	Wait until the tank pressure returns to the target (start level of P2 calculation).	0 — 25290 ms + 0 + Value of Map 2
Mode D (Negative pressure change calculated)	Calculate the time it takes for the tank pressure to change to the Mode E shifting pressure. If the tank pressure does not change to the Mode E shifting pressure, make advanced OK judgement.	0 — 0 ms + 200000 ms
Mode E (Evaporation generated amount calculation)	Calculate the amount of evaporation (P1).	0 — 0 ms + 200000 ms + Value of Map 3

Map 1

Fuel level (ℓ, US gal, Imp gal)	0	10, 2.64, 2.2	20, 5.28, 4.4	30, 7.93, 6.6	40, 10.57, 8.8	50, 13.21, 11	60, 15.85, 13.2
Time Needed for Diagnosis (ms)	13800	13800	11400	9000	7000	5000	5000

Map 2

Fuel level (ℓ, US gal, Imp gal)	0	10, 2.64, 2.2	20, 5.28, 4.4	30, 7.93, 6.6	40, 10.57, 8.8	50, 13.21, 11	60, 15.85, 13.2
Time Needed for Diagnosis (ms)	20030	20030	20800	21580	21970	22360	22360

Map 3

Fuel level (ℓ, US gal, Imp gal)	0	10, 2.64, 2.2	20, 5.28, 4.4	30, 7.93, 6.6	40, 10.57, 8.8	50, 13.21, 11	60, 15.85, 13.2
Time Needed for Diagnosis (ms)	80000	80000	70000	60000	60000	60000	60000

Diagnostic Trouble Code (DTC) Detecting Criteria

GENERAL DESCRIPTION

2. COMPONENT DESCRIPTION

Pressure control solenoid valve

PCV controls the fuel tank pressure to be equal to the atmospheric air pressure. Normally, the solenoid is set to OFF. The valve opens and closes mechanically in accordance with the pressure difference between tank and atmospheric air, or tank and canister.

The valve is forcibly opened by setting the solenoid to ON at the time of diagnosis.

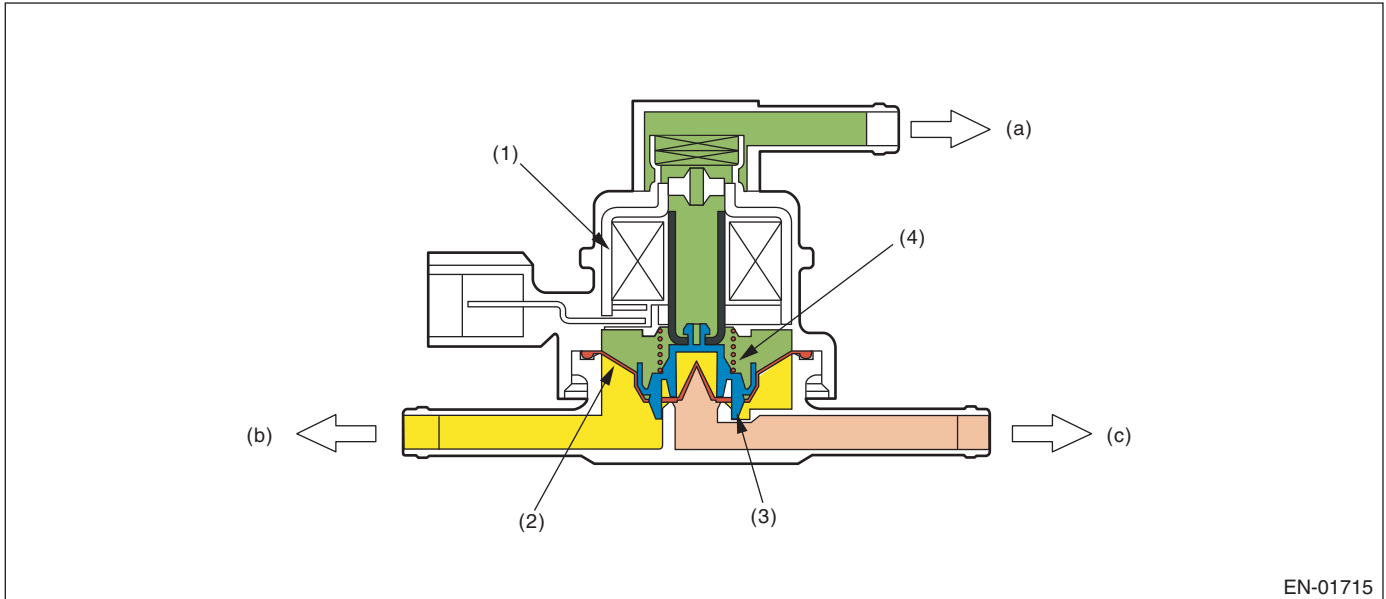

(a) Barometric pressure

(b) Fuel tank

(c) Canister

(1) Solenoid

(3) Valve

(4) Spring

(2) Diaphragm

Diagnostic Trouble Code (DTC) Detecting Criteria

GENERAL DESCRIPTION

Valve Operation and Air Flow

In the figure below, divided by the diaphragm, the part above X is charged with atmospheric air pressure, and the part below X is charged with tank pressure. Also, the part above Y is charged with tank pressure, and the part below Y is charged with canister pressure.

If the atmospheric air pressure port is A, tank pressure port is B, and canister pressure port is C, the air flows according to pressure difference from each port as shown in the table below.

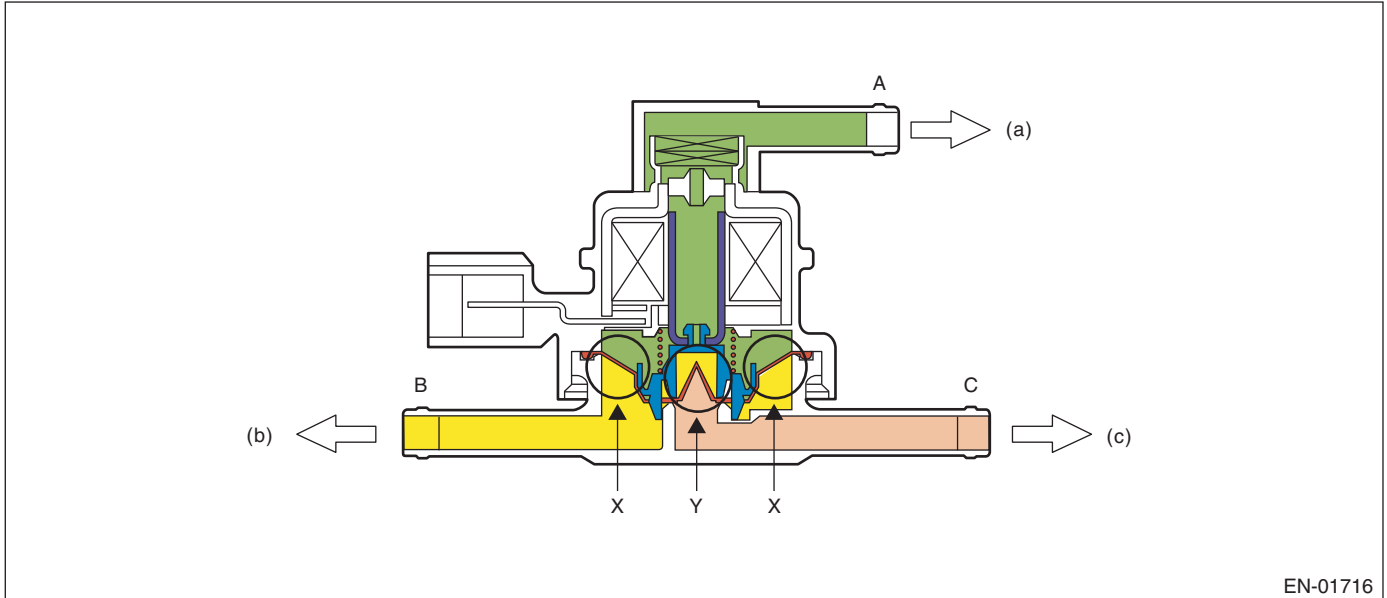

EN-01716

(a) Barometric pressure

(b) Fuel tank

(c) Canister

Condition of pressure	Flow
$A < B$ (solenoid OFF)	$B \rightarrow C$
$B < C$ (solenoid OFF)	$C \rightarrow B$
Solenoid ON	$B \leftrightarrow C$

When $A < B$ (solenoid OFF)

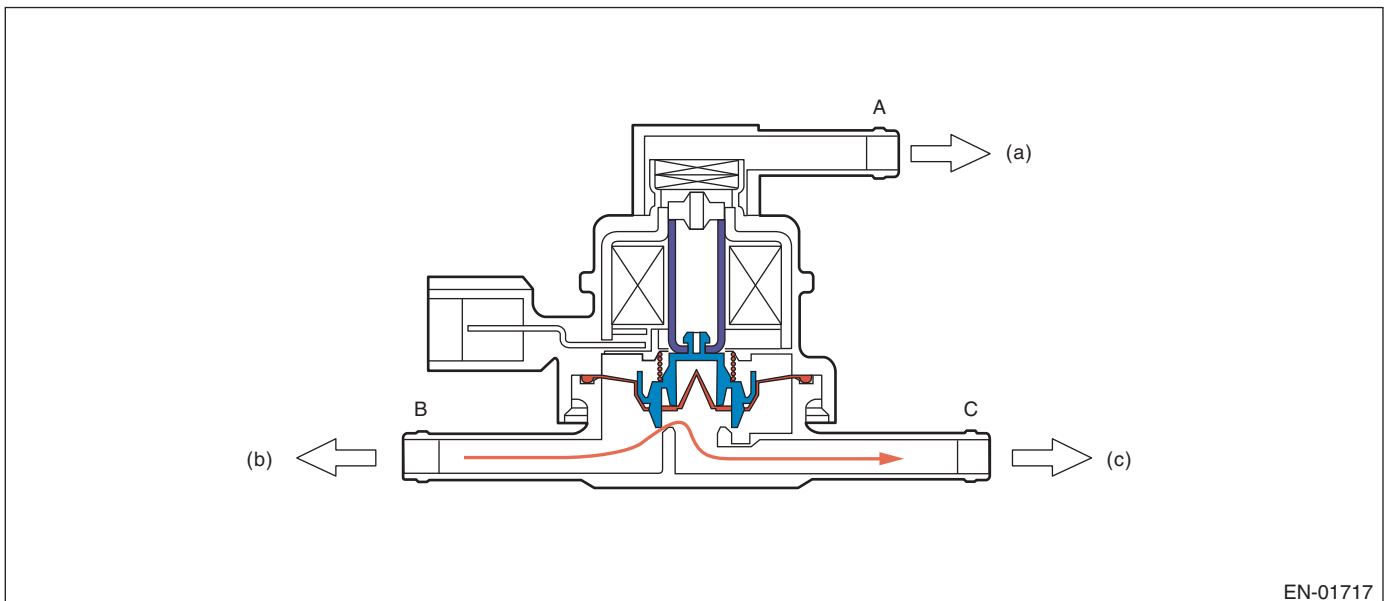

EN-01717

(a) Barometric pressure

(b) Fuel tank

(c) Canister

Diagnostic Trouble Code (DTC) Detecting Criteria

GENERAL DESCRIPTION

When $B < C$ (solenoid OFF)

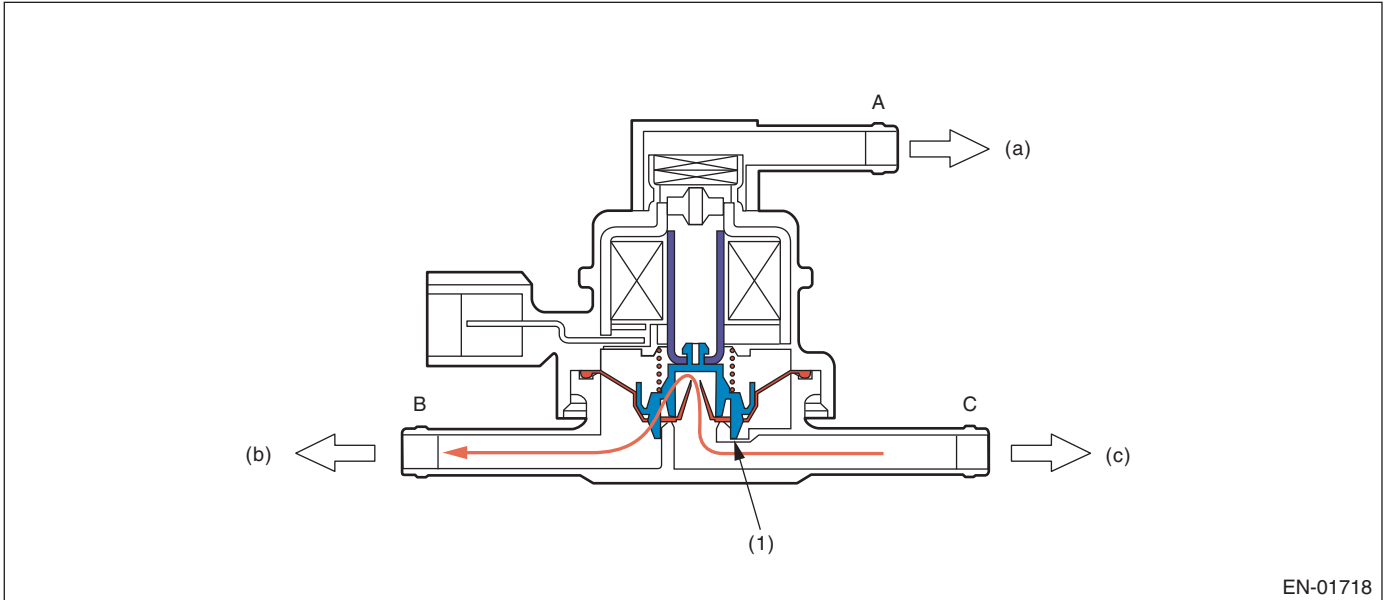

(a) Barometric pressure

(b) Fuel tank

(c) Canister

(1) Valve

When Solenoid is ON

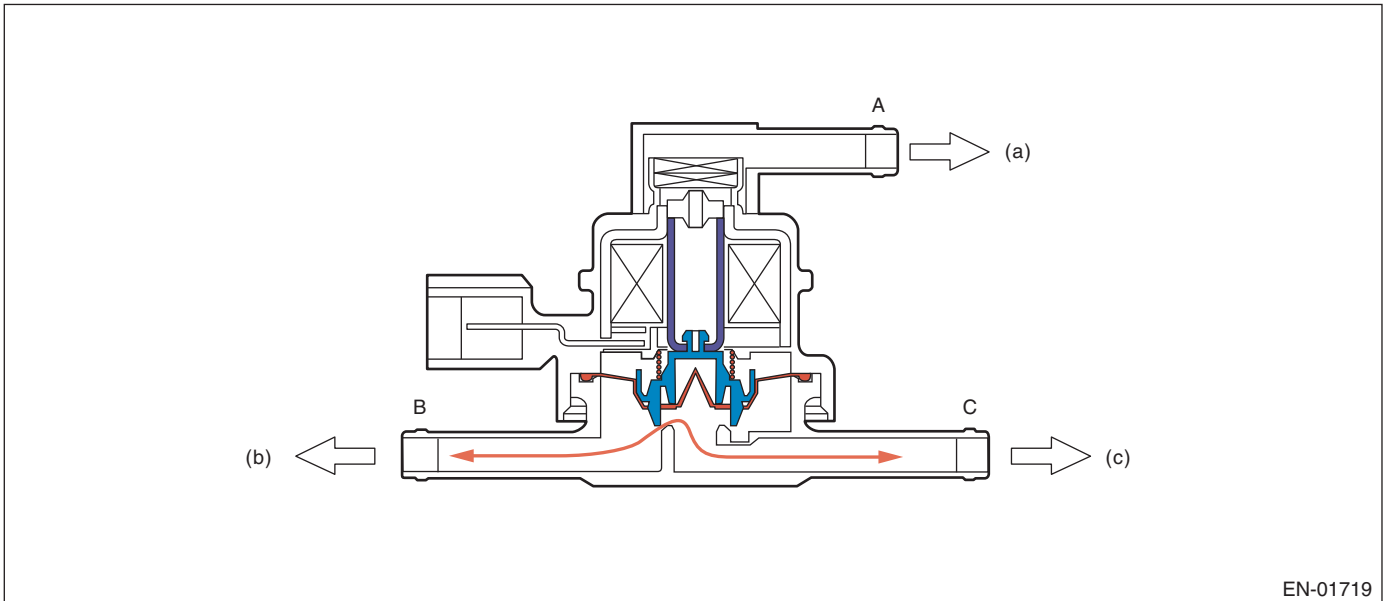

(a) Barometric pressure

(b) Fuel tank

(c) Canister

Diagnostic Trouble Code (DTC) Detecting Criteria

GENERAL DESCRIPTION

Drain valve

Drain valve controls the ambient air to be introduced to the canister.

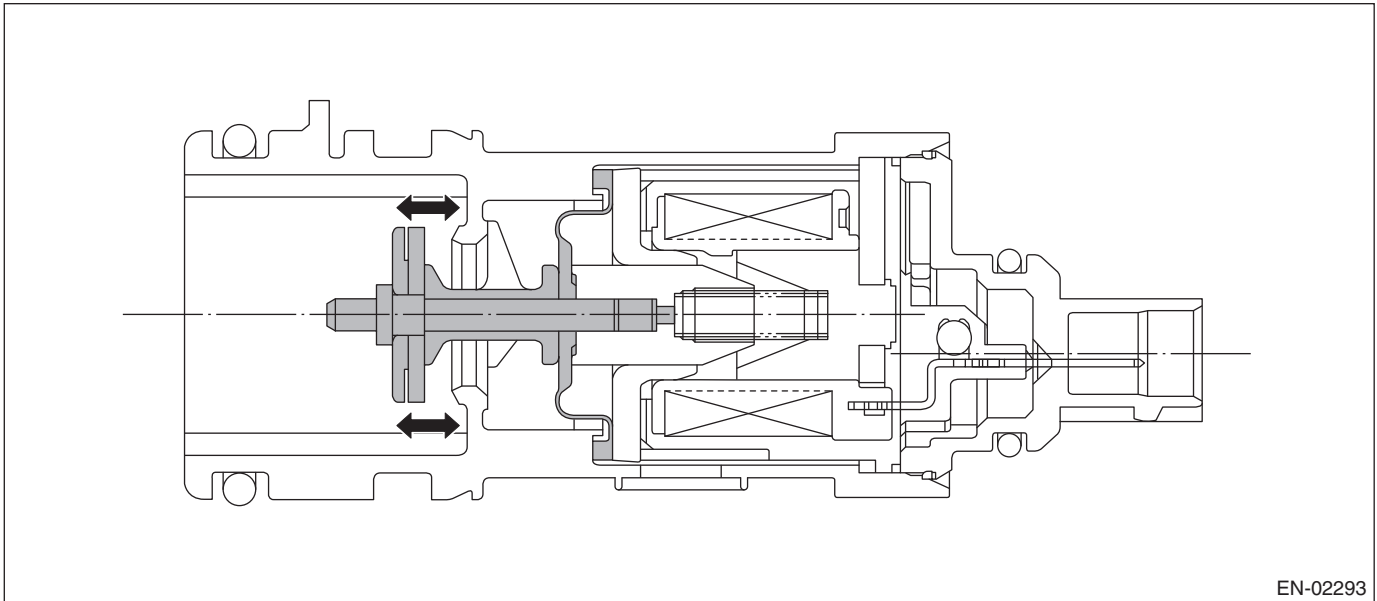

3. ENABLE CONDITION

0.04-inch Diagnosis

Secondary Parameters	Enable Conditions
Battery voltage	≥ 10.9 V
Barometric pressure	≥ 75 kPa (563 mmHg, 22.2 inHg)
Total time of canister purge operation	≥ 120000 ms
Elapsed time after starting the engine	≥ 856 s
Learning value of evaporation gas density	< 0.08
Engine speed	1050 rpm — 6000 rpm
Fuel tank pressure	≥ -4 kPa (-30 mmHg, -1.2 inHg)
Intake manifold relative vacuum (relative pressure)	≥ -26.7 kPa (-200 mmHg, -7.9 inHg)
Vehicle speed	≥ 32 km/h (19.9 MPH)
Fuel level	9.6 ℓ (2.54 US gal, 2.11 Imp gal) — 54.4 ℓ (14.37 US gal, 11.97 Imp gal)
Closed air/fuel ratio control	In operation
Fuel temperature	-10 °C (14 °F) — 45 °C (113 °F)
Intake air temperature	≥ -10 °C (14 °F)
Pressure change every one second	< 1.7 mmHg (Mode A) < 1.7 mmHg (Mode D)
Minimum pressure change value every one second – Maximum pressure change value every one second	< 1.7 mmHg (Mode A) < 1.7 mmHg (Mode D)
Change of fuel level per 128 milliseconds	< 2 ℓ (0.53 US gal, 0.44 Imp gal)
Air fuel ratio	0.76 — 1.25

Diagnostic Trouble Code (DTC) Detecting Criteria

GENERAL DESCRIPTION

0.02-inch Diagnosis

Secondary Parameters	Enable Conditions
At starting a diagnosis	
Evap. diagnosis	Incomplete
Battery voltage	≥ 10.9 V
Barometric pressure	≥ 75 kPa (563 mmHg, 22.2 inHg)
Time since last incomplete 0.02-inch leakage diagnosis	
When cancelling in mode A	> 120000 ms
When cancelling in other than mode A	> 600000 ms
Total time of canister purge operation	≥ 120000 ms
Elapsed time after starting the engine	≥ 120 s
Fuel temperature	-10 °C (14 °F) — 55 °C (131 °F)
Fuel level	9.6 ℓ (2.54 US gal, 2.11 Imp gal) — 54.4 ℓ (14.37 US gal, 11.97 Imp gal)
Intake manifold relative vacuum (relative pressure)	≥ -8 kPa (-60 mmHg, -2.4 inHg)
Fuel tank pressure	-0.7 kPa (-5 mmHg, -0.2 inHg) — 1.4 kPa (10.7 mmHg, 0.4 inHg)
Vehicle speed	50 km/h (31.1 MPH) — 510 km/h (316.9 MPH) continues for 125000 ms
Closed air/fuel ratio control	In operation
Engine speed	1050 rpm — 6000 rpm
During diagnosis	
Change of fuel level	≤ Value of Map 4
Pressure change every one second	< 0.1 kPa (0.44 mmHg, 0 inHg)
Minimum pressure change value every one second – Maximum pressure change value every one second	< 0.1 kPa (0.51 mmHg, 0 inHg) (Mode D)
Pressure change in tank every second	≤ 0.1 kPa (0.75 mmHg, 0 inHg)
Barometric pressure change	-0.5 kPa (-3.6 mmHg, -0.1 inHg) — 0.3 kPa (2.4 mmHg, 0.1 inHg) (Mode D) -0.3 kPa (-2.4 mmHg, -0.1 inHg) — 0.3 kPa (2.4 mmHg, 0.1 inHg) (Mode E)

Map 4

Fuel level (ℓ , US gal, Imp gal)	0	10, 2.64, 2.2	20, 5.28, 4.4	30, 7.93, 6.6	40, 10.57, 8.8	50, 13.21, 11	60, 15.85, 13.2
Change (ℓ , US gal, Imp gal)	5, 1.32, 1.1	5, 1.32, 1.1	5, 1.32, 1.1	5, 1.32, 1.1	5, 1.32, 1.1	5, 1.32, 1.1	5, 1.32, 1.1

4. GENERAL DRIVING CYCLE

0.04-inch Diagnosis

- Perform the diagnosis only once in 856 seconds or more after starting the engine, at a constant speed of 32 km/h (20 MPH) or more.
- Pay attention to the fuel temperature and fuel level.

0.02-inch Diagnosis

- Perform the diagnosis 125 seconds or more at a constant engine speed of 50 km/h (31 MPH) or higher to judge as NG or OK.
- If judgement cannot be made, repeat the diagnosis.
- Pay attention to the fuel level.

Diagnostic Trouble Code (DTC) Detecting Criteria

GENERAL DESCRIPTION

5. DIAGNOSTIC METHOD

Purge control solenoid valve stuck open fault diagnosis

DTC

P0457 Evaporative Emission Control System Leak Detected (Fuel Cap Loose/Off)

Purpose of Mode Z

When performing the leakage diagnosis of EVAP system, the purge control solenoid valve must operate normally. Therefore, mode Z is used to diagnose the purge control solenoid valve stuck open condition. Note that if a purge control solenoid valve stuck open fault is detected, the EVAP system leakage diagnosis is cancelled.

Diagnostic method

Purge control solenoid valve functional diagnosis is performed by monitoring the tank pressure in mode Z.

• Abnormality Judgement

If OK judgement cannot be made, extend Mode Z, and Judge as NG when the following conditions are established after predetermined amount of time.

Judgement Value

Malfunction Criteria	Threshold Value	DTC
evptez – evptezha	> 0.9 kPa (6.5 mmHg, 0.3 inHg)	P0457
evptezini	≤ 1.4 kPa (10.7 mmHg, 0.4 inHg)	
Time of 2 ℓ (0.53 US gal, 0.44 Imp gal) or more fuel no sloshing	≥ 40000 ms	

Time Needed for Diagnosis: 0 ms + 3000 ms + 13000 ms

Malfunction Indicator Light Illumination: Illuminates when malfunction occurs in 2 continuous driving cycles.

When judgement for purge control solenoid valve stuck open NG is made, end the evaporative diagnosis. Cancel the evaporative diagnosis when the OK/NG judgement for purge control solenoid valve stuck open cannot be made in Mode Z.

• Normality Judgement

Judge as OK and change to Mode A when the following conditions are established after predetermined time has passed since Mode Z started.

Judgement Value

Malfunction Criteria	Threshold Value	DTC
evptez – evptezha	≤ 0.4 kPa (3 mmHg, 0.1 inHg)	P0457

Diagnostic Trouble Code (DTC) Detecting Criteria

GENERAL DESCRIPTION

Normal

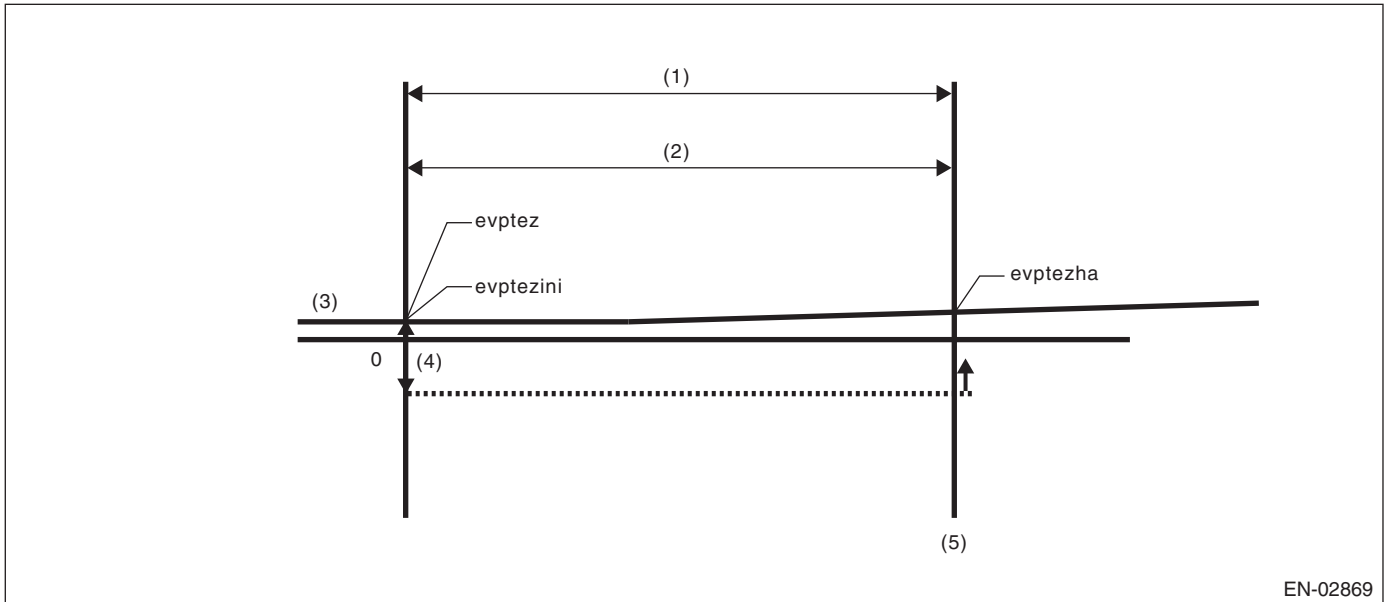

EN-02869

- (1) Mode Z
- (2) 3000 ms

- (3) Fuel tank pressure
- (4) 0.4 kPa (3 mmHg, 0.1 inHg)

- (5) OK judgement

Normal when $evptez - evptezha \leq 0.4 \text{ kPa (3 mmHg, 0.1 inHg)}$ is established

Time Needed for Diagnosis: 0 ms + 3000 ms

Diagnostic Trouble Code (DTC) Detecting Criteria

GENERAL DESCRIPTION

Purge control solenoid valve Open Fixation

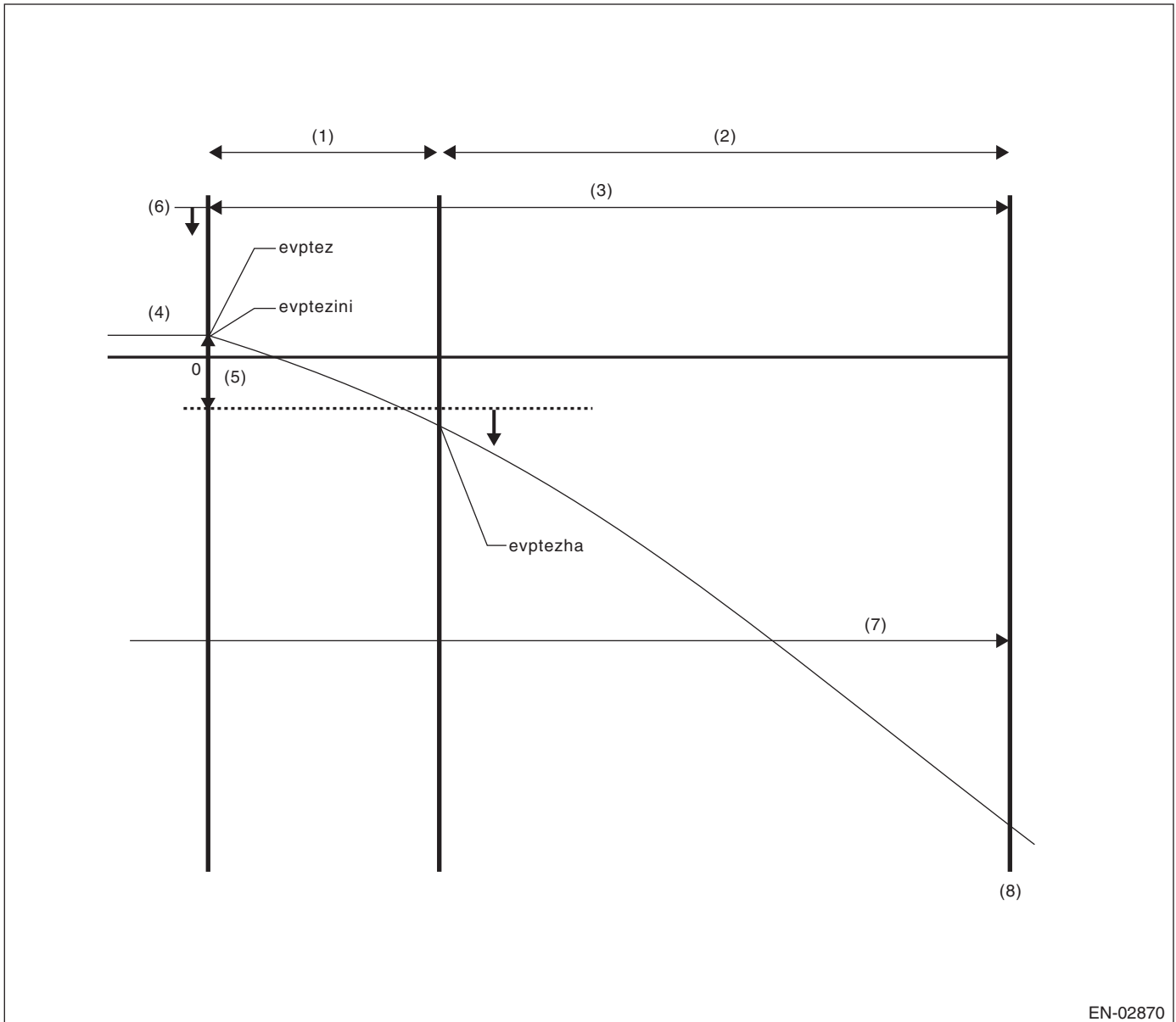

EN-02870

- | | | |
|------------------------|-----------------------------------|-------------------------------|
| (1) Mode Z | (4) Fuel tank pressure | (7) 40000 ms no fuel sloshing |
| (2) Extended mode Z | (5) 0.9 kPa (6.5 mmHg, 0.3 inHg) | (8) NG judgement |
| (3) 3000 ms + 13000 ms | (6) 1.4 kPa (10.7 mmHg, 0.4 inHg) | |

- $evptezini \leq 1.4 \text{ kPa (10.7 mmHg, 0.4 inHg)}$
 - $evptez - evptezha > 0.9 \text{ kPa (6.5 mmHg, 0.3 inHg)}$
 - No fuel sloshing of over 2 \varnothing (0.53 US gal, 0.44 Imp gal) lasts for more than 40000 ms.
- Judge as abnormal when all are established.

Diagnostic Trouble Code (DTC) Detecting Criteria

GENERAL DESCRIPTION

Leak Diagnosis

DTC

P0442 Evaporative Emission Control System Leak Detected (Small Leak)

P0457 Evaporative Emission Control System Leak Detected (Fuel Cap Loose/Off)

- The diagnostic consists of creating a sealed vacuum in the fuel tank and then determining the presence of leakage from the speed at which the tank internal pressure returns to barometric pressure.
- The diagnosis is divided into the following five phases.

Mode A: (Estimated evaporation gas amount)

Calculate the tank pressure change amount (P1) when using mode A. After calculating P1, switch to mode B.

Mode B: (Negative pressure sealed)

Introduce negative pressure in the intake manifold to the tank.

Approx. 0 → -1.4 kPa (0 → -10.5 mmHg, 0 → -0.4 inHg)

When the pressure above (desired negative pressure) is reached, enters Mode C.

In this case, if the tank pressure does not reach the target negative pressure, judge that there is a large leakage in the system and terminate the evaporative emission control system diagnosis.

Abnormality Judgement

Judge as NG (large leakage) when the following conditions are established.

Judgement Value

Malfunction Criteria	Threshold Value	DTC
Time to reach target negative pressure or Mode B time	≥ 10000 ms + 25000 ms	P0457
(Min. pressure value in tank when in mode B) – (Tank pressure when mode B started)	≥ 10000 ms	
	> -0.3 kPa (-2.5 mmHg, -0.1 inHg)	

Time Needed for Diagnosis: 0 ms + 3000 ms + 10000 ms + 10000 ms + 25000 ms

Mode C: (Check pressure rise)

Stop the introduction of negative pressure. (Wait until the tank pressure returns to the start level of P2 calculation.)

Change to Mode D when the tank pressure returns to the start level of P2 calculation.

Judge advanced OK and change to Mode E when it does not return in spite of spending the specified time.

Tank pressure when starting calculation of P2	Time for advanced OK judgement
-1.4 kPa (-10.5 mmHg, -0.4 inHg)	18600 ms

Time Needed for Diagnosis: 0 ms + 3000 ms + 10000 ms + 10000 ms + 25000 ms + 18600 ms

Mode D: (Measure amount of negative pressure change)

Monitor the tank pressure change amount when using mode D. In this case, the tank pressure increases, (nears barometric pressure) because evaporation occurs. However, if any leakage exists, the pressure increases additionally in proportion to this leakage. The pressure variation of this tank is P2.

After calculating P2, perform a small leak diagnosis according to the items below.

When Mode D is ended

Assign tank variations measured in Mode A and Mode D, P1 and P2, to the formula below, judge small leaks in the system. If the measured judgement value exceeds the threshold value, it is judged to be a malfunction.

Abnormality Judgement

Judge as NG when the following conditions are established within the predetermined time. Judge as OK and clear the NG if the following conditions are not established within the predetermined time.

Judgement Value

Malfunction Criteria	Threshold Value	DTC
P2 – 1.5 – × P1 P2: Tank pressure that changes every 10000 ms in mode D P1: Tank pressure that changes every 10000 ms in mode A	> Value of Map 5	P0442

*1.5 –: Evaporation amount compensation value when below negative pressure (Amount of evaporation occurrence increases as a vacuum condition increases.)

Diagnostic Trouble Code (DTC) Detecting Criteria

GENERAL DESCRIPTION

Map 5 Malfunction criteria limit for evaporation diagnosis

Fuel temperature vs. Fuel level	25 °C (77 °F)	30 °C (86 °F)	35 °C (95 °F)	40 °C (104 °F)	45 °C (113 °F)
0 ℓ (0 US gal, 0 Imp gal)	0.3 kPa (2.1 mmHg, 0.1 inHg)	0.3 kPa (2.2 mmHg, 0.1 inHg)	0.3 kPa (2.3 mmHg, 0.1 inHg)	0.3 kPa (2.35 mmHg, 0.1 inHg)	0.3 kPa (2.4 mmHg, 0.1 inHg)
10 ℓ (2.64 US gal, 2.2 Imp gal)	0.3 kPa (2.1 mmHg, 0.1 inHg)	0.3 kPa (2.2 mmHg, 0.1 inHg)	0.3 kPa (2.3 mmHg, 0.1 inHg)	0.3 kPa (2.35 mmHg, 0.1 inHg)	0.3 kPa (2.4 mmHg, 0.1 inHg)
20 ℓ (5.28 US gal, 4.4 Imp gal)	0.3 kPa (2.3 mmHg, 0.1 inHg)	0.3 kPa (2.4 mmHg, 0.1 inHg)	0.3 kPa (2.5 mmHg, 0.1 inHg)	0.3 kPa (2.6 mmHg, 0.1 inHg)	0.4 kPa (2.7 mmHg, 0.1 inHg)
30 ℓ (7.93 US gal, 6.6 Imp gal)	0.4 kPa (2.9 mmHg, 0.1 inHg)	0.4 kPa (3.05 mmHg, 0.1 inHg)	0.4 kPa (3.15 mmHg, 0.1 inHg)	0.4 kPa (3.25 mmHg, 0.1 inHg)	0.4 kPa (3.35 mmHg, 0.1 inHg)
40 ℓ (10.57 US gal, 8.8 Imp gal)	0.4 kPa (2.9 mmHg, 0.1 inHg)	0.4 kPa (3.15 mmHg, 0.1 inHg)	0.4 kPa (3.3 mmHg, 0.1 inHg)	0.5 kPa (3.4 mmHg, 0.1 inHg)	0.5 kPa (3.5 mmHg, 0.1 inHg)
50 ℓ (13.21 US gal, 11 Imp gal)	0.4 kPa (3.2 mmHg, 0.1 inHg)	0.4 kPa (3.3 mmHg, 0.1 inHg)	0.5 kPa (3.5 mmHg, 0.1 inHg)	0.5 kPa (3.6 mmHg, 0.1 inHg)	0.5 kPa (3.7 mmHg, 0.1 inHg)
60 ℓ (15.85 US gal, 13.2 Imp gal)	0.4 kPa (3.2 mmHg, 0.1 inHg)	0.4 kPa (3.3 mmHg, 0.1 inHg)	0.5 kPa (3.5 mmHg, 0.1 inHg)	0.5 kPa (3.6 mmHg, 0.1 inHg)	0.5 kPa (3.7 mmHg, 0.1 inHg)

Time Needed for Diagnosis: 0 ms + 3000 ms + 10000 ms + 10000 ms + 25000 ms + 18600 ms + 10000 ms

Malfunction Indicator Light Illumination: Illuminates when malfunction occurs in 2 continuous driving cycles.

Leak Diagnosis

DTC

P0456 Evaporative Emission Control System Leak Detected (very small leak)

- The diagnostic consists of creating a sealed vacuum in the fuel tank and then determining the presence of leakage from the speed at which the tank internal pressure returns to barometric pressure.
- The diagnosis is divided into the following five phases.

Mode A: (0 point compensation)

When the pressure in the tank is not near 0 mmHg, wait until it returns to 0 point (near 0 mmHg). Shift to mode B when returned to the 0 point. Cancel the diagnosis when 0 point does not return in the specified time.

Mode B: (Negative pressure introduced)

Introduce negative pressure in the intake manifold to the tank.

Approx. 0 → -2 kPa (0 → -15 mmHg, 0 → -0.6 inHg)

When the pressure above (desired negative pressure) is reached, enters Mode C.

When the tank internal pressure does not reach the target negative pressure, the diagnosis is cancelled.

Mode C: (Negative pressure maintained)

Stop the introduction of negative pressure. (Wait until the tank pressure returns to the start level of P2 calculation.)

Change to Mode D either when the tank pressure returns to the start level of P2 calculation, or when the predetermined amount of time has passed.

Mode D: (Calculate the amount of negative pressure change)

Monitor the tank pressure in mode D, calculate the pressure change in the tank (P2), and measure the time (evpdset) for the tank pressure to change to the Mode E shifting pressure. When the Mode E shifting pressure is reached, Mode E is entered. If it does not change to the Mode E shifting pressure after the predetermined amount of time has passed, make advanced OK judgement or cancel the diagnosis according to the value of P2.

Diagnostic Trouble Code (DTC) Detecting Criteria

GENERAL DESCRIPTION

Normality Judgement

Judge as OK when the following conditions are established.

Judgement Value

Malfunction Criteria	Threshold Value
Advanced OK judgement 1	
Mode D time	$\geq 0 \text{ ms} + 10000 \text{ ms}$
Tank internal pressure	$\leq \text{Value of Map 6}$
Advanced OK judgement 2	
Mode D time	$\geq 0 \text{ ms} + 200000 \text{ ms}$
P2	$\leq \text{Value of Map 7}$

Map 6

Fuel level (ℓ, US gal, Imp gal)	0, 0, 0	10, 2.64, 2.2	20, 5.28, 4.4	30, 7.93, 6.6	40, 10.57, 8.8	50, 13.21, 11	60, 15.85, 13.2
Tank pressure (kPa, mmHg, inHg)	-1.9, -14.62, -0.6	-1.9, -14.62, -0.6	-1.9, -14.59, -0.6	-1.9, -14.56, -0.6	-1.9, -14.42, -0.6	-1.9, -14.28, -0.6	-1.9, -14.28, -0.6

Map 7

Fuel level (ℓ, US gal, Imp gal)	0, 0, 0	10, 2.64, 2.2	20, 5.28, 4.4	30, 7.93, 6.6	40, 10.57, 8.8	50, 13.21, 11	60, 15.85, 13.2
Tank pressure (kPa, mmHg, inHg)	0.9, 7, 0.3	0.9, 7, 0.3	0.9, 7.05, 0.3	0.9, 7.1, 0.3	1.1, 8.2, 0.3	1.3, 9.6, 0.4	1.3, 9.6, 0.4

Mode E: (Evaporation occurrence amount calculation)

Calculate the change of tank pressure with the time evpdset (P1) to judge as NG/OK according to the value of P1. (ambiguous determination acceptable).

Diagnostic Trouble Code (DTC) Detecting Criteria

GENERAL DESCRIPTION

• Abnormality Judgement

Judge as NG when the following conditions are established.

Judgement Value

Malfunction Criteria	Threshold Value
P1	< Value of Map 8

Map 8 Malfunction criteria limit for evaporation diagnosis

Time (evpdset) vs. Fuel level	0 ms	30000 ms	50000 ms	100000 ms	160000 ms	200000 ms
0 ℓ (0 US gal, 0 Imp gal)	0 kPa (0 mmHg, 0 inHg)	0.1 kPa (0.5 mmHg, 0 inHg)	0.2 kPa (1.7 mmHg, 0.1 inHg)	0.4 kPa (2.7 mmHg, 0.1 inHg)	0.4 kPa (2.7 mmHg, 0.1 inHg)	0.4 kPa (2.7 mmHg, 0.1 inHg)
10 ℓ (2.64 US gal, 2.2 Imp gal)	0 kPa (0 mmHg, 0 inHg)	0.1 kPa (0.5 mmHg, 0 inHg)	0.2 kPa (1.7 mmHg, 0.1 inHg)	0.4 kPa (2.7 mmHg, 0.1 inHg)	0.4 kPa (2.7 mmHg, 0.1 inHg)	0.4 kPa (2.7 mmHg, 0.1 inHg)
20 ℓ (5.28 US gal, 4.4 Imp gal)	0 kPa (0 mmHg, 0 inHg)	0.1 kPa (0.5 mmHg, 0 inHg)	0.2 kPa (1.7 mmHg, 0.1 inHg)	0.4 kPa (2.7 mmHg, 0.1 inHg)	0.4 kPa (2.7 mmHg, 0.1 inHg)	0.4 kPa (2.7 mmHg, 0.1 inHg)
30 ℓ (7.93 US gal, 6.6 Imp gal)	0 kPa (0 mmHg, 0 inHg)	0.1 kPa (0.5 mmHg, 0 inHg)	0.2 kPa (1.7 mmHg, 0.1 inHg)	0.4 kPa (2.7 mmHg, 0.1 inHg)	0.4 kPa (2.7 mmHg, 0.1 inHg)	0.4 kPa (2.7 mmHg, 0.1 inHg)
40 ℓ (10.57 US gal, 8.8 Imp gal)	0 kPa (0 mmHg, 0 inHg)	0.1 kPa (0.5 mmHg, 0 inHg)	0.2 kPa (1.85 mmHg, 0.1 inHg)	0.3 kPa (2.5 mmHg, 0.1 inHg)	0.3 kPa (2.5 mmHg, 0.1 inHg)	0.3 kPa (2.5 mmHg, 0.1 inHg)
50 ℓ (13.21 US gal, 11 Imp gal)	0 kPa (0 mmHg, 0 inHg)	0.1 kPa (0.5 mmHg, 0 inHg)	0.3 kPa (2 mmHg, 0.1 inHg)	0.3 kPa (2.3 mmHg, 0.1 inHg)	0.3 kPa (2.3 mmHg, 0.1 inHg)	0 kPa (0 mmHg, 0 inHg)
60 ℓ (15.85 US gal, 13.2 Imp gal)	0 kPa (0 mmHg, 0 inHg)	0.1 kPa (0.5 mmHg, 0 inHg)	0.3 kPa (2 mmHg, 0.1 inHg)	0.3 kPa (2.3 mmHg, 0.1 inHg)	0.3 kPa (2.3 mmHg, 0.1 inHg)	0 kPa (0 mmHg, 0 inHg)

Time Needed for Diagnosis: Value of Map 1 + Value of Map 2 + 25290 ms + 0 + Value of Map 2 + 0 ms + 200000 ms + Value of Map 3 + 0 ms + 200000 ms

Malfunction Indicator Light Illumination: Illuminates when malfunction occurs in 2 continuous driving cycles.

Diagnostic Trouble Code (DTC) Detecting Criteria

GENERAL DESCRIPTION

• Normality Judgement

Judge as OK when the following conditions are established.

Judgement Value

Malfunction Criteria	Threshold Value
P1	> Value of Map 9

Map 9 Malfunction criteria limit for evaporation diagnosis

Time (evpdset) vs. Fuel level	0 ms	30000 ms	50000 ms	100000 ms	160000 ms	200000 ms
0 ℓ (0 US gal, 0 Imp gal)	0.1 kPa (1 mmHg, 0 inHg)	0.5 kPa (3.5 mmHg, 0.1 inHg)	0.6 kPa (4.2 mmHg, 0.2 inHg)	0.6 kPa (4.2 mmHg, 0.2 inHg)	0.6 kPa (4.2 mmHg, 0.2 inHg)	0.6 kPa (4.2 mmHg, 0.2 inHg)
10 ℓ (2.64 US gal, 2.2 Imp gal)	0.1 kPa (1 mmHg, 0 inHg)	0.5 kPa (3.5 mmHg, 0.1 inHg)	0.6 kPa (4.2 mmHg, 0.2 inHg)	0.6 kPa (4.2 mmHg, 0.2 inHg)	0.6 kPa (4.2 mmHg, 0.2 inHg)	0.6 kPa (4.2 mmHg, 0.2 inHg)
20 ℓ (5.28 US gal, 4.4 Imp gal)	0.1 kPa (1 mmHg, 0 inHg)	0.4 kPa (3.25 mmHg, 0.1 inHg)	0.5 kPa (4.1 mmHg, 0.2 inHg)	0.5 kPa (4.1 mmHg, 0.2 inHg)	0.5 kPa (4.1 mmHg, 0.2 inHg)	0.5 kPa (4.1 mmHg, 0.2 inHg)
30 ℓ (7.93 US gal, 6.6 Imp gal)	0.1 kPa (1 mmHg, 0 inHg)	0.4 kPa (3 mmHg, 0.1 inHg)	0.5 kPa (3.9 mmHg, 0.2 inHg)	0.5 kPa (3.9 mmHg, 0.2 inHg)	0.5 kPa (3.9 mmHg, 0.2 inHg)	0.5 kPa (3.9 mmHg, 0.2 inHg)
40 ℓ (10.57 US gal, 8.8 Imp gal)	0.1 kPa (1 mmHg, 0 inHg)	0.3 kPa (2.25 mmHg, 0.1 inHg)	0.5 kPa (3.4 mmHg, 0.1 inHg)	0.5 kPa (3.4 mmHg, 0.1 inHg)	0.5 kPa (3.4 mmHg, 0.1 inHg)	0.5 kPa (3.4 mmHg, 0.1 inHg)
50 ℓ (13.21 US gal, 11 Imp gal)	0.1 kPa (1 mmHg, 0 inHg)	0.2 kPa (1.5 mmHg, 0.1 inHg)	0.4 kPa (2.9 mmHg, 0.1 inHg)	0.4 kPa (2.9 mmHg, 0.1 inHg)	0.4 kPa (2.9 mmHg, 0.1 inHg)	0.4 kPa (2.9 mmHg, 0.1 inHg)
60 ℓ (15.85 US gal, 13.2 Imp gal)	0.1 kPa (1 mmHg, 0 inHg)	0.2 kPa (1.5 mmHg, 0.1 inHg)	0.4 kPa (2.9 mmHg, 0.1 inHg)	0.4 kPa (2.9 mmHg, 0.1 inHg)	0.4 kPa (2.9 mmHg, 0.1 inHg)	0.4 kPa (2.9 mmHg, 0.1 inHg)

Time Needed for Diagnosis: Value of Map 1 + Value of Map 2 + 25290 ms + 0 + Value of Map 2 + 0 ms + 200000 ms + Value of Map 3 + 0 ms + 200000 ms

Diagnostic Trouble Code (DTC) Detecting Criteria

GENERAL DESCRIPTION

BG:DTC P0447 EVAPORATIVE EMISSION CONTROL SYSTEM VENT CONTROL CIRCUIT OPEN

1. OUTLINE OF DIAGNOSIS

Detect open or short circuit of the drain valve.

Judge as NG when the ECM output level differs from the actual terminal level.

2. COMPONENT DESCRIPTION

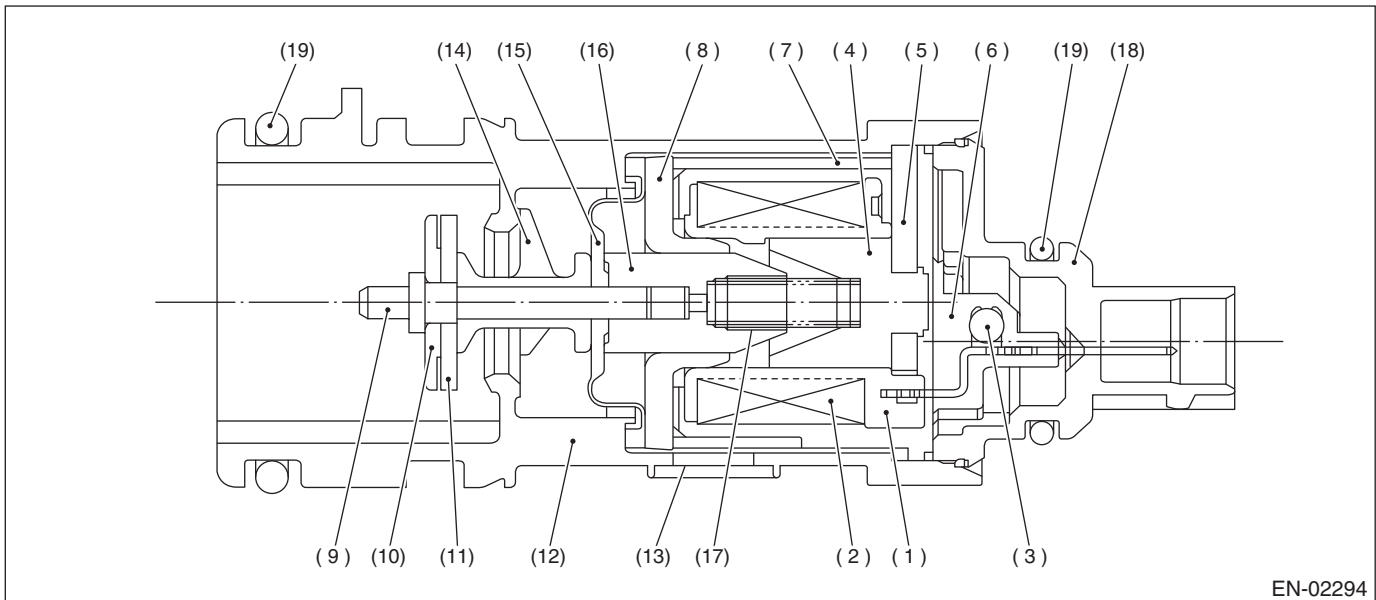

- | | | |
|-----------------|--------------------|-------------------|
| (1) Bobbin | (8) Magnetic plate | (14) Retainer |
| (2) Coil | (9) Shaft | (15) Diaphragm |
| (3) Diode | (10) Plate | (16) Movable core |
| (4) Stator core | (11) Valve | (17) Spring |
| (5) End plate | (12) Housing | (18) Cover |
| (6) Body | (13) Filter | (19) O-ring |
| (7) Yoke | | |

3. ENABLE CONDITION

Secondary Parameters	Enable Conditions
None	

4. GENERAL DRIVING CYCLE

Always perform the diagnosis continuously.

Diagnostic Trouble Code (DTC) Detecting Criteria

GENERAL DESCRIPTION

5. DIAGNOSTIC METHOD

• Abnormality Judgement

If the duration of time while the following conditions are met is longer than the time indicated, judge as NG.

Judgement Value

Malfunction Criteria	Threshold Value
Battery voltage	≥ 10.9 V
Elapsed time after starting the engine	≥ 1 second
Terminal output voltage when ECM outputs OFF signal	Low

Time Needed for Diagnosis: 2500 ms

Malfunction Indicator Light Illumination: Illuminates as soon as a malfunction occurs.

• Normality Judgement

Judge as OK and clear the NG if the continuous time while the following conditions are established is more than the predetermined time.

Judgement Value

Malfunction Criteria	Threshold Value
Battery voltage	≥ 10.9 V
Elapsed time after starting the engine	≥ 1 second
Terminal output voltage when ECM outputs OFF signal	High

Time Needed for Diagnosis: Less than 1 second

Diagnostic Trouble Code (DTC) Detecting Criteria

GENERAL DESCRIPTION

BH:DTC P0448 EVAPORATIVE EMISSION CONTROL SYSTEM VENT CONTROL CIRCUIT SHORTED

1. OUTLINE OF DIAGNOSIS

Detect open or short circuit of the drain valve.

Judge as NG when the ECM output level differs from the actual terminal level.

2. COMPONENT DESCRIPTION

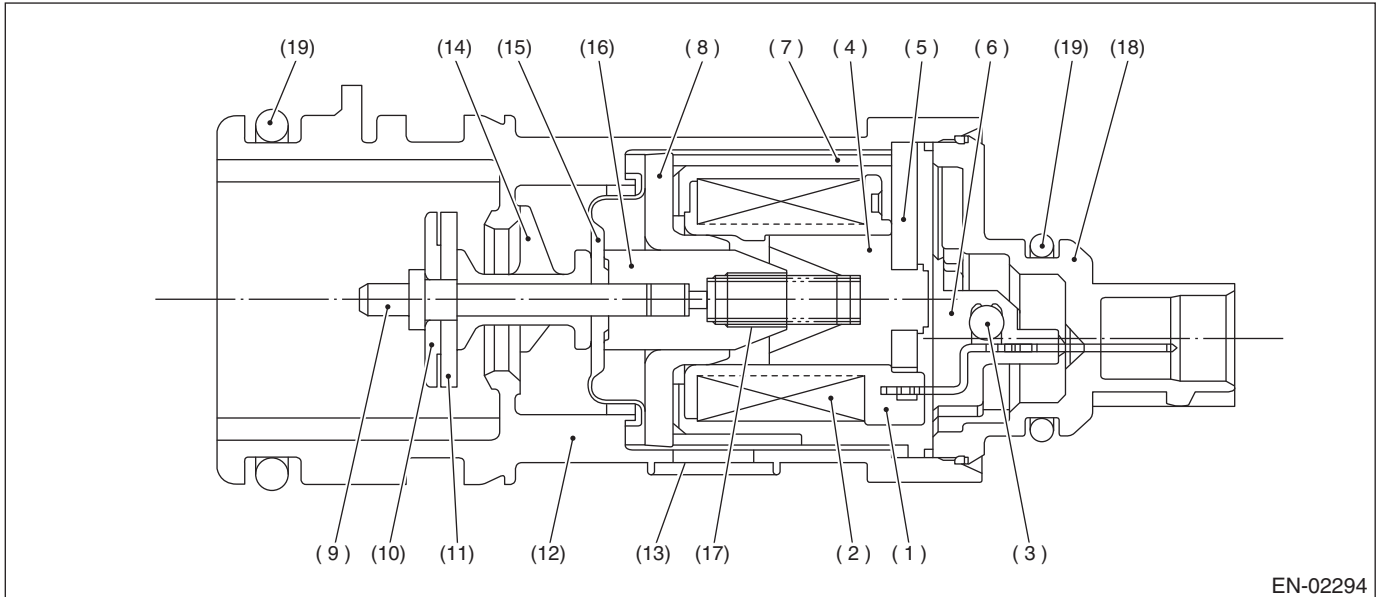

- | | | |
|-----------------|--------------------|-------------------|
| (1) Bobbin | (8) Magnetic plate | (14) Retainer |
| (2) Coil | (9) Shaft | (15) Diaphragm |
| (3) Diode | (10) Plate | (16) Movable core |
| (4) Stator core | (11) Valve | (17) Spring |
| (5) End plate | (12) Housing | (18) Cover |
| (6) Body | (13) Filter | (19) O-ring |
| (7) Yoke | | |

3. ENABLE CONDITION

Secondary Parameters	Enable Conditions
None	

4. GENERAL DRIVING CYCLE

Always perform the diagnosis continuously.

Diagnostic Trouble Code (DTC) Detecting Criteria

GENERAL DESCRIPTION

5. DIAGNOSTIC METHOD

• Abnormality Judgement

If the duration of time while the following conditions are met is longer than the time indicated, judge as NG.

Judgement Value

Malfunction Criteria	Threshold Value
Battery voltage	≥ 10.9 V
Elapsed time after starting the engine	≥ 1 second
Terminal output voltage when ECM outputs ON signal	High

Time Needed for Diagnosis: 2500 ms

Malfunction Indicator Light Illumination: Illuminates as soon as a malfunction occurs.

• Normality Judgement

Judge as OK and clear the NG if the continuous time while the following conditions are established is more than the predetermined time.

Judgement Value

Malfunction Criteria	Threshold Value
Battery voltage	≥ 10.9 V
Elapsed time after starting the engine	≥ 1 second
Terminal output voltage when ECM outputs ON signal	Low

Time Needed for Diagnosis: Less than 1 second

Diagnostic Trouble Code (DTC) Detecting Criteria

GENERAL DESCRIPTION

BI: DTC P0451 EVAPORATIVE EMISSION CONTROL SYSTEM PRESSURE SENSOR

1. OUTLINE OF DIAGNOSIS

Detect the tank pressure sensor output property abnormality.

Judge as NG when there is no pressure variation, which should exist in the tank, considering the engine status.

2. COMPONENT DESCRIPTION

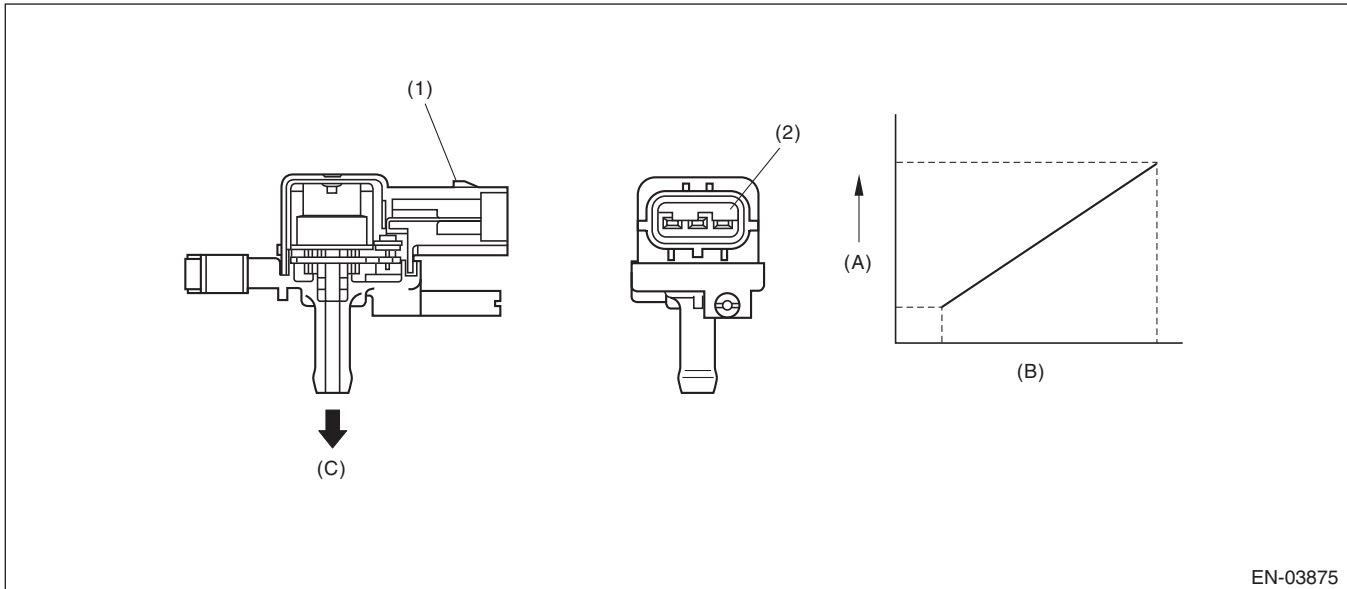

EN-03875

(A) Output voltage

(B) Input voltage

(C) To fuel tank

(1) Connector

(2) Terminals

3. ENABLE CONDITION

Secondary Parameters	Enable Conditions
Elapsed time after starting the engine	≥ 60 s
Fuel level	≥ 9.6 l (2.54 US gal, 2.11 Imp gal)
Fuel temperature	< 35 °C (95 °F)
Battery voltage	≥ 10.9 V
Barometric pressure	≥ 75 kPa (563 mmHg, 22.2 inHg)

4. GENERAL DRIVING CYCLE

- Perform the diagnosis continuously after 60 s have passed since the engine started.
- Pay attention to the fuel level and temperature.

Diagnostic Trouble Code (DTC) Detecting Criteria

GENERAL DESCRIPTION

5. DIAGNOSTIC METHOD

• Abnormality Judgement

If the duration of time while the following conditions are met is longer than the time indicated, judge as NG.

Judgement Value

Malfunction Criteria	Threshold Value
Number of times that the difference between the Max. fuel level every 60 s and Min. fuel level every 60 s is 2 ℓ (0.53 US gal, 0.44 Imp gal) or more (with enable condition established)	≥ 16 time(s)
Maximum – Minimum tank pressure (with enable condition completed)	< 0 kPa (0.375 mmHg, 0 inHg)
Maximum – Minimum fuel temperature (with enable condition completed)	≥ 7 °C (44.6 °F)

If the difference between the Max. fuel level every 60 s and Min. fuel level every 60 s is less than 2 ℓ (0.53 US gal, 0.44 Imp gal), extend 60 s and make judgement with the Max. and Min. values for the fuel level in 60 s × 2. If a difference does not appear, extend the time (60 s × 3, 60 s × 4, 60 s × 5) and continue the judgement. If the difference between the Max. fuel level every 60 s and Min. fuel level every 60 s is 2 ℓ (0.53 US gal, 0.44 Imp gal) or more, the diagnosis counter counts up.

Time Needed for Diagnosis: 60 s × 16 time(s) or more

Malfunction Indicator Light Illumination: Illuminates when malfunction occurs in 2 continuous driving cycles.

• Normality Judgement

Judge as OK and clear the NG if the continuous time while the following conditions are established is more than the predetermined time.

Judgement Value

Malfunction Criteria	Threshold Value
Maximum — Minimum tank pressure	≥ 0 kPa (0.375 mmHg, 0 inHg)

Time Needed for Diagnosis: Less than 1 second

Diagnostic Trouble Code (DTC) Detecting Criteria

GENERAL DESCRIPTION

BJ:DTC P0452 EVAPORATIVE EMISSION CONTROL SYSTEM PRESSURE SENSOR LOW INPUT

1. OUTLINE OF DIAGNOSIS

Detect the open or short circuit of the fuel tank pressure sensor.
Judge as NG if out of specification.

2. COMPONENT DESCRIPTION

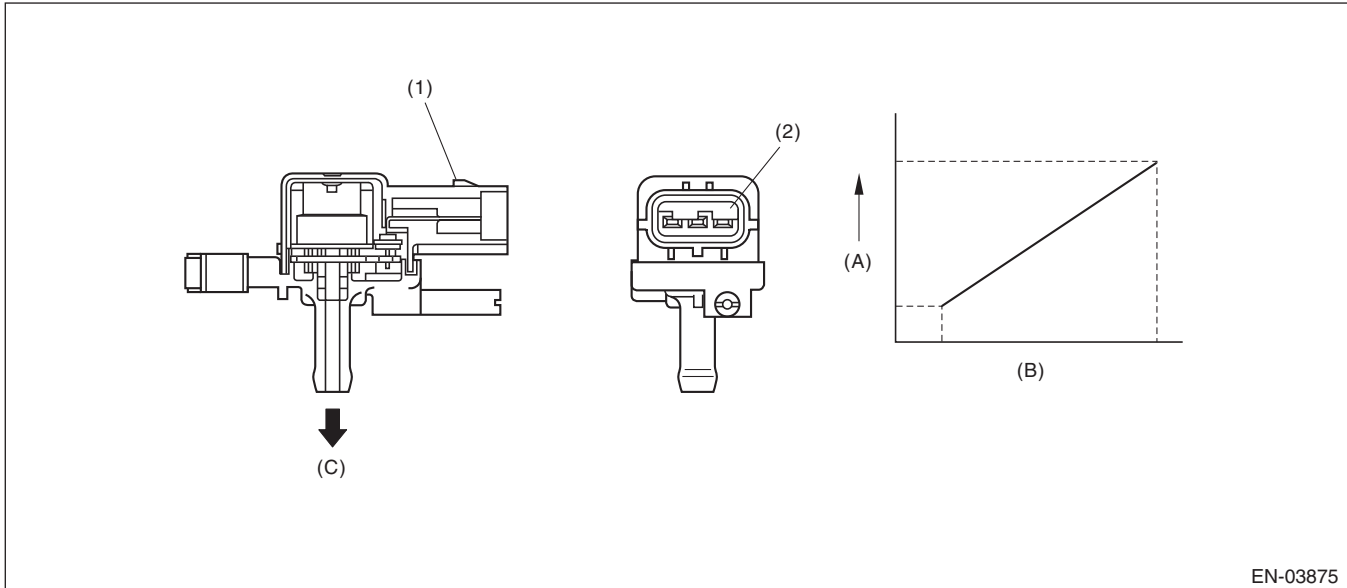

EN-03875

(A) Output voltage

(B) Input voltage

(C) To fuel tank

(1) Connector

(2) Terminals

3. ENABLE CONDITION

Secondary Parameters	Enable Conditions
None	

4. GENERAL DRIVING CYCLE

Always perform the diagnosis continuously.

Diagnostic Trouble Code (DTC) Detecting Criteria

GENERAL DESCRIPTION

5. DIAGNOSTIC METHOD

• Abnormality Judgement

If the duration of time while the following conditions are met is longer than the time indicated, judge as NG.

Judgement Value

Malfunction Criteria	Threshold Value
Fuel tank pressure	< -7.5 kPa (-55.9 mmHg, -2.2 inHg)
Battery voltage	≥ 10.9 V

Time Needed for Diagnosis: 15000 ms

Malfunction Indicator Light Illumination: Illuminates as soon as a malfunction occurs.

• Normality Judgement

Judge as OK and clear the NG if the continuous time while the following conditions are established is more than the predetermined time.

Judgement Value

Malfunction Criteria	Threshold Value
Fuel tank pressure	≥ -7.5 kPa (-55.9 mmHg, -2.2 inHg)
Battery voltage	≥ 10.9 V

Time Needed for Diagnosis: Less than 1 second

BK:DTC P0453 EVAPORATIVE EMISSION CONTROL SYSTEM PRESSURE SENSOR HIGH INPUT

1. OUTLINE OF DIAGNOSIS

Detect the open or short circuit of the fuel tank pressure sensor.

Judge as NG if out of specification.

2. COMPONENT DESCRIPTION

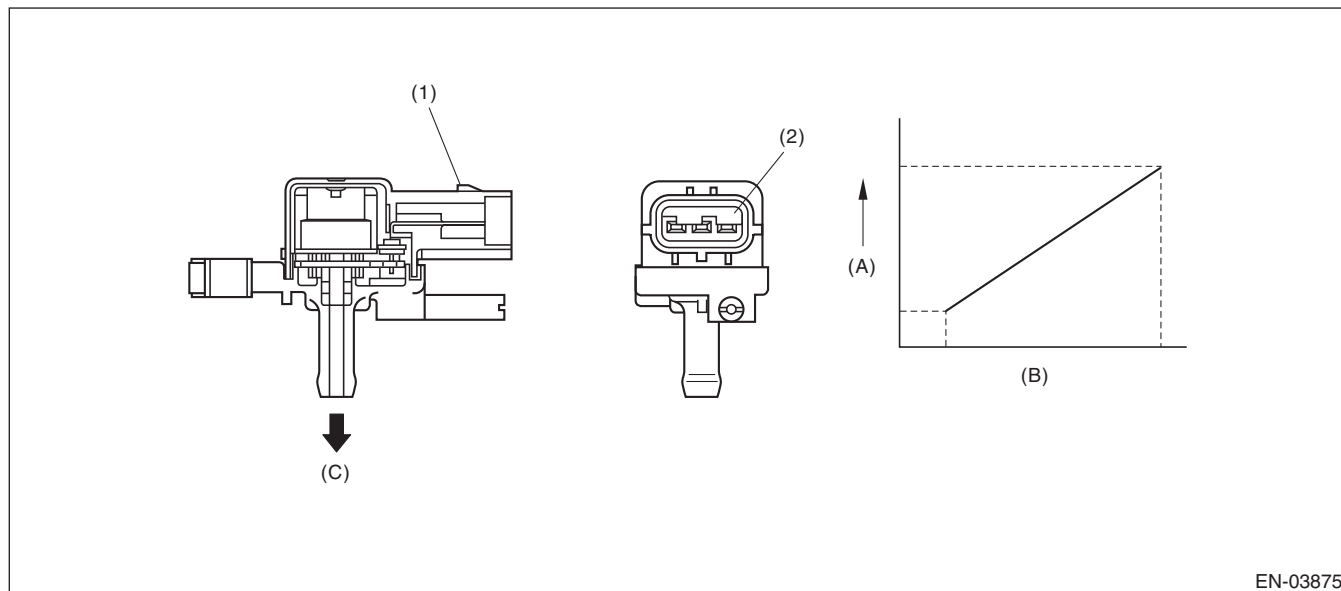

EN-03875

(A) Output voltage

(B) Input voltage

(C) To fuel tank

(1) Connector

(2) Terminals

3. ENABLE CONDITION

Secondary Parameters	Enable Conditions
Time needed for all secondary parameters to be in enable conditions	≥ 5000 ms
Vehicle speed	≥ 2 km/h (1.2 MPH)
All conditions of EVAP canister purge	Completed
Learning value of evaporation gas concentration (left and right)	< 0.08
Main feedback compensation coefficient (left and right)	≥ 0.9
Battery voltage	≥ 10.9 V

4. GENERAL DRIVING CYCLE

Perform the diagnosis when purging enable conditions are met without idling.

Diagnostic Trouble Code (DTC) Detecting Criteria

GENERAL DESCRIPTION

5. DIAGNOSTIC METHOD

• Abnormality Judgement

If the duration of time while the following conditions are met is longer than the time indicated, judge as NG.

Judgement Value

Malfunction Criteria	Threshold Value
Fuel tank pressure	≥ 7.9 kPa (59.6 mmHg, 2.3 inHg)
Fuel temperature	< 35 °C (95 °F)
Barometric pressure	≥ 75 kPa (563 mmHg, 22.2 inHg)

Time Needed for Diagnosis: 15000 ms

Malfunction Indicator Light Illumination: Illuminates as soon as a malfunction occurs.

• Normality Judgement

Judge as OK and clear the NG if the continuous time while the following conditions are established is more than the predetermined time.

Judgement Value

Malfunction Criteria	Threshold Value
Fuel tank pressure	< 7.9 kPa (59.6 mmHg, 2.3 inHg)

Time Needed for Diagnosis: Less than 1 second

Diagnostic Trouble Code (DTC) Detecting Criteria

GENERAL DESCRIPTION

BL:DTC P0456 EVAPORATIVE EMISSION CONTROL SYSTEM LEAK DETECTED (VERY SMALL LEAK)

1. OUTLINE OF DIAGNOSIS

NOTE:

For the detection standard, refer to DTC P0442. <Ref. to GD(H4SO)-99, DTC P0442 EVAPORATIVE EMISSION CONTROL SYSTEM LEAK DETECTED (SMALL LEAK), Diagnostic Trouble Code (DTC) Detecting Criteria.>

BM:DTC P0457 EVAPORATIVE EMISSION CONTROL SYSTEM LEAK DETECTED (FUEL CAP LOOSE/OFF)

1. OUTLINE OF DIAGNOSIS

NOTE:

For the detection standard, refer to DTC P0442. <Ref. to GD(H4SO)-99, DTC P0442 EVAPORATIVE EMISSION CONTROL SYSTEM LEAK DETECTED (SMALL LEAK), Diagnostic Trouble Code (DTC) Detecting Criteria.>

Diagnostic Trouble Code (DTC) Detecting Criteria

GENERAL DESCRIPTION

BN:DTC P0458 EVAPORATIVE EMISSION SYSTEM PURGE CONTROL VALVE CIRCUIT LOW

1. OUTLINE OF DIAGNOSIS

Detect open or short circuit of the purge control solenoid valve.

Judge as NG when the ECM output level differs from the actual terminal level.

2. COMPONENT DESCRIPTION

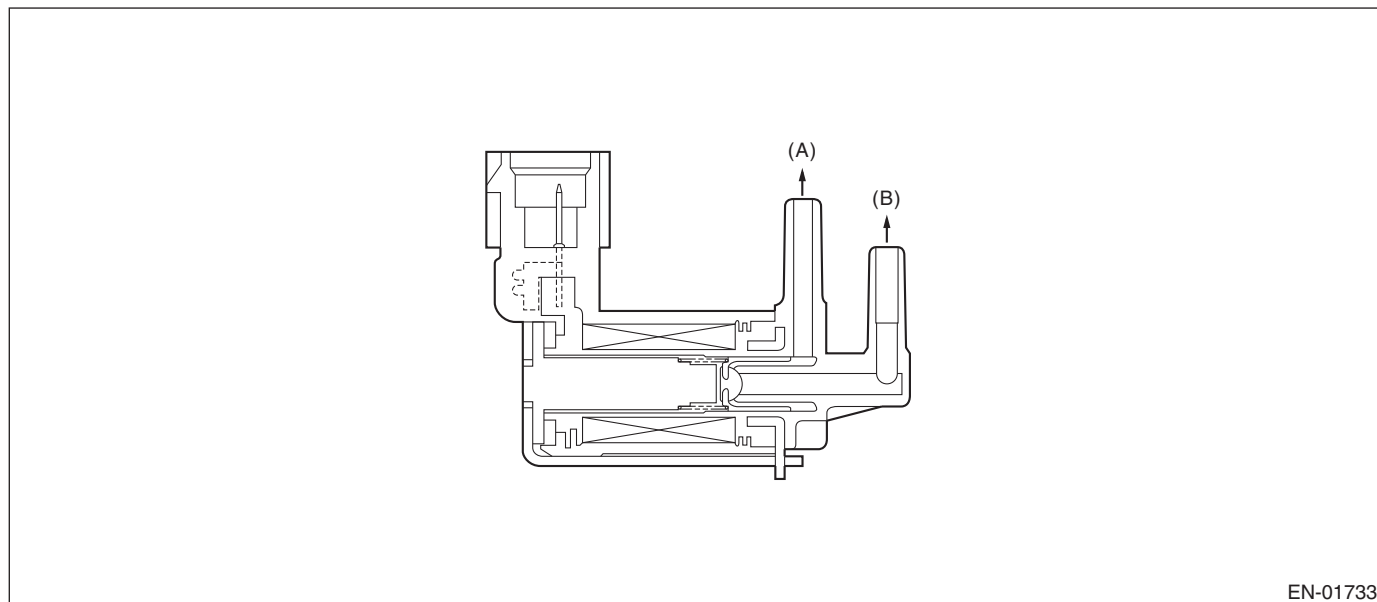

(A) To canister

(B) To intake manifold

3. ENABLE CONDITION

Secondary Parameters	Enable Conditions
Battery voltage	$\geq 10.9 \text{ V}$
Elapsed time after starting the engine	$\geq 1 \text{ second}$

4. GENERAL DRIVING CYCLE

Always perform the diagnosis after starting the engine.

5. DIAGNOSTIC METHOD

• Abnormality Judgement

If the duration of time while the following conditions are met is longer than the time indicated, judge as NG.

Judgement Value

Malfunction Criteria	Threshold Value
Duty ratio of "ON"	< 0.75
Terminal output voltage	Low

Time Needed for Diagnosis: 2500 ms

Malfunction Indicator Light Illumination: Illuminates when malfunction occurs in 2 continuous driving cycles.

• Normality Judgement

Judge as OK and clear the NG if the continuous time while the following conditions are established is more than the predetermined time.

Judgement Value

Malfunction Criteria	Threshold Value
Terminal output voltage	High

Time Needed for Diagnosis: Less than 1 second

BO:DTC P0459 EVAPORATIVE EMISSION SYSTEM PURGE CONTROL VALVE CIRCUIT HIGH

1. OUTLINE OF DIAGNOSIS

Detect open or short circuit of the purge control solenoid valve.
 Judge as NG when the ECM output level differs from the actual terminal level.

2. COMPONENT DESCRIPTION

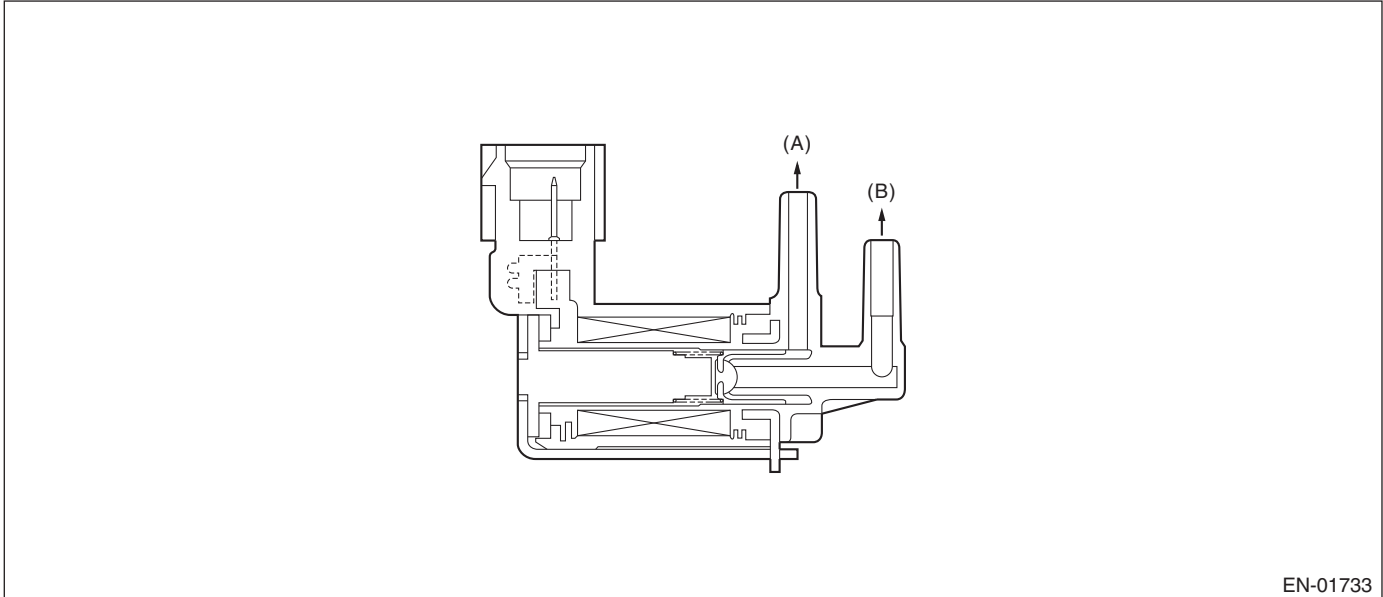

EN-01733

(A) To canister

(B) To intake manifold

3. ENABLE CONDITION

Secondary Parameters	Enable Conditions
Battery voltage	$\geq 10.9 \text{ V}$
Elapsed time after starting the engine	$\geq 1 \text{ second}$

4. GENERAL DRIVING CYCLE

Always perform the diagnosis after starting the engine.

5. DIAGNOSTIC METHOD

• Abnormality Judgement

If the duration of time while the following conditions are met is longer than the time indicated, judge as NG.

Judgement Value

Malfunction Criteria	Threshold Value
Duty ratio of "ON"	≥ 0.25
Terminal output voltage	High

Time Needed for Diagnosis: 2500 ms

Malfunction Indicator Light Illumination: Illuminates when malfunction occurs in 2 continuous driving cycles.

• Normality Judgement

Judge as OK and clear the NG if the continuous time while the following conditions are established is more than the predetermined time.

Judgement Value

Malfunction Criteria	Threshold Value
Terminal output voltage	Low

Time Needed for Diagnosis: Less than 1 second

Diagnostic Trouble Code (DTC) Detecting Criteria

GENERAL DESCRIPTION

BP:DTC P0461 FUEL LEVEL SENSOR "A" CIRCUIT RANGE/PERFORMANCE

1. OUTLINE OF DIAGNOSIS

Detect malfunctions of the fuel level sensor output property.

If the fuel level does not vary in a particular driving condition / engine condition where it should, judge as NG.

2. COMPONENT DESCRIPTION

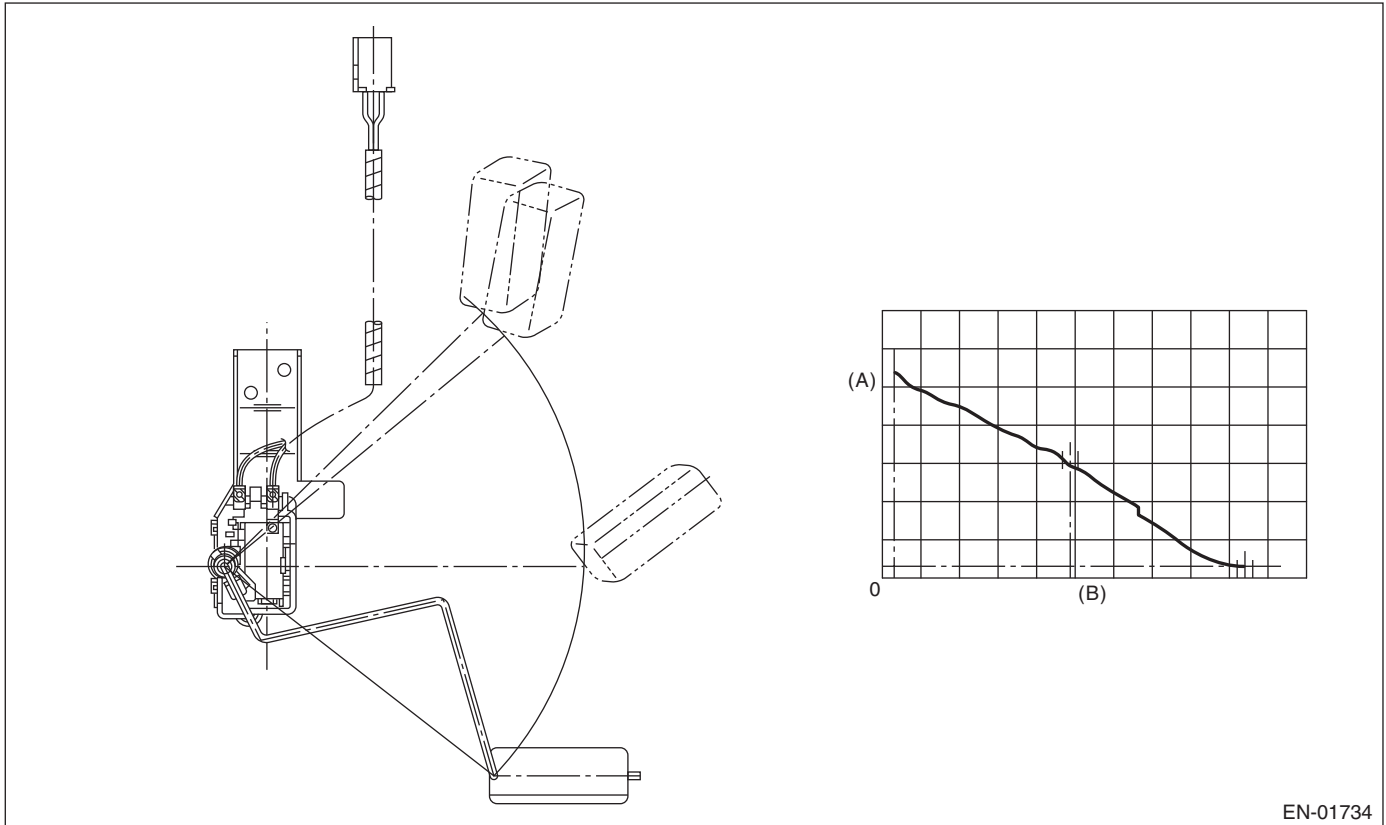

EN-01734

(A) Fuel level

(B) Resistance

3. ENABLE CONDITION

Secondary Parameters	Enable Conditions
None	

4. GENERAL DRIVING CYCLE

Always perform the diagnosis continuously.

Diagnostic Trouble Code (DTC) Detecting Criteria

GENERAL DESCRIPTION

5. DIAGNOSTIC METHOD

• Abnormality Judgement

Judge as NG when the following conditions are established.

Judgement Value

Malfunction Criteria	Threshold Value
Accumulated amount of intake air	≥ 330957 g (11672.85 oz)
Max. – Min. values of fuel level output	< 2.6 ℓ (0.69 US gal, 0.57 Imp gal)
Battery voltage	≥ 10.9 V
Engine speed	< 6000 rpm
Elapsed time after starting the engine	≥ 5000 ms

Time Needed for Diagnosis: Less than 1 second

Malfunction Indicator Light Illumination: Illuminates when malfunction occurs in 2 continuous driving cycles.

• Normality Judgement

Judge as OK and clear the NG if the following conditions are established.

Judgement Value

Malfunction Criteria	Threshold Value
Accumulated amount of intake air	≥ 330957 g (11672.85 oz)
Max. – Min. values of fuel level output	≥ 2.6 ℓ (0.69 US gal, 0.57 Imp gal)
Battery voltage	≥ 10.9 V
Engine speed	< 6000 rpm
Elapsed time after starting the engine	≥ 5000 ms

Time Needed for Diagnosis: Less than 1 second

Diagnostic Trouble Code (DTC) Detecting Criteria

GENERAL DESCRIPTION

BQ:DTC P0462 FUEL LEVEL SENSOR “A” CIRCUIT LOW

1. OUTLINE OF DIAGNOSIS

Detect the open or short circuit of fuel level sensor. Judge as NG if out of specification.

2. COMPONENT DESCRIPTION

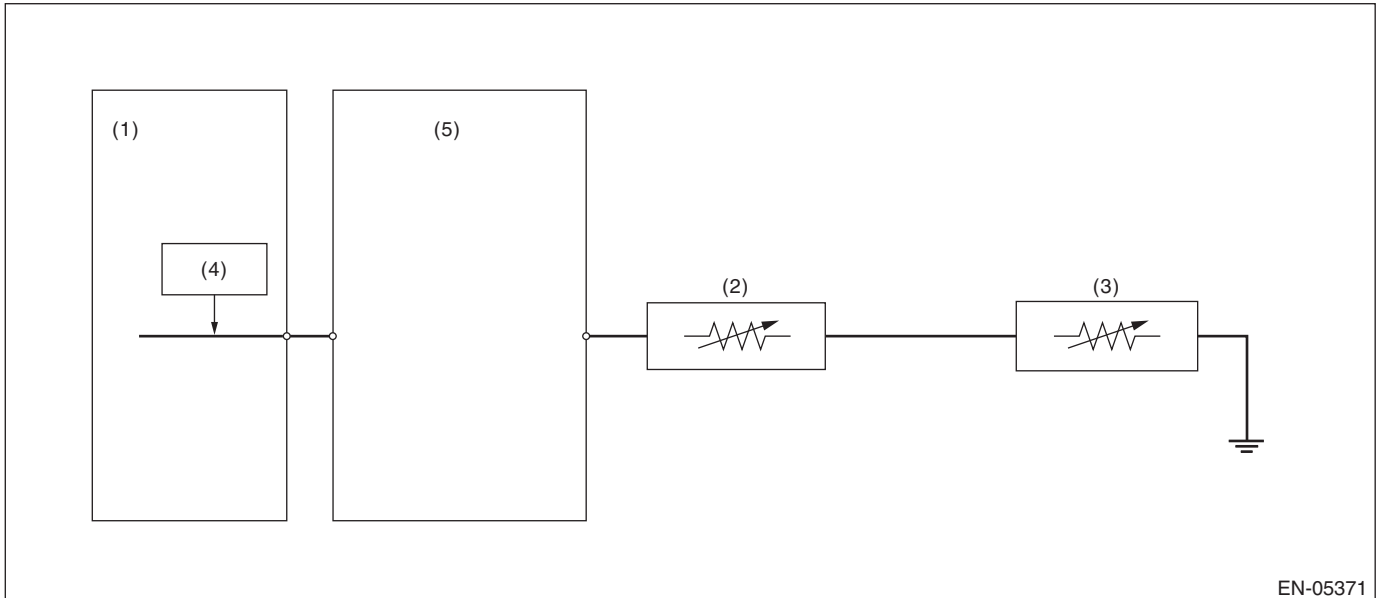

(1) Engine control module (ECM)

(3) Fuel sub level sensor

(5) Body integrated unit

(2) Fuel level sensor

(4) Detecting circuit

3. ENABLE CONDITION

Secondary Parameters	Enable Conditions
None	

4. GENERAL DRIVING CYCLE

Always perform the diagnosis continuously.

Diagnostic Trouble Code (DTC) Detecting Criteria

GENERAL DESCRIPTION

5. DIAGNOSTIC METHOD

• Abnormality Judgement

If the duration of time while the following conditions are met is longer than the time indicated, judge as NG.

Judgement Value

Malfunction Criteria	Threshold Value
Battery voltage	≥ 10.9 V
Elapsed time after starting the engine	≥ 3000 ms
Output voltage	< 0.173 V

Time Needed for Diagnosis: 2500 ms

Malfunction Indicator Light Illumination: Illuminates when malfunction occurs in 2 continuous driving cycles.

• Normality Judgement

Judge as OK and clear the NG if the continuous time while the following conditions are established is more than the predetermined time.

Judgement Value

Malfunction Criteria	Threshold Value
Battery voltage	≥ 10.9 V
Elapsed time after starting the engine	≥ 3000 ms
Output voltage	≥ 0.173 V

Time Needed for Diagnosis: Less than 1 second

Diagnostic Trouble Code (DTC) Detecting Criteria

GENERAL DESCRIPTION

BR:DTC P0463 FUEL LEVEL SENSOR “A” CIRCUIT HIGH

1. OUTLINE OF DIAGNOSIS

Detect the open or short circuit of fuel level sensor. Judge as NG if out of specification.

2. COMPONENT DESCRIPTION

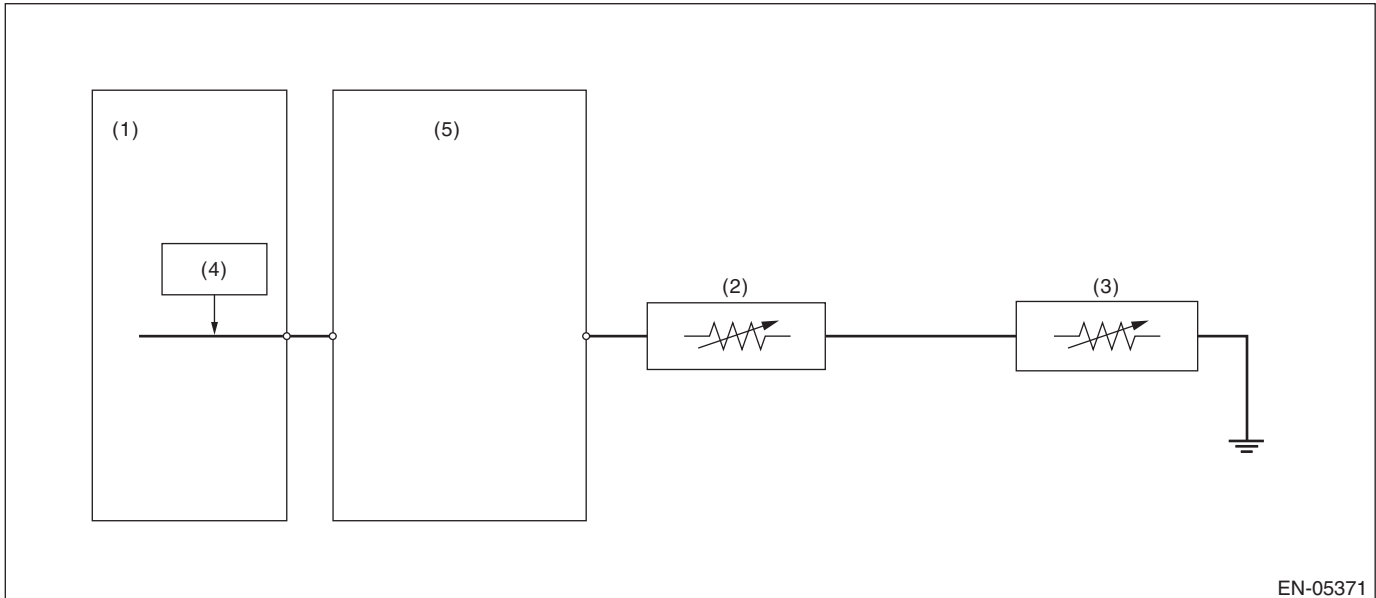

(1) Engine control module (ECM)

(3) Fuel sub level sensor

(5) Body integrated unit

(2) Fuel level sensor

(4) Detecting circuit

3. ENABLE CONDITION

Secondary Parameters	Enable Conditions
None	

4. GENERAL DRIVING CYCLE

Always perform the diagnosis continuously.

Diagnostic Trouble Code (DTC) Detecting Criteria

GENERAL DESCRIPTION

5. DIAGNOSTIC METHOD

• Abnormality Judgement

If the duration of time while the following conditions are met is longer than the time indicated, judge as NG.

Judgement Value

Malfunction Criteria	Threshold Value
Battery voltage	≥ 10.9 V
Elapsed time after starting the engine	≥ 3000 ms
Output voltage	≥ 7.212 V

Time Needed for Diagnosis: 1000 ms

Malfunction Indicator Light Illumination: Illuminates when malfunction occurs in 2 continuous driving cycles.

• Normality Judgement

Judge as OK and clear the NG if the continuous time while the following conditions are established is more than the predetermined time.

Judgement Value

Malfunction Criteria	Threshold Value
Battery voltage	≥ 10.9 V
Elapsed time after starting the engine	≥ 3000 ms
Output voltage	< 7.212 V

Time Needed for Diagnosis: Less than 1 second

Diagnostic Trouble Code (DTC) Detecting Criteria

GENERAL DESCRIPTION

BS:DTC P0464 FUEL LEVEL SENSOR CIRCUIT INTERMITTENT

1. OUTLINE OF DIAGNOSIS

Detect the unstable output faults from the fuel level sensor caused by noise. Judge as NG when the max. value and cumulative value of output voltage variation of the fuel level sensor is larger than the threshold value.

2. ENABLE CONDITION

Malfunction Criteria	Threshold Value
Engine speed	≥ 500 rpm
Elapsed time after starting the engine	≥ 1 second
Battery voltage	≥ 10.9 V
Idle switch	ON
Fuel level	≥ 9.6 ℓ (2.54 US gal, 2.11 Imp gal) and < 54.4 ℓ (14.37 US gal, 11.97 Imp gal)
Vehicle speed = 0 km/h (0 MPH)	≥ 10000 ms

3. GENERAL DRIVING CYCLE

- Always perform the diagnosis continuously at idle speed.
- Pay attention to the fuel level.

Diagnostic Trouble Code (DTC) Detecting Criteria

GENERAL DESCRIPTION

4. DIAGNOSTIC METHOD

Calculate the Max. value (DELFLMAX) and cumulative value (SUMFL) of output voltage variation of fuel level sensor during 12.2 seconds. Judge it normal when both max. and cumulative values are not over the threshold value. Otherwise, when either of them is over the threshold value, the diagnosis counter counts up. Judge as NG if the counter indicated 4 time(s).

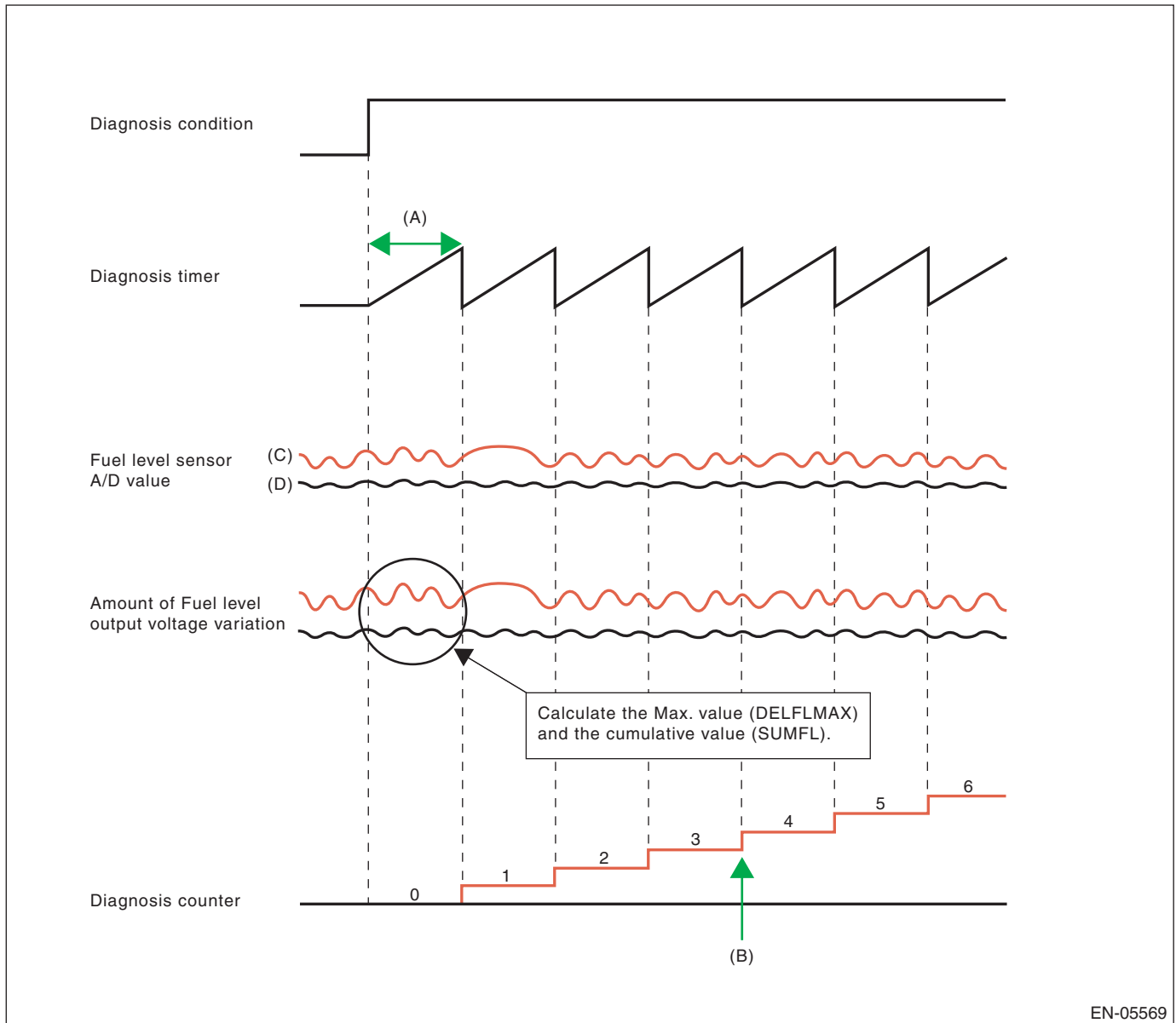

- (A) 12288 ms
- (B) NG at 4 time(s) counts

(C) Malfunction

(D) Normal

Diagnostic Trouble Code (DTC) Detecting Criteria

GENERAL DESCRIPTION

• Abnormality Judgement

If the duration of time while the following conditions are met is longer than the time indicated, judge as NG.

Judgement Value

Malfunction Criteria	Threshold Value
Integrated times of the condition reaching follows, DELFLMAX or SUMFL At this time, DELFLMAX: Maximum difference of sensor output for 12288 ms SUMFL: Integrated value of the sensor output deviation for 12288 ms	≥ 4 time(s) \geq Value from Map ≥ 25.92 V

Map

Fuel level (ℓ , US gal, Imp gal)	0, 0, 0	10, 2.64, 2.2	20, 5.28, 4.4	30, 7.93, 6.6	40, 10.57, 8.8	50, 13.21, 11	60, 15.85, 13.2
Measured voltage (V)	0.27	0.27	0.426	0.582	0.738	0.894	0.894

The diagnosis counter does not count up when the following conditions are completed within 12288 ms.

Maximum value – Minimum value of change of tank pressure during 12288 ms	≥ 0 kPa (0.375 mmHg, 0 inHg)
Maximum value – Minimum value of battery voltage during 12288 ms	≥ 1.09 V

Time Needed for Diagnosis:12288 ms \times 4 time(s)

Malfunction Indicator Light Illumination: Illuminates when malfunction occurs in 2 continuous driving cycles.

• Normality Judgement

Judge as OK and clear the NG if the continuous time while the following conditions are established is more than the predetermined time.

Judgement Value

Malfunction Criteria	Threshold Value
DELFLMAX SUMFL At this time, DELFLMAX: Maximum difference of sensor output for 12288 ms SUMFL: Integrated value of the sensor output deviation for 12288 ms	$<$ Value from Map < 25.92 V

Time Needed for Diagnosis:12288 ms

Diagnostic Trouble Code (DTC) Detecting Criteria

GENERAL DESCRIPTION

BT:DTC P0500 VEHICLE SPEED SENSOR "A"

1. OUTLINE OF DIAGNOSIS

Judge as NG when outside of the judgement value.

Judge NG when the received data from ABSCM&H/U is abnormal vehicle speed, and the vehicle speed data is impossible.

2. COMPONENT DESCRIPTION

Vehicle speed signals are taken in to the ABS control module and hydraulic control unit, and normal/erroneous data of the ABS wheel speed sensor is received by CAN communication from the ABS control module and hydraulic control unit.

3. ENABLE CONDITION

Secondary Parameters	Enable Conditions
Battery voltage	≥ 10.9 V
Elapsed time after engine starting	≥ 2000 ms

4. GENERAL DRIVING CYCLE

Always perform diagnosis more than 2000 ms after starting the engine.

5. DIAGNOSTIC METHOD

• Abnormality Judgement

If the duration of time while the following conditions are met is longer than the time indicated, judge as NG.

Judgement Value

Malfunction Criteria	Threshold Value
Front ABS wheel speed sensor status	Malfunction
Either of the following is established	
Front left wheel speed	≥ 300 km/h (186.4 MPH)
Front right wheel speed	≥ 300 km/h (186.4 MPH)

Time Needed for Diagnosis:2500 ms

Malfunction Indicator Light Illumination: Illuminates as soon as a malfunction occurs.

• Normality Judgement

Judge as OK and clear the NG if the continuous time while the following conditions are established is more than the predetermined time.

Judgement Value

Malfunction Criteria	Threshold Value
Front left wheel speed	> 0 km/h (0 MPH) and < 300 km/h (186.4 MPH)
Front right wheel speed	> 0 km/h (0 MPH) and < 300 km/h (186.4 MPH)

Time Needed for Diagnosis:2500 ms

Diagnostic Trouble Code (DTC) Detecting Criteria

GENERAL DESCRIPTION

BU:DTC P0506 IDLE AIR CONTROL SYSTEM RPM LOWER THAN EXPECTED

1. OUTLINE OF DIAGNOSIS

Detect the malfunction that actual engine speed is not close to target engine speed during idling. Judge as NG when actual engine speed is not close to target engine speed during idling.

2. ENABLE CONDITION

Secondary Parameters	Enable Conditions
Engine coolant temperature	$\geq 75\text{ }^{\circ}\text{C}$ (167 $^{\circ}\text{F}$)
Battery voltage	$\geq 10.9\text{ V}$
Barometric pressure	$\geq 75\text{ kPa}$ (563 mmHg, 22.2 inHg)
Fuel level	$\geq 9.6\text{ }\ell$ (2.54 US gal, 2.11 Imp gal)
Elapsed time after starting the engine	$\geq 10.49\text{ s}$
Feedback of ISC	In operation
Lambda value (left and right)	≥ 0.81 and < 1.1
After switching air conditioner to ON/OFF	$\geq 5.1\text{ s}$
After intake manifold pressure changes by 4 kPa (30 mmHg, 1.2 inHg) or more.	$> 5.1\text{ s}$
Elapsed time after switching neutral position switch to ON/OFF	$> 5.1\text{ s}$
Vehicle speed	0 km/h (0 MPH)

3. GENERAL DRIVING CYCLE

Perform the diagnosis continuously at idling after warming up engine.

4. DIAGNOSTIC METHOD

• Abnormality Judgement

If the duration of time while the following conditions are met is longer than the time indicated, judge as NG.

Judgement Value

Malfunction Criteria	Threshold Value
Actual engine speed — Targeted engine speed	$< -100\text{ rpm}$
Feedback value for ISC	Max.

Time Needed for Diagnosis: 10 s \times 3 time(s)

Malfunction Indicator Light Illumination: Illuminates when malfunction occurs in 2 continuous driving cycles.

• Normality Judgement

Judge as OK and clear the NG if the continuous time while the following conditions are established is more than the predetermined time.

Judgement Value

Malfunction Criteria	Threshold Value
Actual engine speed — Targeted engine speed	$\geq -100\text{ rpm}$

Time Needed for Diagnosis: 10 s

Diagnostic Trouble Code (DTC) Detecting Criteria

GENERAL DESCRIPTION

BV:DTC P0507 IDLE AIR CONTROL SYSTEM RPM HIGHER THAN EXPECTED

1. OUTLINE OF DIAGNOSIS

Detect the malfunction that actual engine speed is not close to target engine speed during idling. Judge as NG when actual engine speed is not close to target engine speed during idling.

2. ENABLE CONDITION

Secondary Parameters	Enable Conditions
Engine coolant temperature	≥ 75 °C (167 °F)
Battery voltage	≥ 10.9 V
Barometric pressure	≥ 75 kPa (563 mmHg, 22.2 inHg)
Fuel level	≥ 9.6 ℓ (2.54 US gal, 2.11 Imp gal)
Elapsed time after starting the engine	≥ 10.49 s
Feedback of ISC	In operation
Lambda value (left and right)	≥ 0.81 and < 1.1
After switching air conditioner to ON/ OFF	≥ 5.1 s
After intake manifold pressure changes by 4 kPa (30 mmHg, 1.2 inHg) or more.	> 5.1 s
Elapsed time after switching neutral position switch to ON/OFF	> 5.1 s
Vehicle speed	0 km/h (0 MPH)

3. GENERAL DRIVING CYCLE

Perform the diagnosis continuously at idling after warming up engine.

4. DIAGNOSTIC METHOD

• Abnormality Judgement

If the duration of time while the following conditions are met is longer than the time indicated, judge as NG.

Judgement Value

Malfunction Criteria	Threshold Value
Actual – Target engine speed	≥ 200 rpm
Feedback value for ISC	Min.

Time Needed for Diagnosis: 10 s × 3 time(s)

Malfunction Indicator Light Illumination: Illuminates when malfunction occurs in 2 continuous driving cycles.

• Normality Judgement

Judge as OK and clear the NG if the continuous time while the following conditions are established is more than the predetermined time.

Judgement Value

Malfunction Criteria	Threshold Value
Actual – Target engine speed	< 200 rpm

Time Needed for Diagnosis: 10 s

Diagnostic Trouble Code (DTC) Detecting Criteria

GENERAL DESCRIPTION

BW:DTC P0512 STARTER REQUEST CIRCUIT

1. OUTLINE OF DIAGNOSIS

Detect the open or short circuit of starter SW.

Judge as ON NG when the starter SW signal remains ON.

2. ENABLE CONDITION

Secondary Parameters	Enable Conditions
None	

3. GENERAL DRIVING CYCLE

Always perform the diagnosis continuously.

4. DIAGNOSTIC METHOD

• Abnormality Judgement

If the duration of time while the following conditions are met is longer than the time indicated, judge as NG.

Judgement Value

Malfunction Criteria	Threshold Value
Engine condition	After engine starting
Starter OFF signal	Not detected
Battery voltage	$\geq 8\text{ V}$

Time Needed for Diagnosis: 180000 ms

Malfunction Indicator Light Illumination: Illuminates when malfunction occurs in 2 continuous driving cycles.

• Normality Judgement

Judge as OK and clear the NG if the continuous time while the following conditions are established is more than the predetermined time.

Judgement Value

Malfunction Criteria	Threshold Value
Starter OFF signal	Detected
Battery voltage	$\geq 8\text{ V}$

Time Needed for Diagnosis: Less than 1 second

Diagnostic Trouble Code (DTC) Detecting Criteria

GENERAL DESCRIPTION

BX:DTC P0513 INCORRECT IMMOBILIZER KEY

1. OUTLINE OF DIAGNOSIS

DTC	Item	OUTLINE OF DIAGNOSIS
P0513	Incorrect Immobilizer Key	Incorrect immobilizer key (Use of unregistered key in body integrated unit)
P1570	Antenna	Faulty antenna
P1571	Reference Code Incompatibility	Reference code incompatibility between body integrated unit and ECM
P1572	IMM Circuit Failure (Except Antenna Circuit)	Communication failure between body integrated unit and ECM
P1574	Key Communication Failure	Failure of body integrated unit to verify key (transponder) ID code or transponder failure
P1576	EGI Control Module EEPROM	ECM malfunctioning
P1577	IMM Control Module EEPROM	Body integrated unit malfunctioning
P1578	Meter Failure	Reference code incompatibility between body integrated unit and combination meter

2. ENABLE CONDITION

When starting the engine.

3. GENERAL DRIVING CYCLE

Perform the diagnosis only after starting the engine.

4. DIAGNOSTIC METHOD

Judge as NG when the conditions for the outline of the diagnosis of the top are established.

Diagnostic Trouble Code (DTC) Detecting Criteria

GENERAL DESCRIPTION

BY:DTC P0600 SERIAL COMMUNICATION LINK

1. OUTLINE OF DIAGNOSIS

Detect malfunction of CAN communication.

When CAN communications is not possible, and CAN communications with TCM is not possible, judge as NG if data from the TCM is not normal.

2. COMPONENT DESCRIPTION

ECM, TCM, VDC CM and body integrated unit are connected by high speed CAN.

(Common Specifications)

CAN Protocol 2.0 B (Active)

Frame Format: 11 Bit ID Frame (Standard Frame)

(High speed CAN)

Conforms to ISO11898

Communication Speed: 500 kbps

3. ENABLE CONDITION

Secondary Parameters	Enable Conditions
None	

4. GENERAL DRIVING CYCLE

Perform the diagnosis continuously after starting the engine.

5. DIAGNOSTIC METHOD

• Abnormality Judgement

Judge as NG when the following conditions are established.

Judgement Value

Malfunction Criteria	Threshold Value
Battery voltage	> 10.9 V
Starter switch	OFF
Engine	run
bus off flag or error warning flag	set (error)
or	
ID received from control module connected to driving system CAN	None during 500 milliseconds
or	
Data updated from control module connected to driving system CAN	None during 500 milliseconds

Time Needed for Diagnosis: Less than 1 second

Malfunction Indicator Light Illumination: Illuminates as soon as a malfunction occurs.

• Normality Judgement

Judge as OK and clear the NG if the continuous time while the following conditions are established is more than the predetermined time.

Judgement Value

Malfunction Criteria	Threshold Value
Battery voltage	> 10.9 V
Starter switch	OFF
Engine	run
bus off flag or error warning flag	clear (No error)
ID received from control module connected to driving system CAN	Yes
Data updated from control module connected to driving system CAN	Yes

Time Needed for Diagnosis: 1000 ms

Malfunction Indicator Light Illumination: Illuminates as soon as a malfunction occurs.

Diagnostic Trouble Code (DTC) Detecting Criteria

GENERAL DESCRIPTION

BZ:DTC P0604 INTERNAL CONTROL MODULE RANDOM ACCESS MEMORY (RAM) ERROR

1. OUTLINE OF DIAGNOSIS

Detect the malfunction of microcomputer (RAM).

When there is a problem in the main CPU normal RAM, or the sub CPU normal RAM, judge as NG. Judge as OK when both are operating properly.

If it is possible to write data to the whole area of RAM in the initial routine, and is possible to read the same data, it is judged as OK, and if not, NG.

2. ENABLE CONDITION

Secondary Parameters	Enable Conditions
None	

Diagnosis with the initial routine.

3. GENERAL DRIVING CYCLE

Perform the diagnosis as soon as the ignition switch is turned to ON.

4. DIAGNOSTIC METHOD

Abnormality Judgement

Judge as NG if the criteria below are met.

Judgement Value

Malfunction Criteria	Threshold Value
Main CPU normal RAM abnormal	
Write 5AA5A55A and then read. (Whole area of RAM)	5AA5A55A cannot be read.
Write A55A5AA5 and then read. (Whole area of RAM)	A55A5AA5 cannot be read.
Sub CPU normal RAM abnormal	
Write 5AA5 and then read. (Whole area of RAM)	5AA5 cannot be read.
Write A55A and then read. (Whole area of RAM)	A55A cannot be read.

Time Needed for Diagnosis: Undetermined

Malfunction Indicator Light Illumination: Illuminates as soon as a malfunction occurs.

Normality Judgement

Judge as OK and clear the NG when the malfunction criteria below are met.

Judgement Value

Malfunction Criteria	Threshold Value
Main CPU normal RAM abnormal	
Write 5AA5A55A and then read. (Whole area of RAM)	5AA5A55A can be read.
And write A55A5AA5 and then read. (Whole area of RAM)	A55A5AA5 can be read.
Sub CPU normal RAM abnormal	
Write 5AA5 and then read. (Whole area of RAM)	5AA5 can be read.
And write A55A and then read. (Whole area of RAM)	A55A can be read.

Diagnostic Trouble Code (DTC) Detecting Criteria

GENERAL DESCRIPTION

CA:DTC P0605 INTERNAL CONTROL MODULE READ ONLY MEMORY (ROM) ERROR

1. OUTLINE OF DIAGNOSIS

Judge as NG when SUM value of ROM is outside the standard value.

2. ENABLE CONDITION

Secondary Parameters	Enable Conditions
Ignition switch	ON

3. GENERAL DRIVING CYCLE

Always perform the diagnosis continuously.

4. DIAGNOSTIC METHOD

Abnormality Judgement

Judge as NG if the criteria below are met.

Judgement Value

Malfunction Criteria	Threshold Value
SUM value of ROM	Standard

Time Needed for Diagnosis: Undetermined

Malfunction Indicator Light Illumination: Illuminates as soon as a malfunction occurs.

Diagnostic Trouble Code (DTC) Detecting Criteria

GENERAL DESCRIPTION

CB:DTC P0607 THROTTLE CONTROL SYSTEM CIRCUIT RANGE/PERFORMANCE

1. OUTLINE OF DIAGNOSIS

Judge as NG when any one of the followings is established.

- 1) When the read value of throttle position sensor 1 signal is mismatched between main CPU and sub CPU.
- 2) When the read value of accelerator pedal position sensor 1 signal is mismatched between main CPU and sub CPU.
- 3) When the sub CPU operates abnormally.
- 4) When the communication between main CPU ↔ sub CPU is abnormal.
- 5) When the input amplifier circuit of throttle position sensor 1 is abnormal.
- 6) When the cruise control cannot be canceled correctly.
- 7) When the signal of brake SW1 and 2 is mismatched.

2. COMPONENT DESCRIPTION

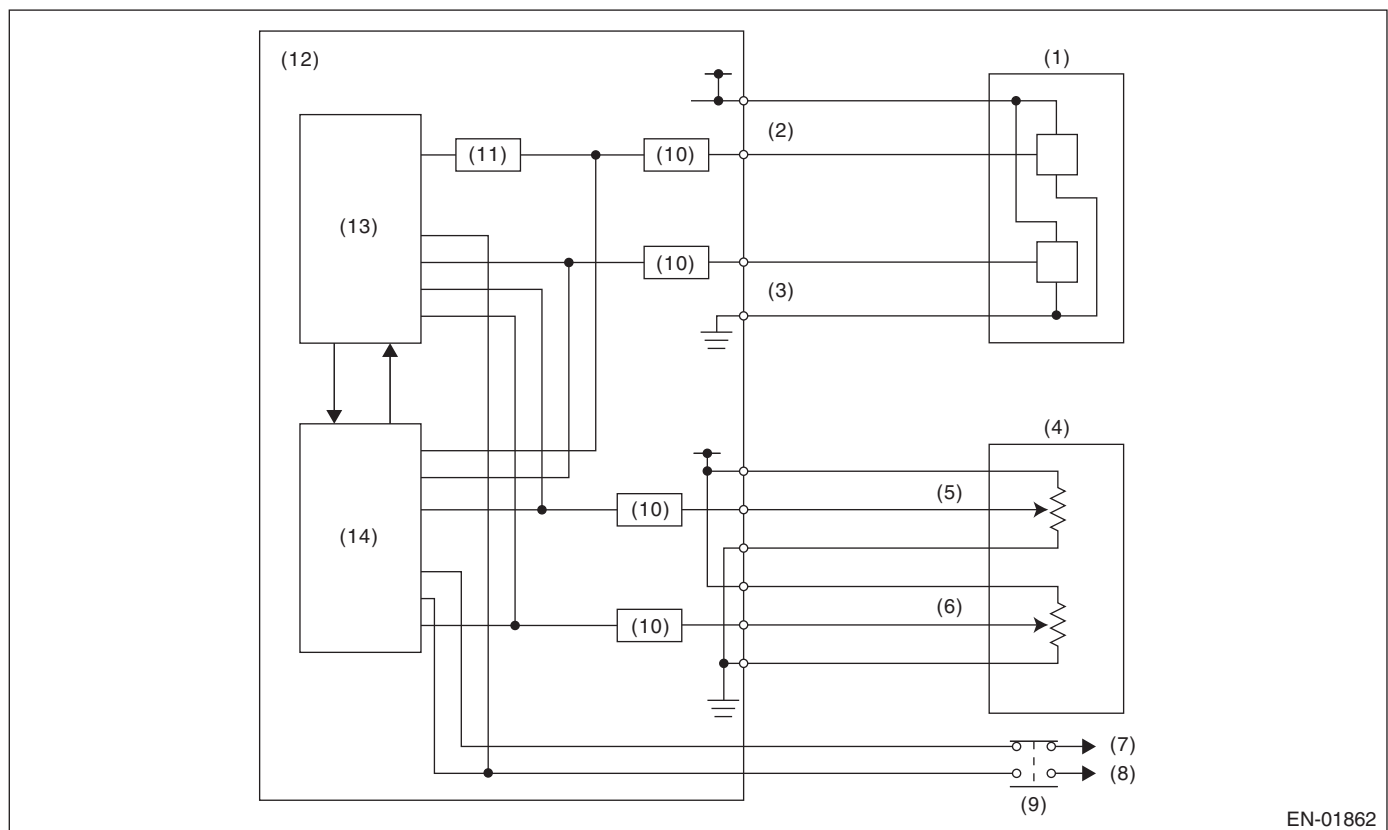

EN-01862

- | | | |
|---|---|----------------------------------|
| (1) Throttle position sensor | (6) Accelerator pedal position sensor 2 | (11) Amplifier circuit |
| (2) Throttle position sensor 1 | (7) Battery | (12) Engine control module (ECM) |
| (3) Throttle position sensor 2 | (8) Stop light | (13) Sub CPU |
| (4) Accelerator pedal position sensor | (9) Brake switch | (14) Main CPU |
| (5) Accelerator pedal position sensor 1 | (10) I/F circuit | |

3. ENABLE CONDITION

Secondary Parameters	Enable Conditions
(1) Ignition switch	ON
(2) Ignition switch	ON
(3) None	—
(4) None	—
(5) Throttle opening angle	—
(6) Brake switch (only with cruise control)	ON
(7) None	—

Diagnostic Trouble Code (DTC) Detecting Criteria

GENERAL DESCRIPTION

4. GENERAL DRIVING CYCLE

- (1) — (4): Always perform the diagnosis continuously.
- (5): Always perform the diagnosis continuously when idling.
- (6): Perform the diagnosis when the brake pedal is depressed.
- (7): Always perform the diagnosis continuously.
- (8): Always perform the diagnosis continuously when the cruise control pedal is not operating.

5. DIAGNOSTIC METHOD

Judge as OK and clear the NG when the malfunction criteria below are met.

Judgement Value

Malfunction Criteria	Threshold Value
(1) Difference of CPU reading value of the throttle position sensor signal	≤ 0.0858 V
(2) Difference of CPU read value of the accelerator pedal position sensor signal	≤ 0.35 V
(3) WD pulse from sub CPU	WD pulse occur
(4) Communication between CPU	Possible to communicate
(5) Throttle position sensor 1 opening angle — (Throttle position sensor 1 opening angle after passing amplifier) 1/4	$< 3^\circ$
(6) Cruise control cancel signal at brake ON	Cruise control cancel signal ON
(7) Brake switch 1, 2 signal	SW 1 and 2 are matched

Time Needed for Diagnosis:

- 1. 600 ms
- 2. 830 ms
- 3. 200 ms
- 4. 200 ms
- 5. 24 ms
- 6. 250 ms
- 7. 200 ms

Malfunction Indicator Light Illumination: Illuminates as soon as a malfunction occurs.

Diagnostic Trouble Code (DTC) Detecting Criteria

GENERAL DESCRIPTION

Details of Judgement Value

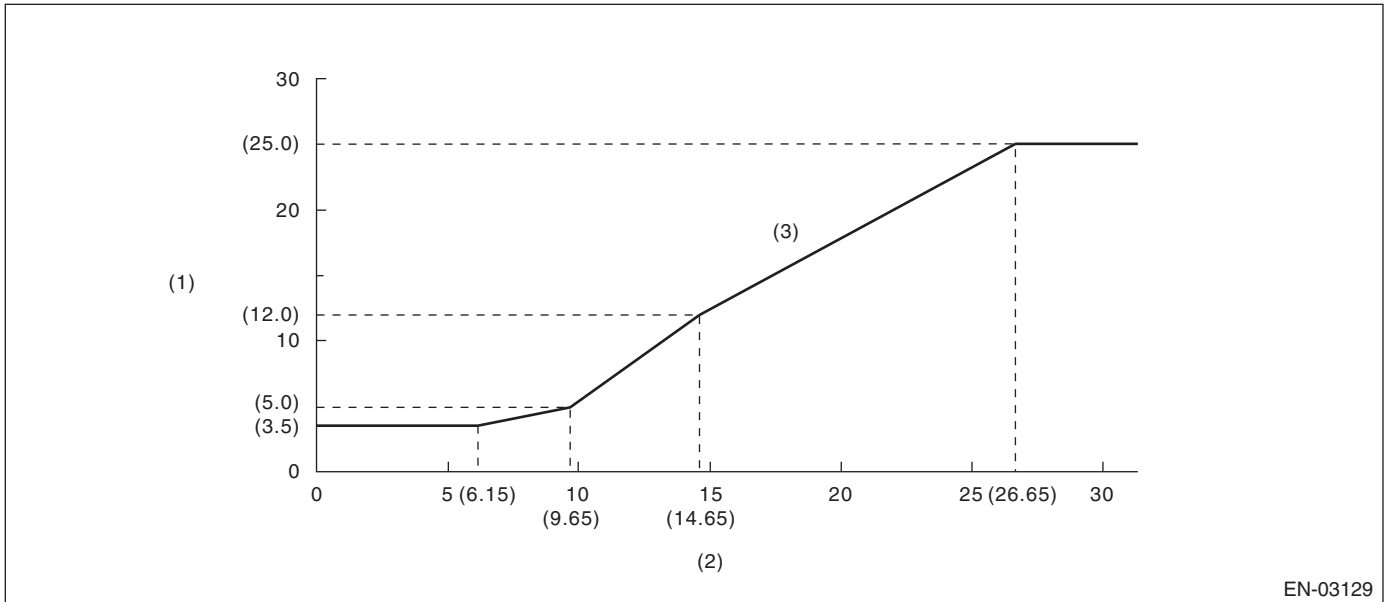

EN-03129

- (1) Difference between target opening angle and actual opening angle (°) (2) Target throttle opening angle (°) (3) NG area

Details of Judgement time (The actual opening angle \leq target opening angle is always 1000 milliseconds)

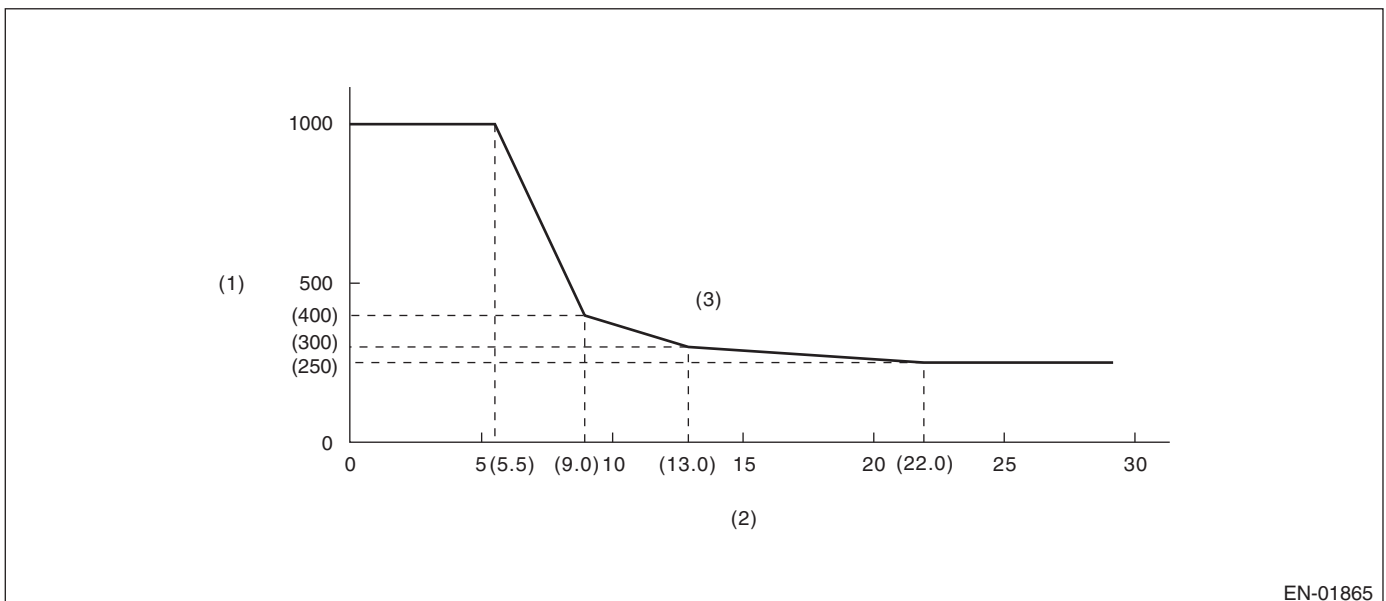

EN-01865

- (1) Judgement time (milliseconds) (2) Throttle position sensor 1 opening angle (3) NG area

Malfunction Indicator Light Illumination: Illuminates as soon as a malfunction occurs.

Diagnostic Trouble Code (DTC) Detecting Criteria

GENERAL DESCRIPTION

CD:DTC P0700 TRANSMISSION CONTROL SYSTEM (MIL REQUEST)

1. OUTLINE OF DIAGNOSIS

Judge as NG when there is CAN communication with the TCM and there is a MIL lighting request.

2. ENABLE CONDITION

Secondary Parameters	Enable Conditions
None	

3. GENERAL DRIVING CYCLE

Always perform the diagnosis continuously.

4. DIAGNOSTIC METHOD

• Abnormality Judgement

If the duration of time while the following conditions are met is longer than the time indicated, judge as NG.

Judgement Value

Malfunction Criteria	Threshold Value
Battery voltage	≥ 10.9 V
MIL lighting request from TCM	Yes

Time Needed for Diagnosis:2500 ms

Malfunction Indicator Light Illumination: Illuminates as soon as a malfunction occurs.

• Normality Judgement

If the duration of time while the following conditions are met is longer than the time indicated, judge as NG.

Judgement Value

Malfunction Criteria	Threshold Value
Battery voltage	≥ 10.9 V
MIL lighting request from TCM	None

Time Needed for Diagnosis: Less than 1 second

Diagnostic Trouble Code (DTC) Detecting Criteria

GENERAL DESCRIPTION

CE:DTC P0851 PARK/NEUTRAL SWITCH INPUT CIRCUIT LOW (AT MODEL)

1. OUTLINE OF DIAGNOSIS

Judge the open or short circuit of the neutral SW.

Judge as NG when the ECM neutral terminal input differs from the reception data from TCM.

2. ENABLE CONDITION

Secondary Parameters	Enable Conditions
Battery voltage	≥ 10.9 V
Starter relay	OFF

3. GENERAL DRIVING CYCLE

Perform the diagnosis continuously in 2 seconds after starting the engine.

4. DIAGNOSTIC METHOD

• Abnormality Judgement

If the duration of time while the following conditions are met is longer than the time indicated, judge as NG.

Judgement Value

Malfunction Criteria	Threshold Value
Neutral switch signal in ECM when "P"/"N" range in TCM are "OFF" and when the other switches are "ON"	LOW (ON)

Time Needed for Diagnosis: 100 time(s)

Malfunction Indicator Light Illumination: Illuminates when malfunction occurs in 2 continuous driving cycles.

• Normality Judgement

Judge as OK and clear the NG if the continuous time while the following conditions are established is more than the predetermined time.

Judgement Value

Malfunction Criteria	Threshold Value
Neutral switch signal in ECM when "P"/"N" range in TCM are "OFF" and when the other switches are "ON"	HIGH (OFF)

Time Needed for Diagnosis: Less than 1 second

Diagnostic Trouble Code (DTC) Detecting Criteria

GENERAL DESCRIPTION

CF:DTC P0851 NEUTRAL SWITCH INPUT CIRCUIT LOW (MT MODEL)

1. OUTLINE OF DIAGNOSIS

Detect the open or short circuit of neutral SW.

Judge as NG when there is no change in the neutral SW even if the driving shift was applied. (There is neutral SW ON/OFF inversion from the vehicle speed and engine speed.)

2. ENABLE CONDITION

Secondary Parameters	Enable Conditions
Battery voltage	≥ 10.9 V
Starter relay	OFF

3. GENERAL DRIVING CYCLE

Perform the diagnosis continuously in 2 seconds after starting the engine.

4. DIAGNOSTIC METHOD

• Abnormality Judgement

Judge NG when the malfunction criteria below are completed determined times or more after the neutral SW change.

Judgement Value

Malfunction Criteria	Threshold Value
Neutral switch signal (while changing from a to b below)	LOW (ON) continues.
Driving condition change	From a) to b)
a) Engine speed 600 rpm — 900 rpm & Vehicle speed = 0 km/h (0 MPH)	
b) Engine speed 1600 rpm — 900 rpm & Vehicle speed ≥ 0 km/h (0 MPH)	

Time Needed for Diagnosis: 3 time(s)

Malfunction Indicator Light Illumination: Illuminates when malfunction occurs in 2 continuous driving cycles.

• Normality Judgement

Judge as OK and clear NG when there is change in the neutral SW.

Judgement Value

Malfunction Criteria	Threshold Value
Neutral switch signal (while changing from a to b below)	Changes to HIGH (OFF).
Driving condition change	From a) to b)
a) Engine speed 600 rpm — 900 rpm & Vehicle speed = 0 km/h (0 MPH)	
b) Engine speed 1600 rpm — 2550 rpm & Vehicle speed ≥ 64 km/h (39.8 MPH)	

Time Needed for Diagnosis: Less than 1 second

Diagnostic Trouble Code (DTC) Detecting Criteria

GENERAL DESCRIPTION

CG:DTC P0852 PARK/NEUTRAL SWITCH INPUT CIRCUIT HIGH (AT MODEL)

1. OUTLINE OF DIAGNOSIS

Judge the open or short circuit of the neutral SW.

Judge as NG when the ECM neutral terminal input differs from the reception data from TCM.

2. ENABLE CONDITION

Secondary Parameters	Enable Conditions
Battery voltage	≥ 10.9 V
Starter relay	OFF

3. GENERAL DRIVING CYCLE

Perform the diagnosis continuously in 2 seconds after starting the engine.

4. DIAGNOSTIC METHOD

• Abnormality Judgement

If the duration of time while the following conditions are met is longer than the time indicated, judge as NG.

Judgement Value

Malfunction Criteria	Threshold Value
Neutral switch signal in ECM when "P"/"N" range in TCM are "ON" and when the other switches are "OFF"	HIGH (OFF)

Time Needed for Diagnosis: 100 time(s)

Malfunction Indicator Light Illumination: Illuminates when malfunction occurs in 2 continuous driving cycles.

• Normality Judgement

Judge as OK and clear the NG if the continuous time while the following conditions are established is more than the predetermined time.

Judgement Value

Malfunction Criteria	Threshold Value
Neutral switch signal in ECM when "P"/"N" range in TCM are "ON" and when the other switches are "OFF"	LOW (ON)

Time Needed for Diagnosis: Less than 1 second

Diagnostic Trouble Code (DTC) Detecting Criteria

GENERAL DESCRIPTION

CH:DTC P0852 NEUTRAL SWITCH INPUT CIRCUIT HIGH (MT MODEL)

1. OUTLINE OF DIAGNOSIS

Detect the open or short circuit of neutral SW.

Judge as NG when there is no change in the neutral SW even if the driving shift was applied. (There is neutral SW ON/OFF inversion from the vehicle speed and engine speed.)

2. ENABLE CONDITION

Secondary Parameters	Enable Conditions
Battery voltage	≥ 10.9 V
Starter relay	OFF

3. GENERAL DRIVING CYCLE

Perform the diagnosis continuously in 2 seconds after starting the engine.

4. DIAGNOSTIC METHOD

• Abnormality Judgement

Judge NG when the malfunction criteria below are completed determined times or more after the neutral SW change.

Judgement Value

Malfunction Criteria	Threshold Value
Neutral switch signal (while changing from a to b below)	HIGH (OFF) continues.
Driving condition change	From a) to b)
a) Engine speed 600 rpm — 900 rpm & Vehicle speed = 0 km/h (0 MPH)	
b) Engine speed 1600 rpm — 2550 rpm & Vehicle speed ≥ 64 km/h (39.8 MPH)	

Time Needed for Diagnosis: 3 time(s)

Malfunction Indicator Light Illumination: Illuminates when malfunction occurs in 2 continuous driving cycles.

• Normality Judgement

Judge as OK and clear NG when there is change in the neutral SW.

Judgement Value

Malfunction Criteria	Threshold Value
Neutral switch signal (while changing from a to b below)	Changes to LOW (ON).
Driving condition change	From a) to b)
a) Engine speed 600 rpm — 900 rpm & Vehicle speed = 0 km/h (0 MPH)	
b) Engine speed 1600 rpm — 2550 rpm & Vehicle speed ≥ 64 km/h (39.8 MPH)	

Time Needed for Diagnosis: Less than 1 second

Diagnostic Trouble Code (DTC) Detecting Criteria

GENERAL DESCRIPTION

CI: DTC P1152 O2 SENSOR CIRCUIT RANGE/PERFORMANCE (LOW) (BANK1 SENSOR1)

1. OUTLINE OF DIAGNOSIS

Detect that λ value remains low.

Judge as NG when lambda value is abnormal in accordance with λ value of front oxygen (A/F) sensor and running conditions such as vehicle speed, amount of intake air, engine coolant temperature, sub feedback control, etc.

λ value = Actual air fuel ratio/Theoretical air fuel ratio
 $\lambda > 1$: Lean
 $\lambda < 1$: Rich

2. COMPONENT DESCRIPTION

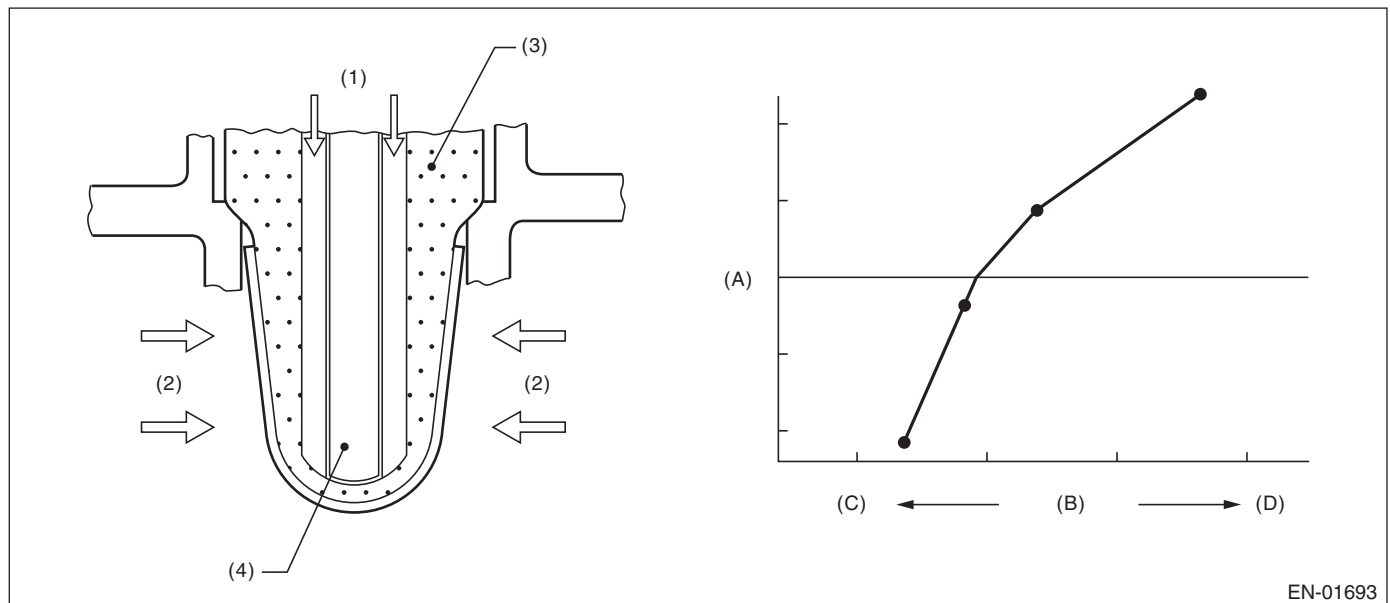

EN-01693

(A) Electromotive force
(D) Rich

(B) Air fuel ratio

(C) Lean

(1) Atmosphere
(2) Exhaust gas

(3) ZrO_2

(4) Ceramic heater

Diagnostic Trouble Code (DTC) Detecting Criteria

GENERAL DESCRIPTION

3. ENABLE CONDITION

Secondary Parameters	Enable Conditions
Time needed for all secondary parameters to be in enable conditions	≥ 4096 ms
Battery voltage	≥ 10.9 V
Barometric pressure	≥ 75 kPa (563 mmHg, 22.2 inHg)
Rear oxygen sensor sub feedback	Execution
Rear oxygen sensor output voltage – Feedback target voltage or	–0.2 V — 0.1 V
Rear oxygen sensor sub feedback compensation coefficient or	On Min.
Rear oxygen sensor sub feedback compensation coefficient	On Max.
Elapsed time after starting the engine	≥ 60000 ms
Engine coolant temperature	≥ 75 °C (167 °F)
Vehicle speed	≥ 20 km/h (12.4 MPH)
Amount of intake air	≥ 6 g/s (0.21 oz/s)
Load change at 180°CA	< 0.02 g/rev (0 oz/rev)
Front oxygen (A/F) sensor impedance	0 Ω — 50 Ω
Learning value of evaporation gas density	< 0.2
Total time of operating canister purge	≥ 19.9 s
Targeted lambda value load compensation coefficient	–0.03 — 0.000

4. GENERAL DRIVING CYCLE

Perform diagnosis continuously at a constant speed of 20 km/h (12.4 MPH) or more after 60000 ms have passed since the engine started.

5. DIAGNOSTIC METHOD

• Abnormality Judgement

If the duration of time while the following conditions are met is longer than the time indicated, judge as NG.

Judgement Value

Malfunction Criteria	Threshold Value
λ value	< 0.85

Time Needed for Diagnosis: 10000 ms

Malfunction Indicator Light Illumination: Illuminates when malfunction occurs in 2 continuous driving cycles.

• Normality Judgement

Judge as OK and clear the NG if the continuous time while the following conditions are established is more than the predetermined time.

Judgement Value

Malfunction Criteria	Threshold Value
λ value	≥ 0.85

Time Needed for Diagnosis: Less than 1 second

Diagnostic Trouble Code (DTC) Detecting Criteria

GENERAL DESCRIPTION

CJ:DTC P1153 O2 SENSOR CIRCUIT RANGE/PERFORMANCE (HIGH) (BANK1 SENSOR1)

1. OUTLINE OF DIAGNOSIS

Detect that λ value remains high.

Judge as NG when lambda value is abnormal in accordance with λ value of front oxygen (A/F) sensor and running conditions such as vehicle speed, amount of intake air, engine coolant temperature, sub feedback control, etc.

λ value = Actual air fuel ratio/Theoretical air fuel ratio
 $\lambda > 1$: Lean
 $\lambda < 1$: Rich

2. COMPONENT DESCRIPTION

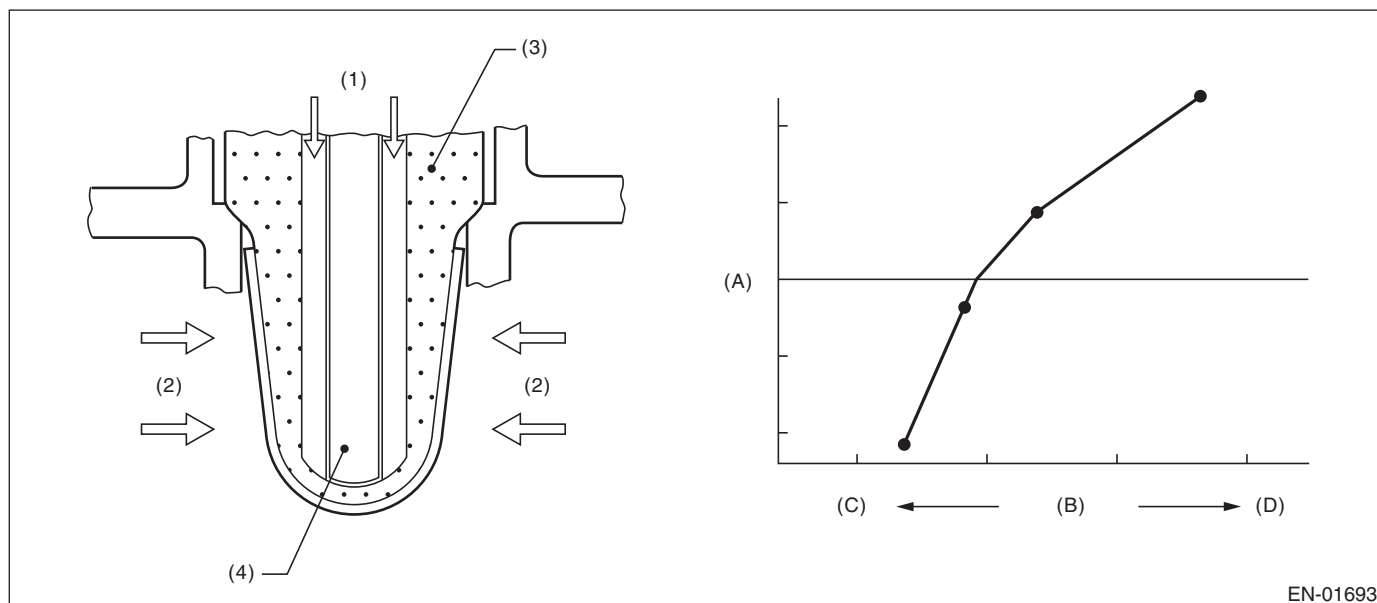

(A) Electromotive force
(D) Rich

(B) Air fuel ratio

(C) Lean

(1) Atmosphere
(2) Exhaust gas

(3) ZrO_2

(4) Ceramic heater

EN-01693

Diagnostic Trouble Code (DTC) Detecting Criteria

GENERAL DESCRIPTION

3. ENABLE CONDITION

Secondary Parameters	Enable Conditions
Time needed for all secondary parameters to be in enable conditions	≥ 4096 ms
Battery voltage	≥ 10.9 V
Barometric pressure	≥ 75 kPa (563 mmHg, 22.2 inHg)
Rear oxygen sensor sub feedback	Execution
Rear oxygen sensor output voltage – Feedback target voltage or Rear oxygen sensor sub feedback compensation coefficient or Rear oxygen sensor sub feedback compensation coefficient	-0.2 V — 0.1 V On Min. On Max.
Elapsed time after starting the engine	≥ 60000 ms
Engine coolant temperature	≥ 75 °C (167 °F)
Vehicle speed	≥ 20 km/h (12.4 MPH)
Amount of intake air	≥ 6 g/s (0.21 oz/s)
Load change at 180°CA	< 0.02 g/rev (0 oz/rev)
Front oxygen (A/F) sensor impedance	0Ω — 50Ω
Learning value of evaporation gas density	< 0.2
Total time of operating canister purge	≥ 19.9 s
Targeted lambda value load compensation coefficient	-0.03 — 0.000

4. GENERAL DRIVING CYCLE

Perform diagnosis continuously at a constant speed of 20 km/h (12.4 MPH) or more after 60000 ms have passed since the engine started.

5. DIAGNOSTIC METHOD

• Abnormality Judgement

If the duration of time while the following conditions are met is longer than the time indicated, judge as NG.

Judgement Value

Malfunction Criteria	Threshold Value
λ value	> 1.15

Time Needed for Diagnosis: 10000 ms

Malfunction Indicator Light Illumination: Illuminates when malfunction occurs in 2 continuous driving cycles.

• Normality Judgement

Judge as OK and clear the NG if the continuous time while the following conditions are established is more than the predetermined time.

Judgement Value

Malfunction Criteria	Threshold Value
λ value	≤ 1.15

Time Needed for Diagnosis: Less than 1 second

Diagnostic Trouble Code (DTC) Detecting Criteria

GENERAL DESCRIPTION

CK:DTC P1160 RETURN SPRING FAILURE

1. OUTLINE OF DIAGNOSIS

Judge as NG when the valve is opened more than the default opening angle, but does not move to the close direction with the motor power stopped.

2. COMPONENT DESCRIPTION

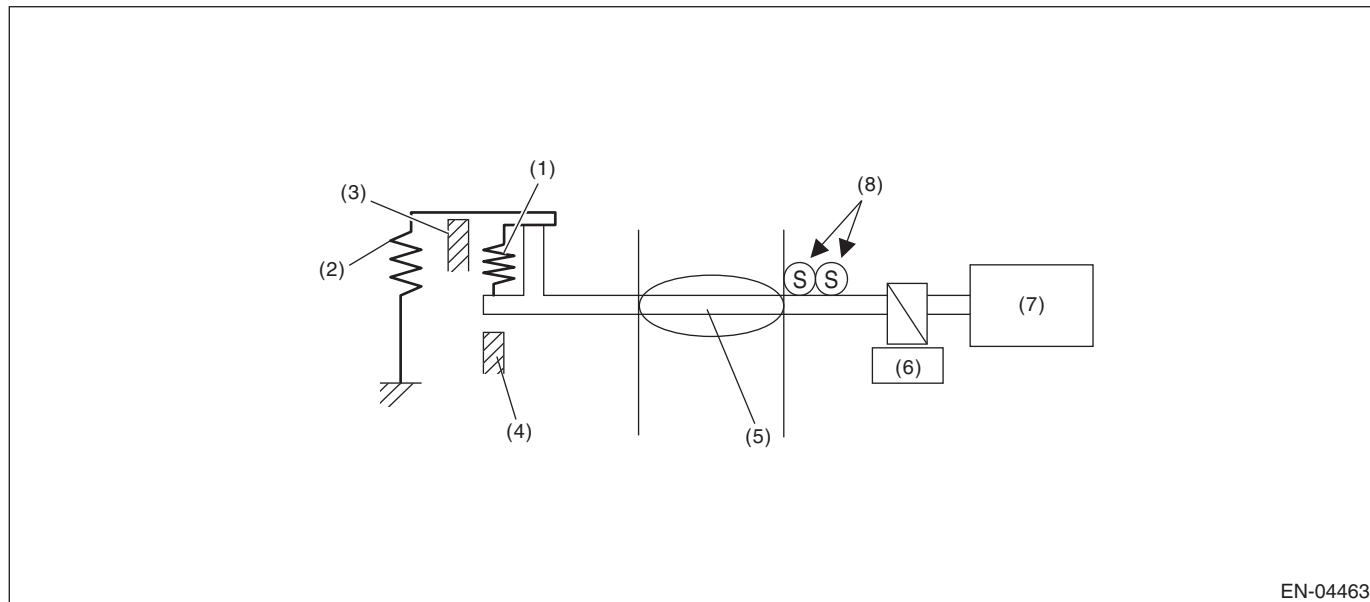

EN-04463

- | | | |
|--------------------------|-------------------------|---|
| (1) Opener spring | (4) Full closed stopper | (7) DC motor |
| (2) Return spring | (5) Throttle valve | (8) Main and sub throttle position sensor |
| (3) Intermediate stopper | (6) Gear | |

3. ENABLE CONDITION

Secondary Parameters	Enable Conditions
Battery voltage	$\geq 6\text{ V}$
Throttle position sensor	Normal

4. GENERAL DRIVING CYCLE

- Ignition switch ON → OFF
- Ignition switch OFF → ON (Only after clearing memory)

5. DIAGNOSTIC METHOD

• Abnormality Judgement

Judge as NG when the following conditions are established.

Judgement Value

Malfunction Criteria	Threshold Value
Opening variation after continuity is set to OFF	$< 2^\circ$

Time Needed for Diagnosis:24 ms

Malfunction Indicator Light Illumination: Illuminates as soon as a malfunction occurs.

• Normality Judgement

Judge as OK and clear the NG if the following conditions are established.

Judgement Value

Malfunction Criteria	Threshold Value
Opening variation after continuity is set to OFF	$\geq 2^\circ$

Time Needed for Diagnosis:3400 ms

CL:DTC P1400 FUEL TANK PRESSURE CONTROL SOLENOID VALVE CIRCUIT LOW

1. OUTLINE OF DIAGNOSIS

Detect the open/short circuit of pressure control solenoid valve.

Judge as NG when ECM output level is different from actual terminal level.

2. COMPONENT DESCRIPTION

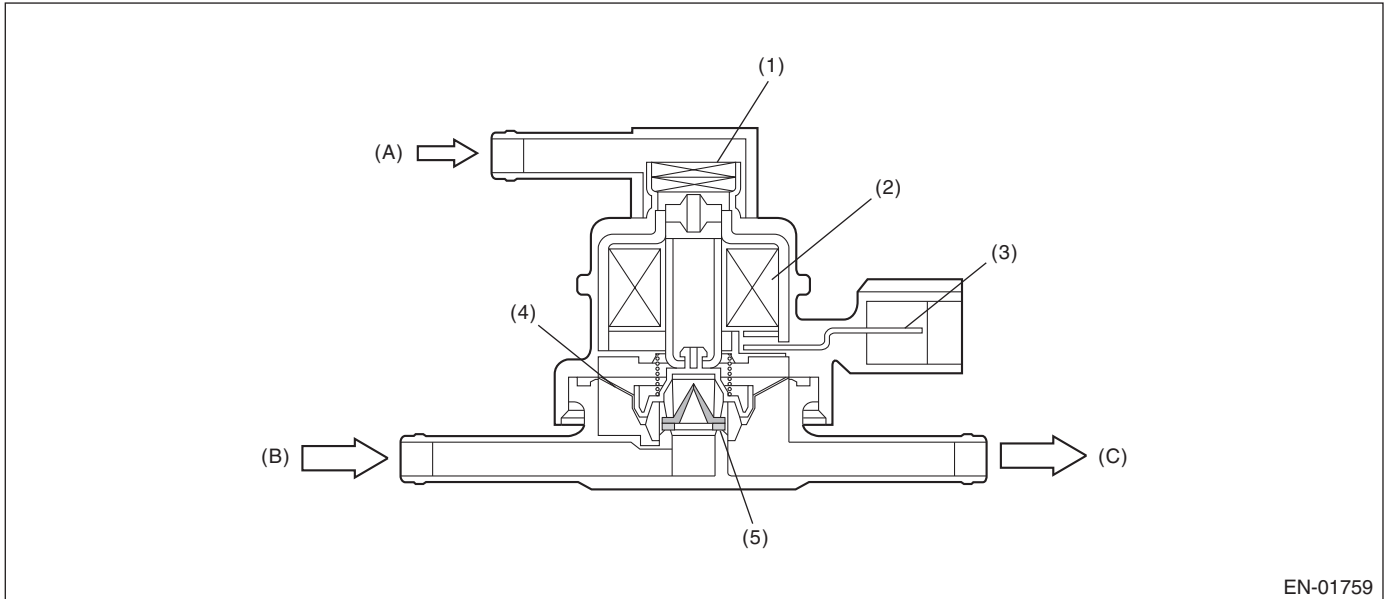

EN-01759

(A) Barometric pressure

(B) Shut-off valve

(C) To fuel tank

(1) Filter

(3) Connector terminal

(5) Valve

(2) Coil

(4) Diaphragm

3. ENABLE CONDITION

Secondary Parameters	Enable Conditions
None	

4. GENERAL DRIVING CYCLE

Always perform the diagnosis after starting the engine.

Diagnostic Trouble Code (DTC) Detecting Criteria

GENERAL DESCRIPTION

5. DIAGNOSTIC METHOD

• Abnormality Judgement

If the duration of time while the following conditions are met is longer than the time indicated, judge as NG.

Judgement Value

Malfunction Criteria	Threshold Value
Battery voltage	≥ 10.9 V
Elapsed time after starting the engine	≥ 1 second
Terminal output voltage when ECM outputs OFF signal	Low

Time Needed for Diagnosis:2500 ms

Malfunction Indicator Light Illumination: Illuminates when malfunction occurs in 2 continuous driving cycles.

• Normality Judgement

Judge as OK and clear the NG if the continuous time while the following conditions are established is more than the predetermined time.

Judgement Value

Malfunction Criteria	Threshold Value
Battery voltage	≥ 10.9 V
Elapsed time after starting the engine	≥ 1 second
Terminal output voltage when ECM outputs OFF signal	High

Time Needed for Diagnosis: Less than 1 second

Diagnostic Trouble Code (DTC) Detecting Criteria

GENERAL DESCRIPTION

CM:DTC P1420 FUEL TANK PRESSURE CONTROL SOL. VALVE CIRCUIT HIGH

1. OUTLINE OF DIAGNOSIS

Detect the open/short circuit of pressure control solenoid valve.

Judge as NG when ECM output level is different from actual terminal level.

2. COMPONENT DESCRIPTION

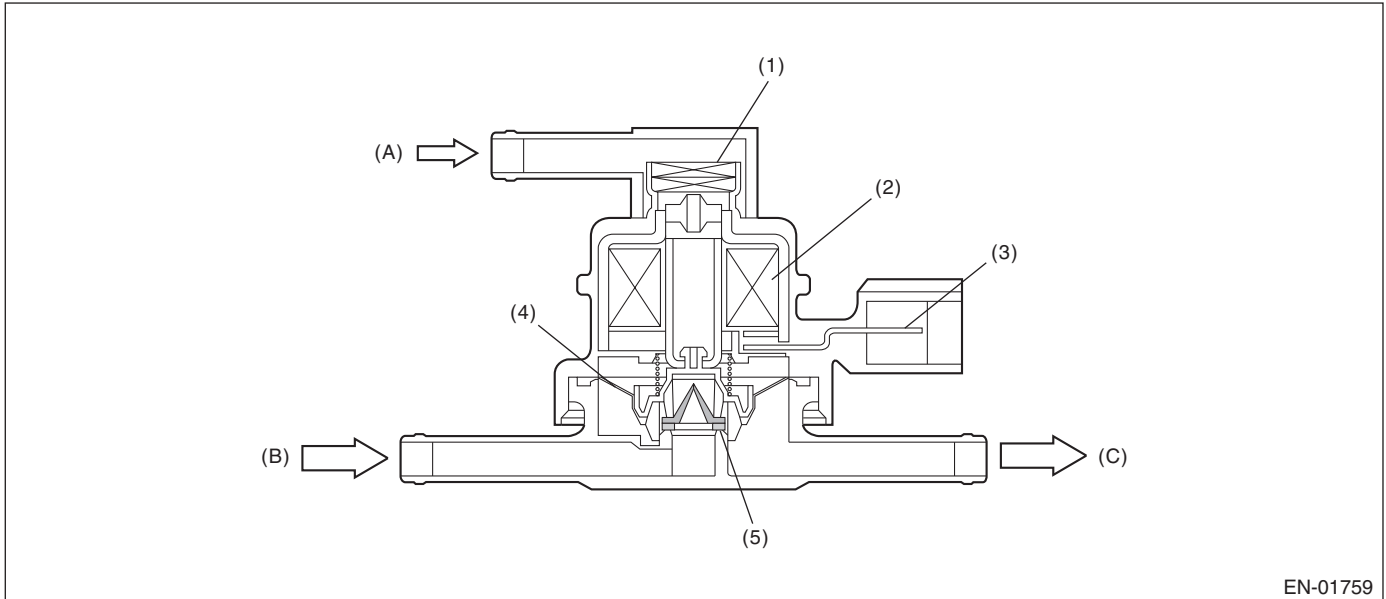

(A) Barometric pressure

(B) Shut-off valve

(C) To fuel tank

(1) Filter

(3) Connector terminal

(5) Valve

(2) Coil

(4) Diaphragm

3. ENABLE CONDITION

Secondary Parameters	Enable Conditions
None	

4. GENERAL DRIVING CYCLE

Always perform the diagnosis after starting the engine.

Diagnostic Trouble Code (DTC) Detecting Criteria

GENERAL DESCRIPTION

5. DIAGNOSTIC METHOD

• Abnormality Judgement

If the duration of time while the following conditions are met is longer than the time indicated, judge as NG.

Judgement Value

Malfunction Criteria	Threshold Value
Battery voltage	≥ 10.9 V
Elapsed time after starting the engine	≥ 1 second
Terminal output voltage when ECM outputs ON signal	High

Time Needed for Diagnosis: 2500 ms

Malfunction Indicator Light Illumination: Illuminates when malfunction occurs in 2 continuous driving cycles.

• Normality Judgement

Judge as OK and clear the NG if the continuous time while the following conditions are established is more than the predetermined time.

Judgement Value

Malfunction Criteria	Threshold Value
Battery voltage	≥ 10.9 V
Elapsed time after starting the engine	≥ 1 second
Terminal output voltage when ECM outputs ON signal	Low

Time Needed for Diagnosis: Less than 1 second

CN:DTC P1443 VENT CONTROL SOLENOID VALVE FUNCTION PROBLEM

1. OUTLINE OF DIAGNOSIS

Detect the abnormal function (stuck closed) of the drain valve.

Judge as NG when fuel tank pressure is low.

2. COMPONENT DESCRIPTION

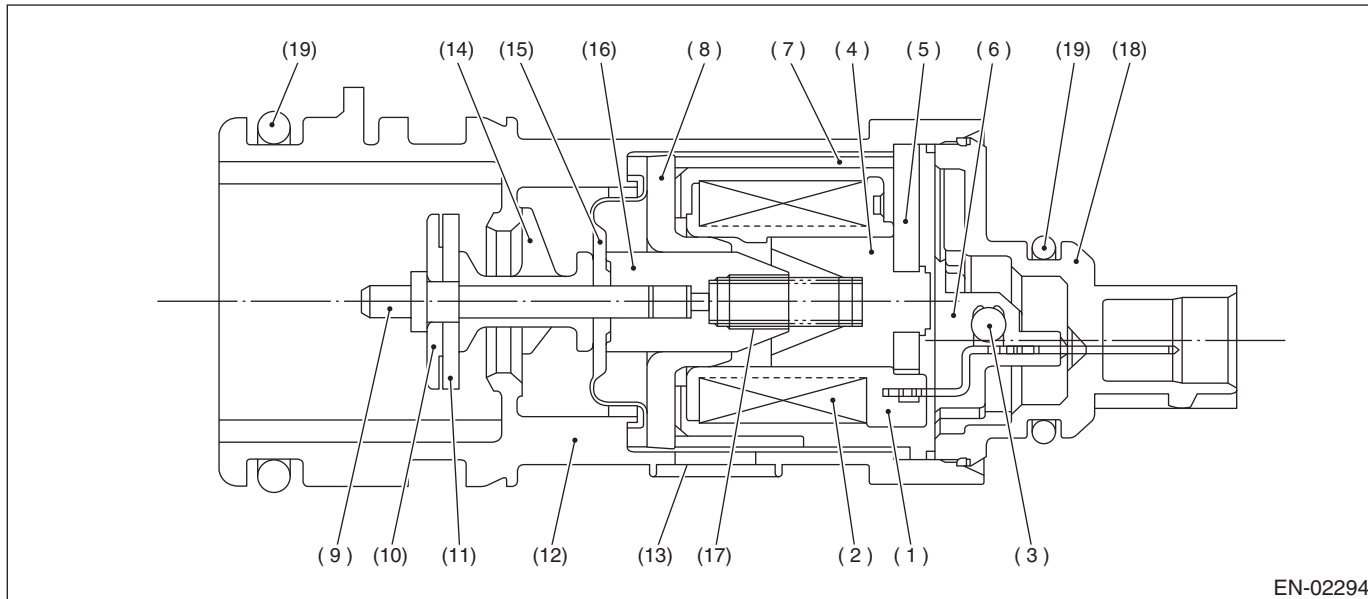

- | | | |
|-----------------|--------------------|-------------------|
| (1) Bobbin | (8) Magnetic plate | (14) Retainer |
| (2) Coil | (9) Shaft | (15) Diaphragm |
| (3) Diode | (10) Plate | (16) Movable core |
| (4) Stator core | (11) Valve | (17) Spring |
| (5) End plate | (12) Housing | (18) Cover |
| (6) Body | (13) Filter | (19) O-ring |
| (7) Yoke | | |

3. ENABLE CONDITION

Secondary Parameters	Enable Conditions
Drain valve	Open
Battery voltage	$\geq 10.9 \text{ V}$
Barometric pressure	$\geq 75 \text{ kPa}$ (563 mmHg, 22.2 inHg)
Tank pressure when starter is OFF → ON	-0.4 kPa (-3.2 mmHg , -0.1 inHg) and 1.4 kPa (10.7 mmHg, 0.4 inHg)

4. GENERAL DRIVING CYCLE

Always perform the diagnosis continuously.

Diagnostic Trouble Code (DTC) Detecting Criteria

GENERAL DESCRIPTION

5. DIAGNOSTIC METHOD

• Abnormality Judgement

If the duration of time while the following conditions are met is longer than the time indicated, judge as NG.

Judgement Value

Malfunction Criteria	Threshold Value
Fuel tank pressure	≤ -4 kPa (-30 mmHg, -1.2 inHg)

Time Needed for Diagnosis: 3000 s

Malfunction Indicator Light Illumination: Illuminates as soon as a malfunction occurs.

• Normality Judgement

Judge as OK and clear the NG if the continuous time while the following conditions are established is more than the predetermined time.

Judgement Value

Malfunction Criteria	Threshold Value
Fuel tank pressure	> -4 kPa (-30 mmHg, -1.2 inHg)
Cumulative time when all the malfunction criteria below are met.	≥ 30000 s
Purge control solenoid valve duty	Not = 0
Fuel temperature	-10 °C (14 °F) — 70 °C (158 °F)
Intake manifold relative pressure	≥ -26.7 kPa (-200 mmHg, -7.9 inHg)

Time Needed for Diagnosis: Less than 1 second

Diagnostic Trouble Code (DTC) Detecting Criteria

GENERAL DESCRIPTION

CO:DTC P1491 POSITIVE CRANKCASE VENTILATION (BLOW-BY) FUNCTION PROBLEM

1. OUTLINE OF DIAGNOSIS

Detect the blow-by hose disconnection abnormality.
Judge as NG when the diagnosis terminal voltage is high.

2. COMPONENT DESCRIPTION

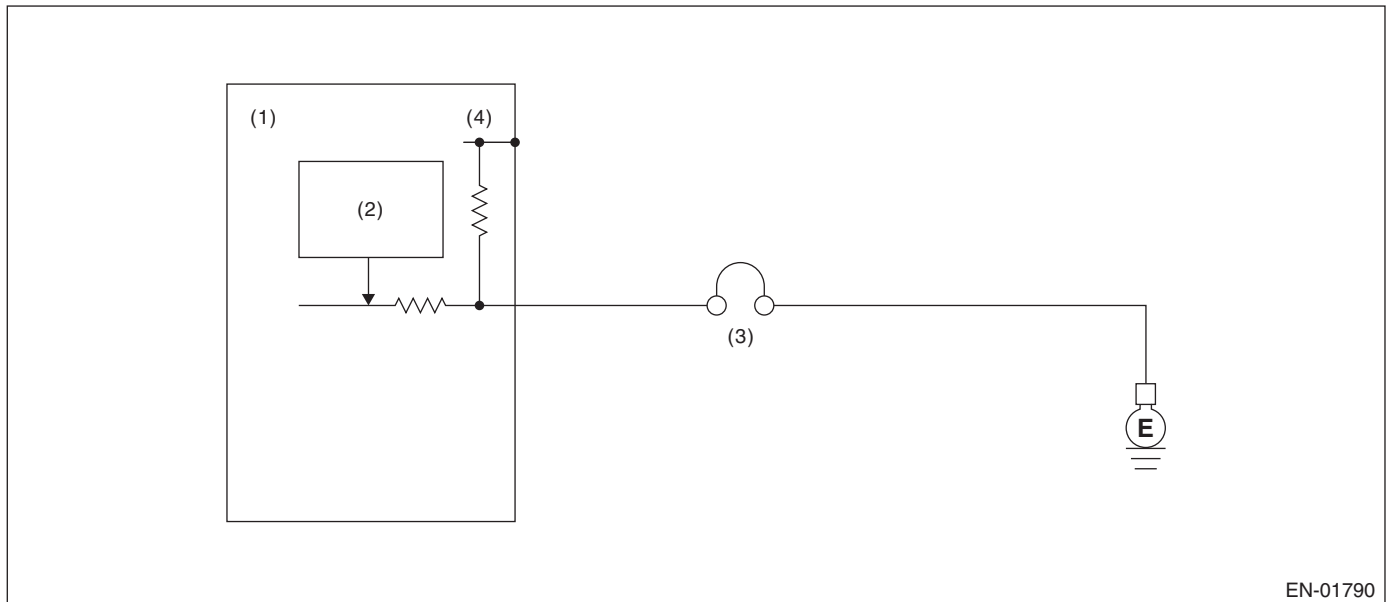

- (1) Engine control module (ECM) (3) PCV diagnosis connector (4) 5 V
(2) Detecting circuit

3. ENABLE CONDITION

Secondary Parameters	Enable Conditions
None	

4. GENERAL DRIVING CYCLE

Always perform the diagnosis continuously.

Diagnostic Trouble Code (DTC) Detecting Criteria

GENERAL DESCRIPTION

5. DIAGNOSTIC METHOD

• Abnormality Judgement

If the duration of time while the following conditions are met is longer than the time indicated, judge as NG.

Judgement Value

Malfunction Criteria	Threshold Value
Battery voltage	≥ 10.9 V
Engine condition	After engine starting
Positive crankcase ventilation diagnosis voltage	High

Time Needed for Diagnosis:2500 ms

Malfunction Indicator Light Illumination: Illuminates as soon as a malfunction occurs.

• Normality Judgement

Judge as OK and clear the NG if the continuous time while the following conditions are established is more than the predetermined time.

Judgement Value

Malfunction Criteria	Threshold Value
Battery voltage	≥ 10.9 V
Engine condition	After engine starting
Positive crankcase ventilation diagnosis voltage	Low

Time Needed for Diagnosis: Less than 1 second

Diagnostic Trouble Code (DTC) Detecting Criteria

GENERAL DESCRIPTION

CP:DTC P1492 EGR SOLENOID VALVE SIGNAL #1 CIRCUIT MALFUNCTION (LOW INPUT)

1. OUTLINE OF DIAGNOSIS

- Detects open or short circuit of EGR.
- Judge as NG when the ECM output level differs from the actual terminal level.

2. COMPONENT DESCRIPTION

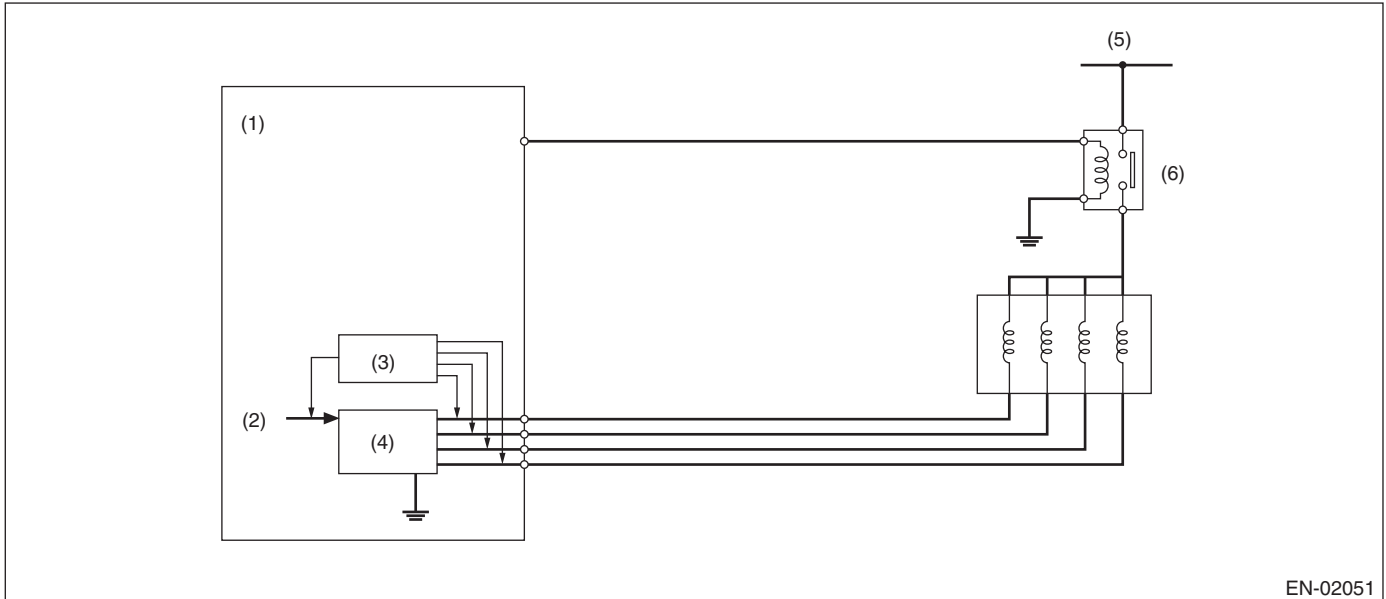

(1) Engine control module (ECM)

(3) Detecting circuit

(5) Battery voltage

(2) Computer unit (CPU)

(4) Switch circuit

(6) Main relay

3. ENABLE CONDITION

Secondary Parameters	Enable Conditions
Elapsed time after starting the engine	≥ 1 second
EGR valve target position	> 0 step
Battery voltage	≥ 10.9 V

4. GENERAL DRIVING CYCLE

Perform diagnosis continuously during EGR operation.

Diagnostic Trouble Code (DTC) Detecting Criteria

GENERAL DESCRIPTION

5. DIAGNOSTIC METHOD

• Abnormality Judgement

If the duration of time while the following conditions are met is longer than the time indicated, judge as NG.

Judgement Value

Malfunction Criteria	Threshold Value
Terminal voltage level when ECM outputs OFF signal or Terminal voltage level when EGR operates	Low level

Time Needed for Diagnosis:2500 ms

Malfunction Indicator Light: Illuminates as soon as a malfunction occurs.

• Normality Judgement

Judge as OK and clear the NG if the continuous time while the following conditions are established is more than the predetermined time.

Judgement Value

Malfunction Criteria	Threshold Value
Terminal voltage level when ECM outputs OFF signal	High level
Terminal voltage level when EGR operates	High level

Time Needed for Diagnosis:128 ms

Diagnostic Trouble Code (DTC) Detecting Criteria

GENERAL DESCRIPTION

CQ:DTC P1493 EGR SOLENOID VALVE SIGNAL #1 CIRCUIT MALFUNCTION (HIGH INPUT)

1. OUTLINE OF DIAGNOSIS

- Detects open or short circuit of EGR.
- Judge as NG when the ECM output level differs from the actual terminal level.

2. COMPONENT DESCRIPTION

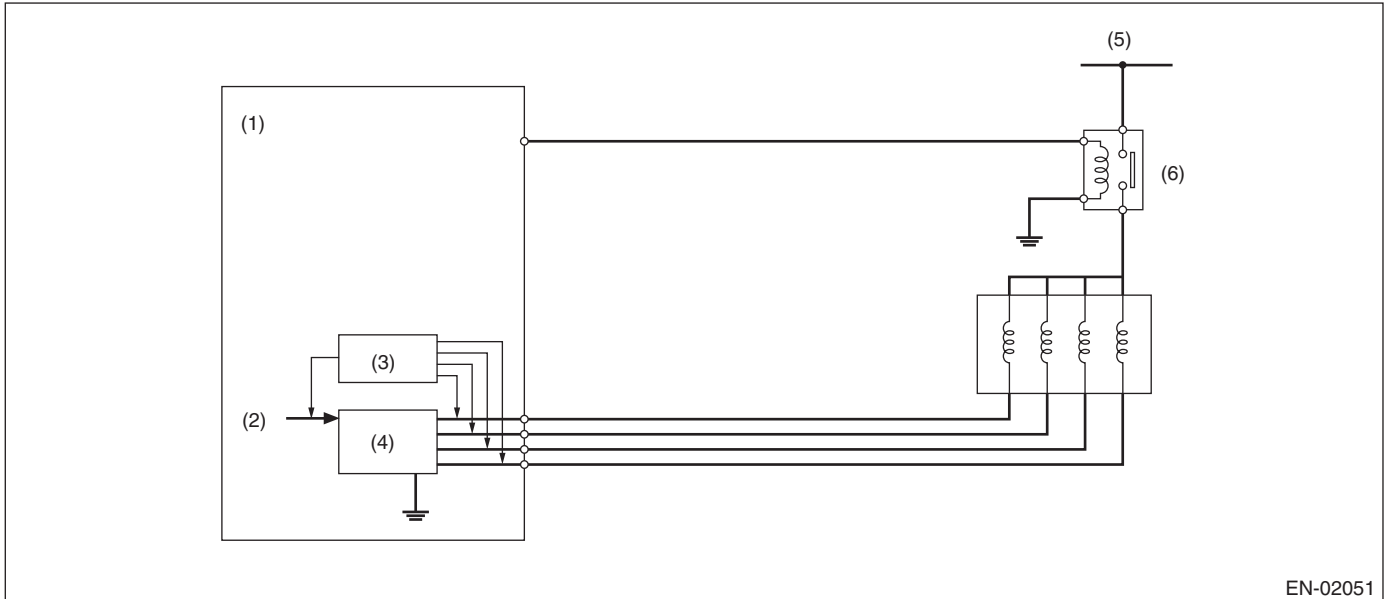

EN-02051

- (1) Engine control module (ECM) (3) Detecting circuit (5) Battery voltage
(2) Computer unit (CPU) (4) Switch circuit (6) Main relay

3. ENABLE CONDITION

Secondary Parameters	Enable Conditions
Elapsed time after starting the engine	≥ 1 second
EGR valve target position	> 0 step
Battery voltage	≥ 10.9 V

4. GENERAL DRIVING CYCLE

Always perform the diagnosis continuously.

Diagnostic Trouble Code (DTC) Detecting Criteria

GENERAL DESCRIPTION

5. DIAGNOSTIC METHOD

• Abnormality Judgement

If the duration of time while the following conditions are met is longer than the time indicated, judge as NG.

Judgement Value

Malfunction Criteria	Threshold Value
Terminal voltage level when ECM outputs OFF signal or Terminal voltage level when EGR operates	High level

Time Needed for Diagnosis:2500 ms

Malfunction Indicator Light: Illuminates as soon as a malfunction occurs.

• Normality Judgement

Judge as OK and clear the NG if the continuous time while the following conditions are established is more than the predetermined time.

Judgement Value

Malfunction Criteria	Threshold Value
Terminal voltage level when ECM outputs OFF signal	Low level
Terminal voltage level when EGR operates	Low level

Time Needed for Diagnosis:128 ms

CR:DTC P1494 EGR SOLENOID VALVE SIGNAL #2 CIRCUIT MALFUNCTION (LOW INPUT)

1. OUTLINE OF DIAGNOSIS

NOTE:

For the detection standard, refer to DTC P1492. <Ref. to GD(H4SO)-167, DTC P1492 EGR SOLENOID VALVE SIGNAL #1 CIRCUIT MALFUNCTION (LOW INPUT), Diagnostic Trouble Code (DTC) Detecting Criteria.>

CS:DTC P1495 EGR SOLENOID VALVE SIGNAL #2 CIRCUIT MALFUNCTION (HIGH INPUT)

1. OUTLINE OF DIAGNOSIS

NOTE:

For the detection standard, refer to DTC P1493. <Ref. to GD(H4SO)-169, DTC P1493 EGR SOLENOID VALVE SIGNAL #1 CIRCUIT MALFUNCTION (HIGH INPUT), Diagnostic Trouble Code (DTC) Detecting Criteria.>

CT:DTC P1496 EGR SOLENOID VALVE SIGNAL #3 CIRCUIT MALFUNCTION (LOW INPUT)

1. OUTLINE OF DIAGNOSIS

NOTE:

For the detection standard, refer to DTC P1492. <Ref. to GD(H4SO)-167, DTC P1492 EGR SOLENOID VALVE SIGNAL #1 CIRCUIT MALFUNCTION (LOW INPUT), Diagnostic Trouble Code (DTC) Detecting Criteria.>

CU:DTC P1497 EGR SOLENOID VALVE SIGNAL #3 CIRCUIT MALFUNCTION (HIGH INPUT)

1. OUTLINE OF DIAGNOSIS

NOTE:

For the detection standard, refer to DTC P1493. <Ref. to GD(H4SO)-169, DTC P1493 EGR SOLENOID VALVE SIGNAL #1 CIRCUIT MALFUNCTION (HIGH INPUT), Diagnostic Trouble Code (DTC) Detecting Criteria.>

CV:DTC P1498 EGR SOLENOID VALVE SIGNAL #4 CIRCUIT MALFUNCTION (LOW INPUT)

1. OUTLINE OF DIAGNOSIS

NOTE:

For the detection standard, refer to DTC P1492. <Ref. to GD(H4SO)-167, DTC P1492 EGR SOLENOID VALVE SIGNAL #1 CIRCUIT MALFUNCTION (LOW INPUT), Diagnostic Trouble Code (DTC) Detecting Criteria.>

CW:DTC P1499 EGR SOLENOID VALVE SIGNAL #4 CIRCUIT MALFUNCTION (HIGH INPUT)

1. OUTLINE OF DIAGNOSIS

NOTE:

For the detection standard, refer to DTC P1493. <Ref. to GD(H4SO)-169, DTC P1493 EGR SOLENOID VALVE SIGNAL #1 CIRCUIT MALFUNCTION (HIGH INPUT), Diagnostic Trouble Code (DTC) Detecting Criteria.>

Diagnostic Trouble Code (DTC) Detecting Criteria

GENERAL DESCRIPTION

CX:DTC P1560 BACK-UP VOLTAGE CIRCUIT MALFUNCTION

1. OUTLINE OF DIAGNOSIS

Detect the open/short circuit of back-up power supply circuit.
Judge as NG when the backup power voltage is low.

2. ENABLE CONDITION

Secondary Parameters	Enable Conditions
None	

3. GENERAL DRIVING CYCLE

Always perform the diagnosis continuously.

4. DIAGNOSTIC METHOD

• Abnormality Judgement

If the duration of time while the following conditions are met is longer than the time indicated, judge as NG.

Judgement Value

Malfunction Criteria	Threshold Value
Voltage of back-up power supply	Low
Battery voltage	≥ 10.9 V
Engine condition	After engine starting

Time Needed for Diagnosis:2500 ms

Malfunction Indicator Light Illumination: Illuminates as soon as a malfunction occurs.

• Normality Judgement

Judge as OK and clear the NG if the continuous time while the following conditions are established is more than the predetermined time.

Judgement Value

Malfunction Criteria	Threshold Value
Voltage of back-up power supply	High
Battery voltage	≥ 10.9 V
Engine condition	After engine starting

Time Needed for Diagnosis: Less than 1 second

CY:DTC P1570 ANTENNA

1. OUTLINE OF DIAGNOSIS

NOTE:

For the detection standard, refer to DTC P0513. <Ref. to GD(H4SO)-141, DTC P0513 INCORRECT IMMOBILIZER KEY, Diagnostic Trouble Code (DTC) Detecting Criteria.>

CZ:DTC P1571 REFERENCE CODE INCOMPATIBILITY

1. OUTLINE OF DIAGNOSIS

NOTE:

For the detection standard, refer to DTC P0513. <Ref. to GD(H4SO)-141, DTC P0513 INCORRECT IMMOBILIZER KEY, Diagnostic Trouble Code (DTC) Detecting Criteria.>

DA:DTC P1572 IMM CIRCUIT FAILURE (EXCEPT ANTENNA CIRCUIT)

1. OUTLINE OF DIAGNOSIS

NOTE:

For the detection standard, refer to DTC P0513. <Ref. to GD(H4SO)-141, DTC P0513 INCORRECT IMMOBILIZER KEY, Diagnostic Trouble Code (DTC) Detecting Criteria.>

DB:DTC P1574 KEY COMMUNICATION FAILURE

1. OUTLINE OF DIAGNOSIS

NOTE:

For the detection standard, refer to DTC P0513. <Ref. to GD(H4SO)-141, DTC P0513 INCORRECT IMMOBILIZER KEY, Diagnostic Trouble Code (DTC) Detecting Criteria.>

DC:DTC P1576 EGI CONTROL MODULE EEPROM

1. OUTLINE OF DIAGNOSIS

NOTE:

For the detection standard, refer to DTC P0513. <Ref. to GD(H4SO)-141, DTC P0513 INCORRECT IMMOBILIZER KEY, Diagnostic Trouble Code (DTC) Detecting Criteria.>

DD:DTC P1577 IMM CONTROL MODULE EEPROM

1. OUTLINE OF DIAGNOSIS

NOTE:

For the detection standard, refer to DTC P0513. <Ref. to GD(H4SO)-141, DTC P0513 INCORRECT IMMOBILIZER KEY, Diagnostic Trouble Code (DTC) Detecting Criteria.>

DE:DTC P1578 METER FAILURE

1. OUTLINE OF DIAGNOSIS

NOTE:

For the detection standard, refer to DTC P0513. <Ref. to GD(H4SO)-141, DTC P0513 INCORRECT IMMOBILIZER KEY, Diagnostic Trouble Code (DTC) Detecting Criteria.>

Diagnostic Trouble Code (DTC) Detecting Criteria

GENERAL DESCRIPTION

DF:DTC P1602 CONTROL MODULE PROGRAMMING ERROR

1. OUTLINE OF DIAGNOSIS

Detect malfunctions of the catalyst advanced idling retard angle control.

Judge as NG when ECM is not controlling the angle properly during catalyst advanced idling retard angle control.

Judge as NG if there is exhaust gas temperature diagnosis and idle speed diagnosis and if either of them is NG.

- Exhaust gas temperature diagnosis

Judge as NG when the estimated exhausted gas temperature in 14 seconds after the cold start is below the specified value.

- Idle speed diagnosis

Judge as NG when actual engine speed is not close to target engine speed after terminating the retard angle control.

2. ENABLE CONDITION

Secondary Parameters	Enable Conditions
Barometric pressure	≥ 75 kPa (563 mmHg, 22.2 inHg)
Battery voltage	≥ 10.9 V
Cold start diagnosis	Incomplete
Vehicle speed	< 2 km/h (1.2 MPH)
Misfire within 200 engine revs.	< 5
Time after starting	= 14 seconds

3. GENERAL DRIVING CYCLE

Perform the diagnosis at cold start.

4. DIAGNOSTIC METHOD

- Exhaust gas temperature diagnosis

Abnormality Judgement

Calculate the estimated exhaust gas temperature when the diagnostic enable condition is established. Judge as NG when the following conditions are established after engine starting within the predetermined time.

Judgement Value

Malfunction Criteria	Threshold Value
Estimated exhaust gas temperature	< Value from Map

Map (U5 model)

Coolant temperature after starting the engine	-40 °C (-40 °F)	-30 °C (-22 °F)	-20 °C (-4 °F)	-10 °C (14 °F)	0 °C (32 °F)	10 °C (50 °F)	20 °C (68 °F)	30 °C (86 °F)	40 °C (104 °F)	50 °C (122 °F)
Threshold value (AT model)	220 °C (428 °F)	220 °C (428 °F)	220 °C (428 °F)	220 °C (428 °F)	220 °C (428 °F)	214 °C (417.2 °F)	206 °C (402.8 °F)	206 °C (402.8 °F)	184 °C (363.2 °F)	178 °C (352.4 °F)
Threshold value (MT model)	214 °C (417.2 °F)	214 °C (417.2 °F)	214 °C (417.2 °F)	214 °C (417.2 °F)	214 °C (417.2 °F)	214 °C (417.2 °F)	214 °C (417.2 °F)	198 °C (388.4 °F)	194 °C (381.2 °F)	190 °C (374 °F)

Map (Other than U5 model)

Coolant temperature after starting the engine	-40 °C (-40 °F)	-30 °C (-22 °F)	-20 °C (-4 °F)	-10 °C (14 °F)	0 °C (32 °F)	10 °C (50 °F)	20 °C (68 °F)	30 °C (86 °F)	40 °C (104 °F)	50 °C (122 °F)
Threshold value (AT model)	162 °C (323.6 °F)	162 °C (323.6 °F)	162 °C (323.6 °F)	162 °C (323.6 °F)	162 °C (323.6 °F)	162 °C (323.6 °F)	162 °C (323.6 °F)	154 °C (309.2 °F)	142 °C (287.6 °F)	142 °C (287.6 °F)
Threshold value (MT model)	168 °C (334.4 °F)	168 °C (334.4 °F)	168 °C (334.4 °F)	168 °C (334.4 °F)	168 °C (334.4 °F)	168 °C (334.4 °F)	168 °C (334.4 °F)	160 °C (320 °F)	145 °C (293 °F)	145 °C (293 °F)

Time Needed for Diagnosis: 14 seconds

Malfunction Indicator Light Illumination: Illuminates when malfunction occurs in 2 continuous driving cycles.

Diagnostic Trouble Code (DTC) Detecting Criteria

GENERAL DESCRIPTION

Normality Judgement

Judge as OK and clear the NG if the following conditions are established.

Judgement Value

Malfunction Criteria	Threshold Value
Estimated exhaust gas temperature	≥ Value from Map

Time Needed for Diagnosis: Less than 1 second

• Idle speed diagnosis

Abnormality Judgement

Judge as NG when the following conditions are established after the predetermined time.

Judgement Value

Malfunction Criteria	Threshold Value
Continuous time of (Target engine speed – Actual engine speed > –200 rpm) (U5 model)	≥ 6000 ms
Continuous time of (Target engine speed – Actual engine speed > –300 rpm) (Other than U5 model)	
Continuous time of (actual retard amount > 30 °CA)	≥ 0 ms

Time Needed for Diagnosis: 14 seconds

Malfunction Indicator Light Illumination: Illuminates when malfunction occurs in 2 continuous driving cycles.

Normality Judgement

Judge as OK and clear the NG if the following conditions are established.

Judgement Value

Malfunction Criteria	Threshold Value
Continuous time of (Target engine speed – Actual engine speed > –200 rpm) (U5 model)	< 6000 ms
Continuous time of (Target engine speed – Actual engine speed > –300 rpm) (Other than U5 model)	
Continuous time of (actual retard amount > 30 °CA)	< 0 ms

Time Needed for Diagnosis: Less than 1 second

Diagnostic Trouble Code (DTC) Detecting Criteria

GENERAL DESCRIPTION

DG:DTC P2096 POST CATALYST FUEL TRIM SYSTEM TOO LEAN (BANK 1)

1. OUTLINE OF DIAGNOSIS

Detect the malfunction of fuel system from the size of the sub feedback learning value.
Control the sub feedback learning and judge as NG when the learning value is in the lean zone.

2. COMPONENT DESCRIPTION

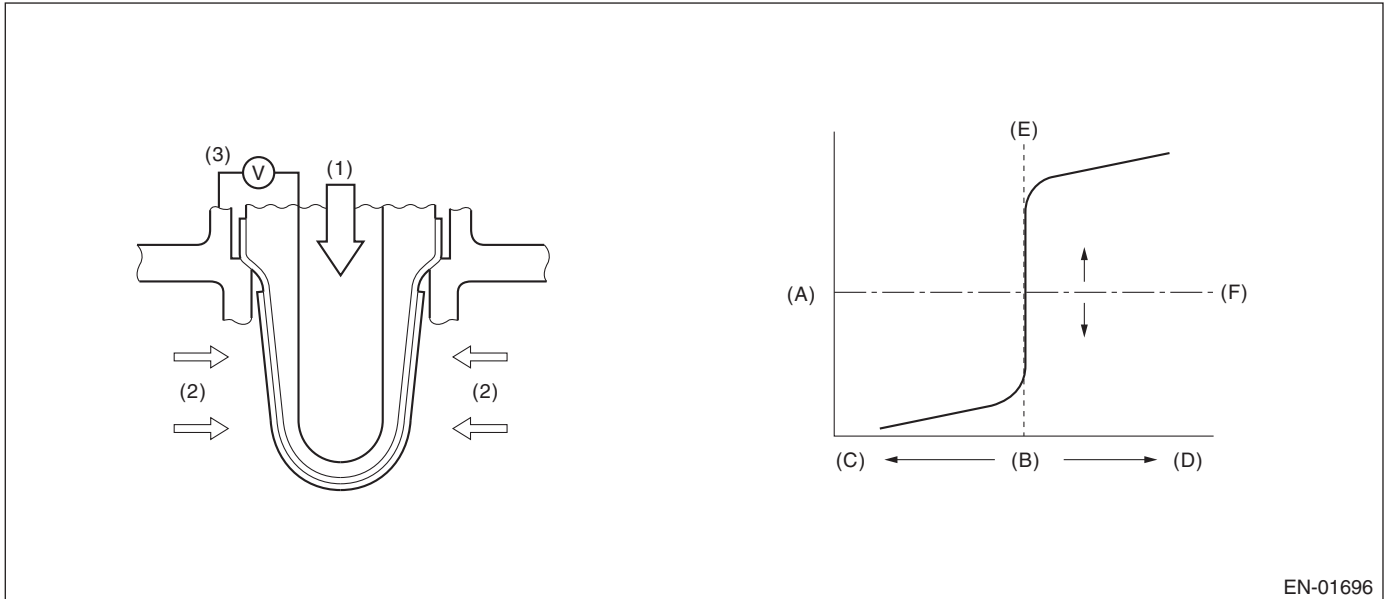

EN-01696

- | | | |
|-------------------------|--------------------------------|-------------------------|
| (A) Electromotive force | (B) Air fuel ratio | (C) Rich |
| (D) Lean | (E) Theoretical air fuel ratio | (F) Comparative voltage |
| (1) Atmosphere | (2) Exhaust gas | (3) Electromotive force |

3. ENABLE CONDITION

Secondary Parameters	Enable Conditions
Conditions for carrying out the sub feedback learning	Completed
Continuous time when all conditions are established.	≥ 1 s

4. GENERAL DRIVING CYCLE

Perform the diagnosis continuously when the vehicle is idling or running at a constant speed of 80 km/h (50 MPH) or more.

Diagnostic Trouble Code (DTC) Detecting Criteria

GENERAL DESCRIPTION

5. DIAGNOSTIC METHOD

• Abnormality Judgement

If the duration of time while the following conditions are met is longer than the time indicated, judge as NG.

Judgement Value

Malfunction Criteria	Threshold Value
Sub feedback learning value	< -0.04 (U5 model) < -0.041 (Other than U5 model)

Time Needed for Diagnosis: 5 s × 1 time(s)

Malfunction Indicator Light Illumination: Illuminates when malfunction occurs in 2 continuous driving cycles.

• Normality Judgement

Judge as OK and clear the NG if the continuous time while the following conditions are established is more than the predetermined time.

Judgement Value

Malfunction Criteria	Threshold Value
Sub feedback learning value	≥ -0.04 + 0 (U5 model) ≥ -0.041 + 0 (Other than U5 model)

Time Needed for Diagnosis: 5 s

Diagnostic Trouble Code (DTC) Detecting Criteria

GENERAL DESCRIPTION

DH:DTC P2097 POST CATALYST FUEL TRIM SYSTEM TOO RICH (BANK 1)

1. OUTLINE OF DIAGNOSIS

Detect the malfunction of fuel system from the size of the sub feedback learning value.

Sub feedback learning is being performed. When the learning value goes to the rich side, judge as NG.

2. COMPONENT DESCRIPTION

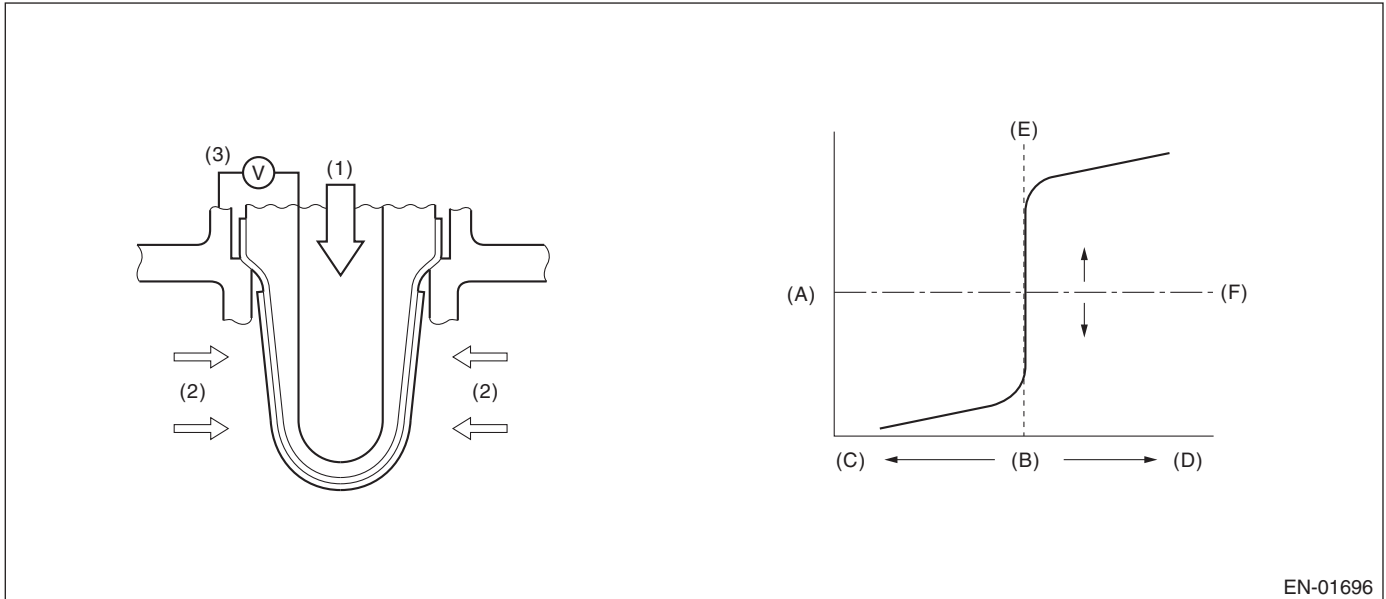

EN-01696

(A) Electromotive force

(B) Air fuel ratio

(C) Rich

(D) Lean

(E) Theoretical air fuel ratio

(F) Comparative voltage

(1) Atmosphere

(2) Exhaust gas

(3) Electromotive force

3. ENABLE CONDITION

Secondary Parameters	Enable Conditions
Conditions for carrying out the sub feedback learning	Completed
Continuous time when all conditions are established.	≥ 1 s

4. GENERAL DRIVING CYCLE

Perform the diagnosis continuously when the vehicle is idling or running at a constant speed of 80 km/h (50 MPH) or more.

Diagnostic Trouble Code (DTC) Detecting Criteria

GENERAL DESCRIPTION

5. DIAGNOSTIC METHOD

• Abnormality Judgement

If the duration of time while the following conditions are met is longer than the time indicated, judge as NG.

Judgement Value

Malfunction Criteria	Threshold Value
Sub feedback learning value	≥ 0.03 (U5 model) ≥ 0.04 (Other than U5 model)

Time Needed for Diagnosis: $5 \text{ s} \times 1 \text{ time(s)}$

Malfunction Indicator Light Illumination: Illuminates when malfunction occurs in 2 continuous driving cycles.

• Normality Judgement

Judge as OK and clear the NG if the continuous time while the following conditions are established is more than the predetermined time.

Judgement Value

Malfunction Criteria	Threshold Value
Sub feedback learning value	$< 0.03 + -0.002$ (U5 model) < 0.04 (Other than U5 model) $+ -0.002$

Time Needed for Diagnosis: 5 s

Diagnostic Trouble Code (DTC) Detecting Criteria

GENERAL DESCRIPTION

DI: DTC P2101 THROTTLE ACTUATOR CONTROL MOTOR CIRCUIT RANGE/ PERFORMANCE

1. OUTLINE OF DIAGNOSIS

Judge as NG when the motor current becomes large or drive circuit is heated.

2. COMPONENT DESCRIPTION

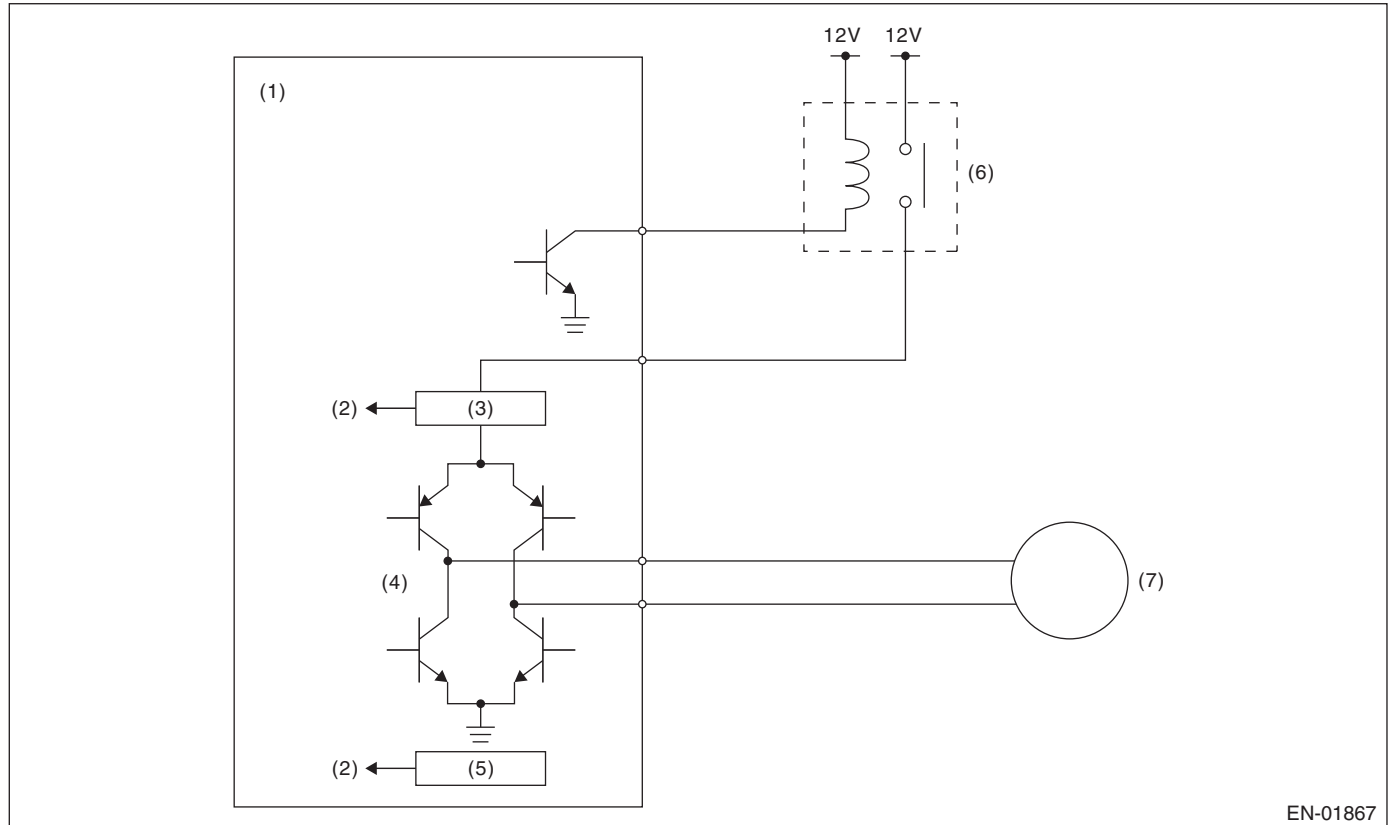

EN-01867

- | | | |
|-----------------------------------|-----------------------------------|---------------------------------------|
| (1) Engine control module (ECM) | (4) Drive circuit | (6) Electronic throttle control relay |
| (2) Detecting circuit | (5) Temperature detection circuit | (7) Motor |
| (3) Overcurrent detection circuit | | |

3. ENABLE CONDITION

Secondary Parameters	Enable Conditions
Under control of electronic throttle control	ON

4. GENERAL DRIVING CYCLE

Always perform the diagnosis continuously.

5. DIAGNOSTIC METHOD

Judge as OK and clear the NG when the malfunction criteria below are met.

Judgement Value

Malfunction Criteria	Threshold Value
Motor current	≤ 8 A
Drive circuit inner temperature	$\leq 175^{\circ}\text{C}$ (347°F)

Time Needed for Diagnosis:

- 500 milliseconds (For NG)
- 2000 milliseconds (For OK)

Malfunction Indicator Light Illumination: Illuminates as soon as a malfunction occurs.

DJ:DTC P2102 THROTTLE ACTUATOR CONTROL MOTOR CIRCUIT LOW

1. OUTLINE OF DIAGNOSIS

Judge as NG when the electronic throttle control power is not supplied even when ECM sets the electric control throttle relay to ON.

2. COMPONENT DESCRIPTION

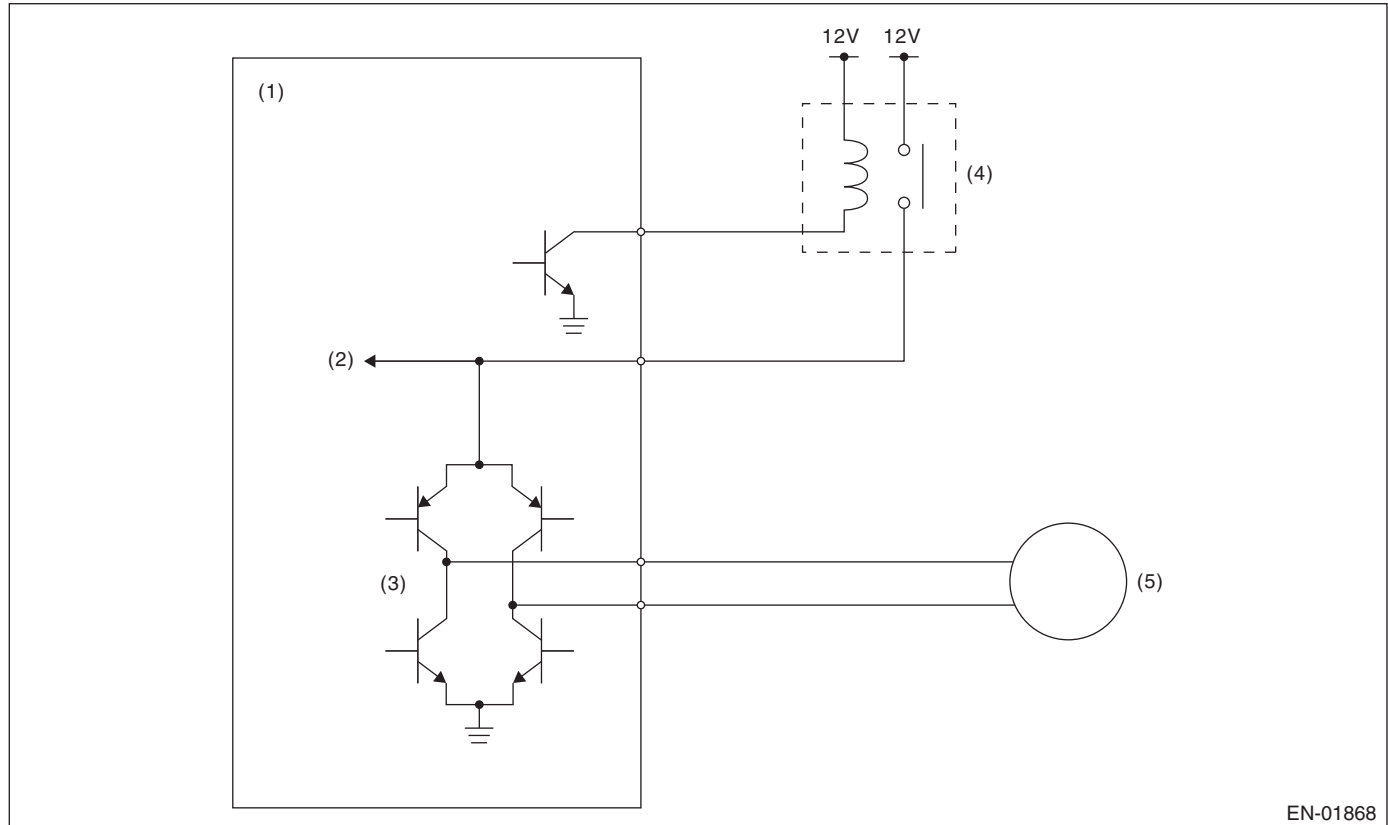

EN-01868

- | | | |
|---------------------------------|---------------------------------------|-----------|
| (1) Engine control module (ECM) | (3) Drive circuit | (5) Motor |
| (2) Voltage detection circuit | (4) Electronic throttle control relay | |

3. ENABLE CONDITION

Secondary Parameters	Enable Conditions
Electronic throttle control relay output	ON

4. GENERAL DRIVING CYCLE

Always perform the diagnosis continuously.

5. DIAGNOSTIC METHOD

Judge as OK and clear the NG when the malfunction criteria below are met.

Judgement Value

Malfunction Criteria	Threshold Value
Motor power voltage	$\geq 5\text{ V}$

Time Needed for Diagnosis:

- 400 milliseconds (For NG)
- 2000 milliseconds (For OK)

Malfunction Indicator Light Illumination: Illuminates as soon as a malfunction occurs.

Diagnostic Trouble Code (DTC) Detecting Criteria

GENERAL DESCRIPTION

DK:DTC P2103 THROTTLE ACTUATOR CONTROL MOTOR CIRCUIT HIGH

1. OUTLINE OF DIAGNOSIS

Judge as NG when the electronic throttle control power is supplied even when ECM sets the electronic throttle control relay to OFF.

2. COMPONENT DESCRIPTION

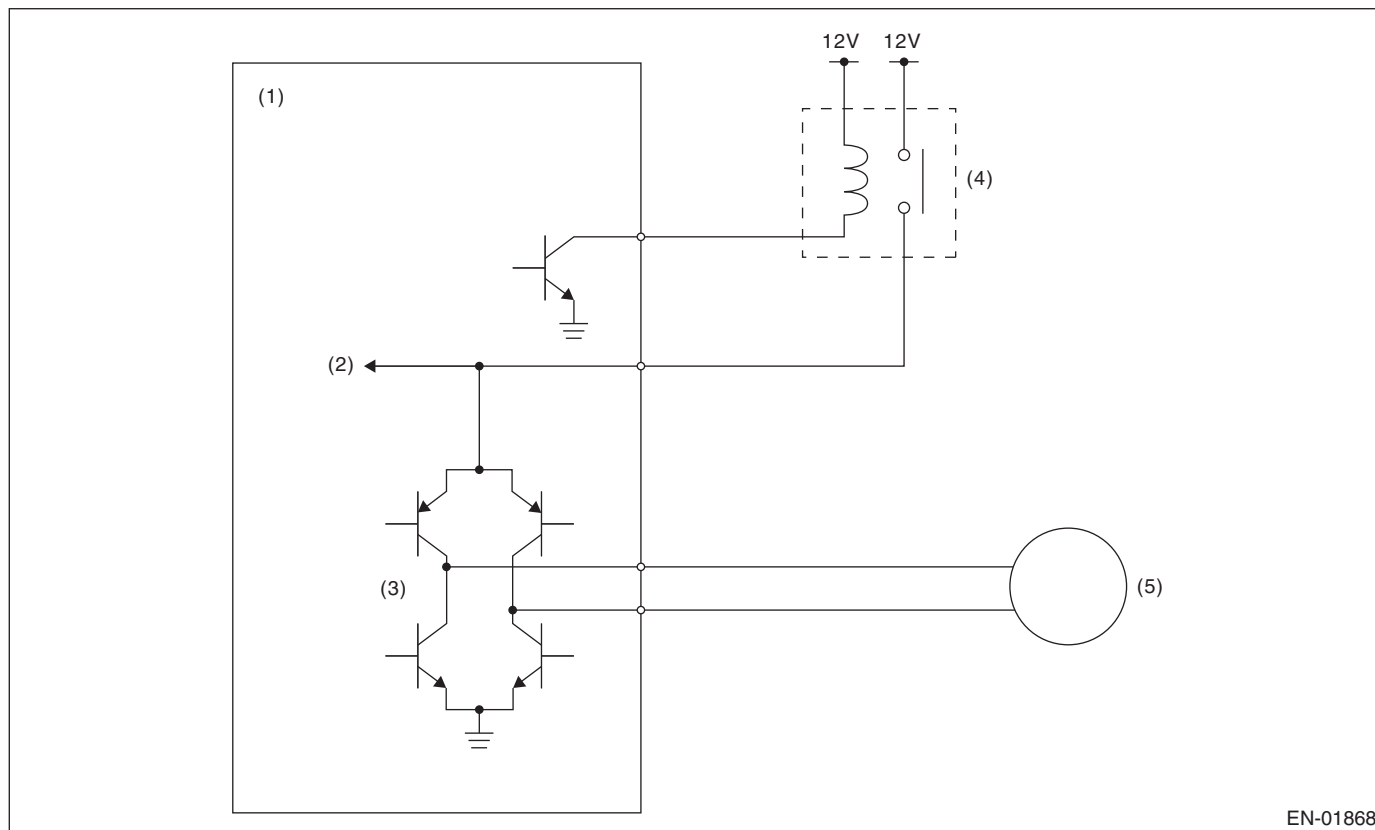

EN-01868

- | | | |
|---------------------------------|---------------------------------------|-----------|
| (1) Engine control module (ECM) | (3) Drive circuit | (5) Motor |
| (2) Voltage detection circuit | (4) Electronic throttle control relay | |

3. ENABLE CONDITION

Secondary Parameters	Enable Conditions
Electronic throttle control relay output	OFF

4. GENERAL DRIVING CYCLE

- When ignition switch ON → OFF
- Ignition switch OFF → ON (Only after clearing memory)

5. DIAGNOSTIC METHOD

Judge as OK and clear the NG when the malfunction criteria below are met.

Judgement Value

Malfunction Criteria	Threshold Value
Motor power voltage	≤ 5 V

Time Needed for Diagnosis:

- 600 milliseconds (For NG)
- 400 milliseconds (For OK)

Malfunction Indicator Light Illumination: Illuminates as soon as a malfunction occurs.

Diagnostic Trouble Code (DTC) Detecting Criteria

GENERAL DESCRIPTION

DL:DTC P2109 THROTTLE/PEDAL POSITION SENSOR “A” MINIMUM STOP PERFORMANCE

1. OUTLINE OF DIAGNOSIS

Judge as NG when full close point learning cannot be conducted or an abnormal value is detected.

2. COMPONENT DESCRIPTION

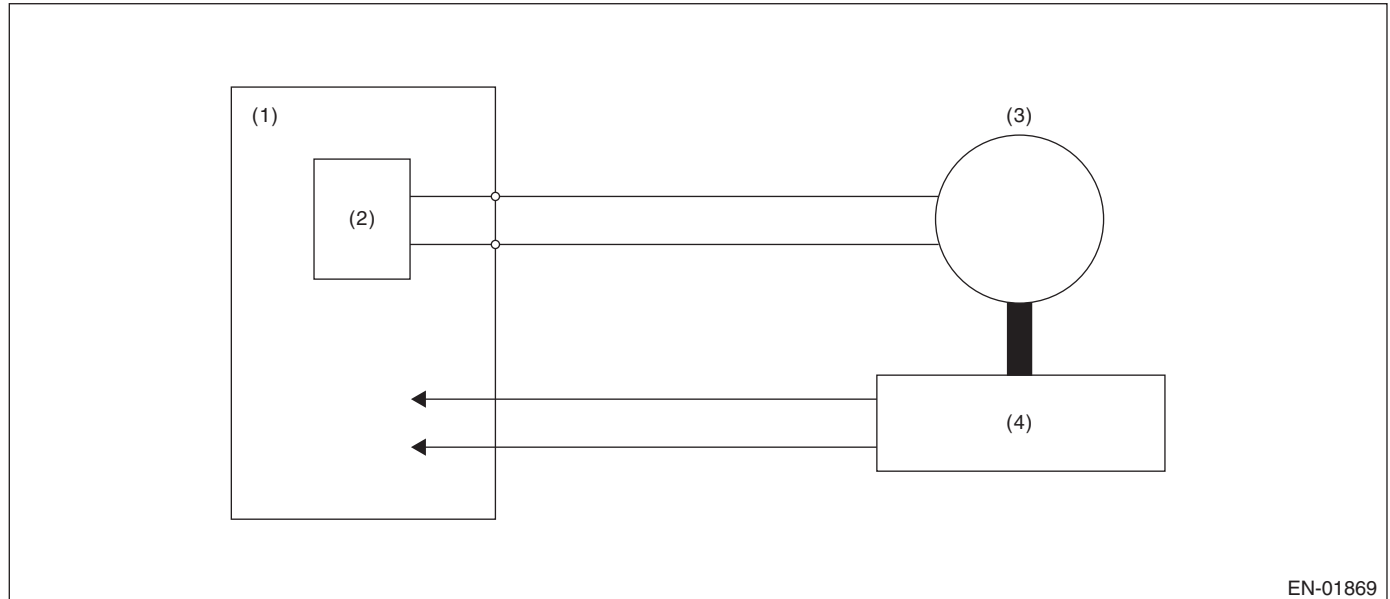

EN-01869

- (1) Engine control module (ECM) (3) Motor (4) Throttle position sensor
 (2) Drive circuit

3. ENABLE CONDITION

Secondary Parameters	Enable Conditions
Ignition switch	ON → OFF
Ignition switch (only after clear memory)	OFF → ON

4. GENERAL DRIVING CYCLE

Perform the diagnosis at full closed point learning.

5. DIAGNOSTIC METHOD

Judge as OK and clear the NG when the malfunction criteria below are met.

Judgement Value

Malfunction Criteria	Threshold Value
Throttle sensor opening angle at full close point learning	10.127° or more, 19.872° or less
Throttle opening angle when the ignition switch is ON – Throttle minimum stop position	≥ 1.683°

Time Needed for Diagnosis: 8 — 80 milliseconds

Malfunction Indicator Light Illumination: Illuminates as soon as a malfunction occurs.

Diagnostic Trouble Code (DTC) Detecting Criteria

GENERAL DESCRIPTION

DM:DTC P2122 THROTTLE/PEDAL POSITION SENSOR/SWITCH “D” CIRCUIT LOW INPUT

1. OUTLINE OF DIAGNOSIS

Detect the open or short circuit of accelerator pedal position sensor 1.
Judge as NG if out of specification.

2. COMPONENT DESCRIPTION

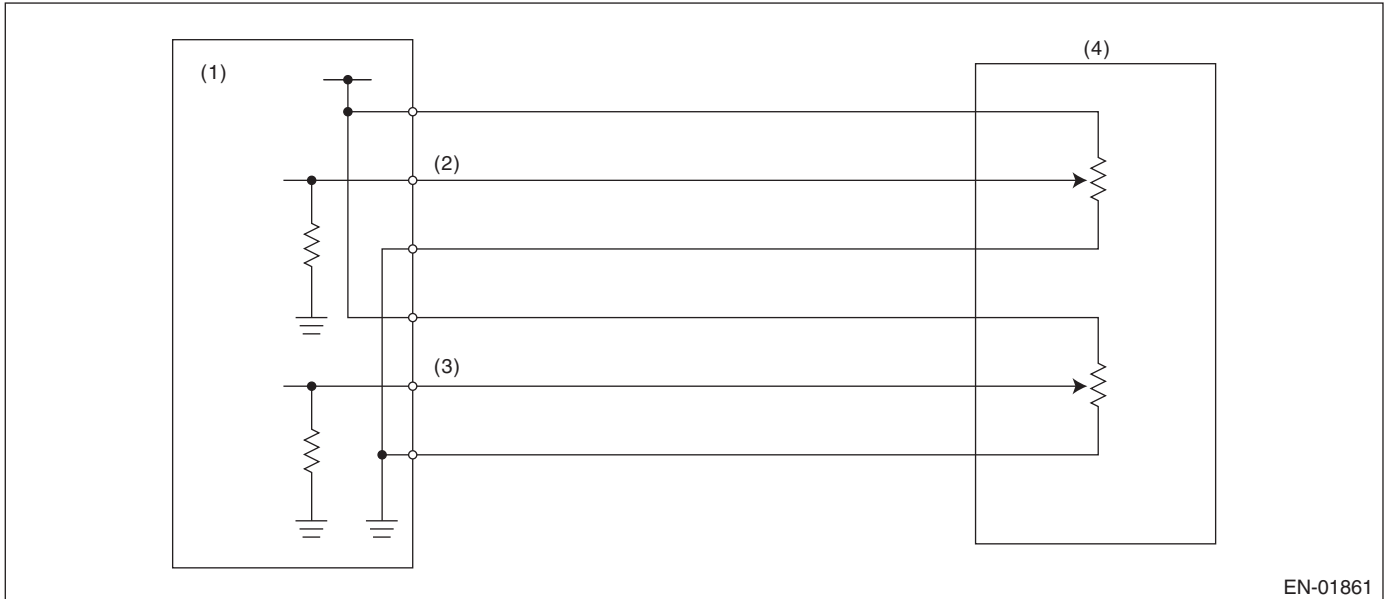

- (1) Engine control module (ECM) (3) Accelerator pedal position sensor 2 signal (4) Accelerator pedal position sensor 2 signal
(2) Accelerator pedal position sensor 1 signal

3. ENABLE CONDITION

Secondary Parameters	Enable Conditions
Ignition switch	ON
Battery voltage	$\geq 6 \text{ V}$

4. GENERAL DRIVING CYCLE

Always perform the diagnosis continuously.

Diagnostic Trouble Code (DTC) Detecting Criteria

GENERAL DESCRIPTION

5. DIAGNOSTIC METHOD

• Abnormality Judgement

If the duration of time while the following conditions are met is longer than the time indicated, judge as NG.

Judgement Value

Malfunction Criteria	Threshold Value
Sensor 1 input voltage	< 0.217 V

Time Needed for Diagnosis:100 ms

Malfunction Indicator Light Illumination: Illuminates as soon as a malfunction occurs.

• Normality Judgement

Judge as OK and clear the NG if the continuous time while the following conditions are established is more than the predetermined time.

Judgement Value

Malfunction Criteria	Threshold Value
Sensor 1 input voltage	\geq 0.217 V

Time Needed for Diagnosis:100 ms

Diagnostic Trouble Code (DTC) Detecting Criteria

GENERAL DESCRIPTION

DN:DTC P2123 THROTTLE/PEDAL POSITION SENSOR/SWITCH “D” CIRCUIT HIGH INPUT

1. OUTLINE OF DIAGNOSIS

Detect the open or short circuit of accelerator pedal position sensor 1.
Judge as NG if out of specification.

2. COMPONENT DESCRIPTION

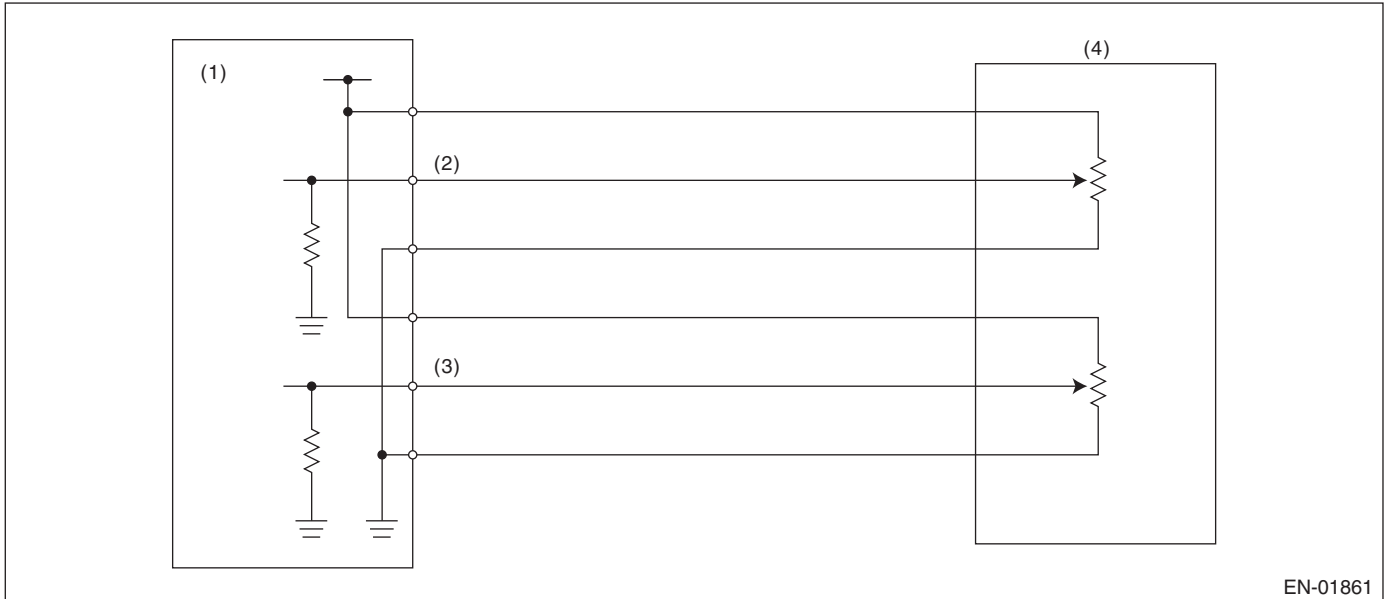

- (1) Engine control module (ECM) (3) Accelerator pedal position sensor 2 signal (4) Accelerator pedal position sensor 2 signal
(2) Accelerator pedal position sensor 1 signal

3. ENABLE CONDITION

Secondary Parameters	Enable Conditions
Ignition switch	ON
Battery voltage	$\geq 6 \text{ V}$

4. GENERAL DRIVING CYCLE

Always perform the diagnosis continuously.

Diagnostic Trouble Code (DTC) Detecting Criteria

GENERAL DESCRIPTION

5. DIAGNOSTIC METHOD

• Abnormality Judgement

If the duration of time while the following conditions are met is longer than the time indicated, judge as NG.

Judgement Value

Malfunction Criteria	Threshold Value
Sensor 1 input voltage	≥ 4.783 V

Time Needed for Diagnosis:32 ms

Malfunction Indicator Light Illumination: Illuminates as soon as a malfunction occurs.

• Normality Judgement

Judge as OK and clear the NG if the continuous time while the following conditions are established is more than the predetermined time.

Judgement Value

Malfunction Criteria	Threshold Value
Sensor 1 input voltage	< 4.783 V

Time Needed for Diagnosis:32 ms

Diagnostic Trouble Code (DTC) Detecting Criteria

GENERAL DESCRIPTION

DO:DTC P2127 THROTTLE/PEDAL POSITION SENSOR/SWITCH “E” CIRCUIT LOW INPUT

1. OUTLINE OF DIAGNOSIS

Detect the open or short circuit of accelerator pedal position sensor 2.
Judge as NG if out of specification.

2. COMPONENT DESCRIPTION

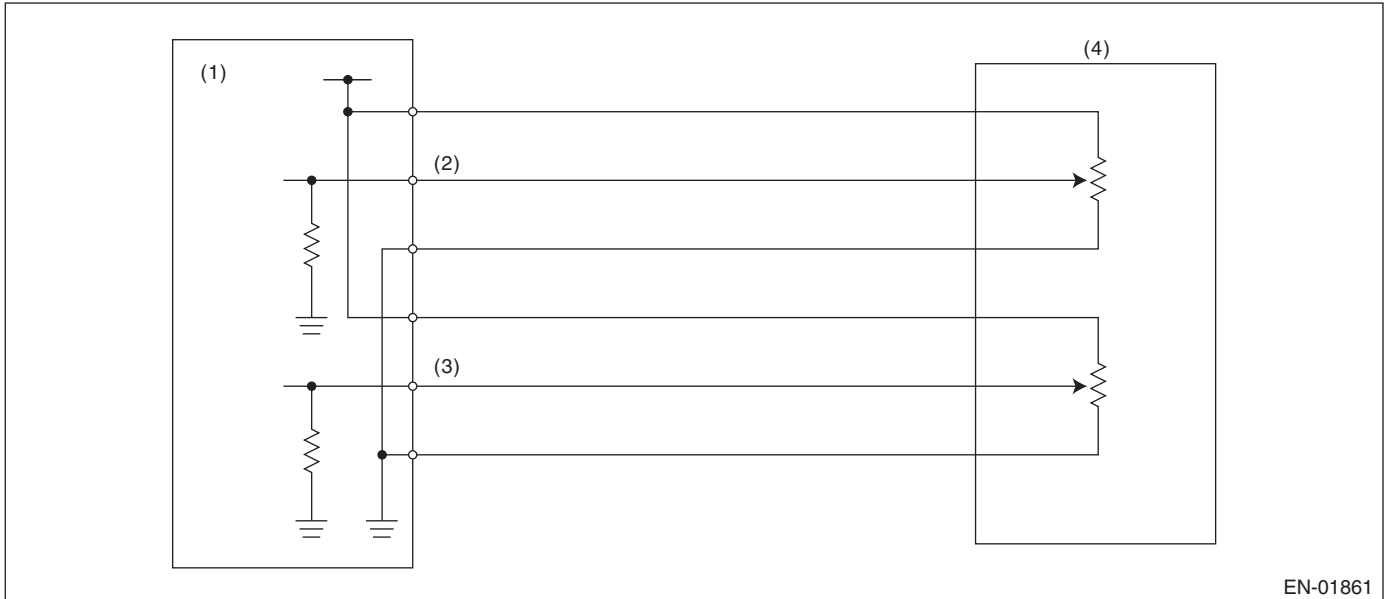

- (1) Engine control module (ECM) (3) Accelerator pedal position sensor 2 signal (4) Accelerator pedal position sensor 2
(2) Accelerator pedal position sensor 1 signal

3. ENABLE CONDITION

Secondary Parameters	Enable Conditions
Ignition switch	ON
Battery voltage	$\geq 6 \text{ V}$

4. GENERAL DRIVING CYCLE

Always perform the diagnosis continuously.

Diagnostic Trouble Code (DTC) Detecting Criteria

GENERAL DESCRIPTION

5. DIAGNOSTIC METHOD

• Abnormality Judgement

If the duration of time while the following conditions are met is longer than the time indicated, judge as NG.

Judgement Value

Malfunction Criteria	Threshold Value
Sensor 2 input voltage	< 0.217 V

Time Needed for Diagnosis:100 ms

Malfunction Indicator Light Illumination: Illuminates as soon as a malfunction occurs.

• Normality Judgement

Judge as OK and clear the NG if the continuous time while the following conditions are established is more than the predetermined time.

Judgement Value

Malfunction Criteria	Threshold Value
Sensor 2 input voltage	\geq 0.217 V

Time Needed for Diagnosis:100 ms

Diagnostic Trouble Code (DTC) Detecting Criteria

GENERAL DESCRIPTION

DP:DTC P2128 THROTTLE/PEDAL POSITION SENSOR/SWITCH “E” CIRCUIT HIGH INPUT

1. OUTLINE OF DIAGNOSIS

Detect the open or short circuit of accelerator pedal position sensor 2.
Judge as NG if out of specification.

2. COMPONENT DESCRIPTION

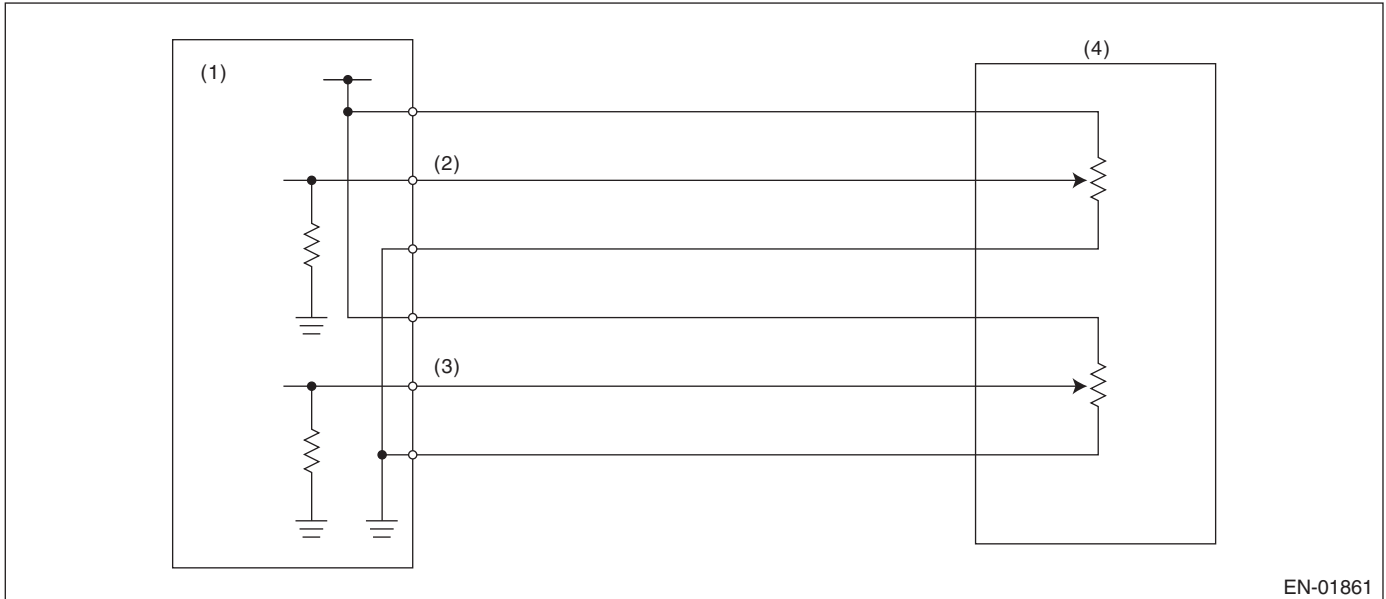

EN-01861

- (1) Engine control module (ECM) (3) Accelerator pedal position sensor 2 signal (4) Accelerator pedal position sensor 2 signal
(2) Accelerator pedal position sensor 1 signal

3. ENABLE CONDITION

Secondary Parameters	Enable Conditions
Ignition switch	ON
Battery voltage	$\geq 6 \text{ V}$

4. GENERAL DRIVING CYCLE

Always perform the diagnosis continuously.

Diagnostic Trouble Code (DTC) Detecting Criteria

GENERAL DESCRIPTION

5. DIAGNOSTIC METHOD

• Abnormality Judgement

If the duration of time while the following conditions are met is longer than the time indicated, judge as NG.

Judgement Value

Malfunction Criteria	Threshold Value
Sensor 2 input voltage	≥ 4.783 V

Time Needed for Diagnosis:100 ms

Malfunction Indicator Light Illumination: Illuminates as soon as a malfunction occurs.

• Normality Judgement

Judge as OK and clear the NG if the continuous time while the following conditions are established is more than the predetermined time.

Judgement Value

Malfunction Criteria	Threshold Value
Sensor 2 input voltage	< 4.783 V

Time Needed for Diagnosis:100 ms

Diagnostic Trouble Code (DTC) Detecting Criteria

GENERAL DESCRIPTION

DQ:DTC P2135 THROTTLE/PEDAL POSITION SENSOR/SWITCH “A”/“B” VOLTAGE CORRELATION

1. OUTLINE OF DIAGNOSIS

Judge as NG when the signal level of throttle position sensor 1 is different from the throttle position sensor 2.

2. COMPONENT DESCRIPTION

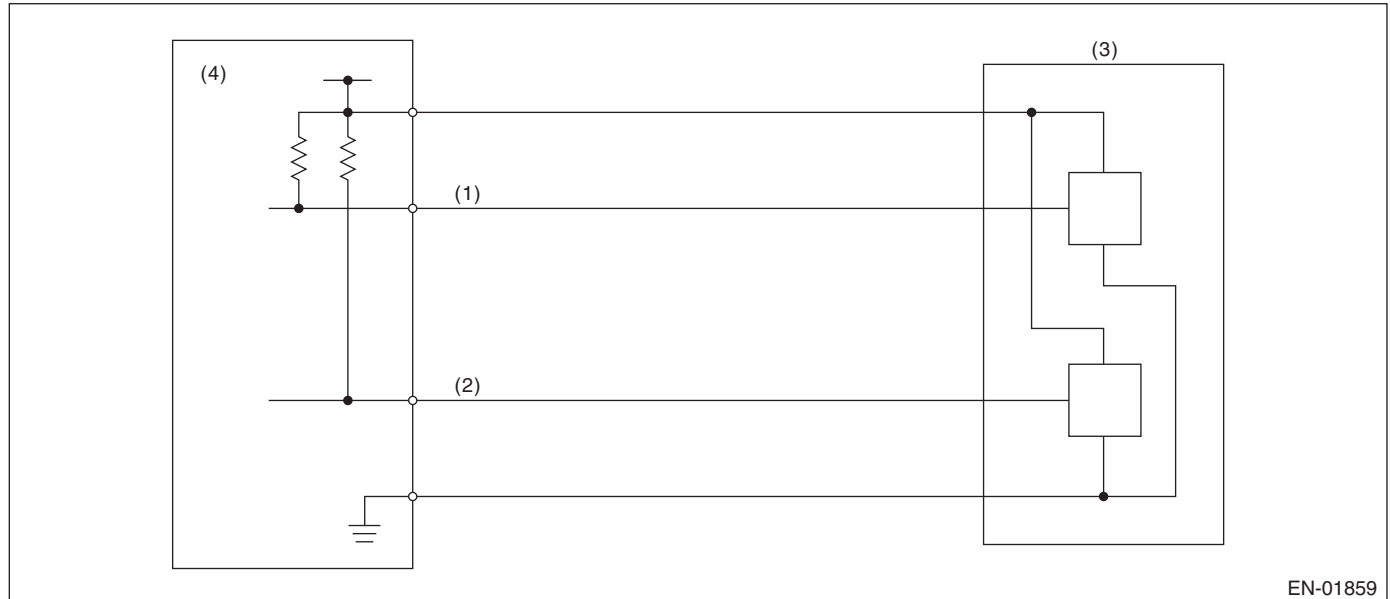

(1) Throttle position sensor 1 signal
(2) Throttle position sensor 2 signal

(3) Throttle position sensor

(4) Engine control module (ECM)

3. ENABLE CONDITION

Secondary Parameters	Enable Conditions
Ignition switch	ON
Battery voltage	$\geq 6\text{ V}$

4. GENERAL DRIVING CYCLE

Always perform the diagnosis continuously.

Diagnostic Trouble Code (DTC) Detecting Criteria

GENERAL DESCRIPTION

5. DIAGNOSTIC METHOD

• Abnormality Judgement

If the duration of time while the following conditions are met is longer than the time indicated, judge as NG.

Judgement Value

Malfunction Criteria	Threshold Value
Signal difference between two sensors	> Value from Map

Map

Throttle position sensor 1 opening angle (°) = d	$0^\circ \leq d < 2.125^\circ$	$2.125^\circ \leq d < 4.25^\circ$	$4.25^\circ \leq d < 9^\circ$	$9^\circ \leq d < 31.625^\circ$	$31.625^\circ \leq d$
Sensor output difference (°)	5.15 °	6.15 °	8.28 °	10.4 °	12.4 °

Time Needed for Diagnosis:212 ms

Malfunction Indicator Light Illumination: Illuminates as soon as a malfunction occurs.

• Normality Judgement

Judge as OK and clear the NG if the continuous time while the following conditions are established is more than the predetermined time.

Judgement Value

Malfunction Criteria	Threshold Value
Signal difference between two sensors	\leq Value from Map

Time Needed for Diagnosis:24 ms

Diagnostic Trouble Code (DTC) Detecting Criteria

GENERAL DESCRIPTION

DR:DTC P2138 THROTTLE/PEDAL POSITION SENSOR/SWITCH “D”/“E” VOLTAGE CORRELATION

1. OUTLINE OF DIAGNOSIS

Judge as NG when the signal level of throttle position sensor 1 is different from the throttle position sensor 2.

2. COMPONENT DESCRIPTION

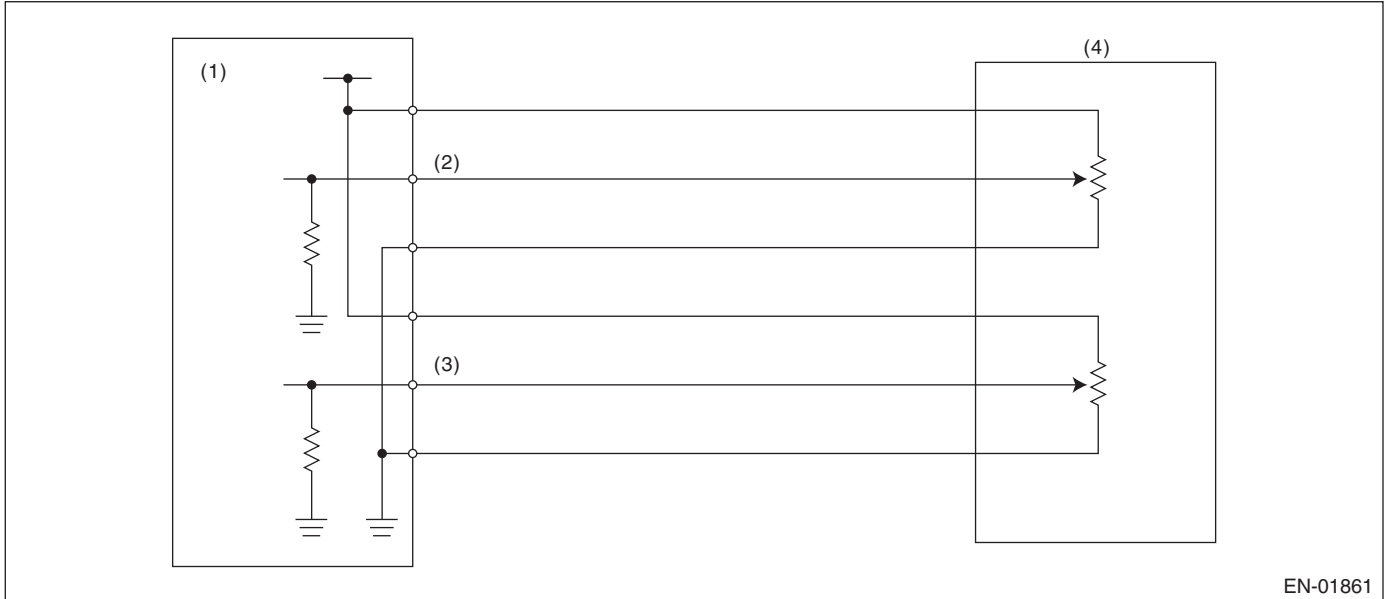

EN-01861

- (1) Engine control module (ECM) (3) Accelerator pedal position sensor (4) Accelerator pedal position sensor
(2) Accelerator pedal position sensor 2 signal
1 signal

3. ENABLE CONDITION

Secondary Parameters	Enable Conditions
Ignition switch	ON
Battery voltage	$\geq 6 \text{ V}$

4. GENERAL DRIVING CYCLE

Always perform the diagnosis continuously.

Diagnostic Trouble Code (DTC) Detecting Criteria

GENERAL DESCRIPTION

5. DIAGNOSTIC METHOD

• Abnormality Judgement

If the duration of time while the following conditions are met is longer than the time indicated, judge as NG.

Judgement Value

Malfunction Criteria	Threshold Value
Signal difference between two sensors	> Value from Map

Map

Throttle position sensor 1 opening angle (°) = d	$0^\circ \leq d < 0.6^\circ$	$0.6^\circ \leq d < 1.2^\circ$	$1.2^\circ \leq d < 2^\circ$	$2^\circ \leq d < 4^\circ$	$4^\circ \leq d$
Sensor output difference (°)	1.465°	1.597°	1.663°	2.455°	3.116°

Time Needed for Diagnosis:116 ms

Malfunction Indicator Light Illumination: Illuminates as soon as a malfunction occurs.

• Normality Judgement

Judge as OK and clear the NG if the continuous time while the following conditions are established is more than the predetermined time.

Judgement Value

Malfunction Criteria	Threshold Value
Signal difference between two sensors	\leq Value from Map

Time Needed for Diagnosis:116 ms

Diagnostic Trouble Code (DTC) Detecting Criteria

GENERAL DESCRIPTION

DS:DTC P2227 BAROMETRIC PRESSURE CIRCUIT RANGE/PERFORMANCE

1. OUTLINE OF DIAGNOSIS

Detect the malfunction of barometric pressure sensor output property.

Judge as NG when the barometric pressure sensor output is largely different from the intake manifold pressure at engine start.

2. COMPONENT DESCRIPTION

The barometric pressure sensor is built into the ECM.

3. ENABLE CONDITION

Secondary Parameters	Enable Conditions
Engine speed	< 300 rpm
Vehicle speed	< 1 km/h (0.6 MPH)

4. GENERAL DRIVING CYCLE

Perform the diagnosis once at ignition switch ON.

5. DIAGNOSTIC METHOD

• Abnormality Judgement

If the duration of time while the following conditions are met is longer than the time indicated, judge as NG.

Judgement Value

Malfunction Criteria	Threshold Value
Barometric pressure – Intake manifold pressure	≥ 26.7 kPa (200 mmHg, 7.9 inHg)
Intake manifold pressure at engine start – Intake manifold pressure	< 1.3 kPa (9.99 mmHg, 0.4 inHg)

Time Needed for Diagnosis:328 ms

Malfunction Indicator Light Illumination: Illuminates when malfunction occurs in 2 continuous driving cycles.

• Normality Judgement

Judge as OK and clear the NG if the continuous time while the following conditions are established is more than the predetermined time.

Judgement Value

Malfunction Criteria	Threshold Value
Barometric pressure – Intake manifold pressure	< 26.7 kPa (200 mmHg, 7.9 inHg)

Time Needed for Diagnosis:262 ms

Diagnostic Trouble Code (DTC) Detecting Criteria

GENERAL DESCRIPTION

DT:DTC P2228 BAROMETRIC PRESSURE CIRCUIT LOW

1. OUTLINE OF DIAGNOSIS

Detect the open/short circuit of the barometric pressure sensor.
Judge as NG if out of specification.

2. COMPONENT DESCRIPTION

The barometric pressure sensor is built into the ECM.

3. ENABLE CONDITION

Secondary Parameters	Enable Conditions
None	

4. GENERAL DRIVING CYCLE

Always perform the diagnosis continuously.

5. DIAGNOSTIC METHOD

• Abnormality Judgement

If the duration of time while the following conditions are met is longer than the time indicated, judge as NG.

Judgement Value

Malfunction Criteria	Threshold Value
Output voltage	< 1.706646812 V

Time Needed for Diagnosis:500 ms

Malfunction Indicator Light Illumination: Illuminates as soon as a malfunction occurs.

• Normality Judgement

Judge as OK and clear the NG if the continuous time while the following conditions are established is more than the predetermined time.

Judgement Value

Malfunction Criteria	Threshold Value
Output voltage	≥ 1.706646812 V

Time Needed for Diagnosis: Less than 1 second

Diagnostic Trouble Code (DTC) Detecting Criteria

GENERAL DESCRIPTION

DU:DTC P2229 BAROMETRIC PRESSURE CIRCUIT HIGH

1. OUTLINE OF DIAGNOSIS

Detect the open/short circuit of the barometric pressure sensor.
Judge as NG if out of specification.

2. COMPONENT DESCRIPTION

The barometric pressure sensor is built into the ECM.

3. ENABLE CONDITION

Secondary Parameters	Enable Conditions
None	

4. GENERAL DRIVING CYCLE

Always perform the diagnosis continuously.

5. DIAGNOSTIC METHOD

• Abnormality Judgement

If the duration of time while the following conditions are met is longer than the time indicated, judge as NG.

Judgement Value

Malfunction Criteria	Threshold Value
Output voltage	≥ 4.233789985 V

Time Needed for Diagnosis: 500 ms

Malfunction Indicator Light Illumination: Illuminates as soon as a malfunction occurs.

• Normality Judgement

Judge as OK and clear the NG if the continuous time while the following conditions are established is more than the predetermined time.

Judgement Value

Malfunction Criteria	Threshold Value
Output voltage	< 4.233789985 V

Time Needed for Diagnosis: Less than 1 second

ENGINE 2 SECTION

This service manual has been prepared to provide SUBARU service personnel with the necessary information and data for the correct maintenance and repair of SUBARU vehicles.

This manual includes the procedures for maintenance, disassembling, reassembling, inspection and adjustment of components and diagnostics for guidance of experienced mechanics.

Please peruse and utilize this manual fully to ensure complete repair work for satisfying our customers by keeping their vehicle in optimum condition. When replacement of parts during repair work is needed, be sure to use SUBARU genuine parts.

All information, illustration and specifications contained in this manual are based on the latest product information available at the time of publication approval.

FUEL INJECTION (FUEL SYSTEMS) FU(H4DOTC)

EMISSION CONTROL (AUX. EMISSION CONTROL DEVICES) EC(H4DOTC)

INTAKE (INDUCTION) IN(H4DOTC)

MECHANICAL ME(H4DOTC)

EXHAUST EX(H4DOTC)

COOLING CO(H4DOTC)

LUBRICATION LU(H4DOTC)

SPEED CONTROL SYSTEMS SP(H4DOTC)

IGNITION IG(H4DOTC)

STARTING/CHARGING SYSTEMS SC(H4DOTC)

**ENGINE (DIAGNOSTICS) EN(H4DOTC)
(diag)**

GENERAL DESCRIPTION GD(H4DOTC)

FUEL INJECTION (FUEL SYSTEMS)

FU(H4DOTC)

	Page
1. General Description	2
2. Throttle Body	13
3. Intake Manifold	14
4. Engine Coolant Temperature Sensor	29
5. Crankshaft Position Sensor	30
6. Camshaft Position Sensor	31
7. Knock Sensor	32
8. Throttle Position Sensor	33
9. Mass Air Flow and Intake Air Temperature Sensor	34
10. Manifold Absolute Pressure Sensor	35
11. Fuel Injector	36
12. Tumble Generator Valve Assembly	39
13. Tumble Generator Valve Actuator	40
14. Oil Flow Control Solenoid Valve	41
15. Wastegate Control Solenoid Valve	42
16. Front Oxygen (A/F) Sensor	43
17. Rear Oxygen Sensor	45
18. Engine Control Module (ECM)	46
19. Main Relay	47
20. Fuel Pump Relay	48
21. Electronic Throttle Control Relay	49
22. Fuel Pump Control Unit	50
23. Fuel	51
24. Fuel Tank	53
25. Fuel Filler Pipe	60
26. Fuel Pump	64
27. Fuel Level Sensor	66
28. Fuel Sub Level Sensor	67
29. Fuel Filter	69
30. Fuel Damper	70
31. Purge Damper	71
32. Fuel Delivery, Return and Evaporation Lines	72
33. Fuel System Trouble in General	76

General Description

FUEL INJECTION (FUEL SYSTEMS)

1. General Description

A: SPECIFICATION

Fuel tank	Capacity	64 ℓ (16.9 US gal, 14.1 Imp gal)
	Location	Under rear seat
Fuel pump	Type	Impeller
	Shutoff discharge pressure	550 — 850 kPa (5.61 — 8.67 kg/cm ² , 79.8 — 123.3 psi)
	Discharge rate	155 ℓ (40.9 US gal, 34.1 Imp gal)/h or more [12 V at 300 kPa (3.06 kg/cm ² , 43.5 psi)]
Fuel filter		In-tank type

B: COMPONENT

1. INTAKE MANIFOLD

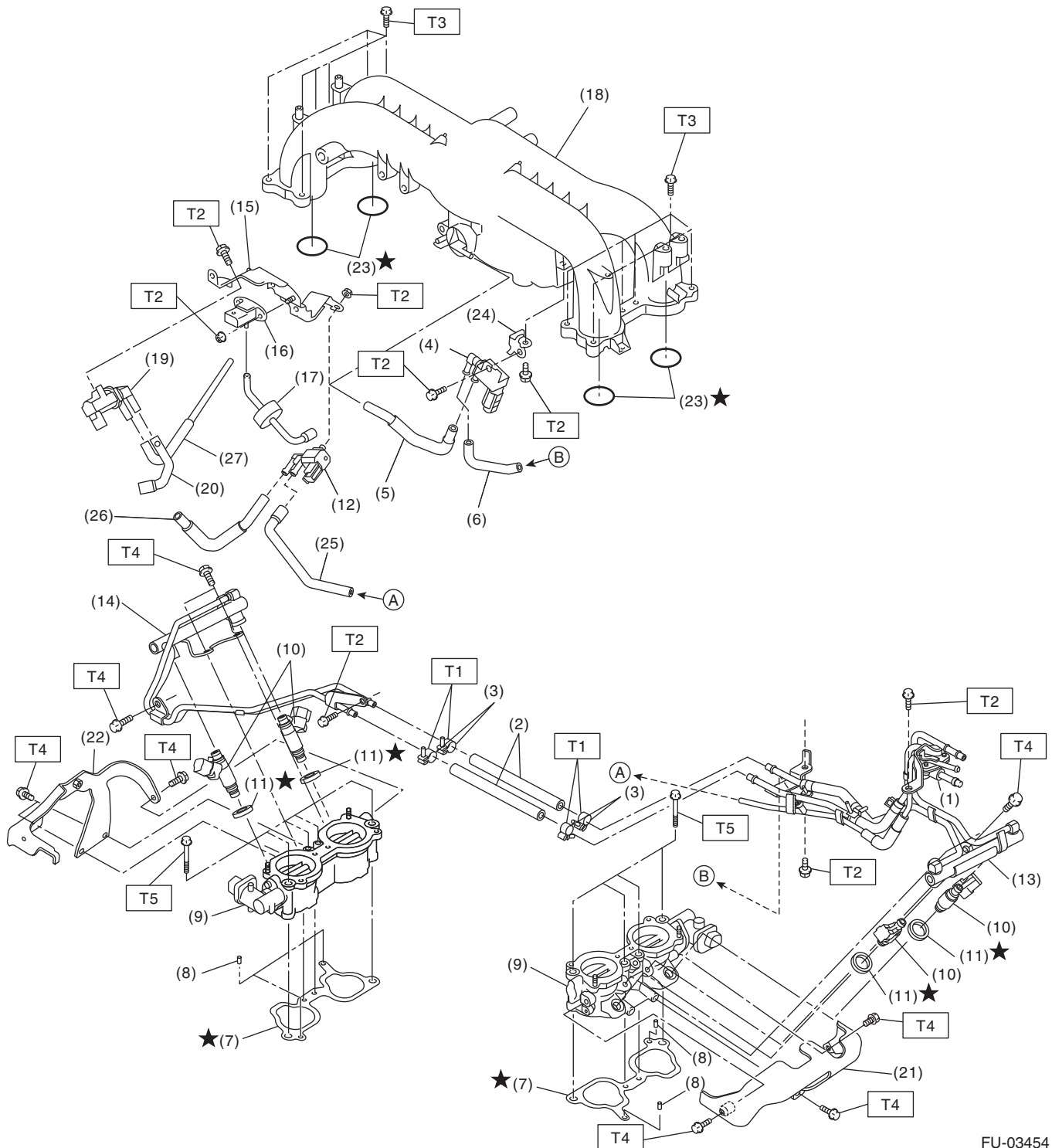

FU-03454

General Description

FUEL INJECTION (FUEL SYSTEMS)

- | | | |
|-------------------------------------|--|-----------------------------|
| (1) Pressure regulator | (13) Fuel injector pipe LH | (24) Solenoid valve bracket |
| (2) Fuel hose | (14) Fuel injector pipe RH | (25) Vacuum hose B |
| (3) Clamp | (15) Solenoid valve bracket | (26) Vacuum hose A |
| (4) Purge control solenoid valve 1 | (16) Manifold absolute pressure sensor | (27) Air control hose |
| (5) Vacuum hose D | (17) Filter | |
| (6) Vacuum hose C | (18) Intake manifold | |
| (7) Intake manifold gasket | (19) Wastegate control solenoid valve ASSY | |
| (8) Guide pin | (20) Vacuum hose | |
| (9) Tumble generator valve ASSY | (21) Fuel pipe protector LH | |
| (10) Fuel injector | (22) Fuel pipe protector RH | |
| (11) Seal ring | (23) O-ring | |
| (12) Purge control solenoid valve 2 | | |

Tightening torque:N-m (kgf-m, ft-lb)

T1: 1.25 (0.1, 0.9)

T2: 6.4 (0.7, 4.7)

T3: 8.3 (0.8, 6.1)

T4: 19 (1.9, 14.0)

T5: 25 (2.5, 18.4)

2. AIR INTAKE SYSTEM

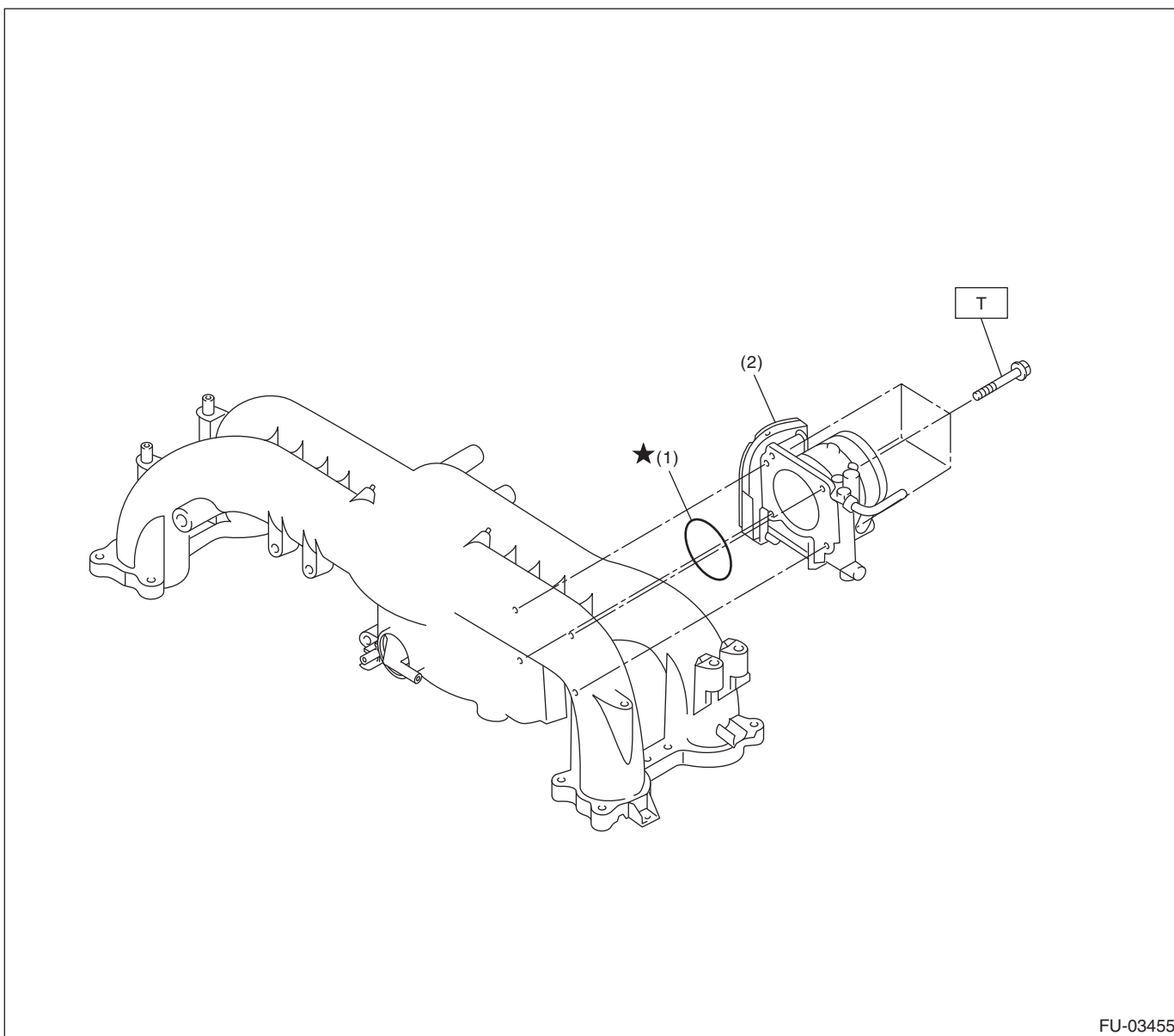

FU-03455

(1) O-ring

(2) Throttle body

Tightening torque:N-m (kgf-m, ft-lb)

T: 8 (0.8, 5.9)

General Description

FUEL INJECTION (FUEL SYSTEMS)

3. CRANKSHAFT POSITION, CAMSHAFT POSITION AND KNOCK SENSORS

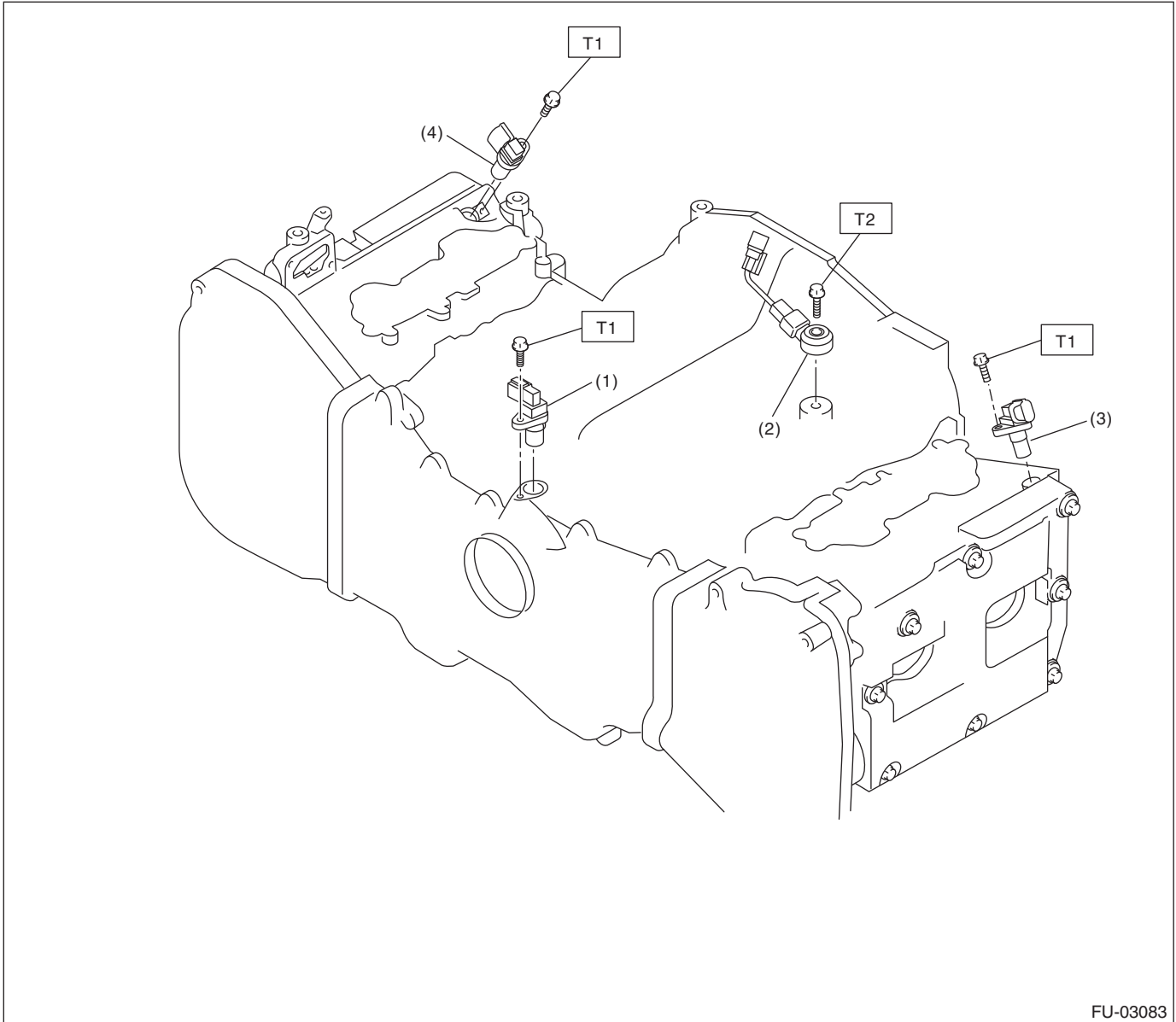

FU-03083

(1) Crankshaft position sensor

(2) Knock sensor

(3) Camshaft position sensor LH

(4) Camshaft position sensor RH

Tightening torque: N·m (kgf·m, ft·lb)

T1: 6.4 (0.7, 4.7)

T2: 24 (2.4, 17.7)

General Description

FUEL INJECTION (FUEL SYSTEMS)

4. FUEL TANK

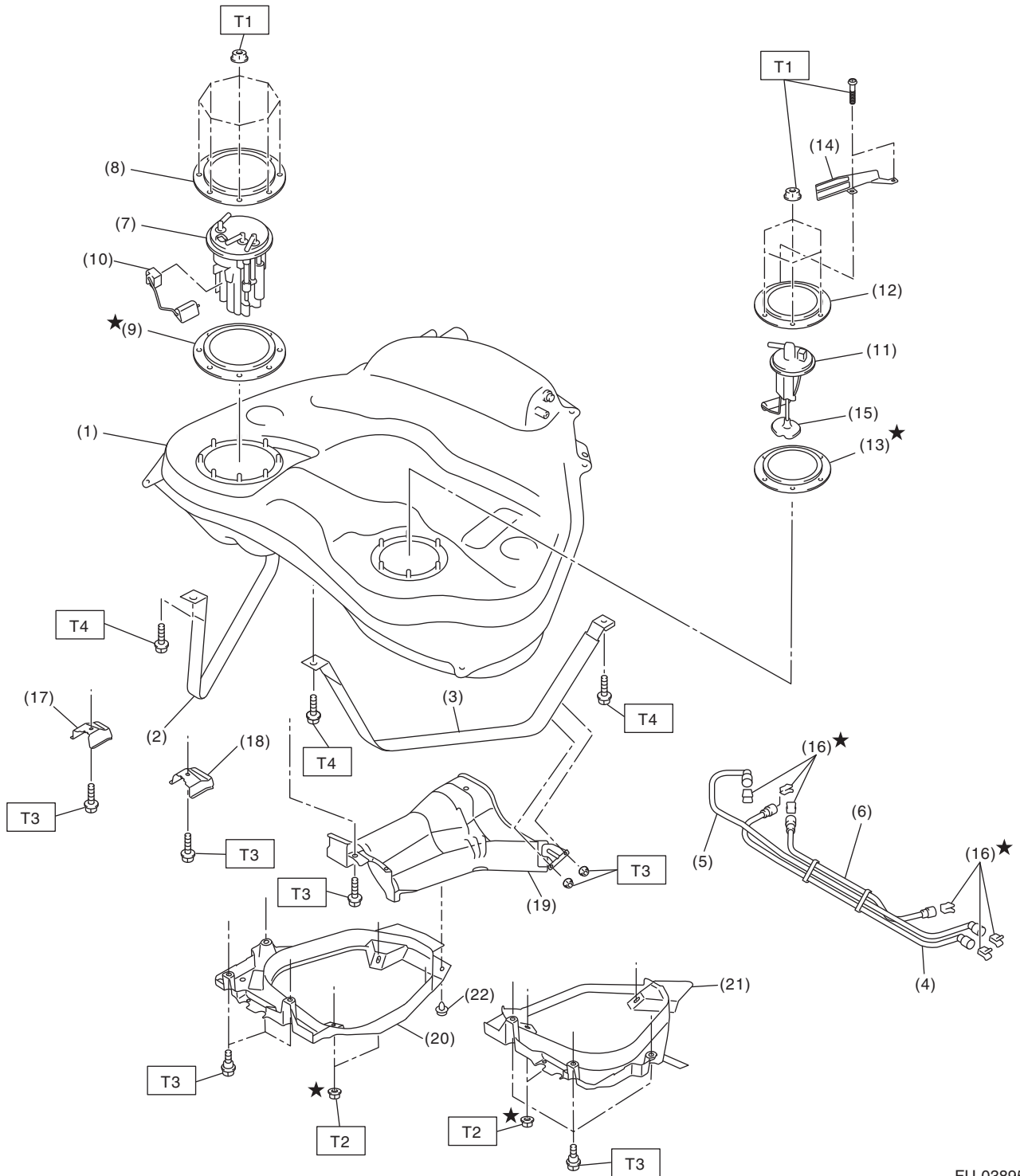

FU-03895

General Description

FUEL INJECTION (FUEL SYSTEMS)

(1) Fuel tank	(11) Fuel sub level sensor	(20) Fuel tank protector RH
(2) Fuel tank band RH	(12) Fuel sub level sensor upper plate	(21) Fuel tank protector LH
(3) Fuel tank band LH	(13) Fuel sub level sensor gasket	(22) Clip
(4) Delivery tube	(14) Fuel sub level sensor protector	
(5) Return tube	(15) Fuel sub level sensor filter	
(6) Jet pump tube	(16) Retainer	
(7) Fuel pump ASSY	(17) Stopper RH	
(8) Fuel pump upper plate	(18) Stopper LH	
(9) Fuel pump gasket	(19) Heat shield cover	
(10) Fuel level sensor		

Tightening torque:N·m (kgf-m, ft-lb)**T1: 4.4 (0.45, 3.2)****T2: 9 (0.9, 6.6)****T3: 18 (1.8, 13.3)****T4: 33 (3.4, 24.3)**

General Description

FUEL INJECTION (FUEL SYSTEMS)

5. FUEL LINE

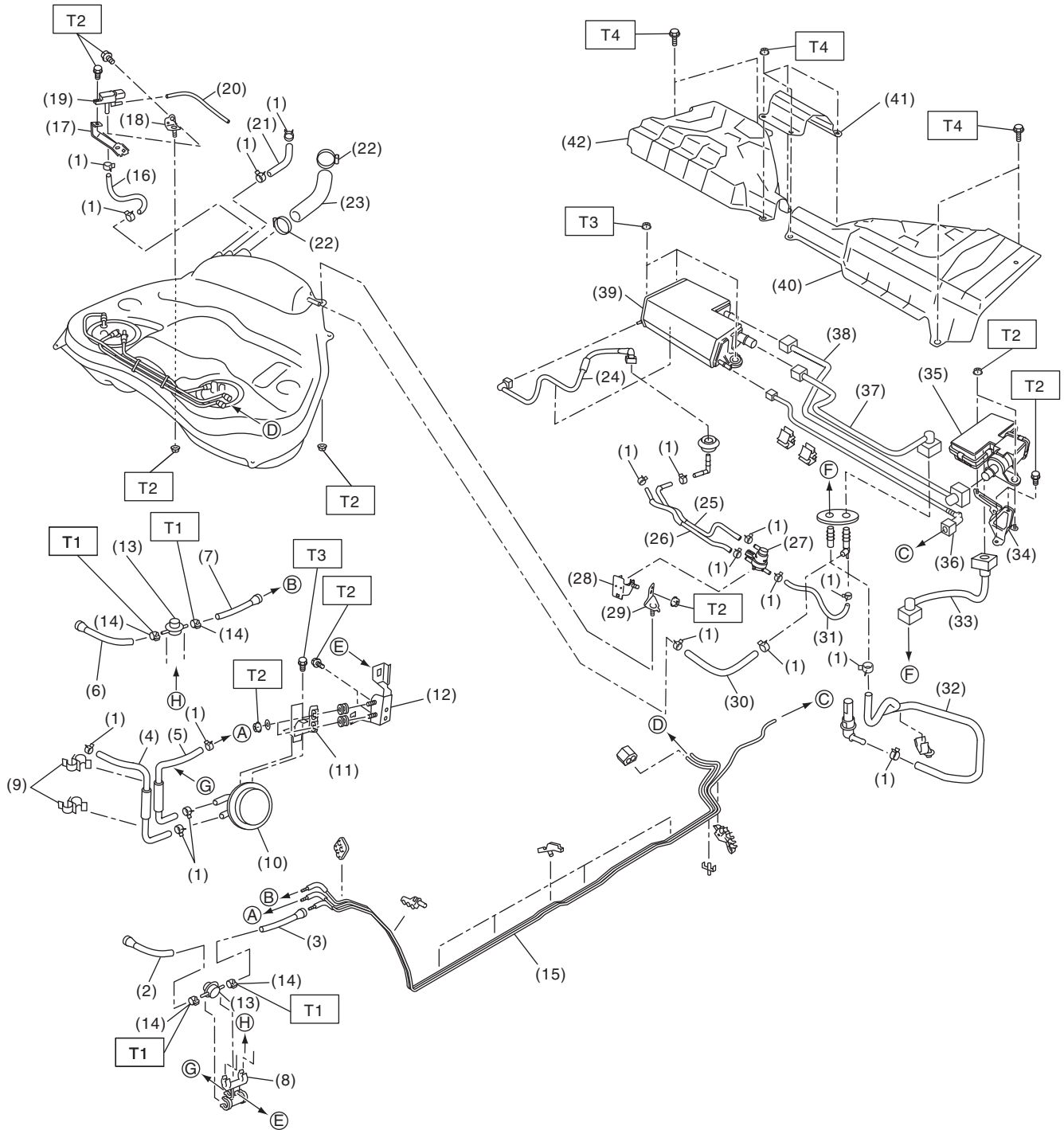

FU-03896

General Description

FUEL INJECTION (FUEL SYSTEMS)

(1) Clip	(18) Fuel tank pressure sensor bracket B	(33) Drain tube A
(2) Fuel return hose A	(19) Fuel tank pressure sensor	(34) Drain valve bracket
(3) Fuel return hose B	(20) Vacuum hose	(35) Drain valve
(4) Evaporation hose A	(21) Evaporation hose C	(36) Purge tube
(5) Evaporation hose B	(22) Clamp	(37) Vent tube
(6) Fuel delivery hose A	(23) Fuel filler hose	(38) Drain tube B
(7) Fuel delivery hose B	(24) PCV drain tube	(39) Canister
(8) Fuel damper holder	(25) Evaporation hose D	(40) Canister cover LH
(9) Clamp	(26) Evaporation hose E	(41) Center canister cover
(10) Purge damper	(27) Pressure control solenoid valve	(42) Canister cover RH
(11) Purge damper bracket	(28) Pressure control solenoid valve bracket A	
(12) Damper bracket		
(13) Fuel damper	(29) Pressure control solenoid valve bracket B	
(14) Clamp		
(15) Fuel pipe ASSY	(30) Evaporation hose F	
(16) Pressure hose	(31) Evaporation hose G	
(17) Fuel tank pressure sensor bracket A	(32) Canister drain hose	

Tightening torque:N·m (kgf-m, ft-lb)**T1: 1.25 (0.1, 0.9)****T2: 7.5 (0.8, 5.5)****T3: 8 (0.8, 5.9)****T4: 18 (1.8, 13.3)**

General Description

FUEL INJECTION (FUEL SYSTEMS)

6. FUEL PIPE

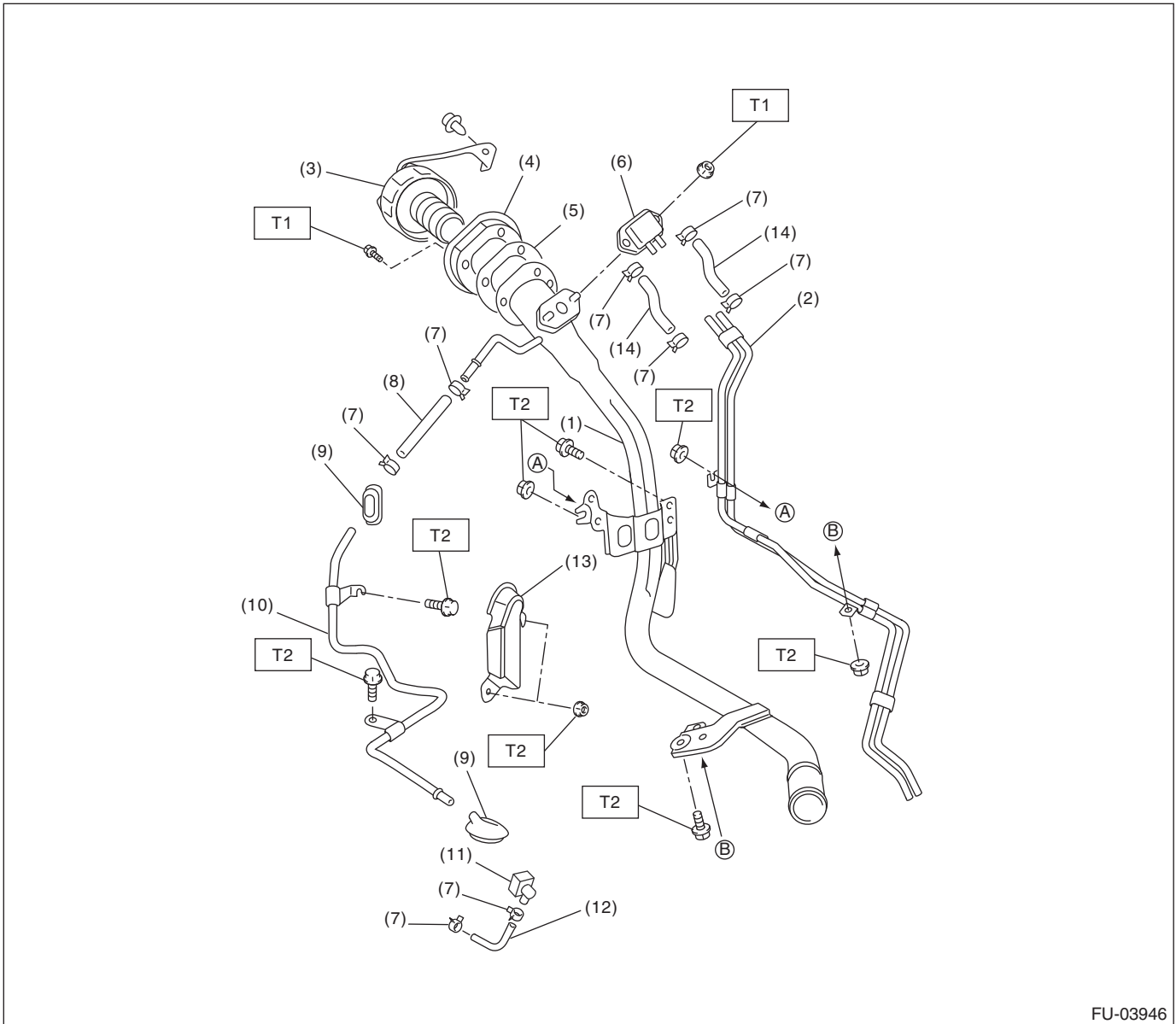

FU-03946

- | | | |
|---------------------------|-------------------------|---------------------------------|
| (1) Fuel filler pipe ASSY | (7) Clip | (13) Evaporation pipe protector |
| (2) Evaporation pipe A | (8) Evaporation hose A | (14) Evaporation hose C |
| (3) Fuel filler cap | (9) Grommet | |
| (4) Filler ring | (10) Evaporation pipe B | |
| (5) Filler pipe gasket | (11) Quick connector | |
| (6) Shut valve | (12) Evaporation hose B | |

Tightening torque: N·m (kgf-m, ft-lb)

T1: 4.4 (0.4, 3.2)

T2: 7.5 (0.8, 5.5)

C: CAUTION

- Wear appropriate work clothing, including a cap, protective goggles and protective shoes when performing any work.
- Remove contamination including dirt and corrosion before removal, installation or disassembly.
- Keep the disassembled parts in order and protect them from dust and dirt.
- Before removal, installation or disassembly, be sure to clarify the failure. Avoid unnecessary removal, installation, disassembly and replacement.
- Vehicle components are extremely hot after driving. Be wary of receiving burns from heated parts.
- Be sure to tighten fasteners including bolts and nuts to the specified torque.
- Place shop jacks or rigid racks at the specified points.
- Before disconnecting connectors of sensors or units, be sure to disconnect the ground cable from the battery.
- Place “NO OPEN FLAMES” signs near the working area.
- Prepare a container and cloth to prevent scattering of fuels when performing work where fuels can be spilled. If the fuel spills, wipe it off immediately to prevent from penetrating into floor or flowing out for environmental protection.
- Follow all government and local regulations concerning disposal of refuse when disposing fuel.

D: PREPARATION TOOL

ILLUSTRATION	TOOL NUMBER	DESCRIPTION	REMARKS
<p style="text-align: center;">ST18371AA000</p>	18371AA000	CONNECTOR REMOVER	Used for disconnecting the quick connector on the fuel return hose of the engine compartment.
<p style="text-align: center;">ST42099AE000</p>	42099AE000	QUICK CONNECTOR RELEASE	Used for disconnecting quick connector on the fuel delivery hose side of the engine compartment.

General Description

FUEL INJECTION (FUEL SYSTEMS)

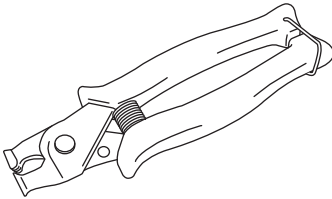
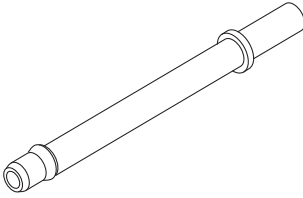
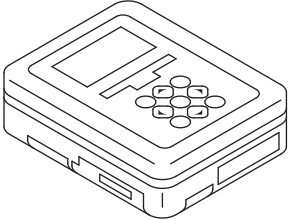
ILLUSTRATION	TOOL NUMBER	DESCRIPTION	REMARKS
 <p style="text-align: center;">ST18353AA000</p>	<p style="text-align: center;">18353AA000</p>	<p style="text-align: center;">CLAMP PLIERS</p>	<ul style="list-style-type: none"> • Used for removing and installing the PCV hose. • This is a general tool made by the French company CAILLAU. (code) 54.0.000.205 <p>To make this easier to obtain in the same way as genuine Subaru parts, it has been provided with a tool number as an ST.</p>
 <p style="text-align: center;">ST18471AA000</p>	<p style="text-align: center;">18471AA000 (Newly adopted tool)</p>	<p style="text-align: center;">FUEL PIPE ADAPTER</p>	<p>Used for draining fuel.</p>
 <p style="text-align: center;">ST1B022XU0</p>	<p style="text-align: center;">1B022XU0 (Newly adopted tool)</p>	<p style="text-align: center;">SUBARU SELECT MONITOR III KIT</p>	<p>Used for draining fuel.</p>

Throttle Body

FUEL INJECTION (FUEL SYSTEMS)

2. Throttle Body

A: REMOVAL

- 1) Set the vehicle on a lift.
- 2) Remove the collector cover.
- 3) Disconnect the ground cable from the battery.

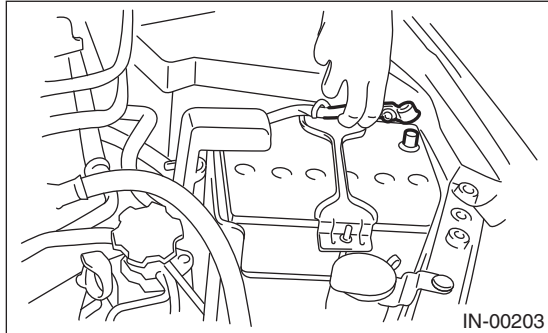

- 4) Lift up the vehicle.
- 5) Remove the under cover.
- 6) Drain approximately 3.0 ℓ (3.2 US qt, 2.6 Imp qt) of coolant. <Ref. to CO(H4DOTC)-13, DRAINING OF ENGINE COOLANT, REPLACEMENT, Engine Coolant.>
- 7) Remove the intercooler. <Ref. to IN(H4DOTC)-11, REMOVAL, Intercooler.>
- 8) Disconnect the connectors from the throttle position sensor.

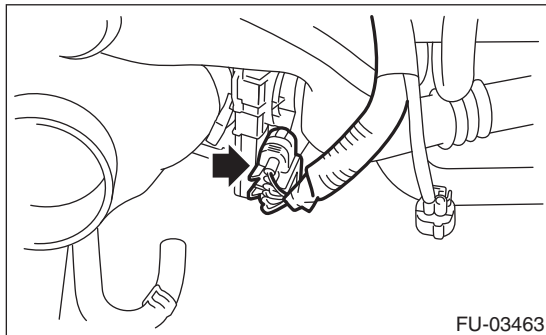

- 9) Remove the bolts which secure the air by-pass pipe and PCV pipe to the intake manifold, and loosen the clamp which connects the throttle body and duct.

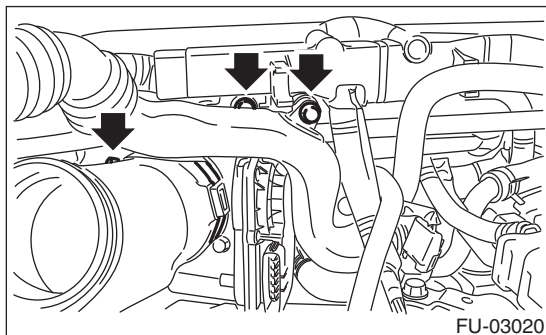

- 10) Remove the duct from the throttle body.

- 11) Disconnect the engine coolant hoses from the throttle body.

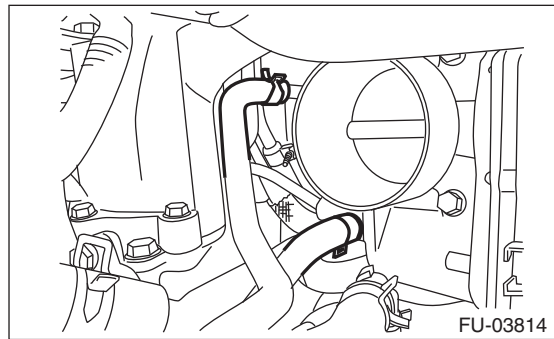

- 12) Remove the bolts which secure the throttle body to the intake manifold, and remove the throttle body.

B: INSTALLATION

Install in the reverse order of removal.

NOTE:

Use new O-rings.

Tightening torque:

8 N·m (0.8 kgf·m, 5.9 ft·lb)

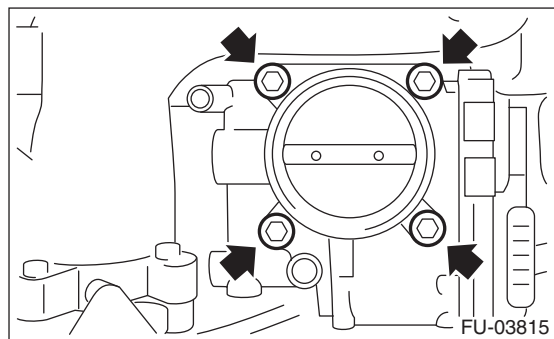

Intake Manifold

FUEL INJECTION (FUEL SYSTEMS)

3. Intake Manifold

A: REMOVAL

- 1) Set the vehicle on a lift.
- 2) Remove the collector cover.
- 3) Collect the refrigerant from the A/C system. <Ref. to AC-17, PROCEDURE, Refrigerant Recovery Procedure.>
- 4) Release the fuel pressure. <Ref. to FU(H4DOTC)-51, RELEASING OF FUEL PRESSURE, PROCEDURE, Fuel.>
- 5) Disconnect the battery cable, and remove the battery from the vehicle.
- 6) Open the fuel filler lid, and remove the fuel filler cap.
- 7) Lift up the vehicle.
- 8) Remove the under cover.
- 9) Drain approximately 3.0 ℓ (3.2 US qt, 2.6 Imp qt) of coolant. <Ref. to CO(H4DOTC)-13, DRAINING OF ENGINE COOLANT, REPLACEMENT, Engine Coolant.>
- 10) Remove the air intake duct (rear) and air cleaner case. <Ref. to IN(H4DOTC)-8, REMOVAL, Air Cleaner Case.> <Ref. to IN(H4DOTC)-9, REMOVAL, Air Intake Duct.>
- 11) Remove the intercooler. <Ref. to IN(H4DOTC)-11, REMOVAL, Intercooler.>
- 12) Remove the generator. <Ref. to SC(H4SO)-15, REMOVAL, Generator.>
- 13) Remove the coolant filler tank. <Ref. to CO(H4DOTC)-29, REMOVAL, Coolant Filler Tank.>
- 14) Disconnect the A/C pressure hoses from A/C compressor. <Ref. to AC-35, REMOVAL, Hose and Pipe.>
- 15) Disconnect the vacuum hose (A) and the connector (B) from the PCV hose assembly.

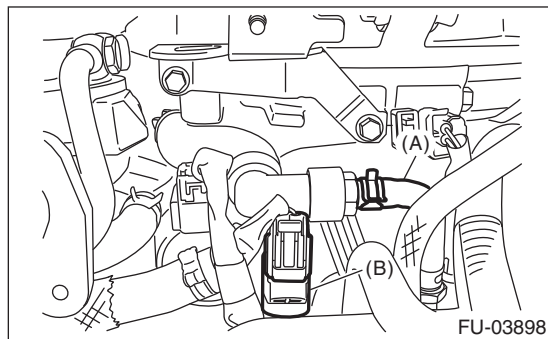

- 16) Remove the connector from the PCV hose assembly.

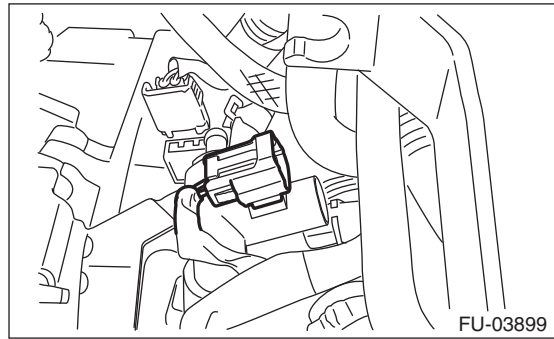

- 17) Remove the bolts which secure the air by-pass pipe and PCV pipe to the intake manifold, and loosen the clamp which connects the throttle body and duct.

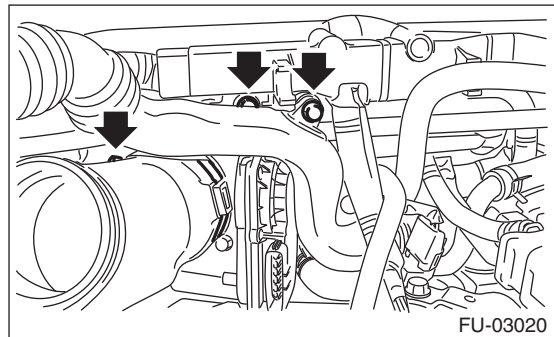

- 18) Remove the duct from the throttle body.
- 19) Disconnect the engine coolant hoses from the throttle body.

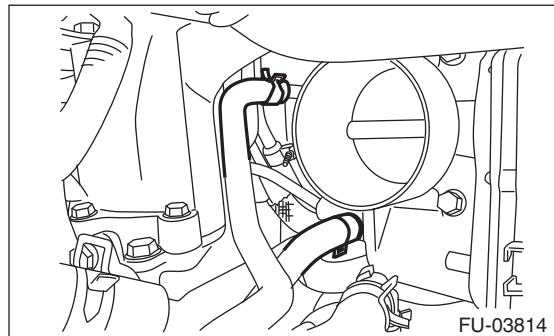

- 20) Disconnect the brake booster vacuum hose.

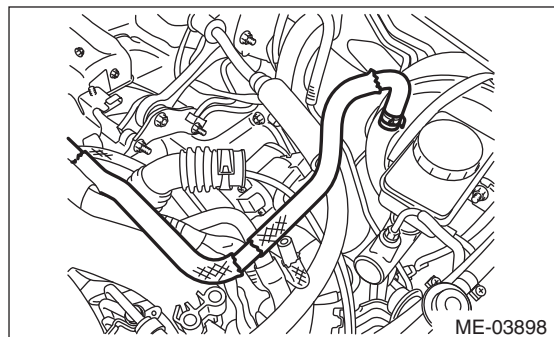

Intake Manifold

FUEL INJECTION (FUEL SYSTEMS)

21) Disconnect the PCV hose from the rocker cover.

NOTE:

Fit the cut out in the ST with the protrusion on the clamp as shown in the figure, unlock the clamp, and disconnect the PCV hose fastened by the clamp.

ST 18353AA000 CLAMP PLIERS

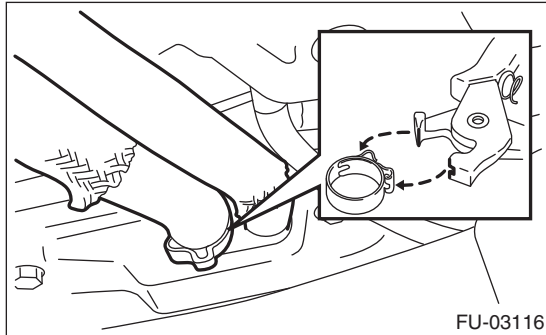

22) Disconnect the air control hose (A) from the wastegate actuator, and loosen the clamp that holds the turbocharger on the intake duct.

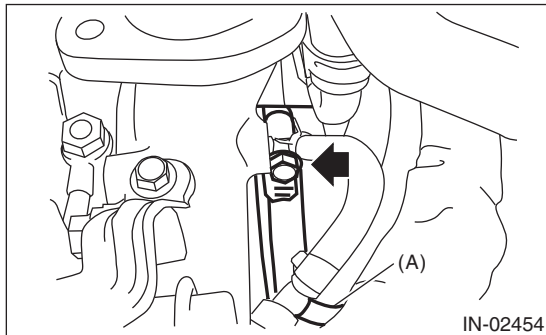

23) Disconnect the engine harness connectors from the bulk head harness connector.

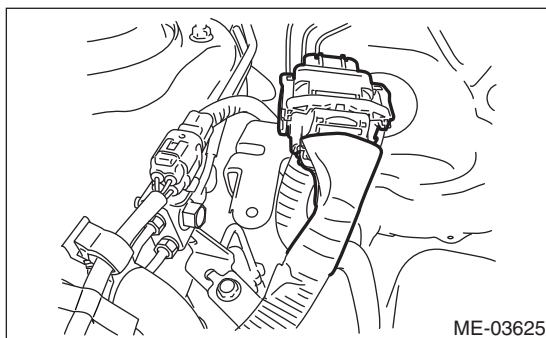

24) Disconnect the connectors from the engine coolant temperature sensor (A), oil pressure switch (B) and crankshaft position sensor (C).

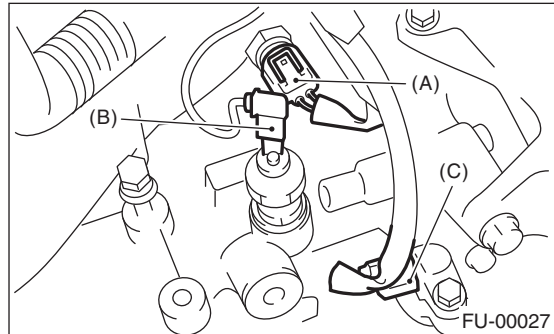

25) Disconnect the connector from power steering pump switch.

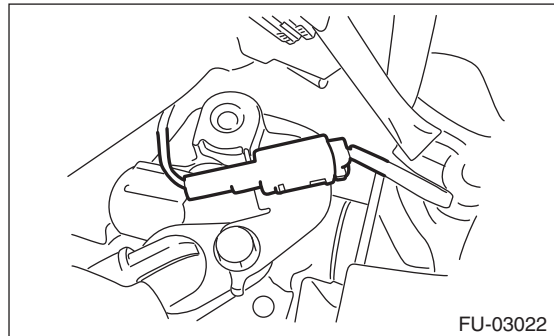

26) Disconnect the knock sensor connector.

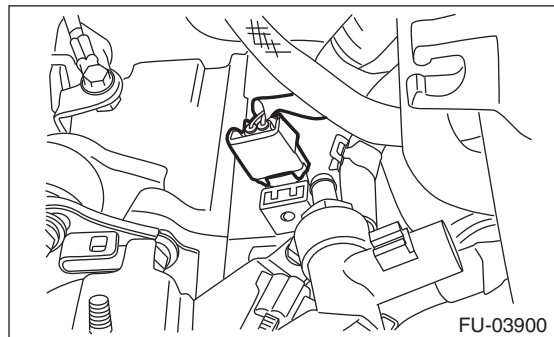

Intake Manifold

FUEL INJECTION (FUEL SYSTEMS)

27) Disconnect the connector from the secondary air combination valve.

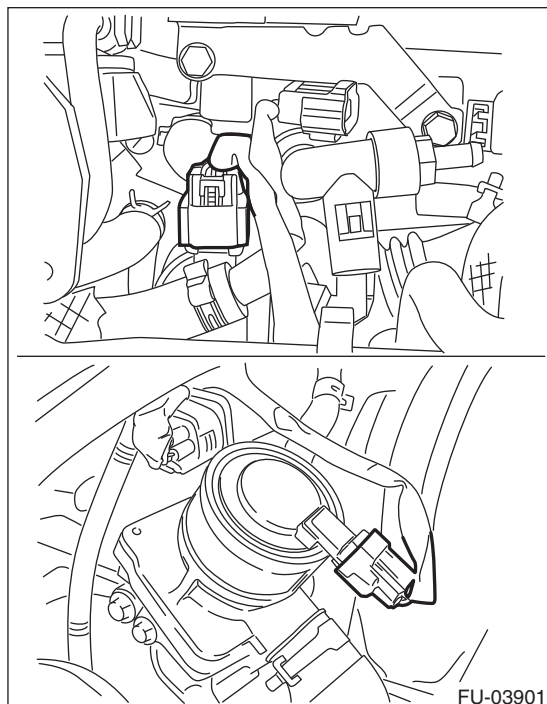

28) Disconnect the connector from the camshaft position sensor.

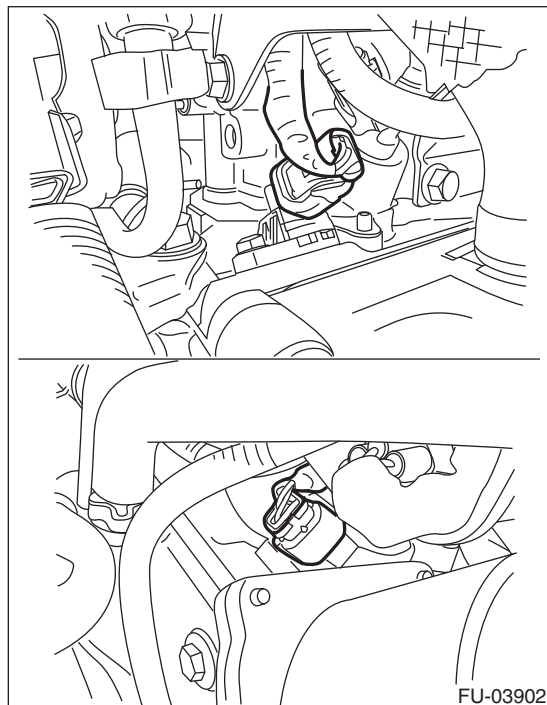

29) Disconnect the connector from the oil flow control solenoid valve.

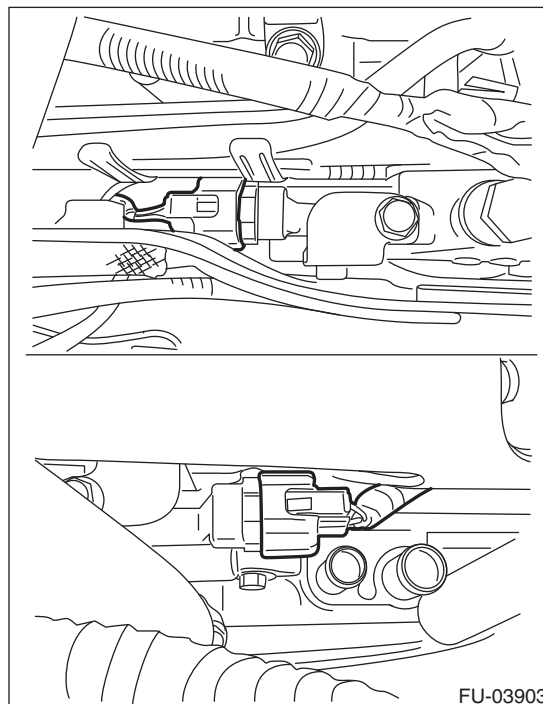

30) Disconnect the air duct from the secondary air pump, and remove the bolts that install the air duct on the rocker cover LH.

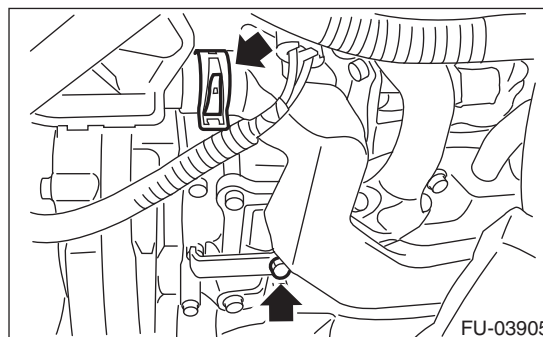

Intake Manifold

FUEL INJECTION (FUEL SYSTEMS)

31) Disconnect the connector from ignition coil.

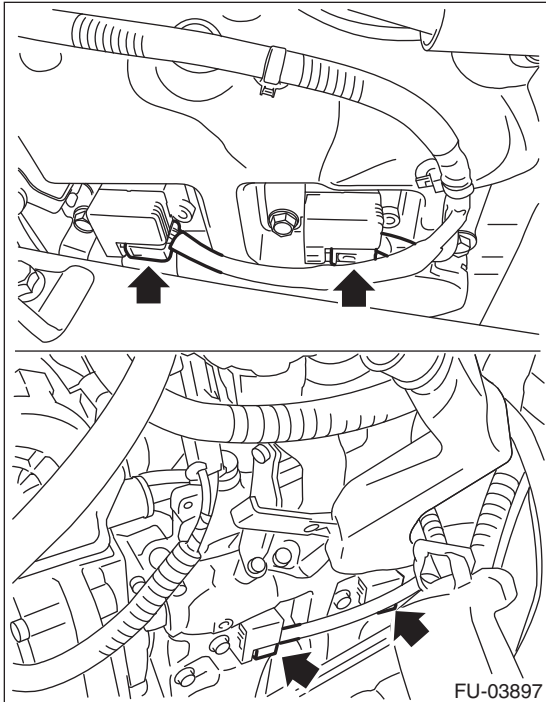

32) Remove the engine harness fixed by clip (A) from the rocker cover.

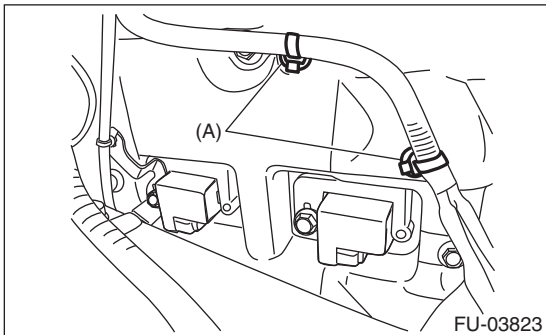

33) Attach ST to the fuel delivery pipe and push ST in the direction of arrow mark to disconnect the fuel delivery hose.

ST 42099AE000 QUICK CONNECTOR RELEASE

CAUTION:

- Be careful not to spill fuel.
- Catch the fuel from hoses using a container or cloth.

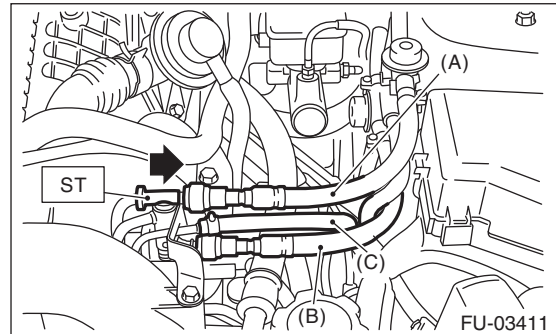

(A) Fuel delivery hose

(B) Fuel return hose

(C) Evaporation hose

34) Disconnect the fuel return hose using the ST.
ST 18371AA000 CONNECTOR REMOVER

CAUTION:

- Be careful not to spill fuel.
- Catch the fuel from hoses using a container or cloth.

(1) Attach ST to the fuel return pipe as shown in the figure.

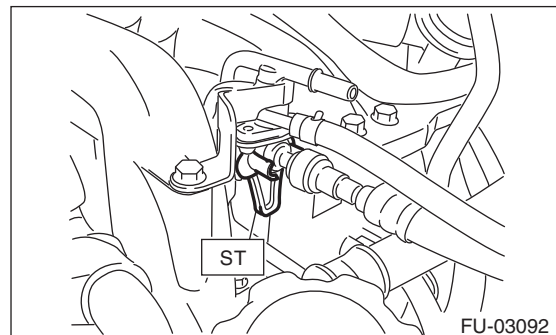

Intake Manifold

FUEL INJECTION (FUEL SYSTEMS)

(2) Insert the front side of ST into the quick connector.

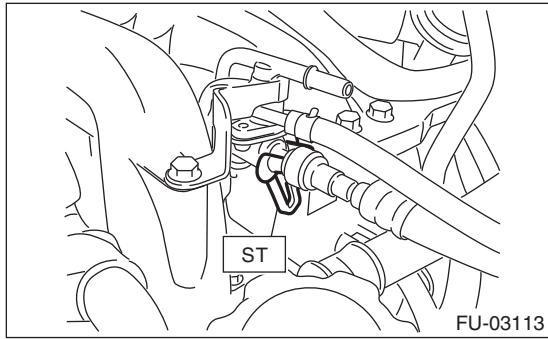

(3) Insert the back side of ST into the quick connector and push ST in the direction of arrow mark to disconnect the fuel return hose.

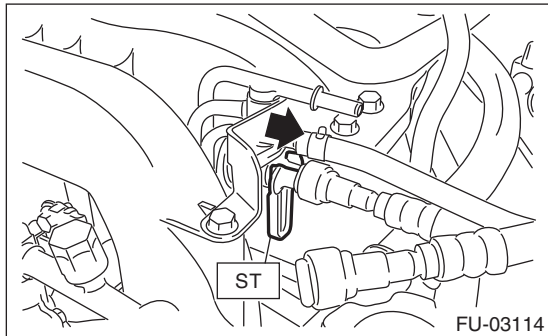

35) Remove the clip and disconnect the evaporation hose from the fuel pipe.

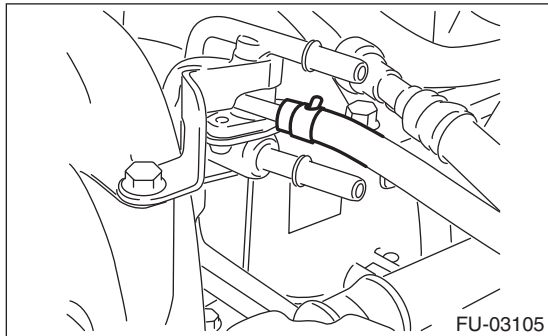

36) Remove the bolts which hold the tumble generator valve assembly onto the cylinder head.

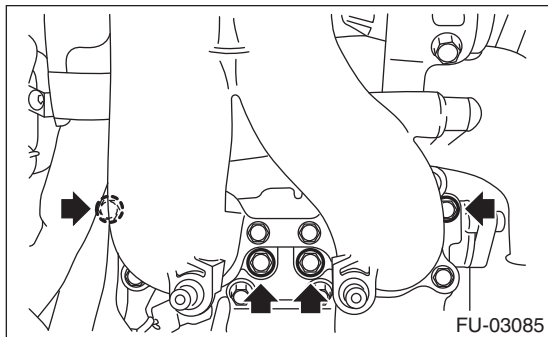

37) Remove the intake manifold.

B: INSTALLATION

1) Install the intake manifold onto cylinder heads.

NOTE:

Use a new gasket.

Tightening torque:

25 N·m (2.5 kgf-m, 18.4 ft-lb)

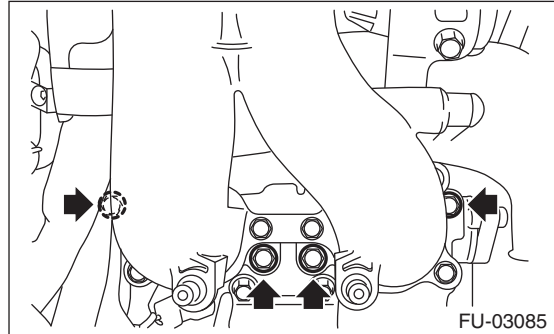

2) Connect the fuel delivery hose, fuel return hose, and evaporation hose. <Ref. to FU(H4DOTC)-74, INSTALLATION, Fuel Delivery, Return and Evaporation Lines.>

NOTE:

If fuel hoses or clamps are damaged, replace them with new parts.

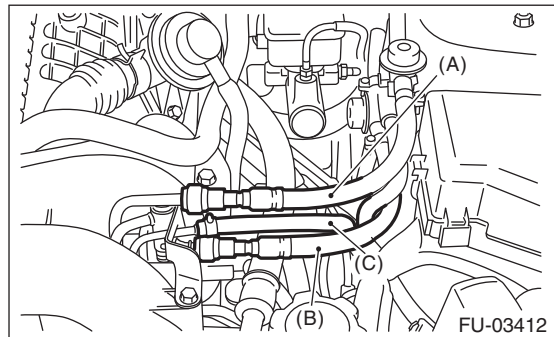

(A) Fuel delivery hose

(B) Fuel return hose

(C) Evaporation hose

Intake Manifold

FUEL INJECTION (FUEL SYSTEMS)

3) Connect the connector to the oil flow control solenoid valve.

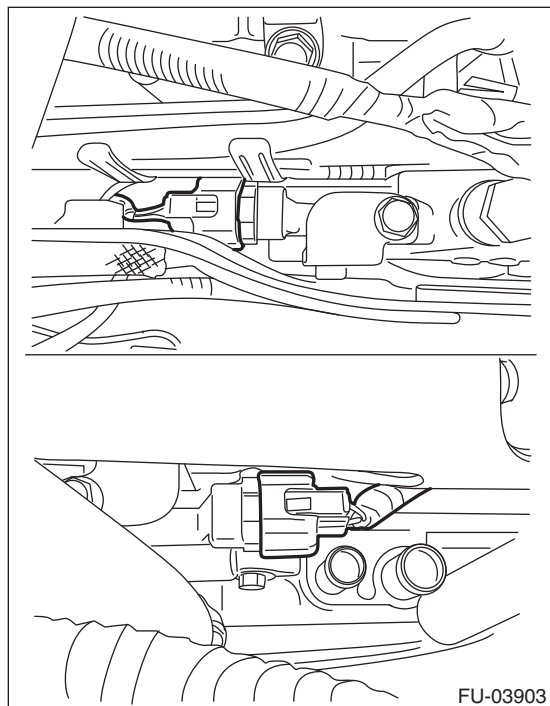

4) Connect the connector to the engine coolant temperature sensor (A), oil pressure switch (B) and crankshaft position sensor (C).

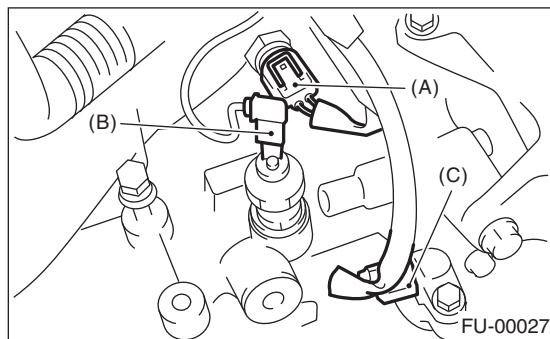

5) Connect the connector to the knock sensor.

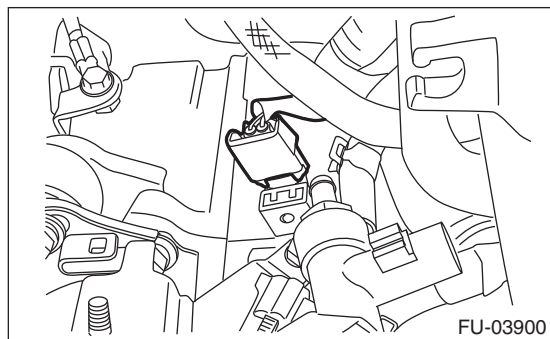

6) Connect the connector to the power steering pump switch.

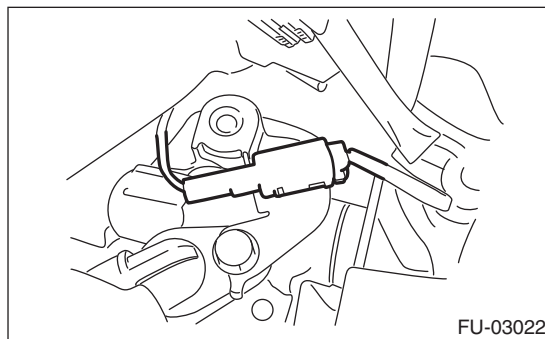

7) Connect the connectors to camshaft position sensor.

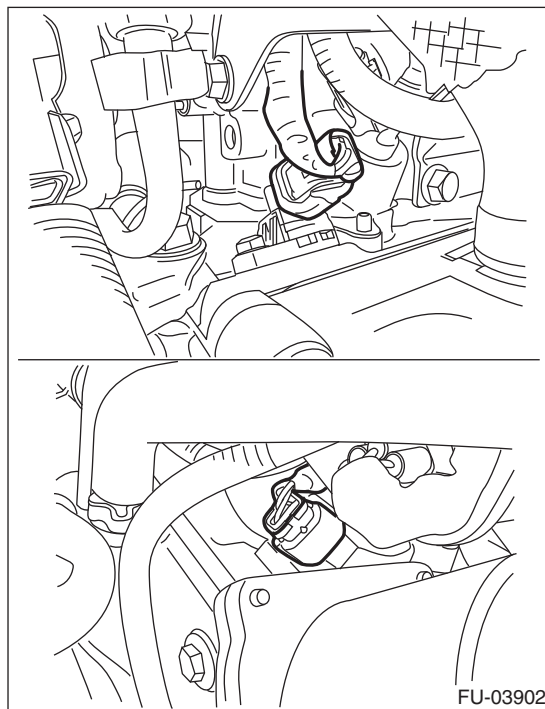

Intake Manifold

FUEL INJECTION (FUEL SYSTEMS)

8) Connect the connector to the secondary air combination valve.

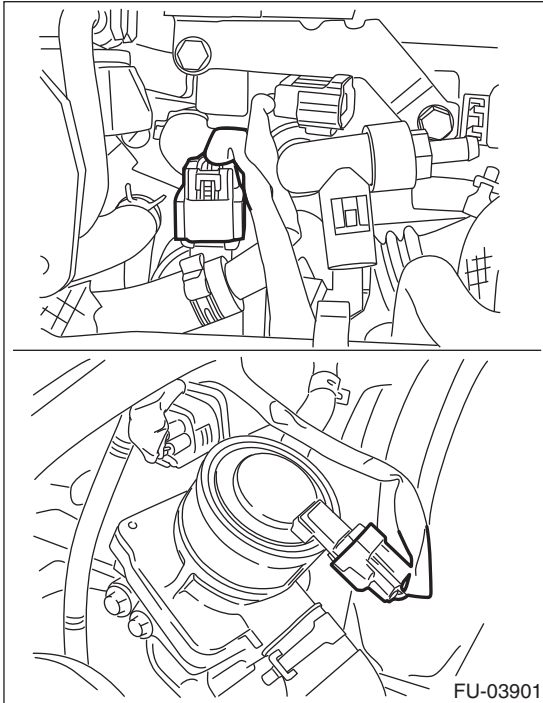

9) Install the engine harness with clip (A) to the rocker cover.

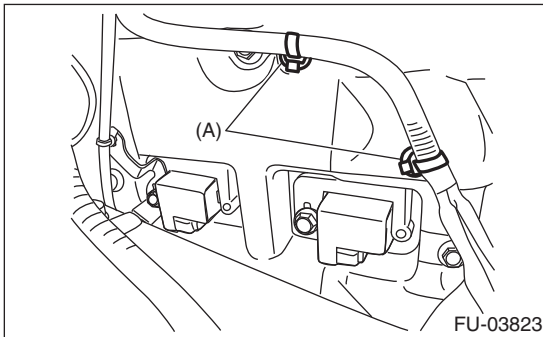

10) Connect the connector to the ignition coil.

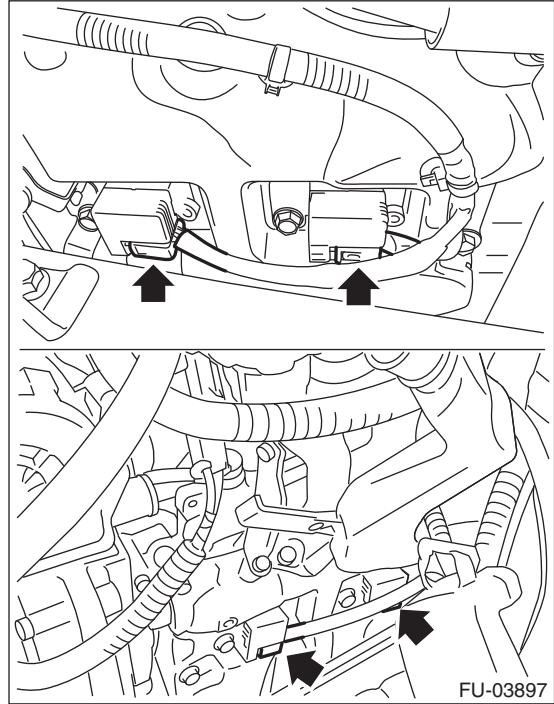

11) Connect the air duct to the secondary air pump, and install the air duct on the rocker cover.

Tightening torque:
9 N·m (0.9 kgf-m, 6.6 ft-lb)

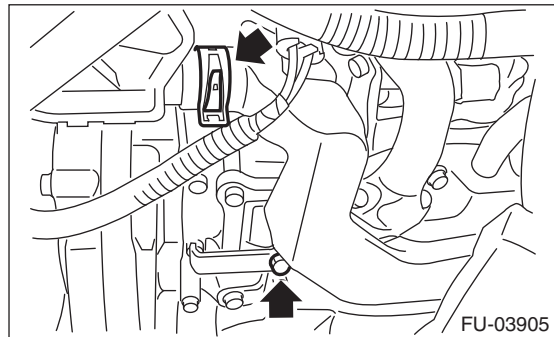

12) Connect the engine harness connectors to the bulkhead harness connectors.

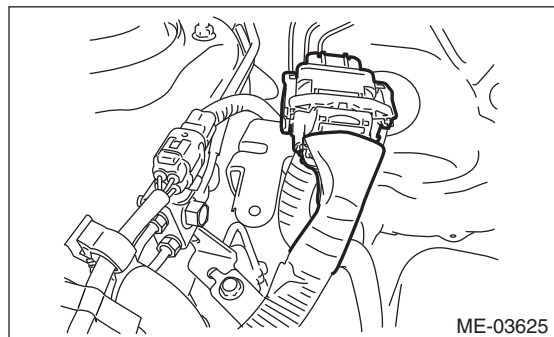

Intake Manifold

FUEL INJECTION (FUEL SYSTEMS)

13) Connect the air control hose (A) to the wastegate actuator, and tighten the clamp that holds the intake duct on the turbocharger.

Tightening torque:

3 N·m (0.3 kgf-m, 2.2 ft-lb)

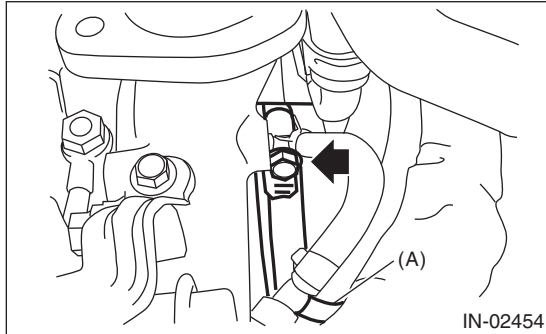

14) Connect the brake booster vacuum hose.

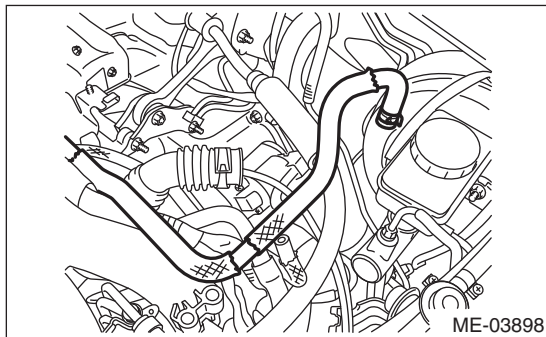

15) Connect the PCV hose to the rocker cover.

NOTE:

Use a new clamp for the PCV hose clamp, fit the cut out in the ST with the protrusion on the clamp as shown in the figure, and lock the clamp.

ST 18353AA000 CLAMP PLIERS

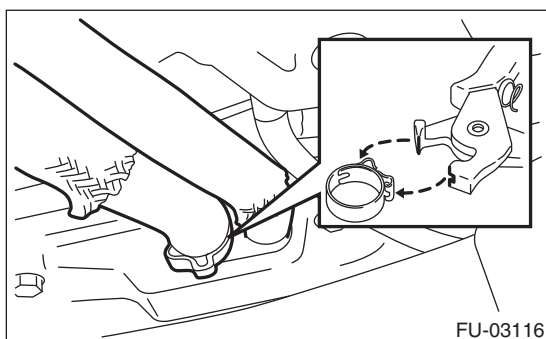

16) Connect the engine coolant hoses to throttle body.

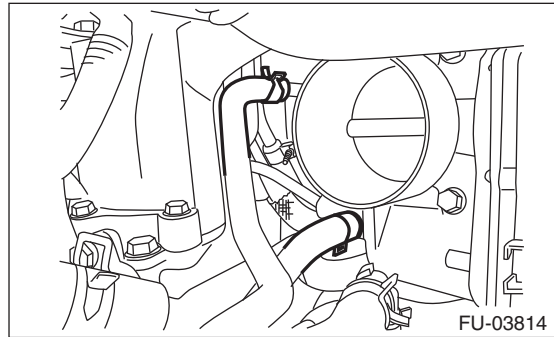

17) Install the duct to the throttle body.

Tightening torque:

3 N·m (0.3 kgf-m, 2.2 ft-lb)

18) Attach the bolts which secure the air by-pass pipe and PCV pipe to the intake manifold.

Tightening torque:

6.4 N·m (0.7 kgf-m, 4.7 ft-lb)

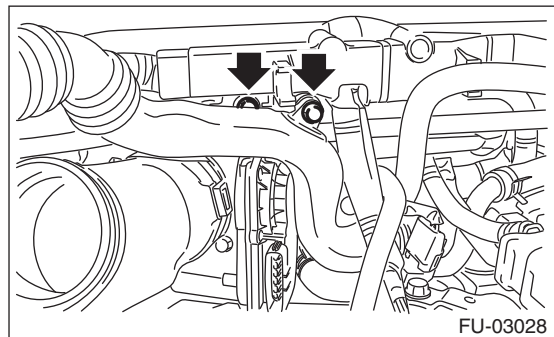

19) Attach the connector to the PCV hose assembly.

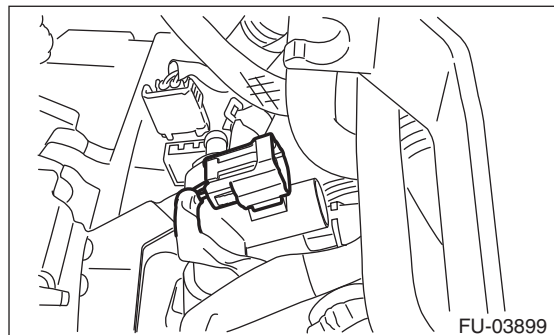

Intake Manifold

FUEL INJECTION (FUEL SYSTEMS)

- 20) Connect the vacuum hose (A) and the connector (B) to the PCV hose assembly.

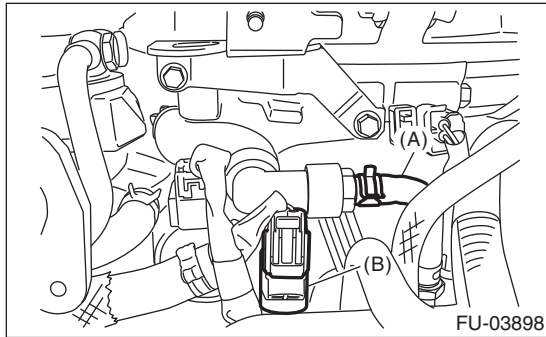

- 21) Install the A/C pressure hoses. <Ref. to AC-35, INSTALLATION, Hose and Pipe.>
22) Install the coolant filler tank. <Ref. to CO(H4DOTC)-29, INSTALLATION, Coolant Filler Tank.>
23) Install the generator. <Ref. to SC(H4SO)-16, INSTALLATION, Generator.>
24) Install the intercooler. <Ref. to IN(H4DOTC)-12, INSTALLATION, Intercooler.>
25) Install the air intake duct and air cleaner case. <Ref. to IN(H4DOTC)-8, INSTALLATION, Air Cleaner Case.> <Ref. to IN(H4DOTC)-9, INSTALLATION, Air Intake Duct.>
26) Install the battery to the vehicle, and connect the battery cables.
27) Lift up the vehicle.
28) Install the under cover.
29) Fill engine coolant. <Ref. to CO(H4DOTC)-13, FILLING OF ENGINE COOLANT, REPLACEMENT, Engine Coolant.>
30) Charge the A/C system with refrigerant. <Ref. to AC-18, PROCEDURE, Refrigerant Charging Procedure.>
31) Install the collector cover.

C: DISASSEMBLY

- 1) Remove the engine ground terminal from the fuel pipe protector LH and remove the fuel pipe protector LH from the intake manifold.

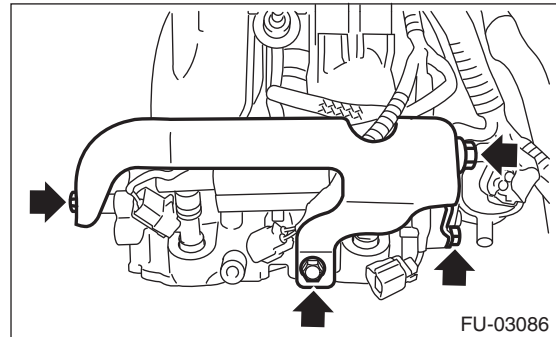

- 2) Remove the fuel pipe protector RH from the intake manifold.

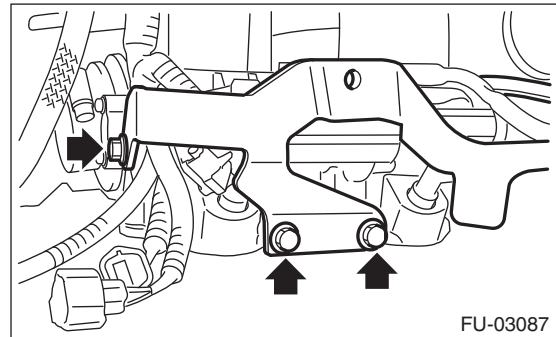

- 3) Disconnect the evaporation hose and the connector from the purge control solenoid valve 1, and remove the purge control solenoid valve 1 from the intake manifold.

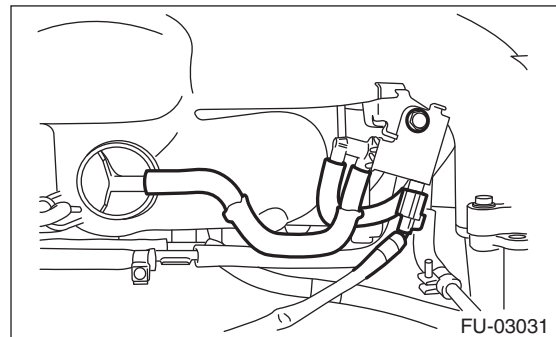

- 4) Disconnect the filter assembly.

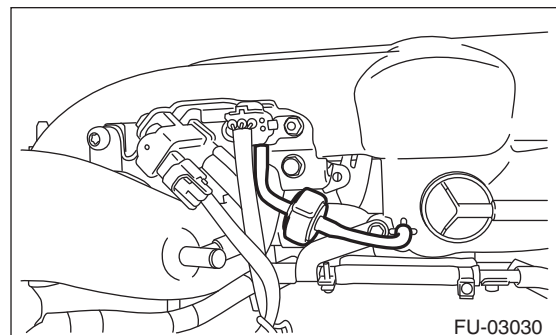

Intake Manifold

FUEL INJECTION (FUEL SYSTEMS)

5) Remove the solenoid valve bracket assembly from the intake manifold, and disconnect the connector from the wastegate control solenoid valve, manifold absolute pressure sensor and purge control solenoid valve 2.

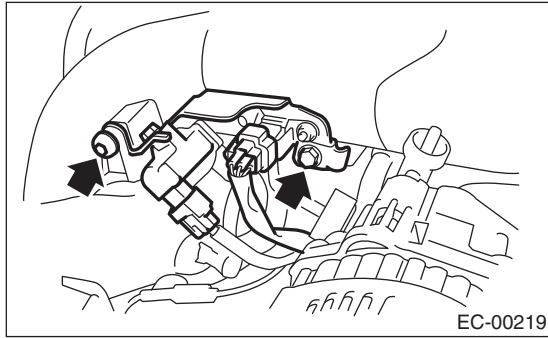

6) Disconnect the evaporation hose of the purge control solenoid valve 2 from the intake duct and fuel pipe assembly.

7) Disconnect the connectors from the throttle position sensor.

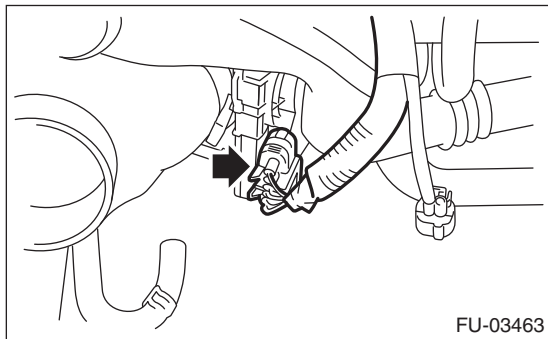

8) Remove the throttle body from the intake manifold.

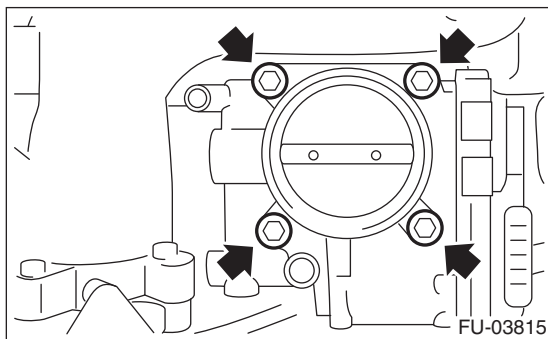

9) Disconnect the connector from the fuel injector and the tumble generator valve assembly.

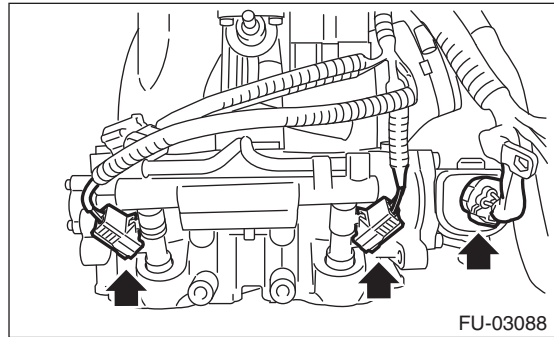

10) Remove the PCV pipe (A), harness assembly (B) and intake duct (C) from the intake manifold.

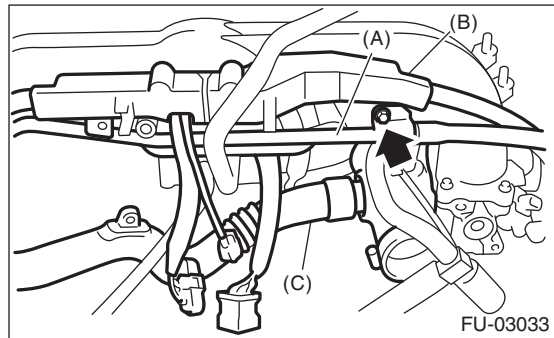

11) Remove the bolt which secures the fuel injector pipe LH onto the front side of intake manifold, and disconnect the pressure regulator vacuum hose from the intake manifold.

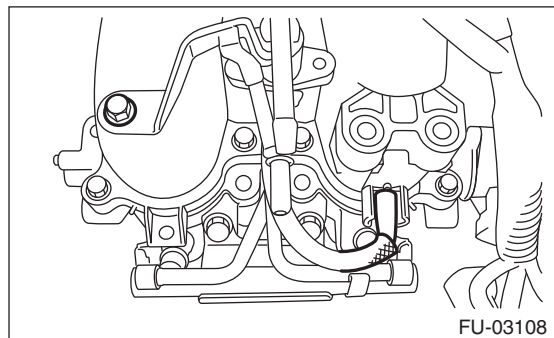

Intake Manifold

FUEL INJECTION (FUEL SYSTEMS)

12) Remove the bolt which holds fuel injector pipe onto intake manifold.

- RH side

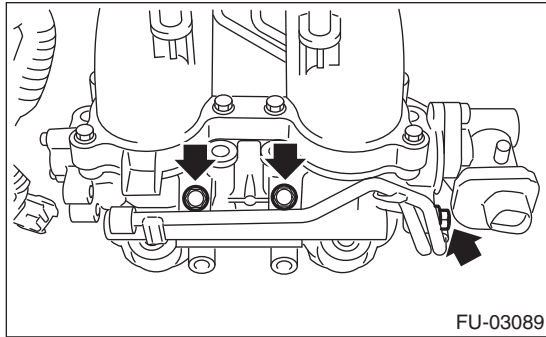

- LH side

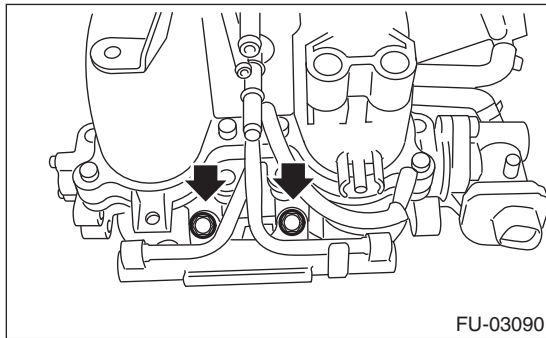

13) Remove the fuel injector.

- RH side

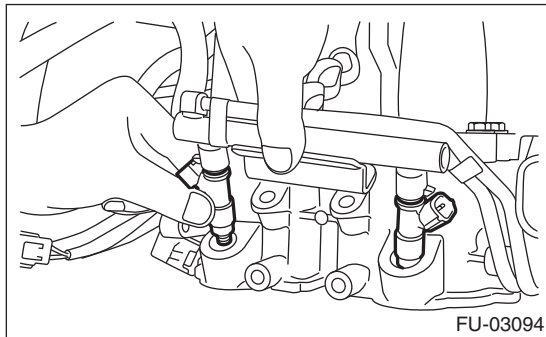

- LH side

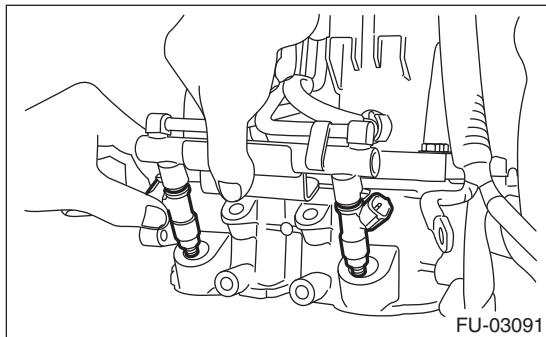

14) Remove the bolt which holds fuel injector pipe onto intake manifold.

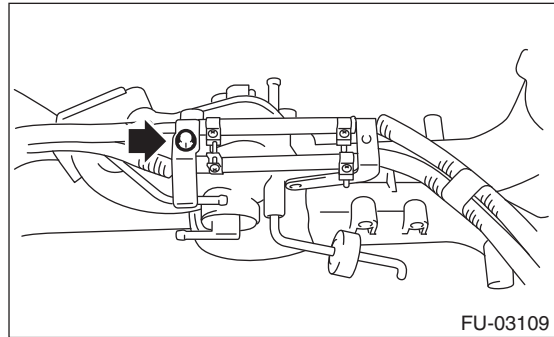

15) Remove the bolt which secures fuel injector pipe RH onto the lower side of the intake manifold.

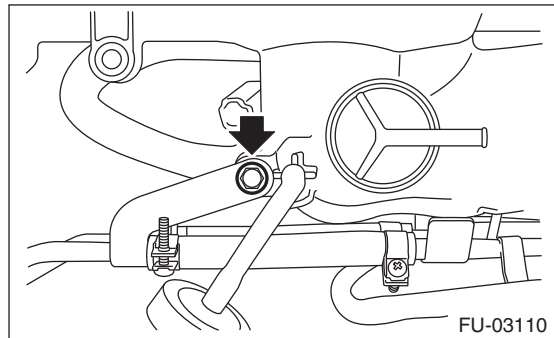

16) Loosen the clamp which holds the fuel hose to the fuel injector pipe, and then disconnect the fuel hose from pipe.

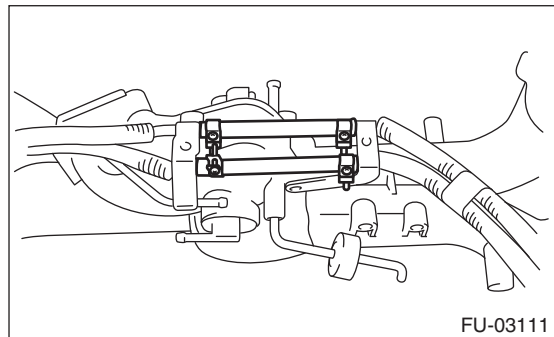

17) Remove the fuel injector pipe.

18) Remove the tumble generator valve assembly from the intake manifold.

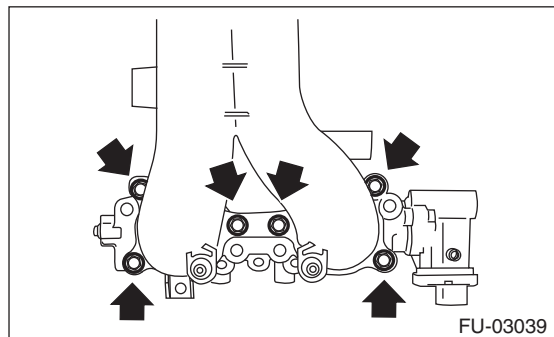

D: ASSEMBLY

1) Install the tumble generator valve assembly onto intake manifold.

NOTE:

Use new O-rings.

Tightening torque:

8.3 N·m (0.8 kgf-m, 6.1 ft-lb)

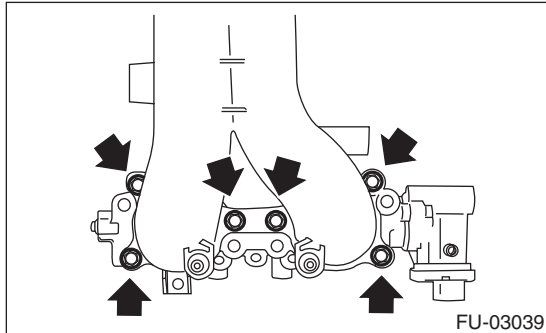

2) Install the fuel injector pipe.

3) Connect fuel hoses to fuel injector pipes on both sides, and secure them with the clamps.

Tightening torque:

1.25 N·m (0.1 kgf-m, 0.9 ft-lb)

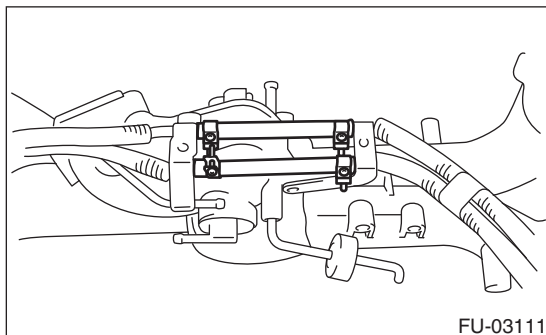

4) Tighten the bolts which secure the fuel injector pipe RH to the lower side of the intake manifold.

Tightening torque:

6.4 N·m (0.7 kgf-m, 4.7 ft-lb)

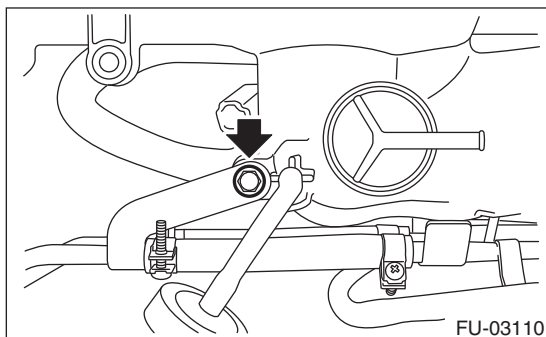

5) Tighten the bolts which secure fuel injector pipe onto intake manifold.

Tightening torque:

6.4 N·m (0.7 kgf-m, 4.7 ft-lb)

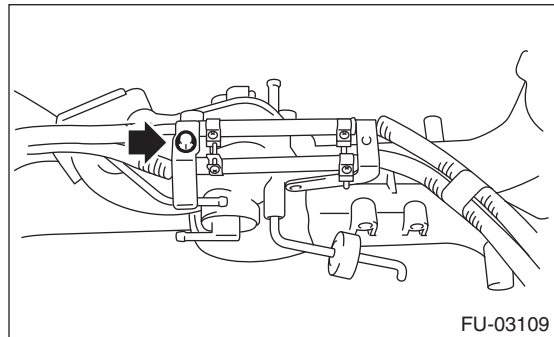

6) Install the fuel injector.

- RH side

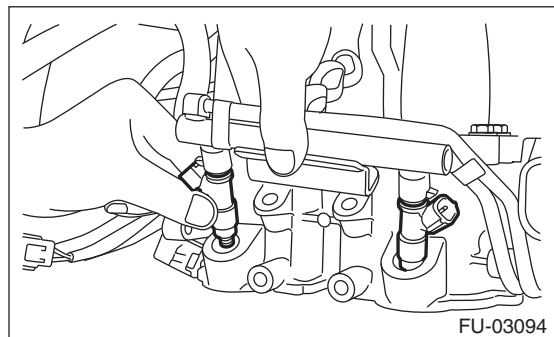

- LH side

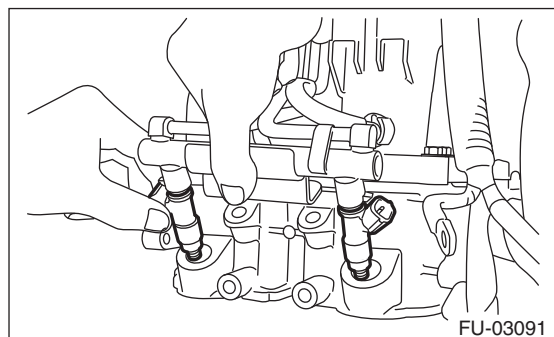

Intake Manifold

FUEL INJECTION (FUEL SYSTEMS)

7) Tighten the bolts which secure fuel injector pipe onto intake manifold.

Tightening torque:

19 N·m (1.9 kgf·m, 14.0 ft·lb)

- LH side

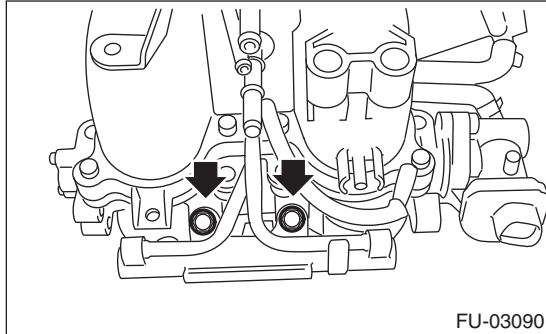

- RH side

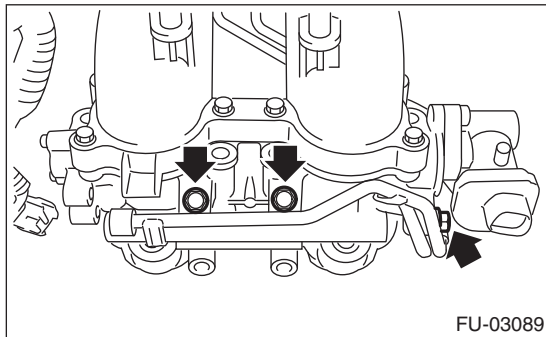

8) Tighten the bolt which holds the fuel injector pipe LH to the front side of the intake manifold, and connect the pressure regulator vacuum hose to the intake manifold.

Tightening torque:

6.4 N·m (0.7 kgf·m, 4.7 ft·lb)

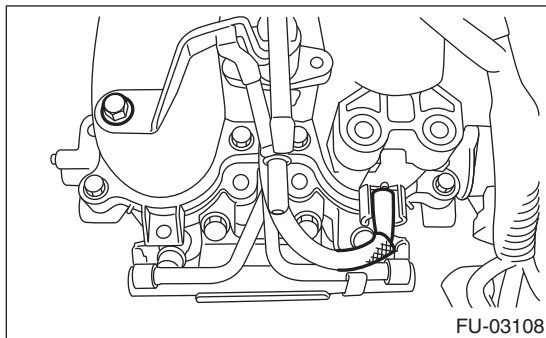

9) Install PCV pipe (A), harness assembly (B) and intake duct (C) to the intake manifold.

Tightening torque:

6.5 N·m (0.7 kgf·m, 4.8 ft·lb)

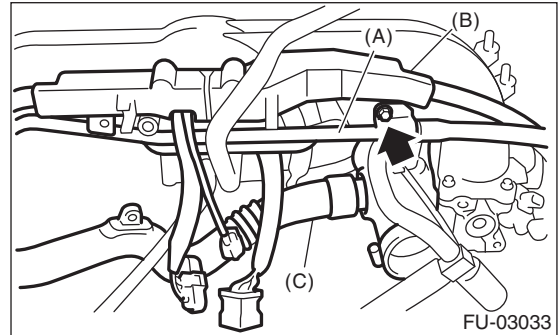

10) Connect the connector to the fuel injector and the tumble generator valve assembly.

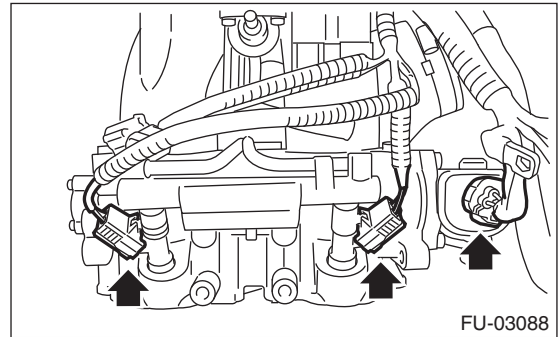

11) Install the throttle body to the intake manifold.

NOTE:

Use new O-rings.

Tightening torque:

8 N·m (0.8 kgf·m, 5.9 ft·lb)

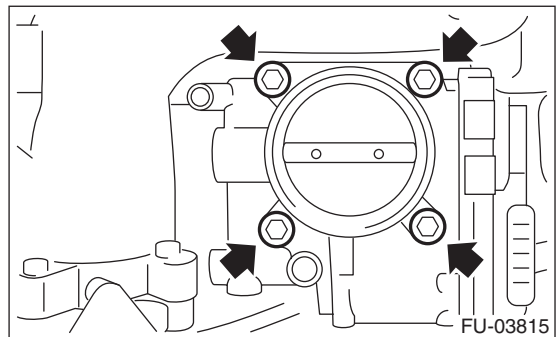

Intake Manifold

FUEL INJECTION (FUEL SYSTEMS)

12) Connect the connector to the throttle position sensor.

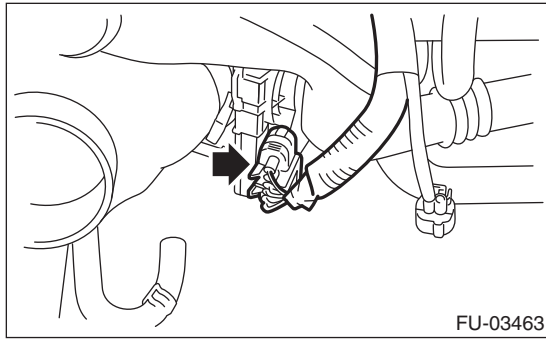

13) Connect the evaporation hose to the purge control solenoid valve 2.

NOTE:

Connect the evaporation hose as shown in the figure.

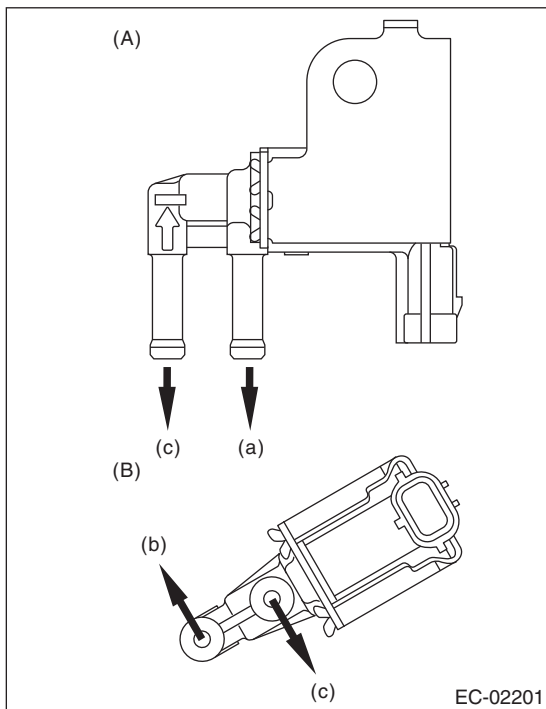

- (A) Purge control solenoid valve 1
- (B) Purge control solenoid valve 2
- (a) To intake manifold
- (b) To intake duct
- (c) To fuel pipe

14) Connect the connectors to the wastegate control solenoid valve, manifold absolute pressure sensor and purge control solenoid valve 2, and install the solenoid valve bracket assembly to the intake manifold.

Tightening torque:

T1: 17 N·m (1.7 kgf-m, 12.5 ft-lb)

T2: 19 N·m (1.9 kgf-m, 14.0 ft-lb)

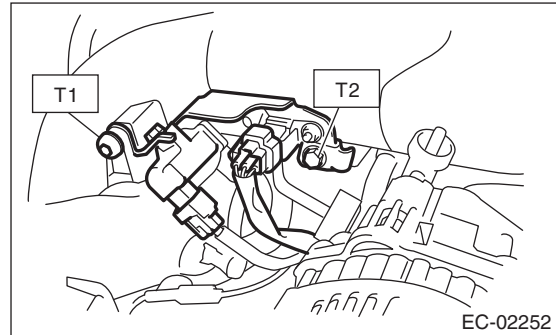

15) Connect the filter assembly.

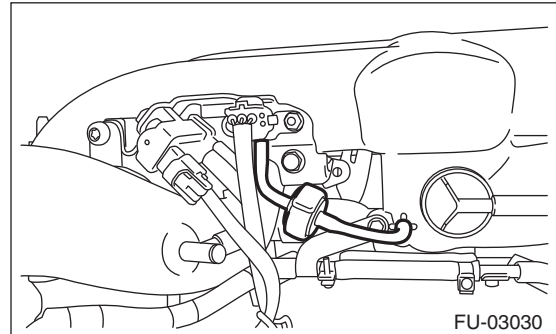

Intake Manifold

FUEL INJECTION (FUEL SYSTEMS)

16) Connect the evaporation hose and the connector to the purge control solenoid valve 1, and install the purge control solenoid valve 1 to the intake manifold.

NOTE:

Connect the evaporation hose as shown in the figure.

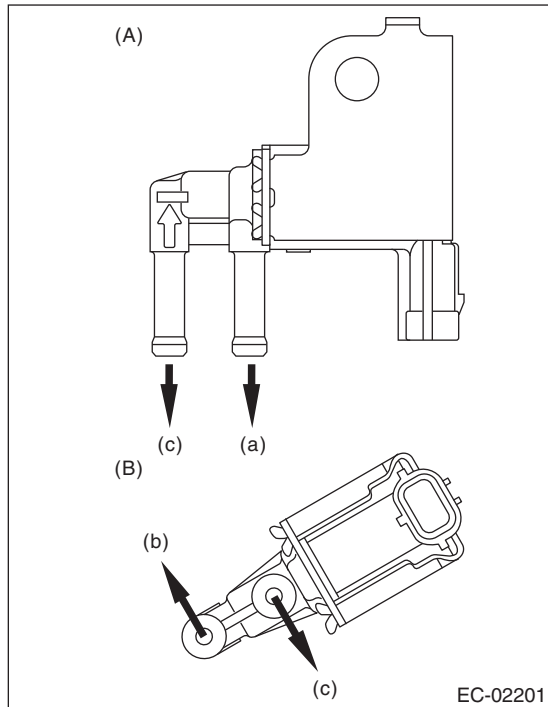

- (A) Purge control solenoid valve 1
- (B) Purge control solenoid valve 2
- (a) To intake manifold
- (b) To intake duct
- (c) To fuel pipe

Tightening torque:

6.4 N·m (0.7 kgf-m, 4.7 ft-lb)

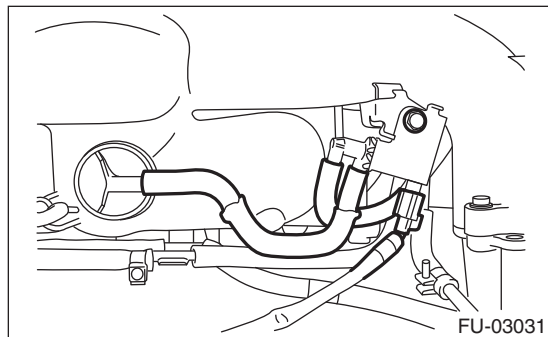

17) Install the fuel pipe protector RH to the intake manifold.

Tightening torque:

19 N·m (1.9 kgf-m, 14.0 ft-lb)

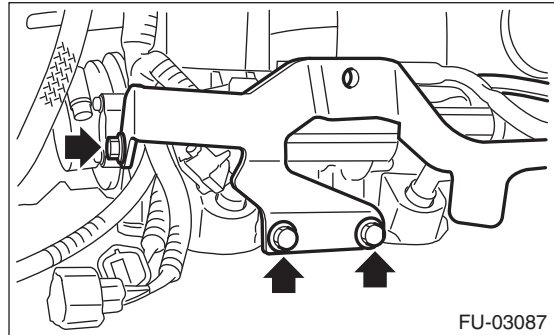

18) Install the fuel pipe protector LH to the intake manifold, and install the engine ground terminal to the fuel pipe protector LH.

Tightening torque:

19 N·m (1.9 kgf-m, 14.0 ft-lb)

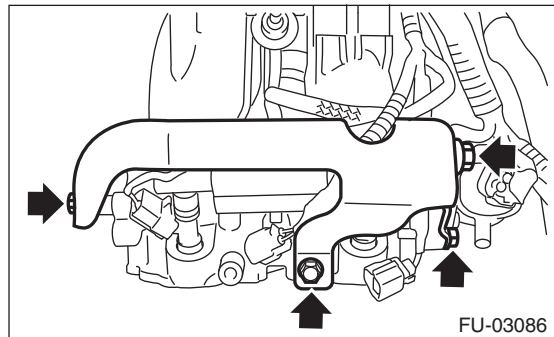

E: INSPECTION

Make sure that the fuel pipe and fuel hose are not cracked and that the connections are tight.

4. Engine Coolant Temperature Sensor

A: REMOVAL

- 1) Remove the collector cover.
- 2) Disconnect the ground cable from the battery.

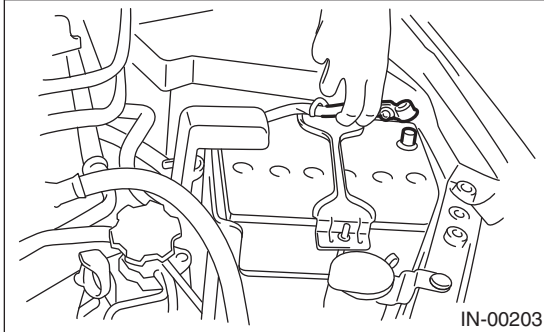

- 3) Remove the generator. <Ref. to SC(H4SO)-15, REMOVAL, Generator.>
- 4) Drain engine coolant. <Ref. to CO(H4DOTC)-13, DRAINING OF ENGINE COOLANT, REPLACEMENT, Engine Coolant.>
- 5) Disconnect the connectors from the engine coolant temperature sensor.

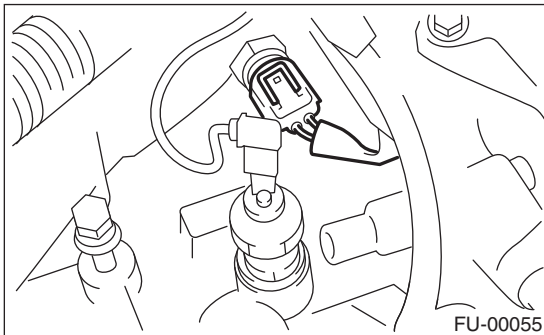

- 6) Remove the engine coolant temperature sensor.

B: INSTALLATION

Install in the reverse order of removal.

NOTE:

Use a new gasket.

Tightening torque:

18 N·m (1.8 kgf·m, 13.3 ft·lb)

Crankshaft Position Sensor

FUEL INJECTION (FUEL SYSTEMS)

5. Crankshaft Position Sensor

A: REMOVAL

- 1) Remove the collector cover.
- 2) Disconnect the ground cable from the battery.

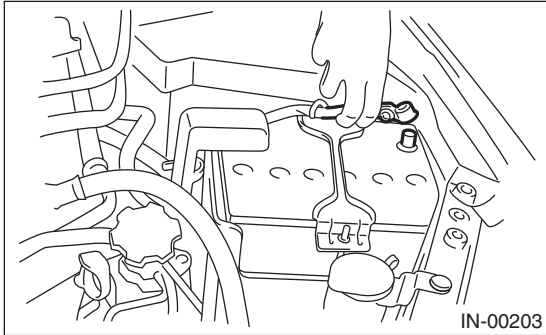

- 3) Remove the bolt which installs crankshaft position sensor to cylinder block.

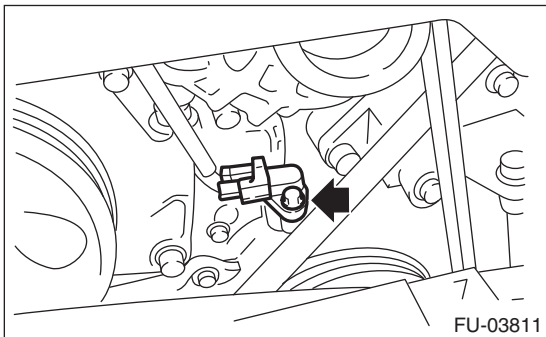

- 4) Remove the crankshaft position sensor, and then disconnect the connector from it.

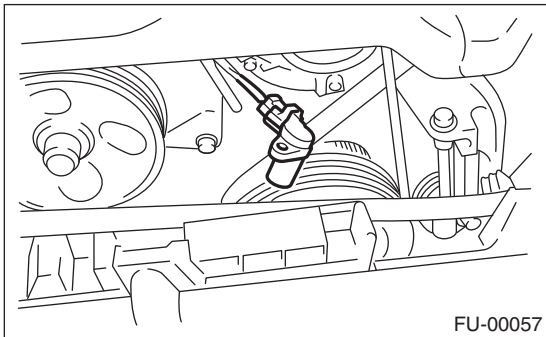

B: INSTALLATION

Install in the reverse order of removal.

Tightening torque:

6.4 N·m (0.7 kgf-m, 4.7 ft-lb)

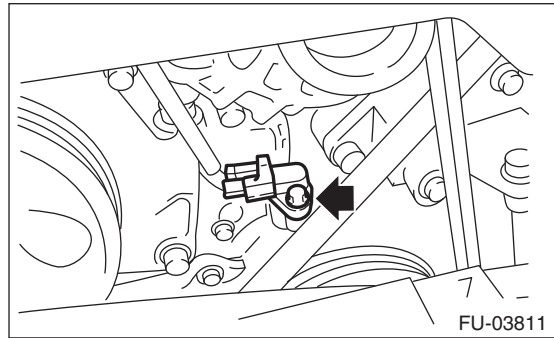

Camshaft Position Sensor

FUEL INJECTION (FUEL SYSTEMS)

6. Camshaft Position Sensor

A: REMOVAL

1. CAMSHAFT POSITION SENSOR RH

- 1) Remove the collector cover.
- 2) Disconnect the ground cable from battery.

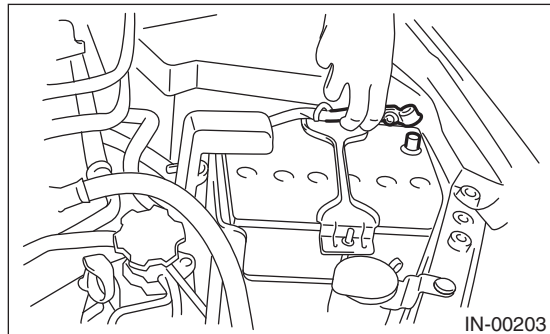

- 3) Disconnect the connector from camshaft position sensor RH.

- 4) Remove the camshaft position sensor RH from the rear side of the cylinder head.

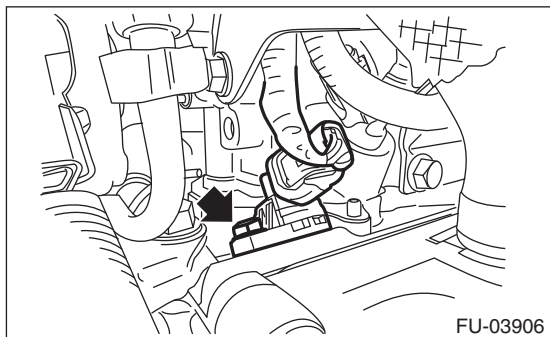

2. CAMSHAFT POSITION SENSOR LH

- 1) Disconnect the ground cable from the battery.

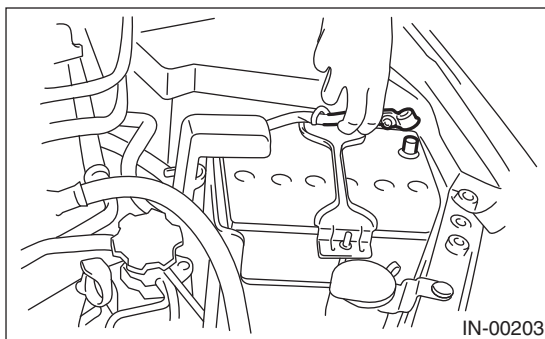

- 2) Remove the intake manifold. <Ref. to FU(H4DOTC)-14, REMOVAL, Intake Manifold.>

- 3) Remove the camshaft position sensor LH.

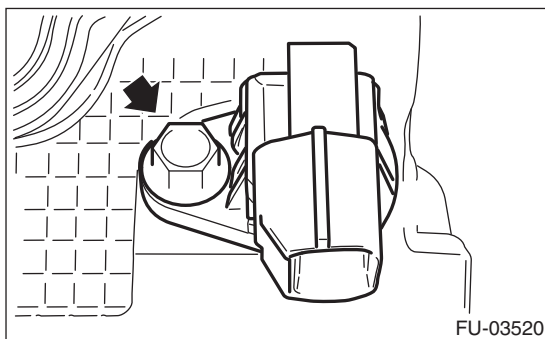

B: INSTALLATION

Install in the reverse order of removal.

Tightening torque:

6.4 N·m (0.7 kgf-m, 4.7 ft-lb)

Knock Sensor

FUEL INJECTION (FUEL SYSTEMS)

7. Knock Sensor

A: REMOVAL

- 1) Remove the collector cover.
- 2) Disconnect the ground cable from the battery.

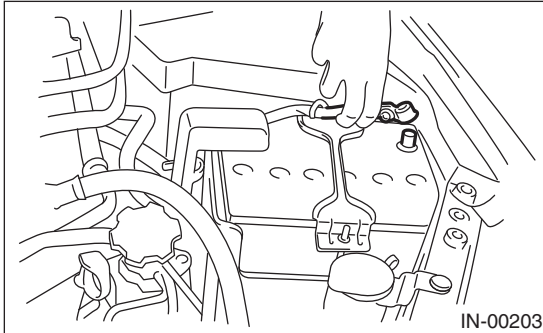

- 3) Remove the intercooler. <Ref. to IN(H4DOTC)-11, REMOVAL, Intercooler.>
- 4) Disconnect the knock sensor connector.

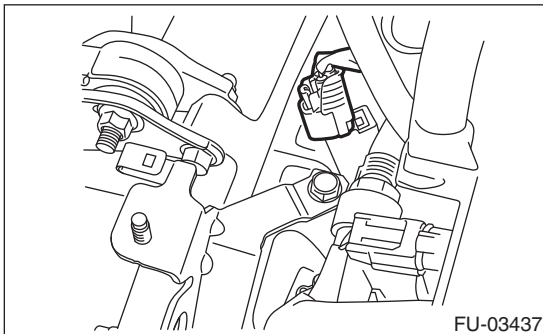

- 5) Remove the knock sensor from the cylinder block.

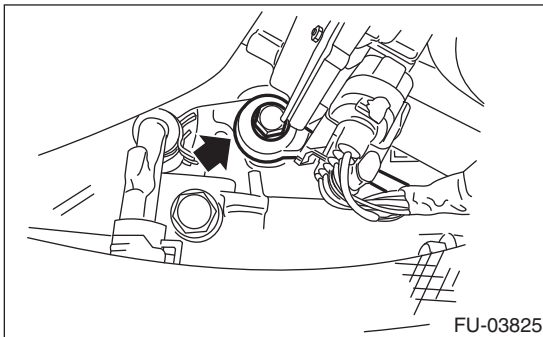

B: INSTALLATION

- 1) Install the knock sensor to the cylinder block.

NOTE:

The portion of the knock sensor cord that is pulled out must be positioned at a 60° angle relative to the engine rear.

Tightening torque:

24 N·m (2.4 kgf·m, 17.7 ft·lb)

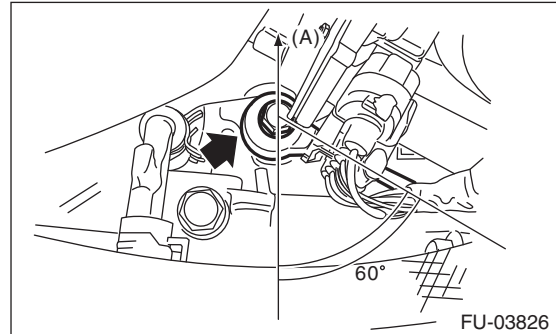

(A) Front side

- 2) Connect the knock sensor connector.

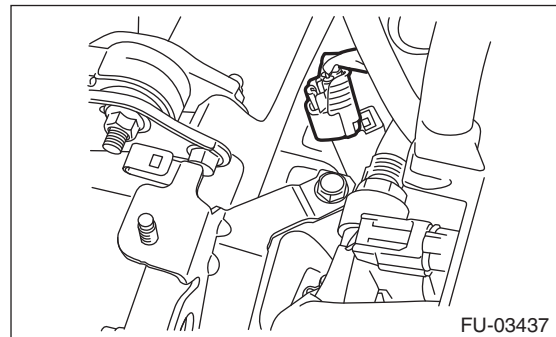

- 3) Install the intercooler.
<Ref. to IN(H4DOTC)-12, INSTALLATION, Intercooler.>
- 4) Connect the ground cable to the battery.

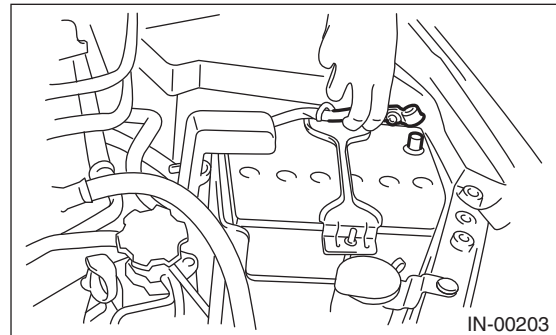

8. Throttle Position Sensor

A: SPECIFICATION

Throttle body is a non-disassembled part, so do not remove the throttle position sensor from throttle body.

Refer to “Throttle Body” for removal and installation procedure. <Ref. to FU(H4DOTC)-13, REMOVAL, Throttle Body.> <Ref. to FU(H4DOTC)-13, INSTALLATION, Throttle Body.>

Mass Air Flow and Intake Air Temperature Sensor

FUEL INJECTION (FUEL SYSTEMS)

9. Mass Air Flow and Intake Air Temperature Sensor

A: REMOVAL

1) Disconnect the ground cable from battery.

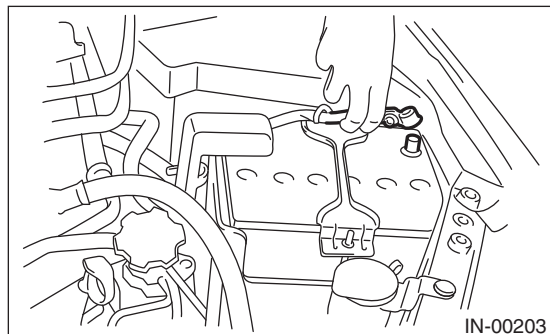

2) Disconnect the connector from the mass air flow and intake air temperature sensor, and remove the mass air flow and intake air temperature sensor.

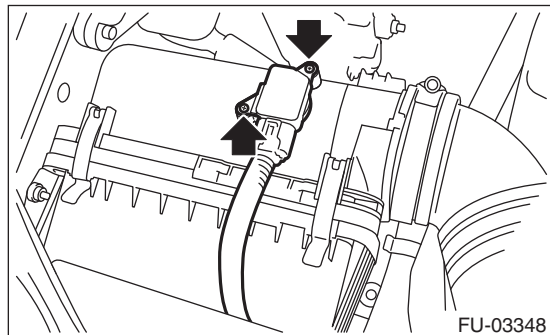

B: INSTALLATION

Install in the reverse order of removal.

Tightening torque:

1 N·m (0.1 kgf·m, 0.7 ft·lb)

10. Manifold Absolute Pressure Sensor

A: REMOVAL

- 1) Remove the collector cover.
- 2) Disconnect the ground cable from battery.

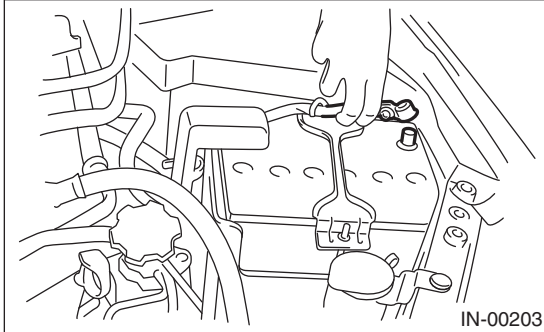

- 3) Disconnect the connector from manifold absolute pressure sensor (A), and remove the filter assembly (B) from intake manifold.
- 4) Remove the manifold absolute pressure sensor from the solenoid valve bracket.

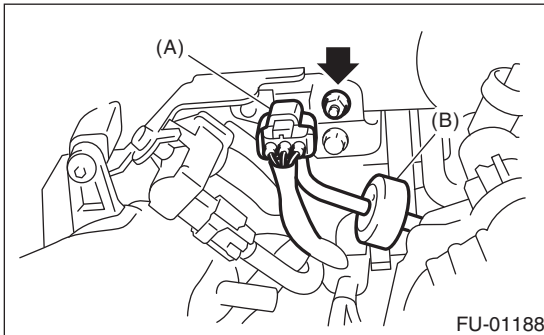

B: INSTALLATION

Install in the reverse order of removal.

Tightening torque:

6.4 N·m (0.7 kgf·m, 4.7 ft·lb)

Fuel Injector

FUEL INJECTION (FUEL SYSTEMS)

11. Fuel Injector

A: REMOVAL

1. RH SIDE

- 1) Release the fuel pressure. <Ref. to FU(H4DOTC)-51, RELEASING OF FUEL PRESSURE, PROCEDURE, Fuel.>
- 2) Remove the collector cover.
- 3) Disconnect the ground cable from battery.

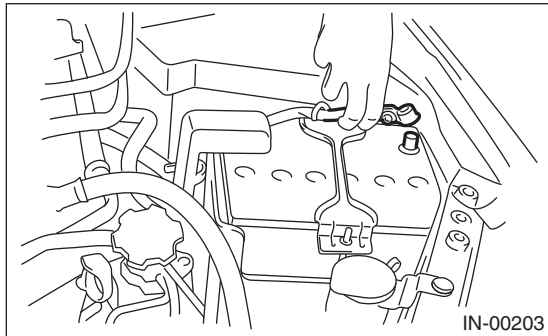

- 4) Open the fuel filler lid, and remove the fuel filler cap.
- 5) Remove the intake manifold. <Ref. to FU(H4DOTC)-14, REMOVAL, Intake Manifold.>
- 6) Remove the fuel pipe protector RH from the intake manifold.

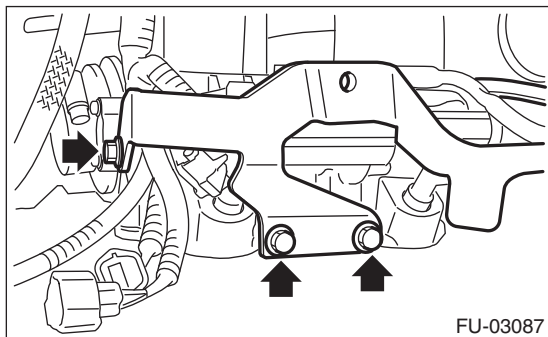

- 7) Disconnect the connector from fuel injector.
- 8) Remove the bolt which holds fuel injector pipe onto intake manifold.

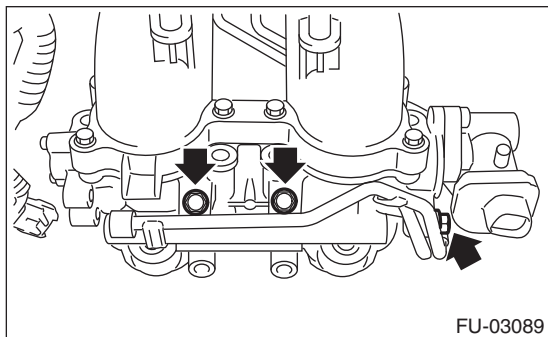

- 9) Remove the fuel injector.

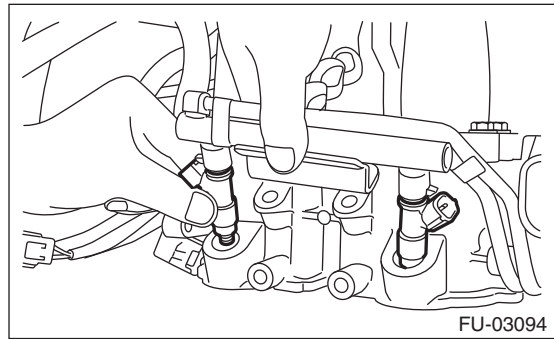

2. LH SIDE

- 1) Release the fuel pressure. <Ref. to FU(H4DOTC)-51, RELEASING OF FUEL PRESSURE, PROCEDURE, Fuel.>
- 2) Remove the collector cover.
- 3) Disconnect the ground cable from battery.

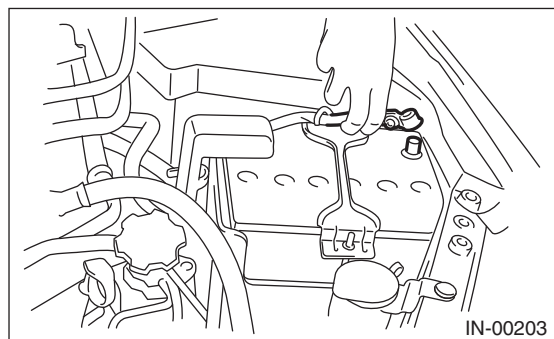

- 4) Open the fuel filler lid, and remove the fuel filler cap.
- 5) Remove the intake manifold. <Ref. to FU(H4DOTC)-14, REMOVAL, Intake Manifold.>
- 6) Remove the engine ground terminal from the fuel pipe protector LH and remove the fuel pipe protector LH from the intake manifold.

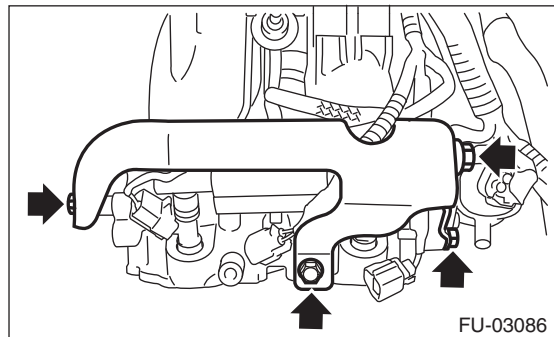

- 7) Disconnect the connector from fuel injector.

8) Remove the bolt which holds fuel injector pipe onto intake manifold.

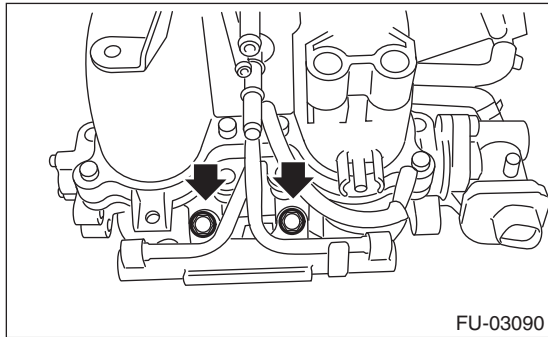
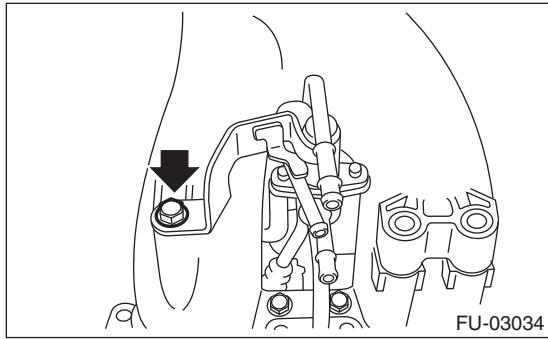

9) Remove the fuel injector.

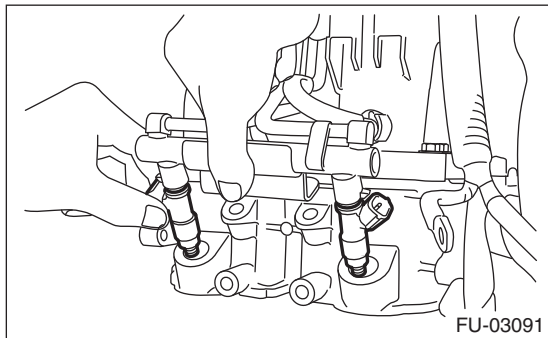

B: INSTALLATION

1. RH SIDE

Install in the reverse order of removal.

NOTE:

Use new O-rings.

Tightening torque:

19 N·m (1.9 kgf·m, 14.0 ft·lb)

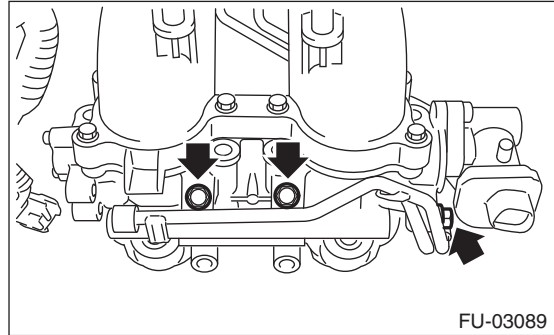

Tightening torque:

19 N·m (1.9 kgf·m, 14.0 ft·lb)

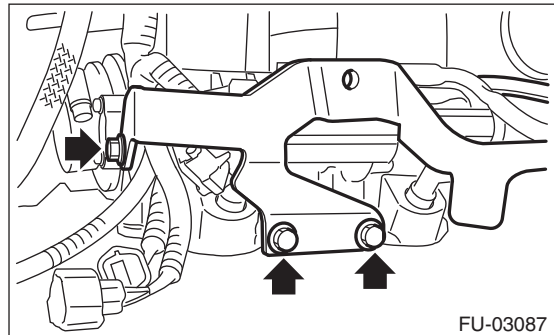

Fuel Injector

FUEL INJECTION (FUEL SYSTEMS)

2. LH SIDE

Install in the reverse order of removal.

NOTE:

Use new O-rings.

Tightening torque:

19 N·m (1.9 kgf-m, 14.0 ft-lb)

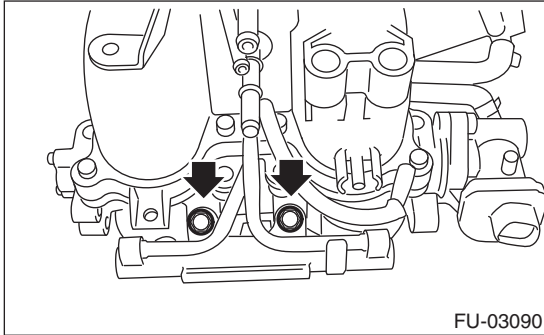

Tightening torque:

6.4 N·m (0.7 kgf-m, 4.7 ft-lb)

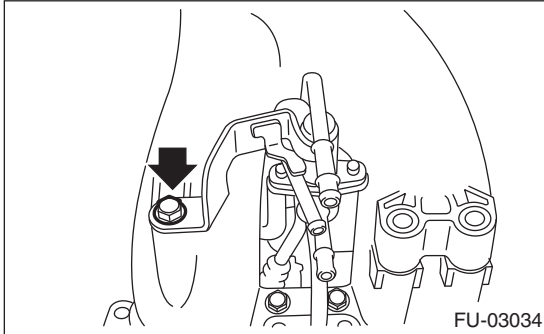

Tightening torque:

19 N·m (1.9 kgf-m, 14.0 ft-lb)

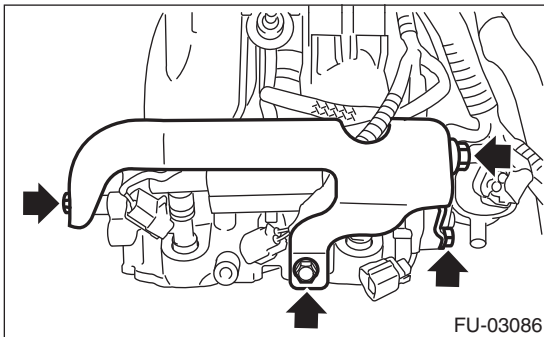

12. Tumble Generator Valve Assembly

A: REMOVAL

- 1) Release the fuel pressure. <Ref. to FU(H4DOTC)-51, RELEASING OF FUEL PRESSURE, PROCEDURE, Fuel.>
- 2) Remove the collector cover.
- 3) Disconnect the ground cable from battery.

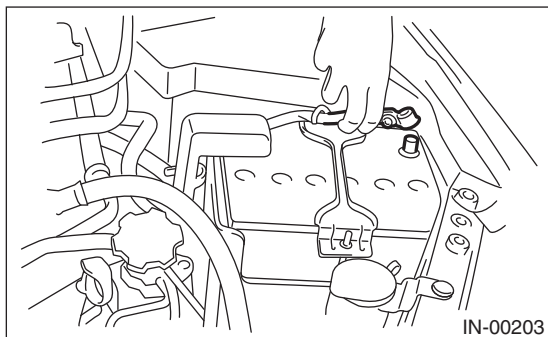

- 4) Open the fuel filler lid, and remove the fuel filler cap.
- 5) Remove the intake manifold. <Ref. to FU(H4DOTC)-14, REMOVAL, Intake Manifold.>
- 6) Disconnect the connector from the tumble generator valve assembly.

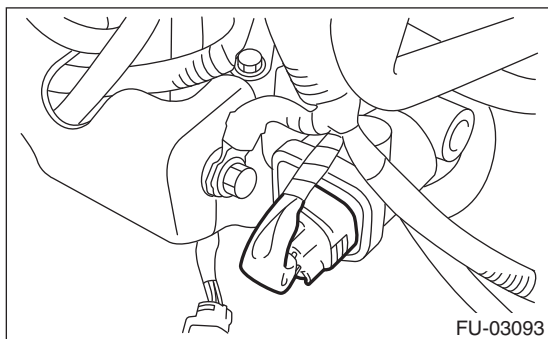

- 7) Remove the fuel injector. <Ref. to FU(H4DOTC)-36, REMOVAL, Fuel Injector.>
- 8) Remove the tumble generator valve body from intake manifold.

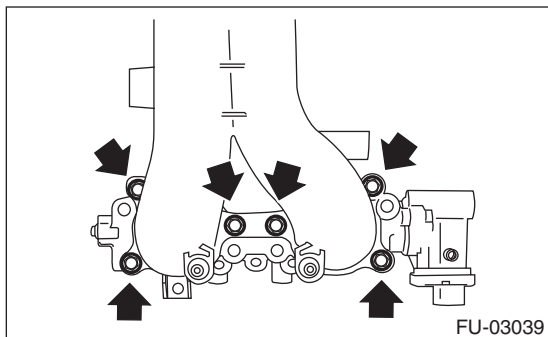

B: INSTALLATION

Install in the reverse order of removal.

NOTE:

Use a new gasket.

Tightening torque:

8.3 N·m (0.8 kgf-m, 6.1 ft-lb)

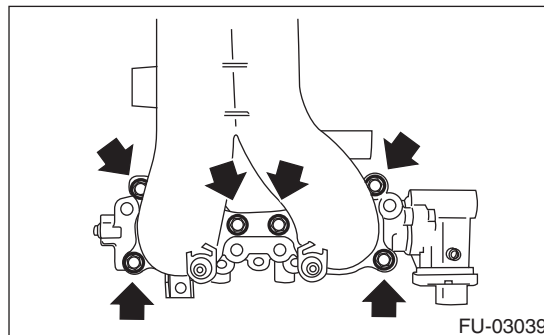

Tumble Generator Valve Actuator

FUEL INJECTION (FUEL SYSTEMS)

13. Tumble Generator Valve Actuator

A: SPECIFICATION

The tumble generator valve assembly cannot be disassembled.

Refer to “Tumble Generator Valve Assembly” for removal and installation procedures. <Ref. to FU(H4DOTC)-39, REMOVAL, Tumble Generator Valve Assembly.> <Ref. to FU(H4DOTC)-39, INSTALLATION, Tumble Generator Valve Assembly.>

14. Oil Flow Control Solenoid Valve

A: REMOVAL

Oil flow control solenoid valve is a unit with camshaft cap.

Refer to “Camshaft” for removal procedures. <Ref. to ME(H4DOTC)-60, REMOVAL, Camshaft.>

B: INSTALLATION

Refer to “Camshaft” for installation procedure. <Ref. to ME(H4DOTC)-61, INSTALLATION, Camshaft.>

C: DISASSEMBLY

- 1) Remove the 2 mounting bolts and remove the oil return cover and gasket.
- 2) Remove the mounting bolt and remove the oil flow control solenoid valve.

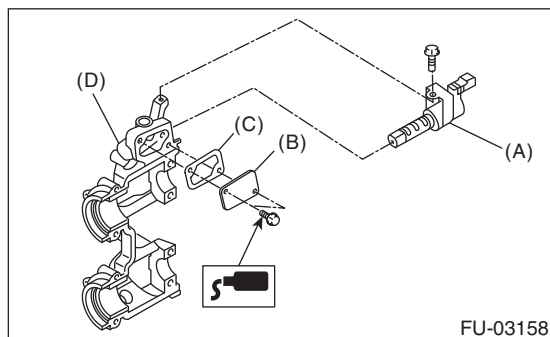

- (A) Oil flow control solenoid valve
- (B) Oil return cover
- (C) Gasket
- (D) Camshaft cap

D: ASSEMBLY

- 1) Install the oil flow control solenoid valve.

Tightening torque:

8 N·m (0.8 kgf-m, 5.9 ft-lb)

- 2) Apply liquid gasket to the two bolts which secure the oil return cover.

Liquid gasket:

THREE BOND 1324 (Part No. 004403042) or equivalent

- 3) Attach the oil return cover and gasket.

Tightening torque:

8 N·m (0.8 kgf-m, 5.9 ft-lb)

NOTE:

Use a new gasket.

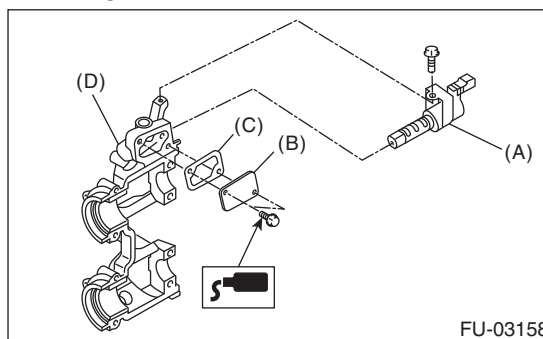

- (A) Oil flow control solenoid valve
- (B) Oil return cover
- (C) Gasket
- (D) Camshaft cap

Wastegate Control Solenoid Valve

FUEL INJECTION (FUEL SYSTEMS)

15. Wastegate Control Solenoid Valve

A: REMOVAL

- 1) Remove the collector cover.
- 2) Disconnect the ground cable from battery.

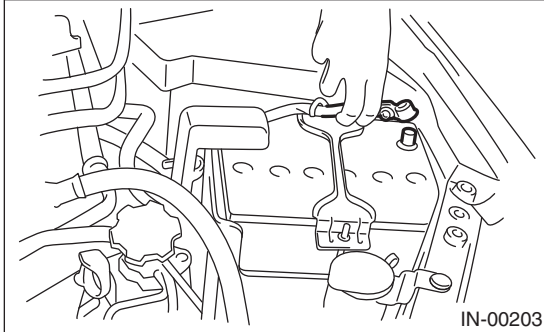

- 3) Disconnect the connector from the wastegate control solenoid valve (A).
- 4) Disconnect pressure hose (B) from the wastegate control solenoid valve.
- 5) Remove the wastegate control solenoid valve from the bracket.

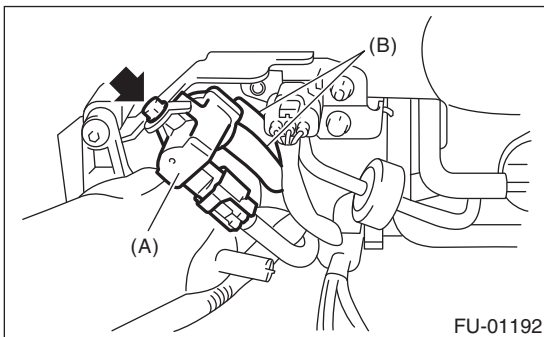

B: INSTALLATION

Install in the reverse order of removal.

Tightening torque:

6.4 N·m (0.7 kgf-m, 4.7 ft-lb)

Front Oxygen (A/F) Sensor

FUEL INJECTION (FUEL SYSTEMS)

16. Front Oxygen (A/F) Sensor

A: REMOVAL

- 1) Set the vehicle on a lift.
- 2) Remove the collector cover.
- 3) Disconnect the ground cable from battery.

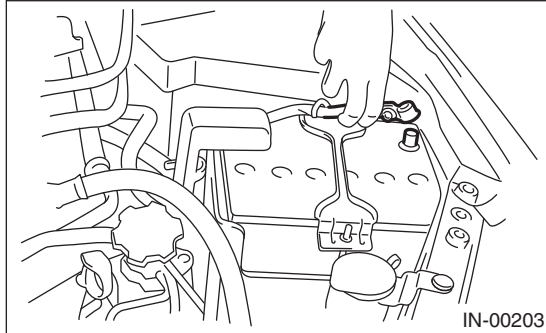

- 4) Disconnect the connector from the front oxygen (A/F) sensor, and remove the clip (A) holding the return hose and the front oxygen (A/F) sensor harness.

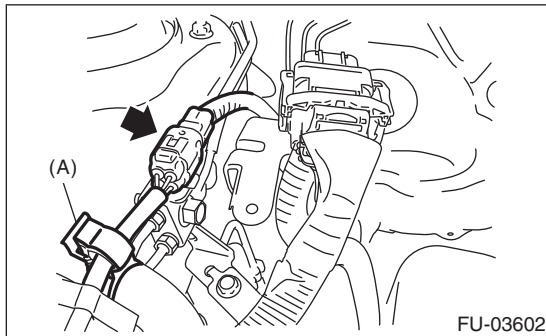

- 5) Remove the clip (A) and (B) holding the front oxygen (A/F) sensor harness.

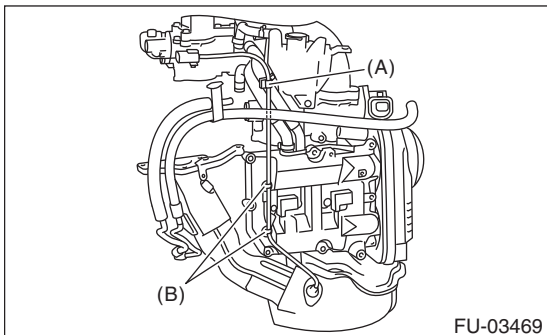

- 6) Lift up the vehicle
- 7) Remove the under cover.
- 8) Apply spray-type lubricant or equivalent to the threaded portion of front oxygen (A/F) sensor, and leave it for one minute or more.

- 9) Remove the front oxygen (A/F) sensor.

CAUTION:

When removing the oxygen (A/F) sensor, wait until exhaust pipe cools, otherwise it will damage the exhaust pipe.

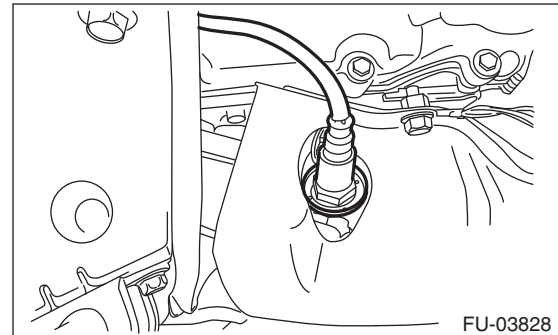

Front Oxygen (A/F) Sensor

FUEL INJECTION (FUEL SYSTEMS)

B: INSTALLATION

1) Before installing front oxygen (A/F) sensor, apply anti-seize compound only to the threaded portion of front oxygen (A/F) sensor to make the next removal easier.

CAUTION:

Never apply anti-seize compound to the protector of front oxygen (A/F) sensor.

Anti-seize compound:

NEVER-SEEZ NSN, JET LUBE SS-30 or equivalent

2) Install the front oxygen (A/F) sensor.

Tightening torque:

30 N·m (3.1 kgf·m, 22.1 ft·lb)

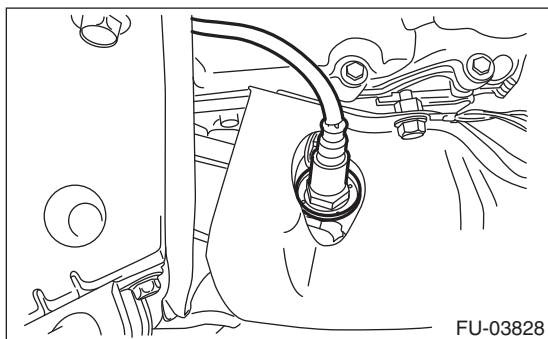

3) Install the under cover.

4) Lower the vehicle.

5) Affix the front oxygen (A/F) sensor harness with the clip (A) and (B).

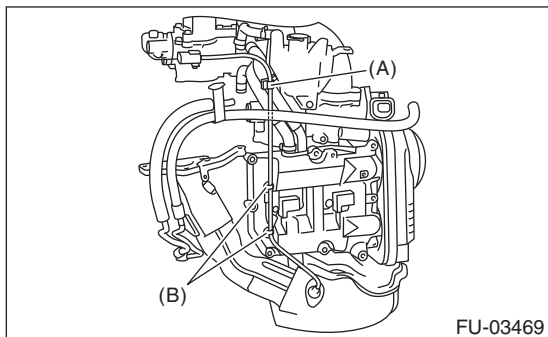

6) Connect the front oxygen (A/F) sensor connector, and hold the return hose and the front oxygen (A/F) sensor harness with the clip (A).

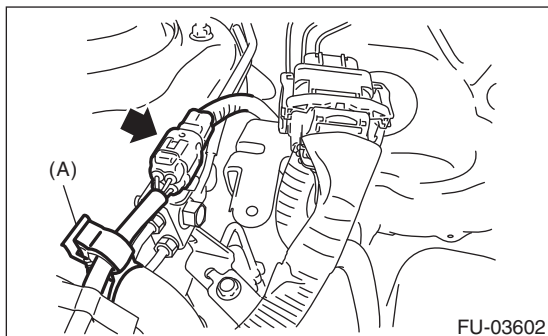

7) Connect the battery ground cable to the battery.

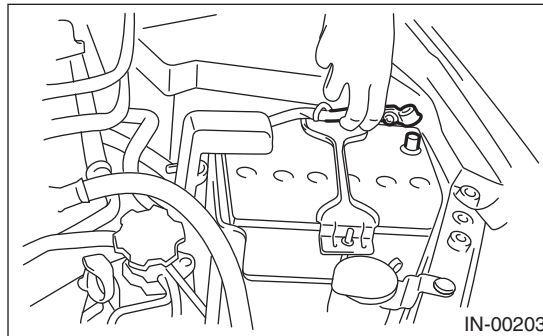

17.Rear Oxygen Sensor

A: REMOVAL

- 1) Set the vehicle on a lift.
- 2) Disconnect the ground cable from battery.

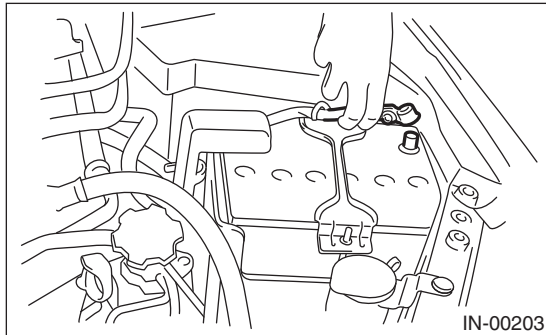

- 3) Lift up the vehicle.
- 4) Disconnect the connector from the rear oxygen sensor, and remove the clip (A) holding the rear oxygen sensor harness.

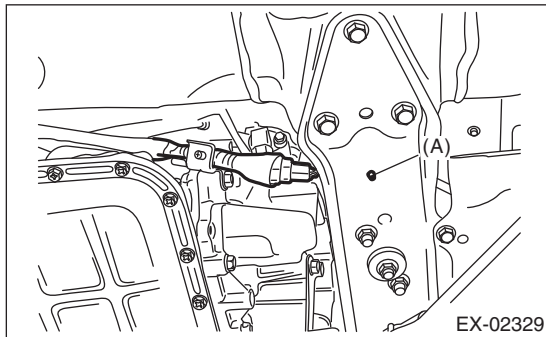

- 5) Apply spray-type lubricant or equivalent to the threaded portion of rear oxygen sensor, and leave it for one minute or more.
- 6) Remove the rear oxygen sensor.

CAUTION:

When removing the rear oxygen sensor, wait until exhaust pipe cools, otherwise it will damage the exhaust pipe.

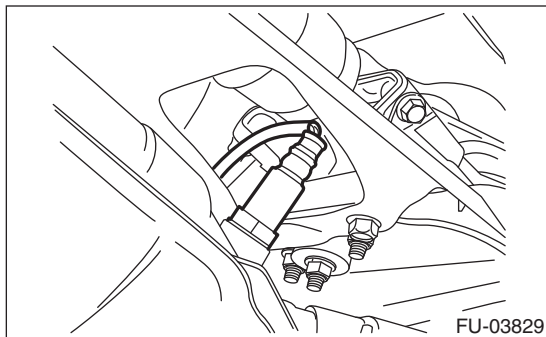

B: INSTALLATION

- 1) Before installing rear oxygen sensor, apply the anti-seize compound only to the threaded portion of rear oxygen sensor to make the next removal easier.

CAUTION:

Never apply anti-seize compound to the protector of rear oxygen sensor.

Anti-seize compound:

NEVER-SEEZ NSN, JET LUBE SS-30 or equivalent

- 2) Install the rear oxygen sensor.

Tightening torque:

21 N·m (2.1 kgf-m, 15.5 ft-lb)

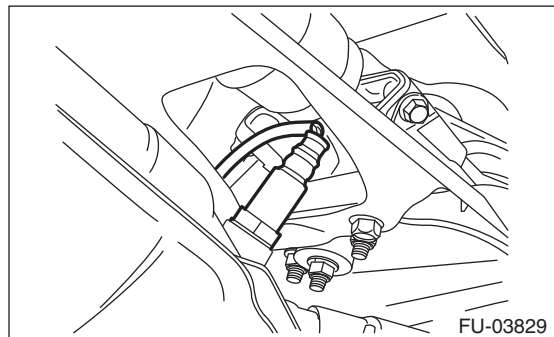

- 3) Connect the connector to the rear oxygen sensor, and hold the rear oxygen sensor harness with clip (A).

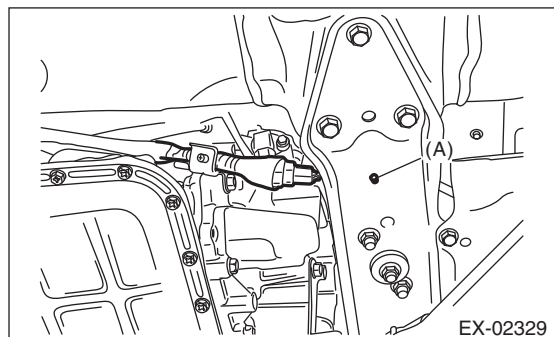

- 4) Lower the vehicle.
- 5) Connect the battery ground cable to the battery.

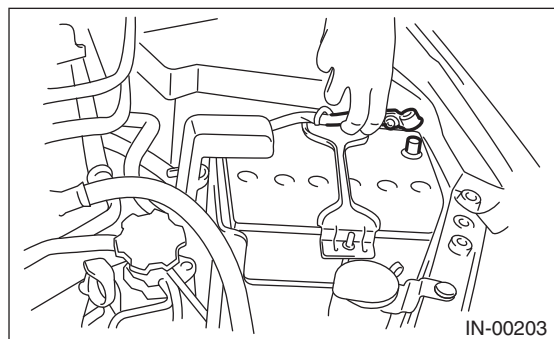

Engine Control Module (ECM)

FUEL INJECTION (FUEL SYSTEMS)

18.Engine Control Module (ECM)

A: REMOVAL

- 1) Disconnect the ground cable from battery.

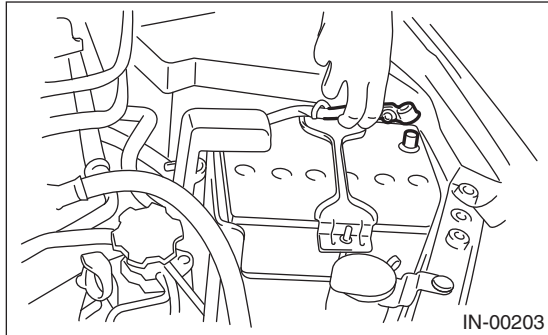

- 2) Remove the glove box lower cover. <Ref. to EI-45, REMOVAL, Glove Box.>
- 3) Remove the lower inner trim of passenger's side. <Ref. to EI-52, REMOVAL, Lower Inner Trim.>
- 4) Turn over the floor mat of passenger's seat.
- 5) Remove the protect cover.

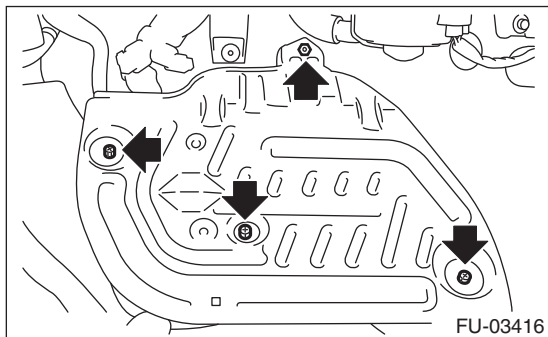

- 6) Remove the bolts and nuts which hold the ECM to the bracket.

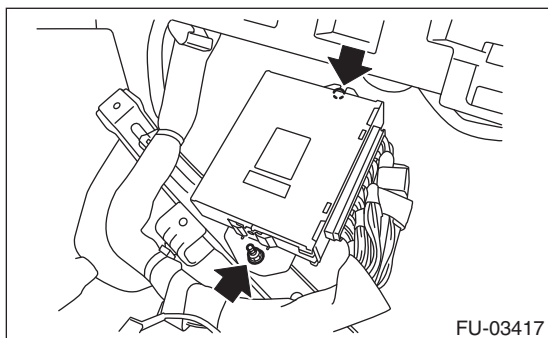

- 7) Disconnect the ECM connectors, and take out the ECM.

B: INSTALLATION

Install in the reverse order of removal.

CAUTION:

When the ECM on a model with immobilizer has been replaced, be sure to perform registration of the immobilizer. (Refer to the "PC application help for Subaru Select Monitor".)

NOTE:

When replacing the ECM, be careful not to use the wrong spec. ECM to avoid any damage on the fuel injection system.

Tightening torque:

7.5 N·m (0.8 kgf·m, 5.5 ft·lb)

19.Main Relay

A: REMOVAL

1) Disconnect the ground cable from battery.

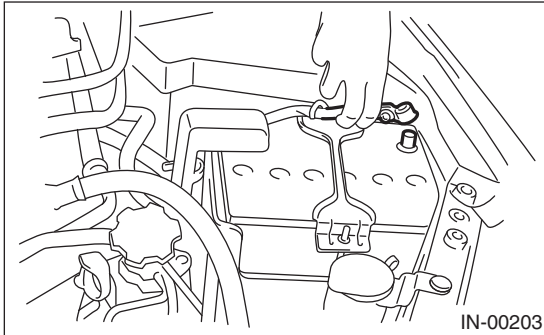

2) Remove the glove box lower cover. <Ref. to EI-45, REMOVAL, Glove Box.>

3) Remove the main relay from the relay block on the back side of the glove box.

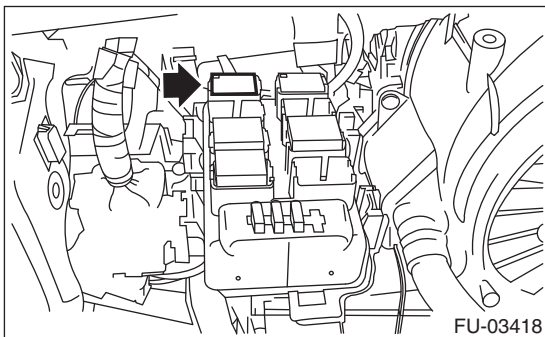

B: INSTALLATION

Install in the reverse order of removal.

Fuel Pump Relay

FUEL INJECTION (FUEL SYSTEMS)

20. Fuel Pump Relay

A: REMOVAL

1) Disconnect the ground cable from battery.

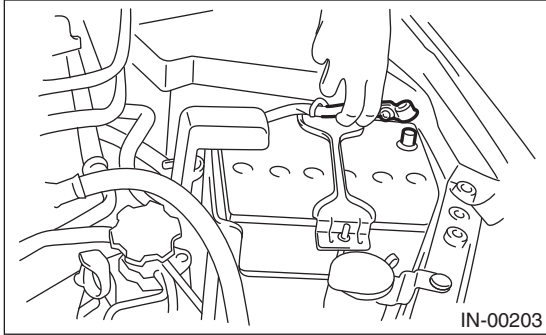

2) Remove the glove box lower cover. <Ref. to EI-45, REMOVAL, Glove Box.>

3) Remove the fuel pump relay from the relay block on the back side of the glove box.



B: INSTALLATION

Install in the reverse order of removal.

21. Electronic Throttle Control Relay

A: REMOVAL

- 1) Disconnect the ground cable from battery.

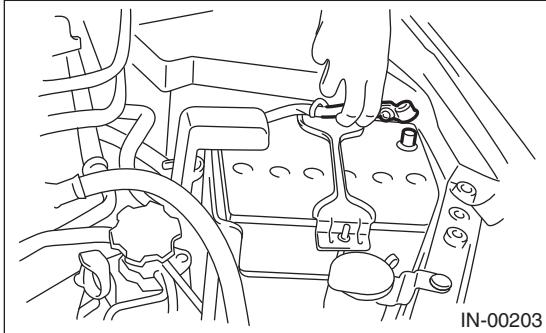

- 2) Remove the glove box lower cover. <Ref. to EI-45, REMOVAL, Glove Box.>

- 3) Remove the electronic throttle control relay from the relay block on the back side of the glove box.



B: INSTALLATION

Install in the reverse order of removal.

Fuel Pump Control Unit

FUEL INJECTION (FUEL SYSTEMS)

22. Fuel Pump Control Unit

A: REMOVAL

1) Disconnect the ground cable from battery.

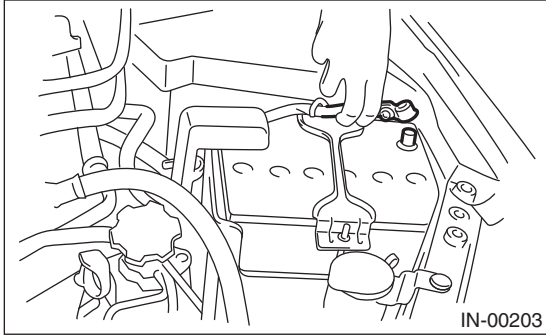

2) Remove the rear quarter trim of the right side.
<Ref. to EI-55, REMOVAL, Rear Quarter Trim.>

3) Remove the fuel pump control unit.

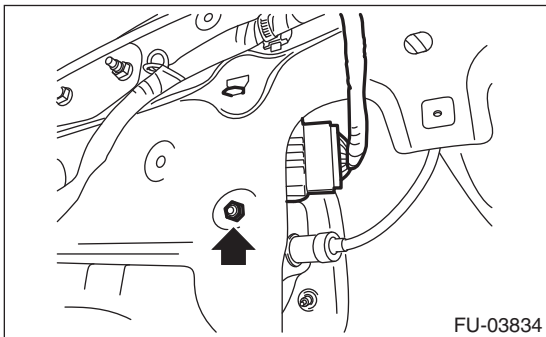

4) Disconnect the connector from fuel pump control unit.

B: INSTALLATION

Install in the reverse order of removal.

Tightening torque:

5 N·m (0.5 kgf·m, 3.7 ft·lb)

23. Fuel

A: PROCEDURE

1. RELEASING OF FUEL PRESSURE

WARNING:

Place “NO OPEN FLAMES” signs near the working area.

CAUTION:

Be careful not to spill fuel.

1) Remove the fuse of fuel pump from main fuse box.

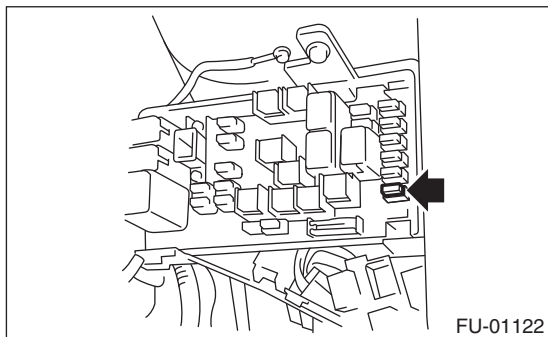

- 2) Start the engine and run it until it stalls.
- 3) After the engine stalls, crank it for five more seconds.
- 4) Turn the ignition switch to OFF.

2. DRAINING FUEL (WITH SUBARU SELECT MONITOR)

WARNING:

Place “NO OPEN FLAMES” signs near the working area.

CAUTION:

Be careful not to spill fuel.

NOTE:

- If the fuel pump cannot be actuated, refer to DRAINING FUEL (THROUGH THE FUEL FILLER HOSE). <Ref. to FU(H4DOTC)-52, DRAINING FUEL (THROUGH THE FUEL FILLER HOSE), PROCEDURE, Fuel.>

- Be careful not to allow the battery to go flat.

- 1) Release the fuel pressure. <Ref. to FU(H4DOTC)-51, RELEASING OF FUEL PRESSURE, PROCEDURE, Fuel.>

- 2) Attach ST to the fuel delivery pipe and push ST in the direction of arrow mark to disconnect the fuel delivery hose.

ST 42099AE000 QUICK CONNECTOR
RELEASE

CAUTION:

- **Be careful not to spill fuel.**
- **Catch the fuel from hoses using a container or cloth.**

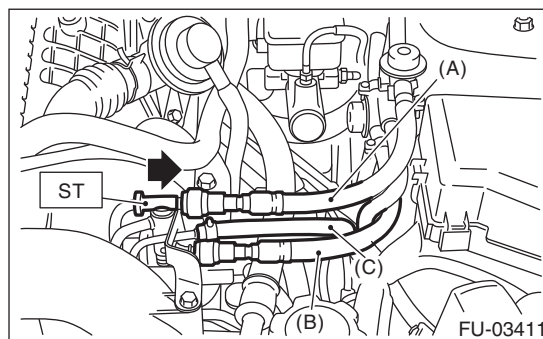

- 3) Connect ST to the fuel delivery hose.
ST 18471AA000 FUEL PIPE ADAPTER
- 4) Connect the gasoline proof hose to ST, and put the hose end into the container.
- 5) Drive the fuel pump and drain the fuel using Subaru Select Monitor. <Ref. to EN(H4DOTC)(diag)-55, FUEL PUMP CONTROL (ON/OFF DRIVE), OPERATION, System Operation Check Mode.>

CAUTION:

Be careful not to spill fuel.

3. DRAINING FUEL (THROUGH THE FUEL FILLER HOSE)

WARNING:

Place “NO OPEN FLAMES” signs near the working area.

CAUTION:

- Be careful not to spill fuel.
- Fuel may remain in the fuel filler pipe. Perform the work after draining the fuel from the fuel filler pipe through the fill opening using the gasoline proof pump and the gasoline proof hose (ø10 or less).

- 1) Set the vehicle on a lift.
- 2) Lift up the vehicle.
- 3) Remove the rear exhaust pipe and muffler. <Ref. to EX(H4DOTC)-12, REMOVAL, Rear Exhaust Pipe.> <Ref. to EX(H4DOTC)-14, REMOVAL, Muffler.>
- 4) Open the fuel filler lid, and remove the fuel filler cap.
- 5) Drain the fuel from the fuel filler pipe through the fill opening using the gasoline proof pump and the gasoline proof hose (ø10 or less).
- 6) Disconnect the fuel filler hose from the fuel filler pipe assembly.

CAUTION:

- Be careful not to spill fuel.
- Catch the fuel from hoses using a container or cloth.

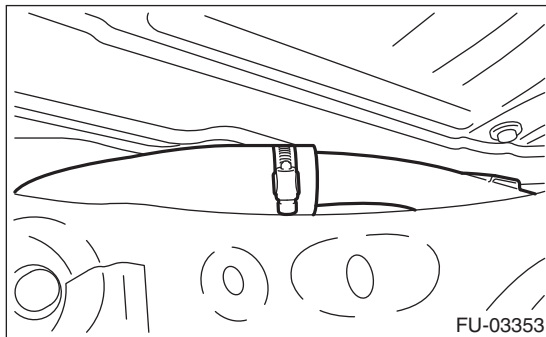

- (A) Fuel filler hose
(B) Evaporation hose

- 7) Set a container under the vehicle and insert a gasoline proof hose of 10 mm dia. or less into the fuel filler hose to drain the fuel.

CAUTION:

Be careful not to spill fuel.

24. Fuel Tank

A: REMOVAL

WARNING:

Place "NO OPEN FLAMES" signs near the working area.

CAUTION:

Be careful not to spill fuel.

- 1) Set the vehicle on a lift.
- 2) Release the fuel pressure. <Ref. to FU(H4DOTC)-51, RELEASING OF FUEL PRESSURE, PROCEDURE, Fuel.>
- 3) Drain fuel from fuel tank. <Ref. to FU(H4DOTC)-51, DRAINING FUEL (WITH SUBARU SELECT MONITOR), PROCEDURE, Fuel.>
- 4) Disconnect the ground cable from the battery.

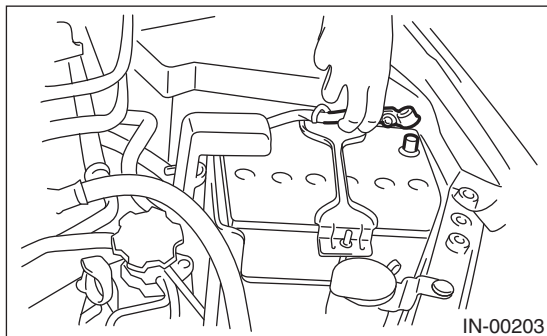

5) Remove the rear seat cushion. <Ref. to SE-15, REMOVAL, Rear Seat.>

6) Remove the service hole cover of fuel pump.

- (1) Separate fuel pump connector (A), and remove clip (B).
- (2) Remove bolt (C).
- (3) Push the grommet (D) down and remove the service hole cover.

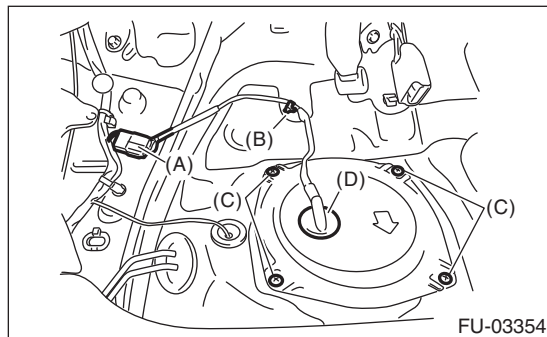

7) Remove the service hole cover of fuel sub level sensor.

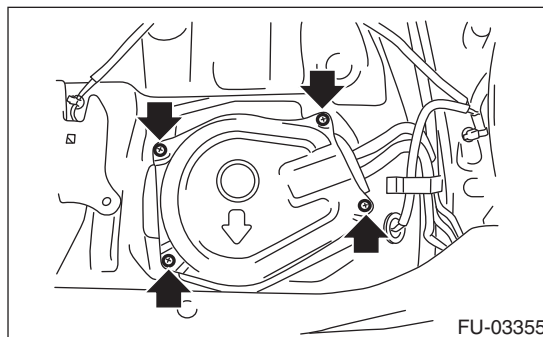

8) Disconnect the quick connector of fuel delivery tube (A) and fuel return tube (B). <Ref. to FU(H4DOTC)-72, REMOVAL, Fuel Delivery, Return and Evaporation Lines.>

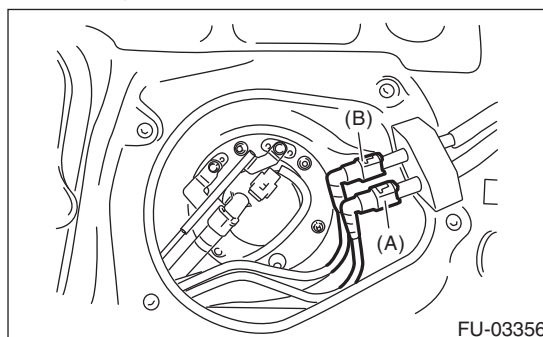

9) Remove the rear wheels.

10) Lift up the vehicle

11) Remove the rear ABS wheel speed sensor from the rear housing.

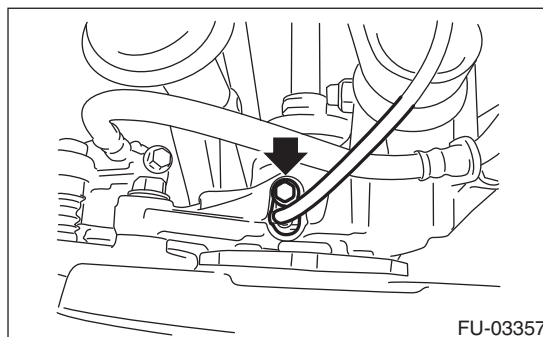

12) Remove the bolt holding the rear brake hose bracket.

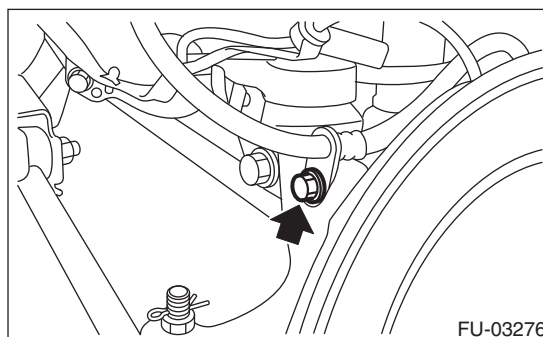

Fuel Tank

FUEL INJECTION (FUEL SYSTEMS)

13) Remove the rear brake caliper and tie it to the body side of the vehicle.

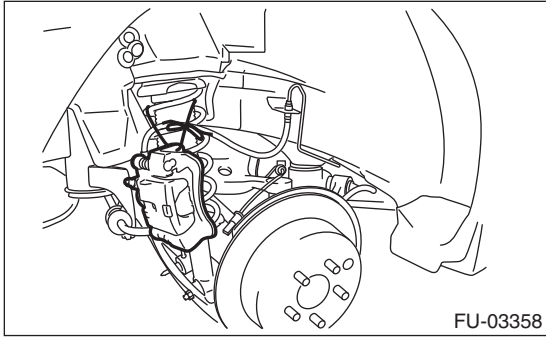

14) Remove the parking brake cable from the parking brake assembly. <Ref. to PB-6, REMOVAL, Parking Brake Assembly (Rear Disc Brake).>

15) Remove the rear exhaust pipe.

<Ref. to EX(H4DOTC)-12, REMOVAL, Rear Exhaust Pipe.>

16) Remove the propeller shaft. <Ref. to DS-10, REMOVAL, Propeller Shaft.>

17) Remove the heat shield cover and fuel tank protector.

18) Disconnect the connector from the rear ABS wheel speed sensor.

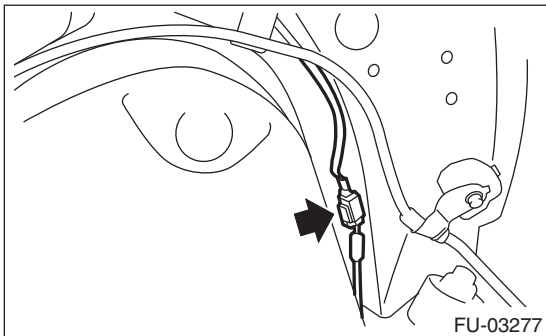

19) Remove the bolts securing the parking brake cable clamp.

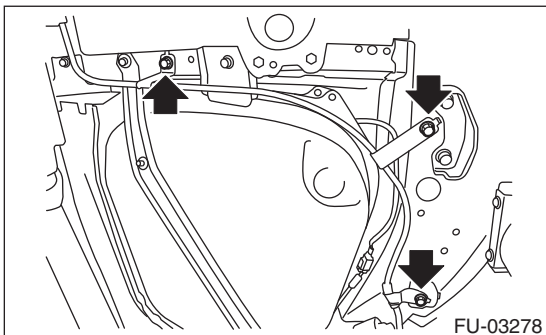

20) Disconnect drain hose (B) from the canister drain connector (A).

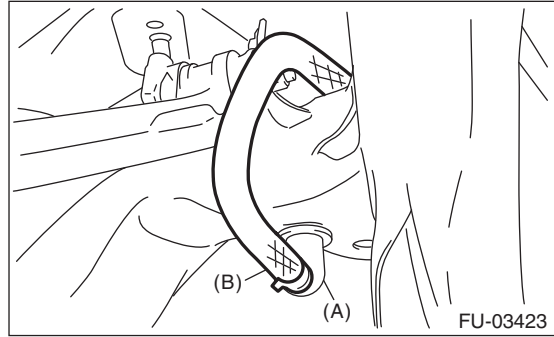

21) Disconnect the connector, remove the nuts, and then remove the rear vehicle height sensor. (models with auto headlight beam leveler, left side only)

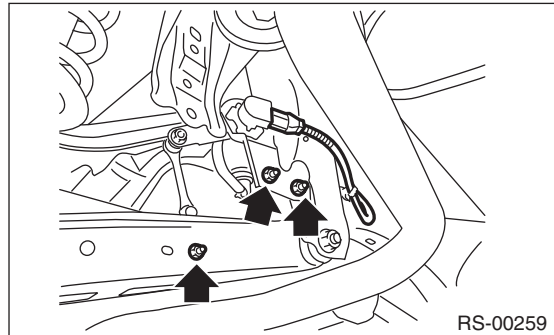

22) Remove the rear suspension assembly.

WARNING:

A helper is required to perform this work.

- (1) Support the rear differential with the transmission jack.
- (2) Remove the bolts which hold the rear shock absorber to the rear suspension arm.

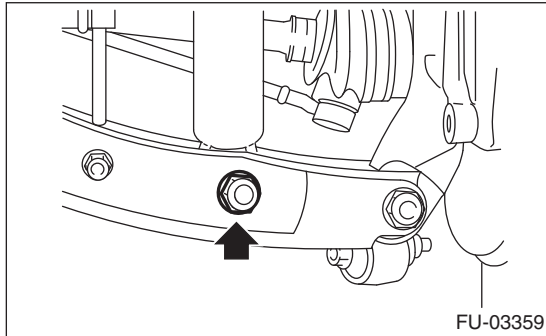

- (3) Remove the bolts which secure the rear suspension assembly to the body.

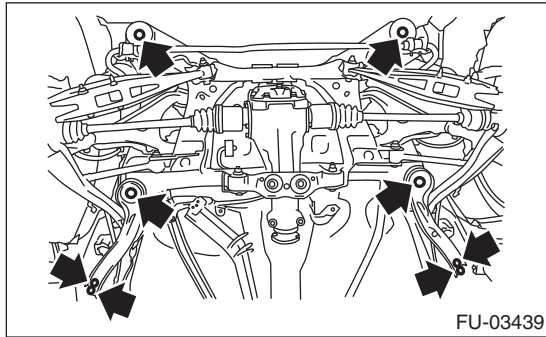

- (4) Remove the rear suspension assembly.

23) Disconnect evaporation hose (B) from connector (A).

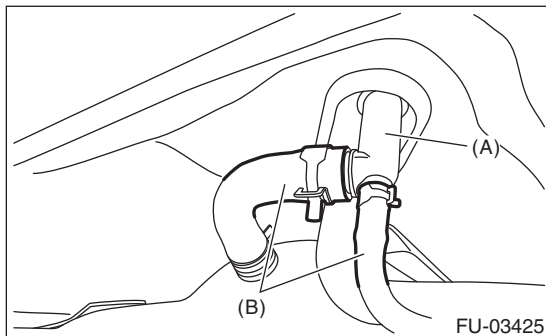

24) Disconnect the quick connector of the evaporation hose from the evaporation pipe.

NOTE:

Disconnect the quick connector as shown in the figure.

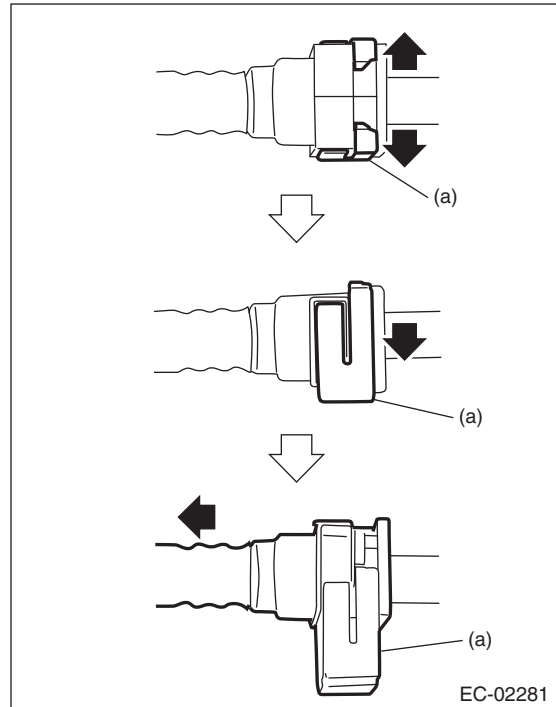

(a) Retainer

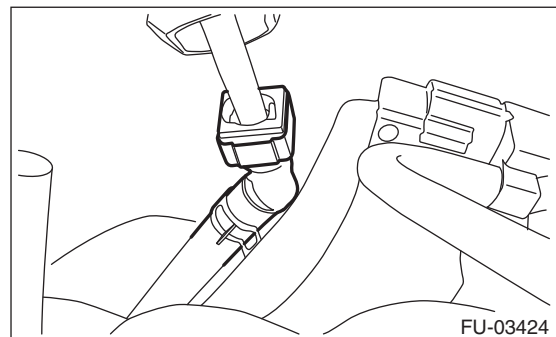

25) Disconnect the fuel filler hose (A) and evaporation hose (B).

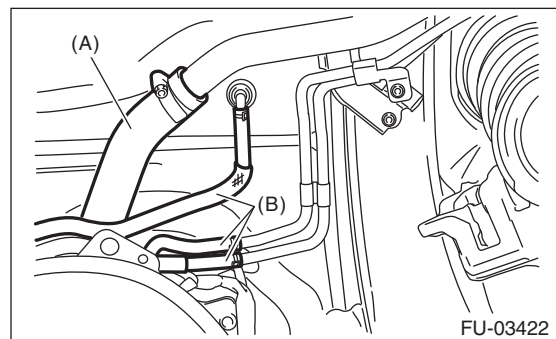

Fuel Tank

FUEL INJECTION (FUEL SYSTEMS)

26) Support the fuel tank with a transmission jack, remove the bolts from the fuel tank band, and remove the fuel tank from the vehicle.

WARNING:

- A helper is required to perform this work.
- Fuel may remain in the fuel tank. This will cause the left and right sides to be unbalanced. Be careful not to drop the fuel tank when removing.

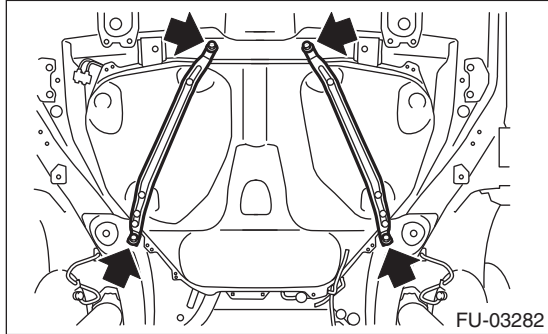

B: INSTALLATION

1) Support the fuel tank with a transmission jack, set the fuel tank in place, and temporarily tighten the bolts of the fuel tank band.

WARNING:

A helper is required to perform this work.

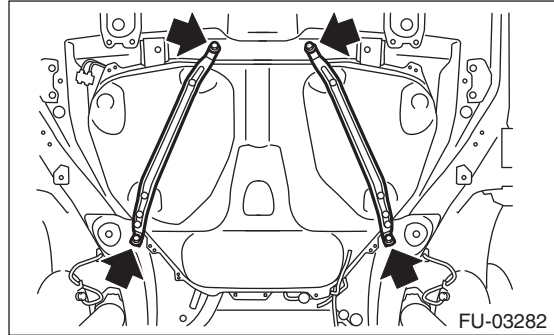

2) Securely insert the fuel filler hose (A) and evaporation hose (B) into the specified position, then attach the clamp or clip as shown in the figure.

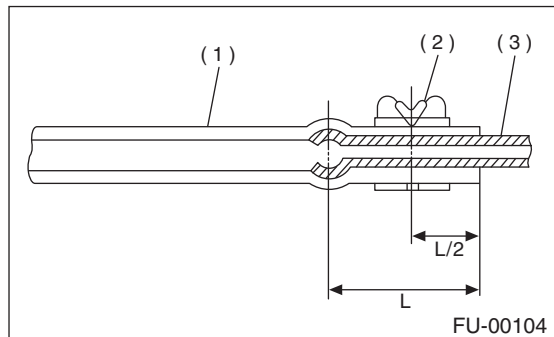
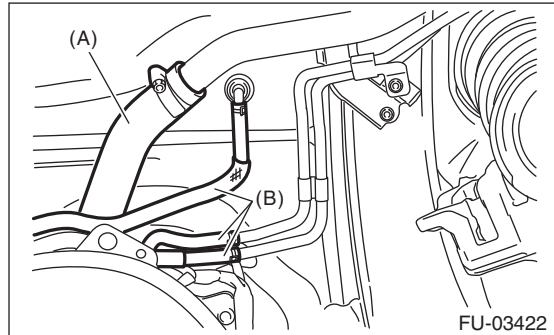

- (1) Hose
- (2) Clip or clamp
- (3) Pipe

Fuel Tank

FUEL INJECTION (FUEL SYSTEMS)

3) Connect the quick connector of the evaporation hose to the evaporation pipe.

CAUTION:

- Check that there is no damage or dust on the quick connector. If necessary, clean seal surface of pipe.
- When connecting the quick connector, insert the pipe all the way in securely, then operate the push lock.
- If it is not possible to perform the push lock operation of the retainer, recheck whether the pipe is securely inserted.
- Confirm that the quick connector is securely connected.

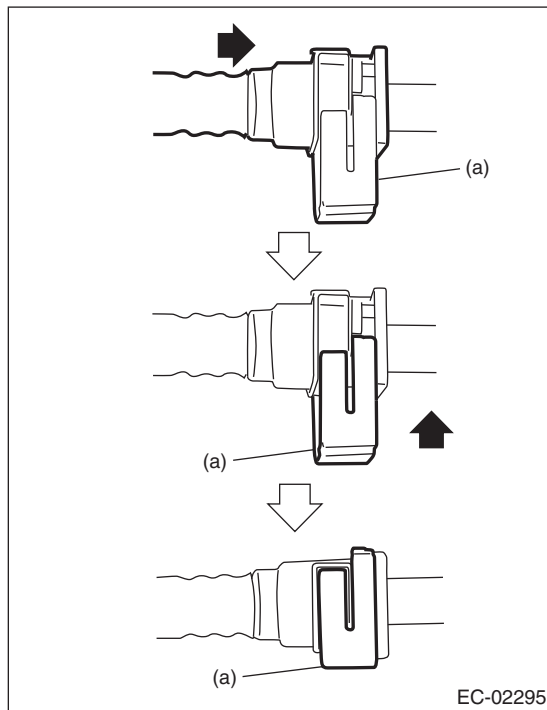

(a) Retainer

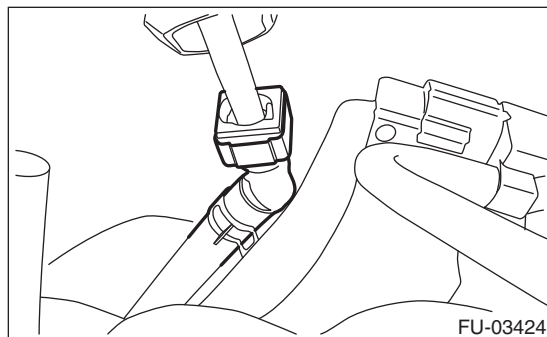

4) Connect evaporation hose (B) to connector (A).

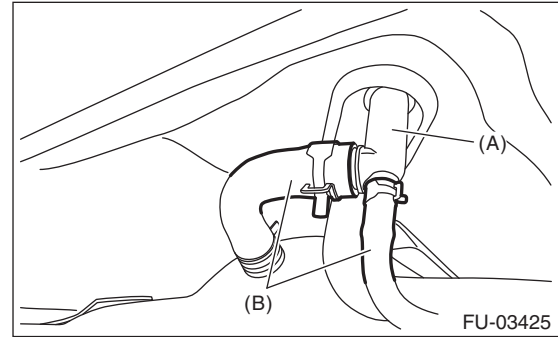

5) Tighten the fuel tank band bolts in the order shown in the figure.

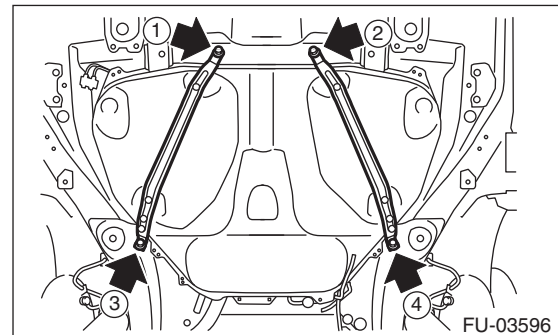

Tightening torque:

33 N·m (3.4 kgf-m, 24.3 ft-lb)

6) Install the rear suspension assembly.

WARNING:

A helper is required to perform this work.

- (1) Support the rear differential with the transmission jack.
- (2) Support the rear suspension assembly, and tighten the bolts which secure the rear suspension assembly to the body.

Tightening torque:

T1: 70 N·m (7.1 kgf-m, 51.6 ft-lb)

T2: 145 N·m (14.8 kgf-m, 106.9 ft-lb)

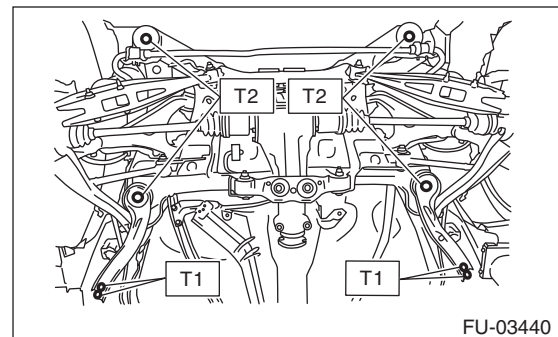

Fuel Tank

FUEL INJECTION (FUEL SYSTEMS)

- (3) Tighten the bolts which hold the rear shock absorber to the rear suspension arm.

Tightening torque:

120 N·m (12.2 kgf-m, 88.5 ft-lb)

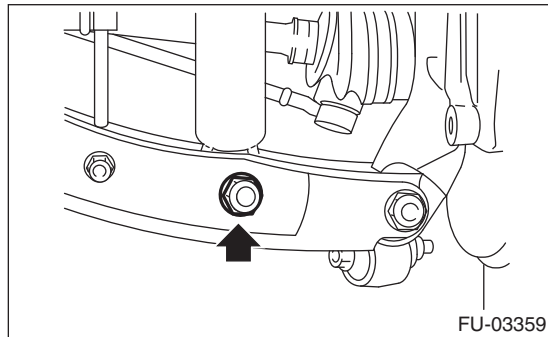

- 7) Install the rear vehicle height sensor. (models with auto headlight beam leveler, left side only)

Tightening torque:

7.5 N·m (0.8 kgf-m, 5.5 ft-lb)

- 8) Install the rear vehicle height sensor connector. (models with auto headlight beam leveler, left side only)

- 9) Connect drain hose (B) to canister drain connector (A).

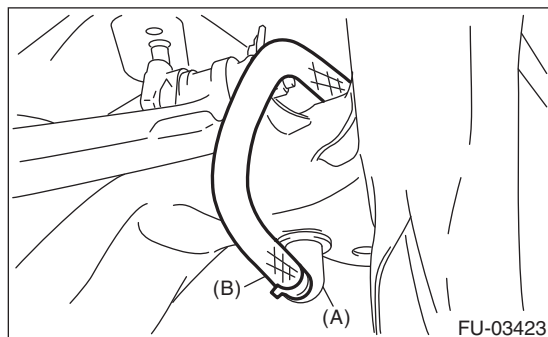

- 10) Tighten the bolts holding the parking brake cable clamp.

Tightening torque:

18 N·m (1.8 kgf-m, 13.3 ft-lb)

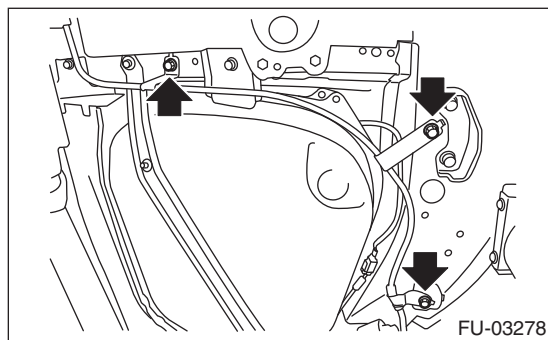

- 11) Connect the connector to the rear ABS wheel speed sensor.

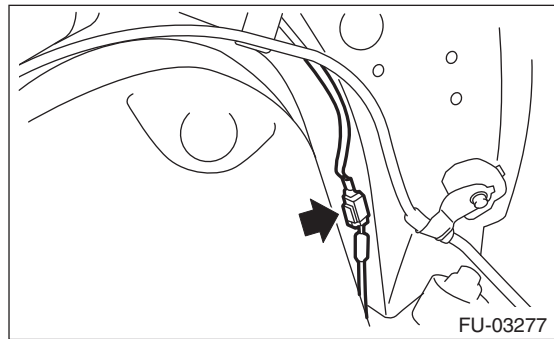

- 12) Install the heat shield cover.

Tightening torque:

18 N·m (1.8 kgf-m, 13.3 ft-lb)

- 13) Install the fuel tank protector.

Tightening torque:

Nut: 9 N·m (0.9 kgf-m, 6.6 ft-lb)

Bolt: 18 N·m (1.8 kgf-m, 13.3 ft-lb)

- 14) Install the propeller shaft. <Ref. to DS-11, INSTALLATION, Propeller Shaft.>

- 15) Install the rear exhaust pipe. <Ref. to EX(H4DOTC)-12, INSTALLATION, Rear Exhaust Pipe.>

- 16) Lower the vehicle.

- 17) Connect the parking brake cable to the parking brake assembly. <Ref. to PB-7, INSTALLATION, Parking Brake Assembly (Rear Disc Brake).>

- 18) Install the rear brake caliper. <Ref. to BR-21, INSTALLATION, Rear Disc Brake Assembly.>

- 19) Tighten the bolts which hold the rear brake hose bracket.

Tightening torque:

33 N·m (3.4 kgf-m, 24.3 ft-lb)

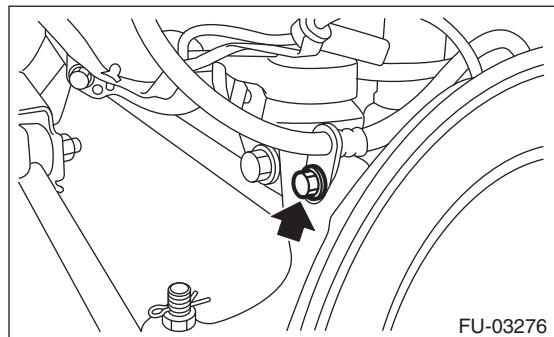

20) Attach the rear ABS wheel speed sensor to the rear housing.

Tightening torque:

7.5 N·m (0.8 kgf·m, 5.5 ft·lb)

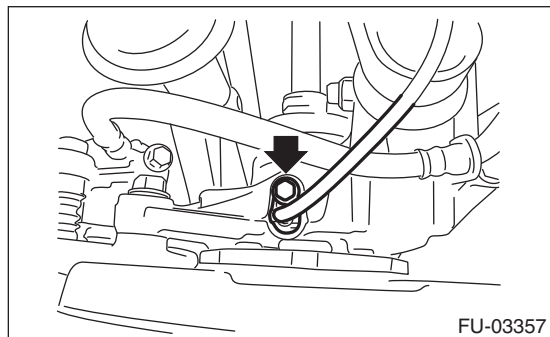

21) Install the rear wheels.

Tightening torque:

100 N·m (10.2 kgf·m, 73.8 ft·lb)

22) Connect the quick connector of fuel delivery tube (A) and fuel return tube (B). <Ref. to FU(H4DOTC)-74, INSTALLATION, Fuel Delivery, Return and Evaporation Lines.>

NOTE:

When connecting, be careful not to reverse the delivery side and return side.

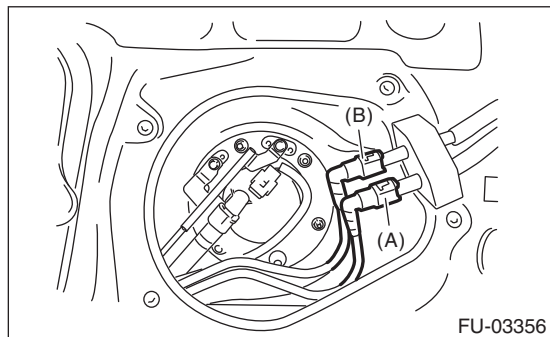

23) Install the service hole cover of fuel sub level sensor.

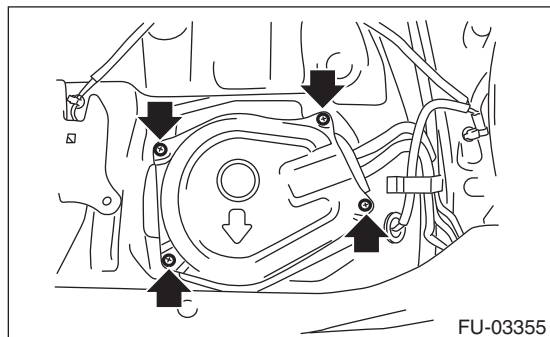

24) Attach the service hole cover of the fuel pump, and secure the connector and clip.

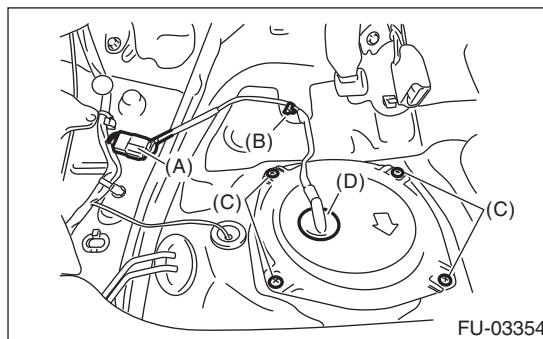

- (A) Connector
- (B) Clip
- (C) Bolt
- (D) Grommet

25) Install the rear seat cushion. <Ref. to SE-16, INSTALLATION, Rear Seat.>

26) Install the fuse of fuel pump to main fuse box.

27) Connect the ground cable to the battery.

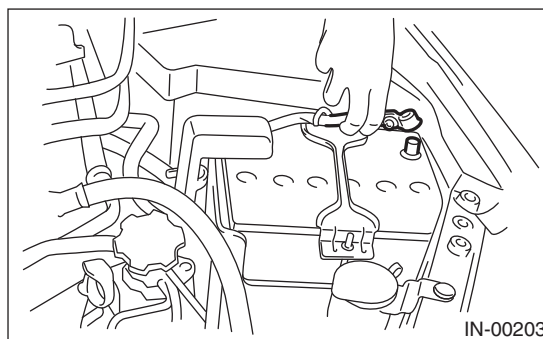

28) Inspect the wheel alignment and adjust if necessary.

29) Re-initialize the auto headlight beam leveler system. <Ref. to LI-15, PROCEDURE, Auto Headlight Beam Leveler System.>

C: INSPECTION

- 1) Check that the fuel tank does not have holes, cracks or is damaged in any other way.
- 2) Make sure that the fuel pipe and fuel hose are not cracked and that the connections are tight.

Fuel Filler Pipe

FUEL INJECTION (FUEL SYSTEMS)

25. Fuel Filler Pipe

A: REMOVAL

WARNING:

Place "NO OPEN FLAMES" signs near the working area.

CAUTION:

Be careful not to spill fuel.

- 1) Set the vehicle on a lift.
- 2) Release the fuel pressure. <Ref. to FU(H4DOTC)-51, RELEASING OF FUEL PRESSURE, PROCEDURE, Fuel.>
- 3) Drain fuel from fuel tank. <Ref. to FU(H4DOTC)-51, DRAINING FUEL (WITH SUBARU SELECT MONITOR), PROCEDURE, Fuel.>
- 4) Disconnect the ground cable from battery.

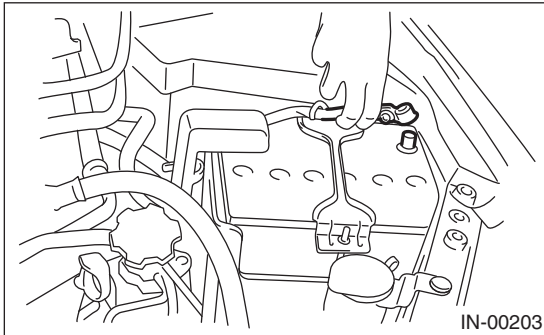

- 5) Open the fuel filler lid, and remove the fuel filler cap.
- 6) Remove the screws which secure gasket.

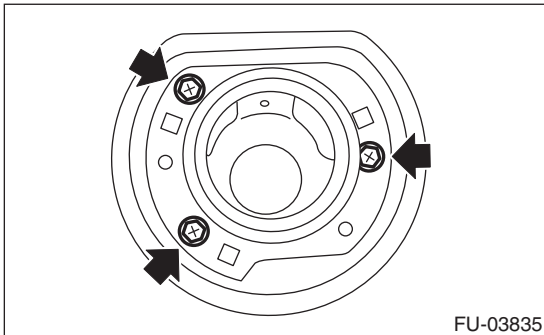

- 7) Remove the rear wheel RH.
- 8) Lift up the vehicle.
- 9) Remove the mud guard. <Ref. to EI-27, REMOVAL, Mud Guard.>
- 10) Remove the rear sub frame. <Ref. to RS-15, REMOVAL, Rear Sub Frame.>

- 11) Remove the bolts which hold fuel filler pipe bracket on the body.

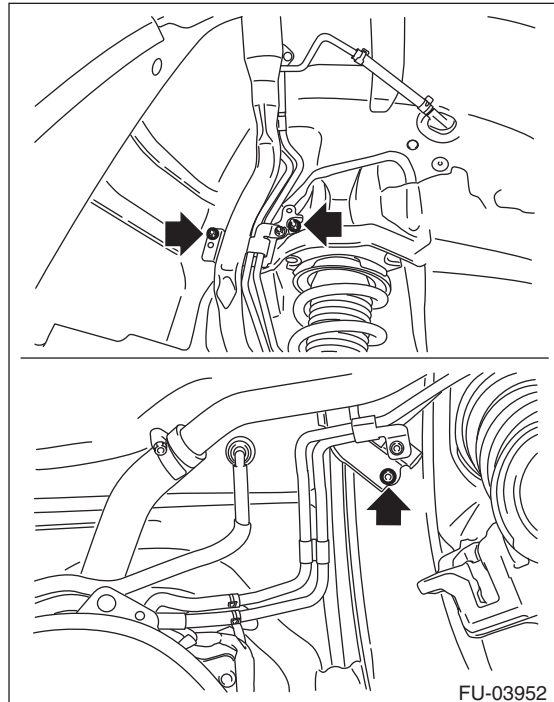

- 12) Loosen the clamp, and disconnect the fuel filler hose (A) and evaporation hose (B).

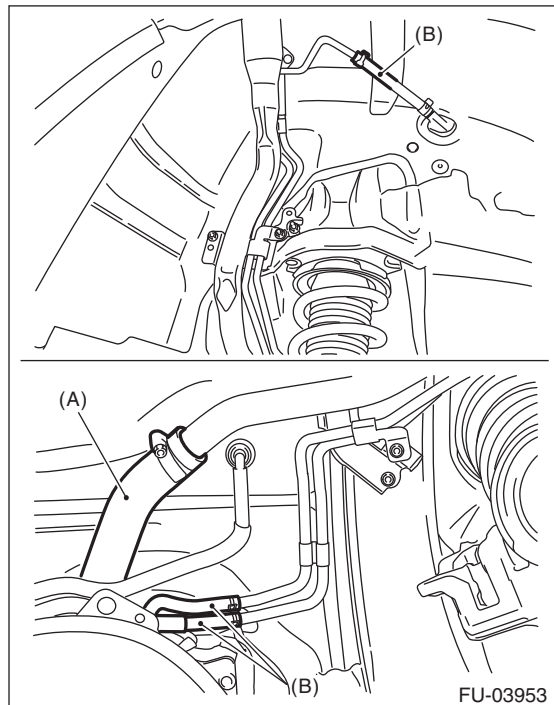

- 13) Remove the fuel filler pipe to the underside of the vehicle.

Fuel Filler Pipe

B: INSTALLATION

- 1) Open the fuel filler lid.
- 2) Set the fuel saucer (A) with rubber seal (C), and insert the fuel filler pipe into hole from the inner side of apron.
- 3) Align the holes in fuel filler pipe neck and set the cup (B), and tighten the screws.

NOTE:

If the edges of rubber seal are folded toward inside, straighten it with a flat tip screwdriver.

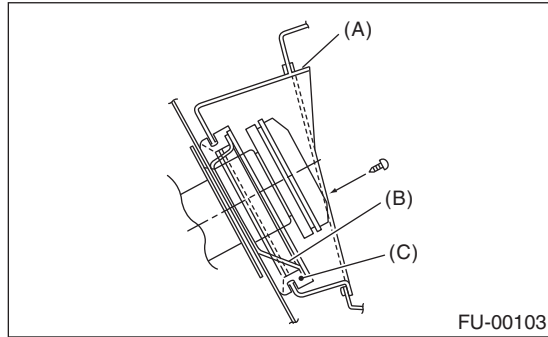

- 4) Securely insert the fuel filler hose (A) and evaporation hose (B) to the specified position, then tighten the clamp.

Tightening torque:

2.5 N·m (0.3 kgf·m, 1.8 ft·lb)

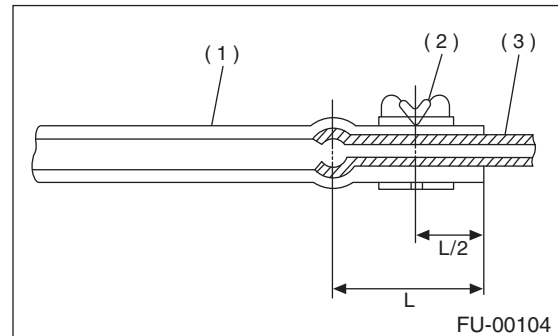
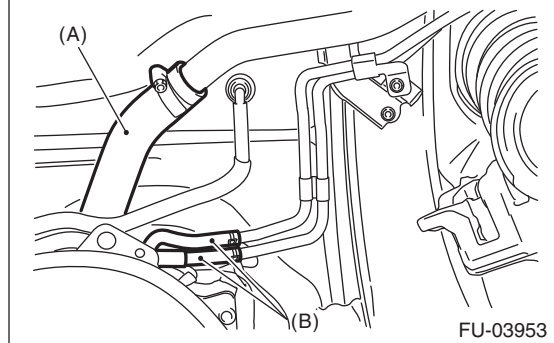
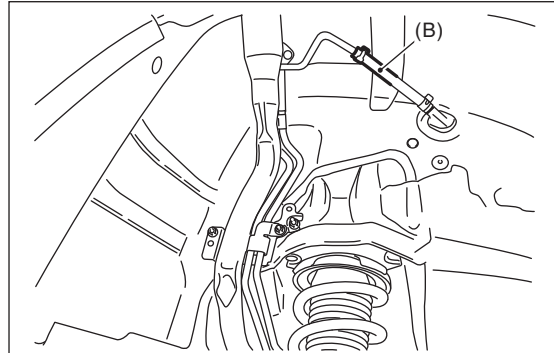

- (1) Hose
- (2) Clip or clamp
- (3) Pipe

Fuel Filler Pipe

FUEL INJECTION (FUEL SYSTEMS)

5) Tighten the bolts which hold fuel filler pipe bracket on the body.

Tightening torque:

7.5 N·m (0.8 kgf·m, 5.5 ft·lb)

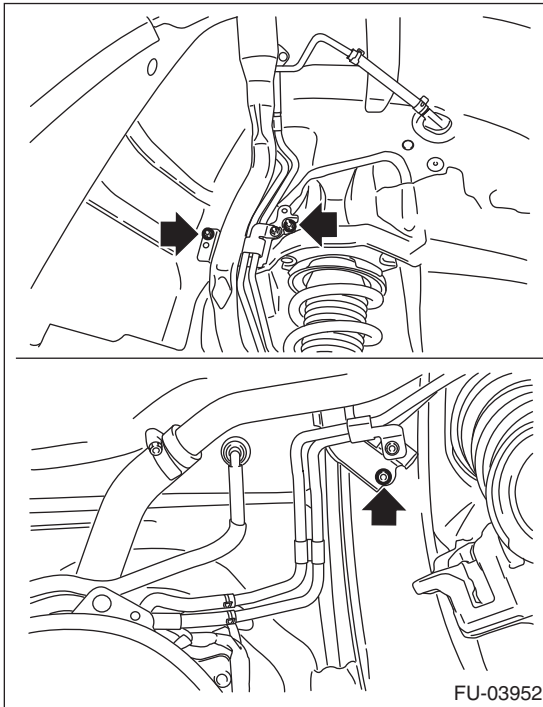

6) Install the rear sub frame. <Ref. to RS-16, INSTALLATION, Rear Sub Frame.>

7) Install the mud guard. <Ref. to EI-27, REMOVAL, Mud Guard.>

8) Lower the vehicle.

9) Install the rear wheel RH.

Tightening torque:

100 N·m (10.2 kgf·m, 73.8 ft·lb)

10) Connect the ground cable to the battery.

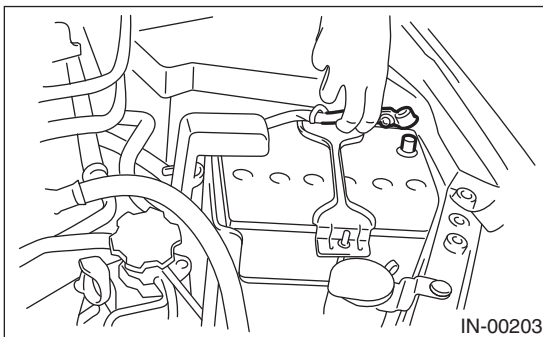

11) Inspect the wheel alignment and adjust if necessary.

12) Re-initialize the auto headlight beam leveler system. <Ref. to LI-15, PROCEDURE, Auto Headlight Beam Leveler System.>

C: INSPECTION

1) Check that the fuel filler pipe does not have holes, cracks or is damaged in any other way.

2) Make sure that the fuel hose is not cracked and that the connections are tight.

D: DISASSEMBLY

1) Remove the shut valve from the fuel filler pipe. <Ref. to EC(H4DOTC)-20, REMOVAL, Shut Valve.>

2) Remove the nut which holds the evaporation pipe assembly to the fuel filler pipe.

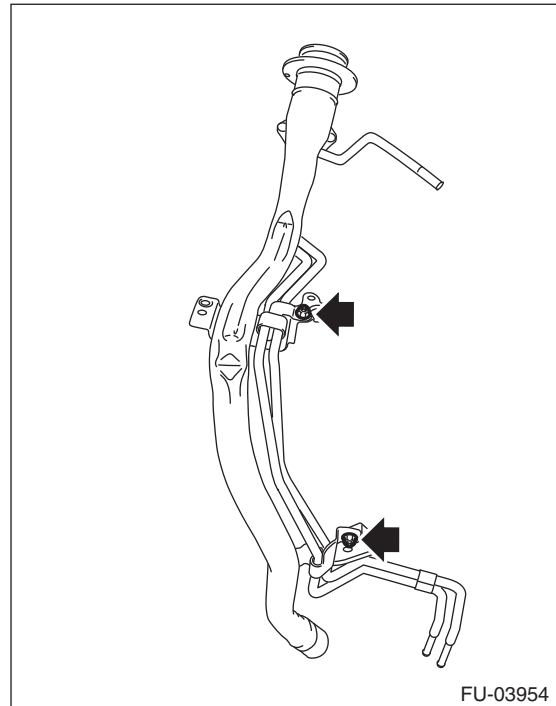

E: ASSEMBLY

1) Tighten the nuts which secure the evaporation pipe assembly to the fuel filler pipe.

Tightening torque:

7.5 N·m (0.8 kgf·m, 5.5 ft·lb)

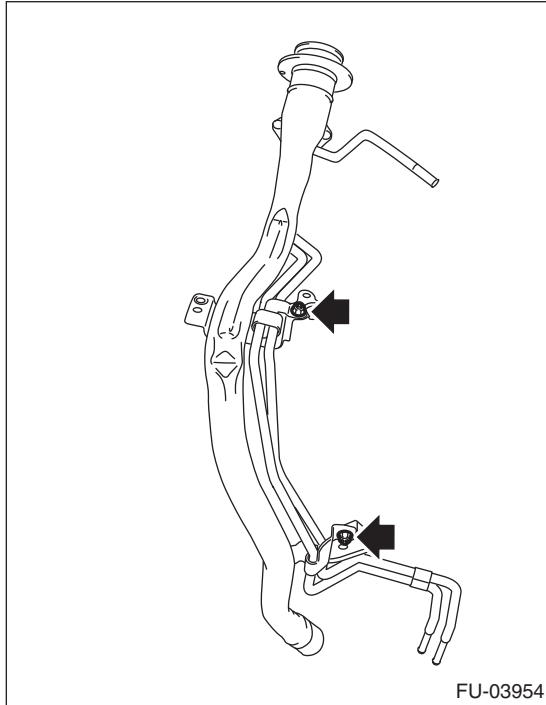

2) Install the shut valve to the fuel filler pipe. <Ref. to EC(H4DOTC)-20, INSTALLATION, Shut Valve.>

Fuel Pump

FUEL INJECTION (FUEL SYSTEMS)

26. Fuel Pump

A: REMOVAL

WARNING:

Place "NO OPEN FLAMES" signs near the working area.

CAUTION:

- Be careful not to spill fuel.
- When the fuel meter indication is higher than two third of the total, perform the work after draining the fuel not to spill the fuel.

NOTE:

Fuel pump assembly consists of fuel pump, fuel filter and fuel level sensor.

- 1) Release the fuel pressure. <Ref. to FU(H4DOTC)-51, RELEASING OF FUEL PRESSURE, PROCEDURE, Fuel.>
- 2) Drain fuel. <Ref. to FU(H4DOTC)-51, DRAINING FUEL (WITH SUBARU SELECT MONITOR), PROCEDURE, Fuel.>
- 3) Disconnect the ground cable from battery.

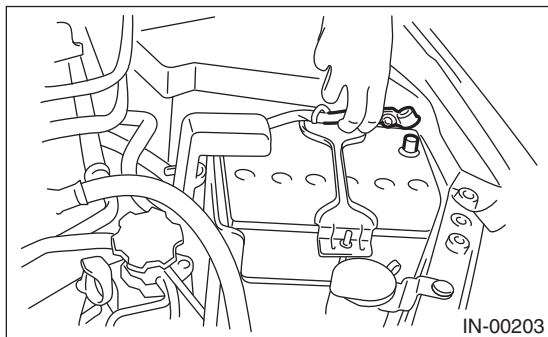

- 4) Remove the rear seat cushion. <Ref. to SE-15, REMOVAL, Rear Seat.>
- 5) Remove the service hole cover.

- (1) Remove the bolt (A).
- (2) Push the grommet (B) down and remove the service hole cover.

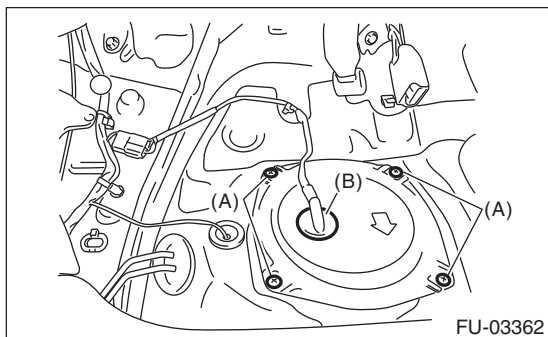

- 6) Disconnect the connector from fuel pump.

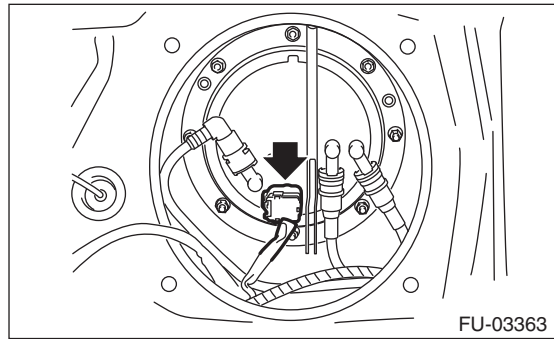

- 7) Disconnect the quick connector, then disconnect the fuel delivery tube, fuel return tube, and jet pump tube. <Ref. to FU(H4DOTC)-72, REMOVAL, Fuel Delivery, Return and Evaporation Lines.>
- 8) Remove the nuts which install fuel pump assembly onto fuel tank.

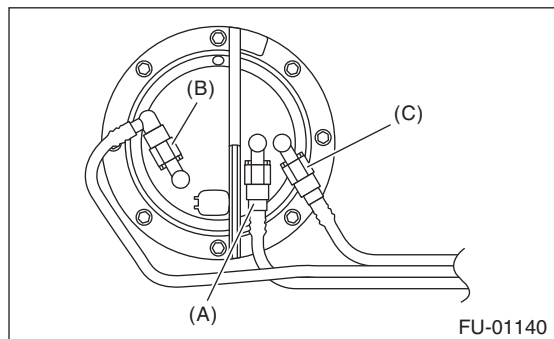

- (A) Fuel delivery tube
- (B) Fuel return tube
- (C) Fuel jet pump tube

- 9) Remove the fuel pump assembly from the fuel tank.

B: INSTALLATION

Install in the reverse order of removal while being careful of the following.

- Make sure the sealing portion is free from fuel or foreign matter before installation.
- Install with the protrusion (A) of gasket aimed at the front side of the vehicle.
- Insert the protrusion (B) of gasket to the upper plate. (3 places)
- Align the protrusion (C) of fuel pump assembly with the cutout on the upper plate.
- Tighten the nuts to the specified torque in the order as shown in the figure.

NOTE:

Use a new gasket and retainer.

Tightening torque:

4.4 N·m (0.4 kgf·m, 3.2 ft·lb)

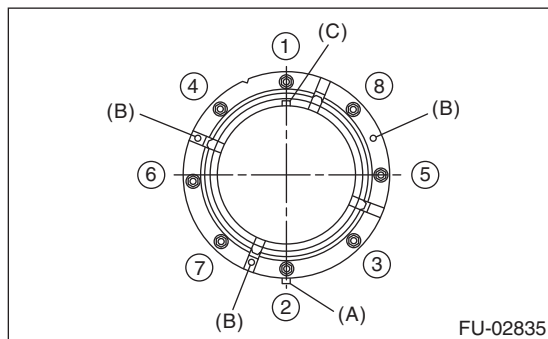

C: INSPECTION

Connect the lead harness to the connector terminal of fuel pump, and apply the battery power supply to check whether the pump operates.

WARNING:

- **Wipe off fuel completely.**
- **Keep the battery as far apart from fuel pump as possible.**
- **Be sure to perform the ON/OFF operation on the battery side.**
- **Do not run the fuel pump for a long time under non-load condition.**

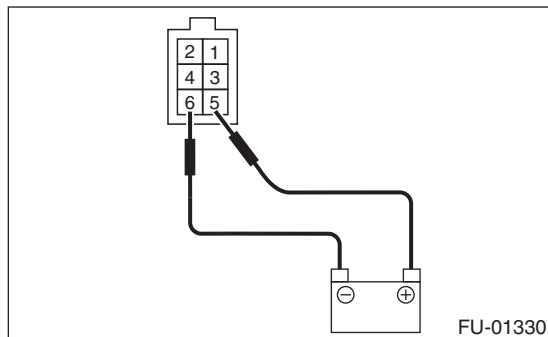

Fuel Level Sensor

FUEL INJECTION (FUEL SYSTEMS)

27. Fuel Level Sensor

A: REMOVAL

WARNING:

Place "NO OPEN FLAMES" signs near the working area.

CAUTION:

- Be careful not to spill fuel.
- When the fuel meter indication is higher than two third of the total, perform the work after draining the fuel not to spill the fuel.

NOTE:

The fuel level sensor is built in fuel pump assembly.

- 1) Remove the fuel pump assembly. <Ref. to FU(H4DOTC)-64, REMOVAL, Fuel Pump.>
- 2) Disconnect the connector from fuel pump bracket.
- 3) Remove the fuel temperature sensor.
- 4) Remove the fuel level sensor.

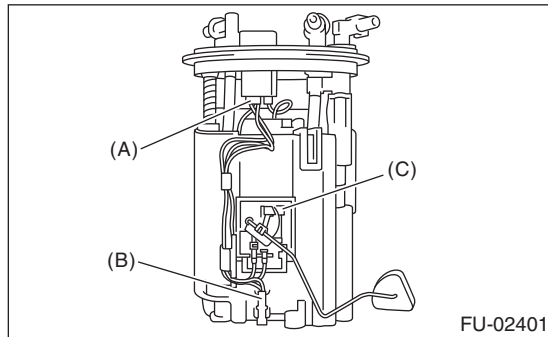

- (A) Connector
- (B) Fuel temperature sensor
- (C) Fuel level sensor

B: INSTALLATION

Install in the reverse order of removal.

NOTE:

Use a new gasket.

Tightening torque:

4.4 N·m (0.4 kgf-m, 3.2 ft-lb)

28. Fuel Sub Level Sensor

A: REMOVAL

WARNING:

Place "NO OPEN FLAMES" signs near the working area.

CAUTION:

- Be careful not to spill fuel.
- When the fuel meter indication is higher than two third of the total, perform the work after draining the fuel not to spill the fuel.

1) Release the fuel pressure. <Ref. to FU(H4DOTC)-51, RELEASING OF FUEL PRESSURE, PROCEDURE, Fuel.>

2) Drain fuel. <Ref. to FU(H4DOTC)-51, DRAINING FUEL (WITH SUBARU SELECT MONITOR), PROCEDURE, Fuel.>

3) Disconnect the ground cable from battery.

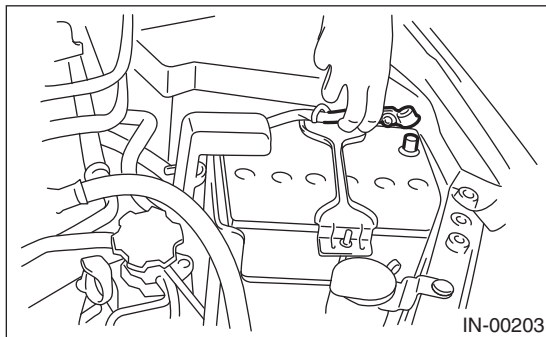

4) Remove the rear seat cushion. <Ref. to SE-15, REMOVAL, Rear Seat.>

5) Remove the service hole cover.

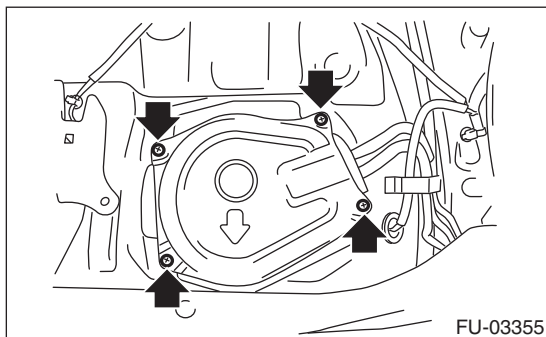

6) Disconnect the connector from the fuel sub level sensor.

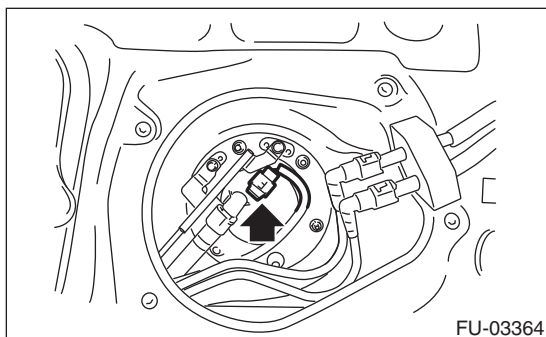

7) Disconnect the quick connector, then disconnect the fuel delivery tube, fuel return tube, and jet pump tube. <Ref. to FU(H4DOTC)-72, REMOVAL, Fuel Delivery, Return and Evaporation Lines.>

8) Remove the nuts and bolts which install fuel sub level sensor on fuel tank.

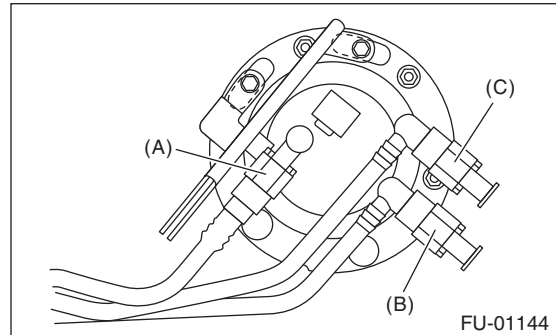

- (A) Jet pump tube
- (B) Fuel delivery tube
- (C) Fuel return tube

9) Remove the fuel sub level sensor.

Fuel Sub Level Sensor

FUEL INJECTION (FUEL SYSTEMS)

B: INSTALLATION

Install in the reverse order of removal while being careful of the following.

- Make sure the sealing portion is free from fuel or foreign matter before installation.
- Align the protrusion (A) of gasket to the position shown in the following figure.
- Align the protrusion (B) of fuel sub level sensor with the cutout portion of fuel sub level sensor upper plate.
- Tighten the nuts and bolts to the specified torque in the order as shown in the figure.

NOTE:

Use a new gasket and retainer.

Tightening torque:

4.4 N·m (0.45 kgf·m, 3.2 ft·lb)

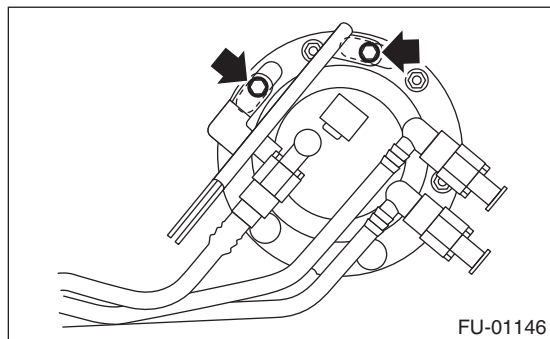
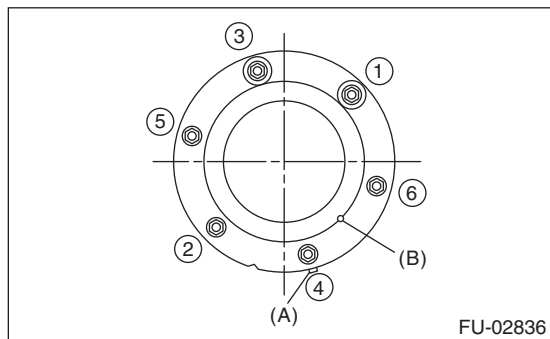

29. Fuel Filter

A: SPECIFICATION

Fuel filter forms a single unit with fuel pump.

Refer to "Fuel Pump" for removal and installation.

<Ref. to FU(H4DOTC)-64, REMOVAL, Fuel Pump.>

<Ref. to FU(H4DOTC)-65, INSTALLATION, Fuel Pump.>

Fuel Damper

FUEL INJECTION (FUEL SYSTEMS)

30. Fuel Damper

A: REMOVAL

WARNING:

Place "NO OPEN FLAMES" signs near the working area.

CAUTION:

- Be careful not to spill fuel.
- Catch the fuel from hoses using a container or cloth.

1) Release the fuel pressure. <Ref. to FU(H4DOTC)-51, RELEASING OF FUEL PRESSURE, PROCEDURE, Fuel.>

2) Remove the fuel damper from fuel delivery hose (A) and fuel return hose (B).

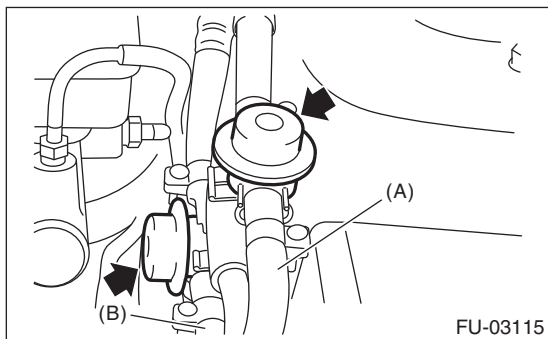

B: INSTALLATION

CAUTION:

If fuel hoses or clamps are damaged, replace them with new parts.

Install in the reverse order of removal.

Tightening torque:

1.25 N·m (0.1 kgf-m, 0.9 ft-lb)

31.Purge Damper

A: REMOVAL

WARNING:

Place “NO OPEN FLAMES” signs near the working area.

1) Remove the purge damper from the purge damper stay.

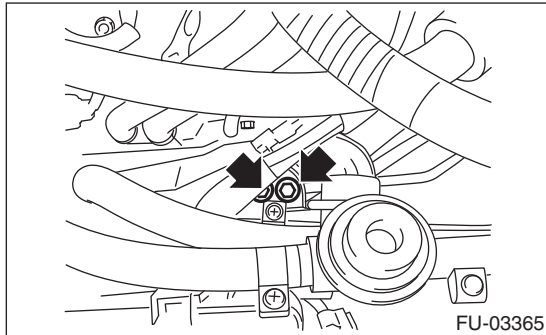

2) Disconnect the evaporation hose from the purge damper.

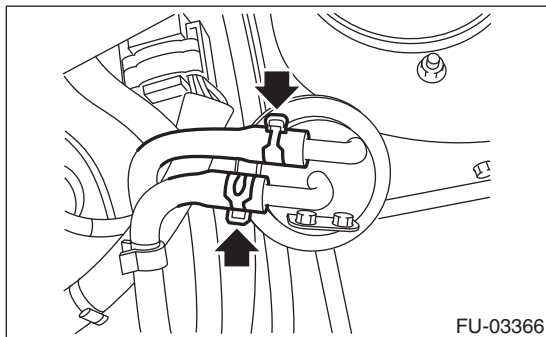

B: INSTALLATION

CAUTION:

If there is damage on the evaporation hose, replace with a new hose.

Install in the reverse order of removal.

Tightening torque:

8 N·m (0.8 kgf·m, 5.9 ft·lb)

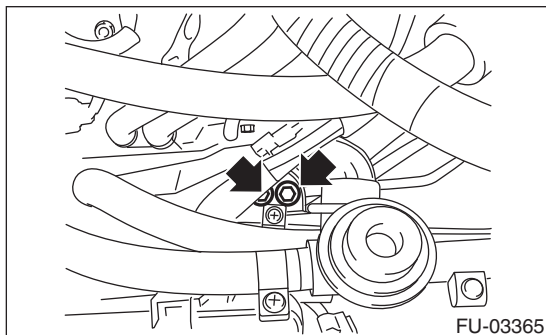

Fuel Delivery, Return and Evaporation Lines

FUEL INJECTION (FUEL SYSTEMS)

32. Fuel Delivery, Return and Evaporation Lines

A: REMOVAL

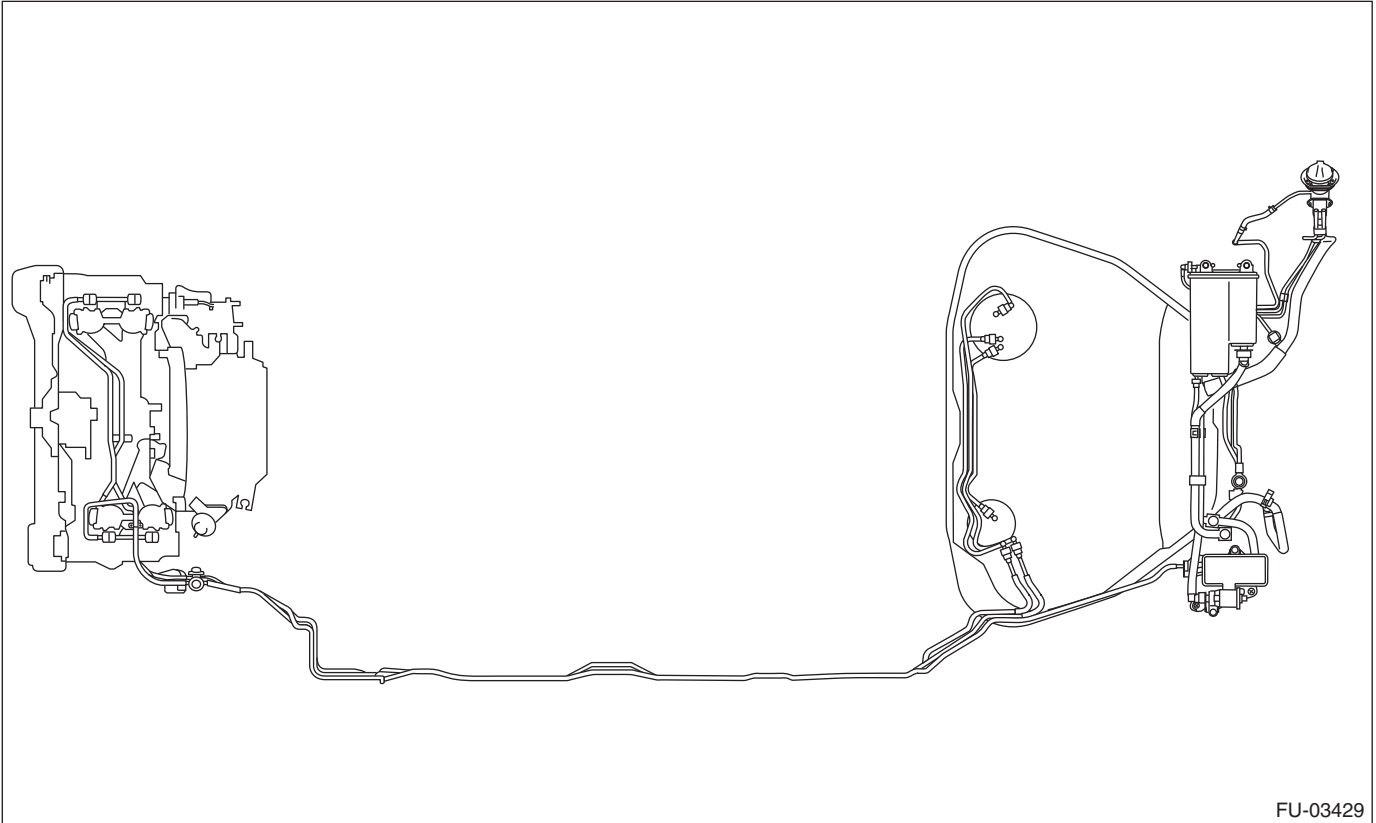

WARNING:
Place "NO OPEN FLAMES" signs near the working area.

CAUTION:
Be careful not to spill fuel.

Fuel Delivery, Return and Evaporation Lines

FUEL INJECTION (FUEL SYSTEMS)

- 1) Set the vehicle on a lift.
- 2) Release the fuel pressure. <Ref. to FU(H4DOTC)-51, RELEASING OF FUEL PRESSURE, PROCEDURE, Fuel.>
- 3) Open the fuel filler lid, and remove the fuel filler cap.
- 4) Remove the floor mat. <Ref. to EI-61, REMOVAL, Floor Mat.>
- 5) In the engine compartment, disconnect the fuel delivery hose, fuel return hose and evaporation hose.

(1) Disconnect the quick connector on the fuel delivery line and return line by pushing the ST in the direction of the arrow.

ST 42099AE000 QUICK CONNECTOR RELEASE

(2) Remove the clip and disconnect the evaporation hose from the fuel pipe.

CAUTION:

- Be careful not to spill fuel.
- Catch the fuel from hoses using a container or cloth.

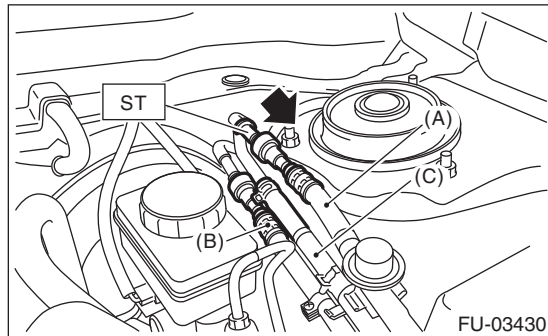

- (A) Fuel delivery hose
- (B) Fuel return hose
- (C) Evaporation hose

- 6) Remove the canister. <Ref. to EC(H4DOTC)-7, REMOVAL, Canister.>
- 7) Remove the fuel tank. <Ref. to FU(H4DOTC)-53, REMOVAL, Fuel Tank.>
- 8) Remove the fuel pipe assembly.

- 9) Disconnect the quick connector, then disconnect the fuel delivery tube, fuel return tube, and jet pump tube.

(1) Clean the pipe and connector, if they are covered with dust.

(2) To prevent from damaging or entering foreign matter, wrap the pipes and connectors with plastic bag etc.

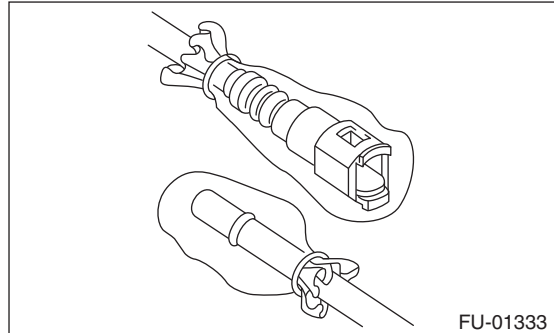

(3) Hold the connector (A) and push the retainer (B) down.

(4) Pull out the connector (A) from the retainer (B).

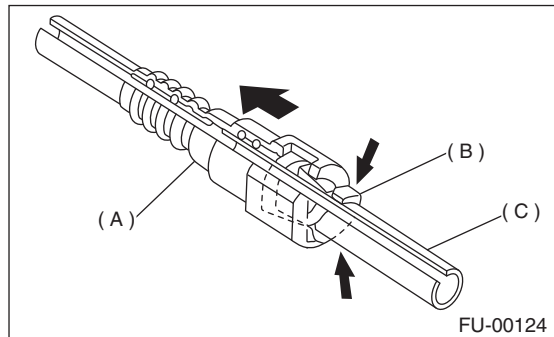

- (A) Connector
- (B) Retainer
- (C) Pipe

Fuel Delivery, Return and Evaporation Lines

FUEL INJECTION (FUEL SYSTEMS)

B: INSTALLATION

Install in the reverse order of removal while being careful of the following.

1. CONNECTING THE FUEL LINE QUICK CONNECTOR

CAUTION:

Make sure there are no damage or dust on connections. If necessary, clean seal surface of pipe.

NOTE:

Use a new retainer.

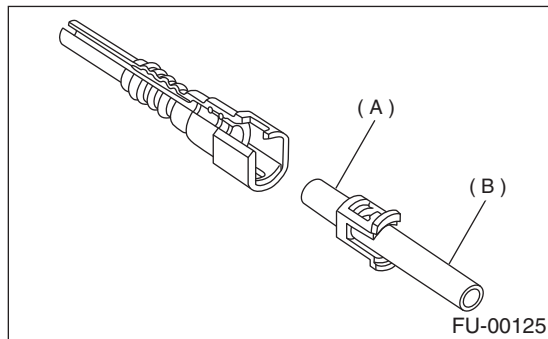

- (A) Seal surface
- (B) Pipe

1) Set the new retainer (B) to connector (A).

2) Push the pipe into the connector completely.

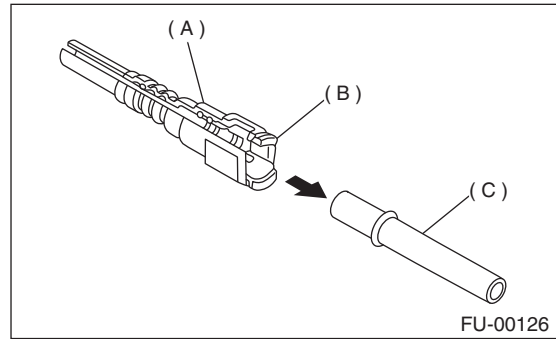

- (A) Connector
- (B) Retainer
- (C) Pipe

CAUTION:

- Pull the connector to ensure it is connected securely.
- Make sure the two retainer claws are engaged in their mating positions in the connector.
- Be sure to inspect hoses and their connections for any leakage of fuel.

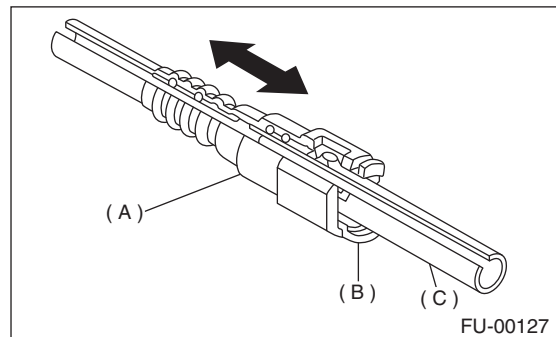

- (A) Connector
- (B) Retainer
- (C) Pipe

2. CONNECT FUEL DELIVERY HOSE AND FUEL RETURN HOSE

Connect the fuel delivery hose and fuel return hose to the pipe with an overlap of 20 to 25 mm (0.79 to 0.98 in).

Type A: When the amount to be inserted is specified.

Type B: When the amount to be inserted is not specified.

L1: 2.5 ± 1.5 mm (0.098 ± 0.059 in)

L2: 22.5 ± 2.5 mm (0.886 ± 0.098 in)

CAUTION:

Be sure to inspect hoses and their connections for any leakage of fuel.

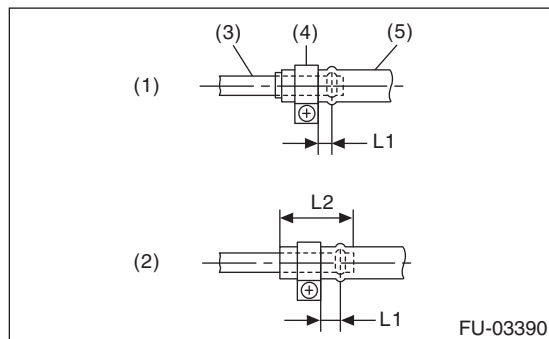

- (1) Type A
- (2) Type B
- (3) Pipe
- (4) Clamp
- (5) Hose

3. EVAPORATION HOSE CONNECTION

Connect the evaporation hose to the pipe with an overlap of 15 to 20 mm (0.59 to 0.79 in).

L = 17.5 ± 2.5 mm (0.689 ± 0.098 in)

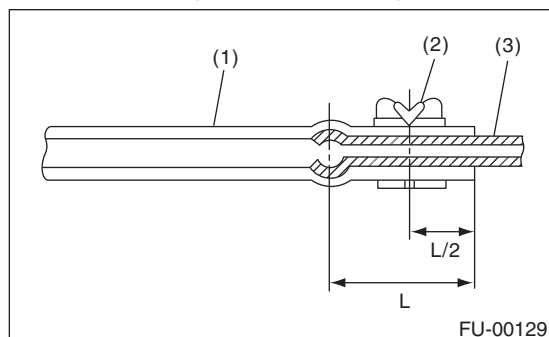

- (1) Hose
- (2) Clip
- (3) Pipe

C: INSPECTION

- 1) Make sure that there are no cracks on the fuel pipes and fuel hoses.
- 2) Make sure the fuel pipe and fuel hose connections are tightened firmly.

Fuel System Trouble in General

FUEL INJECTION (FUEL SYSTEMS)

33. Fuel System Trouble in General

A: INSPECTION

Trouble and possible cause		Corrective action
1. Insufficient fuel supply to injector		
1)	Fuel pump does not operate.	
	○ Defective terminal contact	Inspect contact, especially ground, and tighten it securely.
	○ Trouble in electromagnetic or electronic circuit parts	Replace the faulty parts.
2)	Decline of fuel pump function	Replace the fuel pump.
3)	Clogged fuel filter	Replace the fuel pump.
4)	Clogged or bent fuel pipe or hose	Clean, correct or replace the fuel pipe or hose.
5)	Air is mixed in the fuel system.	Inspect or retighten each connection part.
6)	Clogged or bent air breather tube or pipe.	Clean, correct or replace the air breather tube or pipe.
7)	Damaged diaphragm of pressure regulator	Replace.
2. Leakage or blow out of fuel		
1)	Loose joints of the fuel pipe	Retighten.
2)	Cracked fuel pipe, hose and fuel tank	Replace.
3)	Defective welding part on the fuel tank	Replace.
4)	Clogged or bent air breather tube or air vent tube	Clean, correct or replace the air breather tube or air vent tube.
3. Gasoline smell inside of compartment		
1)	Loose joints at air breather tube, air vent tube and fuel filler pipe	Retighten.
2)	Problem in tightness of the fuel saucer gasket air	Correct or replace the gasket.
3)	Inoperative fuel pump modulator or circuit	Replace.
4. Defective fuel meter indicator		
1)	Defective operation of fuel level sensor	Replace.
2)	Defective operation of fuel meter	Replace.
5. Noise		
1)	Large operation noise or vibration of fuel pump	Replace.

NOTE:

- When the vehicle is left unattended for an extended period of time, water may accumulate in the fuel tank. Fill fuel fully to prevent the problem.
- In snow-covered areas, mountainous areas, skiing areas, etc. where ambient temperatures drop below 0°C (32°F) throughout the winter season, use a water removing agent in the fuel system to prevent freezing fuel system and accumulating water.
- When water is accumulated in fuel filter, fill the water removing agent in the fuel tank.
- Before using water removing agent, follow the cautions noted on the bottle.

EMISSION CONTROL (AUX. EMISSION CONTROL DEVICES) *EC(H4DOTC)*

	Page
1. General Description	2
2. Front Catalytic Converter	5
3. Rear Catalytic Converter	6
4. Canister	7
5. Purge Control Solenoid Valve	11
6. Fuel Level Sensor	14
7. Fuel Temperature Sensor	15
8. Fuel Sub Level Sensor	16
9. Fuel Tank Pressure Sensor	17
10. Pressure Control Solenoid Valve	18
11. Drain Filter	19
12. Shut Valve	20
13. Drain Valve	21
14. PCV Hose Assembly	22
15. Secondary Air Pump	23
16. Secondary Air Combination Valve	24

General Description

EMISSION CONTROL (AUX. EMISSION CONTROL DEVICES)

1. General Description

A: COMPONENT

1. SECONDARY AIR PUMP

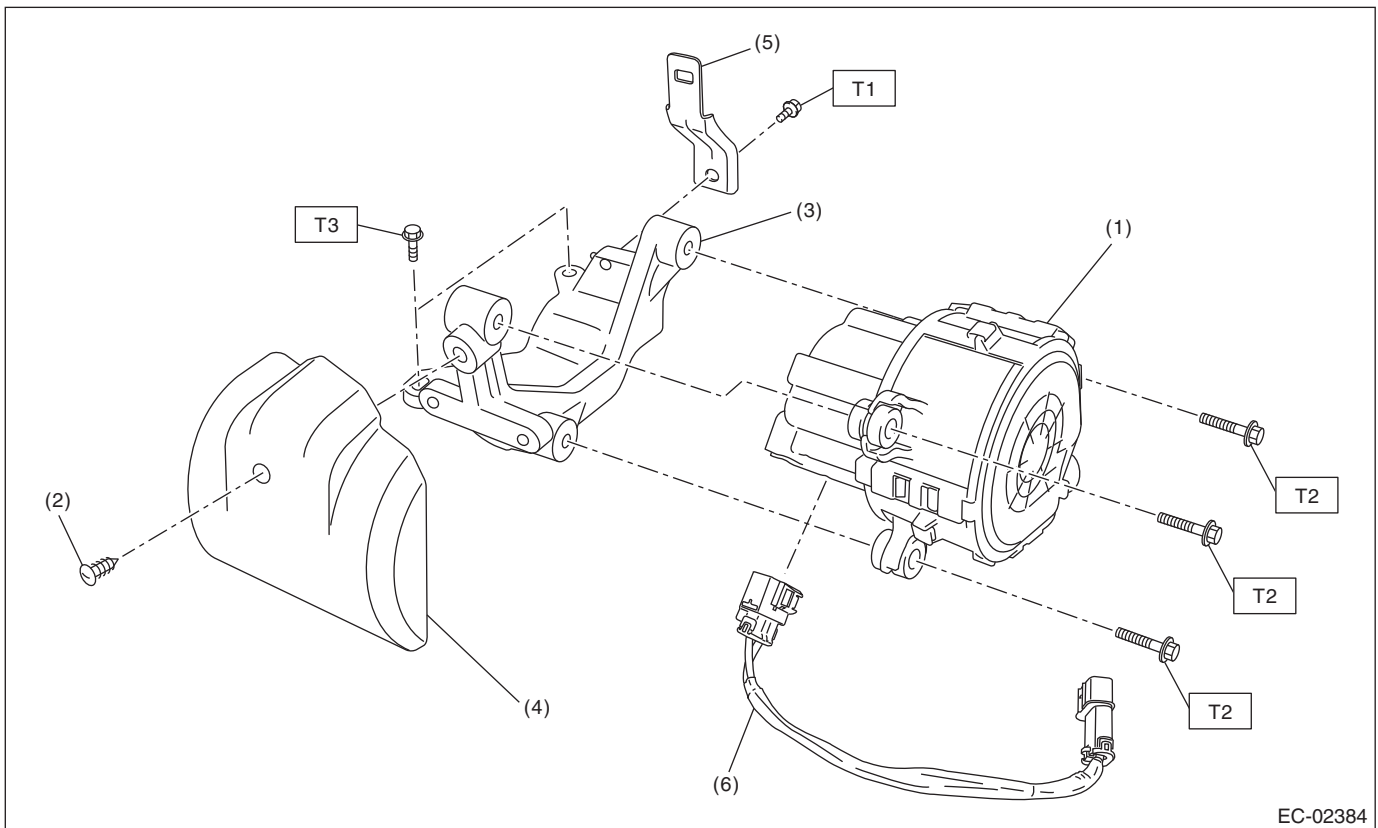

- | | |
|--------------------------------|--------------------------------|
| (1) Secondary air pump | (4) Secondary air pump cover |
| (2) Clip | (5) Harness stay |
| (3) Secondary air pump bracket | (6) Secondary air pump harness |

Tightening torque: N·m (kgf·m, ft·lb)

T1: 6.4 (0.7, 4.7)

T2: 9 (0.9, 6.6)

T3: 19 (1.9, 14.0)

General Description

EMISSION CONTROL (AUX. EMISSION CONTROL DEVICES)

2. SECONDARY AIR COMBINATION VALVE

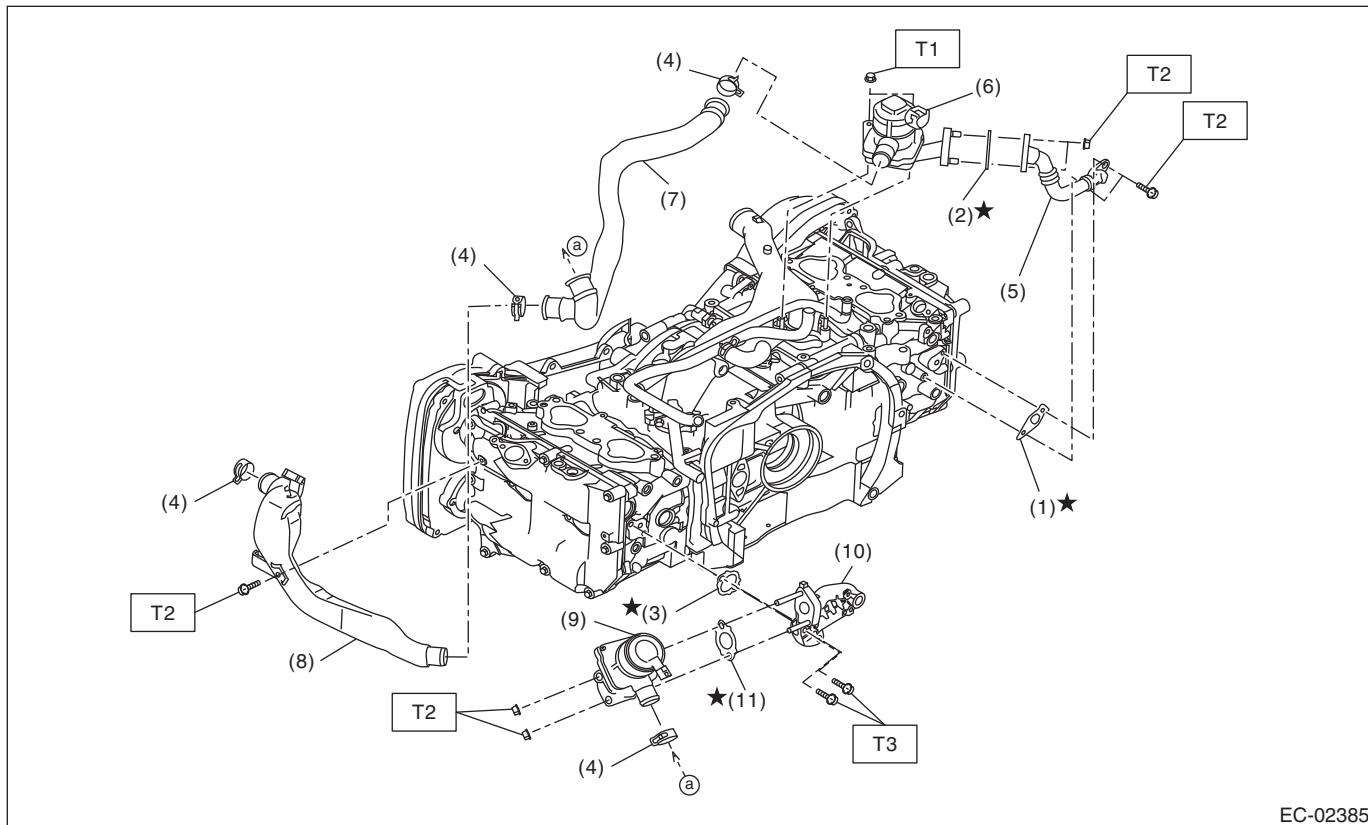

- | | |
|--|--|
| (1) Gasket | (7) Air duct A |
| (2) Gasket | (8) Air duct B |
| (3) Gasket | (9) Secondary air combination valve LH |
| (4) Clamp | (10) Secondary air pipe LH |
| (5) Secondary air pipe RH | (11) Gasket |
| (6) Secondary air combination valve RH | |

Tightening torque: N-m (kgf-m, ft-lb)

T1: 6.4 (0.7, 4.7)

T2: 9 (0.9, 6.6)

T3: 19 (1.9, 14.0)

General Description

EMISSION CONTROL (AUX. EMISSION CONTROL DEVICES)

B: CAUTION

- Wear appropriate work clothing, including a cap, protective goggles and protective shoes when performing any work.
- Remove contamination including dirt and corrosion before removal, installation or disassembly.
- Keep the disassembled parts in order and protect them from dust and dirt.
- Before removal, installation or disassembly, be sure to clarify the failure. Avoid unnecessary removal, installation, disassembly and replacement.
- Vehicle components are extremely hot after driving. Be wary of receiving burns from heated parts.
- Be sure to tighten fasteners including bolts and nuts to the specified torque.
- Place shop jacks or rigid racks at the specified points.
- Before disconnecting connectors of sensors or units, be sure to disconnect the ground cable from the battery.

C: PREPARATION TOOL

1. SPECIAL TOOL

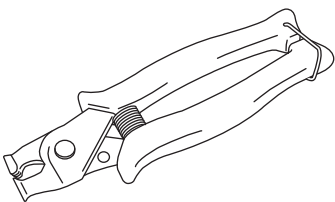
ILLUSTRATION	TOOL NUMBER	DESCRIPTION	REMARKS
 ST18353AA000	18353AA000	CLAMP PLIERS	<ul style="list-style-type: none">• Used for removing and installing the PCV hose.• This is a general tool made by the French company CAILLAU. (code) 54.0.000.205 To make this easier to obtain in the same way as genuine Subaru parts, it has been provided with a tool number as an ST.

Front Catalytic Converter

EMISSION CONTROL (AUX. EMISSION CONTROL DEVICES)

2. Front Catalytic Converter

A: REMOVAL

The front catalytic converter is integrated into the center exhaust pipe (front). Refer to “Center Exhaust Pipe” for removal procedures. <Ref. to EX(H4DOTC)-7, REMOVAL, Center Exhaust Pipe.>

B: INSTALLATION

The front catalytic converter is integrated into the center exhaust pipe (front). Refer to “Center Exhaust Pipe” for installation procedures. <Ref. to EX(H4DOTC)-8, INSTALLATION, Center Exhaust Pipe.>

C: INSPECTION

- 1) Check the connections and welds for exhaust leaks.
- 2) Make sure there are no holes or rusting.

Rear Catalytic Converter

EMISSION CONTROL (AUX. EMISSION CONTROL DEVICES)

3. Rear Catalytic Converter

A: REMOVAL

The rear catalytic converter is integrated into the center exhaust pipe (rear). Refer to "Center Exhaust Pipe" for removal procedures. <Ref. to EX(H4DOTC)-7, REMOVAL, Center Exhaust Pipe.>

B: INSTALLATION

The rear catalytic converter is integrated into the center exhaust pipe (rear). Refer to "Center Exhaust Pipe" for installation procedures. <Ref. to EX(H4DOTC)-8, INSTALLATION, Center Exhaust Pipe.>

C: INSPECTION

- 1) Check the connections and welds for exhaust leaks.
- 2) Make sure there are no holes or rusting.

Canister

EMISSION CONTROL (AUX. EMISSION CONTROL DEVICES)

4. Canister

A: REMOVAL

1) Disconnect the ground cable from the battery.

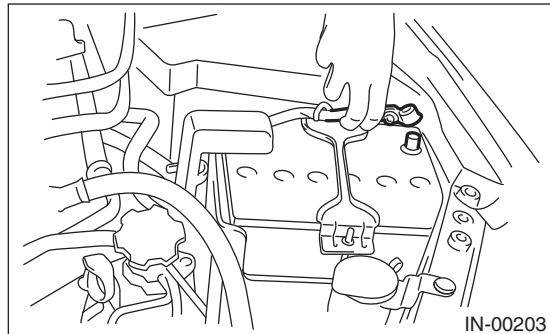

2) Open the rear gate, and remove the luggage floor mat.

3) Remove the center sub trunk (A) (model with center sub trunk), and remove the sub trunk RH (B) and sub trunk LH (C) fixed by clips.

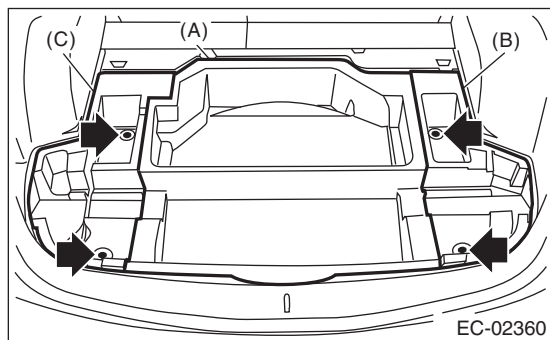

4) Tilt the rear seat backrest forward.

5) Remove the clips that is holding the rear seat backrest cover on the canister cover, and turn over the rear seat backrest cover toward the front side of the vehicle.

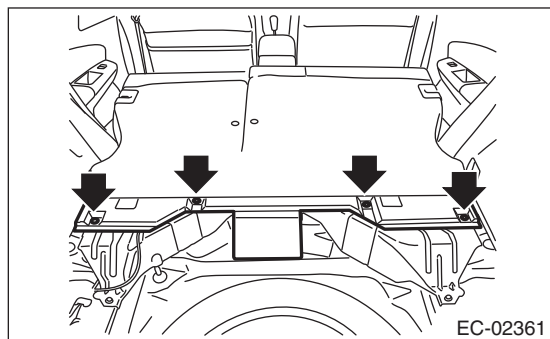

6) Remove the center canister cover.

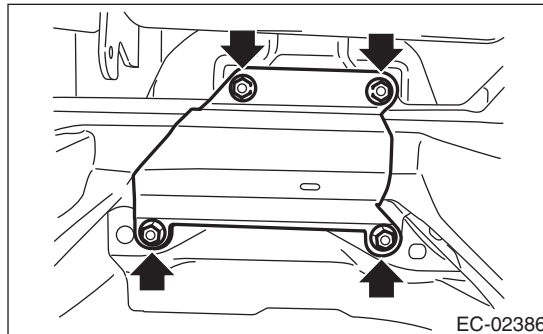

7) Remove the canister cover RH.

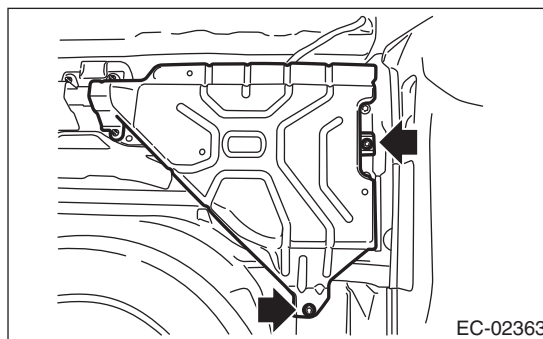

Canister

EMISSION CONTROL (AUX. EMISSION CONTROL DEVICES)

8) Disconnect the purge tube (A), vent tube (B), drain tube A (C) and PCV drain tube (D).

NOTE:

Disconnect the quick connector as shown in the figure.

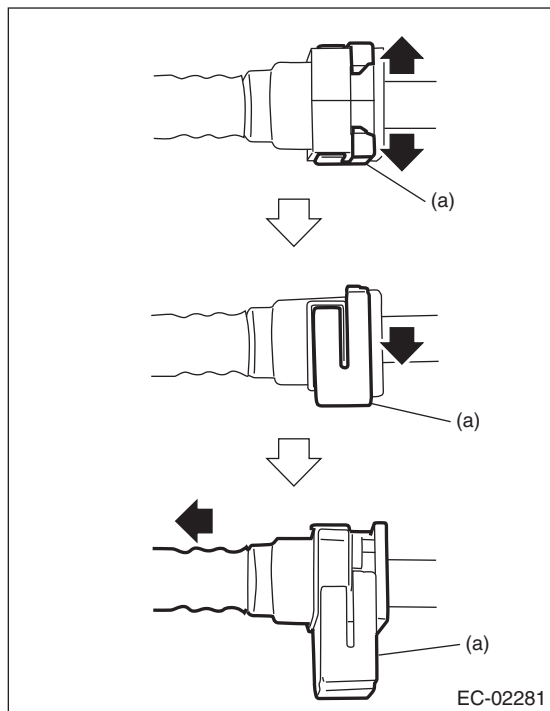

(a) Retainer

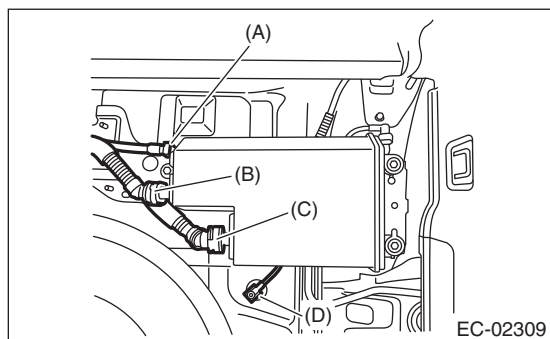

9) Remove the canister.

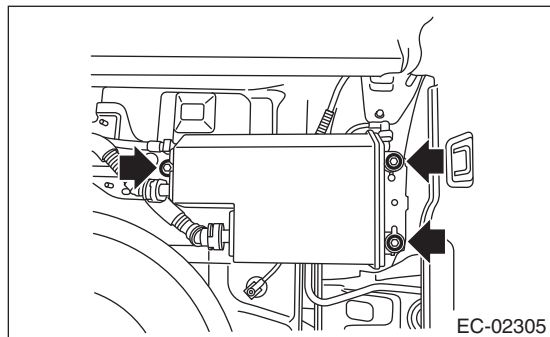

10) Remove the canister cover LH.

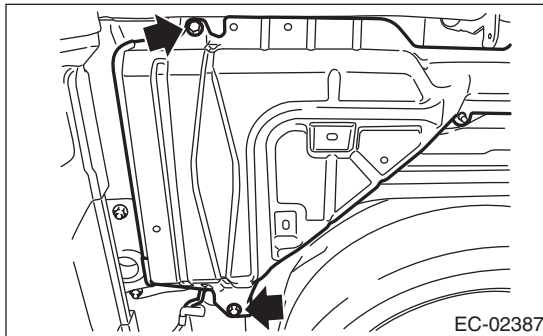

11) Disconnect drain tube A (A) and drain tube B (B).

NOTE:

Disconnect the quick connector as shown in the figure.

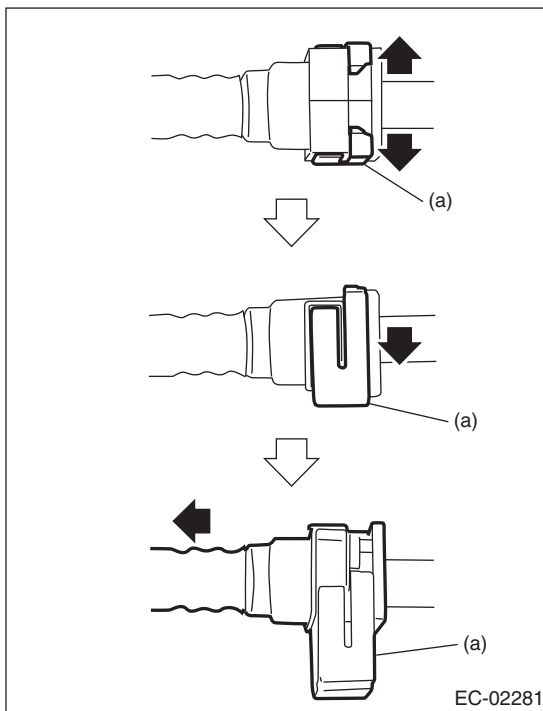

(a) Retainer

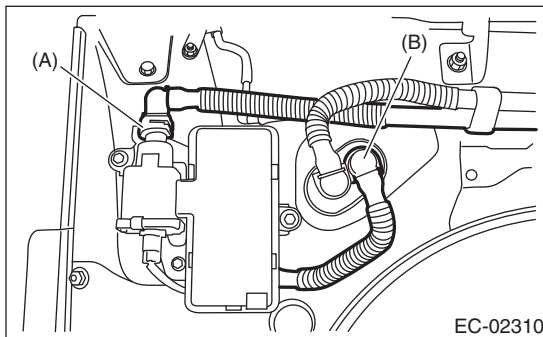

Canister

EMISSION CONTROL (AUX. EMISSION CONTROL DEVICES)

12) Disconnect connector (C) from the drain valve, and remove the drain valve.

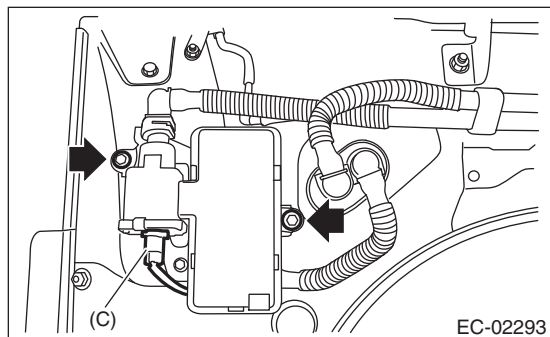

14) Remove purge tube (A), vent tube (B), and drain tube A (C).

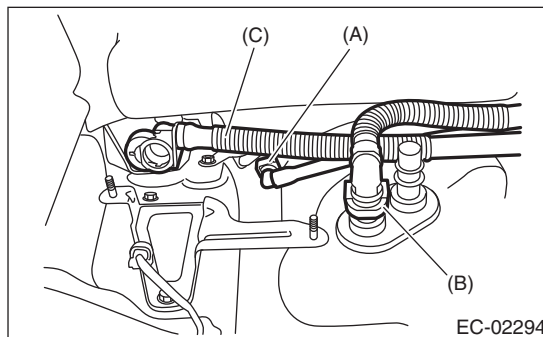

13) Disconnect purge tube (A) and vent tube (B).

NOTE:

Disconnect the quick connector as shown in the figure.

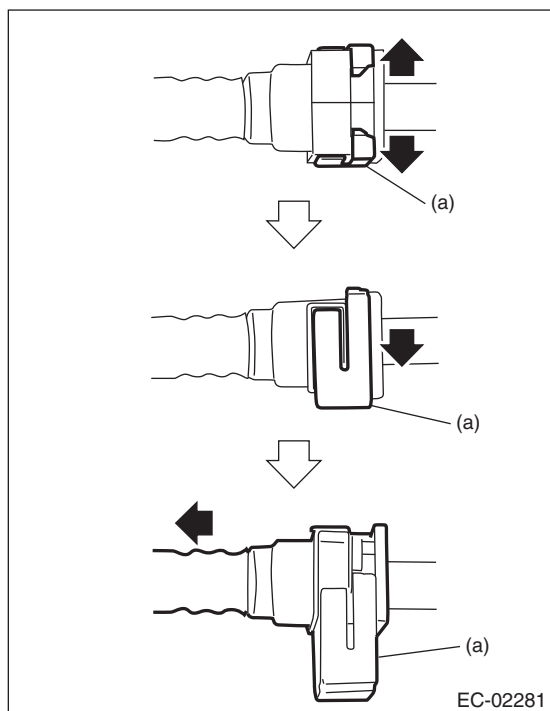

(a) Retainer

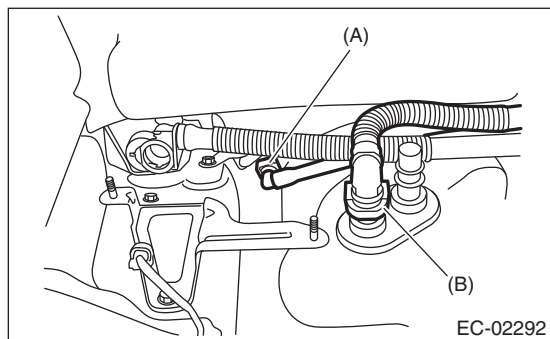

Canister

EMISSION CONTROL (AUX. EMISSION CONTROL DEVICES)

B: INSTALLATION

Install in the reverse order of removal while being careful of the following.

- Connect the quick connector as shown in the figure.

CAUTION:

- Check that there is no damage or dust on the quick connector. If necessary, clean seal surface of pipe.
- When connecting the quick connector, insert the pipe all the way in securely, then operate the push lock.
- If it is not possible to perform the push lock operation of the retainer, recheck whether the pipe is securely inserted.
- Confirm that the quick connector is securely connected.

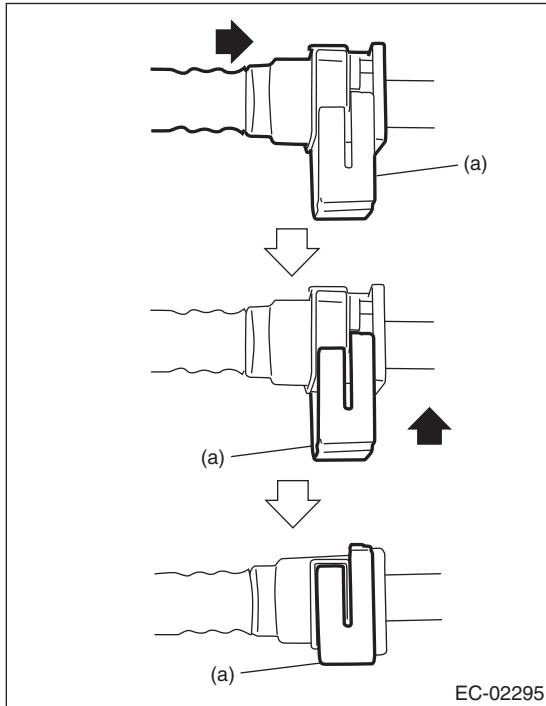

(a) Retainer

Tightening torque:
18 N·m (1.8 kgf·m, 13.3 ft·lb)

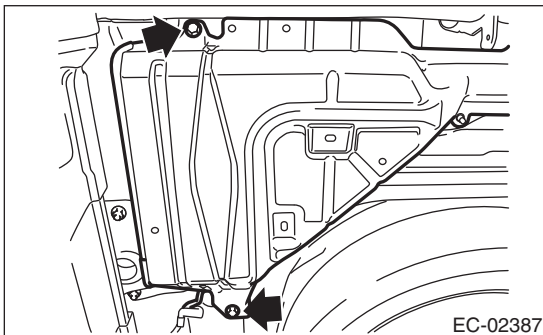

Tightening torque:
8 N·m (0.8 kgf·m, 5.9 ft·lb)

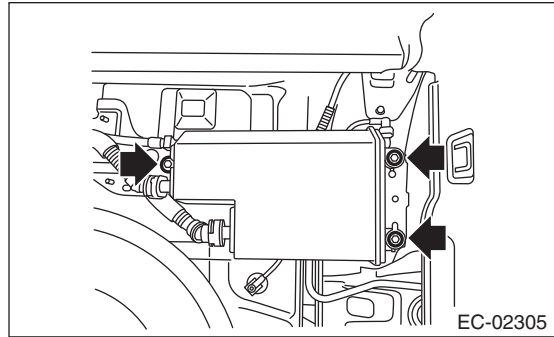

Tightening torque:
7.5 N·m (0.8 kgf·m, 5.5 ft·lb)

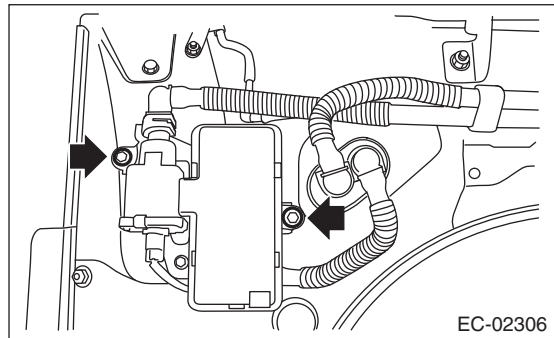

Tightening torque:
18 N·m (1.8 kgf·m, 13.3 ft·lb)

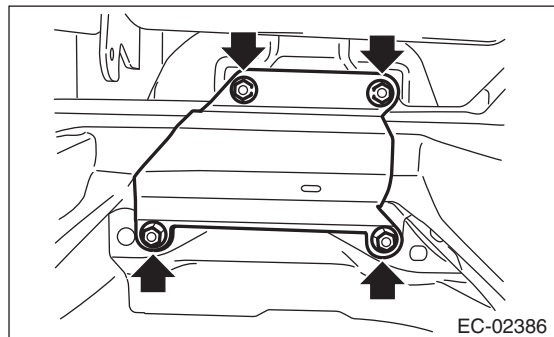
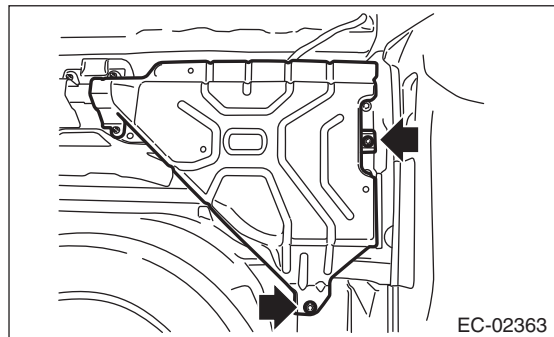

C: INSPECTION

Make sure that the canister, drain valve and tube are not cracked or loose.

Purge Control Solenoid Valve

EMISSION CONTROL (AUX. EMISSION CONTROL DEVICES)

5. Purge Control Solenoid Valve

A: REMOVAL

1. PURGE CONTROL SOLENOID VALVE 1

- 1) Remove the collector cover.
- 2) Disconnect the ground cable from the battery.

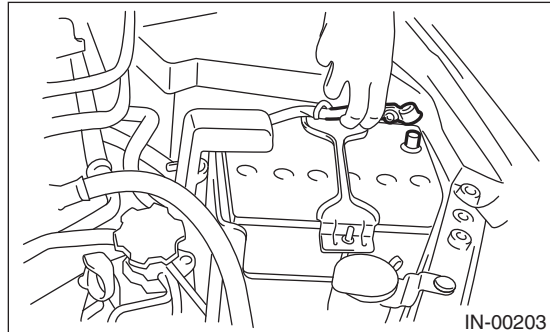

- 3) Remove the bolts that attach the purge control solenoid valve 1 to the intake manifold. Then disconnect the connector from the purge control solenoid valve 1.

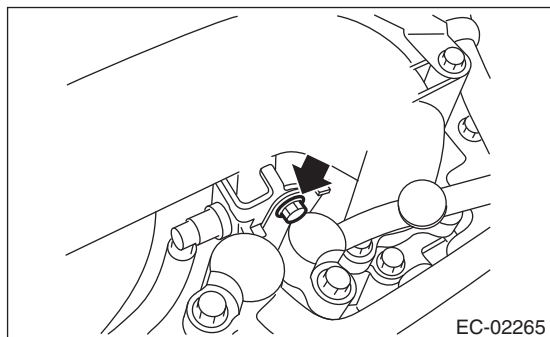

- 4) Disconnect the evaporation hose from the intake manifold and fuel pipe assembly.

2. PURGE CONTROL SOLENOID VALVE 2

- 1) Remove the collector cover.
- 2) Disconnect the ground cable from the battery.

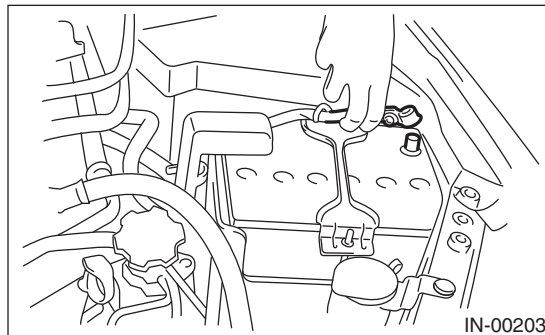

- 3) Remove the solenoid valve bracket assembly from intake manifold.

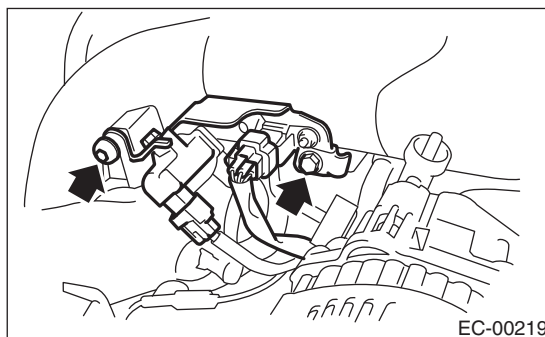

- 4) Disconnect the connector from purge control solenoid valve 2.
- 5) Disconnect the evaporation hose from the intake duct and fuel pipe assembly.
- 6) Remove the purge control solenoid valve 2 from the solenoid valve bracket assembly.

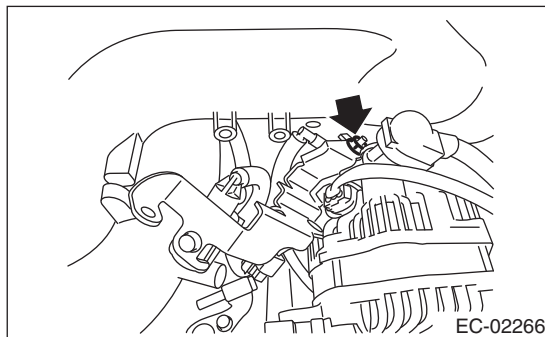

Purge Control Solenoid Valve

EMISSION CONTROL (AUX. EMISSION CONTROL DEVICES)

B: INSTALLATION

1. PURGE CONTROL SOLENOID VALVE 1

Install in the reverse order of removal.

NOTE:

Connect the evaporation hose as shown in the figure.

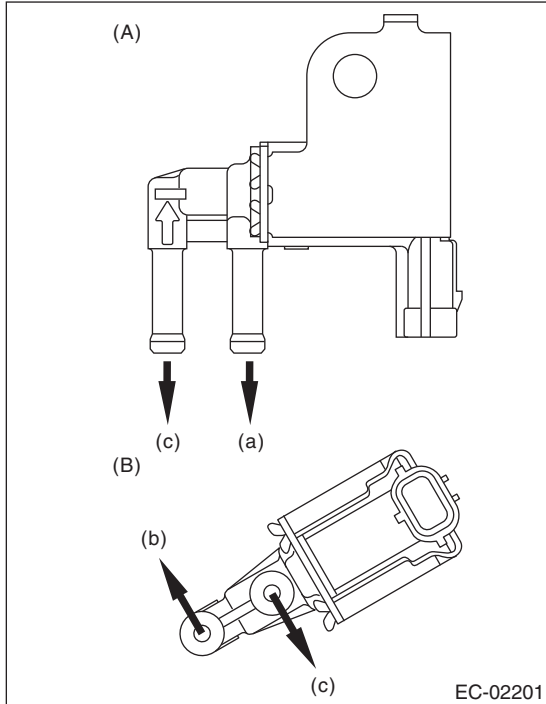

- (A) Purge Control Solenoid Valve 1
- (B) Purge Control Solenoid Valve 2
- (a) To intake manifold
- (b) To intake duct
- (c) To fuel pipe

Tightening torque:

6.4 N·m (0.7 kgf·m, 4.7 ft·lb)

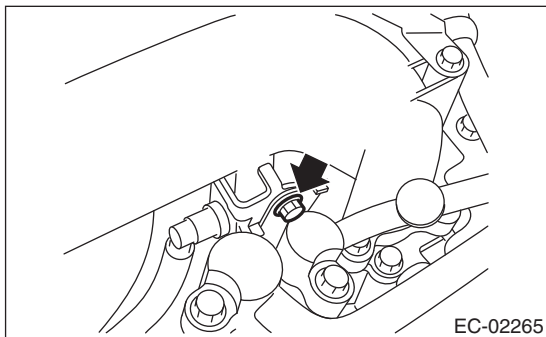

2. PURGE CONTROL SOLENOID VALVE 2

Install in the reverse order of removal.

NOTE:

Connect the evaporation hose as shown in the figure.

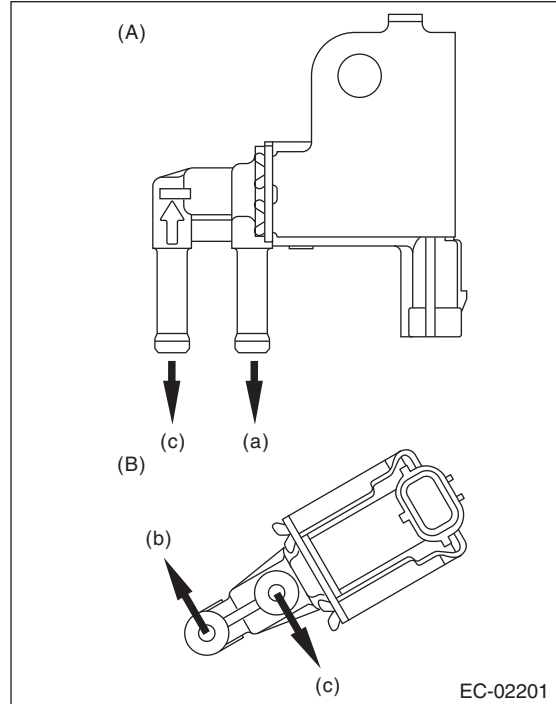

- (A) Purge Control Solenoid Valve 1
- (B) Purge Control Solenoid Valve 2
- (a) To intake manifold
- (b) To intake duct
- (c) To fuel pipe

Tightening torque:

6.4 N·m (0.7 kgf·m, 4.7 ft·lb)

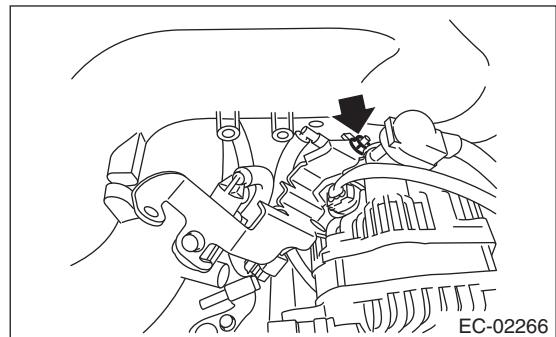

Purge Control Solenoid Valve

EMISSION CONTROL (AUX. EMISSION CONTROL DEVICES)

Tightening torque:

T1: 17 N·m (1.7 kgf-m, 12.5 ft-lb)

T2: 19 N·m (1.9 kgf-m, 14.0 ft-lb)

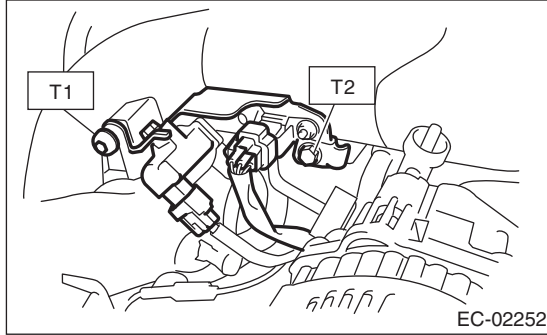

C: INSPECTION

Make sure the hoses are not cracked or loose.

Fuel Level Sensor

EMISSION CONTROL (AUX. EMISSION CONTROL DEVICES)

6. Fuel Level Sensor

A: REMOVAL

For removal procedures, refer to the "FU(H4DOTC)" section. <Ref. to FU(H4DOTC)-66, REMOVAL, Fuel Level Sensor.>

B: INSTALLATION

For installation procedures, refer to the "FU(H4DOTC)" section. <Ref. to FU(H4DOTC)-66, INSTALLATION, Fuel Level Sensor.>

Fuel Temperature Sensor

EMISSION CONTROL (AUX. EMISSION CONTROL DEVICES)

7. Fuel Temperature Sensor

A: REMOVAL

The fuel temperature sensor is integrated into the fuel level sensor as one unit; therefore, refer to “Fuel Level Sensor” for removal procedures. <Ref. to FU(H4DOTC)-66, REMOVAL, Fuel Level Sensor.>

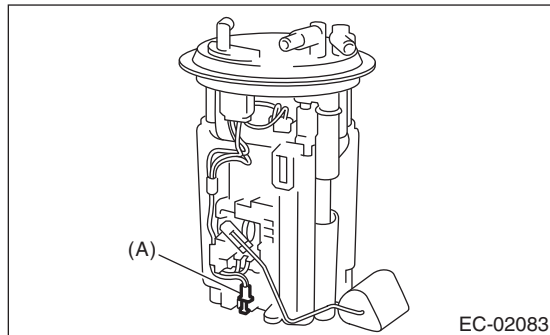

(A) Fuel temperature sensor

B: INSTALLATION

The fuel temperature sensor and fuel level sensor are integrated into one unit; therefore, refer to “Fuel Level Sensor” for installation procedure. <Ref. to FU(H4DOTC)-66, INSTALLATION, Fuel Level Sensor.>

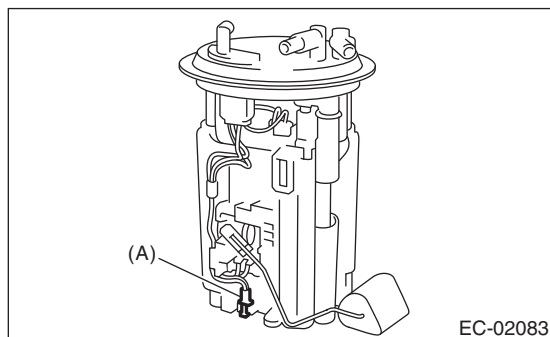

(A) Fuel temperature sensor

Fuel Sub Level Sensor

EMISSION CONTROL (AUX. EMISSION CONTROL DEVICES)

8. Fuel Sub Level Sensor

A: REMOVAL

For removal procedures, refer to the "FU(H4DOTC)" section. <Ref. to FU(H4DOTC)-67, REMOVAL, Fuel Sub Level Sensor.>

B: INSTALLATION

For installation procedures, refer to the "FU(H4DOTC)" section. <Ref. to FU(H4DOTC)-68, INSTALLATION, Fuel Sub Level Sensor.>

Fuel Tank Pressure Sensor

EMISSION CONTROL (AUX. EMISSION CONTROL DEVICES)

9. Fuel Tank Pressure Sensor

A: REMOVAL

WARNING:

Place "NO OPEN FLAMES" signs near the working area.

- 1) Set the vehicle on a lift.
- 2) Disconnect the ground cable from the battery.

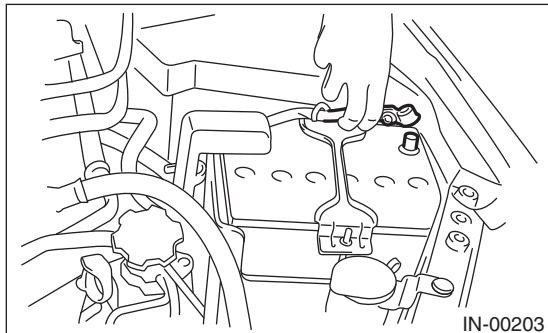

- 3) Open the fuel filler lid, and remove the fuel filler cap.
- 4) Lift up the vehicle.
- 5) Disconnect the connector from the fuel tank pressure sensor (A).
- 6) Disconnect the pressure hose from the fuel tank pressure sensor (B).
- 7) Remove the fuel tank pressure sensor along with the bracket.

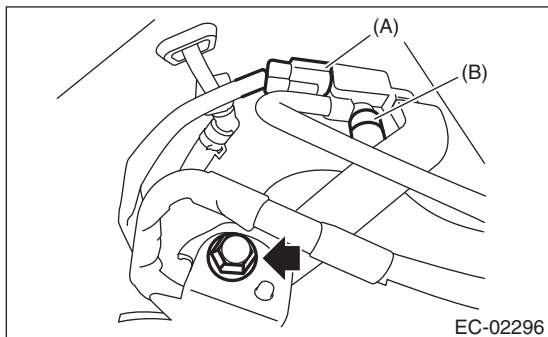

- 8) Remove the fuel pressure sensor from the bracket.

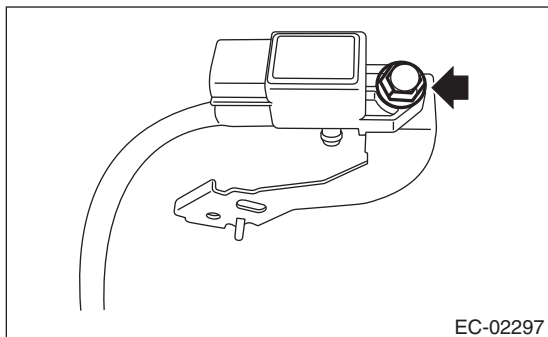

B: INSTALLATION

Install in the reverse order of removal.

Tightening torque:

7.35 N·m (0.7 kgf-m, 5.4 ft-lb)

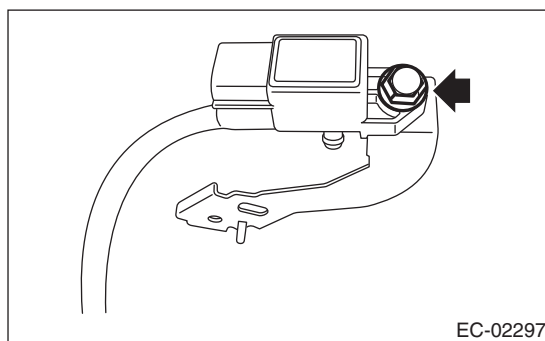
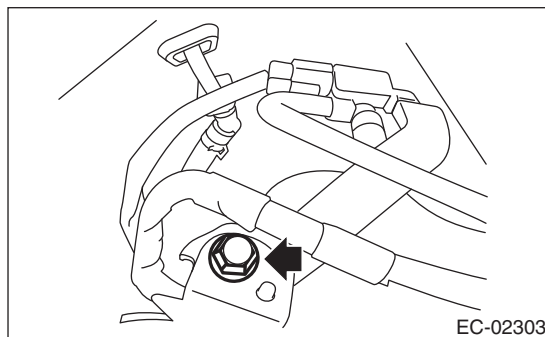

C: INSPECTION

Make sure the hoses are not cracked or loose.

Pressure Control Solenoid Valve

EMISSION CONTROL (AUX. EMISSION CONTROL DEVICES)

10. Pressure Control Solenoid Valve

A: REMOVAL

- 1) Set the vehicle on a lift.
- 2) Disconnect the ground cable from the battery.

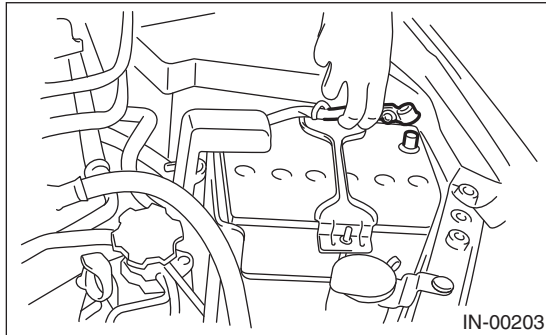

- 3) Lift up the vehicle.
- 4) Disconnect connector (A) from the pressure control solenoid valve.
- 5) Disconnect the evaporation hose (B) from the pressure control solenoid valve.
- 6) Remove the bolts (C) which secure the bracket to the fuel tank.

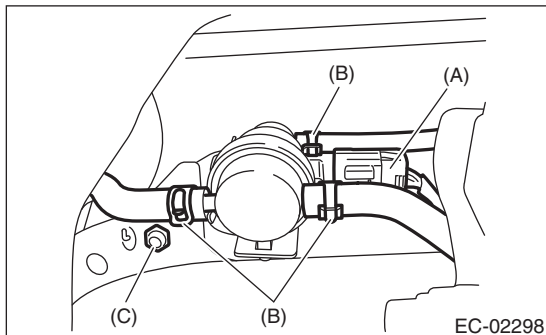

- 7) Remove the pressure control solenoid valve and bracket as a unit.
- 8) Remove the pressure control solenoid valve from the bracket.

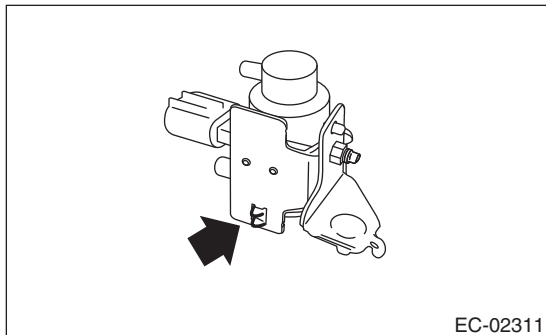

B: INSTALLATION

Install in the reverse order of removal.

Tightening torque:

7.35 N·m (0.7 kgf-m, 5.4 ft-lb)

C: INSPECTION

1. PRESSURE CONTROL SOLENOID VALVE

- 1) Check that the pressure control solenoid valve has no deformation, cracks or other damages.
- 2) Check the resistance between the pressure control solenoid valve terminals.

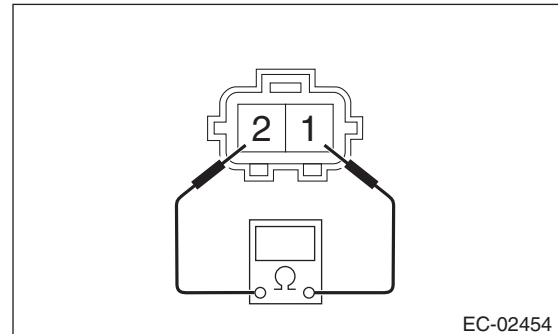

Terminal No.	Standard
1 and 2	20 — 30 Ω

- 3) Connect the Mighty Vac to fuel tank side of the pressure control solenoid valve.

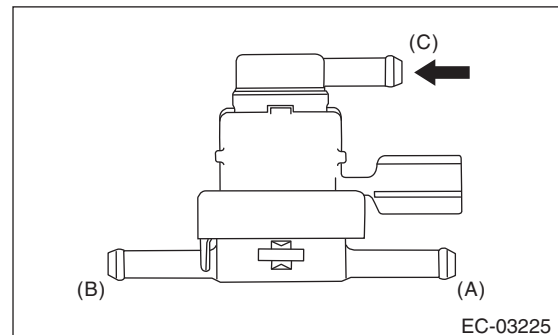

- (A) Fuel tank side
- (B) Canister side
- (C) Barometric pressure

- 4) Using the Mighty Vac, generate the positive pressure. Check that the Mighty Vac gauge needle rises at the pressure (0.55 — 1.55 kPa (0.006 — 0.016 kgf/cm², 0.08 — 0.23 psi)) then lowers.

- 5) Using the Mighty Vac, generate the negative pressure. Check that the Mighty Vac gauge needle does not rise.

2. OTHER INSPECTIONS

Check that the evaporation hose has no cracks, damage or loose part.

11.Drain Filter

A: SPECIFICATION

The drain valve is a non-disassembled part, so do not remove the drain filter from drain valve. Refer to “Canister” for removal and installation procedures.
<Ref. to EC(H4DOTC)-7, REMOVAL, Canister.>
<Ref. to EC(H4DOTC)-10, INSTALLATION, Canister.>

Shut Valve

EMISSION CONTROL (AUX. EMISSION CONTROL DEVICES)

12.Shut Valve

A: REMOVAL

WARNING:

Place "NO OPEN FLAMES" signs near the working area.

CAUTION:

Be careful not to spill fuel.

1) Remove the fuel filler pipe.

<Ref. to FU(H4DOTC)-60, REMOVAL, Fuel Filler Pipe.>

2) Disconnect the evaporation hose from the shut valve.

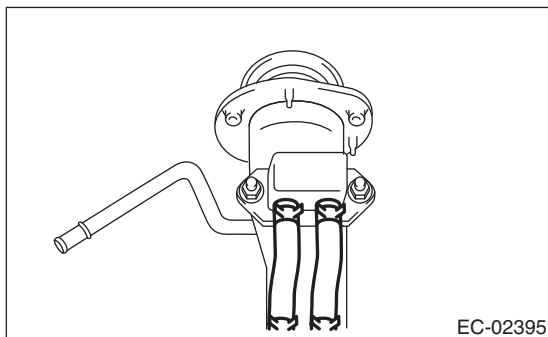

3) Remove the shut valve from the fuel filler pipe.

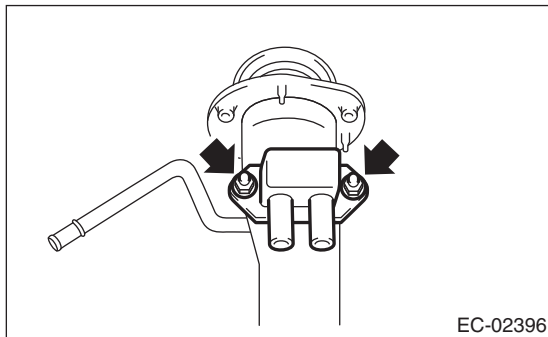

B: INSTALLATION

Install in the reverse order of removal.

Tightening torque:

4.5 N·m (0.5 kgf-m, 3.3 ft-lb)

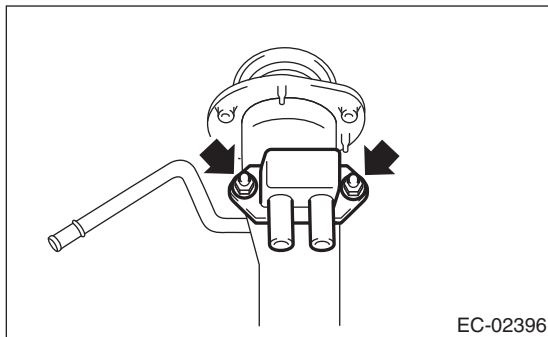

C: INSPECTION

Make sure the hoses are not cracked or loose.

13.Drain Valve

A: REMOVAL

Refer to “Canister” for removal procedures. <Ref. to EC(H4DOTC)-7, REMOVAL, Canister.>

B: INSTALLATION

Refer to “Canister” for installation procedures. <Ref. to EC(H4DOTC)-10, INSTALLATION, Canister.>

PCV Hose Assembly

EMISSION CONTROL (AUX. EMISSION CONTROL DEVICES)

14.PCV Hose Assembly

A: REMOVAL

CAUTION:

Do not remove unless the PCV hose, diagnostics connector and PCV valve are damaged.

- 1) Remove the collector cover.
- 2) Remove the intake manifold.
<Ref. to FU(H4DOTC)-14, REMOVAL, Intake Manifold.>
- 3) Remove the secondary air combination valve RH.
<Ref. to EC(H4DOTC)-24, SECONDARY AIR COMBINATION VALVE RH, REMOVAL, Secondary Air Combination Valve.>
- 4) Fit the depression in the ST with the protrusion on the clamp to unlock.
- 5) Remove the PCV hose assembly.

ST 18353AA000 CLAMP PLIERS

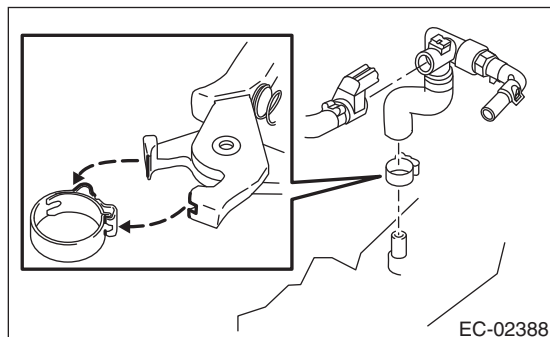

B: INSTALLATION

- 1) Install the PCV hose assembly, then lock by fitting the ST on the clamp protrusion.

NOTE:

Use a new clamp.

ST 18353AA000 CLAMP PLIERS

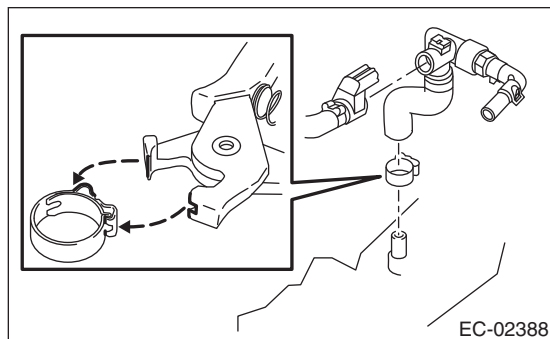

- 2) Install the secondary air combination valve RH.
<Ref. to EC(H4DOTC)-25, SECONDARY AIR COMBINATION VALVE RH, INSTALLATION, Secondary Air Combination Valve.>
- 3) Install the intake manifold.
<Ref. to FU(H4DOTC)-18, INSTALLATION, Intake Manifold.>
- 4) Install the collector cover.

Secondary Air Pump

EMISSION CONTROL (AUX. EMISSION CONTROL DEVICES)

15. Secondary Air Pump

A: REMOVAL

- 1) Remove the collector cover.
- 2) Disconnect the ground cable from the battery.

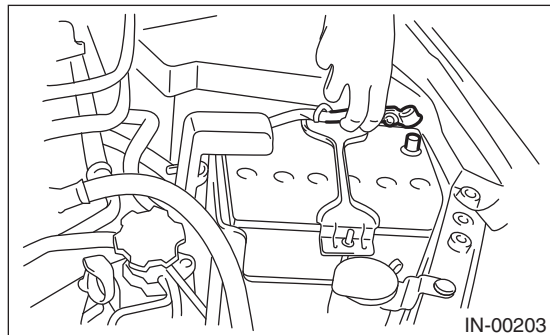

- 3) Disconnect the connector (A) and air duct (B) from secondary air pump.

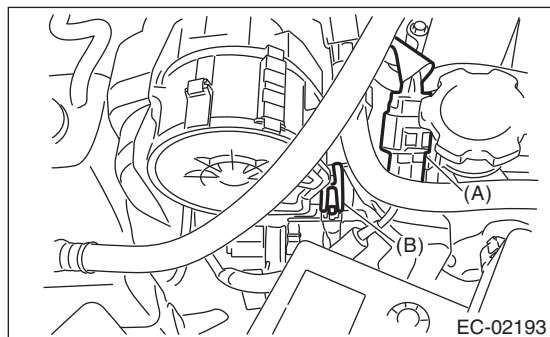

- 4) Remove the clip (A) which holds the harness on the harness stay and remove the bolts (B) which holds the secondary air pump on the vehicle.

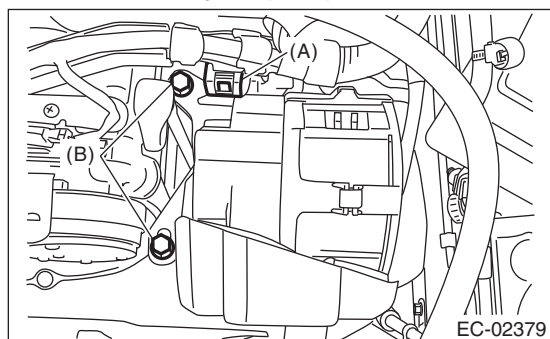

B: INSTALLATION

Install in the reverse order of removal.

Tightening torque:

19 N·m (1.9 kgf-m, 14.0 ft-lb)

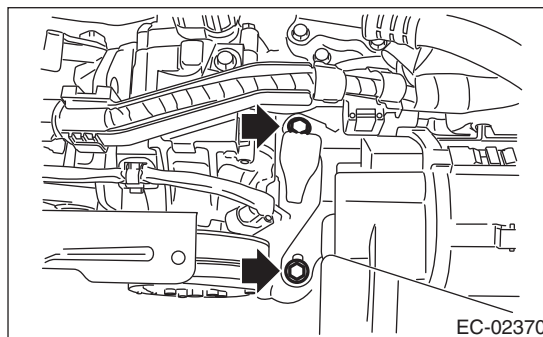

C: INSPECTION

Make sure the air duct is not cracked or loose.

Secondary Air Combination Valve

EMISSION CONTROL (AUX. EMISSION CONTROL DEVICES)

16. Secondary Air Combination Valve

A: REMOVAL

1. SECONDARY AIR COMBINATION VALVE LH

- 1) Remove the collector cover.
- 2) Disconnect the ground cable from the battery.

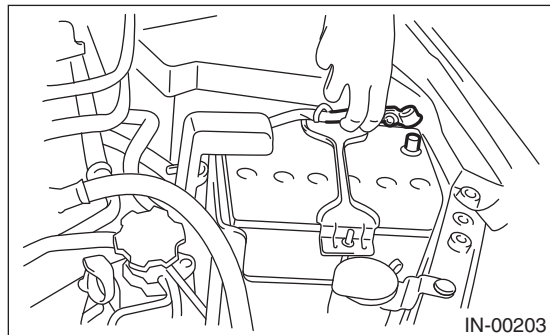

- 3) Remove the intercooler. <Ref. to IN(H4DOTC)-11, REMOVAL, Intercooler.>
- 4) Disconnect the connector from the secondary air combination valve LH.
- 5) Disconnect the air duct A.
- 6) Remove the secondary air pipe LH.
- 7) Remove the secondary air combination valve LH.

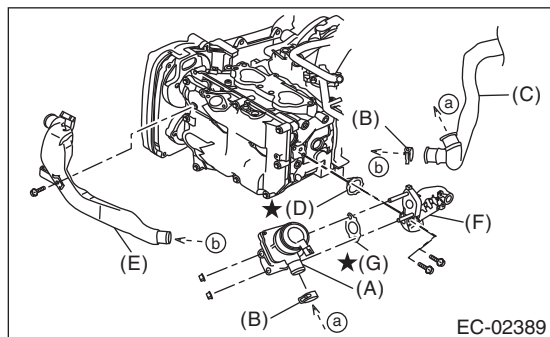

- (A) Secondary air combination valve LH
- (B) Clamp
- (C) Air duct A
- (D) Gasket
- (E) Air duct B
- (F) Secondary air pipe LH
- (G) Gasket

2. SECONDARY AIR COMBINATION VALVE RH

- 1) Remove the collector cover.
- 2) Disconnect the ground cable from the battery.

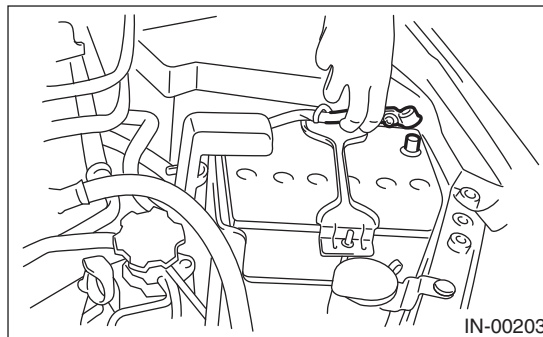

- 3) Remove the intercooler. <Ref. to IN(H4DOTC)-11, REMOVAL, Intercooler.>
- 4) Remove the intake manifold. <Ref. to FU(H4DOTC)-14, REMOVAL, Intake Manifold.>
- 5) Disconnect the air duct A.
- 6) Remove the secondary air pipe RH.
- 7) Remove the secondary air combination valve RH.

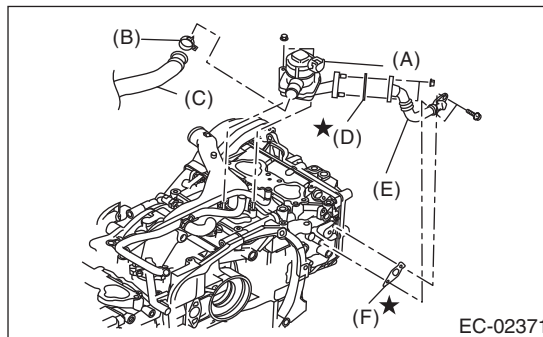

- (A) Secondary air combination valve RH
- (B) Clamp
- (C) Air duct A
- (D) Gasket
- (E) Secondary air pipe RH
- (F) Gasket

Secondary Air Combination Valve

EMISSION CONTROL (AUX. EMISSION CONTROL DEVICES)

B: INSTALLATION

1. SECONDARY AIR COMBINATION VALVE LH

Install in the reverse order of removal.

NOTE:

Use a new gasket.

Tightening torque:

T1: 9 N·m (0.9 kgf-m, 6.6 ft-lb)

T2: 19 N·m (1.9 kgf-m, 14.0 ft-lb)

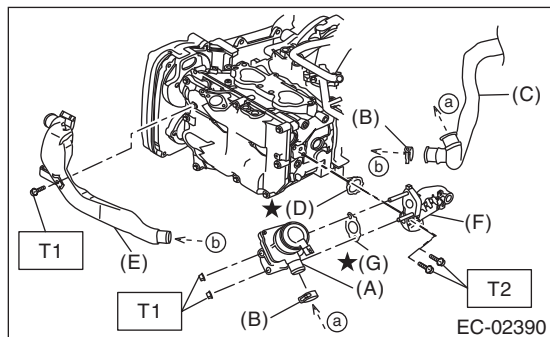

- (A) Secondary air combination valve LH
- (B) Clamp
- (C) Air duct A
- (D) Gasket
- (E) Air duct B
- (F) Secondary air pipe LH
- (G) Gasket

2. SECONDARY AIR COMBINATION VALVE RH

Install in the reverse order of removal.

NOTE:

Use a new gasket.

Tightening torque:

T1: 6.4 N·m (0.7 kgf-m, 4.7 ft-lb)

T2: 9 N·m (0.9 kgf-m, 6.6 ft-lb)

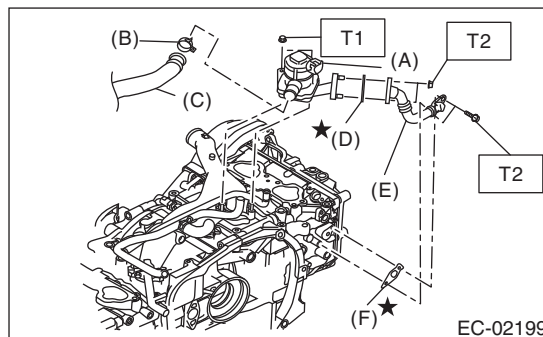

- (A) Secondary air combination valve RH
- (B) Clamp
- (C) Air duct A
- (D) Gasket
- (E) Secondary air pipe RH
- (F) Gasket

C: INSPECTION

Check the air duct and pipe for looseness.

Secondary Air Combination Valve

EMISSION CONTROL (AUX. EMISSION CONTROL DEVICES)

INTAKE (INDUCTION)

IN(H4DOTC)

	Page
1. General Description	2
2. Air Cleaner Element	7
3. Air Cleaner Case	8
4. Air Intake Duct	9
5. Intake Duct	10
6. Intercooler	11
7. Turbocharger	13
8. Air By-pass Valve	17
9. Resonator Chamber	18

General Description

INTAKE (INDUCTION)

2. INTAKE DUCT

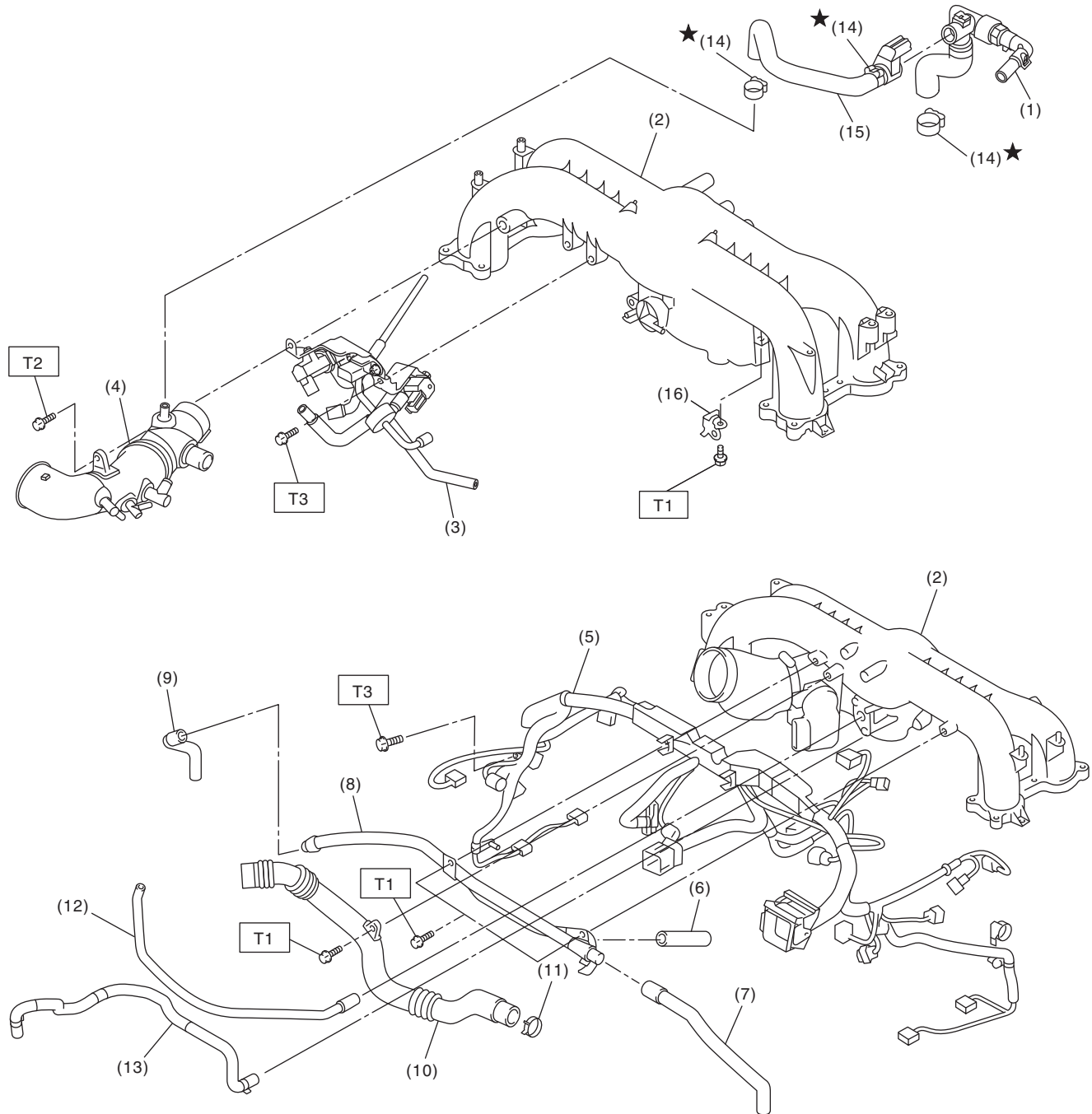

IN-02297

- | | | |
|---------------------------------|--------------------------------|-----------------------------|
| (1) PCV hose ASSY A | (8) PCV pipe | (15) PCV hose ASSY B |
| (2) Intake manifold | (9) Vacuum hose | (16) Solenoid valve bracket |
| (3) Solenoid valve bracket ASSY | (10) Air by-pass pipe | |
| (4) Intake duct | (11) Clamp | |
| (5) Engine harness ASSY | (12) Vacuum hose | |
| (6) Vacuum hose | (13) Brake booster vacuum hose | |
| (7) Vacuum hose | (14) Clamp | |

Tightening torque: N·m (kgf·m, ft·lb)

T1: 6.4 (0.7, 4.7)

T2: 17 (1.7, 12.5)

T3: 19 (1.9, 14.0)

IN(H4DOTC)-3

General Description

INTAKE (INDUCTION)

3. INTERCOOLER

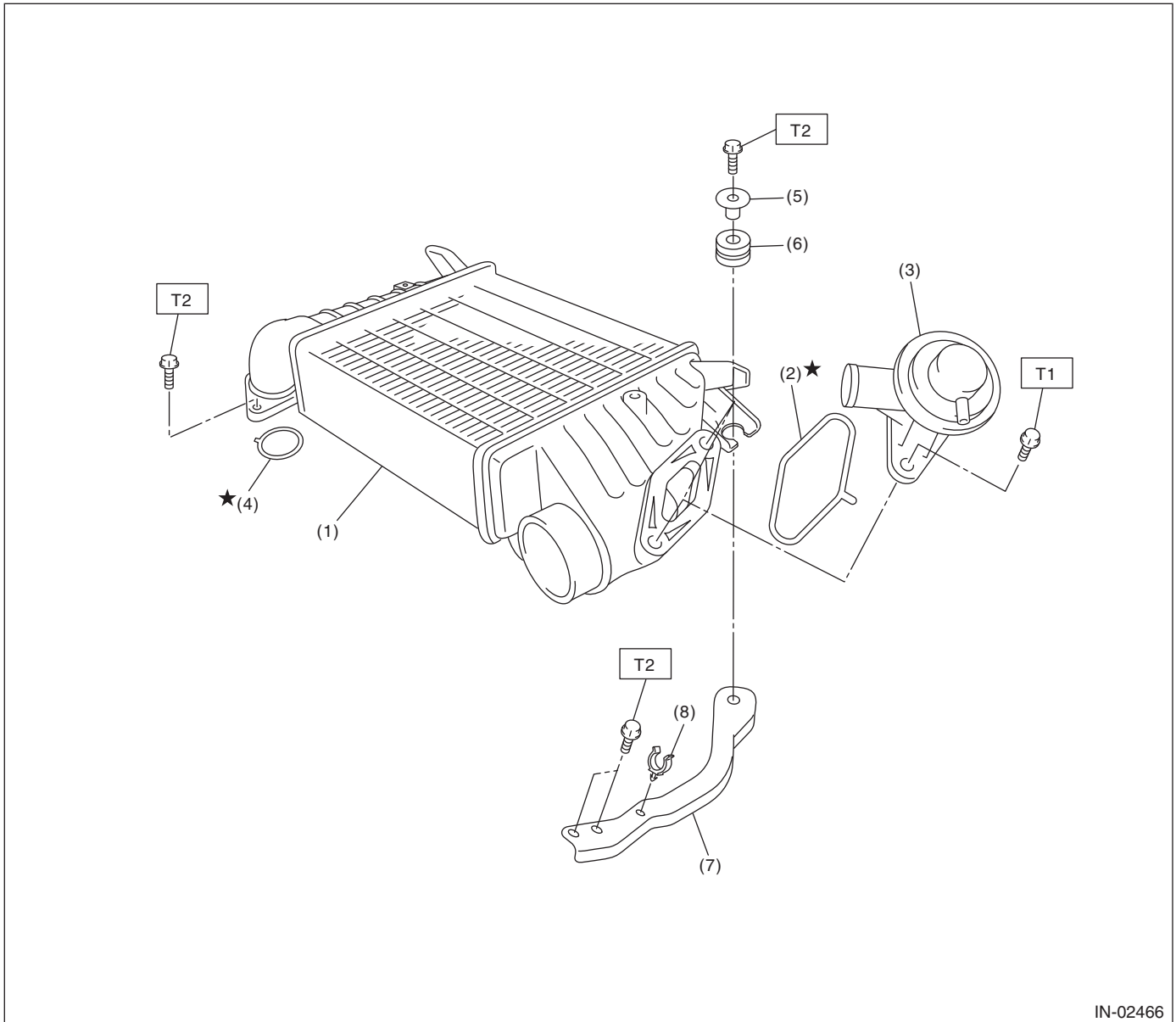

IN-02466

- | | |
|-----------------------|------------------------------------|
| (1) Intercooler | (5) Spacer |
| (2) O-ring | (6) Cushion |
| (3) Air by-pass valve | (7) Intercooler stay |
| (4) O-ring | (8) Brake booster vacuum hose clip |

Tightening torque: N·m (kgf·m, ft·lb)

T1: 6.5 (0.7, 4.8)

T2: 16 (1.6, 11.8)

4. TURBOCHARGER

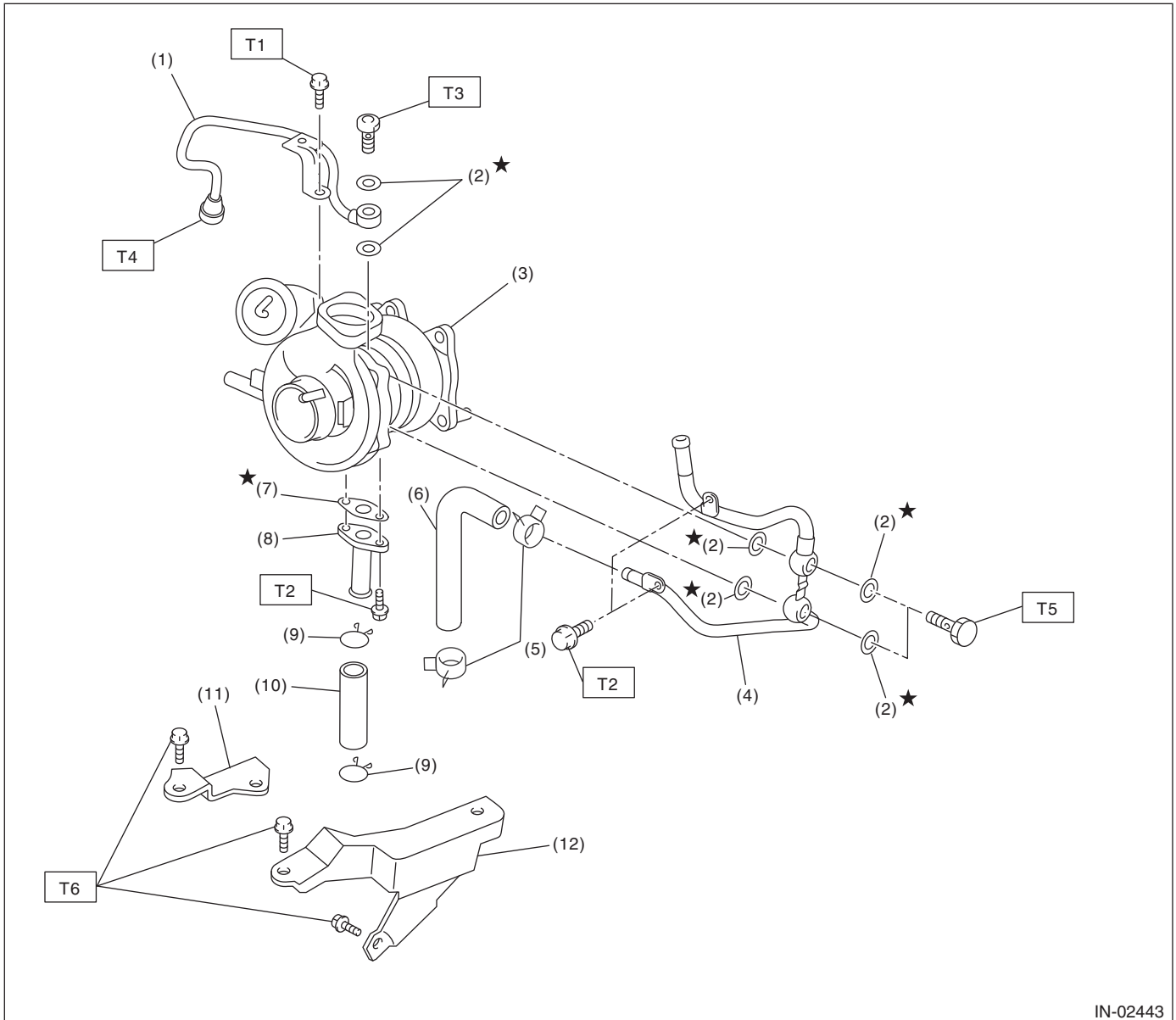

IN-02443

- | | |
|-------------------------|------------------------------|
| (1) Oil inlet pipe | (7) Gasket |
| (2) Metal gasket | (8) Oil outlet pipe |
| (3) Turbocharger | (9) Clip |
| (4) Water pipe | (10) Oil outlet hose |
| (5) Clip | (11) Turbocharger bracket RH |
| (6) Engine coolant hose | (12) Turbocharger bracket LH |

Tightening torque: N·m (kgf·m, ft·lb)

- T1: 5 (0.5, 3.7)**
T2: 7.8 (0.8, 5.8)
T3: 16 (1.6, 11.8)
T4: 20 (2.0, 14.8)
T5: 23 (2.3, 17.0)
T6: 33 (3.4, 24.3)

General Description

INTAKE (INDUCTION)

B: PREPARATION TOOL

1. GENERAL TOOL

TOOL NAME	REMARKS
Mighty Vac	Used to inspect the waste gate actuator.

C: CAUTION

- Wear appropriate work clothing, including a cap, protective goggles and protective shoes when performing any work.
- Remove contamination including dirt and corrosion before removal, installation or disassembly.
- Keep the disassembled parts in order and protect them from dust and dirt.
- Before removal, installation or disassembly, be sure to clarify the failure. Avoid unnecessary removal, installation, disassembly and replacement.
- Vehicle components are extremely hot after driving. Be wary of receiving burns from heated parts.
- Be sure to tighten fasteners including bolts and nuts to the specified torque.
- Place shop jacks or rigid racks at the specified points.
- Before disconnecting connectors of sensors or units, be sure to disconnect the ground cable from the battery.

2. Air Cleaner Element

A: REMOVAL

1) Disconnect the ground cable from battery.

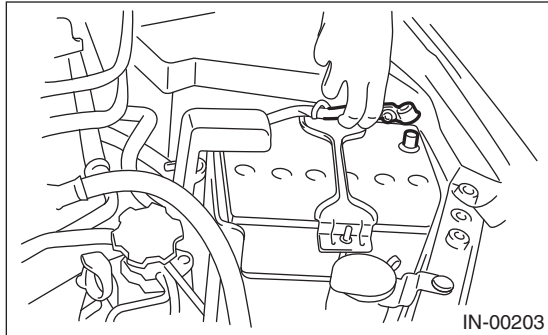

2) Remove the air intake duct (rear). <Ref. to IN(H4DOTC)-9, REMOVAL, Air Intake Duct.>

3) Disconnect the connector (A) from mass air flow and intake air temperature sensor.

4) Remove the clip (B) from the air cleaner case.

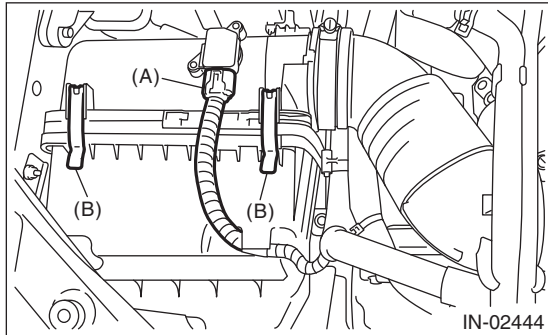

5) Open the air cleaner case, and remove the air cleaner element.

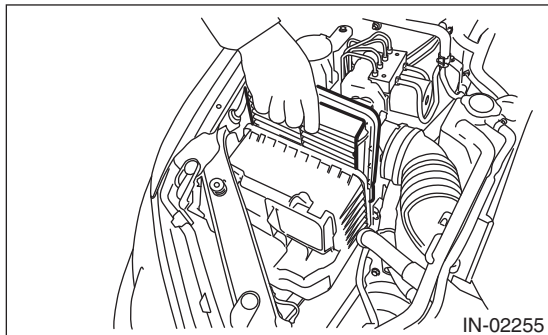

B: INSTALLATION

Install in the reverse order of removal.

CAUTION:

Be sure to use SUBARU genuine air cleaner element depending on the engine type when replacing the air cleaner elements. Otherwise engine performance may be damaged.

NOTE:

Check that there are no foreign objects in the air cleaner case.

C: INSPECTION

Replace if excessively damaged or dirty.

Air Cleaner Case

INTAKE (INDUCTION)

3. Air Cleaner Case

A: REMOVAL

- 1) Remove the collector cover.
- 2) Disconnect the ground cable from the battery.

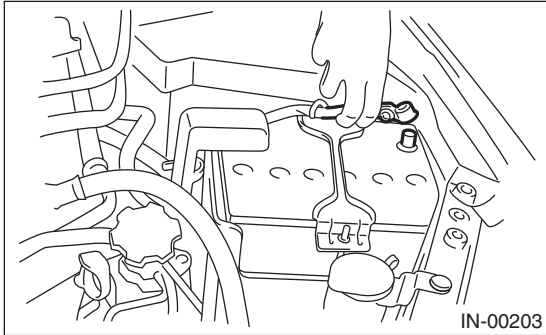

- 3) Remove the air intake duct (rear). <Ref. to IN(H4DOTC)-9, REMOVAL, Air Intake Duct.>
- 4) Disconnect the connector (A) from mass air flow and intake air temperature sensor.
- 5) Loosen the clamp (B) which connects the air intake boot and intake duct.
- 6) Remove the clip (C) from the air cleaner case.

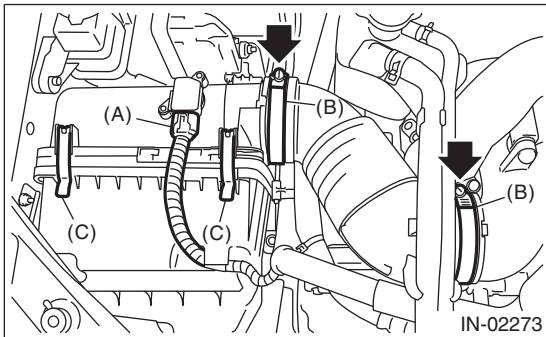

- 7) Remove the air cleaner case (rear) and air intake boot.
- 8) Remove the air cleaner element.
- 9) Remove the bolts (A) and nuts (B) which secure the air cleaner case (front) to the body.

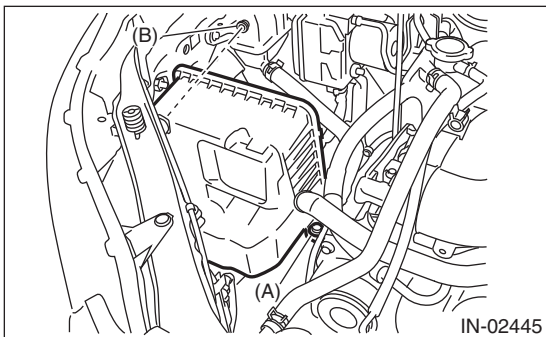

- 10) Remove the air cleaner case (front).

B: INSTALLATION

Install in the reverse order of removal.

NOTE:

When installing the air cleaner case (rear), align the protrusion of the air cleaner case (rear) to the hole on the air cleaner case (front) to install.

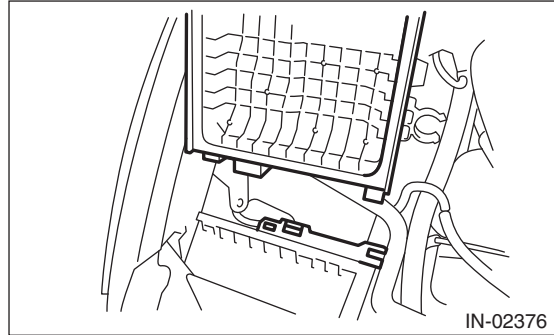

Tightening torque:

Bolt (A)

6 N·m (0.6 kgf-m, 4.4 ft-lb)

Nut (B)

7.5 N·m (0.8 kgf-m, 5.5 ft-lb)

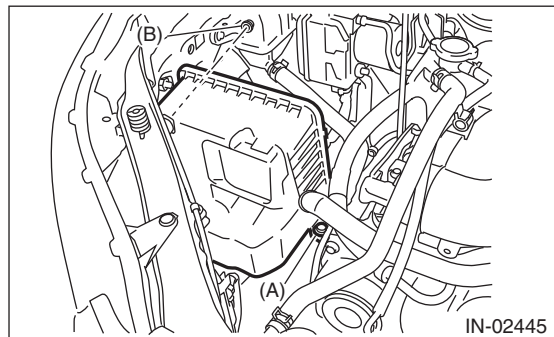

Tightening torque:

2.5 N·m (0.3 kgf-m, 1.8 ft-lb)

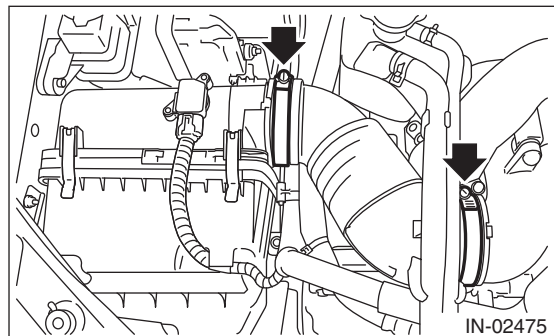

C: INSPECTION

Check for cracks or loose connections.

4. Air Intake Duct

A: REMOVAL

- 1) Remove the clip which installs the air intake duct (rear) on the front side of body.
- 2) Remove the air intake duct (rear).

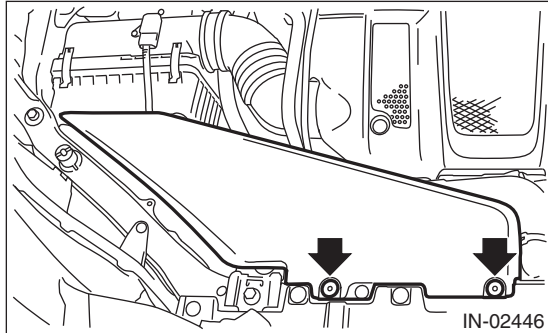

- 3) Remove the clip (A) and four claws and then remove the air intake duct (front).

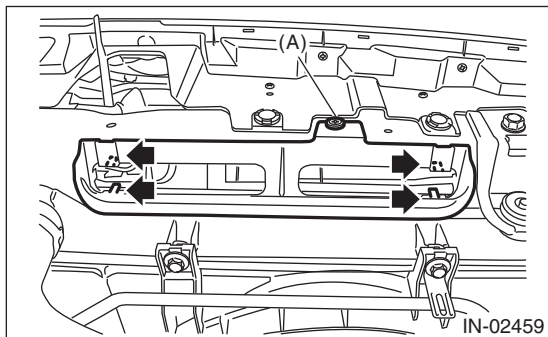

B: INSTALLATION

Install in the reverse order of removal.

C: INSPECTION

- 1) Check for cracks or clip damage.
- 2) Inspect that no foreign objects in the air intake duct.

5. Intake Duct

A: REMOVAL

- 1) Remove the collector cover.
- 2) Disconnect the ground cable from the battery.

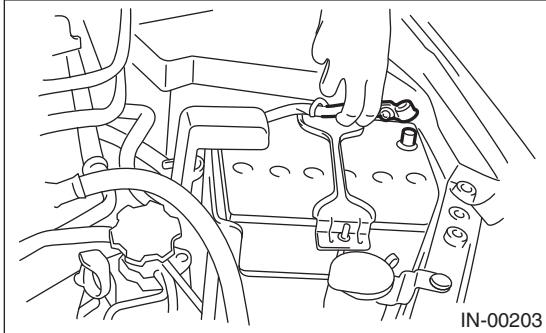

- 3) Remove the intake manifold. <Ref. to FU(H4DOTC)-14, REMOVAL, Intake Manifold.>
- 4) Remove the sensor, engine harness and fuel pipe attached to the intake manifold. <Ref. to FU(H4DOTC)-22, DISASSEMBLY, Intake Manifold.>
- 5) Remove the intake duct from intake manifold.

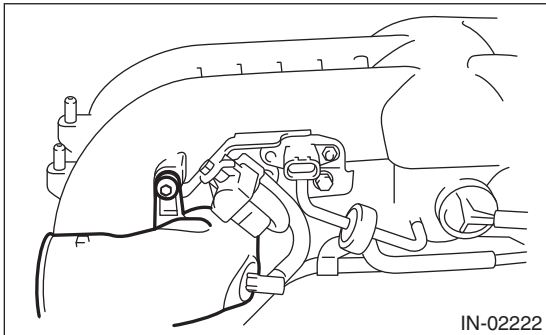

B: INSTALLATION

Install in the reverse order of removal.

Tightening torque:

17 N·m (1.7 kgf·m, 12.5 ft·lb)

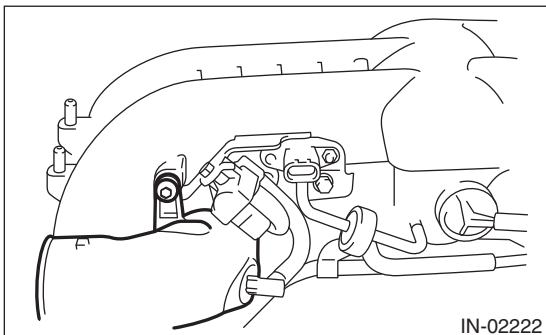

6. Intercooler

A: REMOVAL

- 1) Remove the collector cover.
- 2) Disconnect the air by-pass pipe (A) and vacuum hose (B) from the air by-pass valve.
- 3) Loosen the clamp (C) which connects the air intercooler and intake duct.

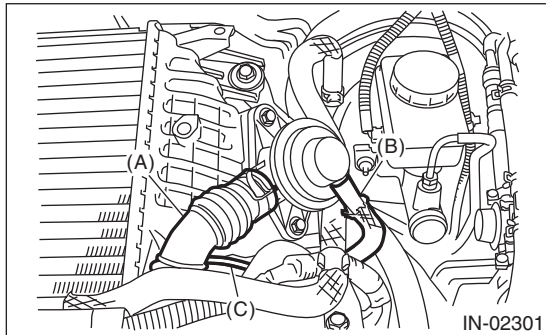

- 6) Remove the brake booster vacuum hose from the brake booster vacuum hose clip (A), and remove the intercooler stay.

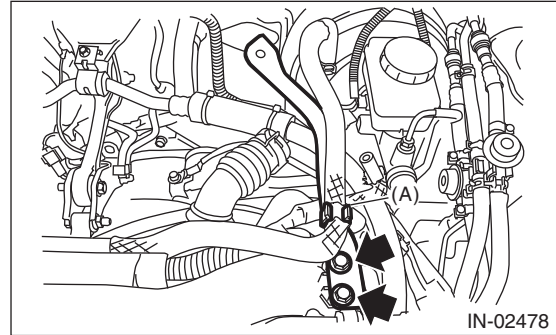

- 4) Remove the bolts which secure the intercooler to the turbocharger.

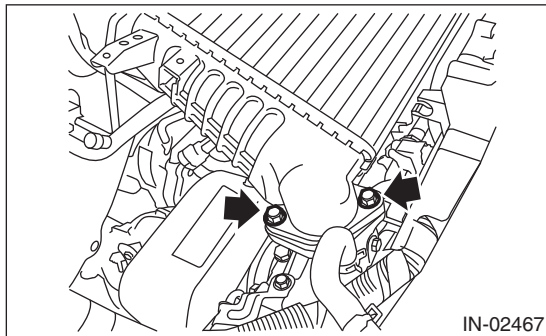

- 5) Remove the bolts which secure the intercooler to the intercooler stay, and remove the intercooler.

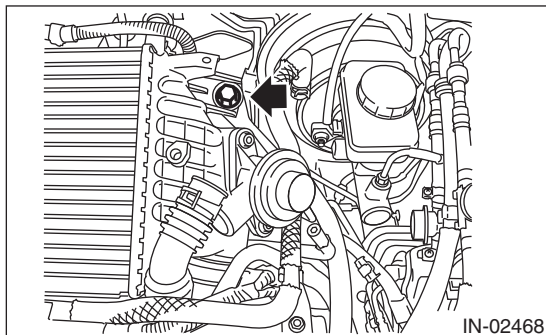

Intercooler

INTAKE (INDUCTION)

B: INSTALLATION

Install in the reverse order of removal.

NOTE:

- Use new O-rings.
- Be careful not to pinch the O-ring.

Tightening torque:

16 N·m (1.6 kgf·m, 11.8 ft·lb)

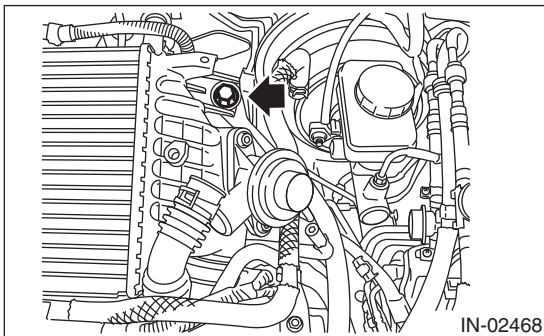
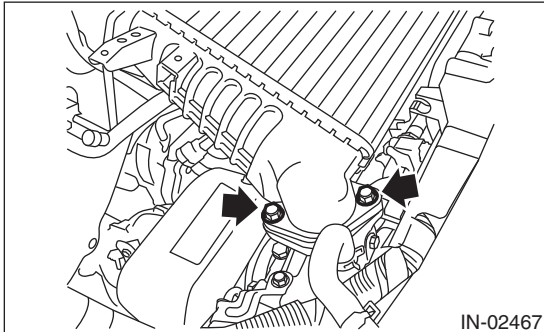
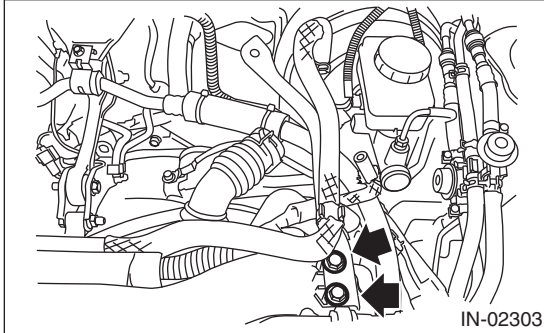

Tightening torque:

3 N·m (0.3 kgf·m, 2.2 ft·lb)

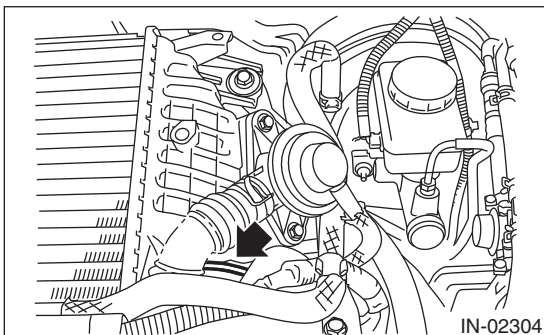

C: DISASSEMBLY

1) Remove the air by-pass valve from intercooler.

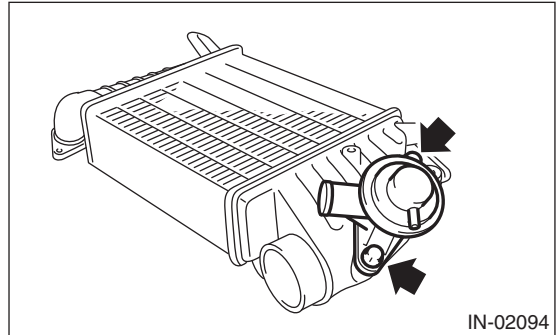

D: ASSEMBLY

Assemble in the reverse order of disassembly.

NOTE:

- Use new O-rings.
- Be careful not to pinch the O-ring.

Tightening torque:

6.5 N·m (0.7 kgf·m, 4.8 ft·lb)

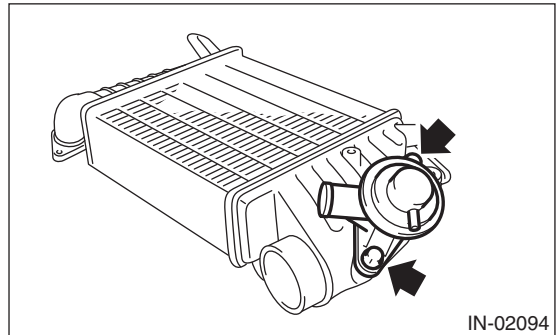

E: INSPECTION

Check for cracks or loose connections.

7. Turbocharger

A: REMOVAL

- 1) Set the vehicle on a lift.
- 2) Remove the collector cover.
- 3) Disconnect the ground cable from the battery.

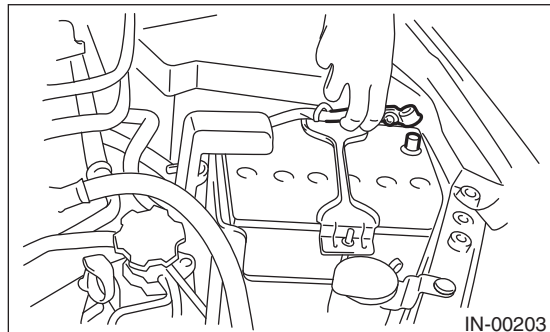

- 4) Lift up the vehicle.
- 5) Drain approximately 3.0 ℓ (3.2 US qt, 2.6 Imp qt) of coolant. <Ref. to CO(H4DOTC)-13, DRAINING OF ENGINE COOLANT, REPLACEMENT, Engine Coolant.>
- 6) Lower the vehicle.
- 7) Remove the intercooler. <Ref. to IN(H4DOTC)-11, REMOVAL, Intercooler.>
- 8) Remove the center exhaust pipe. <Ref. to EX(H4DOTC)-7, REMOVAL, Center Exhaust Pipe.>
- 9) Lower the vehicle.
- 10) Separate the turbocharger joint pipe from turbocharger.

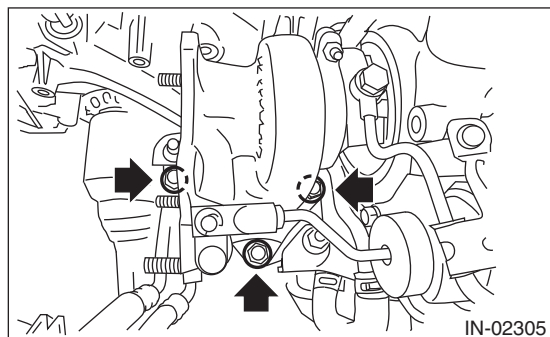

- 11) Disconnect the engine coolant hose which is connected to coolant filler tank.

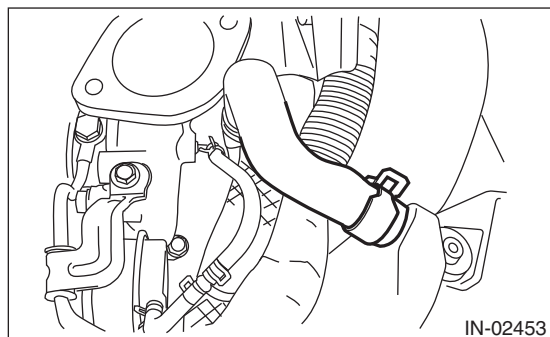

- 12) Disconnect the air control hose (A), and loosen the clamp that holds the turbocharger on the intake duct.

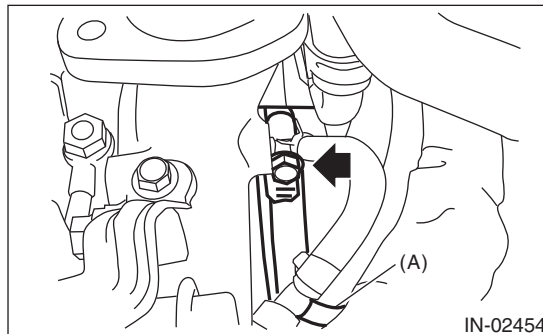

- 13) Remove the oil inlet pipe from the turbocharger.

CAUTION:

In order to prevent damaging the oil pipe on the cylinder head side, fix the section (a) shown in the figure when loosening the oil inlet pipe flare nut, and avoid the part from rotating together while loosening the nut.

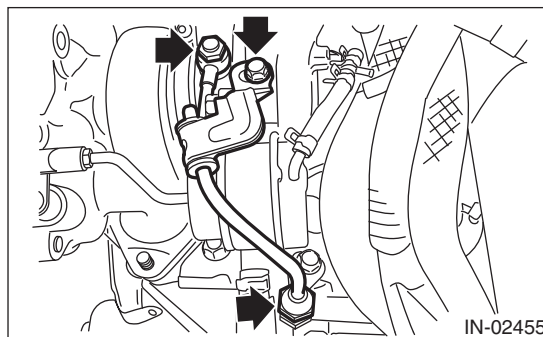
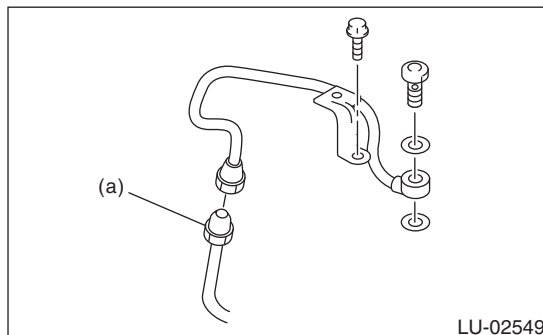

- 14) Disconnect the engine coolant hose from the water pipe.

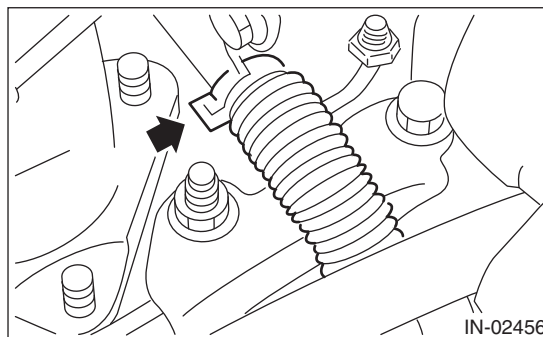

Turbocharger

INTAKE (INDUCTION)

15) Disconnect the oil outlet hose from the oil outlet pipe.

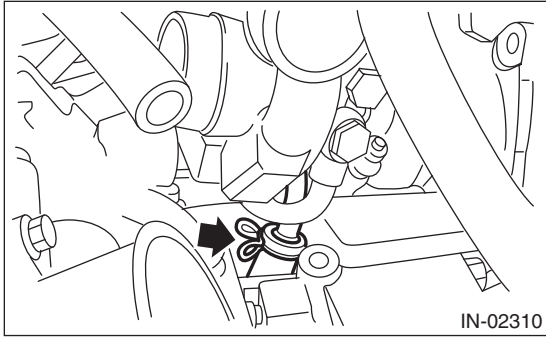

16) Take out the turbocharger from engine compartment.

17) Remove the turbocharger stay.

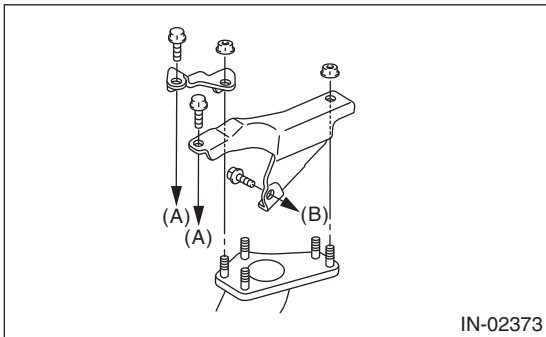

- (A) To cylinder head RH
- (B) To cylinder block RH

B: INSTALLATION

CAUTION:

When replacing the turbocharger, check the filter part of union screw for clogging. <Ref. to LU(H4DOTC)-24, INSPECTING UNION SCREW WITH FILTER, INSPECTION, Oil Pipe.>

1) Install the turbocharger stay.

Tightening torque:

T1: 33 N·m (3.4 kgf-m, 24.3 ft-lb)

T2: 42.5 N·m (4.3 kgf-m, 31.3 ft-lb)

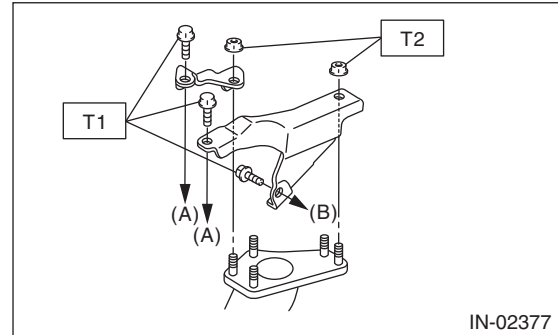

- (A) To cylinder head RH
- (B) To cylinder block RH

2) Connect the oil outlet hose to the oil outlet pipe.

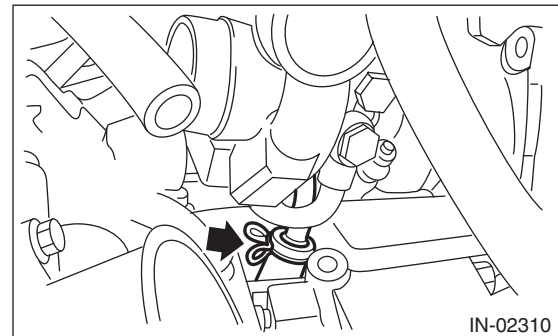

3) Connect the engine coolant hoses to the water pipe.

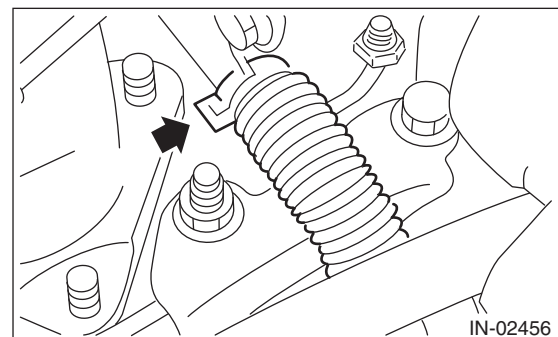

4) Install the oil inlet pipe to the turbocharger.

CAUTION:

In order to prevent damaging the oil pipe on the cylinder head side, fix the section (a) shown in the figure when tightening the oil inlet pipe flare nut, and avoid the part from rotating together while tightening the nut.

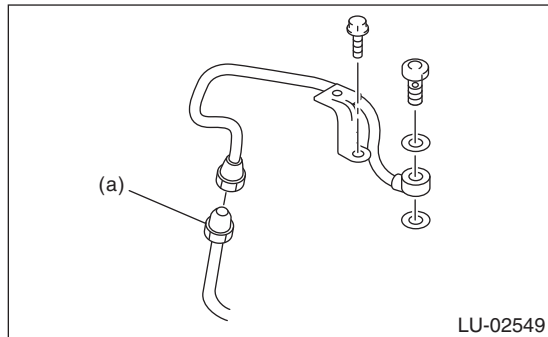

Tightening torque:

T1: 5 N·m (0.5 kgf-m, 3.7 ft-lb)

T2: 16 N·m (1.6 kgf-m, 11.8 ft-lb)

T3: 20 N·m (2.0 kgf-m, 14.5 ft-lb)

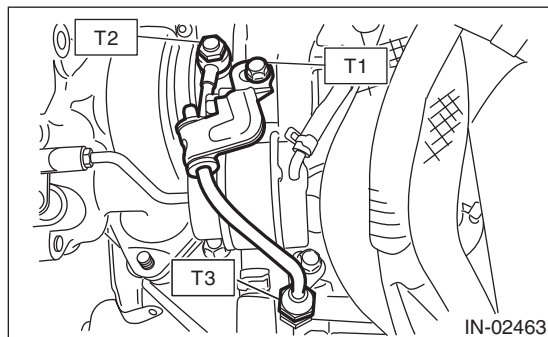

5) Connect the air control hose (A), and install the turbocharger to the intake duct.

Tightening torque:

3 N·m (0.3 kgf-m, 2.2 ft-lb)

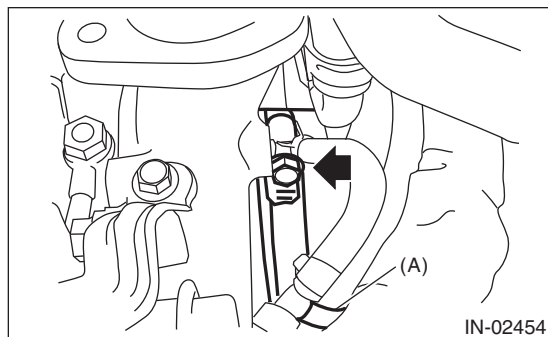

6) Connect the engine coolant hose which is connected to the coolant filler tank.

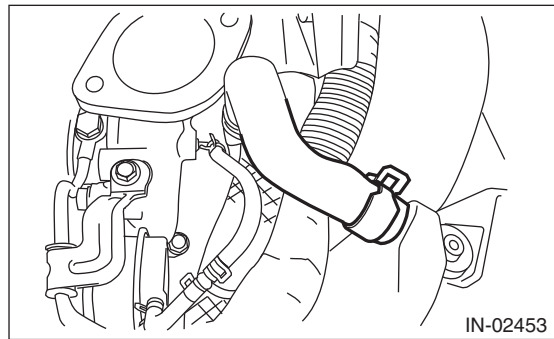

7) Install the joint pipe to turbocharger.

NOTE:

Replace the gasket with a new part.

Tightening torque:

42.5 N·m (4.3 kgf-m, 31.3 ft-lb)

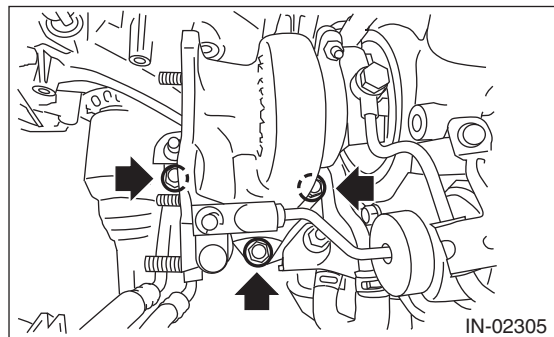

8) Lift up the vehicle.

9) Install the center exhaust pipe. <Ref. to EX(H4DOTC)-8, INSTALLATION, Center Exhaust Pipe.>

10) Lower the vehicle.

11) Install the intercooler. <Ref. to IN(H4DOTC)-12, INSTALLATION, Intercooler.>

12) Fill engine coolant. <Ref. to CO(H4DOTC)-13, FILLING OF ENGINE COOLANT, REPLACEMENT, Engine Coolant.>

13) Connect the ground cable to battery.

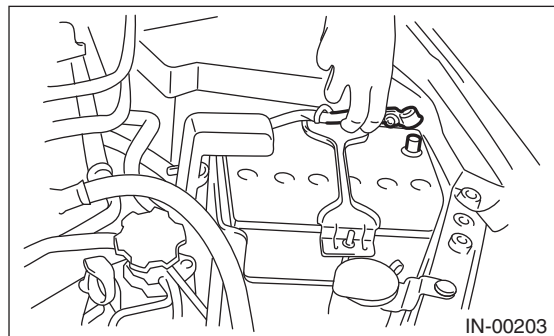

14) Install the collector cover.

Turbocharger

INTAKE (INDUCTION)

C: INSPECTION

1. WASTE GATE ACTUATOR

- 1) Remove the collector cover.
- 2) Remove the intercooler. <Ref. to IN(H4DOTC)-11, REMOVAL, Intercooler.>
- 3) Remove the turbocharger upper cover.

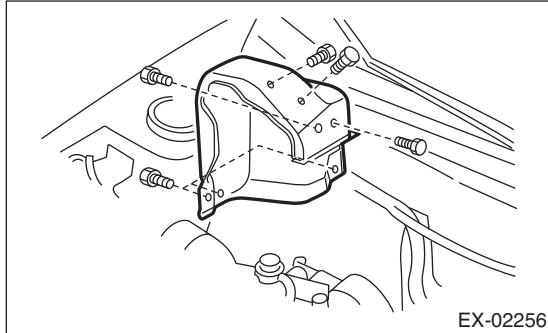

- 4) Remove the boost hose (B) from the waste gate actuator (A) of the turbo charger, and connect the Mighty Vac to the waste gate actuator (A).

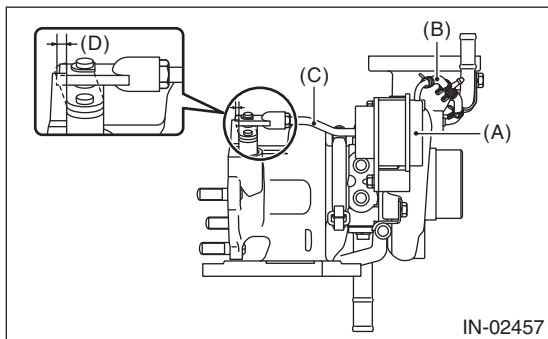

- (A) Waste gate actuator
- (B) Boost hose
- (C) Control rod
- (D) Control rod stroke

- 5) Pressurize slowly with the Mighty Vac, and measure the pressure when the control rod stroke (D) becomes 1 mm (0.04 in). If it is not within the standard, replace the turbocharger assembly.

CAUTION:

Do not pressurize over 56.0 kPa (0.57 kgf/cm², 8.12 psi) to prevent damaging the waste gate actuator.

Control pressure

(Control rod stroke 1 mm (0.04 in)):

Standard value

44.0 — 46.6 kPa

(0.45 — 0.48 kgf/cm², 6.38 — 6.76 psi)

- 6) After inspection, install the related parts in the reverse order of removal.

Tightening torque:

7.5 N·m (0.8 kgf·m, 5.5 ft·lb)

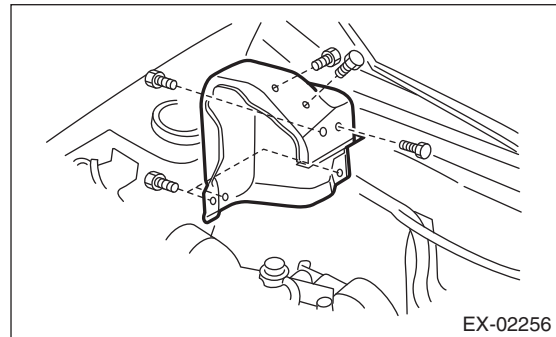

2. OIL PIPE AND WATER PIPE

- Check that there are no oil leaks or water leaks from the pipe attachment section.
- Check for cracks or loose connections.

8. Air By-pass Valve

A: REMOVAL

- 1) Install the collector cover.
- 2) Disconnect the air by-pass pipe (A) and vacuum hose (B) from the air by-pass valve (C).
- 3) Remove the air by-pass valve (C) from the inter-cooler.

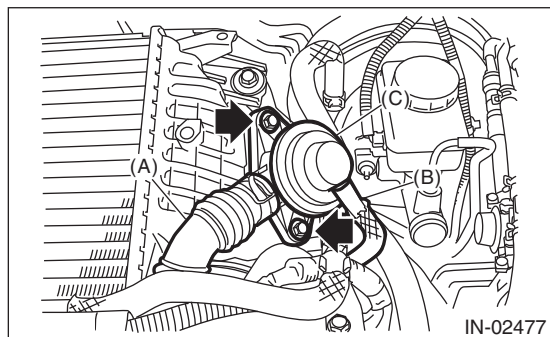

B: INSTALLATION

Install in the reverse order of removal.

NOTE:

- Use new O-rings.
- Be careful not to pinch the O-ring.

Tightening torque:

6.5 N·m (0.7 kgf·m, 4.8 ft·lb)

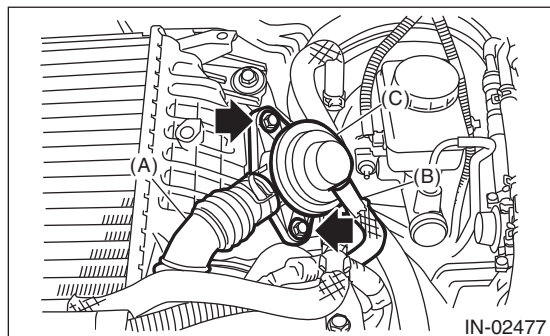

- (A) Air by-pass pipe
- (B) Vacuum hose
- (C) Air by-pass valve

9. Resonator Chamber

A: REMOVAL

The resonator chamber and air cleaner case are integrated into one unit; therefore, refer to “Air Cleaner Case” for the removal procedure. <Ref. to IN(H4DOTC)-8, REMOVAL, Air Cleaner Case.>

B: INSTALLATION

The resonator chamber and air cleaner case are integrated into one unit; therefore, refer to “Air Cleaner Case” for installation procedure. <Ref. to IN(H4DOTC)-8, INSTALLATION, Air Cleaner Case.>

C: INSPECTION

Check for cracks or loose connections.

MECHANICAL

ME(H4DOTC)

	Page
1. General Description	2
2. Compression	20
3. Idle Speed	21
4. Ignition Timing	22
5. Intake Manifold Vacuum	23
6. Engine Oil Pressure	24
7. Fuel Pressure	25
8. Valve Clearance	26
9. Engine Assembly	30
10. Engine Mounting	37
11. Preparation for Overhaul	38
12. V-belt	39
13. Crank Pulley	47
14. Timing Belt Cover	49
15. Timing Belt	50
16. Cam Sprocket	57
17. Crank Sprocket	59
18. Camshaft	60
19. Cylinder Head	66
20. Cylinder Block	75
21. Intake and Exhaust Valve	97
22. Piston	98
23. Connecting Rod	99
24. Crankshaft	100
25. Engine Trouble in General	101
26. Engine Noise	107

General Description

MECHANICAL

1. General Description

A: SPECIFICATION

Engine	Model		2.5 L		
	Cylinder arrangement		Horizontally opposed, liquid cooled, 4-cylinder, 4-stroke gasoline engine		
	Valve system mechanism		Belt driven, double overhead camshaft, 4-valve/cylinder		
	Bore × Stroke		mm (in)		
	Piston displacement		cm ³ (cu in)		
	Compression ratio		8.4		
	Compression pressure (at 200 — 300 rpm)		kPa (kg/cm ² , psi)		
	Number of piston rings		Pressure ring: 2, Oil ring: 1		
	Intake valve timing		Open	Max. retard	ATDC 5°
				Min. advance	BTDC 35°
			Close	Max. retard	ABDC 65°
				Min. advance	ABDC 25°
	Exhaust valve timing		Open	BBDC 55°	
			Close	ATDC 5°	
	Valve clearance		Inspection value	Intake	0.20 ^{+0.04} _{-0.06} (0.0079 ^{+0.0016} _{-0.0024})
				Exhaust	0.35±0.05 (0.0138±0.0020)
			Adjustment value	Intake	0.20 ^{+0.01} _{-0.03} (0.0079 ^{+0.0004} _{-0.0012})
				Exhaust	0.35±0.02 (0.0138±0.0008)
Idle speed ["P" or "N" range]		rpm	No load	700±100	
			A/C ON	825±100	
Ignition order		1 → 3 → 2 → 4			
Ignition timing		BTDC/rpm		17°±10°/700	

General Description

MECHANICAL

NOTE:

OS: Oversize US: Undersize

Belt tension adjuster	Protrusion of adjuster rod			mm (in)	5.2 — 6.2 (0.205 — 0.244)
Camshaft	Bending limit			mm (in)	0.020 (0.00079)
	Thrust clearance		mm (in)	Standard	0.068 — 0.116 (0.0027 — 0.0047)
	Cam lobe height	mm (in)	Intake	Standard	46.55 — 46.65 (1.833 — 1.837)
			Exhaust	Standard	46.75 — 46.85 (1.841 — 1.844)
	Journal O.D.	mm (in)	Standard	Front	37.946 — 37.963 (1.4939 — 1.4946)
Center rear				29.946 — 29.963 (1.1790 — 1.1796)	
Journal clearance		mm (in)	Standard	0.037 — 0.072 (0.0015 — 0.0028)	
Cylinder head	Surface warpage limit			mm (in)	0.035 (0.0014)
	Grinding limit			mm (in)	0.3 (0.012)
	Standard height			mm (in)	127.5 (5.02)
Valve seat	Seating angle				90°
	Contacting width	mm (in)	Intake	Standard	0.6 — 1.4 (0.024 — 0.055)
			Exhaust	Standard	1.2 — 1.8 (0.047 — 0.071)
Valve guide	Inside diameter			mm (in)	6.000 — 6.012 (0.2362 — 0.2367)
	Protrusion above head			mm (in)	15.8 — 16.2 (0.622 — 0.638)
Valve	Head edge thickness	mm (in)	Intake	Standard	1.0 — 1.4 (0.039 — 0.055)
			Exhaust	Standard	1.3 — 1.7 (0.051 — 0.067)
	Stem outer diameter	mm (in)	Intake		5.955 — 5.970 (0.2344 — 0.2350)
			Exhaust		5.945 — 5.960 (0.2341 — 0.2346)
	Valve stem gap	mm (in)	Standard	Intake	0.030 — 0.057 (0.0012 — 0.0022)
Exhaust				0.040 — 0.067 (0.0016 — 0.0026)	
Overall length	mm (in)	Intake		104.4 (4.110)	
		Exhaust		104.65 (4.1201)	
Valve spring	Free length			mm (in)	47.32 (1.863)
	Squareness				2.5°, 2.1 mm (0.083 in) or less
	Tension/spring height	N (kgf, lb)/mm (in)	Set		205 — 235 (20.9 — 24.0, 46.1 — 52.8)/36.0 (1.417)
			Lift		426 — 490 (43.4 — 50.0, 95.8 — 110)/26.5 (1.043)
Valve lifter	Outer diameter		mm (in)	Standard	34.959 — 34.975 (1.3763 — 1.3770)
	Inner diameter (cylinder head)		mm (in)	Standard	34.994 — 35.016 (1.3777 — 1.3786)
	Valve lifter clearance		mm (in)	Standard	0.019 — 0.057 (0.0007 — 0.0022)
Cylinder block	Surface warpage limit (Mating surface with cylinder head)			mm (in)	0.025 (0.0098)
	Grinding limit			mm (in)	0.1 (0.004)
	Standard height			mm (in)	201.0 (7.91)
	Cylinder inner diameter	mm (in)	Standard	A	99.505 — 99.515 (3.9175 — 3.9179)
				B	99.495 — 99.505 (3.9171 — 3.9175)
	Taper		mm (in)	Standard	0.015 (0.0006)
	Out-of-roundness		mm (in)	Standard	0.010 (0.0004)
	Piston clearance		mm (in)	Standard	-0.010 — 0.010 (-0.00039 — 0.00039)
Cylinder inner diameter boring limit (diameter)			mm (in)	To 100.005 (3.9372)	
Piston	Outer diameter	mm (in)	Standard	A	99.505 — 99.515 (3.9175 — 3.9179)
				B	99.495 — 99.505 (3.9171 — 3.9175)
			0.25 (0.0098) OS		99.745 — 99.765 (3.9270 — 3.9278)
			0.50 (0.0197) OS		99.995 — 100.015 (3.9368 — 3.9376)

ME(H4DOTC)-3

General Description

MECHANICAL

Piston pin	Standard clearance between piston and piston pin		mm (in)	Standard	0.004 — 0.008 (0.0002 — 0.0003)
	Degree of fit				Piston pin must be fitted into position with thumb at 20°C (68°F).
Piston ring	Ring closed gap	mm (in)	Top ring	Standard	0.20 — 0.25 (0.0079 — 0.0098)
			Second ring	Standard	0.37 — 0.52 (0.015 — 0.0203)
			Oil ring	Standard	0.20 — 0.50 (0.0079 — 0.0197)
	Ring groove gap	mm (in)	Top ring	Standard	0.040 — 0.080 (0.0016 — 0.0031)
Second ring			Standard	0.030 — 0.070 (0.0012 — 0.0028)	
Connecting rod	Bend or twist per 100 mm (3.94 in) in length		mm (in)	Limit	0.1 (0.0039)
	Thrust clearance		mm (in)	Standard	0.070 — 0.330 (0.0028 — 0.0130)
Bearing of large end	Oil clearance		mm (in)	Standard	0.017 — 0.045 (0.0007 — 0.0018)
	Bearing size (Thickness at center)	mm (in)	Standard		1.490 — 1.502 (0.0587 — 0.0591)
			0.03 (0.0012) US		1.504 — 1.512 (0.0592 — 0.0595)
			0.05 (0.0020) US		1.514 — 1.522 (0.0596 — 0.0599)
0.25 (0.0098) US			1.614 — 1.622 (0.0635 — 0.0639)		
Bushing of small end	Clearance between piston pin and bushing		mm (in)	Standard	0 — 0.022 (0 — 0.0009)
Crankshaft	Bending limit		mm (in)		0.035 (0.0014)
	Crank pin	Out-of-roundness		mm (in)	0.003 (0.0001)
		Cylindricality		mm (in)	0.004 (0.0002)
		Grinding limit (dia.)		mm (in)	To 51.750 (2.0374)
	Crank journal	Out-of-roundness		mm (in)	0.005 (0.0002)
		Cylindricality		mm (in)	0.006 (0.0002)
		Grinding limit (dia.)		mm (in)	To 59.758 (2.3527)
	Crank pin outer diameter	mm (in)	Standard		51.984 — 52.000 (2.0466 — 2.0472)
			0.03 (0.0012) US		51.954 — 51.970 (2.0454 — 2.0461)
			0.05 (0.0020) US		51.934 — 51.950 (2.0447 — 2.0453)
			0.25 (0.0098) US		51.734 — 51.750 (2.0368 — 2.0374)
	Crank journal outer diameter	mm (in)	Standard		59.992 — 60.008 (2.3619 — 2.3625)
			0.03 (0.0012) US		59.962 — 59.978 (2.3607 — 2.3613)
0.05 (0.0020) US			59.942 — 59.958 (2.3599 — 2.3605)		
0.25 (0.0098) US			59.742 — 59.758 (2.3520 — 2.3527)		
Thrust clearance		mm (in)	Standard	0.030 — 0.115 (0.0012 — 0.0045)	
Oil clearance		mm (in)		0.010 — 0.030 (0.0004 — 0.0012)	
Main bearing	Bearing size (Thickness at center) mm (in)	#1, #3	Standard		1.998 — 2.011 (0.0787 — 0.0792)
			0.03 (0.0012) US		2.017 — 2.020 (0.0794 — 0.0795)
			0.05 (0.0020) US		2.027 — 2.030 (0.0798 — 0.0799)
			0.25 (0.0098) US		2.127 — 2.130 (0.0837 — 0.0839)
		#2, #4, #5	Standard		2.000 — 2.013 (0.0787 — 0.0793)
			0.03 (0.0012) US		2.019 — 2.022 (0.0795 — 0.0796)
			0.05 (0.0020) US		2.029 — 2.032 (0.0799 — 0.0800)
			0.25 (0.0098) US		2.129 — 2.132 (0.0838 — 0.0839)

B: COMPONENT

1. TIMING BELT

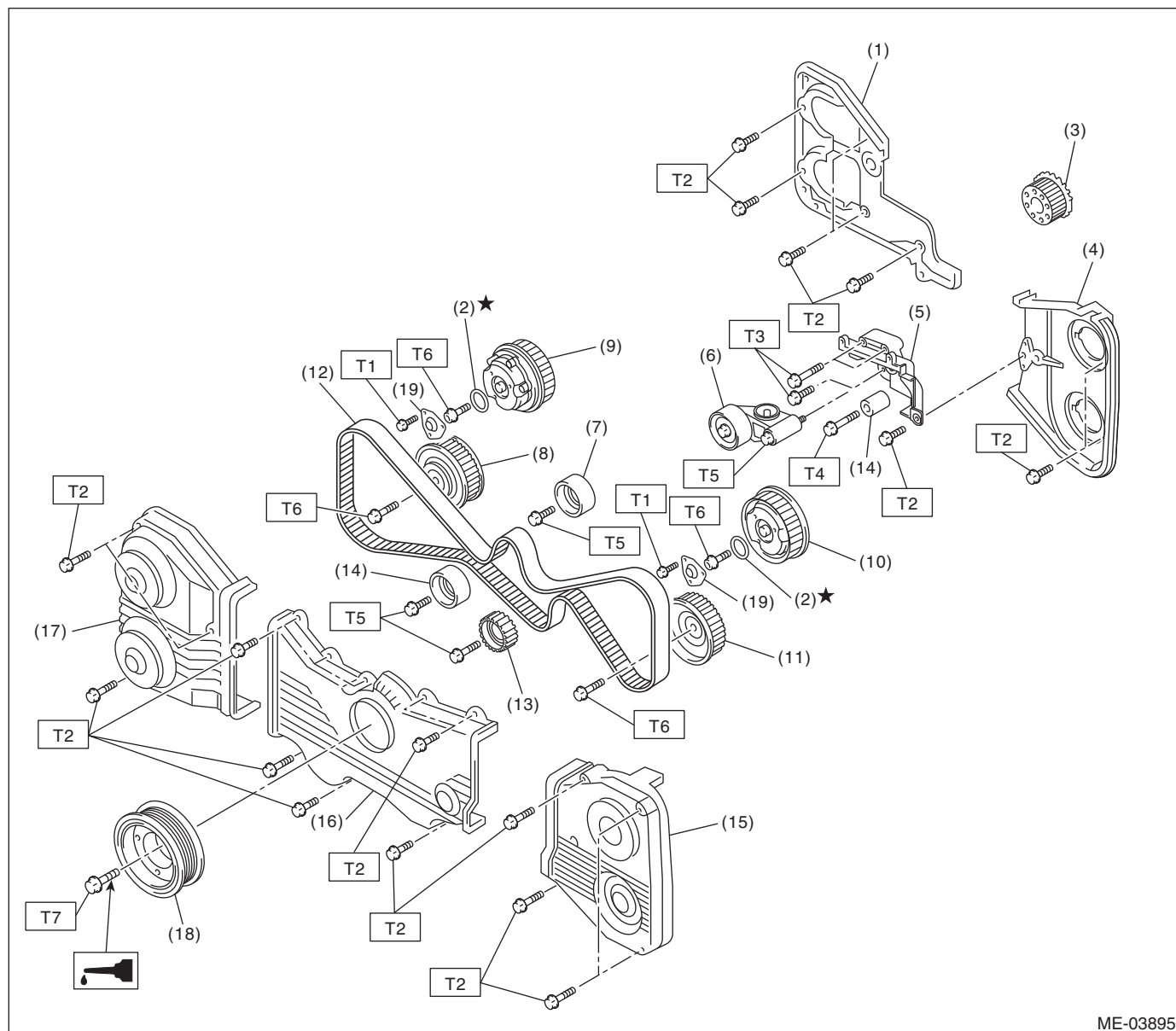

- | | |
|--|------------------------------|
| (1) Timing belt cover No. 2 RH | (10) Intake cam sprocket LH |
| (2) O-ring | (11) Exhaust cam sprocket LH |
| (3) Crank sprocket | (12) Timing belt |
| (4) Timing belt cover No. 2 LH | (13) Belt idler No. 2 |
| (5) Tensioner bracket | (14) Belt idler |
| (6) Automatic belt tension adjuster ASSY | (15) Timing belt cover LH |
| (7) Belt idler | (16) Front belt cover |
| (8) Exhaust cam sprocket RH | (17) Timing belt cover RH |
| (9) Intake cam sprocket RH | (18) Crank pulley |
| | (19) Actuator cover |

Tightening torque: N·m (kgf·m, ft·lb)

T1: 3.4 (0.3, 2.5)

T2: 5 (0.5, 3.7)

T3: 24.5 (2.5, 18.1)

T4: 25 (2.5, 18.4)

T5: 39 (4.0, 28.8)

T6: <Ref. to ME(H4DOTC)-57, INSTALLATION, Cam Sprocket.>

T7: <Ref. to ME(H4DOTC)-47, INSTALLATION, Crank Pulley.>

General Description

MECHANICAL

- | | |
|-------------------------------------|---|
| (1) Rocker cover RH | (18) Front camshaft cap LH |
| (2) Rocker cover gasket RH | (19) Intake camshaft cap LH |
| (3) Front camshaft cap RH | (20) Exhaust camshaft cap LH |
| (4) Intake camshaft cap RH | (21) Rocker cover gasket LH |
| (5) Intake camshaft RH | (22) Rocker cover LH |
| (6) Oil flow control solenoid valve | (23) Oil filler cap |
| (7) Exhaust camshaft cap RH | (24) Oil filler duct |
| (8) Gasket | (25) O-ring |
| (9) Oil return cover | (26) Oil pipe LH |
| (10) Exhaust camshaft RH | (27) Gasket |
| (11) Cylinder head bolt | (28) Oil pipe RH |
| (12) Oil seal | (29) Stud bolt |
| (13) Cylinder head RH | (30) Union screw with filter
(with protrusion) |
| (14) Cylinder head gasket | (31) Union screw without filter
(without protrusion) |
| (15) Cylinder head LH | |
| (16) Intake camshaft LH | |
| (17) Exhaust camshaft LH | |

- (32) Gasket

Tightening torque:N·m (kgf·m, ft·lb)

**T1: <Ref. to ME(H4DOTC)-67,
INSTALLATION, Cylinder Head.>**

T2: 8 (0.8, 5.9)

**T3: <Ref. to ME(H4DOTC)-61,
INSTALLATION, Camshaft.>**

T4: 6.4 (0.7, 4.7)

**T5: <Ref. to ME(H4DOTC)-61,
INSTALLATION, Camshaft.>**

T6: 29 (3.0, 21.4)

**T7: <Ref. to ME(H4DOTC)-61,
INSTALLATION, Camshaft.>**

General Description

MECHANICAL

3. CYLINDER HEAD AND VALVE ASSEMBLY

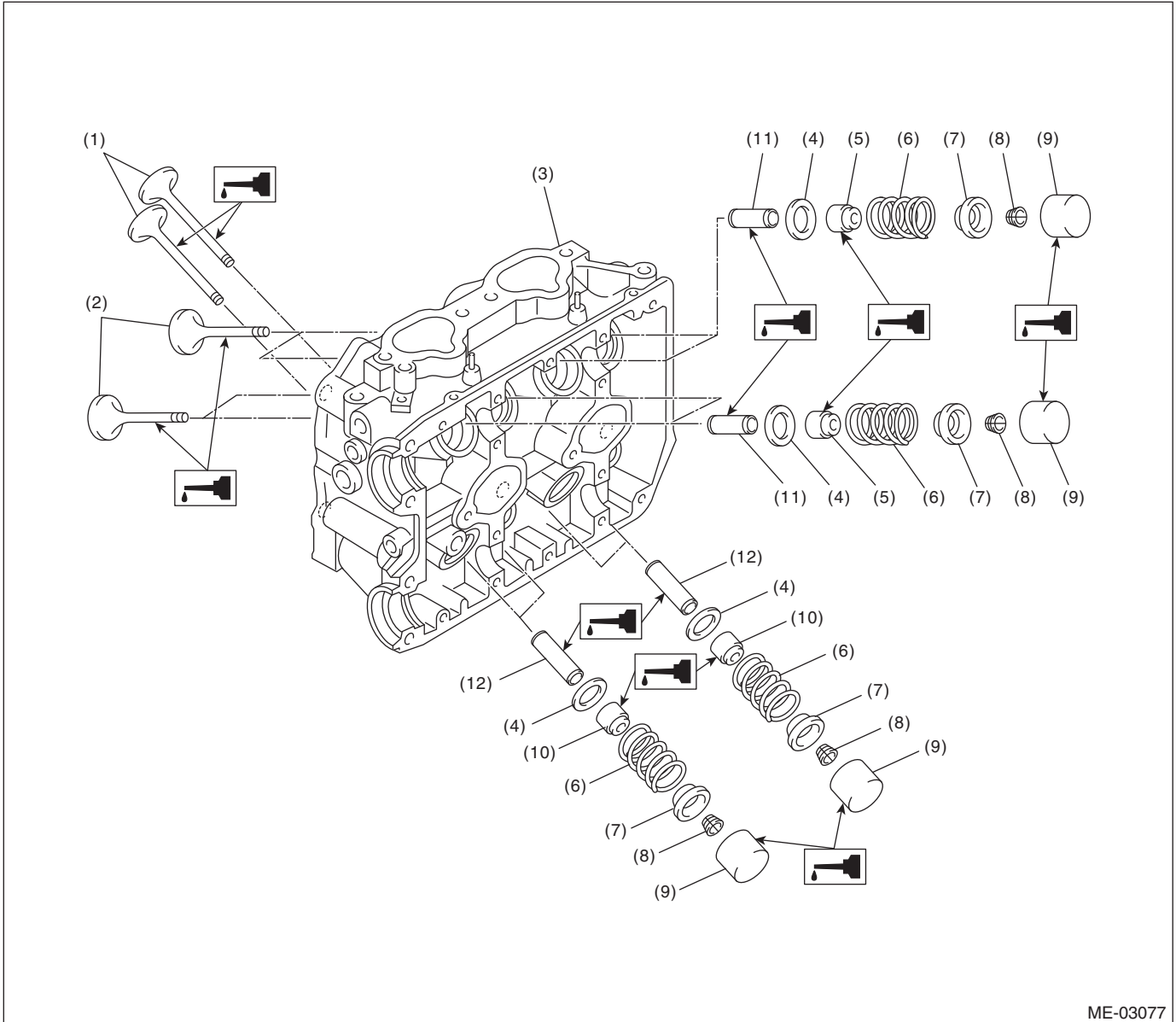

ME-03077

- | | | |
|-----------------------|---------------------------|-----------------------------|
| (1) Exhaust valve | (5) Intake valve oil seal | (9) Valve lifter |
| (2) Intake valve | (6) Valve spring | (10) Exhaust valve oil seal |
| (3) Cylinder head | (7) Retainer | (11) Intake valve guide |
| (4) Valve spring seat | (8) Retainer key | (12) Exhaust valve guide |

4. CYLINDER BLOCK

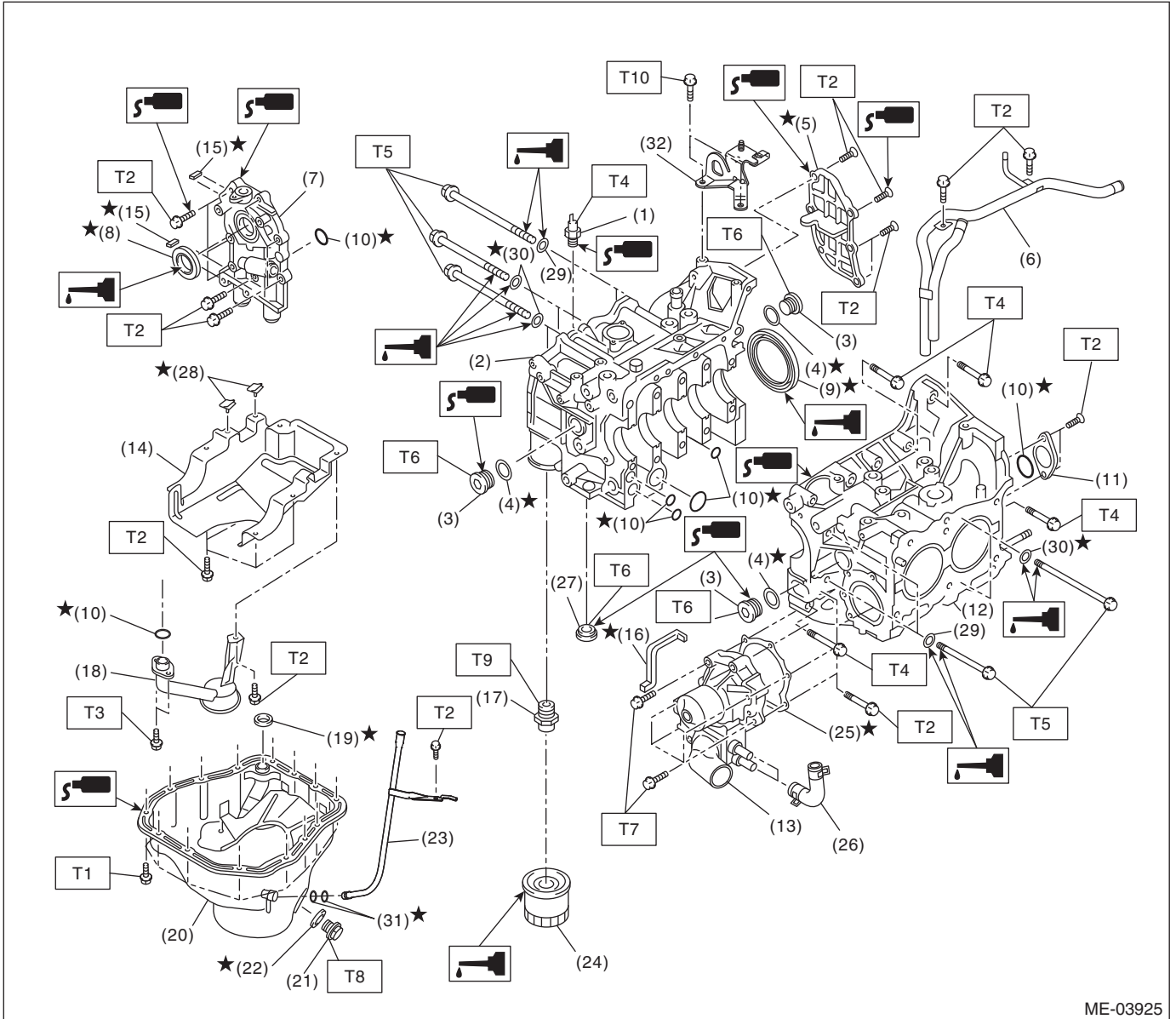

ME-03925

General Description

MECHANICAL

(1) Oil pressure switch	(17) Oil filter connector	(32) Engine rear hanger
(2) Cylinder block RH	(18) Oil strainer	
(3) Service hole plug	(19) Gasket	<hr/> Tightening torque:N·m (kgf-m, ft-lb)
(4) Gasket	(20) Oil pan	T1: 5 (0.5, 3.7)
(5) Oil separator cover	(21) Drain plug	T2: 6.4 (0.7, 4.7)
(6) Water by-pass pipe	(22) Drain plug gasket	T3: 10 (1.0, 7.2)
(7) Oil pump	(23) Oil level gauge guide	T4: 25 (2.5, 18.4)
(8) Front oil seal	(24) Oil filter	T5: <Ref. to ME(H4DOTC)-79, INSTALLATION, Cylinder Block.>
(9) Rear oil seal	(25) Gasket	
(10) O-ring	(26) Water pump hose	T6: 70 (7.1, 51.6)
(11) Service hole cover	(27) Plug	T7: First 12 (1.2, 8.9) Second 12 (1.2, 8.9)
(12) Cylinder block LH	(28) Seal	
(13) Water pump	(29) Washer	T8: 44 (4.5, 32.5)
(14) Baffle plate	(30) Seal washer	T9: 45 (4.6, 33.2)
(15) Oil pump seal	(31) O-ring	T10: 16 (1.6, 11.8)
(16) Water pump sealing		<hr/>

5. CRANKSHAFT AND PISTON

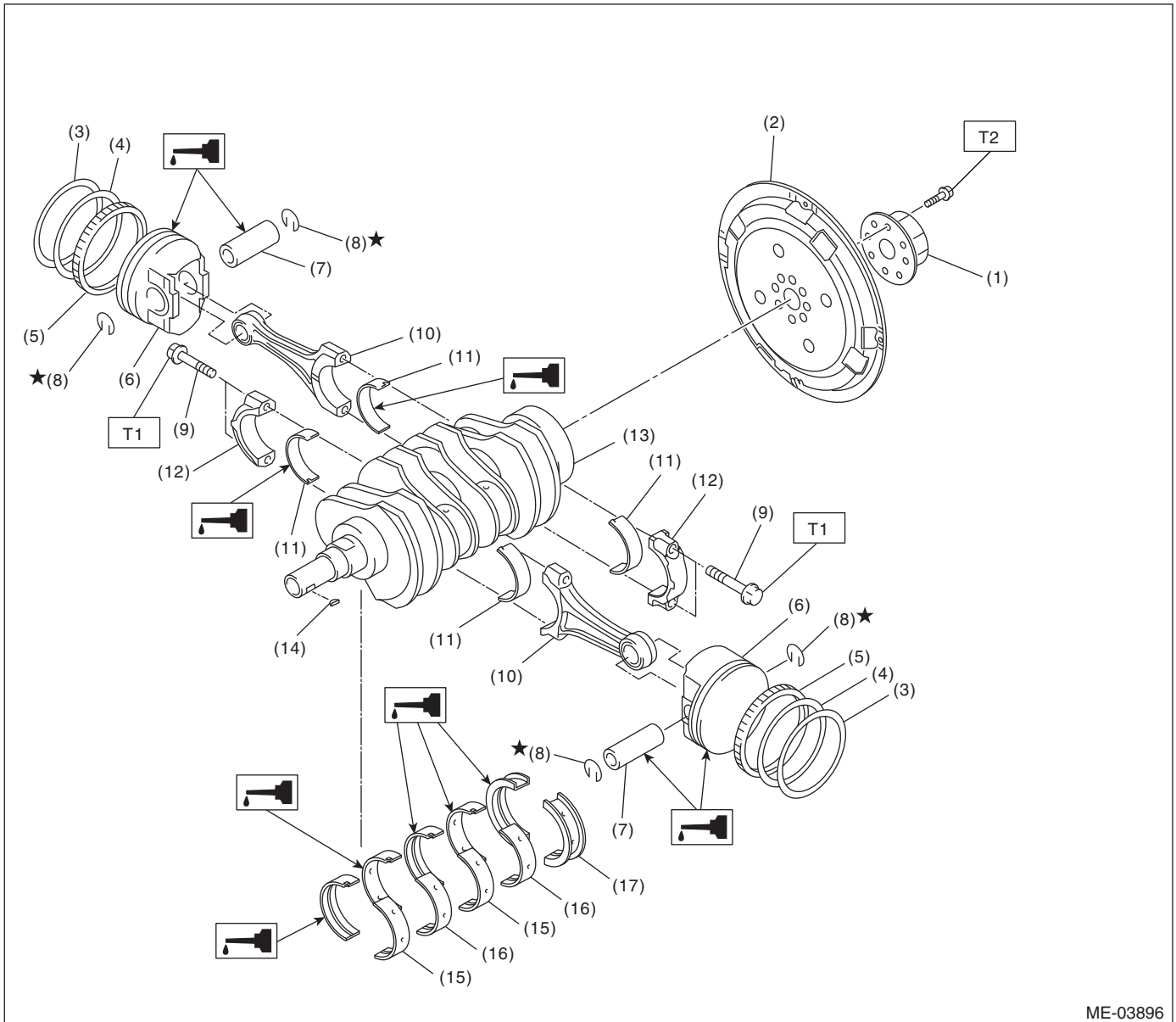

ME-03896

- | | | |
|-------------------|--------------------------------|--------------------------------|
| (1) Reinforcement | (9) Connecting rod bolt | (16) Crankshaft bearing #2, #4 |
| (2) Drive plate | (10) Connecting rod | (17) Crankshaft bearing #5 |
| (3) Top ring | (11) Connecting rod bearing | |
| (4) Second ring | (12) Connecting rod cap | |
| (5) Oil ring | (13) Crankshaft | |
| (6) Piston | (14) Woodruff key | |
| (7) Piston pin | (15) Crankshaft bearing #1, #3 | |
| (8) Snap ring | | |

Tightening torque: N·m (kgf-m, ft-lb)

T1: 52 (5.3, 38.4)

T2: <Ref. to 4AT-67, INSTALLATION, Drive Plate.>

General Description

MECHANICAL

6. ENGINE MOUNTING

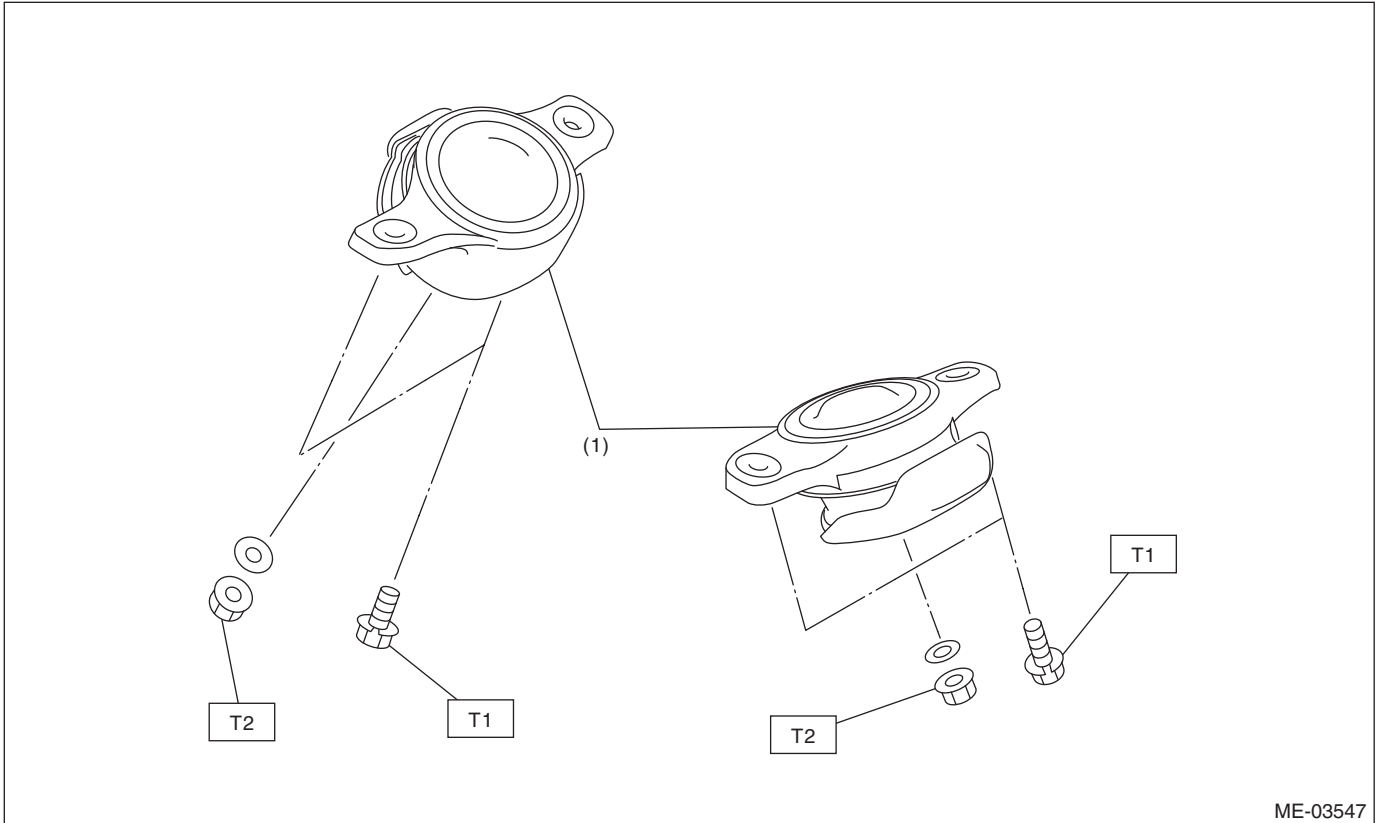

(1) Front cushion rubber

Tightening torque: N·m (kgf-m, ft-lb)

T1: 35 (3.6, 25.8)

T2: 85 (8.7, 62.7)

C: CAUTION

- Wear appropriate work clothing, including a cap, protective goggles and protective shoes when performing any work.
- Remove contamination including dirt and corrosion before removal, installation or disassembly.
- Keep the disassembled parts in order and protect them from dust and dirt.
- Before removal, installation or disassembly, be sure to clarify the failure. Avoid unnecessary removal, installation, disassembly and replacement.
- Vehicle components are extremely hot after driving. Be wary of receiving burns from heated parts.
- Be sure to tighten fasteners including bolts and nuts to the specified torque.
- Place shop jacks or rigid racks at the specified points.
- Before disconnecting connectors of sensors or units, be sure to disconnect the ground cable from the battery.
- All parts should be thoroughly cleaned, paying special attention to engine oil passages, pistons and bearings.
- Rotating parts and sliding parts such as piston, bearing and gear should be coated with oil prior to assembly.
- Be careful not to let oil, grease or engine coolant contact the timing belt, clutch disc and flywheel.
- All removed parts, if to be reused, should be reinstalled in the original positions and directions.
- Bolts, nuts and washers should be replaced with new parts as required.
- Even if necessary inspections have been made in advance, proceed with assembly work while making rechecks.
- Remove or install the engine in an area where chain hoists, lifting devices, etc. are available for ready use.
- Be sure not to damage coated surfaces of body panels with tools, or not to stain seats and windows with coolant or oil. Place a cover over fender, as required, for protection.
- Prior to starting work, prepare the following:

Service tools, clean cloth, containers to catch coolant and oil, wire ropes, chain hoist, transmission jacks, etc.

- Lift up or lower the vehicle when necessary. Make sure to support the correct positions.

D: PREPARATION TOOL

1. SPECIAL TOOL

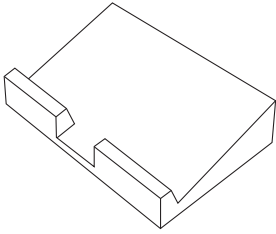
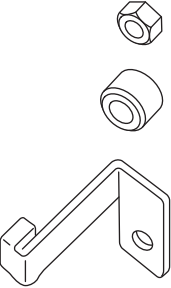
ILLUSTRATION	TOOL NUMBER	DESCRIPTION	REMARKS
 ST-498267600	498267600	CYLINDER HEAD TABLE	<ul style="list-style-type: none"> • Used for replacing valve guides. • Used for removing and installing valve spring.
 ST-498277200	498277200	STOPPER SET	Used for installing automatic transmission assembly to engine.

General Description

MECHANICAL

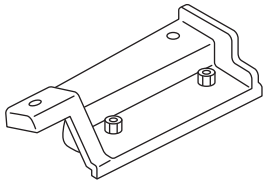
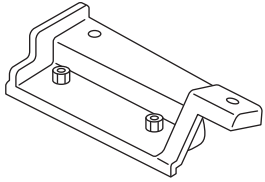
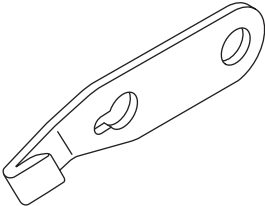
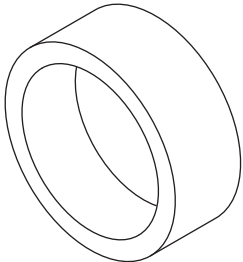
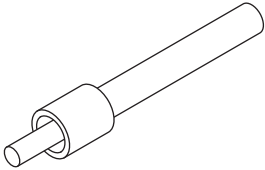
ILLUSTRATION	TOOL NUMBER	DESCRIPTION	REMARKS
 <p style="text-align: center;">ST-498457000</p>	498457000	ENGINE STAND ADAPTER RH	Used together with the ENGINE STAND (499817100).
 <p style="text-align: center;">ST-498457100</p>	498457100	ENGINE STAND ADAPTER LH	Used together with the ENGINE STAND (499817100).
 <p style="text-align: center;">ST-498497100</p>	498497100	CRANKSHAFT STOPPER	Used for removing and installing the drive plate.
 <p style="text-align: center;">ST-498747300</p>	498747300	PISTON GUIDE	Used for installing the cup to the wheel cylinder piston. (2.5 L model)
 <p style="text-align: center;">ST-498857100</p>	498857100	VALVE OIL SEAL GUIDE	Used for press-fitting of intake and exhaust valve guide oil seals.

General Description

MECHANICAL

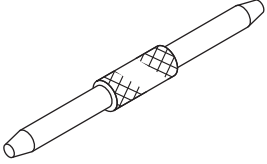
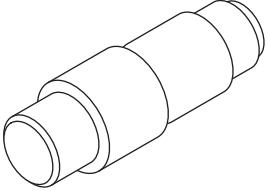
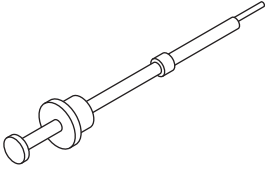
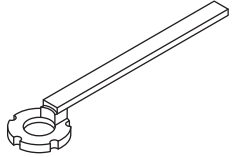
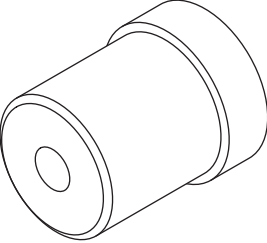
ILLUSTRATION	TOOL NUMBER	DESCRIPTION	REMARKS
 <p style="text-align: center;">ST-499017100</p>	499017100	PISTON PIN GUIDE	Used for installing piston pin, piston and connecting rod.
 <p style="text-align: center;">ST-499037100</p>	499037100	CONNECTING ROD BUSHING REMOVER AND INSTALLER	Used for removing and installing connecting rod bushing.
 <p style="text-align: center;">ST-499097700</p>	499097700	PISTON PIN REMOVER ASSY	Used for removing piston pin.
 <p style="text-align: center;">ST-499207400</p>	499207400	CAM SPROCKET WRENCH	Used for removing and installing exhaust cam sprocket.
 <p style="text-align: center;">ST-499587100</p>	499587100	OIL SEAL INSTALLER	Used for installing oil pump oil seal.

General Description

MECHANICAL

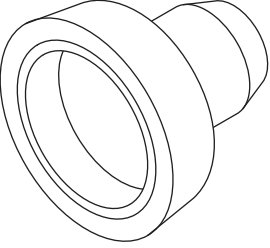
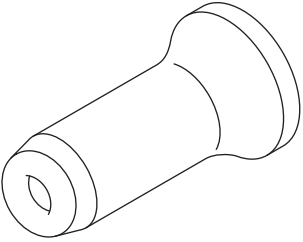
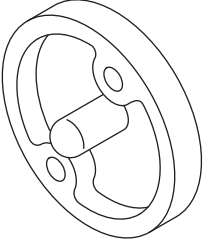
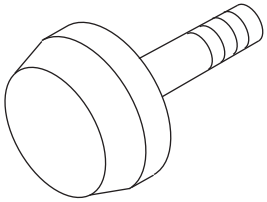
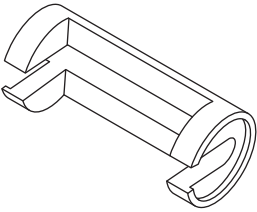
ILLUSTRATION	TOOL NUMBER	DESCRIPTION	REMARKS
 <p style="text-align: center;">ST-499587200</p>	499587200	CRANKSHAFT OIL SEAL INSTALLER	<ul style="list-style-type: none"> • Used for installing crankshaft oil seal. • Used together with the CRANKSHAFT OIL SEAL GUIDE (499597100).
 <p style="text-align: center;">ST-499587600</p>	499587600	OIL SEAL INSTALLER	Used for installing camshaft oil seal for DOHC engine.
 <p style="text-align: center;">ST-499597100</p>	499597100	CRANKSHAFT OIL SEAL GUIDE	<ul style="list-style-type: none"> • Used for installing crankshaft oil seal. • Used together with the CRANKSHAFT OIL SEAL INSTALLER (499587200).
 <p style="text-align: center;">ST-499597200</p>	499597200	OIL SEAL GUIDE	<ul style="list-style-type: none"> • Used for installing camshaft oil seal for DOHC engine. • Used together with the OIL SEAL INSTALLER (499587600).
 <p style="text-align: center;">ST-499718000</p>	499718000	VALVE SPRING REMOVER	Used for removing and installing valve spring.

General Description

MECHANICAL

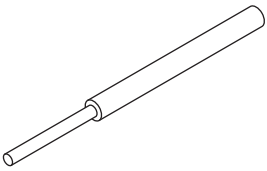
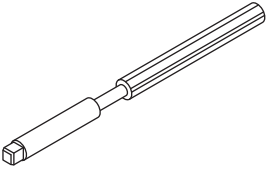
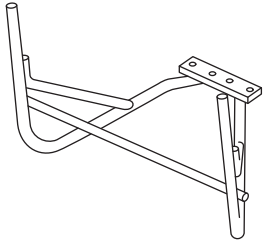
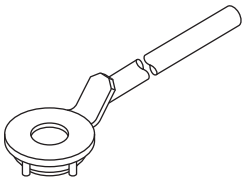
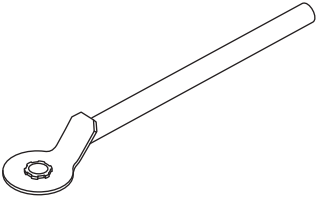
ILLUSTRATION	TOOL NUMBER	DESCRIPTION	REMARKS
 <p style="text-align: center;">ST-499767200</p>	499767200	VALVE GUIDE REMOVER	Used for removing valve guides.
 <p style="text-align: center;">ST-499767400</p>	499767400	VALVE GUIDE REAMER	Used for reaming valve guides.
 <p style="text-align: center;">ST-499817100</p>	499817100	ENGINE STAND	<ul style="list-style-type: none"> • Stand used for engine disassembly and assembly. • Used together with the ENGINE STAND ADAPTER RH (498457000) & LH (498457100).
 <p style="text-align: center;">ST-499977400</p>	499977400	CRANK PULLEY WRENCH	Used to stop rotation of the crank pulley when loosening or tightening crank pulley bolts.
 <p style="text-align: center;">ST-499977500</p>	499977500	CAM SPROCKET WRENCH	Used for removing and installing intake cam sprocket.

General Description

MECHANICAL

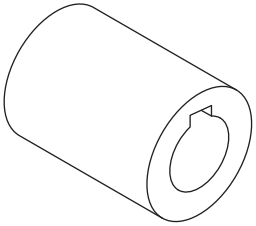
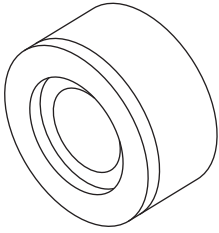
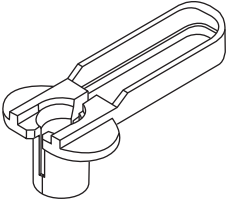
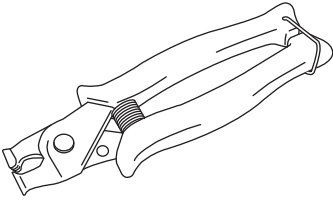
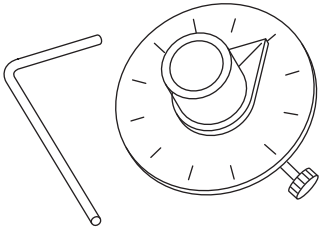
ILLUSTRATION	TOOL NUMBER	DESCRIPTION	REMARKS
 <p style="text-align: center;">ST-499987500</p>	499987500	CRANKSHAFT SOCKET	Used for rotating crankshaft.
 <p style="text-align: center;">ST18251AA020</p>	18251AA020	VALVE GUIDE ADJUSTER	Used for installing intake and exhaust valve guides.
 <p style="text-align: center;">ST18371AA000</p>	18371AA000	CONNECTOR REMOVER	Used for disconnecting the quick connector on the fuel return hose of the engine compartment.
 <p style="text-align: center;">ST18353AA000</p>	18353AA000	CLAMP PLIERS	<ul style="list-style-type: none"> • Used for removing and installing the PCV hose. • This is a general tool made by the French company CAILLAU. (code) 54.0.000.205 To make this easier to obtain in the same way as genuine Subaru parts, it has been provided with a tool number as an ST.
 <p style="text-align: center;">ST18854AA000</p>	18854AA000	ANGLE GAUGE	Used for installing the crank pulley.

General Description

MECHANICAL

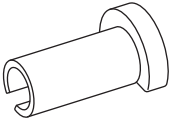
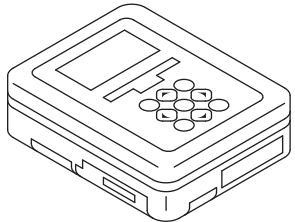
ILLUSTRATION	TOOL NUMBER	DESCRIPTION	REMARKS
 <p>ST42099AE000</p>	42099AE000	QUICK CONNECTOR RELEASE	Used for disconnecting quick connector of the engine compartment.
 <p>ST1B022XU0</p>	1B022XU0 (Newly adopted tool)	SUBARU SELECT MONITOR III KIT	Used for troubleshooting the electrical system.

2. GENERAL TOOL

TOOL NAME	REMARKS
Compression gauge	Used for measuring compression.
Timing light	Used for measuring ignition timing.
Vacuum gauge	Used for measuring intake manifold vacuum.
Oil pressure gauge	Used for measuring engine oil pressure.
Fuel pressure gauge	Used for measuring fuel pressure.

E: PROCEDURE

It is possible to conduct the following service procedures with engine on vehicle, however, the procedures described in this section are based on the condition that the engine is removed from vehicle.

- V-belt
- Timing belt
- Camshaft
- Cylinder head

2. Compression

A: INSPECTION

CAUTION:

After warming-up, engine becomes very hot. Be careful not to burn yourself during measurement.

- 1) Remove the collector cover.
- 2) After warming-up the engine, turn the ignition switch to OFF.
- 3) Make sure that the battery is fully charged.
- 4) Release the fuel pressure. <Ref. to FU(H4DOTC)-51, RELEASING OF FUEL PRESSURE, PROCEDURE, Fuel.>
- 5) Remove all the spark plugs. <Ref. to IG(H4DOTC)-4, REMOVAL, Spark Plug.>
- 6) Fully open the throttle valve.
- 7) Check the starter motor for satisfactory performance and operation.
- 8) Hold the compression gauge tightly against the spark plug hole.

NOTE:

When using a screw-in type compression gauge, the screw should be less than 18 mm (0.71 in) long.

- 9) Crank the engine by the starter motor, and read the maximum value on the gauge when the needle of gauge is steady.

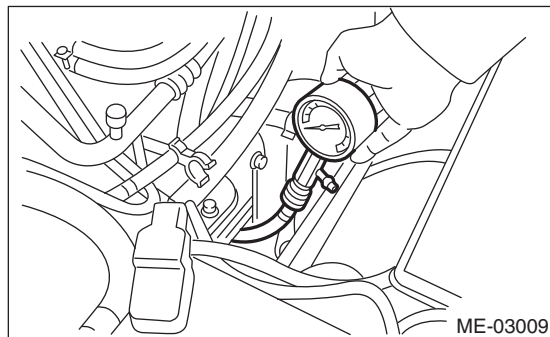

- 10) Perform at least two measurements per cylinder, and check that the values are correct.

Compression (fully open throttle):

Standard

981 — 1,177 kPa (10 — 12 kgf/cm²,

142 — 171 psi)

Difference between cylinders

49 kPa (0.5 kgf/cm², 7 psi), or less

- 11) After inspection, install the related parts in the reverse order of removal.

3. Idle Speed

A: INSPECTION

1) Before checking the idle speed, check the following item:

(1) Check the air cleaner element is free from clogging, ignition timing is correct, spark plugs are in good condition, and hoses are connected properly.

(2) Check the malfunction indicator light does not illuminate.

2) Warm-up the engine.

3) Read the engine idle speed using Subaru Select Monitor. <Ref. to EN(H4DOTC)(diag)-35, READ CURRENT DATA FOR ENGINE (NORMAL MODE), OPERATION, Subaru Select Monitor.>

4) Check the idle speed when no-loaded. (Headlight, heater fan, rear defroster, radiator fan, A/C and etc. are OFF)

Idle speed [No load and gears in “P” or “N” range]:

700±100 rpm

5) Check the idle speed under load condition. (Turn the A/C switch to “ON” and operate the compressor for at least one minute before measurement.)

Idle speed [A/C ON and gears in “P” or “N” range]:

825±100 rpm

NOTE:

Idle speed cannot be adjusted manually, because the idle speed is automatically adjusted. If the specified idle speed cannot be maintained, refer to the General On-board Diagnosis Table under “Engine Control System”. <Ref. to EN(H4DOTC)(diag)-2, Basic Diagnostic Procedure.>

4. Ignition Timing

A: INSPECTION

CAUTION:

After warming-up, engine becomes very hot. Be careful not to burn yourself at measurement.

1. METHOD WITH SUBARU SELECT MONITOR

1) Before checking the ignition timing, check the following item:

(1) Check the air cleaner element is free from clogging, spark plugs are in good condition, and hoses are connected properly.

(2) Check the malfunction indicator light does not illuminate.

2) Warm-up the engine.

3) Read the ignition timing using Subaru Select Monitor. <Ref. to EN(H4DOTC)(diag)-35, READ CURRENT DATA FOR ENGINE (NORMAL MODE), OPERATION, Subaru Select Monitor.>

Ignition timing [BTDC/rpm]:

$17^{\circ} \pm 10^{\circ} / 700$

If the timing is not correct, check the ignition control system. Refer to "Engine Control System". <Ref. to EN(H4DOTC)(diag)-2, Basic Diagnostic Procedure.>

2. METHOD WITH TIMING LIGHT

1) Before checking the ignition timing, check the following item:

(1) Check the air cleaner element is free from clogging, spark plugs are in good condition, and hoses are connected properly.

(2) Check the malfunction indicator light does not illuminate.

2) Warm-up the engine.

3) Stop the engine, and turn the ignition switch to OFF.

4) Remove the collector cover.

5) Remove the air intake duct (rear).

6) Disconnect the connectors of the mass air flow and intake air temperature sensor.

7) Remove the air cleaner case and element.

8) Connect the timing light to the power wire of #1 ignition coil.

9) Attach the air cleaner case, element and connector of mass air flow and intake air temperature sensor.

10) Start the engine, turn the timing light to the crank pulley, and check the ignition timing by means of crank pulley indicator.

Ignition timing [BTDC/rpm]:

$17^{\circ} \pm 10^{\circ} / 700$

If the timing is not correct, check the ignition control system. Refer to "Engine Control System". <Ref. to EN(H4DOTC)(diag)-2, Basic Diagnostic Procedure.>

5. Intake Manifold Vacuum

A: INSPECTION

- 1) Warm-up the engine.
- 2) Remove the collector cover.
- 3) Remove the intercooler. <Ref. to IN(H4DOTC)-11, REMOVAL, Intercooler.>
- 4) Disconnect the brake booster vacuum hose from the intake manifold, and then install the vacuum gauge.
- 5) Install the intercooler. <Ref. to IN(H4DOTC)-12, INSTALLATION, Intercooler.>
- 6) Keep the engine at idle speed and read the vacuum gauge indication.

By observing the gauge needle movement, the internal condition of the engine can be diagnosed as described below.

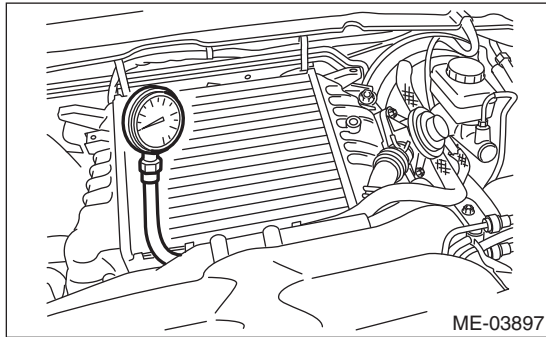

Vacuum pressure (at idling, A/C OFF):
-68.0 kPa (-510 mmHg, -20.08 inHg) or more

Diagnosis of engine condition by measurement of intake manifold vacuum	
Vacuum gauge indication	Possible engine condition
1. Needle is steady but lower than normal position. This tendency becomes more evident as engine temperature rises.	Leakage around intake manifold gasket, or disconnected or damaged vacuum hose
2. Needle intermittently drops to position lower than normal position.	Leakage around cylinder
3. Needle drops suddenly and intermittently from normal position.	Sticky valve
4. When engine speed is gradually increased, needle begins to vibrate rapidly at certain speed, and then vibration increases as engine speed increases.	Weak or broken valve springs
5. Needle vibrates above and below normal position in narrow range.	Defective ignition system

Engine Oil Pressure

MECHANICAL

6. Engine Oil Pressure

A: INSPECTION

- 1) Remove the collector cover.
- 2) Disconnect the ground cable from the battery.

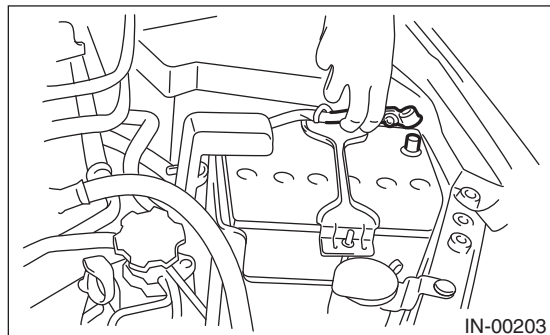

- 3) Remove the oil pressure switch. <Ref. to LU(H4DOTC)-19, REMOVAL, Oil Pressure Switch.>
- 4) Connect the oil pressure gauge hose to cylinder block.
- 5) Connect the battery ground cable to the battery.

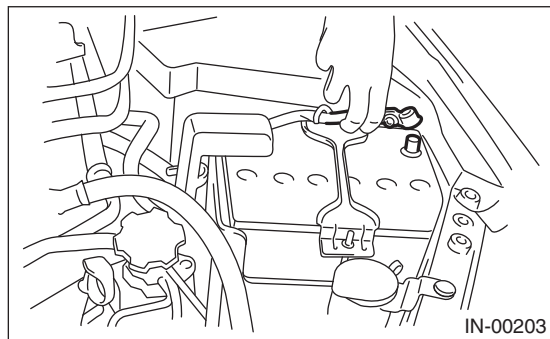

- 6) Start the engine, and measure the oil pressure.

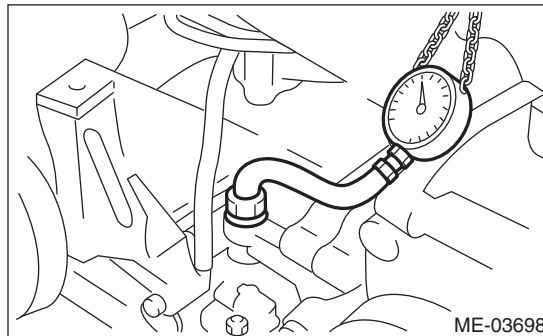

Oil pressure:

Standard

**98 kPa (1.0 kgf/cm², 14 psi) or more
(at 600 rpm)**

**294 kPa (3.0 kgf/cm², 43 psi) or more
(at 5,000 rpm)**

- If the oil pressure is out of specification, check oil pump, oil filter and lubrication line. <Ref. to LU(H4DOTC)-26, INSPECTION, Engine Lubrication System Trouble in General.>
- If the oil pressure warning light is ON and oil pressure is within specification, check the oil pressure switch. <Ref. to LU(H4DOTC)-26, INSPECTION, Engine Lubrication System Trouble in General.>

NOTE:

Standard value is based on an engine oil temperature of 80°C (176°F).

- 7) After measuring the oil pressure, install the oil pressure switch. <Ref. to LU(H4DOTC)-19, INSTALLATION, Oil Pressure Switch.>

7. Fuel Pressure

A: INSPECTION

CAUTION:

- Before removing the fuel pressure gauge, release the fuel pressure.
- Be careful not to spill fuel.
- Catch the fuel from hoses using a container or cloth.

NOTE:

If the fuel pressure is out of specification, check or replace the pressure regulator and pressure regulator vacuum hose.

- 1) Remove the collector cover.
- 2) Release the fuel pressure. <Ref. to FU(H4DOTC)-51, RELEASING OF FUEL PRESSURE, PROCEDURE, Fuel.>
- 3) Open the fuel filler lid, and remove the fuel filler cap.
- 4) Disconnect the fuel delivery hose from the fuel damper, and connect the fuel pressure gauge.

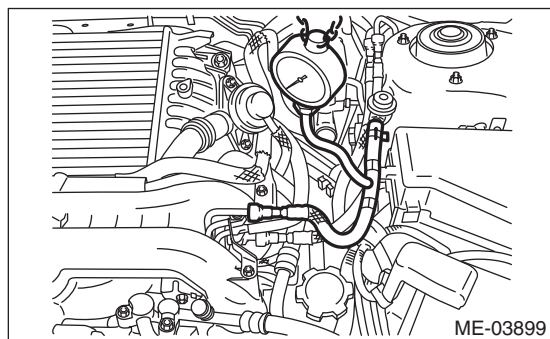

- 5) Install the fuse of fuel pump to the main fuse box.

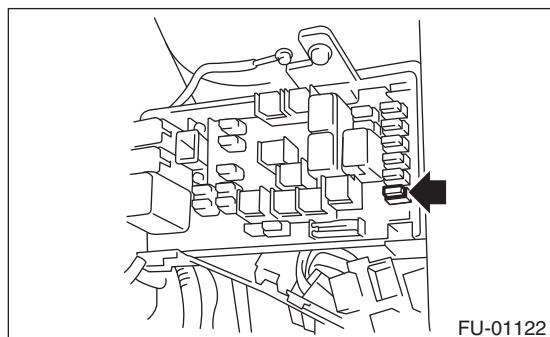

- 6) Start the engine.

- 7) Measure the fuel pressure while disconnecting the pressure regulator vacuum hose from the intake manifold.

NOTE:

The fuel pressure gauge registers 10 to 20 kPa (0.1 to 0.2 kgf/cm², 1 to 3 psi) higher than standard values during high-altitude operations.

Fuel pressure:

Standard

**284 — 314 kPa (2.9 — 3.2 kgf/cm²,
41 — 46 psi)**

- 8) After connecting the pressure regulator vacuum hose, measure the fuel pressure.

NOTE:

The fuel pressure gauge registers 10 to 20 kPa (0.1 to 0.2 kgf/cm², 1 to 3 psi) higher than standard values during high-altitude operations.

Fuel pressure:

Standard

**230 — 260 kPa (2.35 — 2.65 kgf/cm²,
33 — 38 psi)**

Valve Clearance

MECHANICAL

8. Valve Clearance

A: INSPECTION

NOTE:

Inspection and adjustment of valve clearance should be performed while engine is cold.

- 1) Set the vehicle on a lift.
- 2) Remove the collector cover.
- 3) Disconnect the ground cable from the battery.

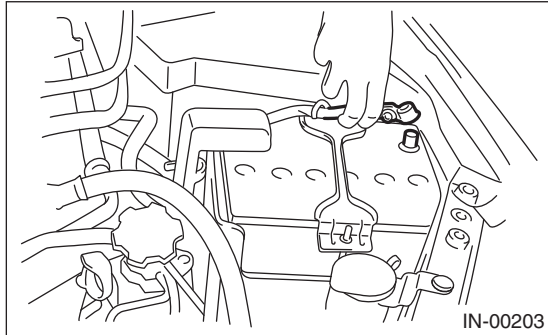

- 4) Remove the air intake duct (rear). <Ref. to IN(H4DOTC)-9, REMOVAL, Air Intake Duct.>
- 5) Remove the bolt which secures timing belt cover RH.
- 6) Lift up the vehicle.
- 7) Remove the under cover.
- 8) Loosen the remaining bolts which secure timing belt cover RH, then remove the timing belt cover.
- 9) Lower the vehicle.
- 10) When inspecting #1 and #3 cylinders

- (1) Remove the air cleaner case. <Ref. to IN(H4DOTC)-8, REMOVAL, Air Cleaner Case.>
- (2) Remove the ignition coil. <Ref. to IG(H4DOTC)-7, REMOVAL, Ignition Coil.>
- (3) Place a suitable container under the vehicle.
- (4) Disconnect the PCV hose from the rocker cover RH.

NOTE:

For the PCV hose affixed with the clamp, fit the depression in the ST with the protrusion of the clamp as shown in the figure below, unlock the clamp and disconnect.

ST 18353AA000 CLAMP PLIERS

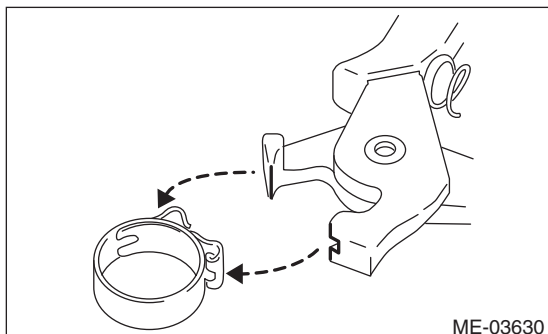

- (5) Remove the bolts, then remove the rocker cover RH.

- 11) When inspecting #2 and #4 cylinders
 - (1) Disconnect the battery cable, and remove the battery from the vehicle.
 - (2) Remove the secondary air pump. <Ref. to EC(H4DOTC)-23, REMOVAL, Secondary Air Pump.>
 - (3) Remove the ignition coil. <Ref. to IG(H4DOTC)-7, REMOVAL, Ignition Coil.>
 - (4) Place a suitable container under the vehicle.
 - (5) Disconnect the PCV hose from the rocker cover LH.

NOTE:

For the PCV hose affixed with the clamp, fit the depression in the ST with the protrusion of the clamp as shown in the figure below, unlock the clamp and disconnect.

ST 18353AA000 CLAMP PLIERS

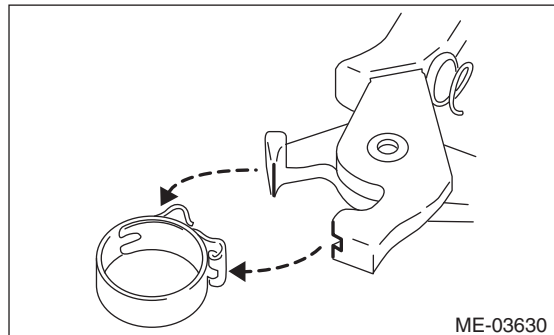

- (6) Remove the bolts, then remove the rocker cover LH.

- 12) Turn the crank pulley clockwise until the round mark and arrow mark on the camshaft sprocket are set to position shown in the figure.

NOTE:

Turn the crank pulley using a socket wrench.

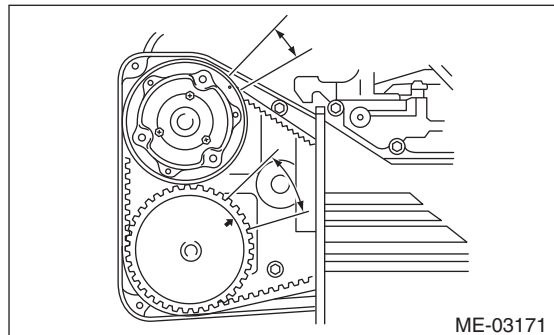

13) Measure the #1 cylinder intake valve and #3 cylinder exhaust valve clearance by using thickness gauge (A).

NOTE:

- Insert a thickness gauge in a direction as horizontal as possible with respect to the valve lifter.
- Lift up the vehicle and measure the exhaust valve clearances.
- If the measured value is not within specification, take notes of the value in order to adjust the valve clearance later on.

Valve clearance (inspection value):

Intake

$$0.20^{+0.04}_{-0.06} \text{ mm } (0.0079^{+0.0016}_{-0.0024} \text{ in})$$

Exhaust

$$0.35 \pm 0.05 \text{ mm } (0.0138 \pm 0.0020 \text{ in})$$

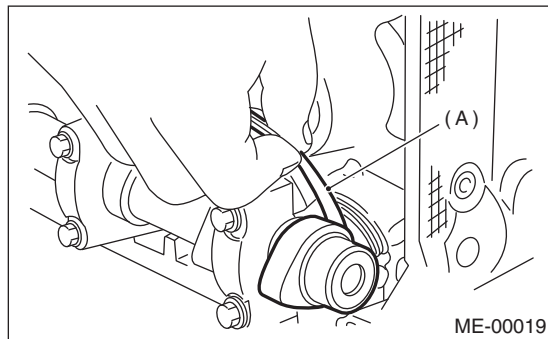

14) If necessary, adjust the valve clearance. <Ref. to ME(H4DOTC)-28, ADJUSTMENT, Valve Clearance.>

15) Further turn the crank pulley clockwise and then measure the valve clearances again.

(1) Set the round mark and arrow mark on cam sprocket to the position shown in the figure, and measure the #2 cylinder exhaust valve and #3 cylinder intake valve clearances.

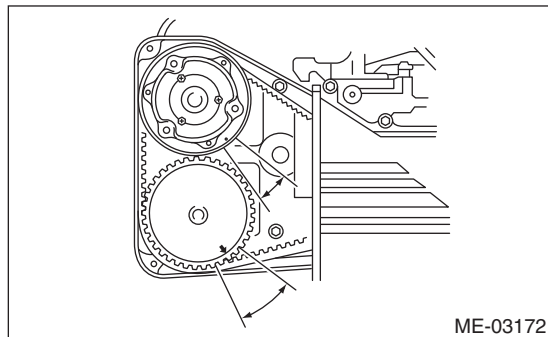

(2) Set the round mark and arrow mark on cam sprocket to the position shown in the figure, and measure the #2 cylinder intake valve and #4 cylinder exhaust valve clearances.

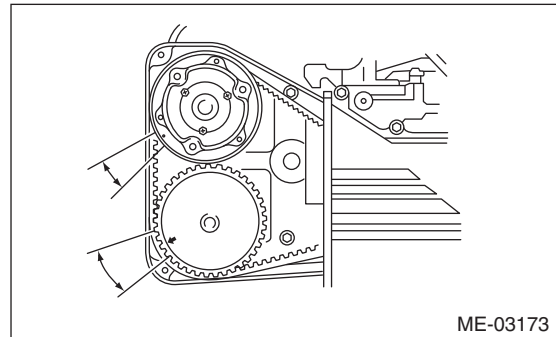

(3) Set the round mark and arrow mark on cam sprocket to the position shown in the figure, and measure the #1 cylinder exhaust valve and #4 cylinder intake valve clearances.

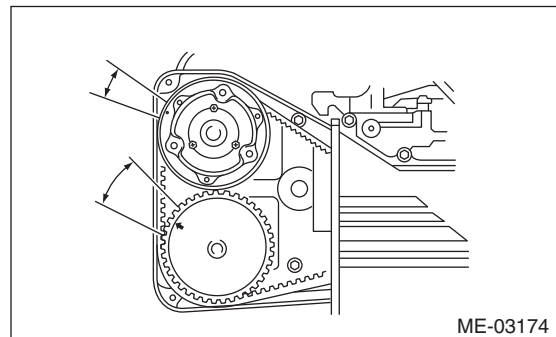

16) After inspection, install the related parts in the reverse order of removal.

NOTE:

- Use a new rocker cover gasket.
- For the PVC hose clamp, use a new clamp. Sandwich the protruding part of the clamp with the ST and lock the clamp.

ST 18353AA000 CLAMP PLIERS

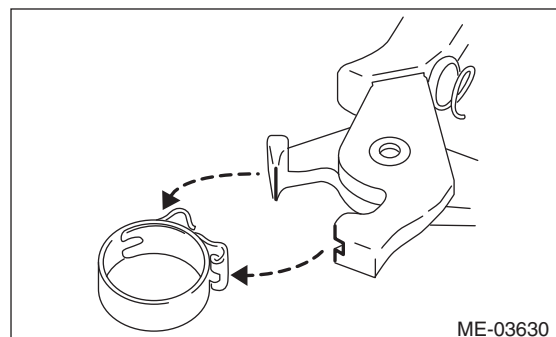

Valve Clearance

MECHANICAL

B: ADJUSTMENT

NOTE:

Adjustment of valve clearance should be performed while engine is cold.

1) Measure all the valve clearances. <Ref. to ME(H4DOTC)-26, INSPECTION, Valve Clearance.>

NOTE:

Record each valve clearance after measurement.

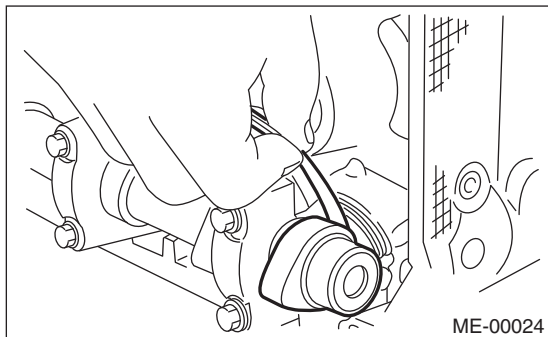

2) Remove the camshaft. <Ref. to ME(H4DOTC)-60, REMOVAL, Camshaft.>

3) Remove the valve lifter.

4) Measure the thickness of valve lifter using micrometer.

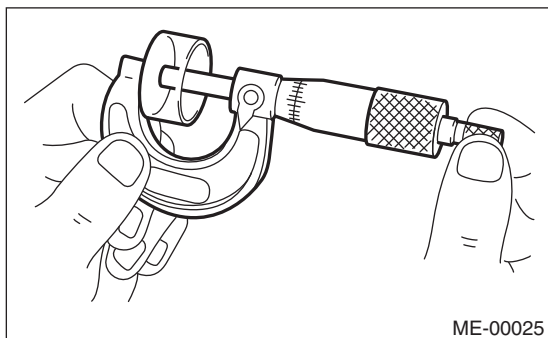

5) Select and install a valve lifter of suitable thickness from the following table, based on the measured valve clearance and valve lifter thickness.

NOTE:

Use new valve lifters.

Unit: (mm)
Intake valve: $S = (V + T) - 0.19$
Exhaust valve: $S = (V + T) - 0.35$
S: Valve lifter thickness required
V: Measured valve clearance
T: Valve lifter thickness to be used

Part No.	Thickness mm (in)
13228 AB102	4.68 (0.1843)
13228 AB112	4.69 (0.1846)
13228 AB122	4.70 (0.1850)
13228 AB132	4.71 (0.1854)
13228 AB142	4.72 (0.1858)
13228 AB152	4.73 (0.1862)
13228 AB162	4.74 (0.1866)
13228 AB172	4.75 (0.1870)
13228 AB182	4.76 (0.1874)
13228 AB192	4.77 (0.1878)
13228 AB202	4.78 (0.1882)
13228 AB212	4.79 (0.1886)
13228 AB222	4.80 (0.1890)
13228 AB232	4.81 (0.1894)
13228 AB242	4.82 (0.1898)
13228 AB252	4.83 (0.1902)
13228 AB262	4.84 (0.1906)
13228 AB272	4.85 (0.1909)
13228 AB282	4.86 (0.1913)
13228 AB292	4.87 (0.1917)
13228 AB302	4.88 (0.1921)
13228 AB312	4.89 (0.1925)
13228 AB322	4.90 (0.1929)
13228 AB332	4.91 (0.1933)
13228 AB342	4.92 (0.1937)
13228 AB352	4.93 (0.1941)
13228 AB362	4.94 (0.1945)
13228 AB372	4.95 (0.1949)
13228 AB382	4.96 (0.1953)
13228 AB392	4.97 (0.1957)
13228 AB402	4.98 (0.1961)
13228 AB412	4.99 (0.1965)
13228 AB422	5.00 (0.1969)
13228 AB432	5.01 (0.1972)
13228 AB442	5.02 (0.1976)
13228 AB452	5.03 (0.1980)
13228 AB462	5.04 (0.1984)
13228 AB472	5.05 (0.1988)
13228 AB482	5.06 (0.1992)
13228 AB492	5.07 (0.1996)
13228 AB502	5.08 (0.2000)
13228 AB512	5.09 (0.2004)
13228 AB522	5.10 (0.2008)
13228 AB532	5.11 (0.2012)
13228 AB542	5.12 (0.2016)
13228 AB552	5.13 (0.2020)
13228 AB562	5.14 (0.2024)
13228 AB572	5.15 (0.2028)
13228 AB582	5.16 (0.2031)
13228 AB592	5.17 (0.2035)

Valve Clearance

MECHANICAL

Part No.	Thickness mm (in)
13228 AB602	5.18 (0.2039)
13228 AB612	5.19 (0.2043)
13228 AB622	5.20 (0.2047)
13228 AB632	5.21 (0.2051)
13228 AB642	5.22 (0.2055)
13228 AB652	5.23 (0.2059)
13228 AB662	5.24 (0.2063)
13228 AB672	5.25 (0.2067)
13228 AB682	5.26 (0.2071)
13228 AB692	5.27 (0.2075)
13228 AB702	4.38 (0.1724)
13228 AB712	4.40 (0.1732)
13228 AB722	4.42 (0.1740)
13228 AB732	4.44 (0.1748)
13228 AB742	4.46 (0.1756)
13228 AB752	4.48 (0.1764)
13228 AB762	4.50 (0.1771)
13228 AB772	4.52 (0.1780)
13228 AB782	4.54 (0.1787)
13228 AB792	4.56 (0.1795)
13228 AB802	4.58 (0.1803)
13228 AB812	4.60 (0.1811)
13228 AB822	4.62 (0.1819)
13228 AB832	4.64 (0.1827)
13228 AB842	4.66 (0.1835)
13228 AB852	5.29 (0.2083)
13228 AB862	5.31 (0.2091)
13228 AB872	5.33 (0.2098)
13228 AB882	5.35 (0.2106)
13228 AB892	5.37 (0.2114)
13228 AB902	5.39 (0.2122)
13228 AB912	5.41 (0.2123)
13228 AB922	5.43 (0.2138)
13228 AB932	5.45 (0.2146)
13228 AB942	5.47 (0.2154)
13228 AB952	5.49 (0.2161)
13228 AB962	5.51 (0.2169)
13228 AB972	5.53 (0.2177)
13228 AB982	5.55 (0.2185)
13228 AB992	5.57 (0.2193)
13228 AC002	5.59 (0.2201)
13228 AC012	5.61 (0.2209)
13228 AC022	5.63 (0.2217)
13228 AC032	5.65 (0.2224)

6) Install the camshaft. <Ref. to ME(H4DOTC)-61, INSTALLATION, Camshaft.>

7) Install the cam sprocket. <Ref. to ME(H4DOTC)-57, INSTALLATION, Cam Sprocket.>

8) Install the timing belt. <Ref. to ME(H4DOTC)-52, TIMING BELT, INSTALLATION, Timing Belt.>

9) Measure all valves for valve clearance again at this time. If the valve clearance is not within the adjustment value, repeat the procedure over again from the first step.

Valve clearance (adjustment value):

Intake

$0.20^{+0.01}_{-0.03}$ mm ($0.0079^{+0.0004}_{-0.0012}$ in)

Exhaust

0.35 ± 0.02 mm (0.0138 ± 0.0008 in)

10) After measuring, install the related parts in the reverse order of removal.

NOTE:

Use a new rocker cover gasket.

Engine Assembly

MECHANICAL

9. Engine Assembly

A: REMOVAL

- 1) Set the vehicle on a lift.
- 2) Change the bolt mounting position from (A) to (B), and completely open the front hood.

Tightening torque:

7.5 N·m (0.8 kgf-m, 5.5 ft-lb)

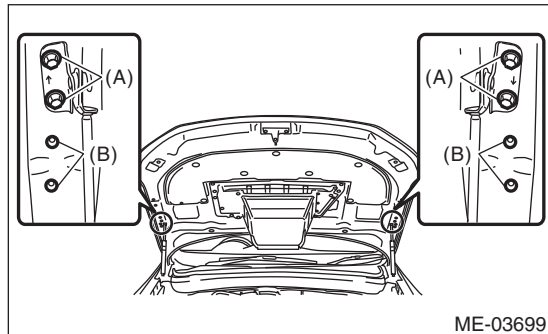

- 3) Remove the collector cover.
- 4) Collect the refrigerant from the A/C system. <Ref. to AC-17, Refrigerant Recovery Procedure.>
- 5) Release the fuel pressure. <Ref. to FU(H4DOTC)-51, RELEASING OF FUEL PRESSURE, PROCEDURE, Fuel.>
- 6) Disconnect the battery cable, and remove the battery from the vehicle.
- 7) Open the fuel filler lid, and remove the fuel filler cap.
- 8) Remove the air intake duct and air cleaner case. <Ref. to IN(H4DOTC)-9, REMOVAL, Air Intake Duct.> <Ref. to IN(H4DOTC)-8, REMOVAL, Air Cleaner Case.>
- 9) Remove the intercooler. <Ref. to IN(H4DOTC)-11, REMOVAL, Intercooler.>
- 10) Remove the radiator from the vehicle. <Ref. to CO(H4DOTC)-19, REMOVAL, Radiator.>
- 11) Remove the coolant filler tank. <Ref. to CO(H4DOTC)-29, REMOVAL, Coolant Filler Tank.>
- 12) Disconnect the A/C pressure hoses from the A/C compressor. <Ref. to AC-35, REMOVAL, Hose and Pipe.>

- 13) Disconnect the following connectors and cables.

(1) Engine harness connectors

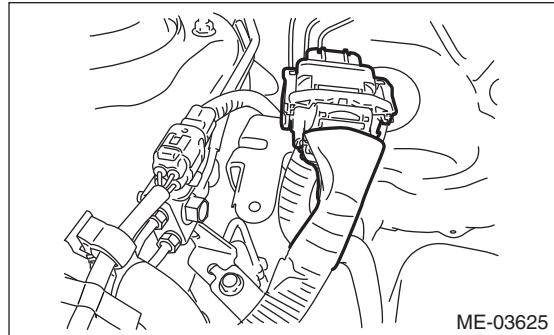

(2) Generator connector and terminal

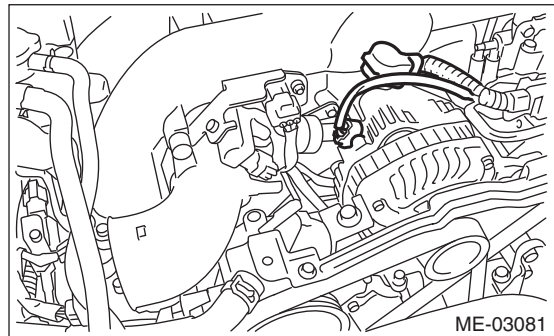

(3) A/C compressor connector

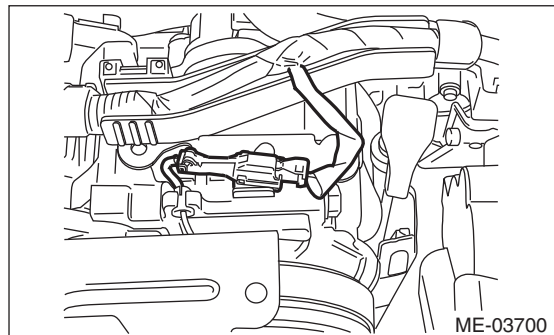

(4) Secondary air pump connector

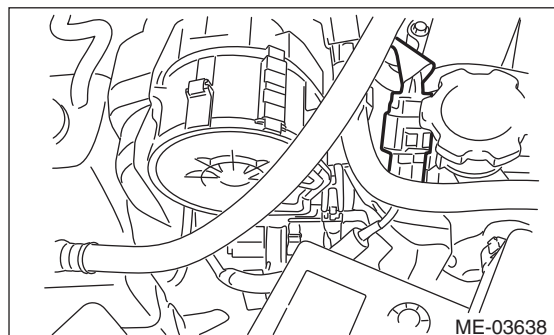

14) Disconnect the following hoses.

(1) Brake booster vacuum hose

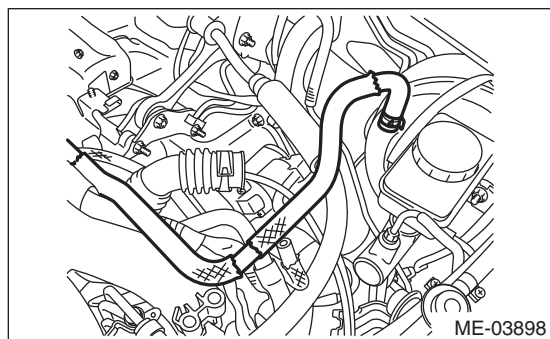

(2) Heater inlet and outlet hoses

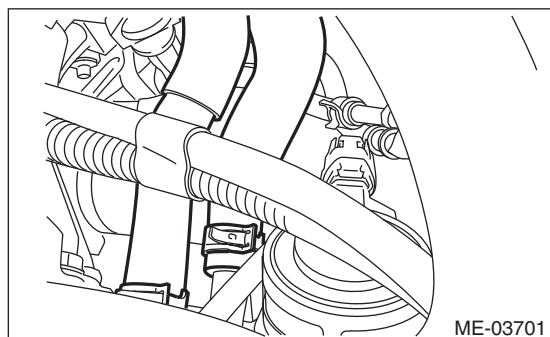

15) Remove the power steering pump.

(1) Remove the front side belts. <Ref. to ME(H4DOTC)-39, FRONT SIDE BELT, REMOVAL, V-belt.>

(2) Disconnect the power steering pump switch connector.

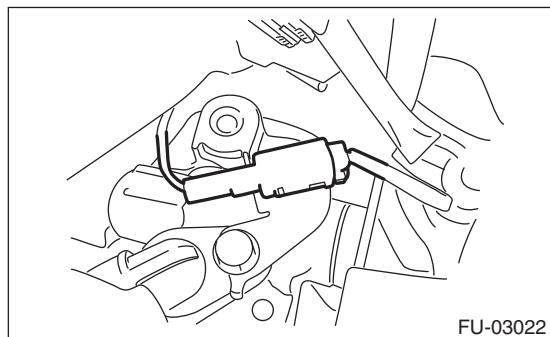

(3) Remove the power steering pump from the engine.

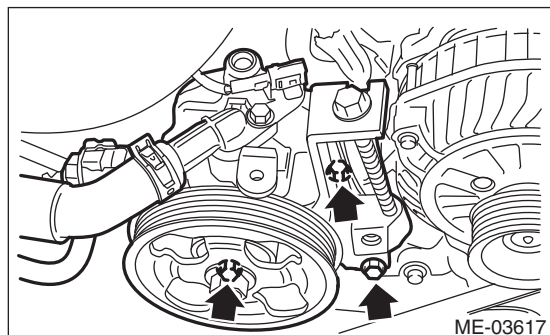

(4) Place the power steering pump on the right side wheel apron.

16) Remove the center exhaust pipe. <Ref. to EX(H4DOTC)-7, REMOVAL, Center Exhaust Pipe.>

17) Remove the turbocharger. <Ref. to IN(H4DOTC)-13, REMOVAL, Turbocharger.>

18) Remove the joint pipe and front exhaust pipe. <Ref. to EX(H4DOTC)-11, REMOVAL, Joint Pipe.> <Ref. to EX(H4DOTC)-5, REMOVAL, Front Exhaust Pipe.>

19) Lift up the vehicle.

20) Disconnect the ground cable on the engine side.

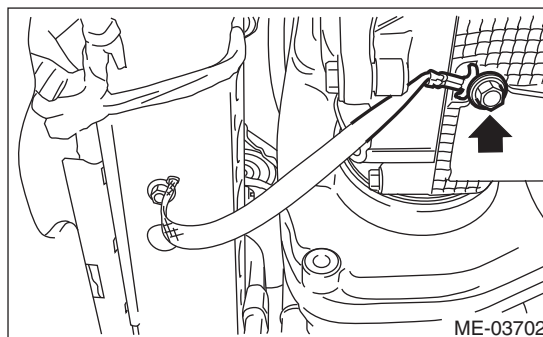

21) Remove the bolts and nuts which hold the lower side of transmission to the engine.

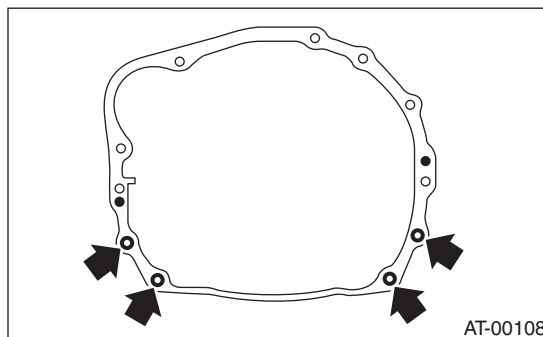

22) Remove the nuts which hold the engine mount to the front crossmember.

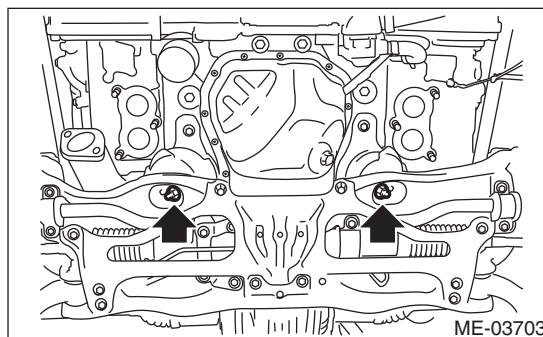

23) Separate the torque converter clutch from drive plate.

(1) Lower the vehicle.

(2) Remove the service hole plug.

(3) Remove the bolts which hold torque converter clutch to drive plate.

Engine Assembly

MECHANICAL

(4) Remove other bolts while rotating the crankshaft using socket wrench.

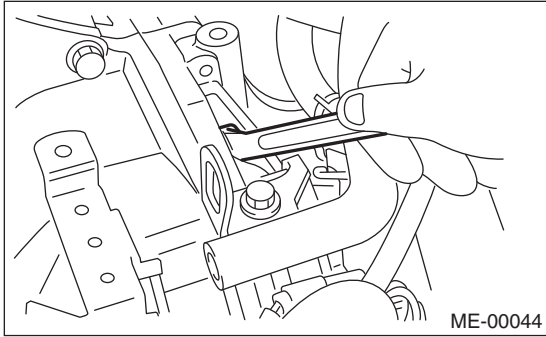

24) Remove the pitching stopper.

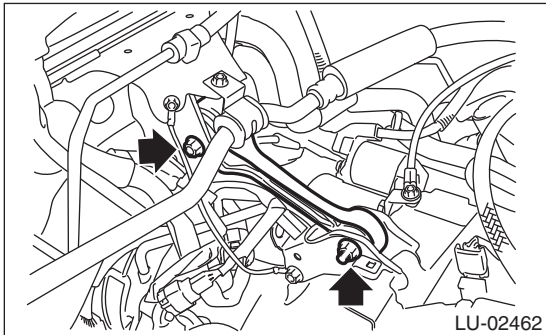

25) Attach ST to the fuel delivery pipe and push ST in the direction of arrow mark to disconnect the fuel delivery hose.

ST 42099AE000 QUICK CONNECTOR RELEASE

CAUTION:

- Be careful not to spill fuel.
- Catch the fuel from hoses using a container or cloth.

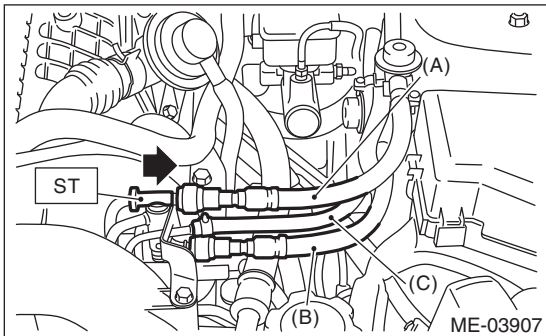

- (A) Fuel delivery hose
- (B) Fuel return hose
- (C) Evaporation hose

26) Disconnect the fuel return hose using the ST.
ST 18371AA000 CONNECTOR REMOVER

CAUTION:

- Be careful not to spill fuel.
- Catch the fuel from hoses using a container or cloth.

(1) Attach the ST to the fuel return pipe as shown in the figure.

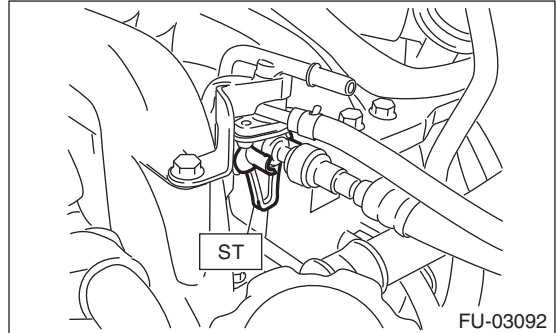

(2) Insert the front side of ST into the quick connector.

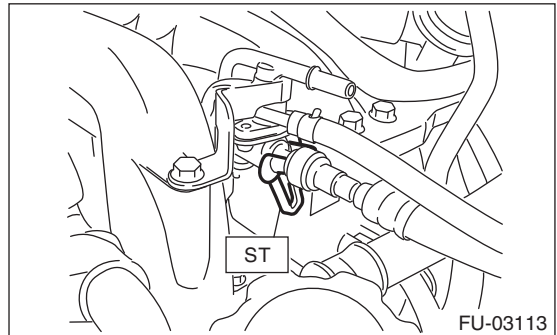

(3) Insert the back side of ST into the quick connector and push ST in the direction of arrow mark to disconnect the fuel return hose.

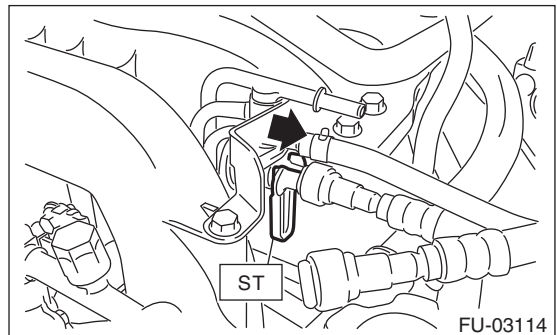

27) Remove the clip and disconnect the evaporation hose from the fuel pipe.

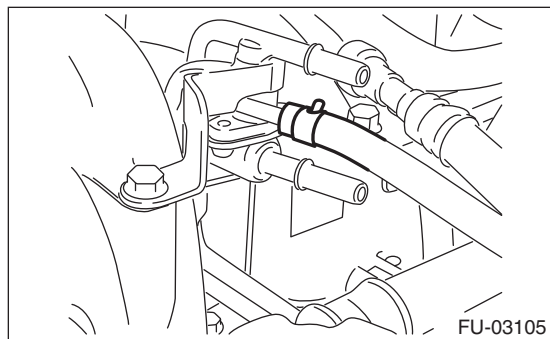

28) Support the engine with a lifting device and wire ropes.

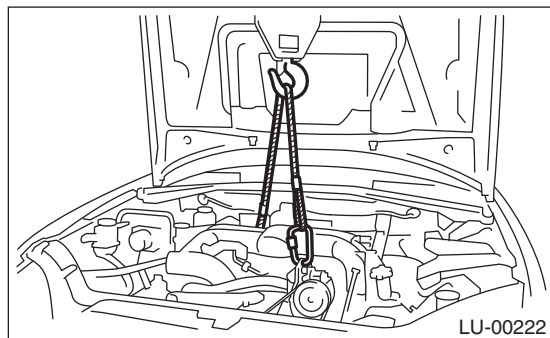

29) Support the transmission with a garage jack.

CAUTION:
Doing this is very important to prevent the transmission from lowering due to its own weight.

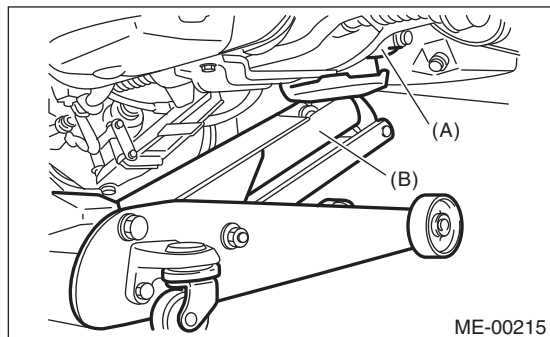

- (A) Transmission
- (B) Garage jack

30) Separation of engine and transmission.

CAUTION:
Before removing the engine away from transmission, check to be sure no work has been overlooked.

- (1) Remove the starter. <Ref. to SC(H4SO)-6, REMOVAL, Starter.>
- (2) Set the ST to torque converter clutch case.
ST 498277200 STOPPER SET

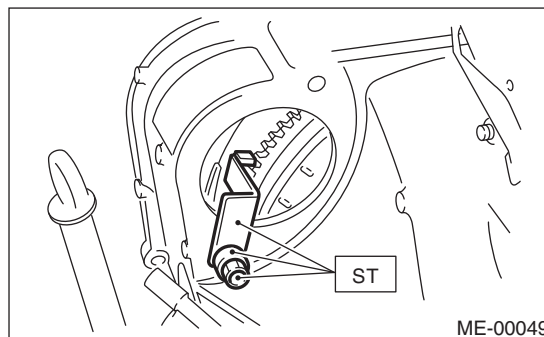

(3) Remove the bolts which hold the upper side of the transmission to the engine.

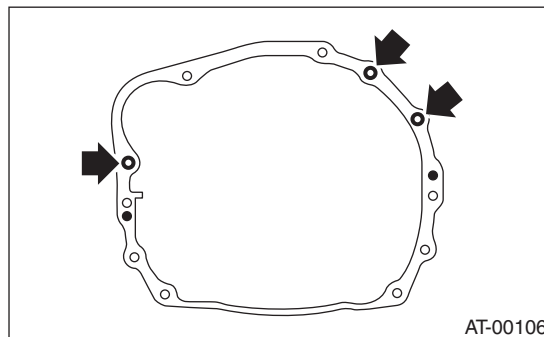

31) Remove the engine from vehicle.

- (1) Slightly raise the engine.
- (2) Raise the transmission with garage jack.
- (3) Slowly move the engine away from engine compartment.

NOTE:
Be careful not to damage adjacent parts or body panels with crank pulley, oil level gauge, etc.

32) Remove the engine mount from the engine.

Engine Assembly

MECHANICAL

B: INSTALLATION

1) Install the engine mount onto the engine.

Tightening torque:

35 N·m (3.6 kgf-m, 25.8 ft-lb)

2) Position the engine in engine compartment and align it with transmission.

NOTE:

Be careful not to damage adjacent parts or body panels with crank pulley, oil level gauge, etc.

3) Tighten the bolts which hold upper side of transmission to engine.

Tightening torque:

50 N·m (5.1 kgf-m, 36.9 ft-lb)

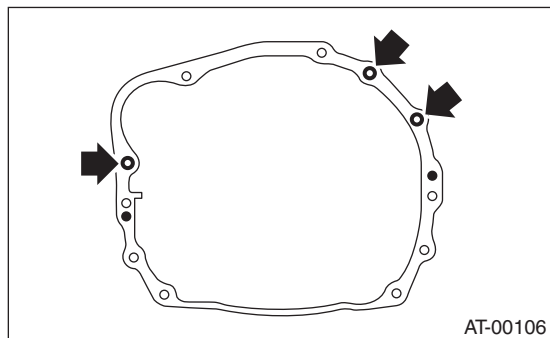

4) Remove the lifting device and wire ropes.

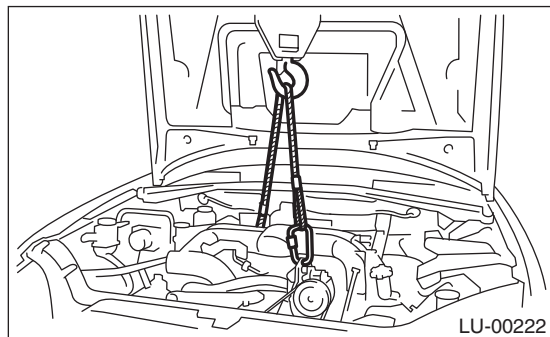

5) Remove the garage jack.

6) Install the pitching stopper.

Tightening torque:

T1: 50 N·m (5.1 kgf-m, 36.9 ft-lb)

T2: 58 N·m (5.9 kgf-m, 42.8 ft-lb)

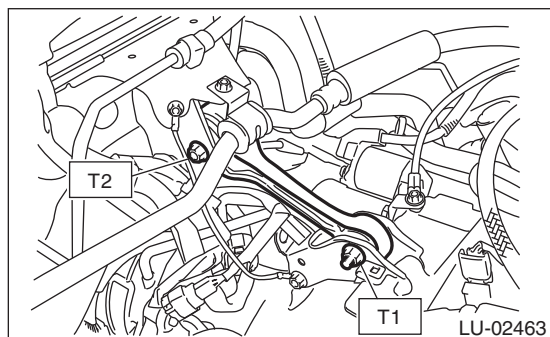

7) Remove the ST from the torque converter clutch case.

NOTE:

Be careful not to drop the ST into the torque converter clutch case when removing the ST.

ST 498277200 STOPPER SET

8) Install the starter. <Ref. to SC(H4SO)-6, INSTALLATION, Starter.>

9) Install the torque converter clutch to drive plate.

(1) Tighten the bolts which hold torque converter clutch to drive plate.

(2) Tighten other bolts while rotating the crankshaft using socket wrench.

NOTE:

Be careful not to drop bolts into the torque converter clutch housing.

Tightening torque:

25 N·m (2.5 kgf-m, 18.4 ft-lb)

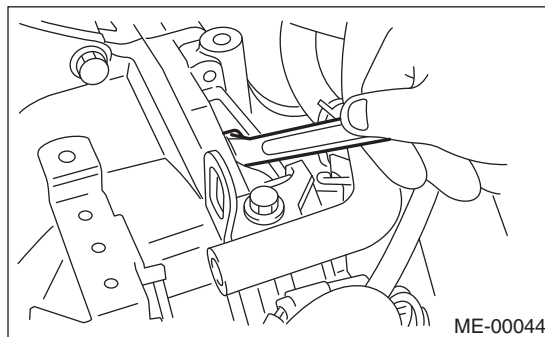

(3) Fit the plug to service hole.

- 10) Install the power steering pump.
 (1) Install the power steering pump.

Tightening torque:

Refer to "COMPONENT" of "Power Steering" for the tightening torque. <Ref. to PS-3, COMPONENT, General Description.>

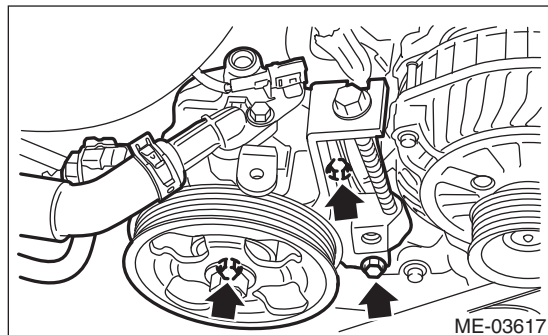

- (2) Connect the power steering pump switch connector.

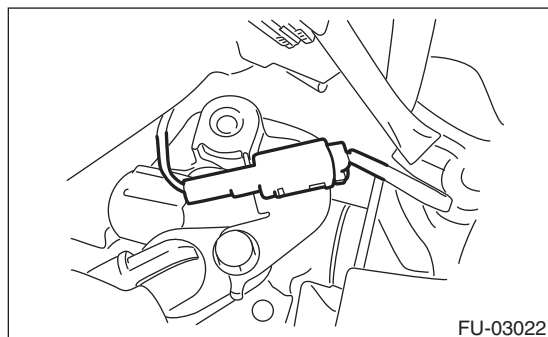

- (3) Install and adjust the front side belt. <Ref. to ME(H4DOTC)-39, FRONT SIDE BELT, INSTALLATION, V-belt.>

- 11) Lift up the vehicle.
 12) Tighten the bolts and nuts which hold lower side of the transmission to engine.

Tightening torque:

50 N·m (5.1 kgf·m, 36.9 ft·lb)

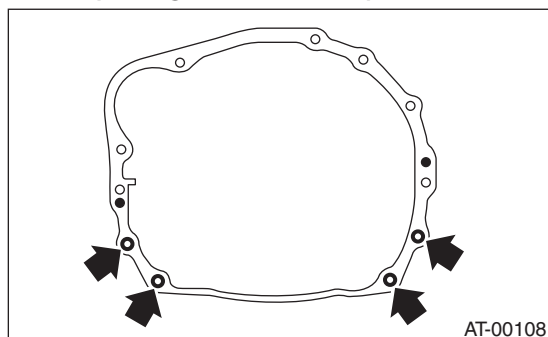

- 13) Tighten the nuts which hold the engine mount to the crossmember.

NOTE:

Make sure that the engine mount nuts (A) and locator (B) are securely installed.

Tightening torque:

85 N·m (8.7 kgf·m, 62.7 ft·lb)

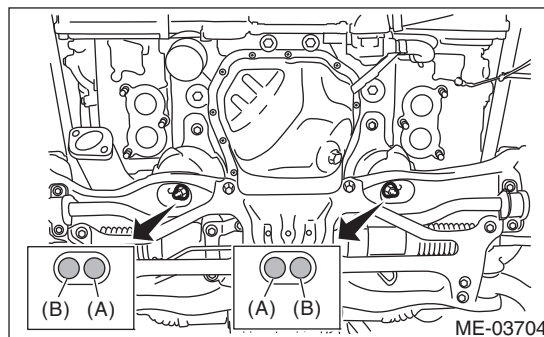

- 14) Install the joint pipe and front exhaust pipe. <Ref. to EX(H4DOTC)-6, INSTALLATION, Front Exhaust Pipe.> <Ref. to EX(H4DOTC)-11, INSTALLATION, Joint Pipe.>

- 15) Attach the turbo charger. <Ref. to IN(H4DOTC)-14, INSTALLATION, Turbocharger.>

- 16) Install the center exhaust pipe. <Ref. to EX(H4DOTC)-8, INSTALLATION, Center Exhaust Pipe.>

- 17) Connect the ground cable.

Tightening torque:

7.5 N·m (0.8 kgf·m, 5.5 ft·lb)

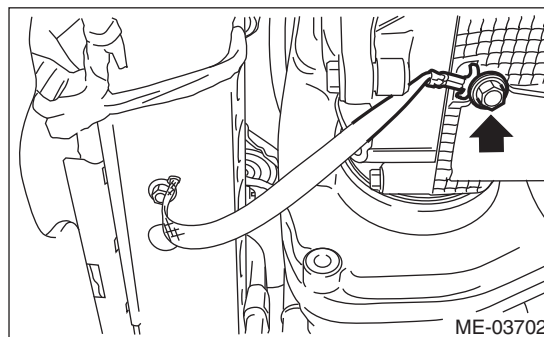

- 18) Lower the vehicle.
 19) Connect the following hoses.

- (1) Fuel delivery hose, fuel return hose and evaporation hose
- (2) Heater inlet and outlet hoses
- (3) Brake booster vacuum hose

Engine Assembly

MECHANICAL

20) Connect the following connectors and terminals.

- (1) Engine harness connectors
- (2) Generator connector and terminal

Tightening torque:

15 N·m (1.5 kgf·m, 11.1 ft·lb)

- (3) A/C compressor connector
- (4) Secondary air pump connector

21) Install the intercooler. <Ref. to IN(H4DOTC)-12, INSTALLATION, Intercooler.>

22) Install the A/C pressure hoses. <Ref. to AC-35, INSTALLATION, Hose and Pipe.>

23) Install the radiator. <Ref. to CO(H4DOTC)-20, INSTALLATION, Radiator.>

24) Install the coolant filler tank. <Ref. to CO(H4DOTC)-29, INSTALLATION, Coolant Filler Tank.>

25) Install the air cleaner case and air intake duct. <Ref. to IN(H4DOTC)-8, INSTALLATION, Air Cleaner Case.> <Ref. to IN(H4DOTC)-9, INSTALLATION, Air Intake Duct.>

26) Install the battery to the vehicle, and connect the battery cables.

27) Fill engine coolant. <Ref. to CO(H4DOTC)-13, FILLING OF ENGINE COOLANT, REPLACEMENT, Engine Coolant.>

28) Charge the A/C system with refrigerant. <Ref. to AC-18, PROCEDURE, Refrigerant Charging Procedure.>

29) Check the ATF level and replenish it if necessary. <Ref. to 4AT-26, INSPECTION, Automatic Transmission Fluid.>

30) Install the collector cover.

31) Change the bolt mounting position from (B) to (A), and close the front hood.

Tightening torque:

7.5 N·m (0.8 kgf·m, 5.5 ft·lb)

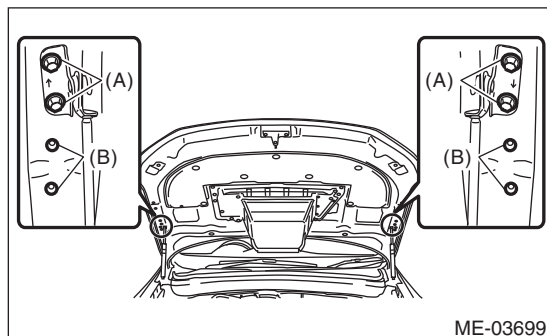

32) Lower the vehicle from the lift.

C: INSPECTION

1) Check that pipes, hoses, connectors and clamps are installed firmly.

2) Check that the engine coolant is at specified level.

3) Check that the ATF is at specified level.

4) Start the engine and check for exhaust gas, engine coolant, leaks of fuel, etc. Also check for noise and vibrations.

10.Engine Mounting

A: REMOVAL

- 1) Remove the engine unit. <Ref. to ME(H4DOTC)-30, REMOVAL, Engine Assembly.>
- 2) Remove the engine mounting from engine assembly.

B: INSTALLATION

Install in the reverse order of removal.

Tightening torque:

35 N·m (3.6 kgf-m, 25.8 ft-lb)

C: INSPECTION

Make sure that no crack or other damages do not exist.

Preparation for Overhaul

MECHANICAL

11. Preparation for Overhaul

A: PROCEDURE

1) After removing the engine from body, secure it to ST in the following procedure.

ST1 498457000 ENGINE STAND ADAPTER
RH

ST2 498457100 ENGINE STAND ADAPTER
LH

ST3 499817100 ENGINE STAND

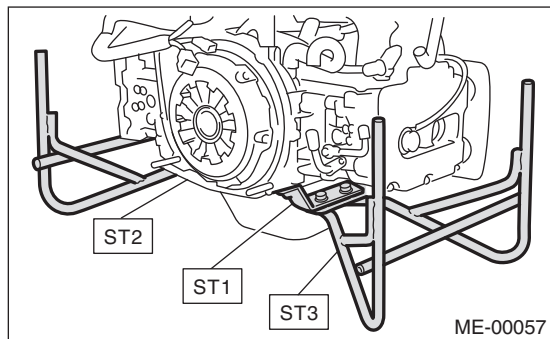

2) In this section the procedures described under each index are all connected and stated in order. The procedure for overhauling of the engine will be completed when you go through all steps in the process.

Therefore, in this section, to conduct the particular procedure within the flow of a section, you need to go back and conduct the procedure described previously in order to do that particular procedure.

12.V-belt

A: REMOVAL

NOTE:

Perform the work with the engine installed to body when replacing a single part.

1. FRONT SIDE BELT

- 1) Remove the collector cover.
- 2) Remove the air intake duct (rear). <Ref. to IN(H4DOTC)-9, REMOVAL, Air Intake Duct.>
- 3) Remove the collector cover bracket.

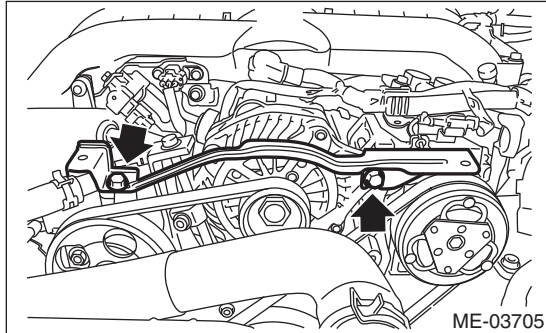

- 4) Loosen the bolt (A).
- 5) Loosen the slider bolt (B).
- 6) Remove the front side belt (C).

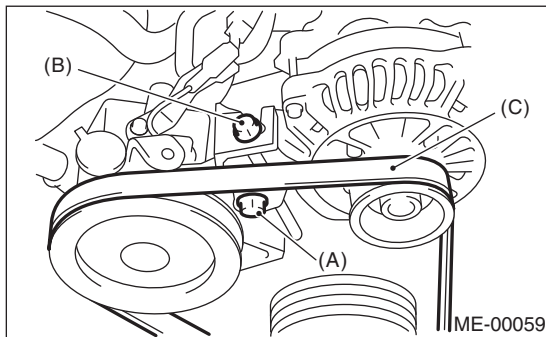

2. REAR SIDE BELT

- 1) Remove the front side belts. <Ref. to ME(H4DOTC)-39, FRONT SIDE BELT, REMOVAL, V-belt.>
- 2) Cut the rear side belt with a wire cutter, etc., and discard.

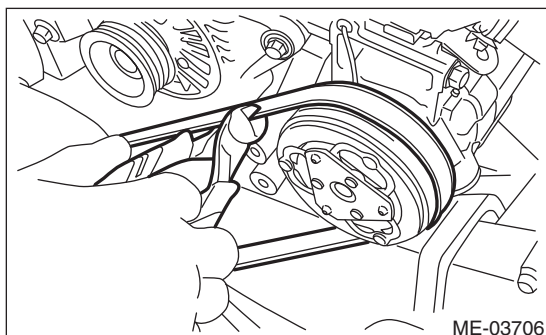

B: INSTALLATION

1. FRONT SIDE BELT

CAUTION:

- When reusing the front side belt, wipe off any sand or water with a cloth.
- Do not reuse the front side belt if there is any oil, grease or coolant on the belt.
- Be careful when touching the belt. If the end face of the belt is rubbed by hand, you may receive injury from bared wires.

- 1) Wipe off any sand, dust, oil or water from the pulley grooves with a cloth.
- 2) Install the front side belt (C), and adjust the slider bolt (B) so as to obtain the specified belt tension. <Ref. to ME(H4DOTC)-45, INSPECTION, V-belt.>
- 3) Tighten the bolt (A).
- 4) Tighten the slider bolt (B).

Tightening torque:

Bolt (A)

25 N·m (2.5 kgf-m, 18.4 ft-lb)

Slider bolt (B)

8 N·m (0.8 kgf-m, 5.9 ft-lb)

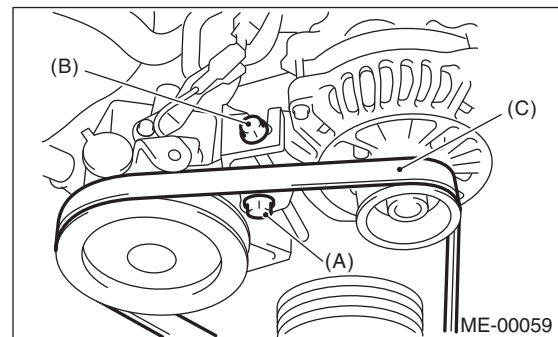

- 5) Install the collector cover bracket.

Tightening torque:

T1: 8.5 N·m (0.9 kgf-m, 6.3 ft-lb)

T2: 25 N·m (2.5 kgf-m, 18.4 ft-lb)

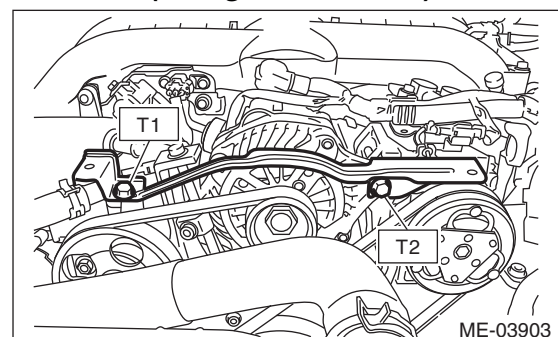

- 6) Install the air intake duct (rear). <Ref. to IN(H4DOTC)-9, INSTALLATION, Air Intake Duct.>
- 7) Install the collector cover.

V-belt

MECHANICAL

2. REAR SIDE BELT

CAUTION:

- Always use new rear side belt.
- Be careful that the new rear side belt does not come into contact with any oil, grease or coolant.
- Be careful when touching the belt. If the end face of the belt is rubbed by hand, you may receive injury from bared wires.
- When installing the rear side belt, always use the provided tools (belt stopper, belt guide, belt guide holder and bolt).

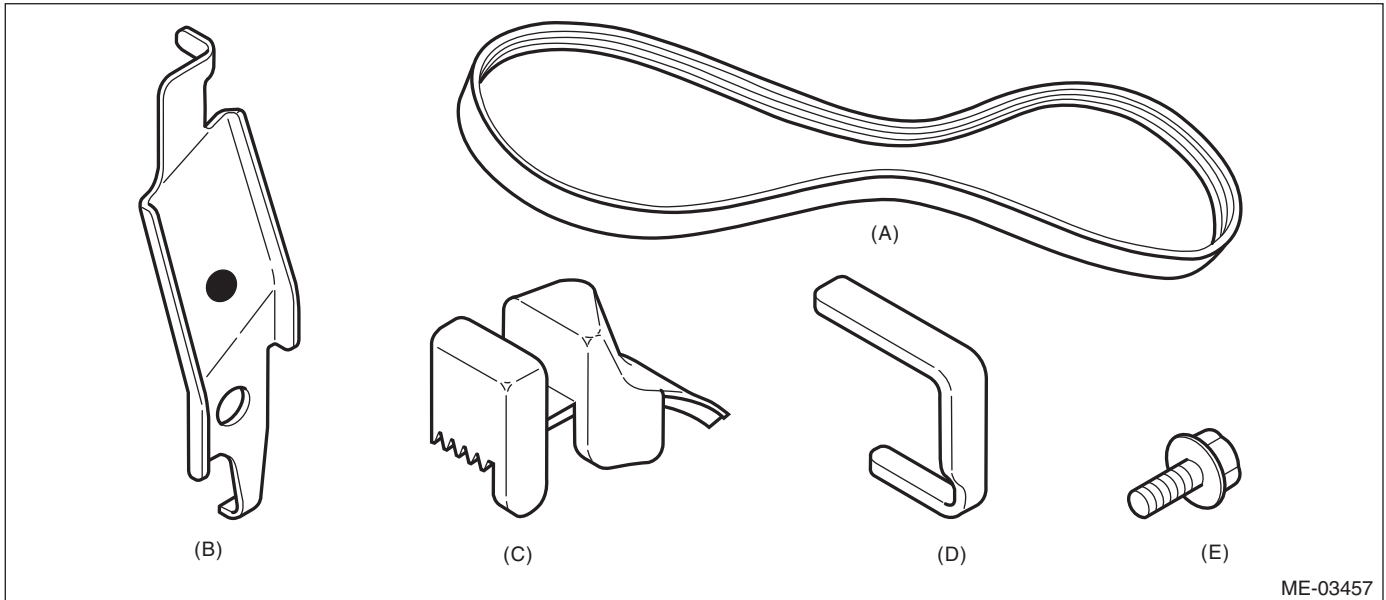

ME-03457

(A) Rear side belt
(B) Belt stopper

(C) Belt guide
(D) Belt guide holder

(E) Bolt

- 1) Wipe off any sand, dust, oil or water from the pulley grooves with a cloth.
- 2) Wipe off any oil, water, mud or rust attached to the front side of the crank pulley with a cloth.
- 3) Turn the crank pulley to the right slowly, until the crank pulley service hole near the top.

CAUTION:

Never turn the crank pulley to the left.

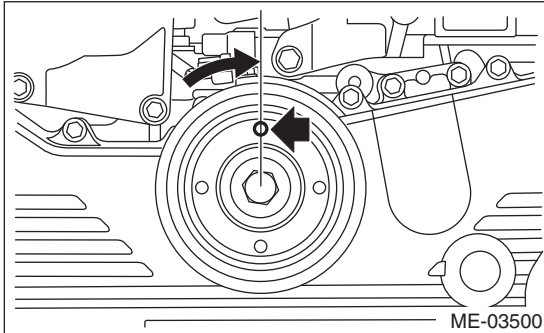

- 4) Attach a new rear side belt on the A/C compressor belt.

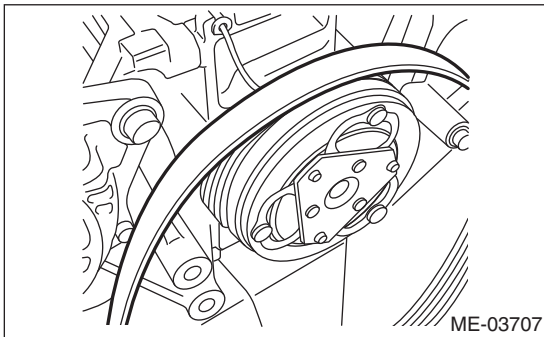

- 5) Insert the claw of the belt stopper (A) into the lower hole (B) on the compressor bracket as shown in the figure, and attach using bolt (C).

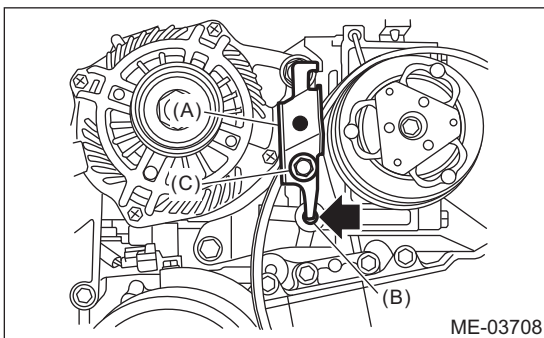

- 6) Mount the belt guide by matching to the belt line on the front side belt of the crank pulley.

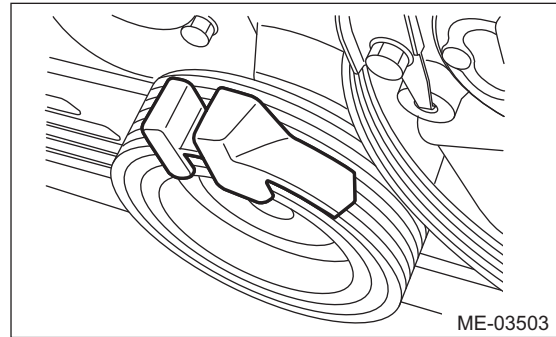

- 7) Insert the belt guide holder into the crank pulley service hole so as to clamp the belt guide.

NOTE:

The longer side of the belt guide holder is the upper side.

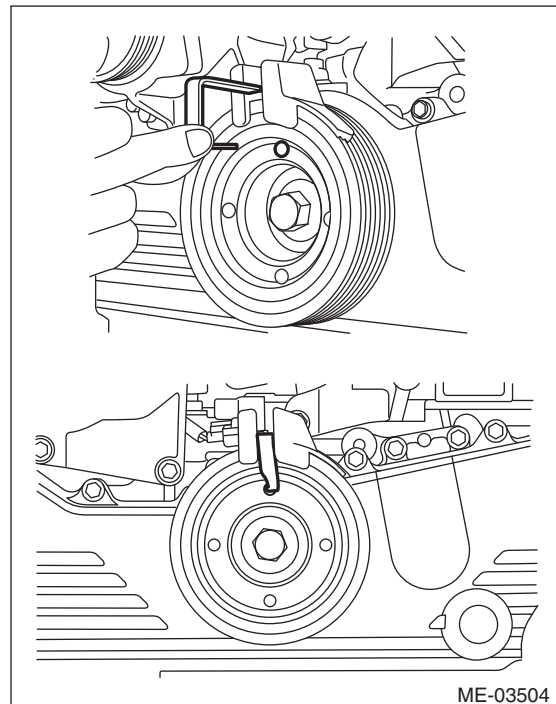

- 8) Turn the crank pulley slowly to the right, and set the belt guide at an approximately 45° position.

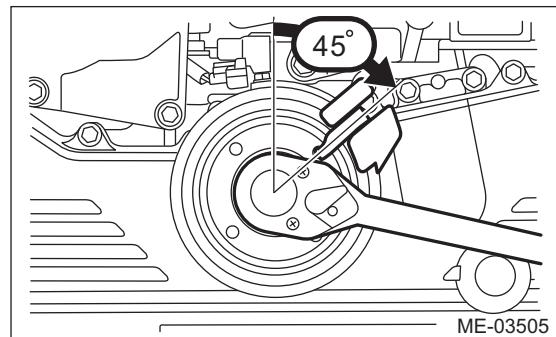

V-belt

MECHANICAL

9) Place the rib face of the rear side belt onto the grooves of the crank pulley, and sandwich the rear side belt with the belt guide holder.

CAUTION:

If the rear side belt does not fit onto the groove of the crank pulley easily, pull out the belt guide holder halfway, then insert the rear side belt into the groove, and sandwich it with the belt guide holder.

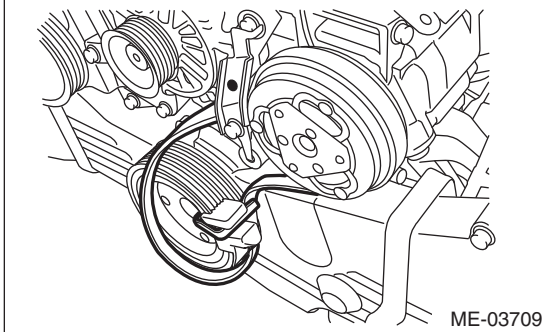

10) Place the tool through the loop of the rear side belt, and set on the crank pulley belt.

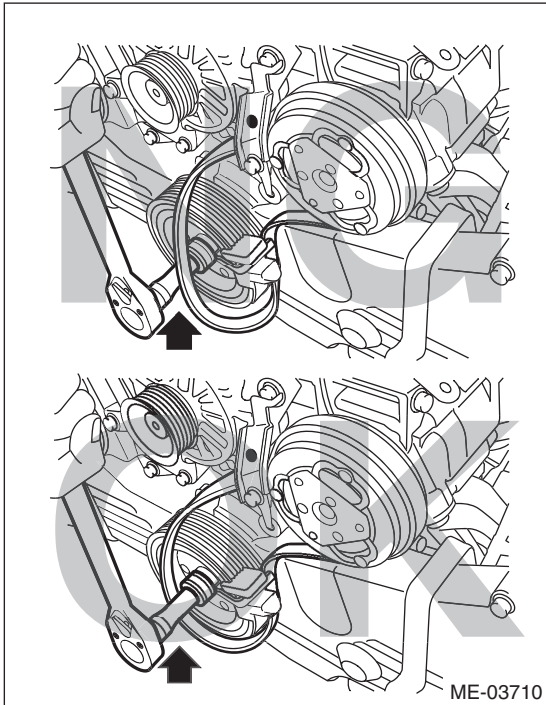

11) While checking for the following, turn the crank pulley slowly to the right by approximately 90° and set the belt guide to the position shown in the figure.

CAUTION:

When rotating the crank pulley, be careful that the belt guide does not deviate from the groove of the crank pulley.

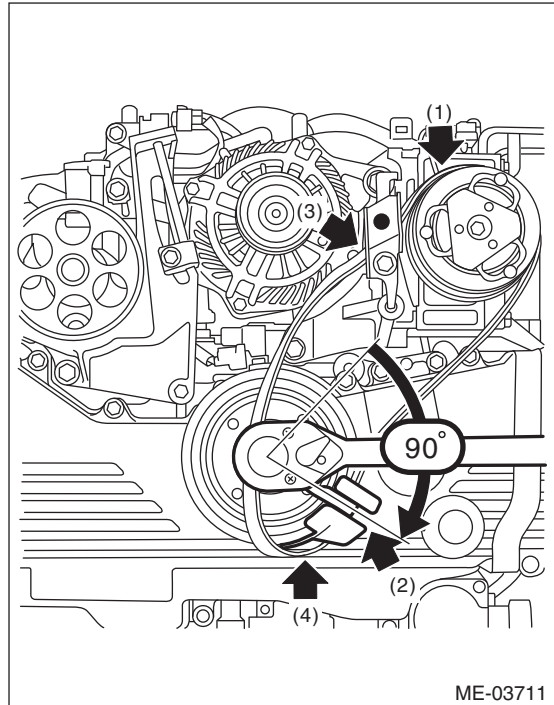

(1) The ribs of the rear side belt are properly riding on the grooves of the A/C compressor pulley.

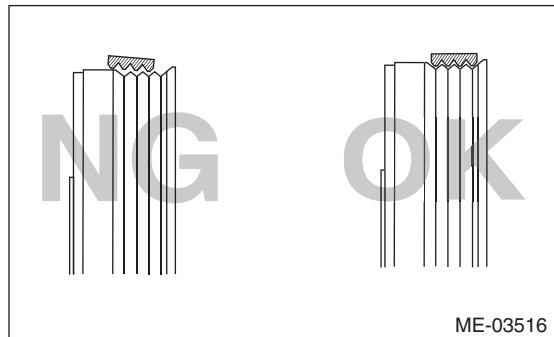

(2) The ribs of the rear side belt are properly riding on the grooves of the crank pulley.

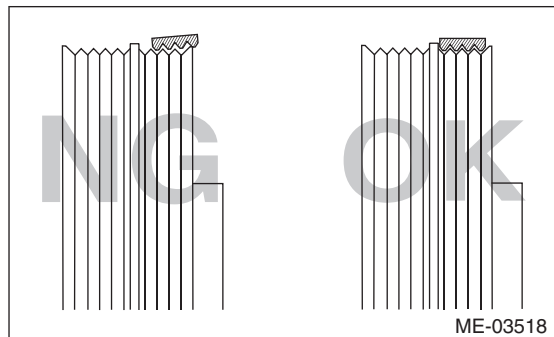

(3) The surface of the rear side belt is being pressed by the belt stopper.

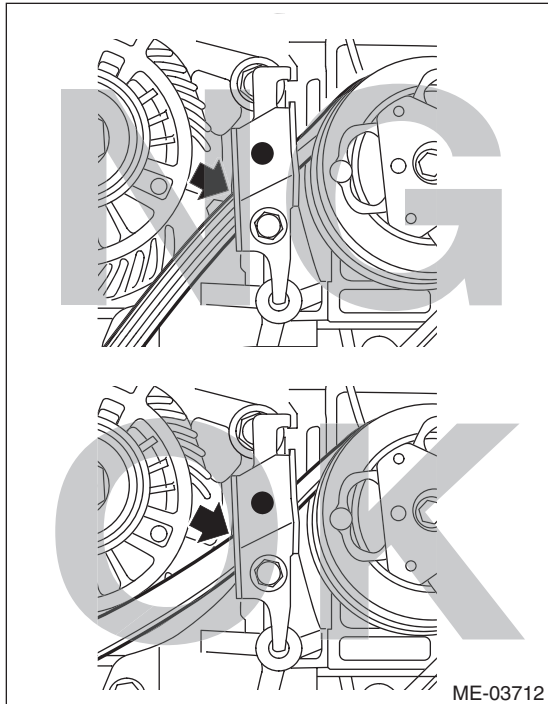

ME-03712

(4) The rear side belt is riding properly on the belt guide.

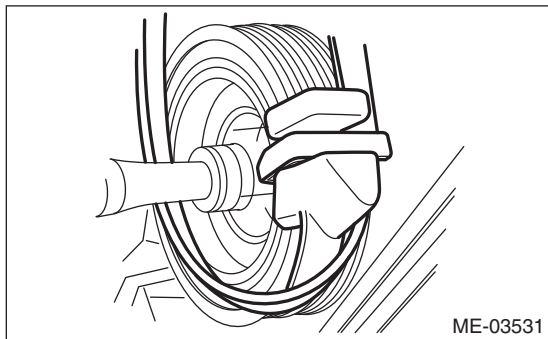

ME-03531

12) While checking for the following, turn the crank pulley slowly to the right by approximately 90° and set the belt guide to the position shown in the figure.

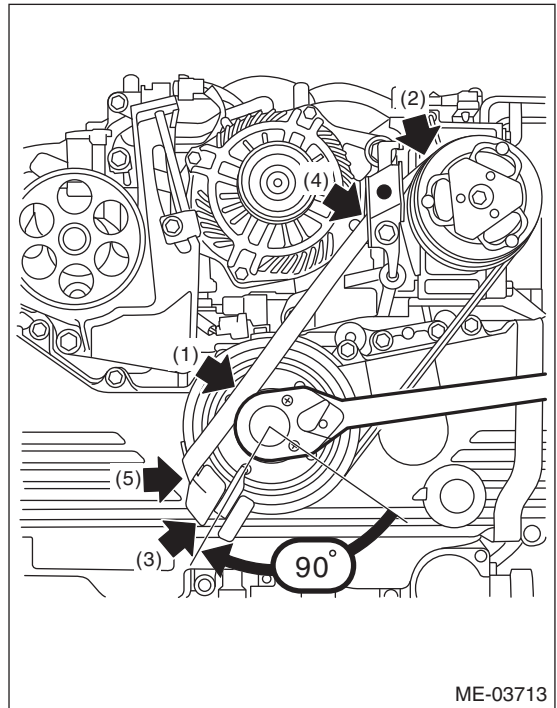

ME-03713

(1) The rear side belt is not twisted.

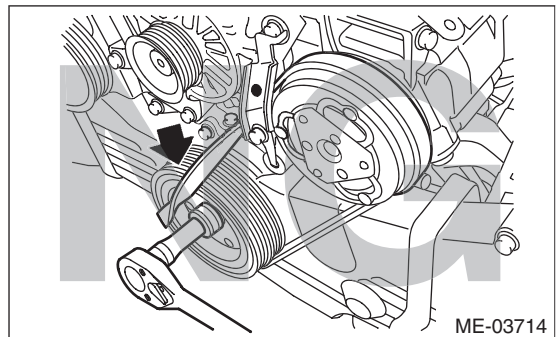

ME-03714

(2) The ribs of the rear side belt are properly riding on the grooves of the A/C compressor pulley.

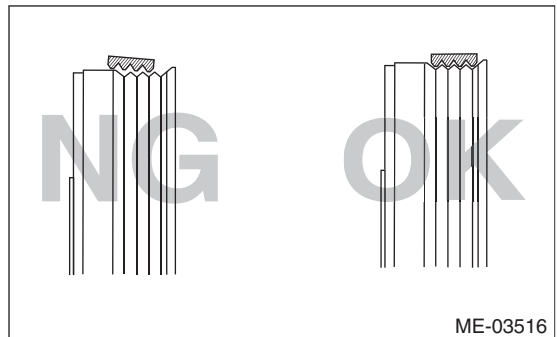

ME-03516

V-belt

MECHANICAL

(3) The ribs of the rear side belt are properly riding on the grooves of the crank pulley.

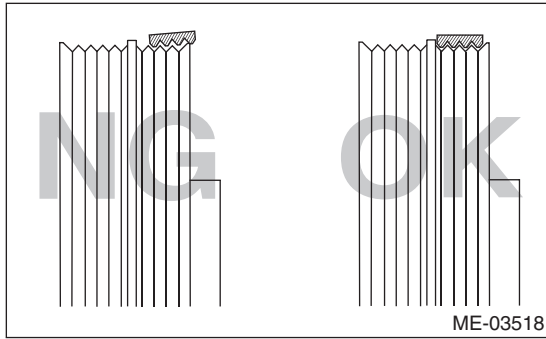

(4) The surface of the rear side belt is being pressed by the belt stopper.

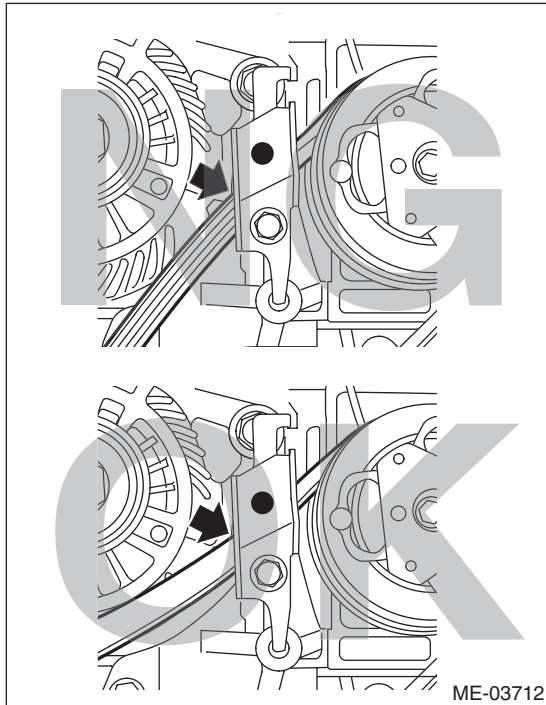

(5) The rear side belt is riding properly on the belt guide.

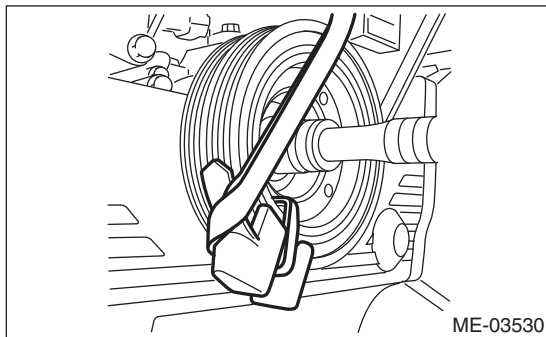

13) Turn the crank pulley slowly to the right, and attach the rear side belt.

CAUTION:

Because there is a possibility of damage to the rear side belt, and the belt guide holder falling off, care must be taken to make sure that the total of steps 8), 11), 12), and 13) does not exceed 330°.

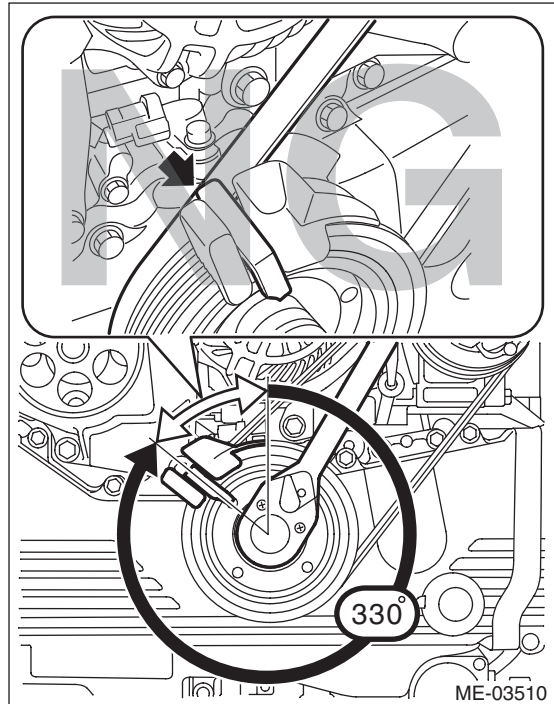

14) Remove the belt guide and belt guide holder from the crank pulley.

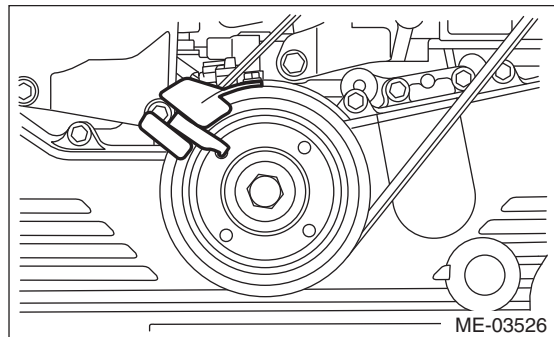

15) Remove the belt stopper from the compressor bracket.

CAUTION:

Make sure to remove the belt stopper, as leaving it on can cause smoke, flames or belt breakage.

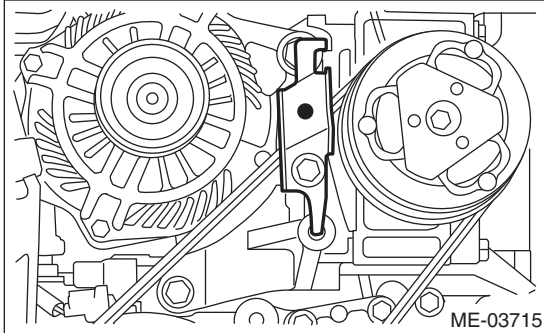

16) Make sure that the belt ribs are properly riding on the grooves of the pulleys, and turn the crank pulley slowly to the right twice to break in the rear side belt.

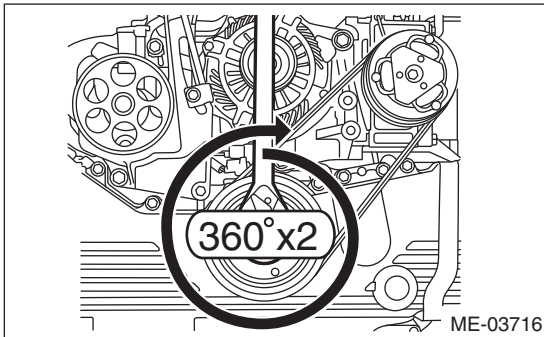

17) Discard the provided tools (belt stopper, belt guide, belt guide holder, bolt).

18) Install the front side belt. <Ref. to ME(H4DOTC)-39, FRONT SIDE BELT, INSTALLATION, V-belt.>

C: INSPECTION

1. FRONT SIDE BELT

- 1) Replace the front side belt, if cracking, fraying or wear is found.
- 2) Check the front side belt tension and adjust it if necessary by adjusting the generator installing position.

Front side belt tension (when using a belt tension gauge):

When installing new parts:

640 — 780 N (65 — 80 kgf, 144 — 175 lbf)

At inspection

490 — 640 N (50 — 65 kgf, 110 — 144 lbf)

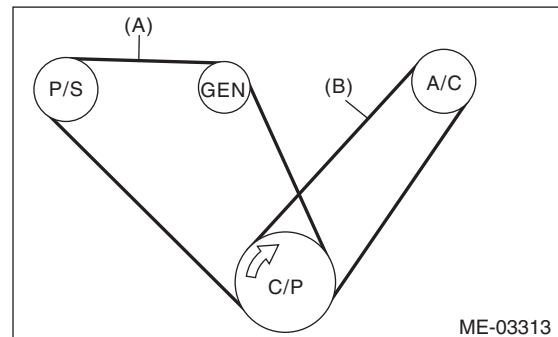

(A) Front side belt

(B) Rear side belt

C/P Crank pulley

GEN Generator

P/S Power steering oil pump pulley

A/C A/C compressor pulley

V-belt

MECHANICAL

Front side belt tension (when not using a belt tension gauge):

When installing new parts

7 — 9 mm (0.276 — 0.354 in)

At inspection

9 — 11 mm (0.354 — 0.433 in)

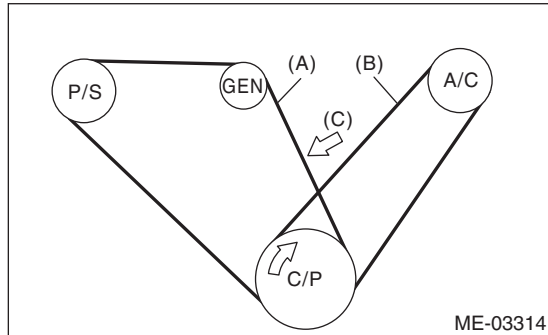

- (A) Front side belt
- (B) Rear side belt
- (C) 98 N (10 kgf, 22 lbf)
- C/P Crank pulley
- GEN Generator
- P/S Power steering oil pump pulley
- A/C A/C compressor pulley

2. REAR SIDE BELT

If cracks, fraying or wear is found, and when abnormal noise is produced, replace the rear side belt.

NOTE:

Because the rear side belt is a stretch type belt, it is not necessary to check deflection and tension.

13.Crank Pulley

A: REMOVAL

1) Remove the V-belts. <Ref. to ME(H4DOTC)-39, REMOVAL, V-belt.>

2) Use the ST to lock the crank pulley, and remove the crank pulley bolt.

ST 499977400 CRANK PULLEY WRENCH

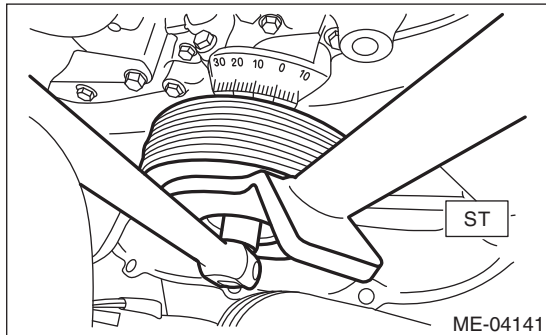

3) Remove the crank pulley.

B: INSTALLATION

1. METHOD WITHOUT ANGLE GAUGE

1) Clean the crankshaft thread using compressed air.

2) Install the crank pulley.

3) Apply engine oil to the crank pulley bolt seat and thread.

4) Tighten the crank pulley bolts.

(1) Use the ST to lock the crank pulley, and temporarily tighten the crank pulley bolt.

ST 499977400 CRANK PULLEY WRENCH

Tightening torque:

47 N·m (4.8 kgf·m, 34.7 ft·lb)

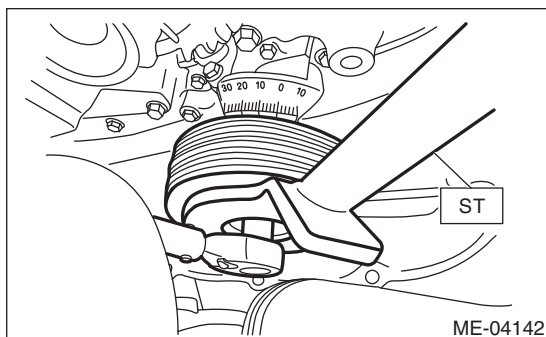

(2) Draw reference lines (A) and (B) using a marker to set the socket to the crank pulley bolt as shown in the figure.

ST 499977400 CRANK PULLEY WRENCH

NOTE:

Set the socket onto the crank pulley bolt so that reference lines (A) and (B) is visible.

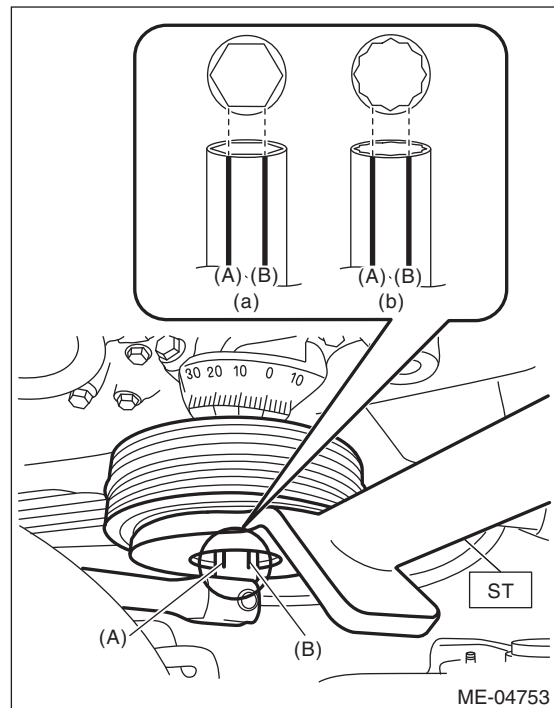

(a) When using 6-point socket

(b) When using 12-point socket

(3) Draw end line (C) on ST using a marker at the same position as reference line (B) was drawn on the socket in step (2).

ST 499977400 CRANK PULLEY WRENCH

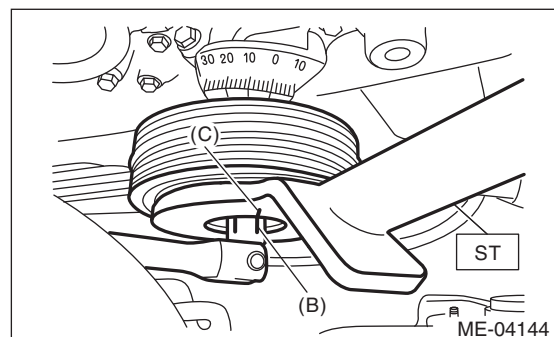

(4) Use the ST to lock the crank pulley, and tighten the crank pulley bolt to the angle where reference line (A) and end line (C) are aligned.

ST 499977400 CRANK PULLEY WRENCH

NOTE:

It should be approx. 60° when reference line (A) and end line (C) are aligned.

Crank Pulley

MECHANICAL

Tightening angle:
 $60^{\circ} \pm 5^{\circ}$

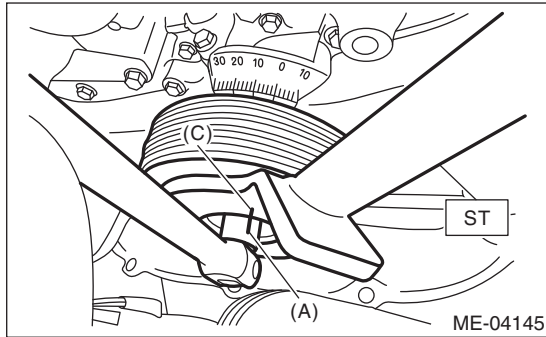

5) Install the V-belts. <Ref. to ME(H4DOTC)-39, INSTALLATION, V-belt.>

2. METHOD WITH ANGLE GAUGE

- 1) Clean the crankshaft thread using compressed air.
- 2) Install the crank pulley.
- 3) Apply engine oil to the crank pulley bolt seat and thread.
- 4) Tighten the crank pulley bolts.

(1) Remove the radiator main fan motor assembly and radiator sub motor assembly. <Ref. to CO(H4DOTC)-24, REMOVAL, Radiator Main Fan and Fan Motor.> <Ref. to CO(H4DOTC)-26, REMOVAL, Radiator Sub Fan and Fan Motor.>

(2) Use the ST1 to lock the crank pulley, and temporarily tighten the crank pulley bolt.

ST1 499977400 CRANK PULLEY WRENCH

Tightening torque:

47 N·m (4.8 kgf·m, 34.7 ft·lb)

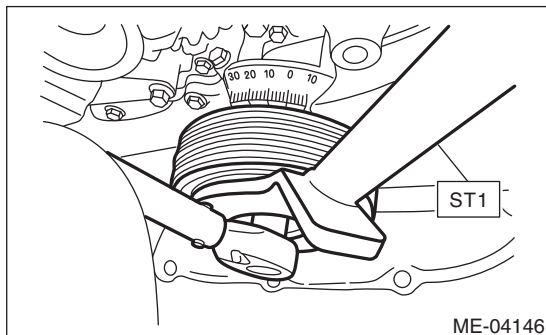

(3) Set the ST2, use the ST1 to lock the crank pulley, and tighten the crank pulley bolt to the specified angle.

ST1 499977400 CRANK PULLEY WRENCH

ST2 18854AA000 ANGLE GAUGE

NOTE:

Attach the magnet used for securing the ST2 (ANGLE GAUGE) to ST1.

Tightening angle:
 $60^{\circ} \pm 5^{\circ}$

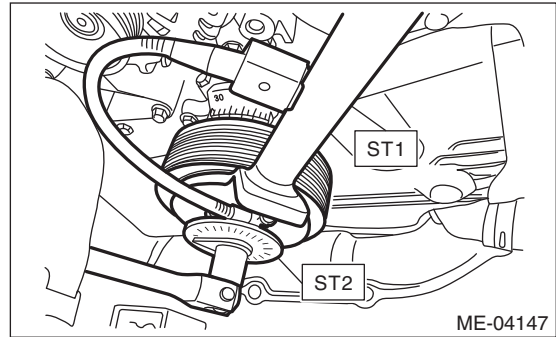

(4) Install the radiator main fan motor assembly and radiator sub motor assembly. <Ref. to CO(H4DOTC)-25, INSTALLATION, Radiator Main Fan and Fan Motor.> <Ref. to CO(H4DOTC)-26, INSTALLATION, Radiator Sub Fan and Fan Motor.>

5) Install the V-belts. <Ref. to ME(H4DOTC)-39, INSTALLATION, V-belt.>

C: INSPECTION

- 1) Check that the crank pulley has no deformation, cracks or other damages.
- 2) Make sure the V-belt is not worn or damaged.
- 3) Check the tension of the front side belt. <Ref. to ME(H4DOTC)-45, INSPECTION, V-belt.>

14. Timing Belt Cover

A: REMOVAL

NOTE:

Perform the work with the engine installed to body when replacing a single part.

- 1) Remove the secondary air pump. <Ref. to EC(H4DOTC)-23, REMOVAL, Secondary Air Pump.>
- 2) Remove the V-belts. <Ref. to ME(H4DOTC)-39, REMOVAL, V-belt.>
- 3) Remove the crank pulley. <Ref. to ME(H4DOTC)-47, REMOVAL, Crank Pulley.>
- 4) Remove the timing belt cover LH (A).
- 5) Remove the timing belt cover RH (B).
- 6) Remove the front timing belt cover (C).

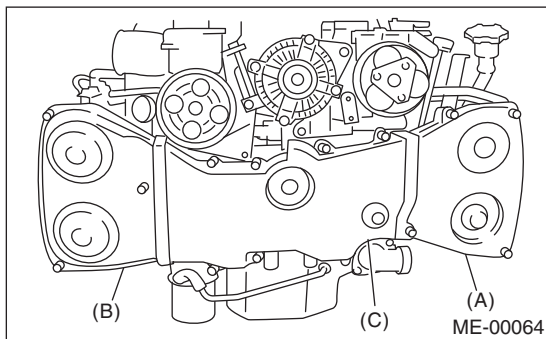

B: INSTALLATION

- 1) Install the front timing belt cover (C).

Tightening torque:

5 N·m (0.5 kgf·m, 3.7 ft·lb)

- 2) Install the timing belt cover RH (B).

Tightening torque:

5 N·m (0.5 kgf·m, 3.7 ft·lb)

- 3) Install the timing belt cover LH (A).

Tightening torque:

5 N·m (0.5 kgf·m, 3.7 ft·lb)

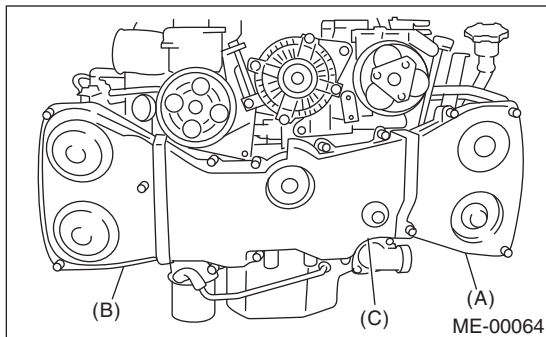

- 4) Install the crank pulley. <Ref. to ME(H4DOTC)-47, INSTALLATION, Crank Pulley.>
- 5) Install the V-belts. <Ref. to ME(H4DOTC)-39, INSTALLATION, V-belt.>
- 6) Install the secondary air pump. <Ref. to EC(H4DOTC)-23, INSTALLATION, Secondary Air Pump.>

Timing Belt

MECHANICAL

15. Timing Belt

A: REMOVAL

NOTE:

Perform the work with the engine installed to body when replacing a single part. For operation procedures, refer to "Timing Belt" in the PM section. <Ref. to PM-14, Timing Belt.>

1. TIMING BELT

1) Remove the V-belts. <Ref. to ME(H4DOTC)-39, REMOVAL, V-belt.>

2) Remove the crank pulley. <Ref. to ME(H4DOTC)-47, REMOVAL, Crank Pulley.>

3) Remove the timing belt cover. <Ref. to ME(H4DOTC)-49, REMOVAL, Timing Belt Cover.>

4) If the alignment mark or arrow mark (which indicates the direction of rotation) on timing belt fade away, put new marks before removing the timing belt as shown in procedures below.

(1) Turn the crankshaft using ST, and align the alignment marks on crank sprocket, intake cam sprocket LH, exhaust cam sprocket LH, intake cam sprocket RH and exhaust cam sprocket RH with notches of the timing belt cover and cylinder block.

ST 499987500 CRANKSHAFT SOCKET

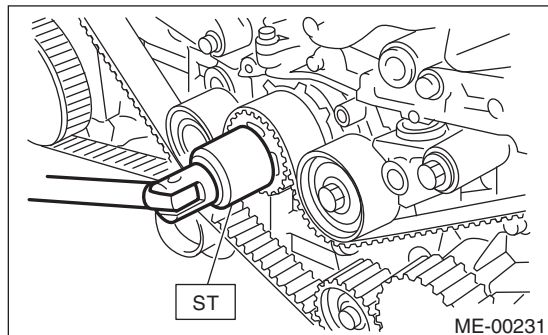

(2) Using white paint, put an alignment mark or an arrow mark on timing belts in relation to the crank sprocket and cam sprockets.

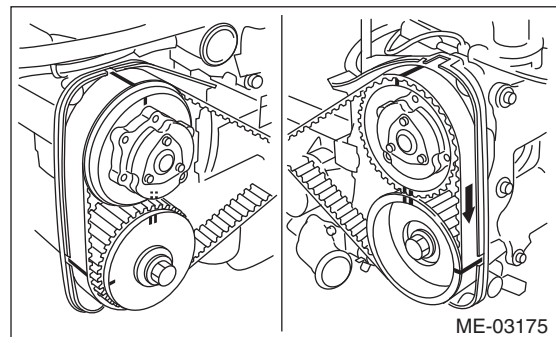
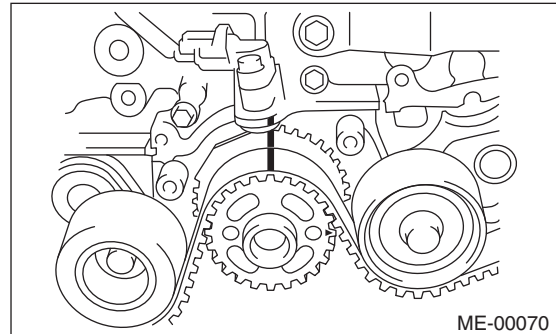

Z₁: 54.5 teeth

Z₂: 51 teeth

Z₃: 28 teeth

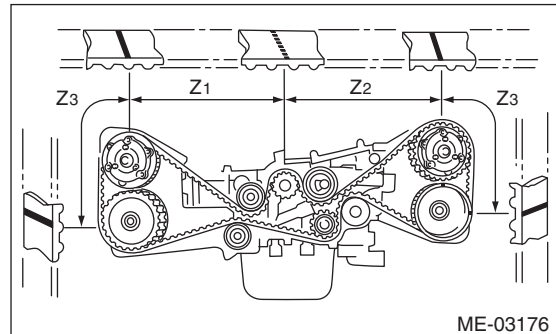

5) Remove the belt idler (A).

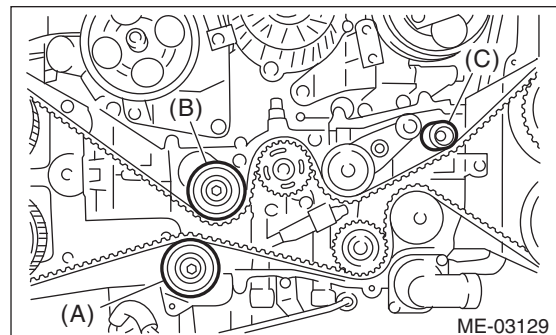

6) Remove the timing belt.

CAUTION:

After the timing belt has been removed, never rotate the intake and exhaust sprocket. If the cam sprocket is rotated, the intake and exhaust valve heads strike together and valve stems are bent.

2. AUTOMATIC BELT TENSION ADJUSTER ASSEMBLY AND BELT IDLER

1) Remove the belt idler (B) and (C).

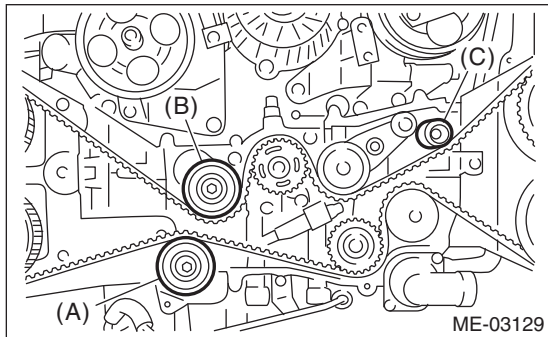

2) Remove the belt idler No. 2.

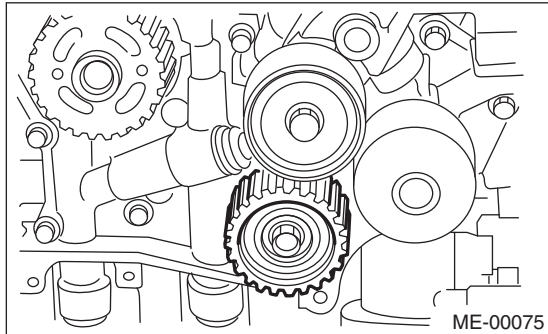

3) Remove the automatic belt tension adjuster assembly.

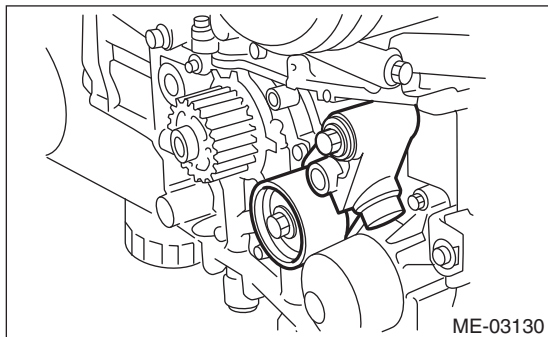

B: INSTALLATION

1. AUTOMATIC BELT TENSION ADJUSTER ASSEMBLY AND BELT IDLER

1) Prepare for installation of the automatic belt tension adjuster assembly.

CAUTION:

- Always use a vertical type pressing tool to move the adjuster rod down.
- Do not use a lateral type vise.
- Push the adjuster rod vertically.
- Press-in the push adjuster rod gradually taking three minutes or more.
- Do not allow press pressure to exceed 9,807 N (1,000 kgf, 2,205 lbf).
- Push in the adjuster rod to the end face of the cylinder. However, do not press the adjuster rod below the end face of the cylinder. Doing so may damage the cylinder.
- Do not release the press pressure until stopper pin is completely inserted.

(1) Attach the automatic belt tension adjuster assembly to vertical pressing tool.

(2) Slowly push in the adjuster rod with a pressure of 165 N (16.8 kgf, 37.1 lb) or more until the adjuster rod is aligned with the stopper pin hole in the cylinder.

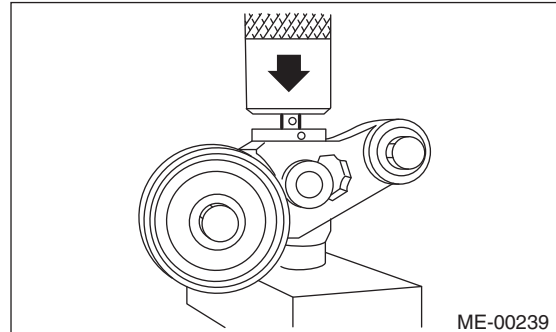

(3) With a 2 mm (0.08 in) dia. stopper pin or a 2 mm (nominal) dia. hex wrench inserted into the stopper pin hole in cylinder, secure the adjuster rod.

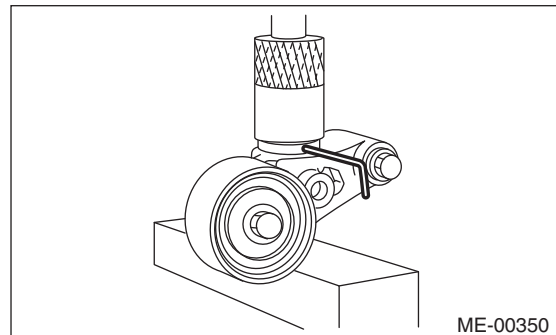

Timing Belt

MECHANICAL

2) Install the automatic belt tension adjuster assembly.

Tightening torque:

39 N·m (4.0 kgf·m, 28.8 ft·lb)

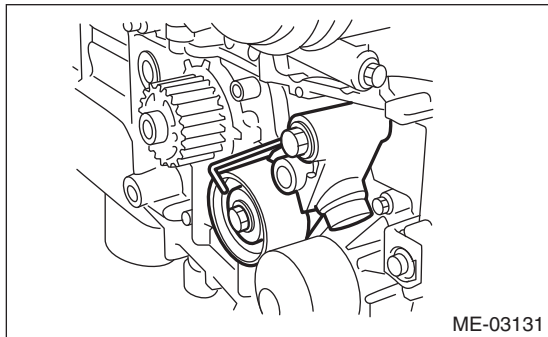

3) Install the belt idler No. 2.

Tightening torque:

39 N·m (4.0 kgf·m, 28.8 ft·lb)

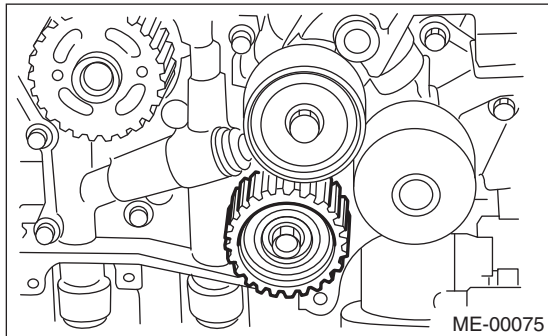

4) Install the belt idlers.

Tightening torque:

39 N·m (4.0 kgf·m, 28.8 ft·lb)

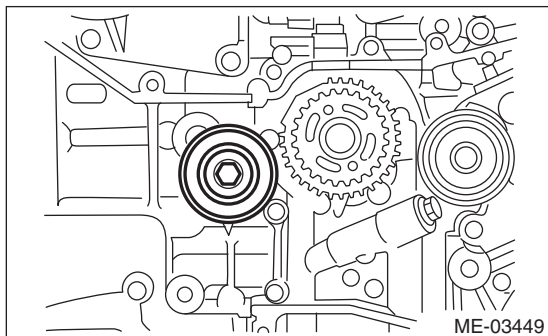

Tightening torque:

25 N·m (2.5 kgf·m, 18.4 ft·lb)

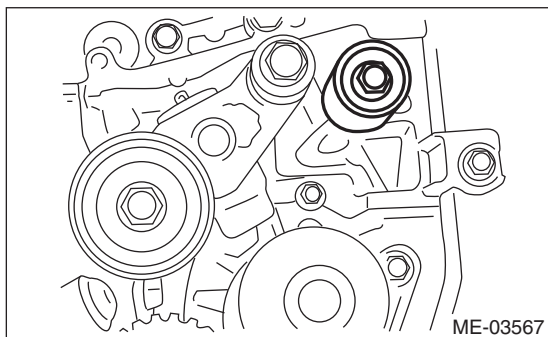

2. TIMING BELT

1) Prepare for installation of the automatic belt tension adjuster assembly. <Ref. to ME(H4DOTC)-51, AUTOMATIC BELT TENSION ADJUSTER ASSEMBLY AND BELT IDLER, INSTALLATION, Timing Belt.>

2) Align the mark (A) on crank sprocket with the mark on oil pump cover at cylinder block.

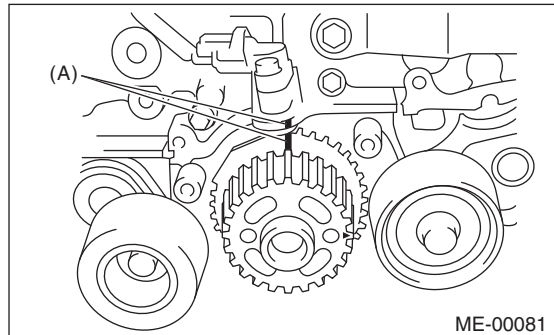

3) Align the single line mark (A) on the exhaust cam sprocket RH with notch (B) on the timing belt cover.

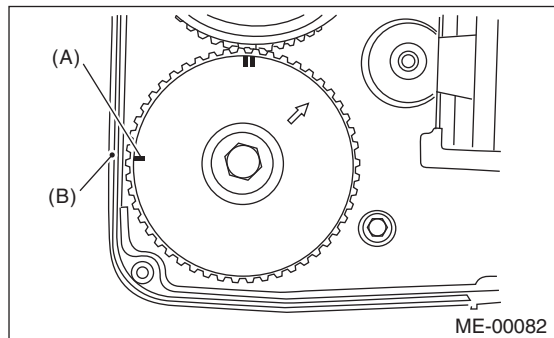

4) Align the single line mark (A) on the intake cam sprocket RH with notch (B) on the timing belt cover. Make sure that the double lines (C) on the intake and exhaust camshaft sprockets are aligned.

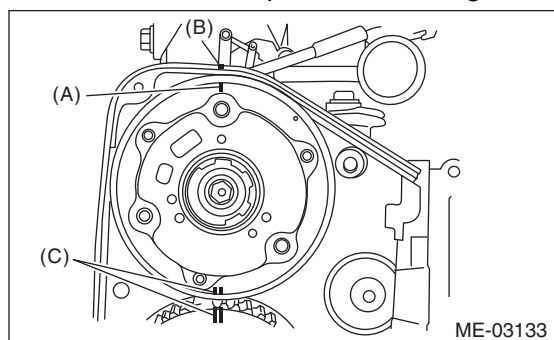

Timing Belt

MECHANICAL

5) Align the single line mark (A) on exhaust cam sprocket LH with notch (B) on the timing belt cover by turning the sprocket counterclockwise (as viewed from front of engine).

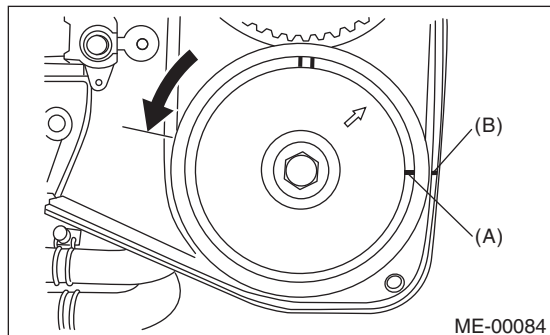

6) Align the single line mark (A) on intake cam sprocket LH with notch (B) on the timing belt cover by turning the sprocket clockwise (as viewed from front of engine). Make sure the double line marks (C) on the intake and exhaust cam sprockets are aligned.

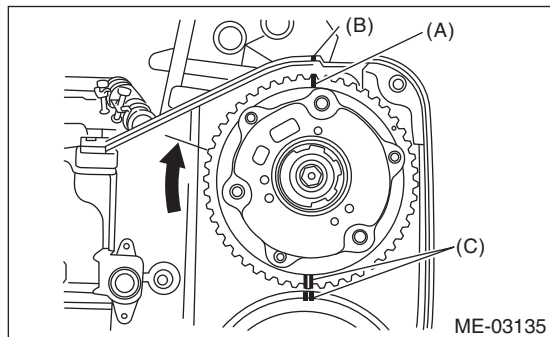

7) Make sure that the cam and crank sprockets are positioned properly.

CAUTION:

- Intake and exhaust camshafts for this DOHC engine can be independently rotated with the timing belts removed. As can be seen from the figure, if the intake and exhaust valves are lifted simultaneously, the valve heads will interfere with each other, resulting in bent valves.

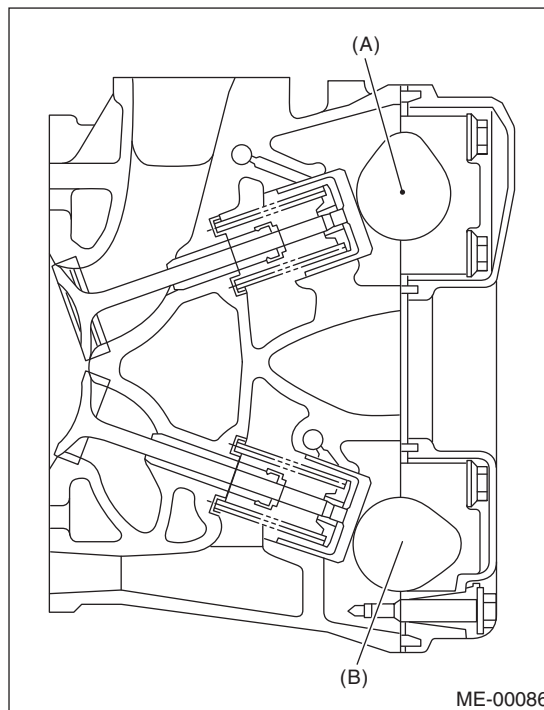

- (A) Intake camshaft
- (B) Exhaust camshaft

Timing Belt

MECHANICAL

- When the timing belts are not installed, four camshafts are held at the “zero-lift” position, where all cams on camshafts are not pushing down on the intake and exhaust valves. (Under this condition, all valves remain unlifted.)
- When the camshafts are rotated to install the timing belts, #2 intake and #4 exhaust cam of camshaft LH are held, pushing their corresponding valves down. (Under this condition, these valves are held lifted.) Camshaft RH are held so that their cams do not push the valves down.
- Camshafts LH must be rotated by the smallest possible angle from zero-lift position to where the timing belt can be installed, in order to prevent mutual interference of intake and exhaust valve heads.
- Do not allow the camshafts to rotate in the direction shown in the upper figure. Doing this may cause both the intake and exhaust valves to lift simultaneously, resulting in mutual interference of heads.

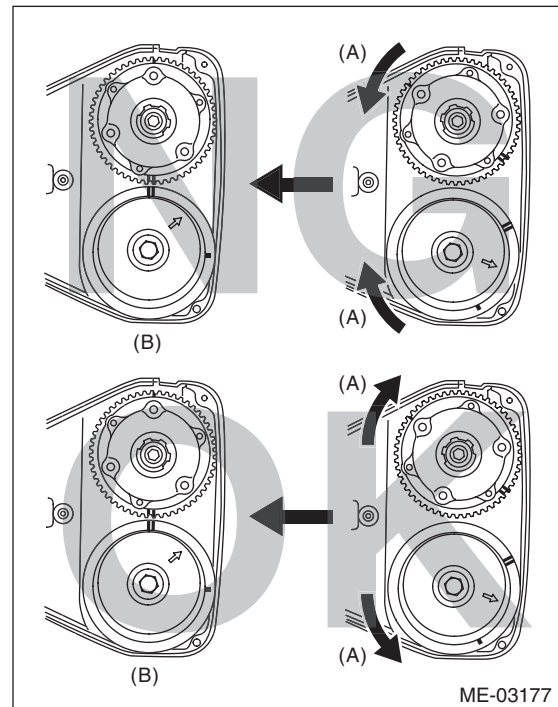

- (A) Direction of rotation
 (B) Timing belt installation position

8) Install the timing belt.

Align the alignment mark on the timing belt with marks on the sprockets in the alphabetical order shown in the figure. While aligning marks, position the timing belt properly.

CAUTION:

- If the timing belt slips by 1 or more teeth, the valve and piston may hit each other.
- Make sure that the direction of belt rotation is correct.

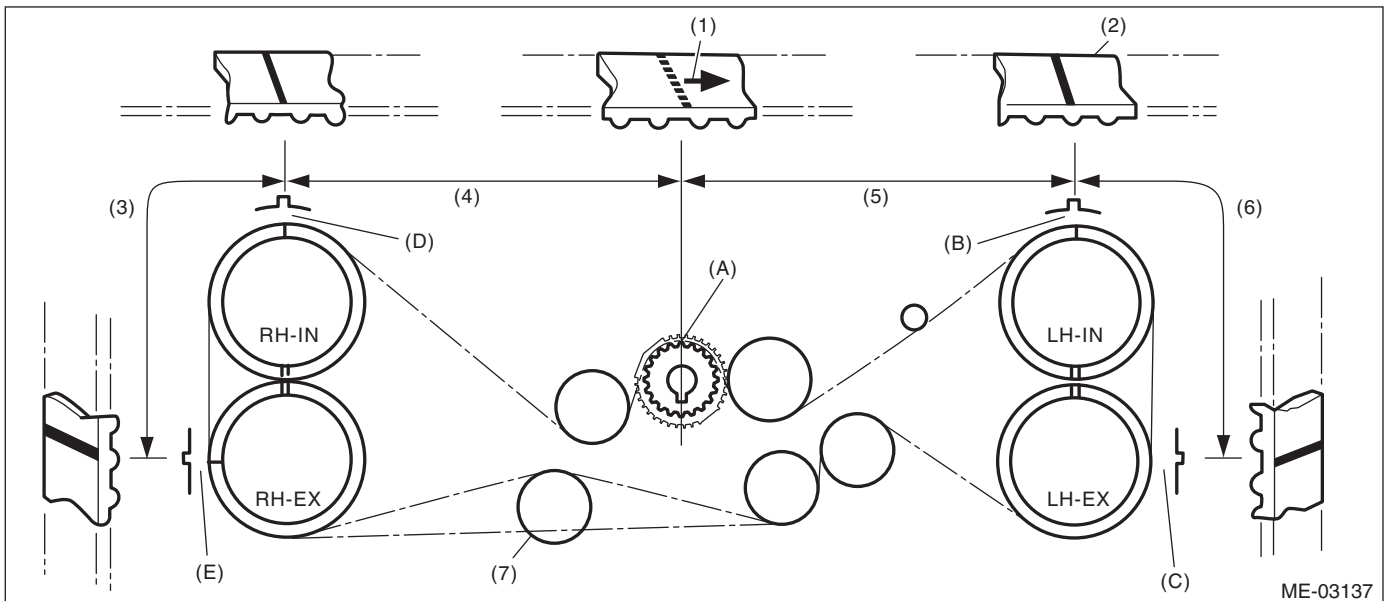

ME-03137

- | | | |
|---------------------|-----------------------|---------------------------|
| (1) Arrow mark | (4) 54.5 tooth length | (6) 28 tooth length |
| (2) Timing belt | (5) 51 tooth length | (7) Install it in the end |
| (3) 28 tooth length | | |

9) Install the belt idlers.

Tightening torque:

39 N·m (4.0 kgf·m, 28.8 ft·lb)

NOTE:

Make sure that the marks on the timing belt and sprockets are aligned.

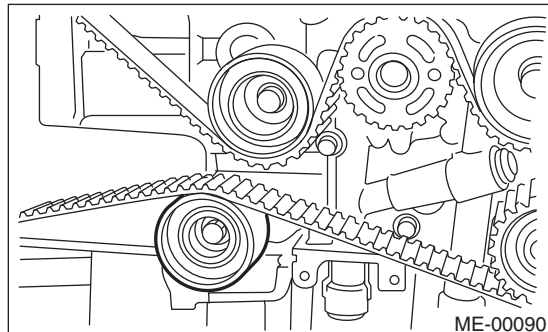

10) After ensuring that the marks on the timing belt and sprockets are aligned, remove the stopper pin from tensioner adjuster.

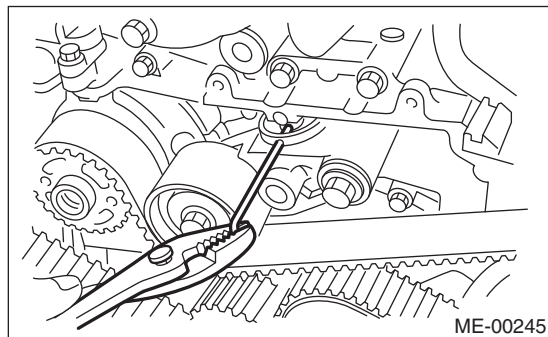

11) Install the timing belt cover.

<Ref. to ME(H4DOTC)-49, INSTALLATION, Timing Belt Cover.>

12) Install the crank pulley.

<Ref. to ME(H4DOTC)-47, INSTALLATION, Crank Pulley.>

13) Install the V-belts. <Ref. to ME(H4DOTC)-39, INSTALLATION, V-belt.>

C: INSPECTION

1. TIMING BELT

- 1) Check the timing belt teeth for breaks, cracks or wear. If any fault is found, replace the timing belt.
- 2) Check the condition on the back surface of the timing belt. If cracks are found, replace the timing belt.

CAUTION:

- Be careful not to let oil, grease or coolant contact the timing belt. Remove quickly and thoroughly if this happens.
- Do not bend the timing belt sharply.

In radial diameter h:

60 mm (2.36 in) or more

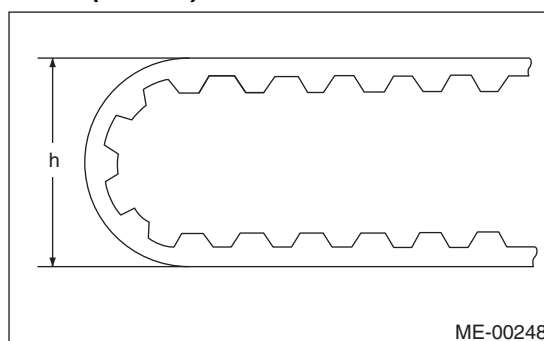

Timing Belt

MECHANICAL

2. AUTOMATIC BELT TENSION ADJUSTER

1) Visually check the oil seals for leaks, and rod ends for abnormal wear and scratches. If necessary, replace the automatic belt tension adjuster assembly.

NOTE:

Slight traces of oil on the oil seal of the rod does not indicate a problem.

2) Check that the adjuster rod does not move when a pressure of 165 N (16.8 kgf, 37.1 lbf) is applied to it. In this check, it is possible to check the stiffness of the adjuster rod.

3) If the adjuster rod is not stiff and moves freely when applying 165 N (16.8 kgf, 37.1 lbf), check it using the following procedures:

(1) Slowly press the adjuster rod down to the end surface of cylinder. Repeat this operation two to three times.

(2) With the adjuster rod moved all the way up, apply a pressure of 165 N (16.8 kgf, 37.1 lbf) to it. Check the adjuster rod stiffness.

(3) If the adjuster rod is not stiff and moves down, replace the automatic belt tension adjuster assembly with a new part.

CAUTION:

- Always use a vertical type pressing tool to move the adjuster rod down.
- Do not use a lateral type vise.
- Push the adjuster rod vertically.
- Press-in the push adjuster rod gradually taking three minutes or more.
- Do not allow press pressure to exceed 9,807 N (1,000 kgf, 2,205 lbf).
- Push in the adjuster rod to the end face of the cylinder. However, do not press the adjuster rod below the end face of the cylinder. Doing so may damage the cylinder.

4) Measure the amount of rod protrusion "H" from the end surface of body. If it is not within the specified range, replace with a new part.

Amount of rod protrusion H:

5.2 — 6.2 mm (0.205 — 0.244 in)

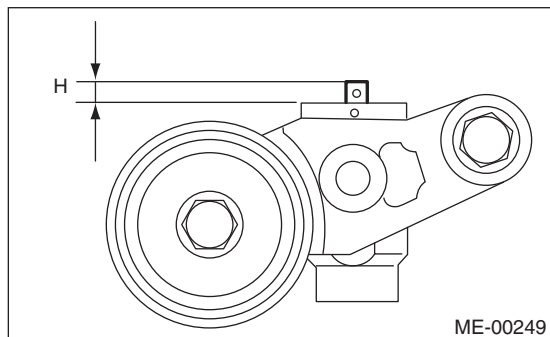

3. BELT TENSION PULLEY

1) Check the mating surfaces of timing belt and contact point of adjuster rod for abnormal wear or scratches. Replace the automatic belt tension adjuster assembly with a new part if faulty.

2) Check the belt tension pulley for smooth rotation. Replace the automatic belt tension adjuster assembly with a new part if abnormal noise or excessive play occurs.

3) Check the belt tension pulley for grease leakage.

4. BELT IDLER

1) Check the belt idler for smooth rotation. Replace if noise or excessive play occurs.

2) Check the outer contacting surfaces of idler pulley for abnormal wear and scratches.

3) Check the belt idler for grease leakage.

16. Cam Sprocket

A: REMOVAL

NOTE:

Perform the work with the engine installed to body when replacing a single part.

1) Remove the V-belts. <Ref. to ME(H4DOTC)-39, REMOVAL, V-belt.>

2) Remove the crank pulley.

<Ref. to ME(H4DOTC)-47, REMOVAL, Crank Pulley.>

3) Remove the timing belt cover.

<Ref. to ME(H4DOTC)-49, REMOVAL, Timing Belt Cover.>

4) Remove the timing belt.

<Ref. to ME(H4DOTC)-50, REMOVAL, Timing Belt.>

5) Remove the actuator cover of the intake cam sprocket.

6) Fasten the cam sprocket and remove from the cam shaft using ST.

ST 499207400 CAM SPROCKET WRENCH

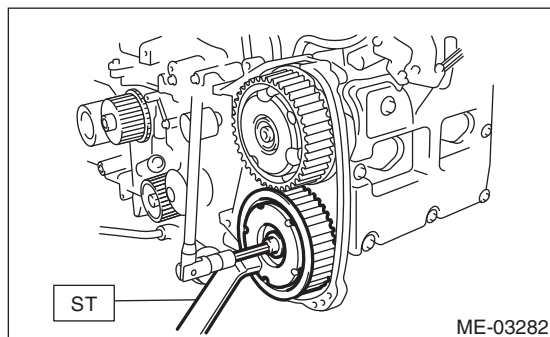

ST 499977500 CAM SPROCKET WRENCH

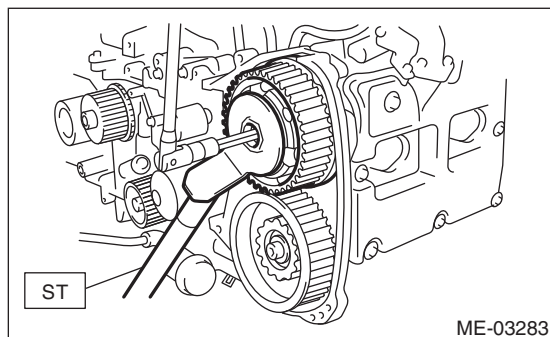

B: INSTALLATION

1) Fasten the cam sprocket and install to the cam shaft using ST.

NOTE:

Do not confuse cam sprockets (LH) and (RH) during installation.

ST 499207400 CAM SPROCKET WRENCH

Tightening torque:

Tighten to 30 N-m (3.1 kgf-m, 22.1 ft-lb) of torque, and then tighten further by 45°.

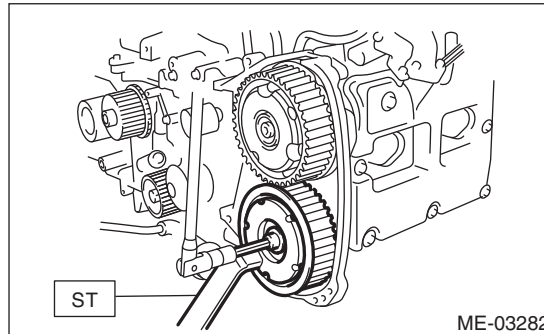

ST 499977500 CAM SPROCKET WRENCH

Tightening torque:

Tighten to 30 N-m (3.1 kgf-m, 22.1 ft-lb) of torque, and then tighten further by 45°.

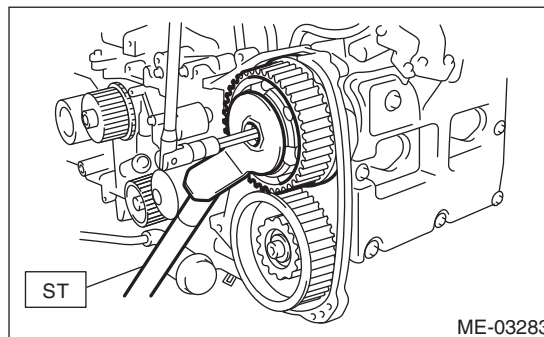

2) Attach the actuator cover of the intake cam sprocket.

NOTE:

Use new O-rings.

Tightening torque:

3.4 N-m (0.3 kgf-m, 2.5 ft-lb)

3) Install the timing belt. <Ref. to ME(H4DOTC)-51, INSTALLATION, Timing Belt.>

4) Install the timing belt cover. <Ref. to ME(H4DOTC)-49, INSTALLATION, Timing Belt Cover.>

5) Install the crank pulley. <Ref. to ME(H4DOTC)-47, INSTALLATION, Crank Pulley.>

6) Install the V-belts. <Ref. to ME(H4DOTC)-39, INSTALLATION, V-belt.>

Cam Sprocket

MECHANICAL

C: INSPECTION

- 1) Check the cam sprocket teeth for abnormal wear and scratches.
- 2) Make sure there is no free play between cam sprocket and key.

17. Crank Sprocket

A: REMOVAL

NOTE:

Perform the work with the engine installed to body when replacing a single part.

- 1) Remove the V-belts. <Ref. to ME(H4DOTC)-39, REMOVAL, V-belt.>
- 2) Remove the crank pulley. <Ref. to ME(H4DOTC)-47, REMOVAL, Crank Pulley.>
- 3) Remove the timing belt cover. <Ref. to ME(H4DOTC)-49, REMOVAL, Timing Belt Cover.>
- 4) Remove the timing belt. <Ref. to ME(H4DOTC)-50, REMOVAL, Timing Belt.>
- 5) Remove the crank sprocket.

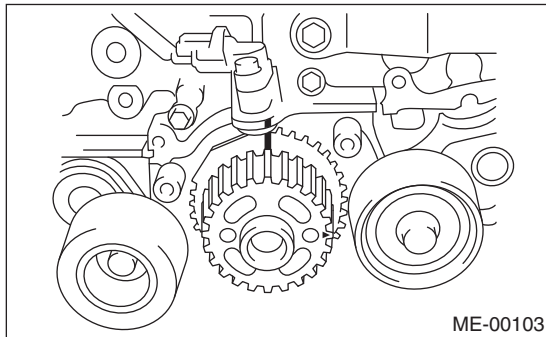

B: INSTALLATION

- 1) Install the crank sprocket.

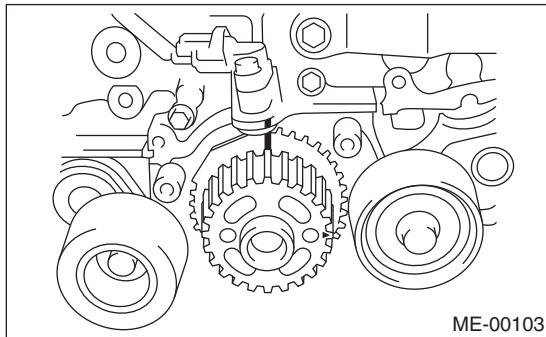

- 2) Install the timing belt. <Ref. to ME(H4DOTC)-51, INSTALLATION, Timing Belt.>
- 3) Install the timing belt cover. <Ref. to ME(H4DOTC)-49, INSTALLATION, Timing Belt Cover.>
- 4) Install the crank pulley. <Ref. to ME(H4DOTC)-47, INSTALLATION, Crank Pulley.>
- 5) Install the V-belts. <Ref. to ME(H4DOTC)-39, INSTALLATION, V-belt.>

C: INSPECTION

- 1) Check the crank sprocket teeth for abnormal wear and scratches.
- 2) Make sure there is no free play between crank sprocket and key.
- 3) Check the crank sprocket protrusion used for sensor for damage and contamination of foreign matter.

18. Camshaft

A: REMOVAL

NOTE:

Perform the work with the engine installed to body when replacing a single part. Refer to "Valve Clearance" for preparation. <Ref. to ME(H4DOTC)-26, INSPECTION, Valve Clearance.>

1) Remove the V-belts. <Ref. to ME(H4DOTC)-39, REMOVAL, V-belt.>

2) Remove the crank pulley. <Ref. to ME(H4DOTC)-47, REMOVAL, Crank Pulley.>

3) Remove the timing belt cover.

<Ref. to ME(H4DOTC)-49, REMOVAL, Timing Belt Cover.>

4) Remove the timing belt. <Ref. to ME(H4DOTC)-50, REMOVAL, Timing Belt.>

5) Remove the cam sprocket. <Ref. to ME(H4DOTC)-57, REMOVAL, Cam Sprocket.>

6) Disconnect the oil flow control solenoid valve connector.

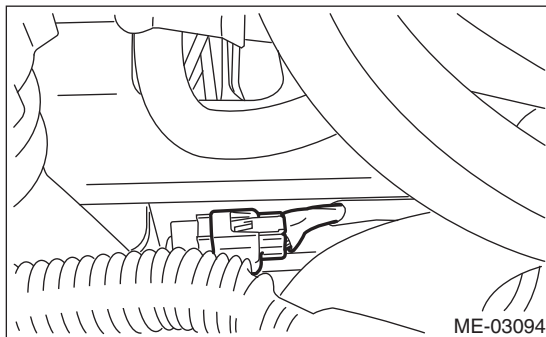

7) Remove the timing belt cover No. 2 LH.

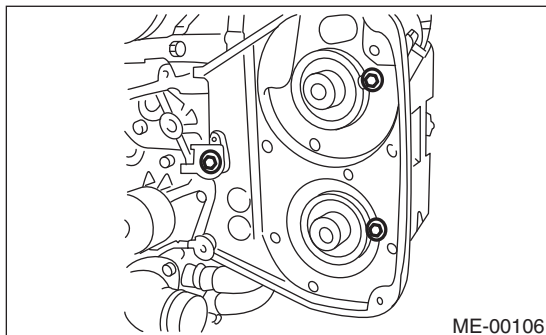

8) Remove the timing belt cover No. 2 RH.

NOTE:

Do not damage or lose the seal rubber when removing the timing belt covers.

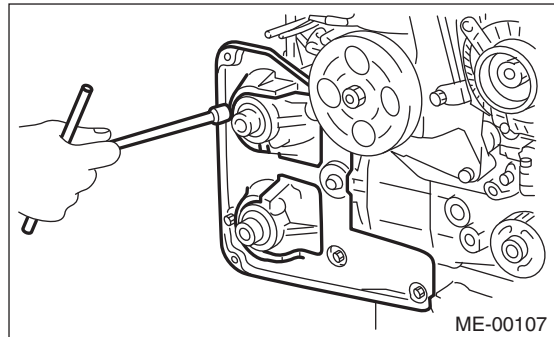

9) Remove the tensioner bracket.

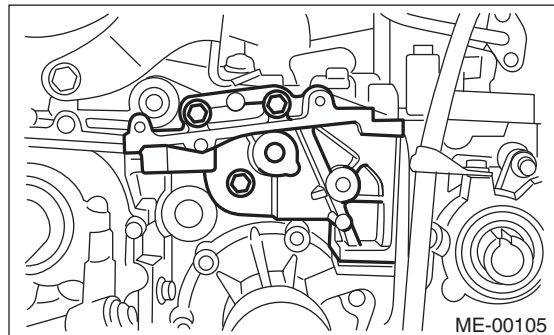

10) Remove the ignition coil. <Ref. to IG(H4DOTC)-7, REMOVAL, Ignition Coil.>

11) Disconnect the PCV hose from the rocker cover.

NOTE:

For the PCV hose affixed with the clamp, fit the depression in the ST with the protrusion of the clamp as shown in the figure below, unlock the clamp and disconnect.

ST 18353AA000 CLAMP PLIERS

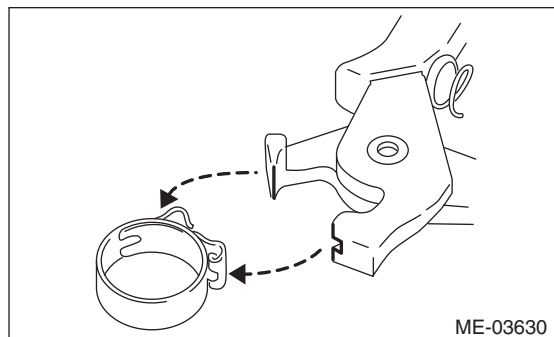

12) Remove the rocker cover and gasket.

13) Remove the oil pipe.

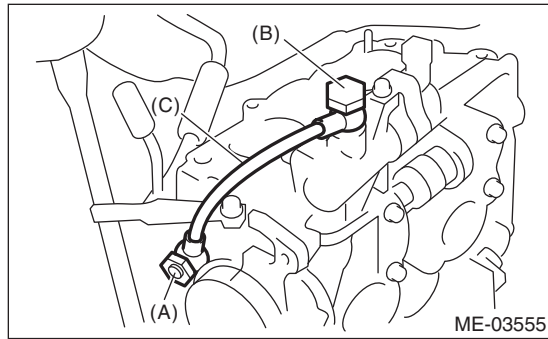

- (A) Union screw with filter (with protrusion)
- (B) Union screw without filter (without protrusion)
- (C) Oil pipe

14) Loosen the front camshaft cap upper area and intake camshaft cap bolts equally, a little at a time in alphabetical order as shown in the figure.

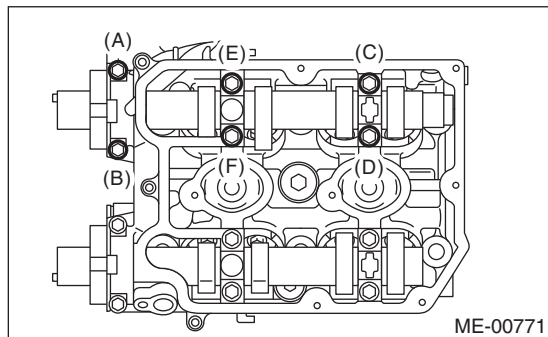

15) Loosen the front camshaft cap lower area and exhaust camshaft cap bolts equally, a little at a time in alphabetical order as shown in the figure.

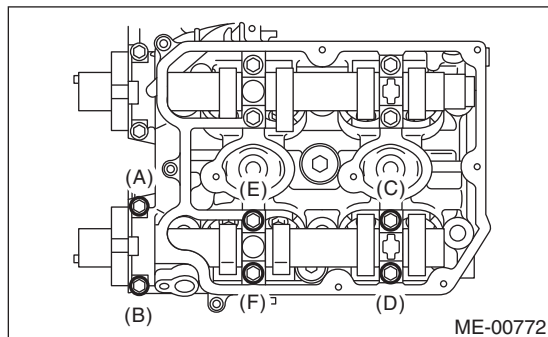

16) Remove the front camshaft cap.

17) Remove the intake camshaft caps and intake camshaft.

18) Remove the exhaust camshaft caps and exhaust camshaft.

NOTE:

Arrange camshaft caps in order so that they can be installed in their original positions.

19) Remove the oil seal.

NOTE:

Do not scratch the journal surface when removing the oil seal.

20) Similarly, remove the camshaft RH and related parts.

B: INSTALLATION

1) Install the camshaft.

Apply engine oil to the cylinder head at camshaft journal installation location before installing the camshaft. Install the camshaft so that each valve is close to or in contact with base circle of the cam lobe.

NOTE:

- Set the camshaft to the position shown in the figure.

- When set at the position shown in the figure, it is not necessary to rotate camshaft RH when installing the timing belt, but it is necessary to rotate camshaft LH slightly.

Intake camshaft LH:

Rotate 80° clockwise.

Exhaust camshaft LH:

Rotate 45° counterclockwise.

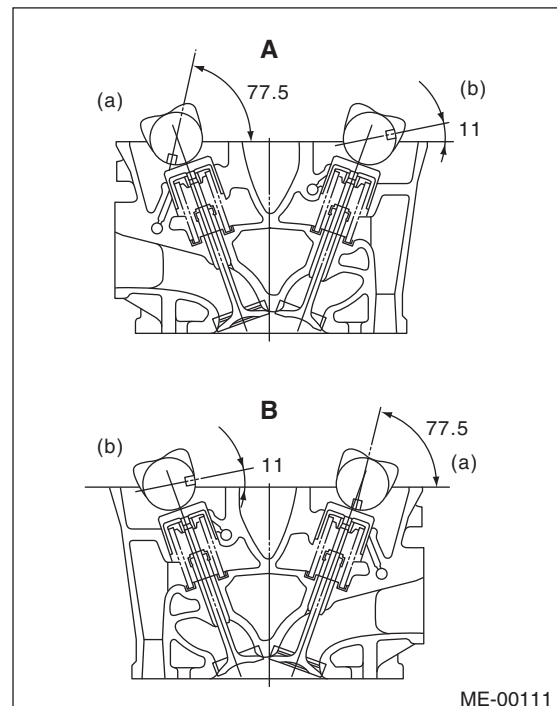

- A Cylinder head LH
- B Cylinder head RH
- (a) Intake camshaft
- (b) Exhaust camshaft

Camshaft

MECHANICAL

2) Install the camshaft cap.

(1) Apply small amount of liquid gasket to the mating surface of cap.

NOTE:

- Install within 5 min. after applying liquid gasket.
- Do not apply liquid gasket excessively. Applying excessively may cause excess gasket to come out and flow toward oil seal, resulting in oil leak.

Liquid gasket:

**THREE BOND 1217G (Part No. K0877Y0100)
or equivalent**

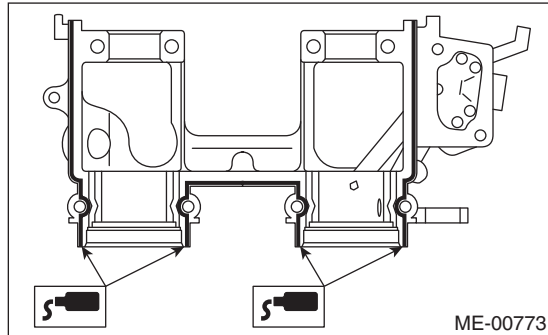

(2) Apply a thin coat of engine oil to the cap journal surface, and install the camshaft cap to the camshaft.

(3) Gradually tighten the camshaft cap in at least two steps, in alphabetical order shown in the figure, and then tighten to the specified torque.

Tightening torque:

T1: 9.75 N·m (1.0 kgf-m, 7.2 ft-lb)

T2: 20 N·m (2.0 kgf-m, 14.8 ft-lb)

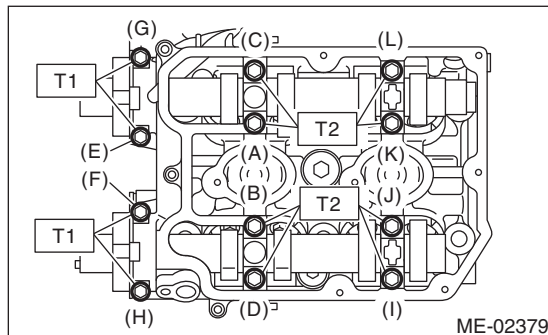

(4) After tightening the camshaft cap, ensure the camshaft rotates only slightly while holding it at base circle.

3) Apply a coat of engine oil to the camshaft oil seal periphery and oil seal lips, then install the oil seal on the camshaft using ST1 and ST2.

NOTE:

Use a new oil seal.

ST1 499587600

ST2 499597200

OIL SEAL INSTALLER

OIL SEAL GUIDE

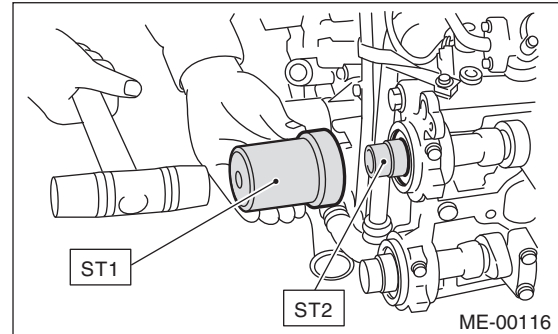

4) Install the oil pipe.

NOTE:

Make sure not to mix up the union screws with filter and without filter as their installation positions are different.

Tightening torque:

29 N·m (3.0 kgf-m, 21.4 ft-lb)

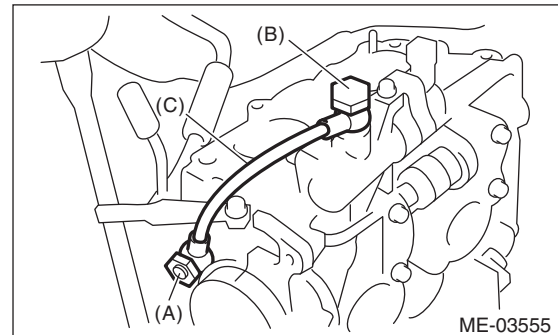

(A) Union screw with filter (with protrusion)

(B) Union screw without filter (without protrusion)

(C) Oil pipe

5) Similarly, install the parts on right-hand side.

6) Install the tensioner bracket.

Tightening torque:

24.5 N·m (2.5 kgf-m, 18.1 ft-lb)

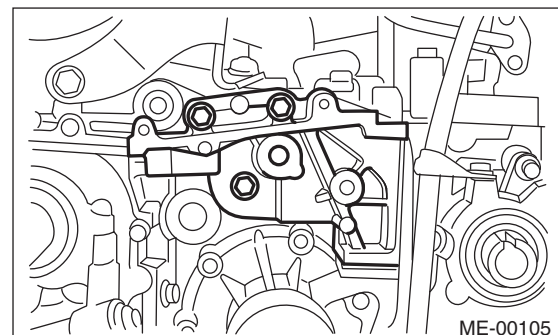

7) Install the timing belt cover No. 2 RH.

Tightening torque:

5 N·m (0.5 kgf·m, 3.7 ft·lb)

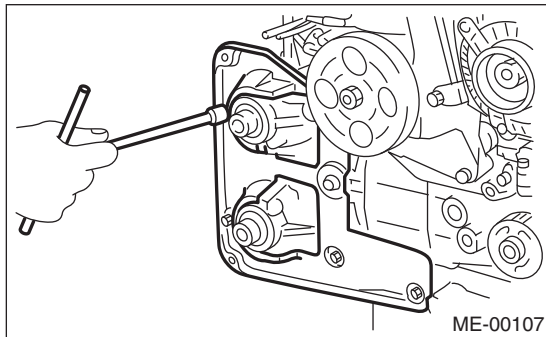

8) Install the timing belt cover No. 2 LH.

Tightening torque:

5 N·m (0.5 kgf·m, 3.7 ft·lb)

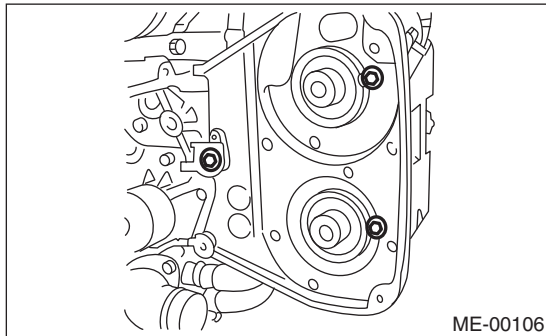

9) Install the cam sprocket.

<Ref. to ME(H4DOTC)-57, INSTALLATION, Cam Sprocket.>

10) Install the timing belt. <Ref. to ME(H4DOTC)-51, INSTALLATION, Timing Belt.>

11) Adjust the valve clearance. <Ref. to ME(H4DOTC)-28, ADJUSTMENT, Valve Clearance.>

12) Install the rocker cover.

(1) Install the rocker cover gasket to the rocker cover. (Outer periphery and ignition coil section)

NOTE:

Use a new rocker cover gasket.

(2) Apply liquid gasket to the specified point of the cylinder head.

NOTE:

Install within 5 min. after applying liquid gasket.

Liquid gasket:

THREE BOND 1217G (Part No. K0877Y0100) or equivalent

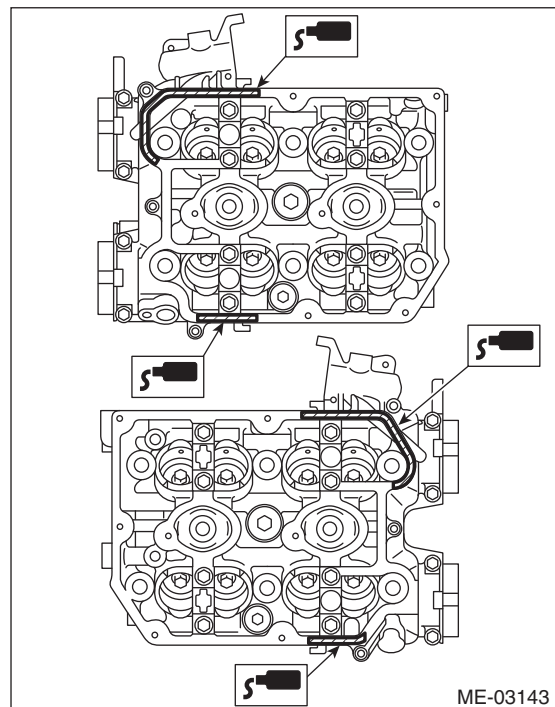

(3) Install the rocker cover on cylinder head. Ensure the gasket is properly positioned during installation.

(4) Temporarily tighten the rocker cover tightening bolt in alphabetical sequence shown in the figure, and then tighten to specified torque in alphabetical order.

Tightening torque:

6.4 N·m (0.7 kgf·m, 4.7 ft·lb)

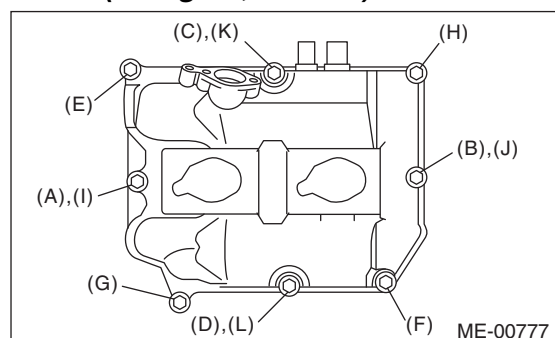

Camshaft

MECHANICAL

13) Connect the PCV hose to the rocker cover.

NOTE:

For the PVC hose clamp, use a new clamp. Sandwich the protruding part of the clamp with the ST and lock the clamp.

ST 18353AA000 CLAMP PLIERS

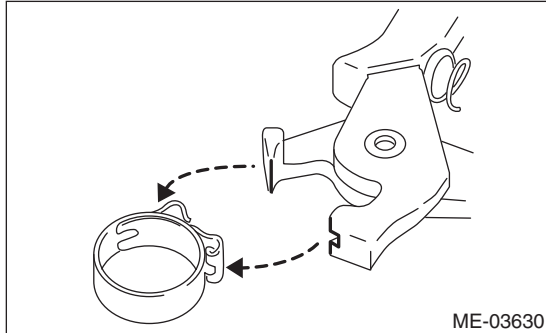

14) Connect the connector to the oil flow control solenoid valve.

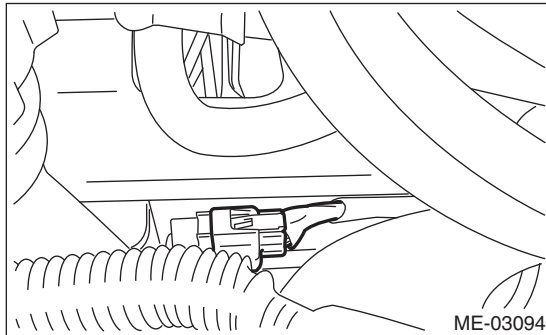

15) Attach the ignition coil. <Ref. to IG(H4DOTC)-7, INSTALLATION, Ignition Coil.>

16) Install the timing belt cover.

<Ref. to ME(H4DOTC)-49, INSTALLATION, Timing Belt Cover.>

17) Install the crank pulley.

<Ref. to ME(H4DOTC)-47, INSTALLATION, Crank Pulley.>

18) Install the V-belts. <Ref. to ME(H4DOTC)-39, INSTALLATION, V-belt.>

C: INSPECTION

1) Measure the bend, and repair or replace if necessary.

Service limit:

0.020 mm (0.00079 in)

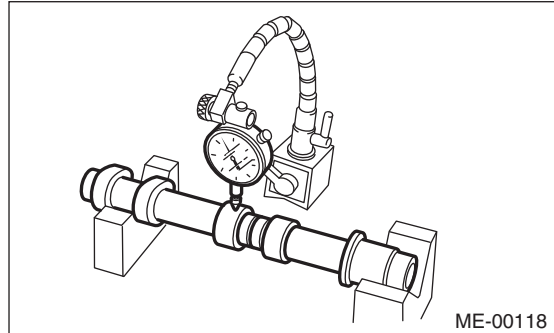

2) Check the journal for damage and wear. Replace if faulty.

3) Check the cutout portion used for camshaft sensor for damage. Replace if faulty.

4) Measure the outside diameter of camshaft journal. If the journal diameter is not within the standard value, check the oil clearance.

	Camshaft journal	
	Front	Center, rear
Standard mm (in)	37.946 — 37.963 (1.4939 — 1.4946)	29.946 — 29.963 (1.1790 — 1.1796)

- 5) Measure the camshaft journal oil clearance.
- (1) Clean the camshaft cap and cylinder head camshaft journal.
 - (2) Place the camshaft on the cylinder head. (Without installing the valve lifter)
 - (3) Place a plastigauge across each camshaft journals.
 - (4) Gradually tighten the camshaft cap in at least two steps, in alphabetical order shown in the figure, and then tighten to the specified torque. Do not turn the camshaft.

Tightening torque:

T1: 9.75 N·m (1.0 kgf-m, 7.2 ft-lb)

T2: 20 N·m (2.0 kgf-m, 14.8 ft-lb)

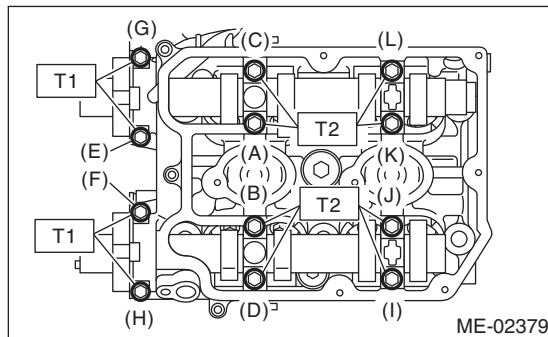

- (5) Remove the camshaft cap.
- (6) Measure the widest point of the plastigauge on each journal. If oil clearance exceeds the standard, replace the camshaft. If necessary, replace the camshaft caps and cylinder head as a set.

Standard:

0.037 — 0.072 mm (0.0015 — 0.0028 in)

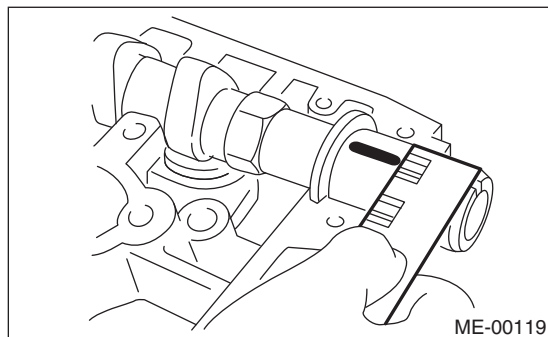

- (7) Completely remove the plastigauge.

- 6) Check the cam face condition; remove the minor faults by grinding with oil stone. Measure the cam height H. If it exceeds the standard or offset wear occurs, replace it.

Cam height H:

Standard

Intake

46.55 — 46.65 mm (1.833 — 1.837 in)

Exhaust

46.75 — 46.85 mm (1.841 — 1.844 in)

Cam base circle diameter A:

37.0 mm (1.457 in)

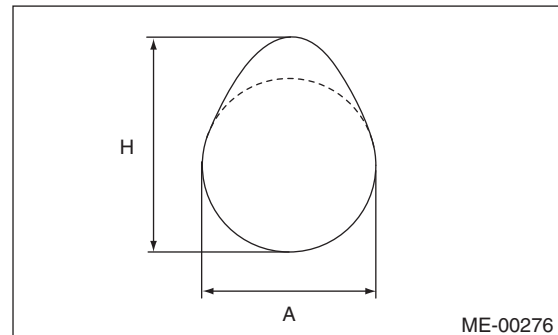

- 7) Measure the thrust clearance of camshaft with setting the dial gauge at end of camshaft. If the thrust clearance is not within the standard or there is offset wear, replace the camshaft caps and cylinder head as a set. If necessary replace the camshaft.

Standard:

0.068 — 0.116 mm (0.0027 — 0.0047 in)

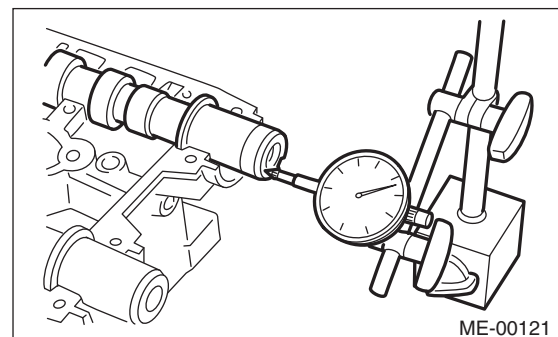

Cylinder Head

MECHANICAL

19. Cylinder Head

A: REMOVAL

NOTE:

Perform the work with the engine installed to body when replacing a single part. Refer to "Valve Clearance" for preparation. <Ref. to ME(H4DOTC)-26, INSPECTION, Valve Clearance.>

1) Remove the V-belts. <Ref. to ME(H4DOTC)-39, REMOVAL, V-belt.>

2) Remove the intake manifold. <Ref. to FU(H4DOTC)-14, REMOVAL, Intake Manifold.>

3) Remove the crank pulley. <Ref. to ME(H4DOTC)-47, REMOVAL, Crank Pulley.>

4) Remove the timing belt cover. <Ref. to ME(H4DOTC)-49, REMOVAL, Timing Belt Cover.>

5) Remove the timing belt. <Ref. to ME(H4DOTC)-50, REMOVAL, Timing Belt.>

6) Remove the cam sprocket. <Ref. to ME(H4DOTC)-57, REMOVAL, Cam Sprocket.>

7) Remove the bolt which installs the A/C compressor bracket on cylinder head.

8) Remove the secondary air combination valve. <Ref. to EC(H4DOTC)-24, REMOVAL, Secondary Air Combination Valve.>

9) Remove the camshaft. <Ref. to ME(H4DOTC)-60, REMOVAL, Camshaft.>

10) Remove the oil level gauge guide. (LH side only)

11) Remove the cylinder head bolts in alphabetical order shown in the figure.

NOTE:

Leave the bolts (A) and (D) engaged by three or four threads to prevent the cylinder head from falling.

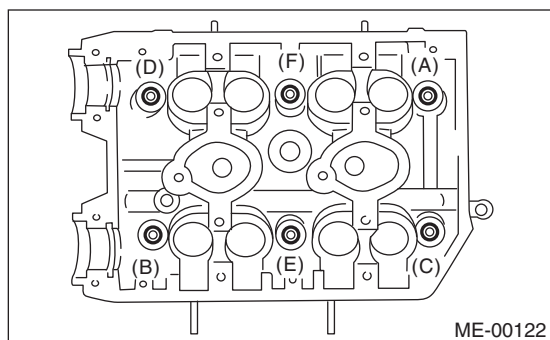

12) While tapping the cylinder head with a plastic hammer, separate it from cylinder block. Remove the bolts (A) and (D) to remove cylinder head.

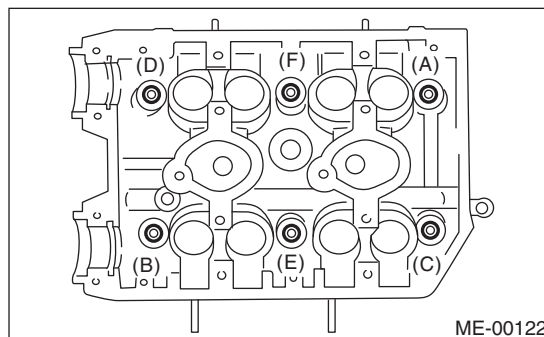

13) Remove the cylinder head gasket.

CAUTION:

Be careful not to scratch the mating surface of cylinder head and cylinder block.

14) Similarly, remove the right side cylinder head.

B: INSTALLATION

1) Install the cylinder head to the cylinder block.

CAUTION:

Be careful not to scratch the mating surface of cylinder head and cylinder block.

NOTE:

Use a new cylinder head gasket.

- (1) Clean the bolt threads and the bolt holes in the cylinder block.

CAUTION:

To avoid erroneous tightening of the bolts, clean out the bolt holes sufficiently by blowing with compressed air to eliminate engine coolant etc.

- (2) Apply a sufficient coat of engine oil to the washer and bolt thread.
 (3) Tighten all bolts to 40 N·m (4.1 kgf-m, 29.5 ft-lb) in alphabetical order.
 (4) Retighten all bolts to 95 N·m (9.7 kgf-m, 70.1 ft-lb) in alphabetical order.

CAUTION:

If the bolt makes stick-slip sound during tightening, repeat the procedure from step (1). In this case, the cylinder head gasket can be re-used.

- (5) Loosen all the bolts by 180° in the reverse order of installing, and loosen them further by 180°.
 (6) Tighten all bolts to 10 N·m (1.0 kgf-m, 7.4 ft-lb) in alphabetical order.
 (7) Retighten all bolts to 30 N·m (3.1 kgf-m, 22.1 ft-lb) in alphabetical order.
 (8) Retighten all bolts to 70 N·m (7.1 kgf-m, 51.6 ft-lb) in alphabetical order.
 (9) Retighten all bolts by 80 — 90° in alphabetical order.
 (10) Retighten all bolts by 40 — 45° in alphabetical order.

CAUTION:

The tightening angle of the bolt should not exceed 45°.

- (11) Retighten bolts (A) and (B) by 40 — 45°.

CAUTION:

Make sure the total “tightening angle” of steps (10) and (11) does not exceed 90°.

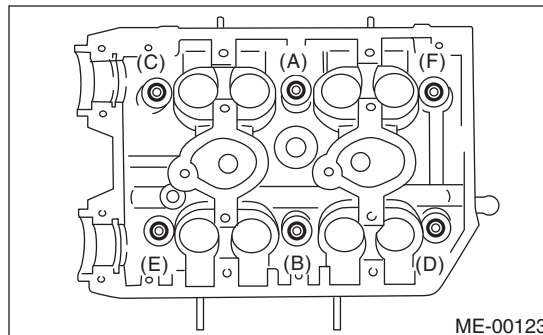

- 2) Install the oil level gauge guide. (LH side only)

Tightening torque:

6.4 N·m (0.7 kgf-m, 4.7 ft-lb)

- 3) Install the camshaft. <Ref. to ME(H4DOTC)-61, INSTALLATION, Camshaft.>
 4) Install the A/C compressor bracket on cylinder head.

Tightening torque:

36 N·m (3.7 kgf-m, 26.6 ft-lb)

- 5) Install the secondary air combination valve. <Ref. to EC(H4DOTC)-25, INSTALLATION, Secondary Air Combination Valve.>
 6) Install the cam sprocket. <Ref. to ME(H4DOTC)-57, INSTALLATION, Cam Sprocket.>
 7) Install the timing belt. <Ref. to ME(H4DOTC)-51, INSTALLATION, Timing Belt.>
 8) Adjust the valve clearance. <Ref. to ME(H4DOTC)-28, ADJUSTMENT, Valve Clearance.>
 9) Install the rocker cover.
 (1) Install the rocker cover gasket to the rocker cover. (Outer periphery and ignition coil section)

NOTE:

Use a new rocker cover gasket.

Cylinder Head

MECHANICAL

(2) Apply liquid gasket to the specified point of the cylinder head.

NOTE:

Install within 5 min. after applying liquid gasket.

Liquid gasket:

THREE BOND 1217G (Part No. K0877Y0100) or equivalent

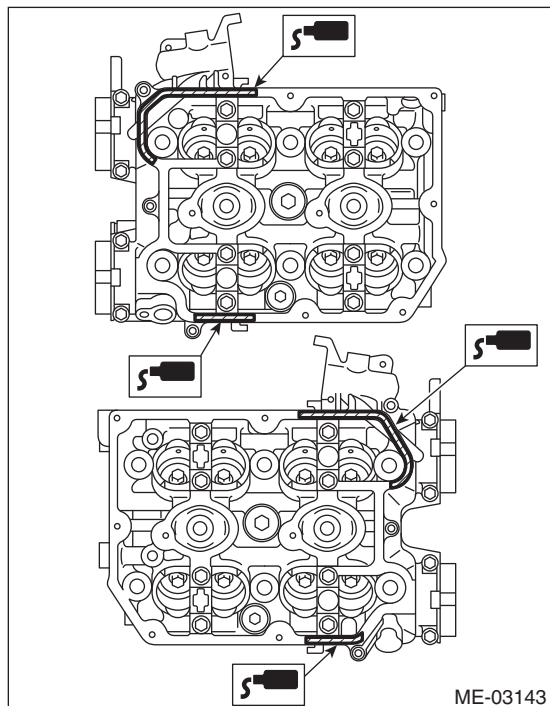

(3) Install the rocker cover on cylinder head. Ensure the gasket is properly positioned during installation.

(4) Temporarily tighten the rocker cover tightening bolt in alphabetical sequence shown in the figure, and then tighten to specified torque in alphabetical order.

Tightening torque:

6.4 N·m (0.7 kgf·m, 4.7 ft·lb)

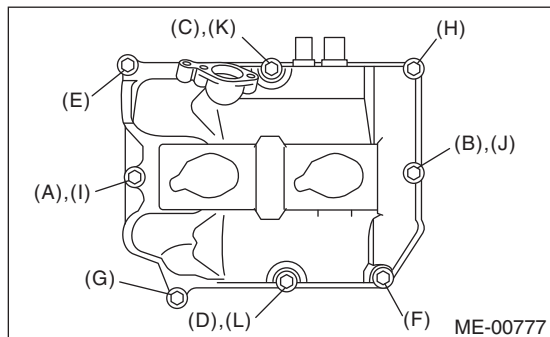

10) Install the timing belt cover.

<Ref. to ME(H4DOTC)-49, INSTALLATION, Timing Belt Cover.>

11) Install the crank pulley.

<Ref. to ME(H4DOTC)-47, INSTALLATION, Crank Pulley.>

12) Install the intake manifold.

<Ref. to FU(H4DOTC)-18, INSTALLATION, Intake Manifold.>

13) Install the V-belts. <Ref. to ME(H4DOTC)-39, INSTALLATION, V-belt.>

C: DISASSEMBLY

1) Remove the valve lifter.

2) Place the cylinder head on ST1.

ST1 498267600 CYLINDER HEAD TABLE

3) Using ST2, compress the valve spring and remove the valve spring retainer key. Remove each valve and valve spring.

ST2 499718000 VALVE SPRING REMOVER

NOTE:

- Mark each valve to prevent confusion.
- Pay careful attention not to damage the lips of intake valve oil seals and exhaust valve oil seals.
- Keep all the removed parts in order for re-installing in their original positions.
- For removal and installation procedures of the valve guide, intake valve oil seal and exhaust valve oil seal, refer to "Inspection". <Ref. to ME(H4DOTC)-71, VALVE GUIDE, INSPECTION, Cylinder Head.> <Ref. to ME(H4DOTC)-74, INTAKE AND EXHAUST VALVE OIL SEAL, INSPECTION, Cylinder Head.>

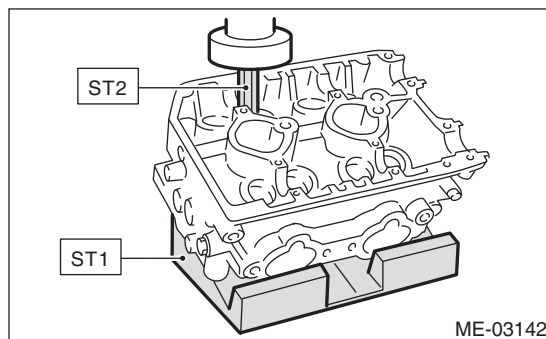

D: ASSEMBLY

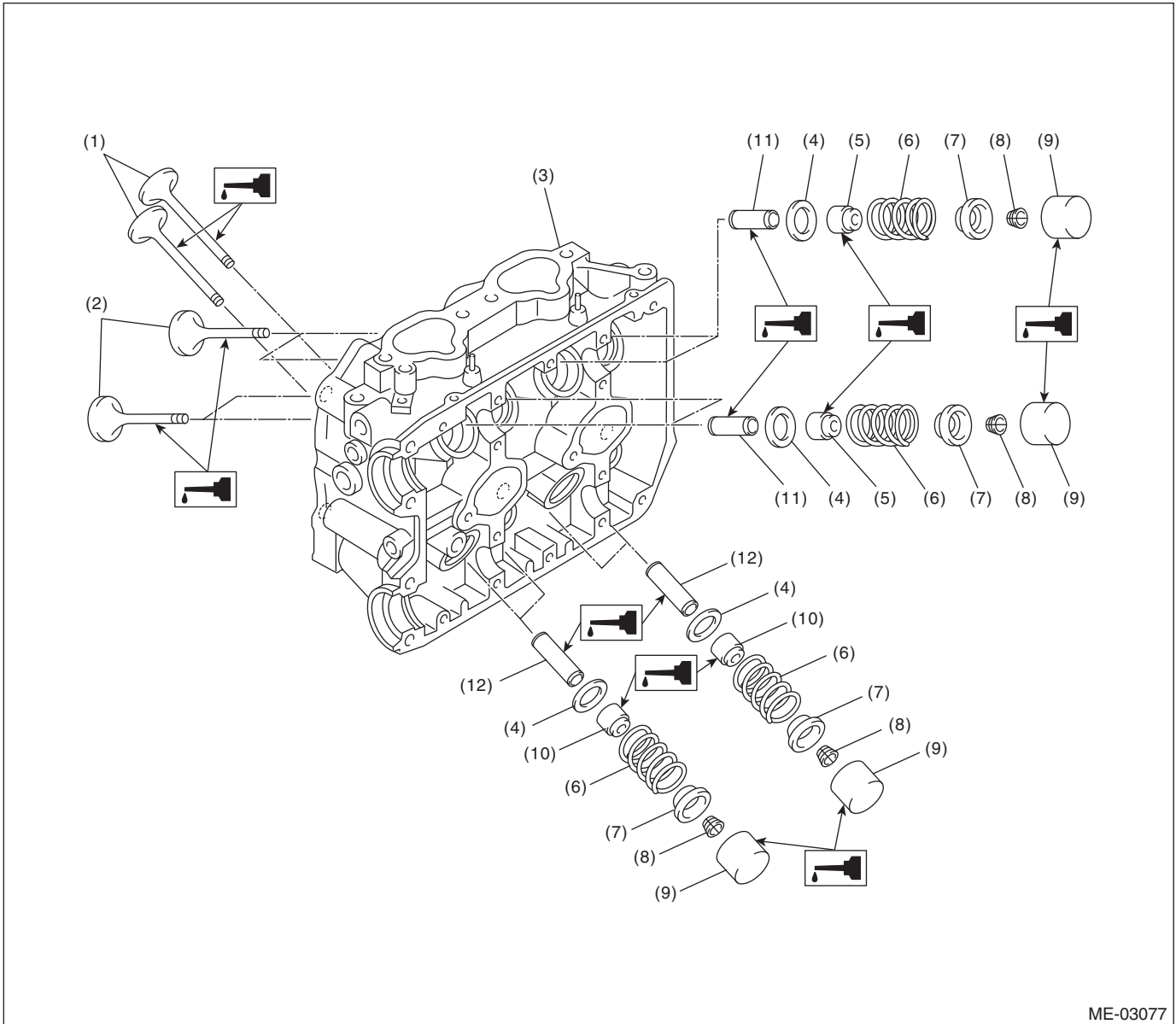

ME-03077

- | | | |
|-----------------------|---------------------------|-----------------------------|
| (1) Exhaust valve | (5) Intake valve oil seal | (9) Valve lifter |
| (2) Intake valve | (6) Valve spring | (10) Exhaust valve oil seal |
| (3) Cylinder head | (7) Retainer | (11) Intake valve guide |
| (4) Valve spring seat | (8) Retainer key | (12) Exhaust valve guide |

Cylinder Head

MECHANICAL

- 1) Install the valve spring and valve.
 - (1) Coat the stem of each valve with engine oil and insert the valve into the valve guide.

NOTE:

When inserting the valve into valve guide, use special care not to damage the oil seal lip.

- (2) Set the cylinder head on ST1.

ST1 498267600 CYLINDER HEAD TABLE

- (3) Install the valve spring and retainer.

NOTE:

Be sure to install the valve spring with its close-coiled end facing the seat on cylinder head.

- (4) Set the ST2 on valve spring.

ST2 499718000 VALVE SPRING
REMOVER

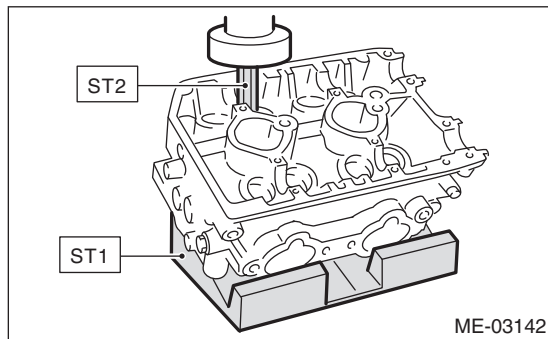

- (5) Compress the valve spring and fit the valve spring retainer key.
 - (6) After installing, tap the valve spring retainers lightly with a plastic hammer for better seating.
- 2) Apply oil to the surfaces of the valve lifter.
 - 3) Install the valve lifter.

E: INSPECTION

1. CYLINDER HEAD

1) Check for cracks or damage. Use liquid penetrant tester on the important sections to check for fissures. Check that there are no marks of gas leaking or water leaking on gasket installing surface.

2) Measure the warping of the cylinder head surface that mates with cylinder block using a straight edge (A) and thickness gauge (B).

If the warping exceeds the limit, correct the surface by grinding it with a surface grinder.

Warping limit:

0.035 mm (0.0014 in)

Grinding limit:

0.3 mm (0.012 in)

Standard height of cylinder head:

127.5 mm (5.02 in)

NOTE:

Uneven torque for the cylinder head bolts can cause warping. When reinstalling, pay special attention to the torque so as to tighten evenly.

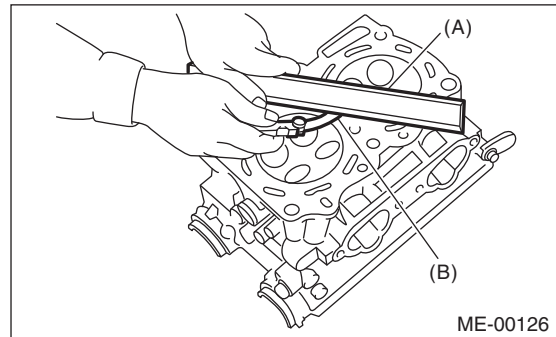

2. VALVE SEAT

Inspect the intake and exhaust valve seats, and correct the contact surfaces with a valve seat cutter if they are defective or when valve guides are replaced.

Valve seat width *W*:

Standard

Intake

0.6 — 1.4 mm (0.024 — 0.055 in)

Exhaust

1.2 — 1.8 mm (0.047 — 0.071 in)

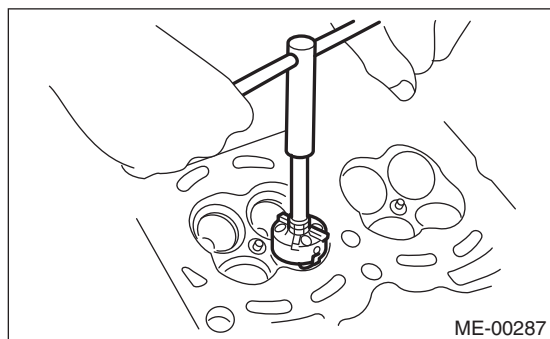
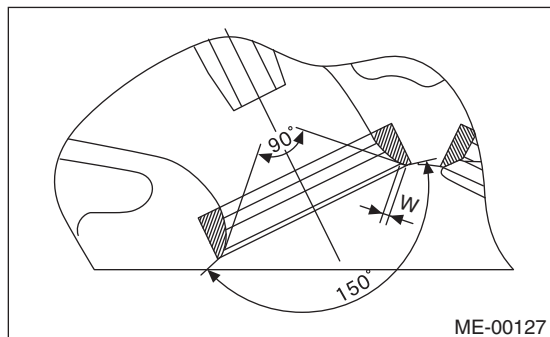

3. VALVE GUIDE

1) Check the clearance between valve guide and valve stem. The clearance can be checked by measuring respectively the outer diameter of valve stem with a micrometer and the inner diameter of valve guide with a caliper gauge.

Clearance between the valve guide and valve stem:

Standard

Intake

0.030 — 0.057 mm (0.0012 — 0.0022 in)

Exhaust

0.040 — 0.067 mm (0.0016 — 0.0026 in)

2) If the clearance between valve guide and valve stem exceeds the standard, replace the valve guide or valve itself whichever shows greater amount of wear or damaged and etc. See the following procedure for valve guide replacement.

Valve guide inner diameter:

6.000 — 6.012 mm (0.2362 — 0.2367 in)

Valve stem outer diameters:

Intake

5.955 — 5.970 mm (0.2344 — 0.2350 in)

Exhaust

5.945 — 5.960 mm (0.2341 — 0.2346 in)

(1) Place the cylinder head on ST1 with the combustion chamber upward so that valve guides fit the holes in ST1.

(2) Insert the ST2 into valve guide and press it down to remove the valve guide.

ST1 498267600 CYLINDER HEAD TABLE
ST2 499767200 VALVE GUIDE REMOVER

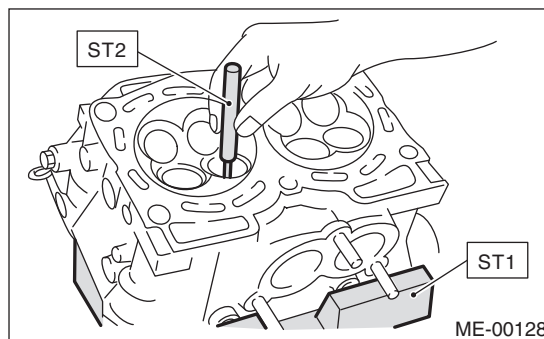

Cylinder Head

MECHANICAL

(3) Turn the cylinder head upside down and place the ST as shown in the figure.

ST 18251AA020 VALVE GUIDE ADJUSTER

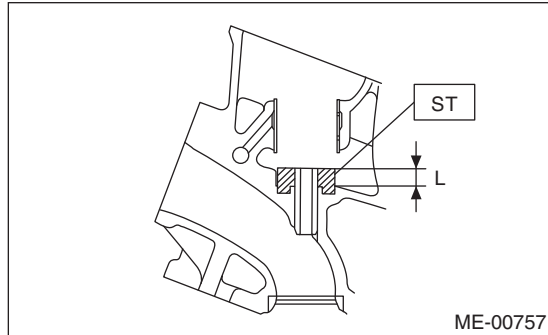

(4) Before installing a new valve guide, make sure that neither scratches nor damages exist on the inner surface of valve guide holes in cylinder head.

(5) Put a new valve guide, coated with sufficient oil, in the cylinder head, and insert the ST1 into valve guide. Press in until the valve guide upper end is flush with the upper surface of ST2.

ST1 499767200 VALVE GUIDE REMOVER

ST2 18251AA020 VALVE GUIDE ADJUSTER

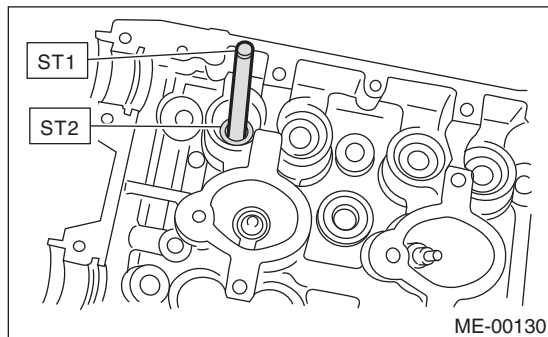

(6) Check the valve guide protrusion.

Valve guide protrusion L:

15.8 — 16.2 mm (0.622 — 0.638 in)

(7) Ream the inside of valve guide using ST. Put the ST in valve guide, and rotate the ST slowly clockwise while pushing it lightly. Bring the ST back while rotating it clockwise.

NOTE:

- Apply engine oil to the ST when reaming.
- If the inner surface of valve guide is damaged, the edge of ST should be slightly ground with oil stone.
- If the inner surface of valve guide becomes lustrous and the ST does not chip, use a new ST or remedy the ST.

ST 499767400

VALVE GUIDE REAMER

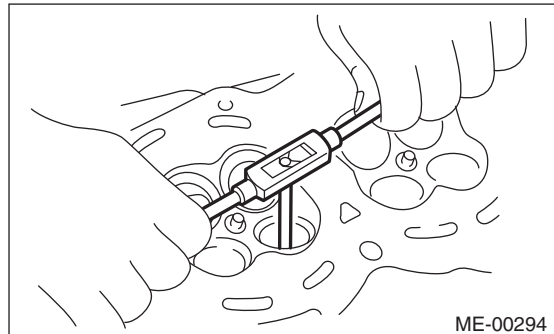

(8) After reaming, clean the valve guide to remove chips.

(9) Recheck the contact condition between valve and valve seat after replacing the valve guide.

4. INTAKE AND EXHAUST VALVE

1) Inspect the flange and stem of valve, and replace the valve with a new part if damaged, worn, deformed, or if dimension "H" in the figure is outside of the specified limit.

Head edge thickness H:

Standard

Intake (A)

1.0 — 1.4 mm (0.039 — 0.055 in)

Exhaust (B)

1.3 — 1.7 mm (0.051 — 0.067 in)

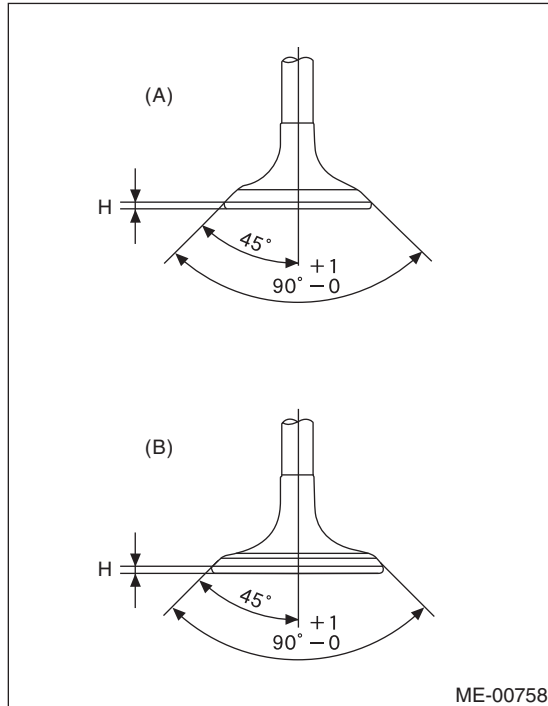

2) Put a small amount of grinding compound on the seat surface, and lap the valve and seat surface. Replace with a new valve oil seal after lapping.

NOTE:

It is possible to differentiate between the intake valve and the exhaust valve by their overall length.

Valve overall length:

Intake

104.4 mm (4.110 in)

Exhaust

104.65 mm (4.1201 in)

5. VALVE SPRING

1) Check the valve springs for damage, free length, and tension. Replace the valve spring if it is not within the standard value presented in the table.

2) To measure the squareness of the valve spring, stand the valve spring on a surface plate and measure its deflection at the top of spring using a right angle gauge.

Free length	mm (in)	47.32 (1.863)
Tension/spring height N (kgf, lbf)/mm (in)	Set	205 — 235 (20.9 — 24.0, 46.1 — 52.8)/36.0 (1.417)
	Lift	426 — 490 (43.4 — 50.0, 95.8 — 110)/26.50 (1.041)
Squareness		2.5°, 2.1 mm (0.083 in) or less

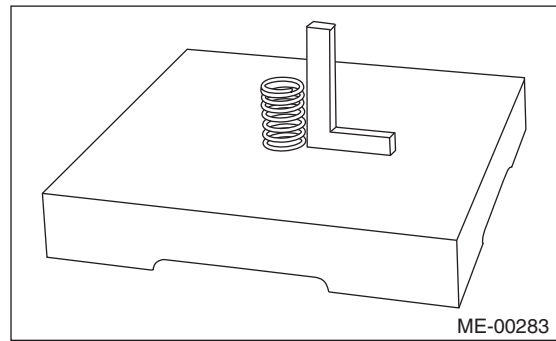

Cylinder Head

MECHANICAL

6. INTAKE AND EXHAUST VALVE OIL SEAL

1) For the following, replace the oil seal with a new part. See the procedure 2) and subsequent for replacement procedures.

- When the lip is damaged.
- When the spring is out of the specified position.
- When readjusting the surfaces of valve and valve seat.
- When replacing the valve guide.

2) Place the cylinder head on ST1, and use ST2 to press-fit the oil seal.

ST1 498267600 CYLINDER HEAD TABLE
ST2 498857100 VALVE OIL SEAL GUIDE

NOTE:

- Apply engine oil to oil seal before press-fitting.
- When press-fitting the oil seal, do not use a hammer, etc. or strike in.
- The intake valve oil seals and exhaust valve oil seals are distinguished by their colors.

Color of rubber part:

Intake [Gray]

Exhaust [Green]

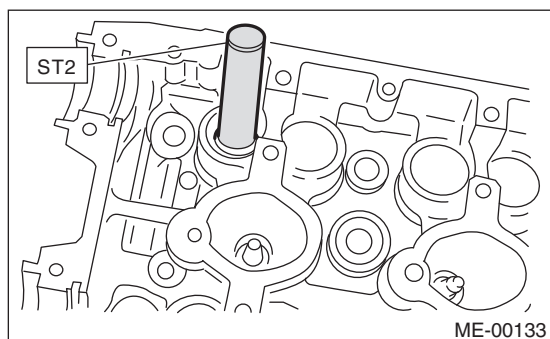

7. VALVE LIFTER

- 1) Check the valve lifter visually.
- 2) Measure the outer diameter of valve lifter.

Outer diameter:

34.959 — 34.975 mm (1.3763 — 1.3770 in)

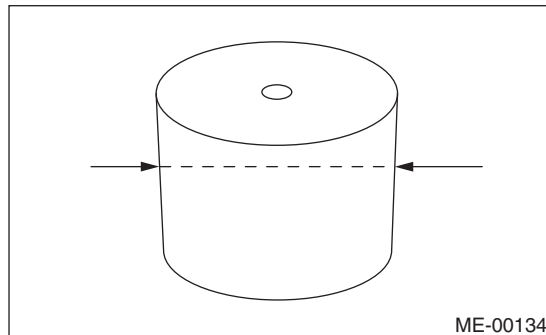

- 3) Measure the inner diameter of valve lifter mating surface on cylinder head.

Inner diameter:

34.994 — 35.016 mm (1.3777 — 1.3786 in)

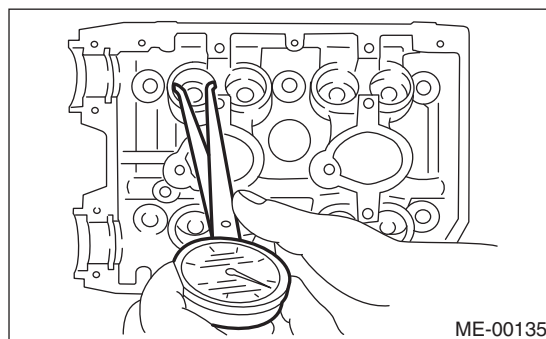

NOTE:

If difference between outer diameter of valve lifter and inner diameter of its mating surface is not within the standard or there is uneven wear, replace the cylinder head.

Standard:

0.019 — 0.057 mm (0.0007 — 0.0022 in)

20. Cylinder Block

A: REMOVAL

NOTE:

Before conducting this procedure, drain the engine oil completely.

1) Remove the V-belts. <Ref. to ME(H4DOTC)-39, REMOVAL, V-belt.>

2) Remove the intake manifold.

<Ref. to FU(H4DOTC)-14, REMOVAL, Intake Manifold.>

3) Remove the crank pulley. <Ref. to ME(H4DOTC)-47, REMOVAL, Crank Pulley.>

4) Remove the timing belt cover.

<Ref. to ME(H4DOTC)-49, REMOVAL, Timing Belt Cover.>

5) Remove the timing belt.

<Ref. to ME(H4DOTC)-50, REMOVAL, Timing Belt.>

6) Remove the cam sprocket.

<Ref. to ME(H4DOTC)-57, REMOVAL, Cam Sprocket.>

7) Remove the crank sprocket. <Ref. to ME(H4DOTC)-59, REMOVAL, Crank Sprocket.>

8) Remove the generator and A/C compressor with their brackets.

9) Remove the camshaft.

<Ref. to ME(H4DOTC)-60, REMOVAL, Camshaft.>

10) Remove the cylinder head. <Ref. to ME(H4DOTC)-66, REMOVAL, Cylinder Head.>

11) Remove the drive plate. <Ref. to 4AT-67, REMOVAL, Drive Plate.>

12) Remove the oil separator cover.

13) Remove the water by-pass pipe for heater.

14) Remove the oil filter. <Ref. to LU(H4DOTC)-25, REMOVAL, Engine Oil Filter.>

15) Remove the water pump. <Ref. to CO(H4DOTC)-15, REMOVAL, Water Pump.>

16) Remove the bolts which install oil pump onto cylinder block.

NOTE:

When disassembling and checking the oil pump, loosen the relief valve plug before removing the oil pump.

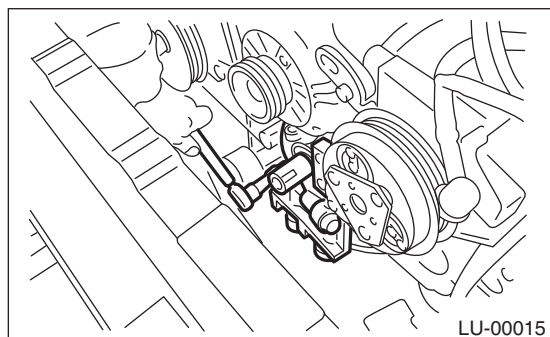

17) Remove the oil pump from cylinder block using a flat tip screwdriver.

CAUTION:

Be careful not to scratch the mating surface of cylinder block and oil pump.

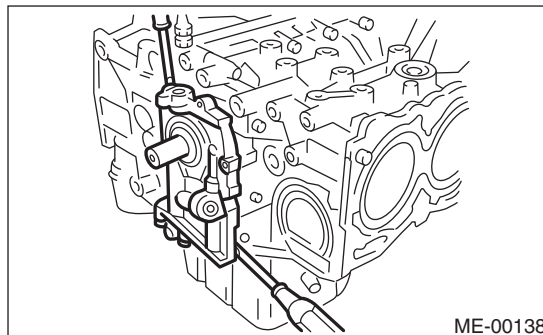

18) Remove the front oil seal from the oil pump.

19) Remove the oil pan.

(1) Set the part so that the cylinder block LH is on the upper side.

(2) Remove the bolts which secure oil pan to cylinder block.

(3) Insert an oil pan cutter blade between cylinder block-to-oil pan clearance and remove the oil pan.

CAUTION:

Do not use a screwdriver or similar tools in place of oil pan cutter.

20) Remove the oil strainer.

21) Remove the baffle plate.

22) Remove the water tank pipe assembly.

Cylinder Block

MECHANICAL

23) Remove the water pipe assembly.

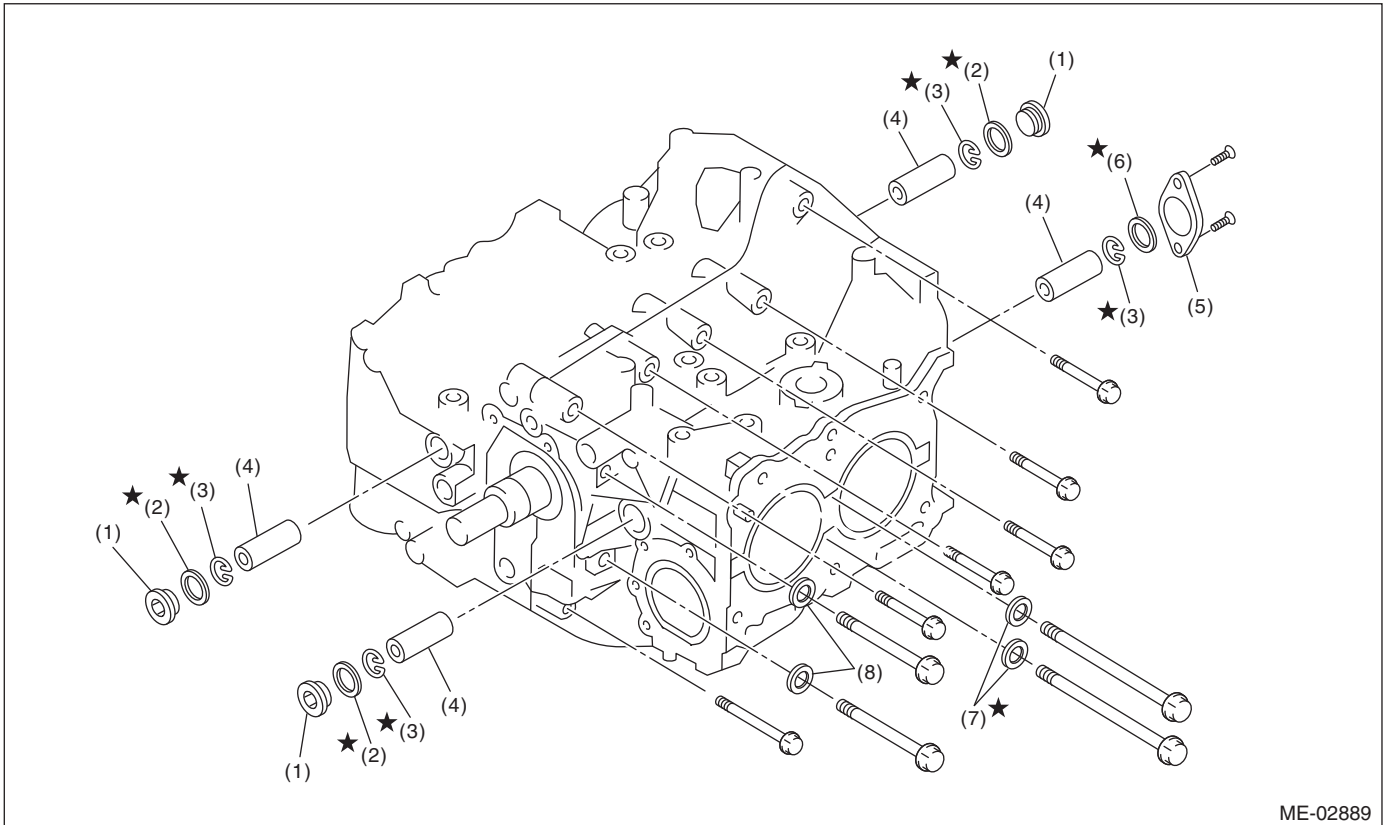
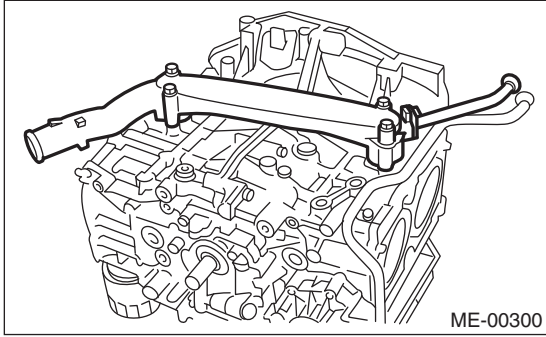

- (1) Service hole plug
- (2) Gasket
- (3) Snap ring

- (4) Piston pin
- (5) Service hole cover
- (6) O-ring

- (7) Seal washer
- (8) Washer

24) Remove the service hole plugs using a hexagon wrench [14 mm].

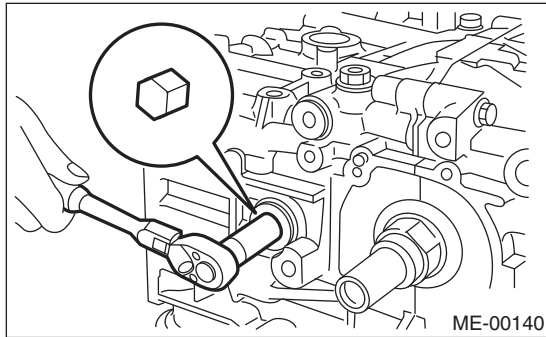

25) Remove the service hole cover.

26) Rotate the crankshaft to bring #1 and #2 pistons to bottom dead center position, then remove the piston snap ring through service hole of #1 and #2 cylinders.

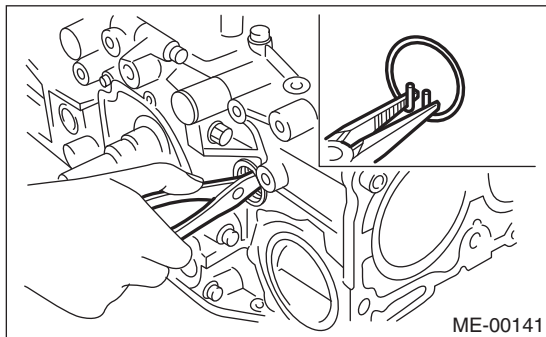

27) Draw out the piston pin from #1 and #2 pistons using ST.

ST 499097700 PISTON PIN REMOVER

NOTE:

Be careful not to confuse the original combination of piston, piston pin and cylinder.

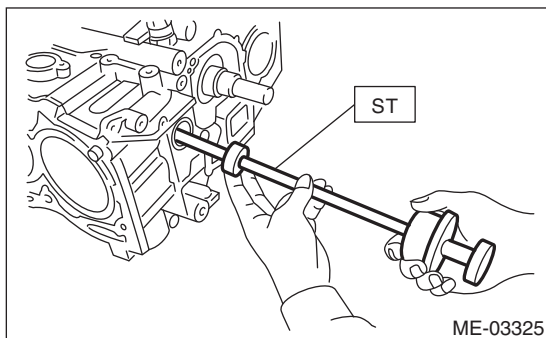

28) Similarly remove the piston pins from #3 and #4 pistons.

29) Remove the cylinder block connecting bolt on the RH side.

30) Loosen the cylinder block connecting bolt on the LH side by 2-3 turns.

31) Set the part so that the cylinder block LH is on the upper side, and remove the cylinder block connecting bolt.

Cylinder Block

MECHANICAL

32) Separate cylinder block LH and RH.

NOTE:

When separating the cylinder block, do not allow the connecting rod to fall and damage the cylinder block.

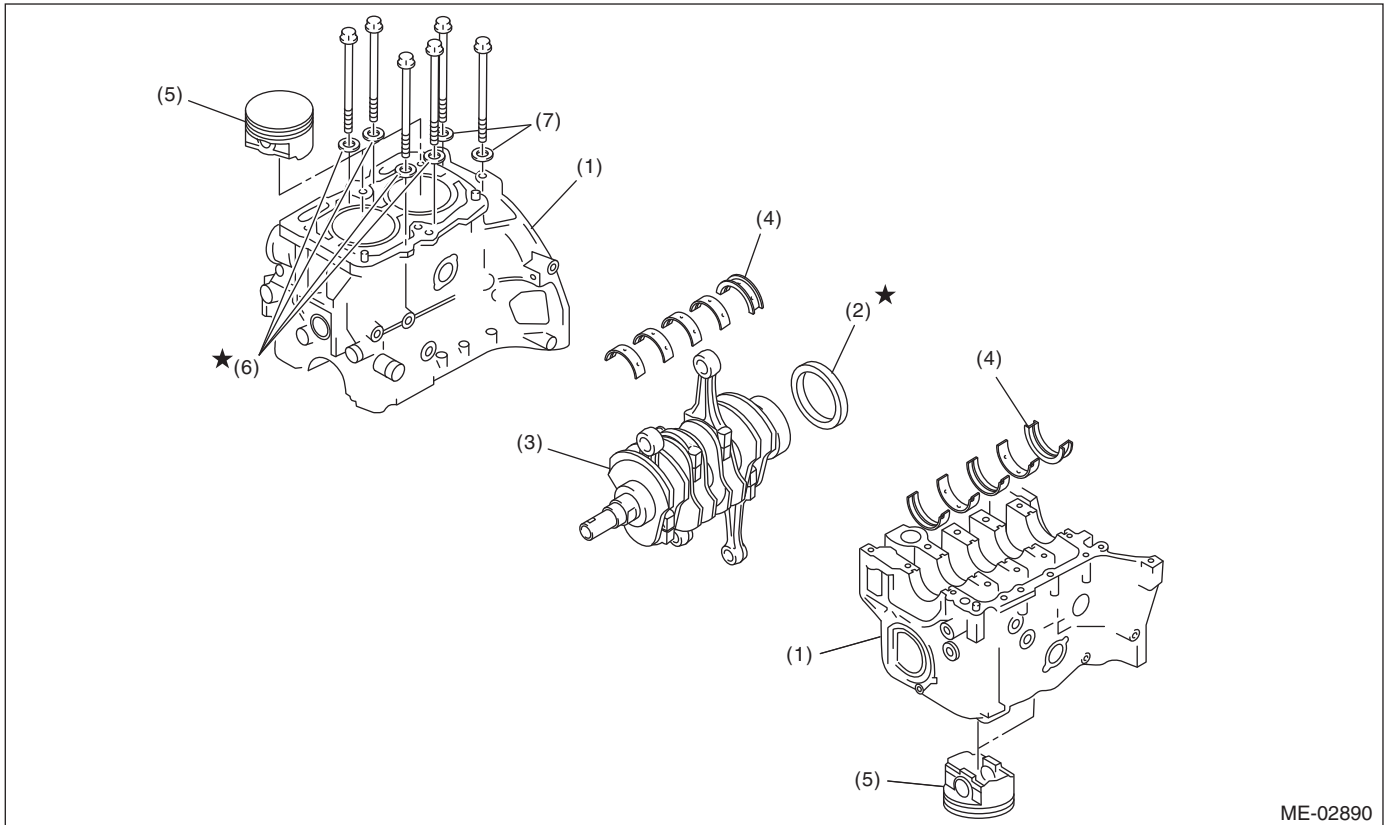

ME-02890

- | | | |
|--------------------|------------------------|-----------------|
| (1) Cylinder block | (4) Crankshaft bearing | (6) Seal washer |
| (2) Rear oil seal | (5) Piston | (7) Washer |
| (3) Crankshaft | | |

33) Remove the rear oil seal.

34) Remove the crankshaft together with connecting rod.

35) Remove the crankshaft bearings from cylinder block using a hammer handle.

NOTE:

- Push the opposite side of the crank shaft bearing locking lip to remove.
- Be careful not to confuse the crankshaft bearing combination.

36) Draw out each piston from cylinder block using wooden bar or hammer handle.

NOTE:

Be careful not to confuse the original combination of piston and cylinder.

B: INSTALLATION

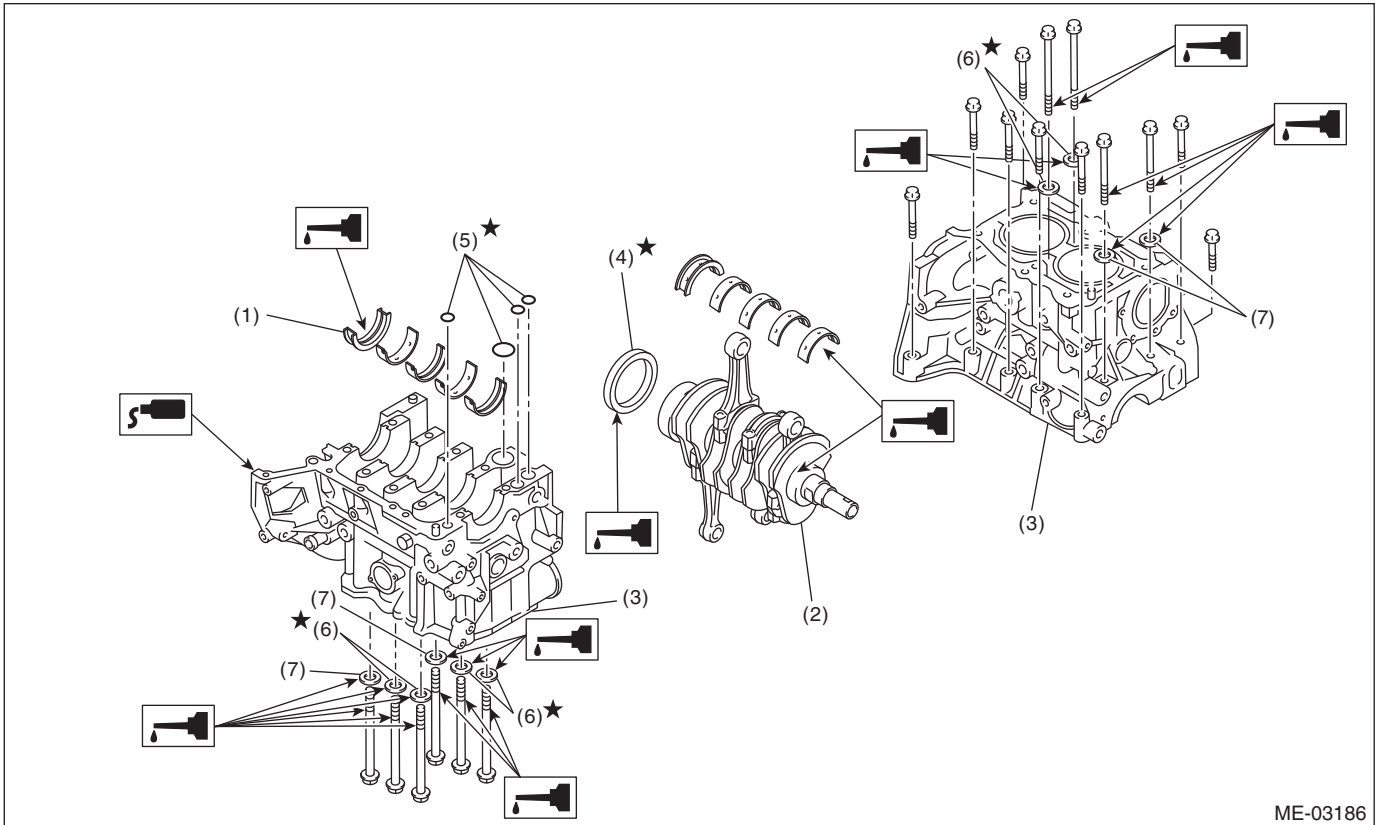

- | | | |
|------------------------|-------------------|-----------------|
| (1) Crankshaft bearing | (4) Rear oil seal | (6) Seal washer |
| (2) Crankshaft | (5) O-ring | (7) Washer |
| (3) Cylinder block | | |

1) Remove oil on the mating surface of cylinder block before installation. Apply a coat of engine oil to the bearing and crankshaft journal.

2) Position the crankshaft and O-ring on cylinder block RH.

NOTE:
Use new O-rings.

3) Apply liquid gasket to the mating surfaces of cylinder block RH, and position cylinder block LH.

NOTE:

- Install within 5 min. after applying liquid gasket.
- Do not allow liquid gasket to jut into O-ring grooves, oil passages, bearing grooves, etc.

Liquid gasket:
THREE BOND 1217G (Part No. K0877Y0100)
or equivalent

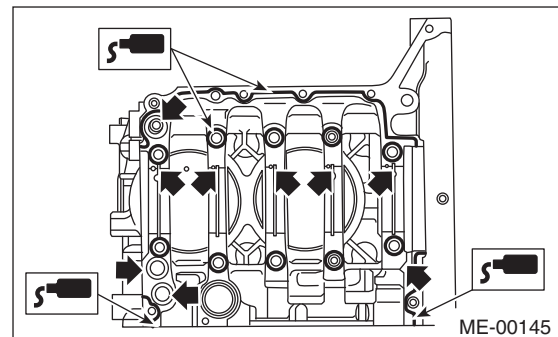

Cylinder Block

MECHANICAL

4) Apply a coat of engine oil to the washer and bolt thread.

NOTE:

Use a new seal washer.

5) Tighten the 10 mm cylinder block connecting bolts on LH side (A — D) in alphabetical sequence.

Tightening torque:

10 N·m (1.0 kgf·m, 7.2 ft·lb)

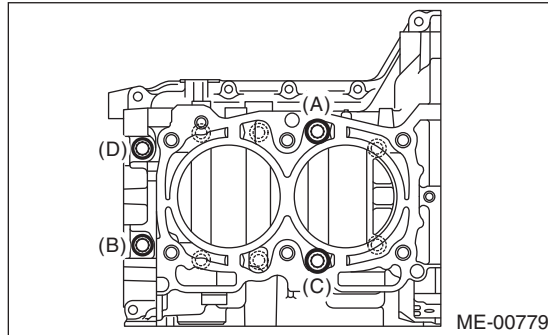

6) Tighten the 10 mm cylinder block connecting bolts on RH side (E — J) in alphabetical sequence.

Tightening torque:

10 N·m (1.0 kgf·m, 7.2 ft·lb)

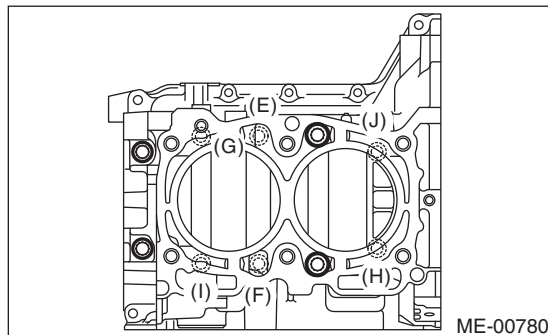

7) Tighten the LH side cylinder block connecting bolts (A — D) further in alphabetical order.

Tightening torque:

18 N·m (1.8 kgf·m, 13.3 ft·lb)

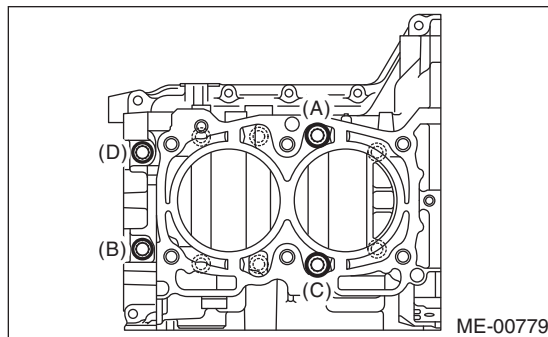

8) Tighten the RH side cylinder block connecting bolts (E — J) further in alphabetical order.

Tightening torque:

18 N·m (1.8 kgf·m, 13.3 ft·lb)

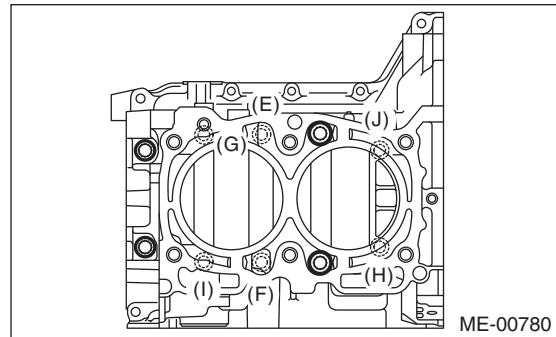

9) Tighten the LH side cylinder block connecting bolts (A — D) further in alphabetical order.

- (A), (C): Angle tightening

Tightening angle:

90°

- (B), (D): Torque tightening

Tightening torque:

40 N·m (4.1 kgf·m, 29.5 ft·lb)

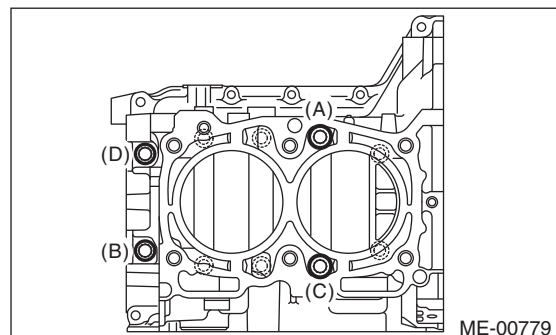

10) Tighten the RH side cylinder block connecting bolts (E — J) further in alphabetical order.

Tightening angle:

90°

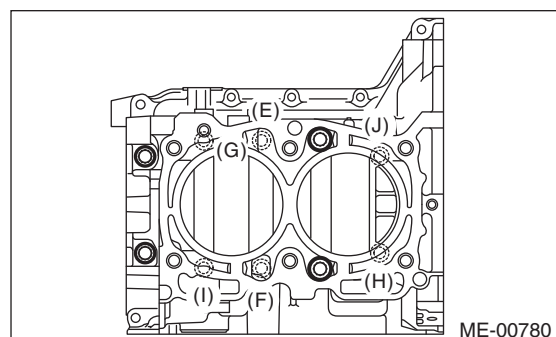

Cylinder Block

MECHANICAL

11) Tighten the 8 mm and 6 mm cylinder block connecting bolts on the LH side (A — H) in alphabetical order.

Tightening torque:

(A) — (G): 25 N·m (2.5 kgf·m, 18.4 ft·lb)

(H): 6.4 N·m (0.7 kgf·m, 4.7 ft·lb)

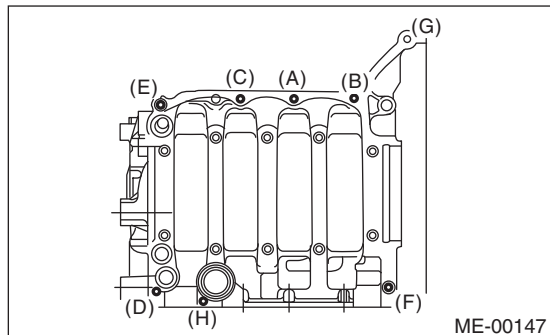

12) Apply a coat of engine oil to the oil seal periphery, then install the rear oil seal using ST1 and ST2.

NOTE:

Use a new rear oil seal.

- | | | |
|-----|-----------|-------------------------------|
| ST1 | 499597100 | CRANKSHAFT OIL SEAL GUIDE |
| ST2 | 499587200 | CRANKSHAFT OIL SEAL INSTALLER |

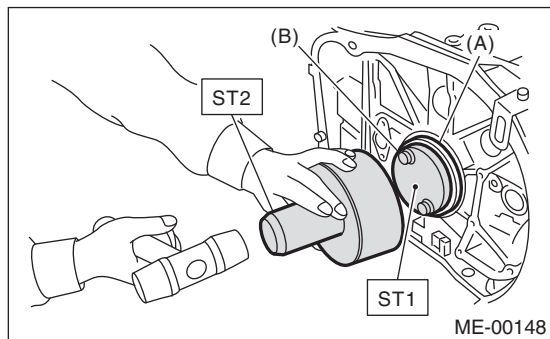

- (A) Rear oil seal
- (B) Flywheel attaching bolt

13) Position the top ring gap at (A) or (B) in the figure.

14) Position the second ring gap at 180° on the reverse side the top ring gap.

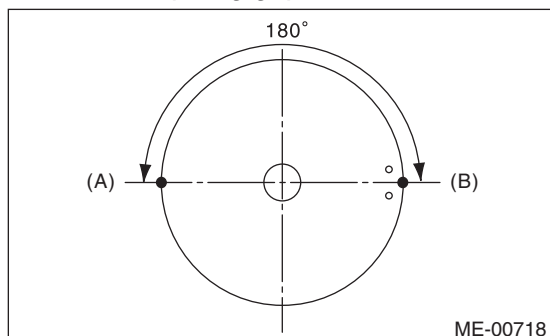

15) Position the upper rail gap at (C) in the figure.

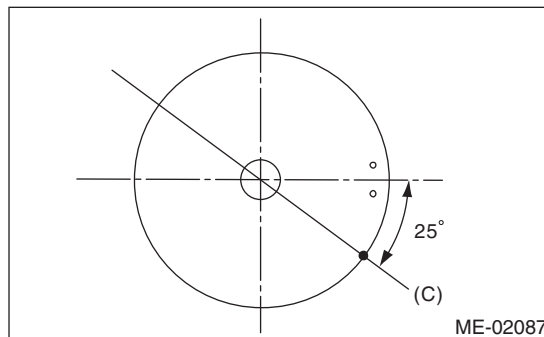

16) Align the upper rail spin stopper (E) to the side hole (D) on the piston.

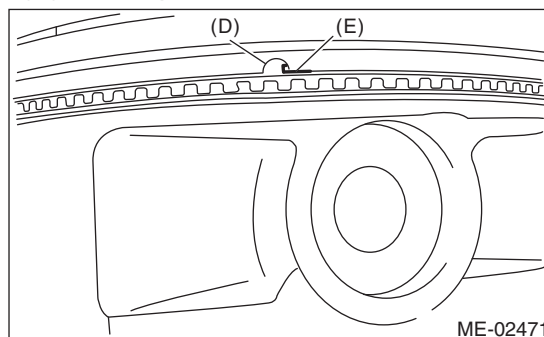

17) Position the expander gap at (F) in the figure on the 180° opposite direction of (C).

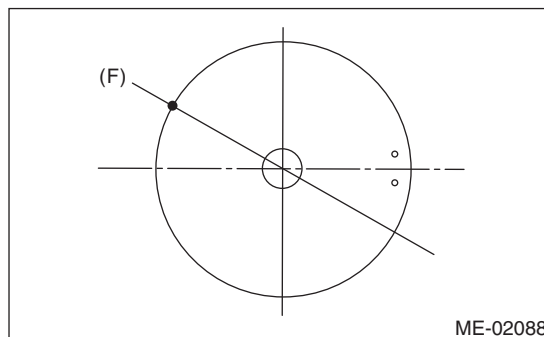

18) Set the lower rail gap at position (G), located 120° clockwise from (C).

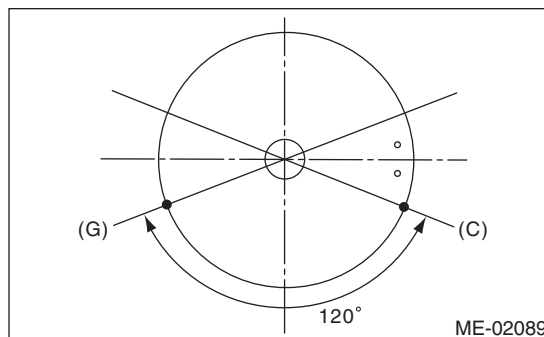

NOTE:

- Make sure ring gaps do not face the same direction.
- Make sure ring gaps are not within the piston skirt area.

Cylinder Block

MECHANICAL

19) Install the snap ring.

Before positioning the piston on the cylinder block, attach the snap ring in the service hole of the cylinder ring in the cylinder block, and the piston hole on the opposite side.

NOTE:

Use new snap rings.

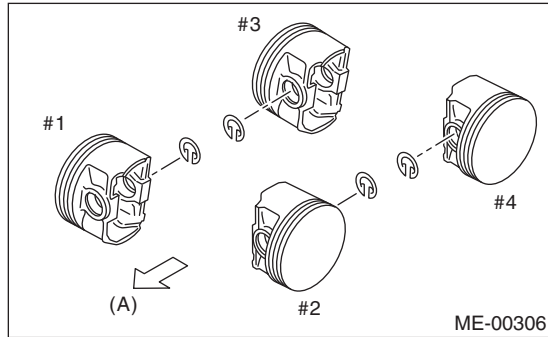

(A) Front side

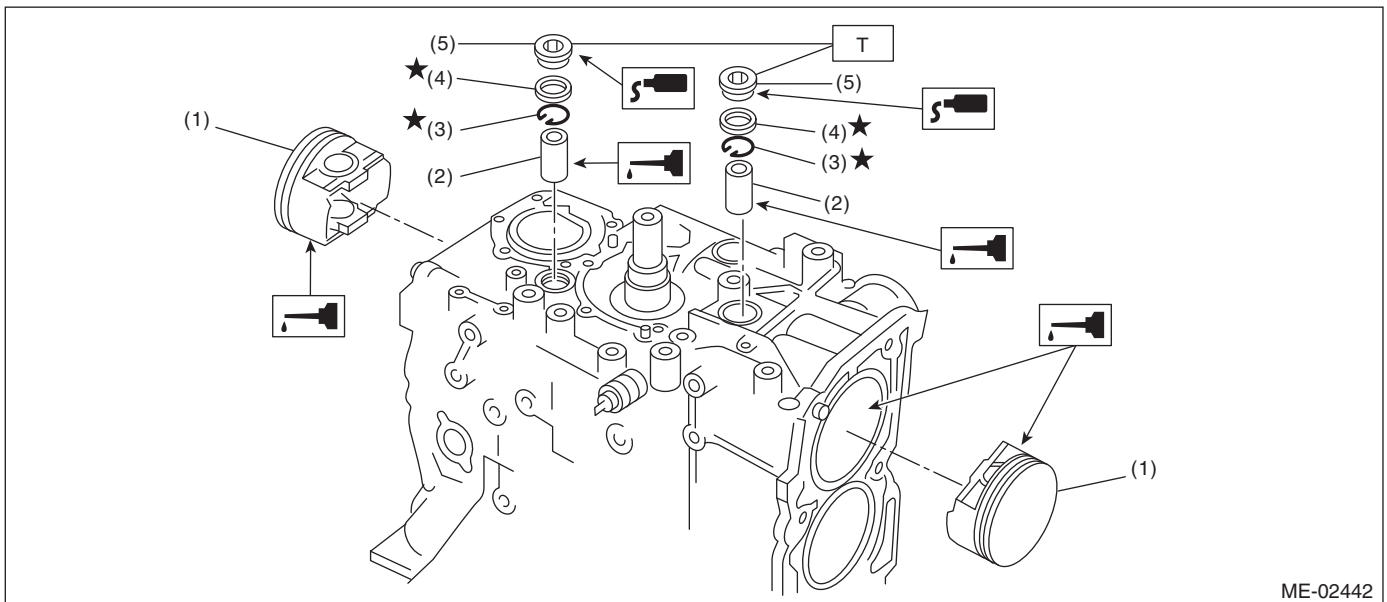

ME-02442

- | | |
|----------------|-----------------------|
| (1) Piston | (4) Gasket |
| (2) Piston pin | (5) Service hole plug |
| (3) Snap ring | |

Tightening torque: N·m (kgf·m, ft·lb)

T: 70 (7.1, 51.6)

20) Install piston.

(1) Set the parts so that the #1 and #2 cylinders are on the upper side.

(2) Using the ST1, turn the crankshaft so that #1 and #2 connecting rods are set at bottom dead center.

ST1 499987500 CRANKSHAFT SOCKET

(3) Apply a coat of engine oil to the pistons and cylinders and insert pistons in their cylinders using ST2.

ST2 498747300 PISTON GUIDE

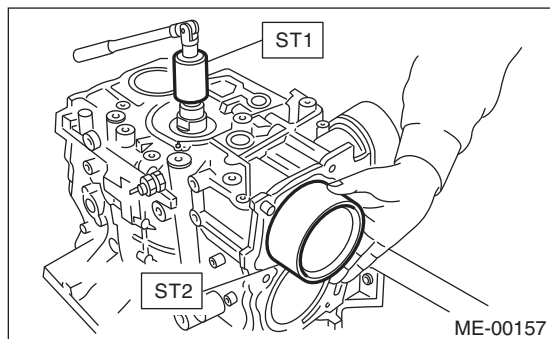

NOTE:

Face the piston front mark towards the front of the engine.

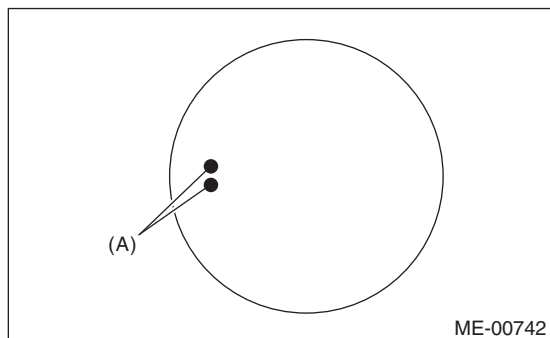

(A) Front mark

21) Install piston pin.

(1) Apply a coat of engine oil to ST3.

(2) Insert ST3 into the service hole to align the piston pin hole and the connecting rod small end.

ST3 499017100 PISTON PIN GUIDE

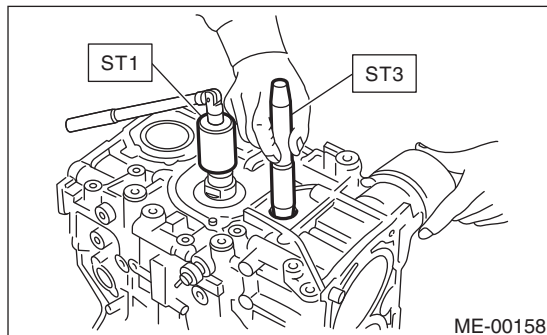

(3) Apply a coat of engine oil to piston pin, and insert the piston pin into piston and connecting rod through service hole.

(4) Install the snap ring.

NOTE:

Use new snap rings.

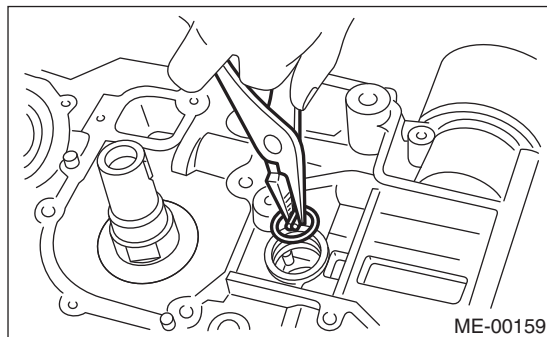

(5) Apply liquid gasket to the threaded portion of the service hole plug.

Liquid gasket:

THREE BOND 1105 (Part No. 004403010) or equivalent

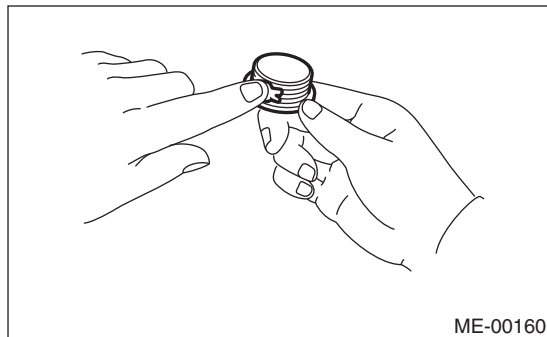

Cylinder Block

MECHANICAL

(6) Install the water pump and gasket.

NOTE:

Use a new gasket.

Tightening torque:

70 N·m (7.1 kgf·m, 51.6 ft·lb)

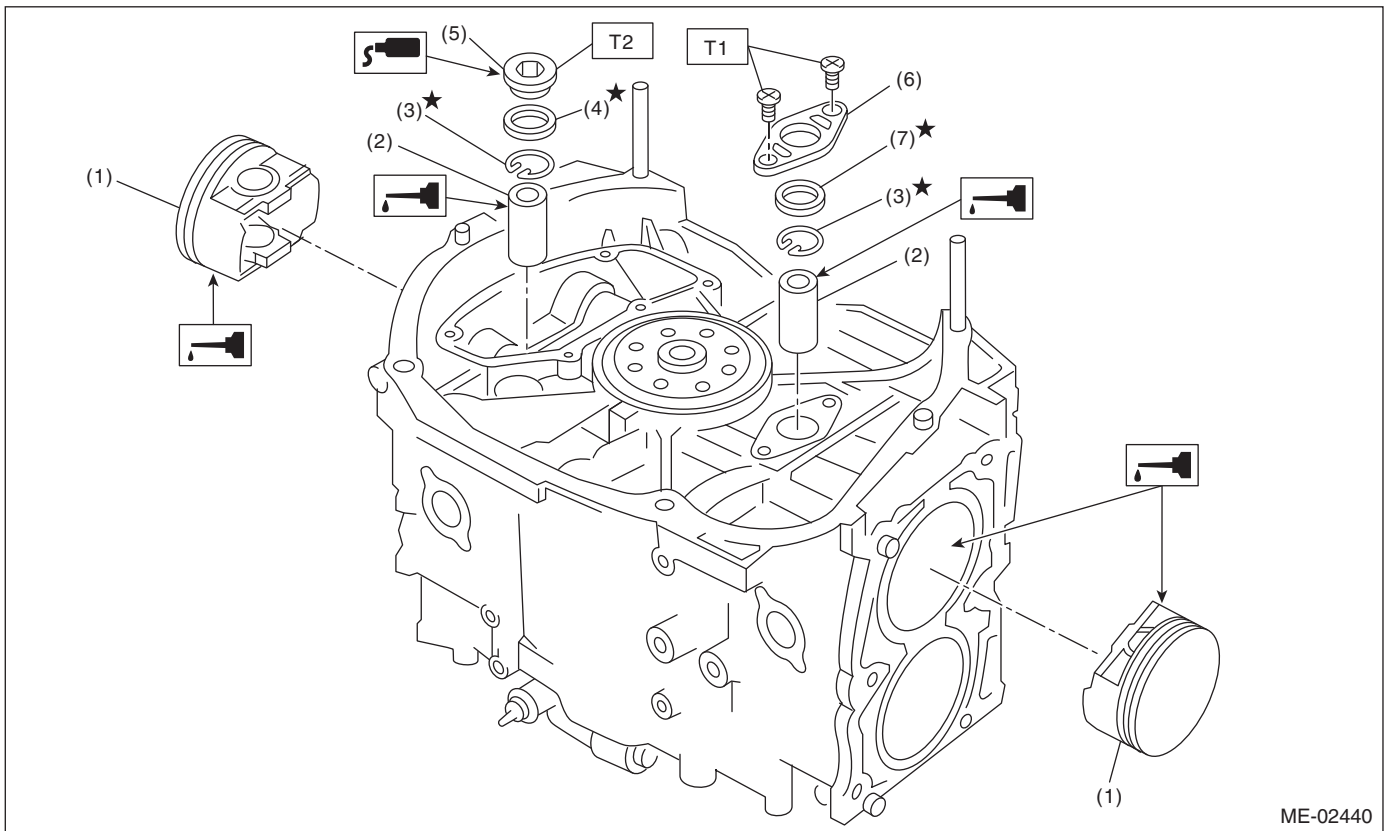
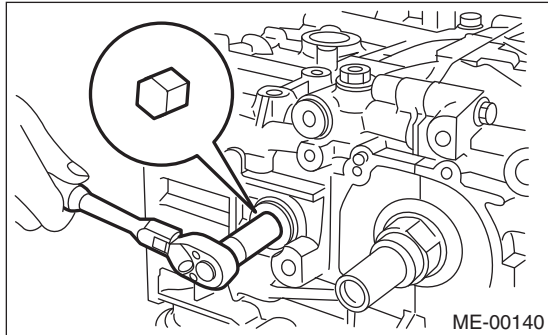

- | | |
|----------------|------------------------|
| (1) Piston | (5) Service hole plug |
| (2) Piston pin | (6) Service hole cover |
| (3) Snap ring | (7) O-ring |
| (4) Gasket | |

Tightening torque: N·m (kgf·m, ft·lb)

T1: 6.4 (0.7, 4.7)

T2: 70 (7.1, 51.6)

- (7) Set the parts so that the #3 and #4 cylinders are on the upper side. Following the same procedures as used for #1 and #2 cylinders, install the pistons and piston pins.
 (8) Install the service hole cover.

NOTE:
 Use new O-rings.

Tightening torque:
6.4 N·m (0.7 kgf-m, 4.7 ft-lb)
 22) Install the water pipe assembly.

NOTE:
 Use new O-rings.

Tightening torque:
6.4 N·m (0.7 kgf-m, 4.7 ft-lb)

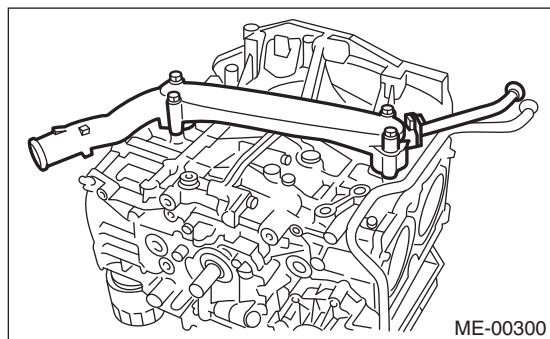

- 23) Install the water tank pipe assembly.

Tightening torque:
6.4 N·m (0.7 kgf-m, 4.7 ft-lb)

- 24) Install the baffle plate.

Tightening torque:
6.4 N·m (0.7 kgf-m, 4.7 ft-lb)

- 25) Install the oil strainer.

NOTE:
 Use new O-rings.

Tightening torque:
10 N·m (1.0 kgf-m, 7.2 ft-lb)

- 26) Tighten the oil strainer stay together with the baffle plate.

Tightening torque:
6.4 N·m (0.7 kgf-m, 4.7 ft-lb)

- 27) Apply liquid gasket to the mating surfaces of oil pan, and install the oil pan.

NOTE:
 Install within 5 min. after applying liquid gasket.

Liquid gasket:
THREE BOND 1217G (Part No. K0877Y0100)
or equivalent

Tightening torque:
5 N·m (0.5 kgf-m, 3.7 ft-lb)

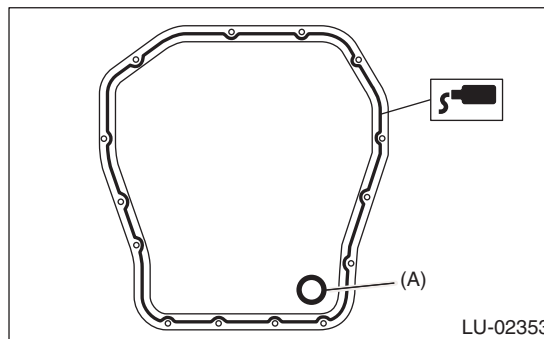

(A) Gasket

- 28) Apply liquid gasket to the mating surface of oil separator cover and the threaded portion of bolt (A) shown in the figure (when reusing the bolt), and then install the oil separator cover.

NOTE:
 • Install within 5 min. after applying liquid gasket.
 • Use new oil separator cover.

Liquid gasket:
Mating surface
THREE BOND 1217G (Part No. K0877Y0100) or equivalent
Bolt thread (A) (when reusing the bolt)
THREE BOND 1324 (Part No. 004403042) or equivalent

Tightening torque:
6.4 N·m (0.7 kgf-m, 4.7 ft-lb)

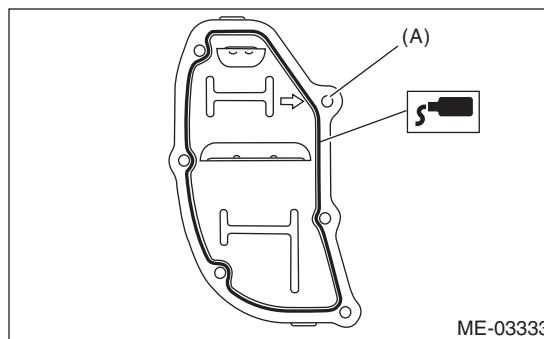

- 29) Install the drive plate. <Ref. to 4AT-67, INSTALLATION, Drive Plate.>

Cylinder Block

MECHANICAL

30) Install the oil pump.

(1) Using the ST, install the front oil seal.

ST 499587100 OIL SEAL INSTALLER

NOTE:

Use a new front oil seal.

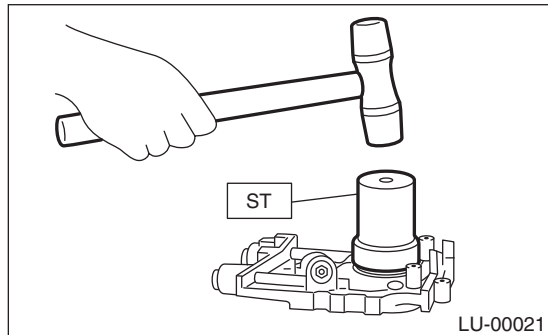

(2) Apply liquid gasket to the matching surface of oil pump.

NOTE:

Install within 5 min. after applying liquid gasket.

Liquid gasket:

THREE BOND 1217G (Part No. K0877Y0100) or equivalent

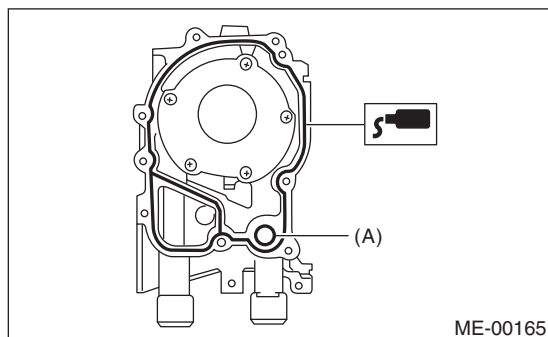

(A) O-ring

(3) Apply a coat of engine oil to the inside of oil seal.

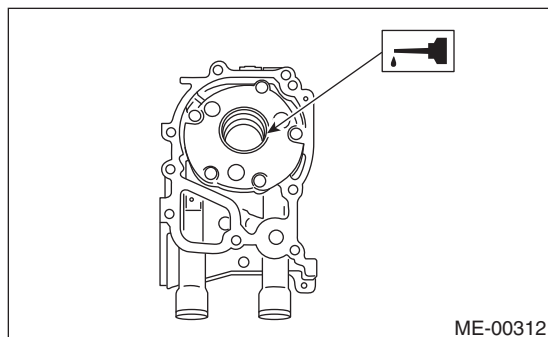

(4) Install the oil pump to cylinder block. Be careful not to damage the oil seal during installation.

NOTE:

- Make sure the oil seal lip is not folded.
- Align the flat surface of oil pump's inner rotor with crankshaft before installation.
- Use new O-rings and oil seals.
- Do not forget to install the O-ring.

(5) Apply liquid gasket to the three bolts thread shown in figure. (when reusing bolts)

Liquid gasket:

THREE BOND 1324 (Part No. 004403042) or equivalent

Tightening torque:

6.4 N·m (0.7 kgf·m, 4.7 ft·lb)

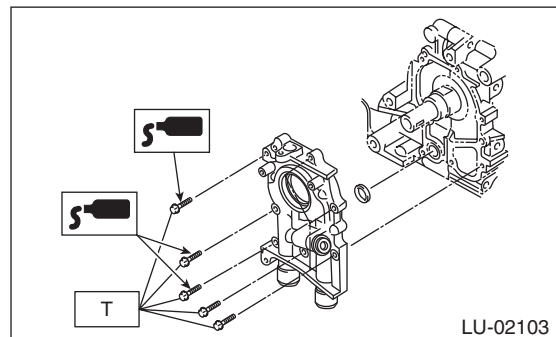

31) Install the water pump and gasket.

NOTE:

- When installing the water pump, tighten bolts in two stages in alphabetical sequence as shown in the figure.
- Use a new gasket.

Tightening torque:

First: 12 N·m (1.2 kgf·m, 8.9 ft·lb)

Second: 12 N·m (1.2 kgf·m, 8.9 ft·lb)

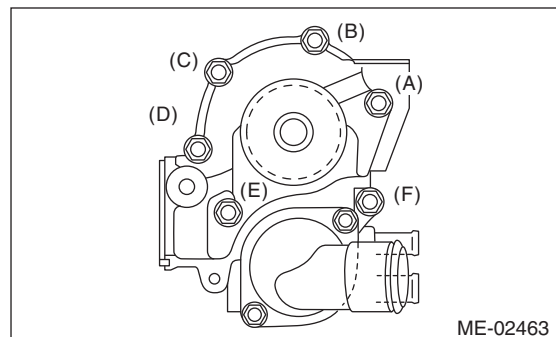

32) Install the water by-pass pipe for heater.

Tightening torque:

6.4 N·m (0.7 kgf·m, 4.7 ft·lb)

33) Install the oil filter. <Ref. to LU(H4DOTC)-25, INSTALLATION, Engine Oil Filter.>

34) Install the cylinder head. <Ref. to ME(H4DOTC)-67, INSTALLATION, Cylinder Head.>

35) Install the camshaft. <Ref. to ME(H4DOTC)-61, INSTALLATION, Camshaft.>

36) Install the generator and A/C compressor with their brackets.

Tightening torque:

36 N·m (3.7 kgf·m, 26.6 ft·lb)

37) Install the crank sprocket. <Ref. to ME(H4DOTC)-59, INSTALLATION, Crank Sprocket.>

38) Install the cam sprocket.

<Ref. to ME(H4DOTC)-57, INSTALLATION, Cam Sprocket.>

39) Install the timing belt.

<Ref. to ME(H4DOTC)-51, INSTALLATION, Timing Belt.>

40) Adjust the valve clearance. <Ref. to ME(H4DOTC)-28, ADJUSTMENT, Valve Clearance.>

41) Install the rocker cover.

(1) Install the rocker cover gasket to the rocker cover. (Outer periphery and ignition coil section)

NOTE:

Use a new rocker cover gasket.

(2) Apply liquid gasket to the specified point of the cylinder head.

NOTE:

Install within 5 min. after applying liquid gasket.

Liquid gasket:

THREE BOND 1217G (Part No. K0877Y0100) or equivalent

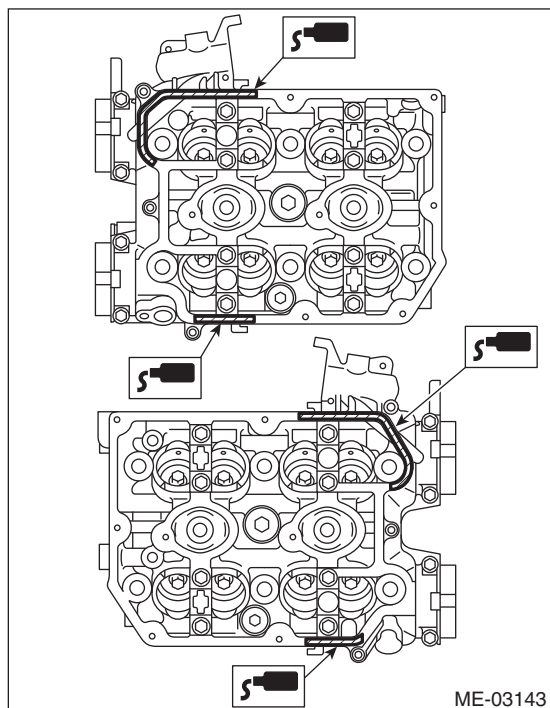

(3) Install the rocker cover on cylinder head. Ensure the gasket is properly positioned during installation.

(4) Temporarily tighten the rocker cover tightening bolt in alphabetical sequence shown in the figure, and then tighten to specified torque in alphabetical order.

Tightening torque:

6.4 N·m (0.7 kgf·m, 4.7 ft·lb)

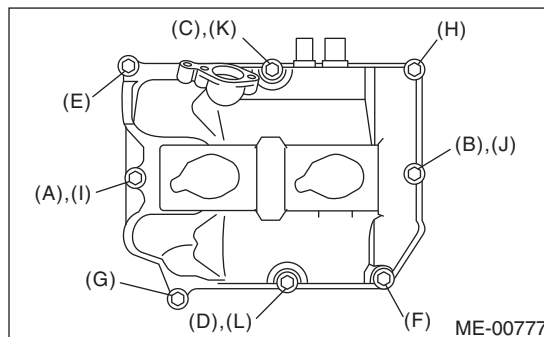

42) Install the timing belt cover.

<Ref. to ME(H4DOTC)-49, INSTALLATION, Timing Belt Cover.>

43) Install the crank pulley.

<Ref. to ME(H4DOTC)-47, INSTALLATION, Crank Pulley.>

44) Install the intake manifold.

<Ref. to FU(H4DOTC)-18, INSTALLATION, Intake Manifold.>

45) Install the V-belts. <Ref. to ME(H4DOTC)-39, INSTALLATION, V-belt.>

Cylinder Block

MECHANICAL

C: DISASSEMBLY

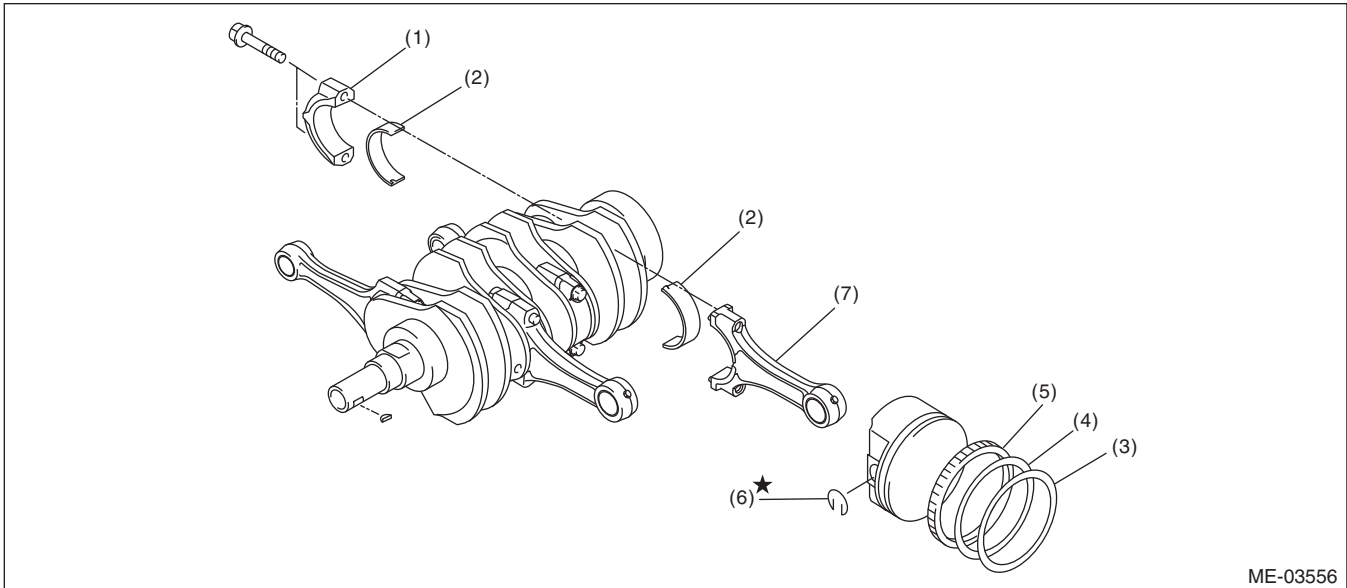

- | | | |
|----------------------------|-----------------|--------------------|
| (1) Connecting rod cap | (4) Second ring | (6) Snap ring |
| (2) Connecting rod bearing | (5) Oil ring | (7) Connecting rod |
| (3) Top ring | | |

- 1) Remove the connecting rod cap.
- 2) Remove the connecting rod bearing.

NOTE:

Keep the removed connecting rods, connecting rod caps and bearings in order so that they are kept in their original combinations/groups, and not mixed together.

- 3) Remove the piston rings using piston ring expander.
- 4) Remove the oil ring by hand.

NOTE:

Arrange the removed piston rings in proper order, to prevent confusion.

- 5) Remove the snap ring.

D: ASSEMBLY

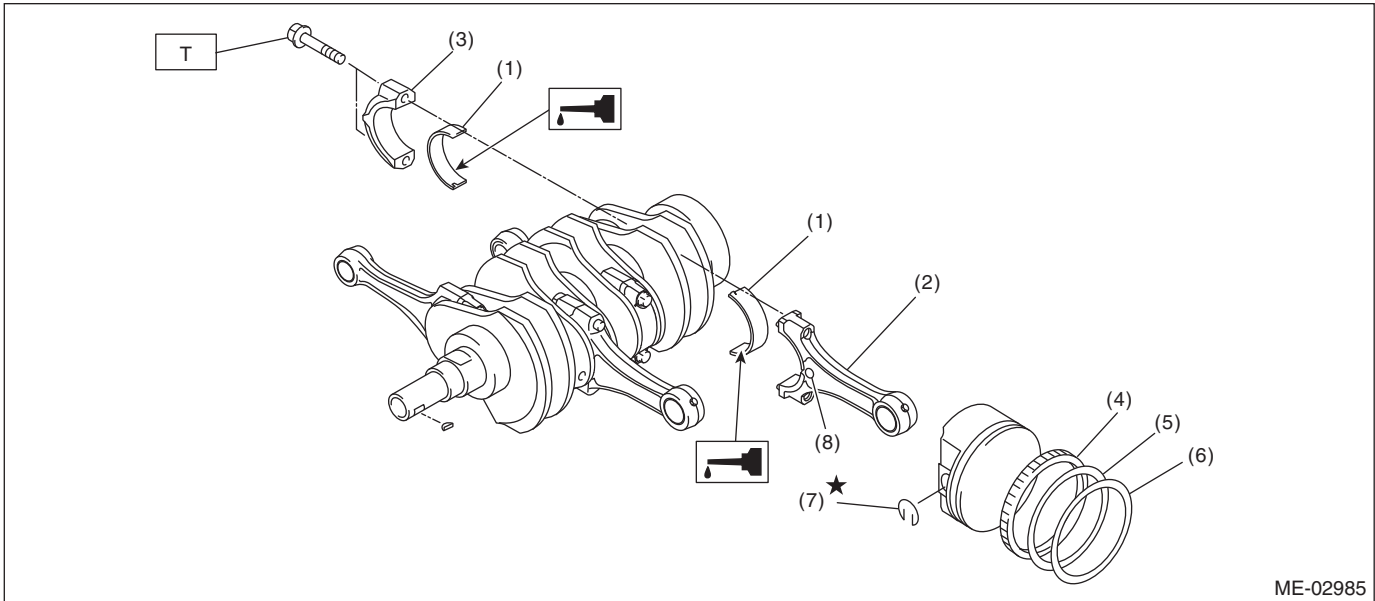

ME-02985

- | | |
|----------------------------|-----------------|
| (1) Connecting rod bearing | (5) Second ring |
| (2) Connecting rod | (6) Top ring |
| (3) Connecting rod cap | (7) Snap ring |
| (4) Oil ring | (8) Side mark |

Tightening torque: N·m (kgf·m, ft·lb)

T: 52 (5.3, 38.4)

1) Apply engine oil to the surface of the connecting rod bearings, and attach the connecting rod bearings to the connecting rods and connecting rod caps.

2) Position each connecting rod with their side marks facing forward, and install.

3) Attach the connecting rod cap, and tighten with the connecting rod bolt. Make sure the arrow mark on connecting rod cap facing front during installation.

NOTE:

- Each connecting rod has its own mating cap. Make sure that they are assembled correctly by checking their matching number.
- When tightening the connecting rod bolts, apply oil on the threads.

Tightening torque:

52 N·m (5.3 kgf·m, 38.4 ft·lb)

4) Install the oil ring upper rail, expander and lower rail by hand.

5) Install the second ring and top ring using piston ring expander.

NOTE:

Assemble so that the piston ring mark "R" faces the top side of the piston.

Cylinder Block

MECHANICAL

E: INSPECTION

1. CYLINDER BLOCK

- 1) Check for cracks or damage. Use liquid penetrant tester on the important sections to check for fissures. Check that there are no marks of gas leaking or water leaking on gasket installing surface.
- 2) Check the oil passages for clogging.
- 3) Inspect the cylinder block surface that mates with cylinder head for warping by using a straight edge, and correct by grinding if necessary.

Warping limit:
0.025 mm (0.00098 in)

Grinding limit:
0.1 mm (0.004 in)

Standard height of cylinder block:
201.0 mm (7.91 in)

2. CYLINDER AND PISTON

- 1) The cylinder bore size is stamped on the front upper face of the cylinder block.

NOTE:

- Measurement should be performed at a temperature of 20°C (68°F).
- Standard sized pistons are classified into two grades, "A" and "B". These grades should be used as guide lines in selecting a standard piston.

Standard diameter:

A: 99.505 — 99.515 mm (3.9175 — 3.9179 in)
B: 99.495 — 99.505 mm (3.9171 — 3.9175 in)

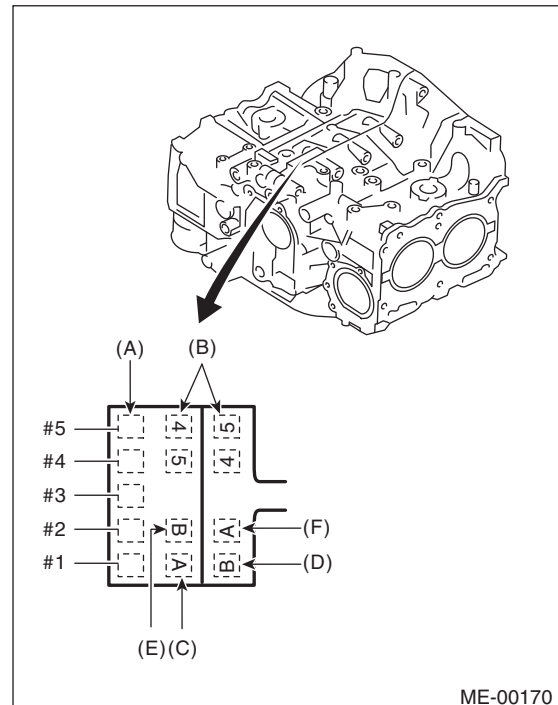

- (A) Main journal size mark
- (B) Cylinder block (RH) – (LH) combination mark
- (C) #1 cylinder bore size mark
- (D) #2 cylinder bore size mark
- (E) #3 cylinder bore size mark
- (F) #4 cylinder bore size mark

2) Measure the inner diameters of the cylinders. Measure the inner diameter of each cylinder in both the thrust and piston pin directions at the heights as shown in the figure, using a cylinder bore gauge.

NOTE:

Measurement should be performed at a temperature of 20°C (68°F).

Taper:

Standard

0.015 mm (0.0006 in)

Out-of-roundness:

Standard

0.010 mm (0.0004 in)

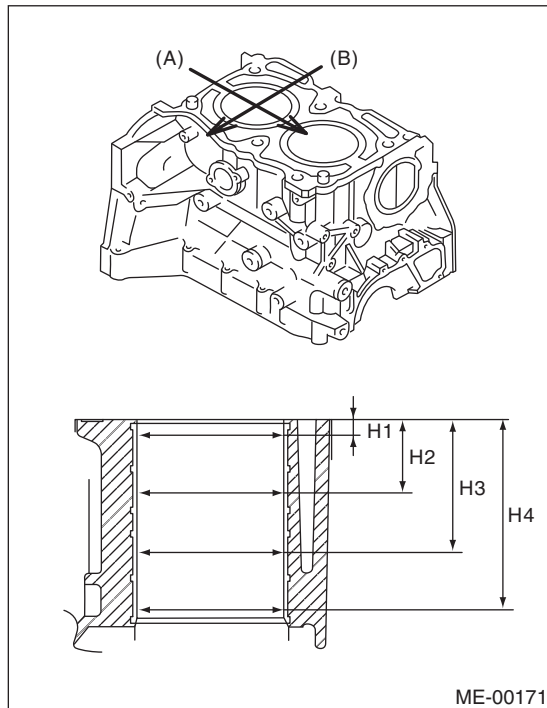

(A) Piston pin direction

(B) Thrust direction

H1: 10 mm (0.39 in)

H2: 45 mm (1.77 in)

H3: 80 mm (3.15 in)

H4: 115 mm (4.53 in)

3) When the piston is to be replaced due to general or cylinder wear, select a suitable sized piston by measuring the piston clearance.

4) Measure the outer diameters of the cylinders. Measure the outer diameter of each piston at the height as shown in the figure. (Thrust direction)

NOTE:

Measurement should be performed at a temperature of 20°C (68°F).

Piston grade point H:

38.2 mm (1.50 in)

Piston outer diameter:

Standard

A: 99.505 — 99.515 mm (3.9175 — 3.9179 in)

B: 99.495 — 99.505 mm (3.9171 — 3.9175 in)

0.25 mm (0.0098 in) oversize

99.745 — 99.765 mm (3.9270 — 3.9278 in)

0.50 mm (0.0197 in) oversize

99.995 — 100.015 mm (3.9368 — 3.9376 in)

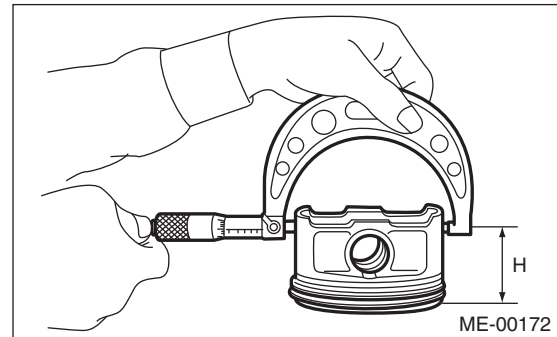

5) Calculate the clearance between cylinder and piston.

NOTE:

Measurement should be performed at a temperature of 20°C (68°F).

Cylinder to piston clearance at 20°C (68°F):

Standard

-0.010 — 0.010 mm (-0.00039 — 0.00039 in)

6) Boring and honing

(1) If any measured value of taper, out-of-roundness or cylinder-to-piston clearance is out of standard or if there is any damage on the cylinder wall, rebores the cylinder for replacement to an oversized piston.

CAUTION:

When any of the cylinders needs reboring, all other cylinders must also be bored at the same time, and replaced with oversize pistons.

(2) If the cylinder inner diameter exceeds the limit after boring and honing, replace the cylinder block.

NOTE:

Immediately after reboring, the cylinder diameter may differ from its real diameter due to temperature rise. Thus, when measuring the cylinder diameter, wait until it has cooled to room temperature.

Cylinder inner diameter boring limit (diameter):

To 100.005 mm (3.9372 in)

Cylinder Block

MECHANICAL

3. PISTON AND PISTON PIN

- 1) Check the piston and piston pin for breaks, cracks or wear. Replace if faulty.
- 2) Check the piston ring groove for wear and damage. Replace if faulty.
- 3) Make sure that the piston pin can be inserted into the piston pin hole with a thumb at 20°C (68°F). Replace if faulty.

Standard clearance between piston pin and hole in piston:

Standard

0.004 — 0.008 mm (0.0002 — 0.0003 in)

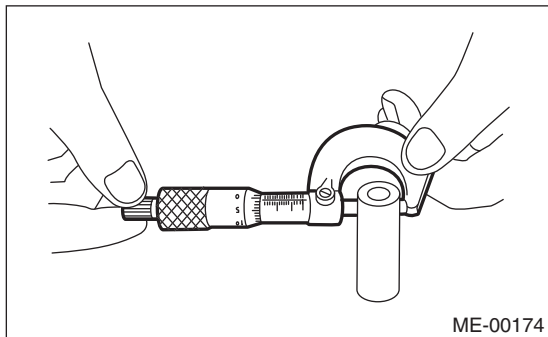
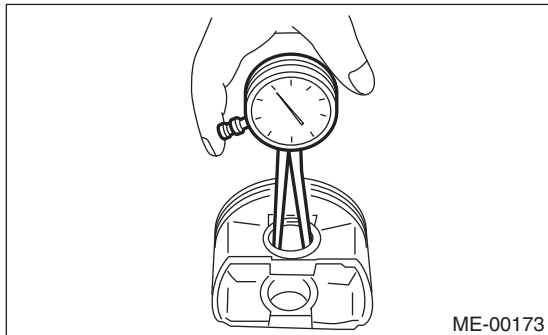

- 4) Check the snap ring installation groove (A) on the piston for burr. If necessary, remove burr from the groove so that the piston pin can lightly move.

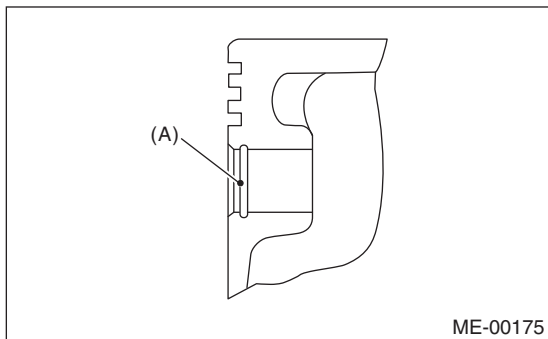

- 5) Check the piston pin snap ring for distortion, cracks and wear.

4. PISTON RING

- 1) If the piston ring is broken, damaged, worn, its tension is insufficient, or when replacing the piston, replace with a new piston ring of the same size as the piston.

NOTE:

- The top ring and second ring have the mark to determine the direction to install on them. When installing the ring to piston, face this mark to the top side.
- Oil ring consists of the upper rail, expander and lower rail. When installing oil ring on piston, be careful of the direction of each rail.

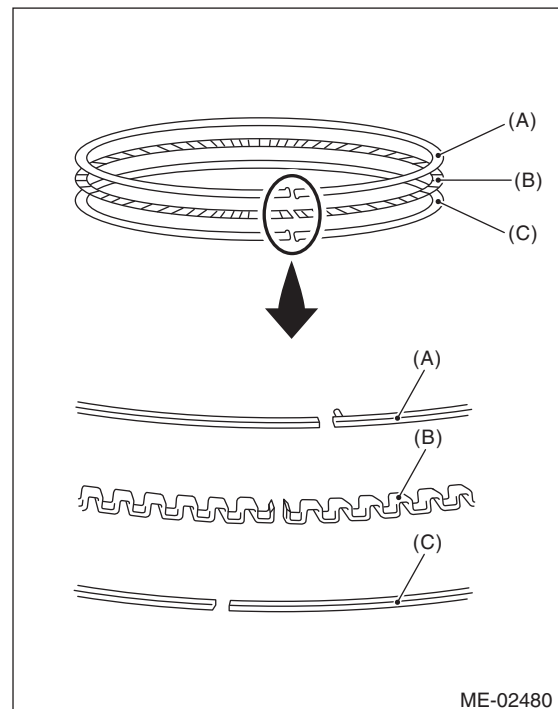

- (A) Upper rail
- (B) Expander
- (C) Lower rail

2) Squarely place the piston ring and oil ring in cylinder using the piston, and measure the piston ring gap with a thickness gauge.

		Standard mm (in)
Piston ring gap	Top ring	0.20 — 0.25 (0.0079 — 0.0098)
	Second ring	0.37 — 0.52 (0.015 — 0.020)
	Oil ring rail	0.20 — 0.50 (0.0079 — 0.0197)

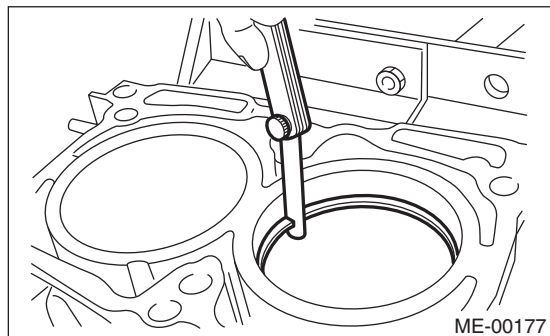

3) Fit the piston ring straight into the piston ring groove, then measure the clearance between piston ring and piston ring groove with a thickness gauge.

NOTE:

Before measuring the clearance, clean the piston ring groove and piston ring.

		Standard mm (in)
Clearance between piston ring and piston ring groove	Top ring	0.040 — 0.080 (0.0016 — 0.0031)
	Second ring	0.030 — 0.070 (0.0012 — 0.0028)

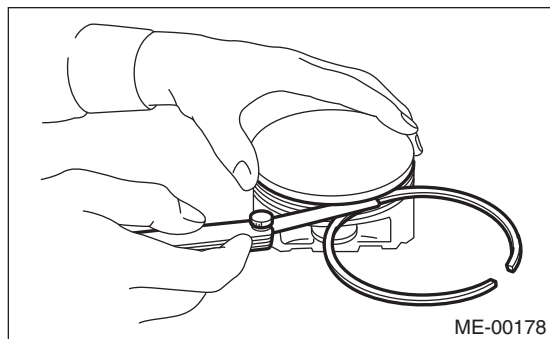

5. CONNECTING ROD

- 1) Replace the connecting rod, if the large or small end thrust surface is damaged.
- 2) Check for bend or twist using a connecting rod aligner. Replace the connecting rod if the bend or twist exceeds the limit.

Limit of bend or twist per 100 mm (3.94 in) in length:
0.10 mm (0.0039 in)

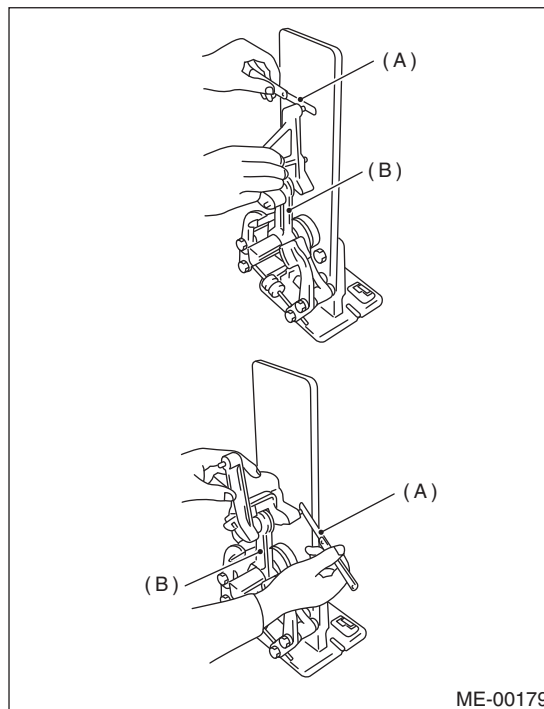

- (A) Thickness gauge
- (B) Connecting rod

3) Install the connecting rod fitted with bearing to the crankshaft, and measure the thrust clearance using a thickness gauge. If the thrust clearance exceeds the standard or uneven wear is found, replace the connecting rod.

Connecting rod thrust clearance:

Standard

0.070 — 0.330 mm (0.0028 — 0.0130 in)

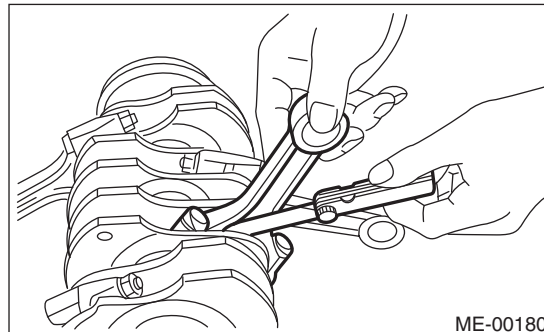

4) Inspect the connecting rod bearing for scar, peeling, seizure, melting, wear, etc.

Cylinder Block

MECHANICAL

5) Measure the oil clearance on each connecting rod bearing using plastigauge. If any oil clearance is not within the standard, replace the defective bearing with a new part of standard size or under-size as necessary.

Connecting rod oil clearance:

Standard

0.017 — 0.045 mm (0.0007 — 0.0018 in)

Unit: mm (in)		
Bearing	Bearing size (Thickness at center)	Outer diameter of crank pin
Standard	1.490 — 1.502 (0.0587 — 0.0591)	51.984 — 52.000 (2.0466 — 2.0472)
0.03 (0.0012) undersize	1.504 — 1.512 (0.0592 — 0.0595)	51.954 — 51.970 (2.0454 — 2.0461)
0.05 (0.0020) undersize	1.514 — 1.522 (0.0596 — 0.0599)	51.934 — 51.950 (2.0447 — 2.0453)
0.25 (0.0098) undersize	1.614 — 1.622 (0.0635 — 0.0639)	51.734 — 51.750 (2.0368 — 2.0374)

6) Inspect the bushing at connecting rod small end, and replace with a new part if worn or damaged.

7) Measure the piston pin clearance at connecting rod small end. If the measured value is not within the standard, replace it with a new part.

Clearance between piston pin and bushing:

Standard

0 — 0.022 mm (0 — 0.0009 in)

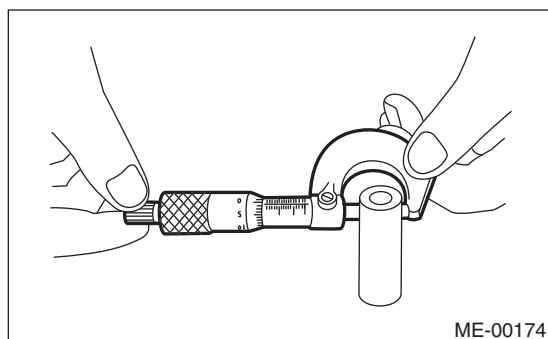
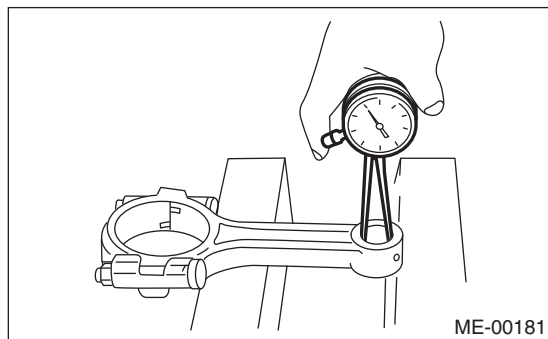

8) The replacement procedure for the connecting rod small end bushing is as follows.

(1) Remove the bushing from connecting rod with ST and press.

(2) Press the bushing with the ST after applying oil on the periphery of new bushing.

ST 499037100 CONNECTING ROD
BUSHING REMOVER AND
INSTALLER

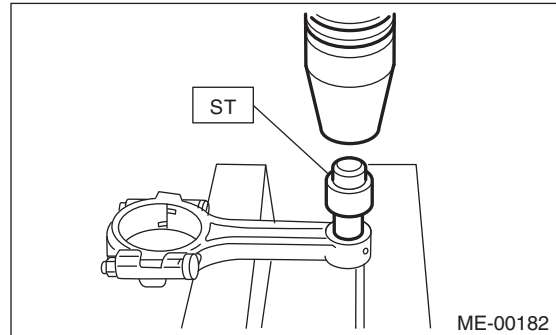

(3) Make two 3 mm (0.12 in) holes in the pressed bushing by aligning with the pre-manufactured holes on the connecting rod, and ream the inside of the bushing.

(4) After completion of reaming, clean the bushing to remove chips.

6. CRANKSHAFT AND CRANKSHAFT BEARING

- 1) Clean the crankshaft completely, and check it for cracks using liquid penetrant tester. If defective, replace the crankshaft.
- 2) Measure warping of the crankshaft. If it exceeds the limit, correct or replace it.

NOTE:

If a suitable V-block is not available, using just the #1 and #5 crankshaft bearings on cylinder block, position the crankshaft on cylinder block. Then, measure the crankshaft bend using a dial gauge.

Crankshaft bend limit:
0.035 mm (0.0014 in)

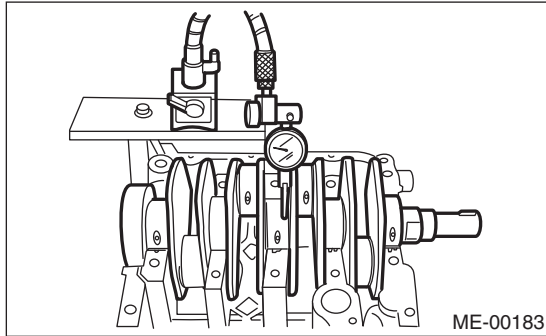

- 3) Inspect the crank journal and crank pin for wear. If they are not within the specification, replace the bearing with a suitable (undersize) one, and replace or grind to correct the crankshaft as necessary. When grinding the crank journal or crank pin, finish them to the specified dimensions according to the undersize bearing to be used.

Crank pin:

Out-of-roundness
0.003 mm (0.0001 in)
Cylindricity
0.004 mm (0.0002 in)
Grinding limit (dia.)
To 51.750 mm (2.0374 in)

Crank journal:

Out-of-roundness
0.005 mm (0.0002 in)
Cylindricity
0.006 mm (0.0002 in)
Grinding limit (dia.)
To 59.758 mm (2.3527 in)

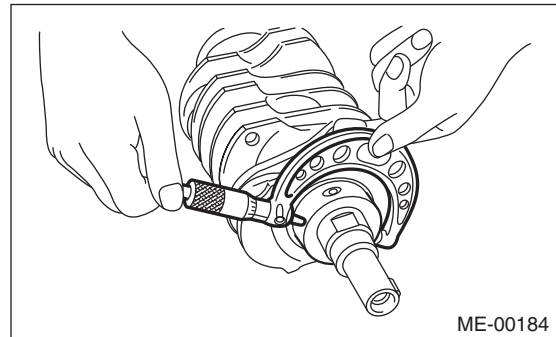

Cylinder Block

MECHANICAL

Unit: mm (in)				
		Crank journal diameter		Crank pin outer diameter
		#1, #3	#2, #4, #5	
Standard	Journal O.D.	59.992 — 60.008 (2.3619 — 2.3625)	59.992 — 60.008 (2.3619 — 2.3625)	51.984 — 52.000 (2.0466 — 2.0472)
	Bearing size (Thickness at center)	1.998 — 2.011 (0.0787 — 0.0792)	2.000 — 2.013 (0.0787 — 0.0793)	1.490 — 1.502 (0.0587 — 0.0591)
0.03 (0.0012) undersize	Journal O.D.	59.962 — 59.978 (2.3607 — 2.3613)	59.962 — 59.978 (2.3607 — 2.3613)	51.954 — 51.970 (2.0454 — 2.0461)
	Bearing size (Thickness at center)	2.017 — 2.020 (0.0794 — 0.0795)	2.019 — 2.022 (0.0795 — 0.0796)	1.504 — 1.512 (0.0592 — 0.0595)
0.05 (0.0020) undersize	Journal O.D.	59.942 — 59.958 (2.3599 — 2.3605)	59.942 — 59.958 (2.3599 — 2.3605)	51.934 — 51.950 (2.0447 — 2.0453)
	Bearing size (Thickness at center)	2.027 — 2.030 (0.0798 — 0.0799)	2.029 — 2.032 (0.0799 — 0.0800)	1.514 — 1.522 (0.0596 — 0.0599)
0.25 (0.0098) undersize	Journal O.D.	59.742 — 59.758 (2.3520 — 2.3527)	59.742 — 59.758 (2.3520 — 2.3527)	51.734 — 51.750 (2.0368 — 2.0374)
	Bearing size (Thickness at center)	2.127 — 2.130 (0.0837 — 0.0839)	2.129 — 2.132 (0.0838 — 0.0839)	1.614 — 1.622 (0.0635 — 0.0639)

4) Use a thickness gauge to measure the thrust clearance of the crankshaft at the #5 crank journal bearing. If clearance exceeds the standard, replace the bearing.

Crankshaft thrust clearance:

Standard

0.030 — 0.115 mm (0.0012 — 0.0045 in)

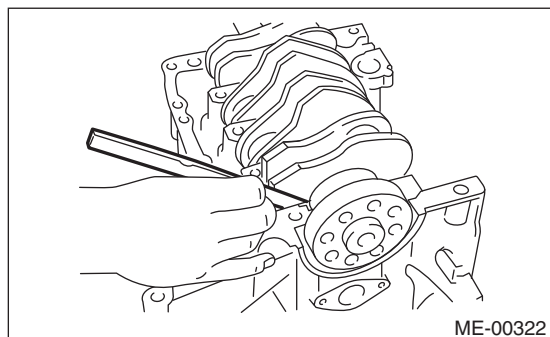

5) Inspect individual crankshaft bearings for signs of flaking, seizure, melting and wear.

6) Measure the oil clearance on each crankshaft bearing using plastigauge. If the measured value is out of standard, replace the defective bearing with an undersize one, and replace or grind to correct the crankshaft as necessary.

Crankshaft oil clearance:

Standard

0.010 — 0.030 mm (0.0004 — 0.0012 in)

21. Intake and Exhaust Valve

A: SPECIFICATION

Refer to "Cylinder Head" for removal and installation procedures of the intake and exhaust valves. <Ref. to ME(H4DOTC)-66, REMOVAL, Cylinder Head.>
<Ref. to ME(H4DOTC)-67, INSTALLATION, Cylinder Head.>

22.Piston

A: SPECIFICATION

Refer to "Cylinder Block" for removal and installation procedures of pistons. <Ref. to ME(H4DOTC)-75, REMOVAL, Cylinder Block.> <Ref. to ME(H4DOTC)-79, INSTALLATION, Cylinder Block.>

23.Connecting Rod

A: SPECIFICATION

Refer to "Cylinder Block" for removal and installation procedures of connecting rod.

<Ref. to ME(H4DOTC)-75, REMOVAL, Cylinder Block.> <Ref. to ME(H4DOTC)-79, INSTALLATION, Cylinder Block.>

24.Crankshaft

A: SPECIFICATION

Refer to "Cylinder Block" for removal and installation procedures of the crankshaft. <Ref. to ME(H4DOTC)-75, REMOVAL, Cylinder Block.>
<Ref. to ME(H4DOTC)-79, INSTALLATION, Cylinder Block.>

25.Engine Trouble in General

A: INSPECTION

NOTE:

The "RANK" shown in the chart shows the possibilities of the cause of trouble in order from "Very often" to "Rarely".

A — Very often

B — Sometimes

C — Rarely

Symptom	Problem parts etc.	Possible cause	RANK
1. Engine does not start.			
1) Starter does not turn.	Starter	Defective battery-to-starter harness	B
		Defective starter switch	C
		Defective inhibitor switch	C
		Defective starter	B
	Battery	Improper connection of terminal	A
		Run-down battery	A
		Defective charging system	B
	Friction	Seizure of crankshaft and connecting rod bearing	C
		Seized camshaft	C
Seized or stuck piston and cylinder		C	
2) Initial combustion does not occur.	Starter	Defective starter	C
	Engine control system <Ref. to EN(H4DOTC)(diag)-2, Basic Diagnostic Procedure.>		A
	Fuel line	Defective fuel pump and relay	A
		Clogged fuel line	C
		Lack of or insufficient fuel	B
	Timing belt	Degradation, etc.	B
		Defective timing	B
	Compression	Incorrect valve clearance	C
		Loosened spark plug or defective gasket	C
		Loosened cylinder head bolt or defective gasket	C
		Improper valve sealing	C
		Defective valve stem	C
		Worn or broken valve spring	B
		Worn or stuck piston rings, cylinder and piston	C
		Incorrect valve timing	B
Improper engine oil (low viscosity)	B		

Engine Trouble in General

MECHANICAL

Symptom	Problem parts etc.	Possible cause	RANK
3) Initial combustion occurs.	Engine control system <Ref. to EN(H4DOTC)(diag)-2, Basic Diagnostic Procedure.>		A
	Intake system	Defective intake manifold gasket	B
		Defective throttle body gasket	B
	Fuel line	Defective fuel pump and relay	C
		Clogged fuel line	C
		Lack of or insufficient fuel	B
	Timing belt	Degradation, etc.	B
		Defective timing	B
	Compression	Incorrect valve clearance	C
		Loosened spark plug or defective gasket	C
		Loosened cylinder head bolt or defective gasket	C
		Improper valve sealing	C
		Defective valve stem	C
		Worn or broken valve spring	B
Worn or stuck piston rings, cylinder and piston		C	
Incorrect valve timing		B	
Improper engine oil (low viscosity)	B		
4) Engine stalls after initial combustion.	Engine control system <Ref. to EN(H4DOTC)(diag)-2, Basic Diagnostic Procedure.>		A
	Intake system	Loosened or cracked intake duct	B
		Loosened or cracked PCV hose	C
		Loosened or cracked vacuum hose	C
		Defective intake manifold gasket	B
		Defective throttle body gasket	B
		Dirty air cleaner element	C
	Fuel line	Clogged fuel line	C
		Lack of or insufficient fuel	B
	Timing belt	Degradation, etc.	B
		Defective timing	B
	Compression	Incorrect valve clearance	C
		Loosened spark plug or defective gasket	C
		Loosened cylinder head bolt or defective gasket	C
		Improper valve sealing	C
		Defective valve stem	C
		Worn or broken valve spring	B
		Worn or stuck piston rings, cylinder and piston	C
Incorrect valve timing		B	
Improper engine oil (low viscosity)	B		

Engine Trouble in General

MECHANICAL

Symptom	Problem parts etc.	Possible cause	RANK
2. Rough idle and engine stall	Engine control system <Ref. to EN(H4DOTC)(diag)-2, Basic Diagnostic Procedure.>		A
	Intake system	Loosened or cracked intake duct	A
		Loosened or cracked PCV hose	A
		Loosened or cracked vacuum hose	A
		Defective intake manifold gasket	B
		Defective throttle body gasket	B
		Defective PCV valve	C
		Loosened oil filler cap	B
		Dirty air cleaner element	C
	Fuel line	Defective fuel pump and relay	C
		Clogged fuel line	C
		Lack of or insufficient fuel	B
	Timing belt	Defective timing	C
	Compression	Incorrect valve clearance	B
		Loosened spark plug or defective gasket	B
		Loosened cylinder head bolt or defective gasket	B
		Improper valve sealing	B
		Defective valve stem	C
		Worn or broken valve spring	B
		Worn or stuck piston rings, cylinder and piston	B
		Incorrect valve timing	A
		Improper engine oil (low viscosity)	B
	Lubrication system	Incorrect oil pressure	B
Defective rocker cover gasket		C	
Cooling system	Overheating	C	
Others	Evaporative emission control system malfunction	A	
	Stuck or damaged throttle valve	B	

Engine Trouble in General

MECHANICAL

Symptom	Problem parts etc.	Possible cause	RANK
3. Low output, hesitation and poor acceleration	Engine control system <Ref. to EN(H4DOTC)(diag)-2, Basic Diagnostic Procedure.>		A
	Intake system	Loosened or cracked intake duct	A
		Loosened or cracked PCV hose	A
		Loosened or cracked vacuum hose	B
		Defective intake manifold gasket	B
		Defective throttle body gasket	B
		Defective PCV valve	B
		Loosened oil filler cap	B
		Dirty air cleaner element	A
	Fuel line	Defective fuel pump and relay	B
		Clogged fuel line	B
		Lack of or insufficient fuel	C
	Timing belt	Defective timing	B
	Compression	Incorrect valve clearance	B
		Loosened spark plug or defective gasket	B
		Loosened cylinder head bolt or defective gasket	B
		Improper valve sealing	B
		Defective valve stem	C
		Worn or broken valve spring	B
		Worn or stuck piston rings, cylinder and piston	C
		Incorrect valve timing	A
	Improper engine oil (low viscosity)	B	
	Lubrication system	Incorrect oil pressure	B
Cooling system	Overheating	C	
	Over-cooling	C	
Others	Evaporative emission control system malfunction	A	
4. Surging	Engine control system <Ref. to EN(H4DOTC)(diag)-2, Basic Diagnostic Procedure.>		A
	Intake system	Loosened or cracked intake duct	A
		Loosened or cracked PCV hose	A
		Loosened or cracked vacuum hose	A
		Defective intake manifold gasket	B
		Defective throttle body gasket	B
		Defective PCV valve	B
		Loosened oil filler cap	B
		Dirty air cleaner element	B
	Fuel line	Defective fuel pump and relay	B
		Clogged fuel line	B
		Lack of or insufficient fuel	C
	Timing belt	Defective timing	B
	Compression	Incorrect valve clearance	B
		Loosened spark plug or defective gasket	C
		Loosened cylinder head bolt or defective gasket	C
		Improper valve sealing	C
		Defective valve stem	C
		Worn or broken valve spring	C
		Worn or stuck piston rings, cylinder and piston	C
		Incorrect valve timing	A
	Improper engine oil (low viscosity)	B	
	Cooling system	Overheating	B
Others	Evaporative emission control system malfunction	C	

Engine Trouble in General

MECHANICAL

Symptom	Problem parts etc.	Possible cause	RANK
5. Engine does not return to idle.	Engine control system <Ref. to EN(H4DOTC)(diag)-2, Basic Diagnostic Procedure.>		A
	Intake system	Loosened or cracked vacuum hose	A
	Others	Stuck or damaged throttle valve	A
6. Dieseling (Run-on)	Engine control system <Ref. to EN(H4DOTC)(diag)-2, Basic Diagnostic Procedure.>		A
	Cooling system	Overheating	B
	Others	Evaporative emission control system malfunction	B
7. After burning in exhaust system	Engine control system <Ref. to EN(H4DOTC)(diag)-2, Basic Diagnostic Procedure.>		A
	Intake system	Loosened or cracked intake duct	C
		Loosened or cracked PCV hose	C
		Loosened or cracked vacuum hose	B
		Defective PCV valve	B
		Loosened oil filler cap	C
	Timing belt	Defective timing	B
	Compression	Incorrect valve clearance	B
		Loosened spark plug or defective gasket	C
		Loosened cylinder head bolt or defective gasket	C
		Improper valve sealing	B
		Defective valve stem	C
		Worn or broken valve spring	C
		Worn or stuck piston rings, cylinder and piston	C
	Incorrect valve timing	A	
	Lubrication system	Incorrect oil pressure	C
Cooling system	Over-cooling	C	
Others	Evaporative emission control system malfunction	C	
8. Knocking	Engine control system <Ref. to EN(H4DOTC)(diag)-2, Basic Diagnostic Procedure.>		A
	Intake system	Loosened oil filler cap	B
	Timing belt	Defective timing	B
	Compression	Incorrect valve clearance	C
		Incorrect valve timing	B
	Cooling system	Overheating	A
9. Excessive engine oil consumption	Intake system	Loosened or cracked PCV hose	A
		Defective PCV valve	B
		Loosened oil filler cap	C
	Compression	Defective valve stem	A
		Worn or stuck piston rings, cylinder and piston	A
	Lubrication system	Loosened oil pump attaching bolts and defective gasket	B
		Defective oil filter gasket	B
		Defective crankshaft oil seal	B
		Defective rocker cover gasket	B
		Loosened oil drain plug or defective gasket	B
	Loosened oil pan fitting bolts or defective oil pan	B	

Engine Trouble in General

MECHANICAL

Symptom	Problem parts etc.	Possible cause	RANK	
10. Excessive fuel consumption	Engine control system <Ref. to EN(H4DOTC)(diag)-2, Basic Diagnostic Procedure.>		A	
	Intake system	Dirty air cleaner element	A	
	Timing belt	Defective timing	B	
	Compression	Incorrect valve clearance		B
		Loosened spark plug or defective gasket		C
		Loosened cylinder head bolt or defective gasket		C
		Improper valve sealing		B
		Defective valve stem		C
		Worn or broken valve spring		C
		Worn or stuck piston rings, cylinder and piston		B
		Incorrect valve timing		B
	Lubrication system	Incorrect oil pressure	C	
	Cooling system	Over-cooling	C	

26.Engine Noise

A: INSPECTION

Type of sound	Condition	Possible cause
Regular clicking sound	Sound increases as engine speed increases.	<ul style="list-style-type: none"> • Valve mechanism is defective. • Incorrect valve clearance • Worn camshaft • Broken valve spring
Heavy and dull clank	Oil pressure is low.	<ul style="list-style-type: none"> • Worn crankshaft main bearing • Worn connecting rod bearing (large end)
	Oil pressure is normal.	<ul style="list-style-type: none"> • Loosened flywheel mounting bolt • Damaged engine mounting
High-pitched clank	Sound is noticeable when accelerating with an overload condition.	<ul style="list-style-type: none"> • Ignition timing advanced • Accumulation of carbon inside combustion chamber • Wrong heat-durability spark plug • Improper octane value gasoline
Clank when engine speed is between 1,000 and 2,000 rpm.	Sound is reduced when fuel injector connector of noisy cylinder is disconnected. (NOTE*)	<ul style="list-style-type: none"> • Worn crankshaft main bearing • Worn connecting rod bearing (large end)
Knocking sound when engine is operating under idling speed and engine is warm	Sound is reduced when fuel injector connector of noisy cylinder is disconnected. (NOTE*)	<ul style="list-style-type: none"> • Worn cylinder liner and piston ring • Broken or stuck piston ring • Worn piston pin and hole at piston end of connecting rod
	Sound is not reduced if each fuel injector connector is disconnected in turn. (NOTE*)	<ul style="list-style-type: none"> • Unusually worn valve lifter • Worn cam sprocket • Worn camshaft journal bore in cylinder head
Squeaky sound	—	Insufficient generator lubrication
Rubbing sound	—	Poor contact of generator brush and rotor
Gear scream when starting engine	—	<ul style="list-style-type: none"> • Defective ignition starter switch • Worn gear and starter pinion
Sound like polishing glass with a dry cloth	—	<ul style="list-style-type: none"> • Loose V-belt • Defective water pump shaft
Hissing sound	—	<ul style="list-style-type: none"> • Insufficient compression • Air leakage in air intake system, hose, connection or manifold
Timing belt noise	—	<ul style="list-style-type: none"> • Loose timing belt • Belt contacting with case/adjacent part
Valve noise	—	Incorrect valve clearance

NOTE*)

When disconnecting the fuel injector connector, the malfunction indicator light illuminates and DTC is stored in ECM memory. Therefore, after connecting the fuel injector connector, perform the Clear Memory Mode <Ref. to EN(H4DOTC)(diag)-52, OPERATION, Clear Memory Mode.> and Inspection Mode <Ref. to EN(H4DOTC)(diag)-42, PROCEDURE, Inspection Mode.>.

Engine Noise

MECHANICAL

EXHAUST

EX(H4DOTC)

	Page
1. General Description	2
2. Front Exhaust Pipe	5
3. Center Exhaust Pipe	7
4. Joint Pipe	11
5. Rear Exhaust Pipe	12
6. Muffler	14

General Description

EXHAUST

1. General Description

A: COMPONENT

1. FRONT EXHAUST PIPE

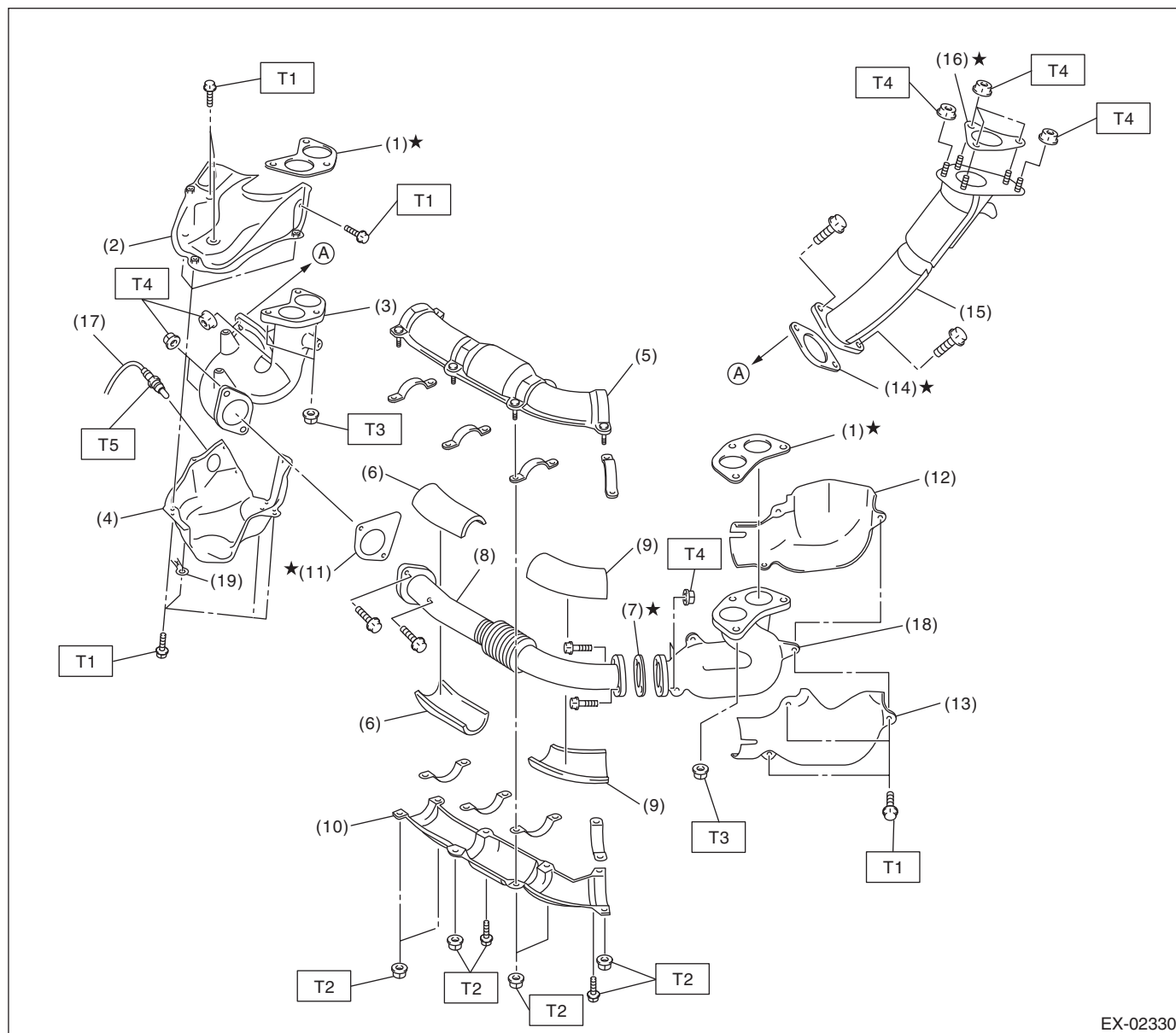

- | | |
|-------------------------------------|--------------------------------------|
| (1) Gasket | (11) Gasket |
| (2) Exhaust manifold RH upper cover | (12) Exhaust manifold LH inner cover |
| (3) Exhaust manifold RH | (13) Exhaust manifold LH outer cover |
| (4) Exhaust manifold RH lower cover | (14) Gasket |
| (5) Front exhaust pipe upper cover | (15) Turbocharger joint pipe |
| (6) Front exhaust pipe insulator RH | (16) Gasket |
| (7) Gasket | (17) Front oxygen (A/F) sensor |
| (8) Front exhaust pipe | (18) Exhaust manifold LH |
| (9) Front exhaust pipe insulator LH | (19) Ground cable |
| (10) Front exhaust pipe lower cover | |

Tightening torque: N·m (kgf·m, ft·lb)

T1: 19 (1.9, 14.0)

T2: 25 (2.5, 18.4)

T3: 40 (4.1, 29.5)

T4: 42.5 (4.3, 31.3)

T5: <Ref. to FU(H4DOTC)-44, INSTALLATION, Front Oxygen (A/F) Sensor.>

General Description

EXHAUST

B: CAUTION

- Wear appropriate work clothing, including a cap, protective goggles and protective shoes when performing any work.
- Remove contamination including dirt and corrosion before removal, installation or disassembly.
- Keep the disassembled parts in order and protect them from dust and dirt.
- Before removal, installation or disassembly, be sure to clarify the failure. Avoid unnecessary removal, installation, disassembly and replacement.
- Vehicle components are extremely hot after driving. Be wary of receiving burns from heated parts.
- Be sure to tighten fasteners including bolts and nuts to the specified torque.
- Place shop jacks or rigid racks at the specified points.
- Before disconnecting connectors of sensors or units, be sure to disconnect the ground cable from the battery.
- If any fat adheres to the exhaust pipe, wipe it off. Otherwise a fire may happen.

2. Front Exhaust Pipe

A: REMOVAL

CAUTION:

Be careful not to burn yourself, because the exhaust pipe becomes extremely hot after running.

- 1) Set the vehicle on a lift.
- 2) Disconnect the ground cable from the battery.

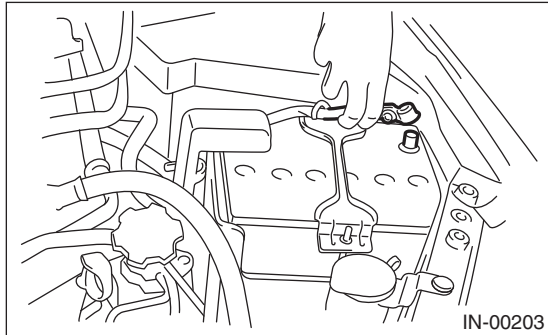

- 3) Lift up the vehicle.
- 4) Remove the under cover.
- 5) Remove the front oxygen (A/F) sensor.
<Ref. to FU(H4DOTC)-43, REMOVAL, Front Oxygen (A/F) Sensor.>
- 6) Remove the exhaust manifold RH lower cover and the exhaust manifold LH cover.

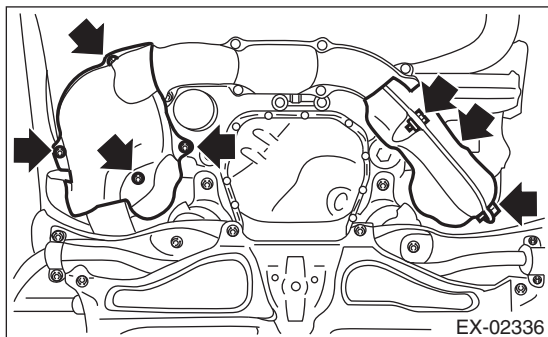

- 7) Remove the bolts and nuts which hold front exhaust pipe assembly onto turbocharger joint pipe.

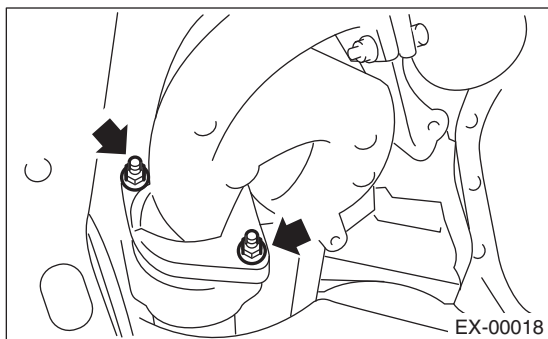

- 8) While holding the front exhaust pipe assembly with one hand, remove the nuts which hold the front exhaust pipe assembly to cylinder head exhaust port.

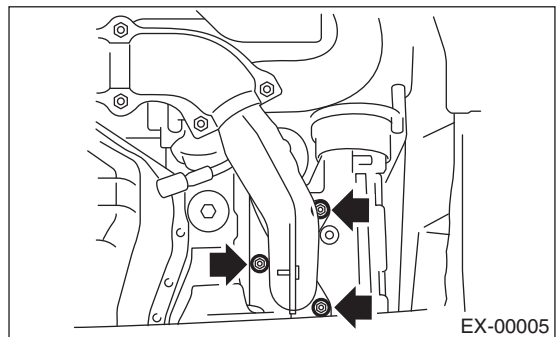
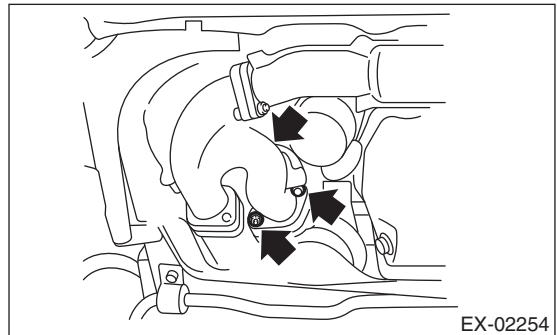

- 9) Remove the front exhaust pipe assembly.
- 10) Remove the exhaust manifold RH upper cover and the front exhaust pipe cover.
- 11) Separate the front exhaust pipe from exhaust manifolds.

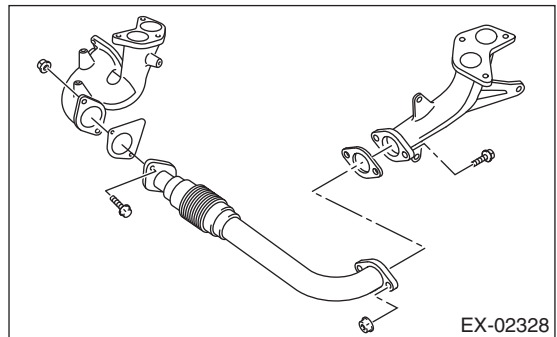

Front Exhaust Pipe

EXHAUST

B: INSTALLATION

1) Install the front exhaust pipe and the exhaust manifold.

NOTE:

Use a new gasket.

Tightening torque:

42.5 N·m (4.3 kgf-m, 31.3 ft-lb)

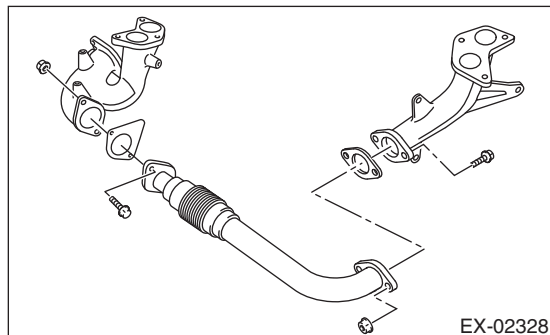

2) Install the front exhaust pipe cover.

Tightening torque:

25 N·m (2.5 kgf-m, 18.4 ft-lb)

3) Install the exhaust manifold RH upper cover.

Tightening torque:

19 N·m (1.9 kgf-m, 14.0 ft-lb)

4) Install the front exhaust pipe assembly.

NOTE:

Use a new gasket.

Tightening torque:

40 N·m (4.1 kgf-m, 29.5 ft-lb)

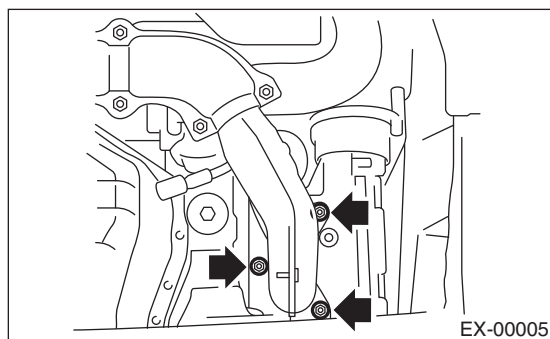
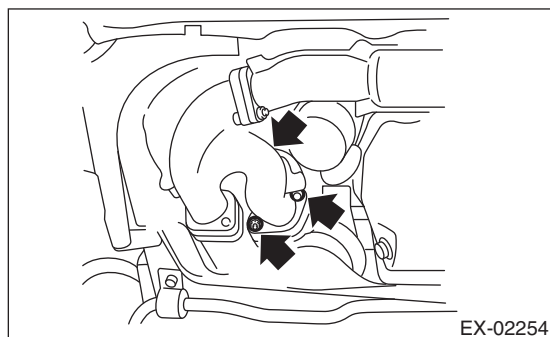

5) Connect the exhaust manifold RH to the turbo-charger joint pipe.

NOTE:

Use a new gasket.

Tightening torque:

42.5 N·m (4.3 kgf-m, 31.3 ft-lb)

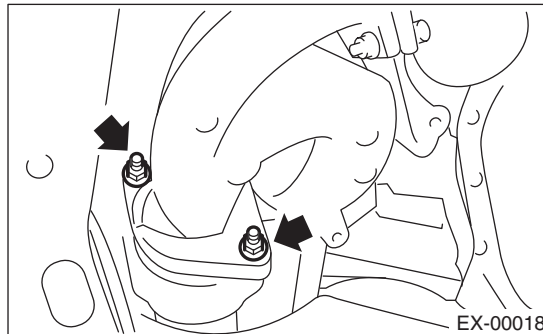

6) Install the exhaust manifold RH lower cover and exhaust manifold LH cover.

Tightening torque:

19 N·m (1.9 kgf-m, 14.0 ft-lb)

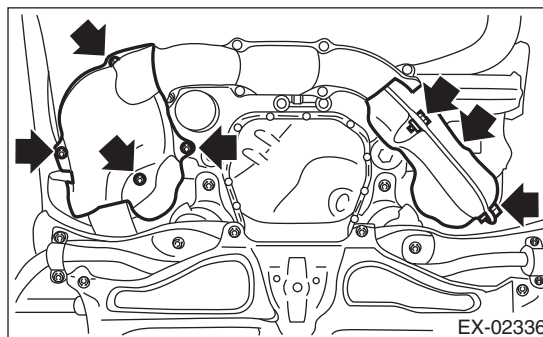

7) Install the front oxygen (A/F) sensor.

<Ref. to FU(H4DOTC)-44, INSTALLATION, Front Oxygen (A/F) Sensor.>

8) Install the under cover.

9) Lower the vehicle.

10) Connect the battery ground cable to battery.

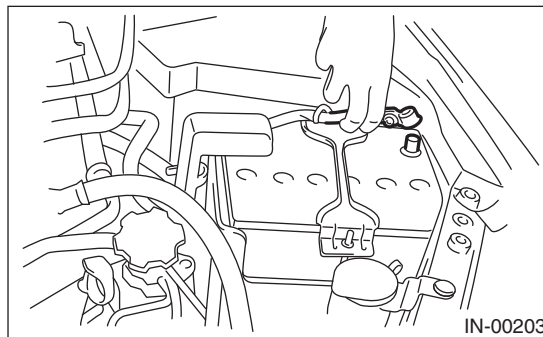

C: INSPECTION

1) Check the connections and welds for exhaust leaks.

2) Make sure there are no holes or rusting.

3. Center Exhaust Pipe

A: REMOVAL

CAUTION:

Be careful not to burn yourself, because the exhaust pipe becomes extremely hot after running.

- 1) Set the vehicle on a lift.
- 2) Remove the collector cover.
- 3) Disconnect the ground cable from the battery.

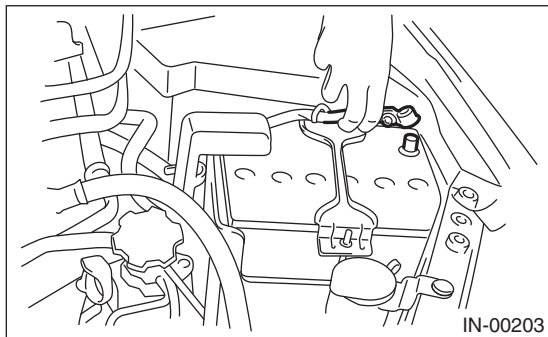

- 4) Remove the intercooler. <Ref. to IN(H4DOTC)-11, REMOVAL, Intercooler.>
- 5) Lift up the vehicle.
- 6) Remove the bolts which hold the lower side of the turbocharger lower cover.

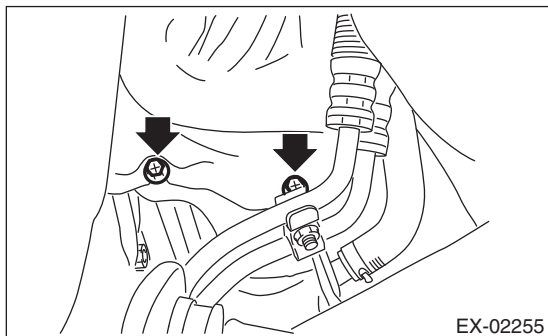

- 7) Lower the vehicle.
- 8) Remove the turbocharger upper cover.

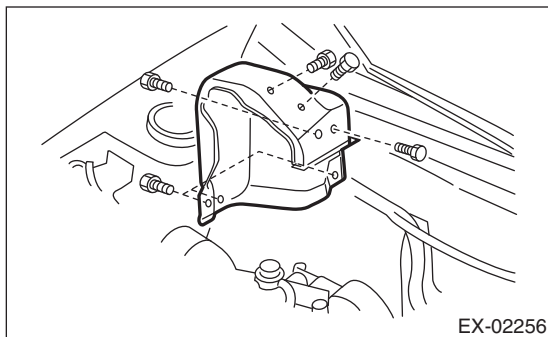

- 9) Remove the bolts which hold the upper side of the turbo charger lower cover.

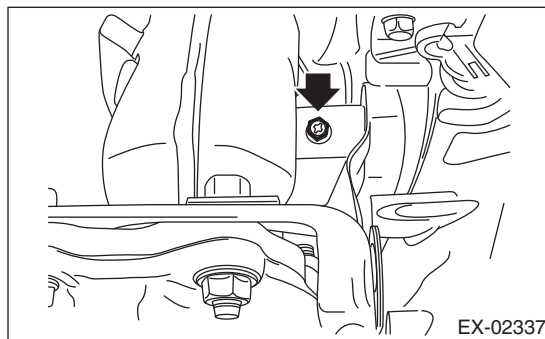

- 10) Remove the upper side bolts and nuts that hold the center exhaust pipe on the turbocharger, and remove the turbocharger cover stay (A).

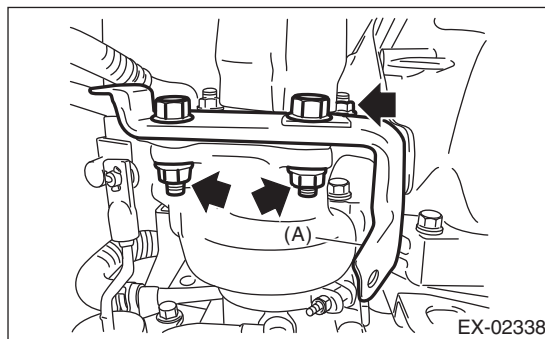

- 11) Lift up the vehicle.
- 12) Remove the lower side nuts (two places) that hold the center exhaust pipe on the turbocharger.

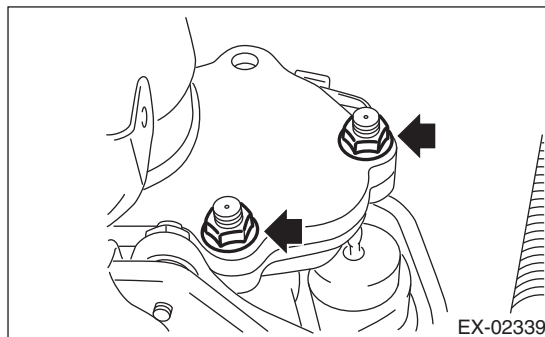

- 13) Disconnect the connector from the rear oxygen sensor, and remove the clip (A) holding the rear oxygen sensor harness.

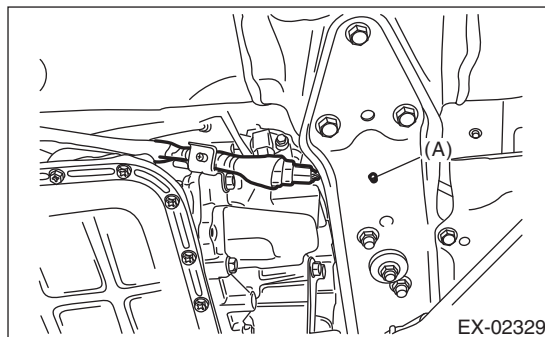

Center Exhaust Pipe

EXHAUST

14) Separate the center exhaust pipe from rear exhaust pipe.

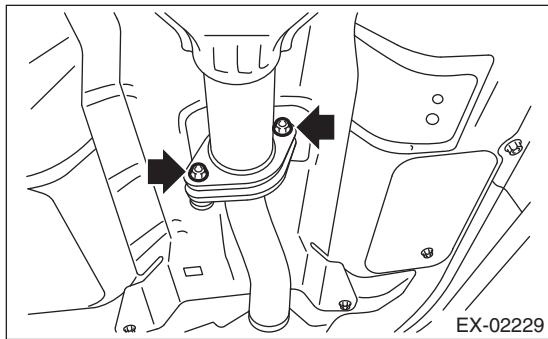

15) Remove the bolt which holds center exhaust pipe bracket to transmission.

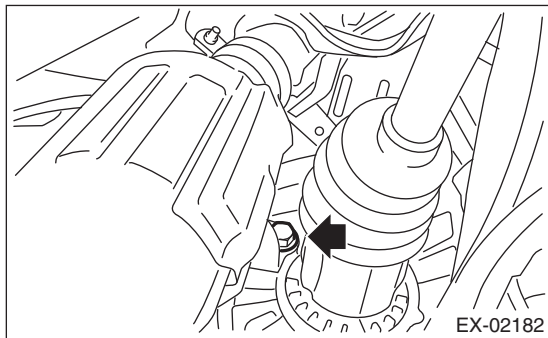

16) Remove the bolts which hold the center exhaust pipe to the hanger bracket, and remove the center exhaust pipe.

CAUTION:

Be careful not to drop the center exhaust pipe.

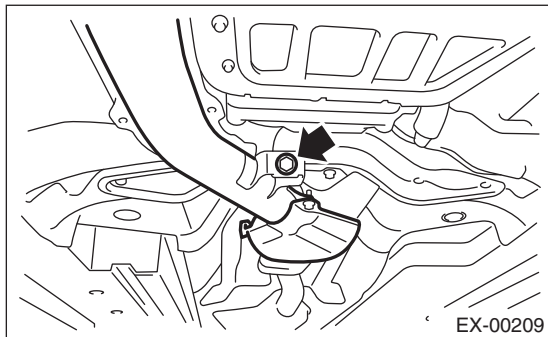

17) Remove the turbocharger lower cover.

18) Separate the center exhaust pipe (front) and center exhaust pipe (rear).

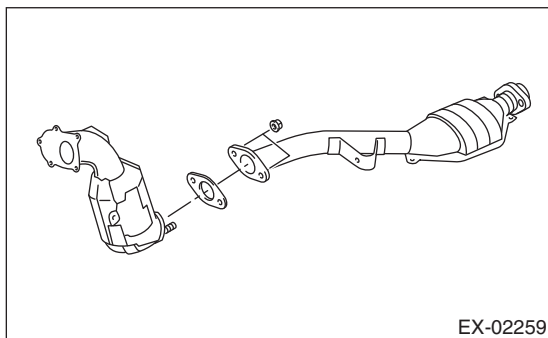

B: INSTALLATION

1) Assemble the center exhaust pipe (front) and center exhaust pipe (rear).

NOTE:

Use a new gasket.

Tightening torque:

42.5 N·m (4.3 kgf·m, 31.3 ft·lb)

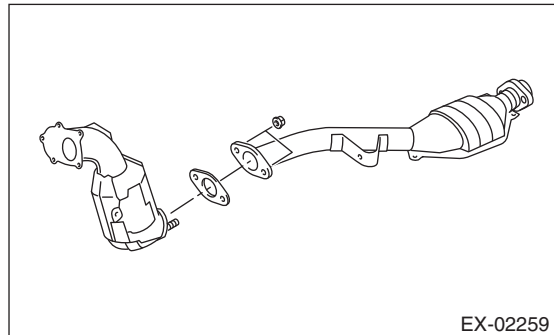

2) Set the turbo charger lower cover, and temporarily tighten the bolt holding the lower side of the turbo charger lower cover.

3) Install the center exhaust pipe and temporarily tighten the bolt which holds center exhaust pipe to hanger bracket.

4) Temporarily tighten the bolt which holds the center exhaust pipe to the transmission.

5) Connect the center exhaust pipe along with the turbo charger cover stay (A) to the turbocharger.

NOTE:

Use a new gasket.

Tightening torque:

42.5 N·m (4.3 kgf·m, 31.3 ft·lb)

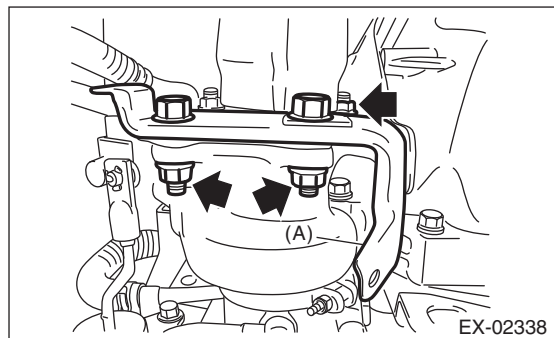
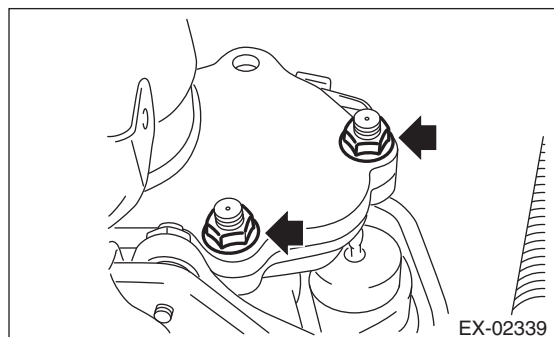

6) Install the center exhaust pipe to rear exhaust pipe.

NOTE:

Use a new gasket.

Tightening torque:

18 N·m (1.8 kgf·m, 13.3 ft·lb)

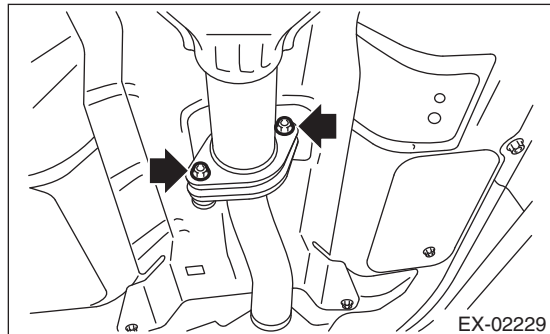

7) Connect the connector to the rear oxygen sensor, and hold the rear oxygen sensor harness with clip (A).

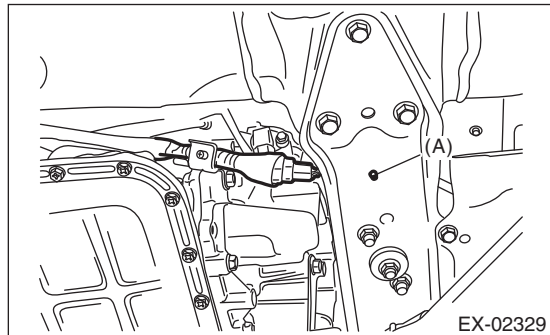

8) Tighten the bolt which holds center exhaust pipe bracket to transmission.

Tightening torque:

30 N·m (3.1 kgf·m, 22.1 ft·lb)

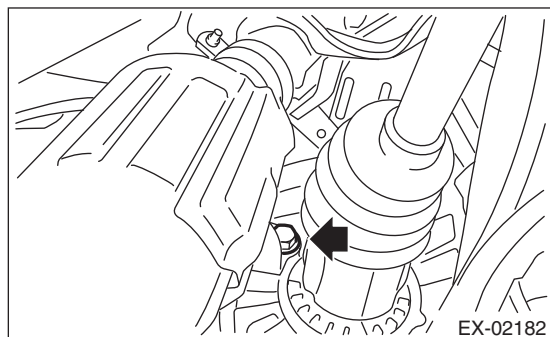

9) Tighten the bolt which holds center exhaust pipe to hanger bracket.

Tightening torque:

35 N·m (3.6 kgf·m, 25.8 ft·lb)

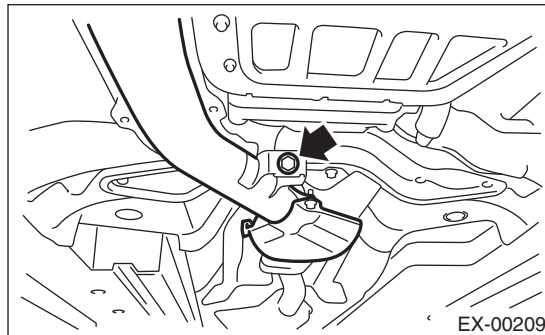

10) Lower the vehicle.

11) Attach the bolts which hold the upper side of the turbo charger lower cover.

Tightening torque:

7.5 N·m (0.8 kgf·m, 5.5 ft·lb)

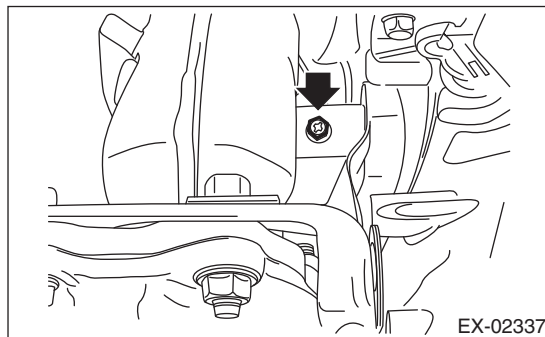

12) Attach the turbo charger upper cover.

Tightening torque:

7.5 N·m (0.8 kgf·m, 5.5 ft·lb)

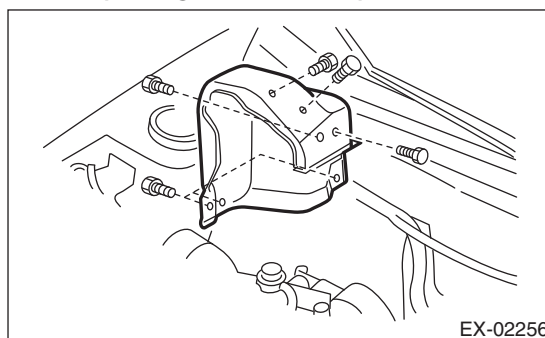

13) Lift up the vehicle.

Center Exhaust Pipe

EXHAUST

14) Tighten the bolts which hold the lower side of the turbo charger lower cover.

Tightening torque:

7.5 N·m (0.8 kgf·m, 5.5 ft·lb)

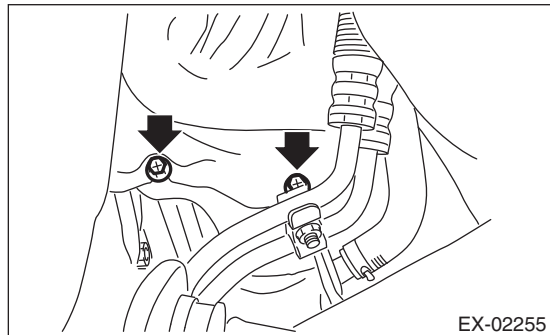

15) Lower the vehicle.

16) Install the intercooler. <Ref. to IN(H4DOTC)-12, INSTALLATION, Intercooler.>

17) Connect the battery ground cable to battery.

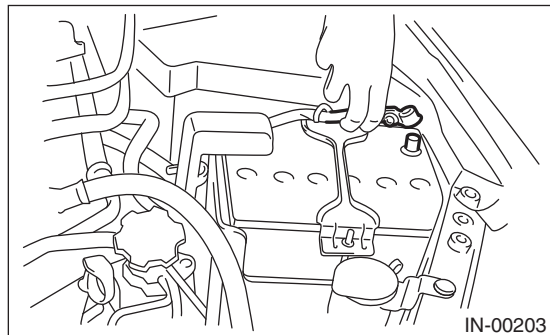

18) Install the collector cover.

C: INSPECTION

- 1) Check the connections and welds for exhaust leaks.
- 2) Make sure there are no holes or rusting.

4. Joint Pipe

A: REMOVAL

CAUTION:

Be careful not to burn yourself, because the exhaust pipe becomes extremely hot after running.

- 1) Set the vehicle on a lift.
- 2) Remove the collector cover.
- 3) Disconnect the ground cable from the battery.

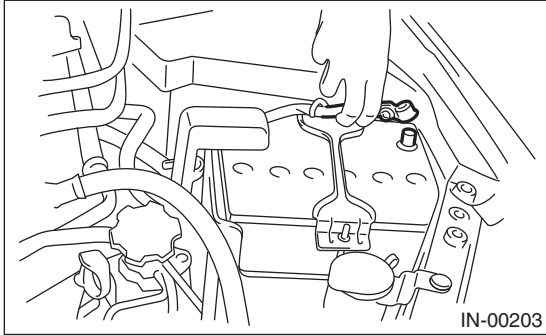

- 4) Lift up the vehicle.
- 5) Remove the under cover.
- 6) Remove the front oxygen (A/F) sensor.
<Ref. to FU(H4DOTC)-43, REMOVAL, Front Oxygen (A/F) Sensor.>
- 7) Remove the exhaust manifold RH lower cover.

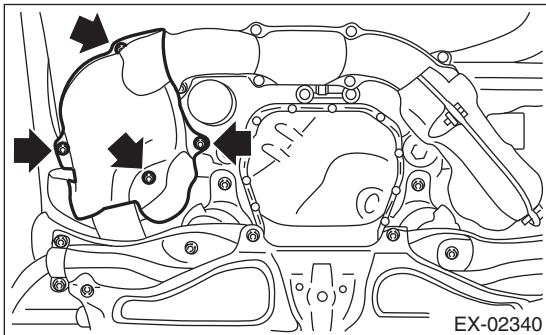

- 8) Remove the bolts and nuts which hold the front exhaust manifold to joint pipe.

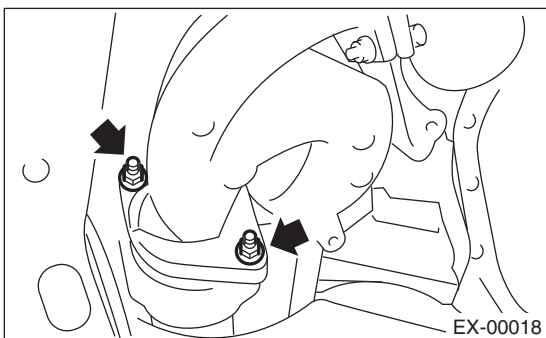

- 9) Remove the center exhaust pipe.
<Ref. to EX(H4DOTC)-7, REMOVAL, Center Exhaust Pipe.>
- 10) Remove the turbocharger. <Ref. to IN(H4DOTC)-13, REMOVAL, Turbocharger.>
- 11) Take off the joint pipe in the upward direction.

B: INSTALLATION

Install in the reverse order of removal.

NOTE:

Use a new gasket.

Tightening torque:

42.5 N·m (4.3 kgf-m, 31.3 ft-lb)

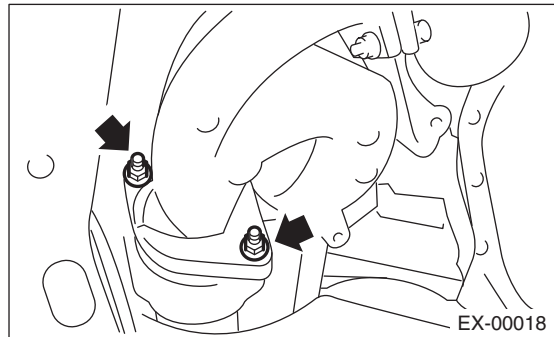

Tightening torque:

19 N·m (1.9 kgf-m, 14.0 ft-lb)

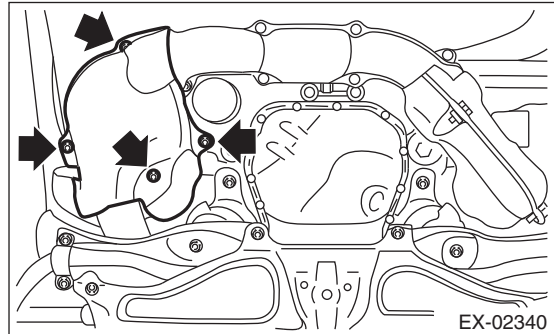

C: INSPECTION

- 1) Check the connections and welds for exhaust leaks.
- 2) Make sure there are no holes or rusting.

Rear Exhaust Pipe

EXHAUST

5. Rear Exhaust Pipe

A: REMOVAL

CAUTION:

Be careful not to burn yourself, because the exhaust pipe becomes extremely hot after running.

- 1) Set the vehicle on a lift.
- 2) Lift up the vehicle.
- 3) Separate the rear exhaust pipe from center exhaust pipe.

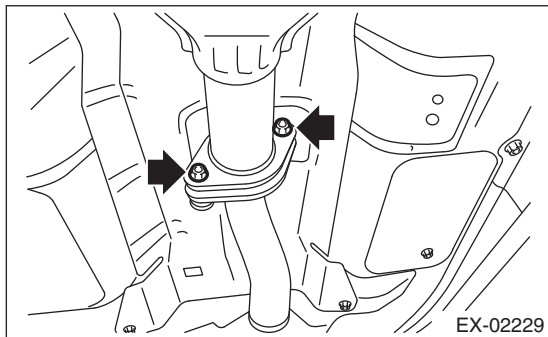

- 4) Separate the rear exhaust pipe from muffler.

CAUTION:

Be careful not to drop the rear exhaust pipe.

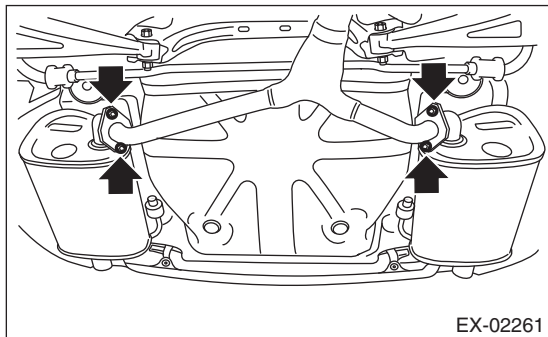

- 5) Apply a coat of spray type lubricant to the mating area of cushion rubber.
- 6) Remove the rear exhaust pipe bracket from cushion rubber.

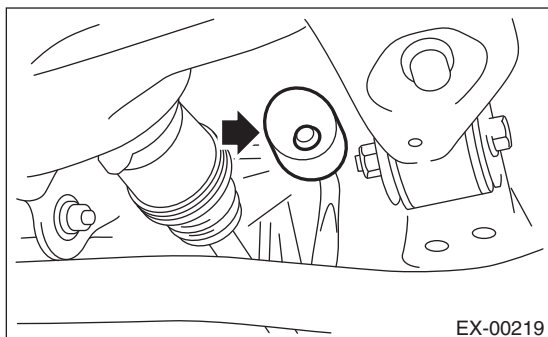

- 7) Remove the rear exhaust pipe.

B: INSTALLATION

- 1) Apply a coat of spray type lubricant to the mating area of cushion rubber.
- 2) Install the rear exhaust pipe bracket to cushion rubber.

NOTE:

After assembling, degrease the lubricant which was applied to the cushion rubber while removing/installing.

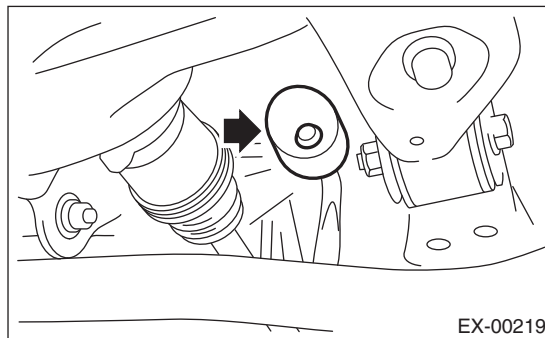

- 3) Install the rear exhaust pipe to muffler.

NOTE:

Use a new gasket and self-locking nut.

Tightening torque:

48 N·m (4.9 kgf·m, 35.4 ft·lb)

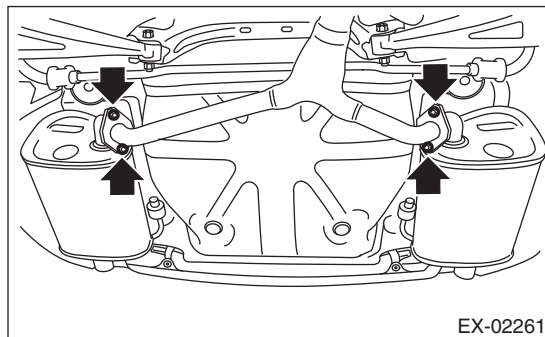

- 4) Install the rear exhaust pipe to center exhaust pipe.

NOTE:

Use a new gasket.

Tightening torque:

18 N·m (1.8 kgf·m, 13.3 ft·lb)

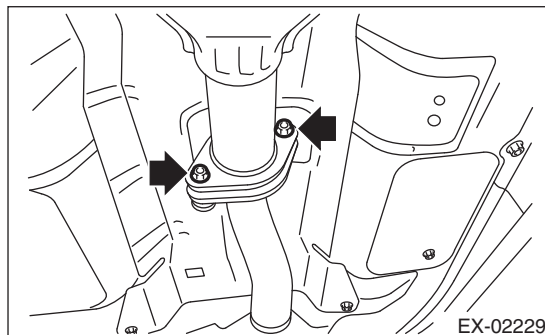

- 5) Lower the vehicle.

C: INSPECTION

- 1) Check the connections and welds for exhaust leaks.
- 2) Make sure there are no holes or rusting.
- 3) Check the cushion rubber for wear or crack.

Muffler

EXHAUST

6. Muffler

A: REMOVAL

CAUTION:

Be careful not to burn yourself, because the exhaust pipe becomes extremely hot after running.

- 1) Set the vehicle on a lift.
- 2) Lift up the vehicle.
- 3) Separate the muffler from rear exhaust pipe.

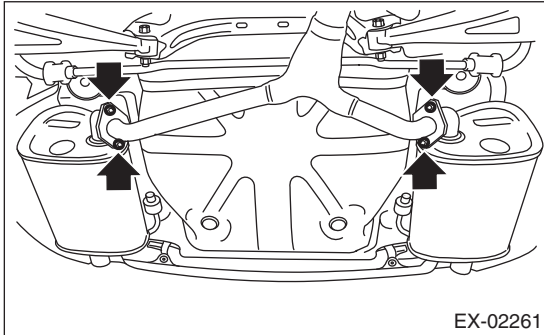

- 4) Apply a coat of spray type lubricant to the mating area of cushion rubber.
- 5) Remove the cushion rubber, and remove the muffler.

CAUTION:

Be careful not to drop the muffler during removal.

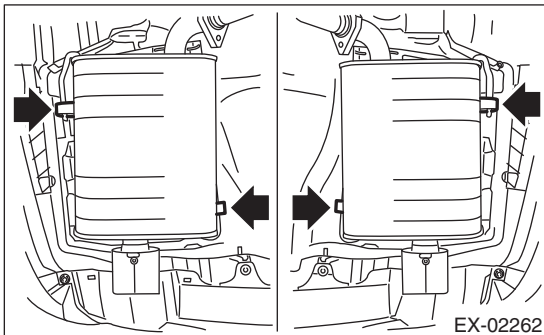

B: INSTALLATION

Install in the reverse order of removal.

NOTE:

- Use a new gasket and self-locking nut.
- After assembling, degrease the lubricant which was applied to the cushion rubber while removing/installing.

Tightening torque:

48 N·m (4.9 kgf-m, 35.4 ft-lb)

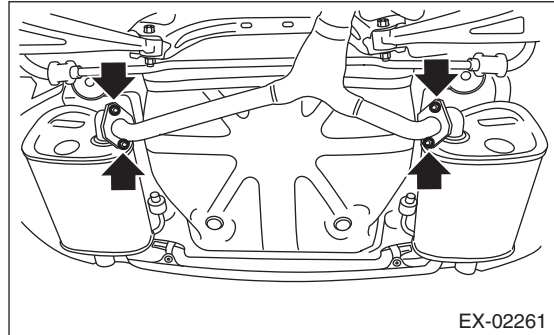

C: INSPECTION

- 1) Check the connections and welds for exhaust leaks.
- 2) Make sure there are no holes or rusting.
- 3) Check the cushion rubber for wear or crack.

COOLING

CO(H4DOTC)

	Page
1. General Description	2
2. Radiator Fan System	7
3. Engine Coolant	13
4. Water Pump	15
5. Thermostat	17
6. Radiator	19
7. Radiator Cap	23
8. Radiator Main Fan and Fan Motor	24
9. Radiator Sub Fan and Fan Motor	26
10. Reservoir Tank	28
11. Coolant Filler Tank	29
12. Engine Cooling System Trouble in General	30

General Description

COOLING

1. General Description

A: SPECIFICATION

Cooling system			Electric fan + Forced engine coolant circulation system	
Total engine coolant capacity			ℓ (US qt, Imp qt)	
			Approx. 8.0 (8.5, 7.0)	
Water pump	Type		Centrifugal impeller type	
	Discharge performance I	Discharge rate	ℓ (US gal, Imp gal) /min	20 (5.3, 4.4)
		Pump speed — Discharge pressure		760 rpm — 2.9 kPa (0.3 mAq)
		Engine coolant temperature		80°C (176°F)
	Discharge performance II	Discharge rate	ℓ (US gal, Imp gal) /min	100 (26.4, 22.0)
		Pump speed — Discharge pressure		3,000 rpm — 49.0 kPa (5.0 mAq)
		Engine coolant temperature		80°C (176°F)
	Discharge performance III	Discharge rate	ℓ (US gal, Imp gal) /min	200 (52.8, 44.0)
		Pump speed — Discharge pressure		6,000 rpm — 225.4 kPa (23.0 mAq)
			Engine coolant temperature	80°C (176°F)
	Impeller diameter		mm (in)	76 (2.99)
Number of impeller vanes			8	
Pump pulley diameter		mm (in)	60 (2.36)	
Clearance between impeller and case	Standard	mm (in)	0.5 — 1.5 (0.020 — 0.059)	
Thermostat	Type		Wax pellet type	
	Starting temperature to open		76 — 80°C (169 — 176°F)	
	Fully opens		91°C (196°F)	
	Valve lift	mm (in)	9.0 (0.354) or more	
	Valve bore	mm (in)	35 (1.38)	
Radiator fan	Motor input	Main fan	W	120
		Sub fan	W	120
	Fan diameter / Blade	Main fan		318.5 mm (12.54 in)/9
		Sub fan		318.5 mm (12.54 in)/11
Radiator	Type		Down flow	
	Core dimensions	Width × Height × Thickness	mm (in)	687.4 × 340 × 16 (27.06 × 13.39 × 0.63)
	Pressure range in which cap valve is open	Coolant filler tank side	kPa (kg/cm ² , psi)	Above: 108±14.7 (1.1±0.15, 16±2.1) Below: -1.0 to -4.9 (-0.01 — -0.05, -0.1 — -0.7)
		Radiator side	kPa (kg/cm ² , psi)	Above only: 137±14.7 (1.40±0.15, 20±2.1)
	Fins			Corrugated fin type
Reservoir tank	Capacity	ℓ (US qt, Imp qt)	0.45 (0.48, 0.40)	

	Recommended materials	Item number	Alternative
Coolant	SUBARU SUPER COOLANT (concentrated type)	—	—
	SUBARU SUPER COOLANT (dilution type)	K0670Y0000	
Water for dilution	Distilled water	—	Soft water or tap water
Cooling system protective agent	Cooling system conditioner	SOA345001	—

B: COMPONENT

1. WATER PUMP

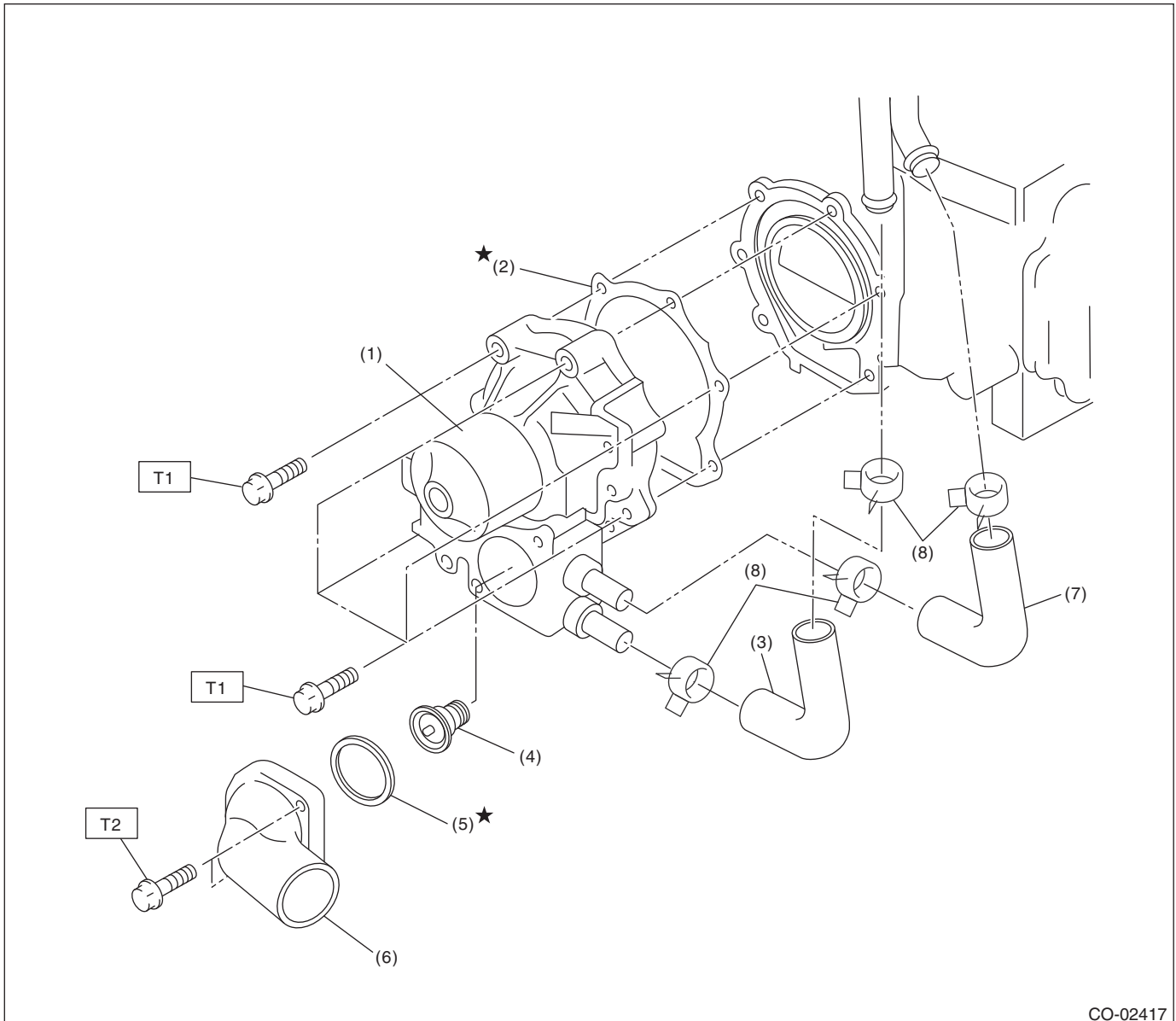

- | | |
|-------------------------|---------------------------------|
| (1) Water pump ASSY | (5) Gasket |
| (2) Gasket | (6) Thermostat cover |
| (3) Heater by-pass hose | (7) Coolant filler by-pass hose |
| (4) Thermostat | (8) Clip |

Tightening torque: N·m (kgf·m, ft·lb)

T1: First 12 (1.2, 8.9)

Second 12 (1.2, 8.9)

T2: 12 (1.2, 8.9)

General Description

COOLING

2. RADIATOR AND RADIATOR FAN

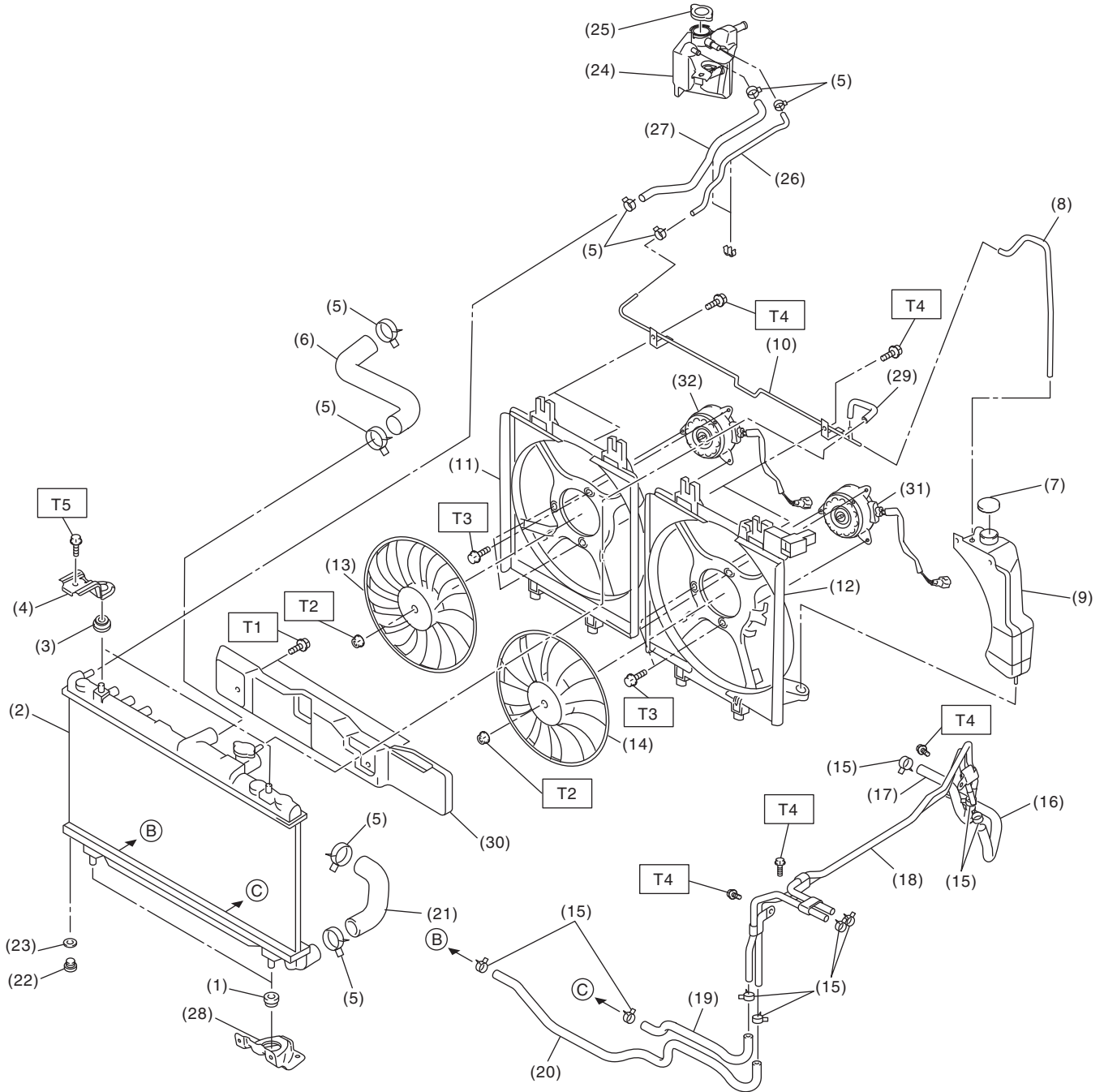

CO-02447

CO(H4DOTC)-4

General Description

COOLING

(1) Radiator lower cushion	(15) ATF hose clamp	(27) Coolant filler tank hose B
(2) Radiator	(16) ATF hose A	(28) Radiator lower bracket
(3) Radiator upper cushion	(17) ATF hose B	(29) Over flow hose B
(4) Radiator upper bracket	(18) ATF pipe	(30) Heat shield cover
(5) Clip	(19) ATF hose C	(31) Main fan motor
(6) Radiator inlet hose	(20) ATF hose D	(32) Sub fan motor
(7) Engine coolant reservoir tank cap	(21) Radiator outlet hose	
(8) Over flow hose A	(22) Radiator drain plug	
(9) Engine coolant reservoir tank	(23) O-ring	
(10) Over flow pipe	(24) Engine coolant filler tank	
(11) Radiator sub fan shroud	(25) Radiator cap	
(12) Radiator main fan shroud	(Engine coolant filler tank cap)	
(13) Radiator sub fan	(26) Coolant filler tank hose A	
(14) Radiator main fan		

Tightening torque:N·m (kgf-m, ft-lb)

T1: 3 (0.3, 2.2)

T2: 3.4 (0.3, 2.5)

T3: 4.41 (0.45, 3.25)

T4: 7.5 (0.8, 5.5)

T5: 12 (1.2, 8.9)

C: CAUTION

- Wear appropriate work clothing, including a cap, protective goggles and protective shoes when performing any work.
- Remove contamination including dirt and corrosion before removal, installation or disassembly.
- Keep the disassembled parts in order and protect them from dust and dirt.
- Before removal, installation or disassembly, be sure to clarify the failure. Avoid unnecessary removal, installation, disassembly and replacement.
- Vehicle components are extremely hot after driving. Be wary of receiving burns from heated parts.
- Be sure to tighten fasteners including bolts and nuts to the specified torque.
- Place shop jacks or rigid racks at the specified points.
- Before disconnecting connectors of sensors or units, be sure to disconnect the ground cable from the battery.
- Prepare a container and cloth to prevent scattering of engine coolant when performing work where engine coolant can be spilled. If the fuel spills, wipe it off immediately to prevent from penetrating into floor or flowing out for environmental protection.
- Follow all government and local regulations concerning disposal of refuse when disposing engine coolant.

General Description

COOLING

D: PREPARATION TOOL

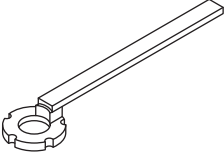
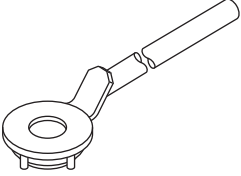
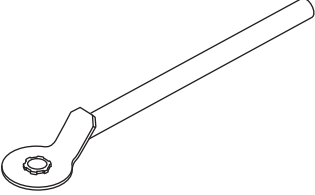
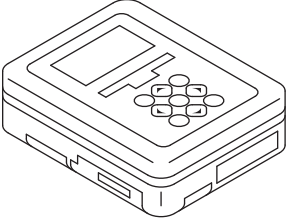
ILLUSTRATION	TOOL NUMBER	DESCRIPTION	REMARKS
 <p style="text-align: center;">ST-499207400</p>	499207400	CAM SPROCKET WRENCH	Used for removing and installing exhaust cam sprocket.
 <p style="text-align: center;">ST-499977400</p>	499977400	CRANK PULLEY WRENCH	Used to stop rotation of the crank pulley when loosening or tightening crank pulley bolts.
 <p style="text-align: center;">ST-499977500</p>	499977500	CAM SPROCKET WRENCH	Used for removing and installing intake cam sprocket.
 <p style="text-align: center;">ST1B022XU0</p>	1B022XU0 (Newly adopted tool)	SUBARU SELECT MONITOR III KIT	Used for troubleshooting for electrical system.

2. Radiator Fan System

A: WIRING DIAGRAM

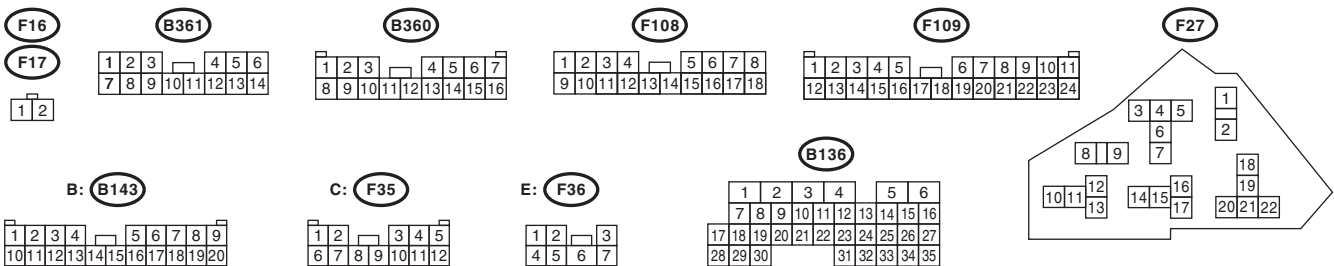
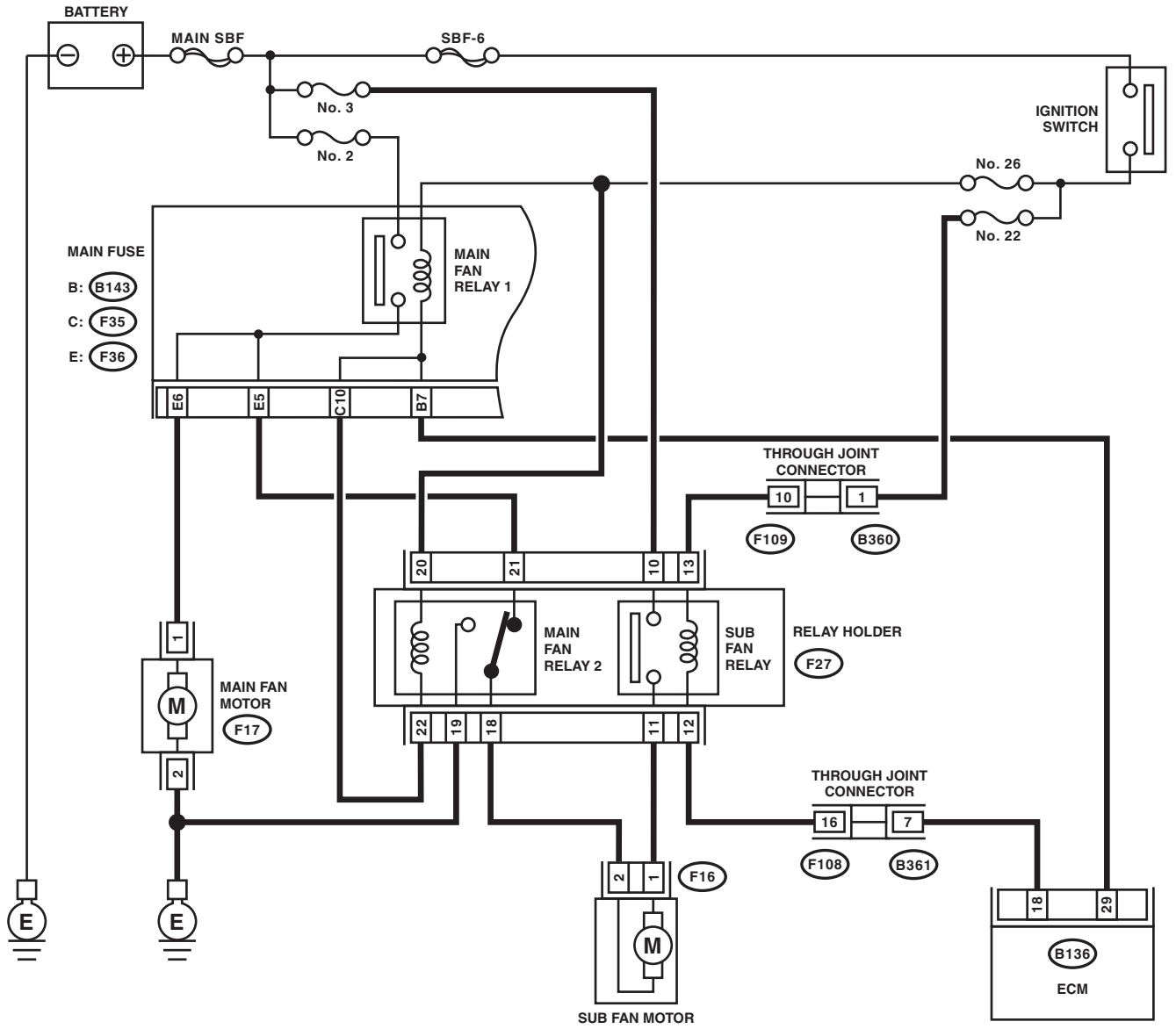

Radiator Fan System

COOLING

B: INSPECTION

OPERATING CONDITION:

Vehicle speed	A/C compressor load	Engine coolant temperature		
		Increase: 94°C (201°F) or less Decrease: 93°C (199°F) or less	Increase: 95 — 96°C (203 — 205°F) Decrease: 94°C (201°F)	Increase: 97°C (207°F) or more Decrease: 95°C (203°F) or more
		Radiator fan operation	Radiator fan operation	Radiator fan operation
During acceleration: 19 km/h (12 MPH) or less During deceleration: 10 km/h (6 MPH) or less	OFF	OFF	Low-Speed	High-Speed
	Low	Low-Speed	Low-Speed	High-Speed
	High	High-Speed	High-Speed	High-Speed
During acceleration: 20 — 69 km/h (12 — 43 MPH) During deceleration: 11 — 64 km/h (7 — 40 MPH)	OFF	OFF	Low-Speed	High-Speed
	Low	High-Speed	High-Speed	High-Speed
	High	High-Speed	High-Speed	High-Speed
During acceleration: 70 — 105 km/h (43 — 65 MPH) During deceleration: 65 — 100 km/h (40 — 62 MPH)	OFF	OFF	Low-Speed	High-Speed
	Low	High-Speed	High-Speed	High-Speed
	High	High-Speed	High-Speed	High-Speed
During acceleration: 106 km/h (66 MPH) or more During deceleration: 101 km/h (63 MPH) or more	OFF	OFF	High-Speed	High-Speed
	Low	High-Speed	High-Speed	High-Speed
	High	High-Speed	High-Speed	High-Speed

Radiator Fan System

COOLING

TROUBLE SYMPTOMS:

Radiator main fan and radiator sub fans do not rotate under the above operating conditions.

Step	Check	Yes	No
1 CHECK OPERATION OF RADIATOR FAN. 1) Connect the test mode connector. 2) Turn the ignition switch to ON. 3) Using the Subaru Select Monitor, check the forced operation of the radiator fan relay. NOTE: <ul style="list-style-type: none"> • When performing a forced operation radiator fan relay check using the Subaru Select Monitor, the radiator main fan and radiator sub fan will repeat low speed revolution → high speed revolution → OFF in this order. • Subaru Select Monitor Refer to Compulsory Valve Operation Check Mode for detailed procedures. <Ref. to EN(H4DOTC)(diag)-53, Compulsory Valve Operation Check Mode.>	Do the radiator main fans and radiator sub fans rotate at low speed?	Go to step 2.	Go to step 3.
2 CHECK OPERATION OF RADIATOR FAN. 1) Connect the test mode connector. 2) Turn the ignition switch to ON. 3) Perform the compulsory operation check for the radiator fan relay using Subaru Select Monitor. NOTE: <ul style="list-style-type: none"> • When performing a forced operation radiator fan relay check using the Subaru Select Monitor, the radiator main fan and radiator sub fan will repeat low speed revolution → high speed revolution → OFF in this order. • Subaru Select Monitor Refer to Compulsory Valve Operation Check Mode for detailed procedures. <Ref. to EN(H4DOTC)(diag)-53, Compulsory Valve Operation Check Mode.>	Do the radiator main fans and radiator sub fans rotate at high speed?	Radiator main fan system is normal.	Go to step 27.
3 CHECK POWER SUPPLY TO SUB FAN RELAY. 1) Turn the ignition switch to OFF. 2) Remove the sub fan relay from the relay holder. 3) Measure the voltage between the sub fan relay terminal and chassis ground. Connector & terminal (F27) No. 10 (+) — Chassis ground (-):	Is the voltage 10 V or more?	Go to step 4.	Go to step 5.
4 CHECK POWER SUPPLY TO SUB FAN RELAY. 1) Turn the ignition switch to ON. 2) Measure the voltage between the sub fan relay terminal and chassis ground. Connector & terminal (F27) No. 13 (+) — Chassis ground (-):	Is the voltage 10 V or more?	Go to step 7.	Go to step 6.
5 CHECK FUSE. 1) Turn the ignition switch to OFF. 2) Remove the fuse No. 3. 3) Check the condition of fuse.	Is the fuse blown out?	Replace the fuse.	Repair the power supply line.
6 CHECK FUSE. 1) Turn the ignition switch to OFF. 2) Remove the fuse No. 22. 3) Check the condition of fuse.	Is the fuse blown out?	Replace the fuse.	Repair the power supply line.

Radiator Fan System

COOLING

Step	Check	Yes	No
7 CHECK SUB FAN RELAY. 1) Turn the ignition switch to OFF. 2) Measure the resistance between sub fan relay terminals. Terminals No. 10 — No. 11:	Is the resistance 1 M Ω or more?	Go to step 8.	Replace the sub fan relay.
8 CHECK SUB FAN RELAY. 1) Connect the battery to terminals No. 12 and No. 13 of the sub fan relay. 2) Measure the resistance between sub fan relay terminals. Terminals No. 10 — No. 11:	Is the resistance less than 1 Ω ?	Go to step 9.	Replace the sub fan relay.
9 CHECK HARNESS BETWEEN SUB FAN RELAY TERMINAL AND SUB FAN MOTOR CONNECTOR. 1) Disconnect the connector from the sub fan motor. 2) Measure the resistance of harness between the sub fan relay terminal and sub fan motor connector. Connector & terminal (F16) No. 1 — (F27) No. 11:	Is the resistance less than 1 Ω ?	Go to step 10.	Repair the open circuit of harness between sub fan relay terminal and sub fan motor connector.
10 CHECK HARNESS BETWEEN SUB FAN MOTOR CONNECTOR AND MAIN FAN RELAY 2 CONNECTOR. 1) Remove the main fan relay 2 from the relay holder. 2) Measure the resistance of harness between sub fan motor connector and main fan relay 2 connector. Connector & terminal (F16) No. 2 — (F27) No. 18:	Is the resistance less than 1 Ω ?	Go to step 11.	Repair the open circuit of the harness between sub fan motor connector and main fan relay 2 connector.
11 CHECK POOR CONTACT. Check for poor contact of sub fan motor connector.	Is there poor contact in the sub fan motor connector?	Repair the poor contact of sub fan motor connector.	Go to step 12.
12 CHECK SUB FAN MOTOR. Connect the battery positive (+) terminal to terminal No. 1 of the sub fan motor, and the ground (-) terminal to terminal No. 2.	Does the radiator sub fan rotate?	Go to step 13.	Replace the sub fan motor.
13 CHECK MAIN FAN RELAY 2. Measure the resistance of main fan relay 2. Terminals No. 21 — No. 18:	Is the resistance less than 1 Ω ?	Go to step 14.	Replace the main fan relay 2.
14 CHECK HARNESS BETWEEN MAIN FAN RELAY 2 AND MAIN FAN MOTOR CONNECTOR. 1) Disconnect the connector from the main fan motor. 2) Measure the resistance of the harness between main fan relay 2 terminal and main fan motor connector. Connector & terminal (F17) No. 1 — (F27) No. 2:	Is the resistance less than 1 Ω ?	Go to step 15.	Repair the open circuit of the harness between main fan relay 2 terminal and main fan motor connector.

Radiator Fan System

COOLING

Step	Check	Yes	No
15 CHECK MAIN FAN MOTOR AND GROUND CIRCUIT. Measure the resistance between main fan motor connector and chassis ground. Connector & terminal (F17) No. 2 — Chassis ground:	Is the resistance less than 5 Ω ?	Go to step 16.	Repair the open circuit of the harness between main fan motor connector and chassis ground.
16 CHECK POOR CONTACT. Check poor contact of main fan motor connector.	Is there poor contact in the main fan motor connector?	Repair the poor contact of main fan motor connector.	Go to step 17.
17 CHECK MAIN FAN MOTOR. Connect the battery positive (+) terminal to terminal No. 1 of the main fan motor, and the ground (-) terminal to terminal No. 2.	Does the radiator main fan rotate?	Go to step 18.	Replace the main fan motor.
18 CHECK HARNESS BETWEEN SUB FAN RELAY AND ECM. 1) Disconnect the connectors from the ECM. 2) Measure the resistance between the sub fan relay terminal and ECM connector. Connector & terminal (B136) No. 18 — (F27) No. 12:	Is the resistance less than 1 Ω ?	Go to step 19.	Repair the open circuit of harness between sub fan relay terminal and ECM.
19 CHECK POOR CONTACT. Check for poor contact of the ECM connector.	Is there poor contact in ECM connector?	Repair the poor contact of the ECM connector.	Check the DTC. Repair the trouble cause. <Ref. to EN(H4DOTC)(diag)-41, Read Diagnostic Trouble Code (DTC).>
20 CHECK MAIN FAN RELAY 1. 1) Turn the ignition switch to OFF. 2) Remove main fan relay 1 from the main fuse box. 3) Measure the resistance of terminal in main fan relay 1 switch.	Is the resistance 1 M Ω or more?	Go to step 21.	Replace the main fan relay 1.
21 CHECK MAIN FAN RELAY 1. 1) Connect the main fan relay 1 coil side terminal to the battery. 2) Measure the resistance between terminals of main fan relay 1 switch.	Is the resistance less than 1 Ω ?	Go to step 22.	Replace the main fan relay 1.
22 CHECK HARNESS BETWEEN MAIN FAN RELAY 1 AND MAIN FAN MOTOR CONNECTOR. 1) Disconnect the connector from the main fan motor. 2) Measure the resistance of the harness between main fan relay 1 terminal and main fan motor connector. Connector & terminal (F17) No. 1 — (F36) No. 6:	Is the resistance less than 1 Ω ?	Go to step 23.	Repair the open circuit of the harness between main fan relay 1 terminal and main fan motor connector.
23 CHECK HARNESS BETWEEN MAIN FAN RELAY 1 AND ECM. 1) Disconnect the connectors from the ECM. 2) Measure the resistance between main fan relay 1 terminal and ECM connector. Connector & terminal (B136) No. 29 — (B143) No. 7:	Is the resistance less than 1 Ω ?	Go to step 24.	Repair the open circuit of the harness between main fan relay 1 terminal and ECM.

Radiator Fan System

COOLING

Step	Check	Yes	No
24 CHECK HARNESS BETWEEN MAIN FAN RELAY 2 AND ECM. Measure the resistance between main fan relay 2 terminal and ECM connector. Connector & terminal (B136) No. 29 — (F27) No. 22:	Is the resistance less than 1 Ω ?	Go to step 25.	Repair the open circuit of the harness between main fan relay 2 terminal and ECM.
25 CHECK FUSE. 1) Turn the ignition switch to OFF. 2) Remove the fuse No. 2 and 26. 3) Check the condition of fuse.	Is the fuse blown out?	Replace the fuse.	Go to step 26.
26 CHECK POOR CONTACT. Check for poor contact of the ECM connector.	Is there poor contact in ECM connector?	Repair the poor contact of the ECM connector.	Repair the power supply circuit to the main fuse box.
27 CHECK OPERATION OF RADIATOR FAN. If the both fans do not rotate at high speed in the condition of step 2, check whether the radiator sub fan is rotating.	Does the radiator sub fan rotate?	Go to step 20.	Go to step 28.
28 CHECK GROUND CIRCUIT OF MAIN FAN RELAY 2. 1) Remove the main fan relay 2 from the relay holder. 2) Measure the resistance between main fan relay 2 terminal and chassis ground. Connector & terminal (F27) No. 19 — Chassis ground:	Is the resistance less than 1 Ω ?	Go to step 29.	Repair the open circuit of harness between main fan relay 2 and chassis ground.
29 CHECK POWER SUPPLY TO MAIN FAN RELAY 2. 1) Turn the ignition switch to ON. 2) Measure the voltage between main fan relay 2 terminal and chassis ground. Connector & terminal (F27) No. 20 (+) — Chassis ground (-):	Is the voltage 10 V or more?	Go to step 30.	Repair the power supply line.
30 CHECK MAIN FAN RELAY 2. 1) Turn the ignition switch to OFF. 2) Remove the main fan relay 2. 3) Measure the resistance of main fan relay 2. Terminals (F27) No. 18 — (F27) No. 19:	Is the resistance 1 M Ω or more?	Go to step 31.	Replace the main fan relay 2.
31 CHECK MAIN FAN RELAY 2. 1) Connect the battery to main fan relay 2 terminals No. 20 and No. 22. 2) Measure the resistance of main fan relay 2. Terminals (F27) No. 18 — (F27) No. 19:	Is the resistance less than 1 Ω ?	Go to step 23.	Replace the main fan relay 2.

3. Engine Coolant

A: REPLACEMENT

1. DRAINING OF ENGINE COOLANT

- 1) Set the vehicle on a lift.
- 2) Lift up the vehicle.
- 3) Remove the under cover.
- 4) Remove the drain plug to drain engine coolant into container.

NOTE:

Remove the coolant filler tank cap so that engine coolant will drain faster.

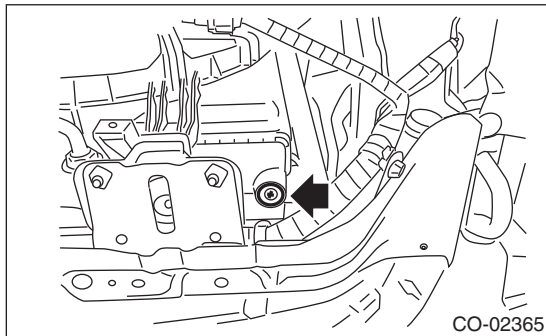

- 5) Install the drain plug.
- 6) Install the under cover.

2. FILLING OF ENGINE COOLANT

- 1) Pour cooling system conditioner through the filler neck.

Cooling system protective agent:

Refer to "SPECIFICATION" for the cooling system protective agent. <Ref. to CO(H4DOTC)-2, SPECIFICATION, General Description.>

- 2) Fill the engine coolant into coolant filler tank up to the filler neck position.

Recommended engine coolant:

Refer to "SPECIFICATION" for the recommended engine coolant. <Ref. to CO(H4DOTC)-2, SPECIFICATION, General Description.>

Coolant level:

Refer to "SPECIFICATION" for the coolant level. <Ref. to CO(H4DOTC)-2, SPECIFICATION, General Description.>

Concentration of coolant:

Refer to "ADJUSTMENT" for the concentration of the coolant. <Ref. to CO(H4DOTC)-14, ADJUSTMENT, Engine Coolant.>

CAUTION:

Do not confuse the cap of coolant filler tank and cap of radiator.

NOTE:

- When pouring the engine coolant, the radiator side cap must not be removed.
- The SUBARU Super Coolant containing anti-freeze and anti-rust agents is especially made for SUBARU engine, which has an aluminum cylinder block. Always use SUBARU Super Coolant, since other coolant may cause corrosion.

- 3) Fill engine coolant into the reservoir tank up to "FULL" level.

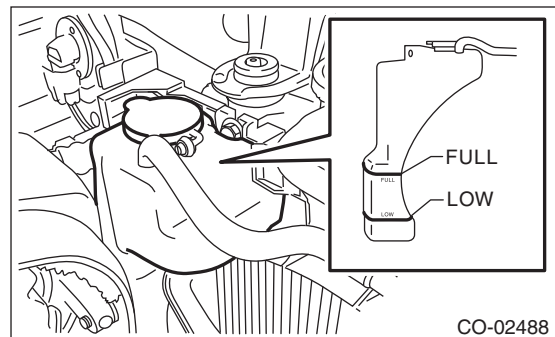

Engine Coolant

COOLING

4) Close the coolant filler tank cap, and start the engine. Race 5 to 6 times at 3,000 rpm or less, then stop the engine. (Complete this operation within 40 seconds.)

5) Wait for one minute after the engine stops, then open the coolant filler tank cap. If the engine coolant level drops, add engine coolant into the coolant filler tank up to the filler neck position.

6) Perform the procedures 4) and 5) again.

7) Install the coolant filler tank cap and reservoir tank cap properly.

8) Start the engine and operate the heater at maximum hot position and the blower speed setting to "LO".

9) Run the engine at 2,000 rpm or less until radiator fan starts and stops.

NOTE:

Be careful with the engine coolant temperature gauge to prevent overheating.

10) Stop the engine and wait until the engine coolant temperature lowers to 30°C (86°F) or less.

11) Open the coolant filler tank cap. If the engine coolant level drops, add engine coolant into the coolant filler tank up to the filler neck position and the reservoir tank to "FULL" level.

12) Install the coolant filler tank cap and reservoir tank cap properly.

13) Set the heater setting to maximum hot position and the blower speed setting to "LO" and start the engine. Perform racing at 3,000 rpm or less. If the flowing sound is heard from heater core, repeat the procedures from step 9) again.

B: ADJUSTMENT

1. PROCEDURE TO ADJUST THE CONCENTRATION OF THE SUBARU SUPER COOLANT

CAUTION:

SUBARU Super Coolant concentration must be used from 50 to 60 % to assure the best performance of the anti-freeze and anti-rust agents.

To adjust the concentration of SUBARU Super Coolant according to temperature, find the proper SUBARU Super Coolant concentration from the table and adjust SUBARU Super Coolant (concentrated type) to the concentration with water for dilution.

RELATIONSHIP OF SUBARU SUPER COOLANT CONCENTRATION AND FREEZING TEMPERATURE			
Concentration of SUBARU Super Coolant	50%	55%	60%
Freezing temperature	-36°C (-33°F)	-41°C (-42°F)	-50°C (-58°F)

Recommended Engine Coolant and Water for Dilution:

Refer to "SPECIFICATION" for the recommended engine coolant and water for dilution. <Ref. to CO(H4DOTC)-2, SPECIFICATION, General Description.>

4. Water Pump

A: REMOVAL

- 1) Remove the collector cover.
- 2) Remove the radiator. <Ref. to CO(H4DOTC)-19, REMOVAL, Radiator.>
- 3) Remove the V-belts. <Ref. to ME(H4DOTC)-39, REMOVAL, V-belt.>
- 4) Remove the crank pulley. <Ref. to ME(H4DOTC)-47, REMOVAL, Crank Pulley.>
- 5) Remove the timing belt cover. <Ref. to ME(H4DOTC)-49, REMOVAL, Timing Belt Cover.>
- 6) Remove the timing belt. <Ref. to ME(H4DOTC)-50, REMOVAL, Timing Belt.>
- 7) Remove the automatic belt tension adjuster (A).
- 8) Remove the belt idler (B).
- 9) Remove the belt idler No. 2 (C).

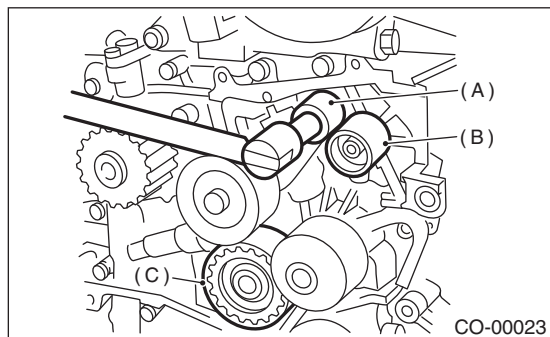

- 10) Remove the cam sprocket LH. <Ref. to ME(H4DOTC)-57, REMOVAL, Cam Sprocket.>
- 11) Remove the belt cover LH No. 2.

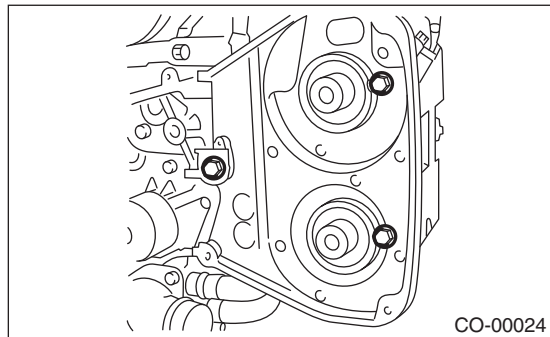

- 12) Remove the tensioner bracket.

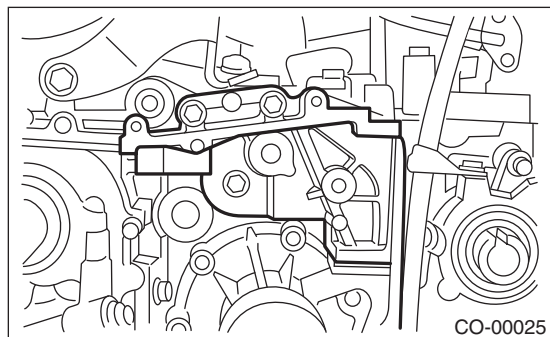

- 13) Disconnect the hose from water pump.

- 14) Remove the water pump.

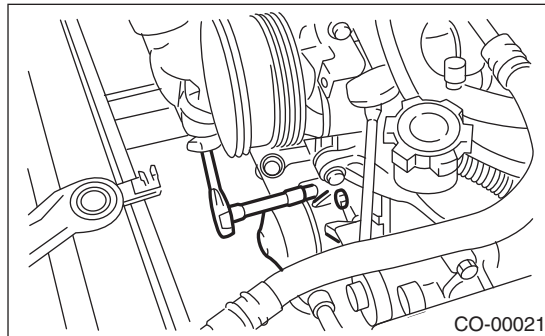

B: INSTALLATION

- 1) Install the water pump onto cylinder block LH.

NOTE:

- Use a new gasket.
- When installing the water pump, tighten the bolts in two stages in alphabetical sequence as shown in figure.

Tightening torque:

First:

12 N·m (1.2 kgf-m, 8.9 ft-lb)

Second:

12 N·m (1.2 kgf-m, 8.9 ft-lb)

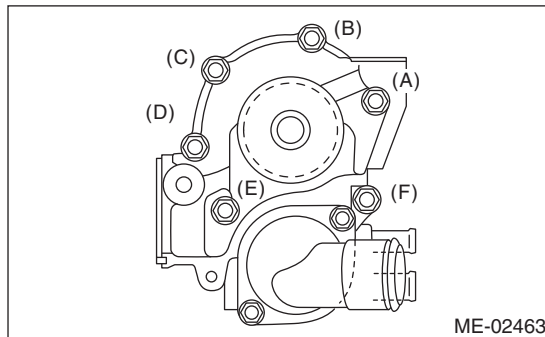

- 2) Install the hose to water pump.
- 3) Install the tensioner bracket.

Tightening torque:

24.5 N·m (2.5 kgf-m, 18.1 ft-lb)

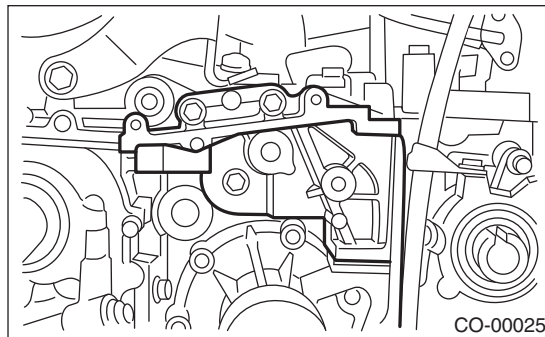

Water Pump

COOLING

4) Install the belt cover No. 2 LH.

Tightening torque:

5 N·m (0.5 kgf·m, 3.7 ft·lb)

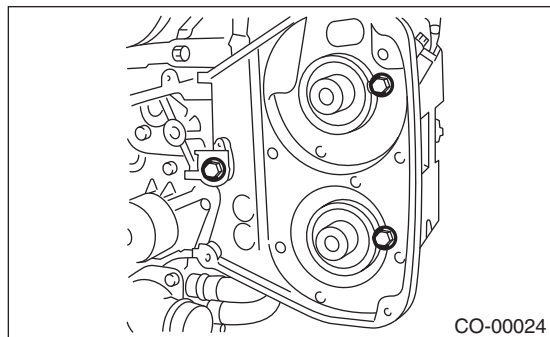

5) Install the cam sprocket LH. <Ref. to ME(H4DOTC)-57, INSTALLATION, Cam Sprocket.>

6) Install the belt idler No. 2 (C).

Tightening torque:

39 N·m (4.0 kgf·m, 28.8 ft·lb)

7) Install the belt idler (B).

Tightening torque:

25 N·m (2.5 kgf·m, 18.4 ft·lb)

8) Install an automatic belt tension adjuster (A) with the tension rod held by a pin. <Ref. to ME(H4DOTC)-51, AUTOMATIC BELT TENSION ADJUSTER ASSEMBLY AND BELT IDLER, INSTALLATION, Timing Belt.>

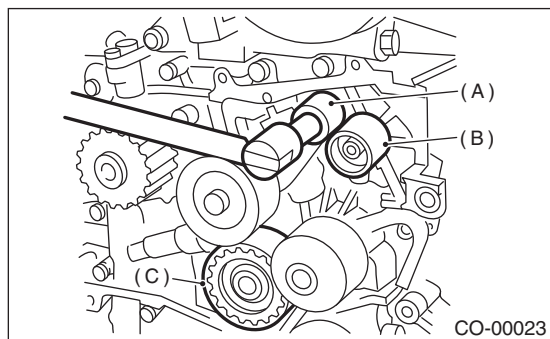

9) Install the timing belt. <Ref. to ME(H4DOTC)-52, TIMING BELT, INSTALLATION, Timing Belt.>

10) Install the timing belt cover. <Ref. to ME(H4DOTC)-49, INSTALLATION, Timing Belt Cover.>

11) Install the crank pulley. <Ref. to ME(H4DOTC)-47, INSTALLATION, Crank Pulley.>

12) Install the V-belts. <Ref. to ME(H4DOTC)-39, INSTALLATION, V-belt.>

13) Install the radiator. <Ref. to CO(H4DOTC)-20, INSTALLATION, Radiator.>

14) Install the collector cover.

C: INSPECTION

- 1) Check the water pump bearing for smooth rotation.
- 2) Check the water pump pulley for abnormalities.
- 3) Make sure the impeller is not deformed or damaged.
- 4) Inspect the clearance between impeller and pump case.

Clearance between impeller and pump case:

Standard

0.5 — 1.5 mm (0.020 — 0.059 in)

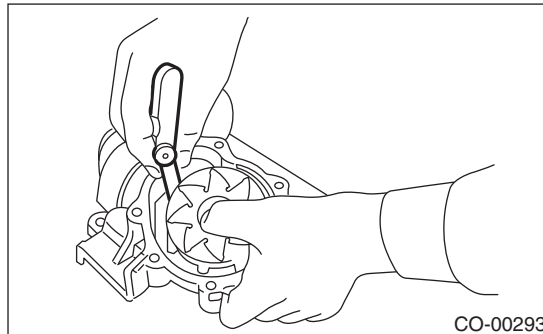

5) After water pump installation, check pulley shaft for engine coolant leaks or noise. If leaks or noise are noted, replace the water pump assembly.

5. Thermostat

A: REMOVAL

- 1) Set the vehicle on a lift.
- 2) Lift up the vehicle.
- 3) Remove the under cover.
- 4) Drain engine coolant completely.
<Ref. to CO(H4DOTC)-13, DRAINING OF ENGINE COOLANT, REPLACEMENT, Engine Coolant.>
- 5) Disconnect the radiator outlet hose from thermostat cover.

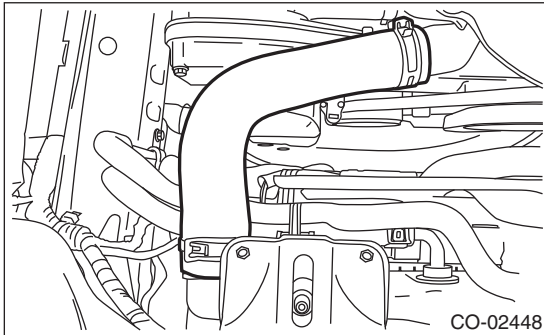

- 6) Remove the thermostat cover, and then remove the gasket and thermostat.

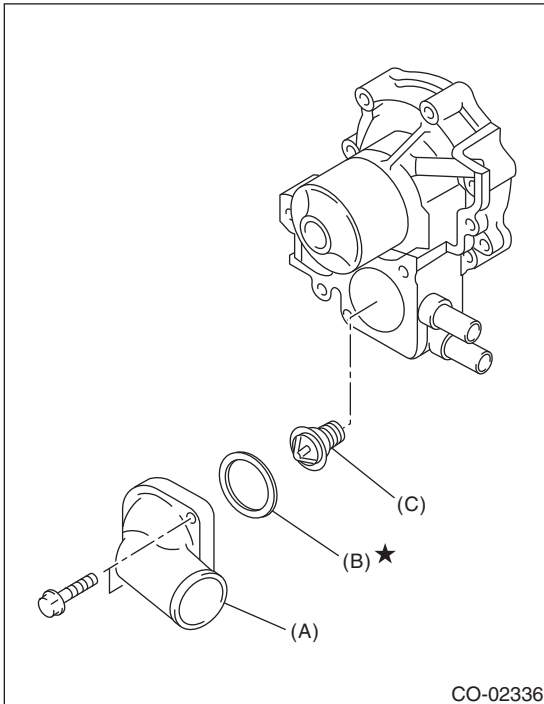

- (A) Thermostat cover
- (B) Gasket
- (C) Thermostat

B: INSTALLATION

- 1) Install a gasket to thermostat.

NOTE:

Use a new gasket.

- 2) Install the thermostat and thermostat cover.

NOTE:

The thermostat must be installed with the jiggle pin facing upward.

Tightening torque:

12 N·m (1.2 kgf·m, 8.9 ft·lb)

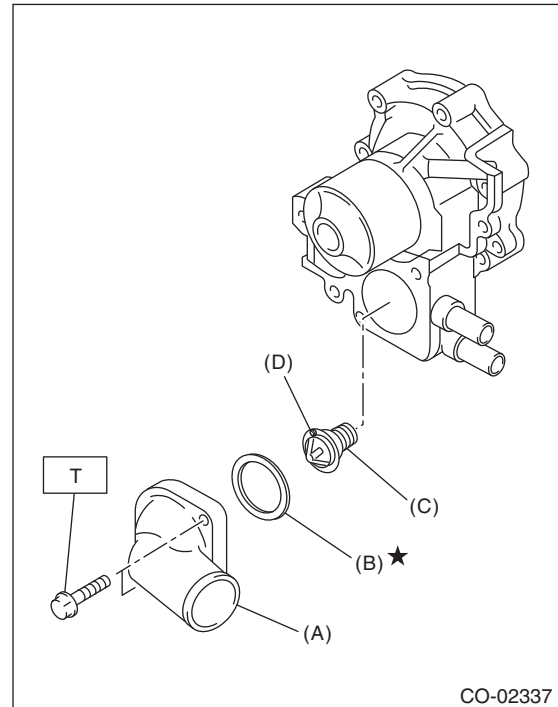

- (A) Thermostat cover
- (B) Gasket
- (C) Thermostat
- (D) Jiggle pin

- 3) Connect the radiator outlet hose to thermostat cover.

- 4) Install the under cover.

- 5) Lower the vehicle.

- 6) Fill engine coolant. <Ref. to CO(H4DOTC)-13, FILLING OF ENGINE COOLANT, REPLACEMENT, Engine Coolant.>

C: INSPECTION

Replace the thermostat if the valve does not close completely at an ambient temperature or if the following test shows unsatisfactory results.

- Inspection method

Immerse the thermostat and a thermometer in water. Raise water temperature gradually, and measure the temperature and valve lift when the valve begins to open and when the valve is fully opened. During the test, agitate the water for even temperature distribution. The measured value should meet the specification.

NOTE:

- Leave the thermostat in the boiling water for five minutes or more before measuring the valve lift.
- Hold the thermostat with a wire or the like to avoid contacting with container bottom.

Opening start temperature:

76 — 80°C (169 — 176°F)

Full open temperature:

91°C (196°F)

Valve lift:

9.0 mm (0.354 in) or more

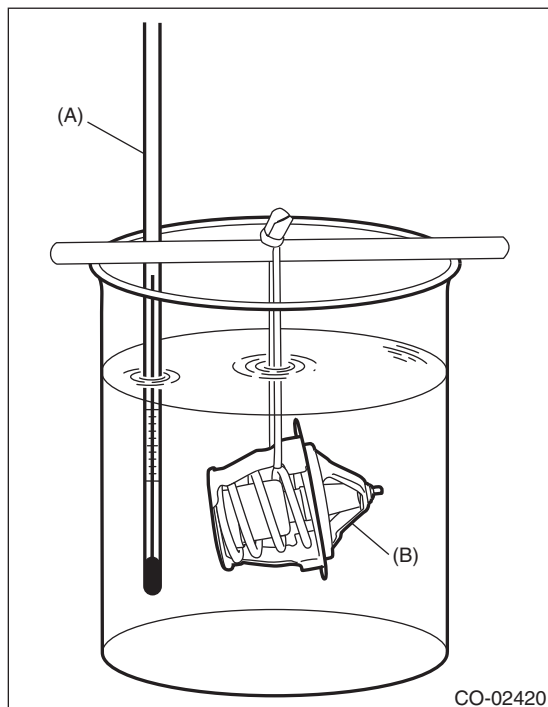

- (A) Thermometer
- (B) Thermostat

6. Radiator

A: REMOVAL

CAUTION:

The radiator is pressurized. Wait until engine cools down before working on the radiator.

- 1) Set the vehicle on a lift.
- 2) Remove the collector cover.
- 3) Disconnect the ground cable from the battery.

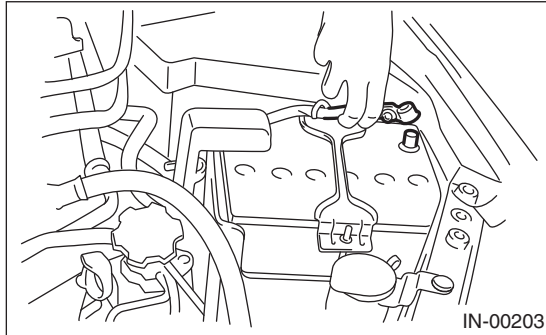

- 4) Lift up the vehicle.
- 5) Remove the under cover.
- 6) Remove the heat shield cover from radiator.

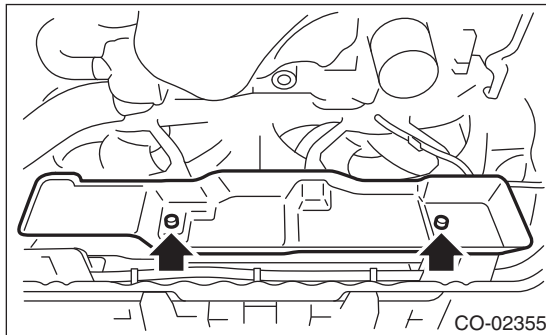

- 7) Drain engine coolant completely.
<Ref. to CO(H4DOTC)-13, DRAINING OF ENGINE COOLANT, REPLACEMENT, Engine Coolant.>

- 8) Disconnect the connectors of main fan motor (A) and sub fan motor (B).

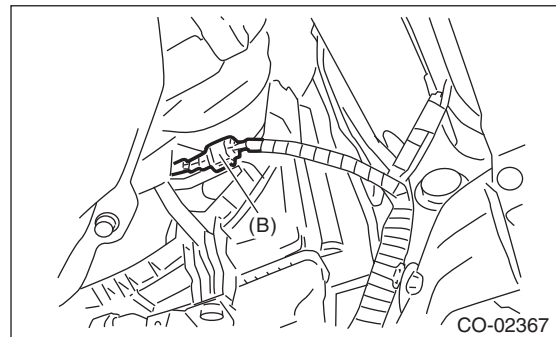
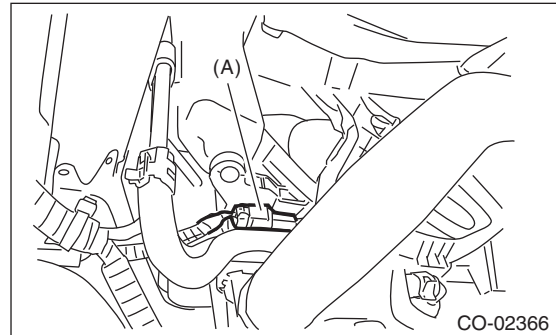

- 9) Disconnect the radiator outlet hose from thermostat cover.

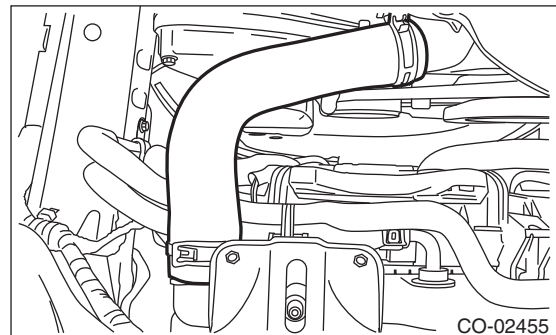

- 10) Disconnect the ATF cooler hoses from ATF pipes.

NOTE:

Plug the ATF pipe to prevent ATF from leaking.

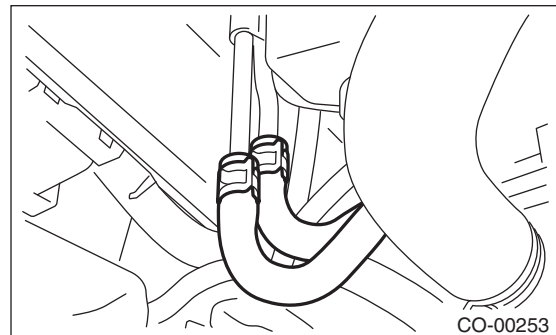

- 11) Lower the vehicle.
- 12) Remove the air intake duct. <Ref. to IN(H4DOTC)-9, REMOVAL, Air Intake Duct.>
- 13) Remove the reservoir tank. <Ref. to CO(H4DOTC)-28, REMOVAL, Reservoir Tank.>

Radiator

COOLING

- 14) Disconnect the radiator inlet hose from the radiator.

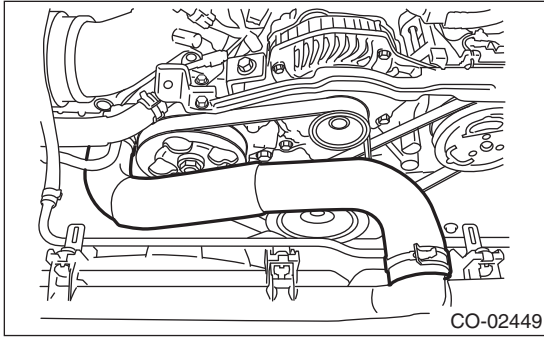

- 15) Disconnect the two coolant filler tank hoses from the radiator.

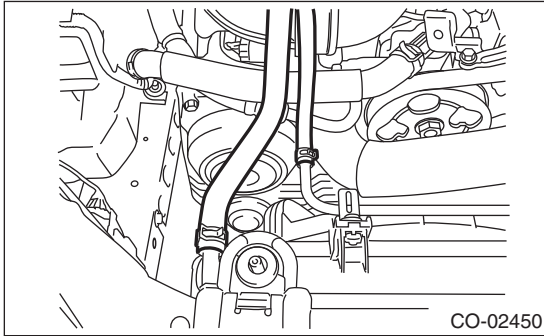

- 16) Remove the radiator upper brackets.

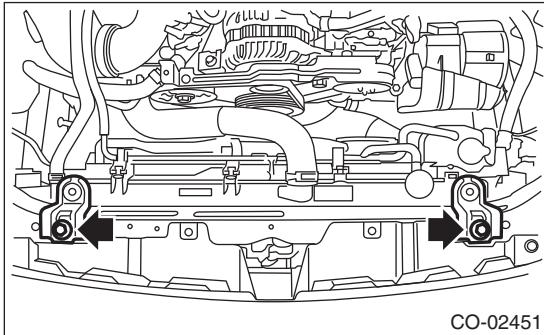

- 17) Move the radiator to the left while lifting it upward.
- 18) Lift the radiator up and away from vehicle.

B: INSTALLATION

- 1) Attach the radiator lower cushion to the hole on the radiator lower bracket.

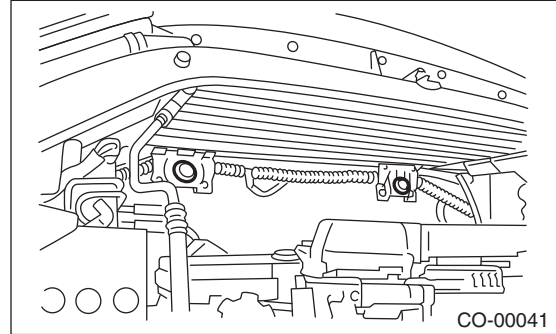

- 2) Install the radiator to vehicle.

NOTE:

Make pins on the lower side of radiator be fitted into the radiator lower cushions on body side.

- 3) Install the radiator upper brackets and tighten the bolts.

Tightening torque:

12 N·m (1.2 kgf·m, 8.9 ft·lb)

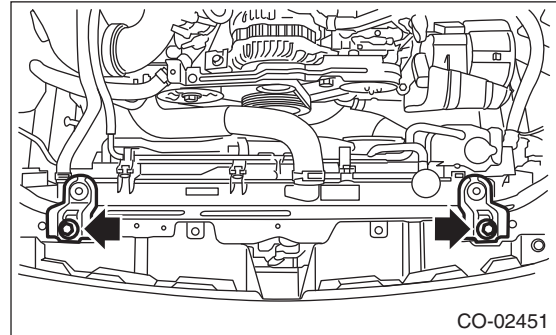

- 4) Connect the two coolant filler tank hoses to the radiator.

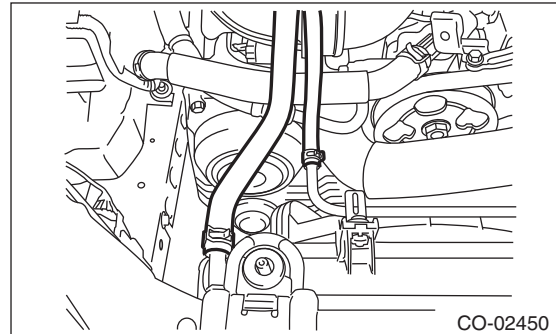

5) Connect the radiator inlet hose.

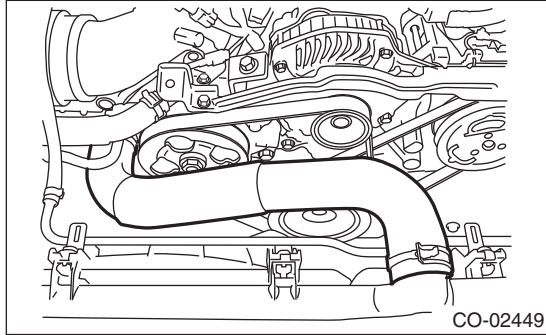

6) Install the reservoir tank. <Ref. to CO(H4DOTC)-28, INSTALLATION, Reservoir Tank.>

7) Install the air intake duct.

<Ref. to IN(H4DOTC)-9, INSTALLATION, Air Intake Duct.>

8) Lift up the vehicle.

9) Connect the ATF cooler hoses.

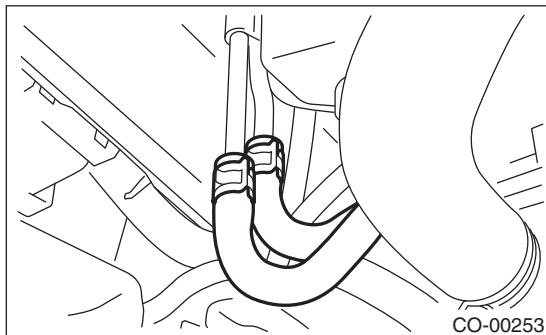

10) Connect the radiator outlet hose.

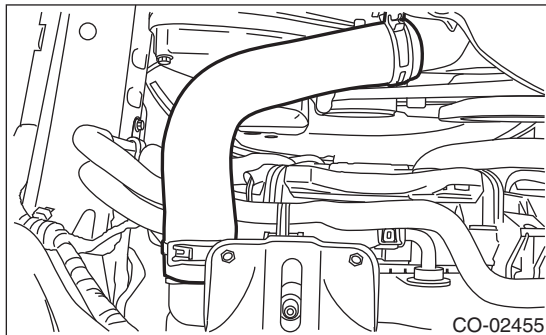

11) Connect the connectors to the main fan motor (A) and sub fan motor (B).

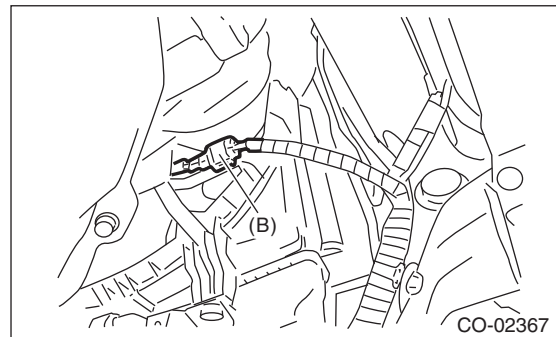
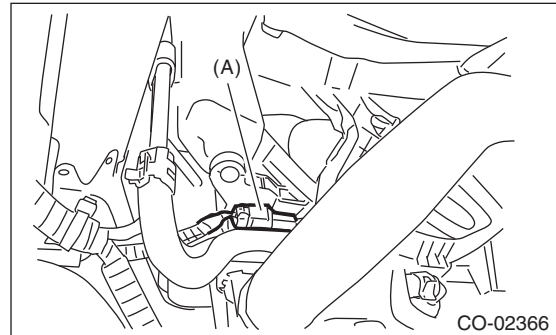

12) Install the heat shield cover to the radiator.

Tightening torque:

3 N·m (0.3 kgf·m, 2.2 ft·lb)

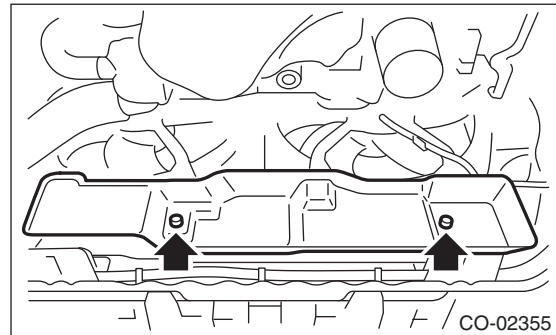

13) Install the under cover.

14) Lower the vehicle.

15) Connect the battery ground cable to battery.

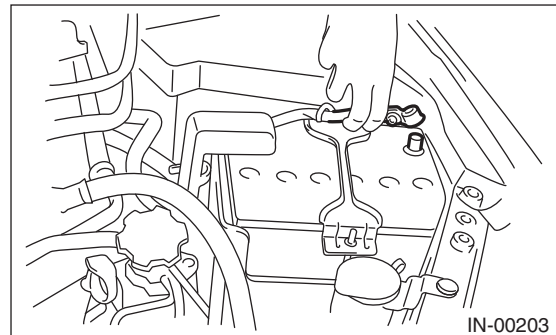

16) Fill engine coolant.

<Ref. to CO(H4DOTC)-13, FILLING OF ENGINE COOLANT, REPLACEMENT, Engine Coolant.>

COOLING

17) Check the ATF level. <Ref. to 4AT-26, INSPECTION, Automatic Transmission Fluid.>

18) Install the collector cover.

C: INSPECTION

1) Remove the coolant filler tank cap, fill the coolant filler tank with engine coolant, then install the tester to the installation position of the cap.

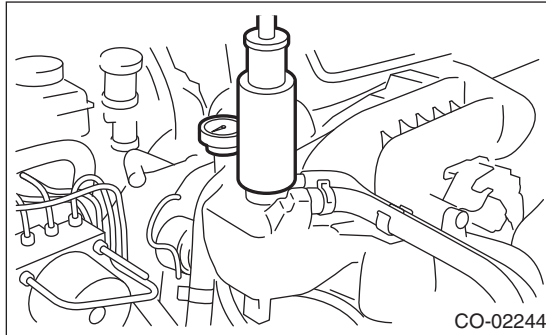

2) Apply a pressure of 122 kPa (1.2 kg/cm², 18 psi) to the radiator and check the following points:

- Leakage from the radiator or its vicinity
- Leakage from the hose or its connections

CAUTION:

- **Inspection must be carried out at the side of coolant filler tank, not at the side of radiator.**
- **Engine should be turned off.**
- **Wipe engine coolant from check points in advance.**
- **Be careful of the spurt of engine coolant when removing the tester.**
- **Be careful not to deform the filler neck of the coolant filler tank when installing and removing the tester.**

7. Radiator Cap

A: INSPECTION

1) Attach the radiator cap to tester.

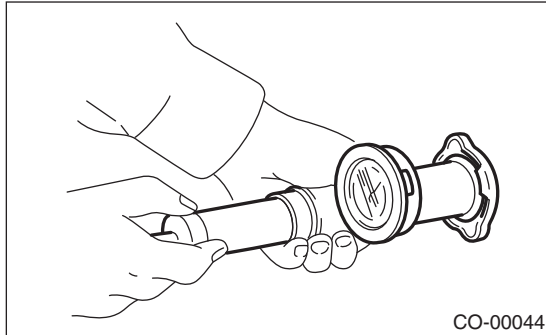

2) Increase pressure until the tester gauge pointer stops. Radiator cap is functioning properly if it holds the service limit pressure for five to six seconds. Remove the cap if it is opened under a pressure less than the service limit value

Coolant filler tank side

Specification:

93 — 123 kPa

(0.95 — 1.25 kg/cm², 14 — 18 psi)

Service limit:

83 kPa (0.85 kg/cm², 12 psi)

Radiator side

Specification:

122 — 152 kPa

(1.24 — 1.55 kg/cm², 18 — 22 psi)

Service limit:

112 kPa (1.14 kg/cm², 16 psi)

CAUTION:

- Be sure to remove foreign matter and rust from the cap in advance. Otherwise, results of pressure test will be incorrect.
- Do not confuse the cap of coolant filler tank and cap of radiator.

Radiator Main Fan and Fan Motor

COOLING

8. Radiator Main Fan and Fan Motor

A: REMOVAL

- 1) Set the vehicle on a lift.
- 2) Remove the collector cover.
- 3) Disconnect the ground cable from the battery.

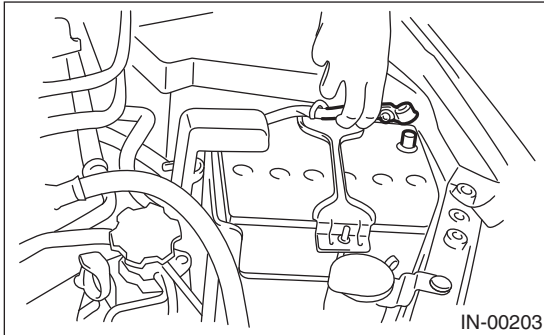

- 4) Lift up the vehicle.
- 5) Remove the under cover.
- 6) Disconnect the main fan motor connector (A).

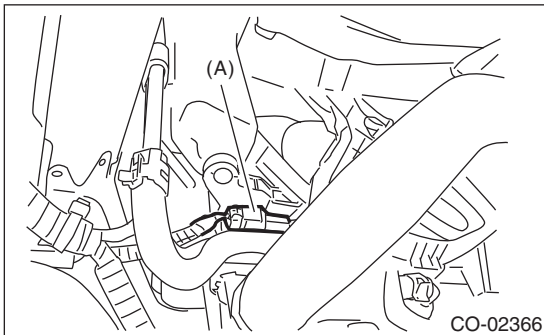

- 7) Remove the heat shield cover from radiator.

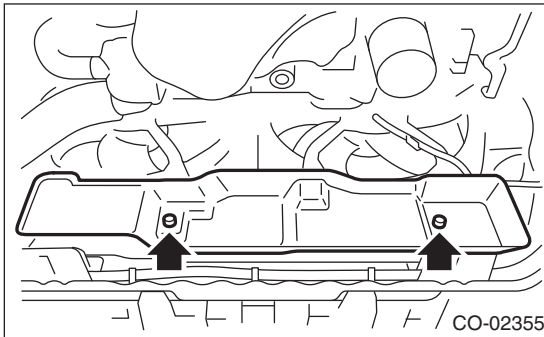

- 8) Remove the ATF hose from the hose clip of the radiator main fan motor assembly.

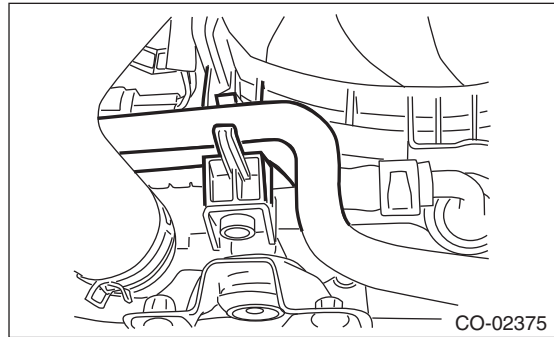

- 9) Lower the vehicle.
- 10) Remove the air intake duct (rear). <Ref. to IN(H4DOTC)-9, REMOVAL, Air Intake Duct.>
- 11) Remove the reservoir tank. <Ref. to CO(H4DOTC)-28, REMOVAL, Reservoir Tank.>
- 12) Remove the bolts that hold the radiator main fan motor assembly and the over flow pipe.

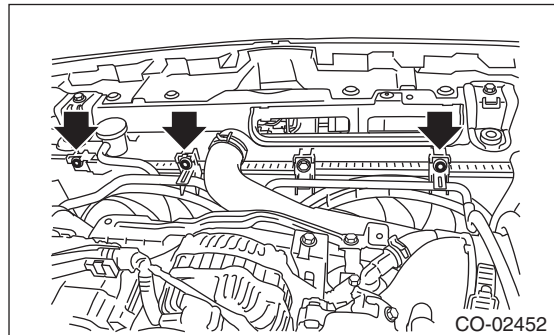

- 13) Remove the radiator main fan motor assembly from the upper side of the vehicle.

B: INSTALLATION

Install in the reverse order of removal.

CAUTION:

Check if the radiator hose and the over flow hose are properly connected.

Tightening torque:

7.5 N·m (0.8 kgf·m, 5.5 ft·lb)

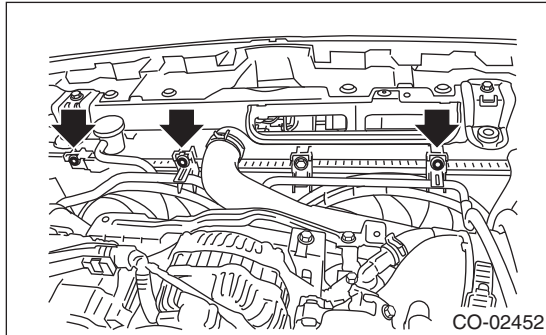

Tightening torque:

3 N·m (0.3 kgf·m, 2.2 ft·lb)

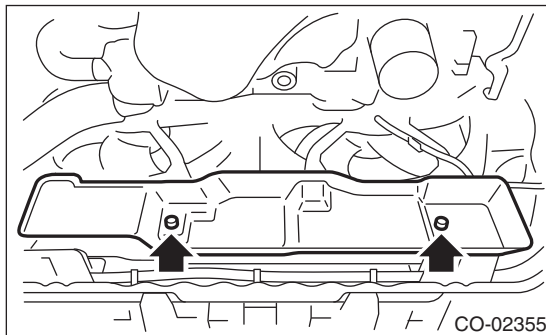

C: DISASSEMBLY

- 1) Remove the clip which holds the main fan motor connector onto the radiator main fan shroud.
- 2) Remove the nut which holds the radiator main fan to the main fan motor.

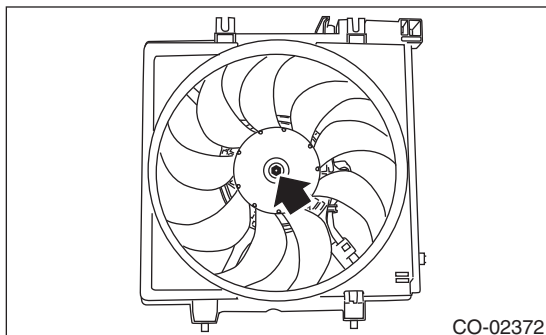

- 3) Remove the bolts which hold the main fan motor onto radiator main fan shroud.

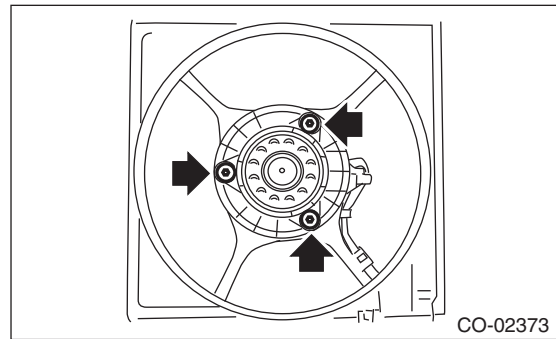

D: ASSEMBLY

Assemble in the reverse order of disassembly.

Tightening torque:

4.41 N·m (0.45 kgf·m, 3.25 ft·lb)

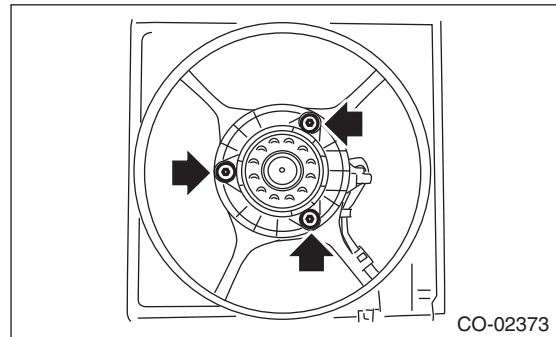

Tightening torque:

3.4 N·m (0.3 kgf·m, 2.5 ft·lb)

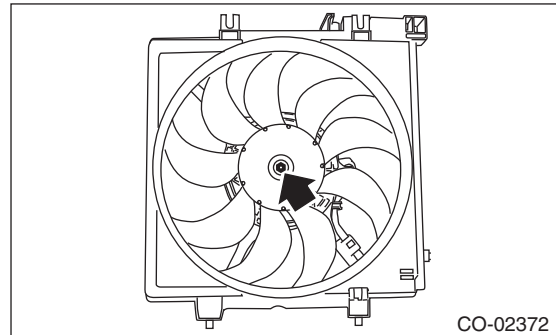

Radiator Sub Fan and Fan Motor

COOLING

9. Radiator Sub Fan and Fan Motor

A: REMOVAL

- 1) Set the vehicle on a lift.
- 2) Remove the collector cover.
- 3) Disconnect the ground cable from the battery.

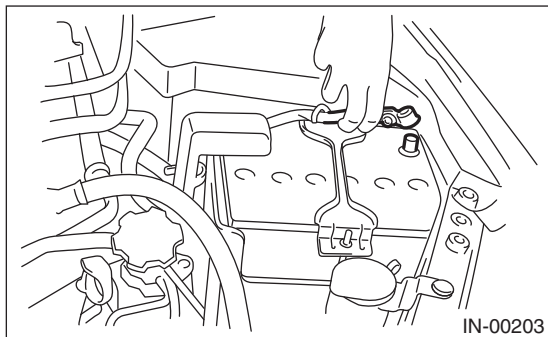

- 4) Lift up the vehicle.
- 5) Remove the under cover.
- 6) Disconnect the sub fan motor connector (B).

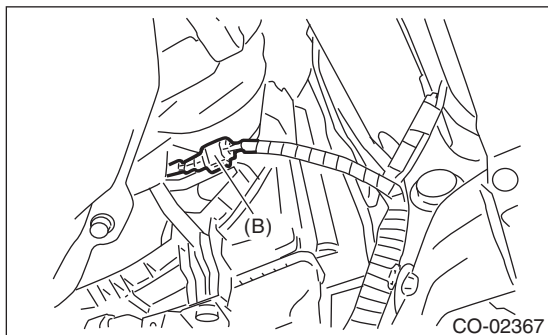

- 7) Remove the heat shield cover from radiator.

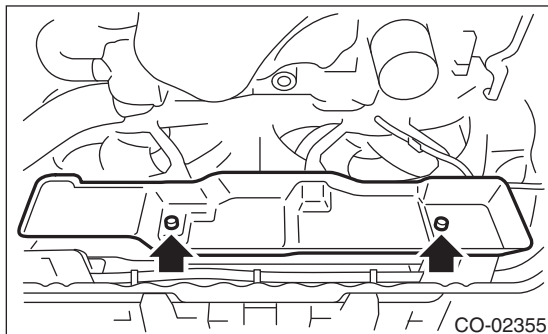

- 8) Lower the vehicle.
- 9) Remove the air intake duct (rear). <Ref. to IN(H4DOTC)-9, REMOVAL, Air Intake Duct.>

- 10) Remove the bolts that hold the radiator sub fan motor assembly and the over flow pipe.

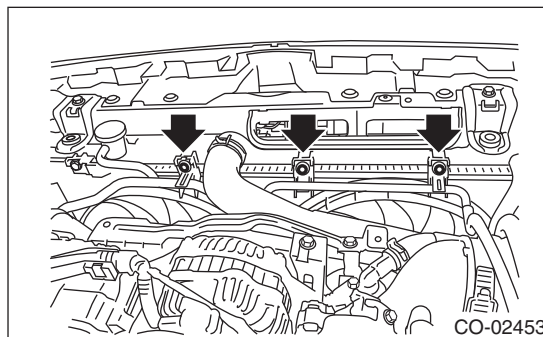

- 11) Raise the radiator sub fan motor assembly slightly, remove the pin of the radiator sub fan motor assembly lower part from the radiator hole, and remove the radiator sub fan motor assembly from the lower side of the vehicle.

B: INSTALLATION

Install in the reverse order of removal.

CAUTION:

Check if the radiator hose and the over flow hose are properly connected.

Tightening torque:

7.5 N·m (0.8 kgf-m, 5.5 ft-lb)

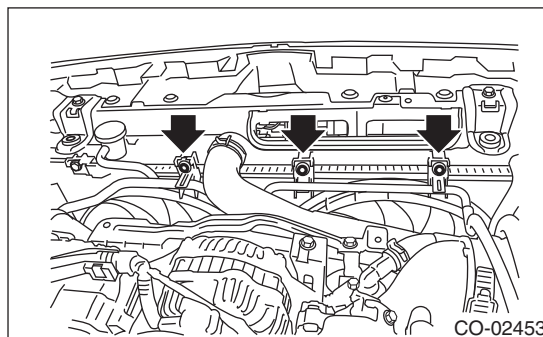

Tightening torque:

3 N·m (0.3 kgf-m, 2.2 ft-lb)

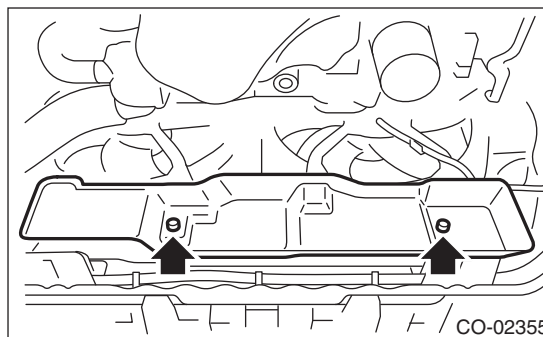

C: DISASSEMBLY

- 1) Remove the clip which holds the sub fan motor connector onto the radiator sub fan shroud.
- 2) Remove the nut which holds the radiator sub fan to the sub fan motor.

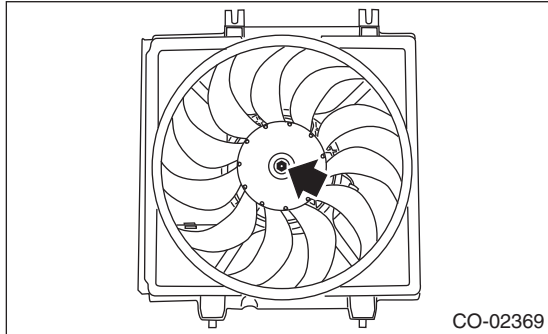

- 3) Remove the bolts which hold the sub fan motor onto the radiator sub fan shroud.

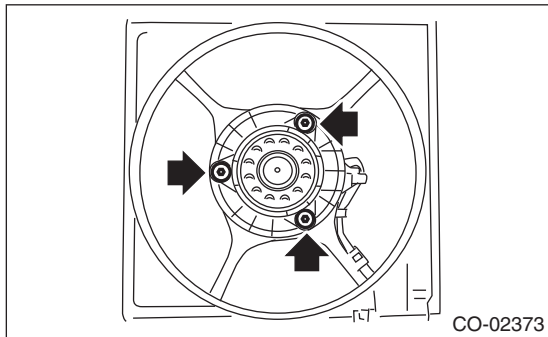

D: ASSEMBLY

Assemble in the reverse order of disassembly.

Tightening torque:

4.41 N·m (0.45 kgf-m, 3.25 ft-lb)

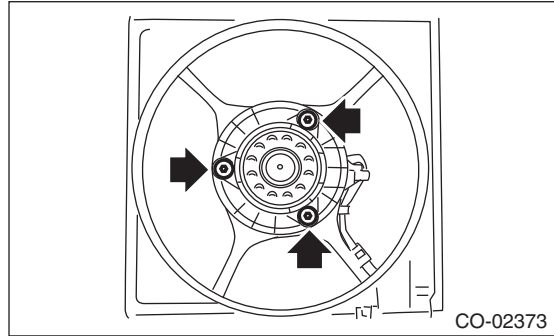

Tightening torque:

3.4 N·m (0.3 kgf-m, 2.5 ft-lb)

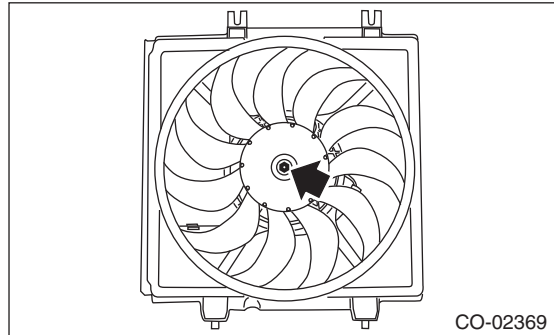

10. Reservoir Tank

A: REMOVAL

- 1) Pull out the over flow hose (A).
- 2) Pull out the reservoir tank to the arrow direction while pushing the claw (B).

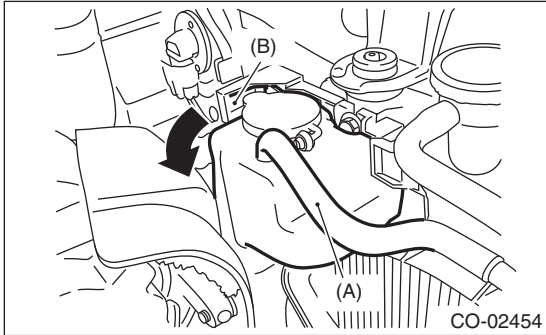

B: INSTALLATION

Install in the reverse order of removal.

C: INSPECTION

Make sure the engine coolant level is between "FULL" and "LOW".

11. Coolant Filler Tank

A: REMOVAL

WARNING:

The radiator is pressurized. Wait until engine cools down before working on the radiator.

- 1) Remove the collector cover.
- 2) Drain approximately 3.0 ℓ (3.2 US qt, 2.6 Imp qt) of coolant. <Ref. to CO(H4DOTC)-13, DRAINING OF ENGINE COOLANT, REPLACEMENT, Engine Coolant.>
- 3) Disconnect the engine coolant hoses from coolant filler tank.
- 4) Remove the bolts which install the coolant filler tank.

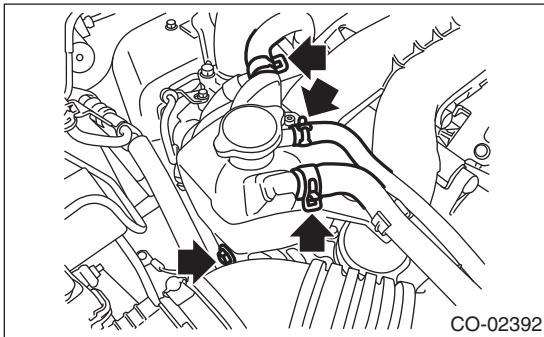

- 5) Disconnect the engine coolant hose which connects the under side of coolant filler tank.
- 6) Remove the coolant filler tank.

B: INSTALLATION

Install in the reverse order of removal.

Tightening torque:

16 N·m (1.6 kgf-m, 11.8 ft-lb)

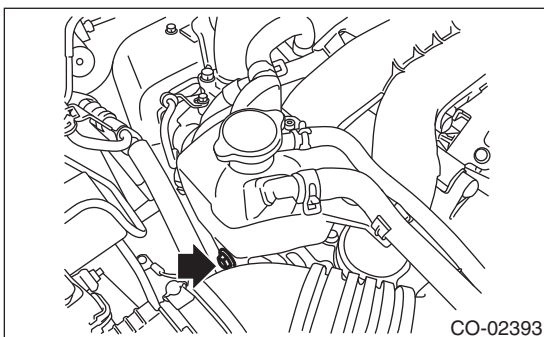

Engine Cooling System Trouble in General

COOLING

12.Engine Cooling System Trouble in General

A: INSPECTION

Trouble	Possible cause	Corrective action
Over-heating	a. Insufficient engine coolant	Replenish engine coolant, inspect for leakage, and repair it if necessary.
	b. Loose timing belt	Repair or replace timing belt tensioner.
	c. Oil on timing belt	Replace.
	d. Malfunction of thermostat	Replace.
	e. Malfunction of water pump	Replace.
	f. Clogged engine coolant passage	Clean.
	g. Improper ignition timing	Inspect and repair ignition control system. <Ref. to EN(H4DOTC)(diag)-2, PROCEDURE, Basic Diagnostic Procedure.>
	h. Clogged or leaking radiator	Clean, repair or replace.
	i. Engine oil mixed in engine coolant	Replace the engine coolant. If defective is not improved, check, repair and replace the engine parts.
	j. Air/fuel mixture ratio too lean	Inspect and repair the fuel injection system. <Ref. to EN(H4DOTC)(diag)-2, PROCEDURE, Basic Diagnostic Procedure.>
	k. Excessive back pressure in exhaust system	Clean or replace.
	l. Insufficient clearance between piston and cylinder	Adjust or replace.
	m. Dragging brake	Adjust.
	n. Defective radiator fan	Inspect the radiator fan relay, engine coolant temperature sensor or fan motor and replace them.
Over-cooling	a. Ambient temperature extremely low	Partly cover radiator front area.
	b. Defective thermostat	Replace.
Engine coolant leaks	a. Loosened or damaged connecting units on hoses	Correct or replace.
	b. Leakage from water pump	Replace.
	c. Leakage from water pipe	Correct or replace.
	d. Leakage around cylinder head gasket	Retighten cylinder head bolts or replace gasket.
	e. Damaged or cracked cylinder head and cylinder block	Correct or replace.
	f. Damaged or cracked thermostat cover	Correct or replace.
	g. Leakage from radiator	Correct or replace.
Noise	a. Timing belt problem	Replace.
	b. Defective radiator fan	Replace.
	c. Defective water pump bearing	Replace water pump.
	d. Defective water pump mechanical seal	Replace water pump.

LUBRICATION

LU(H4DOTC)

	Page
1. General Description	2
2. Oil Pressure System	6
3. Engine Oil	8
4. Oil Pump	10
5. Oil Pan and Strainer	15
6. Oil Pressure Switch	19
7. Oil Pipe	21
8. Engine Oil Filter	25
9. Engine Lubrication System Trouble in General	26

General Description

LUBRICATION

1. General Description

A: SPECIFICATION

Lubrication method			Forced lubrication	
Oil pump	Pump type		Trochoid type	
	Number of teeth	Inner rotor	9	
		Outer rotor	10	
	Outer rotor diameter × thickness		mm (in) 76 × 10 (2.99 × 0.47)	
	Tip clearance between inner and outer rotors		mm (in) 0.04 — 0.14 (0.0016 — 0.0055)	
	Side clearance between inner rotor and pump case		mm (in) 0.02 — 0.07 (0.0008 — 0.0028)	
	Case clearance between outer rotor and pump case		Standard mm (in) 0.10 — 0.175 (0.0039 — 0.0069)	
	Performance (Oil temperature 80°C (176°F))	600 rpm	Discharge pressure	kPa (kg/cm ² , psi) 98 (1.0, 14)
			Discharge rate	ℓ (US qt, Imp qt)/min. 4.6 (4.9, 4.0) or more
		5,000 rpm	Discharge pressure	kPa (kg/cm ² , psi) 294 (3.0, 43)
Discharge rate			ℓ (US qt, Imp qt)/min. 47.0 (49.7, 41.4) or more	
Relief valve working pressure		kPa (kg/cm ² , psi) 588 (6.0, 85)		
Oil filter	Filter type		Full-flow filter type	
	Filtration area		cm ² (sq in) 800 (124)	
	By-pass valve opening pressure		kPa (kg/cm ² , psi) 160 (1.63, 23.2)	
	Outer diameter × width		mm (in) 68 × 65 (2.68 × 2.56)	
	Installation screw specifications		M 20 × 1.5	
Oil pressure switch	Type		Immersed contact point type	
	Operating voltage — power consumption		12 V — 3.4 W or less	
	Warning light operating pressure		kPa (kg/cm ² , psi) 14.7 (0.15, 2.1)	
	Proof pressure		kPa (kg/cm ² , psi) 981 (10, 142) or more	
Engine oil	Total capacity (Overhaul)		ℓ (US qt, Imp qt) 5.0 (5.3, 4.4)	
	When replacing engine oil and oil filter		ℓ (US qt, Imp qt) 4.2 (4.4, 3.7)	
	When replacing engine oil only		ℓ (US qt, Imp qt) 4.0 (4.2, 3.5)	

Recommended oil:

Oil suitable for the standard from the followings.

- **For API standard, oil with SM “Energy Conserving” logo**
- **For ILSAC standard, oil with GF-4 “Star burst mark” label on the container**

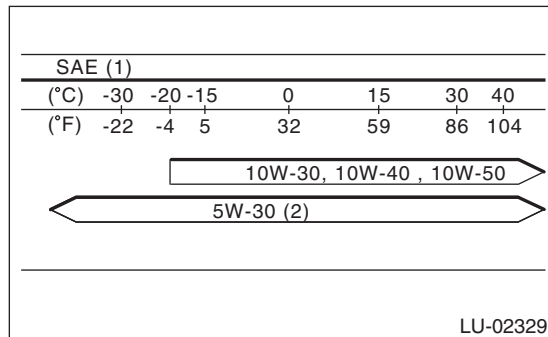

- (1) SAE viscosity No. and applicable temperature
- (2) Recommended

CAUTION:

It is acceptable to fill an engine with oil of another brand when replacing the oil, but make sure to use an oil with an API standard and SAE viscosity number specified by Subaru.

NOTE:

- The proper viscosity oil helps the engine maintain its ideal temperature, and cranking speed increased by reducing viscosity friction in hot condition.
- If the vehicle is used in regions with high temperatures or in other severe environments, use oil with the viscosities shown below.

API standard: SM or SL

SAE Viscosity No.: 30, 40, 10W-50, 20W-40, 20W-50

C: CAUTION

- Wear appropriate work clothing, including a cap, protective goggles and protective shoes when performing any work.
- Remove contamination including dirt and corrosion before removal, installation or disassembly.
- Keep the disassembled parts in order and protect them from dust and dirt.
- Before removal, installation or disassembly, be sure to clarify the failure. Avoid unnecessary removal, installation, disassembly and replacement.
- Vehicle components are extremely hot after driving. Be wary of receiving burns from heated parts.
- Be sure to tighten fasteners including bolts and nuts to the specified torque.
- Place shop jacks or rigid racks at the specified points.
- Before disconnecting connectors of sensors or units, be sure to disconnect the ground cable from the battery.
- If the engine oil is spilt over exhaust pipe or the under cover, wipe it off with cloth to avoid emitting smoke or causing a fire.
- Prepare a container and cloth when performing work which oil possibly spills. If oil spills, wipe it off immediately to prevent from penetrating into floor or flowing out for environmental protection.
- Follow all government and local regulations concerning disposal of refuse when disposing oil.

D: PREPARATION TOOL

1. SPECIAL TOOL

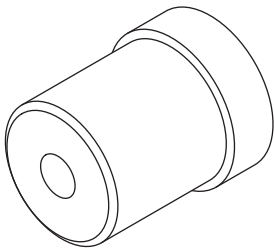
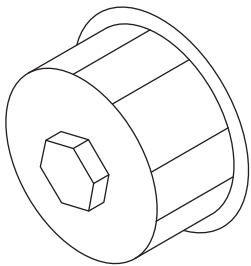
ILLUSTRATION	TOOL NUMBER	DESCRIPTION	REMARKS
 ST-499587100	499587100	OIL SEAL INSTALLER	Used for installing oil seal into oil pump.
 ST18332AA000	18332AA000	OIL FILTER WRENCH	Used for removing and installing the black oil filter (outer diameter: 68 mm (2.68 in)).

2. GENERAL TOOL

TOOL NAME	REMARKS
Oil filter wrench (65/67 mm 14 Flutes)	Used for removing and installing the blue oil filter (outer diameter: 67.4 mm (2.65 in)).

Oil Pressure System

LUBRICATION

2. Oil Pressure System

A: WIRING DIAGRAM

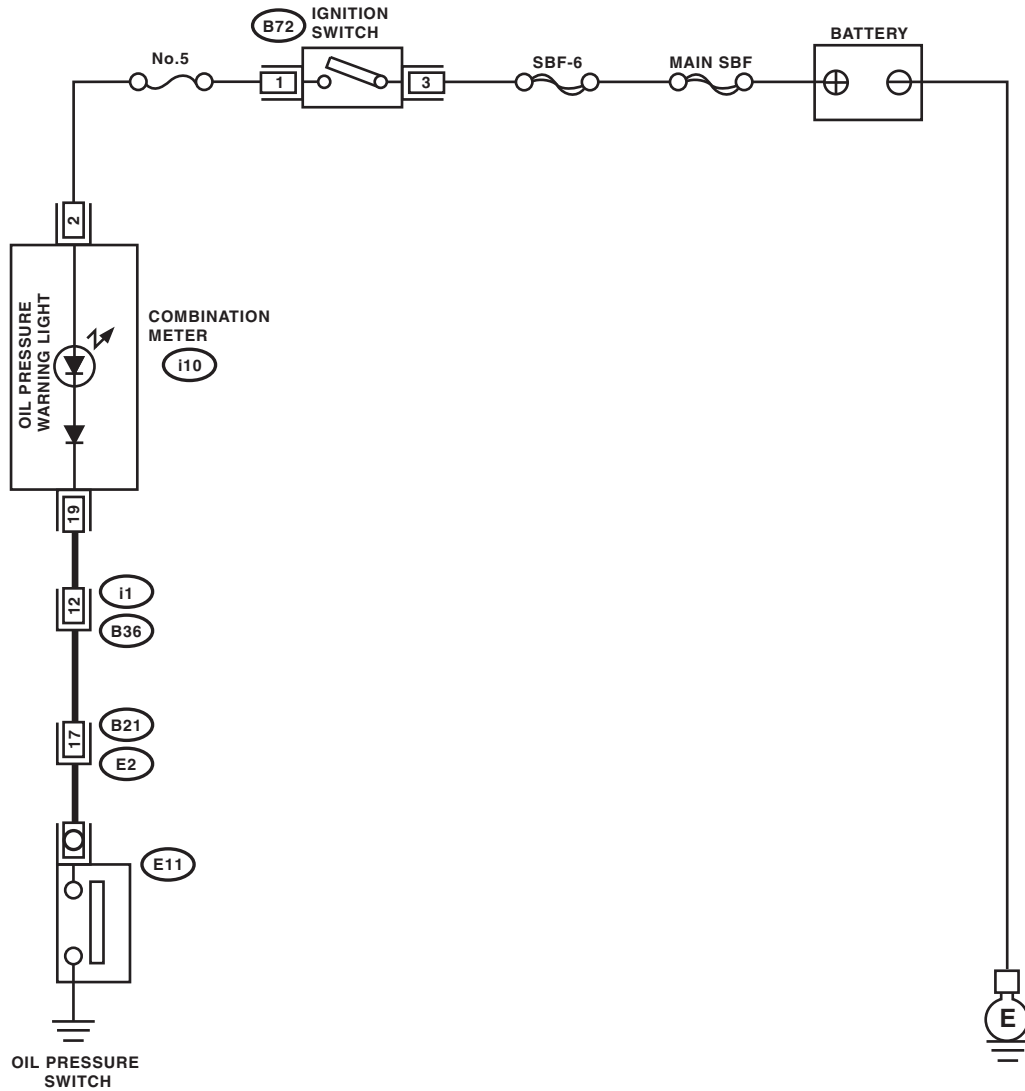

B72



i1

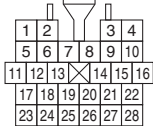

i10

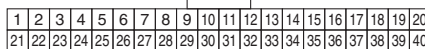

B21

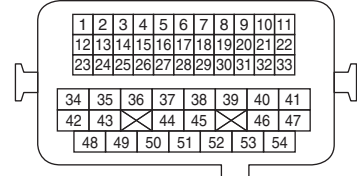

LU-02394

B: INSPECTION

Step	Check	Yes	No
1 CHECK COMBINATION METER. 1) Turn the ignition switch to ON. (engine OFF) 2) Check the warning light in the combination meter.	Does the warning light illuminate?	Go to step 2.	Repair or replace the combination meter. <Ref. to IDI-4, INSPECTION, Combination Meter System.>
2 CHECK HARNESS CONNECTOR BETWEEN COMBINATION METER AND OIL PRESSURE SWITCH. 1) Turn the ignition switch to OFF. 2) Disconnect the connector from oil pressure switch. 3) Turn the ignition switch to ON. 4) Measure the voltage of harness between oil pressure switch connector and chassis ground. Connector & terminal (E11) No. 1 (+) — Chassis ground (-):	Is the voltage 10 V or more?	Replace the oil pressure switch. <Ref. to LU(H4DOTC)-19, Oil Pressure Switch.>	Go to step 3.
3 CHECK COMBINATION METER. 1) Turn the ignition switch to OFF. 2) Remove the combination meter. 3) Measure the resistance of combination meter. Terminals (i10) No. 2 — No. 19:	Is the resistance less than 10 Ω?	Repair the harness and connector. NOTE: In this case, repair the following item: • Open circuit of harness between combination meter and oil pressure switch • Poor contact in combination meter connector • Poor contact in oil pressure switch connector • Poor contact of coupling connector	Repair or replace the combination meter. <Ref. to IDI-4, INSPECTION, Combination Meter System.>

3. Engine Oil

A: INSPECTION

CAUTION:

If the engine oil is spilt over exhaust pipe or the under cover, wipe it off with cloth to avoid emitting smoke or causing a fire.

- 1) Park the vehicle on a level surface.
- 2) Remove the oil level gauge and wipe away the oil.
- 3) Reinsert the oil level gauge all the way. Be sure that the oil level gauge is correctly inserted and properly orientated.
- 4) Remove the oil level gauge again and check the reading. If the engine oil level is below "L" line, check for oil leakage from engine and add oil to bring the level up to "F" line.
- 5) Start the engine and warm it up for a time.
- 6) After turning off the engine, wait a few minutes for the oil to return to the oil pan before checking the level.

NOTE:

- Just after driving or while the engine is warm, engine oil level shows in the range between "F" line and cutout portion. This is caused by thermal expansion of engine oil.
- To prevent overfilling of engine oil, do not add oil above "F" line when the engine is cold.
- As the oil level gauge is used for daily maintenance, the "F" line and "L" line is set assuming that the engine is cold.

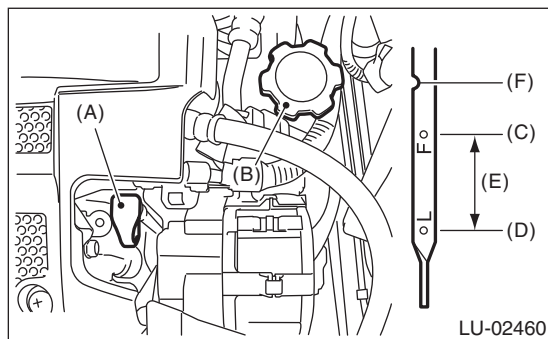

- (A) Oil level gauge
- (B) Engine oil filler cap
- (C) "F" line
- (D) "L" line
- (E) Approx. 1.0 ℓ (1.1 US qt, 0.9 Imp qt)
- (F) Notch mark

B: REPLACEMENT

CAUTION:

If the engine oil is spilt over exhaust pipe or the under cover, wipe it off with cloth to avoid emitting smoke or causing a fire.

- 1) Set the vehicle on a lift.
- 2) Open the engine oil filler cap for quick draining of engine oil.
- 3) Lift up the vehicle.
- 4) Drain engine oil by loosening the engine oil drain plug.

NOTE:

Prepare the container for draining of engine oil.

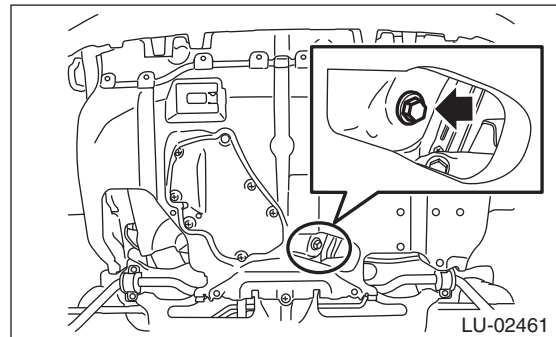

- 5) Tighten the engine oil drain plug after draining engine oil.

NOTE:

Use a new drain plug gasket.

Tightening torque:

44 N·m (4.5 kgf·m, 32.5 ft·lb)

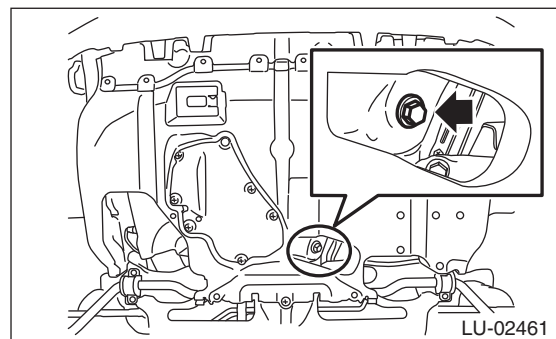

- 6) Lower the vehicle.
- 7) Using engine oil of proper quality and viscosity, fill engine oil through the oil filler duct to the "F" line on oil level gauge. Make sure that the vehicle is parked on a level surface when checking oil level.

Recommended oil:

Refer to "SPECIFICATION" for the recommended oil. <Ref. to LU(H4DOTC)-2, SPECIFICATION, General Description.>

Engine oil capacity:

Refer to "SPECIFICATION" for the engine oil capacity. <Ref. to LU(H4DOTC)-2, SPECIFICATION, General Description.>

- 8) Close the engine oil filler cap.
- 9) Start the engine, and spreads the oil in engine room.
- 10) After the engine stops, recheck the oil level. If necessary, add engine oil up to the "F" line on oil level gauge.

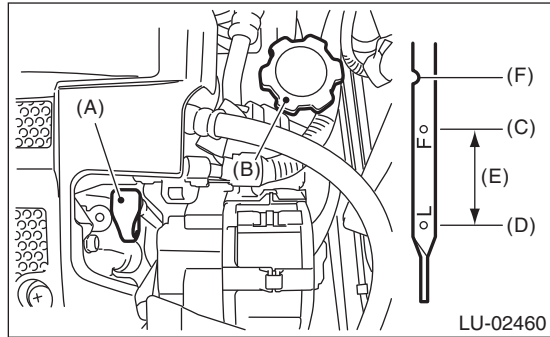

- (A) Oil level gauge
- (B) Engine oil filler cap
- (C) "F" line
- (D) "L" line
- (E) Approx. 1.0 ℓ (1.1 US qt, 0.9 Imp qt)
- (F) Notch mark

4. Oil Pump

A: REMOVAL

- 1) Set the vehicle on a lift.
- 2) Remove the collector cover.
- 3) Disconnect the ground cable from the battery.

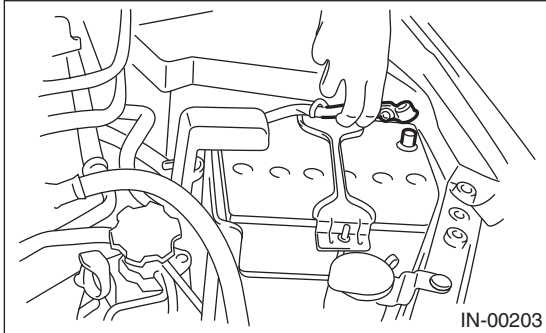

- 4) Lift up the vehicle.
- 5) Remove the under cover.
- 6) Lower the vehicle.
- 7) Remove the radiator. <Ref. to CO(H4DOTC)-19, REMOVAL, Radiator.>
- 8) Remove the crankshaft position sensor. <Ref. to FU(H4DOTC)-30, REMOVAL, Crankshaft Position Sensor.>
- 9) Remove the water pump. <Ref. to CO(H4DOTC)-15, REMOVAL, Water Pump.>
- 10) Remove the crank sprocket. <Ref. to ME(H4DOTC)-59, REMOVAL, Crank Sprocket.>
- 11) Remove the bolts which install oil pump onto cylinder block.

NOTE:

When disassembling and checking the oil pump, loosen the relief valve plug before removing the oil pump.

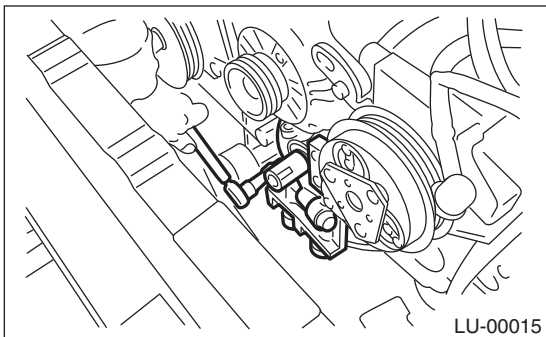

- 12) Remove the oil pump by using flat tip screwdriver.

CAUTION:

Be careful not to scratch mating surfaces of cylinder block and oil pump.

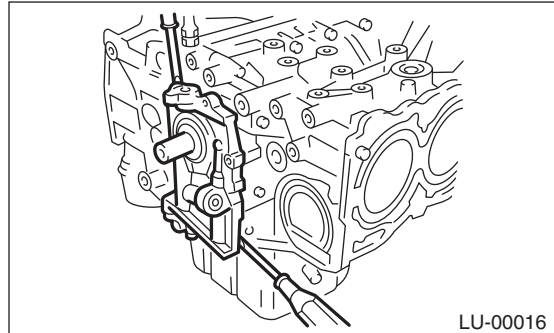

- 13) Remove the front oil seal from the oil pump.

B: INSTALLATION

1) Using the ST, install the front oil seal.
ST 499587100 OIL SEAL INSTALLER

NOTE:

Use a new front oil seal.

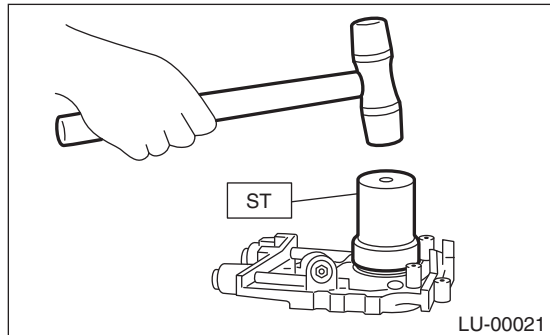

2) Apply liquid gasket to the mating surfaces of oil pump.

NOTE:

Install within 5 min. after applying liquid gasket.

Liquid gasket:

THREE BOND 1217G (Part No. K0877Y0100) or equivalent

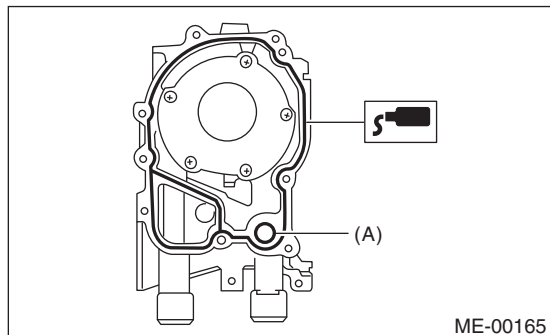

(A) O-ring

3) Apply a coat of engine oil to the inside of front oil seal.

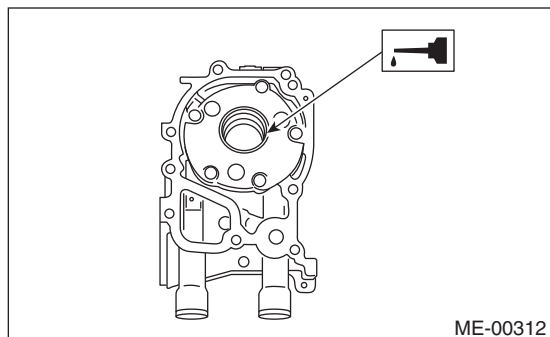

4) Install the oil pump to cylinder block. Be careful not to damage the front oil seal during installation.

NOTE:

- Make sure the front oil seal lip is not folded.
- Align the flat surface of oil pump's inner rotor with crankshaft before installation.
- Use new O-rings.
- Do not forget to assemble O-rings.

5) Apply liquid gasket to the three bolts thread shown in figure. (when reuse the bolts)

Liquid gasket:

THREE BOND 1324 (Part No. 004403042) or equivalent

Tightening torque:

6.4 N·m (0.7 kgf-m, 4.7 ft-lb)

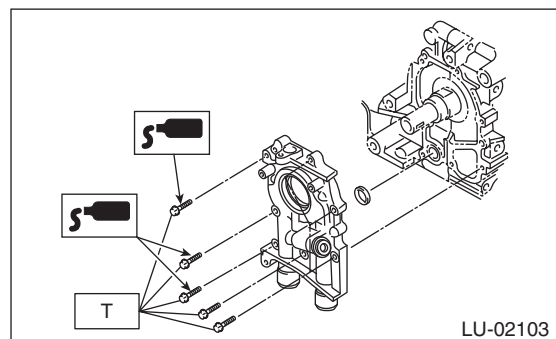

6) Install the crank sprocket. <Ref. to ME(H4DOTC)-59, INSTALLATION, Crank Sprocket.>

7) Install the water pump. <Ref. to CO(H4DOTC)-15, INSTALLATION, Water Pump.>

8) Install the crankshaft position sensor. <Ref. to FU(H4DOTC)-30, INSTALLATION, Crankshaft Position Sensor.>

9) Install the radiator. <Ref. to CO(H4DOTC)-20, INSTALLATION, Radiator.>

10) Lift up the vehicle.

11) Install the under cover.

12) Lower the vehicle.

13) Connect the ground cable to the battery.

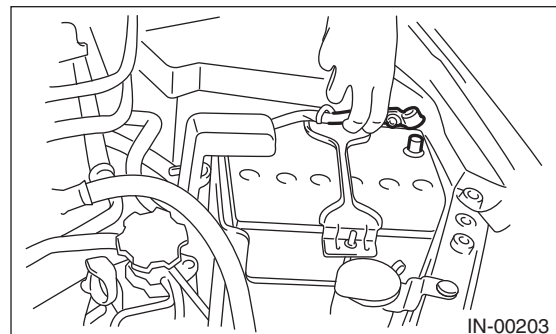

14) Install the collector cover.

Oil Pump

LUBRICATION

C: DISASSEMBLY

Remove the screw which secures oil pump cover and then disassemble oil pump. Inscribe alignment marks on the inner and outer rotors so that they can be replaced in their original positions during reassembly.

NOTE:

Before disassembling the oil pump, remove the relief valve.

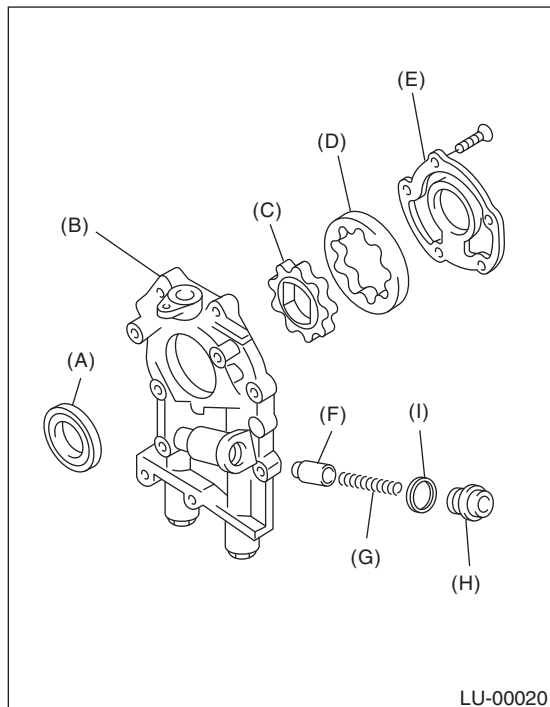

- (A) Front oil seal
- (B) Oil pump case
- (C) Inner rotor
- (D) Outer rotor
- (E) Oil pump cover
- (F) Relief valve
- (G) Relief valve spring
- (H) Plug
- (I) Gasket

D: ASSEMBLY

1) Using the ST, install the front oil seal.
ST 499587100 OIL SEAL INSTALLER

NOTE:

Use a new front oil seal.

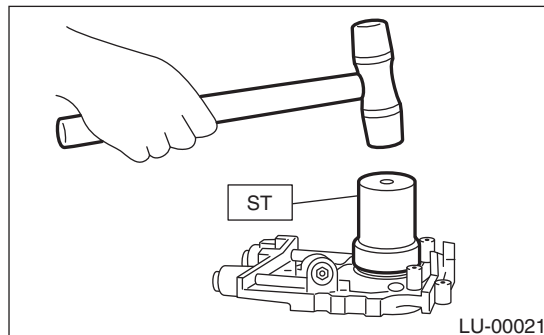

2) Apply a coat of engine oil to inner and outer rotors.

3) Assemble the inner and outer rotors in their original positions.

4) Assemble the oil relief valve and install relief valve spring and plug.

NOTE:

Use a new gasket.

5) Install the oil pump cover.

Tightening torque:

T1: 5.4 N·m (0.6 kgf-m, 4.0 ft-lb)

T2: 44 N·m (4.5 kgf-m, 32.5 ft-lb)

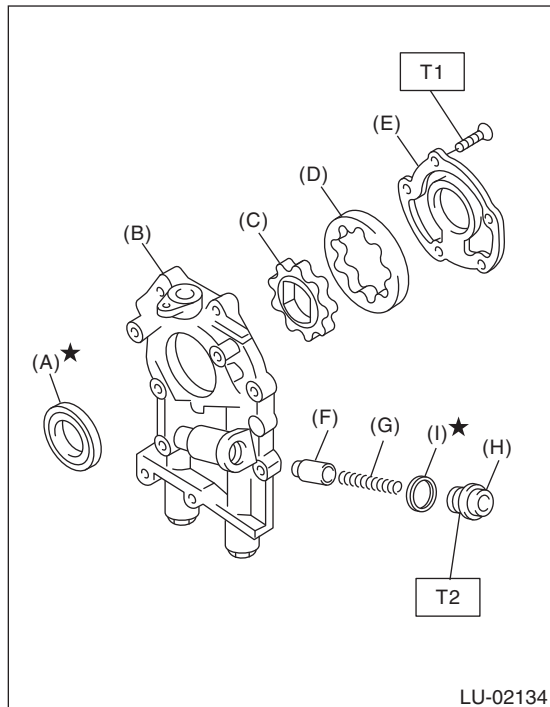

- (A) Front oil seal
- (B) Oil pump case
- (C) Inner rotor
- (D) Outer rotor
- (E) Oil pump cover
- (F) Relief valve
- (G) Relief valve spring
- (H) Plug
- (I) Gasket

E: INSPECTION

1. TIP CLEARANCE

Measure the tip clearance of rotors. If the clearance is out of specification, replace the rotors as a set.

Tip clearance:

Standard

0.04 — 0.14 mm (0.0016 — 0.0055 in)

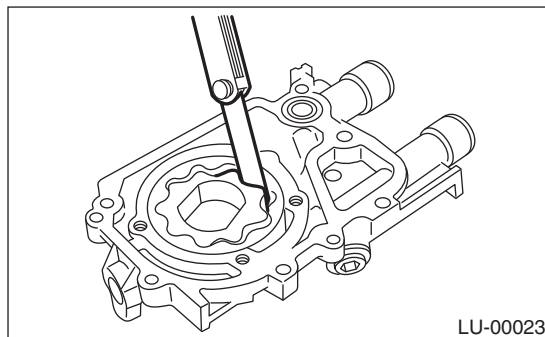

2. CASE CLEARANCE

Measure the clearance between the outer rotor and the oil pump case. If clearance is out of standard, replace the oil pump case.

Case clearance:

Standard

0.10 — 0.175 mm (0.0039 — 0.0069 in)

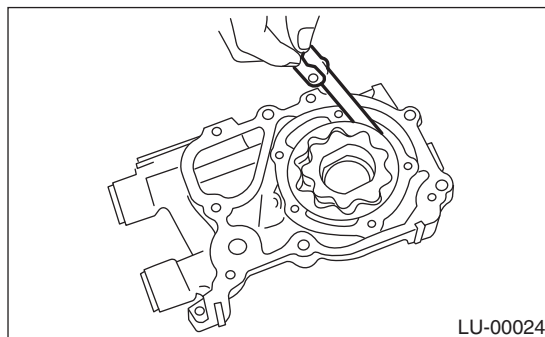

3. SIDE CLEARANCE

Measure the gap between the inner rotor and the oil pump case to measure the clearance between the oil pump inner rotor and the oil pump cover as shown in the figure. If the clearance is out of specification, replace the rotors and the oil pump case.

Side clearance:

Standard

0.02 — 0.07 mm (0.0008 — 0.0028 in)

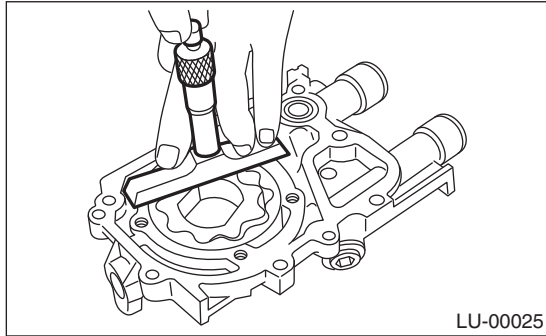

4. OIL RELIEF VALVE

Check the valve for assembly condition and damage, and the relief valve spring for damage and deterioration. Replace the parts if defective.

Relief valve spring:

Free length

73.7 mm (2.902 in)

Installed length

54.7 mm (2.154 in)

Load when installed

93.1 N (9.49 kgf, 20.88 lbf)

5. OIL PUMP CASE

Check for worn shaft hole, clogged oil passage, worn rotor chamber, cracks and other faults.

6. FRONT OIL SEAL

Check the front oil seal lips for deformation and hardening, wear.

5. Oil Pan and Strainer

A: REMOVAL

- 1) Set the vehicle on a lift.
- 2) Remove the collector cover.
- 3) Disconnect the ground cable from the battery.

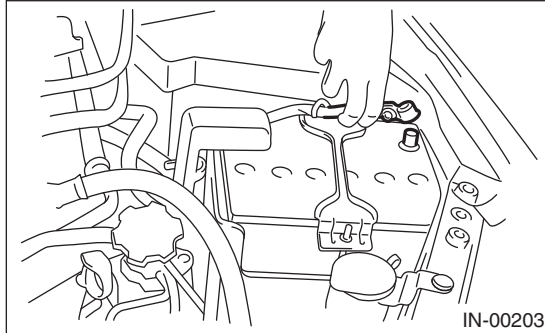

- 4) Remove the air intake duct. <Ref. to IN(H4DOTC)-9, REMOVAL, Air Intake Duct.>
- 5) Remove the air intake boot.

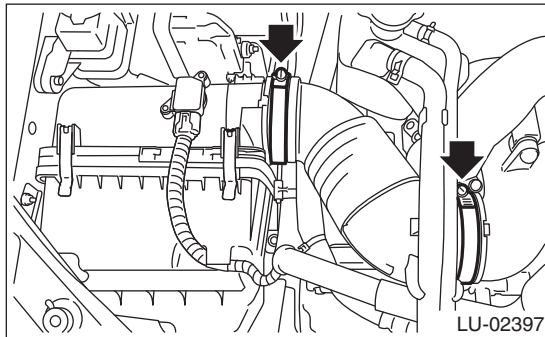

- 6) Remove the intercooler. <Ref. to IN(H4DOTC)-11, REMOVAL, Intercooler.>
- 7) Remove the pitching stopper.

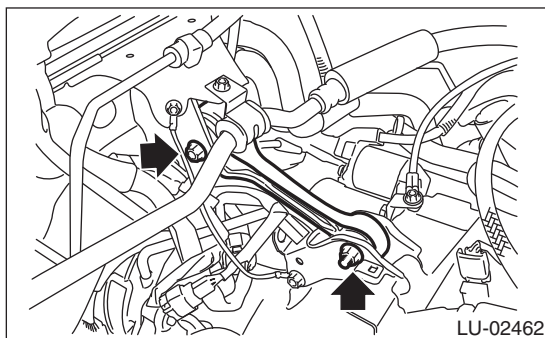

- 8) Remove the radiator upper brackets.

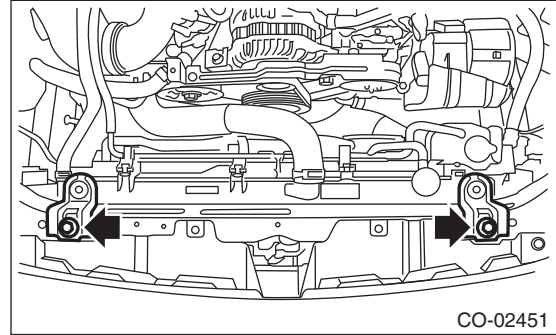

- 9) Support the engine with a lifting device and wire ropes.

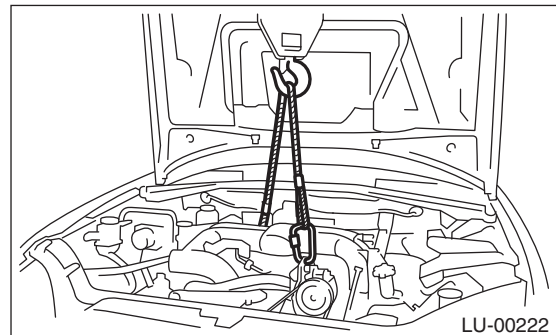

- 10) Lift up the vehicle.

CAUTION:

When lifting up the vehicle, raise up wire ropes at the same time.

- 11) Remove the under cover.
- 12) Drain the engine oil. <Ref. to LU(H4DOTC)-8, REPLACEMENT, Engine Oil.>
- 13) Remove the front exhaust pipe. <Ref. to EX(H4DOTC)-5, REMOVAL, Front Exhaust Pipe.>
- 14) Remove the nuts which install engine mount onto front crossmember.

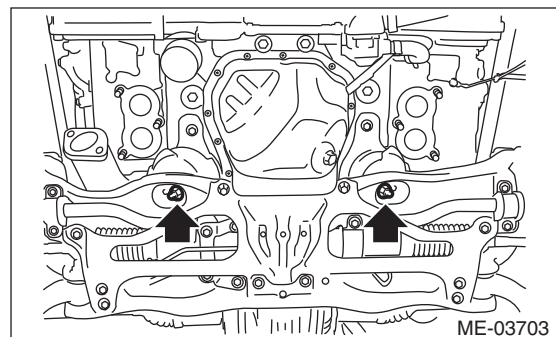

- 15) Remove the bolts which install oil pan on cylinder block with the engine raised up.
- 16) Insert an oil pan cutter blade between cylinder block-to-oil pan clearance and remove the oil pan.

CAUTION:

Do not use a screwdriver or similar tool in place of oil pan cutter.

- 17) Remove the oil strainer.

Oil Pan and Strainer

LUBRICATION

18) Remove the baffle plate.

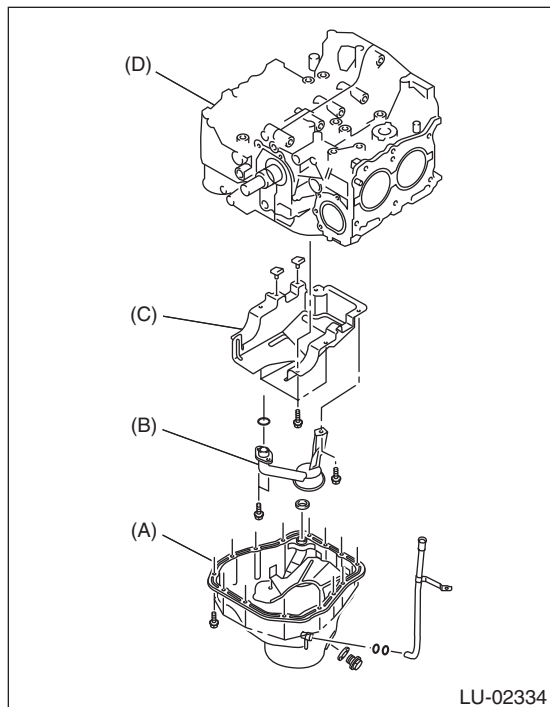

- (A) Oil pan
- (B) Oil strainer
- (C) Baffle plate
- (D) Cylinder block

B: INSTALLATION

NOTE:

Before installing the oil pan, clean the mating surface of oil pan and engine block.

1) Make sure that the seals (A) are installed securely on the baffle plate in a direction as shown in the figure below.

NOTE:

Use new seals.

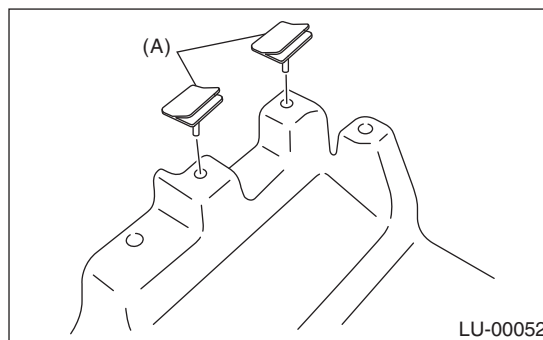

2) Install the baffle plate.

Tightening torque:

6.4 N·m (0.7 kgf·m, 4.7 ft·lb)

3) Install the oil strainer to the cylinder block.

NOTE:

Use new O-rings.

Tightening torque:

10 N·m (1.0 kgf·m, 7.2 ft·lb)

4) Tighten the oil strainer stay together with the baffle plate.

Tightening torque:

6.4 N·m (0.7 kgf·m, 4.7 ft·lb)

5) Apply liquid gasket to the mating surfaces of the oil pan, and install the oil pan.

NOTE:

- Use a new gasket.
- Install within 5 min. after applying liquid gasket.

Liquid gasket:

**THREE BOND 1217G (Part No. K0877Y0100)
or equivalent**

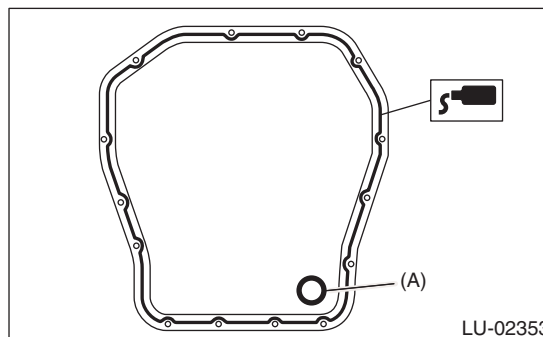

- (A) Gasket

6) Tighten the bolts which install oil pan to cylinder block.

Tightening torque:

- T1: 5 N·m (0.5 kgf-m, 3.7 ft-lb)**
- T2: 6.4 N·m (0.7 kgf-m, 4.7 ft-lb)**
- T3: 10 N·m (1.0 kgf-m, 7.2 ft-lb)**

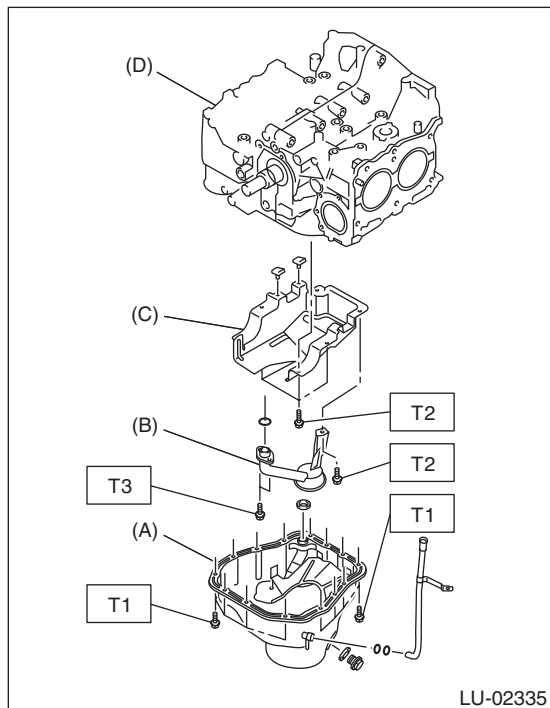

- (A) Oil pan
- (B) Oil strainer
- (C) Baffle plate
- (D) Cylinder block

7) Lower the engine onto front crossmember.

8) Tighten the nuts which install engine mount onto front crossmember.

NOTE:

Make sure that the engine mount nuts (A) and locator (B) are securely installed.

Tightening torque:

- 85 N·m (8.7 kgf-m, 62.7 ft-lb)**

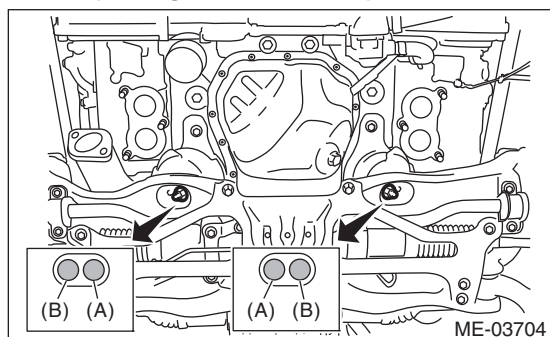

9) Install the front exhaust pipe. <Ref. to EX(H4DOTC)-6, INSTALLATION, Front Exhaust Pipe.>

10) Install the under cover.

11) Lower the vehicle.

CAUTION:

When lowering the vehicle, lower the lift up device and wire ropes at the same time.

12) Remove the lifting device and wire ropes.

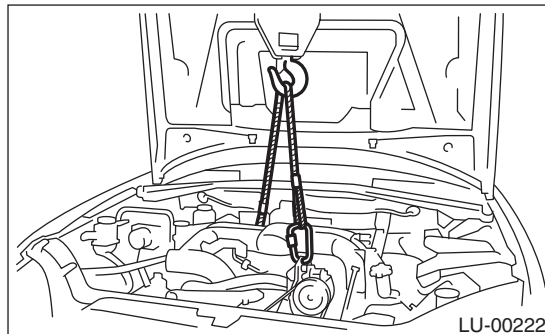

13) Install the pitching stopper.

Tightening torque:

- T1: 50 N·m (5.1 kgf-m, 36.9 ft-lb)**
- T2: 58 N·m (5.9 kgf-m, 42.8 ft-lb)**

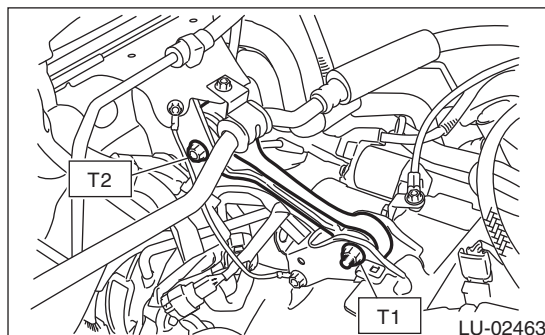

14) Install the radiator upper brackets.

Tightening torque:

- 12 N·m (1.2 kgf-m, 8.9 ft-lb)**

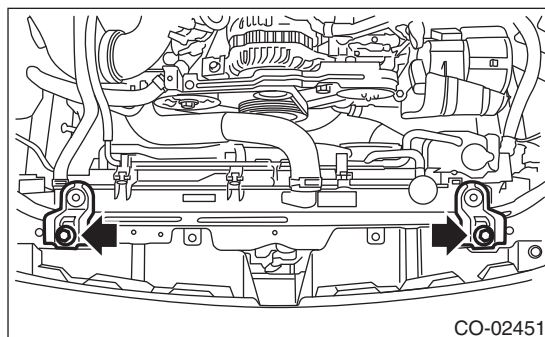

15) Install the intercooler. <Ref. to IN(H4DOTC)-12, INSTALLATION, Intercooler.>

Oil Pan and Strainer

LUBRICATION

16) Install the air intake boot.

Tightening torque:

2.5 N·m (0.3 kgf·m, 1.8 ft·lb)

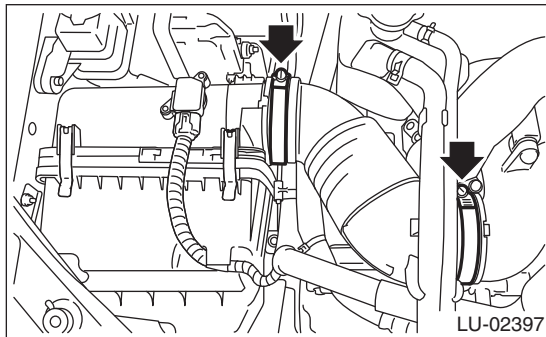

17) Install the air intake duct. <Ref. to IN(H4DOTC)-9, INSTALLATION, Air Intake Duct.>

18) Connect the ground cable to the battery.

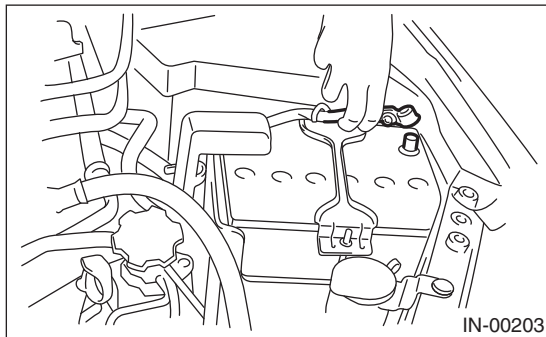

19) Refill the engine oil. <Ref. to LU(H4DOTC)-8, REPLACEMENT, Engine Oil.>

20) Install the collector cover.

C: INSPECTION

Visually check that the oil pan, oil strainer, oil strainer stay and baffle plate are not damaged.

6. Oil Pressure Switch

A: REMOVAL

- 1) Remove the collector cover.
- 2) Disconnect the ground cable from the battery.

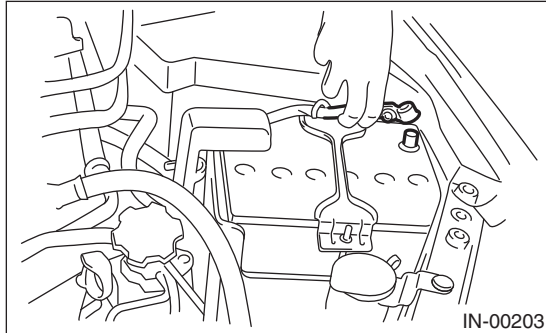

- 3) Remove the generator from the bracket. <Ref. to SC(H4SO)-15, REMOVAL, Generator.>
- 4) Disconnect the terminal from oil pressure switch.

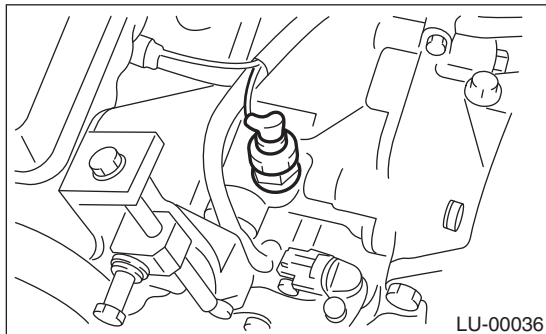

- 5) Remove the oil pressure switch.

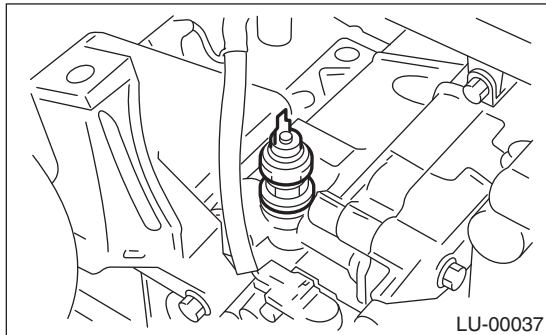

B: INSTALLATION

- 1) Apply liquid gasket to the oil pressure switch threads.

Liquid gasket:

THREE BOND 1324 (Part No. 004403007) or equivalent

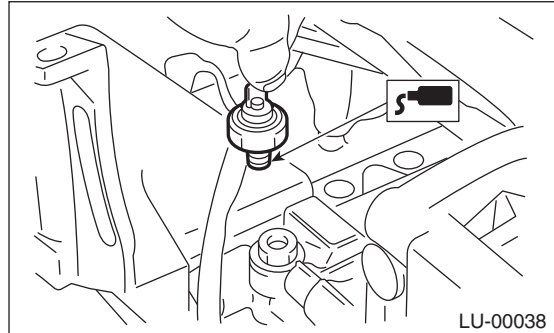

- 2) Install the oil pressure switch to the cylinder block.

Tightening torque:

25 N·m (2.5 kgf·m, 18.4 ft·lb)

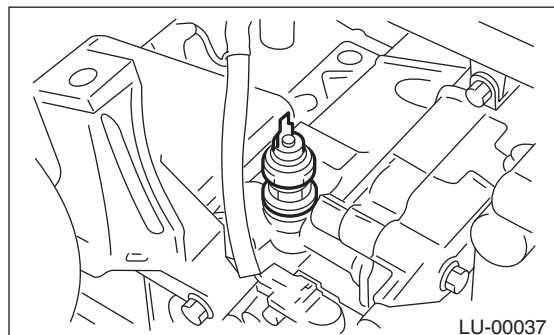

- 3) Connect the terminal to the oil pressure switch.

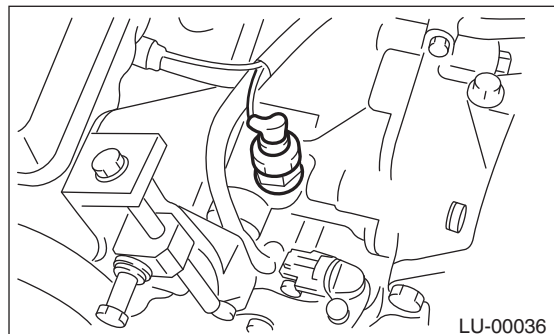

- 4) Install the generator to the bracket. <Ref. to SC(H4SO)-16, INSTALLATION, Generator.>

Oil Pressure Switch

LUBRICATION

5) Connect the ground cable to the battery.

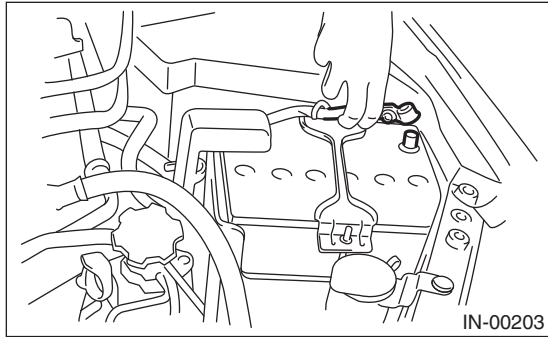

6) Install the collector cover.

C: INSPECTION

Check the oil pressure switch installation portion for oil leakage and oil seepage.

7. Oil Pipe

A: REMOVAL

- 1) Remove the collector cover.
- 2) Disconnect the ground cable from battery.

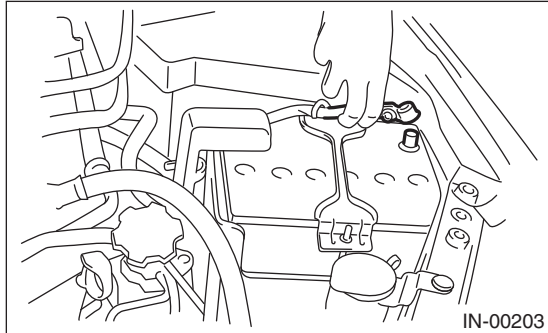

- 3) Remove the intercooler. <Ref. to IN(H4DOTC)-11, REMOVAL, Intercooler.>
- 4) Remove the intercooler bracket RH.
- 5) Remove the turbocharger upper cover.

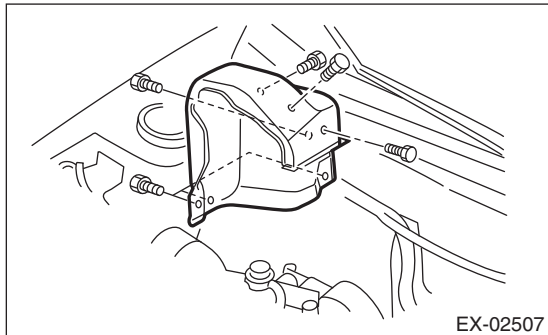

- 6) Remove the oil inlet pipe from the turbocharger.

CAUTION:

In order to prevent damaging the oil pipe on the cylinder head side, fix the section (a) shown in the figure when loosening the oil inlet pipe flare nut, and avoid the part from rotating together while loosening the nut.

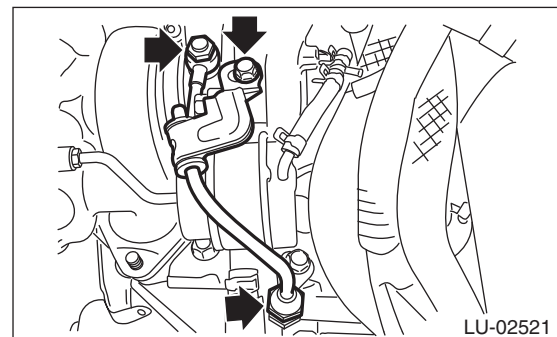
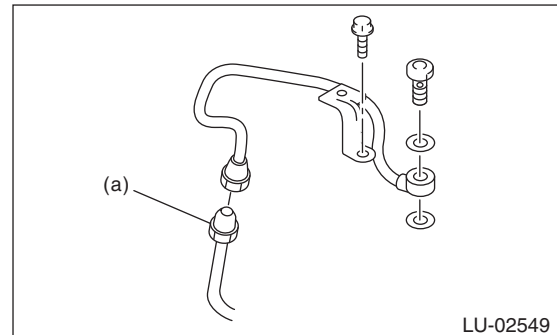

- 7) Remove the intake manifold. <Ref. to FU(H4DOTC)-14, REMOVAL, Intake Manifold.>
- 8) Remove the secondary air pump. <Ref. to EC(H4DOTC)-23, REMOVAL, Secondary Air Pump.>
- 9) Remove the radiator main fan and radiator sub fan. <Ref. to CO(H4DOTC)-24, REMOVAL, Radiator Main Fan and Fan Motor.> <Ref. to CO(H4DOTC)-26, REMOVAL, Radiator Sub Fan and Fan Motor.>
- 10) Remove the V-belts. <Ref. to ME(H4DOTC)-39, REMOVAL, V-belt.>
- 11) Remove the crank pulley. <Ref. to ME(H4DOTC)-47, REMOVAL, Crank Pulley.>
- 12) Remove the timing belt cover. <Ref. to ME(H4DOTC)-49, REMOVAL, Timing Belt Cover.>
- 13) Remove the timing belt. <Ref. to ME(H4DOTC)-50, TIMING BELT, REMOVAL, Timing Belt.>
- 14) Remove the cam sprocket LH. <Ref. to ME(H4DOTC)-57, REMOVAL, Cam Sprocket.>

Oil Pipe

LUBRICATION

15) Remove the belt cover No. 2 LH.

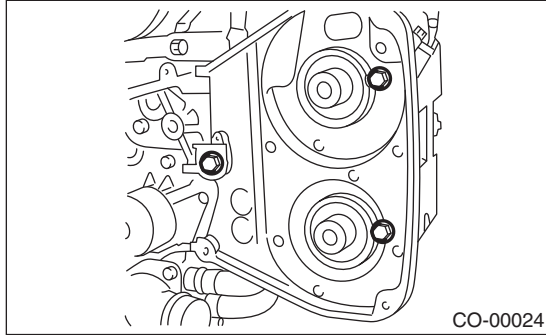

16) Remove the oil pipe.

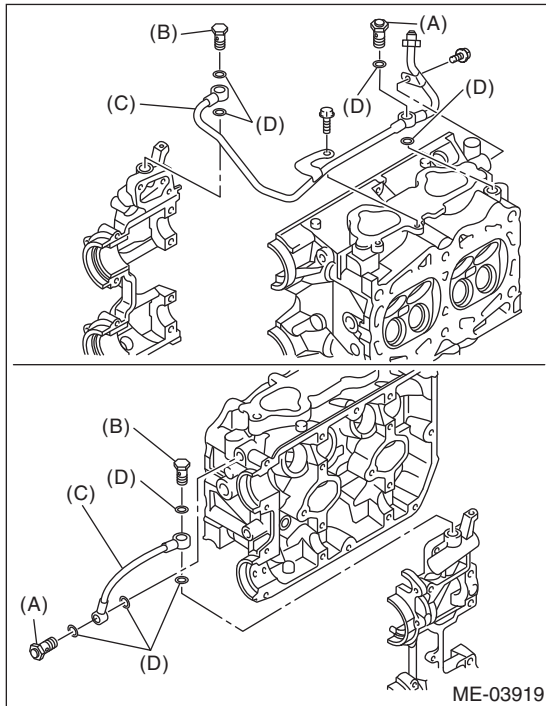

- (A) Union screw with filter (with protrusion)
- (B) Union screw without filter (without protrusion)
- (C) Oil pipe
- (D) Gasket

B: INSTALLATION

- 1) Inspect the union screw with filter. <Ref. to LU(H4DOTC)-24, INSPECTING UNION SCREW WITH FILTER, INSPECTION, Oil Pipe.>
- 2) Install the oil pipe.

NOTE:

- Make sure not to mix up the union screws with filter and without filter as their installation positions are different.
- Use a new gasket.

Tightening torque:

T1: 8 N·m (0.8 kgf-m, 5.9 ft-lb)

T2: 29 N·m (3.0 kgf-m, 21.4 ft-lb)

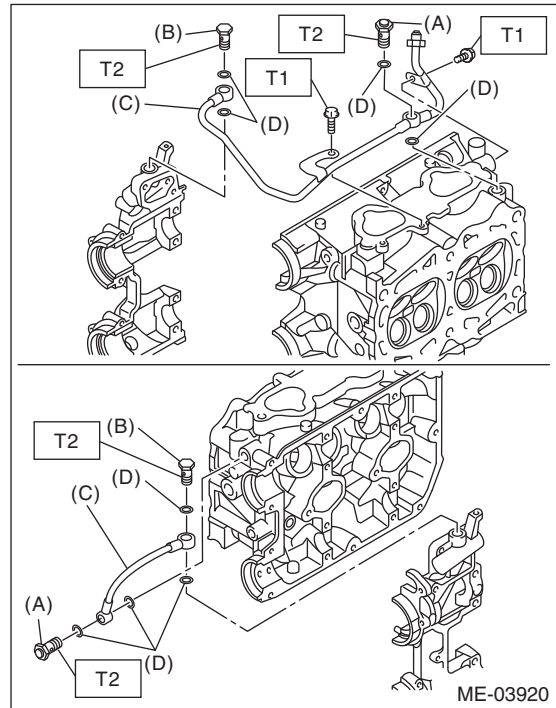

- (A) Union screw with filter (with protrusion)
- (B) Union screw without filter (without protrusion)
- (C) Oil pipe
- (D) Gasket

3) Install the belt cover No. 2 LH.

Tightening torque:

5 N·m (0.5 kgf-m, 3.7 ft-lb)

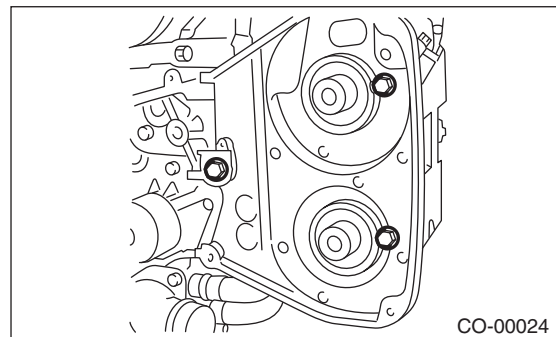

- 4) Install the cam sprocket LH. <Ref. to ME(H4DOTC)-57, INSTALLATION, Cam Sprocket.>
- 5) Install the timing belt. <Ref. to ME(H4DOTC)-52, TIMING BELT, INSTALLATION, Timing Belt.>
- 6) Install the timing belt cover. <Ref. to ME(H4DOTC)-49, INSTALLATION, Timing Belt Cover.>
- 7) Install the crank pulley. <Ref. to ME(H4DOTC)-47, INSTALLATION, Crank Pulley.>
- 8) Install the V-belts. <Ref. to ME(H4DOTC)-39, INSTALLATION, V-belt.>
- 9) Install the radiator main fan and the radiator sub fan. <Ref. to CO(H4DOTC)-25, INSTALLATION, Radiator Main Fan and Fan Motor.> <Ref. to CO(H4DOTC)-26, INSTALLATION, Radiator Sub Fan and Fan Motor.>
- 10) Install the secondary air pump. <Ref. to EC(H4DOTC)-23, INSTALLATION, Secondary Air Pump.>
- 11) Install the intake manifold. <Ref. to FU(H4DOTC)-18, INSTALLATION, Intake Manifold.>
- 12) Temporarily tighten the bolts and flare nuts which secure the oil inlet pipe to the turbocharger.

NOTE:

Use a new gasket.

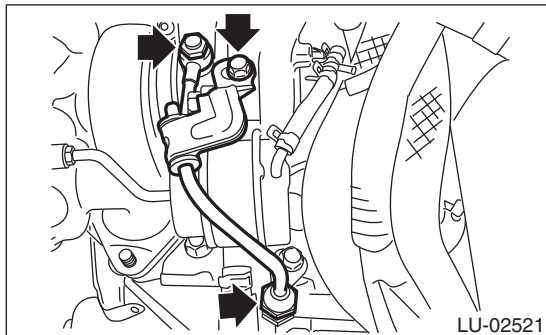

- 13) Tighten the union screws and flare nuts which secure the oil inlet pipe to the turbocharger.

CAUTION:

In order to prevent damaging the oil pipe on the cylinder head side, fix the section (a) shown in the figure when tightening the oil inlet pipe flare nut, and avoid the part from rotating together while tightening the nut.

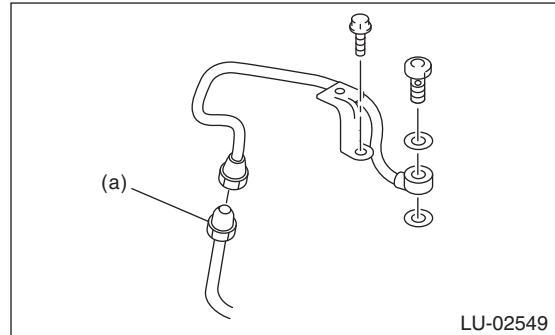

Tightening torque:

T1: 16 N·m (1.6 kgf-m, 11.8 ft-lb)

T2: 20 N·m (2.0 kgf-m, 14.8 ft-lb)

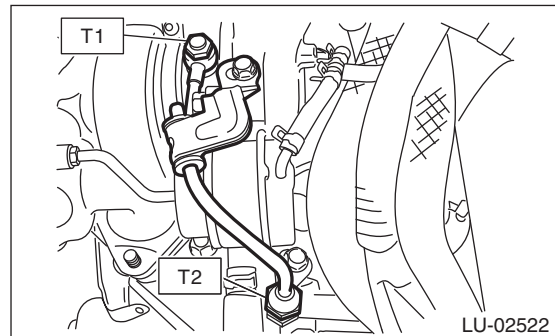

- 14) Tighten the bolts which hold the oil inlet pipe stay to the turbocharger.

Tightening torque:

5 N·m (0.5 kgf-m, 3.7 ft-lb)

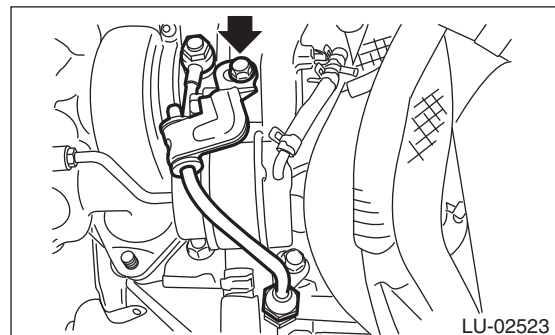

Oil Pipe

LUBRICATION

15) Install the turbocharger upper cover.

Tightening torque:

7.5 N·m (0.8 kgf·m, 5.5 ft·lb)

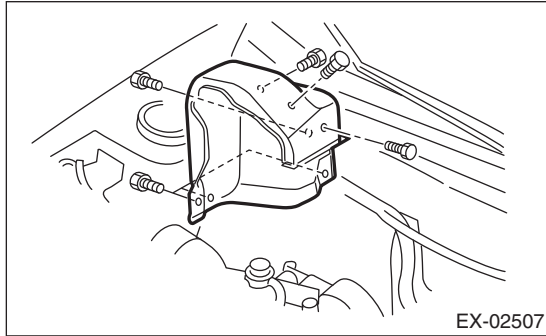

16) Install the intercooler bracket RH.

17) Install the intercooler. <Ref. to IN(H4DOTC)-12, INSTALLATION, Intercooler.>

18) Connect the ground cable to battery.

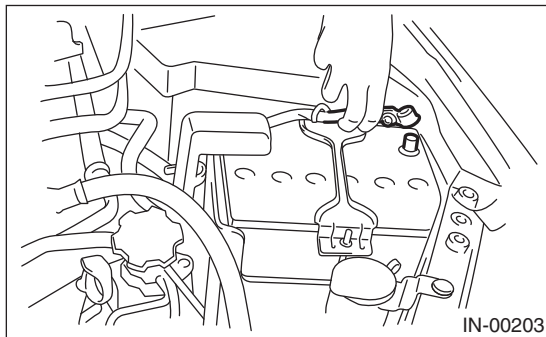

19) Install the collector cover.

C: INSPECTION

1. INSPECTING UNION SCREW WITH FILTER

Check the filter part of union screw for clogging or damage, and if defective, replace the union screw with filter with a new part.

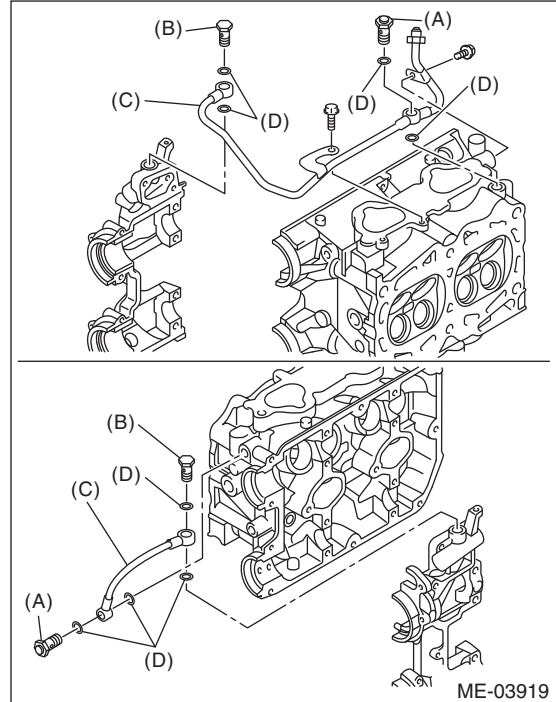

- (A) Union screw with filter (with protrusion)
- (B) Union screw without filter (without protrusion)
- (C) Oil pipe
- (D) Gasket

2. OTHER INSPECTIONS

- 1) Check that the oil pipe and union screw have no deformation, cracks and other damages.
- 2) Check that there are no oil leaks or oil oozing from the oil pipe attachment section.

8. Engine Oil Filter

A: REMOVAL

CAUTION:

If the engine oil is spilt over exhaust pipe or the under cover, wipe it off with cloth to avoid emitting smoke or causing a fire.

- 1) Set the vehicle on a lift.
- 2) Lift up the vehicle.
- 3) Remove the clips (A) holding the service hole cover of the under cover, and turn the service hole cover in the direction of the arrow.

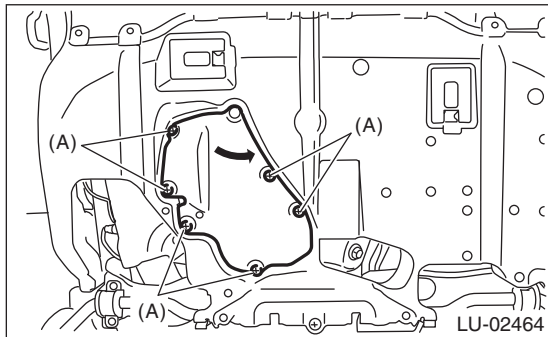

- 4) Remove the oil filter (A).

- Black oil filter

Remove using the ST.

ST 18332AA000 OIL FILTER WRENCH (OUTER DIAMETER: 68 MM (2.68 IN) FOR OIL FILTER)

- Blue oil filter

Remove using the general tool (65/67 mm 14 Flutes).

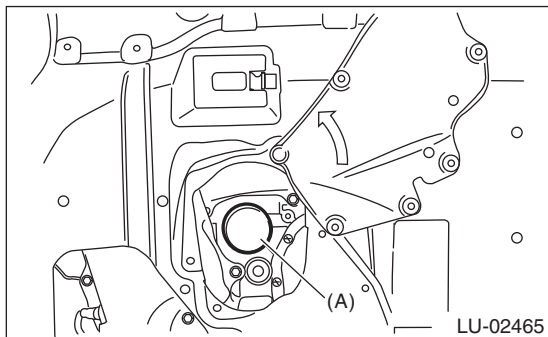

(A) Oil filter

B: INSTALLATION

CAUTION:

Do not tighten excessively, or oil may leak.

- 1) Clean the oil filter installing surface of cylinder block.
- 2) Obtain a new oil filter and apply a thin coat of engine oil to the seal rubber.
- 3) Install the oil filter turning it by hand, being careful not to damage the seal rubber of the oil filter.
 - Tighten the black oil filter (outer diameter: 68 mm (2.68 in)) (approx. one rotation) after the seal rubber of the oil filter comes in contact with cylinder block. When using a torque wrench, tighten to 14 N·m (1.4 kgf-m, 10.3 ft-lb).
 - Tighten the blue oil filter (outer diameter: 67.4 mm (2.65 in)) (approx. 7/8 rotations) after the seal rubber of the oil filter comes in contact with cylinder block. When using a torque wrench, tighten to 12 N·m (1.2 kgf-m, 8.9 ft-lb).
- 4) Return the service hole cover to the original position.
- 5) Lower the vehicle.

C: INSPECTION

- 1) After installing the oil filter, run the engine and make sure that no oil is leaking around seal rubber.

NOTE:

The filter element and filter case are permanently jointed; therefore, interior cleaning is not necessary.

- 2) Check the engine oil level. <Ref. to LU(H4DOTC)-8, INSPECTION, Engine Oil.>

Engine Lubrication System Trouble in General

LUBRICATION

9. Engine Lubrication System Trouble in General

A: INSPECTION

Before performing diagnostics, make sure that the engine oil level is correct and no oil leakage exists.

Symptoms	Possible cause	Corrective action	
1. Warning light remains ON.	1) Oil pressure switch failure	Cracked diaphragm or oil leakage within switch	Replace.
		Broken spring or seized contacts	Replace.
	2) Low oil pressure	Clogging of oil filter	Replace.
		Malfunction of oil by-pass valve in oil filter	Clean or replace.
		Malfunction of oil relief valve in oil pump	Clean or replace.
		Clogged oil passage	Clean.
		Excessive tip clearance and side clearance of oil pump rotor	Replace.
		Clogged oil strainer or broken pipe	Clean or replace.
	3) No oil pressure	Insufficient engine oil (degradation, etc.)	Replace.
		Broken pipe of oil strainer	Replace.
Stuck oil pump rotor		Replace.	
2. Warning light does not turn on.	1) Malfunction of combination meter	Replace.	
	2) Poor contact of switch contact points	Replace.	
	3) Disconnection of wiring	Repair.	
3. Warning light flickers momentarily.	1) Poor contact of terminals	Repair.	
	2) Defective wiring harness	Repair.	
	3) Low oil pressure	Check for the same possible causes as listed 1) — 2).	

SPEED CONTROL SYSTEMS

SP(H4DOTC)

	Page
1. General Description	2



1. General Description

A: SPECIFICATION

Specifications for the turbo model are the same as the SOHC model. <Ref. to SP(H4SO)-2, General Description.>

IGNITION

IG(H4DOTC)

	Page
1. General Description	2
2. Spark Plug	4
3. Ignition Coil	7

General Description

IGNITION

1. General Description

A: SPECIFICATION

Item		Specification
Ignition coil	Type	FK0334
	Ignition system	Independent ignition coil
	Manufacturer	Diamond Electric
Spark plug	Manufacturer and type	NGK: SILFR6A
	Thread size (diameter, pitch, length)	mm 14, 1.25, 26.5
	Spark plug gap	mm (in) 0.7 — 0.8 (0.028 — 0.031)
	Electrode	Iridium

B: COMPONENT

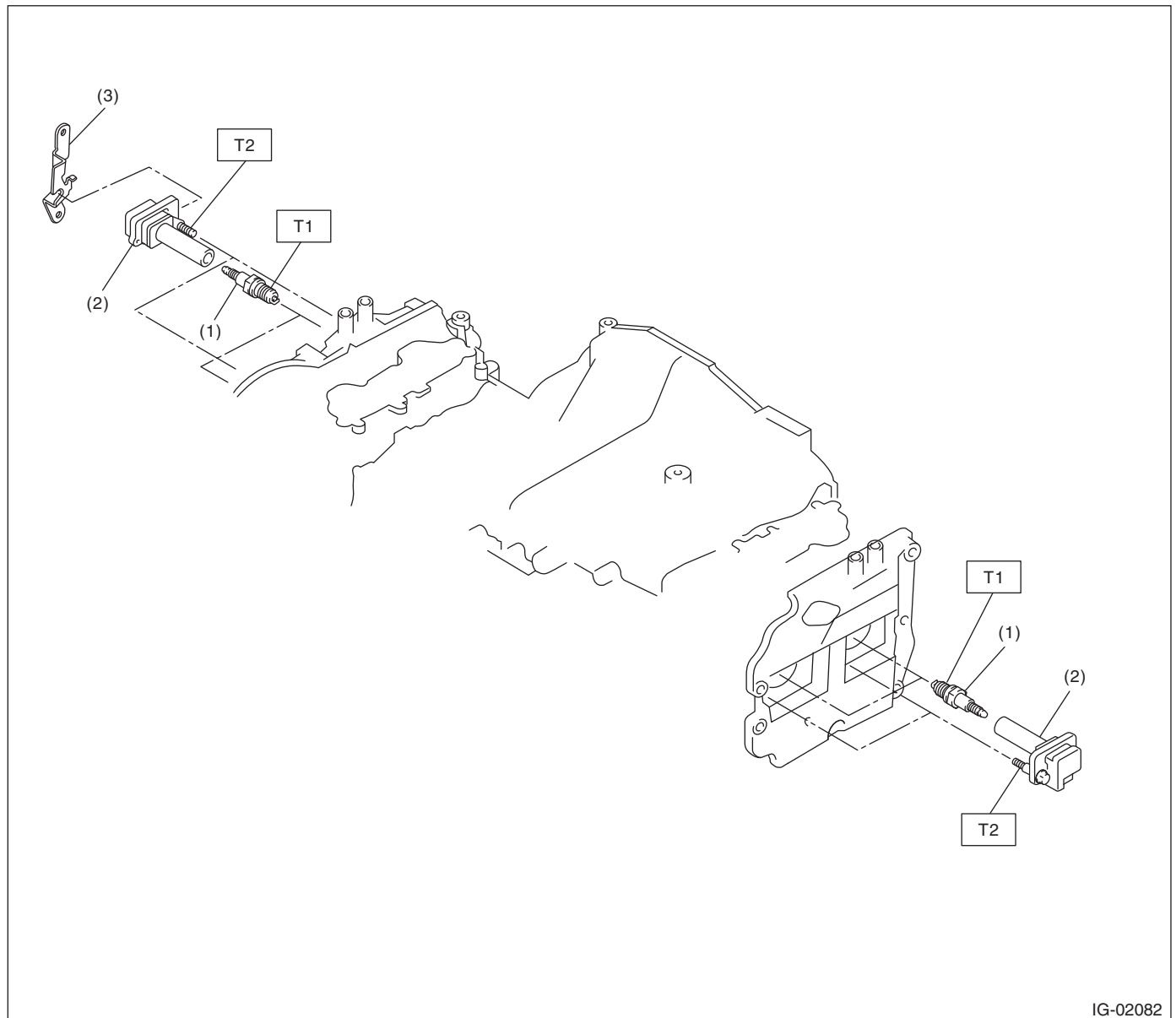

- (1) Spark plug
- (2) Ignition coil

- (3) Engine harness stay
(#3 ignition coil side)

Tightening torque: N·m (kgf·m, ft·lb)
T1: 21 (2.1, 15.5)
T2: 16 (1.6, 11.8)

C: CAUTION

- Wear appropriate work clothing, including a cap, protective goggles and protective shoes when performing any work.
- Remove contamination including dirt and corrosion before removal, installation or disassembly.
- Keep the disassembled parts in order and protect them from dust and dirt.
- Before removal, installation or disassembly, be sure to clarify the failure. Avoid unnecessary removal, installation, disassembly and replacement.
- Vehicle components are extremely hot after driving. Be wary of receiving burns from heated parts.
- Be sure to tighten fasteners including bolts and nuts to the specified torque.
- Place shop jacks or rigid racks at the specified points.
- Before disconnecting connectors of sensors or units, be sure to disconnect the ground cable from the battery.

Spark Plug

IGNITION

2. Spark Plug

A: REMOVAL

Spark plug:

Refer to "SPECIFICATION" for the spark plug. <Ref. to IG(H4DOTC)-2, SPECIFICATION, General Description.>

1. RH SIDE

- 1) Remove the collector cover.
- 2) Disconnect the ground cable from the battery.

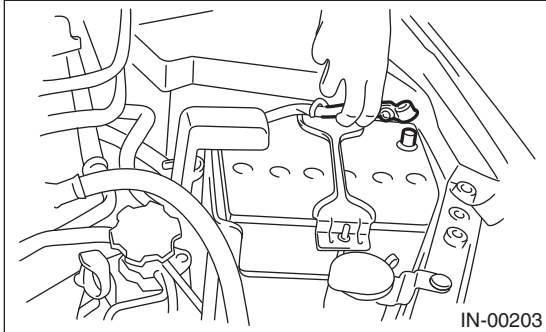

- 3) Remove the air cleaner case. <Ref. to IN(H4DOTC)-8, REMOVAL, Air Cleaner Case.>
- 4) Disconnect the connector from ignition coil.
- 5) Remove the ignition coil.

NOTE:

Turn #3 ignition coil by 180 degrees to remove it.

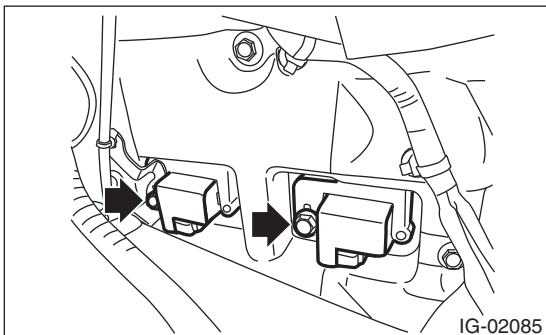

- 6) Remove the spark plug with a spark plug socket.

2. LH SIDE

- 1) Remove the collector cover.
- 2) Remove the battery and battery carrier.
- 3) Disconnect the air duct from the secondary air pump.
- 4) Remove the bolts that attach the air pump duct to the rocker cover LH, and raise the air pump duct.

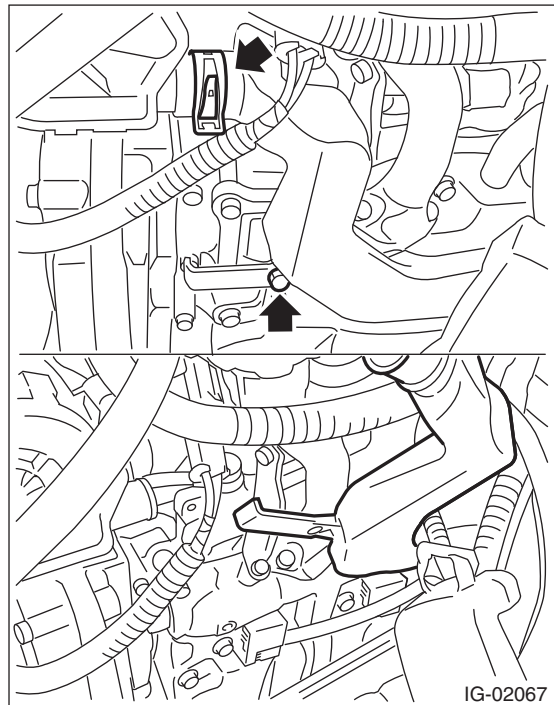

- 5) Disconnect the connector from ignition coil.
- 6) Remove the ignition coil.

NOTE:

Turn #4 ignition coil by 180 degrees to remove it.

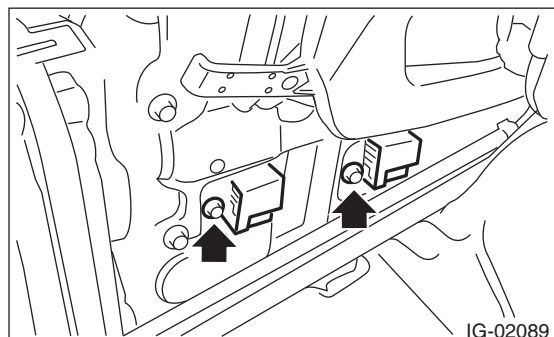

- 7) Remove the spark plug with a spark plug socket.

B: INSTALLATION

1. RH SIDE

Install in the reverse order of removal.

Tightening torque (Spark plug):
21 N·m (2.1 kgf·m, 15.5 ft·lb)

Tightening torque (Ignition coil):
16 N·m (1.6 kgf·m, 11.8 ft·lb)

2. LH SIDE

Install in the reverse order of removal.

Tightening torque (Spark plug):
21 N·m (2.1 kgf·m, 15.5 ft·lb)

Tightening torque (Ignition coil):
16 N·m (1.6 kgf·m, 11.8 ft·lb)

Tightening torque (Air pump duct):
9 N·m (0.9 kgf·m, 6.6 ft·lb)

C: INSPECTION

Check the electrodes and inner and outer ceramic insulator of plugs, noting the type of deposits and the degree of electrode erosion.

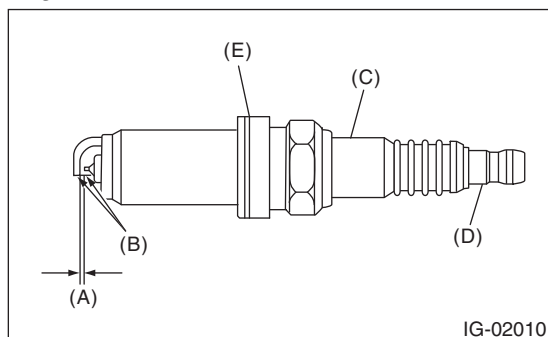

- (A) Spark plug gap
- (B) Carbon accumulation or wear
- (C) Crack
- (D) Damage
- (E) Damaged gasket

1) Normal:

Brown to grayish-tan deposits and slight electrode wear indicate correct spark plug heat range.

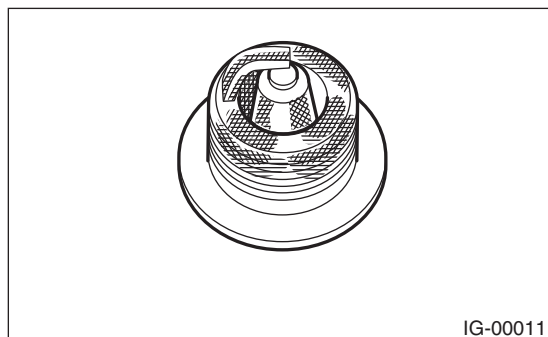

2) Carbon fouled:

Dry fluffy carbon deposits on insulator and electrode are mostly caused by slow speed driving in the city, weak ignition, too rich fuel mixture and dirty air cleaner.

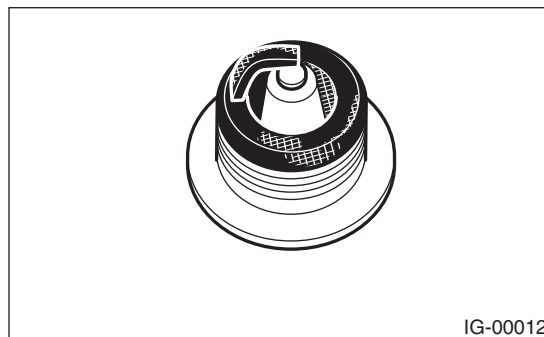

3) Oil fouled:

Wet black deposits show oil entrance into the combustion chamber through worn rings and excessive clearance between valve guides and stems.

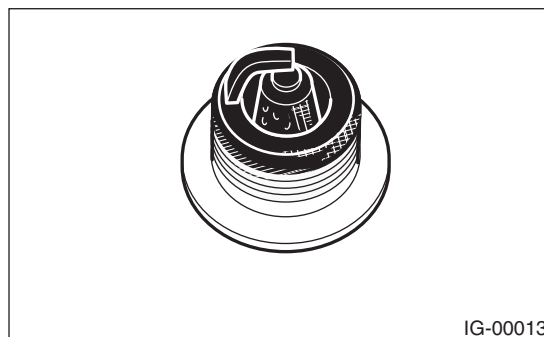

4) Overheating:

White or light gray insulator with black or brown spots and bluish burnt electrodes indicate engine overheating, incorrect ignition timing, wrong selection of fuel, and loose spark plugs.

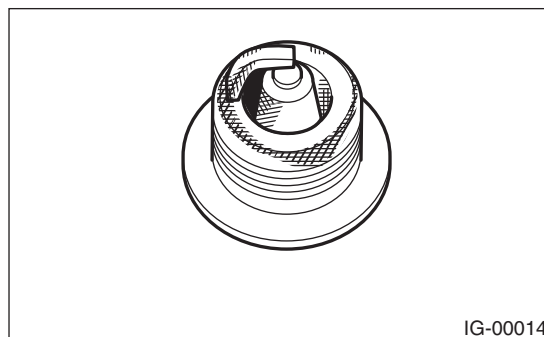

Spark Plug

IGNITION

D: ADJUSTMENT

Clean up the spark plug using nylon brush or equivalent. Clean and remove the carbon or oxide deposits. If deposits are too stubborn, replace the spark plugs. After cleaning the spark plugs, measure the spark plug gap using a gap gauge.

NOTE:

- Never use a plug cleaner.
- Never use a metal brush because it makes insulator worn.

Spark plug gap: L

0.7 — 0.8 mm (0.028 — 0.031 in)

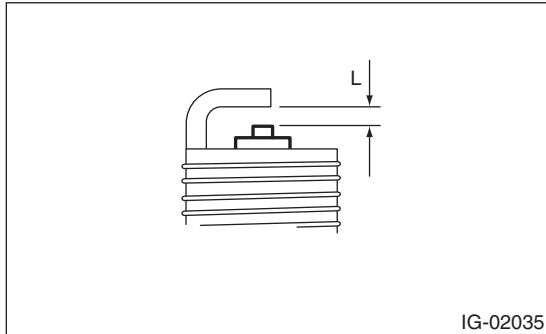

3. Ignition Coil

A: REMOVAL

Direct ignition type has been adopted. Refer to "Removing Spark Plugs" for removal procedure. <Ref. to IG(H4DOTC)-4, REMOVAL, Spark Plug.>

B: INSTALLATION

Install in the reverse order of removal.

Tightening torque:

16 N·m (1.6 kgf-m, 11.8 ft-lb)

C: INSPECTION

For inspection procedure, refer to "Diagnostics for Engine Starting Failure". <Ref. to EN(H4DOTC) (diag)-72, IGNITION CONTROL SYSTEM, Diagnostics for Engine Starting Failure.>

Ignition Coil

IGNITION

STARTING/CHARGING SYSTEMS

SC(H4DOTC)

	Page
1. General Description	2



General Description

STARTING/CHARGING SYSTEMS

1. General Description

A: SPECIFICATION

Specifications for the turbo model are included in the SC(H4SO) section. <Ref. to SC(H4SO)-2, General Description.>

ENGINE (DIAGNOSTICS)

EN(H4DOTC)(diag)

	Page
1. Basic Diagnostic Procedure	2
2. Check List for Interview	3
3. General Description	5
4. Electrical Component Location	8
5. Engine Control Module (ECM) I/O Signal	17
6. Engine Condition Data	27
7. Data Link Connector	28
8. General Scan Tool	29
9. Subaru Select Monitor	34
10. Read Diagnostic Trouble Code (DTC)	41
11. Inspection Mode	42
12. Drive Cycle	47
13. Clear Memory Mode	52
14. Compulsory Valve Operation Check Mode	53
15. System Operation Check Mode	55
16. Malfunction Indicator Light	57
17. Diagnostics for Engine Starting Failure	66
18. Diagnostic Procedure for Subaru Select Monitor Communication	78
19. List of Diagnostic Trouble Code (DTC)	80
20. Diagnostic Procedure with Diagnostic Trouble Code (DTC)	88
21. General Diagnostic Table	366

Basic Diagnostic Procedure

ENGINE (DIAGNOSTICS)

1. Basic Diagnostic Procedure

A: PROCEDURE

1. ENGINE

	Step	Check	Yes	No
1	<p>CHECK ENGINE START FAILURE.</p> <p>1) Ask the customer when and how the trouble occurred using the interview check list. <Ref. to EN(H4DOTC)(diag)-3, CHECK, Check List for Interview.></p> <p>2) Start the engine.</p>	Does the engine start?	Go to step 2.	Inspection using “Diagnostics for Engine Start Failure”. <Ref. to EN(H4DOTC)(diag)-66, Diagnostics for Engine Starting Failure.>
2	<p>CHECK ILLUMINATION OF MALFUNCTION INDICATOR LIGHT.</p>	Does the malfunction indicator light illuminate?	Go to step 3.	Inspection using “General Diagnostic Table” <Ref. to EN(H4DOTC)(diag)-366, General Diagnostic Table.>
3	<p>CHECK THE COMMUNICATION STATUS.</p> <p>1) Turn the ignition switch to OFF.</p> <p>2) Connect the Subaru Select Monitor or general scan tool to data link connector.</p> <p>3) Turn the ignition switch to ON, and run the Subaru Select Monitor or general scan tool.</p> <p>NOTE:</p> <ul style="list-style-type: none"> Subaru Select Monitor <p>For detailed procedures, refer to “Subaru Select Monitor”. <Ref. to EN(H4DOTC)(diag)-34, Subaru Select Monitor.></p> <ul style="list-style-type: none"> General scan tool <p>For detailed operation procedures, refer to the general scan tool operation manual.</p>	Does Subaru select monitor or general scan tool communicate with vehicle normally?	Go to step 4.	Inspection using “Diagnostics Procedure for Subaru Select Monitor Communication”. <Ref. to EN(H4DOTC)(diag)-78, Diagnostic Procedure for Subaru Select Monitor Communication.>
4	<p>CHECK DTC.</p> <p>Read DTC using Subaru Select Monitor or general scan tool.</p> <p>NOTE:</p> <ul style="list-style-type: none"> Subaru Select Monitor <p>Refer to “Read Diagnostic Trouble Code” for detailed operation procedure. <Ref. to EN(H4DOTC)(diag)-41, Read Diagnostic Trouble Code (DTC).></p> <ul style="list-style-type: none"> General scan tool <p>For detailed operation procedures, refer to the general scan tool operation manual.</p>	Is DTC displayed on the Subaru Select Monitor or general scan tool?	Record the DTC. Repair the trouble cause. <Ref. to EN(H4DOTC)(diag)-80, List of Diagnostic Trouble Code (DTC).> Go to step 5.	Repair the related parts. NOTE: If DTC is not shown on display although the malfunction indicator light illuminates, perform the diagnosis of malfunction indicator light circuit or combination meter. <Ref. to EN(H4DOTC)(diag)-57, Malfunction Indicator Light.>
5	<p>PERFORM DIAGNOSIS.</p> <p>1) Perform the Clear Memory Mode. <Ref. to EN(H4DOTC)(diag)-52, Clear Memory Mode.></p> <p>2) Perform the Inspection Mode. <Ref. to EN(H4DOTC)(diag)-42, Inspection Mode.></p>	Is DTC displayed on the Subaru Select Monitor or general scan tool?	Inspect using “Diagnostic Procedure with Diagnostic Trouble Code (DTC)”. <Ref. to EN(H4DOTC)(diag)-88, Diagnostic Procedure with Diagnostic Trouble Code (DTC).>	Finish the diagnosis.

Check List for Interview

ENGINE (DIAGNOSTICS)

2. Check List for Interview

A: CHECK

1. CHECK LIST NO. 1

Check the following item when problem has occurred.

NOTE:

Use copies of this page for interviewing customers.

Customer's name		Engine No.	
Date of purchase		Fuel type	
Date of repair		Odometer reading	km
V.I.N.			miles
Weather	<input type="checkbox"/> Fine <input type="checkbox"/> Cloudy <input type="checkbox"/> Rainy <input type="checkbox"/> Snowy <input type="checkbox"/> Various/Others:		
Ambient air temperature	°C (°F)		
	<input type="checkbox"/> Hot <input type="checkbox"/> Warm <input type="checkbox"/> Cool <input type="checkbox"/> Cold		
Place	<input type="checkbox"/> Highway <input type="checkbox"/> Suburbs <input type="checkbox"/> Inner city <input type="checkbox"/> Uphill <input type="checkbox"/> Downhill <input type="checkbox"/> Rough road <input type="checkbox"/> Others:		
	<input type="checkbox"/> Cold <input type="checkbox"/> Warming up <input type="checkbox"/> After warming up <input type="checkbox"/> Any temperature <input type="checkbox"/> Others:		
Engine speed	rpm		
Vehicle speed	km/h (MPH)		
Driving conditions	<input type="checkbox"/> Not affected <input type="checkbox"/> At starting <input type="checkbox"/> While idling <input type="checkbox"/> At racing <input type="checkbox"/> While accelerating <input type="checkbox"/> While cruising <input type="checkbox"/> While decelerating <input type="checkbox"/> While turning (RH/LH)		
	<input type="checkbox"/> ON/ <input type="checkbox"/> OFF		
Headlight		Rear defogger	<input type="checkbox"/> ON/ <input type="checkbox"/> OFF
Blower	<input type="checkbox"/> ON/ <input type="checkbox"/> OFF	Audio	<input type="checkbox"/> ON/ <input type="checkbox"/> OFF
A/C compressor	<input type="checkbox"/> ON/ <input type="checkbox"/> OFF	CD/Cassette	<input type="checkbox"/> ON/ <input type="checkbox"/> OFF
Radiator fan	<input type="checkbox"/> ON/ <input type="checkbox"/> OFF	Car phone	<input type="checkbox"/> ON/ <input type="checkbox"/> OFF
Front wiper	<input type="checkbox"/> ON/ <input type="checkbox"/> OFF	Wireless device	<input type="checkbox"/> ON/ <input type="checkbox"/> OFF
Rear wiper	<input type="checkbox"/> ON/ <input type="checkbox"/> OFF		

Check List for Interview

ENGINE (DIAGNOSTICS)

2. CHECK LIST NO. 2

Check the following item about the vehicle's state when malfunction indicator light illuminates.

NOTE:

Use copies of this page for interviewing customers.

a) Other warning lights or indicators illuminate. <input type="checkbox"/> Yes / <input type="checkbox"/> No
<input type="checkbox"/> Low fuel warning light <input type="checkbox"/> Charge indicator light <input type="checkbox"/> Coolant temperature indicator light <input type="checkbox"/> Oil pressure indicator light <input type="checkbox"/> ATF temperature indicator light or SPORT indicator light <input type="checkbox"/> Drivers control center differential indicator light <input type="checkbox"/> ABS warning light <input type="checkbox"/> VDC warning light <input type="checkbox"/> Cruise indicator light <input type="checkbox"/> SI-CRUISE indicator light <input type="checkbox"/> Immobilizer indicator light <input type="checkbox"/> STEERING indicator light <input type="checkbox"/> Others:
b) Fuel level
<ul style="list-style-type: none">• Lack of gasoline: <input type="checkbox"/> Yes / <input type="checkbox"/> No• Indicator position of fuel gauge:• Experienced running out of fuel: <input type="checkbox"/> Yes / <input type="checkbox"/> No
c) Intentional connecting or disconnecting of harness connectors or spark plug cords: <input type="checkbox"/> Yes / <input type="checkbox"/> No
<ul style="list-style-type: none">• What:
d) Intentional connecting or disconnecting of hoses: <input type="checkbox"/> Yes / <input type="checkbox"/> No
<ul style="list-style-type: none">• What:
e) Installing of parts other than genuine parts: <input type="checkbox"/> Yes / <input type="checkbox"/> No
<ul style="list-style-type: none">• What:• Where:
f) Occurrence of noise: <input type="checkbox"/> Yes / <input type="checkbox"/> No
<ul style="list-style-type: none">• From where:• What kind:
g) Occurrence of smell: <input type="checkbox"/> Yes / <input type="checkbox"/> No
<ul style="list-style-type: none">• From where:• What kind:
h) Intrusion of water into engine compartment or passenger compartment: <input type="checkbox"/> Yes / <input type="checkbox"/> No
i) Troubles occurred
<input type="checkbox"/> Engine does not start. <input type="checkbox"/> Engine stalls during idling. <input type="checkbox"/> Engine stalls while driving. <input type="checkbox"/> Engine speed decreases. <input type="checkbox"/> Engine speed does not decrease. <input type="checkbox"/> Rough idling <input type="checkbox"/> Poor acceleration <input type="checkbox"/> Back fire <input type="checkbox"/> After fire <input type="checkbox"/> Does not shift. <input type="checkbox"/> Excessive shift shock

3. General Description

A: CAUTION

1) Airbag system wiring harness is routed near the ECM, main relay and fuel pump relay.

CAUTION:

- Do not use the electrical test equipment on airbag system circuits.
- Be careful not to damage the airbag system wiring harness when servicing the ECM, TCM, main relay and fuel pump relay.

2) Never connect the battery in reverse polarity. Doing so will damage the ECM instantly, and other parts will also be damaged.

3) Do not disconnect the battery terminals while the engine is running. A large counter electromotive force will be generated in the generator, and this voltage may damage electronic parts such as ECM etc.

4) Before disconnecting the connectors of each sensor and ECM, be sure to turn the ignition switch to OFF. Perform the Clear Memory Mode after connecting the connectors. <Ref. to EN(H4DOTC)(diag)-52, Clear Memory Mode.>

5) Measure the voltage or resistance of individual sensor or all electrical control modules using a tapered pin with a diameter of less than 0.6 mm (0.024 in). Do not insert the pin 4 mm (0.16 in) or more into the part.

CAUTION:

When replacing the ECM, be careful not to use the wrong spec. ECM to avoid any damage on the fuel injection system.

NOTE:

When replacing the ECM of the models with Immobilizer, immobilizer system must be registered. To do so, all ignition keys and ID cards need to be prepared. For detailed operation procedure, refer to the "PC application help for Subaru Select Monitor".

6) Take care not to allow water to get into the connectors when servicing or washing the vehicle in rainy weather. Avoid exposure to water even if the connectors are waterproof.

7) Use ECM mounting stud bolts at the body side grounding point when measuring voltage and resistance inside the passenger compartment.

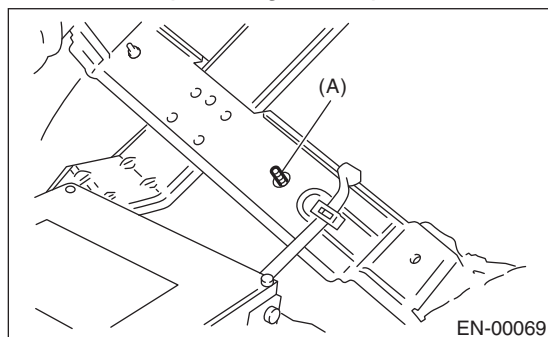

(A) Stud bolt

8) Use the engine ground terminal or engine assembly as the grounding point to chassis when measuring the voltage and resistance in engine compartment.

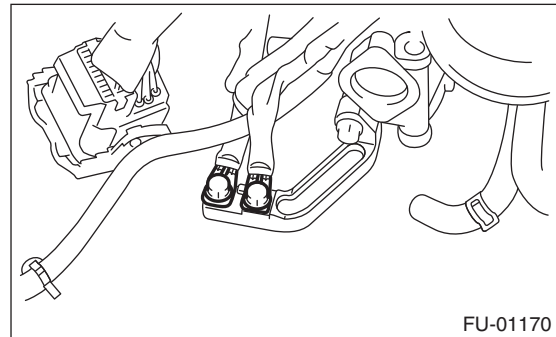

9) Every engine control system-related part is a precision part. Do not drop them.

10) Observe the following cautions when installing a radio in vehicle.

CAUTION:

- The antenna must be kept as far apart as possible from control module. (ECM is installed under the passenger's side floor mat.)
- The antenna feeder must be placed as far apart as possible from the ECM and engine control system harness.
- Carefully adjust the antenna for correct matching.
- When mounting a large power type radio, pay special attention to the three items mentioned above.
- Incorrect installation of the radio may affect the operation of ECM.

11) When disconnecting the fuel hose, release the fuel pressure. <Ref. to FU(H4DOTC)-51, RELEASING OF FUEL PRESSURE, PROCEDURE, Fuel.>

12) ABS warning light may illuminate when performing driving test with jacked-up or lifted-up condition, but this is not a system malfunction. The reason for this is the speed difference between the front and rear wheels. After diagnosis of engine control system, perform the ABS memory clear procedure of self-diagnosis function.

General Description

ENGINE (DIAGNOSTICS)

B: INSPECTION

Before performing diagnostics, check the following item which might affect engine problems.

1. BATTERY

1) Measure the battery voltage and specific gravity of the electrolyte.

Standard voltage: 12 V

Specific gravity: 1.260 or more

2) Check the condition of the main and other fuses, and harnesses and connectors. Also check for proper grounding.

2. ENGINE GROUND

Check if the engine ground terminal is properly connected to engine.

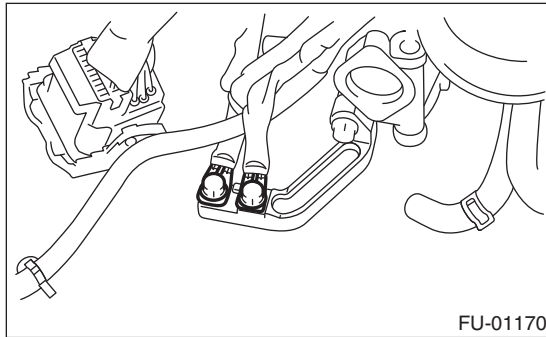

C: NOTE

- The on-board diagnostic (OBD) system detects and indicates a fault in various inputs and outputs of the complex electronic control. Malfunction indicator light in the combination meter indicates occurrence of a fault or trouble.
- Further, against such a failure or sensors as may disable the drive, the fail-safe function is provided to ensure the minimal driveability.
- The OBD system incorporated with the vehicles within this type of engine complies with OBD-II regulations. The OBD system monitors the components and the system malfunction listed in "Engine Section" which affects on emissions.
- When the system decides that a malfunction occurs, malfunction indicator light illuminates. At the same time of the malfunction indicator light illumination or blinking, a DTC and a freeze frame engine conditions are stored into on-board computer.
- The OBD system stores freeze frame engine condition data (engine load, engine coolant temperature, fuel trim, engine speed and vehicle speed, etc.) into on-board computer when it detects a malfunction.
- The freeze frame engine condition data are stored until DTCs are cleared. However, if any faults concerning fuel trim or misfiring are detected while the freeze frame engine condition data are stored, these data are rewritten to those concerning fuel trim or misfiring.
- When the malfunction does not occur again for three consecutive driving cycles, malfunction indicator light is turned off, but DTC remains at on-board computer.
- When troubleshooting the vehicle which complies with OBD-II regulations, connect the Subaru Select Monitor or general scan tool to the vehicle.

General Description

ENGINE (DIAGNOSTICS)

D: PREPARATION TOOL

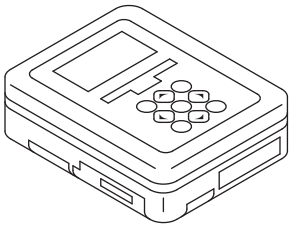
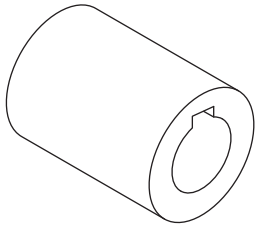
ILLUSTRATION	TOOL NUMBER	DESCRIPTION	REMARKS
 ST1B022XU0	1B022XU0 (Newly adopted tool)	SUBARU SELECT MONITOR III KIT	Used for troubleshooting the electrical system.
 ST-499987500	499987500	CRANKSHAFT SOCKET	Used for rotating crankshaft.

Electrical Component Location

ENGINE (DIAGNOSTICS)

4. Electrical Component Location

A: LOCATION

1. ENGINE

- Control module

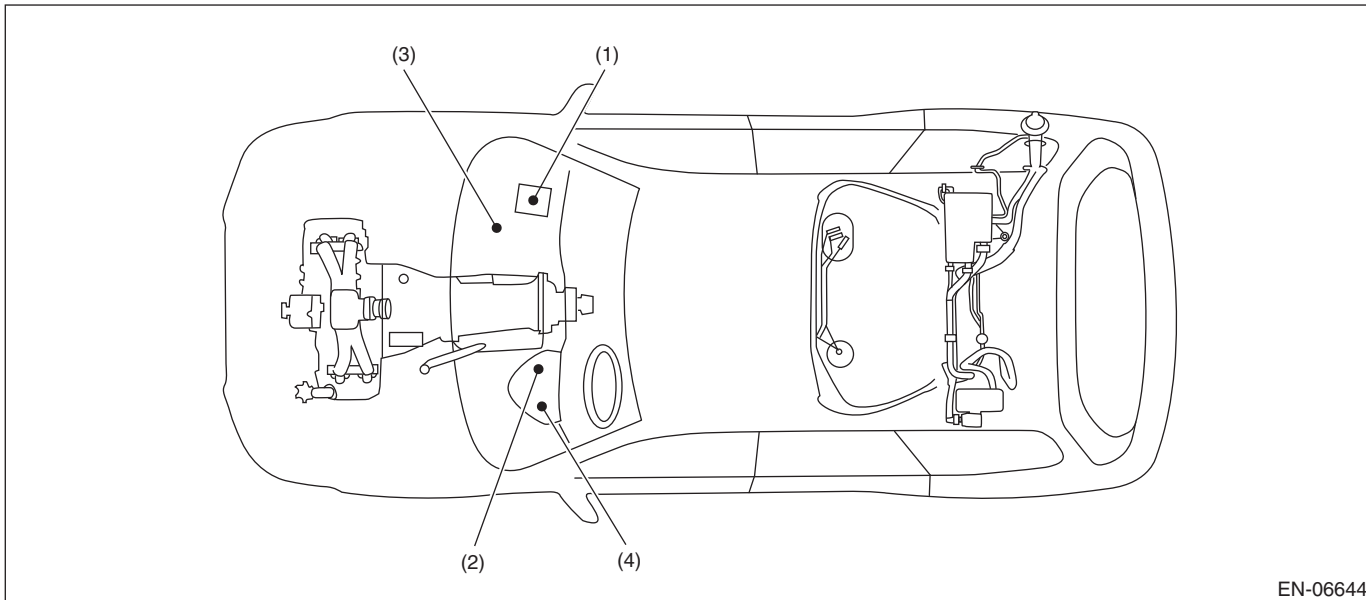

- (1) Engine control module (ECM) (3) Delivery (test) mode connector (4) Data link connector
(2) Malfunction indicator light

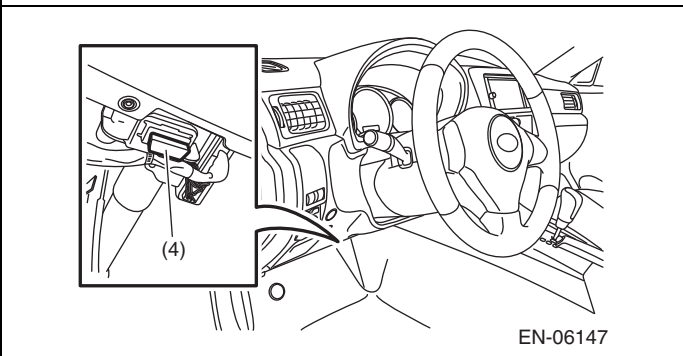
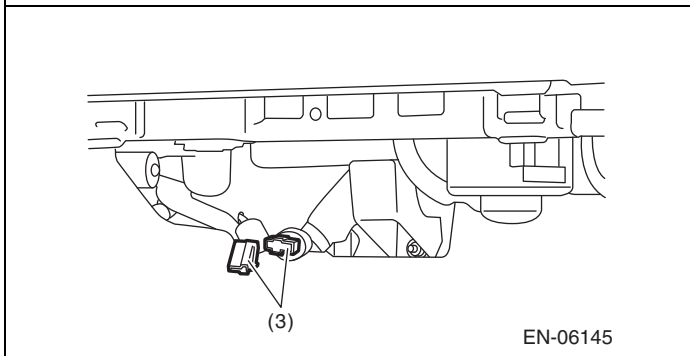
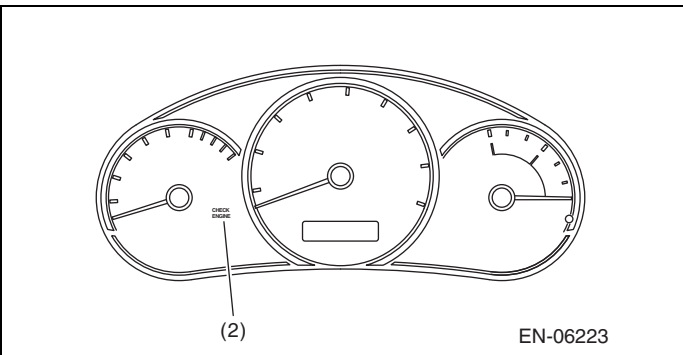
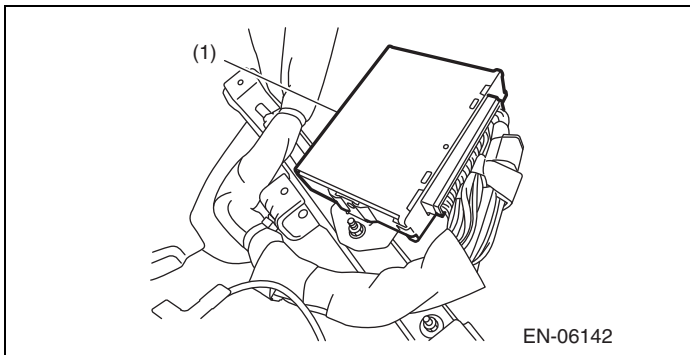

Electrical Component Location

ENGINE (DIAGNOSTICS)

- Sensor

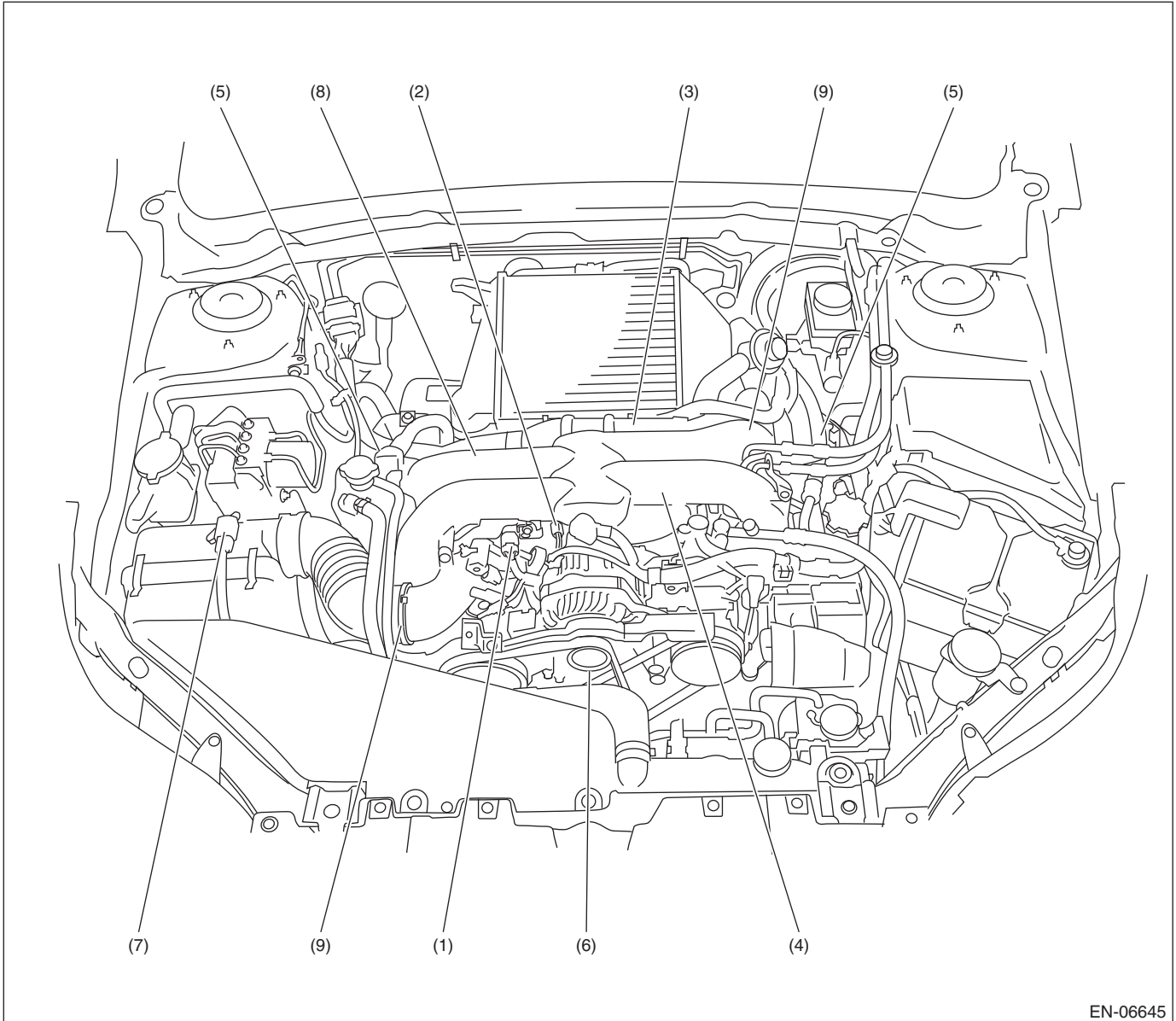

- | | | |
|---------------------------------------|---|---|
| (1) Manifold absolute pressure sensor | (5) Intake camshaft position sensor | (8) Secondary air pipe pressure sensor (with built-in secondary air combination valve RH) |
| (2) Engine coolant temperature sensor | (6) Crankshaft position sensor | (9) Tumble generator valve position sensor |
| (3) Electronic throttle control | (7) Mass air flow and intake air temperature sensor | |
| (4) Knock sensor | | |

Electrical Component Location

ENGINE (DIAGNOSTICS)

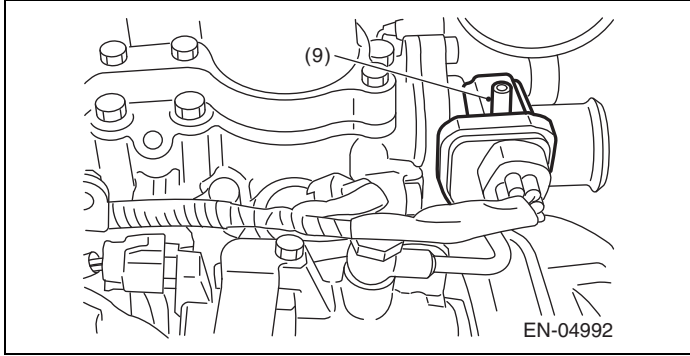
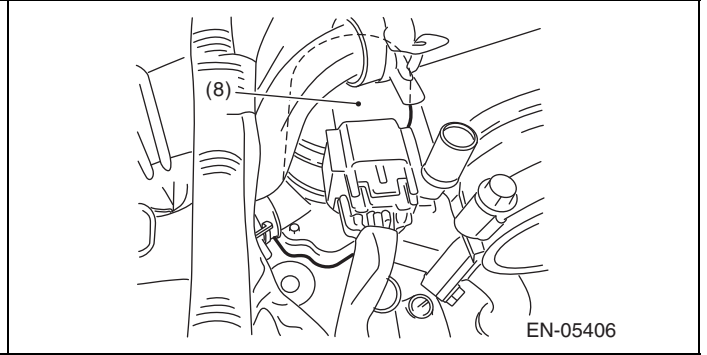
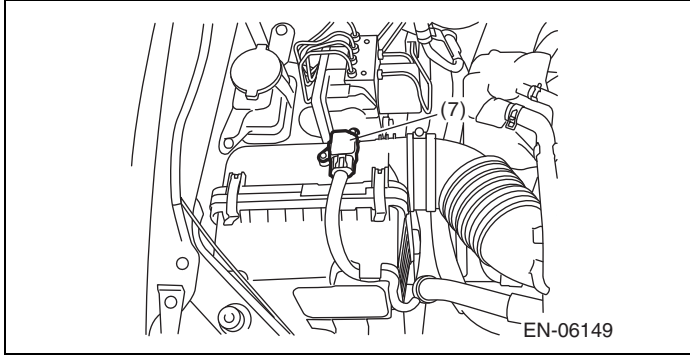
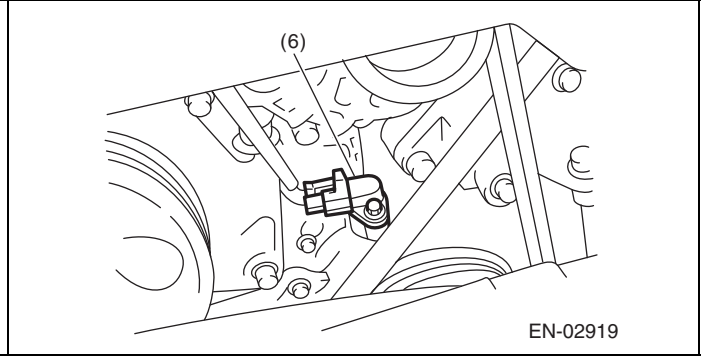
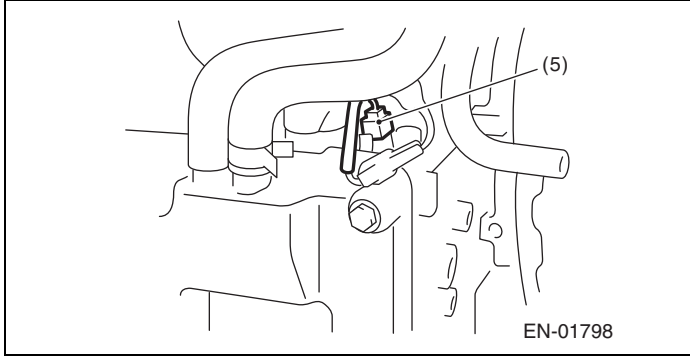
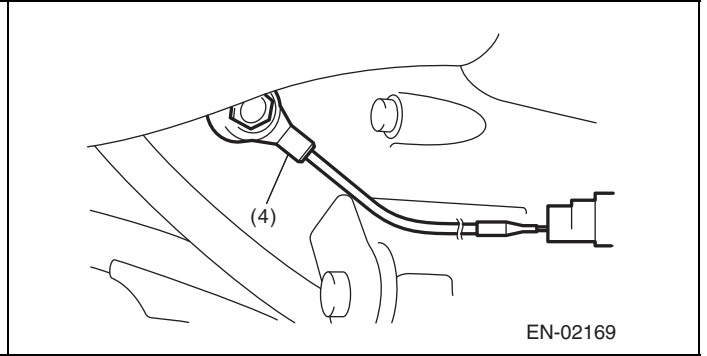
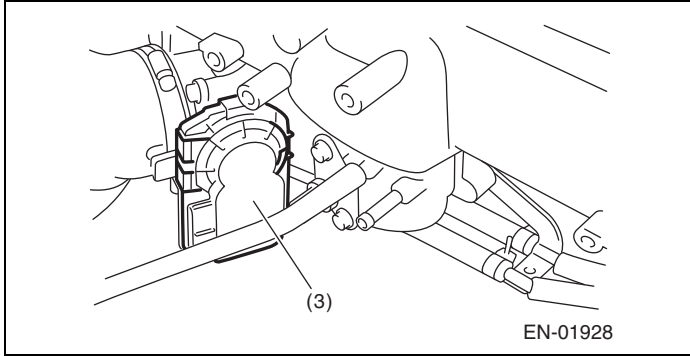
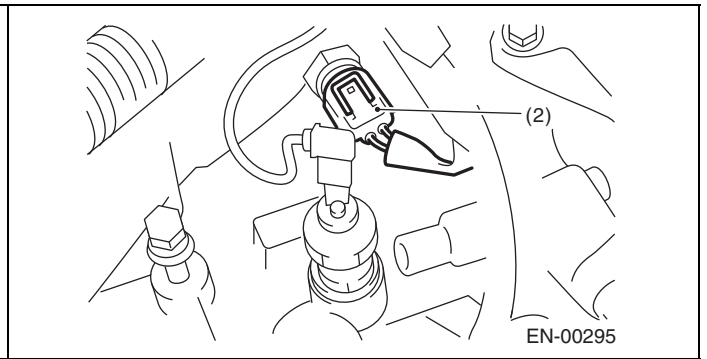
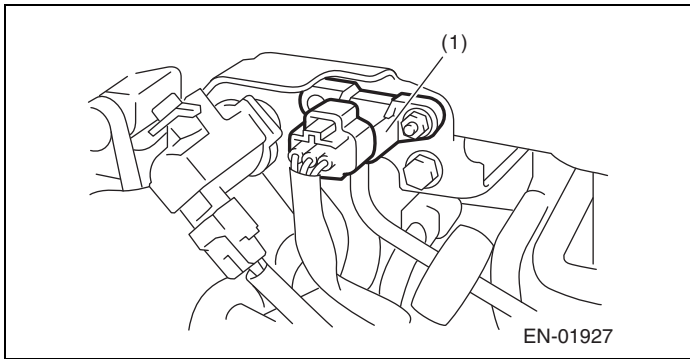

SUBARU.

Electrical Component Location

ENGINE (DIAGNOSTICS)

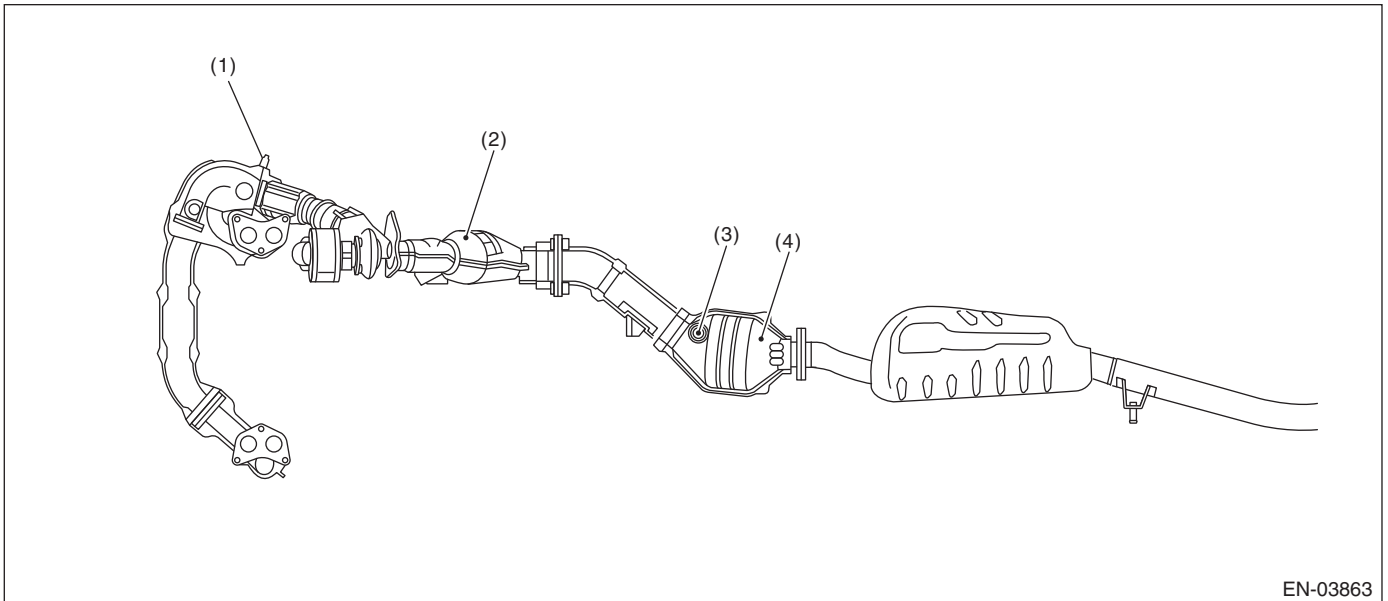

(1) Front oxygen (A/F) sensor
(2) Front catalytic converter

(3) Rear oxygen sensor

(4) Rear catalytic converter

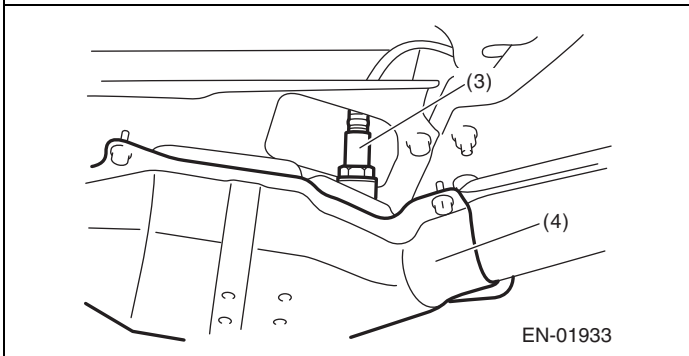
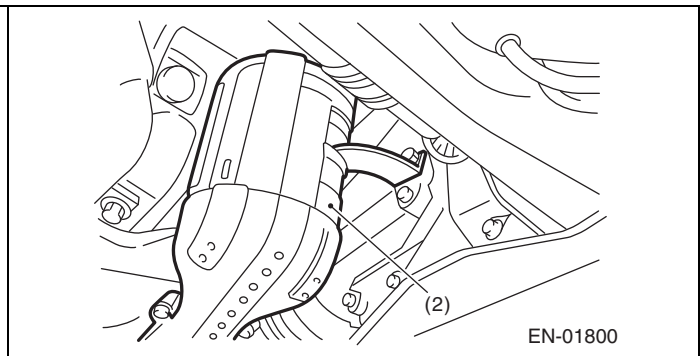
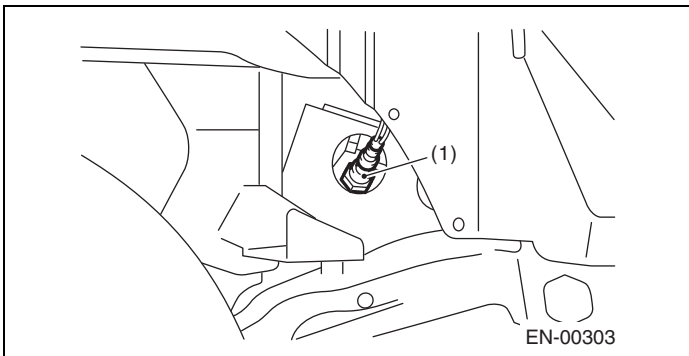

SUBARU.

Electrical Component Location

ENGINE (DIAGNOSTICS)

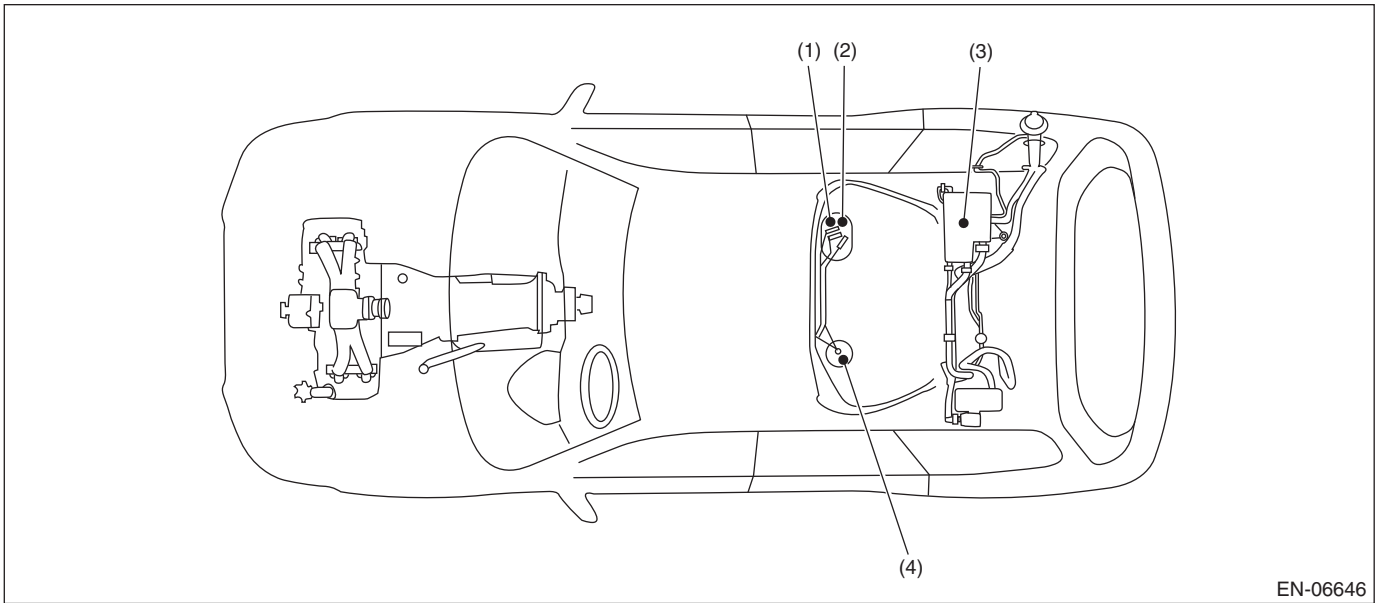

(1) Fuel level sensor

(3) Fuel tank pressure sensor

(4) Fuel sub level sensor

(2) Fuel temperature sensor

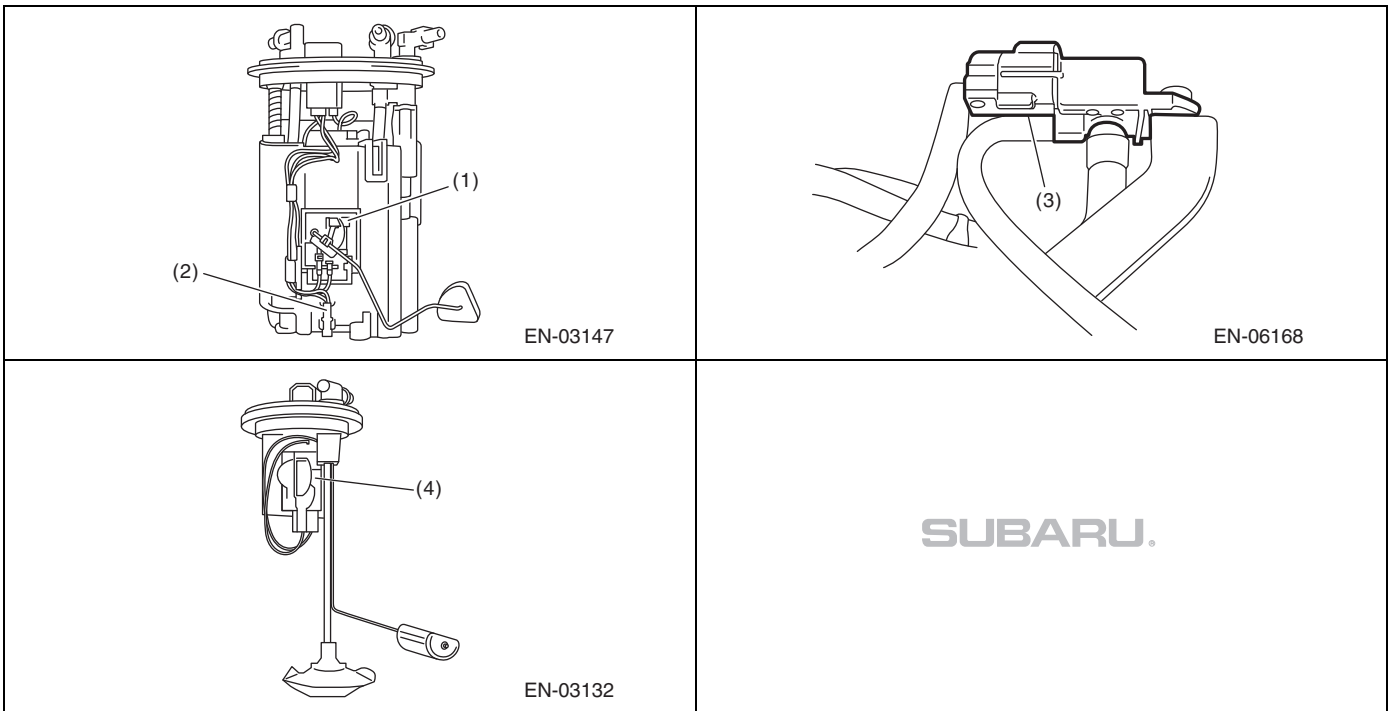

Electrical Component Location

ENGINE (DIAGNOSTICS)

- Solenoid valve, actuator, emission control system parts and ignition system parts

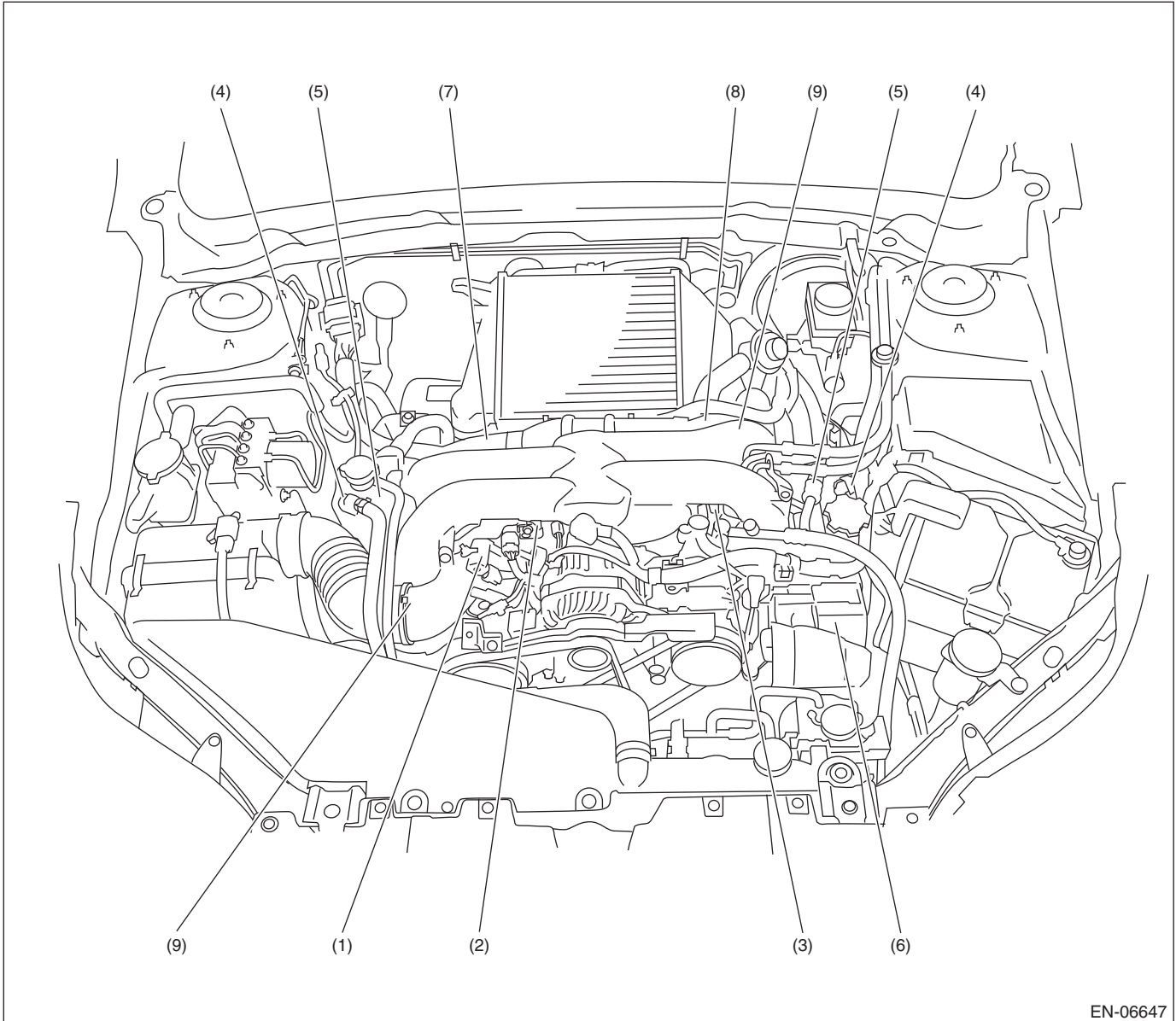

EN-06647

- | | | |
|--------------------------------------|--|--|
| (1) Wastegate control solenoid valve | (5) Intake oil flow control solenoid valve | (8) Secondary air combination valve LH |
| (2) Purge control solenoid valve 2 | (6) Secondary air pump | |
| (3) Purge control solenoid valve 1 | (7) Secondary air combination valve RH | (9) Tumble generator valve ASSY |
| (4) Ignition coil | | |

Electrical Component Location

ENGINE (DIAGNOSTICS)

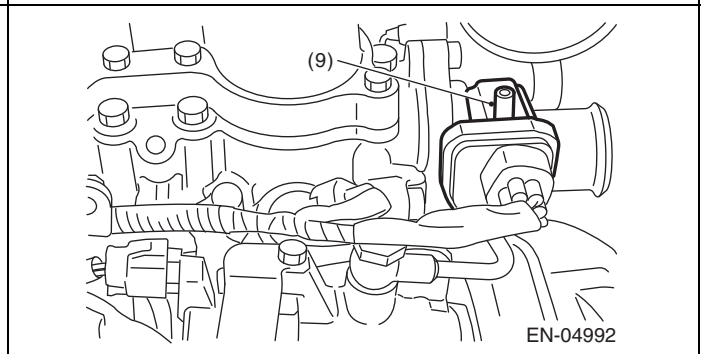
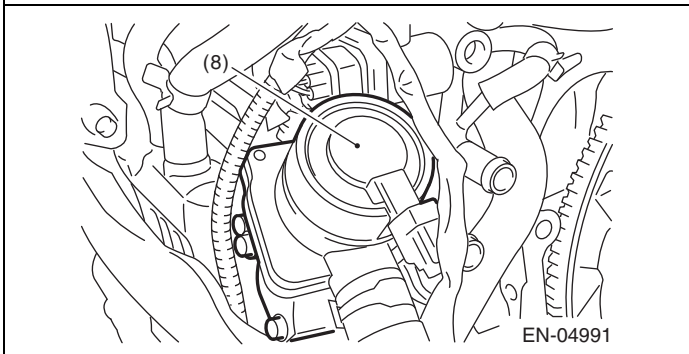
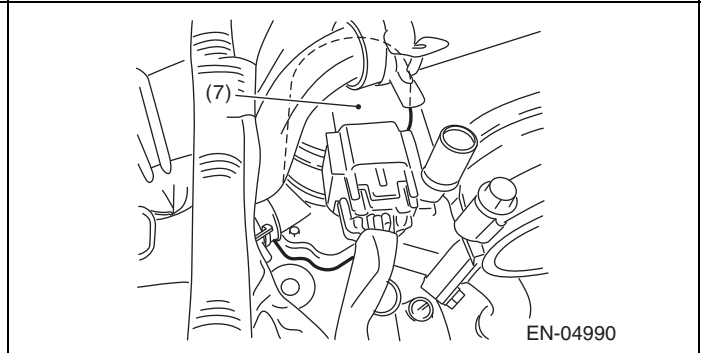
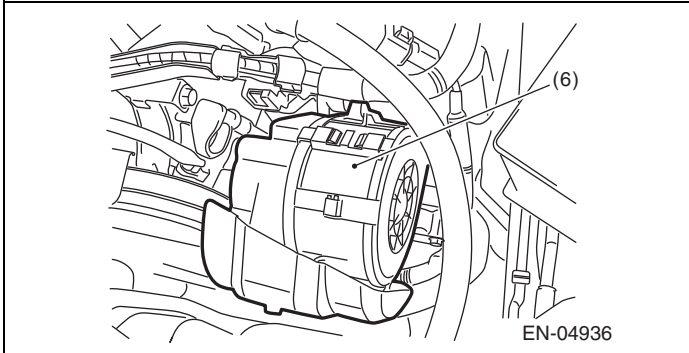
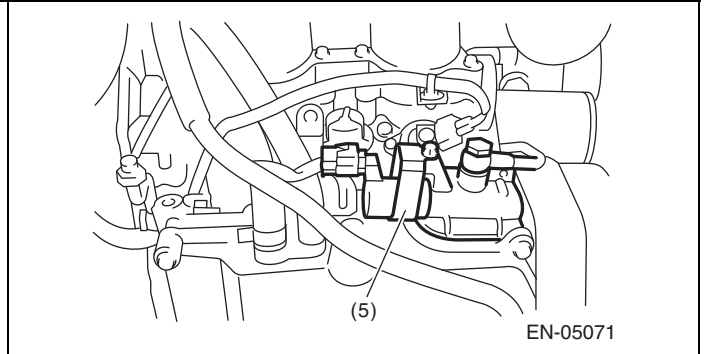
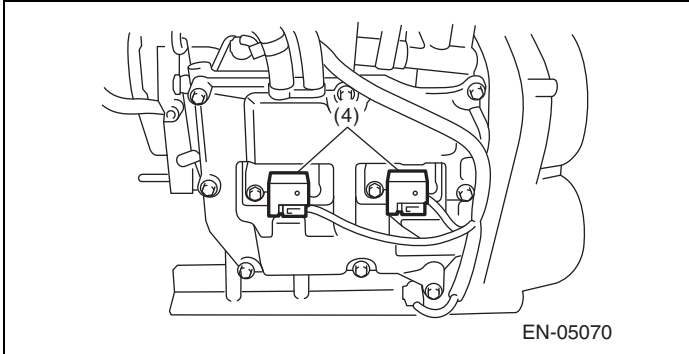
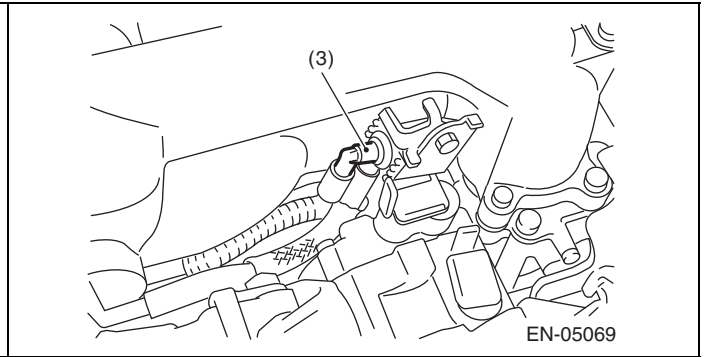
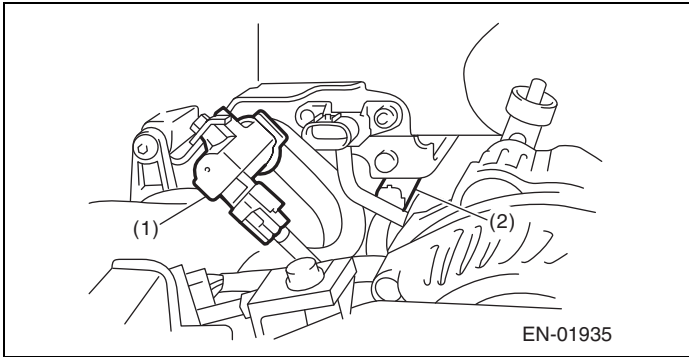

Electrical Component Location

ENGINE (DIAGNOSTICS)

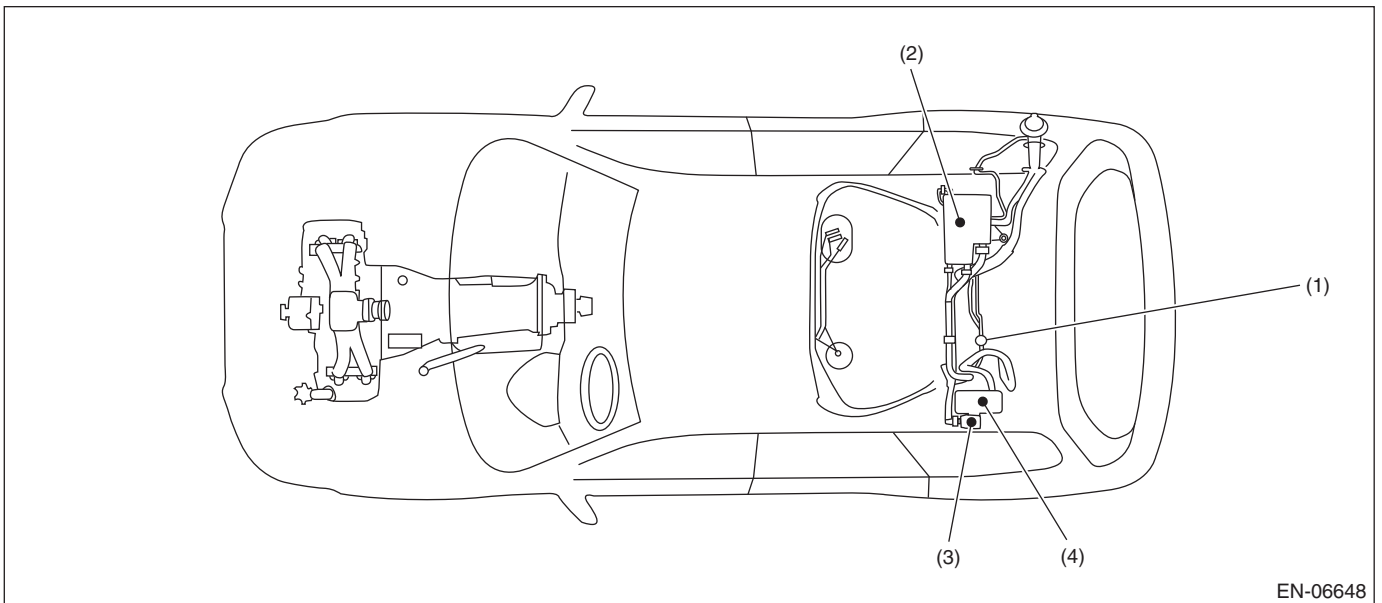

EN-06648

(1) Pressure control solenoid valve

(3) Drain valve

(4) Drain filter

(2) Canister

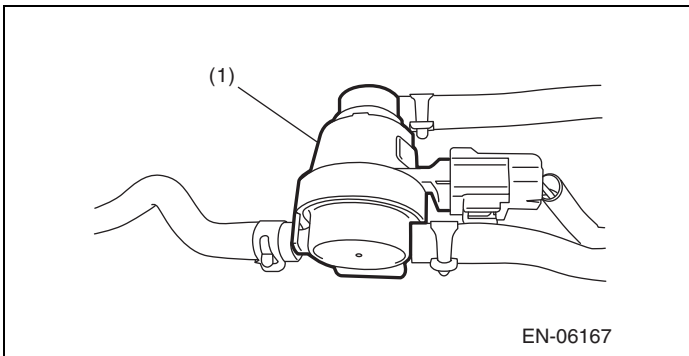

EN-06167

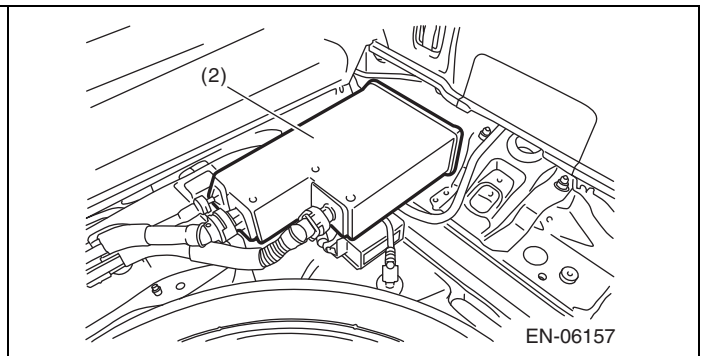

EN-06157

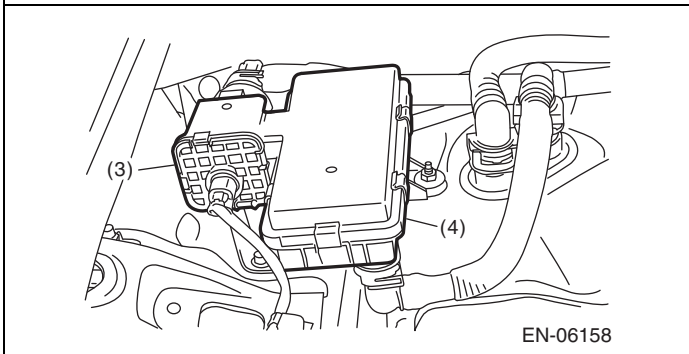

EN-06158

SUBARU.

Electrical Component Location

ENGINE (DIAGNOSTICS)

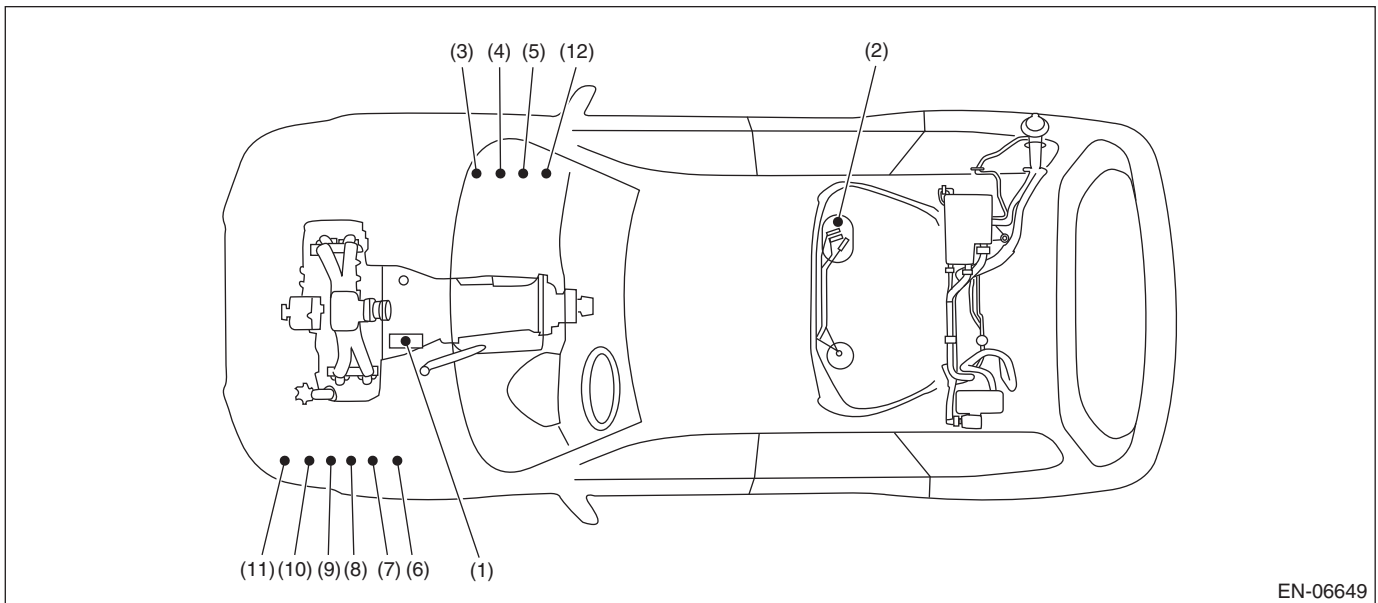

- | | | |
|---------------------------------------|---|--|
| (1) Starter | (6) Radiator main fan relay 1 | (10) Secondary air combination valve relay 2 |
| (2) Fuel pump | (7) Radiator sub fan relay | (11) Secondary air pump relay |
| (3) Main relay | (8) Radiator main fan relay 2 | (12) A/F, oxygen sensor relay relay 1 |
| (4) Fuel pump relay | (9) Secondary air combination valve relay 1 | |
| (5) Electronic throttle control relay | | |

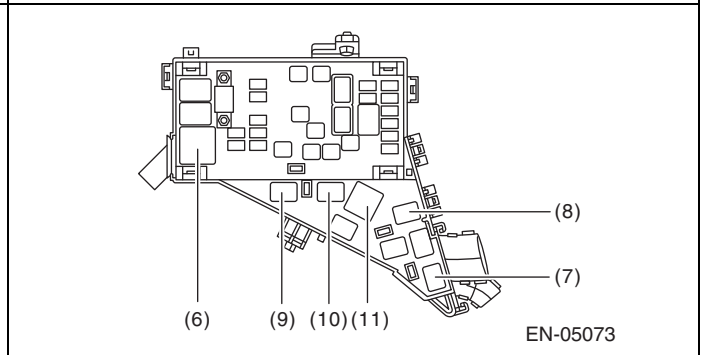
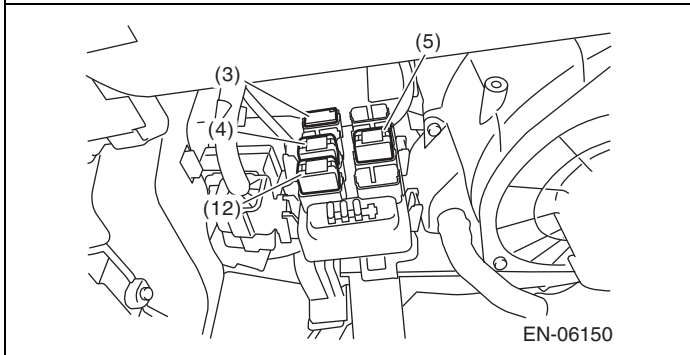
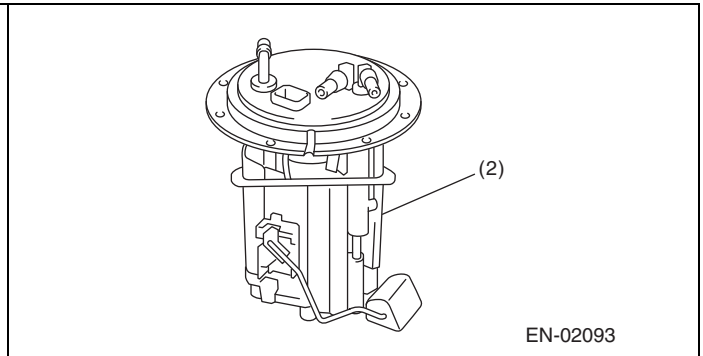
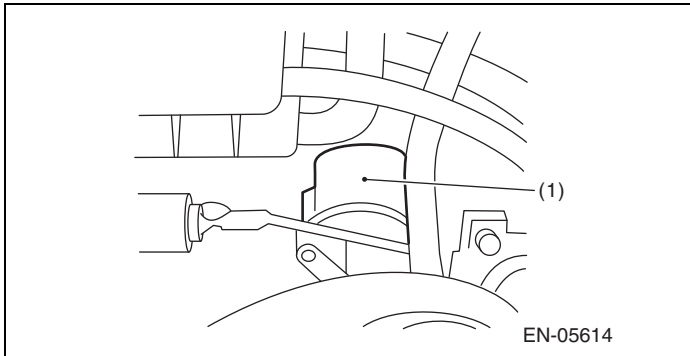

5. Engine Control Module (ECM) I/O Signal

A: ELECTRICAL SPECIFICATION

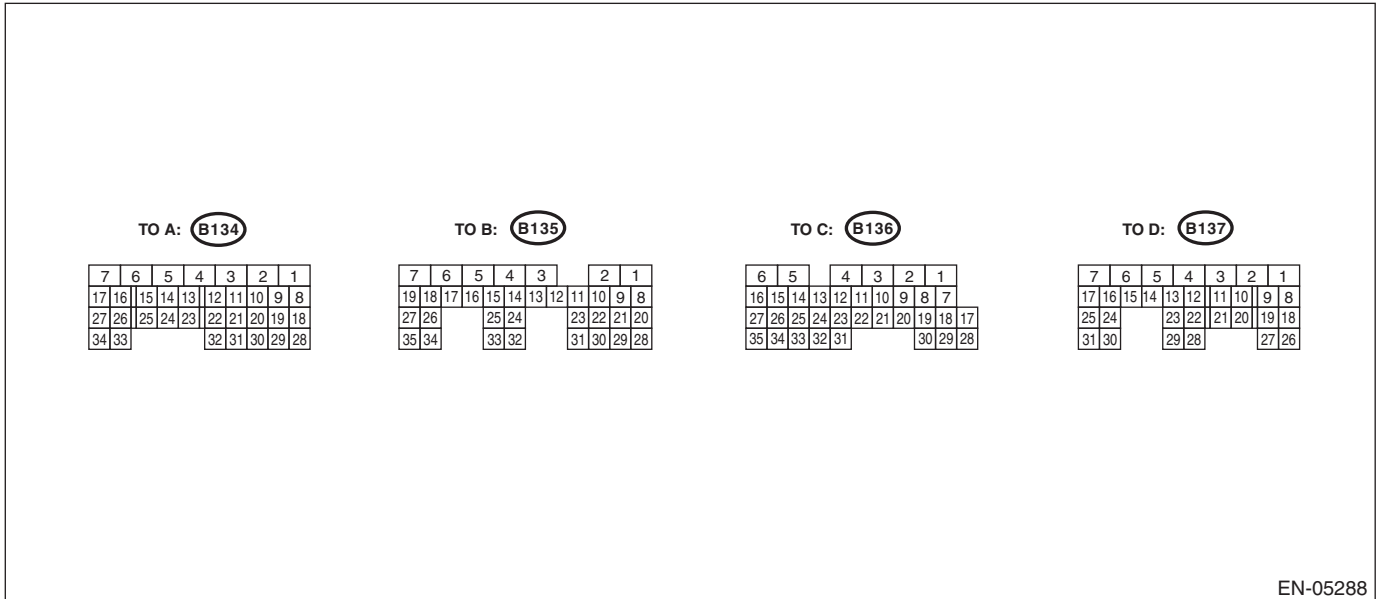

EN-05288

Contents		Connector No.	Terminal No.	Signal (V)		Note
				Ignition SW ON (engine OFF)	Engine ON (idling)	
Crankshaft position sensor	Signal (+)	B134	13	0	-7 — +7	Waveform
	Signal (-)	B134	14	0	0	—
	Shield	B134	24	0	0	—
Rear oxygen sensor	Signal	B135	4	0	0 — 0.9	—
	Shield	B135	1	0	0	—
	GND (sensor)	B135	30	0	0	—
Front oxygen (A/F) sensor heater	Signal 1	B136	3	—	—	Waveform
	Signal 2	B136	2	—	—	Waveform
Rear oxygen sensor heater signal		B136	4	0 — 13	12 — 14	Waveform
Engine coolant temperature sensor	Signal	B134	34	1.0 — 1.4	1.0 — 1.4	After engine is warmed up.
	GND (sensor)	B134	29	0	0	After engine is warmed up.
Air flow sensor	Signal	B135	26	—	0.3 — 4.5	—
	Shield	B135	35	0	0	—
	GND	B135	34	0	0	—
Intake air temperature sensor signal		B135	18	0.3 — 4.6	0.3 — 4.6	—
Wastegate control solenoid valve		B137	27	0 or 10 — 13	0 or 12 — 14	Waveform
Starter switch		B136	32	0	0	Cranking: 8 — 14
A/C switch		B136	24	ON: 10 — 13 OFF: 0	ON: 12 — 14 OFF: 0	—
Ignition switch		B135	19	10 — 13	12 — 14	—
Neutral position switch		B136	31	ON: 0 OFF: 10 — 13	ON: 0 OFF: 12 — 14	—

Engine Control Module (ECM) I/O Signal

ENGINE (DIAGNOSTICS)

Contents		Connector No.	Terminal No.	Signal (V)		Note
				Ignition SW ON (engine OFF)	Engine ON (idling)	
Delivery (test) mode connector		B135	27	10 — 13	13 — 14	When connected: 0
Knock sensor	Signal	B134	15	2.8	2.8	—
	Shield	B134	25	0	0	—
Back-up power supply		B135	5	10 — 13	12 — 14	Ignition switch "OFF": 10 — 13
Control module power supply		B134	7	10 — 13	12 — 14	—
		B135	2	10 — 13	12 — 14	—
Sensor power supply		B134	19	5	5	—
Ignition control	#1	B137	18	0	12 — 14	Waveform
	#2	B137	19	0	12 — 14	Waveform
	#3	B137	20	0	12 — 14	Waveform
	#4	B137	21	0	12 — 14	Waveform
Fuel injector	#1	B137	8	10 — 13	1 — 14	Waveform
	#2	B137	9	10 — 13	1 — 14	Waveform
	#3	B137	10	10 — 13	1 — 14	Waveform
	#4	B137	11	10 — 13	1 — 14	Waveform
Fuel pump control unit	Signal 1	B135	33	10 — 13	12 — 14	—
	Signal 2	B136	12	0 or 5	0 or 5	Waveform
A/C relay control		B136	9	ON: 0.5 or less OFF: 10 — 13	ON: 0.5 or less OFF: 12 — 14	—
Radiator fan relay 1 control		B136	18	ON: 0.5 or less OFF: 10 — 13	ON: 0.5 or less OFF: 12 — 14	—
Radiator fan relay 2 control		B136	29	ON: 0.5 or less OFF: 10 — 13	ON: 0.5 or less OFF: 12 — 14	Model with A/C only
Malfunction indicator light		B136	11	—	—	Light "ON": 1 or less Light "OFF": 10 — 14
Engine speed output		B136	22	—	0 — 13 or more	Waveform
Purge control solenoid valve 1		B137	29	ON: 1 or less OFF: 10 — 13	ON: 1 or less OFF: 12 — 14	Waveform
Purge control solenoid valve 2		B136	7	ON: 1 or less OFF: 10 — 13	ON: 1 or less OFF: 12 — 14	Waveform
Manifold absolute pressure sensor	Signal	B134	6	1.7 — 2.4	1.1 — 1.6	—
	Power supply	B134	19	5	5	
	GND (sensor)	B134	29	0	0	
Power steering oil pressure switch		B134	33	10 — 13	ON: 0 OFF: 12 — 14	—
Front oxygen (A/F) sensor signal (+)		B135	9	2.8 — 3.2	2.8 — 3.2	—
Front oxygen (A/F) sensor signal (-)		B135	8	2.4 — 2.7	2.4 — 2.7	—
Front oxygen (A/F) sensor shield		B135	1	0	0	—
SSM/GST communication line		B136	16	1 or less ←→ 4 or more	1 or less ←→ 4 or more	—
Intake camshaft position sensor (LH)		B134	21	0 or 5	0 or 5	Waveform
Intake camshaft position sensor (RH)		B134	11	0 or 5	0 or 5	Waveform
Intake camshaft position sensor ground		B134	22	0	0	—

Engine Control Module (ECM) I/O Signal

ENGINE (DIAGNOSTICS)

Contents		Connector No.	Terminal No.	Signal (V)		Note
				Ignition SW ON (engine OFF)	Engine ON (idling)	
Electronic throttle control	Main	B134	18	0.64 — 0.72 Fully opened: 3.96	0.64 — 0.72 (After engine is warmed up.)	Fully closed: 0.6 Fully opened: 3.96
	Sub	B134	28	1.51 — 1.58 Fully opened: 4.17	1.51 — 1.58 (After engine is warmed up.)	Fully closed: 1.48 Fully opened: 4.17
	Power supply	B134	19	5	5	—
	GND (sensor)	B134	29	0	0	—
Electronic throttle control motor (+)		B137	5	Duty waveform	Duty waveform	Drive frequency: 500 Hz
Electronic throttle control motor (-)		B137	4	Duty waveform	Duty waveform	Drive frequency: 500 Hz
Electronic throttle control motor power supply		B136	1	10 — 13	12 — 14	—
Electronic throttle control motor relay		B136	21	ON: 0 OFF: 10 — 13	ON: 0 OFF: 12 — 14	When ignition switch is turned to ON: ON
Intake oil flow control solenoid valve (LH)	Signal (+)	B137	15	ON: 10 — 13 OFF: 0	ON: 12 — 14 OFF: 0	—
	Signal (-)	B137	14	0	0	—
Intake oil flow control solenoid valve (RH)	Signal (+)	B137	17	ON: 10 — 13 OFF: 0	ON: 12 — 14 OFF: 0	—
	Signal (-)	B137	16	0	0	—
Accelerator pedal position sensor	Main sensor signal	B135	23	Fully closed: 1 Fully opened: 3.3	Fully closed: 1 Fully opened: 3.3	—
	Main power supply	B135	21	5	5	—
	GND (main sensor)	B135	29	0	0	—
	Shield	B136	6	0	0	—
	Sub sensor signal	B135	31	Fully closed: 1 Fully opened: 3.3	Fully closed: 1 Fully opened: 3.3	—
	Sub power supply	B135	22	5	5	—
	GND (sub sensor)	B135	30	0	0	—
Starter relay		B136	20	ON: 0 OFF: 10 — 13	ON: 0 OFF: 12 — 14	ON: cranking
A/C middle pressure switch		B136	33	ON: 0 OFF: 10 — 13	ON: 0 OFF: 12 — 14	—
Blower fan switch		B135	11	ON: 0 OFF: 10 — 13	ON: 0 OFF: 12 — 14	Manual A/C model
Clutch switch		B136	25	When clutch pedal is depressed: 0 When clutch pedal is released: 10 — 13	When clutch pedal is depressed: 0 When clutch pedal is released: 12 — 14	—
Brake switch 1		B135	20	When brake pedal is depressed: 0 When brake pedal is released: 10 — 13	When brake pedal is depressed: 0 When brake pedal is released: 12 — 14	—

Engine Control Module (ECM) I/O Signal

ENGINE (DIAGNOSTICS)

Contents	Connector No.	Terminal No.	Signal (V)		Note	
			Ignition SW ON (engine OFF)	Engine ON (idling)		
Brake switch 2	B135	28	When brake pedal is depressed: 10 — 13 When brake pedal is released: 0	When brake pedal is depressed: 12 — 14 When brake pedal is released: 0	—	
Cruise control command switch	B135	24	When operating nothing: 3.5 — 4.5 When operating RES/ACC: 2.5 — 3.5 When operating SET/COAST: 0.5 — 1.5 When operating cancel: 0 — 0.5	When operating nothing: 3.5 — 4.5 When operating RES/ACC: 2.5 — 3.5 When operating SET/COAST: 0.5 — 1.5 When operating cancel: 0 — 0.5	—	
Cruise control main switch	B135	12	ON: 0 OFF: 5	ON: 0 OFF: 5	—	
Fuel tank pressure sensor	B135	32	2.3 — 2.7	2.3 — 2.7	—	
Pressure control solenoid valve	B136	28	ON: 1 or less OFF: 10 — 13	ON: 1 or less OFF: 12 — 14	—	
Drain valve	B136	17	ON: 1 or less OFF: 10 — 13	ON: 1 or less OFF: 12 — 14	—	
Fuel temperature sensor	B135	17	2.5 — 3.8	2.5 — 3.8	Ambient temperature: 25°C (77°F)	
Immobilizer	Signal 1	B136	26	—	—	
	Signal 2	B136	34	—	—	
CAN communication (+)	B136	27	—	—	—	
CAN communication (-)	B136	35	—	—	—	
AT/MT identification	B136	15	0	0	—	
Blow-by leak diagnosis	B134	30	0	0	At the time of open circuit (fault): 5	
Tumble generator valve position sensor signal (RH)	B134	26	Fully closed: 0.4 — 1.2 Fully opened: 2.8 — 4.6	Fully closed: 0.4 — 1.2 Fully opened: 2.8 — 4.6	—	
Tumble generator valve position sensor signal (LH)	B134	16	Fully closed: 0.4 — 1.2 Fully opened: 2.8 — 4.6	Fully closed: 0.4 — 1.2 Fully opened: 2.8 — 4.6	—	
Tumble generator valve RH (closed)	B137	23	0 or 10 — 13	0 or 12 — 14	—	
Tumble generator valve LH (closed)	B137	13	0 or 10 — 13	0 or 12 — 14	—	
Tumble generator valve RH (open)	B137	22	0 or 10 — 13	0 or 12 — 14	—	
Tumble generator valve LH (open)	B137	12	0 or 10 — 13	0 or 12 — 14	—	
Secondary air pipe pressure sensor	Signal	B134	27	2.2 — 2.8	2.2 — 2.8	When secondary air is inducted: 3.2 — 4.9
	Power supply	B134	19	5.12	5.12	—
	GND (sensor)	B134	29	0	0	—
Secondary air combination valve relay 1	B135	15	ON: 0 OFF: 10 — 13	ON: 0 OFF: 12 — 14	—	
Secondary air combination valve relay 2	B135	14	ON: 0 OFF: 10 — 13	ON: 0 OFF: 12 — 14	—	
Secondary air pump relay	B136	8	ON: 0 OFF: 10 — 13	ON: 0 OFF: 12 — 14	—	
Self-shutoff control	B136	23	10 — 13	12 — 14	—	

Engine Control Module (ECM) I/O Signal

ENGINE (DIAGNOSTICS)

Contents	Connector No.	Terminal No.	Signal (V)		Note
			Ignition SW ON (engine OFF)	Engine ON (idling)	
GND (ignition system)	B137	26	0	0	—
	B137	6	0	0	—
Ground (engine 1)	B134	5	0	0	—
Ground (engine 2)	B137	7	0	0	—
Ground (engine 3)	B137	2	0	0	—
Ground (engine 4)	B137	1	0	0	—
Ground (engine 5)	B137	3	0	0	—
Ground (body)	B136	6	0	0	—

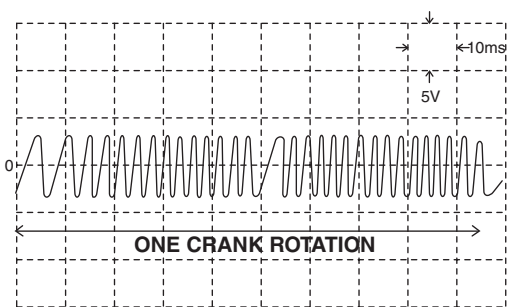
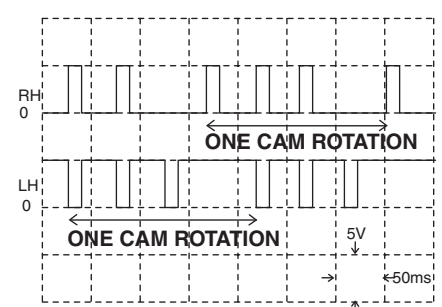
Input/output name	Measuring condition	Waveform
1. Crankshaft position sensor	At idling	 <p style="text-align: right;">EN-05322</p>
2. Camshaft position sensor	At idling	 <p style="text-align: right;">EN-05359</p>

Engine Control Module (ECM) I/O Signal

ENGINE (DIAGNOSTICS)

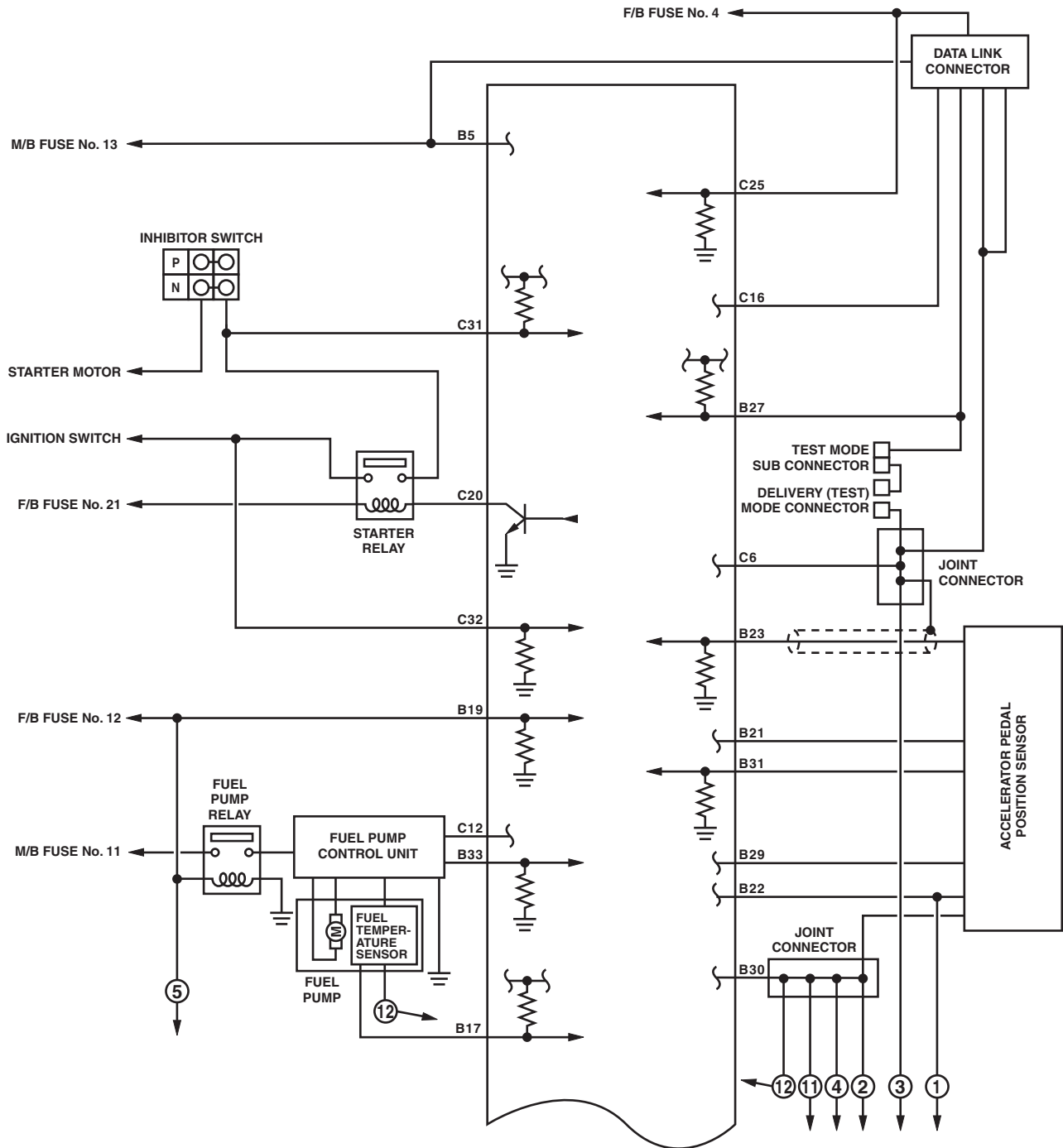

EN-06650

Engine Control Module (ECM) I/O Signal

ENGINE (DIAGNOSTICS)

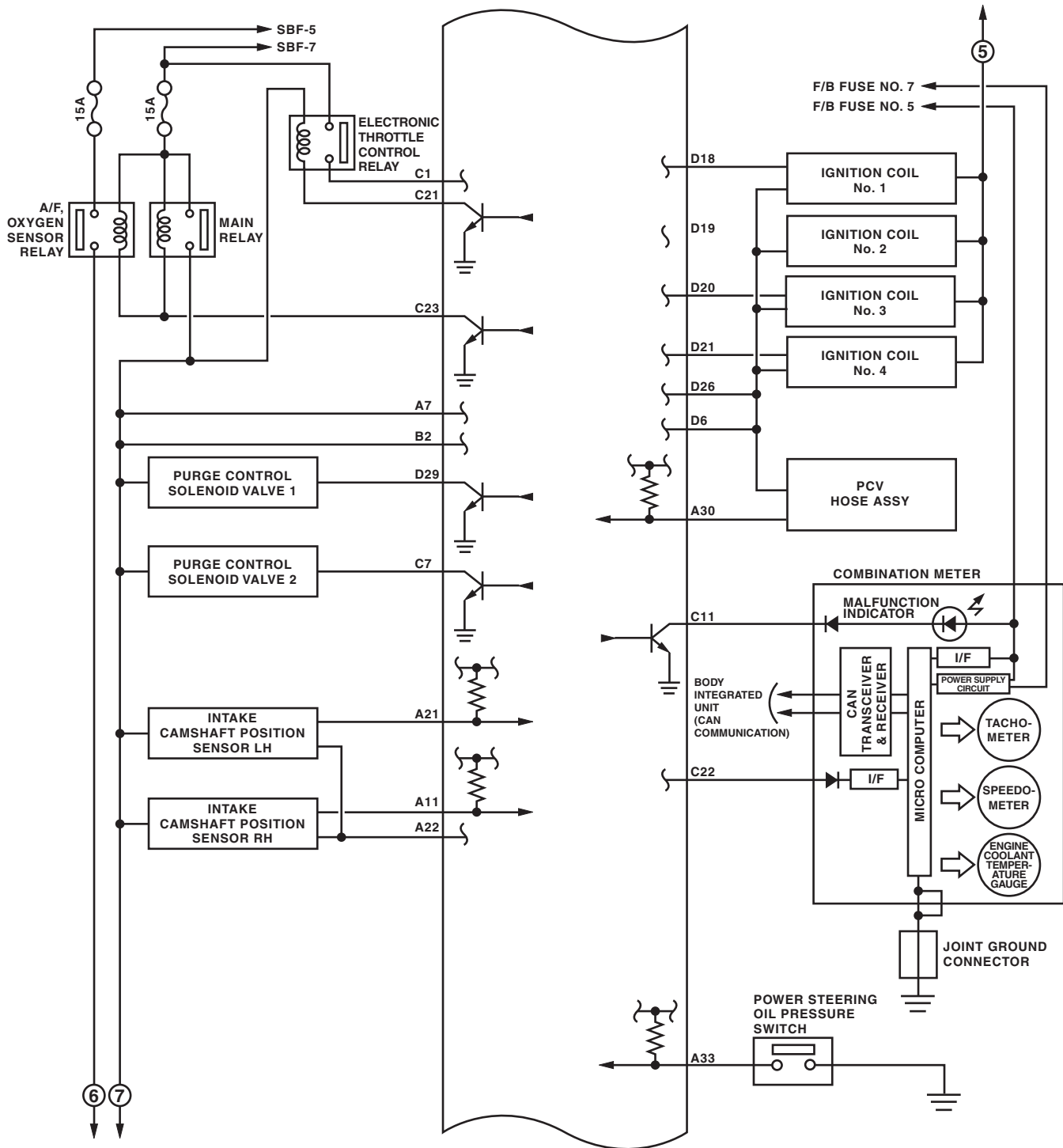

EN-06125

Engine Control Module (ECM) I/O Signal

ENGINE (DIAGNOSTICS)

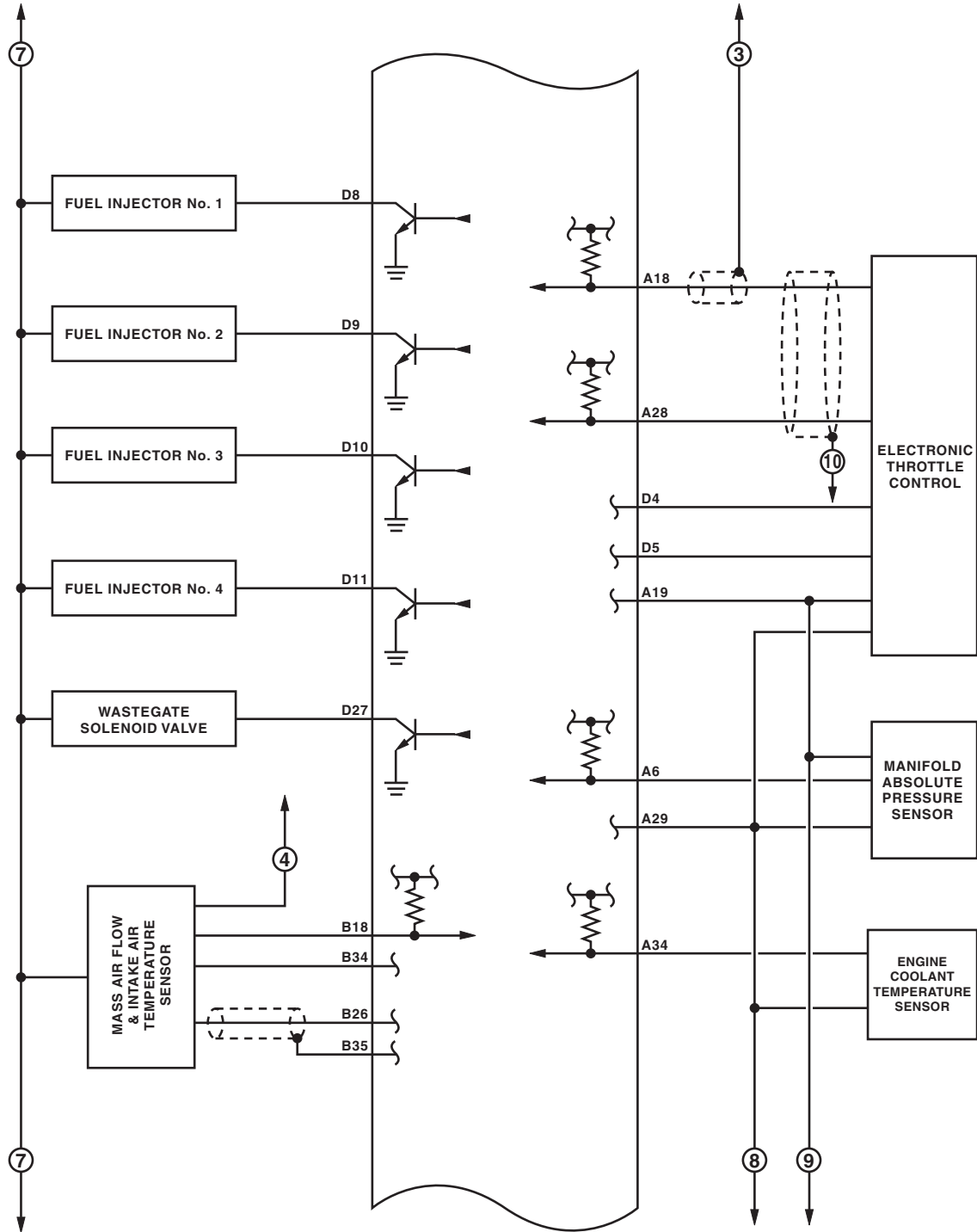

EN-06126

Engine Control Module (ECM) I/O Signal

ENGINE (DIAGNOSTICS)

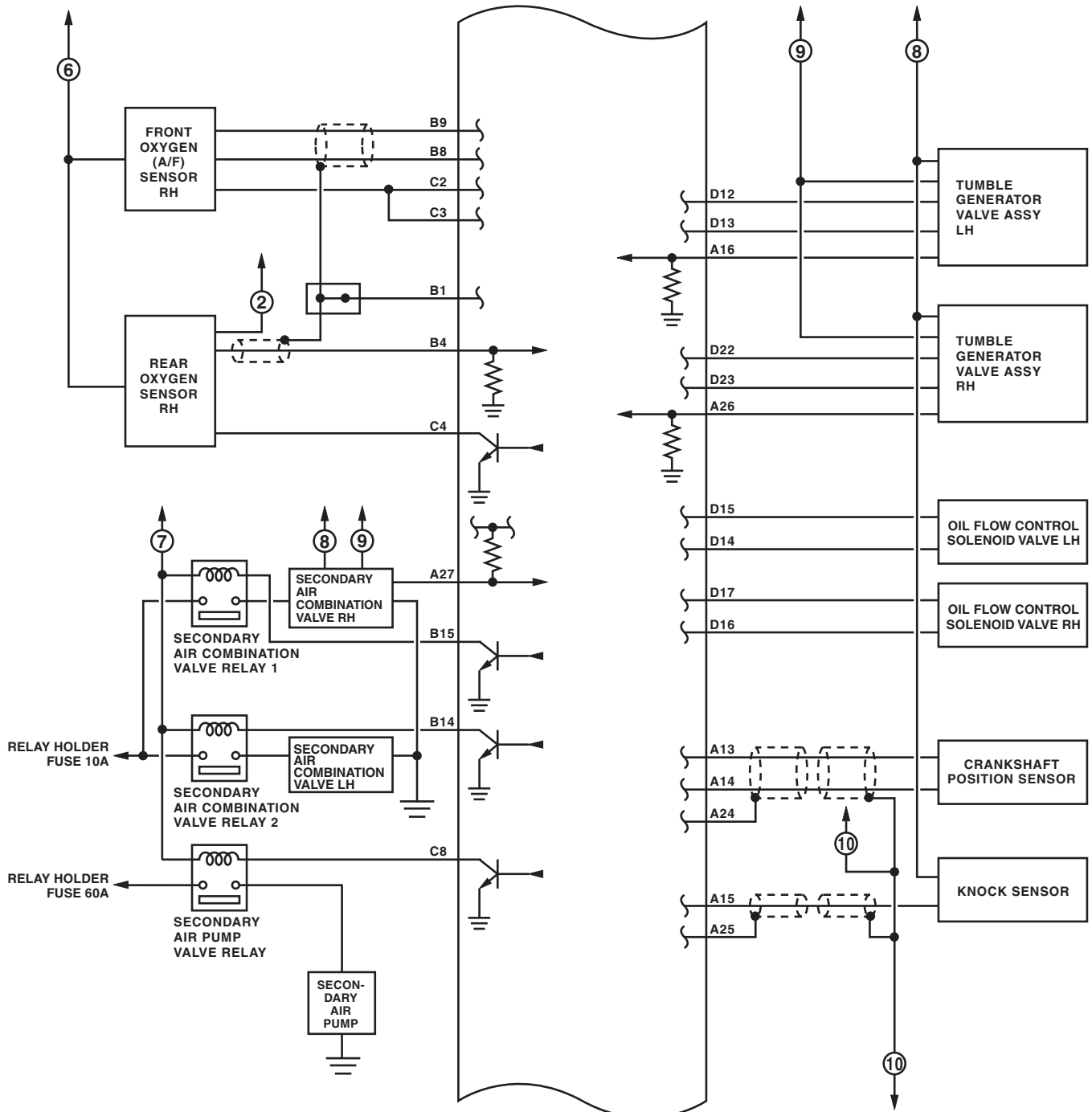

EN-06127

Engine Control Module (ECM) I/O Signal

ENGINE (DIAGNOSTICS)

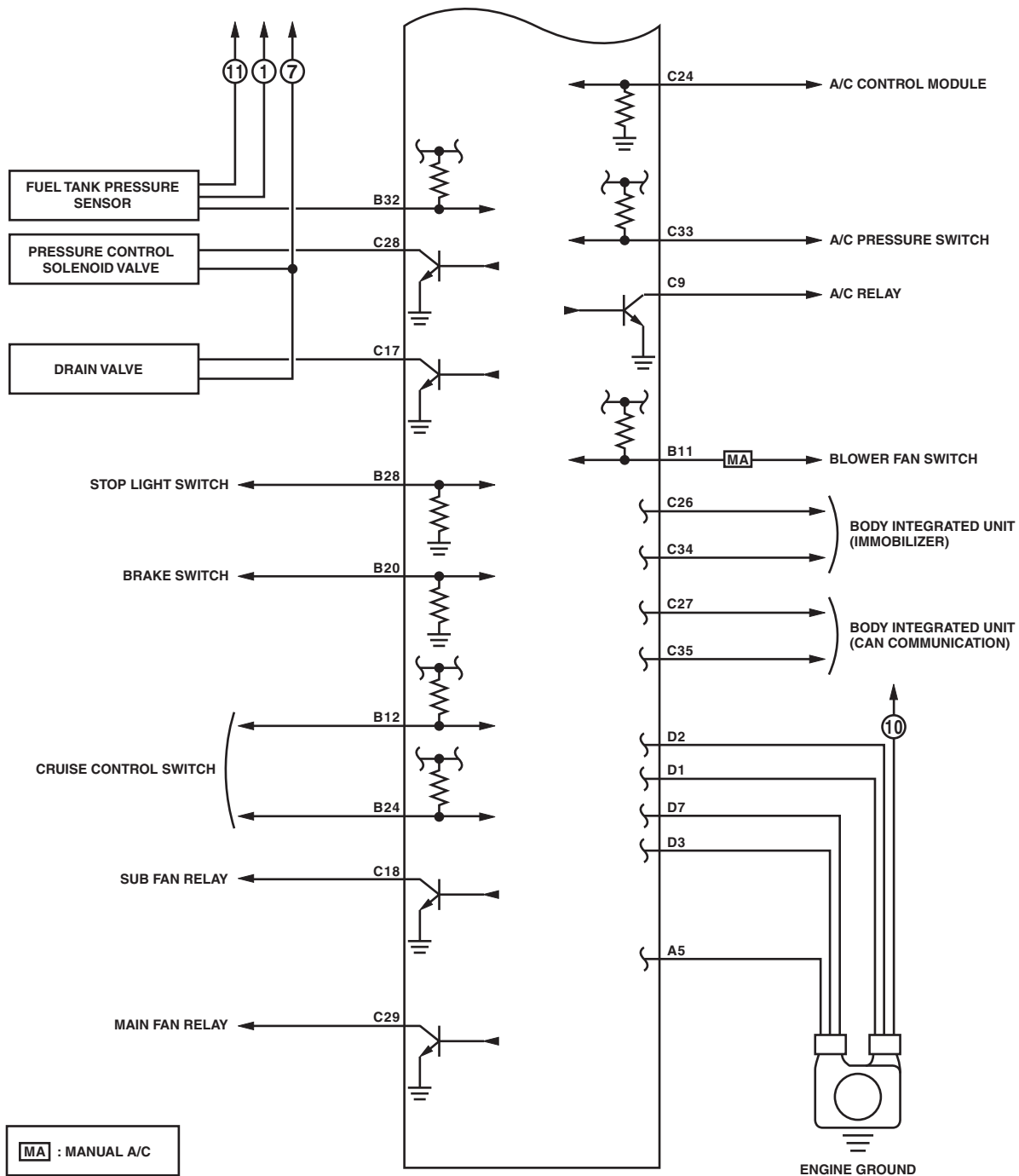

EN-06651

6. Engine Condition Data

A: ELECTRICAL SPECIFICATION

Contents	Specification
Engine Load	17.6 — 35.64 (%): Idling
	13.2 — 26.73 (%): 2,500 rpm racing

Measuring condition:

- After engine is warmed up.
- Place the select lever in “P” range or “N” range.
- Turn the A/C to OFF.
- Turn all the accessory switches to OFF.

Data Link Connector

ENGINE (DIAGNOSTICS)

7. Data Link Connector

A: NOTE

This connector is used for Subaru Select Monitor.

CAUTION:

Do not connect any scan tools except Subaru Select Monitor or general scan tool because the circuit for Subaru Select Monitor may be damaged.

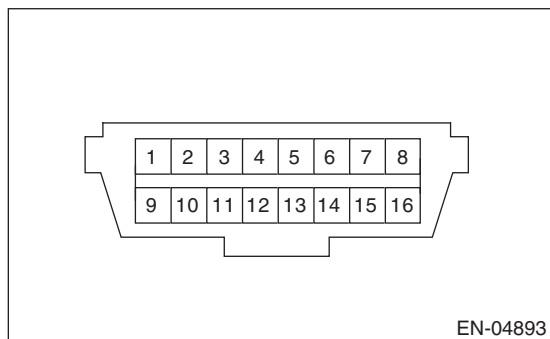

Terminal No.	Contents	Terminal No.	Contents
1	Power supply	9	Empty
2	Empty	10	Empty
3	Empty	11	Empty
4	Ground	12	Empty
5	Ground	13	Empty
6	CAN communication (+)	14	CAN communication (-)
7	Subaru Select Monitor signal	15	Empty
8	Empty	16	Power supply

8. General Scan Tool

A: OPERATION

1. HOW TO USE GENERAL SCAN TOOL

- 1) Prepare a scan tool (general scan tool) required by SAE J1978.
- 2) Open the cover and connect the general scan tool to the data link connector located in the lower portion of instrument panel (on the driver's side).

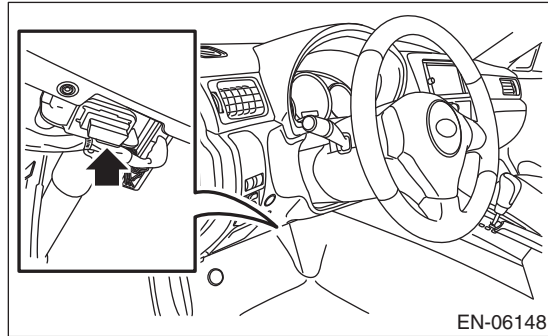

- 3) Using the general scan tool, call up DTC and freeze frame data. General scan tool functions consist of:

- (1) MODE \$01: Current powertrain diagnostic data
- (2) MODE \$02: Powertrain freeze frame data
- (3) MODE \$03: Emission-related powertrain DTC
- (4) MODE \$04: Clear/Reset emission-related diagnostic information
- (5) MODE \$06: Request on-board monitoring test results for intermittently monitored systems
- (6) MODE \$07: Request on-board monitoring test results for continuously monitored systems
- (7) MODE \$09: Request vehicle information

- 4) Read out the data according to repair procedures. (For detailed operation procedure, refer to the general scan tool instruction manual.)

NOTE:

For details concerning DTC, refer to "List of Diagnostic Trouble Code (DTC)". <Ref. to EN(H4DOTC)(diag)-80, List of Diagnostic Trouble Code (DTC).>

General Scan Tool

ENGINE (DIAGNOSTICS)

2. MODE \$01 (CURRENT POWERTRAIN DIAGNOSTIC DATA)

Refer to data denoting the current operating condition of analog input/output, digital input/output or the powertrain system.

A list of the support data and PID (Parameter Identification) codes are shown in the following table.

PID	Data	Unit of measure
\$01	Number of emission-related powertrain DTC, and malfunction indicator light status and diagnosis support information	—
\$03	Fuel system control status	—
\$04	Calculated engine load value	%
\$05	Engine coolant temperature	°C
\$06	Short term fuel trim	%
\$07	Long term fuel trim	%
\$0B	Intake manifold absolute pressure	kPa
\$0C	Engine speed	rpm
\$0D	Vehicle speed	MPH
\$0E	Ignition timing advance	°
\$0F	Intake air temperature	°C
\$10	Air flow rate from mass air flow sensor	g/s
\$11	Throttle valve absolute opening angle	%
\$12	Secondary air control status	—
\$13	Check whether oxygen sensor is installed.	—
\$15	Oxygen sensor output voltage and short term fuel trim associated with oxygen sensor	V and %
\$1C	Supporting OBD system	—
\$1F	Elapsed time after starting the engine	sec
\$21	Running distance after MIL turns on	miles
\$24	A/F value and A/F sensor output voltage	— and V
\$2E	Evaporative purge	%
\$2F	Fuel level	%
\$30	Number of warm ups after DTC clear	—
\$31	Travel distance after DTC clear	miles
\$32	Fuel tank pressure	Pa
\$33	Atmospheric pressure	kPa
\$34	A/F sensor λ value, current	— and mA
\$3C	Catalyzer temperature	°C
\$41	Diagnostic monitor of each drive cycle	—
\$42	ECM power voltage	V
\$43	Absolute load	%
\$44	A/F target lambda	—
\$45	Relative throttle opening angle	%
\$46	Ambient temperature	°C
\$47	Absolute throttle opening angle 2	%
\$49	Absolute accelerator opening angle 1	%
\$4A	Absolute accelerator opening angle 2	%
\$4C	Target throttle opening angle	%
\$4D	Engine operation time during MIL on	min
\$4E	Elapsed time after DTC clear	min
\$51	Fuel used	—
\$5A	Relative accelerator opening angle	%

NOTE:

Refer to general scan tool manufacturer's instruction manual to access generic OBD-II PIDs (MODE \$01).

3. MODE \$02 (POWERTRAIN FREEZE FRAME DATA)

Refer to data denoting the operating condition when trouble is detected by on-board diagnosis system. A list of the support data and PID (Parameter Identification) codes are shown in the following table.

PID	Data	Unit of measure
\$02	DTC that caused the freeze frame data storage required by CARB.	—
\$03	Fuel system control status	—
\$04	Calculated engine load value	%
\$05	Engine coolant temperature	°C
\$06	Short term fuel trim	%
\$07	Long term fuel trim	%
\$0B	Intake manifold absolute pressure	kPa
\$0C	Engine speed	rpm
\$0D	Vehicle speed	MPH
\$0E	Ignition timing advance	°
\$0F	Intake air temperature	°C
\$10	Air flow rate from mass air flow sensor	g/s
\$11	Throttle valve absolute opening angle	%
\$12	Secondary air control status	—
\$13	Air fuel ratio sensor	—
\$15	Rear oxygen sensor voltage, compensation value	V and %
\$1C	Supporting OBD system	—
\$1F	Elapsed time after starting the engine	sec
\$2E	Evaporative purge	%
\$2F	Fuel level	%
\$32	Fuel tank pressure	Pa
\$33	Atmospheric pressure	kPa
\$42	ECM power voltage	V
\$43	Absolute load	%
\$44	A/F target lambda	—
\$45	Relative throttle opening angle	%
\$46	Ambient temperature	°C
\$47	Absolute throttle opening angle 2	%
\$49	Absolute accelerator opening angle 1	%
\$4A	Absolute accelerator opening angle 2	%
\$4C	Target throttle opening angle	%

NOTE:

Refer to general scan tool manufacturer's instruction manual to access freeze frame data (MODE \$02).

4. MODE \$03 (EMISSION-RELATED POWERTRAIN DTC)

Refer to "List of Diagnostic Trouble Code (DTC)" for information about data denoting emission-related powertrain DTC. <Ref. to EN(H4DOTC)(diag)-80, List of Diagnostic Trouble Code (DTC).>

5. MODE \$04 (CLEAR/RESET EMISSION-RELATED DIAGNOSTIC INFORMATION)

Refer to the mode used to clear or reset emission-related diagnostic information (OBD-II trouble diagnostic information).

NOTE:

Refer to general scan tool manufacturer's instruction manual to clear the emission-related diagnostic information (MODE \$04).

General Scan Tool

ENGINE (DIAGNOSTICS)

6. MODE \$06

Refer to test value of troubleshooting and data of test limit indicated on the support data bit sequence table. A list of the support data is shown in the following table.

OBDMID	TID	SID	Diagnostic item
\$01	\$81	\$0A	A/F sensor continuity abnormal (Bank 1 Sensor 1)
	\$82	\$8D	
	\$83	\$14	
	\$84	\$1E	A/F sensor range abnormal (Bank 1 Sensor 1)
	\$85	\$1E	
	\$86	\$20	A/F sensor response abnormal (Bank 1 Sensor 1)
\$02	\$07	\$0B	Oxygen sensor drop abnormal (Bank 1 Sensor 2)
	\$08	\$0B	
	\$A5	\$0B	
	\$05	\$10	Oxygen sensor response abnormal (Bank 1 Sensor 2)
	\$06	\$10	
\$21	\$89	\$20	Catalyst deterioration diagnosis (Bank 1)
\$39	\$93	\$FE	Evaporative emission control system leak detected (Fuel filler cap off)
\$3B	\$94	\$FE	Evaporative emission control system (0.04 inch leak)
	\$95	\$FE	
\$3C	\$96	\$FE	Evaporative emission control system (0.02 inch leak)
	\$97	\$FE	
\$3D	\$98	\$FE	Evaporative emission control system (Purge flow)
\$41	\$99	\$24	A/F sensor heater abnormal (Bank 1 Sensor 1)
	\$9A	\$24	
	\$9B	\$14	A/F sensor heater characteristics abnormal (Bank 1 Sensor 1)
\$42	\$9C	\$24	Oxygen sensor heater abnormal (Bank 1 Sensor 2)
	\$9D	\$24	
\$71	\$9E	\$17	Secondary air system (whole system)
	\$9F	\$0B	
	\$A0	\$0B	
	\$B0	\$17	Secondary air system (relay 2 — combination valve 2)
	\$B1	\$0B	
	\$B1	\$17	
	\$B2	\$0B	
	\$B2	\$17	
	\$B3	\$0B	
	\$B4	\$0B	
	\$B5	\$0B	
	\$B6	\$31	
	\$B7	\$31	
\$A1	\$0B	\$24	Misfire monitoring (All cylinders)
	\$0C	\$24	
\$A2	\$0B	\$24	Misfire monitoring (#1 cylinder)
	\$0C	\$24	
\$A3	\$0B	\$24	Misfire monitoring (#2 cylinder)
	\$0C	\$24	
\$A4	\$0B	\$24	Misfire monitoring (#3 cylinder)
	\$0C	\$24	
\$A5	\$0B	\$24	Misfire monitoring (#4 cylinder)
	\$0C	\$24	

7. MODE \$07

Refer to the data of DTC (pending code) for troubleshooting result about emission in the first time.

8. MODE \$09

Refer to the data of vehicle specification (V.I.N., calibration ID, etc.).

9. Subaru Select Monitor

A: OPERATION

1. HOW TO USE THE SUBARU SELECT MONITOR

1) Prepare the Subaru Select Monitor kit. <Ref. to EN(H4DOTC)(diag)-7, PREPARATION TOOL, General Description.>

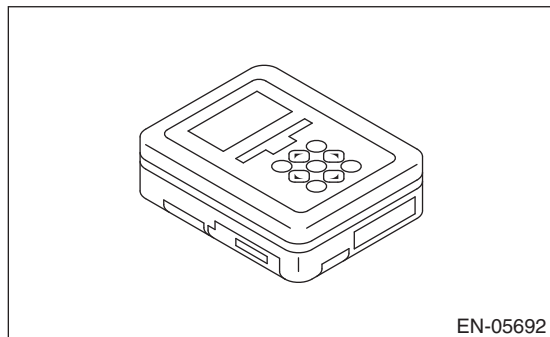

2) Prepare the personal computer which has been installed the Subaru Select Monitor.

3) Connect the USB cable between SDI (Subaru Diagnosis Interface) and USB port on the personal computer (dedicated port for the Subaru Select Monitor).

NOTE:

The dedicated port for the Subaru Select Monitor means the USB port which was used to install the Subaru Select Monitor.

4) Connect the diagnosis cable to the SDI.

5) Connect the SDI to data link connector located in the lower portion of the instrument panel (on the driver's side).

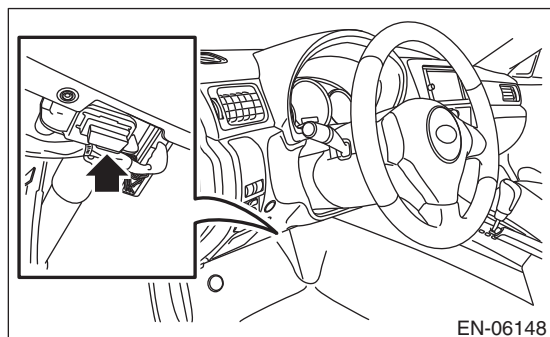

CAUTION:

Do not connect the scan tools except for Subaru Select Monitor and general scan tool.

6) Start up the personal computer.

7) Turn the ignition switch to ON (engine OFF), and run the "PC application for Subaru Select Monitor".

8) Call up DTC and data, then record them.

NOTE:

For detailed operation procedure, refer to the "PC application help for Subaru Select Monitor".

2. READ CURRENT DATA FOR ENGINE (NORMAL MODE)

- 1) On the «Main Menu» display screen, select the {Each System Check}.
 - 2) On the «System Selection Menu» display screen, select the {Engine Control System}.
 - 3) Click the [OK] button after the information of engine type has been displayed.
 - 4) On the «Engine Diagnosis» display screen, select the {Current Data Display & Save}.
 - 5) On the «Current Data Display & Save» display screen, select the {Normal Sampling}.
 - 6) Using the scroll key, scroll the display screen up or down until the desired data is shown.
- A list of the support data is shown in the following table.

Remarks	Display	Unit of measure	Note (at idling)
Engine Load	Engine Load	%	21.0%
Engine coolant temperature signal	Coolant Temp.	°C or °F	80 — 100°C or 176 — 212°F
A/F correction 1	A/F Correction #1	%	-10 — +10%
A/F learning 1	A/F Learning #1	%	-15 — +15%
Intake manifold absolute pressure	Mani. Absolute Pressure	mmHg, kPa, inHg or psig	220 — 275 mmHg, 29.5 — 37 kPa, 8.7 — 10 inHg or 4.2 — 5.3 psig
Engine speed signal	Engine Speed	rpm	630 — 770 rpm (Agree with the tachometer indication)
Meter vehicle speed signal	Vehicle Speed	km/h or MPH	0 km/h or 0 MPH (at parking)
Ignition timing signal	Ignition Timing	deg	10 — 15 deg
Intake air temperature signal	Intake Air Temp.	°C or °F	20 — 50°C or 68 — 122°F
Amount of intake air	Mass Air Flow	g/s or lb/m	2.1 — 3.1 g/s or 0.35 — 0.40 lb/m
Throttle opening angle signal	Throttle Opening Angle	%	2.0 — 2.4%
Rear oxygen sensor voltage	Rear O2 Sensor	V	0 — 1.0 V
Battery voltage	Battery Voltage	V	12 — 15 V
Mass air flow voltage	Air Flow Sensor Voltage	V	1.0 — 1.7 V
Injection 1 pulse width	Fuel Injection #1 Pulse	ms	1.2 — 2.2 ms
Barometric pressure	Atmosphere Pressure	mmHg, kPa, inHg or psig	—
Intake manifold relative pressure	Mani. Relative Pressure	mmHg, kPa, inHg or psig	(Intake manifold absolute pressure — atmosphere pressure)
Ignition learning value	Learned Ignition Timing	deg	0 deg
Acceleration opening angle signal	Accel. Opening Angle	%	0.0%
Fuel temperature signal	Fuel Temp.	°C or °F	+28°C or 82°F
Primary supercharged pressure control signal	Primary Control	%	0.0%
Purge control solenoid duty ratio	CPC Valve Duty Ratio	%	0 — 25%
Tumble generator valve RH opening signal	TGV Position Sensor R	V	0.81 V
Tumble generator valve LH opening signal	TGV Position Sensor L	V	0.81 V
Fuel pump duty ratio	Fuel Pump Duty	%	30 — 40%
AVCS advance angle amount RH	VVT Adv. Ang. Amount R	deg	5 deg
AVCS advance angle amount LH	VVT Adv. Ang. Amount L	deg	5 deg
Oil flow control solenoid valve duty RH (AVCS)	OCV Duty R	%	0 — 20%
Oil flow control solenoid valve duty LH (AVCS)	OCV Duty L	%	0 — 20%
Oil flow control solenoid valve current RH	OCV Current R	mA	40 — 100 mA
Oil flow control solenoid valve current LH	OCV Current L	mA	40 — 100 mA
A/F sensor current value 1	A/F Sensor #1 Current	mA	-20 — 20 mA
A/F sensor resistance value 1	A/F Sensor #1 Resistance	Ω	27 — 35 mA

Subaru Select Monitor

ENGINE (DIAGNOSTICS)

Remarks	Display	Unit of measure	Note (at idling)
A/F sensor output lambda 1	A/F Sensor #1	—	1.0
A/F correction 3	A/F Correction #3	%	0.00%
A/F learning 3	A/F Learning #3	%	0.00%
Throttle motor duty	Throttle Motor Duty	%	-5%
Throttle power supply voltage	Throttle Motor Voltage	V	12 — 15 V
Sub throttle sensor voltage	Sub-Throttle Sensor	V	1.5 V
Main throttle sensor voltage	Main-Throttle Sensor	V	0.6 V
Sub accelerator sensor voltage	Sub-Accelerator Sensor	V	1.1 V
Main accelerator sensor voltage	Main-Accelerator Sensor	V	1.0 V
Secondary air supply piping pressure signal	Sec. Air Piping Pressure	mmHg, kPa, inHg or psig	765 mmHg, 102 kPa, 30.1 inHg or 14.8 psig
Secondary airflow signal	Sec. Air Flow	g/s or lb/m	0.00 g/s or 0.00 lb/m
Memory vehicle speed	Memorized Cruise Speed	km/h or MPH	—
Fuel level sensor resistance	Fuel level resistance	Ω	4 — 96 Ω
Odometer Estimated calculation of driving distance	Odometer	km	—
#1 cylinder roughness monitor	Roughness Monitor #1	—	0
#2 cylinder roughness monitor	Roughness Monitor #2	—	0
#3 cylinder roughness monitor	Roughness Monitor #3	—	0
#4 cylinder roughness monitor	Roughness Monitor #4	—	0
Knock sensor compensation	Knocking Correction	deg	0.0 deg
Fuel tank pressure signal	Fuel Tank Pressure	mmHg, kPa, inHg or psig	+8.8 mmHg, +1.2 kPa, +0.4 inHg or +0.2 psig
AT/MT identification terminal	AT Vehicle ID Signal	—	AT/MT
Delivery (test) mode terminal	Test Mode Signal	—	OFF
D check request flag	D-check Require Flag	—	OFF
Delivery (test) mode terminal	Delivery Mode Connector (Test Mode Connector)	—	OFF
Neutral position switch signal	Neutral Position Switch	—	ON
Soft idle switch signal	Idle Switch Signal	—	ON
Ignition switch signal	Ignition Switch	—	ON input
Power steering switch signal	P/S Switch	—	OFF (when OFF)
Air conditioning switch signal	A/C Switch	—	OFF (when OFF)
Starter switch signal	Starter Switch	—	OFF
Rear oxygen monitor	Rear O2 Rich Signal	—	ON/OFF
Knocking signal	Knocking Signal	—	OFF
Crankshaft position sensor signal	Crankshaft Position Sig.	—	ON
Camshaft position sensor signal	Camshaft Position Sig.	—	ON
Rear defogger switch signal	Rear Defogger SW	—	OFF (when OFF)
Blower fan switch signal	Blower Fan SW	—	OFF (when OFF)
Light switch signal	Light Switch	—	OFF (when OFF)
A/C middle pressure switch signal	A/C Mid Pressure Switch	—	OFF (when OFF)
Air conditioner compressor relay output signal	A/C Compressor Signal	—	OFF (when OFF)
Radiator fan relay 1 signal	Radiator Fan Relay #1	—	OFF (when OFF)
Radiator fan relay 2 signal	Radiator Fan Relay #2	—	OFF (when OFF)
PCV hose assembly diagnosis signal	Blow-by leak Connector	—	Connected
Pressure control solenoid valve signal	PCV Solenoid Valve	—	OFF (when OFF)
Tumble generator valve output signal	TGV Output	—	OFF
Tumble generator valve drive signal	TGV Drive	—	Closing direction
Drain valve signal	Vent. Solenoid Valve	—	OFF (when OFF)
Purge control solenoid valve 2 signal	CPC Solenoid 2	—	OFF (when OFF)

Subaru Select Monitor

ENGINE (DIAGNOSTICS)

Remarks	Display	Unit of measure	Note (at idling)
AT coordinate retard angle demand signal	Retard Signal from AT	—	OFF
AT coordinate fuel cut demand signal	Fuel Cut signal from AT	—	OFF
Vehicle dynamics control (VDC) torque down prohibition output	Ban of Torque Down	—	ON
Vehicle dynamics control (VDC) torque down demand	Request Torque Down VDC	—	OFF
AT coordinate permission signal	Torque Permission Signal	—	ON/OFF
ETC motor relay signal	ETC Motor Relay	—	ON
Clutch switch signal	Clutch Switch	—	OFF (when OFF)
Stop light switch signal	Stop Light Switch	—	OFF (when OFF)
SET/COAST switch signal	SET/COAST Switch	—	OFF (when OFF)
RES/ACC switch signal	RESUME/ACCEL Switch	—	OFF (when OFF)
Brake switch signal	Brake Switch	—	OFF (when OFF)
Main switch signal	Main Switch	—	OFF (when OFF)
Body int. unit data reception	Body Int. Unit Data	—	ON
Body integrated unit counter update	Body Int. Unit Count	—	ON
Secondary air combination valve relay 2 signal	Sec. Air Combi V Relay 2	—	OFF (when OFF)
Secondary air pump relay signal	Secondary Air Pump Relay	—	OFF (when OFF)
Secondary air combination valve relay 1 signal	Sec. Air Combi V Relay 1	—	OFF (when OFF)
Cruise control cancel switch signal	CC Cancel SW	—	OFF (when OFF)
Malfunction indicator light signal	MIL On Flag	—	OFF (when unlit)

NOTE:

For detailed operation procedure, refer to the “PC application help for Subaru Select Monitor”.

Subaru Select Monitor

ENGINE (DIAGNOSTICS)

3. READ CURRENT DATA FOR ENGINE (OBD MODE)

- 1) On the «Main Menu» display screen, select the {Each System Check}.
 - 2) On the «System Selection Menu» display screen, select the {Engine Control System}.
 - 3) Click the [OK] button after the information of engine type has been displayed.
 - 4) On the «Engine Diagnosis» display screen, select the {OBD System}.
 - 5) On the «OBD Menu» display screen, select the {Current Data Display & Save}.
 - 6) On the «Current Data Display & Save» display screen, select the {All Data Display}.
 - 7) Using the scroll key, scroll the display screen up or down until the desired data is shown.
- A list of the support data is shown in the following table.

Remarks	Display	Referential value (at idling)	Unit of measure
Number of diagnosis code	Number of Diag. Code:	0	—
Condition of malfunction indicator light	MI(MIL)	OFF	—
Monitoring test of misfire	Misfire monitoring (Supp)	YES	—
Monitoring test of misfire	Misfire monitoring (Rdy)	YES	—
Monitoring test of fuel system	Fuel system monitoring (Supp)	YES	—
Monitoring test of fuel system	Fuel system monitoring (Rdy)	YES	—
Monitoring test of comprehensive component	Component monitoring (Supp)	YES	—
Monitoring test of comprehensive component	Component monitoring (Rdy)	YES	—
Test of catalyst	Catalyst Diagnosis (Supp)	YES	—
Test of catalyst	Catalyst Diagnosis (Rdy)	NO	—
Test of heating-type catalyst	Heated catalyst (Supp)	NO	—
Test of heating-type catalyst	Heated catalyst (Rdy)	N/A	—
Test of evaporative emission purge control system	Evaporative purge system (Supp)	YES	—
Test of evaporative emission purge control system	Evaporative purge system (Rdy)	NO	—
Secondary air system test	Secondary air system (Supp)	YES	—
Secondary air system test	Secondary air system (Rdy)	NO	—
Test of air conditioning system refrigerant	A/C system refrigerant (Supp)	NO	—
Test of air conditioning system refrigerant	A/C system refrigerant (Rdy)	N/A	—
Test of oxygen sensor	Oxygen sensor (Supp)	YES	—
Test of oxygen sensor	Oxygen sensor (Rdy)	NO	—
Test of oxygen sensor heater	O ₂ Heater Diagnosis (Supp)	YES	—
Test of oxygen sensor heater	O ₂ Heater Diagnosis (Rdy)	YES	—
Test of EGR system	EGR system (Supp)	NO	—
Test of EGR system	EGR system (Rdy)	N/A	—
Air fuel ratio control system for bank 1	Fuel system for Bank 1	Cl_normal	—
Engine load data	Calculated load value	19.2	%
Engine coolant temperature signal	Coolant Temp.	96	°C
Short term fuel trim by front oxygen (A/F) sensor (Bank 1)	Short term fuel trim B1	17.2	%
Long term fuel trim by front oxygen (A/F) sensor (Bank 1)	Long term fuel trim B1	5.5	%
Intake manifold absolute pressure signal	Mani. Absolute Pressure	248	mmHg
Engine speed signal	Engine Speed	846	rpm
Vehicle speed signal	Vehicle Speed	0	km/h
#1 Cylinder ignition timing	Ignition timing adv. #1	13.5	°
Intake air temperature signal	Intake Air Temp.	44	°C
Amount of intake air	Mass Air Flow	3.6	g/s
Throttle position signal	Throttle Opening Angle	13	%
Secondary air control status	Secondary air system	Stop	—
Oxygen sensor (Bank 1 Sensor 2)	Oxygen sensor #12	0.1 — 0.7	V
A/F correction (Bank 1 Sensor 2)	Short term fuel trim #12	0.0	%
On-board diagnostic system	OBD System	OBD/OBD2	—
Front oxygen (A/F) sensor (Bank 1 Sensor 1)	Oxygen sensor #11	Supported	—
Oxygen sensor (Bank 1 Sensor 2)	Oxygen sensor #12	Supported	—

Subaru Select Monitor

ENGINE (DIAGNOSTICS)

Remarks	Display	Referential value (at idling)	Unit of measure
Time elapsed after engine start	Time Since Engine Start	—	sec
Driving distance after the malfunction indicator light illuminates	Lighted MI lamp history	—	km
A/F lambda signal (Bank 1 Sensor 1)	A/F Sensor #11	0.951	—
A/F sensor output signal (Bank 1 Sensor 1)	A/F Sensor #11	2.468	V
Evaporative purge	Commanded Evap Purge	0	%
Fuel level signal	Fuel Level	—	%
Number of warm ups after DTC clear	Number of warm ups	—	—
Driving distance after DTC clear	Meter since DTC cleared	—	km
Fuel tank pressure signal	Fuel Tank Pressure	9.664	mmHg
Barometric pressure signal	Atmosphere Pressure	Barometric pressure	mmHg
A/F lambda signal (Bank 1 Sensor 1)	A/F Sensor #11	0.957	—
A/F sensor output signal (Bank 1 Sensor 1)	A/F Sensor #11	-0.18	mA
Catalyst temperature #1	Catalyst Temperature #11	—	°C
Monitoring test of misfire	Misfire monitoring (Enable)	YES	—
Monitoring test of misfire	Misfire monitoring (Comp)	YES	—
Monitoring test of fuel system	Fuel system monitoring (Enable)	YES	—
Monitoring test of fuel system	Fuel system monitoring (Comp)	NO	—
Monitoring test of comprehensive component	Component monitoring (Enable)	NO	—
Monitoring test of comprehensive component	Component monitoring (Comp)	NO	—
Test of catalyst	Catalyst Diagnosis (Enable)	YES	—
Test of catalyst	Catalyst Diagnosis (Comp)	NO	—
Test of heating-type catalyst	Heated catalyst (Enable)	N/A	—
Test of heating-type catalyst	Heated catalyst (Comp)	N/A	—
Test of evaporative emission purge control system	Evaporative purge system (Enable)	YES	—
Test of evaporative emission purge control system	Evaporative purge system (Comp)	NO	—
Secondary air system test	Secondary air system (Enable)	YES	—
Secondary air system test	Secondary air system (Comp)	NO	—
Test of air conditioning system refrigerant	A/C system refrigerant (Enable)	N/A	—
Test of air conditioning system refrigerant	A/C system refrigerant (Comp)	N/A	—
Test of oxygen sensor	Oxygen sensor (Enable)	YES	—
Test of oxygen sensor	Oxygen sensor (Comp)	NO	—
Test of oxygen sensor heater	O2 Heater Diagnosis (Enable)	YES	—
Test of oxygen sensor heater	O2 Heater Diagnosis (Comp)	YES	—
Test of EGR system	EGR system (Enable)	N/A	—
Test of EGR system	EGR system (Comp)	N/A	—
ECM power voltage	Control module voltage	13.848	V
Absolute load	Absolute Load Value	21	%
A/F ratio target lambda	Target Equivalence Ratio	0.993	—
Relative throttle opening angle	Relative Throttle Pos.	2	%
Ambient temperature	Ambient Temperature	Ambient temperature	°C
Absolute throttle opening angle 2	Absolute Throttle Pos.#2	31	%
Absolute accelerator opening angle 1	Accelerator Pedal Pos.#1	13	%
Absolute accelerator opening angle 2	Accelerator Pedal Pos.#2	13	%
Target throttle opening angle	Target Throt. Act. Cont.	0	%
Engine operating time while malfunction indicator lit	Time while MIL lighted	—	min
Time elapsed after DTC clear	Time since DTC cleared	—	min
Fuel used	Type of fuel	GAS	—
Relative accelerator opening angle	Relative Accelerator Pos.	0	%

NOTE:

For detailed operation procedure, refer to the “PC application help for Subaru Select Monitor”.

Subaru Select Monitor

ENGINE (DIAGNOSTICS)

4. READ FREEZE FRAME DATA FOR ENGINE (OBD MODE)

- 1) On the «Main Menu» display screen, select the {Each System Check}.
 - 2) On the «System Selection Menu» display screen, select the {Engine Control System}.
 - 3) Click the [OK] button after the information of engine type has been displayed.
 - 4) On the «Engine Diagnosis» display screen, select the {OBD System}.
 - 5) On the «OBD Menu» display screen, select the {Freeze Frame Data Display}.
- A list of the support data is shown in the following table.

Remarks	Display	Unit of measure
DTC of freeze frame data	Freeze frame data	Diagnostic code
Air fuel ratio control system for bank 1	Fuel system for Bank 1	—
Engine load data	Calculated load value	%
Engine coolant temperature signal	Coolant Temp.	°C or °F
Short term fuel trim by front oxygen (A/F) sensor (Bank 1)	Short term fuel trim B1	%
Long term fuel trim by front oxygen (A/F) sensor (Bank 1)	Long term fuel trim B1	%
Intake manifold absolute pressure signal	Mani. Absolute Pressure	mmHg, kPa, inHg or psi
Engine speed signal	Engine Speed	rpm
Vehicle speed signal	Vehicle Speed	km/h or MPH
Ignition timing #1	Ignition timing adv. #1	°
Intake air temperature	Intake Air Temp.	°C
Amount of intake air	Mass Air Flow	g/s
Throttle opening angle	Throttle Opening Angle	%
Secondary air control status	Secondary air system	—
Oxygen sensor #12	Oxygen sensor #12	V
A/F correction #12	Short term fuel trim #12	%
OBD system	OBD System	—
Oxygen sensor #11	Oxygen sensor #11	Supported
Oxygen sensor #12	Oxygen sensor #12	Supported
Elapsed time after starting the engine	Time Since Engine Start	sec
Evaporative purge	Commanded Evap Purge	%
Fuel level	Fuel Level	%
Fuel tank pressure	Fuel Tank Pressure	mmHg, kPa, inHg or psig
Atmospheric pressure	Atmosphere Pressure	mmHg, kPa, inHg or psig
ECM power voltage	Control module voltage	V
Absolute load	Absolute Load Value	%
A/F target lambda	Target Equivalence Ratio	—
Relative throttle opening angle	Relative Throttle Pos.	%
Ambient temperature	Ambient Temperature	°C or °F
Absolute throttle opening angle 2	Absolute Throttle Pos.#2	%
Absolute accelerator opening angle 1	Accelerator Pedal Pos.#1	%
Absolute accelerator opening angle 2	Accelerator Pedal Pos.#2	%
Target throttle opening angle	Target Throt. Act. Cont.	%

NOTE:

For detailed operation procedure, refer to the «PC application help for Subaru Select Monitor».

5. V.I.N. REGISTRATION

- 1) On the «Main Menu» display screen, select the {Each System Check}.
- 2) On the «System Selection Menu» display screen, select the {Engine Control System}.
- 3) Click the [OK] button after the information of engine type has been displayed.
- 4) On the «Engine Diagnosis» display screen, select the {Entry VIN}.
- 5) Perform the procedures shown on the display screen.

NOTE:

For detailed operation procedure, refer to the “PC application help for Subaru Select Monitor”.

10. Read Diagnostic Trouble Code (DTC)

A: OPERATION

1. SUBARU SELECT MONITOR (NORMAL MODE)

- 1) On the «Main Menu» display screen, select the {Each System Check}.
- 2) On the «System Selection Menu» display screen, select the {Engine Control System}.
- 3) Click the [OK] button after the information of engine type has been displayed.
- 4) On the «Engine Diagnosis» display screen, select the {Diagnostic Code(s) Display}.
- 5) On the «Diagnostic Code(s) Display» screen, select the {Temporary Diagnostic Code(s)} or {Memorized Diagnostic Code(s)}.

NOTE:

- For detailed operation procedure, refer to the “PC application help for Subaru Select Monitor”.
- For details concerning DTC, refer to “List of Diagnostic Trouble Code (DTC)”. <Ref. to EN(H4DOTC)(diag)-80, List of Diagnostic Trouble Code (DTC).>

2. SUBARU SELECT MONITOR (OBD MODE)

- 1) On the «Main Menu» display screen, select the {Each System Check}.
- 2) On the «System Selection Menu» display screen, select the {Engine Control System}.
- 3) Click the [OK] button after the information of engine type has been displayed.
- 4) On the «Engine Diagnosis» display screen, select the {OBD System}.
- 5) On the «OBD Menu» display screen, select the {Diagnostic Code(s) Display}.
- 6) Make sure DTC is shown on the screen.

NOTE:

- For detailed operation procedure, refer to the “PC application help for Subaru Select Monitor”.
- For details concerning DTC, refer to “List of Diagnostic Trouble Code (DTC)”. <Ref. to EN(H4DOTC)(diag)-80, List of Diagnostic Trouble Code (DTC).>

3. GENERAL SCAN TOOL

Refer to data denoting emission-related powertrain DTC.

For details concerning DTC, refer to “List of Diagnostic Trouble Code (DTC)”. <Ref. to EN(H4DOTC)(diag)-80, List of Diagnostic Trouble Code (DTC).>

NOTE:

Refer to general scan tool manufacturer’s instruction manual to access powertrain DTC (MODE \$03).

Inspection Mode

ENGINE (DIAGNOSTICS)

11. Inspection Mode

A: PROCEDURE

Perform the diagnosis shown in the following DTC table.

When performing the diagnosis not listed in “List of Diagnostic Trouble Code (DTC)”, refer to the item on the drive cycle. <Ref. to EN(H4DOTC)(diag)-47, Drive Cycle.>

DTC	Item	Condition
P0011	Intake Camshaft Position - Timing Over-Advanced or System Performance (Bank 1)	—
P0016	Crankshaft Position - Camshaft Position Correlation (Bank1)	—
P0018	Crankshaft Position - Camshaft Position Correlation (Bank2)	—
P0021	Intake Camshaft Position - Timing Over-Advanced or System Performance (Bank 2)	—
P0031	HO2S Heater Control Circuit Low (Bank 1 Sensor 1)	—
P0032	HO2S Heater Control Circuit High (Bank 1 Sensor 1)	—
P0037	HO2S Heater Control Circuit Low (Bank 1 Sensor 2)	—
P0038	HO2S Heater Control Circuit High (Bank 1 Sensor 2)	—
P0102	Mass or Volume Air Flow Circuit Low Input	—
P0103	Mass or Volume Air Flow Circuit High Input	—
P0107	Manifold Absolute Pressure/Barometric Pressure Circuit Low Input	—
P0108	Manifold Absolute Pressure/Barometric Pressure Circuit High Input	—
P0112	Intake Air Temperature Sensor 1 Circuit Low	—
P0113	Intake Air Temperature Sensor 1 Circuit High	—
P0117	Engine Coolant Temperature Circuit Low	—
P0118	Engine Coolant Temperature Circuit High	—
P0122	Throttle/Pedal Position Sensor/Switch “A” Circuit Low	—
P0123	Throttle/Pedal Position Sensor/Switch “A” Circuit High	—
P0131	O2 Sensor Circuit Low Voltage (Bank 1 Sensor 1)	—
P0132	O2 Sensor Circuit High Voltage (Bank 1 Sensor 1)	—
P0137	O2 Sensor Circuit Low Voltage (Bank 1 Sensor 2)	—
P0138	O2 Sensor Circuit High Voltage (Bank 1 Sensor 2)	—
P0140	O2 Sensor Circuit No Activity Detected (Bank 1 Sensor 2)	—
P0182	Fuel Temperature Sensor “A” Circuit Low Input	—
P0183	Fuel Temperature Sensor “A” Circuit High Input	—
P0222	Throttle/Pedal Position Sensor/Switch “B” Circuit Low	—
P0223	Throttle/Pedal Position Sensor/Switch “B” Circuit High	—
P0230	Fuel Pump Primary Circuit	—
P0245	Turbo/Super Charger Wastegate Solenoid “A” Low	—
P0327	Knock Sensor 1 Circuit Low (Bank 1 or Single Sensor)	—
P0328	Knock Sensor 1 Circuit High (Bank 1 or Single Sensor)	—
P0335	Crankshaft Position Sensor “A” Circuit	—
P0336	Crankshaft Position Sensor “A” Circuit Range/Performance	—
P0340	Camshaft Position Sensor “A” Circuit (Bank 1 or Single Sensor)	—
P0345	Camshaft Position Sensor “A” Circuit (Bank 2)	—
P0413	Secondary Air Injection System Switching Valve “A” Circuit Open	—
P0416	Secondary Air Injection System Switching Valve “B” Circuit Open	—
P0418	Secondary Air Injection System Control “A” Circuit Open	—
P0447	Evaporative Emission Control System Vent Control Circuit Open	—
P0448	Evaporative Emission Control System Vent Control Circuit Shorted	—
P0452	Evaporative Emission Control System Pressure Sensor Low Input	—
P0453	Evaporative Emission Control System Pressure Sensor High Input	—

Inspection Mode

ENGINE (DIAGNOSTICS)

DTC	Item	Condition
P0458	Evaporative Emission System Purge Control Valve Circuit Low	—
P0462	Fuel Level Sensor "A" Circuit Low	—
P0463	Fuel Level Sensor "A" Circuit High	—
P0500	Vehicle Speed Sensor "A"	—
P0512	Starter Request Circuit	—
P0513	Incorrect Immobilizer Key	—
P0600	Serial Communication Link	—
P0604	Internal Control Module Random Access Memory (RAM) Error	—
P0605	Internal Control Module Read Only Memory (ROM) Error	—
P0607	Throttle Control System Circuit Range/Performance	—
P0638	Throttle Actuator Control Range/Performance (Bank 1)	—
P0700	Transmission Control System (MIL Request)	—
P0851	Park/Neutral Switch Input Circuit Low	—
P0852	Park/Neutral Switch Input Circuit High	—
P1152	O2 Sensor Circuit Range/Performance (Low) (Bank 1 Sensor 1)	—
P1153	O2 Sensor Circuit Range/Performance (High) (Bank 1 Sensor 1)	—
P1160	Return Spring Failure	—
P1400	Fuel Tank Pressure Control Solenoid Valve Circuit Low	—
P1410	Secondary Air Injection System Switching Valve Stuck Open	—
P1420	Fuel Tank Pressure Control Sol. Valve Circuit High	—
P1491	Positive Crankcase Ventilation (Blow-by) Function Problem	—
P1560	Back-up Voltage Circuit Malfunction	—
P1570	Antenna	—
P1571	Reference Code Incompatibility	—
P1572	IMM Circuit Failure (Except Antenna Circuit)	—
P1574	Key Communication Failure	—
P1576	EGI Control Module EEPROM	—
P1577	IMM Control Module EEPROM	—
P1578	Meter Failure	—
P2006	Intake Manifold Runner Control Stuck Closed (Bank 1)	—
P2007	Intake Manifold Runner Control Stuck Closed (Bank 2)	—
P2008	Intake Manifold Runner Control Circuit / Open (Bank 1)	—
P2009	Intake Manifold Runner Control Circuit Low (Bank 1)	—
P2011	Intake Manifold Runner Control Circuit / Open (Bank 2)	—
P2012	Intake Manifold Runner Control Circuit Low (Bank 2)	—
P2016	Intake Manifold Runner Position Sensor / Switch Circuit Low (Bank 1)	—
P2017	Intake Manifold Runner Position Sensor / Switch Circuit High (Bank 1)	—
P2021	Intake Manifold Runner Position Sensor / Switch Circuit Low (Bank 2)	—
P2022	Intake Manifold Runner Position Sensor / Switch Circuit High (Bank 2)	—
P2088	Intake Camshaft Position Actuator Control Circuit Low (Bank 1)	—
P2089	Intake Camshaft Position Actuator Control Circuit High (Bank 1)	—
P2092	Intake Camshaft Position Actuator Control Circuit Low (Bank 2)	—
P2093	Intake Camshaft Position Actuator Control Circuit High (Bank 2)	—
P2101	Throttle Actuator Control Motor Circuit Range/Performance	—
P2102	Throttle Actuator Control Motor Circuit Low	—
P2103	Throttle Actuator Control Motor Circuit High	—
P2109	Throttle/Pedal Position Sensor "A" Minimum Stop Performance	—
P2122	Throttle/Pedal Position Sensor/Switch "D" Circuit Low Input	—
P2123	Throttle/Pedal Position Sensor/Switch "D" Circuit High Input	—
P2127	Throttle/Pedal Position Sensor/Switch "E" Circuit Low Input	—

Inspection Mode

ENGINE (DIAGNOSTICS)

DTC	Item	Condition
P2128	Throttle/Pedal Position Sensor/Switch "E" Circuit High Input	—
P2135	Throttle/Pedal Position Sensor/Switch "A" / "B" Voltage Correlation	—
P2138	Throttle/Pedal Position Sensor/Switch "D" / "E" Voltage Correlation	—
P2419	Evaporative Emission System Switching Valve Control Circuit Low	—
P2420	Evaporative Emission System Switching Valve Control Circuit High	—
P2431	Secondary Air Injection System Air Flow / Pressure Sensor Circuit Range/ Performance	—
P2432	Secondary Air Injection System Air Flow / Pressure Sensor Circuit Low	—
P2433	Secondary Air Injection System Air Flow / Pressure Sensor Circuit High	—
P2444	Secondary Air Injection System Pump Stuck ON	—

1. PREPARATION FOR THE INSPECTION MODE

1) Check that the battery voltage is 12 V or more and fuel remains approx. half [20 — 40 ℓ (5.3 — 10.6 US gal, 4.4 — 8.8 Imp gal)].

2) Lift up the vehicle using a garage jack and place it on rigid racks, or drive the vehicle onto free rollers.

WARNING:

- Before raising the vehicle, ensure parking brakes are applied.
- Do not use a pantograph jack in place of a rigid rack.
- Secure a rope or wire to the front or rear towing hooks to prevent the lateral runout of front wheels.
- Before rotating the wheels, make sure that there is no one in front of the vehicle. Besides while the wheels are rotating, make sure that no one approaches the vehicle front side.
- Make sure that there is nothing around the wheels. For AWD model, pay special attention to all four wheels.
- While servicing, do not depress or release the clutch pedal or accelerator pedal quickly regardless of the engine speed. Quick operation may cause the vehicle to drop off the free roller.
- To prevent the vehicle from slipping due to vibration, do not place anything between rigid rack and the vehicle.

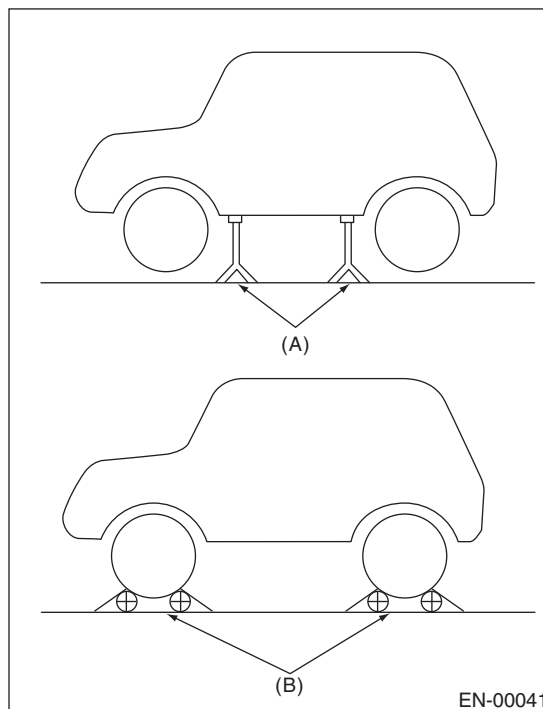

- (A) Rigid racks
(B) Free rollers

2. SUBARU SELECT MONITOR

1) After clearing the memory, check for any remaining unresolved trouble data. <Ref. to EN(H4DOTC)(diag)-52, Clear Memory Mode.>

2) Warm up the engine.

3) Prepare the Subaru Select Monitor kit. <Ref. to EN(H4DOTC)(diag)-7, PREPARATION TOOL, General Description.>

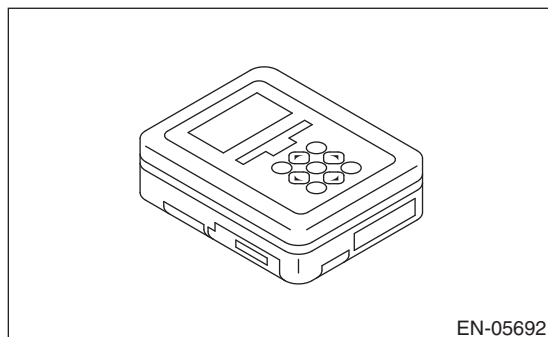

4) Prepare the personal computer which has been installed the Subaru Select Monitor.

5) Connect the USB cable between SDI (Subaru Diagnosis Interface) and USB port on the personal computer (dedicated port for the Subaru Select Monitor).

NOTE:

The dedicated port for the Subaru Select Monitor means the USB port which was used to install the Subaru Select Monitor.

6) Connect the diagnosis cable to the SDI.

7) Connect the delivery (test) mode connector (A) located under the glove box.

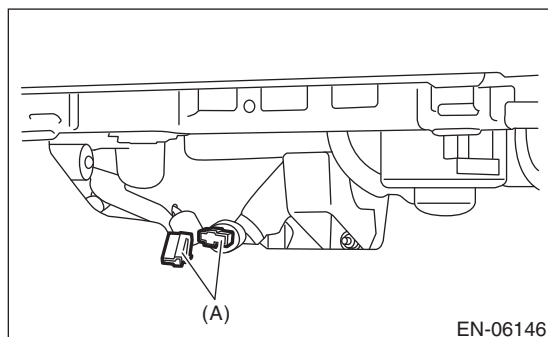

8) Connect the SDI to data link connector located in the lower portion of the instrument panel (on the driver's side).

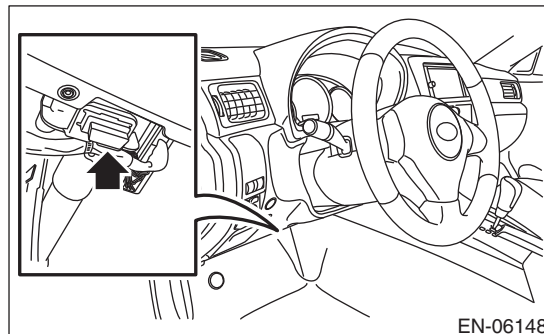

CAUTION:

Do not connect any scan tools except Subaru Select Monitor and general scan tool.

9) Start up the personal computer.

10) Turn the ignition switch to ON (engine OFF), and run the "PC application for Subaru Select Monitor".

11) On the «Main Menu» display screen, select the {Each System Check}.

12) On the «System Selection Menu» display screen, select the {Engine Control System}.

13) Click the [OK] button after the information of engine type has been displayed.

14) On the «Engine Diagnosis» display screen, select the {Dealer Check Mode Procedure}.

15) When the «Perform Inspection (Dealer Check) Mode» is shown on the screen, click the [Next] button.

16) Perform subsequent procedures as instructed on the display screen.

- If trouble still remains in the memory, the corresponding DTC appears on the display screen.

NOTE:

- For detailed operation procedure, refer to the "PC application help for Subaru Select Monitor".

- For details concerning DTC, refer to "List of Diagnostic Trouble Code (DTC)". <Ref. to EN(H4DOTC)(diag)-80, List of Diagnostic Trouble Code (DTC).>

- Release the parking brake.

- The speed difference between front and rear wheels may illuminate the ABS warning light, but this does not indicate a malfunction. When engine control diagnosis is finished, perform the ABS memory clearance procedure of the self-diagnosis system. <Ref. to VDC(diag)-24, Clear Memory Mode.>

Inspection Mode

ENGINE (DIAGNOSTICS)

3. GENERAL SCAN TOOL

1) After clearing the memory, check for any remaining unresolved trouble data. <Ref. to EN(H4DOTC)(diag)-52, Clear Memory Mode.>

2) Warm up the engine.

3) Connect the delivery (test) mode connector (A) located under the glove box.

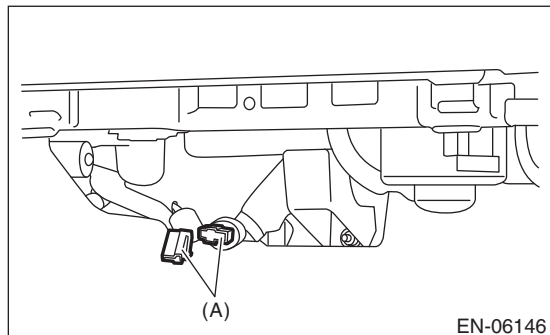

4) Connect the general scan tool to data link connector located in the lower portion of the instrument panel (on the driver's side).

CAUTION:

Do not connect any scan tools except Subaru Select Monitor and general scan tool.

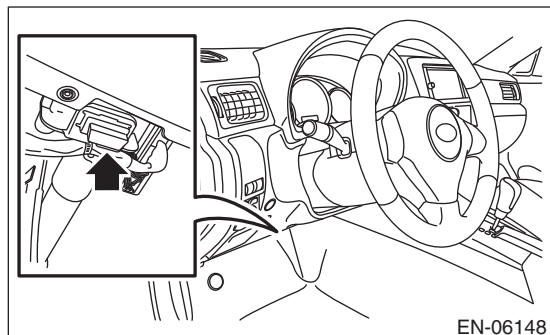

5) Start the engine.

NOTE:

Ensure the selector lever is placed in "P" range before starting.

6) Turn the neutral position switch to ON using select lever.

7) Depress the brake pedal to turn the brake switch ON.

8) Keep the engine speed in 2,500 — 3,000 rpm range for 40 seconds.

9) Place the select lever in "D" position and drive the vehicle at 5 to 10 km/h (3 to 6 MPH).

NOTE:

- For AWD model, release the parking brake.
- The speed difference between front and rear wheels may illuminate the ABS warning light, but this indicates no malfunctions. When engine control diagnosis is finished, perform the ABS memory clearance procedure of self-diagnosis system. <Ref. to VDC(diag)-24, Clear Memory Mode.>

10) Using the general scan tool, check DTC and record the result(s).

NOTE:

- For detailed operation procedures, refer to the general scan tool operation manual.
- For details concerning DTC, refer to "List of Diagnostic Trouble Code (DTC)". <Ref. to EN(H4DOTC)(diag)-80, List of Diagnostic Trouble Code (DTC).>

12. Drive Cycle

A: PROCEDURE

For the troubleshooting, there are driving patterns described below. Driving in the specified pattern allows to diagnose malfunctioning items listed below. After the repair of the following trouble items, be sure to drive the vehicle with the specified drive patterns to check whether the function is resumed correctly.

1. PREPARATION FOR DRIVE CYCLE

- 1) Check that the battery voltage is 12 V or more and fuel remains approx. half [20 — 40 ℓ (5.3 — 10.6 US gal, 4.4 — 8.8 Imp gal)].
- 2) After performing the diagnostics and clearing the memory, check for any remaining unresolved trouble data. <Ref. to EN(H4DOTC)(diag)-52, Clear Memory Mode.>
- 3) Disconnect the delivery (test) mode connector.

NOTE:

- Perform the diagnosis after warming up the engine except when the engine coolant temperature at starting is specified.
- Perform the diagnosis twice if the DTC marked with *. After completing the first diagnosis, stop the engine and perform second diagnosis in same condition.

2. DRIVE CYCLE A — DRIVE THE VEHICLE WITH 80 KM/H (50 MPH) FOR 20 MINUTES, AND THEN IDLE THE ENGINE FOR A MINUTE

DTC	Item	Condition
*P0125	Insufficient Coolant Temperature for Closed Loop Fuel Control	Engine coolant temperature at engine start is less than 20°C (68°F).
*P0126	Insufficient Engine Coolant Temperature For Stable Operation	—
*P0128	Coolant Thermostat (Engine Coolant Temperature Below Thermostat Regulating Temperature)	Engine coolant temperature at engine start is less than 55°C (131°F).
*P0133	O2 Sensor Circuit Slow Response (Bank 1 Sensor 1)	—
*P0171	System Too Lean (Bank 1)	Diagnosis completes in drive cycle B or C as well.
*P0172	System Too Rich (Bank 2)	Diagnosis completes in drive cycle B or C as well.
*P0301	Cylinder 1 Misfire Detected	Diagnosis completes in drive cycle B or C as well.
*P0302	Cylinder 2 Misfire Detected	Diagnosis completes in drive cycle B or C as well.
*P0303	Cylinder 3 Misfire Detected	Diagnosis completes in drive cycle B or C as well.
*P0304	Cylinder 4 Misfire Detected	Diagnosis completes in drive cycle B or C as well.
*P0420	Catalyst System Efficiency below Threshold (Bank 1)	—
*P0442	Evaporative Emission Control System Leak Detected (Small Leak)	Engine coolant temperature at engine start is less than 25°C (77°F).
*P0451	Evaporative Emission Control System Pressure Sensor	—
*P0456	Evaporative Emission Control System Leak Detected (Very Small Leak)	Engine coolant temperature at engine start is less than 25°C (77°F).
*P0457	Evaporative Emission Control System Leak Detected (Fuel Cap Loose/ Off)	Engine coolant temperature at engine start is less than 25°C (77°F).
P0459	Evaporative Emission System Purge Control Valve Circuit High	—
P1443	Vent Control Solenoid Valve Function Problem	—
*P2096	Post Catalyst Fuel Trim System Too Lean Bank 1	Diagnosis completes in drive cycle B or C as well.
*P2097	Post Catalyst Fuel Trim System Too Rich Bank 1	Diagnosis completes in drive cycle B or C as well.

Drive Cycle

ENGINE (DIAGNOSTICS)

3. DRIVE CYCLE B — 10 MINUTES IDLING

NOTE:

Drive the vehicle at 10 km/h (6 MPH) or faster before diagnosis.

DTC	Item	Condition
*P0171	System Too Lean (Bank 1)	Diagnosis completes in drive cycle A or C as well.
*P0172	System Too Rich (Bank 2)	Diagnosis completes in drive cycle A or C as well.
*P0301	Cylinder 1 Misfire Detected	Diagnosis completes in drive cycle A or C as well.
*P0302	Cylinder 2 Misfire Detected	Diagnosis completes in drive cycle A or C as well.
*P0303	Cylinder 3 Misfire Detected	Diagnosis completes in drive cycle A or C as well.
*P0304	Cylinder 4 Misfire Detected	Diagnosis completes in drive cycle A or C as well.
*P0464	Fuel Level Sensor Circuit Intermittent	—
*P0506	Idle Air Control System RPM Lower Than Expected	—
*P0507	Idle Air Control System RPM Higher Than Expected	—
*P2096	Post Catalyst Fuel Trim System Too Lean Bank 1	Diagnosis completes in drive cycle A or C as well.
*P2097	Post Catalyst Fuel Trim System Too Rich Bank 1	Diagnosis completes in drive cycle A or C as well.

4. DRIVE CYCLE C — DRIVE THE VEHICLE WITH FOLLOWING DRIVE PATTERNS

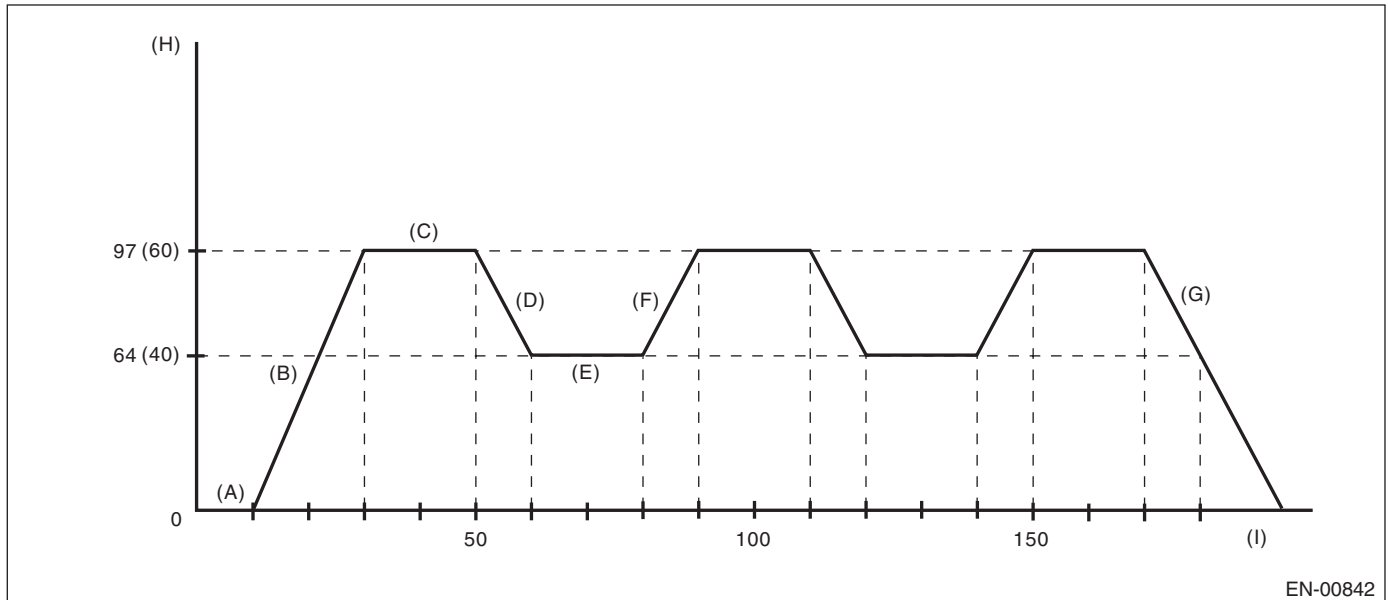

- | | | |
|---|--|--|
| (A) Idle the engine for 10 seconds or more. | (D) Decelerate with fully closed throttle to 64 km/h (40 MPH). | (G) Stop the vehicle with throttle fully closed. |
| (B) Accelerate to 97 km/h (60 MPH) within 20 seconds. | (E) Drive the vehicle at 64 km/h (40 MPH) for 20 seconds. | (H) Vehicle speed km/h (MPH) |
| (C) Drive the vehicle at 97 km/h (60 MPH) for 20 seconds. | (F) Accelerate to 97 km/h (60 MPH) within 10 seconds. | (I) Sec. |

DTC	Item	Condition
*P0030	HO2S Heater Control Circuit (Bank 1 Sensor 1)	—
P0068	MAP/MAF - Throttle Position Correlation	—
*P0101	Mass or Volume Air Flow Circuit Range/Performance	—
P0134	O2 Sensor Circuit No Activity Detected (Bank 1 Sensor 1)	—
*P0139	O2 Sensor Circuit Slow Response (Bank 1 Sensor 2)	—
*P0171	System Too Lean (Bank 1)	Diagnosis completes in drive cycle A or B as well.
*P0172	System Too Rich (Bank 2)	Diagnosis completes in drive cycle A or B as well.
*P0244	Turbo/Super Charger Wastegate Solenoid "A" Range/Performance	—
P0246	Turbo/Super Charger Wastegate Solenoid "A" High	—
*P0301	Cylinder 1 Misfire Detected	Diagnosis completes in drive cycle A or B as well.
*P0302	Cylinder 2 Misfire Detected	Diagnosis completes in drive cycle A or B as well.
*P0303	Cylinder 3 Misfire Detected	Diagnosis completes in drive cycle A or B as well.
*P0304	Cylinder 4 Misfire Detected	Diagnosis completes in drive cycle A or B as well.
P2004	Intake Manifold Runner Control Stuck Open (Bank 1)	—
P2005	Intake Manifold Runner Control Stuck Open (Bank 2)	—
*P2096	Post Catalyst Fuel Trim System Too Lean Bank 1	Diagnosis completes in drive cycle A or B as well.
*P2097	Post Catalyst Fuel Trim System Too Rich Bank 1	Diagnosis completes in drive cycle A or B as well.

Drive Cycle

ENGINE (DIAGNOSTICS)

5. DRIVE CYCLE D

DRIFT DIAGNOSIS

- 1) Check that the engine coolant temperature at engine start is less than 30°C (86°F).
- 2) Make sure that fuel remains 10 ℓ (2.6 US gal, 2.2 Imp gal) or more and the battery voltage is 10.9 V or more.
- 3) Start the engine, and check that the engine coolant temperature increases by 10°C (18°F) or more, and reaches 75°C (167°F) or more, when the engine is warmed up.
- 4) Idle the engine for 120 seconds or more in the condition of step 3.

STUCK DIAGNOSIS

- 1) Make sure that the battery voltage is 10.9 V or more.
- 2) Perform the Clear Memory Mode. <Ref. to EN(H4DOTC)(diag)-52, Clear Memory Mode.>
- 3) Drive the vehicle for the distance equal to the fuel of 50 ℓ (13.2 US gal, 11 Imp gal).

NOTE:

- It is acceptable to drive the vehicle intermittently.
- Do not disconnect the battery terminals while diagnosing. (Data will be cleared by disconnecting the battery terminals.)

DTC	Item	Condition
P0181	Fuel Temperature Sensor "A" Circuit Range/Performance	—

6. DRIVE CYCLE E

- 1) Make sure that the battery voltage is 10.9 V or more.
- 2) Perform the Clear Memory Mode. <Ref. to EN(H4DOTC)(diag)-52, Clear Memory Mode.>
- 3) Drive the vehicle for the distance equal to the fuel of 30 ℓ (7.9 US gal, 6.6 Imp gal).

NOTE:

- It is acceptable to drive the vehicle intermittently.
- Do not disconnect the battery terminals while diagnosing. (Data will be cleared by disconnecting the battery terminals.)

DTC	Item	Condition
P0461	Fuel Level Sensor "A" Circuit Range/Performance	—

7. DRIVE CYCLE F

- 1) Check that the engine coolant temperature at engine start is less than 30°C (86°F).
- 2) Start the engine, and warm it up until engine coolant temperature increases over 95°C (203°F).
- 3) After the engine has reached the state of procedure 2), idle the engine for 10 minutes or more.

NOTE:

Do not disconnect the battery terminals while diagnosing. (Data will be cleared by disconnecting the battery terminals.)

DTC	Item	Condition
P0111	Intake Air Temperature Sensor 1 Circuit Range/Performance	—

8. DRIVE CYCLE G

- 1) Remove the battery negative terminal, and reconnect after 10 seconds have passed.
- 2) Start the engine and warm up engine until coolant temperature is 80°C (176°F).
- 3) Start the engine and warm up engine until coolant temperature is 40°C (104°F) or less.

NOTE:

Do not let engine coolant temperature drop below 5°C (41°F).

- 4) Start the engine and warm up engine until coolant temperature is 80°C (176°F).
- 5) Start the engine and warm up engine until coolant temperature is 40°C (104°F) or less.

NOTE:

Do not let engine coolant temperature drop below 5°C (41°F).

- 6) Start and idle the engine.

DTC	Item	Condition
*P0410	Secondary Air Injection System	—
*P0411	Secondary Air Injection System Incorrect Flow Detected	—
P0414	Secondary Air Injection System Switching Valve "A" Circuit Shorted	—
P0417	Secondary Air Injection System Switching Valve "B" Circuit Shorted	—
P1418	Secondary Air Injection System Control "A" Circuit Shorted	—
*P2440	Secondary Air Injection System Switching Valve Stuck Open (Bank 1)	—
*P2441	Secondary Air Injection System Switching Valve Stuck Closed (Bank 1)	—
*P2442	Secondary Air Injection System Switching Valve Stuck Open (Bank 2)	—
*P2443	Secondary Air Injection System Switching Valve Stuck Closed (Bank 2)	—

9. DRIVE CYCLE H

- 1) Perform the Clear Memory Mode. <Ref. to EN(H4DOTC)(diag)-52, Clear Memory Mode.>
- 2) With the ignition switch ON, read the engine coolant temperature, intake air temperature and fuel temperature. <Ref. to EN(H4DOTC)(diag)-35, READ CURRENT DATA FOR ENGINE (NORMAL MODE), OPERATION, Subaru Select Monitor.>
- 3) If the values from step 2) satisfy the following two conditions, start the engine.

Condition:

|Engine coolant temperature — intake air temperature| ≤ 5°C (41°F)

|Engine coolant temperature — Fuel temperature| ≤ 2°C (36°F)

NOTE:

- If the conditions are not satisfied, turn the ignition switch to OFF and wait until the parameters are satisfied.
 - Place the select lever in "P" range and start the engine.
- 4) Idle the engine for 1 minute under the conditions in step 3).

DTC	Item	Condition
*P1602	Control Module Programming Error	—

Clear Memory Mode

ENGINE (DIAGNOSTICS)

13. Clear Memory Mode

A: OPERATION

NOTE:

If the Clear Memory Mode is executed from Subaru Select Monitor OBD mode, only DTCs are cleared.

1. SUBARU SELECT MONITOR (NORMAL MODE)

- 1) On the «Main Menu» display screen, select the {Each System Check}.
- 2) On the «System Selection Menu» display screen, select the {Engine Control System}.
- 3) Click the [OK] button after the information of engine type has been displayed.
- 4) On the «Engine Diagnosis» display screen, select the {Clear Memory}.
- 5) When the “Clear Memory?” is shown on the screen, click the [Yes] button.
- 6) When “Done” and “Turn ignition switch to OFF” is shown on the display screen, turn the ignition switch to OFF.

NOTE:

- Initial diagnosis of electronic throttle control is performed after memory clearance. For this reason, start the engine after 10 seconds or more have elapsed since the ignition switch was turned to ON.
- For detailed operation procedure, refer to the “PC application help for Subaru Select Monitor”.

2. SUBARU SELECT MONITOR (OBD MODE)

- 1) On the «Main Menu» display screen, select the {Each System Check}.
- 2) On the «System Selection Menu» display screen, select the {Engine Control System}.
- 3) Click the [OK] button after the information of engine type has been displayed.
- 4) On the «Engine Diagnosis» display screen, select the {OBD System}.
- 5) On the «OBD Menu» display screen, select the {Clear Diagnostic Code?}.
- 6) When the “Clear Diagnostic Code?” is shown on the screen, click the [Yes] button.
- 7) When “Done” and “Turn ignition switch to OFF” is shown on the display screen, turn the ignition switch to OFF.

NOTE:

- Initial diagnosis of electronic throttle control is performed after memory clearance. For this reason, start the engine after 10 seconds or more have elapsed since the ignition switch was turned to ON.
- For detailed operation procedure, refer to the “PC application help for Subaru Select Monitor”.

3. GENERAL SCAN TOOL

For procedures clearing memory using the general scan tool, refer to the general scan tool operation manual.

NOTE:

Initial diagnosis of electronic throttle control is performed after memory clearance. For this reason, start the engine after 10 seconds or more have elapsed since the ignition switch was turned to ON.

14. Compulsory Valve Operation Check Mode

A: OPERATION

1) Prepare the Subaru Select Monitor kit. <Ref. to EN(H4DOTC)(diag)-7, PREPARATION TOOL, General Description.>

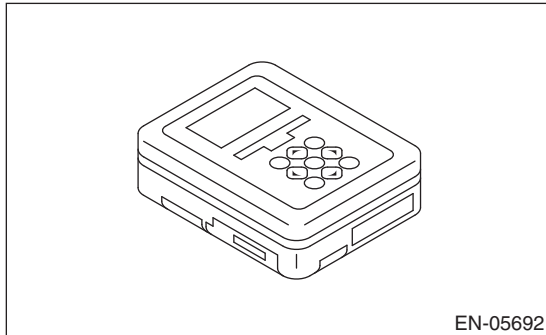

2) Prepare the personal computer which has been installed the Subaru Select Monitor.

3) Connect the USB cable between SDI (Subaru Diagnosis Interface) and USB port on the personal computer (dedicated port for the Subaru Select Monitor).

NOTE:

The dedicated port for the Subaru Select Monitor means the USB port which was used to install the Subaru Select Monitor.

4) Connect the diagnosis cable to the SDI.

5) Connect the delivery (test) mode connector (A) located under the glove box.

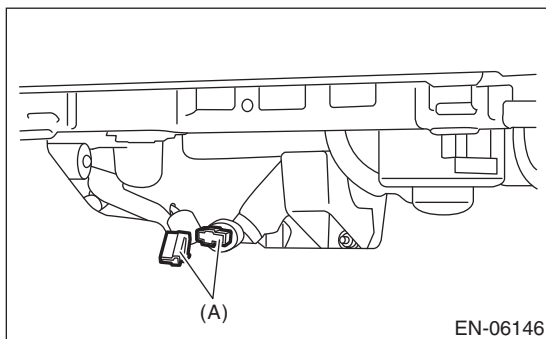

6) Connect the SDI to data link connector located in the lower portion of the instrument panel (on the driver's side).

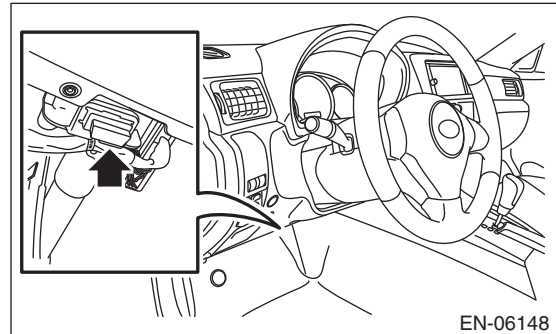

CAUTION:

Do not connect any scan tools except Subaru Select Monitor and general scan tool.

7) Start up the personal computer.

8) Turn the ignition switch to ON (engine OFF), and run the "PC application for Subaru Select Monitor".

9) On the «Main Menu» display screen, select the {Each System Check}.

10) On the «System Selection Menu» display screen, select the {Engine Control System}.

11) Click the [OK] button after the information of engine type has been displayed.

12) On the «Engine Diagnosis» display screen, select the {System Operation Check Mode}.

13) On the «System Operation Check Mode» display screen, select the {Actuator ON/OFF Operation}.

14) Select the desired compulsory actuator on the «Actuator ON/OFF Operation» display screen and click the [Next] button.

Compulsory Valve Operation Check Mode

ENGINE (DIAGNOSTICS)

15) Clicking the [End] button completes the compulsory valve operation check mode. The display will then return to the «Actuator ON/OFF Operation» screen.

- A list of the support data is shown in the following table.

Description	Display
Compulsory fuel pump relay operation check	Fuel Pump Relay
Compulsory purge control solenoid valve operation check	CPC Solenoid Valve
Compulsory purge control solenoid valve 2 operation check	CPC Solenoid 2
Compulsory radiator fan relay operation check	Radiator Fan Relay
Compulsory air conditioning relay operation check	A/C Compressor Relay
Compulsory wastegate control solenoid valve operation check	Turbocharger Wastegate Solenoid
Compulsory pressure control solenoid valve operation check	PCV Solenoid Valve
Compulsory drain valve operation check	Vent. Solenoid Valve
Compulsory secondary air combination valve 1 operation check	Secondary Air Combi Valve 1
Compulsory secondary air combination valve 2 operation check	Secondary Air Combi Valve 2
Compulsory secondary air pump relay operation check	Secondary Air Pump Relay

NOTE:

- The following parts will be displayed but not functional.

Display
EGR Solenoid Valve
ASV Solenoid Valve
FICD Solenoid
Pressure Switching Sol.1
Pressure Switching Sol.2
AAI Solenoid Valve
Tank Sensor Cntl Valve
EXH. Bypass Control Permit Flag
Sub Fuel Pump Relay
Fuel Pressure Switching Solenoid

- For detailed operation procedure, refer to the “PC application help for Subaru Select Monitor”.

15. System Operation Check Mode

A: OPERATION

1) Prepare the Subaru Select Monitor kit. <Ref. to EN(H4DOTC)(diag)-7, PREPARATION TOOL, General Description.>

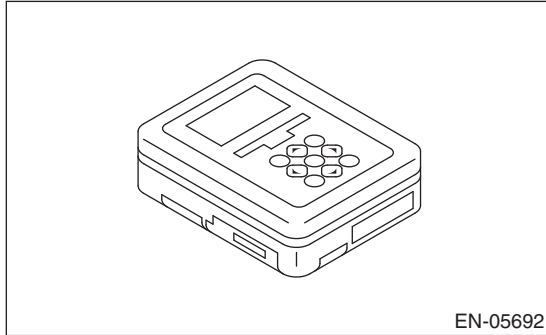

2) Prepare the personal computer which has been installed the Subaru Select Monitor.

3) Connect the USB cable between SDI (Subaru Diagnosis Interface) and USB port on the personal computer (dedicated port for the Subaru Select Monitor).

NOTE:

The dedicated port for the Subaru Select Monitor means the USB port which was used to install the Subaru Select Monitor.

4) Connect the diagnosis cable to the SDI.

5) Connect the SDI to data link connector located in the lower portion of the instrument panel (on the driver's side).

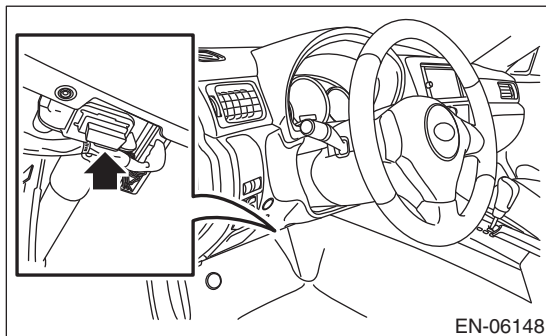

CAUTION:

Do not connect any scan tools except Subaru Select Monitor and general scan tool.

6) Start up the personal computer.

7) Turn the ignition switch to ON (engine OFF), and run the "PC application for Subaru Select Monitor".

8) On the «Main Menu» display screen, select the {Each System Check}.

9) On the «System Selection Menu» display screen, select the {Engine Control System}.

10) Click the [OK] button after the information of engine type has been displayed.

11) On the «Engine Diagnosis» display screen, select the {System Operation Check Mode}.

12) The following items will be displayed on screen.

Display
Actuator ON/OFF Operation
Immobilizer System
Fuel Pump Control
Fixed Idle Ignition Timing
Idle Speed Control
Injector Control

1. FUEL PUMP CONTROL (OFF DRIVE)

CAUTION:

After executing the operation check mode, execute the Clear Memory Mode. <Ref. to EN(H4DOTC)(diag)-52, OPERATION, Clear Memory Mode.>

1) On the «System Operation Check Mode» display, select the {Fuel Pump Control}.

2) On the «Fuel Pump Control» display screen, select the {OFF Drive}.

3) On the «Start the Engine» display screen, start the engine and click the [OK] button.

4) On the «OFF Drive» display screen, click the [Execution] button and execute OFF drive.

5) Click the [Cancel] button to stop the OFF drive.

6) Click the [F12 Exit] button to end the OFF drive. The screen will return to the «Fuel Pump Control» screen.

NOTE:

For detailed operation procedure, refer to the "PC application help for Subaru Select Monitor".

2. FUEL PUMP CONTROL (ON/OFF DRIVE)

CAUTION:

After executing the operation check mode, execute the Clear Memory Mode. <Ref. to EN(H4DOTC)(diag)-52, OPERATION, Clear Memory Mode.>

1) On the «System Operation Check Mode» display, select the {Fuel Pump Control}.

2) On the «Fuel Pump Control» display screen, select the {ON/OFF Dr.}.

3) On the «Turn Ignition Switch ON with Engine OFF» display screen, turn the ignition switch to ON and click the [OK] button.

4) On the «ON/OFF Dr.» display screen, click the [Execution] button and execute ON/OFF drive.

5) Click the [Cancel] button to stop the ON/OFF drive.

6) Click the [F12 Exit] button to end the ON/OFF drive. The screen will return to the «Fuel Pump Control» screen.

NOTE:

For detailed operation procedure, refer to the "PC application help for Subaru Select Monitor".

System Operation Check Mode

ENGINE (DIAGNOSTICS)

3. IDLING IGNITION TIMING FIXED

CAUTION:

After executing the operation check mode, execute the Clear Memory Mode. <Ref. to EN(H4DOTC)(diag)-52, OPERATION, Clear Memory Mode.>

- 1) On the «System Operation Check Mode» display screen, select the {Fixed Idle Ignition Timing}.
- 2) On the «Start the Engine» display screen, start the engine and click the [OK] button.
- 3) On the «Fixed Idle Ignition Timing» display screen, click the [Execution] button and execute idling ignition timing fixed.
- 4) Click the [Cancel] button to stop the idling ignition timing fixed.
- 5) Click the [Exit] button to end the idling ignition timing fixed. The screen will return to the «System Operation Check Mode» screen.

NOTE:

For detailed operation procedure, refer to the “PC application help for Subaru Select Monitor”.

4. IDLE SPEED CONTROL

CAUTION:

After executing the operation check mode, execute the Clear Memory Mode. <Ref. to EN(H4DOTC)(diag)-52, OPERATION, Clear Memory Mode.>

- 1) On the «System Operation Check Mode» display screen, select the {Idle Speed Control}.
- 2) On the «Start the Engine» display screen, start the engine and click the [OK] button.
- 3) In the «Idle Speed Control» display screen, click the [△] button or the [▽] button to change the setting values, then click the [OK] button.
Setting is possible in a range from 500 rpm to 2,000 rpm, in increments of 50 rpm. However, the engine speed that can actually be controlled will vary depending on the vehicle.
- 4) Click the [Cancel] button to stop the idle speed control.
- 5) Click the [Exit] button to end the idle speed control. The screen will return to the «System Operation Check Mode» screen.

NOTE:

For detailed operation procedure, refer to the “PC application help for Subaru Select Monitor”.

5. INJECTOR CONTROL (INJECTION STOP MODE)

CAUTION:

After executing the operation check mode, execute the Clear Memory Mode. <Ref. to EN(H4DOTC)(diag)-52, OPERATION, Clear Memory Mode.>

- 1) On the «System Operation Check Mode» display, select the {Injector Control}.
- 2) On the «Injector Control» display screen, select the {Injection Stop Mode}.
- 3) On the «Injection Stop Mode» display screen, select a fuel injector to be stopped.
- 4) On the «Start the Engine» display screen, start the engine and click the [OK] button.
- 5) On the «Fuel Injector #» display screen, click the [Execution] button and execute injection stop mode.
- 6) Click the [Cancel] button to stop the injection stop mode.
- 7) Click the [Exit] button to return the «Injection Stop Mode» display screen.
- 8) On the «Injection Stop Mode» display screen, click the [Return] button to end the «Injection Stop Mode». The screen will return to the «Injector Control» screen.

NOTE:

For detailed operation procedure, refer to the “PC application help for Subaru Select Monitor”.

6. INJECTOR CONTROL (INJECTION QUANTITY CONTROL)

CAUTION:

After executing the operation check mode, execute the Clear Memory Mode. <Ref. to EN(H4DOTC)(diag)-52, OPERATION, Clear Memory Mode.>

- 1) On the «System Operation Check Mode» display, select the {Injector Control}.
- 2) On the «Injector Control» display screen, select the {Injection Quantity Control}.
- 3) On the «Start the Engine» display screen, start the engine and click the [OK] button.
- 4) In the «Injection Quantity Control» screen, click the [△] button or the [▽] button to change the setting values, then click the [OK] button.
Setting is possible in a range from 0 to 20%, in increments of 1%.
- 5) Click the [Cancel] button to stop the injection quantity control.
- 6) Click the [Exit] button to end the injection quantity control. The screen will return to the «Injector Control» screen.

NOTE:

For detailed operation procedure, refer to the “PC application help for Subaru Select Monitor”.

16. Malfunction Indicator Light

A: PROCEDURE

1. Activation of malfunction indicator light. <Ref. to EN(H4DOTC)(diag)-58, ACTIVATION OF MALFUNCTION INDICATOR LIGHT, Malfunction Indicator Light.>
↓
2. Malfunction indicator light does not come on. <Ref. to EN(H4DOTC)(diag)-59, MALFUNCTION INDICATOR LIGHT DOES NOT COME ON, Malfunction Indicator Light.>
↓
3. Malfunction indicator light does not go off. <Ref. to EN(H4DOTC)(diag)-61, MALFUNCTION INDICATOR LIGHT DOES NOT GO OFF, Malfunction Indicator Light.>
↓
4. Malfunction indicator light does not blink. <Ref. to EN(H4DOTC)(diag)-62, MALFUNCTION INDICATOR LIGHT DOES NOT BLINK, Malfunction Indicator Light.>
↓
5. Malfunction indicator light remains blinking. <Ref. to EN(H4DOTC)(diag)-64, MALFUNCTION INDICATOR LIGHT REMAINS BLINKING, Malfunction Indicator Light.>

Malfunction Indicator Light

ENGINE (DIAGNOSTICS)

B: ACTIVATION OF MALFUNCTION INDICATOR LIGHT

1) When the ignition switch is turned to ON (engine OFF), the malfunction indicator light (A) in the combination meter illuminates.

NOTE:

If the malfunction indicator light does not illuminate, perform diagnostics of the malfunction indicator light circuit or the combination meter circuit. <Ref. to EN(H4DOTC)(diag)-59, MALFUNCTION INDICATOR LIGHT DOES NOT COME ON, Malfunction Indicator Light.>

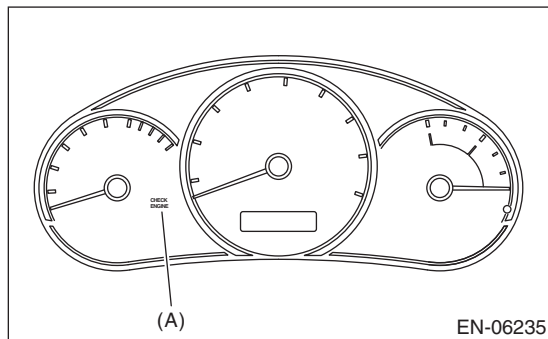

2) After starting the engine, the malfunction indicator light goes out. If it does not go off, either the engine or emission control system has malfunction.

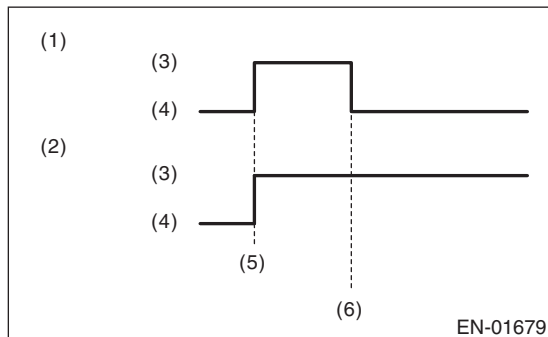

- (1) No DTC
- (2) Trouble occurs
- (3) ON
- (4) OFF
- (5) Ignition switch ON
- (6) Engine start

3) Turn the ignition switch to OFF and connect the delivery (test) mode connector.

(1) When the ignition switch is turned to ON (engine OFF), the malfunction indicator light illuminates.

(2) After the engine starts, malfunction indicator light blinks in a cycle of 0.5 Hz. (During diagnosis)

(3) Malfunction indicator light blinks at a cycle of 3 Hz after diagnosis if there is no trouble. Malfunction indicator light illuminates if faulty.

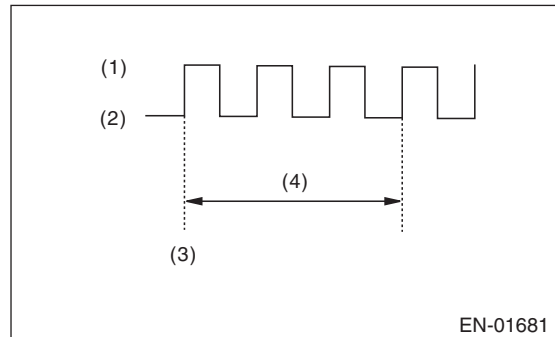

- (1) ON
- (2) OFF
- (3) Ignition switch ON
- (4) 1 second

Malfunction Indicator Light

ENGINE (DIAGNOSTICS)

C: MALFUNCTION INDICATOR LIGHT DOES NOT COME ON

DIAGNOSIS:

The malfunction indicator light circuit is open or shorted.

TROUBLE SYMPTOM:

When the ignition switch is turned to ON (engine OFF), malfunction indicator light does not come on.

WIRING DIAGRAM:

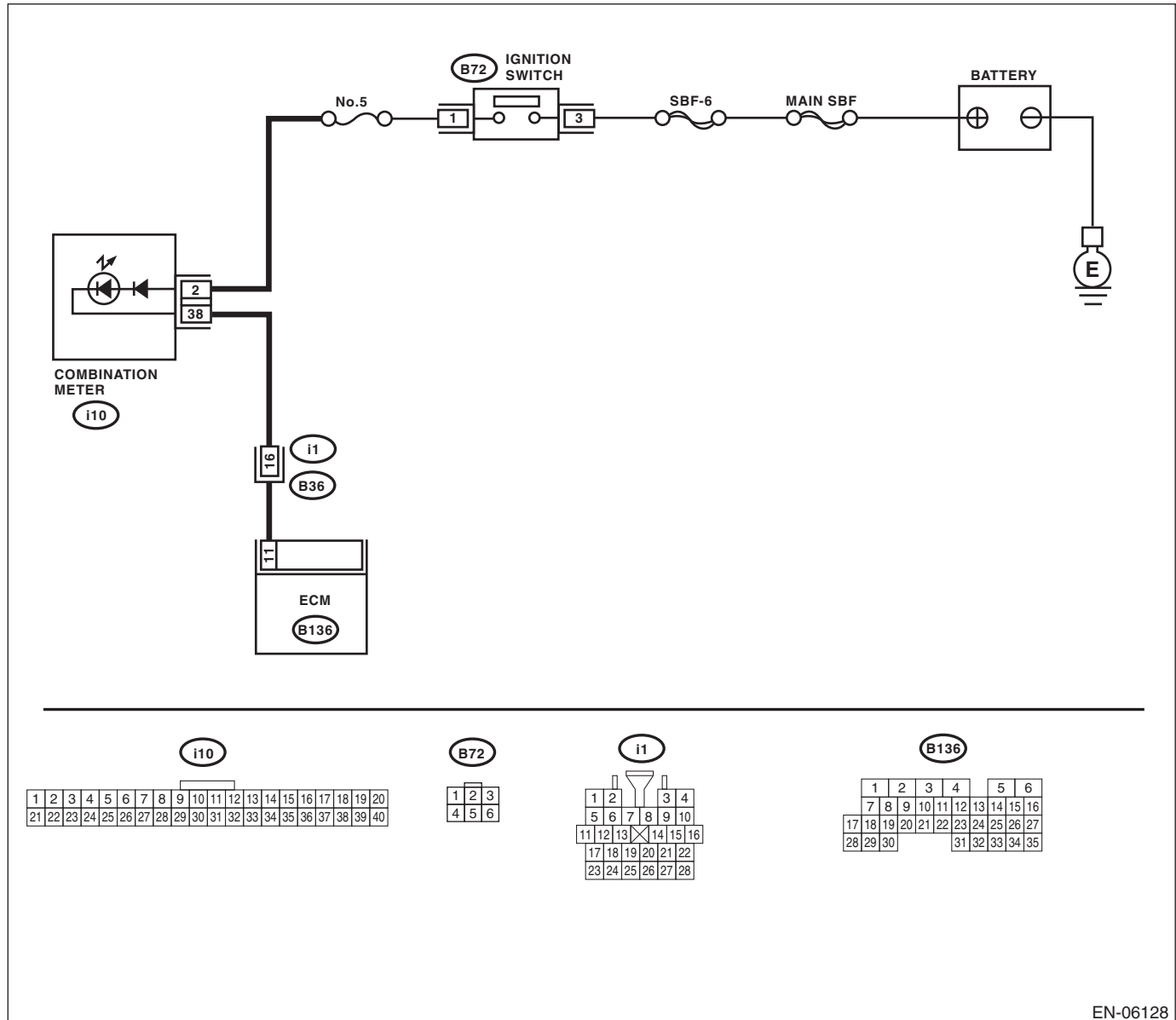

EN-06128

Malfunction Indicator Light

ENGINE (DIAGNOSTICS)

Step	Check	Yes	No
1 CHECK OUTPUT SIGNAL OF ECM. 1) Turn the ignition switch to ON. 2) Measure the voltage between ECM and chassis ground. Connector & terminal (B136) No. 11 (+) — Chassis ground (-):	Is the voltage less than 1 V?	Go to step 4.	Go to step 2.
2 CHECK POOR CONTACT. Check for poor connection by shaking or pulling ECM connector and harness.	Does the malfunction indicator light illuminate?	Repair poor contact of the ECM connector.	Go to step 3.
3 CHECK ECM CONNECTOR. Check the connection of ECM connector.	Is the ECM connector correctly connected?	Replace the ECM. <Ref. to FU(H4DOTC)-46, Engine Control Module (ECM).>	Repair the connection of ECM connector.
4 CHECK HARNESS BETWEEN COMBINATION METER AND ECM CONNECTOR. 1) Turn the ignition switch to OFF. 2) Remove the combination meter. <Ref. to IDI-16, Combination Meter.> 3) Disconnect the connector from the ECM and combination meter. 4) Measure the resistance of harness between ECM and combination meter connector. Connector & terminal (B136) No. 11 — (i10) No. 38:	Is the resistance less than 1 Ω ?	Go to step 5.	Repair the harness and connector. NOTE: In this case, repair the following item: • Open circuit of harness between ECM and combination meter connector • Poor contact of coupling connector
5 CHECK POOR CONTACT. Check poor contact of combination meter connector.	Is there poor contact in combination meter connector?	Repair the poor contact of combination meter connector.	Go to step 6.
6 CHECK HARNESS BETWEEN COMBINATION METER AND IGNITION SWITCH CONNECTOR. 1) Turn the ignition switch to ON. 2) Measure the voltage between combination meter connector and chassis ground. Connector & terminal (i10) No. 2 (+) — Chassis ground (-):	Is the voltage 10 V or more?	Replace the combination meter circuit board. <Ref. to IDI-16, Combination Meter.>	Check the following item and repair if necessary. NOTE: • Blown out of fuse (No. 5) • Open or short circuit in harness between fuse (No. 5) and battery terminal • Poor contact of ignition switch connector

Malfunction Indicator Light

ENGINE (DIAGNOSTICS)

D: MALFUNCTION INDICATOR LIGHT DOES NOT GO OFF

DIAGNOSIS:

The malfunction indicator light circuit is shorted.

TROUBLE SYMPTOM:

Although malfunction indicator light illuminates when the engine runs, DTC is not shown on the Subaru Select Monitor display.

WIRING DIAGRAM:

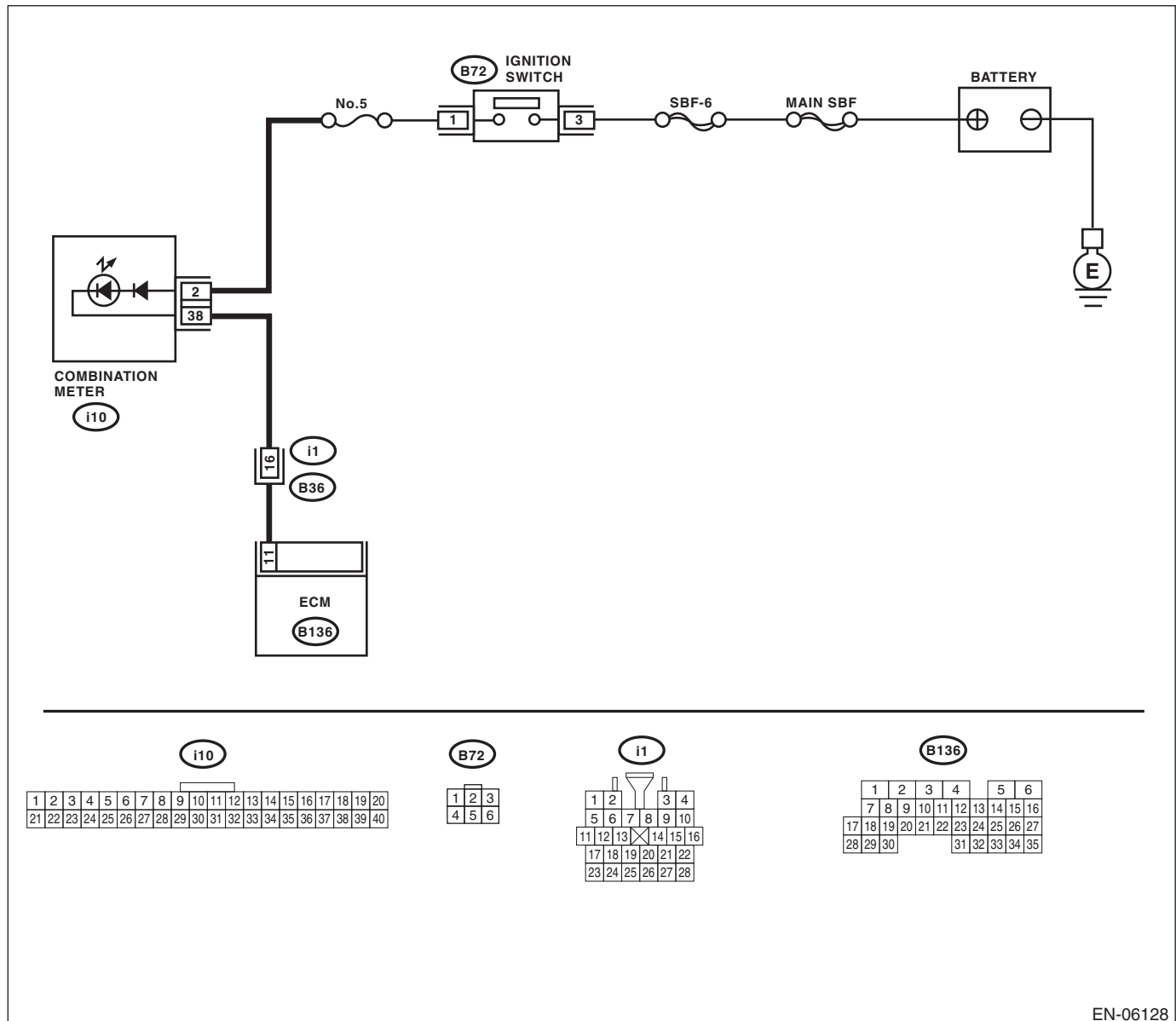

EN-06128

Step	Check	Yes	No
1 CHECK HARNESS BETWEEN COMBINATION METER AND ECM. 1) Turn the ignition switch to OFF. 2) Disconnect the connectors from the ECM. 3) Turn the ignition switch to ON.	Does the malfunction indicator light illuminate?	Repair the ground short circuit of harness between combination meter and ECM connector.	Replace the ECM. <Ref. to FU(H4DOTC)-46, Engine Control Module (ECM).>

Malfunction Indicator Light

ENGINE (DIAGNOSTICS)

E: MALFUNCTION INDICATOR LIGHT DOES NOT BLINK

DIAGNOSIS:

- The malfunction indicator light circuit is open or shorted.
- The delivery (test) mode connector circuit is open.

TROUBLE SYMPTOM:

Malfunction indicator light does not blink during Inspection Mode.

WIRING DIAGRAM:

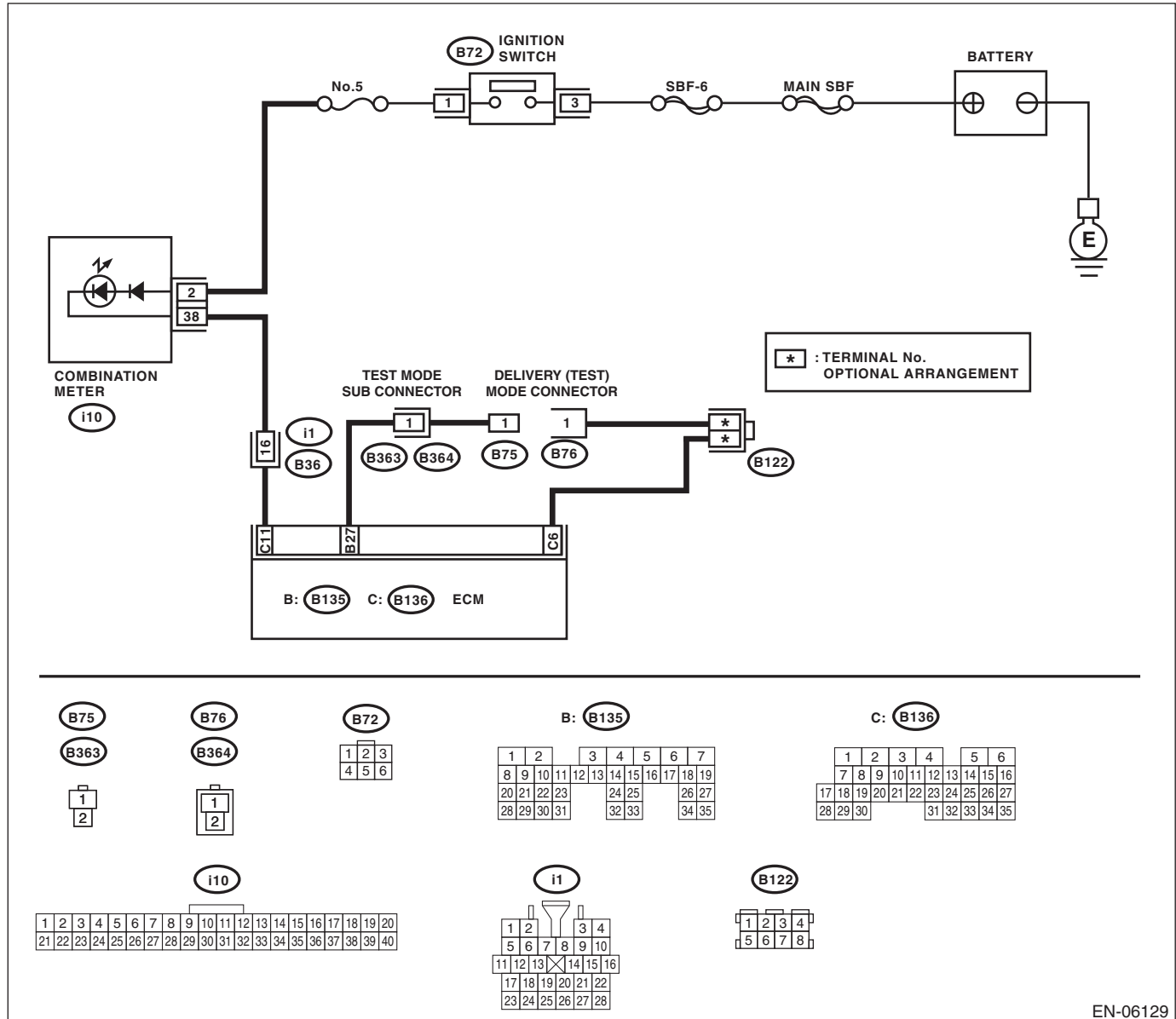

EN-06129

Malfunction Indicator Light

ENGINE (DIAGNOSTICS)

Step	Check	Yes	No
1 CHECK STATUS OF MALFUNCTION INDICATOR LIGHT. 1) Turn the ignition switch to OFF. 2) Disconnect the delivery (test) mode connector. 3) Turn the ignition switch to ON. (engine OFF)	Does the malfunction indicator light illuminate?	Go to step 2.	Repair the malfunction indicator light circuit. <Ref. to EN(H4DOTC)(diag)-59, MALFUNCTION INDICATOR LIGHT DOES NOT COME ON, Malfunction Indicator Light.>
2 CHECK HARNESS BETWEEN ECM AND COMBINATION METER CONNECTOR. 1) Turn the ignition switch to OFF. 2) Disconnect the connectors from the ECM. 3) Turn the ignition switch to ON.	Does the malfunction indicator light illuminate?	Repair the ground short circuit of harness between ECM and combination meter connector.	Go to step 3.
3 CHECK HARNESS BETWEEN ECM AND DELIVERY (TEST) MODE CONNECTOR. 1) Turn the ignition switch to OFF. 2) Disconnect the connectors from the ECM. 3) Measure the resistance of harness between ECM and delivery (test) mode connector. Connector & terminal (B76) No. 1 — (B136) No. 6: (B75) No. 1 — (B135) No. 27:	Is the resistance less than 1 Ω?	Go to step 4.	Repair the harness and connector. NOTE: In this case, repair the following item: • Open circuit of harness between ECM and delivery (test) mode connector • Poor contact of joint connector
4 CHECK POOR CONTACT. Check for poor contact of the ECM connector.	Is there poor contact in ECM connector?	Repair poor contact of the ECM connector.	Replace the ECM. <Ref. to FU(H4DOTC)-46, Engine Control Module (ECM).>

Malfunction Indicator Light

ENGINE (DIAGNOSTICS)

F: MALFUNCTION INDICATOR LIGHT REMAINS BLINKING

DIAGNOSIS:

The delivery (test) mode connector circuit is shorted.

TROUBLE SYMPTOM:

Malfunction indicator light blinks when delivery (test) mode connector is not connected.

WIRING DIAGRAM:

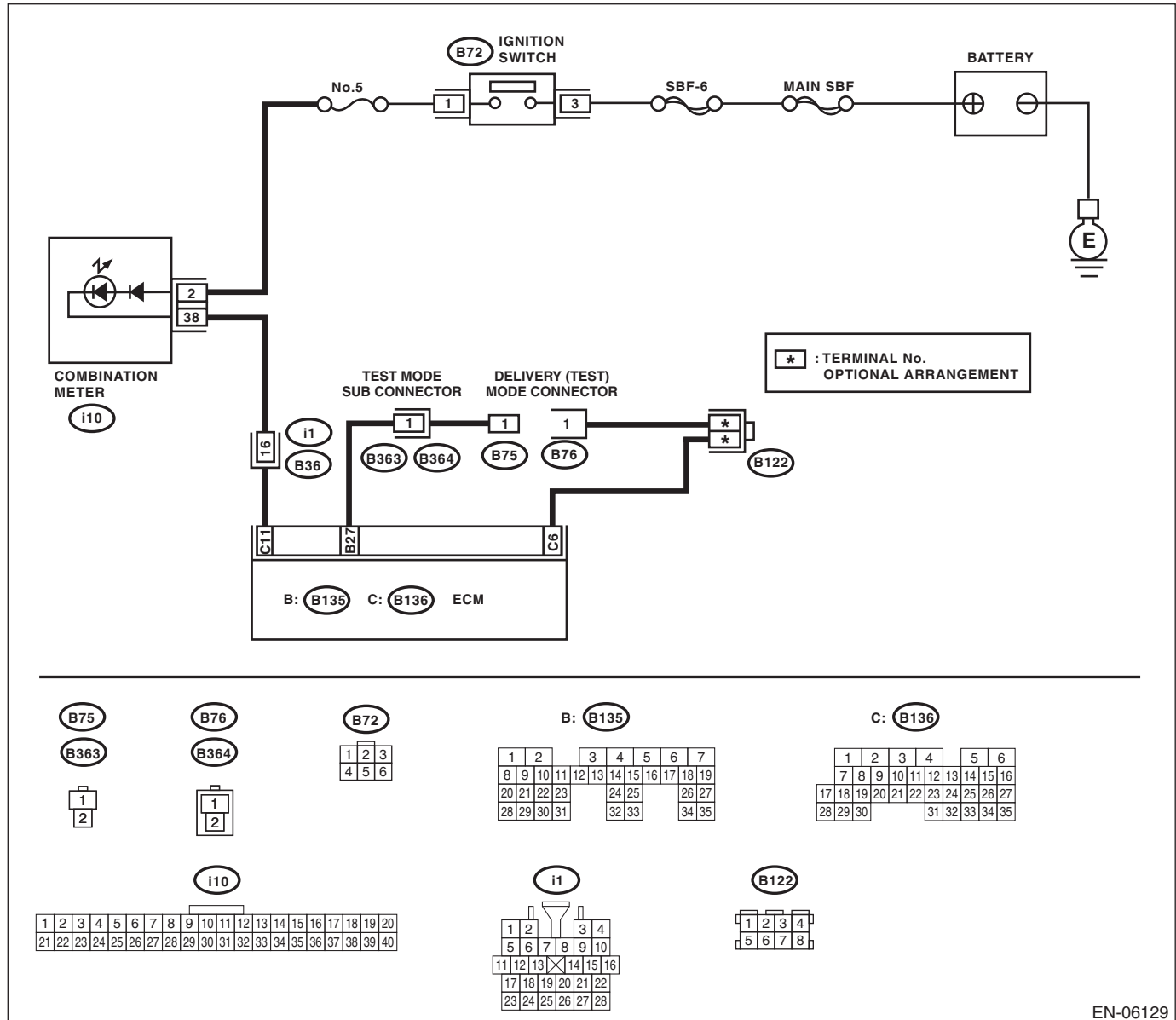

EN-06129

Malfunction Indicator Light

ENGINE (DIAGNOSTICS)

Step	Check	Yes	No
1 CHECK DELIVERY (TEST) MODE CONNECTOR. 1) Disconnect the delivery (test) mode connector. 2) Turn the ignition switch to ON.	Does the malfunction indicator light blink?	Go to step 2.	System is normal. NOTE: Malfunction indicator light blinks when delivery (test) mode connector is connected.
2 CHECK HARNESS BETWEEN ECM AND CHASSIS GROUND TERMINAL. 1) Turn the ignition switch to OFF. 2) Disconnect the connectors from the ECM. 3) Measure the resistance of harness between ECM and chassis ground. Connector & terminal (B135) No. 27 — Chassis ground:	Is the resistance less than 5 Ω?	Repair the short circuit to ground in harness between ECM and delivery (test) mode connector.	Replace the ECM. <Ref. to FU(H4DOTC)-46, Engine Control Module (ECM).>

Diagnostics for Engine Starting Failure

ENGINE (DIAGNOSTICS)

17. Diagnostics for Engine Starting Failure

A: PROCEDURE

1. Check for fuel amount.
↓
2. Inspection of starter motor circuit. <Ref. to EN(H4DOTC)(diag)-67, STARTER MOTOR CIRCUIT, Diagnostics for Engine Starting Failure.>
↓
3. Inspection of ECM power supply and ground line. <Ref. to EN(H4DOTC)(diag)-70, CHECK POWER SUPPLY AND GROUND LINE OF ENGINE CONTROL MODULE (ECM), Diagnostics for Engine Starting Failure.>
↓
4. Inspection of ignition control system. <Ref. to EN(H4DOTC)(diag)-72, IGNITION CONTROL SYSTEM, Diagnostics for Engine Starting Failure.>
↓
5. Inspection of fuel pump circuit. <Ref. to EN(H4DOTC)(diag)-75, FUEL PUMP CIRCUIT, Diagnostics for Engine Starting Failure.>
↓
6. Inspection of fuel injector circuit. <Ref. to EN(H4DOTC)(diag)-76, FUEL INJECTOR CIRCUIT, Diagnostics for Engine Starting Failure.>

B: STARTER MOTOR CIRCUIT

CAUTION:

After repair or replacement of faulty parts, perform Clear Memory Mode <Ref. to EN(H4DOTC)(diag)-52, OPERATION, Clear Memory Mode.> and Inspection Mode <Ref. to EN(H4DOTC)(diag)-42, PROCEDURE, Inspection Mode.>.

WIRING DIAGRAM:

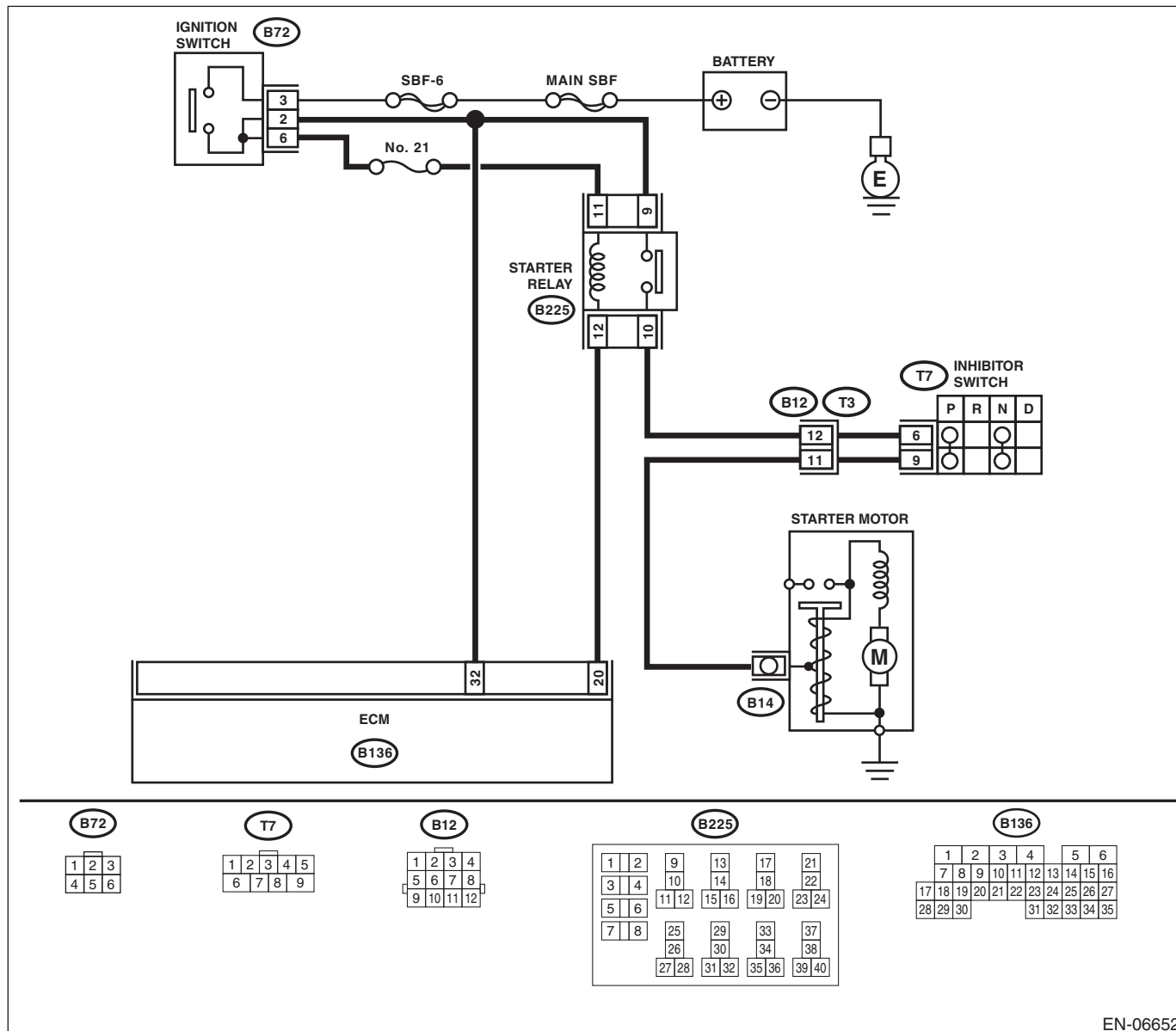

EN-06652

Diagnostics for Engine Starting Failure

ENGINE (DIAGNOSTICS)

Step	Check	Yes	No	
1	CHECK BATTERY. Check the battery voltage.	Is the voltage 12 V or more?	Go to step 2.	Charge or replace the battery.
2	CHECK OPERATION OF STARTER MOTOR.	Does the starter motor operate?	Go to step 3.	Go to step 4.
3	CHECK DTC.	Is DTC displayed? <Ref. to EN(H4DOTC)(diag)-41, OPERATION, Read Diagnostic Trouble Code (DTC).>	Check the appropriate DTC using the List of Diagnostic Trouble Code (DTC). <Ref. to EN(H4DOTC)(diag)-80, List of Diagnostic Trouble Code (DTC).>	The circuit has returned to a normal condition at this time. Reproduce the fault condition, and reperform the check. NOTE: In this case, there may be a temporary connector contact failure.
4	CHECK INPUT SIGNAL FOR STARTER MOTOR. 1) Turn the ignition switch to OFF. 2) Disconnect the connector from starter motor. 3) Place the select lever in "P" range or "N" range. 4) Turn the ignition switch to START. 5) Measure the voltage between the starter motor connector and the engine ground. Connector & terminal (B14) No. 1 (+) — Engine ground (-):	Is the voltage 10 V or more?	Check the starter motor. <Ref. to SC(H4SO)-6, Starter.>	Go to step 5.
5	CHECK HARNESS BETWEEN BATTERY AND IGNITION SWITCH CONNECTOR. 1) Turn the ignition switch to OFF. 2) Disconnect the connector from ignition switch. 3) Measure the voltage between ignition switch connector and chassis ground. Connector & terminal (B72) No. 3 (+) — Chassis ground (-):	Is the voltage 10 V or more?	Go to step 6.	Check the following item and repair if necessary. • Blown out of fuse • Open or ground short circuit of harness between ignition switch connector and battery
6	CHECK IGNITION SWITCH. Measure the resistance between ignition switch terminals after turning the ignition switch to START position. Terminals No. 3 — No. 2: No. 3 — No. 6:	Is the resistance less than 1 Ω ?	Go to step 7.	Replace the ignition switch. <Ref. to SL-36, REPLACEMENT, Ignition Key Lock.>
7	CHECK INPUT VOLTAGE OF STARTER RELAY. 1) Remove the starter relay. 2) Connect the connector to ignition switch. 3) Measure the voltage between starter relay connector and chassis ground after turning the ignition switch to START position. Connector & terminal (B225) No. 9 (+) — Chassis ground (-): (B225) No. 11 (+) — Chassis ground (-):	Is the voltage 10 V or more?	Go to step 8.	Repair open circuit or short circuit to ground in harness between starter relay connector and ignition switch connector.

Diagnostics for Engine Starting Failure

ENGINE (DIAGNOSTICS)

Step	Check	Yes	No
8 CHECK STARTER RELAY. 1) Connect the battery to starter relay terminals No. 11 and No. 12. 2) Measure the resistance between starter relay terminals. <i>Terminals</i> <i>No. 9 — No. 10:</i>	Is the resistance less than 1 Ω ?	Go to step 9.	Replace the starter relay.
9 CHECK HARNESS BETWEEN ECM AND STARTER RELAY CONNECTOR. 1) Turn the ignition switch to OFF. 2) Disconnect the connectors from the ECM. 3) Measure the resistance of harness between ECM and starter relay connector. <i>Connector & terminal</i> <i>(B136) No. 20 — (B225) No. 12:</i>	Is the resistance less than 1 Ω ?	Go to step 10.	Repair the open circuit of harness between ECM and starter relay connector.
10 CHECK HARNESS BETWEEN ECM AND IGNITION SWITCH. 1) Turn the ignition switch to OFF. 2) Measure the resistance of harness between the ECM and ignition switch connector. <i>Connector & terminal</i> <i>(B136) No. 32 — (B72) No. 2:</i>	Is the resistance less than 1 Ω ?	Go to step 11.	Repair the open circuit in harness between ECM and ignition switch connector.
11 CHECK INPUT VOLTAGE OF INHIBITOR SWITCH. 1) Turn the ignition switch to OFF. 2) Disconnect the connector from inhibitor switch. 3) Connect the starter relay and ECM. 4) Measure the input voltage between inhibitor switch connector and engine ground after turning the ignition switch to START position. <i>Connector & terminal</i> <i>(T7) No. 6 (+) — Engine ground (-):</i>	Is the voltage 10 V or more?	Go to step 12.	Repair the open circuit in harness between inhibitor switch connector and starter relay connector.
12 CHECK INHIBITOR SWITCH. 1) Place the select lever in "P" range or "N" range. 2) Measure the resistance between inhibitor switch terminals. <i>Terminals</i> <i>No. 6 — No. 9:</i>	Is the resistance less than 1 Ω ?	Go to step 13.	Replace the inhibitor switch. <Ref. to 4AT-46, Inhibitor Switch.>
13 CHECK HARNESS BETWEEN INHIBITOR SWITCH AND STARTER MOTOR. Measure the resistance of harness between the inhibitor switch connector and starter motor. <i>Connector & terminal</i> <i>(T7) No. 9 — (B14) No. 1:</i>	Is the resistance less than 1 Ω ?	Check the ECM power supply and ground line. <Ref. to EN(H4DOTC)(diag)-70, CHECK POWER SUPPLY AND GROUND LINE OF ENGINE CONTROL MODULE (ECM), Diagnostics for Engine Starting Failure.>	Repair the harness and connector. NOTE: In this case, repair the following item: • Open circuit in harness between inhibitor switch connector and starter motor • Poor contact of coupling connector

Diagnostics for Engine Starting Failure

ENGINE (DIAGNOSTICS)

C: CHECK POWER SUPPLY AND GROUND LINE OF ENGINE CONTROL MODULE (ECM)

CAUTION:

After repair or replacement of faulty parts, perform Clear Memory Mode <Ref. to EN(H4DOTC)(diag)-52, OPERATION, Clear Memory Mode.> and Inspection Mode <Ref. to EN(H4DOTC)(diag)-42, PROCEDURE, Inspection Mode.>.

WIRING DIAGRAM:

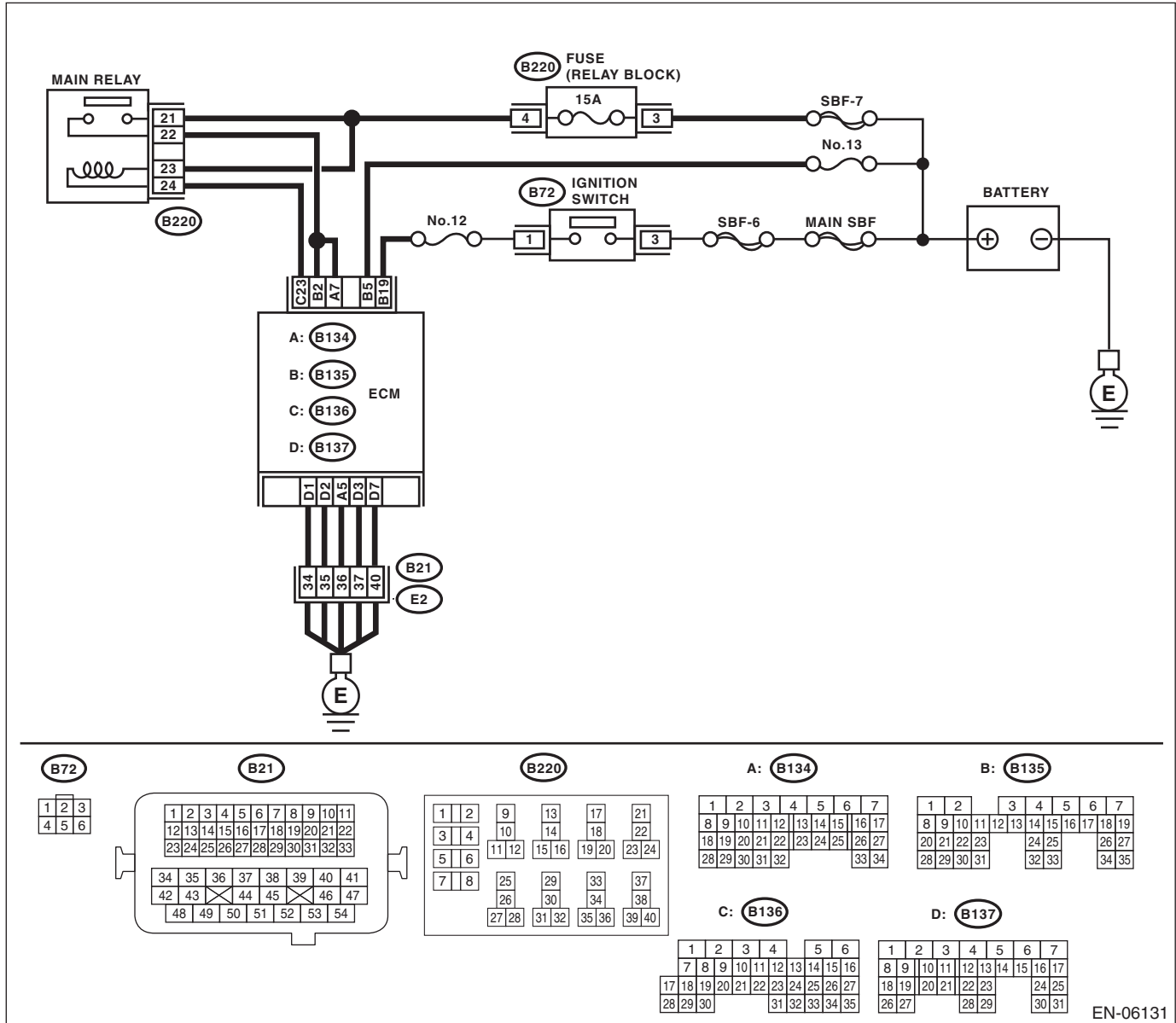

EN-06131

Diagnostics for Engine Starting Failure

ENGINE (DIAGNOSTICS)

Step	Check	Yes	No
1 CHECK MAIN RELAY. 1) Turn the ignition switch to OFF. 2) Remove the main relay. 3) Connect the battery to main relay terminals No. 23 and No. 24. 4) Measure the resistance between main relay terminals. Terminals No. 21 — No. 22:	Is the resistance less than 1 Ω?	Go to step 2.	Replace the main relay. <Ref. to EN(H4DOTC)(diag)-8, Electrical Component Location.>
2 CHECK GROUND CIRCUIT FOR ECM. 1) Disconnect the connectors from the ECM. 2) Measure the resistance of harness between ECM and chassis ground. Connector & terminal (B134) No. 5 — Chassis ground: (B137) No. 1 — Chassis ground: (B137) No. 2 — Chassis ground: (B137) No. 3 — Chassis ground: (B137) No. 7 — Chassis ground:	Is the resistance less than 5 Ω?	Go to step 3.	Repair the harness and connector. NOTE: In this case, repair the following item: • Open circuit in harness between ECM connector and engine ground • Poor contact of coupling connector
3 CHECK INPUT VOLTAGE OF ECM. 1) Turn the ignition switch to ON. 2) Measure the voltage between ECM and chassis ground. Connector & terminal (B135) No. 5 (+) — Chassis ground (-): (B135) No. 19 (+) — Chassis ground (-):	Is the voltage 10 V or more?	Go to step 4.	Repair the open or ground short circuit of power supply circuit.
4 CHECK INPUT VOLTAGE OF MAIN RELAY. Measure the voltage between main relay connector and chassis ground. Connector & terminal (B220) No. 21 (+) — Chassis ground (-): (B220) No. 23 (+) — Chassis ground (-):	Is the voltage 10 V or more?	Go to step 5.	Repair the open or ground short circuit of harness of power supply circuit.
5 CHECK INPUT VOLTAGE OF ECM. 1) Turn the ignition switch to OFF. 2) Install the main relay. 3) Turn the ignition switch to ON. 4) Measure the voltage between ECM and chassis ground. Connector & terminal (B136) No. 23 (+) — Chassis ground (-):	Is the voltage 10 V or more?	Go to step 6.	Repair the open circuit of harness between ECM and main relay connector.
6 CHECK INPUT VOLTAGE OF ECM. 1) Turn the ignition switch to OFF. 2) Connect the connector to ECM. 3) Turn the ignition switch to ON. 4) Measure the voltage between ECM and chassis ground. Connector & terminal (B134) No. 7 (+) — Chassis ground (-): (B135) No. 2 (+) — Chassis ground (-):	Is the voltage 10 V or more?	Check ignition control system. <Ref. to EN(H4DOTC)(diag)-72, IGNITION CONTROL SYSTEM, Diagnostics for Engine Starting Failure.>	Repair the open or ground short circuit of harness between ECM and main relay connector.

Diagnostics for Engine Starting Failure

ENGINE (DIAGNOSTICS)

D: IGNITION CONTROL SYSTEM

CAUTION:

After repair or replacement of faulty parts, perform Clear Memory Mode <Ref. to EN(H4DOTC)(diag)-52, OPERATION, Clear Memory Mode.> and Inspection Mode <Ref. to EN(H4DOTC)(diag)-42, PROCEDURE, Inspection Mode.>.

WIRING DIAGRAM:

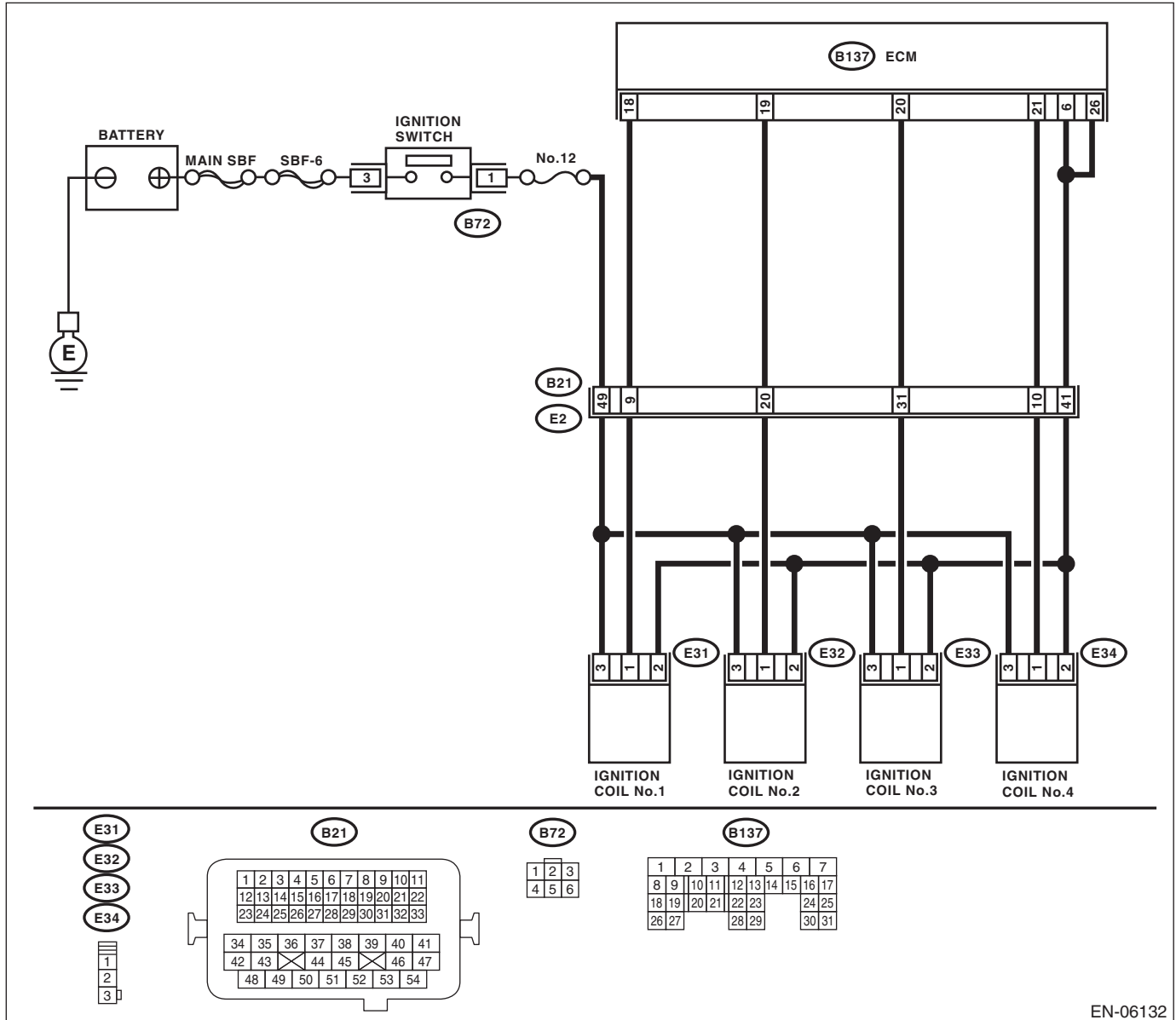

EN-06132

Diagnostics for Engine Starting Failure

ENGINE (DIAGNOSTICS)

Step	Check	Yes	No
<p>1 CHECK SPARK PLUG CONDITION. 1) Remove the spark plug. <Ref. to IG(H4DOTC)-4, REMOVAL, Spark Plug.> 2) Check the spark plug condition. <Ref. to IG(H4DOTC)-5, INSPECTION, Spark Plug.></p>	Is the spark plug condition normal?	Go to step 2.	Replace the spark plug. <Ref. to IG(H4DOTC)-4, Spark Plug.>
<p>2 CHECK IGNITION SYSTEM FOR SPARKS. 1) Connect the spark plug to ignition coil. 2) Release the fuel pressure. <Ref. to FU(H4DOTC)-51, RELEASING OF FUEL PRESSURE, PROCEDURE, Fuel.> 3) Contact the spark plug thread portion to engine. 4) While opening the throttle valve fully, crank the engine to check that spark occurs at each cylinder.</p>	Does spark occur at each cylinder?	Check fuel pump system. <Ref. to EN(H4DOTC)(diag)-75, FUEL PUMP CIRCUIT, Diagnostics for Engine Starting Failure.>	Go to step 3.
<p>3 CHECK POWER SUPPLY CIRCUIT FOR IGNITION COIL. 1) Turn the ignition switch to OFF. 2) Disconnect the connector from ignition coil. 3) Turn the ignition switch to ON. 4) Measure the power supply voltage between ignition coil connector and engine ground. Connector & terminal (E31) No. 3 (+) — Engine ground (-): (E32) No. 3 (+) — Engine ground (-): (E33) No. 3 (+) — Engine ground (-): (E34) No. 3 (+) — Engine ground (-):</p>	Is the voltage 10 V or more?	Go to step 4.	Repair the harness and connector. NOTE: In this case, repair the following item: • Open circuit in harness between ignition coil connector and ignition switch connector • Poor contact of coupling connector
<p>4 CHECK HARNESS OF IGNITION COIL GROUND CIRCUIT. 1) Turn the ignition switch to OFF. 2) Measure the resistance between ECM and ignition coil connector. Connector & terminal (E31) No. 2 — (B137) No. 6: (E32) No. 2 — (B137) No. 6: (E33) No. 2 — (B137) No. 6: (E34) No. 2 — (B137) No. 6: (E31) No. 2 — (B137) No. 26: (E32) No. 2 — (B137) No. 26: (E33) No. 2 — (B137) No. 26: (E34) No. 2 — (B137) No. 26:</p>	Is the resistance less than 1 Ω?	Go to step 5.	Repair the harness and connector. NOTE: In this case, repair the following item: • Open circuit of harness between the ECM and ignition coil connector • Poor contact of coupling connector
<p>5 CHECK HARNESS BETWEEN ECM AND IGNITION COIL CONNECTOR. 1) Turn the ignition switch to OFF. 2) Disconnect the connector from ECM and ignition coil. 3) Measure the resistance of harness between the ECM and ignition coil connector. Connector & terminal (B137) No. 18 — (E31) No. 1: (B137) No. 19 — (E32) No. 1: (B137) No. 20 — (E33) No. 1: (B137) No. 21 — (E34) No. 1:</p>	Is the resistance less than 1 Ω?	Go to step 6.	Repair the harness and connector. NOTE: In this case, repair the following item: • Open circuit of harness between the ECM and ignition coil connector • Poor contact of coupling connector

Diagnostics for Engine Starting Failure

ENGINE (DIAGNOSTICS)

Step	Check	Yes	No
6 CHECK HARNESS BETWEEN ECM AND IGNITION COIL CONNECTOR. Measure the resistance of harness between ECM and engine ground. Connector & terminal <i>(B137) No. 18 — Engine ground:</i> <i>(B137) No. 19 — Engine ground:</i> <i>(B137) No. 20 — Engine ground:</i> <i>(B137) No. 21 — Engine ground:</i>	Is the resistance 1 M Ω or more?	Go to step 7.	Repair the ground short circuit of harness between the ECM and ignition coil connector.
7 CHECK POOR CONTACT. Check for poor contact of the ECM connector.	Is there poor contact in ECM connector?	Repair poor contact of the ECM connector.	Replace the ignition coil. <Ref. to IG(H4DOTC)-7, Ignition Coil.>

E: FUEL PUMP CIRCUIT

CAUTION:

After repair or replacement of faulty parts, perform Clear Memory Mode <Ref. to EN(H4DOTC)(diag)-52, OPERATION, Clear Memory Mode.> and Inspection Mode <Ref. to EN(H4DOTC)(diag)-42, PROCEDURE, Inspection Mode.>.

WIRING DIAGRAM:

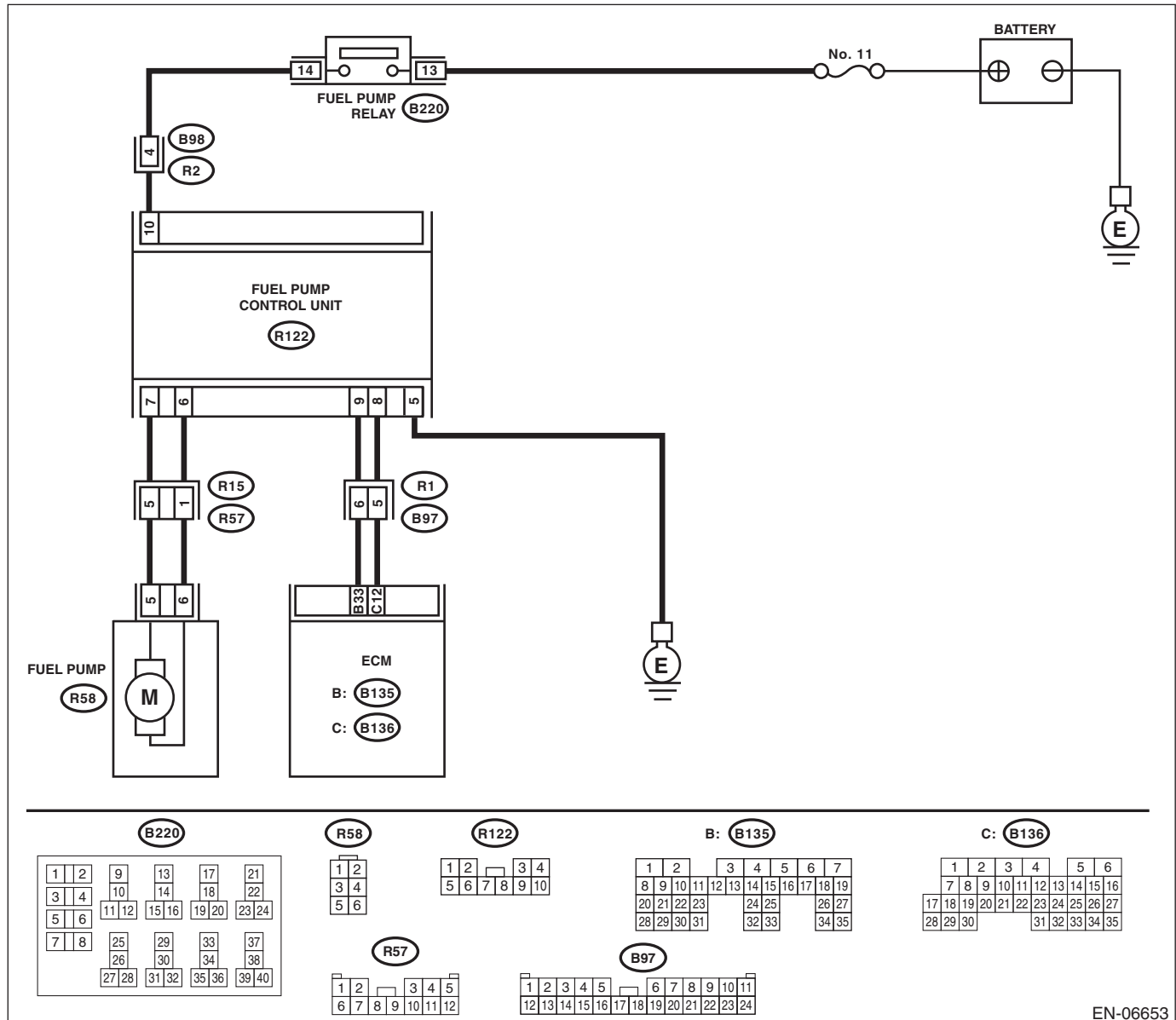

Step	Check	Yes	No
<p>1</p> <p>CHECK OPERATING SOUND OF FUEL PUMP.</p> <p>Make sure that the fuel pump operates for two seconds when turning the ignition switch to ON.</p> <p>NOTE: Fuel pump operation can be executed using the Subaru Select Monitor. Regarding the procedures, refer to "Compulsory Valve Operation Check Mode". <Ref. to EN(H4DOTC)(diag)-53, Compulsory Valve Operation Check Mode.></p>	<p>Does the fuel pump emit operating sound?</p>	<p>Check the fuel injector circuit. <Ref. to EN(H4DOTC)(diag)-76, FUEL INJECTOR CIRCUIT, Diagnostics for Engine Starting Failure.></p>	<p>Display the DTC. <Ref. to EN(H4DOTC)(diag)-41, OPERATION, Read Diagnostic Trouble Code (DTC).></p>

Diagnostics for Engine Starting Failure

ENGINE (DIAGNOSTICS)

F: FUEL INJECTOR CIRCUIT

CAUTION:

- Check or repair only faulty parts.
- After repair or replacement of faulty parts, perform Clear Memory Mode <Ref. to EN(H4DOTC)(diag)-52, OPERATION, Clear Memory Mode.> and Inspection Mode <Ref. to EN(H4DOTC)(diag)-42, PROCEDURE, Inspection Mode.>

WIRING DIAGRAM:

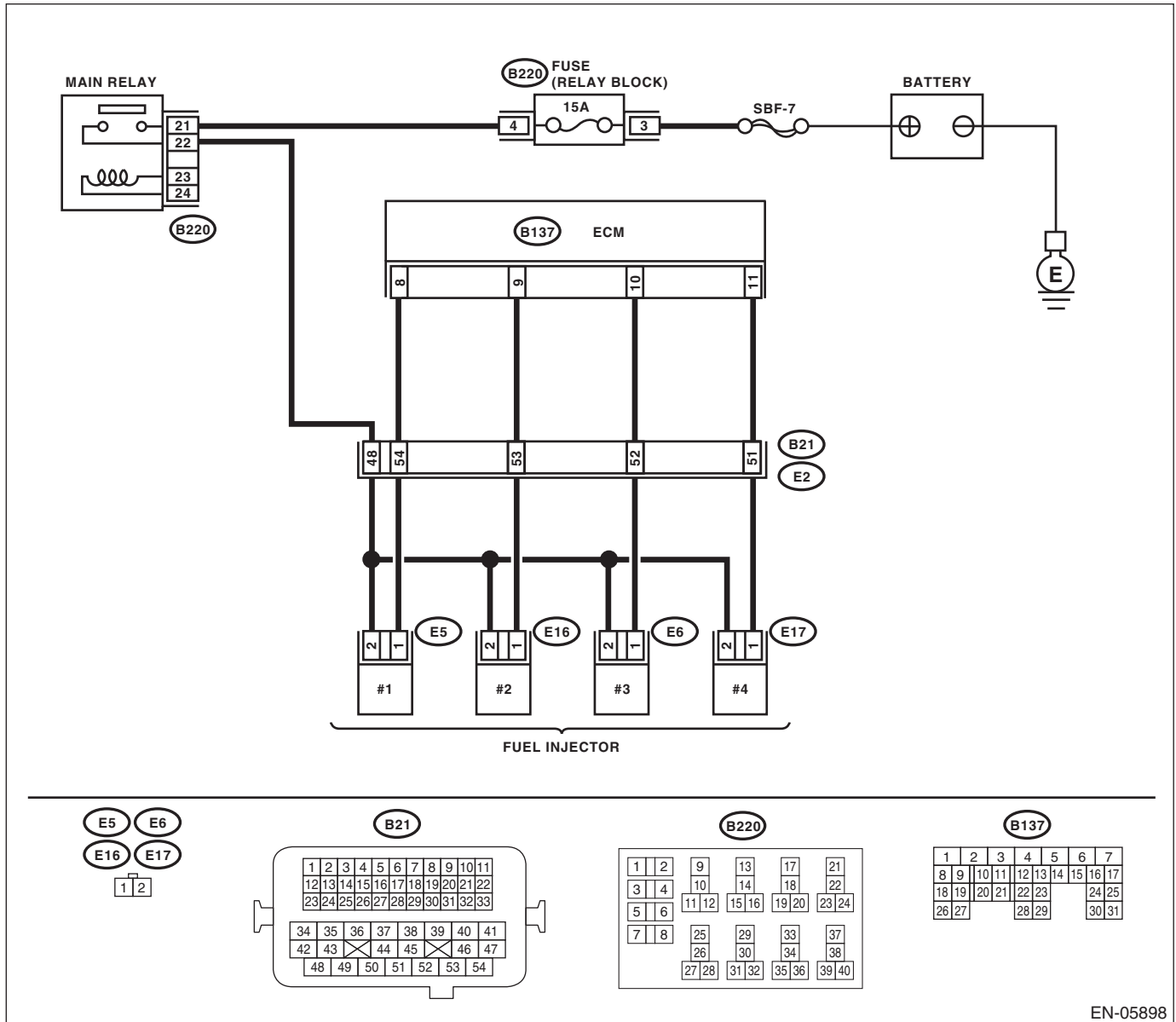

EN-05898

Diagnostics for Engine Starting Failure

ENGINE (DIAGNOSTICS)

Step	Check	Yes	No
1 CHECK OPERATION OF EACH FUEL INJECTOR. While cranking the engine, check each fuel injector emits operating sound. Use a sound scope or attach a screwdriver to the injector for this check.	Does the fuel injector emit operating sound?	Check the fuel pressure. <Ref. to ME(H4DOTC)-25, INSPECTION, Fuel Pressure.>	Go to step 2.
2 CHECK POWER SUPPLY TO EACH FUEL INJECTOR. 1) Turn the ignition switch to OFF. 2) Disconnect the connector from fuel injector. 3) Turn the ignition switch to ON. 4) Measure the power supply voltage between fuel injector terminal and engine ground. Connector & terminal #1 (E5) No. 2 (+) — Engine ground (-): #2 (E16) No. 2 (+) — Engine ground (-): #3 (E6) No. 2 (+) — Engine ground (-): #4 (E17) No. 2 (+) — Engine ground (-):	Is the voltage 10 V or more?	Go to step 3.	Repair the harness and connector. NOTE: In this case, repair the following item: • Open circuit in harness between main relay connector and fuel injector connector • Poor contact of main relay connector • Poor contact of coupling connector
3 CHECK HARNESS BETWEEN ECM AND FUEL INJECTOR CONNECTOR. 1) Turn the ignition switch to OFF. 2) Disconnect the connectors from the ECM. 3) Measure the resistance of harness between ECM and fuel injector connector. Connector & terminal (B137) No. 8 — (E5) No. 1: (B137) No. 9 — (E16) No. 1: (B137) No. 10 — (E6) No. 1: (B137) No. 11 — (E17) No. 1:	Is the resistance less than 1 Ω?	Go to step 4.	Repair the harness and connector. NOTE: In this case, repair the following item: • Open circuit of harness between ECM and fuel injector connector • Poor contact of coupling connector
4 CHECK HARNESS BETWEEN ECM AND FUEL INJECTOR CONNECTOR. Measure the resistance of harness between ECM and chassis ground. Connector & terminal (B137) No. 8 — Chassis ground: (B137) No. 9 — Chassis ground: (B137) No. 10 — Chassis ground: (B137) No. 11 — Chassis ground:	Is the resistance 1 MΩ or more?	Go to step 5.	Repair the ground short circuit of harness between ECM and fuel injector connector.
5 CHECK EACH FUEL INJECTOR. Measure the resistance between each fuel injector terminals. Terminals No. 1 — No. 2:	Is the resistance between 5 — 20 Ω?	Go to step 6.	Replace the faulty fuel injector. <Ref. to FU(H4DOTC)-36, Fuel Injector.>
6 CHECK POOR CONTACT. Check for poor contact of the ECM connector.	Is there poor contact in ECM connector?	Repair poor contact of the ECM connector.	Inspection using “General Diagnostic Table” <Ref. to EN(H4DOTC)(diag)-366, INSPECTION, General Diagnostic Table.>

Diagnostic Procedure for Subaru Select Monitor Communication

ENGINE (DIAGNOSTICS)

18. Diagnostic Procedure for Subaru Select Monitor Communication

A: COMMUNICATION FOR INITIALIZING IMPOSSIBLE

DIAGNOSIS:

Open or short circuit in data link connector

TROUBLE SYMPTOM:

Subaru Select Monitor communication failure

WIRING DIAGRAM:

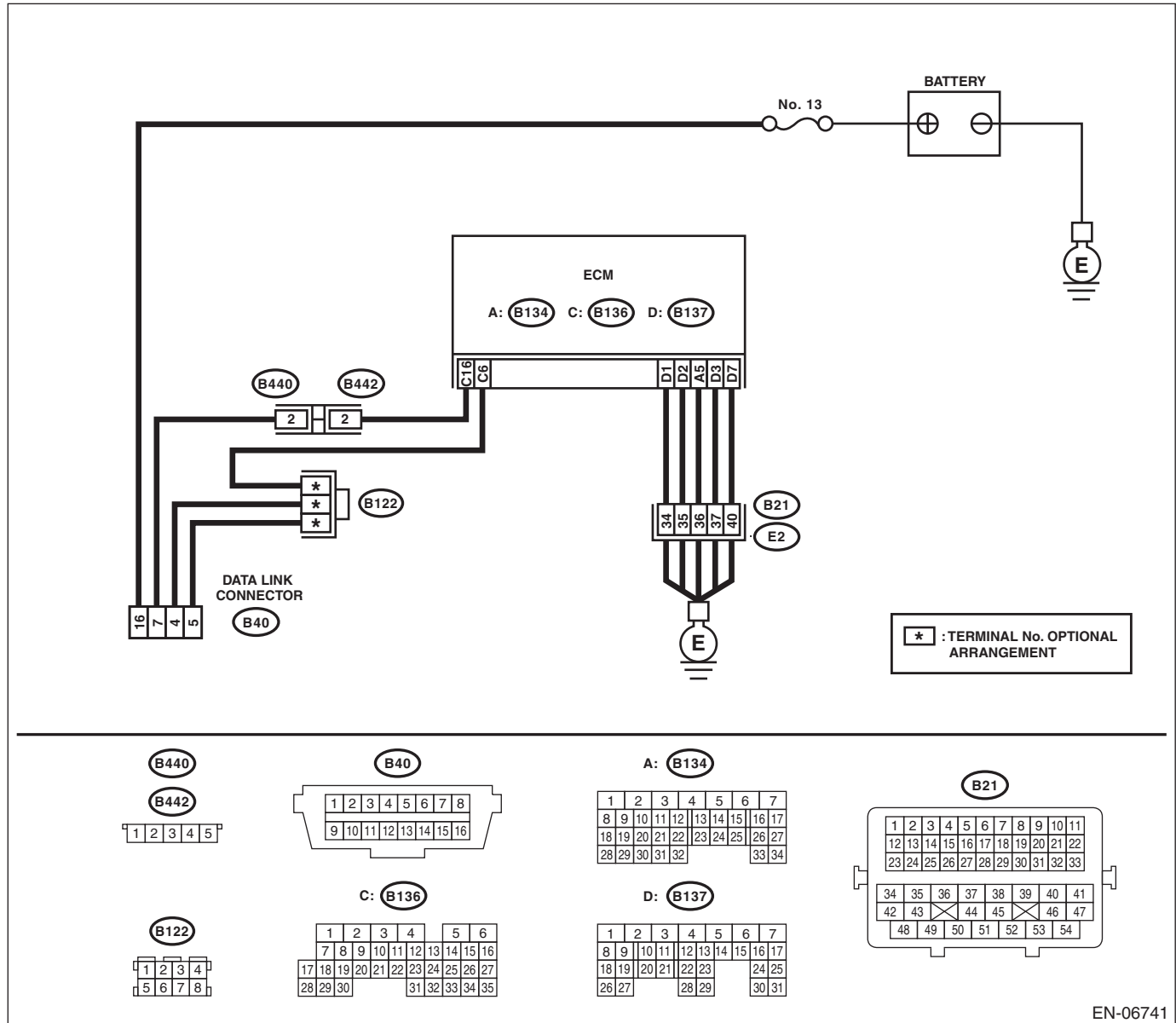

EN-06741

Diagnostic Procedure for Subaru Select Monitor Communication

ENGINE (DIAGNOSTICS)

	Step	Check	Yes	No
1	CHECK POWER SUPPLY CIRCUIT. Connect the SDI (Subaru Diagnosis Interface) or general scan tool to data link connector.	Does SDI or general scan tool turn ON?	Go to step 4.	Go to step 2.
2	CHECK POWER SUPPLY CIRCUIT. Measure the voltage between data link connector and chassis ground. Connector & terminal (B40) No. 16 (+) — Chassis ground (-):	Is the voltage 10 V or more?	Go to step 3.	Repair the power supply circuit. NOTE: In this case, repair the following item: <ul style="list-style-type: none"> • Open or ground short circuit of harness between battery and data link connector • Blown out of fuse (M/B No. 13)
3	CHECK HARNESS BETWEEN DATA LINK CONNECTOR AND CHASSIS GROUND. 1) Turn the ignition switch to OFF. 2) Measure the resistance of harness between data link connector and chassis ground. Connector & terminal (B40) No. 4 — Chassis ground: (B40) No. 5 — Chassis ground:	Is the resistance less than 5 Ω?	Repair the poor contact of data link connector.	Repair the harness and connector. NOTE: In this case, repair the following item: <ul style="list-style-type: none"> • Open circuit of harness between ECM and data link connector • Open circuit of harness between ECM and engine ground • Poor contact in ECM connector • Poor contact of coupling connector
4	CHECK HARNESS BETWEEN ECM AND DATA LINK CONNECTOR. 1) Disconnect the connector from ECM, TCM, VDC CU, airbag CM and body integrated unit. CAUTION: When disconnecting the connector from airbag control module, always follow the precautions on AB section. <Ref. to AB-5, CAUTION, General Description.> 2) Measure the resistance of harness between ECM and data link connector. Connector & terminal (B136) No. 16 — (B40) No. 7:	Is the resistance less than 1 Ω?	Go to step 5.	Repair the harness and connector. NOTE: In this case, repair the following item: <ul style="list-style-type: none"> • Open circuit of harness between ECM and data link connector • Poor contact of coupling connector
5	CHECK HARNESS BETWEEN ECM AND DATA LINK CONNECTOR. Measure the resistance between data link connector and chassis ground. Connector & terminal (B40) No. 7 — Chassis ground:	Is the resistance 1 MΩ or more?	Repair the poor contact in the ECM or data link connector.	Repair the ground short circuit of harness between ECM and data link connector.

List of Diagnostic Trouble Code (DTC)

ENGINE (DIAGNOSTICS)

19. List of Diagnostic Trouble Code (DTC)

A: LIST

DTC	Item	Reference
P0011	Intake Camshaft Position - Timing Over-Advanced or System Performance (Bank 1)	<Ref. to EN(H4DOTC)(diag)-88, DTC P0011 INTAKE CAMSHAFT POSITION - TIMING OVER-ADVANCED OR SYSTEM PERFORMANCE (BANK 1), Diagnostic Procedure with Diagnostic Trouble Code (DTC).>
P0016	Crankshaft Position - Camshaft Position Correlation (Bank 1)	<Ref. to EN(H4DOTC)(diag)-89, DTC P0016 CRANKSHAFT POSITION - CAMSHAFT POSITION CORRELATION (BANK1), Diagnostic Procedure with Diagnostic Trouble Code (DTC).>
P0018	Crankshaft Position - Camshaft Position Correlation (Bank 2)	<Ref. to EN(H4DOTC)(diag)-90, DTC P0018 CRANKSHAFT POSITION - CAMSHAFT POSITION CORRELATION (BANK2), Diagnostic Procedure with Diagnostic Trouble Code (DTC).>
P0021	Intake Camshaft Position - Timing Over-Advanced or System Performance (Bank 2)	<Ref. to EN(H4DOTC)(diag)-91, DTC P0021 INTAKE CAMSHAFT POSITION - TIMING OVER-ADVANCED OR SYSTEM PERFORMANCE (BANK 2), Diagnostic Procedure with Diagnostic Trouble Code (DTC).>
P0030	HO2S Heater Control Circuit (Bank 1 Sensor 1)	<Ref. to EN(H4DOTC)(diag)-92, DTC P0030 HO2S HEATER CONTROL CIRCUIT (BANK 1 SENSOR 1), Diagnostic Procedure with Diagnostic Trouble Code (DTC).>
P0031	HO2S Heater Control Circuit Low (Bank 1 Sensor 1)	<Ref. to EN(H4DOTC)(diag)-94, DTC P0031 HO2S HEATER CONTROL CIRCUIT LOW (BANK 1 SENSOR 1), Diagnostic Procedure with Diagnostic Trouble Code (DTC).>
P0032	HO2S Heater Control Circuit High (Bank 1 Sensor 1)	<Ref. to EN(H4DOTC)(diag)-96, DTC P0032 HO2S HEATER CONTROL CIRCUIT HIGH (BANK 1 SENSOR 1), Diagnostic Procedure with Diagnostic Trouble Code (DTC).>
P0037	HO2S Heater Control Circuit Low (Bank 1 Sensor 2)	<Ref. to EN(H4DOTC)(diag)-98, DTC P0037 HO2S HEATER CONTROL CIRCUIT LOW (BANK 1 SENSOR 2), Diagnostic Procedure with Diagnostic Trouble Code (DTC).>
P0038	HO2S Heater Control Circuit High (Bank 1 Sensor 2)	<Ref. to EN(H4DOTC)(diag)-100, DTC P0038 HO2S HEATER CONTROL CIRCUIT HIGH (BANK 1 SENSOR 2), Diagnostic Procedure with Diagnostic Trouble Code (DTC).>
P0068	MAP/MAF - Throttle Position Correlation	<Ref. to EN(H4DOTC)(diag)-102, DTC P0068 MAP/MAF - THROTTLE POSITION CORRELATION, Diagnostic Procedure with Diagnostic Trouble Code (DTC).>
P0101	Mass or Volume Air Flow Circuit Range/Performance	<Ref. to EN(H4DOTC)(diag)-104, DTC P0101 MASS OR VOLUME AIR FLOW CIRCUIT RANGE/PERFORMANCE, Diagnostic Procedure with Diagnostic Trouble Code (DTC).>
P0102	Mass or Volume Air Flow Circuit Low Input	<Ref. to EN(H4DOTC)(diag)-106, DTC P0102 MASS OR VOLUME AIR FLOW CIRCUIT LOW INPUT, Diagnostic Procedure with Diagnostic Trouble Code (DTC).>
P0103	Mass or Volume Air Flow Circuit High Input	<Ref. to EN(H4DOTC)(diag)-108, DTC P0103 MASS OR VOLUME AIR FLOW CIRCUIT HIGH INPUT, Diagnostic Procedure with Diagnostic Trouble Code (DTC).>
P0107	Manifold Absolute Pressure/Barometric Pressure Circuit Low Input	<Ref. to EN(H4DOTC)(diag)-110, DTC P0107 MANIFOLD ABSOLUTE PRESSURE/BAROMETRIC PRESSURE CIRCUIT LOW INPUT, Diagnostic Procedure with Diagnostic Trouble Code (DTC).>
P0108	Manifold Absolute Pressure/Barometric Pressure Circuit High Input	<Ref. to EN(H4DOTC)(diag)-112, DTC P0108 MANIFOLD ABSOLUTE PRESSURE/BAROMETRIC PRESSURE CIRCUIT HIGH INPUT, Diagnostic Procedure with Diagnostic Trouble Code (DTC).>
P0111	Intake Air Temperature Sensor 1 Circuit Range/Performance	<Ref. to EN(H4DOTC)(diag)-114, DTC P0111 INTAKE AIR TEMPERATURE SENSOR 1 CIRCUIT RANGE/PERFORMANCE, Diagnostic Procedure with Diagnostic Trouble Code (DTC).>
P0112	Intake Air Temperature Sensor 1 Circuit Low	<Ref. to EN(H4DOTC)(diag)-116, DTC P0112 INTAKE AIR TEMPERATURE SENSOR 1 CIRCUIT LOW, Diagnostic Procedure with Diagnostic Trouble Code (DTC).>

List of Diagnostic Trouble Code (DTC)

ENGINE (DIAGNOSTICS)

DTC	Item	Reference
P0113	Intake Air Temperature Sensor 1 Circuit High	<Ref. to EN(H4DOTC)(diag)-118, DTC P0113 INTAKE AIR TEMPERATURE SENSOR 1 CIRCUIT HIGH, Diagnostic Procedure with Diagnostic Trouble Code (DTC).>
P0117	Engine Coolant Temperature Circuit Low	<Ref. to EN(H4DOTC)(diag)-120, DTC P0117 ENGINE COOLANT TEMPERATURE CIRCUIT LOW, Diagnostic Procedure with Diagnostic Trouble Code (DTC).>
P0118	Engine Coolant Temperature Circuit High	<Ref. to EN(H4DOTC)(diag)-122, DTC P0118 ENGINE COOLANT TEMPERATURE CIRCUIT HIGH, Diagnostic Procedure with Diagnostic Trouble Code (DTC).>
P0122	Throttle/Pedal Position Sensor/Switch "A" Circuit Low	<Ref. to EN(H4DOTC)(diag)-124, DTC P0122 THROTTLE/PEDAL POSITION SENSOR/SWITCH "A" CIRCUIT LOW, Diagnostic Procedure with Diagnostic Trouble Code (DTC).>
P0123	Throttle/Pedal Position Sensor/Switch "A" Circuit High	<Ref. to EN(H4DOTC)(diag)-126, DTC P0123 THROTTLE/PEDAL POSITION SENSOR/SWITCH "A" CIRCUIT HIGH, Diagnostic Procedure with Diagnostic Trouble Code (DTC).>
P0125	Insufficient Coolant Temperature for Closed Loop Fuel Control	<Ref. to EN(H4DOTC)(diag)-128, DTC P0125 INSUFFICIENT COOLANT TEMPERATURE FOR CLOSED LOOP FUEL CONTROL, Diagnostic Procedure with Diagnostic Trouble Code (DTC).>
P0126	Insufficient Engine Coolant Temperature for Stable Operation	<Ref. to EN(H4DOTC)(diag)-129, DTC P0126 INSUFFICIENT ENGINE COOLANT TEMPERATURE FOR STABLE OPERATION, Diagnostic Procedure with Diagnostic Trouble Code (DTC).>
P0128	Coolant Thermostat (Engine Coolant Temperature Below Thermostat Regulating Temperature)	<Ref. to EN(H4DOTC)(diag)-131, DTC P0128 COOLANT THERMOSTAT (ENGINE COOLANT TEMPERATURE BELOW THERMOSTAT REGULATING TEMPERATURE), Diagnostic Procedure with Diagnostic Trouble Code (DTC).>
P0131	O2 Sensor Circuit Low Voltage (Bank 1 Sensor 1)	<Ref. to EN(H4DOTC)(diag)-132, DTC P0131 O2 SENSOR CIRCUIT LOW VOLTAGE (BANK 1 SENSOR 1), Diagnostic Procedure with Diagnostic Trouble Code (DTC).>
P0132	O2 Sensor Circuit High Voltage (Bank 1 Sensor 1)	<Ref. to EN(H4DOTC)(diag)-134, DTC P0132 O2 SENSOR CIRCUIT HIGH VOLTAGE (BANK 1 SENSOR 1), Diagnostic Procedure with Diagnostic Trouble Code (DTC).>
P0133	O2 Sensor Circuit Slow Response (Bank 1 Sensor 1)	<Ref. to EN(H4DOTC)(diag)-136, DTC P0133 O2 SENSOR CIRCUIT SLOW RESPONSE (BANK 1 SENSOR 1), Diagnostic Procedure with Diagnostic Trouble Code (DTC).>
P0134	O2 Sensor Circuit No Activity Detected (Bank 1 Sensor 1)	<Ref. to EN(H4DOTC)(diag)-138, DTC P0134 O2 SENSOR CIRCUIT NO ACTIVITY DETECTED (BANK 1 SENSOR 1), Diagnostic Procedure with Diagnostic Trouble Code (DTC).>
P0137	O2 Sensor Circuit Low Voltage (Bank 1 Sensor 2)	<Ref. to EN(H4DOTC)(diag)-140, DTC P0137 O2 SENSOR CIRCUIT LOW VOLTAGE (BANK 1 SENSOR 2), Diagnostic Procedure with Diagnostic Trouble Code (DTC).>
P0138	O2 Sensor Circuit High Voltage (Bank 1 Sensor 2)	<Ref. to EN(H4DOTC)(diag)-142, DTC P0138 O2 SENSOR CIRCUIT HIGH VOLTAGE (BANK 1 SENSOR 2), Diagnostic Procedure with Diagnostic Trouble Code (DTC).>
P0139	O2 Sensor Circuit Slow Response (Bank 1 Sensor 2)	<Ref. to EN(H4DOTC)(diag)-144, DTC P0139 O2 SENSOR CIRCUIT SLOW RESPONSE (BANK 1 SENSOR 2), Diagnostic Procedure with Diagnostic Trouble Code (DTC).>
P0140	O2 Sensor Circuit No Activity Detected (Bank 1 Sensor 2)	<Ref. to EN(H4DOTC)(diag)-146, DTC P0140 O2 SENSOR CIRCUIT NO ACTIVITY DETECTED (BANK 1 SENSOR 2), Diagnostic Procedure with Diagnostic Trouble Code (DTC).>
P0171	System Too Lean (Bank 1)	<Ref. to EN(H4DOTC)(diag)-148, DTC P0171 SYSTEM TOO LEAN (BANK 1), Diagnostic Procedure with Diagnostic Trouble Code (DTC).>
P0172	System Too Rich (Bank 1)	<Ref. to EN(H4DOTC)(diag)-149, DTC P0172 SYSTEM TOO RICH (BANK 1), Diagnostic Procedure with Diagnostic Trouble Code (DTC).>
P0181	Fuel Temperature Sensor "A" Circuit Range/Performance	<Ref. to EN(H4DOTC)(diag)-151, DTC P0181 FUEL TEMPERATURE SENSOR "A" CIRCUIT RANGE/PERFORMANCE, Diagnostic Procedure with Diagnostic Trouble Code (DTC).>

List of Diagnostic Trouble Code (DTC)

ENGINE (DIAGNOSTICS)

DTC	Item	Reference
P0182	Fuel Temperature Sensor "A" Circuit Low Input	<Ref. to EN(H4DOTC)(diag)-153, DTC P0182 FUEL TEMPERATURE SENSOR "A" CIRCUIT LOW INPUT, Diagnostic Procedure with Diagnostic Trouble Code (DTC).>
P0183	Fuel Temperature Sensor "A" Circuit High Input	<Ref. to EN(H4DOTC)(diag)-155, DTC P0183 FUEL TEMPERATURE SENSOR "A" CIRCUIT HIGH INPUT, Diagnostic Procedure with Diagnostic Trouble Code (DTC).>
P0222	Throttle/Pedal Position Sensor/Switch "B" Circuit Low	<Ref. to EN(H4DOTC)(diag)-157, DTC P0222 THROTTLE/PEDAL POSITION SENSOR/SWITCH "B" CIRCUIT LOW, Diagnostic Procedure with Diagnostic Trouble Code (DTC).>
P0223	Throttle/Pedal Position Sensor/Switch "B" Circuit High	<Ref. to EN(H4DOTC)(diag)-159, DTC P0223 THROTTLE/PEDAL POSITION SENSOR/SWITCH "B" CIRCUIT HIGH, Diagnostic Procedure with Diagnostic Trouble Code (DTC).>
P0230	Fuel Pump Primary Circuit	<Ref. to EN(H4DOTC)(diag)-161, DTC P0230 FUEL PUMP PRIMARY CIRCUIT, Diagnostic Procedure with Diagnostic Trouble Code (DTC).>
P0244	Turbo/Super Charger Wastegate Solenoid "A" Range/Performance	<Ref. to EN(H4DOTC)(diag)-164, DTC P0244 TURBO/SUPER CHARGER WASTEGATE SOLENOID "A" RANGE/PERFORMANCE, Diagnostic Procedure with Diagnostic Trouble Code (DTC).>
P0245	Turbo/Super Charger Wastegate Solenoid "A" Low	<Ref. to EN(H4DOTC)(diag)-166, DTC P0245 TURBO/SUPER CHARGER WASTEGATE SOLENOID "A" LOW, Diagnostic Procedure with Diagnostic Trouble Code (DTC).>
P0246	Turbo/Super Charger Wastegate Solenoid "A" High	<Ref. to EN(H4DOTC)(diag)-168, DTC P0246 TURBO/SUPER CHARGER WASTEGATE SOLENOID "A" HIGH, Diagnostic Procedure with Diagnostic Trouble Code (DTC).>
P0301	Cylinder 1 Misfire Detected	<Ref. to EN(H4DOTC)(diag)-169, DTC P0301 CYLINDER 1 MISFIRE DETECTED, Diagnostic Procedure with Diagnostic Trouble Code (DTC).>
P0302	Cylinder 2 Misfire Detected	<Ref. to EN(H4DOTC)(diag)-169, DTC P0302 CYLINDER 2 MISFIRE DETECTED, Diagnostic Procedure with Diagnostic Trouble Code (DTC).>
P0303	Cylinder 3 Misfire Detected	<Ref. to EN(H4DOTC)(diag)-169, DTC P0303 CYLINDER 3 MISFIRE DETECTED, Diagnostic Procedure with Diagnostic Trouble Code (DTC).>
P0304	Cylinder 4 Misfire Detected	<Ref. to EN(H4DOTC)(diag)-170, DTC P0304 CYLINDER 4 MISFIRE DETECTED, Diagnostic Procedure with Diagnostic Trouble Code (DTC).>
P0327	Knock Sensor 1 Circuit Low (Bank 1 or Single Sensor)	<Ref. to EN(H4DOTC)(diag)-176, DTC P0327 KNOCK SENSOR 1 CIRCUIT LOW (BANK 1 OR SINGLE SENSOR), Diagnostic Procedure with Diagnostic Trouble Code (DTC).>
P0328	Knock Sensor 1 Circuit High (Bank 1 or Single Sensor)	<Ref. to EN(H4DOTC)(diag)-178, DTC P0328 KNOCK SENSOR 1 CIRCUIT HIGH (BANK 1 OR SINGLE SENSOR), Diagnostic Procedure with Diagnostic Trouble Code (DTC).>
P0335	Crankshaft Position Sensor "A" Circuit	<Ref. to EN(H4DOTC)(diag)-180, DTC P0335 CRANKSHAFT POSITION SENSOR "A" CIRCUIT, Diagnostic Procedure with Diagnostic Trouble Code (DTC).>
P0336	Crankshaft Position Sensor "A" Circuit Range/Performance	<Ref. to EN(H4DOTC)(diag)-182, DTC P0336 CRANKSHAFT POSITION SENSOR "A" CIRCUIT RANGE/PERFORMANCE, Diagnostic Procedure with Diagnostic Trouble Code (DTC).>
P0340	Camshaft Position Sensor "A" Circuit (Bank 1 or Single Sensor)	<Ref. to EN(H4DOTC)(diag)-184, DTC P0340 CAMSHAFT POSITION SENSOR "A" CIRCUIT (BANK 1 OR SINGLE SENSOR), Diagnostic Procedure with Diagnostic Trouble Code (DTC).>
P0345	Camshaft Position Sensor "A" Circuit (Bank 2)	<Ref. to EN(H4DOTC)(diag)-186, DTC P0345 CAMSHAFT POSITION SENSOR "A" CIRCUIT (BANK 2), Diagnostic Procedure with Diagnostic Trouble Code (DTC).>
P0410	Secondary Air Injection System	<Ref. to EN(H4DOTC)(diag)-188, DTC P0410 SECONDARY AIR INJECTION SYSTEM, Diagnostic Procedure with Diagnostic Trouble Code (DTC).>
P0411	Secondary Air Injection System Incorrect Flow Detected	<Ref. to EN(H4DOTC)(diag)-192, DTC P0411 SECONDARY AIR INJECTION SYSTEM INCORRECT FLOW DETECTED, Diagnostic Procedure with Diagnostic Trouble Code (DTC).>

List of Diagnostic Trouble Code (DTC)

ENGINE (DIAGNOSTICS)

DTC	Item	Reference
P0413	Secondary Air Injection System Switching Valve "A" Circuit Open	<Ref. to EN(H4DOTC)(diag)-195, DTC P0413 SECONDARY AIR INJECTION SYSTEM SWITCHING VALVE "A" CIRCUIT OPEN, Diagnostic Procedure with Diagnostic Trouble Code (DTC).>
P0414	Secondary Air Injection System Switching Valve "A" Circuit Shorted	<Ref. to EN(H4DOTC)(diag)-198, DTC P0414 SECONDARY AIR INJECTION SYSTEM SWITCHING VALVE "A" CIRCUIT SHORTED, Diagnostic Procedure with Diagnostic Trouble Code (DTC).>
P0416	Secondary Air Injection System Switching Valve "B" Circuit Open	<Ref. to EN(H4DOTC)(diag)-201, DTC P0416 SECONDARY AIR INJECTION SYSTEM SWITCHING VALVE "B" CIRCUIT OPEN, Diagnostic Procedure with Diagnostic Trouble Code (DTC).>
P0417	Secondary Air Injection System Switching Valve "B" Circuit Shorted	<Ref. to EN(H4DOTC)(diag)-204, DTC P0417 SECONDARY AIR INJECTION SYSTEM SWITCHING VALVE "B" CIRCUIT SHORTED, Diagnostic Procedure with Diagnostic Trouble Code (DTC).>
P0418	Secondary Air Injection System Control "A" Circuit Open	<Ref. to EN(H4DOTC)(diag)-207, DTC P0418 SECONDARY AIR INJECTION SYSTEM CONTROL "A" CIRCUIT OPEN, Diagnostic Procedure with Diagnostic Trouble Code (DTC).>
P0420	Catalyst System Efficiency below Threshold (Bank 1)	<Ref. to EN(H4DOTC)(diag)-210, DTC P0420 CATALYST SYSTEM EFFICIENCY BELOW THRESHOLD (BANK 1), Diagnostic Procedure with Diagnostic Trouble Code (DTC).>
P0442	Evaporative Emission Control System Leak Detected (Small Leak)	<Ref. to EN(H4DOTC)(diag)-214, DTC P0442 EVAPORATIVE EMISSION CONTROL SYSTEM LEAK DETECTED (SMALL LEAK), Diagnostic Procedure with Diagnostic Trouble Code (DTC).>
P0447	Evaporative Emission Control System Vent Control Circuit Open	<Ref. to EN(H4DOTC)(diag)-217, DTC P0447 EVAPORATIVE EMISSION CONTROL SYSTEM VENT CONTROL CIRCUIT OPEN, Diagnostic Procedure with Diagnostic Trouble Code (DTC).>
P0448	Evaporative Emission Control System Vent Control Circuit Shorted	<Ref. to EN(H4DOTC)(diag)-219, DTC P0448 EVAPORATIVE EMISSION CONTROL SYSTEM VENT CONTROL CIRCUIT SHORTED, Diagnostic Procedure with Diagnostic Trouble Code (DTC).>
P0451	Evaporative Emission Control System Pressure Sensor	<Ref. to EN(H4DOTC)(diag)-221, DTC P0451 EVAPORATIVE EMISSION CONTROL SYSTEM PRESSURE SENSOR, Diagnostic Procedure with Diagnostic Trouble Code (DTC).>
P0452	Evaporative Emission Control System Pressure Sensor Low Input	<Ref. to EN(H4DOTC)(diag)-223, DTC P0452 EVAPORATIVE EMISSION CONTROL SYSTEM PRESSURE SENSOR LOW INPUT, Diagnostic Procedure with Diagnostic Trouble Code (DTC).>
P0453	Evaporative Emission Control System Pressure Sensor High Input	<Ref. to EN(H4DOTC)(diag)-225, DTC P0453 EVAPORATIVE EMISSION CONTROL SYSTEM PRESSURE SENSOR HIGH INPUT, Diagnostic Procedure with Diagnostic Trouble Code (DTC).>
P0456	Evaporative Emission Control System Leak Detected (Very Small Leak)	<Ref. to EN(H4DOTC)(diag)-229, DTC P0456 EVAPORATIVE EMISSION CONTROL SYSTEM LEAK DETECTED (VERY SMALL LEAK), Diagnostic Procedure with Diagnostic Trouble Code (DTC).>
P0457	Evaporative Emission Control System Leak Detected (Fuel Cap Loose/Off)	<Ref. to EN(H4DOTC)(diag)-232, DTC P0457 EVAPORATIVE EMISSION CONTROL SYSTEM LEAK DETECTED (FUEL CAP LOOSE/OFF), Diagnostic Procedure with Diagnostic Trouble Code (DTC).>
P0458	Evaporative Emission System Purge Control Valve Circuit Low	<Ref. to EN(H4DOTC)(diag)-235, DTC P0458 EVAPORATIVE EMISSION SYSTEM PURGE CONTROL VALVE CIRCUIT LOW, Diagnostic Procedure with Diagnostic Trouble Code (DTC).>
P0459	Evaporative Emission System Purge Control Valve Circuit High	<Ref. to EN(H4DOTC)(diag)-237, DTC P0459 EVAPORATIVE EMISSION SYSTEM PURGE CONTROL VALVE CIRCUIT HIGH, Diagnostic Procedure with Diagnostic Trouble Code (DTC).>
P0461	Fuel Level Sensor "A" Circuit Range/Performance	<Ref. to EN(H4DOTC)(diag)-239, DTC P0461 FUEL LEVEL SENSOR "A" CIRCUIT RANGE/PERFORMANCE, Diagnostic Procedure with Diagnostic Trouble Code (DTC).>
P0462	Fuel Level Sensor "A" Circuit Low	<Ref. to EN(H4DOTC)(diag)-239, DTC P0462 FUEL LEVEL SENSOR "A" CIRCUIT LOW, Diagnostic Procedure with Diagnostic Trouble Code (DTC).>
P0463	Fuel Level Sensor "A" Circuit High	<Ref. to EN(H4DOTC)(diag)-239, DTC P0463 FUEL LEVEL SENSOR "A" CIRCUIT HIGH, Diagnostic Procedure with Diagnostic Trouble Code (DTC).>

List of Diagnostic Trouble Code (DTC)

ENGINE (DIAGNOSTICS)

DTC	Item	Reference
P0464	Fuel Level Sensor Circuit Intermittent	<Ref. to EN(H4DOTC)(diag)-240, DTC P0464 FUEL LEVEL SENSOR CIRCUIT INTERMITTENT, Diagnostic Procedure with Diagnostic Trouble Code (DTC).>
P0500	Vehicle Speed Sensor "A"	<Ref. to EN(H4DOTC)(diag)-240, DTC P0500 VEHICLE SPEED SENSOR "A", Diagnostic Procedure with Diagnostic Trouble Code (DTC).>
P0506	Idle Air Control System RPM Lower Than Expected	<Ref. to EN(H4DOTC)(diag)-241, DTC P0506 IDLE AIR CONTROL SYSTEM RPM LOWER THAN EXPECTED, Diagnostic Procedure with Diagnostic Trouble Code (DTC).>
P0507	Idle Air Control System RPM Higher Than Expected	<Ref. to EN(H4DOTC)(diag)-243, DTC P0507 IDLE AIR CONTROL SYSTEM RPM HIGHER THAN EXPECTED, Diagnostic Procedure with Diagnostic Trouble Code (DTC).>
P0512	Starter Request Circuit	<Ref. to EN(H4DOTC)(diag)-245, DTC P0512 STARTER REQUEST CIRCUIT, Diagnostic Procedure with Diagnostic Trouble Code (DTC).>
P0513	Incorrect Immobilizer Key	<Ref. to IM(diag)-16, DTC P0513 INCORRECT IMMOBILIZER KEY, Diagnostic Procedure with Diagnostic Trouble Code (DTC).>
P0600	Serial Communication Link	<Ref. to EN(H4DOTC)(diag)-246, DTC P0600 SERIAL COMMUNICATION LINK, Diagnostic Procedure with Diagnostic Trouble Code (DTC).>
P0604	Internal Control Module Random Access Memory (RAM) Error	<Ref. to EN(H4DOTC)(diag)-247, DTC P0604 INTERNAL CONTROL MODULE RANDOM ACCESS MEMORY (RAM) ERROR, Diagnostic Procedure with Diagnostic Trouble Code (DTC).>
P0605	Internal Control Module Read Only Memory (ROM) Error	<Ref. to EN(H4DOTC)(diag)-248, DTC P0605 INTERNAL CONTROL MODULE READ ONLY MEMORY (ROM) ERROR, Diagnostic Procedure with Diagnostic Trouble Code (DTC).>
P0607	Throttle Control System Circuit Range/Performance	<Ref. to EN(H4DOTC)(diag)-249, DTC P0607 THROTTLE CONTROL SYSTEM CIRCUIT RANGE/PERFORMANCE, Diagnostic Procedure with Diagnostic Trouble Code (DTC).>
P0638	Throttle Actuator Control Range/Performance (Bank 1)	<Ref. to EN(H4DOTC)(diag)-250, DTC P0638 THROTTLE ACTUATOR CONTROL RANGE/PERFORMANCE (BANK 1), Diagnostic Procedure with Diagnostic Trouble Code (DTC).>
P0700	Transmission Control System (MIL Request)	<Ref. to EN(H4DOTC)(diag)-250, DTC P0700 TRANSMISSION CONTROL SYSTEM (MIL REQUEST), Diagnostic Procedure with Diagnostic Trouble Code (DTC).>
P0851	Park/Neutral Switch Input Circuit Low (AT Model)	<Ref. to EN(H4DOTC)(diag)-251, DTC P0851 PARK/NEUTRAL SWITCH INPUT CIRCUIT LOW (AT MODEL), Diagnostic Procedure with Diagnostic Trouble Code (DTC).>
P0852	Park/Neutral Switch Input Circuit High (AT Model)	<Ref. to EN(H4DOTC)(diag)-253, DTC P0852 PARK/NEUTRAL SWITCH INPUT CIRCUIT HIGH (AT MODEL), Diagnostic Procedure with Diagnostic Trouble Code (DTC).>
P1152	O2 Sensor Circuit Range/Performance (Low) (Bank 1 Sensor 1)	<Ref. to EN(H4DOTC)(diag)-255, DTC P1152 O2 SENSOR CIRCUIT RANGE/PERFORMANCE (LOW) (BANK1 SENSOR1), Diagnostic Procedure with Diagnostic Trouble Code (DTC).>
P1153	O2 Sensor Circuit Range/Performance (High) (Bank 1 Sensor 1)	<Ref. to EN(H4DOTC)(diag)-257, DTC P1153 O2 SENSOR CIRCUIT RANGE/PERFORMANCE (HIGH) (BANK1 SENSOR1), Diagnostic Procedure with Diagnostic Trouble Code (DTC).>
P1160	Return Spring Failure	<Ref. to EN(H4DOTC)(diag)-258, DTC P1160 RETURN SPRING FAILURE, Diagnostic Procedure with Diagnostic Trouble Code (DTC).>
P1400	Fuel Tank Pressure Control Solenoid Valve Circuit Low	<Ref. to EN(H4DOTC)(diag)-259, DTC P1400 FUEL TANK PRESSURE CONTROL SOLENOID VALVE CIRCUIT LOW, Diagnostic Procedure with Diagnostic Trouble Code (DTC).>
P1410	Secondary Air Injection System Switching Valve Stuck Open	<Ref. to EN(H4DOTC)(diag)-261, DTC P1410 SECONDARY AIR INJECTION SYSTEM SWITCHING VALVE STUCK OPEN, Diagnostic Procedure with Diagnostic Trouble Code (DTC).>
P1418	Secondary Air Injection System Control "A" Circuit Shorted	<Ref. to EN(H4DOTC)(diag)-264, DTC P1418 SECONDARY AIR INJECTION SYSTEM CONTROL "A" CIRCUIT SHORTED, Diagnostic Procedure with Diagnostic Trouble Code (DTC).>

List of Diagnostic Trouble Code (DTC)

ENGINE (DIAGNOSTICS)

DTC	Item	Reference
P1420	Fuel Tank Pressure Control Sol. Valve Circuit High	<Ref. to EN(H4DOTC)(diag)-267, DTC P1420 FUEL TANK PRESSURE CONTROL SOL. VALVE CIRCUIT HIGH, Diagnostic Procedure with Diagnostic Trouble Code (DTC).>
P1443	Vent Control Solenoid Valve Function Problem	<Ref. to EN(H4DOTC)(diag)-269, DTC P1443 VENT CONTROL SOLENOID VALVE FUNCTION PROBLEM, Diagnostic Procedure with Diagnostic Trouble Code (DTC).>
P1491	Positive Crankcase Ventilation (Blow-by) Function Problem	<Ref. to EN(H4DOTC)(diag)-271, DTC P1491 POSITIVE CRANKCASE VENTILATION (BLOW-BY) FUNCTION PROBLEM, Diagnostic Procedure with Diagnostic Trouble Code (DTC).>
P1560	Back-up Voltage Circuit Malfunction	<Ref. to EN(H4DOTC)(diag)-273, DTC P1560 BACK-UP VOLTAGE CIRCUIT MALFUNCTION, Diagnostic Procedure with Diagnostic Trouble Code (DTC).>
P1570	Antenna	<Ref. to IM(diag)-17, DTC P1570 ANTENNA, Diagnostic Procedure with Diagnostic Trouble Code (DTC).>
P1571	Reference Code Incompatibility	<Ref. to IM(diag)-19, DTC P1571 REFERENCE CODE INCOMPATIBILITY, Diagnostic Procedure with Diagnostic Trouble Code (DTC).>
P1572	IMM Circuit Failure (Except Antenna Circuit)	<Ref. to IM(diag)-20, DTC P1572 IMM CIRCUIT FAILURE (EXCEPT ANTENNA CIRCUIT), Diagnostic Procedure with Diagnostic Trouble Code (DTC).>
P1574	Key Communication Failure	<Ref. to IM(diag)-22, DTC P1574 KEY COMMUNICATION FAILURE, Diagnostic Procedure with Diagnostic Trouble Code (DTC).>
P1576	EGI Control Module EEPROM	<Ref. to IM(diag)-23, DTC P1576 EGI CONTROL MODULE EEPROM, Diagnostic Procedure with Diagnostic Trouble Code (DTC).>
P1577	IMM Control Module EEPROM	<Ref. to IM(diag)-23, DTC P1577 IMM CONTROL MODULE EEPROM, Diagnostic Procedure with Diagnostic Trouble Code (DTC).>
P1578	Meter Failure	<Ref. to IM(diag)-24, DTC P1578 METER FAILURE, Diagnostic Procedure with Diagnostic Trouble Code (DTC).>
P1602	Control Module Programming Error	<Ref. to EN(H4DOTC)(diag)-275, DTC P1602 CONTROL MODULE PROGRAMMING ERROR, Diagnostic Procedure with Diagnostic Trouble Code (DTC).>
P2004	Intake Manifold Runner Control Stuck Open (Bank 1)	<Ref. to EN(H4DOTC)(diag)-284, DTC P2004 INTAKE MANIFOLD RUNNER CONTROL STUCK OPEN (BANK 1), Diagnostic Procedure with Diagnostic Trouble Code (DTC).>
P2005	Intake Manifold Runner Control Stuck Open (Bank 2)	<Ref. to EN(H4DOTC)(diag)-284, DTC P2005 INTAKE MANIFOLD RUNNER CONTROL STUCK OPEN (BANK 2), Diagnostic Procedure with Diagnostic Trouble Code (DTC).>
P2006	Intake Manifold Runner Control Stuck Closed (Bank 1)	<Ref. to EN(H4DOTC)(diag)-285, DTC P2006 INTAKE MANIFOLD RUNNER CONTROL STUCK CLOSED (BANK 1), Diagnostic Procedure with Diagnostic Trouble Code (DTC).>
P2007	Intake Manifold Runner Control Stuck Closed (Bank 2)	<Ref. to EN(H4DOTC)(diag)-286, DTC P2007 INTAKE MANIFOLD RUNNER CONTROL STUCK CLOSED (BANK 2), Diagnostic Procedure with Diagnostic Trouble Code (DTC).>
P2008	Intake Manifold Runner Control Circuit / Open (Bank 1)	<Ref. to EN(H4DOTC)(diag)-287, DTC P2008 INTAKE MANIFOLD RUNNER CONTROL CIRCUIT / OPEN (BANK 1), Diagnostic Procedure with Diagnostic Trouble Code (DTC).>
P2009	Intake Manifold Runner Control Circuit Low (Bank 1)	<Ref. to EN(H4DOTC)(diag)-289, DTC P2009 INTAKE MANIFOLD RUNNER CONTROL CIRCUIT LOW (BANK 1), Diagnostic Procedure with Diagnostic Trouble Code (DTC).>
P2011	Intake Manifold Runner Control Circuit / Open (Bank 2)	<Ref. to EN(H4DOTC)(diag)-291, DTC P2011 INTAKE MANIFOLD RUNNER CONTROL CIRCUIT / OPEN (BANK 2), Diagnostic Procedure with Diagnostic Trouble Code (DTC).>
P2012	Intake Manifold Runner Control Circuit Low (Bank 2)	<Ref. to EN(H4DOTC)(diag)-293, DTC P2012 INTAKE MANIFOLD RUNNER CONTROL CIRCUIT LOW (BANK 2), Diagnostic Procedure with Diagnostic Trouble Code (DTC).>

List of Diagnostic Trouble Code (DTC)

ENGINE (DIAGNOSTICS)

DTC	Item	Reference
P2016	Intake Manifold Runner Position Sensor / Switch Circuit Low (Bank 1)	<Ref. to EN(H4DOTC)(diag)-295, DTC P2016 INTAKE MANIFOLD RUNNER POSITION SENSOR / SWITCH CIRCUIT LOW (BANK 1), Diagnostic Procedure with Diagnostic Trouble Code (DTC).>
P2017	Intake Manifold Runner Position Sensor / Switch Circuit High (Bank 1)	<Ref. to EN(H4DOTC)(diag)-297, DTC P2017 INTAKE MANIFOLD RUNNER POSITION SENSOR / SWITCH CIRCUIT HIGH (BANK 1), Diagnostic Procedure with Diagnostic Trouble Code (DTC).>
P2021	Intake Manifold Runner Position Sensor / Switch Circuit Low (Bank 2)	<Ref. to EN(H4DOTC)(diag)-299, DTC P2021 INTAKE MANIFOLD RUNNER POSITION SENSOR / SWITCH CIRCUIT LOW (BANK 2), Diagnostic Procedure with Diagnostic Trouble Code (DTC).>
P2022	Intake Manifold Runner Position Sensor / Switch Circuit High (Bank 2)	<Ref. to EN(H4DOTC)(diag)-301, DTC P2022 INTAKE MANIFOLD RUNNER POSITION SENSOR / SWITCH CIRCUIT HIGH (BANK 2), Diagnostic Procedure with Diagnostic Trouble Code (DTC).>
P2088	Intake Camshaft Position Actuator Control Circuit Low (Bank 1)	<Ref. to EN(H4DOTC)(diag)-303, DTC P2088 INTAKE CAMSHAFT POSITION ACTUATOR CONTROL CIRCUIT LOW (BANK 1), Diagnostic Procedure with Diagnostic Trouble Code (DTC).>
P2089	Intake Camshaft Position Actuator Control Circuit High (Bank 1)	<Ref. to EN(H4DOTC)(diag)-305, DTC P2089 INTAKE CAMSHAFT POSITION ACTUATOR CONTROL CIRCUIT HIGH (BANK 1), Diagnostic Procedure with Diagnostic Trouble Code (DTC).>
P2092	Intake Camshaft Position Actuator Control Circuit Low (Bank 2)	<Ref. to EN(H4DOTC)(diag)-307, DTC P2092 INTAKE CAMSHAFT POSITION ACTUATOR CONTROL CIRCUIT LOW (BANK 2), Diagnostic Procedure with Diagnostic Trouble Code (DTC).>
P2093	Intake Camshaft Position Actuator Control Circuit High (Bank 2)	<Ref. to EN(H4DOTC)(diag)-309, DTC P2093 INTAKE CAMSHAFT POSITION ACTUATOR CONTROL CIRCUIT HIGH (BANK 2), Diagnostic Procedure with Diagnostic Trouble Code (DTC).>
P2096	Post Catalyst Fuel Trim System Too Lean (Bank 1)	<Ref. to EN(H4DOTC)(diag)-310, DTC P2096 POST CATALYST FUEL TRIM SYSTEM TOO LEAN (BANK 1), Diagnostic Procedure with Diagnostic Trouble Code (DTC).>
P2097	Post Catalyst Fuel Trim System Too Rich (Bank 1)	<Ref. to EN(H4DOTC)(diag)-311, DTC P2097 POST CATALYST FUEL TRIM SYSTEM TOO RICH (BANK 1), Diagnostic Procedure with Diagnostic Trouble Code (DTC).>
P2101	Throttle Actuator Control Motor Circuit Range/Performance	<Ref. to EN(H4DOTC)(diag)-318, DTC P2101 THROTTLE ACTUATOR CONTROL MOTOR CIRCUIT RANGE/PERFORMANCE, Diagnostic Procedure with Diagnostic Trouble Code (DTC).>
P2102	Throttle Actuator Control Motor Circuit Low	<Ref. to EN(H4DOTC)(diag)-323, DTC P2102 THROTTLE ACTUATOR CONTROL MOTOR CIRCUIT LOW, Diagnostic Procedure with Diagnostic Trouble Code (DTC).>
P2103	Throttle Actuator Control Motor Circuit High	<Ref. to EN(H4DOTC)(diag)-325, DTC P2103 THROTTLE ACTUATOR CONTROL MOTOR CIRCUIT HIGH, Diagnostic Procedure with Diagnostic Trouble Code (DTC).>
P2109	Throttle/Pedal Position Sensor "A" Minimum Stop Performance	<Ref. to EN(H4DOTC)(diag)-326, DTC P2109 THROTTLE/PEDAL POSITION SENSOR "A" MINIMUM STOP PERFORMANCE, Diagnostic Procedure with Diagnostic Trouble Code (DTC).>
P2122	Throttle/Pedal Position Sensor/Switch "D" Circuit Low Input	<Ref. to EN(H4DOTC)(diag)-327, DTC P2122 THROTTLE/PEDAL POSITION SENSOR/SWITCH "D" CIRCUIT LOW INPUT, Diagnostic Procedure with Diagnostic Trouble Code (DTC).>
P2123	Throttle/Pedal Position Sensor/Switch "D" Circuit High Input	<Ref. to EN(H4DOTC)(diag)-329, DTC P2123 THROTTLE/PEDAL POSITION SENSOR/SWITCH "D" CIRCUIT HIGH INPUT, Diagnostic Procedure with Diagnostic Trouble Code (DTC).>
P2127	Throttle/Pedal Position Sensor/Switch "E" Circuit Low Input	<Ref. to EN(H4DOTC)(diag)-331, DTC P2127 THROTTLE/PEDAL POSITION SENSOR/SWITCH "E" CIRCUIT LOW INPUT, Diagnostic Procedure with Diagnostic Trouble Code (DTC).>
P2128	Throttle/Pedal Position Sensor/Switch "E" Circuit High Input	<Ref. to EN(H4DOTC)(diag)-333, DTC P2128 THROTTLE/PEDAL POSITION SENSOR/SWITCH "E" CIRCUIT HIGH INPUT, Diagnostic Procedure with Diagnostic Trouble Code (DTC).>
P2135	Throttle/Pedal Position Sensor/Switch "A"/"B" Voltage Correlation	<Ref. to EN(H4DOTC)(diag)-335, DTC P2135 THROTTLE/PEDAL POSITION SENSOR/SWITCH "A"/"B" VOLTAGE CORRELATION, Diagnostic Procedure with Diagnostic Trouble Code (DTC).>

List of Diagnostic Trouble Code (DTC)

ENGINE (DIAGNOSTICS)

DTC	Item	Reference
P2138	Throttle/Pedal Position Sensor/Switch "D"/"E" Voltage Correlation	<Ref. to EN(H4DOTC)(diag)-338, DTC P2138 THROTTLE/PEDAL POSITION SENSOR/SWITCH "D"/"E" VOLTAGE CORRELATION, Diagnostic Procedure with Diagnostic Trouble Code (DTC).>
P2419	Evaporative Emission System Switching Valve Control Circuit Low	<Ref. to EN(H4DOTC)(diag)-340, DTC P2419 EVAPORATIVE EMISSION SYSTEM SWITCHING VALVE CONTROL CIRCUIT LOW, Diagnostic Procedure with Diagnostic Trouble Code (DTC).>
P2420	Evaporative Emission System Switching Valve Control Circuit High	<Ref. to EN(H4DOTC)(diag)-342, DTC P2420 EVAPORATIVE EMISSION SYSTEM SWITCHING VALVE CONTROL CIRCUIT HIGH, Diagnostic Procedure with Diagnostic Trouble Code (DTC).>
P2431	Secondary Air Injection System Air Flow /Pressure Sensor Circuit Range/Performance	<Ref. to EN(H4DOTC)(diag)-344, DTC P2431 SECONDARY AIR INJECTION SYSTEM AIR FLOW /PRESSURE SENSOR CIRCUIT RANGE/PERFORMANCE, Diagnostic Procedure with Diagnostic Trouble Code (DTC).>
P2432	Secondary Air Injection System Air Flow /Pressure Sensor Circuit Low	<Ref. to EN(H4DOTC)(diag)-347, DTC P2432 SECONDARY AIR INJECTION SYSTEM AIR FLOW /PRESSURE SENSOR CIRCUIT LOW, Diagnostic Procedure with Diagnostic Trouble Code (DTC).>
P2433	Secondary Air Injection System Air Flow /Pressure Sensor Circuit High	<Ref. to EN(H4DOTC)(diag)-350, DTC P2433 SECONDARY AIR INJECTION SYSTEM AIR FLOW /PRESSURE SENSOR CIRCUIT HIGH, Diagnostic Procedure with Diagnostic Trouble Code (DTC).>
P2440	Secondary Air Injection System Switching Valve Stuck Open (Bank 1)	<Ref. to EN(H4DOTC)(diag)-353, DTC P2440 SECONDARY AIR INJECTION SYSTEM SWITCHING VALVE STUCK OPEN (BANK 1), Diagnostic Procedure with Diagnostic Trouble Code (DTC).>
P2441	Secondary Air Injection System Switching Valve Stuck Closed (Bank 1)	<Ref. to EN(H4DOTC)(diag)-357, DTC P2441 SECONDARY AIR INJECTION SYSTEM SWITCHING VALVE STUCK CLOSED (BANK 1), Diagnostic Procedure with Diagnostic Trouble Code (DTC).>
P2442	Secondary Air Injection System Switching Valve Stuck Open (Bank 2)	<Ref. to EN(H4DOTC)(diag)-358, DTC P2442 SECONDARY AIR INJECTION SYSTEM SWITCHING VALVE STUCK OPEN (BANK2), Diagnostic Procedure with Diagnostic Trouble Code (DTC).>
P2443	Secondary Air Injection System Switching Valve Stuck Closed (Bank 2)	<Ref. to EN(H4DOTC)(diag)-362, DTC P2443 SECONDARY AIR INJECTION SYSTEM SWITCHING VALVE STUCK CLOSED (BANK2), Diagnostic Procedure with Diagnostic Trouble Code (DTC).>
P2444	Secondary Air Injection System Pump Stuck ON	<Ref. to EN(H4DOTC)(diag)-363, DTC P2444 SECONDARY AIR INJECTION SYSTEM PUMP STUCK ON, Diagnostic Procedure with Diagnostic Trouble Code (DTC).>

Diagnostic Procedure with Diagnostic Trouble Code (DTC)

ENGINE (DIAGNOSTICS)

20. Diagnostic Procedure with Diagnostic Trouble Code (DTC)

A: DTC P0011 INTAKE CAMSHAFT POSITION - TIMING OVER-ADVANCED OR SYSTEM PERFORMANCE (BANK 1)

DTC DETECTING CONDITION:

- Detected when two consecutive driving cycles with fault occur.
- GENERAL DESCRIPTION <Ref. to GD(H4DOTC)-9, DTC P0011 INTAKE CAMSHAFT POSITION - TIMING OVER-ADVANCED OR SYSTEM PERFORMANCE (BANK 1), Diagnostic Trouble Code (DTC) Detecting Criteria.>

TROUBLE SYMPTOM:

- Engine stalls.
- Improper idling

CAUTION:

After repair or replacement of faulty parts, perform Clear Memory Mode <Ref. to EN(H4DOTC)(diag)-52, OPERATION, Clear Memory Mode.> and Inspection Mode <Ref. to EN(H4DOTC)(diag)-42, PROCEDURE, Inspection Mode.>.

Step	Check	Yes	No
<p>1</p> <p>CHECK CURRENT DATA. 1) Start the engine and let it idle. 2) Measure the AVCS system operating angle using the Subaru Select Monitor or general scan tool.</p> <p>NOTE: • Subaru Select Monitor For detailed operation procedures, refer to "READ CURRENT DATA FOR ENGINE". <Ref. to EN(H4DOTC)(diag)-34, Subaru Select Monitor.> • General scan tool For detailed operation procedures, refer to the general scan tool operation manual.</p>	<p>Is the AVCS system operating angle approx. 0°?</p>	<p>Go to step 2.</p>	<p>Check the following item and repair or replace if necessary.</p> <ul style="list-style-type: none"> • Oil pipe (clog) • Oil flow control solenoid valve (clog or dirt of oil routing, setting of spring) • Intake camshaft (dirt, damage of camshaft)
<p>2</p> <p>CHECK CURRENT DATA. 1) Drive (accelerate or decelerate) the vehicle at 80 km/h (50 MPH) or less.</p> <p>NOTE: Drive the vehicle so that duty output of the oil flow control solenoid valve increases. 2) Measure the AVCS system operating angle and oil flow control solenoid valve duty output using Subaru Select Monitor or general scan tool.</p> <p>NOTE: • Subaru Select Monitor For detailed operation procedures, refer to "READ CURRENT DATA FOR ENGINE". <Ref. to EN(H4DOTC)(diag)-34, Subaru Select Monitor.> • General scan tool For detailed operation procedures, refer to the general scan tool operation manual.</p>	<p>When the oil flow control solenoid valve duty output exceeds 10%, is the AVCS system operating angle approx. 0°?</p>	<p>Check the following item and repair or replace if necessary.</p> <ul style="list-style-type: none"> • Oil pipe (clog) • Oil flow control solenoid valve (clog or dirt of oil routing, setting of spring) • Intake camshaft (dirt, damage of camshaft) 	<p>Perform the following procedures, and clean the oil routing.</p> <p>Replace the engine oil and idle the engine for 5 minutes, then replace the oil filter and engine oil. <Ref. to LU(H4DOTC)-8, REPLACEMENT, Engine Oil.> <Ref. to LU(H4DOTC)-25, Engine Oil Filter.></p>

Diagnostic Procedure with Diagnostic Trouble Code (DTC)

ENGINE (DIAGNOSTICS)

B: DTC P0016 CRANKSHAFT POSITION - CAMSHAFT POSITION CORRELATION (BANK1)

DTC DETECTING CONDITION:

- Detected when two consecutive driving cycles with fault occur.
- GENERAL DESCRIPTION <Ref. to GD(H4DOTC)-11, DTC P0016 CRANKSHAFT POSITION - CAMSHAFT POSITION CORRELATION (BANK1), Diagnostic Trouble Code (DTC) Detecting Criteria.>

TROUBLE SYMPTOM:

- Engine stalls.
- Improper idling

CAUTION:

After repair or replacement of faulty parts, perform Clear Memory Mode <Ref. to EN(H4DOTC)(diag)-52, OPERATION, Clear Memory Mode.> and Inspection Mode <Ref. to EN(H4DOTC)(diag)-42, PROCEDURE, Inspection Mode.>.

	Step	Check	Yes	No
1	<p>CHECK CURRENT DATA.</p> <p>1) Start the engine and let it idle.</p> <p>2) Measure the AVCS system operating angle and oil flow control solenoid valve duty output using Subaru Select Monitor or general scan tool.</p> <p>NOTE:</p> <ul style="list-style-type: none"> • Subaru Select Monitor <p>For detailed operation procedures, refer to "READ CURRENT DATA FOR ENGINE". <Ref. to EN(H4DOTC)(diag)-34, Subaru Select Monitor.></p> <ul style="list-style-type: none"> • General scan tool <p>For detailed operation procedures, refer to the general scan tool operation manual.</p>	<p>Is the AVCS system operating angle approx. 0°, and oil flow control solenoid valve duty output approx. 10%?</p>	<p>Perform the following procedures, and clean the oil routing.</p> <p>Replace the engine oil and idle the engine for 5 minutes, then replace the oil filter and engine oil.</p> <p><Ref. to LU(H4DOTC)-8, REPLACEMENT, Engine Oil.> <Ref. to LU(H4DOTC)-25, Engine Oil Filter.></p>	<p>Check the following item and repair or replace if necessary.</p> <ul style="list-style-type: none"> • Oil pipe (clog) • Oil flow control solenoid valve (clog or dirt of oil routing, setting of spring) • Intake camshaft (dirt, damage of camshaft) • Timing belt (matching of timing mark)

Diagnostic Procedure with Diagnostic Trouble Code (DTC)

ENGINE (DIAGNOSTICS)

C: DTC P0018 CRANKSHAFT POSITION - CAMSHAFT POSITION CORRELATION (BANK2)

DTC DETECTING CONDITION:

- Detected when two consecutive driving cycles with fault occur.
- GENERAL DESCRIPTION <Ref. to GD(H4DOTC)-13, DTC P0018 CRANKSHAFT POSITION - CAMSHAFT POSITION CORRELATION (BANK2), Diagnostic Trouble Code (DTC) Detecting Criteria.>

TROUBLE SYMPTOM:

- Engine stalls.
- Improper idling

CAUTION:

After repair or replacement of faulty parts, perform Clear Memory Mode <Ref. to EN(H4DOTC)(diag)-52, OPERATION, Clear Memory Mode.> and Inspection Mode <Ref. to EN(H4DOTC)(diag)-42, PROCEDURE, Inspection Mode.>.

	Step	Check	Yes	No
1	<p>CHECK CURRENT DATA.</p> <p>1) Start the engine and let it idle.</p> <p>2) Measure the AVCS system operating angle and oil flow control solenoid valve duty output using Subaru Select Monitor or general scan tool.</p> <p>NOTE:</p> <ul style="list-style-type: none"> • Subaru Select Monitor <p>For detailed operation procedures, refer to "READ CURRENT DATA FOR ENGINE". <Ref. to EN(H4DOTC)(diag)-34, Subaru Select Monitor.></p> <ul style="list-style-type: none"> • General scan tool <p>For detailed operation procedures, refer to the general scan tool operation manual.</p>	<p>Is the AVCS system operating angle approx. 0°, and oil flow control solenoid valve duty output approx. 10%?</p>	<p>Perform the following procedures, and clean the oil routing.</p> <p>Replace the engine oil and idle the engine for 5 minutes, then replace the oil filter and engine oil.</p> <p><Ref. to LU(H4DOTC)-8, REPLACEMENT, Engine Oil.> <Ref. to LU(H4DOTC)-25, Engine Oil Filter.></p>	<p>Check the following item and repair or replace if necessary.</p> <ul style="list-style-type: none"> • Oil pipe (clog) • Oil flow control solenoid valve (clog or dirt of oil routing, setting of spring) • Intake camshaft (dirt, damage of camshaft) • Timing belt (matching of timing mark)

Diagnostic Procedure with Diagnostic Trouble Code (DTC)

ENGINE (DIAGNOSTICS)

D: DTC P0021 INTAKE CAMSHAFT POSITION - TIMING OVER-ADVANCED OR SYSTEM PERFORMANCE (BANK 2)

DTC DETECTING CONDITION:

- Detected when two consecutive driving cycles with fault occur.
- GENERAL DESCRIPTION <Ref. to GD(H4DOTC)-13, DTC P0021 INTAKE CAMSHAFT POSITION - TIMING OVER-ADVANCED OR SYSTEM PERFORMANCE (BANK 2), Diagnostic Trouble Code (DTC) Detecting Criteria.>

TROUBLE SYMPTOM:

- Engine stalls.
- Improper idling

CAUTION:

After repair or replacement of faulty parts, perform Clear Memory Mode <Ref. to EN(H4DOTC)(diag)-52, OPERATION, Clear Memory Mode.> and Inspection Mode <Ref. to EN(H4DOTC)(diag)-42, PROCEDURE, Inspection Mode.>.

	Step	Check	Yes	No
1	<p>CHECK CURRENT DATA.</p> <p>1) Start the engine and let it idle.</p> <p>2) Measure the AVCS system operating angle using the Subaru Select Monitor or general scan tool.</p> <p>NOTE:</p> <ul style="list-style-type: none"> • Subaru Select Monitor <p>For detailed operation procedures, refer to "READ CURRENT DATA FOR ENGINE". <Ref. to EN(H4DOTC)(diag)-34, Subaru Select Monitor.></p> <ul style="list-style-type: none"> • General scan tool <p>For detailed operation procedures, refer to the general scan tool operation manual.</p>	Is the AVCS system operating angle approx. 0°?	Go to step 2.	<p>Check the following item and repair or replace if necessary.</p> <ul style="list-style-type: none"> • Oil pipe (clog) • Oil flow control solenoid valve (clog or dirt of oil routing, setting of spring) • Intake camshaft (dirt, damage of camshaft)
2	<p>CHECK CURRENT DATA.</p> <p>1) Drive (accelerate or decelerate) the vehicle at 80 km/h (50 MPH) or less.</p> <p>NOTE:</p> <p>Drive the vehicle so that duty output of the oil flow control solenoid valve increases.</p> <p>2) Measure the AVCS system operating angle and oil flow control solenoid valve duty output using Subaru Select Monitor or general scan tool.</p> <p>NOTE:</p> <ul style="list-style-type: none"> • Subaru Select Monitor <p>For detailed operation procedures, refer to "READ CURRENT DATA FOR ENGINE". <Ref. to EN(H4DOTC)(diag)-34, Subaru Select Monitor.></p> <ul style="list-style-type: none"> • General scan tool <p>For detailed operation procedures, refer to the general scan tool operation manual.</p>	When the oil flow control solenoid valve duty output exceeds 10%, is the AVCS system operating angle approx. 0°?	<p>Check the following item and repair or replace if necessary.</p> <ul style="list-style-type: none"> • Oil pipe (clog) • Oil flow control solenoid valve (clog or dirt of oil routing, setting of spring) • Intake camshaft (dirt, damage of camshaft) 	<p>Perform the following procedures, and clean the oil routing.</p> <p>Replace the engine oil and idle the engine for 5 minutes, then replace the oil filter and engine oil.</p> <p><Ref. to LU(H4DOTC)-8, REPLACEMENT, Engine Oil.> <Ref. to LU(H4DOTC)-25, Engine Oil Filter.></p>

Diagnostic Procedure with Diagnostic Trouble Code (DTC)

ENGINE (DIAGNOSTICS)

E: DTC P0030 HO2S HEATER CONTROL CIRCUIT (BANK 1 SENSOR 1)

DTC DETECTING CONDITION:

- Detected when two consecutive driving cycles with fault occur.
- GENERAL DESCRIPTION <Ref. to GD(H4DOTC)-14, DTC P0030 HO2S HEATER CONTROL CIRCUIT (BANK 1 SENSOR 1), Diagnostic Trouble Code (DTC) Detecting Criteria.>

CAUTION:

After repair or replacement of faulty parts, perform Clear Memory Mode <Ref. to EN(H4DOTC)(diag)-52, OPERATION, Clear Memory Mode.> and Inspection Mode <Ref. to EN(H4DOTC)(diag)-42, PROCEDURE, Inspection Mode.>.

WIRING DIAGRAM:

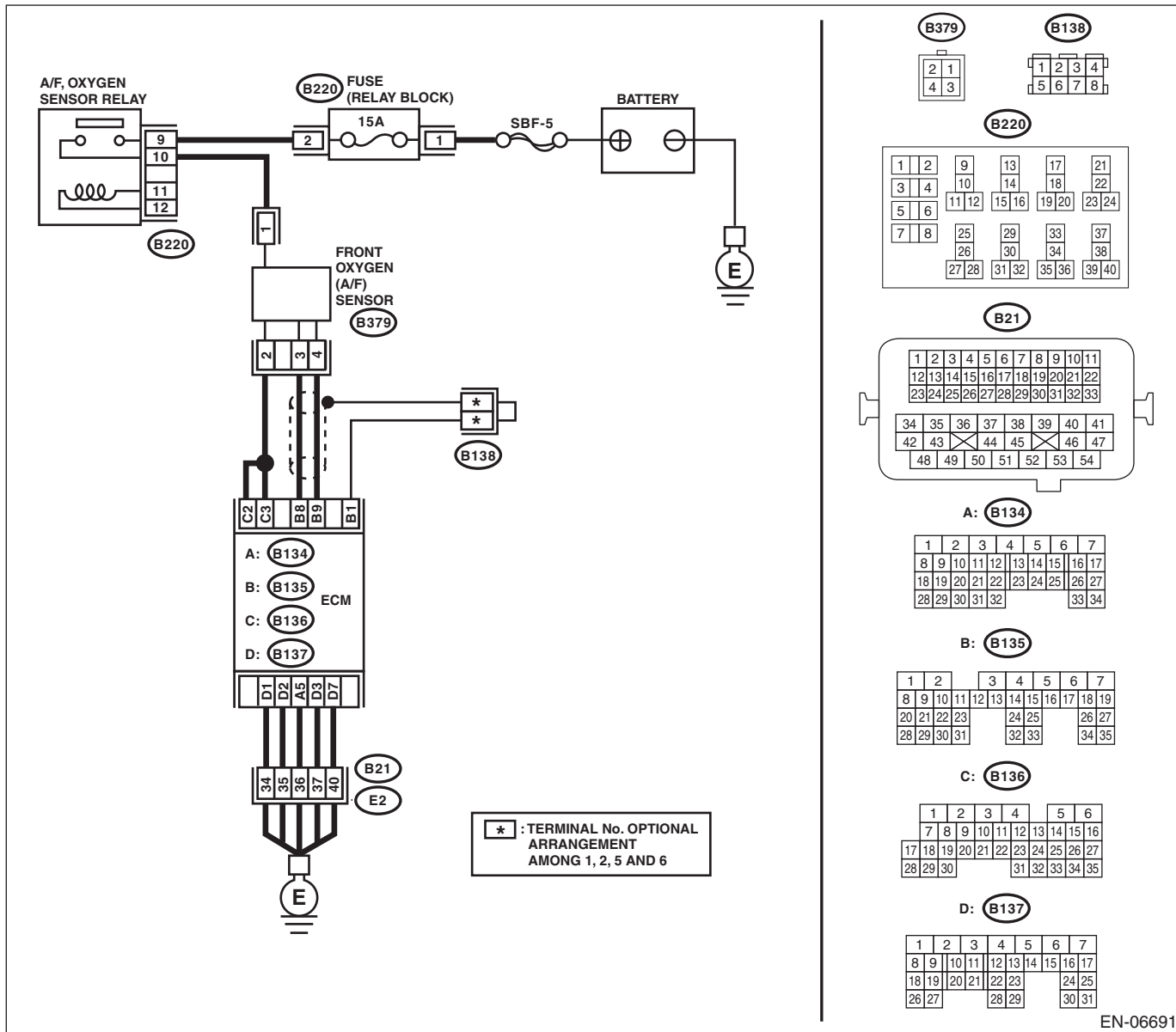

Diagnostic Procedure with Diagnostic Trouble Code (DTC)

ENGINE (DIAGNOSTICS)

Step	Check	Yes	No
<p>1 CHECK HARNESS BETWEEN ECM AND FRONT OXYGEN (A/F) SENSOR CONNECTOR.</p> <p>1) Start and warm up the engine. 2) Turn the ignition switch to OFF. 3) Disconnect the connectors from the ECM and front oxygen (A/F) sensor. 4) Measure the resistance of harness between ECM and front oxygen (A/F) sensor connector.</p> <p>Connector & terminal (B136) No. 3 — (B379) No. 2: (B136) No. 2 — (B379) No. 2:</p>	Is the resistance less than 1 Ω?	Go to step 2.	Repair the harness and connector. NOTE: In this case, repair the following item: • Open circuit in harness between ECM and front oxygen (A/F) sensor connector • Poor contact of coupling connector
<p>2 CHECK HARNESS BETWEEN ECM AND FRONT OXYGEN (A/F) SENSOR CONNECTOR.</p> <p>Measure the resistance of harness between ECM and front oxygen (A/F) sensor connector.</p> <p>Connector & terminal (B135) No. 9 — (B379) No. 4: (B135) No. 8 — (B379) No. 3:</p>	Is the resistance less than 1 Ω?	Go to step 3.	Repair the harness and connector. NOTE: In this case, repair the following item: • Open circuit in harness between ECM and front oxygen (A/F) sensor connector • Poor contact of coupling connector
<p>3 CHECK FRONT OXYGEN (A/F) SENSOR.</p> <p>Measure the resistance between front oxygen (A/F) sensor terminals.</p> <p>Terminals No. 2 — No. 1:</p>	Is the resistance less than 2 — 3 Ω?	Go to step 4.	Replace the front oxygen (A/F) sensor. <Ref. to FU(H4DOTC)-43, Front Oxygen (A/F) Sensor.>
<p>4 CHECK POOR CONTACT.</p> <p>Check poor contact of ECM and front oxygen (A/F) sensor connector.</p>	Is there poor contact in ECM or front oxygen (A/F) sensor connector?	Repair the poor contact of ECM or front oxygen (A/F) sensor connector.	Replace the front oxygen (A/F) sensor. <Ref. to FU(H4DOTC)-43, Front Oxygen (A/F) Sensor.>

Diagnostic Procedure with Diagnostic Trouble Code (DTC)

ENGINE (DIAGNOSTICS)

F: DTC P0031 HO2S HEATER CONTROL CIRCUIT LOW (BANK 1 SENSOR 1)

DTC DETECTING CONDITION:

- Immediately at fault recognition
- GENERAL DESCRIPTION <Ref. to GD(H4DOTC)-16, DTC P0031 HO2S HEATER CONTROL CIRCUIT LOW (BANK 1 SENSOR 1), Diagnostic Trouble Code (DTC) Detecting Criteria.>

CAUTION:

After repair or replacement of faulty parts, perform Clear Memory Mode <Ref. to EN(H4DOTC)(diag)-52, OPERATION, Clear Memory Mode.> and Inspection Mode <Ref. to EN(H4DOTC)(diag)-42, PROCEDURE, Inspection Mode.>.

WIRING DIAGRAM:

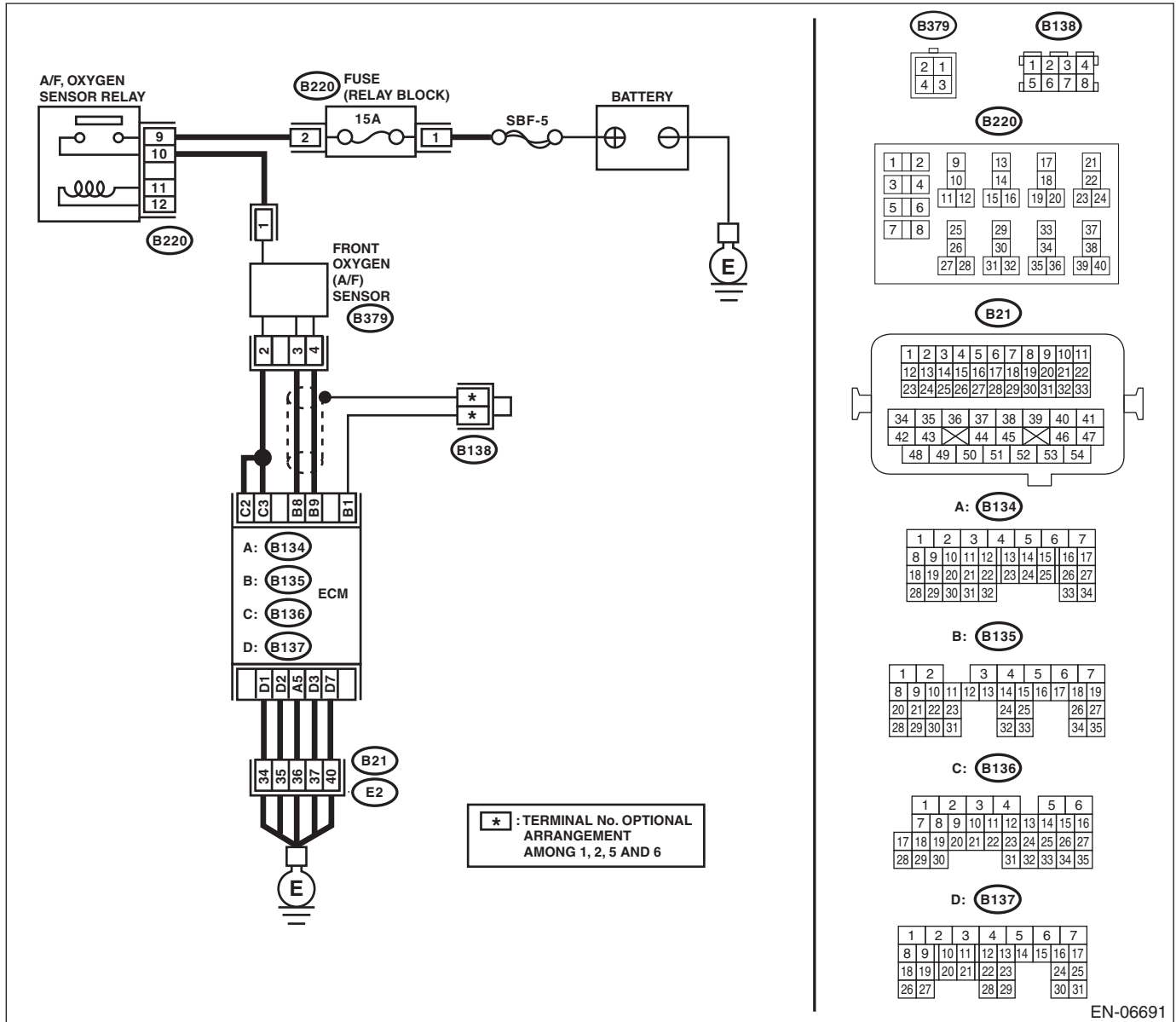

EN-06691

Diagnostic Procedure with Diagnostic Trouble Code (DTC)

ENGINE (DIAGNOSTICS)

Step	Check	Yes	No
<p>1</p> <p>CHECK POWER SUPPLY TO FRONT OXYGEN (A/F) SENSOR.</p> <p>1) Turn the ignition switch to OFF. 2) Disconnect the connector from front oxygen (A/F) sensor. 3) Turn the ignition switch to ON. 4) Measure the voltage between front oxygen (A/F) sensor connector and engine ground.</p> <p>Connector & terminal (B379) No. 1 (+) — Engine ground (-):</p>	<p>Is the voltage 10 V or more?</p>	<p>Go to step 2.</p>	<p>Repair the power supply line. Or replace the main relay.</p> <p>NOTE: In this case, repair the following item:</p> <ul style="list-style-type: none"> • Open circuit in harness between A/F, oxygen sensor relay and front oxygen (A/F) sensor connector • Poor contact of A/F, oxygen sensor relay connector
<p>2</p> <p>CHECK HARNESS BETWEEN ECM AND FRONT OXYGEN (A/F) SENSOR.</p> <p>1) Turn the ignition switch to OFF. 2) Disconnect the connectors from the ECM. 3) Measure the resistance between ECM and front oxygen (A/F) sensor connector.</p> <p>Connector & terminal (B136) No. 3 — (B379) No. 2: (B136) No. 2 — (B379) No. 2:</p>	<p>Is the resistance less than 1 Ω?</p>	<p>Go to step 3.</p>	<p>Repair the open circuit of harness between ECM and front oxygen (A/F) sensor connector.</p>
<p>3</p> <p>CHECK GROUND CIRCUIT FOR ECM.</p> <p>Measure the resistance of harness between ECM and chassis ground.</p> <p>Connector & terminal (B134) No. 5 — Chassis ground: (B137) No. 1 — Chassis ground: (B137) No. 2 — Chassis ground: (B137) No. 3 — Chassis ground: (B137) No. 7 — Chassis ground:</p>	<p>Is the resistance less than 5 Ω?</p>	<p>Go to step 4.</p>	<p>Repair the harness and connector.</p> <p>NOTE: In this case, repair the following item:</p> <ul style="list-style-type: none"> • Open circuit of harness between ECM and engine ground • Poor contact of coupling connector
<p>4</p> <p>CHECK FRONT OXYGEN (A/F) SENSOR.</p> <p>Measure the resistance between front oxygen (A/F) sensor terminals.</p> <p>Terminals No. 2 — No. 1:</p>	<p>Is the resistance between 2 — 3 Ω?</p>	<p>Repair poor contact of the ECM connector.</p>	<p>Replace the front oxygen (A/F) sensor. <Ref. to FU(H4DOTC)-43, Front Oxygen (A/F) Sensor.></p>

Diagnostic Procedure with Diagnostic Trouble Code (DTC)

ENGINE (DIAGNOSTICS)

G: DTC P0032 HO2S HEATER CONTROL CIRCUIT HIGH (BANK 1 SENSOR 1)

DTC DETECTING CONDITION:

- Immediately at fault recognition
- GENERAL DESCRIPTION <Ref. to GD(H4DOTC)-18, DTC P0032 HO2S HEATER CONTROL CIRCUIT HIGH (BANK 1 SENSOR 1), Diagnostic Trouble Code (DTC) Detecting Criteria.>

CAUTION:

After repair or replacement of faulty parts, perform Clear Memory Mode <Ref. to EN(H4DOTC)(diag)-52, OPERATION, Clear Memory Mode.> and Inspection Mode <Ref. to EN(H4DOTC)(diag)-42, PROCEDURE, Inspection Mode.>.

WIRING DIAGRAM:

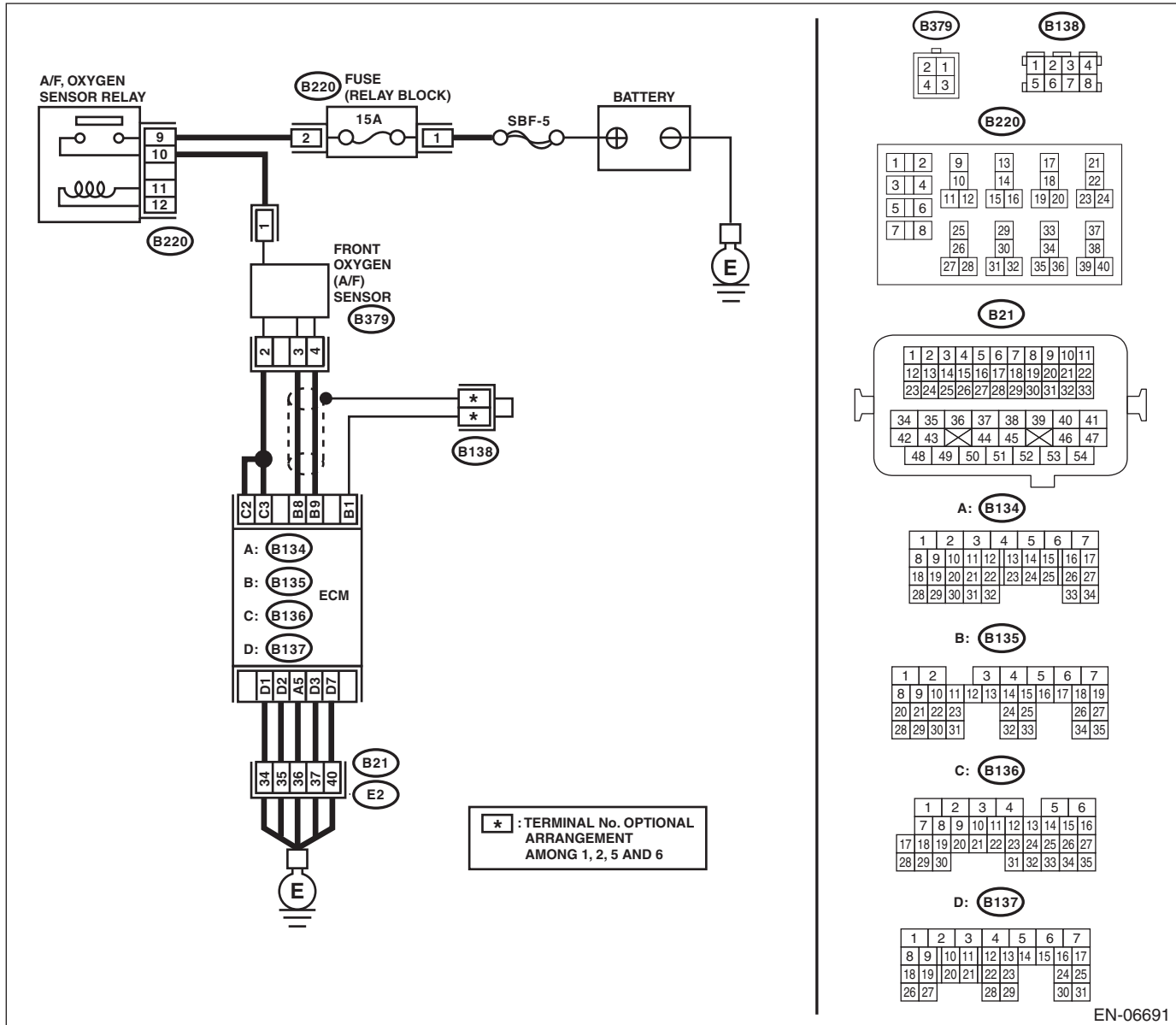

Diagnostic Procedure with Diagnostic Trouble Code (DTC)

ENGINE (DIAGNOSTICS)

Step	Check	Yes	No
<p>1 CHECK HARNESS BETWEEN ECM AND FRONT OXYGEN (A/F) SENSOR. 1) Turn the ignition switch to OFF. 2) Measure the voltage between ECM and chassis ground. Connector & terminal (B136) No. 3 (+) — Chassis ground (-): (B136) No. 2 (+) — Chassis ground (-):</p>	<p>Is the voltage 10 V or more?</p>	<p>Repair the short circuit to power in the harness between the ECM and front oxygen (A/F) sensor connector.</p>	<p>Go to step 2.</p>
<p>2 CHECK GROUND CIRCUIT FOR ECM. 1) Disconnect the connectors from the ECM. 2) Measure the resistance between ECM and chassis ground. Connector & terminal (B134) No. 5 — Chassis ground: (B137) No. 1 — Chassis ground: (B137) No. 2 — Chassis ground: (B137) No. 3 — Chassis ground: (B137) No. 7 — Chassis ground:</p>	<p>Is the resistance less than 5 Ω?</p>	<p>Repair the poor contact of the ECM connector.</p>	<p>Repair the harness and connector. NOTE: In this case, repair the following item: • Open circuit of harness between ECM and engine ground • Poor contact of coupling connector</p>

Diagnostic Procedure with Diagnostic Trouble Code (DTC)

ENGINE (DIAGNOSTICS)

H: DTC P0037 HO2S HEATER CONTROL CIRCUIT LOW (BANK 1 SENSOR 2)

DTC DETECTING CONDITION:

- Detected when two consecutive driving cycles with fault occur.
- GENERAL DESCRIPTION <Ref. to GD(H4DOTC)-20, DTC P0037 HO2S HEATER CONTROL CIRCUIT LOW (BANK 1 SENSOR 2), Diagnostic Trouble Code (DTC) Detecting Criteria.>

CAUTION:

After repair or replacement of faulty parts, perform Clear Memory Mode <Ref. to EN(H4DOTC)(diag)-52, OPERATION, Clear Memory Mode.> and Inspection Mode <Ref. to EN(H4DOTC)(diag)-42, PROCEDURE, Inspection Mode.>.

WIRING DIAGRAM:

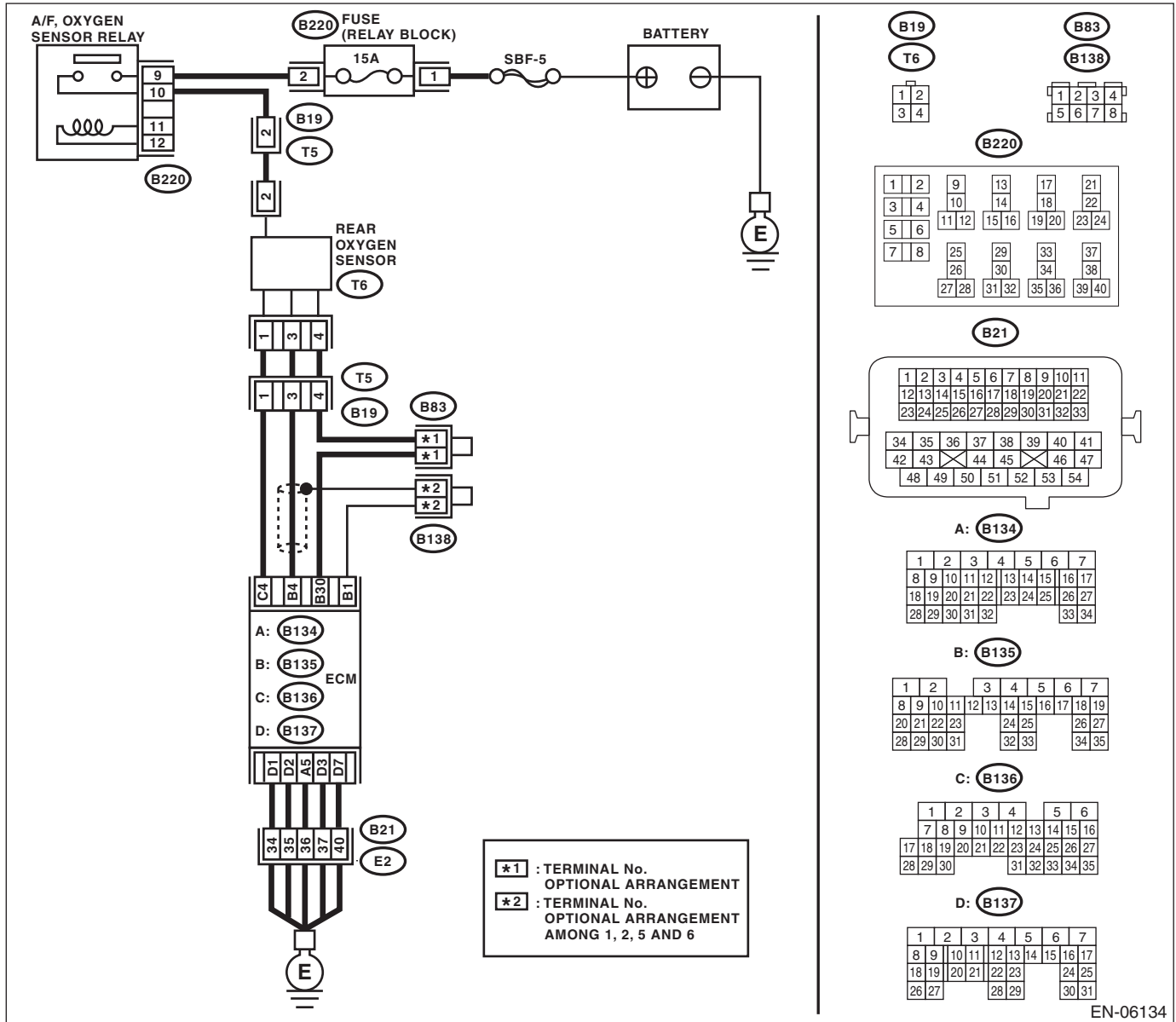

EN-06134

Diagnostic Procedure with Diagnostic Trouble Code (DTC)

ENGINE (DIAGNOSTICS)

	Step	Check	Yes	No
1	<p>CHECK POWER SUPPLY TO REAR OXYGEN SENSOR.</p> <p>1) Turn the ignition switch to OFF. 2) Disconnect the connector from the rear oxygen sensor. 3) Turn the ignition switch to ON. 4) Measure the voltage between rear oxygen sensor connector and engine ground.</p> <p>Connector & terminal (T6) No. 2 (+) — Engine ground (-):</p>	Is the voltage 10 V or more?	Go to step 2.	<p>Repair the power supply line. Or replace the main relay.</p> <p>NOTE: In this case, repair the following item:</p> <ul style="list-style-type: none"> • Open circuit in harness between A/F, oxygen sensor relay and rear oxygen sensor connector • Poor contact of A/F, oxygen sensor relay connector • Poor contact of coupling connector
2	<p>CHECK HARNESS BETWEEN ECM AND REAR OXYGEN SENSOR.</p> <p>1) Turn the ignition switch to OFF. 2) Disconnect the connectors from the ECM. 3) Measure the resistance between ECM and oxygen sensor connector.</p> <p>Connector & terminal (B136) No. 4 — (T6) No. 1:</p>	Is the resistance less than 1 Ω ?	Go to step 3.	<p>Repair the harness and connector.</p> <p>NOTE: In this case, repair the following item:</p> <ul style="list-style-type: none"> • Open circuit in harness between ECM and rear oxygen sensor connector • Poor contact of coupling connector
3	<p>CHECK GROUND CIRCUIT FOR ECM.</p> <p>Measure the resistance of harness between ECM and chassis ground.</p> <p>Connector & terminal (B134) No. 5 — Chassis ground: (B137) No. 1 — Chassis ground: (B137) No. 2 — Chassis ground: (B137) No. 3 — Chassis ground: (B137) No. 7 — Chassis ground:</p>	Is the resistance less than 5 Ω ?	Go to step 4.	<p>Repair the harness and connector.</p> <p>NOTE: In this case, repair the following item:</p> <ul style="list-style-type: none"> • Open circuit of harness between ECM and engine ground • Poor contact of coupling connector
4	<p>CHECK REAR OXYGEN SENSOR.</p> <p>Measure the resistance between rear oxygen sensor terminals.</p> <p>Terminals No. 1 — No. 2:</p>	Is the resistance between 5 — 7 Ω ?	Repair poor contact of the ECM connector.	<p>Replace the rear oxygen sensor.</p> <p><Ref. to FU(H4DOTC)-45, Rear Oxygen Sensor.></p>

Diagnostic Procedure with Diagnostic Trouble Code (DTC)

ENGINE (DIAGNOSTICS)

Step	Check	Yes	No
1 CHECK HARNESS BETWEEN ECM AND REAR OXYGEN SENSOR. 1) Turn the ignition switch to OFF. 2) Measure the voltage between ECM and chassis ground. Connector & terminal (B136) No. 4 (+) — Chassis ground (-):	Is the voltage 10 V or more?	Repair the short circuit to power in the harness between ECM and rear oxygen sensor connector.	Go to step 2.
2 CHECK GROUND CIRCUIT FOR ECM. 1) Disconnect the connectors from the ECM. 2) Measure the resistance between ECM and chassis ground. Connector & terminal (B134) No. 5 — Chassis ground: (B137) No. 1 — Chassis ground: (B137) No. 2 — Chassis ground: (B137) No. 3 — Chassis ground: (B137) No. 7 — Chassis ground:	Is the resistance less than 5 Ω ?	Repair the poor contact of the ECM connector.	Repair the harness and connector. NOTE: In this case, repair the following item: <ul style="list-style-type: none">• Open circuit of harness between ECM and engine ground• Poor contact of coupling connector

Diagnostic Procedure with Diagnostic Trouble Code (DTC)

ENGINE (DIAGNOSTICS)

J: DTC P0068 MAP/MAF - THROTTLE POSITION CORRELATION

DTC DETECTING CONDITION:

- Detected when two consecutive driving cycles with fault occur.
- GENERAL DESCRIPTION <Ref. to GD(H4DOTC)-24, DTC P0068 MAP/MAF - THROTTLE POSITION CORRELATION, Diagnostic Trouble Code (DTC) Detecting Criteria.>

CAUTION:

After repair or replacement of faulty parts, perform Clear Memory Mode <Ref. to EN(H4DOTC)(diag)-52, OPERATION, Clear Memory Mode.> and Inspection Mode <Ref. to EN(H4DOTC)(diag)-42, PROCEDURE, Inspection Mode.>.

WIRING DIAGRAM:

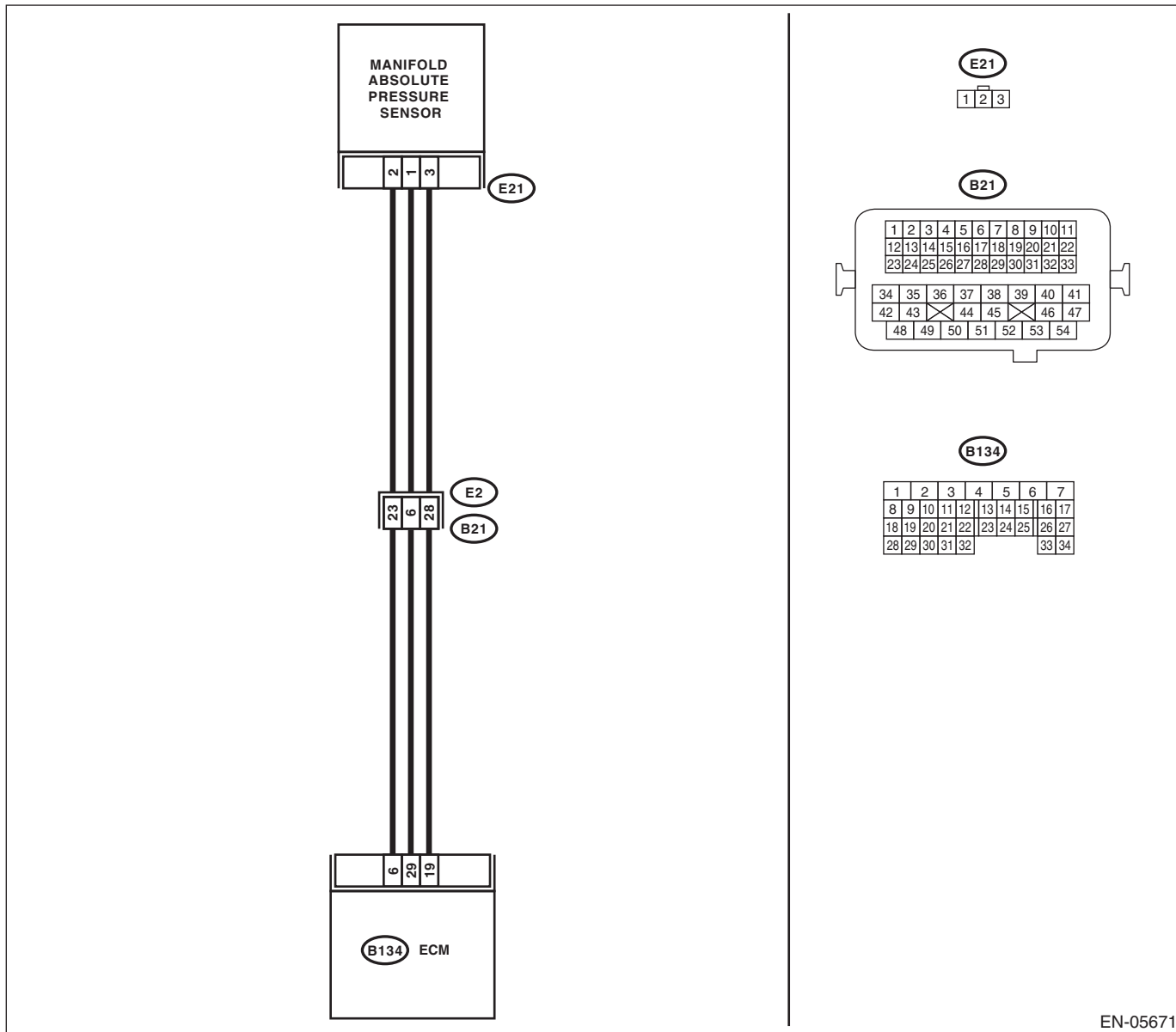

EN-05671

Diagnostic Procedure with Diagnostic Trouble Code (DTC)

ENGINE (DIAGNOSTICS)

Step	Check	Yes	No
1 CHECK AIR INTAKE SYSTEM.	Are there holes, loose bolts or disconnection of hose on air intake system?	Repair the air intake system.	Go to step 2.
2 CHECK MANIFOLD ABSOLUTE PRESSURE SENSOR. 1) Start the engine and warm up engine until coolant temperature is higher than 75°C (167°F). 2) Place the select lever in “P” range or “N” range. 3) Turn the A/C switch to OFF. 4) Turn all the accessory switches to OFF. 5) Read the data of intake manifold pressure sensor signal using Subaru Select Monitor or general scan tool. NOTE: <ul style="list-style-type: none"> • Subaru Select Monitor For detailed operation procedures, refer to “READ CURRENT DATA FOR ENGINE”. <Ref. to EN(H4DOTC)(diag)-34, Subaru Select Monitor.> <ul style="list-style-type: none"> • General scan tool For detailed operation procedures, refer to the “General Scan Tool Instruction Manual”.	Is the measured value 73.3 — 106.6 kPa (550 — 800 mmHg, 21.65 — 31.50 inHg) when the ignition is turned ON, and 20.0 — 46.7 kPa (150 — 350 mmHg, 5.91 — 13.78 inHg) during idling?	Go to step 3.	Replace the manifold absolute pressure sensor. <Ref. to FU(H4DOTC)-35, Manifold Absolute Pressure Sensor.>
3 CHECK THROTTLE OPENING ANGLE. Read the data of throttle position signal using Subaru Select Monitor or general scan tool. NOTE: <ul style="list-style-type: none"> • Subaru Select Monitor For detailed operation procedures, refer to “READ CURRENT DATA FOR ENGINE”. <Ref. to EN(H4DOTC)(diag)-34, Subaru Select Monitor.> <ul style="list-style-type: none"> • General scan tool For detailed operation procedures, refer to the “General Scan Tool Instruction Manual”.	Is the measured value less than 5% when throttle is fully closed?	Go to step 4.	Replace the electronic throttle control. <Ref. to FU(H4DOTC)-13, Throttle Body.>
4 CHECK THROTTLE OPENING ANGLE.	Is the measured value 85% or more when throttle is fully open?	Replace the manifold absolute pressure sensor. <Ref. to FU(H4DOTC)-35, Manifold Absolute Pressure Sensor.>	Replace the electronic throttle control. <Ref. to FU(H4DOTC)-13, Throttle Body.>

Diagnostic Procedure with Diagnostic Trouble Code (DTC)

ENGINE (DIAGNOSTICS)

K: DTC P0101 MASS OR VOLUME AIR FLOW CIRCUIT RANGE/PERFORMANCE

DTC DETECTING CONDITION:

- Detected when two consecutive driving cycles with fault occur.
- GENERAL DESCRIPTION <Ref. to GD(H4DOTC)-26, DTC P0101 MASS OR VOLUME AIR FLOW CIRCUIT RANGE/PERFORMANCE, Diagnostic Trouble Code (DTC) Detecting Criteria.>

TROUBLE SYMPTOM:

- Improper idling
- Engine stalls.
- Poor driving performance

CAUTION:

After repair or replacement of faulty parts, perform Clear Memory Mode <Ref. to EN(H4DOTC)(diag)-52, OPERATION, Clear Memory Mode.> and Inspection Mode <Ref. to EN(H4DOTC)(diag)-42, PROCEDURE, Inspection Mode.>.

WIRING DIAGRAM:

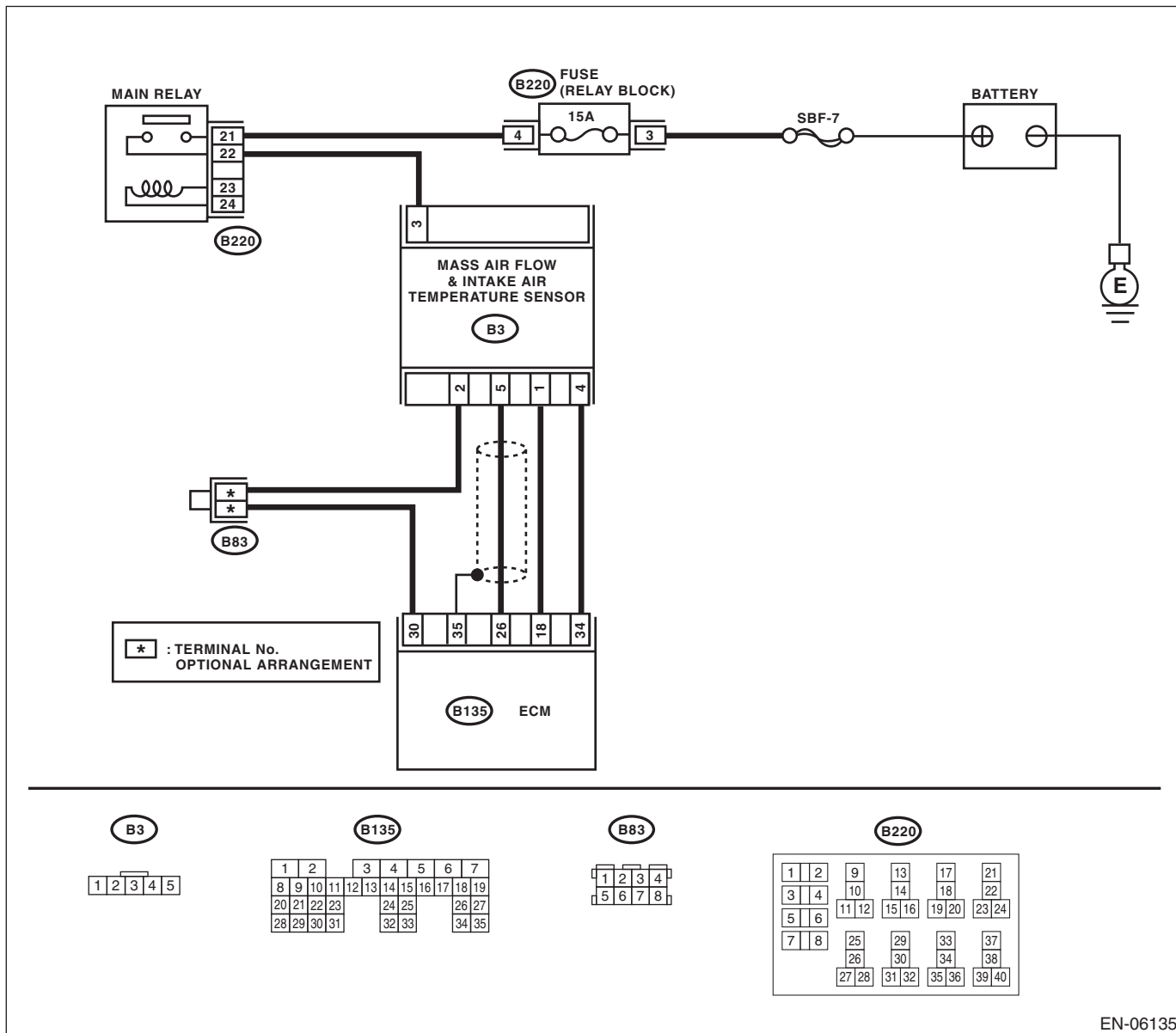

EN-06135

Diagnostic Procedure with Diagnostic Trouble Code (DTC)

ENGINE (DIAGNOSTICS)

Step	Check	Yes	No
1 CHECK FOR ANY OTHER DTC ON DISPLAY.	Is any other DTC displayed?	Check the appropriate DTC using the "List of Diagnostic Trouble Code (DTC)". <Ref. to EN(H4DOTC)(diag)-80, List of Diagnostic Trouble Code (DTC).>	Replace the mass air flow and intake air temperature sensor. <Ref. to FU(H4DOTC)-34, Mass Air Flow and Intake Air Temperature Sensor.>

Diagnostic Procedure with Diagnostic Trouble Code (DTC)

ENGINE (DIAGNOSTICS)

L: DTC P0102 MASS OR VOLUME AIR FLOW CIRCUIT LOW INPUT

DTC DETECTING CONDITION:

- Immediately at fault recognition
- GENERAL DESCRIPTION <Ref. to GD(H4DOTC)-28, DTC P0102 MASS OR VOLUME AIR FLOW CIRCUIT LOW INPUT, Diagnostic Trouble Code (DTC) Detecting Criteria.>

TROUBLE SYMPTOM:

- Improper idling
- Engine stalls.
- Poor driving performance

CAUTION:

After repair or replacement of faulty parts, perform Clear Memory Mode <Ref. to EN(H4DOTC)(diag)-52, OPERATION, Clear Memory Mode.> and Inspection Mode <Ref. to EN(H4DOTC)(diag)-42, PROCEDURE, Inspection Mode.>.

WIRING DIAGRAM:

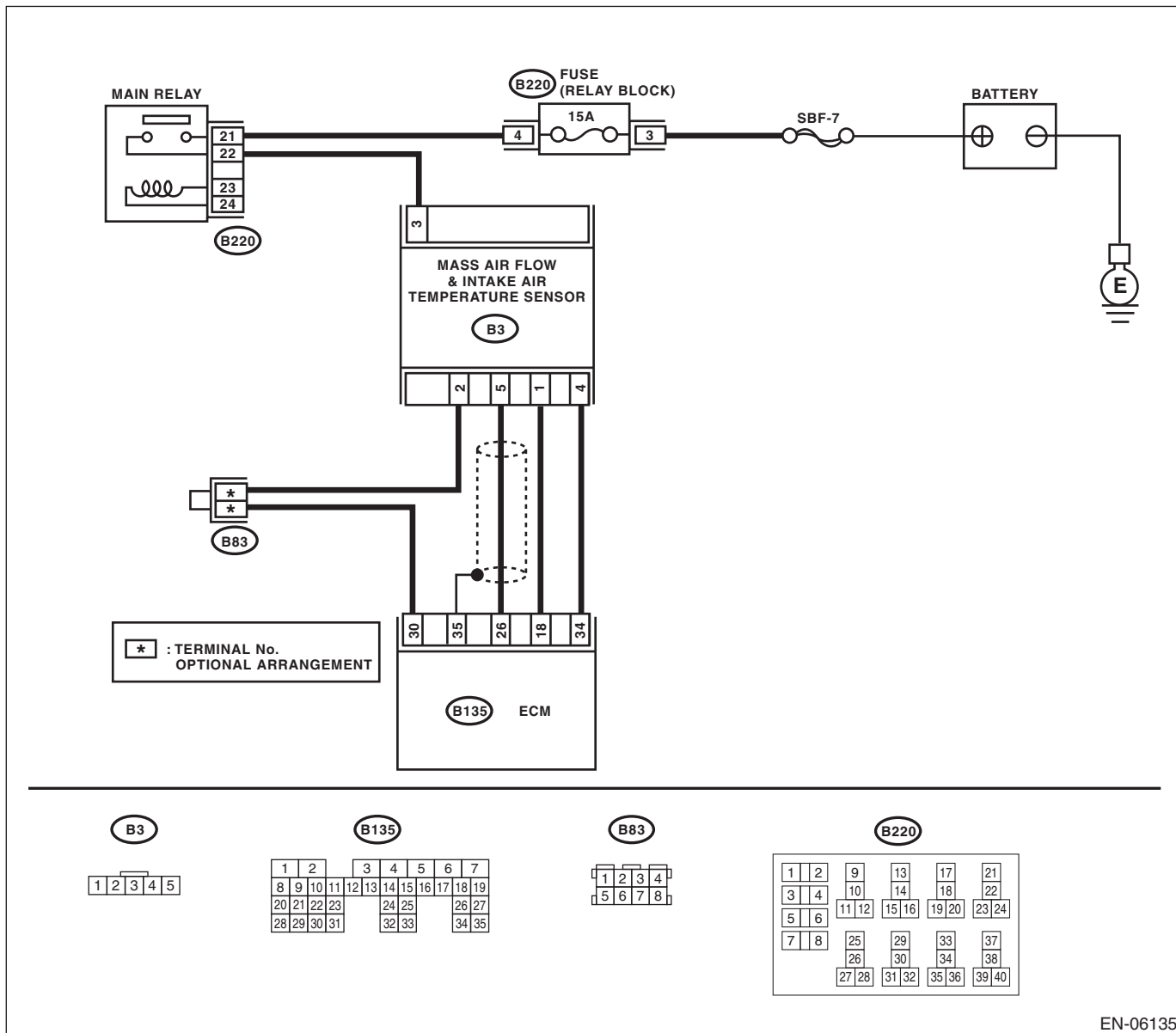

EN-06135

Diagnostic Procedure with Diagnostic Trouble Code (DTC)

ENGINE (DIAGNOSTICS)

Step	Check	Yes	No
1 CHECK CURRENT DATA. 1) Start the engine. 2) Read the data of air flow sensor signal using the Subaru Select Monitor or general scan tool. NOTE: • Subaru Select Monitor For detailed operation procedures, refer to "READ CURRENT DATA FOR ENGINE". <Ref. to EN(H4DOTC)(diag)-34, Subaru Select Monitor.> • General scan tool For detailed operation procedures, refer to the general scan tool operation manual.	Is the voltage less than 0.2 V?	Go to step 2.	Even if the malfunction indicator light illuminates, the circuit has returned to a normal condition at this time. Reproduce the fault condition, and reperform the check. NOTE: In this case, there may be a temporary connector contact failure.
2 CHECK POWER SUPPLY OF MASS AIR FLOW AND INTAKE AIR TEMPERATURE SENSOR. 1) Turn the ignition switch to OFF. 2) Disconnect the connector from the mass air flow and intake air temperature sensor. 3) Turn the ignition switch to ON. 4) Measure the voltage between mass air flow and intake air temperature sensor connector and engine ground. Connector & terminal (B3) No. 3 (+) — Engine ground (-):	Is the voltage 10 V or more?	Go to step 3.	Repair the harness and connector. NOTE: In this case, repair the following item: • Open circuit in harness between main relay connector and mass air flow and intake air temperature sensor connector • Poor contact of main relay connector
3 CHECK HARNESS BETWEEN ECM, MASS AIR FLOW AND INTAKE AIR TEMPERATURE SENSOR CONNECTORS. 1) Turn the ignition switch to OFF. 2) Disconnect the connectors from the ECM. 3) Measure the resistance of harness between ECM and the mass air flow and intake air temperature sensor connector. Connector & terminal (B135) No. 26 — (B3) No. 5:	Is the resistance less than 1 Ω?	Go to step 4.	Repair the open circuit of harness between the ECM and the mass air flow and intake air temperature sensor connector.
4 CHECK HARNESS BETWEEN ECM, MASS AIR FLOW AND INTAKE AIR TEMPERATURE SENSOR CONNECTORS. Measure the resistance between ECM and chassis ground. Connector & terminal (B135) No. 26 — Chassis ground:	Is the resistance 1 MΩ or more?	Go to step 5.	Repair the ground short circuit of harness between the ECM and the mass air flow and intake air temperature sensor connector.
5 CHECK POOR CONTACT. Check for any poor contact in the ECM or the mass air flow & intake air temperature sensor connectors.	Is there poor contact in the ECM or the mass air flow & intake air temperature sensor connectors?	Repair any poor contact in the ECM or the mass air flow & intake air temperature sensor connectors.	Replace the mass air flow and intake air temperature sensor. <Ref. to FU(H4DOTC)-34, Mass Air Flow and Intake Air Temperature Sensor.>

Diagnostic Procedure with Diagnostic Trouble Code (DTC)

ENGINE (DIAGNOSTICS)

M: DTC P0103 MASS OR VOLUME AIR FLOW CIRCUIT HIGH INPUT

DTC DETECTING CONDITION:

- Immediately at fault recognition
- GENERAL DESCRIPTION <Ref. to GD(H4DOTC)-29, DTC P0103 MASS OR VOLUME AIR FLOW CIRCUIT HIGH INPUT, Diagnostic Trouble Code (DTC) Detecting Criteria.>

TROUBLE SYMPTOM:

- Improper idling
- Engine stalls.
- Poor driving performance

CAUTION:

After repair or replacement of faulty parts, perform Clear Memory Mode <Ref. to EN(H4DOTC)(diag)-52, OPERATION, Clear Memory Mode.> and Inspection Mode <Ref. to EN(H4DOTC)(diag)-42, PROCEDURE, Inspection Mode.>.

WIRING DIAGRAM:

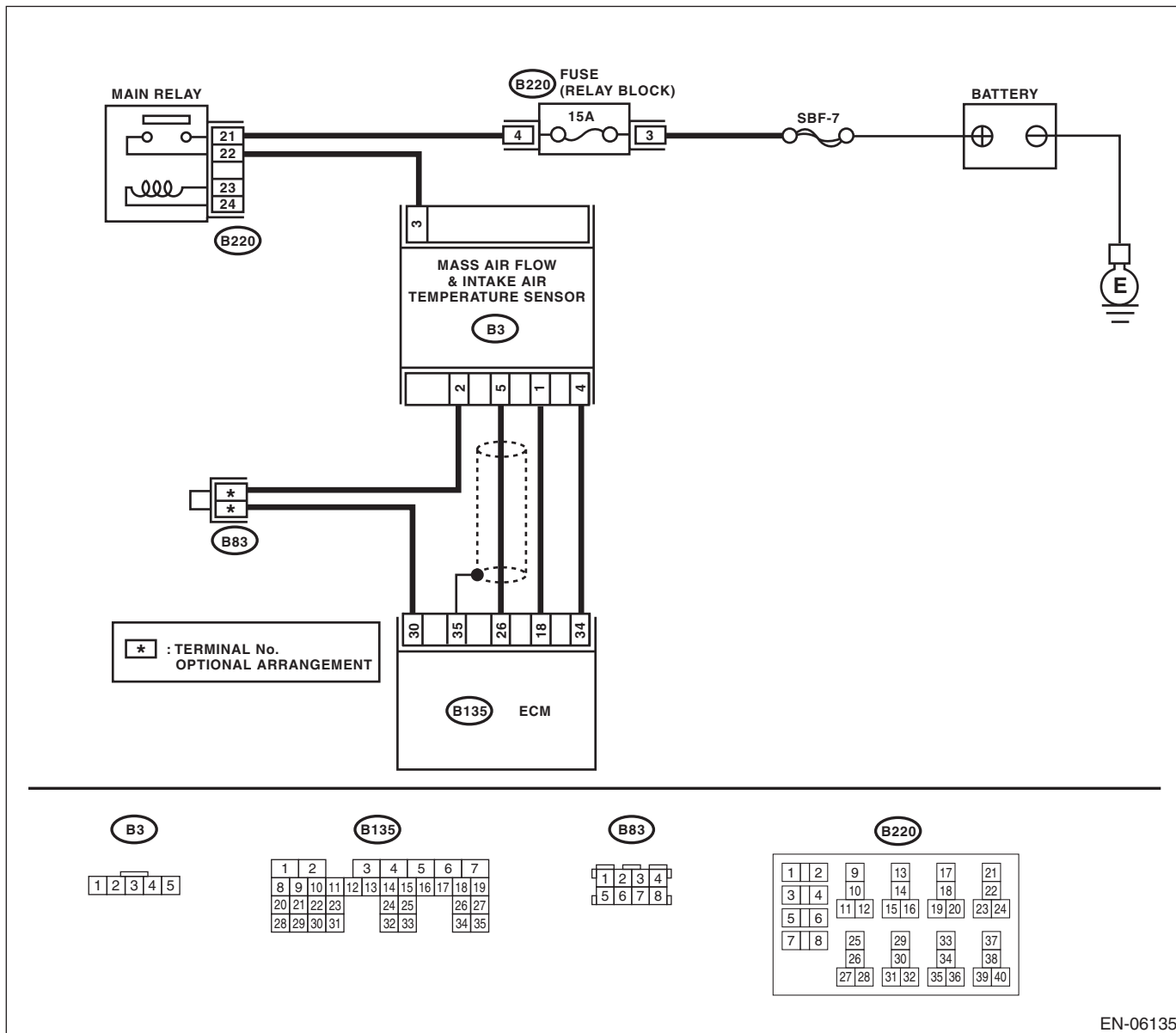

EN-06135

Diagnostic Procedure with Diagnostic Trouble Code (DTC)

ENGINE (DIAGNOSTICS)

Step	Check	Yes	No
<p>1 CHECK CURRENT DATA.</p> <p>1) Start the engine.</p> <p>2) Read the data of air flow sensor signal using the Subaru Select Monitor or general scan tool.</p> <p>NOTE:</p> <ul style="list-style-type: none"> Subaru Select Monitor <p>For detailed operation procedures, refer to "READ CURRENT DATA FOR ENGINE". <Ref. to EN(H4DOTC)(diag)-34, Subaru Select Monitor.></p> <ul style="list-style-type: none"> General scan tool <p>For detailed operation procedures, refer to the general scan tool operation manual.</p>	<p>Is the voltage 5 V or more?</p>	<p>Go to step 2.</p>	<p>Even if the malfunction indicator light illuminates, the circuit has returned to a normal condition at this time. Reproduce the fault condition, and reperform the check.</p> <p>NOTE:</p> <p>In this case, there may be a temporary connector contact failure.</p>
<p>2 CHECK HARNESS BETWEEN ECM, MASS AIR FLOW AND INTAKE AIR TEMPERATURE SENSOR CONNECTORS.</p> <p>1) Turn the ignition switch to OFF.</p> <p>2) Disconnect the connector from the mass air flow and intake air temperature sensor.</p> <p>3) Start the engine.</p> <p>4) Read the data of air flow sensor signal using the Subaru Select Monitor or general scan tool.</p> <p>NOTE:</p> <ul style="list-style-type: none"> Subaru Select Monitor <p>For detailed operation procedures, refer to "READ CURRENT DATA FOR ENGINE". <Ref. to EN(H4DOTC)(diag)-34, Subaru Select Monitor.></p> <ul style="list-style-type: none"> General scan tool <p>For detailed operation procedures, refer to the general scan tool operation manual.</p>	<p>Is the voltage 5 V or more?</p>	<p>Repair the short circuit to power in the harness between the ECM and the mass air flow & intake air temperature sensor connectors.</p>	<p>Go to step 3.</p>
<p>3 CHECK HARNESS BETWEEN ECM, MASS AIR FLOW AND INTAKE AIR TEMPERATURE SENSOR CONNECTORS.</p> <p>1) Turn the ignition switch to OFF.</p> <p>2) Measure the resistance of harness between the mass air flow and intake air temperature sensor connector and engine ground.</p> <p>Connector & terminal</p> <p>(B3) No. 4 — Engine ground:</p>	<p>Is the resistance less than 5 Ω?</p>	<p>Go to step 4.</p>	<p>Repair the harness and connector.</p> <p>NOTE:</p> <p>In this case, repair the following item:</p> <ul style="list-style-type: none"> Open circuit of harness between ECM, mass air flow and intake air temperature sensor connectors. Poor contact in ECM connector
<p>4 CHECK POOR CONTACT.</p> <p>Check for any poor contact between the mass air flow and intake air temperature sensor connectors.</p>	<p>Is there poor contact in the mass air flow and intake air temperature sensor connectors?</p>	<p>Repair any poor contact of the mass air flow and intake air temperature sensor connectors.</p>	<p>Replace the mass air flow and intake air temperature sensor. <Ref. to FU(H4DOTC)-34, Mass Air Flow and Intake Air Temperature Sensor.></p>

Diagnostic Procedure with Diagnostic Trouble Code (DTC)

ENGINE (DIAGNOSTICS)

N: DTC P0107 MANIFOLD ABSOLUTE PRESSURE/BAROMETRIC PRESSURE CIRCUIT LOW INPUT

DTC DETECTING CONDITION:

- Immediately at fault recognition
- GENERAL DESCRIPTION <Ref. to GD(H4DOTC)-30, DTC P0107 MANIFOLD ABSOLUTE PRESSURE/BAROMETRIC PRESSURE CIRCUIT LOW INPUT, Diagnostic Trouble Code (DTC) Detecting Criteria.>

CAUTION:

After repair or replacement of faulty parts, perform Clear Memory Mode <Ref. to EN(H4DOTC)(diag)-52, OPERATION, Clear Memory Mode.> and Inspection Mode <Ref. to EN(H4DOTC)(diag)-42, PROCEDURE, Inspection Mode.>.

WIRING DIAGRAM:

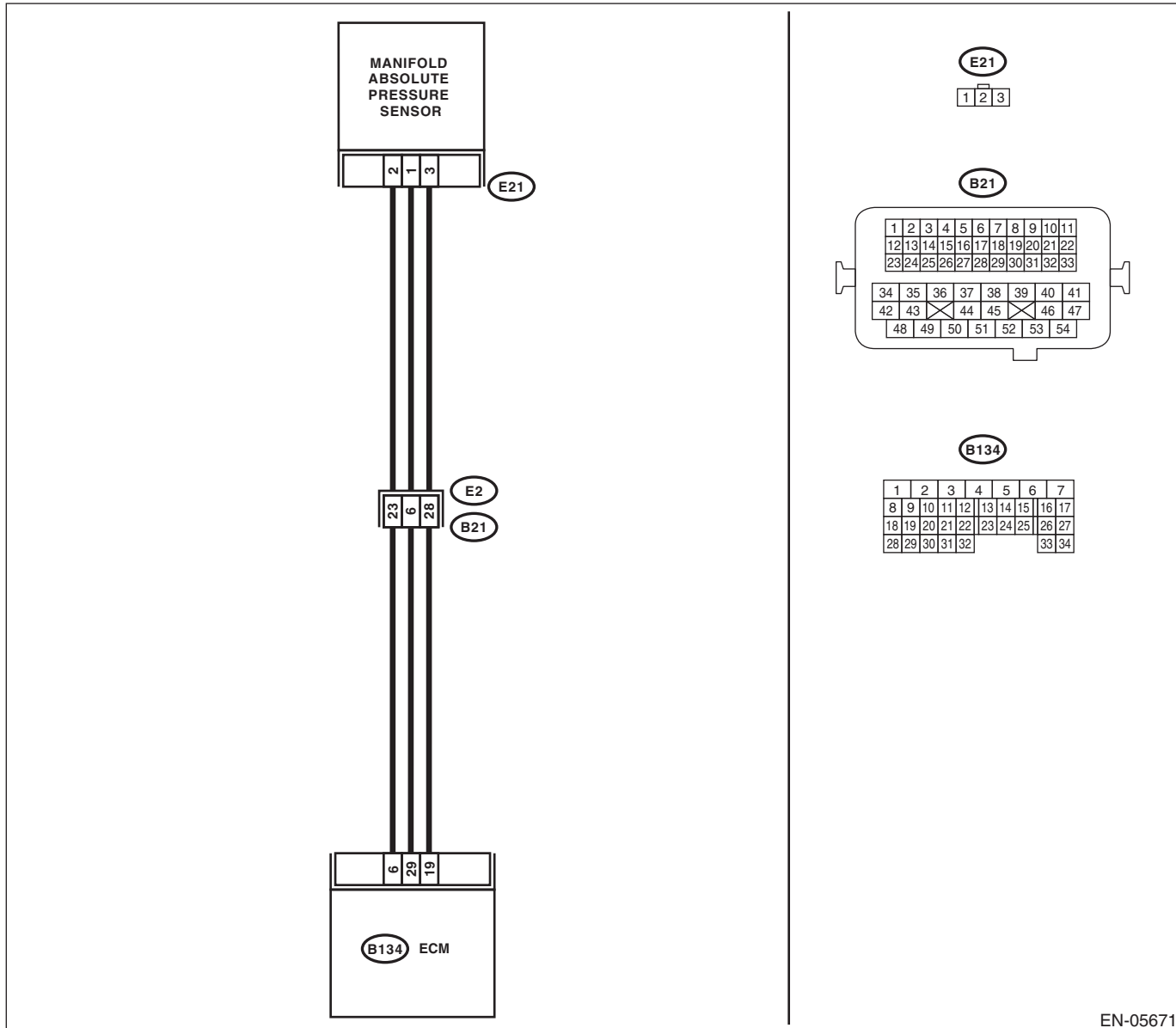

EN-05671

Diagnostic Procedure with Diagnostic Trouble Code (DTC)

ENGINE (DIAGNOSTICS)

Step	Check	Yes	No
<p>1</p> <p>CHECK CURRENT DATA.</p> <p>1) Start the engine.</p> <p>2) Read the data of intake manifold absolute pressure signal using Subaru Select Monitor or general scan tool.</p> <p>NOTE:</p> <ul style="list-style-type: none"> • Subaru Select Monitor <p>For detailed operation procedures, refer to "READ CURRENT DATA FOR ENGINE". <Ref. to EN(H4DOTC)(diag)-34, Subaru Select Monitor.></p> <ul style="list-style-type: none"> • General scan tool <p>For detailed operation procedures, refer to the general scan tool operation manual.</p>	<p>Is the measured value less than 13.3 kPa (100 mmHg, 3.94 inHg) ?</p>	<p>Go to step 2.</p>	<p>Even if the malfunction indicator light illuminates, the circuit has returned to a normal condition at this time. Reproduce the fault condition, and reperform the check.</p> <p>NOTE:</p> <p>In this case, there may be a temporary connector contact failure.</p>
<p>2</p> <p>CHECK POWER SUPPLY OF THE MANIFOLD ABSOLUTE PRESSURE SENSOR.</p> <p>1) Turn the ignition switch to OFF.</p> <p>2) Disconnect the connector from manifold absolute pressure sensor.</p> <p>3) Turn the ignition switch to ON.</p> <p>4) Measure the voltage between manifold absolute pressure sensor connector and engine ground.</p> <p>Connector & terminal (E21) No. 3 (+) — Engine ground (-):</p>	<p>Is the voltage 4.5 V or more?</p>	<p>Go to step 3.</p>	<p>Repair the harness and connector.</p> <p>NOTE:</p> <p>In this case, repair the following item:</p> <ul style="list-style-type: none"> • Open circuit of harness between ECM and manifold absolute pressure sensor connector. • Poor contact in ECM connector • Poor contact of coupling connector
<p>3</p> <p>CHECK HARNESS BETWEEN ECM AND MANIFOLD ABSOLUTE PRESSURE SENSOR CONNECTOR.</p> <p>1) Turn the ignition switch to OFF.</p> <p>2) Disconnect the connectors from the ECM.</p> <p>3) Measure the resistance of harness between ECM and manifold absolute pressure sensor connector.</p> <p>Connector & terminal (B134) No. 6 — (E21) No. 2:</p>	<p>Is the resistance less than 1 Ω?</p>	<p>Go to step 4.</p>	<p>Repair the harness and connector.</p> <p>NOTE:</p> <p>In this case, repair the following item:</p> <ul style="list-style-type: none"> • Open circuit of harness between ECM and manifold absolute pressure sensor connector. • Poor contact of coupling connector
<p>4</p> <p>CHECK HARNESS BETWEEN ECM AND MANIFOLD ABSOLUTE PRESSURE SENSOR CONNECTOR.</p> <p>Measure the resistance between ECM and chassis ground.</p> <p>Connector & terminal (B134) No. 6 — Chassis ground:</p>	<p>Is the resistance 1 MΩ or more?</p>	<p>Go to step 5.</p>	<p>Repair ground short circuit of harness between ECM and manifold absolute pressure sensor connector.</p>
<p>5</p> <p>CHECK POOR CONTACT.</p> <p>Check for poor contact between the ECM and manifold pressure sensor connector.</p>	<p>Is there poor contact in the ECM or manifold absolute pressure sensor connector?</p>	<p>Repair the poor contact in the ECM or manifold absolute pressure sensor connector.</p>	<p>Replace the manifold absolute pressure sensor. <Ref. to FU(H4DOTC)-35, Manifold Absolute Pressure Sensor.></p>

Diagnostic Procedure with Diagnostic Trouble Code (DTC)

ENGINE (DIAGNOSTICS)

O: DTC P0108 MANIFOLD ABSOLUTE PRESSURE/BAROMETRIC PRESSURE CIRCUIT HIGH INPUT

DTC DETECTING CONDITION:

- Immediately at fault recognition
- GENERAL DESCRIPTION <Ref. to GD(H4DOTC)-31, DTC P0108 MANIFOLD ABSOLUTE PRESSURE/BAROMETRIC PRESSURE CIRCUIT HIGH INPUT, Diagnostic Trouble Code (DTC) Detecting Criteria.>

CAUTION:

After repair or replacement of faulty parts, perform Clear Memory Mode <Ref. to EN(H4DOTC)(diag)-52, OPERATION, Clear Memory Mode.> and Inspection Mode <Ref. to EN(H4DOTC)(diag)-42, PROCEDURE, Inspection Mode.>.

WIRING DIAGRAM:

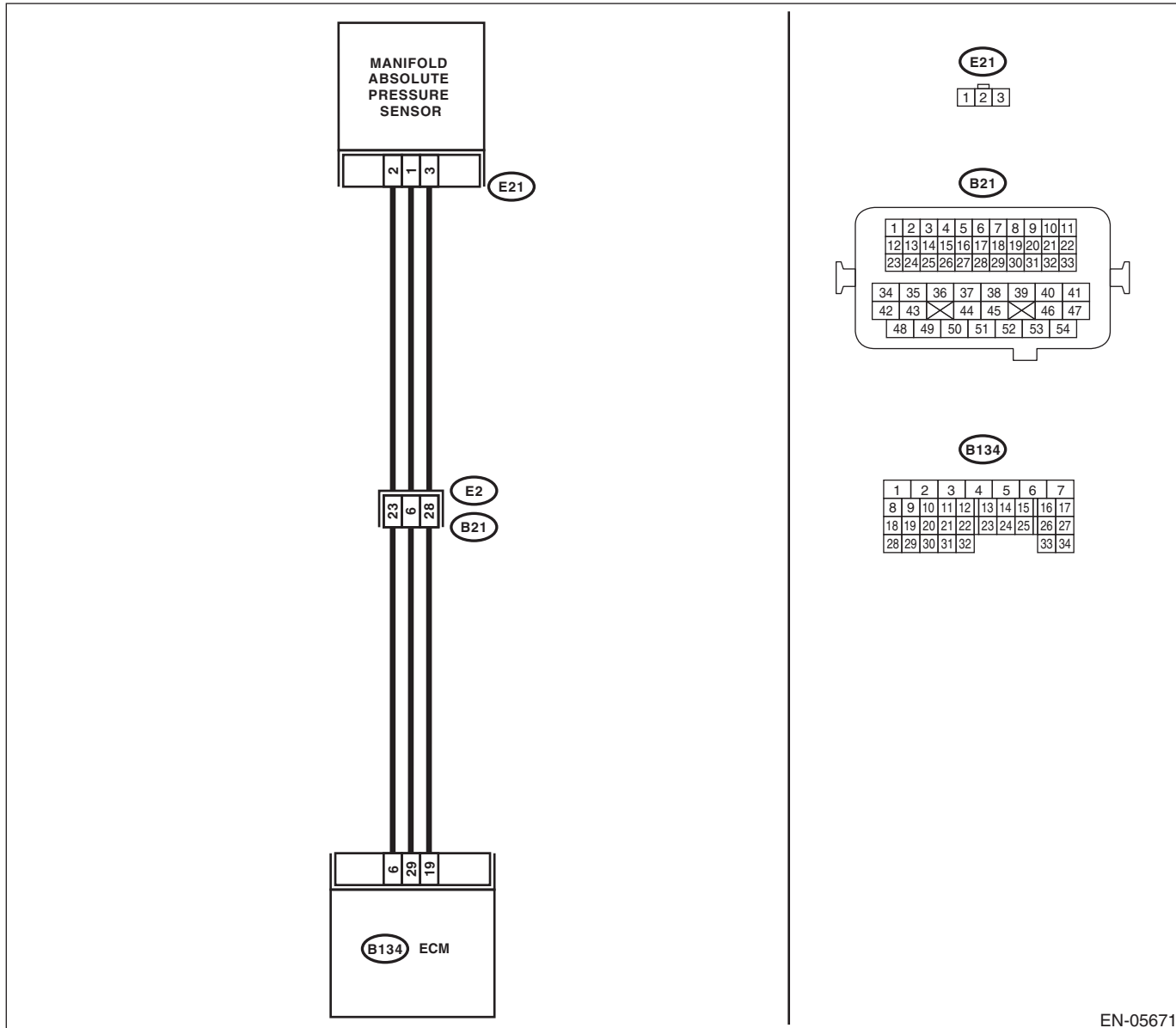

EN-05671

Diagnostic Procedure with Diagnostic Trouble Code (DTC)

ENGINE (DIAGNOSTICS)

Step	Check	Yes	No
<p>1</p> <p>CHECK CURRENT DATA.</p> <p>1) Start the engine.</p> <p>2) Read the data of intake manifold absolute pressure signal using Subaru Select Monitor or general scan tool.</p> <p>NOTE:</p> <ul style="list-style-type: none"> • Subaru Select Monitor <p>For detailed operation procedures, refer to "READ CURRENT DATA FOR ENGINE". <Ref. to EN(H4DOTC)(diag)-34, Subaru Select Monitor.></p> <ul style="list-style-type: none"> • General scan tool <p>For detailed operation procedures, refer to the general scan tool operation manual.</p>	<p>Is the measured value 119.5 kPa (896.5 mmHg, 35.29 inHg) or more?</p>	<p>Go to step 2.</p>	<p>Even if the malfunction indicator light illuminates, the circuit has returned to a normal condition at this time. Reproduce the fault condition, and reperform the check.</p> <p>NOTE:</p> <p>In this case, there may be a temporary connector contact failure.</p>
<p>2</p> <p>CHECK HARNESS BETWEEN ECM AND MANIFOLD ABSOLUTE PRESSURE SENSOR CONNECTOR.</p> <p>1) Turn the ignition switch to OFF.</p> <p>2) Disconnect the connector from manifold absolute pressure sensor.</p> <p>3) Start the engine.</p> <p>4) Read the data of intake manifold absolute pressure signal using Subaru Select Monitor or general scan tool.</p> <p>NOTE:</p> <ul style="list-style-type: none"> • Subaru Select Monitor <p>For detailed operation procedures, refer to "READ CURRENT DATA FOR ENGINE". <Ref. to EN(H4DOTC)(diag)-34, Subaru Select Monitor.></p> <ul style="list-style-type: none"> • General scan tool <p>For detailed operation procedures, refer to the general scan tool operation manual.</p>	<p>Is the measured value 119.5 kPa (896.5 mmHg, 35.29 inHg) or more?</p>	<p>Repair the short circuit to power in the harness between ECM and manifold absolute pressure sensor connector.</p>	<p>Go to step 3.</p>
<p>3</p> <p>CHECK HARNESS BETWEEN ECM AND MANIFOLD ABSOLUTE PRESSURE SENSOR CONNECTOR.</p> <p>1) Turn the ignition switch to OFF.</p> <p>2) Measure the resistance of harness between manifold absolute pressure sensor connector and engine ground.</p> <p>Connector & terminal (E21) No. 1 — Engine ground:</p>	<p>Is the resistance less than 5 Ω?</p>	<p>Go to step 4.</p>	<p>Repair the harness and connector.</p> <p>NOTE:</p> <p>In this case, repair the following item:</p> <ul style="list-style-type: none"> • Open circuit of harness between ECM and manifold absolute pressure sensor connector. • Poor contact in ECM connector • Poor contact of coupling connector
<p>4</p> <p>CHECK POOR CONTACT.</p> <p>Check for poor contact of the manifold absolute pressure sensor connector.</p>	<p>Is there poor contact in manifold absolute pressure sensor connector?</p>	<p>Repair the poor contact of manifold absolute pressure sensor connector.</p>	<p>Replace the manifold absolute pressure sensor. <Ref. to FU(H4DOTC)-35, Manifold Absolute Pressure Sensor.></p>

Diagnostic Procedure with Diagnostic Trouble Code (DTC)

ENGINE (DIAGNOSTICS)

P: DTC P0111 INTAKE AIR TEMPERATURE SENSOR 1 CIRCUIT RANGE/ PERFORMANCE

DTC DETECTING CONDITION:

- Detected when two consecutive driving cycles with fault occur.
- GENERAL DESCRIPTION <Ref. to GD(H4DOTC)-32, DTC P0111 INTAKE AIR TEMPERATURE SENSOR 1 CIRCUIT RANGE/PERFORMANCE, Diagnostic Trouble Code (DTC) Detecting Criteria.>

TROUBLE SYMPTOM:

- Improper idling
- Poor driving performance

CAUTION:

After repair or replacement of faulty parts, perform Clear Memory Mode <Ref. to EN(H4DOTC)(diag)-52, OPERATION, Clear Memory Mode.> and Inspection Mode <Ref. to EN(H4DOTC)(diag)-42, PROCEDURE, Inspection Mode.>.

WIRING DIAGRAM:

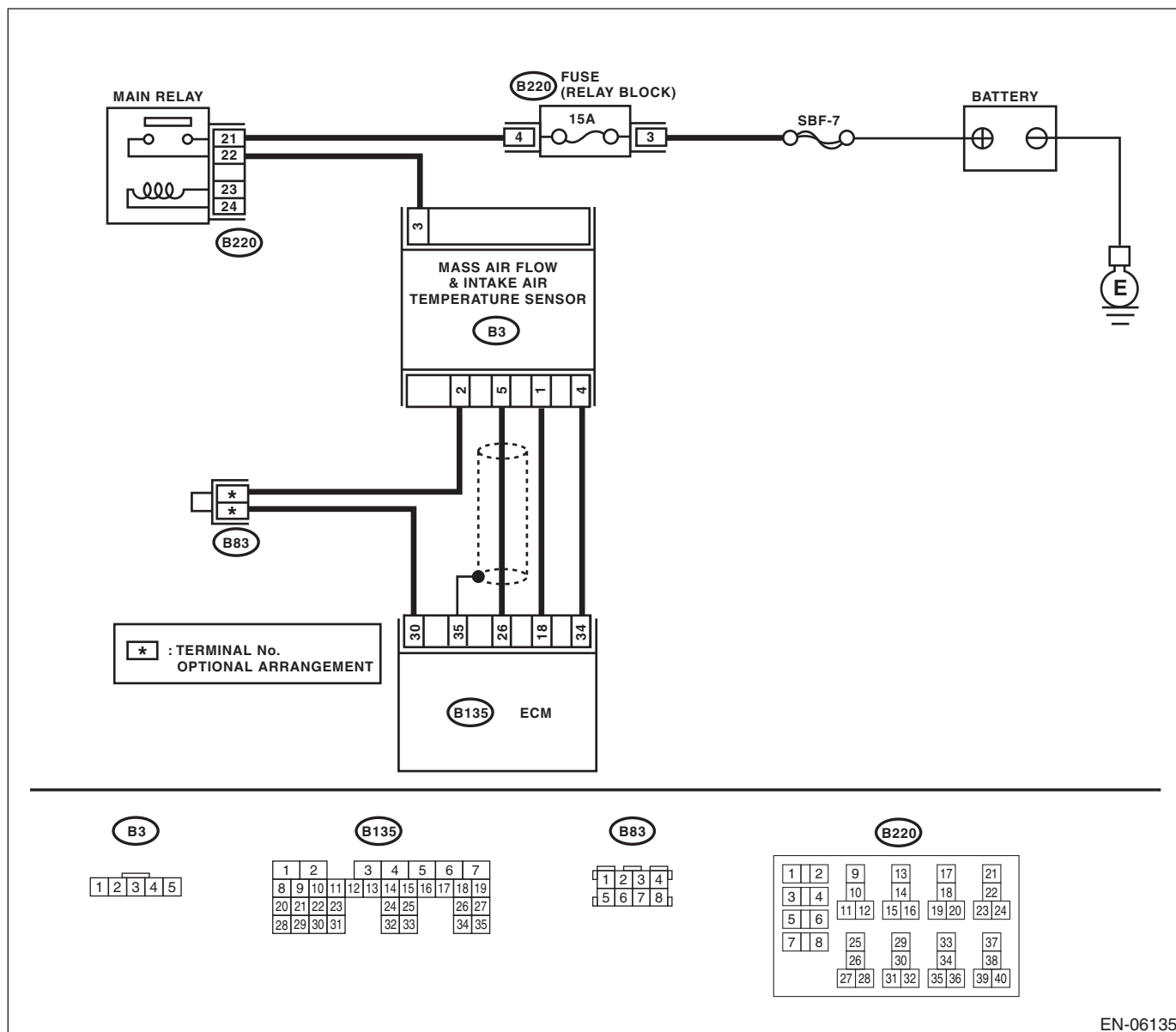

EN-06135

Diagnostic Procedure with Diagnostic Trouble Code (DTC)

ENGINE (DIAGNOSTICS)

	Step	Check	Yes	No
1	<p>CHECK ENGINE COOLANT TEMPERATURE.</p> <p>1) Start the engine and warm up completely. 2) Measure the engine coolant temperature using the Subaru Select Monitor or general scan tool.</p> <p>NOTE:</p> <ul style="list-style-type: none">• Subaru Select Monitor <p>For detailed operation procedures, refer to "READ CURRENT DATA FOR ENGINE". <Ref. to EN(H4DOTC)(diag)-34, Subaru Select Monitor.></p> <ul style="list-style-type: none">• General scan tool <p>For detailed operation procedures, refer to the general scan tool operation manual.</p>	Is the engine coolant temperature 75°C (167°F) or higher?	Replace the mass air flow and intake air temperature sensor. <Ref. to FU(H4DOTC)-34, Mass Air Flow and Intake Air Temperature Sensor.>	Check DTC P0125 using "List of Diagnostic Trouble Code (DTC)". <Ref. to EN(H4DOTC)(diag)-80, List of Diagnostic Trouble Code (DTC).>

Diagnostic Procedure with Diagnostic Trouble Code (DTC)

ENGINE (DIAGNOSTICS)

Q: DTC P0112 INTAKE AIR TEMPERATURE SENSOR 1 CIRCUIT LOW

DTC DETECTING CONDITION:

- Immediately at fault recognition
- GENERAL DESCRIPTION <Ref. to GD(H4DOTC)-34, DTC P0112 INTAKE AIR TEMPERATURE SENSOR 1 CIRCUIT LOW, Diagnostic Trouble Code (DTC) Detecting Criteria.>

TROUBLE SYMPTOM:

- Improper idling
- Poor driving performance

CAUTION:

After repair or replacement of faulty parts, perform Clear Memory Mode <Ref. to EN(H4DOTC)(diag)-52, OPERATION, Clear Memory Mode.> and Inspection Mode <Ref. to EN(H4DOTC)(diag)-42, PROCEDURE, Inspection Mode.>.

WIRING DIAGRAM:

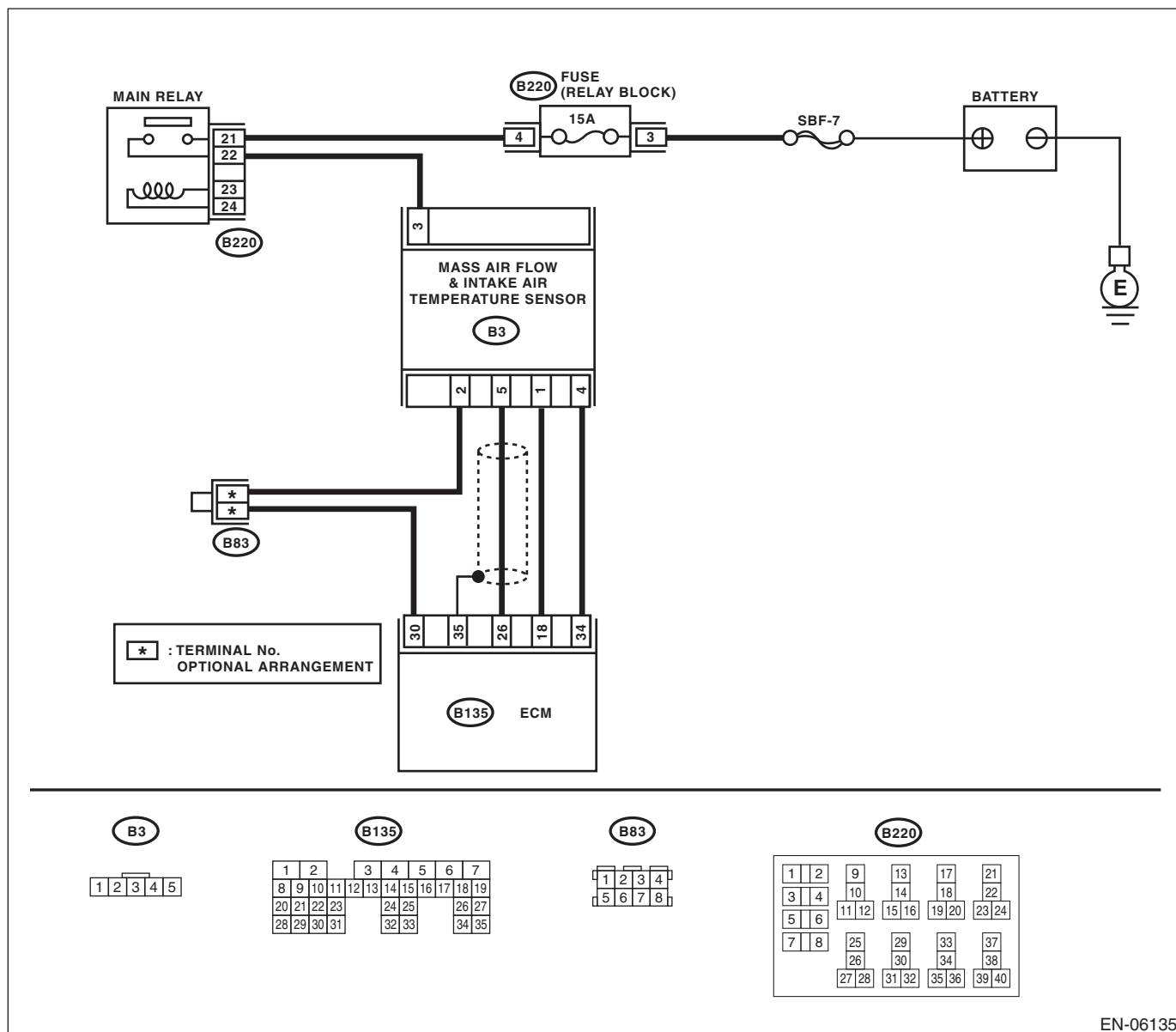

EN-06135

Diagnostic Procedure with Diagnostic Trouble Code (DTC)

ENGINE (DIAGNOSTICS)

	Step	Check	Yes	No
1	<p>CHECK CURRENT DATA.</p> <ol style="list-style-type: none"> 1) Start the engine. 2) Read the data of intake air temperature sensor signal using Subaru Select Monitor or general scan tool. <p>NOTE:</p> <ul style="list-style-type: none"> • Subaru Select Monitor <p>For detailed operation procedures, refer to "READ CURRENT DATA FOR ENGINE". <Ref. to EN(H4DOTC)(diag)-34, Subaru Select Monitor.></p> <ul style="list-style-type: none"> • General scan tool <p>For detailed operation procedures, refer to the general scan tool operation manual.</p>	<p>Is the intake air temperature 120°C (248°F) or more?</p>	<p>Go to step 2.</p>	<p>Even if the malfunction indicator light illuminates, the circuit has returned to a normal condition at this time. Reproduce the fault condition, and reperform the check.</p> <p>NOTE: In this case, there may be a temporary connector contact failure.</p>
2	<p>CHECK HARNESS BETWEEN ECM, MASS AIR FLOW AND INTAKE AIR TEMPERATURE SENSOR CONNECTORS.</p> <ol style="list-style-type: none"> 1) Turn the ignition switch to OFF. 2) Disconnect the connector from the ECM and the mass air flow & intake air temperature sensor. 3) Measure the resistance between ECM and chassis ground. <p>Connector & terminal (B135) No. 18 — Chassis ground:</p>	<p>Is the resistance 1 MΩ or more?</p>	<p>Replace the mass air flow and intake air temperature sensor. <Ref. to FU(H4DOTC)-34, Mass Air Flow and Intake Air Temperature Sensor.></p>	<p>Repair the ground short circuit of harness between the ECM and the mass air flow & intake air temperature sensor connectors.</p>

Diagnostic Procedure with Diagnostic Trouble Code (DTC)

ENGINE (DIAGNOSTICS)

R: DTC P0113 INTAKE AIR TEMPERATURE SENSOR 1 CIRCUIT HIGH

DTC DETECTING CONDITION:

- Immediately at fault recognition
- GENERAL DESCRIPTION <Ref. to GD(H4DOTC)-35, DTC P0113 INTAKE AIR TEMPERATURE SENSOR 1 CIRCUIT HIGH, Diagnostic Trouble Code (DTC) Detecting Criteria.>

TROUBLE SYMPTOM:

- Improper idling
- Poor driving performance

CAUTION:

After repair or replacement of faulty parts, perform Clear Memory Mode <Ref. to EN(H4DOTC)(diag)-52, OPERATION, Clear Memory Mode.> and Inspection Mode <Ref. to EN(H4DOTC)(diag)-42, PROCEDURE, Inspection Mode.>.

WIRING DIAGRAM:

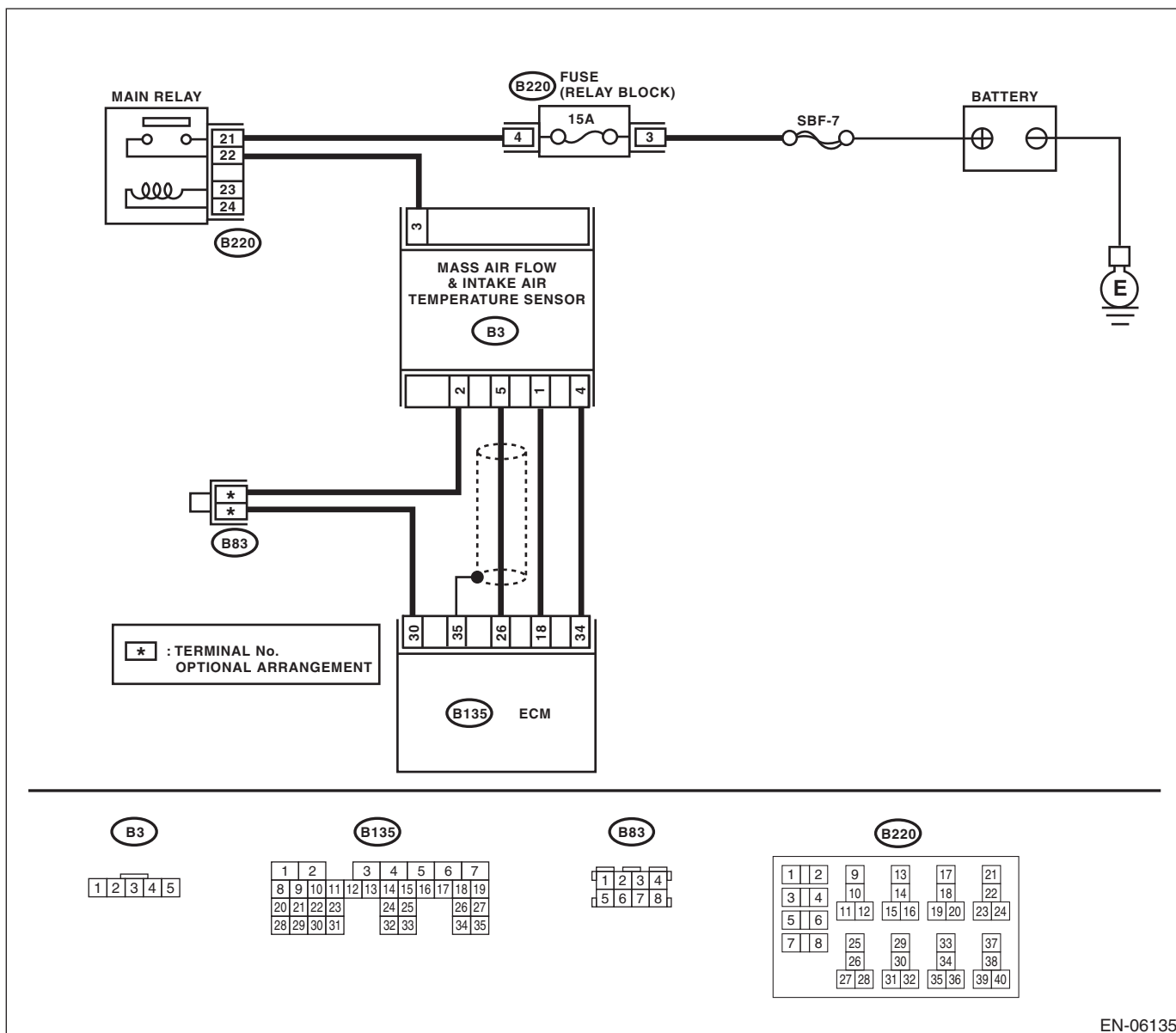

EN-06135

Diagnostic Procedure with Diagnostic Trouble Code (DTC)

ENGINE (DIAGNOSTICS)

Step	Check	Yes	No
1 CHECK CURRENT DATA. 1) Start the engine. 2) Read the data of intake air temperature sensor signal using Subaru Select Monitor or general scan tool. NOTE: • Subaru Select Monitor For detailed operation procedures, refer to "READ CURRENT DATA FOR ENGINE". <Ref. to EN(H4DOTC)(diag)-34, Subaru Select Monitor.> • General scan tool For detailed operation procedures, refer to the general scan tool operation manual.	Is the intake air temperature less than -40°C (-40°F) ?	Go to step 2.	Even if the malfunction indicator light illuminates, the circuit has returned to a normal condition at this time. Reproduce the fault condition, and reperform the check. NOTE: In this case, there may be a temporary connector contact failure.
2 CHECK POOR CONTACT. Repair any poor contact between the ECM and the mass air flow & intake air temperature sensor connectors.	Is there poor contact in the ECM or the mass air flow & intake air temperature sensor connectors?	Repair any poor contact between the ECM and the mass air flow & intake air temperature sensor connectors.	Go to step 3.
3 CHECK HARNESS BETWEEN ECM, MASS AIR FLOW AND INTAKE AIR TEMPERATURE SENSOR CONNECTORS. 1) Turn the ignition switch to OFF. 2) Disconnect the connector from the ECM and the mass air flow & intake air temperature sensor. 3) Measure the resistance of harness between ECM and mass air flow & intake air temperature sensor connectors. <i>Connector & terminal</i> <i>(B135) No. 18 — (B3) No. 1:</i> <i>(B135) No. 30 — (B3) No. 2:</i>	Is the resistance less than $1\ \Omega$?	Go to step 4.	Repair the open circuit of harness between the ECM and mass air flow & intake air temperature sensor connectors.
4 CHECK HARNESS BETWEEN ECM, MASS AIR FLOW AND INTAKE AIR TEMPERATURE SENSOR CONNECTORS. 1) Connect all connectors. 2) Turn the ignition switch to OFF. 3) Measure the voltage between ECM and chassis ground. <i>Connector & terminal</i> <i>(B135) No. 18 (+) — Chassis ground (-):</i>	Is the voltage 5 V or more?	Repair the short circuit to power in the harness between the ECM and the mass air flow & intake air temperature sensor connectors.	Replace the mass air flow and intake air temperature sensor. <Ref. to FU(H4DOTC)-34, Mass Air Flow and Intake Air Temperature Sensor.>

Diagnostic Procedure with Diagnostic Trouble Code (DTC)

ENGINE (DIAGNOSTICS)

S: DTC P0117 ENGINE COOLANT TEMPERATURE CIRCUIT LOW

DTC DETECTING CONDITION:

- Immediately at fault recognition
- GENERAL DESCRIPTION <Ref. to GD(H4DOTC)-36, DTC P0117 ENGINE COOLANT TEMPERATURE CIRCUIT LOW, Diagnostic Trouble Code (DTC) Detecting Criteria.>

TROUBLE SYMPTOM:

- Hard to start
- Improper idling
- Poor driving performance

CAUTION:

After repair or replacement of faulty parts, perform Clear Memory Mode <Ref. to EN(H4DOTC)(diag)-52, OPERATION, Clear Memory Mode.> and Inspection Mode <Ref. to EN(H4DOTC)(diag)-42, PROCEDURE, Inspection Mode.>.

WIRING DIAGRAM:

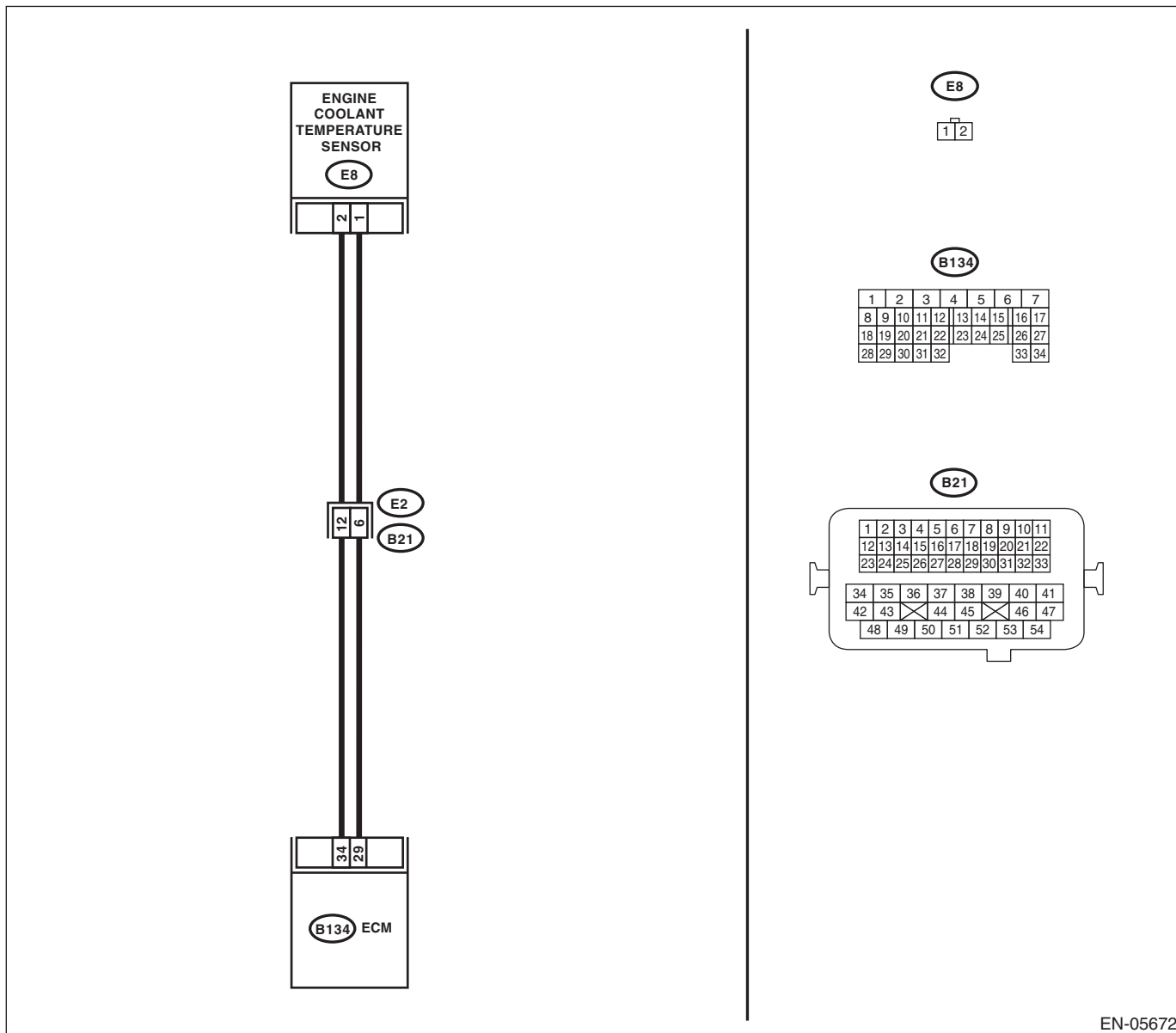

EN-05672

Diagnostic Procedure with Diagnostic Trouble Code (DTC)

ENGINE (DIAGNOSTICS)

	Step	Check	Yes	No
1	<p>CHECK CURRENT DATA.</p> <p>1) Start the engine.</p> <p>2) Read the data of engine coolant temperature sensor signal using Subaru Select Monitor or general scan tool.</p> <p>NOTE:</p> <ul style="list-style-type: none"> Subaru Select Monitor <p>For detailed operation procedures, refer to "READ CURRENT DATA FOR ENGINE". <Ref. to EN(H4DOTC)(diag)-34, Subaru Select Monitor.></p> <ul style="list-style-type: none"> General scan tool <p>For detailed operation procedures, refer to the general scan tool operation manual.</p>	Is the engine coolant temperature 150°C (302°F) or higher?	Go to step 2.	<p>Even if the malfunction indicator light illuminates, the circuit has returned to a normal condition at this time. Reproduce the fault condition, and reperform the check.</p> <p>NOTE:</p> <p>In this case, there may be a temporary connector contact failure.</p>
2	<p>CHECK HARNESS BETWEEN ECM AND ENGINE COOLANT TEMPERATURE SENSOR CONNECTOR.</p> <p>1) Turn the ignition switch to OFF.</p> <p>2) Disconnect the connectors from the ECM and engine coolant temperature sensor.</p> <p>3) Measure the resistance between ECM and chassis ground.</p> <p>Connector & terminal (B134) No. 34 — Chassis ground:</p>	Is the resistance 1 MΩ or more?	Replace the engine coolant temperature sensor. <Ref. to FU(H4DOTC)-29, Engine Coolant Temperature Sensor.>	Repair short circuit in harness to ground between ECM and engine coolant temperature sensor connector.

Diagnostic Procedure with Diagnostic Trouble Code (DTC)

ENGINE (DIAGNOSTICS)

T: DTC P0118 ENGINE COOLANT TEMPERATURE CIRCUIT HIGH

DTC DETECTING CONDITION:

- Immediately at fault recognition
- GENERAL DESCRIPTION <Ref. to GD(H4DOTC)-37, DTC P0118 ENGINE COOLANT TEMPERATURE CIRCUIT HIGH, Diagnostic Trouble Code (DTC) Detecting Criteria.>

TROUBLE SYMPTOM:

- Hard to start
- Improper idling
- Poor driving performance

CAUTION:

After repair or replacement of faulty parts, perform Clear Memory Mode <Ref. to EN(H4DOTC)(diag)-52, OPERATION, Clear Memory Mode.> and Inspection Mode <Ref. to EN(H4DOTC)(diag)-42, PROCEDURE, Inspection Mode.>.

WIRING DIAGRAM:

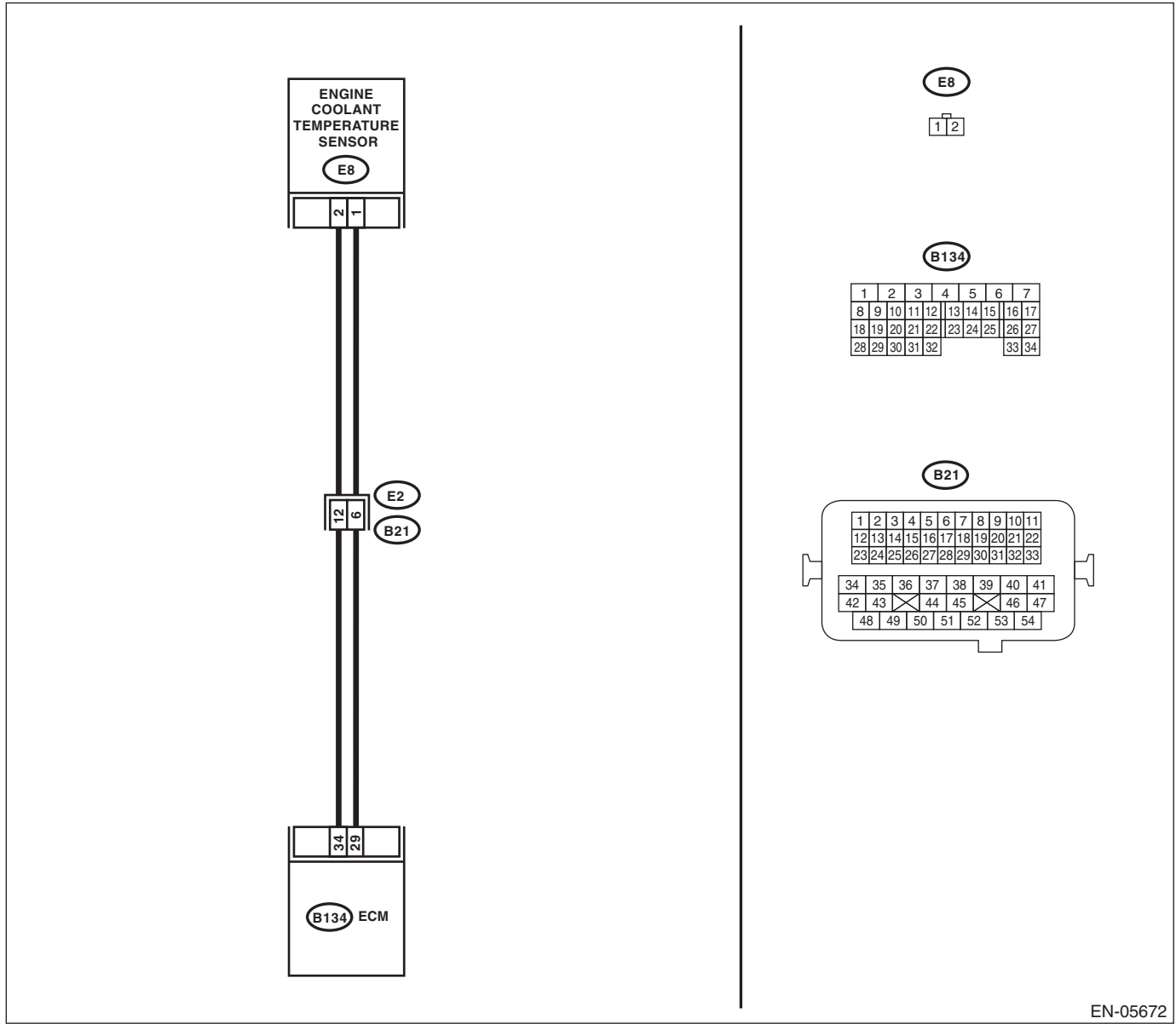

EN-05672

Diagnostic Procedure with Diagnostic Trouble Code (DTC)

ENGINE (DIAGNOSTICS)

	Step	Check	Yes	No
1	<p>CHECK CURRENT DATA.</p> <p>1) Start the engine.</p> <p>2) Read the data of engine coolant temperature sensor signal using Subaru Select Monitor or general scan tool.</p> <p>NOTE:</p> <ul style="list-style-type: none"> Subaru Select Monitor <p>For detailed operation procedures, refer to "READ CURRENT DATA FOR ENGINE". <Ref. to EN(H4DOTC)(diag)-34, Subaru Select Monitor.></p> <ul style="list-style-type: none"> General scan tool <p>For detailed operation procedures, refer to the general scan tool operation manual.</p>	Is the engine coolant temperature less than -40°C (-40°F) ?	Go to step 2.	<p>Even if the malfunction indicator light illuminates, the circuit has returned to a normal condition at this time. Reproduce the fault condition, and reperform the check.</p> <p>NOTE:</p> <p>In this case, there may be a temporary connector contact failure.</p>
2	<p>CHECK POOR CONTACT.</p> <p>Repair any poor contact between the ECM and engine coolant temperature sensor connectors.</p>	Is there poor contact in the ECM or engine coolant temperature sensor connectors?	Repair any poor contact between the ECM and engine coolant temperature sensor connectors.	Go to step 3.
3	<p>CHECK HARNESS BETWEEN ECM AND ENGINE COOLANT TEMPERATURE SENSOR CONNECTOR.</p> <p>1) Turn the ignition switch to OFF.</p> <p>2) Disconnect the connectors from the ECM and engine coolant temperature sensor.</p> <p>3) Measure the resistance of the harness between the ECM and engine coolant temperature sensor connector.</p> <p>Connector & terminal (B134) No. 34 — (E8) No. 2: (B134) No. 29 — (E8) No. 1:</p>	Is the resistance less than $1\ \Omega$?	Go to step 4.	<p>Repair the harness and connector.</p> <p>NOTE:</p> <p>In this case, repair the following item:</p> <ul style="list-style-type: none"> Open circuit in harness between ECM and engine coolant temperature sensor connector Poor contact of coupling connector
4	<p>CHECK HARNESS BETWEEN ECM AND ENGINE COOLANT TEMPERATURE SENSOR CONNECTOR.</p> <p>1) Connect all connectors.</p> <p>2) Turn the ignition switch to ON.</p> <p>3) Measure the voltage between ECM and chassis ground.</p> <p>Connector & terminal (B134) No. 34 (+) — Chassis ground (-):</p>	Is the voltage 5 V or more?	Repair the short circuit to power in the harness between the ECM and engine coolant temperature sensor connector.	Replace the engine coolant temperature sensor. <Ref. to FU(H4DOTC)-29, Engine Coolant Temperature Sensor.>

Diagnostic Procedure with Diagnostic Trouble Code (DTC)

ENGINE (DIAGNOSTICS)

U: DTC P0122 THROTTLE/PEDAL POSITION SENSOR/SWITCH "A" CIRCUIT LOW

DTC DETECTING CONDITION:

- Immediately at fault recognition
- GENERAL DESCRIPTION <Ref. to GD(H4DOTC)-38, DTC P0122 THROTTLE/PEDAL POSITION SENSOR/SWITCH "A" CIRCUIT LOW, Diagnostic Trouble Code (DTC) Detecting Criteria.>

TROUBLE SYMPTOM:

- Improper idling
- Engine stalls.
- Poor driving performance

CAUTION:

After repair or replacement of faulty parts, perform Clear Memory Mode <Ref. to EN(H4DOTC)(diag)-52, OPERATION, Clear Memory Mode.> and Inspection Mode <Ref. to EN(H4DOTC)(diag)-42, PROCEDURE, Inspection Mode.>.

WIRING DIAGRAM:

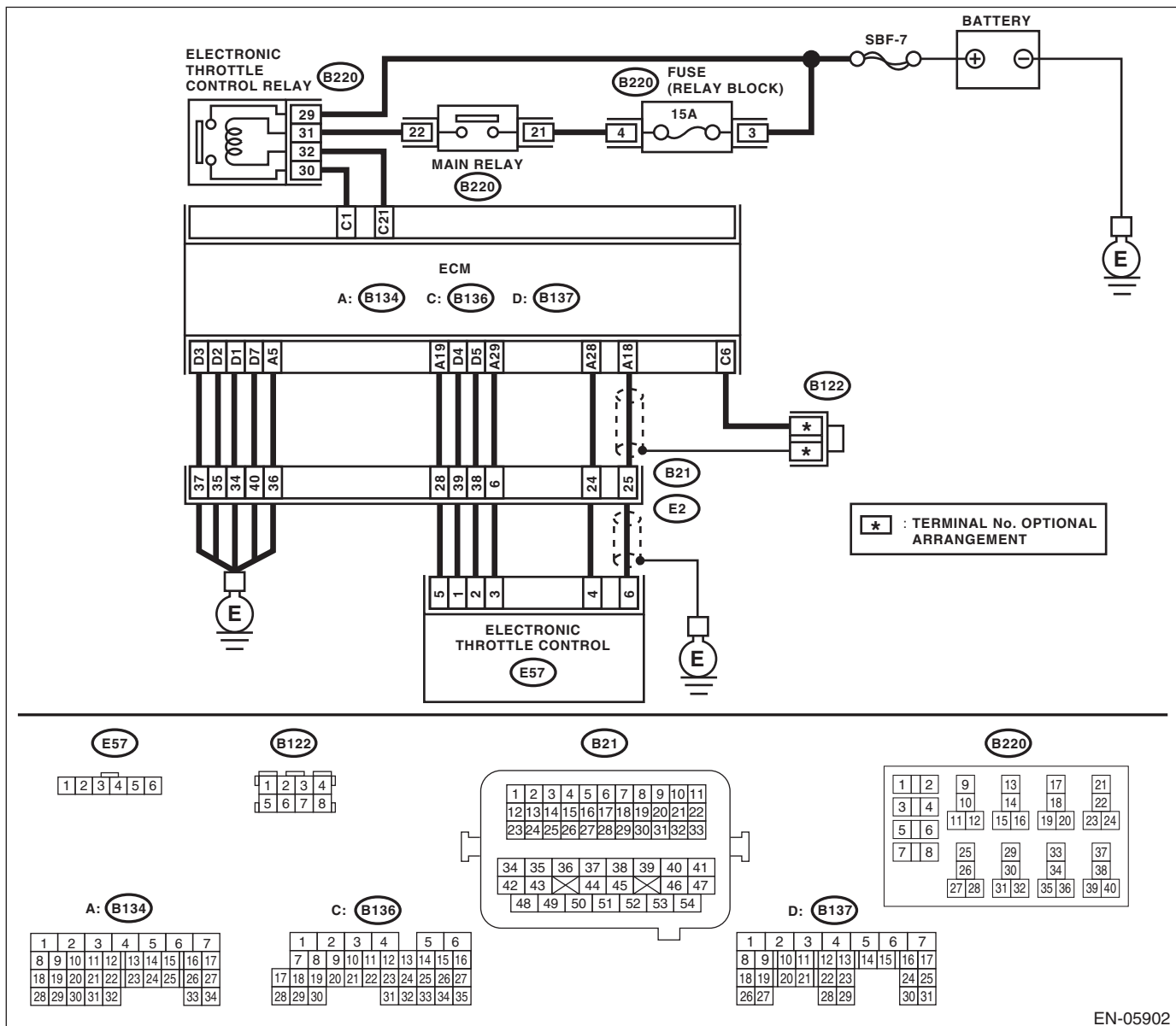

EN-05902

Diagnostic Procedure with Diagnostic Trouble Code (DTC)

ENGINE (DIAGNOSTICS)

	Step	Check	Yes	No
1	<p>CHECK HARNESS BETWEEN ECM AND ELECTRONIC THROTTLE CONTROL.</p> <p>1) Turn the ignition switch to OFF.</p> <p>2) Disconnect the connectors from ECM and electronic throttle control.</p> <p>3) Measure the resistance between ECM and chassis ground.</p> <p>Connector & terminal (B134) No. 19 — Chassis ground: (B134) No. 18 — Chassis ground: (B134) No. 18 — (B136) No. 6:</p>	<p>Is the resistance 1 MΩ or more?</p>	<p>Go to step 2.</p>	<p>Repair the ground short circuit of harness between ECM and electronic throttle control connector.</p>
2	<p>CHECK SHORT CIRCUIT INSIDE THE ECM.</p> <p>1) Connect the ECM.</p> <p>2) Measure the resistance between electronic throttle control connector and engine ground.</p> <p>Connector & terminal (E57) No. 6 — Engine ground:</p>	<p>Is the resistance 1 MΩ or more?</p>	<p>Replace the electronic throttle control. <Ref. to FU(H4DOTC)-13, Throttle Body.></p>	<p>Repair the short circuit to ground in harness between ECM and electronic throttle control connector. Replace the ECM if defective. <Ref. to FU(H4DOTC)-46, Engine Control Module (ECM).></p>

Diagnostic Procedure with Diagnostic Trouble Code (DTC)

ENGINE (DIAGNOSTICS)

V: DTC P0123 THROTTLE/PEDAL POSITION SENSOR/SWITCH "A" CIRCUIT HIGH

DTC DETECTING CONDITION:

- Immediately at fault recognition
- GENERAL DESCRIPTION <Ref. to GD(H4DOTC)-39, DTC P0123 THROTTLE/PEDAL POSITION SENSOR/SWITCH "A" CIRCUIT HIGH, Diagnostic Trouble Code (DTC) Detecting Criteria.>

TROUBLE SYMPTOM:

- Improper idling
- Engine stalls.
- Poor driving performance

CAUTION:

After repair or replacement of faulty parts, perform Clear Memory Mode <Ref. to EN(H4DOTC)(diag)-52, OPERATION, Clear Memory Mode.> and Inspection Mode <Ref. to EN(H4DOTC)(diag)-42, PROCEDURE, Inspection Mode.>.

WIRING DIAGRAM:

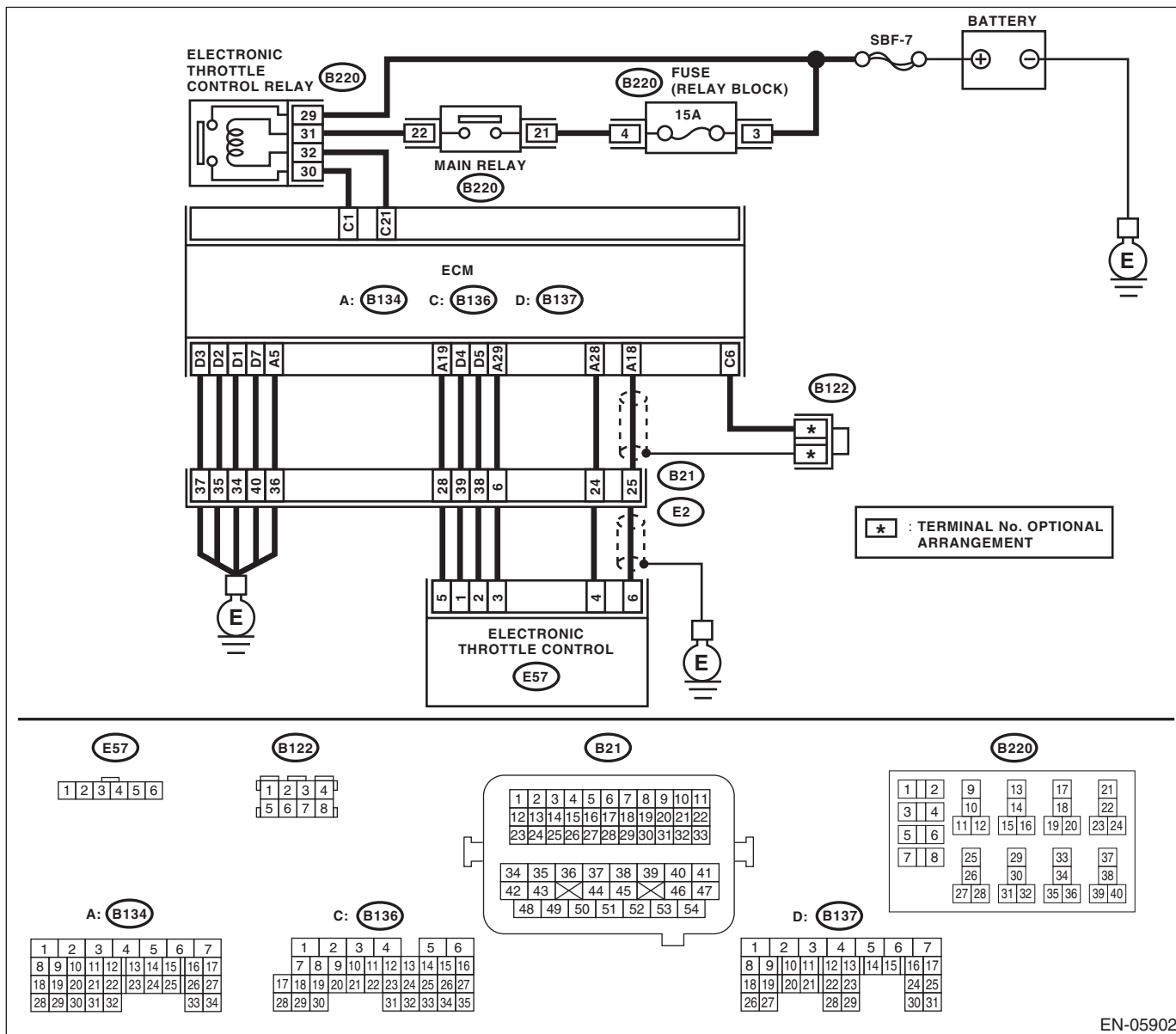

EN-05902

Diagnostic Procedure with Diagnostic Trouble Code (DTC)

ENGINE (DIAGNOSTICS)

Step	Check	Yes	No
<p>1 CHECK HARNESS BETWEEN ECM AND ELECTRONIC THROTTLE CONTROL. 1) Turn the ignition switch to OFF. 2) Disconnect the connectors from ECM and electronic throttle control. 3) Measure the resistance of harness between ECM and electronic throttle control connector. Connector & terminal (B134) No. 18 — (E57) No. 6: (B134) No. 29 — (E57) No. 3:</p>	<p>Is the resistance less than 1 Ω?</p>	<p>Go to step 2.</p>	<p>Repair the harness and connector. NOTE: In this case, repair the following item: • Open circuit in harness between ECM and electronic throttle control connector • Poor contact of coupling connector</p>
<p>2 CHECK HARNESS BETWEEN ECM AND ELECTRONIC THROTTLE CONTROL. 1) Connect the ECM. 2) Measure the resistance between electronic throttle control connector and engine ground. Connector & terminal (E57) No. 3 — Engine ground:</p>	<p>Is the resistance less than 5 Ω?</p>	<p>Go to step 3.</p>	<p>Repair the harness and connector. NOTE: In this case, repair the following item: • Open circuit of harness between ECM and engine ground • Poor contact in ECM connector • Poor contact of coupling connector</p>
<p>3 CHECK HARNESS BETWEEN ECM AND ELECTRONIC THROTTLE CONTROL. 1) Turn the ignition switch to ON. 2) Measure the voltage between electronic throttle control connector and engine ground. Connector & terminal (E57) No. 6 (+) — Engine ground (-):</p>	<p>Is the voltage 4.85 V or more?</p>	<p>Repair the short circuit to power in the harness between ECM and electronic throttle control connector.</p>	<p>Go to step 4.</p>
<p>4 CHECK HARNESS BETWEEN ECM AND ELECTRONIC THROTTLE CONTROL. 1) Turn the ignition switch to OFF. 2) Disconnect the connectors from the ECM. 3) Measure the resistance between ECM connectors. Connector & terminal (B134) No. 19 — (B134) No. 18:</p>	<p>Is the resistance 1 MΩ or more?</p>	<p>Repair poor contact of the electronic throttle control connector. Replace the electronic throttle control if defective. <Ref. to FU(H4DOTC)-13, Throttle Body.></p>	<p>Repair the short circuit to power in the harness between ECM and electronic throttle control connector.</p>

Diagnostic Procedure with Diagnostic Trouble Code (DTC)

ENGINE (DIAGNOSTICS)

W: DTC P0125 INSUFFICIENT COOLANT TEMPERATURE FOR CLOSED LOOP FUEL CONTROL

DTC DETECTING CONDITION:

- Detected when two consecutive driving cycles with fault occur.
- GENERAL DESCRIPTION <Ref. to GD(H4DOTC)-40, DTC P0125 INSUFFICIENT COOLANT TEMPERATURE FOR CLOSED LOOP FUEL CONTROL, Diagnostic Trouble Code (DTC) Detecting Criteria.>

TROUBLE SYMPTOM:

Engine does not return to idle.

CAUTION:

After repair or replacement of faulty parts, perform Clear Memory Mode <Ref. to EN(H4DOTC)(diag)-52, OPERATION, Clear Memory Mode.> and Inspection Mode <Ref. to EN(H4DOTC)(diag)-42, PROCEDURE, Inspection Mode.>.

	Step	Check	Yes	No
1	CHECK TIRE SIZE.	Is the tire size as specified? and the same size as other three wheels?	Go to step 2.	Replace the tire.
2	CHECK ENGINE COOLANT. Check the following items: <ul style="list-style-type: none">• Amount of engine coolant• Engine coolant freeze• Contamination of engine coolant	Is the engine coolant normal?	Go to step 3.	Fill or replace the engine coolant. <Ref. to CO(H4DOTC)-13, Engine Coolant.>
3	CHECK THERMOSTAT.	Does the thermostat remain opened?	Replace the thermostat. <Ref. to CO(H4DOTC)-17, Thermostat.>	Replace the engine coolant temperature sensor. <Ref. to FU(H4DOTC)-29, Engine Coolant Temperature Sensor.>

Diagnostic Procedure with Diagnostic Trouble Code (DTC)

ENGINE (DIAGNOSTICS)

X: DTC P0126 INSUFFICIENT ENGINE COOLANT TEMPERATURE FOR STABLE OPERATION

DTC DETECTING CONDITION:

- Detected when two consecutive driving cycles with fault occur.
- GENERAL DESCRIPTION <Ref. to GD(H4DOTC)-42, DTC P0126 INSUFFICIENT ENGINE COOLANT TEMPERATURE FOR STABLE OPERATION, Diagnostic Trouble Code (DTC) Detecting Criteria.>

TROUBLE SYMPTOM:

- Hard to start
- Improper idling
- Poor driving performance

CAUTION:

After repair or replacement of faulty parts, perform Clear Memory Mode <Ref. to EN(H4DOTC)(diag)-52, OPERATION, Clear Memory Mode.> and Inspection Mode <Ref. to EN(H4DOTC)(diag)-42, PROCEDURE, Inspection Mode.>.

WIRING DIAGRAM:

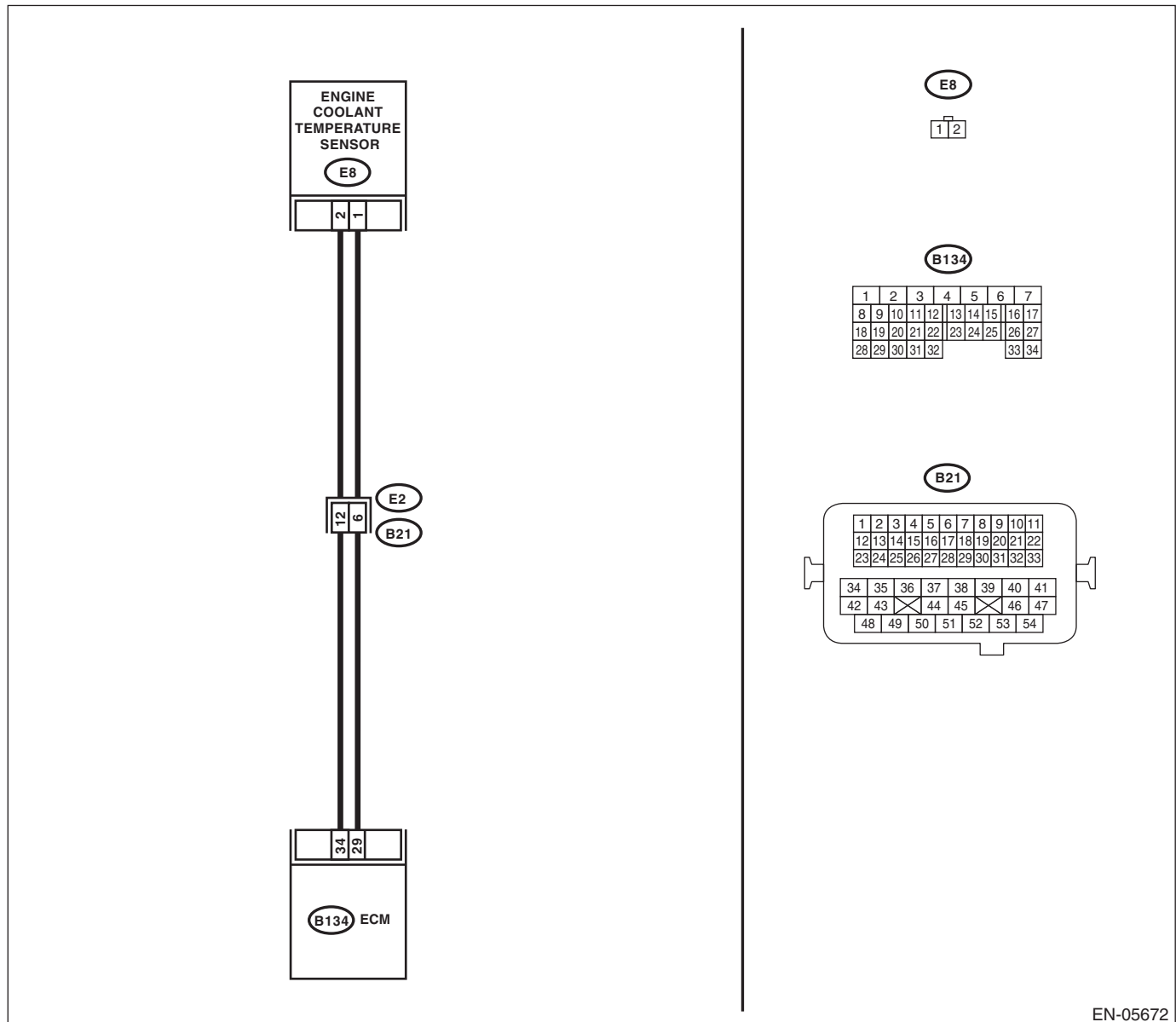

EN-05672

Diagnostic Procedure with Diagnostic Trouble Code (DTC)

ENGINE (DIAGNOSTICS)

	Step	Check	Yes	No
1 CHECK ENGINE COOLANT TEMPERATURE SENSOR. Measure the resistance between engine coolant temperature sensor terminals when the engine coolant is cold and after warmed up. Terminals No. 1 — No. 2:		Is the resistance of engine coolant temperature sensor different between when engine coolant is cold and after warmed up?	Repair the poor contact of the ECM connector.	Replace the engine coolant temperature sensor. <Ref. to FU(H4DOTC)-29, Engine Coolant Temperature Sensor.>

Diagnostic Procedure with Diagnostic Trouble Code (DTC)

ENGINE (DIAGNOSTICS)

Y: DTC P0128 COOLANT THERMOSTAT (ENGINE COOLANT TEMPERATURE BELOW THERMOSTAT REGULATING TEMPERATURE)

DTC DETECTING CONDITION:

- Detected when two consecutive driving cycles with fault occur.
- GENERAL DESCRIPTION <Ref. to GD(H4DOTC)-44, DTC P0128 COOLANT THERMOSTAT (ENGINE COOLANT TEMPERATURE BELOW THERMOSTAT REGULATING TEMPERATURE), Diagnostic Trouble Code (DTC) Detecting Criteria.>

TROUBLE SYMPTOM:

Thermostat remains open.

CAUTION:

After repair or replacement of faulty parts, perform Clear Memory Mode <Ref. to EN(H4DOTC)(diag)-52, OPERATION, Clear Memory Mode.> and Inspection Mode <Ref. to EN(H4DOTC)(diag)-42, PROCEDURE, Inspection Mode.>.

	Step	Check	Yes	No
1	CHECK ENGINE COOLANT.	Are the coolant level and mixture ratio of engine coolant to anti-freeze solution correct?	Go to step 2.	Replace the engine coolant. <Ref. to CO(H4DOTC)-13, REPLACEMENT, Engine Coolant.>
2	CHECK RADIATOR FAN. 1) Start the engine. 2) Check the radiator fan operation.	Does the radiator fan continuously rotate for 3 minutes or more during idling?	Repair radiator fan circuit. <Ref. to CO(H4DOTC)-24, Radiator Main Fan and Fan Motor.> <Ref. to CO(H4DOTC)-26, Radiator Sub Fan and Fan Motor.>	Replace the thermostat. <Ref. to CO(H4DOTC)-17, Thermostat.>

Diagnostic Procedure with Diagnostic Trouble Code (DTC)

ENGINE (DIAGNOSTICS)

	Step	Check	Yes	No
1	CHECK FRONT OXYGEN (A/F) SENSOR CONNECTOR AND COUPLING CONNECTOR.	Has water entered the connector?	Completely remove any water inside.	Go to step 2.
2	CHECK HARNESS BETWEEN ECM AND FRONT OXYGEN (A/F) SENSOR CONNECTOR. 1) Turn the ignition switch to OFF. 2) Disconnect the connectors from the ECM and front oxygen (A/F) sensor. 3) Measure the resistance between ECM and chassis ground. Connector & terminal (B135) No. 9 — Chassis ground: (B135) No. 8 — Chassis ground:	Is the resistance 1 MΩ or more?	Go to step 3.	Repair the ground short circuit of harness between ECM and front oxygen (A/F) sensor connector.
3	CHECK POOR CONTACT. Check poor contact of front oxygen (A/F) sensor connector.	Is there poor contact in front oxygen (A/F) sensor connector?	Repair the poor contact of the front oxygen (A/F) sensor connector.	Replace the front oxygen (A/F) sensor. <Ref. to FU(H4DOTC)-43, Front Oxygen (A/F) Sensor.>

Diagnostic Procedure with Diagnostic Trouble Code (DTC)

ENGINE (DIAGNOSTICS)

AA:DTC P0132 O2 SENSOR CIRCUIT HIGH VOLTAGE (BANK 1 SENSOR 1)

DTC DETECTING CONDITION:

- Immediately at fault recognition
- GENERAL DESCRIPTION <Ref. to GD(H4DOTC)-48, DTC P0132 O2 SENSOR CIRCUIT HIGH VOLTAGE (BANK 1 SENSOR 1), Diagnostic Trouble Code (DTC) Detecting Criteria.>

CAUTION:

After repair or replacement of faulty parts, perform Clear Memory Mode <Ref. to EN(H4DOTC)(diag)-52, OPERATION, Clear Memory Mode.> and Inspection Mode <Ref. to EN(H4DOTC)(diag)-42, PROCEDURE, Inspection Mode.>.

WIRING DIAGRAM:

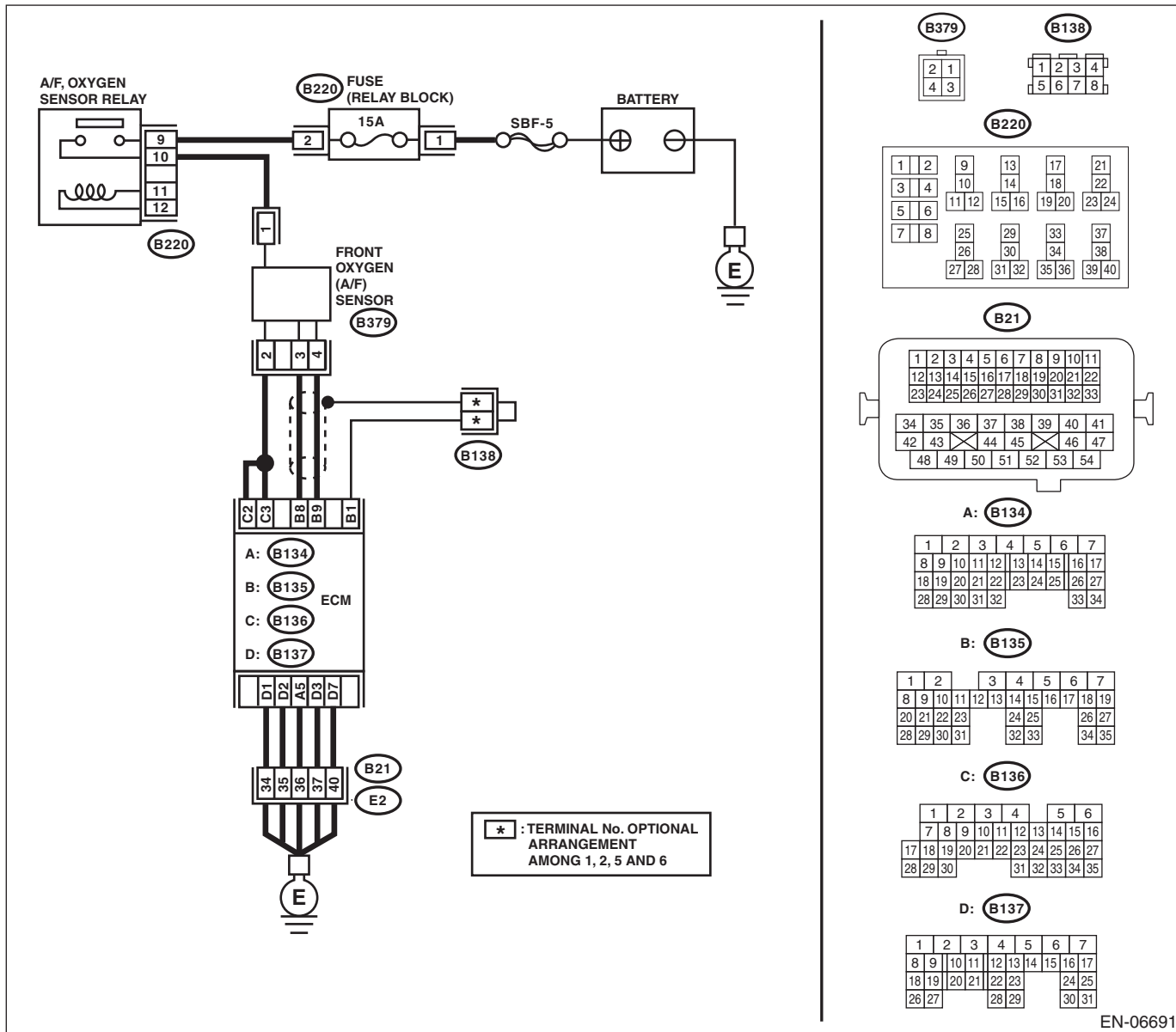

EN-06691

Diagnostic Procedure with Diagnostic Trouble Code (DTC)

ENGINE (DIAGNOSTICS)

	Step	Check	Yes	No
1	CHECK FRONT OXYGEN (A/F) SENSOR CONNECTOR AND COUPLING CONNECTOR.	Has water entered the connector?	Completely remove any water inside.	Go to step 2.
2	CHECK HARNESS BETWEEN ECM AND FRONT OXYGEN (A/F) SENSOR CONNECTOR. 1) Turn the ignition switch to OFF. 2) Disconnect the connector from front oxygen (A/F) sensor. 3) Turn the ignition switch to ON. 4) Measure the voltage between ECM and chassis ground. Connector & terminal (B135) No. 9 (+) — Chassis ground (-): (B135) No. 8 (+) — Chassis ground (-):	Is the voltage 8 V or more?	Repair the short circuit to power in the harness between the ECM and front oxygen (A/F) sensor connector.	Replace the front oxygen (A/F) sensor. <Ref. to FU(H4DOTC)-43, Front Oxygen (A/F) Sensor.>

Diagnostic Procedure with Diagnostic Trouble Code (DTC)

ENGINE (DIAGNOSTICS)

AB:DTC P0133 O2 SENSOR CIRCUIT SLOW RESPONSE (BANK 1 SENSOR 1)

DTC DETECTING CONDITION:

- Detected when two consecutive driving cycles with fault occur.
- GENERAL DESCRIPTION <Ref. to GD(H4DOTC)-50, DTC P0133 O2 SENSOR CIRCUIT SLOW RESPONSE (BANK 1 SENSOR 1), Diagnostic Trouble Code (DTC) Detecting Criteria.>

CAUTION:

After repair or replacement of faulty parts, perform Clear Memory Mode <Ref. to EN(H4DOTC)(diag)-52, OPERATION, Clear Memory Mode.> and Inspection Mode <Ref. to EN(H4DOTC)(diag)-42, PROCEDURE, Inspection Mode.>.

WIRING DIAGRAM:

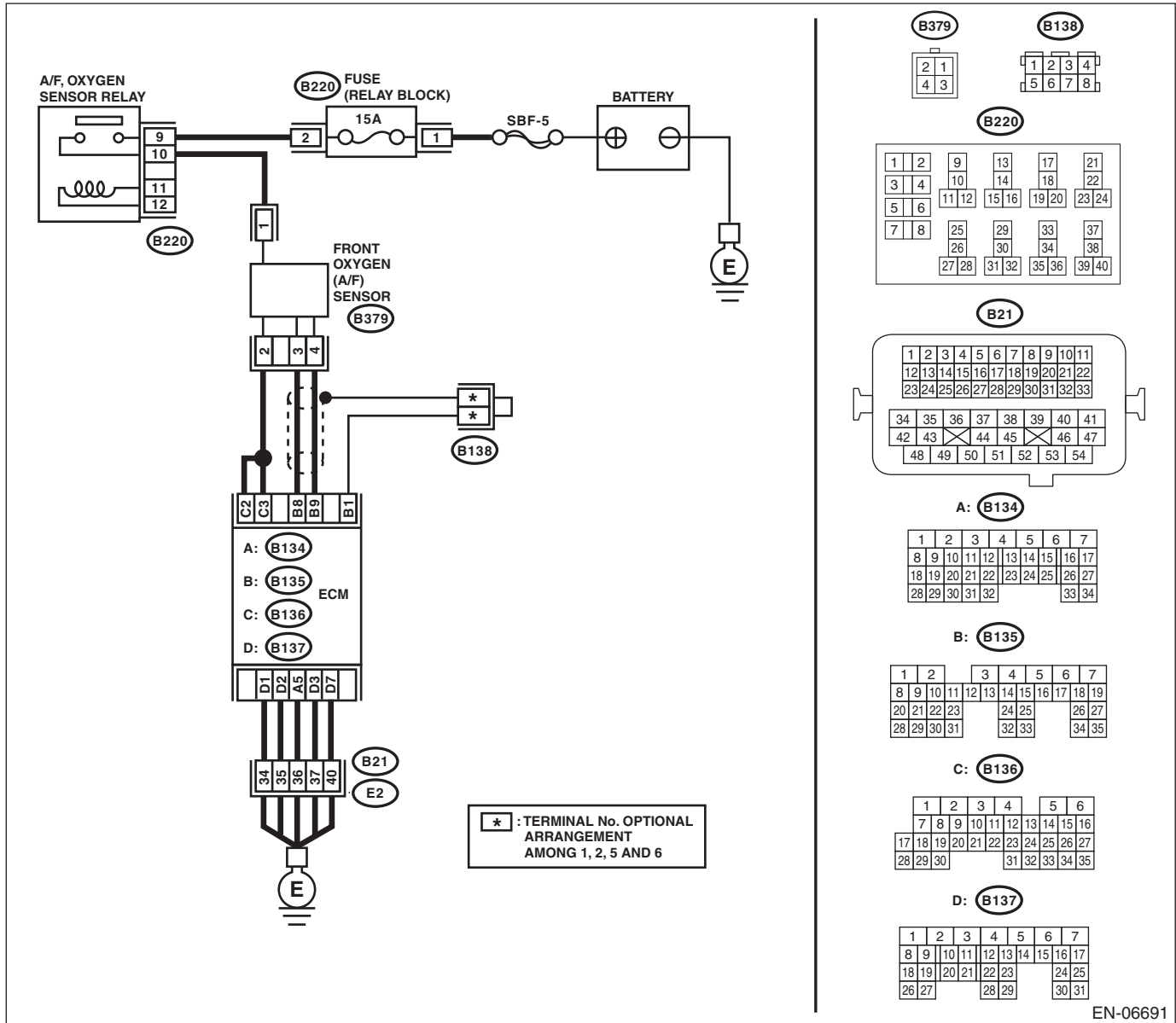

Diagnostic Procedure with Diagnostic Trouble Code (DTC)

ENGINE (DIAGNOSTICS)

Step	Check	Yes	No
1 CHECK EXHAUST SYSTEM. NOTE: Check the following items. <ul style="list-style-type: none">• Loose installation of front portion of exhaust pipe onto cylinder heads• Loose connection between front exhaust pipe and front catalytic converter• Damage of exhaust pipe resulting in a hole	Is there any fault in exhaust system?	Repair the exhaust system.	Replace the front oxygen (A/F) sensor. <Ref. to FU(H4DOTC)-43, Front Oxygen (A/F) Sensor.>

Diagnostic Procedure with Diagnostic Trouble Code (DTC)

ENGINE (DIAGNOSTICS)

AC:DTC P0134 O2 SENSOR CIRCUIT NO ACTIVITY DETECTED (BANK 1 SENSOR 1)

DTC DETECTING CONDITION:

- Immediately at fault recognition
- GENERAL DESCRIPTION <Ref. to GD(H4DOTC)-53, DTC P0134 O2 SENSOR CIRCUIT NO ACTIVITY DETECTED (BANK 1 SENSOR 1), Diagnostic Trouble Code (DTC) Detecting Criteria.>

CAUTION:

After repair or replacement of faulty parts, perform Clear Memory Mode <Ref. to EN(H4DOTC)(diag)-52, OPERATION, Clear Memory Mode.> and Inspection Mode <Ref. to EN(H4DOTC)(diag)-42, PROCEDURE, Inspection Mode.>.

WIRING DIAGRAM:

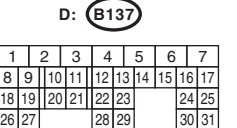
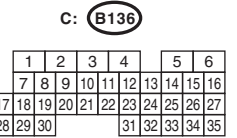
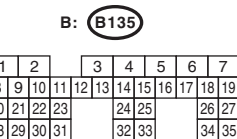
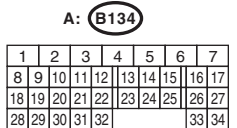
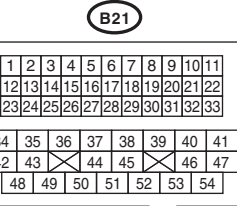
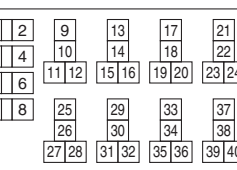
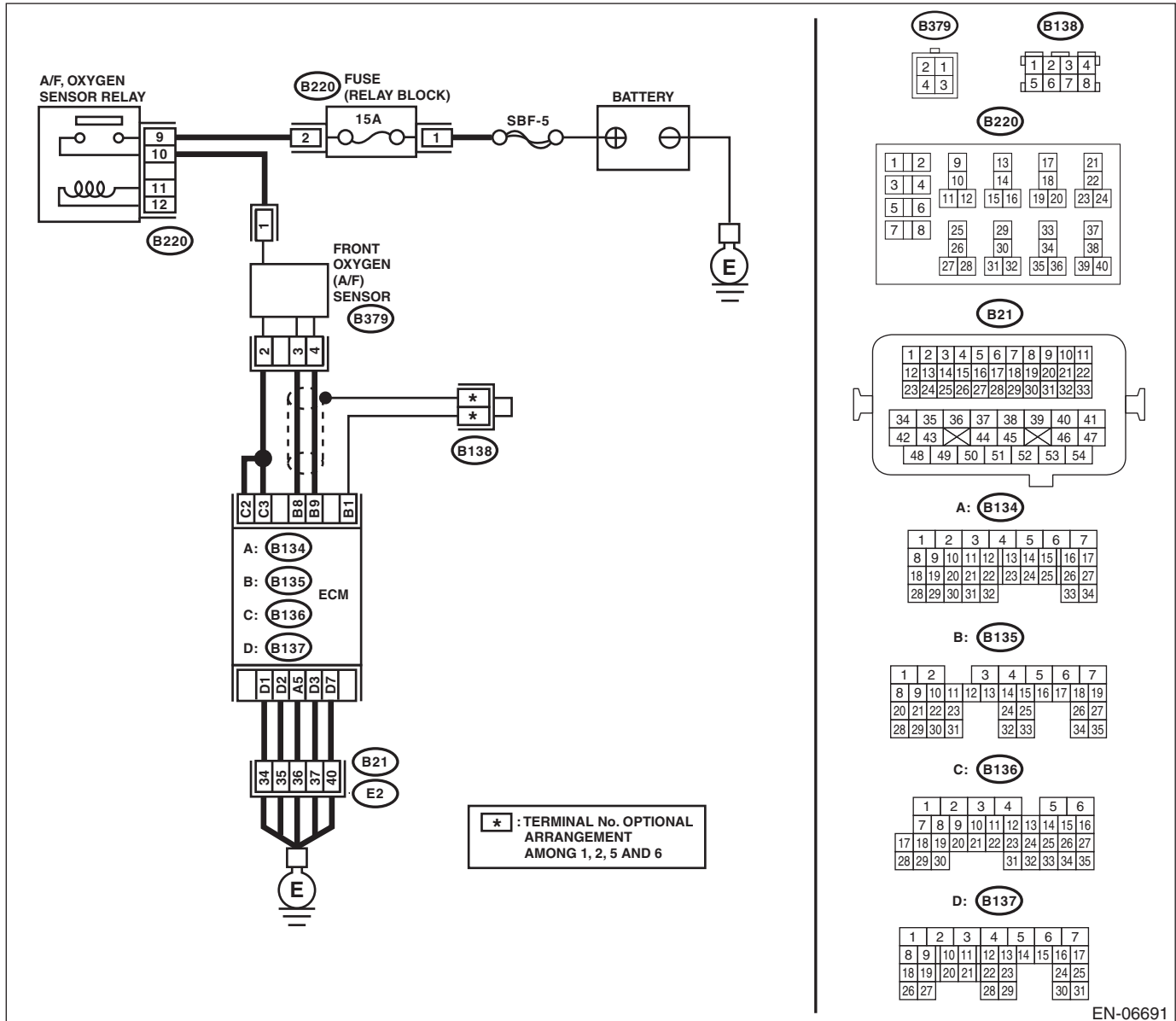

EN-06691

Diagnostic Procedure with Diagnostic Trouble Code (DTC)

ENGINE (DIAGNOSTICS)

	Step	Check	Yes	No
1	CHECK HARNESS BETWEEN ECM AND FRONT OXYGEN (A/F) SENSOR CONNECTOR. 1) Turn the ignition switch to OFF. 2) Disconnect the connectors from the ECM and front oxygen (A/F) sensor. 3) Measure the resistance of harness between ECM and front oxygen (A/F) sensor connector. Connector & terminal (B135) No. 9 — (B379) No. 4: (B135) No. 8 — (B379) No. 3:	Is the resistance less than 1 Ω ?	Go to step 2.	Repair the open circuit of harness between ECM and front oxygen (A/F) sensor connector.
2	CHECK POOR CONTACT. Check poor contact of ECM and front oxygen (A/F) sensor connector.	Is there poor contact in ECM or front oxygen (A/F) sensor connector?	Repair the poor contact of ECM or front oxygen (A/F) sensor connector.	Replace the front oxygen (A/F) sensor. <Ref. to FU(H4DOTC)-43, Front Oxygen (A/F) Sensor.>

Diagnostic Procedure with Diagnostic Trouble Code (DTC)

ENGINE (DIAGNOSTICS)

AD:DTC P0137 O2 SENSOR CIRCUIT LOW VOLTAGE (BANK 1 SENSOR 2)

DTC DETECTING CONDITION:

- Detected when two consecutive driving cycles with fault occur.
- GENERAL DESCRIPTION <Ref. to GD(H4DOTC)-55, DTC P0137 O2 SENSOR CIRCUIT LOW VOLTAGE (BANK 1 SENSOR 2), Diagnostic Trouble Code (DTC) Detecting Criteria.>

CAUTION:

After repair or replacement of faulty parts, perform Clear Memory Mode <Ref. to EN(H4DOTC)(diag)-52, OPERATION, Clear Memory Mode.> and Inspection Mode <Ref. to EN(H4DOTC)(diag)-42, PROCEDURE, Inspection Mode.>.

WIRING DIAGRAM:

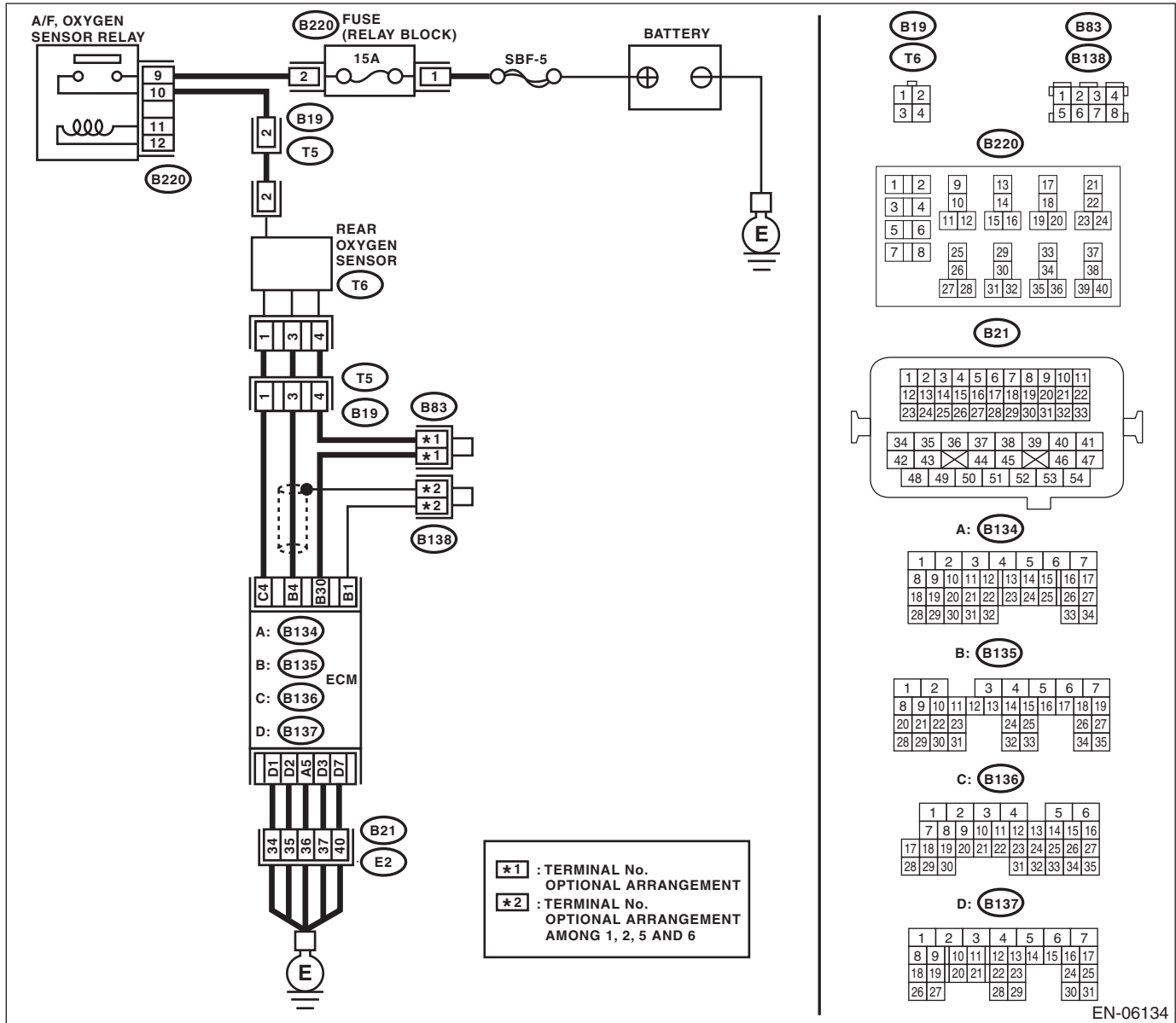

EN-06134

Diagnostic Procedure with Diagnostic Trouble Code (DTC)

ENGINE (DIAGNOSTICS)

	Step	Check	Yes	No
1	<p>CHECK REAR OXYGEN SENSOR DATA.</p> <p>1) Warm up the engine until engine coolant temperature is above 75°C (167°F), and keep the engine speed at 3,000 rpm. (2 minutes maximum)</p> <p>2) Read the data of rear oxygen sensor signal using Subaru Select Monitor or general scan tool.</p> <p>NOTE:</p> <ul style="list-style-type: none"> Subaru Select Monitor <p>For detailed operation procedures, refer to "READ CURRENT DATA FOR ENGINE". <Ref. to EN(H4DOTC)(diag)-34, Subaru Select Monitor.></p> <ul style="list-style-type: none"> General scan tool <p>For detailed operation procedures, refer to the general scan tool operation manual.</p>	Is the voltage 490 mV or more?	Go to step 5.	Go to step 2.
2	<p>CHECK REAR OXYGEN SENSOR CONNECTOR AND COUPLING CONNECTOR.</p>	Has water entered the connector?	Completely remove any water inside.	Go to step 3.
3	<p>CHECK HARNESS BETWEEN ECM AND REAR OXYGEN SENSOR CONNECTOR.</p> <p>1) Turn the ignition switch to OFF.</p> <p>2) Disconnect the connector from ECM and rear oxygen sensor.</p> <p>3) Measure the resistance of harness between ECM and rear oxygen sensor connector.</p> <p>Connector & terminal</p> <p>(B135) No. 4 — (T6) No. 3:</p> <p>(B135) No. 30 — (T6) No. 4:</p>	Is the resistance less than 1 Ω?	Go to step 4.	<p>Repair the harness and connector.</p> <p>NOTE:</p> <p>In this case, repair the following item:</p> <ul style="list-style-type: none"> Open circuit in harness between ECM and rear oxygen sensor connector Poor contact of coupling connector
4	<p>CHECK HARNESS BETWEEN ECM AND REAR OXYGEN SENSOR.</p> <p>1) Turn the ignition switch to OFF.</p> <p>2) Disconnect the connector from rear oxygen sensor.</p> <p>3) Turn the ignition switch to ON.</p> <p>4) Measure the voltage between rear oxygen sensor connector and chassis ground.</p> <p>Connector & terminal</p> <p>(T6) No. 3 (+) — Chassis ground (-):</p>	Is the voltage 0.2 — 0.5 V?	<p>Replace the rear oxygen sensor.</p> <p><Ref. to FU(H4DOTC)-45, Rear Oxygen Sensor.></p>	<p>Repair the harness and connector.</p> <p>NOTE:</p> <p>In this case, repair the following item:</p> <ul style="list-style-type: none"> Open circuit in harness between ECM and rear oxygen sensor connector Poor contact in ECM connector Poor contact of coupling connector
5	<p>CHECK EXHAUST SYSTEM.</p> <p>Check exhaust system parts.</p> <p>NOTE:</p> <p>Check the following items.</p> <ul style="list-style-type: none"> Loose part and incomplete installation of exhaust system Damage (crack, hole etc.) of parts Loose part and improper installation between front oxygen (A/F) sensor and rear oxygen sensor 	Is there any fault in exhaust system?	Repair or replace faulty parts.	<p>Replace the rear oxygen sensor.</p> <p><Ref. to FU(H4DOTC)-45, Rear Oxygen Sensor.></p>

Diagnostic Procedure with Diagnostic Trouble Code (DTC)

ENGINE (DIAGNOSTICS)

AE:DTC P0138 O2 SENSOR CIRCUIT HIGH VOLTAGE (BANK 1 SENSOR 2)

DTC DETECTING CONDITION:

- Detected when two consecutive driving cycles with fault occur.
- GENERAL DESCRIPTION <Ref. to GD(H4DOTC)-58, DTC P0138 O2 SENSOR CIRCUIT HIGH VOLTAGE (BANK 1 SENSOR 2), Diagnostic Trouble Code (DTC) Detecting Criteria.>

CAUTION:

After repair or replacement of faulty parts, perform Clear Memory Mode <Ref. to EN(H4DOTC)(diag)-52, OPERATION, Clear Memory Mode.> and Inspection Mode <Ref. to EN(H4DOTC)(diag)-42, PROCEDURE, Inspection Mode.>.

WIRING DIAGRAM:

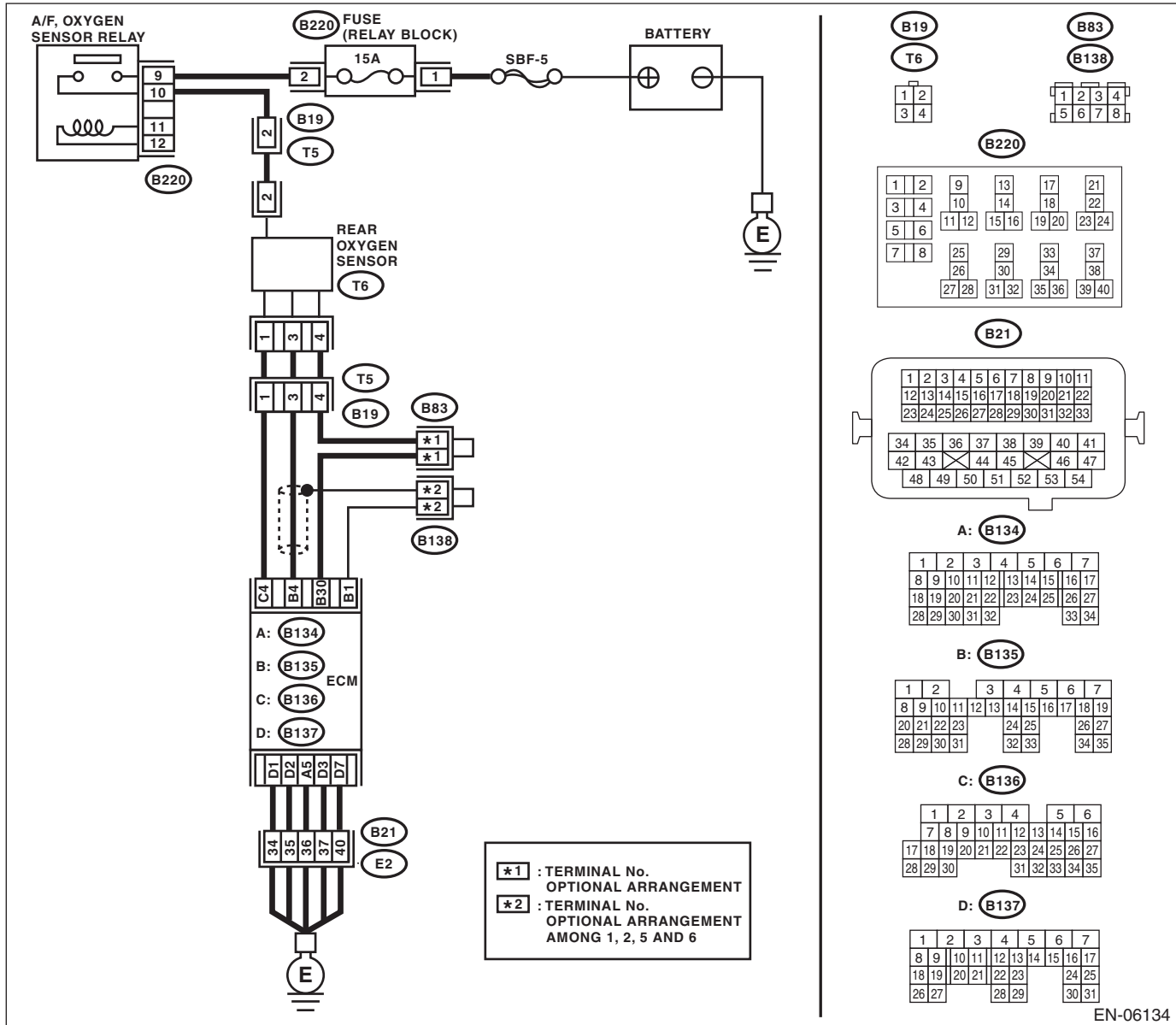

Diagnostic Procedure with Diagnostic Trouble Code (DTC)

ENGINE (DIAGNOSTICS)

Step	Check	Yes	No
<p>1 CHECK REAR OXYGEN SENSOR DATA. 1) Warm up the engine until engine coolant temperature is higher than 75°C (167°F), and rapidly reduce the engine speed from 3,000 rpm. 2) Read the data of rear oxygen sensor signal using Subaru Select Monitor or general scan tool.</p> <p>NOTE: • Subaru Select Monitor For detailed operation procedures, refer to "READ CURRENT DATA FOR ENGINE". <Ref. to EN(H4DOTC)(diag)-34, Subaru Select Monitor.> • General scan tool For detailed operation procedures, refer to the general scan tool operation manual.</p>	Is the voltage 250 mV or less?	Go to step 5.	Go to step 2.
<p>2 CHECK REAR OXYGEN SENSOR CONNECTOR AND COUPLING CONNECTOR.</p>	Has water entered the connector?	Completely remove any water inside.	Go to step 3.
<p>3 CHECK HARNESS BETWEEN ECM AND REAR OXYGEN SENSOR CONNECTOR. 1) Turn the ignition switch to OFF. 2) Disconnect the connector from ECM and rear oxygen sensor. 3) Measure the resistance of harness between ECM and rear oxygen sensor connector.</p> <p>Connector & terminal (B135) No. 4 — (T6) No. 3: (B135) No. 30 — (T6) No. 4:</p>	Is the resistance less than 1 Ω?	Go to step 4.	Repair the harness and connector. NOTE: In this case, repair the following item: • Open circuit in harness between ECM and rear oxygen sensor connector • Poor contact of coupling connector
<p>4 CHECK HARNESS BETWEEN ECM AND REAR OXYGEN SENSOR. 1) Turn the ignition switch to OFF. 2) Disconnect the connector from rear oxygen sensor. 3) Turn the ignition switch to ON. 4) Measure the voltage between rear oxygen sensor connector and chassis ground.</p> <p>Connector & terminal (T6) No. 3 (+) — Chassis ground (-):</p>	Is the voltage 0.2 — 0.5 V?	Replace the rear oxygen sensor. <Ref. to FU(H4DOTC)-45, Rear Oxygen Sensor.>	Repair the harness and connector. NOTE: In this case, repair the following item: • Open circuit in harness between ECM and rear oxygen sensor connector • Poor contact in ECM connector • Poor contact of coupling connector
<p>5 CHECK EXHAUST SYSTEM. Check exhaust system parts.</p> <p>NOTE: Check the following items. • Loose part and incomplete installation of exhaust system • Damage (crack, hole etc.) of parts • Loose part and improper installation between front oxygen (A/F) sensor and rear oxygen sensor</p>	Is there any fault in exhaust system?	Repair or replace faulty parts.	Replace the rear oxygen sensor. <Ref. to FU(H4DOTC)-45, Rear Oxygen Sensor.>

Diagnostic Procedure with Diagnostic Trouble Code (DTC)

ENGINE (DIAGNOSTICS)

AF:DTC P0139 O2 SENSOR CIRCUIT SLOW RESPONSE (BANK 1 SENSOR 2)

DTC DETECTING CONDITION:

- Detected when two consecutive driving cycles with fault occur.
- GENERAL DESCRIPTION <Ref. to GD(H4DOTC)-59, DTC P0139 O2 SENSOR CIRCUIT SLOW RESPONSE (BANK 1 SENSOR 2), Diagnostic Trouble Code (DTC) Detecting Criteria.>

CAUTION:

After repair or replacement of faulty parts, perform Clear Memory Mode <Ref. to EN(H4DOTC)(diag)-52, OPERATION, Clear Memory Mode.> and Inspection Mode <Ref. to EN(H4DOTC)(diag)-42, PROCEDURE, Inspection Mode.>.

WIRING DIAGRAM:

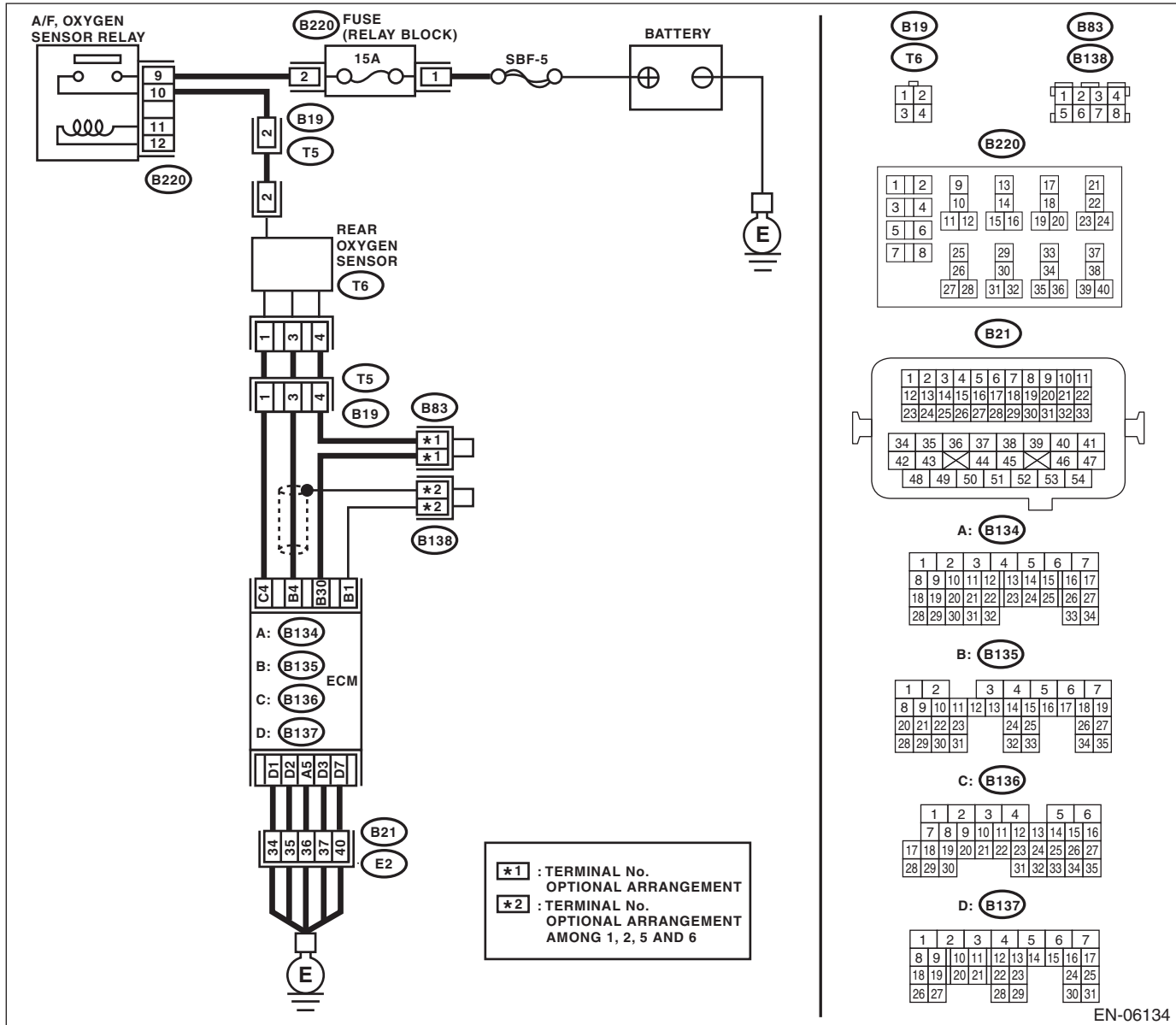

Diagnostic Procedure with Diagnostic Trouble Code (DTC)

ENGINE (DIAGNOSTICS)

Step	Check	Yes	No
<p>1 CHECK HARNESS BETWEEN ECM AND REAR OXYGEN SENSOR CONNECTOR. 1) Turn the ignition switch to OFF. 2) Disconnect the connector from ECM and rear oxygen sensor. 3) Measure the resistance of harness between ECM and rear oxygen sensor connector. Connector & terminal (B135) No. 4 — (T6) No. 3:</p>	<p>Is the resistance less than 1 Ω?</p>	<p>Go to step 2.</p>	<p>Repair the harness and connector. NOTE: In this case, repair the following item: • Open circuit in harness between ECM and rear oxygen sensor connector • Poor contact of coupling connector</p>
<p>2 CHECK HARNESS BETWEEN ECM AND REAR OXYGEN SENSOR CONNECTOR. Measure the resistance between rear oxygen sensor connector and chassis ground. Connector & terminal (T6) No. 3 — Chassis ground:</p>	<p>Is the resistance 1 MΩ or more?</p>	<p>Go to step 3.</p>	<p>Repair the ground short circuit of harness between ECM and rear oxygen sensor connector.</p>
<p>3 CHECK REAR OXYGEN SENSOR. Measure the resistance between rear oxygen sensor terminals. Terminals No. 3 — No. 4</p>	<p>Is the resistance less than 1 Ω?</p>	<p>Replace the rear oxygen sensor. <Ref. to FU(H4DOTC)-45, Rear Oxygen Sensor.></p>	<p>Even if the malfunction indicator light illuminates, the circuit has returned to a normal condition at this time. Reproduce the fault condition, and reperform the check. NOTE: In this case, there may be a temporary connector contact failure.</p>

Diagnostic Procedure with Diagnostic Trouble Code (DTC)

ENGINE (DIAGNOSTICS)

AG:DTC P0140 O2 SENSOR CIRCUIT NO ACTIVITY DETECTED (BANK 1 SENSOR 2)

DTC DETECTING CONDITION:

- Detected when two consecutive driving cycles with fault occur.
- GENERAL DESCRIPTION <Ref. to GD(H4DOTC)-64, DTC P0140 O2 SENSOR CIRCUIT NO ACTIVITY DETECTED (BANK 1 SENSOR 2), Diagnostic Trouble Code (DTC) Detecting Criteria.>

CAUTION:

After repair or replacement of faulty parts, perform Clear Memory Mode <Ref. to EN(H4DOTC)(diag)-52, OPERATION, Clear Memory Mode.> and Inspection Mode <Ref. to EN(H4DOTC)(diag)-42, PROCEDURE, Inspection Mode.>.

WIRING DIAGRAM:

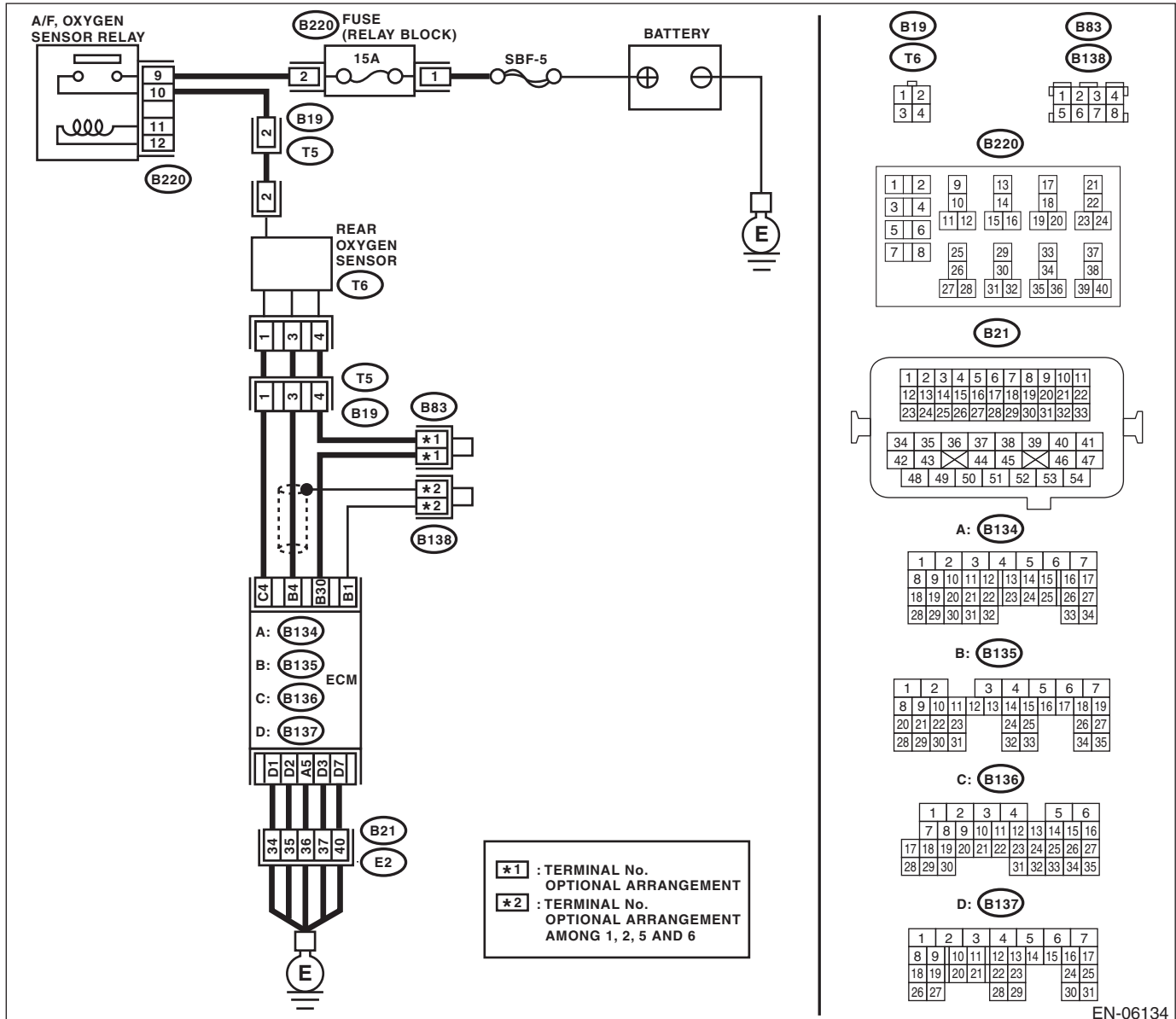

EN-06134

Diagnostic Procedure with Diagnostic Trouble Code (DTC)

ENGINE (DIAGNOSTICS)

Step	Check	Yes	No
1 CHECK REAR OXYGEN SENSOR DATA. 1) Warm up the engine until engine coolant temperature is above 75°C (167°F), and keep the engine speed at 3,000 rpm. (2 minutes maximum) 2) Read the data of rear oxygen sensor signal using Subaru Select Monitor or general scan tool. NOTE: • Subaru Select Monitor For detailed operation procedures, refer to "READ CURRENT DATA FOR ENGINE". <Ref. to EN(H4DOTC)(diag)-34, Subaru Select Monitor.> • General scan tool For detailed operation procedures, refer to the general scan tool operation manual.	Is the voltage 490 mV or more?	Go to step 6.	Go to step 2.
2 CHECK REAR OXYGEN SENSOR DATA. 1) Warm up the engine until engine coolant temperature is higher than 75°C (167°F), and rapidly reduce the engine speed from 3,000 rpm. 2) Read the data of rear oxygen sensor signal using Subaru Select Monitor or general scan tool. NOTE: • Subaru Select Monitor For detailed operation procedures, refer to "READ CURRENT DATA FOR ENGINE". <Ref. to EN(H4DOTC)(diag)-34, Subaru Select Monitor.> • General scan tool For detailed operation procedures, refer to the general scan tool operation manual.	Is the voltage 250 mV or less?	Go to step 6.	Go to step 3.
3 CHECK REAR OXYGEN SENSOR CONNECTOR AND COUPLING CONNECTOR.	Has water entered the connector?	Completely remove any water inside.	Go to step 4.
4 CHECK HARNESS BETWEEN ECM AND REAR OXYGEN SENSOR CONNECTOR. 1) Turn the ignition switch to OFF. 2) Disconnect the connector from ECM and rear oxygen sensor. 3) Measure the resistance of harness between ECM and rear oxygen sensor connector. Connector & terminal (B135) No. 4 — (T6) No. 3: (B135) No. 30 — (T6) No. 4:	Is the resistance less than 1 Ω?	Go to step 5.	Repair the harness and connector. NOTE: In this case, repair the following item: • Open circuit in harness between ECM and rear oxygen sensor connector • Poor contact of coupling connector

Diagnostic Procedure with Diagnostic Trouble Code (DTC)

ENGINE (DIAGNOSTICS)

Step	Check	Yes	No
5 CHECK HARNESS BETWEEN ECM AND REAR OXYGEN SENSOR. 1) Turn the ignition switch to OFF. 2) Disconnect the connector from rear oxygen sensor. 3) Turn the ignition switch to ON. 4) Measure the voltage between rear oxygen sensor connector and chassis ground. Connector & terminal (T6) No. 3 (+) — Chassis ground (-):	Is the voltage 0.2 — 0.5 V?	Replace the rear oxygen sensor. <Ref. to FU(H4DOTC)-45, Rear Oxygen Sensor.>	Repair the harness and connector. NOTE: In this case, repair the following item: <ul style="list-style-type: none"> • Open circuit in harness between ECM and rear oxygen sensor connector • Poor contact in ECM connector • Poor contact of coupling connector
6 CHECK EXHAUST SYSTEM. Check exhaust system parts. NOTE: Check the following items. <ul style="list-style-type: none"> • Loose part and incomplete installation of exhaust system • Damage (crack, hole etc.) of parts • Loose part and improper installation between front oxygen (A/F) sensor and rear oxygen sensor 	Is there any fault in exhaust system?	Repair or replace faulty parts.	Replace the rear oxygen sensor. <Ref. to FU(H4DOTC)-45, Rear Oxygen Sensor.>

AH:DTC P0171 SYSTEM TOO LEAN (BANK 1)

Refer to DTC P0172 for diagnostic procedure. <Ref. to EN(H4DOTC)(diag)-149, DTC P0172 SYSTEM TOO RICH (BANK 1), Diagnostic Procedure with Diagnostic Trouble Code (DTC).>

Diagnostic Procedure with Diagnostic Trouble Code (DTC)

ENGINE (DIAGNOSTICS)

AI: DTC P0172 SYSTEM TOO RICH (BANK 1)

DTC DETECTING CONDITION:

- Detected when two consecutive driving cycles with fault occur.
- GENERAL DESCRIPTION <Ref. to GD(H4DOTC)-67, DTC P0172 SYSTEM TOO RICH (BANK 1), Diagnostic Trouble Code (DTC) Detecting Criteria.>

TROUBLE SYMPTOM:

- Improper idling
- Engine stalls.
- Poor driving performance

CAUTION:

After repair or replacement of faulty parts, perform Clear Memory Mode <Ref. to EN(H4DOTC)(diag)-52, OPERATION, Clear Memory Mode.> and Inspection Mode <Ref. to EN(H4DOTC)(diag)-42, PROCEDURE, Inspection Mode.>.

Step	Check	Yes	No
1	CHECK EXHAUST SYSTEM.	Are there holes or loose bolts on exhaust system?	Repair the exhaust system. Go to step 2.
2	CHECK AIR INTAKE SYSTEM.	Are there holes, loose bolts or disconnection of hose on air intake system?	Repair the air intake system. Go to step 3.
3	CHECK FUEL PRESSURE. WARNING: Place “NO OPEN FLAMES” signs near the working area. CAUTION: Be careful not to spill fuel. Measure the fuel pressure while disconnecting pressure regulator vacuum hose from intake manifold. <Ref. to ME(H4DOTC)-25, INSPECTION, Fuel Pressure.> CAUTION: Release fuel pressure before removing the fuel pressure gauge. NOTE: If fuel pressure does not increase, squeeze the fuel return hose 2 to 3 times, then measure fuel pressure again.	Is the measured value 284 — 314 kPa (2.9 — 3.2 kg/cm ² , 41 — 46 psi)?	Go to step 4. Repair the following item. Fuel pressure is too high: • Clogged fuel return line or bent hose Fuel pressure is too low: • Improper fuel pump discharge • Clogged fuel supply line
4	CHECK FUEL PRESSURE. After connecting the pressure regulator vacuum hose, measure fuel pressure. <Ref. to ME(H4DOTC)-25, INSPECTION, Fuel Pressure.> CAUTION: Release fuel pressure before removing the fuel pressure gauge. NOTE: • If fuel pressure does not increase, squeeze fuel return hose 2 to 3 times, then measure fuel pressure again. • If the measured value at this step is out of specification, check or replace pressure regulator and pressure regulator vacuum hose.	Is the measured value 230 — 260 kPa (2.35 — 2.65 kg/cm ² , 33 — 38 psi)?	Go to step 5. Repair the following item. Fuel pressure is too high: • Faulty pressure regulator • Clogged fuel return line or bent hose Fuel pressure is too low: • Faulty pressure regulator • Improper fuel pump discharge • Clogged fuel supply line

Diagnostic Procedure with Diagnostic Trouble Code (DTC)

ENGINE (DIAGNOSTICS)

Step	Check	Yes	No
<p>5 CHECK ENGINE COOLANT TEMPERATURE SENSOR.</p> <p>1) Start the engine and warm up completely.</p> <p>2) Read the data of engine coolant temperature sensor signal using Subaru Select Monitor or general scan tool.</p> <p>NOTE:</p> <ul style="list-style-type: none"> • Subaru Select Monitor <p>For detailed operation procedures, refer to "READ CURRENT DATA FOR ENGINE". <Ref. to EN(H4DOTC)(diag)-34, Subaru Select Monitor.></p> <ul style="list-style-type: none"> • General scan tool <p>For detailed operation procedures, refer to the general scan tool operation manual.</p>	<p>Is the engine coolant temperature 75°C (167°F) or higher?</p>	<p>Go to step 6.</p>	<p>Replace the engine coolant temperature sensor. <Ref. to FU(H4DOTC)-29, Engine Coolant Temperature Sensor.></p>
<p>6 CHECK MASS AIR FLOW AND INTAKE AIR TEMPERATURE SENSOR.</p> <p>1) Start the engine and warm up engine until coolant temperature is higher than 75°C (167°F).</p> <p>2) Place the select lever in "P" range or "N" range.</p> <p>3) Turn the A/C switch to OFF.</p> <p>4) Turn all the accessory switches to OFF.</p> <p>5) Read the data of mass air flow and intake air temperature sensor signal using Subaru Select Monitor or general scan tool.</p> <p>NOTE:</p> <ul style="list-style-type: none"> • Subaru Select Monitor <p>For detailed operation procedures, refer to "READ CURRENT DATA FOR ENGINE". <Ref. to EN(H4DOTC)(diag)-34, Subaru Select Monitor.></p> <ul style="list-style-type: none"> • General scan tool <p>For detailed operation procedures, refer to the general scan tool operation manual.</p>	<p>Is the measured value 2.0 — 5.0 g/s (0.26 — 0.66 lb/m)?</p>	<p>Go to step 7.</p>	<p>Replace the mass air flow and intake air temperature sensor. <Ref. to FU(H4DOTC)-34, Mass Air Flow and Intake Air Temperature Sensor.></p>
<p>7 CHECK MASS AIR FLOW AND INTAKE AIR TEMPERATURE SENSOR.</p> <p>1) Start the engine and warm up engine until coolant temperature is higher than 75°C (167°F).</p> <p>2) Place the select lever in "P" range or "N" range.</p> <p>3) Turn the A/C switch to OFF.</p> <p>4) Turn all the accessory switches to OFF.</p> <p>5) Open the front hood.</p> <p>6) Measure the ambient temperature.</p> <p>7) Read the data of mass air flow and intake air temperature sensor signal using Subaru Select Monitor or general scan tool.</p> <p>NOTE:</p> <ul style="list-style-type: none"> • Subaru Select Monitor <p>For detailed operation procedures, refer to "READ CURRENT DATA FOR ENGINE". <Ref. to EN(H4DOTC)(diag)-34, Subaru Select Monitor.></p> <ul style="list-style-type: none"> • General scan tool <p>For detailed operation procedures, refer to the general scan tool operation manual.</p>	<p>Subtract ambient temperature from intake air temperature. Is the obtained value -10 — 50°C (-18 — 90°F)?</p>	<p>Repair the poor contact of the ECM connector.</p>	<p>Check the mass air flow and intake air temperature sensor. <Ref. to FU(H4DOTC)-34, Mass Air Flow and Intake Air Temperature Sensor.></p>

AJ:DTC P0181 FUEL TEMPERATURE SENSOR “A” CIRCUIT RANGE/ PERFORMANCE

DTC DETECTING CONDITION:

- Detected when two consecutive driving cycles with fault occur.
- GENERAL DESCRIPTION <Ref. to GD(H4DOTC)-68, DTC P0181 FUEL TEMPERATURE SENSOR “A” CIRCUIT RANGE/PERFORMANCE, Diagnostic Trouble Code (DTC) Detecting Criteria.>

CAUTION:

After repair or replacement of faulty parts, perform Clear Memory Mode <Ref. to EN(H4DOTC)(diag)-52, OPERATION, Clear Memory Mode.> and Inspection Mode <Ref. to EN(H4DOTC)(diag)-42, PROCEDURE, Inspection Mode.>.

WIRING DIAGRAM:

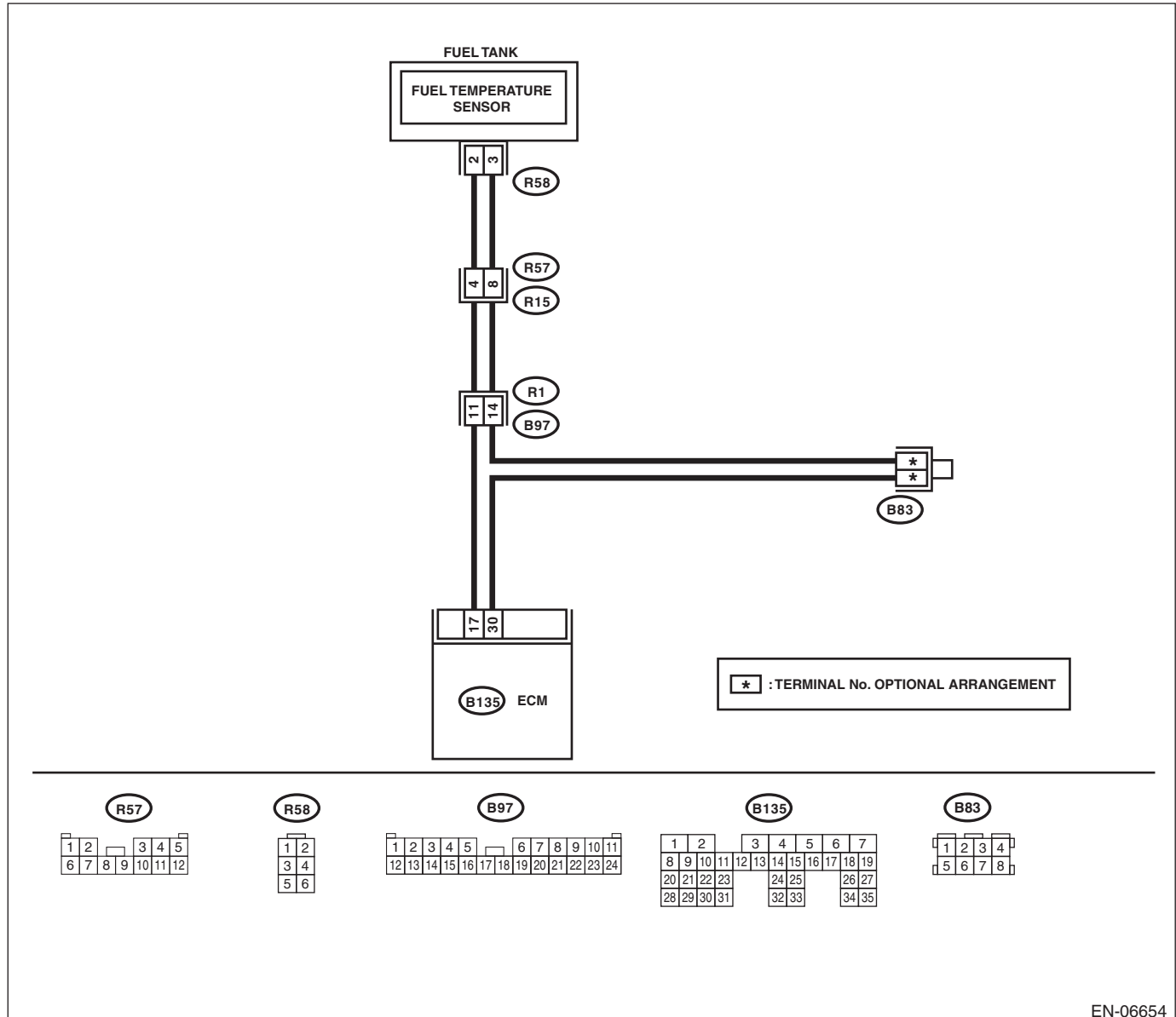

Diagnostic Procedure with Diagnostic Trouble Code (DTC)

ENGINE (DIAGNOSTICS)

Step	Check	Yes	No
1 CHECK FOR ANY OTHER DTC ON DISPLAY.	Is any other DTC displayed?	Check the appropriate DTC using the "List of Diagnostic Trouble Code (DTC)". <Ref. to EN(H4DOTC)(diag)-80, List of Diagnostic Trouble Code (DTC).>	Replace the fuel temperature sensor. <Ref. to EC(H4DOTC)-15, Fuel Temperature Sensor.>

Diagnostic Procedure with Diagnostic Trouble Code (DTC)

ENGINE (DIAGNOSTICS)

AK:DTC P0182 FUEL TEMPERATURE SENSOR "A" CIRCUIT LOW INPUT

DTC DETECTING CONDITION:

- Immediately at fault recognition
- GENERAL DESCRIPTION <Ref. to GD(H4DOTC)-71, DTC P0182 FUEL TEMPERATURE SENSOR "A" CIRCUIT LOW INPUT, Diagnostic Trouble Code (DTC) Detecting Criteria.>

CAUTION:

After repair or replacement of faulty parts, perform Clear Memory Mode <Ref. to EN(H4DOTC)(diag)-52, OPERATION, Clear Memory Mode.> and Inspection Mode <Ref. to EN(H4DOTC)(diag)-42, PROCEDURE, Inspection Mode.>.

WIRING DIAGRAM:

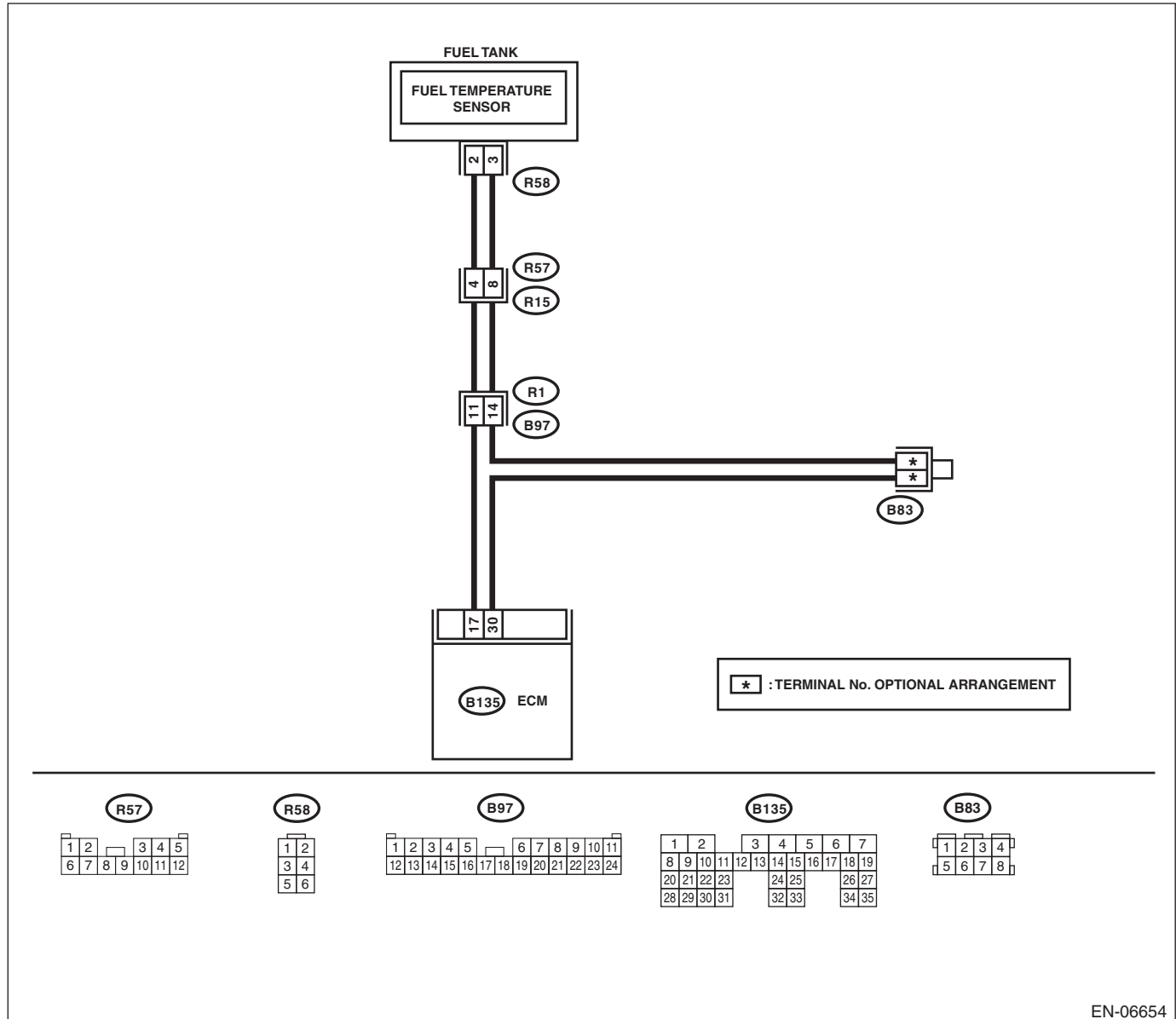

Diagnostic Procedure with Diagnostic Trouble Code (DTC)

ENGINE (DIAGNOSTICS)

	Step	Check	Yes	No
1	<p>CHECK CURRENT DATA.</p> <p>1) Start the engine.</p> <p>2) Read the data of fuel temperature sensor signal using Subaru Select Monitor.</p> <p>NOTE: For detailed operation procedures, refer to "READ CURRENT DATA FOR ENGINE". <Ref. to EN(H4DOTC)(diag)-34, Subaru Select Monitor.></p>	Is the temperature 120°C (248°F) or higher?	Go to step 2.	<p>Even if the malfunction indicator light illuminates, the circuit has returned to a normal condition at this time. Reproduce the fault condition, and reperform the check.</p> <p>NOTE: In this case, there may be a temporary connector contact failure.</p>
2	<p>CHECK HARNESS BETWEEN ECM AND FUEL TEMPERATURE SENSOR CONNECTOR.</p> <p>1) Turn the ignition switch to OFF.</p> <p>2) Disconnect the connectors from the ECM and fuel temperature sensor.</p> <p>3) Measure the resistance between ECM and chassis ground.</p> <p>Connector & terminal (B135) No. 17 — Chassis ground:</p>	Is the resistance 1 MΩ or more?	Replace the fuel temperature sensor. <Ref. to EC(H4DOTC)-15, Fuel Temperature Sensor.>	Repair the ground short circuit of harness between ECM and fuel pump connector.

AL:DTC P0183 FUEL TEMPERATURE SENSOR “A” CIRCUIT HIGH INPUT

DTC DETECTING CONDITION:

- Immediately at fault recognition
- GENERAL DESCRIPTION <Ref. to GD(H4DOTC)-72, DTC P0183 FUEL TEMPERATURE SENSOR “A” CIRCUIT HIGH INPUT, Diagnostic Trouble Code (DTC) Detecting Criteria.>

CAUTION:

After repair or replacement of faulty parts, perform Clear Memory Mode <Ref. to EN(H4DOTC)(diag)-52, OPERATION, Clear Memory Mode.> and Inspection Mode <Ref. to EN(H4DOTC)(diag)-42, PROCEDURE, Inspection Mode.>.

WIRING DIAGRAM:

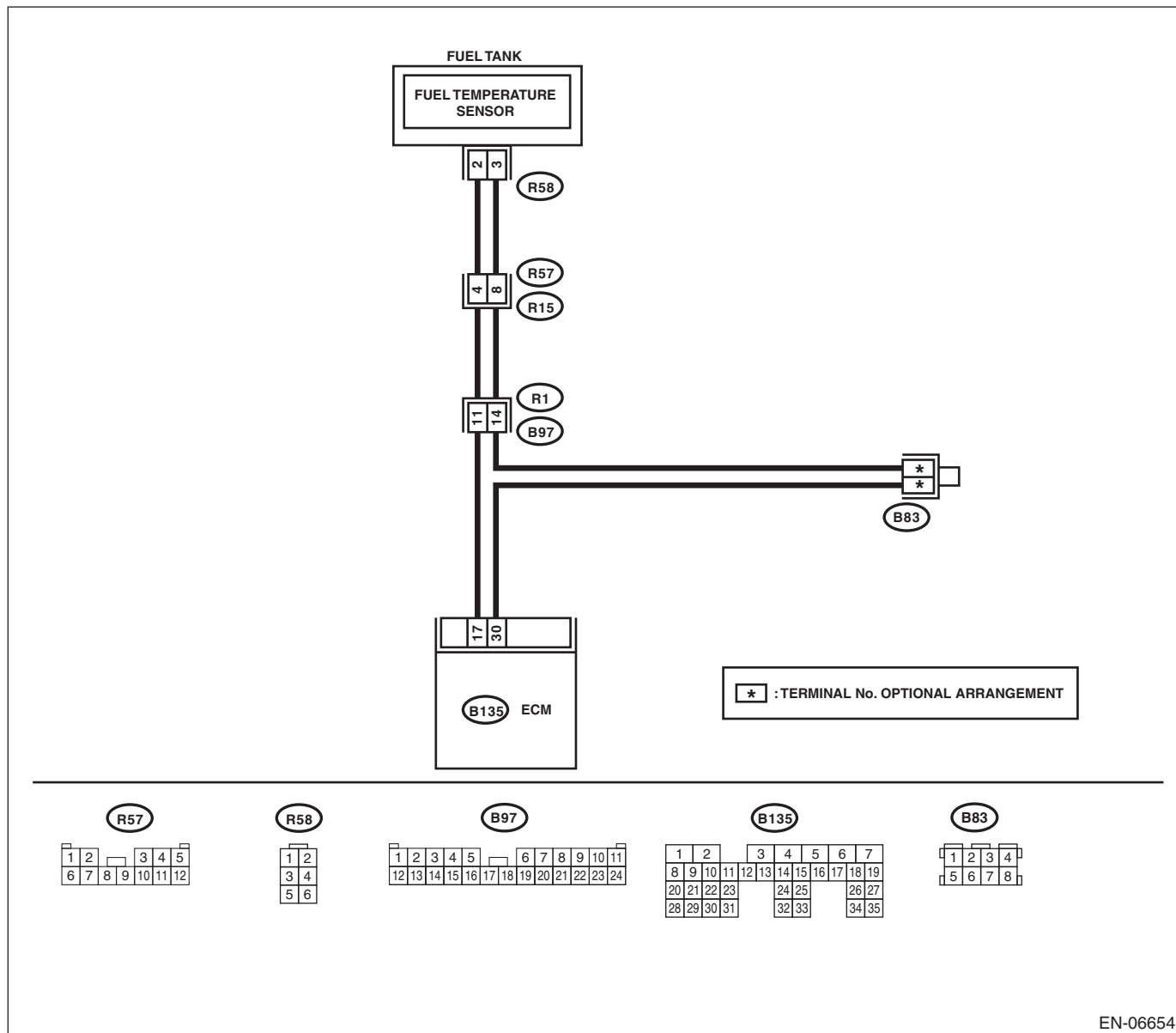

Diagnostic Procedure with Diagnostic Trouble Code (DTC)

ENGINE (DIAGNOSTICS)

	Step	Check	Yes	No
1	<p>CHECK CURRENT DATA.</p> <p>1) Start the engine.</p> <p>2) Read the data of fuel temperature sensor signal using Subaru Select Monitor.</p> <p>NOTE: For detailed operation procedures, refer to "READ CURRENT DATA FOR ENGINE". <Ref. to EN(H4DOTC)(diag)-34, Subaru Select Monitor.></p>	Is the temperature less than -40°C (-40°F)?	Go to step 2.	Even if the malfunction indicator light illuminates, the circuit has returned to a normal condition at this time. Reproduce the fault condition, and reperform the check. NOTE: In this case, there may be a temporary connector contact failure.
2	<p>CHECK POOR CONTACT.</p> <p>Repair any poor contact between the ECM and fuel temperature sensor connectors.</p>	Is there poor contact in the ECM or fuel temperature sensor connectors?	Repair any poor contact between the ECM and fuel temperature sensor connectors.	Go to step 3.
3	<p>CHECK HARNESS BETWEEN ECM AND FUEL TEMPERATURE SENSOR CONNECTOR.</p> <p>1) Turn the ignition switch to OFF.</p> <p>2) Disconnect the connectors from the ECM and fuel temperature sensor.</p> <p>3) Measure the resistance of the harness between the ECM and fuel temperature sensor connector.</p> <p>Connector & terminal (B135) No. 17 — (R58) No. 2: (B135) No. 30 — (R58) No. 3:</p>	Is the resistance less than $1\ \Omega$?	Go to step 4.	Repair the harness and connector. NOTE: In this case, repair the following item: • Open circuit in harness between ECM and fuel temperature sensor connector • Poor contact of coupling connector
4	<p>CHECK HARNESS BETWEEN ECM AND FUEL TEMPERATURE SENSOR CONNECTOR.</p> <p>1) Connect all connectors.</p> <p>2) Turn the ignition switch to ON.</p> <p>3) Measure the voltage between ECM and chassis ground.</p> <p>Connector & terminal (B135) No. 17 (+) — Chassis ground (-):</p>	Is the voltage 5 V or more?	Repair the short circuit to power in the harness between the ECM and fuel temperature sensor connector.	Replace the fuel temperature sensor. <Ref. to EC(H4DOTC)-15, Fuel Temperature Sensor.>

Diagnostic Procedure with Diagnostic Trouble Code (DTC)

ENGINE (DIAGNOSTICS)

AM:DTC P0222 THROTTLE/PEDAL POSITION SENSOR/SWITCH "B" CIRCUIT LOW

DTC DETECTING CONDITION:

- Immediately at fault recognition
- GENERAL DESCRIPTION <Ref. to GD(H4DOTC)-73, DTC P0222 THROTTLE/PEDAL POSITION SENSOR/SWITCH "B" CIRCUIT LOW, Diagnostic Trouble Code (DTC) Detecting Criteria.>

TROUBLE SYMPTOM:

- Improper idling
- Poor driving performance
- Engine stalls.

CAUTION:

After repair or replacement of faulty parts, perform Clear Memory Mode <Ref. to EN(H4DOTC)(diag)-52, OPERATION, Clear Memory Mode.> and Inspection Mode <Ref. to EN(H4DOTC)(diag)-42, PROCEDURE, Inspection Mode.>.

WIRING DIAGRAM:

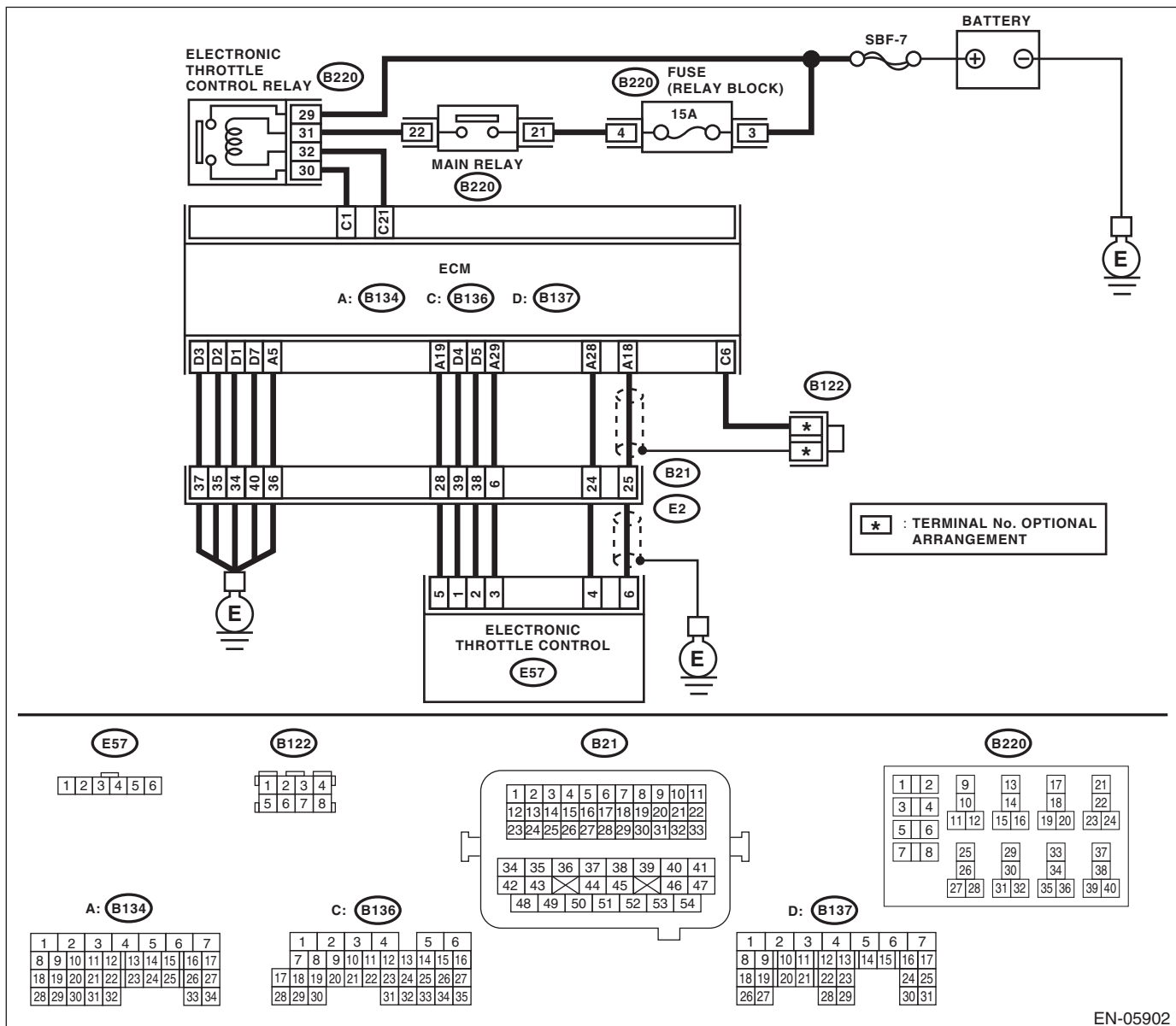

EN-05902

Diagnostic Procedure with Diagnostic Trouble Code (DTC)

ENGINE (DIAGNOSTICS)

Step	Check	Yes	No
<p>1</p> <p>CHECK HARNESS BETWEEN ECM AND ELECTRONIC THROTTLE CONTROL.</p> <p>1) Turn the ignition switch to OFF. 2) Disconnect the connectors from ECM and electronic throttle control. 3) Measure the resistance between ECM and chassis ground.</p> <p>Connector & terminal (B134) No. 19 — Chassis ground: (B134) No. 28 — Chassis ground:</p>	<p>Is the resistance 1 MΩ or more?</p>	<p>Go to step 2.</p>	<p>Repair the ground short circuit of harness between ECM and electronic throttle control connector.</p>
<p>2</p> <p>CHECK SHORT CIRCUIT INSIDE THE ECM.</p> <p>1) Connect the ECM. 2) Measure the resistance between electronic throttle control connector and engine ground.</p> <p>Connector & terminal (E57) No. 4 — Engine ground:</p>	<p>Is the resistance 1 MΩ or more?</p>	<p>Replace the electronic throttle control. <Ref. to FU(H4DOTC)-13, Throttle Body.></p>	<p>Repair the short circuit to ground in harness between ECM and electronic throttle control connector. Replace the ECM if defective. <Ref. to FU(H4DOTC)-46, Engine Control Module (ECM).></p>

AN:DTC P0223 THROTTLE/PEDAL POSITION SENSOR/SWITCH "B" CIRCUIT HIGH

DTC DETECTING CONDITION:

- Immediately at fault recognition
- GENERAL DESCRIPTION <Ref. to GD(H4DOTC)-74, DTC P0223 THROTTLE/PEDAL POSITION SENSOR/SWITCH "B" CIRCUIT HIGH, Diagnostic Trouble Code (DTC) Detecting Criteria.>

TROUBLE SYMPTOM:

- Improper idling
- Poor driving performance
- Engine stalls.

CAUTION:

After repair or replacement of faulty parts, perform Clear Memory Mode <Ref. to EN(H4DOTC)(diag)-52, OPERATION, Clear Memory Mode.> and Inspection Mode <Ref. to EN(H4DOTC)(diag)-42, PROCEDURE, Inspection Mode.>.

WIRING DIAGRAM:

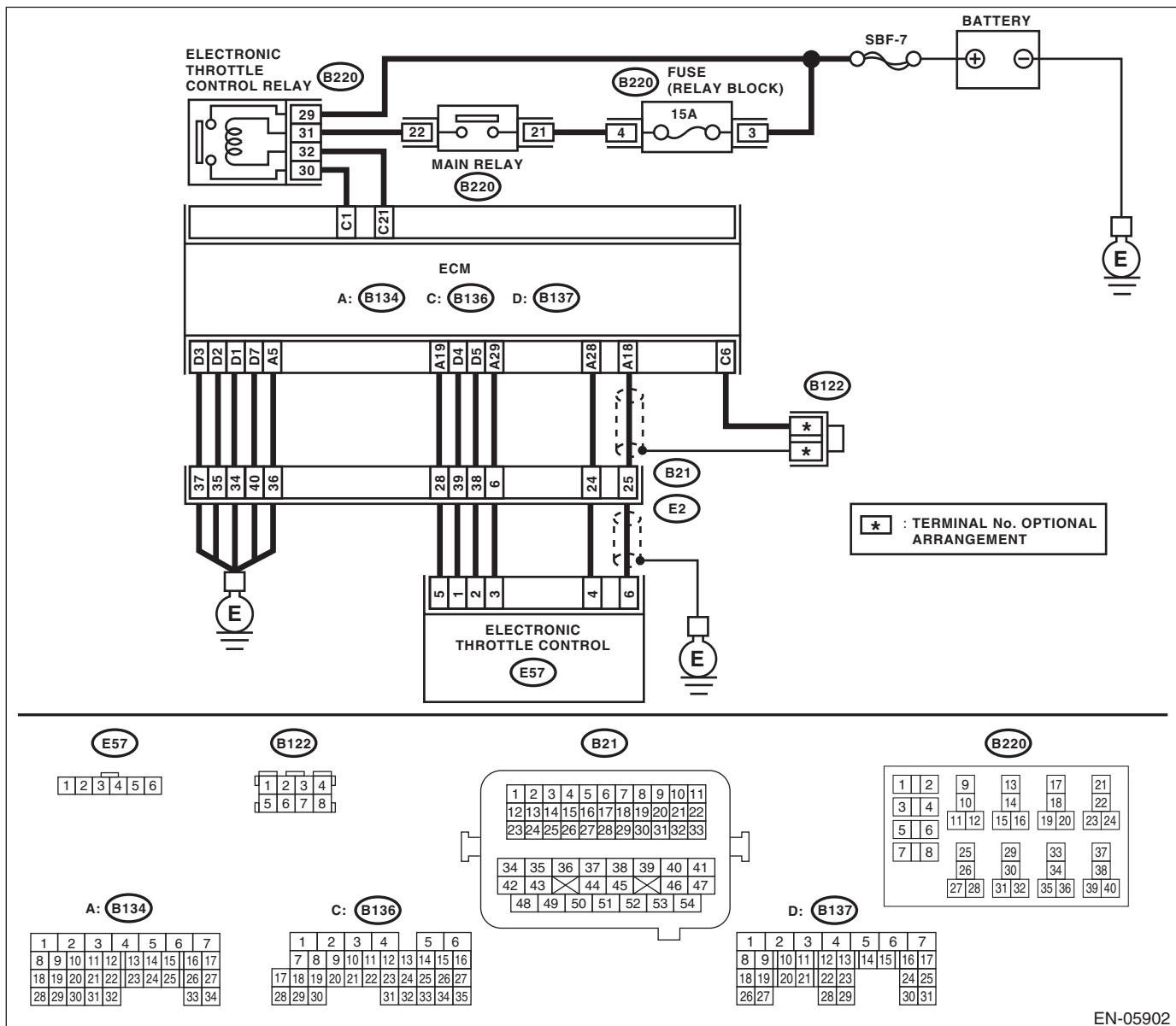

Diagnostic Procedure with Diagnostic Trouble Code (DTC)

ENGINE (DIAGNOSTICS)

Step	Check	Yes	No
1 CHECK HARNESS BETWEEN ECM AND ELECTRONIC THROTTLE CONTROL. 1) Turn the ignition switch to OFF. 2) Disconnect the connectors from ECM and electronic throttle control. 3) Measure the resistance of harness between ECM and electronic throttle control connector. Connector & terminal (B134) No. 28 — (E57) No. 4: (B134) No. 29 — (E57) No. 3:	Is the resistance less than 1 Ω ?	Go to step 2.	Repair the harness and connector. NOTE: In this case, repair the following item: <ul style="list-style-type: none"> • Open circuit in harness between ECM and electronic throttle control connector • Poor contact of coupling connector
2 CHECK HARNESS BETWEEN ECM AND ELECTRONIC THROTTLE CONTROL. 1) Connect the ECM. 2) Measure the resistance between electronic throttle control connector and engine ground. Connector & terminal (E57) No. 3 — Engine ground:	Is the resistance less than 5 Ω ?	Go to step 3.	Repair the harness and connector. NOTE: In this case, repair the following item: <ul style="list-style-type: none"> • Open circuit of harness between ECM and engine ground • Poor contact in ECM connector • Poor contact of coupling connector
3 CHECK HARNESS BETWEEN ECM AND ELECTRONIC THROTTLE CONTROL. 1) Turn the ignition switch to ON. 2) Measure the voltage between electronic throttle control connector and engine ground. Connector & terminal (E57) No. 4 (+) — Engine ground (-):	Is the voltage 4.85 V or more?	Repair the short circuit to power in the harness between ECM and electronic throttle control connector.	Go to step 4.
4 CHECK HARNESS BETWEEN ECM AND ELECTRONIC THROTTLE CONTROL. 1) Turn the ignition switch to OFF. 2) Disconnect the connectors from the ECM. 3) Measure the resistance between ECM connectors. Connector & terminal (B134) No. 19 — (B134) No. 28:	Is the resistance 1 M Ω or more?	Repair poor contact of the electronic throttle control connector. Replace the electronic throttle control if defective. <Ref. to FU(H4DOTC)-13, Throttle Body.>	Repair the short circuit to power in the harness between ECM and electronic throttle control connector.

Diagnostic Procedure with Diagnostic Trouble Code (DTC)

ENGINE (DIAGNOSTICS)

AO:DTC P0230 FUEL PUMP PRIMARY CIRCUIT

DTC DETECTING CONDITION:

- Detected when two consecutive driving cycles with fault occur.
- GENERAL DESCRIPTION <Ref. to GD(H4DOTC)-75, DTC P0230 FUEL PUMP PRIMARY CIRCUIT, Diagnostic Trouble Code (DTC) Detecting Criteria.>

CAUTION:

After repair or replacement of faulty parts, perform Clear Memory Mode <Ref. to EN(H4DOTC)(diag)-52, OPERATION, Clear Memory Mode.> and Inspection Mode <Ref. to EN(H4DOTC)(diag)-42, PROCEDURE, Inspection Mode.>.

WIRING DIAGRAM:

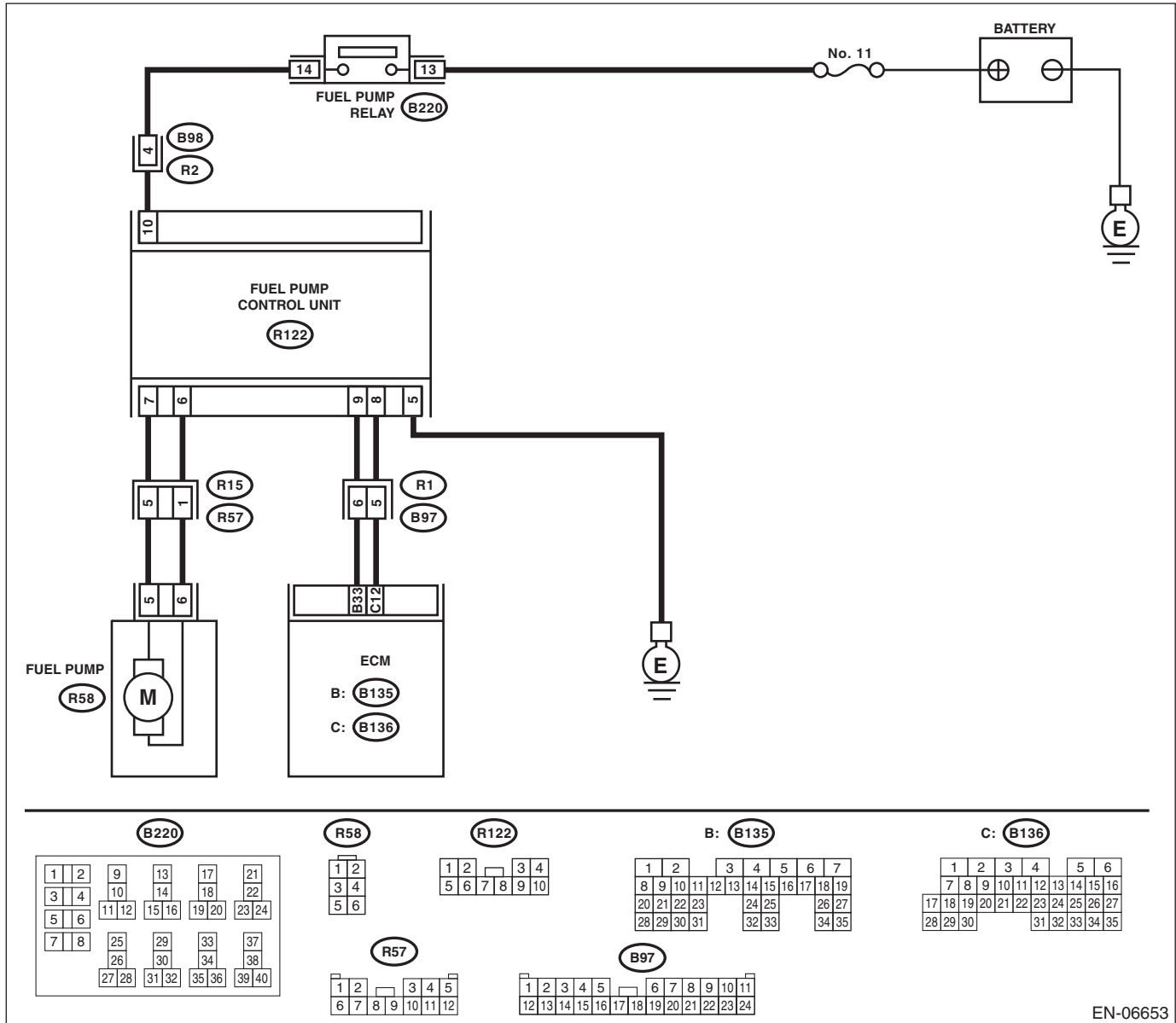

EN-06653

Diagnostic Procedure with Diagnostic Trouble Code (DTC)

ENGINE (DIAGNOSTICS)

Step	Check	Yes	No
<p>1 CHECK POWER SUPPLY CIRCUIT TO FUEL PUMP CONTROL UNIT.</p> <p>1) Turn the ignition switch to OFF. 2) Disconnect the connector from fuel pump control unit. 3) Turn the ignition switch to ON. 4) Measure the voltage between fuel pump control unit and chassis ground.</p> <p>Connector & terminal (R122) No. 10 (+) — Chassis ground (-):</p>	Is the voltage 10 V or more?	Go to step 2.	<p>Repair the power supply circuit.</p> <p>NOTE: In this case, repair the following item:</p> <ul style="list-style-type: none"> • Open circuit or short circuit to ground in harness between fuel pump relay connector and fuel pump control unit connector • Poor contact of fuel pump relay connector • Poor contact of coupling connector
<p>2 CHECK GROUND CIRCUIT OF FUEL PUMP CONTROL UNIT.</p> <p>1) Turn the ignition switch to OFF. 2) Measure the resistance of harness between fuel pump control unit connector and chassis ground.</p> <p>Connector & terminal (R122) No. 5 — Chassis ground:</p>	Is the resistance less than 5 Ω?	Go to step 3.	<p>Repair the open circuit in harness between fuel pump control unit connector and chassis ground.</p>
<p>3 CHECK HARNESS BETWEEN FUEL PUMP CONTROL UNIT AND FUEL PUMP CONNECTOR.</p> <p>1) Disconnect the connector from fuel pump. 2) Measure the resistance of harness between fuel pump control unit and fuel pump connector.</p> <p>Connector & terminal (R122) No. 7 — (R58) No. 5: (R122) No. 6 — (R58) No. 6:</p>	Is the resistance less than 1 Ω?	Go to step 4.	<p>Repair the harness and connector.</p> <p>NOTE: In this case, repair the following item:</p> <ul style="list-style-type: none"> • Open circuit in harness between fuel pump control unit connector and fuel pump connector • Poor contact of coupling connector
<p>4 CHECK HARNESS BETWEEN FUEL PUMP CONTROL UNIT AND FUEL PUMP CONNECTOR.</p> <p>Measure the resistance between fuel pump control unit connector and chassis ground.</p> <p>Connector & terminal (R122) No. 7 — Chassis ground: (R122) No. 6 — Chassis ground:</p>	Is the resistance 1 MΩ or more?	Go to step 5.	<p>Repair the short circuit to ground in harness between fuel pump control unit connector and fuel pump connector.</p>
<p>5 CHECK HARNESS BETWEEN ECM AND FUEL PUMP CONTROL UNIT.</p> <p>1) Disconnect the connectors from the ECM. 2) Measure the resistance of the harness between the ECM and fuel pump control unit.</p> <p>Connector & terminal (B135) No. 33 — (R122) No. 9: (B136) No. 12 — (R122) No. 8:</p>	Is the resistance less than 1 Ω?	Go to step 6.	<p>Repair the harness and connector.</p> <p>NOTE: In this case, repair the following item:</p> <ul style="list-style-type: none"> • Open circuit in harness between ECM and fuel pump control unit • Poor contact of coupling connector

Diagnostic Procedure with Diagnostic Trouble Code (DTC)

ENGINE (DIAGNOSTICS)

Step	Check	Yes	No
6 CHECK HARNESS BETWEEN ECM AND FUEL PUMP CONTROL UNIT. Measure the resistance between fuel pump control unit connector and chassis ground. <i>Connector & terminal</i> <i>(R122) No. 9 — Chassis ground:</i> <i>(R122) No. 8 — Chassis ground:</i>	Is the resistance 1 M Ω or more?	Go to step 7.	Repair the short circuit to ground in harness between ECM and fuel pump control unit connector.
7 CHECK POOR CONTACT. Check poor contact of ECM and fuel pump control unit connector.	Is there poor contact of ECM or fuel pump control unit connector?	Repair the poor contact of ECM or fuel pump control unit connector.	Go to step 8.
8 CHECK EXPERIENCE OF RUNNING OUT OF FUEL.	Has the vehicle experienced running out of fuel?	Finish the diagnosis. NOTE: DTC may be recorded as a result of fuel pump idling while running out of fuel.	Replace the fuel pump control unit. <Ref. to FU(H4DOTC)-50, Fuel Pump Control Unit.>

Diagnostic Procedure with Diagnostic Trouble Code (DTC)

ENGINE (DIAGNOSTICS)

AP:DTC P0244 TURBO/SUPER CHARGER WASTEGATE SOLENOID "A" RANGE/PERFORMANCE

DTC DETECTING CONDITION:

- Immediately at fault recognition
- GENERAL DESCRIPTION <Ref. to GD(H4DOTC)-77, DTC P0244 TURBO/SUPER CHARGER WASTEGATE SOLENOID "A" RANGE/PERFORMANCE, Diagnostic Trouble Code (DTC) Detecting Criteria.>

TROUBLE SYMPTOM:

Poor driving performance

CAUTION:

After repair or replacement of faulty parts, perform Clear Memory Mode <Ref. to EN(H4DOTC)(diag)-52, OPERATION, Clear Memory Mode.> and Inspection Mode <Ref. to EN(H4DOTC)(diag)-42, PROCEDURE, Inspection Mode.>.

WIRING DIAGRAM:

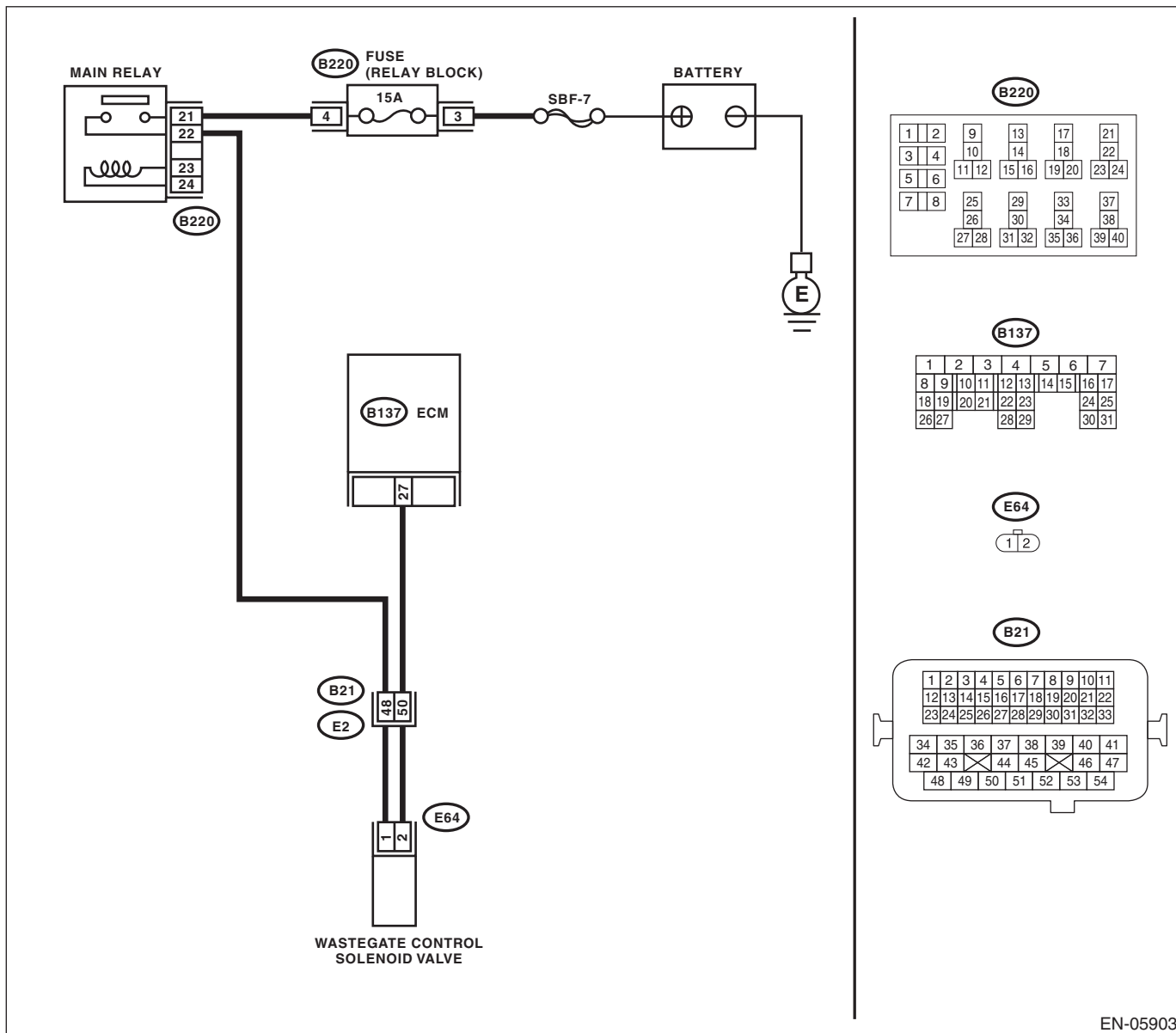

EN-05903

Diagnostic Procedure with Diagnostic Trouble Code (DTC)

ENGINE (DIAGNOSTICS)

Step	Check	Yes	No
1 CHECK FOR ANY OTHER DTC ON DISPLAY.	Is any other DTC displayed?	Check the appropriate DTC using the "List of Diagnostic Trouble Code (DTC)". <Ref. to EN(H4DOTC)(diag)-80, List of Diagnostic Trouble Code (DTC).>	Replace the wastegate control solenoid valve. <Ref. to FU(H4DOTC)-42, Wastegate Control Solenoid Valve.>

Diagnostic Procedure with Diagnostic Trouble Code (DTC)

ENGINE (DIAGNOSTICS)

	Step	Check	Yes	No
1	<p>CHECK OUTPUT SIGNAL OF ECM. 1) Turn the ignition switch to ON. 2) Measure the voltage between ECM and chassis ground. Connector & terminal (B137) No. 27 (+) — Chassis ground (-):</p>	Is the voltage 10 V or more?	Go to step 2.	Go to step 3.
2	<p>CHECK FOR POOR CONTACT. Check for poor contact of ECM connector.</p>	Is there poor contact of ECM connector?	Repair the poor contact of ECM connector.	Even if DTC is detected, the circuit has returned to a normal condition at this time. Reproduce the failure, and then perform the diagnosis again. NOTE: In this case, temporary open or short circuit of harness or temporary poor contact of connector may be the cause.
3	<p>CHECK POWER SUPPLY TO WASTEGATE CONTROL SOLENOID VALVE. Measure the voltage between wastegate control solenoid valve and engine ground. Connector & terminal (E64) No. 1 (+) — Engine ground (-):</p>	Is the voltage 10 V or more?	Go to step 4.	Repair the power supply circuit.
4	<p>CHECK HARNESS BETWEEN ECM AND WASTEGATE CONTROL SOLENOID VALVE. 1) Turn the ignition switch to OFF. 2) Disconnect the connectors from ECM and wastegate control solenoid valve. 3) Measure the resistance between wastegate control solenoid valve connector and engine ground. Connector & terminal (E64) No. 2 — Engine ground:</p>	Is the resistance 1 M Ω or more?	Go to step 5.	Repair ground short circuit of harness between ECM and wastegate control solenoid valve connector.
5	<p>CHECK HARNESS BETWEEN ECM AND WASTEGATE CONTROL SOLENOID VALVE. Measure the resistance of harness between ECM and wastegate control solenoid valve connector. Connector & terminal (B137) No. 27 — (E64) No. 2:</p>	Is the resistance less than 1 Ω ?	Go to step 6.	Repair the harness and connector. NOTE: In this case, repair the following item: <ul style="list-style-type: none"> • Open circuit of harness between ECM and wastegate control solenoid valve connector • Poor contact of coupling connector
6	<p>CHECK WASTEGATE CONTROL SOLENOID VALVE. 1) Remove the wastegate control solenoid valve. 2) Measure the resistance between wastegate control solenoid valve terminals. Terminals No. 1 — No. 2:</p>	Is the resistance between 10 — 100 Ω ?	Repair poor contact in wastegate control solenoid valve connector.	Replace the wastegate control solenoid valve. <Ref. to FU(H4DOTC)-42, Wastegate Control Solenoid Valve.>

Diagnostic Procedure with Diagnostic Trouble Code (DTC)

ENGINE (DIAGNOSTICS)

AR:DTC P0246 TURBO/SUPER CHARGER WASTEGATE SOLENOID "A" HIGH

DTC DETECTING CONDITION:

- Immediately at fault recognition
- GENERAL DESCRIPTION <Ref. to GD(H4DOTC)-80, DTC P0246 TURBO/SUPER CHARGER WASTEGATE SOLENOID "A" HIGH, Diagnostic Trouble Code (DTC) Detecting Criteria.>

TROUBLE SYMPTOM:

Poor driving performance

CAUTION:

After repair or replacement of faulty parts, perform Clear Memory Mode <Ref. to EN(H4DOTC)(diag)-52, OPERATION, Clear Memory Mode.> and Inspection Mode <Ref. to EN(H4DOTC)(diag)-42, PROCEDURE, Inspection Mode.>.

WIRING DIAGRAM:

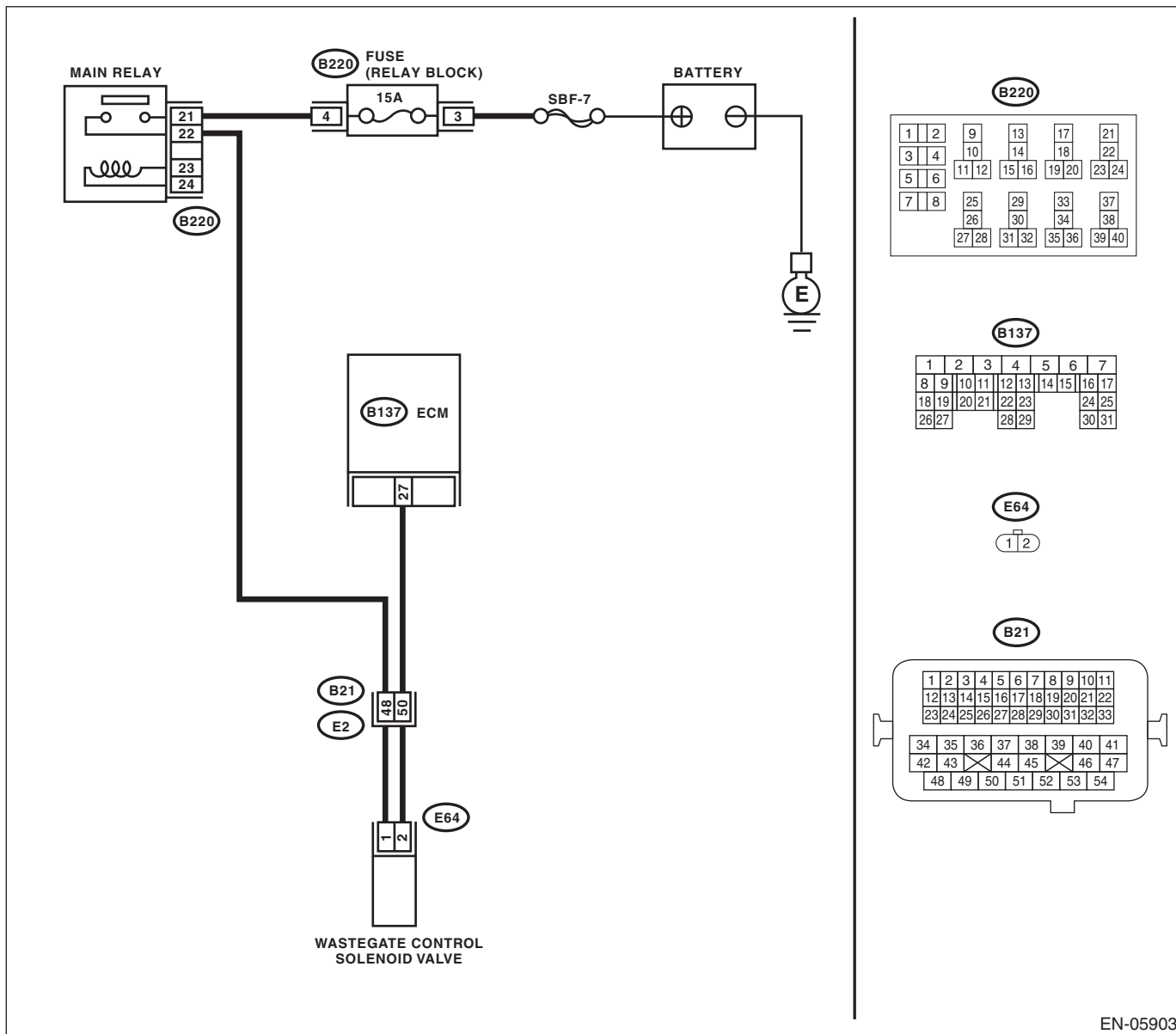

EN-05903

Diagnostic Procedure with Diagnostic Trouble Code (DTC)

ENGINE (DIAGNOSTICS)

	Step	Check	Yes	No
1	CHECK HARNESS BETWEEN ECM AND WASTEGATE CONTROL SOLENOID VALVE. 1) Turn the ignition switch to OFF. 2) Disconnect the connectors from ECM and wastegate control solenoid valve. 3) Turn the ignition switch to ON. 4) Measure the voltage between ECM and chassis ground. Connector & terminal (B137) No. 27 (+) — Chassis ground (-):	Is the voltage 10 V or more?	Repair short circuit to power in the harness between ECM and wastegate control solenoid valve connector.	Go to step 2.
2	CHECK WASTEGATE CONTROL SOLENOID VALVE. 1) Turn the ignition switch to OFF. 2) Measure the resistance between wastegate control solenoid valve terminals. Terminals No. 1 — No. 2:	Is the resistance less than 1 Ω ?	Replace the wastegate control solenoid valve. <Ref. to FU(H4DOTC)-42, Wastegate Control Solenoid Valve.>	Repair the poor contact of the ECM connector.

AS:DTC P0301 CYLINDER 1 MISFIRE DETECTED

NOTE:

For the diagnostic procedure, refer to DTC P0304. <Ref. to EN(H4DOTC)(diag)-170, DTC P0304 CYLINDER 4 MISFIRE DETECTED, Diagnostic Procedure with Diagnostic Trouble Code (DTC).>

AT:DTC P0302 CYLINDER 2 MISFIRE DETECTED

NOTE:

For the diagnostic procedure, refer to DTC P0304. <Ref. to EN(H4DOTC)(diag)-170, DTC P0304 CYLINDER 4 MISFIRE DETECTED, Diagnostic Procedure with Diagnostic Trouble Code (DTC).>

AU:DTC P0303 CYLINDER 3 MISFIRE DETECTED

NOTE:

For the diagnostic procedure, refer to DTC P0304. <Ref. to EN(H4DOTC)(diag)-170, DTC P0304 CYLINDER 4 MISFIRE DETECTED, Diagnostic Procedure with Diagnostic Trouble Code (DTC).>

Diagnostic Procedure with Diagnostic Trouble Code (DTC)

ENGINE (DIAGNOSTICS)

AV:DTC P0304 CYLINDER 4 MISFIRE DETECTED

DTC DETECTING CONDITION:

- Detected when two consecutive driving cycles with fault occur.
- Immediately at fault recognition (A misfire which could damage catalyst occurs.)
- GENERAL DESCRIPTION <Ref. to GD(H4DOTC)-86, DTC P0304 CYLINDER 4 MISFIRE DETECTED, Diagnostic Trouble Code (DTC) Detecting Criteria.>

TROUBLE SYMPTOM:

- Engine stalls.
- Improper idling
- Rough driving

CAUTION:

After repair or replacement of faulty parts, perform Clear Memory Mode <Ref. to EN(H4DOTC)(diag)-52, OPERATION, Clear Memory Mode.> and Inspection Mode <Ref. to EN(H4DOTC)(diag)-42, PROCEDURE, Inspection Mode.>.

WIRING DIAGRAM:

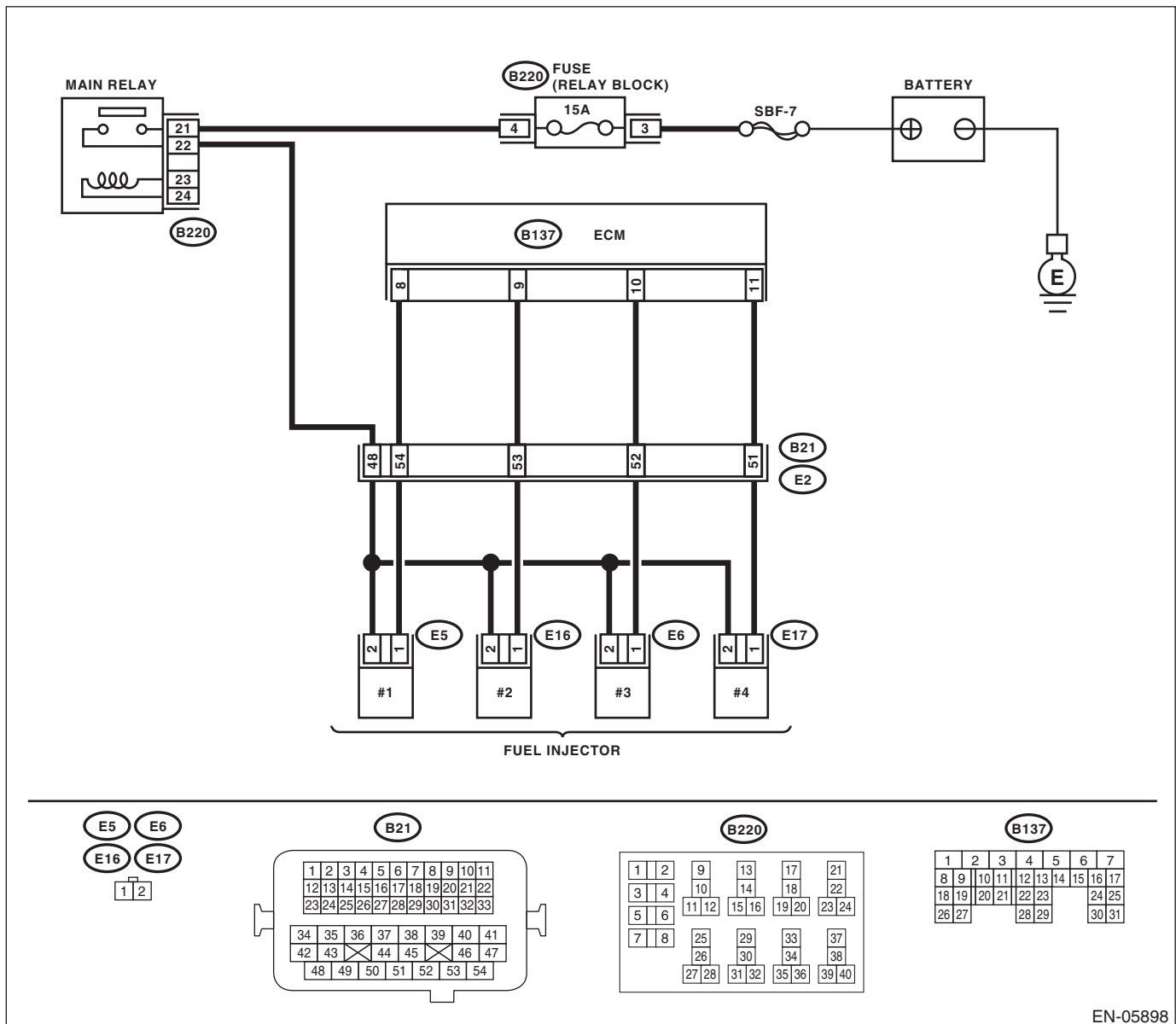

EN-05898

Diagnostic Procedure with Diagnostic Trouble Code (DTC)

ENGINE (DIAGNOSTICS)

	Step	Check	Yes	No
1	<p>CHECK OUTPUT SIGNAL OF ECM.</p> <p>1) Turn the ignition switch to ON.</p> <p>2) Measure the voltage between the ECM and chassis ground for faulty cylinders.</p> <p>Connector & terminal</p> <p>#1 (B137) No. 8 (+) — Chassis ground (-):</p> <p>#2 (B137) No. 9 (+) — Chassis ground (-):</p> <p>#3 (B137) No. 10 (+) — Chassis ground (-):</p> <p>#4 (B137) No. 11 (+) — Chassis ground (-):</p>	Is the voltage 10 V or more?	Go to step 6.	Go to step 2.
2	<p>CHECK HARNESS BETWEEN ECM AND FUEL INJECTOR.</p> <p>1) Turn the ignition switch to OFF.</p> <p>2) Disconnect the connector from fuel injector on faulty cylinders.</p> <p>3) Measure the resistance between the fuel injector connector and engine ground on faulty cylinders.</p> <p>Connector & terminal</p> <p>#1 (E5) No. 1 — Engine ground:</p> <p>#2 (E16) No. 1 — Engine ground:</p> <p>#3 (E6) No. 1 — Engine ground:</p> <p>#4 (E17) No. 1 — Engine ground:</p>	Is the resistance 1 M Ω or more?	Go to step 3.	Repair the short circuit to ground in harness between ECM and fuel injector connector.
3	<p>CHECK HARNESS BETWEEN ECM AND FUEL INJECTOR.</p> <p>Measure the resistance of harness between the ECM and fuel injector on faulty cylinders.</p> <p>Connector & terminal</p> <p>#1 (B137) No. 8 — (E5) No. 1:</p> <p>#2 (B137) No. 9 — (E16) No. 1:</p> <p>#3 (B137) No. 10 — (E6) No. 1:</p> <p>#4 (B137) No. 11 — (E17) No. 1:</p>	Is the resistance less than 1 Ω ?	Go to step 4.	<p>Repair the harness and connector.</p> <p>NOTE:</p> <p>In this case, repair the following item:</p> <ul style="list-style-type: none"> • Open circuit of harness between ECM and fuel injector connector • Poor contact of coupling connector
4	<p>CHECK FUEL INJECTOR.</p> <p>Measure the resistance between fuel injector terminals on faulty cylinder.</p> <p>Terminals</p> <p>No. 1 — No. 2:</p>	Is the resistance between 5 — 20 Ω ?	Go to step 5.	Replace the faulty fuel injector. <Ref. to FU(H4DOTC)-36, Fuel Injector.>
5	<p>CHECK POWER SUPPLY LINE.</p> <p>1) Turn the ignition switch to ON.</p> <p>2) Measure the voltage between fuel injector and engine ground on faulty cylinders.</p> <p>Connector & terminal</p> <p>#1 (E5) No. 2 (+) — Engine ground (-):</p> <p>#2 (E16) No. 2 (+) — Engine ground (-):</p> <p>#3 (E6) No. 2 (+) — Engine ground (-):</p> <p>#4 (E17) No. 2 (+) — Engine ground (-):</p>	Is the voltage 10 V or more?	Repair the poor contact of all connectors in fuel injector circuit.	<p>Repair the harness and connector.</p> <p>NOTE:</p> <p>In this case, repair the following item:</p> <ul style="list-style-type: none"> • Open circuit in harness between the main relay connector and fuel injector connector on faulty cylinders • Poor contact of coupling connector • Poor contact of main relay connector

Diagnostic Procedure with Diagnostic Trouble Code (DTC)

ENGINE (DIAGNOSTICS)

Step	Check	Yes	No
6 CHECK HARNESS BETWEEN ECM AND FUEL INJECTOR. 1) Turn the ignition switch to OFF. 2) Disconnect the connector from fuel injector on faulty cylinders. 3) Turn the ignition switch to ON. 4) Measure the voltage between the ECM and chassis ground for faulty cylinders. Connector & terminal #1 (B137) No. 8 (+) — Chassis ground (-): #2 (B137) No. 9 (+) — Chassis ground (-): #3 (B137) No. 10 (+) — Chassis ground (-): #4 (B137) No. 11 (+) — Chassis ground (-):	Is the voltage 10 V or more?	Repair the short circuit to power in harness between ECM and fuel injector connector.	Go to step 7.
7 CHECK FUEL INJECTOR. 1) Turn the ignition switch to OFF. 2) Measure the resistance between fuel injector terminals on faulty cylinder. Terminals No. 1 — No. 2:	Is the resistance less than 1 Ω ?	Replace the faulty fuel injector. <Ref. to FU(H4DOTC)-36, Fuel Injector.>	Go to step 8.
8 CHECK INSTALLATION OF CAMSHAFT POSITION SENSOR/CRANKSHAFT POSITION SENSOR.	Is the camshaft position sensor or crankshaft position sensor loosely installed?	Tighten the camshaft position sensor or crankshaft position sensor.	Go to step 9.
9 CHECK CRANK SPROCKET. Remove the timing belt cover.	Is the crank sprocket rusted or does it have damaged teeth?	Replace the crank sprocket. <Ref. to ME(H4DOTC)-59, Crank Sprocket.>	Go to step 10.
10 CHECK INSTALLATION CONDITION OF TIMING BELT. Turn the crankshaft, and align alignment mark on crank sprocket with alignment mark on cylinder block. ST 499987500 CRANKSHAFT SOCKET	Is the timing belt dislocated from its proper position?	Repair the installation condition of timing belt. <Ref. to ME(H4DOTC)-50, Timing Belt.>	Go to step 11.
11 CHECK FUEL LEVEL.	Is the fuel meter indication higher than the "Lower" level?	Go to step 12.	Replenish fuel so that fuel meter indication is higher than the "Lower" level. After replenishing fuel, Go to step 12.
12 CHECK STATUS OF MALFUNCTION INDICATOR LIGHT. 1) Clear the memory using the Subaru Select Monitor or general scan tool. <Ref. to EN(H4DOTC)(diag)-52, Clear Memory Mode.> 2) Start the engine, and drive the vehicle 10 minutes or more.	Does the malfunction indicator light illuminate or blink?	Go to step 14.	Go to step 13.

Diagnostic Procedure with Diagnostic Trouble Code (DTC)

ENGINE (DIAGNOSTICS)

Step	Check	Yes	No
13	CHECK CAUSE OF MISFIRE.	Was the cause of misfire identified when the engine is running?	Finish diagnostics operation, if the engine has no abnormality.
			Repair the poor contact of connector. NOTE: In this case, repair the following item: <ul style="list-style-type: none"> • Poor contact of ignition coil connector • Poor contact of fuel injector connector on faulty cylinders • Poor contact in ECM connector • Poor contact of coupling connector
14	CHECK AIR INTAKE SYSTEM.	Is there any fault in air intake system?	Repair the air intake system. NOTE: Check the following items. <ul style="list-style-type: none"> • Are there air leaks or air suction caused by loose or dislocated nuts and bolts? • Are there cracks or any disconnection of hoses?
15	CHECK MISFIRE SYMPTOM. 1) Turn the ignition switch to ON. 2) Read DTC. NOTE: <ul style="list-style-type: none"> • Subaru Select Monitor For detailed operation procedures, refer to "READ CURRENT DATA FOR ENGINE". <Ref. to EN(H4DOTC)(diag)-34, Subaru Select Monitor.> <ul style="list-style-type: none"> • General scan tool For detailed operation procedures, refer to the general scan tool operation manual.	Does the Subaru Select Monitor or general scan tool indicate only one DTC?	Go to step 20.
16	CHECK DTC.	Are DTCs P0301 and P0302 displayed on the Subaru Select Monitor or general scan tool?	Go to step 17.
17	CHECK DTC.	Are DTCs P0303 and P0304 displayed on the Subaru Select Monitor or general scan tool?	Go to step 18.
18	CHECK DTC.	Are DTCs P0301 and P0303 displayed on the Subaru Select Monitor or general scan tool?	Go to step 19.
19	CHECK DTC.	Are DTCs P0302 and P0304 displayed on the Subaru Select Monitor or general scan tool?	Go to step 20.

Diagnostic Procedure with Diagnostic Trouble Code (DTC)

ENGINE (DIAGNOSTICS)

Step	Check	Yes	No
20 ONLY ONE CYLINDER.	Is there any fault in the cylinder?	Repair or replace faulty parts. NOTE: Check the following items. • Spark plug • Spark plug cord • Fuel injector • Compression ratio	Go to DTC P0171. <Ref. to EN(H4DOTC)(diag)-148, DTC P0171 SYSTEM TOO LEAN (BANK 1), Diagnostic Procedure with Diagnostic Trouble Code (DTC).>
21 GROUP OF #1 AND #2 CYLINDERS.	Are there any faults in #1 and #2 cylinders?	Repair or replace faulty parts. NOTE: • Check the following items. • Spark plug • Fuel injector • Ignition coil • Compression ratio • If any fault are not found, check the "IGNITION CONTROL SYSTEM" of #1 and #2 cylinders side. <Ref. to EN(H4DOTC)(diag)-72, IGNITION CONTROL SYSTEM, Diagnostics for Engine Starting Failure.>	Go to DTC P0171. <Ref. to EN(H4DOTC)(diag)-148, DTC P0171 SYSTEM TOO LEAN (BANK 1), Diagnostic Procedure with Diagnostic Trouble Code (DTC).>
22 GROUP OF #3 AND #4 CYLINDERS.	Are there any faults in #3 and #4 cylinders?	Repair or replace faulty parts. NOTE: • Check the following items. • Spark plug • Fuel injector • Ignition coil • Compression ratio • If any fault are not found, check the "IGNITION CONTROL SYSTEM" of #3 and #4 cylinders side. <Ref. to EN(H4DOTC)(diag)-72, IGNITION CONTROL SYSTEM, Diagnostics for Engine Starting Failure.>	Go to DTC P0171. <Ref. to EN(H4DOTC)(diag)-148, DTC P0171 SYSTEM TOO LEAN (BANK 1), Diagnostic Procedure with Diagnostic Trouble Code (DTC).>

Diagnostic Procedure with Diagnostic Trouble Code (DTC)

ENGINE (DIAGNOSTICS)

Step	Check	Yes	No
23 GROUP OF #1 AND #3 CYLINDERS.	Are there any faults in #1 and #3 cylinders?	Repair or replace faulty parts. NOTE: Check the following items. • Spark plug • Fuel injector • Compression ratio • Skipping timing belt teeth	Go to DTC P0171. <Ref. to EN(H4DOTC)(diag)-148, DTC P0171 SYSTEM TOO LEAN (BANK 1), Diagnostic Procedure with Diagnostic Trouble Code (DTC).>
24 GROUP OF #2 AND #4 CYLINDERS.	Are there any faults in #2 and #4 cylinders?	Repair or replace faulty parts. NOTE: Check the following items. • Spark plug • Fuel injector • Compression ratio • Skipping timing belt teeth	Go to DTC P0171. <Ref. to EN(H4DOTC)(diag)-148, DTC P0171 SYSTEM TOO LEAN (BANK 1), Diagnostic Procedure with Diagnostic Trouble Code (DTC).>
25 CYLINDER AT RANDOM.	Is the engine idle rough?	Go to DTC P0171. <Ref. to EN(H4DOTC)(diag)-148, DTC P0171 SYSTEM TOO LEAN (BANK 1), Diagnostic Procedure with Diagnostic Trouble Code (DTC).>	Repair or replace faulty parts. NOTE: Check the following items. • Spark plug • Fuel injector • Compression ratio

Diagnostic Procedure with Diagnostic Trouble Code (DTC)

ENGINE (DIAGNOSTICS)

AW:DTC P0327 KNOCK SENSOR 1 CIRCUIT LOW (BANK 1 OR SINGLE SENSOR)

DTC DETECTING CONDITION:

- Immediately at fault recognition
- GENERAL DESCRIPTION <Ref. to GD(H4DOTC)-87, DTC P0327 KNOCK SENSOR 1 CIRCUIT LOW (BANK 1 OR SINGLE SENSOR), Diagnostic Trouble Code (DTC) Detecting Criteria.>

TROUBLE SYMPTOM:

- Poor driving performance
- Knocking occurs.

CAUTION:

After repair or replacement of faulty parts, perform Clear Memory Mode <Ref. to EN(H4DOTC)(diag)-52, OPERATION, Clear Memory Mode.> and Inspection Mode <Ref. to EN(H4DOTC)(diag)-42, PROCEDURE, Inspection Mode.>.

WIRING DIAGRAM:

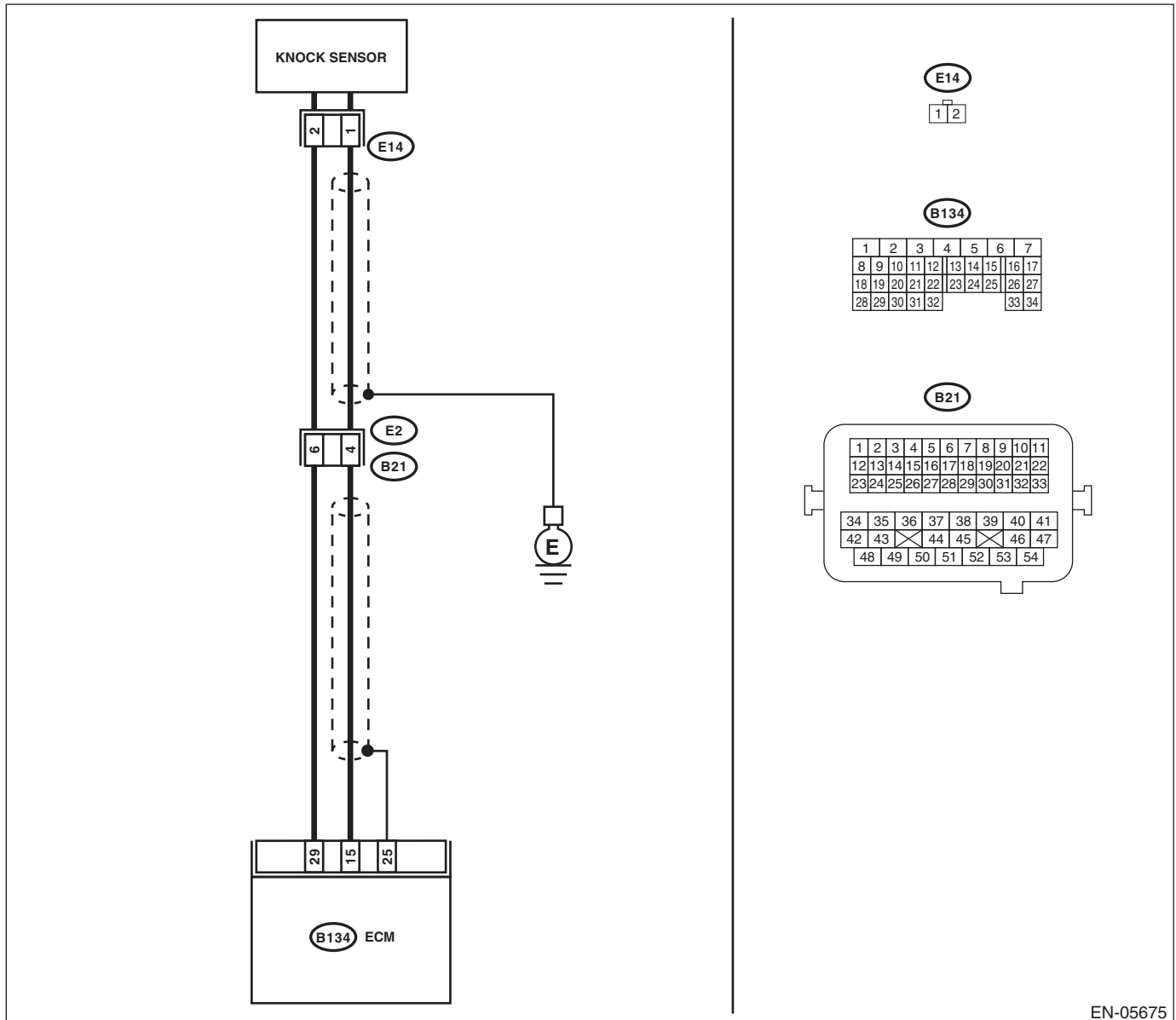

EN-05675

Diagnostic Procedure with Diagnostic Trouble Code (DTC)

ENGINE (DIAGNOSTICS)

Step	Check	Yes	No
<p>1 CHECK HARNESS BETWEEN ECM AND KNOCK SENSOR. 1) Turn the ignition switch to OFF. 2) Disconnect the connectors from the ECM. 3) Measure the resistance between ECM connectors. Connector & terminal (B134) No. 15 — (B134) No. 29:</p>	<p>Is the resistance 600 kΩ or more?</p>	<p>Go to step 2.</p>	<p>Repair poor contact of the ECM connector.</p>
<p>2 CHECK KNOCK SENSOR. 1) Disconnect the connector from knock sensor. 2) Measure the resistance between knock sensor terminals. Terminals No. 1 — No. 2:</p>	<p>Is the resistance 600 kΩ or more?</p>	<p>Replace the knock sensor. <Ref. to FU(H4DOTC)-32, Knock Sensor.></p>	<p>Repair the harness and connector. NOTE: In this case, repair the following item: • Open circuit in harness between ECM and knock sensor connector • Poor contact of knock sensor connector • Poor contact of coupling connector</p>

Diagnostic Procedure with Diagnostic Trouble Code (DTC)

ENGINE (DIAGNOSTICS)

AX:DTC P0328 KNOCK SENSOR 1 CIRCUIT HIGH (BANK 1 OR SINGLE SENSOR)

DTC DETECTING CONDITION:

- Immediately at fault recognition
- GENERAL DESCRIPTION <Ref. to GD(H4DOTC)-88, DTC P0328 KNOCK SENSOR 1 CIRCUIT HIGH (BANK 1 OR SINGLE SENSOR), Diagnostic Trouble Code (DTC) Detecting Criteria.>

TROUBLE SYMPTOM:

- Poor driving performance
- Knocking occurs.

CAUTION:

After repair or replacement of faulty parts, perform Clear Memory Mode <Ref. to EN(H4DOTC)(diag)-52, OPERATION, Clear Memory Mode.> and Inspection Mode <Ref. to EN(H4DOTC)(diag)-42, PROCEDURE, Inspection Mode.>.

WIRING DIAGRAM:

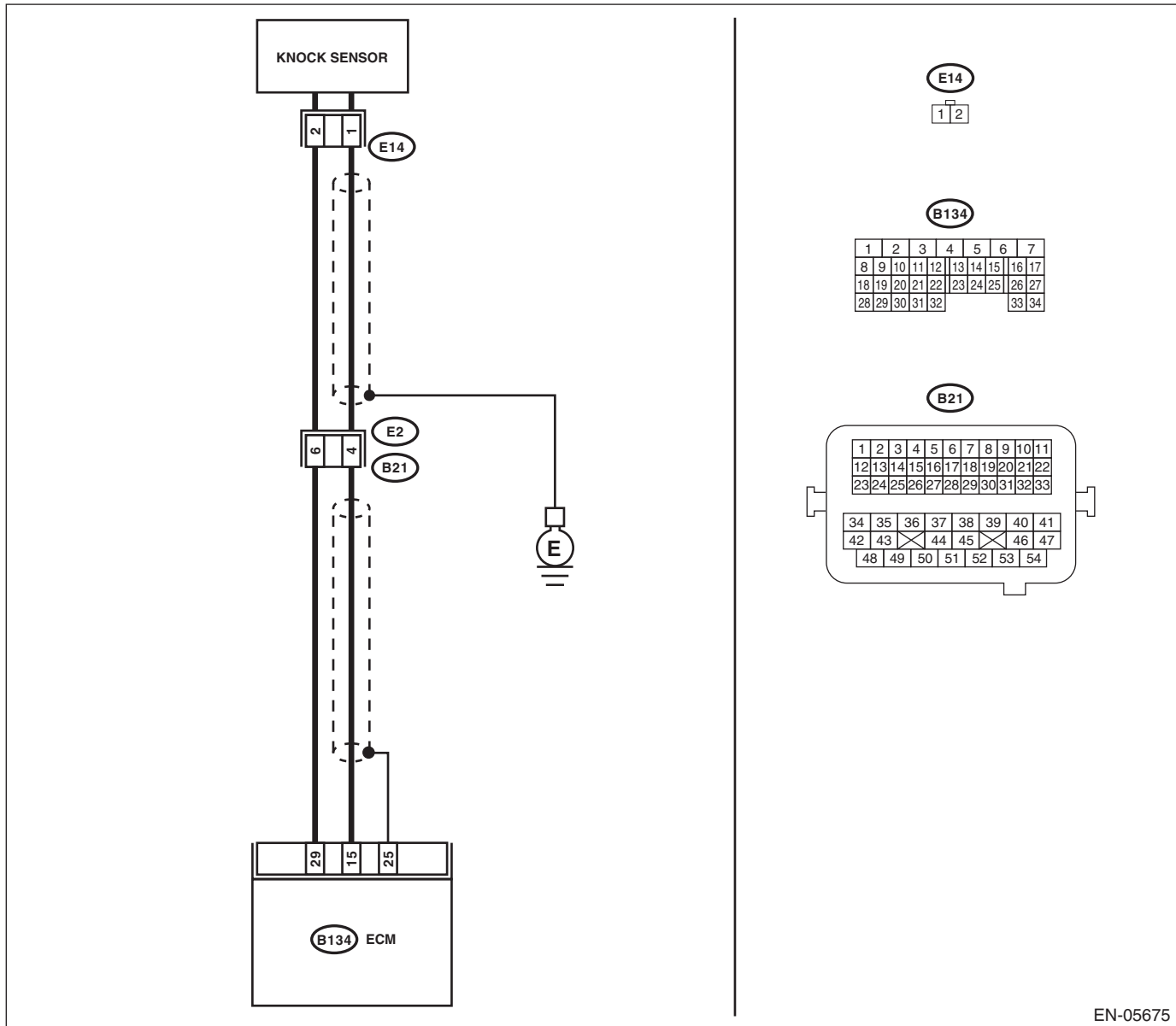

EN-05675

Diagnostic Procedure with Diagnostic Trouble Code (DTC)

ENGINE (DIAGNOSTICS)

Step	Check	Yes	No
<p>1 CHECK HARNESS BETWEEN ECM AND KNOCK SENSOR. 1) Turn the ignition switch to OFF. 2) Disconnect the connectors from the ECM. 3) Measure the resistance between ECM connectors.</p> <p>Connector & terminal (B134) No. 15 — (B134) No. 29:</p>	<p>Is the resistance less than 500 kΩ?</p>	<p>Go to step 2.</p>	<p>Go to step 3.</p>
<p>2 CHECK KNOCK SENSOR. 1) Disconnect the connector from knock sensor. 2) Measure the resistance between knock sensor connectors.</p> <p>Terminals No. 1 — No. 2:</p>	<p>Is the resistance less than 500 kΩ?</p>	<p>Replace the knock sensor. <Ref. to FU(H4DOTC)-32, Knock Sensor.></p>	<p>Repair the ground short circuit of harness between the ECM and knock sensor connector.</p> <p>NOTE: The harness between both connectors are shielded. Remove the shield and repair the short circuit of the harness circuit.</p>
<p>3 CHECK INPUT SIGNAL OF ECM. 1) Connect the ECM. 2) Turn the ignition switch to ON. 3) Measure the voltage between ECM and chassis ground.</p> <p>Connector & terminal (B134) No. 15 (+) — Chassis ground (-):</p>	<p>Is the voltage 2 V or more?</p>	<p>Even if the malfunction indicator light illuminates, the circuit has returned to a normal condition at this time. Reproduce the fault condition, and reperform the check.</p> <p>NOTE: In this case, there may be a temporary connector contact failure.</p>	<p>Repair poor contact of the ECM connector.</p>

Diagnostic Procedure with Diagnostic Trouble Code (DTC)

ENGINE (DIAGNOSTICS)

AY:DTC P0335 CRANKSHAFT POSITION SENSOR "A" CIRCUIT

DTC DETECTING CONDITION:

- Immediately at fault recognition
- GENERAL DESCRIPTION <Ref. to GD(H4DOTC)-89, DTC P0335 CRANKSHAFT POSITION SENSOR "A" CIRCUIT, Diagnostic Trouble Code (DTC) Detecting Criteria.>

TROUBLE SYMPTOM:

- Engine stalls.
- Failure of engine to start

CAUTION:

After repair or replacement of faulty parts, perform Clear Memory Mode <Ref. to EN(H4DOTC)(diag)-52, OPERATION, Clear Memory Mode.> and Inspection Mode <Ref. to EN(H4DOTC)(diag)-42, PROCEDURE, Inspection Mode.>.

WIRING DIAGRAM:

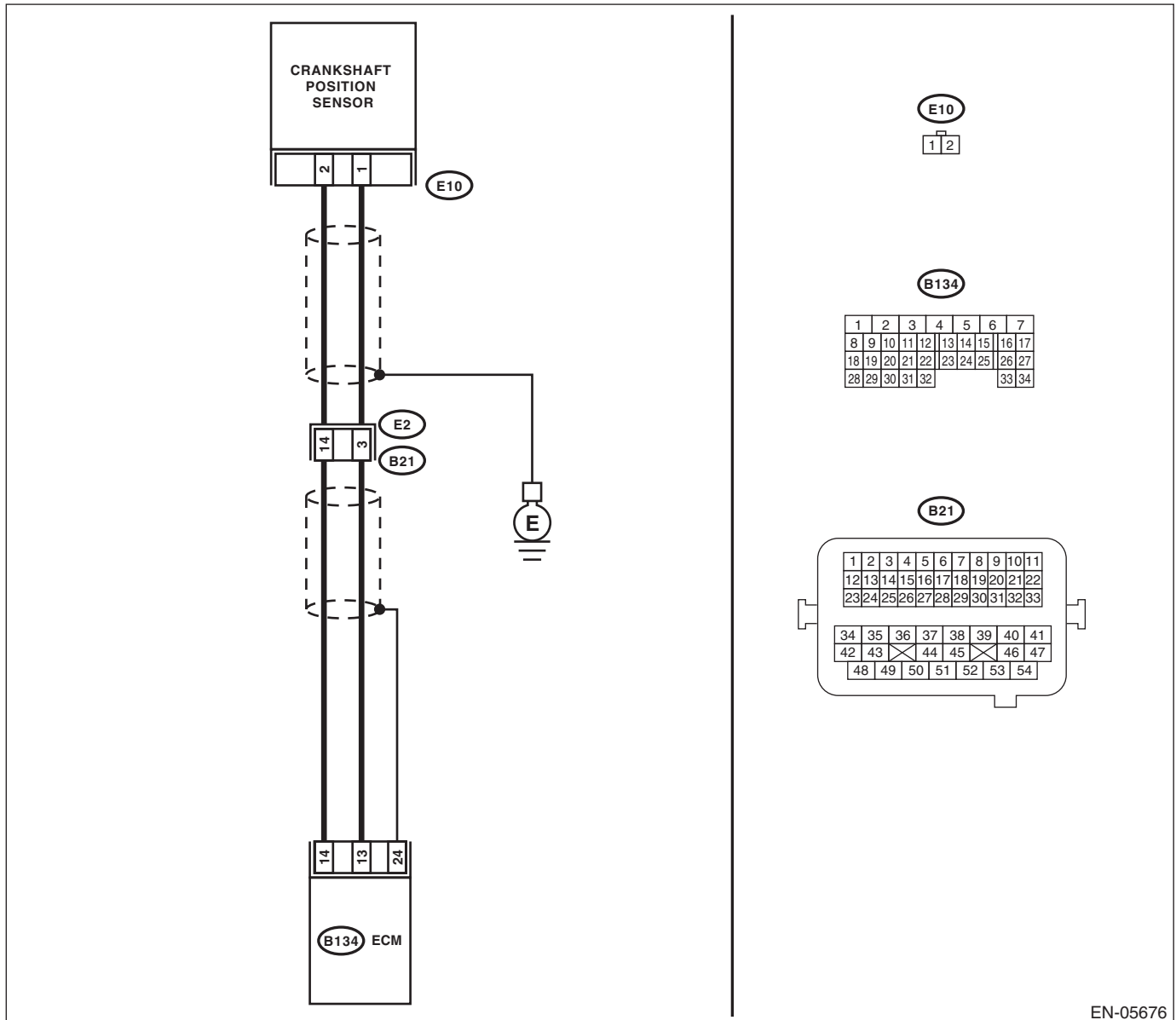

EN-05676

Diagnostic Procedure with Diagnostic Trouble Code (DTC)

ENGINE (DIAGNOSTICS)

Step	Check	Yes	No
1 CHECK CONDITION OF CRANKSHAFT POSITION SENSOR.	Is the crankshaft position sensor installation bolt tightened securely?	Go to step 2.	Tighten the crankshaft position sensor installation bolt securely.
2 CHECK CRANKSHAFT POSITION SENSOR. 1) Turn the ignition switch to OFF. 2) Remove the crankshaft position sensor. 3) Measure the resistance between terminals of crankshaft position sensor. Terminals No. 1 — No. 2:	Is the resistance between 1 — 4 k Ω ?	Go to step 3.	Replace the crankshaft position sensor. <Ref. to FU(H4DOTC)-30, Crankshaft Position Sensor.>
3 CHECK HARNESS BETWEEN ECM AND CRANK SHAFT POSITION SENSOR. 1) Disconnect the connectors from the ECM. 2) Measure the resistance of harness between the ECM and crankshaft position sensor connector. Connector & terminal (B134) No. 13 — (E10) No. 1: (B134) No. 14 — (E10) No. 2:	Is the resistance less than 1 Ω ?	Repair the poor contact of the ECM and crankshaft position sensor connector.	Repair the harness and connector. NOTE: In this case, repair the following item: <ul style="list-style-type: none"> • Open circuit of harness between ECM and crankshaft position sensor connector • Poor contact of coupling connector

Diagnostic Procedure with Diagnostic Trouble Code (DTC)

ENGINE (DIAGNOSTICS)

AZ:DTC P0336 CRANKSHAFT POSITION SENSOR "A" CIRCUIT RANGE/ PERFORMANCE

DTC DETECTING CONDITION:

- Detected when two consecutive driving cycles with fault occur.
- GENERAL DESCRIPTION <Ref. to GD(H4DOTC)-91, DTC P0336 CRANKSHAFT POSITION SENSOR "A" CIRCUIT RANGE/PERFORMANCE, Diagnostic Trouble Code (DTC) Detecting Criteria.>

TROUBLE SYMPTOM:

- Engine stalls.
- Failure of engine to start

CAUTION:

After repair or replacement of faulty parts, perform Clear Memory Mode <Ref. to EN(H4DOTC)(diag)-52, OPERATION, Clear Memory Mode.> and Inspection Mode <Ref. to EN(H4DOTC)(diag)-42, PROCEDURE, Inspection Mode.>.

WIRING DIAGRAM:

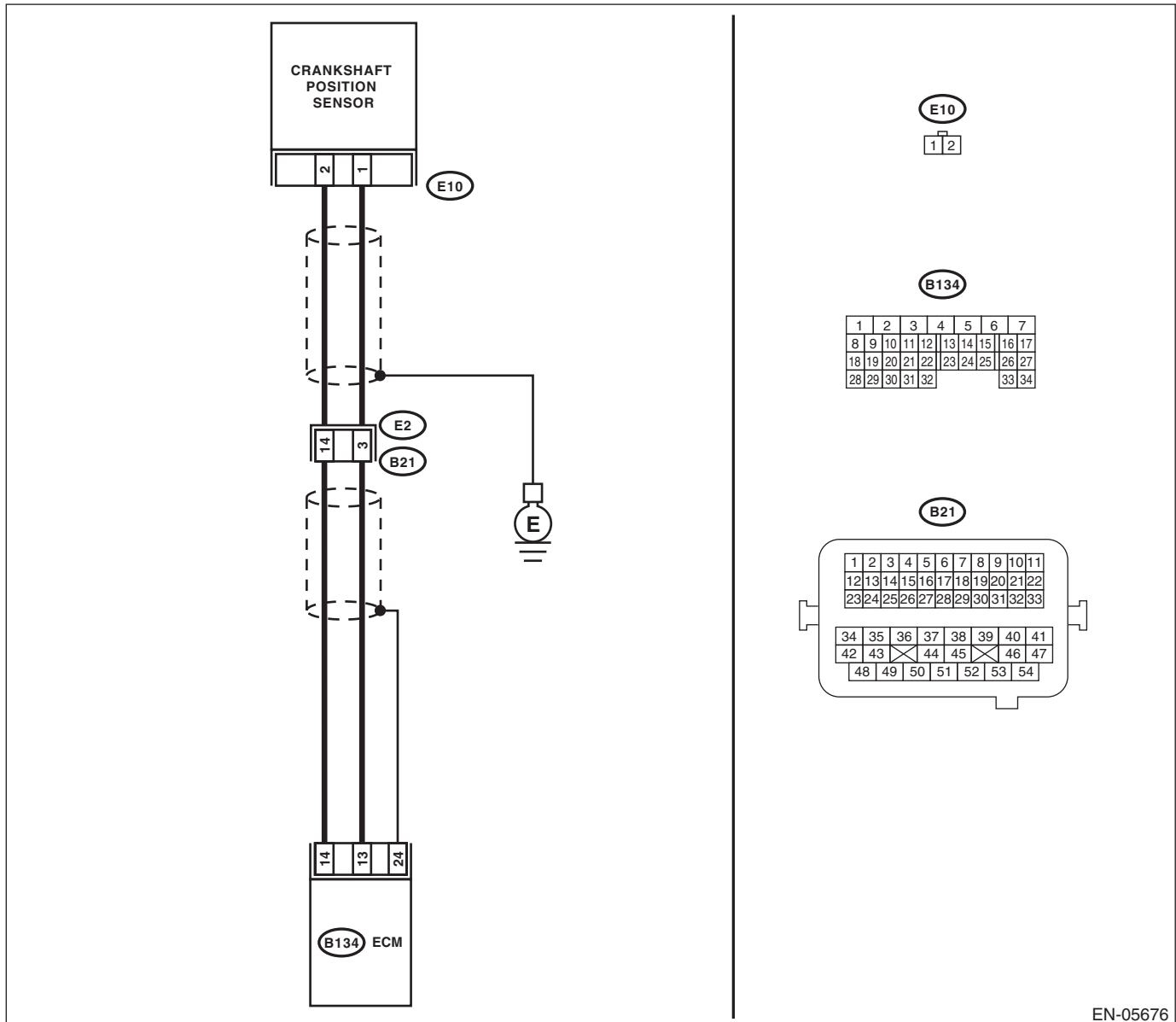

EN-05676

Diagnostic Procedure with Diagnostic Trouble Code (DTC)

ENGINE (DIAGNOSTICS)

	Step	Check	Yes	No
1	CHECK CONDITION OF CRANKSHAFT POSITION SENSOR. Turn the ignition switch to OFF.	Is the crankshaft position sensor installation bolt tightened securely?	Go to step 2.	Tighten the crankshaft position sensor installation bolt securely.
2	CHECK CRANK SPROCKET. Remove the timing belt cover.	Are crank sprocket teeth cracked or damaged?	Replace the crank sprocket. <Ref. to ME(H4DOTC)-59, Crank Sprocket.>	Go to step 3.
3	CHECK INSTALLATION CONDITION OF TIMING BELT. Turn the crankshaft, and align alignment mark on crank sprocket with alignment mark on cylinder block.	Is the timing belt dislocated from its proper position?	Repair the installation condition of timing belt. <Ref. to ME(H4DOTC)-50, Timing Belt.>	Replace the crankshaft position sensor. <Ref. to FU(H4DOTC)-30, Crankshaft Position Sensor.>

Diagnostic Procedure with Diagnostic Trouble Code (DTC)

ENGINE (DIAGNOSTICS)

BA:DTC P0340 CAMSHAFT POSITION SENSOR "A" CIRCUIT (BANK 1 OR SINGLE SENSOR)

DTC DETECTING CONDITION:

- Immediately at fault recognition
- GENERAL DESCRIPTION <Ref. to GD(H4DOTC)-93, DTC P0340 CAMSHAFT POSITION SENSOR "A" CIRCUIT (BANK 1 OR SINGLE SENSOR), Diagnostic Trouble Code (DTC) Detecting Criteria.>

TROUBLE SYMPTOM:

- Engine stalls.
- Failure of engine to start

CAUTION:

After repair or replacement of faulty parts, perform Clear Memory Mode <Ref. to EN(H4DOTC)(diag)-52, OPERATION, Clear Memory Mode.> and Inspection Mode <Ref. to EN(H4DOTC)(diag)-42, PROCEDURE, Inspection Mode.>.

WIRING DIAGRAM:

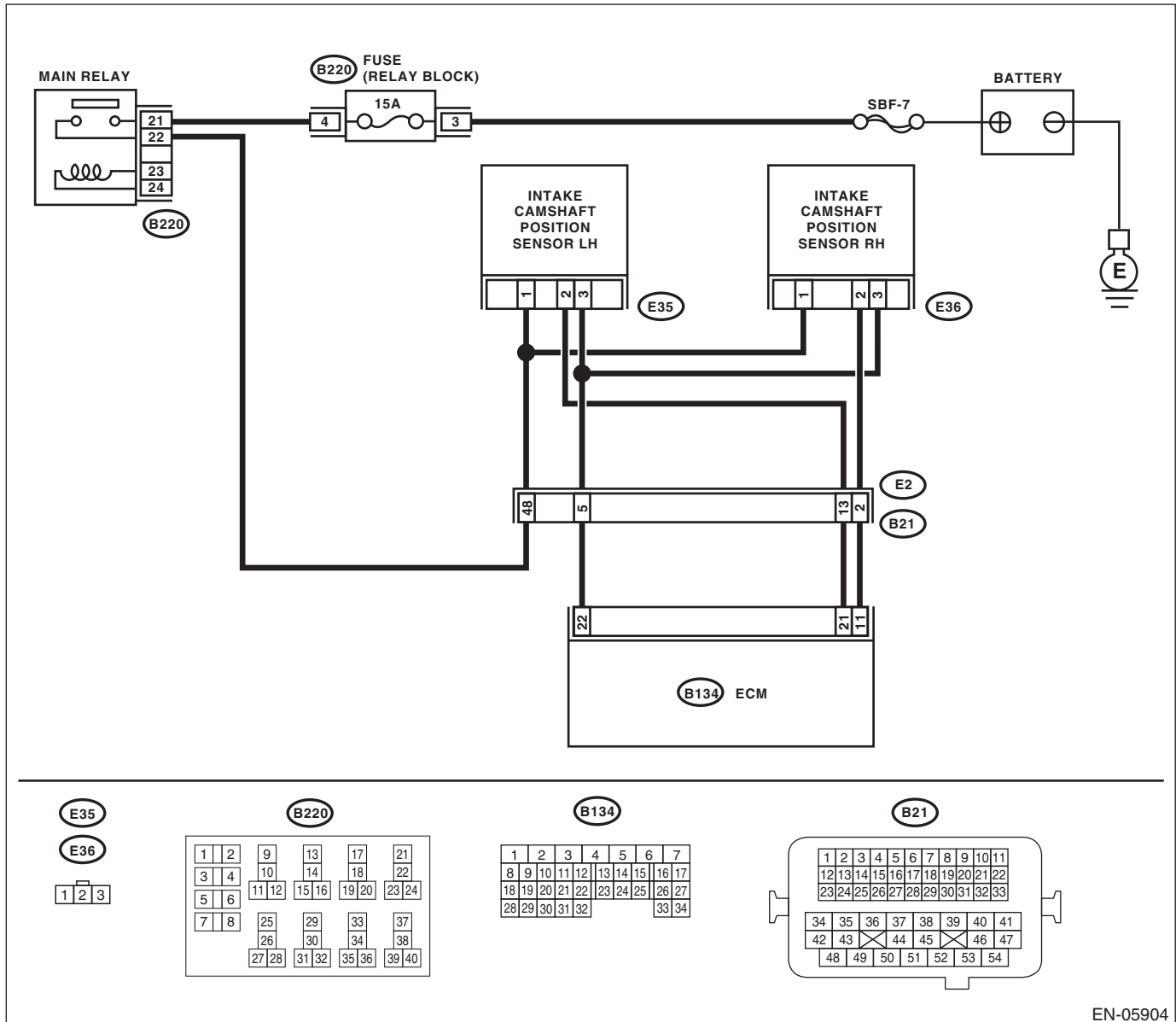

EN-05904

Diagnostic Procedure with Diagnostic Trouble Code (DTC)

ENGINE (DIAGNOSTICS)

Step	Check	Yes	No
1 CHECK POWER SUPPLY OF CAMSHAFT POSITION SENSOR. 1) Turn the ignition switch to OFF. 2) Disconnect the connector from the camshaft position sensor. 3) Turn the ignition switch to ON. 4) Measure the voltage between camshaft position sensor connector and engine ground. Connector & terminal (E36) No. 1 (+) — Engine ground (-):	Is the voltage 10 V or more?	Go to step 2.	Repair the harness and connector. NOTE: In this case, repair the following item: • Open circuit or short circuit to ground in harness between main relay connector and camshaft position sensor connector • Poor contact of coupling connector
2 CHECK HARNESS BETWEEN ECM AND CAMSHAFT POSITION SENSOR CONNECTOR. 1) Turn the ignition switch to OFF. 2) Disconnect the connectors from the ECM. 3) Measure the resistance between the ECM and camshaft position sensor connector. Connector & terminal (B134) No. 11 — (E36) No. 2: (B134) No. 22 — (E36) No. 3:	Is the resistance less than 1 Ω?	Go to step 3.	Repair the harness and connector. NOTE: In this case, repair the following item: • Open circuit in harness between the ECM and camshaft position sensor connector • Poor contact of coupling connector
3 CHECK HARNESS BETWEEN ECM AND CAMSHAFT POSITION SENSOR CONNECTOR. Measure the resistance between camshaft position sensor connector and engine ground. Connector & terminal (E36) No. 2 — Engine ground:	Is the resistance 1 MΩ or more?	Go to step 4.	Repair short circuit to ground in harness between ECM and camshaft position sensor connector.
4 CHECK HARNESS BETWEEN ECM AND CAMSHAFT POSITION SENSOR CONNECTOR. Measure the voltage between camshaft position sensor connector and engine ground. Connector & terminal (E36) No. 2 (+) — Engine ground (-):	Is the voltage 5 V or more?	Repair the short circuit to power in the harness between ECM and camshaft position sensor connector.	Go to step 5.
5 CHECK CONDITION OF CAMSHAFT POSITION SENSOR.	Is the camshaft position sensor installation bolt tightened securely?	Go to step 6.	Tighten the camshaft position sensor installation bolt securely.
6 CHECK CAMSHAFT POSITION SENSOR. Check the waveform of the camshaft position sensor. <Ref. to EN(H4DOTC)(diag)-17, Engine Control Module (ECM) I/O Signal.>	Is there any abnormality in waveform?	Replace the camshaft position sensor. <Ref. to FU(H4DOTC)-31, Camshaft Position Sensor.>	Repair the following item. • Poor contact in ECM connector • Poor contact of camshaft position sensor connector • Poor contact of coupling connector

Diagnostic Procedure with Diagnostic Trouble Code (DTC)

ENGINE (DIAGNOSTICS)

BB:DTC P0345 CAMSHAFT POSITION SENSOR "A" CIRCUIT (BANK 2)

DTC DETECTING CONDITION:

- Immediately at fault recognition
- GENERAL DESCRIPTION <Ref. to GD(H4DOTC)-95, DTC P0345 CAMSHAFT POSITION SENSOR "A" CIRCUIT (BANK 2), Diagnostic Trouble Code (DTC) Detecting Criteria.>

TROUBLE SYMPTOM:

- Engine stalls.
- Failure of engine to start

CAUTION:

After repair or replacement of faulty parts, perform Clear Memory Mode <Ref. to EN(H4DOTC)(diag)-52, OPERATION, Clear Memory Mode.> and Inspection Mode <Ref. to EN(H4DOTC)(diag)-42, PROCEDURE, Inspection Mode.>.

WIRING DIAGRAM:

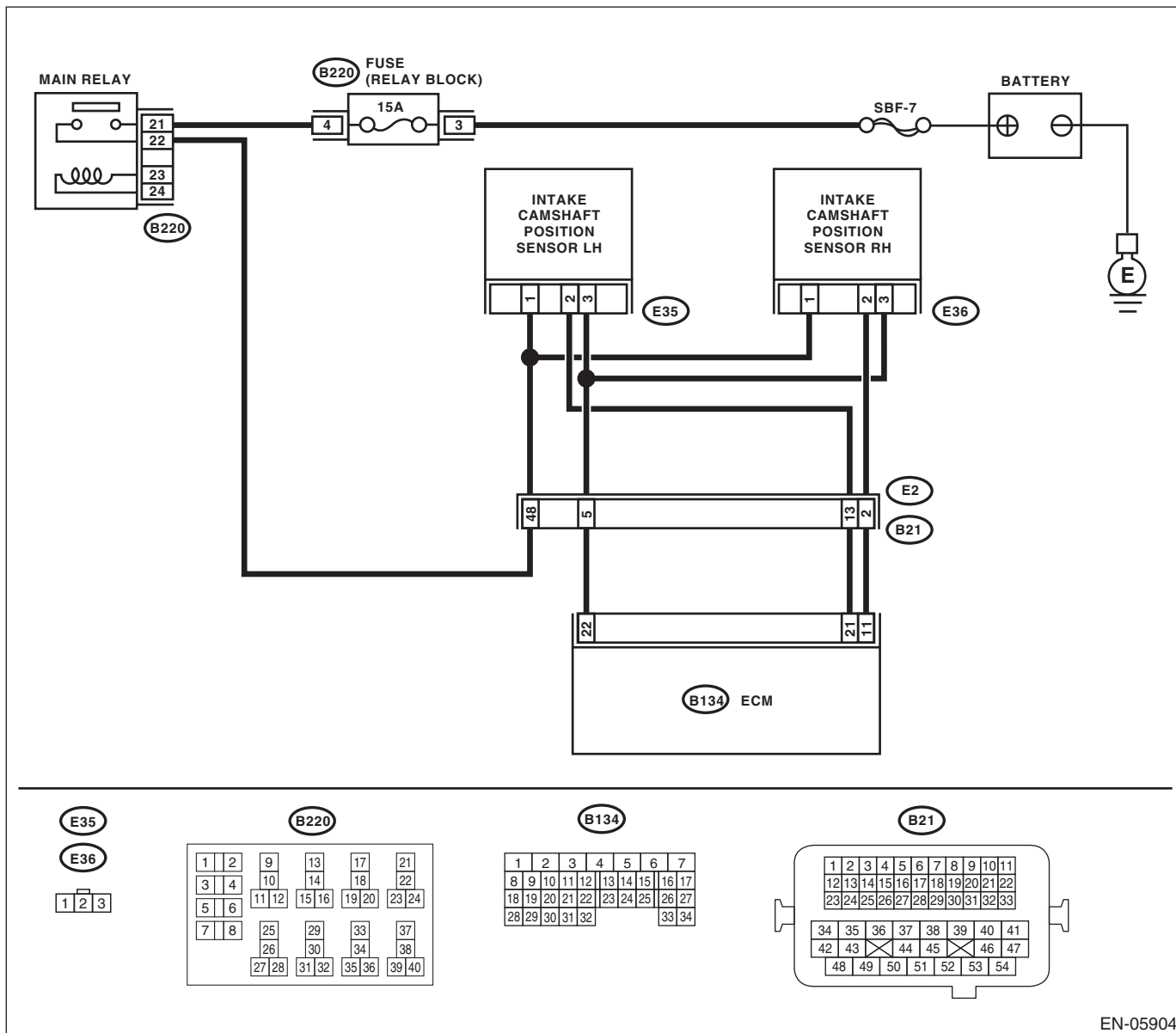

EN-05904

Diagnostic Procedure with Diagnostic Trouble Code (DTC)

ENGINE (DIAGNOSTICS)

Step	Check	Yes	No
<p>1</p> <p>CHECK POWER SUPPLY OF CAMSHAFT POSITION SENSOR.</p> <p>1) Turn the ignition switch to OFF. 2) Disconnect the connector from the camshaft position sensor. 3) Turn the ignition switch to ON. 4) Measure the voltage between camshaft position sensor connector and engine ground.</p> <p>Connector & terminal (E35) No. 1 (+) — Engine ground (-):</p>	<p>Is the voltage 10 V or more?</p>	<p>Go to step 2.</p>	<p>Repair the harness and connector.</p> <p>NOTE: In this case, repair the following item:</p> <ul style="list-style-type: none"> • Open circuit or short circuit to ground in harness between main relay connector and camshaft position sensor connector • Poor contact of coupling connector
<p>2</p> <p>CHECK HARNESS BETWEEN ECM AND CAMSHAFT POSITION SENSOR CONNECTOR.</p> <p>1) Turn the ignition switch to OFF. 2) Disconnect the connectors from the ECM. 3) Measure the resistance between the ECM and camshaft position sensor connector.</p> <p>Connector & terminal (B134) No. 21 — (E35) No. 2: (B134) No. 22 — (E35) No. 3:</p>	<p>Is the resistance less than 1 Ω?</p>	<p>Go to step 3.</p>	<p>Repair the harness and connector.</p> <p>NOTE: In this case, repair the following item:</p> <ul style="list-style-type: none"> • Open circuit in harness between ECM connector and camshaft position sensor connector • Poor contact of coupling connector
<p>3</p> <p>CHECK HARNESS BETWEEN ECM AND CAMSHAFT POSITION SENSOR CONNECTOR.</p> <p>Measure the resistance between camshaft position sensor connector and engine ground.</p> <p>Connector & terminal (E35) No. 2 — Engine ground:</p>	<p>Is the resistance 1 MΩ or more?</p>	<p>Go to step 4.</p>	<p>Repair short circuit to ground in harness between ECM and camshaft position sensor connector.</p>
<p>4</p> <p>CHECK HARNESS BETWEEN ECM AND CAMSHAFT POSITION SENSOR CONNECTOR.</p> <p>Measure the voltage between camshaft position sensor connector and engine ground.</p> <p>Connector & terminal (E35) No. 2 (+) — Engine ground (-):</p>	<p>Is the voltage 5 V or more?</p>	<p>Repair the short circuit to power in the harness between ECM and camshaft position sensor connector.</p>	<p>Go to step 5.</p>
<p>5</p> <p>CHECK CONDITION OF CAMSHAFT POSITION SENSOR.</p>	<p>Is the camshaft position sensor installation bolt tightened securely?</p>	<p>Go to step 6.</p>	<p>Tighten the camshaft position sensor installation bolt securely.</p>
<p>6</p> <p>CHECK CAMSHAFT POSITION SENSOR.</p> <p>Check the waveform of the camshaft position sensor. <Ref. to EN(H4DOTC)(diag)-17, Engine Control Module (ECM) I/O Signal.></p>	<p>Is there any abnormality in waveform?</p>	<p>Replace the camshaft position sensor. <Ref. to FU(H4DOTC)-31, Camshaft Position Sensor.></p>	<p>Repair the following item.</p> <ul style="list-style-type: none"> • Poor contact in ECM connector • Poor contact of camshaft position sensor connector • Poor contact of coupling connector

Diagnostic Procedure with Diagnostic Trouble Code (DTC)

ENGINE (DIAGNOSTICS)

BC:DTC P0410 SECONDARY AIR INJECTION SYSTEM

DTC DETECTING CONDITION:

- Detected when two consecutive driving cycles with fault occur.
- GENERAL DESCRIPTION <Ref. to GD(H4DOTC)-96, DTC P0410 SECONDARY AIR INJECTION SYSTEM, Diagnostic Trouble Code (DTC) Detecting Criteria.>

CAUTION:

After repair or replacement of faulty parts, perform Clear Memory Mode <Ref. to EN(H4DOTC)(diag)-52, OPERATION, Clear Memory Mode.> and Inspection Mode <Ref. to EN(H4DOTC)(diag)-42, PROCEDURE, Inspection Mode.>.

Diagnostic Procedure with Diagnostic Trouble Code (DTC)

ENGINE (DIAGNOSTICS)

WIRING DIAGRAM:

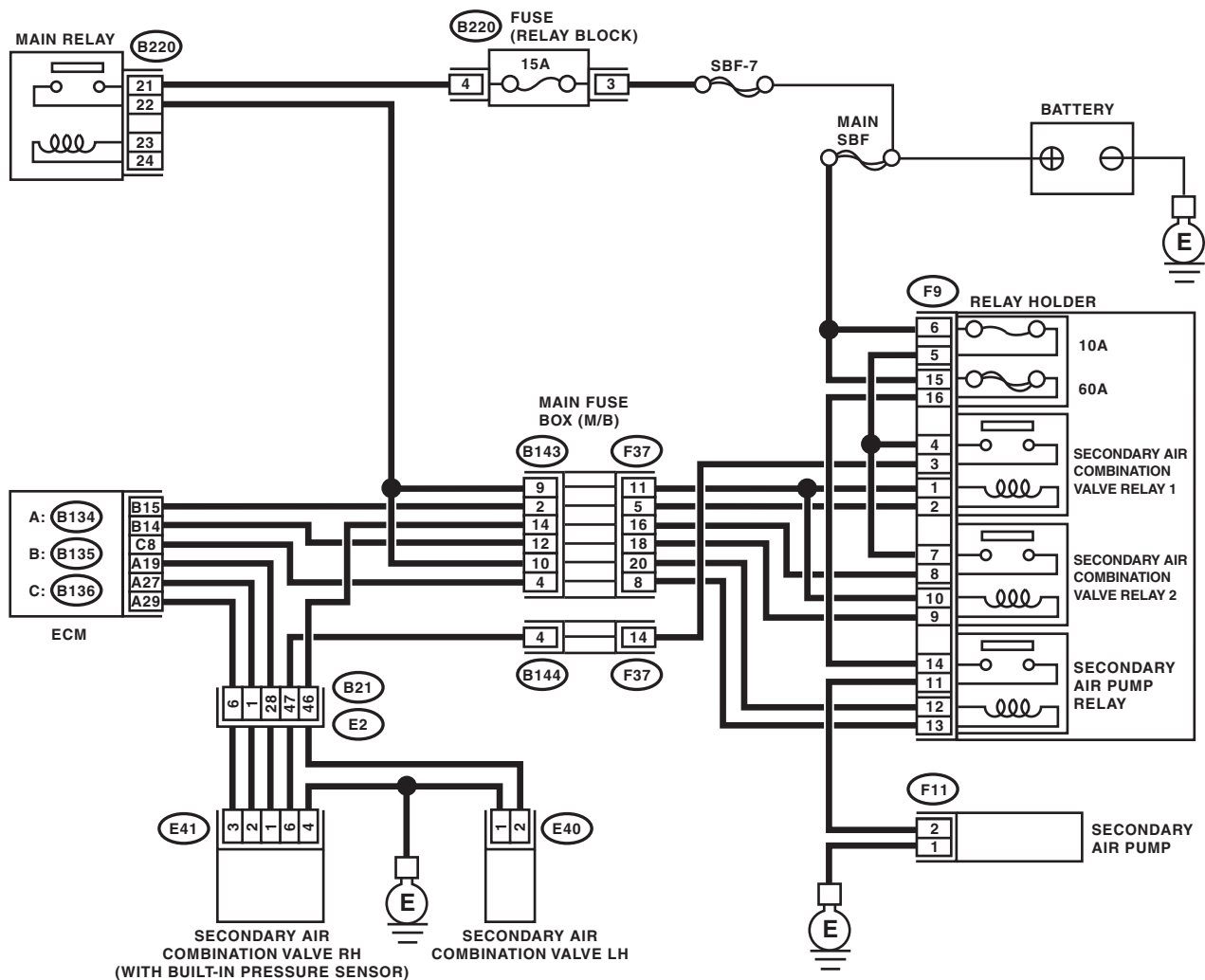

A: (B134)

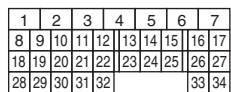

B: (B135)

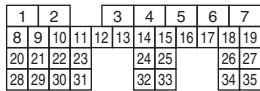

C: (B136)

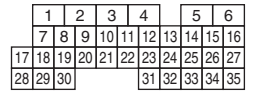

(B220)

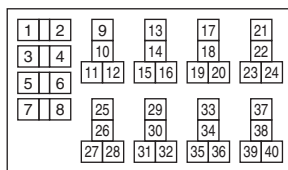

(B21)

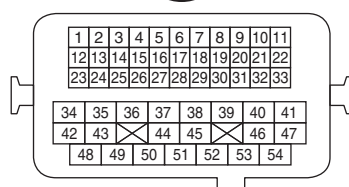

(F9)

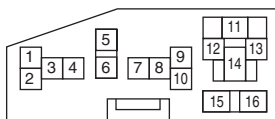

(F37)

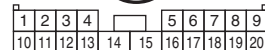

(B143)

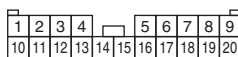

(E40)



(E41)



(B144)

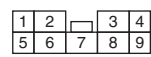

EN-06137

Diagnostic Procedure with Diagnostic Trouble Code (DTC)

ENGINE (DIAGNOSTICS)

Step	Check	Yes	No
1 CHECK SECONDARY AIR PUMP FUSE. Check if the secondary air pump fuse (60 A) is blown out.	Is the fuse blown out?	Go to step 2.	Go to step 3.
2 CHECK HARNESS BETWEEN FUSE BOX AND SECONDARY AIR PUMP. 1) Remove the secondary air pump fuse from the fuse box. 2) Disconnect the secondary air pump connector. 3) Measure the resistance between the secondary air pump fuse and secondary air pump connector, and chassis ground. Connector & terminal (F9) No. 16 — Chassis ground: (F11) No. 2 — Chassis ground:	Is the resistance 1 MΩ or more?	Replace the fuse with a new part, and connect the secondary air pump connector. Go to step 3.	Repair the short circuit to ground in harness between fuse box and the secondary air pump connector.
3 CHECK SECONDARY AIR PUMP OPERATION. 1) Connect the delivery (test) mode connector. 2) Turn the ignition switch to ON. 3) Perform the Clear Memory Mode. 4) Perform operation check for the secondary air pump using the Subaru Select Monitor. NOTE: • Subaru Select Monitor Refer to “Clear Memory Mode” <Ref. to EN(H4DOTC)(diag)-52, Clear Memory Mode.> and “Compulsory Valve Operation Check Mode” <Ref. to EN(H4DOTC)(diag)-53, Compulsory Valve Operation Check Mode.> for more operation procedures. • The compulsory operation using the Subaru Select Monitor is performed only for 5 seconds in order to protect the secondary air pump. When operating again, perform the Clear Memory Mode.	Does the secondary air pump operate?	Go to step 4.	Go to step 5.
4 CHECK DUCT BETWEEN SECONDARY AIR PUMP AND COMBINATION VALVE. Check the duct between the secondary air pump and combination valve.	Is there damage, clog or disconnection of the duct?	Replace, clean or connect the duct.	Replace the secondary air combination valve RH. <Ref. to EC(H4DOTC)-24, Secondary Air Combination Valve.>
5 CHECK POWER SUPPLY TO SECONDARY AIR PUMP. 1) Perform the Clear Memory Mode. 2) Turn the ignition switch to OFF. 3) Disconnect the secondary air pump connector. 4) In the condition of step 3, measure the voltage between the secondary air pump connector and the chassis ground. NOTE: For detailed procedures, refer to “Clear Memory Mode”. <Ref. to EN(H4DOTC)(diag)-52, Clear Memory Mode.> Connector & terminal (F11) No. 2 (+) — Chassis ground (-):	Is the voltage 10 V or more?	Replace the secondary air pump. <Ref. to EC(H4DOTC)-23, Secondary Air Pump.>	Go to step 6.

Diagnostic Procedure with Diagnostic Trouble Code (DTC)

ENGINE (DIAGNOSTICS)

Step	Check	Yes	No
6 CHECK HARNESS BETWEEN SECONDARY AIR PUMP RELAY AND SECONDARY AIR PUMP CONNECTOR. 1) Turn the ignition switch to OFF. 2) Remove the secondary air pump relay. 3) Measure the resistance of harness between secondary air pump relay connector and secondary air pump connector. Connector & terminal (F9) No. 11 — (F11) No. 2:	Is the resistance less than 1 Ω ?	Go to step 7.	Repair the open circuit in harness between secondary air pump relay connector and secondary air pump connector.
7 CHECK HARNESS BETWEEN SECONDARY AIR PUMP CONNECTOR AND CHASSIS GROUND. Measure the resistance of the harness between secondary air pump connector and chassis ground. Connector & terminal (F11) No. 1 — Chassis ground:	Is the resistance less than 5 Ω ?	Go to step 8.	Repair the open circuit of the harness between secondary air pump connector and chassis ground.
8 CHECK SECONDARY AIR PUMP RELAY. 1) Connect the battery to terminals No. 12 and No. 13 of the secondary air pump relay. 2) Measure the resistance between secondary air pump relay terminals. Terminals No. 14 — No. 11:	Is the resistance less than 1 Ω ?	Go to step 9.	Replace the secondary air pump relay. <Ref. to EN(H4DOTC)(diag)-8, Electrical Component Location.>
9 CHECK SECONDARY AIR PUMP RELAY POWER SOURCE. 1) Turn the ignition switch to ON. 2) Measure the voltage between the secondary air pump relay connector and chassis ground. Connector & terminal (F9) No. 14 (+) — Chassis ground (-): (F9) No. 12 (+) — Chassis ground (-):	Is the voltage 10 V or more?	Go to step 10.	Repair the open or ground short circuit of power supply circuit.
10 CHECK HARNESS BETWEEN ECM AND SECONDARY AIR PUMP RELAY CONNECTOR. 1) Turn the ignition switch to OFF. 2) Disconnect the connector of ECM. 3) Measure the resistance of harness between ECM and secondary air pump relay connector. Connector & terminal (B136) No. 8 — (F9) No. 13:	Is the resistance less than 1 Ω ?	Repair the poor contact of the ECM connector.	Repair the harness and connector. NOTE: In this case, repair the following item: • Repair the open circuit in harness between ECM connector and secondary air pump relay connector. • Poor contact of coupling connector

Diagnostic Procedure with Diagnostic Trouble Code (DTC)

ENGINE (DIAGNOSTICS)

BD:DTC P0411 SECONDARY AIR INJECTION SYSTEM INCORRECT FLOW DETECTED

DTC DETECTING CONDITION:

- Detected when two consecutive driving cycles with fault occur.
- GENERAL DESCRIPTION <Ref. to GD(H4DOTC)-105, DTC P0411 SECONDARY AIR INJECTION SYSTEM INCORRECT FLOW DETECTED, Diagnostic Trouble Code (DTC) Detecting Criteria.>

CAUTION:

After repair or replacement of faulty parts, perform Clear Memory Mode <Ref. to EN(H4DOTC)(diag)-52, OPERATION, Clear Memory Mode.> and Inspection Mode <Ref. to EN(H4DOTC)(diag)-42, PROCEDURE, Inspection Mode.>.

Diagnostic Procedure with Diagnostic Trouble Code (DTC)

ENGINE (DIAGNOSTICS)

WIRING DIAGRAM:

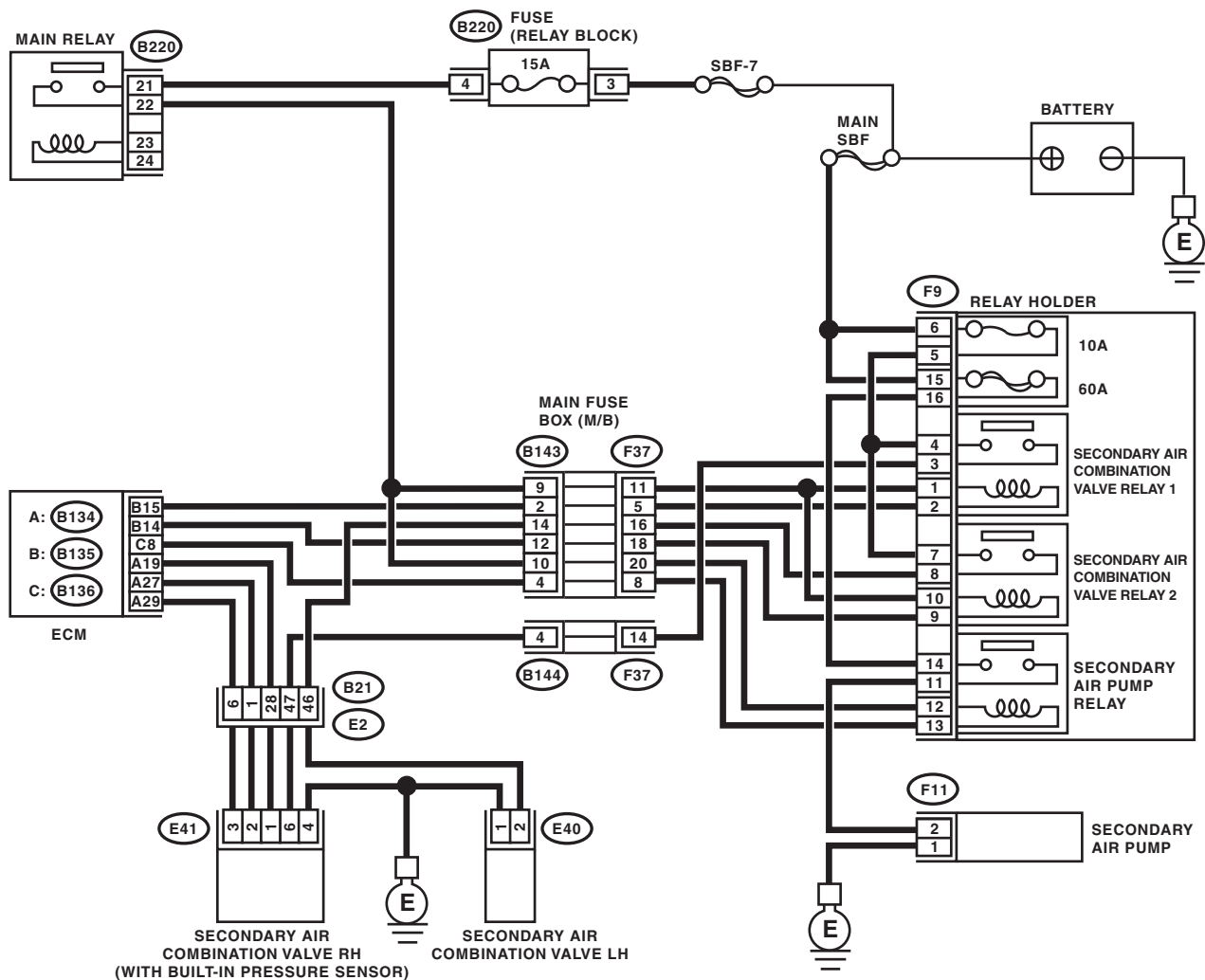

A: (B134)

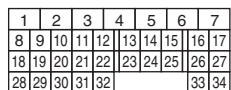

B: (B135)

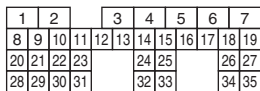

C: (B136)



(B220)

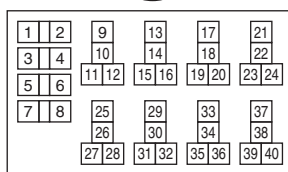

(B21)

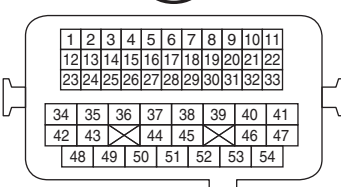

(F9)

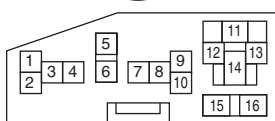

(F37)



(B143)



(E40)



(E41)



(B144)

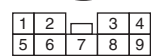

EN-06137

Diagnostic Procedure with Diagnostic Trouble Code (DTC)

ENGINE (DIAGNOSTICS)

	Step	Check	Yes	No
1	CHECK SECONDARY AIR COMBINATION VALVE. Inspection of the pipe between the secondary air combination valve and cylinder head.	Is there damage or disconnection of the pipe?	Replace the pipe between secondary air combination valve and cylinder head.	Go to step 2.
2	CHECK SECONDARY AIR COMBINATION VALVE. Race the engine at 2,000 rpm to check whether or not the exhaust leak is heard.	Is there any exhaust leak?	Replace the pipe between secondary air combination valve and cylinder head.	Repair the poor contact of the ECM connector.

BE:DTC P0413 SECONDARY AIR INJECTION SYSTEM SWITCHING VALVE “A” CIRCUIT OPEN

DTC DETECTING CONDITION:

- Immediately at fault recognition
- GENERAL DESCRIPTION <Ref. to GD(H4DOTC)-106, DTC P0413 SECONDARY AIR INJECTION SYSTEM SWITCHING VALVE “A” CIRCUIT OPEN, Diagnostic Trouble Code (DTC) Detecting Criteria.>

CAUTION:

After repair or replacement of faulty parts, perform Clear Memory Mode <Ref. to EN(H4DOTC)(diag)-52, OPERATION, Clear Memory Mode.> and Inspection Mode <Ref. to EN(H4DOTC)(diag)-42, PROCEDURE, Inspection Mode.>.

Diagnostic Procedure with Diagnostic Trouble Code (DTC)

ENGINE (DIAGNOSTICS)

WIRING DIAGRAM:

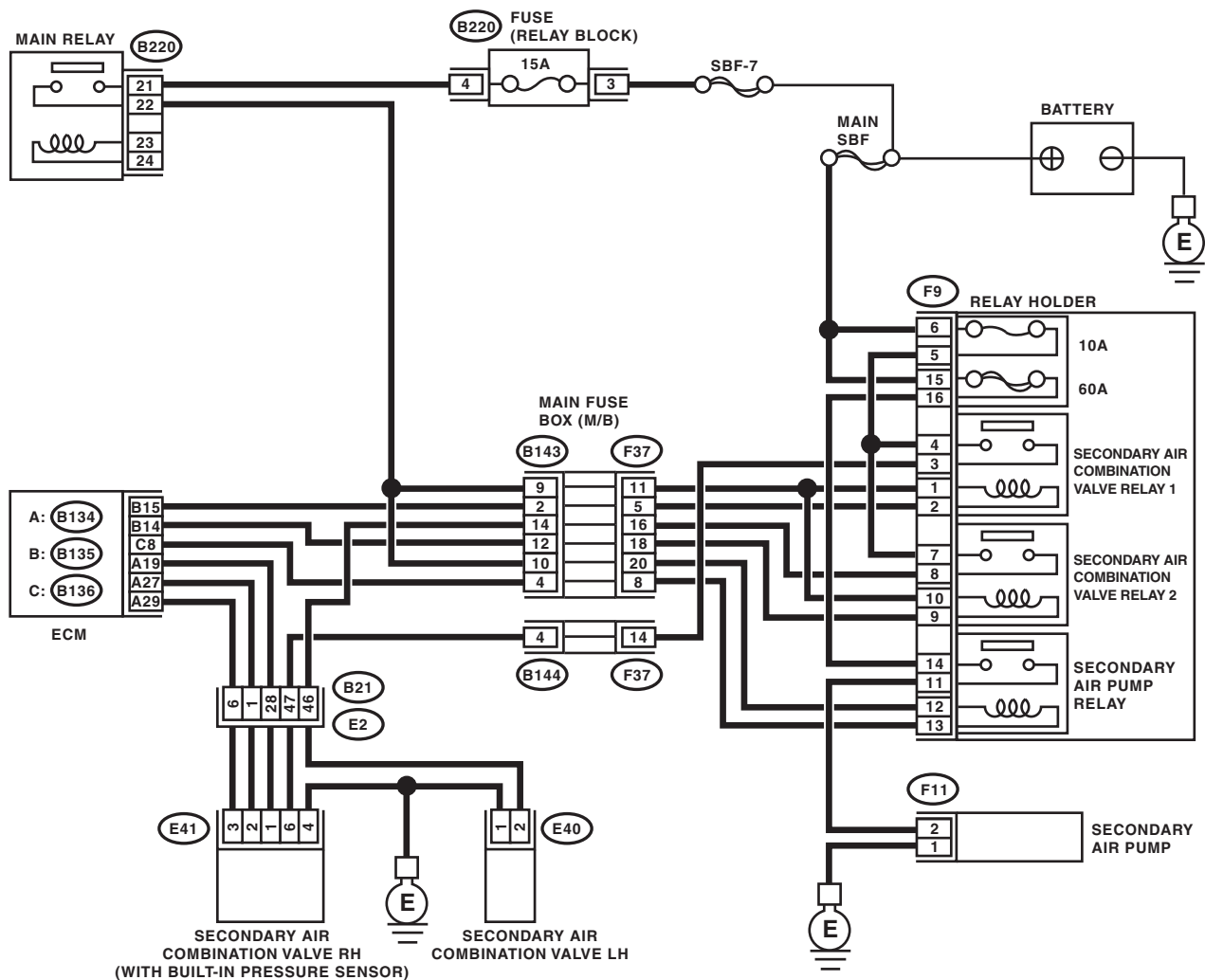

A: (B134)

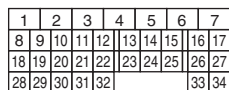

B: (B135)

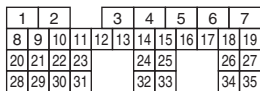

C: (B136)

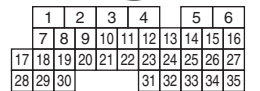

(B220)

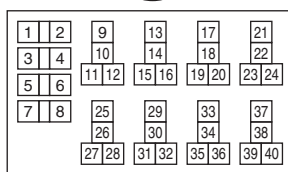

(B21)

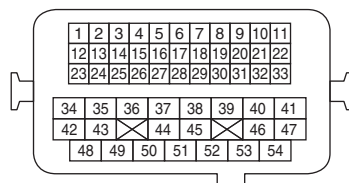

(F9)

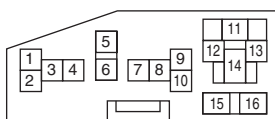

(F37)



(B143)



(E40)



(E41)



(B144)

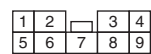

EN-06137

Diagnostic Procedure with Diagnostic Trouble Code (DTC)

ENGINE (DIAGNOSTICS)

	Step	Check	Yes	No
1	<p>CHECK HARNESS BETWEEN ECM AND SECONDARY AIR COMBINATION VALVE RELAY 1.</p> <p>1) Turn the ignition switch to OFF. 2) Disconnect the connector from ECM and secondary air combination valve relay 1. 3) Measure the resistance of harness between ECM and secondary air combination valve relay 1.</p> <p>Connector & terminal (B135) No. 15 — (F9) No. 2:</p>	Is the resistance less than 1 Ω?	Go to step 2.	<p>Repair the harness and connector.</p> <p>NOTE: In this case, repair the following item:</p> <ul style="list-style-type: none"> • Open circuit in harness between ECM and secondary air combination valve relay 1 connector • Poor contact of coupling connector
2	<p>CHECK HARNESS BETWEEN ECM AND SECONDARY AIR COMBINATION VALVE RELAY 1.</p> <p>Measure the resistance between ECM and chassis ground.</p> <p>Connector & terminal (B135) No. 15 — Chassis ground:</p>	Is the resistance 1 MΩ or more?	<p>Even if the malfunction indicator light illuminates, the circuit has returned to a normal condition at this time. Reproduce the failure, and then perform the diagnosis again.</p> <p>NOTE: In this case, there may be a temporary connector contact failure.</p>	Repair the short circuit to ground in harness between ECM and secondary air combination valve relay 1 connector.

Diagnostic Procedure with Diagnostic Trouble Code (DTC)

ENGINE (DIAGNOSTICS)

BF:DTC P0414 SECONDARY AIR INJECTION SYSTEM SWITCHING VALVE “A” CIRCUIT SHORTED

DTC DETECTING CONDITION:

- Immediately at fault recognition
- GENERAL DESCRIPTION <Ref. to GD(H4DOTC)-107, DTC P0414 SECONDARY AIR INJECTION SYSTEM SWITCHING VALVE “A” CIRCUIT SHORTED, Diagnostic Trouble Code (DTC) Detecting Criteria.>

CAUTION:

After repair or replacement of faulty parts, perform Clear Memory Mode <Ref. to EN(H4DOTC)(diag)-52, OPERATION, Clear Memory Mode.> and Inspection Mode <Ref. to EN(H4DOTC)(diag)-42, PROCEDURE, Inspection Mode.>.

Diagnostic Procedure with Diagnostic Trouble Code (DTC)

ENGINE (DIAGNOSTICS)

WIRING DIAGRAM:

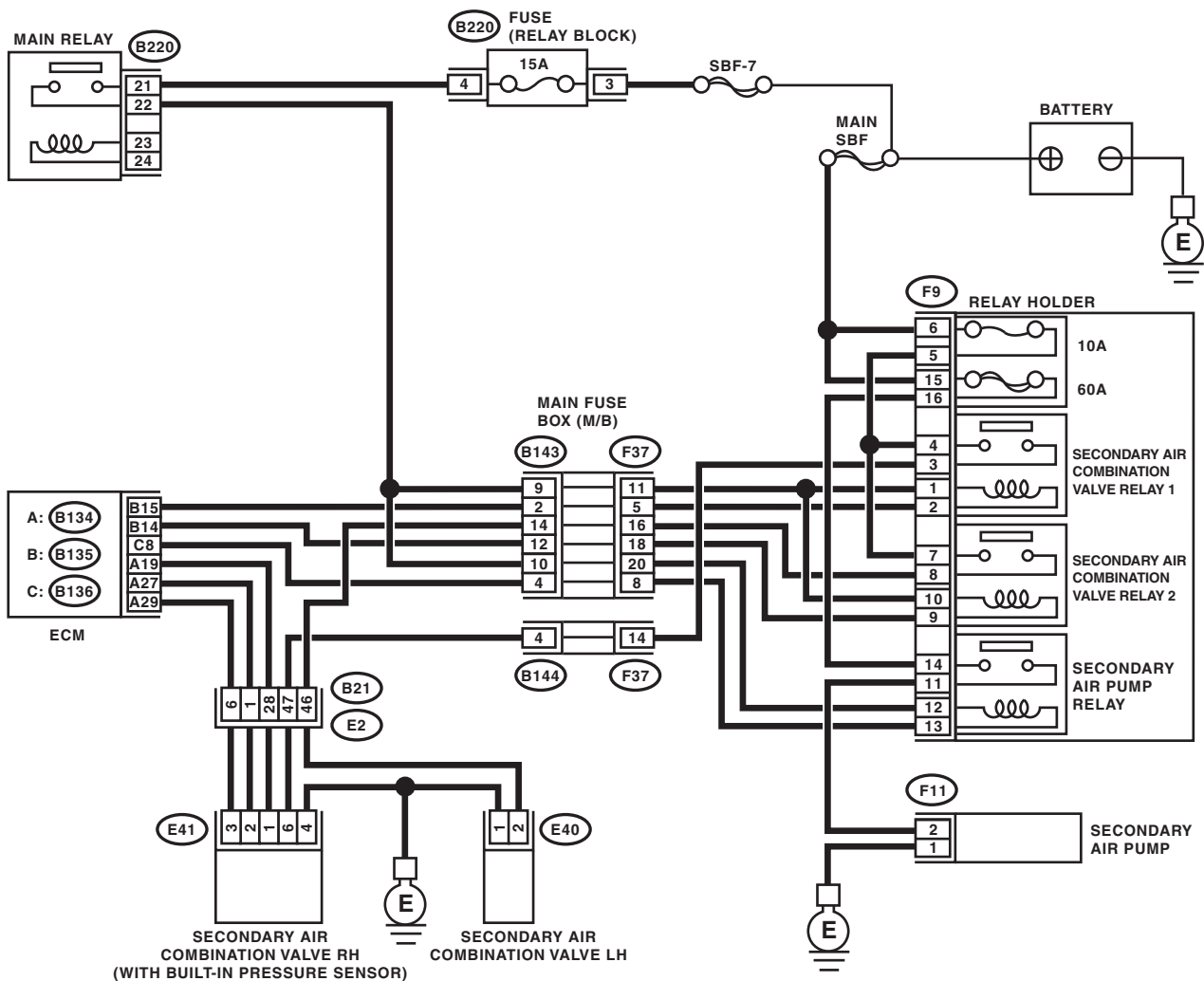

A: (B134)

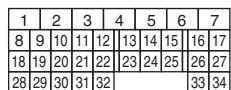

B: (B135)

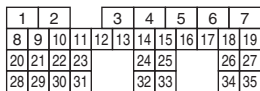

C: (B136)

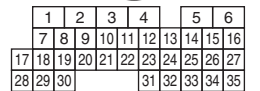

(F37)

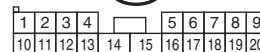

(B220)

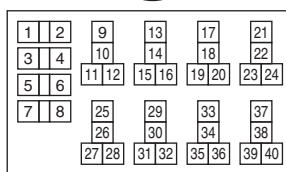

(B143)

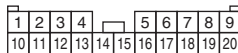

(E40)



(B21)

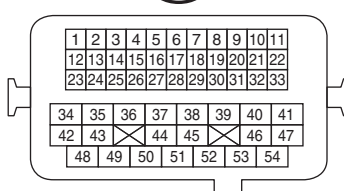

(E41)



(B144)

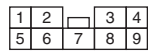

(F9)

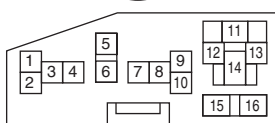

(F11)



EN-06137

Diagnostic Procedure with Diagnostic Trouble Code (DTC)

ENGINE (DIAGNOSTICS)

	Step	Check	Yes	No
1	CHECK HARNESS BETWEEN ECM AND SECONDARY AIR COMBINATION VALVE RELAY 1. 1) Turn the ignition switch to OFF. 2) Disconnect the connector from ECM and secondary air combination valve relay 1. 3) Measure the voltage between ECM and chassis ground. Connector & terminal (B135) No. 15 (+) — Chassis ground (-):	Is the voltage 10 V or more?	Repair the short circuit to power in harness between ECM and secondary air combination valve relay 1 connector.	Repair the poor contact of the ECM connector.

BG:DTC P0416 SECONDARY AIR INJECTION SYSTEM SWITCHING VALVE “B” CIRCUIT OPEN

DTC DETECTING CONDITION:

- Immediately at fault recognition
- GENERAL DESCRIPTION <Ref. to GD(H4DOTC)-108, DTC P0416 SECONDARY AIR INJECTION SYSTEM SWITCHING VALVE “B” CIRCUIT OPEN, Diagnostic Trouble Code (DTC) Detecting Criteria.>

CAUTION:

After repair or replacement of faulty parts, perform Clear Memory Mode <Ref. to EN(H4DOTC)(diag)-52, OPERATION, Clear Memory Mode.> and Inspection Mode <Ref. to EN(H4DOTC)(diag)-42, PROCEDURE, Inspection Mode.>.

Diagnostic Procedure with Diagnostic Trouble Code (DTC)

ENGINE (DIAGNOSTICS)

WIRING DIAGRAM:

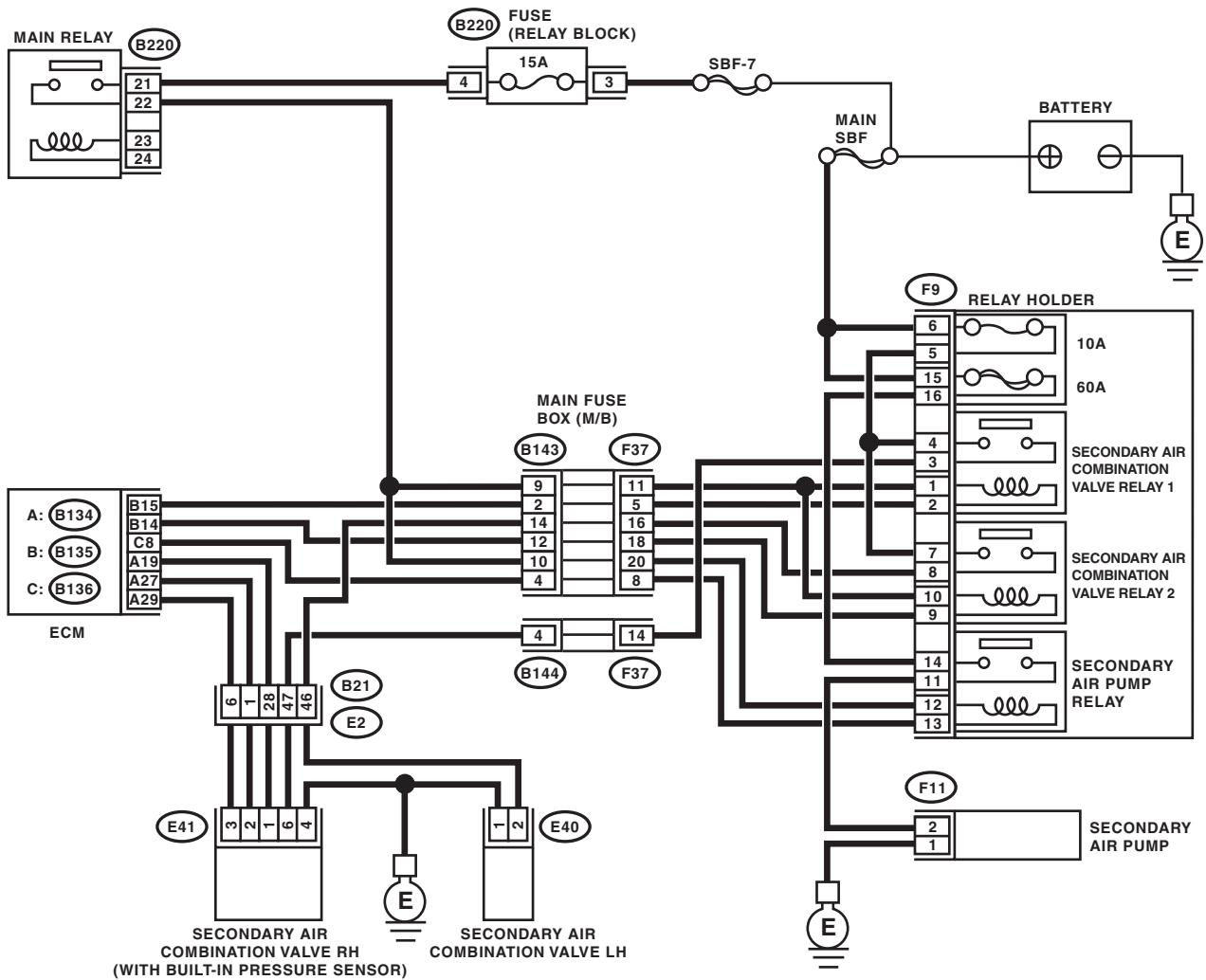

A: (B134)

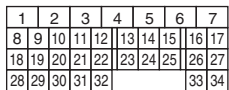

B: (B135)

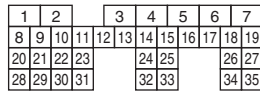

C: (B136)

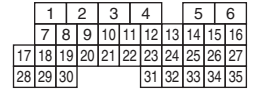

(B220)

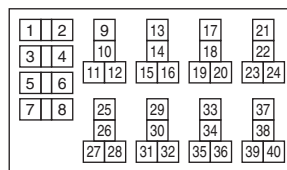

(B21)

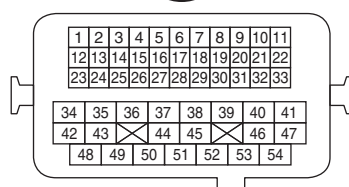

(F9)

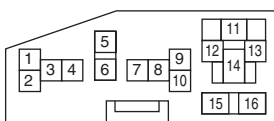

(F37)

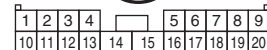

(B143)



(E40)



(E41)



(B144)

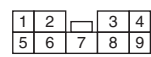

EN-06137

Diagnostic Procedure with Diagnostic Trouble Code (DTC)

ENGINE (DIAGNOSTICS)

	Step	Check	Yes	No
1	<p>CHECK HARNESS BETWEEN ECM AND SECONDARY AIR COMBINATION VALVE RELAY 2.</p> <p>1) Turn the ignition switch to OFF. 2) Disconnect the connector from ECM and secondary air combination valve relay 2. 3) Measure the resistance of harness between ECM and secondary air combination valve relay 2.</p> <p>Connector & terminal (B135) No. 14 — (F9) No. 9:</p>	Is the resistance less than 1 Ω?	Go to step 2.	<p>Repair the harness and connector.</p> <p>NOTE: In this case, repair the following item:</p> <ul style="list-style-type: none"> • Open circuit in harness between ECM and secondary air combination valve relay 2 connector • Poor contact of coupling connector
2	<p>CHECK HARNESS BETWEEN ECM AND SECONDARY AIR COMBINATION VALVE RELAY 2.</p> <p>Measure the resistance between ECM and chassis ground.</p> <p>Connector & terminal (B135) No. 14 — Chassis ground:</p>	Is the resistance 1 MΩ or more?	<p>Even if the malfunction indicator light illuminates, the circuit has returned to a normal condition at this time. Reproduce the failure, and then perform the diagnosis again.</p> <p>NOTE: In this case, there may be a temporary connector contact failure.</p>	Repair the short circuit to ground in harness between ECM and secondary air combination valve relay 2 connector.

Diagnostic Procedure with Diagnostic Trouble Code (DTC)

ENGINE (DIAGNOSTICS)

BH:DTC P0417 SECONDARY AIR INJECTION SYSTEM SWITCHING VALVE “B” CIRCUIT SHORTED

DTC DETECTING CONDITION:

- Immediately at fault recognition
- GENERAL DESCRIPTION <Ref. to GD(H4DOTC)-108, DTC P0417 SECONDARY AIR INJECTION SYSTEM SWITCHING VALVE “B” CIRCUIT SHORTED, Diagnostic Trouble Code (DTC) Detecting Criteria.>

CAUTION:

After repair or replacement of faulty parts, perform Clear Memory Mode <Ref. to EN(H4DOTC)(diag)-52, OPERATION, Clear Memory Mode.> and Inspection Mode <Ref. to EN(H4DOTC)(diag)-42, PROCEDURE, Inspection Mode.>.

Diagnostic Procedure with Diagnostic Trouble Code (DTC)

ENGINE (DIAGNOSTICS)

WIRING DIAGRAM:

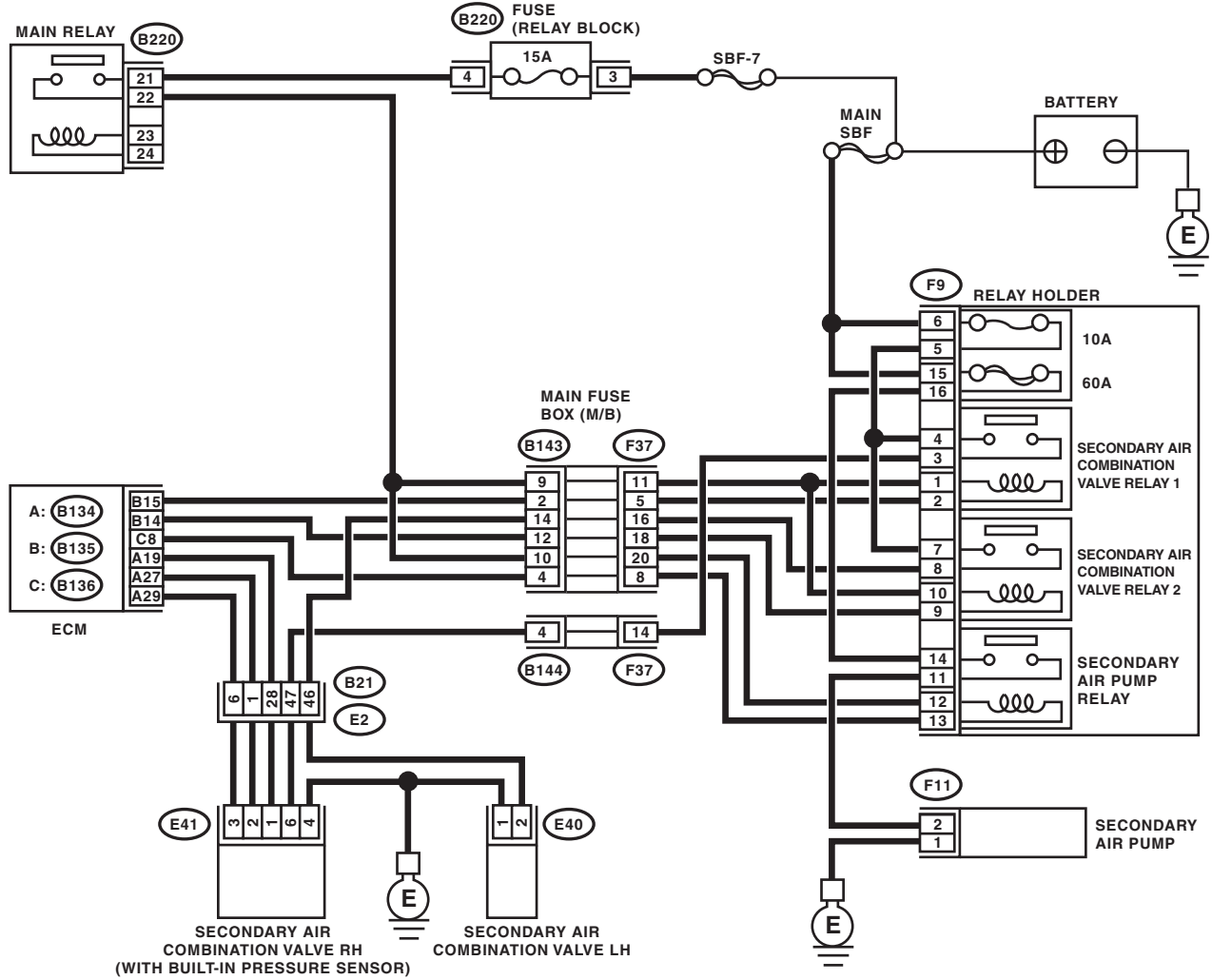

A: (B134)

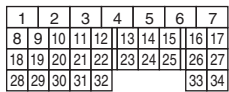

B: (B135)

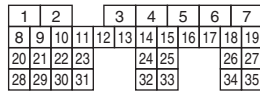

C: (B136)

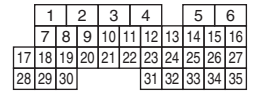

(B220)

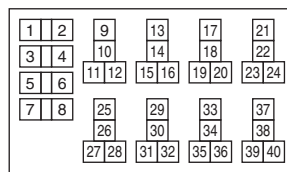

(B21)

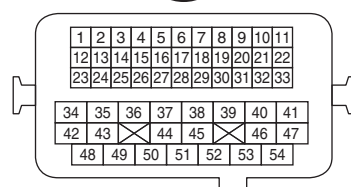

(F9)

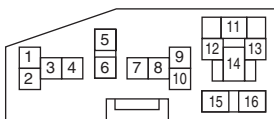

(F37)

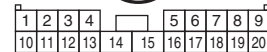

(B143)



(E40)



(E41)



(B144)

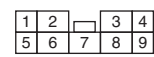

EN-06137

Diagnostic Procedure with Diagnostic Trouble Code (DTC)

ENGINE (DIAGNOSTICS)

Step	Check	Yes	No
<p>1 CHECK HARNESS BETWEEN ECM AND SECONDARY AIR COMBINATION VALVE RELAY 2.</p> <p>1) Turn the ignition switch to OFF. 2) Disconnect the connector from ECM and secondary air combination valve relay 2. 3) Measure the voltage between ECM and chassis ground.</p> <p>Connector & terminal (B135) No. 14 (+) — Chassis ground (-):</p>	Is the voltage 10 V or more?	Repair the short circuit to power in harness between ECM and secondary air combination valve relay 2 connector.	Repair the poor contact of the ECM connector.

BI: DTC P0418 SECONDARY AIR INJECTION SYSTEM CONTROL “A” CIRCUIT OPEN

DTC DETECTING CONDITION:

- Immediately at fault recognition
- GENERAL DESCRIPTION <Ref. to GD(H4DOTC)-109, DTC P0418 SECONDARY AIR INJECTION SYSTEM CONTROL “A” CIRCUIT OPEN, Diagnostic Trouble Code (DTC) Detecting Criteria.>

CAUTION:

After repair or replacement of faulty parts, perform Clear Memory Mode <Ref. to EN(H4DOTC)(diag)-52, OPERATION, Clear Memory Mode.> and Inspection Mode <Ref. to EN(H4DOTC)(diag)-42, PROCEDURE, Inspection Mode.>.

Diagnostic Procedure with Diagnostic Trouble Code (DTC)

ENGINE (DIAGNOSTICS)

WIRING DIAGRAM:

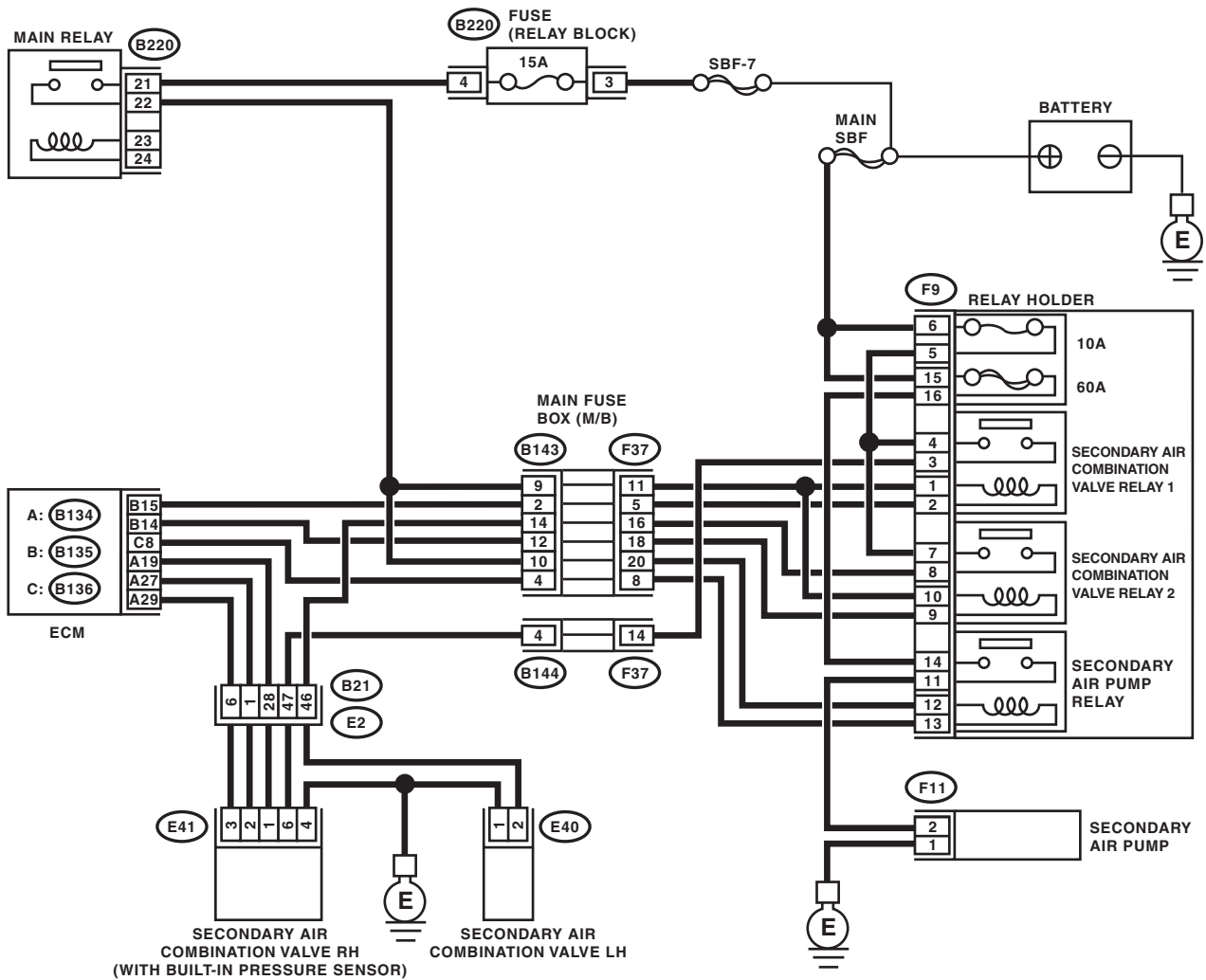

A: (B134)

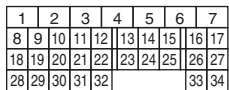

B: (B135)

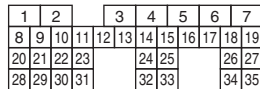

C: (B136)

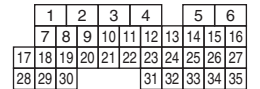

(B220)

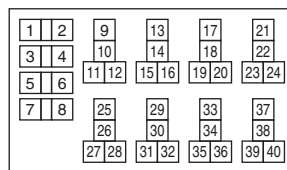

(B21)

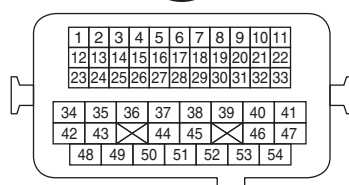

(F9)

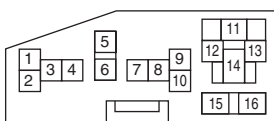

(F37)

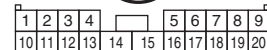

(B143)

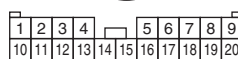

(E40)



(E41)



(B144)

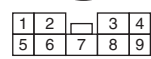

EN-06137

Diagnostic Procedure with Diagnostic Trouble Code (DTC)

ENGINE (DIAGNOSTICS)

Step	Check	Yes	No
<p>1</p> <p>CHECK HARNESS BETWEEN ECM AND SECONDARY AIR PUMP RELAY.</p> <p>1) Turn the ignition switch to OFF. 2) Disconnect the connector from the ECM and secondary air pump relay. 3) Measure the resistance of harness between ECM and secondary air pump relay connector.</p> <p>Connector & terminal (B136) No. 8 — (F9) No. 13:</p>	<p>Is the resistance less than 1 Ω?</p>	<p>Go to step 2.</p>	<p>Repair the harness and connector.</p> <p>NOTE: In this case, repair the following item:</p> <ul style="list-style-type: none"> • Open circuit in harness between ECM and secondary air pump relay connector • Poor contact of coupling connector
<p>2</p> <p>CHECK HARNESS BETWEEN ECM AND SECONDARY AIR PUMP RELAY.</p> <p>Measure the resistance between ECM and chassis ground.</p> <p>Connector & terminal (B136) No. 8 — Chassis ground:</p>	<p>Is the resistance 1 MΩ or more?</p>	<p>Even if the malfunction indicator light illuminates, the circuit has returned to a normal condition at this time. Reproduce the fault condition, and reperform the check.</p> <p>NOTE: In this case, there may be a temporary connector contact failure.</p>	<p>Repair the short circuit to ground in harness between ECM and secondary air pump relay connector.</p>

Diagnostic Procedure with Diagnostic Trouble Code (DTC)

ENGINE (DIAGNOSTICS)

BJ:DTC P0420 CATALYST SYSTEM EFFICIENCY BELOW THRESHOLD (BANK 1)

DTC DETECTING CONDITION:

- Detected when two consecutive driving cycles with fault occur.
- GENERAL DESCRIPTION <Ref. to GD(H4DOTC)-110, DTC P0420 CATALYST SYSTEM EFFICIENCY BELOW THRESHOLD (BANK 1), Diagnostic Trouble Code (DTC) Detecting Criteria.>

TROUBLE SYMPTOM:

- Engine stalls.
- Idle mixture is out of specifications.

CAUTION:

After repair or replacement of faulty parts, perform Clear Memory Mode <Ref. to EN(H4DOTC)(diag)-52, OPERATION, Clear Memory Mode.> and Inspection Mode <Ref. to EN(H4DOTC)(diag)-42, PROCEDURE, Inspection Mode.>.

WIRING DIAGRAM:

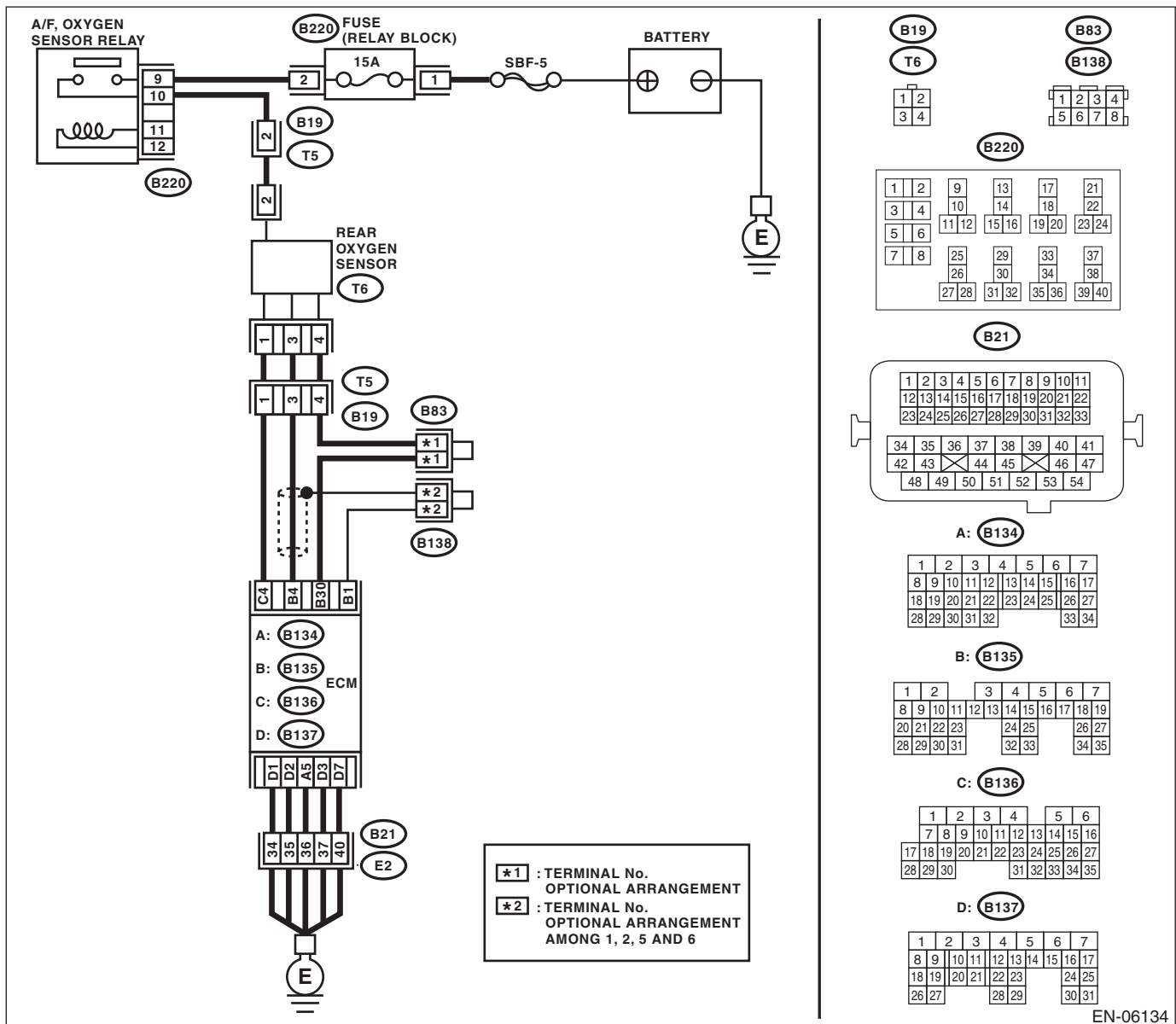

EN-06134

Diagnostic Procedure with Diagnostic Trouble Code (DTC)

ENGINE (DIAGNOSTICS)

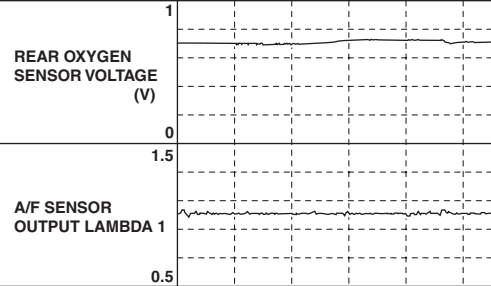
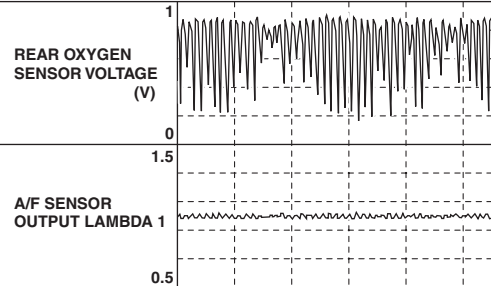
Step	Check	Yes	No
<p>1</p> <p>CHECK EXHAUST SYSTEM. Check for gas leaks or air suction caused by loose or dislocated nuts and bolts, and open hole at exhaust pipes.</p> <p>NOTE: Check the following positions.</p> <ul style="list-style-type: none"> • Between cylinder head and front exhaust pipe • Between front exhaust pipe and front catalytic converter • Between front catalytic converter and rear catalytic converter • Loose or improperly attached front oxygen (A/F) sensor or rear oxygen sensor 	<p>Is there any fault in exhaust system?</p>	<p>Repair or replace the exhaust system. <Ref. to EX(H4DOTC)-2, General Description.></p>	<p>Go to step 2.</p>
<p>2</p> <p>CHECK WAVEFORM DATA ON THE SUBARU SELECT MONITOR (WHILE DRIVING).</p> <p>1) Drive at a constant speed between 80 — 112 km/h (50 — 70 MPH).</p> <p>2) After 5 minutes have elapsed in the condition of step 1), use the Subaru Select Monitor while still driving to read the waveform data.</p> <ul style="list-style-type: none"> • At normal condition  <p>10 sec/div EN-06666</p> <ul style="list-style-type: none"> • At abnormal condition (numerous inversion)  <p>10 sec/div EN-06667</p>	<p>Is a normal waveform displayed?</p>	<p>Even if the malfunction indicator light illuminates, the circuit has returned to a normal condition at this time. Reproduce the failure, and then perform the diagnosis again.</p> <p>NOTE: In this case, temporary poor contact of connector may be the cause.</p>	<p>Go to step 3.</p>

Diagnostic Procedure with Diagnostic Trouble Code (DTC)

ENGINE (DIAGNOSTICS)

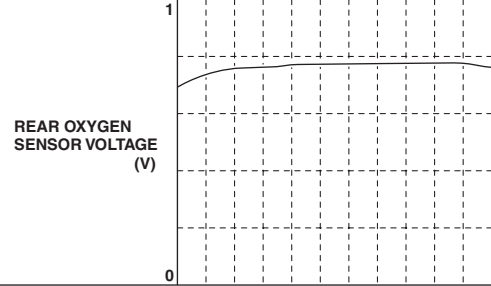
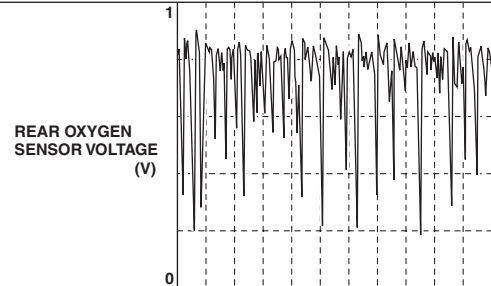
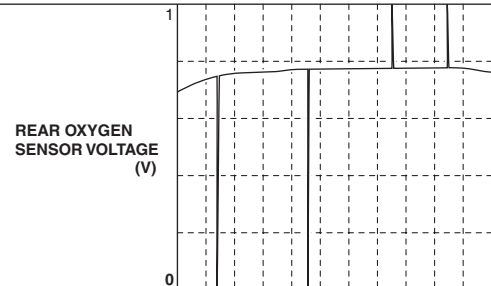
Step	Check	Yes	No
<p>3 CHECK WAVEFORM DATA ON THE SUBARU SELECT MONITOR (WHILE IDLING).</p> <p>1) Run the engine at idle. 2) In the condition of step 1), use the Subaru Select Monitor to read the waveform data.</p> <ul style="list-style-type: none"> At normal condition  <p>10 sec/div EN-06668</p> <ul style="list-style-type: none"> At abnormal condition 1 (numerous inversion)  <p>10 sec/div EN-06669</p> <ul style="list-style-type: none"> At abnormal condition 2 (noise input)  <p>10 sec/div EN-06670</p>	<p>Is a normal waveform displayed?</p>	<p>Go to step 4.</p>	<ul style="list-style-type: none"> The waveform is displayed at abnormal condition 1: Go to step 4. The waveform is displayed at abnormal condition 2: Go to step 5.
<p>4 CHECK CATALYTIC CONVERTER.</p>	<p>Is the catalytic converter damaged?</p>	<p>Replace the catalytic converter. <Ref. to EC(H4DOTC)-5, Front Catalytic Converter.></p>	<p>Go to step 5.</p>
<p>5 CHECK REAR OXYGEN SENSOR CONNECTOR AND COUPLING CONNECTOR.</p>	<p>Has water entered the connector?</p>	<p>Completely remove any water inside.</p>	<p>Go to step 6.</p>

Diagnostic Procedure with Diagnostic Trouble Code (DTC)

ENGINE (DIAGNOSTICS)

Step	Check	Yes	No
6 CHECK HARNESS BETWEEN ECM AND REAR OXYGEN SENSOR CONNECTOR. 1) Turn the ignition switch to OFF. 2) Disconnect the connector from ECM and rear oxygen sensor. 3) Measure the resistance of harness between ECM and rear oxygen sensor connector. Connector & terminal (B135) No. 4 — (T6) No. 3: (B135) No. 30 — (T6) No. 4:	Is the resistance less than 1 Ω ?	Go to step 7.	Repair the harness and connector. NOTE: Repair the following locations. • Open circuit in harness between ECM and rear oxygen sensor connector • Poor contact of coupling connector
7 CHECK HARNESS BETWEEN ECM AND REAR OXYGEN SENSOR CONNECTOR. 1) Turn the ignition switch to ON. 2) Measure the voltage between rear oxygen sensor connector and chassis ground. Connector & terminal (T6) No. 3 (+) — Chassis ground (-):	Is the voltage 0.2 — 0.5 V?	Go to step 8.	Repair the harness and connector. NOTE: Repair the following locations. • Open circuit in harness between ECM and rear oxygen sensor connector • Poor contact in ECM connector • Poor contact of coupling connector
8 CHECK REAR OXYGEN SENSOR SHIELD. 1) Turn the ignition switch to OFF. 2) Expose the rear oxygen sensor connector body side harness sensor shield. 3) Measure the resistance between the sensor shield and chassis ground.	Is the resistance less than 1 Ω ?	Replace the rear oxygen sensor. <Ref. to FU(H4DOTC)-45, Rear Oxygen Sensor.>	Repair the open circuit in the rear oxygen sensor harness.

Diagnostic Procedure with Diagnostic Trouble Code (DTC)

ENGINE (DIAGNOSTICS)

BK:DTC P0442 EVAPORATIVE EMISSION CONTROL SYSTEM LEAK DETECTED (SMALL LEAK)

DTC DETECTING CONDITION:

- Detected when two consecutive driving cycles with fault occur.
- GENERAL DESCRIPTION <Ref. to GD(H4DOTC)-112, DTC P0442 EVAPORATIVE EMISSION CONTROL SYSTEM LEAK DETECTED (SMALL LEAK), Diagnostic Trouble Code (DTC) Detecting Criteria.>

TROUBLE SYMPTOM:

- Fuel odor
- There is a hole of more than 1.0 mm (0.04 in) dia. in evaporation system or fuel tank.

CAUTION:

After repair or replacement of faulty parts, perform Clear Memory Mode <Ref. to EN(H4DOTC)(diag)-52, OPERATION, Clear Memory Mode.> and Inspection Mode <Ref. to EN(H4DOTC)(diag)-42, PROCEDURE, Inspection Mode.>.

WIRING DIAGRAM:

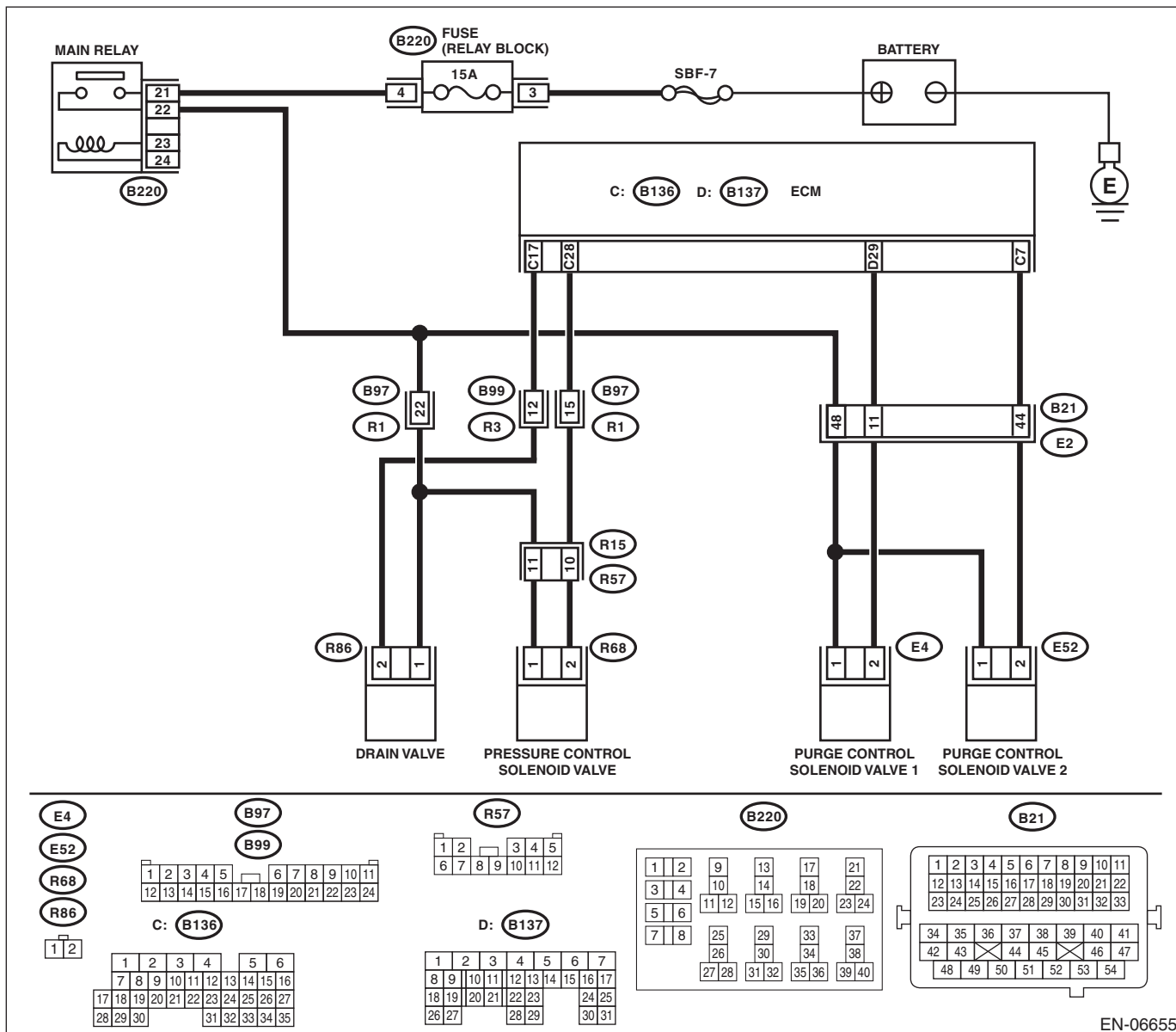

EN-06655

Diagnostic Procedure with Diagnostic Trouble Code (DTC)

ENGINE (DIAGNOSTICS)

Step	Check	Yes	No
1 CHECK FUEL FILLER CAP. 1) Turn the ignition switch to OFF. 2) Check the fuel filler cap. NOTE: The DTC is stored in memory if fuel filler cap is or was loose or if the cap chain has caught while tightening.	Is the fuel filler cap tightened securely?	Go to step 2.	Tighten fuel filler cap securely.
2 CHECK FUEL FILLER CAP.	Is the fuel filler cap genuine?	Go to step 3.	Replace with a genuine fuel filler cap.
3 CHECK FUEL FILLER PIPE GASKET.	Is there any damage to the seal between fuel filler cap and fuel filler pipe?	Repair or replace the fuel filler cap and fuel filler pipe. <Ref. to FU(H4DOTC)-60, Fuel Filler Pipe.>	Go to step 4.
4 CHECK DRAIN VALVE. 1) Connect the delivery (test) mode connector. 2) Turn the ignition switch to ON. 3) Operate the drain valve using the Subaru Select Monitor. NOTE: Drain valve operation can be executed using Subaru Select Monitor. Regarding the procedures, refer to "Compulsory Valve Operation Check Mode". <Ref. to EN(H4DOTC)(diag)-53, Compulsory Valve Operation Check Mode.>	Does the drain valve operate?	Go to step 5.	Replace the drain valve. <Ref. to EC(H4DOTC)-21, Drain Valve.>
5 CHECK PURGE CONTROL SOLENOID VALVE. Operate the purge control solenoid valve using the Subaru Select Monitor. NOTE: Purge control solenoid valve operation can be executed using Subaru Select Monitor. Regarding the procedures, refer to "Compulsory Valve Operation Check Mode". <Ref. to EN(H4DOTC)(diag)-53, Compulsory Valve Operation Check Mode.>	Does the purge control solenoid valve operate?	Go to step 6.	Replace the purge control solenoid valve. <Ref. to EC(H4DOTC)-11, Purge Control Solenoid Valve.>
6 CHECK PRESSURE CONTROL SOLENOID VALVE. Operate the pressure control solenoid valve using the Subaru Select Monitor. NOTE: The pressure control solenoid valve operation can be executed using the Subaru Select Monitor. Regarding the procedures, refer to "Compulsory Valve Operation Check Mode". <Ref. to EN(H4DOTC)(diag)-53, Compulsory Valve Operation Check Mode.>	Does the pressure control solenoid valve operate?	Go to step 7.	Replace the pressure control solenoid valve. <Ref. to EC(H4DOTC)-18, Pressure Control Solenoid Valve.>
7 CHECK EVAPORATIVE EMISSION CONTROL SYSTEM LINE. 1) Turn the ignition switch to OFF. 2) Disconnect the delivery (test) mode connector.	Is there any hole of more than 1.0 mm (0.04 in) dia. on evaporation line?	Repair or replace the evaporation line. <Ref. to FU(H4DOTC)-72, Fuel Delivery, Return and Evaporation Lines.>	Go to step 8.

Diagnostic Procedure with Diagnostic Trouble Code (DTC)

ENGINE (DIAGNOSTICS)

	Step	Check	Yes	No
8	CHECK CANISTER.	Is the canister damaged or is there a hole of more than 1.0 mm (0.04 in) dia. in it?	Repair or replace the canister. <Ref. to EC(H4DOTC)-7, Canister.>	Go to step 9.
9	CHECK FUEL TANK. Remove the fuel tank. <Ref. to FU(H4DOTC)-53, Fuel Tank.>	Is the fuel tank damaged or is there any hole of more than 1.0 mm (0.04 in) dia. in it?	Repair or replace the fuel tank. <Ref. to FU(H4DOTC)-53, Fuel Tank.>	Go to step 10.
10	CHECK ANY OTHER MECHANICAL TROUBLE IN EVAPORATIVE EMISSION CONTROL SYSTEM.	Is there any hole of more than 1.0 mm (0.04 in) dia., crack, clogging, or disconnections, bend, misconnection of hoses or pipes in evaporative emission control system?	Repair or replace the hoses or pipes.	Repair the poor contact of the ECM connector.

Diagnostic Procedure with Diagnostic Trouble Code (DTC)

ENGINE (DIAGNOSTICS)

BL:DTC P0447 EVAPORATIVE EMISSION CONTROL SYSTEM VENT CONTROL CIRCUIT OPEN

DTC DETECTING CONDITION:

- Immediately at fault recognition
- GENERAL DESCRIPTION <Ref. to GD(H4DOTC)-128, DTC P0447 EVAPORATIVE EMISSION CONTROL SYSTEM VENT CONTROL CIRCUIT OPEN, Diagnostic Trouble Code (DTC) Detecting Criteria.>

CAUTION:

After repair or replacement of faulty parts, perform Clear Memory Mode <Ref. to EN(H4DOTC)(diag)-52, OPERATION, Clear Memory Mode.> and Inspection Mode <Ref. to EN(H4DOTC)(diag)-42, PROCEDURE, Inspection Mode.>.

WIRING DIAGRAM:

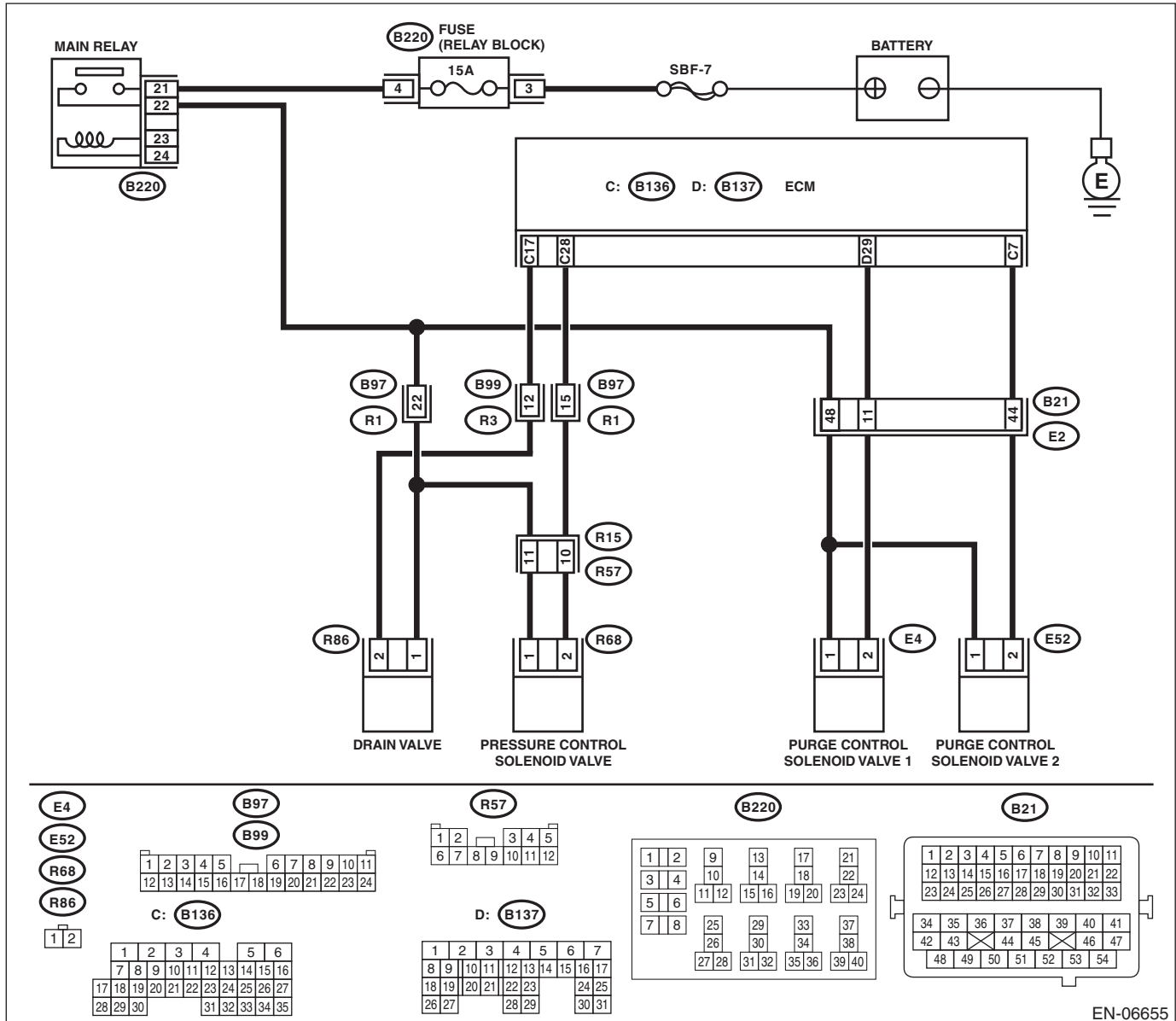

EN-06655

Diagnostic Procedure with Diagnostic Trouble Code (DTC)

ENGINE (DIAGNOSTICS)

Step	Check	Yes	No
1 CHECK OUTPUT SIGNAL OF ECM. 1) Turn the ignition switch to ON. 2) Measure the voltage between ECM and chassis ground. Connector & terminal (B136) No. 17 (+) — Chassis ground (-):	Is the voltage 10 V or more?	Go to step 2.	Go to step 3.
2 CHECK FOR POOR CONTACT. Check for poor contact of ECM connector.	Is there poor contact of ECM connector?	Repair the poor contact of ECM connector.	Even if DTC is detected, the circuit has returned to a normal condition at this time. Reproduce the failure, and then perform the diagnosis again. NOTE: In this case, temporary open or short circuit of harness or temporary poor contact of connector may be the cause.
3 CHECK POWER SUPPLY TO DRAIN VALVE. Measure the voltage between drain valve and chassis ground. Connector & terminal (R86) No. 1 (+) — Chassis ground (-):	Is the voltage 10 V or more?	Go to step 4.	Repair the power supply circuit.
4 CHECK HARNESS BETWEEN ECM AND DRAIN VALVE. 1) Turn the ignition switch to OFF. 2) Disconnect the connectors from the ECM and drain valve. 3) Measure the resistance between the drain valve connector and chassis ground. Connector & terminal (R86) No. 2 — Chassis ground:	Is the resistance 1 M Ω or more?	Go to step 5.	Repair the ground short circuit of harness between ECM and drain valve connector.
5 CHECK HARNESS BETWEEN ECM AND DRAIN VALVE. Measure the resistance of harness between ECM and drain valve connector. Connector & terminal (B136) No. 17 — (R86) No. 2:	Is the resistance less than 1 Ω ?	Go to step 6.	Repair the harness and connector. NOTE: In this case, repair the following item: <ul style="list-style-type: none"> • Open circuit of harness between ECM and drain valve connector • Poor contact of coupling connector
6 CHECK DRAIN VALVE. Measure the resistance between drain valve terminals. Terminals No. 1 — No. 2:	Is the resistance between 10 — 100 Ω ?	Repair the poor contact of drain valve connector.	Replace the drain valve. <Ref. to EC(H4DOTC)-21, Drain Valve.>

Diagnostic Procedure with Diagnostic Trouble Code (DTC)

ENGINE (DIAGNOSTICS)

BM:DTC P0448 EVAPORATIVE EMISSION CONTROL SYSTEM VENT CONTROL CIRCUIT SHORTED

DTC DETECTING CONDITION:

- Immediately at fault recognition
- GENERAL DESCRIPTION <Ref. to GD(H4DOTC)-130, DTC P0448 EVAPORATIVE EMISSION CONTROL SYSTEM VENT CONTROL CIRCUIT SHORTED, Diagnostic Trouble Code (DTC) Detecting Criteria.>

CAUTION:

After repair or replacement of faulty parts, perform Clear Memory Mode <Ref. to EN(H4DOTC)(diag)-52, OPERATION, Clear Memory Mode.> and Inspection Mode <Ref. to EN(H4DOTC)(diag)-42, PROCEDURE, Inspection Mode.>.

WIRING DIAGRAM:

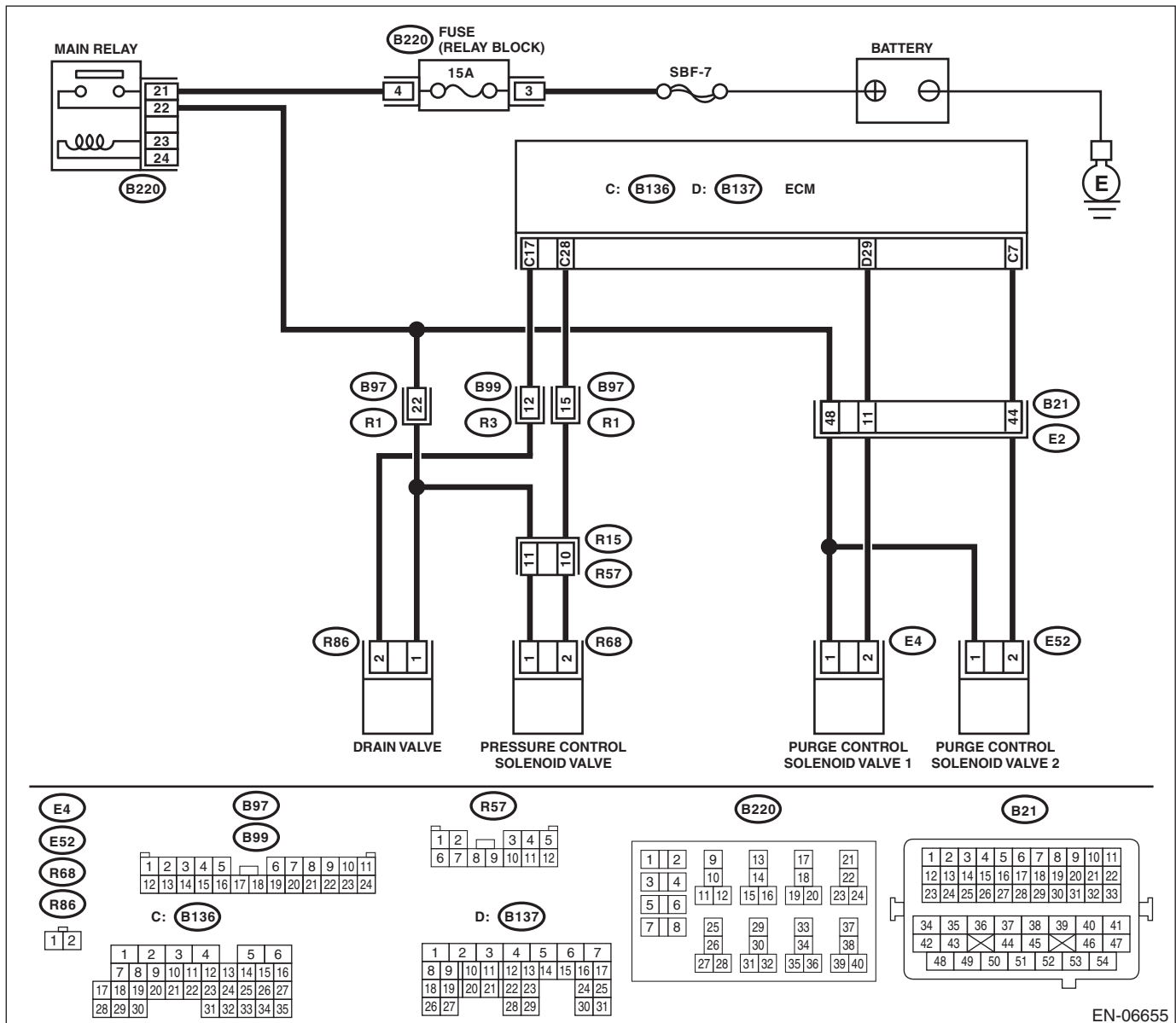

EN-06655

Diagnostic Procedure with Diagnostic Trouble Code (DTC)

ENGINE (DIAGNOSTICS)

Step	Check	Yes	No
<p>1 CHECK HARNESS BETWEEN ECM AND DRAIN VALVE. 1) Turn the ignition switch to OFF. 2) Disconnect the connectors from the ECM and drain valve. 3) Turn the ignition switch to ON. 4) Measure the voltage between ECM and chassis ground. Connector & terminal (B136) No. 17 (+) — Chassis ground (-):</p>	Is the voltage 10 V or more?	Repair the short circuit to power in the harness between ECM and drain valve connector.	Go to step 2.
<p>2 CHECK DRAIN VALVE. 1) Turn the ignition switch to OFF. 2) Measure the resistance between drain valve terminals. Terminals No. 1 — No. 2:</p>	Is the resistance less than 1 Ω ?	Replace the drain valve. <Ref. to EC(H4DOTC)-21, Drain Valve.>	Repair the poor contact of the ECM connector.

BN:DTC P0451 EVAPORATIVE EMISSION CONTROL SYSTEM PRESSURE SENSOR

DTC DETECTING CONDITION:

- Detected when two consecutive driving cycles with fault occur.
- GENERAL DESCRIPTION <Ref. to GD(H4DOTC)-132, DTC P0451 EVAPORATIVE EMISSION CONTROL SYSTEM PRESSURE SENSOR, Diagnostic Trouble Code (DTC) Detecting Criteria.>

CAUTION:

After repair or replacement of faulty parts, perform Clear Memory Mode <Ref. to EN(H4DOTC)(diag)-52, OPERATION, Clear Memory Mode.> and Inspection Mode <Ref. to EN(H4DOTC)(diag)-42, PROCEDURE, Inspection Mode.>.

WIRING DIAGRAM:

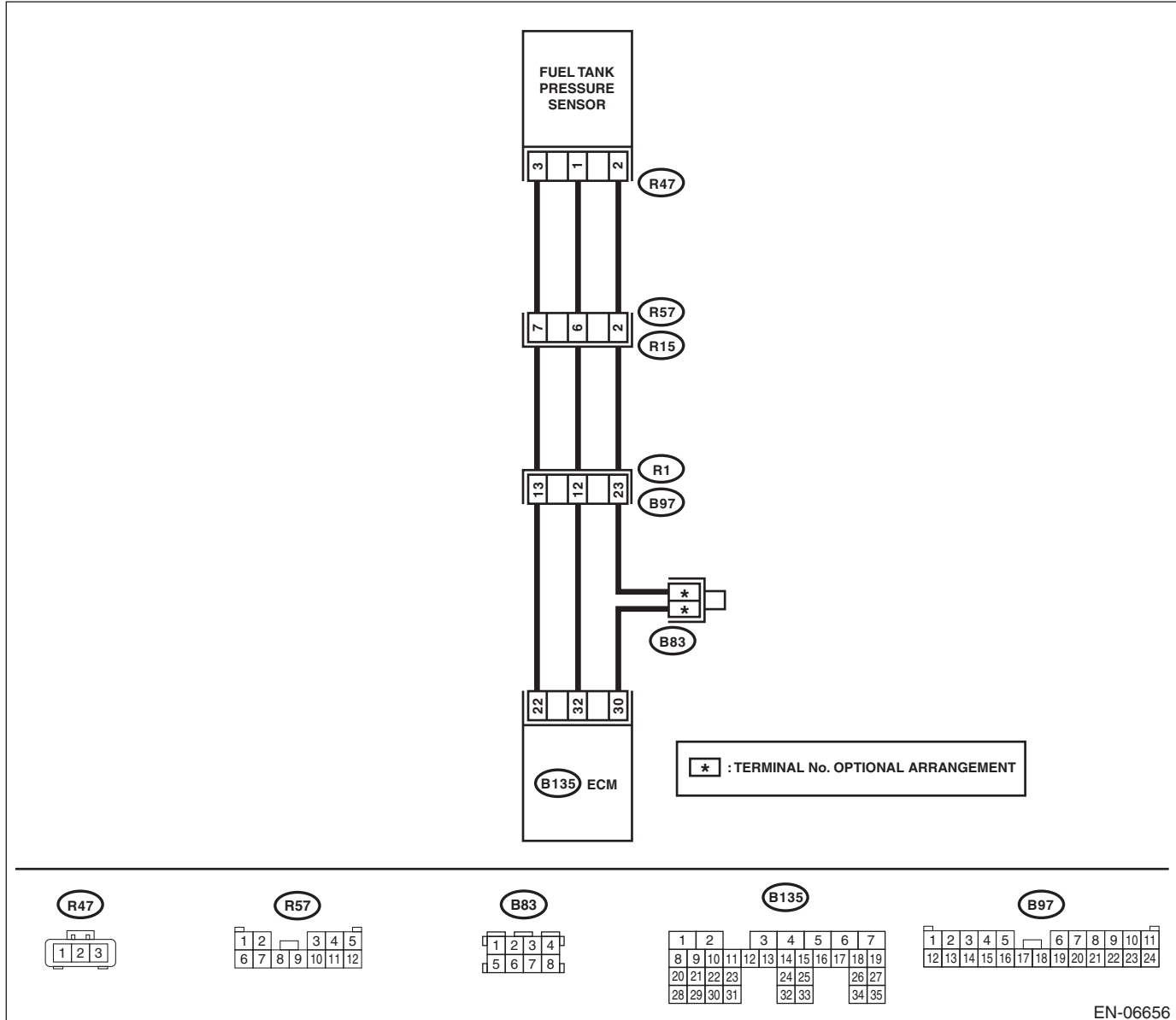

Diagnostic Procedure with Diagnostic Trouble Code (DTC)

ENGINE (DIAGNOSTICS)

	Step	Check	Yes	No
1	CHECK FUEL FILLER CAP. 1) Turn the ignition switch to OFF. 2) Open the fuel flap.	Is the fuel filler cap tightened securely?	Go to step 2.	Tighten fuel filler cap securely.
2	CHECK PRESSURE VACUUM LINE. NOTE: Check the following items. <ul style="list-style-type: none">• Disconnection, leakage and clogging of the vacuum hoses and pipes between fuel tank pressure sensor and fuel tank• Disconnection, leakage and clogging of air ventilation hoses and pipes between fuel filler pipe and fuel tank	Is there any fault in pressure/vacuum line?	Repair or replace the hoses and pipes.	Replace the fuel tank pressure sensor. <Ref. to EC(H4DOTC)-17, Fuel Tank Pressure Sensor.>

BO:DTC P0452 EVAPORATIVE EMISSION CONTROL SYSTEM PRESSURE SENSOR LOW INPUT

DTC DETECTING CONDITION:

- Immediately at fault recognition
- GENERAL DESCRIPTION <Ref. to GD(H4DOTC)-134, DTC P0452 EVAPORATIVE EMISSION CONTROL SYSTEM PRESSURE SENSOR LOW INPUT, Diagnostic Trouble Code (DTC) Detecting Criteria.>

CAUTION:

After repair or replacement of faulty parts, perform Clear Memory Mode <Ref. to EN(H4DOTC)(diag)-52, OPERATION, Clear Memory Mode.> and Inspection Mode <Ref. to EN(H4DOTC)(diag)-42, PROCEDURE, Inspection Mode.>.

WIRING DIAGRAM:

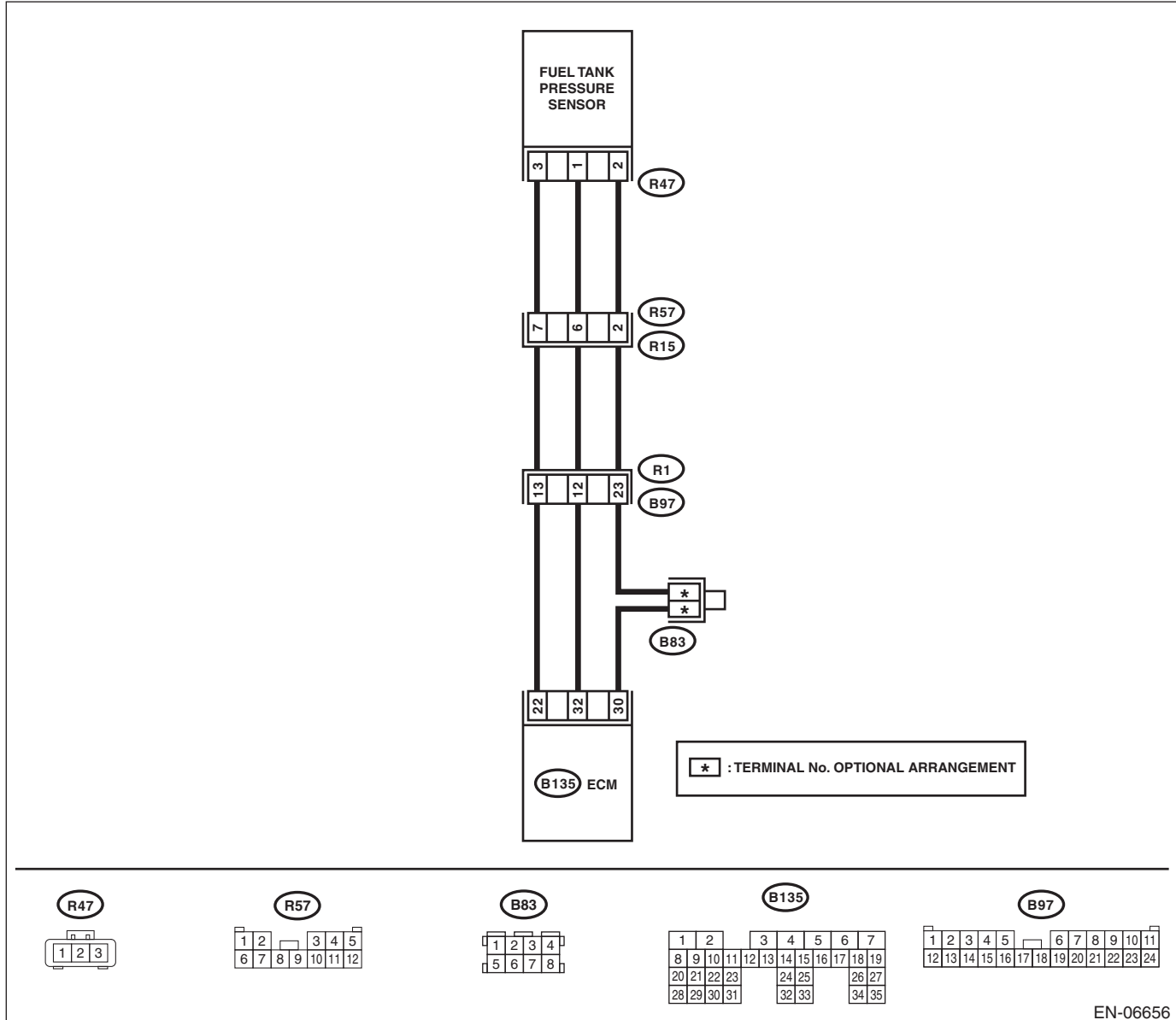

EN-06656

Diagnostic Procedure with Diagnostic Trouble Code (DTC)

ENGINE (DIAGNOSTICS)

Step	Check	Yes	No
<p>1 CHECK CURRENT DATA.</p> <p>1) Turn the ignition switch to ON.</p> <p>2) Read the data of fuel tank pressure sensor signal using the Subaru Select Monitor or general scan tool.</p> <p>NOTE:</p> <ul style="list-style-type: none"> • Subaru Select Monitor <p>For detailed operation procedures, refer to "READ CURRENT DATA FOR ENGINE". <Ref. to EN(H4DOTC)(diag)-34, Subaru Select Monitor.></p> <ul style="list-style-type: none"> • General scan tool <p>For detailed operation procedures, refer to the general scan tool operation manual.</p>	<p>Is the measured value less than -7.45 kPa (-55.89 mmHg, -2.2003 inHg) ?</p>	<p>Go to step 2.</p>	<p>Even if the malfunction indicator light illuminates, the circuit has returned to a normal condition at this time. Reproduce the fault condition, and reperform the check.</p> <p>NOTE:</p> <p>In this case, there may be a temporary connector contact failure.</p>
<p>2 CHECK FUEL TANK PRESSURE SENSOR POWER SOURCE.</p> <p>1) Turn the ignition switch to OFF.</p> <p>2) Disconnect the connector from the fuel tank pressure sensor.</p> <p>3) Turn the ignition switch to ON.</p> <p>4) Measure the voltage between the fuel tank pressure sensor connector and chassis ground.</p> <p>Connector & terminal (R47) No. 3 (+) — Chassis ground (-):</p>	<p>Is the voltage 4.5 V or more?</p>	<p>Go to step 3.</p>	<p>Repair the harness and connector.</p> <p>NOTE:</p> <p>In this case, repair the following item:</p> <ul style="list-style-type: none"> • Open circuit of harness between ECM and fuel tank pressure sensor connector • Poor contact in ECM connector • Poor contact of coupling connector
<p>3 CHECK HARNESS BETWEEN ECM AND FUEL TANK PRESSURE SENSOR CONNECTOR.</p> <p>1) Turn the ignition switch to OFF.</p> <p>2) Disconnect the connectors from the ECM.</p> <p>3) Measure the resistance of harness between the ECM and fuel tank pressure sensor connector.</p> <p>Connector & terminal (B135) No. 32 — (R47) No. 1:</p>	<p>Is the resistance less than 1 Ω?</p>	<p>Go to step 4.</p>	<p>Repair the harness and connector.</p> <p>NOTE:</p> <p>In this case, repair the following item:</p> <ul style="list-style-type: none"> • Open circuit of harness between ECM and fuel tank pressure sensor connector • Poor contact of coupling connector
<p>4 CHECK HARNESS BETWEEN ECM AND FUEL TANK PRESSURE SENSOR CONNECTOR.</p> <p>Measure the resistance between ECM and chassis ground.</p> <p>Connector & terminal (B135) No. 32 — Chassis ground:</p>	<p>Is the resistance 1 MΩ or more?</p>	<p>Go to step 5.</p>	<p>Repair the ground short circuit of harness between ECM and fuel tank pressure sensor connector.</p>
<p>5 CHECK POOR CONTACT.</p> <p>Check for poor contact between the ECM and fuel tank pressure sensor connector.</p>	<p>Is there poor contact in the ECM or fuel tank pressure sensor connector?</p>	<p>Repair the poor contact in the ECM or fuel tank pressure sensor connector.</p>	<p>Replace the fuel tank pressure sensor. <Ref. to EC(H4DOTC)-17, Fuel Tank Pressure Sensor.></p>

BP:DTC P0453 EVAPORATIVE EMISSION CONTROL SYSTEM PRESSURE SENSOR HIGH INPUT

DTC DETECTING CONDITION:

- Immediately at fault recognition
- GENERAL DESCRIPTION <Ref. to GD(H4DOTC)-136, DTC P0453 EVAPORATIVE EMISSION CONTROL SYSTEM PRESSURE SENSOR HIGH INPUT, Diagnostic Trouble Code (DTC) Detecting Criteria.>

CAUTION:

After repair or replacement of faulty parts, perform Clear Memory Mode <Ref. to EN(H4DOTC)(diag)-52, OPERATION, Clear Memory Mode.> and Inspection Mode <Ref. to EN(H4DOTC)(diag)-42, PROCEDURE, Inspection Mode.>.

WIRING DIAGRAM:

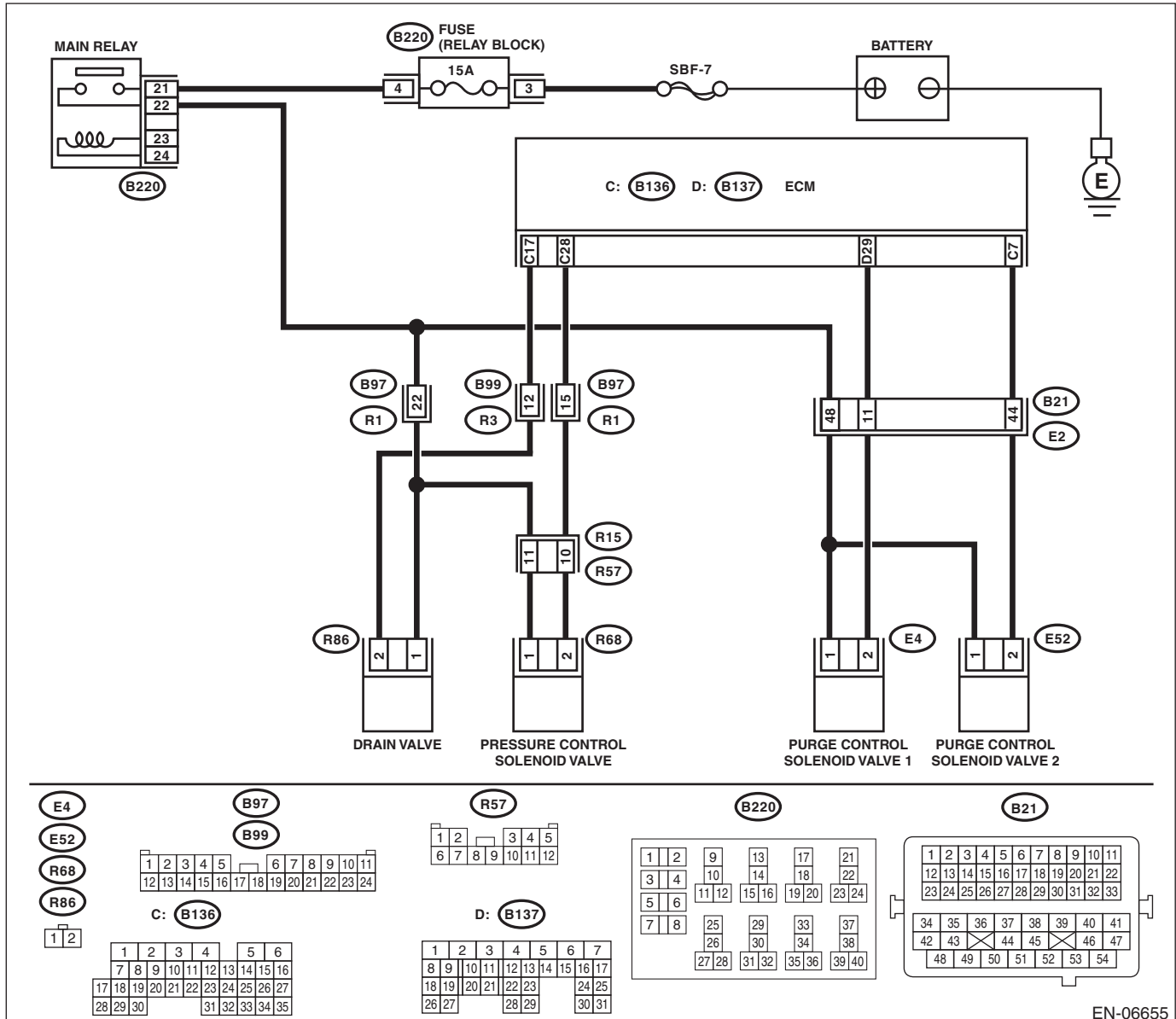

EN-06655

Diagnostic Procedure with Diagnostic Trouble Code (DTC)

ENGINE (DIAGNOSTICS)

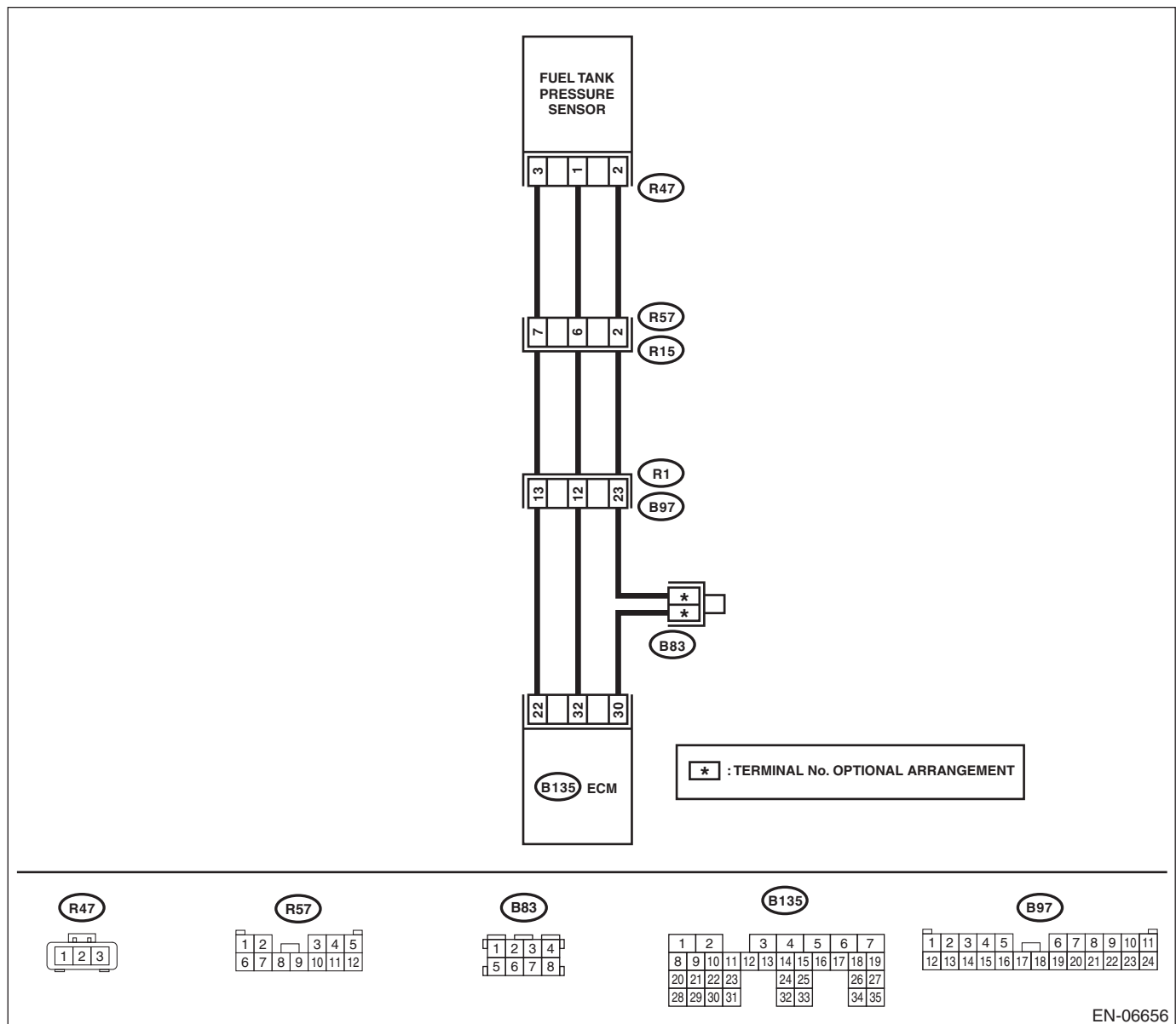

EN-06656

Step	Check	Yes	No
1 CHECK PRESSURE CONTROL SOLENOID VALVE AND EVAPORATION HOSE. Check the pressure control solenoid valve and the evaporation hose. <Ref. to EC(H4DOTC)-18, INSPECTION, Pressure Control Solenoid Valve.>	Is the pressure control solenoid valve and the evaporation hose normal?	Go to step 2.	Replace the pressure control solenoid valve or the evaporation hose. <Ref. to EC(H4DOTC)-18, Pressure Control Solenoid Valve.>
2 CHECK HARNESS BETWEEN ECM AND PRESSURE CONTROL SOLENOID VALVE. 1) Turn the ignition switch to OFF. 2) Disconnect the connector from the ECM and pressure control solenoid valve. 3) Turn the ignition switch to ON. 4) Measure the voltage between ECM and chassis ground. Connector & terminal (B136) No. 28 (+) — Chassis ground (-):	Is the voltage 10 V or more?	Repair the short circuit to power in the harness between ECM and pressure control solenoid valve connector.	Go to step 3.

Diagnostic Procedure with Diagnostic Trouble Code (DTC)

ENGINE (DIAGNOSTICS)

Step	Check	Yes	No
3 CHECK PRESSURE CONTROL SOLENOID VALVE. 1) Turn the ignition switch to OFF. 2) Measure the resistance between pressure control solenoid valve terminals. Terminals No. 1 — No. 2:	Is the resistance 20 — 30 Ω?	Go to step 4.	Replace the pressure control solenoid valve. <Ref. to EC(H4DOTC)-18, Pressure Control Solenoid Valve.>
4 CHECK FOR POOR CONTACT. Check for poor contact of ECM connector.	Is there poor contact of ECM connector?	Repair the poor contact of ECM connector.	Go to step 5.
5 CHECK CURRENT DATA. 1) Turn the ignition switch to ON. 2) Read the data of fuel tank pressure sensor signal using the Subaru Select Monitor or general scan tool. NOTE: <ul style="list-style-type: none"> Subaru Select Monitor For detailed operation procedures, refer to "READ CURRENT DATA FOR ENGINE". <Ref. to EN(H4DOTC)(diag)-34, Subaru Select Monitor.> <ul style="list-style-type: none"> General scan tool For detailed operation procedures, refer to the general scan tool operation manual.	Is the measured value 7.95 kPa (59.6 mmHg, 2.347 inHg) or more?	Go to step 6.	Even if the malfunction indicator light illuminates, the circuit has returned to a normal condition at this time. Reproduce the fault condition, and reperform the check. NOTE: In this case, there may be a temporary connector contact failure.
6 CHECK HARNESS BETWEEN ECM AND FUEL TANK PRESSURE SENSOR CONNECTOR. 1) Turn the ignition switch to OFF. 2) Disconnect the connector from the fuel tank pressure sensor. 3) Turn the ignition switch to ON. 4) Read the data of fuel tank pressure sensor signal using the Subaru Select Monitor or general scan tool. NOTE: <ul style="list-style-type: none"> Subaru Select Monitor For detailed operation procedures, refer to "READ CURRENT DATA FOR ENGINE". <Ref. to EN(H4DOTC)(diag)-34, Subaru Select Monitor.> <ul style="list-style-type: none"> General scan tool For detailed operation procedures, refer to the general scan tool operation manual.	Is the measured value 7.95 kPa (59.6 mmHg, 2.347 inHg) or more?	Repair the short circuit to power in the harness between ECM and fuel tank pressure sensor connector.	Go to step 7.
7 CHECK HARNESS BETWEEN ECM AND FUEL TANK PRESSURE SENSOR CONNECTOR. 1) Turn the ignition switch to OFF. 2) Measure the resistance of harness between fuel tank pressure sensor connector and engine ground. Connector & terminal (R47) No. 2 — Engine ground:	Is the resistance less than 5 Ω?	Go to step 8.	Repair the harness and connector. NOTE: In this case, repair the following item: <ul style="list-style-type: none"> Open circuit of harness between ECM and fuel tank pressure sensor connector Poor contact in ECM connector Poor contact of coupling connector

Diagnostic Procedure with Diagnostic Trouble Code (DTC)

ENGINE (DIAGNOSTICS)

	Step	Check	Yes	No
8	CHECK FOR POOR CONTACT. Check for poor contact of the fuel tank pressure sensor connector.	Is there poor contact in fuel tank pressure sensor connector?	Repair the poor contact in fuel tank pressure sensor connector.	Replace the fuel tank pressure sensor. <Ref. to EC(H4DOTC)-17, Fuel Tank Pressure Sensor.>

Diagnostic Procedure with Diagnostic Trouble Code (DTC)

ENGINE (DIAGNOSTICS)

BQ:DTC P0456 EVAPORATIVE EMISSION CONTROL SYSTEM LEAK DETECTED (VERY SMALL LEAK)

DTC DETECTING CONDITION:

- Detected when two consecutive driving cycles with fault occur.
- GENERAL DESCRIPTION <Ref. to GD(H4DOTC)-138, DTC P0456 EVAPORATIVE EMISSION CONTROL SYSTEM LEAK DETECTED (VERY SMALL LEAK), Diagnostic Trouble Code (DTC) Detecting Criteria.>

TROUBLE SYMPTOM:

- Fuel odor
- There is a hole of more than 0.5 mm (0.020 in) dia. in evaporation system or fuel tank.

CAUTION:

After repair or replacement of faulty parts, perform Clear Memory Mode <Ref. to EN(H4DOTC)(diag)-52, OPERATION, Clear Memory Mode.> and Inspection Mode <Ref. to EN(H4DOTC)(diag)-42, PROCEDURE, Inspection Mode.>.

WIRING DIAGRAM:

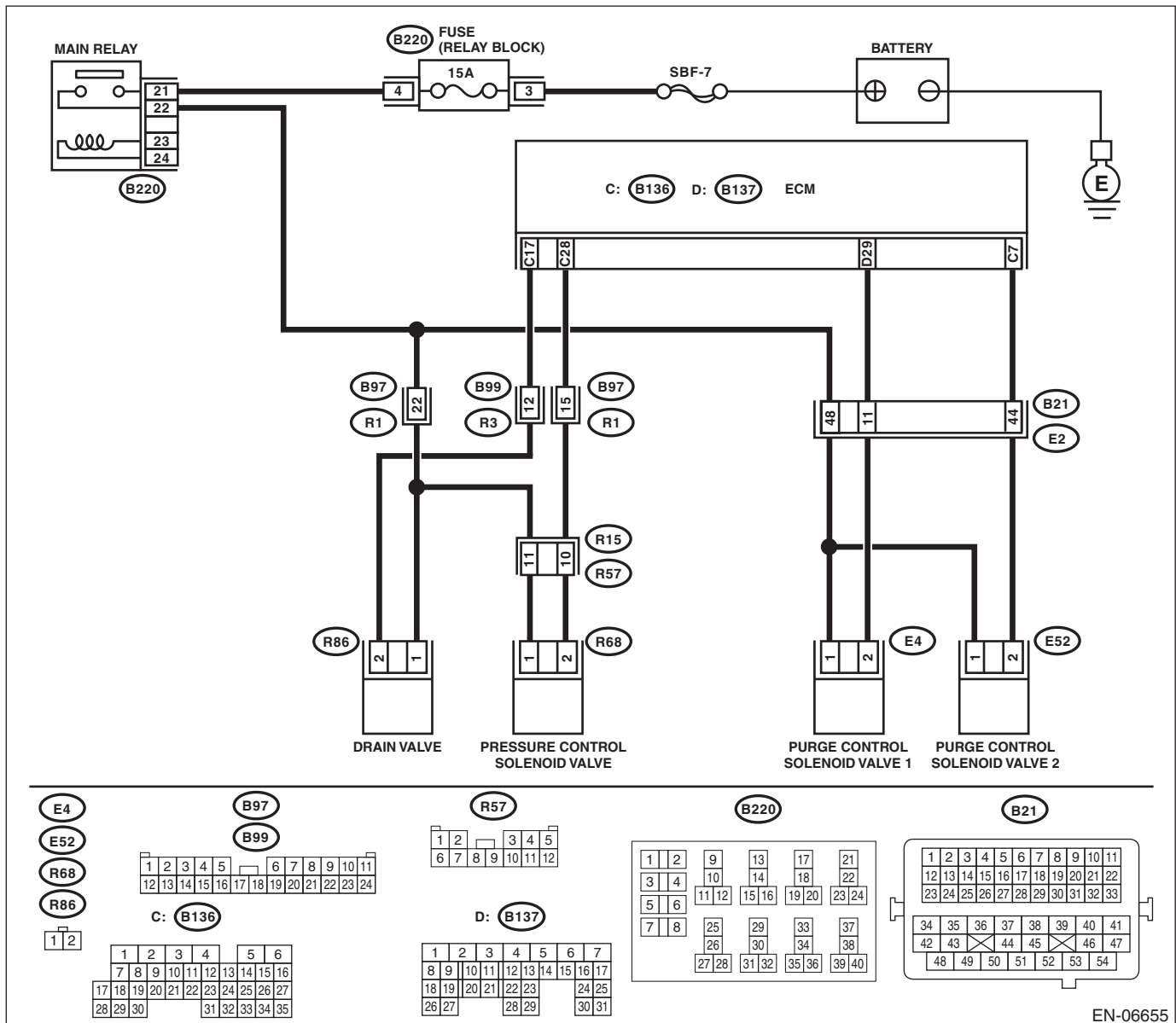

EN-06655

Diagnostic Procedure with Diagnostic Trouble Code (DTC)

ENGINE (DIAGNOSTICS)

Step	Check	Yes	No
1 CHECK FUEL FILLER CAP. 1) Turn the ignition switch to OFF. 2) Check the fuel filler cap. NOTE: The DTC is stored in memory if fuel filler cap is or was loose or if the cap chain has caught while tightening.	Is the fuel filler cap tightened securely?	Go to step 2.	Tighten fuel filler cap securely.
2 CHECK FUEL FILLER CAP.	Is the fuel filler cap genuine?	Go to step 3.	Replace with a genuine fuel filler cap.
3 CHECK FUEL FILLER PIPE GASKET.	Is there any damage to the seal between fuel filler cap and fuel filler pipe?	Repair or replace the fuel filler cap and fuel filler pipe. <Ref. to FU(H4DOTC)-60, Fuel Filler Pipe.>	Go to step 4.
4 CHECK DRAIN VALVE. 1) Connect the delivery (test) mode connector. 2) Turn the ignition switch to ON. 3) Operate the drain valve using the Subaru Select Monitor. NOTE: Drain valve can be operated using the Subaru Select Monitor. Regarding the procedures, refer to "Compulsory Valve Operation Check Mode". <Ref. to EN(H4DOTC)(diag)-53, Compulsory Valve Operation Check Mode.>	Does the drain valve operate?	Go to step 5.	Replace the drain valve. <Ref. to EC(H4DOTC)-21, Drain Valve.>
5 CHECK PURGE CONTROL SOLENOID VALVE. Operate the purge control solenoid valve using the Subaru Select Monitor. NOTE: Purge control solenoid valve operation can be executed using Subaru Select Monitor. Regarding the procedures, refer to "Compulsory Valve Operation Check Mode". <Ref. to EN(H4DOTC)(diag)-53, Compulsory Valve Operation Check Mode.>	Does the purge control solenoid valve operate?	Go to step 6.	Replace the purge control solenoid valve. <Ref. to EC(H4DOTC)-11, Purge Control Solenoid Valve.>
6 CHECK PRESSURE CONTROL SOLENOID VALVE. Operate the pressure control solenoid valve using the Subaru Select Monitor. NOTE: The pressure control solenoid valve operation can be executed using the Subaru Select Monitor. Regarding the procedures, refer to "Compulsory Valve Operation Check Mode". <Ref. to EN(H4DOTC)(diag)-53, Compulsory Valve Operation Check Mode.>	Does the pressure control solenoid valve operate?	Go to step 7.	Replace the pressure control solenoid valve. <Ref. to EC(H4DOTC)-18, Pressure Control Solenoid Valve.>
7 CHECK EVAPORATIVE EMISSION CONTROL SYSTEM LINE. 1) Turn the ignition switch to OFF. 2) Disconnect the delivery (test) mode connector.	Is there any hole of more than 0.5 mm (0.020 in) dia. on evaporation line?	Repair or replace the evaporation line. <Ref. to FU(H4DOTC)-72, Fuel Delivery, Return and Evaporation Lines.>	Go to step 8.

Diagnostic Procedure with Diagnostic Trouble Code (DTC)

ENGINE (DIAGNOSTICS)

	Step	Check	Yes	No
8	CHECK CANISTER.	Is the canister damaged or is there a hole of more than 0.5 mm (0.020 in) dia. in it?	Repair or replace the canister. <Ref. to EC(H4DOTC)-7, Canister.>	Go to step 9.
9	CHECK FUEL TANK. Remove the fuel tank. <Ref. to FU(H4DOTC)-53, Fuel Tank.>	Is the fuel tank damaged or is there any hole of more than 0.5 mm (0.020 in) dia. in it?	Repair or replace the fuel tank. <Ref. to FU(H4DOTC)-53, Fuel Tank.>	Go to step 10.
10	CHECK ANY OTHER MECHANICAL TROUBLE IN EVAPORATIVE EMISSION CONTROL SYSTEM.	Is there any hole of more than 0.5 mm (0.020 in) dia., crack, clogging, or disconnections, bend, misconnection of hoses or pipes in evaporative emission control system?	Repair or replace the hoses or pipes.	Repair the poor contact of the ECM connector.

Diagnostic Procedure with Diagnostic Trouble Code (DTC)

ENGINE (DIAGNOSTICS)

BR:DTC P0457 EVAPORATIVE EMISSION CONTROL SYSTEM LEAK DETECTED (FUEL CAP LOOSE/OFF)

DTC DETECTING CONDITION:

- Detected when two consecutive driving cycles with fault occur.
- GENERAL DESCRIPTION <Ref. to GD(H4DOTC)-138, DTC P0457 EVAPORATIVE EMISSION CONTROL SYSTEM LEAK DETECTED (FUEL CAP LOOSE/OFF), Diagnostic Trouble Code (DTC) Detecting Criteria.>

TROUBLE SYMPTOM:

- Fuel odor
- Fuel filler cap loose or lost

CAUTION:

After repair or replacement of faulty parts, perform Clear Memory Mode <Ref. to EN(H4DOTC)(diag)-52, OPERATION, Clear Memory Mode.> and Inspection Mode <Ref. to EN(H4DOTC)(diag)-42, PROCEDURE, Inspection Mode.>.

WIRING DIAGRAM:

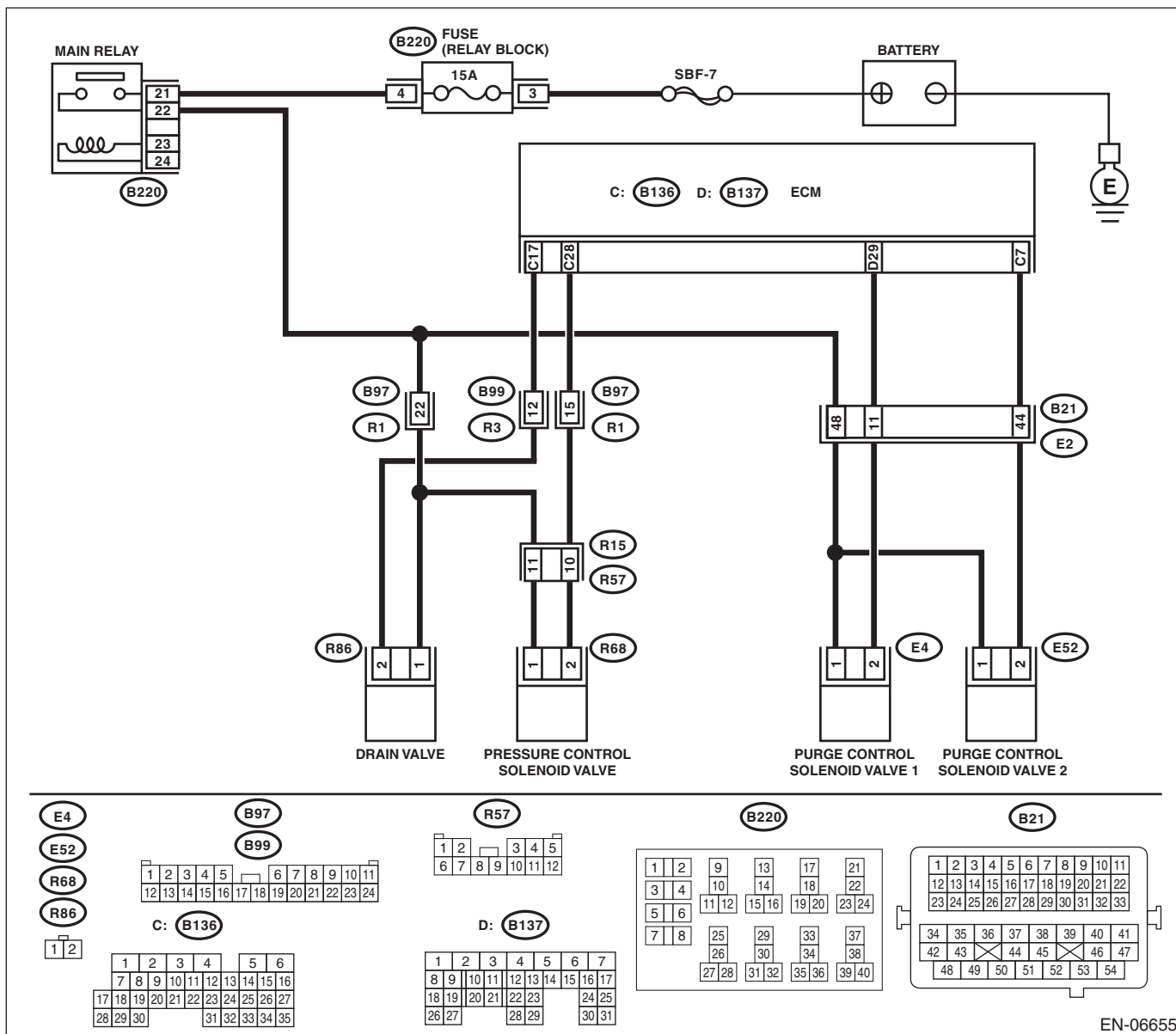

EN-06655

Diagnostic Procedure with Diagnostic Trouble Code (DTC)

ENGINE (DIAGNOSTICS)

Step	Check	Yes	No
1 CHECK FUEL FILLER CAP. 1) Turn the ignition switch to OFF. 2) Check the fuel filler cap. NOTE: The DTC is stored in memory if fuel filler cap is or was loose or if the cap chain has caught while tightening.	Is the fuel filler cap tightened securely?	Go to step 2.	Tighten fuel filler cap securely.
2 CHECK FUEL FILLER CAP.	Is the fuel filler cap genuine?	Go to step 3.	Replace with a genuine fuel filler cap.
3 CHECK FUEL FILLER PIPE GASKET.	Is there any damage to the seal between fuel filler cap and fuel filler pipe?	Repair or replace the fuel filler cap and fuel filler pipe. <Ref. to FU(H4DOTC)-60, Fuel Filler Pipe.>	Go to step 4.
4 CHECK DRAIN VALVE. 1) Connect the delivery (test) mode connector. 2) Turn the ignition switch to ON. 3) Operate the drain valve using the Subaru Select Monitor. NOTE: Drain valve operation can be executed using the Subaru Select Monitor. Regarding the procedures, refer to "Compulsory Valve Operation Check Mode". <Ref. to EN(H4DOTC)(diag)-53, Compulsory Valve Operation Check Mode.>	Does the drain valve operate?	Go to step 5.	Replace the drain valve. <Ref. to EC(H4DOTC)-21, Drain Valve.>
5 CHECK PURGE CONTROL SOLENOID VALVE. Operate the purge control solenoid valve using the Subaru Select Monitor. NOTE: Purge control solenoid valve operation can be executed using Subaru Select Monitor. Regarding the procedures, refer to "Compulsory Valve Operation Check Mode". <Ref. to EN(H4DOTC)(diag)-53, Compulsory Valve Operation Check Mode.>	Does the purge control solenoid valve operate?	Go to step 6.	Replace the purge control solenoid valve. <Ref. to EC(H4DOTC)-11, Purge Control Solenoid Valve.>
6 CHECK PRESSURE CONTROL SOLENOID VALVE. Operate the pressure control solenoid valve using the Subaru Select Monitor. NOTE: The pressure control solenoid valve operation can be executed using the Subaru Select Monitor. Regarding the procedures, refer to "Compulsory Valve Operation Check Mode". <Ref. to EN(H4DOTC)(diag)-53, Compulsory Valve Operation Check Mode.>	Does the pressure control solenoid valve operate?	Go to step 7.	Replace the pressure control solenoid valve. <Ref. to EC(H4DOTC)-18, Pressure Control Solenoid Valve.>
7 CHECK EVAPORATIVE EMISSION CONTROL SYSTEM LINE. 1) Turn the ignition switch to OFF. 2) Disconnect the delivery (test) mode connector.	Is there any disconnection, damage or clogging on the evaporation line?	Repair or replace the evaporation line. <Ref. to FU(H4DOTC)-72, Fuel Delivery, Return and Evaporation Lines.>	Go to step 8.

Diagnostic Procedure with Diagnostic Trouble Code (DTC)

ENGINE (DIAGNOSTICS)

	Step	Check	Yes	No
8	CHECK CANISTER.	Is the canister damaged?	Repair or replace the canister. <Ref. to EC(H4DOTC)-7, Canister.>	Go to step 9.
9	CHECK FUEL TANK. Remove the fuel tank. <Ref. to FU(H4DOTC)-53, Fuel Tank.>	Is the fuel tank damaged?	Repair or replace the fuel tank. <Ref. to FU(H4DOTC)-53, Fuel Tank.>	Go to step 10.
10	CHECK ANY OTHER MECHANICAL TROUBLE IN EVAPORATIVE EMISSION CONTROL SYSTEM.	Are there holes, cracks, clogging, or disconnections, misconnection of hoses or pipes in evaporative emission control system?	Repair or replace the hoses or pipes.	Repair the poor contact of the ECM connector.

Diagnostic Procedure with Diagnostic Trouble Code (DTC)

ENGINE (DIAGNOSTICS)

BS:DTC P0458 EVAPORATIVE EMISSION SYSTEM PURGE CONTROL VALVE CIRCUIT LOW

DTC DETECTING CONDITION:

- Detected when two consecutive driving cycles with fault occur.
- GENERAL DESCRIPTION <Ref. to GD(H4DOTC)-139, DTC P0458 EVAPORATIVE EMISSION SYSTEM PURGE CONTROL VALVE CIRCUIT LOW, Diagnostic Trouble Code (DTC) Detecting Criteria.>

TROUBLE SYMPTOM:

Improper idling

CAUTION:

After repair or replacement of faulty parts, perform Clear Memory Mode <Ref. to EN(H4DOTC)(diag)-52, OPERATION, Clear Memory Mode.> and Inspection Mode <Ref. to EN(H4DOTC)(diag)-42, PROCEDURE, Inspection Mode.>.

WIRING DIAGRAM:

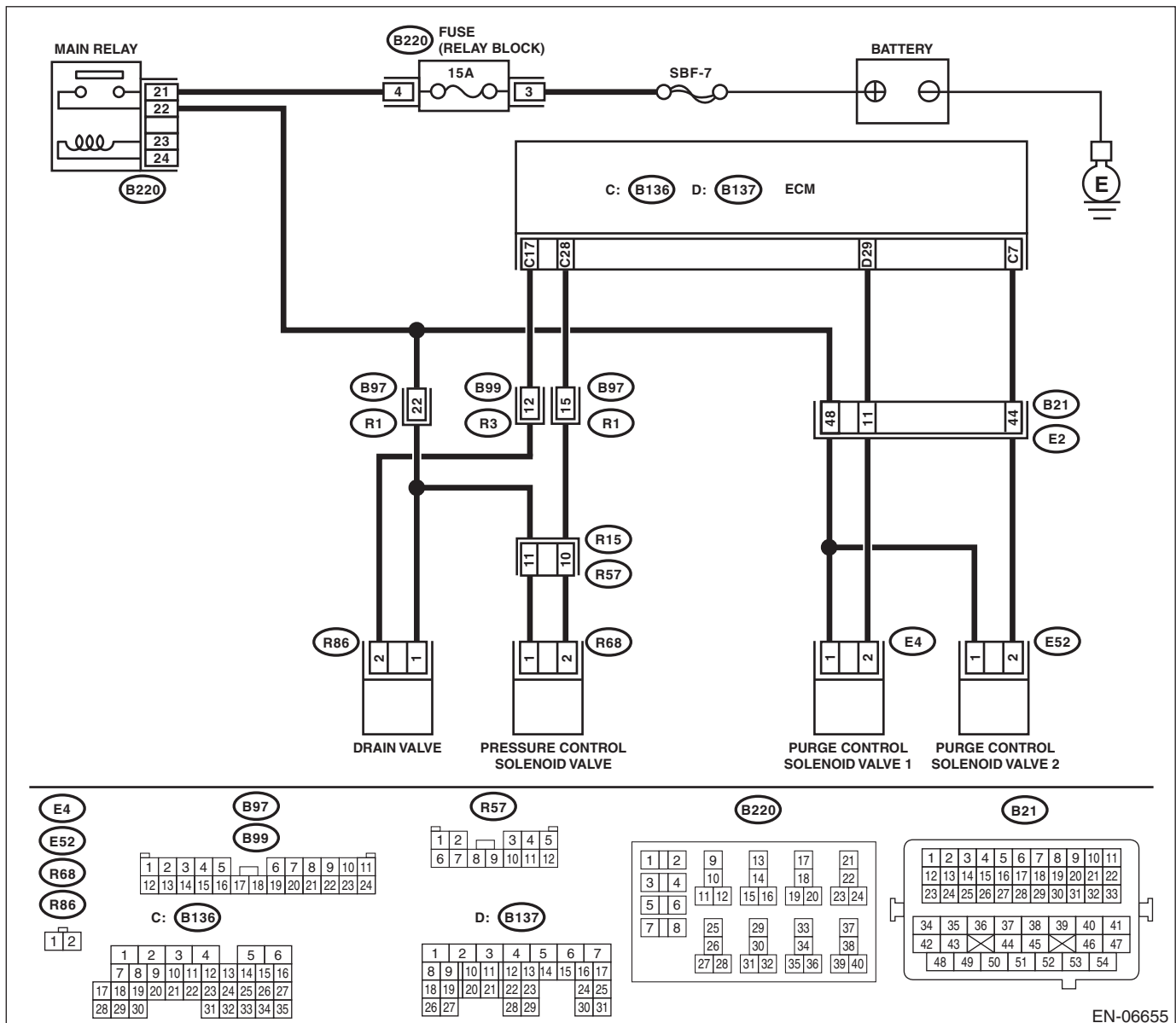

EN-06655

Diagnostic Procedure with Diagnostic Trouble Code (DTC)

ENGINE (DIAGNOSTICS)

Step	Check	Yes	No
1 CHECK OUTPUT SIGNAL OF ECM. 1) Turn the ignition switch to ON. 2) Measure the voltage between ECM and chassis ground. Connector & terminal (B137) No. 29 (+) — Chassis ground (-):	Is the voltage 10 V or more?	Go to step 2.	Go to step 3.
2 CHECK FOR POOR CONTACT. Check for poor contact of ECM connector.	Is there poor contact of ECM connector?	Repair the poor contact of ECM connector.	Even if DTC is detected, the circuit has returned to a normal condition at this time. Reproduce the failure, and then perform the diagnosis again. NOTE: In this case, temporary open or short circuit of harness or temporary poor contact of connector may be the cause.
3 CHECK POWER SUPPLY TO PURGE CONTROL SOLENOID VALVE. Measure the voltage between purge control solenoid valve and engine ground. Connector & terminal (E4) No. 1 (+) — Engine ground (-):	Is the voltage 10 V or more?	Go to step 4.	Repair the power supply circuit.
4 CHECK HARNESS BETWEEN ECM AND PURGE CONTROL SOLENOID VALVE. 1) Turn the ignition switch to OFF. 2) Disconnect the connectors from ECM and purge control solenoid valve. 3) Measure the resistance between the purge control solenoid valve connector and engine ground. Connector & terminal (E4) No. 2 — Engine ground:	Is the resistance 1 M Ω or more?	Go to step 5.	Repair the ground short circuit of harness between ECM and purge control solenoid valve connector.
5 CHECK HARNESS BETWEEN ECM AND PURGE CONTROL SOLENOID VALVE. Measure the resistance of harness between ECM and purge control solenoid valve. Connector & terminal (B137) No. 29 — (E4) No. 2:	Is the resistance less than 1 Ω ?	Go to step 6.	Repair the harness and connector. NOTE: In this case, repair the following item: <ul style="list-style-type: none"> • Open circuit of harness between ECM and purge control solenoid valve connector • Poor contact of coupling connector
6 CHECK PURGE CONTROL SOLENOID VALVE. 1) Remove the purge control solenoid valve. 2) Measure the resistance between purge control solenoid valve terminals. Terminals No. 1 — No. 2:	Is the resistance between 10 — 100 Ω ?	Repair the poor contact of purge control solenoid valve connector.	Replace the purge control solenoid valve. <Ref. to EC(H4DOTC)-11, Purge Control Solenoid Valve.>

Diagnostic Procedure with Diagnostic Trouble Code (DTC)

ENGINE (DIAGNOSTICS)

BT:DTC P0459 EVAPORATIVE EMISSION SYSTEM PURGE CONTROL VALVE CIRCUIT HIGH

DTC DETECTING CONDITION:

- Detected when two consecutive driving cycles with fault occur.
- GENERAL DESCRIPTION <Ref. to GD(H4DOTC)-140, DTC P0459 EVAPORATIVE EMISSION SYSTEM PURGE CONTROL VALVE CIRCUIT HIGH, Diagnostic Trouble Code (DTC) Detecting Criteria.>

TROUBLE SYMPTOM:

Improper idling

CAUTION:

After repair or replacement of faulty parts, perform Clear Memory Mode <Ref. to EN(H4DOTC)(diag)-52, OPERATION, Clear Memory Mode.> and Inspection Mode <Ref. to EN(H4DOTC)(diag)-42, PROCEDURE, Inspection Mode.>.

WIRING DIAGRAM:

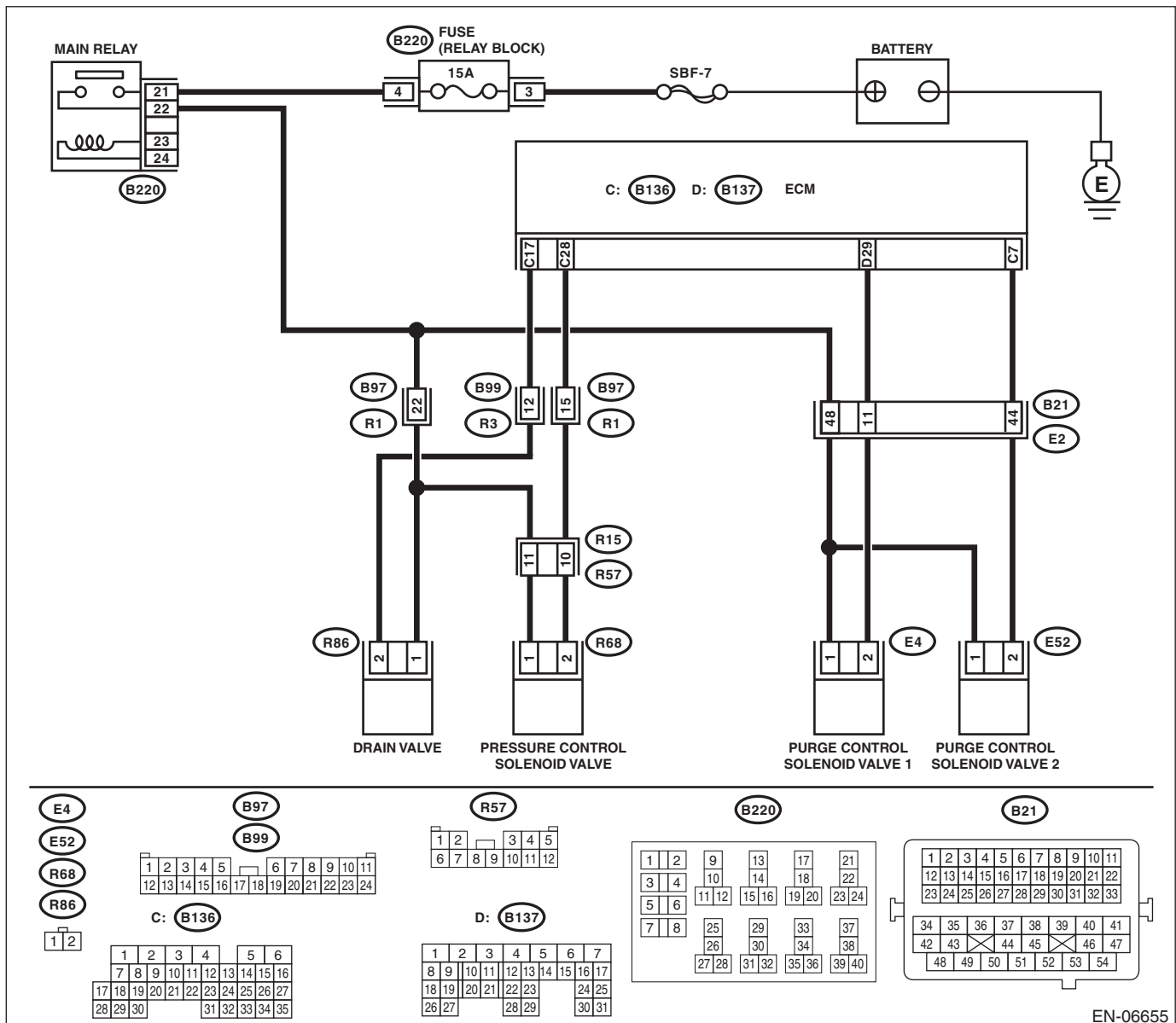

EN-06655

Diagnostic Procedure with Diagnostic Trouble Code (DTC)

ENGINE (DIAGNOSTICS)

Step	Check	Yes	No
<p>1</p> <p>CHECK HARNESS BETWEEN ECM AND PURGE CONTROL SOLENOID VALVE.</p> <p>1) Turn the ignition switch to OFF. 2) Disconnect the connectors from ECM and purge control solenoid valve. 3) Turn the ignition switch to ON. 4) Measure the voltage between ECM and chassis ground.</p> <p>Connector & terminal (B137) No. 29 (+) — Chassis ground (-):</p>	Is the voltage 10 V or more?	Repair the short circuit to power in the harness between the ECM and purge control solenoid valve connector.	Go to step 2.
<p>2</p> <p>CHECK PURGE CONTROL SOLENOID VALVE.</p> <p>1) Turn the ignition switch to OFF. 2) Measure the resistance between purge control solenoid valve terminals.</p> <p>Terminals No. 1 — No. 2:</p>	Is the resistance less than 1 Ω ?	Replace the purge control solenoid valve. <Ref. to EC(H4DOTC)-11, Purge Control Solenoid Valve.>	Repair the poor contact of the ECM connector.

Diagnostic Procedure with Diagnostic Trouble Code (DTC)

ENGINE (DIAGNOSTICS)

BU:DTC P0461 FUEL LEVEL SENSOR “A” CIRCUIT RANGE/PERFORMANCE

DTC DETECTING CONDITION:

- Detected when two consecutive driving cycles with fault occur.
- GENERAL DESCRIPTION <Ref. to GD(H4DOTC)-141, DTC P0461 FUEL LEVEL SENSOR “A” CIRCUIT RANGE/PERFORMANCE, Diagnostic Trouble Code (DTC) Detecting Criteria.>

CAUTION:

After repair or replacement of faulty parts, perform Clear Memory Mode <Ref. to EN(H4DOTC)(diag)-52, OPERATION, Clear Memory Mode.> and Inspection Mode <Ref. to EN(H4DOTC)(diag)-42, PROCEDURE, Inspection Mode.>.

Step	Check	Yes	No
1 CHECK FOR ANY OTHER DTC ON DISPLAY.	Is any other DTC displayed?	Check the appropriate DTC using the “List of Diagnostic Trouble Code (DTC)”. <Ref. to EN(H4DOTC)(diag)-80, List of Diagnostic Trouble Code (DTC).>	Replace the fuel level sensor and fuel sub level sensor. <Ref. to FU(H4DOTC)-66, Fuel Level Sensor.> <Ref. to FU(H4DOTC)-67, Fuel Sub Level Sensor.>

BV:DTC P0462 FUEL LEVEL SENSOR “A” CIRCUIT LOW

NOTE:

For the diagnostic procedure, refer to DTC P0463. <Ref. to EN(H4DOTC)(diag)-239, DTC P0463 FUEL LEVEL SENSOR “A” CIRCUIT HIGH, Diagnostic Procedure with Diagnostic Trouble Code (DTC).>

BW:DTC P0463 FUEL LEVEL SENSOR “A” CIRCUIT HIGH

DTC DETECTING CONDITION:

- Detected when two consecutive driving cycles with fault occur.
- GENERAL DESCRIPTION <Ref. to GD(H4DOTC)-145, DTC P0463 FUEL LEVEL SENSOR “A” CIRCUIT HIGH, Diagnostic Trouble Code (DTC) Detecting Criteria.>

CAUTION:

After repair or replacement of faulty parts, perform Clear Memory Mode <Ref. to EN(H4DOTC)(diag)-52, OPERATION, Clear Memory Mode.> and Inspection Mode <Ref. to EN(H4DOTC)(diag)-42, PROCEDURE, Inspection Mode.>.

Step	Check	Yes	No
1 CHECK FOR ANY OTHER DTC ON DISPLAY.	Is DTC P0462 or P0463 displayed on the Subaru Select Monitor?	Check the combination meter. <Ref. to IDI-8, CHECK FUEL LEVEL SENSOR, INSPECTION, Combination Meter System.>	Even if the malfunction indicator light illuminates, the circuit has returned to a normal condition at this time. Reproduce the fault condition, and reperform the check. NOTE: In this case, there may be a temporary connector contact failure.

Diagnostic Procedure with Diagnostic Trouble Code (DTC)

ENGINE (DIAGNOSTICS)

BX:DTC P0464 FUEL LEVEL SENSOR CIRCUIT INTERMITTENT

DTC DETECTING CONDITION:

- Detected when two consecutive driving cycles with fault occur.
- GENERAL DESCRIPTION <Ref. to GD(H4DOTC)-147, DTC P0464 FUEL LEVEL SENSOR CIRCUIT INTERMITTENT, Diagnostic Trouble Code (DTC) Detecting Criteria.>

CAUTION:

After repair or replacement of faulty parts, perform Clear Memory Mode <Ref. to EN(H4DOTC)(diag)-52, OPERATION, Clear Memory Mode.> and Inspection Mode <Ref. to EN(H4DOTC)(diag)-42, PROCEDURE, Inspection Mode.>.

Step	Check	Yes	No
1 CHECK FOR ANY OTHER DTC ON DISPLAY.	Is DTC P0464 displayed on the display?	Check the combination meter. <Ref. to IDI-8, CHECK FUEL LEVEL SENSOR, INSPECTION, Combination Meter System.>	Even if the malfunction indicator light illuminates, the circuit has returned to a normal condition at this time. Reproduce the fault condition, and reperform the check. NOTE: In this case, there may be a temporary connector contact failure.

BY:DTC P0500 VEHICLE SPEED SENSOR "A"

DTC DETECTING CONDITION:

- Immediately at fault recognition
- GENERAL DESCRIPTION <Ref. to GD(H4DOTC)-150, DTC P0500 VEHICLE SPEED SENSOR "A", Diagnostic Trouble Code (DTC) Detecting Criteria.>

CAUTION:

After repair or replacement of faulty parts, perform Clear Memory Mode <Ref. to EN(H4DOTC)(diag)-52, OPERATION, Clear Memory Mode.> and Inspection Mode <Ref. to EN(H4DOTC)(diag)-42, PROCEDURE, Inspection Mode.>.

Step	Check	Yes	No
1 CHECK DTC OF VDC. Check DTC of VDC.	Is DTC of VDC displayed?	Perform the diagnosis according to DTC. <Ref. to VDC(diag)-32, List of Diagnostic Trouble Code (DTC).>	Repair the poor contact of the ECM connector.

Diagnostic Procedure with Diagnostic Trouble Code (DTC)

ENGINE (DIAGNOSTICS)

BZ:DTC P0506 IDLE AIR CONTROL SYSTEM RPM LOWER THAN EXPECTED

DTC DETECTING CONDITION:

- Detected when two consecutive driving cycles with fault occur.
- GENERAL DESCRIPTION <Ref. to GD(H4DOTC)-151, DTC P0506 IDLE AIR CONTROL SYSTEM RPM LOWER THAN EXPECTED, Diagnostic Trouble Code (DTC) Detecting Criteria.>

TROUBLE SYMPTOM:

- Hard to start the engine.
- Engine does not start.
- Improper idling
- Engine stalls.

CAUTION:

After repair or replacement of faulty parts, perform Clear Memory Mode <Ref. to EN(H4DOTC)(diag)-52, OPERATION, Clear Memory Mode.> and Inspection Mode <Ref. to EN(H4DOTC)(diag)-42, PROCEDURE, Inspection Mode.>.

WIRING DIAGRAM:

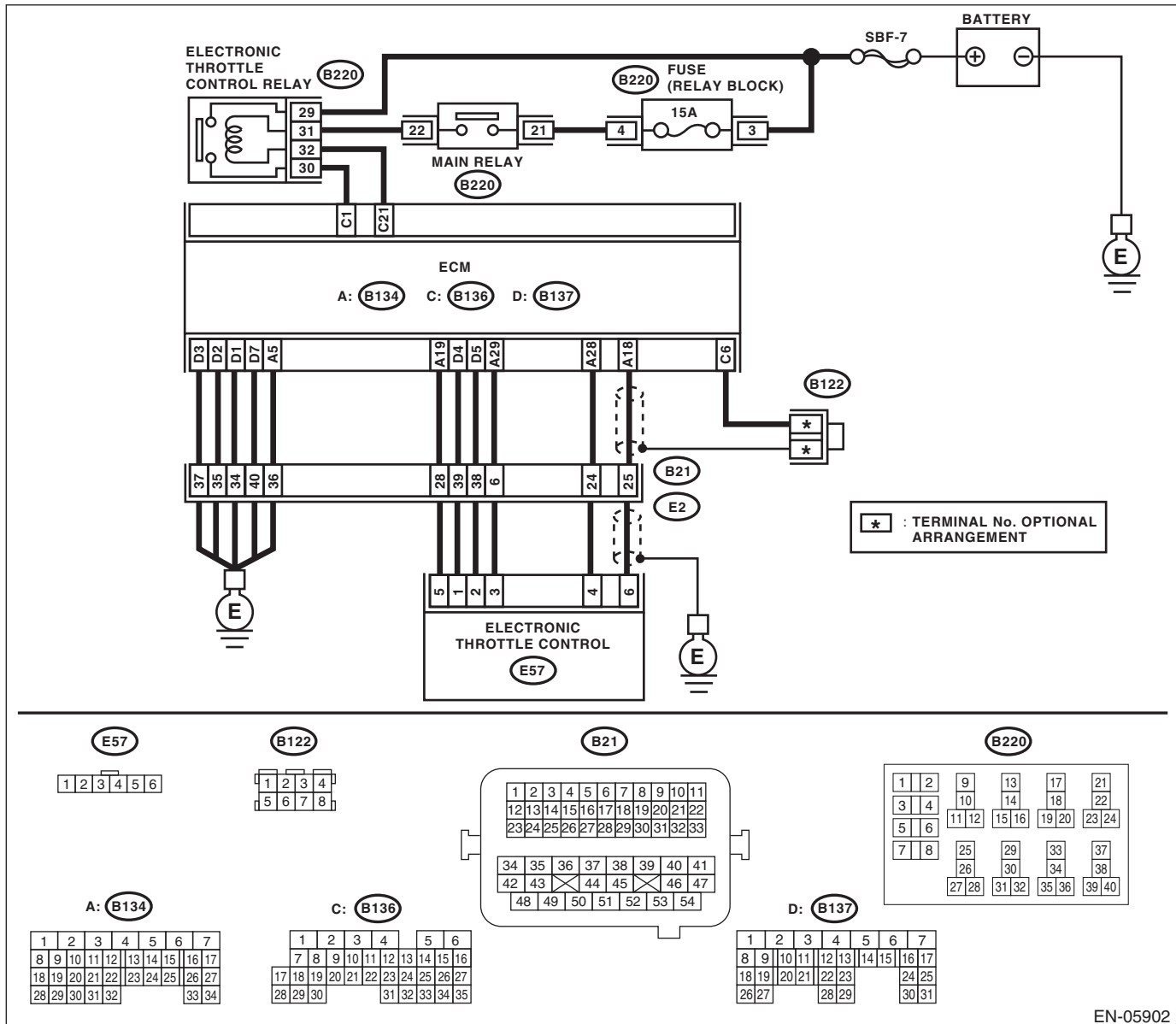

EN-05902

Diagnostic Procedure with Diagnostic Trouble Code (DTC)

ENGINE (DIAGNOSTICS)

Step	Check	Yes	No
1 CHECK FOR ANY OTHER DTC ON DISPLAY.	Is any other DTC displayed?	Check the appropriate DTC using the "List of Diagnostic Trouble Code (DTC)". <Ref. to EN(H4DOTC)(diag)-80, List of Diagnostic Trouble Code (DTC).>	Go to step 2.
2 CHECK AIR CLEANER ELEMENT. 1) Turn the ignition switch to OFF. 2) Check the air cleaner element.	Is there excessive clogging on air cleaner element?	Replace the air cleaner element. <Ref. to IN(H4DOTC)-7, Air Cleaner Element.>	Go to step 3.
3 CHECK ELECTRONIC THROTTLE CONTROL. 1) Remove the electronic throttle control. 2) Check the electronic throttle control.	Are foreign matter found inside electronic throttle control?	Remove foreign matter from electronic throttle control.	Perform the diagnosis of DTC P2101. <Ref. to EN(H4DOTC)(diag)-318, DTC P2101 THROTTLE ACTUATOR CONTROL MOTOR CIRCUIT RANGE/PERFORMANCE, Diagnostic Procedure with Diagnostic Trouble Code (DTC).>

Diagnostic Procedure with Diagnostic Trouble Code (DTC)

ENGINE (DIAGNOSTICS)

CA:DTC P0507 IDLE AIR CONTROL SYSTEM RPM HIGHER THAN EXPECTED

DTC DETECTING CONDITION:

- Detected when two consecutive driving cycles with fault occur.
- GENERAL DESCRIPTION <Ref. to GD(H4DOTC)-152, DTC P0507 IDLE AIR CONTROL SYSTEM RPM HIGHER THAN EXPECTED, Diagnostic Trouble Code (DTC) Detecting Criteria.>

TROUBLE SYMPTOM:

Engine keeps running at higher speed than specified idle speed.

CAUTION:

After repair or replacement of faulty parts, perform Clear Memory Mode <Ref. to EN(H4DOTC)(diag)-52, OPERATION, Clear Memory Mode.> and Inspection Mode <Ref. to EN(H4DOTC)(diag)-42, PROCEDURE, Inspection Mode.>.

WIRING DIAGRAM:

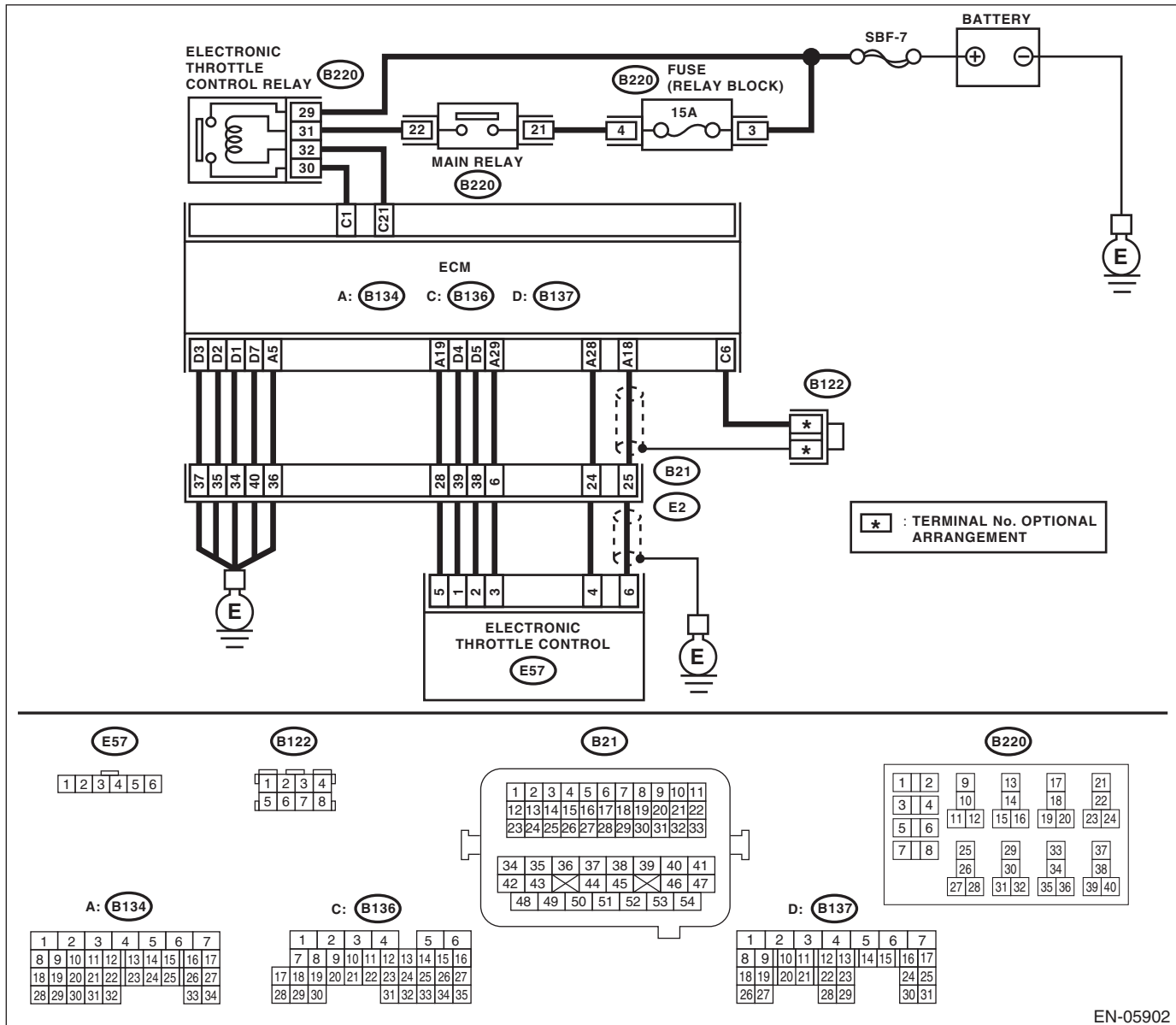

EN-05902

Diagnostic Procedure with Diagnostic Trouble Code (DTC)

ENGINE (DIAGNOSTICS)

Step	Check	Yes	No
1 CHECK FOR ANY OTHER DTC ON DISPLAY.	Is any other DTC displayed?	Check the appropriate DTC using the "List of Diagnostic Trouble Code (DTC)". <Ref. to EN(H4DOTC)(diag)-80, List of Diagnostic Trouble Code (DTC).>	Go to step 2.
2 CHECK AIR INTAKE SYSTEM. 1) Start and idle the engine. 2) Check the following items. <ul style="list-style-type: none"> • Loose installation of intake manifold and throttle body • Cracks of intake manifold gasket and throttle body gasket • Disconnection of vacuum hoses 	Is there any fault in air intake system?	Repair air suction and leaks.	Go to step 3.
3 CHECK ELECTRONIC THROTTLE CONTROL. 1) Turn the ignition switch to OFF. 2) Remove the electronic throttle control. 3) Check the electronic throttle control.	Are foreign matter found inside electronic throttle control?	Remove foreign matter from electronic throttle control.	Perform the diagnosis of DTC P2101. <Ref. to EN(H4DOTC)(diag)-318, DTC P2101 THROTTLE ACTUATOR CONTROL MOTOR CIRCUIT RANGE/PERFORMANCE, Diagnostic Procedure with Diagnostic Trouble Code (DTC).>

CB:DTC P0512 STARTER REQUEST CIRCUIT

DTC DETECTING CONDITION:

- Detected when two consecutive driving cycles with fault occur.
- GENERAL DESCRIPTION <Ref. to GD(H4DOTC)-153, DTC P0512 STARTER REQUEST CIRCUIT, Diagnostic Trouble Code (DTC) Detecting Criteria.>

TROUBLE SYMPTOM:

Failure of engine to start

CAUTION:

After repair or replacement of faulty parts, perform Clear Memory Mode <Ref. to EN(H4DOTC)(diag)-52, OPERATION, Clear Memory Mode.> and Inspection Mode <Ref. to EN(H4DOTC)(diag)-42, PROCEDURE, Inspection Mode.>.

WIRING DIAGRAM:

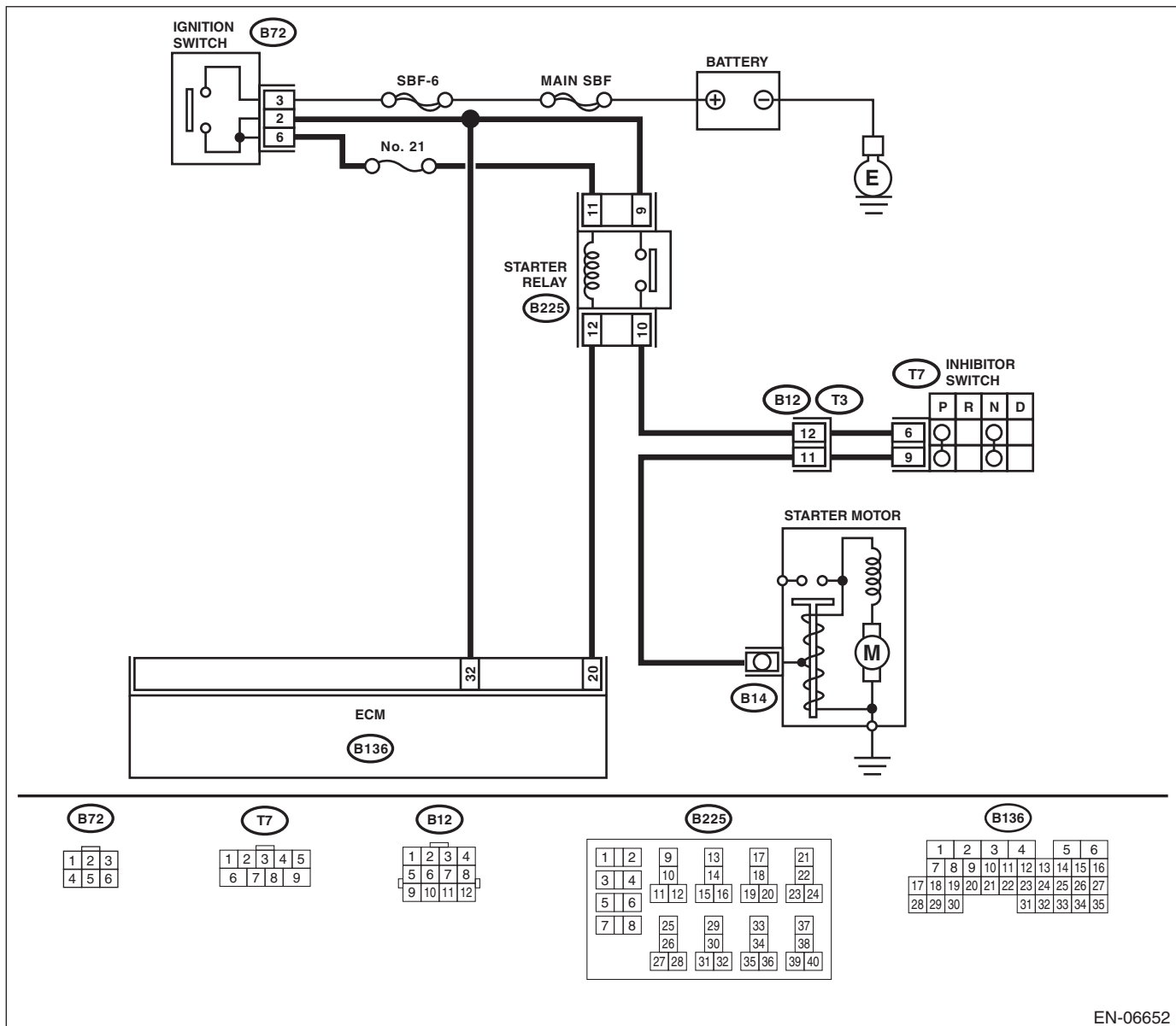

EN-06652

Diagnostic Procedure with Diagnostic Trouble Code (DTC)

ENGINE (DIAGNOSTICS)

Step	Check	Yes	No
1 CHECK FOR ANY OTHER DTC ON DISPLAY.	Is any other DTC displayed?	Check the appropriate DTC using the "List of Diagnostic Trouble Code (DTC)". <Ref. to EN(H4DOTC)(diag)-80, List of Diagnostic Trouble Code (DTC).>	Go to step 2.
2 CHECK HARNESS BETWEEN ECM AND IGNITION SWITCH. 1) Turn the ignition switch to OFF. 2) Disconnect the connectors from the ECM. 3) Turn the ignition switch to ON. 4) Measure the voltage between ECM and chassis ground. Connector & terminal (B136) No. 32 (+) — Chassis ground (-):	Is the voltage 10 V or more?	Repair the short circuit to power in harness between ECM and ignition switch connector.	Repair the poor contact of the ECM connector.

CC:DTC P0600 SERIAL COMMUNICATION LINK

NOTE:

For the diagnostic procedure, refer to LAN section. <Ref. to LAN(diag)-2, Basic Diagnostic Procedure.>

Diagnostic Procedure with Diagnostic Trouble Code (DTC)

ENGINE (DIAGNOSTICS)

Step	Check	Yes	No
1 CHECK FOR ANY OTHER DTC ON DISPLAY.	Is any other DTC displayed?	Check the appropriate DTC using the "List of Diagnostic Trouble Code (DTC)". <Ref. to EN(H4DOTC)(diag)-80, List of Diagnostic Trouble Code (DTC).>	Even if the malfunction indicator light illuminates, the circuit has returned to a normal condition at this time. Reproduce the fault condition, and reperform the check. NOTE: In this case, there may be a temporary connector contact failure.

CE:DTC P0605 INTERNAL CONTROL MODULE READ ONLY MEMORY (ROM) ERROR

NOTE:

For the diagnostic procedure, refer to DTC P0607. <Ref. to EN(H4DOTC)(diag)-249, DTC P0607 THROTTLE CONTROL SYSTEM CIRCUIT RANGE/PERFORMANCE, Diagnostic Procedure with Diagnostic Trouble Code (DTC).>

Diagnostic Procedure with Diagnostic Trouble Code (DTC)

ENGINE (DIAGNOSTICS)

CF:DTC P0607 THROTTLE CONTROL SYSTEM CIRCUIT RANGE/PERFORMANCE

DTC DETECTING CONDITION:

- Depending on the content of malfunction, adapt either of the followings.
 - Immediately at fault recognition
 - Detected when two consecutive driving cycles with fault occur.
- GENERAL DESCRIPTION <Ref. to GD(H4DOTC)-158, DTC P0607 THROTTLE CONTROL SYSTEM CIRCUIT RANGE/PERFORMANCE, Diagnostic Trouble Code (DTC) Detecting Criteria.>

TROUBLE SYMPTOM:

- Improper idling
- Poor driving performance

CAUTION:

After repair or replacement of faulty parts, perform Clear Memory Mode <Ref. to EN(H4DOTC)(diag)-52, OPERATION, Clear Memory Mode.> and Inspection Mode <Ref. to EN(H4DOTC)(diag)-42, PROCEDURE, Inspection Mode.>.

WIRING DIAGRAM:

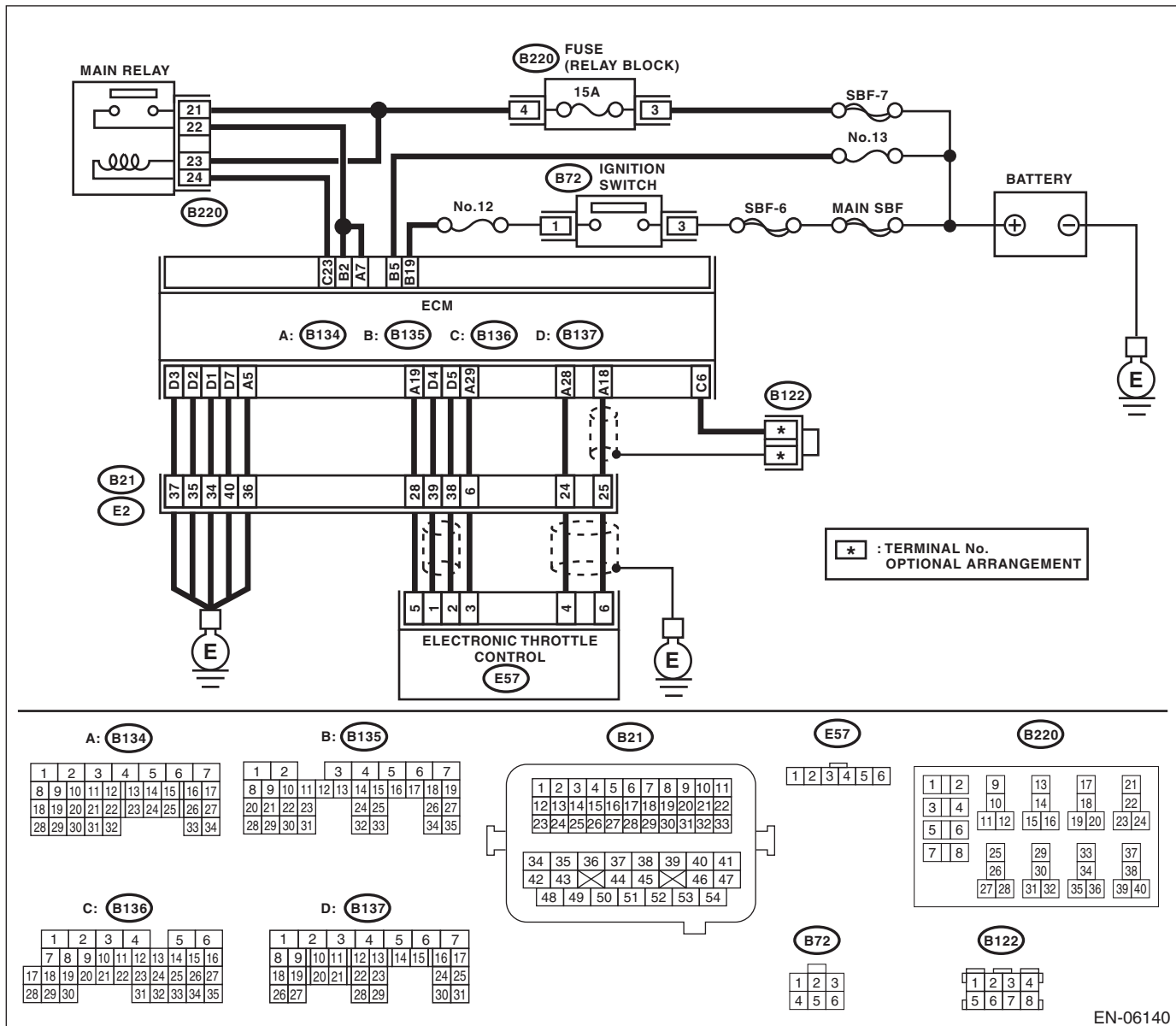

EN-06140

Diagnostic Procedure with Diagnostic Trouble Code (DTC)

ENGINE (DIAGNOSTICS)

Step	Check	Yes	No
1 CHECK INPUT VOLTAGE OF ECM. 1) Turn the ignition switch to ON. 2) Measure the voltage between ECM and chassis ground. <i>Connector & terminal</i> <i>(B134) No. 7 (+) — Chassis ground (-):</i> <i>(B135) No. 2 (+) — Chassis ground (-):</i>	Is the voltage 10 — 13 V?	Go to step 2.	Repair the open or ground short circuit of power supply circuit.
2 CHECK INPUT VOLTAGE OF ECM. 1) Start the engine. 2) Measure the voltage between ECM and chassis ground. <i>Connector & terminal</i> <i>(B134) No. 7 (+) — Chassis ground (-):</i> <i>(B135) No. 2 (+) — Chassis ground (-):</i>	Is the voltage 13 — 15 V?	Go to step 3.	Repair the open or ground short circuit of power supply circuit.
3 CHECK HARNESS BETWEEN ECM AND ELECTRONIC THROTTLE CONTROL. 1) Turn the ignition switch to OFF. 2) Disconnect the connectors from ECM and electronic throttle control. 3) Measure the resistance of harness between ECM and electronic throttle control connector. <i>Connector & terminal</i> <i>(B134) No. 19 — (E57) No. 5:</i> <i>(B134) No. 29 — (E57) No. 3:</i>	Is the resistance less than 1 Ω ?	Go to step 4.	Repair the open circuit of harness between ECM and electronic throttle control connector.
4 CHECK ECM GROUND HARNESS. 1) Connect all connectors. 2) Turn the ignition switch to ON. 3) Measure the voltage between ECM and chassis ground. <i>Connector & terminal</i> <i>(B134) No. 5 (+) — Chassis ground (-):</i> <i>(B137) No. 1 (+) — Chassis ground (-):</i> <i>(B137) No. 2 (+) — Chassis ground (-):</i> <i>(B137) No. 3 (+) — Chassis ground (-):</i> <i>(B137) No. 7 (+) — Chassis ground (-):</i>	Is the voltage less than 1 V?	Repair the poor contact of the ECM connector.	Repair the following item. <ul style="list-style-type: none"> • Open circuit in ground circuit • Further tightening of the engine ground terminal • Poor contact in ECM connector • Poor contact of coupling connector

CG:DTC P0638 THROTTLE ACTUATOR CONTROL RANGE/PERFORMANCE (BANK 1)

NOTE:

For the diagnostic procedure, refer to DTC P2101. <Ref. to EN(H4DOTC)(diag)-318, DTC P2101 THROTTLE ACTUATOR CONTROL MOTOR CIRCUIT RANGE/PERFORMANCE, Diagnostic Procedure with Diagnostic Trouble Code (DTC).>

CH:DTC P0700 TRANSMISSION CONTROL SYSTEM (MIL REQUEST)

NOTE:

For the diagnostic procedure, refer to AT section. <Ref. to 4AT(diag)-2, Basic Diagnostic Procedure.>

Diagnostic Procedure with Diagnostic Trouble Code (DTC)

ENGINE (DIAGNOSTICS)

CI: DTC P0851 PARK/NEUTRAL SWITCH INPUT CIRCUIT LOW (AT MODEL)

DTC DETECTING CONDITION:

- Detected when two consecutive driving cycles with fault occur.
- GENERAL DESCRIPTION <Ref. to GD(H4DOTC)-163, DTC P0851 PARK/NEUTRAL SWITCH INPUT CIRCUIT LOW (AT MODEL), Diagnostic Trouble Code (DTC) Detecting Criteria.>

TROUBLE SYMPTOM:

Improper idling

CAUTION:

After repair or replacement of faulty parts, perform Clear Memory Mode <Ref. to EN(H4DOTC)(diag)-52, OPERATION, Clear Memory Mode.> and Inspection Mode <Ref. to EN(H4DOTC)(diag)-42, PROCEDURE, Inspection Mode.>.

WIRING DIAGRAM:

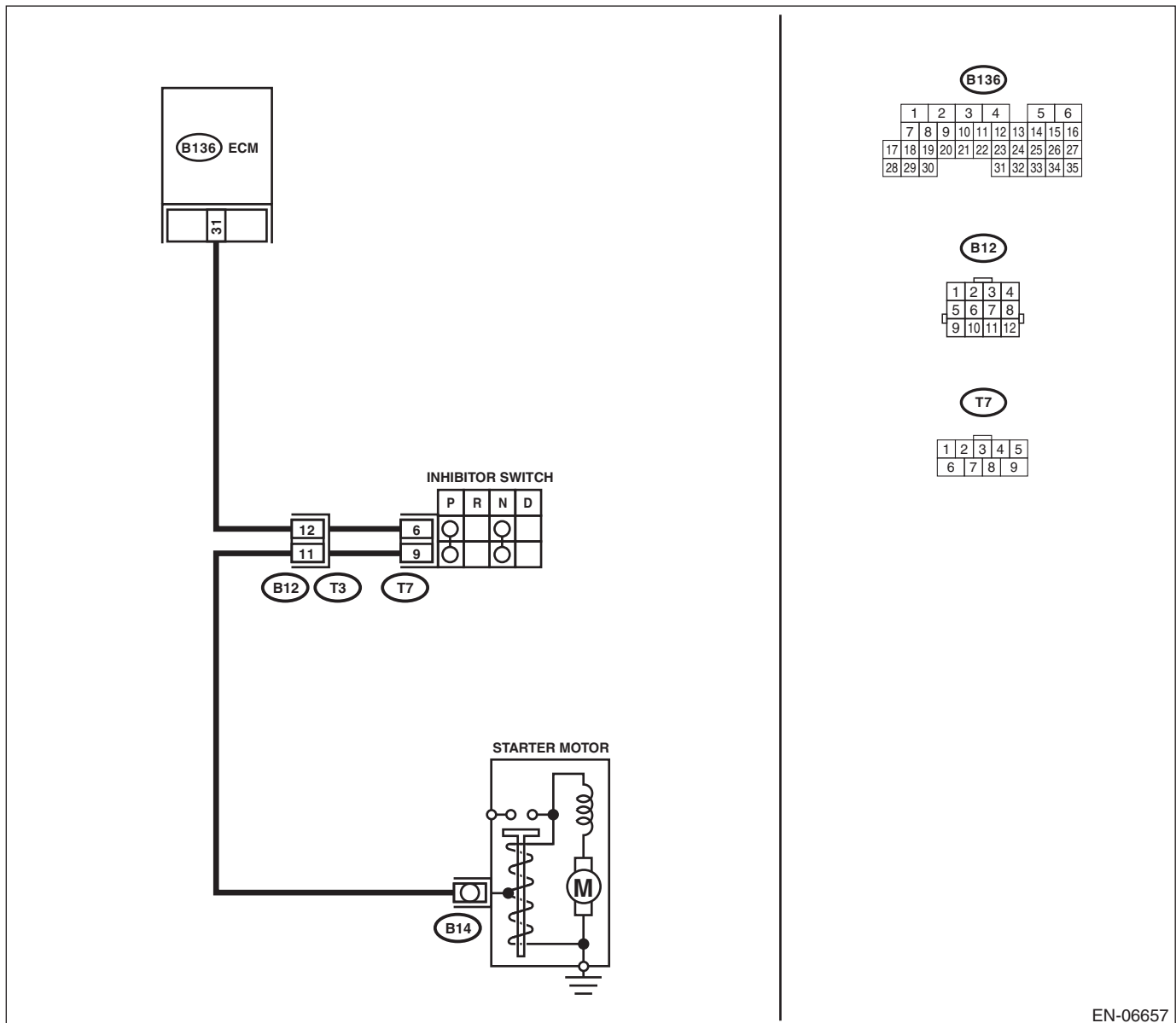

EN-06657

Diagnostic Procedure with Diagnostic Trouble Code (DTC)

ENGINE (DIAGNOSTICS)

Step	Check	Yes	No
1 CHECK SELECT CABLE.	Are there any faults in the select cable?	Repair or adjust the select cable. <Ref. to CS-25, Select Cable.>	Go to step 2.
2 CHECK INPUT SIGNAL OF ECM. 1) Turn the ignition switch to ON. 2) Place the select lever in other than "P" range and "N" range. 3) Measure the voltage between ECM and chassis ground. Connector & terminal (B136) No. 31 (+) — Chassis ground (-):	Is the voltage 10 V or more?	Repair poor contact in ECM connector.	Go to step 3.
3 CHECK HARNESS BETWEEN ECM AND TRANSMISSION HARNESS CONNECTOR. 1) Turn the ignition switch to OFF. 2) Disconnect the connectors from ECM and transmission harness connector (T3). 3) Measure the resistance between ECM and chassis ground. Connector & terminal (B136) No. 31 — Chassis ground:	Is the resistance 1 MΩ or more?	Go to step 4.	Repair the ground short circuit of harness between ECM and transmission harness connector.
4 CHECK TRANSMISSION HARNESS CONNECTOR. 1) Disconnect the connector from inhibitor switch. 2) Measure the resistance between the transmission harness connector and engine ground. Connector & terminal (T3) No. 12 — Engine ground:	Is the resistance 1 MΩ or more?	Replace the inhibitor switch. <Ref. to 4AT-46, Inhibitor Switch.>	Repair short circuit to ground in harness between transmission harness connector and inhibitor switch connector.

Diagnostic Procedure with Diagnostic Trouble Code (DTC)

ENGINE (DIAGNOSTICS)

CJ:DTC P0852 PARK/NEUTRAL SWITCH INPUT CIRCUIT HIGH (AT MODEL)

DTC DETECTING CONDITION:

- Detected when two consecutive driving cycles with fault occur.
- GENERAL DESCRIPTION <Ref. to GD(H4DOTC)-164, DTC P0852 PARK/NEUTRAL SWITCH INPUT CIRCUIT HIGH (AT MODEL), Diagnostic Trouble Code (DTC) Detecting Criteria.>

TROUBLE SYMPTOM:

Improper idling

CAUTION:

After repair or replacement of faulty parts, perform Clear Memory Mode <Ref. to EN(H4DOTC)(diag)-52, OPERATION, Clear Memory Mode.> and Inspection Mode <Ref. to EN(H4DOTC)(diag)-42, PROCEDURE, Inspection Mode.>.

WIRING DIAGRAM:

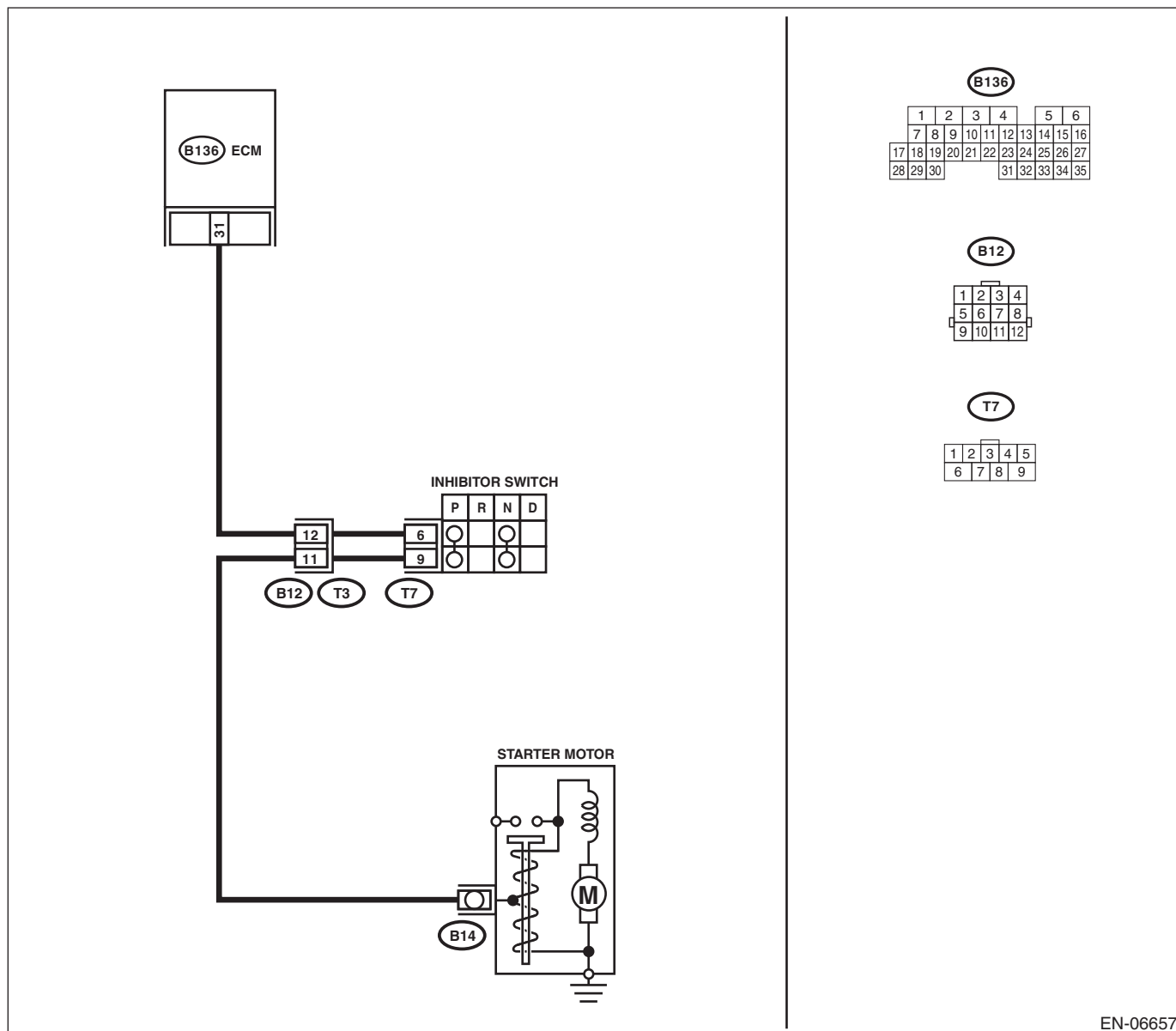

EN-06657

Diagnostic Procedure with Diagnostic Trouble Code (DTC)

ENGINE (DIAGNOSTICS)

Step	Check	Yes	No
1 CHECK SELECT CABLE.	Are there any faults in the select cable?	Repair or adjust the select cable. <Ref. to CS-25, Select Cable.>	Go to step 2.
2 CHECK INPUT SIGNAL OF ECM. 1) Turn the ignition switch to ON. 2) Measure the voltage between ECM and chassis ground with select lever at "P" range and "N" range. Connector & terminal (B136) No. 31 (+) — Chassis ground (-):	Is the voltage less than 1 V?	Repair poor contact in ECM connector.	Go to step 3.
3 CHECK HARNESS BETWEEN ECM AND INHIBITOR SWITCH CONNECTOR. 1) Turn the ignition switch to OFF. 2) Disconnect the connectors from ECM and inhibitor switch. 3) Measure the resistance of harness between ECM and inhibitor switch connector. Connector & terminal (B136) No. 31 — (T7) No. 6:	Is the resistance less than 1 Ω?	Go to step 4.	Repair the harness and connector. NOTE: In this case, repair the following item: • Open circuit in harness between ECM and inhibitor switch connector • Poor contact of coupling connector
4 CHECK INHIBITOR SWITCH GROUND LINE. Measure the resistance of harness between inhibitor switch connector and engine ground. Connector & terminal (T7) No. 9 — Engine ground:	Is the resistance less than 5 Ω?	Replace the inhibitor switch. <Ref. to 4AT-46, Inhibitor Switch.>	Repair the harness and connector. NOTE: In this case, repair the following item: • Open circuit in harness between inhibitor switch connector and starter motor • Poor contact of coupling connector • Poor contact in starter motor connector • Poor contact in starter motor ground • Starter motor

Diagnostic Procedure with Diagnostic Trouble Code (DTC)

ENGINE (DIAGNOSTICS)

CK:DTC P1152 O2 SENSOR CIRCUIT RANGE/PERFORMANCE (LOW) (BANK1 SENSOR1)

DTC DETECTING CONDITION:

- Detected when two consecutive driving cycles with fault occur.
- GENERAL DESCRIPTION <Ref. to GD(H4DOTC)-165, DTC P1152 O2 SENSOR CIRCUIT RANGE/PERFORMANCE (LOW) (BANK1 SENSOR1), Diagnostic Trouble Code (DTC) Detecting Criteria.>

CAUTION:

After repair or replacement of faulty parts, perform Clear Memory Mode <Ref. to EN(H4DOTC)(diag)-52, OPERATION, Clear Memory Mode.> and Inspection Mode <Ref. to EN(H4DOTC)(diag)-42, PROCEDURE, Inspection Mode.>.

WIRING DIAGRAM:

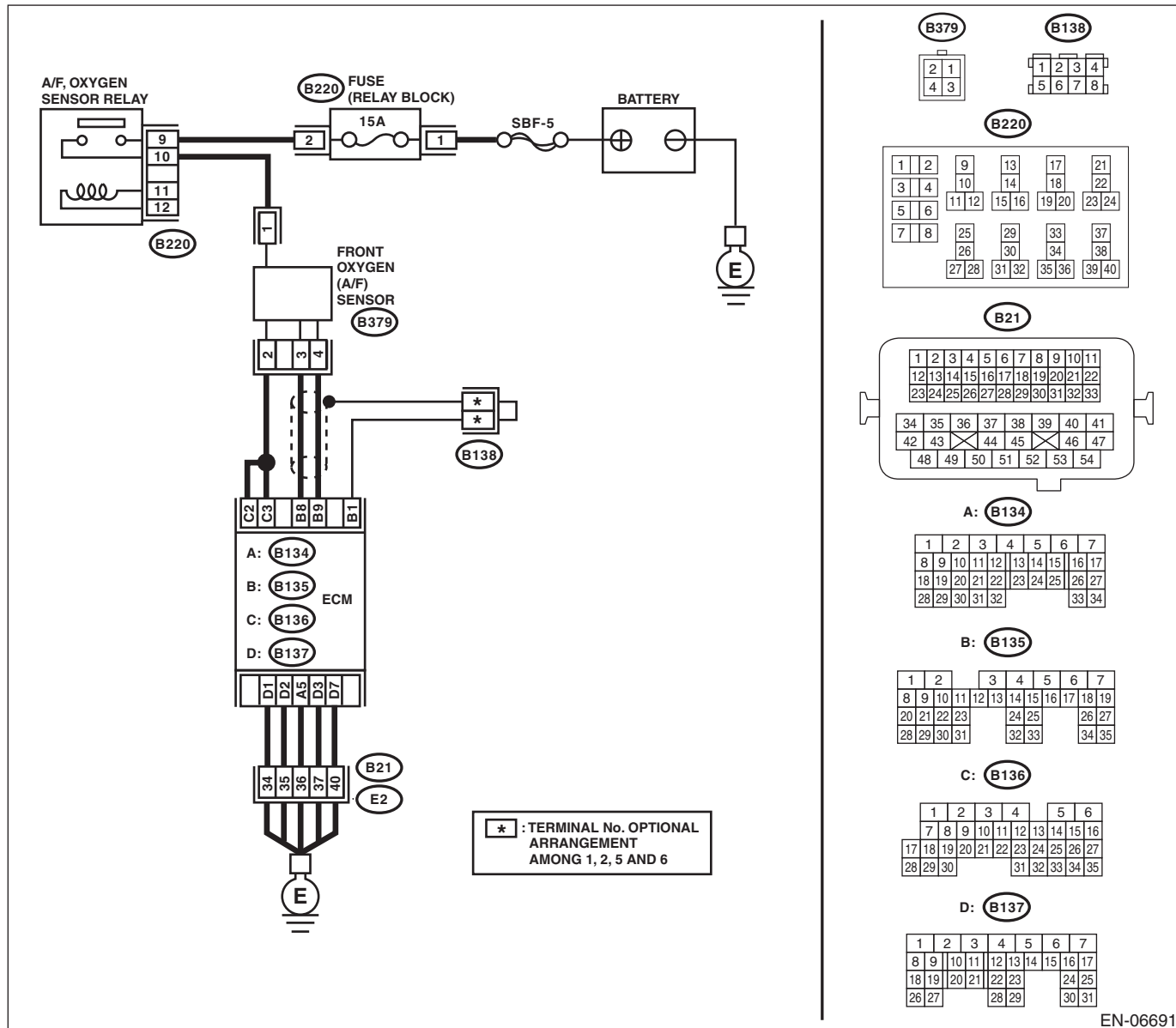

EN-06691

Diagnostic Procedure with Diagnostic Trouble Code (DTC)

ENGINE (DIAGNOSTICS)

Step	Check	Yes	No
1 CHECK FRONT OXYGEN (A/F) SENSOR CONNECTOR AND COUPLING CONNECTOR.	Has water entered the connector?	Completely remove any water inside.	Go to step 2.
2 CHECK HARNESS BETWEEN ECM AND FRONT OXYGEN (A/F) SENSOR CONNECTOR. 1) Turn the ignition switch to OFF. 2) Disconnect the connectors from the ECM and front oxygen (A/F) sensor. 3) Measure the resistance of harness between ECM and front oxygen (A/F) sensor connector. Connector & terminal (B135) No. 9 — (B379) No. 4: (B135) No. 8 — (B379) No. 3:	Is the resistance less than 1 Ω?	Go to step 3.	Repair the open circuit of harness between ECM and front oxygen (A/F) sensor connector.
3 CHECK POOR CONTACT. Check poor contact of front oxygen (A/F) sensor connector.	Is there poor contact in front oxygen (A/F) sensor connector?	Repair the poor contact of the front oxygen (A/F) sensor connector.	Replace the front oxygen (A/F) sensor. <Ref. to FU(H4DOTC)-43, Front Oxygen (A/F) Sensor.>

Diagnostic Procedure with Diagnostic Trouble Code (DTC)

ENGINE (DIAGNOSTICS)

CL:DTC P1153 O2 SENSOR CIRCUIT RANGE/PERFORMANCE (HIGH) (BANK1 SENSOR1)

DTC DETECTING CONDITION:

- Detected when two consecutive driving cycles with fault occur.
- GENERAL DESCRIPTION <Ref. to GD(H4DOTC)-167, DTC P1153 O2 SENSOR CIRCUIT RANGE/PERFORMANCE (HIGH) (BANK1 SENSOR1), Diagnostic Trouble Code (DTC) Detecting Criteria.>

CAUTION:

After repair or replacement of faulty parts, perform Clear Memory Mode <Ref. to EN(H4DOTC)(diag)-52, OPERATION, Clear Memory Mode.> and Inspection Mode <Ref. to EN(H4DOTC)(diag)-42, PROCEDURE, Inspection Mode.>.

WIRING DIAGRAM:

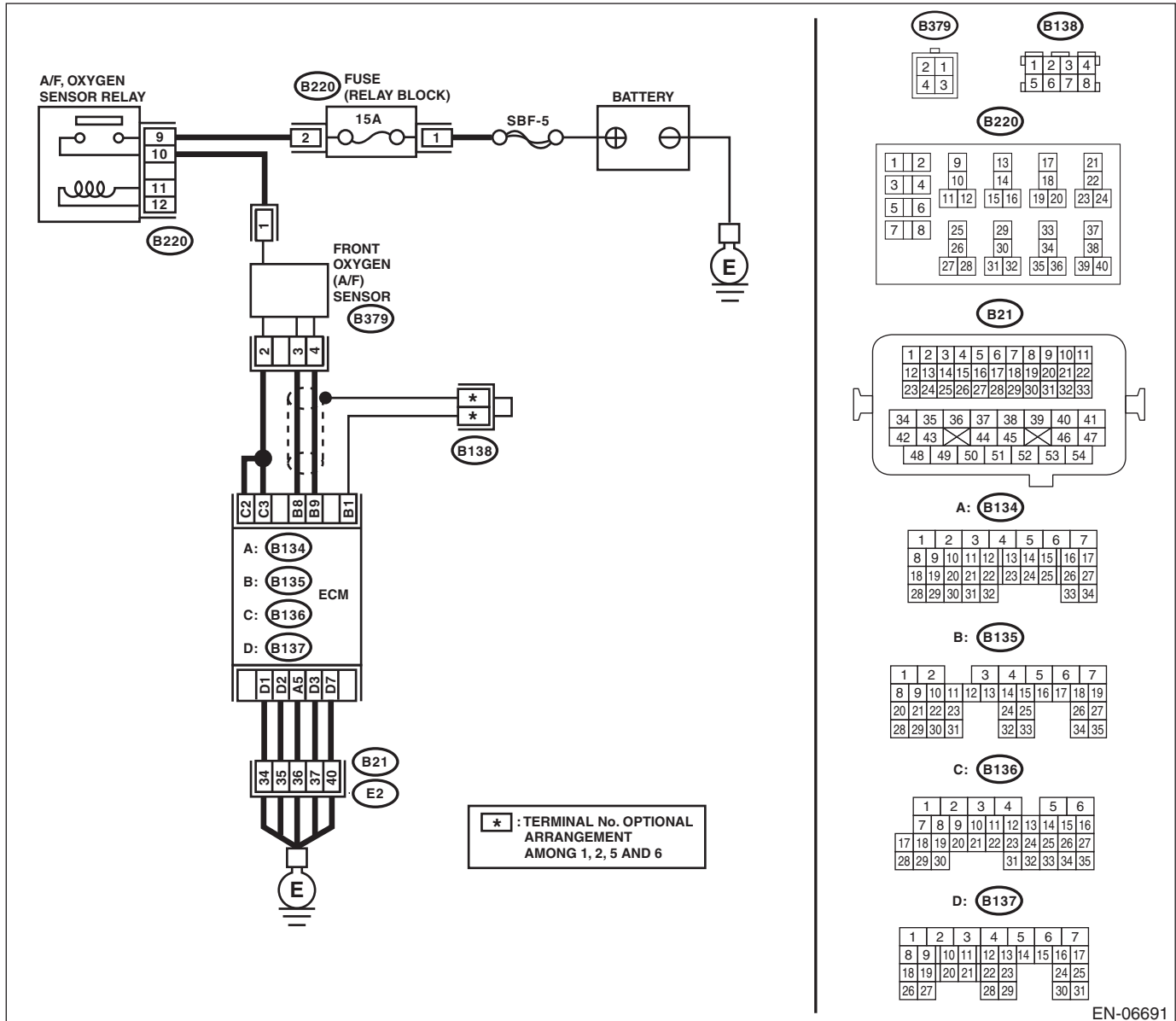

Diagnostic Procedure with Diagnostic Trouble Code (DTC)

ENGINE (DIAGNOSTICS)

Step	Check	Yes	No
1 CHECK FRONT OXYGEN (A/F) SENSOR CONNECTOR AND COUPLING CONNECTOR.	Has water entered the connector?	Completely remove any water inside.	Go to step 2.
2 CHECK HARNESS BETWEEN ECM AND FRONT OXYGEN (A/F) SENSOR CONNECTOR. 1) Turn the ignition switch to OFF. 2) Disconnect the connectors from the ECM. 3) Measure the resistance between ECM and chassis ground. Connector & terminal (B135) No. 9 — Chassis ground: (B135) No. 8 — Chassis ground:	Is the resistance 1 MΩ or more?	Go to step 3.	Repair the ground short circuit of harness between ECM and front oxygen (A/F) sensor connector.
3 CHECK OUTPUT SIGNAL FOR ECM. 1) Connect the connector to ECM. 2) Turn the ignition switch to ON. 3) Measure the voltage between ECM and chassis ground. Connector & terminal (B135) No. 9 (+) — Chassis ground (-):	Is the voltage 4.5 V or more?	Go to step 5.	Go to step 4.
4 CHECK OUTPUT SIGNAL FOR ECM. Measure the voltage between ECM and chassis ground. Connector & terminal (B135) No. 8 (+) — Chassis ground (-):	Is the voltage 4.95 V or more?	Go to step 5.	Replace the front oxygen (A/F) sensor. <Ref. to FU(H4DOTC)-43, Front Oxygen (A/F) Sensor.>
5 CHECK OUTPUT SIGNAL FOR ECM. Measure the voltage between ECM and chassis ground. Connector & terminal (B135) No. 9 (+) — Chassis ground (-): (B135) No. 8 (+) — Chassis ground (-):	Is the voltage 8 V or more?	Repair the short circuit to power in the harness between the ECM and front oxygen (A/F) sensor connector. After repair, replace the ECM. <Ref. to FU(H4DOTC)-46, Engine Control Module (ECM).>	Repair poor contact of the ECM connector.

CM:DTC P1160 RETURN SPRING FAILURE

NOTE:

For the diagnostic procedure, refer to DTC P2101. <Ref. to EN(H4DOTC)(diag)-318, DTC P2101 THROTTLE ACTUATOR CONTROL MOTOR CIRCUIT RANGE/PERFORMANCE, Diagnostic Procedure with Diagnostic Trouble Code (DTC).>

CN:DTC P1400 FUEL TANK PRESSURE CONTROL SOLENOID VALVE CIRCUIT LOW

DTC DETECTING CONDITION:

- Detected when two consecutive driving cycles with fault occur.
- GENERAL DESCRIPTION <Ref. to GD(H4DOTC)-171, DTC P1400 FUEL TANK PRESSURE CONTROL SOLENOID VALVE CIRCUIT LOW, Diagnostic Trouble Code (DTC) Detecting Criteria.>

CAUTION:

After repair or replacement of faulty parts, perform Clear Memory Mode <Ref. to EN(H4DOTC)(diag)-52, OPERATION, Clear Memory Mode.> and Inspection Mode <Ref. to EN(H4DOTC)(diag)-42, PROCEDURE, Inspection Mode.>.

WIRING DIAGRAM:

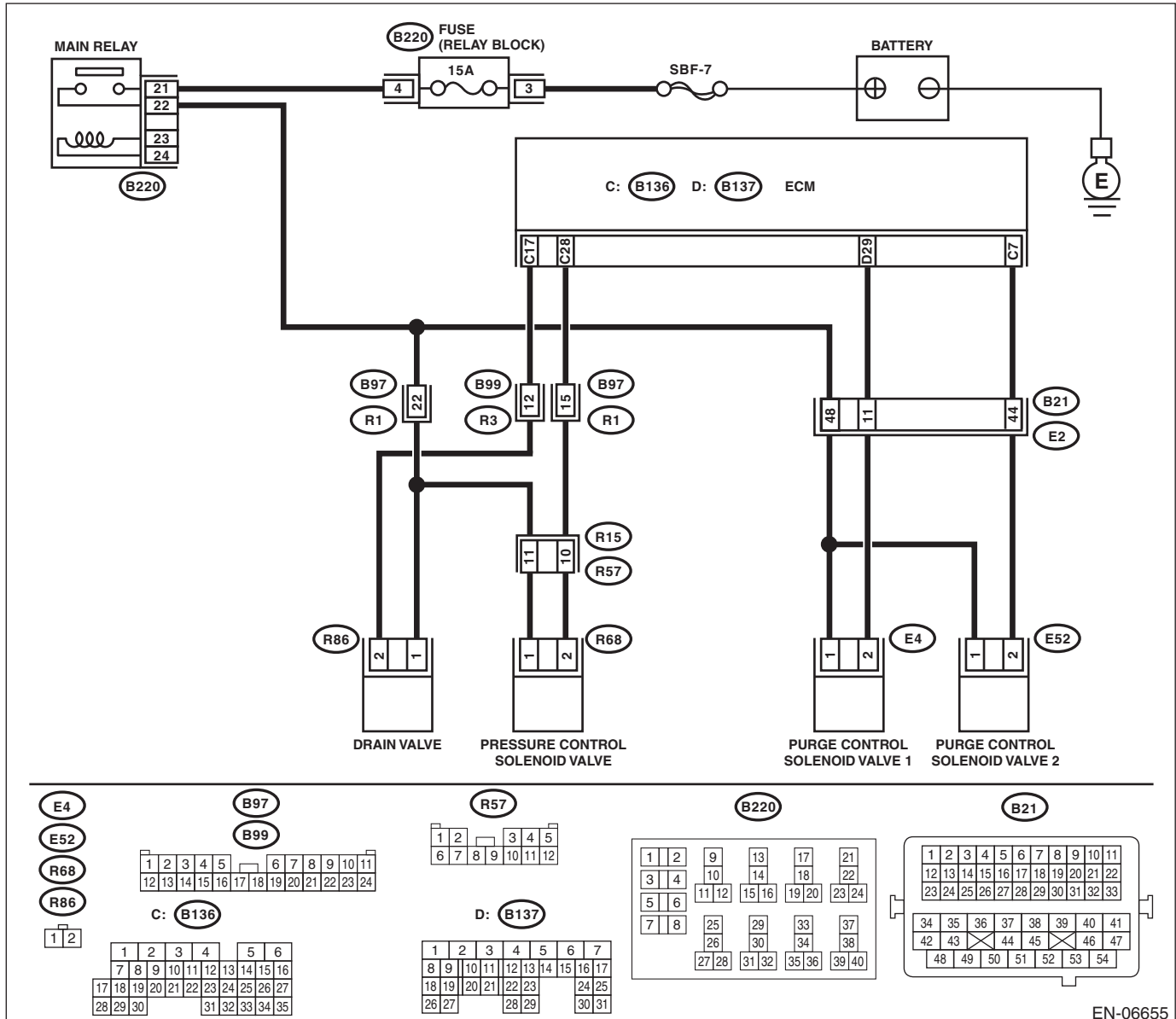

EN-06655

Diagnostic Procedure with Diagnostic Trouble Code (DTC)

ENGINE (DIAGNOSTICS)

Step	Check	Yes	No
1 CHECK OUTPUT SIGNAL OF ECM. 1) Turn the ignition switch to ON. 2) Measure the voltage between ECM and chassis ground. Connector & terminal (B136) No. 28 (+) — Chassis ground (-):	Is the voltage 10 V or more?	Go to step 2.	Go to step 3.
2 CHECK FOR POOR CONTACT. Check for poor contact of ECM connector.	Is there poor contact of ECM connector?	Repair the poor contact of ECM connector.	Even if DTC is detected, the circuit has returned to a normal condition at this time. Reproduce the failure, and then perform the diagnosis again. NOTE: In this case, temporary open or short circuit of harness or temporary poor contact of connector may be the cause.
3 CHECK POWER SUPPLY TO THE PRESSURE CONTROL SOLENOID VALVE. Measure the voltage between pressure control solenoid valve and chassis ground. Connector & terminal (R68) No. 1 (+) — Chassis ground (-):	Is the voltage 10 V or more?	Go to step 4.	Repair the power supply circuit.
4 CHECK HARNESS BETWEEN ECM AND PRESSURE CONTROL SOLENOID VALVE. 1) Turn the ignition switch to OFF. 2) Disconnect the connector from the ECM and pressure control solenoid valve. 3) Measure the resistance between pressure control solenoid valve and chassis ground. Connector & terminal (R68) No. 2 — Chassis ground:	Is the resistance 1 M Ω or more?	Go to step 5.	Repair the ground short circuit of harness between ECM and pressure control solenoid valve connector.
5 CHECK HARNESS BETWEEN ECM AND PRESSURE CONTROL SOLENOID VALVE. Measure the resistance of harness between ECM and pressure control solenoid valve connector. Connector & terminal (B136) No. 28 — (R68) No. 2:	Is the resistance less than 1 Ω ?	Go to step 6.	Repair the harness and connector. NOTE: In this case, repair the following item: <ul style="list-style-type: none"> • Open circuit in harness between ECM and pressure control solenoid valve connector • Poor contact of coupling connector
6 CHECK PRESSURE CONTROL SOLENOID VALVE. Measure the resistance between pressure control solenoid valve terminals. Terminals No. 1 — No. 2:	Is the resistance between 10 — 100 Ω ?	Repair the poor contact of pressure control solenoid valve connector.	Replace the pressure control solenoid valve. <Ref. to EC(H4DOTC)-18, Pressure Control Solenoid Valve.>

CO:DTC P1410 SECONDARY AIR INJECTION SYSTEM SWITCHING VALVE STUCK OPEN

DTC DETECTING CONDITION:

- Immediately at fault recognition
- GENERAL DESCRIPTION <Ref. to GD(H4DOTC)-173, DTC P1410 SECONDARY AIR INJECTION SYSTEM SWITCHING VALVE STUCK OPEN, Diagnostic Trouble Code (DTC) Detecting Criteria.>

CAUTION:

After repair or replacement of faulty parts, perform Clear Memory Mode <Ref. to EN(H4DOTC)(diag)-52, OPERATION, Clear Memory Mode.> and Inspection Mode <Ref. to EN(H4DOTC)(diag)-42, PROCEDURE, Inspection Mode.>.

Diagnostic Procedure with Diagnostic Trouble Code (DTC)

ENGINE (DIAGNOSTICS)

WIRING DIAGRAM:

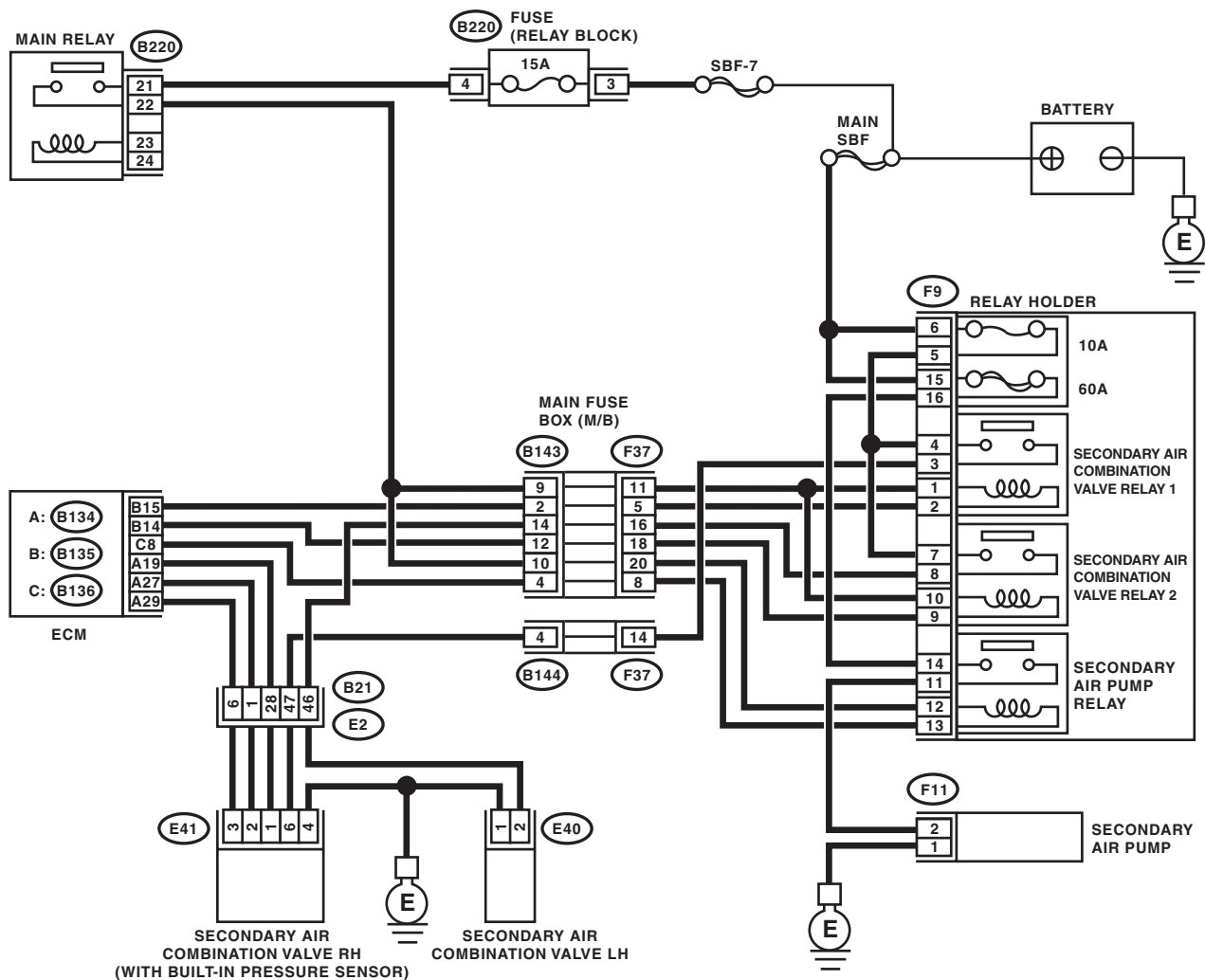

A: (B134)

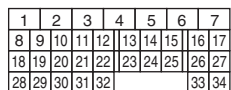

B: (B135)

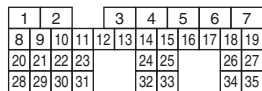

C: (B136)

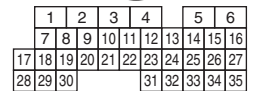

(F37)



(B220)

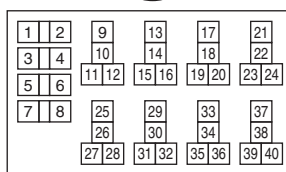

(B143)

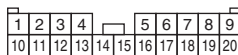

(E40)



(B21)

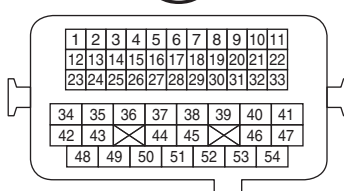

(E41)



(B144)

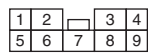

(F9)

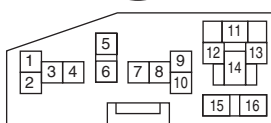

EN-06137

Diagnostic Procedure with Diagnostic Trouble Code (DTC)

ENGINE (DIAGNOSTICS)

	Step	Check	Yes	No
1	CHECK SECONDARY AIR COMBINATION VALVE. 1) Remove the secondary air combination valve. <Ref. to EC(H4DOTC)-24, Secondary Air Combination Valve.> 2) Blow in air from the secondary air combination valve air inlet, and check whether there are leaks at the pipe connections.	Are there air leaks from the pipe connections?	Replace the secondary air combination valve on the side with the air leak. <Ref. to EC(H4DOTC)-24, Secondary Air Combination Valve.>	Perform the diagnostic procedure of P2440. <Ref. to EN(H4DOTC)(diag)-353, DTC P2440 SECONDARY AIR INJECTION SYSTEM SWITCHING VALVE STUCK OPEN (BANK 1), Diagnostic Procedure with Diagnostic Trouble Code (DTC).>

Diagnostic Procedure with Diagnostic Trouble Code (DTC)

ENGINE (DIAGNOSTICS)

CP:DTC P1418 SECONDARY AIR INJECTION SYSTEM CONTROL “A” CIRCUIT SHORTED

DTC DETECTING CONDITION:

- Immediately at fault recognition
- GENERAL DESCRIPTION <Ref. to GD(H4DOTC)-174, DTC P1418 SECONDARY AIR INJECTION SYSTEM CONTROL “A” CIRCUIT SHORTED, Diagnostic Trouble Code (DTC) Detecting Criteria.>

CAUTION:

After repair or replacement of faulty parts, perform Clear Memory Mode <Ref. to EN(H4DOTC)(diag)-52, OPERATION, Clear Memory Mode.> and Inspection Mode <Ref. to EN(H4DOTC)(diag)-42, PROCEDURE, Inspection Mode.>.

Diagnostic Procedure with Diagnostic Trouble Code (DTC)

ENGINE (DIAGNOSTICS)

WIRING DIAGRAM:

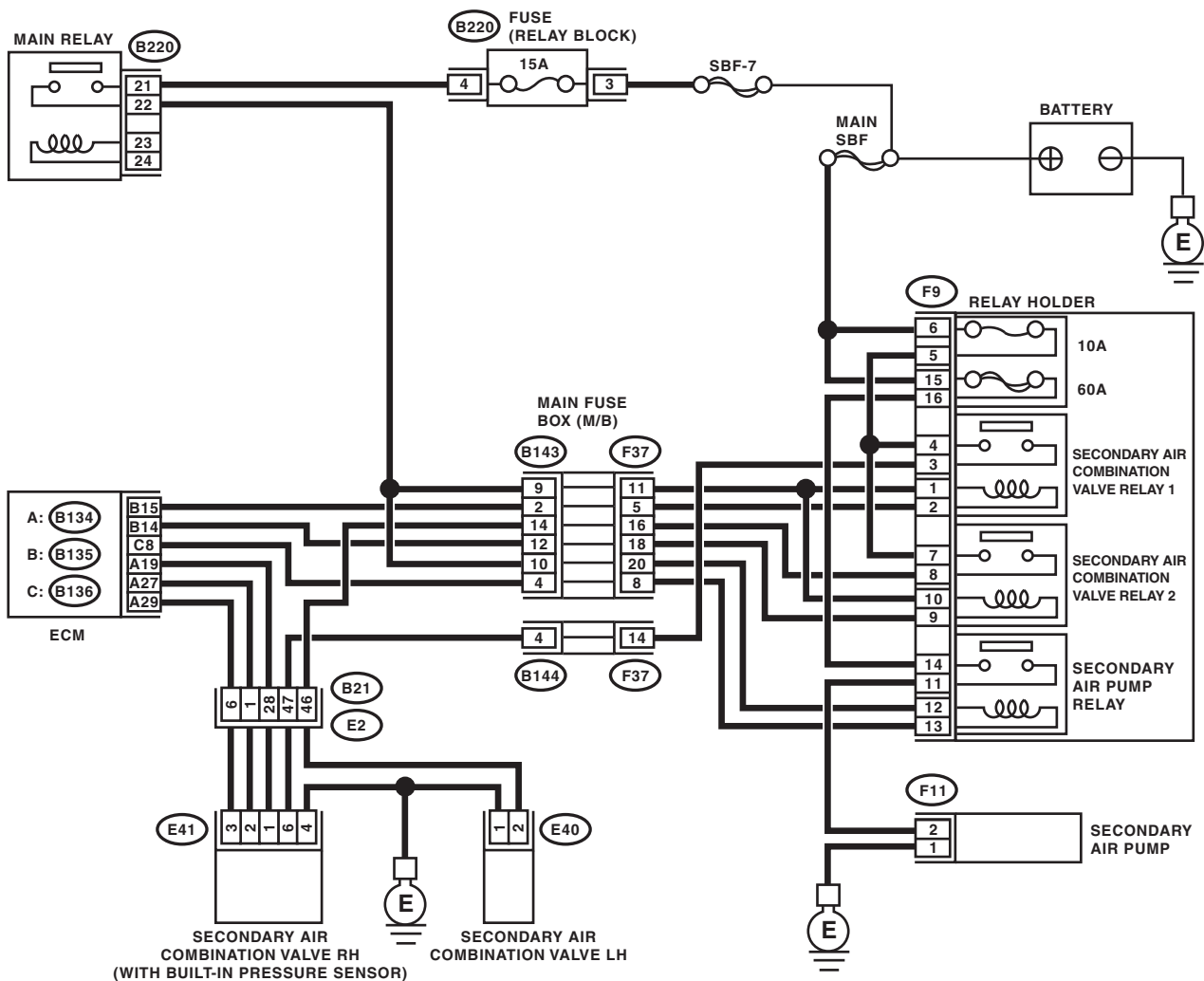

A: (B134)

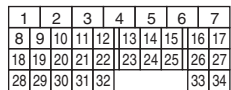

B: (B135)

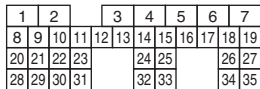

C: (B136)

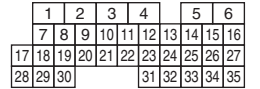

(F37)



(B220)

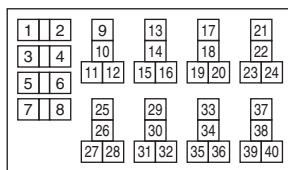

(B143)

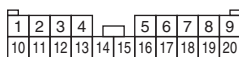

(E40)



(B21)

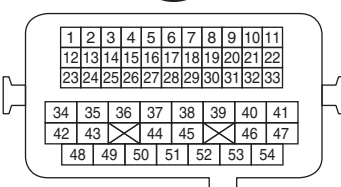

(E41)



(B144)

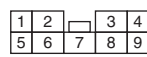

(F9)

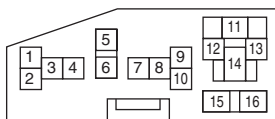

EN-06137

Diagnostic Procedure with Diagnostic Trouble Code (DTC)

ENGINE (DIAGNOSTICS)

	Step	Check	Yes	No
1	CHECK HARNESS BETWEEN ECM AND SECONDARY AIR PUMP RELAY. 1) Turn the ignition switch to OFF. 2) Disconnect the connector from the ECM and secondary air pump relay. 3) Measure the voltage between ECM and chassis ground. Connector & terminal (B136) No. 8 (+) — Chassis ground (-):	Is the voltage 10 V or more?	Repair the short circuit to power in harness between ECM and secondary air pump relay connector.	Even if the malfunction indicator light illuminates, the circuit has returned to a normal condition at this time. Reproduce the failure, and then perform the diagnosis again. NOTE: In this case, temporary poor contact of connector may be the cause.

Diagnostic Procedure with Diagnostic Trouble Code (DTC)

ENGINE (DIAGNOSTICS)

CQ:DTC P1420 FUEL TANK PRESSURE CONTROL SOL. VALVE CIRCUIT HIGH

DTC DETECTING CONDITION:

- Detected when two consecutive driving cycles with fault occur.
- GENERAL DESCRIPTION <Ref. to GD(H4DOTC)-175, DTC P1420 FUEL TANK PRESSURE CONTROL SOL. VALVE CIRCUIT HIGH, Diagnostic Trouble Code (DTC) Detecting Criteria.>

CAUTION:

After repair or replacement of faulty parts, perform Clear Memory Mode <Ref. to EN(H4DOTC)(diag)-52, OPERATION, Clear Memory Mode.> and Inspection Mode <Ref. to EN(H4DOTC)(diag)-42, PROCEDURE, Inspection Mode.>.

WIRING DIAGRAM:

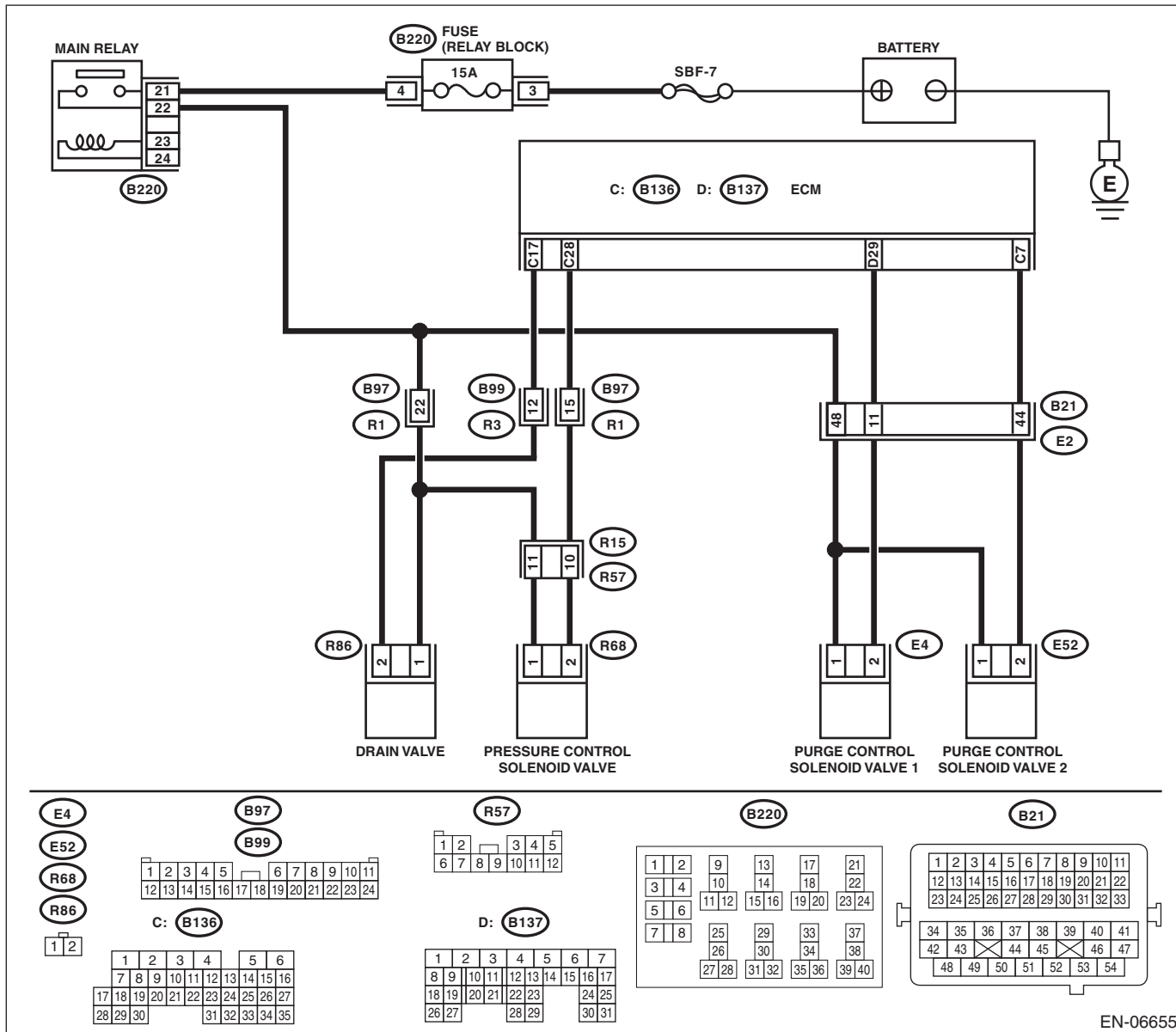

EN-06655

Diagnostic Procedure with Diagnostic Trouble Code (DTC)

ENGINE (DIAGNOSTICS)

Step	Check	Yes	No
<p>1 CHECK HARNESS BETWEEN ECM AND PRESSURE CONTROL SOLENOID VALVE. 1) Turn the ignition switch to OFF. 2) Disconnect the connector from the ECM and pressure control solenoid valve. 3) Turn the ignition switch to ON. 4) Measure the voltage between ECM and chassis ground. Connector & terminal (B136) No. 28 (+) — Chassis ground (-):</p>	Is the voltage 10 V or more?	Repair the short circuit to power in the harness between ECM and pressure control solenoid valve connector.	Go to step 2.
<p>2 CHECK PRESSURE CONTROL SOLENOID VALVE. 1) Turn the ignition switch to OFF. 2) Measure the resistance between pressure control solenoid valve terminals. Terminals No. 1 — No. 2:</p>	Is the resistance less than 1 Ω ?	Replace the pressure control solenoid valve. <Ref. to EC(H4DOTC)-18, Pressure Control Solenoid Valve.>	Repair the poor contact of the ECM connector.

Diagnostic Procedure with Diagnostic Trouble Code (DTC)

ENGINE (DIAGNOSTICS)

CR:DTC P1443 VENT CONTROL SOLENOID VALVE FUNCTION PROBLEM

DTC DETECTING CONDITION:

- Immediately at fault recognition
- GENERAL DESCRIPTION <Ref. to GD(H4DOTC)-177, DTC P1443 VENT CONTROL SOLENOID VALVE FUNCTION PROBLEM, Diagnostic Trouble Code (DTC) Detecting Criteria.>

TROUBLE SYMPTOM:

Improper fuel supply

CAUTION:

After repair or replacement of faulty parts, perform Clear Memory Mode <Ref. to EN(H4DOTC)(diag)-52, OPERATION, Clear Memory Mode.> and Inspection Mode <Ref. to EN(H4DOTC)(diag)-42, PROCEDURE, Inspection Mode.>.

WIRING DIAGRAM:

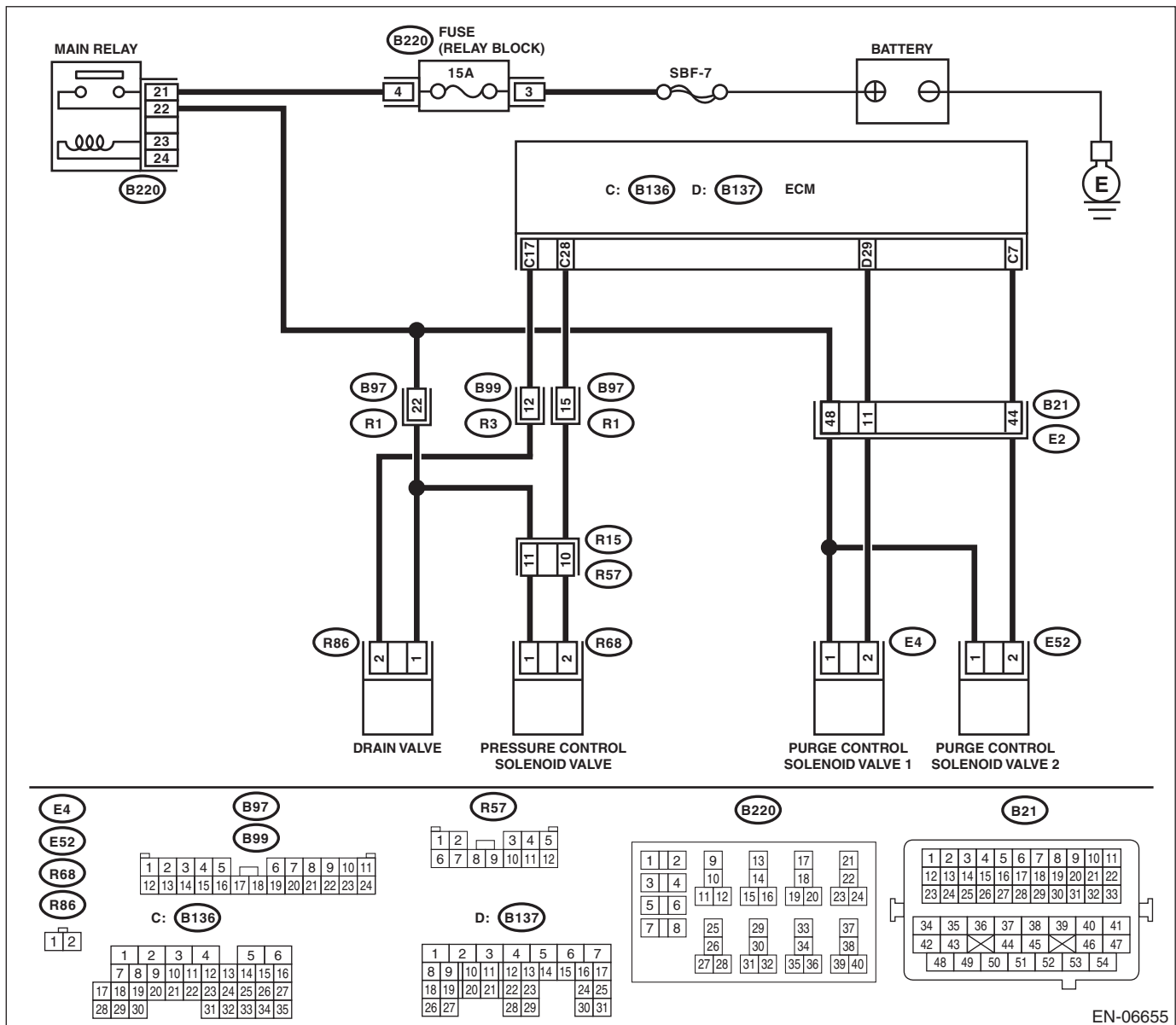

EN-06655

Diagnostic Procedure with Diagnostic Trouble Code (DTC)

ENGINE (DIAGNOSTICS)

Step	Check	Yes	No
1 CHECK FOR ANY OTHER DTC ON DISPLAY.	Is any other DTC displayed?	Check the appropriate DTC using the "List of Diagnostic Trouble Code (DTC)". <Ref. to EN(H4DOTC)(diag)-80, List of Diagnostic Trouble Code (DTC).>	Go to step 2.
2 CHECK DRAIN HOSE. Check the drain hose for clogging.	Is there clogging in the drain hose?	Replace the drain hose.	Go to step 3.
3 CHECK DRAIN VALVE OPERATION. 1) Turn the ignition switch to OFF. 2) Connect the delivery (test) mode connector at the lower portion of instrument panel (on the driver's side). 3) Turn the ignition switch to ON. 4) Operate the drain valve. NOTE: Drain valve operation can be executed using the Subaru Select Monitor. Regarding the procedures, refer to "Compulsory Valve Operation Check Mode". <Ref. to EN(H4DOTC)(diag)-53, Compulsory Valve Operation Check Mode.>	Does the drain valve operate?	Repair the poor contact of the ECM connector.	Replace the drain valve. <Ref. to EC(H4DOTC)-21, Drain Valve.>

Diagnostic Procedure with Diagnostic Trouble Code (DTC)

ENGINE (DIAGNOSTICS)

CS:DTC P1491 POSITIVE CRANKCASE VENTILATION (BLOW-BY) FUNCTION PROBLEM

DTC DETECTING CONDITION:

- Immediately at fault recognition
- GENERAL DESCRIPTION <Ref. to GD(H4DOTC)-179, DTC P1491 POSITIVE CRANKCASE VENTILATION (BLOW-BY) FUNCTION PROBLEM, Diagnostic Trouble Code (DTC) Detecting Criteria.>

TROUBLE SYMPTOM:

Improper idling

CAUTION:

After repair or replacement of faulty parts, perform Clear Memory Mode <Ref. to EN(H4DOTC)(diag)-52, OPERATION, Clear Memory Mode.> and Inspection Mode <Ref. to EN(H4DOTC)(diag)-42, PROCEDURE, Inspection Mode.>.

WIRING DIAGRAM:

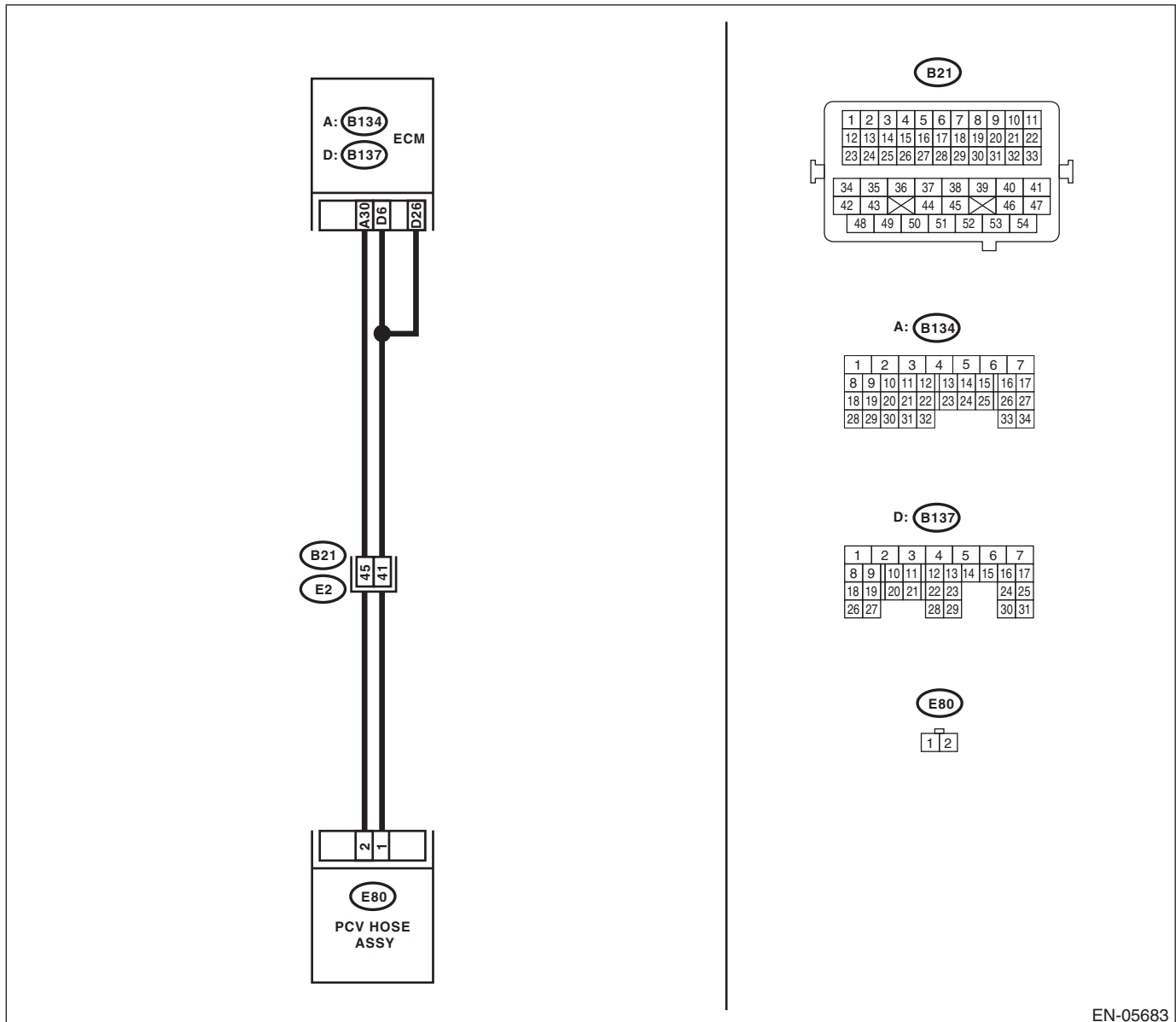

EN-05683

Diagnostic Procedure with Diagnostic Trouble Code (DTC)

ENGINE (DIAGNOSTICS)

Step	Check	Yes	No
1 CHECK BLOW-BY HOSE. Check the blow-by hose condition.	Is there any disconnection or crack in blow-by hose?	Repair or replace the blow-by hose.	Go to step 2.
2 CHECK HARNESS BETWEEN ECM AND PCV HOSE ASSEMBLY. 1) Turn the ignition switch to OFF. 2) Disconnect the connectors from the ECM and PCV hose assembly. 3) Measure the resistance of harness between ECM and PCV hose assembly connector. Connector & terminal (B134) No. 30 — (E80) No. 2:	Is the resistance less than 1 Ω ?	Go to step 3.	Repair the harness and connector. NOTE: In this case, repair the following item: • Open circuit in harness between ECM and PCV hose assembly connector • Poor contact of coupling connector
3 CHECK HARNESS BETWEEN ECM AND PCV HOSE ASSEMBLY. Measure the resistance between PCV hose assembly connector and chassis ground. Connector & terminal (B134) No. 30 — Chassis ground:	Is the resistance 1 M Ω or more?	Go to step 4.	Repair the short circuit to ground in harness between ECM and PCV hose assembly connector.
4 CHECK GROUND CIRCUIT OF PCV HOSE ASSEMBLY. Measure the resistance of harness between PCV hose assembly connector and engine ground. Connector & terminal (E80) No. 1 — Engine ground:	Is the resistance less than 5 Ω ?	Go to step 5.	Repair the open circuit in harness between PCV hose assembly connector and engine ground.
5 CHECK THE PCV HOSE ASSEMBLY. Measure the resistance between the PCV hose assembly terminals. Terminals No. 1 — No. 2:	Is the resistance less than 1 Ω ?	Repair the poor contact in ECM and PCV hose assembly connector.	Replace the PCV hose assembly.

Diagnostic Procedure with Diagnostic Trouble Code (DTC)

ENGINE (DIAGNOSTICS)

CT:DTC P1560 BACK-UP VOLTAGE CIRCUIT MALFUNCTION

DTC DETECTING CONDITION:

- Immediately at fault recognition
- GENERAL DESCRIPTION <Ref. to GD(H4DOTC)-181, DTC P1560 BACK-UP VOLTAGE CIRCUIT MALFUNCTION, Diagnostic Trouble Code (DTC) Detecting Criteria.>

CAUTION:

After repair or replacement of faulty parts, perform Clear Memory Mode <Ref. to EN(H4DOTC)(diag)-52, OPERATION, Clear Memory Mode.> and Inspection Mode <Ref. to EN(H4DOTC)(diag)-42, PROCEDURE, Inspection Mode.>.

WIRING DIAGRAM:

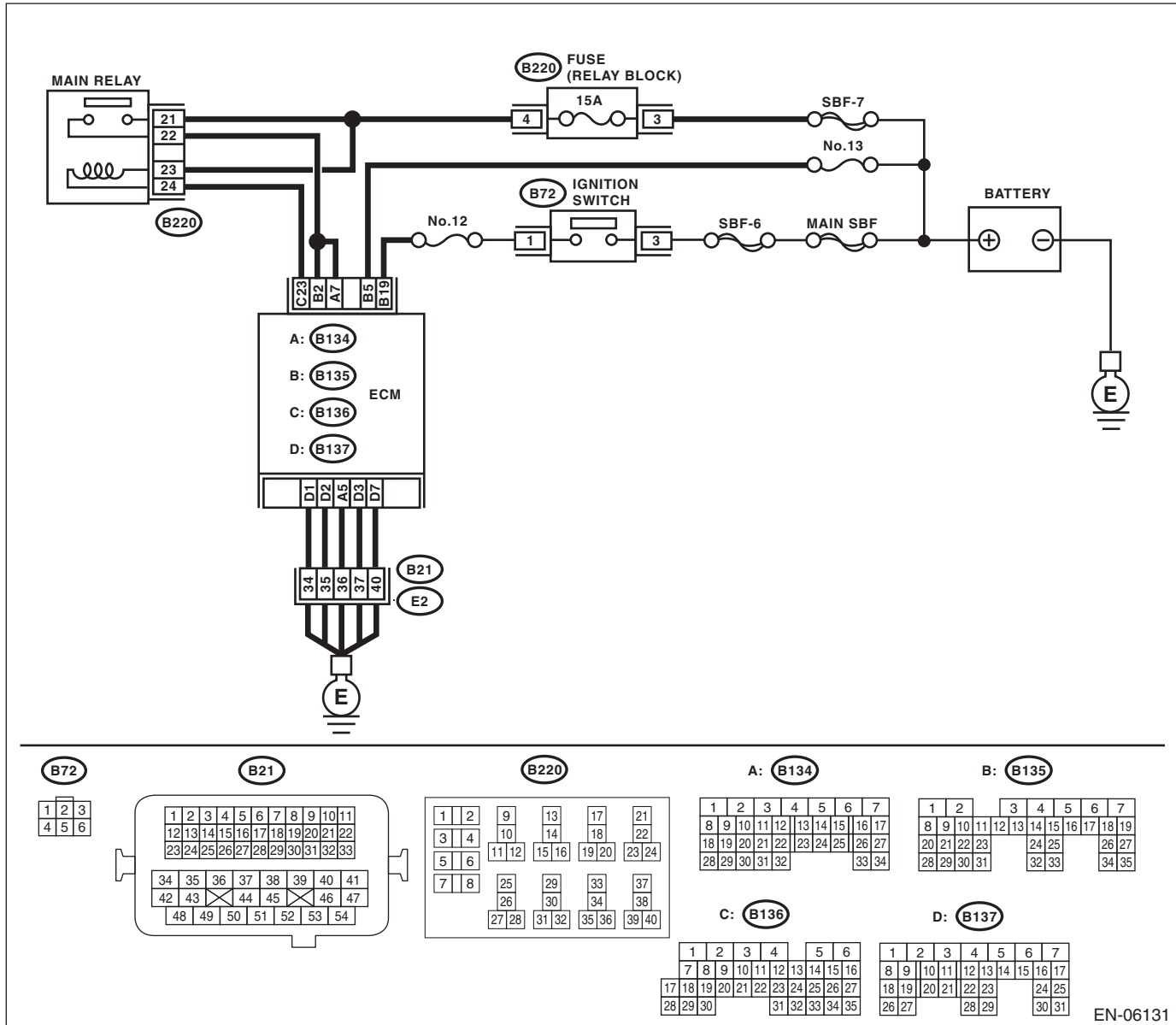

Diagnostic Procedure with Diagnostic Trouble Code (DTC)

ENGINE (DIAGNOSTICS)

	Step	Check	Yes	No
1	CHECK INPUT SIGNAL OF ECM. 1) Turn the ignition switch to OFF. 2) Measure the voltage between ECM and chassis ground. <i>Connector & terminal</i> <i>(B135) No. 5 (+) — Chassis ground (-):</i>	Is the voltage 10 V or more?	Repair poor contact of the ECM connector.	Go to step 2.
2	CHECK HARNESS BETWEEN ECM AND MAIN FUSE BOX CONNECTOR. 1) Disconnect the connectors from the ECM. 2) Measure the resistance between ECM and chassis ground. <i>Connector & terminal</i> <i>(B135) No. 5 — Chassis ground:</i>	Is the resistance 1 MΩ or more?	Go to step 3.	Repair the ground short circuit of harness between ECM and battery terminal.
3	CHECK FUSE NO. 13.	Is the fuse blown out?	Replace the fuse.	Repair the harness and connector. NOTE: In this case, repair the following item: <ul style="list-style-type: none"> • Open circuit of harness between ECM and battery • Poor contact in ECM connector • Poor contact of battery terminal

Diagnostic Procedure with Diagnostic Trouble Code (DTC)

ENGINE (DIAGNOSTICS)

CU:DTC P1602 CONTROL MODULE PROGRAMMING ERROR

DTC DETECTING CONDITION:

- Detected when two consecutive driving cycles with fault occur.
- GENERAL DESCRIPTION <Ref. to GD(H4DOTC)-183, DTC P1602 CONTROL MODULE PROGRAMMING ERROR, Diagnostic Trouble Code (DTC) Detecting Criteria.>

TROUBLE SYMPTOM:

- Engine keeps running at higher speed than specified idle speed.
- Engine keeps running at a lower speed than the specified idle speed.
- Engine stalls.

CAUTION:

After repair or replacement of faulty parts, perform Clear Memory Mode <Ref. to EN(H4DOTC)(diag)-52, OPERATION, Clear Memory Mode.> and Inspection Mode <Ref. to EN(H4DOTC)(diag)-42, PROCEDURE, Inspection Mode.>.

WIRING DIAGRAM:

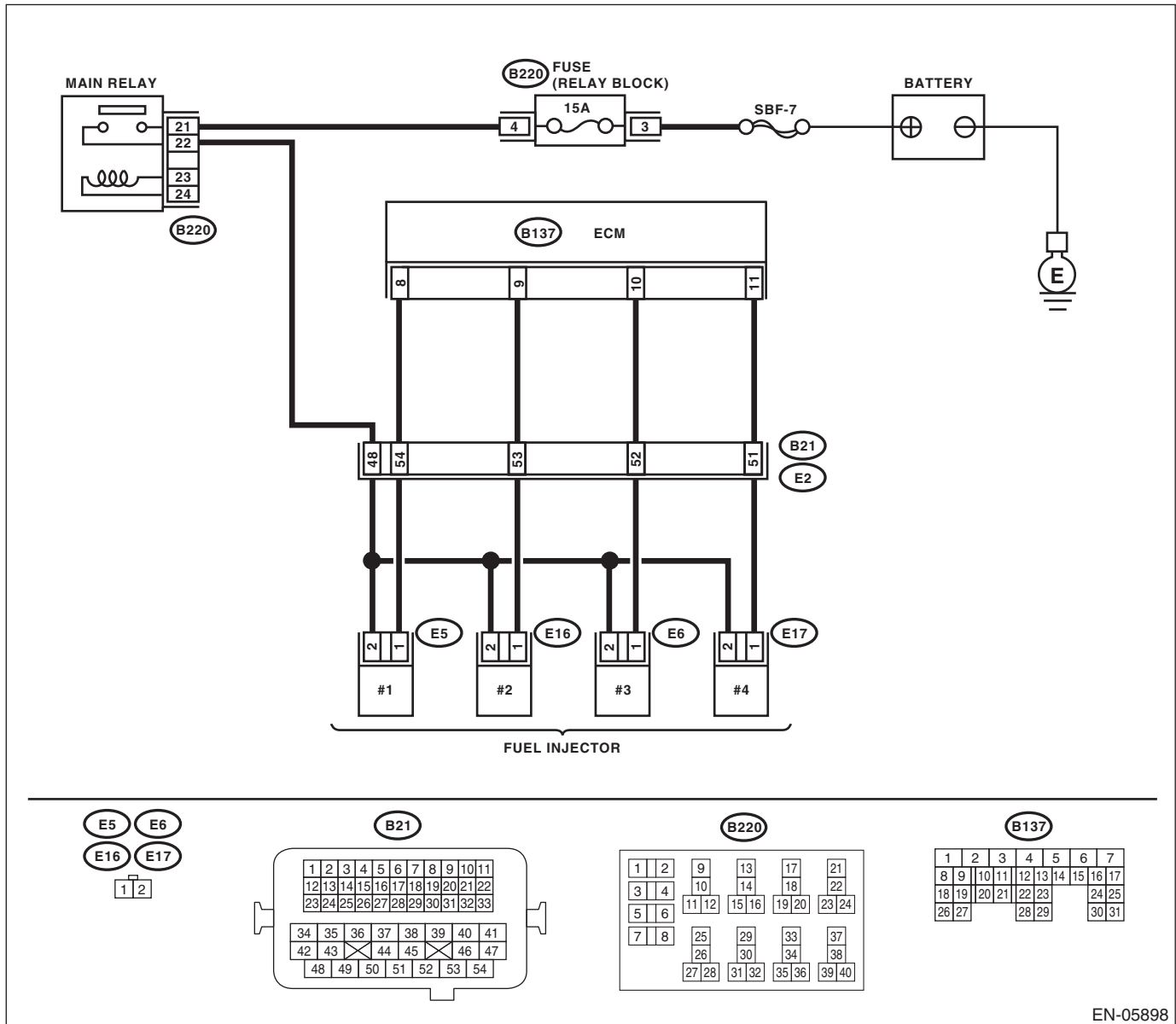

EN-05898

Diagnostic Procedure with Diagnostic Trouble Code (DTC)

ENGINE (DIAGNOSTICS)

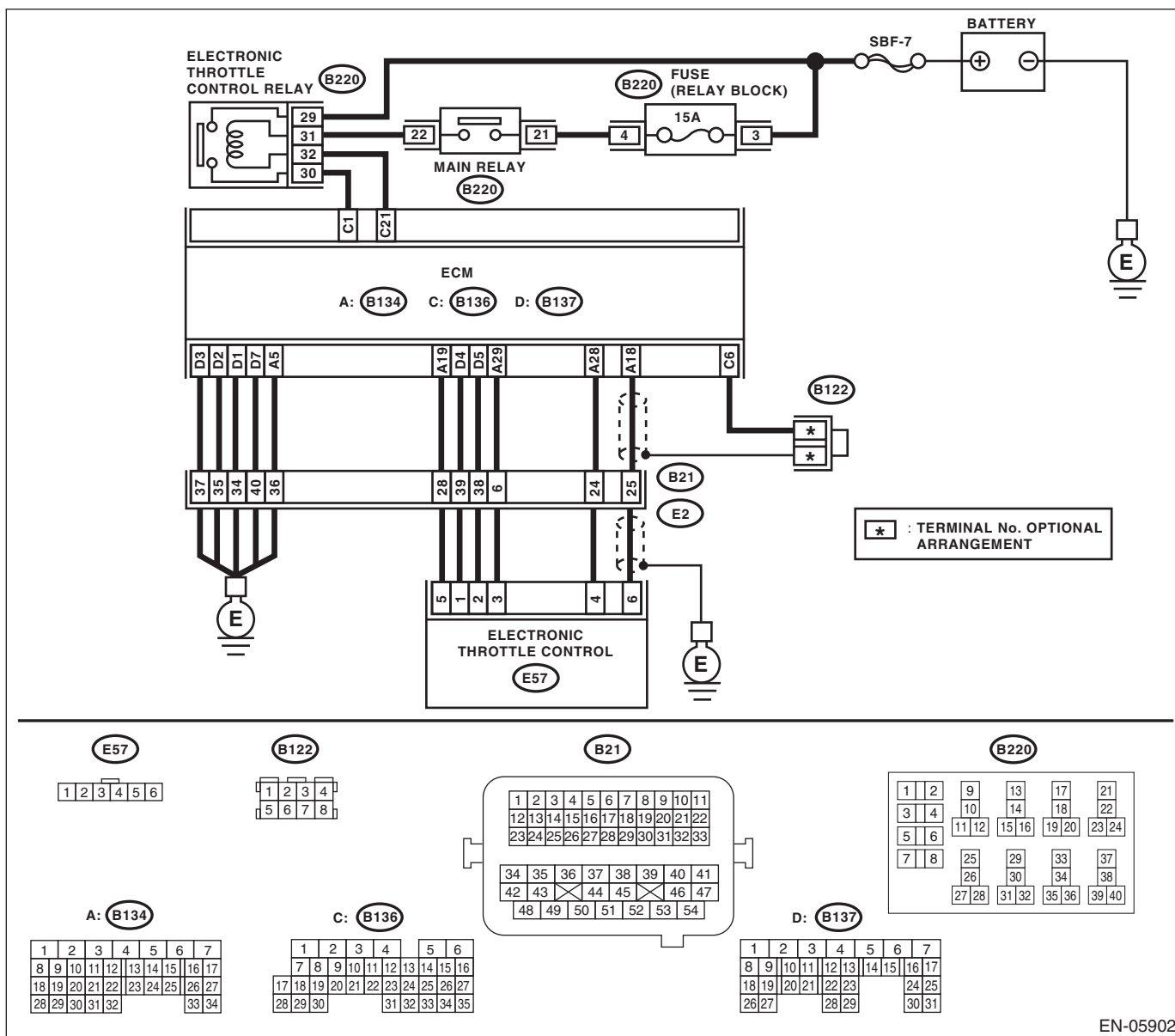

EN-05902

Diagnostic Procedure with Diagnostic Trouble Code (DTC)

ENGINE (DIAGNOSTICS)

	Step	Check	Yes	No
1	CHECK FOR ANY OTHER DTC ON DISPLAY.	Is any other DTC displayed?	Check the appropriate DTC using the "List of Diagnostic Trouble Code (DTC)". <Ref. to EN(H4DOTC)(diag)-80, List of Diagnostic Trouble Code (DTC).>	Go to step 2.
2	CHECK ENGINE OIL.	Is there a proper amount of engine oil?	Go to step 3.	Replace engine oil. <Ref. to LU(H4DOTC)-8, REPLACEMENT, Engine Oil.>
3	CHECK EXHAUST SYSTEM.	Are there holes or loose bolts on exhaust system?	Repair the exhaust system.	Go to step 4.
4	CHECK AIR INTAKE SYSTEM.	Are there holes, loose bolts or disconnection of hose on air intake system?	Repair the air intake system.	Go to step 5.
5	<p>CHECK FUEL PRESSURE.</p> <p>WARNING: Place "NO OPEN FLAMES" signs near the working area.</p> <p>CAUTION: Be careful not to spill fuel.</p> <p>Measure the fuel pressure while disconnecting pressure regulator vacuum hose from intake manifold. <Ref. to ME(H4DOTC)-25, INSPECTION, Fuel Pressure.></p> <p>CAUTION: Release fuel pressure before removing the fuel pressure gauge.</p> <p>NOTE: If fuel pressure does not increase, squeeze the fuel return hose 2 to 3 times, then measure fuel pressure again.</p>	Is the measured value 284 — 314 kPa (2.9 — 3.2 kg/cm ² , 41 — 46 psi)?	Go to step 6.	Repair the following item. Fuel pressure is too high: • Clogged fuel return line or bent hose Fuel pressure is too low: • Improper fuel pump discharge • Clogged fuel supply line
6	<p>CHECK FUEL PRESSURE.</p> <p>After connecting the pressure regulator vacuum hose, measure fuel pressure. <Ref. to ME(H4DOTC)-25, INSPECTION, Fuel Pressure.></p> <p>CAUTION: Release fuel pressure before removing the fuel pressure gauge.</p> <p>NOTE: • If fuel pressure does not increase, squeeze fuel return hose 2 to 3 times, then measure fuel pressure again. • If the measured value at this step is out of specification, check or replace pressure regulator and pressure regulator vacuum hose.</p>	Is the measured value 230 — 260 kPa (2.35 — 2.65 kg/cm ² , 33 — 38 psi)?	Go to step 7.	Repair the following item. Fuel pressure is too high: • Faulty pressure regulator • Clogged fuel return line or bent hose Fuel pressure is too low: • Faulty pressure regulator • Improper fuel pump discharge • Clogged fuel supply line

Diagnostic Procedure with Diagnostic Trouble Code (DTC)

ENGINE (DIAGNOSTICS)

Step	Check	Yes	No
<p>7</p> <p>CHECK ENGINE COOLANT TEMPERATURE SENSOR.</p> <p>1) Start the engine and warm up completely.</p> <p>2) Read the data of engine coolant temperature sensor signal using Subaru Select Monitor or general scan tool.</p> <p>NOTE:</p> <ul style="list-style-type: none"> • Subaru Select Monitor <p>For detailed operation procedures, refer to "READ CURRENT DATA FOR ENGINE". <Ref. to EN(H4DOTC)(diag)-34, Subaru Select Monitor.></p> <ul style="list-style-type: none"> • General scan tool <p>For detailed operation procedures, refer to the general scan tool operation manual.</p>	<p>Is the engine coolant temperature 75°C (167°F) or higher?</p>	<p>Go to step 8.</p>	<p>Replace the engine coolant temperature sensor. <Ref. to FU(H4DOTC)-29, Engine Coolant Temperature Sensor.></p>
<p>8</p> <p>CHECK MASS AIR FLOW AND INTAKE AIR TEMPERATURE SENSOR.</p> <p>1) Start the engine and warm up engine until coolant temperature is higher than 75°C (167°F).</p> <p>2) Place the select lever in "P" range or "N" range.</p> <p>3) Turn the A/C switch to OFF.</p> <p>4) Turn all the accessory switches to OFF.</p> <p>5) Read the data of mass air flow and intake air temperature sensor signal using Subaru Select Monitor or general scan tool.</p> <p>NOTE:</p> <ul style="list-style-type: none"> • Subaru Select Monitor <p>For detailed operation procedures, refer to "READ CURRENT DATA FOR ENGINE". <Ref. to EN(H4DOTC)(diag)-34, Subaru Select Monitor.></p> <ul style="list-style-type: none"> • General scan tool <p>For detailed operation procedures, refer to the general scan tool operation manual.</p>	<p>Is the measured value 2.0 — 5.0 g/s (0.26 — 0.66 lb/m)?</p>	<p>Go to step 9.</p>	<p>Replace the mass air flow and intake air temperature sensor. <Ref. to FU(H4DOTC)-34, Mass Air Flow and Intake Air Temperature Sensor.></p>
<p>9</p> <p>CHECK MASS AIR FLOW AND INTAKE AIR TEMPERATURE SENSOR.</p> <p>1) Start the engine and warm up engine until coolant temperature is higher than 75°C (167°F).</p> <p>2) Place the select lever in "P" range or "N" range.</p> <p>3) Turn the A/C switch to OFF.</p> <p>4) Turn all the accessory switches to OFF.</p> <p>5) Open the front hood.</p> <p>6) Measure the ambient temperature.</p> <p>7) Read the data of mass air flow and intake air temperature sensor signal using Subaru Select Monitor or general scan tool.</p> <p>NOTE:</p> <ul style="list-style-type: none"> • Subaru Select Monitor <p>For detailed operation procedures, refer to "READ CURRENT DATA FOR ENGINE". <Ref. to EN(H4DOTC)(diag)-34, Subaru Select Monitor.></p> <ul style="list-style-type: none"> • General scan tool <p>For detailed operation procedures, refer to the general scan tool operation manual.</p>	<p>Subtract ambient temperature from intake air temperature. Is the obtained value -10 — 50°C (-18 — 90°F)?</p>	<p>Go to step 10.</p>	<p>Check the mass air flow and intake air temperature sensor. <Ref. to FU(H4DOTC)-34, Mass Air Flow and Intake Air Temperature Sensor.></p>

Diagnostic Procedure with Diagnostic Trouble Code (DTC)

ENGINE (DIAGNOSTICS)

Step	Check	Yes	No
10 CHECK OUTPUT SIGNAL OF ECM. 1) Turn the ignition switch to ON. 2) Measure the voltage between the ECM and chassis ground for faulty cylinders. Connector & terminal <i>#1 (B137) No. 8 (+) — Chassis ground (-):</i> <i>#2 (B137) No. 9 (+) — Chassis ground (-):</i> <i>#3 (B137) No. 10 (+) — Chassis ground (-):</i> <i>#4 (B137) No. 11 (+) — Chassis ground (-):</i>	Is the voltage 10 V or more?	Go to step 15.	Go to step 11.
11 CHECK HARNESS BETWEEN ECM AND FUEL INJECTOR. 1) Turn the ignition switch to OFF. 2) Disconnect the connector from fuel injector on faulty cylinders. 3) Measure the resistance between the fuel injector connector and engine ground on faulty cylinders. Connector & terminal <i>#1 (E5) No. 1 — Engine ground:</i> <i>#2 (E16) No. 1 — Engine ground:</i> <i>#3 (E6) No. 1 — Engine ground:</i> <i>#4 (E17) No. 1 — Engine ground:</i>	Is the resistance 1 M Ω or more?	Go to step 12.	Repair the short circuit to ground in harness between ECM and fuel injector connector.
12 CHECK HARNESS BETWEEN ECM AND FUEL INJECTOR. Measure the resistance of harness between ECM and fuel injector connector on faulty cylinders. Connector & terminal <i>#1 (B137) No. 8 — (E5) No. 1:</i> <i>#2 (B137) No. 9 — (E16) No. 1:</i> <i>#3 (B137) No. 10 — (E6) No. 1:</i> <i>#4 (B137) No. 11 — (E17) No. 1:</i>	Is the resistance less than 1 Ω ?	Go to step 13.	Repair the harness and connector. NOTE: In this case, repair the following item: <ul style="list-style-type: none"> • Open circuit in harness between ECM and fuel injector connector • Poor contact of coupling connector
13 CHECK FUEL INJECTOR. Measure the resistance between fuel injector terminals on faulty cylinder. Terminals <i>No. 1 — No. 2:</i>	Is the resistance between 5 — 20 Ω ?	Go to step 14.	Replace the faulty fuel injector. <Ref. to FU(H4DOTC)-36, Fuel Injector.>
14 CHECK POWER SUPPLY LINE. 1) Turn the ignition switch to ON. 2) Measure the voltage between fuel injector and engine ground on faulty cylinders. Connector & terminal <i>#1 (E5) No. 2 (+) — Engine ground (-):</i> <i>#2 (E16) No. 2 (+) — Engine ground (-):</i> <i>#3 (E6) No. 2 (+) — Engine ground (-):</i> <i>#4 (E17) No. 2 (+) — Engine ground (-):</i>	Is the voltage 10 V or more?	Repair the poor contact of all connectors in fuel injector circuit.	Repair the harness and connector. NOTE: In this case, repair the following item: <ul style="list-style-type: none"> • Open circuit in harness between the main relay connector and fuel injector connector on faulty cylinders • Poor contact of coupling connector • Poor contact of main relay connector

Diagnostic Procedure with Diagnostic Trouble Code (DTC)

ENGINE (DIAGNOSTICS)

Step	Check	Yes	No
15 CHECK HARNESS BETWEEN ECM AND FUEL INJECTOR. 1) Turn the ignition switch to OFF. 2) Disconnect the connector from fuel injector on faulty cylinders. 3) Turn the ignition switch to ON. 4) Measure the voltage between the ECM and chassis ground for faulty cylinders. Connector & terminal #1 (B137) No. 8 (+) — Chassis ground (-): #2 (B137) No. 9 (+) — Chassis ground (-): #3 (B137) No. 10 (+) — Chassis ground (-): #4 (B137) No. 11 (+) — Chassis ground (-):	Is the voltage 10 V or more?	Repair the short circuit to power in harness between ECM and fuel injector connector.	Go to step 16.
16 CHECK FUEL INJECTOR. 1) Turn the ignition switch to OFF. 2) Measure the resistance between fuel injector terminals on faulty cylinder. Terminals No. 1 — No. 2:	Is the resistance less than 1 Ω ?	Replace the faulty fuel injector. <Ref. to FU(H4DOTC)-36, Fuel Injector.>	Go to step 17.
17 CHECK INSTALLATION OF CAMSHAFT POSITION SENSOR/CRANKSHAFT POSITION SENSOR.	Is the camshaft position sensor or crankshaft position sensor loosely installed?	Tighten the camshaft position sensor or crankshaft position sensor.	Go to step 18.
18 CHECK CRANK SPROCKET. Remove the timing belt cover. <Ref. to ME(H4DOTC)-49, REMOVAL, Timing Belt Cover.>	Is the crank sprocket rusted or does it have damaged teeth?	Replace the crank sprocket. <Ref. to ME(H4DOTC)-59, Crank Sprocket.>	Go to step 19.
19 CHECK INSTALLATION CONDITION OF TIMING BELT. Turn the crankshaft, and align alignment mark on crank sprocket with alignment mark on cylinder block. ST 499987500 CRANKSHAFT SOCKET	Is the timing belt dislocated from its proper position?	Repair the installation condition of timing belt. <Ref. to ME(H4DOTC)-50, Timing Belt.>	Go to step 20.
20 CHECK ELECTRONIC THROTTLE CONTROL RELAY. 1) Turn the ignition switch to OFF. 2) Remove the electronic throttle control relay. 3) Connect the battery to terminals No. 31 and No. 32 of electronic throttle control relay. 4) Measure the resistance between electronic throttle control relay terminals. Terminals No. 29 — No. 30:	Is the resistance less than 1 Ω ?	Go to step 21.	Replace the electronic throttle control relay. <Ref. to FU(H4DOTC)-49, Electronic Throttle Control Relay.>
21 CHECK POWER SUPPLY OF ELECTRONIC THROTTLE CONTROL RELAY. Measure the voltage between electronic throttle control relay connector and chassis ground. Connector & terminal (B220) No. 29 (+) — Chassis ground (-):	Is the voltage 10 V or more?	Go to step 22.	Repair the open or ground short circuit of power supply circuit.
22 CHECK HARNESS BETWEEN ECM AND ELECTRONIC THROTTLE CONTROL RELAY. 1) Disconnect the connectors from the ECM. 2) Turn the ignition switch to ON. 3) Measure the voltage between electronic throttle control relay connector and chassis ground. Connector & terminal (B220) No. 32 (+) — Chassis ground (-):	Is the voltage 10 V or more?	Repair the short circuit to power in the harness between ECM and electronic throttle control relay connector.	Go to step 23.

Diagnostic Procedure with Diagnostic Trouble Code (DTC)

ENGINE (DIAGNOSTICS)

Step	Check	Yes	No
23 CHECK HARNESS BETWEEN ECM AND ELECTRONIC THROTTLE CONTROL RELAY. 1) Turn the ignition switch to OFF. 2) Measure the resistance between electronic throttle control relay connector and chassis ground. <i>Connector & terminal</i> (B220) No. 32 — Chassis ground: (B220) No. 30 — Chassis ground:	Is the resistance 1 M Ω or more?	Go to step 24.	Repair the short circuit in harness to ground between ECM and electronic throttle control relay connector.
24 CHECK HARNESS BETWEEN ECM AND ELECTRONIC THROTTLE CONTROL RELAY. Measure the resistance between the ECM and electronic throttle control relay connector. <i>Connector & terminal</i> (B136) No. 21 — (B220) No. 32: (B136) No. 1 — (B220) No. 30:	Is the resistance less than 1 Ω ?	Go to step 25.	Repair the open circuit in harness between ECM and electronic throttle control relay connector.
25 CHECK HARNESS BETWEEN ECM AND ELECTRONIC THROTTLE CONTROL. 1) Turn the ignition switch to OFF. 2) Disconnect the connectors from ECM and electronic throttle control. 3) Measure the resistance between ECM and chassis ground. <i>Connector & terminal</i> (B134) No. 19 — Chassis ground: (B134) No. 18 — Chassis ground: (B134) No. 18 — (B136) No. 6: (B134) No. 28 — Chassis ground:	Is the resistance 1 M Ω or more?	Go to step 26.	Repair the ground short circuit of harness between ECM and electronic throttle control connector.
26 CHECK SHORT CIRCUIT INSIDE THE ECM. 1) Connect the connector to ECM. 2) Measure the resistance between electronic throttle control connector and engine ground. <i>Connector & terminal</i> (E57) No. 6 — Engine ground: (E57) No. 4 — Engine ground:	Is the resistance 1 M Ω or more?	Go to step 27.	Repair the ground short circuit of harness between ECM and electronic throttle control connector. Replace the ECM if defective. <Ref. to FU(H4DOTC)-46, Engine Control Module (ECM).>
27 CHECK HARNESS BETWEEN ECM AND ELECTRONIC THROTTLE CONTROL. 1) Disconnect the connectors from the ECM. 2) Measure the resistance of harness between ECM and electronic throttle control connector. <i>Connector & terminal</i> (B134) No. 18 — (E57) No. 6: (B134) No. 28 — (E57) No. 4: (B134) No. 29 — (E57) No. 3:	Is the resistance less than 1 Ω ?	Go to step 28.	Repair the harness and connector. NOTE: In this case, repair the following item: • Open circuit in harness between ECM and electronic throttle control connector • Poor contact of coupling connector

Diagnostic Procedure with Diagnostic Trouble Code (DTC)

ENGINE (DIAGNOSTICS)

Step	Check	Yes	No
28 CHECK HARNESS BETWEEN ECM AND ELECTRONIC THROTTLE CONTROL. 1) Connect the ECM. 2) Measure the resistance between electronic throttle control connector and engine ground. Connector & terminal (E57) No. 3 — Engine ground:	Is the resistance less than 5 Ω ?	Go to step 29 .	Repair the harness and connector. NOTE: In this case, repair the following item: • Open circuit of harness between ECM and engine ground • Poor contact in ECM connector • Poor contact of coupling connector
29 CHECK HARNESS BETWEEN ECM AND ELECTRONIC THROTTLE CONTROL. 1) Turn the ignition switch to ON. 2) Measure the voltage between electronic throttle control connector and engine ground. Connector & terminal (E57) No. 6 (+) — Engine ground (-): (E57) No. 4 (+) — Engine ground (-):	Is the voltage 4.85 V or more?	Repair the short circuit to power in the harness between ECM and electronic throttle control connector.	Go to step 30 .
30 CHECK HARNESS BETWEEN ECM AND ELECTRONIC THROTTLE CONTROL. 1) Turn the ignition switch to OFF. 2) Disconnect the connectors from the ECM. 3) Measure the resistance between ECM connectors. Connector & terminal (B134) No. 19 — (B134) No. 18: (B134) No. 19 — (B134) No. 28:	Is the resistance 1 M Ω or more?	Go to step 31 .	Repair the short circuit to power in the harness between ECM and electronic throttle control connector.
31 CHECK SENSOR OUTPUT. 1) Connect all connectors. 2) Turn the ignition switch to ON. 3) Read the data of main throttle sensor signal using Subaru Select Monitor. NOTE: For detailed operation procedures, refer to "READ CURRENT DATA FOR ENGINE". <Ref. to EN(H4DOTC)(diag)-34, Subaru Select Monitor.>	Is the voltage 0.81 — 0.87 V?	Go to step 32 .	Repair poor contact of the electronic throttle control connector. Replace the electronic throttle control if defective. <Ref. to FU(H4DOTC)-13, Throttle Body.>
32 CHECK SENSOR OUTPUT. Read the data of sub throttle sensor signal using Subaru Select Monitor. NOTE: Subaru Select Monitor For detailed operation procedures, refer to "READ CURRENT DATA FOR ENGINE". <Ref. to EN(H4DOTC)(diag)-34, Subaru Select Monitor.>	Is the voltage 1.64 — 1.70 V?	Go to step 33 .	Repair poor contact of the electronic throttle control connector. Replace the electronic throttle control if defective. <Ref. to FU(H4DOTC)-13, Throttle Body.>

Diagnostic Procedure with Diagnostic Trouble Code (DTC)

ENGINE (DIAGNOSTICS)

Step	Check	Yes	No
33 CHECK HARNESS BETWEEN ECM AND ELECTRONIC THROTTLE CONTROL MOTOR. 1) Turn the ignition switch to OFF. 2) Disconnect the connectors from ECM and electronic throttle control. 3) Measure the resistance between ECM and electronic throttle control connector. Connector & terminal (B137) No. 5 — (E57) No. 2: (B137) No. 4 — (E57) No. 1:	Is the resistance less than 1 Ω ?	Go to step 34.	Repair the harness and connector. NOTE: In this case, repair the following item: <ul style="list-style-type: none"> • Open circuit in harness between ECM and electronic throttle control connector • Poor contact of coupling connector
34 CHECK HARNESS BETWEEN ECM AND ELECTRONIC THROTTLE CONTROL MOTOR. 1) Connect the connector to ECM. 2) Turn the ignition switch to ON. 3) Measure the voltage between electronic throttle control connector and engine ground. Connector & terminal (E57) No. 2 (+) — Engine ground (-): (E57) No. 1 (+) — Engine ground (-):	Is the voltage 5 V or more?	Repair the short circuit to power in the harness between ECM and electronic throttle control connector.	Go to step 35.
35 CHECK HARNESS BETWEEN ECM AND ELECTRONIC THROTTLE CONTROL MOTOR. 1) Turn the ignition switch to OFF. 2) Disconnect the connectors from the ECM. 3) Measure the resistance between electronic throttle control connector and engine ground. Connector & terminal (E57) No. 2 — Engine ground: (E57) No. 1 — Engine ground:	Is the resistance 1 M Ω or more?	Go to step 36.	Repair the short circuit to ground in harness between ECM and electronic throttle control connector.
36 CHECK ELECTRONIC THROTTLE CONTROL MOTOR HARNESS. Measure the resistance between the electronic throttle control connector terminals. Connector & terminal (E57) No. 2 — (E57) No. 1:	Is the resistance 1 M Ω or more?	Go to step 37.	Repair the short circuit of harness between ECM and electronic throttle control connector.
37 CHECK ELECTRONIC THROTTLE CONTROL GROUND CIRCUIT. Measure the resistance between ECM and chassis ground. Connector & terminal (B134) No. 5 — Chassis ground: (B137) No. 1 — Chassis ground: (B137) No. 2 — Chassis ground: (B137) No. 3 — Chassis ground: (B137) No. 7 — Chassis ground:	Is the resistance less than 5 Ω ?	Go to step 38.	Repair the harness and connector. NOTE: In this case, repair the following item: <ul style="list-style-type: none"> • Open circuit of harness between ECM and engine ground • Poor contact of coupling connector
38 CHECK ELECTRONIC THROTTLE CONTROL. Measure the resistance between electronic throttle control terminals. Terminals No. 1 — No. 2:	Is the resistance 50 Ω or less?	Go to step 39.	Replace the electronic throttle control. <Ref. to FU(H4DOTC)-13, Throttle Body.>
39 CHECK ELECTRONIC THROTTLE CONTROL. Move the throttle valve to the fully open and fully closed positions with fingers. Check that the valve returns to the specified position when releasing fingers.	Does the valve return to the specified position? Standard value: 3 mm (0.12 in) from fully closed position	Repair the poor contact of the ECM connector.	Replace the electronic throttle control. <Ref. to FU(H4DOTC)-13, Throttle Body.>

Diagnostic Procedure with Diagnostic Trouble Code (DTC)

ENGINE (DIAGNOSTICS)

CV:DTC P2004 INTAKE MANIFOLD RUNNER CONTROL STUCK OPEN (BANK 1)

DTC DETECTING CONDITION:

- Immediately at fault recognition
- GENERAL DESCRIPTION <Ref. to GD(H4DOTC)-185, DTC P2004 INTAKE MANIFOLD RUNNER CONTROL STUCK OPEN (BANK 1), Diagnostic Trouble Code (DTC) Detecting Criteria.>

CAUTION:

After repair or replacement of faulty parts, perform Clear Memory Mode <Ref. to EN(H4DOTC)(diag)-52, OPERATION, Clear Memory Mode.> and Inspection Mode <Ref. to EN(H4DOTC)(diag)-42, PROCEDURE, Inspection Mode.>.

Step	Check	Yes	No	
1	CHECK FOR ANY OTHER DTC ON DISPLAY.	Is any other DTC displayed?	Check the appropriate DTC using the "List of Diagnostic Trouble Code (DTC)". <Ref. to EN(H4DOTC)(diag)-80, List of Diagnostic Trouble Code (DTC).>	Go to step 2.
2	CHECK TUMBLE GENERATOR VALVE. 1) Remove the tumble generator valve assembly RH. 2) Check the tumble generator valve body.	Is there any dirt or clogging with foreign objects in the tumble generator valve?	Clean the tumble generator valve.	Replace the tumble generator valve assembly RH. <Ref. to FU(H4DOTC)-39, Tumble Generator Valve Assembly.>

CW:DTC P2005 INTAKE MANIFOLD RUNNER CONTROL STUCK OPEN (BANK 2)

DTC DETECTING CONDITION:

- Immediately at fault recognition
- GENERAL DESCRIPTION <Ref. to GD(H4DOTC)-186, DTC P2005 INTAKE MANIFOLD RUNNER CONTROL STUCK OPEN (BANK 2), Diagnostic Trouble Code (DTC) Detecting Criteria.>

CAUTION:

After repair or replacement of faulty parts, perform Clear Memory Mode <Ref. to EN(H4DOTC)(diag)-52, OPERATION, Clear Memory Mode.> and Inspection Mode <Ref. to EN(H4DOTC)(diag)-42, PROCEDURE, Inspection Mode.>.

Step	Check	Yes	No	
1	CHECK FOR ANY OTHER DTC ON DISPLAY.	Is any other DTC displayed?	Check the appropriate DTC using the "List of Diagnostic Trouble Code (DTC)". <Ref. to EN(H4DOTC)(diag)-80, List of Diagnostic Trouble Code (DTC).>	Go to step 2.
2	CHECK TUMBLE GENERATOR VALVE. 1) Remove the tumble generator valve assembly LH. 2) Check the tumble generator valve body.	Is there any dirt or clogging with foreign objects in the tumble generator valve?	Clean the tumble generator valve.	Replace the tumble generator valve assembly LH. <Ref. to FU(H4DOTC)-39, Tumble Generator Valve Assembly.>

Diagnostic Procedure with Diagnostic Trouble Code (DTC)

ENGINE (DIAGNOSTICS)

CX:DTC P2006 INTAKE MANIFOLD RUNNER CONTROL STUCK CLOSED (BANK 1)

DTC DETECTING CONDITION:

- Immediately at fault recognition
- GENERAL DESCRIPTION <Ref. to GD(H4DOTC)-187, DTC P2006 INTAKE MANIFOLD RUNNER CONTROL STUCK CLOSED (BANK 1), Diagnostic Trouble Code (DTC) Detecting Criteria.>

CAUTION:

After repair or replacement of faulty parts, perform Clear Memory Mode <Ref. to EN(H4DOTC)(diag)-52, OPERATION, Clear Memory Mode.> and Inspection Mode <Ref. to EN(H4DOTC)(diag)-42, PROCEDURE, Inspection Mode.>.

Step	Check	Yes	No
1 CHECK FOR ANY OTHER DTC ON DISPLAY.	Is any other DTC displayed?	Check the appropriate DTC using the "List of Diagnostic Trouble Code (DTC)". <Ref. to EN(H4DOTC)(diag)-80, List of Diagnostic Trouble Code (DTC).>	Go to step 2.
2 CHECK TUMBLE GENERATOR VALVE. 1) Remove the tumble generator valve assembly RH. 2) Check the tumble generator valve body.	Is there any dirt or clogging with foreign objects in the tumble generator valve?	Clean the tumble generator valve.	Replace the tumble generator valve assembly RH. <Ref. to FU(H4DOTC)-39, Tumble Generator Valve Assembly.>

Diagnostic Procedure with Diagnostic Trouble Code (DTC)

ENGINE (DIAGNOSTICS)

CY:DTC P2007 INTAKE MANIFOLD RUNNER CONTROL STUCK CLOSED (BANK 2)

DTC DETECTING CONDITION:

- Immediately at fault recognition
- GENERAL DESCRIPTION <Ref. to GD(H4DOTC)-188, DTC P2007 INTAKE MANIFOLD RUNNER CONTROL STUCK CLOSED (BANK 2), Diagnostic Trouble Code (DTC) Detecting Criteria.>

CAUTION:

After repair or replacement of faulty parts, perform Clear Memory Mode <Ref. to EN(H4DOTC)(diag)-52, OPERATION, Clear Memory Mode.> and Inspection Mode <Ref. to EN(H4DOTC)(diag)-42, PROCEDURE, Inspection Mode.>.

Step	Check	Yes	No
1 CHECK FOR ANY OTHER DTC ON DISPLAY.	Is any other DTC displayed?	Check the appropriate DTC using the "List of Diagnostic Trouble Code (DTC)". <Ref. to EN(H4DOTC)(diag)-80, List of Diagnostic Trouble Code (DTC).>	Go to step 2.
2 CHECK TUMBLE GENERATOR VALVE. 1) Remove the tumble generator valve assembly LH. 2) Check the tumble generator valve body.	Is there any dirt or clogging with foreign objects in the tumble generator valve?	Clean the tumble generator valve.	Replace the tumble generator valve assembly LH. <Ref. to FU(H4DOTC)-39, Tumble Generator Valve Assembly.>

CZ:DTC P2008 INTAKE MANIFOLD RUNNER CONTROL CIRCUIT / OPEN (BANK 1)

DTC DETECTING CONDITION:

- Immediately at fault recognition
- GENERAL DESCRIPTION <Ref. to GD(H4DOTC)-189, DTC P2008 INTAKE MANIFOLD RUNNER CONTROL CIRCUIT / OPEN (BANK 1), Diagnostic Trouble Code (DTC) Detecting Criteria.>

CAUTION:

After repair or replacement of faulty parts, perform Clear Memory Mode <Ref. to EN(H4DOTC)(diag)-52, OPERATION, Clear Memory Mode.> and Inspection Mode <Ref. to EN(H4DOTC)(diag)-42, PROCEDURE, Inspection Mode.>.

WIRING DIAGRAM:

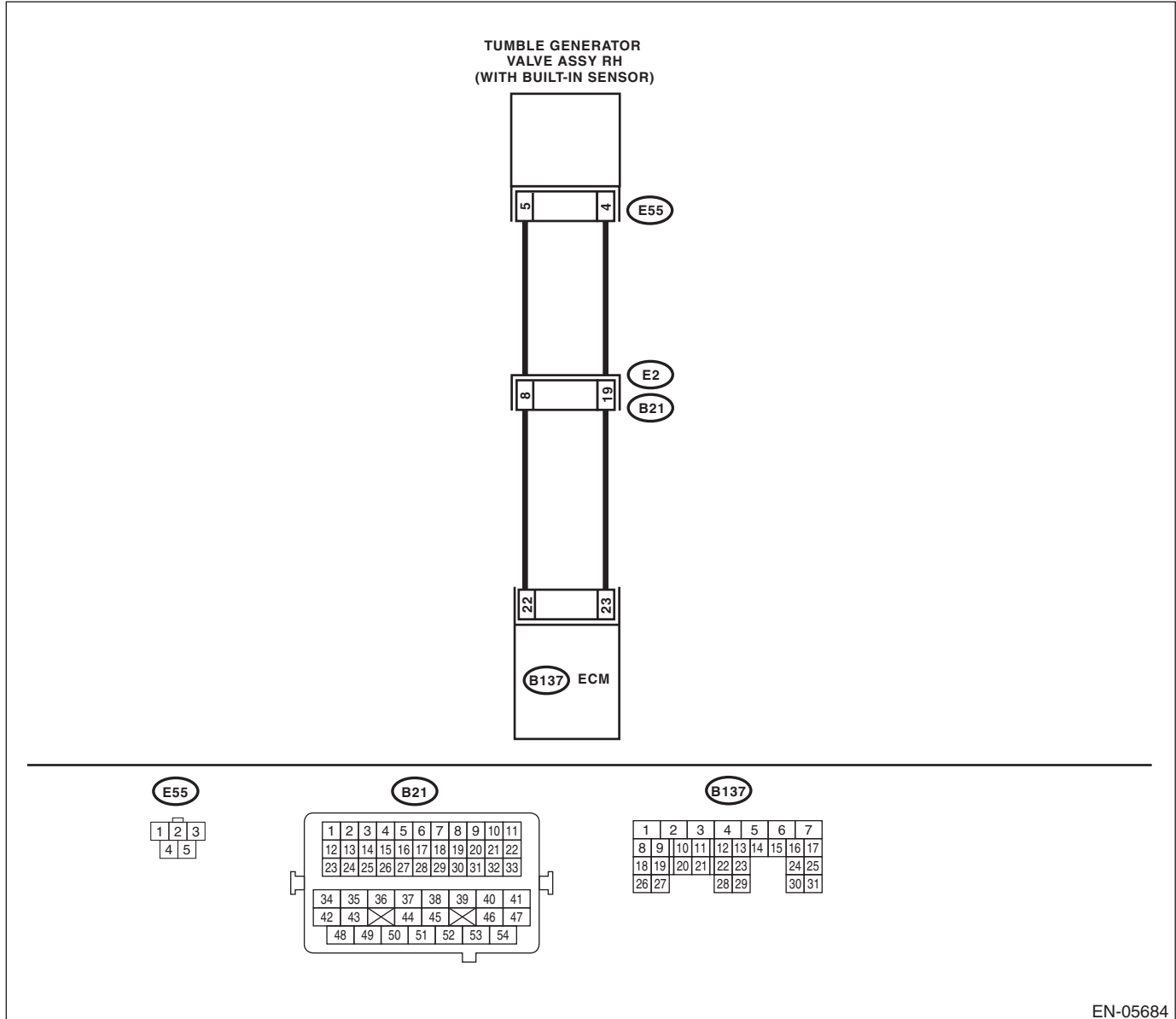

Diagnostic Procedure with Diagnostic Trouble Code (DTC)

ENGINE (DIAGNOSTICS)

Step	Check	Yes	No
1 CHECK HARNESS BETWEEN ECM AND TUMBLE GENERATOR VALVE ASSEMBLY RH CONNECTOR. 1) Turn the ignition switch to OFF. 2) Disconnect the connectors from the ECM and tumble generator valve assembly RH. 3) Measure the resistance of harness between ECM and tumble generator valve assembly RH. Connector & terminal (B137) No. 22 — (E55) No. 5: (B137) No. 23 — (E55) No. 4:	Is the resistance less than 1 Ω?	Go to step 2.	Repair the harness and connector. NOTE: In this case, repair the following item: • Open circuit in harness between ECM and tumble generator valve assembly RH connector • Poor contact of coupling connector
2 CHECK HARNESS BETWEEN ECM AND TUMBLE GENERATOR VALVE ASSEMBLY RH CONNECTOR. Measure the resistance between ECM and chassis ground. Connector & terminal (B137) No. 22 — Chassis ground: (B137) No. 23 — Chassis ground:	Is the resistance 1 MΩ or more?	Go to step 3.	Repair the short circuit to ground in harness between ECM and tumble generator valve assembly RH connector.
3 CHECK POOR CONTACT. Check for poor contact of tumble generator valve assembly RH connector.	Is there poor contact in the tumble generator valve assembly RH connector?	Repair the poor contact of tumble generator valve assembly RH connector.	Replace the tumble generator valve assembly RH. <Ref. to FU(H4DOTC)-39, Tumble Generator Valve Assembly.>

Diagnostic Procedure with Diagnostic Trouble Code (DTC)

ENGINE (DIAGNOSTICS)

DA:DTC P2009 INTAKE MANIFOLD RUNNER CONTROL CIRCUIT LOW (BANK 1)

DTC DETECTING CONDITION:

- Immediately at fault recognition
- GENERAL DESCRIPTION <Ref. to GD(H4DOTC)-190, DTC P2009 INTAKE MANIFOLD RUNNER CONTROL CIRCUIT LOW (BANK 1), Diagnostic Trouble Code (DTC) Detecting Criteria.>

CAUTION:

After repair or replacement of faulty parts, perform Clear Memory Mode <Ref. to EN(H4DOTC)(diag)-52, OPERATION, Clear Memory Mode.> and Inspection Mode <Ref. to EN(H4DOTC)(diag)-42, PROCEDURE, Inspection Mode.>.

WIRING DIAGRAM:

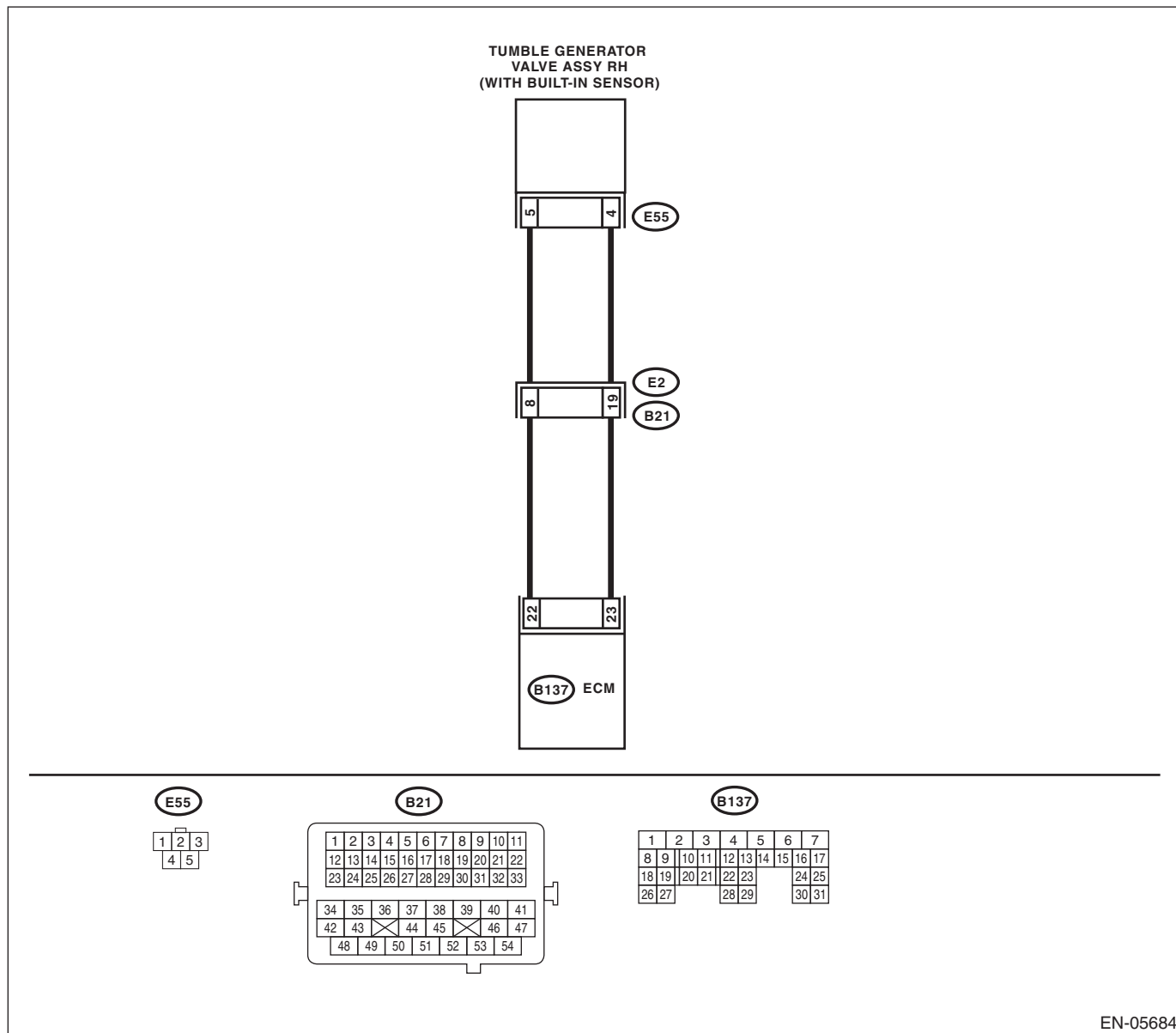

EN-05684

Diagnostic Procedure with Diagnostic Trouble Code (DTC)

ENGINE (DIAGNOSTICS)

Step	Check	Yes	No
<p>1 CHECK HARNESS BETWEEN ECM AND TUMBLE GENERATOR VALVE ASSEMBLY RH CONNECTOR.</p> <p>1) Turn the ignition switch to OFF. 2) Disconnect the connectors from the ECM. 3) Measure the voltage between ECM and chassis ground.</p> <p>Connector & terminal (B137) No. 22 (+) — Chassis ground (-): (B137) No. 23 (+) — Chassis ground (-):</p>	Is the voltage 5 V or more?	Repair the short circuit to power in harness between ECM and tumble generator valve assembly RH connector.	Replace the tumble generator valve assembly RH. <Ref. to FU(H4DOTC)-39, Tumble Generator Valve Assembly.>

DB:DTC P2011 INTAKE MANIFOLD RUNNER CONTROL CIRCUIT / OPEN (BANK 2)

DTC DETECTING CONDITION:

- Immediately at fault recognition
- GENERAL DESCRIPTION <Ref. to GD(H4DOTC)-191, DTC P2011 INTAKE MANIFOLD RUNNER CONTROL CIRCUIT / OPEN (BANK 2), Diagnostic Trouble Code (DTC) Detecting Criteria.>

CAUTION:

After repair or replacement of faulty parts, perform Clear Memory Mode <Ref. to EN(H4DOTC)(diag)-52, OPERATION, Clear Memory Mode.> and Inspection Mode <Ref. to EN(H4DOTC)(diag)-42, PROCEDURE, Inspection Mode.>.

WIRING DIAGRAM:

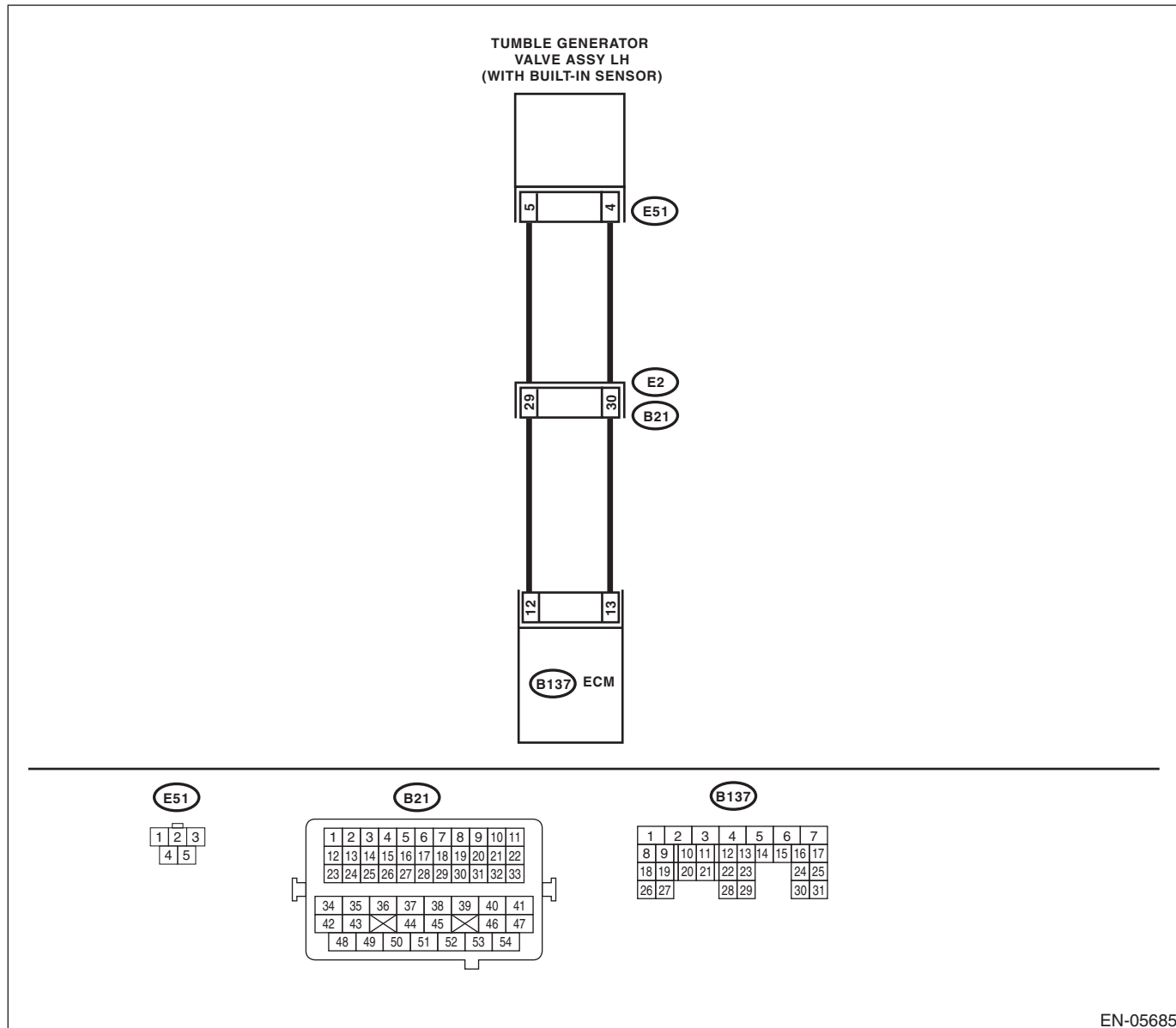

Diagnostic Procedure with Diagnostic Trouble Code (DTC)

ENGINE (DIAGNOSTICS)

Step	Check	Yes	No
<p>1</p> <p>CHECK HARNESS BETWEEN ECM AND TUMBLE GENERATOR VALVE ASSEMBLY LH CONNECTOR.</p> <p>1) Turn the ignition switch to OFF. 2) Disconnect the connectors from ECM and tumble generator valve assembly LH. 3) Measure the resistance of harness between ECM and tumble generator valve assembly LH.</p> <p>Connector & terminal (B137) No. 12 — (E51) No. 5: (B137) No. 13 — (E51) No. 4:</p>	<p>Is the resistance less than 1 Ω?</p>	<p>Go to step 2.</p>	<p>Repair the harness and connector.</p> <p>NOTE: In this case, repair the following item:</p> <ul style="list-style-type: none"> • Open circuit in harness between ECM and tumble generator valve assembly LH connector • Poor contact of coupling connector
<p>2</p> <p>CHECK HARNESS BETWEEN ECM AND TUMBLE GENERATOR VALVE ASSEMBLY LH CONNECTOR.</p> <p>Measure the resistance between ECM and chassis ground.</p> <p>Connector & terminal (B137) No. 12 — Chassis ground: (B137) No. 13 — Chassis ground:</p>	<p>Is the resistance 1 MΩ or more?</p>	<p>Go to step 3.</p>	<p>Repair the short circuit to ground in harness between ECM and tumble generator valve assembly LH connector.</p>
<p>3</p> <p>CHECK POOR CONTACT.</p> <p>Check for poor contact of tumble generator valve assembly LH connector.</p>	<p>Is there poor contact in the tumble generator valve assembly LH connector?</p>	<p>Repair the poor contact of tumble generator valve assembly LH connector.</p>	<p>Replace the tumble generator valve assembly LH.</p> <p><Ref. to FU(H4DOTC)-39, Tumble Generator Valve Assembly.></p>

Diagnostic Procedure with Diagnostic Trouble Code (DTC)

ENGINE (DIAGNOSTICS)

DC:DTC P2012 INTAKE MANIFOLD RUNNER CONTROL CIRCUIT LOW (BANK 2)

DTC DETECTING CONDITION:

- Immediately at fault recognition
- GENERAL DESCRIPTION <Ref. to GD(H4DOTC)-192, DTC P2012 INTAKE MANIFOLD RUNNER CONTROL CIRCUIT LOW (BANK 2), Diagnostic Trouble Code (DTC) Detecting Criteria.>

CAUTION:

After repair or replacement of faulty parts, perform Clear Memory Mode <Ref. to EN(H4DOTC)(diag)-52, OPERATION, Clear Memory Mode.> and Inspection Mode <Ref. to EN(H4DOTC)(diag)-42, PROCEDURE, Inspection Mode.>.

WIRING DIAGRAM:

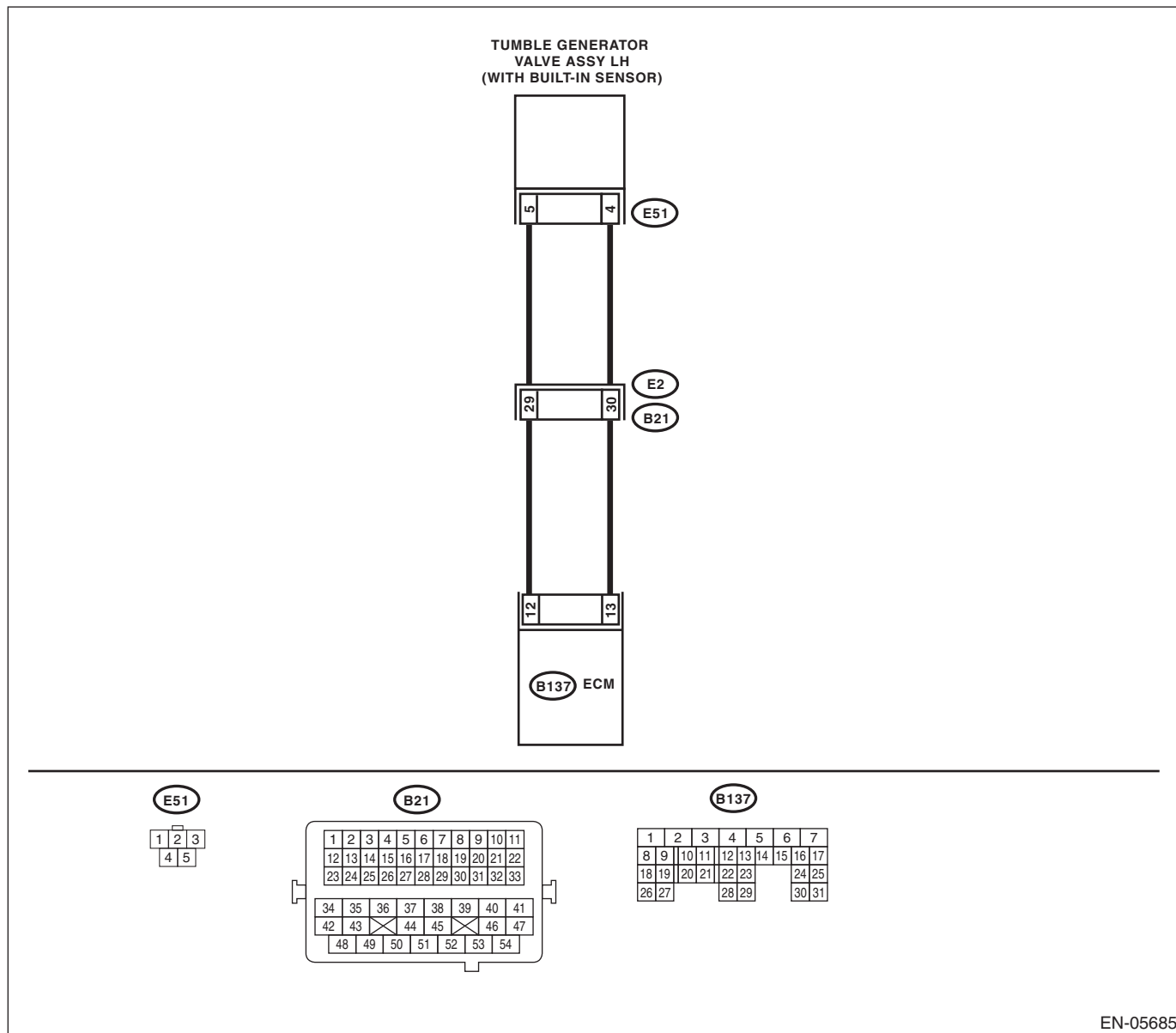

Diagnostic Procedure with Diagnostic Trouble Code (DTC)

ENGINE (DIAGNOSTICS)

Step	Check	Yes	No
<p>1 CHECK HARNESS BETWEEN ECM AND TUMBLE GENERATOR VALVE ASSEMBLY LH CONNECTOR.</p> <p>1) Turn the ignition switch to OFF. 2) Disconnect the connectors from the ECM. 3) Measure the voltage between ECM and chassis ground.</p> <p>Connector & terminal (B137) No. 12 (+) — Chassis ground (-): (B137) No. 13 (+) — Chassis ground (-):</p>	Is the voltage 5 V or more?	Repair the short circuit to power in harness between ECM and tumble generator valve assembly LH connector.	Replace the tumble generator valve assembly LH. <Ref. to FU(H4DOTC)-39, Tumble Generator Valve Assembly.>

DD:DTC P2016 INTAKE MANIFOLD RUNNER POSITION SENSOR / SWITCH CIRCUIT LOW (BANK 1)

DTC DETECTING CONDITION:

- Immediately at fault recognition
- GENERAL DESCRIPTION <Ref. to GD(H4DOTC)-193, DTC P2016 INTAKE MANIFOLD RUNNER POSITION SENSOR / SWITCH CIRCUIT LOW (BANK 1), Diagnostic Trouble Code (DTC) Detecting Criteria.>

TROUBLE SYMPTOM:

- Improper idling
- Engine stalls.
- Poor driving performance

CAUTION:

After repair or replacement of faulty parts, perform Clear Memory Mode <Ref. to EN(H4DOTC)(diag)-52, OPERATION, Clear Memory Mode.> and Inspection Mode <Ref. to EN(H4DOTC)(diag)-42, PROCEDURE, Inspection Mode.>.

WIRING DIAGRAM:

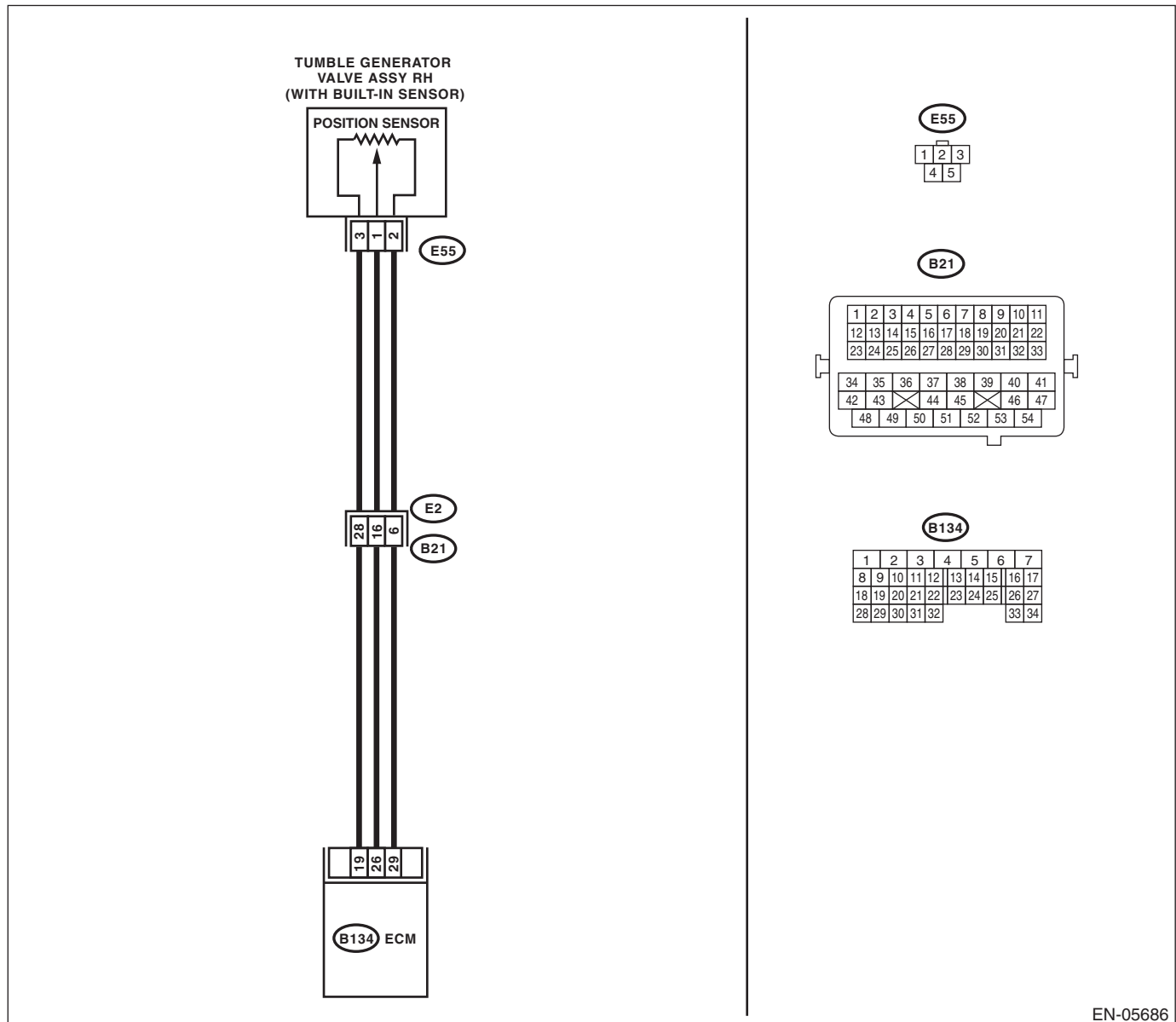

EN-05686

Diagnostic Procedure with Diagnostic Trouble Code (DTC)

ENGINE (DIAGNOSTICS)

Step	Check	Yes	No
1 CHECK CURRENT DATA. 1) Start the engine. 2) Read the data of tumble generator valve position sensor signal (RH) using Subaru Select Monitor or general scan tool. NOTE: <ul style="list-style-type: none"> • Subaru Select Monitor For detailed operation procedures, refer to "READ CURRENT DATA FOR ENGINE". <Ref. to EN(H4DOTC)(diag)-34, Subaru Select Monitor.> <ul style="list-style-type: none"> • General scan tool For detailed operation procedures, refer to the general scan tool operation manual.	Is the voltage less than 0.2 V?	Go to step 2.	Even if the malfunction indicator light illuminates, the circuit has returned to a normal condition at this time. Reproduce the fault condition, and reperform the check. NOTE: In this case, there may be a temporary connector contact failure.
2 CHECK POWER SUPPLY OF TUMBLE GENERATOR VALVE ASSEMBLY RH. 1) Turn the ignition switch to OFF. 2) Disconnect the connector from tumble generator valve assembly RH. 3) Turn the ignition switch to ON. 4) Measure the voltage between tumble generator valve assembly RH connector and engine ground. Connector & terminal (E55) No. 3 (+) — Engine ground (-):	Is the voltage 4.5 V or more?	Go to step 3.	Repair the harness and connector. NOTE: In this case, repair the following item: <ul style="list-style-type: none"> • Open circuit in harness between ECM and tumble generator valve assembly RH connector • Poor contact in ECM connector • Poor contact of coupling connector
3 CHECK HARNESS BETWEEN ECM AND TUMBLE GENERATOR VALVE ASSEMBLY RH CONNECTOR. 1) Turn the ignition switch to OFF. 2) Disconnect the connectors from the ECM. 3) Measure the resistance of harness between ECM and tumble generator valve assembly RH. Connector & terminal (B134) No. 26 — (E55) No. 1:	Is the resistance less than 1 Ω?	Go to step 4.	Repair the harness and connector. NOTE: In this case, repair the following item: <ul style="list-style-type: none"> • Open circuit in harness between ECM and tumble generator valve assembly RH connector • Poor contact of coupling connector
4 CHECK HARNESS BETWEEN ECM AND TUMBLE GENERATOR VALVE ASSEMBLY RH CONNECTOR. Measure the resistance between ECM and chassis ground. Connector & terminal (B134) No. 26 — Chassis ground:	Is the resistance 1 MΩ or more?	Go to step 5.	Repair the short circuit to ground in harness between ECM and tumble generator valve assembly RH connector.
5 CHECK POOR CONTACT. Check for poor contact of tumble generator valve assembly RH connector.	Is there poor contact in ECM or the tumble generator valve assembly RH connector?	Repair the poor contact in ECM or tumble generator valve assembly RH connector.	Replace the tumble generator valve assembly RH. <Ref. to FU(H4DOTC)-39, Tumble Generator Valve Assembly.>

DE:DTC P2017 INTAKE MANIFOLD RUNNER POSITION SENSOR / SWITCH CIRCUIT HIGH (BANK 1)

DTC DETECTING CONDITION:

- Immediately at fault recognition
- GENERAL DESCRIPTION <Ref. to GD(H4DOTC)-194, DTC P2017 INTAKE MANIFOLD RUNNER POSITION SENSOR / SWITCH CIRCUIT HIGH (BANK 1), Diagnostic Trouble Code (DTC) Detecting Criteria.>

TROUBLE SYMPTOM:

- Improper idling
- Engine stalls.
- Poor driving performance

CAUTION:

After repair or replacement of faulty parts, perform Clear Memory Mode <Ref. to EN(H4DOTC)(diag)-52, OPERATION, Clear Memory Mode.> and Inspection Mode <Ref. to EN(H4DOTC)(diag)-42, PROCEDURE, Inspection Mode.>.

WIRING DIAGRAM:

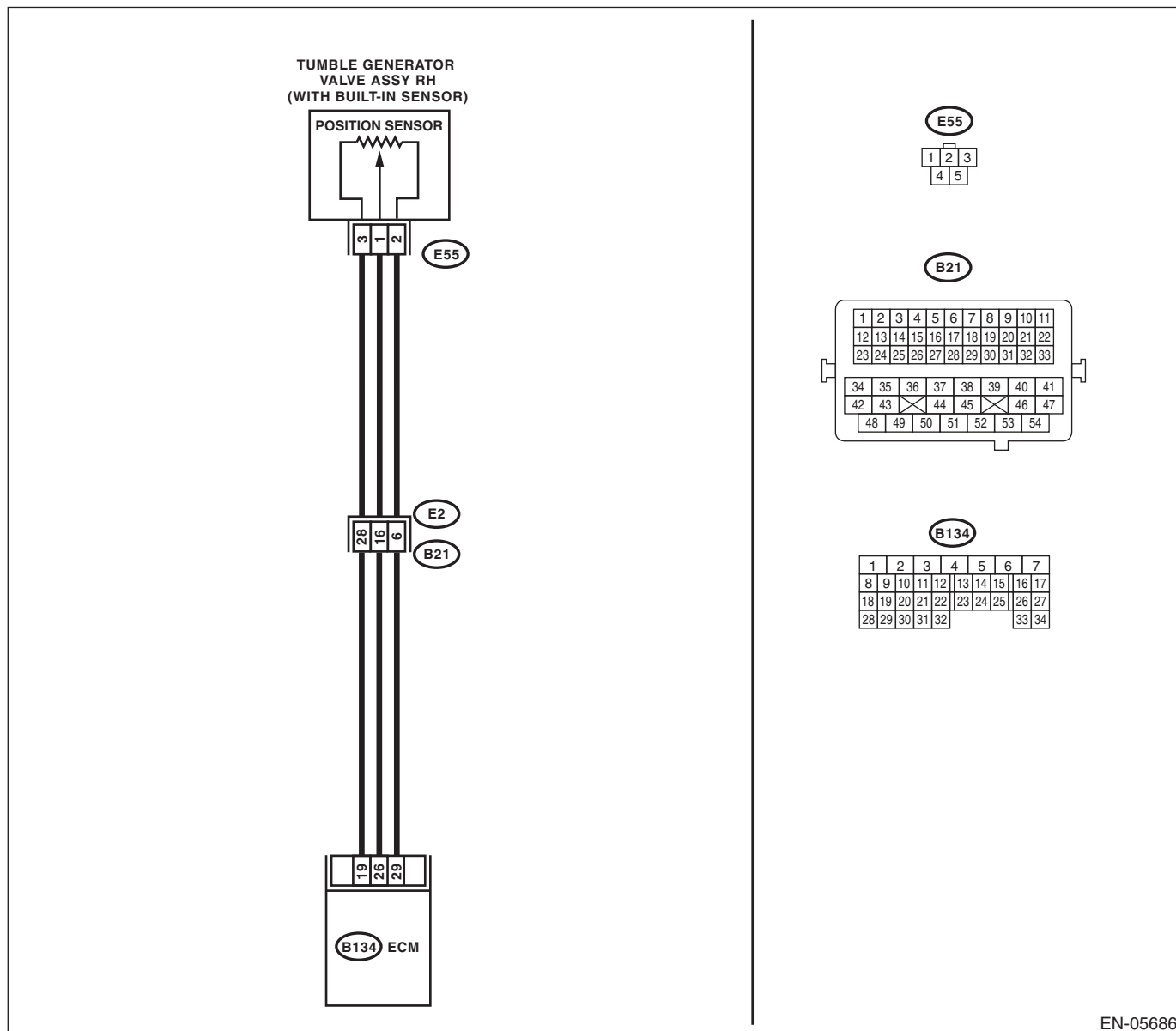

EN-05686

Diagnostic Procedure with Diagnostic Trouble Code (DTC)

ENGINE (DIAGNOSTICS)

Step	Check	Yes	No
<p>1 CHECK CURRENT DATA.</p> <p>1) Start the engine.</p> <p>2) Read the data of tumble generator valve position sensor signal (RH) using Subaru Select Monitor or general scan tool.</p> <p>NOTE:</p> <ul style="list-style-type: none"> • Subaru Select Monitor <p>For detailed operation procedures, refer to "READ CURRENT DATA FOR ENGINE". <Ref. to EN(H4DOTC)(diag)-34, Subaru Select Monitor.></p> <ul style="list-style-type: none"> • General scan tool <p>For detailed operation procedures, refer to the general scan tool operation manual.</p>	Is the voltage 5 V or more?	Go to step 2.	<p>Even if the malfunction indicator light illuminates, the circuit has returned to a normal condition at this time. Reproduce the fault condition, and reperform the check.</p> <p>NOTE:</p> <p>In this case, there may be a temporary connector contact failure.</p>
<p>2 CHECK HARNESS BETWEEN ECM AND TUMBLE GENERATOR VALVE ASSEMBLY RH CONNECTOR.</p> <p>1) Turn the ignition switch to OFF.</p> <p>2) Disconnect the connector from tumble generator valve assembly RH.</p> <p>3) Start the engine.</p> <p>4) Read the data of tumble generator valve position sensor signal (RH) using Subaru Select Monitor or general scan tool.</p> <p>NOTE:</p> <ul style="list-style-type: none"> • Subaru Select Monitor <p>For detailed operation procedures, refer to "READ CURRENT DATA FOR ENGINE". <Ref. to EN(H4DOTC)(diag)-34, Subaru Select Monitor.></p> <ul style="list-style-type: none"> • General scan tool <p>For detailed operation procedures, refer to the general scan tool operation manual.</p>	Is the voltage 5 V or more?	Repair the short circuit to power in harness between ECM and tumble generator valve assembly RH connector.	Go to step 3.
<p>3 CHECK HARNESS BETWEEN ECM AND TUMBLE GENERATOR VALVE ASSEMBLY RH CONNECTOR.</p> <p>1) Turn the ignition switch to OFF.</p> <p>2) Measure the resistance of harness between tumble generator valve assembly RH connector and engine ground.</p> <p>Connector & terminal (E55) No. 2 — Engine ground:</p>	Is the resistance less than 5 Ω?	Go to step 4.	<p>Repair the harness and connector.</p> <p>NOTE:</p> <p>In this case, repair the following item:</p> <ul style="list-style-type: none"> • Open circuit in harness between ECM and tumble generator valve assembly RH connector • Poor contact in ECM connector • Poor contact of coupling connector
<p>4 CHECK POOR CONTACT.</p> <p>Check for poor contact of tumble generator valve assembly RH connector.</p>	Is there poor contact in the tumble generator valve assembly RH connector?	Repair the poor contact of tumble generator valve assembly RH connector.	<p>Replace the tumble generator valve assembly RH.</p> <p><Ref. to FU(H4DOTC)-39, Tumble Generator Valve Assembly.></p>

DF:DTC P2021 INTAKE MANIFOLD RUNNER POSITION SENSOR / SWITCH CIRCUIT LOW (BANK 2)

DTC DETECTING CONDITION:

- Immediately at fault recognition
- GENERAL DESCRIPTION <Ref. to GD(H4DOTC)-195, DTC P2021 INTAKE MANIFOLD RUNNER POSITION SENSOR / SWITCH CIRCUIT LOW (BANK 2), Diagnostic Trouble Code (DTC) Detecting Criteria.>

TROUBLE SYMPTOM:

- Improper idling
- Engine stalls.
- Poor driving performance

CAUTION:

After repair or replacement of faulty parts, perform Clear Memory Mode <Ref. to EN(H4DOTC)(diag)-52, OPERATION, Clear Memory Mode.> and Inspection Mode <Ref. to EN(H4DOTC)(diag)-42, PROCEDURE, Inspection Mode.>.

WIRING DIAGRAM:

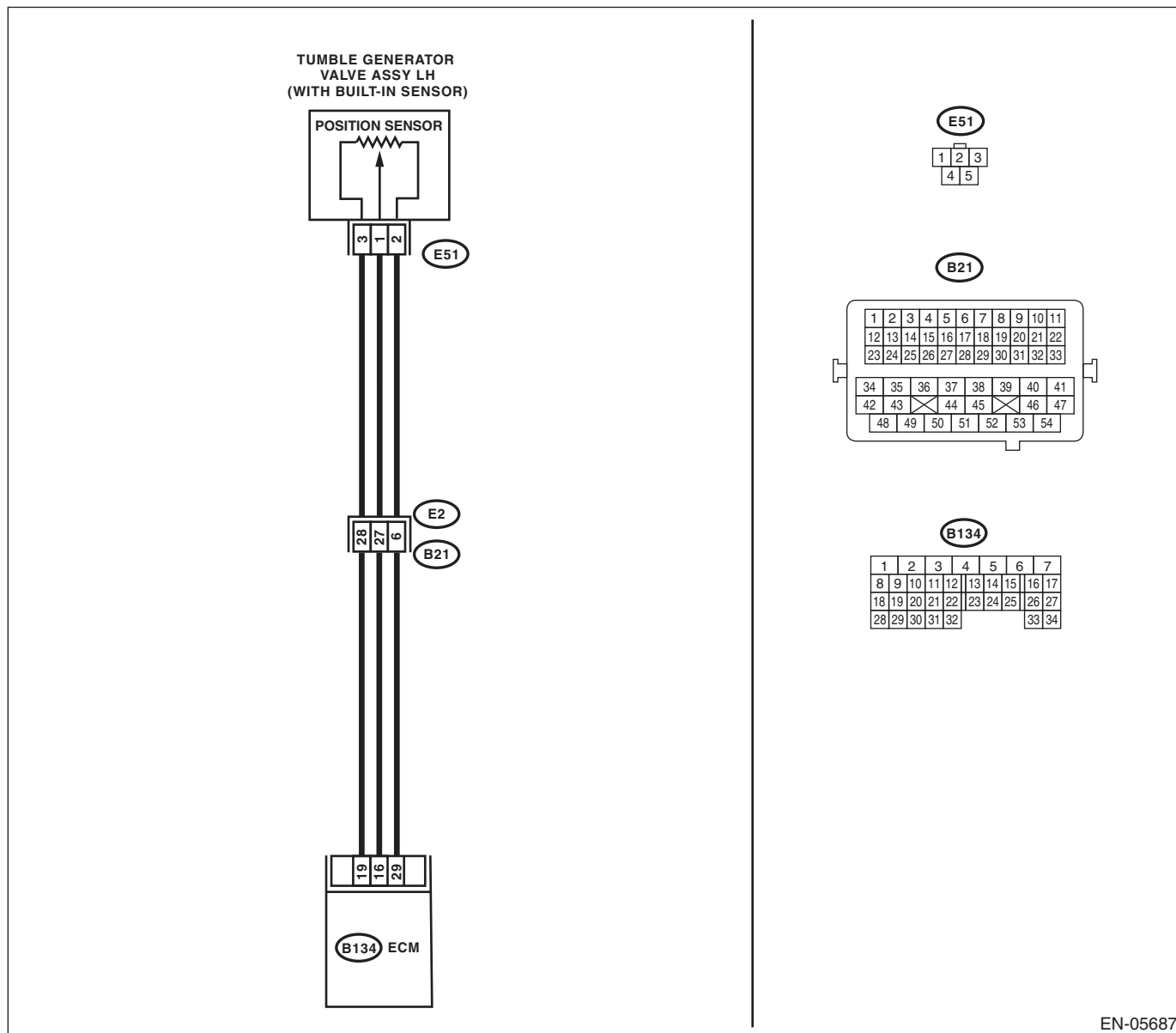

EN-05687

Diagnostic Procedure with Diagnostic Trouble Code (DTC)

ENGINE (DIAGNOSTICS)

Step	Check	Yes	No
<p>1 CHECK CURRENT DATA.</p> <p>1) Start the engine.</p> <p>2) Read the data of tumble generator valve position sensor signal (LH) using Subaru Select Monitor or general scan tool.</p> <p>NOTE:</p> <ul style="list-style-type: none"> Subaru Select Monitor <p>For detailed operation procedures, refer to "READ CURRENT DATA FOR ENGINE". <Ref. to EN(H4DOTC)(diag)-34, Subaru Select Monitor.></p> <ul style="list-style-type: none"> General scan tool <p>For detailed operation procedures, refer to the general scan tool operation manual.</p>	Is the voltage less than 0.2 V?	Go to step 2.	<p>Even if the malfunction indicator light illuminates, the circuit has returned to a normal condition at this time. Reproduce the fault condition, and reperform the check.</p> <p>NOTE:</p> <p>In this case, there may be a temporary connector contact failure.</p>
<p>2 CHECK POWER SUPPLY OF TUMBLE GENERATOR VALVE ASSEMBLY LH.</p> <p>1) Turn the ignition switch to OFF.</p> <p>2) Disconnect the connector from tumble generator valve assembly LH.</p> <p>3) Turn the ignition switch to ON.</p> <p>4) Measure the voltage between tumble generator valve assembly LH connector and engine ground.</p> <p>Connector & terminal (E51) No. 3 (+) — Engine ground (-):</p>	Is the voltage 4.5 V or more?	Go to step 3.	<p>Repair the harness and connector.</p> <p>NOTE:</p> <p>In this case, repair the following item:</p> <ul style="list-style-type: none"> Open circuit in harness between ECM and tumble generator valve assembly LH connector Poor contact in ECM connector Poor contact of coupling connector
<p>3 CHECK HARNESS BETWEEN ECM AND TUMBLE GENERATOR VALVE ASSEMBLY LH CONNECTOR.</p> <p>1) Turn the ignition switch to OFF.</p> <p>2) Disconnect the connectors from the ECM.</p> <p>3) Measure the resistance of harness between ECM and tumble generator valve assembly LH.</p> <p>Connector & terminal (B134) No. 16 — (E51) No. 1:</p>	Is the resistance less than 1 Ω?	Go to step 4.	<p>Repair the harness and connector.</p> <p>NOTE:</p> <p>In this case, repair the following item:</p> <ul style="list-style-type: none"> Open circuit in harness between ECM and tumble generator valve assembly LH connector Poor contact of coupling connector
<p>4 CHECK HARNESS BETWEEN ECM AND TUMBLE GENERATOR VALVE ASSEMBLY LH CONNECTOR.</p> <p>Measure the resistance between ECM and chassis ground.</p> <p>Connector & terminal (B134) No. 16 — Chassis ground:</p>	Is the resistance 1 MΩ or more?	Go to step 5.	<p>Repair the short circuit to ground in harness between ECM and tumble generator valve assembly LH connector.</p>
<p>5 CHECK POOR CONTACT.</p> <p>Check for poor contact of tumble generator valve assembly LH connector.</p>	Is there poor contact in ECM or the tumble generator valve assembly LH connector?	Repair the poor contact in ECM or tumble generator valve assembly LH connector.	<p>Replace the tumble generator valve assembly LH.</p> <p><Ref. to FU(H4DOTC)-39, Tumble Generator Valve Assembly.></p>

DG:DTC P2022 INTAKE MANIFOLD RUNNER POSITION SENSOR / SWITCH CIRCUIT HIGH (BANK 2)

DTC DETECTING CONDITION:

- Immediately at fault recognition
- GENERAL DESCRIPTION <Ref. to GD(H4DOTC)-196, DTC P2022 INTAKE MANIFOLD RUNNER POSITION SENSOR / SWITCH CIRCUIT HIGH (BANK 2), Diagnostic Trouble Code (DTC) Detecting Criteria.>

TROUBLE SYMPTOM:

- Improper idling
- Engine stalls.
- Poor driving performance

CAUTION:

After repair or replacement of faulty parts, perform Clear Memory Mode <Ref. to EN(H4DOTC)(diag)-52, OPERATION, Clear Memory Mode.> and Inspection Mode <Ref. to EN(H4DOTC)(diag)-42, PROCEDURE, Inspection Mode.>.

WIRING DIAGRAM:

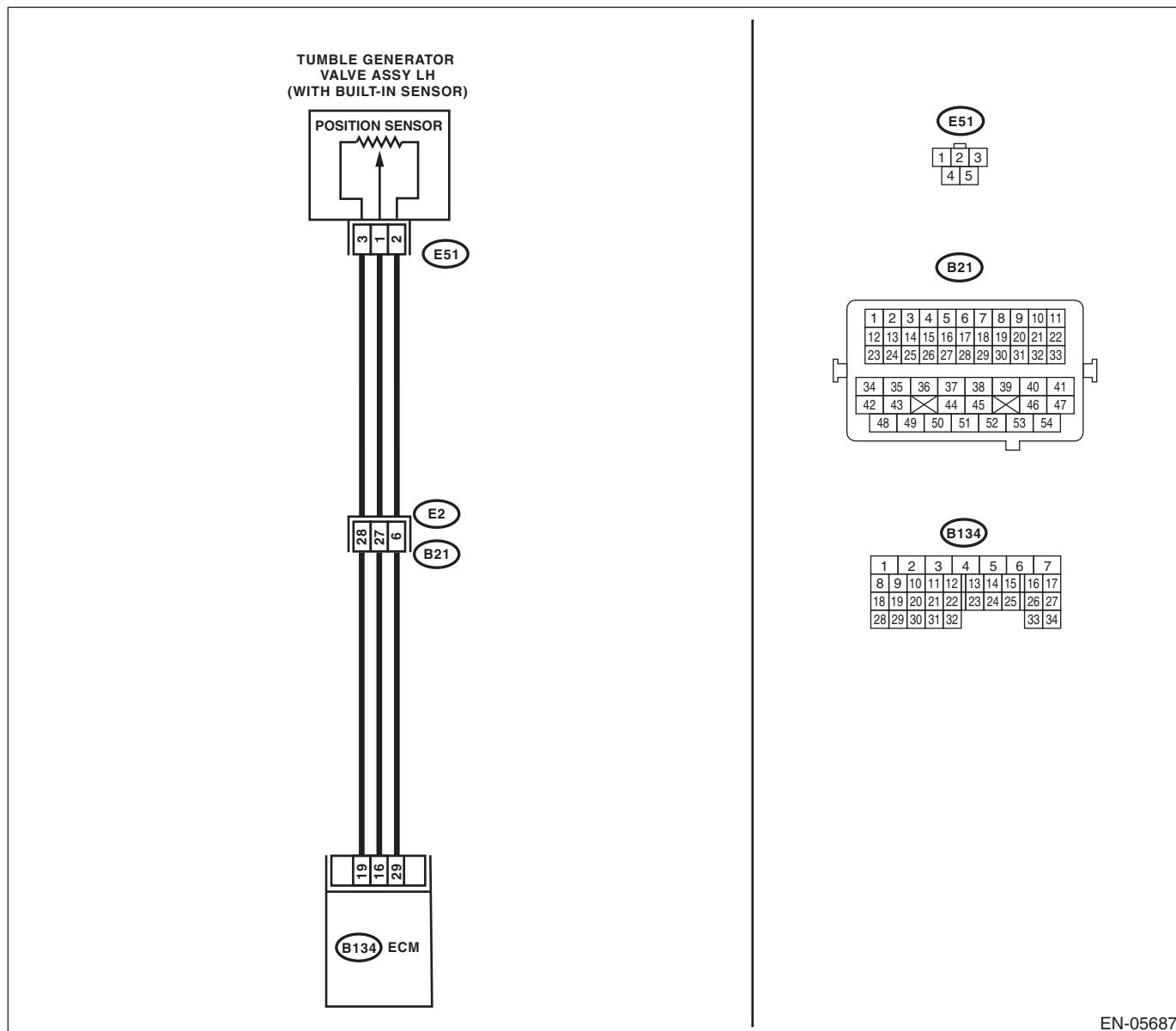

EN-05687

Diagnostic Procedure with Diagnostic Trouble Code (DTC)

ENGINE (DIAGNOSTICS)

Step	Check	Yes	No
<p>1 CHECK CURRENT DATA.</p> <p>1) Start the engine.</p> <p>2) Read the data of tumble generator valve position sensor signal (LH) using Subaru Select Monitor or general scan tool.</p> <p>NOTE:</p> <ul style="list-style-type: none"> • Subaru Select Monitor <p>For detailed operation procedures, refer to "READ CURRENT DATA FOR ENGINE". <Ref. to EN(H4DOTC)(diag)-34, Subaru Select Monitor.></p> <ul style="list-style-type: none"> • General scan tool <p>For detailed operation procedures, refer to the general scan tool operation manual.</p>	Is the voltage 5 V or more?	Go to step 2.	<p>Even if the malfunction indicator light illuminates, the circuit has returned to a normal condition at this time. Reproduce the fault condition, and reperform the check.</p> <p>NOTE:</p> <p>In this case, there may be a temporary connector contact failure.</p>
<p>2 CHECK HARNESS BETWEEN ECM AND TUMBLE GENERATOR VALVE ASSEMBLY LH CONNECTOR.</p> <p>1) Turn the ignition switch to OFF.</p> <p>2) Disconnect the connector from tumble generator valve assembly LH.</p> <p>3) Start the engine.</p> <p>4) Read the data of tumble generator valve position sensor signal (LH) using Subaru Select Monitor or general scan tool.</p> <p>NOTE:</p> <ul style="list-style-type: none"> • Subaru Select Monitor <p>For detailed operation procedures, refer to "READ CURRENT DATA FOR ENGINE". <Ref. to EN(H4DOTC)(diag)-34, Subaru Select Monitor.></p> <ul style="list-style-type: none"> • General scan tool <p>For detailed operation procedures, refer to the general scan tool operation manual.</p>	Is the voltage 5 V or more?	Repair the short circuit to power in harness between ECM and tumble generator valve assembly LH connector.	Go to step 3.
<p>3 CHECK HARNESS BETWEEN ECM AND TUMBLE GENERATOR VALVE ASSEMBLY LH CONNECTOR.</p> <p>1) Turn the ignition switch to OFF.</p> <p>2) Measure the resistance of harness between tumble generator valve assembly LH connector and engine ground.</p> <p>Connector & terminal (E51) No. 2 — Engine ground:</p>	Is the resistance less than 5 Ω?	Go to step 4.	<p>Repair the harness and connector.</p> <p>NOTE:</p> <p>In this case, repair the following item:</p> <ul style="list-style-type: none"> • Open circuit in harness between ECM and tumble generator valve assembly LH connector • Poor contact in ECM connector • Poor contact of coupling connector
<p>4 CHECK POOR CONTACT.</p> <p>Check for poor contact of tumble generator valve assembly LH connector.</p>	Is there poor contact in the tumble generator valve assembly LH connector?	Repair the poor contact of tumble generator valve assembly LH connector.	<p>Replace the tumble generator valve assembly LH.</p> <p><Ref. to FU(H4DOTC)-39, Tumble Generator Valve Assembly.></p>

Diagnostic Procedure with Diagnostic Trouble Code (DTC)

ENGINE (DIAGNOSTICS)

DH:DTC P2088 INTAKE CAMSHAFT POSITION ACTUATOR CONTROL CIRCUIT LOW (BANK 1)

DTC DETECTING CONDITION:

- Immediately at fault recognition
- GENERAL DESCRIPTION <Ref. to GD(H4DOTC)-197, DTC P2088 INTAKE CAMSHAFT POSITION ACTUATOR CONTROL CIRCUIT LOW (BANK 1), Diagnostic Trouble Code (DTC) Detecting Criteria.>

TROUBLE SYMPTOM:

Improper idling

CAUTION:

After repair or replacement of faulty parts, perform Clear Memory Mode <Ref. to EN(H4DOTC)(diag)-52, OPERATION, Clear Memory Mode.> and Inspection Mode <Ref. to EN(H4DOTC)(diag)-42, PROCEDURE, Inspection Mode.>.

WIRING DIAGRAM:

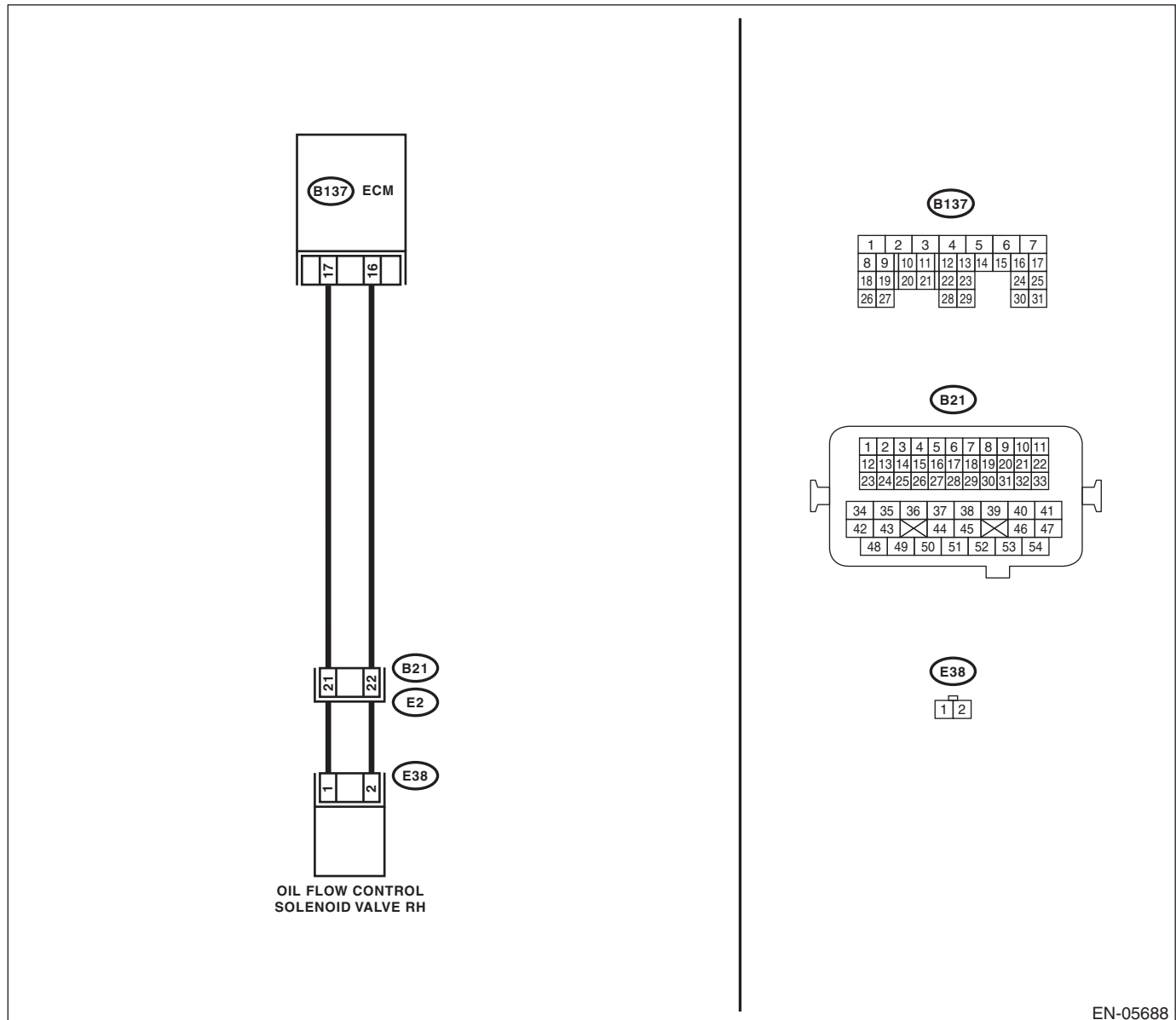

EN-05688

Diagnostic Procedure with Diagnostic Trouble Code (DTC)

ENGINE (DIAGNOSTICS)

Step	Check	Yes	No
1 CHECK HARNESS BETWEEN ECM AND OIL FLOW CONTROL SOLENOID VALVE. 1) Turn the ignition switch to OFF. 2) Disconnect the connectors from ECM and oil flow control solenoid valve. 3) Measure the resistance of harness between ECM and oil flow control solenoid valve. Connector & terminal <i>(B137) No. 17 — (E38) No. 1:</i> <i>(B137) No. 16 — (E38) No. 2:</i>	Is the resistance less than 1 Ω ?	Go to step 2.	Repair the harness and connector. NOTE: In this case, repair the following item: <ul style="list-style-type: none"> • Open circuit of the harness between the ECM and oil flow control solenoid valve connector • Poor contact of coupling connector
2 CHECK HARNESS BETWEEN ECM AND OIL FLOW CONTROL SOLENOID VALVE. Measure the resistance between ECM and chassis ground. Connector & terminal <i>(B137) No. 17 — Chassis ground:</i> <i>(B137) No. 16 — Chassis ground:</i>	Is the resistance 1 M Ω or more?	Go to step 3.	Repair the ground short circuit of harness between ECM and oil flow control solenoid valve connector.
3 CHECK OIL FLOW CONTROL SOLENOID VALVE. Measure the resistance between oil flow control solenoid valve terminals. Terminals <i>No. 1 — No. 2:</i>	Is the resistance between 6 — 12 Ω ?	Repair the poor contact of the ECM and oil flow control solenoid valve connector.	Replace the oil flow control solenoid valve. <Ref. to ME(H4DOTC)-60, Camshaft.>

DI: DTC P2089 INTAKE CAMSHAFT POSITION ACTUATOR CONTROL CIRCUIT HIGH (BANK 1)

DTC DETECTING CONDITION:

- Immediately at fault recognition
- GENERAL DESCRIPTION <Ref. to GD(H4DOTC)-198, DTC P2089 INTAKE CAMSHAFT POSITION ACTUATOR CONTROL CIRCUIT HIGH (BANK 1), Diagnostic Trouble Code (DTC) Detecting Criteria.>

TROUBLE SYMPTOM:

Improper idling

CAUTION:

After repair or replacement of faulty parts, perform Clear Memory Mode <Ref. to EN(H4DOTC)(diag)-52, OPERATION, Clear Memory Mode.> and Inspection Mode <Ref. to EN(H4DOTC)(diag)-42, PROCEDURE, Inspection Mode.>.

WIRING DIAGRAM:

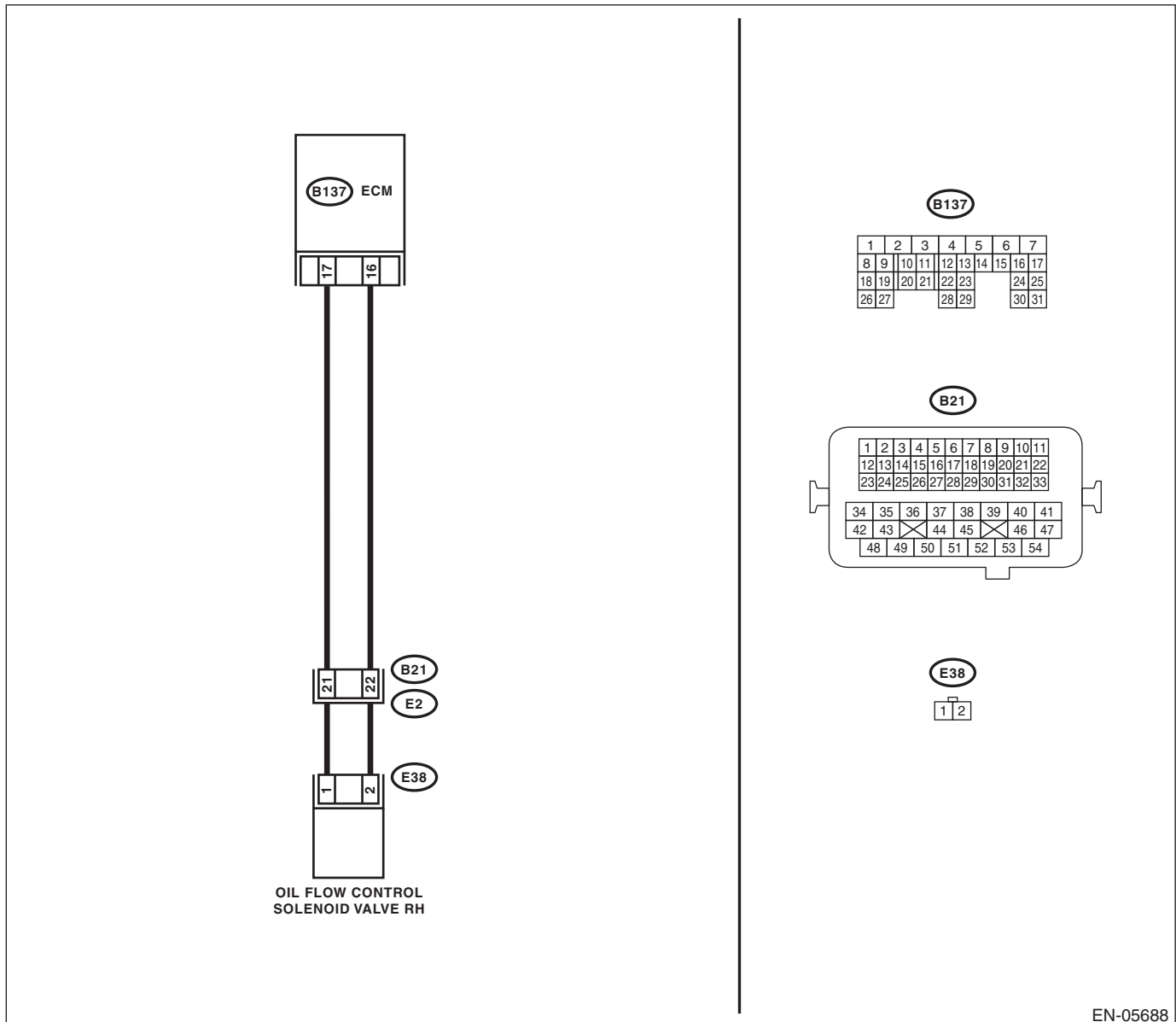

Diagnostic Procedure with Diagnostic Trouble Code (DTC)

ENGINE (DIAGNOSTICS)

Step	Check	Yes	No
<p>1 CHECK HARNESS BETWEEN ECM AND OIL FLOW CONTROL SOLENOID VALVE. 1) Turn the ignition switch to OFF. 2) Disconnect the connectors from ECM and oil flow control solenoid valve. 3) Measure the voltage between ECM and chassis ground. Connector & terminal (B137) No. 17 (+) — Chassis ground (-): (B137) No. 16 (+) — Chassis ground (-):</p>	<p>Is the voltage less than 1 V?</p>	<p>Go to step 2.</p>	<p>Repair the short circuit to power in the harness between the ECM and oil flow control solenoid valve connector.</p>
<p>2 CHECK HARNESS BETWEEN ECM AND OIL FLOW CONTROL SOLENOID VALVE. Measure the resistance of harness between ECM and oil flow control solenoid valve connector. Connector & terminal (B137) No. 17 — (E38) No. 1: (B137) No. 16 — (E38) No. 2:</p>	<p>Is the resistance less than 1 Ω?</p>	<p>Go to step 3.</p>	<p>Repair the harness and connector. NOTE: In this case, repair the following item: • Open circuit of the harness between the ECM and oil flow control solenoid valve connector • Poor contact of coupling connector</p>
<p>3 CHECK OIL FLOW CONTROL SOLENOID VALVE. Measure the resistance between oil flow control solenoid valve terminals. Terminals No. 1 — No. 2:</p>	<p>Is the resistance between 6 — 12 Ω?</p>	<p>Repair the poor contact of the ECM and oil flow control solenoid valve connector.</p>	<p>Replace the oil flow control solenoid valve. <Ref. to ME(H4DOTC)-60, Camshaft.></p>

Diagnostic Procedure with Diagnostic Trouble Code (DTC)

ENGINE (DIAGNOSTICS)

DJ:DTC P2092 INTAKE CAMSHAFT POSITION ACTUATOR CONTROL CIRCUIT LOW (BANK 2)

DTC DETECTING CONDITION:

- Immediately at fault recognition
- GENERAL DESCRIPTION <Ref. to GD(H4DOTC)-199, DTC P2092 INTAKE CAMSHAFT POSITION ACTUATOR CONTROL CIRCUIT LOW (BANK 2), Diagnostic Trouble Code (DTC) Detecting Criteria.>

TROUBLE SYMPTOM:

Improper idling

CAUTION:

After repair or replacement of faulty parts, perform Clear Memory Mode <Ref. to EN(H4DOTC)(diag)-52, OPERATION, Clear Memory Mode.> and Inspection Mode <Ref. to EN(H4DOTC)(diag)-42, PROCEDURE, Inspection Mode.>.

WIRING DIAGRAM:

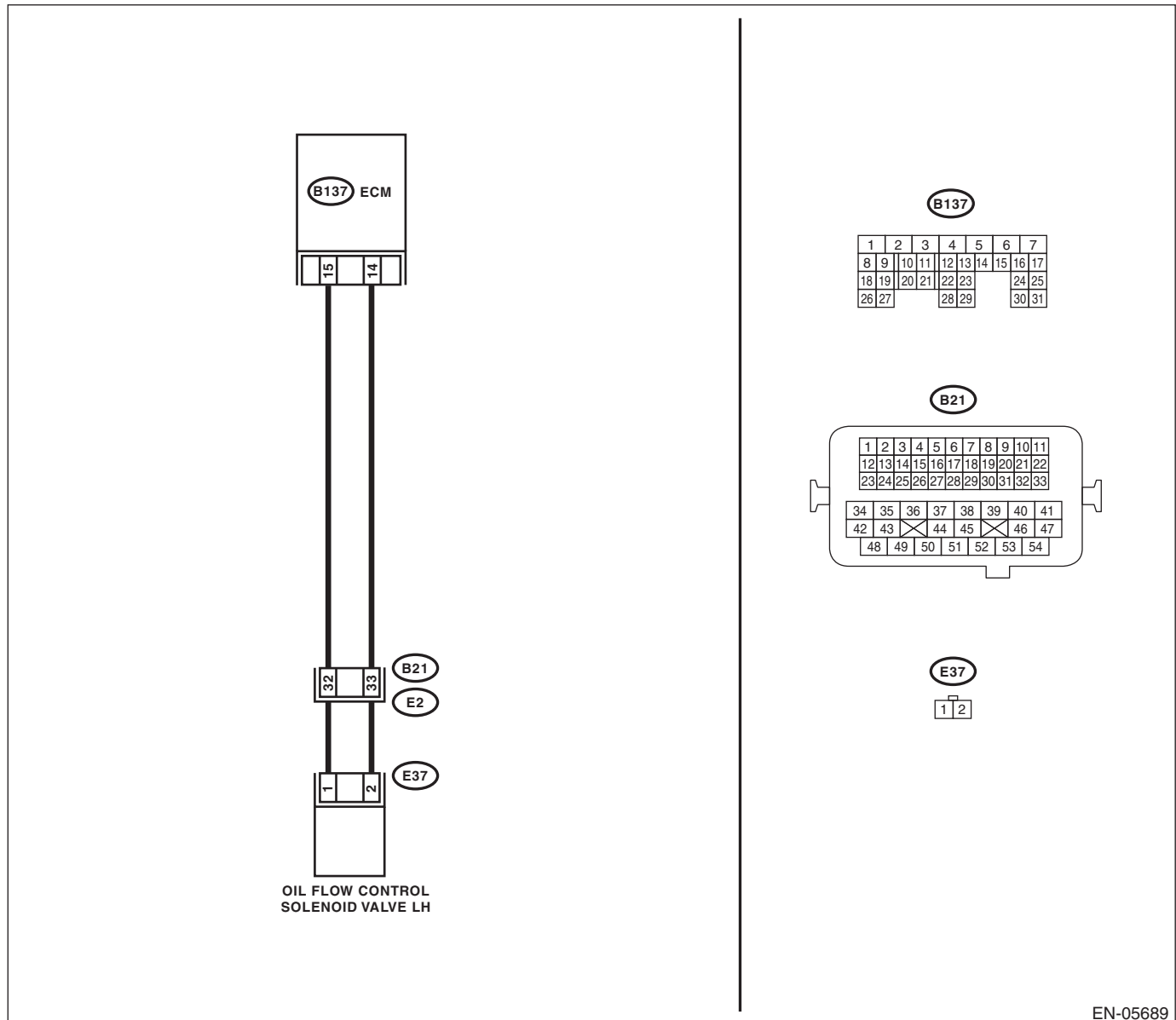

EN-05689

Diagnostic Procedure with Diagnostic Trouble Code (DTC)

ENGINE (DIAGNOSTICS)

Step	Check	Yes	No
<p>1 CHECK HARNESS BETWEEN ECM AND OIL FLOW CONTROL SOLENOID VALVE. 1) Turn the ignition switch to OFF. 2) Disconnect the connectors from ECM and oil flow control solenoid valve. 3) Measure the resistance of harness between ECM and oil flow control solenoid valve. Connector & terminal (B137) No. 15 — (E37) No. 1: (B137) No. 14 — (E37) No. 2:</p>	<p>Is the resistance less than 1 Ω?</p>	<p>Go to step 2.</p>	<p>Repair the harness and connector. NOTE: In this case, repair the following item: • Open circuit of the harness between the ECM and oil flow control solenoid valve connector • Poor contact of coupling connector</p>
<p>2 CHECK HARNESS BETWEEN ECM AND OIL FLOW CONTROL SOLENOID VALVE. Measure the resistance between ECM and chassis ground. Connector & terminal (B137) No. 15 — Chassis ground: (B137) No. 14 — Chassis ground:</p>	<p>Is the resistance 1 MΩ or more?</p>	<p>Go to step 3.</p>	<p>Repair the ground short circuit of harness between ECM and oil flow control solenoid valve connector.</p>
<p>3 CHECK OIL FLOW CONTROL SOLENOID VALVE. Measure the resistance between oil flow control solenoid valve terminals. Terminals No. 1 — No. 2:</p>	<p>Is the resistance between 6 — 12 Ω?</p>	<p>Repair the poor contact of the ECM and oil flow control solenoid valve connector.</p>	<p>Replace the oil flow control solenoid valve. <Ref. to ME(H4DOTC)-60, Camshaft.></p>

DK:DTC P2093 INTAKE CAMSHAFT POSITION ACTUATOR CONTROL CIRCUIT HIGH (BANK 2)

DTC DETECTING CONDITION:

- Immediately at fault recognition
- GENERAL DESCRIPTION <Ref. to GD(H4DOTC)-199, DTC P2093 INTAKE CAMSHAFT POSITION ACTUATOR CONTROL CIRCUIT HIGH (BANK 2), Diagnostic Trouble Code (DTC) Detecting Criteria.>

TROUBLE SYMPTOM:

Improper idling

CAUTION:

After repair or replacement of faulty parts, perform Clear Memory Mode <Ref. to EN(H4DOTC)(diag)-52, OPERATION, Clear Memory Mode.> and Inspection Mode <Ref. to EN(H4DOTC)(diag)-42, PROCEDURE, Inspection Mode.>.

WIRING DIAGRAM:

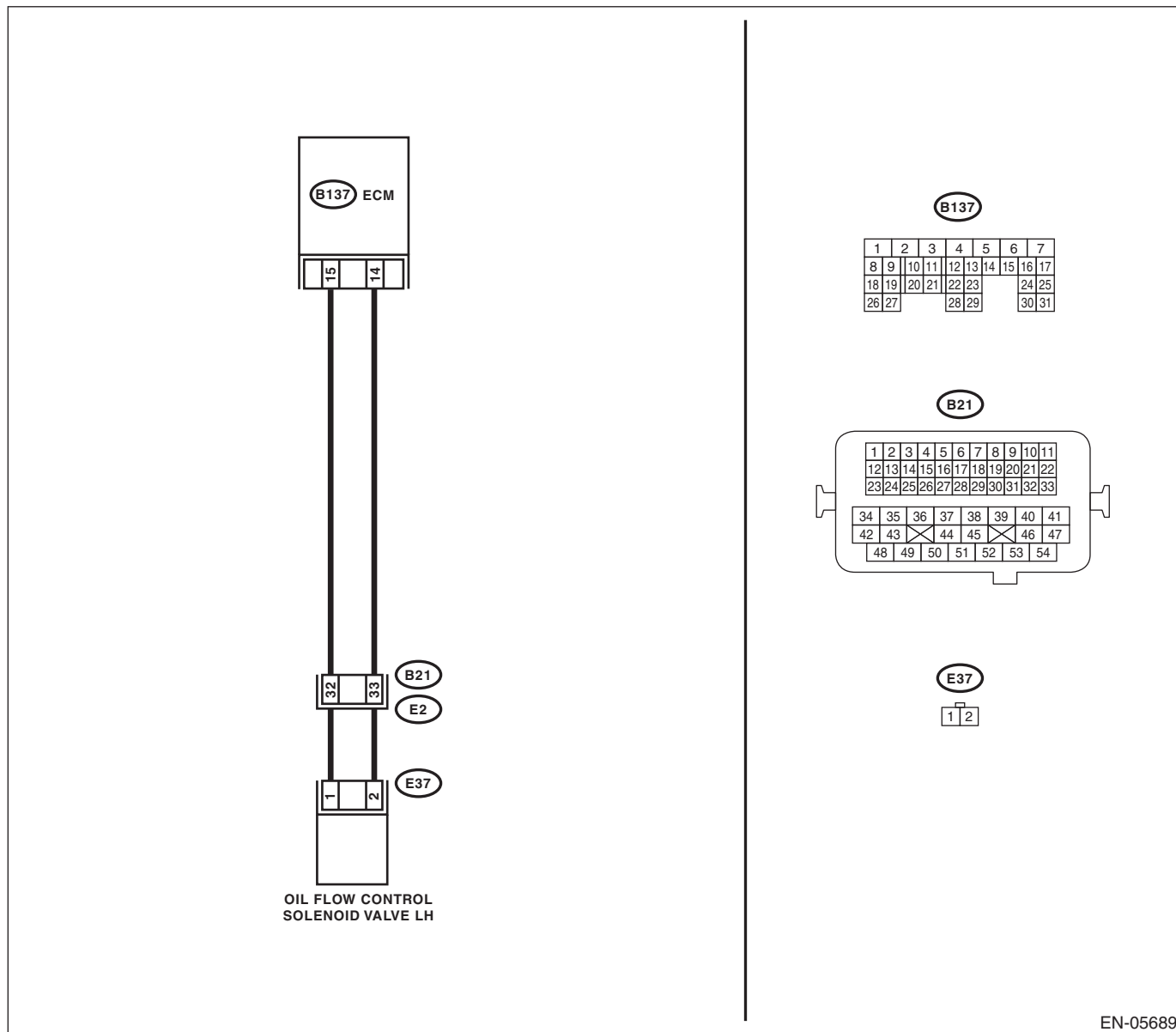

EN-05689

Diagnostic Procedure with Diagnostic Trouble Code (DTC)

ENGINE (DIAGNOSTICS)

Step	Check	Yes	No
1 CHECK HARNESS BETWEEN ECM AND OIL FLOW CONTROL SOLENOID VALVE. 1) Turn the ignition switch to OFF. 2) Disconnect the connectors from ECM and oil flow control solenoid valve. 3) Measure the voltage between ECM and chassis ground. Connector & terminal (B137) No. 15 (+) — Chassis ground (-): (B137) No. 14 (+) — Chassis ground (-):	Is the voltage less than 1 V?	Go to step 2.	Repair the short circuit to power in the harness between the ECM and oil flow control solenoid valve connector.
2 CHECK HARNESS BETWEEN ECM AND OIL FLOW CONTROL SOLENOID VALVE. Measure the resistance of harness between ECM and oil flow control solenoid valve connector. Connector & terminal (B137) No. 15 — (E37) No. 1: (B137) No. 14 — (E37) No. 2:	Is the resistance less than 1 Ω ?	Go to step 3.	Repair the harness and connector. NOTE: In this case, repair the following item: <ul style="list-style-type: none"> • Open circuit of the harness between the ECM and oil flow control solenoid valve connector • Poor contact of coupling connector
3 CHECK OIL FLOW CONTROL SOLENOID VALVE. Measure the resistance between oil flow control solenoid valve terminals. Terminals No. 1 — No. 2:	Is the resistance between 6 — 12 Ω ?	Repair the poor contact of the ECM and oil flow control solenoid valve connector.	Replace the oil flow control solenoid valve. <Ref. to ME(H4DOTC)-60, Camshaft.>

DL:DTC P2096 POST CATALYST FUEL TRIM SYSTEM TOO LEAN (BANK 1)

Refer to DTC P2097 for diagnostic procedure. <Ref. to EN(H4DOTC)(diag)-311, DTC P2097 POST CATALYST FUEL TRIM SYSTEM TOO RICH (BANK 1), Diagnostic Procedure with Diagnostic Trouble Code (DTC).>

Diagnostic Procedure with Diagnostic Trouble Code (DTC)

ENGINE (DIAGNOSTICS)

DM:DTC P2097 POST CATALYST FUEL TRIM SYSTEM TOO RICH (BANK 1)

DTC DETECTING CONDITION:

- Detected when two consecutive driving cycles with fault occur.
- GENERAL DESCRIPTION <Ref. to GD(H4DOTC)-202, DTC P2097 POST CATALYST FUEL TRIM SYSTEM TOO RICH (BANK 1), Diagnostic Trouble Code (DTC) Detecting Criteria.>

CAUTION:

After repair or replacement of faulty parts, perform Clear Memory Mode <Ref. to EN(H4DOTC)(diag)-52, OPERATION, Clear Memory Mode.> and Inspection Mode <Ref. to EN(H4DOTC)(diag)-42, PROCEDURE, Inspection Mode.>.

WIRING DIAGRAM:

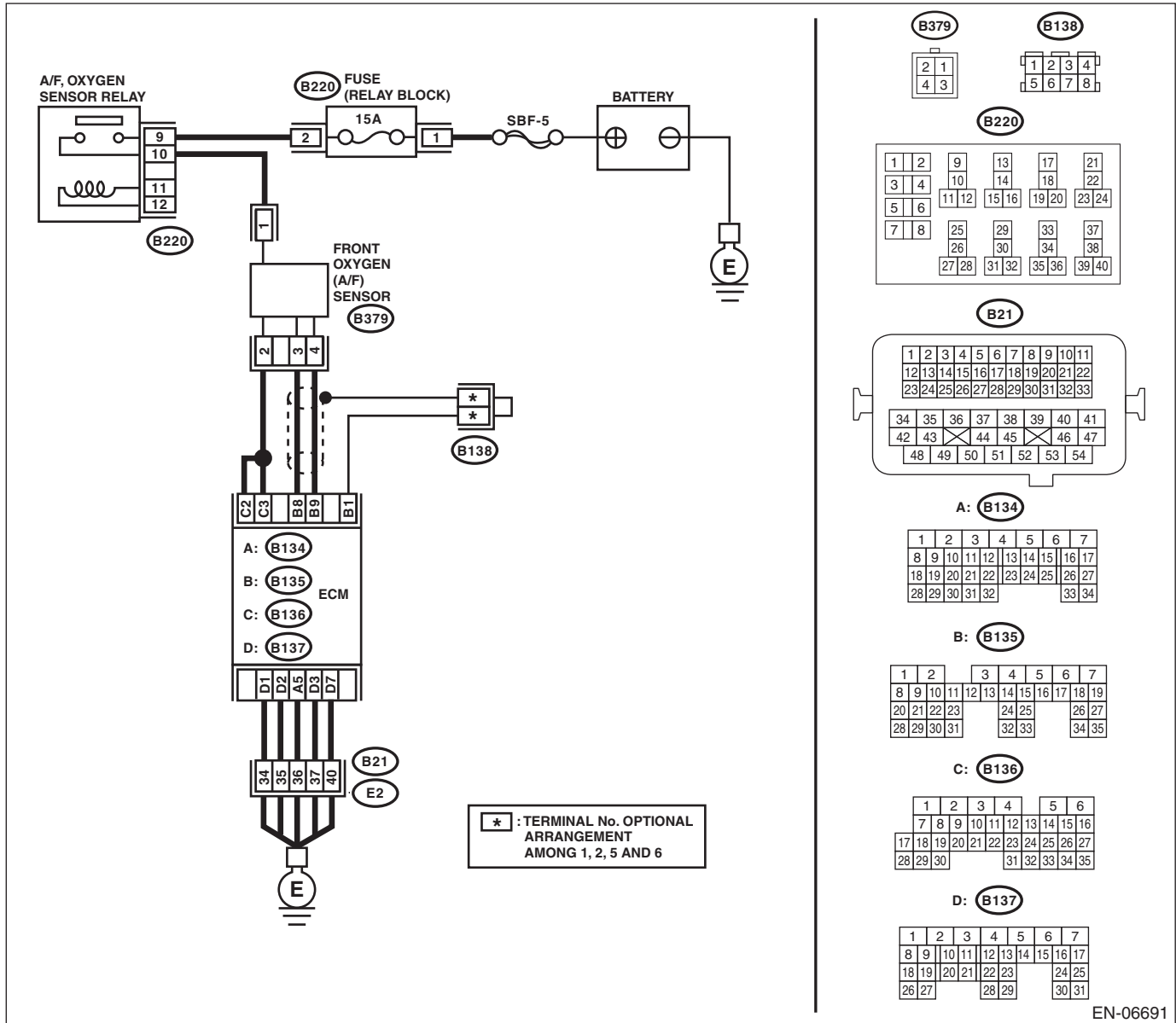

EN-06691

Diagnostic Procedure with Diagnostic Trouble Code (DTC)

ENGINE (DIAGNOSTICS)

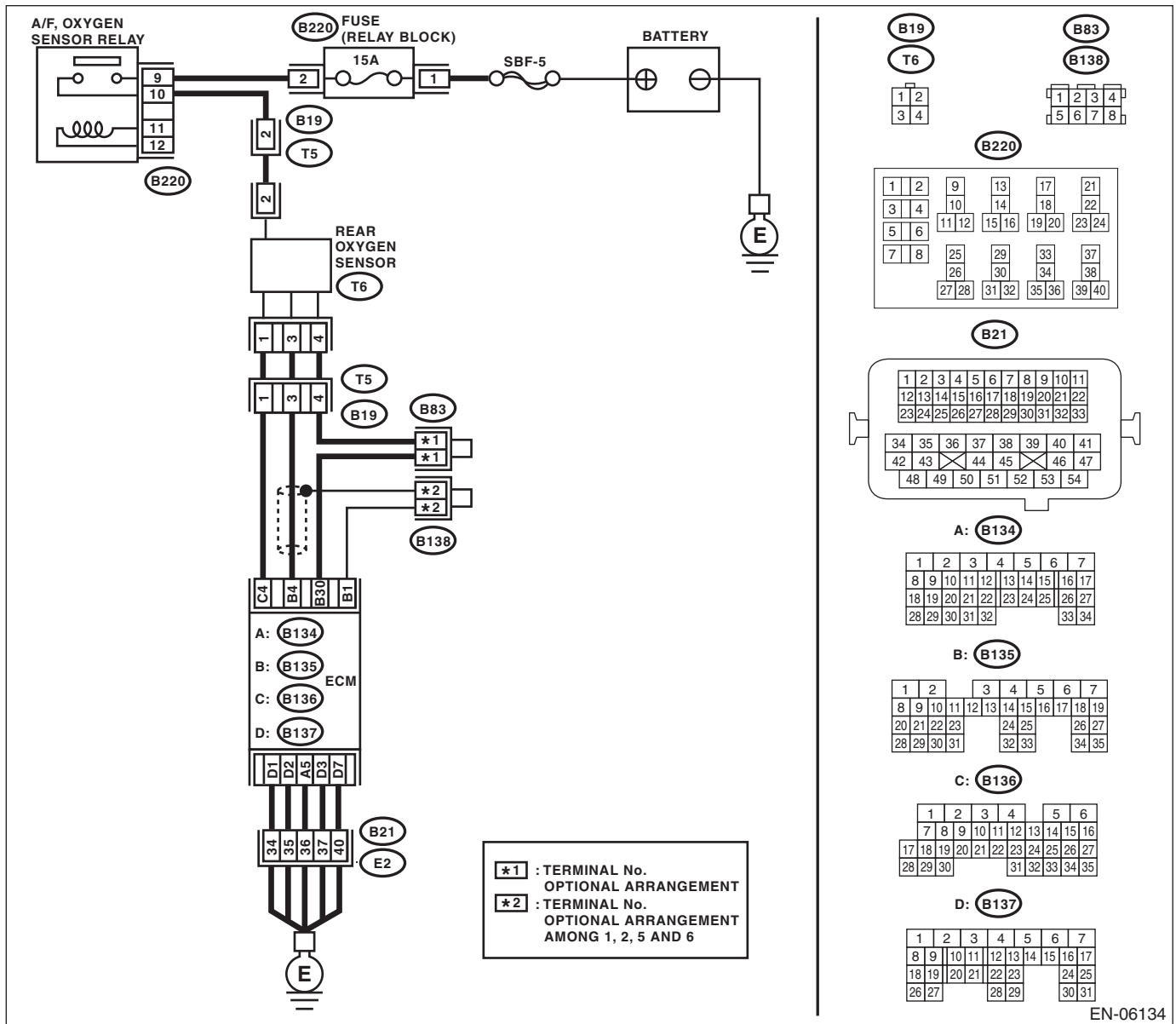

EN-06134

Diagnostic Procedure with Diagnostic Trouble Code (DTC)

ENGINE (DIAGNOSTICS)

Step	Check	Yes	No	
1	CHECK FOR ANY OTHER DTC ON DISPLAY.	Is any other DTC displayed?	Check DTC using "List of Diagnostic Trouble Code (DTC)". <Ref. to EN(H4DOTC)(diag)-80, List of Diagnostic Trouble Code (DTC).>	Go to step 2.
2	CHECK FRONT OXYGEN (A/F) SENSOR CONNECTOR AND COUPLING CONNECTOR.	Has water entered the connector?	Completely remove any water inside.	Go to step 3.
3	CHECK HARNESS BETWEEN ECM AND FRONT OXYGEN (A/F) SENSOR CONNECTOR. 1) Turn the ignition switch to OFF. 2) Disconnect the connectors from the ECM and front oxygen (A/F) sensor. 3) Measure the resistance of harness between ECM and front oxygen (A/F) sensor connector. Connector & terminal (B135) No. 9 — (B379) No. 4: (B135) No. 8 — (B379) No. 3:	Is the resistance less than 1 Ω?	Go to step 4.	Repair the harness and connector. NOTE: In this case, repair the following item: • Open circuit in harness between ECM and front oxygen (A/F) sensor connector • Poor contact of coupling connector
4	CHECK HARNESS BETWEEN ECM AND FRONT OXYGEN (A/F) SENSOR CONNECTOR. Measure the resistance between ECM and chassis ground. Connector & terminal (B135) No. 9 — Chassis ground: (B135) No. 8 — Chassis ground:	Is the resistance 1 MΩ or more?	Go to step 5.	Repair the ground short circuit of harness between ECM and front oxygen (A/F) sensor connector.
5	CHECK OUTPUT SIGNAL FOR ECM. 1) Connect the ECM. 2) Turn the ignition switch to ON. 3) Measure the voltage between front oxygen (A/F) sensor connector and chassis ground. Connector & terminal (B379) No. 4 (+) — Chassis ground (-):	Is the voltage 4.5 V or more?	Go to step 7.	Go to step 6.
6	CHECK OUTPUT SIGNAL FOR ECM. Measure the voltage between front oxygen (A/F) sensor connector and chassis ground. Connector & terminal (B379) No. 3 (+) — Chassis ground (-):	Is the voltage 4.95 V or more?	Go to step 7.	Go to step 8.
7	CHECK OUTPUT SIGNAL FOR ECM. Measure the voltage between front oxygen (A/F) sensor connector and chassis ground. Connector & terminal (B379) No. 3 (+) — Chassis ground (-): (B379) No. 4 (+) — Chassis ground (-):	Is the voltage 8 V or more?	Repair the short circuit to power in the harness between the ECM and front oxygen (A/F) sensor connector. After repair, replace the ECM. <Ref. to FU(H4DOTC)-46, Engine Control Module (ECM).>	Repair poor contact of the ECM connector.
8	CHECK EXHAUST SYSTEM.	Are there holes or loose bolts on exhaust system?	Repair the exhaust system.	Go to step 9.

Diagnostic Procedure with Diagnostic Trouble Code (DTC)

ENGINE (DIAGNOSTICS)

	Step	Check	Yes	No
9	CHECK AIR INTAKE SYSTEM.	Are there holes, loose bolts or disconnection of hose on air intake system?	Repair the air intake system.	Go to step 10.
10	CHECK FUEL PRESSURE. WARNING: Place “NO OPEN FLAMES” signs near the working area. CAUTION: Be careful not to spill fuel. 1) Connect the front oxygen (A/F) sensor connector. 2) Measure the fuel pressure while disconnecting pressure regulator vacuum hose from intake manifold. <Ref. to ME(H4DOTC)-25, INSPECTION, Fuel Pressure.> CAUTION: Release fuel pressure before removing the fuel pressure gauge. NOTE: If fuel pressure does not increase, squeeze the fuel return hose 2 to 3 times, then measure fuel pressure again.	Is the measured value 284 — 314 kPa (2.9 — 3.2 kgf/cm ² , 41 — 46 psi)?	Go to step 11.	Repair the following item. Fuel pressure is too high: <ul style="list-style-type: none"> • Clogged fuel return line or bent hose Fuel pressure is too low: <ul style="list-style-type: none"> • Improper fuel pump discharge • Clogged fuel supply line
11	CHECK FUEL PRESSURE. After connecting the pressure regulator vacuum hose, measure fuel pressure. <Ref. to ME(H4DOTC)-25, INSPECTION, Fuel Pressure.> CAUTION: Release fuel pressure before removing the fuel pressure gauge. NOTE: <ul style="list-style-type: none"> • If fuel pressure does not increase, squeeze fuel return hose 2 to 3 times, then measure fuel pressure again. • If the measured value at this step is out of specification, check or replace pressure regulator and pressure regulator vacuum hose. 	Is the measured value 230 — 260 kPa (2.35 — 2.65 kgf/cm ² , 33 — 38 psi)?	Go to step 12.	Repair the following item. Fuel pressure is too high: <ul style="list-style-type: none"> • Faulty pressure regulator • Clogged fuel return line or bent hose Fuel pressure is too low: <ul style="list-style-type: none"> • Faulty pressure regulator • Improper fuel pump discharge • Clogged fuel supply line
12	CHECK ENGINE COOLANT TEMPERATURE SENSOR. 1) Start the engine and warm up completely. 2) Read the data of engine coolant temperature sensor signal using Subaru Select Monitor or general scan tool. NOTE: <ul style="list-style-type: none"> • Subaru Select Monitor For detailed operation procedures, refer to “READ CURRENT DATA FOR ENGINE”. <Ref. to EN(H4DOTC)(diag)-34, Subaru Select Monitor.> <ul style="list-style-type: none"> • General scan tool For detailed operation procedures, refer to the general scan tool operation manual.	Is the engine coolant temperature 75°C (167°F) or higher?	Go to step 13.	Replace the engine coolant temperature sensor. <Ref. to FU(H4DOTC)-29, Engine Coolant Temperature Sensor.>

Diagnostic Procedure with Diagnostic Trouble Code (DTC)

ENGINE (DIAGNOSTICS)

Step	Check	Yes	No
<p>13 CHECK MASS AIR FLOW AND INTAKE AIR TEMPERATURE SENSOR.</p> <p>1) Start the engine and warm up engine until coolant temperature is higher than 75°C (167°F).</p> <p>2) Place the select lever in “P” range or “N” range.</p> <p>3) Turn the A/C switch to OFF.</p> <p>4) Turn all the accessory switches to OFF.</p> <p>5) Read the data of mass air flow and intake air temperature sensor signal using Subaru Select Monitor or general scan tool.</p> <p>NOTE:</p> <ul style="list-style-type: none"> • Subaru Select Monitor <p>For detailed operation procedures, refer to “READ CURRENT DATA FOR ENGINE”. <Ref. to EN(H4DOTC)(diag)-34, Subaru Select Monitor.></p> <ul style="list-style-type: none"> • General scan tool <p>For detailed operation procedures, refer to the general scan tool operation manual.</p>	<p>Is the measured value 2.0 — 5.0 g/s (0.26 — 0.66 lb/s) ?</p>	<p>Go to step 14.</p>	<p>Replace the mass air flow and intake air temperature sensor. <Ref. to FU(H4DOTC)-34, Mass Air Flow and Intake Air Temperature Sensor.></p>
<p>14 CHECK MASS AIR FLOW AND INTAKE AIR TEMPERATURE SENSOR.</p> <p>1) Start the engine and warm up engine until coolant temperature is higher than 75°C (167°F).</p> <p>2) Place the select lever in “P” range or “N” range.</p> <p>3) Turn the A/C switch to OFF.</p> <p>4) Turn all the accessory switches to OFF.</p> <p>5) Open the front hood.</p> <p>6) Measure the ambient temperature.</p> <p>7) Read the data of mass air flow and intake air temperature sensor signal using Subaru Select Monitor or general scan tool.</p> <p>NOTE:</p> <ul style="list-style-type: none"> • Subaru Select Monitor <p>For detailed operation procedures, refer to “READ CURRENT DATA FOR ENGINE”. <Ref. to EN(H4DOTC)(diag)-34, Subaru Select Monitor.></p> <ul style="list-style-type: none"> • General scan tool <p>For detailed operation procedures, refer to the general scan tool operation manual.</p>	<p>Subtract ambient temperature from intake air temperature. Is the obtained value -10 — 50°C (-18 — 90°F)?</p>	<p>Go to step 15.</p>	<p>Check the mass air flow and intake air temperature sensor. <Ref. to FU(H4DOTC)-34, Mass Air Flow and Intake Air Temperature Sensor.></p>

Diagnostic Procedure with Diagnostic Trouble Code (DTC)

ENGINE (DIAGNOSTICS)

Step	Check	Yes	No
15 CHECK REAR OXYGEN SENSOR DATA. 1) Warm up the engine until engine coolant temperature is higher than 75°C (167°F), and keep the engine speed at 3,000 rpm. (2 minutes maximum) 2) Read the data of rear oxygen sensor signal using Subaru Select Monitor or general scan tool. NOTE: • Subaru Select Monitor For detailed operation procedures, refer to "READ CURRENT DATA FOR ENGINE". <Ref. to EN(H4DOTC)(diag)-34, Subaru Select Monitor.> • General scan tool For detailed operation procedures, refer to the general scan tool operation manual.	Is the voltage 490 mV or more?	Go to step 16.	Go to step 17.
16 CHECK REAR OXYGEN SENSOR DATA. 1) Warm up the engine until engine coolant temperature is higher than 75°C (167°F), and rapidly reduce the engine speed from 3,000 rpm. 2) Read the data of rear oxygen sensor signal using Subaru Select Monitor or general scan tool. NOTE: • Subaru Select Monitor For detailed operation procedures, refer to "READ CURRENT DATA FOR ENGINE". <Ref. to EN(H4DOTC)(diag)-34, Subaru Select Monitor.> • General scan tool For detailed operation procedures, refer to the general scan tool operation manual.	Is the voltage 250 mV or less?	Go to step 18.	Go to step 17.
17 CHECK REAR OXYGEN SENSOR CONNECTOR AND COUPLING CONNECTOR.	Has water entered the connector?	Completely remove any water inside.	Go to step 19.
18 CHECK FRONT OXYGEN (A/F) SENSOR AND REAR OXYGEN SENSOR DATA. 1) Warm up the engine until engine coolant temperature is higher than 75°C (167°F), then keep the engine idling for 5 minutes or more. 2) Read the data of rear oxygen sensor signal using Subaru Select Monitor or general scan tool. NOTE: • Subaru Select Monitor For detailed operation procedures, refer to "READ CURRENT DATA FOR ENGINE". <Ref. to EN(H4DOTC)(diag)-34, Subaru Select Monitor.> • General scan tool For detailed operation procedures, refer to the general scan tool operation manual.	Is a voltage of 0.8 V or more maintained for 5 minutes or more?	Replace the front oxygen (A/F) sensor. <Ref. to FU(H4DOTC)-43, Front Oxygen (A/F) Sensor.>	Go to step 19.

Diagnostic Procedure with Diagnostic Trouble Code (DTC)

ENGINE (DIAGNOSTICS)

Step	Check	Yes	No
<p>19 CHECK HARNESS BETWEEN ECM AND REAR OXYGEN SENSOR CONNECTOR. 1) Turn the ignition switch to OFF. 2) Disconnect the connector from ECM and rear oxygen sensor. 3) Measure the resistance of harness between ECM and rear oxygen sensor connector. Connector & terminal (B135) No. 4 — (T6) No. 3: (B135) No. 30 — (T6) No. 4:</p>	<p>Is the resistance less than 1 Ω?</p>	<p>Go to step 20.</p>	<p>Repair the harness and connector. NOTE: In this case, repair the following item: • Open circuit in harness between ECM and rear oxygen sensor connector • Poor contact of coupling connector</p>
<p>20 CHECK HARNESS BETWEEN ECM AND REAR OXYGEN SENSOR CONNECTOR. 1) Connect the connector to ECM. 2) Turn the ignition switch to ON. 3) Measure the voltage between rear oxygen sensor connector and chassis ground. Connector & terminal (T6) No. 3 (+) — Chassis ground (-):</p>	<p>Is the voltage 0.2 — 0.5 V?</p>	<p>Replace the rear oxygen sensor. <Ref. to FU(H4DOTC)-45, Rear Oxygen Sensor.></p>	<p>Repair the harness and connector. NOTE: In this case, repair the following item: • Open circuit in harness between ECM and rear oxygen sensor connector • Poor contact in ECM connector • Poor contact of coupling connector</p>

Diagnostic Procedure with Diagnostic Trouble Code (DTC)

ENGINE (DIAGNOSTICS)

DN:DTC P2101 THROTTLE ACTUATOR CONTROL MOTOR CIRCUIT RANGE/ PERFORMANCE

DTC DETECTING CONDITION:

- Immediately at fault recognition
- GENERAL DESCRIPTION <Ref. to GD(H4DOTC)-204, DTC P2101 THROTTLE ACTUATOR CONTROL MOTOR CIRCUIT RANGE/PERFORMANCE, Diagnostic Trouble Code (DTC) Detecting Criteria.>

TROUBLE SYMPTOM:

- Improper idling
- Poor driving performance
- Engine stalls.

CAUTION:

After repair or replacement of faulty parts, perform Clear Memory Mode <Ref. to EN(H4DOTC)(diag)-52, OPERATION, Clear Memory Mode.> and Inspection Mode <Ref. to EN(H4DOTC)(diag)-42, PROCEDURE, Inspection Mode.>.

WIRING DIAGRAM:

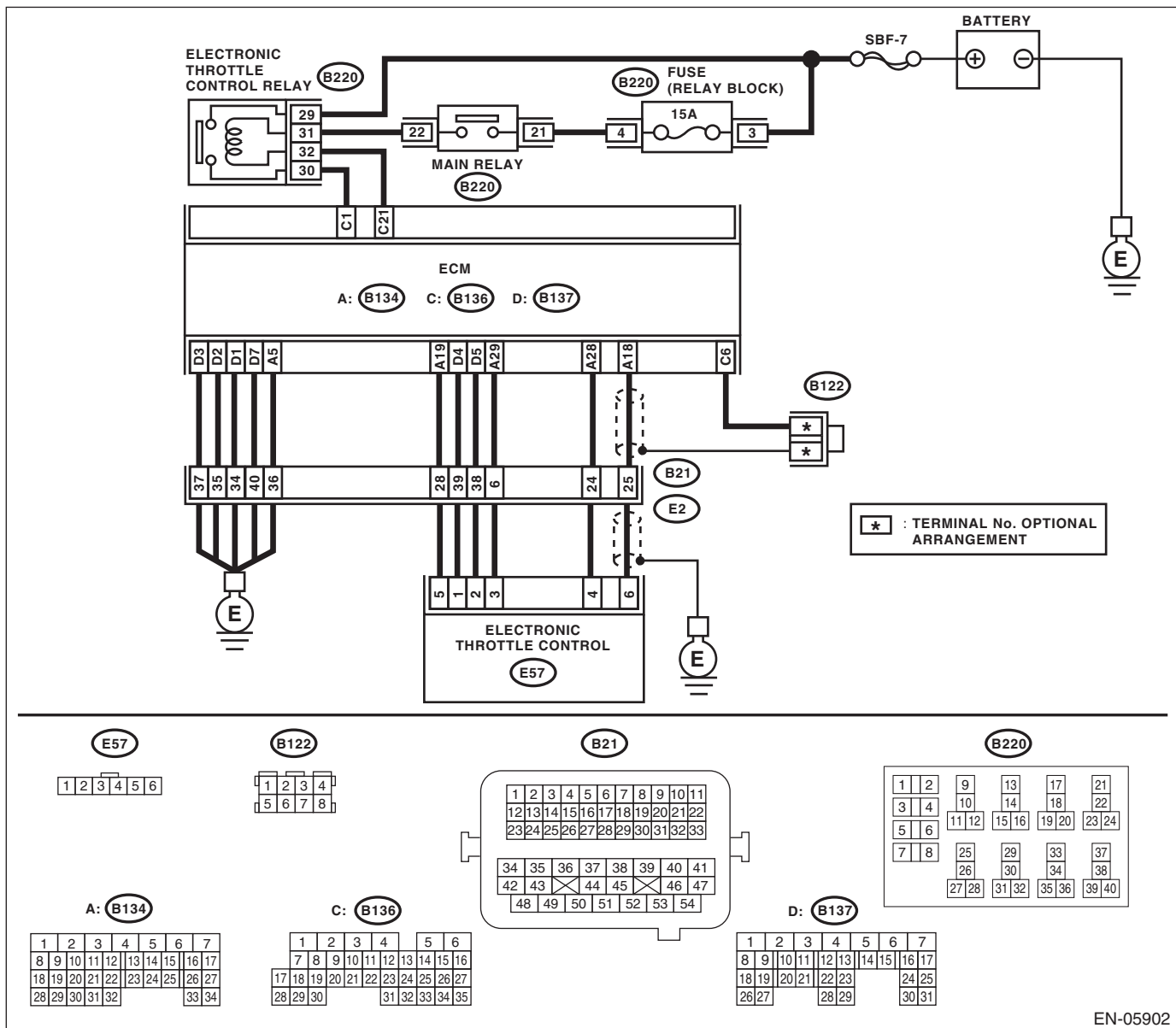

EN-05902

Diagnostic Procedure with Diagnostic Trouble Code (DTC)

ENGINE (DIAGNOSTICS)

Step	Check	Yes	No
<p>1 CHECK ELECTRONIC THROTTLE CONTROL RELAY.</p> <p>1) Turn the ignition switch to OFF. 2) Remove the electronic throttle control relay. 3) Connect the battery to terminals No. 31 and No. 32 of electronic throttle control relay. 4) Measure the resistance between electronic throttle control relay terminals.</p> <p>Terminals No. 29 — No. 30:</p>	Is the resistance less than 1 Ω?	Go to step 2.	Replace the electronic throttle control relay. <Ref. to FU(H4DOTC)-49, Electronic Throttle Control Relay.>
<p>2 CHECK POWER SUPPLY OF ELECTRONIC THROTTLE CONTROL RELAY.</p> <p>Measure the voltage between electronic throttle control relay connector and chassis ground.</p> <p>Connector & terminal (B220) No. 29 (+) — Chassis ground (-):</p>	Is the voltage 10 V or more?	Go to step 3.	Repair the open or ground short circuit of power supply circuit.
<p>3 CHECK HARNESS BETWEEN ECM AND ELECTRONIC THROTTLE CONTROL RELAY.</p> <p>1) Disconnect the connectors from the ECM. 2) Turn the ignition switch to ON. 3) Measure the voltage between electronic throttle control relay connector and chassis ground.</p> <p>Connector & terminal (B220) No. 32 (+) — Chassis ground (-):</p>	Is the voltage 10 V or more?	Repair the short circuit to power in the harness between ECM and electronic throttle control relay connector.	Go to step 4.
<p>4 CHECK HARNESS BETWEEN ECM AND ELECTRONIC THROTTLE CONTROL RELAY.</p> <p>1) Turn the ignition switch to OFF. 2) Measure the resistance between electronic throttle control relay connector and chassis ground.</p> <p>Connector & terminal (B220) No. 32 — Chassis ground: (B220) No. 30 — Chassis ground:</p>	Is the resistance 1 MΩ or more?	Go to step 5.	Repair the short circuit in harness to ground between ECM and electronic throttle control relay connector.
<p>5 CHECK HARNESS BETWEEN ECM AND ELECTRONIC THROTTLE CONTROL RELAY.</p> <p>Measure the resistance between the ECM and electronic throttle control relay connector.</p> <p>Connector & terminal (B136) No. 21 — (B220) No. 32: (B136) No. 1 — (B220) No. 30:</p>	Is the resistance less than 1 Ω?	Go to step 6.	Repair the open circuit in harness between ECM and electronic throttle control relay connector.
<p>6 CHECK HARNESS BETWEEN ECM AND ELECTRONIC THROTTLE CONTROL.</p> <p>1) Turn the ignition switch to OFF. 2) Disconnect the connectors from electronic throttle control. 3) Measure the resistance between ECM and chassis ground.</p> <p>Connector & terminal (B134) No. 19 — Chassis ground: (B134) No. 18 — Chassis ground: (B134) No. 18 — (B136) No. 6: (B134) No. 28 — Chassis ground:</p>	Is the resistance 1 MΩ or more?	Go to step 7.	Repair the ground short circuit of harness between ECM and electronic throttle control connector.

Diagnostic Procedure with Diagnostic Trouble Code (DTC)

ENGINE (DIAGNOSTICS)

Step	Check	Yes	No
7 CHECK SHORT CIRCUIT INSIDE THE ECM. 1) Connect the ECM. 2) Measure the resistance between electronic throttle control connector and engine ground. Connector & terminal <i>(E57) No. 6 — Engine ground:</i> <i>(E57) No. 4 — Engine ground:</i>	Is the resistance 1 M Ω or more?	Go to step 8.	Repair the ground short circuit of harness between ECM and electronic throttle control connector. Replace the ECM if defective. <Ref. to FU(H4DOTC)-46, Engine Control Module (ECM).>
8 CHECK HARNESS BETWEEN ECM AND ELECTRONIC THROTTLE CONTROL. 1) Disconnect the connectors from the ECM. 2) Measure the resistance of harness between ECM and electronic throttle control connector. Connector & terminal <i>(B134) No. 18 — (E57) No. 6:</i> <i>(B134) No. 28 — (E57) No. 4:</i> <i>(B134) No. 29 — (E57) No. 3:</i>	Is the resistance less than 1 Ω ?	Go to step 9.	Repair the harness and connector. NOTE: In this case, repair the following item: <ul style="list-style-type: none"> • Open circuit in harness between ECM and electronic throttle control connector • Poor contact of coupling connector
9 CHECK HARNESS BETWEEN ECM AND ELECTRONIC THROTTLE CONTROL. 1) Connect the ECM. 2) Measure the resistance between electronic throttle control connector and engine ground. Connector & terminal <i>(E57) No. 3 — Engine ground:</i>	Is the resistance less than 5 Ω ?	Go to step 10.	Repair the harness and connector. NOTE: In this case, repair the following item: <ul style="list-style-type: none"> • Open circuit of harness between ECM and engine ground • Poor contact in ECM connector • Poor contact of coupling connector
10 CHECK HARNESS BETWEEN ECM AND ELECTRONIC THROTTLE CONTROL. 1) Turn the ignition switch to ON. 2) Measure the voltage between electronic throttle control connector and engine ground. Connector & terminal <i>(E57) No. 6 (+) — Engine ground (-):</i> <i>(E57) No. 4 (+) — Engine ground (-):</i>	Is the voltage 4.85 V or more?	Repair the short circuit to power in the harness between ECM and electronic throttle control connector.	Go to step 11.
11 CHECK HARNESS BETWEEN ECM AND ELECTRONIC THROTTLE CONTROL. 1) Turn the ignition switch to OFF. 2) Disconnect the connectors from the ECM. 3) Measure the resistance between ECM connectors. Connector & terminal <i>(B134) No. 19 — (B134) No. 18:</i> <i>(B134) No. 19 — (B134) No. 28:</i>	Is the resistance 1 M Ω or more?	Go to step 12.	Repair the short circuit to power in the harness between ECM and electronic throttle control connector.

Diagnostic Procedure with Diagnostic Trouble Code (DTC)

ENGINE (DIAGNOSTICS)

Step	Check	Yes	No
12 CHECK SENSOR OUTPUT. 1) Connect all connectors. 2) Turn the ignition switch to ON. 3) Read the data of main throttle sensor signal using Subaru Select Monitor. NOTE: For detailed operation procedures, refer to "READ CURRENT DATA FOR ENGINE". <Ref. to EN(H4DOTC)(diag)-34, Subaru Select Monitor.>	Is the voltage 0.81 — 0.87 V?	Go to step 13.	Repair poor contact of the electronic throttle control connector. Replace the electronic throttle control if defective. <Ref. to FU(H4DOTC)-13, Throttle Body.>
13 CHECK SENSOR OUTPUT. Read the data of sub throttle sensor signal using Subaru Select Monitor. NOTE: Subaru Select Monitor For detailed operation procedures, refer to "READ CURRENT DATA FOR ENGINE". <Ref. to EN(H4DOTC)(diag)-34, Subaru Select Monitor.>	Is the voltage 1.64 — 1.70 V?	Go to step 14.	Repair poor contact of the electronic throttle control connector. Replace the electronic throttle control if defective. <Ref. to FU(H4DOTC)-13, Throttle Body.>
14 CHECK HARNESS BETWEEN ECM AND ELECTRONIC THROTTLE CONTROL MOTOR. 1) Turn the ignition switch to OFF. 2) Disconnect the connectors from ECM and electronic throttle control. 3) Measure the resistance between ECM and electronic throttle control connector. <i>Connector & terminal</i> <i>(B137) No. 5 — (E57) No. 2:</i> <i>(B137) No. 4 — (E57) No. 1:</i>	Is the resistance less than 1 Ω?	Go to step 15.	Repair the harness and connector. NOTE: In this case, repair the following item: • Open circuit in harness between ECM and electronic throttle control connector • Poor contact of coupling connector
15 CHECK HARNESS BETWEEN ECM AND ELECTRONIC THROTTLE CONTROL MOTOR. 1) Connect the ECM. 2) Turn the ignition switch to ON. 3) Measure the voltage between electronic throttle control connector and engine ground. <i>Connector & terminal</i> <i>(E57) No. 2 (+) — Engine ground (-):</i> <i>(E57) No. 1 (+) — Engine ground (-):</i>	Is the voltage 5 V or more?	Repair the short circuit to power in the harness between ECM and electronic throttle control connector.	Go to step 16.
16 CHECK HARNESS BETWEEN ECM AND ELECTRONIC THROTTLE CONTROL MOTOR. 1) Turn the ignition switch to OFF. 2) Disconnect the connectors from the ECM. 3) Measure the resistance between electronic throttle control connector and engine ground. <i>Connector & terminal</i> <i>(E57) No. 2 — Engine ground:</i> <i>(E57) No. 1 — Engine ground:</i>	Is the resistance 1 MΩ or more?	Go to step 17.	Repair the short circuit to ground in harness between ECM and electronic throttle control connector.
17 CHECK ELECTRONIC THROTTLE CONTROL MOTOR HARNESS. Measure the resistance between the electronic throttle control connector terminals. <i>Connector & terminal</i> <i>(E57) No. 2 — (E57) No. 1:</i>	Is the resistance 1 MΩ or more?	Go to step 18.	Repair the short circuit of harness between ECM and electronic throttle control connector.

Diagnostic Procedure with Diagnostic Trouble Code (DTC)

ENGINE (DIAGNOSTICS)

Step	Check	Yes	No
18 CHECK ELECTRONIC THROTTLE CONTROL GROUND CIRCUIT. Measure the resistance between ECM and chassis ground. Connector & terminal <i>(B134) No. 5 — Chassis ground:</i> <i>(B137) No. 1 — Chassis ground:</i> <i>(B137) No. 2 — Chassis ground:</i> <i>(B137) No. 3 — Chassis ground:</i> <i>(B137) No. 7 — Chassis ground:</i>	Is the resistance less than 5 Ω ?	Go to step 19 .	Repair the harness and connector. NOTE: In this case, repair the following item: <ul style="list-style-type: none"> • Open circuit of harness between ECM and engine ground • Poor contact of coupling connector
19 CHECK ELECTRONIC THROTTLE CONTROL. Measure the resistance between electronic throttle control terminals. Terminals No. 2 — No. 1:	Is the resistance 50 Ω or less?	Go to step 20 .	Replace the electronic throttle control. <Ref. to FU(H4DOTC)-13, Throttle Body.>
20 CHECK ELECTRONIC THROTTLE CONTROL. Move the throttle valve to the fully open and fully closed positions with fingers. Check that the valve returns to the specified position when releasing fingers.	Does the valve return to the specified position? Standard value: 3 mm (0.12 in) from fully closed position	Repair the poor contact of the ECM connector.	Replace the electronic throttle control. <Ref. to FU(H4DOTC)-13, Throttle Body.>

DO:DTC P2102 THROTTLE ACTUATOR CONTROL MOTOR CIRCUIT LOW

DTC DETECTING CONDITION:

- Immediately at fault recognition
- GENERAL DESCRIPTION <Ref. to GD(H4DOTC)-205, DTC P2102 THROTTLE ACTUATOR CONTROL MOTOR CIRCUIT LOW, Diagnostic Trouble Code (DTC) Detecting Criteria.>

TROUBLE SYMPTOM:

- Improper idling
- Poor driving performance
- Engine stalls.

CAUTION:

After repair or replacement of faulty parts, perform Clear Memory Mode <Ref. to EN(H4DOTC)(diag)-52, OPERATION, Clear Memory Mode.> and Inspection Mode <Ref. to EN(H4DOTC)(diag)-42, PROCEDURE, Inspection Mode.>.

WIRING DIAGRAM:

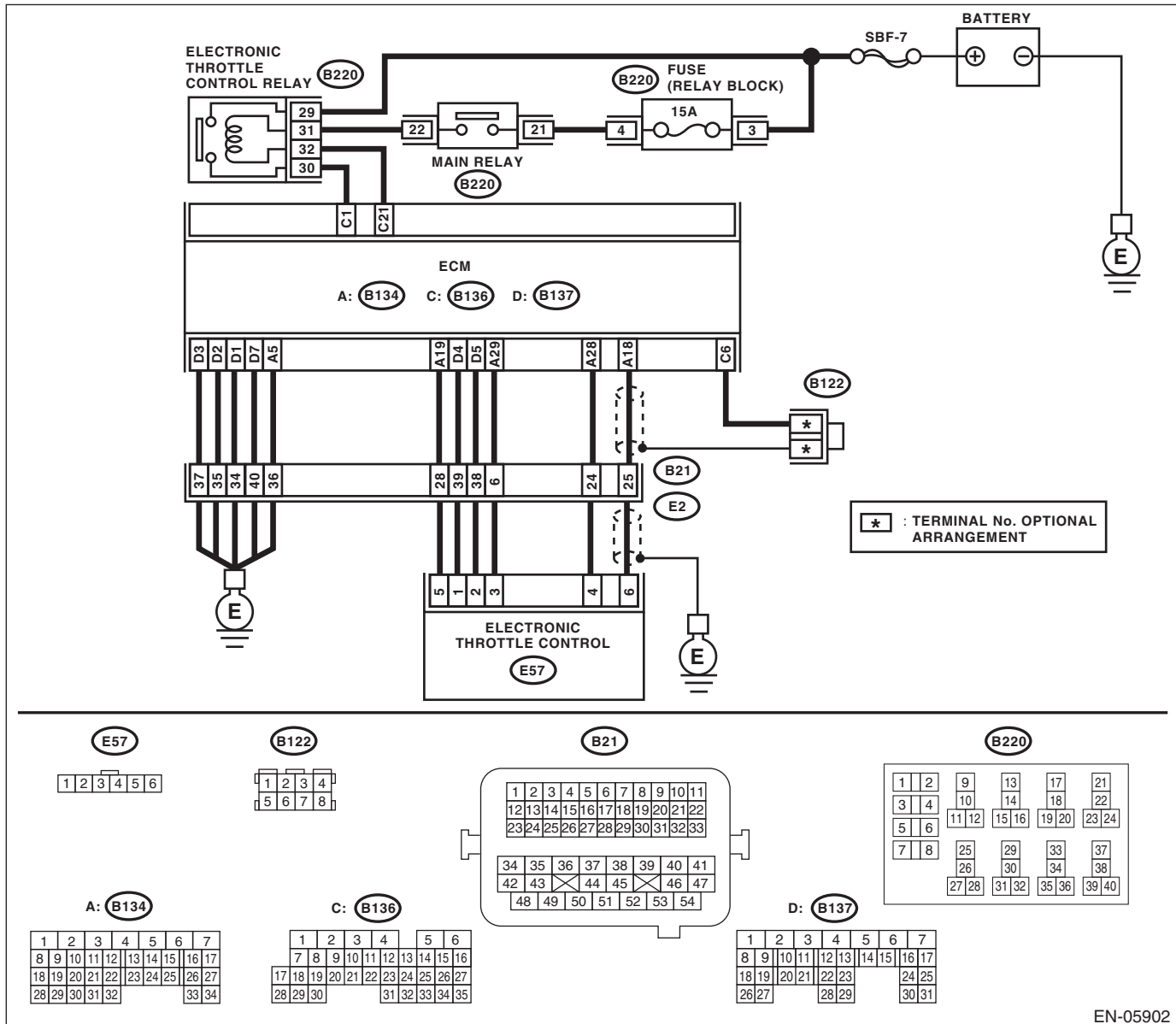

EN-05902

Diagnostic Procedure with Diagnostic Trouble Code (DTC)

ENGINE (DIAGNOSTICS)

Step	Check	Yes	No
1 CHECK ELECTRONIC THROTTLE CONTROL RELAY. 1) Turn the ignition switch to OFF. 2) Remove the electronic throttle control relay. 3) Connect the battery to terminals No. 31 and No. 32 of electronic throttle control relay. 4) Measure the resistance between electronic throttle control relay terminals. Terminals No. 29 — No. 30:	Is the resistance less than 1 Ω ?	Go to step 2.	Replace the electronic throttle control relay. <Ref. to FU(H4DOTC)-49, Electronic Throttle Control Relay.>
2 CHECK POWER SUPPLY OF ELECTRONIC THROTTLE CONTROL RELAY. Measure the voltage between electronic throttle control relay connector and chassis ground. Connector & terminal (B220) No. 29 (+) — Chassis ground (-):	Is the voltage 10 V or more?	Go to step 3.	Repair the open or ground short circuit of power supply circuit.
3 CHECK HARNESS BETWEEN ECM AND ELECTRONIC THROTTLE CONTROL RELAY. 1) Disconnect the connectors from the ECM. 2) Turn the ignition switch to ON. 3) Measure the voltage between electronic throttle control relay connector and chassis ground. Connector & terminal (B220) No. 32 (+) — Chassis ground (-):	Is the voltage 10 V or more?	Repair the short circuit to power in the harness between ECM and electronic throttle control relay connector.	Go to step 4.
4 CHECK HARNESS BETWEEN ECM AND ELECTRONIC THROTTLE CONTROL RELAY. 1) Turn the ignition switch to OFF. 2) Measure the resistance between electronic throttle control relay connector and chassis ground. Connector & terminal (B220) No. 32 — Chassis ground: (B220) No. 30 — Chassis ground:	Is the resistance 1 M Ω or more?	Go to step 5.	Repair the short circuit in harness to ground between ECM and electronic throttle control relay connector.
5 CHECK HARNESS BETWEEN ECM AND ELECTRONIC THROTTLE CONTROL RELAY. Measure the resistance between the ECM and electronic throttle control relay connector. Connector & terminal (B136) No. 21 — (B220) No. 32: (B136) No. 1 — (B220) No. 30:	Is the resistance less than 1 Ω ?	Repair the poor contact of the ECM connector.	Repair the open circuit in harness between ECM and electronic throttle control relay connector.

Diagnostic Procedure with Diagnostic Trouble Code (DTC)

ENGINE (DIAGNOSTICS)

DP:DTC P2103 THROTTLE ACTUATOR CONTROL MOTOR CIRCUIT HIGH

DTC DETECTING CONDITION:

- Immediately at fault recognition
- GENERAL DESCRIPTION <Ref. to GD(H4DOTC)-206, DTC P2103 THROTTLE ACTUATOR CONTROL MOTOR CIRCUIT HIGH, Diagnostic Trouble Code (DTC) Detecting Criteria.>

CAUTION:

After repair or replacement of faulty parts, perform Clear Memory Mode <Ref. to EN(H4DOTC)(diag)-52, OPERATION, Clear Memory Mode.> and Inspection Mode <Ref. to EN(H4DOTC)(diag)-42, PROCEDURE, Inspection Mode.>.

WIRING DIAGRAM:

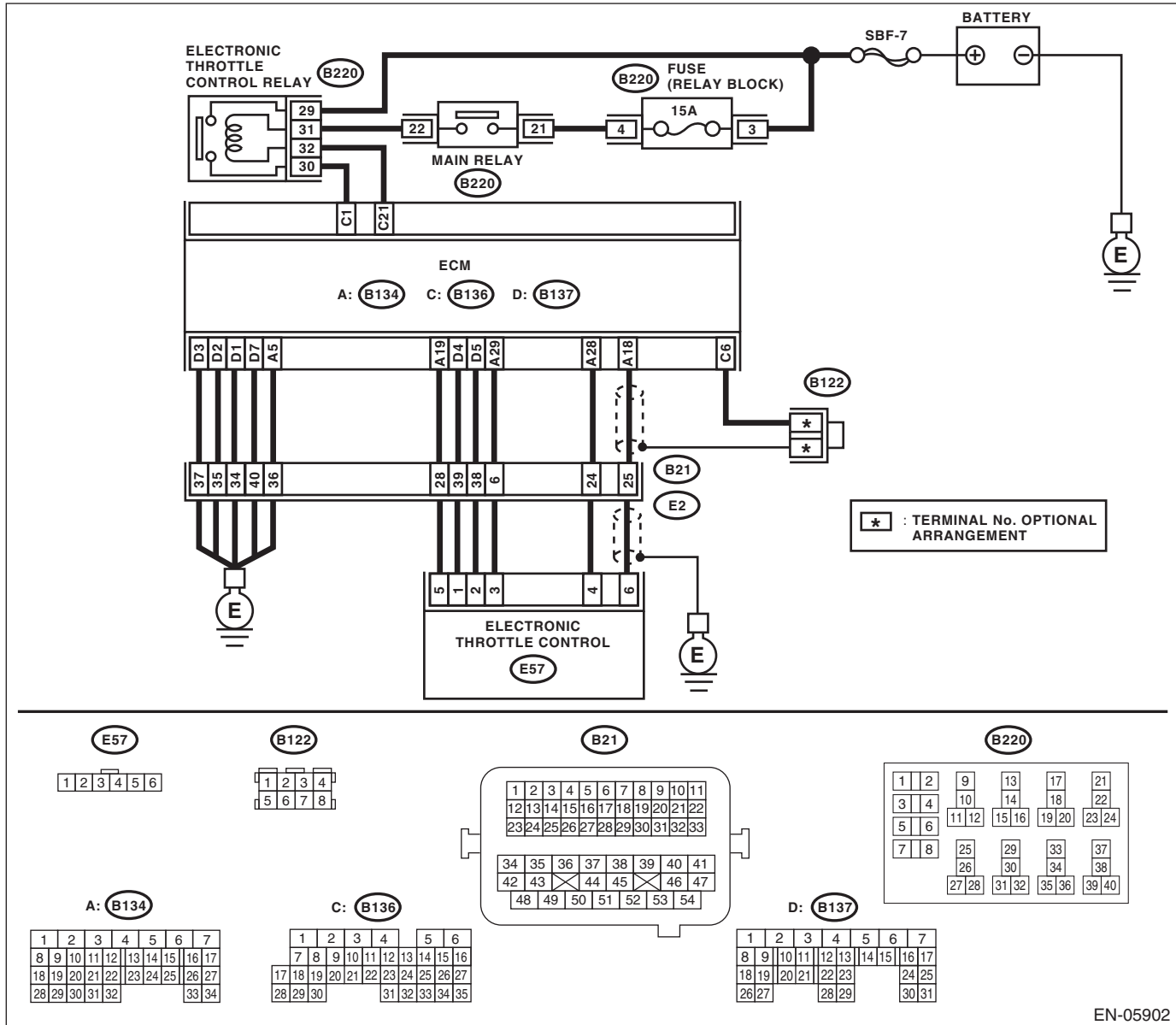

EN-05902

Diagnostic Procedure with Diagnostic Trouble Code (DTC)

ENGINE (DIAGNOSTICS)

Step	Check	Yes	No
1 CHECK ELECTRONIC THROTTLE CONTROL RELAY. 1) Turn the ignition switch to OFF. 2) Remove the electronic throttle control relay. 3) Measure the resistance between electronic throttle control relay terminals. <i>Terminals</i> <i>No. 29 — No. 30:</i>	Is the resistance 1 MΩ or more?	Go to step 2.	Replace the electronic throttle control relay. <Ref. to FU(H4DOTC)-49, Electronic Throttle Control Relay.>
2 CHECK SHORT CIRCUIT OF ELECTRONIC THROTTLE CONTROL RELAY POWER SUPPLY. 1) Turn the ignition switch to ON. 2) Measure the voltage between electronic throttle control relay connector and chassis ground. <i>Connector & terminal</i> <i>(B220) No. 30 (+) — Chassis ground (-):</i>	Is the voltage 10 V or more?	Repair the short circuit to power in the harness between ECM and electronic throttle control relay connector.	Go to step 3.
3 CHECK HARNESS BETWEEN ECM AND ELECTRONIC THROTTLE CONTROL RELAY. 1) Turn the ignition switch to OFF. 2) Disconnect the connectors from the ECM. 3) Measure the resistance between ECM and chassis ground. <i>Connector & terminal</i> <i>(B136) No. 21 — Chassis ground:</i>	Is the resistance 1 MΩ or more?	Repair the poor contact of the ECM connector.	Repair the short circuit in harness to ground between ECM and electronic throttle control relay connector.

DQ:DTC P2109 THROTTLE/PEDAL POSITION SENSOR “A” MINIMUM STOP PERFORMANCE

NOTE:

For the diagnostic procedure, refer to DTC P2101. <Ref. to EN(H4DOTC)(diag)-318, DTC P2101 THROTTLE ACTUATOR CONTROL MOTOR CIRCUIT RANGE/PERFORMANCE, Diagnostic Procedure with Diagnostic Trouble Code (DTC).>

DR:DTC P2122 THROTTLE/PEDAL POSITION SENSOR/SWITCH "D" CIRCUIT LOW INPUT

DTC DETECTING CONDITION:

- Immediately at fault recognition
- GENERAL DESCRIPTION <Ref. to GD(H4DOTC)-208, DTC P2122 THROTTLE/PEDAL POSITION SENSOR/SWITCH "D" CIRCUIT LOW INPUT, Diagnostic Trouble Code (DTC) Detecting Criteria.>

TROUBLE SYMPTOM:

- Improper idling
- Poor driving performance

CAUTION:

After repair or replacement of faulty parts, perform Clear Memory Mode <Ref. to EN(H4DOTC)(diag)-52, OPERATION, Clear Memory Mode.> and Inspection Mode <Ref. to EN(H4DOTC)(diag)-42, PROCEDURE, Inspection Mode.>.

WIRING DIAGRAM:

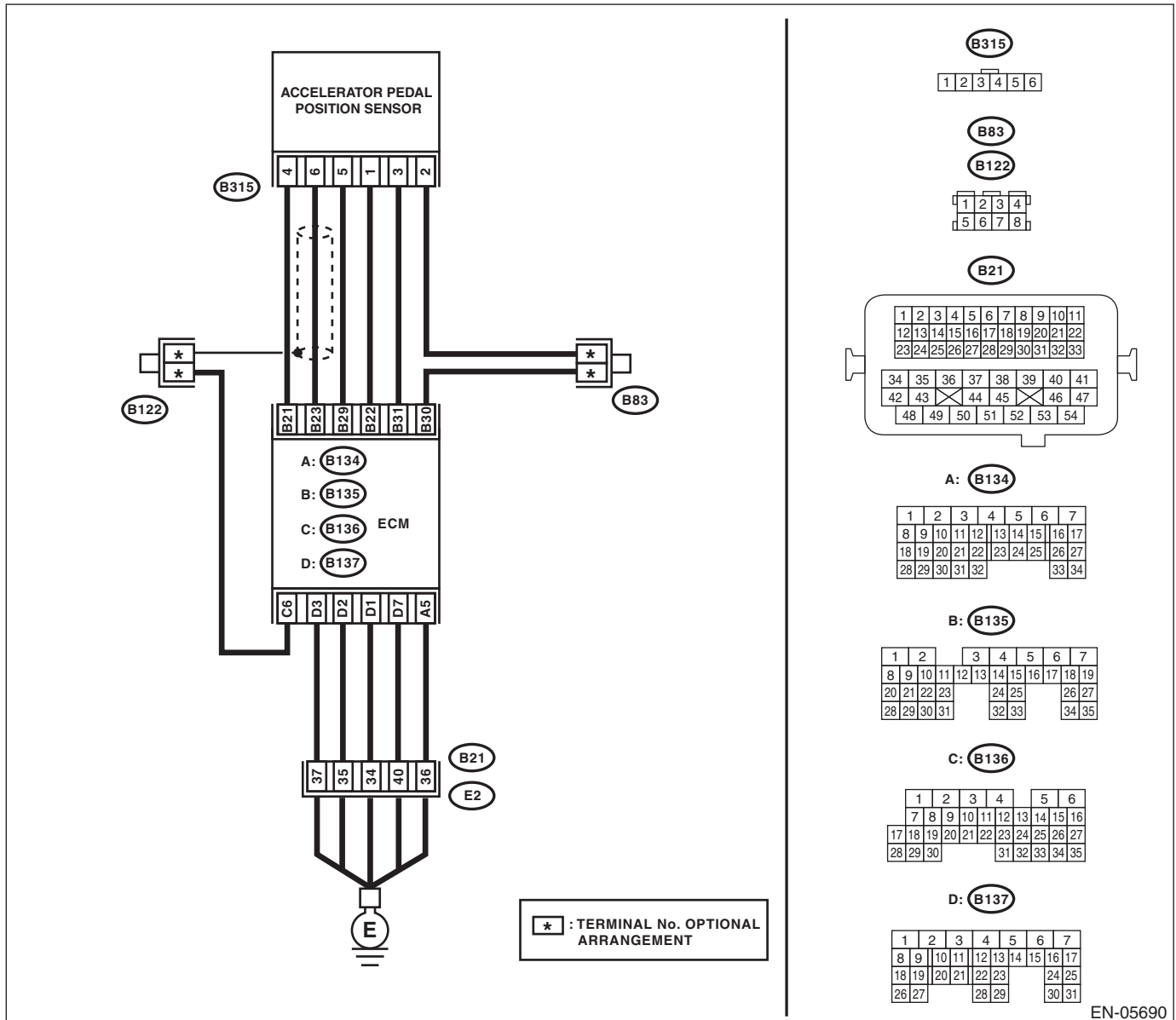

EN-05690

Diagnostic Procedure with Diagnostic Trouble Code (DTC)

ENGINE (DIAGNOSTICS)

Step	Check	Yes	No
<p>1</p> <p>CHECK HARNESS BETWEEN ECM AND ACCELERATOR PEDAL POSITION SENSOR.</p> <p>1) Turn the ignition switch to OFF. 2) Disconnect the connector from the ECM and accelerator pedal position sensor. 3) Measure the resistance between ECM and chassis ground.</p> <p>Connector & terminal (B135) No. 21 — Chassis ground: (B135) No. 23 — Chassis ground: (B135) No. 23 — (B136) No. 6:</p>	<p>Is the resistance 1 MΩ or more?</p>	<p>Go to step 2.</p>	<p>Repair the ground short of the harness between the ECM and accelerator pedal position sensor connector.</p>
<p>2</p> <p>CHECK SHORT CIRCUIT INSIDE THE ECM.</p> <p>1) Connect the ECM. 2) Measure the resistance between accelerator pedal position sensor connector and chassis ground.</p> <p>Connector & terminal (B315) No. 6 — Chassis ground:</p>	<p>Is the resistance 1 MΩ or more?</p>	<p>Replace the accelerator pedal. <Ref. to SP(H4SO)-3, Accelerator Pedal.></p>	<p>Repair the short circuit to ground in harness between ECM and accelerator pedal position sensor connector. Replace the ECM if defective. <Ref. to FU(H4DOTC)-46, Engine Control Module (ECM).></p>

Diagnostic Procedure with Diagnostic Trouble Code (DTC)

ENGINE (DIAGNOSTICS)

Step	Check	Yes	No
<p>1 CHECK HARNESS BETWEEN ECM AND ACCELERATOR PEDAL POSITION SENSOR.</p> <p>1) Turn the ignition switch to OFF. 2) Disconnect the connector from the ECM and accelerator pedal position sensor. 3) Measure the resistance of harness between ECM and accelerator pedal position sensor connector.</p> <p>Connector & terminal (B135) No. 23 — (B315) No. 6: (B135) No. 29 — (B315) No. 5:</p>	Is the resistance less than 1 Ω?	Go to step 2.	Repair the open circuit of the harness between the ECM and accelerator pedal position sensor connector.
<p>2 CHECK HARNESS BETWEEN ECM AND ACCELERATOR PEDAL POSITION SENSOR.</p> <p>1) Connect the ECM. 2) Measure the resistance between accelerator pedal position sensor connector and chassis ground.</p> <p>Connector & terminal (B315) No. 5 — Chassis ground:</p>	Is the resistance less than 5 Ω?	Go to step 3.	Repair the harness and connector. NOTE: In this case, repair the following item: • Open circuit of harness between ECM and engine ground • Poor contact in ECM connector • Poor contact of coupling connector
<p>3 CHECK HARNESS BETWEEN ECM AND ACCELERATOR PEDAL POSITION SENSOR.</p> <p>1) Turn the ignition switch to ON. 2) Measure the voltage between accelerator pedal position sensor connector and chassis ground.</p> <p>Connector & terminal (B315) No. 6 (+) — Chassis ground (-):</p>	Is the voltage 4.85 V or more?	Repair the short circuit to power source in the harness between the ECM and accelerator pedal position sensor connector.	Go to step 4.
<p>4 CHECK HARNESS BETWEEN ECM AND ACCELERATOR PEDAL POSITION SENSOR.</p> <p>1) Turn the ignition switch to OFF. 2) Disconnect the connectors from the ECM. 3) Measure the resistance between ECM connectors.</p> <p>Connector & terminal (B135) No. 21 — (B135) No. 23:</p>	Is the resistance 1 MΩ or more?	Repair the poor contact of accelerator pedal position sensor connector. Replace the accelerator pedal if defective. <Ref. to SP(H4SO)-3, Accelerator Pedal.>	Repair the short circuit to power source in the harness between the ECM and accelerator pedal position sensor connector.

DT:DTC P2127 THROTTLE/PEDAL POSITION SENSOR/SWITCH “E” CIRCUIT LOW INPUT

DTC DETECTING CONDITION:

- Immediately at fault recognition
- GENERAL DESCRIPTION <Ref. to GD(H4DOTC)-212, DTC P2127 THROTTLE/PEDAL POSITION SENSOR/SWITCH “E” CIRCUIT LOW INPUT, Diagnostic Trouble Code (DTC) Detecting Criteria.>

TROUBLE SYMPTOM:

- Improper idling
- Poor driving performance

CAUTION:

After repair or replacement of faulty parts, perform Clear Memory Mode <Ref. to EN(H4DOTC)(diag)-52, OPERATION, Clear Memory Mode.> and Inspection Mode <Ref. to EN(H4DOTC)(diag)-42, PROCEDURE, Inspection Mode.>.

WIRING DIAGRAM:

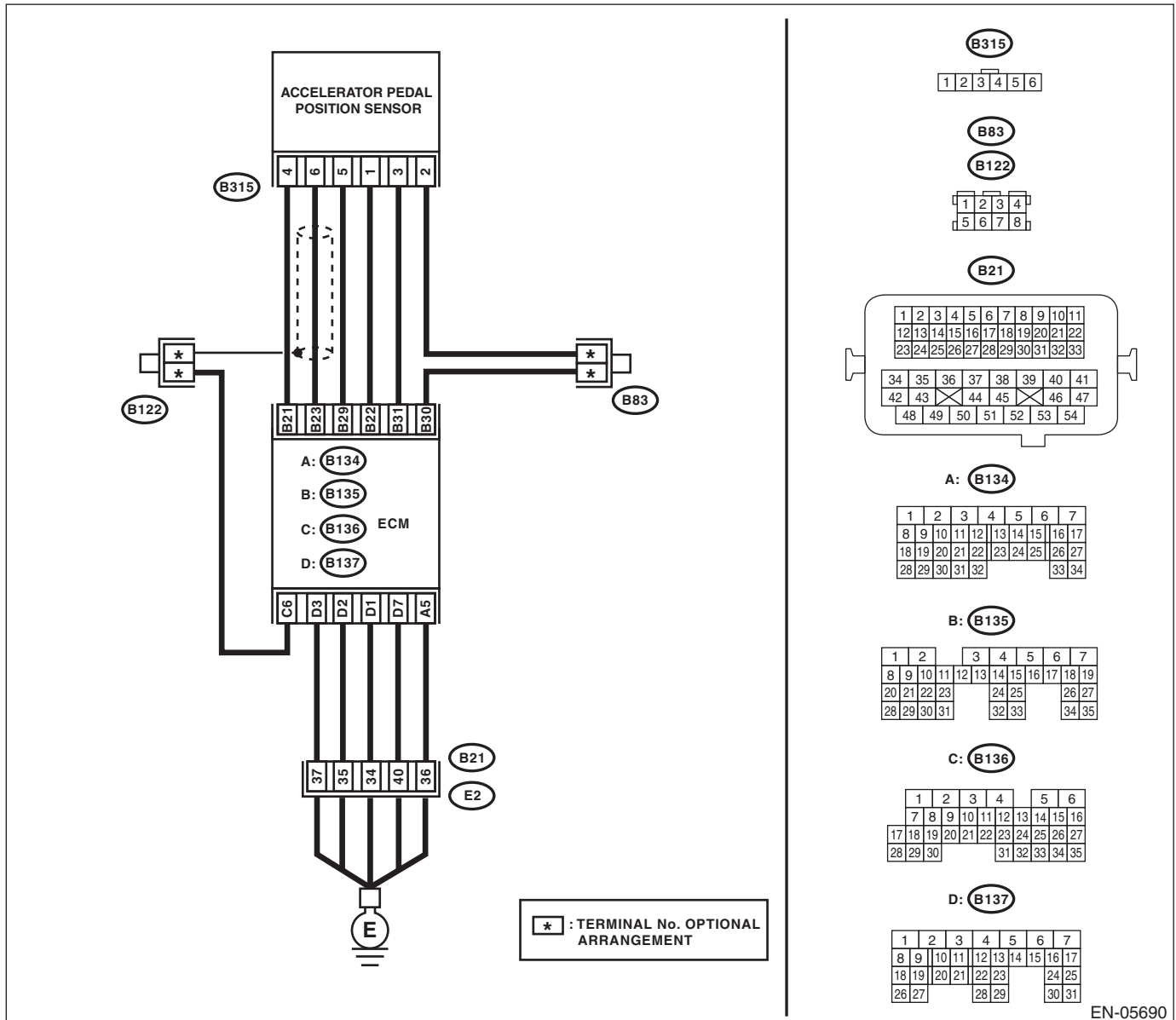

EN-05690

Diagnostic Procedure with Diagnostic Trouble Code (DTC)

ENGINE (DIAGNOSTICS)

Step	Check	Yes	No
<p>1</p> <p>CHECK HARNESS BETWEEN ECM AND ACCELERATOR PEDAL POSITION SENSOR.</p> <p>1) Turn the ignition switch to OFF. 2) Disconnect the connector from the ECM and accelerator pedal position sensor. 3) Measure the resistance between ECM and chassis ground.</p> <p>Connector & terminal (B135) No. 22 — Chassis ground: (B135) No. 31 — Chassis ground:</p>	<p>Is the resistance 1 MΩ or more?</p>	<p>Go to step 2.</p>	<p>Repair the ground short of the harness between the ECM and accelerator pedal position sensor connector.</p>
<p>2</p> <p>CHECK SHORT CIRCUIT INSIDE THE ECM.</p> <p>1) Connect the ECM. 2) Measure the resistance between accelerator pedal position sensor connector and chassis ground.</p> <p>Connector & terminal (B315) No. 3 — Chassis ground:</p>	<p>Is the resistance 1 MΩ or more?</p>	<p>Replace the accelerator pedal. <Ref. to SP(H4SO)-3, Accelerator Pedal.></p>	<p>Repair the short circuit to ground in harness between ECM and accelerator pedal position sensor connector. Replace the ECM if defective. <Ref. to FU(H4DOTC)-46, Engine Control Module (ECM).></p>

DU:DTC P2128 THROTTLE/PEDAL POSITION SENSOR/SWITCH “E” CIRCUIT HIGH INPUT

DTC DETECTING CONDITION:

- Immediately at fault recognition
- GENERAL DESCRIPTION <Ref. to GD(H4DOTC)-214, DTC P2128 THROTTLE/PEDAL POSITION SENSOR/SWITCH “E” CIRCUIT HIGH INPUT, Diagnostic Trouble Code (DTC) Detecting Criteria.>

TROUBLE SYMPTOM:

- Improper idling
- Poor driving performance

CAUTION:

After repair or replacement of faulty parts, perform Clear Memory Mode <Ref. to EN(H4DOTC)(diag)-52, OPERATION, Clear Memory Mode.> and Inspection Mode <Ref. to EN(H4DOTC)(diag)-42, PROCEDURE, Inspection Mode.>.

WIRING DIAGRAM:

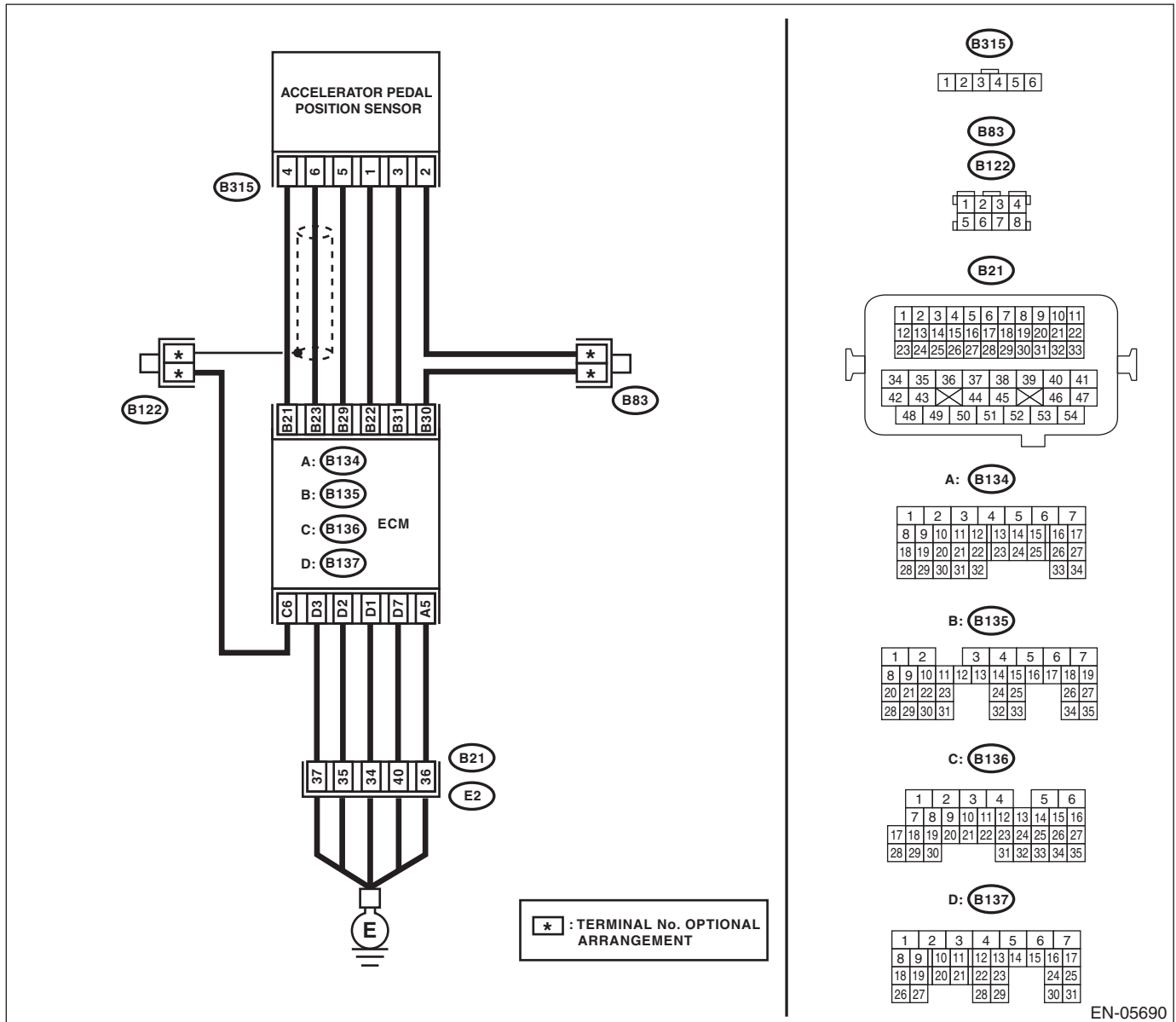

EN-05690

Diagnostic Procedure with Diagnostic Trouble Code (DTC)

ENGINE (DIAGNOSTICS)

Step	Check	Yes	No
<p>1 CHECK HARNESS BETWEEN ECM AND ACCELERATOR PEDAL POSITION SENSOR.</p> <p>1) Turn the ignition switch to OFF. 2) Disconnect the connector from the ECM and accelerator pedal position sensor. 3) Measure the resistance of harness between ECM and accelerator pedal position sensor connector.</p> <p>Connector & terminal (B135) No. 31 — (B315) No. 3: (B135) No. 30 — (B315) No. 2:</p>	Is the resistance less than 1 Ω?	Go to step 2.	Repair the open circuit of the harness between the ECM and accelerator pedal position sensor connector.
<p>2 CHECK HARNESS BETWEEN ECM AND ACCELERATOR PEDAL POSITION SENSOR.</p> <p>1) Connect the ECM. 2) Measure the resistance between accelerator pedal position sensor connector and chassis ground.</p> <p>Connector & terminal (B315) No. 2 — Chassis ground:</p>	Is the resistance less than 1 Ω?	Go to step 3.	Repair the harness and connector. NOTE: In this case, repair the following item: • Open circuit of harness between ECM and engine ground • Poor contact in ECM connector • Poor contact of coupling connector
<p>3 CHECK HARNESS BETWEEN ECM AND ACCELERATOR PEDAL POSITION SENSOR.</p> <p>1) Turn the ignition switch to ON. 2) Measure the voltage between accelerator pedal position sensor connector and chassis ground.</p> <p>Connector & terminal (B315) No. 3 (+) — Chassis ground (-):</p>	Is the voltage 4.85 V or more?	Repair the short circuit to power source in the harness between the ECM and accelerator pedal position sensor connector.	Go to step 4.
<p>4 CHECK HARNESS BETWEEN ECM AND ACCELERATOR PEDAL POSITION SENSOR.</p> <p>1) Turn the ignition switch to OFF. 2) Disconnect the connectors from the ECM. 3) Measure the resistance between ECM connectors.</p> <p>Connector & terminal (B135) No. 22 — (B135) No. 31:</p>	Is the resistance 1 MΩ or more?	Repair the poor contact of accelerator pedal position sensor connector. Replace the accelerator pedal if defective. <Ref. to SP(H4SO)-3, Accelerator Pedal.>	Repair the short circuit to power source in the harness between the ECM and accelerator pedal position sensor connector.

Diagnostic Procedure with Diagnostic Trouble Code (DTC)

ENGINE (DIAGNOSTICS)

DV:DTC P2135 THROTTLE/PEDAL POSITION SENSOR/SWITCH "A"/"B" VOLTAGE CORRELATION

DTC DETECTING CONDITION:

- Immediately at fault recognition
- GENERAL DESCRIPTION <Ref. to GD(H4DOTC)-216, DTC P2135 THROTTLE/PEDAL POSITION SENSOR/SWITCH "A"/"B" VOLTAGE CORRELATION, Diagnostic Trouble Code (DTC) Detecting Criteria.>

TROUBLE SYMPTOM:

- Improper idling
- Poor driving performance

CAUTION:

After repair or replacement of faulty parts, perform Clear Memory Mode <Ref. to EN(H4DOTC)(diag)-52, OPERATION, Clear Memory Mode.> and Inspection Mode <Ref. to EN(H4DOTC)(diag)-42, PROCEDURE, Inspection Mode.>

WIRING DIAGRAM:

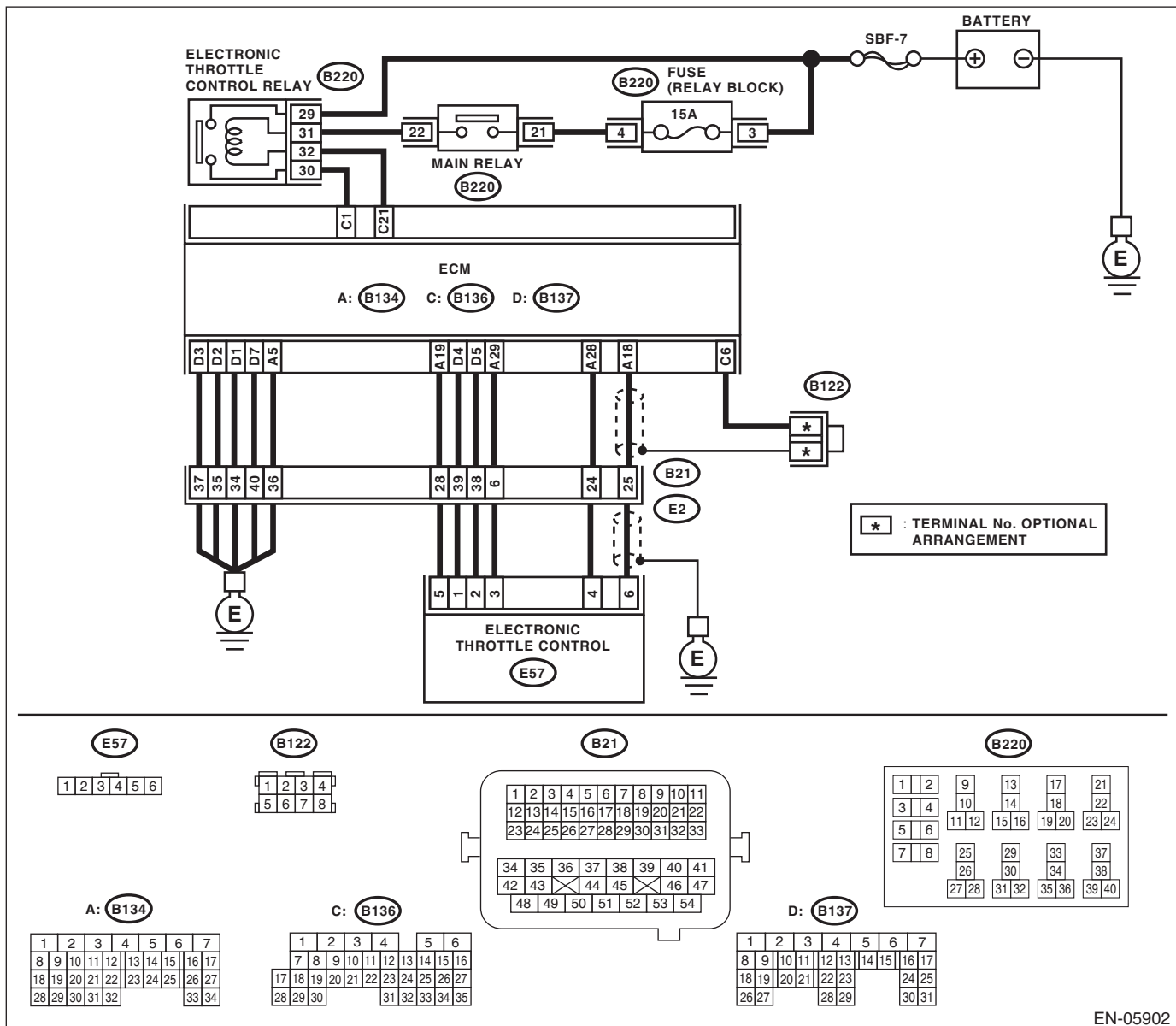

EN-05902

Diagnostic Procedure with Diagnostic Trouble Code (DTC)

ENGINE (DIAGNOSTICS)

Step	Check	Yes	No
<p>1 CHECK HARNESS BETWEEN ECM AND ELECTRONIC THROTTLE CONTROL.</p> <p>1) Turn the ignition switch to OFF. 2) Disconnect the connectors from ECM and electronic throttle control. 3) Measure the resistance between ECM and chassis ground.</p> <p>Connector & terminal (B134) No. 19 — Chassis ground: (B134) No. 18 — Chassis ground: (B134) No. 18 — (B136) No. 6: (B134) No. 28 — Chassis ground:</p>	Is the resistance 1 MΩ or more?	Go to step 2.	Repair the ground short circuit of harness between ECM and electronic throttle control connector.
<p>2 CHECK SHORT CIRCUIT INSIDE THE ECM.</p> <p>1) Connect the ECM. 2) Measure the resistance between electronic throttle control connector and engine ground.</p> <p>Connector & terminal (E57) No. 6 — Engine ground: (E57) No. 4 — Engine ground:</p>	Is the resistance 1 MΩ or more?	Go to step 3.	Repair the ground short circuit of harness between ECM and electronic throttle control connector. Replace the ECM if defective. <Ref. to FU(H4DOTC)-46, Engine Control Module (ECM).>
<p>3 CHECK HARNESS BETWEEN ECM AND ELECTRONIC THROTTLE CONTROL.</p> <p>1) Disconnect the connectors from the ECM. 2) Measure the resistance of harness between ECM and electronic throttle control connector.</p> <p>Connector & terminal (B134) No. 18 — (E57) No. 6: (B134) No. 28 — (E57) No. 4: (B134) No. 29 — (E57) No. 3:</p>	Is the resistance less than 1 Ω?	Go to step 4.	Repair the harness and connector. NOTE: In this case, repair the following item: • Open circuit in harness between ECM and electronic throttle control connector • Poor contact of coupling connector
<p>4 CHECK HARNESS BETWEEN ECM AND ELECTRONIC THROTTLE CONTROL.</p> <p>1) Connect the ECM. 2) Measure the resistance between electronic throttle control connector and engine ground.</p> <p>Connector & terminal (E57) No. 3 — Engine ground:</p>	Is the resistance less than 5 Ω?	Go to step 5.	Repair the harness and connector. NOTE: In this case, repair the following item: • Open circuit of harness between ECM and engine ground • Poor contact in ECM connector • Poor contact of coupling connector
<p>5 CHECK HARNESS BETWEEN ECM AND ELECTRONIC THROTTLE CONTROL.</p> <p>1) Turn the ignition switch to ON. 2) Measure the voltage between electronic throttle control connector and engine ground.</p> <p>Connector & terminal (E57) No. 6 (+) — Engine ground (-): (E57) No. 4 (+) — Engine ground (-):</p>	Is the voltage 4.85 V or more?	Repair the short circuit to power in the harness between ECM and electronic throttle control connector.	Go to step 6.

Diagnostic Procedure with Diagnostic Trouble Code (DTC)

ENGINE (DIAGNOSTICS)

Step	Check	Yes	No
<p>6</p> <p>CHECK HARNESS BETWEEN ECM AND ELECTRONIC THROTTLE CONTROL.</p> <p>1) Turn the ignition switch to OFF. 2) Disconnect the connectors from the ECM. 3) Measure the resistance between ECM connectors.</p> <p>Connector & terminal (B134) No. 19 — (B134) No. 18: (B134) No. 19 — (B134) No. 28:</p>	<p>Is the resistance 1 MΩ or more?</p>	<p>Repair poor contact of the electronic throttle control connector. Replace the electronic throttle control if defective. <Ref. to FU(H4DOTC)-13, Throttle Body.></p>	<p>Repair the short circuit to power in the harness between ECM and electronic throttle control connector.</p>

Diagnostic Procedure with Diagnostic Trouble Code (DTC)

ENGINE (DIAGNOSTICS)

DW:DTC P2138 THROTTLE/PEDAL POSITION SENSOR/SWITCH “D”/“E” VOLTAGE CORRELATION

DTC DETECTING CONDITION:

- Immediately at fault recognition
- GENERAL DESCRIPTION <Ref. to GD(H4DOTC)-218, DTC P2138 THROTTLE/PEDAL POSITION SENSOR/SWITCH “D”/“E” VOLTAGE CORRELATION, Diagnostic Trouble Code (DTC) Detecting Criteria.>

TROUBLE SYMPTOM:

- Improper idling
- Poor driving performance

CAUTION:

After repair or replacement of faulty parts, perform Clear Memory Mode <Ref. to EN(H4DOTC)(diag)-52, OPERATION, Clear Memory Mode.> and Inspection Mode <Ref. to EN(H4DOTC)(diag)-42, PROCEDURE, Inspection Mode.>.

WIRING DIAGRAM:

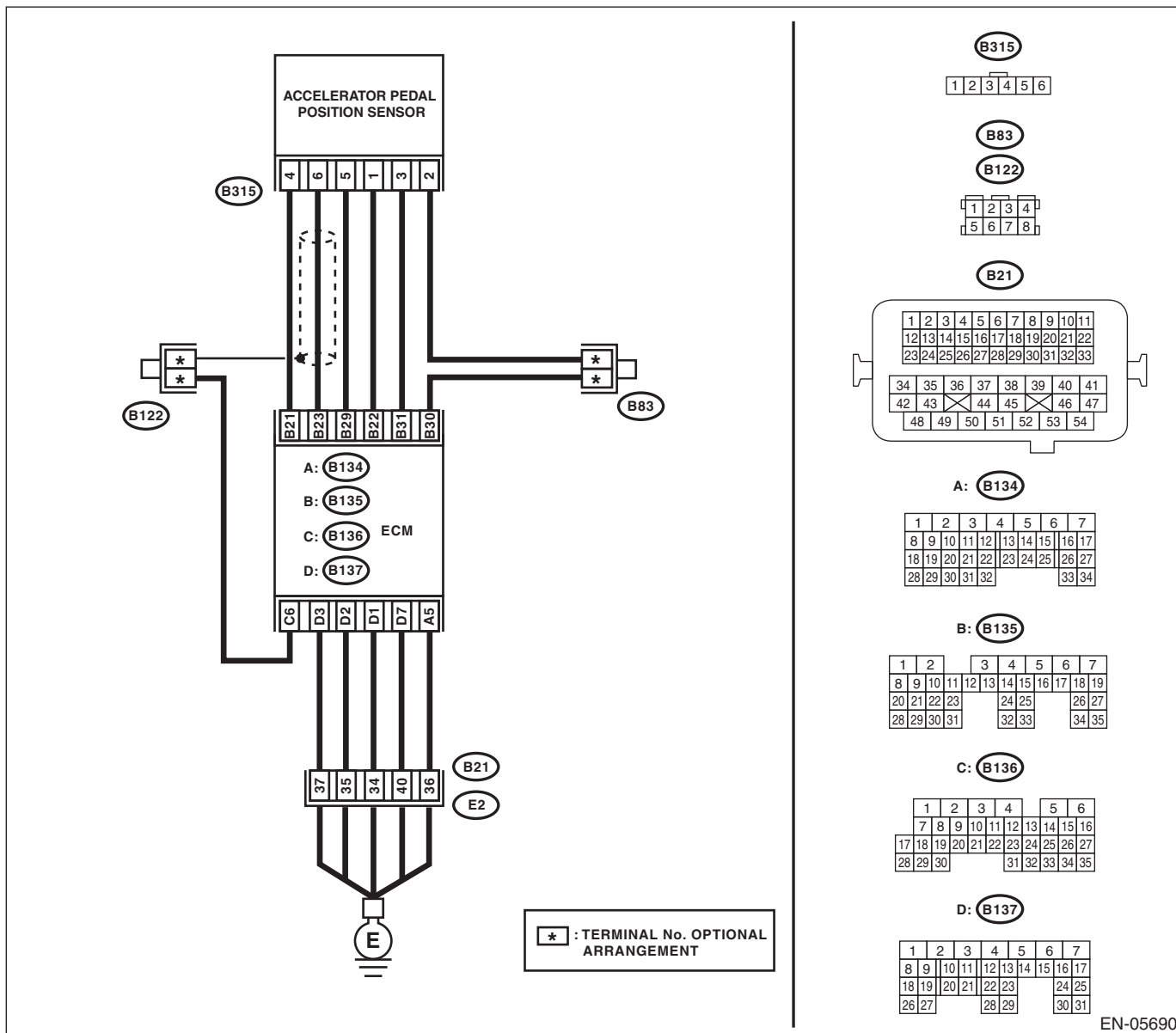

EN-05690

Diagnostic Procedure with Diagnostic Trouble Code (DTC)

ENGINE (DIAGNOSTICS)

Step	Check	Yes	No
<p>1 CHECK ACCELERATOR PEDAL POSITION SENSOR OUTPUT. 1) Turn the ignition switch to ON. 2) Measure the voltage between ECM and chassis ground. <i>Connector & terminal</i> <i>Main accelerator pedal position sensor signal</i> <i>(B135) No. 23 (+) — Chassis ground (-):</i> <i>Sub accelerator pedal position sensor signal</i> <i>(B135) No. 31 (+) — Chassis ground (-):</i></p>	<p>Is the difference in measured values for the main accelerator pedal position sensor signal and the sub accelerator pedal position sensor signal 0 V?</p>	<p>Go to step 3.</p>	<p>Go to step 2.</p>
<p>2 CHECK ACCELERATOR PEDAL POSITION SENSOR OUTPUT. 1) Measure the voltage between accelerator pedal position sensor connector and chassis ground. <i>Connector & terminal</i> <i>(B315) No. 6 (+) — Chassis ground (-):</i> <i>(B315) No. 3 (+) — Chassis ground (-):</i></p>	<p>Is the difference in measured values for the main accelerator pedal position sensor signal and the sub accelerator pedal position sensor signal 0 V?</p>	<p>Replace the accelerator pedal. <Ref. to SP(H4SO)-3, Accelerator Pedal.></p>	<p>Repair the harness and connector. NOTE: In this case, repair the following item: • Open circuit of harness between the ECM and accelerator pedal position sensor connector. • Ground short circuit of harness between the ECM and accelerator pedal position sensor connectors. • Poor contact of coupling connector</p>
<p>3 CHECK HARNESS BETWEEN ECM AND ACCELERATOR PEDAL POSITION SENSOR CONNECTOR. Measure the resistance of harness between accelerator pedal position sensor connector and chassis ground. <i>Connector & terminal</i> <i>(B315) No. 5 — Chassis ground:</i> <i>(B315) No. 2 — Chassis ground:</i></p>	<p>Is the resistance less than 5 Ω?</p>	<p>Repair poor contact of the ECM connector.</p>	<p>Repair the harness and connector. NOTE: In this case, repair the following item: • Open circuit of harness between the ECM and accelerator pedal position sensor connector. • Open circuit of harness between ECM and engine ground • Poor contact in ECM connector • Poor contact of coupling connector</p>

Diagnostic Procedure with Diagnostic Trouble Code (DTC)

ENGINE (DIAGNOSTICS)

DX:DTC P2419 EVAPORATIVE EMISSION SYSTEM SWITCHING VALVE CONTROL CIRCUIT LOW

DTC DETECTING CONDITION:

- Detected when two consecutive driving cycles with fault occur.
- GENERAL DESCRIPTION <Ref. to GD(H4DOTC)-220, DTC P2419 EVAPORATIVE EMISSION SYSTEM SWITCHING VALVE CONTROL CIRCUIT LOW, Diagnostic Trouble Code (DTC) Detecting Criteria.>

TROUBLE SYMPTOM:

Improper idling

CAUTION:

After repair or replacement of faulty parts, perform Clear Memory Mode <Ref. to EN(H4DOTC)(diag)-52, OPERATION, Clear Memory Mode.> and Inspection Mode <Ref. to EN(H4DOTC)(diag)-42, PROCEDURE, Inspection Mode.>.

WIRING DIAGRAM:

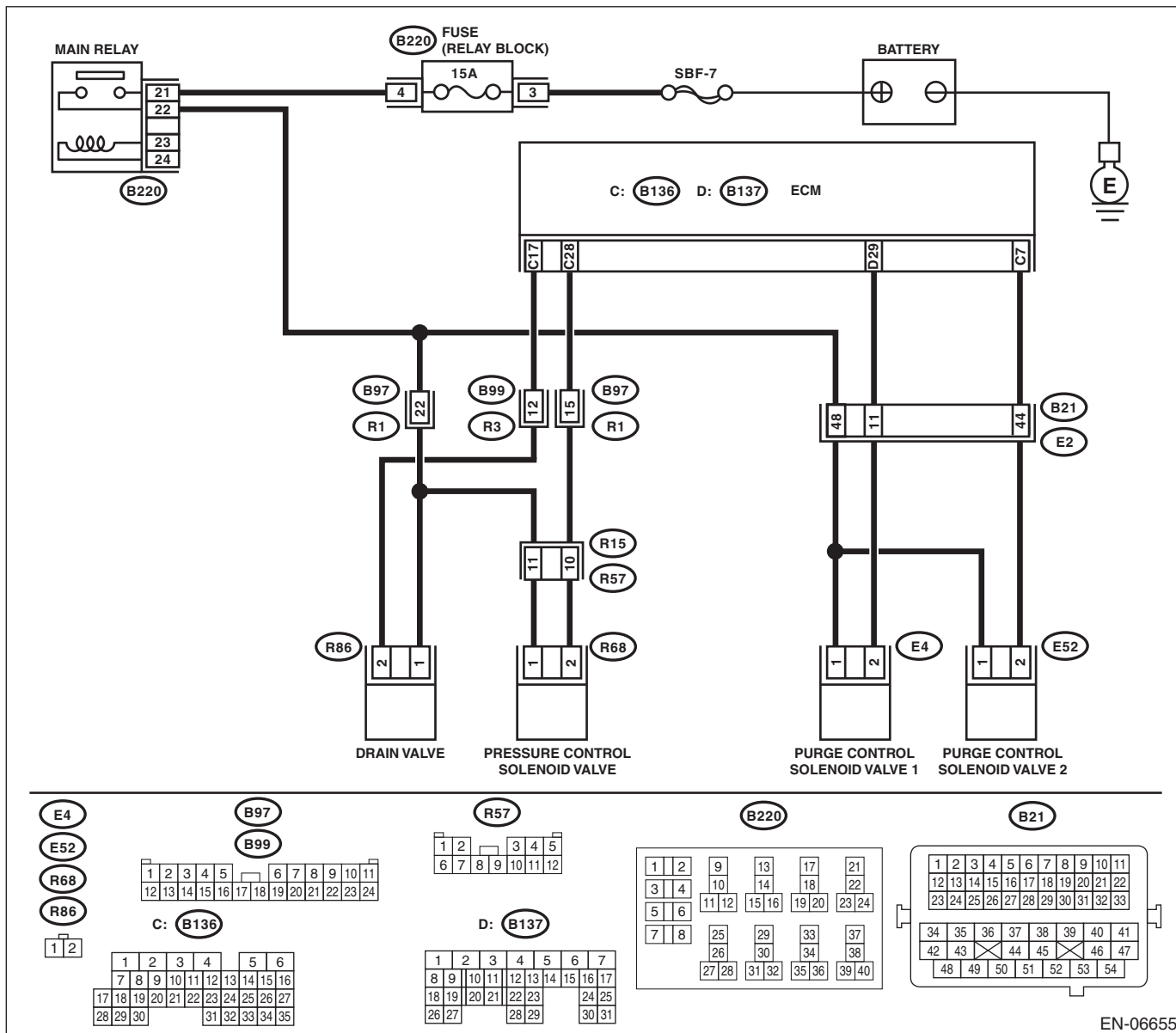

EN-06655

Diagnostic Procedure with Diagnostic Trouble Code (DTC)

ENGINE (DIAGNOSTICS)

Step	Check	Yes	No
1 CHECK OUTPUT SIGNAL OF ECM. 1) Turn the ignition switch to ON. 2) Measure the voltage between ECM and chassis ground. <i>Connector & terminal</i> <i>(B136) No. 7 (+) — Chassis ground (-):</i>	Is the voltage 10 V or more?	Go to step 2.	Go to step 3.
2 CHECK FOR POOR CONTACT. Check for poor contact of ECM connector.	Is there poor contact of ECM connector?	Repair the poor contact of ECM connector.	Even if DTC is detected, the circuit has returned to a normal condition at this time. Reproduce the failure, and then perform the diagnosis again. NOTE: In this case, temporary open or short circuit of harness or temporary poor contact of connector may be the cause.
3 CHECK POWER SUPPLY TO PURGE CONTROL SOLENOID VALVE 2. Measure the voltage between purge control solenoid valve 2 and engine ground. <i>Connector & terminal</i> <i>(E52) No. 1 (+) — Engine ground (-):</i>	Is the voltage 10 V or more?	Go to step 4.	Repair the power supply circuit.
4 CHECK HARNESS BETWEEN ECM AND PURGE CONTROL SOLENOID VALVE 2. 1) Turn the ignition switch to OFF. 2) Disconnect the connectors from ECM and purge control solenoid valve 2. 3) Measure the resistance between the purge control solenoid valve 2 connector and engine ground. <i>Connector & terminal</i> <i>(E52) No. 2 — Engine ground:</i>	Is the resistance 1 M Ω or more?	Go to step 5.	Repair the ground short circuit of harness between ECM and purge control solenoid valve 2 connector.
5 CHECK HARNESS BETWEEN ECM AND PURGE CONTROL SOLENOID VALVE 2. Measure the resistance of harness between ECM and purge control solenoid valve 2. <i>Connector & terminal</i> <i>(B136) No. 7 — (E52) No. 2:</i>	Is the resistance less than 1 Ω ?	Go to step 6.	Repair the harness and connector. NOTE: In this case, repair the following item: <ul style="list-style-type: none"> • Open circuit of harness between ECM and purge control solenoid valve 2 connector • Poor contact of coupling connector
6 CHECK PURGE CONTROL SOLENOID VALVE 2. 1) Remove the purge control solenoid valve 2. 2) Measure the resistance between purge control solenoid valve 2 terminals. <i>Terminals</i> <i>No. 1 — No. 2:</i>	Is the resistance between 10 — 100 Ω ?	Repair the poor contact in the purge control solenoid valve 2 connector.	Replace the purge control solenoid valve 2. <Ref. to EC(H4DOTC)-11, Purge Control Solenoid Valve.>

Diagnostic Procedure with Diagnostic Trouble Code (DTC)

ENGINE (DIAGNOSTICS)

DY:DTC P2420 EVAPORATIVE EMISSION SYSTEM SWITCHING VALVE CONTROL CIRCUIT HIGH

DTC DETECTING CONDITION:

- Detected when two consecutive driving cycles with fault occur.
- GENERAL DESCRIPTION <Ref. to GD(H4DOTC)-221, DTC P2420 EVAPORATIVE EMISSION SYSTEM SWITCHING VALVE CONTROL CIRCUIT HIGH, Diagnostic Trouble Code (DTC) Detecting Criteria.>

TROUBLE SYMPTOM:

Improper idling

CAUTION:

After repair or replacement of faulty parts, perform Clear Memory Mode <Ref. to EN(H4DOTC)(diag)-52, OPERATION, Clear Memory Mode.> and Inspection Mode <Ref. to EN(H4DOTC)(diag)-42, PROCEDURE, Inspection Mode.>.

WIRING DIAGRAM:

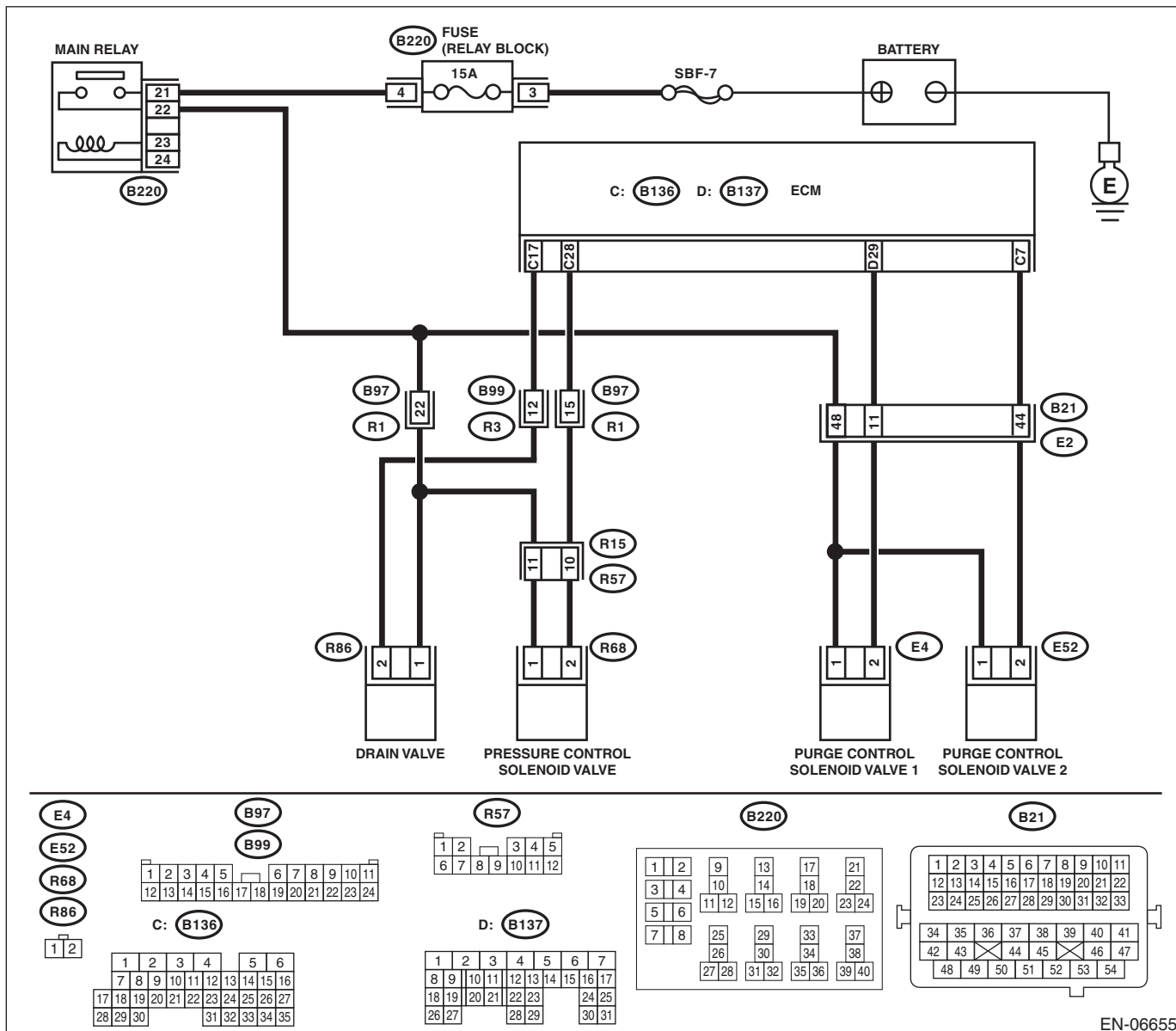

EN-06655

Diagnostic Procedure with Diagnostic Trouble Code (DTC)

ENGINE (DIAGNOSTICS)

Step	Check	Yes	No
<p>1 CHECK HARNESS BETWEEN ECM AND PURGE CONTROL SOLENOID VALVE 2. 1) Turn the ignition switch to OFF. 2) Disconnect the connectors from ECM and purge control solenoid valve 2. 3) Turn the ignition switch to ON. 4) Measure the voltage between ECM and chassis ground. Connector & terminal (B136) No. 7 (+) — Chassis ground (-):</p>	Is the voltage 10 V or more?	Repair the short to power in the harness between ECM and purge control solenoid valve 2 connector.	Go to step 2.
<p>2 CHECK PURGE CONTROL SOLENOID VALVE 2. 1) Turn the ignition switch to OFF. 2) Measure the resistance between purge control solenoid valve 2 terminals. Terminals No. 1 — No. 2:</p>	Is the resistance less than 1 Ω ?	Replace the purge control solenoid valve 2. <Ref. to EC(H4DOTC)-11, Purge Control Solenoid Valve.>	Repair the poor contact of the ECM connector.

Diagnostic Procedure with Diagnostic Trouble Code (DTC)

ENGINE (DIAGNOSTICS)

DZ:DTC P2431 SECONDARY AIR INJECTION SYSTEM AIR FLOW /PRESSURE SENSOR CIRCUIT RANGE/PERFORMANCE

DTC DETECTING CONDITION:

- Detected when two consecutive driving cycles with fault occur.
- GENERAL DESCRIPTION <Ref. to GD(H4DOTC)-222, DTC P2431 SECONDARY AIR INJECTION SYSTEM AIR FLOW /PRESSURE SENSOR CIRCUIT RANGE/PERFORMANCE, Diagnostic Trouble Code (DTC) Detecting Criteria.>

CAUTION:

After repair or replacement of faulty parts, perform Clear Memory Mode <Ref. to EN(H4DOTC)(diag)-52, OPERATION, Clear Memory Mode.> and Inspection Mode <Ref. to EN(H4DOTC)(diag)-42, PROCEDURE, Inspection Mode.>.

Diagnostic Procedure with Diagnostic Trouble Code (DTC)

ENGINE (DIAGNOSTICS)

WIRING DIAGRAM:

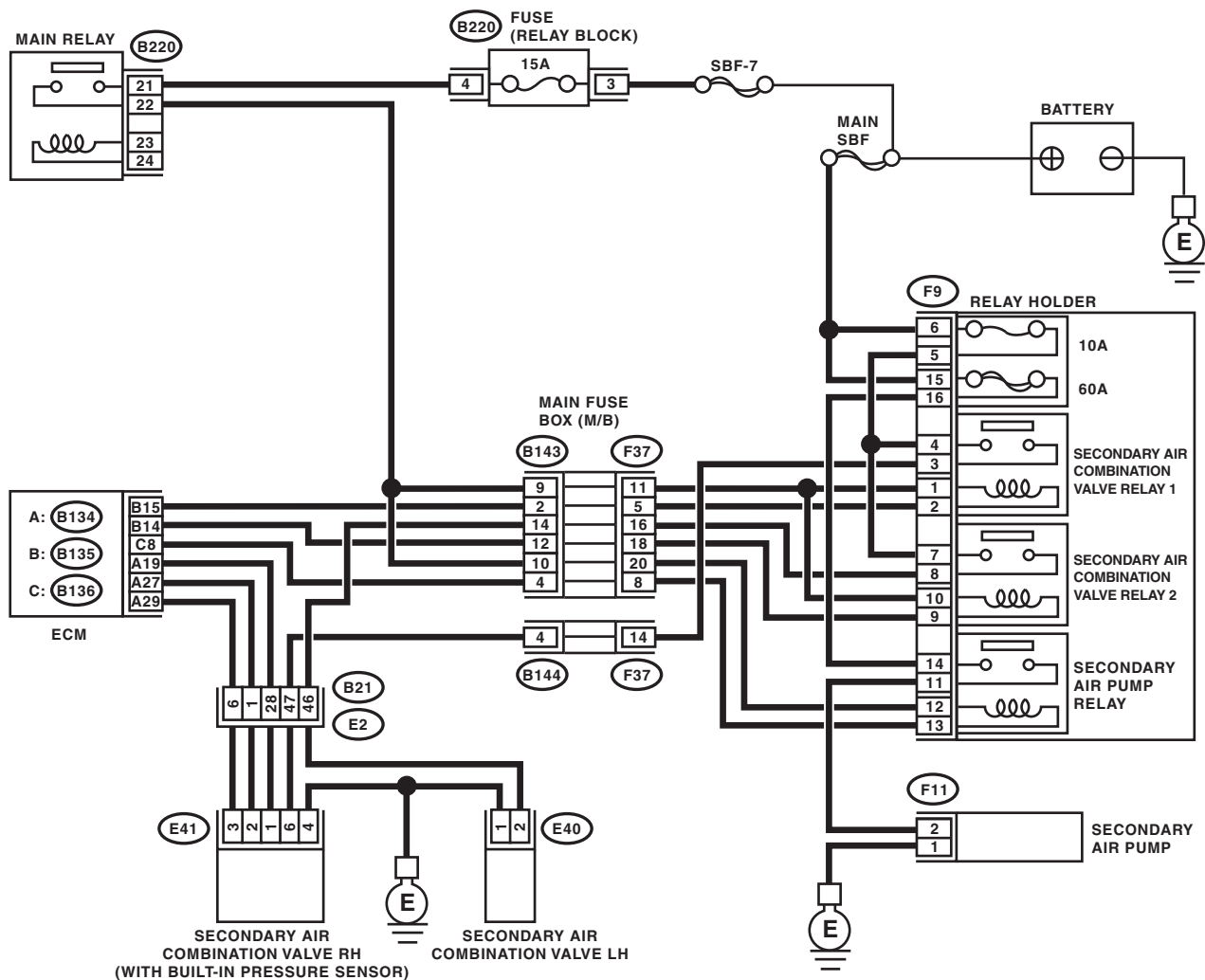

A: (B134)

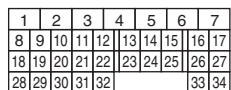

B: (B135)

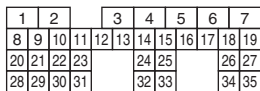

C: (B136)

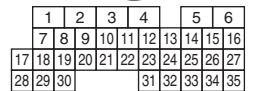

(B220)

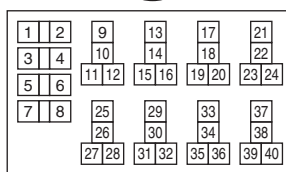

(B21)

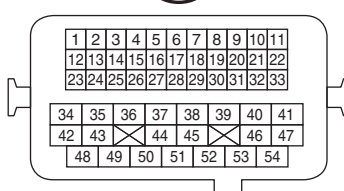

(F9)

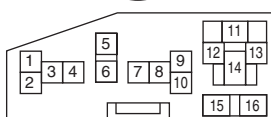

(F37)



(B143)

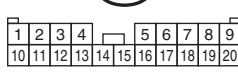

(E40)



(E41)



(B144)

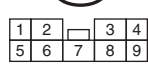

EN-06137

Diagnostic Procedure with Diagnostic Trouble Code (DTC)

ENGINE (DIAGNOSTICS)

Step	Check	Yes	No
<p>1 CHECK FOR ANY OTHER DTC ON DISPLAY.</p>	<p>Is any other DTC displayed?</p>	<p>Check the appropriate DTC using the "List of Diagnostic Trouble Code (DTC)". <Ref. to EN(H4DOTC)(diag)-80, List of Diagnostic Trouble Code (DTC).></p>	<p>Go to step 2.</p>
<p>2 CHECK CURRENT DATA. 1) Turn the ignition switch to ON (engine OFF). 2) Using the Subaru Select Monitor, read secondary air piping pressure, intake pipe absolute pressure and atmospheric pressure, and compare with the actual atmospheric pressure. NOTE: For detailed operation procedures, refer to "READ CURRENT DATA FOR ENGINE". <Ref. to EN(H4DOTC)(diag)-34, Subaru Select Monitor.></p>	<p>Is the actual difference with atmospheric pressure 200 mmHg (27 kPa, 8 inHg, 3.9 psig) or more?</p>	<p>Replace the secondary air combination valve RH. <Ref. to EC(H4DOTC)-24, Secondary Air Combination Valve.></p>	<p>Even if the malfunction indicator light illuminates, the circuit has returned to a normal condition at this time. Reproduce the fault condition, and reperform the check. NOTE: In this case, there may be a temporary connector contact failure.</p>

EA:DTC P2432 SECONDARY AIR INJECTION SYSTEM AIR FLOW /PRESSURE SENSOR CIRCUIT LOW

DTC DETECTING CONDITION:

- Immediately at fault recognition
- GENERAL DESCRIPTION <Ref. to GD(H4DOTC)-223, DTC P2432 SECONDARY AIR INJECTION SYSTEM AIR FLOW /PRESSURE SENSOR CIRCUIT LOW, Diagnostic Trouble Code (DTC) Detecting Criteria.>

CAUTION:

After repair or replacement of faulty parts, perform Clear Memory Mode <Ref. to EN(H4DOTC)(diag)-52, OPERATION, Clear Memory Mode.> and Inspection Mode <Ref. to EN(H4DOTC)(diag)-42, PROCEDURE, Inspection Mode.>.

Diagnostic Procedure with Diagnostic Trouble Code (DTC)

ENGINE (DIAGNOSTICS)

WIRING DIAGRAM:

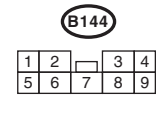
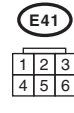
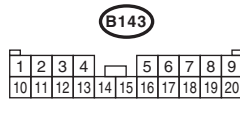
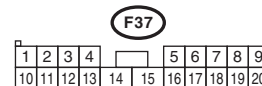
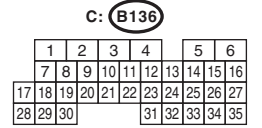
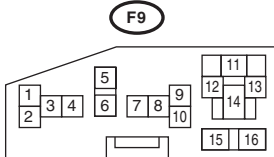
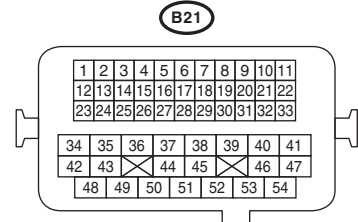
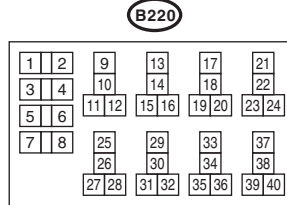
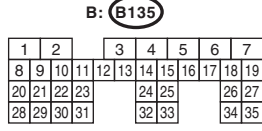
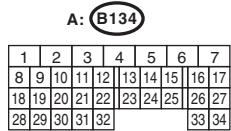
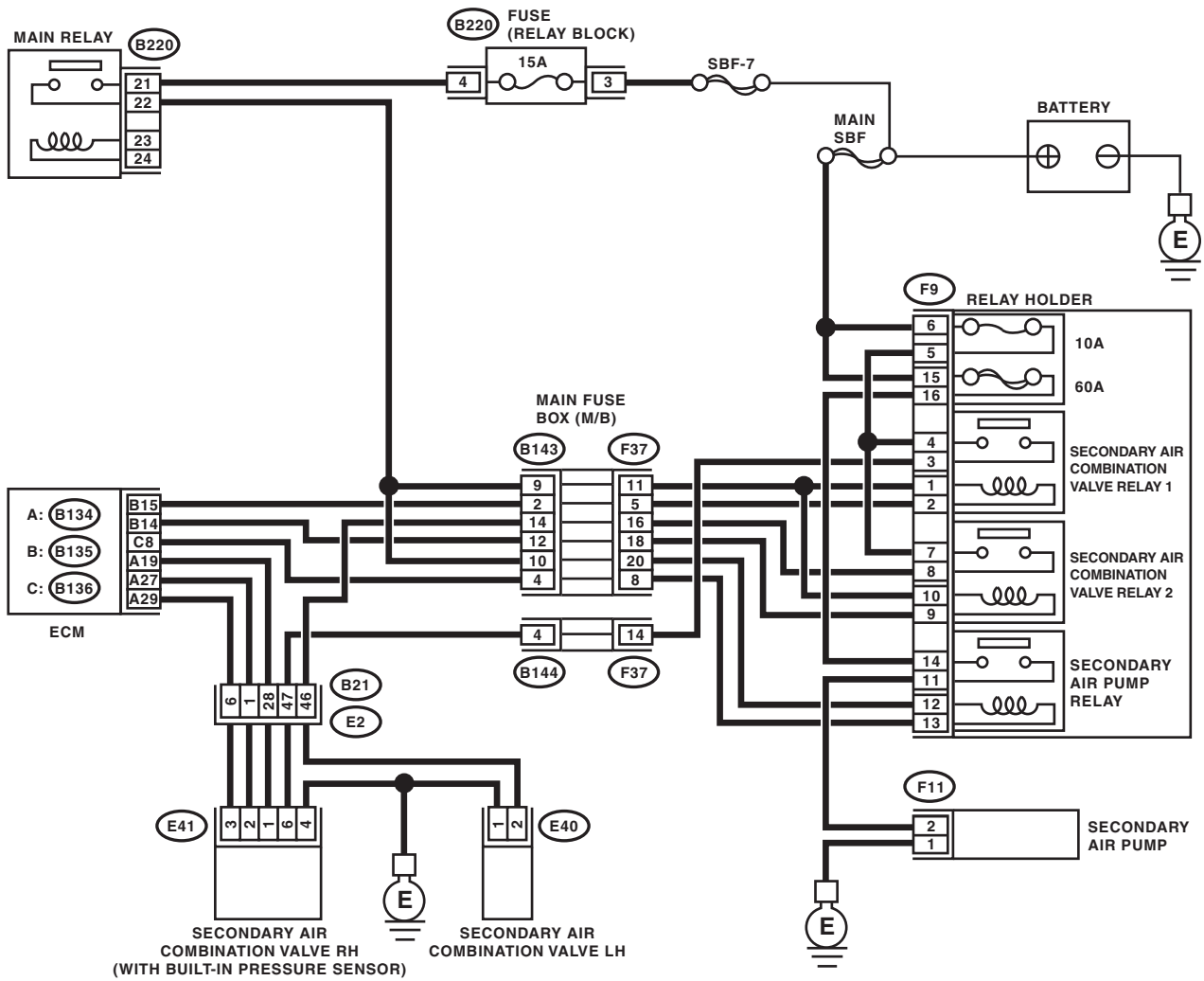

EN-06137

Diagnostic Procedure with Diagnostic Trouble Code (DTC)

ENGINE (DIAGNOSTICS)

Step	Check	Yes	No
<p>1 CHECK CURRENT DATA. 1) Turn the ignition switch to ON. 2) Read the data of secondary air pipe pressure signal using the Subaru Select Monitor or general scan tool. NOTE: • Subaru Select Monitor For detailed operation procedures, refer to "READ CURRENT DATA FOR ENGINE". <Ref. to EN(H4DOTC)(diag)-34, Subaru Select Monitor.> • General scan tool For detailed operation procedures, refer to the general scan tool operation manual.</p>	<p>Is the measured value less than 53.3 kPa (400 mmHg, 15.8 inHg)?</p>	<p>Go to step 2.</p>	<p>Even if the malfunction indicator light illuminates, the circuit has returned to a normal condition at this time. Reproduce the fault condition, and reperform the check. NOTE: In this case, there may be a temporary connector contact failure.</p>
<p>2 CHECK SECONDARY AIR COMBINATION VALVE RH POWER SOURCE. 1) Turn the ignition switch to OFF. 2) Disconnect the connector from the secondary air combination valve RH. 3) Turn the ignition switch to ON. 4) Measure the voltage between the secondary air combination valve RH connector and chassis ground. Connector & terminal (E41) No. 1 (+) — Chassis ground (-):</p>	<p>Is the voltage 4.5 V or more?</p>	<p>Go to step 3.</p>	<p>Repair the harness and connector. NOTE: In this case, repair the following item: • Open circuit in harness between ECM and secondary air combination valve RH connector • Poor contact in ECM connector • Poor contact of coupling connector</p>
<p>3 CHECK HARNESS BETWEEN ECM AND SECONDARY AIR COMBINATION VALVE RH CONNECTOR. 1) Turn the ignition switch to OFF. 2) Disconnect the connectors from the ECM. 3) Measure the resistance of the harness between the ECM and secondary air combination valve RH connector. Connector & terminal (B134) No. 27 — (E41) No. 2:</p>	<p>Is the resistance less than 1 Ω?</p>	<p>Go to step 4.</p>	<p>Repair the harness and connector. NOTE: In this case, repair the following item: • Open circuit in harness between ECM and secondary air combination valve RH connector • Poor contact of coupling connector</p>
<p>4 CHECK HARNESS BETWEEN ECM AND SECONDARY AIR COMBINATION VALVE RH CONNECTOR. Measure the resistance between ECM and chassis ground. Connector & terminal (B134) No. 27 — Chassis ground:</p>	<p>Is the resistance 1 MΩ or more?</p>	<p>Go to step 5.</p>	<p>Repair the ground short circuit of harness between ECM and secondary air combination valve RH connector.</p>
<p>5 CHECK POOR CONTACT. Check for poor contact in the ECM and secondary air combination valve RH connector.</p>	<p>Is there poor contact in the ECM or secondary air combination valve RH connector?</p>	<p>Repair the poor contact in the ECM or secondary air combination valve RH connector.</p>	<p>Replace the secondary air combination valve RH. <Ref. to EC(H4DOTC)-24, Secondary Air Combination Valve.></p>

Diagnostic Procedure with Diagnostic Trouble Code (DTC)

ENGINE (DIAGNOSTICS)

EB:DTC P2433 SECONDARY AIR INJECTION SYSTEM AIR FLOW /PRESSURE SENSOR CIRCUIT HIGH

DTC DETECTING CONDITION:

- Immediately at fault recognition
- GENERAL DESCRIPTION <Ref. to GD(H4DOTC)-224, DTC P2433 SECONDARY AIR INJECTION SYSTEM AIR FLOW /PRESSURE SENSOR CIRCUIT HIGH, Diagnostic Trouble Code (DTC) Detecting Criteria.>

CAUTION:

After repair or replacement of faulty parts, perform Clear Memory Mode <Ref. to EN(H4DOTC)(diag)-52, OPERATION, Clear Memory Mode.> and Inspection Mode <Ref. to EN(H4DOTC)(diag)-42, PROCEDURE, Inspection Mode.>.

Diagnostic Procedure with Diagnostic Trouble Code (DTC)

ENGINE (DIAGNOSTICS)

WIRING DIAGRAM:

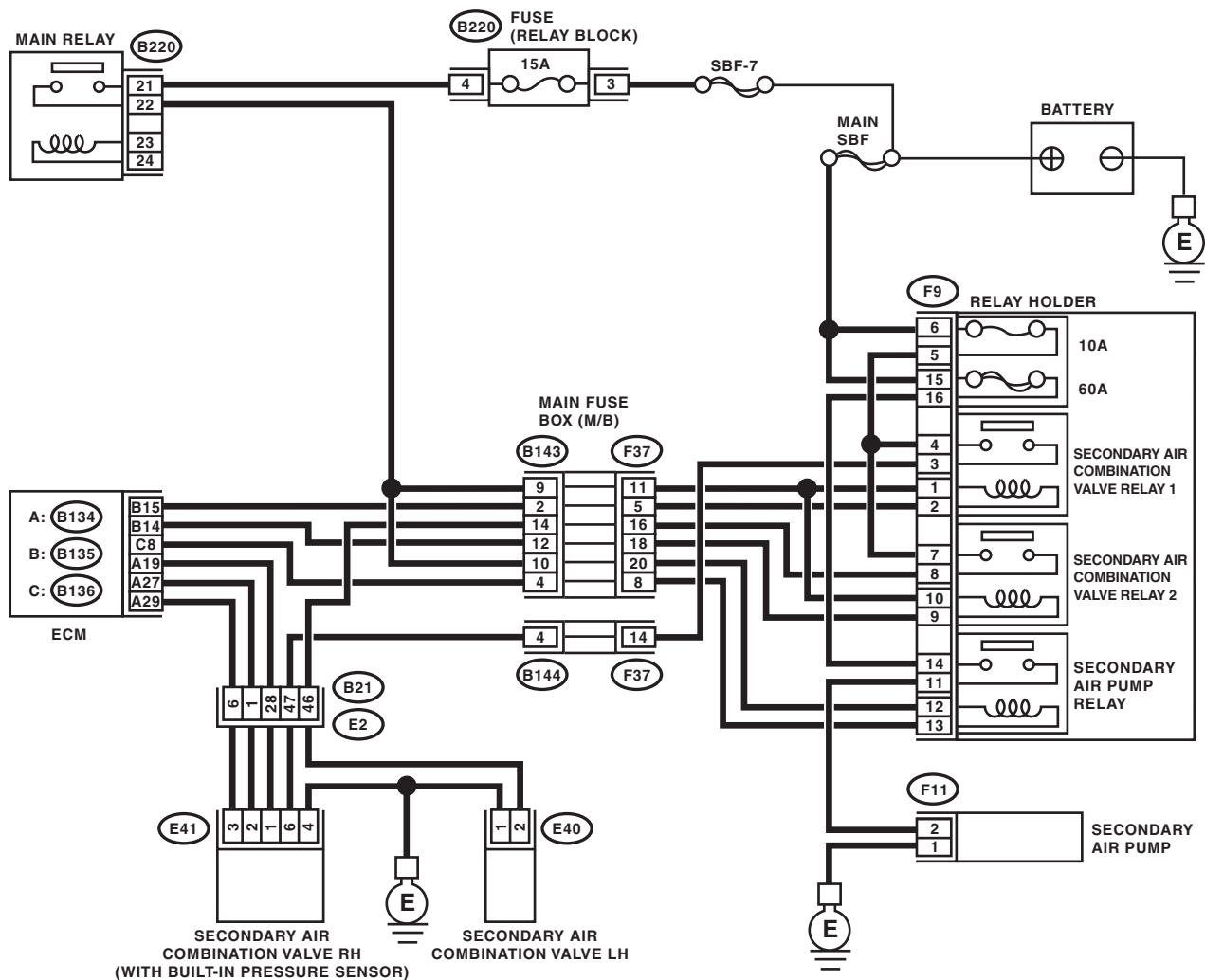

A: (B134)

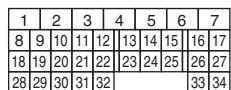

B: (B135)

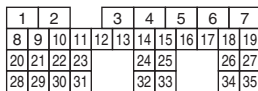

C: (B136)

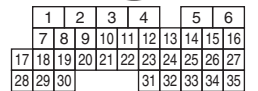

(B220)

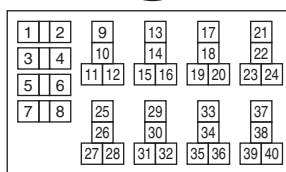

(B21)

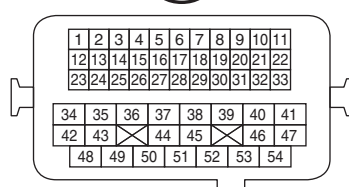

(F9)

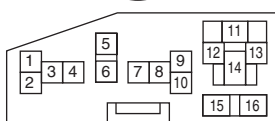

(F37)



(B143)

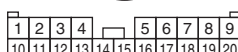

(E40)



(E41)



(B144)

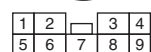

EN-06137

Diagnostic Procedure with Diagnostic Trouble Code (DTC)

ENGINE (DIAGNOSTICS)

Step	Check	Yes	No
<p>1 CHECK CURRENT DATA.</p> <p>1) Turn the ignition switch to ON.</p> <p>2) Read the data of secondary air pipe pressure signal using the Subaru Select Monitor or general scan tool.</p> <p>NOTE:</p> <ul style="list-style-type: none"> • Subaru Select Monitor <p>For detailed operation procedures, refer to "READ CURRENT DATA FOR ENGINE". <Ref. to EN(H4DOTC)(diag)-34, Subaru Select Monitor.></p> <ul style="list-style-type: none"> • General scan tool <p>For detailed operation procedures, refer to the general scan tool operation manual.</p>	<p>Is the measured value 133.3 kPa (1000 mmHg, 39.4 inHg) or more?</p>	<p>Go to step 2.</p>	<p>Even if the malfunction indicator light illuminates, the circuit has returned to a normal condition at this time. Reproduce the fault condition, and reperform the check.</p> <p>NOTE:</p> <p>In this case, there may be a temporary connector contact failure.</p>
<p>2 CHECK HARNESS BETWEEN ECM AND SECONDARY AIR COMBINATION VALVE RH CONNECTOR.</p> <p>1) Turn the ignition switch to OFF.</p> <p>2) Disconnect the connector from the secondary air combination valve RH.</p> <p>3) Turn the ignition switch to ON.</p> <p>4) Read the data of secondary air pipe pressure signal using the Subaru Select Monitor or general scan tool.</p> <p>NOTE:</p> <ul style="list-style-type: none"> • Subaru Select Monitor <p>For detailed operation procedures, refer to "READ CURRENT DATA FOR ENGINE". <Ref. to EN(H4DOTC)(diag)-34, Subaru Select Monitor.></p> <ul style="list-style-type: none"> • General scan tool <p>For detailed operation procedures, refer to the general scan tool operation manual.</p>	<p>Is the measured value 133.3 kPa (1000 mmHg, 39.4 inHg) or more?</p>	<p>Repair the short circuit to power in the harness between ECM and secondary air combination valve RH connectors.</p>	<p>Go to step 3.</p>
<p>3 CHECK HARNESS BETWEEN ECM AND SECONDARY AIR COMBINATION VALVE RH CONNECTOR.</p> <p>1) Turn the ignition switch to OFF.</p> <p>2) Measure the resistance of the harness between the secondary air combination valve RH connector and engine ground.</p> <p>Connector & terminal (E41) No. 3 — Engine ground:</p>	<p>Is the resistance less than 5 Ω?</p>	<p>Go to step 4.</p>	<p>Repair the harness and connector.</p> <p>NOTE:</p> <p>In this case, repair the following item:</p> <ul style="list-style-type: none"> • Open circuit in harness between ECM and secondary air combination valve RH connector • Poor contact in ECM connector • Poor contact of coupling connector
<p>4 CHECK POOR CONTACT.</p> <p>Check for poor contact of the secondary air combination valve RH connector.</p>	<p>Is there poor contact of the secondary air combination valve RH connector?</p>	<p>Repair the poor contact of the secondary air combination valve RH connector.</p>	<p>Replace the secondary air combination valve RH. <Ref. to EC(H4DOTC)-24, Secondary Air Combination Valve.></p>

EC:DTC P2440 SECONDARY AIR INJECTION SYSTEM SWITCHING VALVE STUCK OPEN (BANK 1)

DTC DETECTING CONDITION:

- Detected when two consecutive driving cycles with fault occur.
- GENERAL DESCRIPTION <Ref. to GD(H4DOTC)-225, DTC P2440 SECONDARY AIR INJECTION SYSTEM SWITCHING VALVE STUCK OPEN (BANK 1), Diagnostic Trouble Code (DTC) Detecting Criteria.>

CAUTION:

After repair or replacement of faulty parts, perform Clear Memory Mode <Ref. to EN(H4DOTC)(diag)-52, OPERATION, Clear Memory Mode.> and Inspection Mode <Ref. to EN(H4DOTC)(diag)-42, PROCEDURE, Inspection Mode.>.

Diagnostic Procedure with Diagnostic Trouble Code (DTC)

ENGINE (DIAGNOSTICS)

WIRING DIAGRAM:

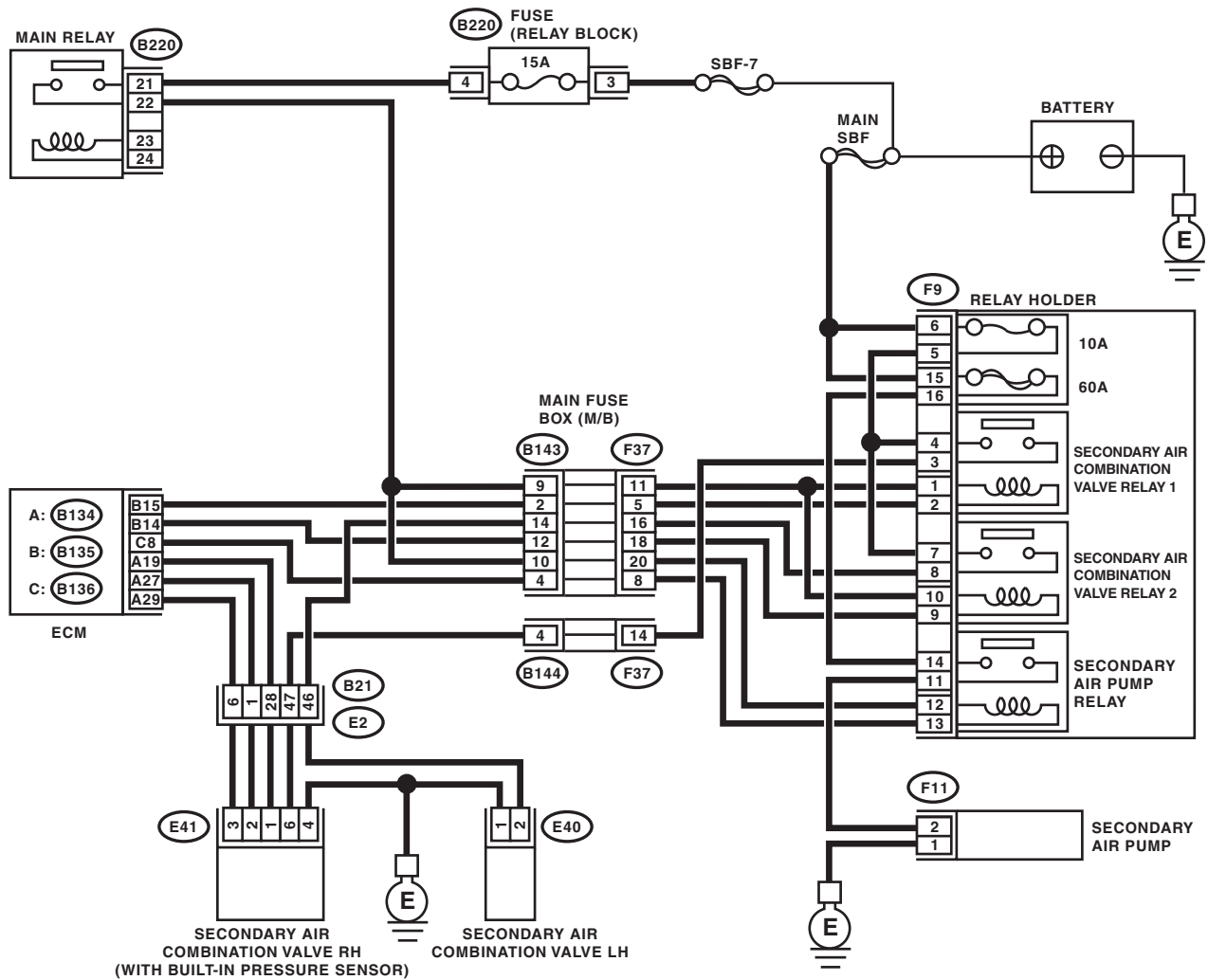

A: (B134)

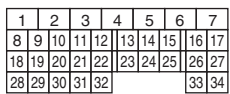

B: (B135)

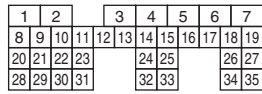

C: (B136)

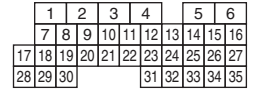

(B220)

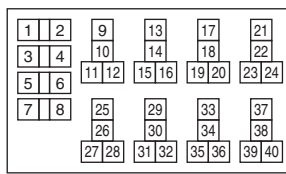

(B21)

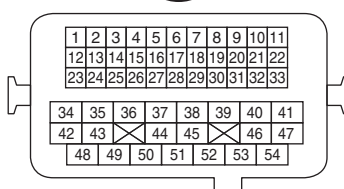

(F9)

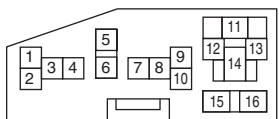

(F37)

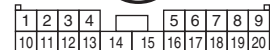

(B143)

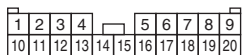

(E40)



(E41)



(B144)

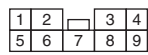

EN-06137

Diagnostic Procedure with Diagnostic Trouble Code (DTC)

ENGINE (DIAGNOSTICS)

	Step	Check	Yes	No
1	CHECK SECONDARY AIR COMBINATION VALVE FUSE. Check if the secondary air combination valve fuse (10 A) is blown out.	Is the fuse blown out?	Go to step 2.	Go to step 3.
2	CHECK HARNESS BETWEEN FUSE BOX AND SECONDARY AIR COMBINATION VALVE RH. 1) Remove the secondary air combination valve fuse (10 A) from the fuse box. 2) Disconnect the connector from the secondary air combination valve RH. 3) Measure the resistance between the secondary air combination valve fuse and secondary air combination valve RH connector, and chassis ground. Connector & terminal (F9) No. 5 — Chassis ground: (E41) No. 6 — Chassis ground:	Is the resistance 1 MΩ or more?	Replace the fuse with a new part, and connect the secondary air combination valve RH connector. Go to step 3.	Repair the short circuit to ground in harness between the fuse box and the secondary air combination valve RH connector.
3	CHECK SECONDARY AIR COMBINATION VALVE RH OPERATION. 1) Connect the delivery (test) mode connector. 2) Turn the ignition switch to ON. 3) Perform operation check for the secondary air combination valve RH using the Subaru Select Monitor. NOTE: Refer to “Compulsory Valve Operation Check Mode” for more operation procedures. <Ref. to EN(H4DOTC)(diag)-53, Compulsory Valve Operation Check Mode.>	Does the secondary air combination valve RH repeatedly switch to ON and OFF?	Go to step 4.	Go to step 6.
4	CHECK DUCT BETWEEN SECONDARY AIR PUMP AND SECONDARY AIR COMBINATION VALVE RH. Check the duct between the secondary air pump and secondary air combination valve RH.	Is there damage, clog or disconnection of the duct?	Replace, clean or connect the duct.	Go to step 5.
5	CHECK PIPE BETWEEN SECONDARY AIR COMBINATION VALVE RH AND CYLINDER HEAD. Check the pipe between the secondary air combination valve RH and cylinder head.	Is there damage, clog or disconnection of the pipe?	Replace, clean or connect the pipe.	Even if the malfunction indicator light illuminates, the circuit has returned to a normal condition at this time. Reproduce the fault condition, and reperform the check. NOTE: In this case, there may be a temporary connector contact failure.

Diagnostic Procedure with Diagnostic Trouble Code (DTC)

ENGINE (DIAGNOSTICS)

Step	Check	Yes	No
6 CHECK POWER SUPPLY TO SECONDARY AIR COMBINATION VALVE RH. 1) Disconnect the connector from the secondary air combination valve RH. 2) In the condition of step 3, measure the voltage between secondary air combination valve RH connector and chassis ground. <i>Connector & terminal</i> <i>(E41) No. 6 (+) — Chassis ground (-):</i>	Does the voltage repeatedly change between 10 V and 0 V?	Replace the secondary air combination valve RH. <Ref. to EC(H4DOTC)-24, Secondary Air Combination Valve.>	Go to step 7.
7 CHECK HARNESS BETWEEN SECONDARY AIR COMBINATION VALVE RH AND CHASSIS GROUND. Measure the resistance between the secondary air combination valve RH connector and chassis ground. <i>Connector & terminal</i> <i>(E41) No. 4 — Chassis ground:</i>	Is the resistance less than 5 Ω ?	Go to step 8.	Repair the open circuit in harness between secondary air combination valve RH connector and chassis ground.
8 CHECK HARNESS BETWEEN SECONDARY AIR COMBINATION VALVE RELAY 1 AND SECONDARY AIR COMBINATION VALVE RH CONNECTOR. 1) Turn the ignition switch to OFF. 2) Remove the secondary air combination valve relay 1 from the relay box. 3) Measure the resistance of the harness between secondary air combination valve relay 1 connector and secondary air combination valve RH connector. <i>Connector & terminal</i> <i>(F9) No. 3 — (E41) No. 6:</i>	Is the resistance less than 1 Ω ?	Go to step 9.	Repair the open circuit in harness between secondary air combination valve relay 1 and secondary air combination valve RH connector.
9 CHECK SECONDARY AIR COMBINATION VALVE RELAY 1. 1) Connect the battery to terminals No. 1 and No. 2 of the secondary air combination valve relay 2. 2) Measure the resistance between the secondary air combination valve relay 1 terminals. <i>Terminals</i> <i>No. 3 — No. 4:</i>	Is the resistance less than 1 Ω ?	Go to step 10.	Replace the secondary air combination valve relay 1. <Ref. to EN(H4DOTC)(diag)-8, Electrical Component Location.>
10 CHECK SECONDARY AIR COMBINATION VALVE RELAY 1. Measure the resistance between the secondary air combination valve relay 1 terminals with the battery disconnected. <i>Terminals</i> <i>No. 3 — No. 4:</i>	Is the resistance 1 M Ω or more?	Go to step 11.	Replace the secondary air combination valve relay 1. <Ref. to EN(H4DOTC)(diag)-8, Electrical Component Location.>
11 CHECK SECONDARY AIR COMBINATION VALVE RELAY 1 POWER SOURCE. 1) Turn the ignition switch to ON. 2) Measure the voltage between the secondary air combination valve relay 1 connector and chassis ground. <i>Connector & terminal</i> <i>(F9) No. 4 (+) — Chassis ground (-):</i> <i>(F9) No. 1 (+) — Chassis ground (-):</i>	Is the voltage 10 V or more?	Go to step 12.	Repair the open or ground short circuit of power supply circuit.

Diagnostic Procedure with Diagnostic Trouble Code (DTC)

ENGINE (DIAGNOSTICS)

Step	Check	Yes	No
12 CHECK HARNESS BETWEEN ECM AND SECONDARY AIR COMBINATION VALVE RELAY 1 CONNECTOR. 1) Turn the ignition switch to OFF. 2) Disconnect the connector of ECM. 3) Measure the resistance of harness between ECM and secondary air combination valve relay 1 connector. <i>Connector & terminal</i> <i>(B135) No. 15 — (F9) No. 2:</i>	Is the resistance less than 1 Ω ?	Go to step 13.	Repair the open circuit of harness between ECM and secondary air combination valve relay 1 connector.
13 CHECK HARNESS BETWEEN ECM AND SECONDARY AIR COMBINATION VALVE RELAY 1 CONNECTOR. Measure the resistance between the secondary air combination valve relay 1 connector and chassis ground. <i>Connector & terminal</i> <i>(F9) No. 2 — Chassis ground:</i>	Is the resistance 1 M Ω or more?	Repair the poor contact of the ECM connector.	Repair the ground short circuit of harness between ECM and secondary air combination valve relay 1 connector.

ED:DTC P2441 SECONDARY AIR INJECTION SYSTEM SWITCHING VALVE STUCK CLOSED (BANK 1)

NOTE:

For the diagnostic procedure, refer to DTC P2440. <Ref. to EN(H4DOTC)(diag)-353, DTC P2440 SECONDARY AIR INJECTION SYSTEM SWITCHING VALVE STUCK OPEN (BANK 1), Diagnostic Procedure with Diagnostic Trouble Code (DTC).>

Diagnostic Procedure with Diagnostic Trouble Code (DTC)

ENGINE (DIAGNOSTICS)

EE:DTC P2442 SECONDARY AIR INJECTION SYSTEM SWITCHING VALVE STUCK OPEN (BANK2)

DTC DETECTING CONDITION:

- Detected when two consecutive driving cycles with fault occur.
- GENERAL DESCRIPTION <Ref. to GD(H4DOTC)-225, DTC P2442 SECONDARY AIR INJECTION SYSTEM SWITCHING VALVE STUCK OPEN (BANK2), Diagnostic Trouble Code (DTC) Detecting Criteria.>

CAUTION:

After repair or replacement of faulty parts, perform Clear Memory Mode <Ref. to EN(H4DOTC)(diag)-52, OPERATION, Clear Memory Mode.> and Inspection Mode <Ref. to EN(H4DOTC)(diag)-42, PROCEDURE, Inspection Mode.>.

Diagnostic Procedure with Diagnostic Trouble Code (DTC)

ENGINE (DIAGNOSTICS)

WIRING DIAGRAM:

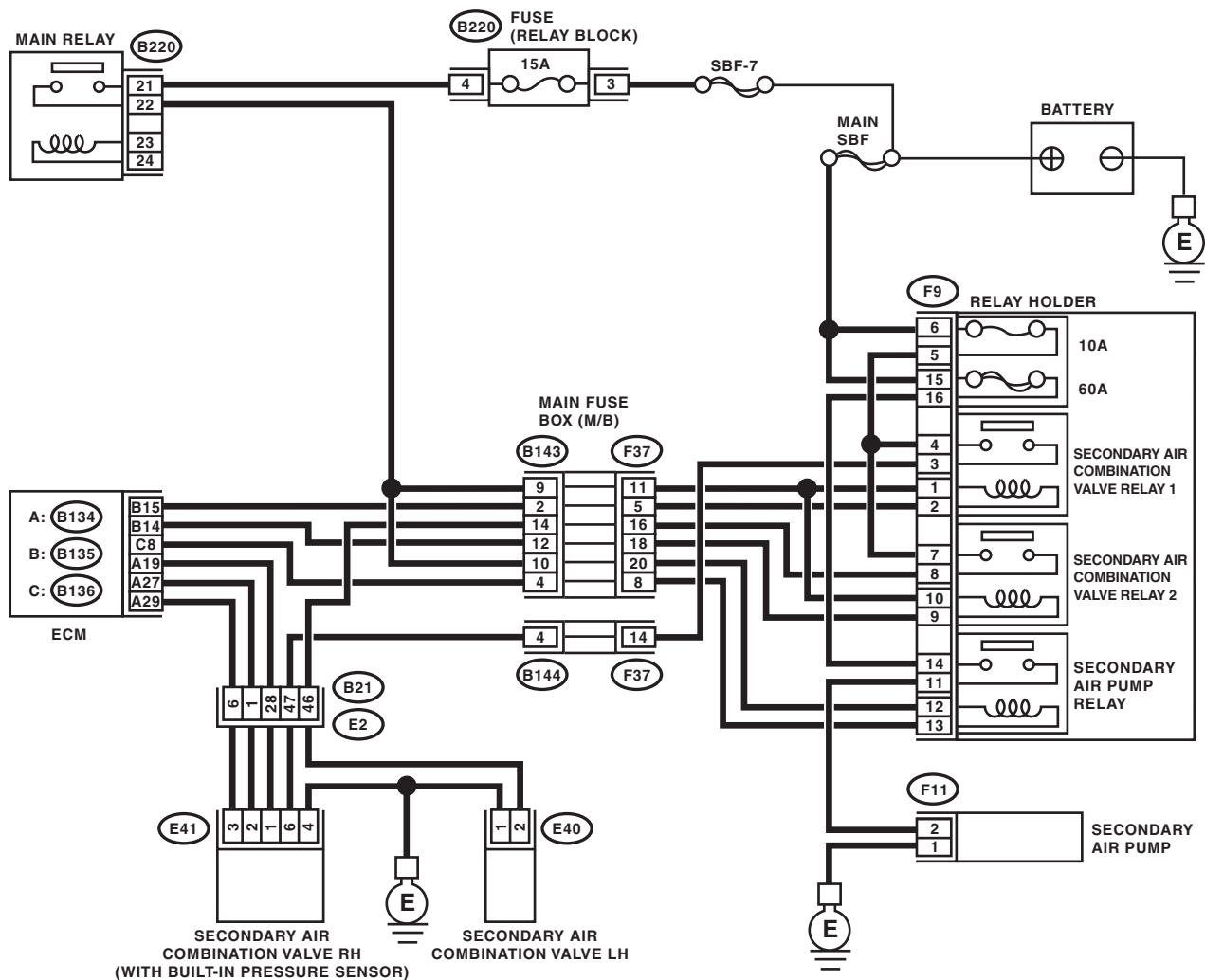

A: (B134)

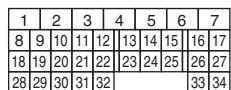

B: (B135)

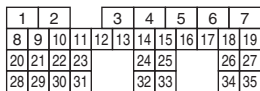

C: (B136)

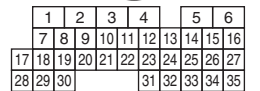

(F37)

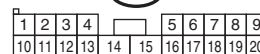

(B220)

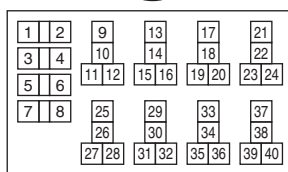

(B143)

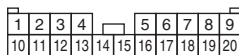

(E40)



(B21)

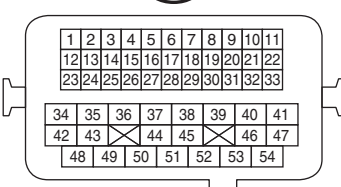

(E41)



(B144)

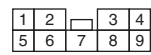

(F9)

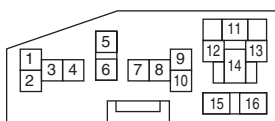

EN-06137

Diagnostic Procedure with Diagnostic Trouble Code (DTC)

ENGINE (DIAGNOSTICS)

Step	Check	Yes	No
1 CHECK SECONDARY AIR COMBINATION VALVE FUSE. Check if the secondary air combination valve fuse (10 A) is blown out.	Is the fuse blown out?	Go to step 2.	Go to step 3.
2 CHECK HARNESS BETWEEN FUSE BOX AND SECONDARY AIR COMBINATION VALVE LH. 1) Remove the secondary air combination valve fuse (10 A) from the fuse box. 2) Disconnect the connector from the secondary air combination valve LH. 3) Measure the resistance between the secondary air combination valve fuse and secondary air combination valve LH connector, and chassis ground. Connector & terminal (F9) No. 5 — Chassis ground: (E40) No. 2 — Chassis ground:	Is the resistance 1 MΩ or more?	Replace the fuse with a new part, and connect the secondary air combination valve LH connector. Go to step 3.	Repair the ground short circuit of harness between the fuse box and the secondary air combination valve LH connector.
3 CHECK SECONDARY AIR COMBINATION VALVE LH OPERATION. 1) Connect the delivery (test) mode connector. 2) Turn the ignition switch to ON. 3) Perform operation check for the secondary air combination valve LH using the Subaru Select Monitor. NOTE: Refer to “Compulsory Valve Operation Check Mode” for more operation procedures. <Ref. to EN(H4DOTC)(diag)-53, Compulsory Valve Operation Check Mode.>	Does the secondary air combination valve LH repeatedly switch to ON and OFF?	Go to step 4.	Go to step 6.
4 CHECK DUCT BETWEEN SECONDARY AIR PUMP AND SECONDARY AIR COMBINATION VALVE LH. Check the duct between the secondary air pump and secondary air combination valve LH.	Is there damage, clog or disconnection of the duct?	Replace, clean or connect the duct.	Go to step 5.
5 CHECK PIPE BETWEEN SECONDARY AIR COMBINATION VALVE LH AND CYLINDER HEAD. Check the pipe between the secondary air combination valve LH and cylinder head.	Is there damage, clog or disconnection of the pipe?	Replace, clean or connect the pipe.	Even if the malfunction indicator light illuminates, the circuit has returned to a normal condition at this time. Reproduce the fault condition, and reperform the check. NOTE: In this case, there may be a temporary connector contact failure.

Diagnostic Procedure with Diagnostic Trouble Code (DTC)

ENGINE (DIAGNOSTICS)

Step	Check	Yes	No
6 CHECK POWER SUPPLY TO SECONDARY AIR COMBINATION VALVE LH. 1) Disconnect the connector from the secondary air combination valve LH. 2) In the condition of step 3, measure the voltage between secondary air combination valve LH connector and chassis ground. Connector & terminal (E40) No. 2 (+) — Chassis ground (-):	Does the voltage repeatedly change between 10 V and 0 V?	Replace the secondary air combination valve LH. <Ref. to EC(H4DOTC)-24, Secondary Air Combination Valve.>	Go to step 7.
7 CHECK HARNESS BETWEEN SECONDARY AIR COMBINATION VALVE LH AND CHASSIS GROUND. Measure the resistance between the secondary air combination valve LH connector and chassis ground. Connector & terminal (E40) No. 1 — Chassis ground:	Is the resistance less than 5 Ω ?	Go to step 8.	Repair the open circuit in harness between secondary air combination valve LH connector and chassis ground.
8 CHECK HARNESS BETWEEN SECONDARY AIR COMBINATION VALVE RELAY 2 AND SECONDARY AIR COMBINATION VALVE LH CONNECTOR. 1) Turn the ignition switch to OFF. 2) Remove the secondary air combination valve relay 2 from the relay box. 3) Measure the resistance of the harness between the secondary air combination valve relay 2 and secondary air combination valve LH connector. Connector & terminal (F9) No. 8 — (E40) No. 2:	Is the resistance less than 1 Ω ?	Go to step 9.	Repair the open circuit in harness between secondary air combination valve relay 2 connector and secondary air combination valve LH connector.
9 CHECK SECONDARY AIR COMBINATION VALVE RELAY 2. 1) Connect the battery to terminals No. 10 and No. 9 of the secondary air combination valve relay 2. 2) Measure the resistance between the secondary air combination valve relay 2 terminals. Terminals No. 7 — No. 8:	Is the resistance less than 1 Ω ?	Go to step 10.	Replace the secondary air combination valve relay 2. <Ref. to EN(H4DOTC)(diag)-8, Electrical Component Location.>
10 CHECK SECONDARY AIR COMBINATION VALVE RELAY 2. Measure the resistance between the secondary air combination valve relay 2 terminals with the battery disconnected. Terminals No. 7 — No. 8:	Is the resistance 1 M Ω or more?	Go to step 11.	Replace the secondary air combination valve relay 2. <Ref. to EN(H4DOTC)(diag)-8, Electrical Component Location.>
11 CHECK SECONDARY AIR COMBINATION VALVE RELAY 2 POWER SOURCE. 1) Turn the ignition switch to ON. 2) Measure the voltage between the secondary air combination valve relay 2 connector and chassis ground. Connector & terminal (F9) No. 7 (+) — Chassis ground (-): (F9) No. 10 (+) — Chassis ground (-):	Is the voltage 10 V or more?	Go to step 12.	Repair the open or ground short circuit of power supply circuit.

Diagnostic Procedure with Diagnostic Trouble Code (DTC)

ENGINE (DIAGNOSTICS)

Step	Check	Yes	No
12 CHECK HARNESS BETWEEN ECM AND SECONDARY AIR COMBINATION VALVE RELAY 2 CONNECTOR. 1) Turn the ignition switch to OFF. 2) Disconnect the connector of ECM. 3) Measure the resistance of harness between ECM and secondary air combination valve relay 2 connector. Connector & terminal (B135) No. 14 — (F9) No. 9:	Is the resistance less than 1 Ω ?	Go to step 13.	Repair the open circuit of harness between ECM and secondary air combination valve relay 2 connector.
13 CHECK HARNESS BETWEEN ECM AND SECONDARY AIR COMBINATION VALVE RELAY 2 CONNECTOR. Measure the resistance between the secondary air combination valve relay 2 connector and chassis ground. Connector & terminal (F9) No. 9 — Chassis ground:	Is the resistance 1 M Ω or more?	Repair the poor contact of the ECM connector.	Repair the ground short circuit of harness between ECM and secondary air combination valve relay 2 connector.

EF:DTC P2443 SECONDARY AIR INJECTION SYSTEM SWITCHING VALVE STUCK CLOSED (BANK2)

NOTE:

For the diagnostic procedure, refer to DTC P2442. <Ref. to EN(H4DOTC)(diag)-358, DTC P2442 SECONDARY AIR INJECTION SYSTEM SWITCHING VALVE STUCK OPEN (BANK2), Diagnostic Procedure with Diagnostic Trouble Code (DTC).>

EG:DTC P2444 SECONDARY AIR INJECTION SYSTEM PUMP STUCK ON

DTC DETECTING CONDITION:

- Immediately at fault recognition
- GENERAL DESCRIPTION <Ref. to GD(H4DOTC)-226, DTC P2444 SECONDARY AIR INJECTION SYSTEM PUMP STUCK ON, Diagnostic Trouble Code (DTC) Detecting Criteria.>

CAUTION:

After repair or replacement of faulty parts, perform Clear Memory Mode <Ref. to EN(H4DOTC)(diag)-52, OPERATION, Clear Memory Mode.> and Inspection Mode <Ref. to EN(H4DOTC)(diag)-42, PROCEDURE, Inspection Mode.>.

Diagnostic Procedure with Diagnostic Trouble Code (DTC)

ENGINE (DIAGNOSTICS)

WIRING DIAGRAM:

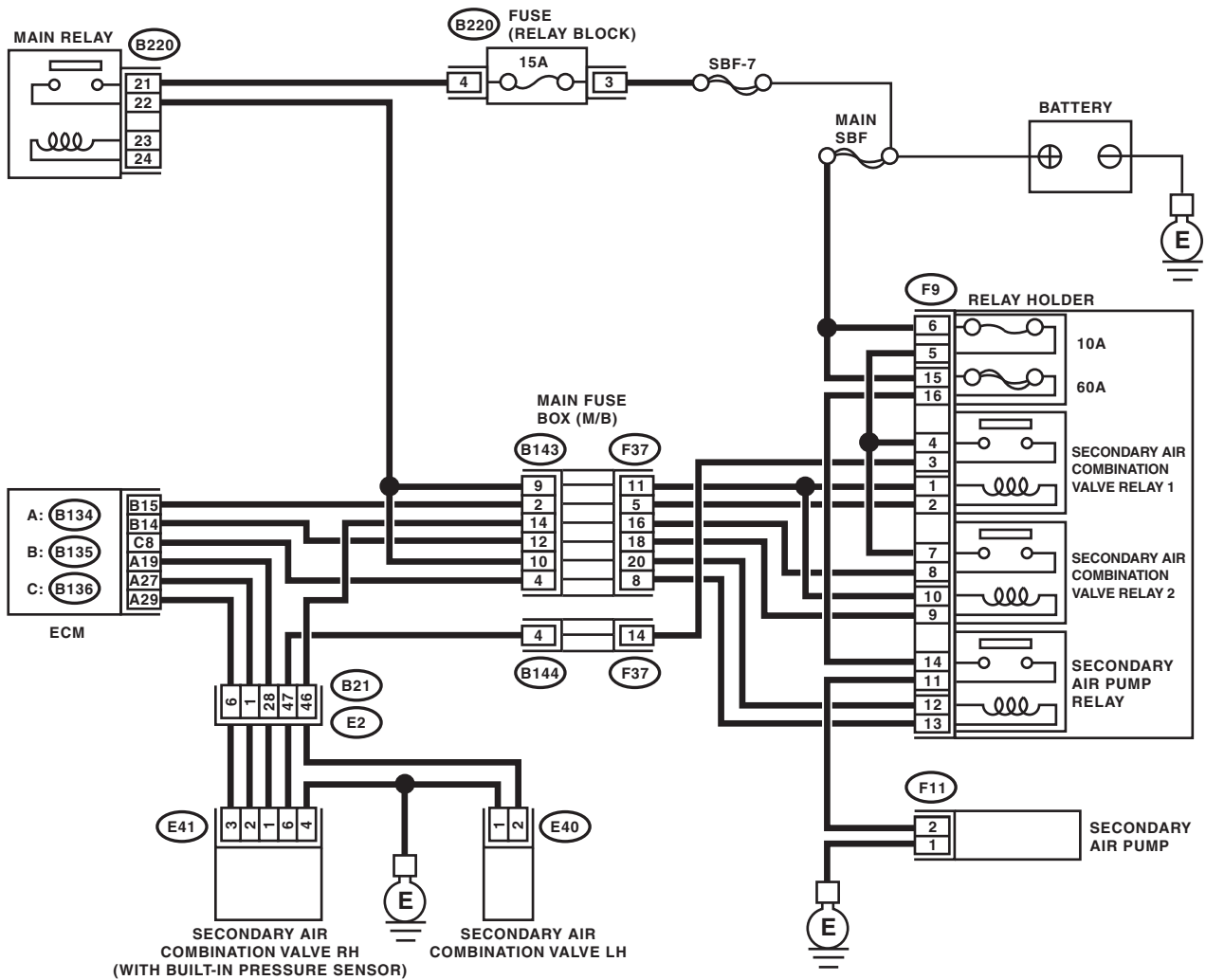

A: (B134)

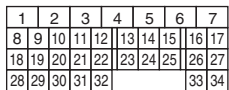

B: (B135)

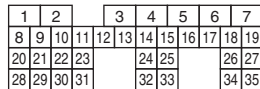

C: (B136)

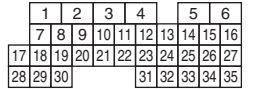

(B220)

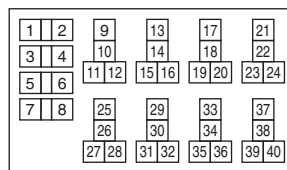

(B21)

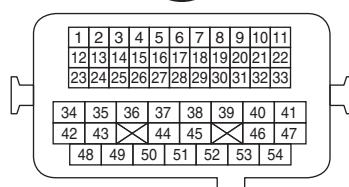

(F9)

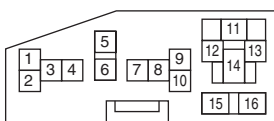

(F37)

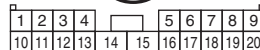

(B143)

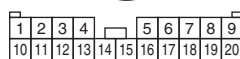

(E40)



(E41)



(B144)

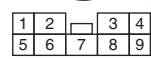

EN-06137

Diagnostic Procedure with Diagnostic Trouble Code (DTC)

ENGINE (DIAGNOSTICS)

	Step	Check	Yes	No
1	<p>CHECK SECONDARY AIR PIPING PRESSURE.</p> <p>1) Turn the ignition switch to ON.</p> <p>2) Using the Subaru Select Monitor, read secondary air piping pressure data, and compare with the actual barometric pressure.</p> <p>NOTE: For detailed operation procedures, refer to "READ CURRENT DATA FOR ENGINE". <Ref. to EN(H4DOTC)(diag)-34, Subaru Select Monitor.></p>	Is the actual difference with atmospheric pressure 50 mmHg (6.7 kPa, 2.0 inHg, 0.97 psig) or more?	Go to step 2.	<p>Even if the malfunction indicator light illuminates, the circuit has returned to a normal condition at this time. Reproduce the fault condition, and reperform the check.</p> <p>NOTE: In this case, there may be a temporary connector contact failure.</p>
2	<p>CHECK SECONDARY AIR PUMP.</p> <p>1) Start the engine and warm up engine until coolant temperature is higher than 75°C (167°F).</p> <p>2) Check whether or not the secondary air pump is operating.</p>	Is the secondary air pump operating?	Go to step 3.	<p>Replace the secondary air combination valve RH.</p> <p><Ref. to EC(H4DOTC)-24, Secondary Air Combination Valve.></p>
3	<p>CHECK HARNESS BETWEEN ECM AND SECONDARY AIR PUMP RELAY CONNECTOR.</p> <p>1) Turn the ignition switch to OFF.</p> <p>2) Remove the secondary air pump relay from the relay box.</p> <p>3) Measure the resistance between the secondary air pump relay connector and engine ground terminals.</p> <p>Connector & terminal (F9) No. 13 — Engine ground:</p>	Is the resistance 1 MΩ or more?	Go to step 4.	<p>Repair the ground short circuit of harness between ECM and secondary air pump relay connector.</p>
4	<p>CHECK SECONDARY AIR PUMP RELAY.</p> <p>Measure the resistance between the secondary air pump relay terminals.</p> <p>Terminals No. 14 — No. 11:</p>	Is the resistance 1 MΩ or more?	Repair the short circuit to power in the harness between secondary air pump relay and secondary air pump connector.	<p>Replace the secondary air pump relay. <Ref. to EN(H4DOTC)(diag)-8, Electrical Component Location.></p>

General Diagnostic Table

ENGINE (DIAGNOSTICS)

21. General Diagnostic Table

A: INSPECTION

1. ENGINE

NOTE:

Malfunction of parts other than those listed is also possible. <Ref. to ME(H4DOTC)-101, Engine Trouble in General.>

Symptom	Problem parts
1. Engine stalls during idling.	1) Electronic throttle control 2) Manifold absolute pressure sensor 3) Mass air flow and intake air temperature sensor 4) Ignition parts (*1) 5) Engine coolant temperature sensor (*2) 6) Crankshaft position sensor (*3) 7) Camshaft position sensor (*3) 8) Fuel injection parts (*4)
2. Rough idling	1) Electronic throttle control 2) Manifold absolute pressure sensor 3) Mass air flow and intake air temperature sensor 4) Engine coolant temperature sensor (*2) 5) Ignition parts (*1) 6) Air intake system (*5) 7) Fuel injection parts (*4) 8) Crankshaft position sensor (*3) 9) Camshaft position sensor (*3) 10) Oxygen sensor 11) Fuel pump and fuel pump relay
3. Engine does not return to idle.	1) Electronic throttle control 2) Engine coolant temperature sensor 3) Manifold absolute pressure sensor 4) Mass air flow sensor
4. Poor acceleration	1) Manifold absolute pressure sensor 2) Mass air flow and intake air temperature sensor 3) Electronic throttle control 4) Fuel injection parts (*4) 5) Fuel pump and fuel pump relay 6) Engine coolant temperature sensor (*2) 7) Crankshaft position sensor (*3) 8) Camshaft position sensor (*3) 9) A/C switch and A/C cut relay 10) Engine torque control signal circuit 11) Ignition parts (*1)
5. Engine stalls, hesitates, or sputters at acceleration.	1) Manifold absolute pressure sensor 2) Mass air flow and intake air temperature sensor 3) Engine coolant temperature sensor (*2) 4) Crankshaft position sensor (*3) 5) Camshaft position sensor (*3) 6) Purge control solenoid valve 7) Fuel injection parts (*4) 8) Fuel pump and fuel pump relay
6. Surging	1) Manifold absolute pressure sensor 2) Mass air flow and intake air temperature sensor 3) Engine coolant temperature sensor (*2) 4) Crankshaft position sensor (*3) 5) Camshaft position sensor (*3) 6) Fuel injection parts (*4) 7) Throttle position sensor 8) Fuel pump and fuel pump relay

General Diagnostic Table

ENGINE (DIAGNOSTICS)

Symptom	Problem parts
7. Spark knock	1) Manifold absolute pressure sensor 2) Mass air flow and intake air temperature sensor 3) Engine coolant temperature sensor 4) Knock sensor 5) Fuel injection parts (*4) 6) Fuel pump and fuel pump relay
8. After burning in exhaust system	1) Manifold absolute pressure sensor 2) Mass air flow and intake air temperature sensor 3) Engine coolant temperature sensor (*2) 4) Fuel injection parts (*4) 5) Fuel pump and fuel pump relay

*1: Check ignition coil and spark plug.

*2: Indicate the symptom occurring only in cold temperatures.

*3: Ensure the secure installation.

*4: Check fuel injector, fuel pressure regulator and fuel filter.

*5: Inspect air leak in air intake system.

General Diagnostic Table

ENGINE (DIAGNOSTICS)

GENERAL DESCRIPTION

GD(H4DOTC)

	Page
1. List of Diagnostic Trouble Code (DTC)	2
2. Diagnostic Trouble Code (DTC) Detecting Criteria	9

List of Diagnostic Trouble Code (DTC)

GENERAL DESCRIPTION

1. List of Diagnostic Trouble Code (DTC)

A: LIST

DTC	Item	Index
P0011	Intake Camshaft Position - Timing Over-Advanced or System Performance (Bank 1)	<Ref. to GD(H4DOTC)-9, DTC P0011 INTAKE CAMSHAFT POSITION - TIMING OVER-ADVANCED OR SYSTEM PERFORMANCE (BANK 1), Diagnostic Trouble Code (DTC) Detecting Criteria.>
P0016	Crankshaft Position - Camshaft Position Correlation (Bank 1)	<Ref. to GD(H4DOTC)-11, DTC P0016 CRANKSHAFT POSITION - CAMSHAFT POSITION CORRELATION (BANK1), Diagnostic Trouble Code (DTC) Detecting Criteria.>
P0018	Crankshaft Position - Camshaft Position Correlation (Bank 2)	<Ref. to GD(H4DOTC)-13, DTC P0018 CRANKSHAFT POSITION - CAMSHAFT POSITION CORRELATION (BANK2), Diagnostic Trouble Code (DTC) Detecting Criteria.>
P0021	Intake Camshaft Position - Timing Over-Advanced or System Performance (Bank 2)	<Ref. to GD(H4DOTC)-13, DTC P0021 INTAKE CAMSHAFT POSITION - TIMING OVER-ADVANCED OR SYSTEM PERFORMANCE (BANK 2), Diagnostic Trouble Code (DTC) Detecting Criteria.>
P0030	HO2S Heater Control Circuit (Bank 1 Sensor 1)	<Ref. to GD(H4DOTC)-14, DTC P0030 HO2S HEATER CONTROL CIRCUIT (BANK 1 SENSOR 1), Diagnostic Trouble Code (DTC) Detecting Criteria.>
P0031	HO2S Heater Control Circuit Low (Bank 1 Sensor 1)	<Ref. to GD(H4DOTC)-16, DTC P0031 HO2S HEATER CONTROL CIRCUIT LOW (BANK 1 SENSOR 1), Diagnostic Trouble Code (DTC) Detecting Criteria.>
P0032	HO2S Heater Control Circuit High (Bank 1 Sensor 1)	<Ref. to GD(H4DOTC)-18, DTC P0032 HO2S HEATER CONTROL CIRCUIT HIGH (BANK 1 SENSOR 1), Diagnostic Trouble Code (DTC) Detecting Criteria.>
P0037	HO2S Heater Control Circuit Low (Bank 1 Sensor 2)	<Ref. to GD(H4DOTC)-20, DTC P0037 HO2S HEATER CONTROL CIRCUIT LOW (BANK 1 SENSOR 2), Diagnostic Trouble Code (DTC) Detecting Criteria.>
P0038	HO2S Heater Control Circuit High (Bank 1 Sensor 2)	<Ref. to GD(H4DOTC)-22, DTC P0038 HO2S HEATER CONTROL CIRCUIT HIGH (BANK 1 SENSOR 2), Diagnostic Trouble Code (DTC) Detecting Criteria.>
P0068	MAP/MAF - Throttle Position Correlation	<Ref. to GD(H4DOTC)-24, DTC P0068 MAP/MAF - THROTTLE POSITION CORRELATION, Diagnostic Trouble Code (DTC) Detecting Criteria.>
P0101	Mass or Volume Air Flow Circuit Range/Performance	<Ref. to GD(H4DOTC)-26, DTC P0101 MASS OR VOLUME AIR FLOW CIRCUIT RANGE/PERFORMANCE, Diagnostic Trouble Code (DTC) Detecting Criteria.>
P0102	Mass or Volume Air Flow Circuit Low Input	<Ref. to GD(H4DOTC)-28, DTC P0102 MASS OR VOLUME AIR FLOW CIRCUIT LOW INPUT, Diagnostic Trouble Code (DTC) Detecting Criteria.>
P0103	Mass or Volume Air Flow Circuit High Input	<Ref. to GD(H4DOTC)-29, DTC P0103 MASS OR VOLUME AIR FLOW CIRCUIT HIGH INPUT, Diagnostic Trouble Code (DTC) Detecting Criteria.>
P0107	Manifold Absolute Pressure/Barometric Pressure Circuit Low Input	<Ref. to GD(H4DOTC)-30, DTC P0107 MANIFOLD ABSOLUTE PRESSURE/BAROMETRIC PRESSURE CIRCUIT LOW INPUT, Diagnostic Trouble Code (DTC) Detecting Criteria.>
P0108	Manifold Absolute Pressure/Barometric Pressure Circuit High Input	<Ref. to GD(H4DOTC)-31, DTC P0108 MANIFOLD ABSOLUTE PRESSURE/BAROMETRIC PRESSURE CIRCUIT HIGH INPUT, Diagnostic Trouble Code (DTC) Detecting Criteria.>
P0111	Intake Air Temperature Sensor 1 Circuit Range/Performance	<Ref. to GD(H4DOTC)-32, DTC P0111 INTAKE AIR TEMPERATURE SENSOR 1 CIRCUIT RANGE/PERFORMANCE, Diagnostic Trouble Code (DTC) Detecting Criteria.>
P0112	Intake Air Temperature Sensor 1 Circuit Low	<Ref. to GD(H4DOTC)-34, DTC P0112 INTAKE AIR TEMPERATURE SENSOR 1 CIRCUIT LOW, Diagnostic Trouble Code (DTC) Detecting Criteria.>
P0113	Intake Air Temperature Sensor 1 Circuit High	<Ref. to GD(H4DOTC)-35, DTC P0113 INTAKE AIR TEMPERATURE SENSOR 1 CIRCUIT HIGH, Diagnostic Trouble Code (DTC) Detecting Criteria.>
P0117	Engine Coolant Temperature Circuit Low	<Ref. to GD(H4DOTC)-36, DTC P0117 ENGINE COOLANT TEMPERATURE CIRCUIT LOW, Diagnostic Trouble Code (DTC) Detecting Criteria.>
P0118	Engine Coolant Temperature Circuit High	<Ref. to GD(H4DOTC)-37, DTC P0118 ENGINE COOLANT TEMPERATURE CIRCUIT HIGH, Diagnostic Trouble Code (DTC) Detecting Criteria.>
P0122	Throttle/Pedal Position Sensor/Switch "A" Circuit Low	<Ref. to GD(H4DOTC)-38, DTC P0122 THROTTLE/PEDAL POSITION SENSOR/SWITCH "A" CIRCUIT LOW, Diagnostic Trouble Code (DTC) Detecting Criteria.>

List of Diagnostic Trouble Code (DTC)

GENERAL DESCRIPTION

DTC	Item	Index
P0123	Throttle/Pedal Position Sensor/ Switch "A" Circuit High	<Ref. to GD(H4DOTC)-39, DTC P0123 THROTTLE/PEDAL POSITION SENSOR/SWITCH "A" CIRCUIT HIGH, Diagnostic Trouble Code (DTC) Detecting Criteria.>
P0125	Insufficient Coolant Temperature for Closed Loop Fuel Control	<Ref. to GD(H4DOTC)-40, DTC P0125 INSUFFICIENT COOLANT TEMPERATURE FOR CLOSED LOOP FUEL CONTROL, Diagnostic Trouble Code (DTC) Detecting Criteria.>
P0126	Insufficient Engine Coolant Temperature for Stable Operation	<Ref. to GD(H4DOTC)-42, DTC P0126 INSUFFICIENT ENGINE COOLANT TEMPERATURE FOR STABLE OPERATION, Diagnostic Trouble Code (DTC) Detecting Criteria.>
P0128	Coolant Thermostat (Engine Coolant Temperature Below Thermostat Regulating Temperature)	<Ref. to GD(H4DOTC)-44, DTC P0128 COOLANT THERMOSTAT (ENGINE COOLANT TEMPERATURE BELOW THERMOSTAT REGULATING TEMPERATURE), Diagnostic Trouble Code (DTC) Detecting Criteria.>
P0131	O2 Sensor Circuit Low Voltage (Bank 1 Sensor 1)	<Ref. to GD(H4DOTC)-46, DTC P0131 O2 SENSOR CIRCUIT LOW VOLTAGE (BANK 1 SENSOR 1), Diagnostic Trouble Code (DTC) Detecting Criteria.>
P0132	O2 Sensor Circuit High Voltage (Bank 1 Sensor 1)	<Ref. to GD(H4DOTC)-48, DTC P0132 O2 SENSOR CIRCUIT HIGH VOLTAGE (BANK 1 SENSOR 1), Diagnostic Trouble Code (DTC) Detecting Criteria.>
P0133	O2 Sensor Circuit Slow Response (Bank 1 Sensor 1)	<Ref. to GD(H4DOTC)-50, DTC P0133 O2 SENSOR CIRCUIT SLOW RESPONSE (BANK 1 SENSOR 1), Diagnostic Trouble Code (DTC) Detecting Criteria.>
P0134	O2 Sensor Circuit No Activity Detected (Bank 1 Sensor 1)	<Ref. to GD(H4DOTC)-53, DTC P0134 O2 SENSOR CIRCUIT NO ACTIVITY DETECTED (BANK 1 SENSOR 1), Diagnostic Trouble Code (DTC) Detecting Criteria.>
P0137	O2 Sensor Circuit Low Voltage (Bank 1 Sensor 2)	<Ref. to GD(H4DOTC)-55, DTC P0137 O2 SENSOR CIRCUIT LOW VOLTAGE (BANK 1 SENSOR 2), Diagnostic Trouble Code (DTC) Detecting Criteria.>
P0138	O2 Sensor Circuit High Voltage (Bank 1 Sensor 2)	<Ref. to GD(H4DOTC)-58, DTC P0138 O2 SENSOR CIRCUIT HIGH VOLTAGE (BANK 1 SENSOR 2), Diagnostic Trouble Code (DTC) Detecting Criteria.>
P0139	O2 Sensor Circuit Slow Response (Bank 1 Sensor 2)	<Ref. to GD(H4DOTC)-59, DTC P0139 O2 SENSOR CIRCUIT SLOW RESPONSE (BANK 1 SENSOR 2), Diagnostic Trouble Code (DTC) Detecting Criteria.>
P0140	O2 Sensor Circuit No Activity Detected (Bank 1 Sensor 2)	<Ref. to GD(H4DOTC)-64, DTC P0140 O2 SENSOR CIRCUIT NO ACTIVITY DETECTED (BANK 1 SENSOR 2), Diagnostic Trouble Code (DTC) Detecting Criteria.>
P0171	System Too Lean (Bank 1)	<Ref. to GD(H4DOTC)-66, DTC P0171 SYSTEM TOO LEAN (BANK 1), Diagnostic Trouble Code (DTC) Detecting Criteria.>
P0172	System Too Rich (Bank 1)	<Ref. to GD(H4DOTC)-67, DTC P0172 SYSTEM TOO RICH (BANK 1), Diagnostic Trouble Code (DTC) Detecting Criteria.>
P0181	Fuel Temperature Sensor "A" Circuit Range/Performance	<Ref. to GD(H4DOTC)-68, DTC P0181 FUEL TEMPERATURE SENSOR "A" CIRCUIT RANGE/PERFORMANCE, Diagnostic Trouble Code (DTC) Detecting Criteria.>
P0182	Fuel Temperature Sensor "A" Circuit Low Input	<Ref. to GD(H4DOTC)-71, DTC P0182 FUEL TEMPERATURE SENSOR "A" CIRCUIT LOW INPUT, Diagnostic Trouble Code (DTC) Detecting Criteria.>
P0183	Fuel Temperature Sensor "A" Circuit High Input	<Ref. to GD(H4DOTC)-72, DTC P0183 FUEL TEMPERATURE SENSOR "A" CIRCUIT HIGH INPUT, Diagnostic Trouble Code (DTC) Detecting Criteria.>
P0222	Throttle/Pedal Position Sensor/ Switch "B" Circuit Low	<Ref. to GD(H4DOTC)-73, DTC P0222 THROTTLE/PEDAL POSITION SENSOR/SWITCH "B" CIRCUIT LOW, Diagnostic Trouble Code (DTC) Detecting Criteria.>
P0223	Throttle/Pedal Position Sensor/ Switch "B" Circuit High	<Ref. to GD(H4DOTC)-74, DTC P0223 THROTTLE/PEDAL POSITION SENSOR/SWITCH "B" CIRCUIT HIGH, Diagnostic Trouble Code (DTC) Detecting Criteria.>
P0230	Fuel Pump Primary Circuit	<Ref. to GD(H4DOTC)-75, DTC P0230 FUEL PUMP PRIMARY CIRCUIT, Diagnostic Trouble Code (DTC) Detecting Criteria.>
P0244	Turbo/Super Charger Wastegate Solenoid "A" Range/Performance	<Ref. to GD(H4DOTC)-77, DTC P0244 TURBO/SUPER CHARGER WASTEGATE SOLENOID "A" RANGE/PERFORMANCE, Diagnostic Trouble Code (DTC) Detecting Criteria.>
P0245	Turbo/Super Charger Wastegate Solenoid "A" Low	<Ref. to GD(H4DOTC)-79, DTC P0245 TURBO/SUPER CHARGER WASTEGATE SOLENOID "A" LOW, Diagnostic Trouble Code (DTC) Detecting Criteria.>

List of Diagnostic Trouble Code (DTC)

GENERAL DESCRIPTION

DTC	Item	Index
P0246	Turbo/Super Charger Wastegate Solenoid "A" High	<Ref. to GD(H4DOTC)-80, DTC P0246 TURBO/SUPER CHARGER WASTEGATE SOLENOID "A" HIGH, Diagnostic Trouble Code (DTC) Detecting Criteria.>
P0301	Cylinder 1 Misfire Detected	<Ref. to GD(H4DOTC)-81, DTC P0301 CYLINDER 1 MISFIRE DETECTED, Diagnostic Trouble Code (DTC) Detecting Criteria.>
P0302	Cylinder 2 Misfire Detected	<Ref. to GD(H4DOTC)-86, DTC P0302 CYLINDER 2 MISFIRE DETECTED, Diagnostic Trouble Code (DTC) Detecting Criteria.>
P0303	Cylinder 3 Misfire Detected	<Ref. to GD(H4DOTC)-86, DTC P0303 CYLINDER 3 MISFIRE DETECTED, Diagnostic Trouble Code (DTC) Detecting Criteria.>
P0304	Cylinder 4 Misfire Detected	<Ref. to GD(H4DOTC)-86, DTC P0304 CYLINDER 4 MISFIRE DETECTED, Diagnostic Trouble Code (DTC) Detecting Criteria.>
P0327	Knock Sensor 1 Circuit Low (Bank 1 or Single Sensor)	<Ref. to GD(H4DOTC)-87, DTC P0327 KNOCK SENSOR 1 CIRCUIT LOW (BANK 1 OR SINGLE SENSOR), Diagnostic Trouble Code (DTC) Detecting Criteria.>
P0328	Knock Sensor 1 Circuit High (Bank 1 or Single Sensor)	<Ref. to GD(H4DOTC)-88, DTC P0328 KNOCK SENSOR 1 CIRCUIT HIGH (BANK 1 OR SINGLE SENSOR), Diagnostic Trouble Code (DTC) Detecting Criteria.>
P0335	Crankshaft Position Sensor "A" Circuit	<Ref. to GD(H4DOTC)-89, DTC P0335 CRANKSHAFT POSITION SENSOR "A" CIRCUIT, Diagnostic Trouble Code (DTC) Detecting Criteria.>
P0336	Crankshaft Position Sensor "A" Circuit Range/Performance	<Ref. to GD(H4DOTC)-91, DTC P0336 CRANKSHAFT POSITION SENSOR "A" CIRCUIT RANGE/PERFORMANCE, Diagnostic Trouble Code (DTC) Detecting Criteria.>
P0340	Camshaft Position Sensor "A" Circuit (Bank 1 or Single Sensor)	<Ref. to GD(H4DOTC)-93, DTC P0340 CAMSHAFT POSITION SENSOR "A" CIRCUIT (BANK 1 OR SINGLE SENSOR), Diagnostic Trouble Code (DTC) Detecting Criteria.>
P0345	Camshaft Position Sensor "A" Circuit (Bank 2)	<Ref. to GD(H4DOTC)-95, DTC P0345 CAMSHAFT POSITION SENSOR "A" CIRCUIT (BANK 2), Diagnostic Trouble Code (DTC) Detecting Criteria.>
P0410	Secondary Air Injection System	<Ref. to GD(H4DOTC)-96, DTC P0410 SECONDARY AIR INJECTION SYSTEM, Diagnostic Trouble Code (DTC) Detecting Criteria.>
P0411	Secondary Air Injection System Incorrect Flow Detected	<Ref. to GD(H4DOTC)-105, DTC P0411 SECONDARY AIR INJECTION SYSTEM INCORRECT FLOW DETECTED, Diagnostic Trouble Code (DTC) Detecting Criteria.>
P0413	Secondary Air Injection System Switching Valve "A" Circuit Open	<Ref. to GD(H4DOTC)-106, DTC P0413 SECONDARY AIR INJECTION SYSTEM SWITCHING VALVE "A" CIRCUIT OPEN, Diagnostic Trouble Code (DTC) Detecting Criteria.>
P0414	Secondary Air Injection System Switching Valve "A" Circuit Shorted	<Ref. to GD(H4DOTC)-107, DTC P0414 SECONDARY AIR INJECTION SYSTEM SWITCHING VALVE "A" CIRCUIT SHORTED, Diagnostic Trouble Code (DTC) Detecting Criteria.>
P0416	Secondary Air Injection System Switching Valve "B" Circuit Open	<Ref. to GD(H4DOTC)-108, DTC P0416 SECONDARY AIR INJECTION SYSTEM SWITCHING VALVE "B" CIRCUIT OPEN, Diagnostic Trouble Code (DTC) Detecting Criteria.>
P0417	Secondary Air Injection System Switching Valve "B" Circuit Shorted	<Ref. to GD(H4DOTC)-108, DTC P0417 SECONDARY AIR INJECTION SYSTEM SWITCHING VALVE "B" CIRCUIT SHORTED, Diagnostic Trouble Code (DTC) Detecting Criteria.>
P0418	Secondary Air Injection System Control "A" Circuit Open	<Ref. to GD(H4DOTC)-109, DTC P0418 SECONDARY AIR INJECTION SYSTEM CONTROL "A" CIRCUIT OPEN, Diagnostic Trouble Code (DTC) Detecting Criteria.>
P0420	Catalyst System Efficiency below Threshold (Bank 1)	<Ref. to GD(H4DOTC)-110, DTC P0420 CATALYST SYSTEM EFFICIENCY BELOW THRESHOLD (BANK 1), Diagnostic Trouble Code (DTC) Detecting Criteria.>
P0442	Evaporative Emission Control System Leak Detected (Small Leak)	<Ref. to GD(H4DOTC)-112, DTC P0442 EVAPORATIVE EMISSION CONTROL SYSTEM LEAK DETECTED (SMALL LEAK), Diagnostic Trouble Code (DTC) Detecting Criteria.>
P0447	Evaporative Emission Control System Vent Control Circuit Open	<Ref. to GD(H4DOTC)-128, DTC P0447 EVAPORATIVE EMISSION CONTROL SYSTEM VENT CONTROL CIRCUIT OPEN, Diagnostic Trouble Code (DTC) Detecting Criteria.>

List of Diagnostic Trouble Code (DTC)

GENERAL DESCRIPTION

DTC	Item	Index
P0448	Evaporative Emission Control System Vent Control Circuit Shorted	<Ref. to GD(H4DOTC)-130, DTC P0448 EVAPORATIVE EMISSION CONTROL SYSTEM VENT CONTROL CIRCUIT SHORTED, Diagnostic Trouble Code (DTC) Detecting Criteria.>
P0451	Evaporative Emission Control System Pressure Sensor	<Ref. to GD(H4DOTC)-132, DTC P0451 EVAPORATIVE EMISSION CONTROL SYSTEM PRESSURE SENSOR, Diagnostic Trouble Code (DTC) Detecting Criteria.>
P0452	Evaporative Emission Control System Pressure Sensor Low Input	<Ref. to GD(H4DOTC)-134, DTC P0452 EVAPORATIVE EMISSION CONTROL SYSTEM PRESSURE SENSOR LOW INPUT, Diagnostic Trouble Code (DTC) Detecting Criteria.>
P0453	Evaporative Emission Control System Pressure Sensor High Input	<Ref. to GD(H4DOTC)-136, DTC P0453 EVAPORATIVE EMISSION CONTROL SYSTEM PRESSURE SENSOR HIGH INPUT, Diagnostic Trouble Code (DTC) Detecting Criteria.>
P0456	Evaporative Emission Control System Leak Detected (Very Small Leak)	<Ref. to GD(H4DOTC)-138, DTC P0456 EVAPORATIVE EMISSION CONTROL SYSTEM LEAK DETECTED (VERY SMALL LEAK), Diagnostic Trouble Code (DTC) Detecting Criteria.>
P0457	Evaporative Emission Control System Leak Detected (Fuel Cap Loose/Off)	<Ref. to GD(H4DOTC)-138, DTC P0457 EVAPORATIVE EMISSION CONTROL SYSTEM LEAK DETECTED (FUEL CAP LOOSE/OFF), Diagnostic Trouble Code (DTC) Detecting Criteria.>
P0458	Evaporative Emission System Purge Control Valve Circuit Low	<Ref. to GD(H4DOTC)-139, DTC P0458 EVAPORATIVE EMISSION SYSTEM PURGE CONTROL VALVE CIRCUIT LOW, Diagnostic Trouble Code (DTC) Detecting Criteria.>
P0459	Evaporative Emission System Purge Control Valve Circuit High	<Ref. to GD(H4DOTC)-140, DTC P0459 EVAPORATIVE EMISSION SYSTEM PURGE CONTROL VALVE CIRCUIT HIGH, Diagnostic Trouble Code (DTC) Detecting Criteria.>
P0461	Fuel Level Sensor "A" Circuit Range/Performance	<Ref. to GD(H4DOTC)-141, DTC P0461 FUEL LEVEL SENSOR "A" CIRCUIT RANGE/PERFORMANCE, Diagnostic Trouble Code (DTC) Detecting Criteria.>
P0462	Fuel Level Sensor "A" Circuit Low	<Ref. to GD(H4DOTC)-143, DTC P0462 FUEL LEVEL SENSOR "A" CIRCUIT LOW, Diagnostic Trouble Code (DTC) Detecting Criteria.>
P0463	Fuel Level Sensor "A" Circuit High	<Ref. to GD(H4DOTC)-145, DTC P0463 FUEL LEVEL SENSOR "A" CIRCUIT HIGH, Diagnostic Trouble Code (DTC) Detecting Criteria.>
P0464	Fuel Level Sensor Circuit Intermittent	<Ref. to GD(H4DOTC)-147, DTC P0464 FUEL LEVEL SENSOR CIRCUIT INTERMITTENT, Diagnostic Trouble Code (DTC) Detecting Criteria.>
P0500	Vehicle Speed Sensor "A"	<Ref. to GD(H4DOTC)-150, DTC P0500 VEHICLE SPEED SENSOR "A", Diagnostic Trouble Code (DTC) Detecting Criteria.>
P0506	Idle Air Control System RPM Lower Than Expected	<Ref. to GD(H4DOTC)-151, DTC P0506 IDLE AIR CONTROL SYSTEM RPM LOWER THAN EXPECTED, Diagnostic Trouble Code (DTC) Detecting Criteria.>
P0507	Idle Air Control System RPM Higher Than Expected	<Ref. to GD(H4DOTC)-152, DTC P0507 IDLE AIR CONTROL SYSTEM RPM HIGHER THAN EXPECTED, Diagnostic Trouble Code (DTC) Detecting Criteria.>
P0512	Starter Request Circuit	<Ref. to GD(H4DOTC)-153, DTC P0512 STARTER REQUEST CIRCUIT, Diagnostic Trouble Code (DTC) Detecting Criteria.>
P0513	Incorrect Immobilizer Key	<Ref. to GD(H4DOTC)-154, DTC P0513 INCORRECT IMMOBILIZER KEY, Diagnostic Trouble Code (DTC) Detecting Criteria.>
P0600	Serial Communication Link	<Ref. to GD(H4DOTC)-155, DTC P0600 SERIAL COMMUNICATION LINK, Diagnostic Trouble Code (DTC) Detecting Criteria.>
P0604	Internal Control Module Random Access Memory (RAM) Error	<Ref. to GD(H4DOTC)-156, DTC P0604 INTERNAL CONTROL MODULE RANDOM ACCESS MEMORY (RAM) ERROR, Diagnostic Trouble Code (DTC) Detecting Criteria.>
P0605	Internal Control Module Read Only Memory (ROM) Error	<Ref. to GD(H4DOTC)-157, DTC P0605 INTERNAL CONTROL MODULE READ ONLY MEMORY (ROM) ERROR, Diagnostic Trouble Code (DTC) Detecting Criteria.>
P0607	Throttle Control System Circuit Range/Performance	<Ref. to GD(H4DOTC)-158, DTC P0607 THROTTLE CONTROL SYSTEM CIRCUIT RANGE/PERFORMANCE, Diagnostic Trouble Code (DTC) Detecting Criteria.>

List of Diagnostic Trouble Code (DTC)

GENERAL DESCRIPTION

DTC	Item	Index
P0638	Throttle Actuator Control Range/Performance (Bank 1)	<Ref. to GD(H4DOTC)-160, DTC P0638 THROTTLE ACTUATOR CONTROL RANGE/PERFORMANCE (BANK 1), Diagnostic Trouble Code (DTC) Detecting Criteria.>
P0700	Transmission Control System (MIL Request)	<Ref. to GD(H4DOTC)-162, DTC P0700 TRANSMISSION CONTROL SYSTEM (MIL REQUEST), Diagnostic Trouble Code (DTC) Detecting Criteria.>
P0851	Park/Neutral Switch Input Circuit Low (AT Model)	<Ref. to GD(H4DOTC)-163, DTC P0851 PARK/NEUTRAL SWITCH INPUT CIRCUIT LOW (AT MODEL), Diagnostic Trouble Code (DTC) Detecting Criteria.>
P0852	Park/Neutral Switch Input Circuit High (AT Model)	<Ref. to GD(H4DOTC)-164, DTC P0852 PARK/NEUTRAL SWITCH INPUT CIRCUIT HIGH (AT MODEL), Diagnostic Trouble Code (DTC) Detecting Criteria.>
P1152	O2 Sensor Circuit Range/Performance (Low) (Bank 1 Sensor 1)	<Ref. to GD(H4DOTC)-165, DTC P1152 O2 SENSOR CIRCUIT RANGE/PERFORMANCE (LOW) (BANK1 SENSOR1), Diagnostic Trouble Code (DTC) Detecting Criteria.>
P1153	O2 Sensor Circuit Range/Performance (High) (Bank 1 Sensor 1)	<Ref. to GD(H4DOTC)-167, DTC P1153 O2 SENSOR CIRCUIT RANGE/PERFORMANCE (HIGH) (BANK1 SENSOR1), Diagnostic Trouble Code (DTC) Detecting Criteria.>
P1160	Return Spring Failure	<Ref. to GD(H4DOTC)-169, DTC P1160 RETURN SPRING FAILURE, Diagnostic Trouble Code (DTC) Detecting Criteria.>
P1400	Fuel Tank Pressure Control Solenoid Valve Circuit Low	<Ref. to GD(H4DOTC)-171, DTC P1400 FUEL TANK PRESSURE CONTROL SOLENOID VALVE CIRCUIT LOW, Diagnostic Trouble Code (DTC) Detecting Criteria.>
P1410	Secondary Air Injection System Switching Valve Stuck Open	<Ref. to GD(H4DOTC)-173, DTC P1410 SECONDARY AIR INJECTION SYSTEM SWITCHING VALVE STUCK OPEN, Diagnostic Trouble Code (DTC) Detecting Criteria.>
P1418	Secondary Air Injection System Control "A" Circuit Shorted	<Ref. to GD(H4DOTC)-174, DTC P1418 SECONDARY AIR INJECTION SYSTEM CONTROL "A" CIRCUIT SHORTED, Diagnostic Trouble Code (DTC) Detecting Criteria.>
P1420	Fuel Tank Pressure Control Sol. Valve Circuit High	<Ref. to GD(H4DOTC)-175, DTC P1420 FUEL TANK PRESSURE CONTROL SOL. VALVE CIRCUIT HIGH, Diagnostic Trouble Code (DTC) Detecting Criteria.>
P1443	Vent Control Solenoid Valve Function Problem	<Ref. to GD(H4DOTC)-177, DTC P1443 VENT CONTROL SOLENOID VALVE FUNCTION PROBLEM, Diagnostic Trouble Code (DTC) Detecting Criteria.>
P1491	Positive Crankcase Ventilation (Blow-by) Function Problem	<Ref. to GD(H4DOTC)-179, DTC P1491 POSITIVE CRANKCASE VENTILATION (BLOW-BY) FUNCTION PROBLEM, Diagnostic Trouble Code (DTC) Detecting Criteria.>
P1560	Back-up Voltage Circuit Malfunction	<Ref. to GD(H4DOTC)-181, DTC P1560 BACK-UP VOLTAGE CIRCUIT MALFUNCTION, Diagnostic Trouble Code (DTC) Detecting Criteria.>
P1570	Antenna	<Ref. to GD(H4DOTC)-182, DTC P1570 ANTENNA, Diagnostic Trouble Code (DTC) Detecting Criteria.>
P1571	Reference Code Incompatibility	<Ref. to GD(H4DOTC)-182, DTC P1571 REFERENCE CODE INCOMPATIBILITY, Diagnostic Trouble Code (DTC) Detecting Criteria.>
P1572	IMM Circuit Failure (Except Antenna Circuit)	<Ref. to GD(H4DOTC)-182, DTC P1572 IMM CIRCUIT FAILURE (EXCEPT ANTENNA CIRCUIT), Diagnostic Trouble Code (DTC) Detecting Criteria.>
P1574	Key Communication Failure	<Ref. to GD(H4DOTC)-182, DTC P1574 KEY COMMUNICATION FAILURE, Diagnostic Trouble Code (DTC) Detecting Criteria.>
P1576	EGI Control Module EEPROM	<Ref. to GD(H4DOTC)-182, DTC P1576 EGI CONTROL MODULE EEPROM, Diagnostic Trouble Code (DTC) Detecting Criteria.>
P1577	IMM Control Module EEPROM	<Ref. to GD(H4DOTC)-182, DTC P1577 IMM CONTROL MODULE EEPROM, Diagnostic Trouble Code (DTC) Detecting Criteria.>
P1578	Meter Failure	<Ref. to GD(H4DOTC)-182, DTC P1578 METER FAILURE, Diagnostic Trouble Code (DTC) Detecting Criteria.>
P1602	Control Module Programming Error	<Ref. to GD(H4DOTC)-183, DTC P1602 CONTROL MODULE PROGRAMMING ERROR, Diagnostic Trouble Code (DTC) Detecting Criteria.>
P2004	Intake Manifold Runner Control Stuck Open (Bank 1)	<Ref. to GD(H4DOTC)-185, DTC P2004 INTAKE MANIFOLD RUNNER CONTROL STUCK OPEN (BANK 1), Diagnostic Trouble Code (DTC) Detecting Criteria.>

List of Diagnostic Trouble Code (DTC)

GENERAL DESCRIPTION

DTC	Item	Index
P2005	Intake Manifold Runner Control Stuck Open (Bank 2)	<Ref. to GD(H4DOTC)-186, DTC P2005 INTAKE MANIFOLD RUNNER CONTROL STUCK OPEN (BANK 2), Diagnostic Trouble Code (DTC) Detecting Criteria.>
P2006	Intake Manifold Runner Control Stuck Closed (Bank 1)	<Ref. to GD(H4DOTC)-187, DTC P2006 INTAKE MANIFOLD RUNNER CONTROL STUCK CLOSED (BANK 1), Diagnostic Trouble Code (DTC) Detecting Criteria.>
P2007	Intake Manifold Runner Control Stuck Closed (Bank 2)	<Ref. to GD(H4DOTC)-188, DTC P2007 INTAKE MANIFOLD RUNNER CONTROL STUCK CLOSED (BANK 2), Diagnostic Trouble Code (DTC) Detecting Criteria.>
P2008	Intake Manifold Runner Control Circuit / Open (Bank 1)	<Ref. to GD(H4DOTC)-189, DTC P2008 INTAKE MANIFOLD RUNNER CONTROL CIRCUIT / OPEN (BANK 1), Diagnostic Trouble Code (DTC) Detecting Criteria.>
P2009	Intake Manifold Runner Control Circuit Low (Bank 1)	<Ref. to GD(H4DOTC)-190, DTC P2009 INTAKE MANIFOLD RUNNER CONTROL CIRCUIT LOW (BANK 1), Diagnostic Trouble Code (DTC) Detecting Criteria.>
P2011	Intake Manifold Runner Control Circuit / Open (Bank 2)	<Ref. to GD(H4DOTC)-191, DTC P2011 INTAKE MANIFOLD RUNNER CONTROL CIRCUIT / OPEN (BANK 2), Diagnostic Trouble Code (DTC) Detecting Criteria.>
P2012	Intake Manifold Runner Control Circuit Low (Bank 2)	<Ref. to GD(H4DOTC)-192, DTC P2012 INTAKE MANIFOLD RUNNER CONTROL CIRCUIT LOW (BANK 2), Diagnostic Trouble Code (DTC) Detecting Criteria.>
P2016	Intake Manifold Runner Position Sensor / Switch Circuit Low (Bank 1)	<Ref. to GD(H4DOTC)-193, DTC P2016 INTAKE MANIFOLD RUNNER POSITION SENSOR / SWITCH CIRCUIT LOW (BANK 1), Diagnostic Trouble Code (DTC) Detecting Criteria.>
P2017	Intake Manifold Runner Position Sensor / Switch Circuit High (Bank 1)	<Ref. to GD(H4DOTC)-194, DTC P2017 INTAKE MANIFOLD RUNNER POSITION SENSOR / SWITCH CIRCUIT HIGH (BANK 1), Diagnostic Trouble Code (DTC) Detecting Criteria.>
P2021	Intake Manifold Runner Position Sensor / Switch Circuit Low (Bank 2)	<Ref. to GD(H4DOTC)-195, DTC P2021 INTAKE MANIFOLD RUNNER POSITION SENSOR / SWITCH CIRCUIT LOW (BANK 2), Diagnostic Trouble Code (DTC) Detecting Criteria.>
P2022	Intake Manifold Runner Position Sensor / Switch Circuit High (Bank 2)	<Ref. to GD(H4DOTC)-196, DTC P2022 INTAKE MANIFOLD RUNNER POSITION SENSOR / SWITCH CIRCUIT HIGH (BANK 2), Diagnostic Trouble Code (DTC) Detecting Criteria.>
P2088	Intake Camshaft Position Actuator Control Circuit Low (Bank 1)	<Ref. to GD(H4DOTC)-197, DTC P2088 INTAKE CAMSHAFT POSITION ACTUATOR CONTROL CIRCUIT LOW (BANK 1), Diagnostic Trouble Code (DTC) Detecting Criteria.>
P2089	Intake Camshaft Position Actuator Control Circuit High (Bank 1)	<Ref. to GD(H4DOTC)-198, DTC P2089 INTAKE CAMSHAFT POSITION ACTUATOR CONTROL CIRCUIT HIGH (BANK 1), Diagnostic Trouble Code (DTC) Detecting Criteria.>
P2092	Intake Camshaft Position Actuator Control Circuit Low (Bank 2)	<Ref. to GD(H4DOTC)-199, DTC P2092 INTAKE CAMSHAFT POSITION ACTUATOR CONTROL CIRCUIT LOW (BANK 2), Diagnostic Trouble Code (DTC) Detecting Criteria.>
P2093	Intake Camshaft Position Actuator Control Circuit High (Bank 2)	<Ref. to GD(H4DOTC)-199, DTC P2093 INTAKE CAMSHAFT POSITION ACTUATOR CONTROL CIRCUIT HIGH (BANK 2), Diagnostic Trouble Code (DTC) Detecting Criteria.>
P2096	Post Catalyst Fuel Trim System Too Lean (Bank 1)	<Ref. to GD(H4DOTC)-200, DTC P2096 POST CATALYST FUEL TRIM SYSTEM TOO LEAN (BANK 1), Diagnostic Trouble Code (DTC) Detecting Criteria.>
P2097	Post Catalyst Fuel Trim System Too Rich (Bank 1)	<Ref. to GD(H4DOTC)-202, DTC P2097 POST CATALYST FUEL TRIM SYSTEM TOO RICH (BANK 1), Diagnostic Trouble Code (DTC) Detecting Criteria.>
P2101	Throttle Actuator Control Motor Circuit Range/Performance	<Ref. to GD(H4DOTC)-204, DTC P2101 THROTTLE ACTUATOR CONTROL MOTOR CIRCUIT RANGE/PERFORMANCE, Diagnostic Trouble Code (DTC) Detecting Criteria.>
P2102	Throttle Actuator Control Motor Circuit Low	<Ref. to GD(H4DOTC)-205, DTC P2102 THROTTLE ACTUATOR CONTROL MOTOR CIRCUIT LOW, Diagnostic Trouble Code (DTC) Detecting Criteria.>
P2103	Throttle Actuator Control Motor Circuit High	<Ref. to GD(H4DOTC)-206, DTC P2103 THROTTLE ACTUATOR CONTROL MOTOR CIRCUIT HIGH, Diagnostic Trouble Code (DTC) Detecting Criteria.>

List of Diagnostic Trouble Code (DTC)

GENERAL DESCRIPTION

DTC	Item	Index
P2109	Throttle/Pedal Position Sensor "A" Minimum Stop Performance	<Ref. to GD(H4DOTC)-207, DTC P2109 THROTTLE/PEDAL POSITION SENSOR "A" MINIMUM STOP PERFORMANCE, Diagnostic Trouble Code (DTC) Detecting Criteria.>
P2122	Throttle/Pedal Position Sensor/Switch "D" Circuit Low Input	<Ref. to GD(H4DOTC)-208, DTC P2122 THROTTLE/PEDAL POSITION SENSOR/SWITCH "D" CIRCUIT LOW INPUT, Diagnostic Trouble Code (DTC) Detecting Criteria.>
P2123	Throttle/Pedal Position Sensor/Switch "D" Circuit High Input	<Ref. to GD(H4DOTC)-210, DTC P2123 THROTTLE/PEDAL POSITION SENSOR/SWITCH "D" CIRCUIT HIGH INPUT, Diagnostic Trouble Code (DTC) Detecting Criteria.>
P2127	Throttle/Pedal Position Sensor/Switch "E" Circuit Low Input	<Ref. to GD(H4DOTC)-212, DTC P2127 THROTTLE/PEDAL POSITION SENSOR/SWITCH "E" CIRCUIT LOW INPUT, Diagnostic Trouble Code (DTC) Detecting Criteria.>
P2128	Throttle/Pedal Position Sensor/Switch "E" Circuit High Input	<Ref. to GD(H4DOTC)-214, DTC P2128 THROTTLE/PEDAL POSITION SENSOR/SWITCH "E" CIRCUIT HIGH INPUT, Diagnostic Trouble Code (DTC) Detecting Criteria.>
P2135	Throttle/Pedal Position Sensor/Switch "A"/"B" Voltage Correlation	<Ref. to GD(H4DOTC)-216, DTC P2135 THROTTLE/PEDAL POSITION SENSOR/SWITCH "A"/"B" VOLTAGE CORRELATION, Diagnostic Trouble Code (DTC) Detecting Criteria.>
P2138	Throttle/Pedal Position Sensor/Switch "D"/"E" Voltage Correlation	<Ref. to GD(H4DOTC)-218, DTC P2138 THROTTLE/PEDAL POSITION SENSOR/SWITCH "D"/"E" VOLTAGE CORRELATION, Diagnostic Trouble Code (DTC) Detecting Criteria.>
P2419	Evaporative Emission System Switching Valve Control Circuit Low	<Ref. to GD(H4DOTC)-220, DTC P2419 EVAPORATIVE EMISSION SYSTEM SWITCHING VALVE CONTROL CIRCUIT LOW, Diagnostic Trouble Code (DTC) Detecting Criteria.>
P2420	Evaporative Emission System Switching Valve Control Circuit High	<Ref. to GD(H4DOTC)-221, DTC P2420 EVAPORATIVE EMISSION SYSTEM SWITCHING VALVE CONTROL CIRCUIT HIGH, Diagnostic Trouble Code (DTC) Detecting Criteria.>
P2431	Secondary Air Injection System Air Flow /Pressure Sensor Circuit Range/Performance	<Ref. to GD(H4DOTC)-222, DTC P2431 SECONDARY AIR INJECTION SYSTEM AIR FLOW /PRESSURE SENSOR CIRCUIT RANGE/PERFORMANCE, Diagnostic Trouble Code (DTC) Detecting Criteria.>
P2432	Secondary Air Injection System Air Flow /Pressure Sensor Circuit Low	<Ref. to GD(H4DOTC)-223, DTC P2432 SECONDARY AIR INJECTION SYSTEM AIR FLOW /PRESSURE SENSOR CIRCUIT LOW, Diagnostic Trouble Code (DTC) Detecting Criteria.>
P2433	Secondary Air Injection System Air Flow /Pressure Sensor Circuit High	<Ref. to GD(H4DOTC)-224, DTC P2433 SECONDARY AIR INJECTION SYSTEM AIR FLOW /PRESSURE SENSOR CIRCUIT HIGH, Diagnostic Trouble Code (DTC) Detecting Criteria.>
P2440	Secondary Air Injection System Switching Valve Stuck Open (Bank 1)	<Ref. to GD(H4DOTC)-225, DTC P2440 SECONDARY AIR INJECTION SYSTEM SWITCHING VALVE STUCK OPEN (BANK 1), Diagnostic Trouble Code (DTC) Detecting Criteria.>
P2441	Secondary Air Injection System Switching Valve Stuck Closed (Bank 1)	<Ref. to GD(H4DOTC)-225, DTC P2441 SECONDARY AIR INJECTION SYSTEM SWITCHING VALVE STUCK CLOSED (BANK 1), Diagnostic Trouble Code (DTC) Detecting Criteria.>
P2442	Secondary Air Injection System Switching Valve Stuck Open (Bank 2)	<Ref. to GD(H4DOTC)-225, DTC P2442 SECONDARY AIR INJECTION SYSTEM SWITCHING VALVE STUCK OPEN (BANK2), Diagnostic Trouble Code (DTC) Detecting Criteria.>
P2443	Secondary Air Injection System Switching Valve Stuck Closed (Bank 2)	<Ref. to GD(H4DOTC)-225, DTC P2443 SECONDARY AIR INJECTION SYSTEM SWITCHING VALVE STUCK CLOSED (BANK2), Diagnostic Trouble Code (DTC) Detecting Criteria.>
P2444	Secondary Air Injection System Pump Stuck ON	<Ref. to GD(H4DOTC)-226, DTC P2444 SECONDARY AIR INJECTION SYSTEM PUMP STUCK ON, Diagnostic Trouble Code (DTC) Detecting Criteria.>

2. Diagnostic Trouble Code (DTC) Detecting Criteria

A: DTC P0011 INTAKE CAMSHAFT POSITION - TIMING OVER-ADVANCED OR SYSTEM PERFORMANCE (BANK 1)

1. OUTLINE OF DIAGNOSIS

Detect the AVCS system malfunction.

Judge NG when the amount of AVCS actual timing advance does not approach to the amount of AVCS target timing advance.

2. COMPONENT DESCRIPTION

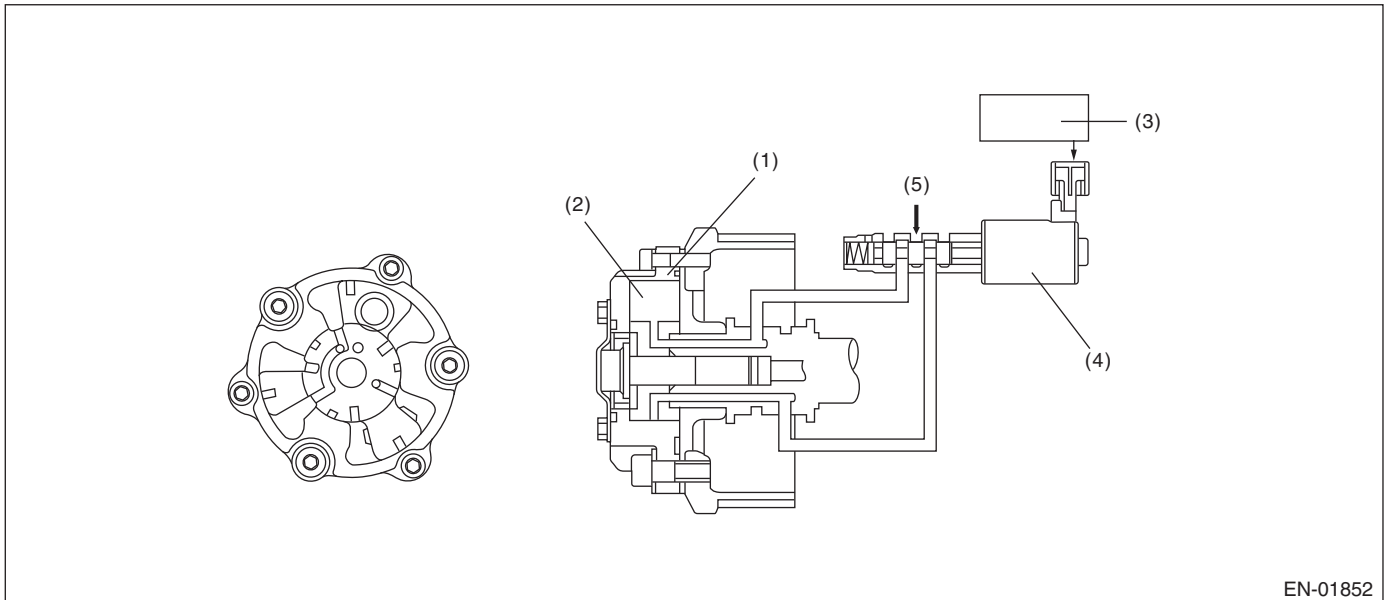

- | | | |
|----------------------------|-------------------------------------|------------------|
| (1) AVCS timing controller | (3) Engine control module (ECM) | (5) Oil pressure |
| (2) Vane | (4) Oil flow control solenoid valve | |

3. ENABLE CONDITION

Secondary Parameters	Enable Conditions
Time of establishing all secondary parameter conditions	≥ 3000 ms
Battery voltage	≥ 10.9 V
Engine speed	≥ 1300 rpm
Engine coolant temperature	≥ 60 °C (140 °F)
AVCS control	Operation
Target timing advance change amount (per 64 ms)	< 1.07 °CA

4. GENERAL DRIVING CYCLE

Perform the diagnosis continuously after warming up when the engine speed increases and AVCS operates.

Diagnostic Trouble Code (DTC) Detecting Criteria

GENERAL DESCRIPTION

5. DIAGNOSTIC METHOD

- 1) When the conditions during which the differences of AVCS target timing advance amount and AVCS actual timing advance amount is large continues for certain amount of time.
- 2) When the differences of target timing advance amount and actual timing advance amount is calculated during AVCS control, and the difference per predetermined time is the specified value or larger.

• Abnormality Judgement

Judge as NG when the following conditions are established within the predetermined time.

Judgement Value

Malfunction Criteria	Threshold Value
$\Sigma(\text{Target position} - \text{Actual position})$	> 8000 °CA (Bank 1) > 8000 °CA (Bank 2)
or	
$\Sigma(\text{Target position} - \text{Actual position})$	< -8000 °CA (Bank 1) < -8000 °CA (Bank 2)

Time Needed for Diagnosis:30000 ms

Malfunction Indicator Light Illumination: Illuminates when malfunction occurs in 2 continuous driving cycles.

• Normality Judgement

Judge as OK and clear the NG if the following conditions are established within the predetermined time.

Judgement Value

Malfunction Criteria	Threshold Value
$\Sigma(\text{Target position} - \text{Actual position})$	≤ 8000 °CA (Bank 1) ≤ 8000 °CA (Bank 2) and ≥ -8000 °CA (Bank 1) ≥ -8000 °CA (Bank 2)

Time Needed for Diagnosis:30000 ms

B: DTC P0016 CRANKSHAFT POSITION - CAMSHAFT POSITION CORRELATION (BANK1)

1. OUTLINE OF DIAGNOSIS

Detect the AVCS system malfunction.

Judge as NG when the timing advance is outside the normal range.

2. COMPONENT DESCRIPTION

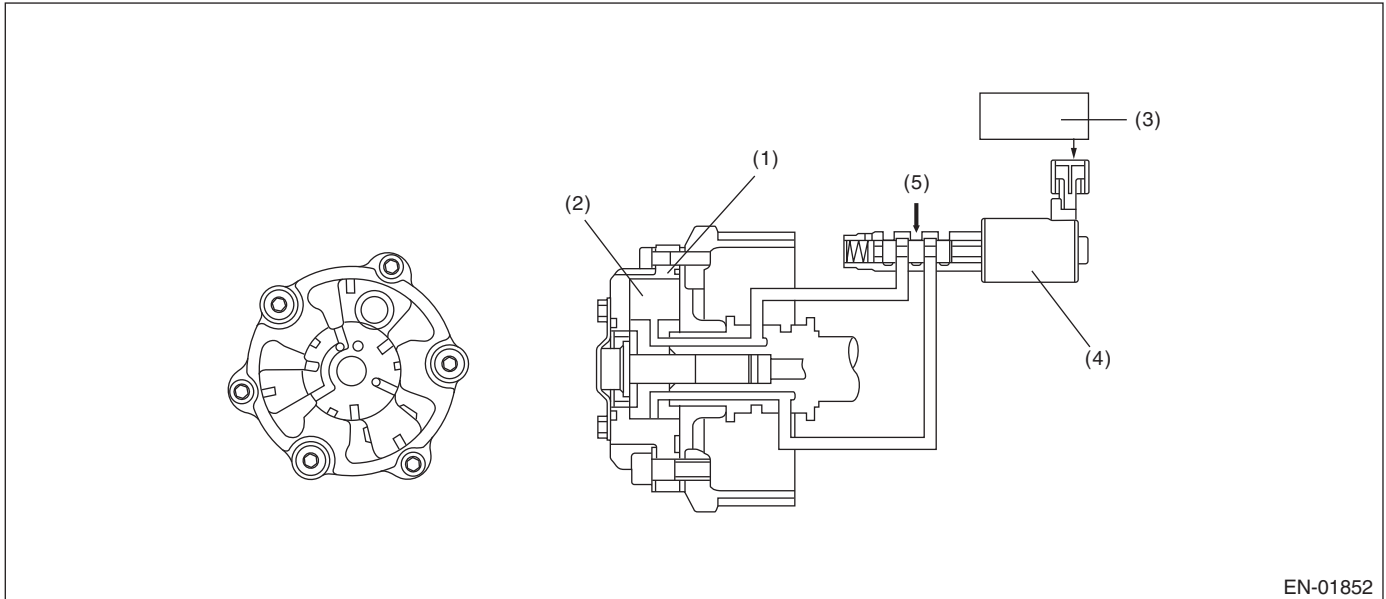

EN-01852

(1) AVCS timing controller

(3) Engine control module (ECM)

(5) Oil pressure

(2) Vane

(4) Oil flow control solenoid valve

3. ENABLE CONDITION

Secondary Parameters	Enable Conditions
Battery voltage	≥ 10.9 V
Engine speed	≥ 500 rpm
Engine coolant temperature	≥ 60 °C (140 °F)
AVCS control	Not in operation
Target timing advance	0°CA

4. GENERAL DRIVING CYCLE

Perform the diagnosis continuously after starting engine and while AVCS is not operating.

Diagnostic Trouble Code (DTC) Detecting Criteria

GENERAL DESCRIPTION

5. DIAGNOSTIC METHOD

Judge as NG when the camshaft sensor input position is not within the normal range.

• Abnormality Judgement

If the duration of time while the following conditions are met is longer than the time indicated, judge as NG.

Judgement Value

Malfunction Criteria	Threshold Value
Crankshaft position when camshaft position sensor signal is input	< BTDC 17 °CA (Bank 1) < BTDC 17 °CA (Bank 2) or > BTDC 55 °CA (Bank 1) > BTDC 55 °CA (Bank 2)

Time Needed for Diagnosis:20000 ms

Malfunction Indicator Light Illumination: Illuminates when malfunction occurs in 2 continuous driving cycles.

• Normality Judgement

Judge as OK and clear the NG if the continuous time while the following conditions are established is more than the predetermined time.

Judgement Value

Malfunction Criteria	Threshold Value
Crankshaft position when camshaft position sensor signal is input	≥ BTDC 17 °CA (Bank 1) ≥ BTDC 17 °CA (Bank 2) and ≤ BTDC 55 °CA (Bank 1) ≤ BTDC 55 °CA (Bank 2)

Time Needed for Diagnosis:1000 ms

Diagnostic Trouble Code (DTC) Detecting Criteria

GENERAL DESCRIPTION

C: DTC P0018 CRANKSHAFT POSITION - CAMSHAFT POSITION CORRELATION (BANK2)

1. OUTLINE OF DIAGNOSIS

NOTE:

For the detection standard, refer to DTC P0016. <Ref. to GD(H4DOTC)-11, DTC P0016 CRANKSHAFT POSITION - CAMSHAFT POSITION CORRELATION (BANK1), Diagnostic Trouble Code (DTC) Detecting Criteria.>

D: DTC P0021 INTAKE CAMSHAFT POSITION - TIMING OVER-ADVANCED OR SYSTEM PERFORMANCE (BANK 2)

1. OUTLINE OF DIAGNOSIS

NOTE:

For the detection standard, refer to DTC P0011. <Ref. to GD(H4DOTC)-9, DTC P0011 INTAKE CAMSHAFT POSITION - TIMING OVER-ADVANCED OR SYSTEM PERFORMANCE (BANK 1), Diagnostic Trouble Code (DTC) Detecting Criteria.>

Diagnostic Trouble Code (DTC) Detecting Criteria

GENERAL DESCRIPTION

E: DTC P0030 HO2S HEATER CONTROL CIRCUIT (BANK 1 SENSOR 1)

1. OUTLINE OF DIAGNOSIS

Detect functional errors of the front oxygen (A/F) sensor heater.

Judge as NG when it is determined that the front oxygen (A/F) sensor impedance is large when looking at engine status such as deceleration fuel cut.

2. COMPONENT DESCRIPTION

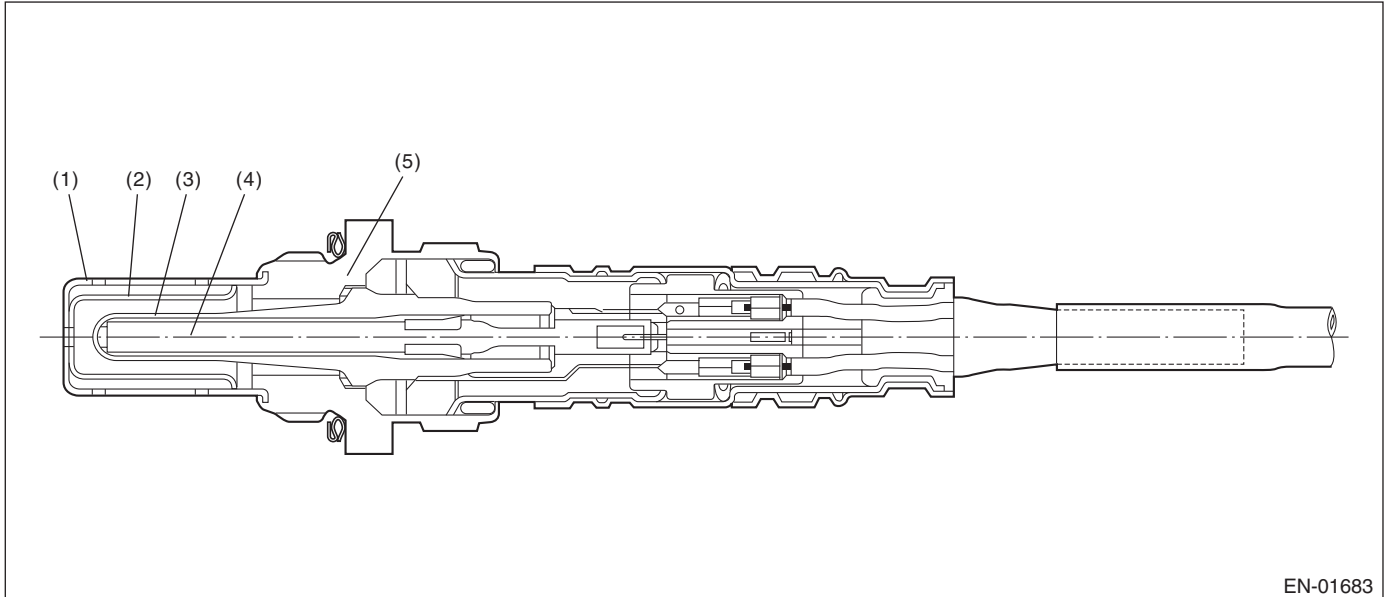

EN-01683

(1) Element cover (outer)

(3) Sensor element

(5) Sensor housing

(2) Element cover (inner)

(4) Ceramic heater

3. ENABLE CONDITION

Secondary Parameters	Enable Conditions
Condition established time	≥ 42000 ms
Battery voltage	≥ 10.9 V
Heater current	Permitted
Control duty ≥ 35 %	Experienced
After fuel cut	≥ 20000 ms

4. GENERAL DRIVING CYCLE

Perform the diagnosis continuously after 42000 ms seconds or more have passed since the engine started.

Diagnostic Trouble Code (DTC) Detecting Criteria

GENERAL DESCRIPTION

5. DIAGNOSTIC METHOD

• Abnormality Judgement

If the duration of time while the following conditions are met is longer than the time indicated, judge as NG.

Judgement Value

Malfunction Criteria	Threshold Value
Front oxygen (A/F) sensor impedance	> 50 Ω

Time Needed for Diagnosis:10000 ms

Malfunction Indicator Light Illumination: Illuminates when malfunction occurs in 2 continuous driving cycles.

• Normality Judgement

Judge as OK and clear the NG if the continuous time while the following conditions are established is more than the predetermined time.

Judgement Value

Malfunction Criteria	Threshold Value
Front oxygen (A/F) sensor impedance	\leq 50 Ω

Time Needed for Diagnosis:10000 ms

Diagnostic Trouble Code (DTC) Detecting Criteria

GENERAL DESCRIPTION

F: DTC P0031 HO2S HEATER CONTROL CIRCUIT LOW (BANK 1 SENSOR 1)

1. OUTLINE OF DIAGNOSIS

Detect front oxygen (A/F) sensor heater open or short circuit.

The front oxygen (A/F) sensor heater performs duty control, and the output terminal voltage at ON is 0 V, and the output terminal voltage at OFF is the battery voltage.

Judge as NG when the terminal voltage remains Low.

2. COMPONENT DESCRIPTION

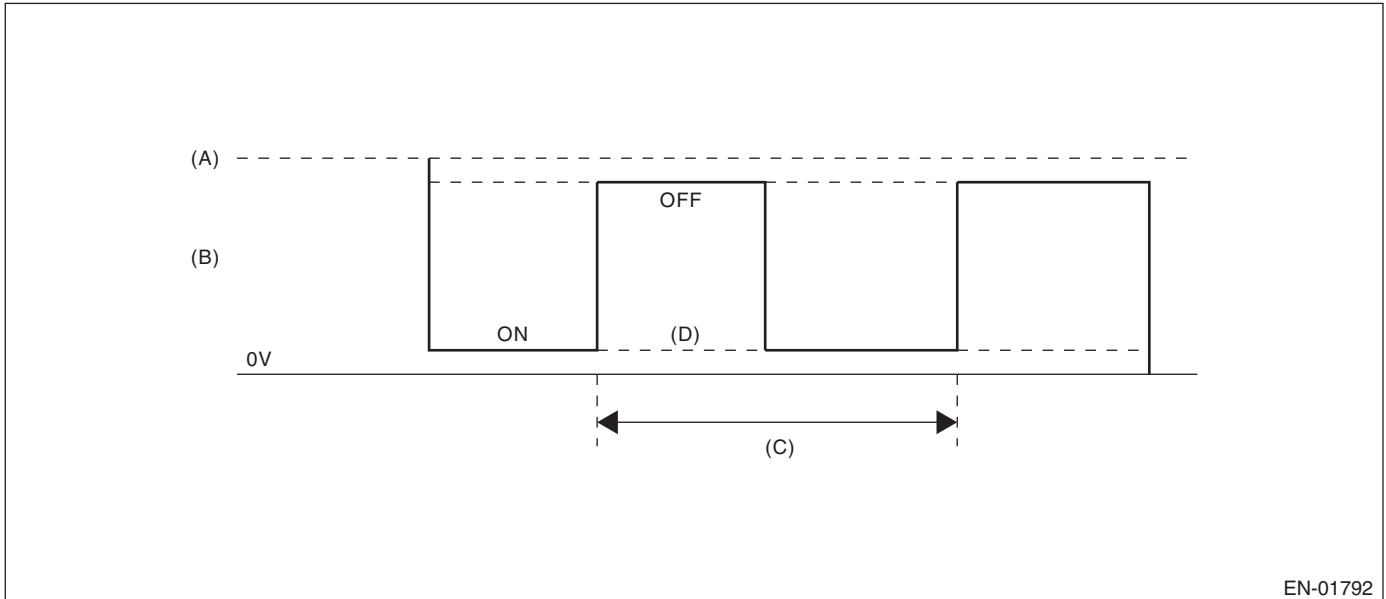

EN-01792

(A) Battery voltage

(B) Front oxygen (A/F) sensor heater
output voltage

(C) 128 milliseconds

(D) Low error

3. ENABLE CONDITION

Secondary Parameters	Enable Conditions
Battery voltage	$\geq 10.9 \text{ V}$

4. GENERAL DRIVING CYCLE

Always perform the diagnosis continuously.

Diagnostic Trouble Code (DTC) Detecting Criteria

GENERAL DESCRIPTION

5. DIAGNOSTIC METHOD

• Abnormality Judgement

If the duration of time while the following conditions are met is longer than the time indicated, judge as NG.

Judgement Value

Malfunction Criteria	Threshold Value
Output voltage level	Low
Front oxygen (A/F) sensor heater control duty	< 87.5 %

Time Needed for Diagnosis: 4 ms × 250 time(s)

Malfunction Indicator Light Illumination: Illuminates as soon as a malfunction occurs.

• Normality Judgement

Judge as OK and clear the NG if the continuous time while the following conditions are established is more than the predetermined time.

Judgement Value

Malfunction Criteria	Threshold Value
Output voltage level	High

Time Needed for Diagnosis: Less than 1 second

Diagnostic Trouble Code (DTC) Detecting Criteria

GENERAL DESCRIPTION

G: DTC P0032 HO2S HEATER CONTROL CIRCUIT HIGH (BANK 1 SENSOR 1)

1. OUTLINE OF DIAGNOSIS

Detect front oxygen (A/F) sensor heater open or short circuit.

The front oxygen (A/F) sensor heater performs duty control, and the output terminal voltage at ON is 0 V, and the output terminal voltage at OFF is the battery voltage.

Judge as NG when the terminal voltage remains High.

2. COMPONENT DESCRIPTION

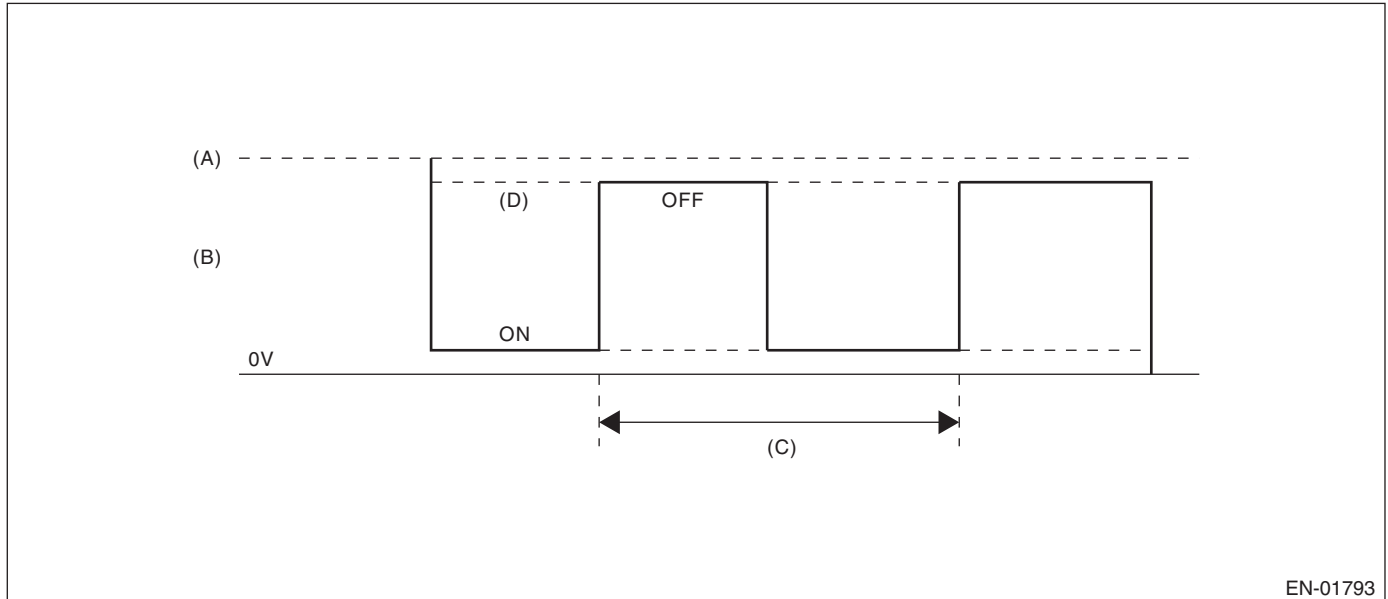

EN-01793

(A) Battery voltage

(B) Front oxygen (A/F) sensor heater
output voltage

(C) 128 milliseconds

(D) High error

3. ENABLE CONDITION

Secondary Parameters	Enable Conditions
Battery voltage	$\geq 10.9 \text{ V}$

4. GENERAL DRIVING CYCLE

Always perform the diagnosis continuously.

Diagnostic Trouble Code (DTC) Detecting Criteria

GENERAL DESCRIPTION

5. DIAGNOSTIC METHOD

• Abnormality Judgement

If the duration of time while the following conditions are met is longer than the time indicated, judge as NG.

Judgement Value

Malfunction Criteria	Threshold Value
Output voltage level	High
Front oxygen (A/F) sensor heater control duty	≥ 12.5 %

Time Needed for Diagnosis: 4 ms × 500 time(s)

Malfunction Indicator Light Illumination: Illuminates as soon as a malfunction occurs.

• Normality Judgement

Judge as OK and clear the NG if the continuous time while the following conditions are established is more than the predetermined time.

Judgement Value

Malfunction Criteria	Threshold Value
Output voltage level	Low

Time Needed for Diagnosis: Less than 1 second

Diagnostic Trouble Code (DTC) Detecting Criteria

GENERAL DESCRIPTION

H: DTC P0037 HO2S HEATER CONTROL CIRCUIT LOW (BANK 1 SENSOR 2)

1. OUTLINE OF DIAGNOSIS

Detect the rear oxygen sensor heater open or short circuit.

The rear oxygen sensor heater performs duty control, and the output terminal voltage at ON is 0 V, and the output terminal voltage at OFF is the battery voltage.

Judge as NG when the terminal voltage remains Low.

2. COMPONENT DESCRIPTION

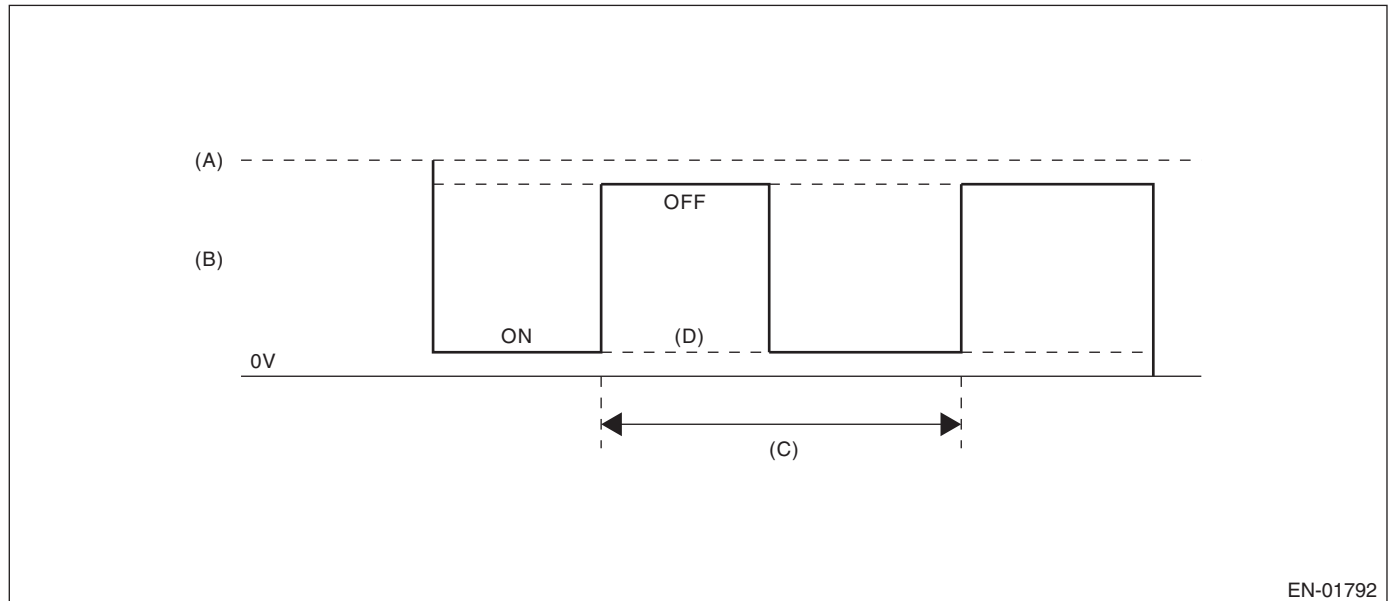

(A) Battery voltage

(B) Output voltage of the rear oxygen sensor heater

(C) 256 milliseconds (cycles)

(D) Low error

3. ENABLE CONDITION

Secondary Parameters	Enable Conditions
Battery voltage	$\geq 10.9 \text{ V}$
Elapsed time after engine starting	$\geq 1 \text{ second}$
Engine speed	$< 8000 \text{ rpm}$

4. GENERAL DRIVING CYCLE

After starting the engine, perform the diagnosis continuously when engine speed is low.

Diagnostic Trouble Code (DTC) Detecting Criteria

GENERAL DESCRIPTION

5. DIAGNOSTIC METHOD

• Abnormality Judgement

If the duration of time while the following conditions are met is longer than the time indicated, judge as NG.

Judgement Value

Malfunction Criteria	Threshold Value
Output voltage level	Low
Rear oxygen sensor heater control duty	< 75 %

Time Needed for Diagnosis: 8 ms × 320 time(s)

Malfunction Indicator Light Illumination: Illuminates when malfunction occurs in 2 continuous driving cycles.

• Normality Judgement

Judge as OK and clear the NG if the continuous time while the following conditions are established is more than the predetermined time.

Judgement Value

Malfunction Criteria	Threshold Value
Output voltage level	High

Time Needed for Diagnosis: Less than 1 second

Diagnostic Trouble Code (DTC) Detecting Criteria

GENERAL DESCRIPTION

I: DTC P0038 HO2S HEATER CONTROL CIRCUIT HIGH (BANK 1 SENSOR 2)

1. OUTLINE OF DIAGNOSIS

Detect the rear oxygen sensor heater open or short circuit.

The rear oxygen sensor heater performs duty control, and the output terminal voltage at ON is 0 V, and the output terminal voltage at OFF is the battery voltage.

Judge as NG when the terminal voltage remains High.

2. COMPONENT DESCRIPTION

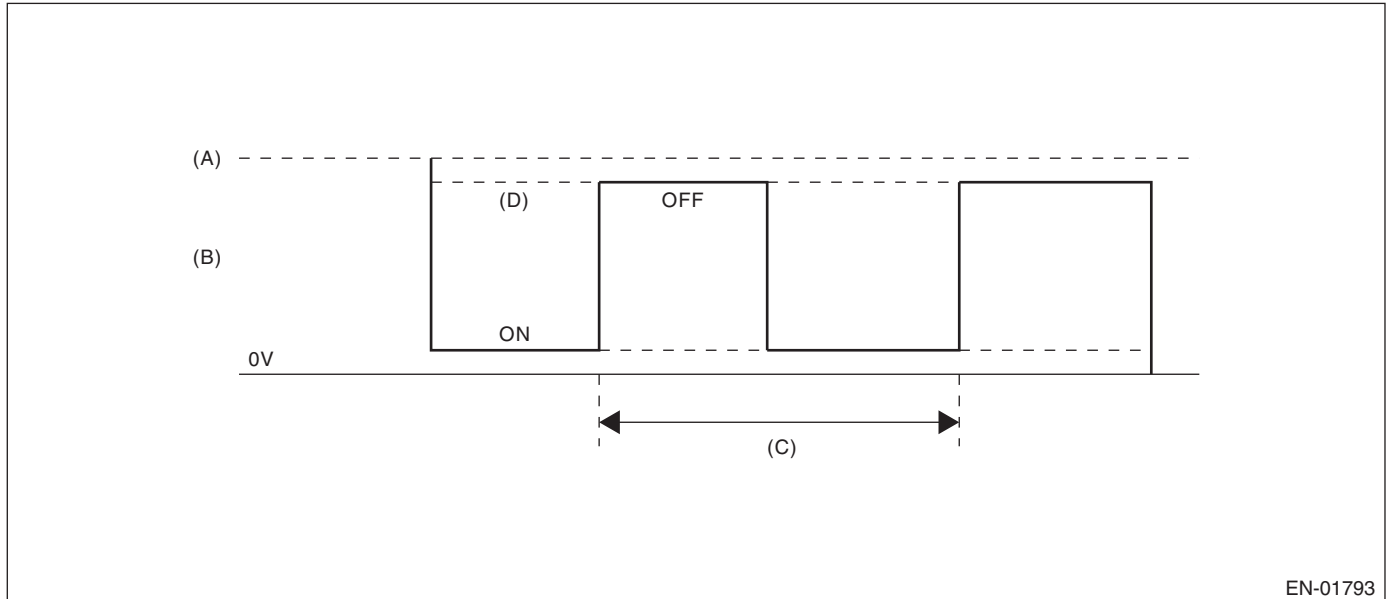

(A) Battery voltage

(B) Output voltage of the rear oxygen sensor heater

(C) 256 milliseconds (cycles)

(D) High error

3. ENABLE CONDITION

Secondary Parameters	Enable Conditions
Battery voltage	$\geq 10.9 \text{ V}$
Elapsed time after engine starting	$\geq 1 \text{ second}$
Engine speed	$< 8000 \text{ rpm}$

4. GENERAL DRIVING CYCLE

After starting the engine, perform the diagnosis continuously when engine speed is low.

Diagnostic Trouble Code (DTC) Detecting Criteria

GENERAL DESCRIPTION

5. DIAGNOSTIC METHOD

• Abnormality Judgement

If the duration of time while the following conditions are met is longer than the time indicated, judge as NG.

Judgement Value

Malfunction Criteria	Threshold Value
Output voltage level	High
Rear oxygen sensor heater control duty	≥ 25 %

Time Needed for Diagnosis: 8 ms × 320 time(s)

Malfunction Indicator Light Illumination: Illuminates when malfunction occurs in 2 continuous driving cycles.

• Normality Judgement

Judge as OK and clear the NG if the continuous time while the following conditions are established is more than the predetermined time.

Judgement Value

Malfunction Criteria	Threshold Value
Output voltage level	Low

Time Needed for Diagnosis: Less than 1 second

Diagnostic Trouble Code (DTC) Detecting Criteria

GENERAL DESCRIPTION

J: DTC P0068 MAP/MAF - THROTTLE POSITION CORRELATION

1. OUTLINE OF DIAGNOSIS

Detect problems in the intake manifold pressure sensor output properties.

Judge as NG when the intake air pressure AD value is Low whereas it seemed to be High from the viewpoint of engine condition, or when it is High whereas it seemed to be Low from the engine condition.

2. COMPONENT DESCRIPTION

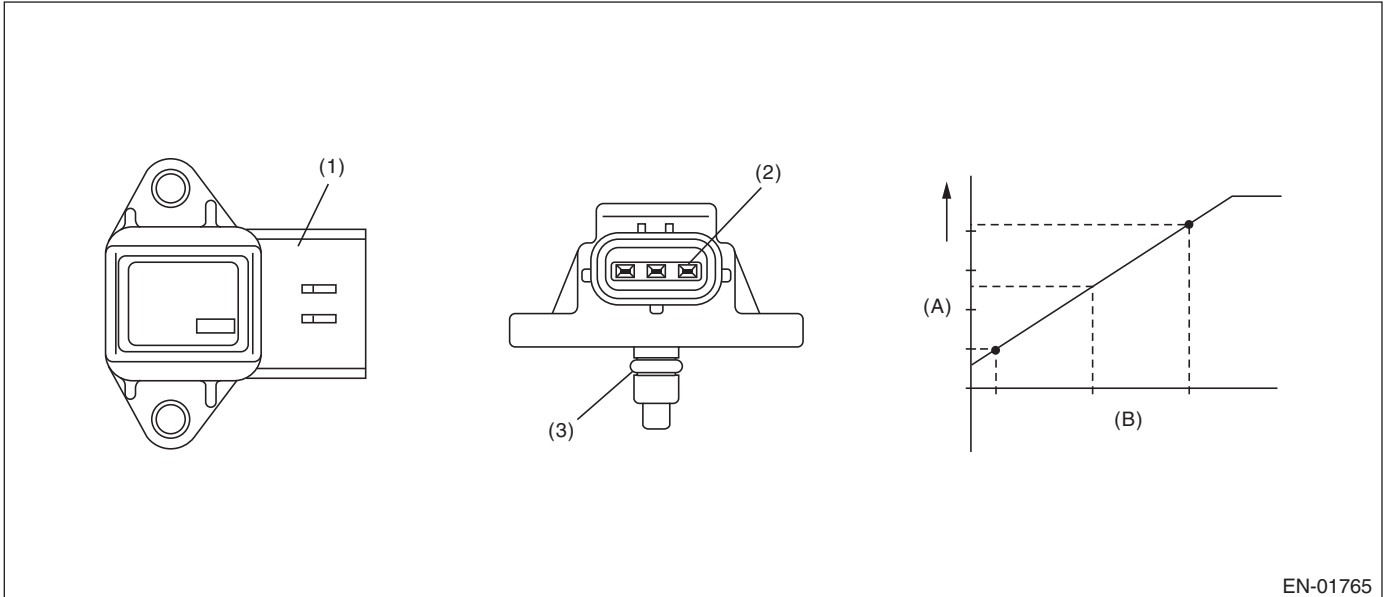

EN-01765

(A) Output voltage

(B) Absolute pressure

(1) Connector

(2) Terminals

(3) O-ring

3. ENABLE CONDITION

Secondary Parameters	Enable Conditions
Engine coolant temperature	$\geq 70\text{ }^{\circ}\text{C}$ (158 °F)

4. GENERAL DRIVING CYCLE

Perform the diagnosis continuously after idling.

Diagnostic Trouble Code (DTC) Detecting Criteria

GENERAL DESCRIPTION

5. DIAGNOSTIC METHOD

• Abnormality Judgement

Judge as NG when Low side or High side becomes NG.

If the duration of time while the following conditions are met is longer than the time indicated, judge as NG.

Judgement Value

Malfunction Criteria	Threshold Value
Low	
Engine speed	< 2500 rpm
Throttle position	$\geq 10^\circ$
Output voltage	< 1 V
Engine load	> 1.356 g/rev (0.05 oz/rev)
High	
Engine speed	600 rpm — 900 rpm
Throttle position	< 2.75°
Output voltage	≥ 2.36 V
Engine load	< 0.4 g/rev (0.01 oz/rev)

Time Needed for Diagnosis:

Low side: 3000 ms

High side: 3000 ms

Malfunction Indicator Light Illumination: Illuminates when malfunction occurs in 2 continuous driving cycles.

• Normality Judgement

Judge as OK and clear the NG when both Low side and High side become OK.

If the duration of time while the following conditions are met is longer than the time indicated, judge as OK.

Judgement Value

Malfunction Criteria	Threshold Value
Low	
Engine speed	< 2500 rpm
Throttle position	$\geq 10^\circ$
Output voltage	≥ 1 V
Engine load	> 1.356 g/rev (0.05 oz/rev)
High	
Engine speed	600 rpm — 900 rpm
Throttle position	< 2.75°
Output voltage	< 2.36 V
Engine load	< 0.4 g/rev (0.01 oz/rev)

Time Needed for Diagnosis:

Low side: Less than 1 second

High side: Less than 1 second

Diagnostic Trouble Code (DTC) Detecting Criteria

GENERAL DESCRIPTION

K: DTC P0101 MASS OR VOLUME AIR FLOW CIRCUIT RANGE/PERFORMANCE

1. OUTLINE OF DIAGNOSIS

Detect the malfunction of air flow sensor output properties.

Judge as a low side NG when the air flow voltage indicates a small value regardless of running in a state where the air flow voltage increases. Judge as a high side NG when the air flow voltage indicates a large value regardless of running in a state where the air flow voltage decreases. Judge air flow sensor property NG when the Low side or High side becomes NG.

2. COMPONENT DESCRIPTION

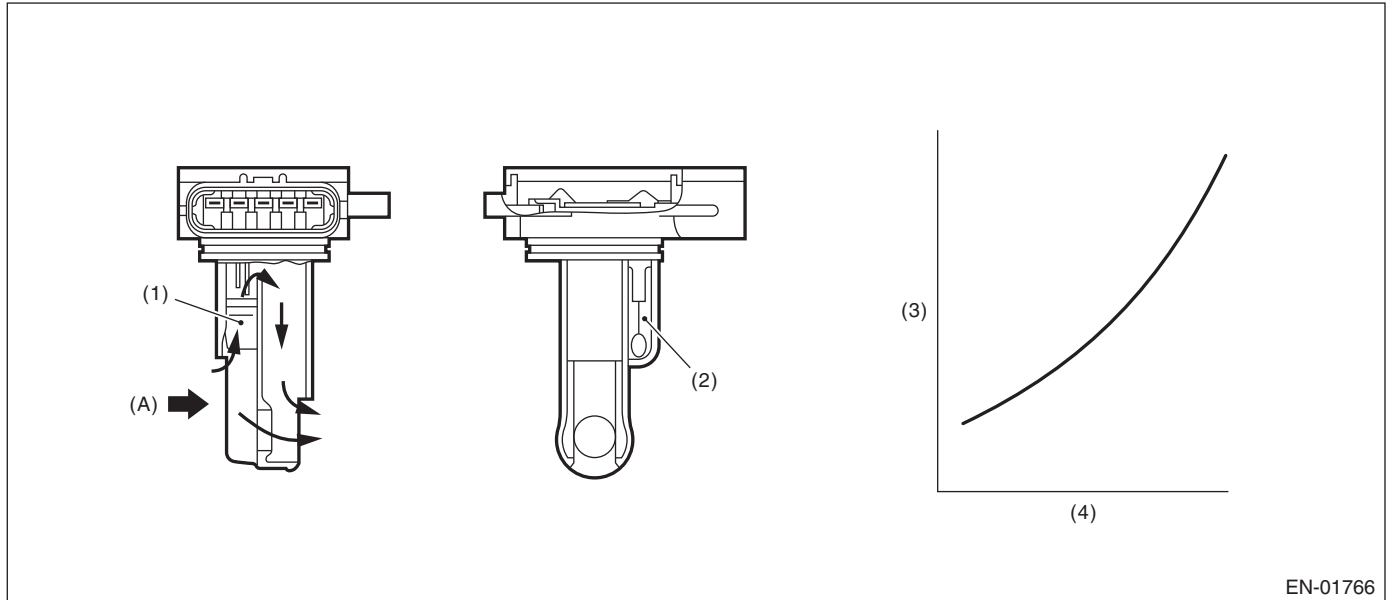

EN-01766

(A) Air

(1) Air flow sensor

(2) Intake air temperature sensor

(3) Voltage (V)

(4) Amount of intake air (kg (lb)/s)

3. ENABLE CONDITION

Secondary Parameters	Enable Conditions
Engine coolant temperature	$\geq 70\text{ }^{\circ}\text{C}$ (158 $^{\circ}\text{F}$)

4. GENERAL DRIVING CYCLE

Perform the diagnosis continuously after idling.

Diagnostic Trouble Code (DTC) Detecting Criteria

GENERAL DESCRIPTION

5. DIAGNOSTIC METHOD

• Abnormality Judgement

Judge as NG when Low side or High side becomes NG.

If the duration of time while the following conditions are met is longer than the time indicated, judge as NG.

Judgement Value

Malfunction Criteria	Threshold Value
Low	
Output voltage	< 1.5 V
Engine speed	≥ 2500 rpm
Throttle opening angle	≥ 15 °
Intake manifold pressure	≥ 53.3 kPa (400 mmHg, 15.7 inHg)
High (1)	
Output voltage	≥ 1.95 V
Engine speed	600 rpm — 900 rpm
Throttle opening angle	< 4.1 °
Intake manifold pressure	< 52.7 kPa (395 mmHg, 15.6 inHg)
High (2)	
Output voltage	≥ 1.70 V
Engine speed	600 rpm — 900 rpm
Throttle opening angle	< 4.1 °
Intake manifold pressure	< 52.7 kPa (395 mmHg, 15.6 inHg)
Fuel system diagnosis	Rich side malfunction

Time Needed for Diagnosis:

Low: 3000 ms

High: 10000 ms

Malfunction Indicator Light Illumination: Illuminates when malfunction occurs in 2 continuous driving cycles.

• Normality Judgement

Judge as OK and clear the NG when both Low side and High side become OK.

Judge as OK and clear the NG if the continuous time while the following conditions are established is more than the predetermined time.

Judgement Value

Malfunction Criteria	Threshold Value
Low	
Output voltage	≥ 1.5 V
Engine speed	≥ 2500 rpm
Throttle opening angle	≥ 15 °
Intake manifold pressure	≥ 53.3 kPa (400 mmHg, 15.7 inHg)
High	
Output voltage	< 1.95 V
Engine speed	600 rpm — 900 rpm
Throttle opening angle	< 4.1 °
Intake manifold pressure	< 52.7 kPa (395 mmHg, 15.6 inHg)
Fuel system diagnosis	Rich side normal

Time Needed for Diagnosis:

Low: Less than 1 second

High: Less than 1 second

Diagnostic Trouble Code (DTC) Detecting Criteria

GENERAL DESCRIPTION

L: DTC P0102 MASS OR VOLUME AIR FLOW CIRCUIT LOW INPUT

1. OUTLINE OF DIAGNOSIS

Detect open or short circuits of the air flow sensor.
Judge as NG if out of specification.

2. COMPONENT DESCRIPTION

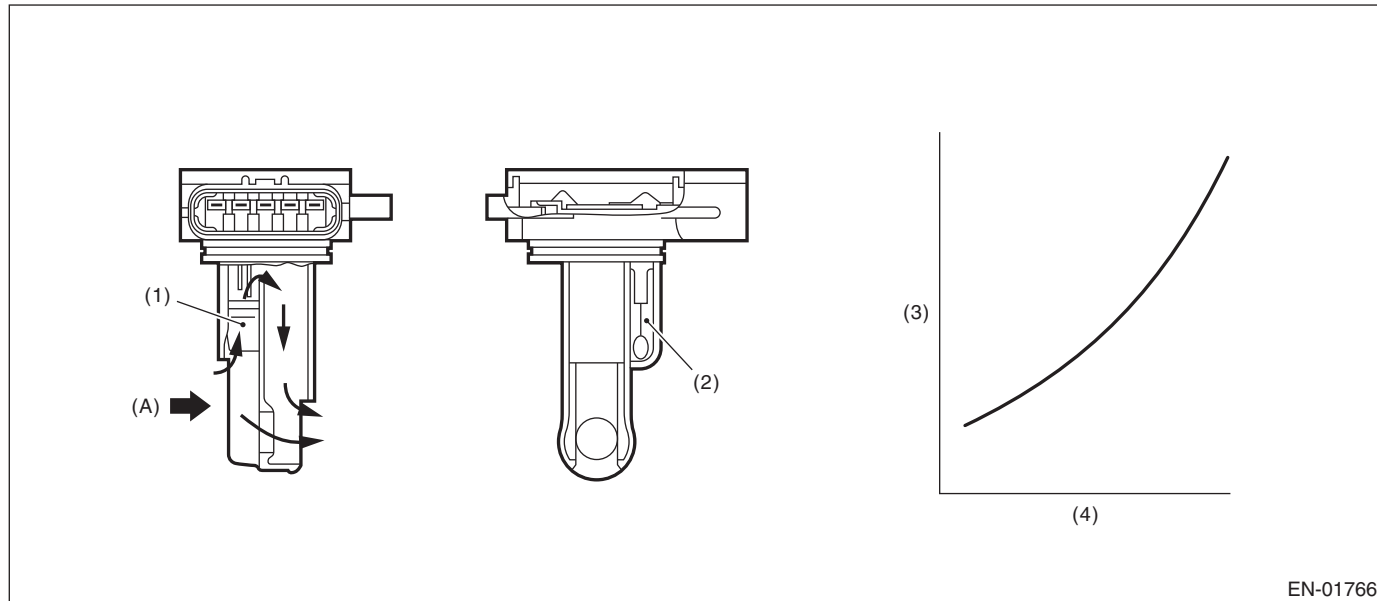

(A) Air

(1) Air flow sensor

(3) Voltage (V)

(4) Amount of intake air (kg (lb)/s)

(2) Intake air temperature sensor

EN-01766

3. ENABLE CONDITION

Secondary Parameters	Enable Conditions
None	

4. GENERAL DRIVING CYCLE

Always perform the diagnosis continuously.

5. DIAGNOSTIC METHOD

• Abnormality Judgement

If the duration of time while the following conditions are met is longer than the time indicated, judge as NG.

Judgement Value

Malfunction Criteria	Threshold Value
Output voltage	$\leq 0.22 \text{ V}$

Time Needed for Diagnosis: 500 ms

Malfunction Indicator Light Illumination: Illuminates as soon as a malfunction occurs.

• Normality Judgement

Judge as OK and clear the NG if the continuous time while the following conditions are established is more than the predetermined time.

Judgement Value

Malfunction Criteria	Threshold Value
Output voltage	$> 0.22 \text{ V}$

Time Needed for Diagnosis: Less than 1 second

M: DTC P0103 MASS OR VOLUME AIR FLOW CIRCUIT HIGH INPUT

1. OUTLINE OF DIAGNOSIS

Detect open or short circuits of the air flow sensor.
Judge as NG if out of specification.

2. COMPONENT DESCRIPTION

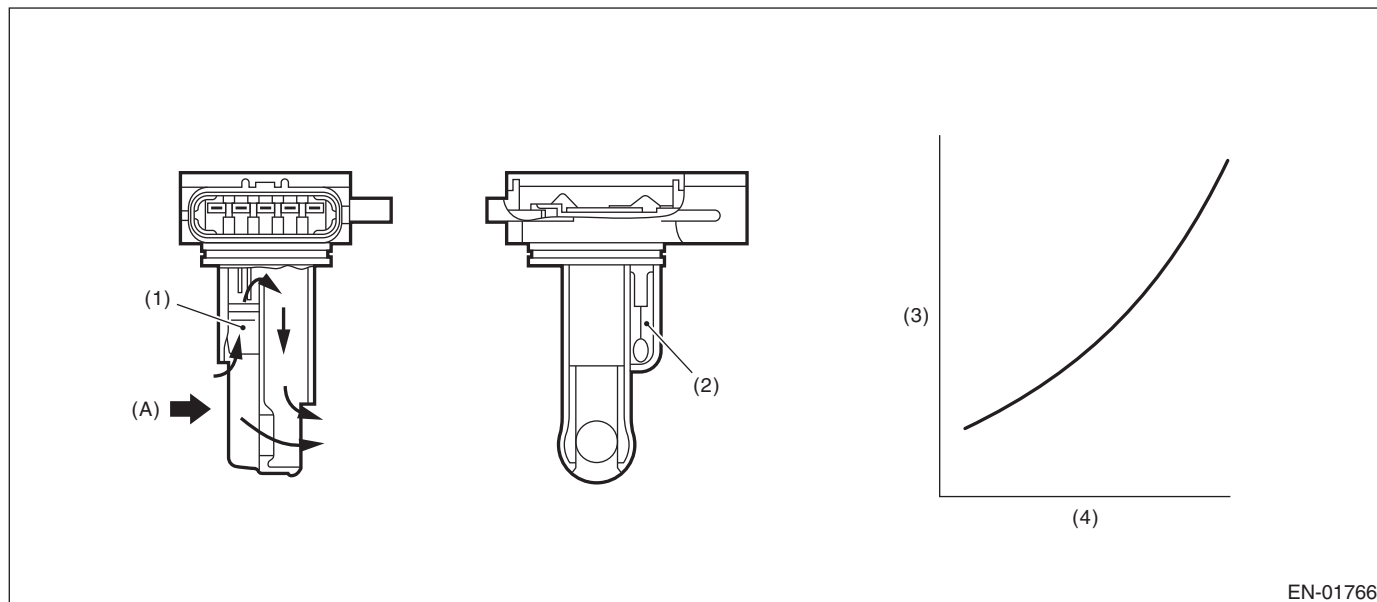

EN-01766

(A) Air

(1) Air flow sensor

(3) Voltage (V)

(4) Amount of intake air (kg (lb)/s)

(2) Intake air temperature sensor

3. ENABLE CONDITION

Secondary Parameters	Enable Conditions
None	

4. GENERAL DRIVING CYCLE

Always perform the diagnosis continuously.

5. DIAGNOSTIC METHOD

• Abnormality Judgement

If the duration of time while the following conditions are met is longer than the time indicated, judge as NG.

Judgement Value

Malfunction Criteria	Threshold Value
Output voltage	≥ 4.98 V

Time Needed for Diagnosis: 500 ms

Malfunction Indicator Light Illumination: Illuminates as soon as a malfunction occurs.

• Normality Judgement

Judge as OK and clear the NG if the continuous time while the following conditions are established is more than the predetermined time.

Judgement Value

Malfunction Criteria	Threshold Value
Output voltage	< 4.98 V

Time Needed for Diagnosis: Less than 1 second

Diagnostic Trouble Code (DTC) Detecting Criteria

GENERAL DESCRIPTION

N: DTC P0107 MANIFOLD ABSOLUTE PRESSURE/BAROMETRIC PRESSURE CIRCUIT LOW INPUT

1. OUTLINE OF DIAGNOSIS

Detect the open or short circuit of intake manifold pressure sensor.
Judge as NG if out of specification.

2. COMPONENT DESCRIPTION

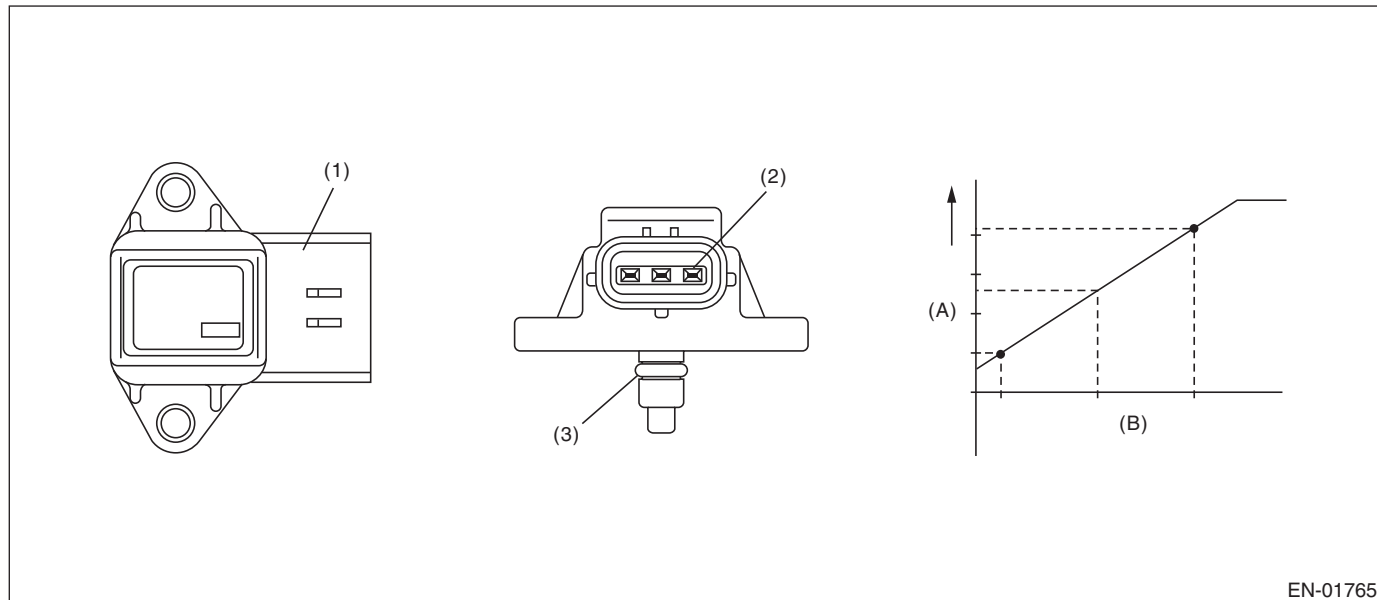

(A) Output voltage

(B) Absolute pressure

(1) Connector

(2) Terminals

(3) O-ring

EN-01765

3. ENABLE CONDITION

Secondary Parameters	Enable Conditions
None	

4. GENERAL DRIVING CYCLE

Always perform the diagnosis continuously.

5. DIAGNOSTIC METHOD

• Abnormality Judgement

If the duration of time while the following conditions are met is longer than the time indicated, judge as NG.

Judgement Value

Malfunction Criteria	Threshold Value
Output voltage	≤ 0.573 V

Time Needed for Diagnosis: 500 ms

Malfunction Indicator Light Illumination: Illuminates as soon as a malfunction occurs.

• Normality Judgement

Judge as OK and clear the NG if the continuous time while the following conditions are established is more than the predetermined time.

Judgement Value

Malfunction Criteria	Threshold Value
Output voltage	> 0.573 V

Time Needed for Diagnosis: Less than 1 second

O: DTC P0108 MANIFOLD ABSOLUTE PRESSURE/BAROMETRIC PRESSURE CIRCUIT HIGH INPUT

1. OUTLINE OF DIAGNOSIS

Detect the open or short circuit of intake manifold pressure sensor.
Judge as NG if out of specification.

2. COMPONENT DESCRIPTION

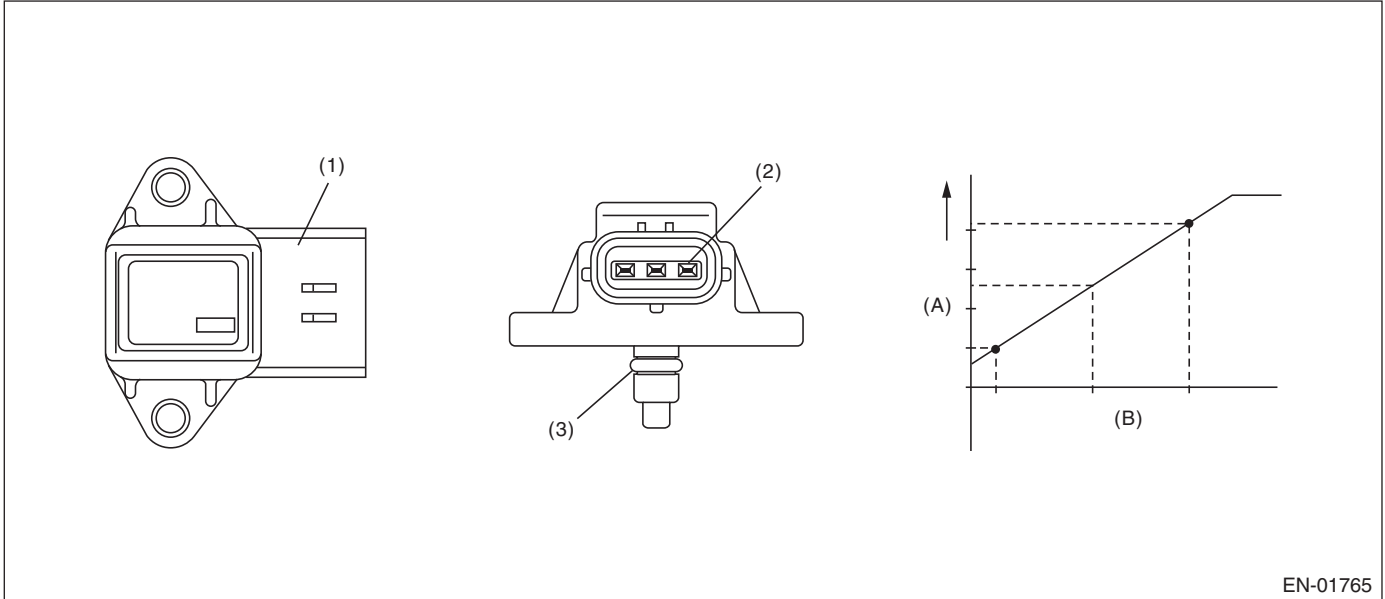

EN-01765

(A) Output voltage

(B) Absolute pressure

(1) Connector

(2) Terminals

(3) O-ring

3. ENABLE CONDITION

Secondary Parameters	Enable Conditions
None	

4. GENERAL DRIVING CYCLE

Always perform the diagnosis continuously.

5. DIAGNOSTIC METHOD

• Abnormality Judgement

If the duration of time while the following conditions are met is longer than the time indicated, judge as NG.

Judgement Value

Malfunction Criteria	Threshold Value
Output voltage	$\geq 4.596499186 \text{ V}$

Time Needed for Diagnosis: 500 ms

Malfunction Indicator Light Illumination: Illuminates as soon as a malfunction occurs.

• Normality Judgement

Judge as OK and clear the NG if the continuous time while the following conditions are established is more than the predetermined time.

Judgement Value

Malfunction Criteria	Threshold Value
Output voltage	$< 4.596499186 \text{ V}$

Time Needed for Diagnosis: Less than 1 second

Diagnostic Trouble Code (DTC) Detecting Criteria

GENERAL DESCRIPTION

P: DTC P0111 INTAKE AIR TEMPERATURE SENSOR 1 CIRCUIT RANGE/PERFORMANCE

1. OUTLINE OF DIAGNOSIS

Detect the malfunction of intake air temperature sensor output property.

Judge as NG when the intake air temperature is not varied whereas it seemed to be varied from the viewpoint of engine condition.

2. COMPONENT DESCRIPTION

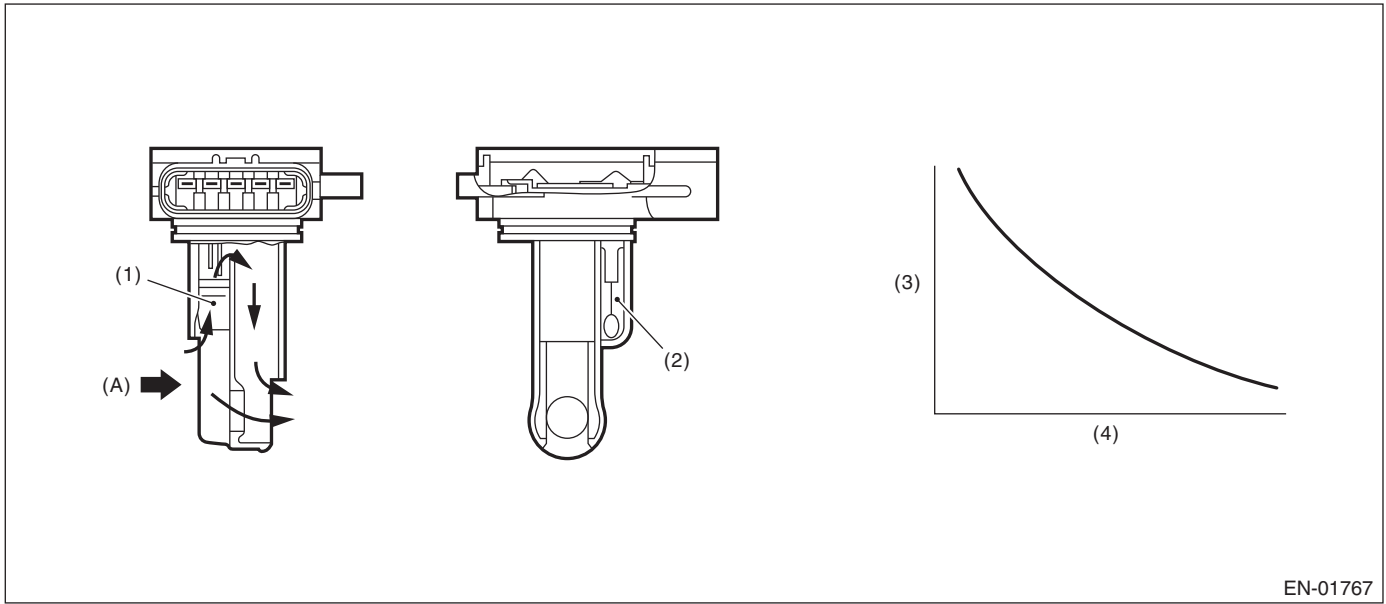

EN-01767

(A) Air

(1) Air flow sensor

(3) Resistance value (Ω)

(4) Intake air temperature $^{\circ}\text{C}$ ($^{\circ}\text{F}$)

(2) Intake air temperature sensor

3. ENABLE CONDITION

Secondary Parameters	Enable Conditions
Engine coolant temperature at engine starting	$< 30^{\circ}\text{C}$ (86°F)
Engine coolant temperature	$\geq 95^{\circ}\text{C}$ (203°F)
Battery voltage	$\geq 10.9\text{ V}$
Continuous time when the vehicle speed is less than 60 km/h (37.3 MPH)	$\geq 600\text{ s}$

4. GENERAL DRIVING CYCLE

Perform the diagnosis when the vehicle speed condition is met after warming up from a cold condition.

Diagnostic Trouble Code (DTC) Detecting Criteria

GENERAL DESCRIPTION

5. DIAGNOSTIC METHOD

• Abnormality Judgement

Judge as NG when the following conditions are established.

Judgement Value

Malfunction Criteria	Threshold Value
Output voltage difference between Max. and Min.	< 0.02 V(Equivalent to approximately 0.5°C (0.9°F) near 25°C)

Time Needed for Diagnosis: Less than 1 second

Malfunction Indicator Light Illumination: Illuminates when malfunction occurs in 2 continuous driving cycles.

• Normality Judgement

Judge as OK and clear the NG if the following conditions are established.

Judgement Value

Malfunction Criteria	Threshold Value
Output voltage difference between Max. and Min.	≥ 0.02 V

Time Needed for Diagnosis: Less than 1 second

Diagnostic Trouble Code (DTC) Detecting Criteria

GENERAL DESCRIPTION

Q: DTC P0112 INTAKE AIR TEMPERATURE SENSOR 1 CIRCUIT LOW

1. OUTLINE OF DIAGNOSIS

Detect open or short circuit of the intake air temperature sensor.
Judge as NG if out of specification.

2. COMPONENT DESCRIPTION

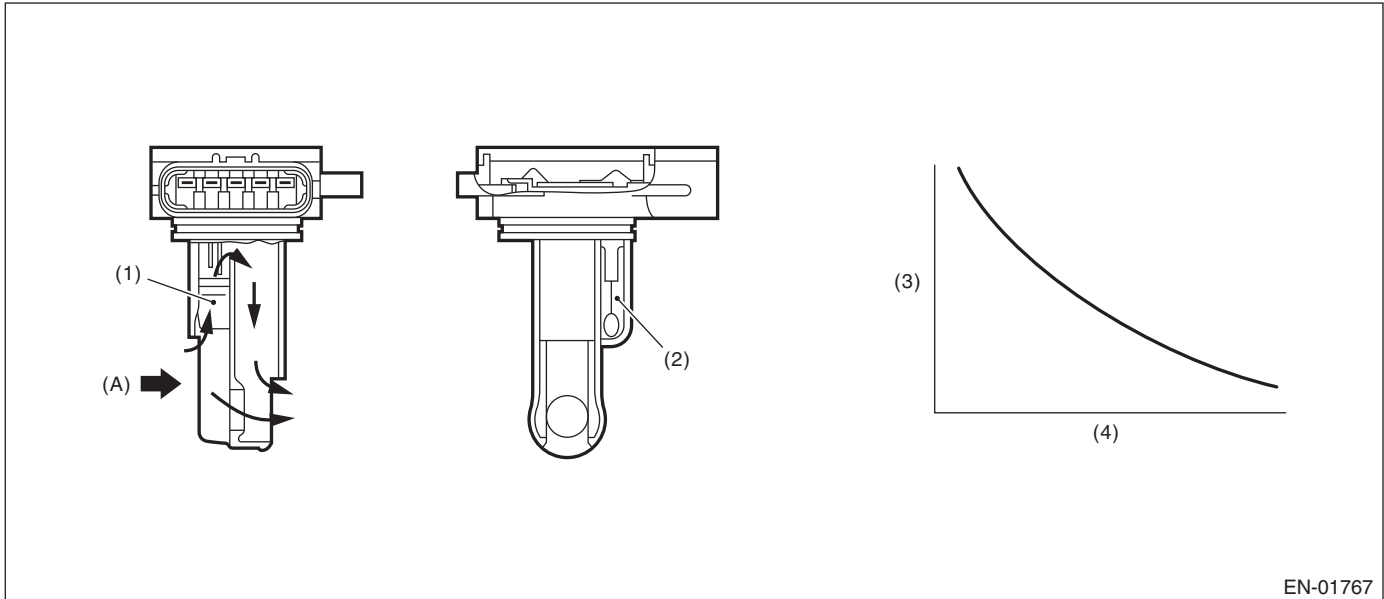

EN-01767

(A) Air

(1) Air flow sensor

(3) Resistance value (Ω)

(4) Intake air temperature °C (°F)

(2) Intake air temperature sensor

3. ENABLE CONDITION

Secondary Parameters	Enable Conditions
None	

4. GENERAL DRIVING CYCLE

Always perform the diagnosis continuously.

5. DIAGNOSTIC METHOD

• Abnormality Judgement

If the duration of time while the following conditions are met is longer than the time indicated, judge as NG.

Judgement Value

Malfunction Criteria	Threshold Value
Output voltage	< 0.230975449 V

Time Needed for Diagnosis: 500 ms

Malfunction Indicator Light Illumination: Illuminates as soon as a malfunction occurs.

• Normality Judgement

Judge as OK and clear the NG if the continuous time while the following conditions are established is more than the predetermined time.

Judgement Value

Malfunction Criteria	Threshold Value
Output voltage	\geq 0.230975449 V

Time Needed for Diagnosis: Less than 1 second

R: DTC P0113 INTAKE AIR TEMPERATURE SENSOR 1 CIRCUIT HIGH

1. OUTLINE OF DIAGNOSIS

Detect open or short circuit of the intake air temperature sensor.
Judge as NG if out of specification.

2. COMPONENT DESCRIPTION

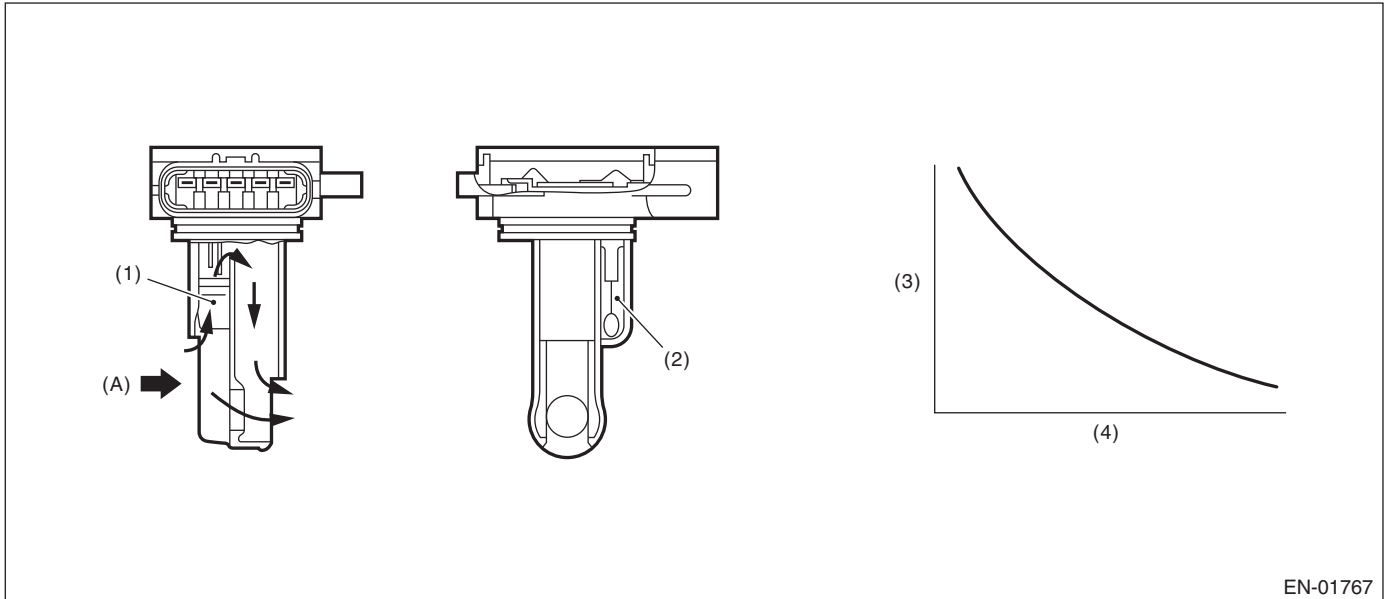

EN-01767

(A) Air

(1) Air flow sensor

(3) Resistance value (Ω)

(4) Intake air temperature °C (°F)

(2) Intake air temperature sensor

3. ENABLE CONDITION

Secondary Parameters	Enable Conditions
None	

4. GENERAL DRIVING CYCLE

Always perform the diagnosis continuously.

5. DIAGNOSTIC METHOD

• Abnormality Judgement

If the duration of time while the following conditions are met is longer than the time indicated, judge as NG.

Judgement Value

Malfunction Criteria	Threshold Value
Output voltage	≥ 4.716 V

Time Needed for Diagnosis: 500 ms

Malfunction Indicator Light Illumination: Illuminates as soon as a malfunction occurs.

• Normality Judgement

Judge as OK and clear the NG if the continuous time while the following conditions are established is more than the predetermined time.

Judgement Value

Malfunction Criteria	Threshold Value
Output voltage	< 4.716 V

Time Needed for Diagnosis: Less than 1 second

Diagnostic Trouble Code (DTC) Detecting Criteria

GENERAL DESCRIPTION

S: DTC P0117 ENGINE COOLANT TEMPERATURE CIRCUIT LOW

1. OUTLINE OF DIAGNOSIS

Detect the open or short circuit of the engine coolant temperature sensor.
Judge as NG if out of specification.

2. COMPONENT DESCRIPTION

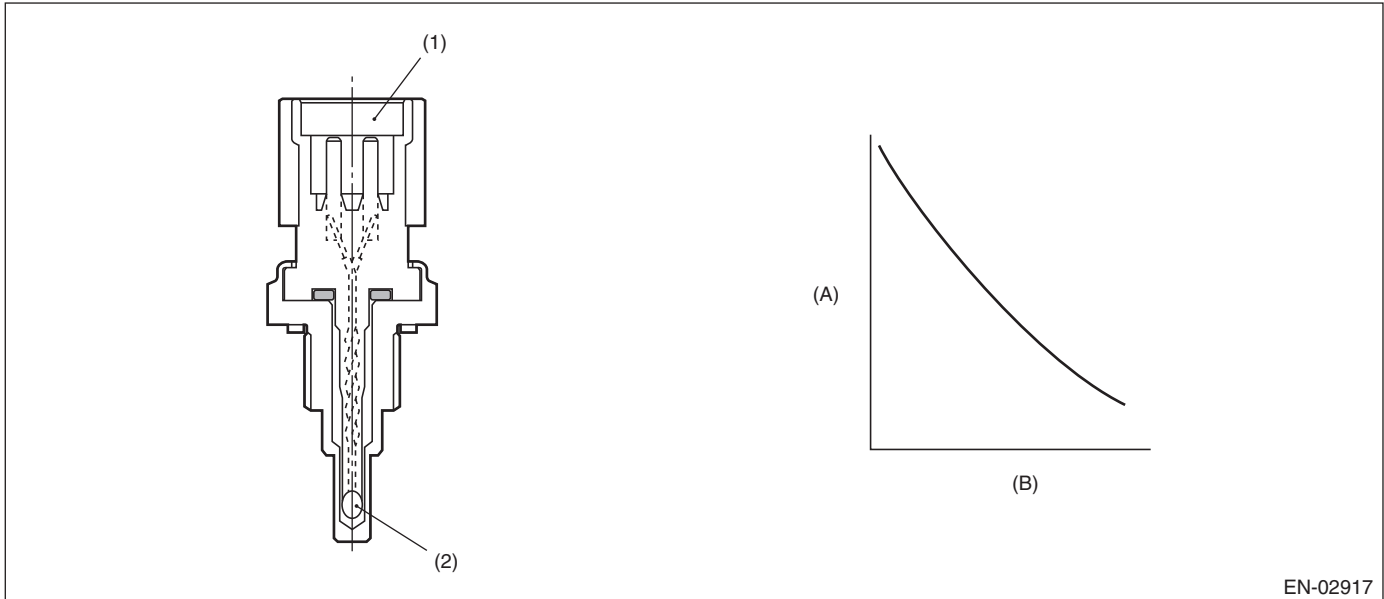

EN-02917

- (A) Resistance value (k Ω) (B) Temperature °C (°F)
(1) Connector (2) Thermistor element

3. ENABLE CONDITION

Secondary Parameters	Enable Conditions
None	

4. GENERAL DRIVING CYCLE

Always perform the diagnosis continuously.

5. DIAGNOSTIC METHOD

• Abnormality Judgement

If the duration of time while the following conditions are met is longer than the time indicated, judge as NG.

Judgement Value

Malfunction Criteria	Threshold Value
Output voltage	< 0.264738528 V

Time Needed for Diagnosis: 500 ms

Malfunction Indicator Light Illumination: Illuminates as soon as a malfunction occurs.

• Normality Judgement

Judge as OK and clear the NG if the continuous time while the following conditions are established is more than the predetermined time.

Judgement Value

Malfunction Criteria	Threshold Value
Output voltage	\geq 0.264738528 V

Time Needed for Diagnosis: Less than 1 second

T: DTC P0118 ENGINE COOLANT TEMPERATURE CIRCUIT HIGH

1. OUTLINE OF DIAGNOSIS

Detect the open or short circuit of the engine coolant temperature sensor.
Judge as NG if out of specification.

2. COMPONENT DESCRIPTION

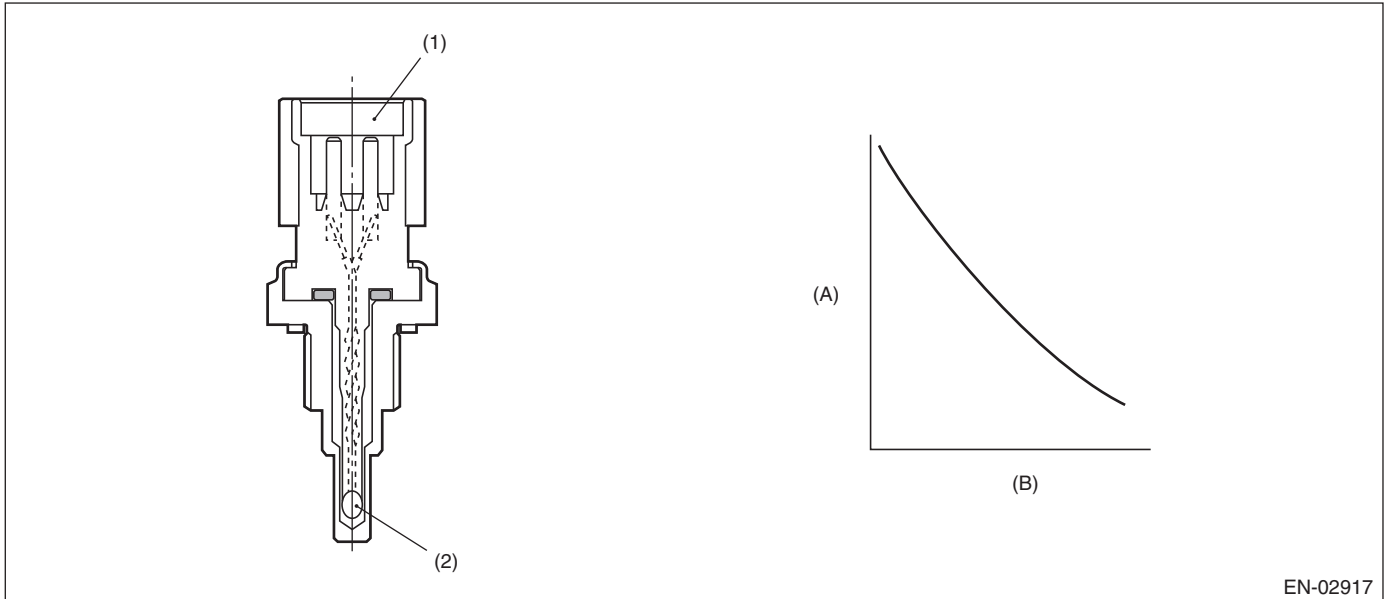

EN-02917

- (A) Resistance value (k Ω) (B) Temperature °C (°F)
- (1) Connector (2) Thermistor element

3. ENABLE CONDITION

Secondary Parameters	Enable Conditions
None	

4. GENERAL DRIVING CYCLE

Always perform the diagnosis continuously.

5. DIAGNOSTIC METHOD

• Abnormality Judgement

If the duration of time while the following conditions are met is longer than the time indicated, judge as NG.

Judgement Value

Malfunction Criteria	Threshold Value
Output voltage	≥ 4.716 V

Time Needed for Diagnosis: 500 ms

Malfunction Indicator Light Illumination: Illuminates as soon as a malfunction occurs.

• Normality Judgement

Judge as OK and clear the NG if the continuous time while the following conditions are established is more than the predetermined time.

Judgement Value

Malfunction Criteria	Threshold Value
Output voltage	< 4.716 V

Time Needed for Diagnosis: Less than 1 second

Diagnostic Trouble Code (DTC) Detecting Criteria

GENERAL DESCRIPTION

U: DTC P0122 THROTTLE/PEDAL POSITION SENSOR/SWITCH “A” CIRCUIT LOW

1. OUTLINE OF DIAGNOSIS

Detect the open or short circuit of throttle position sensor 1.
Judge as NG if out of specification.

2. COMPONENT DESCRIPTION

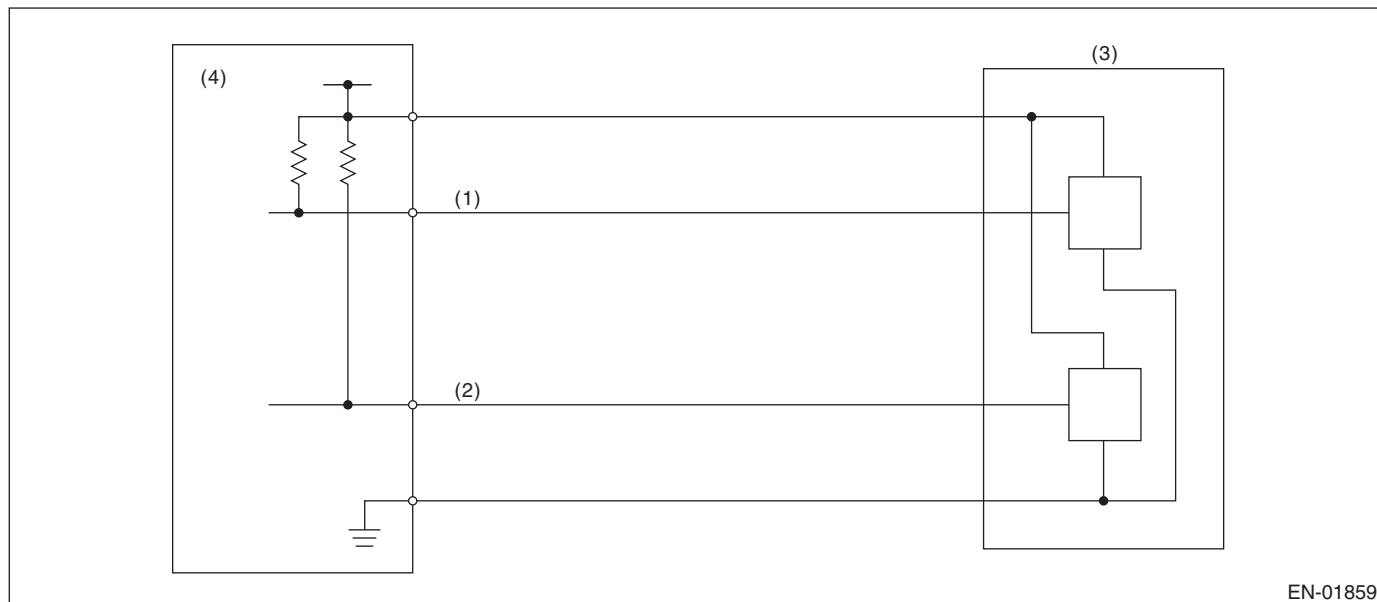

- (1) Throttle position sensor 1 signal (3) Throttle position sensor (4) Engine control module (ECM)
(2) Throttle position sensor 2 signal

3. ENABLE CONDITION

Secondary Parameters	Enable Conditions
Ignition switch	ON
Battery voltage	$\geq 6 \text{ V}$

4. GENERAL DRIVING CYCLE

Always perform the diagnosis continuously.

5. DIAGNOSTIC METHOD

• Abnormality Judgement

If the duration of time while the following conditions are met is longer than the time indicated, judge as NG.

Judgement Value

Malfunction Criteria	Threshold Value
Sensor 1 input voltage	$\leq 0.217 \text{ V}$

Time Needed for Diagnosis: 24 ms

Malfunction Indicator Light Illumination: Illuminates as soon as a malfunction occurs.

• Normality Judgement

Judge as OK and clear the NG if the continuous time while the following conditions are established is more than the predetermined time.

Judgement Value

Malfunction Criteria	Threshold Value
Sensor 1 input voltage	$> 0.217 \text{ V}$

Time Needed for Diagnosis: 24 ms

V: DTC P0123 THROTTLE/PEDAL POSITION SENSOR/SWITCH “A” CIRCUIT HIGH

1. OUTLINE OF DIAGNOSIS

Detect the open or short circuit of throttle position sensor 1.
Judge as NG if out of specification.

2. COMPONENT DESCRIPTION

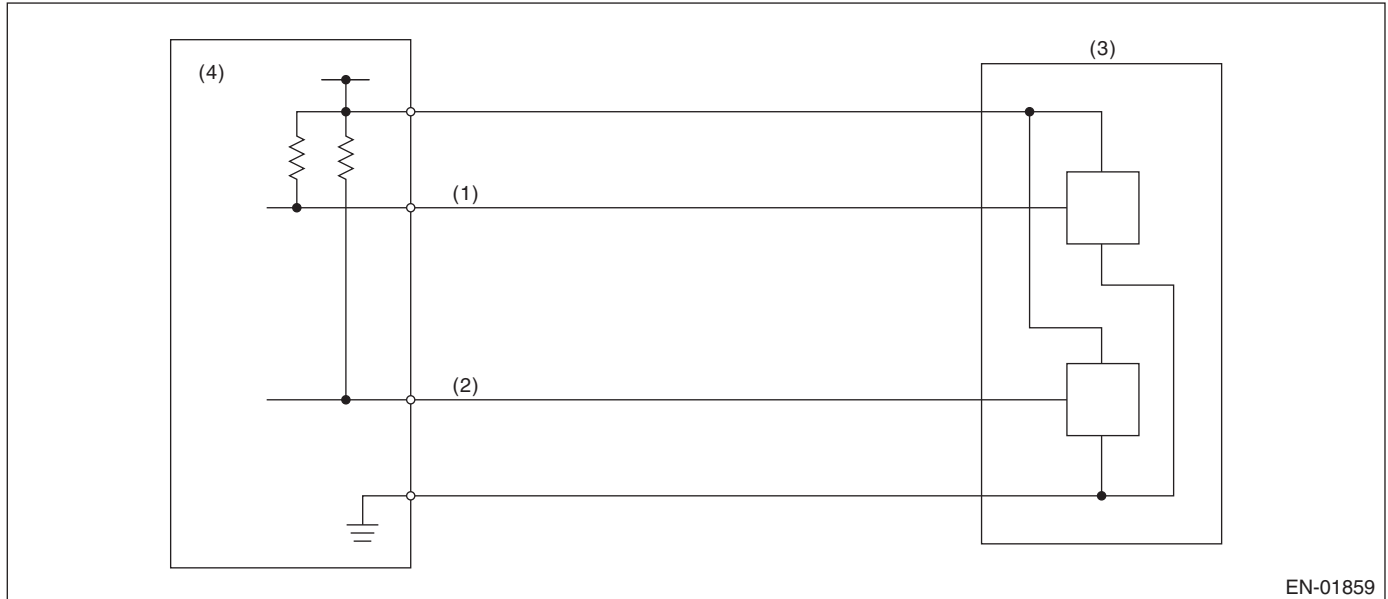

EN-01859

- (1) Throttle position sensor 1 signal (3) Throttle position sensor (4) Engine control module (ECM)
 (2) Throttle position sensor 2 signal

3. ENABLE CONDITION

Secondary Parameters	Enable Conditions
Ignition switch	ON
Battery voltage	≥ 6 V

4. GENERAL DRIVING CYCLE

Always perform the diagnosis continuously.

5. DIAGNOSTIC METHOD

• Abnormality Judgement

If the duration of time while the following conditions are met is longer than the time indicated, judge as NG.

Judgement Value

Malfunction Criteria	Threshold Value
Sensor 1 input voltage	≥ 4.858 V

Time Needed for Diagnosis: 24 ms

Malfunction Indicator Light Illumination: Illuminates as soon as a malfunction occurs.

• Normality Judgement

Judge as OK and clear the NG if the continuous time while the following conditions are established is more than the predetermined time.

Judgement Value

Malfunction Criteria	Threshold Value
Sensor 1 input voltage	< 4.858 V

Time Needed for Diagnosis: 24 ms

Diagnostic Trouble Code (DTC) Detecting Criteria

GENERAL DESCRIPTION

W: DTC P0125 INSUFFICIENT COOLANT TEMPERATURE FOR CLOSED LOOP FUEL CONTROL

1. OUTLINE OF DIAGNOSIS

Detect the malfunction of engine coolant temperature output property.

Judge as NG when the engine coolant temperature does not rise in driving conditions where it should.

2. COMPONENT DESCRIPTION

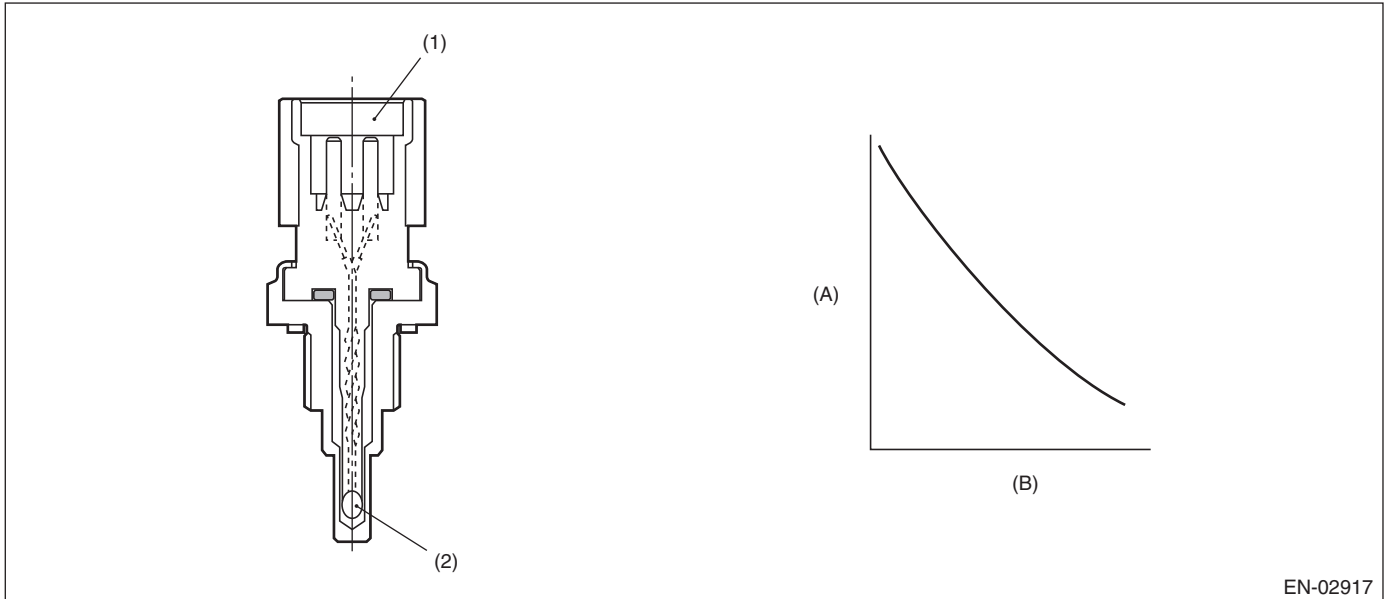

EN-02917

(A) Resistance value (k Ω)

(B) Temperature $^{\circ}\text{C}$ ($^{\circ}\text{F}$)

(1) Connector

(2) Thermistor element

3. ENABLE CONDITION

Secondary Parameters	Enable Conditions
Engine speed	\geq Value from Map
Battery voltage	$\geq 10.9 \text{ V}$

Map

Engine coolant temperature $^{\circ}\text{C}$ ($^{\circ}\text{F}$)	-40 (-40)	-30 (-22)	-20 (-4)	-10 (14)	0 (32)	10 (50)	20 (68)	30 (86)
Engine speed rpm	500	500	500	500	500	500	500	500

Engine coolant temperature $^{\circ}\text{C}$ ($^{\circ}\text{F}$)	40 (104)	50 (122)	60 (140)	70 (158)	80 (176)	90 (194)	100 (212)	110 (230)
Engine speed rpm	500	500	500	500	500	500	500	500

4. GENERAL DRIVING CYCLE

Perform the diagnosis only once after engine start.

Diagnostic Trouble Code (DTC) Detecting Criteria

GENERAL DESCRIPTION

5. DIAGNOSTIC METHOD

• Abnormality Judgement

Judge as NG if the criteria below are met.

Judgement Value

Malfunction Criteria	Threshold Value
Engine coolant temperature	< 20 °C (68 °F)
Timer for diagnosis after engine start	≥ Judgement value of timer after engine start

Timer for diagnosis after engine start

a. Timer stop at fuel cut

b. During the driving conditions except a) above, timer counts up as follows.

64 milliseconds + TWCNT milliseconds (at the time of 64 milliseconds)

TWCNT is defined as follows,

TWCNT = 0 at idle switch ON,

TWCNT show on the following table at idle switch OFF.

		Vehicle speed km/h (MPH)							
		0 (0)	8 (5)	16 (9.9)	24 (14.9)	32 (19.9)	40 (24.9)	48 (29.8)	56 (34.8)
Temperature °C (°F)	-20 (-4)	0 ms	37.136 ms	74.272 ms	111.41 ms	126.66 ms	141.91 ms	163.59 ms	185.26 ms
	-10 (14)	0 ms	27.391 ms	54.782 ms	82.173 ms	99.65 ms	117.13 ms	135.96 ms	154.8 ms
	0 (32)	0 ms	17.646 ms	35.292 ms	52.938 ms	72.64 ms	92.341 ms	108.34 ms	124.33 ms
	10 (50)	0 ms	7.9012 ms	15.802 ms	23.704 ms	45.63 ms	67.556 ms	80.711 ms	93.867 ms
	20 (68)	0 ms	7.9012 ms	15.802 ms	23.704 ms	45.63 ms	67.556 ms	80.711 ms	93.867 ms

Judgement value of timer after engine starting

$$t = 451056 \text{ ms} - 25870 \text{ ms} \times T_i$$

T_i : The lowest coolant temperature after engine start

Time Needed for Diagnosis: Less than 1 second

Malfunction Indicator Light Illumination: Illuminates when malfunction occurs in 2 continuous driving cycles.

• Normality Judgement

Judge as OK and clear the NG when the malfunction criteria below are met.

Judgement Value

Malfunction Criteria	Threshold Value
Engine coolant temperature	≥ 20 °C (68 °F)

Time Needed for Diagnosis: Less than 1 second

Diagnostic Trouble Code (DTC) Detecting Criteria

GENERAL DESCRIPTION

X: DTC P0126 INSUFFICIENT ENGINE COOLANT TEMPERATURE FOR STABLE OPERATION

1. OUTLINE OF DIAGNOSIS

Detect the malfunction of the engine coolant temperature sensor characteristics.

Memorize the engine coolant temperature and fuel temperature at the last engine stop, and use them to judge as NG when the engine coolant temperature does not decrease when it should.

2. COMPONENT DESCRIPTION

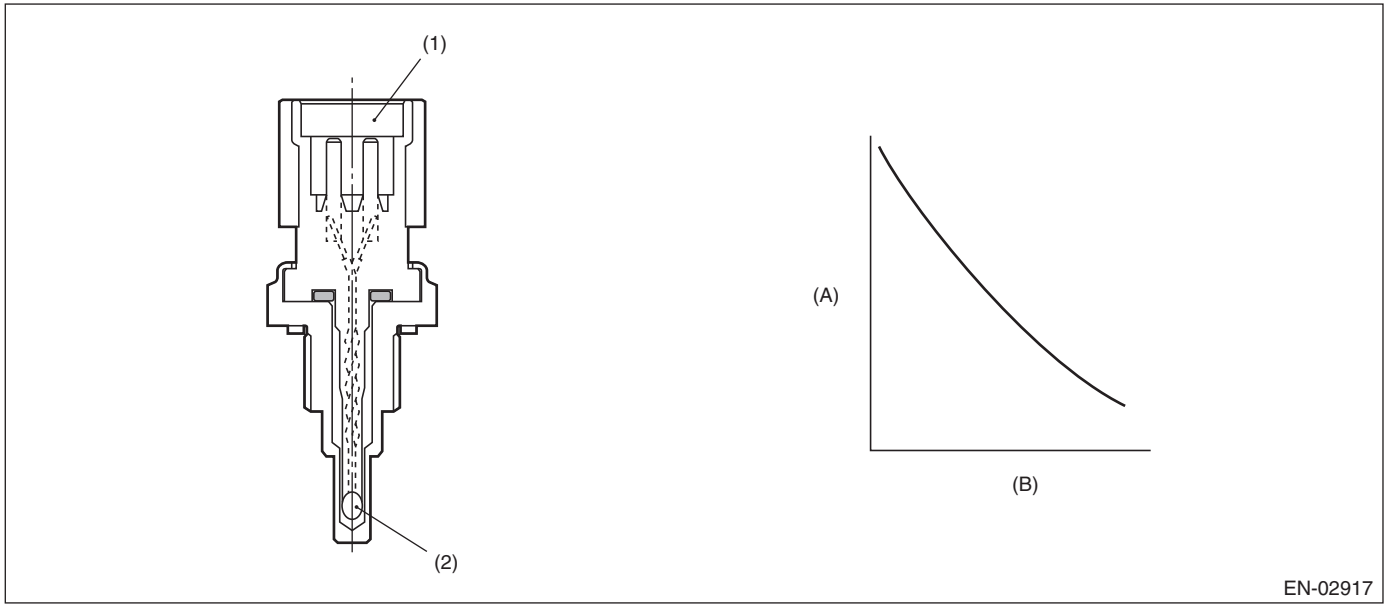

EN-02917

(A) Resistance value (k Ω)

(B) Temperature °C (°F)

(1) Connector

(2) Thermistor element

3. ENABLE CONDITION

Secondary Parameters	Enable Conditions
Battery voltage	≥ 10.9 V
Refueling from the last engine stop till the current engine start	None
Fuel level	≥ 15 ℓ (3.96 US gal, 3.3 Imp gal)
Engine coolant temperature at the last engine stop	≥ 70 °C (158 °F)

4. GENERAL DRIVING CYCLE

Perform the diagnosis only once after starting the engine.

Diagnostic Trouble Code (DTC) Detecting Criteria

GENERAL DESCRIPTION

5. DIAGNOSTIC METHOD

• Abnormality Judgement

If the duration of time while the following conditions are met is longer than the time indicated, judge as NG.

Judgement Value

Malfunction Criteria	Threshold Value
Engine coolant temperature at the last engine stop — Minimum engine coolant temperature after the engine start	< 2.5 °C (36.5 °F)
Fuel temperature at the last engine stop — Fuel temperature	≥ 5 °C (41 °F)
Intake air temperature — Fuel temperature	< 2.5 °C (36.5 °F)
Fuel temperature	< 35 °C (95 °F)

Time Needed for Diagnosis: 2500 ms

Malfunction Indicator Light Illumination: Illuminates when malfunction occurs in 2 continuous driving cycles.

• Normality Judgement

Judge as OK and clear the NG if the continuous time while the following conditions are established is more than the predetermined time.

Judgement Value

Malfunction Criteria	Threshold Value
Engine coolant temperature at the last engine stop — Minimum engine coolant temperature after the engine start	≥ 2.5 °C (36.5 °F)

Time Needed for Diagnosis: Less than 1 second

Diagnostic Trouble Code (DTC) Detecting Criteria

GENERAL DESCRIPTION

Y: DTC P0128 COOLANT THERMOSTAT (ENGINE COOLANT TEMPERATURE BELOW THERMOSTAT REGULATING TEMPERATURE)

1. OUTLINE OF DIAGNOSIS

Detect malfunctions of the thermostat function.

Judge as NG when the engine coolant temperature is lower than the estimated engine coolant temperature and the difference between them is large. Judge as OK when the engine coolant temperature becomes to 75°C (167°F), and the difference is small, before judging NG.

2. COMPONENT DESCRIPTION

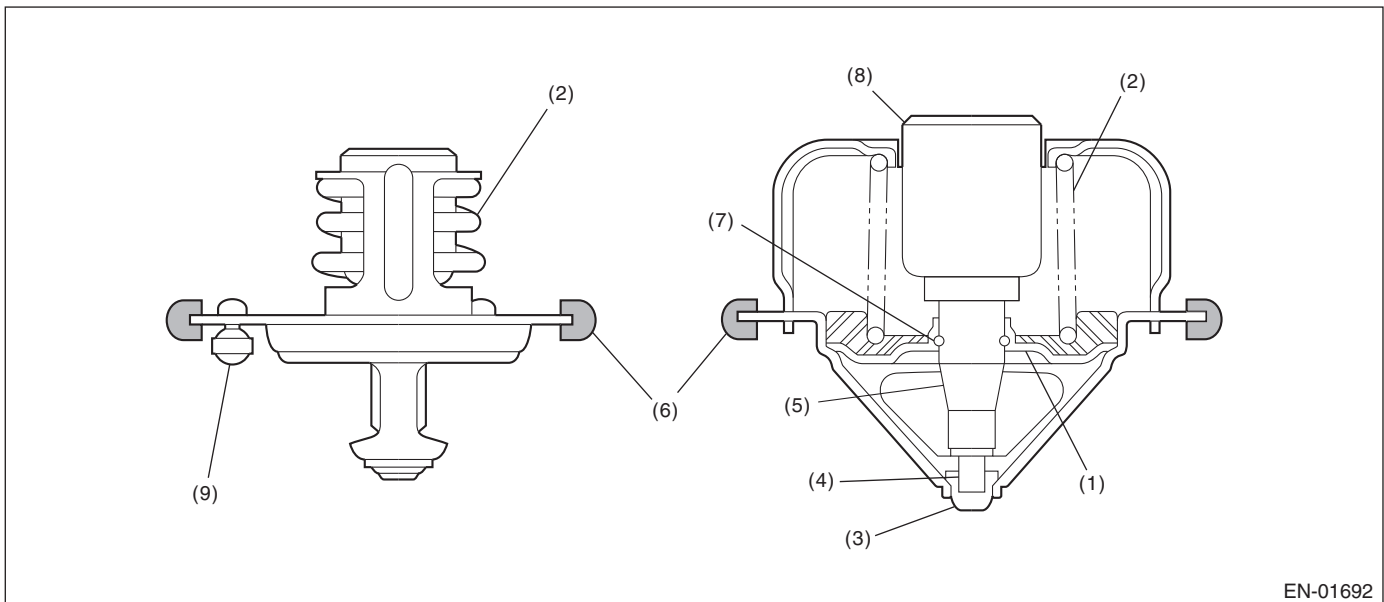

EN-01692

- | | | |
|-------------|-----------------|------------------|
| (1) Valve | (4) Piston | (7) Stop ring |
| (2) Spring | (5) Guide | (8) Wax element |
| (3) Stopper | (6) Rubber seal | (9) Jiggle valve |

3. ENABLE CONDITION

Secondary Parameters	Enable Conditions
None	

4. GENERAL DRIVING CYCLE

Always perform the diagnosis continuously.

Diagnostic Trouble Code (DTC) Detecting Criteria

GENERAL DESCRIPTION

5. DIAGNOSTIC METHOD

• Abnormality Judgement

If the duration of time while the following conditions are met is longer than the time indicated, judge as NG.

Judgement Value

Malfunction Criteria	Threshold Value
Battery voltage	≥ 10.9 V
Estimate ambient temperature	≥ -7 °C (19.4 °F)
Thermostat malfunction diagnosis	Incomplete
Engine coolant temperature at engine starting	< 55 °C (131 °F)
Estimated coolant temperature	≥ 70 °C (158 °F)
Engine coolant temperature	≤ 70 °C (158 °F)
(Estimated – measured) Engine coolant temperature	> 30 °C (86 °F)
Vehicle speed	≥ 30 km/h (18.6 MPH)

Time Needed for Diagnosis: 64 ms × 3 time(s) × 152 time(s)

Malfunction Indicator Light Illumination: Illuminates when malfunction occurs in 2 continuous driving cycles.

• Normality Judgement

Judge as OK and clear the NG if the continuous time while the following conditions are established is more than the predetermined time.

Judgement Value

Malfunction Criteria	Threshold Value
Battery voltage	≥ 10.9 V
Estimate ambient temperature	≥ -7 °C (19.4 °F)
Thermostat malfunction diagnosis	Incomplete
Engine coolant temperature at engine starting	< 55 °C (131 °F)
Engine coolant temperature	≥ 70 °C (158 °F)
(Estimated – measured) Engine coolant temperature	≤ 30 °C (86 °F)

Time Needed for Diagnosis: Less than 1 second

Diagnostic Trouble Code (DTC) Detecting Criteria

GENERAL DESCRIPTION

Z: DTC P0131 O2 SENSOR CIRCUIT LOW VOLTAGE (BANK 1 SENSOR 1)

1. OUTLINE OF DIAGNOSIS

Detect the open or short circuit of sensor.

Judge as NG, when the element voltage is out of the specified range.

2. COMPONENT DESCRIPTION

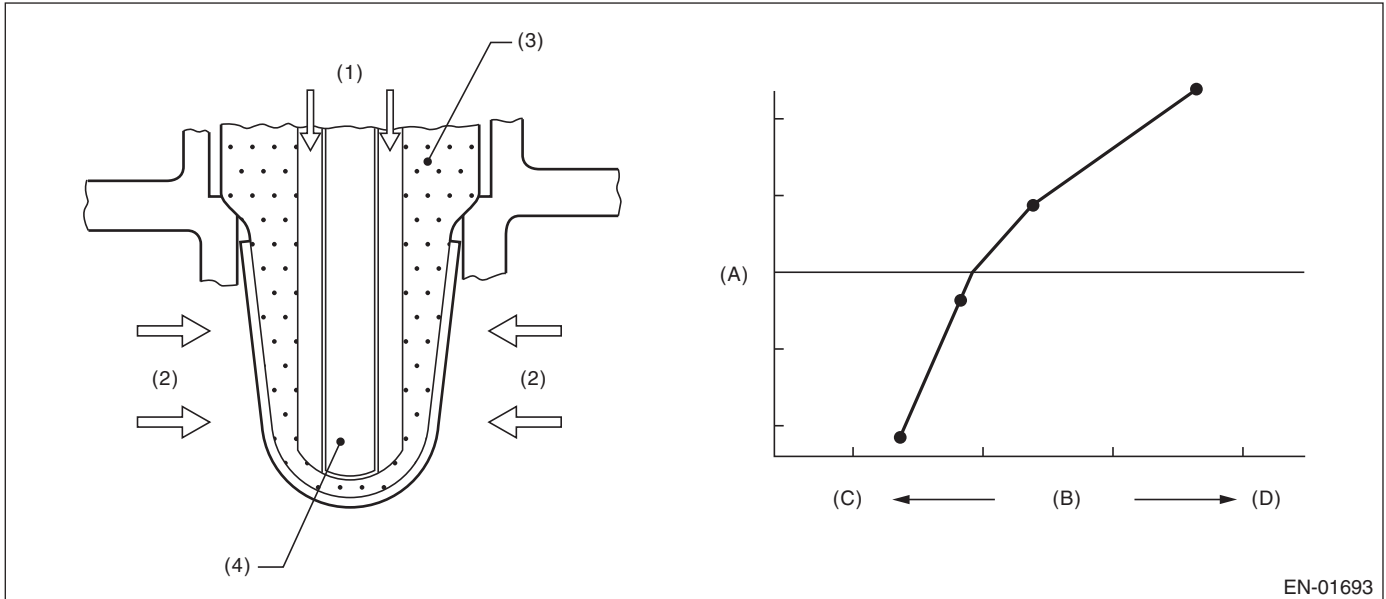

EN-01693

(A) Electromotive force

(B) Air fuel ratio

(C) Lean

(D) Rich

(1) Atmosphere

(3) ZrO₂

(4) Ceramic heater

(2) Exhaust gas

3. ENABLE CONDITION

Secondary Parameters	Enable Conditions
Battery voltage	≥ 10.9 V

4. GENERAL DRIVING CYCLE

Always perform the diagnosis continuously.

Diagnostic Trouble Code (DTC) Detecting Criteria

GENERAL DESCRIPTION

5. DIAGNOSTIC METHOD

• Abnormality Judgement

If the duration of time while the following conditions are met is longer than the time indicated, judge as NG.

Judgement Value

Malfunction Criteria	Threshold Value
Input voltage (+) or Input voltage (-)	< 1.128 V
or Input voltage (+) – Input voltage (-)	< 0.23 V
	< 0.644 V

Time Needed for Diagnosis:

Input voltage (+): 1000 ms

Input voltage (-): 1000 ms

|Input voltage (+) – Input voltage (-)|: 1000 ms

Malfunction Indicator Light Illumination: Illuminates as soon as a malfunction occurs.

• Normality Judgement

Judge as OK and clear the NG if the continuous time while the following conditions are established is more than the predetermined time.

Judgement Value

Malfunction Criteria	Threshold Value
Input voltage (+)	≥ 1.128 V
Input voltage (-)	≥ 0.23 V
Input voltage (+) – Input voltage (-)	≥ 0.644 V

Time Needed for Diagnosis: Less than 1 second

Diagnostic Trouble Code (DTC) Detecting Criteria

GENERAL DESCRIPTION

AA:DTC P0132 O2 SENSOR CIRCUIT HIGH VOLTAGE (BANK 1 SENSOR 1)

1. OUTLINE OF DIAGNOSIS

Detect the open or short circuit of sensor.

Judge as NG, when the element voltage is out of the specified range.

2. COMPONENT DESCRIPTION

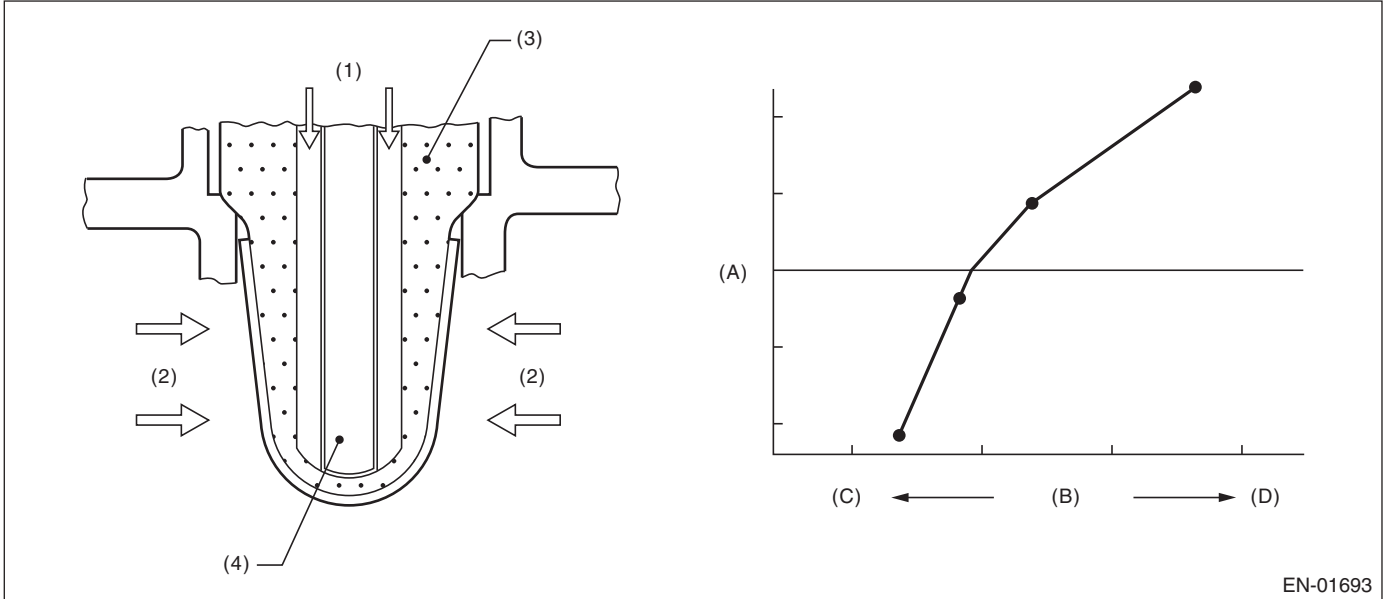

EN-01693

(A) Electromotive force

(B) Air fuel ratio

(C) Lean

(D) Rich

(1) Atmosphere

(3) ZrO₂

(4) Ceramic heater

(2) Exhaust gas

3. ENABLE CONDITION

Secondary Parameters	Enable Conditions
Battery voltage	≥ 10.9 V

4. GENERAL DRIVING CYCLE

Always perform the diagnosis continuously.

Diagnostic Trouble Code (DTC) Detecting Criteria

GENERAL DESCRIPTION

5. DIAGNOSTIC METHOD

• Abnormality Judgement

If the duration of time while the following conditions are met is longer than the time indicated, judge as NG.

Judgement Value

Malfunction Criteria	Threshold Value
Input voltage (+) or Input voltage (-)	> 3.589 V > 3.541 V

Time Needed for Diagnosis:

Input voltage (+): 1000 ms

Input voltage (-): 1000 ms

Malfunction Indicator Light Illumination: Illuminates as soon as a malfunction occurs.

• Normality Judgement

Judge as OK and clear the NG if the continuous time while the following conditions are established is more than the predetermined time.

Judgement Value

Malfunction Criteria	Threshold Value
Input voltage (+) Input voltage (-)	≤ 3.589 V ≤ 3.541 V

Time Needed for Diagnosis: Less than 1 second

Diagnostic Trouble Code (DTC) Detecting Criteria

GENERAL DESCRIPTION

AB:DTC P0133 O2 SENSOR CIRCUIT SLOW RESPONSE (BANK 1 SENSOR 1)

1. OUTLINE OF DIAGNOSIS

Detect the slow response of front oxygen (A/F) sensor.

Front oxygen (A/F) sensor cover has some ventilation holes for exhaust gas. Clogged ventilation holes are diagnosed.

When the holes are clogged, the A/F output variation becomes slow comparing with the actual A/F variation because oxygen which reaches the zirconia layer is insufficient. Therefore, if the sensor cover holes are clogged, the rich to lean judgement in the ECM is delayed when the actual change from rich to lean occurs. Judge as NG when the actual movement in comparison to the ECM control amount is slow.

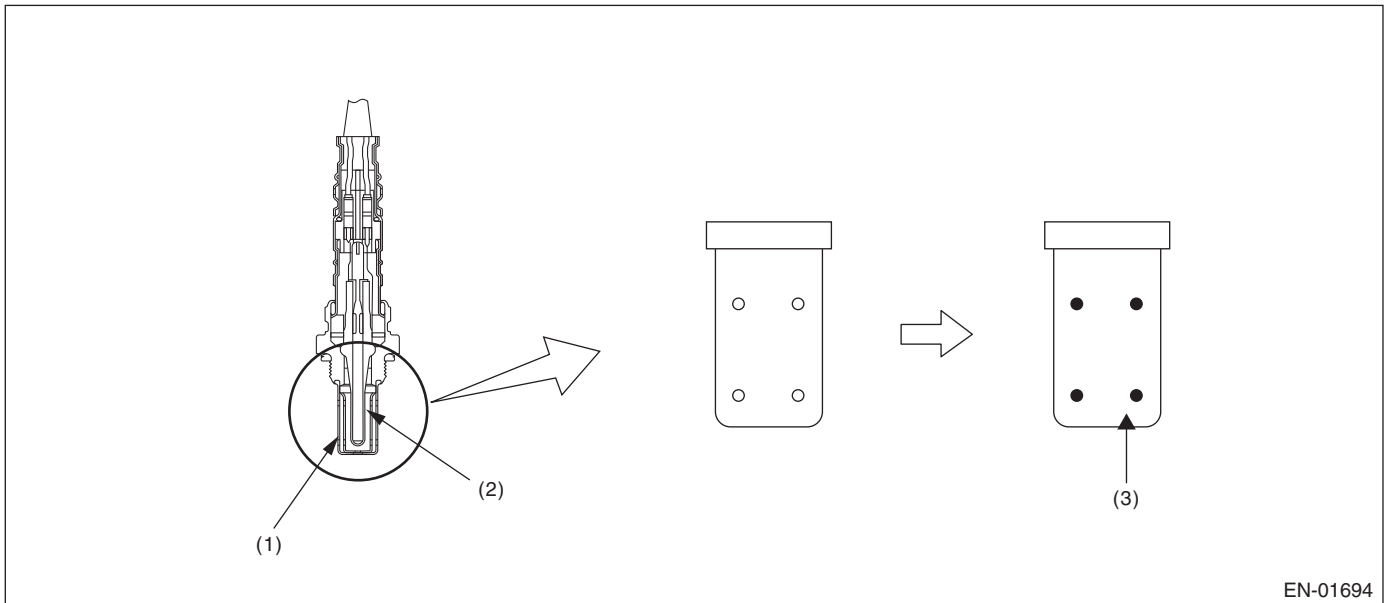

EN-01694

(1) Cover

(2) Zirconia

(3) Clogging

Diagnostic Trouble Code (DTC) Detecting Criteria

GENERAL DESCRIPTION

2. COMPONENT DESCRIPTION

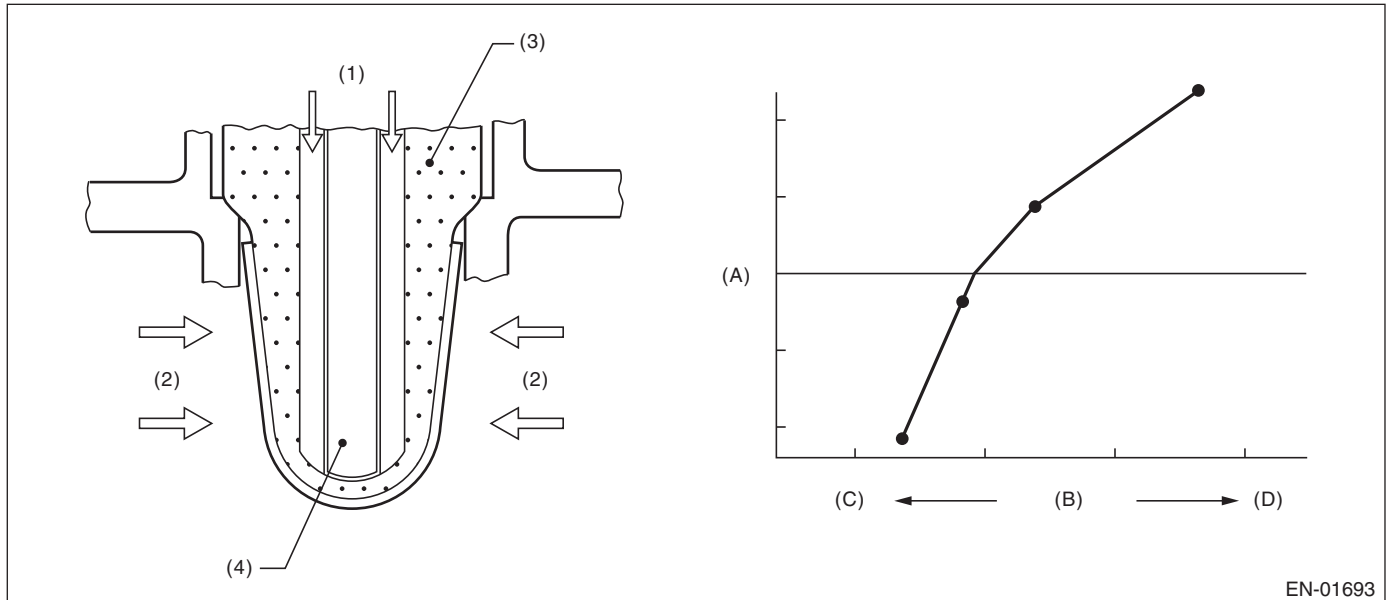

EN-01693

(A) Electromotive force
(D) Rich

(B) Air fuel ratio

(C) Lean

(1) Atmosphere
(2) Exhaust gas

(3) ZrO₂

(4) Ceramic heater

3. ENABLE CONDITION

Secondary Parameters	Enable Conditions
Time needed for all secondary parameters to be in enable conditions	≥ 1024 ms
Battery voltage	≥ 10.9 V
Barometric pressure	> 75 kPa (563 mmHg, 22.2 inHg)
Closed loop control with main feedback	Operation
Front oxygen (A/F) sensor impedance	0 Ω — 50 Ω
Elapsed time after starting the engine	≥ 120000 ms
Engine coolant temperature	≥ 70 °C (158 °F)
Engine speed	1000 rpm — 3200 rpm
Vehicle speed	10 km/h — 120 km/h (6.2 MPH — 74.6 MPH)
Amount of intake air	10 g/s — 31 g/s (0.35 oz/s — 1.09 oz/s)
Engine load	< 0.02 g/rev (0 oz/rev)
Learning value of EVAP conc. during purge	< 0.2
Total time of operating canister purge	≥ 19.9 s

4. GENERAL DRIVING CYCLE

Perform diagnosis only once at a constant speed of 10 km/h — 120 km/h (6.2 MPH — 74.6 MPH) 120000 ms or more after starting the engine.

Diagnostic Trouble Code (DTC) Detecting Criteria

GENERAL DESCRIPTION

5. DIAGNOSTIC METHOD

Calculate faf difference every $32 \text{ ms} \times 4$, and the λ value difference. Calculate the diagnosis value after calculating 820 time(s).

• Abnormality Judgement

If the duration of time while the following conditions are met is longer than the time indicated, judge as NG.

Judgement Value

Malfunction Criteria	Threshold Value
$\text{parafca} = \text{td2faf}/\text{td2lmd}$ where, $\text{td2faf} (N) = \text{td2faf} (n-1) + \text{d2faf} (n) $ $\text{td2lmd} (N) = \text{td2lmd} (n-1) + \text{d2lmd} (n) $ add up to $32 \text{ ms} \times 4 \times 820 \text{ time(s)}$. $\text{d2faf} (n) = (\text{faf} (n) - \text{faf} (n-1)) - (\text{faf} (n-1) - \text{faf} (n-2))$ $\text{d2lmd} (n) = (\text{lmd} (n) - \text{lmd} (n-1)) - (\text{lmd} (n-1) - \text{lmd} (n-2))$ faf = main feedback compensation coefficient every 128 milliseconds lmd = output lambda every 128 milliseconds	> 0.22

Time Needed for Diagnosis: $32 \text{ ms} \times 4 \times 820 \text{ time(s)}$

Malfunction Indicator Light Illumination: Illuminates when malfunction occurs in 2 continuous driving cycles.

• Normality Judgement

Judge as OK and clear the NG if the continuous time while the following conditions are established is more than the predetermined time.

Judgement Value

Malfunction Criteria	Threshold Value
$\text{parafca} = \text{td2faf}/\text{td2lmd}$ where, $\text{td2faf} (N) = \text{td2faf} (n-1) + \text{d2faf} (n) $ $\text{td2lmd} (N) = \text{td2lmd} (n-1) + \text{d2lmd} (n) $ add up to $32 \text{ ms} \times 4 \times 820 \text{ time(s)}$. $\text{d2faf} (n) = (\text{faf} (n) - \text{faf} (n-1)) - (\text{faf} (n-1) - \text{faf} (n-2))$ $\text{d2lmd} (n) = (\text{lmd} (n) - \text{lmd} (n-1)) - (\text{lmd} (n-1) - \text{lmd} (n-2))$ faf = main feedback compensation coefficient every 128 milliseconds lmd = output lambda every 128 milliseconds	≤ 0.22

Time Needed for Diagnosis: $32 \text{ ms} \times 4 \times 820 \text{ time(s)}$

AC:DTC P0134 O2 SENSOR CIRCUIT NO ACTIVITY DETECTED (BANK 1 SENSOR 1)

1. OUTLINE OF DIAGNOSIS

Detect open circuits of the sensor.

Judge as NG when the impedance of the element is large.

2. COMPONENT DESCRIPTION

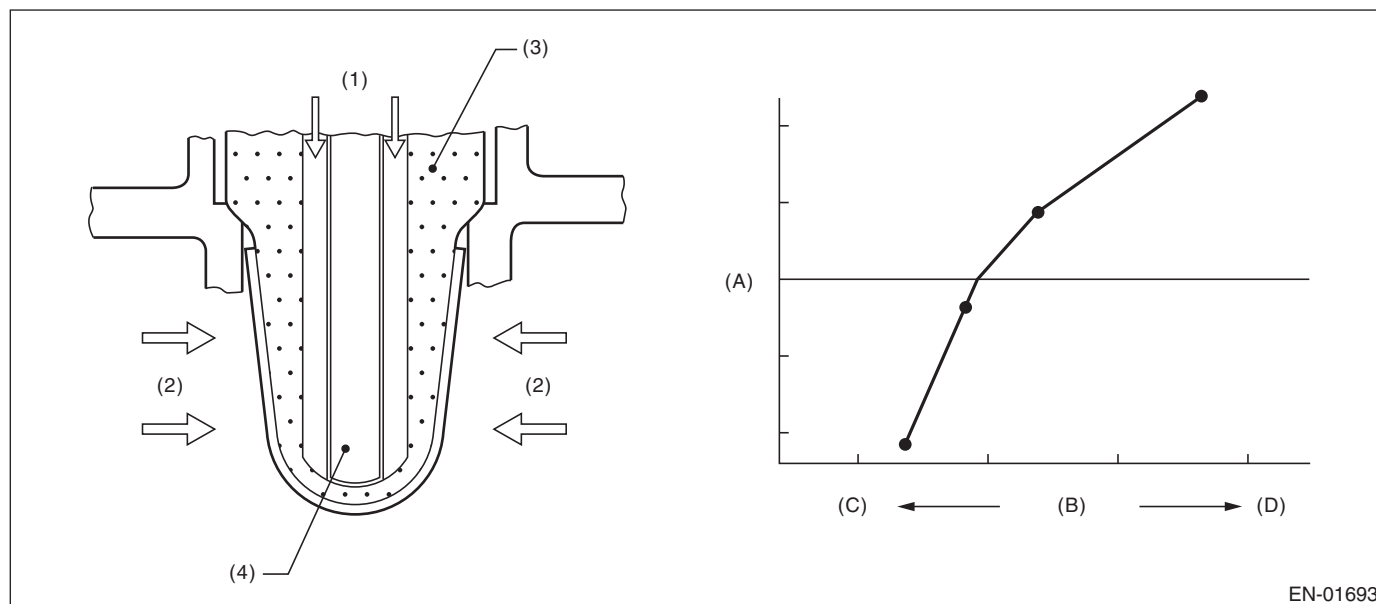

(A) Electromotive force

(B) Air fuel ratio

(C) Lean

(D) Rich

(1) Atmosphere

(3) ZrO₂

(4) Ceramic heater

(2) Exhaust gas

3. ENABLE CONDITION

Secondary Parameters	Enable Conditions
None	

4. GENERAL DRIVING CYCLE

Always perform the diagnosis continuously.

Diagnostic Trouble Code (DTC) Detecting Criteria

GENERAL DESCRIPTION

5. DIAGNOSTIC METHOD

• Abnormality Judgement

If the duration of time while the following conditions are met is longer than the time indicated, judge as NG.

Judgement Value

Malfunction Criteria	Threshold Value
Battery voltage	≥ 10.9 V
Time of heater control duty at 70 % or more	≥ 36000 ms
Front oxygen (A/F) sensor impedance.	> 500 Ω

Time Needed for Diagnosis:5000 ms

Malfunction Indicator Light Illumination: Illuminates as soon as a malfunction occurs.

• Normality Judgement

Judge as OK and clear the NG if the continuous time while the following conditions are established is more than the predetermined time.

Judgement Value

Malfunction Criteria	Threshold Value
Battery voltage	≥ 10.9 V
Front oxygen (A/F) sensor impedance.	≤ 500 Ω

Time Needed for Diagnosis: Less than 1 second

Diagnostic Trouble Code (DTC) Detecting Criteria

GENERAL DESCRIPTION

AD:DTC P0137 O2 SENSOR CIRCUIT LOW VOLTAGE (BANK 1 SENSOR 2)

1. OUTLINE OF DIAGNOSIS

Detect continuity NG of the oxygen sensor. If the oxygen sensor voltage reading is not within the probable range considering the operating conditions, judge as NG.

2. COMPONENT DESCRIPTION

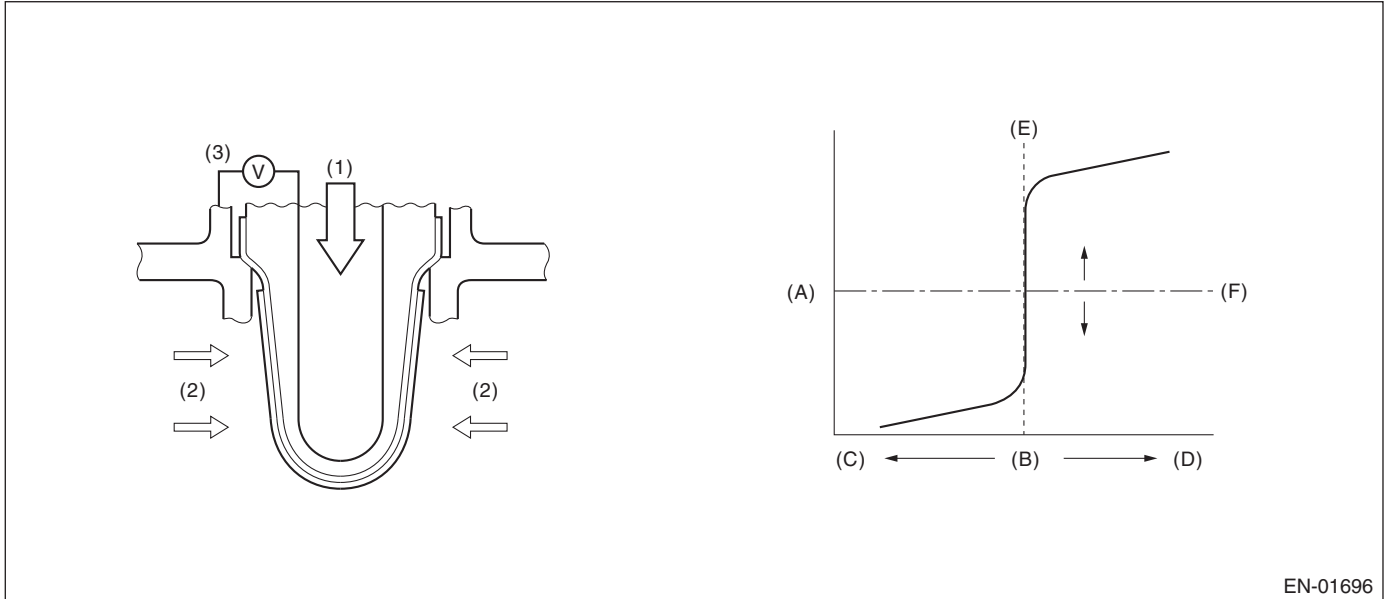

EN-01696

(A) Electromotive force

(D) Lean

(1) Atmosphere

(B) Air fuel ratio

(E) Theoretical air fuel ratio

(2) Exhaust gas

(C) Rich

(F) Comparative voltage

(3) Electromotive force

Diagnostic Trouble Code (DTC) Detecting Criteria

GENERAL DESCRIPTION

3. ENABLE CONDITION

Used for abnormality judgement

Secondary Parameters	Enable Conditions
High Secondary air system Closed loop control at the oxygen sensor Misfire detection every 200 rotations Front oxygen (A/F) sensor compensation coefficient Battery voltage Engine coolant temperature	Not in operation In operation < 5 time(s) Not in limit value ≥ 10.9 V ≥ 70 °C (158 °F)
Low (1) Secondary air system Closed loop control at the oxygen sensor Misfire detection every 200 rotations Front oxygen (A/F) sensor compensation coefficient Battery voltage Engine coolant temperature Amount of intake air	Not in operation In operation < 5 time(s) Not in limit value ≥ 10.9 V ≥ 70 °C (158 °F) ≥ 10 g/s (0.35 oz/s)
Low (2) Secondary air system Closed loop control at the oxygen sensor Misfire detection every 200 rotations Front oxygen (A/F) sensor compensation coefficient Battery voltage Engine coolant temperature Amount of intake air Current continuation time of the rear oxygen sensor heater	Not in operation In operation < 5 time(s) Not in limit value ≥ 10.9 V ≥ 70 °C (158 °F) < 10 g/s (0.35 oz/s) ≥ 25000 ms
Low (3) Secondary air system Closed loop control at the oxygen sensor Misfire detection every 200 rotations Front oxygen (A/F) sensor compensation coefficient Battery voltage Engine coolant temperature Amount of intake air Current continuation time of the rear oxygen sensor heater Fuel cut	Not in operation In operation < 5 time(s) Not in limit value ≥ 10.9 V ≥ 70 °C (158 °F) < 10 g/s (0.35 oz/s) ≥ 25000 ms Experienced

Used for normality judgement

Secondary Parameters	Enable Conditions
Secondary air system Closed loop control at the oxygen sensor Misfire detection every 200 rotations Front oxygen (A/F) sensor compensation coefficient Battery voltage Engine coolant temperature	Not in operation In operation < 5 time(s) Not in limit value ≥ 10.9 V ≥ 70 °C (158 °F)

4. GENERAL DRIVING CYCLE

After starting the engine, continuously perform the diagnosis with the same engine condition.

Diagnostic Trouble Code (DTC) Detecting Criteria

GENERAL DESCRIPTION

5. DIAGNOSTIC METHOD

• Abnormality Judgement

If the duration of time while the following conditions are met is longer than the time indicated, judge as NG.

Judgement Value

Malfunction Criteria	Threshold Value	DTC
High Sensor output voltage	> 1.2 V	P0138
Low Sensor output voltage	< 0.03 V	P0137

Time Needed for Diagnosis

High: 2500 ms
Low (1): 20000 ms
Low (2): 150000 ms
Low (3): Value from Map

Map

Fuel Cut Time (second)	0	2000	10000
Time Needed for Diagnosis (second)	150000	150000	150000

Malfunction Indicator Light Illumination: Illuminates when malfunction occurs in 2 continuous driving cycles.

• Normality Judgement

Judge as OK and clear the NG if the continuous time while the following conditions are established is more than the predetermined time.

Judgement Value

Malfunction Criteria	Threshold Value	DTC
High Sensor output voltage	≤ 1.2 V	P0138
Low Sensor output voltage	≥ 0.03 V	P0137

Time Needed for Diagnosis

High: Less than 1 second
Low (1): Less than 1 second
Low (2): Less than 1 second
Low (3): Less than 1 second

Diagnostic Trouble Code (DTC) Detecting Criteria

GENERAL DESCRIPTION

AE:DTC P0138 O2 SENSOR CIRCUIT HIGH VOLTAGE (BANK 1 SENSOR 2)

1. OUTLINE OF DIAGNOSIS

NOTE:

For the detection standard, refer to DTC P0137. <Ref. to GD(H4DOTC)-55, DTC P0137 O2 SENSOR CIRCUIT LOW VOLTAGE (BANK 1 SENSOR 2), Diagnostic Trouble Code (DTC) Detecting Criteria.>

Diagnostic Trouble Code (DTC) Detecting Criteria

GENERAL DESCRIPTION

AF:DTC P0139 O2 SENSOR CIRCUIT SLOW RESPONSE (BANK 1 SENSOR 2)

1. OUTLINE OF DIAGNOSIS

Detect the slow response of the oxygen sensor.

Judge as NG if either of the rich to lean response diagnosis or lean to rich response diagnosis is NG, and Judge as OK if both are OK.

[Rich → lean diagnosis response]

1. Measure the response time for oxygen sensor output changes when the A/F ratio changes to rich to lean. If the measured response time is larger than the threshold value, it is NG. If it is smaller, it is OK.

2. Judge as NG when the oxygen sensor voltage is large (rich) when recovering from a deceleration fuel cut.

[Lean → rich diagnosis response]

1. Measure the response time for oxygen sensor output changes when the A/F ratio changes to lean to rich. If the measured response time is larger than the threshold value, it is NG.

2. Judge as NG when the oxygen sensor voltage remains small when recovering from a deceleration fuel cut.

DIAGNOSTIC METHOD

Measure the response time of the output change of the oxygen sensor when the A/F ratio changes to rich to lean. And Judge as NG when the measured response time is larger than the threshold value.

2. COMPONENT DESCRIPTION

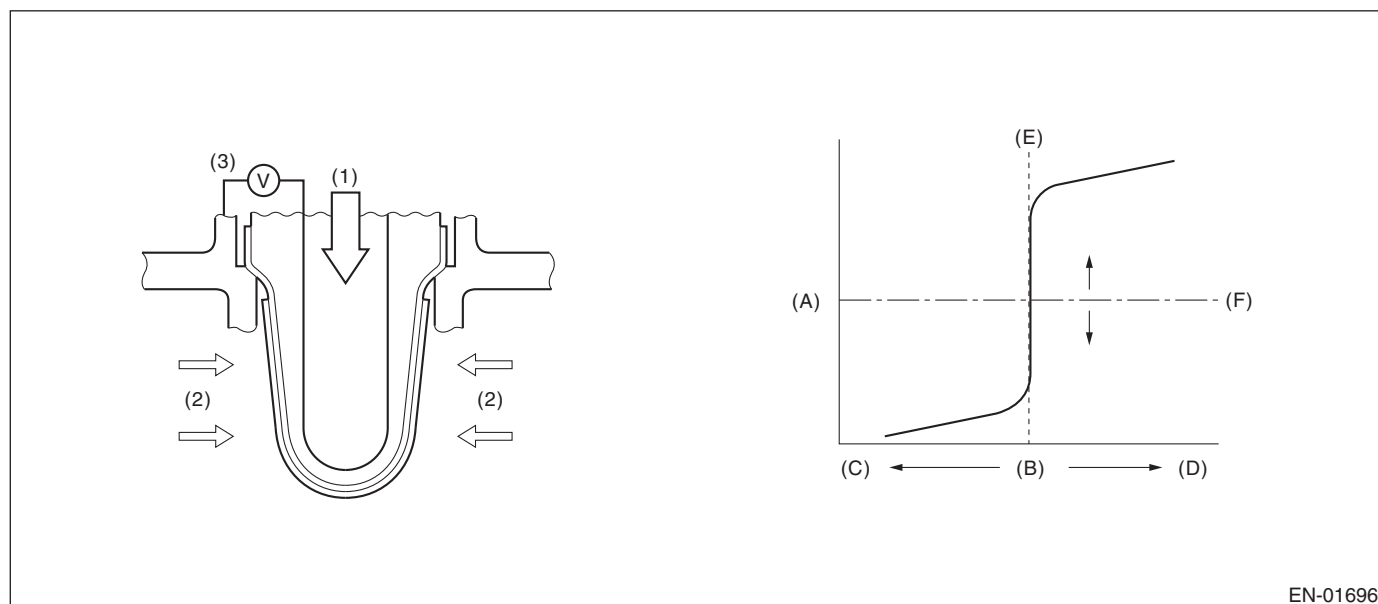

EN-01696

(A) Electromotive force

(B) Air fuel ratio

(C) Rich

(D) Lean

(E) Theoretical air fuel ratio

(F) Comparative voltage

(1) Atmosphere

(2) Exhaust gas

(3) Electromotive force

3. ENABLE CONDITION

Rich → lean diagnosis response

Secondary Parameters	Enable Conditions
Battery voltage	≥ 10.9 V
A/F main feedback control condition	Completed
Deceleration fuel cut time is 5000 ms or more.	Experienced
After fuel cut	≥ 2000 ms
Current calculation time of the rear oxygen sensor heater	≥ 60000 ms
Current continuation time of the rear oxygen sensor heater	≥ 30000 ms
Estimated catalyst temperature	≥ 400 °C (752 °F)
Number of deceleration fuel cut	≥ 1 time(s)

Diagnostic Trouble Code (DTC) Detecting Criteria

GENERAL DESCRIPTION

4. GENERAL DRIVING CYCLE

Perform the diagnosis only once when deceleration fuel cut occurs after rapid acceleration. (Pay attention to the oxygen sensor voltage for the timing of the deceleration.)

5. DIAGNOSTIC METHOD

When the oxygen sensor output voltage changes from 0.55 V (rich) to 0.15 V (lean), calculate the minimum response time for output change between 0.5 V and 0.2 V for the judgement criteria.

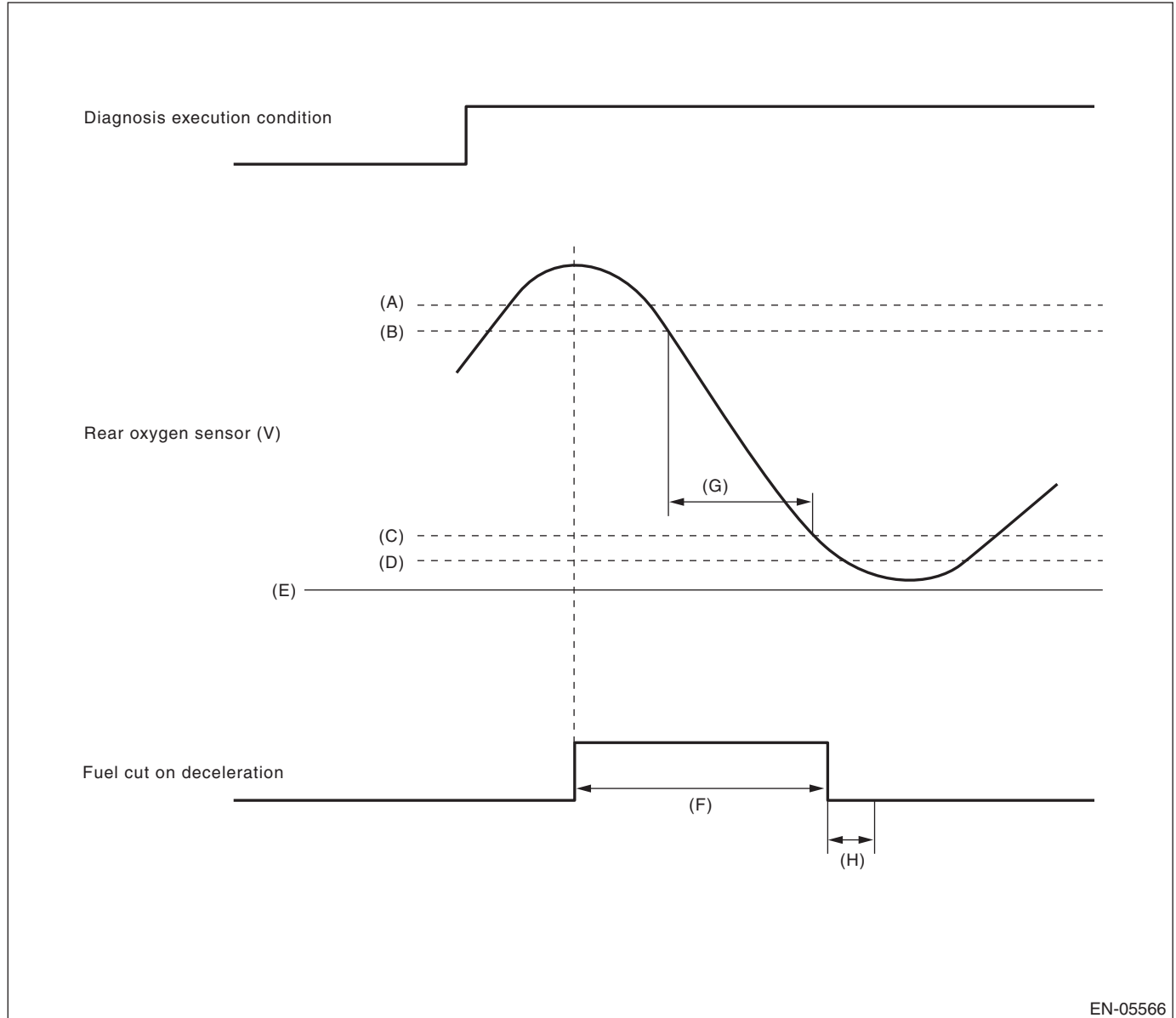

- (A) 0.55 V
- (B) 0.5 V
- (C) 0.2 V
- (D) 0.15 V

- (E) 0 V
- (F) More than 5000 ms
- (G) Measure the response time.

- (H) Execute the malfunction judgement in 2000 ms from the recovery of fuel cut on deceleration.

Diagnostic Trouble Code (DTC) Detecting Criteria

GENERAL DESCRIPTION

• Abnormality Judgement

1) Judge as NG when the judgement value is larger than the threshold value after deceleration fuel cut.
Response time (diagnosis value) > Threshold value → abnormal

NOTE:

Variation time of rear oxygen sensor output voltage is short during fuel cut in deceleration. NG judgement should be performed after deceleration fuel cut. Even without deceleration fuel cut, judge as OK if the value is below the threshold.

When the deceleration fuel cut time is 5000 ms or more, judge as NG if the following criteria are met 2000 ms after recovering from the deceleration fuel cut.

2) Judge as NG when the oxygen sensor voltage at recovery from a deceleration fuel cut is large.

If the fuel cut time in a deceleration fuel cut is long (5000 ms or more), and even after recovering from a deceleration fuel cut, the oxygen sensor voltage is high (0.55 V or more), judge as NG.

Judgement Value

Malfunction Criteria	Threshold Value
Shortest time change from rich (0.5 V O ₂ output) to lean (0.2 V) when voltage reduces from 0.55 V to 0.15 V or Longest time over 0.55 V	> 837 ms ≥ 2000 ms

Time Needed for Diagnosis: 1 time(s)

Malfunction Indicator Light Illumination: Illuminates when malfunction occurs in 2 continuous driving cycles.

• Normality Judgement

1) Regardless of a deceleration fuel cut, if the response time (diagnosis value) when the oxygen sensor voltage has changed from rich to lean is shorter than the threshold value (judgement value), judge as a normal condition.

Response time (diagnosis value) ≤ threshold value → normal

2) Do not judge as a normal condition.

Judge as OK and clear the NG if the following conditions are established.

Judgement Value

Malfunction Criteria	Threshold Value
Shortest time change from rich (0.5 V O ₂ output) to lean (0.2 V) when voltage reduces from 0.55 V to 0.15 V	≤ 837 ms

Time Needed for Diagnosis: 1 time(s)

6. ENABLE CONDITION

Lean → rich response diagnosis

Secondary Parameters	Enable Conditions
Battery voltage	≥ 10.9 V
A/F main feedback control condition	Completed
Deceleration fuel cut time is 6000 ms or more.	Experienced
After fuel cut	≥ 2000 ms
Current calculation time of the rear oxygen sensor heater	≥ 0 ms
Current continuation time of the rear oxygen sensor heater	≥ 0 ms
Estimated catalyst temperature	≥ 0 °C (32 °F)
Number of deceleration fuel cut	≥ 1 time(s)

7. GENERAL DRIVING CYCLE

Perform the diagnosis only once when deceleration fuel cut occurs after rapid acceleration. (Pay attention to the oxygen sensor voltage for the timing of the deceleration.)

Diagnostic Trouble Code (DTC) Detecting Criteria

GENERAL DESCRIPTION

• Abnormality Judgement

- 1) Judge as NG when the judgement value is larger than the threshold value after deceleration fuel cut.
Response time (diagnosis value) > Threshold value → abnormal
- 2) If the oxygen sensor voltage is small after recovering from a deceleration fuel cut, and remains small, judge as NG.

Judgement Value

Malfunction Criteria	Threshold Value
Shortest time change from lean (0.3 V O ₂ output) to rich (0.5 V) when voltage changes from 0.25 V to 0.55 V or Longest time under 0.25 V	> 4000 ms ≥ 120000 ms

Time Needed for Diagnosis: 1 time(s)

Malfunction Indicator Light Illumination: Illuminates when malfunction occurs in 2 continuous driving cycles.

• Normality Judgement

- 1) Regardless of a deceleration fuel cut, if the response time (diagnosis value) when the oxygen sensor voltage has changed from rich to lean is shorter than the threshold value (judgement value), judge as a normal condition.

Response time (diagnosis value) ≤ threshold value → normal

- 2) Do not judge as a normal condition.

Judge as OK and clear the NG if the following conditions are established.

Judgement Value

Malfunction Criteria	Threshold Value
Shortest time change from lean (0.3 V O ₂ output) to rich (0.5 V) when voltage changes from 0.25 V to 0.55 V	≤ 4000 ms

Time Needed for Diagnosis: 1 time(s)

Diagnostic Trouble Code (DTC) Detecting Criteria

GENERAL DESCRIPTION

AG:DTC P0140 O2 SENSOR CIRCUIT NO ACTIVITY DETECTED (BANK 1 SENSOR 2)

1. OUTLINE OF DIAGNOSIS

Detect the rear oxygen sensor open or short circuit. Judge as NG when the rear oxygen sensor voltage can be determined to be abnormal considering conditions such as intake air amount, engine coolant temperature, main feedback control and deceleration fuel cut.

2. COMPONENT DESCRIPTION

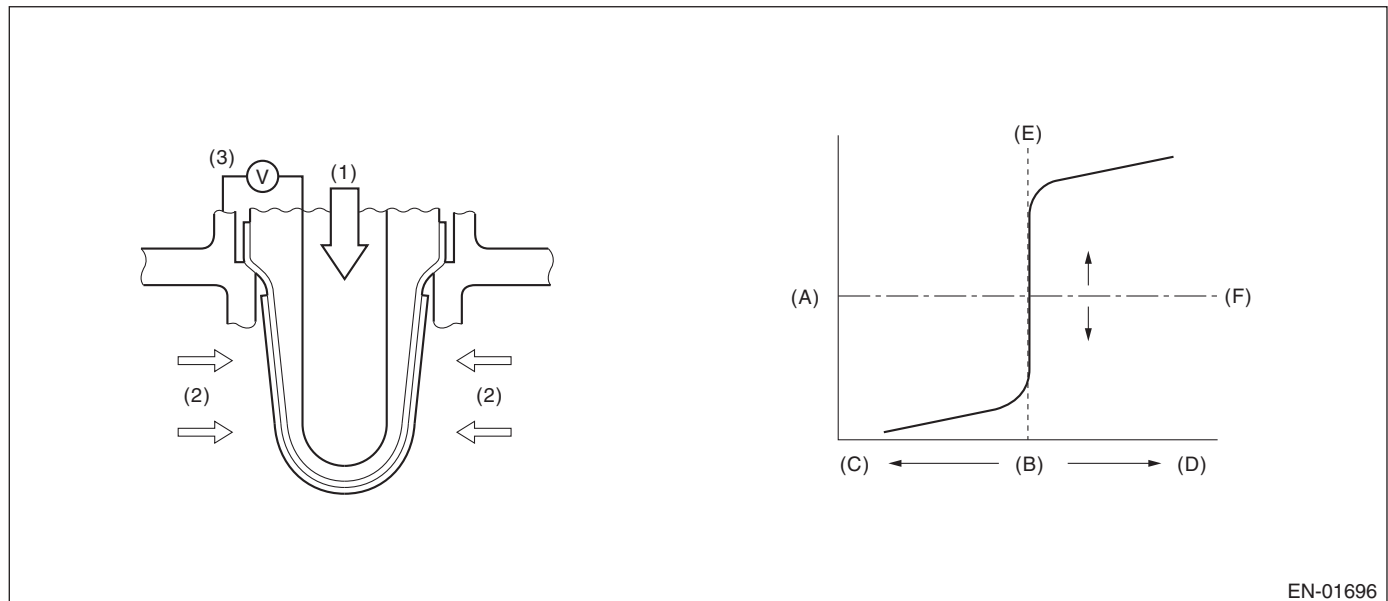

EN-01696

- | | | |
|-------------------------|--------------------------------|-------------------------|
| (A) Electromotive force | (B) Air fuel ratio | (C) Rich |
| (D) Lean | (E) Theoretical air fuel ratio | (F) Comparative voltage |
| (1) Atmosphere | (2) Exhaust gas | (3) Electromotive force |

3. ENABLE CONDITION (USED ONLY FOR MALFUNCTION JUDGEMENT)

Secondary Parameters	Enable Conditions
Closed loop control at the rear oxygen sensor	In operation
Target output voltage of rear oxygen sensor	$\geq 0.55 \text{ V} + 0.05 \text{ V}$
Amount of intake air	$\geq 10 \text{ g/s}$ (0.35 oz/s)
Engine coolant temperature	$\geq 70 \text{ }^\circ\text{C}$ (158 $^\circ\text{F}$)
Misfire detection every 200 rotations	$< 5 \text{ time(s)}$
Front oxygen (A/F) sensor compensation coefficient	Not in limit value
Battery voltage	$\geq 10.9 \text{ V}$
Deceleration fuel cut of 5000 ms or more.	Experienced

4. GENERAL DRIVING CYCLE

Perform the diagnosis once after starting the engine.

Diagnostic Trouble Code (DTC) Detecting Criteria

GENERAL DESCRIPTION

5. DIAGNOSTIC METHOD

• Abnormality Judgement

If the duration of time while the following conditions are met is longer than the time indicated, judge as NG.

Judgement Value

Malfunction Criteria	Threshold Value
Minimum output voltage or Maximum output voltage	> 0.15 V < 0.55 V

Time Needed for Diagnosis: 200000 ms

Malfunction Indicator Light Illumination: Illuminates when malfunction occurs in 2 continuous driving cycles.

• Normality Judgement

Judge as OK and clear the NG if the following conditions are established.

Judgement Value

Malfunction Criteria	Threshold Value
Diagnosis of the rear oxygen sensor voltage low side	Incomplete
Minimum output voltage	≤ 0.15 V
Maximum output voltage	≥ 0.55 V

Time Needed for Diagnosis: Less than 1 second

Diagnostic Trouble Code (DTC) Detecting Criteria

GENERAL DESCRIPTION

AH:DTC P0171 SYSTEM TOO LEAN (BANK 1)

1. OUTLINE OF DIAGNOSIS

Detect fuel system malfunction by the amount of main feedback control.

DIAGNOSTIC METHOD

Fuel system is diagnosed by comparing the target air fuel ratio calculated by ECM with the actual air fuel ratio measured by sensor.

2. ENABLE CONDITION

Secondary Parameters	Enable Conditions
A/F main learning system	In operation
Engine coolant temperature	$\geq 70\text{ }^{\circ}\text{C}$ (158 $^{\circ}\text{F}$)
Engine load change	$< 0.02\text{ g/rev}$ (0 oz/rev)
Engine load	\geq Value of Map 1

MAP 1

Engine speed (rpm)	Idling	800	1200	1600	2000	2400	2800	3200	3600	4000	4400
Measured value (g(oz)/rev)	na	0.228 (0.01)	0.22 (0.01)	0.22 (0.01)	0.22 (0.01)	0.228 (0.01)	0.23 (0.01)	0.234 (0.01)	0.242 (0.01)	0.25 (0.01)	0.25 (0.01)

3. GENERAL DRIVING CYCLE

Perform the diagnosis continuously at idling or at a constant speed after warming up the engine.

4. DIAGNOSTIC METHOD

• Abnormality Judgement

Compare the diagnosed value (fsobd) with the threshold value, and if a condition meeting the malfunction criteria below continues for 10 s \times 5 time(s) or more, judge that there is a fault in the fuel system.

Judgement Value

Malfunction Criteria	Threshold Value
$\text{fsobd} = (\text{sglmd} - \text{tglmda}) + \text{faf} + \text{flaf}$ In this case: sglmd = measured lambda tglmda = target lambda faf = main feedback compensation coefficient every 64 milliseconds flaf = main feedback learning compensation coefficient	\geq Value of Map 2

MAP 2

Amount of air (g (oz)/s)	0 (0)	2.34375 (0.08)	4.6875 (0.17)	7.03125 (0.25)	9.375 (0.33)	11.71875 (0.41)	14.0625 (0.5)
fsobdL1 (%)	1.4	1.4	1.368623	1.319185	1.26975	1.265	1.265

Time Needed for Diagnosis: 10 s \times 5 time(s)

Malfunction Indicator Light Illumination: Illuminates when malfunction occurs in 2 continuous driving cycles.

• Normality Judgement

Judge as OK and clear the NG if the continuous time while the following conditions are established is more than the predetermined time.

Judgement Value

Malfunction Criteria	Threshold Value
$\text{fsobd} = (\text{sglmd} - \text{tglmda}) + \text{faf} + \text{flaf}$	< 1.2

Time Needed for Diagnosis: 10 s

Diagnostic Trouble Code (DTC) Detecting Criteria

GENERAL DESCRIPTION

AI: DTC P0172 SYSTEM TOO RICH (BANK 1)

1. OUTLINE OF DIAGNOSIS

Detect fuel system malfunction by the amount of main feedback control.

Diagnostic method

Fuel system is diagnosed by comparing the target air fuel ratio calculated by ECM with the actual air fuel ratio measured by sensor.

2. ENABLE CONDITION

Secondary Parameters	Enable Conditions
A/F main learning system	In operation
Engine coolant temperature	≥ 70 °C (158 °F)
Engine load change	≤ 0.02 g/rev (0 oz/rev)
Learning value of EVAP conc.	< 0.1
Cumulative time of canister purge after engine start	≥ 20 s
Continuous period after canister purge starting	≥ 29884 ms
Engine load	≥ Value of Map 1

MAP 1

Engine speed (rpm)	Idling	800	1200	1600	2000	2400	2800	3200	3600	4000	4400
Measured value (g(oz)/rev)	na	0.228 (0.01)	0.22 (0.01)	0.22 (0.01)	0.22 (0.01)	0.228 (0.01)	0.23 (0.01)	0.234 (0.01)	0.242 (0.01)	0.25 (0.01)	0.25 (0.01)

3. GENERAL DRIVING CYCLE

Perform the diagnosis continuously at idling or at a constant speed after warming up the engine.

4. DIAGNOSTIC METHOD

• Abnormality Judgement

Compare the diagnosed value (fsobd) with the threshold value, and if a condition meeting the malfunction criteria below continues for 10 s × 5 time(s) or more, judge that there is a fault in the fuel system.

Judgement Value

Malfunction Criteria	Threshold Value
$fsobd = (sglmd - tglmda) + faf + flaf$ In this case: sglmd = measured lambda tglmda = target lambda faf = main feedback compensation coefficient every 64 milliseconds flaf = main feedback learning compensation coefficient	< Value of Map 2

MAP 2

Amount of air (g (oz)/s)	0 (0)	2.34375 (0.08)	4.6875 (0.17)	7.03125 (0.25)	9.375 (0.33)	11.7187 5 (0.41)	14.0625 (0.5)
fsobdL1 (%)	0.6	0.6	0.63137	0.68082	0.71025	0.72525	0.73025

Time Needed for Diagnosis: 10 s × 5 time(s)

Malfunction Indicator Light Illumination: Illuminates when malfunction occurs in 2 continuous driving cycles.

• Normality Judgement

Judge as OK when the malfunction criteria below continues for 10 seconds.

Judgement Value

Malfunction Criteria	Threshold Value
$fsobd = (sglmd - tglmda) + faf + flaf$	≥ 0.8

Time Needed for Diagnosis: 10 s

Diagnostic Trouble Code (DTC) Detecting Criteria

GENERAL DESCRIPTION

AJ:DTC P0181 FUEL TEMPERATURE SENSOR "A" CIRCUIT RANGE/ PERFORMANCE

1. OUTLINE OF DIAGNOSIS

Detect faults in the fuel temperature sensor output properties.

Diagnosis is performed in two methods (drift diagnosis and stuck diagnosis). If either is NG, judge as NG. If both are OK, Judge as OK and clear the NG.

DRIFT DIAGNOSIS

Normally fuel temperature is lower than engine coolant temperature. When the fuel temperature becomes higher than the engine coolant temperature, the range is considered to be shifted, and judged as NG.

STUCK DIAGNOSIS

As the engine warms up (cumulative amount of intake air after starting is large), if the fuel temperature which should rise does not, determine as being stuck and NG.

2. COMPONENT DESCRIPTION

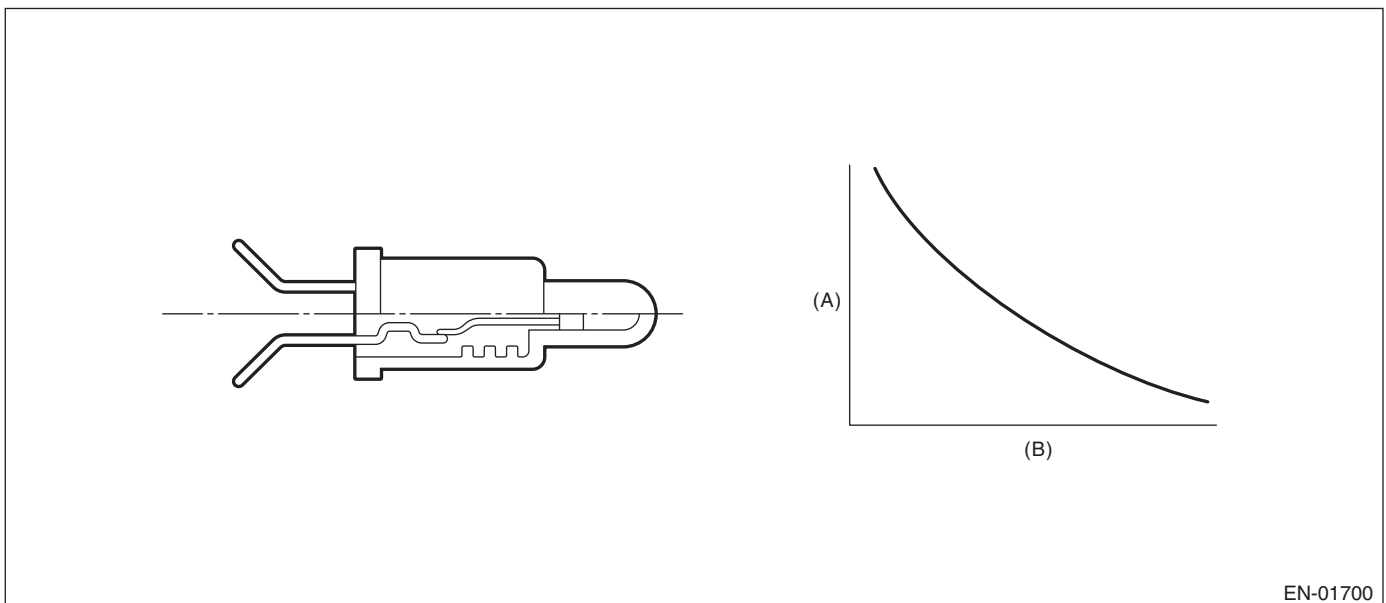

EN-01700

(A) Resistance value (Ω)

(B) Fuel temperature °C (°F)

3. ENABLE CONDITION

DRIFT DIAGNOSIS

Secondary Parameters	Enable Conditions
None	

4. GENERAL DRIVING CYCLE

Always perform the diagnosis continuously.

Diagnostic Trouble Code (DTC) Detecting Criteria

GENERAL DESCRIPTION

5. DIAGNOSTIC METHOD

• Abnormality Judgement

If the duration of time while the following conditions are met is longer than the time indicated, judge as NG.

Judgement Value

Malfunction Criteria	Threshold Value
Fuel level	$\geq 9.6 \text{ l}$ (2.54 US gal, 2.11 Imp gal)
Elapsed time after starting the engine	$\geq 20 \text{ s}$
Engine coolant temperature – Engine coolant temperature at engine start	$> 10 \text{ }^\circ\text{C}$ (50 °F)
Fuel temperature – Engine coolant temperature	$\geq 10 \text{ }^\circ\text{C}$ (50 °F)
Battery voltage	$\geq 10.9 \text{ V}$

Time Needed for Diagnosis: 120 s

Malfunction Indicator Light Illumination: Illuminates when malfunction occurs in 2 continuous driving cycles.

• Normality Judgement

Judge as OK and clear the NG if the continuous time while the following conditions are established is more than the predetermined time.

Judgement Value

Malfunction Criteria	Threshold Value
Fuel level	$\geq 9.6 \text{ l}$ (2.54 US gal, 2.11 Imp gal)
Elapsed time after starting the engine	$\geq 20 \text{ s}$
Engine coolant temperature – Engine coolant temperature at engine start	$> 10 \text{ }^\circ\text{C}$ (50 °F)
Fuel temperature – Engine coolant temperature	$< 10 \text{ }^\circ\text{C}$ (50 °F)
Battery voltage	$\geq 10.9 \text{ V}$
Engine coolant temperature	$< 70 \text{ }^\circ\text{C}$ (158 °F)

Time Needed for Diagnosis: Less than 1 second

6. ENABLE CONDITION

STUCK DIAGNOSIS

Secondary Parameters	Enable Conditions
Elapsed time after starting the engine	$\geq 20000 \text{ ms}$
Battery voltage	$\geq 10.9 \text{ V}$

7. GENERAL DRIVING CYCLE

Always perform diagnosis after 20 seconds have passed since the engine started.

Diagnostic Trouble Code (DTC) Detecting Criteria

GENERAL DESCRIPTION

8. DIAGNOSTIC METHOD

- **Abnormality Judgement**

Judge as NG when the following conditions are established.

Judgement Value

Malfunction Criteria	Threshold Value
Accumulated amount of intake air	≥ 551043 g (19435.29 oz)
Fuel temperature difference between Max. and Min.	< 2 °C (35.6 °F)

Time Needed for Diagnosis: Less than 1 second

Malfunction Indicator Light Illumination: Illuminates when malfunction occurs in 2 continuous driving cycles.

- **Normality Judgement**

Judge as OK and clear the NG if the following conditions are established.

Judgement Value

Malfunction Criteria	Threshold Value
Fuel temperature difference between Max. and Min.	≥ 2 °C (35.6 °F)

Time Needed for Diagnosis: Less than 1 second

Diagnostic Trouble Code (DTC) Detecting Criteria

GENERAL DESCRIPTION

AK:DTC P0182 FUEL TEMPERATURE SENSOR "A" CIRCUIT LOW INPUT

1. OUTLINE OF DIAGNOSIS

Detect the open or short circuit of fuel temperature sensor.
Judge as NG if out of specification.

2. COMPONENT DESCRIPTION

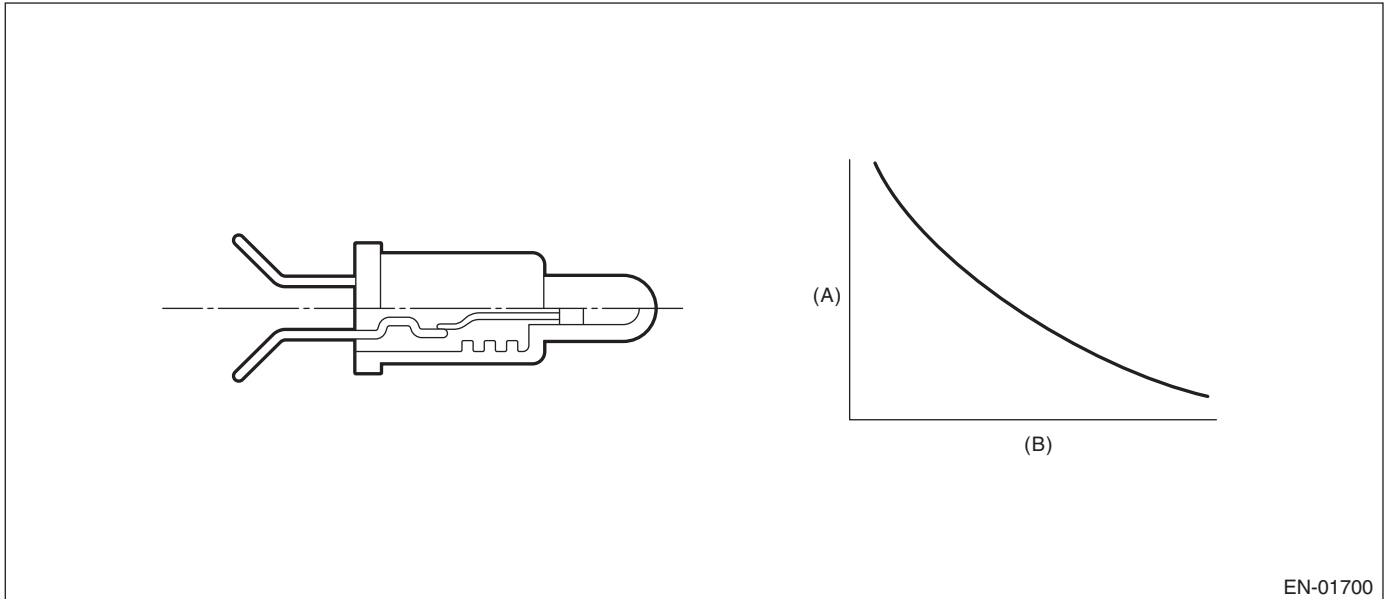

EN-01700

(A) Resistance value (Ω)

(B) Fuel temperature °C (°F)

3. ENABLE CONDITION

Secondary Parameters	Enable Conditions
None	

4. GENERAL DRIVING CYCLE

Always perform the diagnosis continuously.

5. DIAGNOSTIC METHOD

• Abnormality Judgement

If the duration of time while the following conditions are met is longer than the time indicated, judge as NG.

Judgement Value

Malfunction Criteria	Threshold Value
Output voltage	< 0.343951474 V
Battery voltage	≥ 10.9 V

Time Needed for Diagnosis:2500 ms

Malfunction Indicator Light Illumination: Illuminates as soon as a malfunction occurs.

• Normality Judgement

Judge as OK and clear the NG if the continuous time while the following conditions are established is more than the predetermined time.

Judgement Value

Malfunction Criteria	Threshold Value
Output voltage	≥ 0.343951474 V
Battery voltage	≥ 10.9 V

Time Needed for Diagnosis: Less than 1 second

Diagnostic Trouble Code (DTC) Detecting Criteria

GENERAL DESCRIPTION

AL:DTC P0183 FUEL TEMPERATURE SENSOR “A” CIRCUIT HIGH INPUT

1. OUTLINE OF DIAGNOSIS

Detect the open or short circuit of fuel temperature sensor.

Judge as NG if out of specification.

2. COMPONENT DESCRIPTION

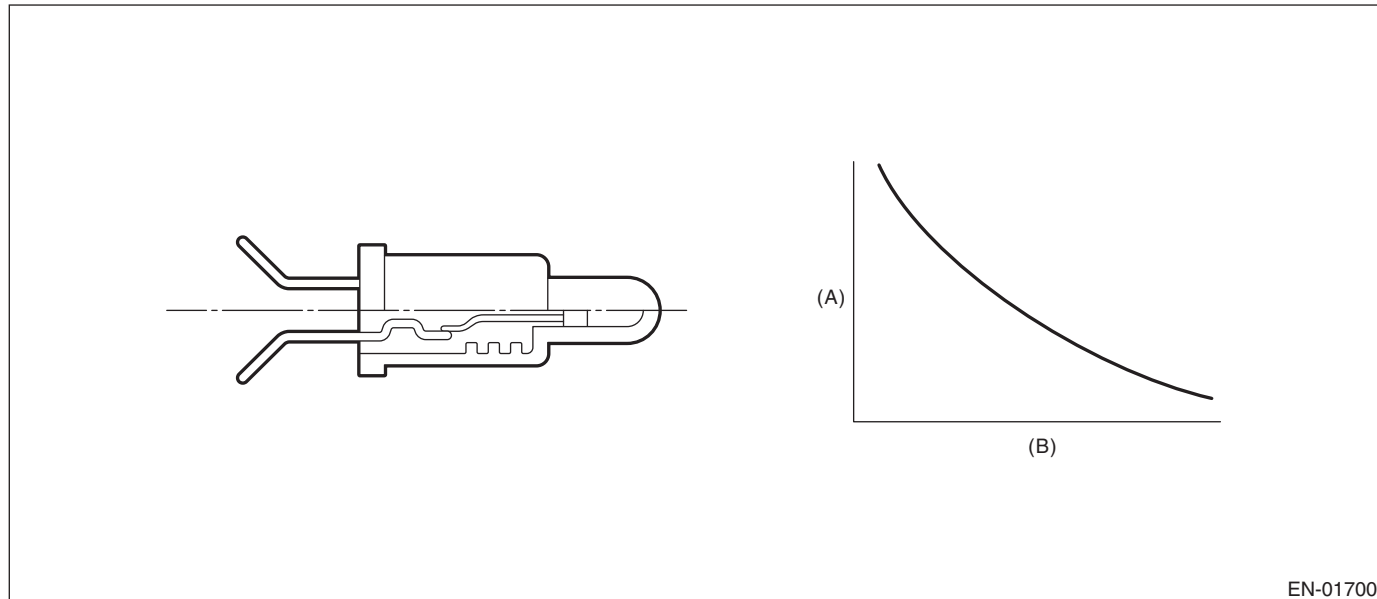

(A) Resistance value (Ω)

(B) Fuel temperature °C (°F)

3. ENABLE CONDITION

Secondary Parameters	Enable Conditions
None	

4. GENERAL DRIVING CYCLE

Always perform the diagnosis continuously.

5. DIAGNOSTIC METHOD

• Abnormality Judgement

If the duration of time while the following conditions are met is longer than the time indicated, judge as NG.

Judgement Value

Malfunction Criteria	Threshold Value
Output voltage	≥ 4.716 V
Battery voltage	≥ 10.9 V

Time Needed for Diagnosis:2500 ms

Malfunction Indicator Light Illumination: Illuminates as soon as a malfunction occurs.

• Normality Judgement

Judge as OK and clear the NG if the continuous time while the following conditions are established is more than the predetermined time.

Judgement Value

Malfunction Criteria	Threshold Value
Output voltage	< 4.716 V
Battery voltage	≥ 10.9 V

Time Needed for Diagnosis: Less than 1 second

AM:DTC P0222 THROTTLE/PEDAL POSITION SENSOR/SWITCH “B” CIRCUIT LOW

1. OUTLINE OF DIAGNOSIS

Detect the open or short circuit of throttle position sensor 2.
Judge as NG if out of specification.

2. COMPONENT DESCRIPTION

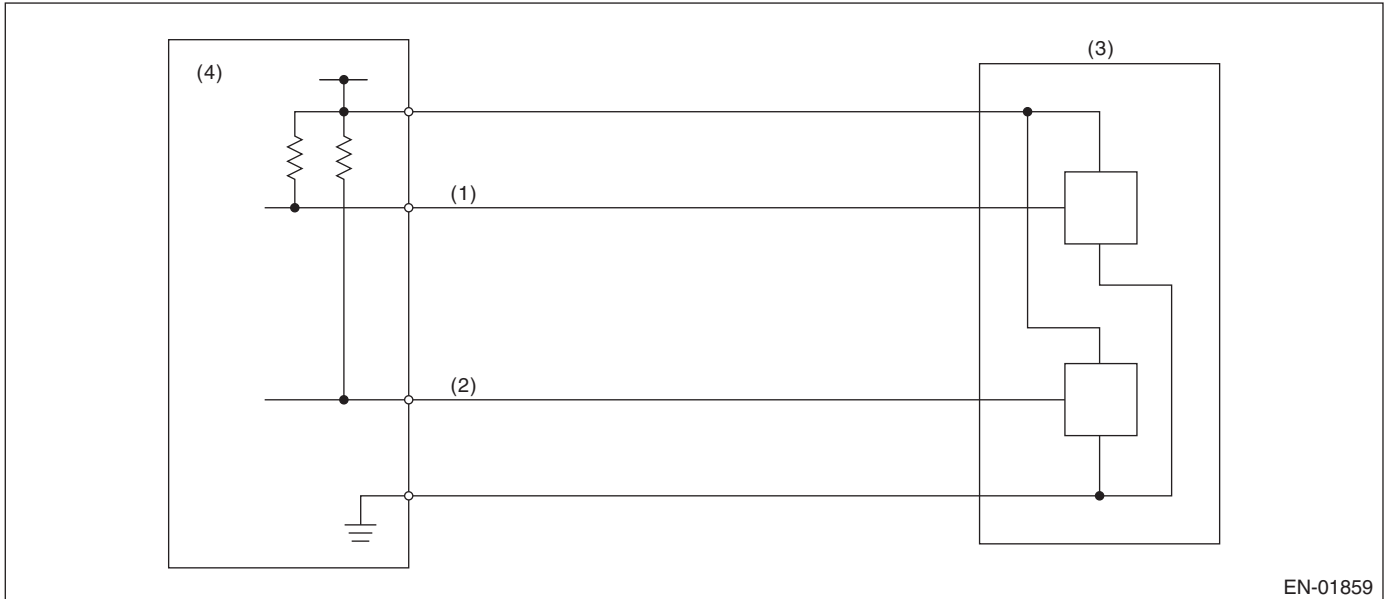

- (1) Throttle position sensor 1 signal (3) Throttle position sensor (4) Engine control module (ECM)
 (2) Throttle position sensor 2 signal

3. ENABLE CONDITION

Secondary Parameters	Enable Conditions
Ignition switch	ON
Battery voltage	≥ 6 V

4. GENERAL DRIVING CYCLE

Always perform the diagnosis continuously.

5. DIAGNOSTIC METHOD

• Abnormality Judgement

If the duration of time while the following conditions are met is longer than the time indicated, judge as NG.

Judgement Value

Malfunction Criteria	Threshold Value
Sensor 2 input voltage	≤ 0.926256 V

Time Needed for Diagnosis: 24 ms

Malfunction Indicator Light Illumination: Illuminates as soon as a malfunction occurs.

• Normality Judgement

Judge as OK and clear the NG if the continuous time while the following conditions are established is more than the predetermined time.

Judgement Value

Malfunction Criteria	Threshold Value
Sensor 2 input voltage	> 0.926256 V

Time Needed for Diagnosis: 24 ms

Diagnostic Trouble Code (DTC) Detecting Criteria

GENERAL DESCRIPTION

AN:DTC P0223 THROTTLE/PEDAL POSITION SENSOR/SWITCH “B” CIRCUIT HIGH

1. OUTLINE OF DIAGNOSIS

Detect the open or short circuit of throttle position sensor 2.
Judge as NG if out of specification.

2. COMPONENT DESCRIPTION

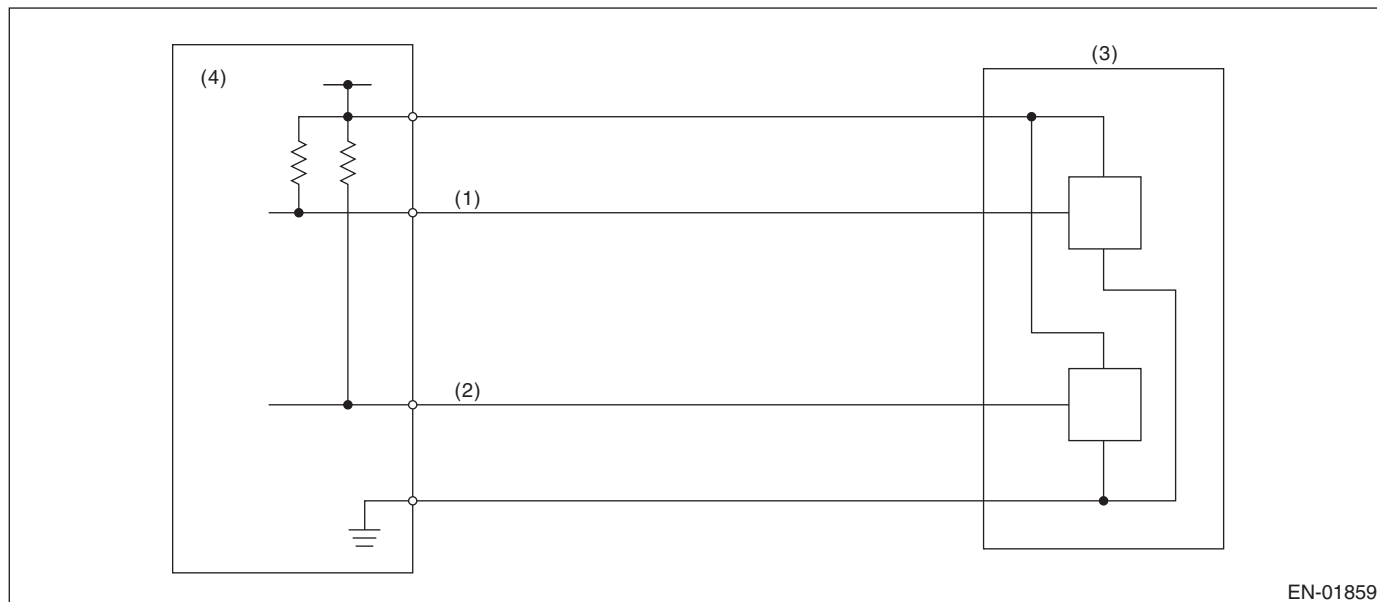

- (1) Throttle position sensor 1 signal (3) Throttle position sensor (4) Engine control module (ECM)
(2) Throttle position sensor 2 signal

3. ENABLE CONDITION

Secondary Parameters	Enable Conditions
Ignition switch	ON
Battery voltage	$\geq 6 \text{ V}$

4. GENERAL DRIVING CYCLE

Always perform the diagnosis continuously.

5. DIAGNOSTIC METHOD

• Abnormality Judgement

If the duration of time while the following conditions are met is longer than the time indicated, judge as NG.

Judgement Value

Malfunction Criteria	Threshold Value
Sensor 2 input voltage	$\geq 4.858 \text{ V}$

Time Needed for Diagnosis:24 ms

Malfunction Indicator Light Illumination: Illuminates as soon as a malfunction occurs.

• Normality Judgement

Judge as OK and clear the NG if the continuous time while the following conditions are established is more than the predetermined time.

Judgement Value

Malfunction Criteria	Threshold Value
Sensor 2 input voltage	$< 4.858 \text{ V}$

Time Needed for Diagnosis:24 ms

Diagnostic Trouble Code (DTC) Detecting Criteria

GENERAL DESCRIPTION

AO:DTC P0230 FUEL PUMP PRIMARY CIRCUIT

1. OUTLINE OF DIAGNOSIS

Detect the malfunction of fuel pump control unit.

Judge as NG when the NG signal is sent through a diagnostic line coming from the fuel pump control unit. Fuel pump control unit detects the open or short circuit malfunction for each line, and then sends NG signals if one of them is found NG.

2. COMPONENT DESCRIPTION

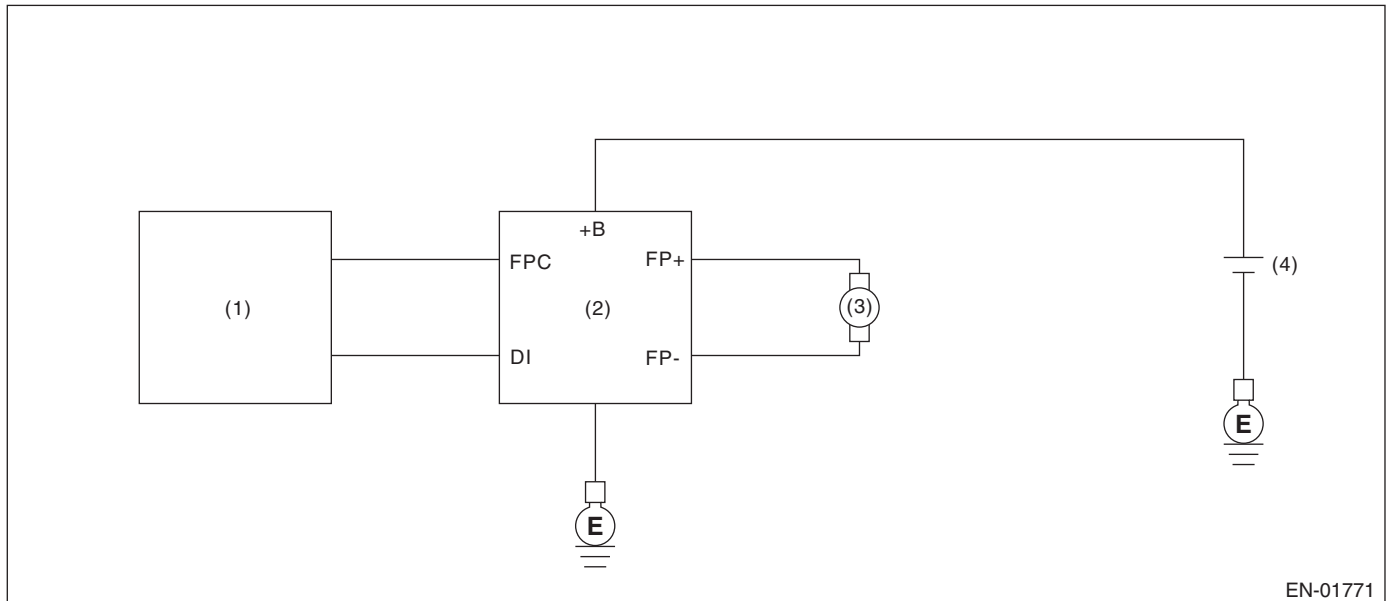

(1) Engine control module (ECM)

(3) Fuel pump

(4) Battery

(2) Fuel pump control unit

3. ENABLE CONDITION

Secondary Parameters	Enable Conditions
None	

4. GENERAL DRIVING CYCLE

Always perform the diagnosis continuously.

Diagnostic Trouble Code (DTC) Detecting Criteria

GENERAL DESCRIPTION

5. DIAGNOSTIC METHOD

• Abnormality Judgement

If the duration of time while the following conditions are met is longer than the time indicated, judge as NG.

Judgement Value

Malfunction Criteria	Threshold Value
Battery voltage	≥ 8 V
Elapsed time after starting the engine	≥ 180000 ms
Fuel pump control	ON
Fuel pump control unit output diagnosis signal	Low
Fuel level	≥ 10 ℓ (2.64 US gal, 2.2 Imp gal)

Time Needed for Diagnosis: 2500 ms

Malfunction Indicator Light Illumination: Illuminates when malfunction occurs in 2 continuous driving cycles.

• Normality Judgement

Judge as OK and clear the NG if the continuous time while the following conditions are established is more than the predetermined time.

Judgement Value

Malfunction Criteria	Threshold Value
Battery voltage	≥ 8 V
Elapsed time after starting the engine	≥ 180000 ms
Fuel pump control	ON
Fuel pump control unit output diagnosis signal	High
Fuel level	≥ 10 ℓ (2.64 US gal, 2.2 Imp gal)

Time Needed for Diagnosis: Less than 1 second

Diagnostic Trouble Code (DTC) Detecting Criteria

GENERAL DESCRIPTION

AP:DTC P0244 TURBO/SUPER CHARGER WASTEGATE SOLENOID "A" RANGE/PERFORMANCE

1. OUTLINE OF DIAGNOSIS

Detect the malfunction of wastegate control solenoid valve function.
Judge as NG when becoming high wastegate pressure.

2. COMPONENT DESCRIPTION

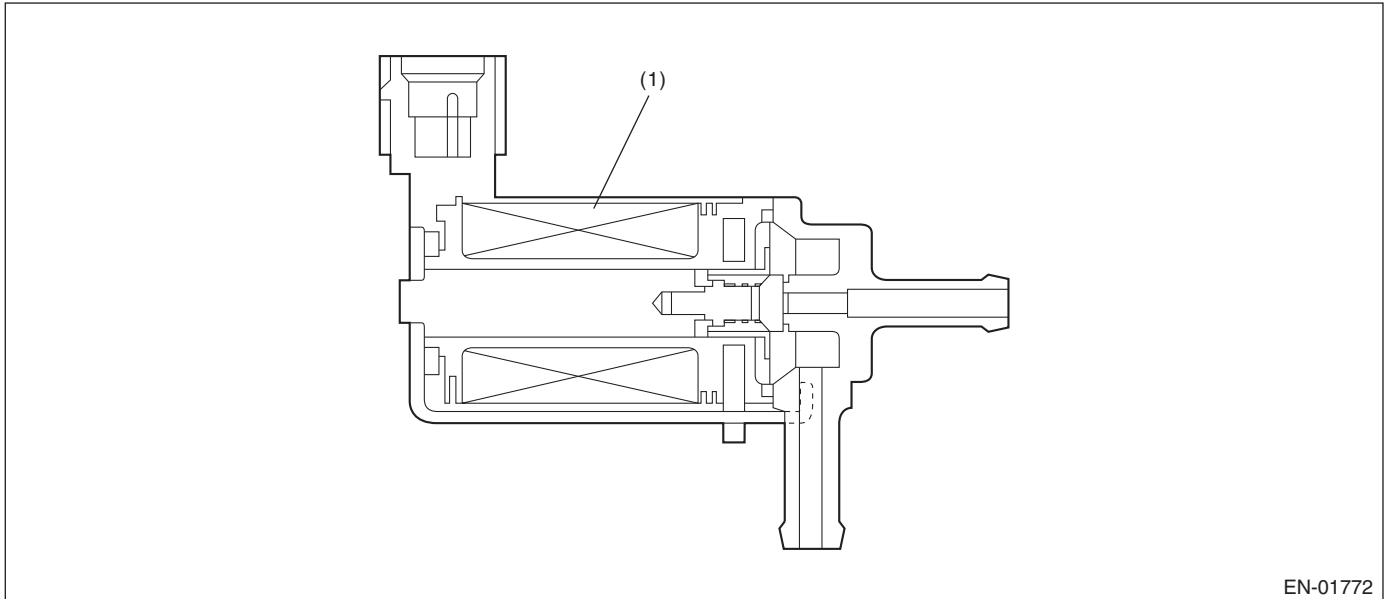

(1) Coil

3. ENABLE CONDITION

Secondary Parameters	Enable Conditions
None	

4. GENERAL DRIVING CYCLE

Always perform the diagnosis continuously.

Diagnostic Trouble Code (DTC) Detecting Criteria

GENERAL DESCRIPTION

5. DIAGNOSTIC METHOD

• Abnormality Judgement

If the duration of time while the following conditions are met is longer than the time indicated, judge as NG.

Judgement Value

Malfunction Criteria	Threshold Value
Intake manifold pressure	≥ Value from Map

Map

		Barometric pressure (kPa (mmHg, inHg))					
		58.7 (440, 17.3)	77.3 (580, 22.8)	89.3 (670, 26.4)	96 (720, 28.3)	98.6 (740, 29.1)	101.3 (760, 29.9)
Engine speed (rpm)	1000	113.4 (851, 33.5)	132.2 (992, 39.1)	144 (1080, 42.5)	144 (1080, 42.5)	144 (1080, 42.5)	144 (1080, 42.5)
	2000	159.8 (1199, 47.2)	188.6 (1415, 55.7)	206.6 (1550, 61)	206.6 (1550, 61)	206.6 (1550, 61)	206.6 (1550, 61)
	3000	159.8 (1199, 47.2)	188.6 (1415, 55.7)	206.6 (1550, 61)	206.6 (1550, 61)	206.6 (1550, 61)	206.6 (1550, 61)
	4000	159.8 (1199, 47.2)	188.6 (1415, 55.7)	206.6 (1550, 61)	206.6 (1550, 61)	206.6 (1550, 61)	206.6 (1550, 61)
	5000	133.4 (1001, 39.4)	160.1 (1201, 47.3)	179.7 (1348, 53.1)	186.9 (1402, 55.2)	204.6 (1535, 60.4)	204.6 (1535, 60.4)
	6000	123.4 (926, 36.5)	147.7 (1108, 43.6)	165.4 (1241, 48.9)	171.8 (1289, 50.7)	188 (1410, 55.5)	188 (1410, 55.5)

kPa (mmHg, inHg)

Time Needed for Diagnosis: 2000 ms

Malfunction Indicator Light Illumination: Illuminates as soon as a malfunction occurs.

• Normality Judgement

Judge as OK and clear the NG if the continuous time while the following conditions are established is more than the predetermined time.

Judgement Value

Malfunction Criteria	Threshold Value
Intake manifold pressure	< Value from Map – 22.4 kPa (168 mmHg, 6.6 inHg)

Time Needed for Diagnosis: Less than 1 second

Diagnostic Trouble Code (DTC) Detecting Criteria

GENERAL DESCRIPTION

AQ:DTC P0245 TURBO/SUPER CHARGER WASTEGATE SOLENOID “A” LOW

1. OUTLINE OF DIAGNOSIS

Detect open or short circuit of the wastegate control solenoid valve.

Judge as NG when the terminal output voltage remains Low during outputting the duty signal.

2. COMPONENT DESCRIPTION

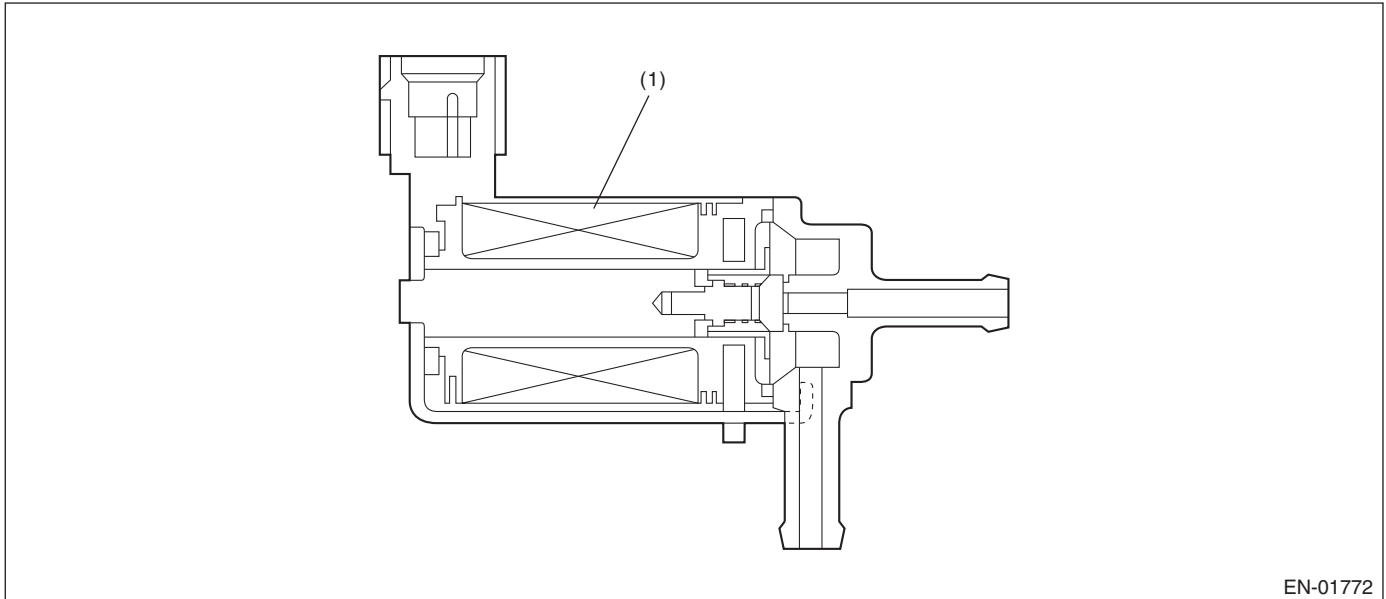

(1) Coil

3. ENABLE CONDITION

Secondary Parameters	Enable Conditions
Battery voltage	$\geq 10.9 \text{ V}$
Elapsed time after starting the engine	$\geq 1 \text{ second}$

4. GENERAL DRIVING CYCLE

Perform the diagnosis continuously after starting the engine.

5. DIAGNOSTIC METHOD

Abnormality Judgement

If the duration of time while the following conditions are met is longer than the time indicated, judge as NG.

Judgement Value

Malfunction Criteria	Threshold Value
Terminal output voltage	Low
Duty ratio of wastegate control	$< 75\%$

Time Needed for Diagnosis: 640 ms

Malfunction Indicator Light Illumination: Illuminates as soon as a malfunction occurs.

Normality Judgement

Judge as OK and clear the NG if the continuous time while the following conditions are established is more than the predetermined time.

Judgement Value

Malfunction Criteria	Threshold Value
Terminal output voltage	High

Time Needed for Diagnosis: Less than 1 second

Diagnostic Trouble Code (DTC) Detecting Criteria

GENERAL DESCRIPTION

AR:DTC P0246 TURBO/SUPER CHARGER WASTEGATE SOLENOID “A” HIGH

1. OUTLINE OF DIAGNOSIS

Detect open or short circuit of the wastegate control solenoid valve.

Judge as NG when the terminal output voltage remains Low or High during outputting the duty signal.

2. COMPONENT DESCRIPTION

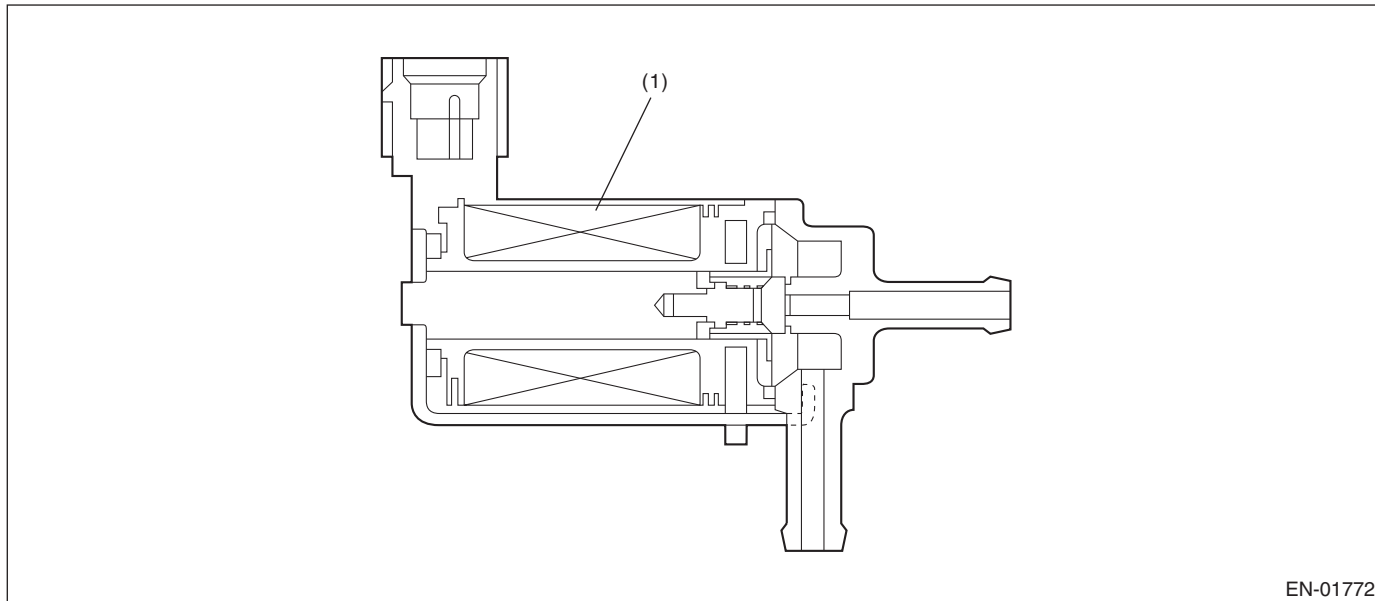

EN-01772

(1) Coil

3. ENABLE CONDITION

Secondary Parameters	Enable Conditions
Battery voltage	$\geq 10.9 \text{ V}$
Elapsed time after starting the engine	$\geq 1 \text{ second}$

4. GENERAL DRIVING CYCLE

Perform the diagnosis continuously after starting the engine.

5. DIAGNOSTIC METHOD

Abnormality Judgement

If the duration of time while the following conditions are met is longer than the time indicated, judge as NG.

Judgement Value

Malfunction Criteria	Threshold Value
Terminal output voltage	High
Duty ratio of wastegate control	$\geq 25\%$

Time Needed for Diagnosis: 640 ms

Malfunction Indicator Light Illumination: Illuminates as soon as a malfunction occurs.

Normality Judgement

Judge as OK and clear the NG if the continuous time while the following conditions are established is more than the predetermined time.

Judgement Value

Malfunction Criteria	Threshold Value
Terminal output voltage	Low

Time Needed for Diagnosis: Less than 1 second

Diagnostic Trouble Code (DTC) Detecting Criteria

GENERAL DESCRIPTION

AS:DTC P0301 CYLINDER 1 MISFIRE DETECTED

1. OUTLINE OF DIAGNOSIS

Detect the presence of misfire occurrence. (Revolution fluctuation method)

Monitoring Misfire which influences exhaust deterioration (1.5 times of FTP) and catalyst damage is made obligatory by the law. Misfire affecting these two has two patterns below.:

- Intermittent misfire (The same cylinder misfires in random, or different cylinders misfire in random.): FTP 1.5 times misfire
- Every time misfire (The same cylinder misfires every time.): FTP 1.5 times misfire, Catalyst damage misfire

The following detecting methods are adopted for these detection.

1) Intermittent misfire: FTP 1.5 times misfire

- 180° Interval Difference Method
- 360° Interval Difference Method (whole range)
- 720° Interval Difference Method (3,000 rpm or more)

2) Misfire every time: FTP 1.5 times misfire, Catalyst damage misfire

- 360° Interval Difference Method

2. ENABLE CONDITION

Secondary Parameters	Enable Conditions
All secondary parameters enable conditions	≥ 1024 ms
Intake manifold pressure change at 180°CA	< Value of Map 1
Throttle position change during 16 milliseconds	< 14 °
Fuel shut-off function	Not in operation
Fuel level	≥ 9.6 ℓ (2.54 US gal, 2.11 Imp gal)
Vehicle dynamic control or AT torque control	Not in operation
Evaporative system leak check	Not in operation
Engine speed	450 rpm — 6650 rpm
Intake manifold pressure	≥ Value of Map 2
Battery voltage	≥ 8 V
Fuel parameter determination	Not extremely low volatility
Elapsed time after starting the engine	≥ 0 ms
Engine load change during 32 milliseconds	< 1000 rpm

MAP 1

rpm	700	1000	1500	2000	2500	3000	3500	4000	4500	5000	5500	6000	6500	6700
kPa	26.7	26.7	26.7	26.7	26.7	26.7	26.7	26.7	26.7	26.7	26.7	26.7	26.7	26.7
(mmHg, inHg)	(200, 7.9)	(200, 7.9)	(200, 7.9)	(200, 7.9)	(200, 7.9)	(200, 7.9)	(200, 7.9)	(200, 7.9)	(200, 7.9)	(200, 7.9)	(200, 7.9)	(200, 7.9)	(200, 7.9)	(200, 7.9)

MAP 2

- Tumble generator valve open

rpm	700	1000	1500	2000	2500	3000	3500	4000	4500	5000	5500	6000	6500	6700
kPa	29.3	26.7	26.7	26.7	27.3	28	29.5	31.3	32.7	34.1	38.2	44	49.5	53.3
(mmHg, inHg)	(220, 8.7)	(200, 7.9)	(200, 7.9)	(200, 7.9)	(205, 8.1)	(210, 8.3)	(221.5, 8.7)	(235, 9.3)	(245.5, 9.7)	(256, 10.1)	(286.5, 11.3)	(330, 13)	(371.5, 14.6)	(400, 15.7)

- Tumble generator valve closed

rpm	700	1000	1500	2000	2500	3000	3500	4000	4500	5000	5500	6000	6500	6700
kPa	29.3	26.7	26.7	26.7	27.3	28	29.5	31.3	32.7	34.1	38.2	44	49.5	53.3
(mmHg, inHg)	(220, 8.7)	(200, 7.9)	(200, 7.9)	(200, 7.9)	(205, 8.1)	(210, 8.3)	(221.5, 8.7)	(235, 9.3)	(245.5, 9.7)	(256, 10.1)	(286.5, 11.3)	(330, 13)	(371.5, 14.6)	(400, 15.7)

Diagnostic Trouble Code (DTC) Detecting Criteria

GENERAL DESCRIPTION

3. GENERAL DRIVING CYCLE

- If conditions are met, it is possible to detect the misfires from idling to high engine speed. However, in case any engine load or breakage occurs, perform with the engine at idle.
- Perform the diagnosis continuously.

4. DIAGNOSTIC METHOD

When a misfire occurs, the engine speed will decreased and the crankshaft position speed will change. Calculate the interval difference value (diagnostic value) from crankshaft position speed by the following formula, and judge whether a misfire is occurring or not comparing the calculated result with judgement value. While counting the number of misfires, if the misfire ratio is higher during 1000 revs. or 200 revs., judge corresponding cylinders as NG.

Diagnostic value calculation (Calculate from angle speed) →	Misfire detection every single ignition (Compare diagnostic value with judgement value) →	NG judgement (Misfire occurrence judgement required by the law) (Compare number of misfire with judgement)
	<ul style="list-style-type: none"> • 180° Interval Difference Method • 360° Interval Difference Method • 720° Interval Difference Method 	<ul style="list-style-type: none"> • FTP 1.5 times misfire NG judgement • Catalyst damage misfire NG judgement

As shown in the following figure, pick a cylinder as the standard and name it omg 0. And the former crankshaft position speed is named omg 1, the second former crankshaft position speed is named omg 2, the third is named omg 3, etc.

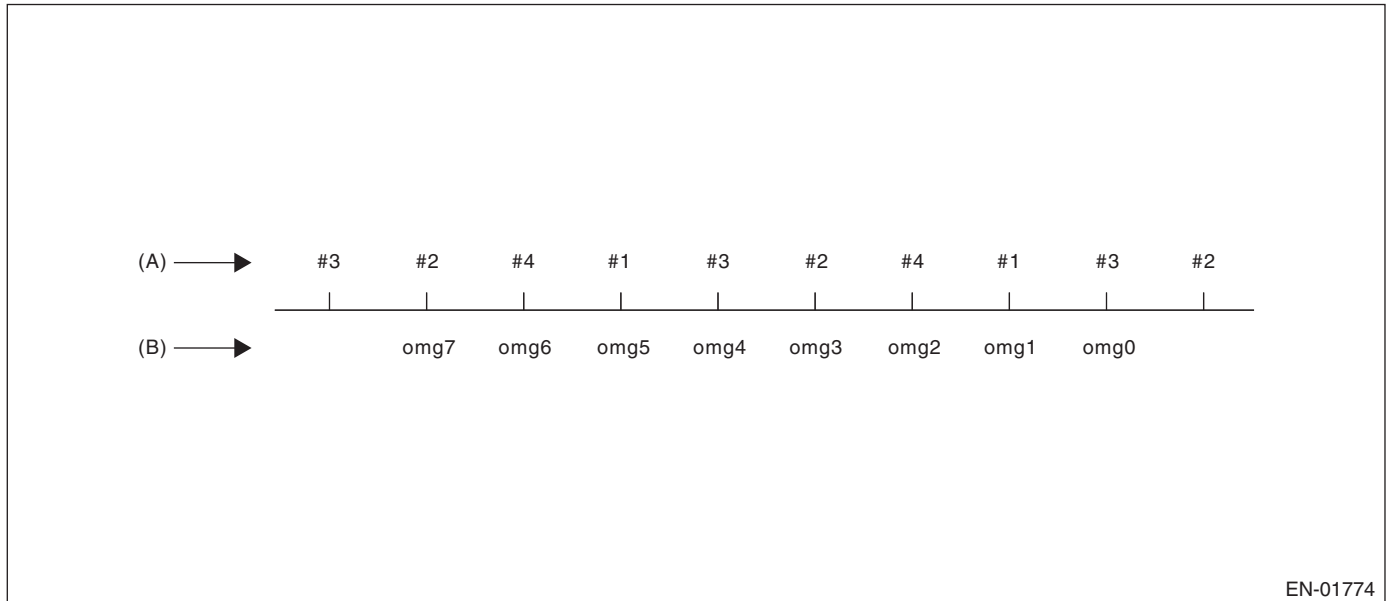

EN-01774

(A) Ignition order

(B) Crankshaft position speed

Diagnostic Trouble Code (DTC) Detecting Criteria

GENERAL DESCRIPTION

180° Interval Difference Method

Diagnostic value	$\text{domg } 180 = (\text{omg } 1 - \text{omg } 0) - (\text{omg } 5 - \text{omg } 1)/4$
------------------	--

Judge as a misfire in the following cases.

- $\text{domg } 180 > \text{judgement value of positive side}$
- $\text{domg } 180 \leq \text{judgement value of negative side}$
(Judgement value before 180° CA)

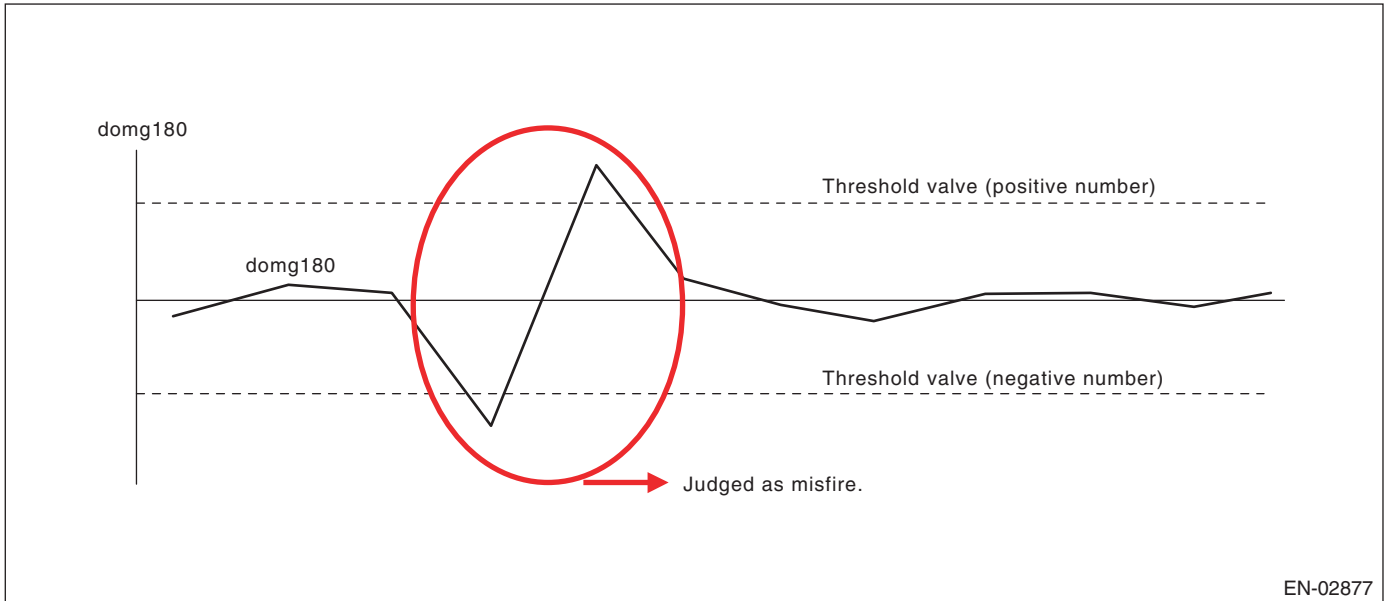

360° Interval Difference Method

Diagnostic value	$\text{domg } 360 = (\text{omg } 1 - \text{omg } 0) - (\text{omg } 3 - \text{omg } 2)$
------------------	--

Misfire judgement	$\text{domg } 360 > \text{Judgement value} \rightarrow \text{Judge as misfire}$
-------------------	---

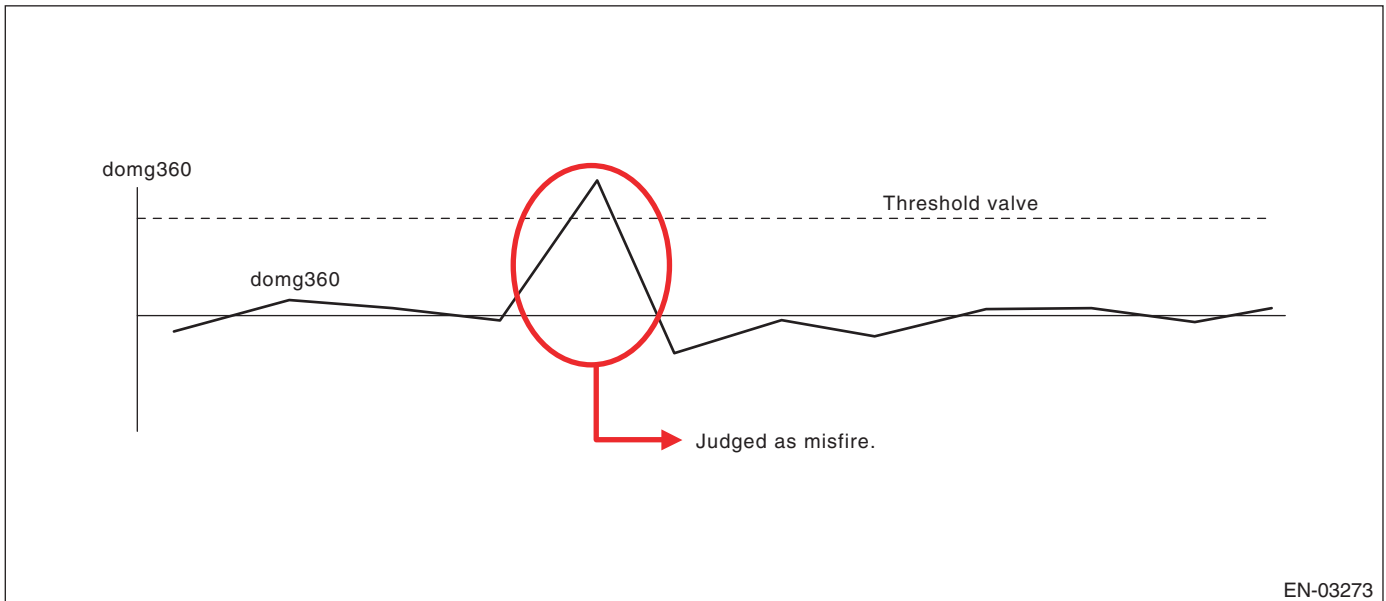

Diagnostic Trouble Code (DTC) Detecting Criteria

GENERAL DESCRIPTION

720° Interval Difference Method

Diagnostic value	$\text{domg 720} = (\text{omg 1} - \text{omg 0}) - (\text{omg 5} - \text{omg 4})$
Misfire judgement	$\text{domg 720} > \text{Judgement value} \rightarrow \text{Judge as misfire}$

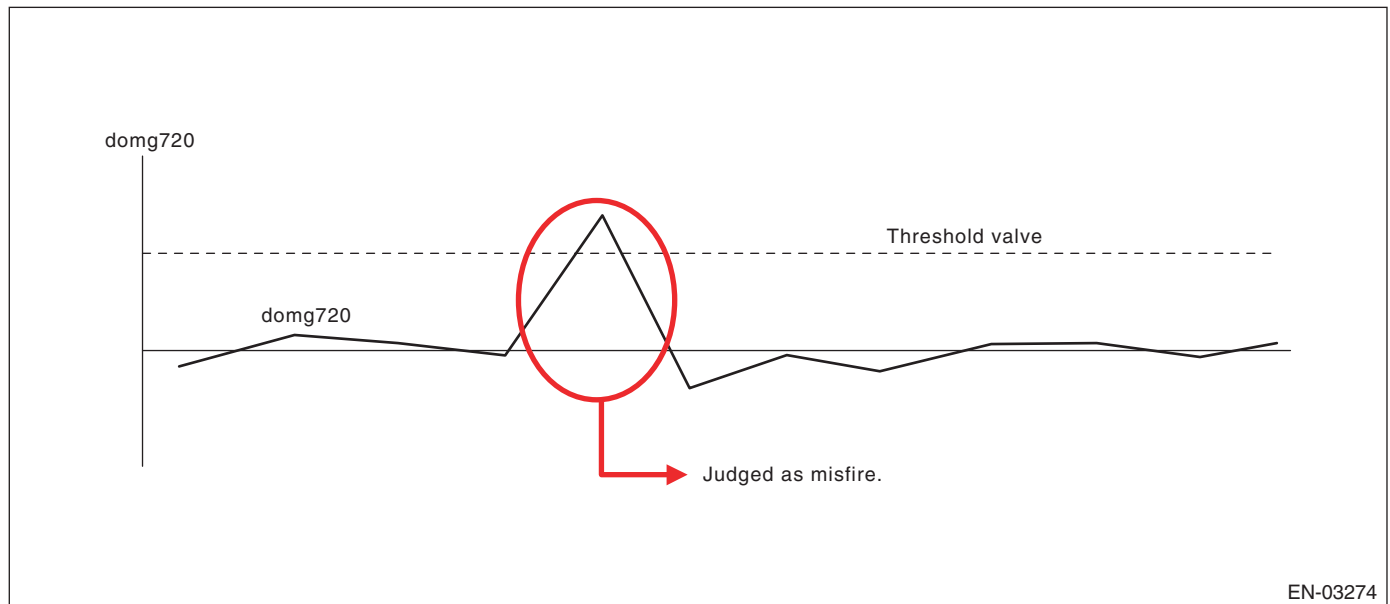

EN-03274

- FTP 1.5 times misfire (Misfire occurrence level which influences exhaust gas)

- Abnormality Judgement

Judgement Value (Judge that malfunction occurs when the misfire ratio is high in 1000 engine revs.)

Malfunction Criteria	Threshold Value
FTP emission judgement value	$\geq 20 \times 100/2000\%$ in 1000 revs.

Time Needed for Diagnosis: 1000 engine revs.

Malfunction Indicator Light Illumination: Illuminates when malfunction occurs in 2 continuous driving cycles.

- Normality Judgement

Judgement Value

Malfunction Criteria	Threshold Value
FTP emission judgement value	$< 20 \times 100/2000\%$ in 1000 revs.

Time Needed for Diagnosis: 1000 engine revs.

Diagnostic Trouble Code (DTC) Detecting Criteria

GENERAL DESCRIPTION

- Catalyst damage misfire (Misfire occurrence level damaging catalyst)
- Abnormality Judgement

Judgement Value

Malfunction Criteria	Threshold Value
Catalyst damage misfire judgement value	≥ Value from Map 3

Map 3

		Intake air (g(oz)/rev)									
		0.2 (0.01)	0.4 (0.01)	0.6 (0.02)	0.8 (0.03)	1 (0.04)	1.2 (0.04)	1.4 (0.05)	1.6 (0.06)	1.8 (0.06)	2 (0.07)
Engine speed (rpm)	700	148	128	116	106	100	90	90	90	90	90
	1000	148	128	114	104	92	85	85	85	85	85
	1500	140	118	102	90	85	85	85	72	72	72
	2000	128	90	90	73	58	43	40	36	32	20
	2500	116	87	57	45	39	36	34	32	30	20
	3000	108	87	58	39	36	36	32	30	28	20
	3500	98	74	43	27	23	22	20	20	20	20
	4000	69	61	40	27	22	20	20	20	20	20
	4500	60	55	34	25	20	20	20	20	20	20
	5000	55	55	34	23	20	20	20	20	20	20
	5500	54	54	33	22	20	20	20	20	20	20
	6000	52	52	32	21	20	20	20	20	20	20
	6500	50	50	30	20	20	20	20	20	20	20
6700	50	50	30	20	20	20	20	20	20	20	

Time Needed for Diagnosis: 200 engine revs.

Malfunction Indicator Light Illumination: Illuminates as soon as a malfunction occurs.

- Normality Judgement

Judgement Value

Malfunction Criteria	Threshold Value
Catalyst damage misfire judgement value	< Value from Map 3

Time Needed for Diagnosis: 200 engine revs.

Diagnostic Trouble Code (DTC) Detecting Criteria

GENERAL DESCRIPTION

AT:DTC P0302 CYLINDER 2 MISFIRE DETECTED

1. OUTLINE OF DIAGNOSIS

NOTE:

For the detection standard, refer to DTC P0301. <Ref. to GD(H4DOTC)-81, DTC P0301 CYLINDER 1 MISFIRE DETECTED, Diagnostic Trouble Code (DTC) Detecting Criteria.>

AU:DTC P0303 CYLINDER 3 MISFIRE DETECTED

1. OUTLINE OF DIAGNOSIS

NOTE:

For the detection standard, refer to DTC P0301. <Ref. to GD(H4DOTC)-81, DTC P0301 CYLINDER 1 MISFIRE DETECTED, Diagnostic Trouble Code (DTC) Detecting Criteria.>

AV:DTC P0304 CYLINDER 4 MISFIRE DETECTED

1. OUTLINE OF DIAGNOSIS

NOTE:

For the detection standard, refer to DTC P0301. <Ref. to GD(H4DOTC)-81, DTC P0301 CYLINDER 1 MISFIRE DETECTED, Diagnostic Trouble Code (DTC) Detecting Criteria.>

Diagnostic Trouble Code (DTC) Detecting Criteria

GENERAL DESCRIPTION

AW:DTC P0327 KNOCK SENSOR 1 CIRCUIT LOW (BANK 1 OR SINGLE SENSOR)

1. OUTLINE OF DIAGNOSIS

Detect the open or short circuit of knock sensor.
Judge as NG if out of specification.

2. COMPONENT DESCRIPTION

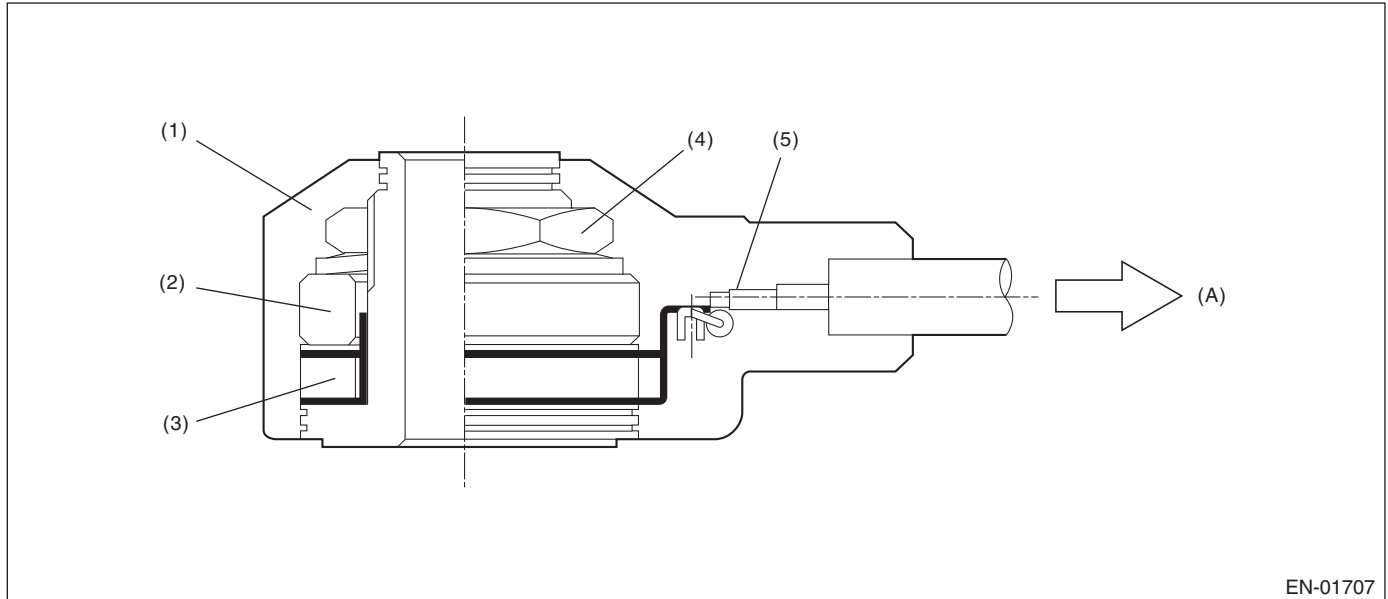

(A) To knock sensor harness

- | | | |
|------------|---------------------------|----------------|
| (1) Case | (3) Piezoelectric element | (5) Resistance |
| (2) Weight | (4) Nut | |

3. ENABLE CONDITION

Secondary Parameters	Enable Conditions
None	

4. GENERAL DRIVING CYCLE

Always perform the diagnosis continuously.

5. DIAGNOSTIC METHOD

• Abnormality Judgement

If the duration of time while the following conditions are met is longer than the time indicated, judge as NG.

Judgement Value

Malfunction Criteria	Threshold Value
Output voltage	< 0.243 V

Time Needed for Diagnosis: 1000 ms

Malfunction Indicator Light Illumination: Illuminates as soon as a malfunction occurs.

• Normality Judgement

Judge as OK and clear the NG if the continuous time while the following conditions are established is more than the predetermined time.

Judgement Value

Malfunction Criteria	Threshold Value
Output voltage	≥ 0.243 V

Time Needed for Diagnosis: Less than 1 second

Diagnostic Trouble Code (DTC) Detecting Criteria

GENERAL DESCRIPTION

AX:DTC P0328 KNOCK SENSOR 1 CIRCUIT HIGH (BANK 1 OR SINGLE SENSOR)

1. OUTLINE OF DIAGNOSIS

Detect the open or short circuit of knock sensor.

Judge as NG if out of specification.

2. COMPONENT DESCRIPTION

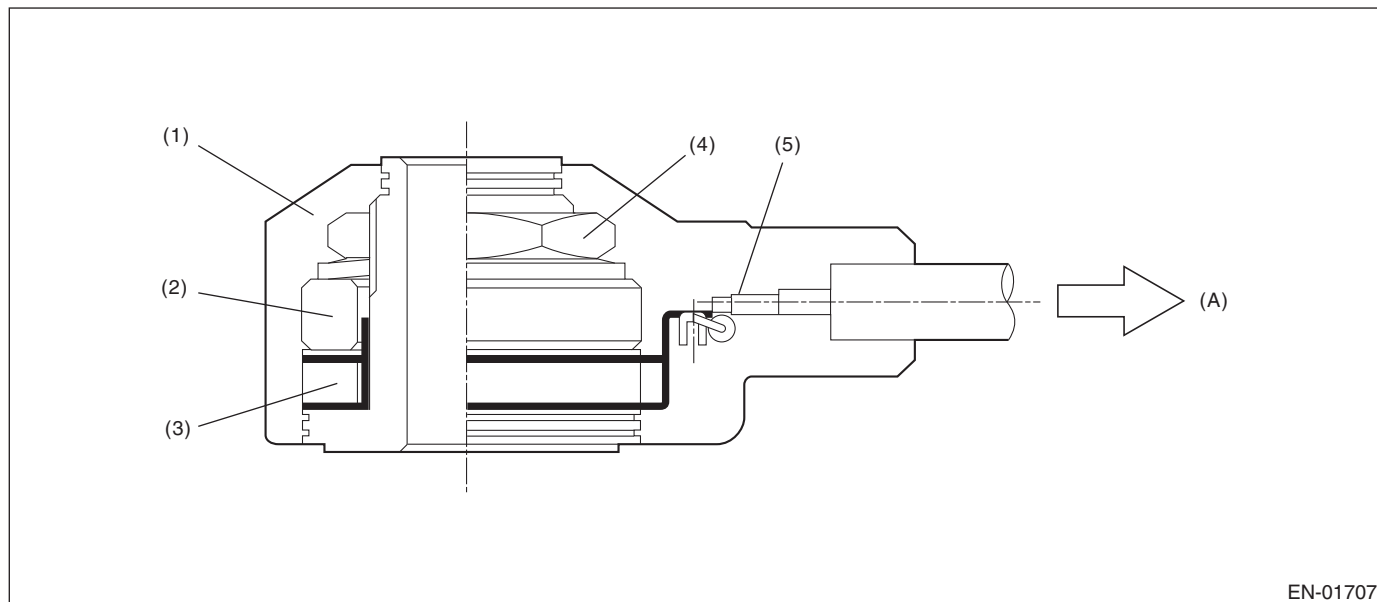

(A) To knock sensor harness

(1) Case

(2) Weight

(3) Piezoelectric element

(4) Nut

(5) Resistance

EN-01707

3. ENABLE CONDITION

Secondary Parameters	Enable Conditions
None	

4. GENERAL DRIVING CYCLE

Always perform the diagnosis continuously.

5. DIAGNOSTIC METHOD

• Abnormality Judgement

If the duration of time while the following conditions are met is longer than the time indicated, judge as NG.

Judgement Value

Malfunction Criteria	Threshold Value
Output voltage	≥ 4.709 V

Time Needed for Diagnosis: 1000 ms

Malfunction Indicator Light Illumination: Illuminates as soon as a malfunction occurs.

• Normality Judgement

Judge as OK and clear the NG if the continuous time while the following conditions are established is more than the predetermined time.

Judgement Value

Malfunction Criteria	Threshold Value
Output voltage	< 4.709 V

Time Needed for Diagnosis: Less than 1 second

AY:DTC P0335 CRANKSHAFT POSITION SENSOR "A" CIRCUIT

1. OUTLINE OF DIAGNOSIS

Detect the open or short circuit of the crankshaft position sensor.

Judge as NG when the crank signal is not input even though the starter was rotated.

2. COMPONENT DESCRIPTION

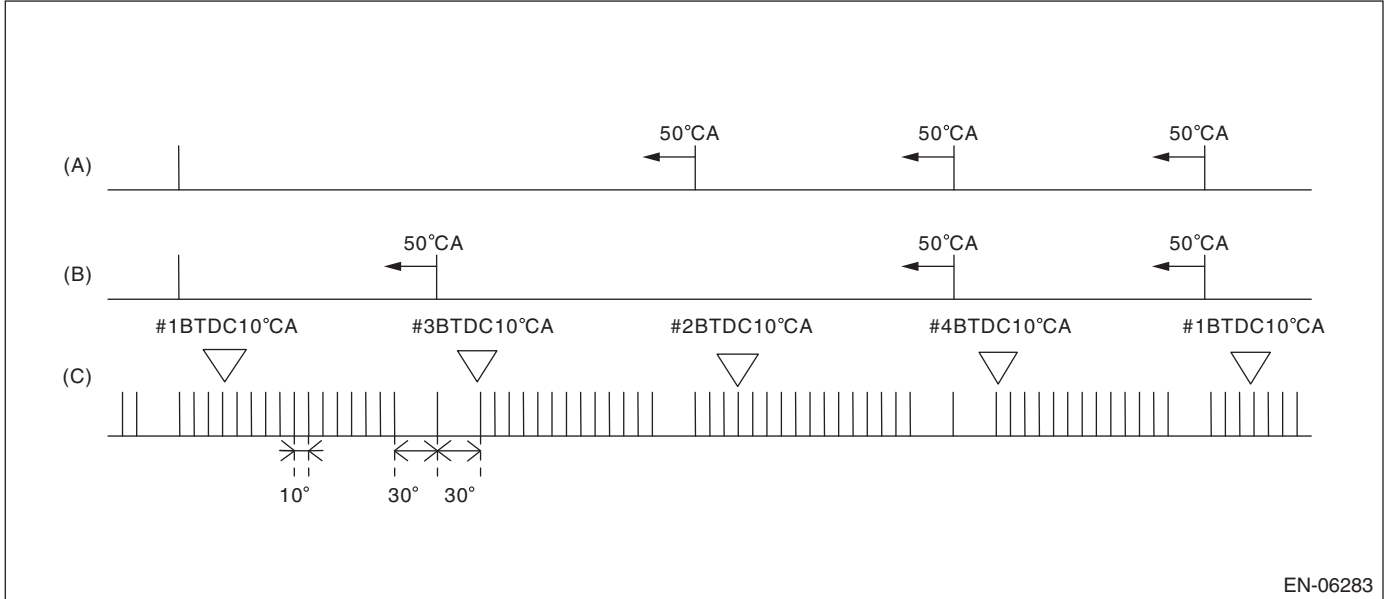

(A) Camshaft signal (RH)

(B) Camshaft signal (LH)

(C) Crankshaft signal

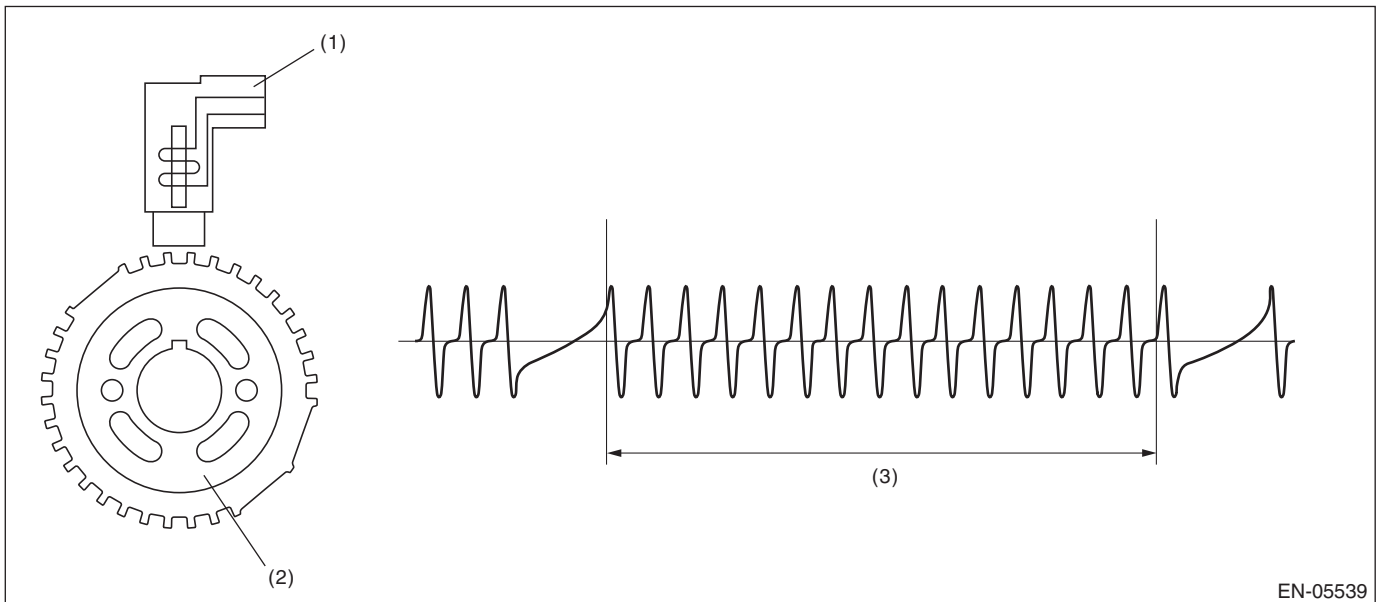

(1) Crankshaft position sensor

(2) Crank sprocket

(3) Crankshaft half-turn

3. ENABLE CONDITION

Secondary Parameters	Enable Conditions
None	

4. GENERAL DRIVING CYCLE

Always perform the diagnosis continuously.

Diagnostic Trouble Code (DTC) Detecting Criteria

GENERAL DESCRIPTION

5. DIAGNOSTIC METHOD

• Abnormality Judgement

If the duration of time while the following conditions are met is longer than the time indicated, judge as NG.

Judgement Value

Malfunction Criteria	Threshold Value
Starter switch	ON
Crankshaft position sensor signal	Not detected
Battery voltage	$\geq 8\text{ V}$

Time Needed for Diagnosis:3000 ms

Malfunction Indicator Light Illumination: Illuminates as soon as a malfunction occurs.

• Normality Judgement

Judge as OK and clear the NG if the continuous time while the following conditions are established is more than the predetermined time.

Judgement Value

Malfunction Criteria	Threshold Value
Crankshaft position sensor signal	Input exists
Battery voltage	$\geq 8\text{ V}$

Time Needed for Diagnosis: Less than 1 second

AZ:DTC P0336 CRANKSHAFT POSITION SENSOR "A" CIRCUIT RANGE/ PERFORMANCE

1. OUTLINE OF DIAGNOSIS

Detect for faults in crankshaft position sensor output properties.

Judge as NG when there is a problem in the number of crankshaft signals for every revolution.

2. COMPONENT DESCRIPTION

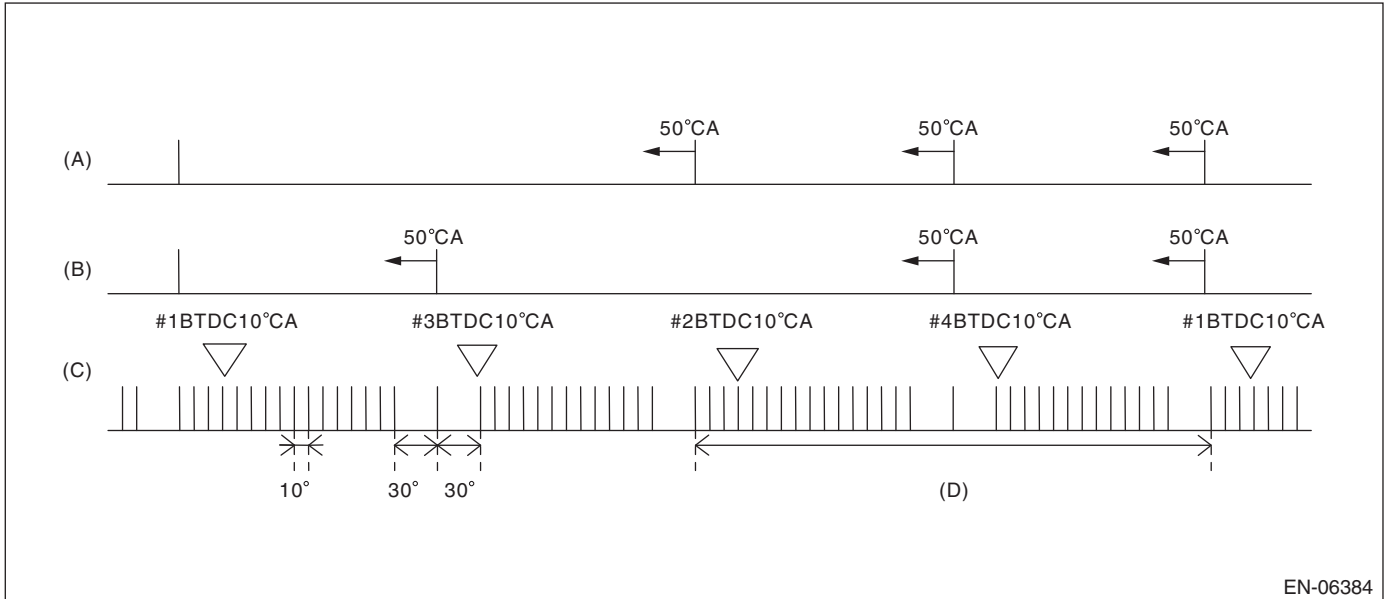

- (A) Camshaft signal (RH)
- (B) Camshaft signal (LH)
- (C) Crankshaft signal
- (D) Number of crankshaft signals = 30 is normal

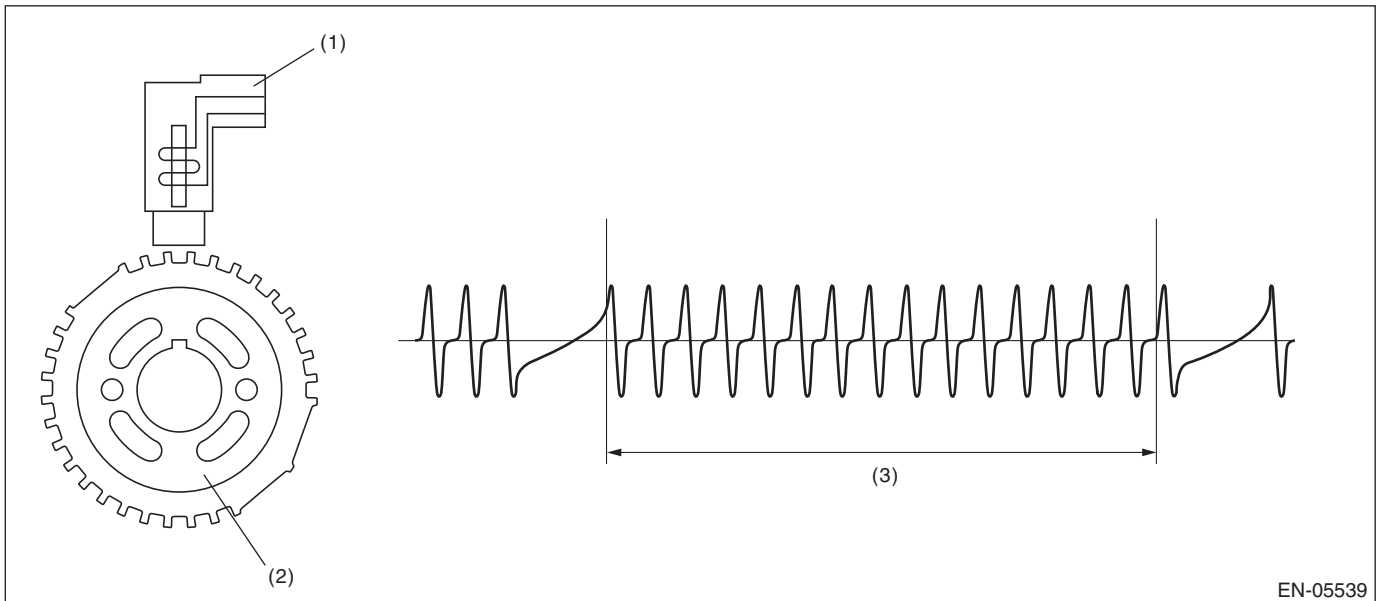

- (1) Crankshaft position sensor
- (2) Crank sprocket
- (3) Crankshaft half-turn

Diagnostic Trouble Code (DTC) Detecting Criteria

GENERAL DESCRIPTION

3. ENABLE CONDITION

Secondary Parameters	Enable Conditions
Battery voltage	≥ 8 V
Engine speed	< 3000 rpm

4. GENERAL DRIVING CYCLE

Perform the diagnosis continuously under 3000 rpm engine revs.

5. DIAGNOSTIC METHOD

• Abnormality Judgement

Judge as NG when the following conditions are established.

Judgement Value

Malfunction Criteria	Threshold Value
Cylinder number identification	Completed
Amount of crank sensor signal during 1 rev.	Not = 30

Time Needed for Diagnosis: 10 engine revs.

Malfunction Indicator Light Illumination: Illuminates when malfunction occurs in 2 continuous driving cycles.

• Normality Judgement

Judge as OK and clear the NG if the continuous time while the following conditions are established is more than the predetermined time.

Judgement Value

Malfunction Criteria	Threshold Value
Cylinder number identification	Completed
Amount of crank sensor signal during 1 rev.	= 30

Time Needed for Diagnosis: Less than 1 second

Diagnostic Trouble Code (DTC) Detecting Criteria

GENERAL DESCRIPTION

BA:DTC P0340 CAMSHAFT POSITION SENSOR "A" CIRCUIT (BANK 1 OR SINGLE SENSOR)

1. OUTLINE OF DIAGNOSIS

Detect the open or short circuit of the camshaft position sensor.

Judge as NG when the number of camshaft signals remains abnormal.

2. COMPONENT DESCRIPTION

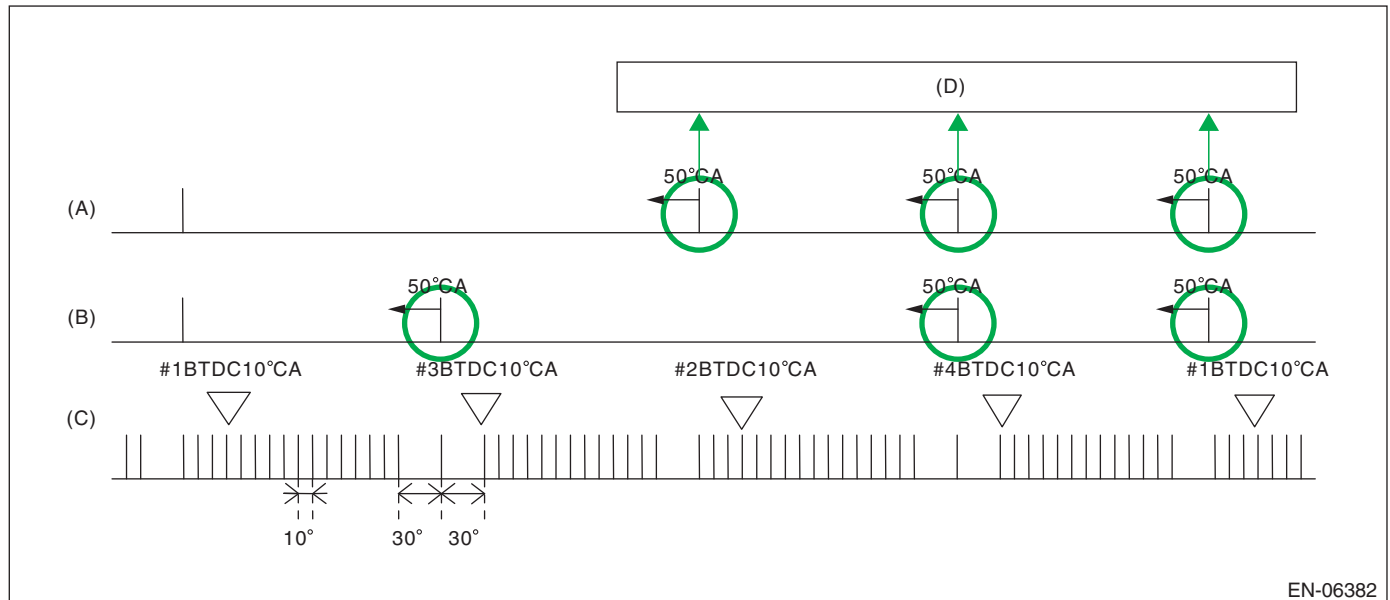

EN-06382

(A) Camshaft signal (RH)

(B) Camshaft signal (LH)

(C) Crankshaft signal

(D) Number of camshaft position signals = When normal, there will be 3 cam signals for every 2 engine revolutions.

3. ENABLE CONDITION

Secondary Parameters	Enable Conditions
Battery voltage	≥ 8 V

4. GENERAL DRIVING CYCLE

Always perform the diagnosis continuously.

Diagnostic Trouble Code (DTC) Detecting Criteria

GENERAL DESCRIPTION

5. DIAGNOSTIC METHOD

• Abnormality Judgement 1

Judge as NG when the condition where the number of camshaft position sensor signals are less than 3 time(s) during 2 engine revs. continues.

Judgement Value

Malfunction Criteria	Threshold Value
Amount of camshaft sensor signal during 2 revs.	< 3 time(s)

Time Needed for Diagnosis: Two engine revs. × 50

Malfunction Indicator Light Illumination: Illuminates as soon as a malfunction occurs.

• Normality Judgement 1

Judge as OK and clear the NG when the malfunction criteria below are met.

Judgement Value

Malfunction Criteria	Threshold Value
Camshaft position sensor signal	≥ 3 time(s)

Time Needed for Diagnosis: Two engine revs.

• Abnormality Judgement 2

If the duration of time while the following conditions are met is longer than the time indicated, judge as NG.

Judgement Value

Malfunction Criteria	Threshold Value
Starter	ON
Camshaft position sensor signal	No input

Time Needed for Diagnosis: 3000 ms

• Normality Judgement 2

Judge as OK and clear the NG if the continuous time while the following conditions are established is more than the predetermined time.

Judgement Value

Malfunction Criteria	Threshold Value
Camshaft position sensor signal	Input exists

Time Needed for Diagnosis: Less than 1 second

Diagnostic Trouble Code (DTC) Detecting Criteria

GENERAL DESCRIPTION

BB:DTC P0345 CAMSHAFT POSITION SENSOR “A” CIRCUIT (BANK 2)

1. OUTLINE OF DIAGNOSIS

NOTE:

For the detection standard, refer to DTC P0340. <Ref. to GD(H4DOTC)-93, DTC P0340 CAMSHAFT POSITION SENSOR “A” CIRCUIT (BANK 1 OR SINGLE SENSOR), Diagnostic Trouble Code (DTC) Detecting Criteria.>

Diagnostic Trouble Code (DTC) Detecting Criteria

GENERAL DESCRIPTION

BC:DTC P0410 SECONDARY AIR INJECTION SYSTEM

1. OUTLINE OF DIAGNOSIS

Detect NG judging from secondary air delivery pipe pressure, pulse of secondary air delivery pipe pressure and secondary air pipe airflow amount.

2. ENABLE CONDITION

Secondary Parameters	Enable Conditions
Pump supply pressure check Estimate ambient temperature Battery voltage Barometric pressure Engine Amount of intake air Secondary air pump Combination valve	≥ 4.4 °C ≥ 10.9 V ≥ 75 kPa (563 mmHg, 22.2 inHg) In operation ≥ 2 g/s (0.07 oz/s) Operating Bank open (Except with both banks closed)
Combination valve one side closed pulse diagnosis Estimate ambient temperature Battery voltage Barometric pressure Engine Feasible area for diagnosis After fuel cut	≥ 4.4 °C ≥ 10.9 V ≥ 75 kPa (563 mmHg, 22.2 inHg) In operation Value of Map 10 ≥ 1 ≥ 0 ms
Combination valve both closed pulse diagnosis Estimate ambient temperature Battery voltage Barometric pressure Engine Engine load After fuel cut	≥ 4.4 °C ≥ 10.9 V ≥ 75 kPa (563 mmHg, 22.2 inHg) In operation ≥ 0.2 g/rev (0.01 oz/rev) ≥ 1000 ms
Combination valve changeover pressure diagnosis Estimate ambient temperature Battery voltage Barometric pressure Engine Amount of intake air Engine speed After fuel cut	≥ 4.4 °C ≥ 10.9 V ≥ 75 kPa (563 mmHg, 22.2 inHg) In operation > 2 g/s (0.07 oz/s) and < 25 g/s (0.88 oz/s) < 4000 rpm ≥ 1000 ms
Overflow diagnosis Estimate ambient temperature Battery voltage Barometric pressure Engine	≥ 4.4 °C ≥ 10.9 V ≥ 75 kPa (563 mmHg, 22.2 inHg) In operation

3. GENERAL DRIVING CYCLE

Perform diagnosis during secondary air pump operation

Diagnostic Trouble Code (DTC) Detecting Criteria

GENERAL DESCRIPTION

4. DIAGNOSTIC METHOD

Measure secondary air delivery pipe pressure, pulse of secondary air delivery pipe pressure and secondary air pipe airflow amount.

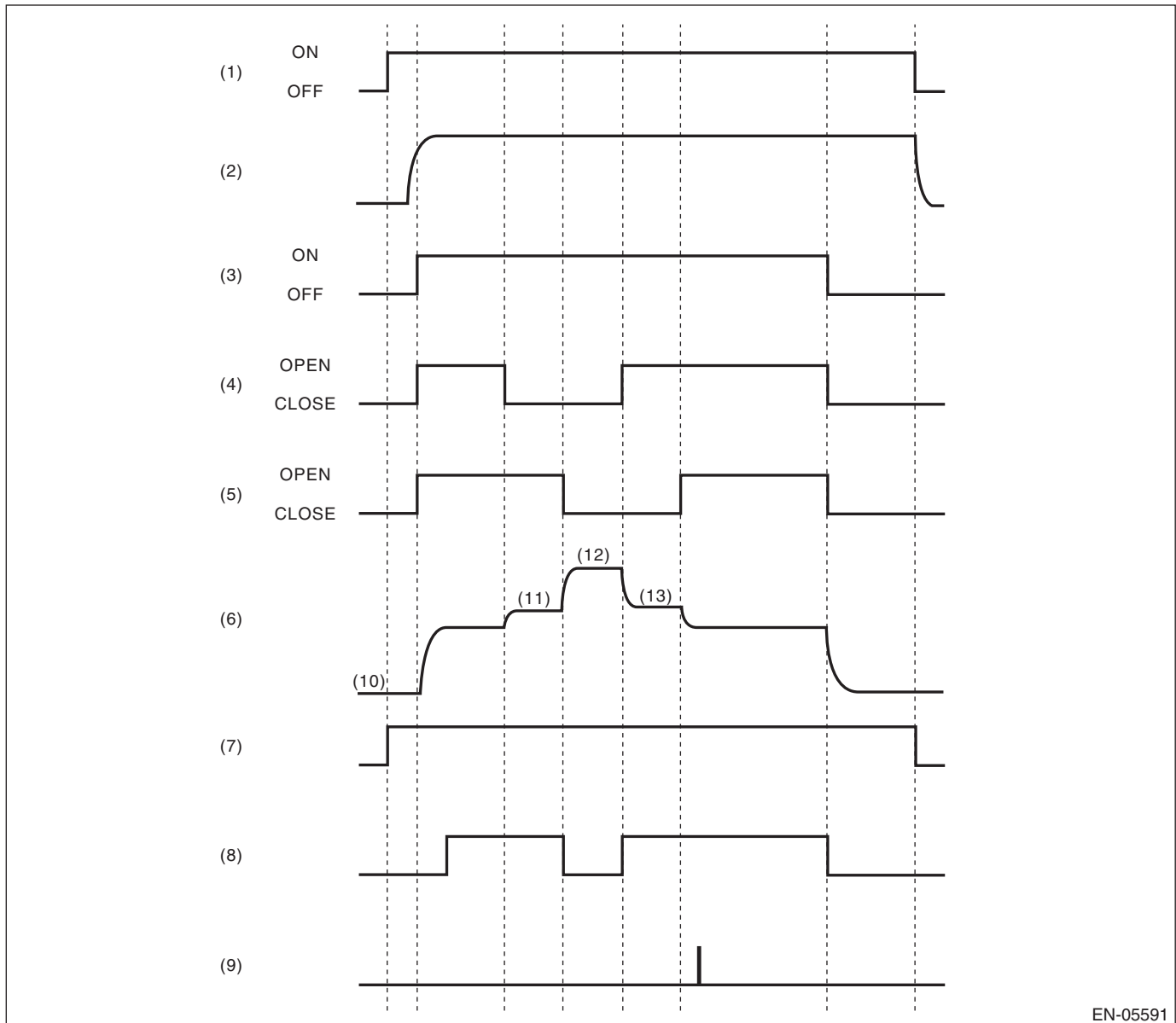

EN-05591

- | | | |
|--|---|--|
| (1) IG | (7) Diagnosis enable condition | (11) Right bank all closed pressure (P0R) measurement |
| (2) Ne | (8) Pump supply pressure check (judgement) | (12) Both banks all closed pressure (P0RL) measurement |
| (3) Secondary air pump operating status | (9) Flow amount check (judgement) | (13) Left bank all closed pressure (P0L) measurement |
| (4) E-COMB valve (right hand) status | (10) Barometric pressure (Pas) measurement before secondary air control | |
| (5) E-COMB valve (left hand) status | | |
| (6) Secondary air delivery pipe pressure (psi) | | |

Diagnostic Trouble Code (DTC) Detecting Criteria

GENERAL DESCRIPTION

Pump supply pressure check

Perform the system function diagnosis with how much the pressure rises when the secondary air pump is turned from OFF to ON.

Judge as NG if delivery pipe pressure does not rise though it should when the secondary air pump turns OFF → ON.

- **Abnormality Judgement**

If the duration of time while the following conditions are met is longer than the time indicated, judge as NG.

Judgement Value

Malfunction Criteria	Threshold Value	DTC
Secondary air supply pipe pressure (after barometric pressure compensation)	< 0.9 kPa (7 mmHg, 0.3 inHg)	P0410

Time Needed for Diagnosis:2000 ms + 2800 ms

Malfunction Indicator Light Illumination: Illuminates when malfunction occurs in 2 continuous driving cycles.

- **Normality Judgement**

Judge as OK and clear the NG if the continuous time while the following conditions are established is more than the predetermined time.

Judgement Value

Malfunction Criteria	Threshold Value	DTC
Secondary air supply pipe pressure (after barometric pressure compensation)	≥ 0.9 kPa (7 mmHg, 0.3 inHg)	P0410

Time Needed for Diagnosis:2000 ms + 2800 ms

Combination valve one side closed pulse diagnosis

Perform close stuck diagnosis of the LH combination valve using delivery pipe pressure pulse when the RH combination valve is closed.

Calculate the voltage pulse of the pump delivery pipe pressure when the RH combination valve is closed and the LH combination valve is open. The calculation of delivery pipe pressure should be large when the LH combination valve is open. Judge that the LH combination valve is close stuck if the calculation is small.

- **Abnormality Judgement**

If the duration of time while the following conditions are met is longer than the time indicated, judge as NG.

Judgement Value

Malfunction Criteria	Threshold Value	DTC
Pulse calculated value when the RH combination valve is closed	< Value of Map 1	P2443

Time Needed for Diagnosis:4000 ms + 992 ms + 992 ms + 992 ms

Malfunction Indicator Light Illumination: Illuminates when malfunction occurs in 2 continuous driving cycles.

- **Normality Judgement**

Judge as OK and clear the NG if the continuous time while the following conditions are established is more than the predetermined time.

Judgement Value

Malfunction Criteria	Threshold Value	DTC
Pulse calculated value when the RH combination valve is closed	≥ Value of Map 1	P2443

Time Needed for Diagnosis:4000 ms + 992 ms + 992 ms + 992 ms

Perform close stuck diagnosis of the RH combination valve using delivery pipe pressure pulse when the LH combination valve is closed.

Calculate the voltage pulse of the pump delivery pipe pressure when the LH combination valve is closed and the RH combination valve is open. The calculation of delivery pipe pressure should be large when the RH combination valve is open. Judge that the RH combination valve is close stuck if the calculation is small.

Diagnostic Trouble Code (DTC) Detecting Criteria

GENERAL DESCRIPTION

• Abnormality Judgement

If the duration of time while the following conditions are met is longer than the time indicated, judge as NG.

Judgement Value

Malfunction Criteria	Threshold Value	DTC
Pulse calculated value when the LH combination valve is closed	< Value of Map 2	P2441

Time Needed for Diagnosis:4000 ms + 992 ms + 992 ms + 992 ms

Malfunction Indicator Light Illumination: Illuminates when malfunction occurs in 2 continuous driving cycles.

• Normality Judgement

Judge as OK and clear the NG if the continuous time while the following conditions are established is more than the predetermined time.

Judgement Value

Malfunction Criteria	Threshold Value	DTC
Pulse calculated value when the LH combination valve is closed	≥ Value of Map 2	P2441

Time Needed for Diagnosis:4000 ms + 992 ms + 992 ms + 992 ms

Combination valve both closed pulse diagnosis

Perform open stuck diagnosis of both combination valves using delivery pipe pressure pulse when both combination valves are closed. Determine which side of valves is stuck open by comparing secondary air flow amount when RH combination valve is closed with that when LH combination valve is closed.

Calculate voltage pulse of the pump supply pipe pressure when both combination valves are closed. The calculation should be small because there is no pulse from supply pipe pressure with both combination valves closed. When the calculation is large, determine that either of the combination valves is stuck open.

Determine which side of valves is stuck open by comparing secondary air flow amount when the RH combination valve is closed with that when the LH combination valve is closed. Air flow amount is larger on the open stuck valve.

• Abnormality Judgement

If the duration of time while the following conditions are met is longer than the time indicated, judge as NG.

Judgement Value

Malfunction Criteria	Threshold Value	DTC
Pulse calculation value when both combination valves are closed	> Value from Map 3	P2440
Air flow amount when the right bank is closed (value from Map 4)	≥ Air flow amount when the left bank is closed (value from Map 5)	
Pulse calculation value when both combination valves are closed	> Value from Map 3	P2442
Air flow amount when the left bank is closed (value from Map 5)	> Air flow amount when the right bank is closed (value from Map 4)	

Time Needed for Diagnosis:4000 ms + 992 ms + 992 ms + 992 ms

Malfunction Indicator Light Illumination: Illuminates when malfunction occurs in 2 continuous driving cycles.

• Normality Judgement

Judge as OK and clear the NG if the continuous time while the following conditions are established is more than the predetermined time.

Judgement Value

Malfunction Criteria	Threshold Value	DTC
Pulse calculation value when both combination valves are closed	≤ Value from Map 3	P2440, P2442

Time Needed for Diagnosis:4000 ms + 992 ms + 992 ms + 992 ms

Diagnostic Trouble Code (DTC) Detecting Criteria

GENERAL DESCRIPTION

Combination valve changeover pressure diagnosis

Perform the RH combination valve stuck closed diagnosis with the variation of delivery pipe pressure when the RH combination valve turns closed → open.

Delivery pipe pressure should vary when the RH combination valve turns closed → open. When the variation is small, determine that the RH combination valve is stuck closed.

- **Abnormality Judgement**

If the duration of time while the following conditions are met is longer than the time indicated, judge as NG.

Judgement Value

Malfunction Criteria	Threshold Value	DTC
Pressure variation value when the RH combination valve is switched	< Value of Map 6	P2441

Time Needed for Diagnosis:4000 ms + 992 ms + 992 ms + 992 ms

Malfunction Indicator Light Illumination: Illuminates when malfunction occurs in 2 continuous driving cycles.

- **Normality Judgement**

Judge as OK and clear the NG if the continuous time while the following conditions are established is more than the predetermined time.

Judgement Value

Malfunction Criteria	Threshold Value	DTC
Pressure variation value when the RH combination valve is switched	≥ Value of Map 6	P2441

Time Needed for Diagnosis:4000 ms + 992 ms + 992 ms + 992 ms

Perform the LH combination valve stuck closed diagnosis with the variation of delivery pipe pressure when the LH combination valve turns open → closed.

Delivery pipe pressure should vary when the LH combination valve turns open → closed. When the variation is small, determine that the LH combination valve is stuck closed.

- **Abnormality Judgement**

If the duration of time while the following conditions are met is longer than the time indicated, judge as NG.

Judgement Value

Malfunction Criteria	Threshold Value	DTC
Pressure variation value when the LH combination valve is switched	< Value of Map 7	P2443

Time Needed for Diagnosis:4000 ms + 992 ms + 992 ms + 992 ms

Malfunction Indicator Light Illumination: Illuminates when malfunction occurs in 2 continuous driving cycles.

- **Normality Judgement**

Judge as OK and clear the NG if the continuous time while the following conditions are established is more than the predetermined time.

Judgement Value

Malfunction Criteria	Threshold Value	DTC
Pressure variation value when the LH combination valve is switched	≥ Value of Map 7	P2443

Time Needed for Diagnosis:4000 ms + 992 ms + 992 ms + 992 ms

Diagnostic Trouble Code (DTC) Detecting Criteria

GENERAL DESCRIPTION

Overflow diagnosis

Perform secondary air system flow abnormality diagnosis using both sides of combination valves secondary air amount when both are closed.

Judge as secondary air system flow abnormality either if there is excessive secondary air flow amount with the RH combination valve closed, or if there is excessive secondary air flow amount with the LH combination valve closed.

• Abnormality Judgement

If the duration of time while the following conditions are met is longer than the time indicated, judge as NG.

Judgement Value

Malfunction Criteria	Threshold Value	DTC
Air flow amount when the right bank is closed (value from Map 4) or Air flow amount when the left bank is closed (value from Map 5)	> Value of Map 8 > Value of Map 9	P0411
Voltage at P0RL measurement – Voltage at P0R measurement	≤ 4 V	
Voltage at P0RL measurement – Voltage at P0L measurement	≤ 4 V	

P0RL: Both banks all closed pressure

P0R: Right bank all closed pressure

P0L: Left bank all closed pressure

Time Needed for Diagnosis:4000 ms + 992 ms + 992 ms + 992 ms

Malfunction Indicator Light Illumination: Illuminates when malfunction occurs in 2 continuous driving cycles.

• Normality Judgement

Judge as OK and clear the NG if the continuous time while the following conditions are established is more than the predetermined time.

Judgement Value

Malfunction Criteria	Threshold Value	DTC
Air flow amount when the right bank is closed (value from Map 4) or Air flow amount when the left bank is closed (value from Map 5)	≤ Value of Map 8 ≤ Value of Map 9	P0411
Voltage at P0RL measurement – Voltage at P0R measurement	≤ 4 V	
Voltage at P0RL measurement – Voltage at P0L measurement	≤ 4 V	

P0RL: Both banks all closed pressure

P0R: Right bank all closed pressure

P0L: Left bank all closed pressure

Time Needed for Diagnosis:4000 ms + 992 ms + 992 ms + 992 ms

MAP 1

Amount of intake air (g (oz)/s)	0 (0)	60 (2.12)
Engine speed (rpm)	0	0
0	0	0
10000	0	0
		(V)

MAP 2

Amount of intake air (g (oz)/s)	0 (0)	60 (2.12)
Engine speed (rpm)	0	0
0	0	0
10000	0	0
		(V)

Diagnostic Trouble Code (DTC) Detecting Criteria

GENERAL DESCRIPTION

Map 3

Intake air (g (oz)/rev)	0.1 (0)	0.25 (0.01)	0.3 (0.01)	1 (0.04)
Threshold value (V)	13	13	3.25	3.25

MAP 4

Secondary air pressure in the pipe when both comb. valve is closing kPa (mmHg, inHg)	69.3 (520, 20.5)	74.6 (560, 22)	80 (600, 23.6)	85.3 (640, 25.2)	90.6 (680, 26.8)	96 (720, 28.3)	101.3 (760, 29.9)	106.6 (800, 31.5)	112 (840, 33.1)	117.3 (880, 34.6)	122.6 (920, 36.2)	128 (960, 37.8)	133.3 (1000, 39.4)	138.6 (1040, 40.9)	144 (1080, 42.5)	149.3 (1120, 44.1)
Secondary air pressure in the pipe when LH comb. valve is closing kPa (mmHg, inHg)	0	200	400	600	800	1000	1200	1400	1600	1800	2000	2200	2400	2400	2400	2400
69.3 (520, 20.5)	0	200	400	600	800	1000	1200	1400	1600	1800	2000	2200	2400	2400	2400	2400
74.6 (560, 22)	-200	0	200	400	600	800	1000	1200	1400	1600	1800	2000	2200	2400	2400	2400
80 (600, 23.6)	-400	-200	0	200	400	600	800	1000	1200	1400	1600	1800	2000	2200	2400	2400
85.3 (640, 25.2)	-600	-400	-200	0	200	400	600	800	1000	1200	1400	1600	1800	2000	2200	2400
90.6 (680, 26.8)	-800	-600	-400	-200	0	200	400	600	800	1000	1200	1400	1600	1800	2000	2200
96 (720, 28.3)	-1000	-800	-600	-400	-200	0	200	400	600	800	1000	1200	1400	1600	1800	2000
101.3 (760, 29.9)	-1200	-1000	-800	-600	-400	-200	0	200	400	600	800	1000	1200	1400	1600	1800
106.6 (800, 31.5)	-1400	-1200	-1000	-800	-600	-400	-200	0	200	400	600	800	1000	1200	1400	1600
112 (840, 33.1)	-1600	-1400	-1200	-1000	-800	-600	-400	-200	0	200	400	600	800	1000	1200	1400
117.3 (880, 34.6)	-1800	-1600	-1400	-1200	-1000	-800	-600	-400	-200	0	200	400	600	800	1000	1200
122.6 (920, 36.2)	-2000	-1800	-1600	-1400	-1200	-1000	-800	-600	-400	-200	0	200	400	600	800	1000
128 (960, 37.8)	-2200	-2000	-1800	-1600	-1400	-1200	-1000	-800	-600	-400	-200	0	200	400	600	800
133.3 (1000, 39.4)	-2400	-2200	-2000	-1800	-1600	-1400	-1200	-1000	-800	-600	-400	-200	0	200	400	600
138.6 (1040, 40.9)	-2400	-2400	-2200	-2000	-1800	-1600	-1400	-1200	-1000	-800	-600	-400	-200	0	200	400
144 (1080, 42.5)	-2400	-2400	-2400	-2200	-2000	-1800	-1600	-1400	-1200	-1000	-800	-600	-400	-200	0	200
149.3 (1120, 44.1)	-2400	-2400	-2400	-2400	-2200	-2000	-1800	-1600	-1400	-1200	-1000	-800	-600	-400	-200	0

(L/min)

Diagnostic Trouble Code (DTC) Detecting Criteria

GENERAL DESCRIPTION

Map 5

Secondary air pressure in the pipe when both comb. valve is closing kPa (mmHg, inHg) Secondary air pressure in the pipe when RH comb. valve is closing kPa (mmHg, inHg)	69.3 (520, 20.5)	74.6 (560, 22)	80 (600, 23.6)	85.3 (640, 25.2)	90.6 (680, 26.8)	96 (720, 28.3)	101.3 (760, 29.9)	106.6 (800, 31.5)	112 (840, 33.1)	117.3 (880, 34.6)	122.6 (920, 36.2)	128 (960, 37.8)	133.3 (1000, 39.4)	138.6 (1040, 40.9)	144 (1080, 42.5)	149.3 (1120, 44.1)
69.3 (520, 20.5)	0	200	400	600	800	1000	1200	1400	1600	1800	2000	2200	2400	2400	2400	2400
74.6 (560, 22)	-200	0	200	400	600	800	1000	1200	1400	1600	1800	2000	2200	2400	2400	2400
80 (600, 23.6)	-400	-200	0	200	400	600	800	1000	1200	1400	1600	1800	2000	2200	2400	2400
85.3 (640, 25.2)	-600	-400	-200	0	200	400	600	800	1000	1200	1400	1600	1800	2000	2200	2400
90.6 (680, 26.8)	-800	-600	-400	-200	0	200	400	600	800	1000	1200	1400	1600	1800	2000	2200
96 (720, 28.3)	-1000	-800	-600	-400	-200	0	200	400	600	800	1000	1200	1400	1600	1800	2000
101.3 (760, 29.9)	-1200	-1000	-800	-600	-400	-200	0	200	400	600	800	1000	1200	1400	1600	1800
106.6 (800, 31.5)	-1400	-1200	-1000	-800	-600	-400	-200	0	200	400	600	800	1000	1200	1400	1600
112 (840, 33.1)	-1600	-1400	-1200	-1000	-800	-600	-400	-200	0	200	400	600	800	1000	1200	1400
117.3 (880, 34.6)	-1800	-1600	-1400	-1200	-1000	-800	-600	-400	-200	0	200	400	600	800	1000	1200
122.6 (920, 36.2)	-2000	-1800	-1600	-1400	-1200	-1000	-800	-600	-400	-200	0	200	400	600	800	1000
128 (960, 37.8)	-2200	-2000	-1800	-1600	-1400	-1200	-1000	-800	-600	-400	-200	0	200	400	600	800
133.3 (1000, 39.4)	-2400	-2200	-2000	-1800	-1600	-1400	-1200	-1000	-800	-600	-400	-200	0	200	400	600
138.6 (1040, 40.9)	-2400	-2400	-2200	-2000	-1800	-1600	-1400	-1200	-1000	-800	-600	-400	-200	0	200	400
144 (1080, 42.5)	-2400	-2400	-2400	-2200	-2000	-1800	-1600	-1400	-1200	-1000	-800	-600	-400	-200	0	200
149.3 (1120, 44.1)	-2400	-2400	-2400	-2400	-2200	-2000	-1800	-1600	-1400	-1200	-1000	-800	-600	-400	-200	0

(L/min)

Diagnostic Trouble Code (DTC) Detecting Criteria

GENERAL DESCRIPTION

MAP 6

Amount of intake air when RH comb. valve switches (g (oz)/s) Battery voltage when RH comb. valve switches (V)	10 (0.35)	15 (0.53)	20 (0.71)	25 (0.88)	26 (0.92)
	0.025	0.025	0.025	0.005	0
	0.035	0.035	0.035	0.015	0
	0.05	0.05	0.05	0.025	0
	0.05	0.05	0.05	0.025	0

MAP 7

Amount of intake air when LH comb. valve switches (g (oz)/s) Battery voltage when LH comb. valve switches (V)	10 (0.35)	15 (0.53)	20 (0.71)	25 (0.88)	26 (0.92)
11	0.025	0.025	0.025	0.005	0
12	0.035	0.035	0.035	0.015	0
13	0.05	0.05	0.05	0.025	0
14	0.05	0.05	0.05	0.025	0
					(V)

Map 8

Amount of intake air when P0R is measuring (g (oz)/s) Battery voltage when P0R measuring (V)	2 (0.07)	25 (0.88)
11.5	345	345
12.5	345	345
13.5	345	345
14.5	390	390
15.5	420	420
		(L/min)

Map 9

Amount of intake air when P0L is measuring (g (oz)/s) Battery voltage when P0L measuring (V)	2 (0.07)	25 (0.88)
11.5	345	345
12.5	345	345
13.5	345	345
14.5	390	390
15.5	420	420
		(L/min)

Map 10

Amount of intake air (g (oz)/s) Engine speed (rpm)	0 (0)	60 (2.12)
500	0	0
5000	0	0

Diagnostic Trouble Code (DTC) Detecting Criteria

GENERAL DESCRIPTION

BD:DTC P0411 SECONDARY AIR INJECTION SYSTEM INCORRECT FLOW DETECTED

1. OUTLINE OF DIAGNOSIS

NOTE:

For the detection standard, refer to DTC P0410. <Ref. to GD(H4DOTC)-96, DTC P0410 SECONDARY AIR INJECTION SYSTEM, Diagnostic Trouble Code (DTC) Detecting Criteria.>

Diagnostic Trouble Code (DTC) Detecting Criteria

GENERAL DESCRIPTION

BE:DTC P0413 SECONDARY AIR INJECTION SYSTEM SWITCHING VALVE "A" CIRCUIT OPEN

1. OUTLINE OF DIAGNOSIS

Judge as NG when the ECM output level differs from the actual terminal level.

2. ENABLE CONDITION

Secondary Parameters	Enable Conditions
None	

3. GENERAL DRIVING CYCLE

Always perform the diagnosis continuously.

4. DIAGNOSTIC METHOD

• Abnormality Judgement

If the duration of time while the following conditions are met is longer than the time indicated, judge as NG.

Judgement Value

Malfunction Criteria	Threshold Value
Battery voltage	≥ 10.9 V
Ignition	ON
Terminal output voltage when ECM outputs OFF signal	LOW

Time Needed for Diagnosis: 2500 ms

Malfunction Indicator Light Illumination: Illuminates as soon as a malfunction occurs.

• Normality Judgement

Judge as OK and clear the NG if the continuous time while the following conditions are established is more than the predetermined time.

Judgement Value

Malfunction Criteria	Threshold Value
Battery voltage	≥ 10.9 V
Ignition	ON
Terminal output voltage when ECM outputs OFF signal	HIGH

Time Needed for Diagnosis: Less than 1 second

Diagnostic Trouble Code (DTC) Detecting Criteria

GENERAL DESCRIPTION

BF:DTC P0414 SECONDARY AIR INJECTION SYSTEM SWITCHING VALVE "A" CIRCUIT SHORTED

1. OUTLINE OF DIAGNOSIS

Judge as NG when the ECM output level differs from the actual terminal level.

2. ENABLE CONDITION

Secondary Parameters	Enable Conditions
None	

3. GENERAL DRIVING CYCLE

Always perform the diagnosis continuously.

4. DIAGNOSTIC METHOD

• Abnormality Judgement

If the duration of time while the following conditions are met is longer than the time indicated, judge as NG.

Judgement Value

Malfunction Criteria	Threshold Value
Battery voltage	≥ 10.9 V
Ignition	ON
Terminal output voltage when ECM outputs ON signal	HIGH

Time Needed for Diagnosis: 2500 ms

Malfunction Indicator Light Illumination: Illuminates as soon as a malfunction occurs.

• Normality Judgement

Judge as OK and clear the NG if the continuous time while the following conditions are established is more than the predetermined time.

Judgement Value

Malfunction Criteria	Threshold Value
Battery voltage	≥ 10.9 V
Ignition	ON
Terminal output voltage when ECM outputs ON signal	LOW

Time Needed for Diagnosis: Less than 1 second

Diagnostic Trouble Code (DTC) Detecting Criteria

GENERAL DESCRIPTION

BG:DTC P0416 SECONDARY AIR INJECTION SYSTEM SWITCHING VALVE “B” CIRCUIT OPEN

1. OUTLINE OF DIAGNOSIS

NOTE:

For the detection standard, refer to DTC P0413. <Ref. to GD(H4DOTC)-106, DTC P0413 SECONDARY AIR INJECTION SYSTEM SWITCHING VALVE “A” CIRCUIT OPEN, Diagnostic Trouble Code (DTC) Detecting Criteria.>

BH:DTC P0417 SECONDARY AIR INJECTION SYSTEM SWITCHING VALVE “B” CIRCUIT SHORTED

1. OUTLINE OF DIAGNOSIS

NOTE:

For the detection standard, refer to DTC P0414. <Ref. to GD(H4DOTC)-107, DTC P0414 SECONDARY AIR INJECTION SYSTEM SWITCHING VALVE “A” CIRCUIT SHORTED, Diagnostic Trouble Code (DTC) Detecting Criteria.>

Diagnostic Trouble Code (DTC) Detecting Criteria

GENERAL DESCRIPTION

BI: DTC P0418 SECONDARY AIR INJECTION SYSTEM CONTROL "A" CIRCUIT OPEN

1. OUTLINE OF DIAGNOSIS

Judge as NG when the ECM output level differs from the actual terminal level.

2. ENABLE CONDITION

Secondary Parameters	Enable Conditions
None	

3. GENERAL DRIVING CYCLE

Always perform the diagnosis continuously.

4. DIAGNOSTIC METHOD

• Abnormality Judgement

If the duration of time while the following conditions are met is longer than the time indicated, judge as NG.

Judgement Value

Malfunction Criteria	Threshold Value
Battery voltage	≥ 10.9 V
Ignition	ON
Terminal output voltage when ECM outputs OFF signal	LOW

Time Needed for Diagnosis: 2500 ms

Malfunction Indicator Light Illumination: Illuminates as soon as a malfunction occurs.

• Normality Judgement

Judge as OK and clear the NG if the continuous time while the following conditions are established is more than the predetermined time.

Judgement Value

Malfunction Criteria	Threshold Value
Battery voltage	≥ 10.9 V
Ignition	ON
Terminal output voltage when ECM outputs OFF signal	HIGH

Time Needed for Diagnosis: Less than 1 second

Diagnostic Trouble Code (DTC) Detecting Criteria

GENERAL DESCRIPTION

BJ:DTC P0420 CATALYST SYSTEM EFFICIENCY BELOW THRESHOLD (BANK 1)

1. OUTLINE OF DIAGNOSIS

Detect the deterioration of the catalyst function.

Though the front oxygen sensor output would change slowly with a new catalyst, the sensor output with a deteriorated catalyst becomes high and the inversion time is shortened.

For this reason, the catalyst diagnosis is carried out by monitoring the front oxygen sensor output and comparing it with the front oxygen (A/F) sensor output.

2. COMPONENT DESCRIPTION

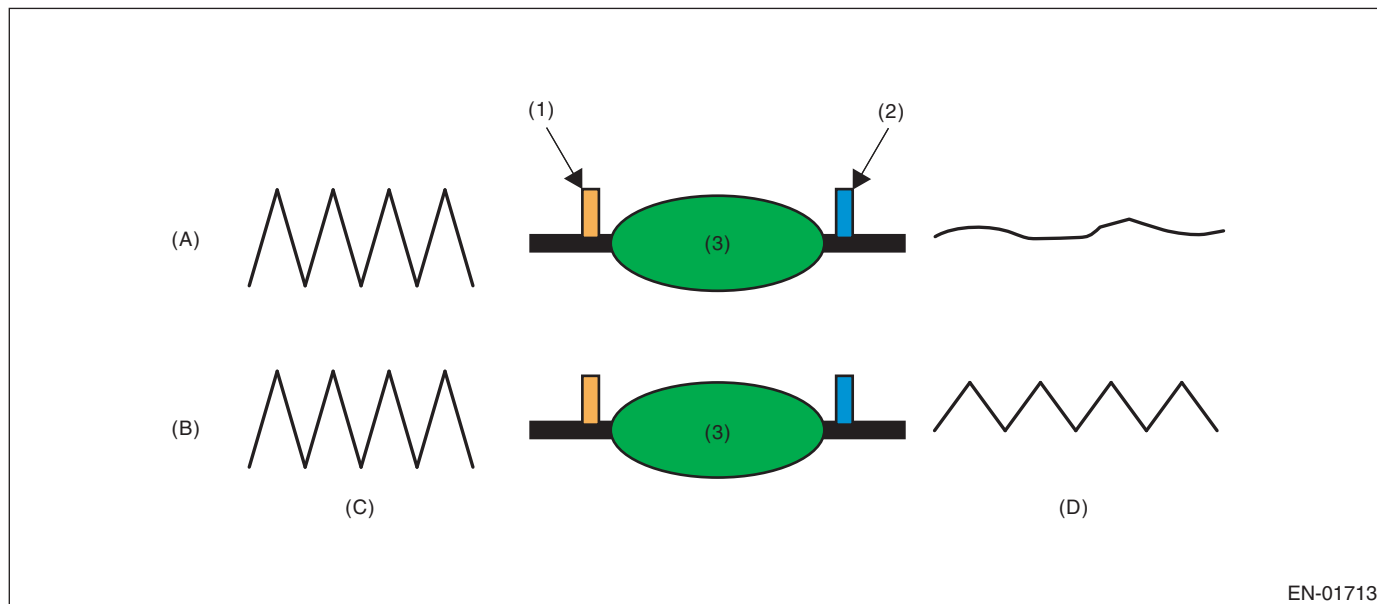

(A) Normal

(B) Deterioration

(C) Output waveform from the front oxygen (A/F) sensor

(D) Output waveform from the rear oxygen Sensor

(1) Front oxygen (A/F) sensor

(2) Front oxygen sensor

(3) Catalytic converter

3. ENABLE CONDITION

Secondary Parameters	Enable Conditions
Battery voltage	≥ 10.9 V
Barometric pressure	≥ 75 kPa (563 mmHg, 22.2 inHg)
Engine coolant temperature	≥ 70 °C (158 °F)
Estimated catalyst temperature	≥ 460 °C (860 °F)
Misfire detection every 200 rotations	< 5 time(s)
Learning value of evaporation gas density	< 0.2
Sub feedback	In operation
Evaporative system diagnosis	Not in operation
Time of difference (< 0.10) between actual lambda and target lambda	≥ 1000 ms
Vehicle speed	> 60 km/h (37.3 MPH)
Amount of intake air	≥ 10 g/s (0.35 oz/s) and < 50 g/s (1.76 oz/s)
Engine load change every 0.5 engine revs.	< 0.02 g/rev (0 oz/rev)
Rear oxygen output change from 660 mV or less to 660 mV or more	Experienced after fuel cut
Elapsed time after starting the engine	≥ 200 s
Purge execution calculated time	≥ 5 s

Diagnostic Trouble Code (DTC) Detecting Criteria

GENERAL DESCRIPTION

4. GENERAL DRIVING CYCLE

Perform the diagnosis only once at a constant 60 km/h (37.3 MPH) or higher.

5. DIAGNOSTIC METHOD

After establishing the execution conditions, calculate the front oxygen (A/F) sensor lambda deviation cumulative value per 32 milliseconds $\times 4$ ($\sum |(sglmd_n - sglmd_{n-1})|$) and rear oxygen sensor output voltage deviation cumulative value ($\sum |(ro2sad_n - ro2sad_{n-1})|$), and when the front oxygen (A/F) sensor lambda deviation cumulative value ($\sum |(sglmd_n - sglmd_{n-1})|$) becomes the predetermined value or more, calculate the diagnostic value.

• Abnormality Judgement

If the duration of time while the following conditions are met is within the time indicated, judge as NG.

Judgement Value

Malfunction Criteria	Threshold Value
$\sum (ro2sad_n - ro2sad_{n-1}) / \sum (sglmd_n - sglmd_{n-1}) $	> 10.5

Time Needed for Diagnosis: 30 — 55 seconds

Malfunction Indicator Light Illumination: Illuminates when malfunction occurs in 2 continuous driving cycles.

• Normality Judgement

Judge as OK and clear the NG if the continuous time while the following conditions are established is within the predetermined time.

Judgement Value

Malfunction Criteria	Threshold Value
$\sum (ro2sad_n - ro2sad_{n-1}) / \sum (sglmd_n - sglmd_{n-1}) $	≤ 10.5

Time Needed for Diagnosis: 30 — 55 seconds

Diagnostic Trouble Code (DTC) Detecting Criteria

GENERAL DESCRIPTION

0.04-inch Diagnosis

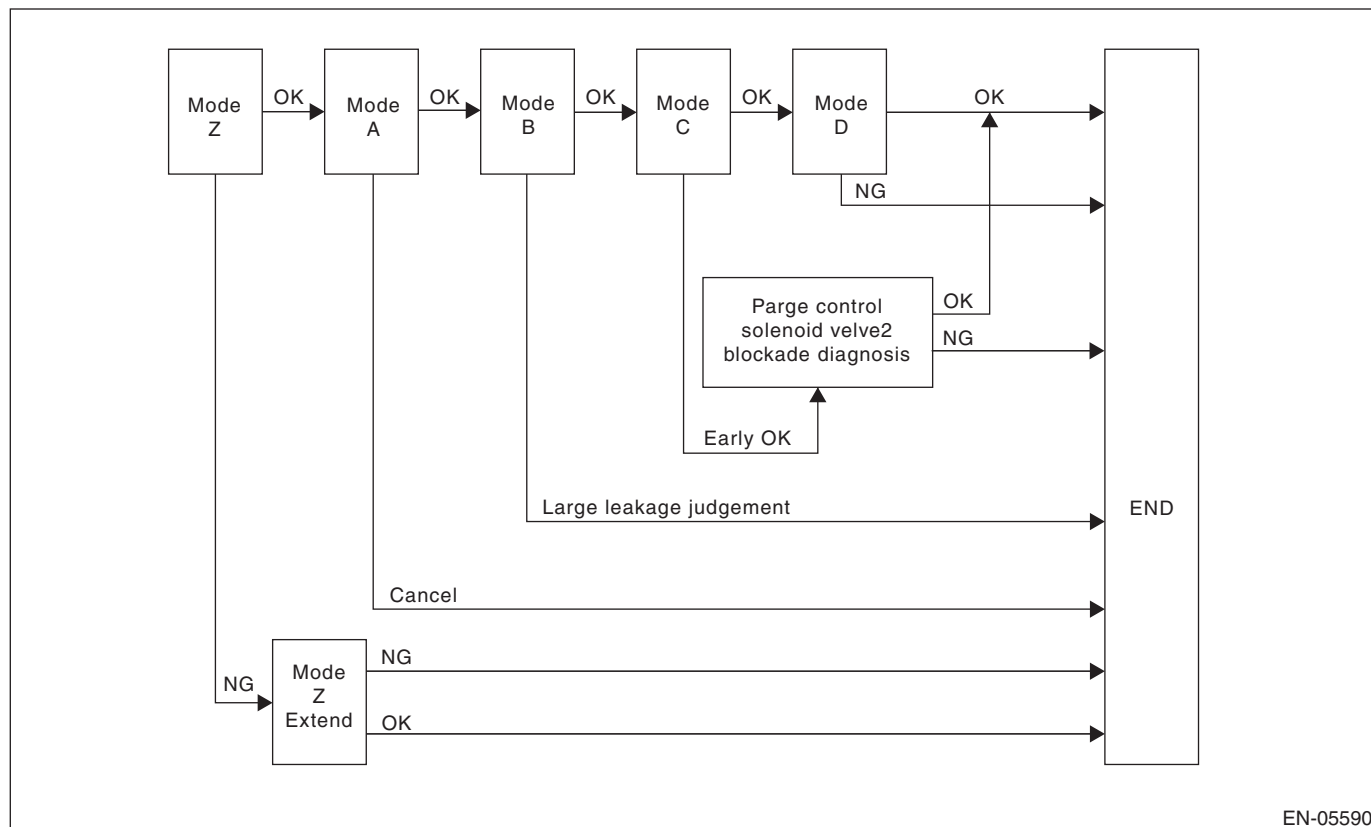

EN-05590

Mode	Mode Description	Diagnosis Period
Mode Z (Purge control solenoid valve opening failure diagnosis)	Perform purge control solenoid valve opening failure diagnosis from the size of tank pressure variation from diagnosis start.	0 ms + 3000 ms — 0 ms + 3000 ms + 13000 ms
Mode A (Estimated evaporation amount)	Calculate the tank pressure change amount (P1).	10000 ms
Mode B (Sealed negative pressure, large leakage judgement)	Decrease the pressure in the tank to the target value by introducing the intake manifold pressure to the fuel tank. If the tank pressure cannot be reduced, it is diagnosed as large leak.	0 — 10000 ms + 25000 ms
Mode C (Pressure increase check, advanced OK judgement)	Wait until the tank pressure returns to the target (start level of P2 calculation). If the tank pressure does not become the value, make advanced OK judgement.	0 — 18600 ms
Mode D (Negative pressure variation measurement, evaporation leakage diagnosis)	Calculate the tank pressure variation (P2), and obtain the diagnostic value using P1 found in Mode A. Perform the evaporation diagnosis using the diagnostic value.	0 ms + 10000 ms

Mode Table for Evaporative Emission Control System Diagnosis

Mode	Behavior of tank internal pressure under normal conditions	Diagnostic item	DTC
Mode Z	Roughly the same as barometric pressure (Same as 0 kPa (0 mmHg, 0 inHg))	Purge control solenoid valve is judged to be open.	P0457
Mode A	Pressure is in proportion to amount of evaporative emission.	—	None
Mode B	Negative pressure is formed due to intake manifold negative pressure	Large leak	P0457
Mode C	Reaches target pressure	—	None
Mode D	Pressure change is small.	EVAP system large leak determination [1.0 mm (0.04 in)]	P0442

Diagnostic Trouble Code (DTC) Detecting Criteria

GENERAL DESCRIPTION

0.02-inch Diagnosis

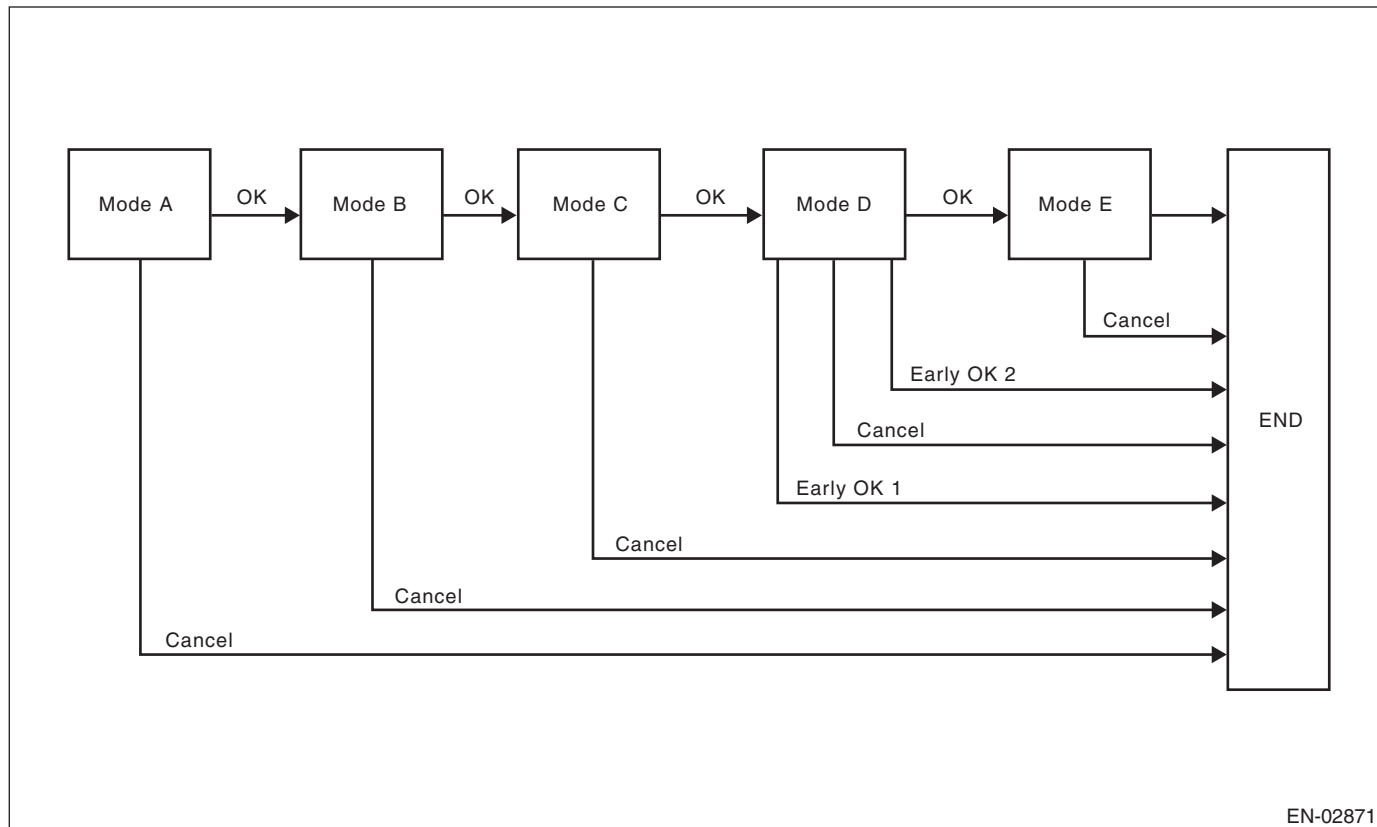

EN-02871

Mode	Mode Description	Diagnosis Period
Mode A (0 point compensation)	When the pressure in the tank is not near 0 mmHg, wait until it returns to 0 point (near 0 mmHg).	0 — Value of Map 1
Mode B (Negative pressure introduced)	Decrease the pressure in the tank to the target value by introducing the intake manifold pressure to the fuel tank.	0 — Value of Map 2
Mode C (Negative pressure maintained)	Wait until the tank pressure returns to the target (start level of P2 calculation).	0 — 22820 ms + 0 + Value from Map 2
Mode D (Negative pressure change calculated)	Calculate the time it takes for the tank pressure to change to the Mode E shifting pressure. If the tank pressure does not change to the Mode E shifting pressure, make advanced OK judgement.	0 — 0 ms + 200000 ms
Mode E (Evaporation generated amount calculation)	Calculate the amount of evaporation (P1).	0 — 0 ms + 200000 ms + Value from Map 3

MAP 1

Fuel level (ℓ , US gal, Imp gal)	0	10, 2.64, 2.2	20, 5.28, 4.4	30, 7.93, 6.6	40, 10.57, 8.8	50, 13.21, 11	60, 15.85, 13.2
Time Needed for Diagnosis (ms)	13800	13800	11400	9000	7000	5000	5000

MAP 2

Fuel level (ℓ , US gal, Imp gal)	0	10, 2.64, 2.2	20, 5.28, 4.4	30, 7.93, 6.6	40, 10.57, 8.8	50, 13.21, 11	60, 15.85, 13.2
Time Needed for Diagnosis (ms)	19520	19520	19850	20180	19975	19770	19770

Map 3

Fuel level (ℓ , US gal, Imp gal)	0	10, 2.64, 2.2	20, 5.28, 4.4	30, 7.93, 6.6	40, 10.57, 8.8	50, 13.21, 11	60, 15.85, 13.2
Time Needed for Diagnosis (ms)	80000	80000	70000	60000	60000	60000	60000

Diagnostic Trouble Code (DTC) Detecting Criteria

GENERAL DESCRIPTION

2. COMPONENT DESCRIPTION

Pressure control solenoid valve

PCV controls the fuel tank pressure to be equal to the atmospheric air pressure. Normally, the solenoid is set to OFF. The valve opens and closes mechanically in accordance with the pressure difference between tank and atmospheric air, or tank and canister.

The valve is forcibly opened by setting the solenoid to ON at the time of diagnosis.

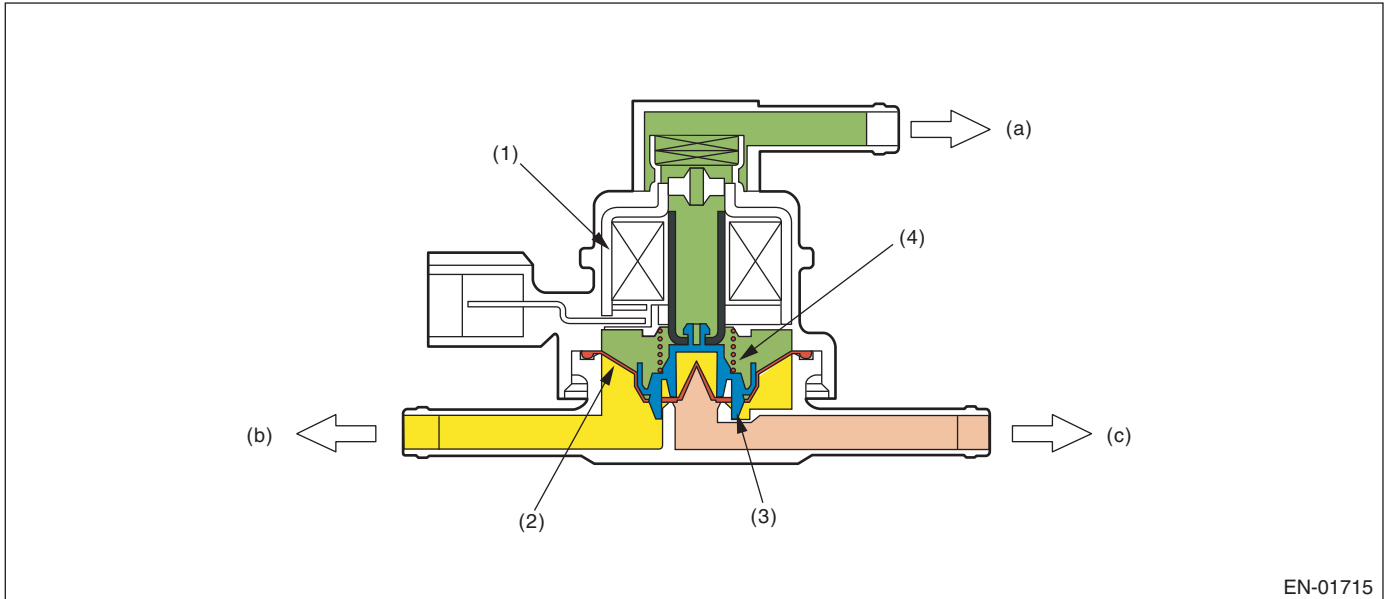

(a) Barometric pressure

(b) Fuel tank

(c) Canister

(1) Solenoid

(3) Valve

(4) Spring

(2) Diaphragm

Diagnostic Trouble Code (DTC) Detecting Criteria

GENERAL DESCRIPTION

Valve Operation and Air Flow

In the figure below, divided by the diaphragm, the part above X is charged with atmospheric air pressure, and the part below X is charged with tank pressure. Also, the part above Y is charged with tank pressure, and the part below Y is charged with canister pressure.

If the atmospheric air pressure port is A, tank pressure port is B, and canister pressure port is C, the air flows according to pressure difference from each port as shown in the table below.

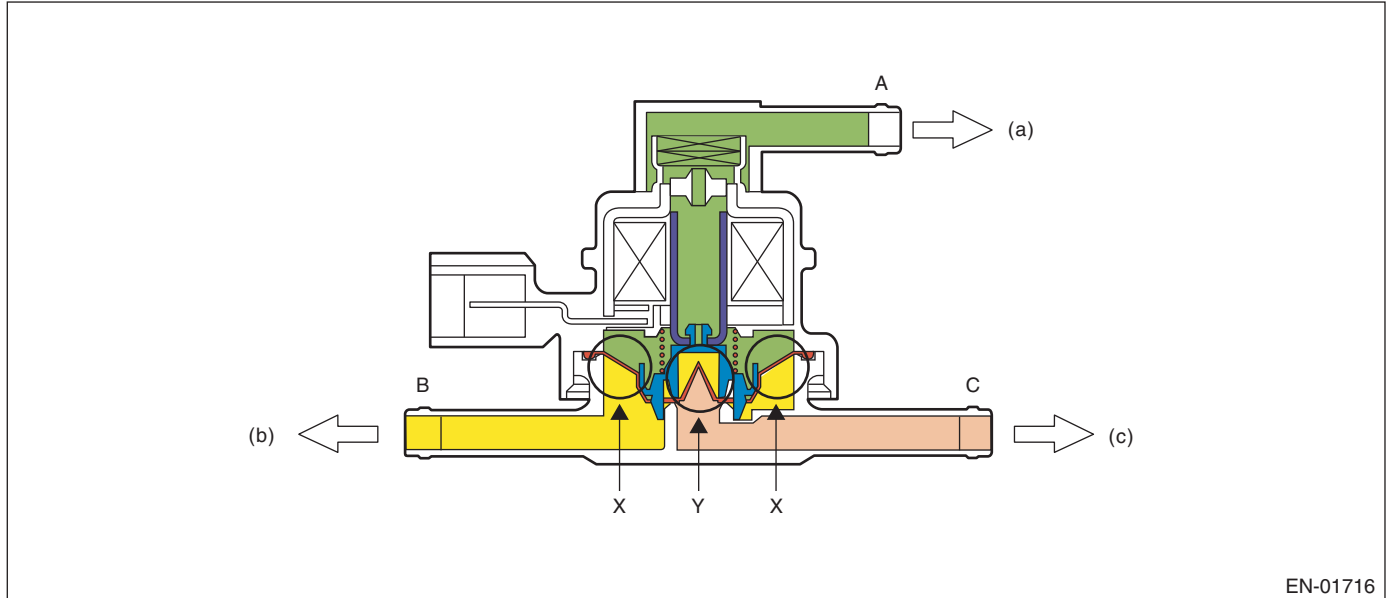

(a) Barometric pressure

(b) Fuel tank

(c) Canister

Condition of pressure	Flow
$A < B$ (solenoid OFF)	$B \rightarrow C$
$B < C$ (solenoid OFF)	$C \rightarrow B$
Solenoid ON	$B \leftrightarrow C$

When $A < B$ (solenoid OFF)

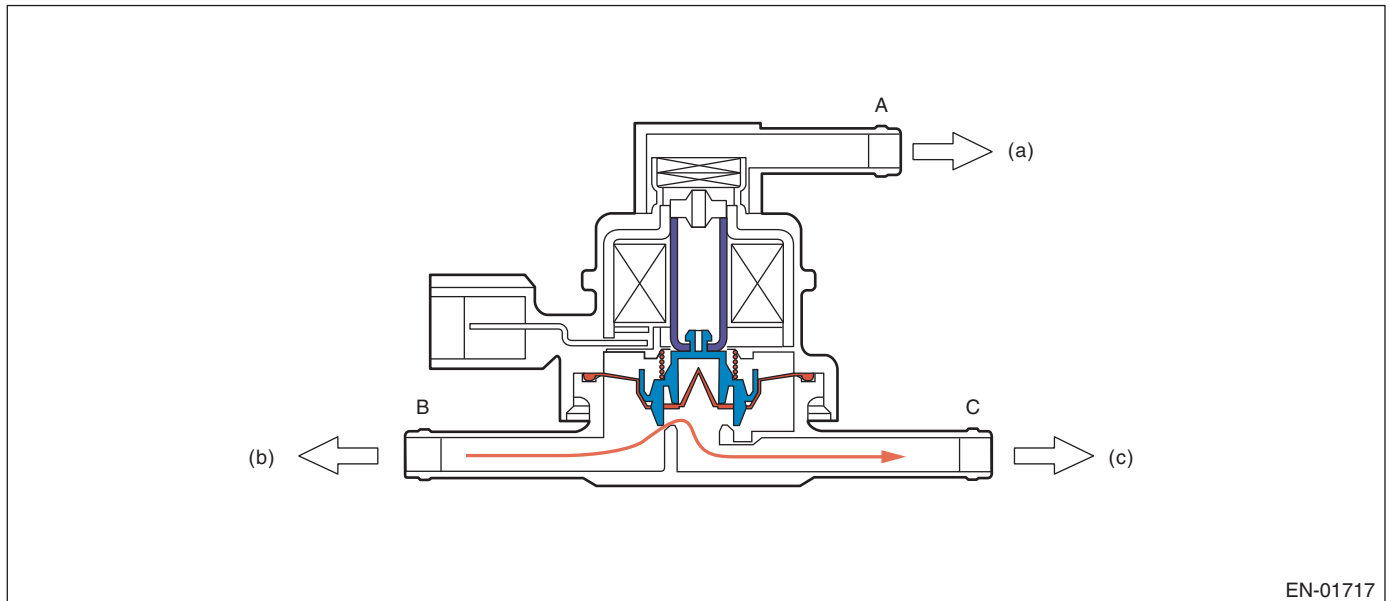

(a) Barometric pressure

(b) Fuel tank

(c) Canister

Diagnostic Trouble Code (DTC) Detecting Criteria

GENERAL DESCRIPTION

When $B < C$ (solenoid OFF)

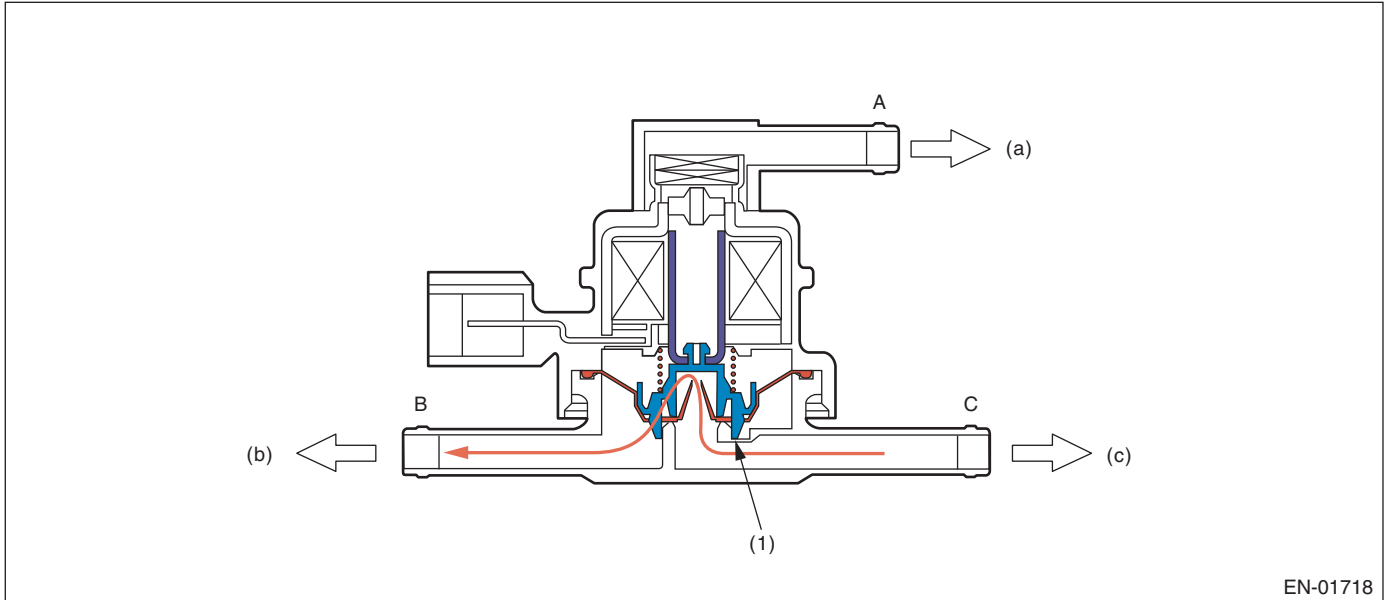

(a) Barometric pressure

(b) Fuel tank

(c) Canister

(1) Valve

When Solenoid is ON

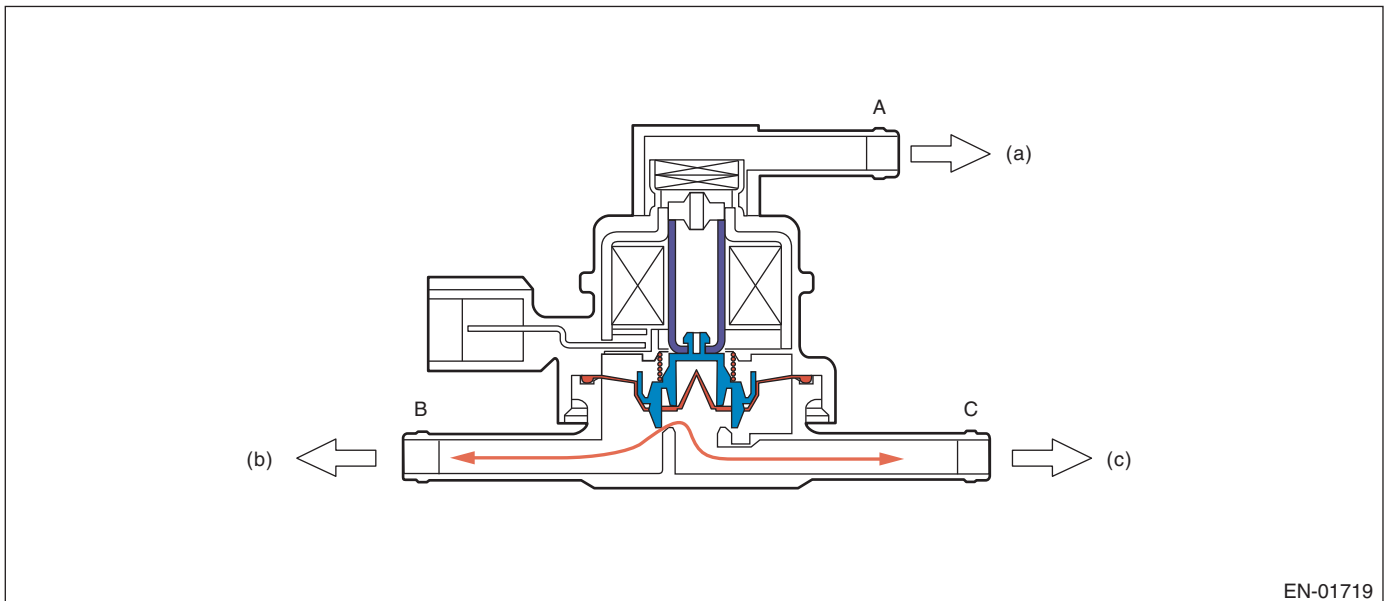

(a) Barometric pressure

(b) Fuel tank

(c) Canister

Diagnostic Trouble Code (DTC) Detecting Criteria

GENERAL DESCRIPTION

Drain valve

Drain valve controls the ambient air to be introduced to the canister.

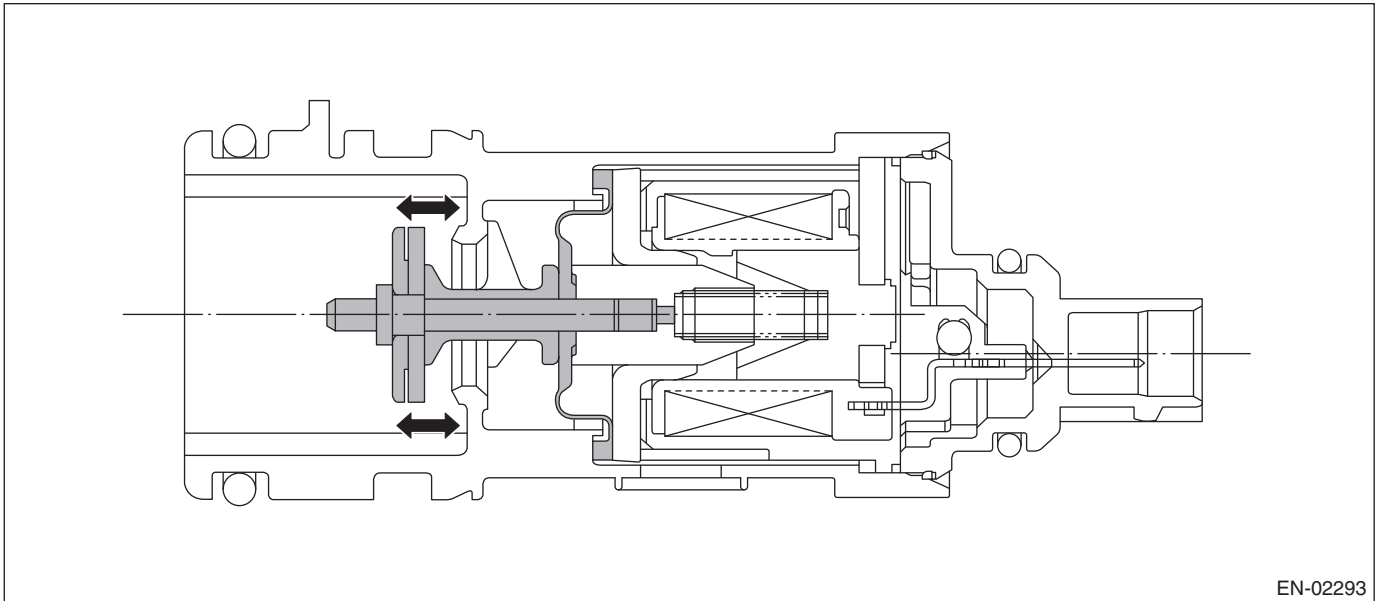

3. ENABLE CONDITION

0.04-inch Diagnosis

Secondary Parameters	Enable Conditions
Battery voltage	$\geq 10.9 \text{ V}$
Barometric pressure	$\geq 75 \text{ kPa}$ (563 mmHg, 22.2 inHg)
Total time of canister purge operation	$\geq 120000 \text{ ms}$
Elapsed time after starting the engine	$\geq 856 \text{ s}$
Learning value of evaporation gas density	< 0.08
Engine speed	1050 rpm — 6500 rpm
Fuel tank pressure	$\geq -4 \text{ kPa}$ (-30 mmHg, -1.2 inHg)
Intake manifold relative vacuum (relative pressure)	$\geq -13.3 \text{ kPa}$ (-100 mmHg, -3.9 inHg)
Vehicle speed	$\geq 32 \text{ km/h}$ (19.9 MPH)
Fuel level	9.6 ℓ (2.54 US gal, 2.11 Imp gal) — 54.4 ℓ (14.37 US gal, 11.97 Imp gal)
Closed air/fuel ratio control	In operation
Fuel temperature	$-10 \text{ }^\circ\text{C}$ (14 $^\circ\text{F}$) — $45 \text{ }^\circ\text{C}$ (113 $^\circ\text{F}$)
Intake air temperature	$\geq -10 \text{ }^\circ\text{C}$ (14 $^\circ\text{F}$)
Pressure change every one second	$< 1.7 \text{ mmHg}$ (Mode A) $< 1.7 \text{ mmHg}$ (Mode D)
Minimum pressure change value every one second – Maximum pressure change value every one second	$< 1.7 \text{ mmHg}$ (Mode A) $< 1.7 \text{ mmHg}$ (Mode D)
Change of fuel level per 128 milliseconds	$< 3 \text{ } \ell$ (0.79 US gal, 0.66 Imp gal)
Air fuel ratio	0.76 — 1.25

Diagnostic Trouble Code (DTC) Detecting Criteria

GENERAL DESCRIPTION

0.02-inch Diagnosis

Secondary Parameters	Enable Conditions
At starting a diagnosis	
Evap. diagnosis	Incomplete
Battery voltage	≥ 10.9 V
Barometric pressure	≥ 75 kPa (563 mmHg, 22.2 inHg)
Time since last incomplete 0.02-inch leakage diagnosis	
When cancelling in mode A	> 120000 ms
When cancelling in other than mode A	> 600000 ms
Total time of canister purge operation	≥ 120000 ms
Elapsed time after starting the engine	≥ 120 s
Fuel temperature	-10 °C (14 °F) — 55 °C (131 °F)
Fuel level	9.6 ℓ (2.54 US gal, 2.11 Imp gal) — 54.4 ℓ (14.37 US gal, 11.97 Imp gal)
Intake manifold relative vacuum (relative pressure)	≥ -13.3 kPa (-100 mmHg, -3.9 inHg)
Fuel tank pressure	-0.7 kPa (-5 mmHg, -0.2 inHg) — 1.4 kPa (10.7 mmHg, 0.4 inHg)
Vehicle speed	50 km/h (31.1 MPH) — 510 km/h (316.9 MPH) continues for 125000 ms
Closed air/fuel ratio control	In operation
Engine speed	1050 rpm — 6000 rpm
During diagnosis	
Change of fuel level	≤ Value of Map 4
Pressure change every one second	< 0.1 kPa (0.44 mmHg, 0 inHg)
Minimum pressure change value every one second – Maximum pressure change value every one second	< 0.1 kPa (0.51 mmHg, 0 inHg) (Mode D)
Pressure change in tank every second	≤ 0.1 kPa (0.75 mmHg, 0 inHg)
Barometric pressure change	-0.5 kPa (-3.6 mmHg, -0.1 inHg) — 0.3 kPa (2.4 mmHg, 0.1 inHg) (Mode D) -0.3 kPa (-2.4 mmHg, -0.1 inHg) — 0.3 kPa (2.4 mmHg, 0.1 inHg) (Mode E)

MAP 4

Fuel level (ℓ, US gal, Imp gal)	0	10, 2.64, 2.2	20, 5.28, 4.4	30, 7.93, 6.6	40, 10.57, 8.8	50, 13.21, 11	60, 15.85, 13.2
Change (ℓ, US gal, Imp gal)	5, 1.32, 1.1	5, 1.32, 1.1	5, 1.32, 1.1	5, 1.32, 1.1	5, 1.32, 1.1	5, 1.32, 1.1	5, 1.32, 1.1

4. GENERAL DRIVING CYCLE

0.04-inch Diagnosis

- Perform the diagnosis only once in 856 seconds or more after starting the engine, at a constant speed of 32 km/h (20 MPH) or more.
- Pay attention to the fuel temperature and fuel level.

0.02-inch Diagnosis

- Perform the diagnosis 125 seconds or more at a constant engine speed of 50 km/h (31 MPH) or higher to judge as NG or OK.
- If judgement cannot be made, repeat the diagnosis.
- Pay attention to the fuel level.

Diagnostic Trouble Code (DTC) Detecting Criteria

GENERAL DESCRIPTION

5. DIAGNOSTIC METHOD

Purge control solenoid valve stuck open fault diagnosis

DTC

P0457 Evaporative Emission Control System Leak Detected (Fuel Cap Loose/Off)

Purpose of Mode Z

When performing the leakage diagnosis of EVAP system, the purge control solenoid valve must operate normally. Therefore, mode Z is used to diagnose the purge control solenoid valve stuck open condition. Note that if a purge control solenoid valve stuck open fault is detected, the EVAP system leakage diagnosis is cancelled.

DIAGNOSTIC METHOD

Purge control solenoid valve functional diagnosis is performed by monitoring the tank pressure in mode Z.

• Abnormality Judgement

If OK judgement cannot be made, extend Mode Z, and Judge as NG when the following conditions are established after predetermined amount of time.

Judgement Value

Malfunction Criteria	Threshold Value	DTC
evptez – evptezha	> 0.9 kPa (6.5 mmHg, 0.3 inHg)	P0457
evptezini	≤ 1.4 kPa (10.7 mmHg, 0.4 inHg)	
Time of 2 ℓ (0.53 US gal, 0.44 Imp gal) or more fuel no sloshing	≥ 40000 ms	

Time Needed for Diagnosis: 0 ms + 3000 ms + 13000 ms

Malfunction Indicator Light Illumination: Illuminates when malfunction occurs in 2 continuous driving cycles.

When judgement for purge control solenoid valve stuck open NG is made, end the evaporative diagnosis. Cancel the evaporative diagnosis when the OK/NG judgement for purge control solenoid valve stuck open cannot be made in Mode Z.

• Normality Judgement

Judge as OK and change to Mode A when the following conditions are established after predetermined time has passed since Mode Z started.

Judgement Value

Malfunction Criteria	Threshold Value	DTC
evptez – evptezha	≤ 0.4 kPa (3 mmHg, 0.1 inHg)	P0457

Diagnostic Trouble Code (DTC) Detecting Criteria

GENERAL DESCRIPTION

Normal

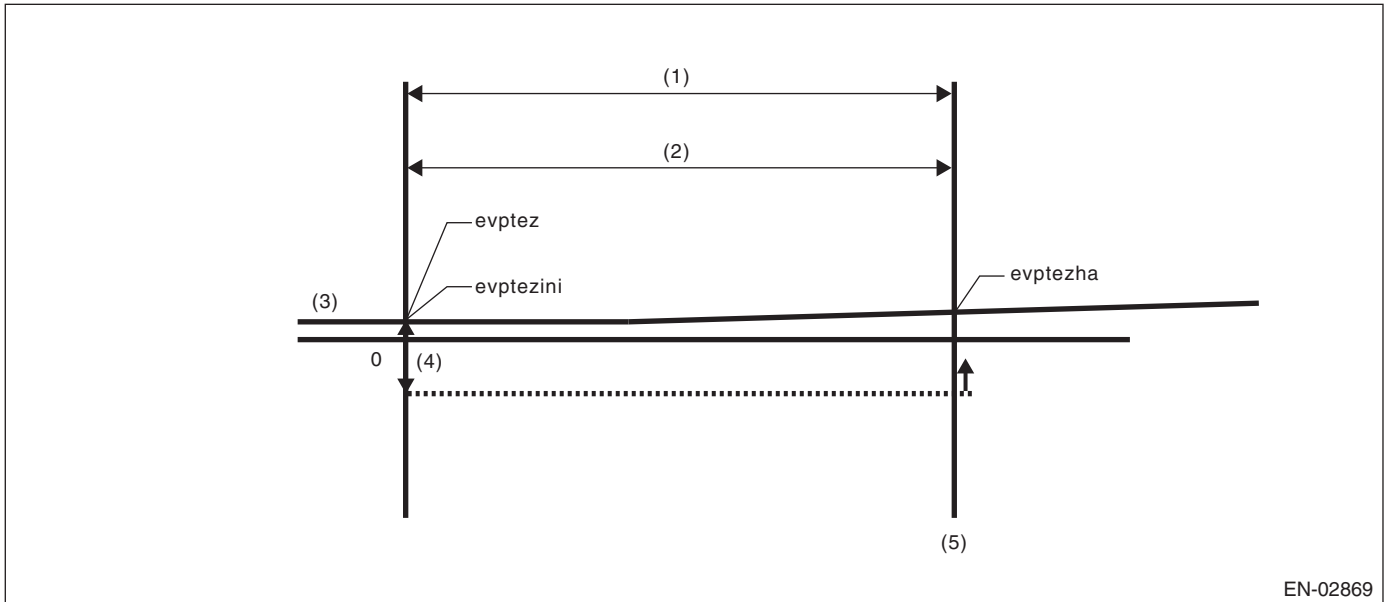

EN-02869

- (1) Mode Z
- (2) 3000 ms

- (3) Fuel tank pressure
- (4) 0.4 kPa (3 mmHg, 0.1 inHg)

- (5) OK judgement

$evptez - evptezha \leq 0.4 \text{ kPa (3 mmHg, 0.1 inHg)}$ Normal when above is established

Time Needed for Diagnosis: 0 ms + 3000 ms

Diagnostic Trouble Code (DTC) Detecting Criteria

GENERAL DESCRIPTION

Purge control solenoid valve Open Fixation

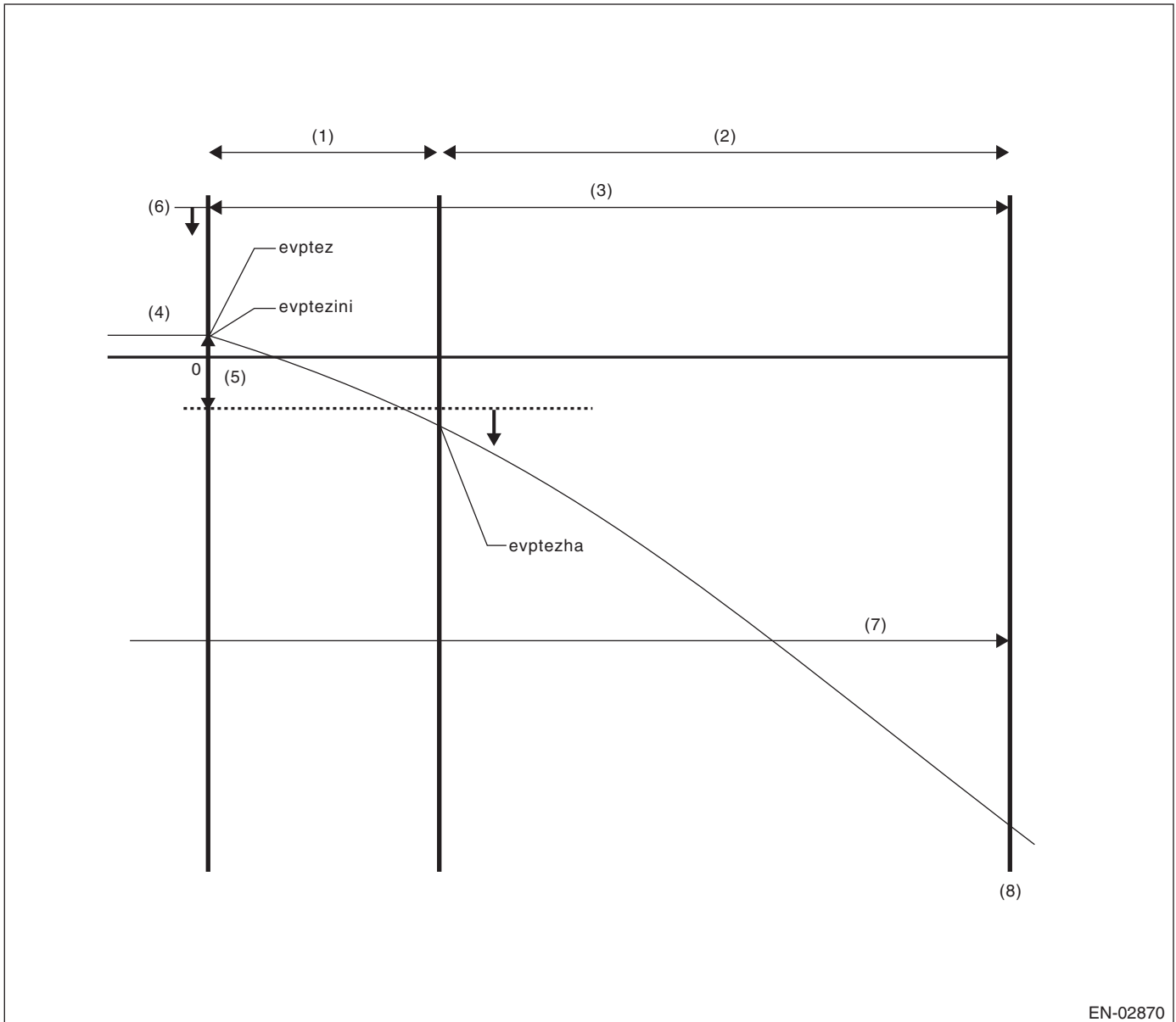

- | | | |
|------------------------|-----------------------------------|-------------------------------|
| (1) Mode Z | (4) Fuel tank pressure | (7) 40000 ms no fuel sloshing |
| (2) Extended mode Z | (5) 0.9 kPa (6.5 mmHg, 0.3 inHg) | (8) NG judgement |
| (3) 3000 ms + 13000 ms | (6) 1.4 kPa (10.7 mmHg, 0.4 inHg) | |

- $evptezini \leq 1.4 \text{ kPa}$ (10.7 mmHg, 0.4 inHg)
 - $evptez - evptezha > 0.9 \text{ kPa}$ (6.5 mmHg, 0.3 inHg)
 - No fuel sloshing of over 2 \varnothing (0.53 US gal, 0.44 Imp gal) lasts for more than 40000 ms.
- Judge as abnormal when all are established.

Diagnostic Trouble Code (DTC) Detecting Criteria

GENERAL DESCRIPTION

Leak Diagnosis

DTC

P0442 Evaporative Emission Control System Leak Detected (Small Leak)

P0457 Evaporative Emission Control System Leak Detected (Fuel Cap Loose/Off)

- The diagnostic consists of creating a sealed vacuum in the fuel tank and then determining the presence of leakage from the speed at which the tank internal pressure returns to barometric pressure.
- The diagnosis is divided into the following five phases.

Mode A: (Estimated evaporation gas amount)

Calculate the tank pressure change amount (P1) when using mode A. After calculating P1, switch to mode B.

Mode B: (Negative pressure sealed)

Introduce negative pressure in the intake manifold to the tank.

Approx. 0 → -1.4 kPa (0 → -10.5 mmHg, 0 → -0.4 inHg)

When the pressure above (desired negative pressure) is reached, enters Mode C.

In this case, if the tank pressure does not reach the target negative pressure, judge that there is a large leakage in the system and terminate the evaporative emission control system diagnosis.

Abnormality Judgement

Judge as NG (large leakage) when the following conditions are established.

Judgement Value

Malfunction Criteria	Threshold Value	DTC
Time to reach target negative pressure or Mode B time (Min. pressure value in tank when in mode B) – (Tank pressure when mode B started)	≥ 10000 ms + 25000 ms ≥ 10000 ms > -0.3 kPa (-2.5 mmHg, -0.1 inHg)	P0457

Time Needed for Diagnosis: 0 ms + 3000 ms + 10000 ms + 10000 ms + 25000 ms

Mode C: (Check pressure rise)

Stop the introduction of negative pressure. (Wait until the tank pressure returns to the start level of P2 calculation.)

Change to Mode D when the tank pressure returns to the start level of P2 calculation.

Judge advanced OK and change to Mode E when it does not return in spite of spending the specified time.

Tank pressure when starting calculation of P2	Time for advanced OK judgement
-1.4 kPa (-10.5 mmHg, -0.4 inHg)	18600 ms

Time Needed for Diagnosis: 0 ms + 3000 ms + 10000 ms + 10000 ms + 25000 ms + 18600 ms

Mode D: (Measure amount of negative pressure change)

Monitor the tank pressure change amount when using mode D. In this case, the tank pressure increases, (nears barometric pressure) because evaporation occurs. However, if any leakage exists, the pressure increases additionally in proportion to this leakage. The pressure variation of this tank is P2.

After calculating P2, perform a small leak diagnosis according to the items below.

When Mode D is ended

Assign tank variations measured in Mode A and Mode D, P1 and P2, to the formula below, judge small leaks in the system. If the measured judgement value exceeds the threshold value, it is judged to be a malfunction.

Abnormality Judgement

Judge as NG when the following conditions are established within the predetermined time. Judge as OK and clear the NG if the following conditions are not established within the predetermined time.

Judgement Value

Malfunction Criteria	Threshold Value	DTC
$P2 - 1.5 - \times P1$ P2: Tank pressure that changes every 10000 ms in mode D P1: Tank pressure that changes every 10000 ms in mode A	> Value of Map 5	P0442

*1.5 –: Evaporation amount compensation value when below negative pressure (Amount of evaporation occurrence increases as a vacuum condition increases.)

Diagnostic Trouble Code (DTC) Detecting Criteria

GENERAL DESCRIPTION

Map 5 Malfunction criteria limit for evaporation diagnosis

Fuel temperature vs. Fuel level	25 °C (77 °F)	30 °C (86 °F)	35 °C (95 °F)	40 °C (104 °F)	45 °C (113 °F)
0 ℓ (0 US gal, 0 Imp gal)	0.3 kPa (2.1 mmHg, 0.1 inHg)	0.3 kPa (2.2 mmHg, 0.1 inHg)	0.3 kPa (2.3 mmHg, 0.1 inHg)	0.3 kPa (2.35 mmHg, 0.1 inHg)	0.3 kPa (2.4 mmHg, 0.1 inHg)
10 ℓ (2.64 US gal, 2.2 Imp gal)	0.3 kPa (2.1 mmHg, 0.1 inHg)	0.3 kPa (2.2 mmHg, 0.1 inHg)	0.3 kPa (2.3 mmHg, 0.1 inHg)	0.3 kPa (2.35 mmHg, 0.1 inHg)	0.3 kPa (2.4 mmHg, 0.1 inHg)
20 ℓ (5.28 US gal, 4.4 Imp gal)	0.3 kPa (2.3 mmHg, 0.1 inHg)	0.3 kPa (2.4 mmHg, 0.1 inHg)	0.3 kPa (2.5 mmHg, 0.1 inHg)	0.3 kPa (2.6 mmHg, 0.1 inHg)	0.4 kPa (2.7 mmHg, 0.1 inHg)
30 ℓ (7.93 US gal, 6.6 Imp gal)	0.4 kPa (2.9 mmHg, 0.1 inHg)	0.4 kPa (3.05 mmHg, 0.1 inHg)	0.4 kPa (3.15 mmHg, 0.1 inHg)	0.4 kPa (3.25 mmHg, 0.1 inHg)	0.4 kPa (3.35 mmHg, 0.1 inHg)
40 ℓ (10.57 US gal, 8.8 Imp gal)	0.4 kPa (2.9 mmHg, 0.1 inHg)	0.4 kPa (3.15 mmHg, 0.1 inHg)	0.4 kPa (3.3 mmHg, 0.1 inHg)	0.5 kPa (3.4 mmHg, 0.1 inHg)	0.5 kPa (3.5 mmHg, 0.1 inHg)
50 ℓ (13.21 US gal, 11 Imp gal)	0.4 kPa (3.2 mmHg, 0.1 inHg)	0.4 kPa (3.3 mmHg, 0.1 inHg)	0.5 kPa (3.5 mmHg, 0.1 inHg)	0.5 kPa (3.6 mmHg, 0.1 inHg)	0.5 kPa (3.7 mmHg, 0.1 inHg)
60 ℓ (15.85 US gal, 13.2 Imp gal)	0.4 kPa (3.2 mmHg, 0.1 inHg)	0.4 kPa (3.3 mmHg, 0.1 inHg)	0.5 kPa (3.5 mmHg, 0.1 inHg)	0.5 kPa (3.6 mmHg, 0.1 inHg)	0.5 kPa (3.7 mmHg, 0.1 inHg)

Leak Diagnosis

DTC

P0456 Evaporative Emission Control System Leak Detected (very small leak)

- The diagnostic consists of creating a sealed vacuum in the fuel tank and then determining the presence of leakage from the speed at which the tank internal pressure returns to barometric pressure.
- The diagnosis is divided into the following five phases.

Mode A: (0 point compensation)

When the pressure in the tank is not near 0 mmHg, wait until it returns to 0 point (near 0 mmHg). Shift to mode B when returned to the 0 point. Cancel the diagnosis when 0 point does not return in the specified time.

Mode B: (Negative pressure introduced)

Introduce negative pressure in the intake manifold to the tank.

Approx. 0 → -2 kPa (0 → -15 mmHg, 0 → -0.6 inHg)

When the pressure above (desired negative pressure) is reached, enters Mode C.

When the tank internal pressure does not reach the target negative pressure, the diagnosis is cancelled.

Mode C: (Negative pressure maintained)

Stop the introduction of negative pressure. (Wait until the tank pressure returns to the start level of P2 calculation.)

Change to Mode D either when the tank pressure returns to the start level of P2 calculation, or when the pre-determined amount of time has passed.

Mode D: (Calculate the amount of negative pressure change)

Monitor the tank pressure in mode D, calculate the pressure change in the tank (P2), and measure the time (evpdset) for the tank pressure to change to the Mode E shifting pressure. When the Mode E shifting pressure is reached, Mode E is entered. If it does not change to the Mode E shifting pressure after the pre-determined amount of time has passed, make advanced OK judgement or cancel the diagnosis according to the value of P2.

Diagnostic Trouble Code (DTC) Detecting Criteria

GENERAL DESCRIPTION

Normality Judgement

Judge as OK when the following conditions are established.

Judgement Value

Malfunction Criteria	Threshold Value
Advanced OK judgement 1	
Mode D time	$\geq 0 \text{ ms} + 10000 \text{ ms}$
Tank internal pressure	$\leq \text{Value of Map 6}$
Advanced OK judgement 2	
Mode D time	$\geq 0 \text{ ms} + 200000 \text{ ms}$
P2	$\leq \text{Value of Map 7}$

Map 6

Fuel level (ℓ, US gal, Imp gal)	0, 0, 0	10, 2.64, 2.2	20, 5.28, 4.4	30, 7.93, 6.6	40, 10.57, 8.8	50, 13.21, 11	60, 15.85, 13.2
Tank pressure (kPa, mmHg, inHg)	-1.9, -14.62, -0.6	-1.9, -14.62, -0.6	-1.9, -14.59, -0.6	-1.9, -14.56, -0.6	-1.9, -14.42, -0.6	-1.9, -14.28, -0.6	-1.9, -14.28, -0.6

Map 7

Fuel level (ℓ, US gal, Imp gal)	0, 0, 0	10, 2.64, 2.2	20, 5.28, 4.4	30, 7.93, 6.6	40, 10.57, 8.8	50, 13.21, 11	60, 15.85, 13.2
Tank pressure (kPa, mmHg, inHg)	0.9, 7, 0.3	0.9, 7, 0.3	0.9, 7.05, 0.3	0.9, 7.1, 0.3	1.1, 8.2, 0.3	1.3, 9.6, 0.4	1.3, 9.6, 0.4

Mode E: (Evaporation occurrence amount calculation)

Calculate the change of tank pressure with the time evpdset (P1) to judge as NG/OK according to the value of P1. (ambiguous determination acceptable).

Diagnostic Trouble Code (DTC) Detecting Criteria

GENERAL DESCRIPTION

• Abnormality Judgement

Judge as NG when the following conditions are established.

Judgement Value

Malfunction Criteria	Threshold Value
P1	< Value of Map 8

Map 8 Malfunction criteria limit for evaporation diagnosis

Time (evpdset) vs. Fuel level	0 ms	30000 ms	50000 ms	100000 ms	160000 ms	200000 ms
0 ℓ (0 US gal, 0 Imp gal)	0 kPa (0 mmHg, 0 inHg)	0.1 kPa (0.5 mmHg, 0 inHg)	0.2 kPa (1.7 mmHg, 0.1 inHg)	0.4 kPa (2.7 mmHg, 0.1 inHg)	0.4 kPa (2.7 mmHg, 0.1 inHg)	0.4 kPa (2.7 mmHg, 0.1 inHg)
10 ℓ (2.64 US gal, 2.2 Imp gal)	0 kPa (0 mmHg, 0 inHg)	0.1 kPa (0.5 mmHg, 0 inHg)	0.2 kPa (1.7 mmHg, 0.1 inHg)	0.4 kPa (2.7 mmHg, 0.1 inHg)	0.4 kPa (2.7 mmHg, 0.1 inHg)	0.4 kPa (2.7 mmHg, 0.1 inHg)
20 ℓ (5.28 US gal, 4.4 Imp gal)	0 kPa (0 mmHg, 0 inHg)	0.1 kPa (0.5 mmHg, 0 inHg)	0.2 kPa (1.7 mmHg, 0.1 inHg)	0.4 kPa (2.7 mmHg, 0.1 inHg)	0.4 kPa (2.7 mmHg, 0.1 inHg)	0.4 kPa (2.7 mmHg, 0.1 inHg)
30 ℓ (7.93 US gal, 6.6 Imp gal)	0 kPa (0 mmHg, 0 inHg)	0.1 kPa (0.5 mmHg, 0 inHg)	0.2 kPa (1.7 mmHg, 0.1 inHg)	0.4 kPa (2.7 mmHg, 0.1 inHg)	0.4 kPa (2.7 mmHg, 0.1 inHg)	0.4 kPa (2.7 mmHg, 0.1 inHg)
40 ℓ (10.57 US gal, 8.8 Imp gal)	0 kPa (0 mmHg, 0 inHg)	0.1 kPa (0.5 mmHg, 0 inHg)	0.2 kPa (1.85 mmHg, 0.1 inHg)	0.3 kPa (2.5 mmHg, 0.1 inHg)	0.3 kPa (2.5 mmHg, 0.1 inHg)	0.3 kPa (2.5 mmHg, 0.1 inHg)
50 ℓ (13.21 US gal, 11 Imp gal)	0 kPa (0 mmHg, 0 inHg)	0.1 kPa (0.5 mmHg, 0 inHg)	0.3 kPa (2 mmHg, 0.1 inHg)	0.3 kPa (2.3 mmHg, 0.1 inHg)	0.3 kPa (2.3 mmHg, 0.1 inHg)	0 kPa (0 mmHg, 0 inHg)
60 ℓ (15.85 US gal, 13.2 Imp gal)	0 kPa (0 mmHg, 0 inHg)	0.1 kPa (0.5 mmHg, 0 inHg)	0.3 kPa (2 mmHg, 0.1 inHg)	0.3 kPa (2.3 mmHg, 0.1 inHg)	0.3 kPa (2.3 mmHg, 0.1 inHg)	0 kPa (0 mmHg, 0 inHg)

Time Needed for Diagnosis: Value of MAP 1 + Value of MAP 2 + 22820 ms + 0 + Value of MAP 2 + 0 ms + 200000 ms + Value of MAP 3 + 0 ms + 200000 ms

Malfunction Indicator Light Illumination: Illuminates when malfunction occurs in 2 continuous driving cycles.

Diagnostic Trouble Code (DTC) Detecting Criteria

GENERAL DESCRIPTION

• Normality Judgement

Judge as OK when the following conditions are established.

Judgement Value

Malfunction Criteria	Threshold Value
P1	> Value of Map 9

Map 9 Malfunction criteria limit for evaporation diagnosis

Time (evpdset) vs. Fuel level	0 ms	30000 ms	50000 ms	100000 ms	160000 ms	200000 ms
0 ℓ (0 US gal, 0 Imp gal)	0.1 kPa (1 mmHg, 0 inHg)	0.5 kPa (3.5 mmHg, 0.1 inHg)	0.6 kPa (4.2 mmHg, 0.2 inHg)	0.6 kPa (4.2 mmHg, 0.2 inHg)	0.6 kPa (4.2 mmHg, 0.2 inHg)	0.6 kPa (4.2 mmHg, 0.2 inHg)
10 ℓ (2.64 US gal, 2.2 Imp gal)	0.1 kPa (1 mmHg, 0 inHg)	0.5 kPa (3.5 mmHg, 0.1 inHg)	0.6 kPa (4.2 mmHg, 0.2 inHg)	0.6 kPa (4.2 mmHg, 0.2 inHg)	0.6 kPa (4.2 mmHg, 0.2 inHg)	0.6 kPa (4.2 mmHg, 0.2 inHg)
20 ℓ (5.28 US gal, 4.4 Imp gal)	0.1 kPa (1 mmHg, 0 inHg)	0.4 kPa (3.25 mmHg, 0.1 inHg)	0.5 kPa (4.1 mmHg, 0.2 inHg)	0.5 kPa (4.1 mmHg, 0.2 inHg)	0.5 kPa (4.1 mmHg, 0.2 inHg)	0.5 kPa (4.1 mmHg, 0.2 inHg)
30 ℓ (7.93 US gal, 6.6 Imp gal)	0.1 kPa (1 mmHg, 0 inHg)	0.4 kPa (3 mmHg, 0.1 inHg)	0.5 kPa (3.9 mmHg, 0.2 inHg)	0.5 kPa (3.9 mmHg, 0.2 inHg)	0.5 kPa (3.9 mmHg, 0.2 inHg)	0.5 kPa (3.9 mmHg, 0.2 inHg)
40 ℓ (10.57 US gal, 8.8 Imp gal)	0.1 kPa (1 mmHg, 0 inHg)	0.3 kPa (2.25 mmHg, 0.1 inHg)	0.5 kPa (3.4 mmHg, 0.1 inHg)	0.5 kPa (3.4 mmHg, 0.1 inHg)	0.5 kPa (3.4 mmHg, 0.1 inHg)	0.5 kPa (3.4 mmHg, 0.1 inHg)
50 ℓ (13.21 US gal, 11 Imp gal)	0.1 kPa (1 mmHg, 0 inHg)	0.2 kPa (1.5 mmHg, 0.1 inHg)	0.4 kPa (2.9 mmHg, 0.1 inHg)	0.4 kPa (2.9 mmHg, 0.1 inHg)	0.4 kPa (2.9 mmHg, 0.1 inHg)	0.4 kPa (2.9 mmHg, 0.1 inHg)
60 ℓ (15.85 US gal, 13.2 Imp gal)	0.1 kPa (1 mmHg, 0 inHg)	0.2 kPa (1.5 mmHg, 0.1 inHg)	0.4 kPa (2.9 mmHg, 0.1 inHg)	0.4 kPa (2.9 mmHg, 0.1 inHg)	0.4 kPa (2.9 mmHg, 0.1 inHg)	0.4 kPa (2.9 mmHg, 0.1 inHg)

Time Needed for Diagnosis: Value of MAP 1 + Value of MAP 2 + 22820 ms + 0 + Value of MAP 2 + 0 ms + 200000 ms + Value of MAP 3 + 0 ms + 200000 ms

Diagnostic Trouble Code (DTC) Detecting Criteria

GENERAL DESCRIPTION

BL:DTC P0447 EVAPORATIVE EMISSION CONTROL SYSTEM VENT CONTROL CIRCUIT OPEN

1. OUTLINE OF DIAGNOSIS

Detect open or short circuit of the drain valve.

Judge as NG when the ECM output level differs from the actual terminal level.

2. COMPONENT DESCRIPTION

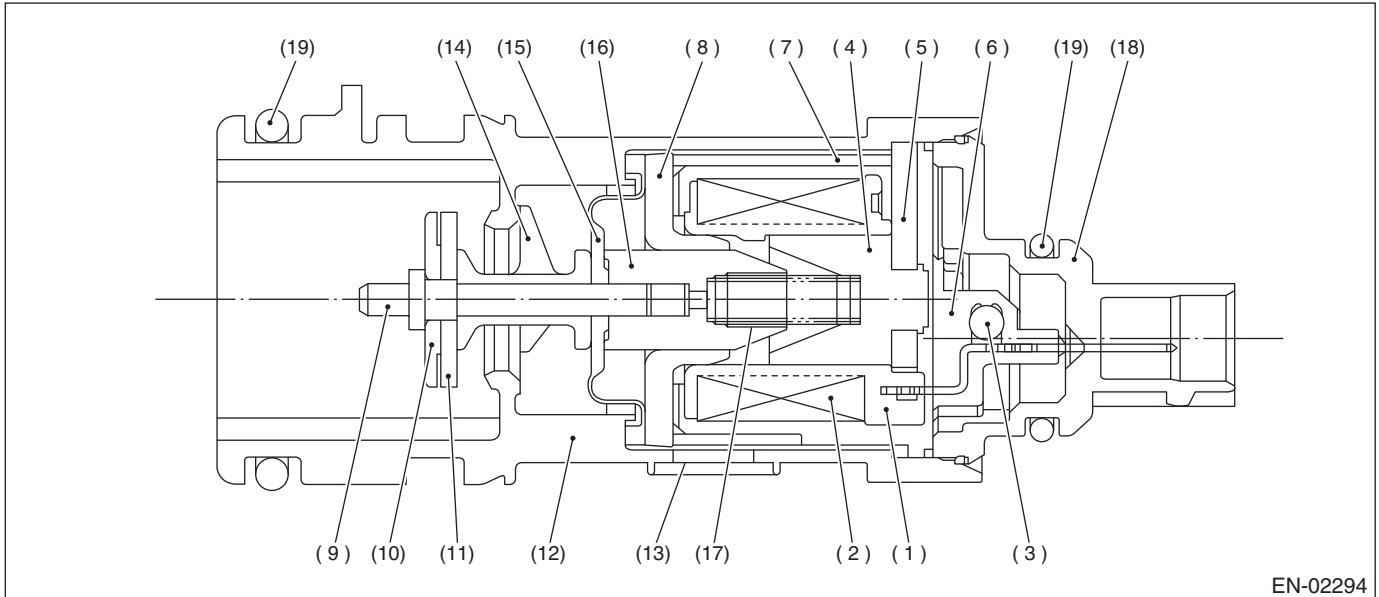

- | | | |
|-----------------|--------------------|-------------------|
| (1) Bobbin | (8) Magnetic plate | (15) Diaphragm |
| (2) Coil | (9) Shaft | (16) Movable core |
| (3) Diode | (10) Plate | (17) Spring |
| (4) Stator core | (11) Valve | (18) Cover |
| (5) End plate | (12) Housing | (19) O-ring |
| (6) Body | (13) Filter | |
| (7) Yoke | (14) Retainer | |

3. ENABLE CONDITION

Secondary Parameters	Enable Conditions
None	

4. GENERAL DRIVING CYCLE

Always perform the diagnosis continuously.

Diagnostic Trouble Code (DTC) Detecting Criteria

GENERAL DESCRIPTION

5. DIAGNOSTIC METHOD

• Abnormality Judgement

If the duration of time while the following conditions are met is longer than the time indicated, judge as NG.

Judgement Value

Malfunction Criteria	Threshold Value
Battery voltage	≥ 10.9 V
Elapsed time after starting the engine	≥ 1 second
Terminal output voltage when ECM outputs OFF signal	Low

Time Needed for Diagnosis: 2500 ms

Malfunction Indicator Light Illumination: Illuminates as soon as a malfunction occurs.

• Normality Judgement

Judge as OK and clear the NG if the continuous time while the following conditions are established is more than the predetermined time.

Judgement Value

Malfunction Criteria	Threshold Value
Battery voltage	≥ 10.9 V
Elapsed time after starting the engine	≥ 1 second
Terminal output voltage when ECM outputs OFF signal	High

Time Needed for Diagnosis: Less than 1 second

Diagnostic Trouble Code (DTC) Detecting Criteria

GENERAL DESCRIPTION

BM:DTC P0448 EVAPORATIVE EMISSION CONTROL SYSTEM VENT CONTROL CIRCUIT SHORTED

1. OUTLINE OF DIAGNOSIS

Detect open or short circuit of the drain valve.

Judge as NG when the ECM output level differs from the actual terminal level.

2. COMPONENT DESCRIPTION

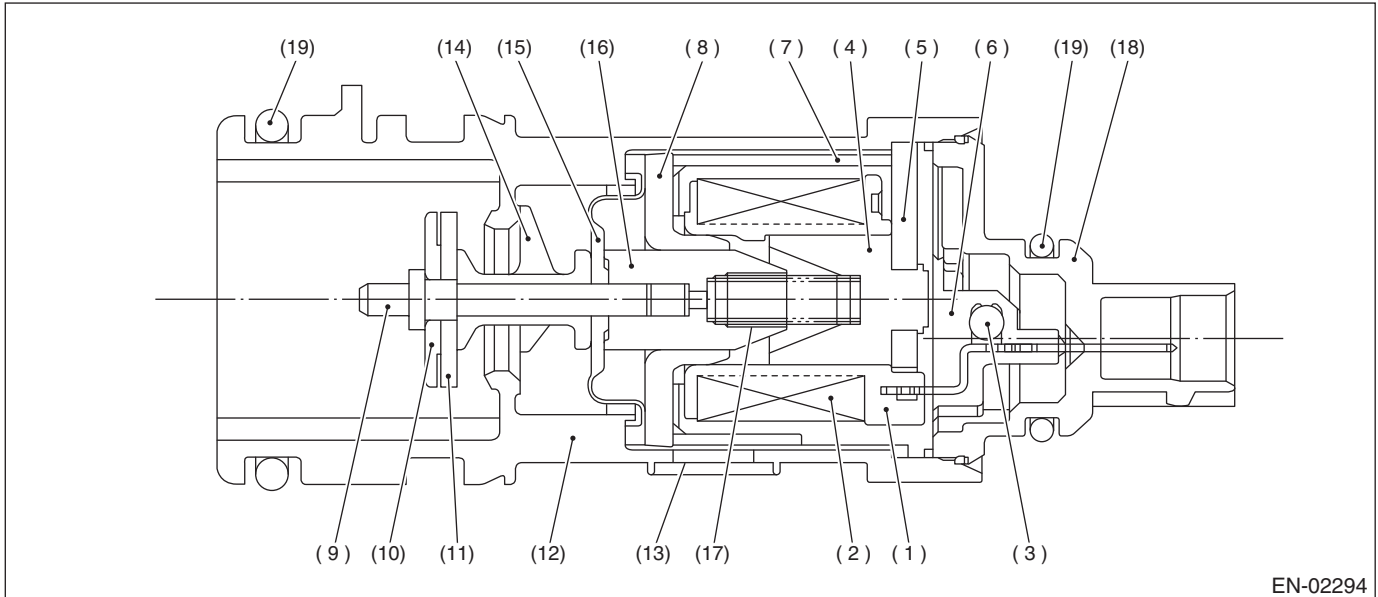

EN-02294

- | | | |
|-----------------|--------------------|-------------------|
| (1) Bobbin | (8) Magnetic plate | (15) Diaphragm |
| (2) Coil | (9) Shaft | (16) Movable core |
| (3) Diode | (10) Plate | (17) Spring |
| (4) Stator core | (11) Valve | (18) Cover |
| (5) End plate | (12) Housing | (19) O-ring |
| (6) Body | (13) Filter | |
| (7) Yoke | (14) Retainer | |

3. ENABLE CONDITION

Secondary Parameters	Enable Conditions
None	

4. GENERAL DRIVING CYCLE

Always perform the diagnosis continuously.

Diagnostic Trouble Code (DTC) Detecting Criteria

GENERAL DESCRIPTION

5. DIAGNOSTIC METHOD

• Abnormality Judgement

If the duration of time while the following conditions are met is longer than the time indicated, judge as NG.

Judgement Value

Malfunction Criteria	Threshold Value
Battery voltage	≥ 10.9 V
Elapsed time after starting the engine	≥ 1 second
Terminal output voltage when ECM outputs ON signal	High

Time Needed for Diagnosis: 2500 ms

Malfunction Indicator Light Illumination: Illuminates as soon as a malfunction occurs.

• Normality Judgement

Judge as OK and clear the NG if the continuous time while the following conditions are established is more than the predetermined time.

Judgement Value

Malfunction Criteria	Threshold Value
Battery voltage	≥ 10.9 V
Elapsed time after starting the engine	≥ 1 second
Terminal output voltage when ECM outputs ON signal	Low

Time Needed for Diagnosis: Less than 1 second

Diagnostic Trouble Code (DTC) Detecting Criteria

GENERAL DESCRIPTION

BN:DTC P0451 EVAPORATIVE EMISSION CONTROL SYSTEM PRESSURE SENSOR

1. OUTLINE OF DIAGNOSIS

Detect the tank pressure sensor output property abnormality.

Judge as NG when there is no pressure variation, which should exist in the tank, considering the engine status.

2. COMPONENT DESCRIPTION

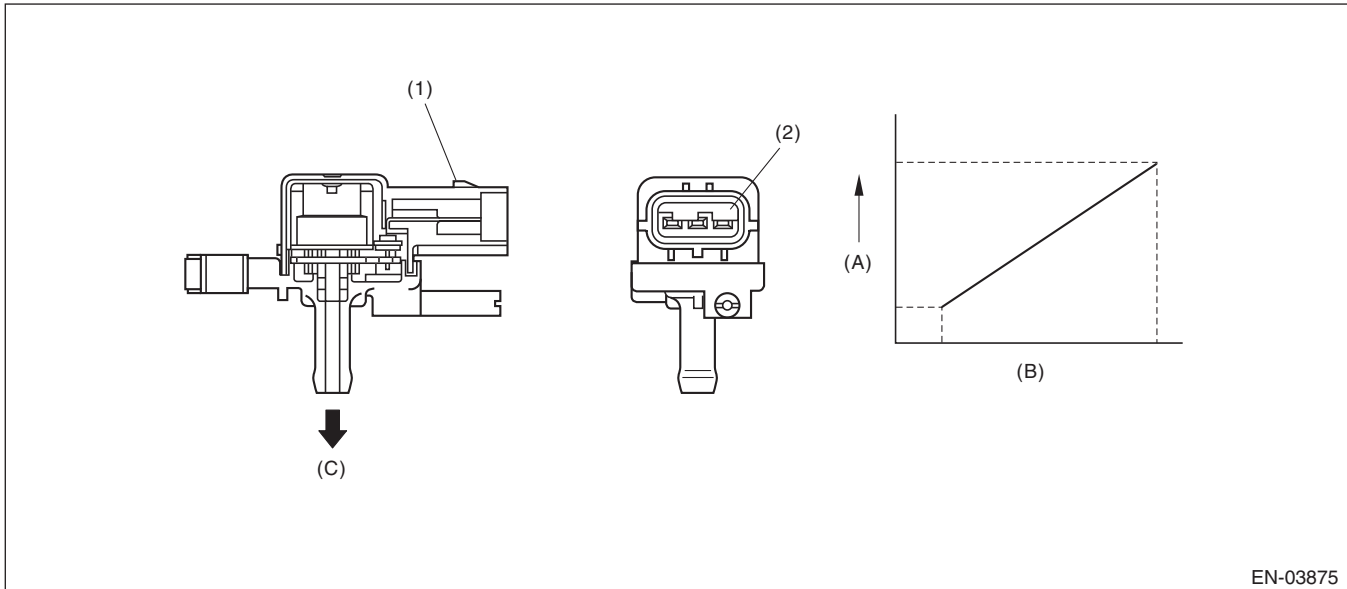

(A) Output voltage

(B) Input voltage

(C) To fuel tank

(1) Connector

(2) Terminals

3. ENABLE CONDITION

Secondary Parameters	Enable Conditions
Elapsed time after starting the engine	≥ 60 s
Fuel level	≥ 9.6 l (2.54 US gal, 2.11 Imp gal)
Fuel temperature	< 35 °C (95 °F)
Battery voltage	≥ 10.9 V
Barometric pressure	≥ 75 kPa (563 mmHg, 22.2 inHg)

4. GENERAL DRIVING CYCLE

- Perform the diagnosis continuously after 60 s have passed since the engine started.
- Pay attention to the fuel level and temperature.

Diagnostic Trouble Code (DTC) Detecting Criteria

GENERAL DESCRIPTION

5. DIAGNOSTIC METHOD

• Abnormality Judgement

If the duration of time while the following conditions are met is longer than the time indicated, judge as NG.

Judgement Value

Malfunction Criteria	Threshold Value
Number of times that the difference between the Max. fuel level every 60 s and Min. fuel level every 60 s is 2 ℓ (0.53 US gal, 0.44 Imp gal) or more (with enable condition established)	≥ 16 time(s)
Maximum – Minimum tank pressure (with enable condition completed)	< 0 kPa (0.375 mmHg, 0 inHg)
Maximum – Minimum fuel temperature (with enable condition completed)	≥ 7 °C (44.6 °F)

If the difference between the Max. fuel level every 60 s and Min. fuel level every 60 s is less than 2 ℓ (0.53 US gal, 0.44 Imp gal), extend 60 s and make judgement with the Max. and Min. values for the fuel level in 60 s × 2. If a difference does not appear, extend the time (60 s × 3, 60 s × 4, 60 s × 5) and continue the judgement. If the difference between the Max. fuel level every 60 s and Min. fuel level every 60 s is 2 ℓ (0.53 US gal, 0.44 Imp gal) or more, the diagnosis counter counts up.

Time Needed for Diagnosis: 60 s × 16 time(s) or more

Malfunction Indicator Light Illumination: Illuminates when malfunction occurs in 2 continuous driving cycles.

• Normality Judgement

Judge as OK and clear the NG if the continuous time while the following conditions are established is more than the predetermined time.

Judgement Value

Malfunction Criteria	Threshold Value
Maximum — Minimum tank pressure	≥ 0 kPa (0.375 mmHg, 0 inHg)

Time Needed for Diagnosis: Less than 1 second

Diagnostic Trouble Code (DTC) Detecting Criteria

GENERAL DESCRIPTION

BO:DTC P0452 EVAPORATIVE EMISSION CONTROL SYSTEM PRESSURE SENSOR LOW INPUT

1. OUTLINE OF DIAGNOSIS

Detect the open or short circuit of the fuel tank pressure sensor.
Judge as NG if out of specification.

2. COMPONENT DESCRIPTION

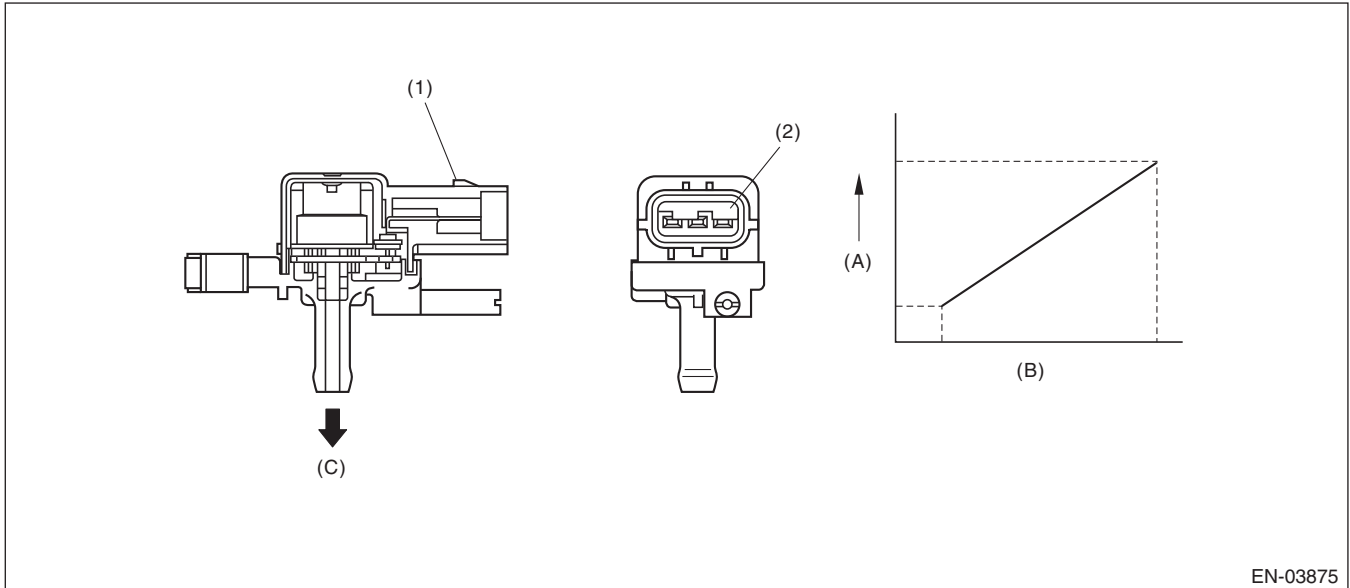

EN-03875

(A) Output voltage

(B) Input voltage

(C) To fuel tank

(1) Connector

(2) Terminals

3. ENABLE CONDITION

Secondary Parameters	Enable Conditions
None	

4. GENERAL DRIVING CYCLE

Always perform the diagnosis continuously.

Diagnostic Trouble Code (DTC) Detecting Criteria

GENERAL DESCRIPTION

5. DIAGNOSTIC METHOD

• Abnormality Judgement

If the duration of time while the following conditions are met is longer than the time indicated, judge as NG.

Judgement Value

Malfunction Criteria	Threshold Value
Fuel tank pressure	< -7.5 kPa (-55.9 mmHg, -2.2 inHg)
Battery voltage	≥ 10.9 V

Time Needed for Diagnosis: 15000 ms

Malfunction Indicator Light Illumination: Illuminates as soon as a malfunction occurs.

• Normality Judgement

Judge as OK and clear the NG if the continuous time while the following conditions are established is more than the predetermined time.

Judgement Value

Malfunction Criteria	Threshold Value
Fuel tank pressure	≥ -7.5 kPa (-55.9 mmHg, -2.2 inHg)
Battery voltage	≥ 10.9 V

Time Needed for Diagnosis: Less than 1 second

Diagnostic Trouble Code (DTC) Detecting Criteria

GENERAL DESCRIPTION

BP:DTC P0453 EVAPORATIVE EMISSION CONTROL SYSTEM PRESSURE SENSOR HIGH INPUT

1. OUTLINE OF DIAGNOSIS

Detect the open or short circuit of the fuel tank pressure sensor.

Judge as NG if out of specification.

2. COMPONENT DESCRIPTION

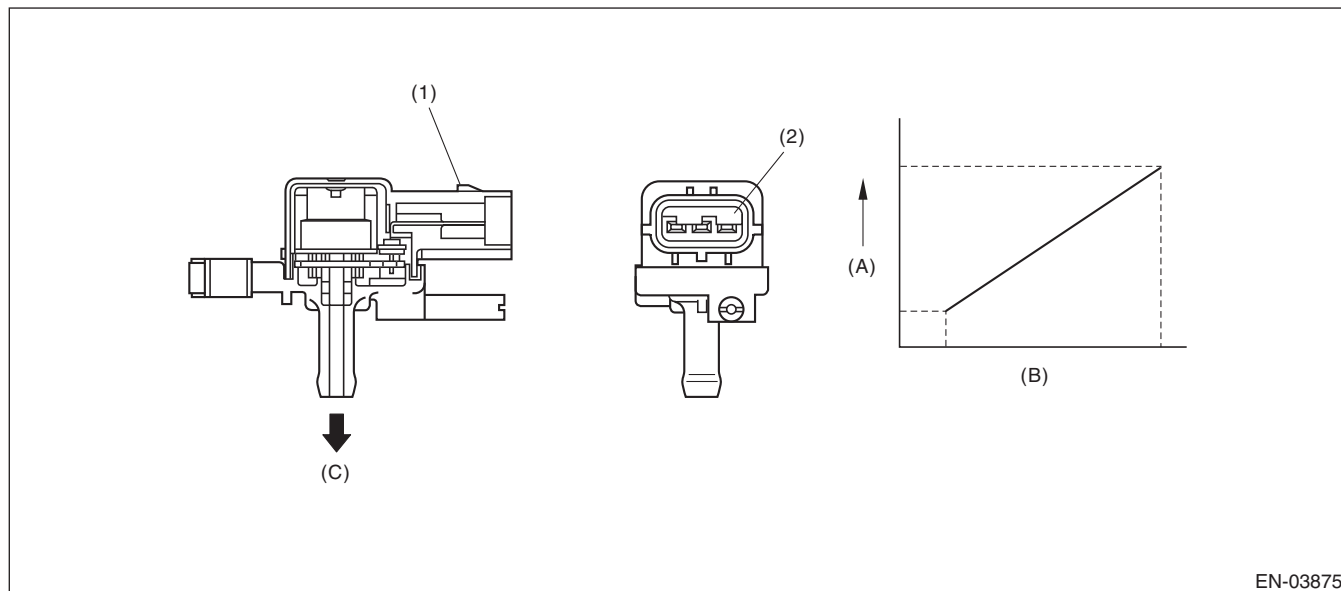

EN-03875

(A) Output voltage

(B) Input voltage

(C) To fuel tank

(1) Connector

(2) Terminals

3. ENABLE CONDITION

Secondary Parameters	Enable Conditions
Time needed for all secondary parameters to be in enable conditions	≥ 5000 ms
Vehicle speed	≥ 2 km/h (1.2 MPH)
All conditions of EVAP canister purge	Completed
Learning value of evaporation gas concentration (left and right)	< 0.08
Main feedback compensation coefficient (left and right)	≥ 0.9
Battery voltage	≥ 10.9 V

4. GENERAL DRIVING CYCLE

Perform the diagnosis when purging enable conditions are met without idling.

Diagnostic Trouble Code (DTC) Detecting Criteria

GENERAL DESCRIPTION

5. DIAGNOSTIC METHOD

• Abnormality Judgement

If the duration of time while the following conditions are met is longer than the time indicated, judge as NG.

Judgement Value

Malfunction Criteria	Threshold Value
Fuel tank pressure	≥ 7.9 kPa (59.6 mmHg, 2.3 inHg)
Fuel temperature	< 35 °C (95 °F)
Barometric pressure	≥ 75 kPa (563 mmHg, 22.2 inHg)

Time Needed for Diagnosis: 15000 ms

Malfunction Indicator Light Illumination: Illuminates as soon as a malfunction occurs.

• Normality Judgement

Judge as OK and clear the NG if the continuous time while the following conditions are established is more than the predetermined time.

Judgement Value

Malfunction Criteria	Threshold Value
Fuel tank pressure	< 7.9 kPa (59.6 mmHg, 2.3 inHg)

Time Needed for Diagnosis: Less than 1 second

Diagnostic Trouble Code (DTC) Detecting Criteria

GENERAL DESCRIPTION

BQ:DTC P0456 EVAPORATIVE EMISSION CONTROL SYSTEM LEAK DETECTED (VERY SMALL LEAK)

1. OUTLINE OF DIAGNOSIS

NOTE:

For the detection standard, refer to DTC P0442. <Ref. to GD(H4DOTC)-112, DTC P0442 EVAPORATIVE EMISSION CONTROL SYSTEM LEAK DETECTED (SMALL LEAK), Diagnostic Trouble Code (DTC) Detecting Criteria.>

BR:DTC P0457 EVAPORATIVE EMISSION CONTROL SYSTEM LEAK DETECTED (FUEL CAP LOOSE/OFF)

1. OUTLINE OF DIAGNOSIS

NOTE:

For the detection standard, refer to DTC P0442. <Ref. to GD(H4DOTC)-112, DTC P0442 EVAPORATIVE EMISSION CONTROL SYSTEM LEAK DETECTED (SMALL LEAK), Diagnostic Trouble Code (DTC) Detecting Criteria.>

BS:DTC P0458 EVAPORATIVE EMISSION SYSTEM PURGE CONTROL VALVE CIRCUIT LOW

1. OUTLINE OF DIAGNOSIS

Detect open or short circuit of the purge control solenoid valve.

Judge as NG when the ECM output level differs from the actual terminal level.

2. COMPONENT DESCRIPTION

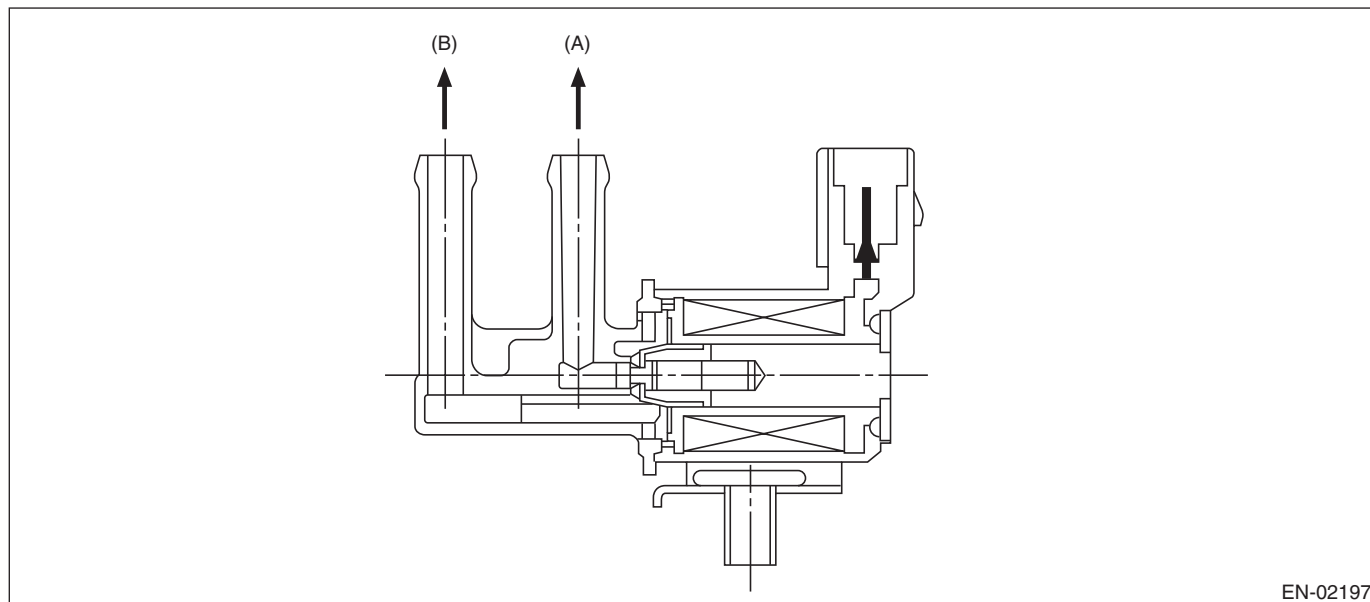

EN-02197

(A) To canister

(B) To intake manifold

3. ENABLE CONDITION

Secondary Parameters	Enable Conditions
Battery voltage	≥ 10.9 V
Elapsed time after starting the engine	≥ 1 second

4. GENERAL DRIVING CYCLE

Always perform the diagnosis after starting the engine.

5. DIAGNOSTIC METHOD

• Abnormality Judgement

If the duration of time while the following conditions are met is longer than the time indicated, judge as NG.

Judgement Value

Malfunction Criteria	Threshold Value
Duty ratio of "ON"	< 0.75
Terminal output voltage	Low

Time Needed for Diagnosis: 2500 ms

Malfunction Indicator Light Illumination: Illuminates when malfunction occurs in 2 continuous driving cycles.

• Normality Judgement

Judge as OK and clear the NG if the continuous time while the following conditions are established is more than the predetermined time.

Judgement Value

Malfunction Criteria	Threshold Value
Terminal output voltage	High

Time Needed for Diagnosis: Less than 1 second

Diagnostic Trouble Code (DTC) Detecting Criteria

GENERAL DESCRIPTION

BT:DTC P0459 EVAPORATIVE EMISSION SYSTEM PURGE CONTROL VALVE CIRCUIT HIGH

1. OUTLINE OF DIAGNOSIS

Detect open or short circuit of the purge control solenoid valve.

Judge as NG when the ECM output level differs from the actual terminal level.

2. COMPONENT DESCRIPTION

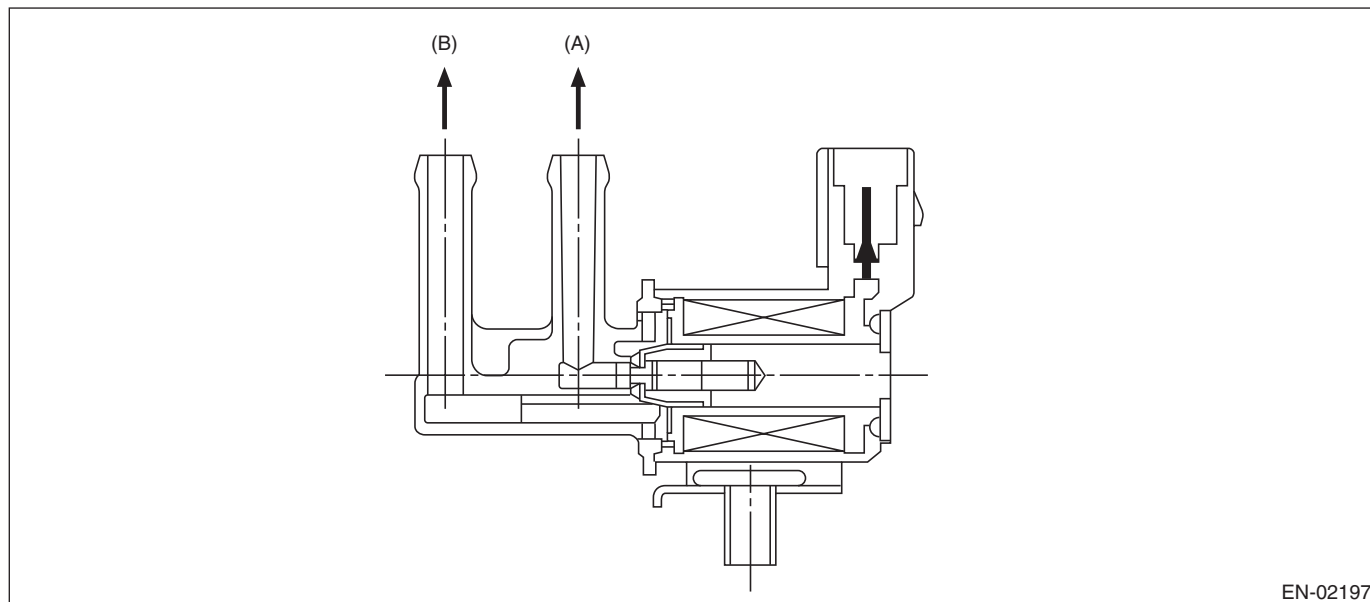

(A) To canister

(B) To intake manifold

3. ENABLE CONDITION

Secondary Parameters	Enable Conditions
Battery voltage	$\geq 10.9 \text{ V}$
Elapsed time after starting the engine	$\geq 1 \text{ second}$

4. GENERAL DRIVING CYCLE

Always perform the diagnosis after starting the engine.

5. DIAGNOSTIC METHOD

• Abnormality Judgement

If the duration of time while the following conditions are met is longer than the time indicated, judge as NG.

Judgement Value

Malfunction Criteria	Threshold Value
Duty ratio of "ON"	≥ 0.25
Terminal output voltage	High

Time Needed for Diagnosis: 2500 ms

Malfunction Indicator Light Illumination: Illuminates when malfunction occurs in 2 continuous driving cycles.

• Normality Judgement

Judge as OK and clear the NG if the continuous time while the following conditions are established is more than the predetermined time.

Judgement Value

Malfunction Criteria	Threshold Value
Terminal output voltage	Low

Time Needed for Diagnosis: Less than 1 second

BU:DTC P0461 FUEL LEVEL SENSOR "A" CIRCUIT RANGE/PERFORMANCE

1. OUTLINE OF DIAGNOSIS

Detect malfunctions of the fuel level sensor output property.

If the fuel level does not vary in a particular driving condition / engine condition where it should, judge as NG.

2. COMPONENT DESCRIPTION

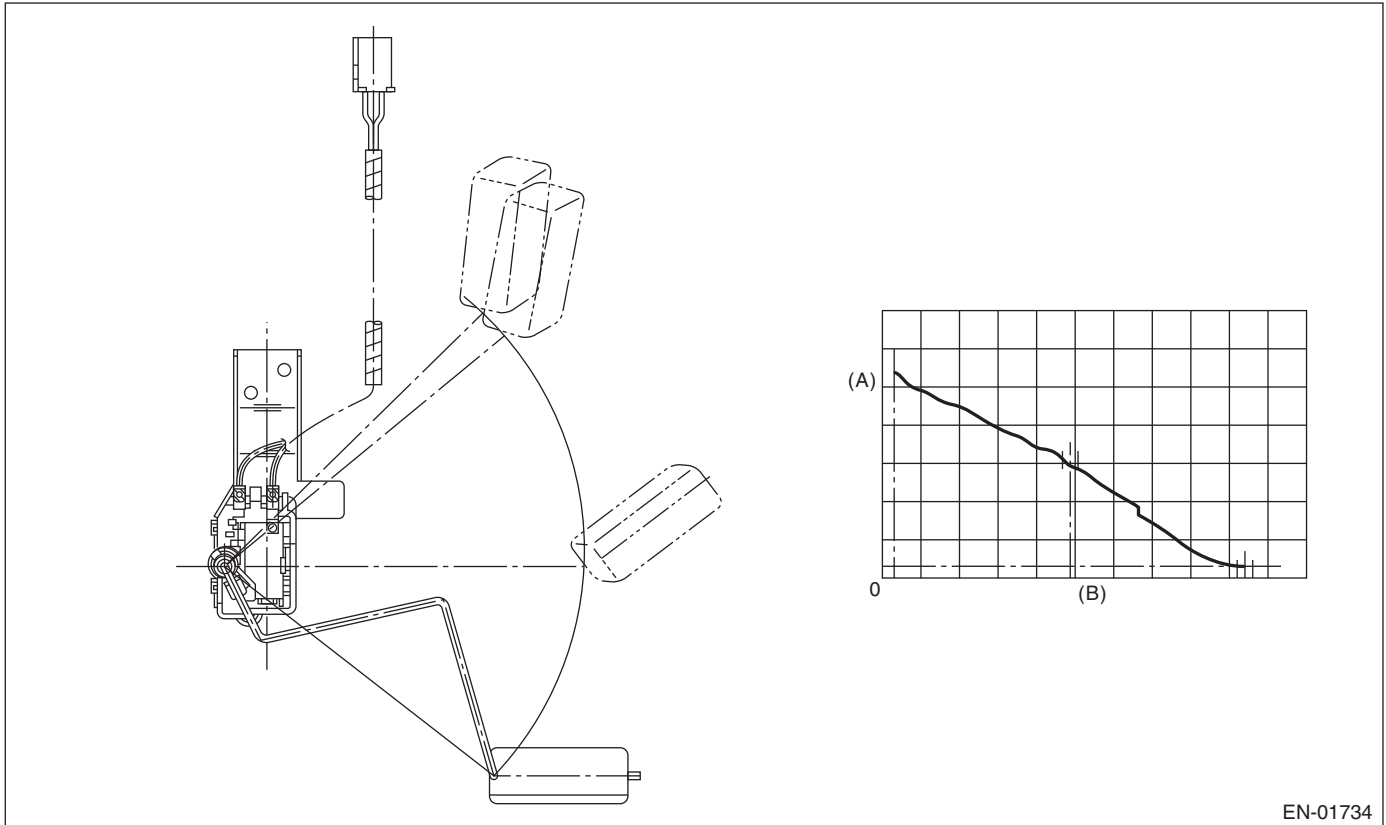

(A) Fuel level

(B) Resistance

3. ENABLE CONDITION

Secondary Parameters	Enable Conditions
None	

4. GENERAL DRIVING CYCLE

Always perform the diagnosis continuously.

Diagnostic Trouble Code (DTC) Detecting Criteria

GENERAL DESCRIPTION

5. DIAGNOSTIC METHOD

• Abnormality Judgement

Judge as NG when the following conditions are established.

Judgement Value

Malfunction Criteria	Threshold Value
Accumulated amount of intake air	≥ 330957 g (11672.85 oz)
Max. – Min. values of fuel level output	< 2.6 ℓ (0.69 US gal, 0.57 Imp gal)
Battery voltage	≥ 10.9 V
Engine speed	< 6500 rpm
Elapsed time after starting the engine	≥ 5000 ms

Time Needed for Diagnosis: Less than 1 second

Malfunction Indicator Light Illumination: Illuminates when malfunction occurs in 2 continuous driving cycles.

• Normality Judgement

Judge as OK and clear the NG if the following conditions are established.

Judgement Value

Malfunction Criteria	Threshold Value
Accumulated amount of intake air	≥ 330957 g (11672.85 oz)
Max. – Min. values of fuel level output	≥ 2.6 ℓ (0.69 US gal, 0.57 Imp gal)
Battery voltage	≥ 10.9 V
Engine speed	< 6500 rpm
Elapsed time after starting the engine	≥ 5000 ms

Time Needed for Diagnosis: Less than 1 second

BV:DTC P0462 FUEL LEVEL SENSOR “A” CIRCUIT LOW

1. OUTLINE OF DIAGNOSIS

Detect the open or short circuit of fuel level sensor. Judge as NG if out of specification.

2. COMPONENT DESCRIPTION

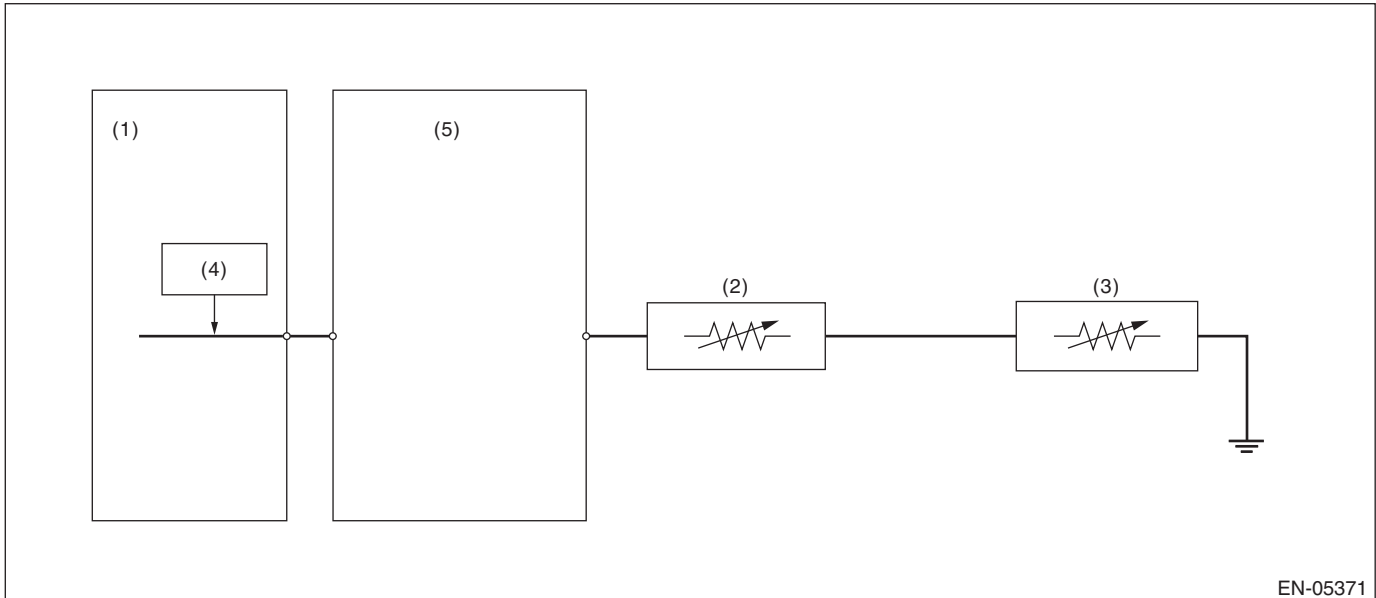

- | | | |
|---------------------------------|---------------------------|--------------------------|
| (1) Engine control module (ECM) | (3) Fuel sub level sensor | (5) Body integrated unit |
| (2) Fuel level sensor | (4) Detecting circuit | |

3. ENABLE CONDITION

Secondary Parameters	Enable Conditions
None	

4. GENERAL DRIVING CYCLE

Always perform the diagnosis continuously.

Diagnostic Trouble Code (DTC) Detecting Criteria

GENERAL DESCRIPTION

5. DIAGNOSTIC METHOD

• Abnormality Judgement

If the duration of time while the following conditions are met is longer than the time indicated, judge as NG.

Judgement Value

Malfunction Criteria	Threshold Value
Battery voltage	≥ 10.9 V
Elapsed time after starting the engine	≥ 3000 ms
Output voltage	< 0.173 V

Time Needed for Diagnosis:2500 ms

Malfunction Indicator Light Illumination: Illuminates when malfunction occurs in 2 continuous driving cycles.

• Normality Judgement

Judge as OK and clear the NG if the continuous time while the following conditions are established is more than the predetermined time.

Judgement Value

Malfunction Criteria	Threshold Value
Battery voltage	≥ 10.9 V
Elapsed time after starting the engine	≥ 3000 ms
Output voltage	≥ 0.173 V

Time Needed for Diagnosis: Less than 1 second

BW:DTC P0463 FUEL LEVEL SENSOR “A” CIRCUIT HIGH

1. OUTLINE OF DIAGNOSIS

Detect the open or short circuit of fuel level sensor. Judge as NG if out of specification.

2. COMPONENT DESCRIPTION

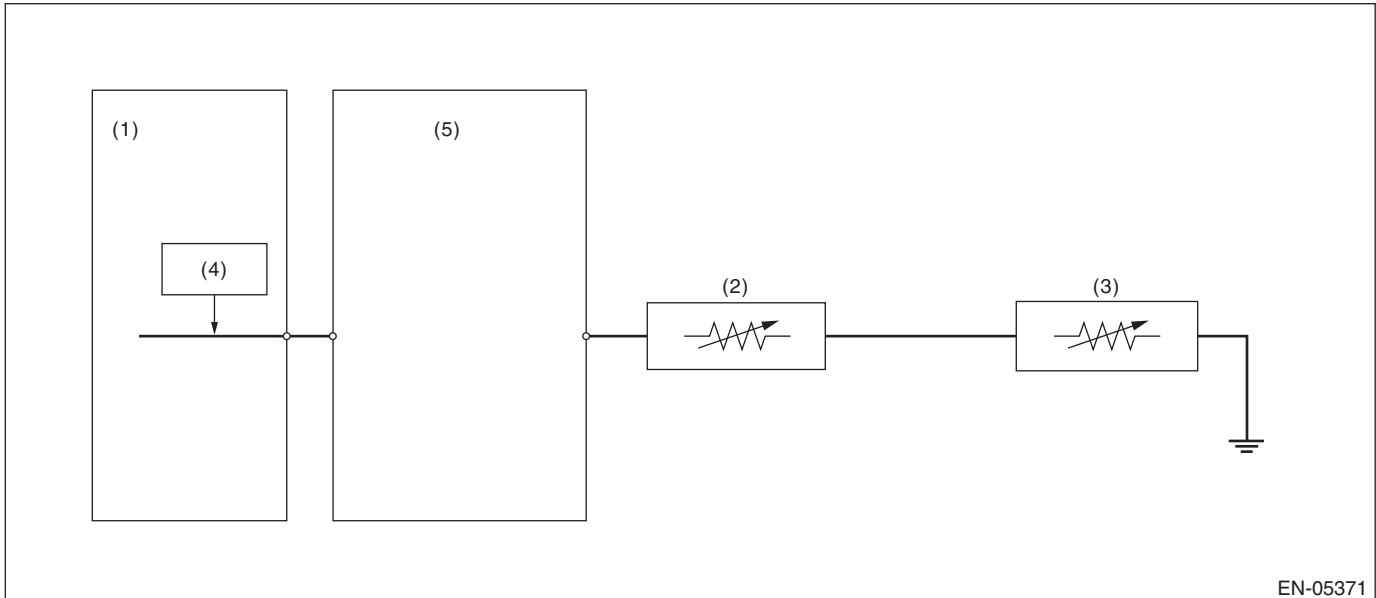

- | | | |
|---------------------------------|---------------------------|--------------------------|
| (1) Engine control module (ECM) | (3) Fuel sub level sensor | (5) Body integrated unit |
| (2) Fuel level sensor | (4) Detecting circuit | |

3. ENABLE CONDITION

Secondary Parameters	Enable Conditions
None	

4. GENERAL DRIVING CYCLE

Always perform the diagnosis continuously.

Diagnostic Trouble Code (DTC) Detecting Criteria

GENERAL DESCRIPTION

5. DIAGNOSTIC METHOD

• Abnormality Judgement

If the duration of time while the following conditions are met is longer than the time indicated, judge as NG.

Judgement Value

Malfunction Criteria	Threshold Value
Battery voltage	≥ 10.9 V
Elapsed time after starting the engine	≥ 3000 ms
Output voltage	≥ 7.212 V

Time Needed for Diagnosis: 1000 ms

Malfunction Indicator Light Illumination: Illuminates when malfunction occurs in 2 continuous driving cycles.

• Normality Judgement

Judge as OK and clear the NG if the continuous time while the following conditions are established is more than the predetermined time.

Judgement Value

Malfunction Criteria	Threshold Value
Battery voltage	≥ 10.9 V
Elapsed time after starting the engine	≥ 3000 ms
Output voltage	< 7.212 V

Time Needed for Diagnosis: Less than 1 second

Diagnostic Trouble Code (DTC) Detecting Criteria

GENERAL DESCRIPTION

BX:DTC P0464 FUEL LEVEL SENSOR CIRCUIT INTERMITTENT

1. OUTLINE OF DIAGNOSIS

Detect the unstable output faults from the fuel level sensor caused by noise. Judge as NG when the max. value and cumulative value of output voltage variation of the fuel level sensor is larger than the threshold value.

2. ENABLE CONDITION

Malfunction Criteria	Threshold Value
Engine speed	≥ 500 rpm
Elapsed time after starting the engine	≥ 1 second
Battery voltage	≥ 10.9 V
Idle switch	ON
Fuel level	≥ 9.6 ℓ (2.54 US gal, 2.11 Imp gal) and < 54.4 ℓ (14.37 US gal, 11.97 Imp gal)
Vehicle speed = 0 km/h (0 MPH)	≥ 10000 ms

3. GENERAL DRIVING CYCLE

- Always perform the diagnosis continuously at idle speed.
- Pay attention to the fuel level.

Diagnostic Trouble Code (DTC) Detecting Criteria

GENERAL DESCRIPTION

4. DIAGNOSTIC METHOD

Calculate the Max. value (DELFLMAX) and cumulative value (SUMFL) of output voltage variation of fuel level sensor during 12.2 seconds. Judge it normal when both max. and cumulative values are not over the threshold value. Otherwise, when either of them is over the threshold value, the diagnosis counter counts up. Judge as NG if the counter indicated 4 time(s).

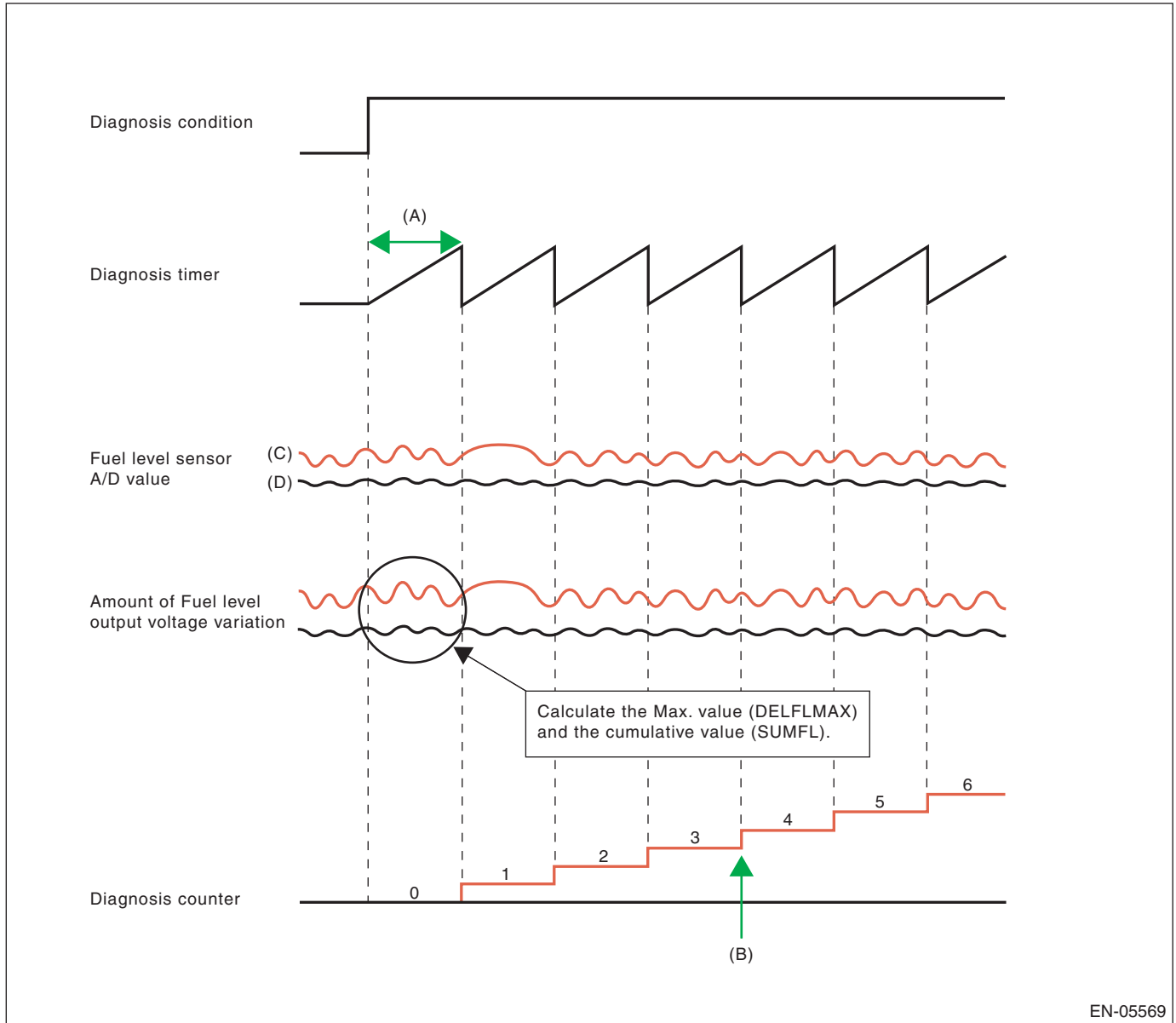

(A) 12288 ms

(B) NG at 4 time(s)

(C) Malfunction

(D) Normal

Diagnostic Trouble Code (DTC) Detecting Criteria

GENERAL DESCRIPTION

• Abnormality Judgement

If the duration of time while the following conditions are met is longer than the time indicated, judge as NG.

Judgement Value

Malfunction Criteria	Threshold Value
Integrated times of the condition reaching follows, DELFLMAX or SUMFL At this time, DELFLMAX: Maximum difference of sensor output for 12288 ms SUMFL: Integrated value of the sensor output deviation for 12288 ms	≥ 4 time(s) \geq Value from Map ≥ 25.92 V

Map

Fuel level (ℓ, US gal, Imp gal)	0, 0, 0	10, 2.64, 2.2	20, 5.28, 4.4	30, 7.93, 6.6	40, 10.57, 8.8	50, 13.21, 11	60, 15.85, 13.2
Measured voltage (V)	0.27	0.27	0.426	0.582	0.738	0.894	0.894

The diagnosis counter does not count up when the following conditions are completed within 12288 ms.

Maximum value – minimum value of change of tank pressure during 12288 ms	≥ 0 kPa (0.375 mmHg, 0 inHg)
Maximum value – minimum value of battery voltage during 12288 ms	≥ 0.969 V

Time Needed for Diagnosis: 12288 ms × 4 time(s)

Malfunction Indicator Light Illumination: Illuminates when malfunction occurs in 2 continuous driving cycles.

• Normality Judgement

Judge as OK and clear the NG if the continuous time while the following conditions are established is more than the predetermined time.

Judgement Value

Malfunction Criteria	Threshold Value
DELFLMAX SUMFL At this time, DELFLMAX: Maximum difference of sensor output for 12288 ms SUMFL: Integrated value of the sensor output deviation for 12288 ms	$<$ Value from Map < 25.92 V

Time Needed for Diagnosis: 12288 ms

Diagnostic Trouble Code (DTC) Detecting Criteria

GENERAL DESCRIPTION

BY:DTC P0500 VEHICLE SPEED SENSOR “A”

1. OUTLINE OF DIAGNOSIS

Judge as NG when outside of the judgement value.

Judge NG when the received data from ABSCM&H/U is abnormal vehicle speed, and the vehicle speed data is impossible.

2. COMPONENT DESCRIPTION

Vehicle speed signals are taken in to the ABS control module and hydraulic control unit, and normal/erroneous data of the ABS wheel speed sensor is received by CAN communication from the ABS control module and hydraulic control unit.

3. ENABLE CONDITION

Secondary Parameters	Enable Conditions
Battery voltage	≥ 10.9 V
Elapsed time after engine starting	≥ 2000 ms

4. GENERAL DRIVING CYCLE

Always perform diagnosis more than 2000 ms after starting the engine.

5. DIAGNOSTIC METHOD

• Abnormality Judgement

If the duration of time while the following conditions are met is longer than the time indicated, judge as NG.

Judgement Value

Malfunction Criteria	Threshold Value
Front ABS wheel speed sensor status	Malfunction
Either of the following is established	
Front left wheel speed	≥ 300 km/h (186.4 MPH)
Front right wheel speed	≥ 300 km/h (186.4 MPH)

Time Needed for Diagnosis:512 ms

Malfunction Indicator Light Illumination: Illuminates as soon as a malfunction occurs.

• Normality Judgement

Judge as OK and clear the NG if the continuous time while the following conditions are established is more than the predetermined time.

Judgement Value

Malfunction Criteria	Threshold Value
Front left wheel speed	> 0 km/h (0 MPH) and < 300 km/h (186.4 MPH)
Front right wheel speed	> 0 km/h (0 MPH) and < 300 km/h (186.4 MPH)

Time Needed for Diagnosis:512 ms

Diagnostic Trouble Code (DTC) Detecting Criteria

GENERAL DESCRIPTION

BZ:DTC P0506 IDLE AIR CONTROL SYSTEM RPM LOWER THAN EXPECTED

1. OUTLINE OF DIAGNOSIS

Detect the malfunction that actual engine speed is not close to target engine speed during idling. Judge as NG when actual engine speed is not close to target engine speed during idling.

2. ENABLE CONDITION

Secondary Parameters	Enable Conditions
Engine coolant temperature	$\geq 70\text{ }^{\circ}\text{C}$ (158 $^{\circ}\text{F}$)
Battery voltage	$\geq 10.9\text{ V}$
Barometric pressure	$\geq 75\text{ kPa}$ (563 mmHg, 22.2 inHg)
Fuel level	$\geq 9.6\text{ }\ell$ (2.54 US gal, 2.11 Imp gal)
Elapsed time after starting the engine	$\geq 10.49\text{ s}$
Feedback of ISC	In operation
Lambda value (left and right)	≥ 0.9 and < 1.1
After switching air conditioner to ON/OFF	$\geq 5.1\text{ s}$
After intake manifold pressure changes by 4 kPa (30 mmHg, 1.2 inHg) or more.	$> 5.1\text{ s}$
Elapsed time after switching neutral position switch to ON/OFF	$> 5.1\text{ s}$
Vehicle speed	0 km/h (0 MPH)

3. GENERAL DRIVING CYCLE

Perform the diagnosis continuously at idling after warming up engine.

4. DIAGNOSTIC METHOD

• Abnormality Judgement

If the duration of time while the following conditions are met is longer than the time indicated, judge as NG.

Judgement Value

Malfunction Criteria	Threshold Value
Actual engine speed — Targeted engine speed	$< -100\text{ rpm}$
Feedback value for ISC	Max.

Time Needed for Diagnosis: 10 s \times 3 time(s)

Malfunction Indicator Light Illumination: Illuminates when malfunction occurs in 2 continuous driving cycles.

• Normality Judgement

Judge as OK and clear the NG if the continuous time while the following conditions are established is more than the predetermined time.

Judgement Value

Malfunction Criteria	Threshold Value
Actual engine speed — Targeted engine speed	$\geq -100\text{ rpm}$

Time Needed for Diagnosis: 10 s

Diagnostic Trouble Code (DTC) Detecting Criteria

GENERAL DESCRIPTION

CA:DTC P0507 IDLE AIR CONTROL SYSTEM RPM HIGHER THAN EXPECTED

1. OUTLINE OF DIAGNOSIS

Detect the malfunction that actual engine speed is not close to target engine speed during idling. Judge as NG when actual engine speed is not close to target engine speed during idling.

2. ENABLE CONDITION

Secondary Parameters	Enable Conditions
Engine coolant temperature	≥ 70 °C (158 °F)
Battery voltage	≥ 10.9 V
Barometric pressure	≥ 75 kPa (563 mmHg, 22.2 inHg)
Fuel level	≥ 9.6 ℓ (2.54 US gal, 2.11 Imp gal)
Elapsed time after starting the engine	≥ 10.49 s
Feedback of ISC	In operation
Lambda value (left and right)	≥ 0.9 and < 1.1
After switching air conditioner to ON/OFF	≥ 5.1 s
After intake manifold pressure changes by 4 kPa (30 mmHg, 1.2 inHg) or more.	> 5.1 s
Elapsed time after switching neutral position switch to ON/OFF	> 5.1 s
Vehicle speed	0 km/h (0 MPH)

3. GENERAL DRIVING CYCLE

Perform the diagnosis continuously at idling after warming up engine.

4. DIAGNOSTIC METHOD

• Abnormality Judgement

If the duration of time while the following conditions are met is longer than the time indicated, judge as NG.

Judgement Value

Malfunction Criteria	Threshold Value
Actual – Target engine speed	≥ 200 rpm
Feedback value for ISC	Min.

Time Needed for Diagnosis: 10 s × 3 time(s)

Malfunction Indicator Light Illumination: Illuminates when malfunction occurs in 2 continuous driving cycles.

• Normality Judgement

Judge as OK and clear the NG if the continuous time while the following conditions are established is more than the predetermined time.

Judgement Value

Malfunction Criteria	Threshold Value
Actual – Target engine speed	< 200 rpm

Time Needed for Diagnosis: 10 s

Diagnostic Trouble Code (DTC) Detecting Criteria

GENERAL DESCRIPTION

CB:DTC P0512 STARTER REQUEST CIRCUIT

1. OUTLINE OF DIAGNOSIS

Detect the open or short circuit of starter SW.

Judge as ON NG when the starter SW signal remains ON.

2. ENABLE CONDITION

Secondary Parameters	Enable Conditions
None	

3. GENERAL DRIVING CYCLE

Always perform the diagnosis continuously.

4. DIAGNOSTIC METHOD

• Abnormality Judgement

If the duration of time while the following conditions are met is longer than the time indicated, judge as NG.

Judgement Value

Malfunction Criteria	Threshold Value
Engine condition	After engine starting
Starter OFF signal	Not detected
Battery voltage	≥ 8 V

Time Needed for Diagnosis: 180000 ms

Malfunction Indicator Light Illumination: Illuminates when malfunction occurs in 2 continuous driving cycles.

• Normality Judgement

Judge as OK and clear the NG if the continuous time while the following conditions are established is more than the predetermined time.

Judgement Value

Malfunction Criteria	Threshold Value
Starter OFF signal	Detected
Battery voltage	≥ 8 V

Time Needed for Diagnosis: Less than 1 second

Diagnostic Trouble Code (DTC) Detecting Criteria

GENERAL DESCRIPTION

CC:DTC P0513 INCORRECT IMMOBILIZER KEY

1. OUTLINE OF DIAGNOSIS

DTC	Item	OUTLINE OF DIAGNOSIS
P0513	Incorrect Immobilizer Key	Incorrect immobilizer key (Use of unregistered key in body integrated unit)
P1570	Antenna	Faulty antenna
P1571	Reference Code Incompatibility	Reference code incompatibility between body integrated unit and ECM
P1572	IMM Circuit Failure (Except Antenna Circuit)	Communication failure between body integrated unit and ECM
P1574	Key Communication Failure	Failure of body integrated unit to verify key (transponder) ID code or transponder failure
P1576	EGI Control Module EEPROM	ECM malfunctioning
P1577	IMM Control Module EEPROM	Body integrated unit malfunctioning
P1578	Meter Failure	Reference code incompatibility between body integrated unit and combination meter

2. ENABLE CONDITION

When starting the engine.

3. GENERAL DRIVING CYCLE

Perform the diagnosis only after starting the engine.

4. DIAGNOSTIC METHOD

Judge as NG when the conditions for the outline of the diagnosis of the top are established.

Diagnostic Trouble Code (DTC) Detecting Criteria

GENERAL DESCRIPTION

CD:DTC P0600 SERIAL COMMUNICATION LINK

1. OUTLINE OF DIAGNOSIS

Detect malfunction of CAN communication.

When CAN communications is not possible, and CAN communications with TCM is not possible, judge as NG if data from the TCM is not normal.

2. COMPONENT DESCRIPTION

ECM, TCM, VDC CM and body integrated unit are connected by high speed CAN.

(Common Specifications)

CAN Protocol 2.0 B (Active)

Frame Format: 11 Bit ID Frame (Standard Frame)

(High speed CAN)

Conforms to ISO11898

Communication Speed: 500 kbps

3. ENABLE CONDITION

Secondary Parameters	Enable Conditions
None	

4. GENERAL DRIVING CYCLE

Perform the diagnosis continuously after starting the engine.

5. DIAGNOSTIC METHOD

• Abnormality Judgement

Judge as NG when the following conditions are established.

Judgement Value

Malfunction Criteria	Threshold Value
Battery voltage	> 10.9 V
Starter switch	OFF
Engine	run
bus off flag or error warning flag	set (error)
or	
ID received from control module connected to driving system CAN	None during 500 milliseconds
or	
Data updated from control module connected to driving system CAN	None during 500 milliseconds

Time Needed for Diagnosis: Less than 1 second

Malfunction Indicator Light Illumination: Illuminates as soon as a malfunction occurs.

• Normality Judgement

Judge as OK and clear the NG if the continuous time while the following conditions are established is more than the predetermined time.

Judgement Value

Malfunction Criteria	Threshold Value
Battery voltage	> 10.9 V
Starter switch	OFF
Engine	run
bus off flag or error warning flag	clear (No error)
ID received from control module connected to driving system CAN	Yes
Data updated from control module connected to driving system CAN	Yes

Time Needed for Diagnosis: 1000 ms

Malfunction Indicator Light Illumination: Illuminates as soon as a malfunction occurs.

Diagnostic Trouble Code (DTC) Detecting Criteria

GENERAL DESCRIPTION

CE:DTC P0604 INTERNAL CONTROL MODULE RANDOM ACCESS MEMORY (RAM) ERROR

1. OUTLINE OF DIAGNOSIS

Detect the malfunction of microcomputer (RAM).

When there is a problem in the main CPU normal RAM, or the sub CPU normal RAM, judge as NG. Judge as OK when both are operating properly.

If it is possible to write data to the whole area of RAM in the initial routine, and is possible to read the same data, it is judged as OK, and if not, NG.

2. ENABLE CONDITION

Secondary Parameters	Enable Conditions
None	

Diagnosis with the initial routine.

3. GENERAL DRIVING CYCLE

Perform the diagnosis as soon as the ignition switch is turned to ON.

4. DIAGNOSTIC METHOD

Abnormality Judgement

Judge as NG if the criteria below are met.

Judgement Value

Malfunction Criteria	Threshold Value
Main CPU normal RAM abnormal	
Write 5AA5A55A and then read. (Whole area of RAM)	5AA5A55A cannot be read.
Write A55A5AA5 and then read. (Whole area of RAM)	A55A5AA5 cannot be read.
Sub CPU normal RAM abnormal	
Write 5AA5 and then read. (Whole area of RAM)	5AA5 cannot be read.
Write A55A and then read. (Whole area of RAM)	A55A cannot be read.

Time Needed for Diagnosis: Undetermined

Malfunction Indicator Light Illumination: Illuminates as soon as a malfunction occurs.

Normality Judgement

Judge as OK and clear the NG when the malfunction criteria below are met.

Judgement Value

Malfunction Criteria	Threshold Value
Main CPU normal RAM abnormal	
Write 5AA5A55A and then read. (Whole area of RAM)	5AA5A55A can be read.
And write A55A5AA5 and then read. (Whole area of RAM)	A55A5AA5 can be read.
Sub CPU normal RAM abnormal	
Write 5AA5 and then read. (Whole area of RAM)	5AA5 can be read.
And write A55A and then read. (Whole area of RAM)	A55A can be read.

Diagnostic Trouble Code (DTC) Detecting Criteria

GENERAL DESCRIPTION

CF:DTC P0605 INTERNAL CONTROL MODULE READ ONLY MEMORY (ROM) ERROR

1. OUTLINE OF DIAGNOSIS

Judge as NG when SUM value of ROM is outside the standard value.

2. ENABLE CONDITION

Secondary Parameters	Enable Conditions
Ignition switch	ON

3. GENERAL DRIVING CYCLE

Always perform the diagnosis continuously.

4. DIAGNOSTIC METHOD

Abnormality Judgement

Judge as NG if the criteria below are met.

Judgement Value

Malfunction Criteria	Threshold Value
SUM value of ROM	Standard

Time Needed for Diagnosis: Undetermined

Malfunction Indicator Light Illumination: Illuminates as soon as a malfunction occurs.

Diagnostic Trouble Code (DTC) Detecting Criteria

GENERAL DESCRIPTION

CG:DTC P0607 THROTTLE CONTROL SYSTEM CIRCUIT RANGE/PERFORMANCE

1. OUTLINE OF DIAGNOSIS

Judge as NG when any one of the followings is established.

- 1) When the read value of throttle position sensor 1 signal is mismatched between main CPU and sub CPU.
- 2) When the read value of accelerator pedal position sensor 1 signal is mismatched between main CPU and sub CPU.
- 3) When the sub CPU operates abnormally.
- 4) When the communication between main CPU \longleftrightarrow sub CPU is abnormal.
- 5) When the input amplifier circuit of throttle position sensor 1 is abnormal.
- 6) When the cruise control cannot be canceled correctly.
- 7) When the signal of brake SW1 and 2 is mismatched.

2. COMPONENT DESCRIPTION

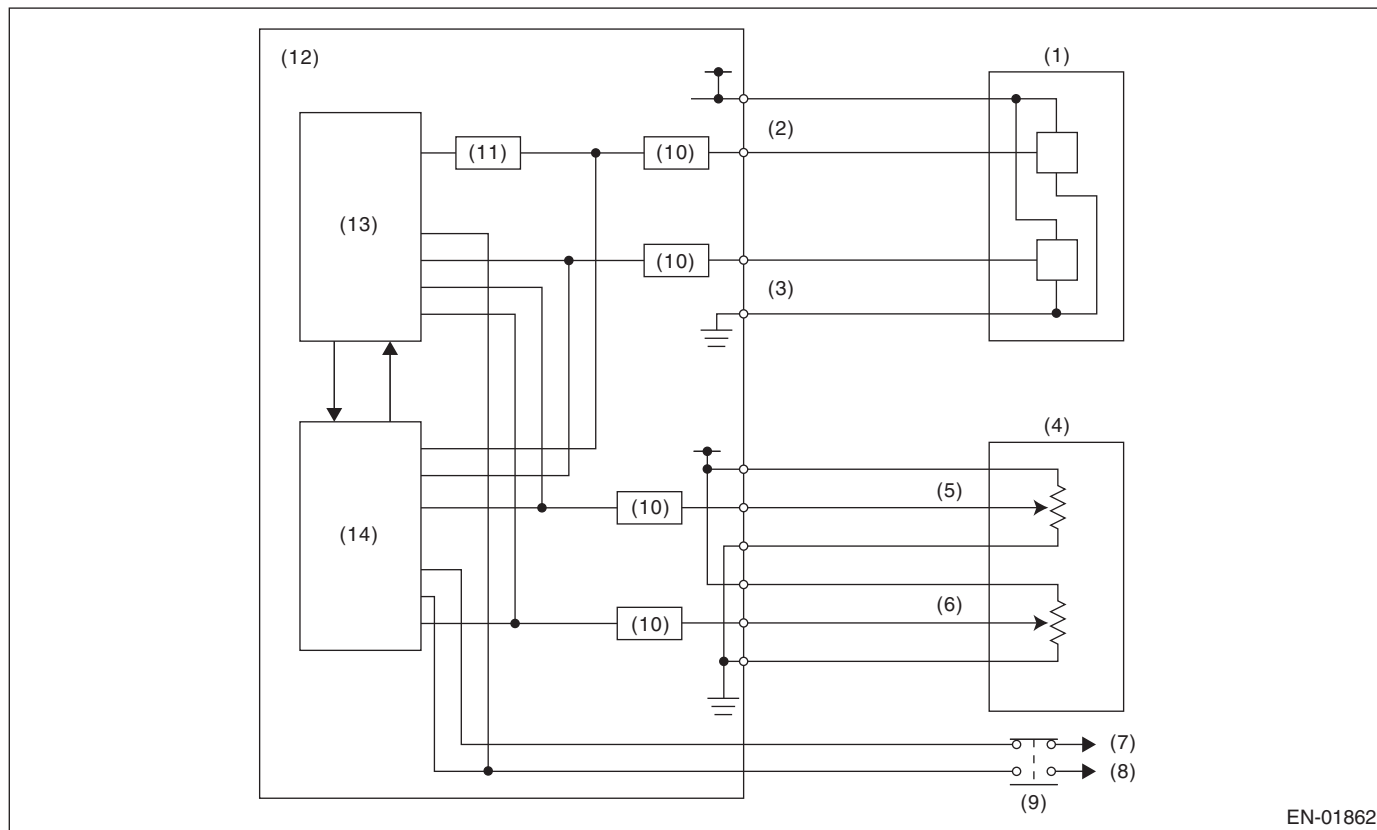

- | | | |
|---|---|----------------------------------|
| (1) Throttle position sensor | (6) Accelerator pedal position sensor 2 | (11) Amplifier circuit |
| (2) Throttle position sensor 1 | (7) Battery | (12) Engine control module (ECM) |
| (3) Throttle position sensor 2 | (8) Stop light | (13) Sub CPU |
| (4) Accelerator pedal position sensor | (9) Brake switch | (14) Main CPU |
| (5) Accelerator pedal position sensor 1 | (10) I/F circuit | |

3. ENABLE CONDITION

Secondary Parameters	Enable Conditions
(1) Ignition switch	ON
(2) Ignition switch	ON
(3) None	—
(4) None	—
(5) Throttle opening angle	—
(6) Brake switch (only with cruise control)	ON
(7) None	—

Diagnostic Trouble Code (DTC) Detecting Criteria

GENERAL DESCRIPTION

4. GENERAL DRIVING CYCLE

- (1) — (4): Always perform the diagnosis continuously.
- (5): Always perform the diagnosis continuously when idling.
- (6): Perform the diagnosis when the brake pedal is depressed.
- (7): Always perform the diagnosis continuously.
- (8): Always perform the diagnosis continuously when the cruise control pedal is not operating.

5. DIAGNOSTIC METHOD

Judge as OK and clear the NG when the malfunction criteria below are met.

Judgement Value

Malfunction Criteria	Threshold Value
(1) Difference of CPU reading value of the throttle position sensor signal	≤ 0.0858 V
(2) Difference of CPU read value of the accelerator pedal position sensor signal	≤ 0.35 V
(3) WD pulse from sub CPU	WD pulse occur
(4) Communication between CPU	Possible to communicate
(5) Throttle position sensor 1 opening angle — (Throttle position sensor 1 opening angle after passing amplifier) 1/4	$< 3^\circ$
(6) Cruise control cancel signal at brake ON	Cruise control cancel signal ON
(7) Brake switch 1, 2 signal	SW 1 and 2 are matched

Time Needed for Diagnosis:

- 1. 600 ms
- 2. 830 ms
- 3. 200 ms
- 4. 200 ms
- 5. 24 ms
- 6. 250 ms
- 7. 200 ms

Malfunction Indicator Light Illumination: Illuminates as soon as a malfunction occurs.

Diagnostic Trouble Code (DTC) Detecting Criteria

GENERAL DESCRIPTION

CH:DTC P0638 THROTTLE ACTUATOR CONTROL RANGE/PERFORMANCE (BANK 1)

1. OUTLINE OF DIAGNOSIS

Judge as NG when the target opening angle and actual opening angle is mismatched or the current to motor is the specified duty or more for specified time continuously.

2. COMPONENT DESCRIPTION

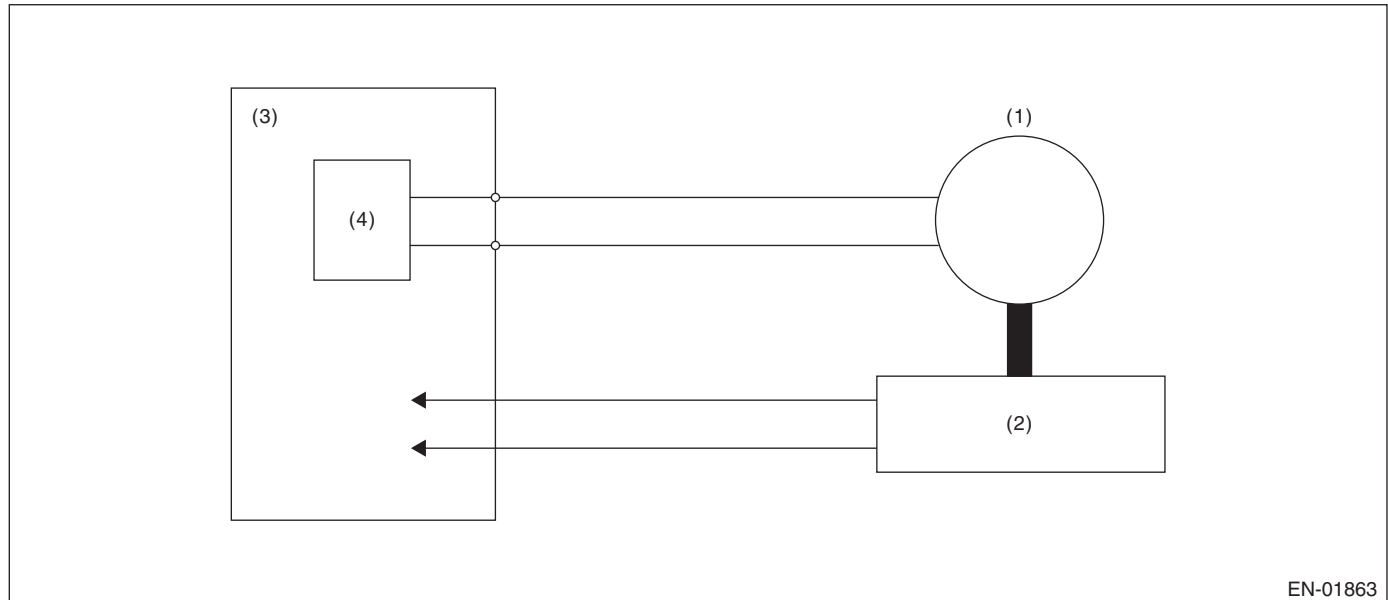

EN-01863

- (1) Motor
(2) Throttle position sensor
(3) Engine control module (ECM)
(4) Drive circuit

3. ENABLE CONDITION

Secondary Parameters	Enable Conditions
Ignition switch	ON
Normal operation of electronic throttle control	ON

4. GENERAL DRIVING CYCLE

Always perform the diagnosis continuously when the electronic throttle control is operating.

5. DIAGNOSTIC METHOD

Judge as OK and clear the NG when the malfunction criteria below are met.

Judgement Value

Malfunction Criteria	Threshold Value
Difference between target opening angle and actual opening angle	3.5° or less
Output duty to drive circuit	95% or less

Time Needed for Diagnosis:

- Target opening angle and actual opening angle: 250 milliseconds (For NG), 2000 milliseconds (For OK)
- Output duty to drive circuit: 2000 milliseconds

Diagnostic Trouble Code (DTC) Detecting Criteria

GENERAL DESCRIPTION

Details of Judgement Value

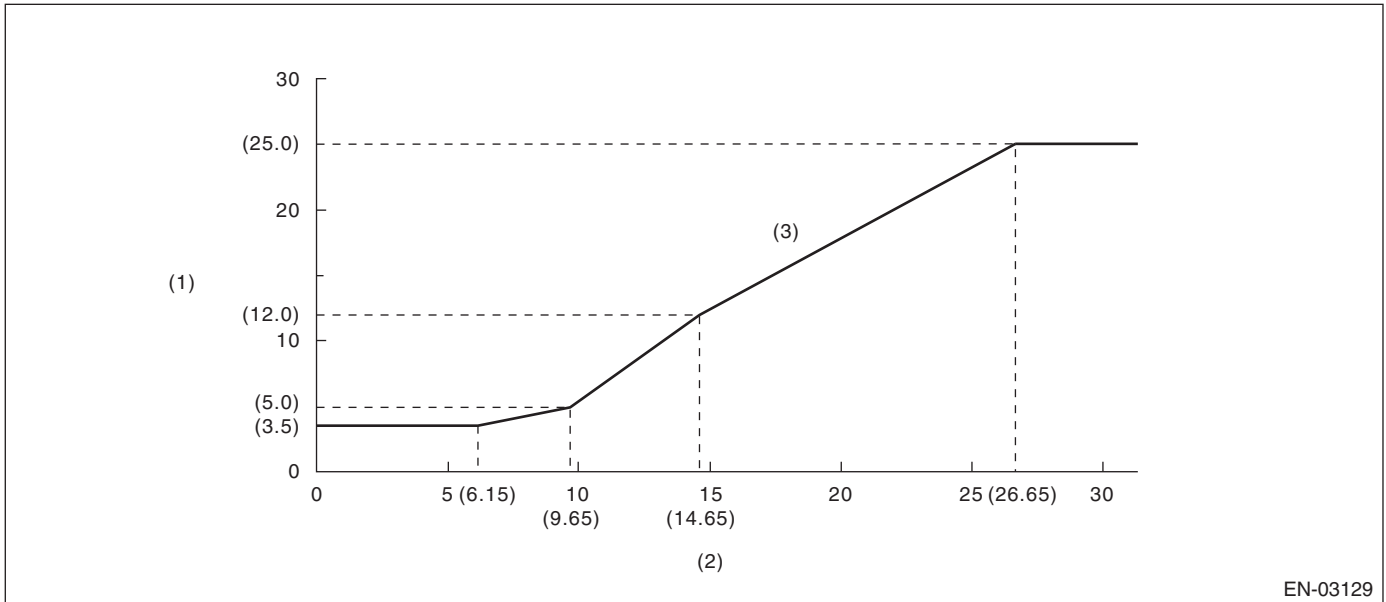

EN-03129

- (1) Difference between target opening angle and actual opening angle (°) (2) Target throttle opening angle (°) (3) NG area

Details of Judgement time (The actual opening angle \leq target opening angle is always 1000 milliseconds)

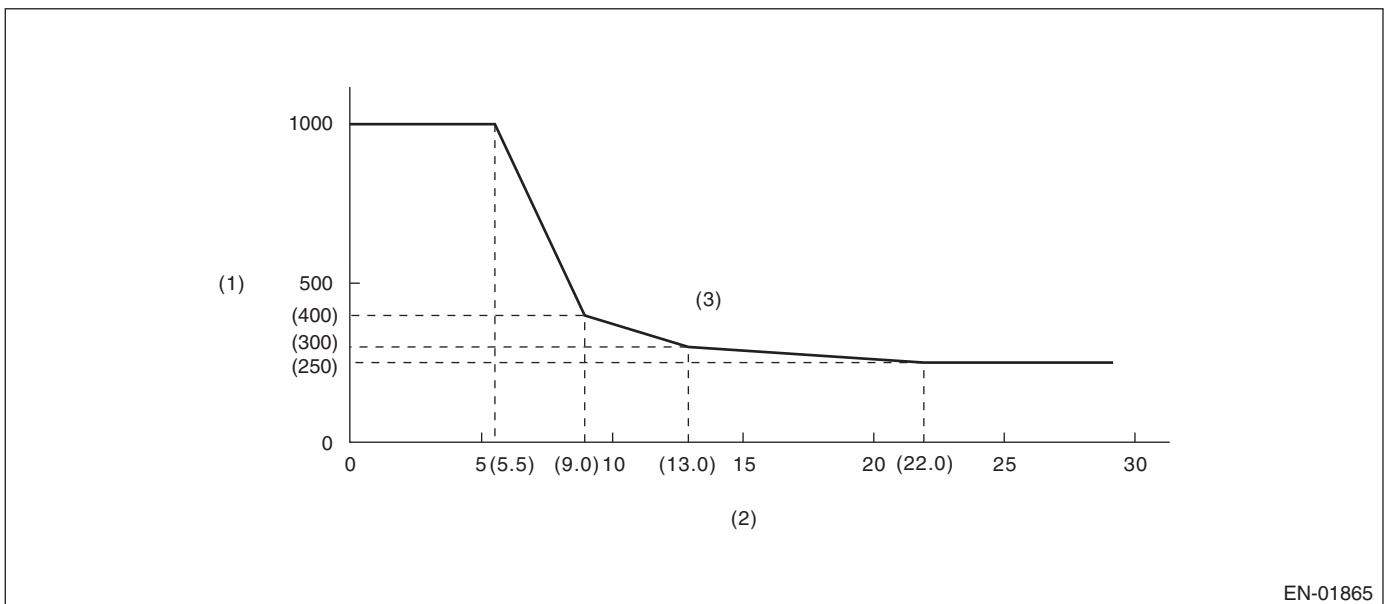

EN-01865

- (1) Judgement time (milliseconds) (2) Throttle position sensor 1 opening angle (3) NG area

Malfunction Indicator Light Illumination: Illuminates as soon as a malfunction occurs.

Diagnostic Trouble Code (DTC) Detecting Criteria

GENERAL DESCRIPTION

CI: DTC P0700 TRANSMISSION CONTROL SYSTEM (MIL REQUEST)

1. OUTLINE OF DIAGNOSIS

Judge as NG when there is CAN communication with the TCM and there is a MIL lighting request.

2. ENABLE CONDITION

Secondary Parameters	Enable Conditions
None	

3. GENERAL DRIVING CYCLE

Always perform the diagnosis continuously.

4. DIAGNOSTIC METHOD

• Abnormality Judgement

If the duration of time while the following conditions are met is longer than the time indicated, judge as NG.

Judgement Value

Malfunction Criteria	Threshold Value
Battery voltage	$\geq 10.9\text{ V}$
MIL lighting request from TCM	Yes

Time Needed for Diagnosis: 2500 ms

Malfunction Indicator Light Illumination: Illuminates as soon as a malfunction occurs.

• Normality Judgement

If the duration of time while the following conditions are met is longer than the time indicated, judge as NG.

Judgement Value

Malfunction Criteria	Threshold Value
Battery voltage	$\geq 10.9\text{ V}$
MIL lighting request from TCM	None

Time Needed for Diagnosis: Less than 1 second

Diagnostic Trouble Code (DTC) Detecting Criteria

GENERAL DESCRIPTION

CJ:DTC P0851 PARK/NEUTRAL SWITCH INPUT CIRCUIT LOW (AT MODEL)

1. OUTLINE OF DIAGNOSIS

Detect the open or short circuit of neutral SW.

Judge as NG when the ECM neutral terminal input differs from the reception data from TCM.

2. ENABLE CONDITION

Secondary Parameters	Enable Conditions
Battery voltage	≥ 10.9 V
Starter relay	OFF

3. GENERAL DRIVING CYCLE

Perform the diagnosis continuously in 2 seconds after starting the engine.

4. DIAGNOSTIC METHOD

• Abnormality Judgement

If the duration of time while the following conditions are met is longer than the time indicated, judge as NG.

Judgement Value

Malfunction Criteria	Threshold Value
Neutral switch signal in ECM when "P"/ "N" range in TCM are "OFF" and when the other switches are "ON"	LOW (ON)

Time Needed for Diagnosis: 100 time(s)

Malfunction Indicator Light Illumination: Illuminates when malfunction occurs in 2 continuous driving cycles.

• Normality Judgement

Judge as OK and clear the NG if the continuous time while the following conditions are established is more than the predetermined time.

Judgement Value

Malfunction Criteria	Threshold Value
Neutral switch signal in ECM when "P"/ "N" range in TCM are "OFF" and when the other switches are "ON"	HIGH (OFF)

Time Needed for Diagnosis: Less than 1 second

Diagnostic Trouble Code (DTC) Detecting Criteria

GENERAL DESCRIPTION

CK:DTC P0852 PARK/NEUTRAL SWITCH INPUT CIRCUIT HIGH (AT MODEL)

1. OUTLINE OF DIAGNOSIS

Judge the open or short circuit of the neutral SW.

Judge as NG when the ECM neutral terminal input differs from the reception data from TCM.

2. ENABLE CONDITION

Secondary Parameters	Enable Conditions
Battery voltage	≥ 10.9 V
Starter relay	OFF

3. GENERAL DRIVING CYCLE

Perform the diagnosis continuously in 2 seconds after starting the engine.

4. DIAGNOSTIC METHOD

• Abnormality Judgement

If the duration of time while the following conditions are met is longer than the time indicated, judge as NG.

Judgement Value

Malfunction Criteria	Threshold Value
Neutral switch signal in ECM when "P"/ "N" range in TCM are "ON" and when the other switches are "OFF"	HIGH (OFF)

Time Needed for Diagnosis: 100 time(s)

Malfunction Indicator Light Illumination: Illuminates when malfunction occurs in 2 continuous driving cycles.

• Normality Judgement

Judge as OK and clear the NG if the continuous time while the following conditions are established is more than the predetermined time.

Judgement Value

Malfunction Criteria	Threshold Value
Neutral switch signal in ECM when "P"/ "N" range in TCM are "ON" and when the other switches are "OFF"	LOW (ON)

Time Needed for Diagnosis: Less than 1 second

Diagnostic Trouble Code (DTC) Detecting Criteria

GENERAL DESCRIPTION

CL:DTC P1152 O2 SENSOR CIRCUIT RANGE/PERFORMANCE (LOW) (BANK1 SENSOR1)

1. OUTLINE OF DIAGNOSIS

Detect that λ value remains low.

Judge as NG when lambda value is abnormal in accordance with λ value of front oxygen (A/F) sensor and running conditions such as vehicle speed, amount of intake air, engine coolant temperature, sub feedback control, etc.

λ value = Actual air fuel ratio/Theoretical air fuel ratio

$\lambda > 1$: Lean

$\lambda < 1$: Rich

2. COMPONENT DESCRIPTION

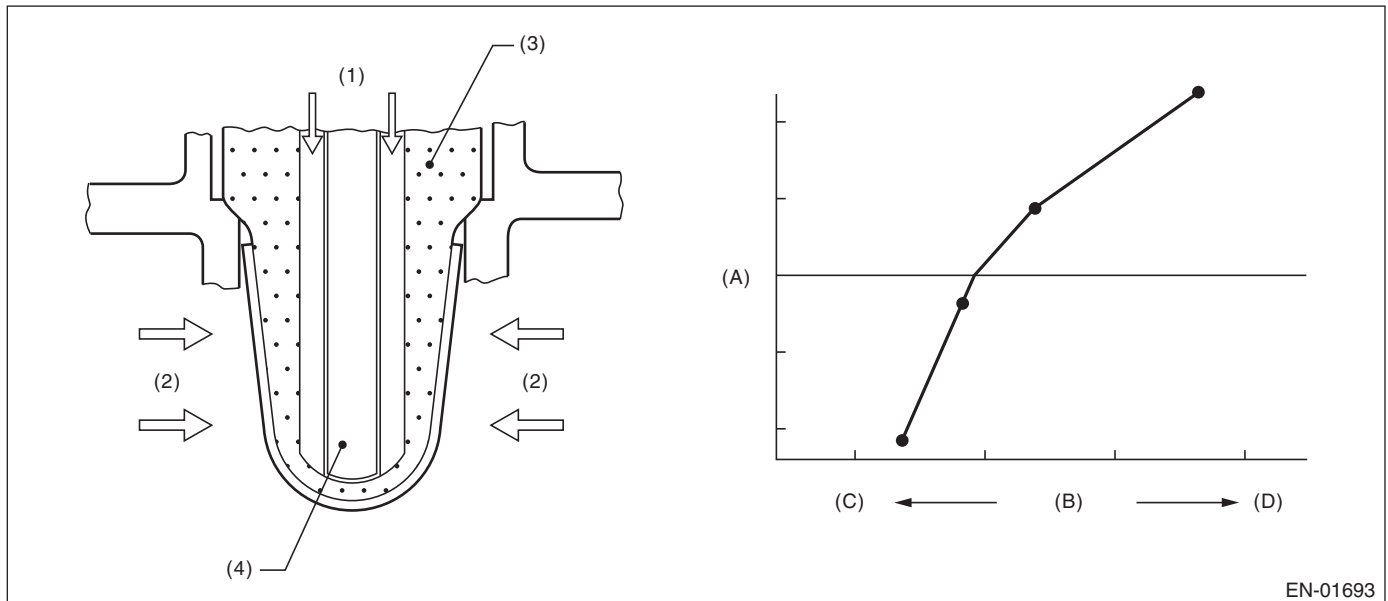

EN-01693

(A) Electromotive force

(B) Air fuel ratio

(C) Lean

(D) Rich

(1) Atmosphere

(3) ZrO_2

(4) Ceramic heater

(2) Exhaust gas

Diagnostic Trouble Code (DTC) Detecting Criteria

GENERAL DESCRIPTION

3. ENABLE CONDITION

Secondary Parameters	Enable Conditions
Time needed for all secondary parameters to be in enable conditions	≥ 4096 ms
Battery voltage	≥ 10.9 V
Barometric pressure	≥ 75 kPa (563 mmHg, 22.2 inHg)
Rear oxygen sensor sub feedback	Execution
Rear oxygen sensor output voltage – Feedback target voltage or Rear oxygen sensor sub feedback compensation coefficient or Rear oxygen sensor sub feedback compensation coefficient	-0.2 V — 0.1 V On Min. On Max.
Elapsed time after starting the engine	≥ 60000 ms
Engine coolant temperature	≥ 70 °C (158 °F)
Vehicle speed	≥ 20 km/h (12.4 MPH)
Amount of intake air	≥ 6 g/s (0.21 oz/s)
Load change at 180°C	< 0.02 g/rev (0 oz/rev)
Front oxygen (A/F) sensor impedance	0Ω — 50Ω
Learning value of evaporation gas density	< 0.2
Total time of operating canister purge	≥ 19.9 s
Targeted lambda value load compensation coefficient	-1 — 1

4. GENERAL DRIVING CYCLE

Perform diagnosis continuously at a constant speed of 20 km/h (12.4 MPH) or more after 60000 ms have passed since the engine started.

5. DIAGNOSTIC METHOD

• Abnormality Judgement

If the duration of time while the following conditions are met is longer than the time indicated, judge as NG.

Judgement Value

Malfunction Criteria	Threshold Value
λ value	< 0.85

Time Needed for Diagnosis: 10000 ms

Malfunction Indicator Light Illumination: Illuminates when malfunction occurs in 2 continuous driving cycles.

• Normality Judgement

Judge as OK and clear the NG if the continuous time while the following conditions are established is more than the predetermined time.

Judgement Value

Malfunction Criteria	Threshold Value
λ value	≥ 0.85

Time Needed for Diagnosis: Less than 1 second

Diagnostic Trouble Code (DTC) Detecting Criteria

GENERAL DESCRIPTION

CM:DTC P1153 O2 SENSOR CIRCUIT RANGE/PERFORMANCE (HIGH) (BANK1 SENSOR1)

1. OUTLINE OF DIAGNOSIS

Detect that λ value remains high.

Judge as NG when lambda value is abnormal in accordance with λ value of front oxygen (A/F) sensor and running conditions such as vehicle speed, amount of intake air, engine coolant temperature, sub feedback control, etc.

λ value = Actual air fuel ratio/Theoretical air fuel ratio

$\lambda > 1$: Lean

$\lambda < 1$: Rich

2. COMPONENT DESCRIPTION

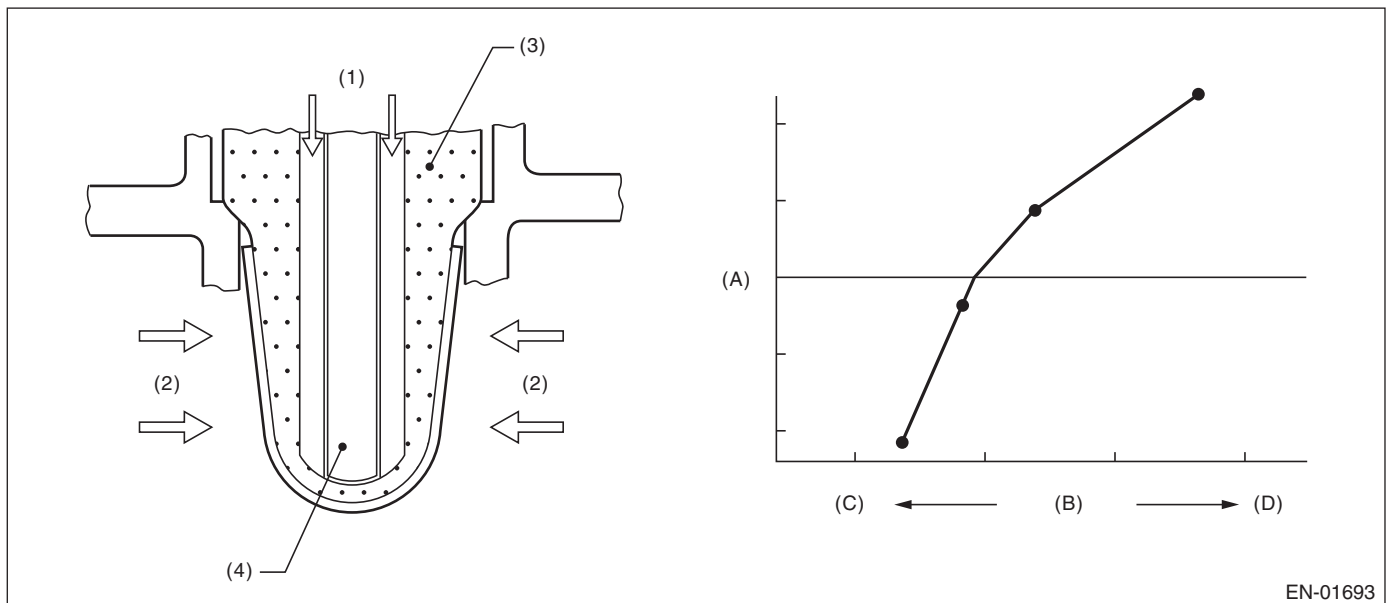

EN-01693

(A) Electromotive force

(B) Air fuel ratio

(C) Lean

(D) Rich

(1) Atmosphere

(3) ZrO_2

(4) Ceramic heater

(2) Exhaust gas

Diagnostic Trouble Code (DTC) Detecting Criteria

GENERAL DESCRIPTION

3. ENABLE CONDITION

Secondary Parameters	Enable Conditions
Time needed for all secondary parameters to be in enable conditions	≥ 4096 ms
Battery voltage	≥ 10.9 V
Barometric pressure	≥ 75 kPa (563 mmHg, 22.2 inHg)
Rear oxygen sensor sub feedback	Execution
Rear oxygen sensor output voltage – Feedback target voltage or	-0.2 V — 0.1 V
Rear oxygen sensor sub feedback compensation coefficient or	On Min.
Rear oxygen sensor sub feedback compensation coefficient	On Max.
Elapsed time after starting the engine	≥ 60000 ms
Engine coolant temperature	≥ 70 °C (158 °F)
Vehicle speed	≥ 20 km/h (12.4 MPH)
Amount of intake air	≥ 6 g/s (0.21 oz/s)
Load change at 180°C	< 0.02 g/rev (0 oz/rev)
Front oxygen (A/F) sensor impedance	0Ω — 50Ω
Learning value of evaporation gas density	< 0.2
Total time of operating canister purge	≥ 19.9 s
Targeted lambda value load compensation coefficient	-1 — 1

4. GENERAL DRIVING CYCLE

Perform diagnosis continuously at a constant speed of 20 km/h (12.4 MPH) or more after 60000 ms have passed since the engine started.

5. DIAGNOSTIC METHOD

• Abnormality Judgement

If the duration of time while the following conditions are met is longer than the time indicated, judge as NG.

Judgement Value

Malfunction Criteria	Threshold Value
λ value	> 1.15

Time Needed for Diagnosis: 10000 ms

Malfunction Indicator Light Illumination: Illuminates when malfunction occurs in 2 continuous driving cycles.

• Normality Judgement

Judge as OK and clear the NG if the continuous time while the following conditions are established is more than the predetermined time.

Judgement Value

Malfunction Criteria	Threshold Value
λ value	≤ 1.15

Time Needed for Diagnosis: Less than 1 second

CN:DTC P1160 RETURN SPRING FAILURE

1. OUTLINE OF DIAGNOSIS

Judge as NG when the valve is opened more than the default opening angle, but does not move to the close direction with the motor power stopped.

2. COMPONENT DESCRIPTION

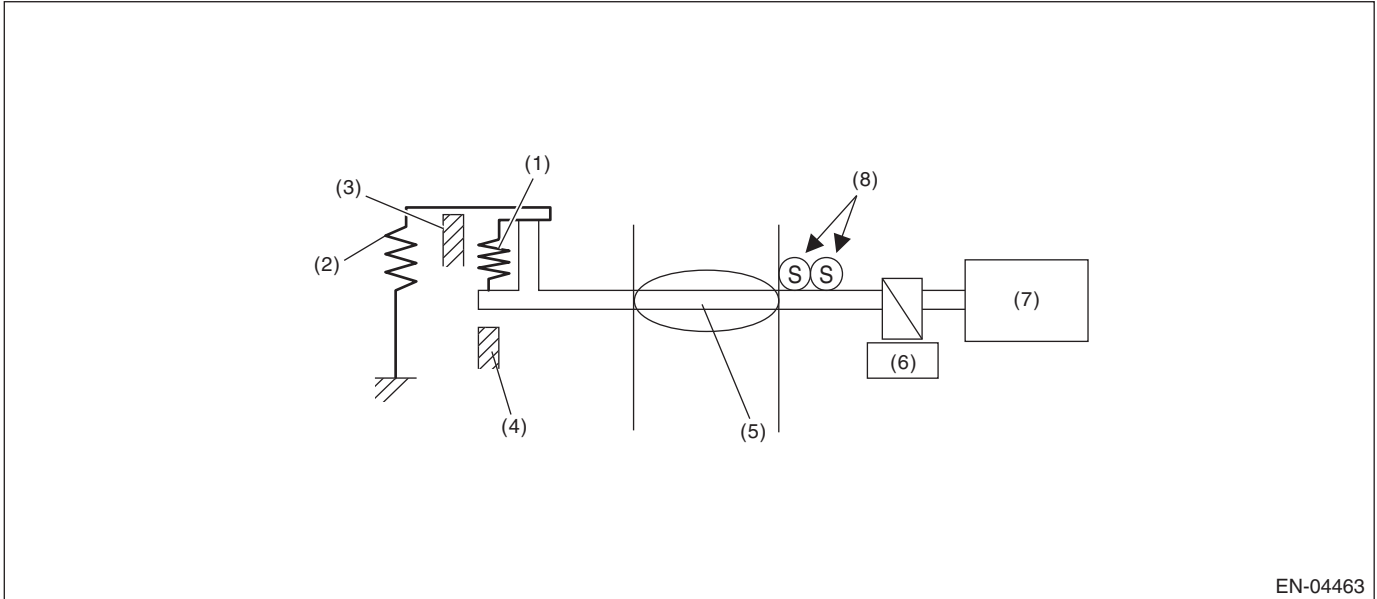

- | | | |
|--------------------------|-------------------------|---|
| (1) Opener spring | (4) Full closed stopper | (7) DC motor |
| (2) Return spring | (5) Throttle valve | (8) Main and sub throttle position sensor |
| (3) Intermediate stopper | (6) Gear | |

3. ENABLE CONDITION

Secondary Parameters	Enable Conditions
Battery voltage	≥ 6 V
Throttle position sensor	Normal

4. GENERAL DRIVING CYCLE

- Ignition switch ON → OFF
- Ignition switch OFF → ON (Only after clearing memory)

Diagnostic Trouble Code (DTC) Detecting Criteria

GENERAL DESCRIPTION

5. DIAGNOSTIC METHOD

- **Abnormality Judgement**

Judge as NG when the following conditions are established.

Judgement Value

Malfunction Criteria	Threshold Value
Opening variation after continuity is set to OFF	$< 2^{\circ}$

Time Needed for Diagnosis:24 ms

Malfunction Indicator Light Illumination: Illuminates as soon as a malfunction occurs.

- **Normality Judgement**

Judge as OK and clear the NG if the following conditions are established.

Judgement Value

Malfunction Criteria	Threshold Value
Opening variation after continuity is set to OFF	$\geq 2^{\circ}$

Time Needed for Diagnosis:3400 ms

CO:DTC P1400 FUEL TANK PRESSURE CONTROL SOLENOID VALVE CIRCUIT LOW

1. OUTLINE OF DIAGNOSIS

Detect the open/short circuit of pressure control solenoid valve.

Judge as NG when ECM output level is different from actual terminal level.

2. COMPONENT DESCRIPTION

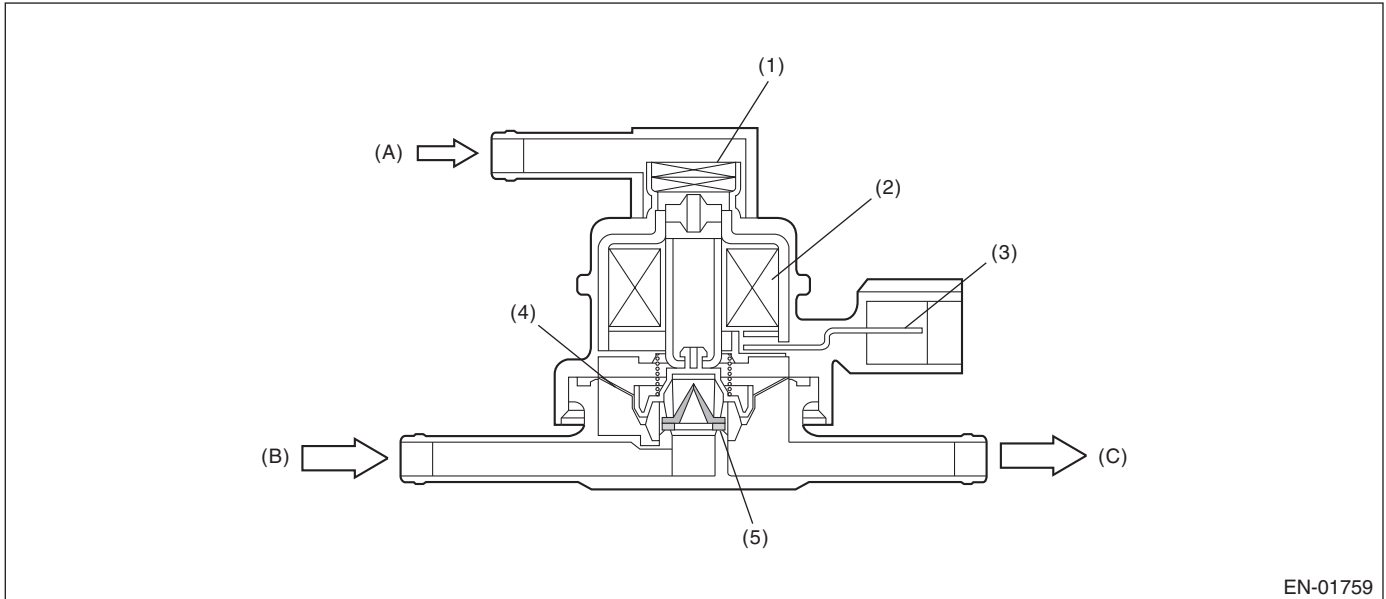

EN-01759

(A) Barometric pressure

(B) Shut-off valve

(C) To fuel tank

(1) Filter

(3) Connector terminal

(5) Valve

(2) Coil

(4) Diaphragm

3. ENABLE CONDITION

Secondary Parameters	Enable Conditions
None	

4. GENERAL DRIVING CYCLE

Always perform the diagnosis after starting the engine.

Diagnostic Trouble Code (DTC) Detecting Criteria

GENERAL DESCRIPTION

5. DIAGNOSTIC METHOD

• Abnormality Judgement

If the duration of time while the following conditions are met is longer than the time indicated, judge as NG.

Judgement Value

Malfunction Criteria	Threshold Value
Battery voltage	≥ 10.9 V
Elapsed time after starting the engine	≥ 1 second
Terminal output voltage when ECM outputs OFF signal	Low

Time Needed for Diagnosis: 2500 ms

Malfunction Indicator Light Illumination: Illuminates when malfunction occurs in 2 continuous driving cycles.

• Normality Judgement

Judge as OK and clear the NG if the continuous time while the following conditions are established is more than the predetermined time.

Judgement Value

Malfunction Criteria	Threshold Value
Battery voltage	≥ 10.9 V
Elapsed time after starting the engine	≥ 1 second
Terminal output voltage when ECM outputs OFF signal	High

Time Needed for Diagnosis: Less than 1 second

Diagnostic Trouble Code (DTC) Detecting Criteria

GENERAL DESCRIPTION

CP:DTC P1410 SECONDARY AIR INJECTION SYSTEM SWITCHING VALVE STUCK OPEN

1. OUTLINE OF DIAGNOSIS

Always detect abnormality that both combination valve electromagnetic valve and the reed valve are open failure.

Calculate the integrated value of Max./Min. value and output voltage deviation of the secondary air delivery pipe pressure sensor output voltage in a given time after engine start. Judge as NG if the integrated value and the difference between Max. and Min. values are large.

2. ENABLE CONDITION

Secondary Parameters	Enable Conditions
Engine speed	≥ 500 rpm and < 10000 rpm
Elapsed time after starting the engine	≥ 9000 ms
After secondary air system stops	≥ 9000 ms
Amount of intake air	≥ 2 g/s (0.07 oz/s) and < 400 g/s (14.11 oz/s)
Battery voltage	≥ 10.9 V
Engine load	> 0 g/rev
After fuel cut	≥ 1000 ms

3. GENERAL DRIVING CYCLE

Perform continuous diagnosis when air flow amount is large during the secondary air pump stop after engine start.

4. DIAGNOSTIC METHOD

When both combination valve electromagnetic valve and the reed valve are open failure, the failure appears as pulses in the secondary air delivery pipe pressure sensor output. Detect abnormality by capturing these pulses using the following method.

• Abnormality Judgement

Calculate Max./Min. value of the secondary air delivery pipe pressure sensor output voltage and the sum of the output voltage deviation for the given time. Compare the difference between Max. and Min. values with threshold value and also compare the sum value with the threshold value. If both values exceed the threshold value, count up NG counter and then judge as NG if the counter reaches the given times.

Judgement Value

Malfunction Criteria	Threshold Value
Pipe inner pressure difference between Max. and Min.	> 0.05 V
Sum of the pipe inner pressure variation value every 4 milliseconds	> 5 V
Barometric pressure variation value	< 26.7 kPa (200 mmHg, 7.9 inHg)

Time Needed for Diagnosis:2000 ms × 20 time(s)

Malfunction Indicator Light Illumination: Illuminates as soon as a malfunction occurs.

• Normality Judgement

Judge as OK and clear NG if neither exceeds the threshold value, or if either of the two exceeds the threshold value.

Judgement Value

Malfunction Criteria	Threshold Value
Pipe inner pressure difference between Max. and Min.	≤ 0.05 V
Sum of the pipe inner pressure variation value every 4 milliseconds	≤ 5 V

Time Needed for Diagnosis:2000 ms

Diagnostic Trouble Code (DTC) Detecting Criteria

GENERAL DESCRIPTION

CQ:DTC P1418 SECONDARY AIR INJECTION SYSTEM CONTROL "A" CIRCUIT SHORTED

1. OUTLINE OF DIAGNOSIS

Judge as NG when the ECM output level differs from the actual terminal level.

2. ENABLE CONDITION

Secondary Parameters	Enable Conditions
None	

3. GENERAL DRIVING CYCLE

Always perform the diagnosis continuously.

4. DIAGNOSTIC METHOD

• Abnormality Judgement

If the duration of time while the following conditions are met is longer than the time indicated, judge as NG.

Judgement Value

Malfunction Criteria	Threshold Value
Battery voltage	≥ 10.9 V
Ignition	ON
Terminal output voltage when ECM outputs ON signal	HIGH

Time Needed for Diagnosis:2500 ms

Malfunction Indicator Light Illumination: Illuminates as soon as a malfunction occurs.

• Normality Judgement

Judge as OK and clear the NG if the continuous time while the following conditions are established is more than the predetermined time.

Judgement Value

Malfunction Criteria	Threshold Value
Battery voltage	≥ 10.9 V
Ignition	ON
Terminal output voltage when ECM outputs ON signal	LOW

Time Needed for Diagnosis: Less than 1 second

Diagnostic Trouble Code (DTC) Detecting Criteria

GENERAL DESCRIPTION

CR:DTC P1420 FUEL TANK PRESSURE CONTROL SOL. VALVE CIRCUIT HIGH

1. OUTLINE OF DIAGNOSIS

Detect the open/short circuit of pressure control solenoid valve.

Judge as NG when ECM output level is different from actual terminal level.

2. COMPONENT DESCRIPTION

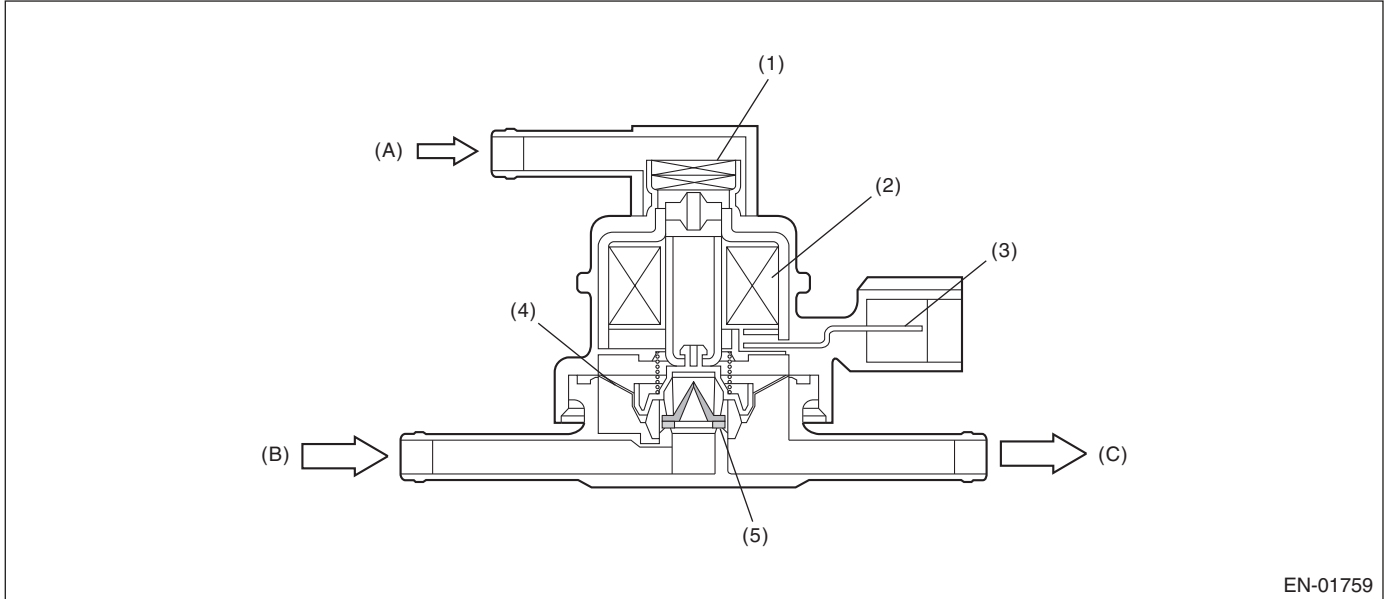

(A) Barometric pressure

(B) Shut-off valve

(C) To fuel tank

(1) Filter

(3) Connector terminal

(5) Valve

(2) Coil

(4) Diaphragm

3. ENABLE CONDITION

Secondary Parameters	Enable Conditions
None	

4. GENERAL DRIVING CYCLE

Always perform the diagnosis after starting the engine.

Diagnostic Trouble Code (DTC) Detecting Criteria

GENERAL DESCRIPTION

5. DIAGNOSTIC METHOD

• Abnormality Judgement

If the duration of time while the following conditions are met is longer than the time indicated, judge as NG.

Judgement Value

Malfunction Criteria	Threshold Value
Battery voltage	≥ 10.9 V
Elapsed time after starting the engine	≥ 1 second
Terminal output voltage when ECM outputs ON signal	High

Time Needed for Diagnosis: 2500 ms

Malfunction Indicator Light Illumination: Illuminates when malfunction occurs in 2 continuous driving cycles.

• Normality Judgement

Judge as OK and clear the NG if the continuous time while the following conditions are established is more than the predetermined time.

Judgement Value

Malfunction Criteria	Threshold Value
Battery voltage	≥ 10.9 V
Elapsed time after starting the engine	≥ 1 second
Terminal output voltage when ECM outputs ON signal	Low

Time Needed for Diagnosis: Less than 1 second

CS:DTC P1443 VENT CONTROL SOLENOID VALVE FUNCTION PROBLEM

1. OUTLINE OF DIAGNOSIS

Detect the abnormal function (stuck closed) of the drain valve.
 Judge as NG when fuel tank pressure is low.

2. COMPONENT DESCRIPTION

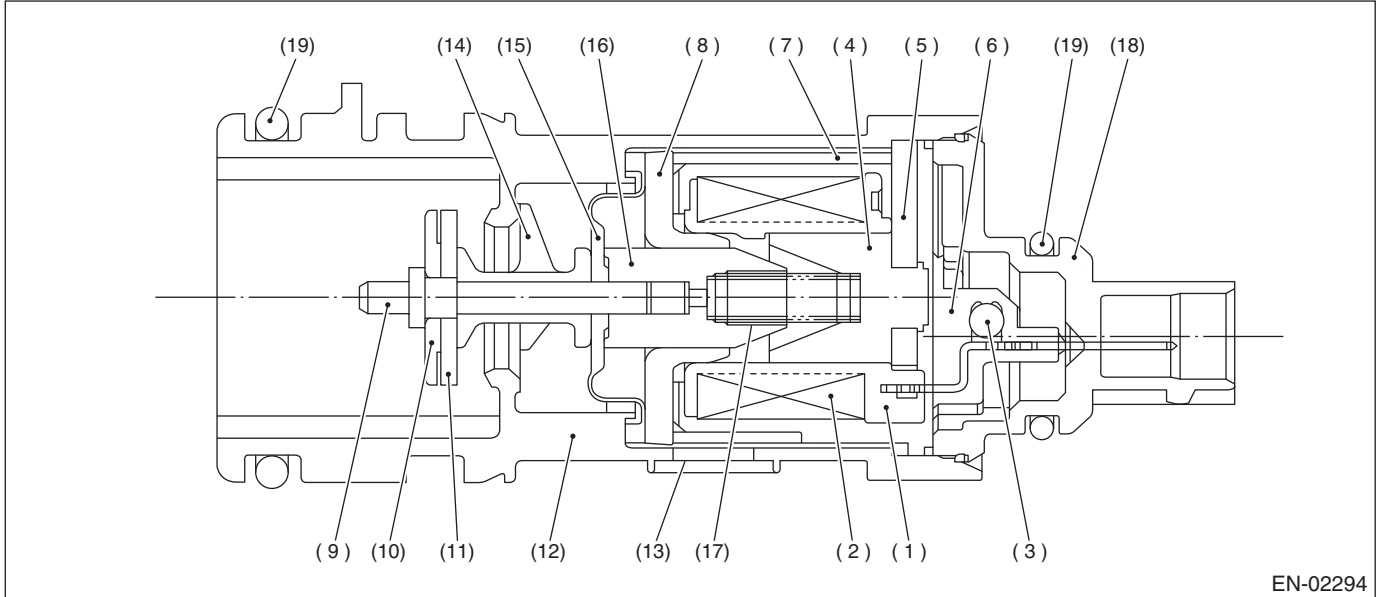

- | | | |
|-----------------|--------------------|-------------------|
| (1) Bobbin | (8) Magnetic plate | (14) Retainer |
| (2) Coil | (9) Shaft | (15) Diaphragm |
| (3) Diode | (10) Plate | (16) Movable core |
| (4) Stator core | (11) Valve | (17) Spring |
| (5) End plate | (12) Housing | (18) Cover |
| (6) Body | (13) Filter | (19) O-ring |
| (7) Yoke | | |

3. ENABLE CONDITION

Secondary Parameters	Enable Conditions
Drain valve	Open
Battery voltage	≥ 10.9 V
Barometric pressure	≥ 75 kPa (563 mmHg, 22.2 inHg)
Tank pressure when starter is OFF → ON	-0.7 kPa (-5 mmHg, -0.2 inHg) and 1.4 kPa (10.7 mmHg, 0.4 inHg)

4. GENERAL DRIVING CYCLE

Always perform the diagnosis continuously.

Diagnostic Trouble Code (DTC) Detecting Criteria

GENERAL DESCRIPTION

5. DIAGNOSTIC METHOD

• Abnormality Judgement

If the duration of time while the following conditions are met is longer than the time indicated, judge as NG.

Judgement Value

Malfunction Criteria	Threshold Value
Fuel tank pressure	≤ -4 kPa (-30 mmHg, -1.2 inHg)

Time Needed for Diagnosis: 3000 ms

Malfunction Indicator Light Illumination: Illuminates as soon as a malfunction occurs.

• Normality Judgement

Judge as OK and clear the NG if the continuous time while the following conditions are established is more than the predetermined time.

Judgement Value

Malfunction Criteria	Threshold Value
Fuel tank pressure	> -4 kPa (-30 mmHg, -1.2 inHg)
Cumulative time when all the malfunction criteria below are met.	≥ 30000 ms
Purge control solenoid valve duty	Not = 0
Fuel temperature	-10 °C (14 °F) — 55 °C (131 °F)
Intake manifold relative pressure	≥ -26.7 kPa (-200 mmHg, -7.9 inHg)

Time Needed for Diagnosis: Less than 1 second

CT:DTC P1491 POSITIVE CRANKCASE VENTILATION (BLOW-BY) FUNCTION PROBLEM

1. OUTLINE OF DIAGNOSIS

Detect the blow-by hose disconnection abnormality.
 Judge as NG when the diagnosis terminal voltage is high.

2. COMPONENT DESCRIPTION

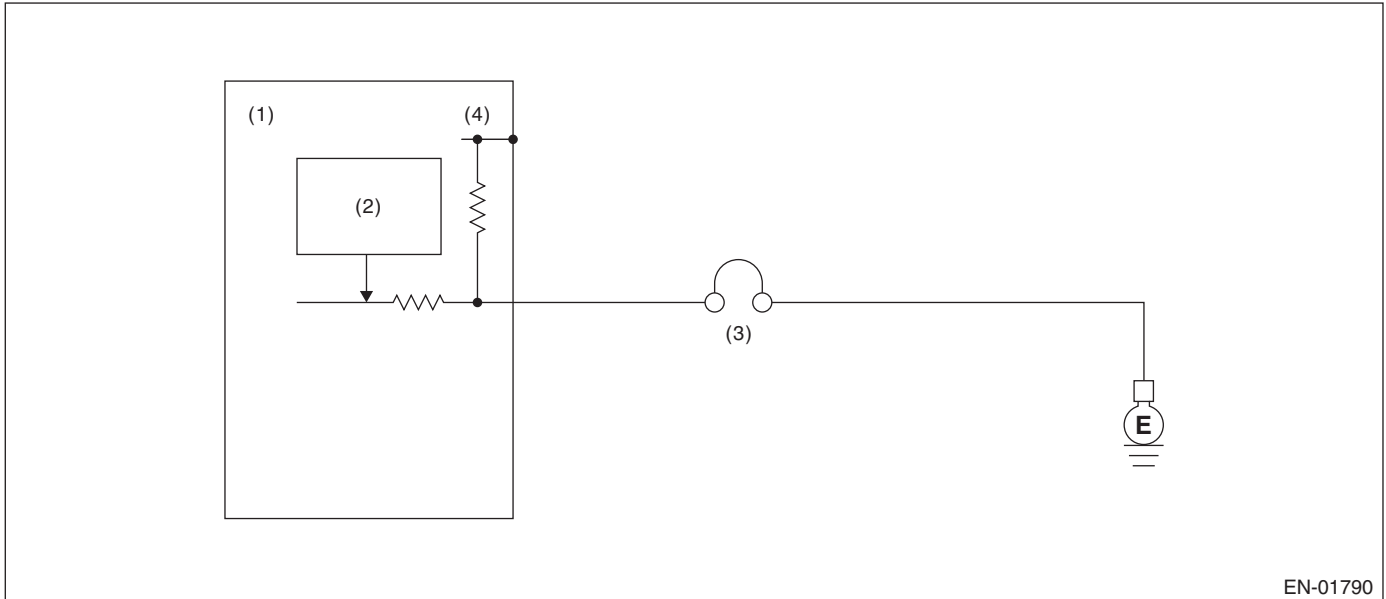

- (1) Engine control module (ECM)
- (2) Detecting circuit
- (3) PCV diagnosis connector
- (4) 5 V

3. ENABLE CONDITION

Secondary Parameters	Enable Conditions
None	

4. GENERAL DRIVING CYCLE

Always perform the diagnosis continuously.

Diagnostic Trouble Code (DTC) Detecting Criteria

GENERAL DESCRIPTION

5. DIAGNOSTIC METHOD

• Abnormality Judgement

If the duration of time while the following conditions are met is longer than the time indicated, judge as NG.

Judgement Value

Malfunction Criteria	Threshold Value
Battery voltage	≥ 10.9 V
Engine condition	After engine starting
Positive crankcase ventilation diagnosis voltage	High

Time Needed for Diagnosis:2500 ms

Malfunction Indicator Light Illumination: Illuminates as soon as a malfunction occurs.

• Normality Judgement

Judge as OK and clear the NG if the continuous time while the following conditions are established is more than the predetermined time.

Judgement Value

Malfunction Criteria	Threshold Value
Battery voltage	≥ 10.9 V
Engine condition	After engine starting
Positive crankcase ventilation diagnosis voltage	Low

Time Needed for Diagnosis: Less than 1 second

Diagnostic Trouble Code (DTC) Detecting Criteria

GENERAL DESCRIPTION

CU:DTC P1560 BACK-UP VOLTAGE CIRCUIT MALFUNCTION

1. OUTLINE OF DIAGNOSIS

Detect the open/short circuit of back-up power supply circuit.
Judge as NG when the backup power voltage is low.

2. ENABLE CONDITION

Secondary Parameters	Enable Conditions
None	

3. GENERAL DRIVING CYCLE

Always perform the diagnosis continuously.

4. DIAGNOSTIC METHOD

• Abnormality Judgement

If the duration of time while the following conditions are met is longer than the time indicated, judge as NG.

Judgement Value

Malfunction Criteria	Threshold Value
Voltage of back-up power supply	Low
Battery voltage	≥ 10.9 V
Engine condition	After engine starting

Time Needed for Diagnosis:2500 ms

Malfunction Indicator Light Illumination: Illuminates as soon as a malfunction occurs.

• Normality Judgement

Judge as OK and clear the NG if the continuous time while the following conditions are established is more than the predetermined time.

Judgement Value

Malfunction Criteria	Threshold Value
Voltage of back-up power supply	High
Battery voltage	≥ 10.9 V
Engine condition	After engine starting

Time Needed for Diagnosis: Less than 1 second

Diagnostic Trouble Code (DTC) Detecting Criteria

GENERAL DESCRIPTION

CV:DTC P1570 ANTENNA

1. OUTLINE OF DIAGNOSIS

NOTE:

For the detection standard, refer to DTC P0513. <Ref. to GD(H4DOTC)-154, DTC P0513 INCORRECT IM-MOBILIZER KEY, Diagnostic Trouble Code (DTC) Detecting Criteria.>

CW:DTC P1571 REFERENCE CODE INCOMPATIBILITY

1. OUTLINE OF DIAGNOSIS

NOTE:

For the detection standard, refer to DTC P0513. <Ref. to GD(H4DOTC)-154, DTC P0513 INCORRECT IM-MOBILIZER KEY, Diagnostic Trouble Code (DTC) Detecting Criteria.>

CX:DTC P1572 IMM CIRCUIT FAILURE (EXCEPT ANTENNA CIRCUIT)

1. OUTLINE OF DIAGNOSIS

NOTE:

For the detection standard, refer to DTC P0513. <Ref. to GD(H4DOTC)-154, DTC P0513 INCORRECT IM-MOBILIZER KEY, Diagnostic Trouble Code (DTC) Detecting Criteria.>

CY:DTC P1574 KEY COMMUNICATION FAILURE

1. OUTLINE OF DIAGNOSIS

NOTE:

For the detection standard, refer to DTC P0513. <Ref. to GD(H4DOTC)-154, DTC P0513 INCORRECT IM-MOBILIZER KEY, Diagnostic Trouble Code (DTC) Detecting Criteria.>

CZ:DTC P1576 EGI CONTROL MODULE EEPROM

1. OUTLINE OF DIAGNOSIS

NOTE:

For the detection standard, refer to DTC P0513. <Ref. to GD(H4DOTC)-154, DTC P0513 INCORRECT IM-MOBILIZER KEY, Diagnostic Trouble Code (DTC) Detecting Criteria.>

DA:DTC P1577 IMM CONTROL MODULE EEPROM

1. OUTLINE OF DIAGNOSIS

NOTE:

For the detection standard, refer to DTC P0513. <Ref. to GD(H4DOTC)-154, DTC P0513 INCORRECT IM-MOBILIZER KEY, Diagnostic Trouble Code (DTC) Detecting Criteria.>

DB:DTC P1578 METER FAILURE

1. OUTLINE OF DIAGNOSIS

NOTE:

For the detection standard, refer to DTC P0513. <Ref. to GD(H4DOTC)-154, DTC P0513 INCORRECT IM-MOBILIZER KEY, Diagnostic Trouble Code (DTC) Detecting Criteria.>

Diagnostic Trouble Code (DTC) Detecting Criteria

GENERAL DESCRIPTION

DC:DTC P1602 CONTROL MODULE PROGRAMMING ERROR

1. OUTLINE OF DIAGNOSIS

Detect malfunctions of the catalyst advanced idling retard angle control.

Judge as NG when ECM is not controlling the angle properly during catalyst advanced idling retard angle control.

Judge as NG if there is exhaust gas temperature diagnosis and idle speed diagnosis and if either of them is NG.

- Exhaust gas temperature diagnosis

Judge as NG when the estimated exhausted gas temperature in 14 seconds after the cold start is below the specified value.

- Idle speed diagnosis

Judge as NG when actual engine speed is not close to target engine speed after terminating the retard angle control.

2. ENABLE CONDITION

Secondary Parameters	Enable Conditions
Barometric pressure	≥ 75 kPa (563 mmHg, 22.2 inHg)
Battery voltage	≥ 10.9 V
Cold start diagnosis	Incomplete
Vehicle speed	< 3 km/h (1.9 MPH)
Misfire within 200 engine revs.	< 5
Time after starting	= 14 seconds

3. GENERAL DRIVING CYCLE

Perform the diagnosis at cold start.

Diagnostic Trouble Code (DTC) Detecting Criteria

GENERAL DESCRIPTION

4. DIAGNOSTIC METHOD

• Exhaust gas temperature diagnosis

Abnormality Judgement

Calculate the estimated exhaust gas temperature when the diagnostic enable condition is established. Judge as NG when the following conditions are established after engine starting within the predetermined time.

Judgement Value

Malfunction Criteria	Threshold Value
Estimated exhaust gas temperature	< Value from Map

Map

Coolant temperature after starting the engine	-40 °C (-40 °F)	-30 °C (-22 °F)	-20 °C (-4 °F)	-10 °C (14 °F)	0 °C (32 °F)	10 °C (50 °F)	20 °C (68 °F)	30 °C (86 °F)	40 °C (104 °F)	45 °C (113 °F)
Threshold Value	200 °C (392 °F)	200 °C (392 °F)	200 °C (392 °F)	200 °C (392 °F)	95 °C (203 °F)	95 °C (203 °F)	89 °C (192.2 °F)	83 °C (181.4 °F)	79 °C (174.2 °F)	79 °C (174.2 °F)

Time Needed for Diagnosis: 14 seconds

Malfunction Indicator Light Illumination: Illuminates when malfunction occurs in 2 continuous driving cycles.

Normality Judgement

Judge as OK and clear the NG if the following conditions are established.

Judgement Value

Malfunction Criteria	Threshold Value
Estimated exhaust gas temperature	≥ Value from Map

Time Needed for Diagnosis: Less than 1 second

• Idle speed diagnosis

Abnormality Judgement

Judge as NG when the following conditions are established after the predetermined time.

Judgement Value

Malfunction Criteria	Threshold Value
Continuous time of (Target engine speed – Actual engine speed > -100 rpm)	≥ 6000 ms
Continuous time of (actual retard amount > 30 °CA)	≥ 0 ms

Time Needed for Diagnosis: 14 seconds

Malfunction Indicator Light Illumination: Illuminates when malfunction occurs in 2 continuous driving cycles.

Normality Judgement

Judge as OK and clear the NG if the following conditions are established.

Judgement Value

Malfunction Criteria	Threshold Value
Continuous time of (Target engine speed – Actual engine speed > -100 rpm)	< 6000 ms
Continuous time of (actual retard amount > 30 °CA)	< 0 ms

Time Needed for Diagnosis: Less than 1 second

Diagnostic Trouble Code (DTC) Detecting Criteria

GENERAL DESCRIPTION

DD:DTC P2004 INTAKE MANIFOLD RUNNER CONTROL STUCK OPEN (BANK 1)

1. OUTLINE OF DIAGNOSIS

Detect the malfunction of tumble generator valve motor function.

Judge open fixing malfunction when the opening degree is large even after finishing the tumble generator valve closing driving.

2. ENABLE CONDITION

Secondary Parameters	Enable Conditions
Battery voltage	≥ 10.9 V
Engine coolant temperature	≥ -30 °C (-22 °F)
Ambient air temperature	≥ -30 °C (-22 °F)

3. GENERAL DRIVING CYCLE

Always perform the diagnosis continuously.

4. DIAGNOSTIC METHOD

• Abnormality Judgement

If the duration of time while the following conditions are met is longer than the time indicated, judge as NG.

Judgement Value

Malfunction Criteria	Threshold Value
Tumble generator valve opening	≥ 64.3 °
Tumble generator valve "close" signal output	≥ 3200 ms

Time Needed for Diagnosis: 3000 ms

Malfunction Indicator Light Illumination: Illuminates as soon as a malfunction occurs.

• Normality Judgement

Judge as OK and clear the NG if the continuous time while the following conditions are established is more than the predetermined time.

Judgement Value

Malfunction Criteria	Threshold Value
Tumble generator valve opening	< 64.3 °
Tumble generator valve "close" signal output	≥ 3200 ms

Time Needed for Diagnosis: Less than 1 second

Diagnostic Trouble Code (DTC) Detecting Criteria

GENERAL DESCRIPTION

DE:DTC P2005 INTAKE MANIFOLD RUNNER CONTROL STUCK OPEN (BANK 2)

1. OUTLINE OF DIAGNOSIS

Detect the malfunction of tumble generator valve motor function.

Judge open fixing malfunction when the opening degree is large even after finishing the tumble generator valve closing driving.

2. ENABLE CONDITION

Secondary Parameters	Enable Conditions
Battery voltage	≥ 10.9 V
Engine coolant temperature	≥ -30 °C (-22 °F)
Ambient air temperature	≥ -30 °C (-22 °F)

3. GENERAL DRIVING CYCLE

Always perform the diagnosis continuously.

4. DIAGNOSTIC METHOD

• Abnormality Judgement

If the duration of time while the following conditions are met is longer than the time indicated, judge as NG.

Judgement Value

Malfunction Criteria	Threshold Value
Tumble generator valve opening	≥ 64.3 °
Tumble generator valve "close" signal output	≥ 3200 ms

Time Needed for Diagnosis: 3000 ms

Malfunction Indicator Light Illumination: Illuminates as soon as a malfunction occurs.

• Normality Judgement

Judge as OK and clear the NG if the continuous time while the following conditions are established is more than the predetermined time.

Judgement Value

Malfunction Criteria	Threshold Value
Tumble generator valve opening	< 64.3 °
Tumble generator valve "close" signal output	≥ 3200 ms

Time Needed for Diagnosis: Less than 1 second

Diagnostic Trouble Code (DTC) Detecting Criteria

GENERAL DESCRIPTION

DF:DTC P2006 INTAKE MANIFOLD RUNNER CONTROL STUCK CLOSED (BANK 1)

1. OUTLINE OF DIAGNOSIS

Detect the malfunction of tumble generator valve motor function.

Judge close fixing malfunction when the opening degree is small even after finishing the tumble generator valve open driving.

2. ENABLE CONDITION

Secondary Parameters	Enable Conditions
Battery voltage	≥ 10.9 V
Engine coolant temperature	≥ -30 °C (-22 °F)
Ambient air temperature	≥ -30 °C (-22 °F)

3. GENERAL DRIVING CYCLE

Always perform the diagnosis continuously.

4. DIAGNOSTIC METHOD

• Abnormality Judgement

If the duration of time while the following conditions are met is longer than the time indicated, judge as NG.

Judgement Value

Malfunction Criteria	Threshold Value
Tumble generator valve opening	< 64.3 °
Tumble generator valve "open" signal output	≥ 4600 ms

Time Needed for Diagnosis: 3000 ms

Malfunction Indicator Light Illumination: Illuminates as soon as a malfunction occurs.

• Normality Judgement

Judge as OK and clear the NG if the continuous time while the following conditions are established is more than the predetermined time.

Judgement Value

Malfunction Criteria	Threshold Value
Tumble generator valve opening	≥ 64.3 °
Tumble generator valve "open" signal output	≥ 4600 ms

Time Needed for Diagnosis: Less than 1 second

Diagnostic Trouble Code (DTC) Detecting Criteria

GENERAL DESCRIPTION

DG:DTC P2007 INTAKE MANIFOLD RUNNER CONTROL STUCK CLOSED (BANK 2)

1. OUTLINE OF DIAGNOSIS

Detect the malfunction of tumble generator valve motor function.

Judge close fixing malfunction when the opening degree is small even after finishing the tumble generator valve open driving.

2. ENABLE CONDITION

Secondary Parameters	Enable Conditions
Battery voltage	≥ 10.9 V
Engine coolant temperature	≥ -30 °C (-22 °F)
Ambient air temperature	≥ -30 °C (-22 °F)

3. GENERAL DRIVING CYCLE

Always perform the diagnosis continuously.

4. DIAGNOSTIC METHOD

• Abnormality Judgement

If the duration of time while the following conditions are met is longer than the time indicated, judge as NG.

Judgement Value

Malfunction Criteria	Threshold Value
Tumble generator valve opening	< 64.3 °
Tumble generator valve "open" signal output	≥ 4600 ms

Time Needed for Diagnosis: 3000 ms

Malfunction Indicator Light Illumination: Illuminates as soon as a malfunction occurs.

• Normality Judgement

Judge as OK and clear the NG if the continuous time while the following conditions are established is more than the predetermined time.

Judgement Value

Malfunction Criteria	Threshold Value
Tumble generator valve opening	≥ 64.3 °
Tumble generator valve "open" signal output	≥ 4600 ms

Time Needed for Diagnosis: Less than 1 second

DH:DTC P2008 INTAKE MANIFOLD RUNNER CONTROL CIRCUIT / OPEN (BANK 1)

1. OUTLINE OF DIAGNOSIS

Detect the open or short circuit of tumble generator valve motor.

Judge as NG when the open signal is sent from IC after tumble generator valve driving IC diagnosis.

2. COMPONENT DESCRIPTION

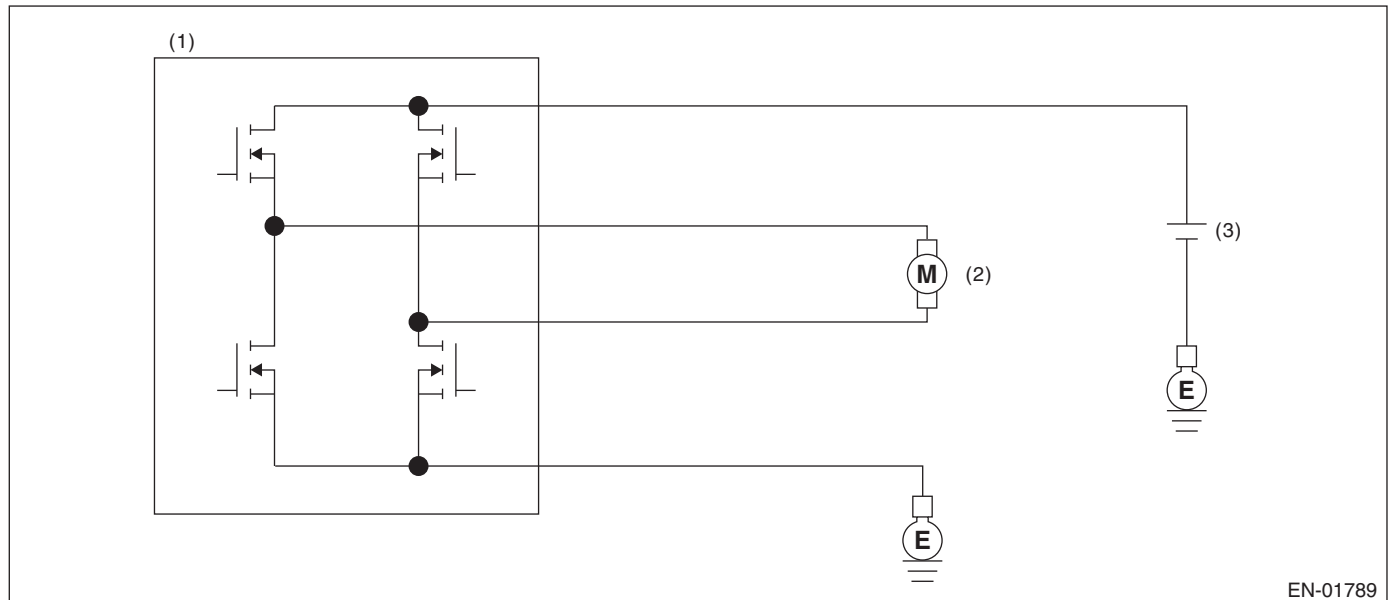

EN-01789

- (1) Engine control module (ECM) (2) Tumble generator valve (3) Battery

3. ENABLE CONDITION

Secondary Parameters	Enable Conditions
Battery voltage	≥ 10.9 V

4. GENERAL DRIVING CYCLE

Always perform the diagnosis continuously.

5. DIAGNOSTIC METHOD

• Abnormality Judgement

At the main IC, check the sent signal at each timing which occurs immediately after the tumble generator valve output is set to OFF → ON, and judge open NG when the open NG signal is sent 96 ms × 20 time(s) in a row.

Judgement Value

Malfunction Criteria	Threshold Value
Open NG signal input	Low

Time Needed for Diagnosis: 96 ms × 20 time(s)

Malfunction Indicator Light Illumination: Illuminates as soon as a malfunction occurs.

• Normality Judgement

Judge as OK and clear the NG when the OK signal is sent.

Judgement Value

Malfunction Criteria	Threshold Value
Open NG signal input	High

Time Needed for Diagnosis: Less than 1 second

Diagnostic Trouble Code (DTC) Detecting Criteria

GENERAL DESCRIPTION

DI: DTC P2009 INTAKE MANIFOLD RUNNER CONTROL CIRCUIT LOW (BANK 1)

1. OUTLINE OF DIAGNOSIS

Detect the open or short circuit of tumble generator valve motor.

Judge as NG when the overcurrent signal is sent from IC after tumble generator valve driving IC diagnosis.

2. COMPONENT DESCRIPTION

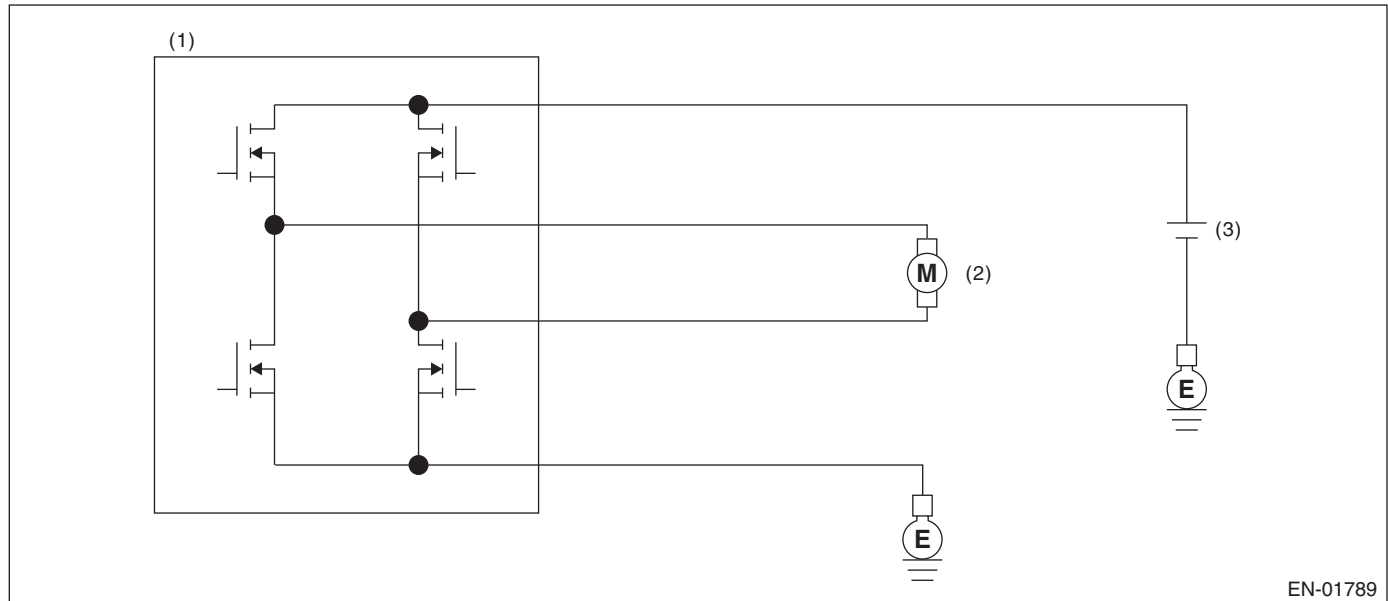

EN-01789

(1) Engine control module (ECM)

(2) Tumble generator valve

(3) Battery

3. ENABLE CONDITION

Secondary Parameters	Enable Conditions
Battery voltage	≥ 10.9 V

4. GENERAL DRIVING CYCLE

Always perform the diagnosis continuously.

5. DIAGNOSTIC METHOD

• Abnormality Judgement

At the main IC, check the sent signal at each timing which occurs immediately after the tumble generator valve output is set to OFF → ON, and judge overcurrent NG when the overcurrent NG signal is sent 96 ms × 10 time(s) in a row.

Judgement Value

Malfunction Criteria	Threshold Value
Overcurrent NG signal input	Low

Time Needed for Diagnosis: 96 ms × 10 time(s)

Malfunction Indicator Light Illumination: Illuminates as soon as a malfunction occurs.

• Normality Judgement

Judge as OK and clear the NG when the OK signal is sent.

Judgement Value

Malfunction Criteria	Threshold Value
Overcurrent NG signal input	High

Time Needed for Diagnosis: Less than 1 second

Diagnostic Trouble Code (DTC) Detecting Criteria

GENERAL DESCRIPTION

DJ:DTC P2011 INTAKE MANIFOLD RUNNER CONTROL CIRCUIT / OPEN (BANK 2)

1. OUTLINE OF DIAGNOSIS

Detect the open or short circuit of tumble generator valve motor.

Judge as NG when the open signal is sent from IC after tumble generator valve driving IC diagnosis.

2. COMPONENT DESCRIPTION

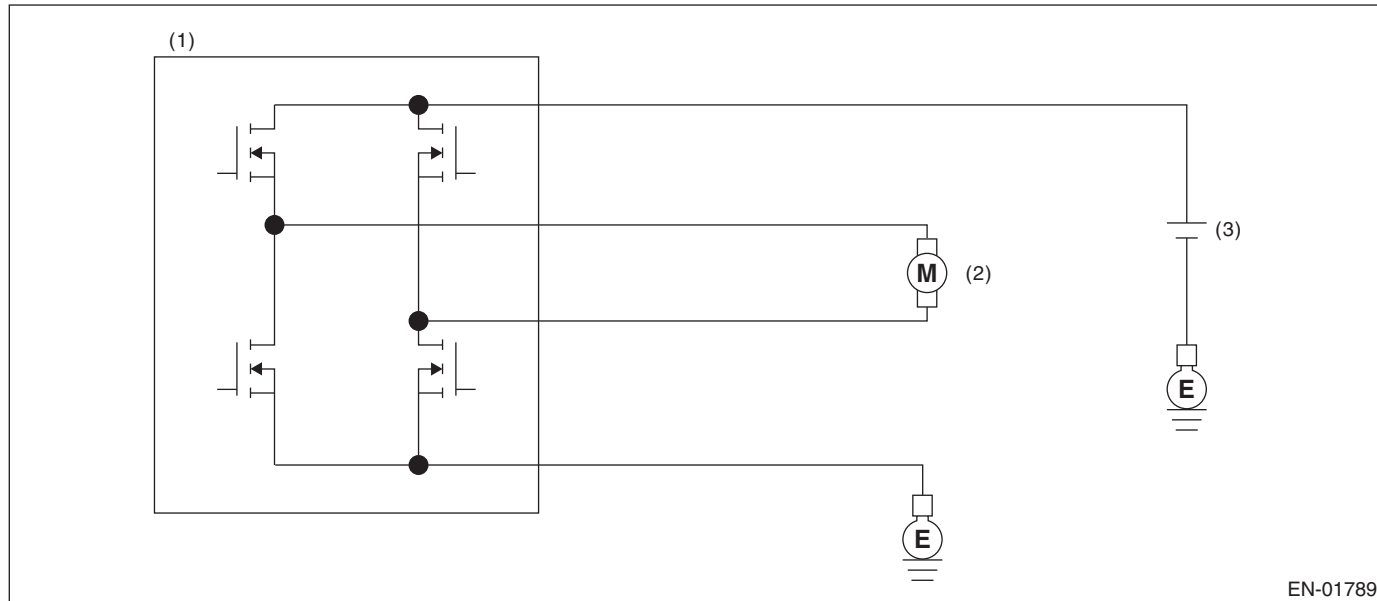

(1) Engine control module (ECM)

(2) Tumble generator valve

(3) Battery

EN-01789

3. ENABLE CONDITION

Secondary Parameters	Enable Conditions
Battery voltage	≥ 10.9 V

4. GENERAL DRIVING CYCLE

Always perform the diagnosis continuously.

5. DIAGNOSTIC METHOD

• Abnormality Judgement

At the main IC, check the sent signal at each timing which occurs immediately after the tumble generator valve output is set to OFF → ON, and judge open NG when the open NG signal is sent 96 ms × 20 time(s) in a row.

Judgement Value

Malfunction Criteria	Threshold Value
Open NG signal input	Low

Time Needed for Diagnosis: 96 ms × 20 time(s)

Malfunction Indicator Light Illumination: Illuminates as soon as a malfunction occurs.

• Normality Judgement

Judge as OK and clear the NG when the OK signal is sent.

Judgement Value

Malfunction Criteria	Threshold Value
Open NG signal input	High

Time Needed for Diagnosis: Less than 1 second

Diagnostic Trouble Code (DTC) Detecting Criteria

GENERAL DESCRIPTION

DK:DTC P2012 INTAKE MANIFOLD RUNNER CONTROL CIRCUIT LOW (BANK 2)

1. OUTLINE OF DIAGNOSIS

Detect the open or short circuit of tumble generator valve motor.

Judge as NG when the overcurrent signal is sent from IC after tumble generator valve driving IC diagnosis.

2. COMPONENT DESCRIPTION

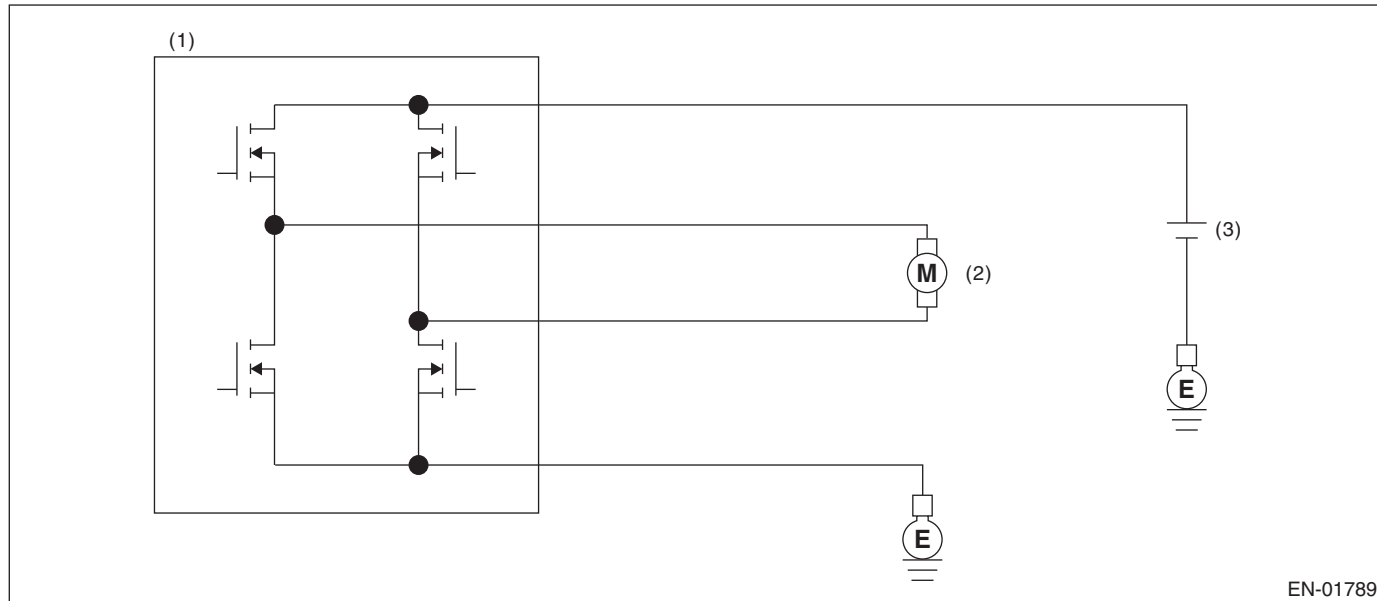

(1) Engine control module (ECM)

(2) Tumble generator valve

(3) Battery

EN-01789

3. ENABLE CONDITION

Secondary Parameters	Enable Conditions
Battery voltage	≥ 10.9 V

4. GENERAL DRIVING CYCLE

Always perform the diagnosis continuously.

5. DIAGNOSTIC METHOD

• Abnormality Judgement

At the main IC, check the sent signal at each timing which occurs immediately after the tumble generator valve output is set to OFF → ON, and judge overcurrent NG when the overcurrent NG signal is sent 96 ms × 10 time(s) in a row.

Judgement Value

Malfunction Criteria	Threshold Value
Overcurrent NG signal input	Low

Time Needed for Diagnosis: 96 ms × 10 time(s)

Malfunction Indicator Light Illumination: Illuminates as soon as a malfunction occurs.

• Normality Judgement

Judge as OK and clear the NG when the OK signal is sent.

Judgement Value

Malfunction Criteria	Threshold Value
Overcurrent NG signal input	High

Time Needed for Diagnosis: Less than 1 second

DL:DTC P2016 INTAKE MANIFOLD RUNNER POSITION SENSOR / SWITCH CIRCUIT LOW (BANK 1)

1. OUTLINE OF DIAGNOSIS

Detect open or short circuit of tumble generator valve position sensor.
Judge as NG if out of specification.

2. COMPONENT DESCRIPTION

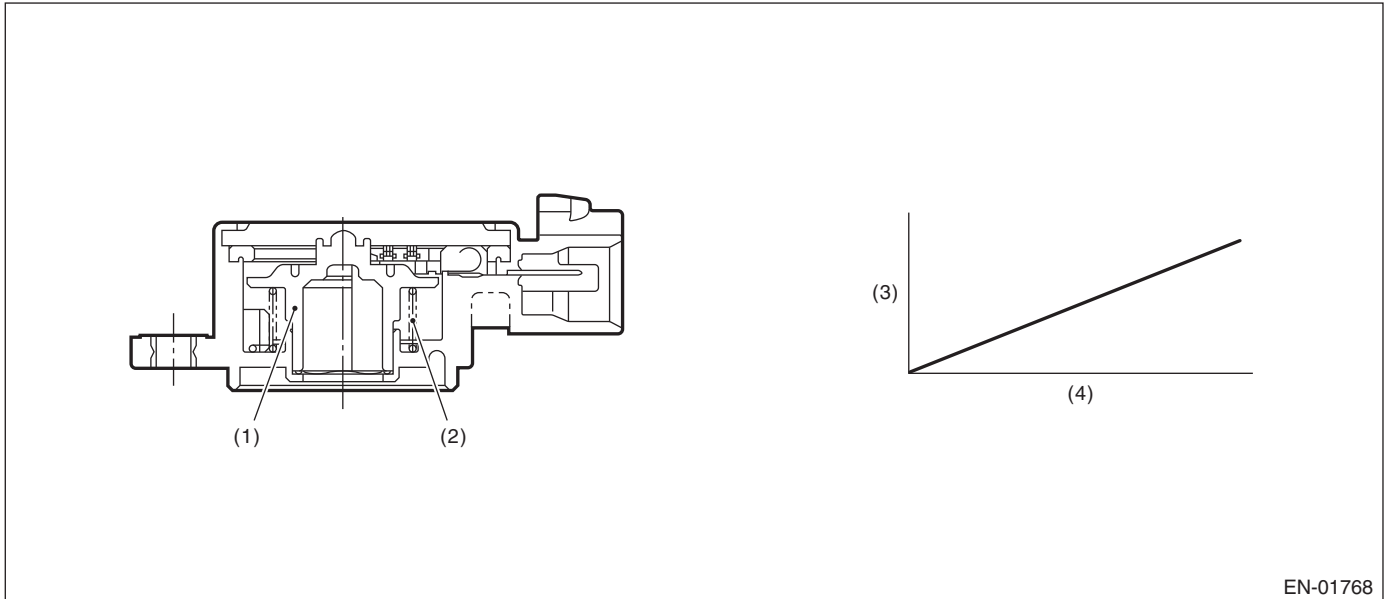

EN-01768

- (1) Rotor
- (2) Return spring
- (3) Voltage (V)
- (4) Tumble generator valve opening (°)

3. ENABLE CONDITION

Secondary Parameters	Enable Conditions
None	

4. GENERAL DRIVING CYCLE

Always perform the diagnosis continuously.

5. DIAGNOSTIC METHOD

• Abnormality Judgement

If the duration of time while the following conditions are met is longer than the time indicated, judge as NG.

Judgement Value

Malfunction Criteria	Threshold Value
Output voltage	$< 0.217 \text{ V}$

Time Needed for Diagnosis: 500 ms

Malfunction Indicator Light Illumination: Illuminates as soon as a malfunction occurs.

• Normality Judgement

Judge as OK and clear the NG if the continuous time while the following conditions are established is more than the predetermined time.

Judgement Value

Malfunction Criteria	Threshold Value
Output voltage	$\geq 0.217 \text{ V}$

Time Needed for Diagnosis: Less than 1 second

Diagnostic Trouble Code (DTC) Detecting Criteria

GENERAL DESCRIPTION

DM:DTC P2017 INTAKE MANIFOLD RUNNER POSITION SENSOR / SWITCH CIRCUIT HIGH (BANK 1)

1. OUTLINE OF DIAGNOSIS

Detect open or short circuit of tumble generator valve position sensor.
Judge as NG if out of specification.

2. COMPONENT DESCRIPTION

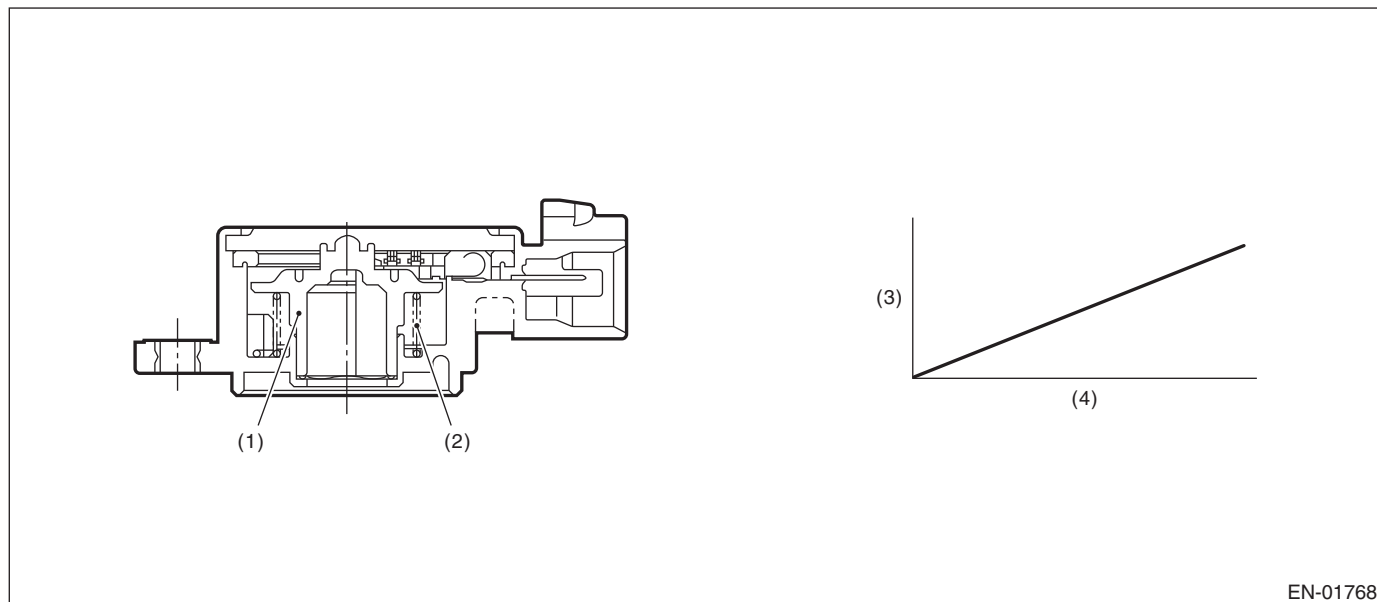

(1) Rotor

(3) Voltage (V)

(4) Tumble generator valve opening (°)

(2) Return spring

3. ENABLE CONDITION

Secondary Parameters	Enable Conditions
None	

4. GENERAL DRIVING CYCLE

Always perform the diagnosis continuously.

5. DIAGNOSTIC METHOD

• Abnormality Judgement

If the duration of time while the following conditions are met is longer than the time indicated, judge as NG.

Judgement Value

Malfunction Criteria	Threshold Value
Output voltage	$\geq 4.783 \text{ V}$

Time Needed for Diagnosis: 500 ms

Malfunction Indicator Light Illumination: Illuminates as soon as a malfunction occurs.

• Normality Judgement

Judge as OK and clear the NG if the continuous time while the following conditions are established is more than the predetermined time.

Judgement Value

Malfunction Criteria	Threshold Value
Output voltage	$< 4.783 \text{ V}$

Time Needed for Diagnosis: Less than 1 second

DN:DTC P2021 INTAKE MANIFOLD RUNNER POSITION SENSOR / SWITCH CIRCUIT LOW (BANK 2)

1. OUTLINE OF DIAGNOSIS

Detect open or short circuit of tumble generator valve position sensor.
Judge as NG if out of specification.

2. COMPONENT DESCRIPTION

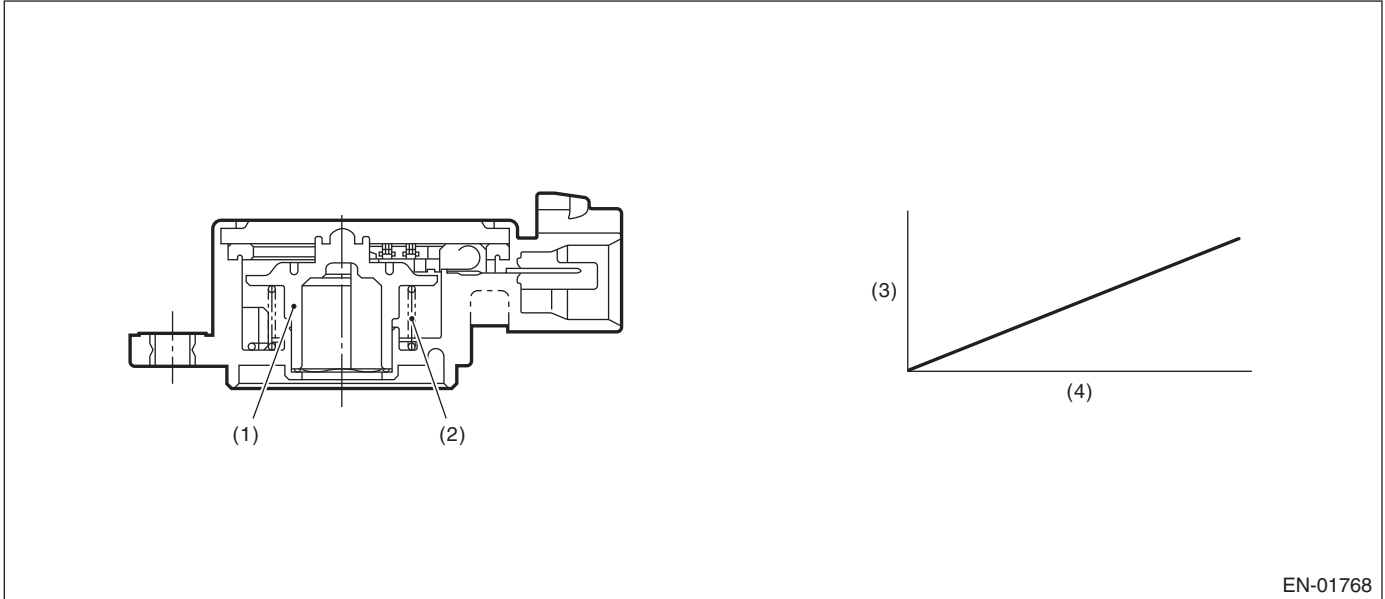

- (1) Rotor
- (2) Return spring
- (3) Voltage (V)
- (4) Tumble generator valve opening (°)

3. ENABLE CONDITION

Secondary Parameters	Enable Conditions
None	

4. GENERAL DRIVING CYCLE

Always perform the diagnosis continuously.

5. DIAGNOSTIC METHOD

• Abnormality Judgement

If the duration of time while the following conditions are met is longer than the time indicated, judge as NG.

Judgement Value

Malfunction Criteria	Threshold Value
Output voltage	$< 0.217 \text{ V}$

Time Needed for Diagnosis: 500 ms

Malfunction Indicator Light Illumination: Illuminates as soon as a malfunction occurs.

• Normality Judgement

Judge as OK and clear the NG if the continuous time while the following conditions are established is more than the predetermined time.

Judgement Value

Malfunction Criteria	Threshold Value
Output voltage	$\geq 0.217 \text{ V}$

Time Needed for Diagnosis: Less than 1 second

Diagnostic Trouble Code (DTC) Detecting Criteria

GENERAL DESCRIPTION

DO:DTC P2022 INTAKE MANIFOLD RUNNER POSITION SENSOR / SWITCH CIRCUIT HIGH (BANK 2)

1. OUTLINE OF DIAGNOSIS

Detect open or short circuit of tumble generator valve position sensor.
Judge as NG if out of specification.

2. COMPONENT DESCRIPTION

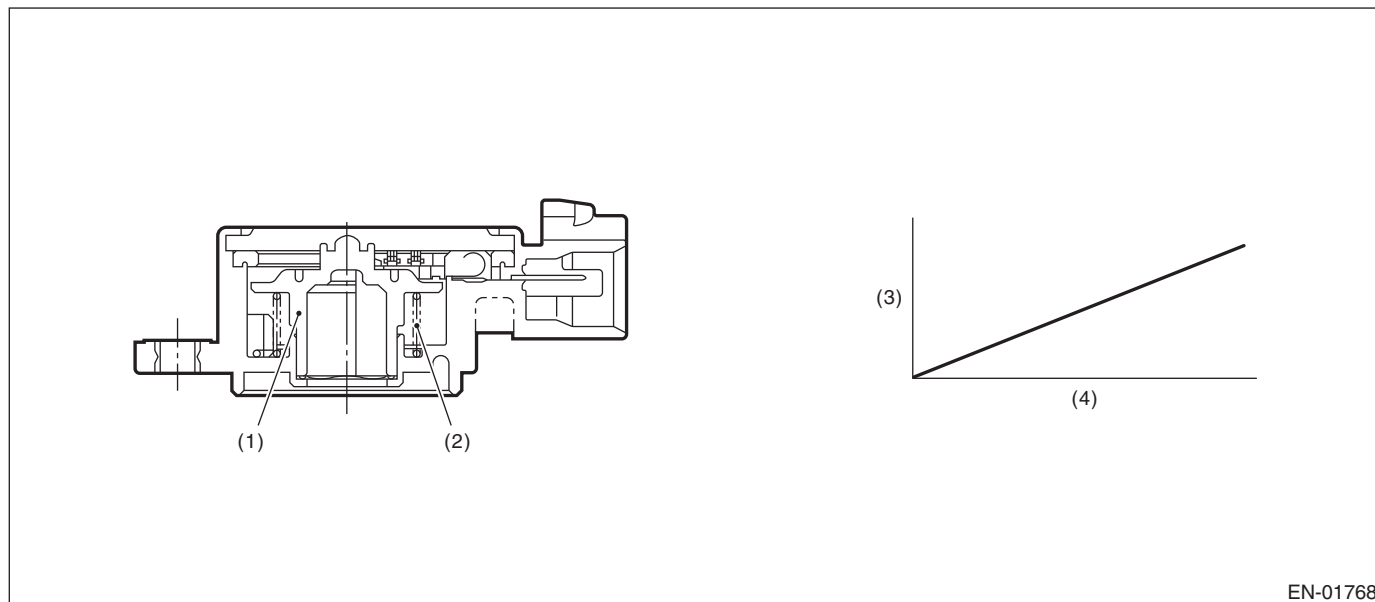

(1) Rotor

(3) Voltage (V)

(4) Tumble generator valve opening (°)

(2) Return spring

3. ENABLE CONDITION

Secondary Parameters	Enable Conditions
None	

4. GENERAL DRIVING CYCLE

Always perform the diagnosis continuously.

5. DIAGNOSTIC METHOD

• Abnormality Judgement

If the duration of time while the following conditions are met is longer than the time indicated, judge as NG.

Judgement Value

Malfunction Criteria	Threshold Value
Output voltage	$\geq 4.783 \text{ V}$

Time Needed for Diagnosis: 500 ms

Malfunction Indicator Light Illumination: Illuminates as soon as a malfunction occurs.

• Normality Judgement

Judge as OK and clear the NG if the continuous time while the following conditions are established is more than the predetermined time.

Judgement Value

Malfunction Criteria	Threshold Value
Output voltage	$< 4.783 \text{ V}$

Time Needed for Diagnosis: Less than 1 second

Diagnostic Trouble Code (DTC) Detecting Criteria

GENERAL DESCRIPTION

DP:DTC P2088 INTAKE CAMSHAFT POSITION ACTUATOR CONTROL CIRCUIT LOW (BANK 1)

1. OUTLINE OF DIAGNOSIS

Detect open or short circuit of the oil flow control solenoid valve.
Judge as NG when the current is small even though the duty signal is large.

2. ENABLE CONDITION

Secondary Parameters	Enable Conditions
None	

3. GENERAL DRIVING CYCLE

Always perform the diagnosis continuously.

4. DIAGNOSTIC METHOD

• Abnormality Judgement

If the duration of time while the following conditions are met is longer than the time indicated, judge as NG.

Judgement Value

Malfunction Criteria	Threshold Value
Battery voltage	$\geq 10.9 \text{ V}$
Oil flow control solenoid valve control duty	$\geq 99.61 \%$
Oil control solenoid valve control present current	$< 0.306 \text{ A}$

Time Needed for Diagnosis:2000 ms

Malfunction Indicator Light Illumination: Illuminates as soon as a malfunction occurs.

• Normality Judgement

Judge as OK and clear the NG if the continuous time while the following conditions are established is more than the predetermined time.

Judgement Value

Malfunction Criteria	Threshold Value
Battery voltage	$\geq 10.9 \text{ V}$
Target current value of the oil flow control solenoid valve	$\geq 0.14 \text{ A}$
Target current value of the oil flow control solenoid valve – Oil flow control solenoid valve control current value	$< 0.08 \text{ A}$

Time Needed for Diagnosis:2000 ms

Diagnostic Trouble Code (DTC) Detecting Criteria

GENERAL DESCRIPTION

DQ:DTC P2089 INTAKE CAMSHAFT POSITION ACTUATOR CONTROL CIRCUIT HIGH (BANK 1)

1. OUTLINE OF DIAGNOSIS

Detect open or short circuit of oil flow control solenoid valve.

Judge as NG when the current is large even though the duty signal is small.

2. ENABLE CONDITION

Secondary Parameters	Enable Conditions
None	

3. GENERAL DRIVING CYCLE

Always perform the diagnosis continuously.

4. DIAGNOSTIC METHOD

• Abnormality Judgement

If the duration of time while the following conditions are met is longer than the time indicated, judge as NG.

Judgement Value

Malfunction Criteria	Threshold Value
Battery voltage	$\geq 10.9 \text{ V}$
Oil flow control solenoid valve control duty	$< 0.39 \%$
Oil control solenoid valve control present current	$\geq 0.306 \text{ A}$

Time Needed for Diagnosis:2000 ms

Malfunction Indicator Light Illumination: Illuminates as soon as a malfunction occurs.

• Normality Judgement

Judge as OK and clear the NG if the continuous time while the following conditions are established is more than the predetermined time.

Judgement Value

Malfunction Criteria	Threshold Value
Battery voltage	$\geq 10.9 \text{ V}$
Target current value of the oil flow control solenoid valve – Oil flow control solenoid valve control current value	$< 0.08 \text{ A}$

Time Needed for Diagnosis:2000 ms

Diagnostic Trouble Code (DTC) Detecting Criteria

GENERAL DESCRIPTION

DR:DTC P2092 INTAKE CAMSHAFT POSITION ACTUATOR CONTROL CIRCUIT LOW (BANK 2)

1. OUTLINE OF DIAGNOSIS

NOTE:

For the detection standard, refer to DTC P2088. <Ref. to GD(H4DOTC)-197, DTC P2088 INTAKE CAMSHAFT POSITION ACTUATOR CONTROL CIRCUIT LOW (BANK 1), Diagnostic Trouble Code (DTC) Detecting Criteria.>

DS:DTC P2093 INTAKE CAMSHAFT POSITION ACTUATOR CONTROL CIRCUIT HIGH (BANK 2)

1. OUTLINE OF DIAGNOSIS

NOTE:

For the detection standard, refer to DTC P2089. <Ref. to GD(H4DOTC)-198, DTC P2089 INTAKE CAMSHAFT POSITION ACTUATOR CONTROL CIRCUIT HIGH (BANK 1), Diagnostic Trouble Code (DTC) Detecting Criteria.>

Diagnostic Trouble Code (DTC) Detecting Criteria

GENERAL DESCRIPTION

DT:DTC P2096 POST CATALYST FUEL TRIM SYSTEM TOO LEAN (BANK 1)

1. OUTLINE OF DIAGNOSIS

Detect the malfunction of fuel system from the size of the sub feedback learning value.
Control the sub feedback learning and judge as NG when the learning value is in the lean zone.

2. COMPONENT DESCRIPTION

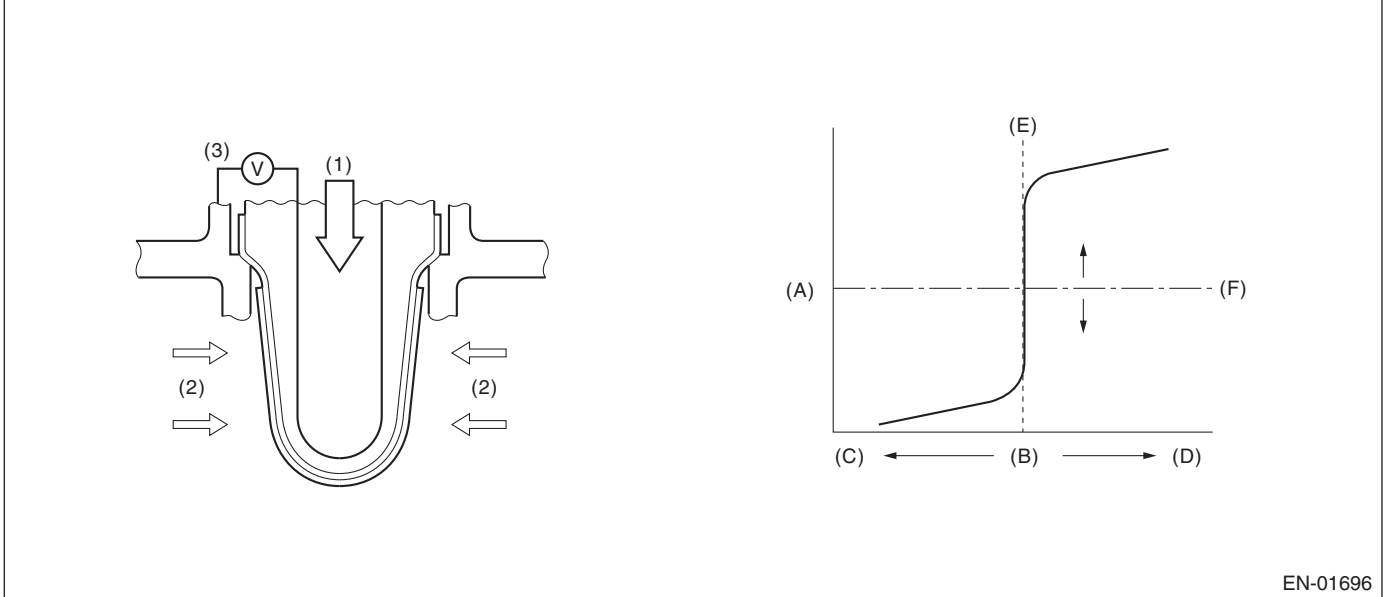

EN-01696

- | | | |
|-------------------------|--------------------------------|-------------------------|
| (A) Electromotive force | (B) Air fuel ratio | (C) Rich |
| (D) Lean | (E) Theoretical air fuel ratio | (F) Comparative voltage |
| (1) Atmosphere | (2) Exhaust gas | (3) Electromotive force |

3. ENABLE CONDITION

Secondary Parameters	Enable Conditions
Conditions for carrying out the sub feedback learning	Completed
Continuous time when all conditions are established.	≥ 1 s

4. GENERAL DRIVING CYCLE

Perform the diagnosis continuously when the vehicle is idling or running at a constant speed of 80 km/h (50 MPH) or more.

Diagnostic Trouble Code (DTC) Detecting Criteria

GENERAL DESCRIPTION

5. DIAGNOSTIC METHOD

• Abnormality Judgement

If the duration of time while the following conditions are met is longer than the time indicated, judge as NG.

Judgement Value

Malfunction Criteria	Threshold Value
Sub feedback learning value	< -0.04

Time Needed for Diagnosis: 5 s × 1 time(s)

Malfunction Indicator Light Illumination: Illuminates when malfunction occurs in 2 continuous driving cycles.

• Normality Judgement

Judge as OK and clear the NG if the continuous time while the following conditions are established is more than the predetermined time.

Judgement Value

Malfunction Criteria	Threshold Value
Sub feedback learning value	≥ -0.04 + 0.005

Time Needed for Diagnosis: 5 s

Diagnostic Trouble Code (DTC) Detecting Criteria

GENERAL DESCRIPTION

DU:DTC P2097 POST CATALYST FUEL TRIM SYSTEM TOO RICH (BANK 1)

1. OUTLINE OF DIAGNOSIS

Detect the malfunction of fuel system from the size of the sub feedback learning value.

Sub feedback learning is being performed. When the learning value goes to the rich side, judge as NG.

2. COMPONENT DESCRIPTION

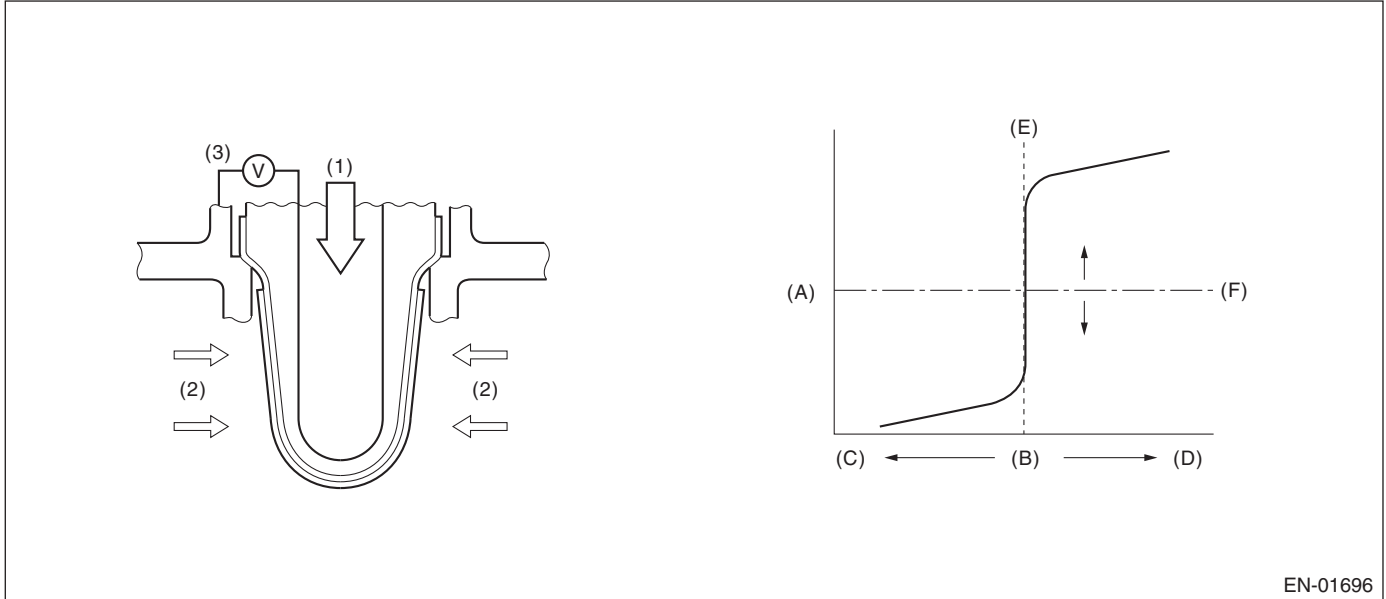

EN-01696

(A) Electromotive force

(B) Air fuel ratio

(C) Rich

(D) Lean

(E) Theoretical air fuel ratio

(F) Comparative voltage

(1) Atmosphere

(2) Exhaust gas

(3) Electromotive force

3. ENABLE CONDITION

Secondary Parameters	Enable Conditions
Conditions for carrying out the sub feedback learning	Completed
Continuous time when all conditions are established.	≥ 1 s

4. GENERAL DRIVING CYCLE

Perform the diagnosis continuously when the vehicle is idling or running at a constant speed of 80 km/h (50 MPH) or more.

Diagnostic Trouble Code (DTC) Detecting Criteria

GENERAL DESCRIPTION

5. DIAGNOSTIC METHOD

• Abnormality Judgement

If the duration of time while the following conditions are met is longer than the time indicated, judge as NG.

Judgement Value

Malfunction Criteria	Threshold Value
Sub feedback learning value	≥ 0.04

Time Needed for Diagnosis: $5 \text{ s} \times 1 \text{ time(s)}$

Malfunction Indicator Light Illumination: Illuminates when malfunction occurs in 2 continuous driving cycles.

• Normality Judgement

Judge as OK and clear the NG if the continuous time while the following conditions are established is more than the predetermined time.

Judgement Value

Malfunction Criteria	Threshold Value
Sub feedback learning value	$< 0.04 + -0.005$

Time Needed for Diagnosis: 5 s

Diagnostic Trouble Code (DTC) Detecting Criteria

GENERAL DESCRIPTION

DV:DTC P2101 THROTTLE ACTUATOR CONTROL MOTOR CIRCUIT RANGE/ PERFORMANCE

1. OUTLINE OF DIAGNOSIS

Judge as NG when the motor current becomes large or drive circuit is heated.

2. COMPONENT DESCRIPTION

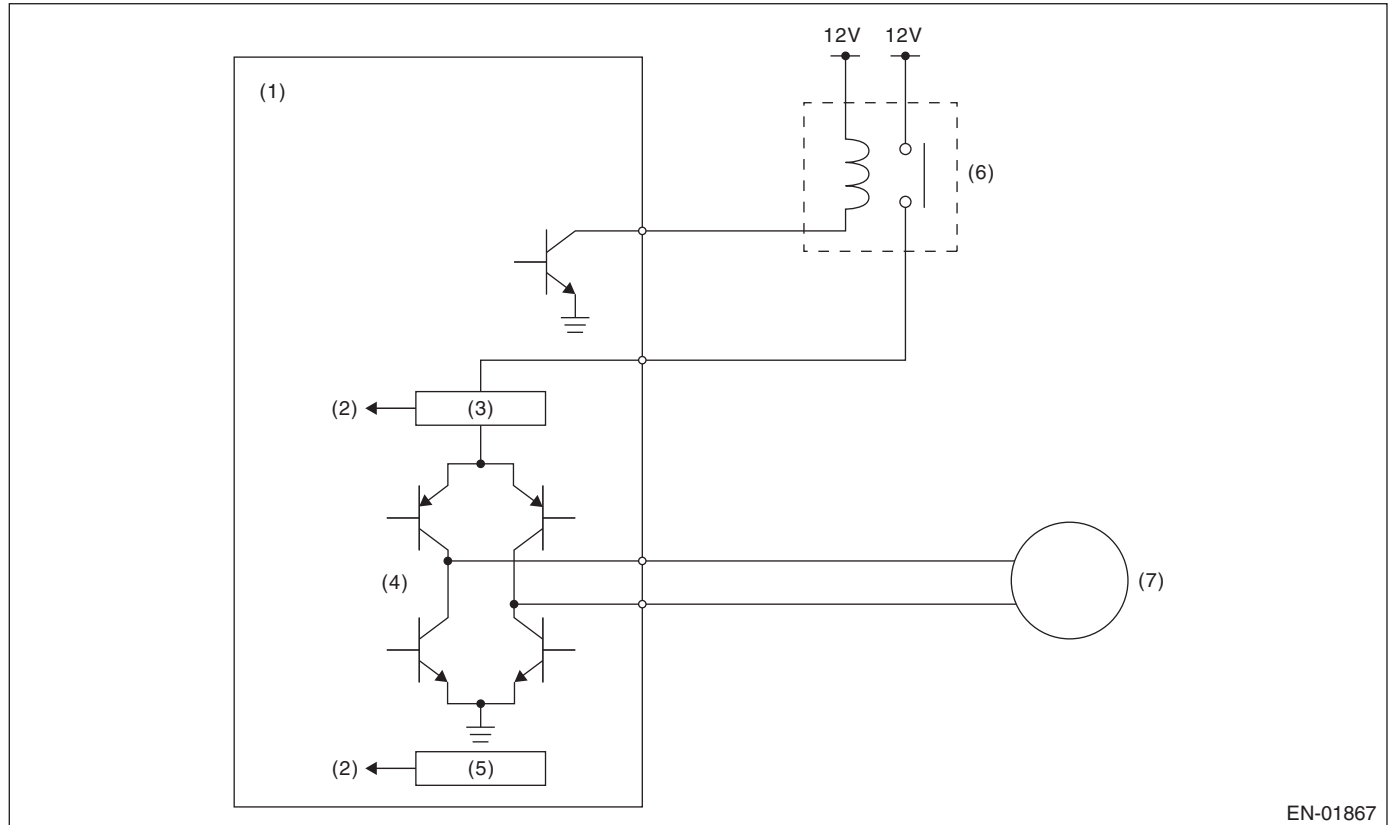

EN-01867

- | | | |
|-----------------------------------|-----------------------------------|---------------------------------------|
| (1) Engine control module (ECM) | (4) Drive circuit | (6) Electronic throttle control relay |
| (2) Detecting circuit | (5) Temperature detection circuit | (7) Motor |
| (3) Overcurrent detection circuit | | |

3. ENABLE CONDITION

Secondary Parameters	Enable Conditions
Under control of electronic throttle control	ON

4. GENERAL DRIVING CYCLE

Always perform the diagnosis continuously.

5. DIAGNOSTIC METHOD

Judge as OK and clear the NG when the malfunction criteria below are met.

Judgement Value

Malfunction Criteria	Threshold Value
Motor current	≤ 8 A
Drive circuit inner temperature	$\leq 175^{\circ}\text{C}$ (347°F)

Time Needed for Diagnosis:

- 500 milliseconds (For NG)
- 2000 milliseconds (For OK)

Malfunction Indicator Light Illumination: Illuminates as soon as a malfunction occurs.

DW:DTC P2102 THROTTLE ACTUATOR CONTROL MOTOR CIRCUIT LOW

1. OUTLINE OF DIAGNOSIS

Judge as NG when the electronic throttle control power is not supplied even when ECM sets the electronic throttle control relay to ON.

2. COMPONENT DESCRIPTION

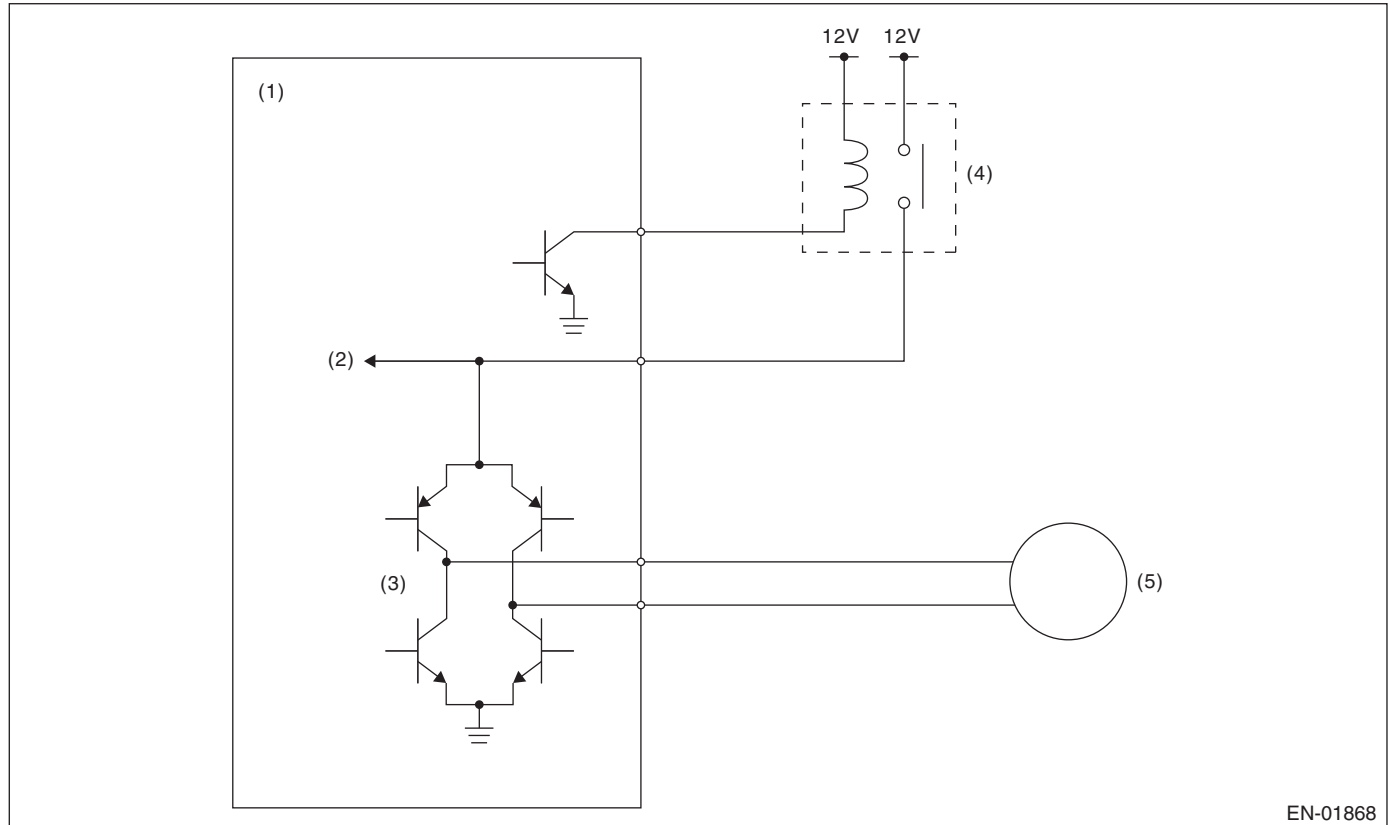

- | | | |
|---------------------------------|---------------------------------------|-----------|
| (1) Engine control module (ECM) | (3) Drive circuit | (5) Motor |
| (2) Voltage detection circuit | (4) Electronic throttle control relay | |

3. ENABLE CONDITION

Secondary Parameters	Enable Conditions
Electronic control relay throttle output	ON

4. GENERAL DRIVING CYCLE

Always perform the diagnosis continuously.

5. DIAGNOSTIC METHOD

Judge as OK and clear the NG when the malfunction criteria below are met.

Judgement Value

Malfunction Criteria	Threshold Value
Motor power voltage	≥ 5 V

Time Needed for Diagnosis:

- 400 milliseconds (For NG)
- 2000 milliseconds (For OK)

Malfunction Indicator Light Illumination: Illuminates as soon as a malfunction occurs.

Diagnostic Trouble Code (DTC) Detecting Criteria

GENERAL DESCRIPTION

DX:DTC P2103 THROTTLE ACTUATOR CONTROL MOTOR CIRCUIT HIGH

1. OUTLINE OF DIAGNOSIS

Judge as NG when the electronic throttle control power is supplied even when ECM sets the electronic throttle control relay to OFF.

2. COMPONENT DESCRIPTION

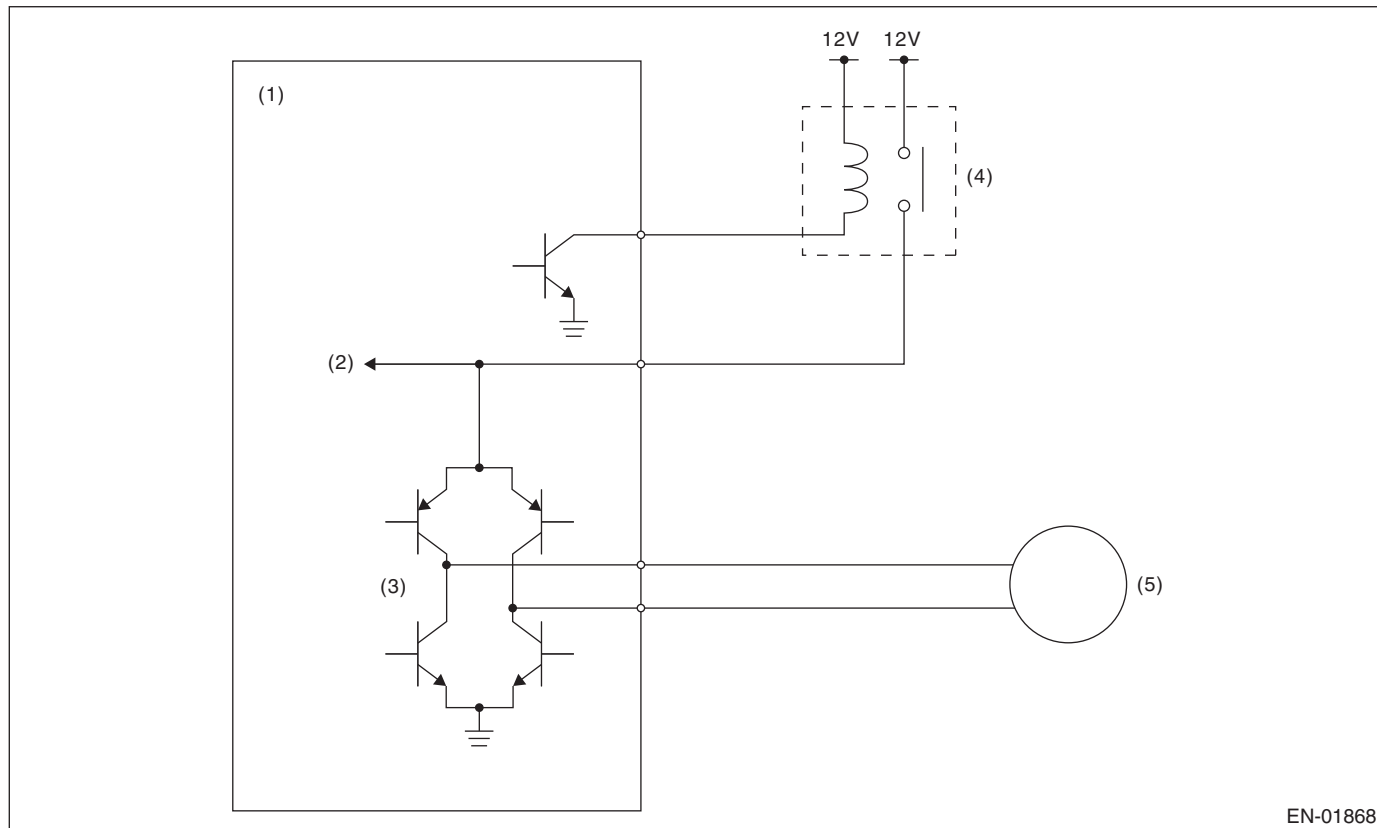

- | | | |
|---------------------------------|---------------------------------------|-----------|
| (1) Engine control module (ECM) | (3) Drive circuit | (5) Motor |
| (2) Voltage detection circuit | (4) Electronic throttle control relay | |

3. ENABLE CONDITION

Secondary Parameters	Enable Conditions
Electronic throttle control relay output	OFF

4. GENERAL DRIVING CYCLE

- When ignition switch ON → OFF
- Ignition switch OFF → ON (Only after clearing memory)

5. DIAGNOSTIC METHOD

Judge as OK and clear the NG when the malfunction criteria below are met.

Judgement Value

Malfunction Criteria	Threshold Value
Motor power voltage	≤ 5 V

Time Needed for Diagnosis:

- 600 milliseconds (For NG)
- 400 milliseconds (For OK)

Malfunction Indicator Light Illumination: Illuminates as soon as a malfunction occurs.

DY:DTC P2109 THROTTLE/PEDAL POSITION SENSOR “A” MINIMUM STOP PERFORMANCE

1. OUTLINE OF DIAGNOSIS

Judge as NG when full close point learning cannot conducted or abnormal value is detected.

2. COMPONENT DESCRIPTION

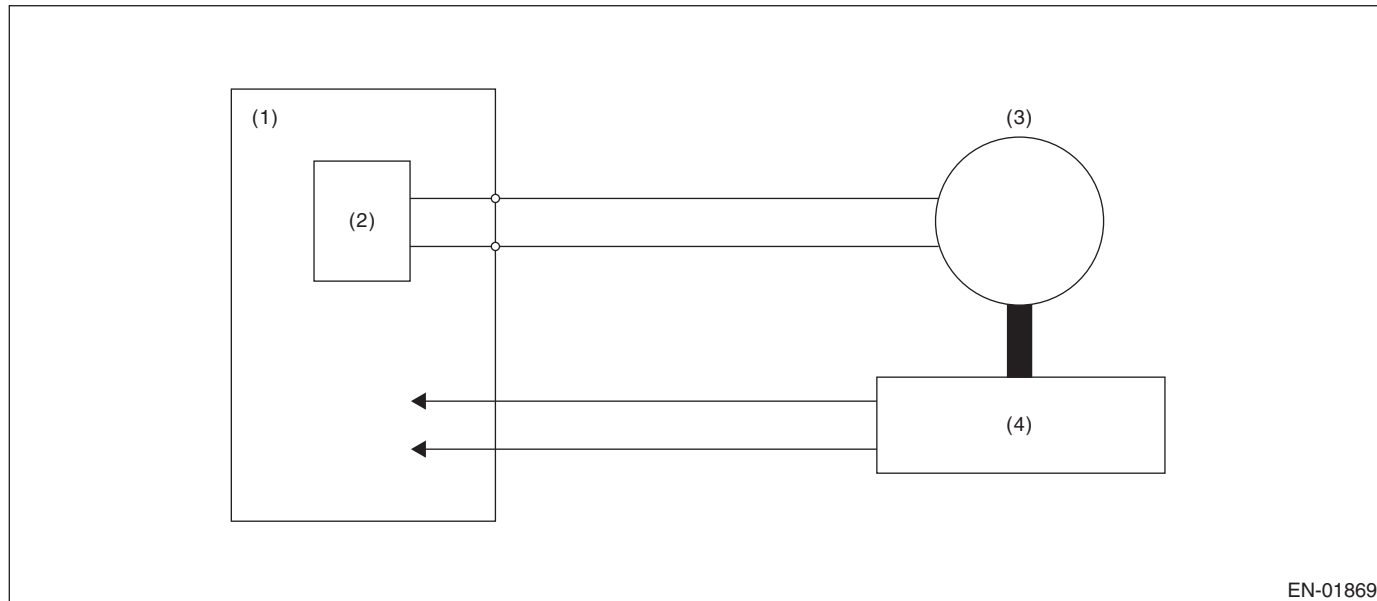

EN-01869

- (1) Engine control module (ECM) (3) Motor (4) Throttle position sensor
 (2) Drive circuit

3. ENABLE CONDITION

Secondary Parameters	Enable Conditions
Ignition switch	ON → OFF
Ignition switch (only after clear memory)	OFF → ON

4. GENERAL DRIVING CYCLE

Perform the diagnosis at full closed point learning.

5. DIAGNOSTIC METHOD

Judge as OK and clear the NG when the malfunction criteria below are met.

Judgement Value

Malfunction Criteria	Threshold Value
Throttle sensor opening angle at full close point learning	10.127° or more, 19.872° or less
Throttle opening angle when the ignition switch is ON – Throttle minimum stop position	≥ 1.683°

Time Needed for Diagnosis: 8 — 80 milliseconds

Malfunction Indicator Light Illumination: Illuminates as soon as a malfunction occurs.

Diagnostic Trouble Code (DTC) Detecting Criteria

GENERAL DESCRIPTION

DZ:DTC P2122 THROTTLE/PEDAL POSITION SENSOR/SWITCH “D” CIRCUIT LOW INPUT

1. OUTLINE OF DIAGNOSIS

Detect the open or short circuit of accelerator pedal position sensor 1.
Judge as NG if out of specification.

2. COMPONENT DESCRIPTION

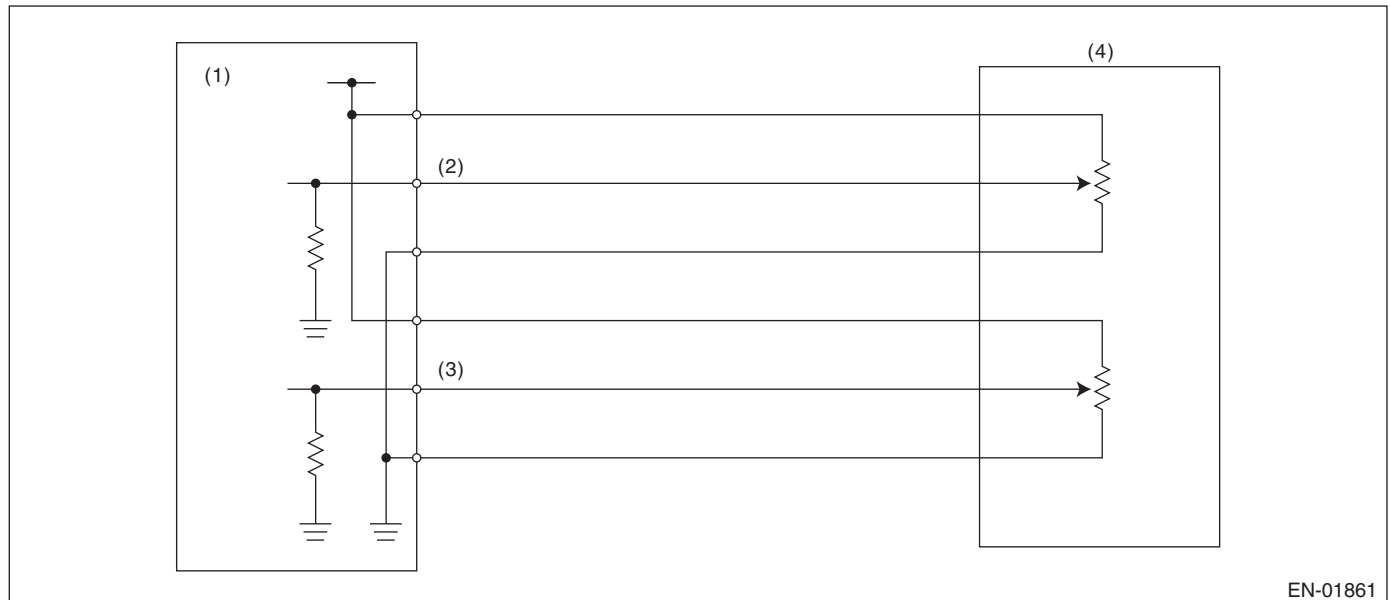

- (1) Engine control module (ECM) (3) Accelerator pedal position sensor 2 signal (4) Accelerator pedal position sensor 2 signal
(2) Accelerator pedal position sensor 1 signal

3. ENABLE CONDITION

Secondary Parameters	Enable Conditions
Ignition switch	ON
Battery voltage	$\geq 6 \text{ V}$

4. GENERAL DRIVING CYCLE

Always perform the diagnosis continuously.

Diagnostic Trouble Code (DTC) Detecting Criteria

GENERAL DESCRIPTION

5. DIAGNOSTIC METHOD

• Abnormality Judgement

If the duration of time while the following conditions are met is longer than the time indicated, judge as NG.

Judgement Value

Malfunction Criteria	Threshold Value
Sensor 1 input voltage	< 0.217 V

Time Needed for Diagnosis: 100 ms

Malfunction Indicator Light Illumination: Illuminates as soon as a malfunction occurs.

• Normality Judgement

Judge as OK and clear the NG if the continuous time while the following conditions are established is more than the predetermined time.

Judgement Value

Malfunction Criteria	Threshold Value
Sensor 1 input voltage	≥ 0.217 V

Time Needed for Diagnosis: 100 ms

Diagnostic Trouble Code (DTC) Detecting Criteria

GENERAL DESCRIPTION

5. DIAGNOSTIC METHOD

• Abnormality Judgement

If the duration of time while the following conditions are met is longer than the time indicated, judge as NG.

Judgement Value

Malfunction Criteria	Threshold Value
Sensor 1 input voltage	≥ 4.783 V

Time Needed for Diagnosis: 32 ms

Malfunction Indicator Light Illumination: Illuminates as soon as a malfunction occurs.

• Normality Judgement

Judge as OK and clear the NG if the continuous time while the following conditions are established is more than the predetermined time.

Judgement Value

Malfunction Criteria	Threshold Value
Sensor 1 input voltage	< 4.783 V

Time Needed for Diagnosis: 32 ms

Diagnostic Trouble Code (DTC) Detecting Criteria

GENERAL DESCRIPTION

5. DIAGNOSTIC METHOD

• Abnormality Judgement

If the duration of time while the following conditions are met is longer than the time indicated, judge as NG.

Judgement Value

Malfunction Criteria	Threshold Value
Sensor 2 input voltage	< 0.217 V

Time Needed for Diagnosis: 100 ms

Malfunction Indicator Light Illumination: Illuminates as soon as a malfunction occurs.

• Normality Judgement

Judge as OK and clear the NG if the continuous time while the following conditions are established is more than the predetermined time.

Judgement Value

Malfunction Criteria	Threshold Value
Sensor 2 input voltage	≥ 0.217 V

Time Needed for Diagnosis: 100 ms

Diagnostic Trouble Code (DTC) Detecting Criteria

GENERAL DESCRIPTION

EC:DTC P2128 THROTTLE/PEDAL POSITION SENSOR/SWITCH "E" CIRCUIT HIGH INPUT

1. OUTLINE OF DIAGNOSIS

Detect the open or short circuit of accelerator pedal position sensor 2.
Judge as NG if out of specification.

2. COMPONENT DESCRIPTION

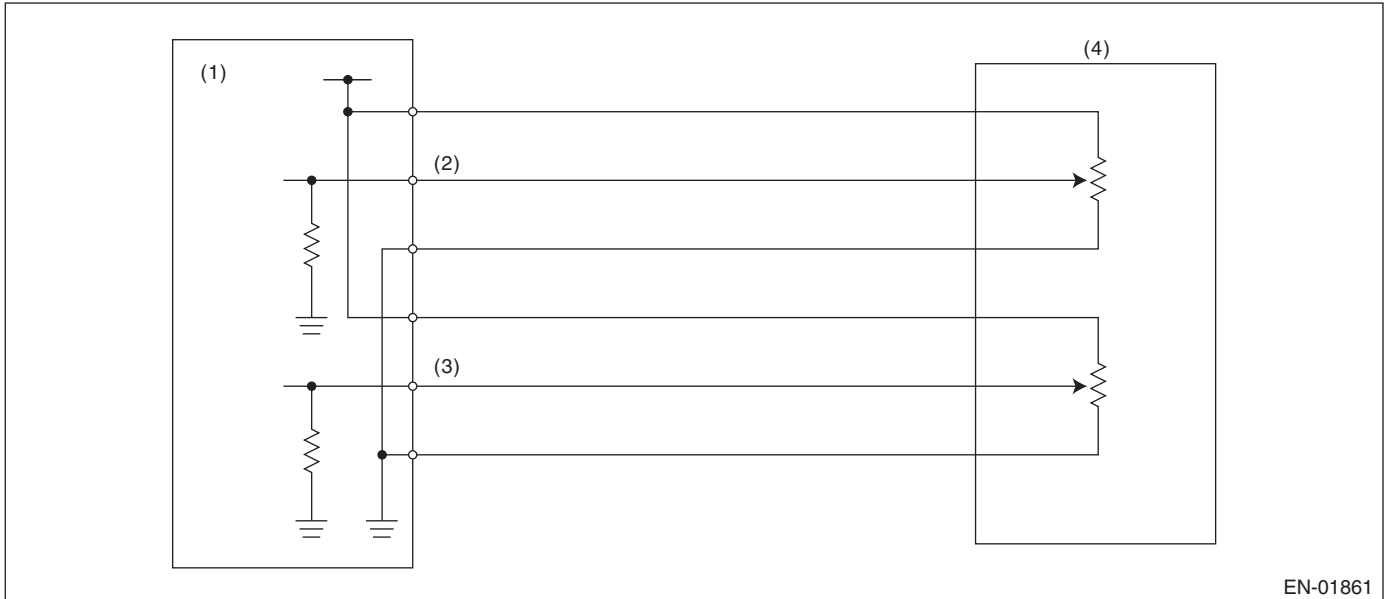

- (1) Engine control module (ECM) (3) Accelerator pedal position sensor 2 signal (4) Accelerator pedal position sensor 2 signal
(2) Accelerator pedal position sensor 1 signal

3. ENABLE CONDITION

Secondary Parameters	Enable Conditions
Ignition switch	ON
Battery voltage	$\geq 6 \text{ V}$

4. GENERAL DRIVING CYCLE

Always perform the diagnosis continuously.

Diagnostic Trouble Code (DTC) Detecting Criteria

GENERAL DESCRIPTION

5. DIAGNOSTIC METHOD

• Abnormality Judgement

If the duration of time while the following conditions are met is longer than the time indicated, judge as NG.

Judgement Value

Malfunction Criteria	Threshold Value
Sensor 2 input voltage	≥ 4.783 V

Time Needed for Diagnosis: 100 ms

Malfunction Indicator Light Illumination: Illuminates as soon as a malfunction occurs.

• Normality Judgement

Judge as OK and clear the NG if the continuous time while the following conditions are established is more than the predetermined time.

Judgement Value

Malfunction Criteria	Threshold Value
Sensor 2 input voltage	< 4.783 V

Time Needed for Diagnosis: 100 ms

Diagnostic Trouble Code (DTC) Detecting Criteria

GENERAL DESCRIPTION

ED:DTC P2135 THROTTLE/PEDAL POSITION SENSOR/SWITCH “A”/“B” VOLTAGE CORRELATION

1. OUTLINE OF DIAGNOSIS

Judge as NG when the signal level of throttle position sensor 1 is different from the throttle position sensor 2.

2. COMPONENT DESCRIPTION

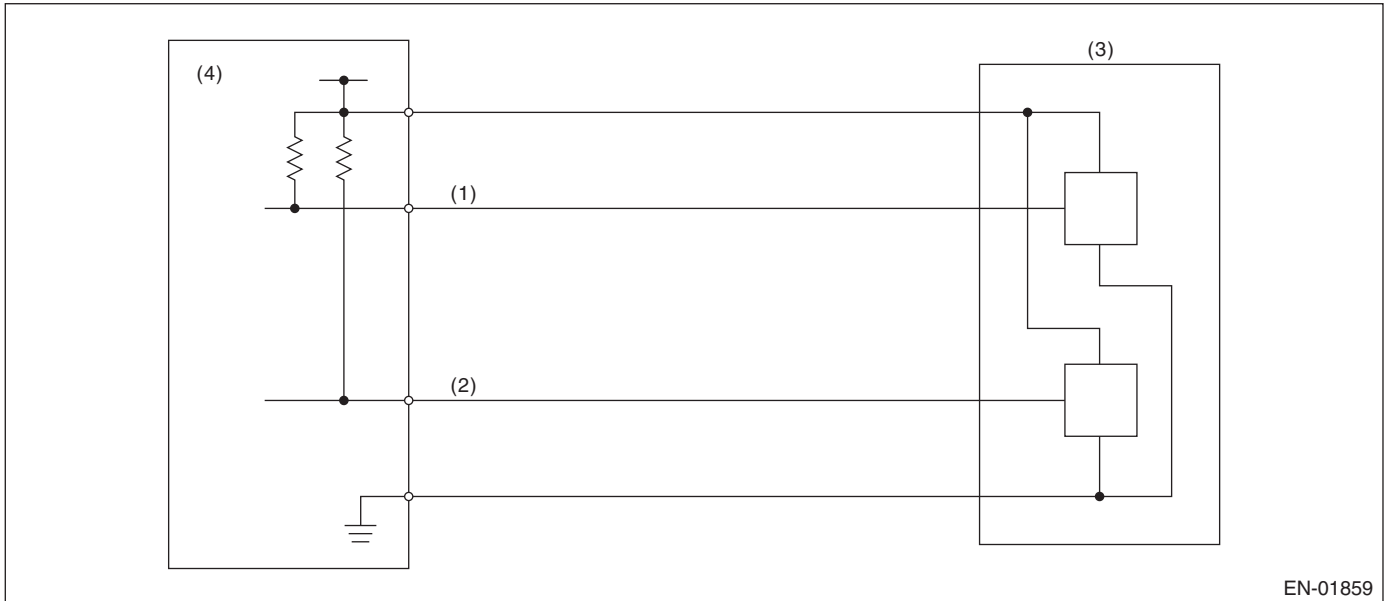

(1) Throttle position sensor 1 signal
(2) Throttle position sensor 2 signal

(3) Throttle position sensor

(4) Engine control module (ECM)

3. ENABLE CONDITION

Secondary Parameters	Enable Conditions
Ignition switch	ON
Battery voltage	$\geq 6\text{ V}$

4. GENERAL DRIVING CYCLE

Always perform the diagnosis continuously.

Diagnostic Trouble Code (DTC) Detecting Criteria

GENERAL DESCRIPTION

5. DIAGNOSTIC METHOD

• Abnormality Judgement

If the duration of time while the following conditions are met is longer than the time indicated, judge as NG.

Judgement Value

Malfunction Criteria	Threshold Value
Signal difference between two sensors	> Value from Map

Map

Throttle position sensor 1 opening angle (°) = d	$0^\circ \leq d < 2.125^\circ$	$2.125^\circ \leq d < 4.25^\circ$	$4.25^\circ \leq d < 9^\circ$	$9^\circ \leq d < 31.625^\circ$	$31.625^\circ \leq d$
Sensor output difference (°)	5.15 °	6.15 °	8.28 °	10.4 °	12.4 °

Time Needed for Diagnosis: 212 ms

Malfunction Indicator Light Illumination: Illuminates as soon as a malfunction occurs.

• Normality Judgement

Judge as OK and clear the NG if the continuous time while the following conditions are established is more than the predetermined time.

Judgement Value

Malfunction Criteria	Threshold Value
Signal difference between two sensors	\leq Value from Map

Time Needed for Diagnosis: 24 ms

Diagnostic Trouble Code (DTC) Detecting Criteria

GENERAL DESCRIPTION

EE:DTC P2138 THROTTLE/PEDAL POSITION SENSOR/SWITCH “D”/“E” VOLTAGE CORRELATION

1. OUTLINE OF DIAGNOSIS

Judge as NG when the signal level of throttle position sensor 1 is different from the throttle position sensor 2.

2. COMPONENT DESCRIPTION

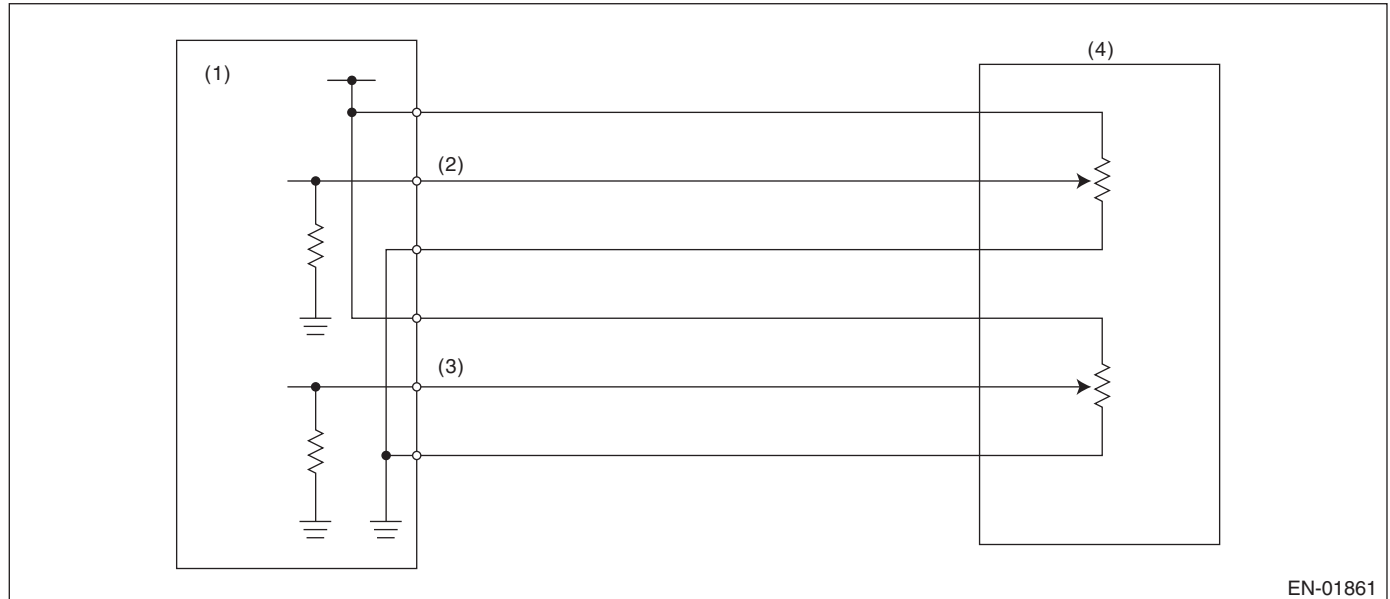

EN-01861

- (1) Engine control module (ECM) (3) Accelerator pedal position sensor
(2) Accelerator pedal position sensor (4) Accelerator pedal position sensor
1 signal 2 signal

3. ENABLE CONDITION

Secondary Parameters	Enable Conditions
Ignition switch	ON
Battery voltage	$\geq 6 \text{ V}$

4. GENERAL DRIVING CYCLE

Always perform the diagnosis continuously.

Diagnostic Trouble Code (DTC) Detecting Criteria

GENERAL DESCRIPTION

5. DIAGNOSTIC METHOD

• Abnormality Judgement

If the duration of time while the following conditions are met is longer than the time indicated, judge as NG.

Judgement Value

Malfunction Criteria	Threshold Value
Signal difference between two sensors	> Value from Map

Map

Throttle position sensor 1 opening angle (°) = d	$0^\circ \leq d < 0.6^\circ$	$0.6^\circ \leq d < 1.2^\circ$	$1.2^\circ \leq d < 2^\circ$	$2^\circ \leq d < 4^\circ$	$4^\circ \leq d$
Sensor output difference (°)	1.465°	1.597°	1.663°	2.455°	3.116°

Time Needed for Diagnosis: 116 ms

Malfunction Indicator Light Illumination: Illuminates as soon as a malfunction occurs.

• Normality Judgement

Judge as OK and clear the NG if the continuous time while the following conditions are established is more than the predetermined time.

Judgement Value

Malfunction Criteria	Threshold Value
Signal difference between two sensors	\leq Value from Map

Time Needed for Diagnosis: 116 ms

Diagnostic Trouble Code (DTC) Detecting Criteria

GENERAL DESCRIPTION

EF:DTC P2419 EVAPORATIVE EMISSION SYSTEM SWITCHING VALVE CONTROL CIRCUIT LOW

1. OUTLINE OF DIAGNOSIS

Detect open or short circuit of the purge control solenoid valve 2.

Judge as NG when the ECM output level differs from the actual terminal level.

2. ENABLE CONDITION

Secondary Parameters	Enable Conditions
None	

3. GENERAL DRIVING CYCLE

Always perform the diagnosis continuously.

4. DIAGNOSTIC METHOD

• Abnormality Judgement

If the duration of time while the following conditions are met is longer than the time indicated, judge as NG.

Judgement Value

Malfunction Criteria	Threshold Value
Battery voltage	≥ 10.9 V
Elapsed time after starting the engine	≥ 1 second
Terminal output voltage when ECM outputs OFF signal	Low

Time Needed for Diagnosis: 2500 ms

Malfunction Indicator Light Illumination: Illuminates as soon as a malfunction occurs.

• Normality Judgement

Judge as OK and clear the NG if the continuous time while the following conditions are established is more than the predetermined time.

Judgement Value

Malfunction Criteria	Threshold Value
Battery voltage	≥ 10.9 V
Elapsed time after starting the engine	≥ 1 second
Terminal output voltage when ECM outputs OFF signal	High

Time Needed for Diagnosis: Less than 1 second

Diagnostic Trouble Code (DTC) Detecting Criteria

GENERAL DESCRIPTION

EG:DTC P2420 EVAPORATIVE EMISSION SYSTEM SWITCHING VALVE CONTROL CIRCUIT HIGH

1. OUTLINE OF DIAGNOSIS

Detect open or short circuit of the purge control solenoid valve 2.
Judge as NG when the ECM output level differs from the actual terminal level.

2. ENABLE CONDITION

Secondary Parameters	Enable Conditions
None	

3. GENERAL DRIVING CYCLE

Always perform the diagnosis continuously.

4. DIAGNOSTIC METHOD

• Abnormality Judgement

If the duration of time while the following conditions are met is longer than the time indicated, judge as NG.

Judgement Value

Malfunction Criteria	Threshold Value
Battery voltage	≥ 10.9 V
Elapsed time after starting the engine	≥ 1 second
Terminal output voltage when ECM outputs ON signal	High

Time Needed for Diagnosis:2500 ms

Malfunction Indicator Light Illumination: Illuminates as soon as a malfunction occurs.

• Normality Judgement

Judge as OK and clear the NG if the continuous time while the following conditions are established is more than the predetermined time.

Judgement Value

Malfunction Criteria	Threshold Value
Battery voltage	≥ 10.9 V
Elapsed time after starting the engine	≥ 1 second
Terminal output voltage when ECM outputs ON signal	Low

Time Needed for Diagnosis: Less than 1 second

Diagnostic Trouble Code (DTC) Detecting Criteria

GENERAL DESCRIPTION

EH:DTC P2431 SECONDARY AIR INJECTION SYSTEM AIR FLOW /PRESSURE SENSOR CIRCUIT RANGE/PERFORMANCE

1. OUTLINE OF DIAGNOSIS

Detect the malfunction of secondary air pressure sensor output property.

Judge as NG when the secondary air pressure sensor output is largely different from the intake manifold pressure at engine start.

2. ENABLE CONDITION

Secondary Parameters	Enable Conditions
Engine speed	< 300 rpm
Vehicle speed	< 1 km/h (0.6 MPH)
After secondary air system stops	≥ 2976 ms

3. GENERAL DRIVING CYCLE

Perform the diagnosis with ignition switch ON.

4. DIAGNOSTIC METHOD

• Abnormality Judgement

If the duration of time while the following conditions are met is longer than the time indicated, judge as NG.

Judgement Value

Malfunction Criteria	Threshold Value
Secondary air pipe pressure – Intake manifold pressure	≥ 26.7 kPa (200 mmHg, 7.9 inHg)
Intake manifold pressure at engine start – Intake manifold pressure	< 1.3 kPa (9.99 mmHg, 0.4 inHg)

Time Needed for Diagnosis:328 ms

Malfunction Indicator Light Illumination: Illuminates when malfunction occurs in 2 continuous driving cycles.

• Normality Judgement

Judge as OK and clear the NG if the continuous time while the following conditions are established is more than the predetermined time.

Judgement Value

Malfunction Criteria	Threshold Value
Secondary air pipe pressure – Intake manifold pressure	< 26.7 kPa (200 mmHg, 7.9 inHg)

Time Needed for Diagnosis:262 ms

Diagnostic Trouble Code (DTC) Detecting Criteria

GENERAL DESCRIPTION

EI: DTC P2432 SECONDARY AIR INJECTION SYSTEM AIR FLOW /PRESSURE SENSOR CIRCUIT LOW

1. OUTLINE OF DIAGNOSIS

Judge as NG if out of specification.

2. ENABLE CONDITION

Secondary Parameters	Enable Conditions
None	

3. GENERAL DRIVING CYCLE

Always perform the diagnosis continuously.

4. DIAGNOSTIC METHOD

• Abnormality Judgement

If the duration of time while the following conditions are met is longer than the time indicated, judge as NG.

Judgement Value

Malfunction Criteria	Threshold Value
Ignition switch	ON
Output voltage	< 0.573 V

Time Needed for Diagnosis:500 ms

Malfunction Indicator Light Illumination: Illuminates as soon as a malfunction occurs.

• Normality Judgement

Judge as OK and clear the NG if the continuous time while the following conditions are established is more than the predetermined time.

Judgement Value

Malfunction Criteria	Threshold Value
Ignition switch	ON
Output voltage	≥ 0.573 V

Time Needed for Diagnosis: Less than 1 second

Diagnostic Trouble Code (DTC) Detecting Criteria

GENERAL DESCRIPTION

EJ: DTC P2433 SECONDARY AIR INJECTION SYSTEM AIR FLOW /PRESSURE SENSOR CIRCUIT HIGH

1. OUTLINE OF DIAGNOSIS

Judge as NG if out of specification.

2. ENABLE CONDITION

Secondary Parameters	Enable Conditions
None	

3. GENERAL DRIVING CYCLE

Always perform the diagnosis continuously.

4. DIAGNOSTIC METHOD

• Abnormality Judgement

If the duration of time while the following conditions are met is longer than the time indicated, judge as NG.

Judgement Value

Malfunction Criteria	Threshold Value
Ignition switch	ON
Output voltage	> 4.916 V

Time Needed for Diagnosis: 500 ms

Malfunction Indicator Light Illumination: Illuminates as soon as a malfunction occurs.

• Normality Judgement

Judge as OK and clear the NG if the continuous time while the following conditions are established is more than the predetermined time.

Judgement Value

Malfunction Criteria	Threshold Value
Ignition switch	ON
Output voltage	≤ 4.916 V

Time Needed for Diagnosis: Less than 1 second

EK:DTC P2440 SECONDARY AIR INJECTION SYSTEM SWITCHING VALVE STUCK OPEN (BANK 1)

1. OUTLINE OF DIAGNOSIS

NOTE:

For the detection standard, refer to DTC P0410. <Ref. to GD(H4DOTC)-96, DTC P0410 SECONDARY AIR INJECTION SYSTEM, Diagnostic Trouble Code (DTC) Detecting Criteria.>

EL:DTC P2441 SECONDARY AIR INJECTION SYSTEM SWITCHING VALVE STUCK CLOSED (BANK 1)

1. OUTLINE OF DIAGNOSIS

NOTE:

For the detection standard, refer to DTC P0410. <Ref. to GD(H4DOTC)-96, DTC P0410 SECONDARY AIR INJECTION SYSTEM, Diagnostic Trouble Code (DTC) Detecting Criteria.>

EM:DTC P2442 SECONDARY AIR INJECTION SYSTEM SWITCHING VALVE STUCK OPEN (BANK2)

1. OUTLINE OF DIAGNOSIS

NOTE:

For the detection standard, refer to DTC P0410. <Ref. to GD(H4DOTC)-96, DTC P0410 SECONDARY AIR INJECTION SYSTEM, Diagnostic Trouble Code (DTC) Detecting Criteria.>

EN:DTC P2443 SECONDARY AIR INJECTION SYSTEM SWITCHING VALVE STUCK CLOSED (BANK2)

1. OUTLINE OF DIAGNOSIS

NOTE:

For the detection standard, refer to DTC P0410. <Ref. to GD(H4DOTC)-96, DTC P0410 SECONDARY AIR INJECTION SYSTEM, Diagnostic Trouble Code (DTC) Detecting Criteria.>

Diagnostic Trouble Code (DTC) Detecting Criteria

GENERAL DESCRIPTION

EO:DTC P2444 SECONDARY AIR INJECTION SYSTEM PUMP STUCK ON

1. OUTLINE OF DIAGNOSIS

Detect the secondary air pump malfunction (always ON).

After the secondary air pump turns to OFF, judge as NG if the secondary air pipe pressure is higher than that before the secondary air pump operation.

2. ENABLE CONDITION

Secondary Parameters	Enable Conditions
Battery voltage	≥ 7 V
Engine	In operation

3. GENERAL DRIVING CYCLE

Always perform the diagnosis continuously.

4. DIAGNOSTIC METHOD

• Abnormality Judgement

If the duration of time while the following conditions are met is longer than the time indicated, judge as NG.

Judgement Value

Malfunction Criteria	Threshold Value
Time since secondary air control completion	≥ 3000 ms and ≤ 8000 ms
Secondary air pipe pressure — Secondary air pressure before operation	> 6.7 kPa (50 mmHg, 2 inHg)

Time Needed for Diagnosis:8000 ms

Malfunction Indicator Light Illumination: Illuminates as soon as a malfunction occurs.

• Normality Judgement

Judge as OK and clear the NG if the continuous time while the following conditions are established is more than the predetermined time.

Judgement Value

Malfunction Criteria	Threshold Value
Time since secondary air control completion	≥ 3000 ms and ≤ 8000 ms
Secondary air pipe pressure — Secondary air pressure before operation	≤ 6.7 kPa (50 mmHg, 2 inHg)

Time Needed for Diagnosis:8000 ms

TRANSMISSION SECTION

This service manual has been prepared to provide SUBARU service personnel with the necessary information and data for the correct maintenance and repair of SUBARU vehicles.

This manual includes the procedures for maintenance, disassembling, reassembling, inspection and adjustment of components and diagnostics for guidance of experienced mechanics.

Please peruse and utilize this manual fully to ensure complete repair work for satisfying our customers by keeping their vehicle in optimum condition. When replacement of parts during repair work is needed, be sure to use SUBARU genuine parts.

All information, illustration and specifications contained in this manual are based on the latest product information available at the time of publication approval.

CONTROL SYSTEMS	CS
AUTOMATIC TRANSMISSION	4AT
AUTOMATIC TRANSMISSION (DIAGNOSTICS)	4AT(diag)
MANUAL TRANSMISSION AND DIFFERENTIAL	5MT
CLUTCH SYSTEM	CL

CONTROL SYSTEMS



	Page
1. General Description	2
2. AT Shift Lock Control System	6
3. Select Lever	20
4. Select Cable	25
5. AT Shift Lock Solenoid and "P" Range Switch	28
6. Body Integrated Unit	31
7. MT Gear Shift Lever	32
8. General Diagnostic Table	40

General Description

CONTROL SYSTEMS

1. General Description

A: SPECIFICATION

Item	Specification
Swing torque of rod against lever N (kgf, lb)	3.7(0.38, 0.83) or less

B: COMPONENT

1. AT SELECT LEVER

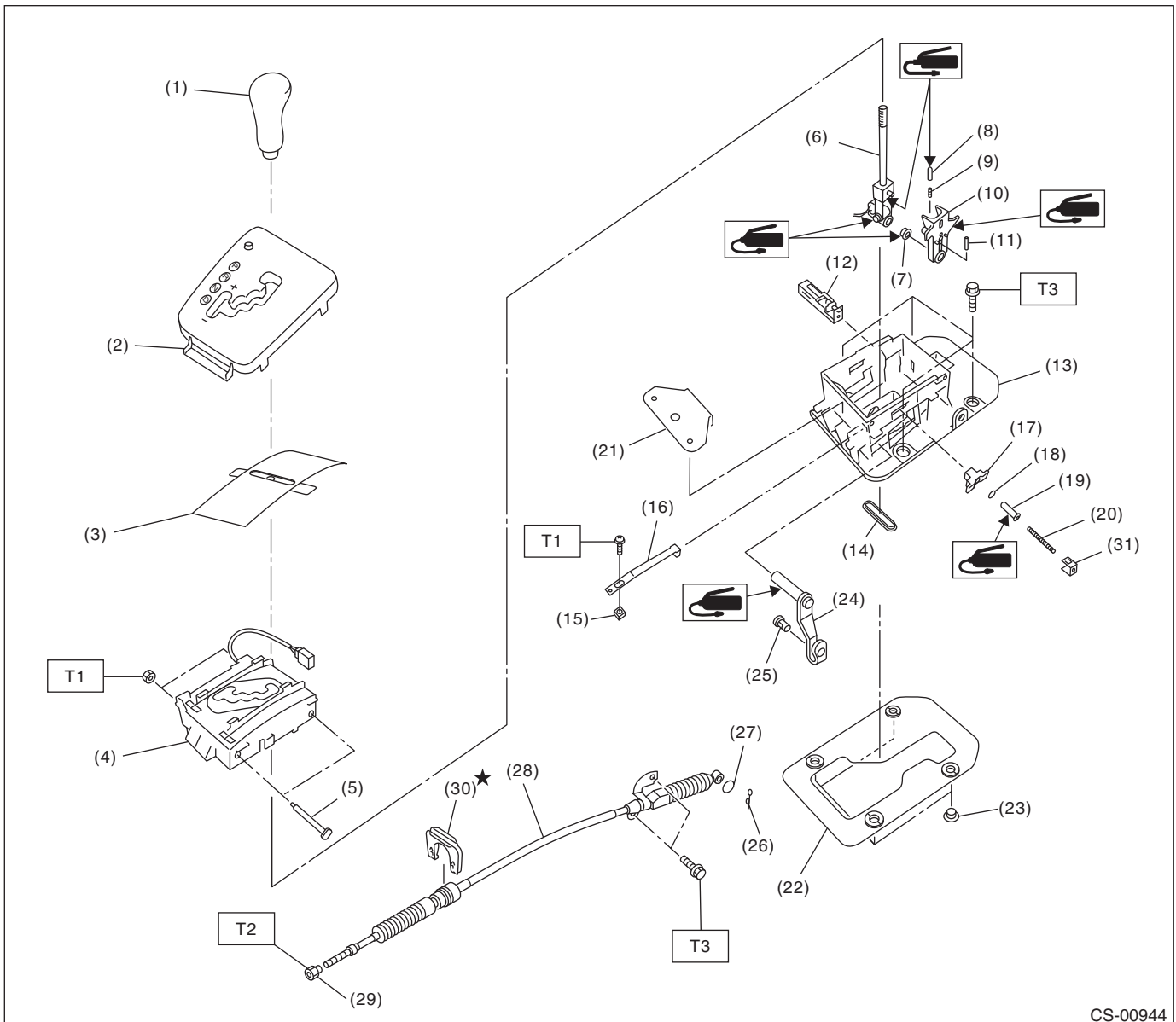

CS-00944

(1) Grip ASSY	(13) Plate COMPL	(25) Connector pin
(2) Indicator ASSY	(14) Grommet	(26) Snap pin
(3) Blind	(15) Plate nut	(27) Washer
(4) Plate guide COMPL	(16) Detent spring	(28) Select cable
(5) Spacer bolt	(17) Bushing	(29) Nut A
(6) Selector lever COMPL	(18) Lock plate cushion	(30) Clamp
(7) Bushing	(19) Select lever rod	(31) Shift lock clamp
(8) Rod detent	(20) Spring A	
(9) Spring detent	(21) Bracket	
(10) Bracket arm detent	(22) Gasket	
(11) Spring pin	(23) Spacer	
(12) Shift lock solenoid unit	(24) Arm ASSY	

Tightening torque: N·m (kgf·m, ft·lb)

T1: 2.2 (0.2, 1.6)

T2: 7.5 (0.8, 5.5)

T3: 18 (1.8, 13.3)

General Description

CONTROL SYSTEMS

2. 5MT GEAR SHIFT LEVER

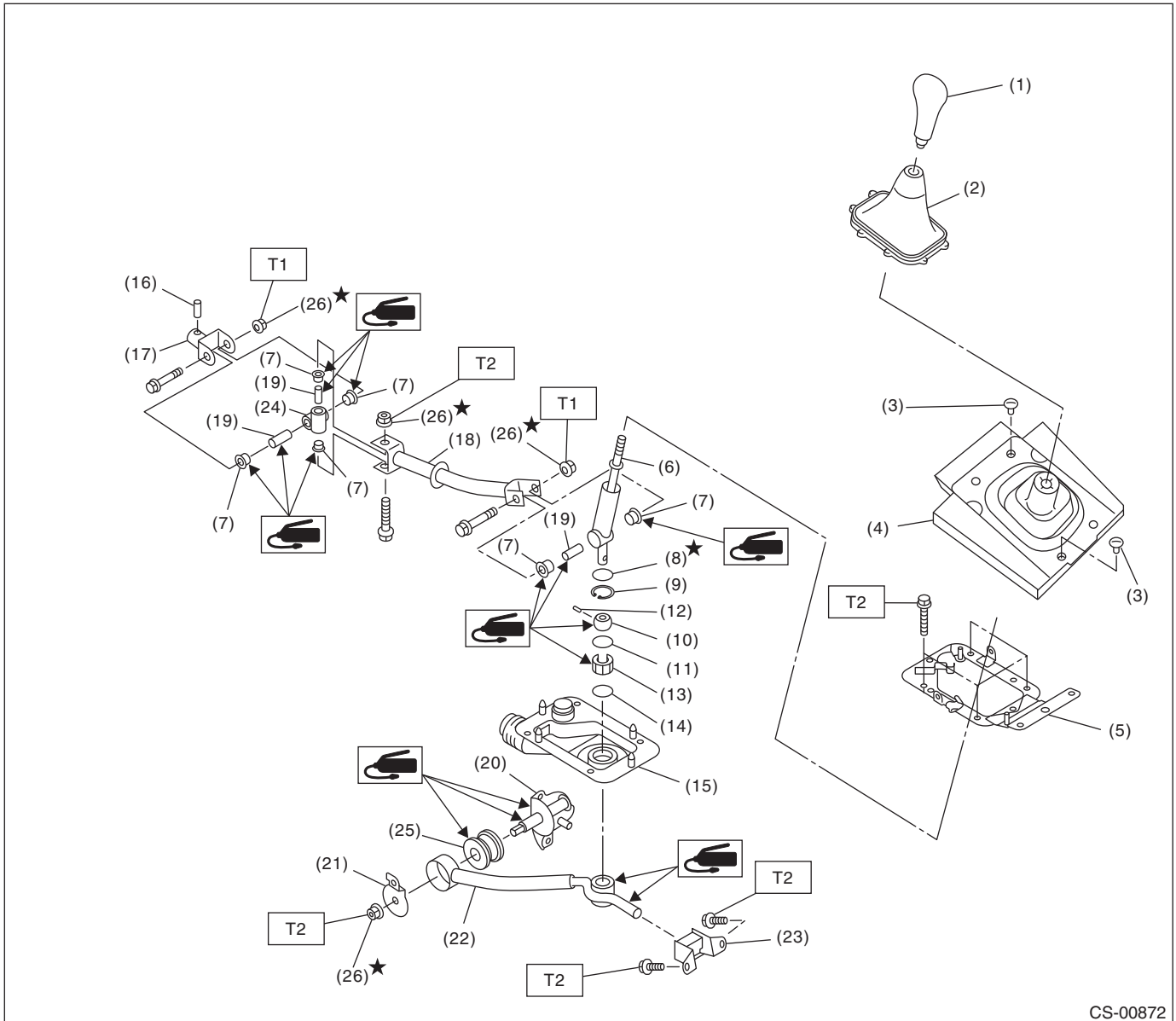

CS-00872

- | | | |
|------------------------|-----------------|-----------------------|
| (1) Gear shift knob | (11) O-ring | (21) Washer |
| (2) Console boot | (12) Spring pin | (22) Stay |
| (3) Clamp | (13) Bushing B | (23) Cushion rubber |
| (4) Boot and insulator | (14) O-ring | (24) Boss |
| (5) Plate ASSY | (15) Boot | (25) Bushing |
| (6) Lever | (16) Spring pin | (26) Self-locking nut |
| (7) Bushing | (17) Joint | |
| (8) Lock wire | (18) Rod | |
| (9) Snap ring | (19) Spacer | |
| (10) Bushing | (20) Bracket | |

Tightening torque: N·m (kgf·m, ft·lb)

T1: 12 (1.2, 8.9)

T2: 18 (1.8, 13.3)

C: PREPARATION TOOL

1. SPECIAL TOOL

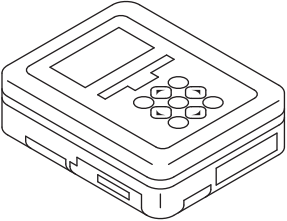
ILLUSTRATION	TOOL NUMBER	DESCRIPTION	REMARKS
 <p style="text-align: center;">ST1B022XU0</p>	<p style="text-align: center;">1B022XU0 (Newly adopted tool)</p>	<p style="text-align: center;">SUBARU SELECT MONITOR III KIT</p>	<p>Used for troubleshooting the electrical system.</p>

D: CAUTION

- Wear appropriate work clothing, including a cap, protective goggles and protective shoes when performing any work.
- Remove contamination including dirt and corrosion before removal, installation or disassembly.
- Keep the disassembled parts in order and protect them from dust and dirt.
- Before removal, installation or disassembly, be sure to clarify the failure. Avoid unnecessary removal, installation, disassembly and replacement.
- Use SUBARU genuine fluid, grease etc. or equivalent. Do not mix fluid, grease, etc. of different grades or manufacturers.
- Be sure to tighten fasteners including bolts and nuts to the specified torque.
- Place shop jacks or rigid racks at the specified points.
- Apply grease onto sliding or revolving surfaces before installation.
- Before installing O-rings or snap rings, apply sufficient amount of fluid to avoid damage and deformation.
- Before securing a part in a vise, place cushioning material such as wood blocks, aluminum plate or cloth between the part and the vise.
- Before disconnecting electrical connectors, be sure to disconnect the negative terminal from battery.

AT Shift Lock Control System

CONTROL SYSTEMS

2. AT Shift Lock Control System

A: LOCATION

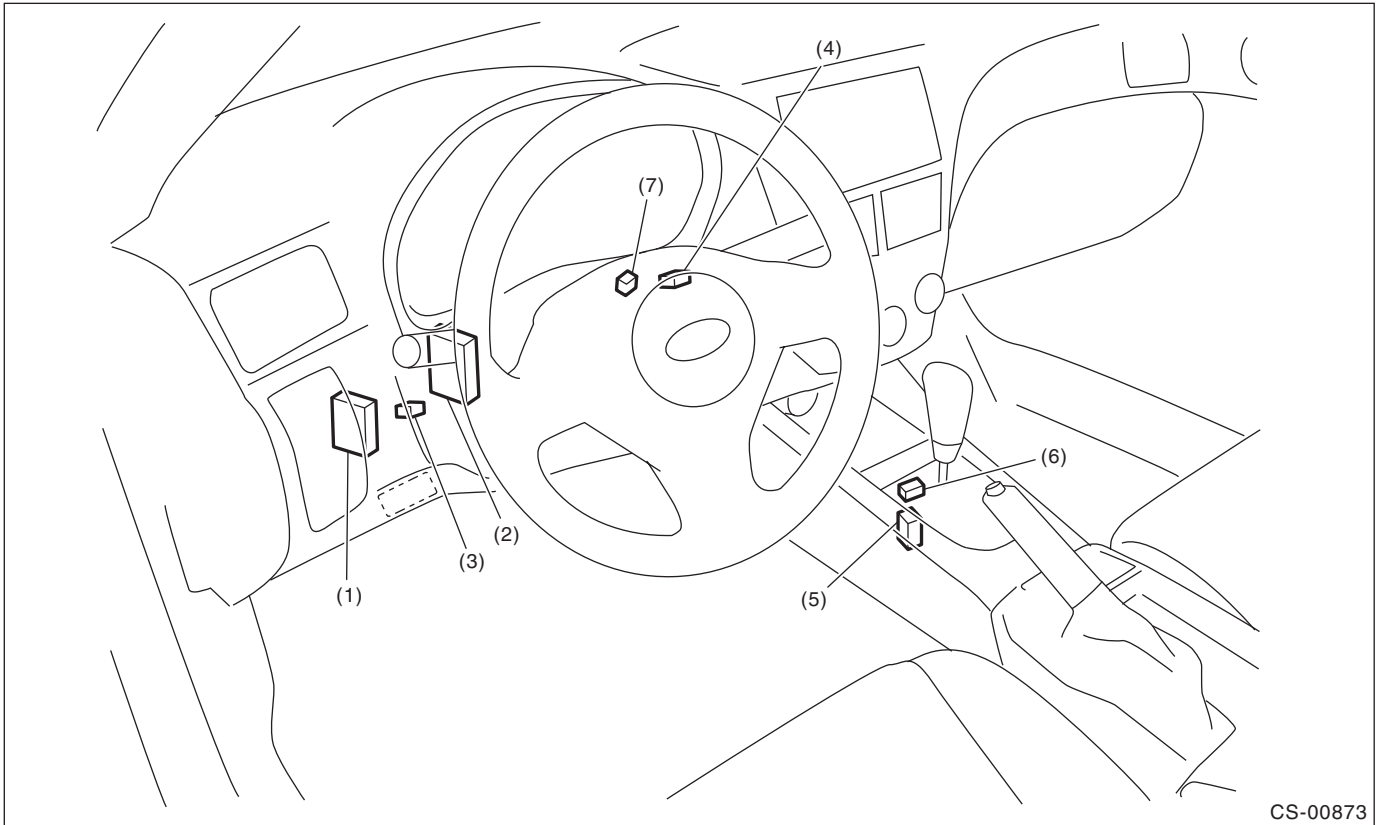

CS-00873

- | | | |
|--------------------------|--|-----------------------|
| (1) TCM ("P" range) | (4) Key cylinder
(with built-in key warning switch) | (6) "P" range switch |
| (2) Body integrated unit | (5) Shift lock solenoid ASSY | (7) Key lock solenoid |
| (3) Stop light switch | | |

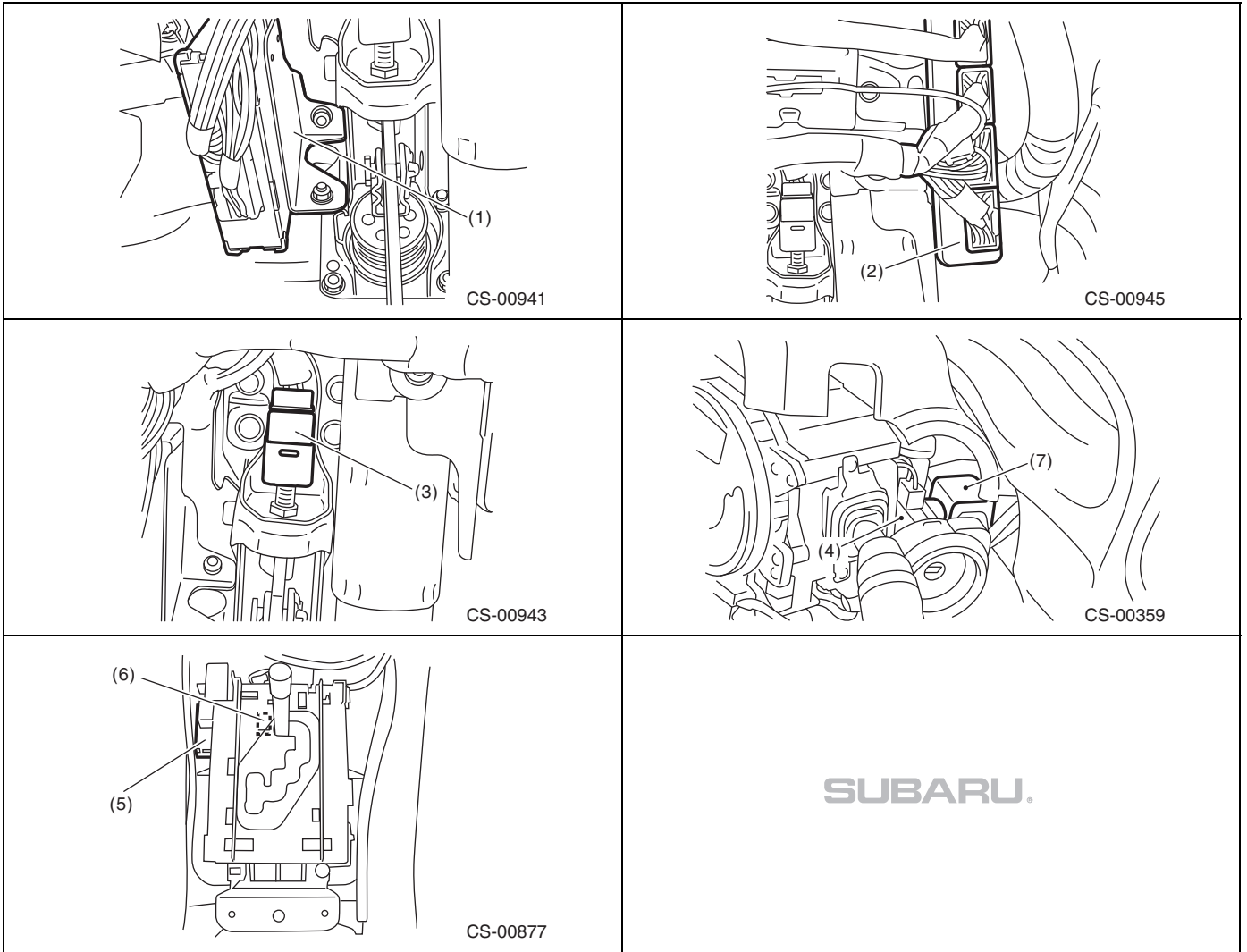

AT Shift Lock Control System

CONTROL SYSTEMS

B: ELECTRICAL SPECIFICATION

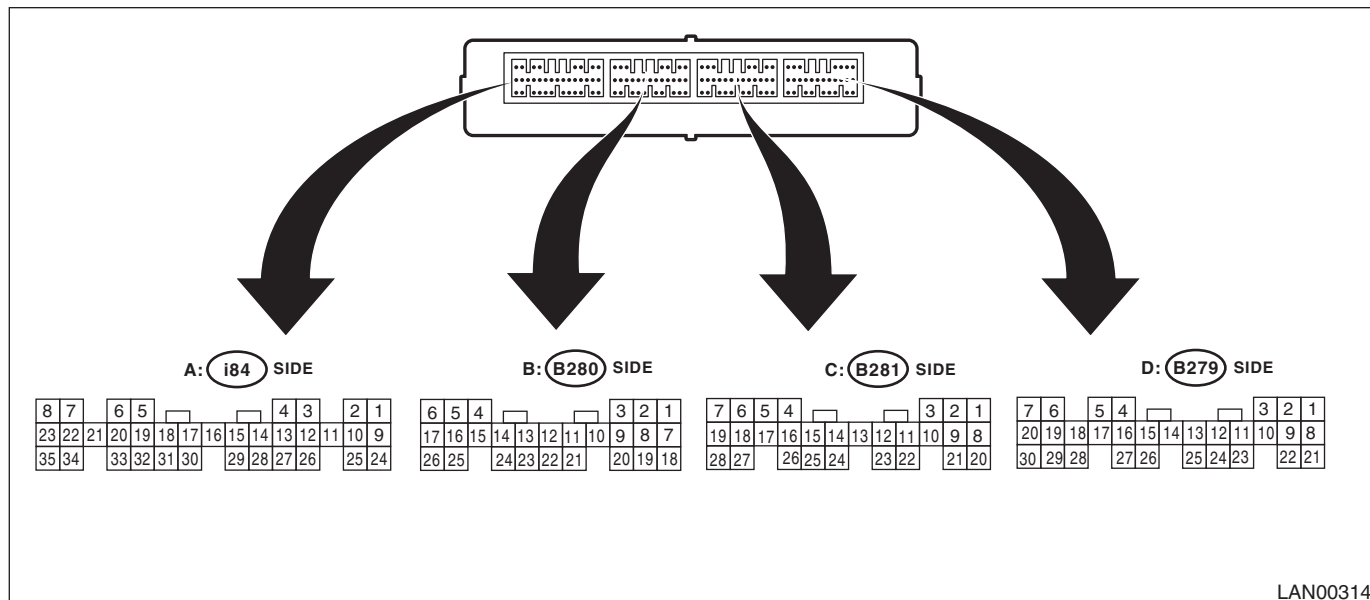

LAN00314

Item	Connector No.	Terminal No.	Input/Output signal
			Measured value and measuring conditions
Battery power supply	B279	22	9 — 16 V
	B280	6	
Ignition power supply	B280	1	10 — 15 V when ignition switch is at ON or START.
		7	10 — 15 V when ignition switch is at ACC.
TCM ("P" range)	B280	3	Pulse signal
		9	
Stop light switch	B280	2	9 — 16 V when stop light switch is ON. 0 V when stop light switch is OFF.
"P" range switch	B281	4	0 V when select lever is in "P" range. 9 — 16 V when select lever is in other positions than "P" range.
Shift lock solenoid signal	B279	12	8.5 — 16 V when shift lock is released. 0 V when shift lock is operating.
Key warning switch signal	B279	2	9 — 16 V when key is inserted. 0 V when key is removed.
Key lock solenoid signal	B279	11	7.5 — 16 V when ignition switch is turned ON, with select lever in "P" range and brake switch ON. 0 V at other conditions than above.
Ground	i84	28	—
	B280	17	
	B281	20	
	B279	27	

C: WIRING DIAGRAM

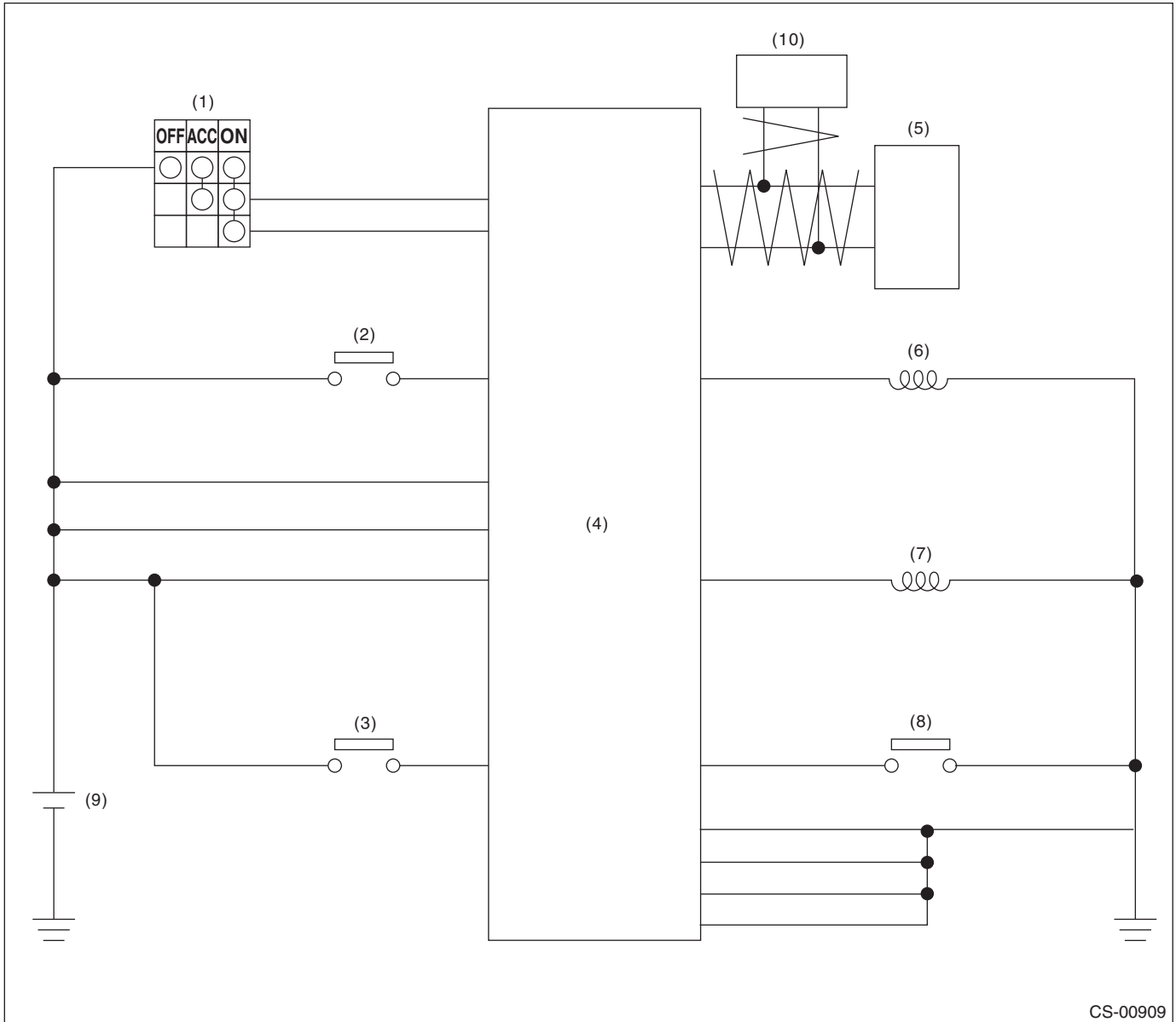

CS-00909

- | | | |
|--------------------------|-----------------------------------|--------------------------------------|
| (1) Ignition switch | (5) TCM (shift range information) | (8) "P" range switch |
| (2) Stop light switch | (6) Key lock solenoid | (9) Battery |
| (3) Key warning switch | (7) Shift lock solenoid | (10) VDC (vehicle speed information) |
| (4) Body integrated unit | | |

AT Shift Lock Control System

CONTROL SYSTEMS

D: INSPECTION

1. SHIFT LOCK OPERATION

Step	Check	Yes	No
1 CHECK SHIFT LOCK. 1) Turn the ignition switch to ON. 2) Shift the select lever to the "P" range.	While brake pedal is not depressed, is it possible to move the select lever from the "P" range to other ranges?	Perform the inspection of "SELECT LEVER CANNOT BE LOCKED OR RELEASED". <Ref. to CS-14, SELECT LEVER CANNOT BE LOCKED OR RELEASED, INSPECTION, AT Shift Lock Control System.>	Go to step 2.
2 CHECK SHIFT LOCK.	While brake pedal is depressed, is it possible to move the select lever from the "P" range to other ranges?	Go to step 3.	Perform the inspection of "SELECT LEVER CANNOT BE LOCKED OR RELEASED". <Ref. to CS-14, SELECT LEVER CANNOT BE LOCKED OR RELEASED, INSPECTION, AT Shift Lock Control System.>
3 CHECK SHIFT LOCK. Shift the select lever to "N" range.	Is it possible to move the select lever from the "N" range to the "P" range?	Go to step 4.	Perform the inspection of "SELECT LEVER CANNOT BE LOCKED OR RELEASED". <Ref. to CS-14, SELECT LEVER CANNOT BE LOCKED OR RELEASED, INSPECTION, AT Shift Lock Control System.>
4 CHECK SHIFT LOCK. 1) Shift the select lever to "N" range. 2) Turn the ignition switch to OFF.	While brake pedal is depressed, is it possible to move the select lever from the "N" range to the "P" range?	Go to step 5.	Perform the inspection of "SELECT LEVER CANNOT BE LOCKED OR RELEASED". <Ref. to CS-14, SELECT LEVER CANNOT BE LOCKED OR RELEASED, INSPECTION, AT Shift Lock Control System.>

AT Shift Lock Control System

CONTROL SYSTEMS

Step	Check	Yes	No
5 CHECK KEY INTERLOCK. 1) Turn the ignition switch to OFF. 2) Shift the select lever to other than "P" range.	Can the ignition key be removed?	Perform the inspection of "KEY INTERLOCK CANNOT BE LOCKED OR RELEASED". <Ref. to CS-17, KEY INTERLOCK CANNOT BE LOCKED OR RELEASED, INSPECTION, AT Shift Lock Control System.>	Go to step 6.
6 CHECK KEY INTERLOCK. Shift the select lever to the "P" range.	Can the ignition key be removed?	AT shift lock system is normal.	Perform the inspection of "KEY INTERLOCK CANNOT BE LOCKED OR RELEASED". <Ref. to CS-17, KEY INTERLOCK CANNOT BE LOCKED OR RELEASED, INSPECTION, AT Shift Lock Control System.>

AT Shift Lock Control System

CONTROL SYSTEMS

2. BODY INTEGRATED UNIT POWER SUPPLY AND GROUND CIRCUIT

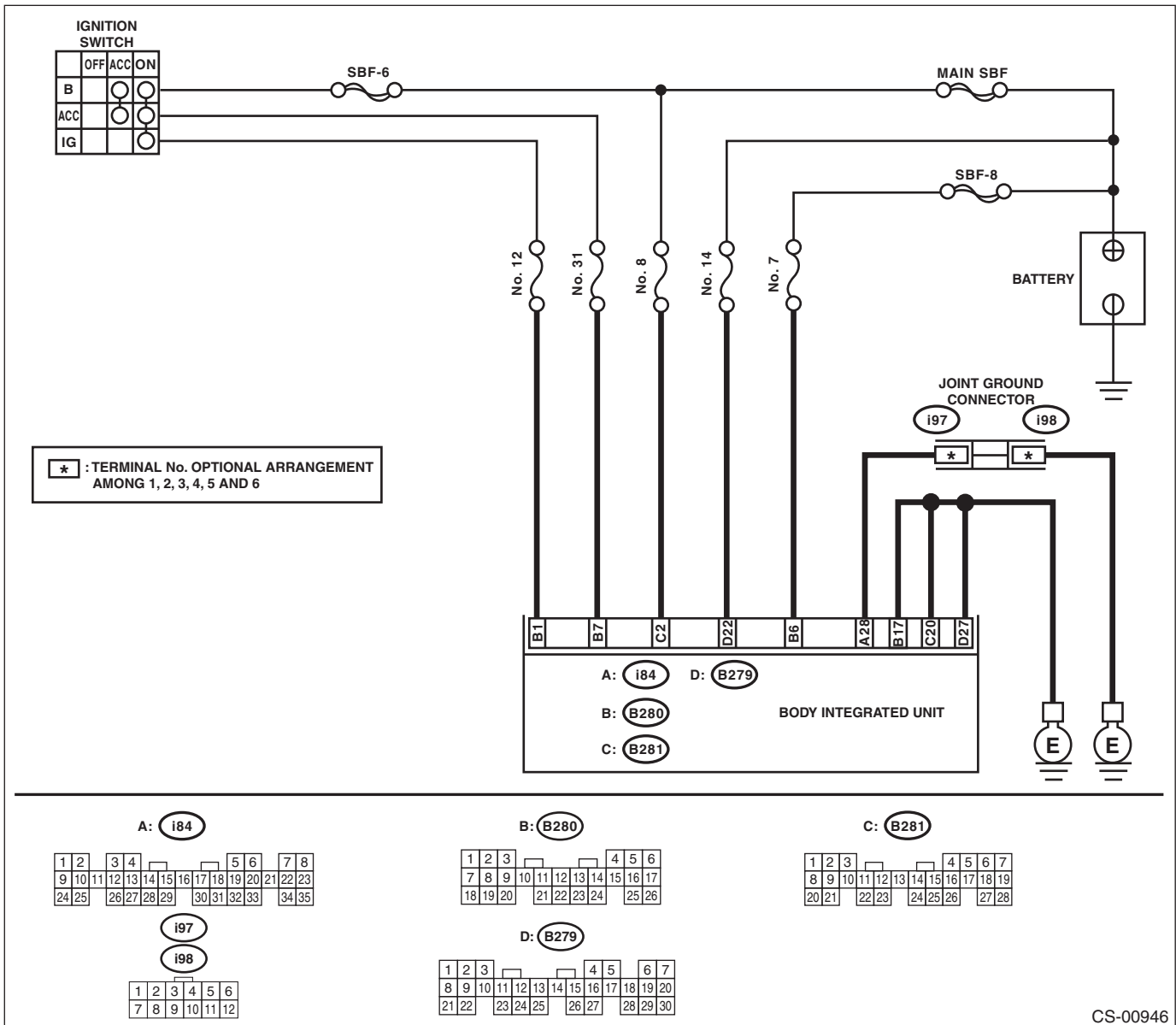

CS-00946

AT Shift Lock Control System

Step	Check	Yes	No
1 CHECK DTC OF BODY INTEGRATED UNIT. Check DTC of body integrated unit. <Ref. to LAN(diag)-14, OPERATION, Subaru Select Monitor.>	Is the DTC of power line displayed on body integrated unit?	Repair or replace it according to the DTC.	Go to step 2.
2 CHECK HARNESS CONNECTOR BETWEEN BODY INTEGRATED UNIT AND CHASSIS GROUND. 1) Turn the ignition switch to ON. 2) Measure the voltage between body integrated unit and chassis ground. Connector & terminal <i>(B280) No. 1 (+) — Chassis ground (-):</i> <i>(B280) No. 6 (+) — Chassis ground (-):</i> <i>(B280) No. 7 (+) — Chassis ground (-):</i> <i>(B281) No. 2 (+) — Chassis ground (-):</i> <i>(B279) No. 22 (+) — Chassis ground (-):</i>	Is the voltage 9 — 16 V?	Go to step 3.	Check harness for open circuit between the body integrated unit and the battery or a blown fuse.
3 CHECK HARNESS CONNECTOR BETWEEN BODY INTEGRATED UNIT AND CHASSIS GROUND. 1) Turn the ignition switch to OFF. 2) Measure the harness resistance between the body integrated unit and chassis ground. Connector & terminal <i>(i84) No. 28 — Chassis ground:</i> <i>(B279) No. 27 — Chassis ground:</i> <i>(B280) No. 17 — Chassis ground:</i> <i>(B281) No. 20 — Chassis ground:</i>	Is the resistance less than 1 Ω?	Go to step 4.	Repair the open circuit of harness between the body integrated unit and chassis ground.
4 CHECK POOR CONTACT.	Is there poor contact in connector?	Repair the poor contact.	Check the body integrated unit.

AT Shift Lock Control System

CONTROL SYSTEMS

3. SELECT LEVER CANNOT BE LOCKED OR RELEASED

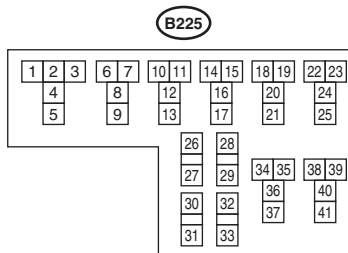
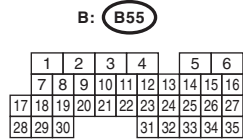
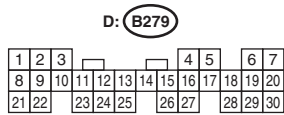
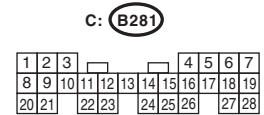
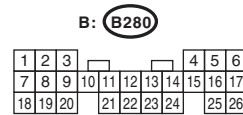
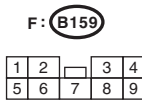
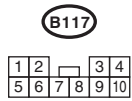
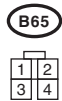
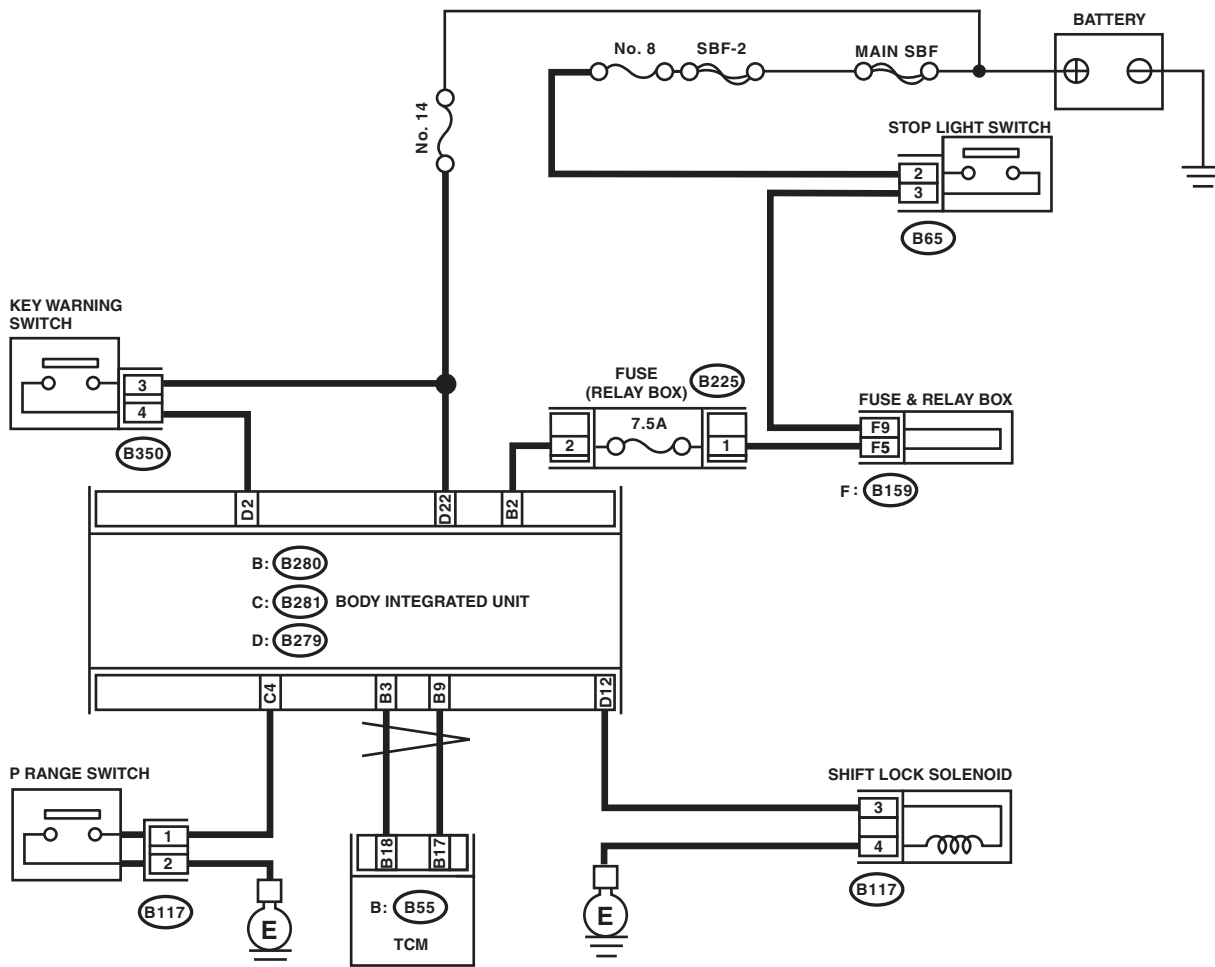

CS-00936

AT Shift Lock Control System

Step	Check	Yes	No
1 CHECK BODY INTEGRATED UNIT POWER SUPPLY AND GROUND CIRCUIT <Ref. to CS-12, BODY INTEGRATED UNIT POWER SUPPLY AND GROUND CIRCUIT, INSPECTION, AT Shift Lock Control System.>	Is there an abnormal condition?	Follow the procedures to perform inspection and repair.	Go to step 2.
2 CHECK CURRENT DATA. 1) Connect the Subaru Select Monitor. 2) Shift the select lever to "P" range. 3) Turn the ignition switch to ON. 4) Display the current data display and display "P SW". <Ref. to LAN(diag)-14, OPERATION, Subaru Select Monitor.>	Is the display "ON" in the P range and "OFF" in ranges other than P?	Go to step 3.	Go to step 8.
3 CHECK CURRENT DATA. Display the current data display and display "Stop Light Switch". <Ref. to LAN(diag)-14, OPERATION, Subaru Select Monitor.>	Is "ON" displayed when the brake pedal is depressed and displayed "OFF" when not depressed?	Go to step 4.	Go to step 11.
4 CHECK BODY INTEGRATED UNIT DTC. Check the DTC of the body integrated unit when the brake pedal is pressed and when it is released. (Hold each condition for 5 seconds or more.)	Is there a DTC of a current malfunction?	Follow the DTC to perform inspection and repair.	Go to step 5.
5 CHECK CURRENT DATA. Select the current data display and display "Shift Lock Solenoid". <Ref. to LAN(diag)-14, OPERATION, Subaru Select Monitor.>	Is "ON" displayed when the brake pedal is depressed and displayed "OFF" when not depressed?	Go to step 6.	Replace the body integrated unit.
6 CHECK CURRENT DATA. Select the current data display and display "Shift Position". <Ref. to LAN(diag)-14, OPERATION, Subaru Select Monitor.>	Is the display "7" in the P range and other than "7" in ranges other than P?	Go to step 7.	Check the following items. <ul style="list-style-type: none"> • Inhibitor switch • Harness between inhibitor switch and TCM • TCM input signal • TCM CAN communication • Body integrated unit CAN receive
7 CHECK CURRENT DATA. 1) Select the current data display and display "Front Wheel Speed". <Ref. to LAN(diag)-14, OPERATION, Subaru Select Monitor.> 2) Start the engine. 3) Raise vehicle speed gradually up to approximately 20 km/h.	Is a figure equivalent to the speedometer being indicated?	Go to step 12.	Check the following items. <ul style="list-style-type: none"> • Wheel speed sensor • VDC/ABS CAN communication • Body integrated unit CAN receive Replace the wheel speed sensor, VDC/ABS, or body integrated unit, or both.

AT Shift Lock Control System

CONTROL SYSTEMS

Step	Check	Yes	No
8 CHECK HARNESS BETWEEN BODY INTEGRATED UNIT AND "P" RANGE SWITCH. 1) Disconnect the connector from body integrated unit. 2) Disconnect the connector of the "P" range switch. 3) Measure the resistance of harness between the body integrated unit and the "P" range switch. <i>Connector & terminal</i> <i>(B281) No. 4 — (B117) No. 1:</i>	Is it less than 10 Ω?	Go to step 9.	Repair or replace the harness between the body integrated unit and the "P" range switch.
9 CHECK HARNESS BETWEEN "P" RANGE SWITCH AND CHASSIS GROUND. Measure the resistance of harness between "P" range switch and chassis ground. <i>Connector & terminal</i> <i>(B117) No. 2 — Chassis ground:</i>	Is it less than 10 Ω?	Go to step 10.	Repair the harness between the "P" range switch and chassis ground.
10 CHECK "P" RANGE SWITCH. Measure the resistance between "P" range switch connector terminals. <i>Terminals</i> <i>No. 2 — No. 1:</i>	Is it less than 10 Ω in the "P" range, and 1 MΩ or more in ranges other than "P"?	Replace the body integrated unit.	Replace the "P" range switch.
11 CHECK STOP LIGHT SWITCH INPUT SIGNAL. 1) Disconnect the connector from body integrated unit. 2) Measure the voltage between the body integrated unit connector terminal and chassis ground. <i>Connector & terminal</i> <i>(B280) No. 2 (+) — Chassis ground (-):</i>	Is the voltage 9 V or more when the brake pedal is depressed, and less than approximately 1.5 V when not pressed?	Replace the body integrated unit.	Check the stop light system.
12 CHECK SHIFT LOCK SOLENOID OPERATION. Connect the battery to the shift lock solenoid unit connector terminal, and operate the solenoid. <i>Terminals</i> <i>No. 3 (+) — No. 4 (-):</i>	Does the shift lock solenoid operate normally?	Check the lock mechanism of the select lever body.	Replace the shift lock solenoid.

4. KEY INTERLOCK CANNOT BE LOCKED OR RELEASED

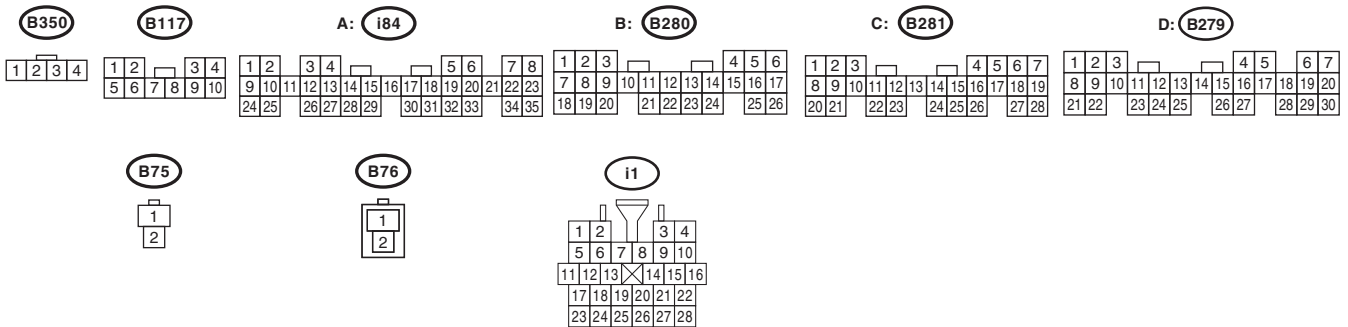
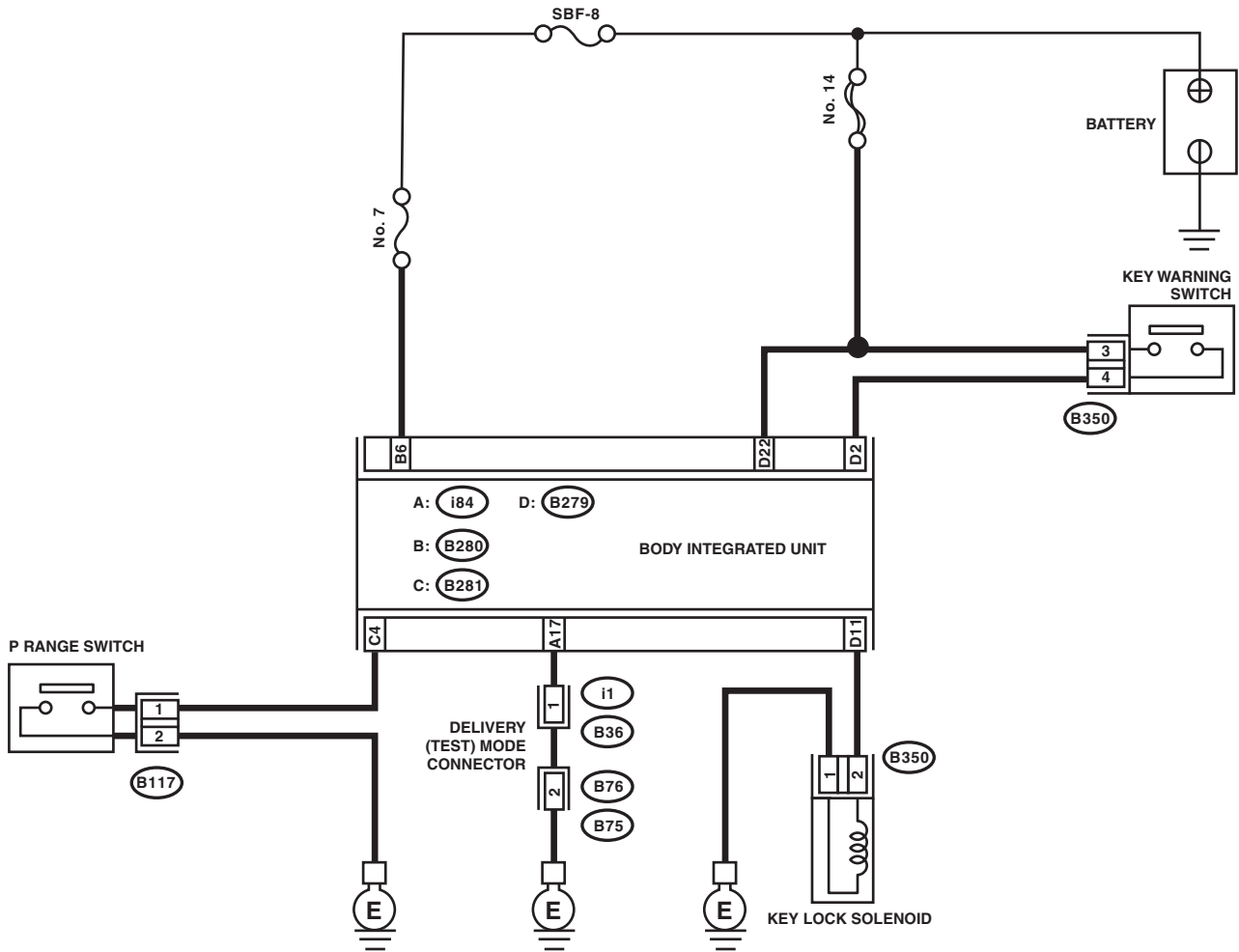

CS-00947

AT Shift Lock Control System

CONTROL SYSTEMS

Step	Check	Yes	No
1 CHECK DELIVERY (TEST) MODE CONNECTOR. Check that the delivery (test) mode connector is disconnected.	Is the delivery (test) mode connector disconnected?	Go to step 2.	Disconnect the delivery (test) mode connector.
2 CHECK BODY INTEGRATED UNIT POWER SUPPLY AND GROUND CIRCUIT <Ref. to CS-12, BODY INTEGRATED UNIT POWER SUPPLY AND GROUND CIRCUIT, INSPECTION, AT Shift Lock Control System.>	Is there an abnormal condition?	Follow the procedures to inspect and repair.	Go to step 3.
3 CHECK CURRENT DATA. 1) Connect the Subaru Select Monitor. 2) Shift the select lever to "P" range. 3) Turn the ignition switch to ON. 4) Display the current data display and display "P SW". <Ref. to LAN(diag)-14, OPERATION, Subaru Select Monitor.>	Is the display "ON" in the P range and "OFF" in ranges other than P?	Go to step 4.	Go to step 7.
4 CHECK CURRENT DATA. 1) Select the current data display and display the "Key-lock warning SW". <Ref. to LAN(diag)-14, OPERATION, Subaru Select Monitor.> 2) Turn the ignition switch to OFF.	Does the display change from "ON" to "OFF" when the key is inserted and removed?	Go to step 5.	Go to step 10.
5 CHECK CURRENT DATA. 1) Turn the ignition switch to ON. 2) Select the current data display and display "Key locking output". <Ref. to LAN(diag)-14, OPERATION, Subaru Select Monitor.>	Is the display "ON" in the P range and "OFF" in ranges other than P?	Go to step 12.	Go to step 6.
6 CHECK DTC OF BODY INTEGRATED UNIT. 1) Set the select lever to other than "P" range. 2) Check DTC of body integrated unit.	Is B1105 (key interlock circuit malfunction) a current malfunction?	Follow the DTC to perform inspection and repair.	Go to step 11.
7 CHECK HARNESS BETWEEN BODY INTEGRATED UNIT AND "P" RANGE SWITCH. 1) Disconnect the connector from body integrated unit. 2) Disconnect the connector of the "P" range switch. 3) Measure the resistance of harness between the body integrated unit and the "P" range switch. <i>Connector & terminal (B281) No. 4 — (B117) No. 1:</i>	Is it less than 10 Ω?	Go to step 8.	Repair or replace the harness between the body integrated unit and the "P" range switch.
8 CHECK HARNESS BETWEEN "P" RANGE SWITCH AND CHASSIS GROUND. Measure the resistance of harness between "P" range switch and chassis ground. <i>Connector & terminal (B117) No. 2 — Chassis ground:</i>	Is it less than 10 Ω?	Go to step 9.	Repair the harness between the "P" range switch and chassis ground.
9 CHECK "P" RANGE SWITCH. Measure the resistance between "P" range switch connector terminals. <i>Terminals No. 2 — No. 1:</i>	Is it less than 10 Ω in the "P" range, and 1 MΩ or more in ranges other than "P"?	Replace the body integrated unit.	Replace the "P" range switch.

AT Shift Lock Control System

Step	Check	Yes	No
10 CHECK HARNESS BETWEEN BATTERY AND KEY WARNING SWITCH AND BODY INTEGRATED UNIT. 1) Disconnect the connector from body integrated unit. 2) Measure the voltage between body integrated unit and chassis ground. <i>Connector & terminal</i> <i>(B279) No. 2 — Chassis ground:</i>	Is the display 9 V or more when the key is inserted, and less than 1.5 V with the key removed?	Replace the body integrated unit.	Check the following items. <ul style="list-style-type: none"> • Key warning switch • Harness/fuse • Ignition circuit
11 CHECK DELIVERY (TEST) MODE CONNECTOR HARNESS. 1) Disconnect the connector of body integrated unit. 2) Measure the resistance between the body integrated unit connector and delivery (test) mode connector. <i>Connector & terminal</i> <i>(I84) No. 17 — (I1) No. 1:</i>	Is it less than 10 Ω?	Go to step 12.	Repair or replace the harness between the body integrated unit connector and delivery (test) mode connector.
12 CHECK HARNESS BETWEEN KEY LOCK SOLENOIDS AND BODY INTEGRATED UNIT. 1) Disconnect the connector from body integrated unit. 2) Disconnect the connector from the key lock solenoid. 3) Measure the harness resistance between the body integrated unit and key lock solenoid. <i>Connector & terminal</i> <i>(B279) No. 11 — (B350) No. 2:</i>	Is it less than 10 Ω?	Go to step 13.	Repair or replace the harness between the body integrated unit and the key lock solenoid.
13 CHECK HARNESS BETWEEN KEY LOCK SOLENOID AND CHASSIS GROUND. Measure the resistance of harness between key lock solenoid and chassis ground. <i>Connector & terminal</i> <i>(B350) No. 1 — Chassis ground:</i>	Is it less than 10 Ω?	Go to step 14.	Repair or replace the harness between the key lock solenoid and chassis ground.
14 CHECK KEY LOCK SOLENOID OPERATION. Connect the battery to the key lock solenoid connector terminal, and operate the solenoid.	Does the key lock solenoid operate normally?	Go to step 15.	Replace the key lock solenoid.
15 CHECK OUTPUT OF BODY INTEGRATED UNIT. 1) Connect all connectors. 2) Press the key. 3) Measure the voltage between body integrated unit and chassis ground. <i>Connector & terminal</i> <i>(B279) No. 11 — Chassis ground:</i>	Is it 5 V or more in ranges other than "P", and less than 1.5 V in the "P" range?	Check the lock mechanism of the steering lock body.	Replace the body integrated unit.

Select Lever

CONTROL SYSTEMS

3. Select Lever

A: REMOVAL

- 1) Set the vehicle on a lift.
- 2) Disconnect the ground cable from the battery.
- 3) Shift the select lever to "N" range.
- 4) Lift up the vehicle.
- 5) Remove the rear exhaust pipe and muffler.
 - Non-turbo model
<Ref. to EX(H4SO)-8, REMOVAL, Rear Exhaust Pipe.> <Ref. to EX(H4SO)-10, REMOVAL, Muffler.>
 - Turbo model
<Ref. to EX(H4DOTC)-12, REMOVAL, Rear Exhaust Pipe.> <Ref. to EX(H4DOTC)-14, REMOVAL, Muffler.>
- 6) Remove the heat shield cover.

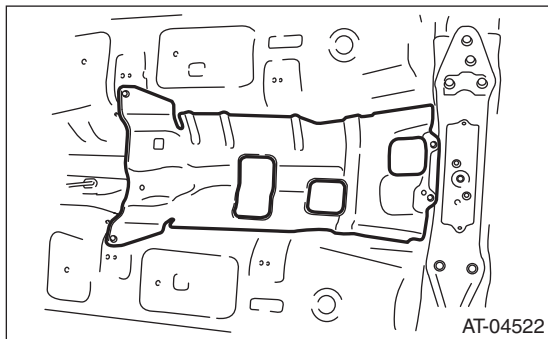

- 7) Remove the cable from arm assembly.

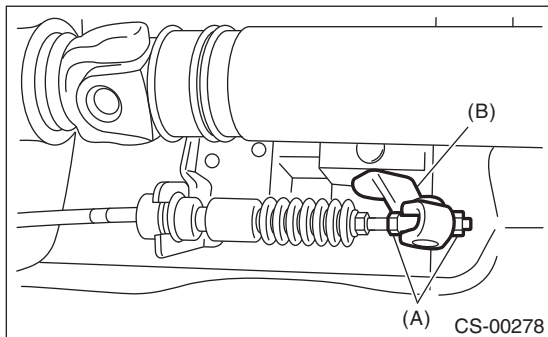

- (A) Adjusting nut
(B) Arm ASSY

- 8) Raise the claw of clamp to remove the cable.

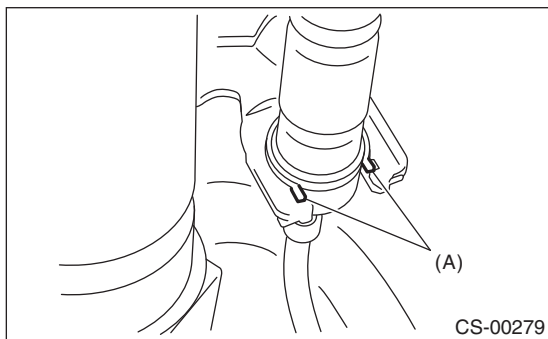

- (A) Claw

- 9) Lower the vehicle.

- 10) Remove the grip.
- 11) Remove the hand brake boot cover.
- 12) Remove the console front panel.

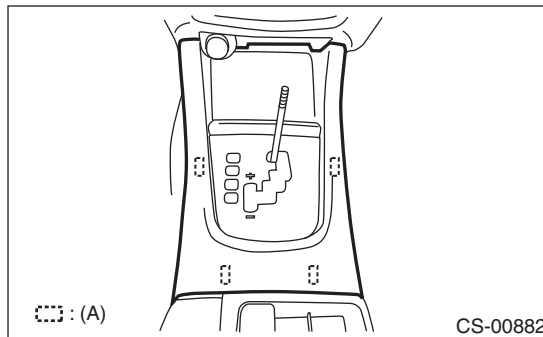

- (A) Hook

- 13) Remove the console cover and console box.
<Ref. to EI-46, REMOVAL, Console Box.>
- 14) Remove the indicator assembly.

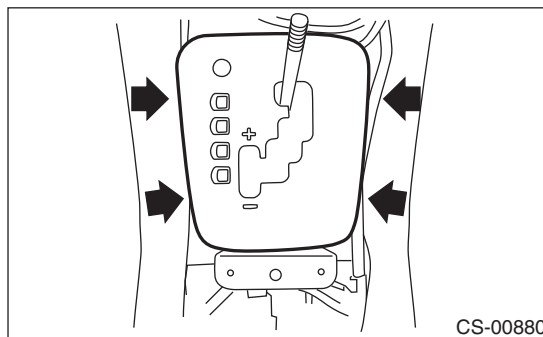

- 15) Remove the harness clips from the bracket.
- 16) Remove the blind.

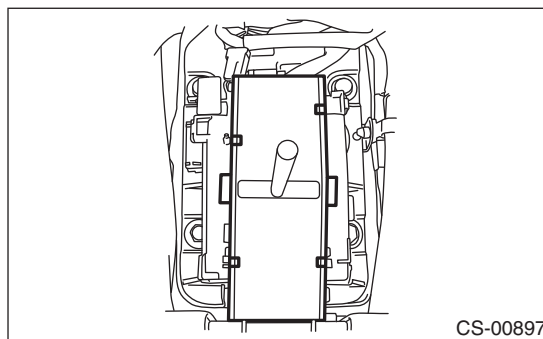

- 17) Disconnect the connectors, and then remove the four bolts to take out the select lever assembly from vehicle body.

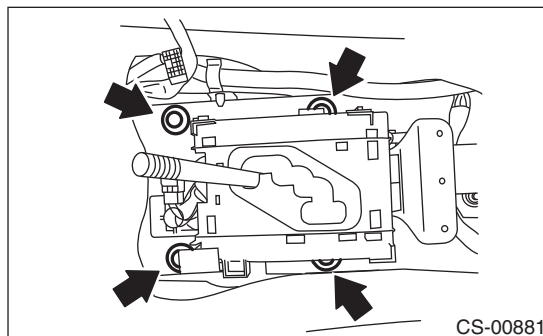

B: INSTALLATION

- 1) Set the select lever to vehicle body.
- 2) Tighten the four bolts to install the select lever to vehicle body, and then connect the connector.
 - (1) Temporarily tighten the bolt A.
 - (2) Tighten the bolt B.
 - (3) Tighten the bolt A.
 - (4) Tighten the bolts C and D.

Tightening torque:

18 N·m (1.8 kgf-m, 13.3 ft-lb)

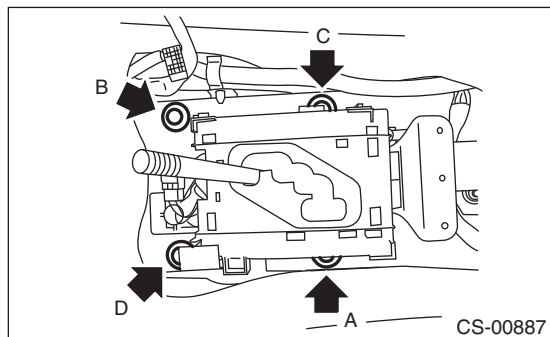

- 3) Install the harness clips to the bracket.
- 4) Install the console cover and console box. <Ref. to EI-46, INSTALLATION, Console Box.>
- 5) Shift the select lever to “N” range.
- 6) Install the blind.

CAUTION:

The blind should be installed so that it is securely caught by tabs of the plate guide COMPL.

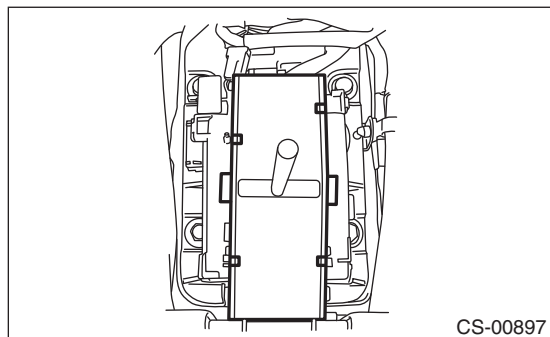

- 7) Install the indicator assembly.
- 8) Install the console front panel.
- 9) Install the hand brake boot cover.
- 10) Install the grip.
- 11) Lift up the vehicle.
- 12) Shift the range select lever to the “N” range.
- 13) Secure the cable to the bracket. <Ref. to CS-26, INSTALLATION, Select Cable.>
- 14) Adjust the select cable position. <Ref. to CS-27, ADJUSTMENT, Select Cable.>
- 15) After the completion of adjustment, confirm that the select lever operates properly at all range positions.

- 16) Install the heat shield cover.

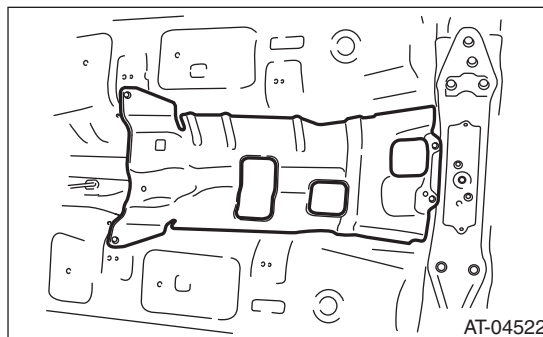

- 17) Install the rear exhaust pipe and muffler.

- Non-turbo model
<Ref. to EX(H4SO)-8, INSTALLATION, Rear Exhaust Pipe.> <Ref. to EX(H4SO)-10, INSTALLATION, Muffler.>
- Turbo model
<Ref. to EX(H4DOTC)-12, INSTALLATION, Rear Exhaust Pipe.> <Ref. to EX(H4DOTC)-14, INSTALLATION, Muffler.>

- 18) Inspect the following items. When a problem is found in the inspection, adjust the select cable and inhibitor switch. <Ref. to CS-27, ADJUSTMENT, Select Cable.> <Ref. to 4AT-46, ADJUSTMENT, Inhibitor Switch.>

- (1) Engine starts when the select lever is in “P” and “N” range, but not in other ranges.
- (2) Back-up light illuminates when the select lever is in the “R” range, but not in other ranges.
- (3) Select lever and indicator positions are matched.

Select Lever

CONTROL SYSTEMS

C: DISASSEMBLY

1) Remove the gasket and plate COMPL.

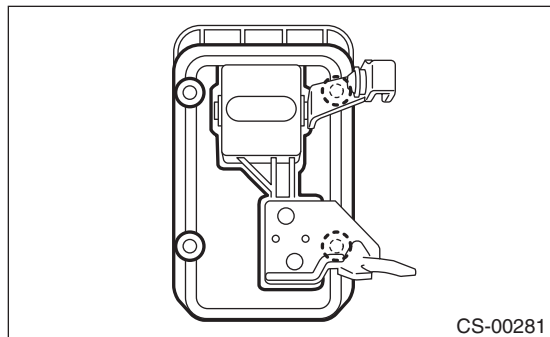

2) Insert a flat-tip screwdriver with a thin tip under the connector and disconnect each connector from the plate COMPL.

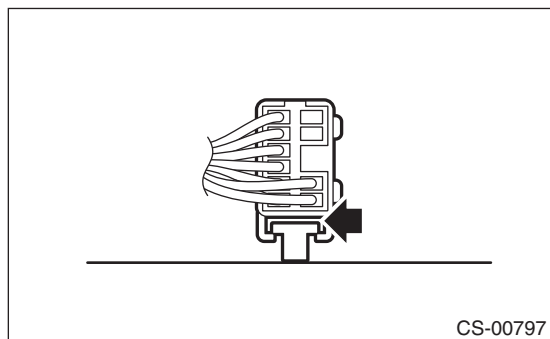

3) Remove the spacer bolt and remove the plate guide COMPL.

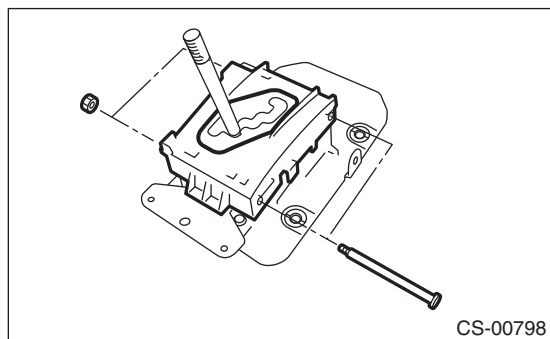

4) Remove the shift lock clamp, spring A, select lever rod, lock plate cushion, and bushing.

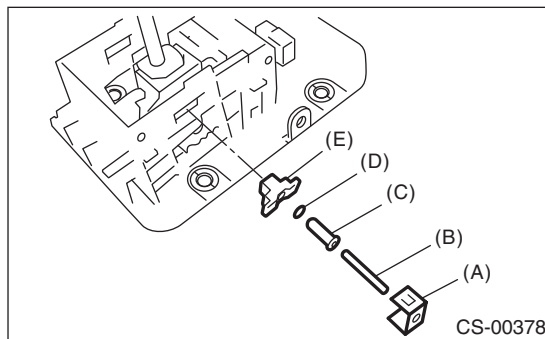

- (A) Shift lock clamp
- (B) Spring A
- (C) Select lever rod
- (D) Lock plate cushion
- (E) Bushing

5) Remove the bracket.

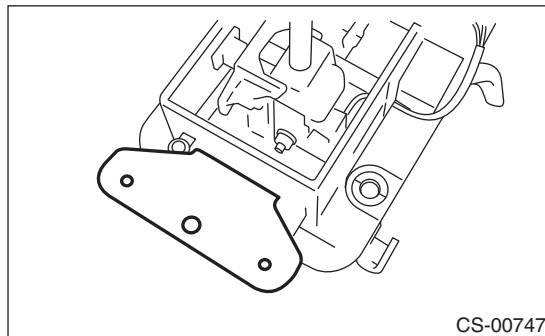

6) Remove the detent spring.

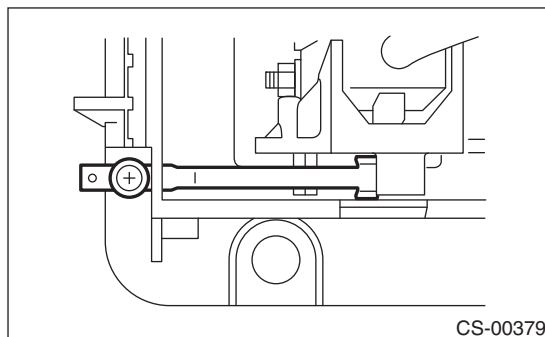

7) Remove the shift lock solenoid unit.

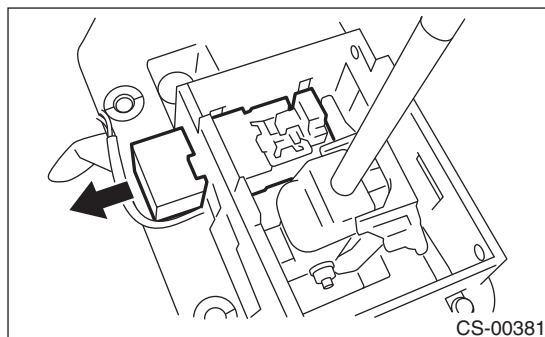

8) Raise the claw of connector.

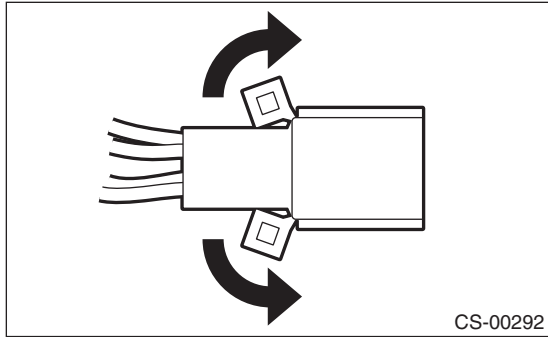

CS-00292

9) Disconnect the terminals of the SPORT mode switch, "P" range switch, and shift lock solenoid from the connector, using a flat-tip screwdriver with a thin tip.

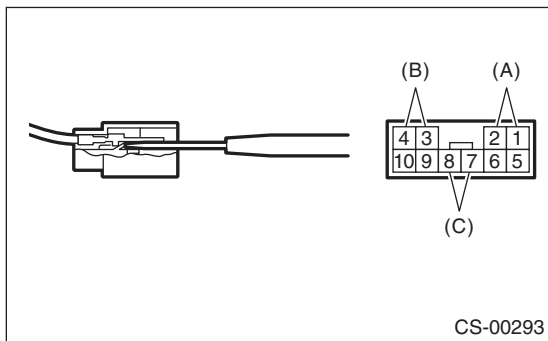

CS-00293

- (A) "P" range switch terminal
- (B) Shift lock solenoid terminal
- (C) SPORT mode switch terminal

10) Remove the grommet.

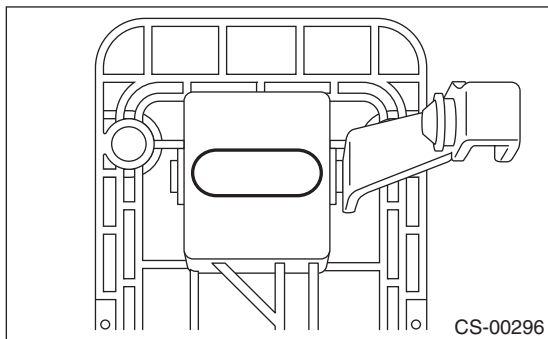

CS-00296

11) Remove the spring pin.

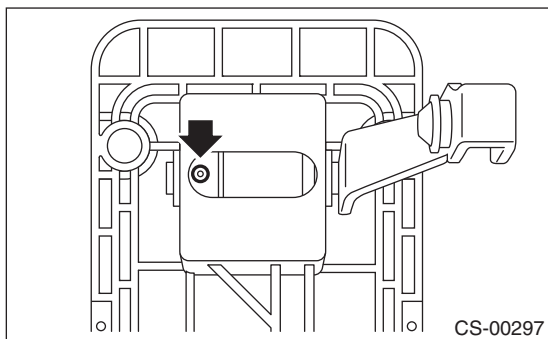

CS-00297

12) Pull out the arm assembly, remove select lever COMPL, and remove bracket arm detent and bushing.

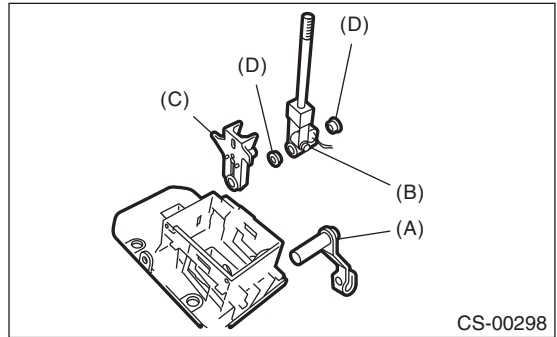

CS-00298

- (A) Arm ASSY
- (B) Selector lever COMPL
- (C) Bracket arm detent
- (D) Bushing

13) Remove the rod detent and spring detent from the bracket arm detent.

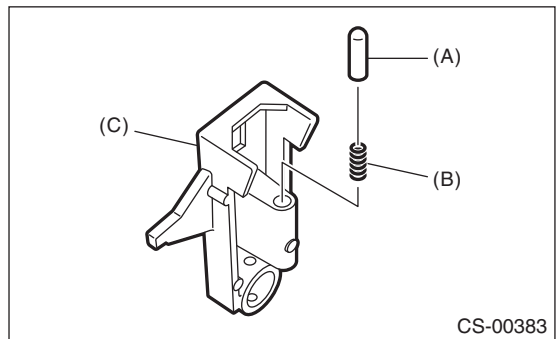

CS-00383

- (A) Rod detent
- (B) Spring detent
- (C) Bracket arm detent

Select Lever

CONTROL SYSTEMS

D: ASSEMBLY

- 1) Clean all the parts before assembly.
- 2) Apply NIGTIGHT LYW No. 2 grease or equivalent to each part. <Ref. to CS-3, AT SELECT LEVER, COMPONENT, General Description.>
- 3) Assemble in the reverse order of disassembly.

NOTE:

- When installing the plate guide COMPL, set the select lever to “D” range (normal mode position), and be careful of the following.
 - Insert protrusion (B) of the plate guide COMPL into the hole on the shift lock solenoid unit (A).
 - Insert link (D) of the shift lock release into link (C) of the shift lock solenoid unit.

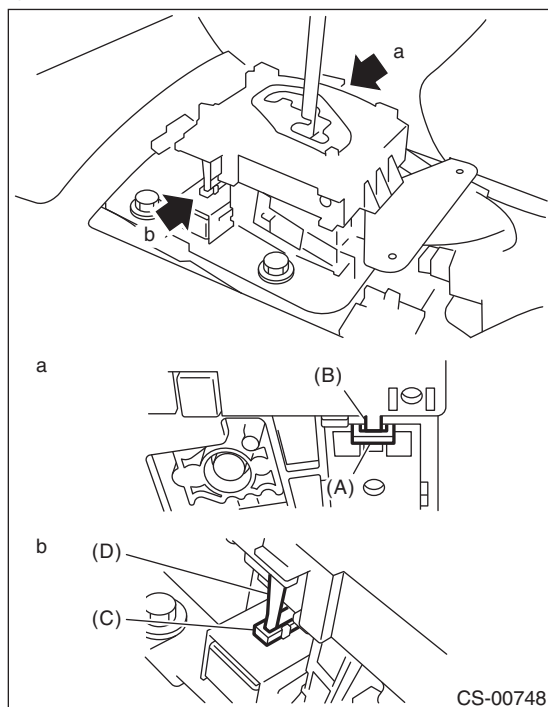

- Connect the switch and solenoid terminals to the connector.

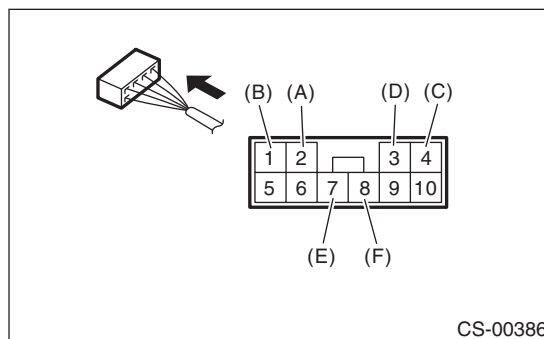

- (A) “P” range switch (color code: white)
- (B) “P” range switch (color code: black)
- (C) Shift lock solenoid (color code: blue/red)
- (D) Shift lock solenoid (color code: black)
- (E) SPORT mode switch (color code: white)
- (F) SPORT mode switch (color code: black)

- 4) After completing installation, shift the select lever from “P” range to “D” range, then check whether the indicator and select lever matches, whether the pointer and position mark matches and what the operating force is.

E: INSPECTION

- 1) Inspect the removed parts by comparing with new parts for deformation, damage and wear. Repair or replace if defective.
- 2) Confirm the select lever assembly operating condition before assembly. Normal if it operates smoothly.

4. Select Cable

A: REMOVAL

- 1) Set the vehicle on a lift.
- 2) Shift the select lever to "N" range.
- 3) Disconnect the ground cable from the battery.
- 4) Lift up the vehicle.
- 5) Remove the front, center and rear exhaust pipes and the muffler. (Non-turbo model)
<Ref. to EX(H4SO)-4, REMOVAL, Front Exhaust Pipe.> <Ref. to EX(H4SO)-8, REMOVAL, Rear Exhaust Pipe.> <Ref. to EX(H4SO)-10, REMOVAL, Muffler.>
- 6) Remove the center and rear exhaust pipes and the muffler. (Turbo model)
<Ref. to EX(H4DOTC)-7, REMOVAL, Center Exhaust Pipe.> <Ref. to EX(H4DOTC)-12, REMOVAL, Rear Exhaust Pipe.> <Ref. to EX(H4DOTC)-14, REMOVAL, Muffler.>
- 7) Remove the heat shield cover.

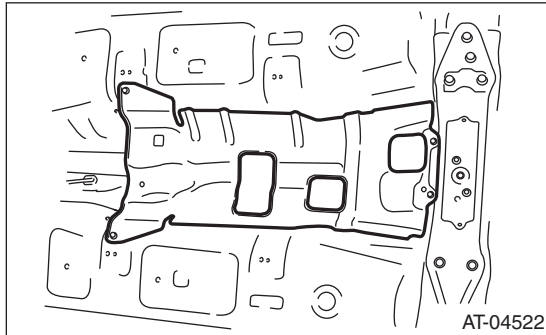

- 8) Remove the snap pin and washer from the shifter arm.

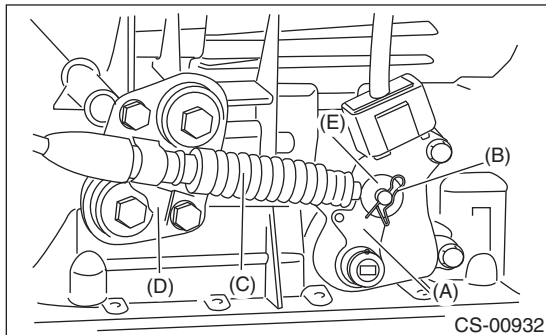

- (A) Shifter arm
- (B) Snap pin
- (C) Select cable
- (D) Plate ASSY
- (E) Washer

- 9) Remove the plate assembly from the transmission case.

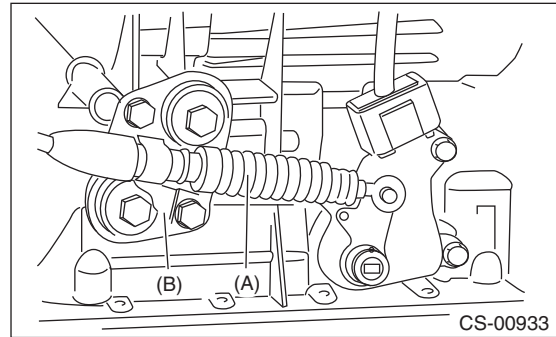

- (A) Select cable
- (B) Plate ASSY

- 10) Disconnect the cable from arm assembly.

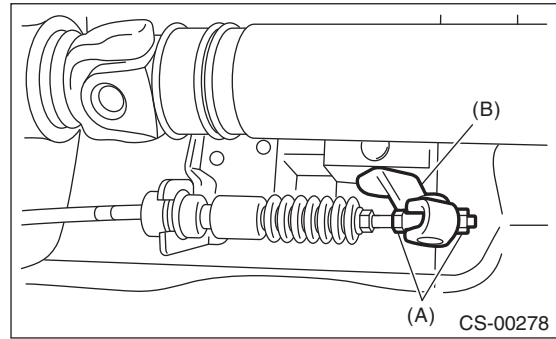

- (A) Adjusting nut
- (B) Arm ASSY

- 11) Raise the claw of clamp to remove the cable from bracket.

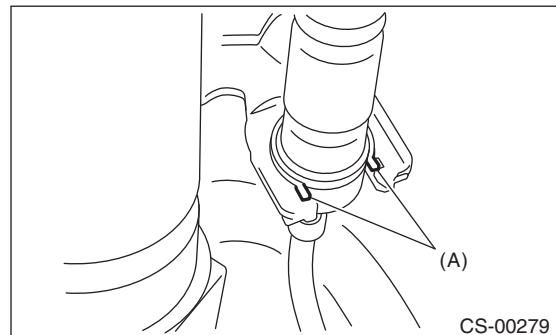

- (A) Claw

- 12) Remove the select cable from plate assembly.

Select Cable

CONTROL SYSTEMS

B: INSTALLATION

1) Install the select cable to plate assembly.

Tightening torque:

18 N·m (1.8 kgf·m, 13.3 ft·lb)

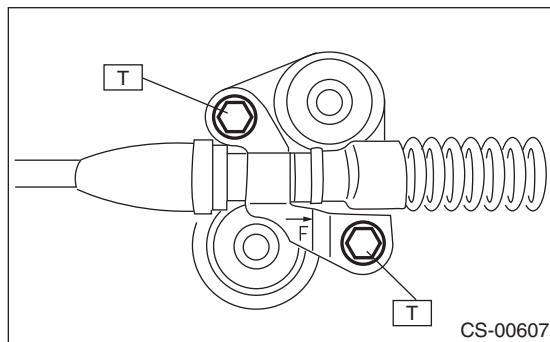

2) Install the select cable to the shifter arm.
3) Install the plate assembly to transmission.

Tightening torque:

T: 25 N·m (2.5 kgf·m, 18.4 ft·lb)

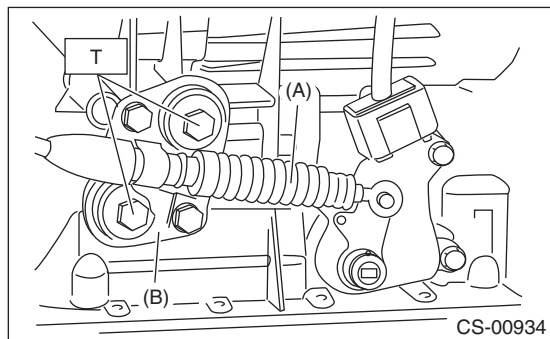

(A) Select cable
(B) Plate ASSY

4) Install the washer and snap pin to the shifter arm.

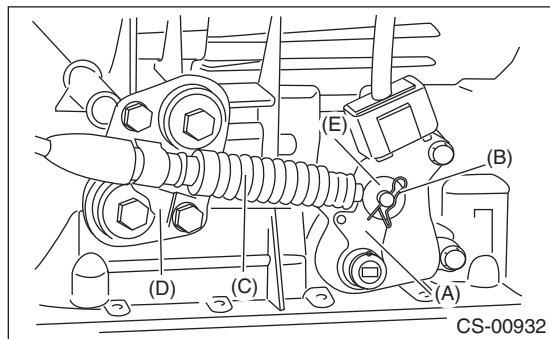

(A) Shifter arm
(B) Snap pin
(C) Select cable
(D) Plate ASSY
(E) Washer

5) Install new clamp paying attention to the installing direction.

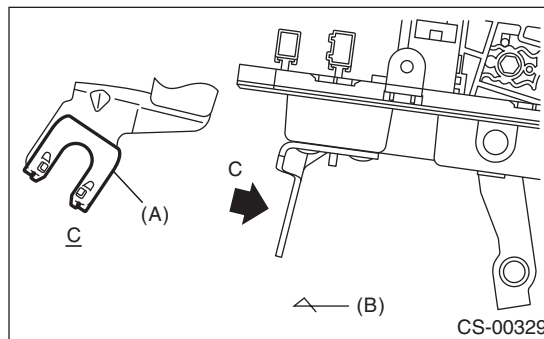

(A) Clamp
(B) Forward

6) Insert the tip of inner cable into connector hole of select lever, and fix the cable to bracket.

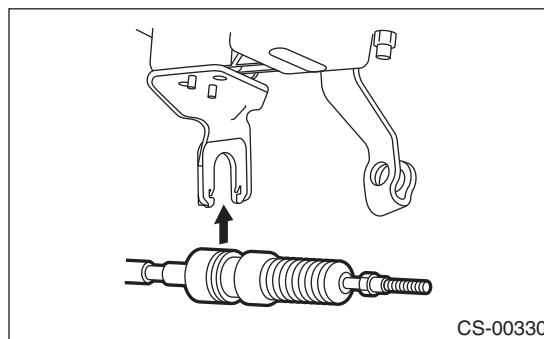

7) Shift the select lever to the "N" range, and adjust the select cable position. <Ref. to CS-27, ADJUSTMENT, Select Cable.>

8) Install the heat shield cover.

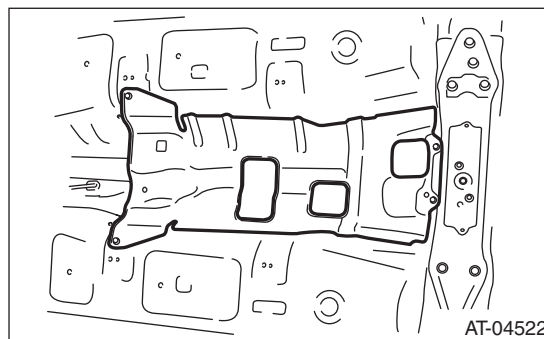

9) Install the front, center and rear exhaust pipes, and the muffler. (Non-turbo model)

<Ref. to EX(H4SO)-5, INSTALLATION, Front Exhaust Pipe.> <Ref. to EX(H4SO)-8, INSTALLATION, Rear Exhaust Pipe.> <Ref. to EX(H4SO)-10, INSTALLATION, Muffler.>

10) Install the center, rear exhaust pipes and the muffler. (Turbo model)

<Ref. to EX(H4DOTC)-8, INSTALLATION, Center Exhaust Pipe.> <Ref. to EX(H4DOTC)-12, INSTALLATION, Rear Exhaust Pipe.> <Ref. to EX(H4DOTC)-14, INSTALLATION, Muffler.>

C: INSPECTION

Check the removed cable and replace or adjust if damaged, rusty or malfunctioning.

- 1) Check the cable for smooth operation.
- 2) Check the inner cable for damage and rust.
- 3) Check the outer cable for damage, bends and cracks.
- 4) Check the boot for damage, cracks, and deterioration.
- 5) Move the select lever from "P" to "D" range. Check the existence of feel to contact the detents in each range. If the detents cannot be felt or the position pointer is improperly aligned, adjust the cable.
- 6) Check if the starter motor rotates when the select lever is set to "P" range.
- 7) Check the back-up light illumination when the select lever is in "R" range.
- 8) Check the parking lock operation when the select lever is in "P" range.

D: ADJUSTMENT

- 1) Set the vehicle on a lift.
- 2) Shift the select lever to "N" range.
- 3) Lift up the vehicle.
- 4) Remove the rear exhaust pipe and muffler.
 - Non-turbo model
<Ref. to EX(H4SO)-8, REMOVAL, Rear Exhaust Pipe.> <Ref. to EX(H4SO)-10, REMOVAL, Muffler.>
 - Turbo model
<Ref. to EX(H4DOTC)-12, REMOVAL, Rear Exhaust Pipe.> <Ref. to EX(H4DOTC)-14, REMOVAL, Muffler.>
- 5) Remove the heat shield cover.

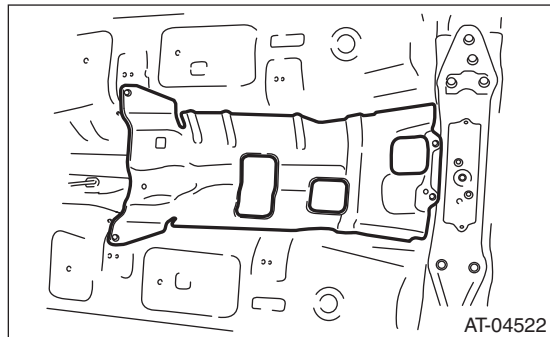

- 6) Loosen the adjusting nuts on both sides.

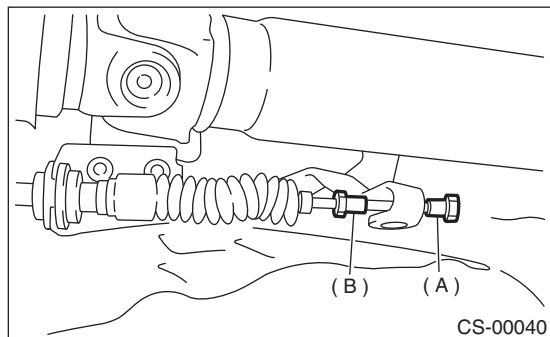

- (A) Adjusting nut A
- (B) Adjusting nut B

- 7) Turn adjusting nut B until it lightly touches the connector.

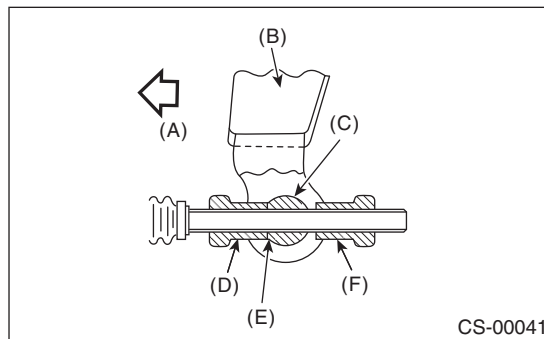

- (A) Forward side
- (B) Select lever
- (C) Connector
- (D) Adjusting nut B
- (E) Contact point
- (F) Adjusting nut A

- 8) Set a spanner wrench to adjusting nut B so that it does not rotate, and then tighten the adjusting nut A.

Tightening torque:

7.5 N·m (0.8 kgf·m, 5.5 ft·lb)

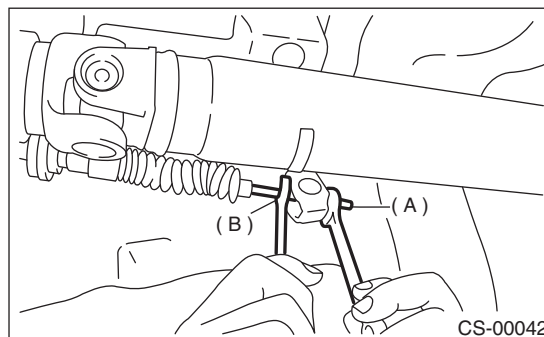

- (A) Adjusting nut A
- (B) Adjusting nut B

- 9) After the completion of adjustment, confirm that the select lever operates normally at all ranges.
- 10) Install in the reverse order of removal.

AT Shift Lock Solenoid and "P" Range Switch

CONTROL SYSTEMS

5. AT Shift Lock Solenoid and "P" Range Switch

A: REMOVAL

- 1) Remove the grip.
- 2) Remove the hand brake boot cover.
- 3) Remove the console front panel.

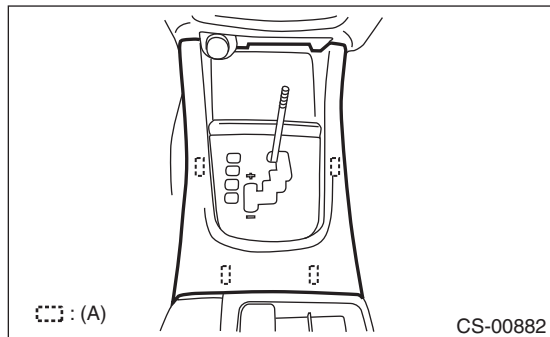

(A) Hook

- 4) Remove the console cover and console box. <Ref. to EI-46, REMOVAL, Console Box.>
- 5) Remove the indicator assembly.

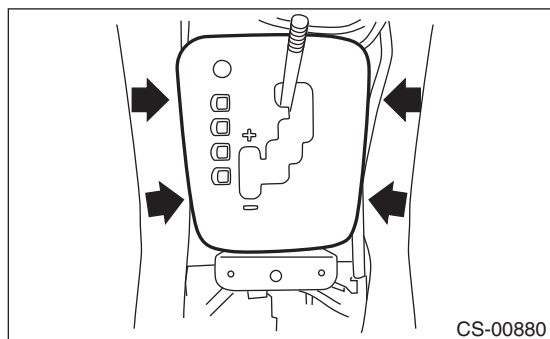

- 6) With the shift lock release button held down, move the select lever to the "N" range.
- 7) Remove the spacer bolt and remove the plate guide COMPL.

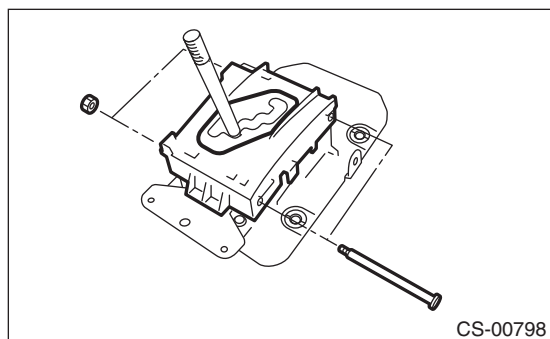

- 8) Using a flat-tip screwdriver with a thin tip, remove the connector from the plate COMPL.

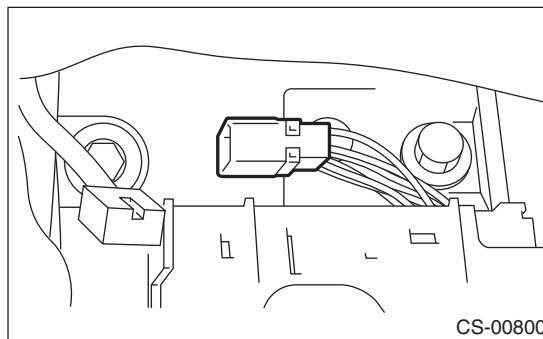

- 9) With detent spring lifted up, push the select lever backward and remove the shift lock solenoid unit.

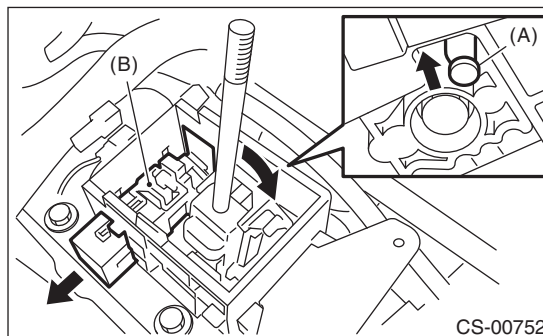

- (A) Detent spring
(B) Shift lock solenoid unit

- 10) Raise the claw of connector.

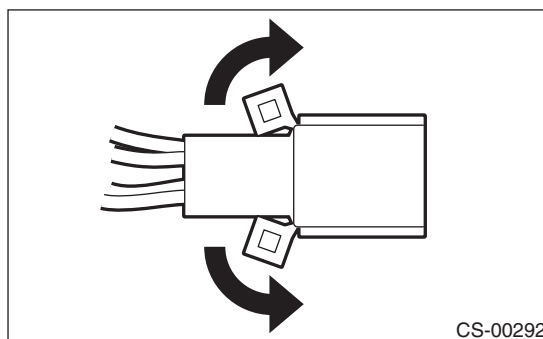

- 11) Disconnect the terminals of "P" range switch and shift lock solenoid unit from the connector, using a flat-tip screwdriver with a thin tip.

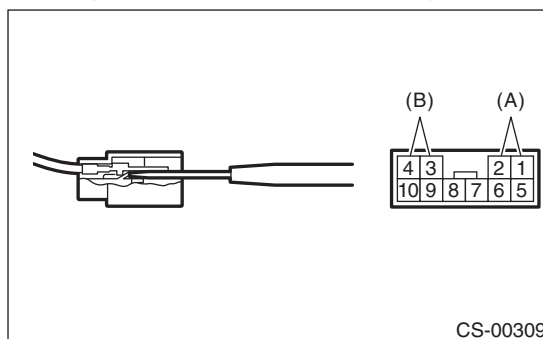

- (A) "P" range switch terminal
(B) Shift lock solenoid terminal

B: INSTALLATION

Install in the reverse order of removal.

NOTE:

- Refer to “COMPONENT” for each tightening torque.
<Ref. to CS-3, COMPONENT, General Description.>
- When installing the plate guide COMPL, set the select lever to “D” range (normal mode position), and be careful of the following.
 - Insert protrusion (B) of the plate guide COMPL into the hole on the shift lock solenoid unit (A).
 - Insert link (D) of the shift lock release into link (C) of the shift lock solenoid unit.

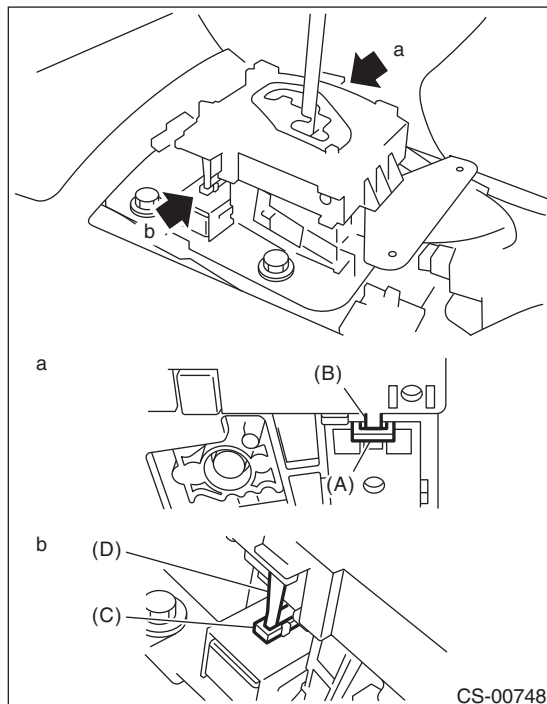

- Connect the switch and solenoid terminals to the connector.

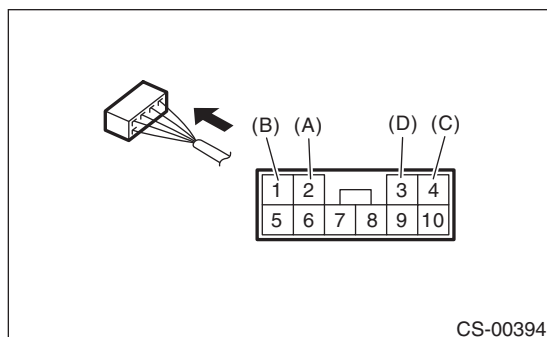

- (A) “P” range switch (color code: white)
- (B) “P” range switch (color code: black)
- (C) Shift lock solenoid (color code: blue/red)
- (D) Shift lock solenoid (color code: black)

AT Shift Lock Solenoid and “P” Range Switch

CONTROL SYSTEMS

C: INSPECTION

Step	Check	Yes	No
1 CHECK SHIFT LOCK SOLENOID. Measure the resistance of shift lock solenoid connector terminals. <i>Terminals</i> <i>No. 4 — No. 3:</i>	Is the resistance 19.8 — 24.2 Ω ?	Go to step 2.	Replace the shift lock solenoid.
2 CHECK SHIFT LOCK SOLENOID. Connect the battery to shift lock solenoid connector terminal, and then operate the solenoid. <i>Terminals</i> <i>No. 3 (+) — No. 4 (-):</i>	Does the shift lock solenoid operate normally?	Go to step 3.	Replace the shift lock solenoid.
3 CHECK “P” RANGE SWITCH. 1) Move the select lever to “P” range. 2) Measure the resistance between “P” range switch connector terminals. <i>Terminals</i> <i>No. 1 — No. 2:</i>	Is the resistance less than 1 Ω ?	Go to step 4.	Replace the “P” range switch.
4 CHECK “P” RANGE SWITCH. 1) Set the select lever to other than “P” range. 2) Measure the resistance between “P” range switch connector terminals. <i>Terminals</i> <i>No. 1 — No. 2:</i>	Is the resistance 1 M Ω or more?	Normal operation	Replace the “P” range switch.

6. Body Integrated Unit

A: NOTE

Refer to “Body Integrated Unit” for removal and installation procedures. <Ref. to SL-42, Body Integrated Unit.>

MT Gear Shift Lever

CONTROL SYSTEMS

7. MT Gear Shift Lever

A: REMOVAL

- 1) Set the vehicle on a lift.
- 2) Disconnect the ground cable from the battery.
- 3) Remove the gear shift knob.
- 4) Remove the console front panel and console boot.

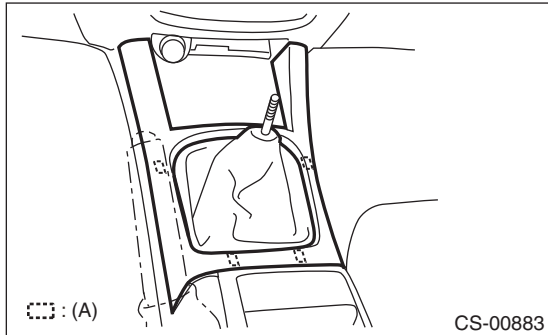

(A) Hook

- 5) Remove the console cover and console box.
<Ref. to EI-46, REMOVAL, Console Box.>
- 6) Remove the clamp.

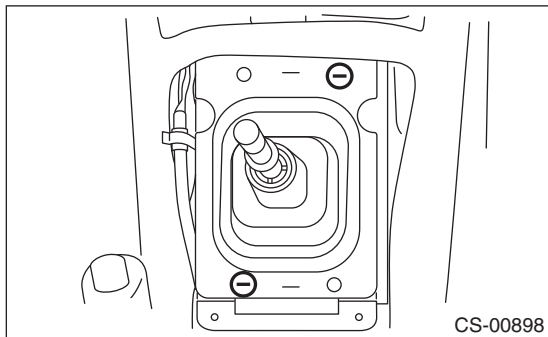

- 7) Remove the boot and insulator assembly.

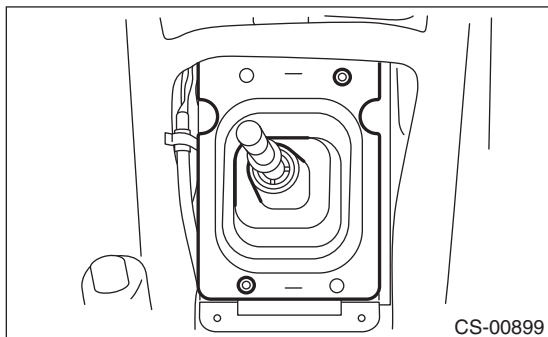

- 8) Remove the harness clamp from the plate assembly.

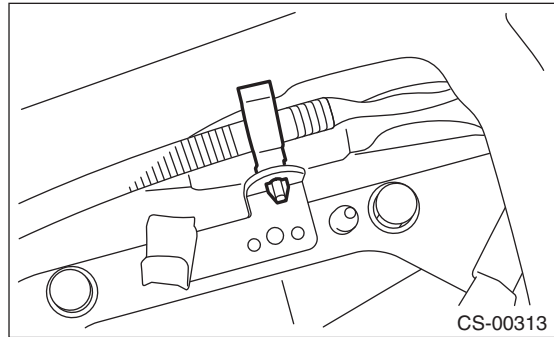

- 9) Remove the plate assembly from the vehicle body.

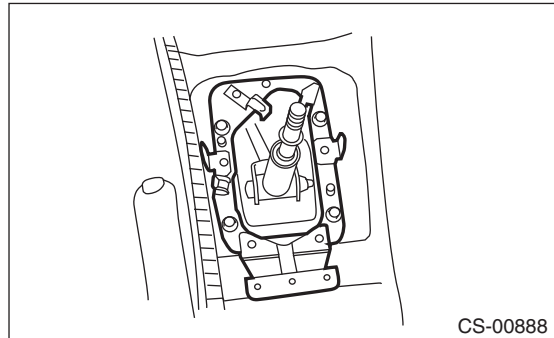

- 10) Lift up the vehicle.
- 11) Remove the rear exhaust pipe and muffler.
 - Non-turbo model
<Ref. to EX(H4SO)-8, REMOVAL, Rear Exhaust Pipe.> <Ref. to EX(H4SO)-10, REMOVAL, Muffler.>
 - Turbo model
<Ref. to EX(H4DOTC)-12, REMOVAL, Rear Exhaust Pipe.> <Ref. to EX(H4DOTC)-14, REMOVAL, Muffler.>
- 12) Remove the heat shield cover.

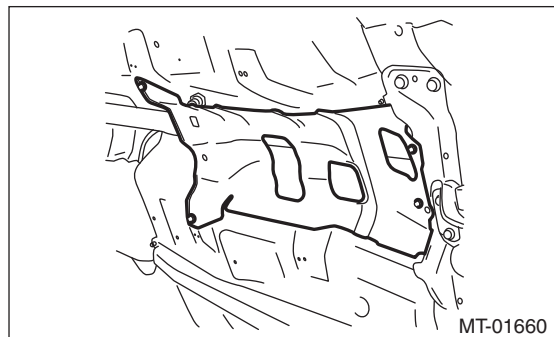

13) Remove the stay from transmission bracket.

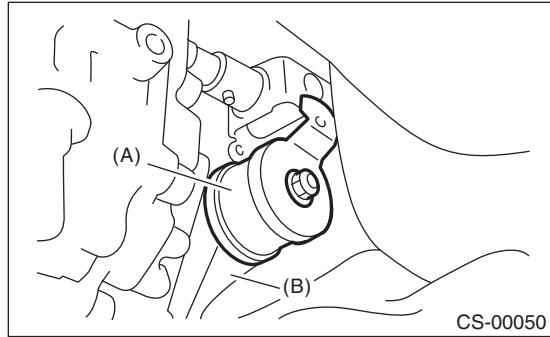

- (A) Stay
- (B) Transmission bracket

16) Extract the spring pin and remove the joint.

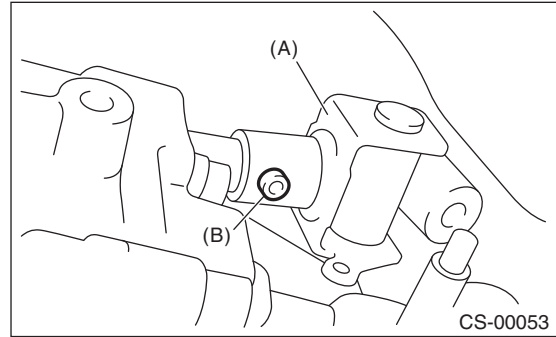

- (A) Joint
- (B) Spring pin

14) Remove the rod from joint.

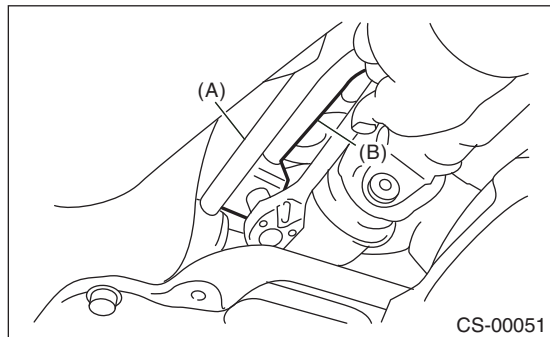

- (A) Stay
- (B) Rod

17) Lower the vehicle.

18) Remove the gear shift lever.

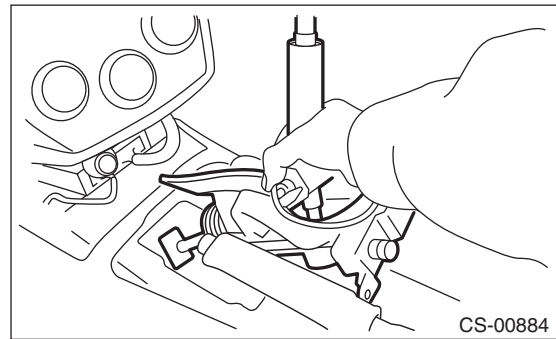

15) Remove the cushion rubber from the vehicle body.

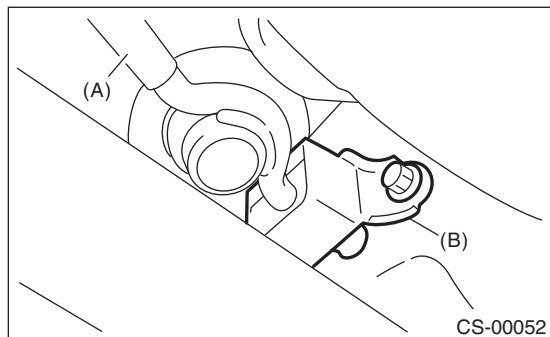

- (A) Stay
- (B) Cushion rubber

MT Gear Shift Lever

CONTROL SYSTEMS

B: INSTALLATION

1) Install the joint to the transmission and secure with a spring pin.

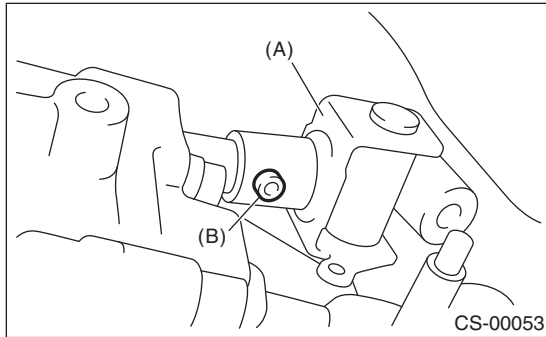

- (A) Joint
- (B) Spring pin

2) Insert the gear shift lever from the room side.

NOTE:

Insert the rod and the stay, and then temporarily set them onto the transmission mount.

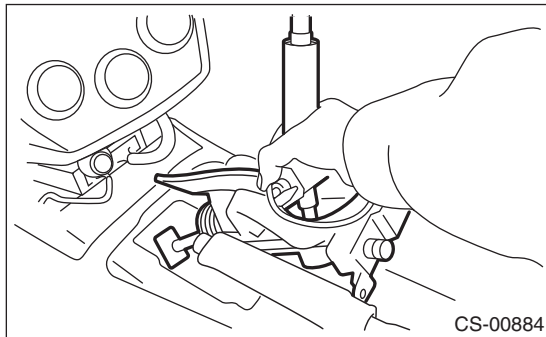

3) Lift up the vehicle.

4) Mount the cushion rubber on the vehicle body.

Tightening torque:

18 N·m (1.8 kgf-m, 13.3 ft-lb)

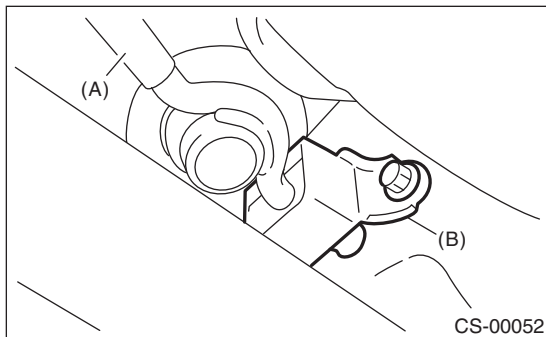

- (A) Stay
- (B) Cushion rubber

5) Using new self-locking nuts, connect the rod to the joint.

Tightening torque:

18 N·m (1.8 kgf-m, 13.3 ft-lb)

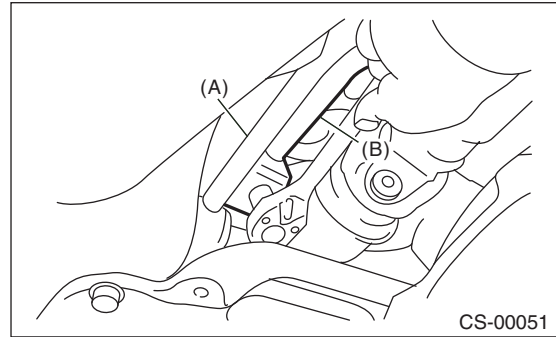

- (A) Stay
- (B) Rod

6) Using new self-locking nuts, connect the stay to the transmission bracket.

Tightening torque:

18 N·m (1.8 kgf-m, 13.3 ft-lb)

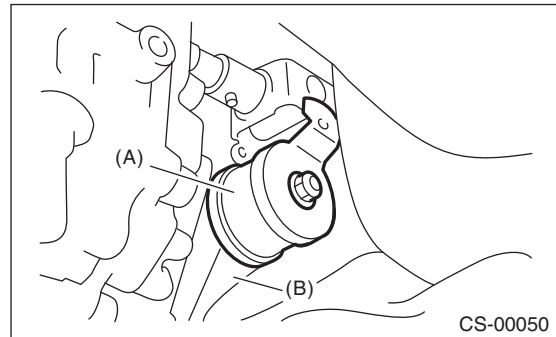

- (A) Stay
- (B) Transmission bracket

7) Install the heat shield cover.

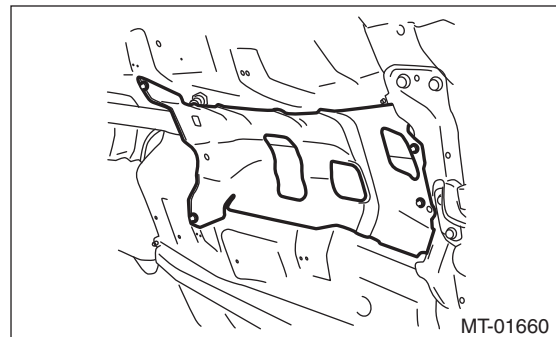

- 8) Install the rear exhaust pipe and muffler.
 - Non-turbo model
<Ref. to EX(H4SO)-8, INSTALLATION, Rear Exhaust Pipe.> <Ref. to EX(H4SO)-10, INSTALLATION, Muffler.>
 - Turbo model
<Ref. to EX(H4DOTC)-12, INSTALLATION, Rear Exhaust Pipe.> <Ref. to EX(H4DOTC)-14, INSTALLATION, Muffler.>
- 9) Install the plate assembly to the vehicle body.

Tightening torque:

18 N·m (1.8 kgf-m, 13.3 ft-lb)

- (1) Set the plate assembly to the vehicle.
- (2) Temporarily tighten the bolt (A).
- (3) Tighten the bolt (B).
- (4) Tighten the bolt (A).
- (5) Tighten the bolts (C) and (D).

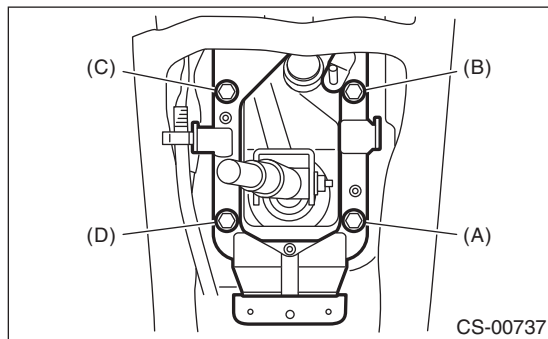

- 10) Install the harness clamp to the plate.
- 11) Install the boot and insulator assembly, and secure with a clamp.

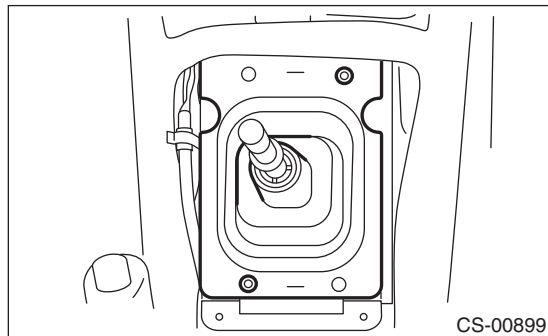

- 12) Install the console cover and console box.
<Ref. to EI-46, INSTALLATION, Console Box.>
- 13) Install the console front panel and console boot.
- 14) Install the gear shift knob.
- 15) Check that the gear can be shifted accurately into each gear ranges.

C: DISASSEMBLY

- 1) Remove the lock wires.

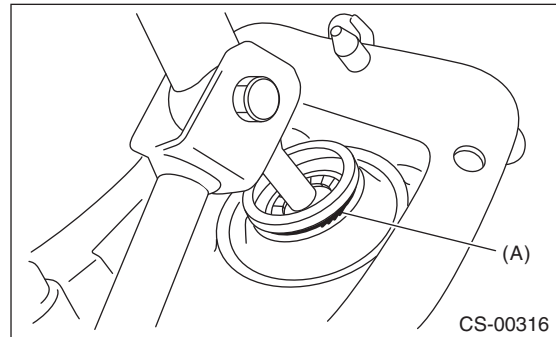

(A) Lock wire

- 2) Remove the rod from lever.

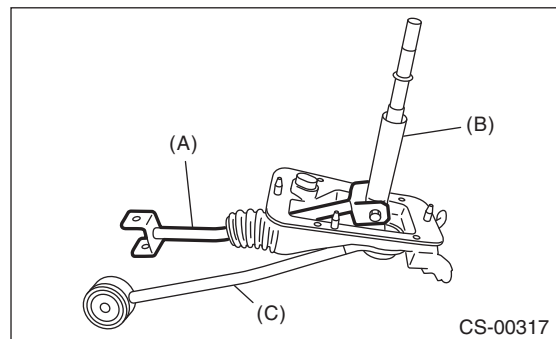

(A) Rod
(B) Lever
(C) Stay

- 3) Separate the rod and inner boot.
- 4) Remove the snap ring from the stay.

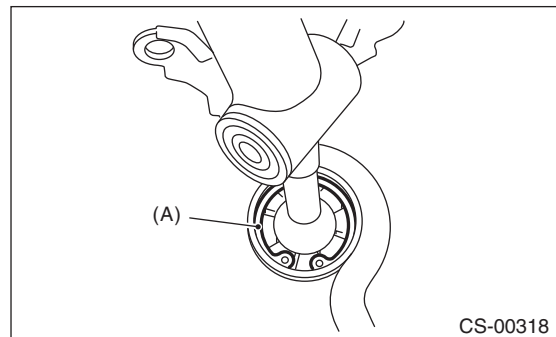

(A) Snap ring

MT Gear Shift Lever

CONTROL SYSTEMS

5) Separate the gear shift lever and the stay.

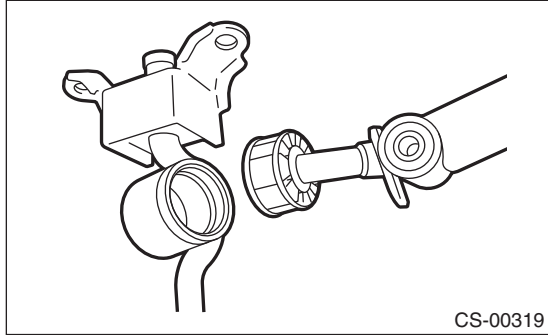

6) Remove the boot, bushing and snap ring from gear shift lever.

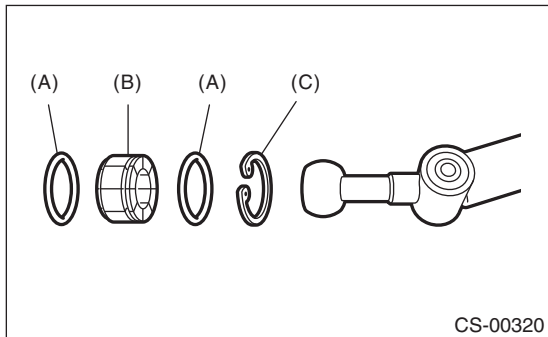

- (A) O-ring
- (B) Bushing
- (C) Snap ring

7) Remove the spring pin, and then remove the bushing and snap ring.

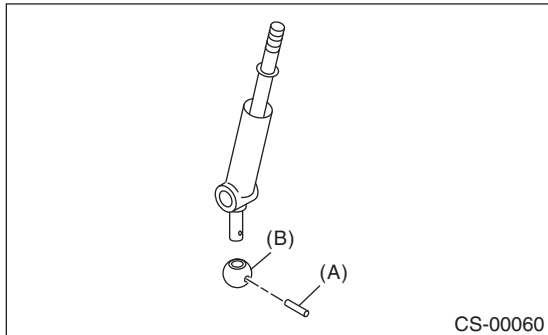

- (A) Spring pin
- (B) Bushing

8) Remove the boss from the joint.

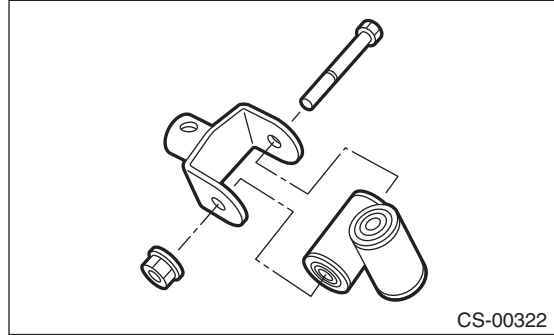

9) Remove the bushing and spacer from the boss.

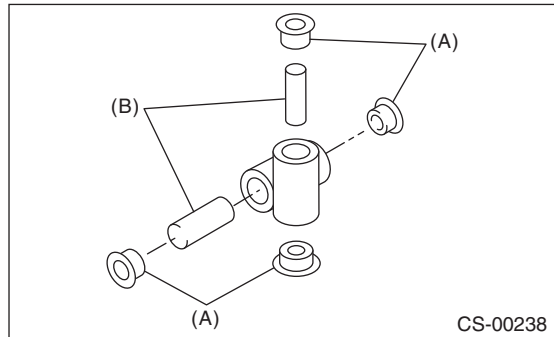

- (A) Bushing
- (B) Spacer

10) Remove the bushing and cushion rubber from the stay.

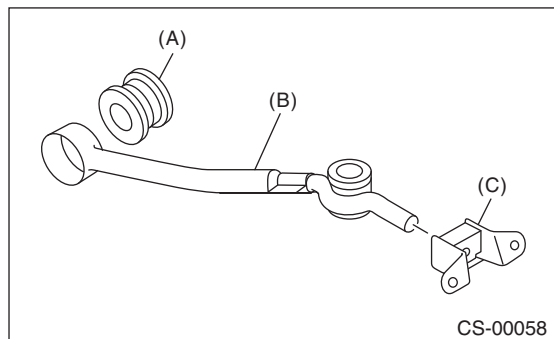

- (A) Bushing B
- (B) Stay
- (C) Cushion rubber

D: ASSEMBLY

NOTE:

- Clean all the parts before assembly.
- Apply NIGTIGHT LYW No. 2 grease or equivalent to each part. <Ref. to CS-4, 5MT GEAR SHIFT LEVER, COMPONENT, General Description.>

1) Mount the bushing and cushion rubber to the stay.

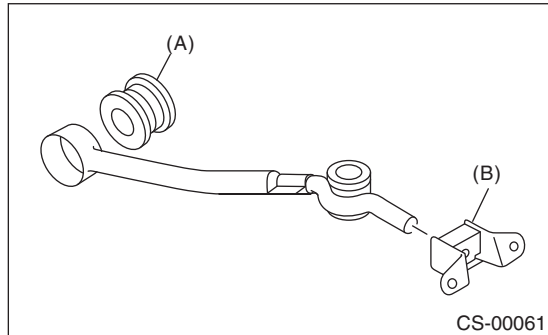

- (A) Bushing
- (B) Cushion rubber

2) Install the bushing and spacer to boss.

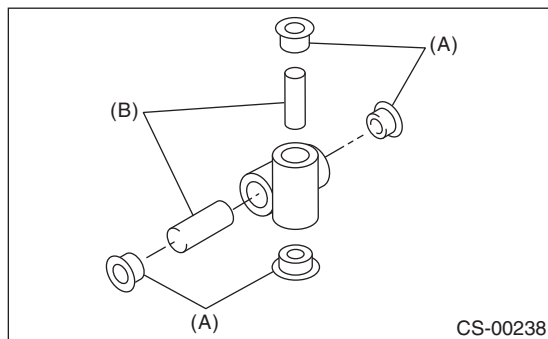

- (A) Bushing
- (B) Spacer

3) Using new self-locking nuts, install the boss to the joint.

Tightening torque:

12 N·m (1.2 kgf·m, 8.9 ft·lb)

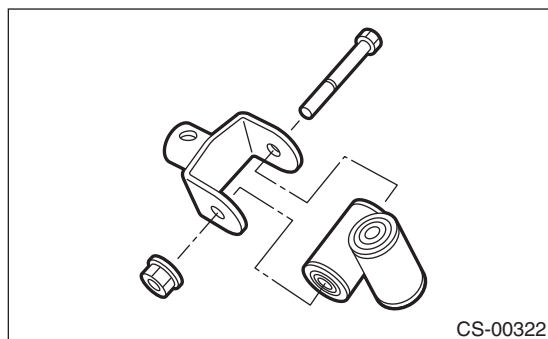

4) Install the snap ring to gear shift lever and install the bushing.

NOTE:

Apply grease to the bushing.

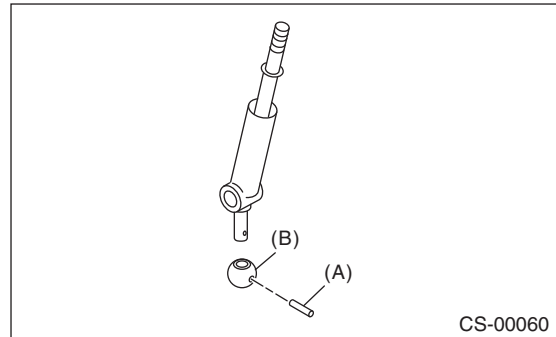

- (A) Spring pin
- (B) Bushing

5) Apply grease to the bushing and O-ring, and then install to gear shift lever.

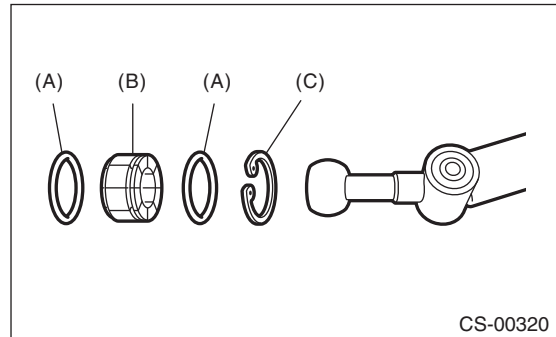

- (A) O-ring
- (B) Bushing
- (C) Snap ring

6) Apply sufficient grease into boss, and then install the gear shift lever to the stay.

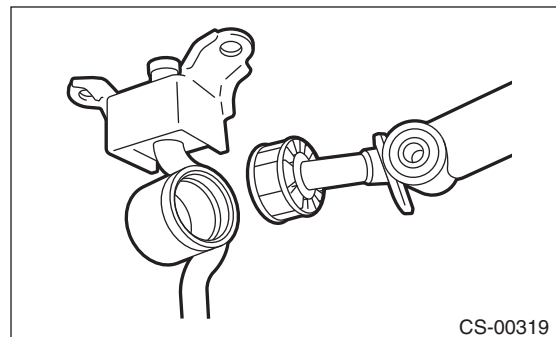

MT Gear Shift Lever

CONTROL SYSTEMS

7) Install the washer and snap ring.

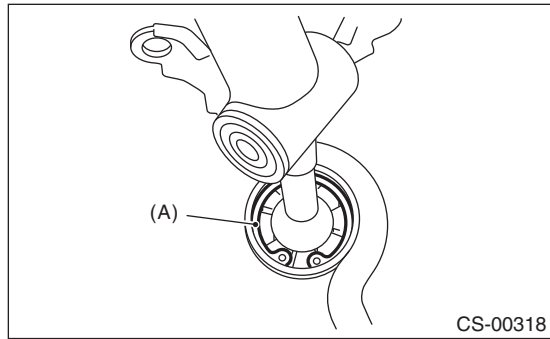

(A) Snap ring

10) Install a new lock wire.

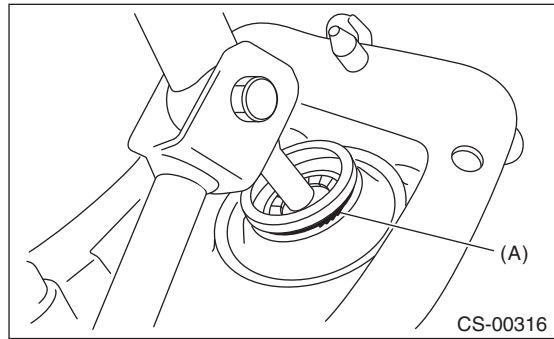

(A) Lock wire

8) Insert the gear shift lever and rod into boot hole.

9) Install the rod.

Tightening torque:

12 N·m (1.2 kgf·m, 8.9 ft·lb)

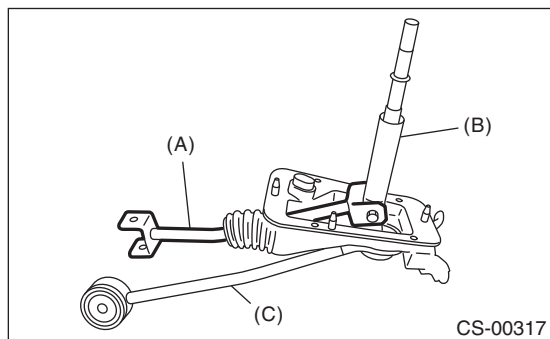

(A) Rod
(B) Lever
(C) Stay

NOTE:

- Install the lock wire to the stay groove.
- Bend the extra wire to the same direction of lock wire winding.

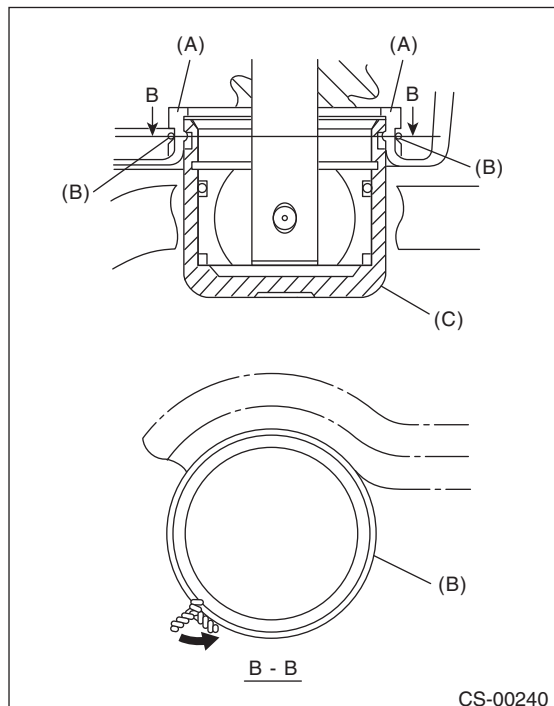

(A) Inner boot
(B) Lock wire
(C) Stay

E: INSPECTION

1) Check the parts (bushing, cushion rubber, spacer, boot, stay and rod, etc.) for deformation, damage and wear. If necessary, correct or replace faulty parts. Compare the removed parts with new parts to judge if there are damages or not.

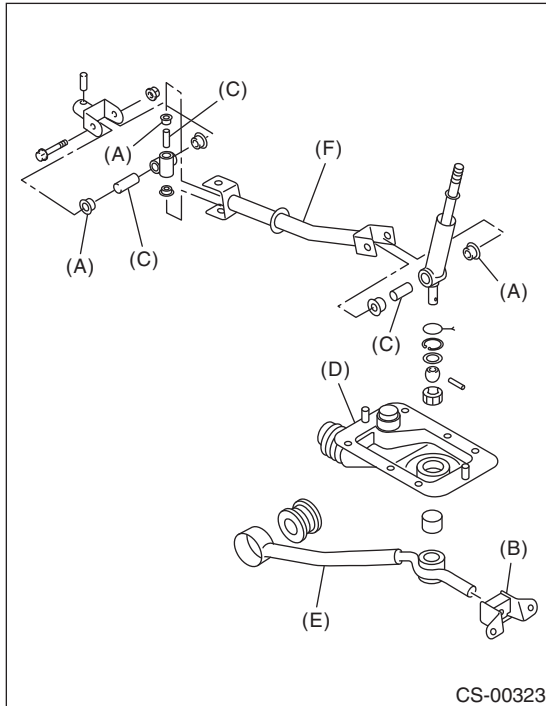

- (A) Bushing
- (B) Cushion rubber
- (C) Spacer
- (D) Boot
- (E) Stay
- (F) Rod

2) Check the swing torque of rod linked with the gear shift lever.
If the torque exceeds the specifications, replace the bushing or retighten nuts.

Swing torque:

3.7 N (0.38 kgf, 0.83 lbf) or less

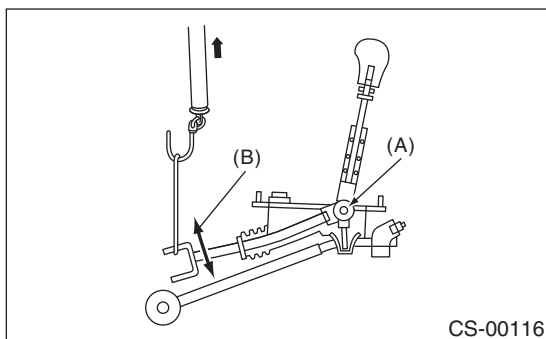

- (A) Pivot
- (B) Swing torque

General Diagnostic Table

CONTROL SYSTEMS

8. General Diagnostic Table

A: INSPECTION

Symptoms	Possible cause	Corrective action
Select lever	Starter does not run.	Adjust the select cable and inhibitor switch, or inspect the circuit.
	Back-up light does not illuminate.	Adjust the select cable and inhibitor switch, or inspect the circuit.
	AT shift lock system does not operate normally.	Adjust the select cable and inhibitor switch, or inspect the circuit.
	Manual mode can not be set.	Adjust the mode switch and select lever, or inspect the circuit.
	Up-shift is not engaged at manual mode.	Check the shift-up switch and circuit.
	Down-shift is not engaged at manual mode.	Check the shift-down switch and circuit.

AUTOMATIC TRANSMISSION

4AT

	Page
1. General Description	2
2. Automatic Transmission Fluid	26
3. Differential Gear Oil	28
4. Road Test	29
5. Stall Test	30
6. Time Lag Test	31
7. Line Pressure Test	32
8. Transfer Clutch Pressure Test	33
9. Automatic Transmission Assembly	34
10. Transmission Mounting System	42
11. Extension Case Oil Seal	44
12. Differential Side Retainer Oil Seal	45
13. Inhibitor Switch	46
14. Front Vehicle Speed Sensor	49
15. Rear Vehicle Speed Sensor	52
16. Torque Converter Turbine Speed Sensor	53
17. Control Valve Strainer	54
18. Control Valve Body	56
19. Air Bleeding of Control Valve	59
20. Transmission Control Module (TCM)	60
21. ATF Cooler Pipe and Hose	61
22. Air Breather Hose	64
23. Oil Charge Pipe	65
24. Torque Converter Clutch Assembly	66
25. Drive Plate	67
26. Extension Case	68
27. Transfer Clutch	70
28. Reduction Driven Gear	75
29. Reduction Drive Gear	77
30. Parking Pawl	79
31. Converter Case	80
32. Oil Pump Housing	83
33. Drive Pinion Shaft Assembly	89
34. Front Differential Assembly	94
35. AT Main Case	100
36. Transmission Control Device	123

General Description

AUTOMATIC TRANSMISSION

1. General Description

A: SPECIFICATION

1. TORQUE CONVERTER

Model	Non-turbo	Turbo
Type	Symmetric, 3 element, single stage, 2 phase torque converter	
Stall torque ratio	2.05 — 2.35	
Nominal diameter mm (in)	246 (9.69)	
Stall speed (at sea level)	2,200 — 2,700 rpm	2,800 — 3,300 rpm
One-way clutch	Sprague type one-way clutch	

2. OIL PUMP

Type	Parachoid constant-displacement pump	
Driving method	Driven by engine	
Number of teeth	Inner rotor	9
	Outer rotor	10

3. TRANSMISSION CONTROL ELEMENT

Type	4-forward, 1-reverse, double-row planetary gears
Multi-plate clutch	3 sets
Multi-plate brake	2 sets
One-way clutch (sprague type)	1 set

4. TRANSMISSION GEAR RATIO

1st	2.785
2nd	1.545
3rd	1.000
4th	0.694
Rev	2.272

5. PLANETARY GEAR AND PLATE

Model	Non-turbo	Turbo
Number of front sun gear teeth	33	
Number of front pinion teeth	21	
Number of front internal gear teeth	75	
Number of rear sun gear teeth	42	
Number of rear pinion teeth	17	
Number of rear internal gear teeth	75	
Number of high clutch drive plates	4	5
Number of low clutch drive plates	5	7
Number of reverse clutch drive plates	2	
Number of drive plates for the 2-4 brake	3	4
Number of drive plates for low & reverse brake	5	7

6. SELECTOR POSITION

P (Park)	Transmission is in neutral, output member is fixed, engine start is possible
R (Reverse)	Transmission is in reverse.
N (Neutral)	Transmission is in neutral and engine start is possible
D (Drive)	4-forward automatic gear change 1st ← → 2nd ↔ 3rd ↔ 4th
SPORT mode	4-forward automatic gear change 1st ↔ 2nd ↔ 3rd ↔ 4th
Manual mode (+)	4-forward manual gear change (shift up) 1st → 2nd → 3rd → 4th
Manual mode (-)	4-forward manual gear change (shift down) 1st ← 2nd ← 3rd ← 4th
Control method	Wire cable type

General Description

AUTOMATIC TRANSMISSION

7. HYDRAULIC CONTROL AND LUBRICATION

Type	Electronic hydraulic control [4 forward gear changes made by electronic signals of vehicle speed and accelerator (throttle) opening]	
Fluid	Recommended materials	SUBARU ATF HP
	Alternative	Idemitsu "ATF HP" CAUTION: Always use recommended or alternative products for the ATF. If those other than recommended or specified as alternatives are used, it will be a cause for problems.
Fluid capacity	ℓ (US qt, Imp qt)	9.3 — 9.6 (9.8 — 10.1, 8.2 — 8.4)
Lubrication system	Forced feed lubrication with oil pump	
Oil	Automatic transmission fluid (see above)	

8. COOLING AND HARNESS

Cooling system	Liquid-cooler
Inhibitor switch	12 poles
Transmission harness	20 poles

9. TRANSFER

Model	Non-turbo	Turbo
Transfer type	Multi-plate transfer (MPT)	
Number of transfer clutch drives & driven plates	5	6
Control method	Electronic hydraulic type	
Lubricant	Same automatic transmission fluid as used in the automatic transmission	
Reduction gear ratio	1.000 (53/53)	

10.FINAL REDUCTION GEAR

Model	Non-turbo	Turbo
Front final reduction gear ratio	4.444 (40/9)	4.111 (37/9)

11.RECOMMENDED GEAR OIL

Lubrication oil	<p>(1) Item (2) Front differential gear oil (3) API standard (4) SAE viscosity No. and applicable temperature</p>	
Front differential oil capacity	ℓ (US qt, Imp qt)	1.1 — 1.3 (1.2 — 1.4, 1.0 — 1.1)

General Description

AUTOMATIC TRANSMISSION

B: COMPONENT

1. TORQUE CONVERTER AND CASE

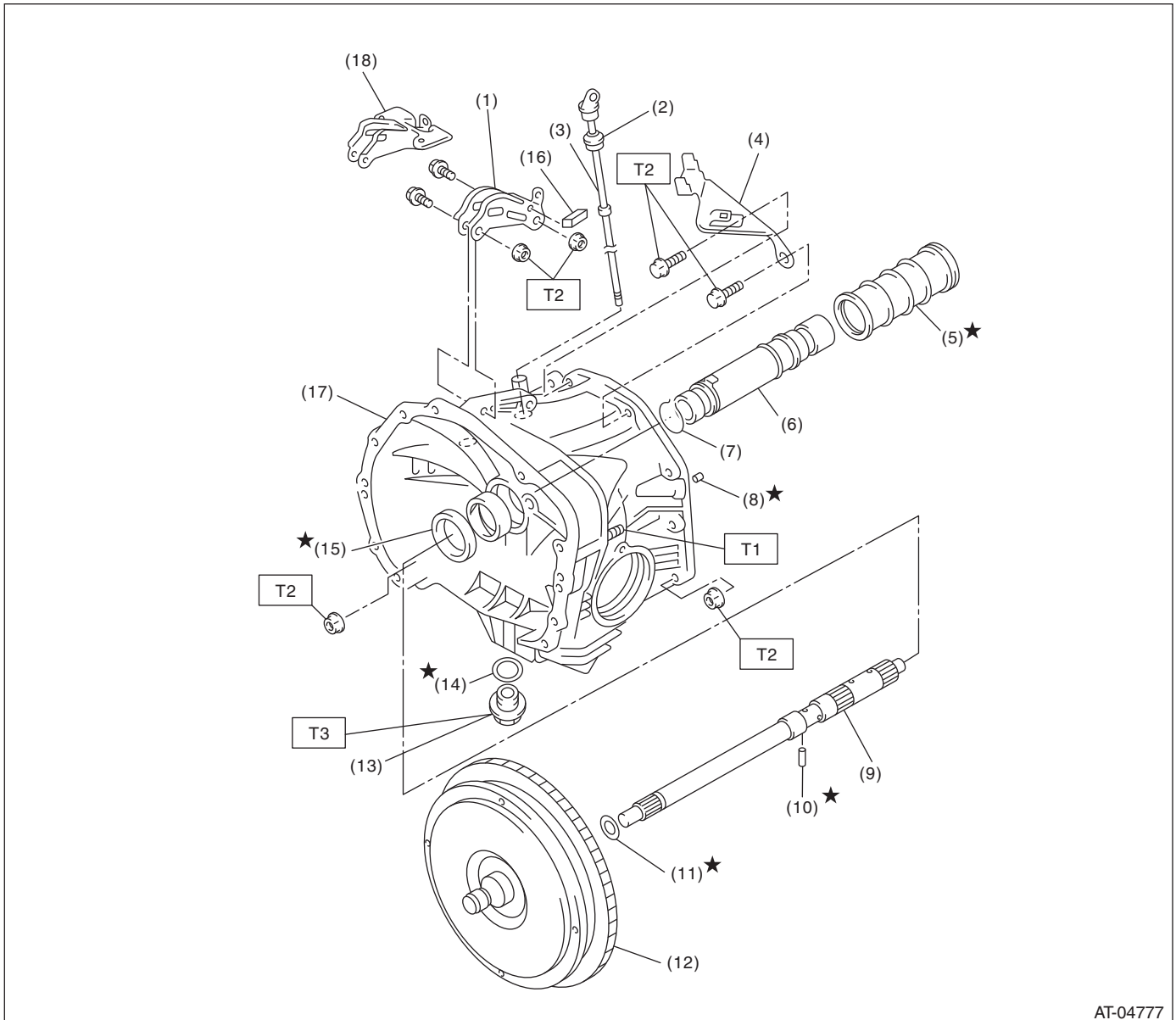

AT-04777

- | | |
|---|---------------------------------------|
| (1) Pitching stopper bracket
(Turbo model) | (9) Input shaft |
| (2) O-ring | (10) Spring pin |
| (3) Differential oil level gauge | (11) O-ring |
| (4) Stay | (12) Torque converter clutch ASSY |
| (5) Seal pipe | (13) Differential gear oil drain plug |
| (6) Oil pump shaft | (14) Gasket |
| (7) Clip | (15) Oil seal |
| (8) Oil drain pipe | (16) Clip (turbo model) |
| | (17) Converter case |

- | |
|--|
| (18) Pitching stopper bracket
(Non-turbo model) |
|--|

Tightening torque: N-m (kgf-m, ft-lb)

T1: 18 (1.8, 13.3)

T2: 41 (4.2, 30.2)

T3: 44 (4.5, 32.5) (Aluminum gasket)

70 (7.1, 51.6) (Copper gasket)

2. OIL PUMP

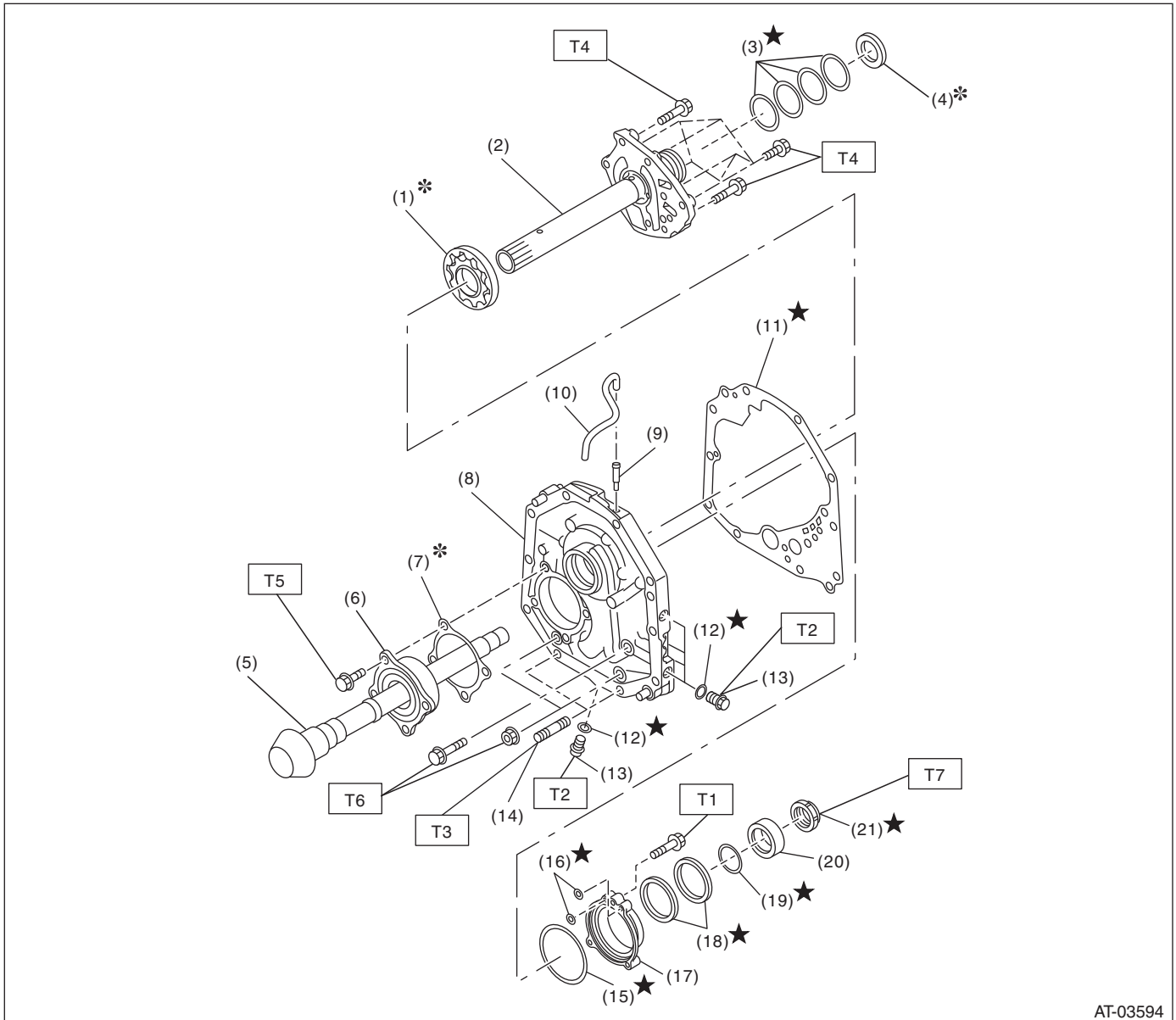

AT-03594

- | | | |
|---------------------------|--------------------------|---------------|
| (1) Oil pump rotor | (11) Gasket | (21) Lock nut |
| (2) Oil pump cover | (12) O-ring | |
| (3) Seal ring | (13) Test plug | |
| (4) Thrust needle bearing | (14) Stud bolt | |
| (5) Drive pinion shaft | (15) O-ring | |
| (6) Roller bearing | (16) O-ring | |
| (7) Shim | (17) Oil seal retainer | |
| (8) Oil pump housing | (18) Oil seal | |
| (9) Nipple | (19) O-ring | |
| (10) Air breather hose | (20) Drive pinion collar | |

Tightening torque: N·m (kgf·m, ft·lb)

T1: 7 (0.7, 5.2)

T2: 13 (1.3, 9.6)

T3: 18 (1.8, 13.3)

T4: 25 (2.5, 18.4)

T5: 40 (4.1, 29.5)

T6: 42 (4.3, 31.0)

T7: 116 (11.8, 85.6)

General Description

AUTOMATIC TRANSMISSION

3. TRANSMISSION CASE AND CONTROL DEVICE

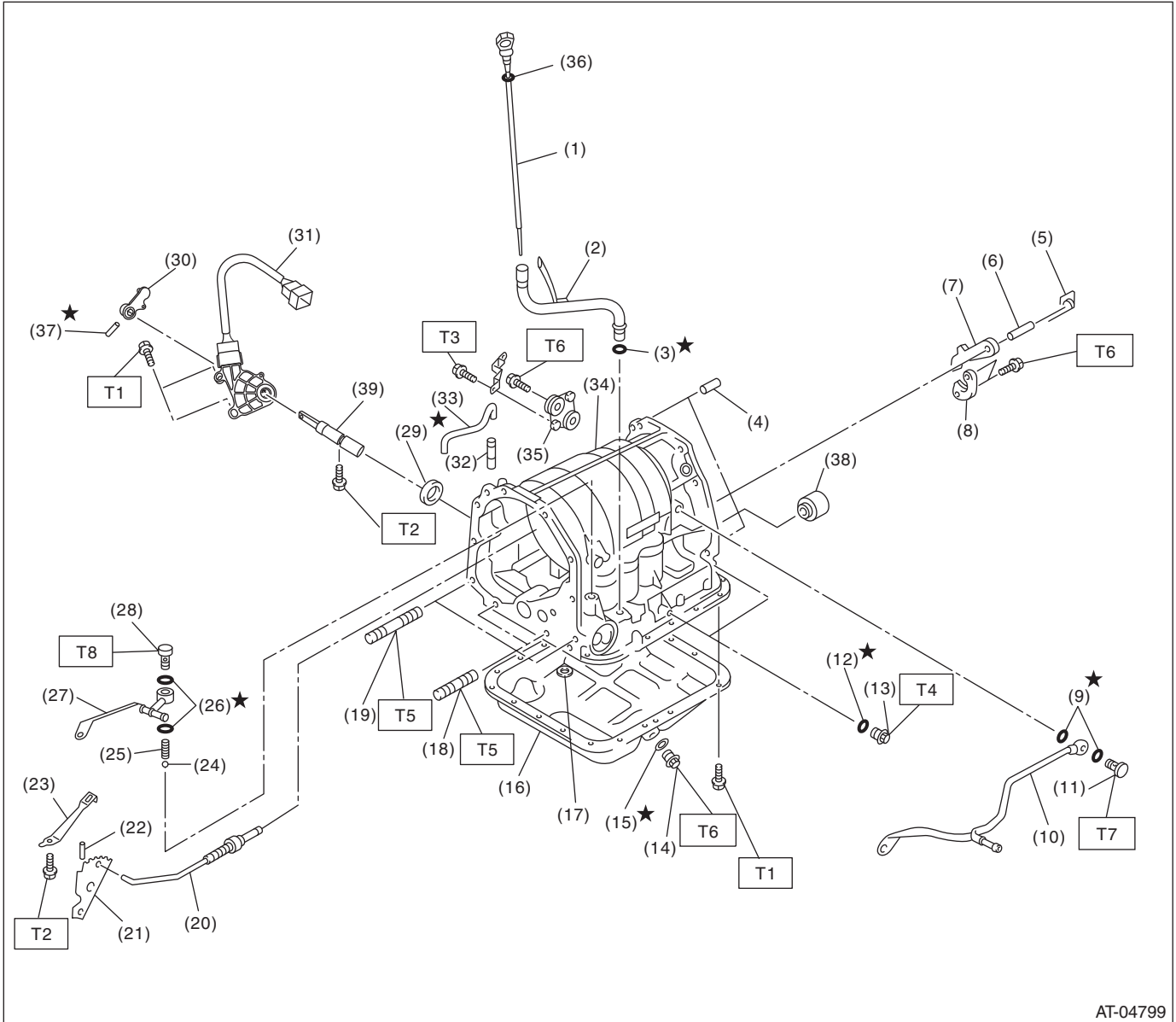

AT-04799

General Description

AUTOMATIC TRANSMISSION

(1) ATF level gauge	(18) Stud bolt (short)	(34) Transmission case
(2) Oil charge pipe	(19) Stud bolt (long)	(35) Plate ASSY
(3) O-ring	(20) Parking rod	(36) O-ring
(4) Straight pin	(21) Manual plate	(37) Straight pin
(5) Return spring	(22) Spring pin	(38) Transfer clutch seal
(6) Shaft	(23) Detent spring	(39) Shifter arm shaft
(7) Parking pawl	(24) Ball	
(8) Parking support	(25) Spring	
(9) Gasket	(26) Gasket	
(10) ATF inlet pipe	(27) ATF outlet pipe	
(11) Union screw	(28) Union screw	
(12) O-ring	(29) Oil seal	
(13) Test plug	(30) Shifter arm	
(14) Drain plug (ATF)	(31) Inhibitor switch ASSY	
(15) Gasket	(32) Nipple	
(16) Oil pan	(33) Air breather hose	
(17) Magnet		

Tightening torque:N·m (kgf-m, ft-lb)**T1: 5 (0.5, 3.7)****T2: 6 (0.6, 4.4)****T3: 12 (1.2, 8.9)****T4: 13 (1.3, 9.6)****T5: 18 (1.8, 13.3)****T6: 25 (2.5, 18.4)****T7: 40 (4.1, 29.5)****T8: 45 (4.6, 33.2)**

General Description

AUTOMATIC TRANSMISSION

4. CONTROL VALVE AND HARNESS ROUTING

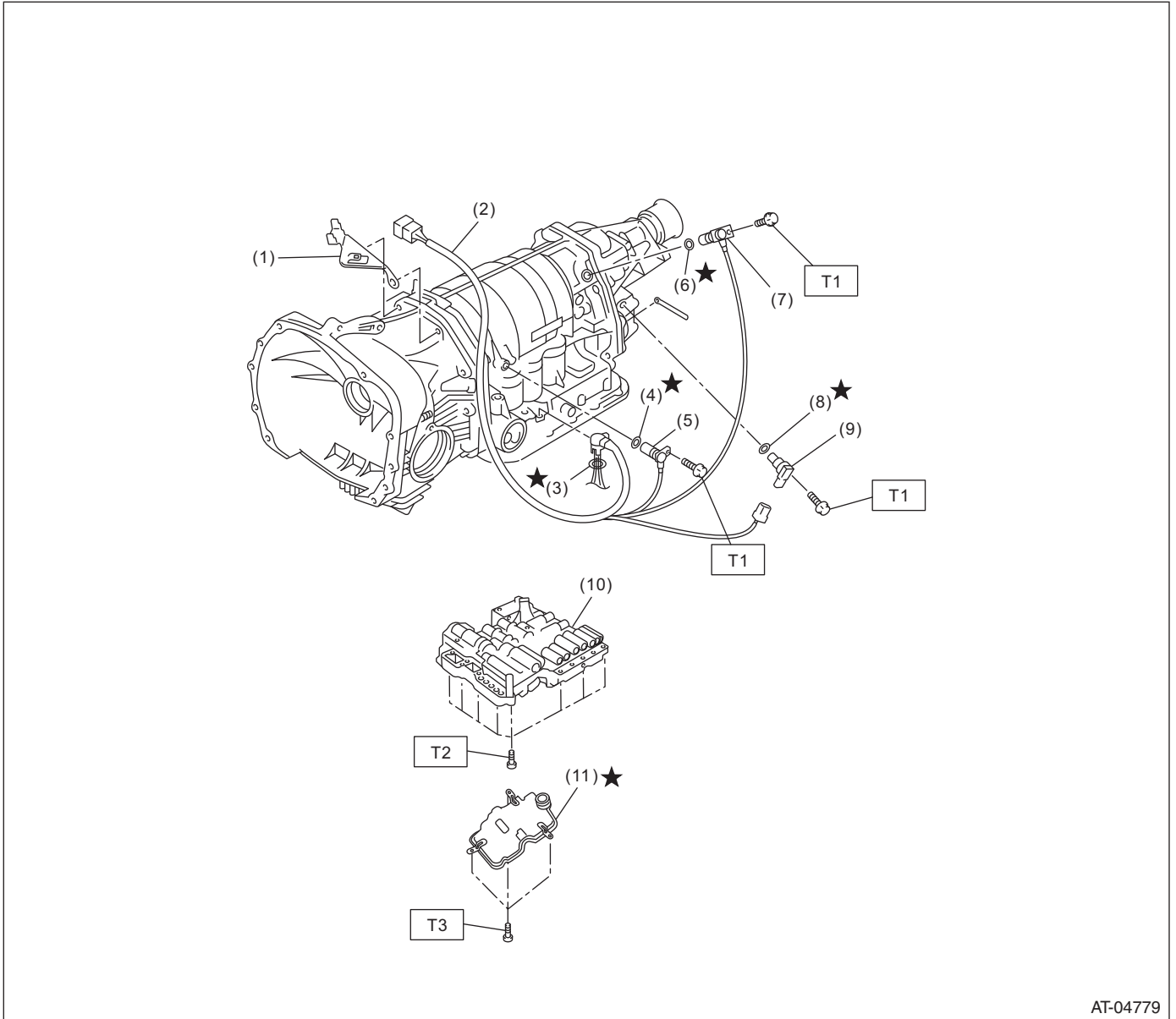

AT-04779

- | | |
|---|--------------------------------|
| (1) Stay | (6) O-ring |
| (2) Transmission harness | (7) Front vehicle speed sensor |
| (3) O-ring | (8) O-ring |
| (4) O-ring | (9) Rear vehicle speed sensor |
| (5) Torque converter turbine speed sensor | (10) Control valve body |
| | (11) Control valve strainer |

Tightening torque: N·m (kgf·m, ft·lb)

T1: 7 (0.7, 5.2)

T2: 8 (0.8, 5.9)

T3: 10 (1.0, 7.4)

5. HIGH CLUTCH AND REVERSE CLUTCH

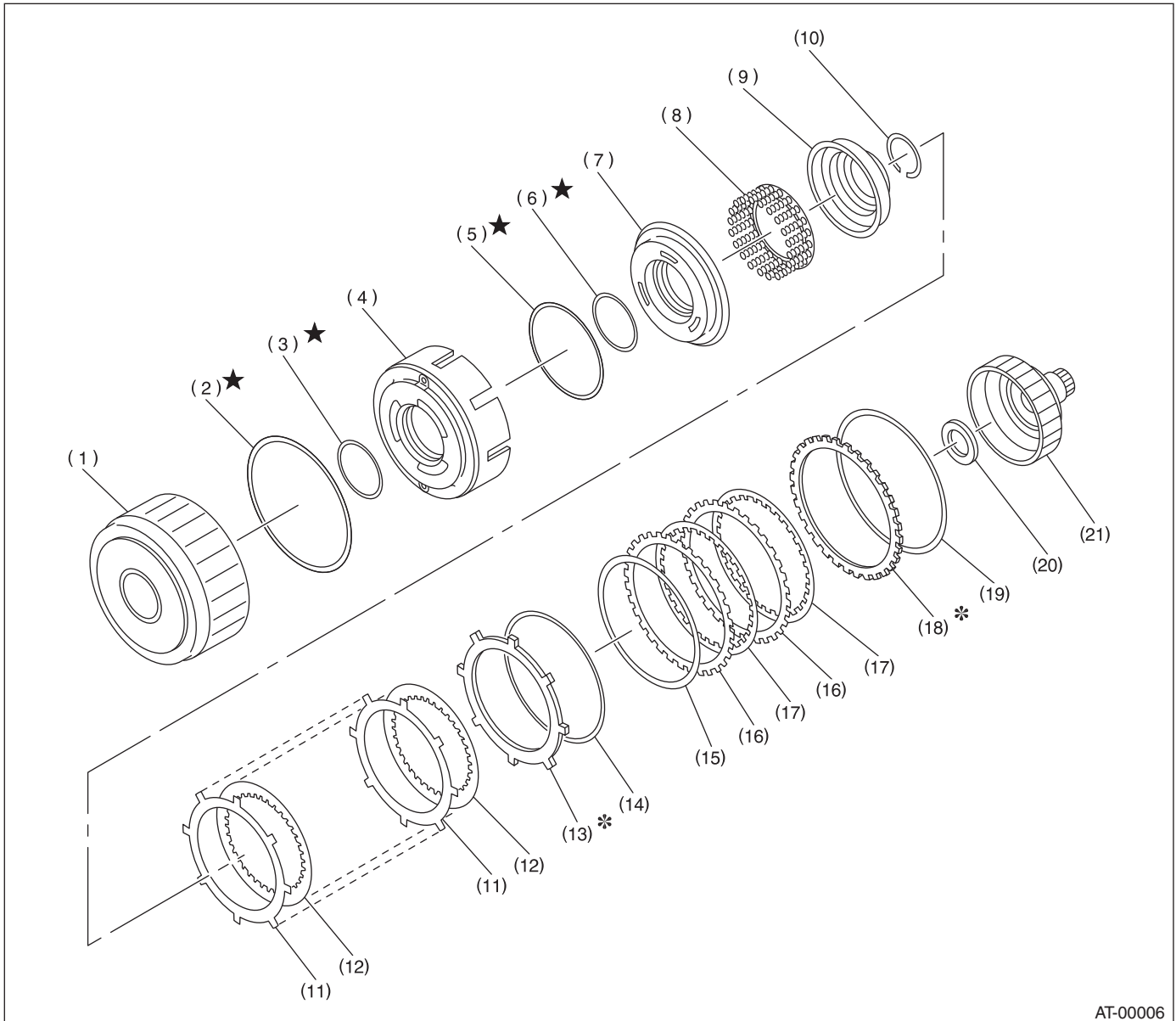

AT-00006

- | | | |
|---------------------------|------------------------------------|---------------------------------------|
| (1) High clutch drum | (8) Spring retainer | (15) Dish plate |
| (2) Lip seal | (9) Clutch cover | (16) Driven plate (reverse clutch) |
| (3) D-ring | (10) Snap ring | (17) Drive plate (reverse clutch) |
| (4) Reverse clutch piston | (11) Driven plate (high clutch) | (18) Retaining plate (reverse clutch) |
| (5) D-ring | (12) Drive plate (high clutch) | (19) Snap ring |
| (6) D-ring | (13) Retaining plate (high clutch) | (20) Thrust needle bearing |
| (7) High clutch piston | (14) Snap ring | (21) High clutch hub |

General Description

AUTOMATIC TRANSMISSION

6. PLANETARY GEAR AND 2-4 BRAKE

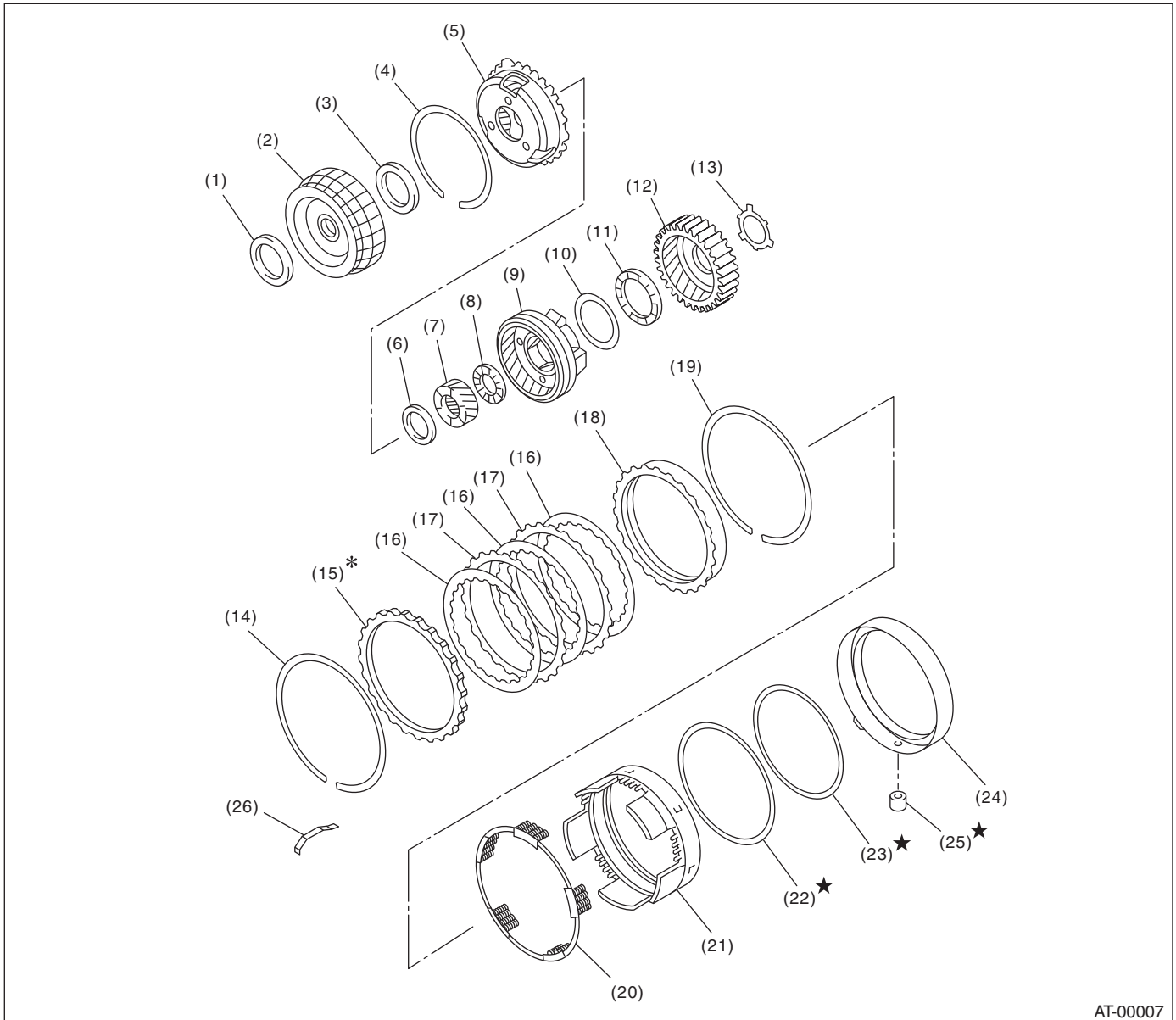

AT-00007

- | | | |
|-----------------------------|----------------------------|--------------------------------|
| (1) Thrust needle bearing | (10) Washer | (19) Snap ring |
| (2) Front sun gear | (11) Thrust needle bearing | (20) Spring retainer |
| (3) Thrust needle bearing | (12) Rear internal gear | (21) 2-4 brake piston |
| (4) Snap ring | (13) Washer | (22) D-ring |
| (5) Front planetary carrier | (14) Snap ring | (23) D-ring |
| (6) Thrust needle bearing | (15) Retaining plate | (24) 2-4 brake piston retainer |
| (7) Rear sun gear | (16) Drive plate | (25) 2-4 brake seal |
| (8) Thrust needle bearing | (17) Driven plate | (26) Leaf spring |
| (9) Rear planetary carrier | (18) Pressure rear plate | |

7. LOW CLUTCH AND LOW & REVERSE BRAKE

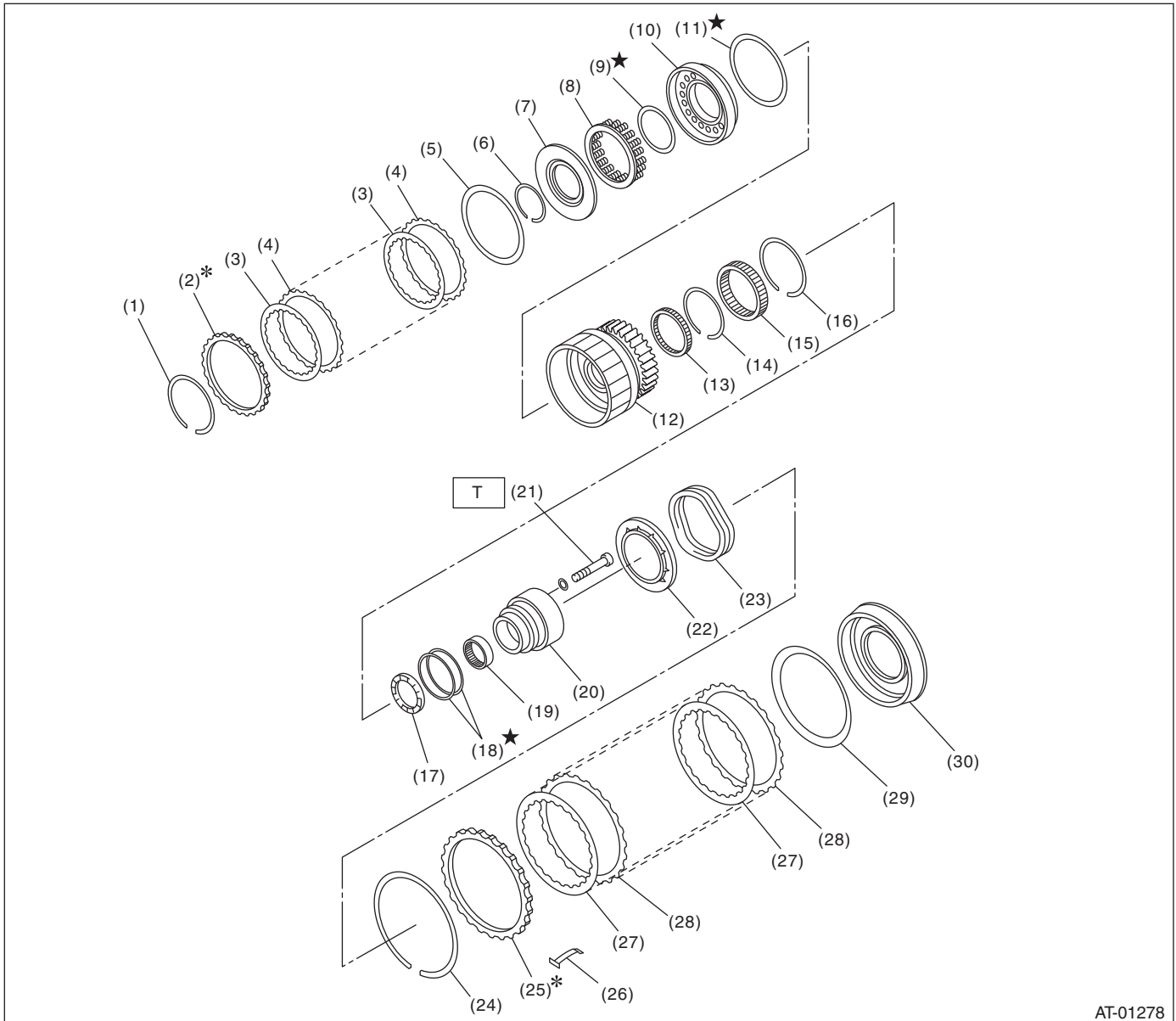

AT-01278

- | | | |
|------------------------|--------------------------------|---------------------------------|
| (1) Snap ring | (12) Low clutch drum | (23) Return spring |
| (2) Retaining plate | (13) Needle bearing | (24) Snap ring |
| (3) Drive plate | (14) Snap ring | (25) Retaining plate |
| (4) Driven plate | (15) One-way clutch | (26) Leaf spring |
| (5) Dish plate | (16) Snap ring | (27) Drive plate |
| (6) Snap ring | (17) Thrust needle bearing | (28) Driven plate |
| (7) Cover | (18) Seal ring | (29) Dish plate |
| (8) Spring retainer | (19) Needle bearing | (30) Low & reverse brake piston |
| (9) D-ring | (20) One-way clutch inner race | |
| (10) Low clutch piston | (21) Socket bolt | |
| (11) D-ring | (22) Spring retainer | |

Tightening torque: N·m (kgf·m, ft·lb)

T: 25 (2.5, 18.4)

General Description

AUTOMATIC TRANSMISSION

8. REDUCTION GEAR

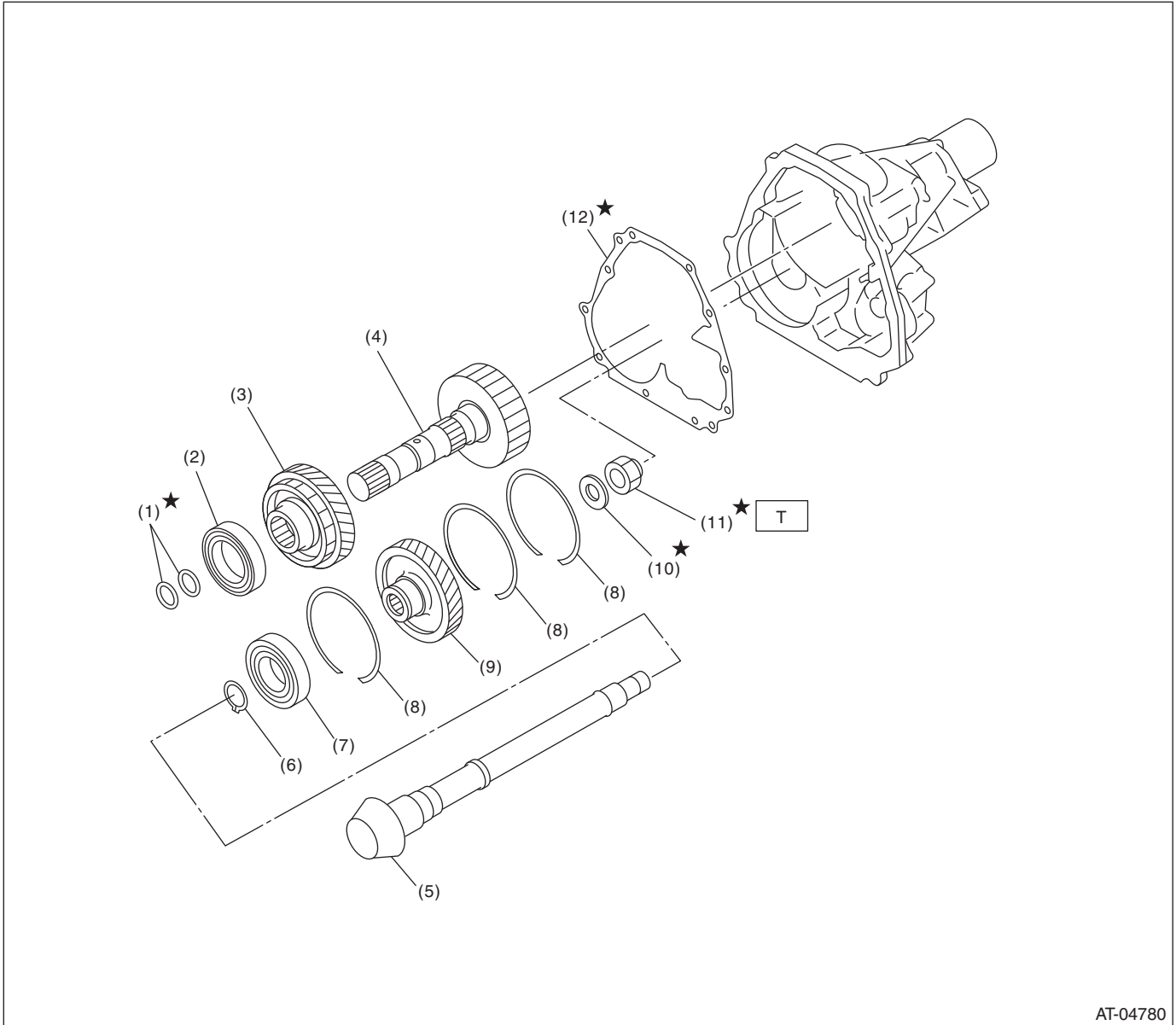

AT-04780

- | | | |
|---------------------------|---------------------------|---------------|
| (1) Seal ring | (6) Snap ring | (11) Lock nut |
| (2) Ball bearing | (7) Ball bearing | (12) Gasket |
| (3) Reduction drive gear | (8) Snap ring | |
| (4) Reduction drive shaft | (9) Reduction driven gear | |
| (5) Drive pinion shaft | (10) Washer | |

Tightening torque: N·m (kgf·m, ft·lb)

T: 100 (10.2, 73.8)

9. DIFFERENTIAL GEAR

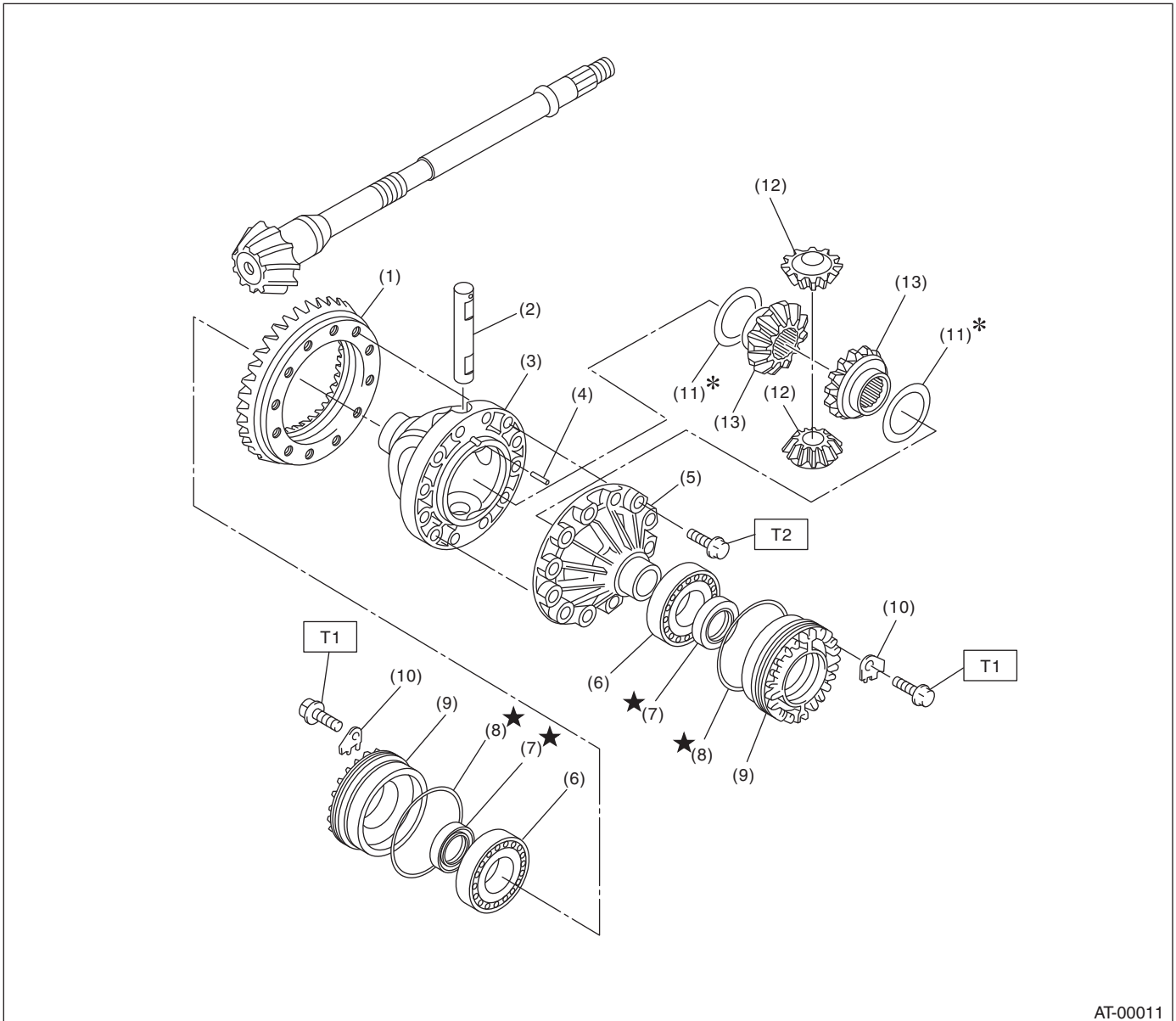

AT-00011

- | | | |
|----------------------------|--------------------------------|------------------------------|
| (1) Hypoid driven gear | (7) Oil seal | (13) Differential bevel gear |
| (2) Pinion shaft | (8) O-ring | |
| (3) Differential case (RH) | (9) Differential side retainer | |
| (4) Straight pin | (10) Lock plate | |
| (5) Differential case (LH) | (11) Washer | |
| (6) Taper roller bearing | (12) Differential bevel pinion | |

Tightening torque: N·m (kgf·m, ft·lb)

T1: 25 (2.5, 18.4)

T2: 62 (6.3, 45.7)

General Description

AUTOMATIC TRANSMISSION

10. TRANSFER AND EXTENSION CASE

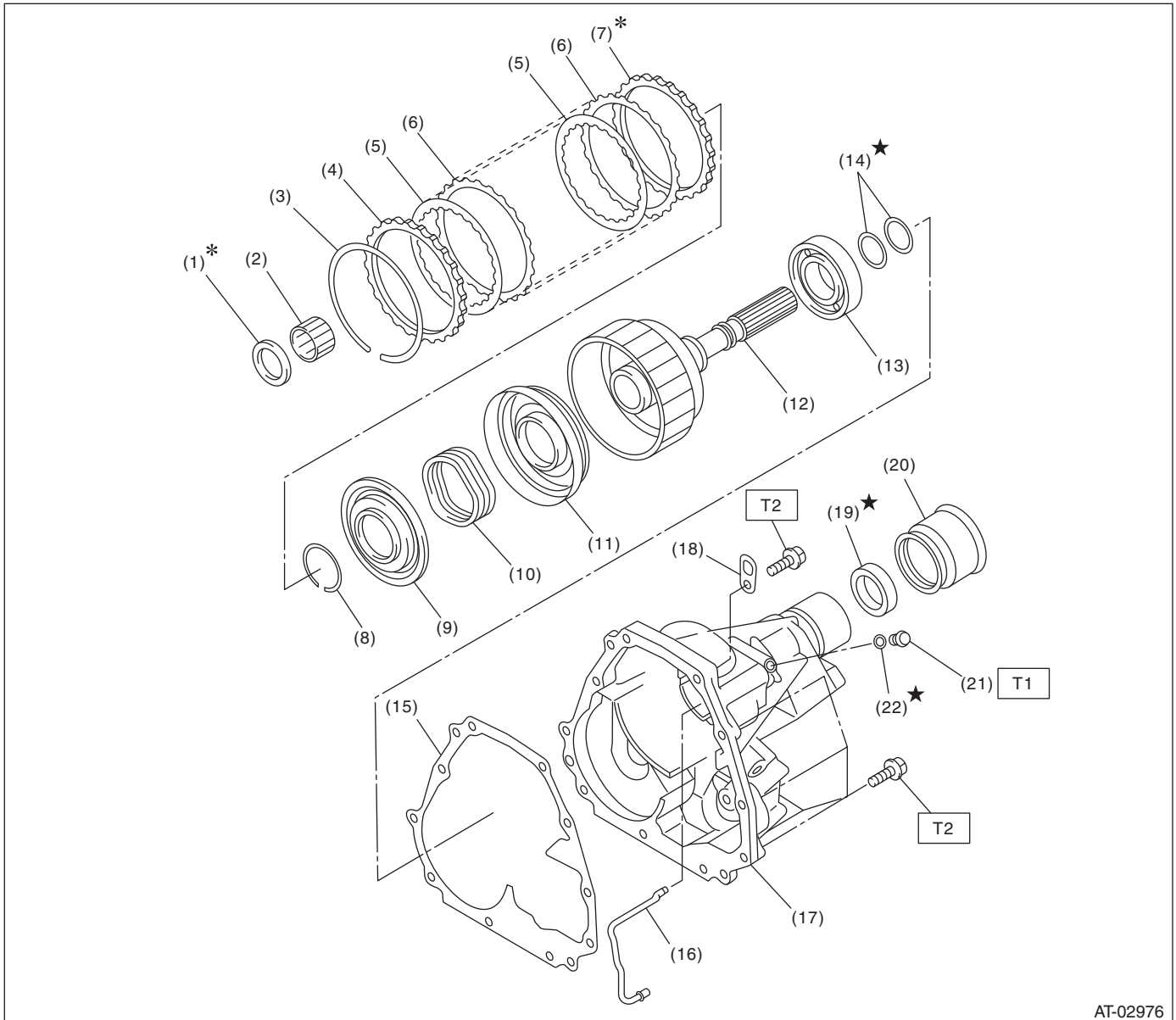

AT-02976

- | | | |
|---------------------------------|-----------------------------|-----------------|
| (1) Thrust needle bearing | (10) Return spring | (19) Oil seal |
| (2) Needle bearing | (11) Transfer clutch piston | (20) Dust cover |
| (3) Snap ring | (12) Rear drive shaft | (21) Test plug |
| (4) Driven plate (thick) | (13) Ball bearing | (22) O-ring |
| (5) Drive plate | (14) Seal ring | |
| (6) Driven plate (thin) | (15) Gasket | |
| (7) Retaining plate | (16) Transfer clutch pipe | |
| (8) Snap ring | (17) Extension case | |
| (9) Transfer clutch piston seal | (18) Transmission hanger | |

Tightening torque: N·m (kgf·m, ft·lb)

T1: 13 (1.3, 9.6)

T2: 25 (2.5, 18.4)

11. TRANSMISSION MOUNTING

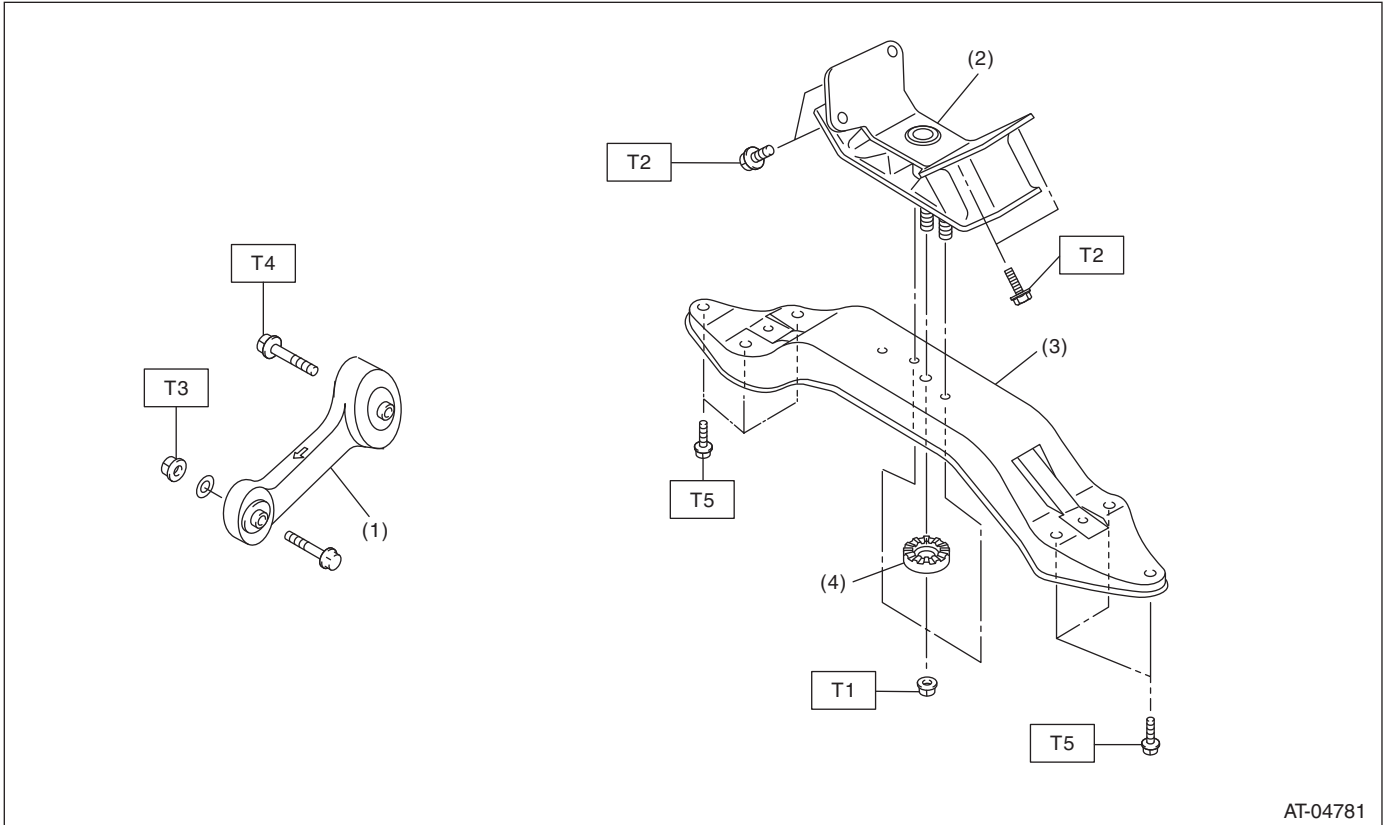

AT-04781

- | | |
|-------------------------|-----------------------------------|
| (1) Pitching stopper | (3) Transmission rear crossmember |
| (2) Rear cushion rubber | (4) Stopper |

Tightening torque: N·m (kgf·m, ft·lb)

T1: 35 (3.6, 25.8)

T2: 40 (4.1, 29.5)

T3: 50 (5.1, 36.9)

T4: 58 (5.9, 42.8)

T5: 70 (7.1, 51.6)

General Description

AUTOMATIC TRANSMISSION

C: CAUTION

- Wear appropriate work clothing, including a cap, protective goggles and protective shoes when performing any work.
- Remove contamination including dirt and corrosion before removal, installation or disassembly.
- Keep the disassembled parts in order and protect them from dust and dirt.
- Do not place the oil pan with its inner side facing up until it is installed, to prevent intrusion of foreign matter into the valve body.
- Before removal, installation or disassembly, be sure to clarify the failure. Avoid unnecessary removal, installation, disassembly and replacement.
- When disassembling the case and other light alloy parts, use a plastic hammer to force it apart. Do not pry apart with screwdrivers or other tools.
- Vehicle components are extremely hot after driving. Be wary of receiving burns from heated parts.
- Use SUBARU genuine gear oil, grease or the equivalent. Do not mix gear oil, grease, etc. of different grades or manufacturers.
- Be sure to tighten bolts and nuts to the specified torque.
- Place lifts, shop jacks or rigid racks at the specified points.
- Apply gear oil or ATF onto sliding or revolution surfaces before installation in view of components usage.
- Replace deformed or damaged snap rings with new parts.
- Before installing O-rings or oil seals, apply sufficient amount of ATF fluid to avoid damage and deformation.
- Be careful not to incorrectly install or fail to install O-rings, snap rings and other such parts.
- Before securing a part on a vise, place cushioning material such as wood blocks, aluminum plate, or cloth between the part and the vise.
- Avoid damaging the mating surface of the case.
- Before applying liquid gasket, completely remove the old gasket.
- When disassembling the AT, be sure to use nylon gloves and paper towels. Do not use cloth gloves or waste cloth.

D: PREPARATION TOOL

1. SPECIAL TOOL

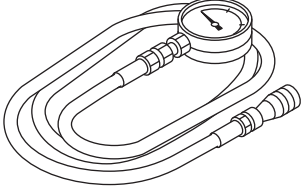
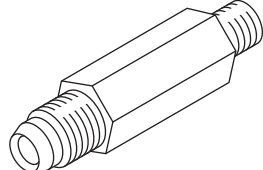
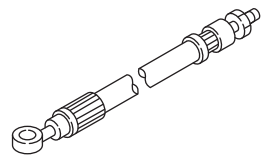
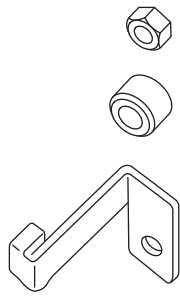
ILLUSTRATION	TOOL NUMBER	DESCRIPTION	REMARKS
 <p style="text-align: center;">ST-498575400</p>	498575400	OIL PRESSURE GAUGE ASSY	Used for measuring oil pressure.
 <p style="text-align: center;">ST-498897200</p>	498897200	OIL PRESSURE GAUGE ADAPTER	Used at the oil pump housing when measuring reverse clutch pressure and line pressure.
 <p style="text-align: center;">ST-498897700</p>	498897700	OIL PRESSURE ADAPTER SET	Used for measuring transfer clutch pressure.
 <p style="text-align: center;">ST-498277200</p>	498277200	STOPPER SET	Used for removing and installing automatic transmission assembly to engine.

General Description

AUTOMATIC TRANSMISSION

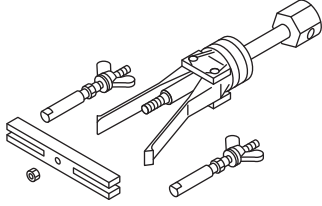
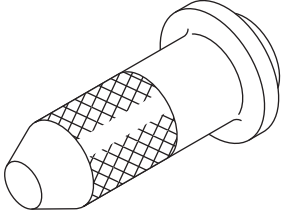
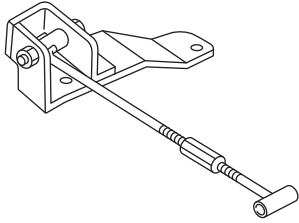
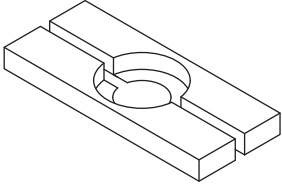
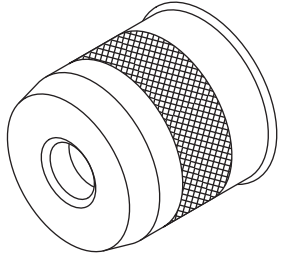
ILLUSTRATION	TOOL NUMBER	DESCRIPTION	REMARKS
 <p style="text-align: center;">ST-398527700</p>	398527700	PULLER ASSY	<ul style="list-style-type: none"> • Used for removing the extension case roller bearing. • Used for removing the extension oil seal. • Used for removing the front differential side retainer bearing outer race. • Used for removing the front differential side retainer oil seal.
 <p style="text-align: center;">ST-498057300</p>	498057300	INSTALLER	Used for installing the extension oil seal.
 <p style="text-align: center;">ST41099AC000</p>	41099AC000	ENGINE SUPPORT ASSY	Used for supporting the engine.
 <p style="text-align: center;">ST-498077000</p>	498077000	REMOVER	Used for removing the differential taper roller bearing.
 <p style="text-align: center;">ST-499247400</p>	499247400	INSTALLER	<ul style="list-style-type: none"> • Used for installing the transfer outer snap ring. • Used together with the GUIDE (499257300).

General Description

AUTOMATIC TRANSMISSION

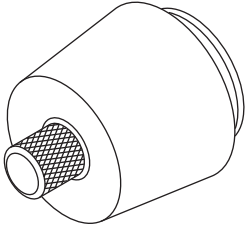
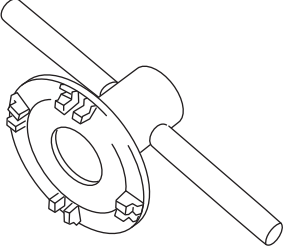
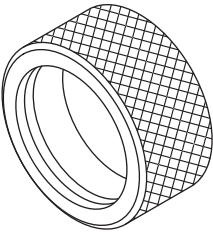
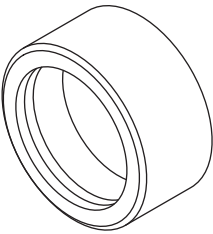
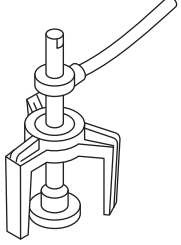
ILLUSTRATION	TOOL NUMBER	DESCRIPTION	REMARKS
 <p data-bbox="337 520 467 541">ST-499257300</p>	499257300	SNAP RING OUTER GUIDE	<ul style="list-style-type: none"> • Used for installing the transfer outer snap ring. • Used together with the INSTALLER (499247400).
 <p data-bbox="324 871 467 892">ST18630AA010</p>	18630AA010	WRENCH COMPL RETAINER	<ul style="list-style-type: none"> • Used for removing and installing the differential side retainer. • WRENCH ASSEMBLY (499787000) can also be used.
 <p data-bbox="337 1222 467 1243">ST-398437700</p>	398437700	DRIFT	Used for installing the converter case oil seal.
 <p data-bbox="337 1570 467 1591">ST-398487700</p>	398487700	INSTALLER	Used for installing the front differential taper roller bearing.
 <p data-bbox="337 1921 467 1942">ST-398673600</p>	398673600	COMPRESSOR	Used for removing and installing the clutch spring.

General Description

AUTOMATIC TRANSMISSION

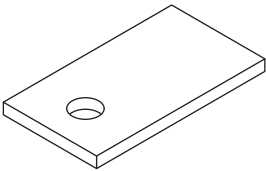
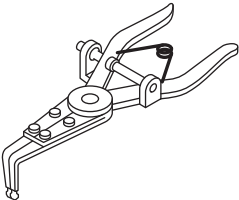
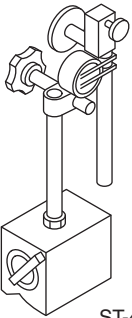
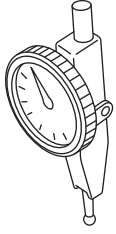
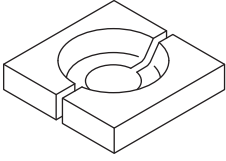
ILLUSTRATION	TOOL NUMBER	DESCRIPTION	REMARKS
 <p style="text-align: center;">ST-498255400</p>	498255400	PLATE	Used for measuring the backlash of hypoid gear.
 <p style="text-align: center;">ST-399893600</p>	399893600	PLIERS	Used for removing and installing the clutch spring.
 <p style="text-align: center;">ST-498247001</p>	498247001	MAGNET BASE	<ul style="list-style-type: none"> • Used for measuring the gear backlash. • Used together with DIAL GAUGE (498247100).
 <p style="text-align: center;">ST-498247100</p>	498247100	DIAL GAUGE	<ul style="list-style-type: none"> • Used for measuring the gear backlash. • Used together with MAGNET BASE (498247001).
 <p style="text-align: center;">ST-498517000</p>	498517000	REPLACER	Used for removing the front roller bearing.

General Description

AUTOMATIC TRANSMISSION

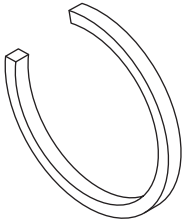
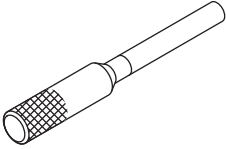
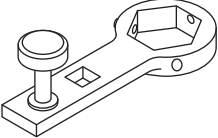
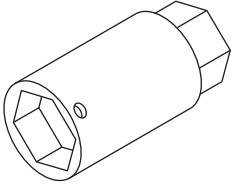
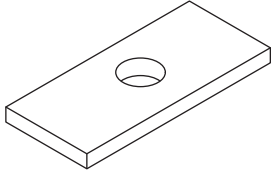
ILLUSTRATION	TOOL NUMBER	DESCRIPTION	REMARKS
 <p data-bbox="337 520 467 543">ST-398623600</p>	398623600	SEAT	Used for removing the spring of the transfer clutch piston.
 <p data-bbox="337 869 467 892">ST-499267300</p>	499267300	STOPPER PIN	Used for installing the inhibitor switch.
 <p data-bbox="337 1222 467 1245">ST-499787700</p>	499787700	WRENCH	Used for removing and installing the drive pinion lock nut.
 <p data-bbox="337 1575 467 1598">ST-499787500</p>	499787500	ADAPTER	Used for removing and installing the drive pinion lock nut.
 <p data-bbox="337 1921 467 1944">ST-398643600</p>	398643600	GAUGE	Used for measuring the total end play, extension end play and drive pinion height.

General Description

AUTOMATIC TRANSMISSION

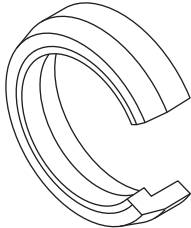
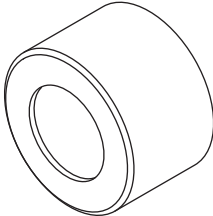
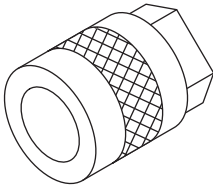
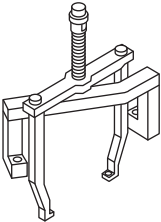
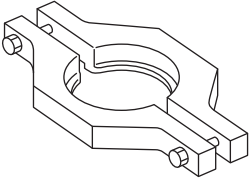
ILLUSTRATION	TOOL NUMBER	DESCRIPTION	REMARKS
 <p style="text-align: center;">ST-498627100</p>	498627100	SEAT	Used for holding the low clutch piston retainer spring when installing snap ring.
 <p style="text-align: center;">ST-499577000</p>	499577000	GAUGE	Used for measuring the mating surface of the transmission to the end face of the reduction gear.
 <p style="text-align: center;">ST-499737000</p>	499737000	PULLER	Used for removing the reduction driven gear assembly.
 <p style="text-align: center;">ST-499737100</p>	499737100	PULLER SET	Used for removing the reduction drive gear assembly.
 <p style="text-align: center;">ST-498077600</p>	498077600	REMOVER	Used for removing the ball bearing.

General Description

AUTOMATIC TRANSMISSION

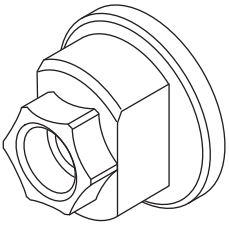
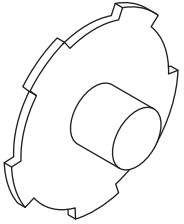
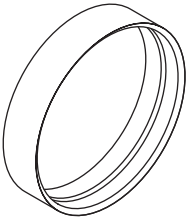
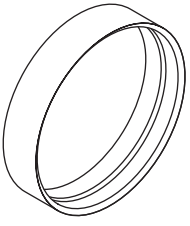
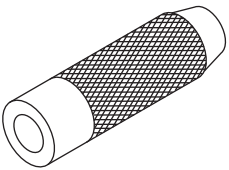
ILLUSTRATION	TOOL NUMBER	DESCRIPTION	REMARKS
 <p>ST-498937110</p>	498937110	HOLDER	Used for removing and installing the drive pinion lock nut.
 <p>ST-498677100</p>	498677100	COMPRESSOR	Used for installing the 2-4 brake snap ring.
 <p>ST-498437000</p>	498437000	HIGH CLUTCH PISTON GUIDE	Used for installing the high clutch piston.
 <p>ST-498437100</p>	498437100	LOW CLUTCH PISTON GUIDE	Used for installing the low clutch piston.
 <p>ST-899580100</p>	899580100	INSTALLER	Used for press-fitting the ball bearing of the transfer clutch.

General Description

AUTOMATIC TRANSMISSION

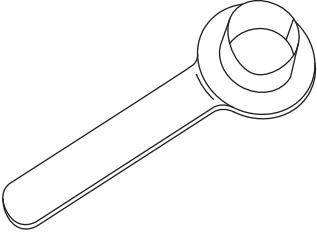
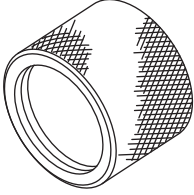
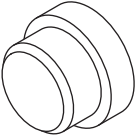
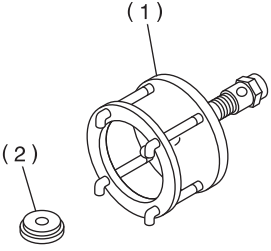
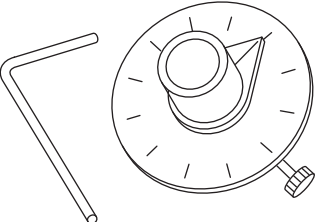
ILLUSTRATION	TOOL NUMBER	DESCRIPTION	REMARKS
 <p style="text-align: center;">ST28399SA010</p>	28399SA010	OIL SEAL PROTECTOR	Used for installing the axle shaft.
 <p style="text-align: center;">ST18675AA000</p>	18675AA000	DIFFERENTIAL SIDE OIL SEAL INSTALLER	Used for installing the differential side retainer oil seal.
 <p style="text-align: center;">ST-398497701</p>	398497701	INSTALLER	Used for installing the needle bearing.
 <p style="text-align: center;">ST-899524100</p>	899524100	PULLER SET	Use only the bolt. <ul style="list-style-type: none"> • Used together with the PULLER SET (499737100). • Used together with the PULLER (499737000). <ol style="list-style-type: none"> 1. Puller 2. Cap
 <p style="text-align: center;">ST18854AA000</p>	18854AA000	ANGLE GAUGE	Used for installing the drive plate.

General Description

AUTOMATIC TRANSMISSION

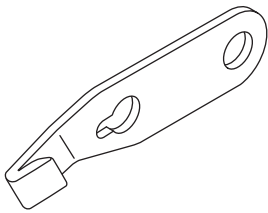
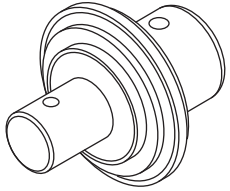
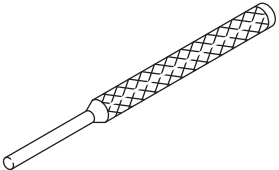
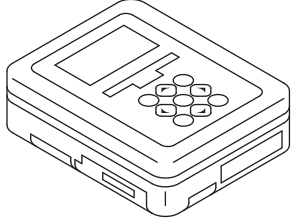
ILLUSTRATION	TOOL NUMBER	DESCRIPTION	REMARKS
 <p>ST-498497100</p>	498497100	CRANKSHAFT STOPPER	Used for stopping the drive plate rotation when removing and installing the drive plate.
 <p>ST-499247300</p>	499247300	INSTALLER	Used for installing the oil pump housing retainer oil seal.
 <p>ST-398791600</p>	398791600	REMOVER	Used for removing the shifter arm spring pin.
 <p>ST1B022XU0</p>	1B022XU0 (Newly adopted tool)	SUBARU SELECT MONITOR III KIT	Troubleshooting for electrical system

2. GENERAL TOOL

TOOL NAME	REMARKS
Depth gauge	Used for measuring the transmission end play.
Thickness gauge	Used for measuring clearance of the clutch, brake and oil pump.
Micrometer	Used for measuring thickness of the drive pinion.
Spring scale	Used for measuring the starting torque of the drive pinion.
Circuit tester	Used for measuring resistance and voltage.
TORX® T70	Used for removing and installing differential gear oil drain plug.
Push/pull gauge	Used for measuring the piston stroke of each clutch.

Automatic Transmission Fluid

AUTOMATIC TRANSMISSION

2. Automatic Transmission Fluid

A: INSPECTION

NOTE:

The level of ATF varies with fluid temperature. Pay attention to the ATF temperature when checking ATF level.

1) Raise the ATF temperature by driving a distance of 5 to 10 km (3 to 6 miles). Otherwise, idle the engine to raise ATF temperature to 70 — 80°C (158 — 176°F) displayed on Subaru Select Monitor. <Ref. to 4AT(diag)-16, OPERATION, Read Current Data.>

2) Park the vehicle on a level surface.

3) After selecting all positions (P, R, N, D), set the select lever in “P” range. Idle the engine for 1 or 2 minutes, and measure the ATF level.

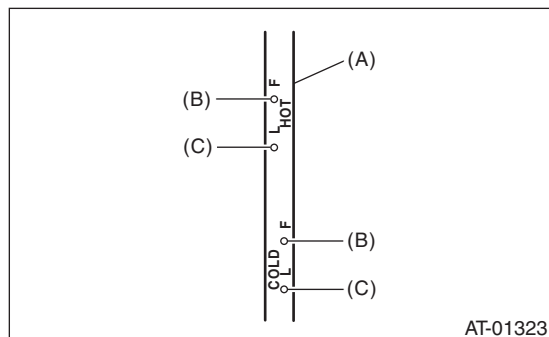

- (A) ATF level gauge
- (B) Upper level
- (C) Lower level

4) Make sure that the ATF level is higher than the center point between upper and lower marks of the HOT side.

If the fluid level is below the lower mark, check the transmission for leaks. If there are leaks, it is necessary to repair or replace gaskets, oil seals, plugs or other parts.

5) If the ATF level is below the center point between upper and lower level marks, add the recommended ATF until the fluid level is above the center point between the upper and lower level marks.

CAUTION:

- Be careful not to exceed the upper level.
- When the transmission is cold, be careful not to add ATF to the upper level. Overfilling of ATF may cause oil splashing.

6) Check ATF level after raising ATF temperature to 70 — 80°C (158 — 176°F) by running the vehicle again or by idling the engine.

B: REPLACEMENT

- 1) Lift up the vehicle.
- 2) Remove the drain plug (ATF) and completely drain the ATF.

CAUTION:

Immediately after the vehicle has been running or after idling for a long time, the ATF will be hot. Be careful not to receive burns.

3) Check the condition of ATF. <Ref. to 4AT-27, CONDITION CHECK, Automatic Transmission Fluid.>

4) Perform replacement with a new gasket, and tighten the drain plug (ATF).

Tightening torque:

25 N·m (2.5 kgf·m, 18.4 ft·lb)

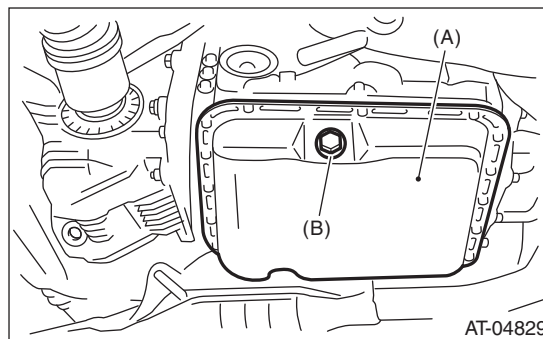

- (A) Oil pan
- (B) Drain plug (ATF)

- 5) Lower the vehicle.
- 6) Pour ATF from the oil charge pipe.

Recommended fluid:

<Ref. to 4AT-3, HYDRAULIC CONTROL AND LUBRICATION, SPECIFICATION, General Description.>

Capacity:

Refill with the same amount of ATF drained from the drain plug hole.

Capacity when transmission is overhauled:

9.3 — 9.6 ℓ (9.8 — 10.1 US qt, 8.2 — 8.4 Imp qt)

- 7) Bleed the air of control valve. <Ref. to 4AT-59, Air Bleeding of Control Valve.>
- 8) Check the level and leaks of ATF. <Ref. to 4AT-26, INSPECTION, Automatic Transmission Fluid.>

C: CONDITION CHECK

NOTE:

When replacing ATF, check the inside condition of transmission body by inspecting the drained ATF.

Fluid condition	Trouble and possible cause	Corrective action
Large amount of metallic pieces are found.	Excessive wear of the internal of the transmission body.	Replace ATF and check if AT operates correctly.
Thick and varnish-form fluid.	Burned clutch, etc.	Replace ATF and check the AT body or vehicle for faulty.
Clouded fluid or bubbles are found in fluid.	Water mixed in fluid.	Replace ATF and check the water entering point.

Differential Gear Oil

AUTOMATIC TRANSMISSION

3. Differential Gear Oil

A: INSPECTION

- 1) Park the vehicle on a level surface.
- 2) Remove the differential oil level gauge and wipe it clean.
- 3) Reinsert the level gauge all the way. Make sure the level gauge is inserted correctly and in the proper orientation.
- 4) Remove the oil level gauge again, and check the level of differential gear oil. If the differential gear oil level is below "L" line, add oil to bring the level up to "F" line.

NOTE:

To prevent overfilling the differential gear oil, do not fill oil to the "F" line or more.

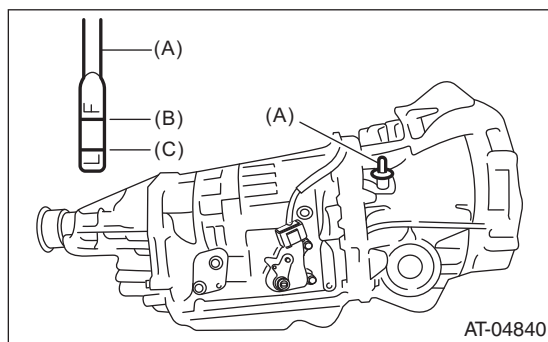

- (A) Oil level gauge
- (B) Upper level
- (C) Lower level

B: REPLACEMENT

- 1) Lift up the vehicle.
- 2) Remove the differential gear oil drain plug using TORX® bit T70, and drain the differential gear oil completely.

CAUTION:

- Immediately after the vehicle has been running or after idling for a long time, the differential gear oil will be hot. Be careful not to receive burns.
- Be careful not to spill differential gear oil on the exhaust pipe to prevent it from emitting smoke or causing a fire. If differential gear oil is spilled on the exhaust pipe, wipe it off completely.

- 3) Replace the gasket with a new part and tighten the differential gear oil drain plug using the TORX® bit T70.

Tightening torque:

Aluminum gasket

44 N·m (4.5 kgf·m, 32.5 ft·lb)

Copper gasket

70 N·m (7.1 kgf·m, 51.6 ft·lb)

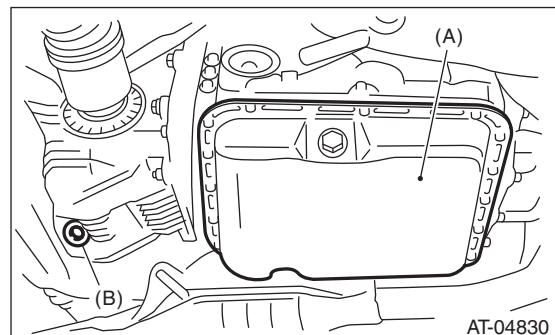

- (A) Oil pan
- (B) Differential gear oil drain plug

- 4) Lower the vehicle.
- 5) Fill the differential with differential gear oil from the level gauge hole.

Recommended gear oil:

<Ref. to 4AT-3, RECOMMENDED GEAR OIL, SPECIFICATION, General Description.>

Gear oil capacity:

1.1 — 1.3 ℓ (1.2 — 1.4 US qt, 1.0 — 1.1 Imp qt)

- 6) Check the level of differential gear oil.
<Ref. to 4AT-28, INSPECTION, Differential Gear Oil.>

4. Road Test

A: INSPECTION

1. GENERAL PRECAUTION

Road tests should be conducted to properly diagnose the condition of automatic transmission.

NOTE:

When performing the test, do not exceed posted speed limit.

2. D RANGE SHIFT FUNCTION

Check shifting between 1st ↔ 2nd ↔ 3rd ↔ 4th while driving on normal city streets.

3. D RANGE SHIFT SHOCK

Check the shock level when shifting up during normal driving.

4. KICK-DOWN FUNCTION

Check kick-down for each gear. Check the shock level during kick-down at the same time.

5. ENGINE BRAKE OPERATION

- Check the 3rd gear engine brake when shifting down from 4th to 3rd range while driving in 4th gear of manual mode [50 — 60 km/h (31 — 37 MPH)].
- Check the 2nd gear engine brake when shifting down from 3rd to 2nd range while driving in 3rd gear of manual mode [40 — 50 km/h (25 — 31 MPH)].
- Check the 1st gear engine brake when shifting down from 2nd to 1st range while driving in 2nd gear of manual mode [20 — 30 km/h (12 — 19 MPH)].

6. LOCK-UP FUNCTION

- When the accelerator is lightly depressed while driving on a flat road in “D” range, check that rpm does not change abruptly.
 - Check slip lock-up with following procedure. Subaru Select Monitor is required for judgement. Before starting the check, make sure that no DTC is displayed using the Subaru Select Monitor. If there is a DTC, perform the corrective action according to the DTC. Recheck to see that the DTC has been cleared, then start the slip lock-up check.
- 1) The check is to be performed on a flat and straight road or on a free roller.

NOTE:

- Slip lock-up will not operate when the vehicle is lifted up off of its wheels, since there is no surface resistance.
 - When checking on the free roller, the driving resistance will be slightly inadequate. It will be easier to judge if the foot brake is lightly applied while performing the check.
- 2) Connect the Subaru Select Monitor.

3) Check the ATF temperature using the Subaru Select Monitor.

NOTE:

- Make sure to perform the check with the ATF temperature between 50 — 100°C (122 — 212°F).
 - If the temperature is low, warm-up the ATF by running the vehicle.
- 4) Start the engine, and set so that the lock-up duty can be read on the data display of the Subaru Select Monitor.
- 5) Drive the vehicle at a constant speed of 35 — 40 km/h (22 — 25 MPH).
- 6) Read the lock-up duty while vehicle is running.

Standard

25 — 45%

NOTE:

- The reading may be slightly lower on a free roller.
- Slip lock-up control is not operating if the lock-up duty is 5% or less, or when the lock-up duty goes down immediately after starting to rise. In these cases, improper ATF or deterioration of the ATF may be the cause. Check the amount of ATF or replace the fluid, then recheck.

7. P RANGE OPERATION

Stop the vehicle on an uphill grade of 5% or more and shift to the “P” range. Check that the vehicle does not move when the parking brake is released.

8. NOISE AND VIBRATION

Check for noise and vibration while driving and during shifting.

9. TRANSFER CLUTCH

Check for tight corner braking phenomenon when the vehicle is moved forward with the steering fully turned.

10. OIL LEAKAGE

After the driving test, inspect for oil leaks.

Stall Test

AUTOMATIC TRANSMISSION

5. Stall Test

A: INSPECTION

NOTE:

The stall test is extremely important in diagnosing the condition of an automatic transmission and engine. The test is necessary to measure the engine stall speeds in “R” and “2nd of manual mode”.

Purposes of the stall test:

- Operational check of the automatic transmission clutch
- Operational check of the torque converter clutch
- Engine performance check
- 1) Check that the throttle valve fully opens.
- 2) Check that the engine oil level is correct.
- 3) Check that the coolant level is correct.
- 4) Check that the ATF level is correct.
- 5) Check that the differential gear oil level is correct.
- 6) Increase the ATF temperature to 70 to 80°C (158 to 176°F) by idling the engine for approximately 30 minutes (with select lever set to “N” or “P”).
- 7) Place the wheel chocks at the front and rear of all wheels and apply the parking brake.
- 8) Move the select lever to ensure it operates properly, then set to “2nd gear of manual mode”.
- 9) While stepping hard on the brake pedal, slowly depress the accelerator pedal to full throttle.
- 10) When the engine speed is stabilized, quickly record the engine speed and release accelerator pedal.
- 11) Shift the select lever to “N” range, and cool down the engine by idling it for one minute or more.
- 12) If the stall speed in “2nd gear of manual mode” is higher than specifications, low clutch slipping and 2-4 brake slipping may occur. To identify this, conduct the same test as above in “R” range.
- 13) Perform the stall tests with the select lever in “D” range.

NOTE:

- Do not perform a stall test for over 5 seconds at a time. (From closed throttle, full open throttle to reading of stall speed) Failure to follow this instruction will cause the engine oil and ATF to deteriorate and the clutch and brake to be adversely affected.
- Be sure to cool down the engine for at least one minute after each stall test with the select lever set in the “P” or “N” range and with the idle speed of 1,200 rpm or less.
- If the stall speed is higher than the specified range, attempt to finish the stall test in as short a time as possible, in order to prevent the automatic transmission from sustaining damage.

Stall speed (at sea level):

Non-turbo model

2,200 — 2,700 rpm

Turbo model

2,800 — 3,300 rpm

Stall speed (at sea level)	Range	Cause
Below specified value	2nd gear on manual mode, R	<ul style="list-style-type: none">• Throttle valve is not fully open• Engine malfunction• One-way clutch of the torque converter is slipping
Over specified value	D	<ul style="list-style-type: none">• Line pressure too low• Low clutch slipping• One-way clutch malfunctioning
	R	<ul style="list-style-type: none">• Line pressure too low• Reverse clutch slipping• Low & reverse brake slipping
	2nd gear of manual mode	<ul style="list-style-type: none">• Line pressure too low• Low clutch slipping• 2-4 brake slipping

6. Time Lag Test

A: INSPECTION

NOTE:

When the select lever is shifted while the engine is idling, there will be a certain time elapse or lag before shock is felt. This is used for checking the condition of the low clutch, reverse clutch, low & reverse brake and one-way clutch.

- Perform the test at normal operation fluid temperature of 70 — 80°C (158 — 176°F).
- Be sure to allow a one minute or more interval between tests.
- Make three measurements and take the average value.

1) Fully apply the parking brake.

2) Start the engine.

Check the idle speed. (A/C OFF)

3) Shift the select lever from “N” to “D” range.

Using a stop watch, measure the time which takes from shifting the lever until the shock is felt.

Time lag: 1.2 seconds or less

If “N” → “D” time lag is longer than specified:

- Line pressure too low
- Low clutch worn
- One-way clutch not operating properly
- D-ring worn

4) In the same manner, measure the time lag of “N” → “R”.

Time lag: 1.5 seconds or less

If “N” → “R” time lag is longer than specified:

- Line pressure too low
- Reverse clutch worn
- Low & reverse brake worn
- D-ring worn

Line Pressure Test

AUTOMATIC TRANSMISSION

7. Line Pressure Test

A: MEASUREMENT

NOTE:

If the clutch or brake shows a signs of slipping or shift feel is not correct, check the line pressure.

- Excessive shock during up-shift may be due to the line pressure being too high.
- Slippage or inability to operate the vehicle may, in most cases, be due to insufficient oil pressure for the operation of clutch, brake or control valve.

1) Line pressure measurement (under no load):

- (1) Before measuring line pressure, raise the vehicle on a lift.
- (2) Maintain the ATF temperature at approx. 70 — 80°C (158 — 176°F) during measurement. (ATF will reach the temperature above after idling the engine for approx. 30 minutes with the select lever in “N” or “P”.)

2) Line pressure measurement (under heavy load)

- (1) Before measuring line pressure, apply both the foot and parking brakes with all wheels chocked on both front and rear of all wheels. (Same conditions as for a stall test)
- (2) Measure the line pressure when the select lever is in “R” or 2nd of manual mode with engine under stall conditions.
- (3) Measure the line pressure within 5 seconds after shifting the select lever to each position. (If the line pressure needs to be measured again, allow the engine to idle and cool it down for more than 1 minute.)
- (4) Maintain the ATF temperature at approx. 70 — 80°C (158 — 176°F) during measurement. (ATF will reach the temperature above after idling the engine for approx. 30 minutes with the select lever in “N” or “P”.)

3) Remove the test plug and attach the ST instead.

ST 498897200 OIL PRESSURE GAUGE ADAPTER

4) Connect the ST1 with ST2.

ST1 498897200 OIL PRESSURE GAUGE ADAPTER
ST2 498575400 OIL PRESSURE GAUGE ASSY

5) Check for duty ratio changes by adjusting the acceleration pedal position using the Subaru Select Monitor.

Standard line pressure			
Range position	Line pressure duty ratio (%)	Throttle valve angle	Line pressure kPa (kg/cm ² , psi)
Manual mode (2nd)	25 — 35	Full open	1,000 — 1,300 (10.2 — 13.3, 145 — 188)
R	15 — 25	Full open	1,500 — 1,850 (15.3 — 18.9, 217 — 268)
D	35 — 43	Full closed	500 — 800 (5.1 — 8.2, 72 — 116)

6) Remove the ST and install the test plug.

Tightening torque:

13 N·m (1.3 kgf-m, 9.6 ft-lb)

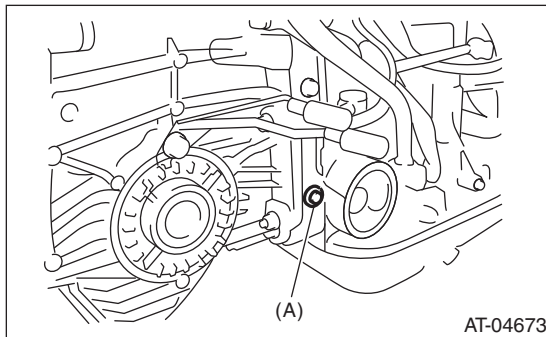

(A) Test plug

8. Transfer Clutch Pressure Test

A: INSPECTION

Check the transfer clutch pressure in accordance with the following chart in the same manner as for line pressure. <Ref. to 4AT-32, Line Pressure Test.>

- ST 498897700 OIL PRESSURE ADAPTER SET
- ST 498575400 OIL PRESSURE GAUGE ASSY

NOTE:

- Before setting to FWD mode, install the spare fuse on the FWD mode switch.

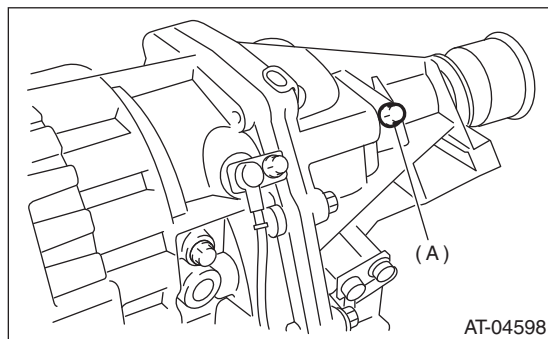

(A) Test plug

- If no oil pressure is produced or if it does not change in AWD mode, there may be a problem in the transfer duty solenoid or control valve body.
- If oil pressure is produced in FWD mode, there is the same problem as the AWD mode.

Range position	ON duty ratio (%)	Acceleration opening angle (%)	Standard transfer clutch pressure kPa (kg/cm ² , psi)	
			AWD mode	FWD mode
Manual mode (2nd)	95	Fully opened (100)	1,000 — 1,200 (10.2 — 12.2, 145 — 174)	—
	60	Adjust ON Duty ratio to 60%.	500 — 700 (5.1 — 7.1, 72 — 101)	—
	5	Fully closed (0)	—	0 (0, 0)
N or P	5	Fully closed (0)	0	—

Automatic Transmission Assembly

AUTOMATIC TRANSMISSION

9. Automatic Transmission Assembly

A: REMOVAL

- 1) Set the vehicle on a lift.
- 2) Open the front hood.
- 3) Disconnect the ground cable from the battery.
- 4) Remove the air intake chamber and intake boot. (Non-turbo model) <Ref. to IN(H4SO)-7, REMOVAL, Air Intake Chamber.>
- 5) Remove the intercooler. (Turbo model) <Ref. to IN(H4DOTC)-11, REMOVAL, Intercooler.>
- 6) Remove the air intake chamber stay. (Non-turbo model)

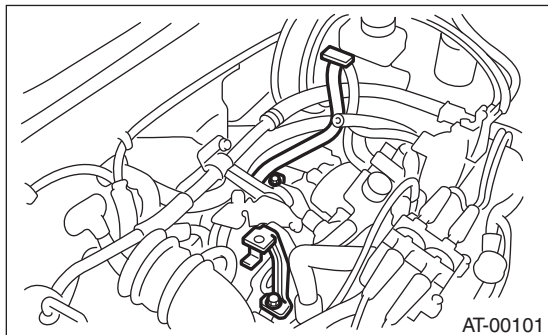

- 7) Disconnect the following connectors and terminals.

- Non-turbo model

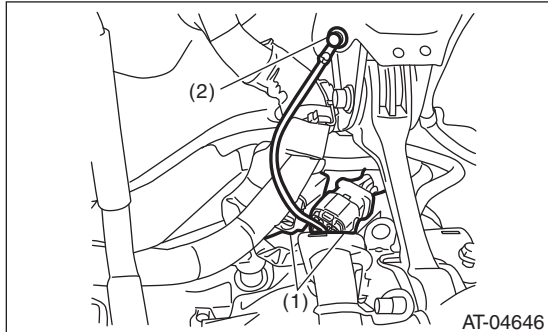

- (1) Transmission harness connectors
- (2) Transmission ground terminal

- Turbo model

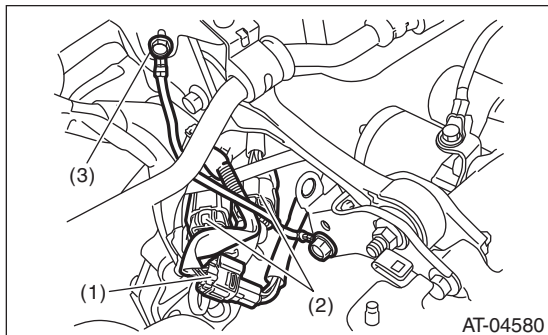

- (1) Rear oxygen sensor connector
- (2) Transmission harness connectors
- (3) Transmission ground terminal

- 8) Remove the starter. <Ref. to SC(H4SO)-6, REMOVAL, Starter.>
- 9) Remove the pitching stopper.

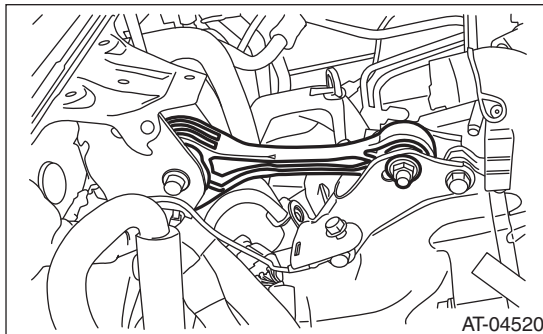

- 10) Remove the throttle body. (Non-turbo model) <Ref. to FU(H4SO)-13, REMOVAL, Throttle Body.>
- 11) Separate the torque converter clutch from the drive plate.

CAUTION:

- Be careful not to damage the mounting bolts.
- Be careful not to drop bolts into the converter case.

- (1) Remove the V-belt covers.
- (2) Remove the service hole plug.
- (3) Remove the bolts which hold torque converter clutch assembly to drive plate.
- (4) Place the wrench on the crank pulley bolt, and remove all the bolts while rotating the crank pulley a little bit at a time.
- (5) Make sure the torque converter moves freely by rotating with finger through the starter installation hole.

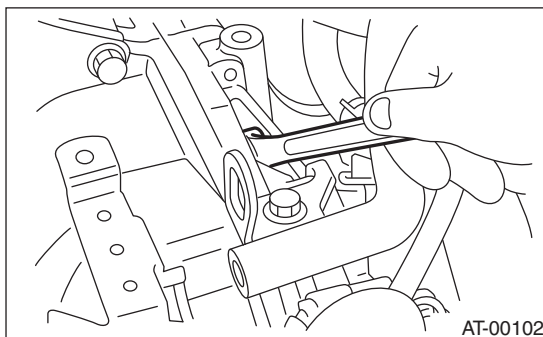

- 12) Attach the ST to the converter case.
ST 498277200 STOPPER SET

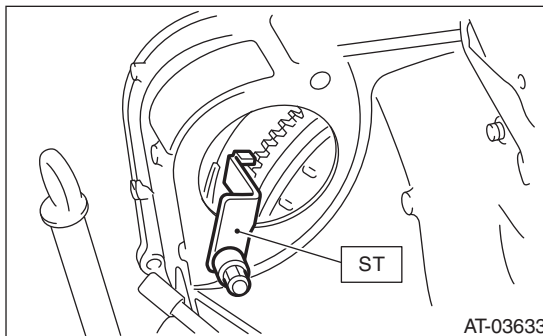

Automatic Transmission Assembly

AUTOMATIC TRANSMISSION

13) Remove the ATF level gauge.

NOTE:

Plug the opening to prevent entry of foreign particles into the transmission fluid.

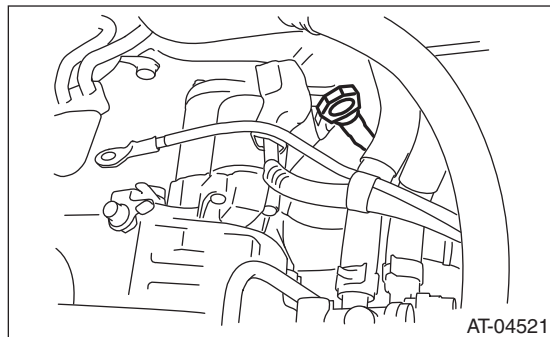

14) Remove the pitching stopper bracket.

15) Disconnect the engine harness, then remove the harness connector from the engine harness bracket. (Non-turbo model)

16) Remove the engine harness bracket. (Non-turbo model)

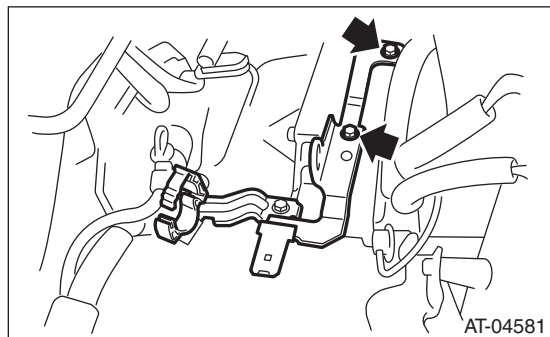

17) Remove the engine hanger. (Turbo model)

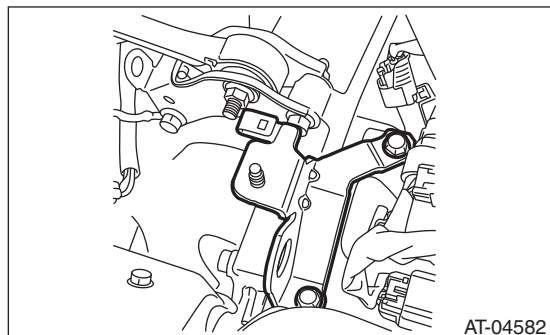

18) Set the ST.

ST 41099AC000 ENGINE SUPPORT ASSY

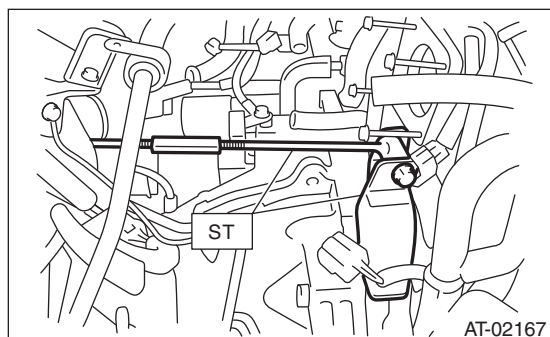

19) Lift up the vehicle.

20) Remove the under cover.

21) Remove the front, center and rear exhaust pipes and the muffler. (Non-turbo model)

<Ref. to EX(H4SO)-4, REMOVAL, Front Exhaust Pipe.> <Ref. to EX(H4SO)-8, REMOVAL, Rear Exhaust Pipe.> <Ref. to EX(H4SO)-10, REMOVAL, Muffler.>

22) Remove the center and rear exhaust pipes and the muffler. (Turbo model)

<Ref. to EX(H4DOTC)-7, REMOVAL, Center Exhaust Pipe.> <Ref. to EX(H4DOTC)-12, REMOVAL, Rear Exhaust Pipe.> <Ref. to EX(H4DOTC)-14, REMOVAL, Muffler.>

23) Remove the bolts which hold upper side of transmission to engine.

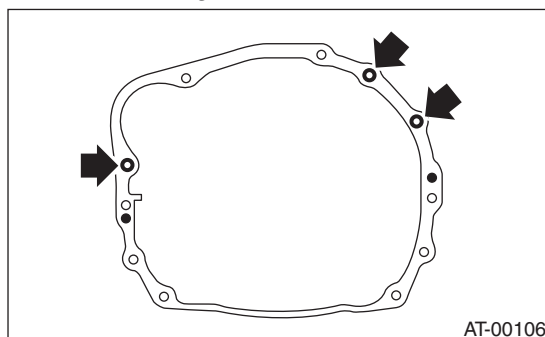

24) Remove the heat shield cover.

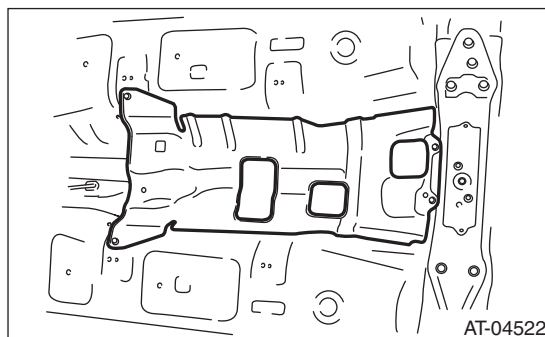

25) Remove the drain plug (ATF) to drain the ATF.

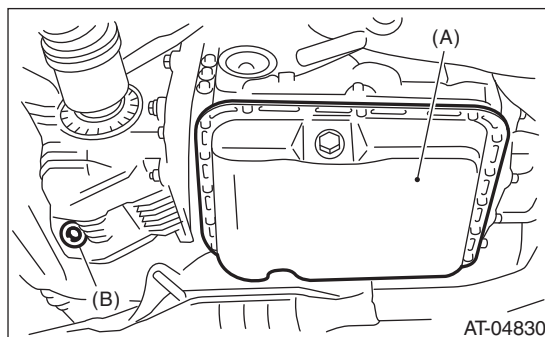

(A) Oil pan

(B) Drain plug (ATF)

Automatic Transmission Assembly

AUTOMATIC TRANSMISSION

26) Disconnect the ATF cooler hoses from the pipes of the transmission side, and remove the oil charge pipe.

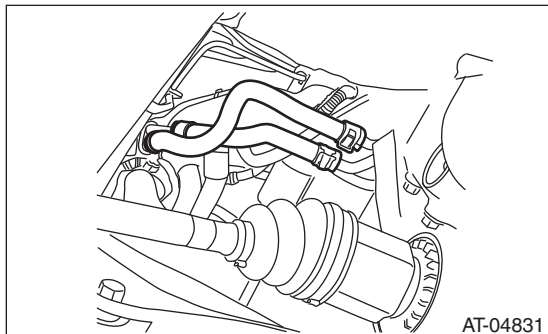

27) Remove the propeller shaft. <Ref. to DS-10, REMOVAL, Propeller Shaft.>

28) Remove the shift select cable from the inhibitor switch and transmission. <Ref. to CS-25, REMOVAL, Select Cable.>

29) Remove the front height sensor. <Ref. to LI-40, REMOVAL, Front Height Sensor.>

30) Disconnect the stabilizer link from the front arm.

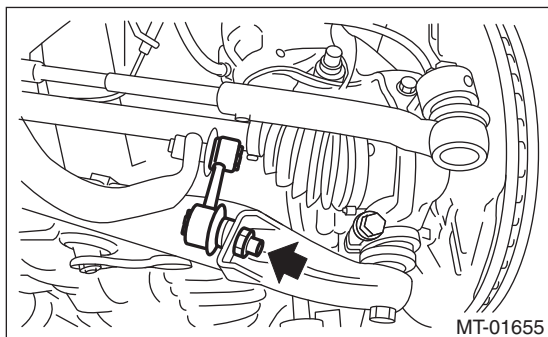

31) Remove the bolt securing the ball joint of the front arm to the front housing, then separate the front arms and the housing.

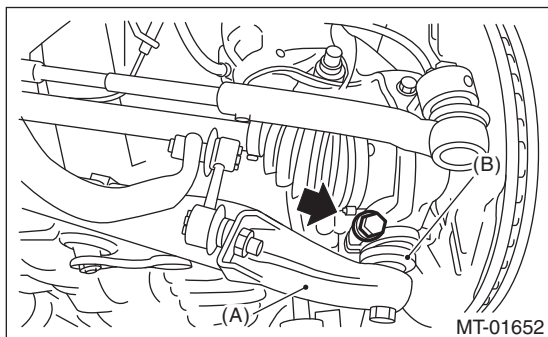

- (A) Front arm
- (B) Ball joint

32) Pull out the front drive shaft from the transmission.

(1) Using a tire lever or a crow bar, etc., pull out until the front drive shaft transmission side joint slides move smoothly.

NOTE:

Place cloth between the tire lever or bar and the transmission in order to avoid damaging the transmission side retainer.

(2) Hold the transmission side joint of the front drive shaft by hand and extract the housing from the transmission while pressing the housing outward, so as not to stretch the boot.

33) Remove the bolts which hold the clutch housing cover.

34) Remove the bolts and nuts which hold lower side of transmission to engine.

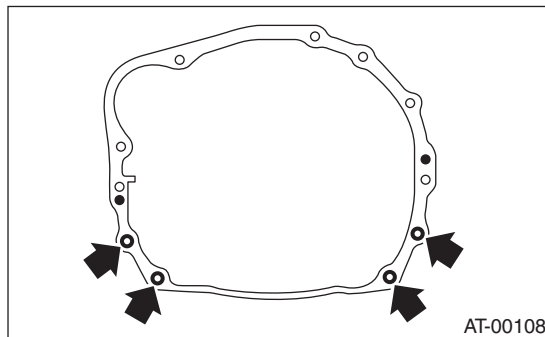

35) Place a transmission jack below the transmission.

NOTE:

Make sure that the support plates of transmission jack do not touch the oil pan.

36) Remove the transmission rear crossmember from the vehicle.

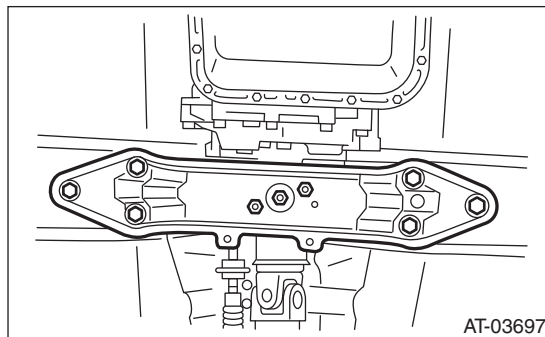

37) While lowering the transmission jack gradually, fully retract the engine support, and then tilt the engine rearward.

38) Remove the transmission.

NOTE:

Remove the transmission and torque converter as a single unit from engine.

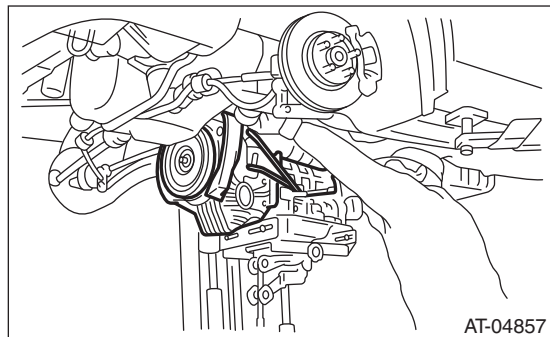

39) Remove the rear cushion rubber from the transmission assembly.

B: INSTALLATION

1) Replace the differential side oil seal with a new part. <Ref. to 4AT-45, Differential Side Retainer Oil Seal.>

NOTE:

When a new oil seal has been installed, replacement is not required.

2) Install the rear cushion rubber to the transmission assembly.

Tightening torque:

40 N·m (4.1 kgf·m, 29.5 ft·lb)

3) Attach the ST to the converter case.

ST 498277200 STOPPER SET

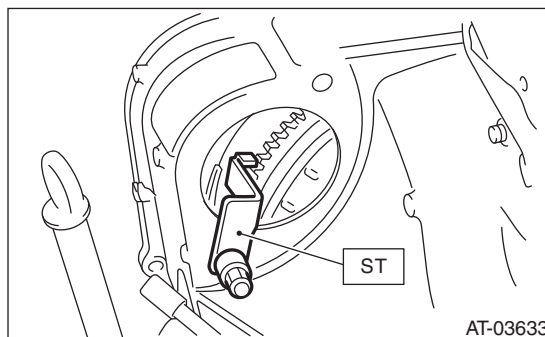

4) Install the transmission onto the engine.

(1) Lift up the transmission gradually using transmission jack.

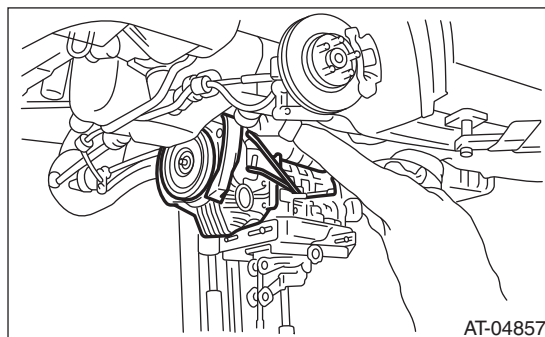

(2) Insert the engine side stud bolt into the transmission bolt hole.

(3) While raising the transmission jack gradually, turn the screw of engine support, then tilt the engine forward and connect.

Automatic Transmission Assembly

AUTOMATIC TRANSMISSION

5) Install the transmission rear crossmember.

Tightening torque:

T1: 35 N·m (3.6 kgf·m, 25.8 ft·lb)

T2: 70 N·m (7.1 kgf·m, 51.6 ft·lb)

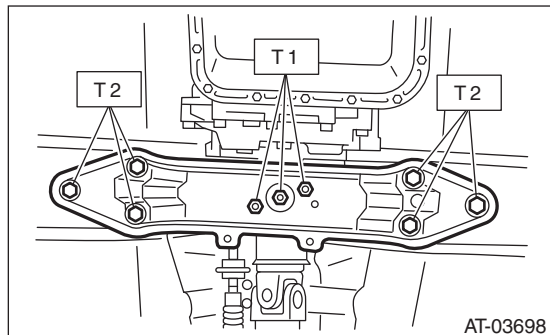

6) Remove the transmission jack.

7) Tighten the bolts and nuts which hold the lower side of transmission to the engine.

Tightening torque:

50 N·m (5.1 kgf·m, 36.9 ft·lb)

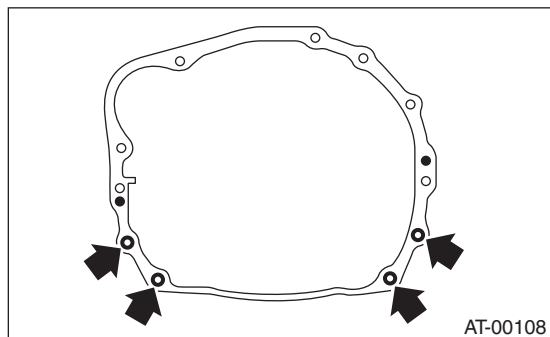

8) Install the clutch housing cover bolts.

9) Lower the lift.

10) Connect the engine and transmission.

(1) Remove the ST from converter case.

NOTE:

When removing the ST, be careful not to drop it into converter case.

ST 498277200 STOPPER SET

(2) Install the starter. <Ref. to SC(H4SO)-6, INSTALLATION, Starter.>

(3) Tighten the bolts which hold the upper side of the transmission to the engine.

Tightening torque:

50 N·m (5.1 kgf·m, 36.9 ft·lb)

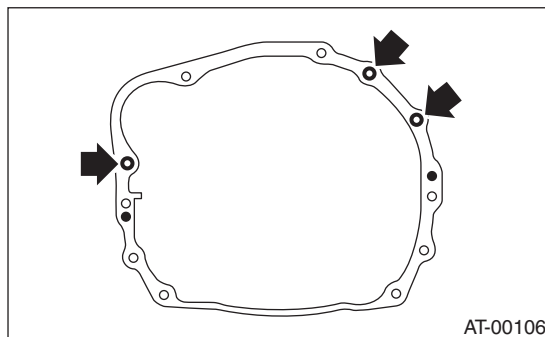

11) Install the torque converter clutch assembly to the drive plate.

CAUTION:

- Be careful not to damage the mounting bolts.
- Be careful not to drop bolts into the converter case.

(1) Tighten the bolts which hold the torque converter clutch to the drive plate.

(2) Place the wrench on the crank pulley bolt, and remove all the bolts while rotating the crank pulley a little bit at a time.

Tightening torque:

25 N·m (2.5 kgf·m, 18.4 ft·lb)

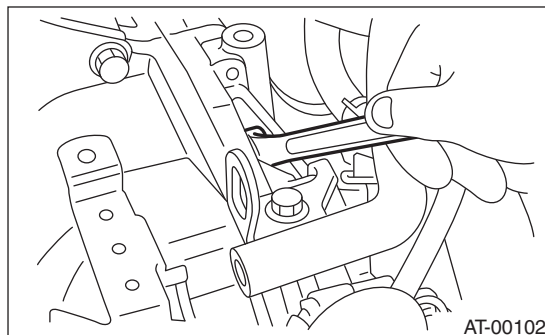

(3) Fit the plug to service hole.

(4) Install the V-belt cover.

12) Remove the ST.

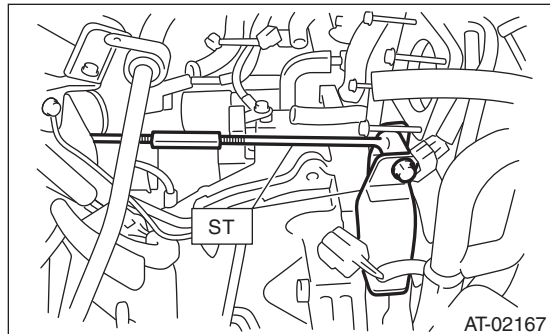

13) Install the engine harness bracket. (Non-turbo model)

Tightening torque:

T: 16 N·m (1.6 kgf-m, 11.8 ft-lb)

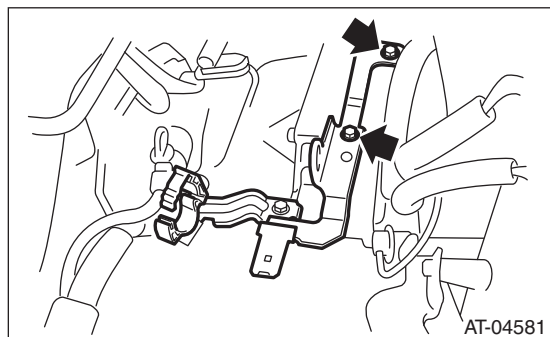

14) Install the harness connector to engine harness bracket, then connect the harness. (Non-turbo model)

15) Install the engine hanger. (Turbo model)

Tightening torque:

16 N·m (1.6 kgf-m, 11.8 ft-lb)

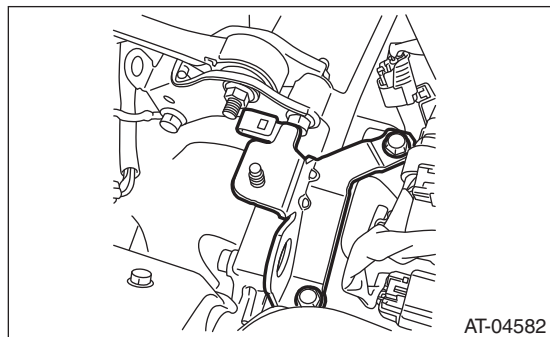

16) Install the pitching stopper bracket.

Tightening torque:

41 N·m (4.2 kgf-m, 30.2 ft-lb)

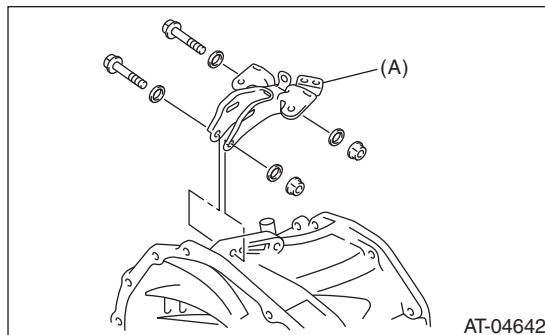

17) Install the throttle body. (Non-turbo model) <Ref. to FU(H4SO)-13, INSTALLATION, Throttle Body.>

18) Install the pitching stopper.

Tightening torque:

T1: 50 N·m (5.1 kgf-m, 36.9 ft-lb)

T2: 58 N·m (5.9 kgf-m, 42.8 ft-lb)

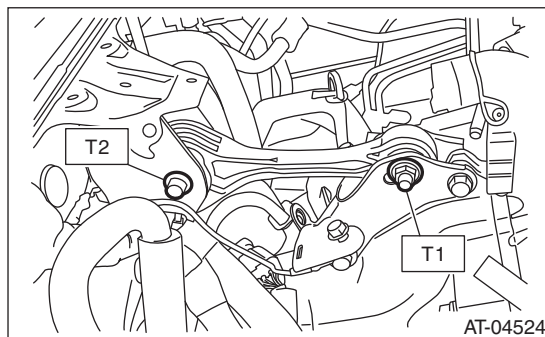

19) Lift up the vehicle.

20) Replace the circlip of the front drive shaft with a new part.

21) Apply grease to the oil seal lip.

22) Attach the ST to side retainer.

ST 28399SA010 OIL SEAL PROTECTOR

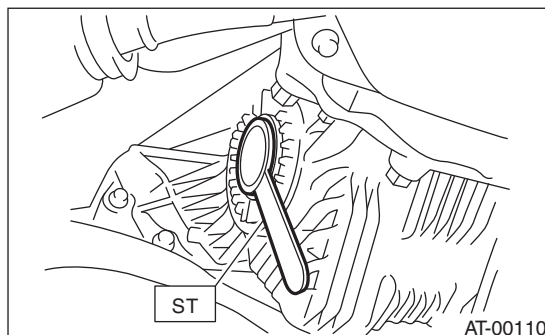

23) Align and insert the spline of the front drive shaft to the splines of the differential bevel gear, and remove the ST.

ST 28399SA010 OIL SEAL PROTECTOR

Automatic Transmission Assembly

AUTOMATIC TRANSMISSION

24) Insert the front drive shaft into the transmission securely by pressing the front housing from the outside.

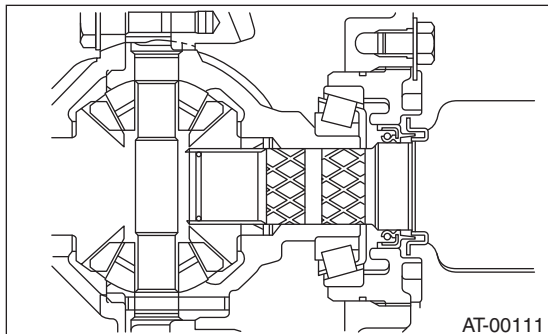

25) Install the ball joint into the front housing.
26) Tighten the attachment bolts.

Tightening torque:

50 N·m (5.1 kgf·m, 36.9 ft·lb)

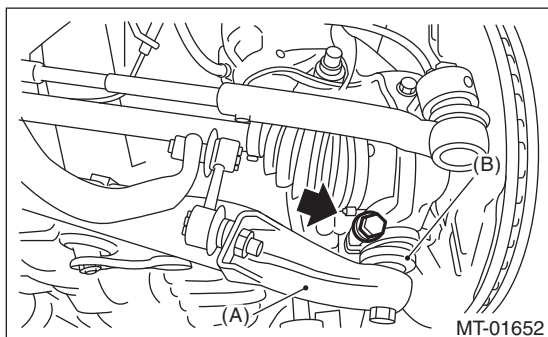

- (A) Front arm
- (B) Ball joint

27) Attach the stabilizer link to the front arm.

Tightening torque:

45 N·m (4.6 kgf·m, 33.2 ft·lb)

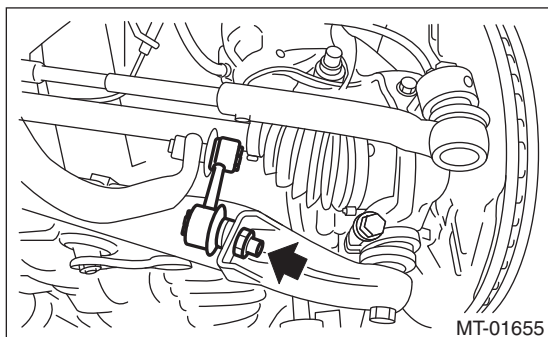

28) Install the front height sensor. <Ref. to LI-40, INSTALLATION, Front Height Sensor.>

29) Install the shift select cable onto the select lever. <Ref. to CS-26, INSTALLATION, Select Cable.>

30) Install the oil charge pipe, and connect the ATF cooler hoses to the pipe.

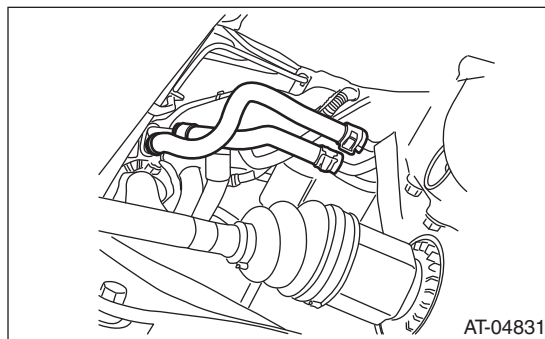

31) Install the propeller shaft. <Ref. to DS-11, INSTALLATION, Propeller Shaft.>

32) Install the heat shield cover.

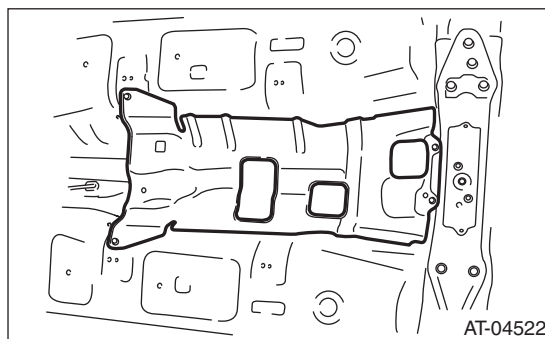

33) Install the rear exhaust pipe and muffler assembly.

- Non-turbo model
<Ref. to EX(H4SO)-8, INSTALLATION, Rear Exhaust Pipe.> <Ref. to EX(H4SO)-10, INSTALLATION, Muffler.>

- Turbo model
<Ref. to EX(H4DOTC)-12, INSTALLATION, Rear Exhaust Pipe.> <Ref. to EX(H4DOTC)-14, INSTALLATION, Muffler.>

34) Install the front and center exhaust pipe. (Non-turbo model)

<Ref. to EX(H4SO)-5, INSTALLATION, Front Exhaust Pipe.>

35) Install the center exhaust pipe. (Turbo model)

<Ref. to EX(H4DOTC)-8, INSTALLATION, Center Exhaust Pipe.>

36) Install the under cover.

37) Lower the lift.

38) Install the ATF level gauge.

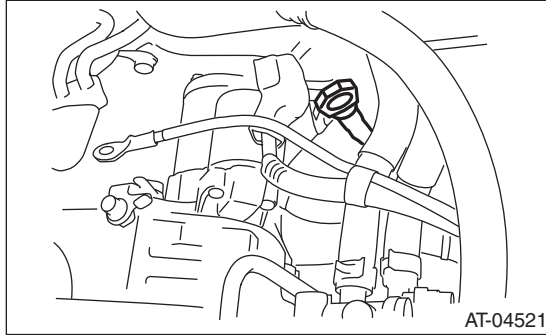

39) Connect the following connectors and terminals.

- Non-turbo model

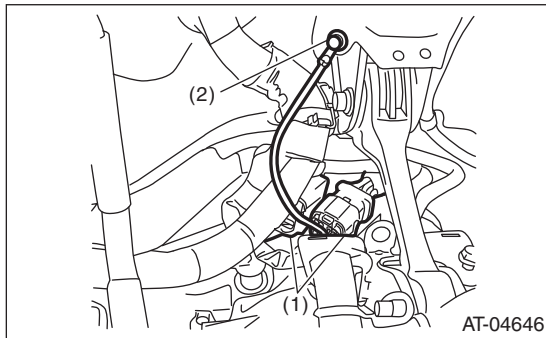

- (1) Transmission harness connectors
- (2) Transmission ground terminal

- Turbo model

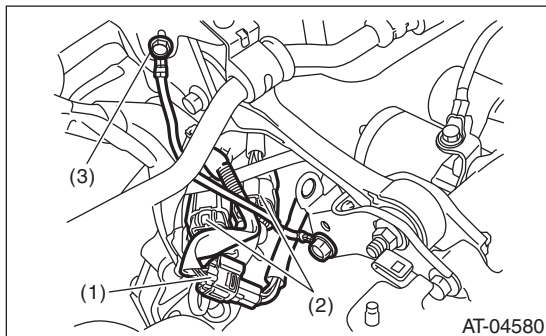

- (1) Rear oxygen sensor connector
- (2) Transmission harness connectors
- (3) Transmission ground terminal

40) Install the air intake chamber stay. (Non-turbo model)

Tightening torque:

16 N·m (1.6 kgf·m, 11.8 ft·lb)

41) Install the air intake chamber and intake boot. (Non-turbo model) <Ref. to IN(H4SO)-7, INSTALLATION, Air Intake Chamber.>

42) Install the intercooler. (Turbo model) <Ref. to IN(H4DOTC)-12, INSTALLATION, Intercooler.>

43) Connect the ground cable to the battery.

44) Fill transmission with ATF through the oil charge pipe until the fluid level is between the upper and lower level on the "COLD" side of the level gauge. <Ref. to 4AT-26, Automatic Transmission Fluid.>

45) Lower the vehicle from the lift.

46) Check the differential gear oil level. <Ref. to 4AT-28, INSPECTION, Differential Gear Oil.>

47) Check the select lever operation. <Ref. to 4AT-46, INSPECTION, Inhibitor Switch.>

48) Bleed the air of control valve. (Turbo model) <Ref. to 4AT-59, PROCEDURE, Air Bleeding of Control Valve.>

49) Check the ATF level. <Ref. to 4AT-26, Automatic Transmission Fluid.>

50) Execute learning control promotion. <Ref. to 4AT(diag)-20, PROCEDURE, Learning Control.>

51) Perform reinitialization of the auto headlight beam leveler. <Ref. to LI-15, PROCEDURE, Auto Headlight Beam Leveler System.>

52) Perform a road test. <Ref. to 4AT-29, Road Test.>

Transmission Mounting System

AUTOMATIC TRANSMISSION

10. Transmission Mounting System

A: REMOVAL

1. PITCHING STOPPER

- 1) Disconnect the ground cable from the battery.
- 2) Remove the air intake chamber and intake boot. (Non-turbo model)
<Ref. to IN(H4SO)-7, REMOVAL, Air Intake Chamber.>
- 3) Remove the intercooler. (Turbo model)
<Ref. to IN(H4DOTC)-11, REMOVAL, Intercooler.>
- 4) Remove the pitching stopper.

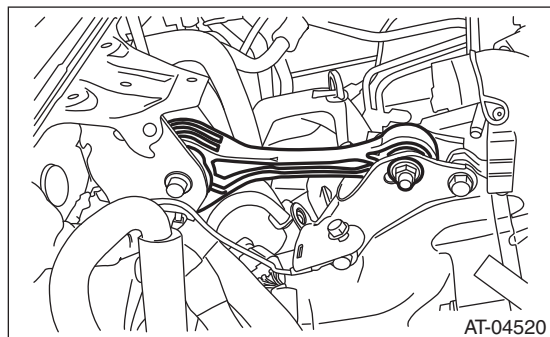

2. TRANSMISSION REAR CROSSMEMBER AND REAR CUSHION RUBBER

- 1) Disconnect the ground cable from the battery.
- 2) Lift up the vehicle.
- 3) Remove the front, center and rear exhaust pipes and the muffler. (Non-turbo model)
<Ref. to EX(H4SO)-4, REMOVAL, Front Exhaust Pipe.> <Ref. to EX(H4SO)-8, REMOVAL, Rear Exhaust Pipe.> <Ref. to EX(H4SO)-10, REMOVAL, Muffler.>
- 4) Remove the center and rear exhaust pipes and the muffler. (Turbo model)
<Ref. to EX(H4DOTC)-7, REMOVAL, Center Exhaust Pipe.> <Ref. to EX(H4DOTC)-12, REMOVAL, Rear Exhaust Pipe.> <Ref. to EX(H4DOTC)-14, REMOVAL, Muffler.>
- 5) Remove the heat shield cover.

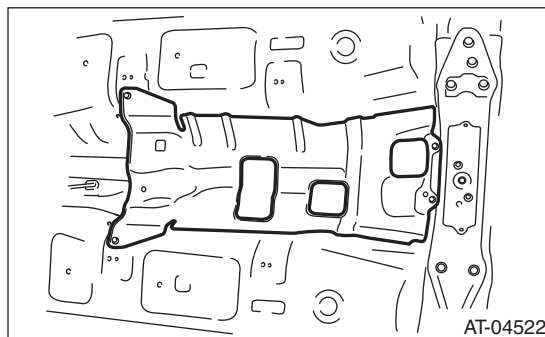

- 6) Set the transmission jack under transmission.

NOTE:

Make sure that the support plate of transmission jack does not touch the oil pan.

- 7) Remove the transmission rear crossmember.

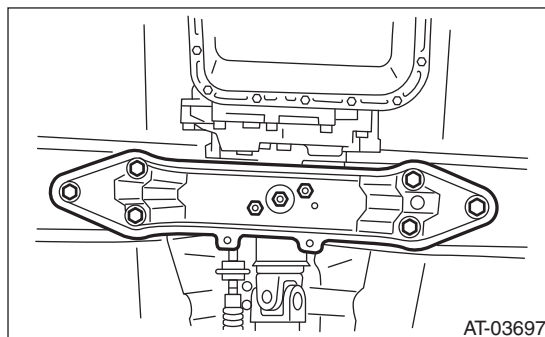

- 8) Remove the rear cushion rubber.

B: INSTALLATION

1. PITCHING STOPPER

1) Install the pitching stopper.

Tightening torque:

T1: 50 N·m (5.1 kgf-m, 36.9 ft-lb)

T2: 58 N·m (5.9 kgf-m, 42.8 ft-lb)

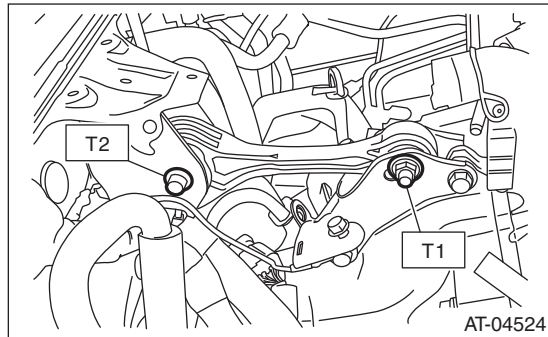

2) Install the air intake chamber and intake boot. (Non-turbo model)

<Ref. to IN(H4SO)-7, INSTALLATION, Air Intake Chamber.>

3) Install the intercooler. (Turbo model)

<Ref. to IN(H4DOTC)-12, INSTALLATION, Intercooler.>

2. TRANSMISSION REAR CROSSMEMBER AND REAR CUSHION RUBBER

1) Install the rear cushion rubber.

Tightening torque:

40 N·m (4.1 kgf-m, 29.5 ft-lb)

2) Install the transmission rear crossmember.

Tightening torque:

T1: 35 N·m (3.6 kgf-m, 25.8 ft-lb)

T2: 70 N·m (7.1 kgf-m, 51.6 ft-lb)

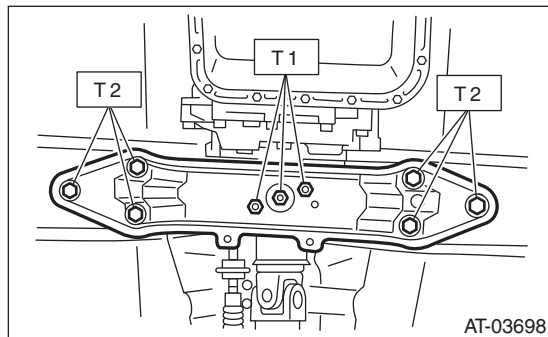

3) Remove the transmission jack.

4) Install the heat shield cover.

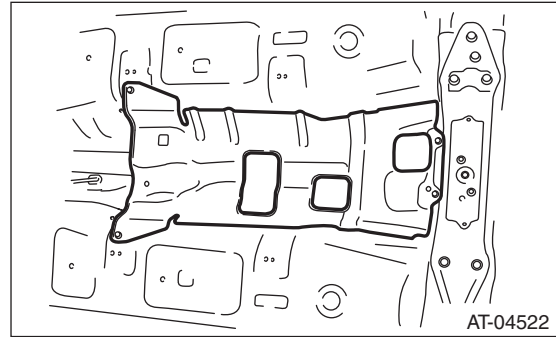

5) Install the front, center and rear exhaust pipes, and the muffler. (Non-turbo model)

<Ref. to EX(H4SO)-5, INSTALLATION, Front Exhaust Pipe.> <Ref. to EX(H4SO)-8, INSTALLATION, Rear Exhaust Pipe.> <Ref. to EX(H4SO)-10, INSTALLATION, Muffler.>

6) Install the center, rear exhaust pipes and the muffler. (Turbo model)

<Ref. to EX(H4DOTC)-8, INSTALLATION, Center Exhaust Pipe.> <Ref. to EX(H4DOTC)-12, INSTALLATION, Rear Exhaust Pipe.> <Ref. to EX(H4DOTC)-14, INSTALLATION, Muffler.>

C: INSPECTION

If problems are found in the following inspection, repair or replace the part.

1. PITCHING STOPPER

Make sure that the pitching stopper is not bent or damaged. Check that there are no cracks, hardening or damage on rubber parts.

2. TRANSMISSION REAR CROSSMEMBER AND REAR CUSHION RUBBER

Make sure that the crossmember is not bent or damaged. Check that there are no cracks, hardening, or damage on cushion rubbers.

Extension Case Oil Seal

AUTOMATIC TRANSMISSION

11. Extension Case Oil Seal

A: INSPECTION

Inspect there is no ATF leakage from the joint of transmission and propeller shaft. If a leak is found, replace the oil seal and inspect the propeller shaft. <Ref. to 4AT-44, REPLACEMENT, Extension Case Oil Seal.>

B: REPLACEMENT

- 1) Lift up the vehicle.
- 2) Clean the transmission exterior.
- 3) Remove the drain plug (ATF) to drain the ATF.

CAUTION:

Because the AFT will be very hot after driving, be very careful not to receive burns.

- 4) Perform replacement with a new gasket, and tighten the drain plug (ATF).

Tightening torque:

25 N·m (2.5 kgf·m, 18.4 ft·lb)

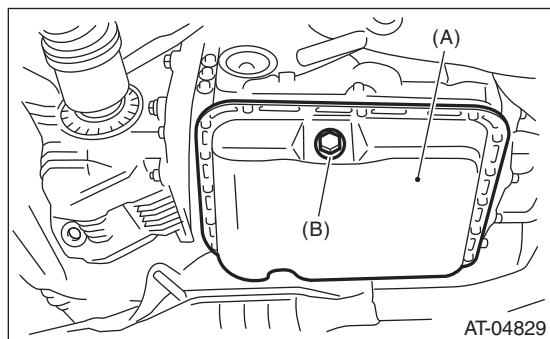

- (A) Oil pan
(B) Drain plug (ATF)

- 5) Remove the rear exhaust pipe and muffler.
 - Non-turbo model
<Ref. to EX(H4SO)-8, REMOVAL, Rear Exhaust Pipe.> <Ref. to EX(H4SO)-10, REMOVAL, Muffler.>
 - Turbo model
<Ref. to EX(H4DOTC)-12, REMOVAL, Rear Exhaust Pipe.> <Ref. to EX(H4DOTC)-14, REMOVAL, Muffler.>
- 6) Remove the heat shield cover.

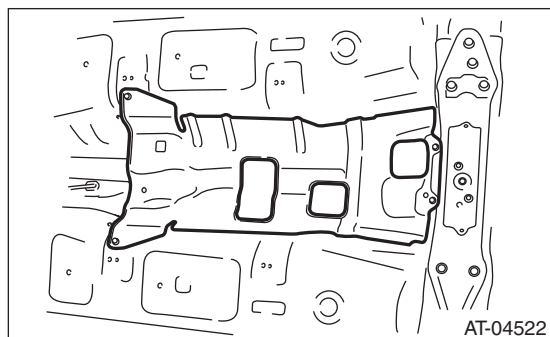

- 7) Remove the propeller shaft. <Ref. to DS-10, REMOVAL, Propeller Shaft.>
- 8) Using the ST, remove the oil seal.
ST 398527700 PULLER ASSY
- 9) Using the ST, install the oil seal.
ST 498057300 INSTALLER
- 10) Install the propeller shaft. <Ref. to DS-11, INSTALLATION, Propeller Shaft.>
- 11) Install the heat shield cover.

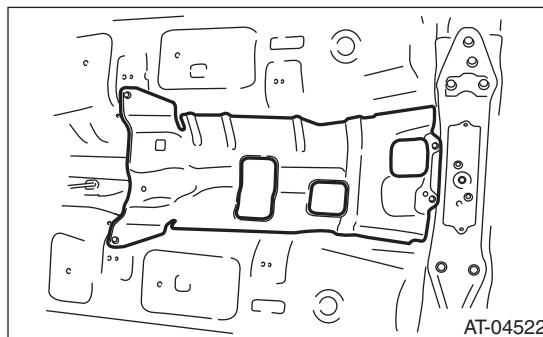

- 12) Install the rear exhaust pipe and muffler.
 - Non-turbo model
<Ref. to EX(H4SO)-8, INSTALLATION, Rear Exhaust Pipe.> <Ref. to EX(H4SO)-10, INSTALLATION, Muffler.>
 - Turbo model
<Ref. to EX(H4DOTC)-12, INSTALLATION, Rear Exhaust Pipe.> <Ref. to EX(H4DOTC)-14, INSTALLATION, Muffler.>
- 13) Fill with ATF. <Ref. to 4AT-26, Automatic Transmission Fluid.>
- 14) Bleed the air of control valve.
<Ref. to 4AT-59, Air Bleeding of Control Valve.>
- 15) Check the level and leaks of the ATF. <Ref. to 4AT-26, Automatic Transmission Fluid.>

12. Differential Side Retainer Oil Seal

A: INSPECTION

Check for leakage of gear oil from differential side retainer oil seal part. If there is an oil leak, replace the oil seal and inspect the drive shaft.

B: REPLACEMENT

- 1) Lift up the vehicle.
- 2) Remove the front exhaust pipe and center exhaust pipe.
 - Non-turbo model
<Ref. to EX(H4SO)-4, REMOVAL, Front Exhaust Pipe.>
 - Turbo model
<Ref. to EX(H4DOTC)-7, REMOVAL, Center Exhaust Pipe.>
- 3) Remove the differential gear oil drain plug using TORX® bit T70, and then drain differential gear oil.

CAUTION:

- Because the differential gear will be very hot after driving, be very careful not to receive burns.
- Be careful not to spill the differential gear oil on exhaust pipe to prevent it from emitting smoke or causing fires. If differential gear oil is spilled on the exhaust pipe, wipe it off completely.

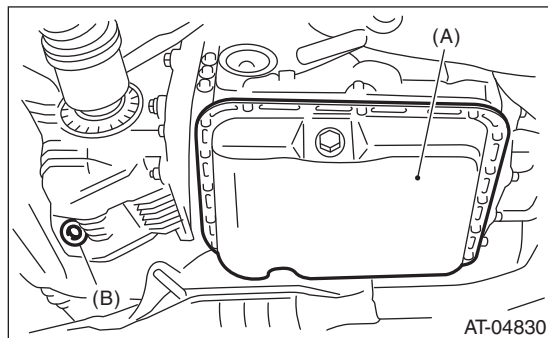

- (A) Oil pan
(B) Differential gear oil drain plug

- 4) Perform replacement with a new gasket, and tighten the differential gear oil drain plug.

Tightening torque:

Aluminum gasket

44 N·m (4.5 kgf·m, 32.5 ft·lb)

Copper gasket

70 N·m (7.1 kgf·m, 51.6 ft·lb)

- 5) Separate the front drive shaft from the transmission. <Ref. to DS-27, REMOVAL, Front Drive Shaft.>
- 6) Remove the differential side retainer oil seal using a screw driver wrapped with vinyl tape etc.

- 7) Using the ST, install the differential side retainer oil seal by lightly tapping with a hammer.

ST 18675AA000 DIFFERENTIAL SIDE OIL SEAL INSTALLER

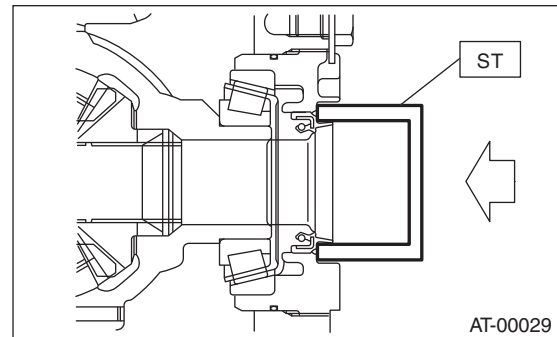

- 8) Apply gear oil to the oil seal lips.
- 9) Install the front drive shaft using the ST. <Ref. to DS-28, INSTALLATION, Front Drive Shaft.>
ST 28399SA010 OIL SEAL PROTECTOR
- 10) Install the front exhaust pipe and the center exhaust pipe.
 - Non-turbo model
<Ref. to EX(H4SO)-5, INSTALLATION, Front Exhaust Pipe.>
 - Turbo model
<Ref. to EX(H4DOTC)-8, INSTALLATION, Center Exhaust Pipe.>
- 11) Lower the vehicle.
- 12) Fill with differential gear oil through the oil level gauge hole.

Recommended gear oil:

<Ref. to 4AT-3, RECOMMENDED GEAR OIL, SPECIFICATION, General Description.>

Gear oil capacity:

1.1 — 1.3 ℓ (1.2 — 1.4 US qt, 1.0 — 1.1 Imp qt)

- 13) Check the level of differential gear oil. <Ref. to 4AT-28, INSPECTION, Differential Gear Oil.>

Inhibitor Switch

AUTOMATIC TRANSMISSION

13. Inhibitor Switch

A: INSPECTION

When the driving condition or starter motor operation is improper, first check the shift linkage for improper operation. If the shift linkage is functioning properly, check the inhibitor switch.

- 1) Disconnect the inhibitor switch connector.
- 2) Check continuity in inhibitor switch circuits with the select lever moved to each position.

NOTE:

- Also check that there is no continuity in the ignition circuit when the select lever is in the “R” and “D” ranges.
- If the inhibitor switch does not operate, check for poor contact of the connector on transmission side.

	Range	Pin No.
Signal sent to TCM	P	4 — 3
	R	4 — 2
	N	4 — 1
	D	4 — 8
Ignition circuit	P/N	12 — 11
Back-up light circuit	R	10 — 9

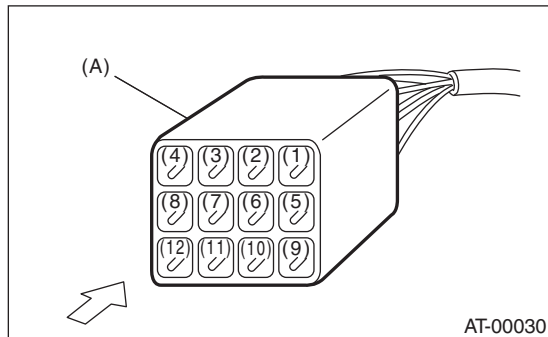

(A) Inhibitor switch connector

- 3) Check that there is continuity at equal points when the select lever is moved 1.5° in both directions from the “N” range.

If there is continuity in only one direction or in other points, adjust the inhibitor switch. <Ref. to 4AT-46, ADJUSTMENT, Inhibitor Switch.>

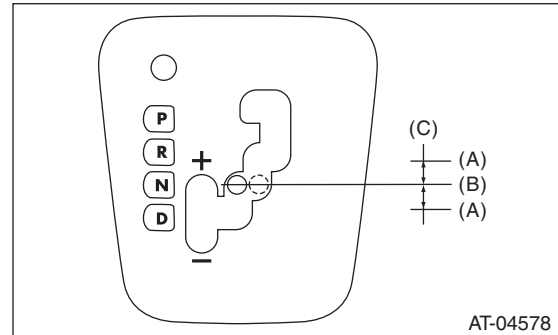

- (A) Continuity does not exist.
 (B) Continuity exists.
 (C) 1.5°

- 4) Repeat the above inspection in other gear ranges. If NG, adjust the select cable. <Ref. to CS-27, ADJUSTMENT, Select Cable.>

B: ADJUSTMENT

- 1) Set the select lever to “N” range.
- 2) Loosen the two bolts holding the inhibitor switch.
- 3) Insert the ST as vertical as possible into the holes of the shifter arm and switch body.
 ST 499267300 STOPPER PIN

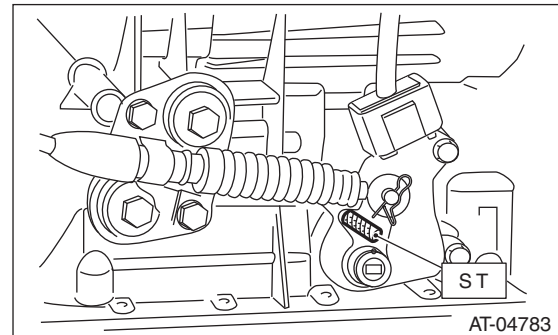

- 4) Tighten the two bolts holding the inhibitor switch.

Tightening torque:

5 N·m (0.5 kgf-m, 3.7 ft-lb)

- 5) Repeat the inspection of the inhibitor switch. If the inhibitor switch is determined to be “faulty”, replace it.

C: REMOVAL

- 1) Set the vehicle on a lift.
- 2) Set the select lever to "N" range.
- 3) Lift up the vehicle.
- 4) Remove the front and center exhaust pipes. (Non-turbo model)
<Ref. to EX(H4SO)-4, REMOVAL, Front Exhaust Pipe.>
- 5) Remove the center exhaust pipe. (Turbo model)
<Ref. to EX(H4DOTC)-7, REMOVAL, Center Exhaust Pipe.>
- 6) Remove the snap pin and washer from the shifter arm.

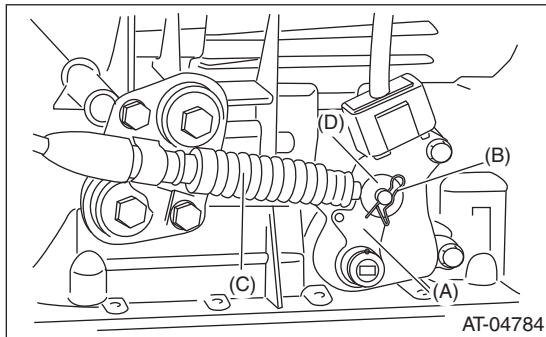

- (A) Shifter arm
- (B) Snap pin
- (C) Select cable
- (D) Washer

- 7) Remove the plate assembly from the transmission case.

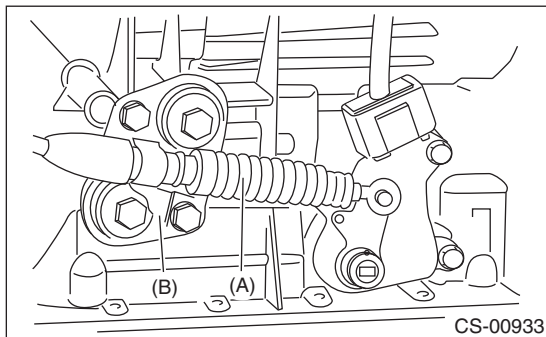

- (A) Select cable
- (B) Plate ASSY

- 8) Remove the spring pin and remove the shifter arm.

ST 398791600 REMOVER

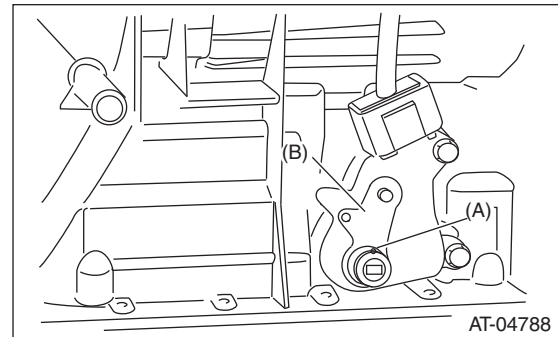

- (A) Spring pin
- (B) Shifter arm

- 9) Remove the two inhibitor switch securing bolts.

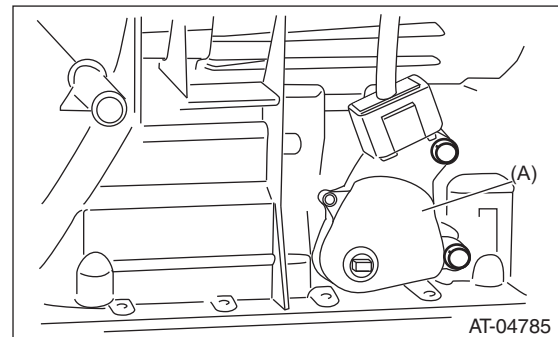

- (A) Inhibitor switch

- 10) Remove the inhibitor switch from the transmission.

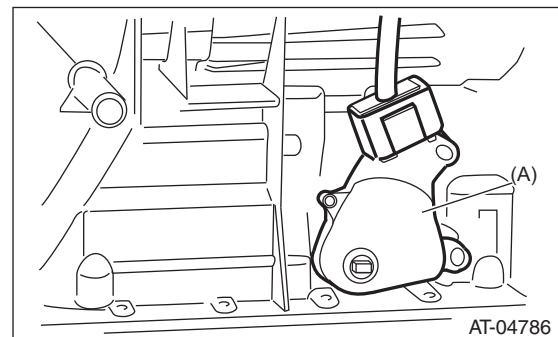

- (A) Inhibitor switch

- 11) Disconnect the inhibitor switch harness connector from the inhibitor switch.

Inhibitor Switch

AUTOMATIC TRANSMISSION

D: INSTALLATION

- 1) Connect the inhibitor switch harness connector to the inhibitor switch.
- 2) Install the inhibitor switch to the transmission case.

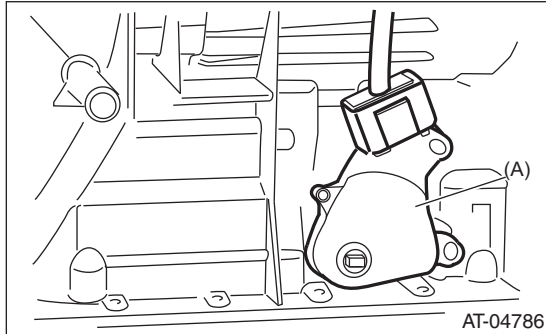

(A) Inhibitor switch

- 3) Install the shifter arm and affix with a new spring pin.

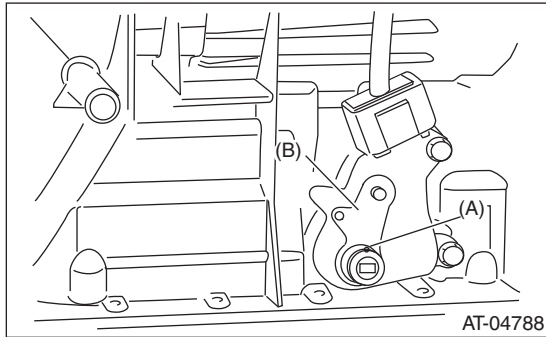

(A) Spring pin
(B) Shifter arm

- 4) Move the shifter arm to the neutral position.
- 5) Using the ST, tighten the two bolts holding the inhibitor switch.

ST 499267300 STOPPER PIN

Tightening torque:

5 N·m (0.5 kgf·m, 3.7 ft·lb)

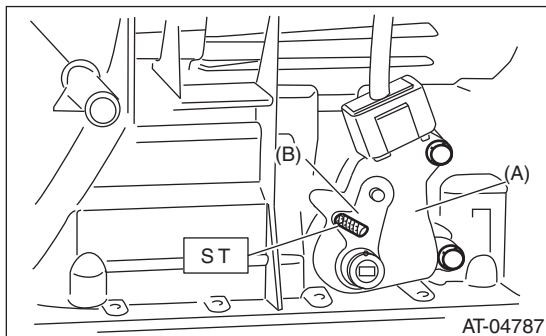

(A) Inhibitor switch
(B) Shifter arm

- 6) Install the select cable to the shifter arm.

- 7) Install the plate assembly to the transmission.

Tightening torque:

T: 25 N·m (2.5 kgf·m, 18.4 ft·lb)

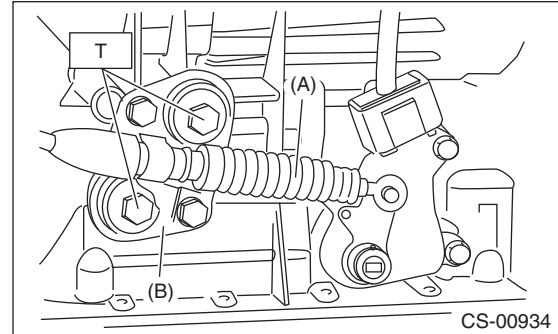

(A) Select cable
(B) Plate ASSY

- 8) Attach the washer and snap pin to the shifter arm.

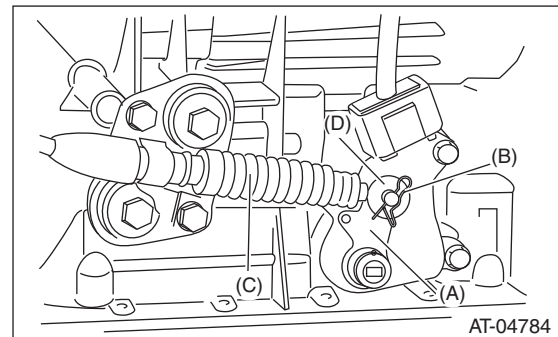

(A) Shifter arm
(B) Snap pin
(C) Select cable
(D) Washer

- 9) Install the front and center exhaust pipe. (Non-turbo model)

<Ref. to EX(H4SO)-5, INSTALLATION, Front Exhaust Pipe.>

- 10) Install the center exhaust pipe. (Turbo model)
- <Ref. to EX(H4DOTC)-8, INSTALLATION, Center Exhaust Pipe.>

- 11) Lower the vehicle.

- 12) Inspect the inhibitor switch. <Ref. to 4AT-46, INSPECTION, Inhibitor Switch.>

14. Front Vehicle Speed Sensor

A: REMOVAL

- 1) Set the vehicle on a lift.
- 2) Disconnect the ground cable from the battery.
- 3) Remove the air intake chamber. (Non-turbo model)
<Ref. to IN(H4SO)-7, REMOVAL, Air Intake Chamber.>
- 4) Remove the intercooler. (Turbo model)
<Ref. to IN(H4DOTC)-11, REMOVAL, Intercooler.>
- 5) Disconnect the transmission harness connector.

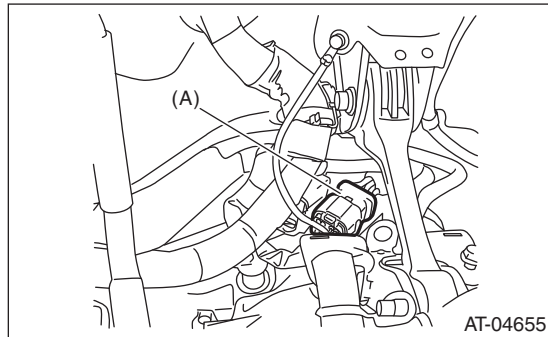

(A) Transmission harness connectors

- 6) Remove the pitching stopper. <Ref. to 4AT-42, REMOVAL, Transmission Mounting System.>
- 7) Remove the transmission harness connector from stay.
- 8) Lift up the vehicle.
- 9) Clean the transmission exterior.
- 10) Remove the drain plug (ATF) to drain the ATF.

CAUTION:

Because the ATF will be very hot after driving, be very careful not to receive burns.

- 11) Perform replacement with a new gasket, and tighten the drain plug (ATF).

Tightening torque:

25 N·m (2.5 kgf·m, 18.4 ft·lb)

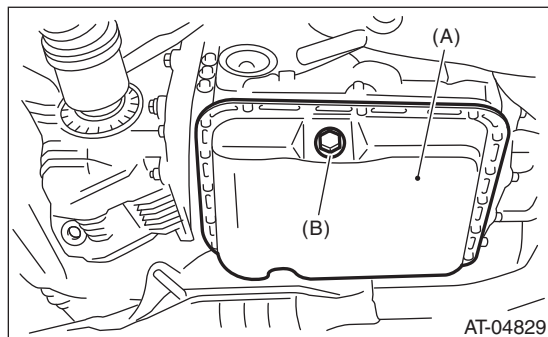

(A) Oil pan
(B) Drain plug (ATF)

- 12) Remove the front, center and rear exhaust pipes and the muffler. (Non-turbo model)
<Ref. to EX(H4SO)-4, REMOVAL, Front Exhaust Pipe.> <Ref. to EX(H4SO)-8, REMOVAL, Rear Exhaust Pipe.> <Ref. to EX(H4SO)-10, REMOVAL, Muffler.>

- 13) Remove the center and rear exhaust pipes and the muffler. (Turbo model)
<Ref. to EX(H4DOTC)-7, REMOVAL, Center Exhaust Pipe.> <Ref. to EX(H4DOTC)-12, REMOVAL, Rear Exhaust Pipe.> <Ref. to EX(H4DOTC)-14, REMOVAL, Muffler.>

- 14) Remove the heat shield cover.

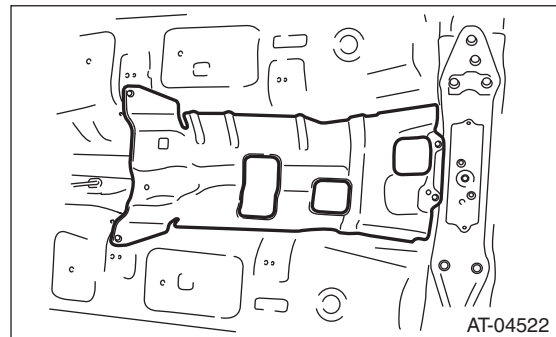

- 15) Remove the propeller shaft. <Ref. to DS-10, REMOVAL, Propeller Shaft.>

- 16) Place the transmission jack under the transmission.

NOTE:

Make sure that the support plate of transmission jack does not touch the cross.

- 17) Remove the transmission rear crossmember bolt.

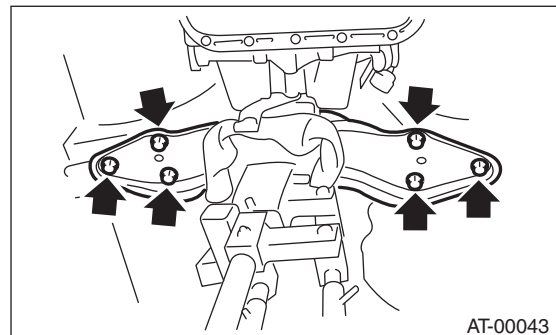

- 18) Lower the transmission jack.

NOTE:

Do not separate the transmission jack and transmission.

- 19) Remove the ATF inlet and outlet pipes.

CAUTION:

When removing the outlet pipe, be careful not to lose the ball and spring used together with the retaining screw.

Front Vehicle Speed Sensor

AUTOMATIC TRANSMISSION

20) Remove the front vehicle speed sensor and torque converter turbine speed sensor.

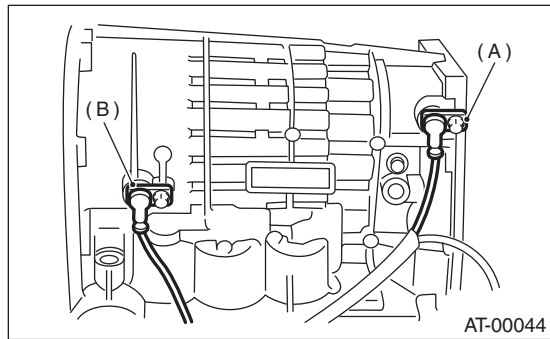

- (A) Front vehicle speed sensor
- (B) Torque converter turbine speed sensor

21) Disconnect the connector from the rear vehicle speed sensor.

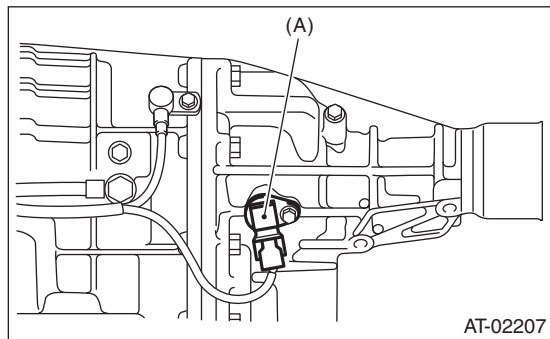

- (A) Rear vehicle speed sensor

22) Remove the oil pan.

CAUTION:

Be careful not to allow foreign matter such as dust or dirt to enter the oil pan.

23) Disconnect the control valve connector and transmission ground terminal.

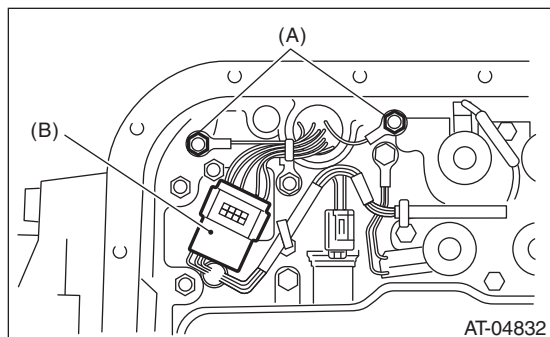

- (A) Transmission ground
- (B) Control valve connector

24) Remove the transmission harness assembly.

B: INSTALLATION

1) Pass the transmission harness assembly through the hole of the transmission case.

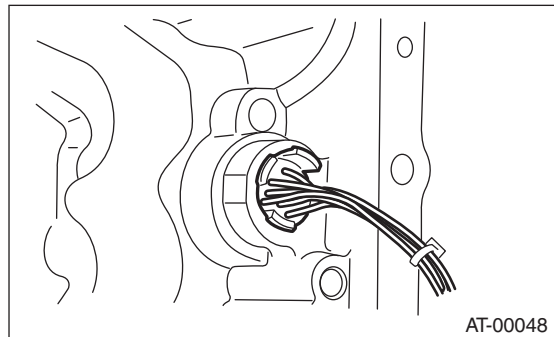

2) Connect the control valve connector and transmission ground.

Tightening torque:

8 N·m (0.8 kgf·m, 5.9 ft·lb)

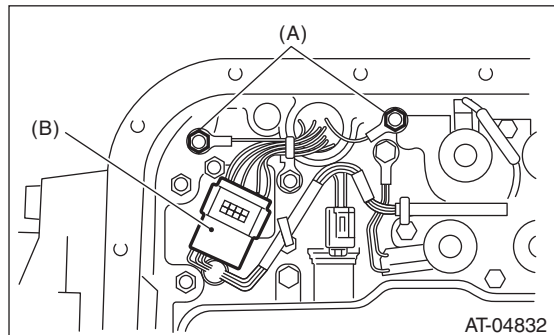

- (A) Transmission ground
- (B) Control valve connector

3) Apply proper amount of liquid gasket to the entire oil pan mating surface.

Liquid gasket:

THREE BOND 1217B (Part No. K0877YA020) or equivalent

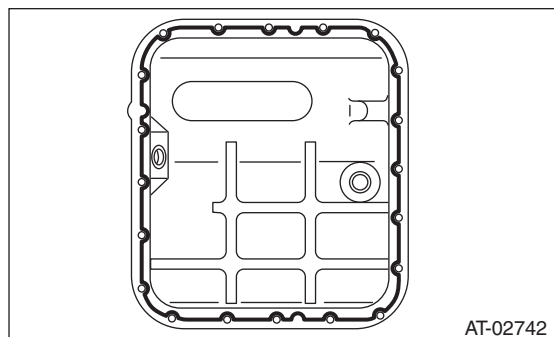

4) Fill the 3 locations of the transmission case excluding the bolt holes with an ample amount of liquid gasket.

Liquid gasket:
THREE BOND 1217B (Part No. K0877YA020)
or equivalent

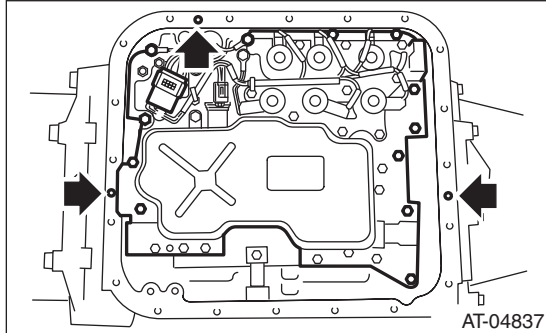

5) Install the oil pan by equally tightening the bolts.

Tightening torque:
5 N·m (0.5 kgf-m, 3.7 ft-lb)

6) Install the front vehicle speed sensor and torque converter turbine speed sensor.

Tightening torque:
7 N·m (0.7 kgf-m, 5.2 ft-lb)

7) Connect the connector to the rear vehicle speed sensor.

8) Install the ATF inlet and outlet pipes.

NOTE:

Use a new copper washer.

Tightening torque:
T1: 25 N·m (2.5 kgf-m, 18.4 ft-lb)
T2: 40 N·m (4.1 kgf-m, 29.5 ft-lb)
T3: 45 N·m (4.6 kgf-m, 33.2 ft-lb)

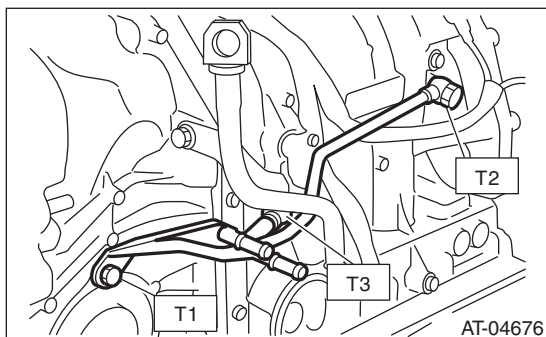

9) Install the transmission rear crossmember bolt.

Tightening torque:
70 N·m (7.1 kgf-m, 51.6 ft-lb)

10) Install the propeller shaft. <Ref. to DS-11, INSTALLATION, Propeller Shaft.>

11) Install the heat shield cover.

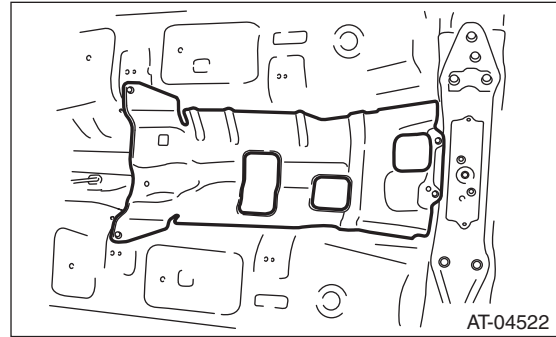

12) Install the front, center and rear exhaust pipes, and the muffler. (Non-turbo model)

<Ref. to EX(H4SO)-5, INSTALLATION, Front Exhaust Pipe.> <Ref. to EX(H4SO)-8, INSTALLATION, Rear Exhaust Pipe.> <Ref. to EX(H4SO)-10, INSTALLATION, Muffler.>

13) Install the center, rear exhaust pipes and the muffler. (Turbo model)

<Ref. to EX(H4DOTC)-8, INSTALLATION, Center Exhaust Pipe.> <Ref. to EX(H4DOTC)-12, INSTALLATION, Rear Exhaust Pipe.> <Ref. to EX(H4DOTC)-14, INSTALLATION, Muffler.>

14) Lower the vehicle.

15) Install the transmission harness connector to the stay.

16) Install the pitching stopper. <Ref. to 4AT-43, INSTALLATION, Transmission Mounting System.>

17) Install the air intake chamber. (Non-turbo model)

<Ref. to IN(H4SO)-7, INSTALLATION, Air Intake Chamber.>

18) Install the intercooler. (Turbo model)

<Ref. to IN(H4DOTC)-12, INSTALLATION, Intercooler.>

19) Fill with the same amount of ATF as drained.

20) Bleed the air of control valve.

<Ref. to 4AT-59, Air Bleeding of Control Valve.>

21) Inspect the level of ATF. <Ref. to 4AT-26, Automatic Transmission Fluid.>

22) Execute the learning control promotion. <Ref. to 4AT(diag)-20, PROCEDURE, Learning Control.>

Rear Vehicle Speed Sensor

AUTOMATIC TRANSMISSION

15.Rear Vehicle Speed Sensor

A: REMOVAL

- 1) Set the vehicle on a lift.
- 2) Disconnect the ground cable from the battery.
- 3) Lift up the vehicle.
- 4) Disconnect the connector from the rear vehicle speed sensor.

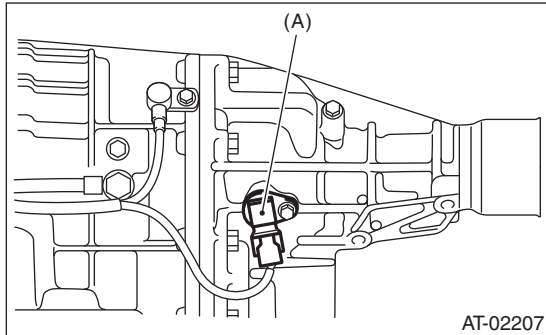

(A) Rear vehicle speed sensor

- 5) Remove the rear vehicle speed sensor.

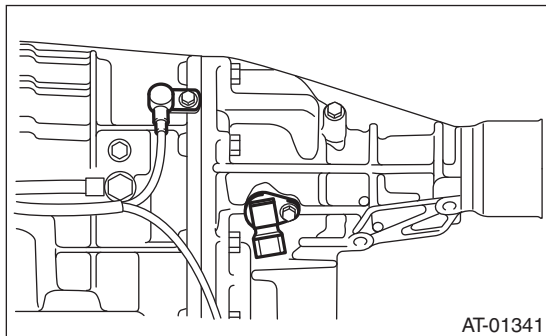

B: INSTALLATION

Install in the reverse order of removal.

NOTE:

Replace the O-ring with a new part.

Tightening torque:

7 N·m (0.7 kgf·m, 5.2 ft·lb)

16. Torque Converter Turbine Speed Sensor

A: REMOVAL

When removing the torque converter turbine speed sensor, refer to "Front Vehicle Speed Sensor".
<Ref. to 4AT-49, REMOVAL, Front Vehicle Speed Sensor.>

B: INSTALLATION

When installing the torque converter turbine speed sensor, refer to "Front Vehicle Speed Sensor".
<Ref. to 4AT-50, INSTALLATION, Front Vehicle Speed Sensor.>

Control Valve Strainer

AUTOMATIC TRANSMISSION

17. Control Valve Strainer

A: REMOVAL

- 1) Set the vehicle on a lift.
- 2) Disconnect the ground cable from the battery.
- 3) Lift up the vehicle.
- 4) Clean the transmission exterior.
- 5) Remove the drain plug (ATF) to drain the ATF.

CAUTION:

Because the AFT will be very hot after driving, be very careful not to receive burns.

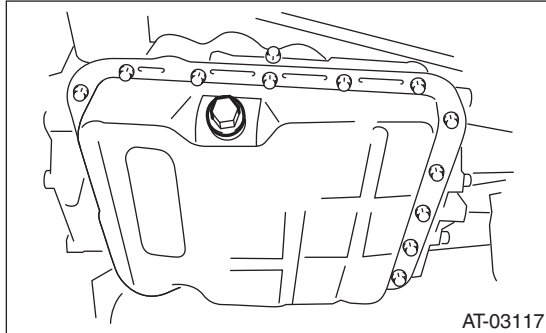

- 6) Perform replacement with a new gasket, and tighten the drain plug (ATF).

Tightening torque:

25 N·m (2.5 kgf·m, 18.4 ft·lb)

- 7) Remove the oil pan.

CAUTION:

Be careful not to allow foreign matter such as dust or dirt to enter the oil pan.

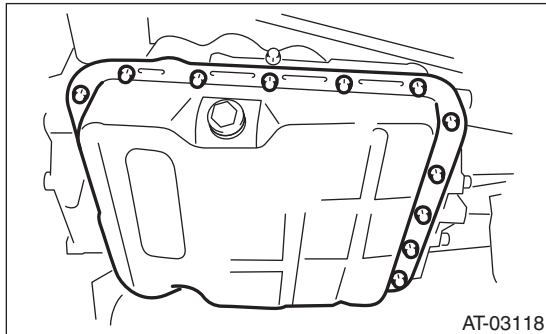

- 8) Remove the magnet.
- 9) Clean the magnet.
- 10) Completely remove the remaining liquid gasket on the transmission case and oil pan.

- 11) Remove the control valve strainer attaching bolts, and remove the control valve strainer from the control valve body.

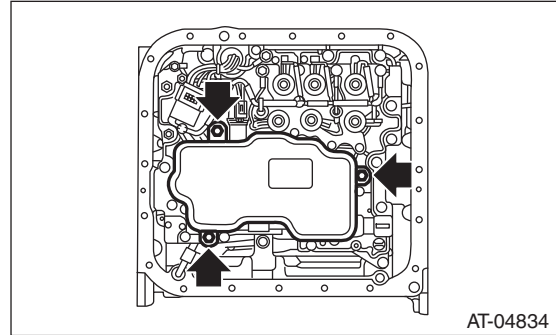

B: INSTALLATION

- 1) Check the control valve body for dust and other foreign matter.
- 2) Attach a new control valve strainer to the control valve body.
 - (1) Apply ATF to the periphery of the O-ring on the control valve strainer.

CAUTION:

When applying ATF, avoid adhesion of dust and foreign matter on the O-ring.

- (2) Attach the control valve strainer to the control valve body from the O-ring side.

CAUTION:

If the control valve strainer is inserted diagonally, this may damage the O-ring. Make sure to insert the control valve strainer so that it does not become angled when installing.

- (3) Tighten the three bolts.

Tightening torque:

10 N·m (1.0 kgf·m, 7.4 ft·lb)

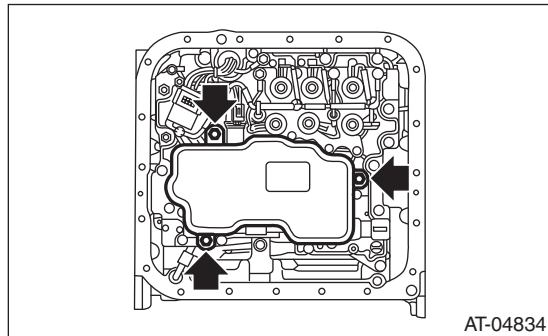

- 3) Attach the magnet at the specified position of the oil pan.

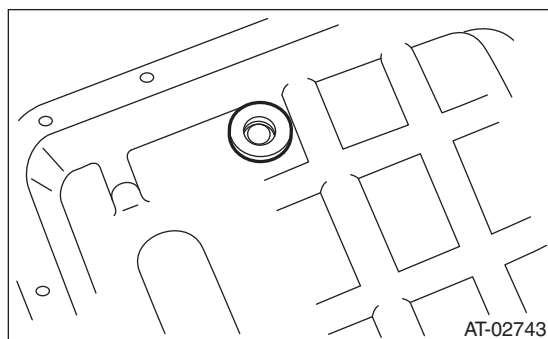

- 4) Apply proper amount of liquid gasket to the entire oil pan mating surface.

Liquid gasket:

THREE BOND 1217B (Part No. K0877YA020) or equivalent

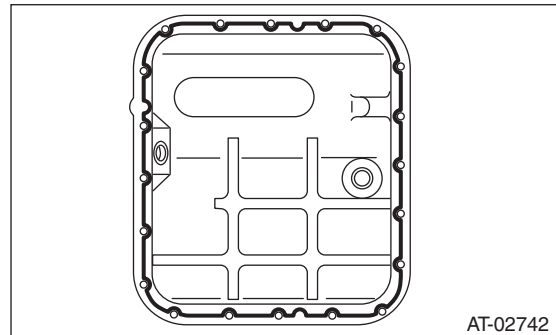

- 5) Fill the 3 holes aside from the bolt holes in the transmission case, with liquid gasket.

Liquid gasket:

THREE BOND 1217B (Part No. K0877YA020) or equivalent

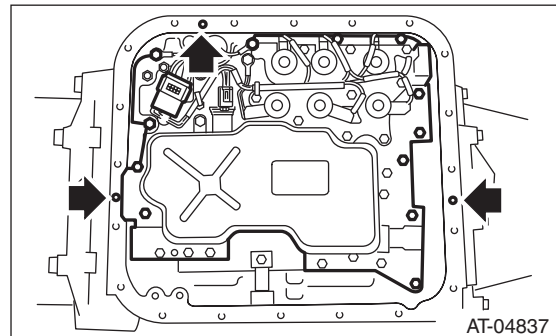

- 6) Install the oil pan by equally tightening the bolts.

Tightening torque:

5 N·m (0.5 kgf·m, 3.7 ft·lb)

- 7) Fill ATF from the oil charger pipe.

Recommended fluid:

<Ref. to 4AT-3, HYDRAULIC CONTROL AND LUBRICATION, SPECIFICATION, General Description.>

Capacity:

Fill with the same amount of ATF as drained.

- 8) Bleed the air of control valve. <Ref. to 4AT-59, Air Bleeding of Control Valve.>
- 9) Check the ATF level. <Ref. to 4AT-26, Automatic Transmission Fluid.>

C: INSPECTION

Check the control valve strainer for holes, damages or adhesion of dust and other foreign particles.

Control Valve Body

AUTOMATIC TRANSMISSION

18. Control Valve Body

A: REMOVAL

- 1) Set the vehicle on a lift.
- 2) Disconnect the ground cable from the battery.
- 3) Lift up the vehicle.
- 4) Clean the transmission exterior.
- 5) Remove the drain plug (ATF) to drain the ATF.

CAUTION:

Because the ATF will be very hot after driving, be very careful not to receive burns.

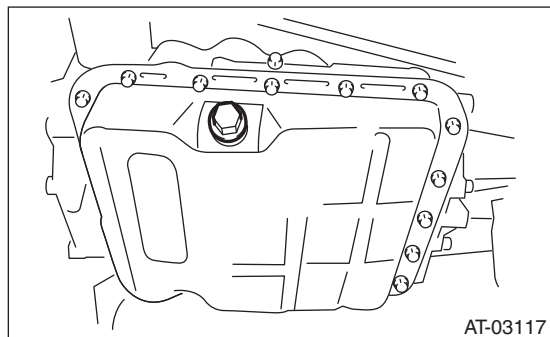

- 6) Perform replacement with a new gasket, and tighten the drain plug (ATF).

Tightening torque:

25 N·m (2.5 kgf·m, 18.4 ft·lb)

- 7) Remove the oil pan.

CAUTION:

Be careful not to allow foreign matter such as dust or dirt to enter the oil pan.

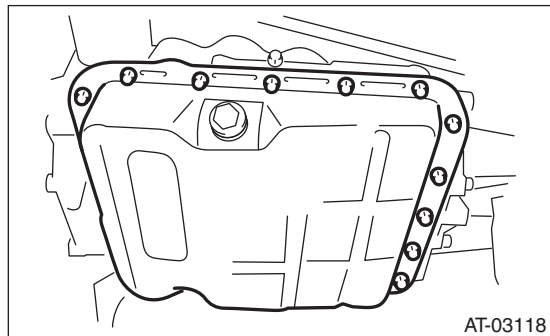

- 8) Remove the magnet.
- 9) Clean the magnet.
- 10) Completely remove the remaining liquid gasket on the transmission case and oil pan.

- 11) Disconnect the control valve connector.

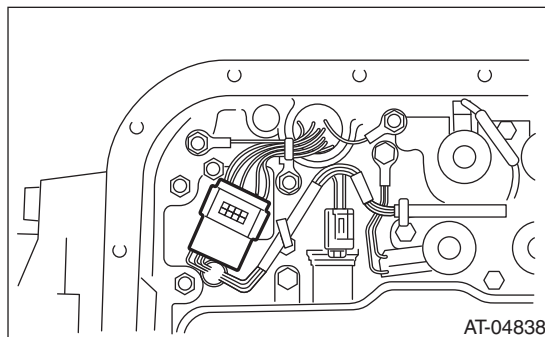

- 12) Remove the oil cooler pipe.

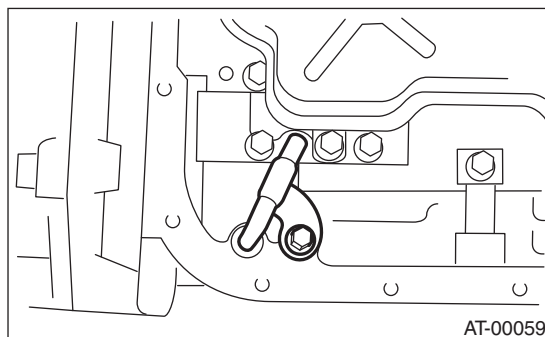

- 13) Remove the control valve body.

NOTE:

The control valve body is replaced as an assembly only, because it is a non-disassembly part.

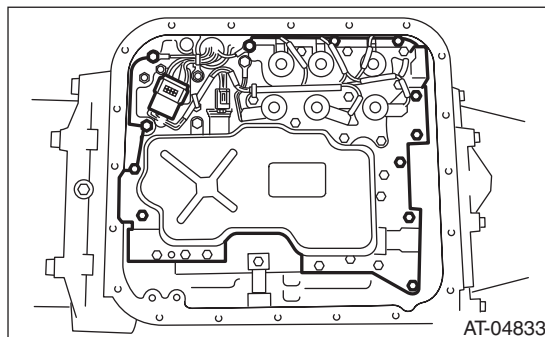

B: INSTALLATION

- 1) Check the control valve body for dust and other foreign matter.
- 2) Temporarily tighten the control valve body to the transmission.
- 3) Install the oil cooler pipe.

Tightening torque:

8 N·m (0.8 kgf-m, 5.9 ft-lb)

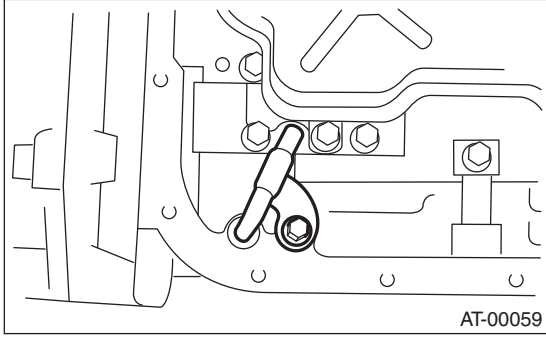

- 4) Tighten the bolts equally.

Tightening torque:

8 N·m (0.8 kgf-m, 5.9 ft-lb)

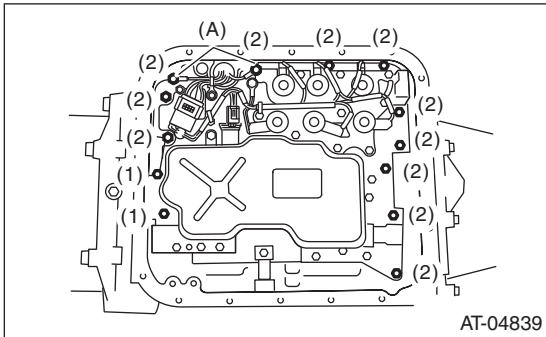

- (A) Transmission ground
Bolt length mm (in)
- | | |
|-----|-----------|
| (1) | 35 (1.38) |
| (2) | 30 (1.18) |

- 5) Connect the control valve connector.

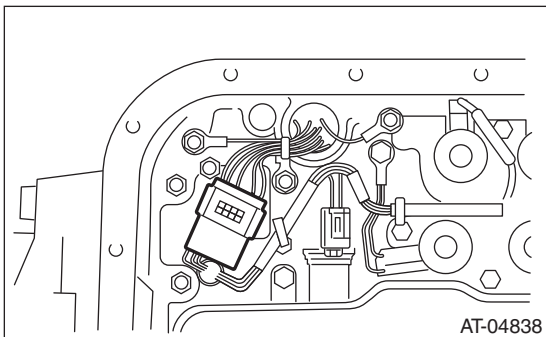

- 6) Attach the magnet at the specified position of the oil pan.

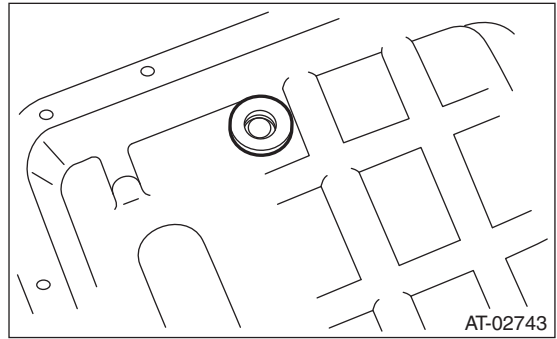

- 7) Apply proper amount of liquid gasket to the entire oil pan mating surface.

Liquid gasket:

THREE BOND 1217B (Part No. K0877YA020) or equivalent

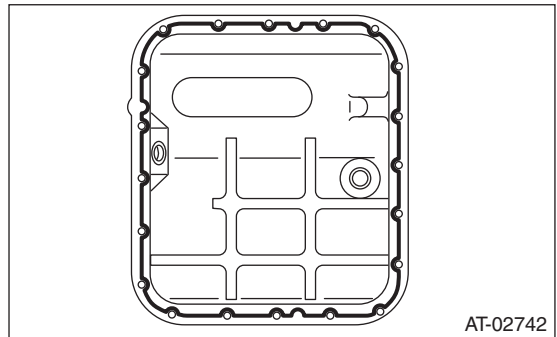

- 8) Fill the 3 holes aside from the bolt holes in the transmission case, with liquid gasket.

Liquid gasket:

THREE BOND 1217B (Part No. K0877YA020) or equivalent

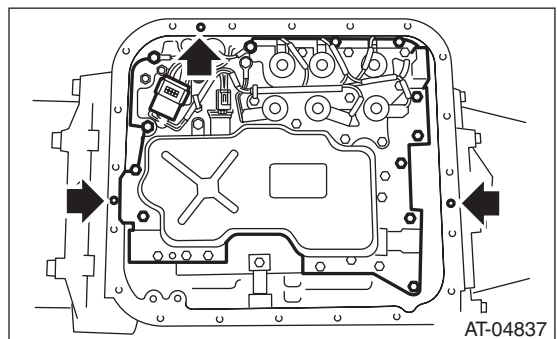

- 9) Install the oil pan by equally tightening the bolts.

Tightening torque:

5 N·m (0.5 kgf-m, 3.7 ft-lb)

Control Valve Body

AUTOMATIC TRANSMISSION

10) Fill ATF from the oil charger pipe.

Recommended fluid:

<Ref. to 4AT-3, HYDRAULIC CONTROL AND LUBRICATION, SPECIFICATION, General Description.>

Capacity:

Fill with the same amount of ATF as drained.

11) Bleed the air of control valve. <Ref. to 4AT-59, Air Bleeding of Control Valve.>

12) Check the ATF level.

<Ref. to 4AT-26, Automatic Transmission Fluid.>

13) Execute the learning control promotion. <Ref. to 4AT(diag)-20, PROCEDURE, Learning Control.>

C: INSPECTION

Check parts for holes, damages or adhesion of dust and other foreign particles

19. Air Bleeding of Control Valve

A: GENERAL DESCRIPTION

- When ATF is drained from the automatic transmission, make sure to bleed air from the control valve after filling with the specified amount of ATF.
- Follow the messages displayed on the Subaru Select Monitor when working.

B: PROCEDURE

1. PREPARATION FOR AIR BLEED

- 1) Cool down until the ATF temperature displayed on the Subaru Select Monitor is 60°C (140°F) or less.
- 2) Move the select lever to “P” range.
- 3) Fully apply the parking brake.
- 4) Lift up the vehicle.

CAUTION:

While working, be sure to keep the lower edge of the tires 30 cm or more above the ground as vehicle will vibrate.

- 5) Connect the Subaru Select Monitor to the data link connector.
- 6) Turn the ignition switch to ON.
- 7) Turn off all switches causing an electrical load, such as headlights, A/C, seat heater and rear defogger.

2. AIR BLEEDING PROCEDURES

CAUTION:

Do not turn the power of the Subaru Select Monitor OFF during work, and do not disconnect the data link connector.

- 1) Select {Learning and inspection mode related to AT} in the «Transmission Diagnosis» screen of the Subaru Select Monitor.
- 2) Select {AT air bleeding mode} in the «Learning and inspection mode related to AT» screen of the Subaru Select Monitor.
- 3) Follow the messages displayed on the Subaru Select Monitor screen when working.

NOTE:

When «AT air bleeding in progress», the «SPORT» light in the combination meter will flash at 2 Hz, and air bleed will start. When the indicator light flashing at 2 Hz turns off, the following message will appear on the screen.

- 4) Air bleed is complete when a message «AT air bleeding normally ended» is displayed.

NOTE:

- If a communication error occurs during air bleed, start the «AT air bleeding» over from the beginning.
- If the message «Execute AT learning again after fixing troubles of the vehicle» appears during air bleed, select [OK] and display the DTC list. After repairing the locations indicated by the DTC, start the «AT air bleeding» over from the beginning.
- If the message «AT air bleeding ended abnormally» is displayed, start the «AT air bleeding» over from the beginning.

Message	Main reasons for abnormal termination
«AT air bleeding ended abnormally»	<ul style="list-style-type: none"> • A failure was detected during AT air bleed • The accelerator was stepped on during AT air bleed. • An unspecified operation was performed during AT air bleed • Brake pedal not stepped on firmly enough. • Side brake not applied strongly enough. • Abnormal idle speed increase

- For operation procedures, refer to the “PC application help for Subaru Select Monitor”.

Transmission Control Module (TCM)

AUTOMATIC TRANSMISSION

20. Transmission Control Module (TCM)

A: REMOVAL

- 1) Disconnect the ground cable from the battery.
- 2) Remove the instrument panel lower cover and disconnect the connector.
- 3) Disconnect the connector from TCM.

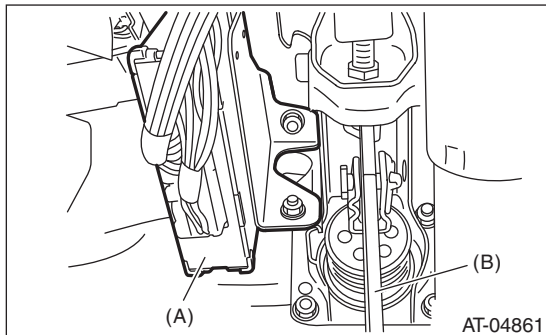

- (A) Transmission control module (TCM)
(B) Brake pedal

- 4) Remove the TCM.

B: INSTALLATION

- 1) Install the TCM.

Tightening torque:

7.5 N·m (0.8 kgf-m, 5.5 ft-lb)

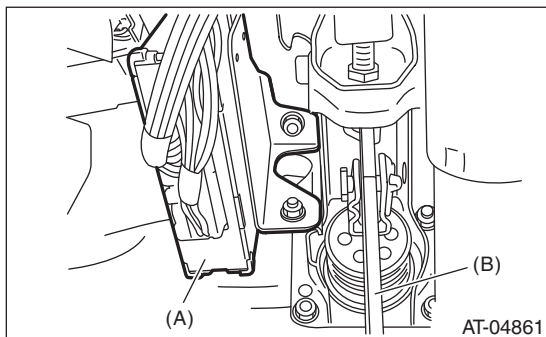

- (A) Transmission control module (TCM)
(B) Brake pedal

- 2) Connect the connector to the TCM.
- 3) Install in the reverse order of removal.
- 4) Execute the learning control promotion. <Ref. to 4AT(diag)-20, PROCEDURE, Learning Control.>

21. ATF Cooler Pipe and Hose

A: REMOVAL

- 1) Set the vehicle on a lift.
- 2) Remove the battery.
- 3) Lift up the vehicle.
- 4) Remove the under cover.
- 5) Remove the heat shield cover.

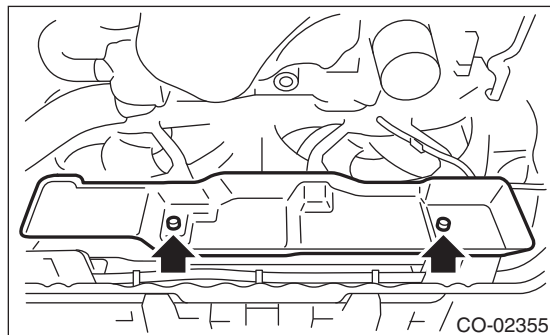

- 6) Disconnect the ATF cooler hose from the radiator.

NOTE:

- Do not use a screwdriver or other pointed tools.
- If it is hard to remove the hose, wrap the hose with cloth to prevent from damaging it, and while turning with pliers, pull straight out by hand.

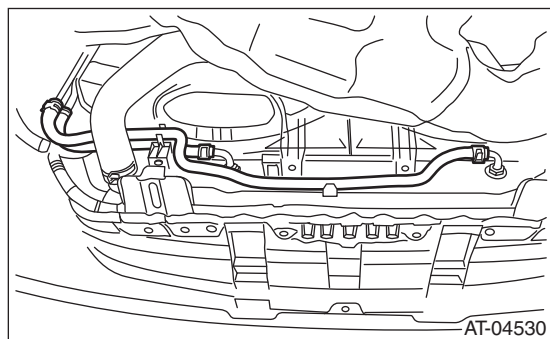

- 7) Disconnect the ATF cooler hoses from the pipes.

NOTE:

- Do not use a screwdriver or other pointed tools.
- If it is hard to remove the hose, wrap the hose with cloth to prevent from damaging it, and while turning with pliers, pull straight out by hand.

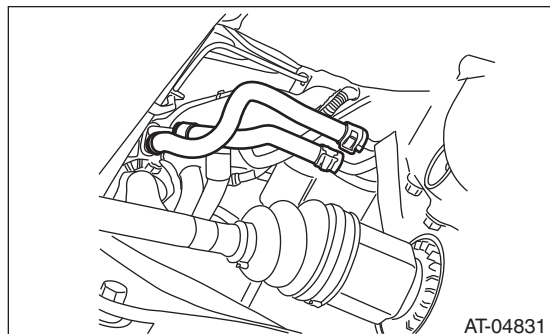

- 8) Disconnect the ATF cooler pipe from frame.

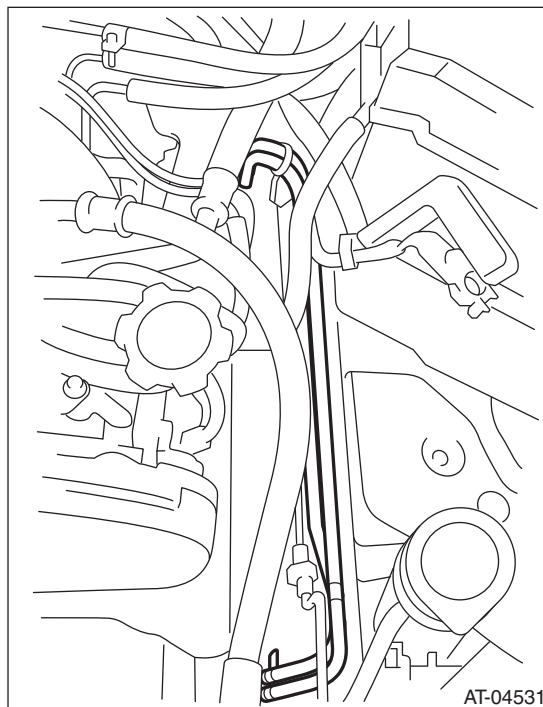

- 9) Remove the ATF inlet pipe and outlet pipe.

CAUTION:

When disconnecting the outlet pipe, be careful not to lose the ball and spring used together with the retaining screw.

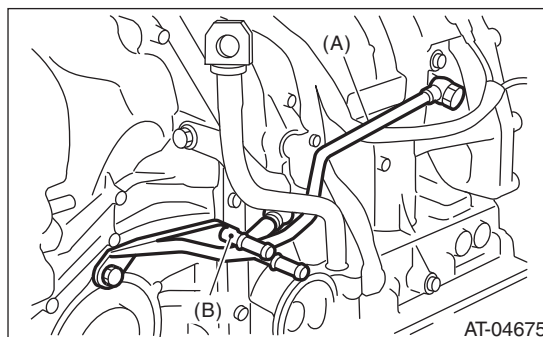

- (A) ATF inlet pipe
- (B) ATF outlet pipe

ATF Cooler Pipe and Hose

AUTOMATIC TRANSMISSION

B: INSTALLATION

1) Install the ATF inlet pipe and outlet pipe along with new washers.

Tightening torque:

T1: 25 N·m (2.5 kgf-m, 18.4 ft-lb)

T2: 40 N·m (4.1 kgf-m, 29.5 ft-lb)

T3: 45 N·m (4.6 kgf-m, 33.2 ft-lb)

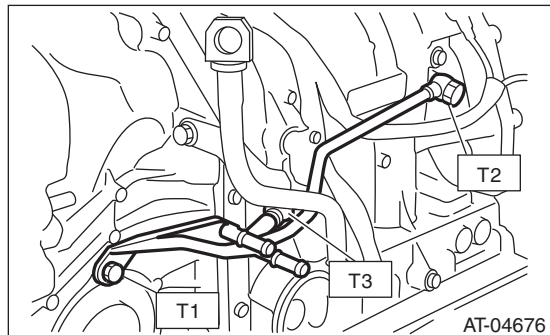

2) Install the ATF cooler pipe to frame.

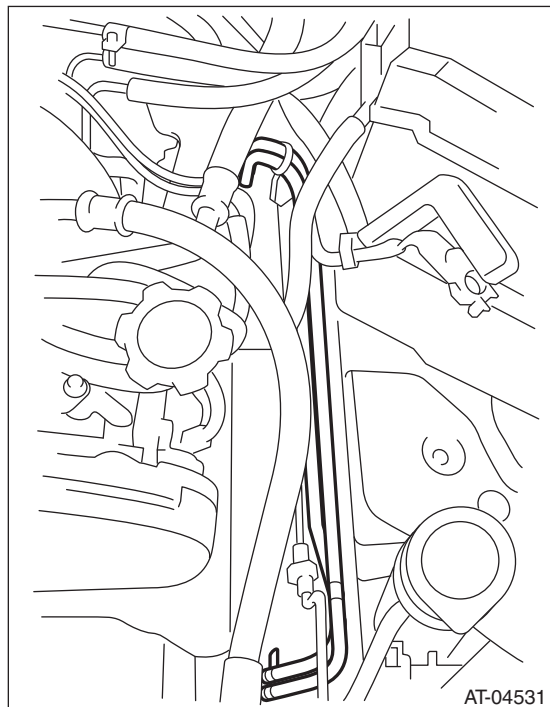

3) Connect the ATF cooler hose to the pipe on the transmission side.

NOTE:

- Install so that the hose is not folded over, excessively bent or twisted.
- Insert the hose to the specified position.

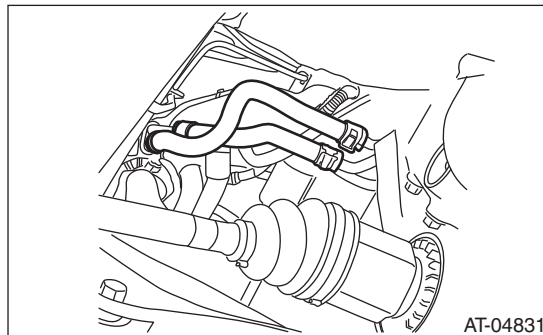

4) Connect the ATF cooler hose to the pipe on the radiator side.

NOTE:

- Install so that the hose is not folded over, excessively bent or twisted.
- Insert the hose to the specified position.

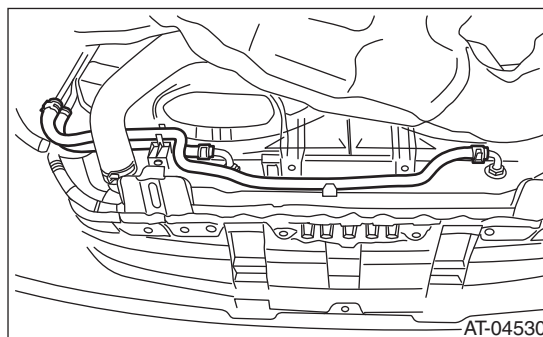

5) Install the heat shield cover.

Tightening torque:

3 N·m (0.3 kgf-m, 2.2 ft-lb)

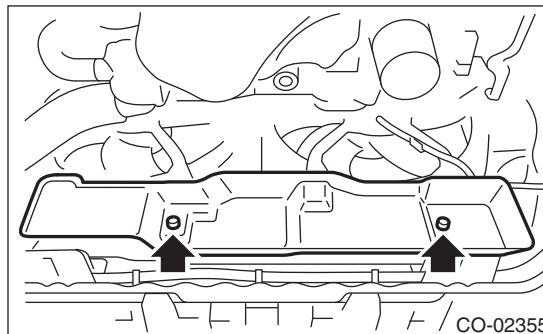

6) Install the under cover.

7) Install the battery.

8) Fill ATF. <Ref. to 4AT-26, Automatic Transmission Fluid.>

NOTE:

Make sure there are no ATF leaks in joints between the transmission, radiator, pipes, and hoses.

C: INSPECTION

Repair or replace any faulty hoses, pipes, clamps, and washers found in the inspection below.

- 1) Check for ATF leaks in joints between the transmission, radiator, pipes, and hoses.
- 2) Check the clamp for deformation.
- 3) Lightly bend the hose and check for cracks in the surface or other damages.
- 4) Pinch the hose with your fingers and check for poor elasticity. Also check for poor elasticity in the parts where the clamp was installed by pressing with your fingernail.
- 5) Check for peeling, cracks, and deformation at the tip of the hose.

Air Breather Hose

AUTOMATIC TRANSMISSION

22. Air Breather Hose

A: REMOVAL

1) Remove the air intake chamber. (Non-turbo model)
<Ref. to IN(H4SO)-7, REMOVAL, Air Intake Chamber.>

2) Remove the intercooler. (Turbo model)
<Ref. to IN(H4DOTC)-11, REMOVAL, Intercooler.>

3) Disconnect the air breather hose.

- Non-turbo model

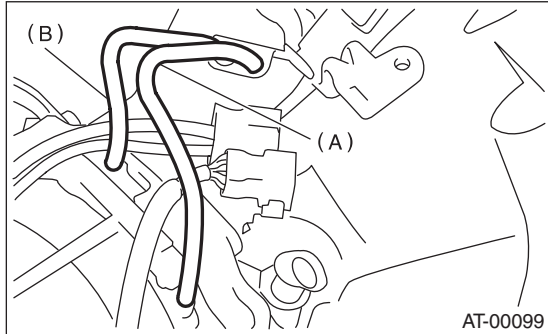

- (A) Air breather hose (Transmission case)
- (B) Air breather hose (Oil pump housing)

- Turbo model

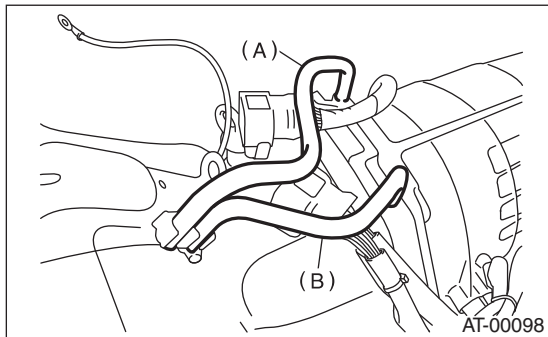

- (A) Air breather hose (Transmission case)
- (B) Air breather hose (Oil pump housing)

B: INSTALLATION

1) Install the air breather hose.

- Non-turbo model

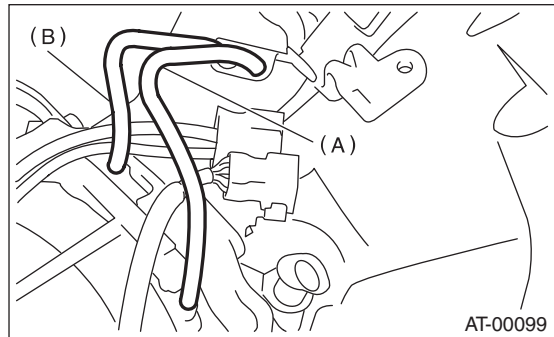

- (A) Air breather hose (Transmission case)
- (B) Air breather hose (Oil pump housing)

- Turbo model

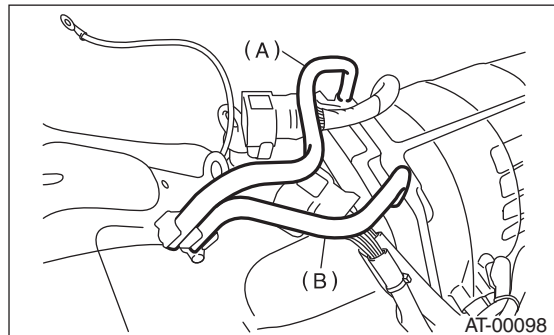

- (A) Air breather hose (Transmission case)
- (B) Air breather hose (Oil pump housing)

2) Install the air intake chamber. (Non-turbo model)
<Ref. to IN(H4SO)-7, INSTALLATION, Air Intake Chamber.>

3) Install the intercooler. (Turbo model)
<Ref. to IN(H4DOTC)-12, INSTALLATION, Intercooler.>

C: INSPECTION

Make sure the hose is not cracked or clogged.

23.Oil Charge Pipe

A: REMOVAL

- 1) Remove the air intake chamber. (Non-turbo model)
<Ref. to IN(H4SO)-7, REMOVAL, Air Intake Chamber.>
- 2) Remove the intercooler. (Turbo model)
<Ref. to IN(H4DOTC)-11, REMOVAL, Intercooler.>
- 3) Remove the oil charge pipe, and then remove the O-ring from the flange side.

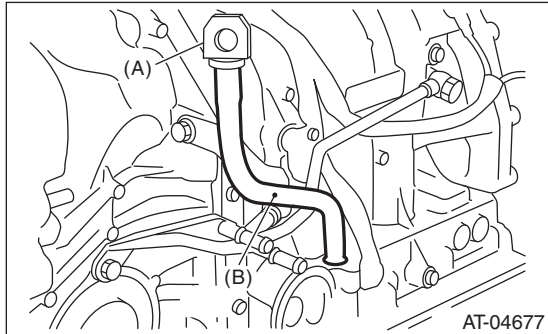

- (A) ATF level gauge
(B) Oil charge pipe

B: INSTALLATION

- 1) Apply ATF on a new O-ring and install together with the oil charge pipe.

NOTE:

Use a new bolt.

Tightening torque:

38 N·m (3.9 kgf·m, 28.0 ft·lb)

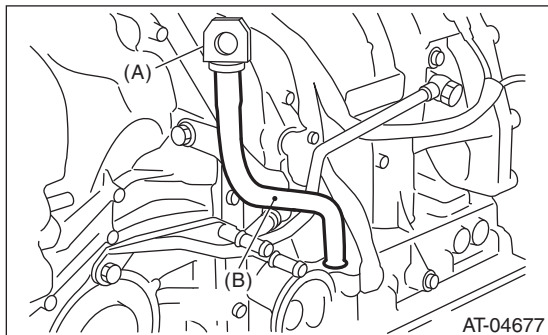

- (A) ATF level gauge
(B) Oil charge pipe

- 2) Install the air intake chamber. (Non-turbo model)
<Ref. to IN(H4SO)-7, INSTALLATION, Air Intake Chamber.>
- 3) Install the intercooler. (Turbo model)
<Ref. to IN(H4DOTC)-12, INSTALLATION, Intercooler.>

C: INSPECTION

Make sure the oil charge pipe is not deformed or damaged.

Torque Converter Clutch Assembly

AUTOMATIC TRANSMISSION

24. Torque Converter Clutch Assembly

A: REMOVAL

- 1) Remove the transmission assembly from the vehicle. <Ref. to 4AT-34, REMOVAL, Automatic Transmission Assembly.>
- 2) Pull out the torque converter clutch assembly and oil pump shaft horizontally.

NOTE:

Be sure not to scratch the inside of bushing in oil pump shaft.

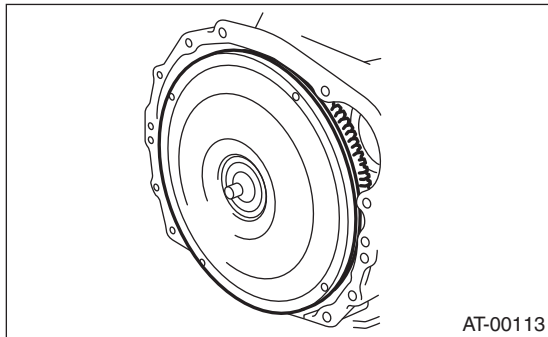

- 3) Remove the input shaft.

NOTE:

When the torque converter clutch assembly is removed, the input shaft will also come off.

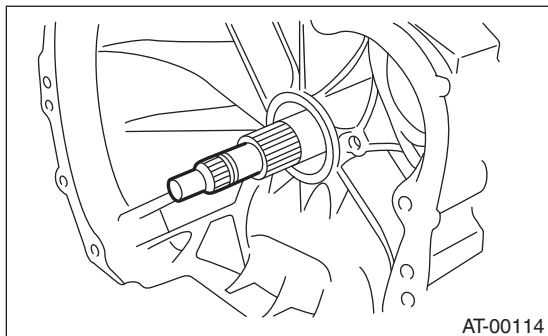

- 4) Remove the oil pump shaft from torque converter clutch assembly as necessary.

B: INSTALLATION

- 1) When the oil pump shaft is removed, install the shaft to converter case.
- 2) Install the oil pump shaft to the torque converter clutch assembly, and make sure the clip is secured on the groove.
- 3) Apply ATF to the O-ring and insert on the input shaft while rotating the shaft slowly by hand.

Normal protrusion A:

50 — 55 mm (1.97 — 2.17 in)

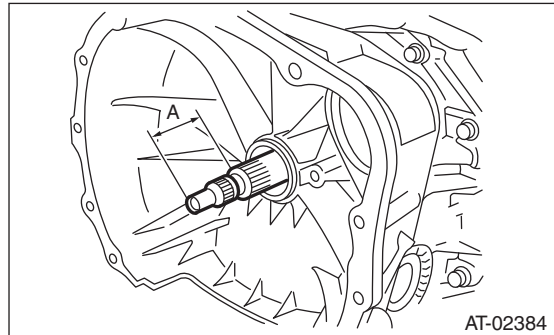

- 4) While holding the torque converter clutch assembly by hand, carefully install it to the torque converter case. Take care not to damage the bushing. Do not allow the oil pump shaft bushing to touch the stator shaft section of the oil pump cover inappropriately.
- 5) Slowly rotate the shaft by hand to engage the splines securely, then check that dimension A is within the specified range.

Dimension A:

2.7 — 2.9 mm (0.106 — 0.114 in)

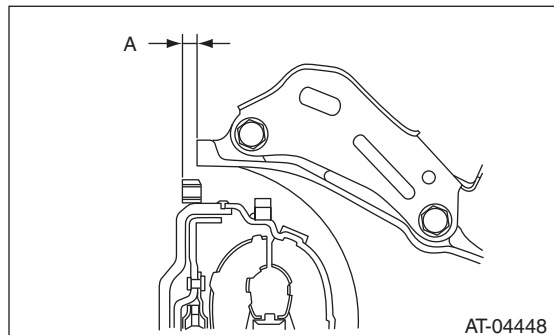

- 6) Install the transmission assembly to the vehicle. <Ref. to 4AT-37, INSTALLATION, Automatic Transmission Assembly.>

C: INSPECTION

Make sure the ring gear and protrusion of the torque converter clutch assembly end are not deformed or damaged.

25. Drive Plate

A: REMOVAL

1) Remove the transmission assembly from the vehicle. <Ref. to 4AT-34, REMOVAL, Automatic Transmission Assembly.>

2) Use the ST to lock the crankshaft, and remove the drive plate.

ST 498497100 CRANKSHAFT STOPPER

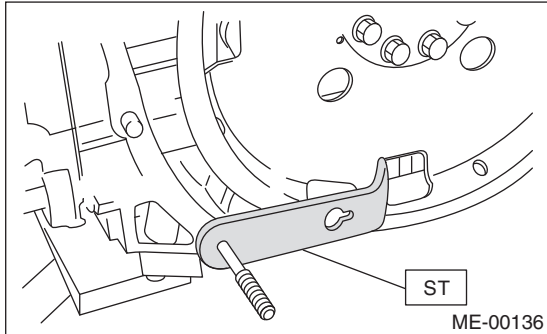

B: INSTALLATION

1) Temporarily tighten the drive plate.

2) Using the ST, lock the crankshaft.

ST 498497100 CRANKSHAFT STOPPER

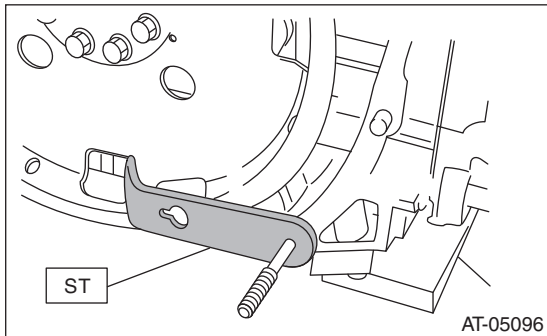

3) Tighten the drive plate in three stages. (turbo model)

(1) Tighten the drive plate mounting bolt.

Tightening torque:

10 N·m (1.0 kgf-m, 7.4 ft-lb)

(2) Additionally tighten the drive plate mounting bolts.

Tightening torque:

40 N·m (4.1 kgf-m, 29.5 ft-lb)

(3) While checking the tightening angle with the ST, further tighten the drive plate mounting bolts.

Tightening angle:

30°±5°

ST 18854AA000 ANGLE GAUGE

4) Tighten the drive plate to the specified torque. (non-turbo model)

NOTE:

Tighten the drive plate mounting bolts gradually. Each bolt should be tightened in a crisscross order.

Tightening torque:

72 N·m (7.3 kgf-m, 53.1 ft-lb)

5) Install the transmission assembly to the vehicle. <Ref. to 4AT-37, INSTALLATION, Automatic Transmission Assembly.>

Extension Case

AUTOMATIC TRANSMISSION

26.Extension Case

A: REMOVAL

- 1) Remove the transmission assembly.
<Ref. to 4AT-34, REMOVAL, Automatic Transmission Assembly.>
- 2) Remove the rear vehicle speed sensor.

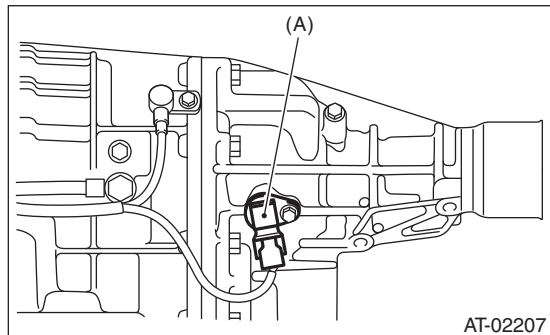

(A) Rear vehicle speed sensor

- 3) Separate the transmission case and extension case section.

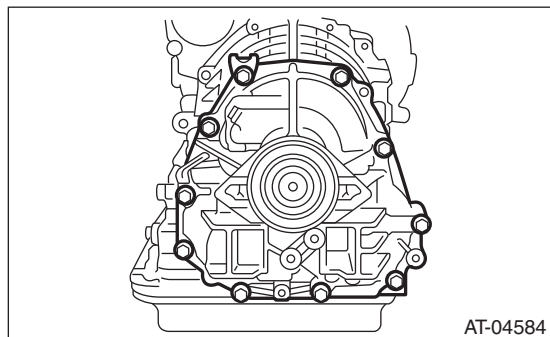

B: INSTALLATION

- 1) Apply vaseline to the contact surface, and attach the selected thrust needle bearing to the end surface of the reduction drive gear.

NOTE:

- Install the thrust needle bearing in the correct direction.
- 2) Install a new gasket.
 - 3) Install the extension case to transmission case.
 - 4) Tighten bolts to secure the extension case.

Tightening torque:

25 N·m (2.5 kgf·m, 18.4 ft·lb)

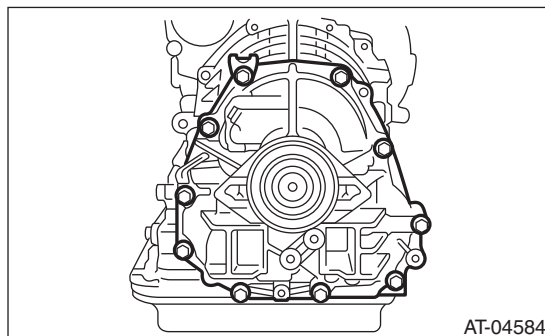

- 5) Install the rear vehicle speed sensor.

Tightening torque:

7 N·m (0.7 kgf·m, 5.2 ft·lb)

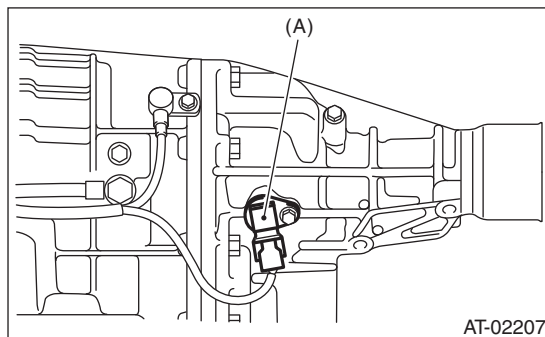

(A) Rear vehicle speed sensor

- 6) Install the transmission assembly.
<Ref. to 4AT-37, INSTALLATION, Automatic Transmission Assembly.>

C: DISASSEMBLY

1) Hit the extension case lightly with a plastic hammer, and take out the transfer clutch.

NOTE:

Be careful not to damage the oil seal of the extension case.

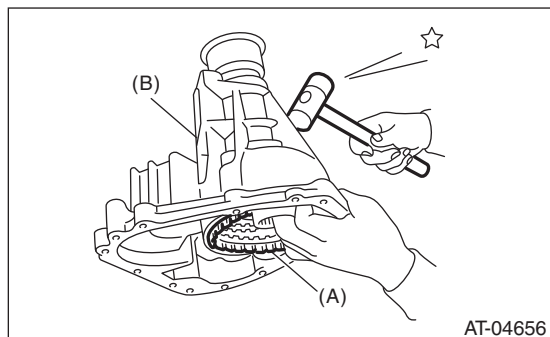

(A) Transfer clutch
(B) Extension case

2) Remove the transfer clutch pipe while being careful not to deform the pipe.

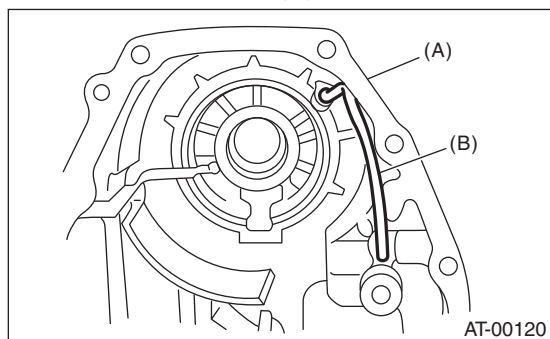

(A) Extension case
(B) Transfer clutch pipe

3) Remove the dust cover from extension case.
4) Remove the oil seal from the extension case.

D: ASSEMBLY

1) Press-fit the new oil seal using ST and the press.
ST 498057300 INSTALLER
2) Press-fit the dust cover.
3) Install the transfer clutch pipe to the extension case while being careful not to deform the pipe.

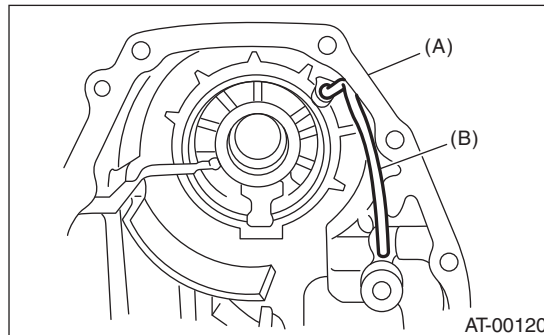

(A) Extension case
(B) Transfer clutch pipe

4) Install the transfer clutch assembly to the case.

NOTE:

- Be careful not to damage the seal ring.
- Insert the transfer clutch assembly all the way to the bottom of the bearing shoulder.

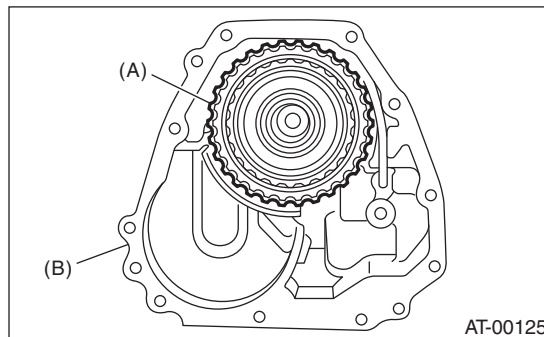

(A) Transfer clutch ASSY
(B) Extension case

E: INSPECTION

- Blow with compressed air to make sure the transfer clutch pipe and extension case routes are not clogged or leaking.
- Inspect the extension end play, and adjust it to within the standard value. <Ref. to 4AT-74, ADJUSTMENT, Transfer Clutch.>

Transfer Clutch

AUTOMATIC TRANSMISSION

27. Transfer Clutch

A: REMOVAL

1) Remove the transmission assembly from vehicle body. <Ref. to 4AT-34, REMOVAL, Automatic Transmission Assembly.>

2) Remove the extension case, and then remove the transfer clutch. <Ref. to 4AT-68, REMOVAL, Extension Case.> <Ref. to 4AT-69, DISASSEMBLY, Extension Case.>

B: INSTALLATION

1) Select the thrust needle bearing. <Ref. to 4AT-74, ADJUSTMENT, Transfer Clutch.>

2) Install the transfer clutch assembly to the case.

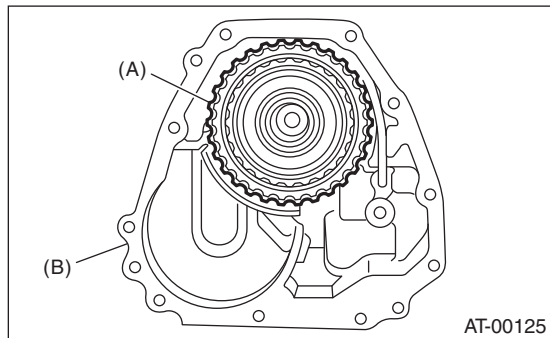

(A) Transfer clutch ASSY
(B) Extension case

3) Tighten the bolts to secure the case.

Tightening torque:

25 N·m (2.5 kgf·m, 18.4 ft·lb)

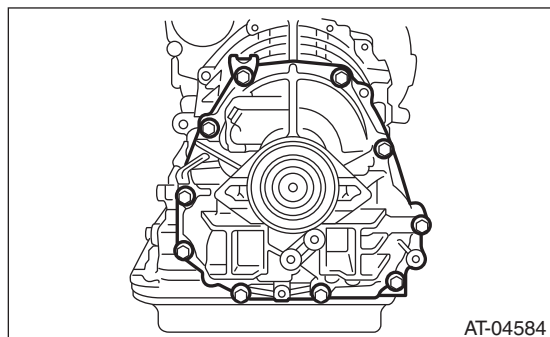

4) Install the transmission assembly to the vehicle. <Ref. to 4AT-37, INSTALLATION, Automatic Transmission Assembly.>

C: DISASSEMBLY

1) Remove the seal ring.

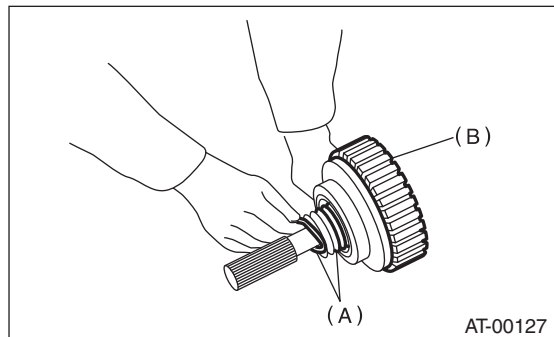

(A) Seal ring
(B) Rear drive shaft

2) Remove the ball bearing using the ST and the press.

ST 498077600

REMOVER

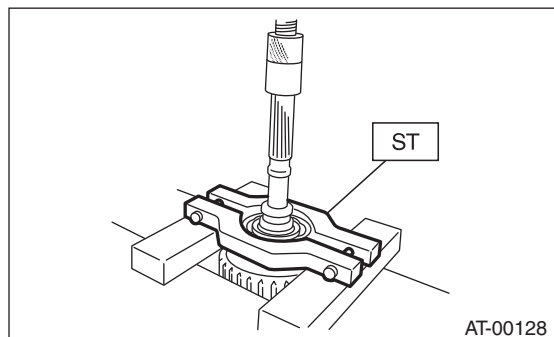

3) Using a flat tip screwdriver, etc. remove the snap ring, and take out the retaining plate, drive plate and driven plate.

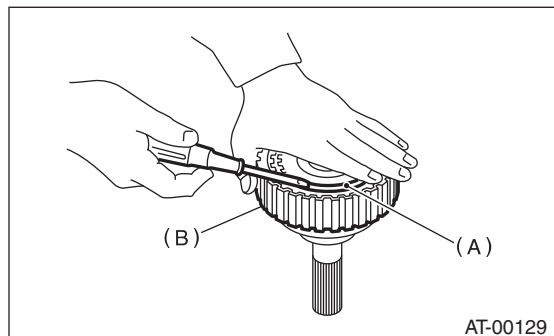

(A) Snap ring
(B) Rear drive shaft

4) Using the ST1, ST2 and ST3, remove the snap ring, then take out the return spring and transfer clutch piston seal.

ST1	399893600	PLIERS
ST2	398673600	COMPRESSOR
ST3	398623600	SEAT

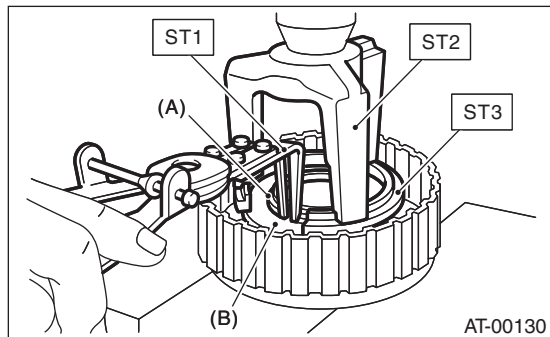

(A) Snap ring
(B) Transfer clutch piston seal

5) Apply compressed air to the rear drive shaft, to remove the transfer clutch piston.

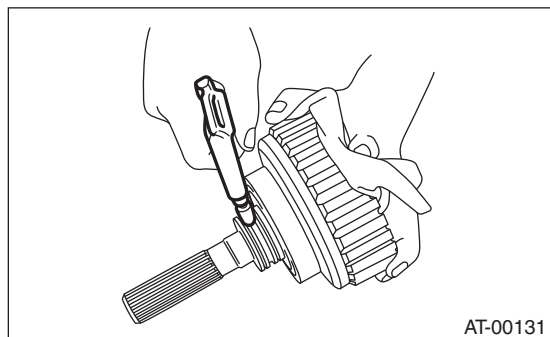

AT-00131

D: ASSEMBLY

1) Install the transfer clutch piston.

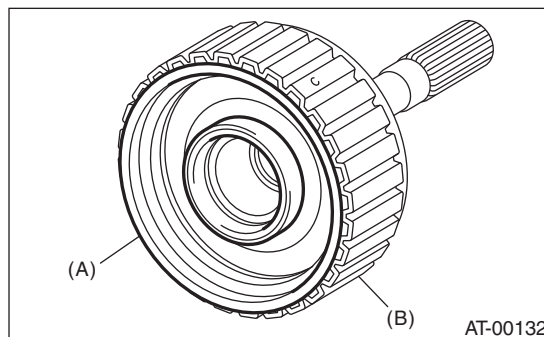

(A) Transfer clutch piston
(B) Rear drive shaft

2) Install the return spring to transfer clutch piston.

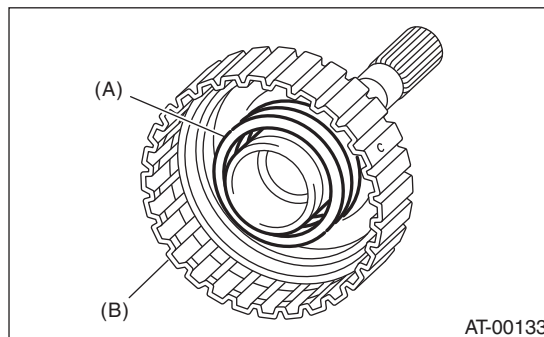

(A) Return spring
(B) Rear drive shaft

3) Apply ATF to the lip of transfer clutch piston seal, then install.

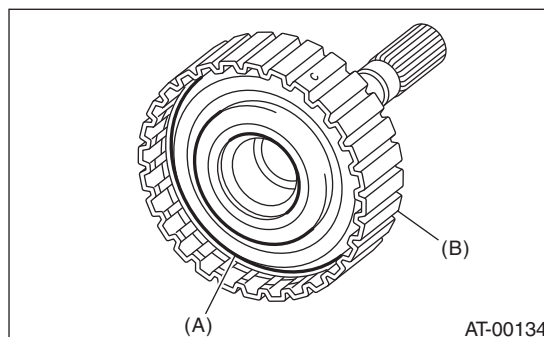

(A) Transfer clutch piston seal
(B) Rear drive shaft

Transfer Clutch

AUTOMATIC TRANSMISSION

- 4) Attach the ST to the rear drive shaft.
ST 499257300 SNAP RING OUTER GUIDE

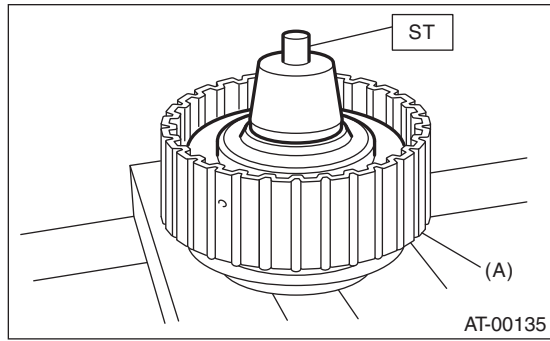

(A) Rear drive shaft

- 7) Install the driven plate, drive plate, retaining plate and snap ring.

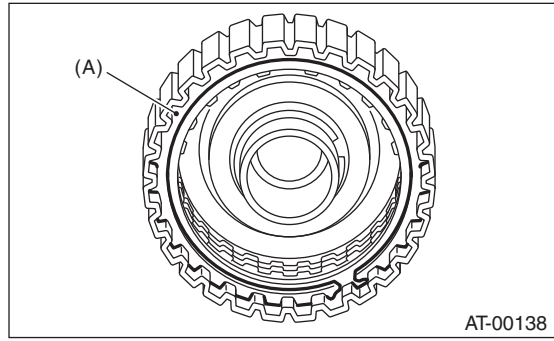

(A) Snap ring

- 5) Install the snap ring to the ST.
ST 499257300 SNAP RING OUTER GUIDE

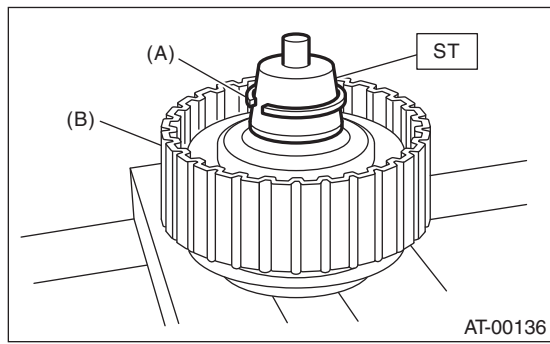

(A) Snap ring
(B) Rear drive shaft

- 8) Apply compressed air to see if the assembled parts move smoothly.

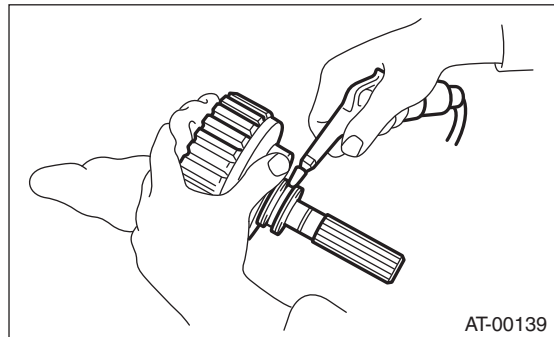

- 9) Check the clearance between the snap ring and retaining plate. <Ref. to 4AT-73, INSPECTION, Transfer Clutch.>

- 6) Install the snap ring to the rear drive shaft using ST1 and ST2.

- ST1 499257300 SNAP RING OUTER GUIDE
ST2 499247400 INSTALLER

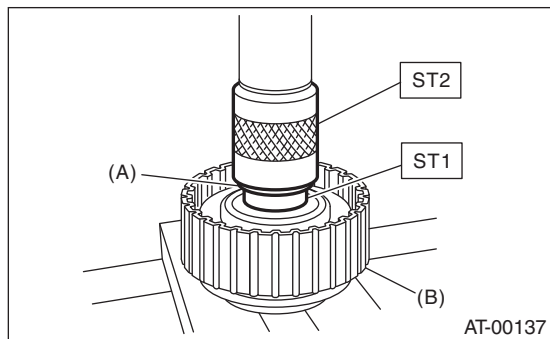

(A) Snap ring
(B) Rear drive shaft

- 10) Press-fit new ball bearing using ST.
ST 899580100 INSTALLER

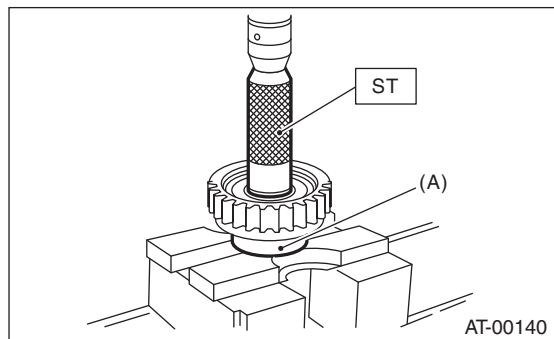

(A) Ball bearing

11) Apply Vaseline to a new seal ring and attach to the seal ring groove of the rear drive shaft.

NOTE:

While installing the seal ring, not to stretch the seal ring excessively.

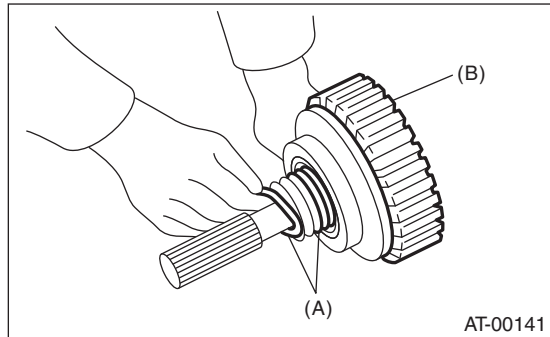

(A) Seal ring
(B) Rear drive shaft

12) Install the transfer clutch assembly while taking care not to damage the seal ring.

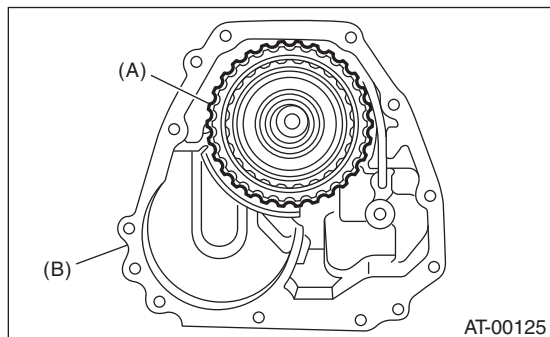

(A) Transfer clutch ASSY
(B) Extension case

E: INSPECTION

- Inspect the drive plate facing for wear and damage.
- Make sure the snap ring is not worn and the return spring has no permanent distortion, damage, or deformation.
- Inspect the D-ring for damage.
- Inspect the extension end play, and adjust it to within the standard value. <Ref. to 4AT-74, ADJUSTMENT, Transfer Clutch.>
 - 1) Check the clearance between the snap ring and retaining plate.
 - 2) Before measuring clearance, place same thickness shims on both sides to prevent the retaining plate from tilting.
 - 3) If the clearance exceeds the service limits, replace the plate set (drive plate and driven plate), and select and adjust a retaining plate to be within the initial standard value.

Initial standard:

0.7 — 1.1 mm (0.028 — 0.043 in)

Limit thickness:

1.6 mm (0.063 in)

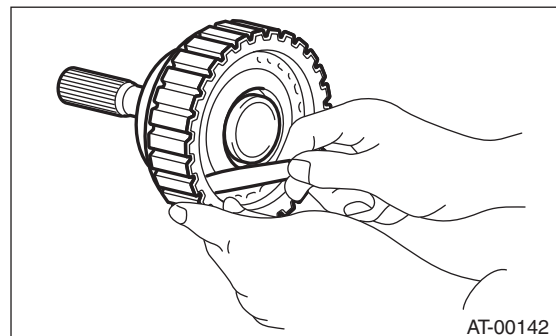

Retaining plate	
Part number	Thickness mm (in)
31593AA151	3.3 (0.130)
31593AA161	3.7 (0.146)
31593AA171	4.1 (0.161)
31593AA181	4.5 (0.177)

4) Check for tight corner braking phenomenon when the vehicle is moved forward with the steering fully turned. If tight corner braking occurs, perform the following procedures.

(1) With the steering wheel held at fully turned position, drive the vehicle in “D” range and with vehicle speed at approx. 5 km/h (3 MPH) in both clockwise and counterclockwise directions for approx. ten times each, while repeating acceleration and braking intermittently.

(2) If the tight corner braking phenomenon still persists, drive the vehicle again in a circle for several laps.

Transfer Clutch

AUTOMATIC TRANSMISSION

F: ADJUSTMENT

1) Measure the distance "A" from the end of ST to the rear drive shaft using the ST.

ST 398643600 GAUGE

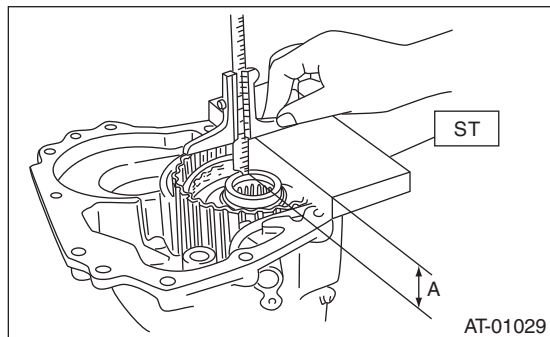

A Measured value

2) Measure distance "B" from the transmission case mating surface to the end of ST using ST1 and ST2.

ST1 398643600 GAUGE

ST2 499577000 GAUGE

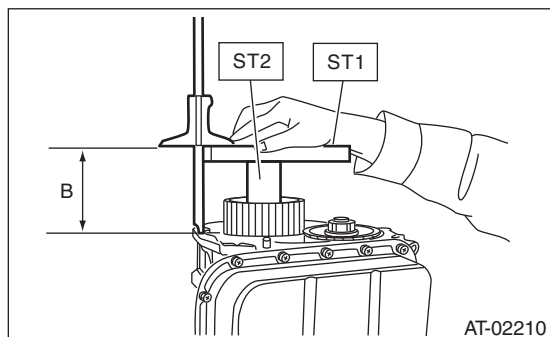

B Measured value

3) Calculation formula:

$$T = A - B + 35.4 \text{ mm}$$

$$[T = A - B + 1.3937 \text{ in}]$$

T: Thrust needle bearing thickness

A: Distance from the end of the ST to end of rear drive shaft

B: Distance from the mating surface of the transmission case to the end of the ST

Thrust needle bearing	
Part number	Thickness mm (in)
806536020	3.8 (0.150)
806535030	4.0 (0.157)
806535040	4.2 (0.165)
806535050	4.4 (0.173)
806535060	4.6 (0.181)
806535070	4.8 (0.189)
806535090	5.0 (0.197)

28.Reduction Driven Gear

A: REMOVAL

- 1) Remove the transmission assembly from vehicle body. <Ref. to 4AT-34, REMOVAL, Automatic Transmission Assembly.>
- 2) Remove the rear wheel speed sensor, and separate the extension case from transmission case. <Ref. to 4AT-68, REMOVAL, Extension Case.>
- 3) Set the range select lever to the "P" range.
- 4) Lift the crimped section, and then remove the lock nut.

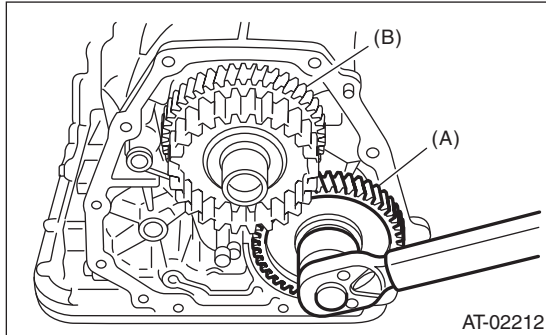

- (A) Reduction driven gear
- (B) Reduction drive gear

- 5) Using the ST1 and ST2, extract the reduction driven gear.

ST1 499737000 PULLER
 ST2 899524100 PULLER SET

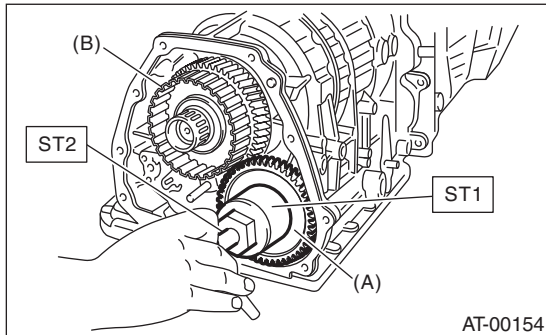

- (A) Reduction driven gear
- (B) Reduction drive gear

B: INSTALLATION

- 1) Set the range select lever to the "P" range.
- 2) Using a plastic hammer, install the reduction driven gear assembly and the new washer, and tighten the new drive pinion lock nut.

Tightening torque:

100 N·m (10.2 kgf-m, 73.8 ft-lb)

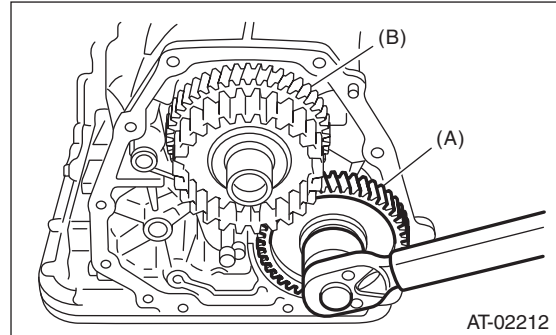

- (A) Reduction driven gear
- (B) Reduction drive gear

- 3) After tightening, stake the lock nut securely.
- 4) Join the transmission case and the extension case, and then install the rear vehicle speed sensor. <Ref. to 4AT-68, INSTALLATION, Extension Case.>
- 5) Install the transmission assembly to the vehicle. <Ref. to 4AT-37, INSTALLATION, Automatic Transmission Assembly.>

Reduction Driven Gear

AUTOMATIC TRANSMISSION

C: DISASSEMBLY

1) Remove the snap ring from reduction driven gear.

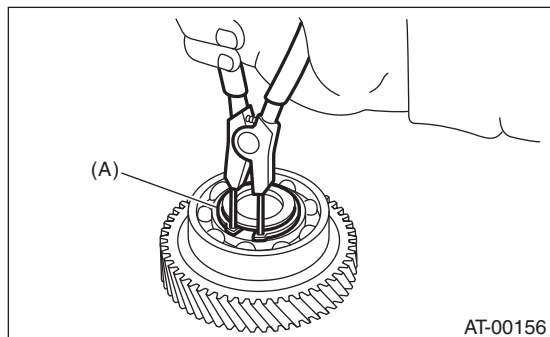

(A) Snap ring

2) Remove the ball bearing from reduction driven gear using ST.

ST 498077600

REMOVER

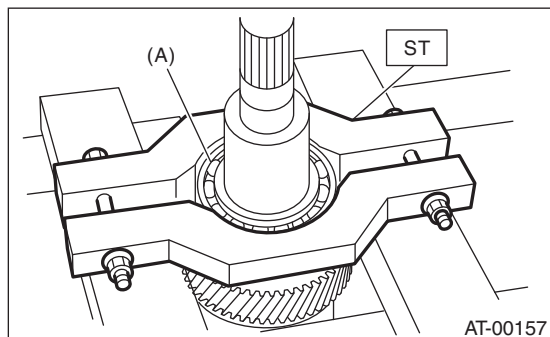

(A) Ball bearing

3) Remove the gear inner groove snap ring from the reduction driven gear.

D: ASSEMBLY

1) Install the snap ring to the gear inner groove on the reduction driven gear.

2) Install the new ball bearing to reduction driven gear using press.

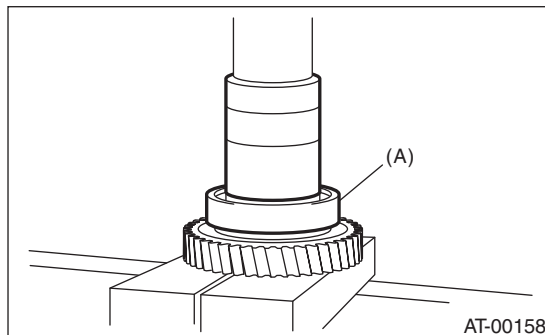

(A) Ball bearing

3) Install the snap ring to reduction driven gear.

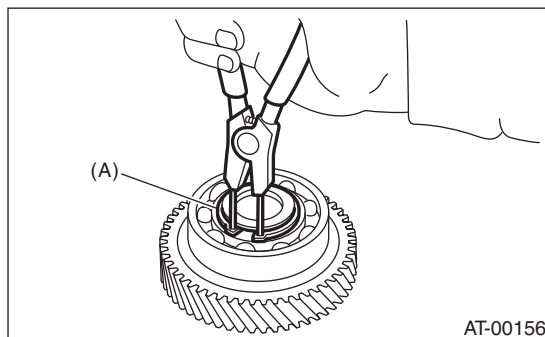

(A) Snap ring

E: INSPECTION

Make sure the ball bearing and gear is not deformed or damaged.

29.Reduction Drive Gear

A: REMOVAL

- 1) Remove the transmission assembly from vehicle body. <Ref. to 4AT-34, REMOVAL, Automatic Transmission Assembly.>
- 2) Remove the rear wheel speed sensor, and separate the extension case from transmission case. <Ref. to 4AT-68, REMOVAL, Extension Case.>
- 3) Remove the reduction driven gear. <Ref. to 4AT-75, REMOVAL, Reduction Driven Gear.>
- 4) Using the ST, extract the reduction drive gear assembly.

ST1 499737100 PULLER
ST2 899524100 PULLER SET

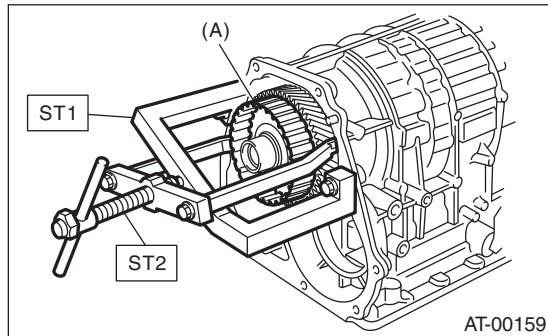

(A) Reduction drive gear ASSY

B: INSTALLATION

- 1) Install the reduction drive gear assembly.

NOTE:

Press-fit it to the bottom of bearing shoulder completely.

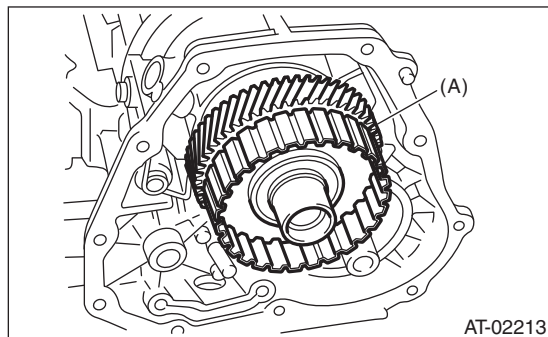

(A) Reduction drive gear ASSY

- 2) Install the reduction driven gear. <Ref. to 4AT-75, INSTALLATION, Reduction Driven Gear.>
- 3) Join the transmission case and the extension case, and then install the rear vehicle speed sensor. <Ref. to 4AT-68, INSTALLATION, Extension Case.>
- 4) Install the transmission assembly to the vehicle. <Ref. to 4AT-37, INSTALLATION, Automatic Transmission Assembly.>

C: DISASSEMBLY

- 1) Take out the seal ring.

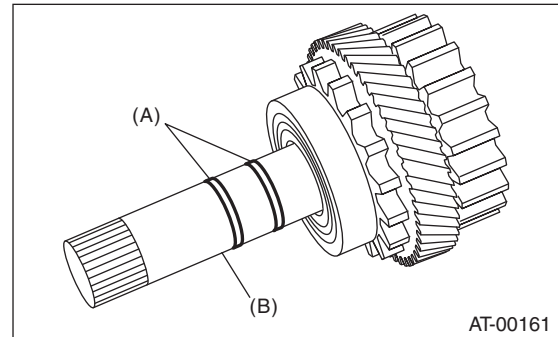

(A) Seal ring
(B) Reduction drive shaft

- 2) Remove the ball bearing using ST.

ST 498077600 REMOVER

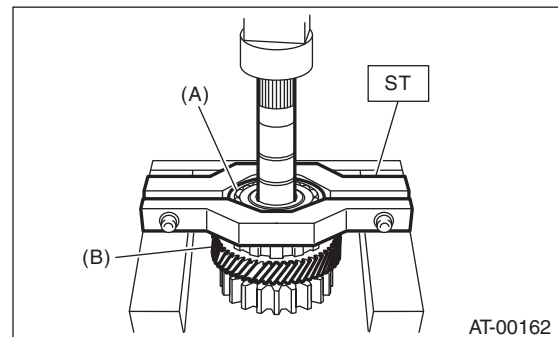

(A) Ball bearing
(B) Reduction drive gear

- 3) Apply vaseline to the outer surface of seal ring and shaft groove.

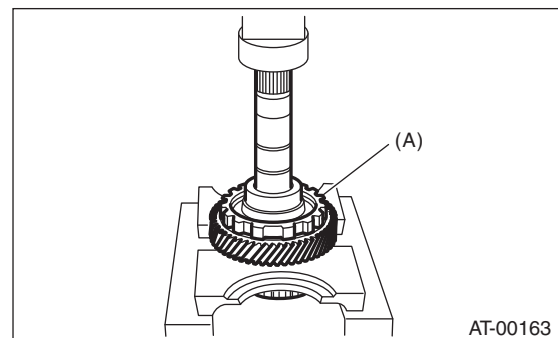

(A) Reduction drive gear

Reduction Drive Gear

AUTOMATIC TRANSMISSION

D: ASSEMBLY

- 1) Press-fit the reduction drive gear to shaft.
- 2) Press-fit the new ball bearing into reduction drive gear.
- 3) Apply vaseline onto the seal ring outer surface and shaft grooves.
- 4) Apply ATF to new seal rings, then install.

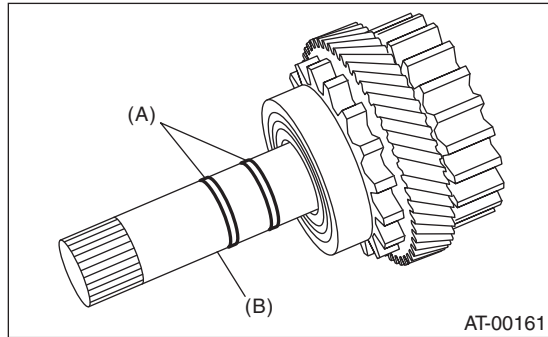

- (A) Seal ring
(B) Reduction drive shaft

E: INSPECTION

- Rotate the bearing by hand, and check that it rotates smoothly.
- Check parts for holes, damage or adhesion of dust and other foreign particles.
- Inspect the extension end play, and adjust it to the standard value. <Ref. to 4AT-74, ADJUSTMENT, Transfer Clutch.>

30. Parking Pawl

A: REMOVAL

- 1) Remove the transmission assembly from vehicle body. <Ref. to 4AT-34, REMOVAL, Automatic Transmission Assembly.>
- 2) Remove the rear wheel speed sensor, and separate the extension case from transmission case. <Ref. to 4AT-68, REMOVAL, Extension Case.>
- 3) Remove the reduction drive gear. <Ref. to 4AT-77, REMOVAL, Reduction Drive Gear.>
- 4) Remove the parking pawl, return spring and shaft.

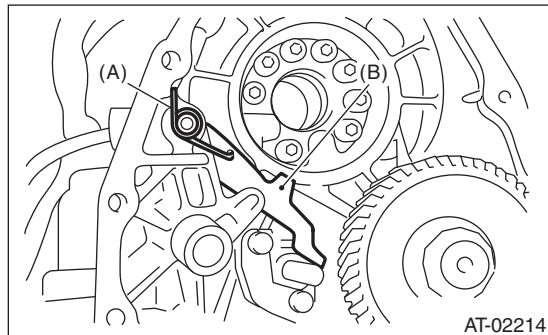

- (A) Return spring
- (B) Parking pawl

B: INSTALLATION

- 1) Install the parking pawl, return spring and shaft.

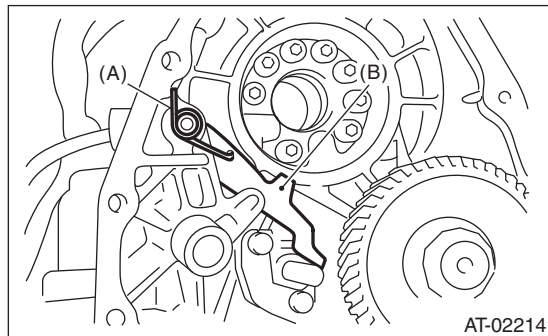

- (A) Return spring
- (B) Parking pawl

- 2) Install the reduction drive gear. <Ref. to 4AT-77, INSTALLATION, Reduction Drive Gear.>
- 3) Install the rear vehicle speed sensor and extension case. <Ref. to 4AT-68, INSTALLATION, Extension Case.>
- 4) Install the transmission assembly to the vehicle. <Ref. to 4AT-37, INSTALLATION, Automatic Transmission Assembly.>

C: INSPECTION

Check the tab of the parking pole on the reduction gear for wear or other damage.

Converter Case

AUTOMATIC TRANSMISSION

31. Converter Case

A: REMOVAL

- 1) Remove the transmission assembly from vehicle body. <Ref. to 4AT-34, REMOVAL, Automatic Transmission Assembly.>
- 2) Pull out the torque converter clutch assembly. <Ref. to 4AT-66, REMOVAL, Torque Converter Clutch Assembly.>
- 3) Remove the input shaft.

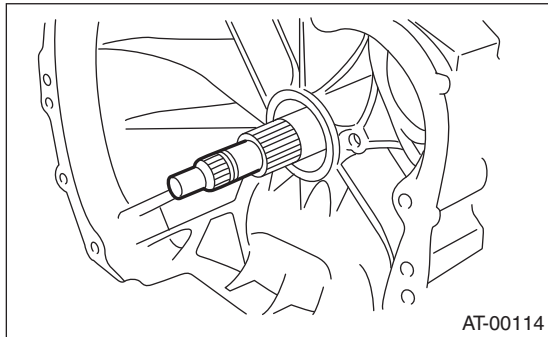

- 4) Lift up the lever on the rear side of transmission harness connector, and then disconnect it from the stay.
- 5) Disconnect the inhibitor switch connector from the stay.

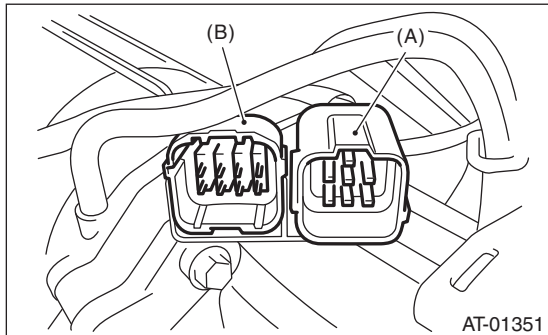

- (A) Transmission harness connectors
- (B) Inhibitor switch connector

- 6) Remove the air breather hose. <Ref. to 4AT-64, REMOVAL, Air Breather Hose.>
- 7) Remove the oil charge pipe. <Ref. to 4AT-65, REMOVAL, Oil Charge Pipe.>
- 8) Remove the ATF inlet and outlet pipes. <Ref. to 4AT-61, REMOVAL, ATF Cooler Pipe and Hose.>

- 9) Remove the converter case alignment bolt, and then separate the transmission case and converter case by lightly tapping with a plastic hammer.

NOTE:

- Be careful not to damage the oil seal and bushing in the converter case with the oil pump cover.
- Be careful not to loosen the rubber seal.

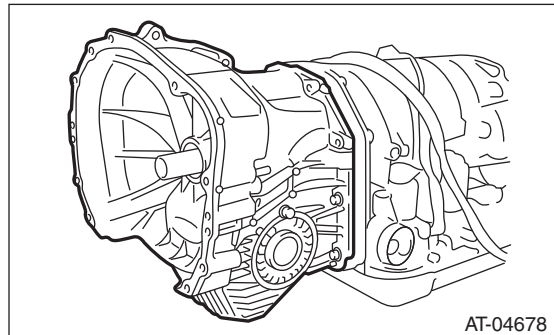

- 10) Remove the seal pipe.

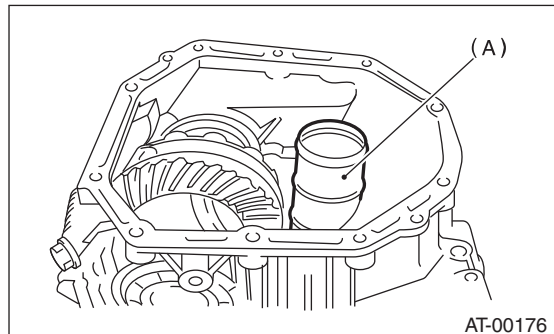

- (A) Seal pipe

- 11) Remove the front differential assembly. <Ref. to 4AT-94, REMOVAL, Front Differential Assembly.>
- 12) Remove the oil seal from converter case.

B: INSTALLATION

- 1) Check the appearance of each component and clean them.
- 2) Press-fit the new oil seal to the converter case using the ST.

ST 398437700 DRIFT

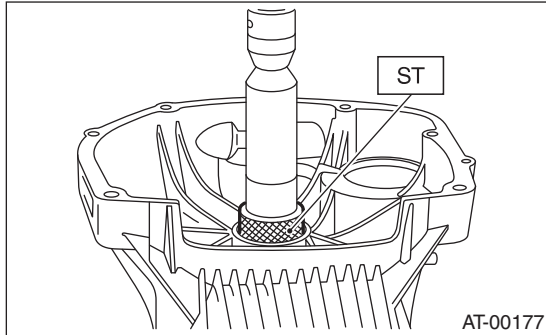

- 3) Install the front differential assembly to the case. <Ref. to 4AT-94, INSTALLATION, Front Differential Assembly.>
- 4) Install the right and left side retainers. <Ref. to 4AT-98, ADJUSTMENT, Front Differential Assembly.>
- 5) Install new seal pipe to converter case.

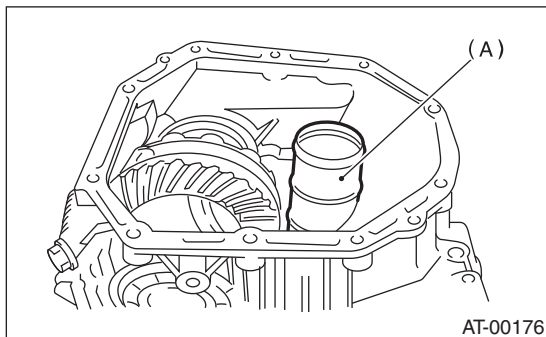

(A) Seal pipe

- 6) Install new rubber seal to converter case.

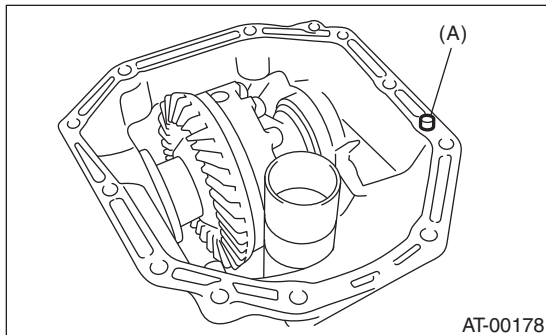

(A) Rubber seal

- 7) Apply proper amount of liquid gasket to the entire matching surface of converter case.

Liquid gasket:

THREE BOND 1215 (Part No. 004403007) or equivalent

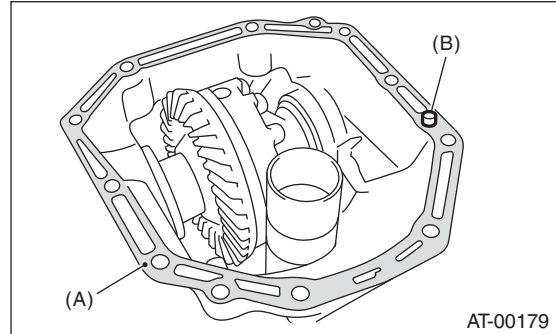

(A) THREE BOND 1215

(B) Rubber seal

- 8) Install the converter case without damaging bushing and oil seal.

NOTE:

Use new bolts for the oil charge pipe.

Tightening torque:

Oil charge pipe section

38 N·m (3.9 kgf·m, 28.0 ft·lb)

Excluding the oil charge pipe section

41 N·m (4.2 kgf·m, 30.2 ft·lb)

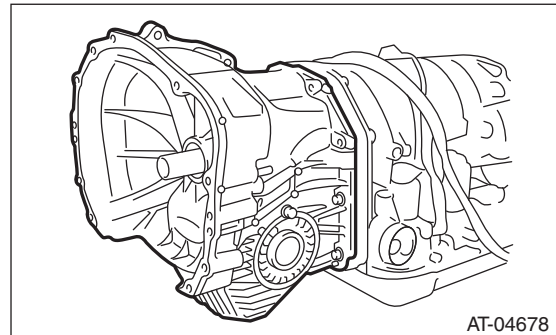

- 9) Insert the inhibitor switch and transmission harness connector to the stay.

- 10) Install the air breather hose. <Ref. to 4AT-64, INSTALLATION, Air Breather Hose.>

- 11) Install the ATF cooler pipe. <Ref. to 4AT-62, INSTALLATION, ATF Cooler Pipe and Hose.>

- 12) Install the oil charge pipe with O-ring. <Ref. to 4AT-65, INSTALLATION, Oil Charge Pipe.>

Converter Case

AUTOMATIC TRANSMISSION

13) Insert the input shaft while rotating it lightly by hand, and then check the amount of protrusion.

Normal protrusion A:

50 — 55 mm (1.97 — 2.17 in)

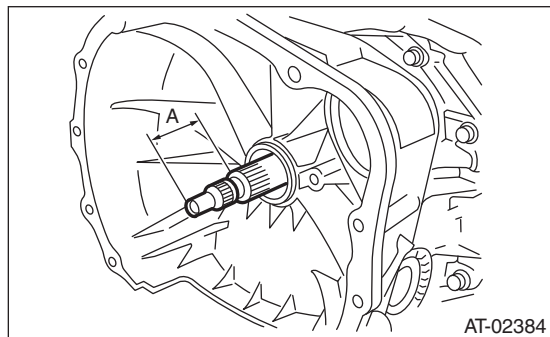

14) Install the torque converter clutch assembly. <Ref. to 4AT-66, INSTALLATION, Torque Converter Clutch Assembly.>

15) Install the transmission assembly to the vehicle. <Ref. to 4AT-37, INSTALLATION, Automatic Transmission Assembly.>

C: INSPECTION

Measure the backlash, and then adjust it to be within standard values. <Ref. to 4AT-92, ADJUSTMENT, Drive Pinion Shaft Assembly.>

32. Oil Pump Housing

A: REMOVAL

- 1) Remove the transmission assembly from vehicle body. <Ref. to 4AT-34, REMOVAL, Automatic Transmission Assembly.>
- 2) Pull out the torque converter clutch assembly. <Ref. to 4AT-66, REMOVAL, Torque Converter Clutch Assembly.>
- 3) Remove the input shaft.

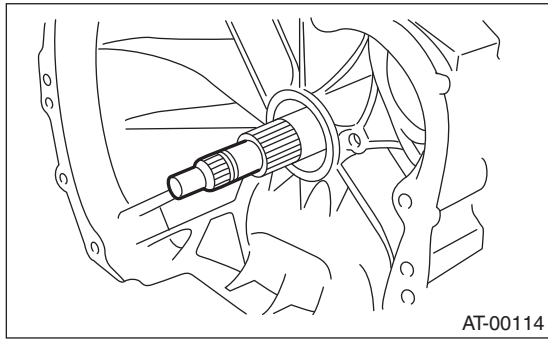

- 4) Lift up the lever on the rear side of transmission harness connector, and then remove it from the stay.
- 5) Remove the inhibitor switch connector from the stay.
- 6) Remove the oil charge pipe. <Ref. to 4AT-65, REMOVAL, Oil Charge Pipe.>
- 7) Remove the ATF inlet and outlet pipes. <Ref. to 4AT-61, REMOVAL, ATF Cooler Pipe and Hose.>
- 8) Separate the converter case and transmission case. <Ref. to 4AT-80, REMOVAL, Converter Case.>
- 9) Separate the transmission case and extension case section. <Ref. to 4AT-68, REMOVAL, Extension Case.>
- 10) Remove the reduction drive gear. <Ref. to 4AT-77, REMOVAL, Reduction Drive Gear.>
- 11) Remove the reduction driven gear. <Ref. to 4AT-75, REMOVAL, Reduction Driven Gear.>
- 12) Loosen the oil pump housing mounting bolts.

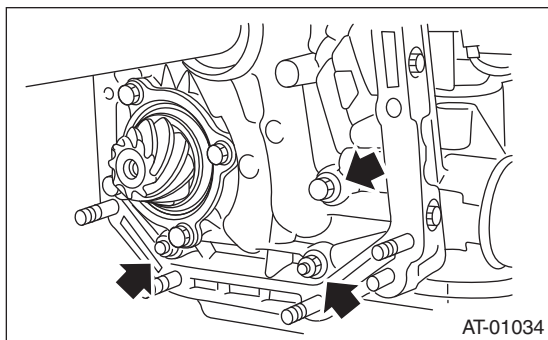

- 13) Place two wooden blocks on the workbench, and stand the transmission case with the rear end facing down.

NOTE:

- Be careful not to scratch the rear mating surface of the transmission case.
- Check the height of the wooden blocks to avoid damaging the parking rod and drive pinion that are protruding from the mating surface.

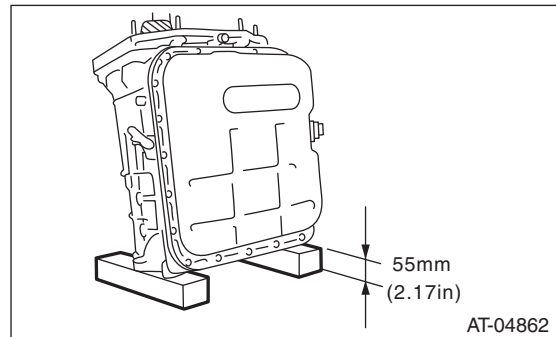

- 14) Remove the oil pump housing and adjusting thrust washer.

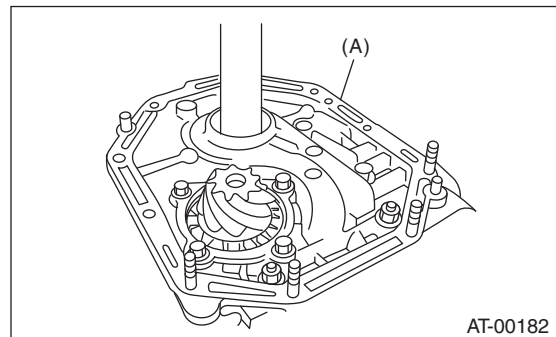

(A) Oil pump housing

Oil Pump Housing

AUTOMATIC TRANSMISSION

B: INSTALLATION

1) Secure the oil pump housing with two nuts and a bolt.

Tightening torque:

42 N·m (4.3 kgf·m, 31.0 ft·lb)

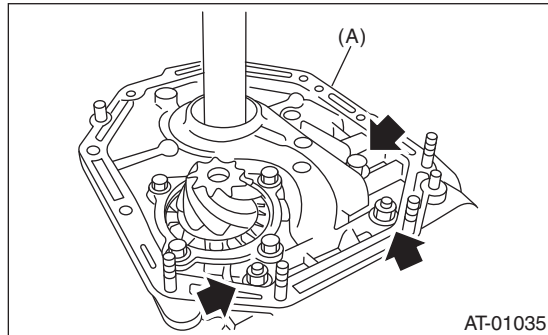

(A) Oil pump housing

2) Install the converter case to the transmission case assembly. <Ref. to 4AT-81, INSTALLATION, Converter Case.>

3) Install the reduction driven gear. <Ref. to 4AT-75, INSTALLATION, Reduction Driven Gear.>

4) Install the reduction drive gear. <Ref. to 4AT-77, INSTALLATION, Reduction Drive Gear.>

5) Join the transmission case and the extension case, and then install the rear vehicle speed sensor. <Ref. to 4AT-68, INSTALLATION, Extension Case.>

6) Insert the inhibitor switch and transmission harness connector to the stay.

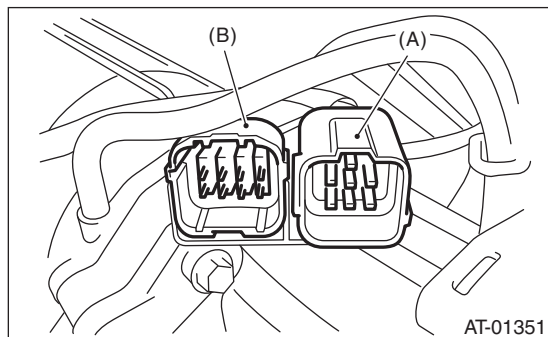

(A) Transmission harness connectors

(B) Inhibitor switch connector

7) Install the ATF cooler pipe. <Ref. to 4AT-62, INSTALLATION, ATF Cooler Pipe and Hose.>

8) Install the oil charge pipe together with an O-ring. <Ref. to 4AT-65, INSTALLATION, Oil Charge Pipe.>

9) Insert the input shaft while rotating it lightly by hand, and then check the amount of protrusion.

Normal protrusion A:

50 — 55 mm (1.97 — 2.17 in)

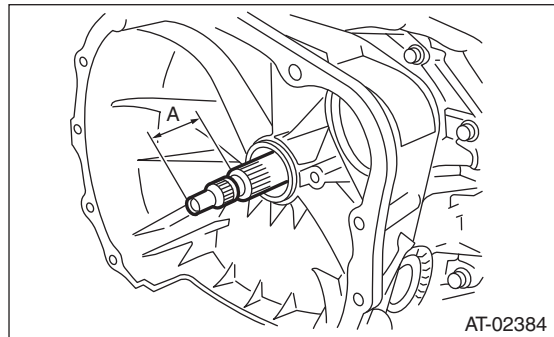

10) Install the torque converter clutch assembly. <Ref. to 4AT-66, INSTALLATION, Torque Converter Clutch Assembly.>

11) Install the transmission assembly to the vehicle. <Ref. to 4AT-37, INSTALLATION, Automatic Transmission Assembly.>

C: DISASSEMBLY

1. OIL PUMP COVER

1) Remove the four seal rings.

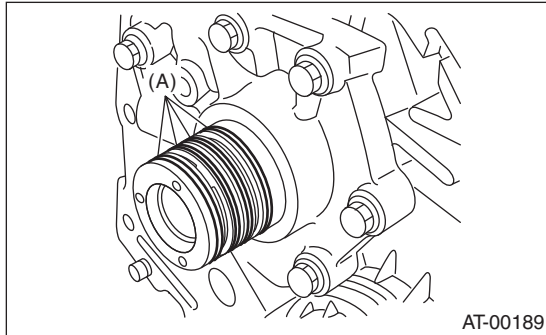

(A) Seal ring

2) Remove attachment bolts, then remove the oil pump cover by lightly tapping the end of the stator shaft.

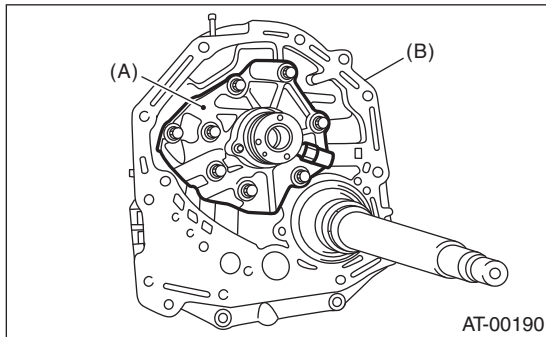

(A) Oil pump cover
(B) Oil pump housing

3) Remove the oil pump inner rotor and outer rotor.

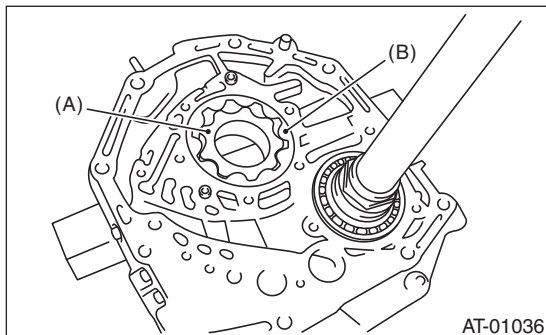

(A) Inner rotor
(B) Outer rotor

2. OIL SEAL RETAINER

1) Remove the oil seal retainer.

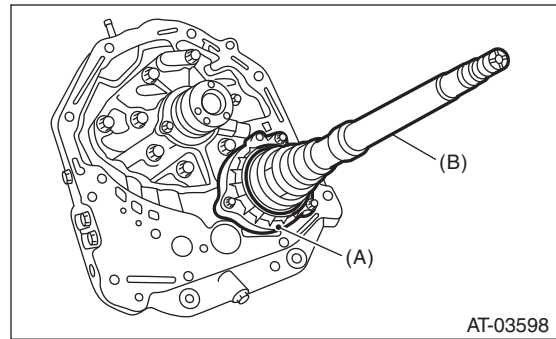

(A) Oil seal retainer
(B) Drive pinion shaft

2) Remove the O-ring.

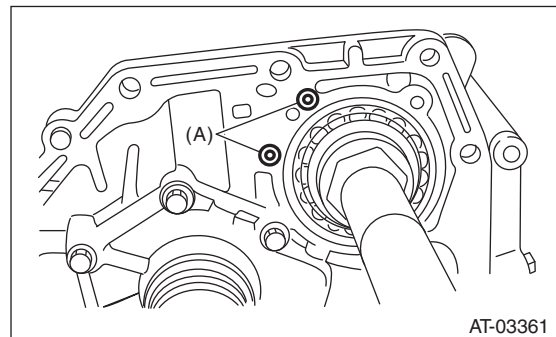

(A) O-ring

3) Remove the oil seal from the oil seal retainer.

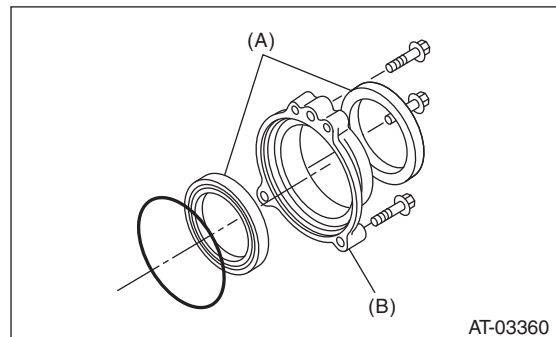

(A) Oil seal
(B) Oil seal retainer

Oil Pump Housing

AUTOMATIC TRANSMISSION

D: ASSEMBLY

1. OIL PUMP COVER

1) Install the oil pump rotor assembly to oil pump housing.

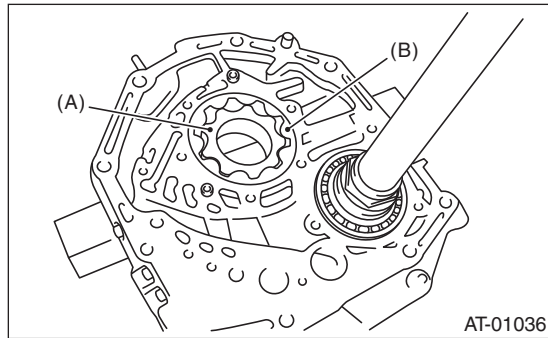

- (A) Inner rotor
- (B) Outer rotor

2) Align both pivots with the pivot holes of the cover, and then install the oil pump cover while being careful not to apply excessive force to the pivots.

Tightening torque:

25 N·m (2.5 kgf·m, 18.4 ft·lb)

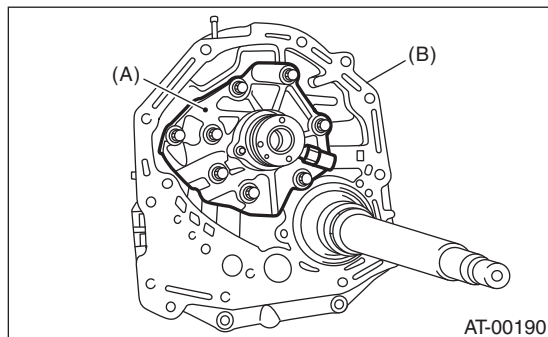

- (A) Oil pump cover
- (B) Oil pump housing

3) After assembling, turn the oil pump shaft to check for smooth rotation of rotor.

4) Apply vaseline to the oil seal retainer and new seal rings, and install them. After installing, adjust the drive pinion backlash and tooth contact. <Ref. to 4AT-88, ADJUSTMENT, Oil Pump Housing.>

NOTE:

There are two types of seals. They are identified by color. Install at the proper positions by referring to the figure.

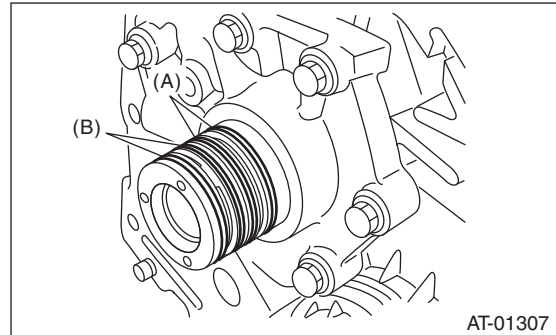

- (A) Seal ring (Black)
- (B) Seal ring (Brown)

2. OIL SEAL RETAINER

1) Apply ATF to two new oil seals and install them to the oil seal retainer in the proper direction using the ST.

ST 499247300 INSTALLER

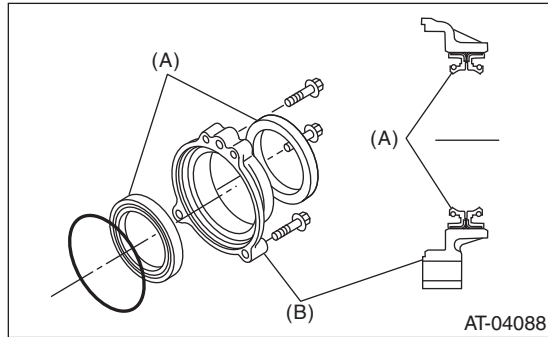

- (A) Oil seal
- (B) Oil seal retainer

2) Apply ATF to a new O-ring and attach to the oil seal retainer. Install the seal to the oil pump housing bore.

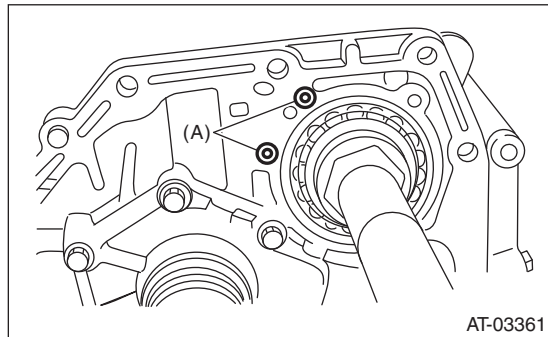

- (A) O-ring

3) Install the oil seal being careful not to damage oil seal lip, and secure it using three bolts.

Tightening torque:

7 N·m (0.7 kgf·m, 5.2 ft·lb)

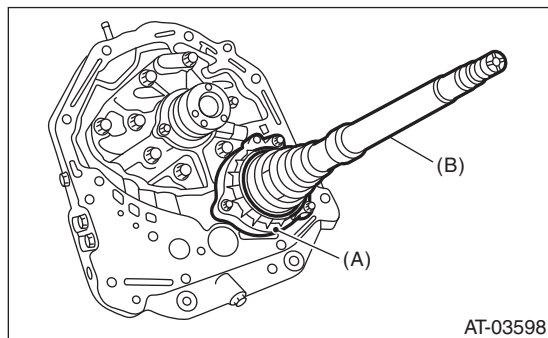

- (A) Oil seal retainer
- (B) Drive pinion shaft

E: INSPECTION

1) Check the seal ring and oil seal for breaks and damage.

2) Check other parts for dents or faults.

3) Oil pump rotor assembly selection

(1) Tip clearance

Install the inner rotor and outer rotor to the oil pump. With rotor gears facing each other, measure the crest-to-crest clearance.

Tip clearance:

0.02 — 0.15 mm (0.0008 — 0.0059 in)

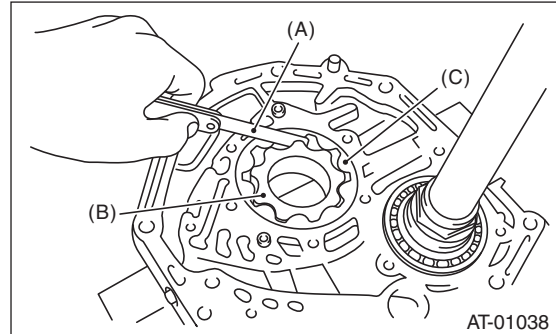

- (A) Thickness gauge
- (B) Inner rotor
- (C) Outer rotor

(2) Side clearance

Set a depth gauge to oil pump housing, then measure the oil pump housing-to-rotor clearance.

Side clearance:

0.02 — 0.04 mm (0.0008 — 0.0016 in)

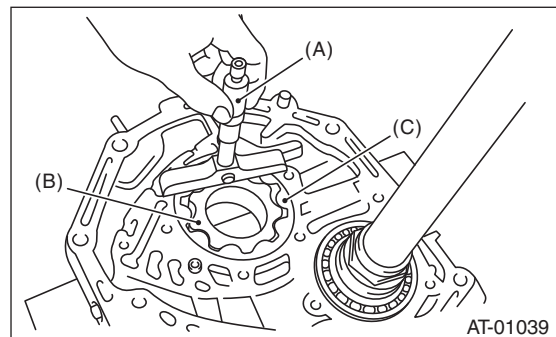

- (A) Depth gauge
- (B) Inner rotor
- (C) Outer rotor

Oil Pump Housing

AUTOMATIC TRANSMISSION

(3) If the depth and side clearance are out of specification, replace the oil pump rotor assembly.

Oil pump rotor assembly	
Part number	Thickness mm (in)
15008AA060	11.37 — 11.38 (0.4476 — 0.4480)
15008AA070	11.38 — 11.39 (0.4480 — 0.4484)
15008AA080	11.39 — 11.40 (0.4484 — 0.4488)

Measure the total end play and adjust it to be within specifications. <Ref. to 4AT-88, ADJUSTMENT, Oil Pump Housing.>

F: ADJUSTMENT

1) Using the ST, measure the length “L”, from the mating surface of the transmission to the recessed portion of the high clutch drum.

ST 398643600 GAUGE

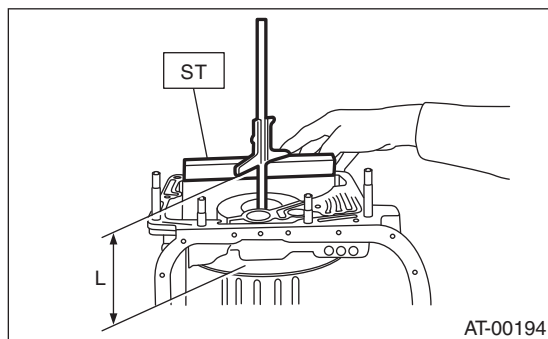

2) Using the ST, measure the length “ \varnothing ” from the oil pump housing mating surface to the top surface of the oil pump cover with the thrust needle bearing.

ST 398643600 GAUGE

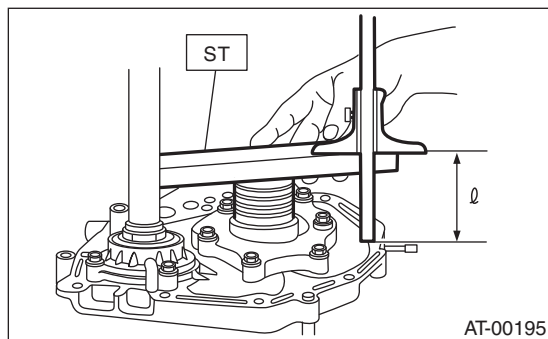

3) Calculation of total end play

Select a suitable bearing race from the table below so that clearance C will be within 0.25 to 0.55 mm (0.0098 to 0.0217 in).

$$C = (L + G) - \varnothing$$

C	Clearance between concave section of high clutch and end of clutch drum support
L	Length from case mating surface to the concave portion of the high clutch
G	Gasket thickness [0.28 mm (0.0110 in)]
\varnothing	Height from the oil pump housing mating surface to the upper surface of the oil pump cover with the thrust needle bearing.

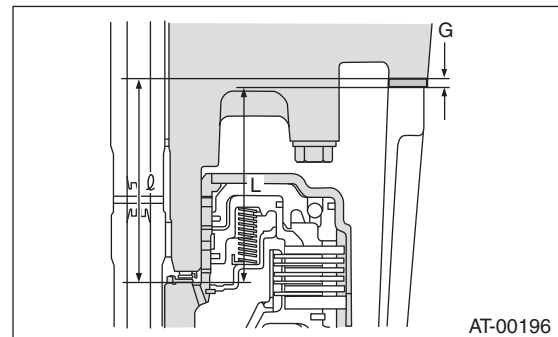

Thrust needle bearing	
Part number	Thickness mm (in)
806528050	4.1 (0.161)
806528060	4.3 (0.169)
806528070	4.5 (0.177)
806528080	4.7 (0.185)
806528090	4.9 (0.193)
806528100	5.1 (0.201)

4) After completing the end play adjustment, insert the bearing race into the high clutch race. Apply vaseline, and install the thrust needle bearing to the oil pump cover.

5) After correctly installing the new gasket to the case mating surface, carefully install the oil pump housing assembly. Be careful to avoid hitting the drive pinion against the inside of case.

6) Install both parts with dowel pins aligned. Make sure there is no clearance at the mating surface.

33. Drive Pinion Shaft Assembly

A: REMOVAL

- 1) Remove the transmission assembly from vehicle body. <Ref. to 4AT-34, REMOVAL, Automatic Transmission Assembly.>
- 2) Pull out the torque converter clutch assembly. <Ref. to 4AT-66, REMOVAL, Torque Converter Clutch Assembly.>
- 3) Remove the input shaft.

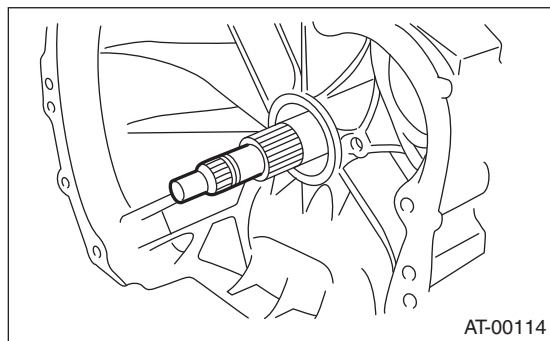

- 4) Lift up the lever on the rear side of transmission harness connector, and then disconnect it from the stay.
- 5) Disconnect the inhibitor switch connector from the stay.
- 6) Disconnect the air breather hose. <Ref. to 4AT-64, REMOVAL, Air Breather Hose.>
- 7) Remove the oil charge pipe. <Ref. to 4AT-65, REMOVAL, Oil Charge Pipe.>
- 8) Remove the ATF inlet and outlet pipes. <Ref. to 4AT-61, REMOVAL, ATF Cooler Pipe and Hose.>
- 9) Separate the converter case and transmission case. <Ref. to 4AT-80, REMOVAL, Converter Case.>
- 10) Separate the transmission case and extension case section. <Ref. to 4AT-68, REMOVAL, Extension Case.>
- 11) Remove the reduction drive gear. <Ref. to 4AT-77, REMOVAL, Reduction Drive Gear.>
- 12) Remove the reduction driven gear. <Ref. to 4AT-75, REMOVAL, Reduction Driven Gear.>
- 13) Remove the drive pinion shaft mounting bolt and remove the drive shaft assembly from oil pump housing.

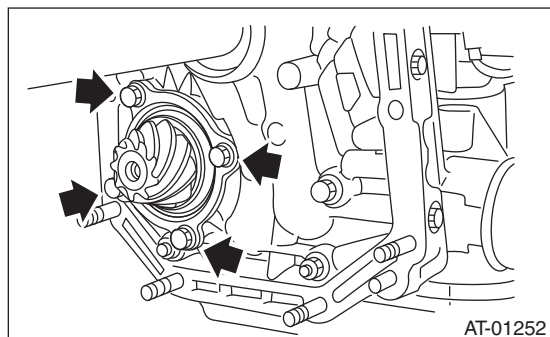

B: INSTALLATION

- 1) Assemble the drive pinion shaft assembly to the oil pump housing.

NOTE:

- Be careful not to bend the shim.
- Be careful not to press-fit the pinion into housing bore.

Tightening torque:

40 N·m (4.0 kgf·m, 29.5 ft·lb)

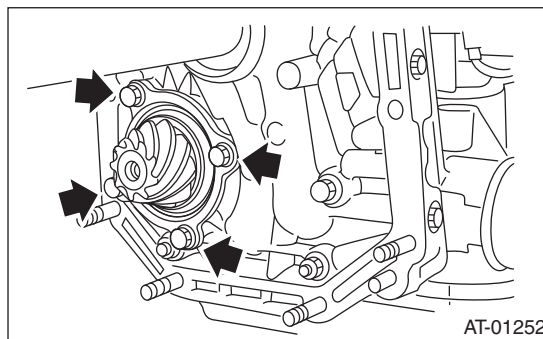

- 2) Join the converter case with the transmission case. <Ref. to 4AT-81, INSTALLATION, Converter Case.>
- 3) Install the reduction driven gear. <Ref. to 4AT-75, INSTALLATION, Reduction Driven Gear.>
- 4) Install the reduction drive gear. <Ref. to 4AT-77, INSTALLATION, Reduction Drive Gear.>
- 5) Join the transmission case and the extension case, and then install the rear vehicle speed sensor. <Ref. to 4AT-68, INSTALLATION, Extension Case.>
- 6) Insert the inhibitor switch and transmission harness connector to the stay.
- 7) Install the air breather hose. <Ref. to 4AT-64, INSTALLATION, Air Breather Hose.>
- 8) Install the ATF inlet and outlet pipes. <Ref. to 4AT-62, INSTALLATION, ATF Cooler Pipe and Hose.>
- 9) Install the oil charge pipe with O-ring.
- 10) Insert the input shaft while rotating it lightly by hand, and then check the amount of protrusion.

Normal protrusion A:

50 — 55 mm (1.97 — 2.17 in)

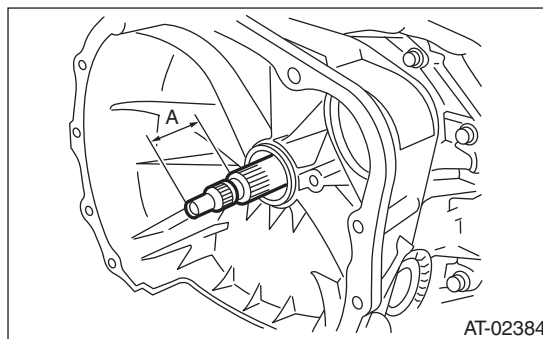

- 11) Install the torque converter clutch assembly. <Ref. to 4AT-66, INSTALLATION, Torque Converter Clutch Assembly.>

Drive Pinion Shaft Assembly

AUTOMATIC TRANSMISSION

12) Install the transmission assembly to the vehicle.
<Ref. to 4AT-37, INSTALLATION, Automatic Transmission Assembly.>

C: DISASSEMBLY

1) Flatten the lock nut tab, and then remove the lock nut while holding the rear spline part of the drive pinion shaft using ST1 and ST2. Pull out the drive pinion collar.

ST1 498937110 HOLDER
ST2 499787700 WRENCH
ST3 499787500 ADAPTER

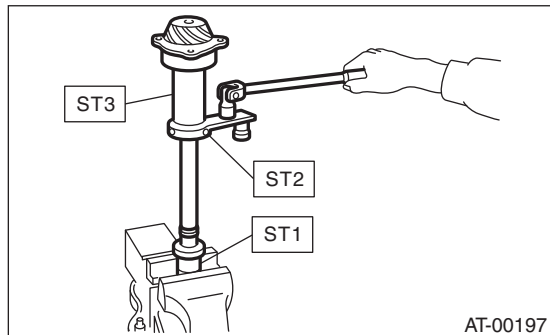

2) Remove the O-ring.

3) Separate the rear roller bearing and outer race from the drive pinion shaft using a press.

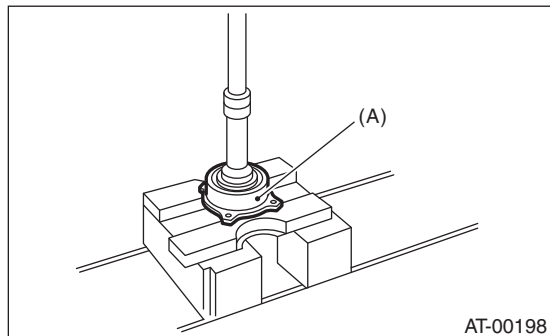

(A) Outer race

4) Separate the front roller bearing from the drive pinion shaft using a press and the ST.

ST 498517000 REPLACER

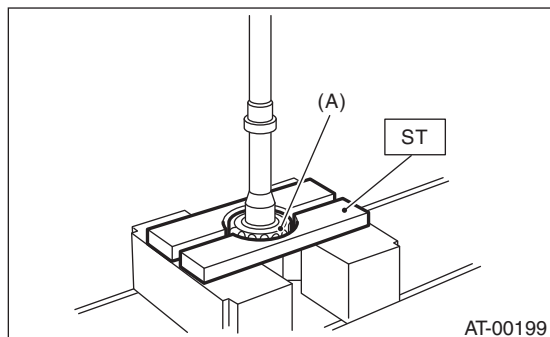

(A) Front roller bearing

D: ASSEMBLY

1) Measure the dimension "A" of the drive pinion shaft.

ST 398643600 GAUGE

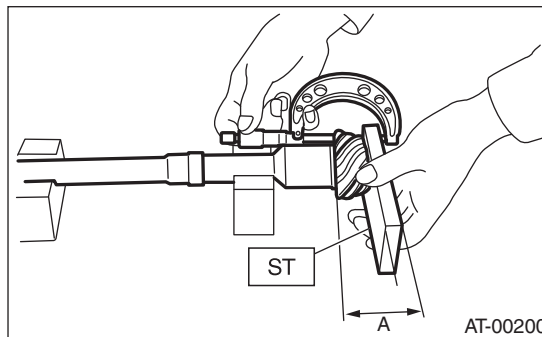

2) Using a press, press-fit the new roller bearing into the specified position.

CAUTION:

Damage may result if too much force is applied to the roller bearing.

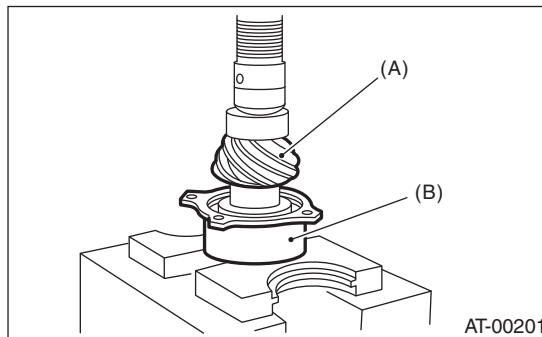

(A) Drive pinion shaft
(B) Roller bearing

3) After applying ATF to a new O-ring and attaching it to the drive pinion shaft, attach the drive pinion collar to the drive pinion shaft.

4) Install the lock washer to drive pinion shaft in the proper direction.

Drive Pinion Shaft Assembly

AUTOMATIC TRANSMISSION

5) Tighten a new lock nut using the ST.
Calculate the lock washer and lock nut specifications using following formula.

$$T2 = L2 / (L1 + L2) \times T1$$

T1: 116 N·m (11.8 kgf·m, 85.6 ft·lb)

[Required torque setting]

T2: Tightening torque

L1: ST2 length 0.072 m (2.83 in)

L2: Torque wrench length

Example:

Torque wrench length m (in)	Tightening torque N·m (kgf·m, ft·lb)
0.4 (15.75)	98 (10.0, 72.3)
0.45 (17.72)	100 (10.2, 73.8)
0.5 (19.69)	101 (10.3, 74.5)
0.55 (21.65)	102 (10.4, 75.2)

ST1 498937110 HOLDER
ST2 499787700 WRENCH
ST3 499787500 ADAPTER

NOTE:

Attach ST2 to torque wrench as straight as possible.

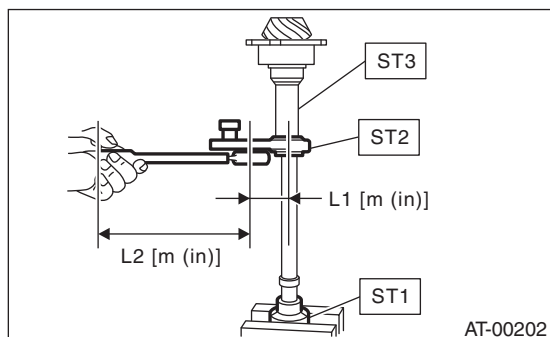

6) Measure the starting torque of the bearing. Make sure the starting torque is within the specified range. If the torque is not within specified range, replace the roller bearing.

Starting torque:

7.6 — 38.1 N (0.77 — 3.88 kgf, 1.7 — 8.6 lb)

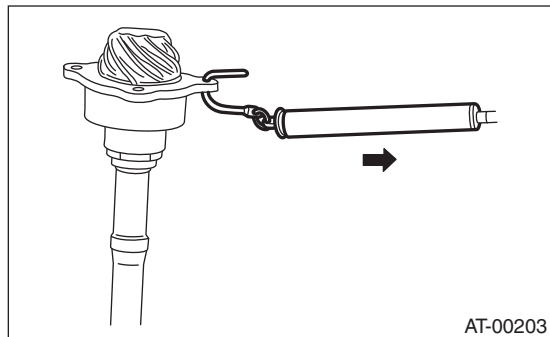

7) Crimp the locknut in 2 locations.

8) Measure the dimension "B" of the drive pinion shaft.

ST 398643600 GAUGE

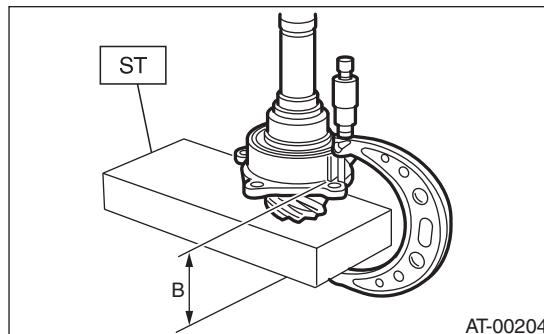

9) Calculate the thickness "t" (mm) of the drive pinion shim.

$$t = 6.5 \pm 0.0625 - (B - A)$$

10) Select three or less shims from following table.

Drive pinion shim	
Part number	Thickness mm (in)
31451AA050	0.150 (0.0059)
31451AA060	0.175 (0.0069)
31451AA070	0.200 (0.0079)
31451AA080	0.225 (0.0089)
31451AA090	0.250 (0.0098)
31451AA100	0.275 (0.0108)

E: INSPECTION

- Make sure that all component parts are free of scratches, holes and other faults.
- Adjust the tooth alignment. <Ref. to 4AT-92, ADJUSTMENT, Drive Pinion Shaft Assembly.>

Drive Pinion Shaft Assembly

AUTOMATIC TRANSMISSION

F: ADJUSTMENT

1) Remove the liquid gasket from the mating surface completely.

2) Install the oil pump housing assembly to the converter case, and secure them by tightening the four bolts evenly.

NOTE:

Use an old gasket or aluminum washer to prevent damaging the mating surface of the housing.

Tightening torque:

41 N·m (4.2 kgf·m, 30.2 ft·lb)

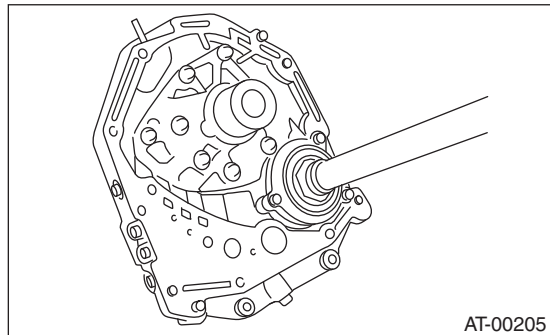

3) Rotate the drive pinion a few times using ST1 and ST2.

ST1 498937110 HOLDER
ST2 499787700 WRENCH

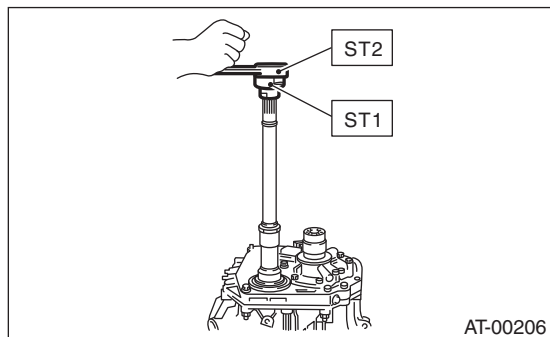

4) Adjust the drive pinion and hypoid driven gear backlash. <Ref. to 4AT-98, ADJUSTMENT, Front Differential Assembly.>

5) Apply lead-free red dye evenly on the surface of three to four teeth of the hypoid driven gear. Rotate the drive pinion back and forward several times. Remove the oil pump housing, and check the teeth contact pattern.

When the contact pattern is not correct, change shim thickness to adjust backlash. <Ref. to 4AT-98, ADJUSTMENT, Front Differential Assembly.>

- Correct tooth contact

Check item: Tooth contact surface is slightly shifted toward the toe side under a no-load condition. (When driving, it moves towards the heel side.)

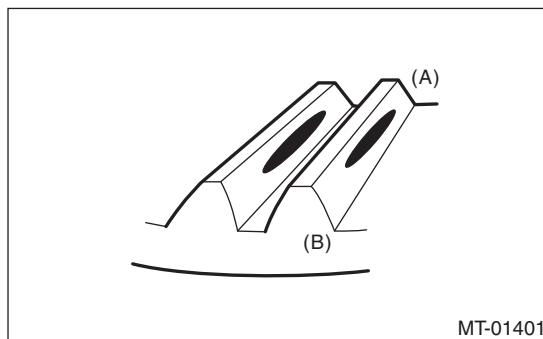

(A) Toe side

(B) Heel side

- Face contact

Check item: Backlash is too large.

Contact pattern

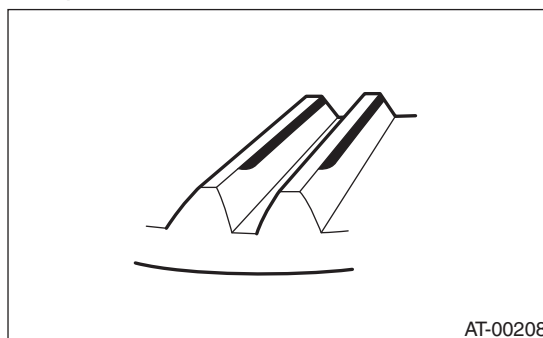

Corrective action: Increase thickness of drive pinion height adjusting washer in order to bring drive pinion shaft close to hypoid driven gear.

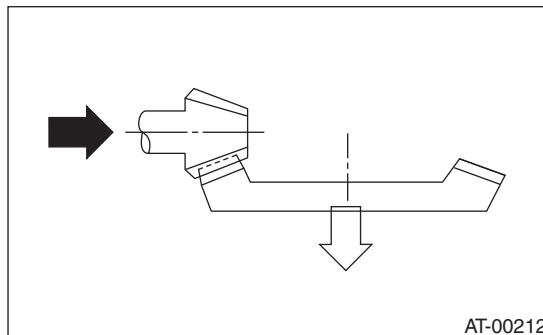

Drive Pinion Shaft Assembly

AUTOMATIC TRANSMISSION

- Flank contact

Check item: Backlash is too small.

Contact pattern

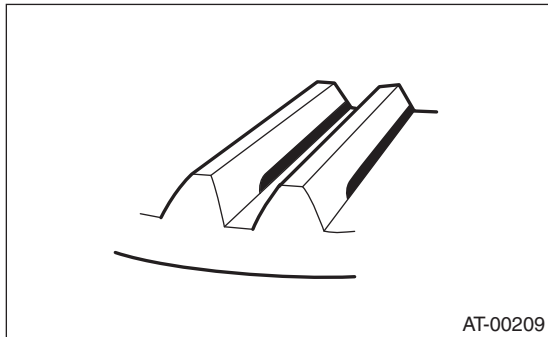

Corrective action: Reduce the thickness of the pinion height adjusting washer according to the procedures for moving the drive pinion shaft away from the hypoid driven gear.

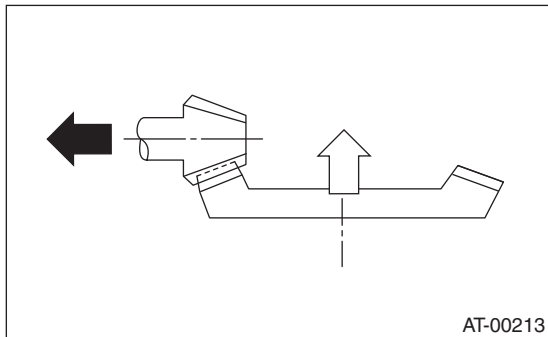

- Toe contact (inside contact)

Check item: Teeth contact area is too small.

Contact pattern

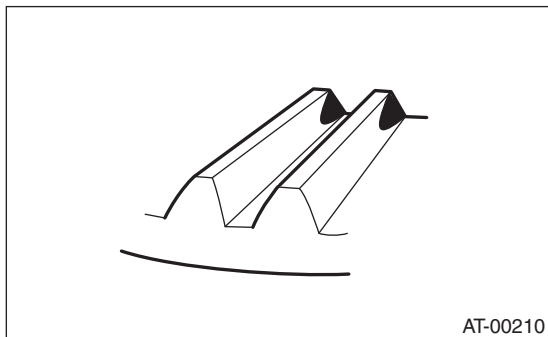

Corrective action: Reduce the thickness of the pinion height adjusting washer according to the procedures for moving the drive pinion shaft away from the hypoid driven gear.

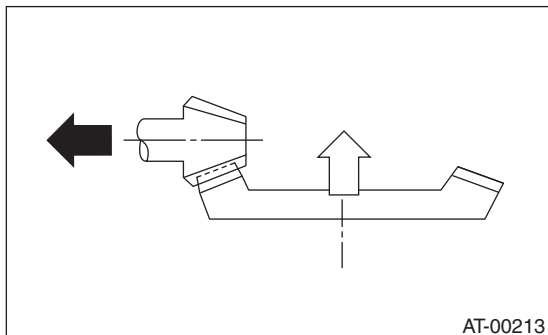

- Heel contact (outside end contact)

Check item: Teeth contact area is too small.

Contact pattern

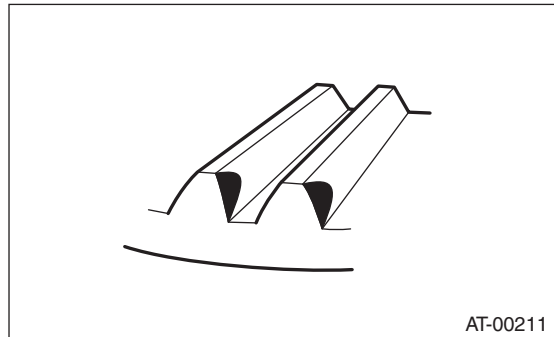

Corrective action: Increase the thickness of the pinion height adjusting washer according to the procedures for moving the drive pinion shaft closer to the hypoid driven gear.

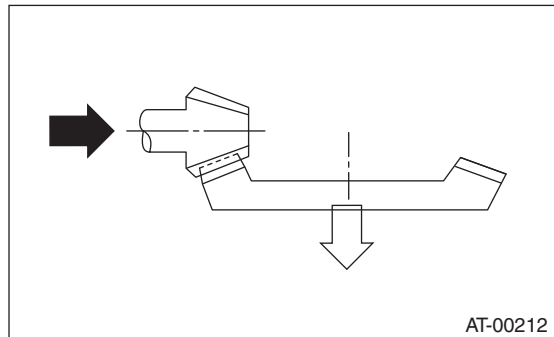

6) If tooth contact is correct, mark the differential side retainer position and loosen. After fitting a new O-ring and oil seal, screw in the differential side retainer to the marked position. Tighten the lock plate with specified torque.

Tightening torque:

25 N·m (2.5 kgf·m, 18.4 ft·lb)

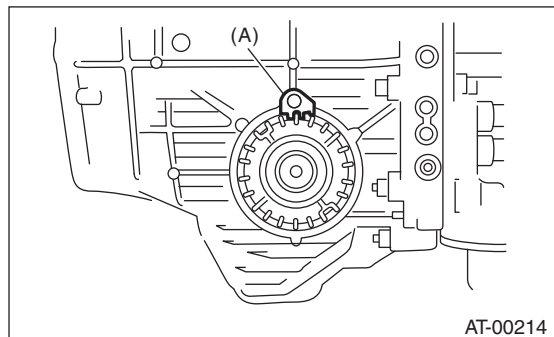

(A) Lock plate

Front Differential Assembly

AUTOMATIC TRANSMISSION

34. Front Differential Assembly

A: REMOVAL

- 1) Remove the transmission assembly from vehicle body. <Ref. to 4AT-34, REMOVAL, Automatic Transmission Assembly.>
- 2) Pull out the torque converter clutch assembly. <Ref. to 4AT-66, REMOVAL, Torque Converter Clutch Assembly.>
- 3) Remove the input shaft.

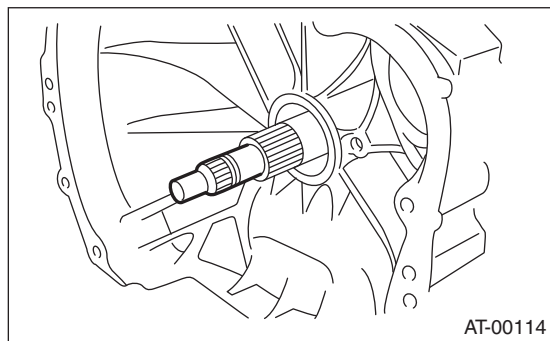

- 4) Lift up the lever on the rear side of transmission harness connector, and then remove it from the stay.
 - 5) Remove the inhibitor switch from the stay.
 - 6) Remove the oil charge pipe. <Ref. to 4AT-65, REMOVAL, Oil Charge Pipe.>
 - 7) Remove the ATF inlet and outlet pipes. <Ref. to 4AT-61, REMOVAL, ATF Cooler Pipe and Hose.>
 - 8) Separate the converter case from the transmission case. <Ref. to 4AT-80, REMOVAL, Converter Case.>
 - 9) Remove the seal pipe.
 - 10) Remove the differential side retainers using ST.
- ST 18630AA010 WRENCH COMPL
RETAINER

NOTE:

- ST WRENCH ASSEMBLY (499787000) can also be used.
 - Hold the differential case assembly by hand to avoid damaging the retainer mounting hole of the converter case.
- 11) Remove the front differential assembly while being careful not to damage the attachment part of the retainer.

B: INSTALLATION

- 1) Install the front differential assembly to the converter case.

NOTE:

Be careful not to damage the inside of the converter case (especially the mating surface of the differential side retainer).

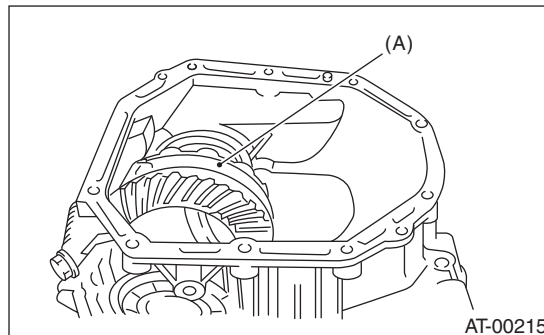

(A) Front differential ASSY

- 2) Install the O-ring to left and right side differential retainers.
- 3) Install the differential side retainers using ST.

<Ref. to 4AT-98, ADJUSTMENT, Front Differential Assembly.>

ST 18630AA010 WRENCH COMPL
RETAINER

NOTE:

- ST WRENCH ASSEMBLY (499787000) can also be used.
- 4) Adjust the backlash of the front differential. <Ref. to 4AT-98, ADJUSTMENT, Front Differential Assembly.>
 - 5) Install the lock plate.

Tightening torque:

25 N·m (2.5 kgf·m, 18.4 ft·lb)

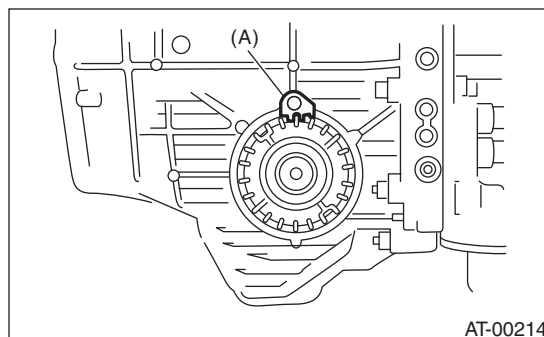

(A) Lock plate

6) Install new seal pipe to converter case.

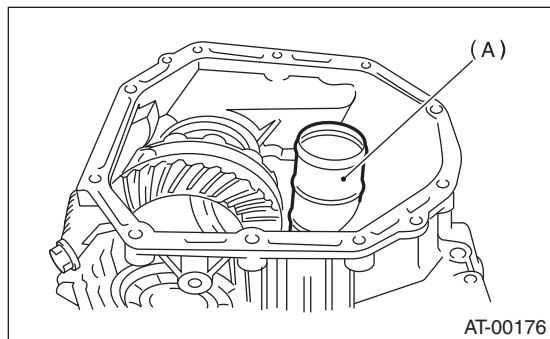

(A) Seal pipe

7) Install the converter case to the transmission case. <Ref. to 4AT-81, INSTALLATION, Converter Case.>

8) Insert the inhibitor switch and transmission harness connector to the stay.

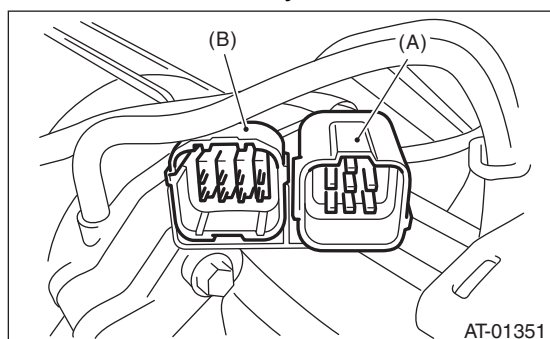

(A) Transmission harness connectors

(B) Inhibitor switch connector

9) Install the ATF cooler pipe. <Ref. to 4AT-62, INSTALLATION, ATF Cooler Pipe and Hose.>

10) Install the oil charge pipe together with an O-ring. <Ref. to 4AT-65, INSTALLATION, Oil Charge Pipe.>

11) Insert the input shaft while rotating it lightly by hand, and then check the amount of protrusion.

Normal protrusion A:

50 — 55 mm (1.97 — 2.17 in)

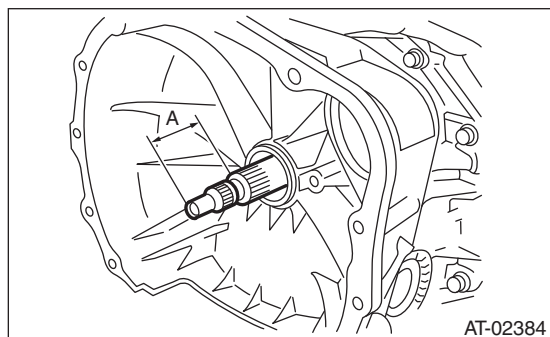

12) Install the torque converter clutch assembly. <Ref. to 4AT-66, INSTALLATION, Torque Converter Clutch Assembly.>

13) Install the transmission assembly to the vehicle. <Ref. to 4AT-37, INSTALLATION, Automatic Transmission Assembly.>

C: DISASSEMBLY

1. DIFFERENTIAL CASE ASSEMBLY

1) Remove the taper roller bearing using the ST and a press.

ST 498077000

REMOVER

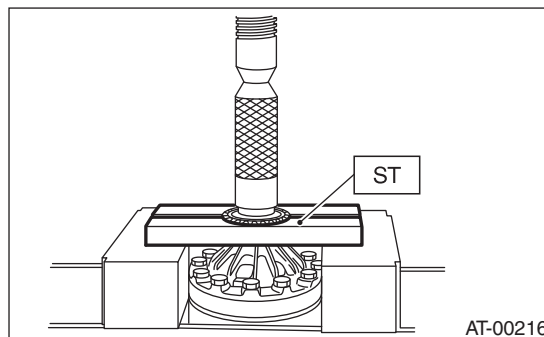

2) Secure the case in a vise, remove the hypoid driven gear tightening bolts, and then separate the hypoid driven gear into differential case (RH) and differential case (LH).

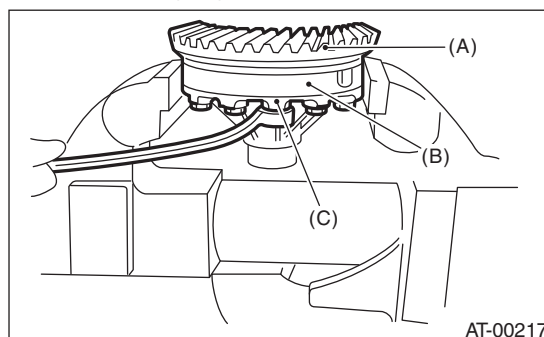

(A) Hypoid driven gear

(B) Differential case (RH)

(C) Differential case (LH)

3) Pull out the straight pin and pinion shaft, then remove the differential bevel gear, washer and differential bevel pinion.

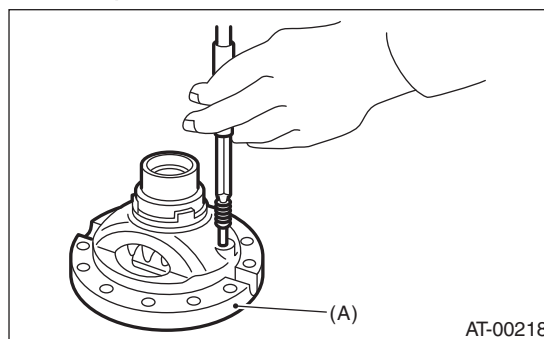

(A) Differential case (RH)

Front Differential Assembly

AUTOMATIC TRANSMISSION

2. SIDE RETAINER

NOTE:

After adjusting the drive pinion backlash and tooth contact, remove and install the oil seal and O-ring.

1) Remove the O-ring.

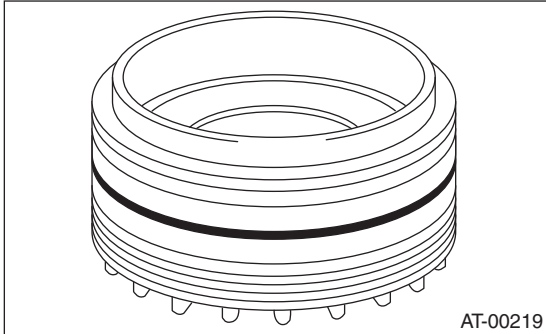

2) Remove the oil seal.

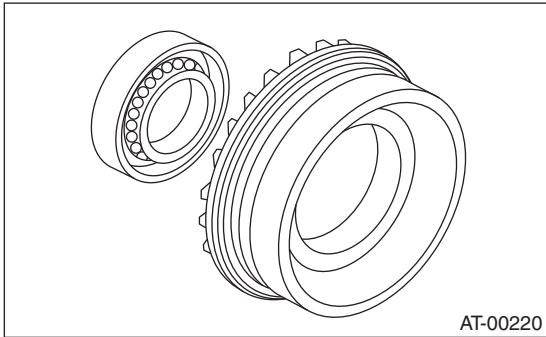

3) Remove the split pin, and then remove the claw.

ST 398527700 PULLER ASSY

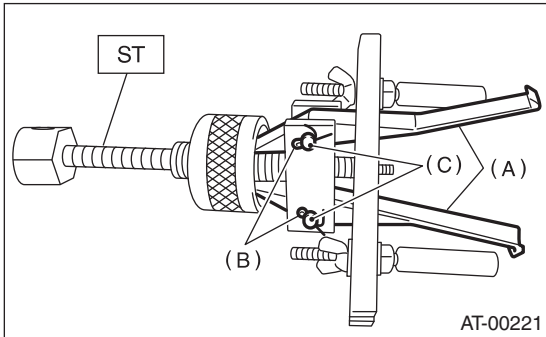

- (A) Claw
- (B) Split pin
- (C) Pin

4) Attach the two claws to the outer race, and set the ST on the differential side retainer.

ST 398527700 PULLER ASSY

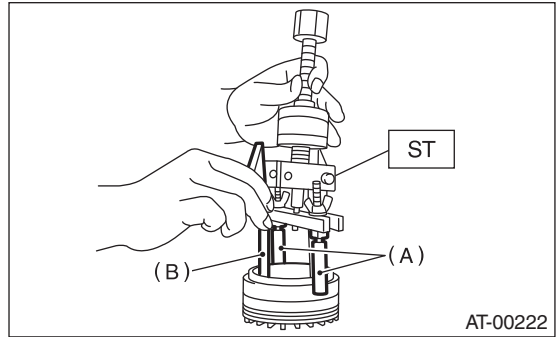

- (A) Shaft
- (B) Claw

5) Restore the removed claws to original position, and install the pin and split pin.

6) Hold the shaft of ST to avoid detachment from the differential side retainer, and remove the bearing outer race.

ST 398527700 PULLER ASSY

NOTE:

Replace the bearing inner and outer races as a single unit.

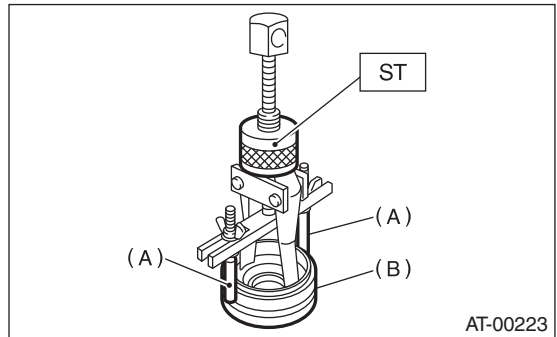

- (A) Shaft
- (B) Side retainer

D: ASSEMBLY

1. DIFFERENTIAL CASE ASSEMBLY

- 1) Install the washer, differential bevel gear and differential bevel pinion in the differential case (RH). Insert the pinion shaft.
- 2) Attach the straight pin in the reverse direction.

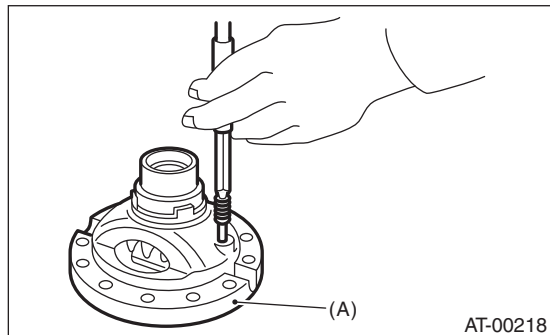

(A) Differential case (RH)

- 3) Install the washer and differential bevel gear to the differential case (LH). Put the differential case (RH) on the case, and assemble two cases.
- 4) Install the hypoid driven gear and secure by tightening the bolt.

Tightening torque:

62 N·m (6.3 kgf-m, 45.7 ft-lb)

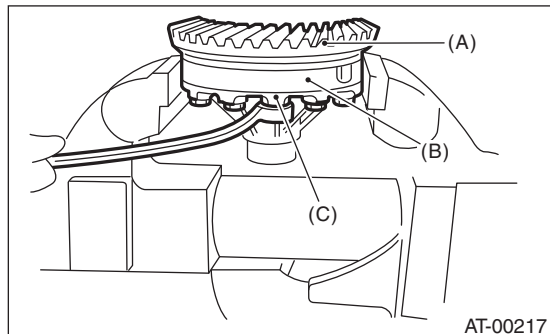

- (A) Hypoid driven gear
- (B) Differential case (RH)
- (C) Differential case (LH)

- 5) Measurement of backlash (Selection of washer)
 - (1) Install the SUBARU genuine axle shaft to differential case.

Part No. 38415AA070 AXLE SHAFT

- (2) Measure the gear backlash using ST1 and ST2, and then insert the ST2 through the access window of case.

ST1 498247001 MAGNET BASE
ST2 498247100 DIAL GAUGE

NOTE:

- Place the tooth of the differential bevel pinion against 2 teeth of the differential bevel gear, and measure the backlash.
- Fix the differential bevel pinion gear in place with a screwdriver covered with cloth or similar tool when measuring.

Standard:

0.13 — 0.18 mm (0.0051 — 0.0071 in)

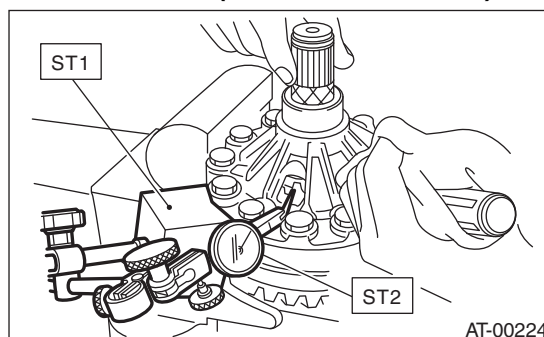

- (3) If the backlash is out of specification, select a washer from the table below.

Washer	
Part number	Thickness mm (in)
803038021	0.95 (0.037)
803038022	1.00 (0.039)
803038023	1.05 (0.041)

- 6) Using the ST, install the taper roller bearing.

ST 398487700 INSTALLER

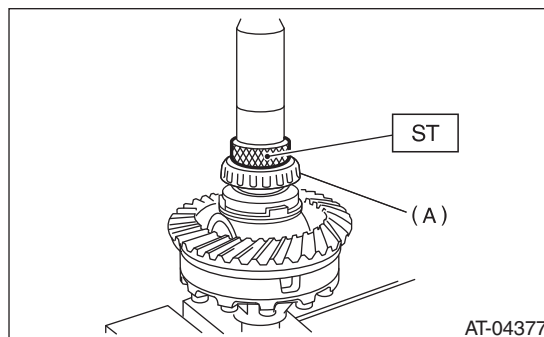

(A) Taper roller bearing

Front Differential Assembly

AUTOMATIC TRANSMISSION

2. SIDE RETAINER

1) Install the bearing outer race to the differential side retainer.

2) Install a new oil seal using the ST and a hammer.
ST 18675AA000 DIFFERENTIAL SIDE OIL SEAL INSTALLER

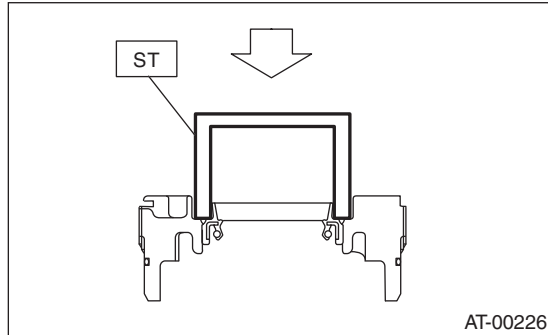

3) Apply gear oil to a new O-ring and install.

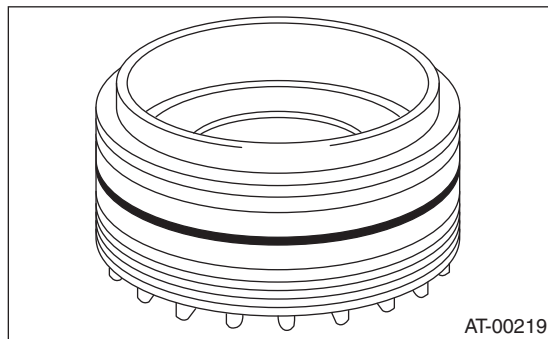

E: INSPECTION

- Check each component for scratches, damage or other faults.
 - Measure the backlash, and then adjust it to be within specification.
- <Ref. to 4AT-98, ADJUSTMENT, Front Differential Assembly.>

F: ADJUSTMENT

1) Using the ST, screw-in the differential side retainer until resistance is felt.

ST 18630AA010 WRENCH COMPL
RETAINER

NOTE:

- Screw-in the RH side slightly deeper than the LH side.
- ST WRENCH ASSEMBLY (499787000) can also be used.

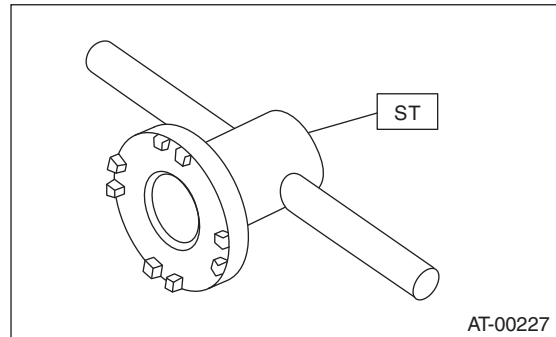

2) Remove the oil pump housing.

3) Remove the liquid gasket from the mating surface completely.

4) Install the oil pump housing assembly to the converter case, and secure them by tightening the four bolts evenly.

NOTE:

Use an old gasket or aluminum washer to prevent damaging the mating surface of the housing.

Tightening torque:

41 N·m (4.2 kgf·m, 30.2 ft·lb)

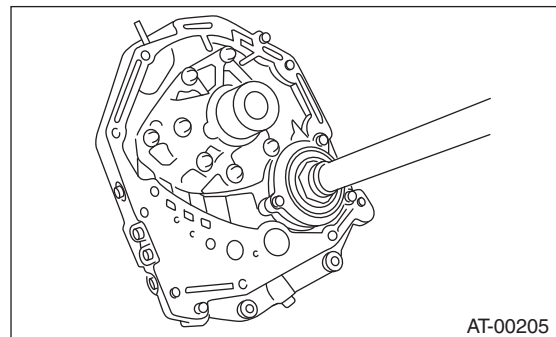

Front Differential Assembly

AUTOMATIC TRANSMISSION

5) Rotate the drive pinion a few times using ST1 and ST2.

ST1 498937110 HOLDER
ST2 499787700 WRENCH

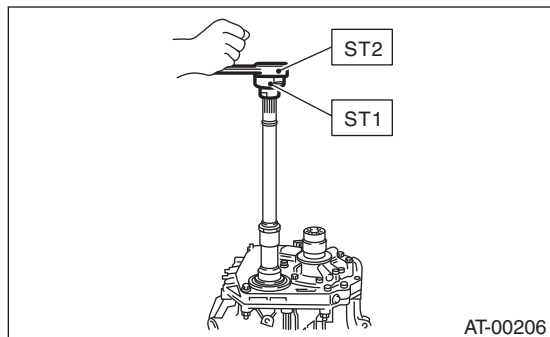

6) Tighten the LH differential side retainer by rotating the shaft until resistance is felt. Then loosen the RH side differential side retainer. Tighten the LH differential side retainer until the pinion shaft no longer turns, and continue to loosen the RH side. This is the “zero” state.

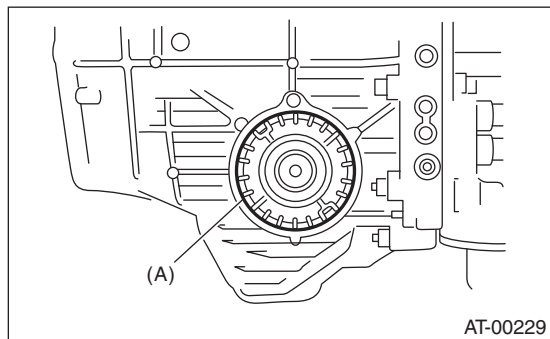

(A) Differential side retainer

7) After reaching the “zero” state, loosen the LH differential side retainer by 3 notches and secure it with the lock plate. Then after returning the RH differential side retainer, retighten until it stops. Rotate the drive pinion 2 or 3 times. Tighten the RH differential side retainer further by 1-3/4 notches. This sets the preload. Finally, secure the differential side retainer with the lock plate.

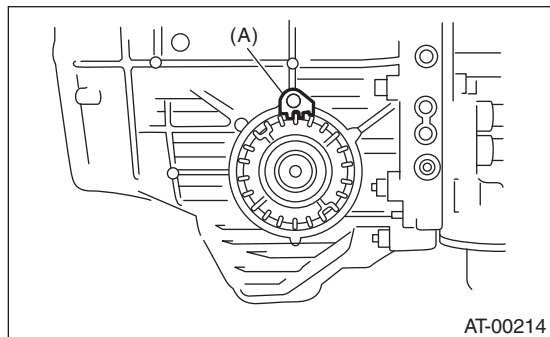

(A) Lock plate

NOTE:

Turning the differential side retainer by one notch changes the backlash approx. 0.05 mm (0.0020 in).

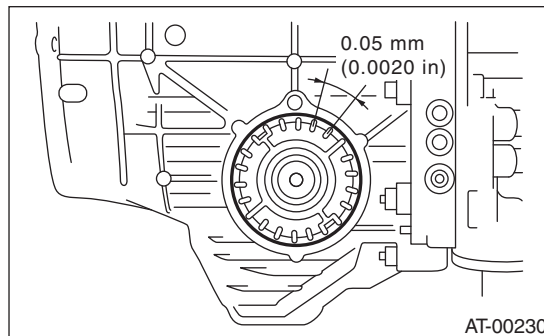

8) Install the Subaru genuine axle shafts to the right and left sides of the front differential. Install the axle shaft to both sides of the front differential section.

Part No. 38415AA000 AXLE SHAFT

9) Turn the drive pinion several times using ST1, and check to see if the backlash is within the specification using ST2, ST3, ST4 and ST5.

ST1 499787700 WRENCH
ST2 498247001 MAGNET BASE
ST3 498247100 DIAL GAUGE
ST4 499787500 ADAPTER
ST5 498255400 PLATE

Backlash:

0.13 — 0.18 mm (0.0051 — 0.0071 in)

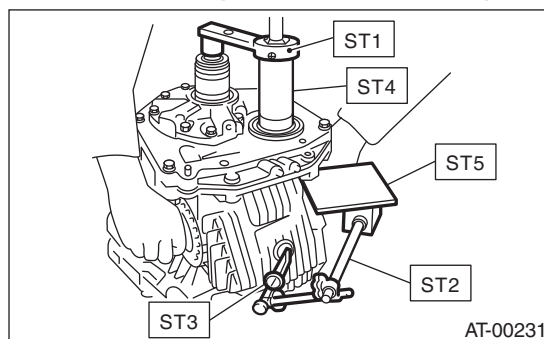

10) Adjust the teeth contact of the front differential and drive pinion shaft. <Ref. to 4AT-92, ADJUSTMENT, Drive Pinion Shaft Assembly.>

35.AT Main Case

A: REMOVAL

- 1) Remove the transmission assembly from vehicle body. <Ref. to 4AT-34, REMOVAL, Automatic Transmission Assembly.>
- 2) Pull out the torque converter clutch assembly. <Ref. to 4AT-66, REMOVAL, Torque Converter Clutch Assembly.>
- 3) Remove the input shaft.

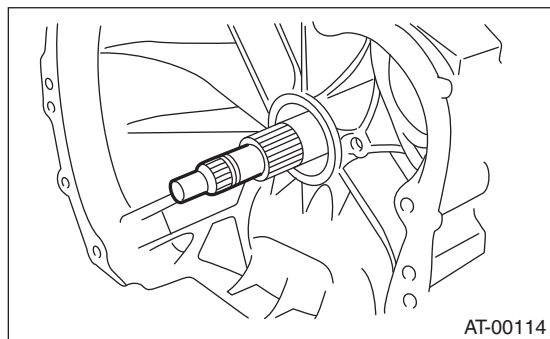

- 4) Lift up the lever on the rear side of transmission harness connector, and then disconnect it from the stay.
- 5) Disconnect the inhibitor switch connector from the stay.
- 6) Disconnect the air breather hose.
- 7) Remove the oil charge pipe. <Ref. to 4AT-65, REMOVAL, Oil Charge Pipe.>
- 8) Remove the ATF inlet and outlet pipes. <Ref. to 4AT-61, REMOVAL, ATF Cooler Pipe and Hose.>
- 9) Separate the converter case from the transmission case. <Ref. to 4AT-80, REMOVAL, Converter Case.>
- 10) Remove the oil pump housing. <Ref. to 4AT-83, REMOVAL, Oil Pump Housing.>
- 11) Take out the high clutch, thrust needle bearing and reverse clutch assembly.

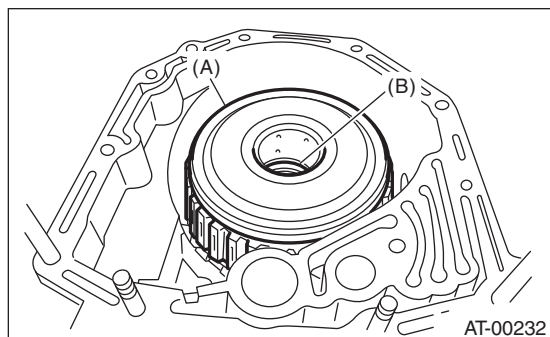

- (A) High clutch and reverse clutch ASSY
- (B) Thrust needle bearing

- 12) Take out the high clutch hub and thrust needle bearing.

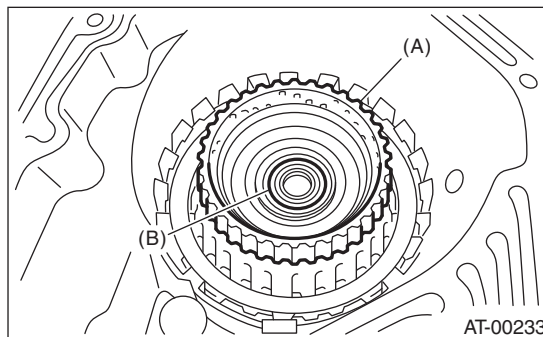

- (A) High clutch hub
- (B) Thrust needle bearing

- 13) Take out the front sun gear and thrust needle bearing.

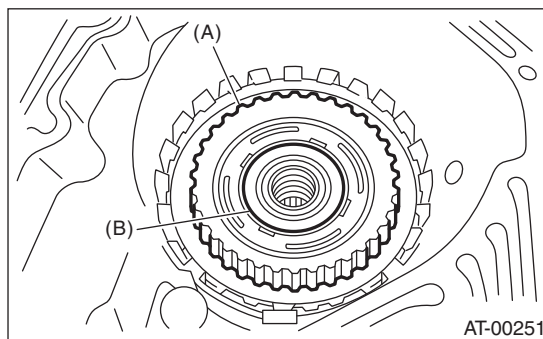

- (A) Front sun gear
- (B) Thrust needle bearing

- 14) Pull out while being careful not to break the leaf spring of the 2-4 brake.

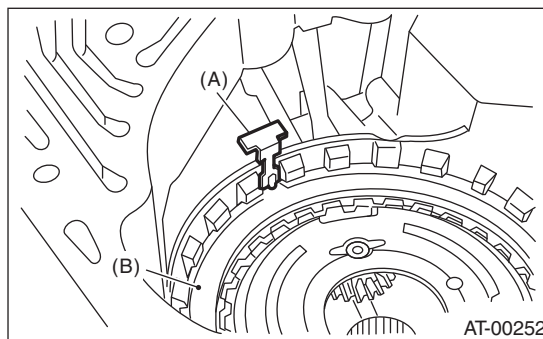

- (A) Leaf spring
- (B) Retaining plate

15) Remove the snap ring and thrust needle bearing.

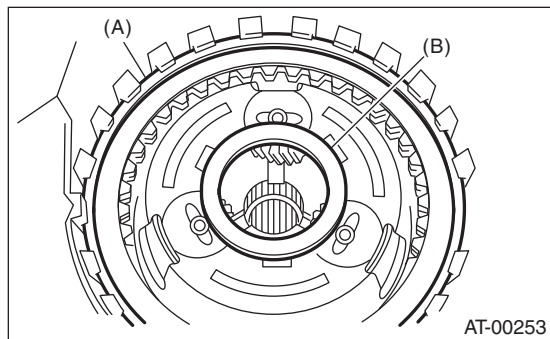

- (A) Snap ring
- (B) Thrust needle bearing

16) Take out the retaining plate, drive plate and driven plate of the 2-4 brake.

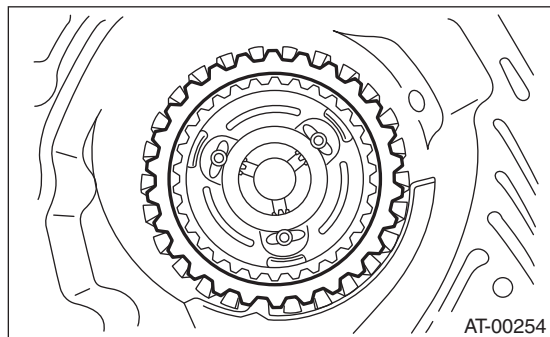

17) Take out the thrust needle bearing, planetary gear assembly and low clutch assembly.

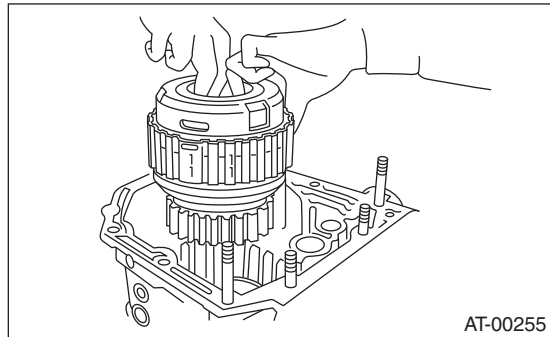

18) Remove the 2-4 brake seal.

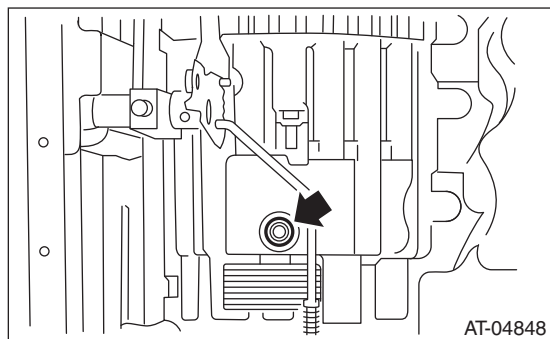

19) Remove the snap ring.

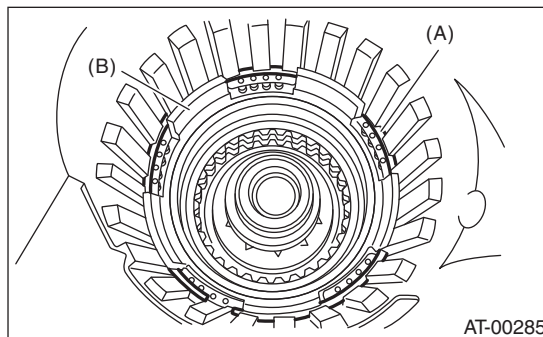

- (A) Snap ring
- (B) 2-4 brake piston

20) Take out the 2-4 brake spring retainer.

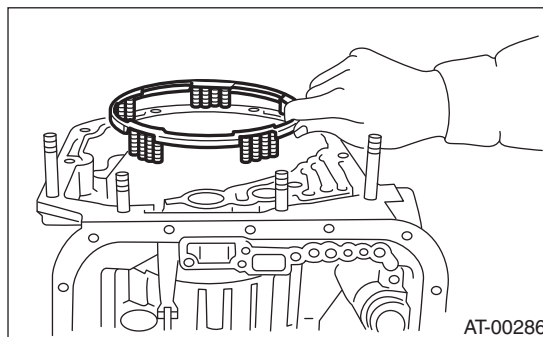

21) Remove the 2-4 brake piston and 2-4 brake piston retainer while taking care not to damage them.

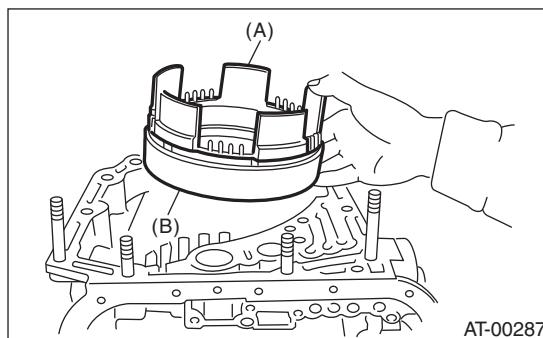

- (A) 2-4 brake piston
- (B) 2-4 brake piston retainer

AT Main Case

AUTOMATIC TRANSMISSION

22) Pull out the leaf spring of the low & reverse brake while being careful not to bend it.

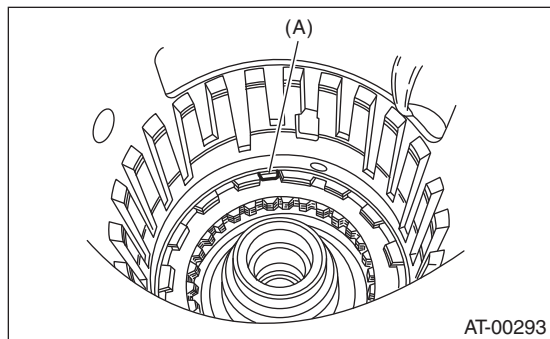

(A) Leaf spring

23) Remove the snap ring.

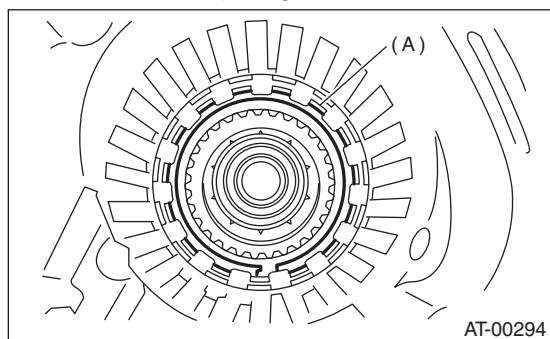

(A) Snap ring

24) Take out the retaining plate, drive plate, driven plate and dish plate of the low & reverse brake.

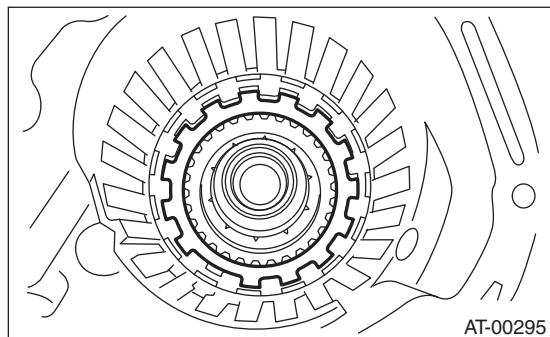

25) Turn the transmission case upside down, and then take out the socket bolts while holding the one-way clutch inner race by hand.

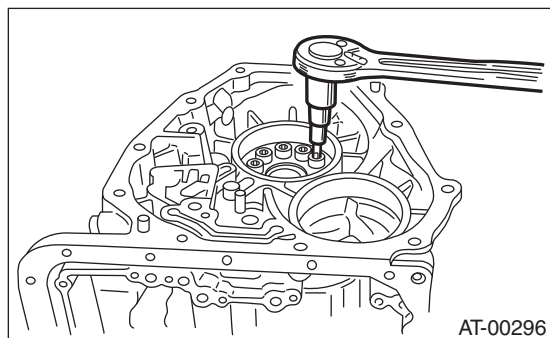

26) Remove the spring retainer.

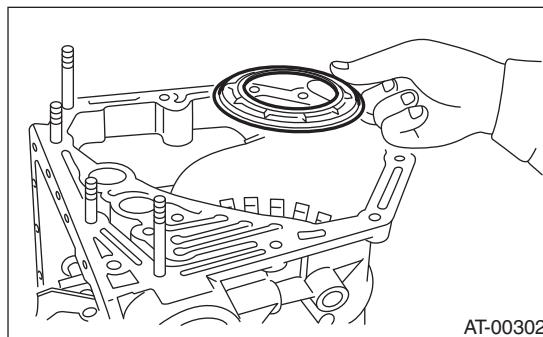

27) Take out the return spring.

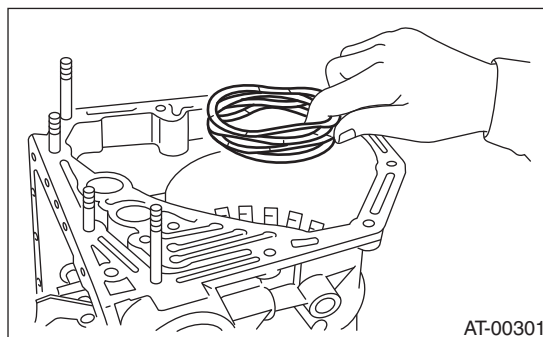

28) Apply compressed air.

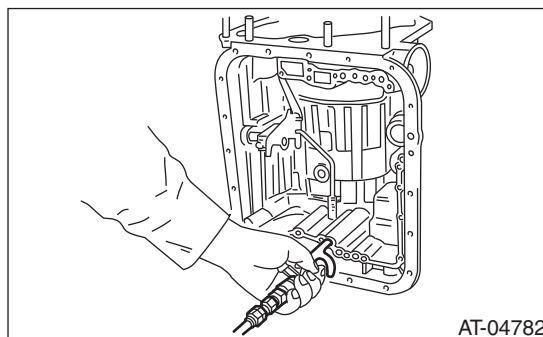

29) Take out the low & reverse brake piston.

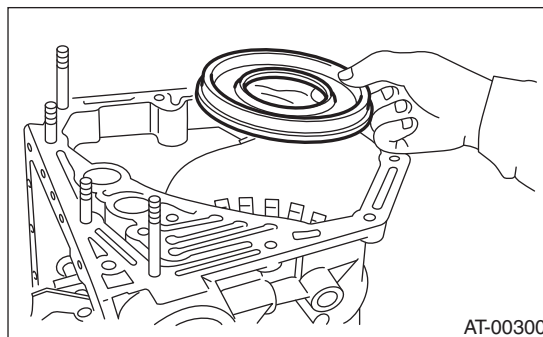

B: INSTALLATION

1) Apply ATF to the lips of the low & reverse brake piston, and install the piston.

NOTE:

Take care not to damage the lip seal.

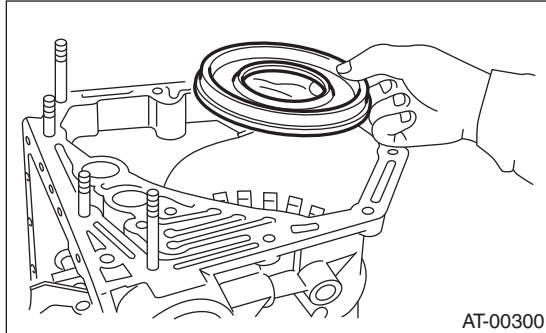

2) Install the return spring.

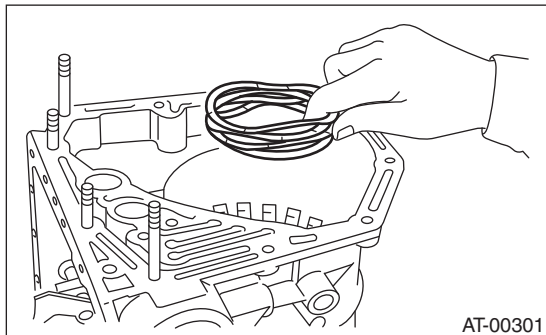

3) Install the spring retainer.

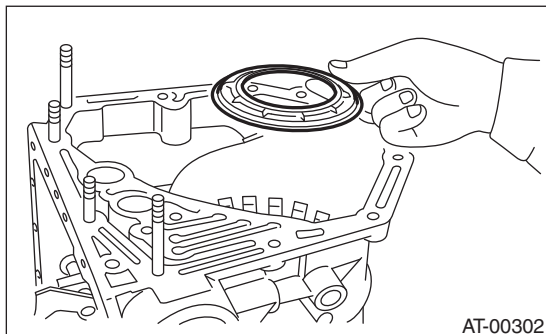

4) Install the one-way clutch inner race.

5) Tighten the socket head bolts evenly from the rear side of transmission case.

Tightening torque:

25 N·m (2.5 kgf·m, 18.4 ft·lb)

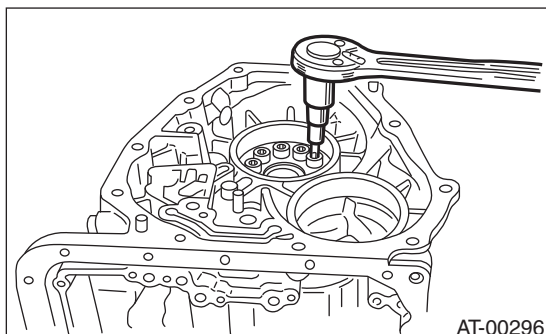

6) Place the front side of transmission body up.

7) Install the thrust needle bearing.

8) Place the dish plate, driven plate, drive plate and retaining plate neatly in this order on surface table.

9) Set the micro gauge to retaining plate, and read its scale.

NOTE:

The value, which is read in the gauge at this time, is zero point.

10) Scale and record the weight "Z" of a flat board which will be put on retaining plate.

NOTE:

- Use a stiff board which does not bend against load as a flat board to be put on retaining plate.

- Use a flat board weighing less than 8.5 kgf (18.7 lb).

11) Put the flat board on retaining plate.

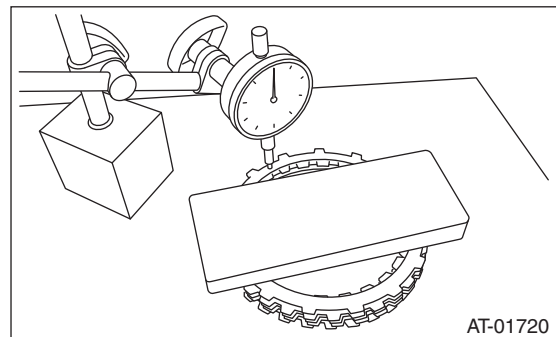

12) Using the following formula, read the push/pull gauge, and calculate "N".

$$N = 83 \text{ N (8.5 kgf, 18.7 lb)} - Z$$

N: Value indicated on push/pull gauge

83 N (8.5 kgf, 18.7 lb): Load applied to clutch plate

Z: Flat board weight

AT Main Case

AUTOMATIC TRANSMISSION

13) Press the center of retaining plate by applying a force of N using push/pull gauge, and then measure and record the height "A". Measure at three or more locations spaced by equal distances and take the average value.

NOTE:

If measuring in three locations, measure every 120°. If measuring in four locations, measure every 90°.

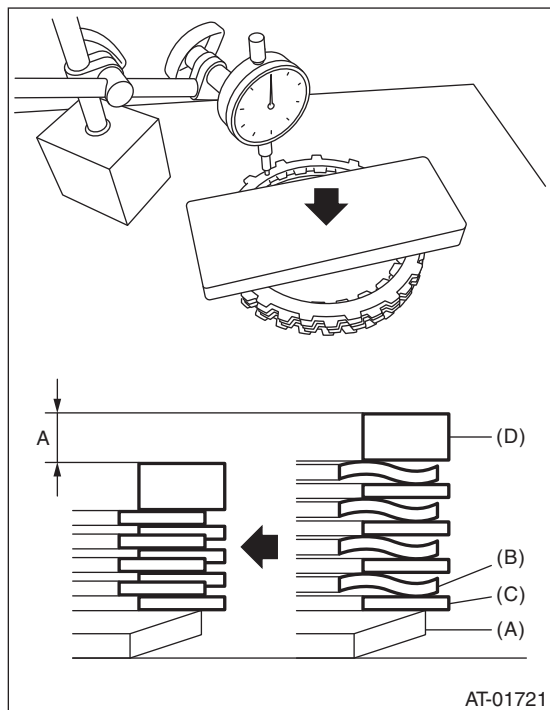

- (A) Dish plate
- (B) Drive plate
- (C) Driven plate
- (D) Retaining plate

14) Installation of the low & reverse brake:
Install the dish plate, driven plate, drive plate and retaining plate, and then secure them with a snap ring.

NOTE:

Pay attention to the orientation of the dish plate.

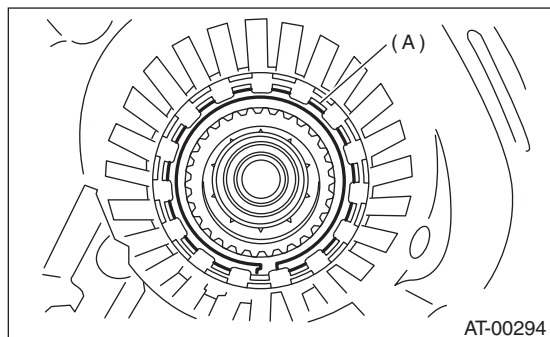

- (A) Snap ring

15) Apply compressed air intermittently to check for operation.

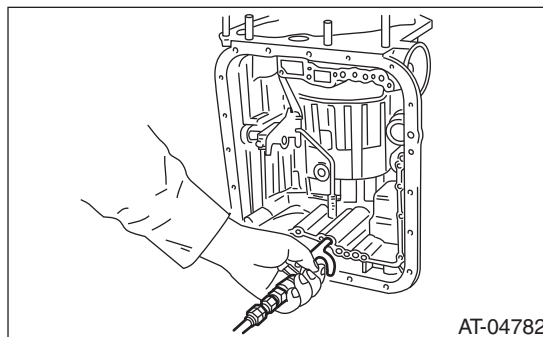

16) Place same thickness shims on both sides to prevent plate from tilting, then measure and record the clearance "B".

NOTE:

Do not push in the shim down with force to a point where the waves on the drive plate will be crushed.

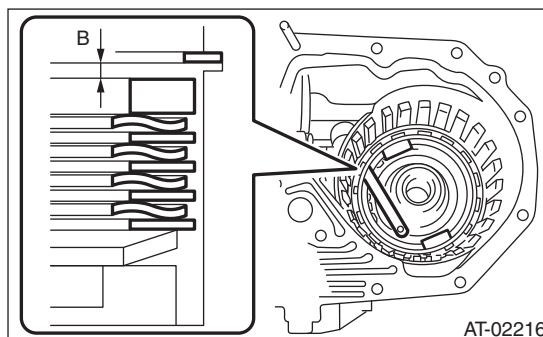

17) Piston stroke calculation

Calculate from the recorded dimension A and B, and if the service limit is exceeded, replace the drive plate with a new part, and select a retaining plate to make an adjustment so that it is within standard.

$$T = A + B$$

T: Piston stroke

A: Amount of drive plate compression

B: Clearance between retaining plate and snap ring

Non-turbo model

Initial standard:

2.15 — 2.65 mm (0.085 — 0.104 in)

Limit thickness:

2.95 mm (0.116 in)

Turbo model

Initial standard:

2.70 — 3.20 mm (0.106 — 0.126 in)

Limit thickness:

3.90 mm (0.154 in)

Retaining plate	
Part number	Thickness mm (in)
31667AA420	3.8 (0.150)
31667AA320	4.1 (0.161)
31667AA330	4.4 (0.173)
31667AA340	4.7 (0.185)
31667AA350	5.0 (0.197)
31667AA360	5.3 (0.209)
31667AA370	5.6 (0.220)
31667AA380	5.9 (0.232)

18) Install the leaf spring of the low & reverse brake.

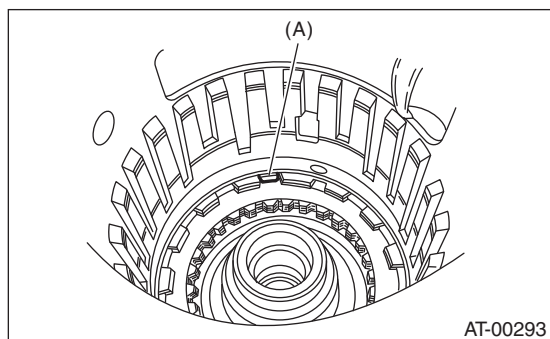

(A) Leaf spring

19) Install the 2-4 brake piston and 2-4 brake retainer by aligning the hole of the 2-4 brake retainer with the hole on the transmission case.

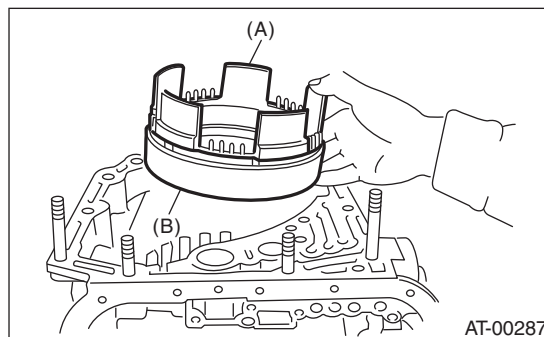

(A) 2-4 brake piston

(B) 2-4 brake piston retainer

20) Install the 2-4 brake piston spring retainer to the transmission case.

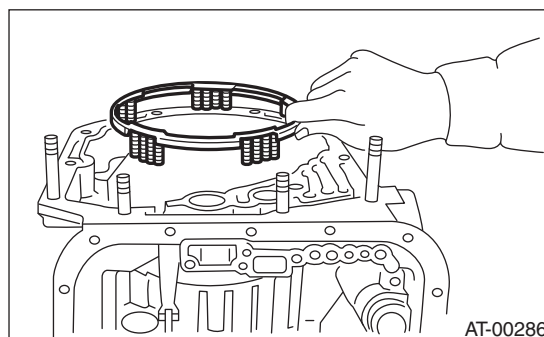

21) Position the snap ring in the transmission. Using ST, press the snap ring into the specified location.

ST 498677100

COMPRESSOR

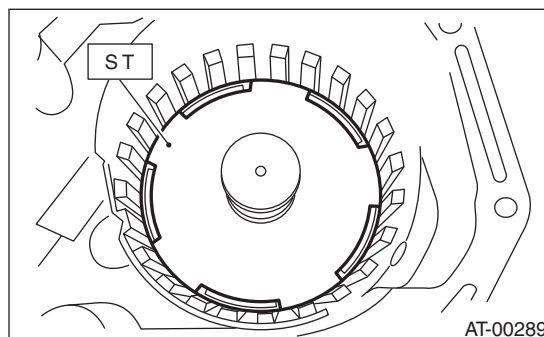

AT Main Case

AUTOMATIC TRANSMISSION

22) Install the planetary gear and low clutch assembly to the transmission case.

NOTE:

Install carefully while rotating the low clutch and planetary gear assembly slowly, being careful not to damage the seal ring.

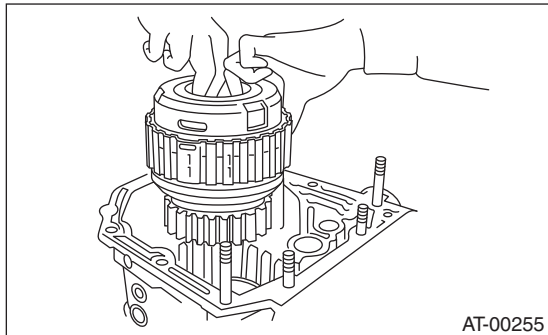

23) Measure and record a amount of drive plate compression. (Non-turbo model)

(1) Place the dish plate, driven plate, drive plate and retaining plate neatly in this order on surface table.

(2) Set the micro gauge to clutch, and read its scale.

NOTE:

The value, which is read in the gauge at this time, is zero point.

(3) Scale and record the weight "Z" of a flat board which will be put on retaining plate.

NOTE:

- Use a stiff board which does not bend against load as a flat board to be put on retaining plate.

- Use a flat board weighing less than 10.2 kg (22.5 lb).

(4) Put the flat board on retaining plate.

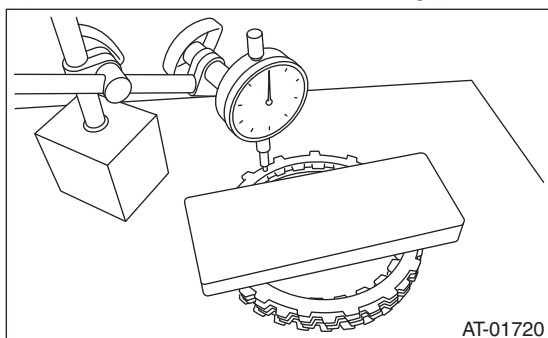

(5) Using the following formula, read the push/pull gauge, and calculate "N".

$$N = 100 N (10.2 \text{ kgf}, 22.5 \text{ lb}) - Z$$

N: Value indicated on push/pull gauge

100 N (10.2 kgf, 22.5 lb): Load applied to clutch plate

Z: Flat board weight

(6) Press the center of retaining plate by applying a force of N using push/pull gauge, and then measure and record the height "A". Measure at three or more locations spaced by equal distances and take the average value.

NOTE:

If measuring in three locations, measure every 120°. If measuring in four locations, measure every 90°.

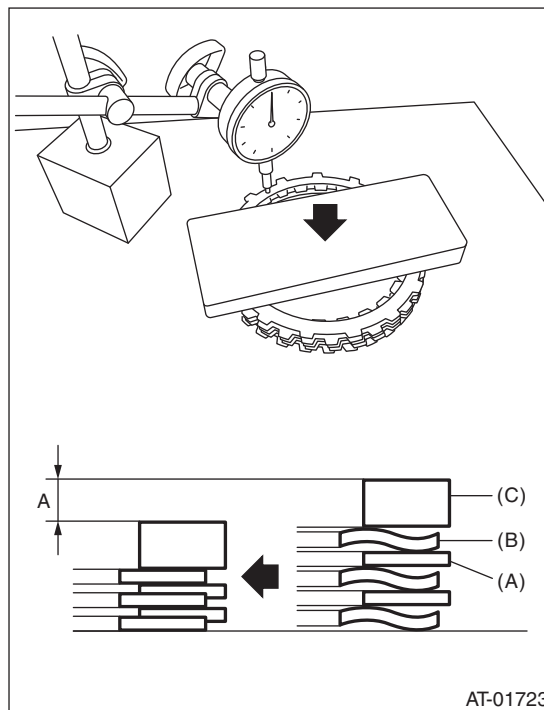

(A) Driven plate

(B) Drive plate

(C) Retaining plate

24) Install pressure rear plate, drive plate of 2-4 brake, driven plate, retaining plate, and snap ring.

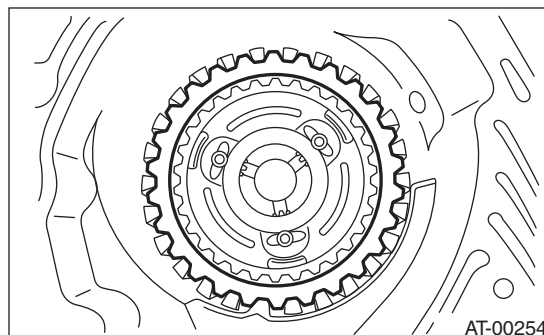

25) Install a new 2-4 brake seal to the transmission case.

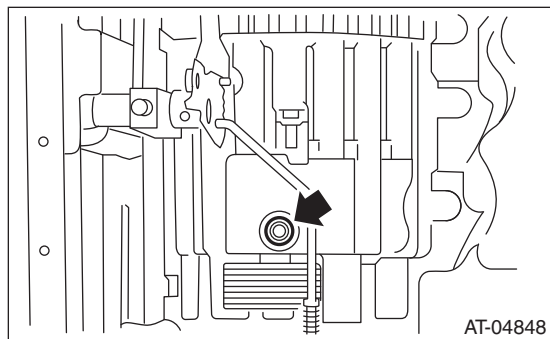

26) After all 2-4 brake component parts have been installed, blow in air intermittently and confirm the operation of the brake.

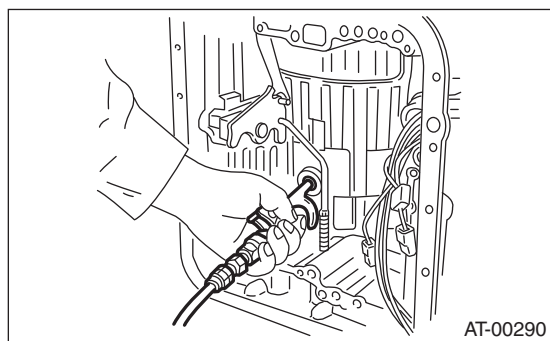

27) Check the piston stroke. (Non-turbo model)

(1) Measure clearance "B" between the retaining plate and snap ring.

At this time, do not press down the retaining plate.

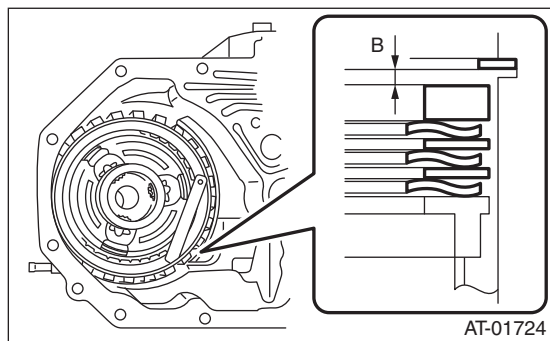

(2) Piston stroke calculation

Calculate with A and B dimensions recorded before. If the calculated value exceeds the service limits, replace the drive plate and select and adjust the retaining plate to be within standard values.

$$T = A + B$$

T: Piston stroke

A: Amount of drive plate compression

B: Clearance between retaining plate and snap ring

Initial standard:

1.7 — 2.1 mm (0.067 — 0.083 in)

Limit thickness:

2.3 mm (0.091 in)

Retaining plate	
Part number	Thickness mm (in)
31567AA991	5.6 (0.220)
31567AB001	5.8 (0.228)
31567AB011	6.0 (0.236)
31567AB021	6.2 (0.244)
31567AB031	6.4 (0.252)
31567AB041	6.6 (0.260)

28) Check the clearance between the retaining plate and snap ring. (Turbo model)

NOTE:

If the clearance exceeds the service limits, replace the driven plate and select and adjust the retaining plate to make the clearance fall within initial standard values.

Initial standard:

0.8 — 1.2 mm (0.031 — 0.047 in)

Limit thickness:

1.5 mm (0.059 in)

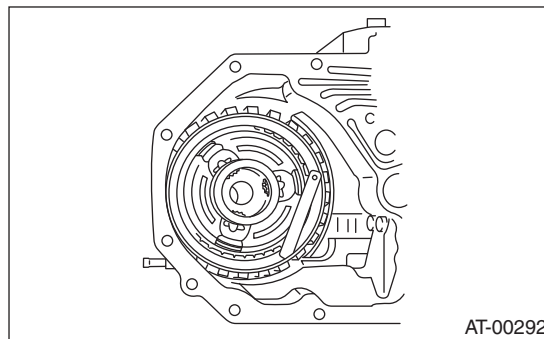

Retaining plate	
Part No.	Thickness mm (in)
31567AA991	5.6 (0.220)
31567AB001	5.8 (0.228)
31567AB011	6.0 (0.236)
31567AB021	6.2 (0.244)
31567AB031	6.4 (0.252)
31567AB041	6.6 (0.260)

AT Main Case

AUTOMATIC TRANSMISSION

29) Be careful not to mistake the location of the leaf spring to be installed.

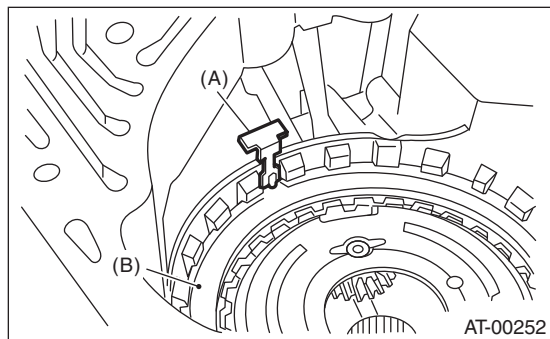

- (A) Leaf spring
- (B) Retaining plate

30) Install the thrust needle bearing in the correct direction.

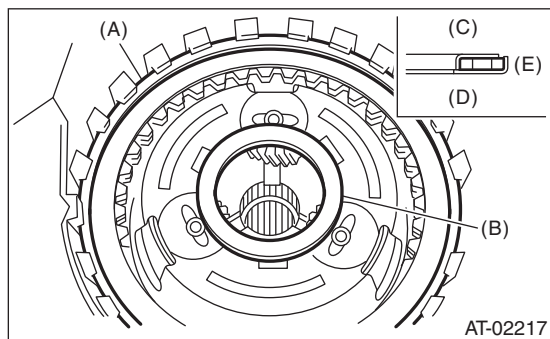

- (A) Snap ring
- (B) Thrust needle bearing
- (C) Upside
- (D) Downside
- (E) Outside

31) Install the front sun gear and the thrust needle bearing.

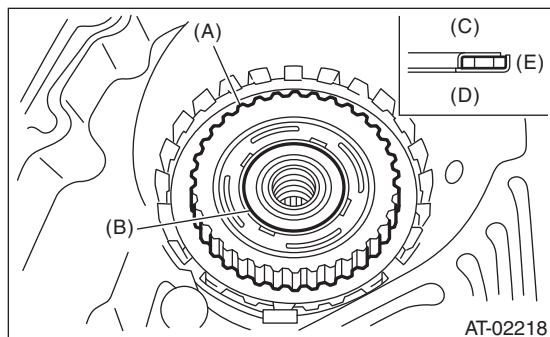

- (A) Front sun gear
- (B) Thrust needle bearing
- (C) Upside
- (D) Downside
- (E) Outside

32) Apply vaseline, and attach the thrust needle bearing to the high clutch hub, then engage the splines of the front planetary carrier correctly to install the high clutch hub.

33) Install the thrust needle bearing in the correct direction.

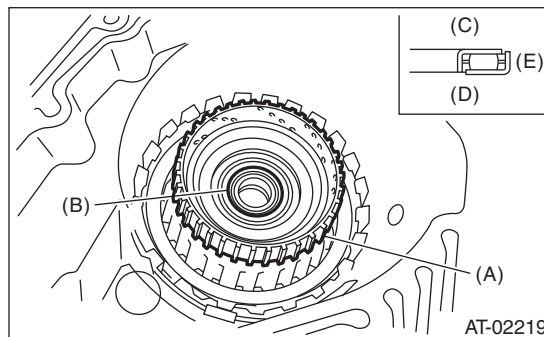

- (A) High clutch hub
- (B) Thrust needle bearing
- (C) Upside
- (D) Downside
- (E) Outside

34) Install the high clutch assembly and reverse clutch assembly.

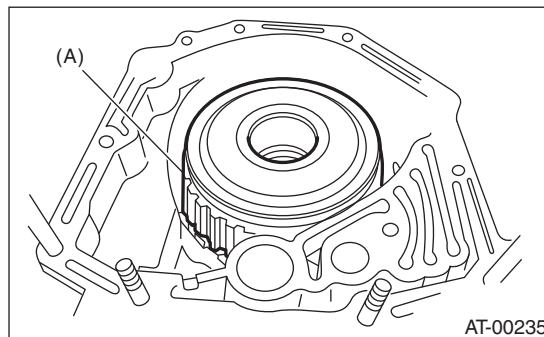

- (A) High clutch ASSY and reverse clutch ASSY

35) Adjust the total end play. <Ref. to 4AT-88, ADJUSTMENT, Oil Pump Housing.>

36) Install the thrust needle bearing in the correct direction.

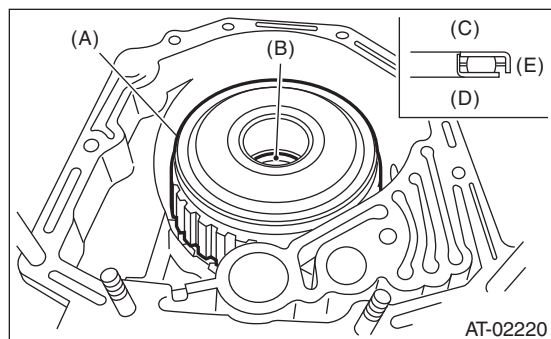

- (A) High clutch ASSY and reverse clutch ASSY
- (B) Thrust needle bearing
- (C) Upside
- (D) Downside
- (E) Outside

37) Install a new gasket along with the oil pump housing assembly. <Ref. to 4AT-84, INSTALLATION, Oil Pump Housing.>

38) Install the converter case to the transmission case assembly. <Ref. to 4AT-81, INSTALLATION, Converter Case.>

39) Insert the inhibitor switch and transmission harness connector to the stay.

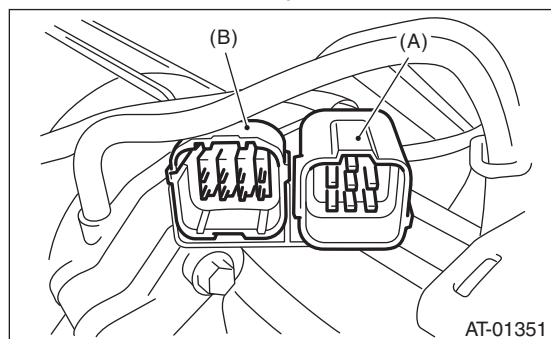

- (A) Transmission harness connectors
- (B) Inhibitor switch connector

40) Install the air breather hose. <Ref. to 4AT-64, INSTALLATION, Air Breather Hose.>

41) Install the ATF cooler pipe. <Ref. to 4AT-62, INSTALLATION, ATF Cooler Pipe and Hose.>

42) Install the oil charge pipe together with an O-ring. <Ref. to 4AT-65, INSTALLATION, Oil Charge Pipe.>

43) Insert the input shaft while rotating it lightly by hand, and then check the amount of protrusion.

Normal protrusion A:
50 — 55 mm (1.97 — 2.17 in)

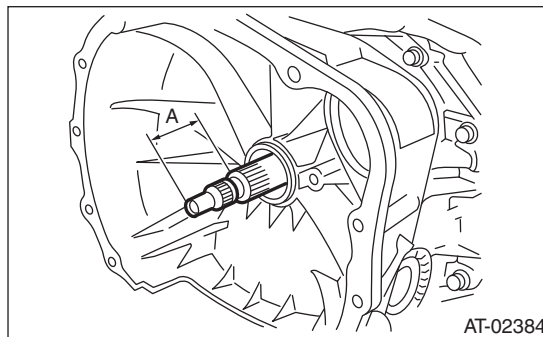

44) Install the torque converter clutch assembly. <Ref. to 4AT-66, INSTALLATION, Torque Converter Clutch Assembly.>

45) Install the transmission assembly to the vehicle. <Ref. to 4AT-37, INSTALLATION, Automatic Transmission Assembly.>

AT Main Case

AUTOMATIC TRANSMISSION

C: DISASSEMBLY

1. HIGH CLUTCH AND REVERSE CLUTCH

1) Remove the snap ring, and then take out the retaining plate, drive plate and driven plate.

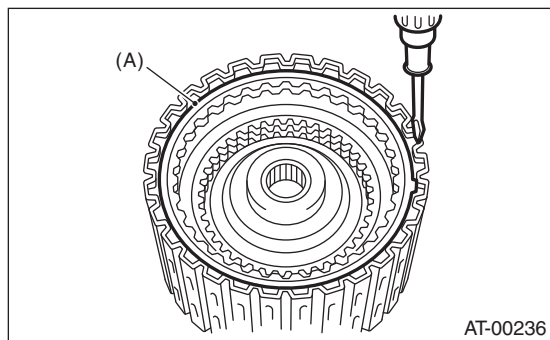

(A) Snap ring

2) Remove the snap ring, and then take out the retaining plate, drive plate and driven plate.

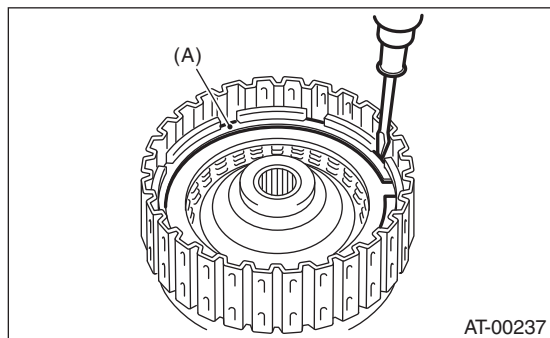

(A) Snap ring

3) Using the ST1 and ST2, remove the snap ring.

ST1 398673600 COMPRESSOR

ST2 498627100 SEAT

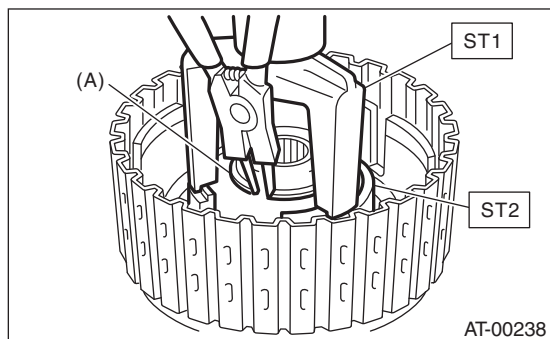

(A) Snap ring

4) Take out the clutch cover, spring retainer, high clutch piston and reverse clutch piston.

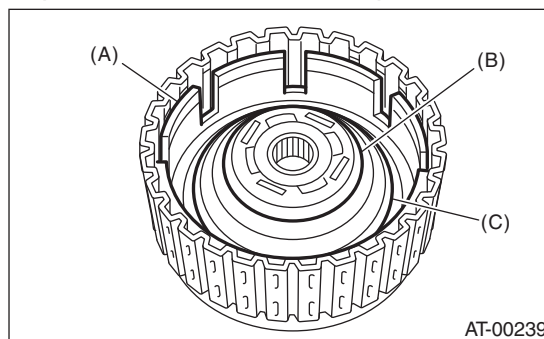

(A) Reverse clutch piston

(B) Clutch cover

(C) Return spring

5) Remove the seal ring and lip seal from the high clutch piston and reverse clutch piston.

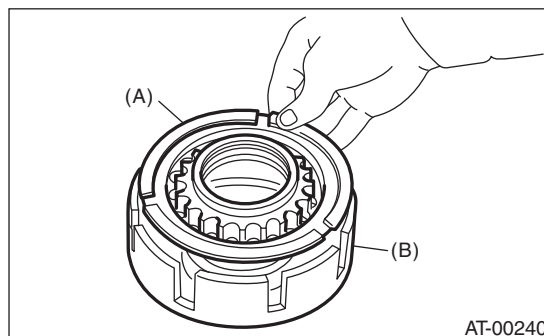

(A) High clutch piston

(B) Reverse clutch piston

2. PLANETARY GEAR AND LOW CLUTCH

1) Remove the snap ring from low clutch drum.

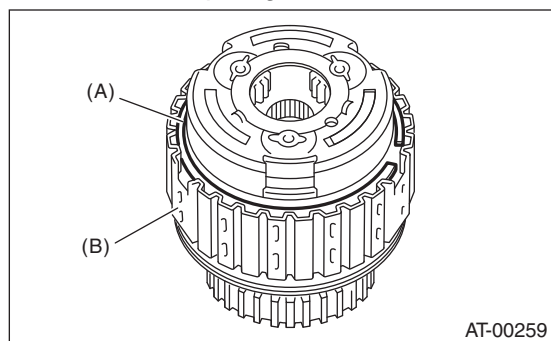

- (A) Snap ring
- (B) Low clutch drum

4) Take out the rear planetary carrier, washer and thrust needle bearing.

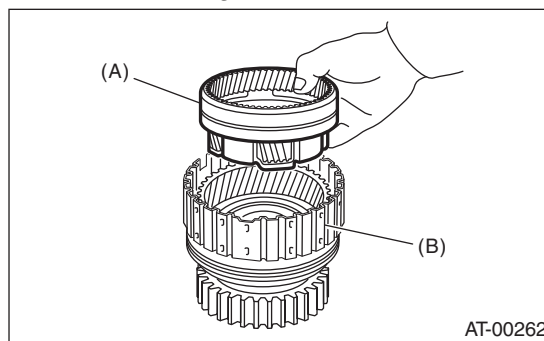

- (A) Rear planetary carrier
- (B) Low clutch drum

2) Take out the front planetary carrier.

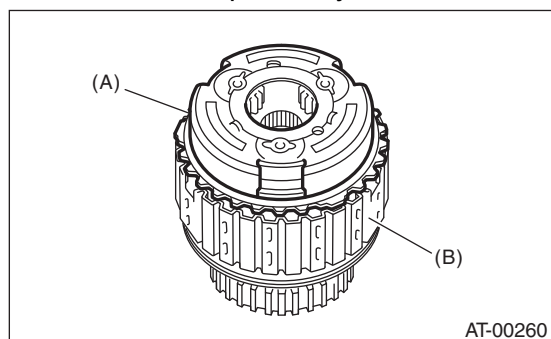

- (A) Front planetary carrier
- (B) Low clutch drum

5) Take out the rear internal gear.

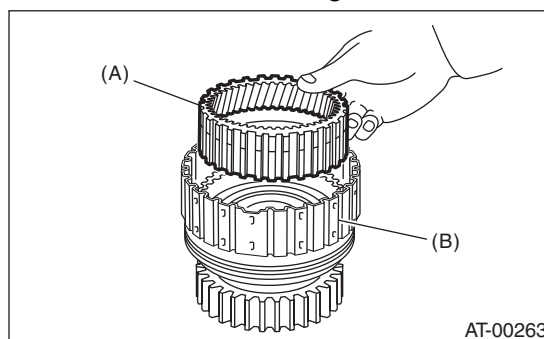

- (A) Rear internal gear
- (B) Low clutch drum

3) Take out the rear sun gear.

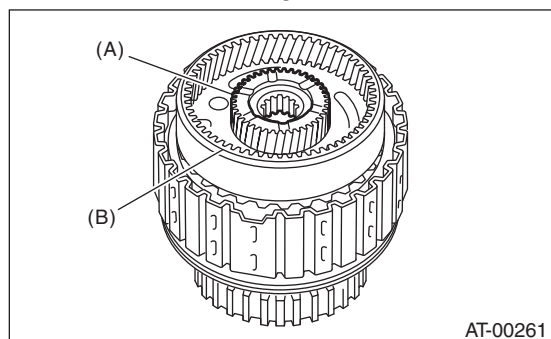

- (A) Rear sun gear
- (B) Rear planetary carrier

6) Remove the snap ring from low clutch drum.

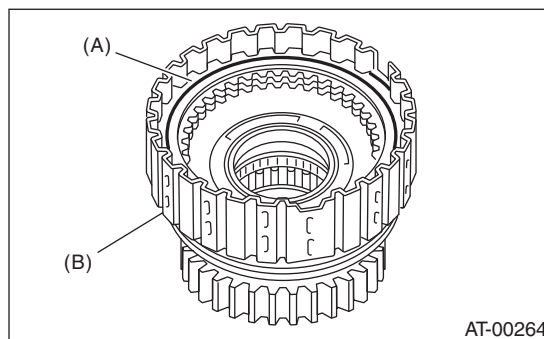

- (A) Snap ring
- (B) Low clutch drum

AT Main Case

AUTOMATIC TRANSMISSION

7) Compress the spring retainer of the low & reverse brake, and remove the snap ring from the low clutch drum using ST1 and ST2.

ST1 498627100 SEAT
ST2 398673600 COMPRESSOR

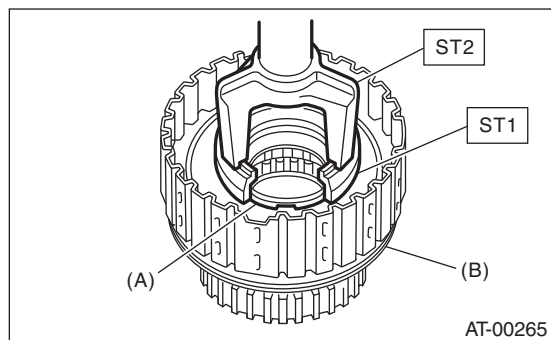

- (A) Snap ring
- (B) Low clutch drum

8) Remove the one-way clutch. <Ref. to 4AT-100, REMOVAL, AT Main Case.>

9) Install the one-way clutch inner race to the low clutch drum, and then apply compressed air to remove the low clutch piston.

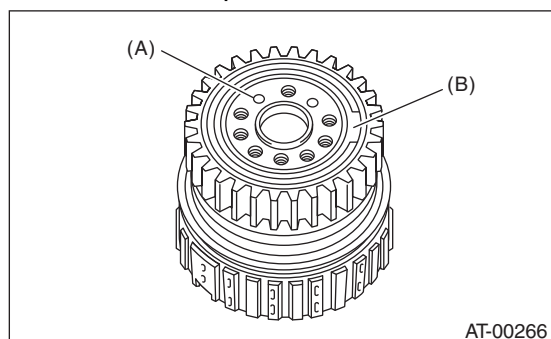

- (A) Apply compressed air.
- (B) One-way clutch inner race

10) Remove the one-way clutch inner race.

11) Remove the one-way clutch after taking out the snap ring.

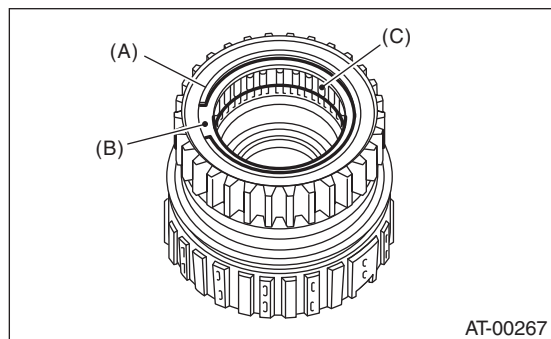

- (A) Snap ring
- (B) Plate
- (C) One-way clutch

12) Remove the needle bearing after taking out the snap ring.

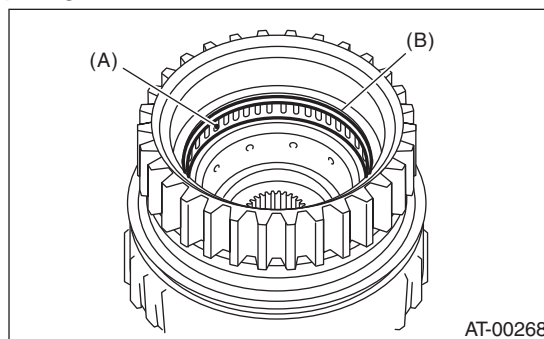

- (A) Needle bearing
- (B) Snap ring

3. 2-4 BRAKE

Separate the 2-4 brake piston and piston retainer.

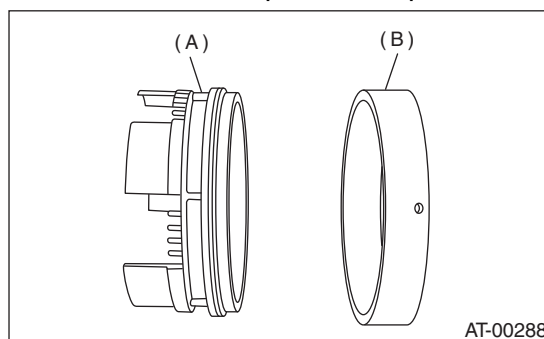

- (A) 2-4 brake piston
- (B) 2-4 brake piston retainer

4. ONE-WAY CLUTCH INNER RACE

1) Remove the seal ring.

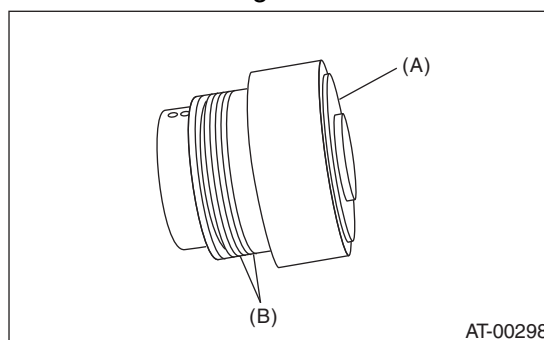

- (A) One-way clutch inner race
- (B) Seal ring

2) Remove the needle bearing using ST.
ST 398527700 PULLER ASSY

5. ONE-WAY CLUTCH OUTER RACE

1) Remove the one-way clutch after taking out the snap ring.

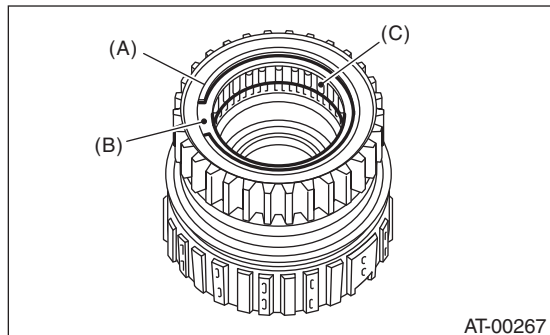

- (A) Snap ring
- (B) Plate
- (C) One-way clutch

2) Remove the needle bearing after taking out the snap ring.

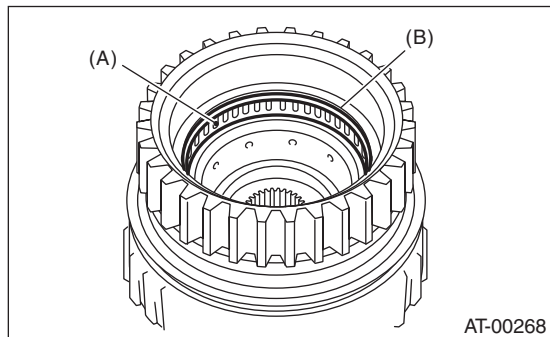

- (A) Needle bearing
- (B) Snap ring

D: ASSEMBLY

1. HIGH CLUTCH AND REVERSE CLUTCH

1) Install a new seal ring and lip seal to the high clutch piston and reverse clutch piston.

2) Install the high clutch piston to the reverse clutch piston.

NOTE:

Be careful not to damage the seal ring and lip seal.

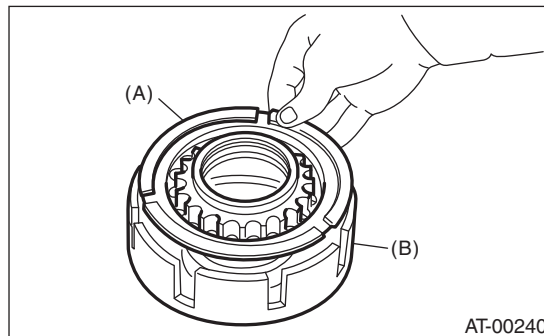

- (A) High clutch piston
- (B) Reverse clutch piston

3) Install the reverse clutch piston to the high clutch drum. Align the groove on reverse clutch piston with the groove on high clutch drum during installation.

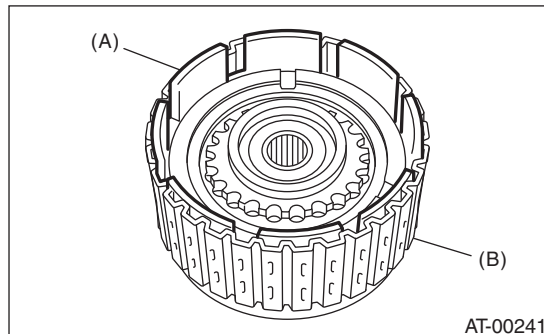

- (A) Reverse clutch piston
- (B) High clutch drum

4) Install the spring retainer to the high clutch piston.

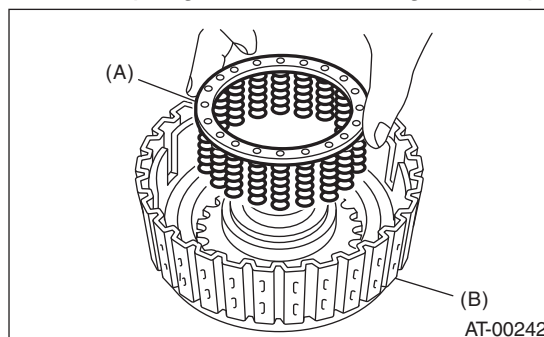

- (A) Spring retainer
- (B) High clutch drum

AT Main Case

AUTOMATIC TRANSMISSION

- 5) Attach the ST to the high clutch piston.
 ST 498437000 HIGH CLUTCH PISTON GUIDE

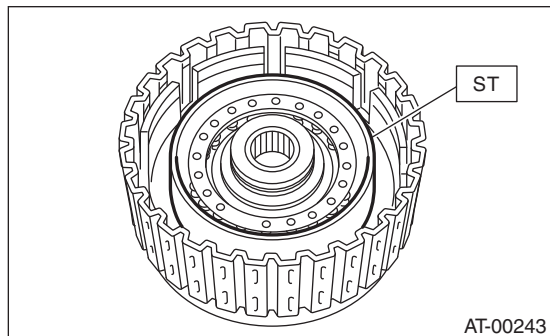

- 6) Install the high clutch piston cover while making sure not to bend the high clutch piston seal.
 7) Using the ST1, ST2 and ST3, install the snap ring.

- ST1 398673600 COMPRESSOR
 ST2 498627100 SEAT
 ST3 498437000 HIGH CLUTCH PISTON GUIDE

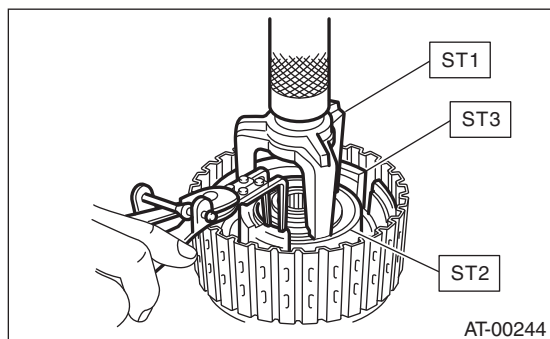

- 8) Measure and record a amount of drive plate compression. (Non-turbo model)

- (1) Place the dish plate, driven plate, drive plate and retaining plate neatly in this order on surface table.
 (2) Set the micro gauge to clutch, and read its scale.

NOTE:

The value, which is read in the gauge at this time, is zero point.

- (3) Scale and record the weight "Z" of a flat board which will be put on retaining plate.

NOTE:

- Use a stiff board which does not bend against load as a flat board to be put on retaining plate.
- Use a flat board weighing less than 25.5 kg (56.2 lb).

- (4) Put the flat board on retaining plate.

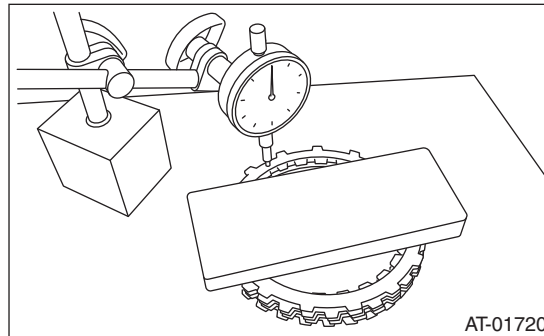

- (5) Using the following formula, read the push/pull gauge, and calculate "N".

$$N = 250 \text{ N (25.5 kgf, 56.2 lb)} - Z$$

N: Value indicated on push/pull gauge

250 N (25.5 kgf, 56.2 lb): Load applied to clutch plate

Z: Flat board weight

- (6) Press the center of retaining plate by applying a force of N using push/pull gauge, and then measure and record the height "A". Measure at three or more locations spaced by equal distances and take the average value.

NOTE:

If measuring in three locations, measure every 120°. If measuring in four locations, measure every 90°.

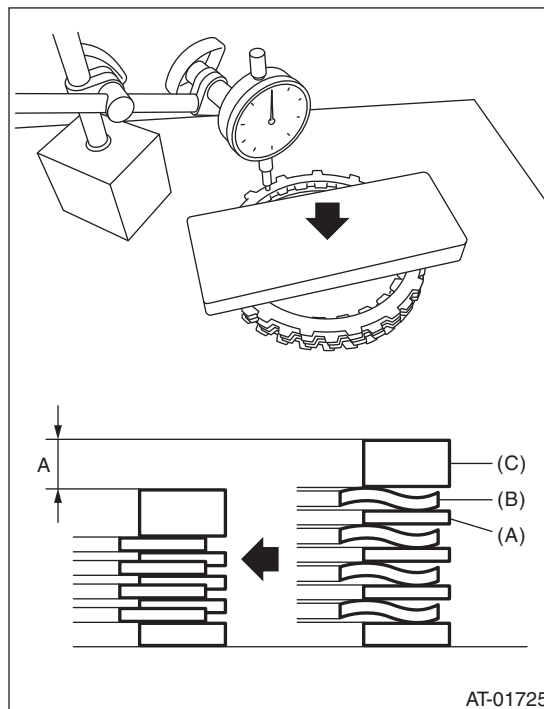

- (A) Driven plate
 (B) Drive plate
 (C) Retaining plate

9) Install the thickest driven plate to piston side, and then install the driven plate, drive plate, retaining plate to high clutch drum.

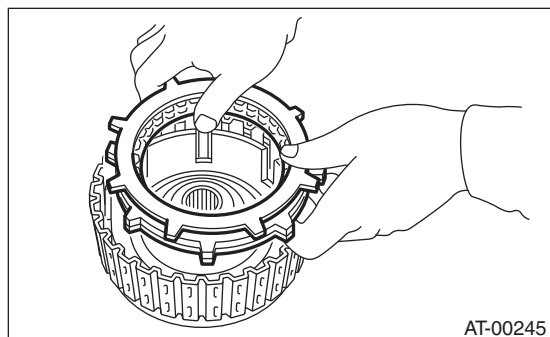

10) Install the snap ring to high clutch drum.

11) Apply compressed air intermittently to check for operation.

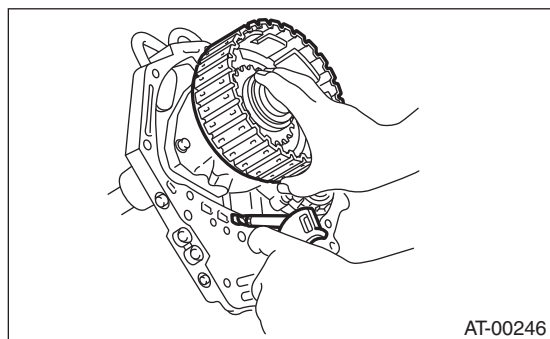

12) Check the piston stroke. (Non-turbo model)

(1) Measure clearance "B" between the retaining plate and snap ring. (High clutch)

At this time, do not press down the retaining plate.

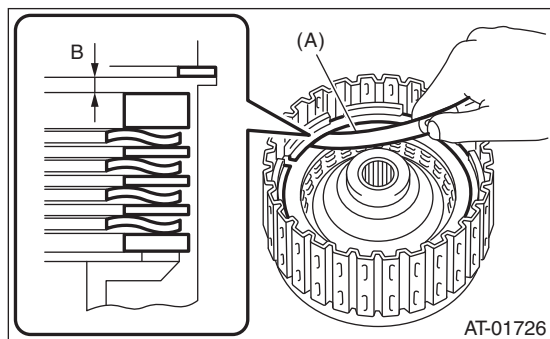

(A) Thickness gauge

(2) Piston stroke calculation

Calculate with A and B dimensions recorded before. If the calculated value exceeds the service limits, replace the drive plate and select and adjust the retaining plate to be within initial standard values.

$$T = A + B$$

T: Piston stroke

A: Amount of drive plate compression

B: Clearance between retaining plate and snap ring

Initial standard:

2.0 — 2.3 mm (0.079 — 0.091 in)

Limit thickness:

2.6 mm (0.102 in)

Retaining plate	
Part No.	Thickness mm (in)
31567AA710	4.7 (0.185)
31567AA720	4.8 (0.189)
31567AA730	4.9 (0.193)
31567AA740	5.0 (0.197)
31567AA670	5.1 (0.201)
31567AA680	5.2 (0.205)
31567AA690	5.3 (0.209)
31567AA700	5.4 (0.213)

AT Main Case

AUTOMATIC TRANSMISSION

13) Measure the clearance between the high clutch retaining plate and snap ring. (Turbo model)
At this time, do not press down the retaining plate.

Initial standard:

0.8 — 1.1 mm (0.031 — 0.043 in)

Limit thickness:

1.5 mm (0.059 in)

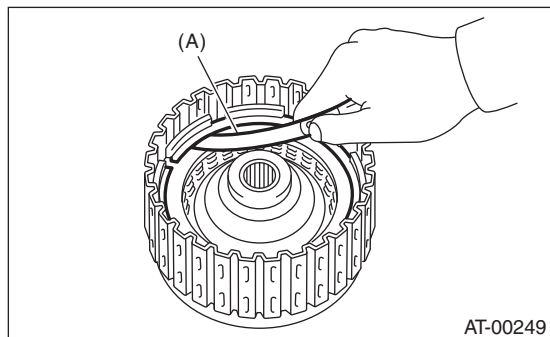

(A) Thickness gauge

If the clearance exceeds the service limits, replace the drive plate and select and adjust the retaining plate to make the clearance fall within initial standard values.

High clutch retaining plate	
Part number	Thickness mm (in)
31567AA710	4.7 (0.185)
31567AA720	4.8 (0.189)
31567AA730	4.9 (0.193)
31567AA740	5.0 (0.197)
31567AA670	5.1 (0.201)
31567AA680	5.2 (0.205)
31567AA690	5.3 (0.209)
31567AA700	5.4 (0.213)

14) Selection of the reverse clutch retaining plate
(1) Place the dish plate, driven plate, drive plate and retaining plate neatly in this order on surface table.
(2) Set the micro gauge to retaining plate, and read its scale.

NOTE:

The value, which is read in the gauge at this time, is zero point.

(3) Scale and record the weight "Z" of a flat board which will be put on retaining plate.

NOTE:

- Use a stiff board which does not bend against load as a flat board to be put on retaining plate.
 - Use a flat board weighing less than 15.3 kg (33.7 lb).
- (4) Put the flat board on retaining plate.

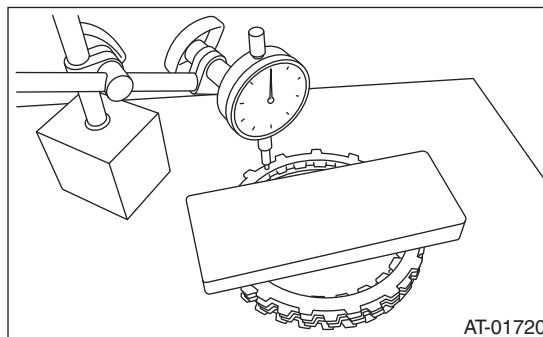

(5) Using the following formula, read the push/pull gauge, and calculate "N".

$$N = 150 \text{ N (15.3 kgf, 33.7 lbf)} - Z$$

N: Value indicated on push/pull gauge

150 N (15.3 kgf, 33.7 lbf): Load applied to the clutch plate

Z: Flat board weight

(6) Press the center of retaining plate by applying a force of N using push/pull gauge, and then measure and record the height "A". Measure at three or more locations spaced by equal distances and take the average value.

NOTE:

If measuring in three locations, measure every 120°. If measuring in four locations, measure every 90°.

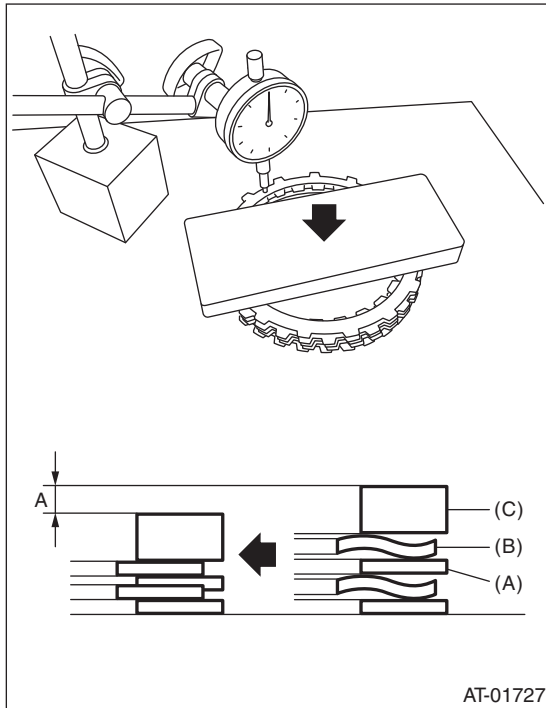

- (A) Driven plate
- (B) Drive plate
- (C) Retaining plate

(7) Install the driven plate, drive plate, retaining plate and snap ring.

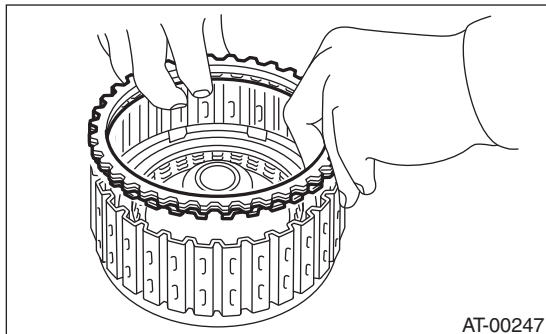

(8) Apply compressed air intermittently to check for operation.

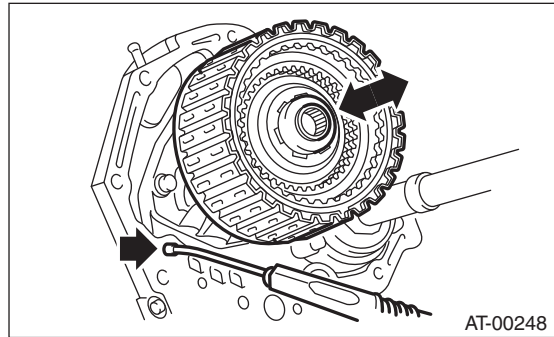

(9) Measure clearance "B" between the retaining plate and snap ring. (Reverse clutch)
At this time, do not press down the retaining plate.

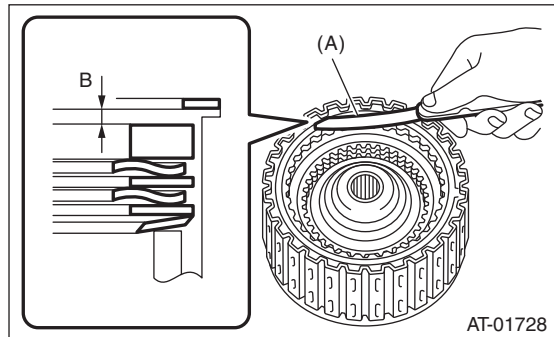

(A) Thickness gauge

(10) Piston stroke calculation

Calculate with A and B dimensions recorded before. If the calculated value exceeds the service limits, replace the drive plate and select and adjust the retaining plate to be within initial standard values.

$$T = A + B$$

T: Piston stroke

A: Amount of drive plate compression

B: Clearance between retaining plate and snap ring

Initial standard:

1.1 — 1.4 mm (0.043 — 0.055 in)

Limit thickness:

1.6 mm (0.063 in)

Retaining plate	
Part number	Thickness mm (in)
31567AA910	4.0 (0.157)
31567AA920	4.2 (0.165)
31567AA930	4.4 (0.173)
31567AA940	4.6 (0.181)
31567AA950	4.8 (0.189)
31567AA960	5.0 (0.197)
31567AA970	5.2 (0.205)
31567AA980	5.4 (0.213)

AT Main Case

AUTOMATIC TRANSMISSION

2. PLANETARY GEAR AND LOW CLUTCH

- 1) Apply ATF to a new D-ring, and install it to the low clutch piston.
- 2) Install the low clutch piston to low clutch drum.

NOTE:

Be careful not to damage the D-ring.

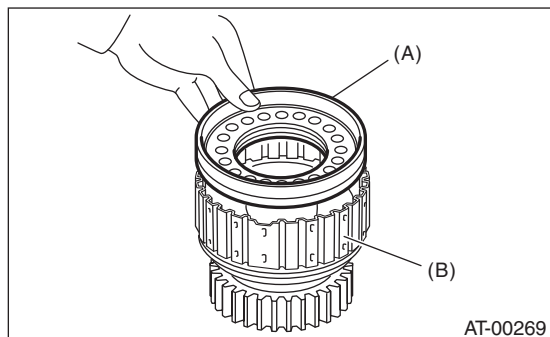

- (A) Low clutch piston
- (B) Low clutch drum

- 3) Install the spring retainer to low clutch piston.

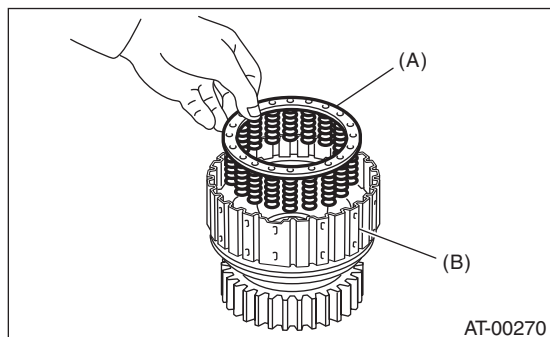

- (A) Spring retainer
- (B) Low clutch drum

- 4) Attach the ST to the low clutch drum.

ST 498437100 **LOW CLUTCH PISTON GUIDE**

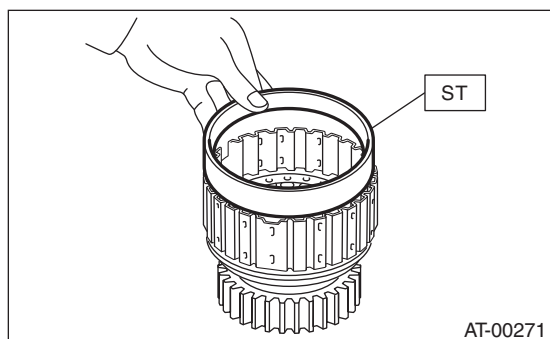

AT-00271

- 5) Using ST1, ST2, and ST3, set the cover on the piston and press against it, and attach the snap ring. At this time, be careful not to bend the cover seal.

ST1 498627100 **SEAT**
 ST2 398673600 **COMPRESSOR**
 ST3 498437100 **LOW CLUTCH PISTON GUIDE**

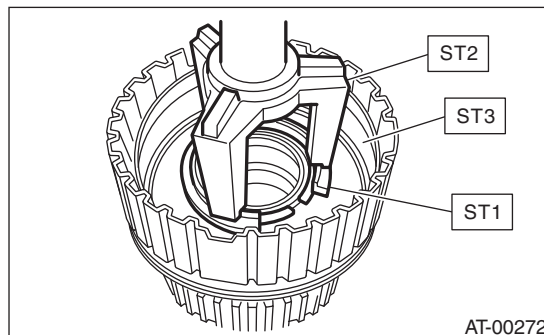

AT-00272

- 6) Install the dish plate, driven plate, drive plate and retaining plate, and then secure them with a snap ring.

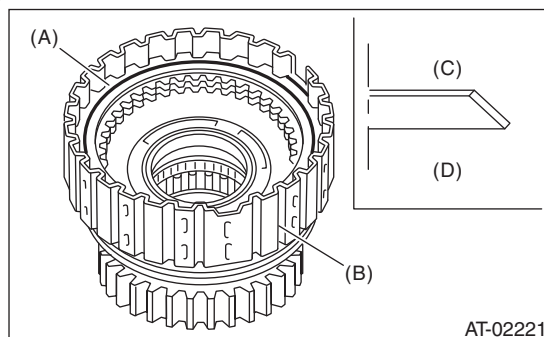

AT-00221

- (A) Snap ring
- (B) Low clutch drum
- (C) Dish plate
- (D) Low clutch piston side

- 7) Check the low clutch for operation.

(1) Remove the one-way clutch. <Ref. to 4AT-100, REMOVAL, AT Main Case.>

(2) Set the one-way clutch inner race, and apply compressed air for checking.

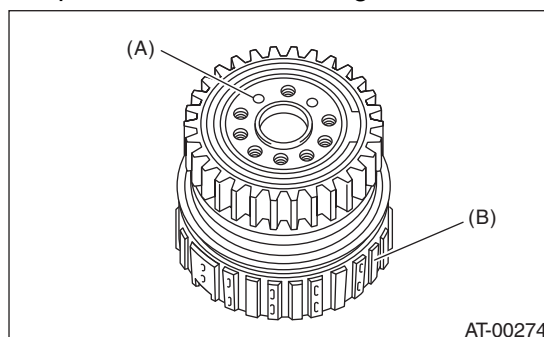

AT-00274

- (A) Apply compressed air.
- (B) Low clutch drum

8) Check the low clutch clearance.

- (1) Place same thickness shims on both sides to prevent plate from tilting.
- (2) Check the clearance between retaining plate and low clutch operation.

Initial standard:

0.7 — 1.1 mm (0.028 — 0.043 in)

Limit thickness:

1.6 mm (0.063 in)

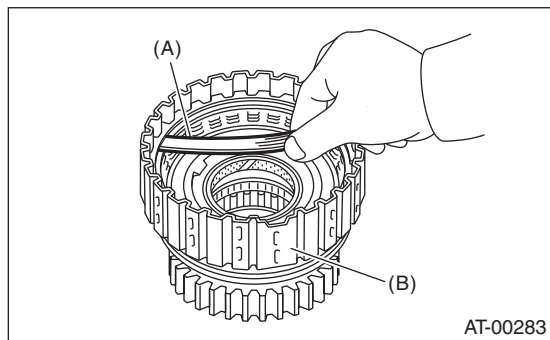

- (A) Thickness gauge
- (B) Low clutch drum

If the clearance exceeds the service limits, replace the drive plate and select and adjust the retaining plate to make the clearance fall within initial standard values.

Retaining plate	
Part number	Thickness mm (in)
31567AB050	3.8 (0.150)
31567AB060	4.0 (0.157)
31567AB070	4.2 (0.165)
31567AB080	4.4 (0.173)
31567AB090	4.6 (0.181)

9) Install the washer to the rear internal gear.

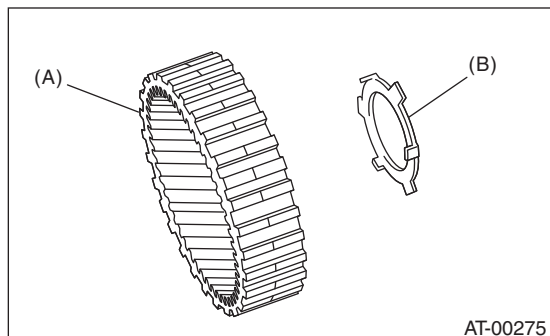

- (A) Rear internal gear
- (B) Washer

10) Install the rear internal gear.

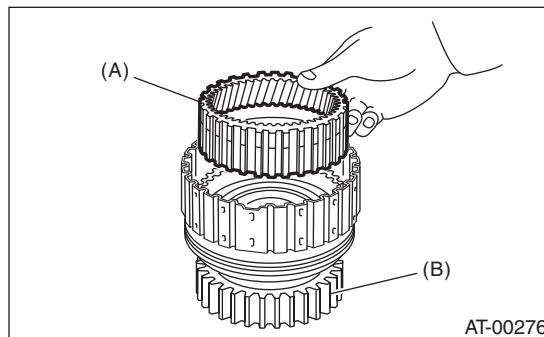

- (A) Rear internal gear
- (B) Low clutch drum

11) Install the thrust needle bearing in the correct direction.

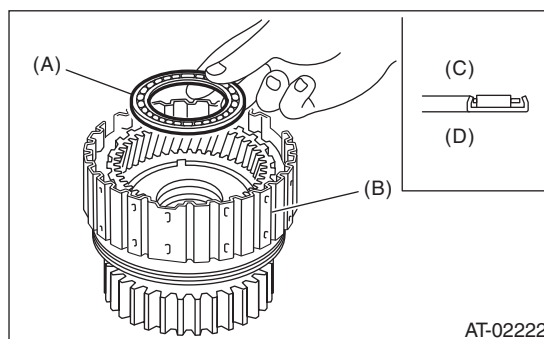

- (A) Thrust needle bearing
- (B) Low clutch drum
- (C) Rear planetary, carrier side
- (D) Low clutch drum side

12) Install the washer by aligning the protrusion of the washer with the hole of the rear planetary carrier.

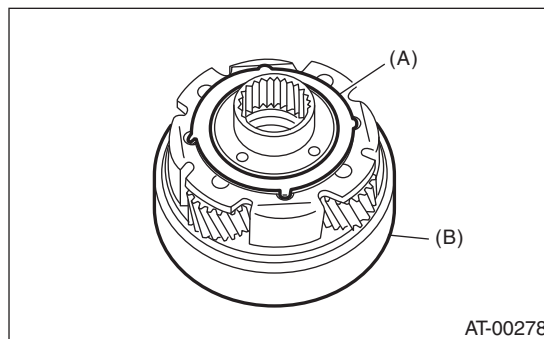

- (A) Washer
- (B) Rear planetary carrier

AT Main Case

AUTOMATIC TRANSMISSION

13) Install the rear planetary carrier to the low clutch drum.

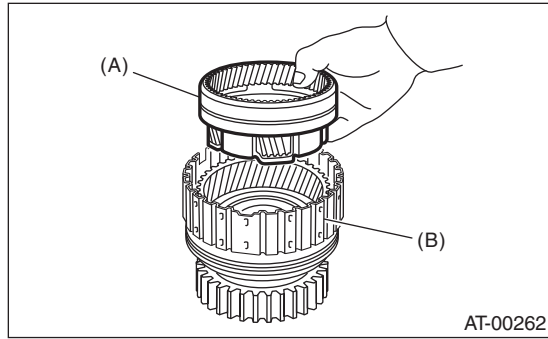

- (A) Rear planetary carrier
- (B) Low clutch drum

14) Install the thrust needle bearing in the correct direction.

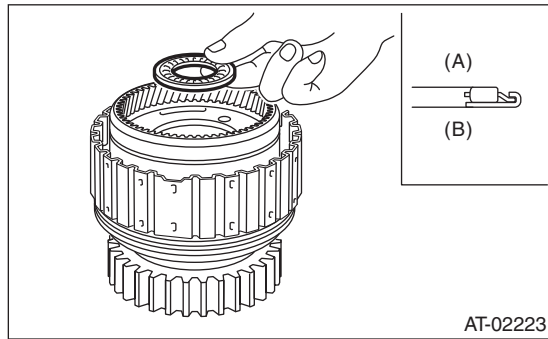

- (A) Rear sun gear side
- (B) Low clutch drum side

15) Install the rear sun gear in the correct direction.

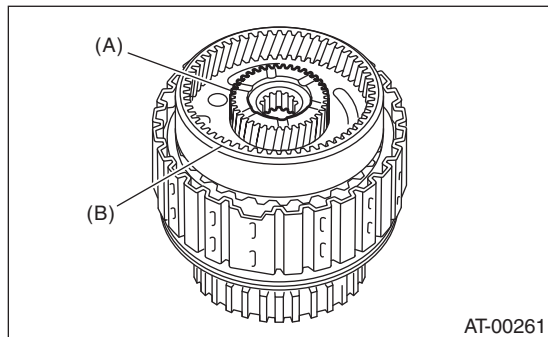

- (A) Rear sun gear
- (B) Rear planetary carrier

16) Install the thrust needle bearing in the correct direction.

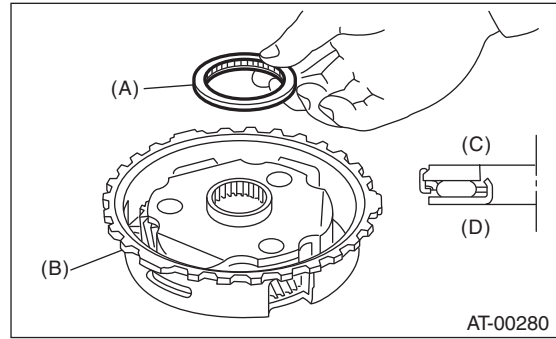

- (A) Thrust needle bearing
- (B) Front planetary carrier
- (C) Rear sun, gear side
- (D) Front planetary carrier side

17) Install the front planetary carrier to the low clutch drum.

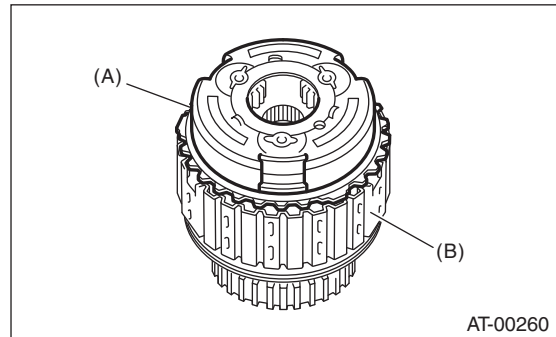

- (A) Front planetary carrier
- (B) Low clutch drum

18) Install the snap ring to the low clutch drum.

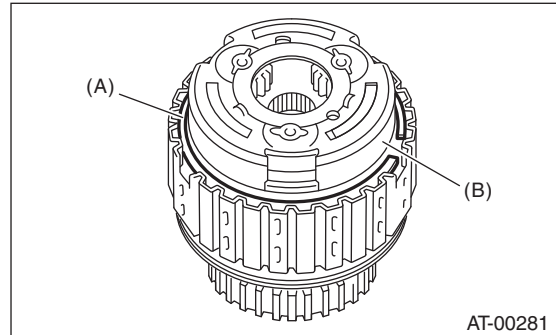

- (A) Snap ring
- (B) Front planetary carrier

19) Install the needle bearing, and then secure with the snap ring.

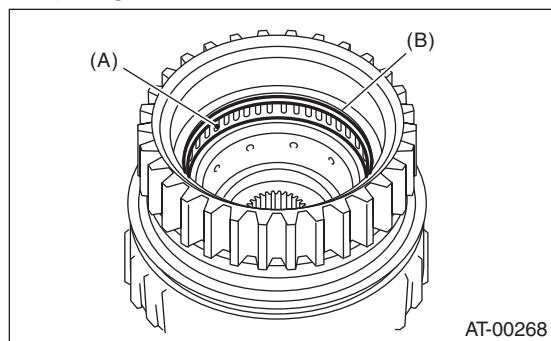

- (A) Needle bearing
- (B) Snap ring

20) Install the one-way clutch and one-way clutch inner race, then secure with the snap ring.

21) Set the inner race. Make sure that the clutch locks in the clockwise direction and rotates freely in the counterclockwise direction.

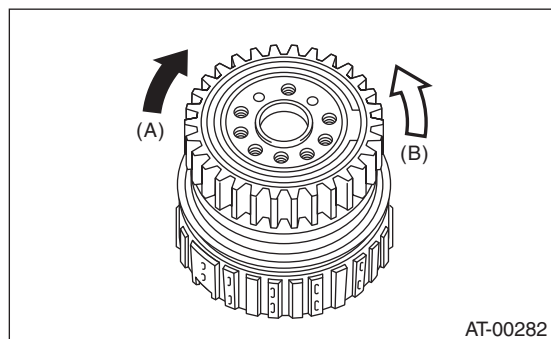

- (A) Lock
- (B) Free

3. 2-4 BRAKE

1) Apply ATF to the new D-ring, then install to the 2-4 brake piston.

2) Install 2-4 brake piston to 2-4 brake piston retainer.

NOTE:

Be careful not to damage the D-ring.

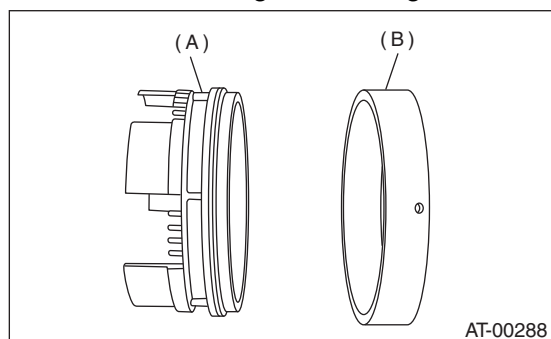

- (A) 2-4 brake piston
- (B) 2-4 brake piston retainer

4. ONE-WAY CLUTCH INNER RACE

1) Install the needle bearing to inner race using ST and a press.

ST 398497701

INSTALLER

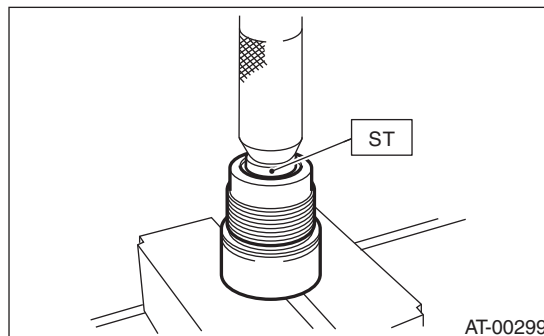

2) Apply vaseline to the groove of the inner race and to the new seal ring.

3) Install two seal rings to the one-way clutch inner race.

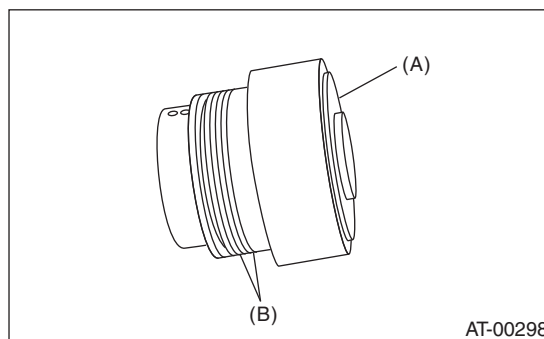

- (A) One-way clutch inner race
- (B) Seal ring

5. ONE-WAY CLUTCH OUTER RACE

1) Install the needle bearing, and then secure with the snap ring.

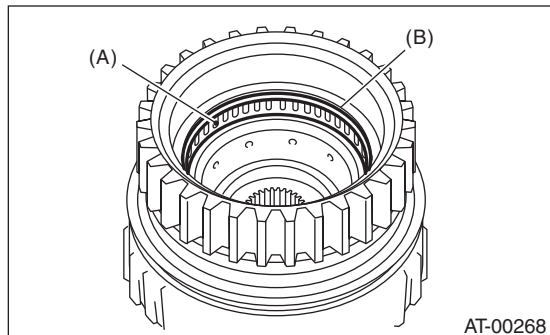

- (A) Needle bearing
- (B) Snap ring

2) Install the one-way clutch and one-way clutch inner race, then secure with the snap ring.

3) Set the inner race. Make sure that the clutch locks in the clockwise direction and rotates freely in the counterclockwise direction.

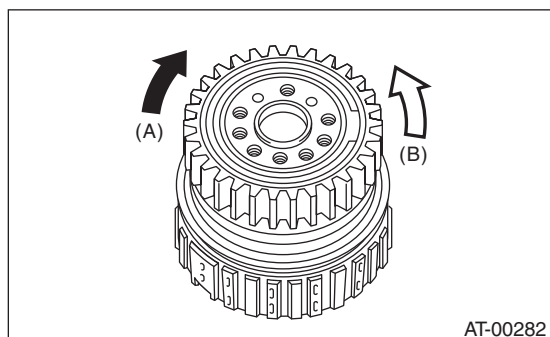

- (A) Lock
- (B) Free

E: INSPECTION

1. HIGH CLUTCH AND REVERSE CLUTCH

Check the following items.

- Drive plate facing for wear or damage
- Driven plate for discoloration (burned color)
- Snap ring wear and spring retainer deformation
- Wear and damage of the lip seal and D-ring
- Piston and piston check ball operation
- Adjust the total end play. <Ref. to 4AT-88, ADJUSTMENT, Oil Pump Housing.>

2. PLANETARY GEAR AND LOW CLUTCH

Check the following items.

- Drive plate facing for wear or damage
- Driven plate for discoloration (burned color)
- Snap ring wear and spring retainer deformation
- Wear and damage of the lip seal and D-ring
- Measure the total end play and adjust it to be within specifications. <Ref. to 4AT-88, ADJUSTMENT, Oil Pump Housing.>

3. 2-4 BRAKE

Check the following items.

- Drive plate facing for wear or damage
- Driven plate for discoloration (burned color)
- Snap ring wear, leaf spring setting and breakage, and spring retainer deformation
- Wear and damage of the lip seal and D-ring
- Measure the total end play and adjust it to be within specifications. <Ref. to 4AT-88, ADJUSTMENT, Oil Pump Housing.>

4. ONE-WAY CLUTCH

- Check that the snap ring is not damaged and the seal ring is not deformed.
- Measure the total end play and adjust it to be within specifications. <Ref. to 4AT-88, ADJUSTMENT, Oil Pump Housing.>

5. LOW & REVERSE BRAKE

Check the following items.

- Drive plate facing for wear or damage
- Driven plate for discoloration (burned color)
- Snap ring wear, leaf spring setting and breakage, and spring retainer deformation
- Lip seal wear and damage

36. Transmission Control Device

A: REMOVAL

- 1) Remove the transmission assembly from vehicle body. <Ref. to 4AT-34, REMOVAL, Automatic Transmission Assembly.>
- 2) Pull out the torque converter clutch assembly. <Ref. to 4AT-66, REMOVAL, Torque Converter Clutch Assembly.>
- 3) Remove the input shaft.
- 4) Lift up the lever on the rear side of transmission harness connector, and then remove it from the stay.
- 5) Disconnect the air breather hose. <Ref. to 4AT-64, REMOVAL, Air Breather Hose.>
- 6) Remove the inhibitor switch connector from the stay.
- 7) Wrap vinyl tape around the nipple attached to the air breather hose.
- 8) Remove the pitching stopper bracket.
- 9) Remove the inhibitor switch. <Ref. to 4AT-47, REMOVAL, Inhibitor Switch.>
- 10) Remove the control valve body assembly. <Ref. to 4AT-56, REMOVAL, Control Valve Body.>
- 11) Pull out the spring pin of manual plate.

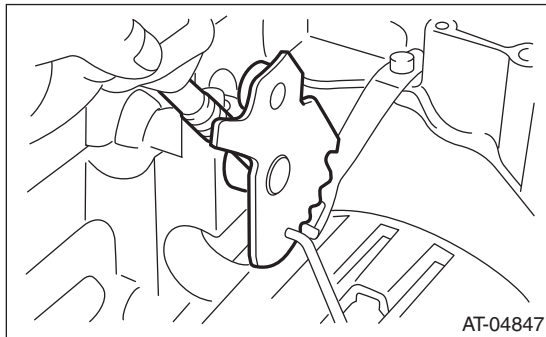

- 12) Remove the bolts securing select lever, and then remove the select lever, manual plate and parking rod.

NOTE:

Be careful not to damage the lips of press-fitted oil seal in the case.

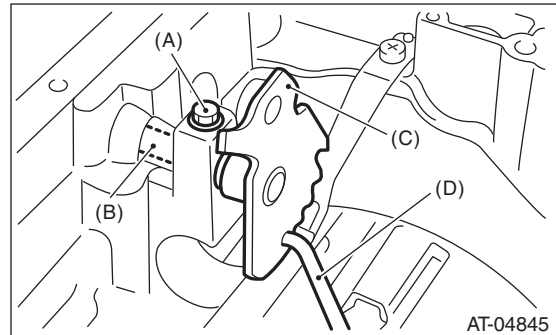

- (A) Bolt
- (B) Range select lever
- (C) Manual plate
- (D) Parking rod

- 13) Remove the detent spring.

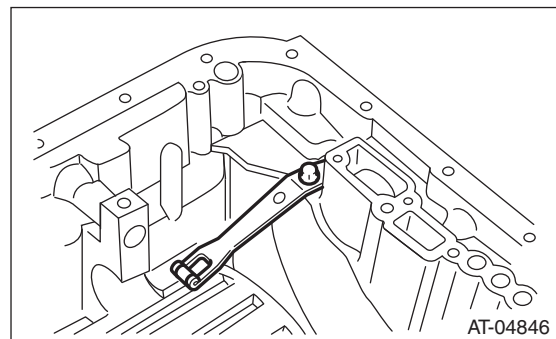

Transmission Control Device

AUTOMATIC TRANSMISSION

B: INSTALLATION

1) Install the detent spring to the transmission case.

Tightening torque:

6 N·m (0.6 kgf·m, 4.4 ft·lb)

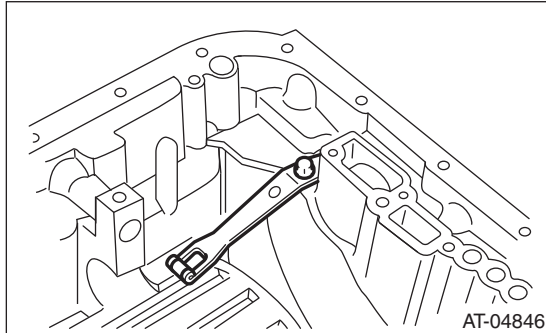

2) Insert the range select lever, then tighten the bolts.

Tightening torque:

6 N·m (0.6 kgf·m, 4.4 ft·lb)

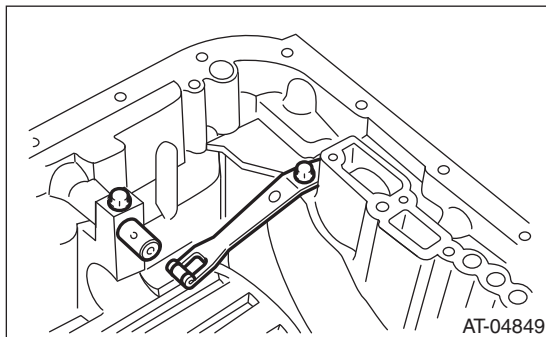

3) Insert the manual plate and parking rod.

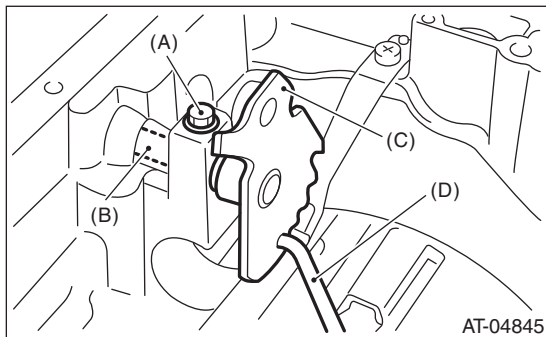

- (A) Bolt
- (B) Range select lever
- (C) Manual plate
- (D) Parking rod

4) Insert a new spring pin to manual plate.

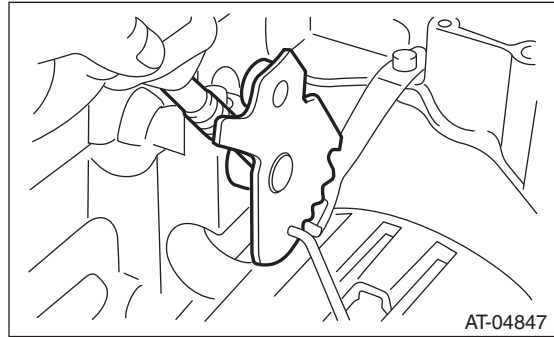

5) Install the oil pan and control valve assembly. <Ref. to 4AT-57, INSTALLATION, Control Valve Body.>

6) Turn over the transmission case to its original position.

7) Install the pitching stopper bracket.

Tightening torque:

41 N·m (4.2 kgf·m, 30.2 ft·lb)

8) Install and adjust the inhibitor switch. <Ref. to 4AT-46, Inhibitor Switch.>

9) Insert the inhibitor switch and transmission harness connector to the stay.

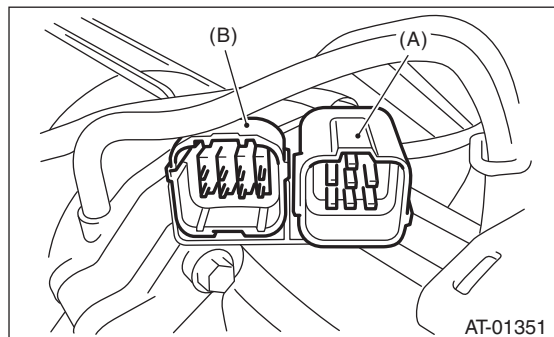

- (A) Transmission harness connectors
- (B) Inhibitor switch connector

10) Install the air breather hose. <Ref. to 4AT-64, INSTALLATION, Air Breather Hose.>

11) Insert the input shaft while rotating it lightly by hand, and then check the amount of protrusion.

Normal protrusion A:

50 — 55 mm (1.97 — 2.17 in)

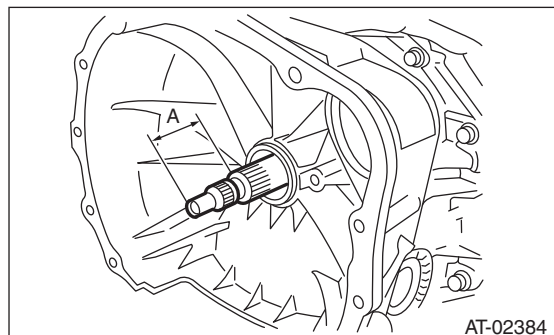

12) Install the torque converter clutch assembly.
<Ref. to 4AT-66, INSTALLATION, Torque Converter Clutch Assembly.>

13) Install the transmission assembly to the vehicle. <Ref. to 4AT-37, INSTALLATION, Automatic Transmission Assembly.>

C: INSPECTION

Make sure that the manual lever and detent spring are not worn or otherwise damaged.

Transmission Control Device

AUTOMATIC TRANSMISSION

AUTOMATIC TRANSMISSION (DIAGNOSTICS)

4AT(diag)

	Page
1. Basic Diagnostic Procedure	2
2. Check List for Interview	4
3. General Description	5
4. Electrical Component Location	7
5. Transmission Control Module (TCM) I/O Signal	12
6. Subaru Select Monitor	15
7. Read Current Data	16
8. Read Diagnostic Trouble Code (DTC)	17
9. Clear Memory Mode	18
10. Inspection Mode	19
11. Learning Control	20
12. AT Oil Temp Warning Light Display	22
13. Diagnostic Procedure for Subaru Select Monitor Communication	25
14. List of Diagnostic Trouble Code (DTC)	29
15. Diagnostic Procedure with Diagnostic Trouble Code (DTC)	31
16. Diagnostic Procedure without Diagnostic Trouble Code (DTC)	80
17. Diagnostics with Phenomenon	88

Basic Diagnostic Procedure

AUTOMATIC TRANSMISSION (DIAGNOSTICS)

1. Basic Diagnostic Procedure

A: PROCEDURE

	Step	Check	Yes	No
1	CHECK PRE-INSPECTION. 1) Ask the customer when and how the trouble occurred using the interview check list. <Ref. to 4AT(diag)-4, Check List for Interview.> 2) Check the following items which may be affecting the AT trouble. <ul style="list-style-type: none"> • General Inspection <Ref. to 4AT(diag)-5, INSPECTION, General Description.> • Disconnection of harness connector • Visual check for harness damage • Oil leakage • Stall speed test <Ref. to 4AT-30, Stall Test.> • Line pressure test <Ref. to 4AT-32, Line Pressure Test.> • Transfer clutch pressure test <Ref. to 4AT-33, Transfer Clutch Pressure Test.> • Time lag test <Ref. to 4AT-31, Time Lag Test.> • Road test <Ref. to 4AT-29, Road Test.> • Inhibitor switch <Ref. to 4AT-46, Inhibitor Switch.> 	Is the item that is thought to influence the AT problem working properly?	Go to step 2.	Repair or replace each item.
2	ATF TEMPERATURE WARNING LIGHT INSPECTION. Turn the ignition switch to ON and wait for at least 2 seconds.	Does the ATF temperature warning light illuminate?	Go to step 3.	Check the ATF temperature warning light.
3	ATF TEMPERATURE WARNING LIGHT INSPECTION. Start the engine and wait for 2 seconds or more.	Is the ATF temperature warning light blinking?	Go to step 4.	Go to step 5.
4	CHECK DTC. Display the DTC. NOTE: If the communication function of Subaru Select Monitor cannot be executed normally, check the communication circuit. <Ref. to 4AT(diag)-25, COMMUNICATION FOR INITIALIZING IMPOSSIBLE, Diagnostic Procedure for Subaru Select Monitor Communication.>	Is DTC displayed on the Subaru Select Monitor?	Go to step 6. NOTE: Record all DTC.	Go to step 5.
5	PERFORM GENERAL DIAGNOSTICS. 1) Inspect by referring to "Diagnostic Procedure without Diagnostic Trouble Code (DTC)". <Ref. to 4AT(diag)-80, Diagnostic Procedure without Diagnostic Trouble Code (DTC).> 2) Inspect by referring to "Diagnostics with Phenomenon". <Ref. to 4AT(diag)-88, Diagnostics with Phenomenon.> 3) Perform the Inspection Mode. <Ref. to 4AT(diag)-19, Inspection Mode.> 4) Display the DTC.	Is DTC displayed on the Subaru Select Monitor?	Go to step 6.	Finish the diagnosis.

Basic Diagnostic Procedure

AUTOMATIC TRANSMISSION (DIAGNOSTICS)

Step	Check	Yes	No
<p>6 PERFORM DIAGNOSIS. 1) Inspect by referring to the "Diagnostic Procedure with Diagnostic Trouble Code (DTC)". <Ref. to 4AT(diag)-31, Diagnostic Procedure with Diagnostic Trouble Code (DTC).> NOTE: For the DTC table, refer to "List of Diagnostic Trouble Code (DTC)". <Ref. to 4AT(diag)-29, List of Diagnostic Trouble Code (DTC).> 2) Repair the trouble cause. 3) Perform the Clear Memory Mode. 4) Perform the Inspection Mode. <Ref. to 4AT(diag)-19, Inspection Mode.> 5) Display the DTC.</p>	Is DTC displayed on the Subaru Select Monitor?	Inspect by referring to the "Diagnostic Procedure with Diagnostic Trouble Code (DTC)". <Ref. to 4AT(diag)-31, Diagnostic Procedure with Diagnostic Trouble Code (DTC).>	Finish the diagnosis.

General Description

AUTOMATIC TRANSMISSION (DIAGNOSTICS)

3. General Description

A: CAUTION

1. SUPPLEMENTAL RESTRAINT SYSTEM “AIRBAG”

The airbag system wiring harness is routed near the TCM.

CAUTION:

- All the airbag system wiring harnesses and connectors are colored yellow. Do not use an electric test equipment to check these circuits.
- Be careful not to damage the airbag system wiring harness when performing TCM diagnostics or servicing.

2. MEASUREMENT

When measuring the voltage and resistance of the ECM, TCM or each sensor, use a tapered pin with a diameter of less than 0.64 mm (0.025 in) in order to avoid poor contact. Do not insert a pin of more than 0.65 mm (0.026 in) diameter.

B: INSPECTION

1. BATTERY

Measure the battery voltage and specific gravity of the electrolyte.

Standard voltage:

12 V or more

Specific gravity:

1.260 or more

2. TRANSMISSION GROUND

Make sure that the ground terminal bolt is tightened securely.

- Chassis side

Tightening torque:

13 N·m (1.3 kgf·m, 9.6 ft·lb)

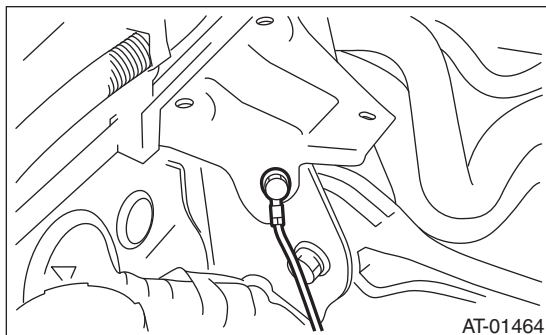

3. ATF LEVEL

Make sure that ATF level is the specified amount. <Ref. to 4AT-26, INSPECTION, Automatic Transmission Fluid.>

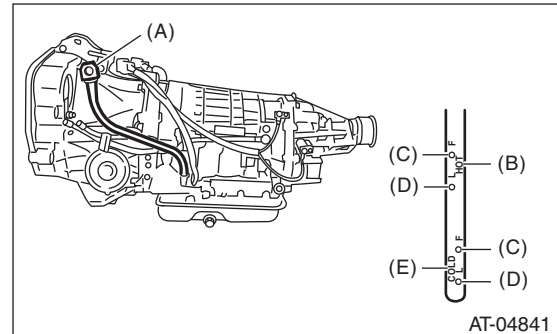

- (A) Level gauge
- (B) Inspection position when “HOT”
- (C) Upper level
- (D) Lower level
- (E) Inspection position when “COLD”

4. FRONT DIFFERENTIAL OIL LEVEL

Make sure the front differential oil level is at the specified amount. <Ref. to 4AT-28, INSPECTION, Differential Gear Oil.>

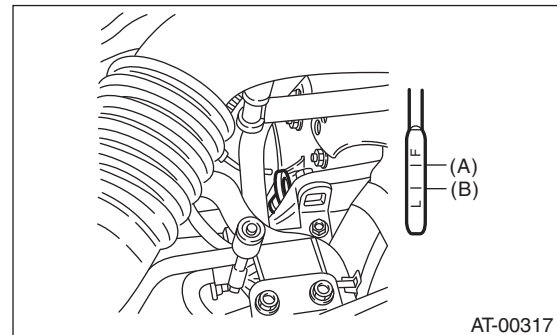

- (A) Upper level
- (B) Lower level

5. OPERATION OF SELECT LEVER

Make sure there is no noise, dragging or contact pattern in each select lever range.

WARNING:

Stop the engine while checking the operation of the select lever.

General Description

AUTOMATIC TRANSMISSION (DIAGNOSTICS)

C: PREPARATION TOOL

1. SPECIAL TOOL

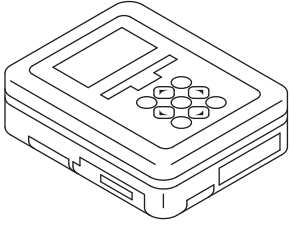
ILLUSTRATION	TOOL NUMBER	DESCRIPTION	REMARKS
 ST1B022XU0	1B022XU0 (Newly adopted tool)	SUBARU SELECT MONITOR III KIT	Used for troubleshooting the electrical system.

2. GENERAL TOOL

TOOL NAME	REMARKS
Circuit tester	Used for measuring resistance, voltage and current.
Oscilloscope	Used for measuring the sensor.

Electrical Component Location

AUTOMATIC TRANSMISSION (DIAGNOSTICS)

4. Electrical Component Location

A: LOCATION

1. CONTROL MODULE

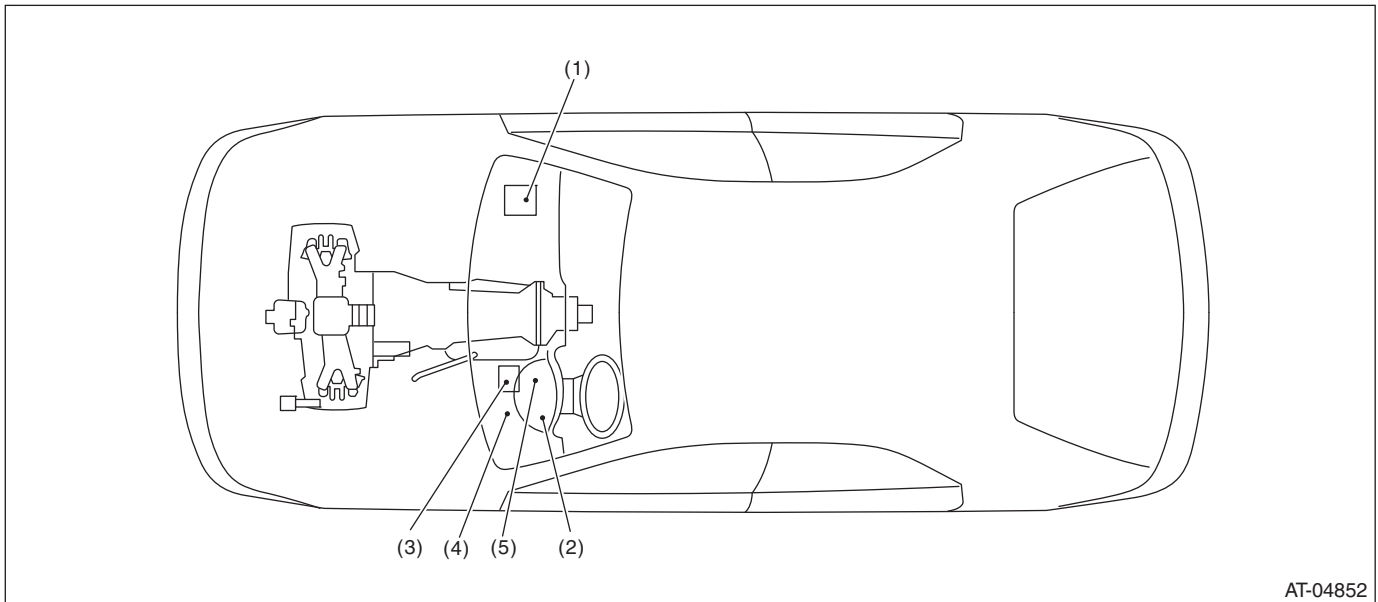

AT-04852

- | | | |
|---|---------------------------------------|--------------------------|
| (1) Engine control module (ECM) | (3) Transmission control module (TCM) | (5) Body integrated unit |
| (2) ATF temperature warning light
(AT temperature warning light) | (4) Data link connector | |

Electrical Component Location

AUTOMATIC TRANSMISSION (DIAGNOSTICS)

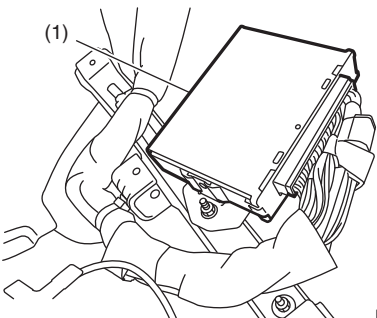
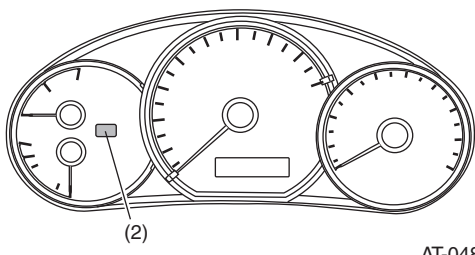
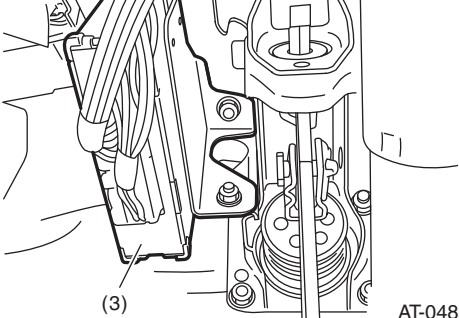
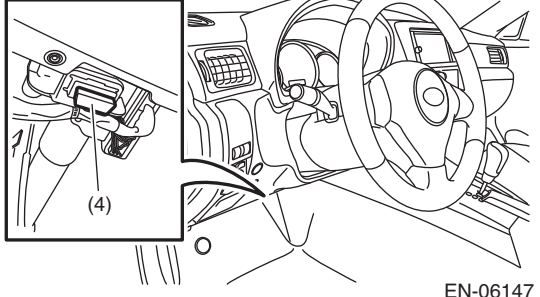
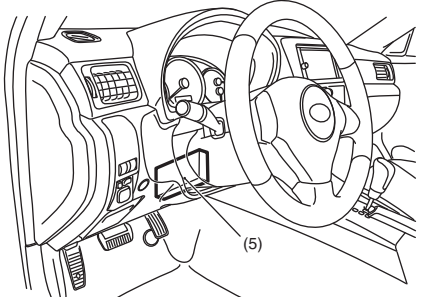
 <p>(1)</p> <p>EN-06142</p>	 <p>(2)</p> <p>AT-04816</p>
 <p>(3)</p> <p>AT-04854</p>	 <p>(4)</p> <p>EN-06147</p>
 <p>(5)</p> <p>AT-04851</p>	<p>SUBARU.</p>

Electrical Component Location

AUTOMATIC TRANSMISSION (DIAGNOSTICS)

2. SENSOR

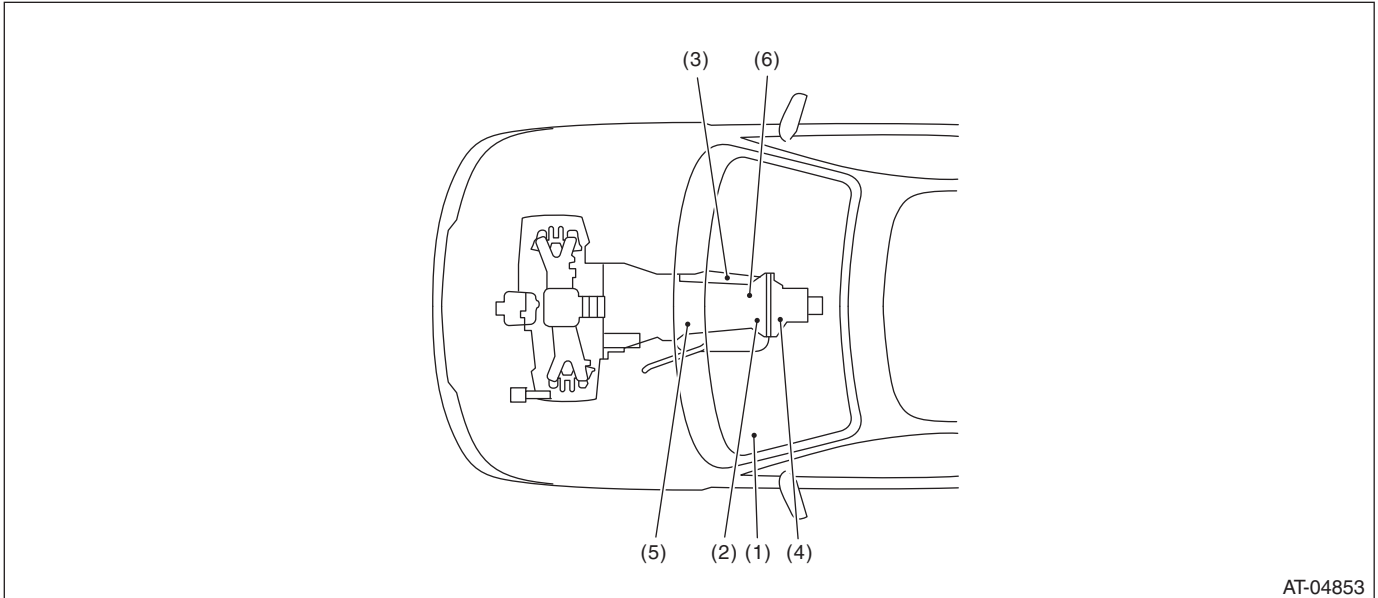

AT-04853

- | | | |
|---------------------------------------|---|----------------------------|
| (1) Accelerator pedal position sensor | (4) Rear vehicle speed sensor | (6) ATF temperature sensor |
| (2) Front vehicle speed sensor | (5) Torque converter turbine speed sensor | |
| (3) Inhibitor switch | | |

Electrical Component Location

AUTOMATIC TRANSMISSION (DIAGNOSTICS)

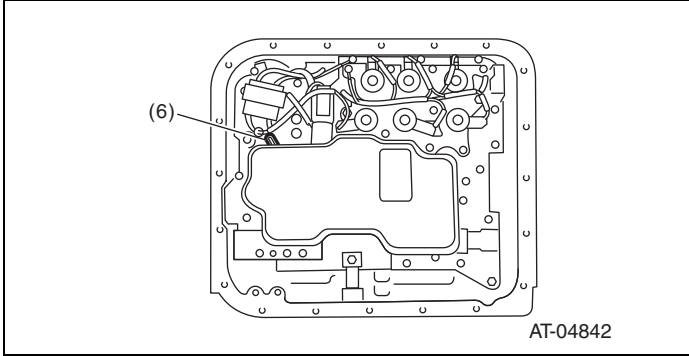
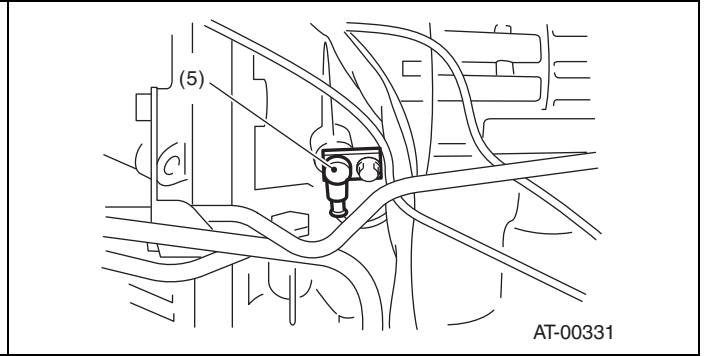
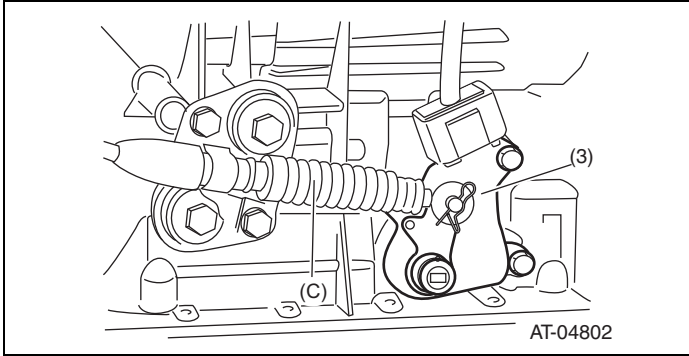
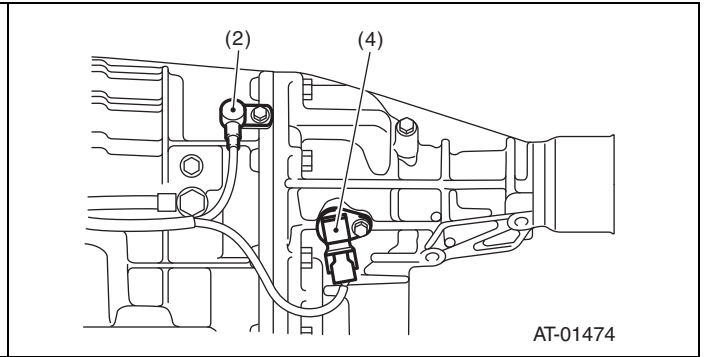
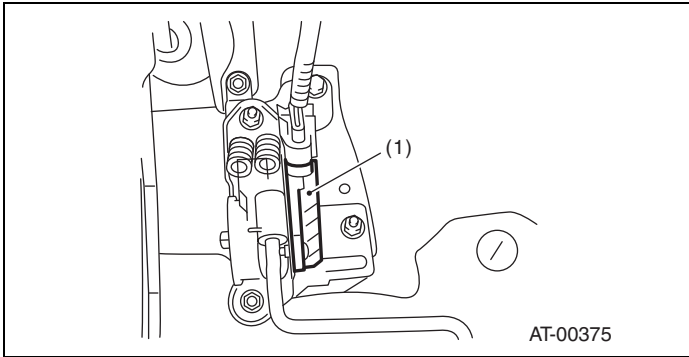

Electrical Component Location

AUTOMATIC TRANSMISSION (DIAGNOSTICS)

3. SOLENOID

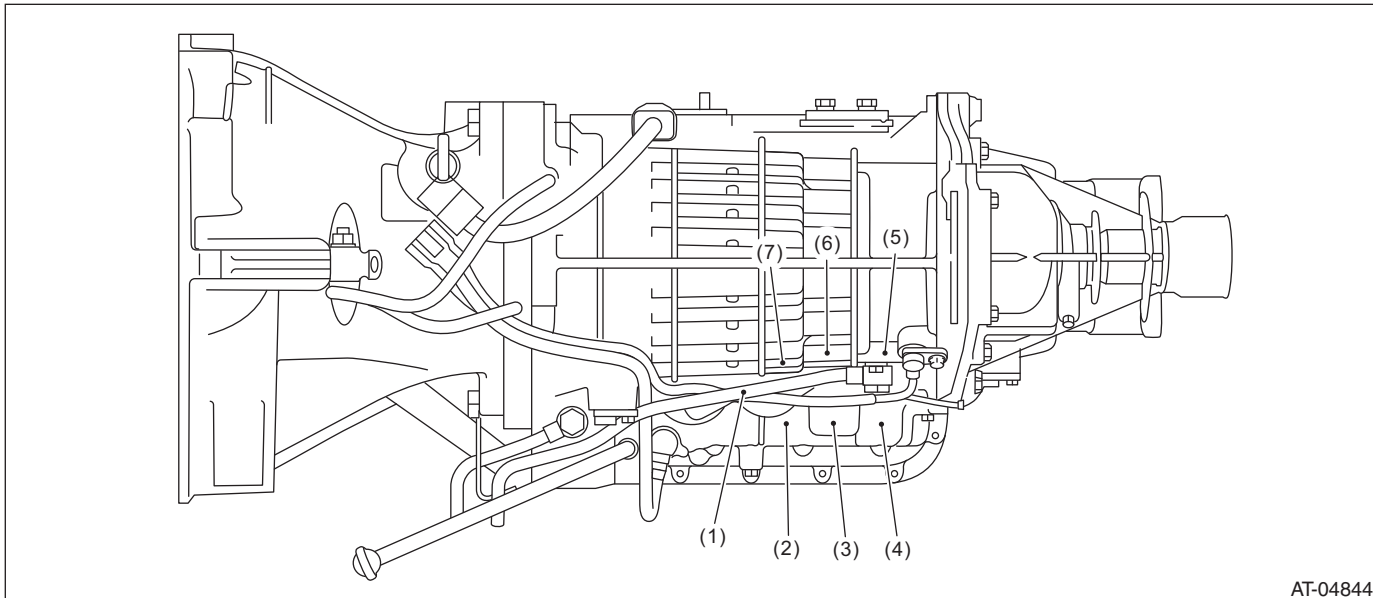

AT-04844

- | | | |
|-----------------------------------|---------------------------------|----------------------------|
| (1) Line pressure linear solenoid | (4) Low & reverse duty solenoid | (6) Transfer duty solenoid |
| (2) High clutch duty solenoid | (5) Low clutch duty solenoid | (7) Lock-up duty solenoid |
| (3) 2-4 brake duty solenoid | | |

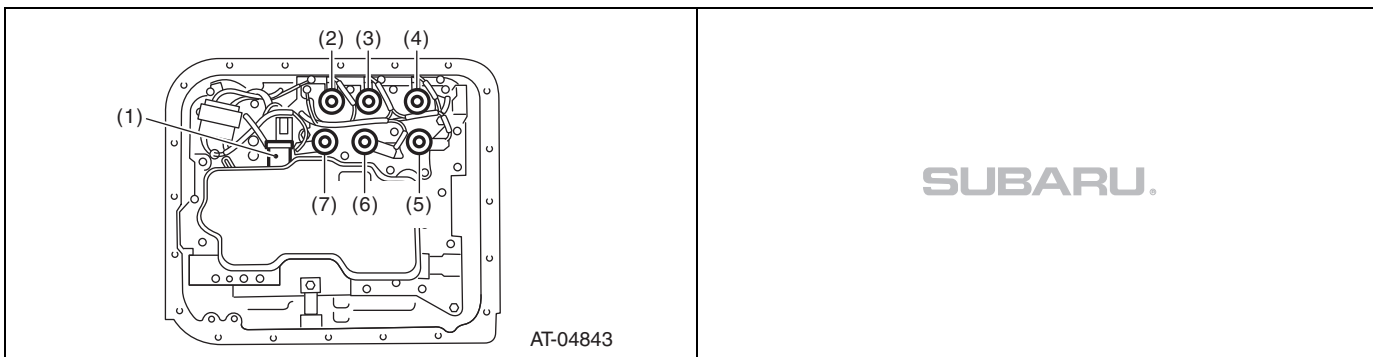

AT-04843

SUBARU.

Transmission Control Module (TCM) I/O Signal

AUTOMATIC TRANSMISSION (DIAGNOSTICS)

Check with ignition switch ON.					
Contents	Measured terminal (Connector & Terminal No.)		Measuring condition	Voltage (V)	Resistance (Ω)
	Positive terminal	Ground terminal			
ATF temperature sensor ground	(B55) No. 12	Chassis ground	—	0	Less than 1
Rear vehicle speed sensor	(B55) No. 26	(B55) No. 15	Vehicle stopped	0	—
			Vehicle speed at least 20 km/h (12 MPH)	2 or more (AC range)	
Rear vehicle speed sensor ground	(B55) No. 15	Chassis ground	—	0	Less than 1
Front vehicle speed sensor	(B55) No. 27	(B55) No. 16	Vehicle stopped	0	450 — 650
			Vehicle speed at least 20 km/h (12 MPH)	1 or more (AC range)	
Front vehicle speed sensor ground	(B55) No. 16	Chassis ground	—	—	—
Torque converter turbine speed sensor	(B55) No. 1	(B55) No. 2	Engine idling after warm-up ("D" range)	0	450 — 650
			Engine idling after warm-up ("N" range)	1 or more (AC range)	
Torque converter turbine speed sensor ground	(B55) No. 2	Chassis ground	—	—	—
Line pressure linear solenoid	(B55) No. 4	(B55) No. 3	Ignition switch ON, throttle fully closed in "R" range after engine warm-up.	3.7 — 7.7	4.0 — 6.0
			Ignition switch ON, throttle fully open in "R" range after engine warm-up.	1.1 — 5.1	
Line pressure linear solenoid ground	(B55) No. 3	Chassis ground	—	Less than 1	Less than 1
Lock-up duty solenoid	(B55) No. 6	Chassis ground	When lock up occurs.	10.5 or more	2.0 — 4.5
			When lock up is released.	Less than 1	
Transfer duty solenoid	(B55) No. 5	Chassis ground	With fuse installed to FWD switch	Less than 1	2.0 — 4.5
			With fuse removed from FWD switch (1st gear)	2.0 — 3.0	
2-4 brake duty solenoid	(B54) No. 4	Chassis ground	P or N range	5.0 or more	2.0 — 4.5
			2nd or 4th gear	Less than 1	
High clutch duty solenoid	(B54) No. 6	Chassis ground	3rd or 4th gear	Less than 1	2.0 — 4.5
			"P" or "N" range	5.0 or more	
Low clutch duty solenoid	(B54) No. 7	Chassis ground	1st or 2nd gear	Less than 1	2.0 — 4.5
			"P" or "N" range	5.0 or more	
Low & reverse duty solenoid	(B54) No. 5	Chassis ground	Except "1" range	5.0 or more	2.0 — 4.5
			1st Range Signal	2.5 — 5.0	
FWD switch	(B54) No. 10	Chassis ground	Fuse removed	10.5 or more	—
			Fuse installed	Less than 1	
CAN communication signal (+)	(B55) No. 18	Chassis ground	Ignition switch ON	Pulse signal	—
CAN communication signal (-)	(B55) No. 17	Chassis ground		Pulse signal	

Transmission Control Module (TCM) I/O Signal

AUTOMATIC TRANSMISSION (DIAGNOSTICS)

Check with ignition switch ON.					
Contents	Measured terminal (Connector & Terminal No.)		Measuring condition	Voltage (V)	Resistance (Ω)
	Positive terminal	Ground terminal			
System ground	(B54) No. 20	Chassis ground	—	0	Less than 1
	(B54) No. 21	Chassis ground			
	(B54) No. 22	Chassis ground			
	(B54) No. 23	Chassis ground			
Data link signal (Subaru Select Monitor)	(B54) No. 8	Chassis ground	—	—	—
SPORT shift switch	(B54) No. 17	Chassis ground	Ignition switch ON When SPORT shift mode switch is ON	Less than 1	—
			Ignition switch ON When SPORT shift mode switch is OFF	8 or more	—
SPORT shift DOWN switch	(B54) No. 18	Chassis ground	Ignition switch ON When SPORT shift up switch is ON	Less than 1	—
			Ignition switch ON When SPORT shift mode switch is OFF	8 or more	—
SPORT shift UP switch	(B54) No. 19	Chassis ground	Ignition switch ON When SPORT shift down switch is ON	Less than 1	—
			Ignition switch ON When SPORT shift mode switch is OFF	8 or more	—

6. Subaru Select Monitor

A: OPERATION

1) Prepare the Subaru Select Monitor kit.

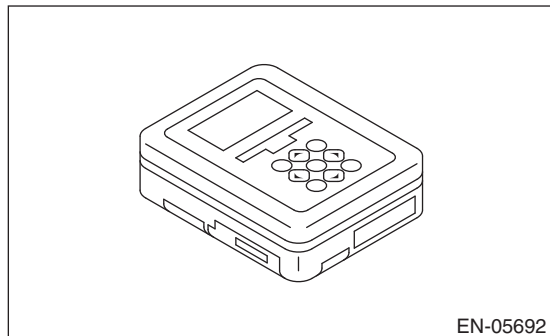

2) Prepare PC with Subaru Select Monitor installed.

3) Connect the SDI (Subaru Diagnostic Interface) to the PC USB port (exclusively for Subaru Selector Monitor) using a USB cable.

NOTE:

Port exclusively for Subaru Select Monitor refers to the USB port used when installing Subaru Select Monitor.

4) Connect the diagnosis cable to SDI.

5) Connect the SDI to data link connector located in the lower portion of the instrument panel (on the driver's side).

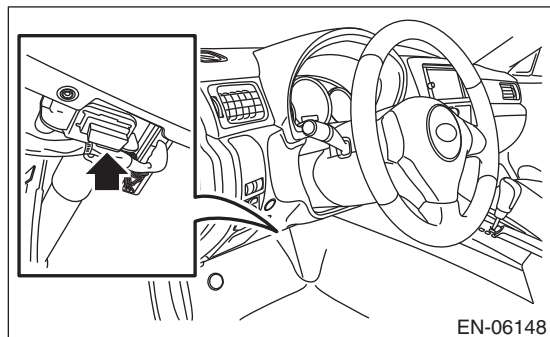

CAUTION:

Do not connect the scan tools other than the Subaru Select Monitor.

6) Start the PC.

7) Turn the ignition switch to ON.

8) Run the "PC application for Subaru Select Monitor".

Read Current Data

AUTOMATIC TRANSMISSION (DIAGNOSTICS)

7. Read Current Data

A: OPERATION

- 1) Using the Subaru Select Monitor, select {Each System Check} in the «Main Menu».
 - 2) On the «System Selection Menu», select {Transmission Control System}.
 - 3) After transmission type information pops up, select [OK].
 - 4) On the «Transmission Diagnosis», select {Current Data Display & Save}.
 - 5) On the «Current Data Display & Save», select {Normal Sampling}.
 - 6) Move the screen up or down with the scroll keys, and display the data you wish to view.
- The support data list is as follows.

Contents	Display	Unit of measure
Battery voltage	Battery Voltage	V
Rear vehicle speed sensor signal	Rear Wheel Speed	km/h or MPH
Front vehicle speed sensor signal	Front Wheel Speed	km/h or MPH
Engine speed signal	Engine Speed	rpm
Automatic transmission fluid temperature signal	ATF Temp.	°C or °F
Gear position	Gear Position	—
Line pressure control duty ratio	Line Pressure Duty Ratio	%
Lock up clutch control duty ratio	Lock Up Duty Ratio	%
Transfer clutch control duty ratio	Transfer Duty Ratio	%
Torque converter turbine speed signal	Turbine Revolution Speed	rpm
2 — 4 brake timing pressure control duty ratio	Brake Clutch Duty Ratio	%
Low clutch duty ratio	Low Clutch Duty	%
High clutch duty ratio	High Clutch Duty	%
Low & reverse brake duty ratio	L&R B Duty	%
Accelerator position	Accel. Opening Angle	%
FWD switch signal	FWD Switch	ON or OFF
Stop light switch signal	Stop Light Switch	ON or OFF
Anti lock brake system signal	ABS Signal	ON or OFF
Parking range signal	P Range	ON or OFF
Neutral range signal	N Range	ON or OFF
Reverse range signal	R Range Signal	ON or OFF
Drive range signal	D Range Signal	ON or OFF
AT diagnosis light output signal	Diagnosis Lamp	ON or OFF
ATF Temperature Light	ATF Temperature Lamp	ON or OFF
Up shift signal	Up Switch	ON or OFF
Down shift signal	Down Switch	ON or OFF
Sport shift signal	Tiptronic Mode Switch	ON or OFF
Cruise control signal	Cruise Control Signal	ON or OFF

NOTE:

For details concerning the operation procedure, refer to the “PC application help for Subaru Select Monitor”.

8. Read Diagnostic Trouble Code (DTC)

A: OPERATION

- 1) Using the Subaru Select Monitor, select {Each System Check} in the «Main Menu».
- 2) On the «Each System Check Menu» screen, select {Transmission Control System}.
- 3) After transmission type information is displayed, select [OK].
- 4) On the «Transmission Diagnosis», select {Diagnostic Code(s) Display}.
- 5) On the «DTC Display» screen, select {Temporary Diagnostic Code(s)} or {Memorized Diagnostic Code(s)}.

NOTE:

- For details concerning the work procedure, refer to the “PC application help for Subaru Select Monitor”.
- For details concerning DTC, refer to List of Diagnostic Trouble Code (DTC). <Ref. to 4AT(diag)-29, List of Diagnostic Trouble Code (DTC).>

Clear Memory Mode

AUTOMATIC TRANSMISSION (DIAGNOSTICS)

9. Clear Memory Mode

A: OPERATION

- 1) Move the select lever to “P” range.
- 2) Using the Subaru Select Monitor, select {Each System Check} in the «Main Menu».
- 3) On the «Each System Check Menu» screen, select {Transmission Control System}.
- 4) After transmission type information is displayed, select [OK].
- 5) On the «Transmission Diagnosis», select {Clear Memory}.
- 6) When “Done. Turn ignition switch OFF” is displayed, select [OK].
- 7) Turn the ignition switch to OFF. When turning the ignition switch to ON again, wait for 10 seconds or more.
- 8) Turn the Subaru Select Monitor OFF.

NOTE:

- If {Clear Memories 2} is executed, DTCs and learned control memory are cleared.
- If {Clear Memories 2} is executed, perform learning. <Ref. to 4AT(diag)-20, Learning Control.>

10. Inspection Mode

A: PROCEDURE

WARNING:

Observe the traffic law when driving on public roads.

- 1) Shift the select lever to the “D” range, and then drive the vehicle at 60 km/h (37 MPH) for at least 10 seconds.
- 2) Drive the vehicle with manual mode.

11. Learning Control

A: GENERAL DESCRIPTION

- After performing the following services, perform the transmission learning operation.

Replacement of TCM/Replacement or disassembly of transmission assembly/Replacement of control valve body/Performing “Clear Memories 2”.

- Perform the procedures according to the message displayed on the Subaru Select Monitor.

B: PROCEDURE

1. PREPARATION FOR LEARNING

- 1) Warm-up or cool down until the ATF temperature displayed on the Subaru Select Monitor reaches 60 — 80°C (140 — 176°F).
- 2) Shift the select lever to “P” range.
- 3) Fully apply the parking brake.
- 4) Lift up the vehicle.

CAUTION:

Be sure to keep the lowest edge of the tires 30 cm or more off the ground because the vehicle vibrates during the work.

- 5) Connect the Subaru Select Monitor to the data link connector.
- 6) Turn the ignition switch to ON.
- 7) Turn OFF all switches, which produce an electrical load, including headlight, air conditioner, seat heater, rear defogger, etc.
- 8) Turn the ECO switch to ON for model with ECO switch. Turn the SPORT mode switch to OFF for model with SPORT mode. Turn the POWER/HOLD switch to OFF for model with POWER/HOLD switch. Set to I mode for model with SI-DRIVE.

NOTE:

Error message is not displayed even when an incorrect mode is set. While the operation is continued, “AT learning promoting” is displayed, but it cannot end normally. If the message does not change after 2 minutes have passed, retry “AT learning mode” from the beginning.

2. SIMPLE LEARNING

NOTE:

Simple learning is learning performed with the vehicle lifted, without actually running the vehicle.

CAUTION:

Do not turn the power of the Subaru Select Monitor to OFF or disconnect the data link connector during the operation.

- 1) Select {Learning and inspection mode related to AT} on the «Transmission Diagnosis» display screen of Subaru Select Monitor.
- 2) Select {AT learning mode} on the «Learning and inspection mode related to AT» display screen of Subaru Select Monitor.
- 3) Perform the procedures according to the message displayed on the Subaru Select Monitor.

NOTE:

During AT learning in progress, SPORT indicator light in the combination meter starts flashing at 2 Hz and the learning operation starts. The following message is displayed on the screen when the SPORT indicator light turns off.

Learning Control

AUTOMATIC TRANSMISSION (DIAGNOSTICS)

4) "AT learning normally ended." is displayed, simple AT learning is completed.

NOTE:

- If communication error occurs during learning, retry "AT learning mode" from the beginning.
- If "Execute AT learning again after fixing troubles of the vehicle" is displayed during learning, select [OK] to display the List of Diagnostics Trouble Code. Retry "AT learning mode" from the beginning after repairing the DTC detecting portion.
- If "AT learning ended abnormally." is displayed, retry "AT learning mode" from the beginning.

Message	Primary cause of abnormal end
"AT learning ended abnormally."	<ul style="list-style-type: none">• Fault is detected during AT learning.• The accelerator pedal is depressed during AT learning.• Operation which is not directed is performed during AT learning.• The brake pedal is not depressed fully.• The parking brake is not applied fully.• Abnormal idle rise occurs. Other similar causes are probable.

- For details concerning the operation procedure, refer to the "PC application help for Subaru Select Monitor".

AT Oil Temp Warning Light Display

AUTOMATIC TRANSMISSION (DIAGNOSTICS)

12.AT Oil Temp Warning Light Display

A: OPERATION

If there is a malfunction with an on-board diagnosis part, the ATF temperature warning light will flash. The flashing will continue from when the malfunction is confirmed after starting the engine, until the ignition switch is turned to OFF. The malfunctioning part or unit can be identified by DTC during the on-board diagnostics operation. Problems which occurred previously can also be identified through the memory function. If the ATF temperature warning light does not show a problem (although a problem is occurring), the problem can be determined by checking the performance characteristics of each sensor using the Subaru Select Monitor. The ATF warning light signal patterns are shown in the figure.

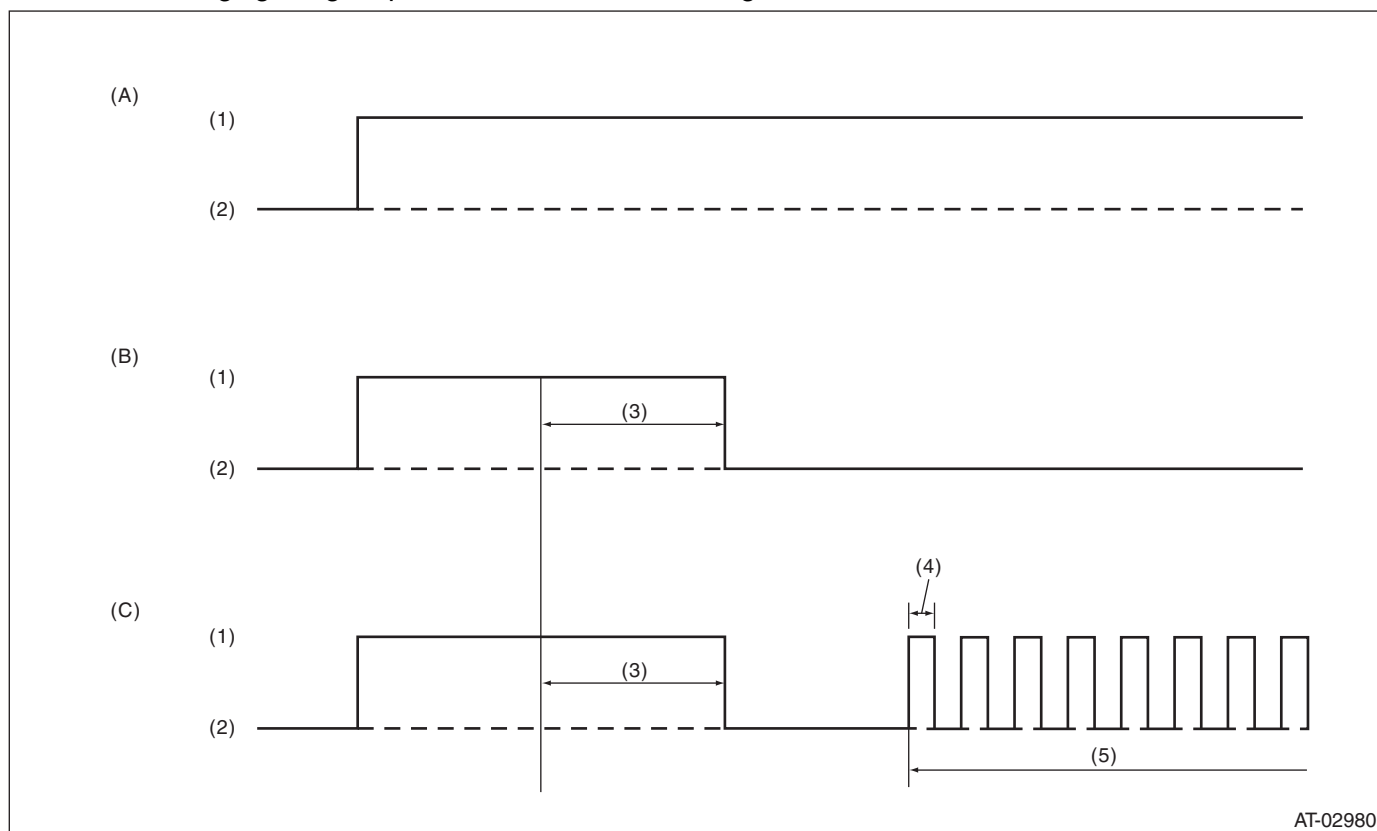

AT-02980

(A) Ignition switch (engine OFF)

(B) Normal (engine ON)

(C) Faulty (engine ON)

(1) ON

(3) 2 seconds

(5) Blink

(2) OFF

(4) 0.25 seconds

If the ATF temperature warning light does not function properly, check the ATF temperature warning light circuit. <Ref. to 4AT(diag)-23, INSPECTION, AT Oil Temp Warning Light Display.>

AT Oil Temp Warning Light Display

AUTOMATIC TRANSMISSION (DIAGNOSTICS)

B: INSPECTION

DIAGNOSIS:

ATF temperature warning light circuit is open or shorted.

TROUBLE SYMPTOM:

When the ignition switch is turned to ON, the ATF temperature warning light does not illuminate.

WIRING DIAGRAM:

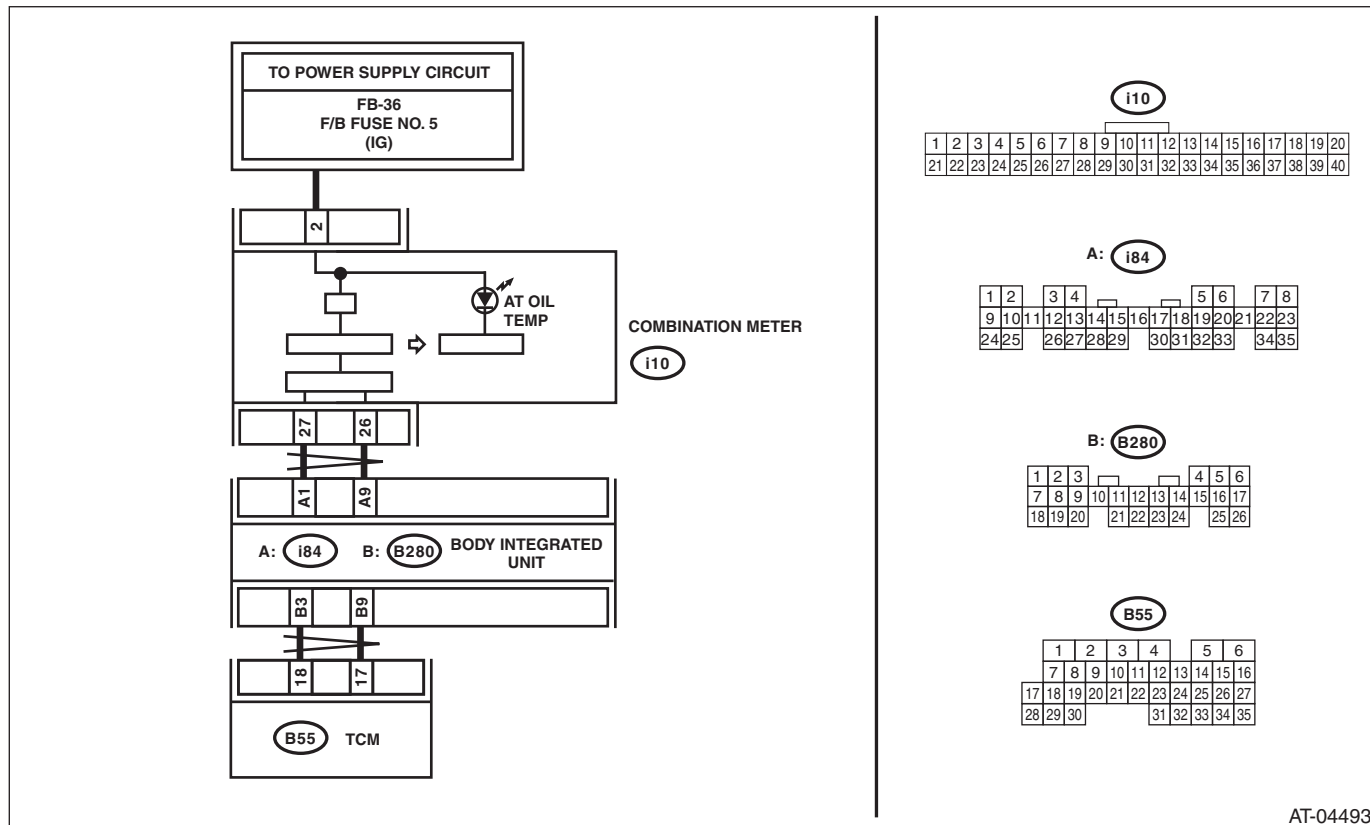

AT-04493

Step	Check	Yes	No
1 ATF TEMPERATURE WARNING LIGHT INSPECTION. Turn the ignition switch to ON.	Does the ATF temperature warning light illuminate?	Go to step 2.	Perform self diagnosis of the combination meter. <Ref. to IDI-4, INSPECTION, Combination Meter System.>
2 ATF TEMPERATURE WARNING LIGHT INSPECTION. After the ignition switch is ON, wait for at least 2 seconds.	Does the ATF temperature warning light illuminate?	Go to step 3.	Go to step 4.
3 ATF TEMPERATURE WARNING LIGHT INSPECTION. Start the engine.	Does the ATF temperature warning light turn off?	Normal. Go back to the "Basic Diagnostic Procedure". <Ref. to 4AT(diag)-2, Basic Diagnostic Procedure.>	Go to step 7.

AT Oil Temp Warning Light Display

AUTOMATIC TRANSMISSION (DIAGNOSTICS)

Step	Check	Yes	No
4 CHECK SUBARU SELECT MONITOR COMMUNICATION. Connect the Subaru Select Monitor to the data link connector.	Is the communication between Subaru Select Monitor and TCM normal?	Go to step 5.	Check the power supply ground circuit of the TCM and the Subaru Select Monitor communication. <Ref. to 4AT(diag)-25, Diagnostic Procedure for Subaru Select Monitor Communication.>
5 CHECK TCM. 1) Connect the Subaru Select Monitor, and display the current data of the TCM. <Ref. to 4AT(diag)-15, OPERATION, Subaru Select Monitor.> 2) Read the data of the "Diagnosis Lamp".	Is "ON" displayed?	Go to step 6.	Replace the TCM. <Ref. to 4AT-60, Transmission Control Module (TCM).>
6 CHECK BODY INTEGRATED UNIT. 1) Connect the Subaru Select Monitor, and display the current data of the body integrated unit. <Ref. to LAN(diag)-14, OPERATION, Subaru Select Monitor.> 2) Read the data of the "ATF Temperature Lamp".	Does the display show "ON"?	Replace the combination meter assembly. <Ref. to IDI-16, Combination Meter.>	Check the DTC of the body integrated unit. <Ref. to LAN(diag)-14, OPERATION, Subaru Select Monitor.>
7 CHECK TCM. 1) Display the current data of TCM using Subaru Select Monitor. 2) Read the data of the "Diagnosis Lamp".	Is "ON" displayed?	Replace the TCM. <Ref. to 4AT-60, Transmission Control Module (TCM).>	Go to step 8.
8 CHECK BODY INTEGRATED UNIT. 1) Connect the Subaru Select Monitor, and display the current data of the body integrated unit. 2) Read the data of the "ATF Temperature Lamp".	Does the display show "ON"?	Check DTC of body integrated unit. Perform diagnosis according to the DTC. <Ref. to LAN(diag)-14, OPERATION, Subaru Select Monitor.>	Perform self diagnosis of the combination meter. <Ref. to IDI-4, INSPECTION, Combination Meter System.>

Diagnostic Procedure for Subaru Select Monitor Communication

AUTOMATIC TRANSMISSION (DIAGNOSTICS)

13. Diagnostic Procedure for Subaru Select Monitor Communication

A: COMMUNICATION FOR INITIALIZING IMPOSSIBLE

DIAGNOSIS:

Defective harness connector

TROUBLE SYMPTOM:

Subaru Select Monitor communication failure

WIRING DIAGRAM:

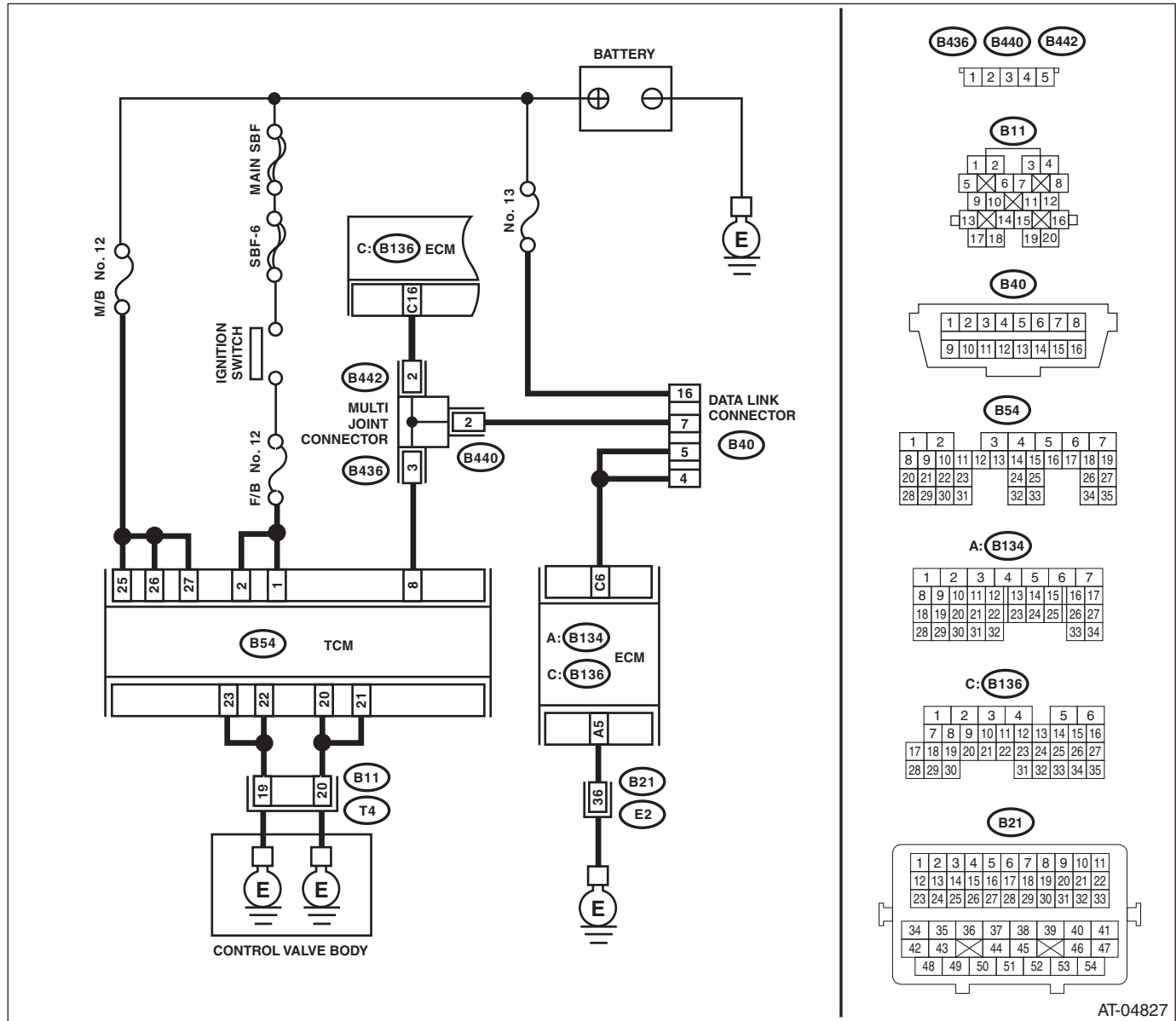

AT-04827

Diagnostic Procedure for Subaru Select Monitor Communication

AUTOMATIC TRANSMISSION (DIAGNOSTICS)

Step	Check	Yes	No
1 CHECK INSTALLATION OF TCM CONNECTOR. Turn the ignition switch to OFF.	Is TCM connector connected to TCM?	Go to step 2.	Connect the TCM connector to TCM.
2 CHECK SUBARU SELECT MONITOR POWER SUPPLY CIRCUIT. Measure the voltage between data link connector and chassis ground. Connector & terminal (B40) No. 16 (+) — Chassis ground (-):	Is the voltage 10 V or more?	Go to step 3.	Repair harness connector between the battery and data link connector, and poor contact of the connector.
3 CHECK SUBARU SELECT MONITOR GROUND CIRCUIT. 1) Disconnect the connectors from the ECM. 2) Measure the resistance of harness between data link connector and ECM. Connector & terminal (B40) No. 4 — (B136) No. 6: (B40) No. 5 — (B136) No. 6:	Is the resistance less than 1 Ω ?	Go to step 4.	Repair the open circuit of harness between data link connector and ECM.
4 CHECK SUBARU SELECT MONITOR GROUND CIRCUIT. Measure the resistance of harness between data link connector and chassis ground. Connector & terminal (B40) No. 16 — Chassis ground:	Is the resistance 1 M Ω or more?	Go to step 5.	Repair the short circuit of harness between data link connector and ground terminals.
5 CHECK ENGINE GROUND CIRCUIT. Check the engine ground circuit.	Is the engine ground circuit normal?	Go to step 6.	Repair ground circuit of ECM.
6 CHECK COMMUNICATION OF SUBARU SELECT MONITOR. 1) Turn the ignition switch to ON. 2) Check the communication with the transmission.	Is the name of system displayed on Subaru Select Monitor?	Go to step 11.	Go to step 7.
7 CHECK COMMUNICATION OF SUBARU SELECT MONITOR. 1) Turn the ignition switch to OFF. 2) Disconnect the TCM connector. 3) Turn the ignition switch to ON. 4) Check the communication with the engine system.	Is the name of system displayed on Subaru Select Monitor?	Go to step 9.	Go to step 8.
8 CHECK OUTPUT SIGNAL OF TCM. 1) Turn the ignition switch to OFF. 2) Connect the connector to the TCM. 3) From the data link connector (B40) No. 7, disconnect the connectors of control modules other than the TCM and ECM. CAUTION: When disconnecting the connector from the airbag control module, always follow the precautions of the AB section. <Ref. to AB-5, CAUTION, General Description.> 4) Turn the ignition switch to ON. 5) Check the communication with the transmission system.	Is the name of system displayed on Subaru Select Monitor?	Check each control module.	Go to step 9.

Diagnostic Procedure for Subaru Select Monitor Communication

AUTOMATIC TRANSMISSION (DIAGNOSTICS)

Step	Check	Yes	No
9 CHECK HARNESS CONNECTOR BETWEEN EACH CONTROL MODULE AND DATA LINK CONNECTOR. 1) Turn the ignition switch to OFF. 2) From the data link connector (B40) No. 7, disconnect the connectors of all control modules. 3) Measure the resistance between TCM connector and chassis ground. Connector & terminal (B40) No. 7 — Chassis ground:	Is the resistance 1 M Ω or more?	Go to step 10.	Check harness and connector between each control module and data link connector.
10 CHECK OUTPUT SIGNAL OF TCM. 1) Turn the ignition switch to ON. 2) Measure the voltage between TCM and chassis ground. Connector & terminal (B40) No. 7 (+) — Chassis ground (-):	Is the voltage 1 V or more?	Check harness and connector between each control module and data link connector.	Go to step 11.
11 CHECK HARNESS CONNECTOR BETWEEN TCM AND DATA LINK CONNECTOR. Measure the resistance between TCM connector and data link connector. Connector & terminal (B40) No. 7 — (B54) No. 8:	Is the resistance less than 1 Ω ?	Go to step 12.	Repair the harness and connector between TCM and data link connector.
12 CHECK INSTALLATION OF TRANSMISSION HARNESS CONNECTOR.	Is the transmission harness connector connected to bulk-head harness connector?	Go to step 13.	Connect the bulk-head harness connector to transmission harness connector.
13 CHECK POOR CONTACT OF CONNECTORS.	Is there poor contact in control module power supply and data link connector?	Repair the poor contact.	Go to step 14.
14 CHECK TCM POWER SUPPLY. 1) Disconnect the connector from TCM. 2) Turn the ignition switch to ON. 3) Measure the voltage between TCM connector and chassis ground. Connector & terminal (B54) No. 25 (+) — Chassis ground (-): (B54) No. 26 (+) — Chassis ground (-): (B54) No. 27 (+) — Chassis ground (-):	Is the voltage 10 — 13 V?	Go to step 16.	Go to step 15.
15 CHECK M/B FUSE (NO. 12). 1) Turn the ignition switch to OFF. 2) Remove the fuse (No. 12).	Is the fuse (No. 12) blown out?	Replace the fuse. If the replaced fuse blows out easily, repair the short circuit in the harness between the fuse and the TCM.	Repair the open circuit of harness between the fuse and the TCM, or the fuse and battery, and poor contacts of connectors.
16 CHECK IGNITION POWER SUPPLY CIRCUIT. 1) Turn the ignition switch to ON. 2) Measure the ignition power supply voltage between TCM connector and chassis ground. Connector & terminal (B54) No. 1 (+) — Chassis ground (-): (B54) No. 2 (+) — Chassis ground (-):	Is the voltage 10 — 13 V?	Go to step 18.	Go to step 17.

Diagnostic Procedure for Subaru Select Monitor Communication

AUTOMATIC TRANSMISSION (DIAGNOSTICS)

Step	Check	Yes	No
17 CHECK F/B FUSE (NO. 12). Remove the fuse (No. 12).	Is the fuse (No. 12) blown out?	Replace the fuse. If the replaced fuse blows out easily, repair the short circuit in the harness between the fuse and the TCM.	Repair the open circuit of harness between the fuse and the TCM, or the fuse and battery, and poor contacts of connectors.
18 CHECK HARNESS CONNECTOR BETWEEN TCM AND TRANSMISSION. 1) Turn the ignition switch to OFF. 2) Disconnect the connectors from TCM and transmission. 3) Measure the resistance of harness between TCM and transmission connector. <i>Connector & terminal</i> (B54) No. 20 — (B11) No. 20: (B54) No. 21 — (B11) No. 20: (B54) No. 22 — (B11) No. 19: (B54) No. 23 — (B11) No. 19:	Is the resistance less than 1 Ω?	Go to step 19.	Repair the open circuit of harness between TCM and transmission harness connector, and poor contact of connector.
19 CHECK HARNESS CONNECTOR BETWEEN TRANSMISSION AND TRANSMISSION GROUND. Measure the resistance of the harness between transmission and transmission ground. <i>Connector & terminal</i> (T4) No. 19 — Transmission ground: (T4) No. 20 — Transmission ground:	Is the resistance less than 1 Ω?	Go to step 20.	Repair the open circuit of the harness between transmission and transmission ground.
20 CHECK POOR CONTACT IN CONNECTORS.	Is there poor contact in TCM power supply, ground and data link connector?	Repair the connector.	Replace the TCM. <Ref. to 4AT-60, Transmission Control Module (TCM).>

List of Diagnostic Trouble Code (DTC)

AUTOMATIC TRANSMISSION (DIAGNOSTICS)

14. List of Diagnostic Trouble Code (DTC)

A: LIST

DTC	Item	Content of diagnosis	Index
P0705	Transmission Range Sensor Circuit (PRNDL Input)	Inhibitor switch malfunction or short circuit	<Ref. to 4AT(diag)-31, DTC P0705 TRANSMISSION RANGE SENSOR CIRCUIT (PRNDL INPUT), Diagnostic Procedure with Diagnostic Trouble Code (DTC).>
P0712	Transmission Fluid Temperature Sensor Circuit Low Input	ATF temperature sensor is faulty or input signal circuit is open.	<Ref. to 4AT(diag)-38, DTC P0712 TRANSMISSION FLUID TEMPERATURE SENSOR CIRCUIT LOW INPUT, Diagnostic Procedure with Diagnostic Trouble Code (DTC).>
P0713	Transmission Fluid Temperature Sensor Circuit High Input	ATF temperature sensor is faulty or input signal circuit is shorted.	<Ref. to 4AT(diag)-41, DTC P0713 TRANSMISSION FLUID TEMPERATURE SENSOR CIRCUIT HIGH INPUT, Diagnostic Procedure with Diagnostic Trouble Code (DTC).>
P0715	Input/Turbine Speed Sensor Circuit	Torque converter turbine speed sensor malfunction, open or shorted input signal circuit	<Ref. to 4AT(diag)-43, DTC P0715 INPUT/TURBINE SPEED SENSOR CIRCUIT, Diagnostic Procedure with Diagnostic Trouble Code (DTC).>
P0719	Brake Switch Circuit Low	Brake switch malfunction, open input signal circuit	<Ref. to 4AT(diag)-45, DTC P0719 BRAKE SWITCH CIRCUIT LOW, Diagnostic Procedure with Diagnostic Trouble Code (DTC).>
P0720	Output Speed Sensor Circuit	Front vehicle speed sensor malfunction, open or shorted input signal circuit	<Ref. to 4AT(diag)-48, DTC P0720 OUTPUT SPEED SENSOR CIRCUIT, Diagnostic Procedure with Diagnostic Trouble Code (DTC).>
P0724	Brake Switch Circuit High	Brake switch malfunction, shorted input signal circuit	<Ref. to 4AT(diag)-50, DTC P0724 BRAKE SWITCH CIRCUIT HIGH, Diagnostic Procedure with Diagnostic Trouble Code (DTC).>
P0731	Gear 1 Incorrect Ratio	Vehicle sensor, torque converter turbine speed sensor or control valve malfunction	<Ref. to 4AT(diag)-52, DTC P0731 GEAR 1 INCORRECT RATIO, Diagnostic Procedure with Diagnostic Trouble Code (DTC).>
P0732	Gear 2 Incorrect Ratio	Vehicle sensor, torque converter turbine speed sensor or control valve malfunction	<Ref. to 4AT(diag)-52, DTC P0732 GEAR 2 INCORRECT RATIO, Diagnostic Procedure with Diagnostic Trouble Code (DTC).>
P0733	Gear 3 Incorrect Ratio	Vehicle sensor, torque converter turbine speed sensor or control valve malfunction	<Ref. to 4AT(diag)-52, DTC P0733 GEAR 3 INCORRECT RATIO, Diagnostic Procedure with Diagnostic Trouble Code (DTC).>
P0734	Gear 4 Incorrect Ratio	Vehicle sensor, torque converter turbine speed sensor or control valve malfunction	<Ref. to 4AT(diag)-52, DTC P0734 GEAR 4 INCORRECT RATIO, Diagnostic Procedure with Diagnostic Trouble Code (DTC).>
P0736	Reverse Incorrect Ratio	Vehicle sensor, torque converter turbine speed sensor or control valve malfunction	<Ref. to 4AT(diag)-53, DTC P0736 REVERSE INCORRECT RATIO, Diagnostic Procedure with Diagnostic Trouble Code (DTC).>
P0741	Torque Converter Clutch Circuit Performance or Stuck Off	Lock-up clutch is faulty or valve is stuck.	<Ref. to 4AT(diag)-54, DTC P0741 TORQUE CONVERTER CLUTCH CIRCUIT PERFORMANCE OR STUCK OFF, Diagnostic Procedure with Diagnostic Trouble Code (DTC).>
P0743	Torque Converter Clutch Circuit Electrical	Lock-up solenoid is faulty or output signal circuit is open or shorted.	<Ref. to 4AT(diag)-55, DTC P0743 TORQUE CONVERTER CLUTCH CIRCUIT ELECTRICAL, Diagnostic Procedure with Diagnostic Trouble Code (DTC).>
P0748	Pressure Control Solenoid "A" Electrical	Line pressure linear solenoid is faulty or output signal circuit is open or shorted.	<Ref. to 4AT(diag)-58, DTC P0748 PRESSURE CONTROL SOLENOID "A" ELECTRICAL, Diagnostic Procedure with Diagnostic Trouble Code (DTC).>

List of Diagnostic Trouble Code (DTC)

AUTOMATIC TRANSMISSION (DIAGNOSTICS)

DTC	Item	Content of diagnosis	Index
P0753	Shift Solenoid "A" Electrical	Low clutch duty solenoid is faulty or output signal circuit is open or shorted.	<Ref. to 4AT(diag)-60, DTC P0753 SHIFT SOLENOID "A" ELECTRICAL, Diagnostic Procedure with Diagnostic Trouble Code (DTC).>
P0758	Shift Solenoid "B" Electrical	2-4 brake duty solenoid is faulty or output signal circuit is open or shorted.	<Ref. to 4AT(diag)-63, DTC P0758 SHIFT SOLENOID "B" ELECTRICAL, Diagnostic Procedure with Diagnostic Trouble Code (DTC).>
P0763	Shift Solenoid "C" Electrical	High clutch duty solenoid is faulty or output signal circuit is open or shorted.	<Ref. to 4AT(diag)-66, DTC P0763 SHIFT SOLENOID "C" ELECTRICAL, Diagnostic Procedure with Diagnostic Trouble Code (DTC).>
P0768	Shift Solenoid "D" Electrical	Low & reverse clutch duty solenoid is faulty or output signal circuit is open or shorted.	<Ref. to 4AT(diag)-69, DTC P0768 SHIFT SOLENOID "D" ELECTRICAL, Diagnostic Procedure with Diagnostic Trouble Code (DTC).>
P0801	Reverse Inhibit Control Circuit	Shift lock solenoid is faulty or output signal circuit is open or shorted.	<Ref. to 4AT(diag)-72, DTC P0801 REVERSE INHIBIT CONTROL CIRCUIT, Diagnostic Procedure with Diagnostic Trouble Code (DTC).>
P1706	AT Vehicle Speed Sensor Circuit Malfunction (rear wheel) (Except for FWD Model)	Rear vehicle speed sensor is faulty or input signal circuit is open or shorted.	<Ref. to 4AT(diag)-74, DTC P1706 AT VEHICLE SPEED SENSOR CIRCUIT MALFUNCTION (REAR WHEEL), Diagnostic Procedure with Diagnostic Trouble Code (DTC).>
P1707	AT AWD Solenoid Valve Circuit Malfunction (Except for FWD Model)	Transfer duty solenoid is faulty or output signal circuit is open or shorted.	<Ref. to 4AT(diag)-76, DTC P1707 AT AWD SOLENOID VALVE CIRCUIT MALFUNCTION, Diagnostic Procedure with Diagnostic Trouble Code (DTC).>
P1718	CAN Communication Circuit	CAN communication circuit is open or shorted.	<Ref. to 4AT(diag)-77, DTC P1718 CAN COMMUNICATION CIRCUIT, Diagnostic Procedure with Diagnostic Trouble Code (DTC).>
P1817	SPORT Mode Switch Circuit	SPORT shift switch is faulty or input signal circuit is open or shorted.	<Ref. to 4AT(diag)-78, DTC P1817 SPORT MODE SWITCH CIRCUIT, Diagnostic Procedure with Diagnostic Trouble Code (DTC).>

15. Diagnostic Procedure with Diagnostic Trouble Code (DTC)

A: DTC P0705 TRANSMISSION RANGE SENSOR CIRCUIT (PRNDL INPUT)

DTC DETECTING CONDITION:

- Inhibitor switch is faulty.
- At least 2 range signal is input.

TROUBLE SYMPTOM:

- Shift characteristics are erroneous.
- The range position of the select lever and the AT select lever position indicator light on the combination meter do not match.

Diagnostic Procedure with Diagnostic Trouble Code (DTC)

AUTOMATIC TRANSMISSION (DIAGNOSTICS)

WIRING DIAGRAM:

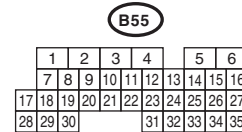
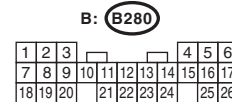
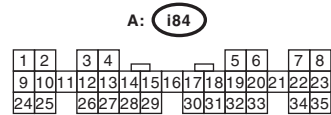
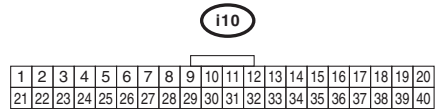
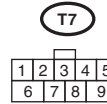
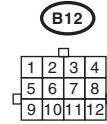
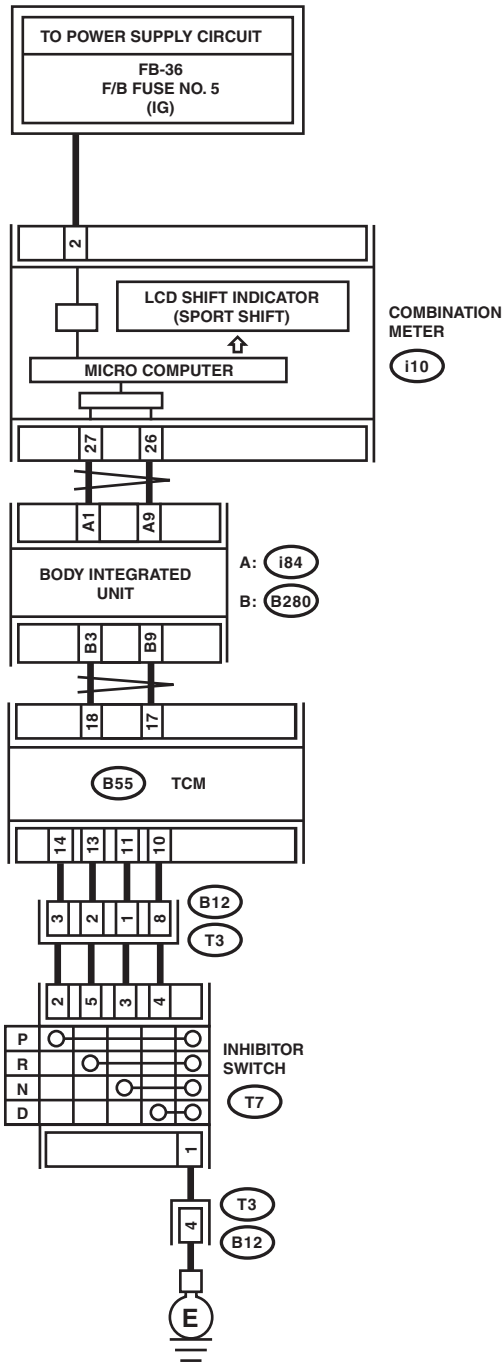

AT-04752

Diagnostic Procedure with Diagnostic Trouble Code (DTC)

AUTOMATIC TRANSMISSION (DIAGNOSTICS)

Step	Check	Yes	No
1 CHECK INDICATOR LIGHT. 1) Turn the ignition switch to ON. 2) Move the select lever to "P" range.	Does the "P" range indicator light in the combination meter illuminate?	Go to step 2.	Go to step 6.
2 CHECK INDICATOR LIGHT. Set the select lever to "R" range.	Does the "P" range indicator light in the combination meter illuminate?	Go to step 20.	Go to step 3.
3 CHECK INDICATOR LIGHT. Move the select lever to "P" range.	Does the "R" range indicator light on combination meter illuminate?	Go to step 27.	Go to step 4.
4 CHECK INDICATOR LIGHT.	Does the "N" range indicator light on combination meter illuminate?	Go to step 34.	Go to step 5.
5 CHECK INDICATOR LIGHT.	Does the "D" range indicator light on combination meter illuminate?	Go to step 41.	Go to step 7.
6 CHECK "P" RANGE SWITCH. Read the data of "P range" using the Subaru Select Monitor.	Is ON displayed?	Go to step 17.	Go to step 13.
7 CHECK INDICATOR LIGHT. Set the select lever to "R" range.	Does the "R" range indicator light on combination meter illuminate?	Go to step 9.	Go to step 8.
8 CHECK "R" RANGE SWITCH. Read the data of "R range" using the Subaru Select Monitor.	Is ON displayed?	Go to step 24.	Go to step 21.
9 CHECK INDICATOR LIGHT. Set the select lever to "N" range.	Does the "N" range indicator light on combination meter illuminate?	Go to step 11.	Go to step 10.
10 CHECK "N" RANGE SWITCH. Read the data of "N range" using the Subaru Select Monitor.	Is ON displayed?	Go to step 31.	Go to step 28.
11 CHECK INDICATOR LIGHT. Set the select lever to the "D" range.	Does the "D" range indicator light on combination meter illuminate?	Check for poor contact in the TCM and transmission harness or connectors, and repair the fault location.	Go to step 12.
12 CHECK "D" RANGE SWITCH. Read the data of "D range" using the Subaru Select Monitor.	Is ON displayed?	Go to step 38.	Go to step 35.
13 CHECK HARNESS CONNECTOR BETWEEN INHIBITOR SWITCH AND CHASSIS GROUND. 1) Turn the ignition switch to OFF. 2) Disconnect the connector from inhibitor switch. 3) Measure the resistance of harness between inhibitor switch and chassis ground. Connector & terminal (T7) No. 1 — Chassis ground:	Is the resistance less than 1 Ω ?	Go to step 14.	Repair the open circuit of harness between inhibitor switch and chassis ground, and poor contact of the connector.
14 CHECK HARNESS CONNECTOR BETWEEN TCM AND INHIBITOR SWITCH. 1) Turn the ignition switch to OFF. 2) Disconnect the connector from TCM and inhibitor switch. 3) Measure the resistance of the harness between TCM and inhibitor switch connector. Connector & terminal (B55) No. 14 — (T7) No. 2:	Is the resistance less than 1 Ω ?	Go to step 15.	Repair the open circuit of harness between TCM and inhibitor switch connector, and poor contact of the connector.

Diagnostic Procedure with Diagnostic Trouble Code (DTC)

AUTOMATIC TRANSMISSION (DIAGNOSTICS)

Step	Check	Yes	No
15 CHECK INPUT SIGNAL FOR TCM. 1) Turn the ignition switch to OFF. 2) Connect the connector to TCM and inhibitor switch. 3) Turn the ignition switch to ON. 4) Move the select lever to "P" range. 5) Measure the voltage between TCM and chassis ground. Connector & terminal (B55) No. 14 (+) — Chassis ground (-):	Is the voltage less than 1 V?	Go to step 16.	Go to step 42.
16 CHECK INPUT SIGNAL FOR TCM. 1) Set the select lever to other than "P" range. 2) Measure the voltage between TCM and chassis ground. Connector & terminal (B55) No. 14 (+) — Chassis ground (-):	Is the voltage 8 V or more?	Go to step 42.	Replace the TCM. <Ref. to 4AT-60, Transmission Control Module (TCM).>
17 CHECK BODY INTEGRATED UNIT. Read the data of the "Inhibitor Switch" using the Subaru Select Monitor. <Ref. to LAN(diag)-14, OPERATION, Subaru Select Monitor.>	Is "7" displayed?	Go to step 18.	Check the body integrated unit.
18 CHECK BODY INTEGRATED UNIT. Check DTC of body integrated unit.	Is DTC of CAN communication displayed?	Perform diagnosis according to the DTC.	Go to step 19.
19 CHECK COMBINATION METER. Check the "P" range indicator light. <Ref. to IDI-4, INSPECTION, Combination Meter System.>	Is the "P" range indicator light bulb OK?	Go to step 42.	Replace the combination meter assembly. <Ref. to IDI-16, Combination Meter.>
20 CHECK HARNESS CONNECTOR BETWEEN TCM AND INHIBITOR SWITCH. 1) Turn the ignition switch to OFF. 2) Disconnect the connectors from TCM, inhibitor switch and combination meter. 3) Measure the resistance of the harness between TCM connector and chassis ground. Connector & terminal (B55) No. 14 — Chassis ground:	Is the resistance 1 M Ω or more?	Go to step 42.	Repair ground short circuit in "P" range circuit.
21 CHECK HARNESS CONNECTOR BETWEEN TCM AND INHIBITOR SWITCH. 1) Turn the ignition switch to OFF. 2) Disconnect the connector from TCM and inhibitor switch. 3) Measure the resistance of the harness between TCM and inhibitor switch connector. Connector & terminal (B55) No. 13 — (T7) No. 5:	Is the resistance less than 1 Ω ?	Go to step 22.	Repair the open circuit of harness between TCM and inhibitor switch connector, and poor contact of the connector.
22 CHECK INPUT SIGNAL FOR TCM. 1) Turn the ignition switch to OFF. 2) Connect the connector to TCM and inhibitor switch. 3) Turn the ignition switch to ON. 4) Set the select lever to "R" range. 5) Measure the voltage between TCM and chassis ground. Connector & terminal (B55) No. 13 (+) — Chassis ground (-):	Is the voltage less than 1 V?	Go to step 23.	Go to step 42.

Diagnostic Procedure with Diagnostic Trouble Code (DTC)

AUTOMATIC TRANSMISSION (DIAGNOSTICS)

Step	Check	Yes	No
23 CHECK INPUT SIGNAL FOR TCM. 1) Set the select lever to a range other than "R". 2) Measure the voltage between TCM and chassis ground. Connector & terminal (B55) No. 13 (+) — Chassis ground (-):	Is the voltage 8 V or more?	Go to step 42.	Replace the TCM. <Ref. to 4AT-60, Transmission Control Module (TCM).>
24 CHECK BODY INTEGRATED UNIT. Using the Subaru Select Monitor, read the data of "Shift Position". <Ref. to LAN(diag)-14, OPERATION, Subaru Select Monitor.>	Is "6" displayed?	Go to step 25.	Check the body integrated unit.
25 CHECK BODY INTEGRATED UNIT. Check DTC of body integrated unit.	Is DTC of CAN communication displayed?	Perform diagnosis according to the DTC.	Go to step 26.
26 CHECK COMBINATION METER. Check the "R" range indicator light. <Ref. to IDI-4, INSPECTION, Combination Meter System.>	Is the "R" range indicator light OK?	Go to step 42.	Replace the combination meter assembly. <Ref. to IDI-16, Combination Meter.>
27 CHECK HARNESS CONNECTOR BETWEEN TCM AND INHIBITOR SWITCH. 1) Turn the ignition switch to OFF. 2) Disconnect the connectors from TCM, inhibitor switch and combination meter. 3) Measure the resistance of the harness between TCM connector and chassis ground. Connector & terminal (B55) No. 13 — Chassis ground:	Is the resistance 1 M Ω or more?	Go to step 42.	Repair ground short circuit in "R" range circuit.
28 CHECK HARNESS CONNECTOR BETWEEN TCM AND INHIBITOR SWITCH. 1) Turn the ignition switch to OFF. 2) Disconnect the connector from TCM and inhibitor switch. 3) Measure the resistance of the harness between TCM and inhibitor switch connector. Connector & terminal (B55) No. 11 — (T7) No. 3:	Is the resistance less than 1 Ω ?	Go to step 29.	Repair the open circuit of harness between TCM and inhibitor switch connector, and poor contact of the connector.
29 CHECK INPUT SIGNAL FOR TCM. 1) Turn the ignition switch to OFF. 2) Connect the connector to TCM and inhibitor switch. 3) Turn the ignition switch to ON. 4) Set the select lever to "N" range. 5) Measure the voltage between TCM and chassis ground. Connector & terminal (B55) No. 11 (+) — Chassis ground (-):	Is the voltage less than 1 V?	Go to step 30.	Go to step 42.
30 CHECK INPUT SIGNAL FOR TCM. 1) Set the select lever to a range other than "N". 2) Measure the voltage between TCM and chassis ground. Connector & terminal (B55) No. 11 (+) — Chassis ground (-):	Is the voltage 8 V or more?	Go to step 42.	Replace the TCM. <Ref. to 4AT-60, Transmission Control Module (TCM).>
31 CHECK BODY INTEGRATED UNIT. Using the Subaru Select Monitor, read the data of "Shift Position". <Ref. to LAN(diag)-14, OPERATION, Subaru Select Monitor.>	Is "5" displayed?	Go to step 32.	Check the body integrated unit.

Diagnostic Procedure with Diagnostic Trouble Code (DTC)

AUTOMATIC TRANSMISSION (DIAGNOSTICS)

Step	Check	Yes	No
32 CHECK BODY INTEGRATED UNIT. Check DTC of body integrated unit.	Is DTC of CAN communication displayed?	Perform diagnosis according to the DTC.	Go to step 33 .
33 CHECK COMBINATION METER. Check the "N" range indicator light. <Ref. to IDI-4, INSPECTION, Combination Meter System.>	Is the "N" range indicator light OK?	Go to step 42 .	Replace the combination meter assembly. <Ref. to IDI-16, Combination Meter.>
34 CHECK HARNESS CONNECTOR BETWEEN TCM AND INHIBITOR SWITCH. 1) Turn the ignition switch to OFF. 2) Disconnect the connectors from TCM, inhibitor switch and combination meter. 3) Measure the resistance of the harness between TCM connector and chassis ground. Connector & terminal (B55) No. 11 — Chassis ground:	Is the resistance 1 MΩ or more?	Go to step 42 .	Repair the ground short circuit in "N" range circuit.
35 CHECK HARNESS CONNECTOR BETWEEN TCM AND INHIBITOR SWITCH. 1) Turn the ignition switch to OFF. 2) Disconnect the connector from TCM and inhibitor switch. 3) Measure the resistance of the harness between TCM and inhibitor switch connector. Connector & terminal (B55) No. 10 — (T7) No. 4:	Is the resistance less than 1 Ω?	Go to step 36 .	Repair the open circuit of harness between TCM and inhibitor switch connector, and poor contact of the connector.
36 CHECK INPUT SIGNAL FOR TCM. 1) Turn the ignition switch to OFF. 2) Connect the connector to TCM and inhibitor switch. 3) Turn the ignition switch to ON. 4) Set the select lever to the "D" range. 5) Measure the voltage between TCM and chassis ground. Connector & terminal (B55) No. 10 (+) — Chassis ground (-):	Is the voltage less than 1 V?	Go to step 37 .	Go to step 42 .
37 CHECK INPUT SIGNAL FOR TCM. 1) Set the select lever to a range other than "D". 2) Measure the voltage between TCM and chassis ground. Connector & terminal (B55) No. 10 (+) — Chassis ground (-):	Is the voltage 8 V or more?	Go to step 42 .	Replace the TCM. <Ref. to 4AT-60, Transmission Control Module (TCM).>
38 CHECK BODY INTEGRATED UNIT. Read the data of the "Inhibitor Switch" using the Subaru Select Monitor. <Ref. to LAN(diag)-14, OPERATION, Subaru Select Monitor.>	Is "4" displayed?	Go to step 39 .	Check the body integrated unit.
39 CHECK BODY INTEGRATED UNIT. Check DTC of body integrated unit.	Is DTC of CAN communication displayed?	Perform diagnosis according to the DTC.	Go to step 40 .
40 CHECK COMBINATION METER. Check the "D" range indicator light. <Ref. to IDI-4, INSPECTION, Combination Meter System.>	Is the "D" range indicator light OK?	Go to step 42 .	Replace the combination meter assembly. <Ref. to IDI-16, Combination Meter.>

Diagnostic Procedure with Diagnostic Trouble Code (DTC)

AUTOMATIC TRANSMISSION (DIAGNOSTICS)

Step	Check	Yes	No
41 CHECK HARNESS CONNECTOR BETWEEN TCM AND INHIBITOR SWITCH. 1) Turn the ignition switch to OFF. 2) Disconnect the connectors from TCM, inhibitor switch and combination meter. 3) Measure the resistance of harness between TCM connector and chassis ground. Connector & terminal (B55) No. 10 — Chassis ground:	Is the resistance 1 M Ω or more?	Go to step 42 .	Repair ground short circuit in "D" range circuit.
42 CHECK POOR CONTACT.	Is there poor contact in the inhibitor switch circuit?	Repair the poor contact.	Go to step 43 .
43 CHECK INHIBITOR SWITCH.	Is the inhibitor switch in a normal position?	Replace the TCM. <Ref. to 4AT-60, Transmission Control Module (TCM).>	Adjust the inhibitor switch and select cable. <Ref. to 4AT-46, Inhibitor Switch.> <Ref. to CS-25, Select Cable.>

Diagnostic Procedure with Diagnostic Trouble Code (DTC)

AUTOMATIC TRANSMISSION (DIAGNOSTICS)

B: DTC P0712 TRANSMISSION FLUID TEMPERATURE SENSOR CIRCUIT LOW INPUT

DTC DETECTING CONDITION:

Input signal circuit to ATF temperature sensor is open or shorted.

TROUBLE SYMPTOM:

Excessive shift shock

WIRING DIAGRAM:

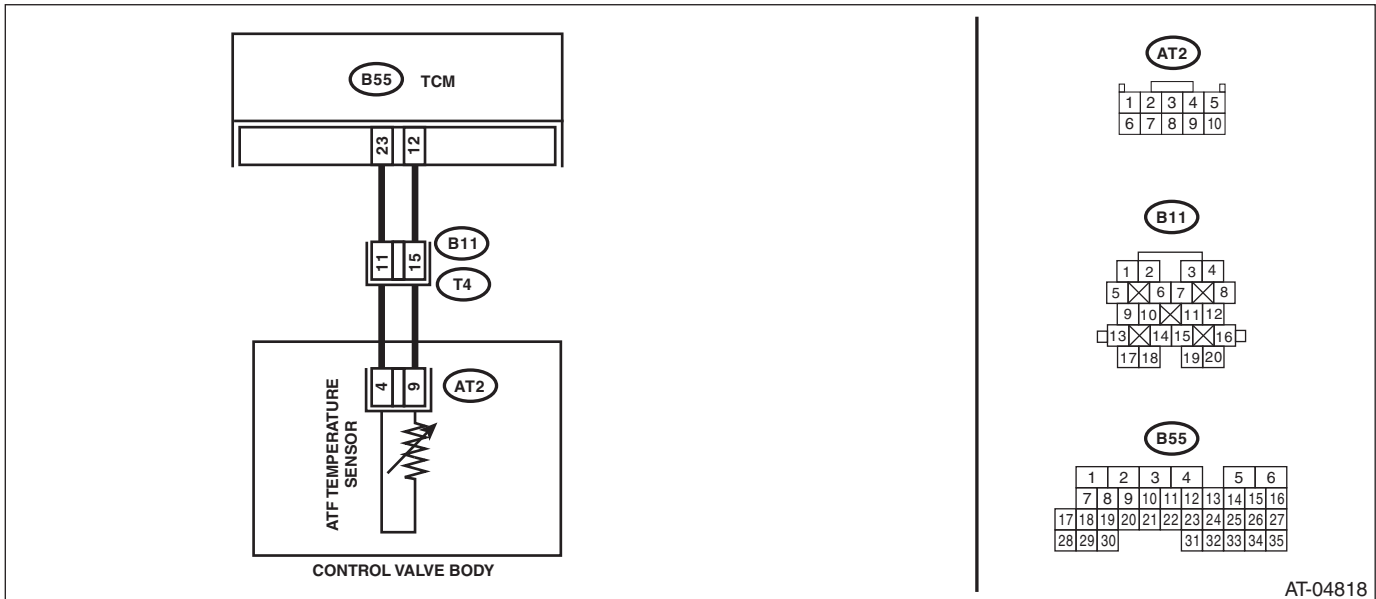

AT-04818

Diagnostic Procedure with Diagnostic Trouble Code (DTC)

AUTOMATIC TRANSMISSION (DIAGNOSTICS)

Step	Check	Yes	No
1 CHECK HARNESS CONNECTOR BETWEEN TCM AND ATF TEMPERATURE SENSOR. 1) Turn the ignition switch to OFF. 2) Disconnect the connector from transmission and TCM. 3) Measure the resistance of harness between TCM and transmission connector. Connector & terminal (B55) No. 23 — (B11) No. 11:	Is the resistance less than 1 Ω?	Go to step 2.	Repair the open circuit of harness between TCM and transmission connector.
2 CHECK HARNESS CONNECTOR BETWEEN TCM AND ATF TEMPERATURE SENSOR. Measure the resistance of harness between TCM and transmission connector. Connector & terminal (B55) No. 12 — (B11) No. 15:	Is the resistance less than 1 Ω?	Go to step 3.	Repair the open circuit of harness between TCM and transmission connector.
3 CHECK ATF TEMPERATURE SENSOR. 1) Turn the ignition switch to OFF. 2) Connect the connectors to transmission and TCM. 3) Start the engine. 4) Warm-up the transmission until the ATF temperature exceeds 80°C (176°F). NOTE: If the ambient temperature is below 0°C (32°F), drive the vehicle until the ATF reaches its operating temperature. 5) Disconnect the connector from transmission. 6) Measure the resistance between transmission connector terminals. Connector & terminal (T4) No. 11 — No. 15:	Is the resistance between 300 — 800 Ω?	Go to step 4.	Go to step 7.
4 CHECK ATF TEMPERATURE SENSOR. Measure the resistance between transmission connector terminals. Connector & terminal (T4) No. 11 — No. 15:	Does the resistance value increase while the ATF temperature decreases?	Go to step 5.	Go to step 7.
5 CHECK INPUT SIGNAL FOR TCM USING SUBARU SELECT MONITOR. 1) Connect the connector to transmission. 2) Connect the Subaru Select Monitor to the data link connector. 3) Turn the ignition switch to ON. 4) Read the data of "ATF Temp." using the Subaru Select Monitor.	Does the ATF temperature gradually decrease?	Check for poor contact in the ATF temperature sensor and transmission connector harness, and repair the fault location.	Go to step 6.
6 CHECK POOR CONTACT.	Is there poor contact in ATF temperature sensor circuit?	Repair the poor contact.	Replace the TCM. <Ref. to 4AT-60, Transmission Control Module (TCM).>

Diagnostic Procedure with Diagnostic Trouble Code (DTC)

AUTOMATIC TRANSMISSION (DIAGNOSTICS)

Step	Check	Yes	No
<p>7</p> <p>CHECK HARNESS CONNECTOR BETWEEN TRANSMISSION AND ATF TEMPERATURE SENSOR.</p> <p>1) Turn the ignition switch to OFF. 2) Disconnect the connector from transmission. 3) Remove the transmission connector from bracket. 4) Lift up the vehicle. 5) Drain the automatic transmission fluid.</p> <p>CAUTION: Do not drain ATF until it cools down.</p> <p>6) Remove the oil pan, and disconnect the connector from the control valve. 7) Measure the resistance of harness between ATF temperature sensor and transmission connector.</p> <p>Connector & terminal (T4) No. 11 — (AT2) No. 4:</p>	Is the resistance less than 1 Ω?	Go to step 8.	Repair the open circuit of harness between ATF temperature sensor and transmission connector.
<p>8</p> <p>CHECK HARNESS CONNECTOR BETWEEN TRANSMISSION AND ATF TEMPERATURE SENSOR.</p> <p>Measure the resistance of harness between ATF temperature sensor and transmission connector.</p> <p>Connector & terminal (T4) No. 15 — (AT2) No. 9:</p>	Is the resistance less than 1 Ω?	Go to step 9.	Repair the open circuit of harness between ATF temperature sensor and transmission connector.
<p>9</p> <p>CHECK HARNESS CONNECTOR BETWEEN TRANSMISSION AND ATF TEMPERATURE SENSOR.</p> <p>Measure the resistance of harness between transmission connector and transmission ground.</p> <p>Connector & terminal (T4) No. 11 — Transmission ground:</p>	Is the resistance 1 MΩ or more?	Go to step 10.	Repair the short circuit of harness between ATF temperature sensor and transmission connector.
<p>10</p> <p>CHECK HARNESS CONNECTOR BETWEEN TRANSMISSION AND ATF TEMPERATURE SENSOR.</p> <p>Measure the resistance of harness between transmission connector and transmission ground.</p> <p>Connector & terminal (T4) No. 15 — Transmission ground:</p>	Is the resistance 1 MΩ or more?	Replace the control valve body. <Ref. to 4AT-56, Control Valve Body.>	Repair the short circuit of harness between ATF temperature sensor and transmission connector.

Diagnostic Procedure with Diagnostic Trouble Code (DTC)

AUTOMATIC TRANSMISSION (DIAGNOSTICS)

C: DTC P0713 TRANSMISSION FLUID TEMPERATURE SENSOR CIRCUIT HIGH INPUT

DTC DETECTING CONDITION:

Input signal circuit to ATF temperature sensor is shorted.

TROUBLE SYMPTOM:

Excessive shift shock

WIRING DIAGRAM:

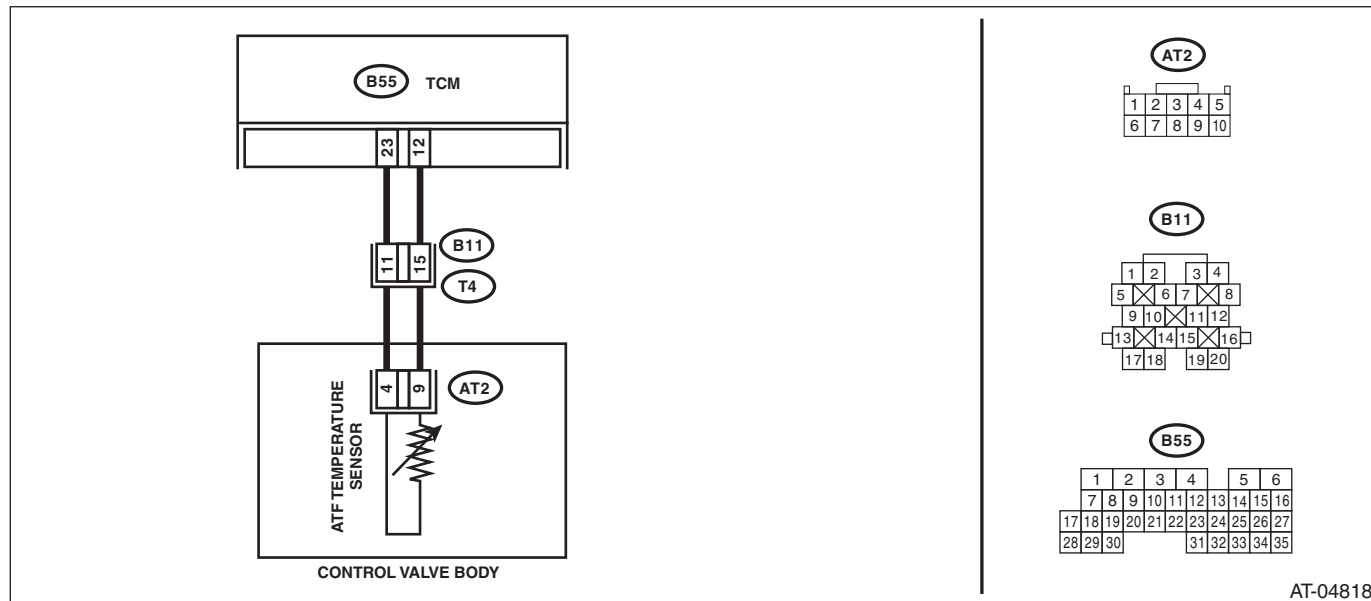

Step	Check	Yes	No
1 CHECK HARNESS CONNECTOR BETWEEN TCM AND ATF TEMPERATURE SENSOR. 1) Turn the ignition switch to OFF. 2) Disconnect the connector from TCM. 3) Measure the resistance between TCM connector terminals. <i>Connector & terminal (B55) No. 23 — No. 12:</i>	Is the resistance 500 Ω or more?	Go to step 2.	Go to step 4.
2 CHECK HARNESS CONNECTOR BETWEEN TCM AND ATF TEMPERATURE SENSOR. Measure the resistance of the harness between TCM connector and chassis ground. <i>Connector & terminal (B55) No. 23 — Chassis ground:</i>	Is the resistance 1 MΩ or more?	Go to step 3.	Go to step 4.
3 CHECK HARNESS. Measure the resistance between TCM connector terminals while shaking the harness. <i>Connector & terminal (B55) No. 23 — No. 12:</i>	Does the resistance change?	Go to step 4.	Replace the TCM. <Ref. to 4AT-60, Transmission Control Module (TCM).>
4 CHECK HARNESS CONNECTOR BETWEEN TCM AND ATF TEMPERATURE SENSOR. 1) Turn the ignition switch to OFF. 2) Disconnect the connector from transmission. 3) Measure the resistance of the harness between TCM connector and chassis ground. <i>Connector & terminal (B55) No. 23 — Chassis ground:</i>	Is the resistance 1 MΩ or more?	Go to step 5.	Repair the short circuit of harness between TCM and transmission harness.

Diagnostic Procedure with Diagnostic Trouble Code (DTC)

AUTOMATIC TRANSMISSION (DIAGNOSTICS)

Step	Check	Yes	No
5 CHECK HARNESS CONNECTOR BETWEEN TCM AND ATF TEMPERATURE SENSOR. Measure the resistance of the harness between TCM connector and chassis ground. <i>Connector & terminal</i> <i>(B55) No. 12 — Chassis ground:</i>	Is the resistance 1 M Ω or more?	Go to step 6.	Repair the short circuit of harness between TCM and transmission harness.
6 CHECK ATF TEMPERATURE SENSOR. Measure the resistance between transmission connector terminals. <i>Connector & terminal</i> <i>(T4) No. 11 — No. 15:</i>	Is the resistance 500 Ω or more?	Check for short circuits in the harness or connectors, and repair the fault location.	Go to step 7.
7 CHECK TRANSMISSION HARNESS. 1) Lift up the vehicle. 2) Drain the automatic transmission fluid. CAUTION: Do not drain ATF until it cools down. 3) Remove the oil pan. 4) Disconnect the harness connector from control valve. 5) Measure the resistance between transmission connector and transmission ground. <i>Connector & terminal</i> <i>(T4) No. 11 — Transmission ground:</i>	Is the resistance 1 M Ω or more?	Go to step 8.	Replace the transmission harness.
8 CHECK TRANSMISSION HARNESS. Measure the resistance between transmission connector and transmission ground. <i>Connector & terminal</i> <i>(T4) No. 15 — Transmission ground:</i>	Is the resistance 1 M Ω or more?	Go to step 9.	Replace the transmission harness.
9 CHECK ATF TEMPERATURE SENSOR. Measure the resistance between control valve connector terminals. <i>Connector & terminal</i> <i>(AT2) No. 4 — No. 9:</i>	Is the resistance 500 Ω or more?	Check for short circuits in the harness or connectors, and repair the fault location.	Replace the control valve body. <Ref. to 4AT-56, Control Valve Body.>

Diagnostic Procedure with Diagnostic Trouble Code (DTC)

AUTOMATIC TRANSMISSION (DIAGNOSTICS)

D: DTC P0715 INPUT/TURBINE SPEED SENSOR CIRCUIT

DTC DETECTING CONDITION:

Input signal circuit of TCM is open or shorted.

TROUBLE SYMPTOM:

Excessive shift shock

WIRING DIAGRAM:

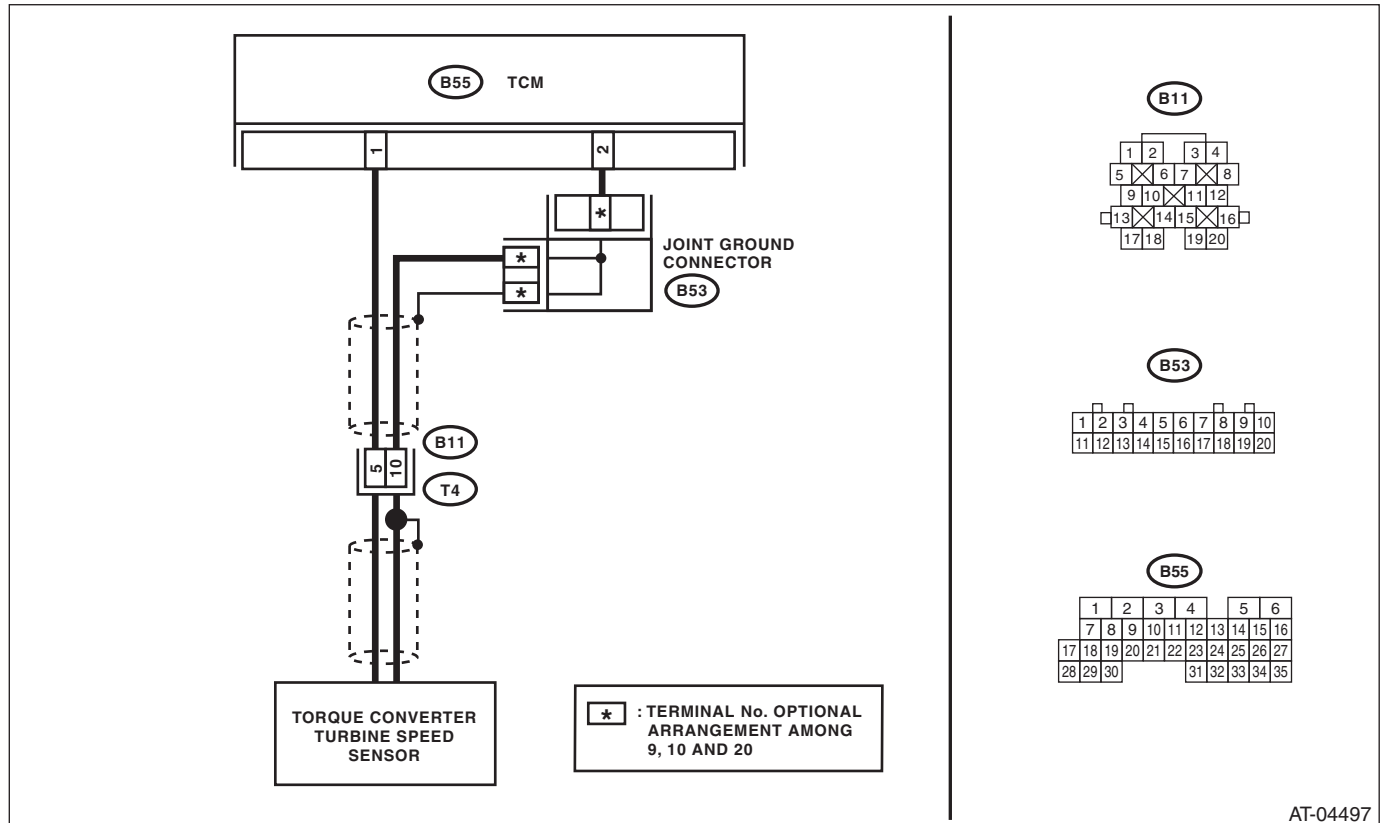

AT-04497

Diagnostic Procedure with Diagnostic Trouble Code (DTC)

AUTOMATIC TRANSMISSION (DIAGNOSTICS)

Step	Check	Yes	No
1 CHECK TORQUE CONVERTER TURBINE SPEED SENSOR. 1) Turn the ignition switch to OFF. 2) Disconnect the connector from transmission. 3) Measure the resistance between transmission connector receptacle's terminals. Connector & terminal (T4) No. 5 — No. 10:	Is the resistance between 450 — 650 Ω ?	Go to step 2.	Replace the torque converter turbine speed sensor. <Ref. to 4AT-53, Torque Converter Turbine Speed Sensor.>
2 CHECK HARNESS CONNECTOR BETWEEN TCM AND TRANSMISSION. 1) Disconnect the connector from TCM. 2) Measure the resistance of the harness between TCM connector and transmission connector. Connector & terminal (B55) No. 1 — (B11) No. 5:	Is the resistance less than 1 Ω ?	Go to step 3.	Repair the open circuit of harness between TCM and transmission connector.
3 CHECK HARNESS CONNECTOR BETWEEN TCM AND TRANSMISSION. Measure the resistance of the harness between TCM connector and transmission connector. Connector & terminal (B55) No. 2 — (B11) No. 10:	Is the resistance less than 1 Ω ?	Go to step 4.	Repair the open circuit of harness between TCM and transmission connector, and poor contact of the connector.
4 CHECK HARNESS CONNECTOR BETWEEN TCM AND TRANSMISSION. Measure the resistance of the harness between TCM connector and chassis ground. Connector & terminal (B55) No. 2 — Chassis ground:	Is the resistance 1 M Ω or more?	Go to step 5.	Repair the short circuit of harness between TCM and transmission connector.
5 CHECK HARNESS CONNECTOR BETWEEN TCM AND TRANSMISSION. Measure the resistance of the harness between TCM connector and chassis ground. Connector & terminal (B55) No. 1 — Chassis ground:	Is the resistance 1 M Ω or more?	Go to step 6.	Repair the short circuit of the harness between TCM and transmission connector, and poor contact of connector.
6 CHECK INPUT SIGNAL FOR TCM USING SUBARU SELECT MONITOR. 1) Connect the connectors to TCM and transmission. 2) Connect the Subaru Select Monitor to the data link connector. 3) Turn the ignition switch to ON. 4) Run the Subaru Select Monitor. 5) Start the engine. 6) Move the select lever to the "P" or "N" range. 7) Read the data of "Turbine Revolution Speed" using Subaru Select Monitor. 8) Compare the tachometer with Subaru Select Monitor indications.	Is the revolution value same as the tachometer reading shown on the combination meter?	Check for poor contact in the TCM and transmission harness or connectors, and repair the fault location.	Go to step 7.
7 CHECK POOR CONTACT.	Is there poor contact in torque converter turbine speed sensor circuit?	Repair the poor contact.	Replace the TCM. <Ref. to 4AT-60, Transmission Control Module (TCM).>

Diagnostic Procedure with Diagnostic Trouble Code (DTC)

AUTOMATIC TRANSMISSION (DIAGNOSTICS)

E: DTC P0719 BRAKE SWITCH CIRCUIT LOW

DTC DETECTING CONDITION:

Brake switch malfunction, open input signal circuit

TROUBLE SYMPTOM:

- Gear is not shifted down when driving a down hill.
- Neutral control does not operate.

WIRING DIAGRAM:

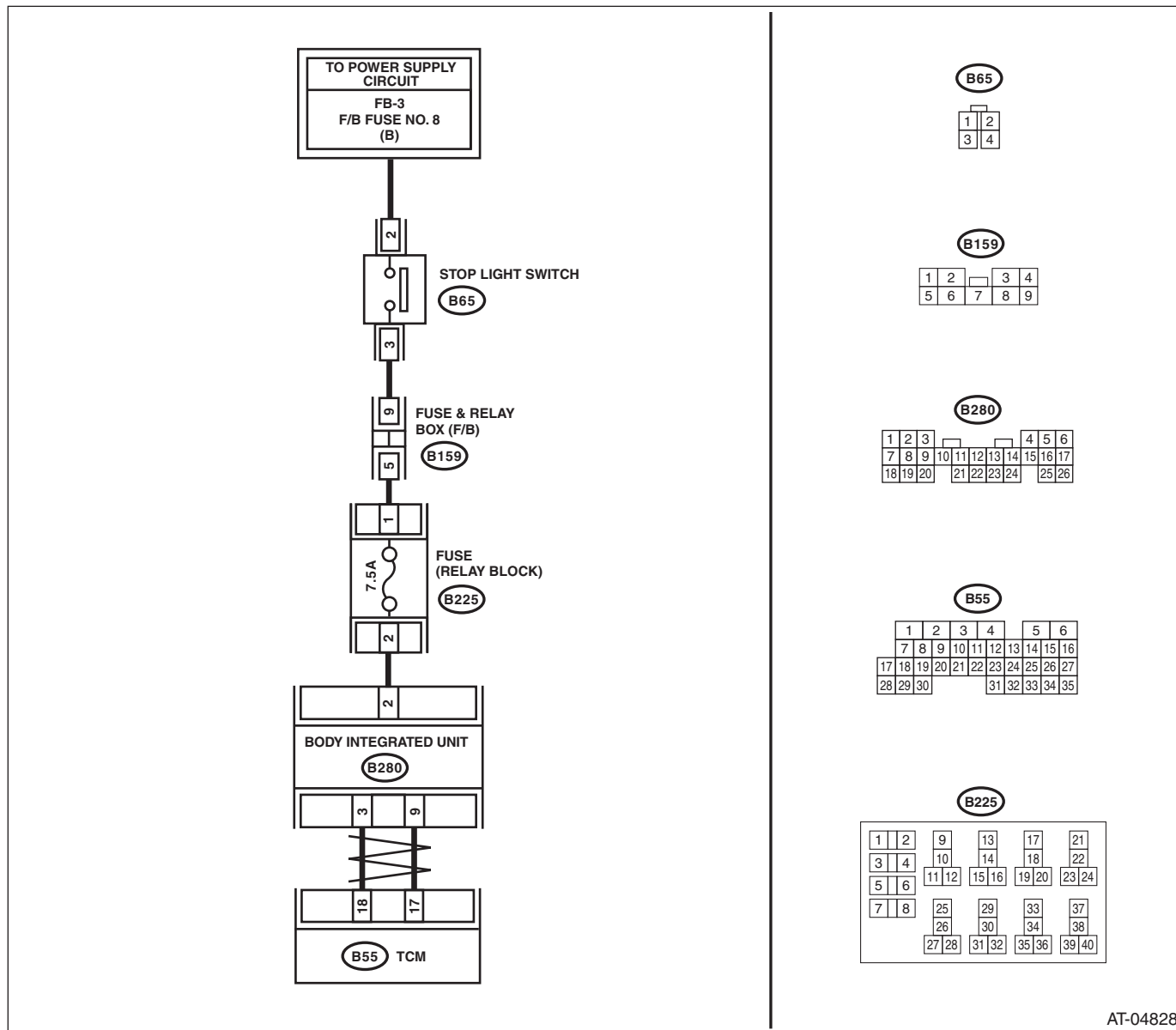

AT-04828

Diagnostic Procedure with Diagnostic Trouble Code (DTC)

AUTOMATIC TRANSMISSION (DIAGNOSTICS)

Step	Check	Yes	No
1 CHECK DTC.	Is DTC of CAN communication displayed?	Perform diagnosis according to the DTC.	Go to step 2.
2 CHECK FUSE (NO. 8). 1) Turn the ignition switch to OFF. 2) Remove the fuse (No. 8).	Is the fuse (No. 8) blown out?	Replace the fuse (No. 8). If the replaced fuse (No. 8) has blown out easily, repair the short circuit of harness between fuse (No. 8) and stop light switch.	Go to step 3.
3 CHECK FUSE. Remove the fuse (7.5A) in the relay block.	Is the fuse (7.5A) blown out?	Replace the fuse (7.5A). If the replaced fuse (7.5A) blows out easily, repair the short circuit in the harness between the fuse (7.5A) and the TCM.	Go to step 4.
4 CHECK BODY INTEGRATED UNIT. 1) Turn the ignition switch to OFF. 2) Connect the Subaru Select Monitor to the data link connector. 3) Turn the ignition switch to ON. 4) Run the Subaru Select Monitor. 5) Depress the brake pedal. 6) Read the data of "Stop Light Switch" using the Subaru Select Monitor. <Ref. to LAN(diag)-14, OPERATION, Subaru Select Monitor.>	Is ON displayed?	Go to step 5.	Go to step 6.
5 CHECK TCM. Read the data of "Stop Light Switch" using the Subaru Select Monitor. <Ref. to 4AT(diag)-15, OPERATION, Subaru Select Monitor.>	Is ON displayed?	Check for poor contact in the connector or harness, and repair the fault location.	Replace the TCM. <Ref. to 4AT-60, Transmission Control Module (TCM).>
6 CHECK BODY INTEGRATED UNIT INPUT SIGNAL. 1) Disconnect the connector from body integrated unit. 2) Depress the brake pedal. 3) Measure the voltage of harness between the body integrated unit and chassis ground. Connector & terminal (B280) No. 2 (+) — Chassis ground (-):	Is the voltage 10 V or more?	Go to step 9.	Go to step 7.
7 CHECK HARNESS CONNECTOR BETWEEN BODY INTEGRATED UNIT AND STOP LIGHT SWITCH. 1) Turn the ignition switch to OFF. 2) Disconnect the connector from stop light switch. 3) Measure the resistance of harness between body integrated unit and stop light switch. Connector & terminal (B280) No. 2 — (B65) No. 3:	Is the resistance less than 1 Ω?	Go to step 8.	Repair the open circuit of harness between body integrated unit and stop light switch.

Diagnostic Procedure with Diagnostic Trouble Code (DTC)

AUTOMATIC TRANSMISSION (DIAGNOSTICS)

Step	Check	Yes	No
8 CHECK HARNESS CONNECTOR BETWEEN BODY INTEGRATED UNIT AND STOP LIGHT SWITCH. Measure the resistance of harness between body integrated unit and stop light switch. Connector & terminal (B280) No. 2 — Chassis ground:	Is the resistance 1 M Ω or more?	Go to step 9.	Repair the short circuit of harness between body integrated unit and stop light switch.
9 CHECK POOR CONTACT.	Is there poor contact in input signal of brake switch?	Repair the poor contact.	Check the body integrated unit.

Diagnostic Procedure with Diagnostic Trouble Code (DTC)

AUTOMATIC TRANSMISSION (DIAGNOSTICS)

F: DTC P0720 OUTPUT SPEED SENSOR CIRCUIT

DTC DETECTING CONDITION:

- The vehicle speed signal is abnormal.
- The harness connector between TCM and vehicle speed sensor is shorted or open.

TROUBLE SYMPTOM:

- Neutral control does not operate.
- Slip lock up control does not operate.
- Driving performance is poor.

WIRING DIAGRAM:

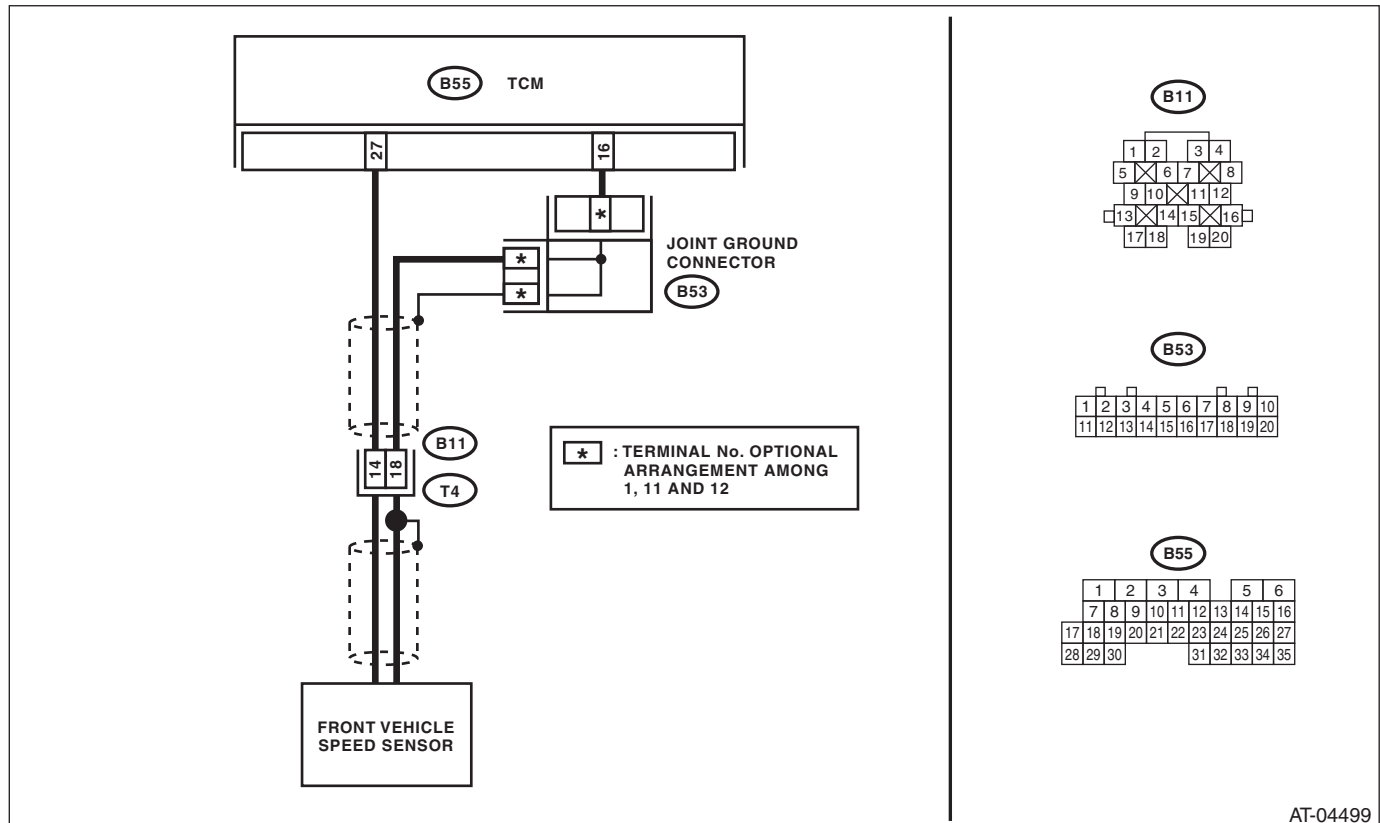

AT-04499

Step	Check	Yes	No	
1	CHECK HARNESS CONNECTOR BETWEEN TCM AND TRANSMISSION. 1) Turn the ignition switch to OFF. 2) Disconnect the connectors from TCM and transmission. 3) Measure the resistance of the harness between TCM connector and transmission connector. Connector & terminal (B55) No. 27 — (B11) No. 14:	Is the resistance less than 1 Ω?	Go to step 2.	Repair the open circuit of harness between TCM and transmission connector.
2	CHECK HARNESS CONNECTOR BETWEEN TCM AND TRANSMISSION. Measure the resistance of the harness between TCM connector and transmission connector. Connector & terminal (B55) No. 16 — (B11) No. 18:	Is the resistance less than 1 Ω?	Go to step 3.	Repair the open circuit of harness between TCM and transmission connector, and poor contact of the connector.

Diagnostic Procedure with Diagnostic Trouble Code (DTC)

AUTOMATIC TRANSMISSION (DIAGNOSTICS)

Step	Check	Yes	No
3 CHECK HARNESS CONNECTOR BETWEEN TCM AND TRANSMISSION. Measure the resistance of harness between TCM connector and chassis ground. <i>Connector & terminal</i> <i>(B55) No. 27 — Chassis ground:</i>	Is the resistance 1 MΩ or more?	Go to step 4.	Repair the short circuit in the harness between the TCM and chassis ground.
4 CHECK HARNESS CONNECTOR BETWEEN TCM AND TRANSMISSION. Measure the resistance of harness between TCM connector and chassis ground. <i>Connector & terminal</i> <i>(B55) No. 16 — Chassis ground:</i>	Is the resistance 1 MΩ or more?	Go to step 5.	Repair the short circuit of the harness and poor contact of connectors between the TCM and chassis ground.
5 CHECK FRONT VEHICLE SPEED SENSOR. Measure the resistance between transmission connector receptacle's terminals. <i>Connector & terminal</i> <i>(T4) No. 14 — No. 18:</i>	Is the resistance between 450 — 650 Ω?	Go to step 6.	Replace the front vehicle speed sensor. <Ref. to 4AT-49, Front Vehicle Speed Sensor.>
6 CHECK INPUT SIGNAL FOR TCM USING SUBARU SELECT MONITOR. 1) Connect all connectors. 2) Connect the Subaru Select Monitor to the data link connector. 3) Lift up the vehicle. 4) Turn the ignition switch to ON. 5) Run the Subaru Select Monitor. 6) Start the engine. 7) Read the data of "front wheel speed" using Subaru Select Monitor. 8) Compare the speedometer with Subaru Select Monitor indications. 9) Slowly increase the vehicle speed to 60 km/h (37 MPH). NOTE: The speed difference between the front and rear wheels will illuminate the ABS warning light or VDC warning light, but this does not indicate a malfunction. If the warning light illuminates, delete the ABS or VDC memory after completing the AT control diagnosis. <Ref. to VDC (diag)-24, Clear Memory Mode.>	Does the speedometer indication increase as the Subaru Select Monitor front wheel speed data increases?	Check for poor contact in the front vehicle speed sensor circuit harness and repair the fault location.	Go to step 7.
7 CHECK POOR CONTACT.	Is there poor contact in front vehicle speed sensor circuit?	Repair the poor contact.	Replace the TCM. <Ref. to 4AT-60, Transmission Control Module (TCM).>

Diagnostic Procedure with Diagnostic Trouble Code (DTC)

AUTOMATIC TRANSMISSION (DIAGNOSTICS)

G: DTC P0724 BRAKE SWITCH CIRCUIT HIGH

DTC DETECTING CONDITION:

Brake switch malfunction, open input signal circuit

TROUBLE SYMPTOM:

- Gear is not shifted down when driving a down hill.
- Neutral control does not operate.

WIRING DIAGRAM:

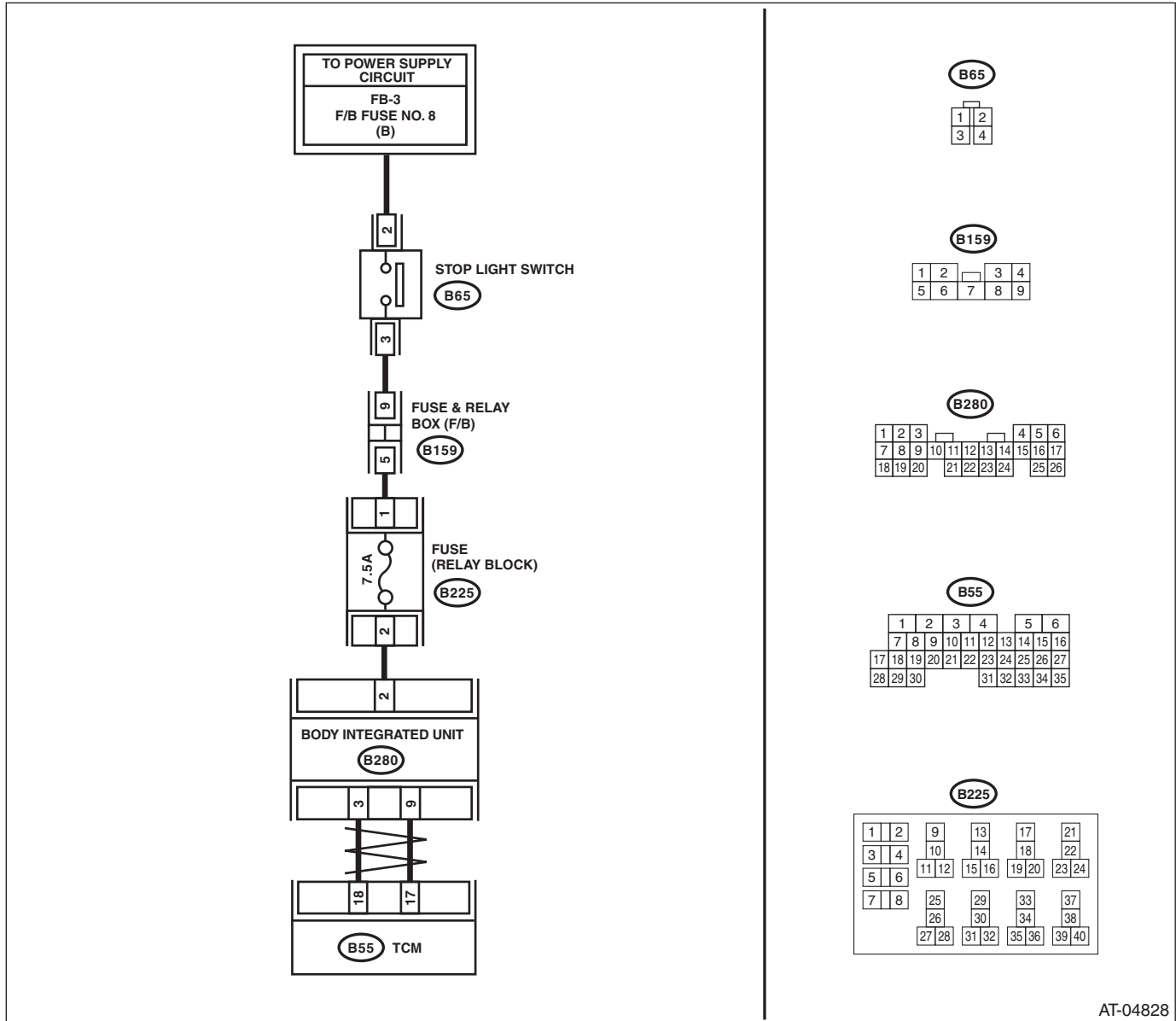

AT-04828

Diagnostic Procedure with Diagnostic Trouble Code (DTC)

AUTOMATIC TRANSMISSION (DIAGNOSTICS)

	Step	Check	Yes	No
1	CHECK DTC.	Is DTC of CAN communication displayed?	Perform diagnosis according to the DTC.	Go to step 2.
2	CHECK BODY INTEGRATED UNIT. 1) Turn the ignition switch to OFF. 2) Connect the Subaru Select Monitor to the data link connector. 3) Turn the ignition switch to ON. 4) Run the Subaru Select Monitor. 5) Read the data of "Stop Light Switch" using the Subaru Select Monitor. <Ref. to 4AT(diag)-15, OPERATION, Subaru Select Monitor.>	Is OFF displayed?	Go to step 3.	Go to step 4.
3	CHECK TCM. Read the data of "Stop Light Switch" using the Subaru Select Monitor. <Ref. to 4AT(diag)-15, OPERATION, Subaru Select Monitor.>	Is OFF displayed?	Check for poor contact in the connector or harness, and repair the fault location.	Replace the TCM. <Ref. to 4AT-60, Transmission Control Module (TCM).>
4	CHECK BODY INTEGRATED UNIT INPUT SIGNAL. 1) Disconnect the harness connector of body integrated unit. 2) Measure the voltage of harness between body integrated unit and stop light switch. Connector & terminal (B280) No. 2 (+) — Chassis ground (-):	Is the voltage 10 V or more?	Go to step 5.	Go to step 7.
5	CHECK STOP LIGHT SWITCH. 1) Turn the ignition switch to OFF. 2) Disconnect the connector from stop light switch. 3) Measure the resistance of harness between stop light switch connectors. Connector & terminal (B65) No. 2 — No. 3:	Is the resistance 1 M Ω or more?	Go to step 6.	Replace the stop light switch.
6	CHECK HARNESS CONNECTOR BETWEEN BODY INTEGRATED UNIT AND STOP LIGHT SWITCH. 1) Turn the ignition switch to ON. 2) Measure the voltage of harness between the body integrated unit and chassis ground. Connector & terminal (B280) No. 2 (+) — Chassis ground (-):	Is the voltage less than 1 V?	Go to step 7.	Repair the short circuit of harness between TCM and stop light switch.
7	CHECK POOR CONTACT.	Is there poor contact in input signal of brake switch?	Repair the poor contact.	Check the body integrated unit.

Diagnostic Procedure with Diagnostic Trouble Code (DTC)

AUTOMATIC TRANSMISSION (DIAGNOSTICS)

H: DTC P0731 GEAR 1 INCORRECT RATIO

NOTE:

Refer to DTC P0736 for diagnostic procedure. <Ref. to 4AT(diag)-53, DTC P0736 REVERSE INCORRECT RATIO, Diagnostic Procedure with Diagnostic Trouble Code (DTC).>

I: DTC P0732 GEAR 2 INCORRECT RATIO

NOTE:

Refer to DTC P0736 for diagnostic procedure. <Ref. to 4AT(diag)-53, DTC P0736 REVERSE INCORRECT RATIO, Diagnostic Procedure with Diagnostic Trouble Code (DTC).>

J: DTC P0733 GEAR 3 INCORRECT RATIO

NOTE:

Refer to DTC P0736 for diagnostic procedure. <Ref. to 4AT(diag)-53, DTC P0736 REVERSE INCORRECT RATIO, Diagnostic Procedure with Diagnostic Trouble Code (DTC).>

K: DTC P0734 GEAR 4 INCORRECT RATIO

NOTE:

Refer to DTC P0736 for diagnostic procedure. <Ref. to 4AT(diag)-53, DTC P0736 REVERSE INCORRECT RATIO, Diagnostic Procedure with Diagnostic Trouble Code (DTC).>

Diagnostic Procedure with Diagnostic Trouble Code (DTC)

AUTOMATIC TRANSMISSION (DIAGNOSTICS)

L: DTC P0736 REVERSE INCORRECT RATIO

DTC DETECTING CONDITION:

Vehicle sensor, torque converter turbine speed sensor or control valve malfunction

TROUBLE SYMPTOM:

- Shift point is too high or too low.
- Excessive shift shock
- Tight corner braking phenomenon occurs.
- Gear is not shifted to reverse.
- Gear position is held by fail safe function.

	Step	Check	Yes	No
1	CHECK ACCELERATOR PEDAL POSITION SENSOR. 1) Connect the Subaru Select Monitor to the data link connector. 2) Turn the ignition switch to ON. 3) Read the data of "Accel. Opening Angle" on the Subaru Select Monitor.	Does the value of accelerator pedal position sensor change from 0% to 100% smoothly when the accelerator pedal is operated from fully closed to fully open?	Go to step 2.	Check the circuit of the accelerator pedal position sensor.
2	CHECK FRONT VEHICLE SPEED SENSOR. 1) Lift up the vehicle. 2) Start the engine. 3) Set the select lever to the "D" range and slowly increase vehicle speed. NOTE: The speed difference between the front and rear wheels will illuminate the ABS warning light or VDC warning light, but this does not indicate a malfunction. If the warning light illuminates, delete the ABS or VDC memory after completing the AT control diagnosis. <Ref. to VDC (diag)-24, Clear Memory Mode.>	Does the vehicle speed displayed by Subaru Select Monitor roughly correspond with vehicle speed indicated by the combination meter?	Go to step 3.	Check the front vehicle speed sensor circuit.
3	CHECK TORQUE CONVERTER TURBINE SPEED SENSOR. 1) Move the select lever to the "P" or "N" range. 2) Idle the engine.	Does the value of torque converter turbine speed sensor displayed by Subaru Select Monitor roughly correspond with the value of tachometer in combination meter?	There are malfunctions in TCM, TCM connector poor contact, or transmission assembly mechanical malfunction.	Check the torque converter turbine speed sensor circuit.

Diagnostic Procedure with Diagnostic Trouble Code (DTC)

AUTOMATIC TRANSMISSION (DIAGNOSTICS)

M: DTC P0741 TORQUE CONVERTER CLUTCH CIRCUIT PERFORMANCE OR STUCK OFF

DTC DETECTING CONDITION:

- Lock up clutch malfunction
- Sticky valve

TROUBLE SYMPTOM:

No lock-up occurs.

Step	Check	Yes	No
1 CHECK LOCK-UP DUTY SOLENOID CIRCUIT. Diagnose according to procedures of DTC P0743.	Is there any fault?	Repair or replace the lock up duty solenoid circuit.	Go to step 2.
2 CHECK INHIBITOR SWITCH CIRCUIT. Diagnose according to procedures of DTC P0705.	Is there any fault?	Repair or replace the inhibitor switch circuit.	Go to step 3.
3 CHECK STOP LIGHT SWITCH CIRCUIT. Diagnose according to procedures of DTC P0719 and P0724.	Is there any fault?	Repair or replace the stop light switch circuit.	Go to step 4.
4 CHECK ATF TEMPERATURE SENSOR CIRCUIT. Diagnose according to procedures of DTC P0712 and P0713.	Is there any fault?	Repair or replace the ATF temperature sensor circuit.	Go to step 5.
5 CHECK ACCELERATOR PEDAL POSITION SENSOR. 1) Connect the Subaru Select Monitor to the data link connector. 2) Turn the ignition switch to ON. 3) Read the data of "Accel Opening Angle" using the Subaru Select Monitor.	Does the value of accelerator pedal position sensor change from 0% to 100% smoothly when the accelerator pedal is operated from fully closed to fully open?	Go to step 6.	Check the accelerator pedal position sensor circuit.
6 CHECK TORQUE CONVERTER TURBINE SPEED SENSOR. 1) Move the select lever to the "P" or "N" range. 2) Idle the engine.	Does the value of turbine speed displayed by Subaru Select Monitor almost correspond with the value of the tachometer?	Go to step 7.	Check the torque converter turbine speed sensor circuit.
7 CHECK ENGINE SPEED SIGNAL. Idle the engine.	Does the value of engine speed displayed by the Subaru Select Monitor almost correspond with the value of the tachometer?	There is transmission assembly mechanical malfunction.	Check the engine speed signal circuit.

Diagnostic Procedure with Diagnostic Trouble Code (DTC)

AUTOMATIC TRANSMISSION (DIAGNOSTICS)

N: DTC P0743 TORQUE CONVERTER CLUTCH CIRCUIT ELECTRICAL

DTC DETECTING CONDITION:

Output signal circuit of lock-up duty solenoid is open or shorted.

TROUBLE SYMPTOM:

No lock-up occurs. (After engine is warmed-up)

WIRING DIAGRAM:

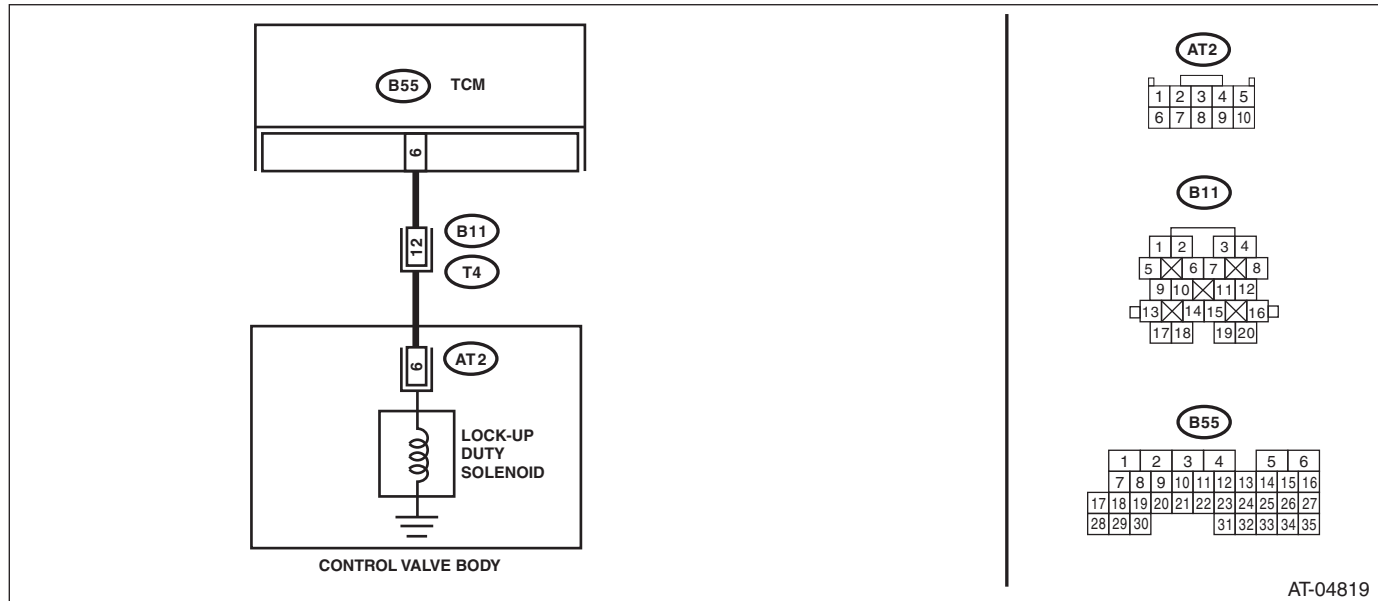

Diagnostic Procedure with Diagnostic Trouble Code (DTC)

AUTOMATIC TRANSMISSION (DIAGNOSTICS)

Step	Check	Yes	No
1 CHECK DTC.	Are DTCs other than P0743 displayed?	Perform diagnosis according to the DTC.	Go to step 2.
2 CHECK HARNESS CONNECTOR BETWEEN TCM AND TRANSMISSION. 1) Turn the ignition switch to OFF. 2) Disconnect the connectors from TCM and transmission. 3) Measure the resistance of the harness between TCM connector and transmission connector. Connector & terminal (B55) No. 6 — (B11) No. 12:	Is the resistance less than 1 Ω?	Go to step 3.	Repair the open circuit of harness between TCM and transmission connector.
3 CHECK HARNESS CONNECTOR BETWEEN TCM AND TRANSMISSION. Measure the resistance of the harness connector between TCM connector and chassis ground. Connector & terminal (B55) No. 6 — Chassis ground:	Is the resistance 1 MΩ or more?	Go to step 4.	Repair the short circuit of harness between TCM and transmission connector.
4 CHECK LOCK-UP DUTY SOLENOID. Measure the resistance between transmission connector receptacle's terminals. Connector & terminal (T4) No. 12 — No. 20:	Is the resistance between 2.0 — 6.0 Ω?	Go to step 5.	Go to step 8.
5 CHECK OUTPUT SIGNAL FROM TCM USING SUBARU SELECT MONITOR. 1) Connect the connectors to TCM and transmission. 2) Lift up the vehicle. 3) Connect the Subaru Select Monitor to the data link connector. 4) Start the engine. 5) Run the Subaru Select Monitor. 6) Warm-up the engine until the ATF temperature exceeds 80°C (176°F). NOTE: If the ambient temperature is below 0°C (32°F), drive the vehicle until the ATF reaches its operating temperature. 7) Read the data of "Lock Up Duty Ratio" using Subaru Select Monitor. 8) Set the select lever to the "D" range, and slowly increase vehicle speed to 60 km/h (37 MPH). NOTE: The speed difference between the front and rear wheels will illuminate the ABS warning light or VDC warning light, but this does not indicate a malfunction. If the warning light illuminates, delete the ABS or VDC memory after completing the AT control diagnosis. <Ref. to VDC (diag)-24, Clear Memory Mode.>	Is the measured value 95%?	Go to step 6.	Go to step 7.

Diagnostic Procedure with Diagnostic Trouble Code (DTC)

AUTOMATIC TRANSMISSION (DIAGNOSTICS)

Step	Check	Yes	No
6 CHECK OUTPUT SIGNAL FROM TCM USING SUBARU SELECT MONITOR. Return the engine speed to idling, set the select lever to the "N" range and read the data. NOTE: The speed difference between the front and rear wheels will illuminate the ABS warning light or VDC warning light, but this does not indicate a malfunction. If the warning light illuminates, delete the ABS or VDC memory after completing the AT control diagnosis. <Ref. to VDC (diag)-24, Clear Memory Mode.>	Is the measured value 0%?	Check for poor contact in the TCM and transmission harness or connectors, and repair the fault location.	Go to step 7.
7 CHECK POOR CONTACT.	Is there poor contact in lock-up duty solenoid circuit?	Repair the poor contact.	Replace the TCM. <Ref. to 4AT-60, Transmission Control Module (TCM).>
8 CHECK LOCK-UP DUTY SOLENOID (IN TRANSMISSION). 1) Disconnect the transmission connector. 2) Drain the automatic transmission fluid. CAUTION: Do not drain ATF until it cools down. 3) Remove the oil pan, and disconnect the connector from control valve body. 4) Measure the resistance between lock-up duty solenoid and transmission ground. Connector & terminal (AT2) No. 6 — Transmission ground:	Is the resistance between 2.0 — 6.0 Ω?	Go to step 9.	Replace the control valve body. <Ref. to 4AT-56, Control Valve Body.>
9 CHECK HARNESS CONNECTOR BETWEEN LOCK-UP DUTY SOLENOID AND TRANSMISSION. Measure the resistance of harness between lock-up duty solenoid and transmission connector. Connector & terminal (T4) No. 12 — (AT2) No. 6:	Is the resistance less than 1 Ω?	Go to step 10.	Repair the open circuit of harness between TCM and transmission connector.
10 CHECK HARNESS CONNECTOR BETWEEN LOCK-UP DUTY SOLENOID AND TRANSMISSION. Measure the resistance of harness between transmission connector and transmission ground. Connector & terminal (T4) No. 12 — Transmission ground:	Is the resistance 1 MΩ or more?	Check for poor contact in the lock up duty solenoid and transmission harness or connectors, and repair the fault location.	Repair the short circuit of harness between lock-up duty solenoid and transmission connector.

Diagnostic Procedure with Diagnostic Trouble Code (DTC)

AUTOMATIC TRANSMISSION (DIAGNOSTICS)

O: DTC P0748 PRESSURE CONTROL SOLENOID "A" ELECTRICAL

DTC DETECTING CONDITION:

Output signal circuit of line pressure linear solenoid is open or shorted.

TROUBLE SYMPTOM:

Excessive shift shock

WIRING DIAGRAM:

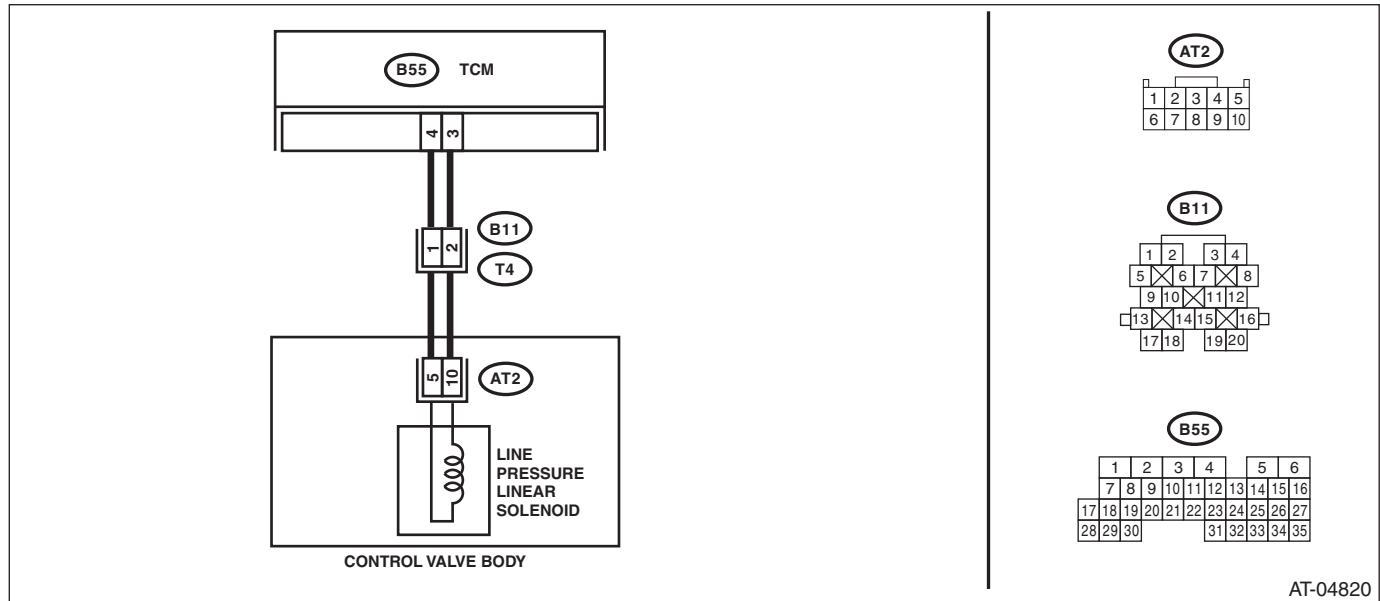

AT-04820

Diagnostic Procedure with Diagnostic Trouble Code (DTC)

AUTOMATIC TRANSMISSION (DIAGNOSTICS)

Step	Check	Yes	No
1 CHECK HARNESS CONNECTOR BETWEEN TCM AND TRANSMISSION. 1) Turn the ignition switch to OFF. 2) Disconnect the connector from transmission and TCM. 3) Measure the resistance of the harness between TCM connector and transmission connector. <i>Connector & terminal</i> (B55) No. 3 — (B11) No. 2: (B55) No. 4 — (B11) No. 1:	Is the resistance less than 1 Ω?	Go to step 2.	Repair the open circuit of harness between TCM and transmission connector.
2 CHECK HARNESS CONNECTOR BETWEEN TCM AND CHASSIS GROUND. Measure the resistance of the harness between TCM connector and chassis ground. <i>Connector & terminal</i> (B55) No. 3 — Chassis ground: (B55) No. 4 — Chassis ground:	Is the resistance 1 MΩ or more?	Go to step 3.	Repair the short circuit of harness between TCM and transmission connector.
3 CHECK LINE PRESSURE LINEAR SOLENOID. Measure the resistance between transmission connector receptacle's terminals. <i>Connector & terminal</i> (T4) No. 1 — No. 2:	Is the resistance between 4 — 8 Ω?	Replace the TCM. <Ref. to 4AT-60, Transmission Control Module (TCM).>	Go to step 4.
4 CHECK LINE PRESSURE LINEAR SOLENOID (IN TRANSMISSION). 1) Remove the transmission connector from bracket. 2) Drain the automatic transmission fluid. CAUTION: Do not drain ATF until it cools down. 3) Remove the oil pan, and disconnect the connector from control valve body. 4) Measure the resistance of line pressure linear solenoid connector terminals. <i>Connector & terminal</i> (AT2) No. 5 — No. 10:	Is the resistance between 4 — 8 Ω?	Go to step 5.	Replace the control valve body. <Ref. to 4AT-56, Control Valve Body.>
5 CHECK HARNESS CONNECTOR BETWEEN TRANSMISSION AND LINE PRESSURE LINEAR SOLENOID. Measure the resistance of harness between line pressure linear solenoid and transmission connector. <i>Connector & terminal</i> (T4) No. 2 — (AT2) No. 10: (T4) No. 1 — (AT2) No. 5:	Is the resistance less than 1 Ω?	Go to step 6.	Repair the open circuit of harness between line pressure linear solenoid and transmission connector.
6 CHECK HARNESS CONNECTOR BETWEEN TRANSMISSION AND LINE PRESSURE LINEAR SOLENOID. Measure the resistance of harness between transmission connector and transmission ground. <i>Connector & terminal</i> (T4) No. 1 — Transmission ground: (T4) No. 2 — Transmission ground:	Is the resistance 1 MΩ or more?	Check for poor contact in the line pressure linear solenoid and transmission harness or connectors, and repair the fault location.	Repair the short circuit of harness between line pressure linear solenoid and transmission connector.

Diagnostic Procedure with Diagnostic Trouble Code (DTC)

AUTOMATIC TRANSMISSION (DIAGNOSTICS)

P: DTC P0753 SHIFT SOLENOID "A" ELECTRICAL

DTC DETECTING CONDITION:

Output signal circuit of low clutch duty solenoid is open or shorted.

TROUBLE SYMPTOM:

Excessive shift shock

WIRING DIAGRAM:

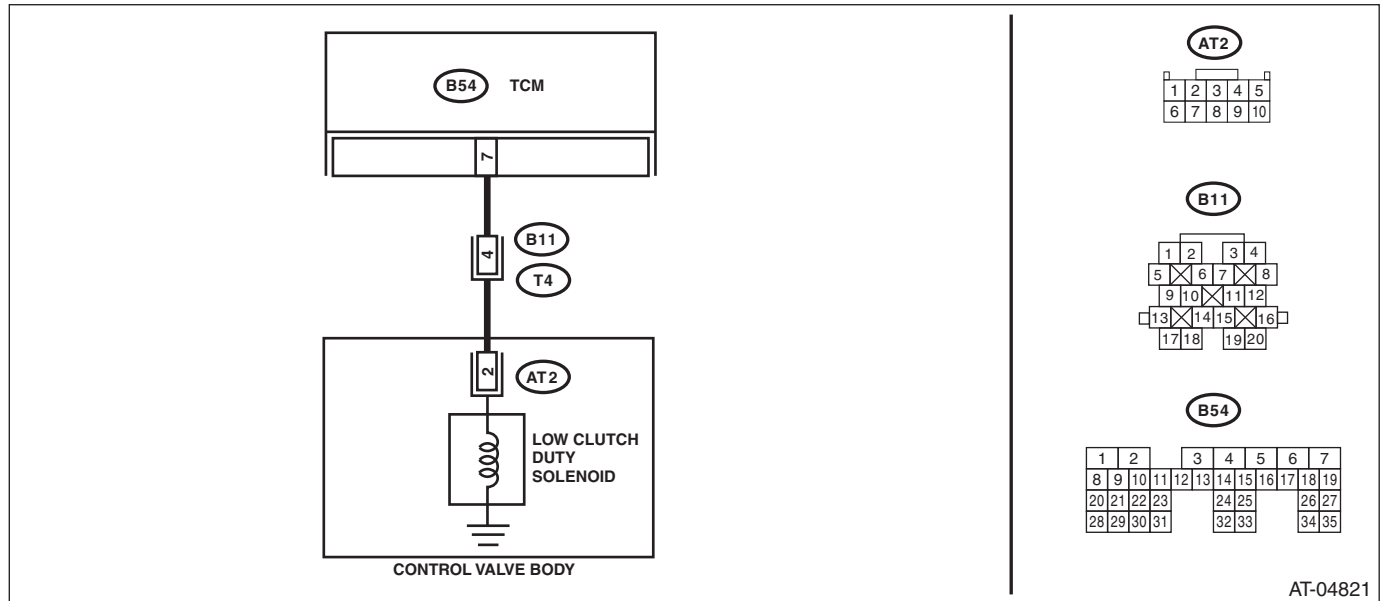

Diagnostic Procedure with Diagnostic Trouble Code (DTC)

AUTOMATIC TRANSMISSION (DIAGNOSTICS)

Step	Check	Yes	No
1 CHECK HARNESS CONNECTOR BETWEEN TCM AND TRANSMISSION. 1) Turn the ignition switch to OFF. 2) Disconnect the connectors from TCM and transmission. 3) Measure the resistance of harness between TCM and transmission connector. Connector & terminal (B54) No. 7 — (B11) No. 4:	Is the resistance less than 1 Ω?	Go to step 2.	Repair the open circuit of harness between TCM and transmission connector.
2 CHECK HARNESS CONNECTOR BETWEEN TCM AND TRANSMISSION. Measure the resistance of harness between TCM connector and transmission ground. Connector & terminal (B54) No. 7 — Chassis ground:	Is the resistance 1 MΩ or more?	Go to step 3.	Repair the short circuit of harness between TCM and transmission connector.
3 CHECK LOW CLUTCH DUTY SOLENOID. Measure the resistance between transmission connector terminals. Connector & terminal (T4) No. 4 — No. 20:	Is the resistance between 2.0 — 6.0 Ω?	Go to step 5.	Go to step 4.
4 CHECK OUTPUT SIGNAL FROM TCM USING SUBARU SELECT MONITOR. 1) Connect the connectors to TCM and transmission. 2) Connect the Subaru Select Monitor to the data link connector. 3) Start the engine. 4) Run the Subaru Select Monitor. 5) Warm-up the transmission until the ATF temperature exceeds approximately 80°C (176°F). NOTE: If the ambient temperature falls below 0°C (32°F), drive the vehicle until the ATF reaches its operating temperature. 6) Stop the engine. 7) Turn the ignition switch to ON. 8) Set the select lever to the “P” or “N” range, and depress the accelerator pedal. 9) Read the data of “Low Clutch Duty Ratio” using Subaru Select Monitor.	Is the measured value 100%?	Go to step 5.	Go to step 7.
5 CHECK OUTPUT SIGNAL FROM TCM USING SUBARU SELECT MONITOR. 1) Turn the ignition switch to ON. 2) Set the select lever to the “D” range. 3) Read the data of “Low Clutch Duty Ratio”.	Is the measured value 0%?	Check for poor contact in the TCM and transmission harness or connectors, and repair the fault location.	Go to step 6.
6 CHECK POOR CONTACT.	Is there poor contact in low clutch duty solenoid circuit?	Repair the poor contact.	Replace the TCM. <Ref. to 4AT-60, Transmission Control Module (TCM).>

Diagnostic Procedure with Diagnostic Trouble Code (DTC)

AUTOMATIC TRANSMISSION (DIAGNOSTICS)

Step	Check	Yes	No
<p>7</p> <p>CHECK LOW CLUTCH DUTY SOLENOID (IN TRANSMISSION).</p> <p>1) Remove the transmission connector from bracket.</p> <p>2) Drain the automatic transmission fluid.</p> <p>CAUTION: Do not drain ATF until it cools down.</p> <p>3) Remove the oil pan, and disconnect the connector from control valve body.</p> <p>4) Measure the resistance between low clutch duty solenoid connector and transmission ground.</p> <p>Connector & terminal (AT2) No. 2 — Transmission ground:</p>	<p>Is the resistance between 2.0 — 6.0 Ω?</p>	<p>Go to step 8.</p>	<p>Replace the control valve body. <Ref. to 4AT-56, Control Valve Body.></p>
<p>8</p> <p>CHECK HARNESS CONNECTOR BETWEEN TRANSMISSION AND LOW CLUTCH DUTY SOLENOID.</p> <p>Measure the resistance of harness between low clutch duty solenoid and transmission connector.</p> <p>Connector & terminal (T4) No. 4 — (AT2) No. 2:</p>	<p>Is the resistance less than 1 Ω?</p>	<p>Go to step 9.</p>	<p>Repair the open circuit of harness between low clutch duty solenoid and transmission connector.</p>
<p>9</p> <p>CHECK HARNESS CONNECTOR BETWEEN TRANSMISSION AND LOW CLUTCH DUTY SOLENOID.</p> <p>Measure the resistance of harness between transmission connector and transmission ground.</p> <p>Connector & terminal (T4) No. 4 — Transmission ground:</p>	<p>Is the resistance 1 MΩ or more?</p>	<p>Check for poor contact in the low clutch duty solenoid and transmission harness or connectors, and repair the fault location.</p>	<p>Repair the short circuit of harness between low clutch duty solenoid and transmission connector.</p>

Diagnostic Procedure with Diagnostic Trouble Code (DTC)

AUTOMATIC TRANSMISSION (DIAGNOSTICS)

Q: DTC P0758 SHIFT SOLENOID "B" ELECTRICAL

DTC DETECTING CONDITION:

Output signal circuit of 2-4 brake duty solenoid is open or shorted.

TROUBLE SYMPTOM:

Excessive shift shock

WIRING DIAGRAM:

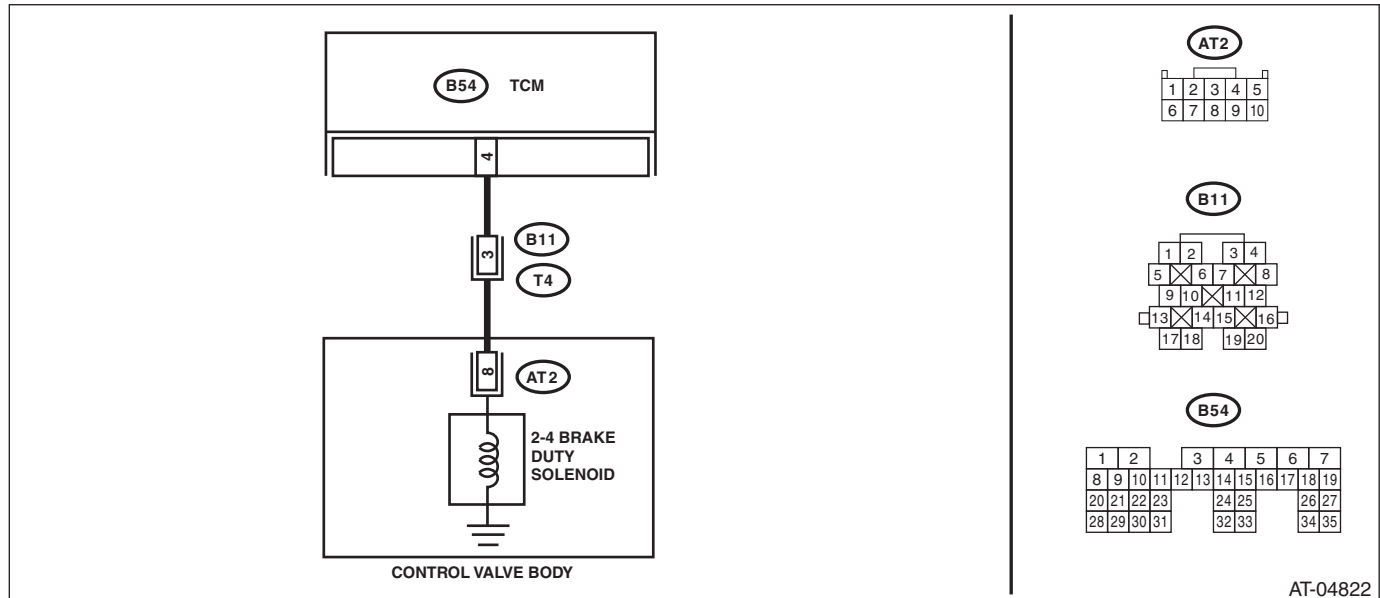

Diagnostic Procedure with Diagnostic Trouble Code (DTC)

AUTOMATIC TRANSMISSION (DIAGNOSTICS)

Step	Check	Yes	No
1 CHECK HARNESS CONNECTOR BETWEEN TCM AND TRANSMISSION. 1) Turn the ignition switch to OFF. 2) Disconnect the connectors from TCM and transmission. 3) Measure the resistance of the harness between TCM connector and transmission connector. <i>Connector & terminal</i> <i>(B54) No. 4 — (B11) No. 3:</i>	Is the resistance less than 1 Ω?	Go to step 2.	Repair the open circuit of harness between TCM and transmission connector.
2 CHECK HARNESS CONNECTOR BETWEEN TCM AND CHASSIS GROUND. Measure the resistance of harness between TCM connector and chassis ground. <i>Connector & terminal</i> <i>(B54) No. 4 — Chassis ground:</i>	Is the resistance 1 MΩ or more?	Go to step 3.	Repair the short circuit of harness between TCM and transmission connector.
3 CHECK 2-4 BRAKE DUTY SOLENOID. Measure the resistance between transmission connector terminals. <i>Connector & terminal</i> <i>(T4) No. 3 — No. 20:</i>	Is the resistance between 2.0 — 6.0 Ω?	Go to step 4.	Go to step 7.
4 CHECK OUTPUT SIGNAL FROM TCM USING SUBARU SELECT MONITOR. 1) Connect all connectors. 2) Connect the Subaru Select Monitor to the data link connector. 3) Start the engine. 4) Run the Subaru Select Monitor. 5) Warm-up the transmission until the ATF temperature exceeds approximately 80°C (176°F). NOTE: If the ambient temperature falls below 0°C (32°F), drive the vehicle until the ATF reaches its operating temperature. 6) Stop the engine. 7) Turn the ignition switch to ON. 8) Set the select lever to the “N” range, and depress the accelerator pedal. 9) Read the data of “Brake Clutch Duty Ratio” using Subaru Select Monitor.	Is the measured value 100%?	Go to step 5.	Go to step 6.
5 CHECK OUTPUT SIGNAL FROM TCM USING SUBARU SELECT MONITOR. Shift the select lever to 2nd on manual mode.	Is the measured value 0%?	Check for poor contact in the TCM and transmission harness or connectors, and repair the fault location.	Go to step 6.
6 CHECK POOR CONTACT.	Is there poor contact in 2-4 brake duty solenoid circuit?	Repair the poor contact.	Replace the TCM. <Ref. to 4AT-60, Transmission Control Module (TCM).>

Diagnostic Procedure with Diagnostic Trouble Code (DTC)

AUTOMATIC TRANSMISSION (DIAGNOSTICS)

Step	Check	Yes	No
<p>7</p> <p>CHECK 2-4 BRAKE DUTY SOLENOID (IN TRANSMISSION).</p> <p>1) Remove the transmission connector from bracket.</p> <p>2) Drain the automatic transmission fluid.</p> <p>CAUTION: Do not drain ATF until it cools down.</p> <p>3) Remove the oil pan, and disconnect the connector from control valve body.</p> <p>4) Measure the resistance of harness between 2-4 brake duty solenoid connector and transmission ground.</p> <p>Connector & terminal (AT2) No. 8 — Transmission ground:</p>	<p>Is the resistance between 2.0 — 6.0 Ω?</p>	<p>Go to step 8.</p>	<p>Replace the control valve body. <Ref. to 4AT-56, Control Valve Body.></p>
<p>8</p> <p>CHECK HARNESS CONNECTOR BETWEEN 2-4 BRAKE DUTY SOLENOID AND TRANSMISSION.</p> <p>Measure the resistance of harness between 2-4 brake duty solenoid and transmission connector.</p> <p>Connector & terminal (T4) No. 3 — (AT2) No. 8:</p>	<p>Is the resistance less than 1 Ω?</p>	<p>Go to step 9.</p>	<p>Repair the open circuit of harness between 2-4 brake duty solenoid and transmission connector.</p>
<p>9</p> <p>CHECK HARNESS CONNECTOR BETWEEN 2-4 BRAKE DUTY SOLENOID AND TRANSMISSION.</p> <p>Measure the resistance of harness between transmission connector and transmission ground.</p> <p>Connector & terminal (T4) No. 3 — Transmission ground:</p>	<p>Is the resistance 1 MΩ or more?</p>	<p>Check for poor contact in the 2-4 brake duty solenoid and transmission harness or connectors, and repair the fault location.</p>	<p>Repair the short circuit of harness between 2-4 brake duty solenoid and transmission connector.</p>

Diagnostic Procedure with Diagnostic Trouble Code (DTC)

AUTOMATIC TRANSMISSION (DIAGNOSTICS)

R: DTC P0763 SHIFT SOLENOID "C" ELECTRICAL

DTC DETECTING CONDITION:

Output signal circuit of high clutch duty solenoid is open or shorted.

TROUBLE SYMPTOM:

Excessive shift shock

WIRING DIAGRAM:

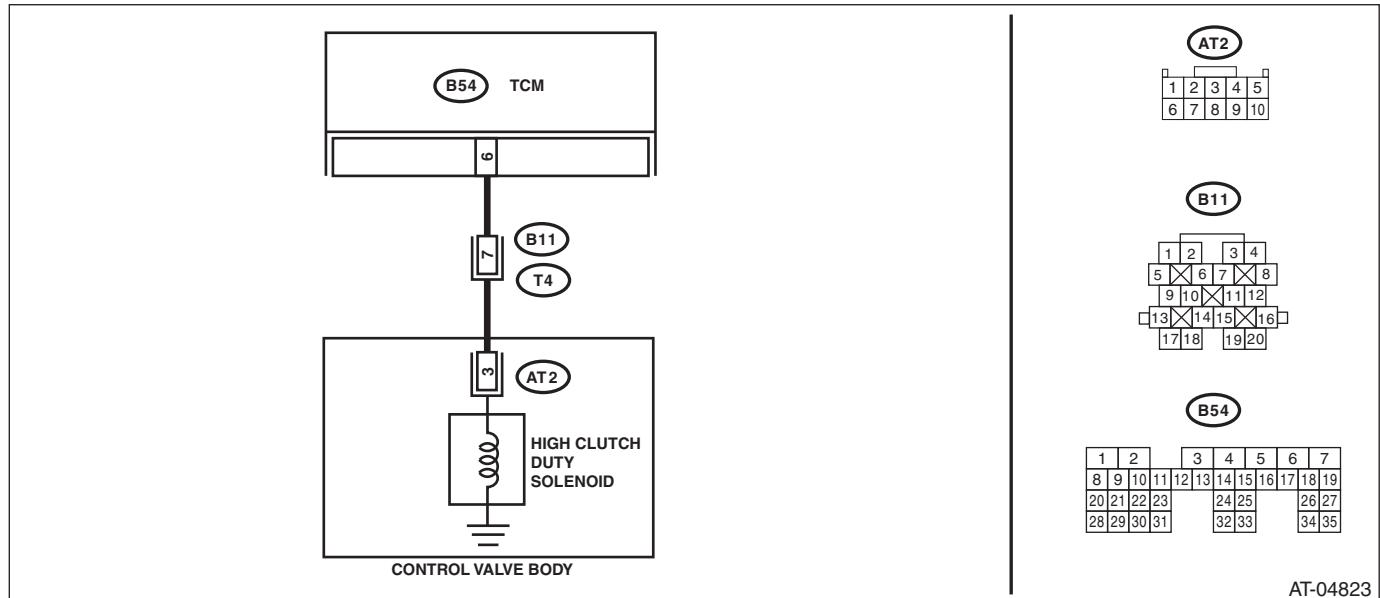

Diagnostic Procedure with Diagnostic Trouble Code (DTC)

AUTOMATIC TRANSMISSION (DIAGNOSTICS)

Step	Check	Yes	No
<p>1 CHECK HARNESS CONNECTOR BETWEEN TCM AND TRANSMISSION. 1) Turn the ignition switch to OFF. 2) Disconnect the connectors from TCM and transmission. 3) Measure the resistance of the harness between TCM connector and transmission connector. Connector & terminal (B54) No. 6 — (B11) No. 7:</p>	<p>Is the resistance less than 1 Ω?</p>	<p>Go to step 2.</p>	<p>Repair the open circuit of harness between TCM and transmission connector.</p>
<p>2 CHECK HARNESS CONNECTOR BETWEEN TCM AND TRANSMISSION. Measure the resistance of the harness connector between TCM connector and chassis ground. Connector & terminal (B54) No. 6 — Chassis ground:</p>	<p>Is the resistance 1 MΩ or more?</p>	<p>Go to step 3.</p>	<p>Repair the short circuit of harness between TCM and transmission connector.</p>
<p>3 CHECK HIGH CLUTCH DUTY SOLENOID. Measure the resistance between transmission connector receptacle's terminals. Connector & terminal (T4) No. 7 — No. 20:</p>	<p>Is the resistance between 2.0 — 6.0 Ω?</p>	<p>Go to step 4.</p>	<p>Go to step 7.</p>
<p>4 CHECK OUTPUT SIGNAL FROM TCM USING SUBARU SELECT MONITOR. 1) Connect the connectors to TCM and transmission. 2) Lift up the vehicle. 3) Connect the Subaru Select Monitor to the data link connector. 4) Start the engine. 5) Run the Subaru Select Monitor. 6) Warm-up the engine until the ATF temperature exceeds 80°C (176°F). NOTE: If the ambient temperature is below 0°C (32°F), drive the vehicle until the ATF reaches its operating temperature. 7) Read the data of "High Clutch Duty" using Subaru Select Monitor. 8) Set the select lever to the "D" range, and slowly increase vehicle speed to measure in 3rd or 4th gear. NOTE: The speed difference between the front and rear wheels will illuminate the ABS warning light or VDC warning light, but this does not indicate a malfunction. If the warning light illuminates, delete the ABS or VDC memory after completing the AT control diagnosis. <Ref. to VDC (diag)-24, Clear Memory Mode.></p>	<p>Is the measured value 0%?</p>	<p>Go to step 5.</p>	<p>Go to step 6.</p>

Diagnostic Procedure with Diagnostic Trouble Code (DTC)

AUTOMATIC TRANSMISSION (DIAGNOSTICS)

Step	Check	Yes	No
5 CHECK OUTPUT SIGNAL FROM TCM USING SUBARU SELECT MONITOR. Return the engine speed to idling and set the select lever to the "N" range. NOTE: The speed difference between the front and rear wheels will illuminate the ABS warning light or VDC warning light, but this does not indicate a malfunction. If the warning light illuminates, delete the ABS or VDC memory after completing the AT control diagnosis. <Ref. to VDC (diag)-24, Clear Memory Mode.>	Is the measured value 100%?	Check for poor contact in the TCM and transmission harness or connectors, and repair the fault location.	Go to step 6.
6 CHECK POOR CONTACT.	Is there poor contact in high clutch duty solenoid circuit?	Repair the poor contact.	Replace the TCM. <Ref. to 4AT-60, Transmission Control Module (TCM).>
7 CHECK HIGH CLUTCH DUTY SOLENOID (IN TRANSMISSION). 1) Remove the transmission connector from bracket. 2) Drain the automatic transmission fluid. CAUTION: Do not drain ATF until it cools down. 3) Remove the oil pan, and disconnect the connector from control valve body. 4) Measure the resistance between high clutch duty solenoid connector and transmission ground. <i>Connector & terminal</i> <i>(AT2) No. 3 — Transmission ground:</i>	Is the resistance between 2.0 — 6.0 Ω ?	Go to step 8.	Replace the control valve body. <Ref. to 4AT-56, Control Valve Body.>
8 CHECK HARNESS CONNECTOR BETWEEN HIGH CLUTCH DUTY SOLENOID AND TRANSMISSION. Measure the resistance of harness between high clutch duty solenoid and transmission connector. <i>Connector & terminal</i> <i>(T4) No. 7 — (AT2) No. 3:</i>	Is the resistance less than 1 Ω ?	Go to step 9.	Repair the open circuit of harness between TCM and transmission connector.
9 CHECK HARNESS CONNECTOR BETWEEN HIGH CLUTCH DUTY SOLENOID AND TRANSMISSION. Measure the resistance of harness between transmission connector and transmission ground. <i>Connector & terminal</i> <i>(T4) No. 7 — Transmission ground:</i>	Is the resistance 1 M Ω or more?	Check for poor contact in the high clutch duty solenoid and transmission harness or connectors, and repair the fault location.	Repair the short circuit of harness between high clutch duty solenoid and transmission connector.

Diagnostic Procedure with Diagnostic Trouble Code (DTC)

AUTOMATIC TRANSMISSION (DIAGNOSTICS)

S: DTC P0768 SHIFT SOLENOID "D" ELECTRICAL

DTC DETECTING CONDITION:

The output signal circuit of low & reverse duty solenoid is open or shorted.

TROUBLE SYMPTOM:

Gear is not changed.

WIRING DIAGRAM:

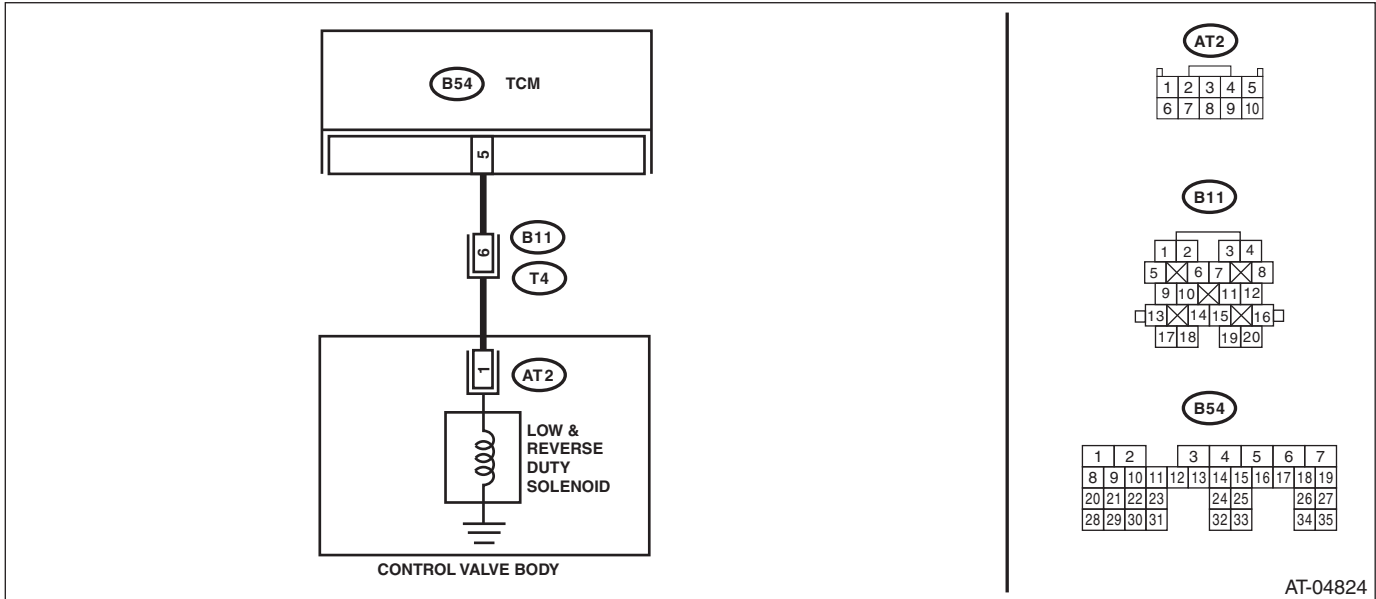

Diagnostic Procedure with Diagnostic Trouble Code (DTC)

AUTOMATIC TRANSMISSION (DIAGNOSTICS)

Step	Check	Yes	No
<p>1 CHECK HARNESS CONNECTOR BETWEEN TCM AND TRANSMISSION.</p> <p>1) Turn the ignition switch to OFF. 2) Disconnect the connector from transmission and TCM. 3) Measure the resistance of the harness between TCM connector and transmission connector.</p> <p>Connector & terminal (B54) No. 5 — (B11) No. 6:</p>	Is the resistance less than 1 Ω ?	Go to step 2.	Repair the open circuit of harness between TCM and transmission connector.
<p>2 CHECK HARNESS CONNECTOR BETWEEN TCM AND CHASSIS GROUND.</p> <p>Measure the resistance of the harness between TCM connector and chassis ground.</p> <p>Connector & terminal (B54) No. 5 — Chassis ground:</p>	Is the resistance 1 M Ω or more?	Go to step 3.	Repair the short circuit of harness between TCM and transmission connector.
<p>3 CHECK LOW & REVERSE DUTY SOLENOID.</p> <p>Measure the resistance between transmission connector terminals.</p> <p>Connector & terminal (T4) No. 6 — No. 20:</p>	Is the resistance between 2.0 — 6.0 Ω ?	Go to step 4.	Go to step 7.
<p>4 CHECK OUTPUT SIGNAL FROM TCM USING SUBARU SELECT MONITOR.</p> <p>1) Connect all connectors. 2) Connect the Subaru Select Monitor to the data link connector. 3) Start the engine. 4) Run the Subaru Select Monitor. 5) Warm-up the transmission until the ATF temperature exceeds approximately 80°C (176°F).</p> <p>NOTE: If the ambient temperature falls below 0°C (32°F), drive the vehicle until the ATF reaches its operating temperature.</p> <p>6) Stop the engine. 7) Turn the ignition switch to ON. 8) Set the select lever to "N" range. 9) Read the data of "L&R/B Duty" using Subaru Select Monitor.</p>	Is the measured value 100%?	Go to step 5.	Go to step 6.
<p>5 CHECK OUTPUT SIGNAL FROM TCM USING SUBARU SELECT MONITOR.</p> <p>1) Lift up the vehicle. 2) Set the select lever to manual mode, and then hold it in 1st gear. Slowly increase the vehicle speed up to 15 km/h (9 MPH), and then return the accelerator pedal.</p> <p>NOTE: The speed difference between the front and rear wheels will illuminate the ABS warning light or VDC warning light, but this does not indicate a malfunction. If the warning light illuminates, delete the ABS or VDC memory of the on-board diagnosis system after completing the AT control diagnosis. <Ref. to VDC(diag)-24, Clear Memory Mode.></p> <p>3) Read the data of the low & reverse duty solenoid.</p>	Is the measured value 55%?	Check for poor contact in the TCM and transmission harness or connectors, and repair the fault location.	Go to step 6.

Diagnostic Procedure with Diagnostic Trouble Code (DTC)

AUTOMATIC TRANSMISSION (DIAGNOSTICS)

Step	Check	Yes	No
6	CHECK POOR CONTACT.	Is there poor contact in the low & reverse duty solenoid circuit?	Repair the poor contact. Replace the TCM. <Ref. to 4AT-60, Transmission Control Module (TCM).>
7	CHECK LOW & REVERSE BRAKE DUTY SOLENOID (IN TRANSMISSION). 1) Remove the transmission connector from bracket. 2) Drain the automatic transmission fluid. CAUTION: Do not drain ATF until it cools down. 3) Remove the oil pan, and disconnect the connector from control valve body. 4) Measure the resistance between low & reverse duty solenoid connector and transmission ground. <i>Connector & terminal</i> <i>(AT2) No. 1 — Transmission ground:</i>	Is the resistance between 2.0 — 6.0 Ω ?	Go to step 8. Replace the control valve body. <Ref. to 4AT-56, Control Valve Body.>
8	CHECK HARNESS CONNECTOR BETWEEN TRANSMISSION AND LOW & REVERSE DUTY SOLENOID. Measure the resistance of harness between low & reverse duty solenoid and transmission connector. <i>Connector & terminal</i> <i>(T4) No. 6 — (AT2) No. 1:</i>	Is the resistance less than 1 Ω ?	Go to step 9. Repair open circuit of harness between low & reverse duty solenoid and transmission connector.
9	CHECK HARNESS CONNECTOR BETWEEN TRANSMISSION AND LOW & REVERSE DUTY SOLENOID. Measure the resistance of harness between transmission connector and transmission ground. <i>Connector & terminal</i> <i>(T4) No. 6 — Transmission ground:</i>	Is the resistance 1 M Ω or more?	Check for poor contact in the low & reverse duty solenoid and transmission harness or connectors, and repair the fault location. Repair the short circuit of the harness between the low & reverse duty solenoid and the transmission connector.

Diagnostic Procedure with Diagnostic Trouble Code (DTC)

AUTOMATIC TRANSMISSION (DIAGNOSTICS)

T: DTC P0801 REVERSE INHIBIT CONTROL CIRCUIT

DTC DETECTING CONDITION:

Shift lock solenoid malfunction, open or short reverse inhibitor control circuit

TROUBLE SYMPTOM:

- Gear is shifted from “N” range to “R” range during driving at 20 km/h (12 MPH) or more.
- Gear cannot be selected from “N” range to “R” range.

WIRING DIAGRAM:

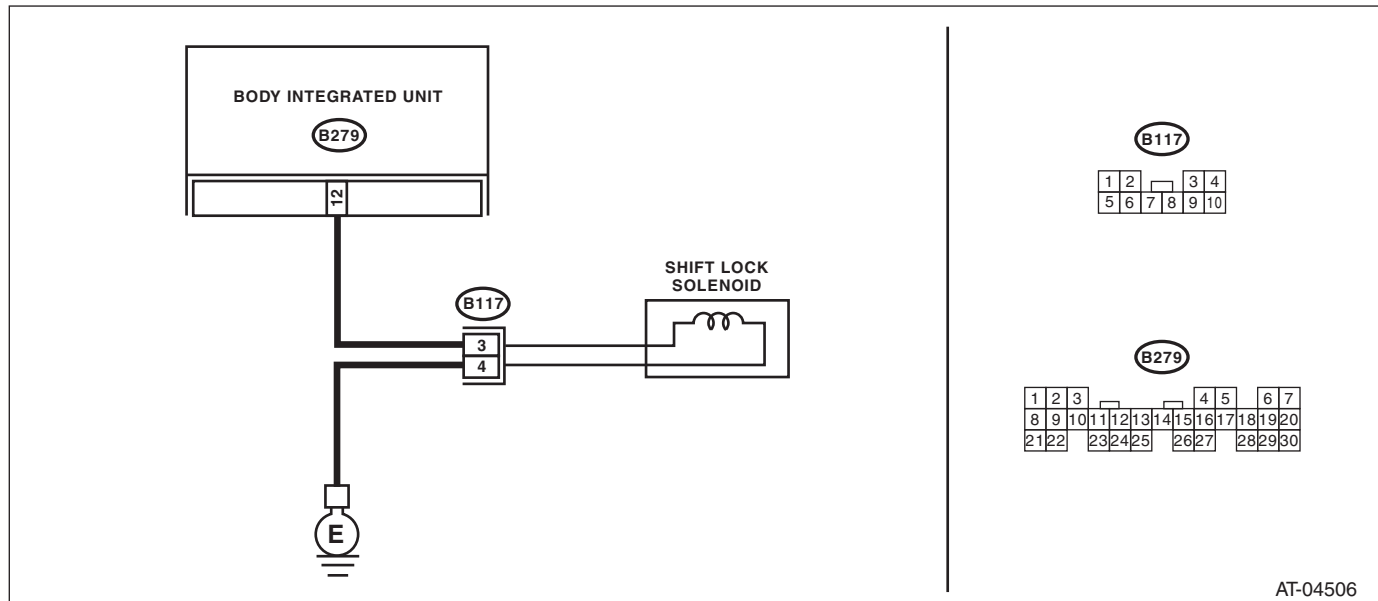

AT-04506

Step	Check	Yes	No
1 CHECK SHIFT LOCK SOLENOID. 1) Force start the integrated unit, and check the operation of shift lock solenoid. (<Ref. to LAN(diag)-15, Read Diagnostic Trouble Code (DTC).>) 2) Operate the select lever without depressing the brake pedal.	Does the select lever operate?	Go to step 2.	Go to step 3.
2 CHECK OUTPUT SIGNAL OF INTEGRATED UNIT. 1) Using the Subaru Select Monitor, display the following items. <ul style="list-style-type: none"> • Key-lock warning SW • Shift Position • P SW • Stop Light Switch 2) Step on the brake and shift the select lever to “P” range.	Do the units of measure of items displayed change?	Go to step 3.	Check the circuits of the items whose values do not change.
3 CHECK HARNESS CONNECTOR BETWEEN BODY INTEGRATED UNIT AND SHIFT LOCK SOLENOID. Measure the harness resistance between the body integrated unit and chassis ground. Connector & terminal (B279) No. 12 — Chassis ground:	Is the resistance 1 MΩ or more?	Go to step 4.	Repair the short circuit of harness between body integrated unit and shift lock solenoid connector.
4 CHECK HARNESS BETWEEN SHIFT LOCK SOLENOID AND CHASSIS GROUND TERMINAL. Measure the resistance of harness between shift lock solenoid and chassis ground. Connector & terminal (B117) No. 4 — Chassis ground:	Is the resistance less than 1 Ω?	Go to step 5.	Repair the open circuit of harness between chassis ground and shift lock solenoid connector.

Diagnostic Procedure with Diagnostic Trouble Code (DTC)

AUTOMATIC TRANSMISSION (DIAGNOSTICS)

Step	Check	Yes	No
5 CHECK SHIFT LOCK SOLENOID. Measure the resistance of shift lock solenoid terminals. <i>Connector & terminal (B117) No. 3 — No. 4:</i>	Is the resistance between 7 — 21 Ω ?	Go to step 6.	Replace the shift lock solenoid.
6 CHECK OUTPUT SIGNAL OF BODY INTEGRATED UNIT. 1) Connect all connectors. 2) Turn the ignition switch to ON. 3) Set the select lever to the “D” range while stepping on the brake pedal. 4) Measure the voltage between body integrated unit and chassis ground. <i>Connector & terminal (B279) No. 12 (+) — Chassis ground (-):</i>	Is the voltage 10.5 V or more?	Go to step 7.	Go to step 8.
7 CHECK OUTPUT SIGNAL OF BODY INTEGRATED UNIT. 1) Lift up the vehicle. 2) Start the engine. 3) Set the select lever to the “D” range and slowly increase vehicle speed to above 20 km/h (12 MPH). NOTE: The speed difference between the front and rear wheels will illuminate the ABS warning light or VDC warning light, but this does not indicate a malfunction. If the warning light illuminates, delete the ABS or VDC memory after completing the AT control diagnosis. <Ref. to VDC (diag)-24, Clear Memory Mode.> 4) Measure the voltage between body integrated unit and chassis ground. <i>Connector & terminal (B279) No. 12 (+) — Chassis ground (-):</i>	Is the voltage less than 1 V?	Check for poor contact in the reverse inhibitor control circuit harness or connectors, and repair the fault location.	Go to step 8.
8 CHECK POOR CONTACT.	Is there poor contact in the reverse inhibitor control circuit?	Repair the poor contact.	Replace the body integrated unit. <Ref. to SL-42, Body Integrated Unit.>

Diagnostic Procedure with Diagnostic Trouble Code (DTC)

AUTOMATIC TRANSMISSION (DIAGNOSTICS)

U: DTC P1706 AT VEHICLE SPEED SENSOR CIRCUIT MALFUNCTION (REAR WHEEL)

DTC DETECTING CONDITION:

Input signal circuit of TCM is open or shorted.

TROUBLE SYMPTOM:

No lock up or tight corner braking phenomenon is occurred.

WIRING DIAGRAM:

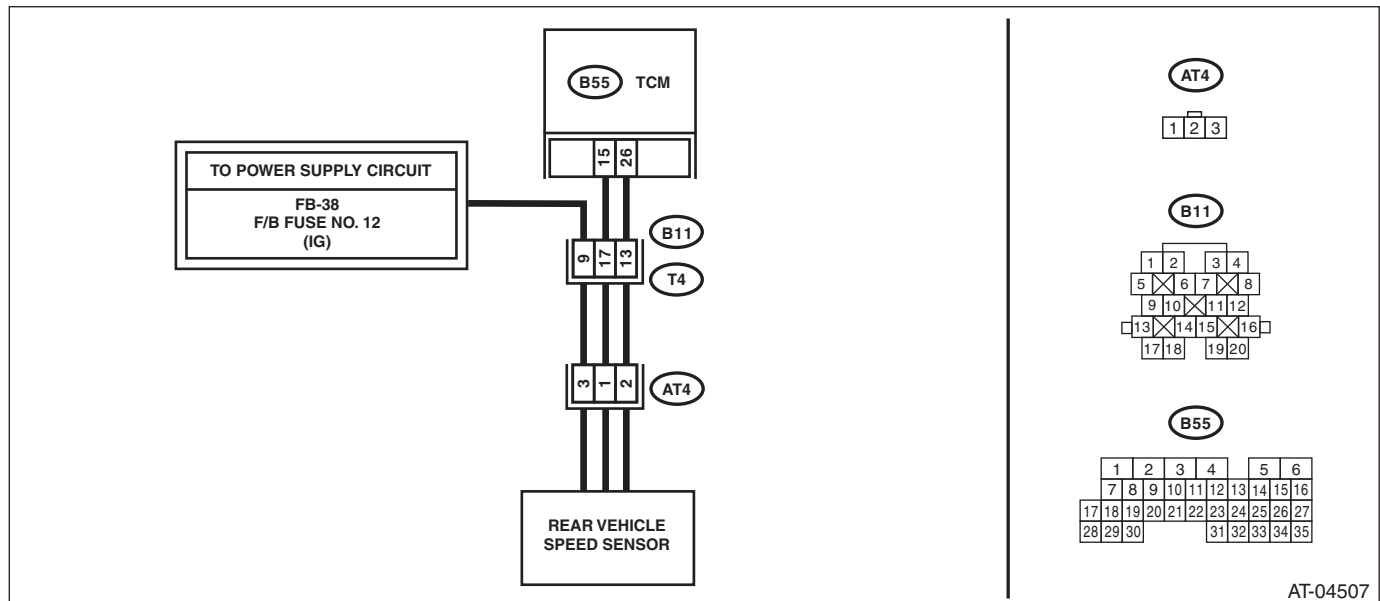

Step	Check	Yes	No
1 CHECK IGNITION POWER SUPPLY CIRCUIT. 1) Turn the ignition switch to OFF. 2) Disconnect the connector from rear vehicle speed sensor. 3) Turn the ignition switch to ON. 4) Measure the ignition power supply voltage between rear vehicle speed sensor connector and transmission ground. Connector & terminal (AT4) No. 3 (+) — Transmission ground (-):	Is the voltage 10 V or more?	Go to step 2.	Check for open circuits, shorts or poor contact in the harness between the rear vehicle speed sensor and battery, and perform repairs.
2 CHECK HARNESS CONNECTOR BETWEEN TCM AND TRANSMISSION. 1) Turn the ignition switch to OFF. 2) Measure the resistance of harness between TCM connector and rear vehicle speed sensor connector. Connector & terminal (B55) No. 15 — (AT4) No. 1:	Is the resistance less than 1 Ω ?	Go to step 3.	Repair the open circuit or poor contact of the connector in harness between TCM and rear vehicle speed sensor connector.
3 CHECK HARNESS CONNECTOR BETWEEN TCM AND TRANSMISSION. Measure the resistance of harness between TCM connector and rear vehicle speed sensor connector. Connector & terminal (B55) No. 26 — (AT4) No. 2:	Is the resistance less than 1 Ω ?	Go to step 4.	Repair the open circuit or poor contact of the connector in harness between TCM and rear vehicle speed sensor connector.

Diagnostic Procedure with Diagnostic Trouble Code (DTC)

AUTOMATIC TRANSMISSION (DIAGNOSTICS)

Step	Check	Yes	No
4 CHECK HARNESS CONNECTOR BETWEEN TCM AND TRANSMISSION. Measure the resistance of the harness between TCM connector and chassis ground. <i>Connector & terminal</i> <i>(B55) No. 15 — Chassis ground:</i>	Is the resistance 1 MΩ or more?	Go to step 5.	Repair the short circuit of harness between TCM and rear vehicle speed sensor connector.
5 CHECK HARNESS CONNECTOR BETWEEN TCM AND TRANSMISSION. Measure the resistance of the harness between TCM connector and chassis ground. <i>Connector & terminal</i> <i>(B55) No. 26 — Chassis ground:</i>	Is the resistance 1 MΩ or more?	Go to step 6.	Repair the short circuit of harness between TCM and rear vehicle speed sensor connector.
6 CHECK INPUT SIGNAL FOR TCM. 1) Connect the connectors to TCM and transmission. 2) Lift up the vehicle. 3) Start the engine and drive the vehicle at 20 km/h (12 MPH). NOTE: The speed difference between the front and rear wheels will illuminate the ABS warning light or VDC warning light, but this does not indicate a malfunction. If the warning light illuminates, delete the ABS or VDC memory after completing the AT control diagnosis. <Ref. to VDC (diag)-24, Clear Memory Mode.> 4) Measure the AC voltage between TCM connector terminals. <i>Connector & terminal</i> <i>(B55) No. 26 (+) — No. 15 (-):</i>	Is the voltage approx. 2 V or more?	Go to step 7.	Replace the rear vehicle speed sensor.
7 CHECK POOR CONTACT.	Is there poor contact in rear vehicle speed sensor circuit?	Repair the poor contact.	Replace the TCM. <Ref. to 4AT-60, Transmission Control Module (TCM).>

Diagnostic Procedure with Diagnostic Trouble Code (DTC)

AUTOMATIC TRANSMISSION (DIAGNOSTICS)

V: DTC P1707 AT AWD SOLENOID VALVE CIRCUIT MALFUNCTION

DTC DETECTING CONDITION:

Output signal circuit of transfer duty solenoid is open or shorted.

TROUBLE SYMPTOM:

- Tight corner braking phenomenon occurs.
- Front wheel slips on slippery roads.

WIRING DIAGRAM:

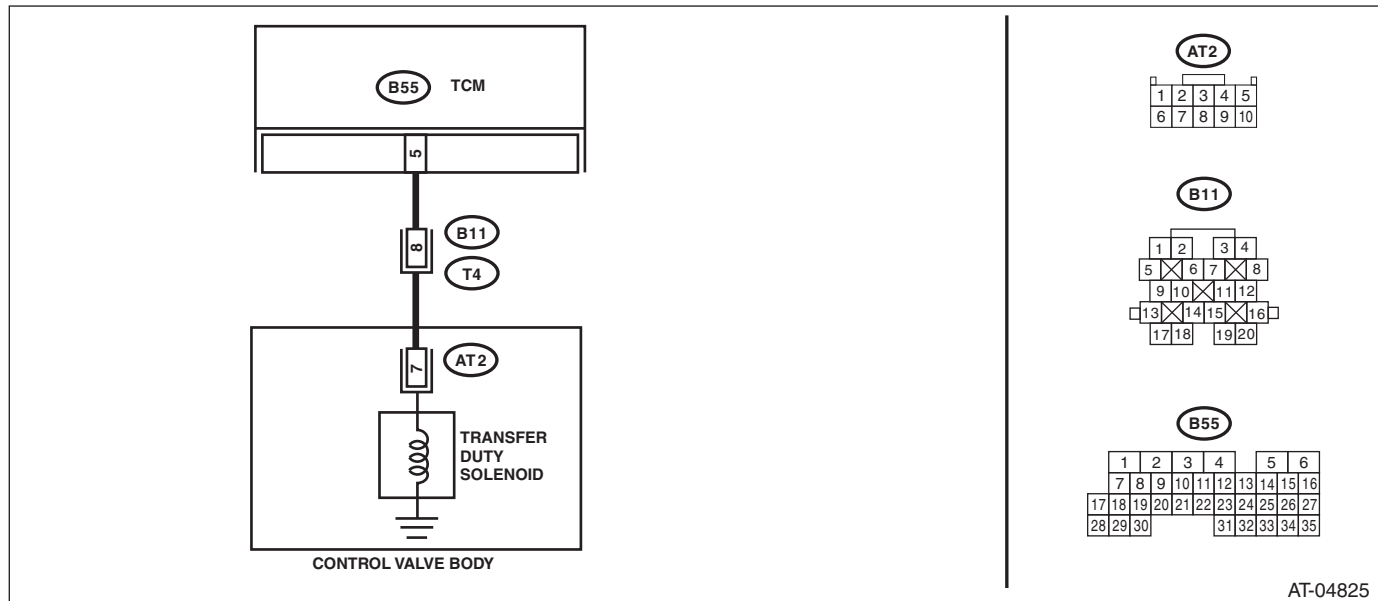

Step	Check	Yes	No
1 CHECK HARNESS CONNECTOR BETWEEN TCM AND TRANSMISSION. 1) Turn the ignition switch to OFF. 2) Disconnect the connectors from TCM and transmission. 3) Measure the resistance of the harness between TCM connector and transmission connector. <i>Connector & terminal (B55) No. 5 — (B11) No. 8:</i>	Is the resistance less than 1 Ω?	Go to step 2.	Repair the open circuit of harness between TCM and transmission connector.
2 CHECK HARNESS CONNECTOR BETWEEN TCM AND TRANSMISSION. Measure the resistance of harness connector between TCM and chassis ground. <i>Connector & terminal (B55) No. 5 — Chassis ground:</i>	Is the resistance 1 MΩ or more?	Go to step 3.	Repair the short circuit of harness between TCM and transmission connector.
3 CHECK TRANSFER DUTY SOLENOID. Measure the resistance between transmission connector and transmission terminals. <i>Connector & terminal (T4) No. 8 — No. 20:</i>	Is the resistance between 2.0 — 6.0 Ω?	Go to step 4.	Go to step 7.

Diagnostic Procedure with Diagnostic Trouble Code (DTC)

AUTOMATIC TRANSMISSION (DIAGNOSTICS)

Step	Check	Yes	No
4 CHECK OUTPUT SIGNAL FROM TCM USING SUBARU SELECT MONITOR. 1) Connect the connectors to TCM and transmission. 2) Connect the Subaru Select Monitor to the data link connector. 3) Turn the ignition switch to ON. 4) Run the Subaru Select Monitor. 5) Set the select lever to the "N" range, and fully close the throttle. (Vehicle speed is 0 km/h (0 MPH)) 6) Using Subaru Select Monitor, read the data of "Transfer Duty Ratio".	Is the value approx. 5%?	Go to step 5.	Go to step 6.
5 CHECK OUTPUT SIGNAL FROM TCM USING SUBARU SELECT MONITOR. 1) Set the select lever to the "D" range. 2) Using Subaru Select Monitor, read the data of "Transfer Duty Ratio".	Is the measured value approx. 18 — 35%?	Check for poor contact in the TCM and transmission harness or connectors, and repair the fault location.	Go to step 6.
6 CHECK POOR CONTACT.	Is there poor contact in transfer duty solenoid circuit?	Repair the poor contact.	Replace the TCM. <Ref. to 4AT-60, Transmission Control Module (TCM).>
7 CHECK TRANSFER DUTY SOLENOID (IN TRANSMISSION). 1) Lift up the vehicle. 2) Drain the automatic transmission fluid. CAUTION: Do not drain ATF until it cools down. 3) Remove the extension case, and disconnect the connector from transfer duty solenoid. 4) Measure the resistance between transfer duty solenoid connector and transmission ground. Connector & terminal (AT2) No. 7 — Transmission ground:	Is the resistance between 2.0 — 6.0 Ω ?	Go to step 8.	Replace the control valve body. <Ref. to 4AT-56, Control Valve Body.>
8 CHECK HARNESS CONNECTOR BETWEEN TRANSFER DUTY SOLENOID AND TRANSMISSION. Measure the resistance of harness between transfer duty solenoid and transmission connector. Connector & terminal (T4) No. 8 — (AT2) No. 7:	Is the resistance less than 1 Ω ?	Go to step 9.	Repair the open circuit of harness between transfer duty solenoid and transmission connector.
9 CHECK HARNESS CONNECTOR BETWEEN TRANSFER DUTY SOLENOID AND TRANSMISSION. Measure the resistance of harness between transmission connector and transmission ground. Connector & terminal (T4) No. 8 — Transmission ground:	Is the resistance 1 M Ω or more?	Check for poor contact in the transfer duty solenoid and transmission harness or connectors, and repair the fault location.	Repair short circuit of the harness between the transfer duty solenoid and transmission connector.

W: DTC P1718 CAN COMMUNICATION CIRCUIT

NOTE:

Refer to "Body Integrated Unit" for diagnosis of P1718. <Ref. to LAN(diag)-2, Basic Diagnostic Procedure.>

Diagnostic Procedure with Diagnostic Trouble Code (DTC)

AUTOMATIC TRANSMISSION (DIAGNOSTICS)

X: DTC P1817 SPORT MODE SWITCH CIRCUIT

DTC DETECTING CONDITION:

Input signal circuit of SPORT shift switch is shorted.

TROUBLE SYMPTOM:

- Manual mode can not be set.
- ATF temperature warning light does not illuminate.
- No SPORT mode occurs.

WIRING DIAGRAM:

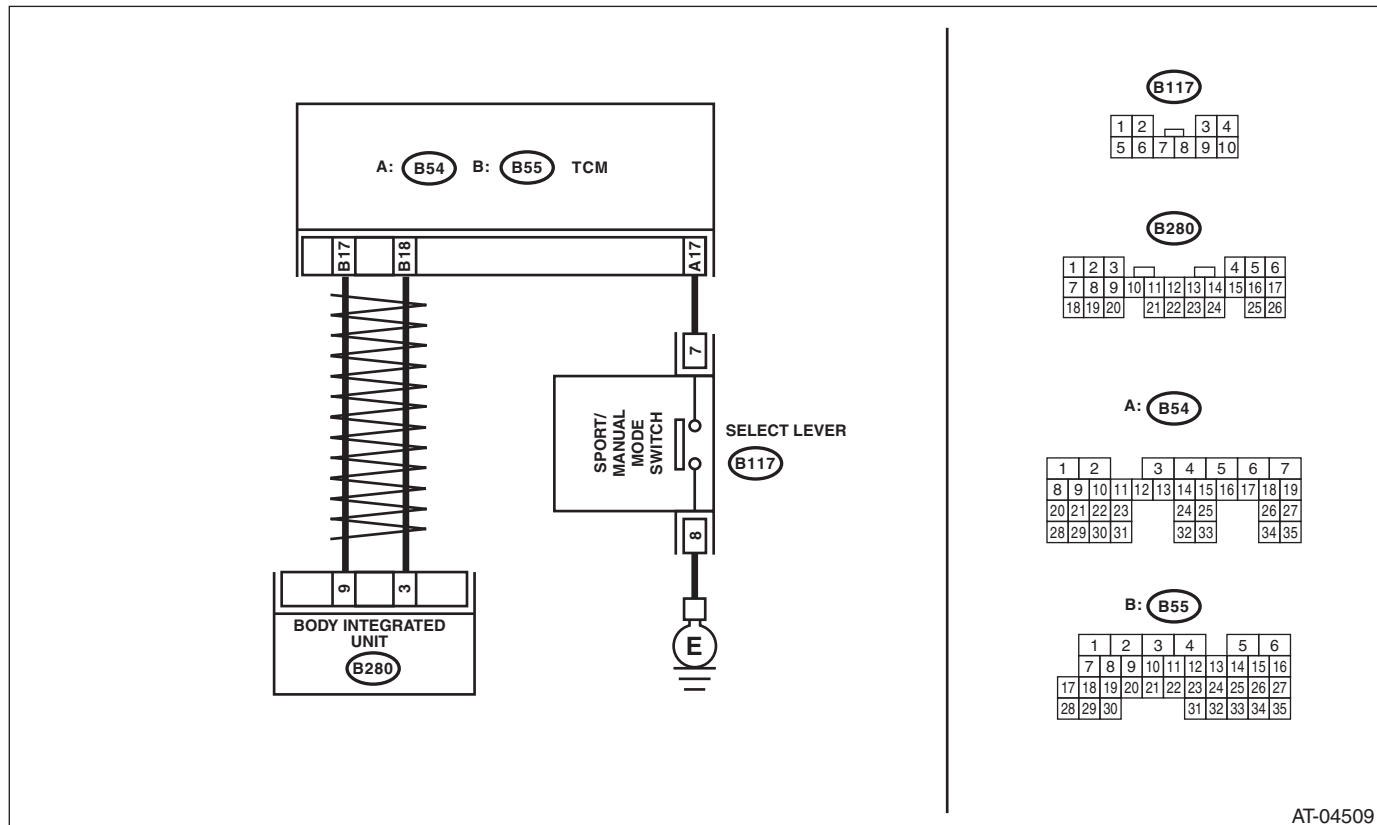

Step	Check	Yes	No
1 CHECK BODY INTEGRATED UNIT. 1) Connect the Subaru Select Monitor to the data link connector. 2) Turn the ignition switch to ON. 3) Read the DTC of the body integrated unit using the Subaru Select Monitor. <Ref. to LAN(diag)-14, OPERATION, Subaru Select Monitor.>	Is DTC displayed?	Perform diagnosis according to the DTC.	Go to step 2.
2 CHECK BODY INTEGRATED UNIT INPUT SIGNAL. 1) Move the select lever to "P" range. 2) Read the "Tiptronic Mode Switch" data of the body integrated unit using the Subaru Select Monitor. <Ref. to LAN(diag)-14, OPERATION, Subaru Select Monitor.>	Is OFF displayed?	Go to step 3.	Go to step 7.

Diagnostic Procedure with Diagnostic Trouble Code (DTC)

AUTOMATIC TRANSMISSION (DIAGNOSTICS)

Step	Check	Yes	No
3 CHECK BODY INTEGRATED UNIT INPUT SIGNAL. 1) Move the select lever from the "P" range to the "D" range. 2) Read the "Tiptronic Mode Switch" data of the body integrated unit using the Subaru Select Monitor. <Ref. to LAN(diag)-14, OPERATION, Subaru Select Monitor.>	Is the indication on each range OFF?	Go to step 4.	Replace the select lever assembly. <Ref. to CS-20, Select Lever.>
4 CHECK BODY INTEGRATED UNIT INPUT SIGNAL. 1) Shift the select lever to the SPORT mode side. 2) Set the select lever to a range other than "D". 3) Read the "Tiptronic Mode Switch" data of the body integrated unit using the Subaru Select Monitor. <Ref. to LAN(diag)-14, OPERATION, Subaru Select Monitor.>	Is OFF displayed?	Go to step 5.	Replace the select lever assembly. <Ref. to CS-20, Select Lever.>
5 CHECK INHIBITOR SWITCH. Move the select lever from the "P" range to the "D" range.	Is the indication of range position indicator light in combination meter synchronized with position of select lever?	Go to step 6.	Adjust the inhibitor switch and select cable. <Ref. to 4AT-46, ADJUSTMENT, Inhibitor Switch.> <Ref. to CS-27, ADJUSTMENT, Select Cable.>
6 CHECK INPUT SIGNAL FROM TCM. 1) Move the select lever from the "P" range to the "D" range. 2) Read the "Tiptronic Mode Switch" data of the TCM using the Subaru Select Monitor. <Ref. to 4AT(diag)-15, OPERATION, Subaru Select Monitor.>	Is the indication on each range OFF?	Check for short circuits in the harness or connectors, and repair the fault location.	Replace the TCM. <Ref. to 4AT-60, Transmission Control Module (TCM).>
7 CHECK HARNESS BETWEEN TCM AND SPORT SHIFT SWITCH. 1) Turn the ignition switch to OFF. 2) Disconnect the harness connectors from the TCM and select lever. 3) Measure the resistance between TCM and chassis ground. <i>Connector & terminal</i> <i>(B54) No. 17 — Chassis ground:</i>	Is the resistance 1 M Ω or more?	Go to step 8.	Repair the short circuit in the harness between the TCM and sports shift switch.
8 CHECK SPORT SHIFT SWITCH. 1) Move the select lever to "P" range. 2) Measure the resistance between the SPORT shift switch connector terminals. <i>Connector & terminal</i> <i>(B117) No. 7 — No. 8:</i>	Is the resistance 1 M Ω or more?	Check the body integrated unit.	Replace the select lever assembly. <Ref. to CS-20, Select Lever.>

Diagnostic Procedure without Diagnostic Trouble Code (DTC)

AUTOMATIC TRANSMISSION (DIAGNOSTICS)

16. Diagnostic Procedure without Diagnostic Trouble Code (DTC)

A: CHECK FWD SWITCH

DIAGNOSIS:

- LED does not illuminate even if FWD switch is ON.
- FWD signal circuit is open or shorted.

WIRING DIAGRAM:

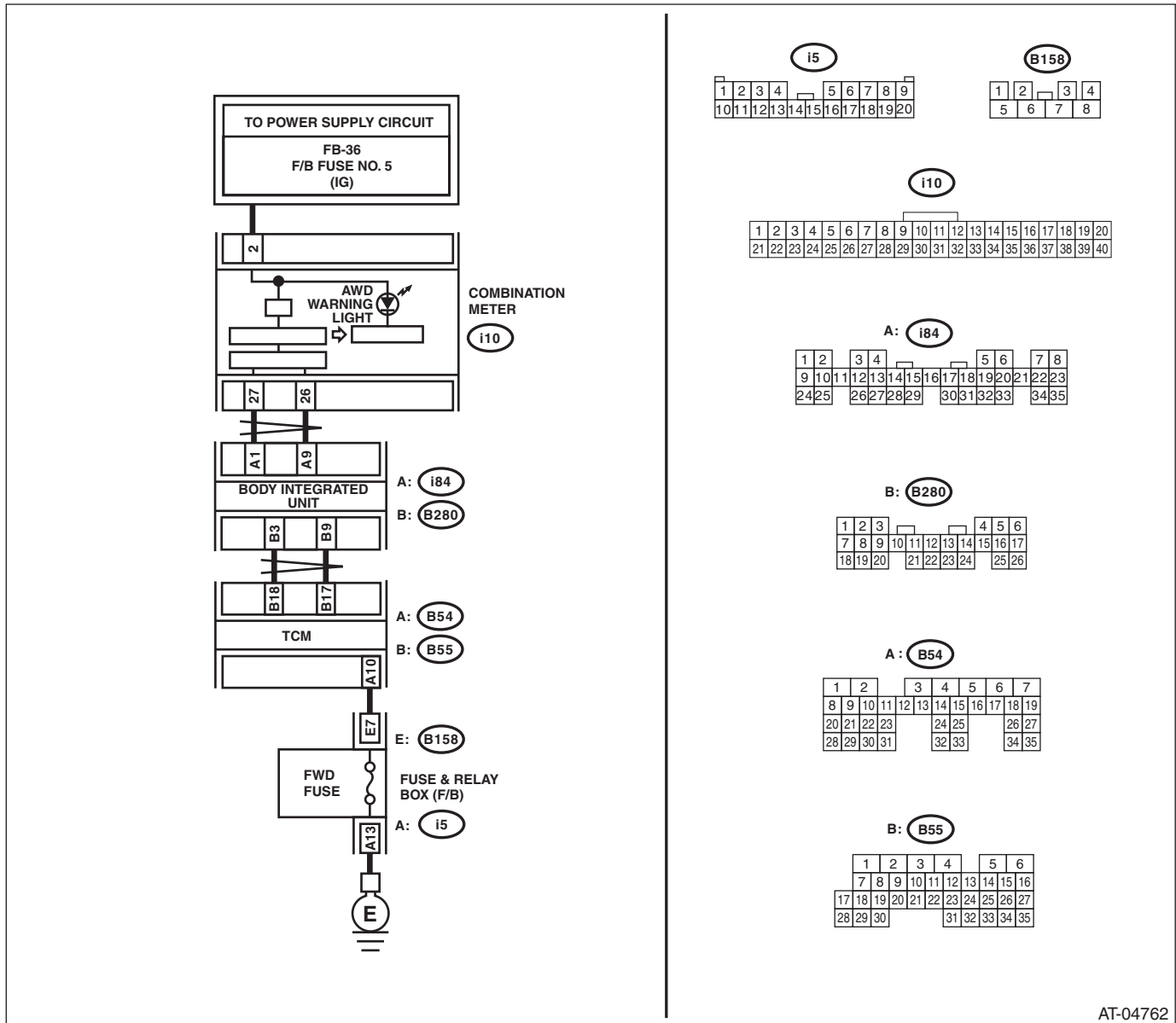

AT-04762

Step	Check	Yes	No
1	CHECK SPARE FUSE.	Go to step 2.	Replace the fuse.
2	CHECK FWD SWITCH. Connect the Subaru Select Monitor to the data link connector.	Go to step 3.	Go to step 4.
		Is the spare fuse OK?	When the fuse is inserted to FWD switch, does the LED illuminate?

Diagnostic Procedure without Diagnostic Trouble Code (DTC)

AUTOMATIC TRANSMISSION (DIAGNOSTICS)

Step	Check	Yes	No
3 CHECK COMBINATION METER.	Does the AWD warning light illuminate?	Check the SPORT shift switch. <Ref. to 4AT(diag)-82, CHECK SPORT SHIFT SWITCH, Diagnostic Procedure without Diagnostic Trouble Code (DTC).>	Go to step 9.
4 CHECK HARNESS CONNECTOR BETWEEN TCM AND FWD SWITCH. 1) Turn the ignition switch to OFF. 2) Disconnect the connector from TCM. 3) Measure the resistance of harness between TCM and FWD switch connector. Connector & terminal (B54) No. 10 — (B158) No. 7:	Is the resistance less than 1 Ω?	Go to step 5.	Repair the open circuit of harness between TCM and FWD switch connectors.
5 CHECK HARNESS CONNECTOR BETWEEN FWD SWITCH AND CHASSIS GROUND. Measure the resistance of harness between FWD switch and chassis ground. Connector & terminal (i5) No. 13 — Chassis ground:	Is the resistance less than 1 Ω?	Go to step 6.	Repair the open circuit of harness between FWD switch connector and chassis ground.
6 CHECK HARNESS CONNECTOR BETWEEN TCM AND FWD SWITCH. Measure the resistance of the harness connector between the TCM and chassis ground to make sure that there are no shorts in the circuit. Connector & terminal (B54) No. 10 — Chassis ground:	Is the resistance 1 MΩ or more?	Go to step 7.	Repair the short circuit of harness between TCM and FWD switch connectors.
7 CHECK INPUT SIGNAL FOR TCM. 1) Turn the ignition switch to OFF. 2) Connect the connector to TCM. 3) Turn the ignition switch to ON. 4) Measure the signal voltage for TCM while installing the fuse to FWD switch connector. Connector & terminal (B54) No. 10 (+) — Chassis ground (-):	Is the voltage less than 1 V?	Go to step 8.	Go to step 10.
8 CHECK INPUT SIGNAL FOR TCM. Measure the signal voltage for TCM with the fuse removed from FWD switch connector. Connector & terminal (B54) No. 10 (+) — Chassis ground (-):	Is the voltage 10.5 V or more?	Go to step 9.	Replace the TCM. <Ref. to 4AT-60, Transmission Control Module (TCM).>
9 CHECK BODY INTEGRATED UNIT. Check DTC of body integrated unit.	Is DTC of CAN communication displayed?	Perform diagnosis according to the DTC.	Go to step 10.
10 CHECK COMBINATION METER. Check the AWD warning light. <Ref. to IDI-4, INSPECTION, Combination Meter System.>	Is the AWD warning light OK?	Go to step 11.	Replace the combination meter assembly. <Ref. to IDI-16, Combination Meter.>
11 CHECK POOR CONTACT.	Is there poor contact in FWD switch circuit?	Repair the poor contact.	Replace the TCM. <Ref. to 4AT-60, Transmission Control Module (TCM).>

Diagnostic Procedure without Diagnostic Trouble Code (DTC)

AUTOMATIC TRANSMISSION (DIAGNOSTICS)

B: CHECK SPORT SHIFT SWITCH

DIAGNOSIS:

Input signal circuit of SPORT shift switch is open or shorted.

TROUBLE SYMPTOM:

Does not shift on manual mode.

WIRING DIAGRAM:

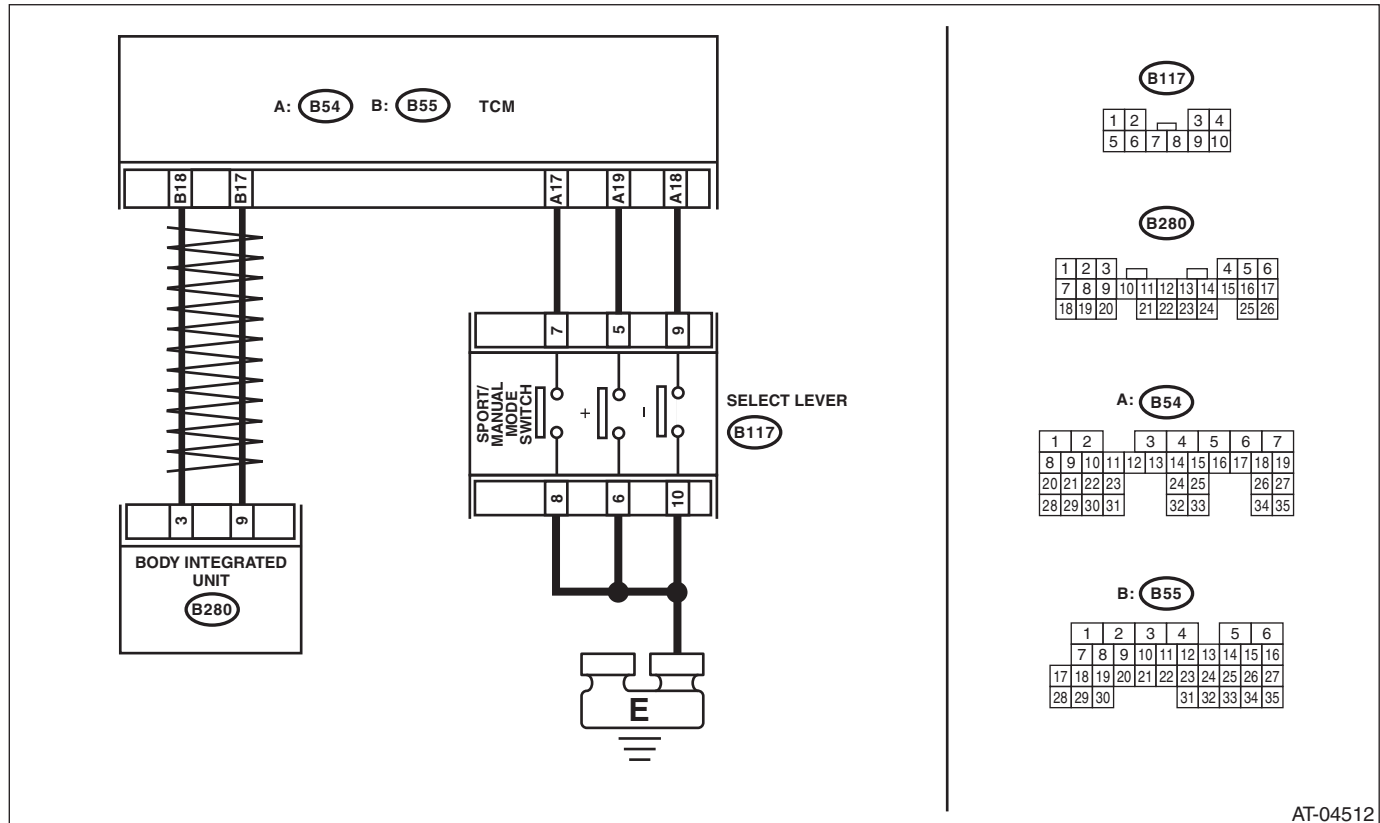

AT-04512

Diagnostic Procedure without Diagnostic Trouble Code (DTC)

AUTOMATIC TRANSMISSION (DIAGNOSTICS)

	Step	Check	Yes	No
1	CHECK SPORT SHIFT SWITCH. 1) Shift the select lever to the SPORT mode. 2) Set and hold the select lever at the + side. 3) Read the "Up Switch" data of the TCM using the Subaru Select Monitor. <Ref. to 4AT(diag)-16, Read Current Data.>	Is ON displayed?	Go to step 2.	Go to step 3.
2	CHECK SPORT SHIFT SWITCH. 1) Set and hold the select lever at the – side. 2) Read the "Down Switch" data of the TCM using the Subaru Select Monitor. <Ref. to 4AT(diag)-16, Read Current Data.>	Is ON displayed?	Go to the procedure "CHECK SPORT SHIFT INDICATOR". <Ref. to 4AT(diag)-85, CHECK SPORT SHIFT INDICATOR, Diagnostic Procedure without Diagnostic Trouble Code (DTC).>	Go to step 14.
3	CHECK BODY INTEGRATED UNIT. 1) Turn the ignition switch to ON. 2) Set and hold the select lever at the + side. 3) Read the "TIP UP SW Input" data of the body integrated unit using the Subaru Select Monitor. <Ref. to LAN(diag)-17, Read Current Data.>	Is ON displayed?	Go to step 4.	Go to step 5.
4	CHECK BODY INTEGRATED UNIT. Check the DTC of the body integrated unit. <Ref. to LAN(diag)-14, OPERATION, Subaru Select Monitor.>	Is DTC of CAN communication displayed?	Perform diagnosis according to the DTC.	Check the TCM.
5	CHECK SPORT SHIFT SWITCH GROUND CIRCUIT. 1) Turn the ignition switch to OFF. 2) Disconnect the connector from SPORT shift switch. 3) Measure the resistance of harness between SPORT shift switch connector and chassis ground. <i>Connector & terminal</i> <i>(B117) No. 6 — Chassis ground:</i> <i>(B117) No. 10 — Chassis ground:</i>	Is the resistance less than 1 Ω?	Go to step 6.	Repair the open circuit of the harness between the SPORT shift switch and chassis ground.
6	CHECK SPORT SHIFT SWITCH. Measure the resistance between SPORT shift switch terminals. <i>Connector & terminal</i> <i>(B117) No. 6 — No. 5:</i> <i>(B117) No. 10 — No. 9:</i>	Is the resistance 1 MΩ or more?	Go to step 7.	Replace the guide plate assembly.
7	CHECK SPORT SHIFT SWITCH. 1) Set and hold the select lever at the + side. 2) Measure the resistance between SPORT shift switch terminals. <i>Connector & terminal</i> <i>(B117) No. 6 — No. 5:</i>	Is the resistance less than 1 Ω?	Go to step 8.	Replace the guide plate assembly.
8	CHECK SPORT SHIFT SWITCH. 1) Set and hold the select lever at the – side. 2) Measure the resistance between SPORT shift switch terminals. <i>Connector & terminal</i> <i>(B117) No. 10 — No. 9:</i>	Is the resistance less than 1 Ω?	Go to step 9.	Replace the guide plate assembly.

Diagnostic Procedure without Diagnostic Trouble Code (DTC)

AUTOMATIC TRANSMISSION (DIAGNOSTICS)

Step	Check	Yes	No
9 CHECK HARNESS CONNECTOR BETWEEN TCM AND SPORT SHIFT SWITCH. 1) Disconnect the connector from TCM. 2) Measure the resistance of harness between TCM connector and sport shift switch connector. Connector & terminal (B117) No. 5 — (B54) No. 19: (B117) No. 9 — (B54) No. 18:	Is the resistance less than 1 Ω ?	Go to step 10.	Repair the open circuit of harness between SPORT shift switch connector and TCM connector, or poor contact in connector.
10 CHECK HARNESS CONNECTOR BETWEEN TCM AND SPORT SHIFT SWITCH. Measure the resistance of harness between SPORT shift switch connector and chassis ground. Connector & terminal (B117) No. 5 — Chassis ground: (B117) No. 9 — Chassis ground:	Is the resistance 1 M Ω or more?	Go to step 11.	Repair the short circuit of the harness between the SPORT shift switch connector and TCM connector.
11 CHECK INPUT SIGNAL TO TCM. 1) Connect all connectors. 2) Turn the ignition switch to ON. 3) Measure the voltage of signal to TCM. Connector & terminal (B54) No. 18 (+) — Chassis ground (-): (B54) No. 19 (+) — Chassis ground (-):	Is the voltage 1.5 — 8 V?	Go to step 12.	Replace the TCM.
12 CHECK INPUT SIGNAL TO TCM. 1) Set and hold the select lever at the + side. 2) Measure the voltage of signal to TCM. Connector & terminal (B54) No. 19 (+) — Chassis ground (-):	Is the voltage less than 1 V?	Go to step 13.	Replace the TCM.
13 CHECK INPUT SIGNAL TO TCM. 1) Set and hold the select lever at the – side. 2) Measure the voltage of signal to TCM. Connector & terminal (B54) No. 18 (+) — Chassis ground (-):	Is the voltage less than 1 V?	Go to step 14.	Replace the TCM. <Ref. to 4AT-60, Transmission Control Module (TCM).>
14 CHECK BODY INTEGRATED UNIT. 1) Turn the ignition switch to ON. 2) Set and hold the select lever at the – side. 3) Read the “TIP UP SW input” data of the body integrated unit using the Subaru Select Monitor. <Ref. to LAN(diag)-17, Read Current Data.>	Is ON displayed?	Go to step 15.	Replace the body integrated unit. <Ref. to SL-42, Body Integrated Unit.>
15 CHECK POOR CONTACT.	Is there poor contact in the circuit?	Repair the poor contact.	A temporary poor contact of the circuit connector or harness.

Diagnostic Procedure without Diagnostic Trouble Code (DTC)

AUTOMATIC TRANSMISSION (DIAGNOSTICS)

C: CHECK SPORT SHIFT INDICATOR

DIAGNOSIS:

Output signal circuit of SPORT shift indicator is open or shorted.

TROUBLE SYMPTOM:

- SPORT shift indicator does not display or remains displayed.
- SPORT shift indicator display does not change.

WIRING DIAGRAM:

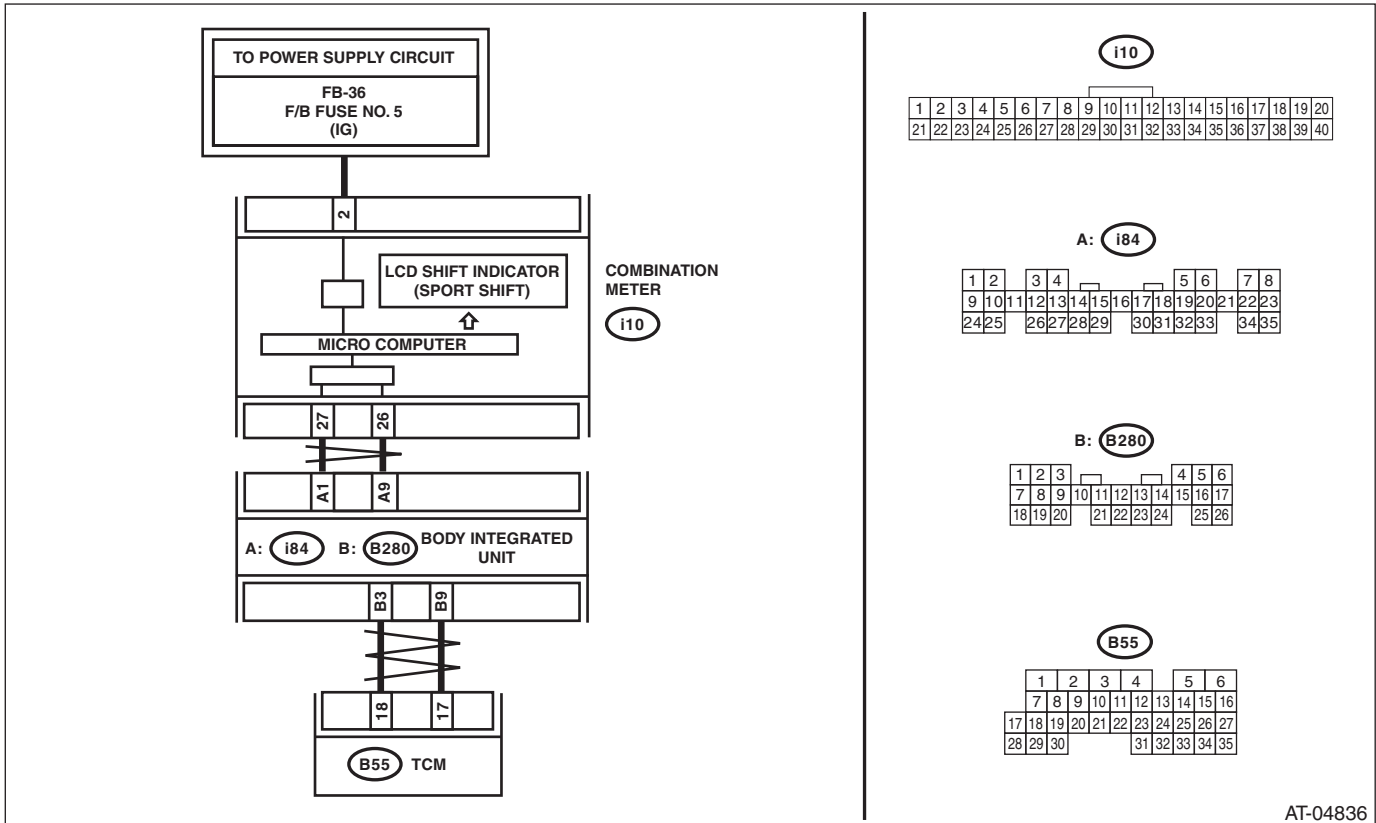

AT-04836

Diagnostic Procedure without Diagnostic Trouble Code (DTC)

AUTOMATIC TRANSMISSION (DIAGNOSTICS)

	Step	Check	Yes	No
1	CHECK BODY INTEGRATED UNIT. Check DTC of body integrated unit.	Is DTC of CAN communication displayed?	Perform diagnosis according to the DTC.	Go to step 2.
2	CHECK TCM. 1) Turn the ignition switch to OFF. 2) Connect the Subaru Select Monitor to the data link connector. 3) Turn the ignition switch to ON. 4) Run the Subaru Select Monitor. 5) Shift the select lever to the SPORT mode side. 6) Read the "Gear Position" data of TCM using Subaru Select Monitor.	Is the gear position 1?	Go to step 3.	Replace the TCM. <Ref. to 4AT-60, Transmission Control Module (TCM).>
3	CHECK TCM. 1) Shift the select lever up. 2) Read the "Gear Position" data of TCM using Subaru Select Monitor.	Is the gear position 2?	Go to step 4.	Replace the TCM. <Ref. to 4AT-60, Transmission Control Module (TCM).>
4	CHECK BODY INTEGRATED UNIT. Using the Subaru Select Monitor, read the data of "Shift Position".	Is the SPORT shift gear position 2?	Go to step 5.	Check the body integrated unit.
5	CHECK COMBINATION METER. <Ref. to IDI-4, INSPECTION, Combination Meter System.>	Is the SPORT shift indicator OK?	Check the buzzer. <Ref. to 4AT(diag)-87, CHECK BUZZER, Diagnostic Procedure without Diagnostic Trouble Code (DTC).>	Replace the combination meter assembly. <Ref. to IDI-16, Combination Meter.>

Diagnostic Procedure without Diagnostic Trouble Code (DTC)

AUTOMATIC TRANSMISSION (DIAGNOSTICS)

D: CHECK BUZZER

DIAGNOSIS:

Output signal circuit of buzzer is open or shorted.

TROUBLE SYMPTOM:

Buzzer remains beeping.

WIRING DIAGRAM:

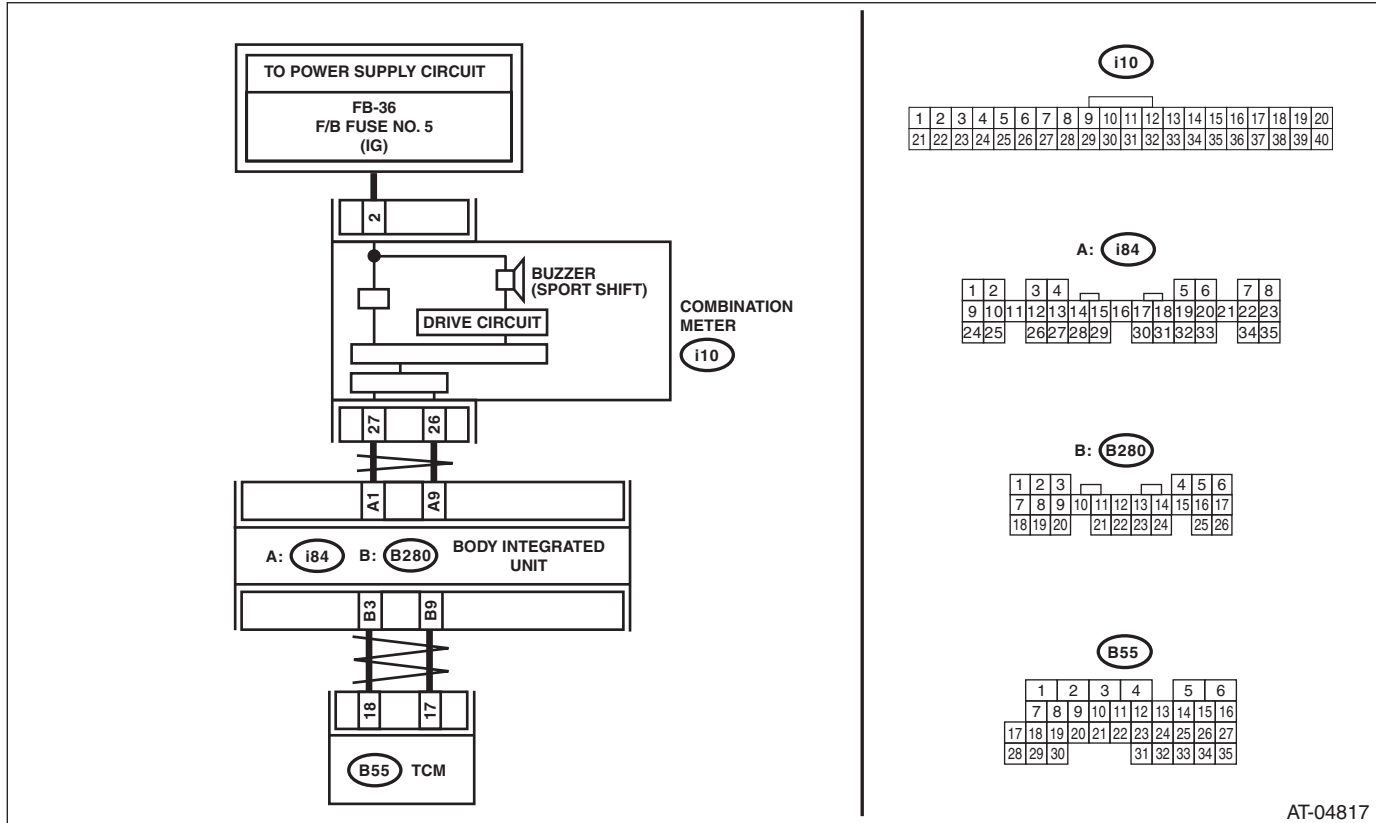

AT-04817

Step	Check	Yes	No
1 CHECK BODY INTEGRATED UNIT. 1) Turn the ignition switch to OFF. 2) Connect the Subaru Select Monitor to the data link connector. 3) Turn the ignition switch to ON. 4) Run the Subaru Select Monitor. 5) Using the Subaru Select Monitor, read the data of "SPORT shift (buzzer 1)" and "SPORT shift (buzzer 2)".	Is ON displayed?	Replace the TCM. <Ref. to 4AT-60, Transmission Control Module (TCM).>	Go to step 2.
2 CHECK COMBINATION METER. <Ref. to IDI-4, INSPECTION, Combination Meter System.>	Is the buzzer OK?	Refer to "Diagnostics with Phenomenon". <Ref. to 4AT(diag)-88, Diagnostics with Phenomenon.>	Replace the combination meter assembly. <Ref. to IDI-16, Combination Meter.>

Diagnostics with Phenomenon

AUTOMATIC TRANSMISSION (DIAGNOSTICS)

17. Diagnostics with Phenomenon

A: INSPECTION

Symptom	Problem parts
Starter does not operate when select lever is in "P" or "N" range. Starter operates when select lever is in "R" or "D" range.	<ul style="list-style-type: none"> • Inhibitor switch • Select cable • Select lever • Starter motor and harness
Abnormal noise when select lever is in "P" or "N".	<ul style="list-style-type: none"> • Strainer • Transfer duty solenoid • Oil pump • Drive plate • ATF level too high or too low
Hissing noise occurs during standing start.	<ul style="list-style-type: none"> • Strainer • ATF level too high or too low
Noise occurs while driving in "D1".	<ul style="list-style-type: none"> • Final gear • Planetary gear • Reduction gear • Differential gear oil level too high or too low
Noise occurs while driving in "D2".	<ul style="list-style-type: none"> • Final gear • Low & reverse brake • Reduction gear • Differential gear oil level too high or too low
Noise occurs while driving in "D3".	<ul style="list-style-type: none"> • Final gear • Low & reverse brake • Planetary gear • Reduction gear • Differential gear oil level too high or too low
Noise occurs while driving in "D4".	<ul style="list-style-type: none"> • Final gear • Low & reverse brake • Planetary gear • Reduction gear • Differential gear oil level too high or too low
Vehicle moves when select lever is in "N" range.	<ul style="list-style-type: none"> • Select cable • Inhibitor switch • TCM • Low clutch
Shock occurs when select lever is shifted from "N" to "D" range.	<ul style="list-style-type: none"> • Accelerator pedal position sensor • ATF temperature sensor • Line pressure linear solenoid • Low clutch duty solenoid • Low clutch • TCM • Harness • Control valve • ATF deterioration
Excessive time lag occurs when select lever is shifted from "N" to "D" range.	<ul style="list-style-type: none"> • Control valve • Low clutch • Line pressure linear solenoid • Seal ring • Front gasket of transmission case
Shock occurs when select lever is shifted from "N" to "R" range.	<ul style="list-style-type: none"> • Accelerator pedal position sensor • ATF temperature sensor • Line pressure linear solenoid • TCM • Harness • Control valve • ATF deterioration
Excessive time lag occurs when select lever is shifted from "N" to "R" range.	<ul style="list-style-type: none"> • Control valve • Low & reverse clutch • Reverse clutch • Line pressure linear solenoid • Seal ring • Front gasket of transmission case

Diagnostics with Phenomenon

AUTOMATIC TRANSMISSION (DIAGNOSTICS)

Symptom	Problem parts
Vehicle does not start in any shift range. (Engine stalls)	<ul style="list-style-type: none"> • Parking brake mechanism • Planetary gear
Vehicle does not start in any shift range. (Engine operates)	<ul style="list-style-type: none"> • Strainer • Line pressure linear solenoid • Control valve • Drive pinion • Hypoid gear • Axle shaft • Differential gear • Oil pump • Input shaft • Output shaft • Planetary gear • Drive plate • ATF level is too low • Front gasket of transmission case
Vehicle does not start only in the "R" range. (Engine operates)	<ul style="list-style-type: none"> • Select cable • Select lever • Line pressure linear solenoid • Control valve • Low & reverse clutch • Reverse clutch
Vehicle does not start only in the "R" range. (Engine stalls)	<ul style="list-style-type: none"> • Low clutch • 2-4 brake • Planetary gear • Parking brake mechanism
Vehicle does not start in "D" range. (Engine operates)	<ul style="list-style-type: none"> • Low clutch • One-way clutch
Vehicle does not start in "D" range. (Engine stalls)	<ul style="list-style-type: none"> • Reverse clutch
Vehicle does not start only in the "R" range. (Engine operates)	<ul style="list-style-type: none"> • Control valve
Acceleration during standing start is poor. (High rpm stall)	<ul style="list-style-type: none"> • Control valve • Low clutch • Reverse clutch • ATF level is too low • ATF deterioration • Front gasket of transmission case • Differential gear oil level too high or too low
Acceleration during standing start is poor. (Low rpm stall)	<ul style="list-style-type: none"> • Oil pump • Torque converter one-way clutch • Engine performance
Acceleration is poor when select lever is in "D" range. (Normal rpm stall)	<ul style="list-style-type: none"> • TCM • Control valve • High clutch • 2-4 brake • Planetary gear
Acceleration is poor when select lever is in "R" range. (Normal rpm stall)	<ul style="list-style-type: none"> • Control valve • High clutch • 2-4 brake • Planetary gear
No shift occurs from 1st to 2nd gear.	<ul style="list-style-type: none"> • TCM • Rear vehicle speed sensor • Front vehicle speed sensor • Accelerator pedal position sensor • Control valve • 2-4 brake
No shift occurs from 2nd to 3rd gear.	<ul style="list-style-type: none"> • TCM • Control valve • High clutch

Diagnostics with Phenomenon

AUTOMATIC TRANSMISSION (DIAGNOSTICS)

Symptom	Problem parts
No shift occurs from 3rd to 4th gear.	<ul style="list-style-type: none"> • TCM • ATF temperature sensor • Control valve • 2-4 brake
Engine brake is not effected when the select lever is shifted from 4th gear to 3rd gear.	<ul style="list-style-type: none"> • Inhibitor switch • TCM • Accelerator pedal position sensor • Control valve
Engine brake is not effected when the select lever is shifted from 3rd gear to 2nd gear.	<ul style="list-style-type: none"> • Control valve
Engine brake is not effected when the select lever is shifted from 2nd gear to 1st gear.	<ul style="list-style-type: none"> • Control valve • Low & reverse brake
Shift characteristics are erroneous.	<ul style="list-style-type: none"> • Inhibitor switch • TCM • Front vehicle speed sensor • Rear vehicle speed sensor • Accelerator pedal position sensor • Control valve • Ground
No lock-up occurs.	<ul style="list-style-type: none"> • TCM • Accelerator pedal position sensor • ATF temperature sensor • Control valve • Lock-up facing • Engine speed signal
Parking brake does not function.	<ul style="list-style-type: none"> • Select cable
Shift lever cannot be moved or is hard to move from "P" range.	<ul style="list-style-type: none"> • Select lever • Parking mechanism
ATF spurts out.	<ul style="list-style-type: none"> • ATF level too high
Differential oil spurts out.	<ul style="list-style-type: none"> • Differential gear oil level too high
Differential oil level changes excessively.	<ul style="list-style-type: none"> • Seal pipe • Double oil seal
Odor is produced from ATF supply pipe.	<ul style="list-style-type: none"> • High clutch • 2-4 brake • Low & reverse clutch • Reverse clutch • Lock-up facing • ATF deterioration
Shock occurs when shifting from 1st to 2nd gear.	<ul style="list-style-type: none"> • TCM • Torque converter turbine speed sensor • Accelerator pedal position sensor • 2-4 brake duty solenoid • ATF temperature sensor • Line pressure linear solenoid • Control valve • 2-4 brake • ATF deterioration • Engine performance • Low & reverse duty solenoid
Slippage occurs when shifting from 1st to 2nd gear.	<ul style="list-style-type: none"> • TCM • Accelerator pedal position sensor • 2-4 brake duty solenoid • ATF temperature sensor • Line pressure linear solenoid • Control valve • 2-4 brake

Diagnostics with Phenomenon

AUTOMATIC TRANSMISSION (DIAGNOSTICS)

Symptom	Problem parts
Shock occurs when shifting from 2nd to 3rd gear.	<ul style="list-style-type: none"> • TCM • Torque converter turbine speed sensor • Accelerator pedal position sensor • 2-4 brake duty solenoid • ATF temperature sensor • Line pressure linear solenoid • Low & reverse duty solenoid • Control valve • High clutch • 2-4 brake • ATF deterioration • Engine performance • High clutch duty solenoid
Slippage occurs when shifting from 2nd to 3rd gear.	<ul style="list-style-type: none"> • TCM • Accelerator pedal position sensor • 2-4 brake duty solenoid • ATF temperature sensor • Line pressure linear solenoid • Control valve • High clutch • 2-4 brake • Low & reverse duty solenoid
Shock occurs when shifting from 3rd to 4th gear.	<ul style="list-style-type: none"> • TCM • Torque converter turbine speed sensor • Accelerator pedal position sensor • 2-4 brake duty solenoid • ATF temperature sensor • Line pressure linear solenoid • Control valve • Low clutch duty solenoid • 2-4 brake • ATF deterioration • Engine performance
Slippage occurs when shifting from 3rd to 4th gear.	<ul style="list-style-type: none"> • TCM • Accelerator pedal position sensor • 2-4 brake duty solenoid • ATF temperature sensor • Line pressure linear solenoid • Control valve • 2-4 brake
Shock occurs when shifting from 3rd to 2nd gear.	<ul style="list-style-type: none"> • TCM • Torque converter turbine speed sensor • Accelerator pedal position sensor • ATF temperature sensor • Line pressure linear solenoid • Control valve • 2-4 brake duty solenoid • 2-4 brake • ATF deterioration • High clutch duty solenoid
Shift shock occurs when shifting from 2nd to 1st gear.	<ul style="list-style-type: none"> • TCM • Torque converter turbine speed sensor • Accelerator pedal position sensor • ATF temperature sensor • Line pressure linear solenoid • Control valve • Low & reverse clutch • ATF deterioration • 2-4 brake duty solenoid • Low & reverse brake duty solenoid

Diagnostics with Phenomenon

AUTOMATIC TRANSMISSION (DIAGNOSTICS)

Symptom	Problem parts
Shock occurs when accelerator pedal is released from medium speed.	<ul style="list-style-type: none"> • TCM • Acceleration pedal position sensor • ATF temperature sensor • Line pressure linear solenoid • Control valve • Lock-up damper • Engine performance
Vibration occurs during straight-forward operation.	<ul style="list-style-type: none"> • TCM • Lock-up duty solenoid • Lock-up facing • Lock-up damper
Vibration occurs during turns. (Tight corner braking phenomenon)	<ul style="list-style-type: none"> • TCM • Front vehicle speed sensor • Rear vehicle speed sensor • Acceleration pedal position sensor • ATF temperature sensor • Transfer clutch • Control valve • Transfer duty solenoid • ATF deterioration • Harness
Front wheel slippage occurs during standing starts.	<ul style="list-style-type: none"> • TCM • Front vehicle speed sensor • Acceleration pedal position sensor • ATF temperature sensor • Control valve • Transfer clutch • Control valve • Transfer pipe • Transfer duty solenoid
It is not set in FWD mode.	<ul style="list-style-type: none"> • TCM • Transfer clutch • Control valve • Transfer duty solenoid
Select lever is hard to move.	<ul style="list-style-type: none"> • Select cable • Select lever • Detent spring • Manual plate
Select lever is excessively hard to move. (Unreasonable resistance)	<ul style="list-style-type: none"> • Detent spring • Manual plate
Select lever slips out of selected shift position during acceleration or while driving on rough terrain.	<ul style="list-style-type: none"> • Select cable • Select lever • Detent spring • Manual plate
Manual mode can not be set.	<ul style="list-style-type: none"> • Sports shift switch • TCM • Body integrated unit
Gear does not change though the select lever is operated in manual mode.	<ul style="list-style-type: none"> • Up shift switch • Down shift switch • TCM • Body integrated unit

MANUAL TRANSMISSION AND DIFFERENTIAL

5MT

	Page
1. General Description	2
2. Transmission Gear Oil	23
3. Manual Transmission Assembly	24
4. Transmission Mounting System	31
5. Oil Seal	33
6. Differential Side Retainer Oil Seal	34
7. Switches and Harness	35
8. Preparation for Overhaul	36
9. Transfer Case and Extension Case Assembly	37
10. Transfer Drive Gear	41
11. Transfer Driven Gear	43
12. Center Differential	45
13. Reverse Check Sleeve	46
14. Transmission Case	49
15. Main Shaft Assembly for Single-range	52
16. Drive Pinion Shaft Assembly	57
17. Front Differential Assembly	66
18. Reverse Idler Gear	73
19. Shifter Fork and Rod	75
20. General Diagnostic Table	79

General Description

MANUAL TRANSMISSION AND DIFFERENTIAL

1. General Description

A: SPECIFICATION

1. MANUAL TRANSMISSION AND DIFFERENTIAL

Model		Non-turbo model	
Type		5-forward speeds with synchromesh and 1-reverse	
Transmission gear ratio		1st	3.454
		2nd	2.062
		3rd	1.448
		4th	1.088
		5th	0.780
		Reverse	3.333
Front reduction gear	Final	Type of gear	Hypoid
		Gear ratio	4.111
Rear reduction gear	Transfer	Type of gear	Helical
		Gear ratio	1.000
	Final	Type of gear	Hypoid
		Gear ratio	4.111
Front differential	Type and number of gear	Straight bevel gear (Bevel pinion: 2, Bevel gear: 2)	
Center differential	Type and number of gear	Straight bevel gear (Bevel pinion: 2, bevel gear: 2 and viscous coupling)	
Transmission gear oil		GL-5	
Transmission gear oil capacity		3.5 ℓ (3.7 US qt, 3.1 Imp qt)	

General Description

MANUAL TRANSMISSION AND DIFFERENTIAL

2. TRANSMISSION GEAR OIL

Recommended oil:

GL-5 (75W-90) or equivalent

3. TRANSMISSION CASE ASSEMBLY

Drive pinion shim adjustment

Hypoid gear backlash:

0.13 — 0.18 mm (0.0051 — 0.0071 in)

Drive pinion shim			
Part number	Thickness mm (in)	Part number	Thickness mm (in)
32295AA031	0.150 (0.0059)	32295AA071	0.250 (0.0098)
32295AA041	0.175 (0.0069)	32295AA081	0.275 (0.0108)
32295AA051	0.200 (0.0079)	32295AA091	0.300 (0.0118)
32295AA061	0.225 (0.0089)	32295AA101	0.500 (0.0197)

Selection of main shaft rear plate

Main shaft rear plate		
Dimension "A" mm (in)	Part number	Mark
4.00 — 4.13 (0.1575 — 0.1626)	32294AA041	1
3.87 — 4.00 (0.1524 — 0.1575)	32294AA051	2

4. DRIVE PINION ASSEMBLY

Preload adjustment of thrust bearing

Starting torque:

0.3 — 0.8 N-m (0.03 — 0.08 kgf-m, 0.2 — 0.6 ft-lb)

Adjusting washer No. 1	
Part number	Thickness mm (in)
803025051	3.925 (0.1545)
803025052	3.950 (0.1555)
803025053	3.975 (0.1565)
803025054	4.000 (0.1575)
803025055	4.025 (0.1585)
803025056	4.050 (0.1594)
803025057	4.075 (0.1604)

Adjusting washer No. 2	
Part number	Thickness mm (in)
803025059	3.850 (0.1516)
803025054	4.000 (0.1575)
803025058	4.150 (0.1634)

5. REVERSE IDLER GEAR

Adjustment of reverse idler gear position

Reverse idler gear to transmission case (LH) wall clearance:

6.0 — 7.5 mm (0.236 — 0.295 in)

Reverse shifter lever		
Part number	Mark	Remarks
32820AA070	7	Further from case wall
32820AA080	8	Standard
32820AA090	9	Closer to the case wall

After installing a suitable reverse shifter lever, adjust the clearance using washers.

Reverse idler gear to transmission case wall clearance:

0 — 0.5 mm (0 — 0.020 in)

Washer (20.5 × 26 × t)			
Part number	Thickness mm (in)	Part number	Thickness mm (in)
803020151	0.4 (0.016)	803020154	1.9 (0.075)
803020152	1.1 (0.043)	803020155	2.3 (0.091)
803020153	1.5 (0.059)	—	—

General Description

MANUAL TRANSMISSION AND DIFFERENTIAL

6. SHIFTER FORK AND ROD

Select a suitable shifter fork so that both the coupling sleeve and reverse driven gear are positioned in the center of their synchromesh mechanisms.

Rod end clearance:

A: 3rd-4th — 5th

0.5 — 1.3 mm (0.020 — 0.051 in)

B: 1st-2nd — 3rd-4th

0.4 — 1.4 mm (0.016 — 0.055 in)

1st-2nd shifter fork		
Part number	Mark	Remarks
32804AA060	1	Approaches 1st gear by 0.2 mm (0.008 in).
32804AA070	No mark	Standard
32804AA080	3	Approaches 2nd gear by 0.2 mm (0.008 in).

3rd-4th shifter fork		
Part number	Mark	Remarks
32810AA061	1	Approaches 4th gear by 0.2 mm (0.008 in).
32810AA071	No mark	Standard
32810AA101	3	Approaches 3rd gear by 0.2 mm (0.008 in).

5th shifter fork		
Part number	Mark	Remarks
32812AA201	7	Approaches 5th gear by 0.2 mm (0.008 in).
32812AA211	No mark	Standard
32812AA221	9	Moves away from 5th gear by 0.2 mm (0.008 in).

7. TRANSFER CASE

Neutral position adjustment

Adjusting shim	
Part number	Thickness mm (in)
32190AA000	0.15 (0.0059)
32190AA010	0.30 (0.0118)

Reverse accent shaft		
Part number	Mark	Remarks
32188AA130	S	Neutral position is closer to 1st.
32188AA140	T	Standard
32188AA150	U	Neutral position is closer to reverse gear.

Reverse check plate adjustment

Reverse check plate			
Part number	Mark	Angle θ	Remarks
32189AA001	0	28°	Arm stops closer to 5th gear.
32189AA011	1	31°	Arm stops closer to 5th gear.
33189AA021	2	34°	Arm stops in the center.
32189AA031	3	37°	Arm stops closer to reverse gear.
32189AA041	4	40°	Arm stops closer to reverse gear.

General Description

MANUAL TRANSMISSION AND DIFFERENTIAL

8. EXTENSION ASSEMBLY

Preload of the taper roller bearing (amount of standard protrusion):

0.15 — 0.25 mm (0.006 — 0.010 in)

NOTE:

Be sure that the amount of preload is within the standard value.

Thrust washer (50 × 61 × t)	
Part number	Thickness mm (in)
803050060	0.50 (0.0197)
803050061	0.55 (0.0217)
803050062	0.60 (0.0236)
803050063	0.65 (0.0256)
803050064	0.70 (0.0276)
803050065	0.75 (0.0295)
803050066	0.80 (0.0315)
803050067	0.85 (0.0335)
803050068	0.90 (0.0354)
803050069	0.95 (0.0374)
803050070	1.00 (0.0394)
803050071	1.05 (0.0413)
803050072	1.10 (0.0433)
803050073	1.15 (0.0453)
803050074	1.20 (0.0472)
803050075	1.25 (0.0492)
803050076	1.30 (0.0512)
803050077	1.35 (0.0531)
803050078	1.40 (0.0551)
803050079	1.45 (0.0571)

Thrust washer to center differential side clearance:

0.15 — 0.35 mm (0.0059 — 0.0138 in)

Thrust washer	
Part number	Thickness mm (in)
803036050	0.9 (0.035)
803036054	1.0 (0.039)
803036051	1.1 (0.043)
803036055	1.2 (0.047)
803036052	1.3 (0.051)
803036056	1.4 (0.055)
803036053	1.5 (0.059)
803036057	1.6 (0.063)
803036058	1.7 (0.067)

9. FRONT DIFFERENTIAL

Bevel gear to pinion backlash:

0.13 — 0.18 mm (0.0051 — 0.0071 in)

Washer (38.1 × 50 × t)			
Part number	Thickness mm (in)	Part number	Thickness mm (in)
803038021	0.925 — 0.950 (0.0364 — 0.0374)	803038023	1.025 — 1.050 (0.0404 — 0.0413)
803038022	0.975 — 1.000 (0.0384 — 0.0394)	—	—

10. TRANSFER DRIVE GEAR

Snap ring (Outer-30) to ball bearing clearance:

0.01 — 0.15 mm (0.0004 — 0.0059 in)

Snap ring (Outer-30)	
Part number	Thickness mm (in)
805030041	1.53 (0.0602)
805030042	1.65 (0.0650)
805030043	1.77 (0.0697)

General Description

MANUAL TRANSMISSION AND DIFFERENTIAL

B: COMPONENT

1. TRANSMISSION CASE

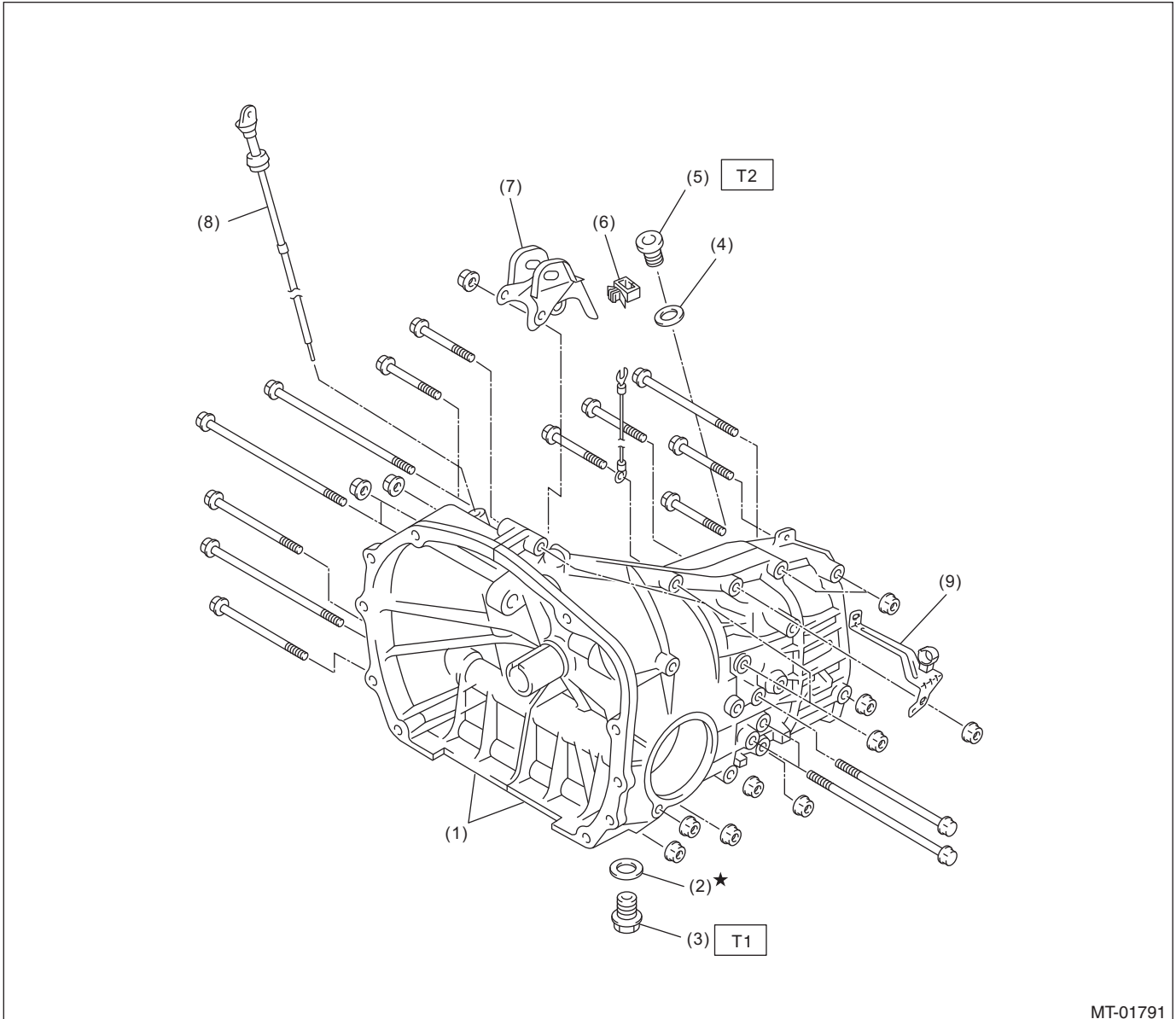

- | | |
|----------------------------|------------------------------|
| (1) Transmission case ASSY | (6) Clamp |
| (2) Gasket | (7) Pitching stopper bracket |
| (3) Drain plug | (8) Oil level gauge |
| (4) Gasket | (9) Harness bracket |
| (5) Plug | |

Tightening torque: N·m (kgf·m, ft·lb)
T1: 44 (4.5, 32.5) (Aluminum gasket)
70 (7.1, 51.6) (Copper gasket)
T2: 60 (6.1, 44.3)

General Description

MANUAL TRANSMISSION AND DIFFERENTIAL

Transmission case tightening torque

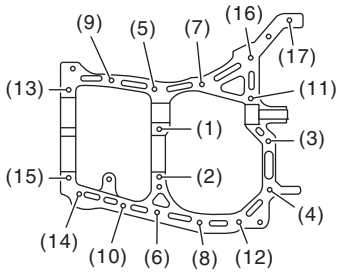
 <p>MT-00003</p>	Bolt No.	Bolt size mm	Tightening torque: N·m (kgf·m, ft·lb)
	(5) — (15)	8	25 (2.5, 18.4)
	(1) — (4) (16), (17)	10	39 (4.0, 28.8)

General Description

MANUAL TRANSMISSION AND DIFFERENTIAL

2. DRIVE PINION ASSEMBLY

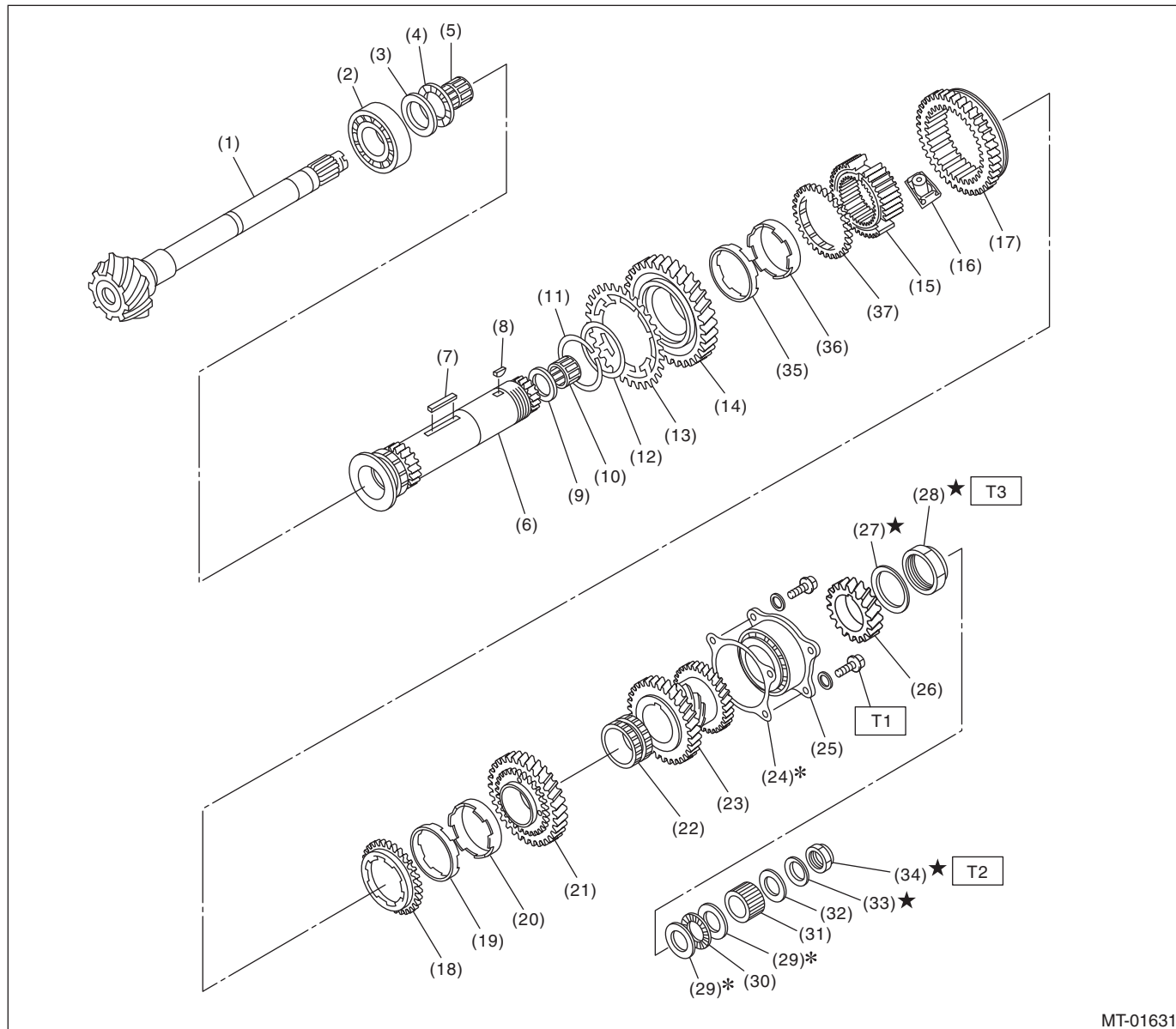

MT-01631

- | | | |
|-------------------------|-------------------------------|-------------------------------------|
| (1) Drive pinion shaft | (15) 1st-2nd synchronizer hub | (29) Adjusting washer |
| (2) Roller bearing | (16) Ball detent | (30) Thrust bearing |
| (3) Washer | (17) Reverse driven gear | (31) Differential bevel gear sleeve |
| (4) Thrust bearing | (18) Outer baulk ring | (32) Washer |
| (5) Needle bearing | (19) Synchro cone | (33) Lock washer |
| (6) Driven shaft | (20) Inner baulk ring | (34) Lock nut |
| (7) Key | (21) 2nd driven gear | (35) Inner baulk ring |
| (8) Woodruff key | (22) 2nd driven gear bushing | (36) Synchro cone |
| (9) Drive pinion collar | (23) 3rd-4th driven gear | (37) Outer baulk ring |
| (10) Needle bearing | (24) Driven pinion shim | |
| (11) Snap ring (Outer) | (25) Roller bearing | |
| (12) Washer | (26) 5th driven gear | |
| (13) Sub gear | (27) Lock washer | |
| (14) 1st driven gear | (28) Lock nut | |

Tightening torque: N·m (kgf·m, ft·lb)

T1: 30 (3.1, 22.1)

T2: 120 (12.2, 88.5)

T3: 260 (26.5, 191.8)

General Description

3. MAIN SHAFT FOR SINGLE-RANGE

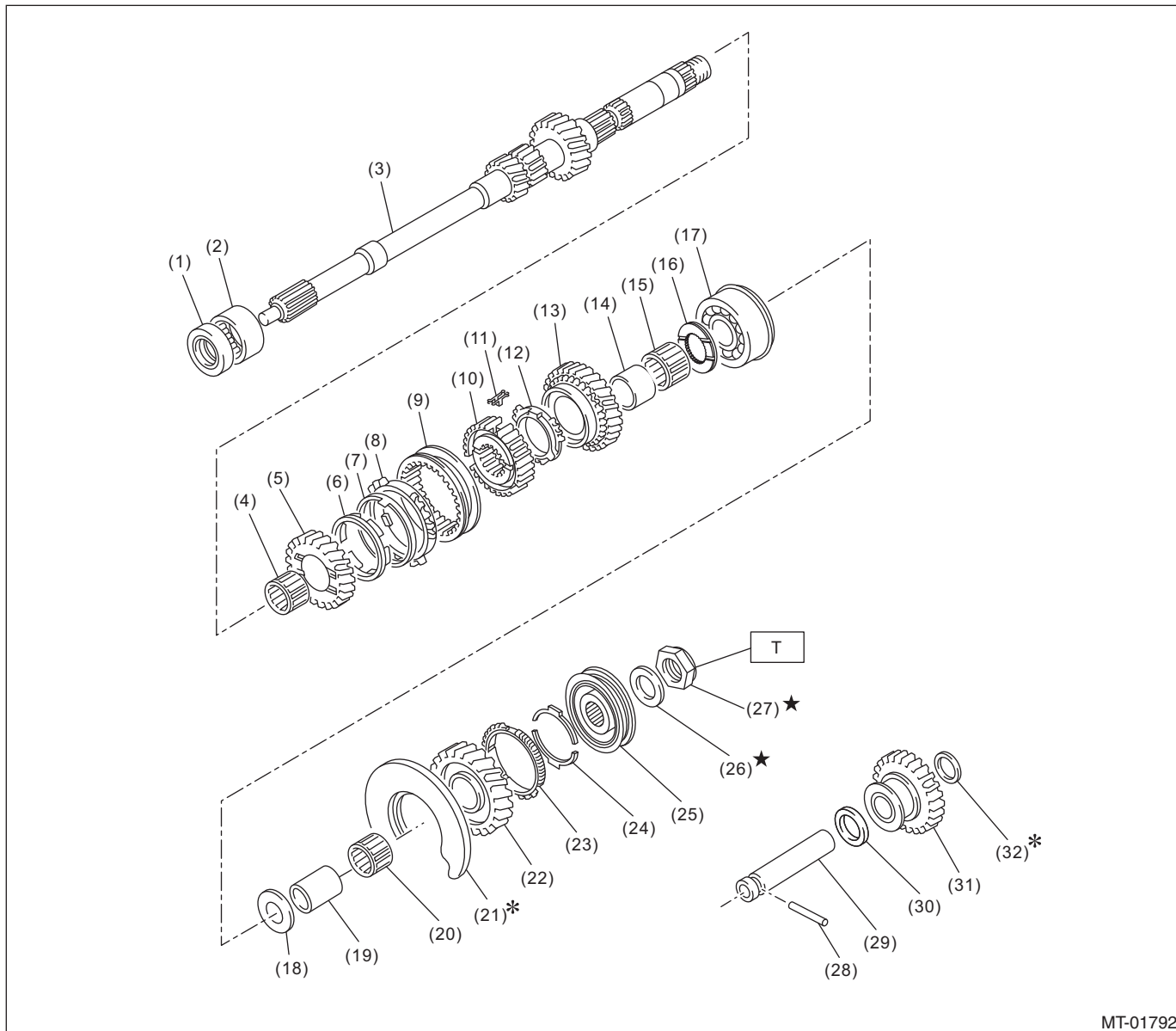

MT-01792

- | | | |
|----------------------------------|------------------------------|-------------------------------|
| (1) Oil seal | (13) 4th drive gear | (25) 5th hub & sleeve No. 2 |
| (2) Needle bearing | (14) 4th needle bearing race | (26) Lock washer |
| (3) Transmission main shaft | (15) Needle bearing | (27) Lock nut |
| (4) Needle bearing | (16) 4th gear thrust washer | (28) Straight pin |
| (5) 3rd drive gear | (17) Ball bearing | (29) Reverse idler gear shaft |
| (6) Inner baulk ring | (18) 5th gear thrust washer | (30) Washer |
| (7) 3rd synchro cone | (19) 5th needle bearing race | (31) Reverse idler gear |
| (8) Outer baulk ring | (20) Needle bearing | (32) Washer |
| (9) 3rd-4th coupling sleeve | (21)* Main shaft rear plate | |
| (10) 3rd-4th synchronizer hub | (22) 5th drive gear | |
| (11) 3rd-4th shifting insert key | (23) 5th baulk ring | |
| (12) 4th baulk ring | (24) Baulk lever | |

Tightening torque: N-m (kgf-m, ft-lb)

T: 120 (12.2, 88.5)

General Description

MANUAL TRANSMISSION AND DIFFERENTIAL

4. SHIFTER FORK AND SHIFTER ROD

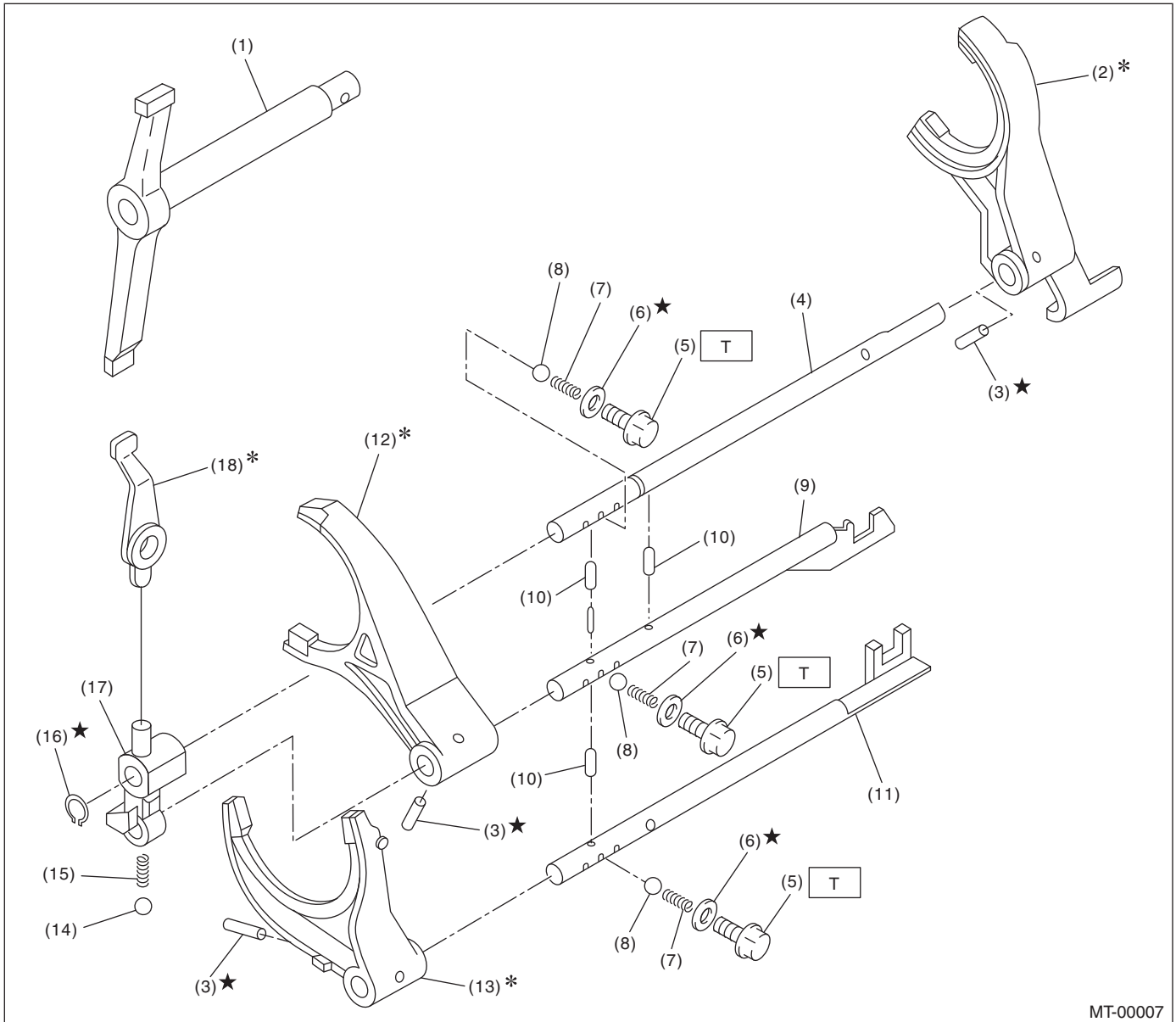

MT-00007

- | | | |
|--------------------------|---------------------------|----------------------------|
| (1) Shifter arm | (8) Ball | (15) Spring |
| (2) 5th shifter fork | (9) 3rd-4th fork rod | (16) Snap ring (Outer) |
| (3) Straight pin | (10) Interlock plunger | (17) Reverse fork rod arm |
| (4) Reverse fork rod | (11) 1st-2nd fork rod | (18) Reverse shifter lever |
| (5) Checking ball plug | (12) 3rd-4th shifter fork | |
| (6) Gasket | (13) 1st-2nd shifter fork | |
| (7) Checking ball spring | (14) Ball | |

Tightening torque: N·m (kgf·m, ft·lb)

T: 20 (2.0, 14.8)

General Description

5. TRANSFER CASE AND EXTENSION

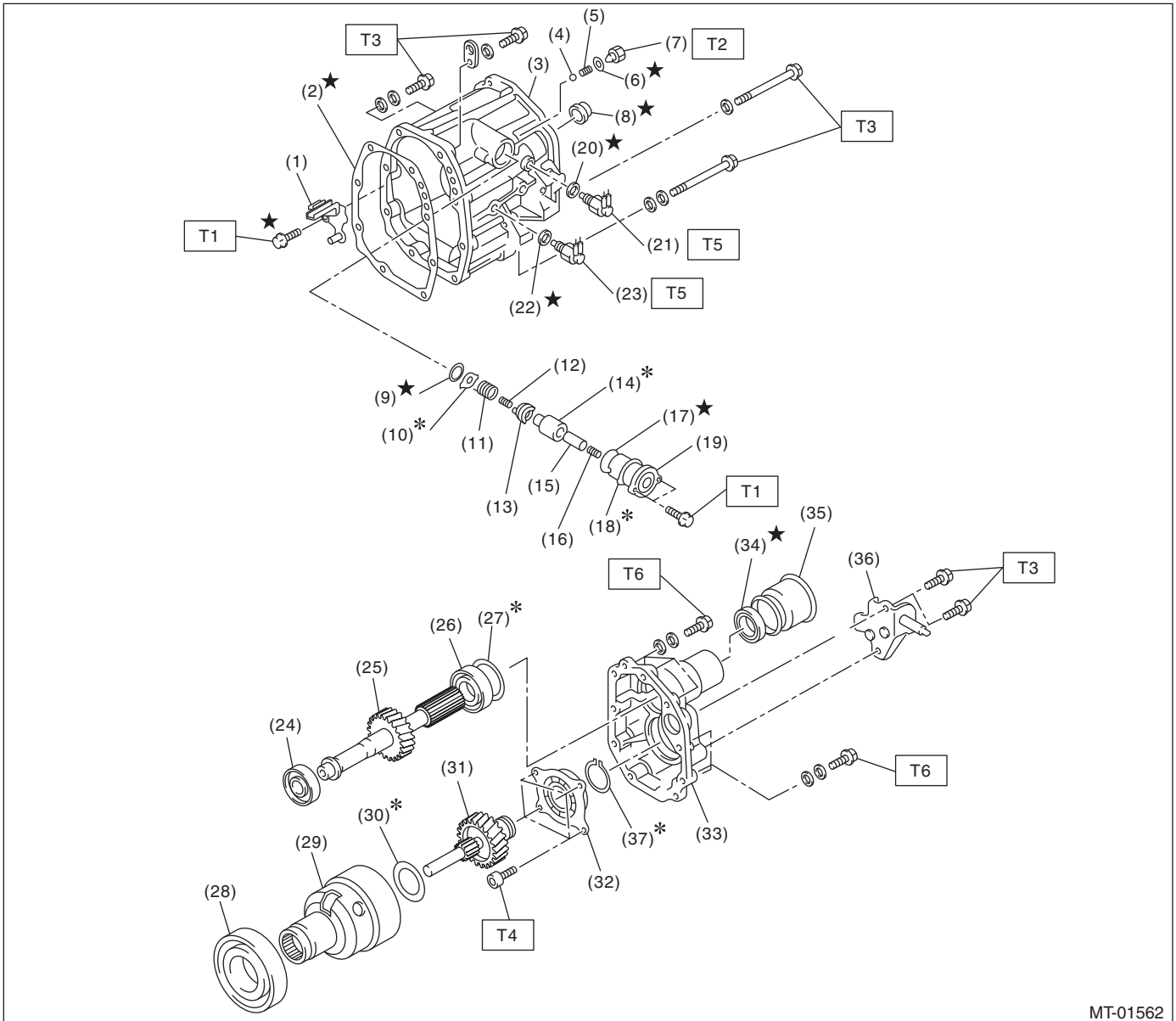

MT-01562

- | | | |
|----------------------------|------------------------------|--------------------------|
| (1) Oil guide | (16) Return spring | (31) Transfer drive gear |
| (2) Gasket | (17) O-ring | (32) Ball bearing |
| (3) Transfer case | (18) Adjusting select shim | (33) Extension case |
| (4) Ball | (19) Reverse check sleeve | (34) Oil seal |
| (5) Reverse accent spring | (20) Gasket | (35) Dust cover |
| (6) Gasket | (21) Neutral position switch | (36) Shift bracket |
| (7) Plug | (22) Gasket | (37) Snap ring |
| (8) Oil seal | (23) Back-up light switch | |
| (9) Snap ring (Inner) | (24) Roller bearing | |
| (10) Reverse check plate | (25) Transfer driven gear | |
| (11) Reverse check spring | (26) Roller bearing | |
| (12) Reverse return spring | (27) Adjusting washer | |
| (13) Reverse check cam | (28) Ball bearing | |
| (14) Reverse accent shaft | (29) Center differential | |
| (15) Return spring cap | (30) Adjusting washer | |

Tightening torque: N·m (kgf·m, ft·lb)

T1: 6.4 (0.7, 4.7)

T2: 9.75 (1.0, 7.2)

T3: 24.5 (2.5, 18.1)

T4: 26 (2.7, 19.2)

T5: 32.3 (3.3, 23.8)

T6: 40 (4.1, 29.5)

General Description

MANUAL TRANSMISSION AND DIFFERENTIAL

6. FRONT DIFFERENTIAL

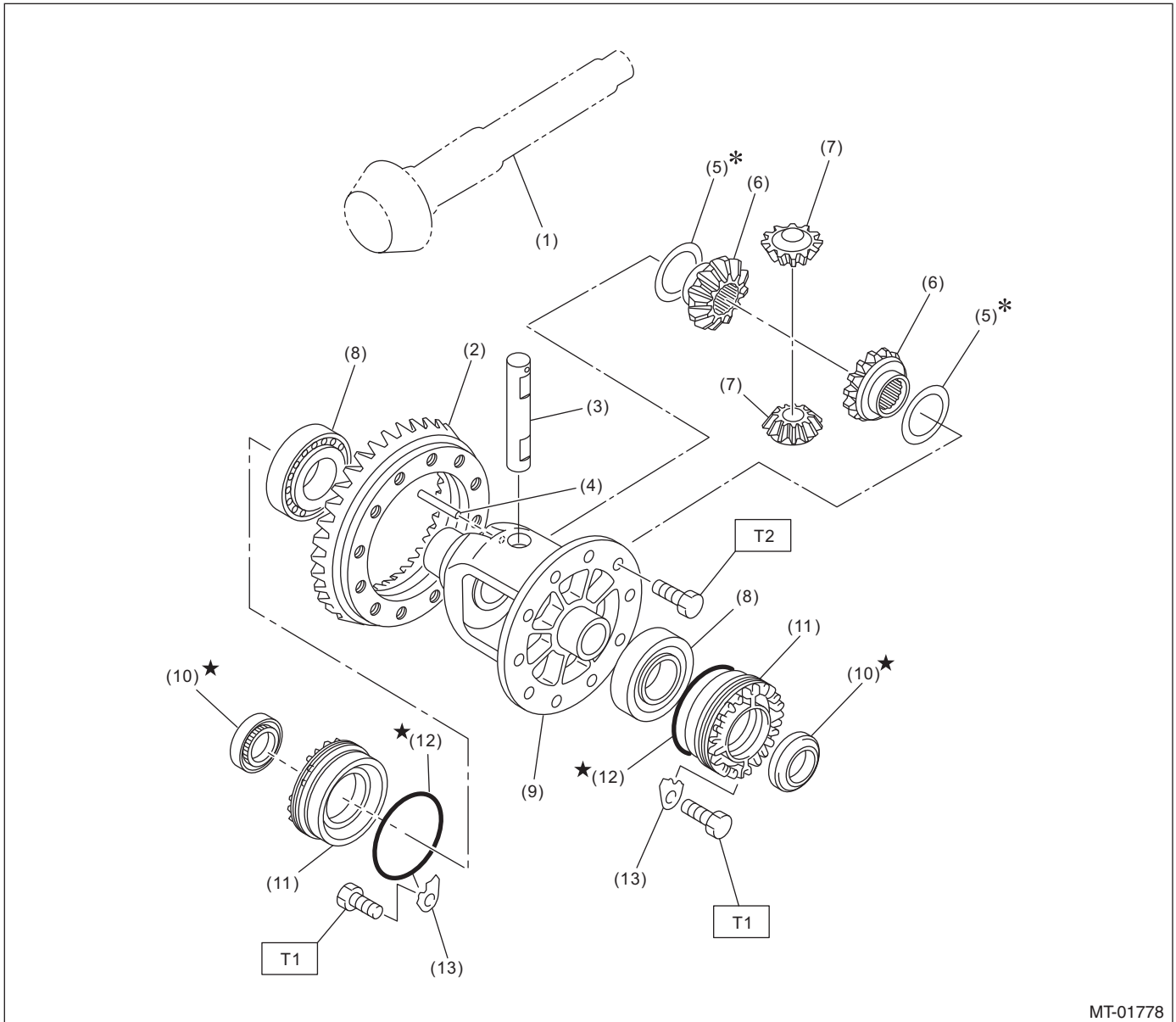

MT-01778

- | | | |
|-----------------------------|---------------------------------|--------------------------|
| (1) Drive pinion shaft | (7) Differential bevel pinion | (13) Retainer lock plate |
| (2) Hypoid driven gear | (8) Roller bearing | |
| (3) Pinion shaft | (9) Differential case | |
| (4) Straight pin | (10) Oil seal | |
| (5) Washer | (11) Differential side retainer | |
| (6) Differential bevel gear | (12) O-ring | |

Tightening torque: N·m (kgf·m, ft·lb)

T1: 25 (2.5, 18.4)

T2: 62 (6.3, 45.7)

General Description

7. TRANSMISSION MOUNTING

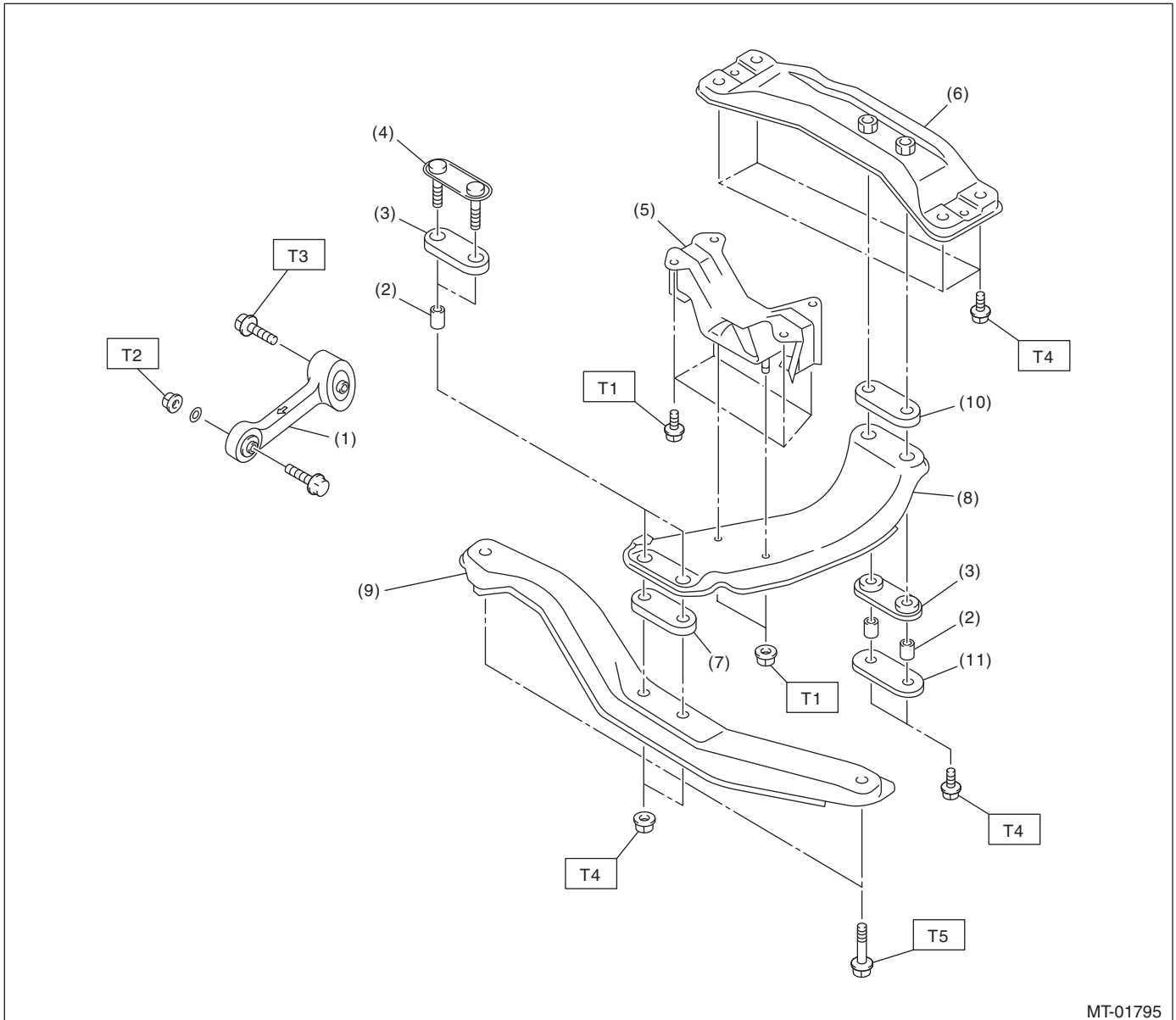

MT-01795

- | | |
|---------------------------------|--------------------------|
| (1) Pitching stopper | (7) Cushion rubber |
| (2) Spacer | (8) Center crossmember |
| (3) Cushion rubber | (9) Front crossmember |
| (4) Front plate | (10) Rear cushion rubber |
| (5) Transmission cushion rubber | (11) Rear plate |
| (6) Rear crossmember | |

Tightening torque: N·m (kgf·m, ft·lb)

T1: 35 (3.6, 25.8)

T2: 50 (5.1, 36.9)

T3: 58 (5.9, 42.8)

T4: 70 (7.1, 51.6)

T5: 140 (14.3, 103.3)

General Description

MANUAL TRANSMISSION AND DIFFERENTIAL

C: CAUTION

- Wear appropriate work clothing, including a cap, protective goggles and protective shoes when performing any work.
- Remove contamination including dirt and corrosion before removal, installation or disassembly.
- Keep the disassembled parts in order and protect them from dust and dirt.
- Before removal, installation or disassembly, be sure to clarify the failure. Avoid unnecessary removal, installation, disassembly and replacement.
- When disassembling the case and other light alloy parts, use a plastic hammer to force it apart. Do not pry apart with screwdrivers or other tools.
- Vehicle components are extremely hot after driving. Be wary of receiving burns from heated parts.
- Use SUBARU genuine gear oil, grease or the equivalent. Do not mix gear oil, grease, etc. of different grades or manufacturers.
- Be sure to tighten fasteners including bolts and nuts to the specified torque.
- Place shop jacks or rigid racks at the specified points.
- Apply gear oil onto sliding or revolving surfaces before installation.
- Replace deformed or damaged snap rings with new parts.
- Before installing O-rings or oil seals, apply sufficient amount of gear oil to avoid damage and deformation.
- Be careful not to incorrectly install or fail to install O-rings, snap rings and other such parts.
- Before securing a part on a vise, place cushioning material such as wood blocks, aluminum plate, or cloth between the part and the vise.
- Avoid damaging the mating surface of the case.
- Before applying liquid gasket, completely remove the liquid gasket.

General Description

MANUAL TRANSMISSION AND DIFFERENTIAL

D: PREPARATION TOOL

1. SPECIAL TOOL

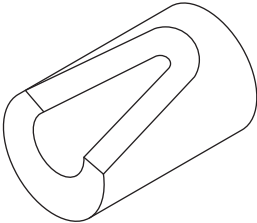
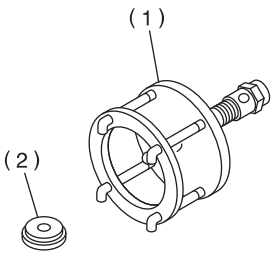
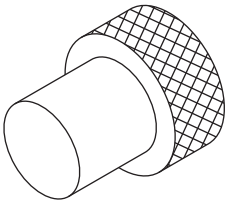
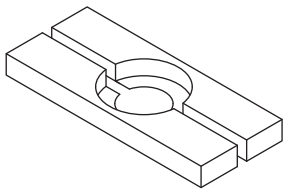
ILLUSTRATION	TOOL NUMBER	DESCRIPTION	REMARKS
 ST-399411700	399411700	ACCENT BALL INSTALLER	Used for installing reverse shifter rail arm.
 ST-899524100	899524100	PULLER SET	Used for removing and installing the roller bearing (Differential). (1) Puller (2) Cap
 ST-399780104	399780104	WEIGHT	Used for measuring preload on the roller bearing.
 ST-498077000	498077000	REMOVER	Used for removing the roller bearing of the drive pinion shaft.

General Description

MANUAL TRANSMISSION AND DIFFERENTIAL

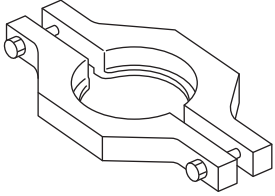
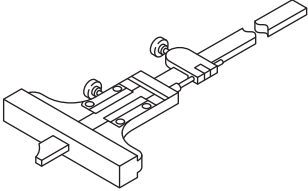
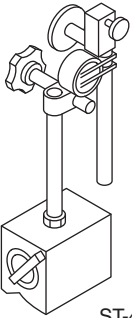
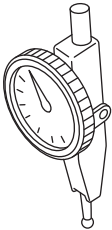
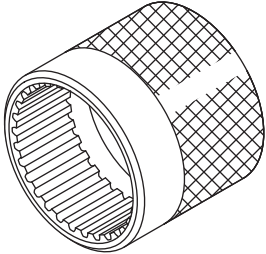
ILLUSTRATION	TOOL NUMBER	DESCRIPTION	REMARKS
 <p style="text-align: center;">ST-498077300</p>	498077300	CENTER DIFFERENTIAL BEARING REMOVER	Used for removing the center differential cover ball bearing.
 <p style="text-align: center;">ST-498147001</p>	498147001	DEPTH GAUGE	Used for adjusting the main shaft axial end play.
 <p style="text-align: center;">ST-498247001</p>	498247001	MAGNET BASE	<ul style="list-style-type: none"> • Used for measuring backlash between the side gear and pinion, and the hypoid gear. • Used together with the DIAL GAUGE (498247100).
 <p style="text-align: center;">ST-498247100</p>	498247100	DIAL GAUGE	<ul style="list-style-type: none"> • Used for measuring backlash between the side gear and pinion, and the hypoid gear. • Used together with the MAGNET BASE (498247001).
 <p style="text-align: center;">ST-498427100</p>	498427100	STOPPER	Used for securing the drive pinion shaft assembly and the driven gear assembly when removing the drive pinion shaft assembly lock nut.

General Description

MANUAL TRANSMISSION AND DIFFERENTIAL

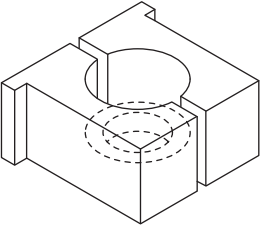
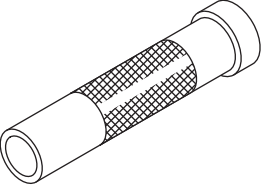
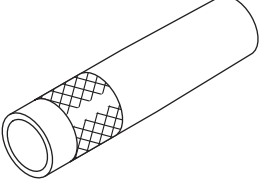
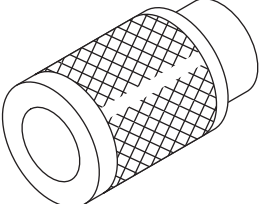
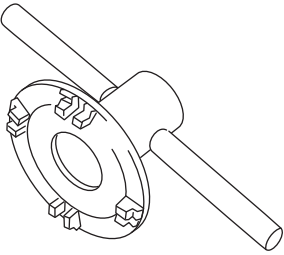
ILLUSTRATION	TOOL NUMBER	DESCRIPTION	REMARKS
 <p data-bbox="337 520 467 541">ST-498937000</p>	498937000	TRANSMISSION HOLDER	Used for removing and installing the lock nut of the transmission main shaft.
 <p data-bbox="337 871 467 892">ST-499277100</p>	499277100	BUSHING 1-2 INSTALLER	<ul style="list-style-type: none"> • Used for installing the 1st driven gear thrust plate and the 1st-2nd driven gear bushing. • Used for installing the roller bearing outer race to the differential case.
 <p data-bbox="337 1222 467 1243">ST-499277200</p>	499277200	INSTALLER	Used for press-fitting the 2nd driven gear, roller bearings and the 5th driven gear onto the driven shaft.
 <p data-bbox="337 1572 467 1593">ST-499757002</p>	499757002	INSTALLER	<ul style="list-style-type: none"> • Used for installing the snap ring (OUT 25), and ball bearing (25 × 26 × 17). • Used for installing the bearing cone of the transfer driven gear (extension core side).
 <p data-bbox="328 1921 467 1942">ST18630AA010</p>	18630AA010	WRENCH COMPL RETAINER	<ul style="list-style-type: none"> • Used for removing and installing the differential side retainer. • WRENCH ASSEMBLY (499787000) can also be used.

General Description

MANUAL TRANSMISSION AND DIFFERENTIAL

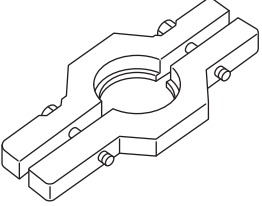
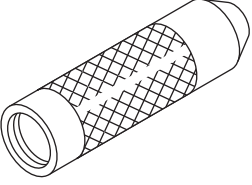
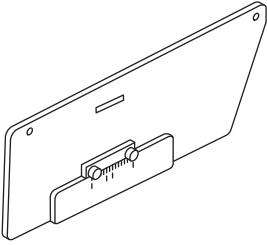
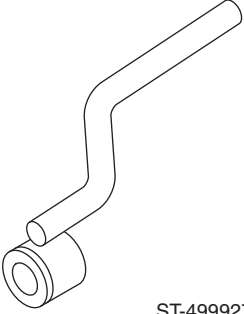
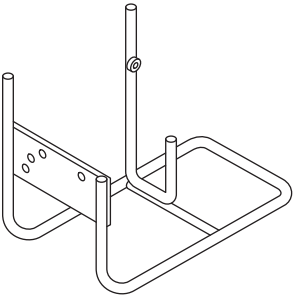
ILLUSTRATION	TOOL NUMBER	DESCRIPTION	REMARKS
 <p style="text-align: center;">ST-499857000</p>	499857000	5TH DRIVEN GEAR REMOVER	Used for removing the 5th driven gear.
 <p style="text-align: center;">ST-499877000</p>	499877000	RACE 4-5 INSTALLER	<ul style="list-style-type: none"> • Used for installing the 4th needle bearing race and ball bearing onto the transmission main shaft. • Used together with the REMOVER (899714110).
 <p style="text-align: center;">ST-499917500</p>	499917500	DRIVE PINION GAUGE ASSY	Used for adjusting the drive pinion shim.
 <p style="text-align: center;">ST-499927100</p>	499927100	HANDLE	Used for fitting the transmission main shaft.
 <p style="text-align: center;">ST-499937100</p>	499937100	TRANSMISSION STAND SET	Used for disassembling and assembling the transmission.

General Description

MANUAL TRANSMISSION AND DIFFERENTIAL

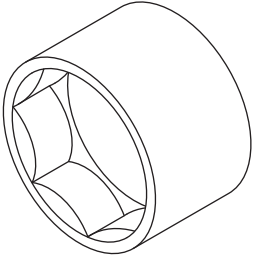
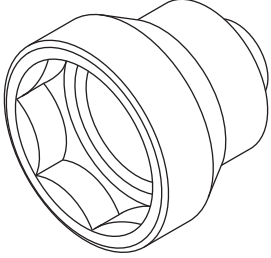
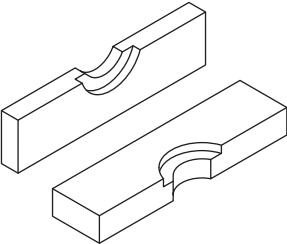
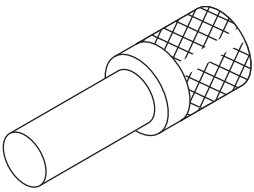
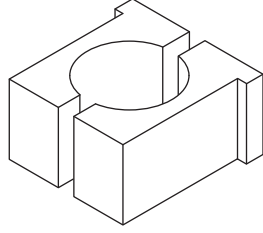
ILLUSTRATION	TOOL NUMBER	DESCRIPTION	REMARKS
 <p data-bbox="337 520 467 541">ST-499987003</p>	499987003	SOCKET WRENCH (35)	Used for removing and installing the driven pinion lock nut and main shaft lock nut.
 <p data-bbox="337 873 467 894">ST-499987300</p>	499987300	SOCKET WRENCH (50)	Used for removing and installing the driven gear assembly lock nut.
 <p data-bbox="337 1224 467 1245">ST-899714110</p>	899714110	REMOVER	Used for fixing the transmission main shaft, drive pinion and rear drive shaft.
 <p data-bbox="337 1577 467 1598">ST-899864100</p>	899864100	REMOVER	Used for removing transmission main shaft and drive pinion parts.
 <p data-bbox="337 1921 467 1942">ST-899884100</p>	899884100	HOLDER	Used for tightening the lock nut on the sleeve.

General Description

MANUAL TRANSMISSION AND DIFFERENTIAL

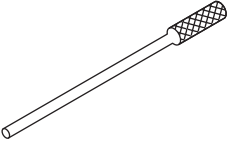
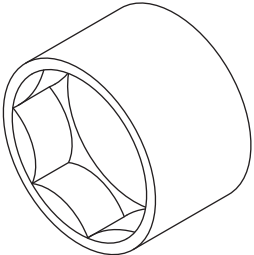
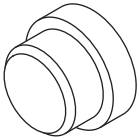
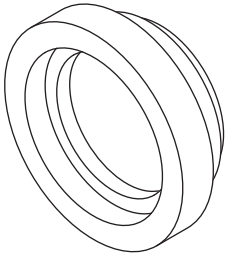
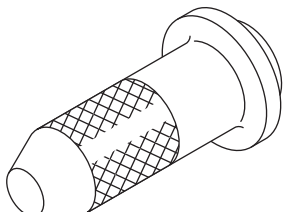
ILLUSTRATION	TOOL NUMBER	DESCRIPTION	REMARKS
 <p style="text-align: center;">ST-899904100</p>	899904100	STRAIGHT PIN REMOVER	Used for removing and installing the straight pin.
 <p style="text-align: center;">ST-899988608</p>	899988608	SOCKET WRENCH (27)	Used for removing and installing the drive pinion lock nut.
 <p style="text-align: center;">ST-398497701</p>	398497701	ADAPTER	<ul style="list-style-type: none"> • Used for installing roller bearing onto the differential case. • Used together with the INSTALLER (499277100).
 <p style="text-align: center;">ST-499587000</p>	499587000	INSTALLER	Used for installing the driven gears to the driven shaft.
 <p style="text-align: center;">ST-498057300</p>	498057300	INSTALLER	Used for installing the extension oil seal.

General Description

MANUAL TRANSMISSION AND DIFFERENTIAL

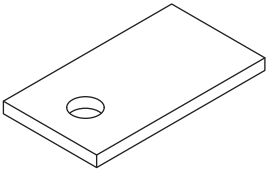
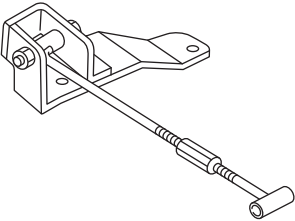
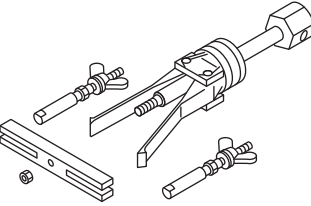
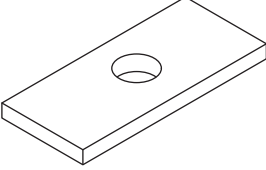
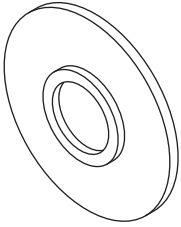
ILLUSTRATION	TOOL NUMBER	DESCRIPTION	REMARKS
 <p data-bbox="337 520 467 541">ST-498255400</p>	498255400	PLATE	Used for measuring backlash.
 <p data-bbox="324 865 467 886">ST41099AC000</p>	41099AC000	ENGINE SUPPORT ASSY	Used for supporting the engine.
 <p data-bbox="337 1222 467 1243">ST-398527700</p>	398527700	PULLER ASSY	Used for removing the extension case roller bearing.
 <p data-bbox="337 1572 467 1593">ST-398643600</p>	398643600	GAUGE	Used for measuring the total end play, extension end play and drive pinion height.
 <p data-bbox="337 1925 467 1946">ST-398177700</p>	398177700	INSTALLER	<ul style="list-style-type: none"> • Used for installing the bearing cone of transfer driven gear (transfer case side). • Used for installing the ball bearing of the transfer drive gear.

General Description

MANUAL TRANSMISSION AND DIFFERENTIAL

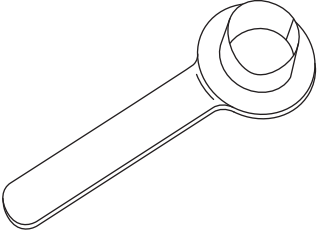
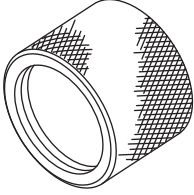
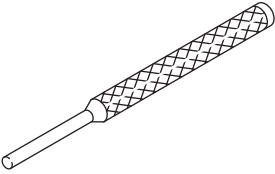
ILLUSTRATION	TOOL NUMBER	DESCRIPTION	REMARKS
 ST28399SA010	28399SA010	OIL SEAL PROTECTOR	Used for protecting the oil seal from damage when inserting the front drive shaft.
 ST18675AA000	18675AA000	DIFFERENTIAL SIDE OIL SEAL INSTALLER	Used for installing the differential side retainer oil seal.
 ST-398791700	398791700	STRAIGHT PIN REMOVER	Used for installing and removing the straight pin.

2. GENERAL TOOL

TOOL NAME	REMARKS
Circuit tester	Used for measuring resistance, voltage and current.
TORX® bit T70	Used for installing and removing the differential gear oil drain plug.

Transmission Gear Oil

MANUAL TRANSMISSION AND DIFFERENTIAL

2. Transmission Gear Oil

A: INSPECTION

- 1) Park the vehicle on a level surface.
- 2) Turn the ignition switch to OFF, and wait until the engine cools.
- 3) Remove the oil level gauge and wipe it clean.
- 4) Reinsert the oil level gauge all the way. Be sure that the oil level gauge is correctly inserted in the proper direction.
- 5) Pull out the oil level gauge again, and check the oil level. If it is at the lower level or less, add oil through the oil level gauge hole to bring the level up to the upper level.

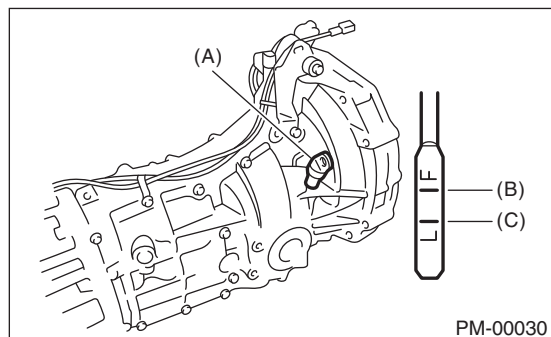

- (A) Oil level gauge
- (B) Upper level
- (C) Lower level

B: REPLACEMENT

- 1) Pull out the oil level gauge.
- 2) Lift up the vehicle.
- 3) Using the TORX® bit T70, remove the drain plug, and drain the transmission gear oil completely.

CAUTION:

- Immediately after the engine has been running, the transmission gear oil is hot. Be careful not to burn yourself.

- Be careful not to spill the transmission gear oil on the exhaust pipe, to prevent emission of smoke or causing a fire. If differential gear oil is spilled on the exhaust pipe, wipe it off completely.

- 4) Using the TORX® bit T70, tighten the transmission gear oil drain plug.

NOTE:

- Tighten the drain plug of the transmission gear oil after draining the transmission gear oil.
- Use a new gasket.

Tightening torque:

44 N·m (4.5 kgf·m, 32.5 ft·lb) (Aluminum gasket)

70 N·m (7.1 kgf·m, 51.6 ft·lb) (Copper gasket)

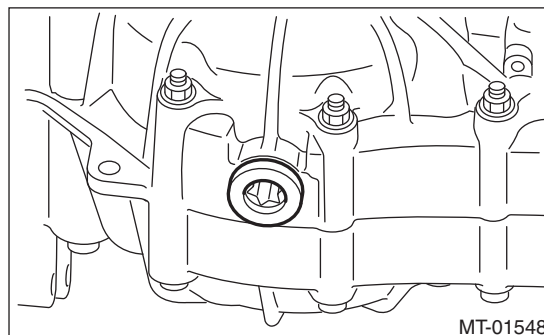

- 5) Lower the vehicle.
- 6) Pour gear oil through the oil level gauge hole.

Recommended gear oil:

GL-5 (75W-90) or equivalent

Gear oil capacity:

3.5 ℓ (3.7 US qt, 3.1 Imp qt)

- 7) Measure the transmission gear oil level to check that it is within specifications.

CAUTION:

When inserting the oil level gauge into transmission, align the protrusion on the top part of the oil level gauge with the notch in the oil level gauge hole.

Manual Transmission Assembly

MANUAL TRANSMISSION AND DIFFERENTIAL

3. Manual Transmission Assembly

A: REMOVAL

- 1) Set the vehicle on a lift.
- 2) Open the front hood.
- 3) Disconnect the ground cable from battery.
- 4) Drain transmission gear oil completely. <Ref. to 5MT-23, REPLACEMENT, Transmission Gear Oil.>
- 5) Remove the air intake chamber and intake boot. <Ref. to IN(H4SO)-7, REMOVAL, Air Intake Chamber.>
- 6) Remove the air intake chamber stay.

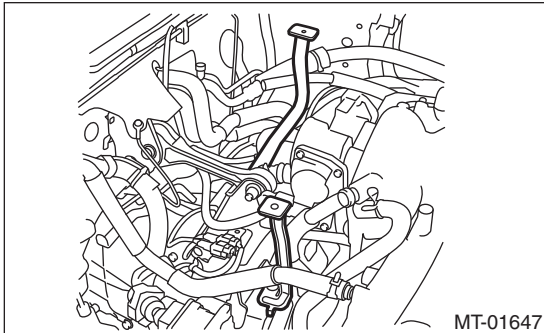

- 7) Disconnect the following connector.

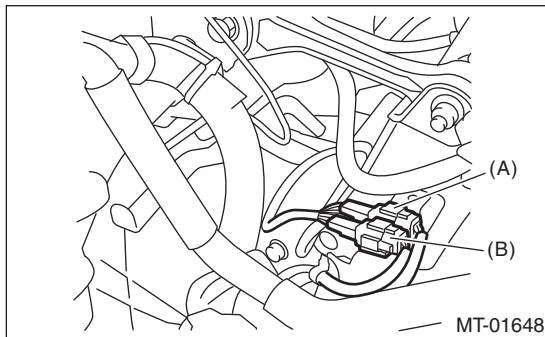

- (A) Neutral position switch connector (Brown)
- (B) Back-up light switch connector (Gray)

- 8) Disconnect the ground cable.

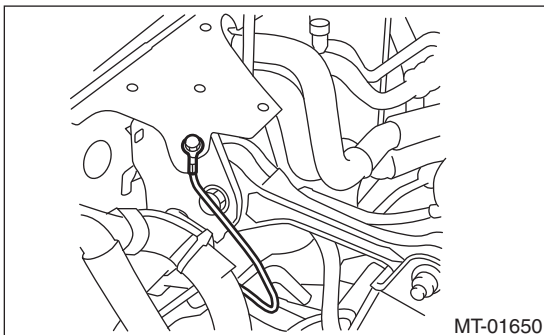

- 9) Disconnect the engine harness connectors, and then remove the engine hanger rear.

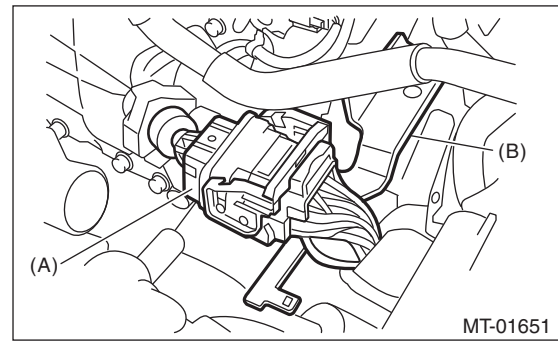

- (A) Engine harness connectors
- (B) Engine hanger rear

- 10) Remove the starter. <Ref. to SC(H4SO)-6, REMOVAL, Starter.>

- 11) Remove the operating cylinder from the transmission, and suspend on a wire.

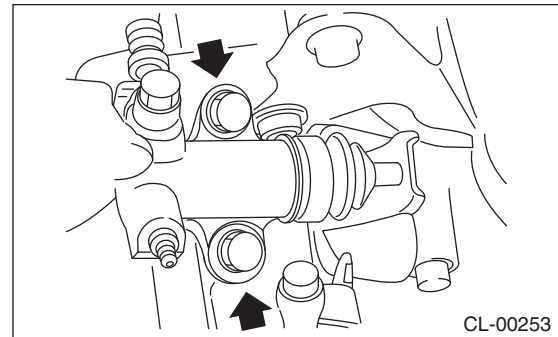

- 12) Remove the throttle body. <Ref. to FU(H4SO)-13, REMOVAL, Throttle Body.>

- 13) Remove the pitching stopper.

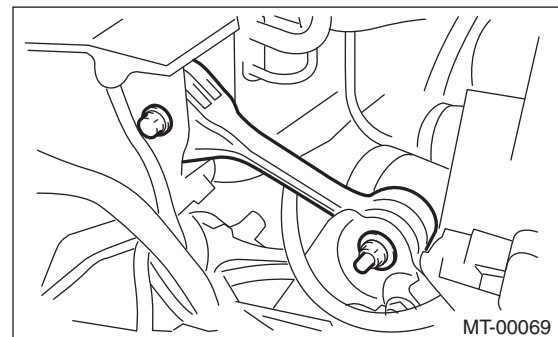

Manual Transmission Assembly

MANUAL TRANSMISSION AND DIFFERENTIAL

- 14) Set the ST.
ST 41099AC000 ENGINE SUPPORT ASSY

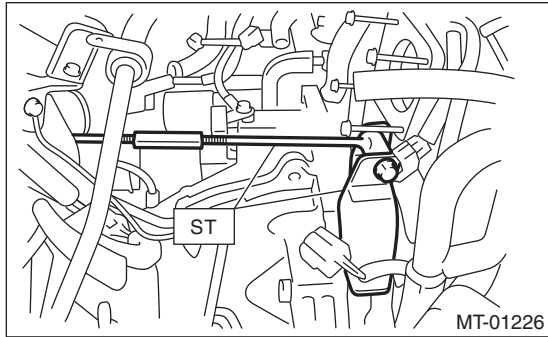

- 15) Remove the bolts which hold upper side of transmission to engine.

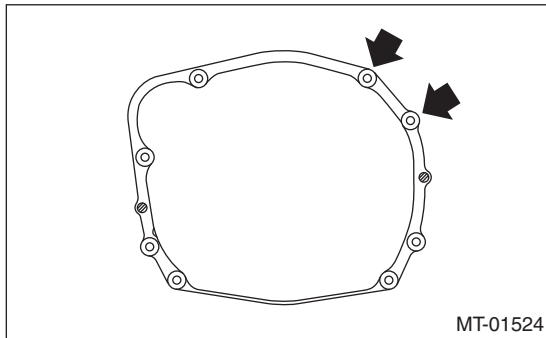

- 16) Lift up the vehicle.
17) Remove the front and center exhaust pipe. <Ref. to EX(H4SO)-4, REMOVAL, Front Exhaust Pipe.>
18) Remove the rear exhaust pipe and muffler. <Ref. to EX(H4SO)-8, REMOVAL, Rear Exhaust Pipe.>

CAUTION:

When removing the exhaust pipes, be careful each exhaust pipe does not drop out.

- 19) Remove the heat shield cover.

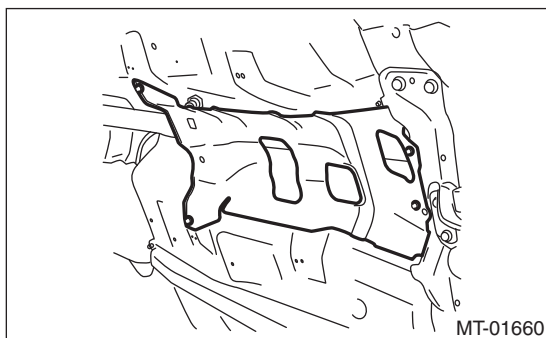

- 20) Remove the hanger bracket from the right side of transmission.

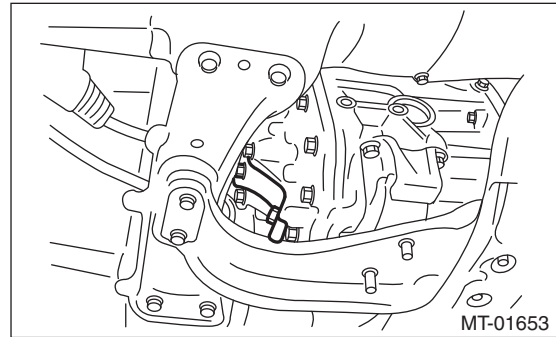

- 21) Remove the propeller shaft. <Ref. to DS-10, REMOVAL, Propeller Shaft.>

- 22) Remove the gear shift rod and the stay from the transmission.

- (1) Disconnect the stay from the transmission.
(2) Disconnect the gear shift rod from the transmission.

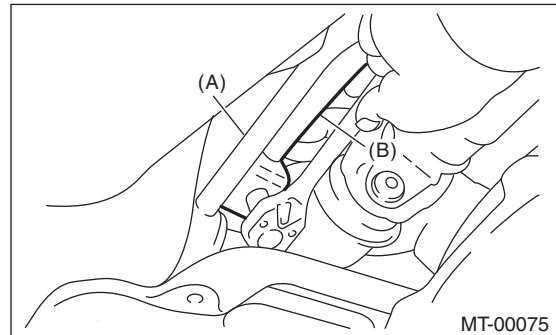

(A) Stay

(B) Gear shift rod

- 23) Remove the front height sensor. <Ref. to LI-40, REMOVAL, Front Height Sensor.>

- 24) Disconnect the stabilizer link from the front arm.

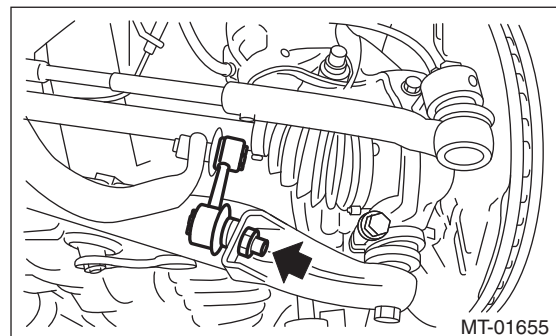

Manual Transmission Assembly

MANUAL TRANSMISSION AND DIFFERENTIAL

25) Remove the bolt securing the ball joint of the front arm to the housing, then separate the front arms and the housing.

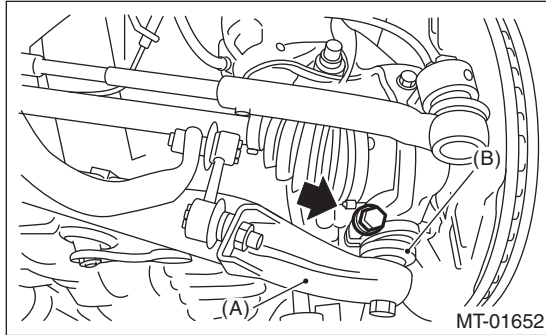

- (A) Front arm
- (B) Ball joint

26) Using a crowbar, remove the left and right front drive shaft from the transmission.

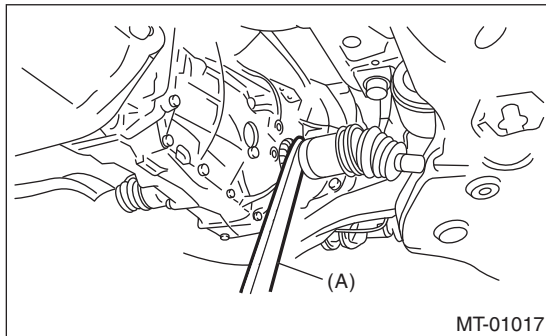

- (A) Bar

27) Remove the bolts and nuts which hold lower side of transmission to engine.

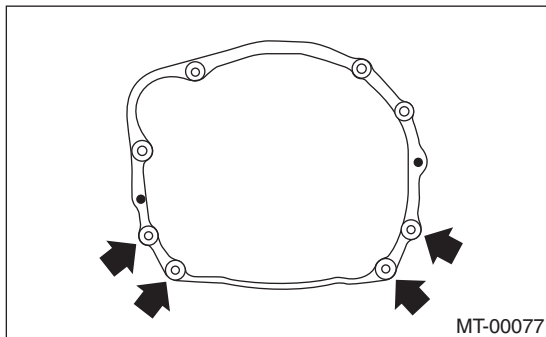

28) Place the transmission jack under the transmission.

CAUTION:

Always support the transmission case with a transmission jack.

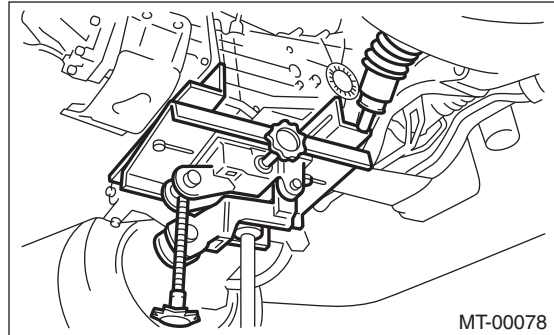

29) Remove the front crossmember and rear crossmember from the vehicle.

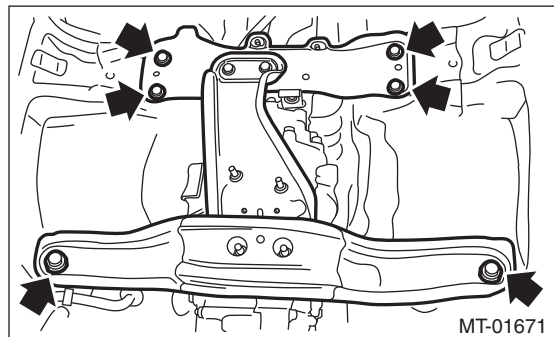

30) Tighten the turnbuckle of the ST while lowering the transmission jack to tilt the engine assembly towards the back.

31) Remove the transmission.

NOTE:

Move the transmission jack towards the rear until the main shaft is withdrawn from the clutch disc.

32) Separate the transmission assembly from the transmission cushion rubber.

Manual Transmission Assembly

MANUAL TRANSMISSION AND DIFFERENTIAL

B: INSTALLATION

1) Replace the differential side retainer oil seal.
<Ref. to 5MT-34, REPLACEMENT, Differential Side Retainer Oil Seal.>

ST 18675AA000 DIFFERENTIAL SIDE OIL SEAL INSTALLER

NOTE:

Be sure to replace the differential side retainer oil seal after the removing the front drive shaft.

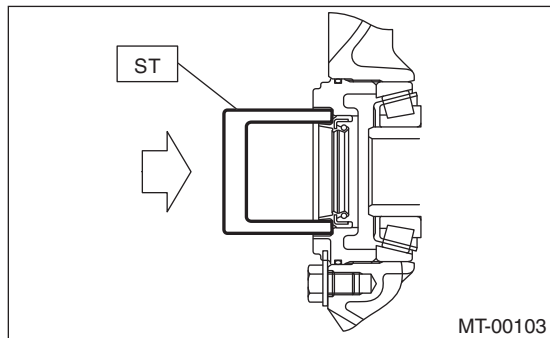

2) Install the transmission cushion rubber to the transmission, and tighten the bolt (A).

3) Install the transmission cushion rubber to the center crossmember, and tighten the nut (B).

Tightening torque:

Bolt (A)

35 N·m (3.6 kgf-m, 25.8 ft-lb)

NUT (B)

35 N·m (3.6 kgf-m, 25.8 ft-lb)

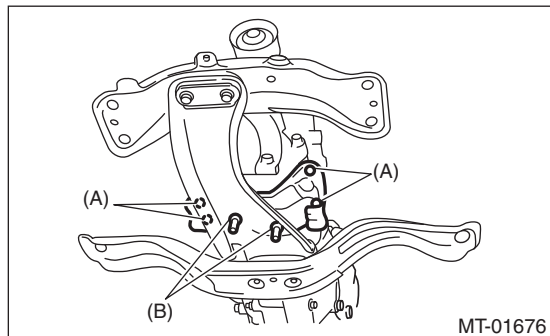

4) Install the transmission onto the engine.

(1) Lift up the transmission gradually using a transmission jack.

(2) Engage at the spline section.

NOTE:

Be careful not to hit the main shaft against the clutch cover.

5) Loosen the turnbuckle of the ST while raising the transmission jack to return the engine to its original position.

6) Install the front crossmember and rear crossmember.

Tightening torque:

T1: 70 N·m (7.1 kgf-m, 51.6 ft-lb)

T2: 140 N·m (14.3 kgf-m, 103.3 ft-lb)

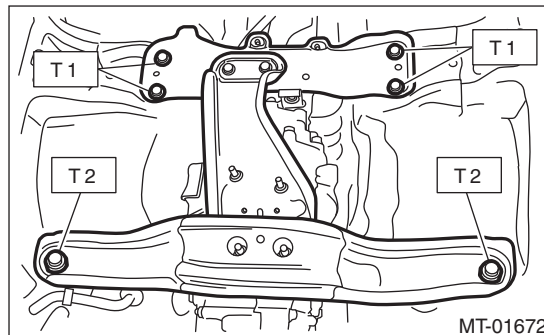

7) Take out the transmission jack.

8) Tighten the bolts and nuts which hold the lower side of transmission to the engine.

Tightening torque:

50 N·m (5.1 kgf-m, 36.9 ft-lb)

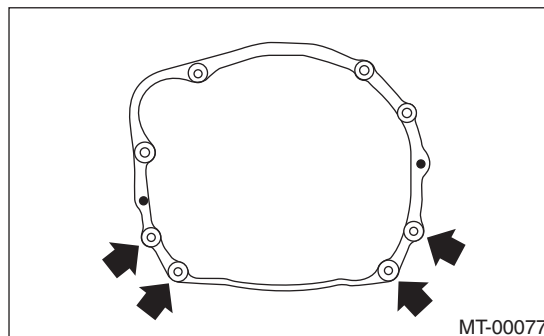

9) Connect the transmission to the engine.

(1) Install the starter. <Ref. to SC(H4SO)-6, INSTALLATION, Starter.>

(2) Tighten the bolts which hold the upper side of the transmission to the engine.

Tightening torque:

50 N·m (5.1 kgf-m, 36.9 ft-lb)

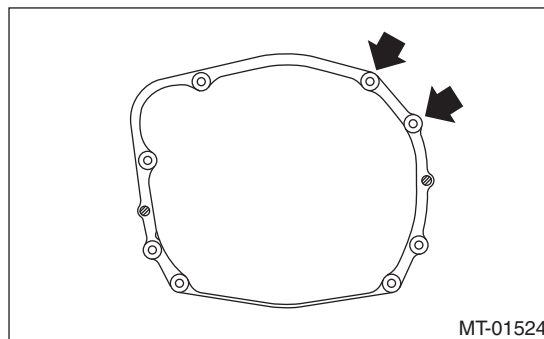

Manual Transmission Assembly

MANUAL TRANSMISSION AND DIFFERENTIAL

10) Remove the ST.

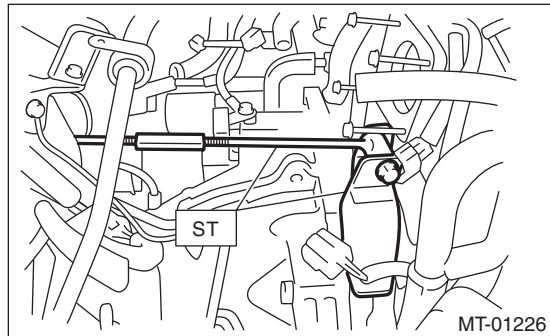

11) Install the pitching stopper.

Tightening torque:

T1: 50 N·m (5.1 kgf-m, 36.9 ft-lb)

T2: 58 N·m (5.9 kgf-m, 42.8 ft-lb)

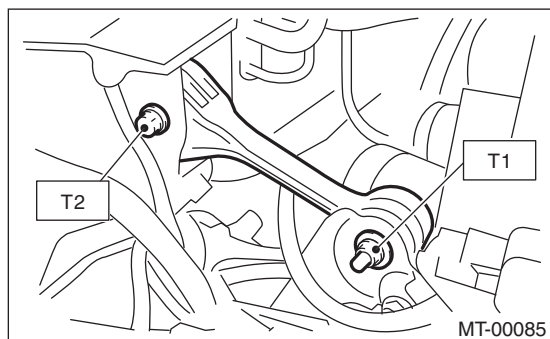

12) Install the throttle body. <Ref. to FU(H4SO)-13, INSTALLATION, Throttle Body.>

13) Lift up the vehicle.

14) Install the front drive shaft into the transmission.

ST 28399SA010 OIL SEAL PROTECTOR

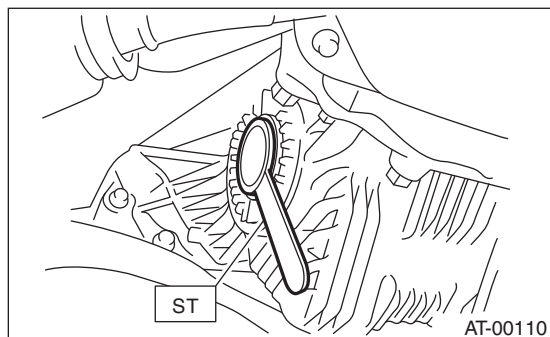

15) Insert the ball joints of the front arm into the housing, then tighten the installing bolts.

Tightening torque:

50 N·m (5.1 kgf-m, 36.9 ft-lb)

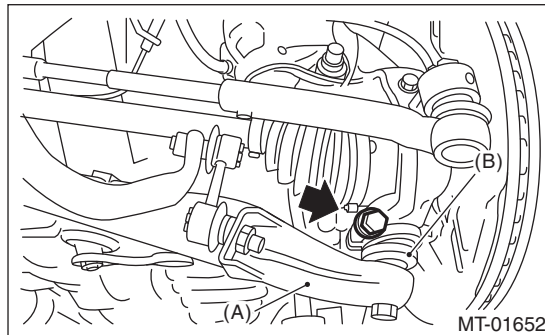

(A) Front arm

(B) Ball joint

16) Attach the stabilizer link to the front arm.

Tightening torque:

30 N·m (3.1 kgf-m, 22.1 ft-lb)

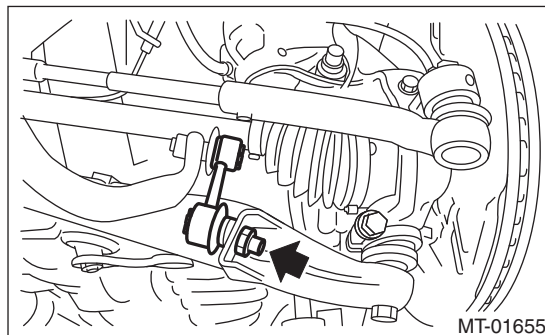

17) Install the front height sensor. <Ref. to LI-40, INSTALLATION, Front Height Sensor.>

Manual Transmission Assembly

MANUAL TRANSMISSION AND DIFFERENTIAL

- 18) Attach the gear shift rod and stay.
(1) Attach the gear shift rod to the transmission.

Tightening torque:

12 N·m (1.2 kgf·m, 8.9 ft·lb)

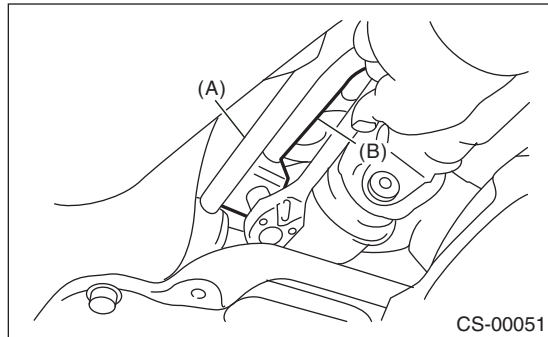

- (A) Stay
(B) Gear shift rod

- (2) Install the stay to the transmission bracket.

Tightening torque:

18 N·m (1.8 kgf·m, 13.3 ft·lb)

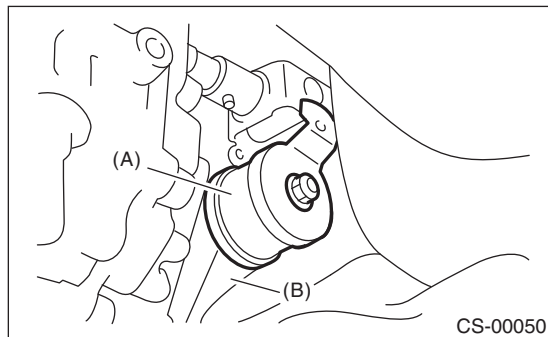

- (A) Stay
(B) Transmission bracket

- 19) Install the propeller shaft. <Ref. to DS-11, INSTALLATION, Propeller Shaft.>

- 20) Install the heat shield cover.

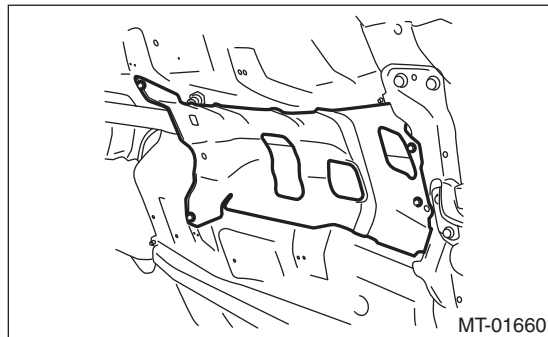

- 21) Install the hanger bracket to the transmission.

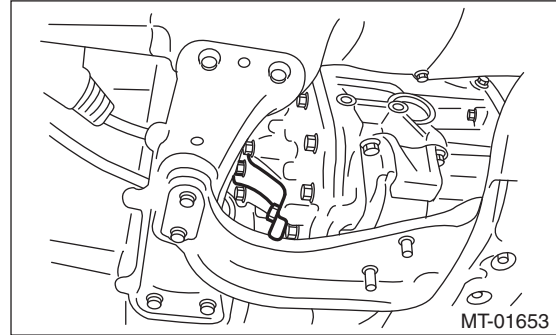

- 22) Install the rear exhaust pipe and muffler. <Ref. to EX(H4SO)-8, INSTALLATION, Rear Exhaust Pipe.>
<Ref. to EX(H4SO)-10, INSTALLATION, Muffler.>

- 23) Install the front and center exhaust pipe. <Ref. to EX(H4SO)-5, INSTALLATION, Front Exhaust Pipe.>

- 24) Install the under cover. <Ref. to EI-25, INSTALLATION, Front Under Cover.>

- 25) Install the operating cylinder.

Tightening torque:

37 N·m (3.8 kgf·m, 27.3 ft·lb)

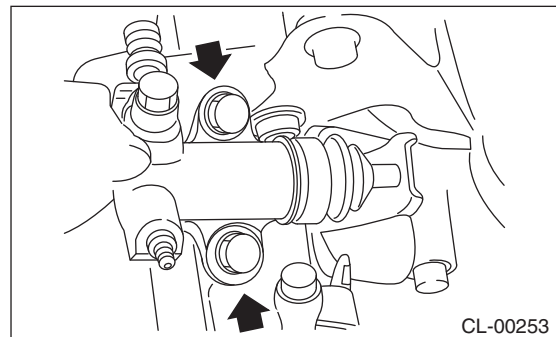

- 26) Install the ground cable.

Tightening torque:

13 N·m (1.3 kgf·m, 9.6 ft·lb)

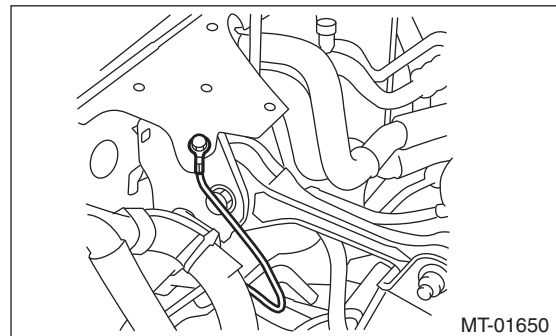

Manual Transmission Assembly

MANUAL TRANSMISSION AND DIFFERENTIAL

27) Install the engine hanger rear, and then connect the engine harness connector.

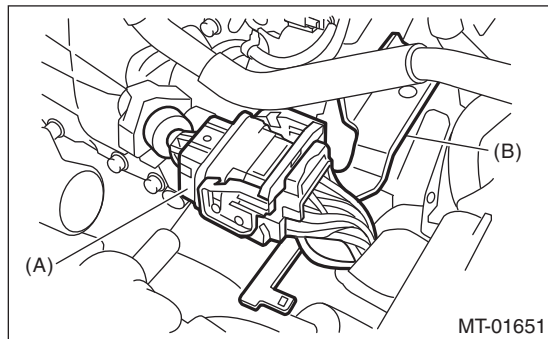

- (A) Engine harness connectors
- (B) Engine connector

28) Connect the following connectors.

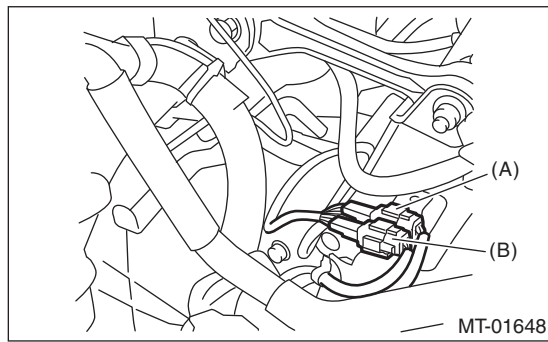

- (A) Neutral position switch connector (Brown)
- (B) Back-up light switch connector (Gray)

29) Install the air intake chamber stay.

Tightening torque:

16 N·m (1.6 kgf·m, 11.8 ft·lb)

30) Install the air intake chamber and intake boot. <Ref. to IN(H4SO)-7, INSTALLATION, Air Intake Chamber.>

31) Connect the battery ground cable to the battery.

32) Remove the lift arm from vehicle.

33) Reinitialize the auto headlight levelizer. <Ref. to LI-15, PROCEDURE, Auto Headlight Beam Leveler System.>

Transmission Mounting System

MANUAL TRANSMISSION AND DIFFERENTIAL

4. Transmission Mounting System

A: REMOVAL

1. PITCHING STOPPER

- 1) Disconnect the ground cable from battery.
- 2) Remove the air intake chamber and intake boot. <Ref. to IN(H4SO)-7, REMOVAL, Air Intake Chamber.>
- 3) Remove the pitching stopper.

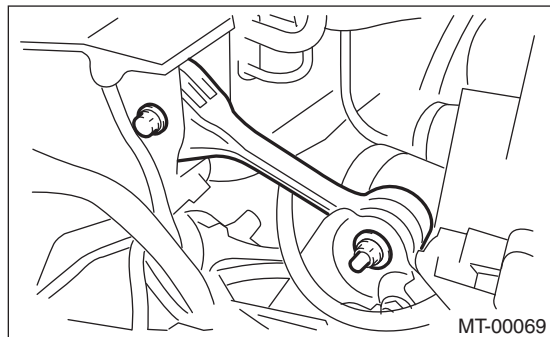

2. CROSSMEMBER AND CUSHION RUBBER

- 1) Disconnect the ground cable from battery.
- 2) Lift up the vehicle.
- 3) Remove the front and center exhaust pipe. <Ref. to EX(H4SO)-4, REMOVAL, Front Exhaust Pipe.>
- 4) Remove the rear exhaust pipe and muffler. <Ref. to EX(H4SO)-8, REMOVAL, Rear Exhaust Pipe.> <Ref. to EX(H4SO)-10, REMOVAL, Muffler.>
- 5) Remove the heat shield cover.

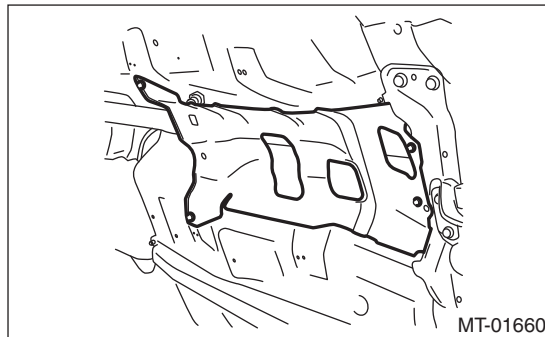

- 6) Set the transmission jack under the transmission body.

CAUTION:

Always support the transmission case with a transmission jack.

- 7) Remove the front crossmember and the rear crossmember.

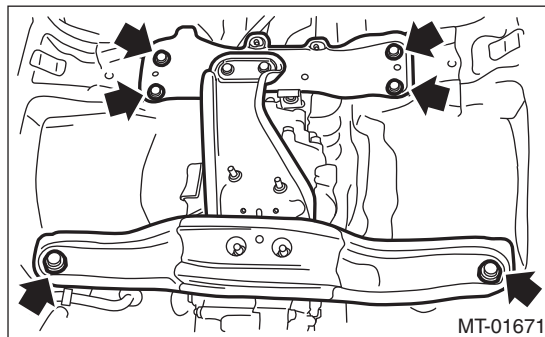

- 8) Remove the transmission cushion rubber.

Transmission Mounting System

MANUAL TRANSMISSION AND DIFFERENTIAL

B: INSTALLATION

1. PITCHING STOPPER

1) Install the pitching stopper.

Tightening torque:

T1: 50 N·m (5.1 kgf-m, 36.9 ft-lb)

T2: 58 N·m (5.9 kgf-m, 42.8 ft-lb)

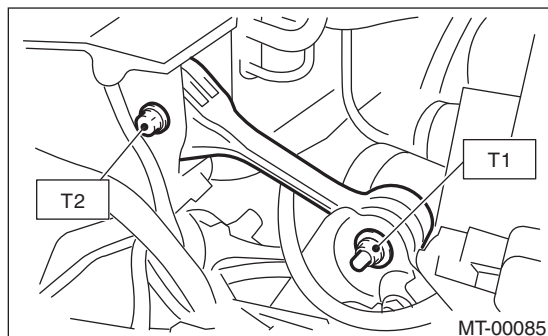

2) Install the air intake chamber and intake boot. <Ref. to IN(H4SO)-7, INSTALLATION, Air Intake Chamber.>

3) Connect the battery ground cable to the battery.

2. CROSSMEMBER AND CUSHION RUBBER

1) Install the transmission cushion rubber to the transmission, and tighten the bolt (A).

2) Install the transmission cushion rubber to the center crossmember, and tighten the nut (B).

Tightening torque:

Bolt (A)

35 N·m (3.6 kgf-m, 25.8 ft-lb)

NUT (B)

35 N·m (3.6 kgf-m, 25.8 ft-lb)

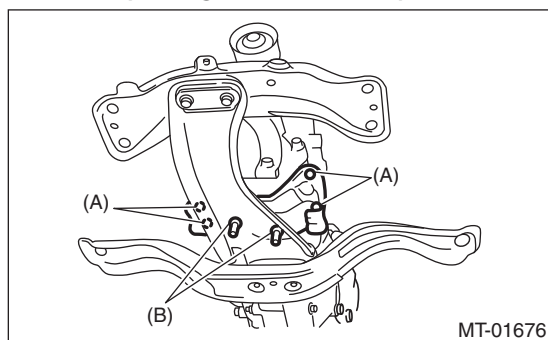

3) Install the front crossmember and rear crossmember.

Tightening torque:

T1: 70 N·m (7.1 kgf-m, 51.6 ft-lb)

T2: 140 N·m (14.3 kgf-m, 103.3 ft-lb)

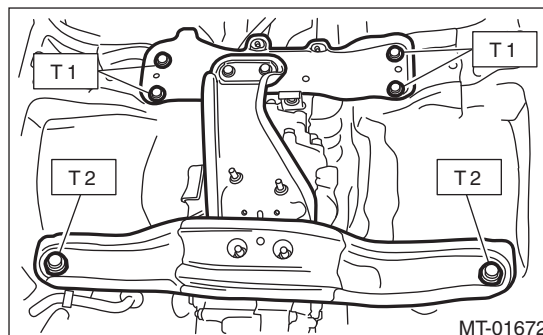

4) Remove the transmission jack.

5) Install the heat shield cover.

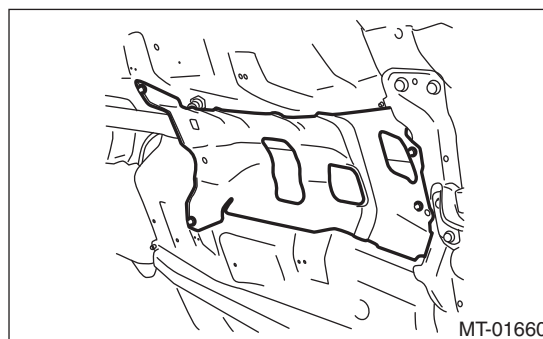

6) Install the front and center exhaust pipe. <Ref. to EX(H4SO)-5, INSTALLATION, Front Exhaust Pipe.>

7) Install the rear exhaust pipe and muffler. <Ref. to EX(H4SO)-8, INSTALLATION, Rear Exhaust Pipe.> <Ref. to EX(H4SO)-10, INSTALLATION, Muffler.>

8) Lower the vehicle.

9) Connect the battery ground cable to the battery.

C: INSPECTION

Perform the following inspection procedures and repair or replace faulty parts.

1. PITCHING STOPPER

Check the pitching stopper for bends or damage. Check that the rubber is not stiff, cracked or otherwise damaged.

2. CROSSMEMBER AND CUSHION RUBBER

Check crossmember for bends or damage. Check that the cushion rubber is not stiff, cracked, or otherwise damaged.

5. Oil Seal

A: INSPECTION

Check for leakage of gear oil from the oil seal. If there is oil leakage, replace the oil seal with the new part and check the propeller shaft.

B: REPLACEMENT

- 1) Clean the transmission exterior.
- 2) Using the TORX® bit T70, remove the drain plug, and drain the transmission gear oil completely.
- 3) Using the TORX® bit T70, tighten the transmission gear oil drain plug.

NOTE:

Use a new gasket.

Tightening torque:

44 N·m (4.5 kgf-m, 32.5 ft-lb) (Aluminum gasket)

70 N·m (7.1 kgf-m, 51.6 ft-lb) (Copper gasket)

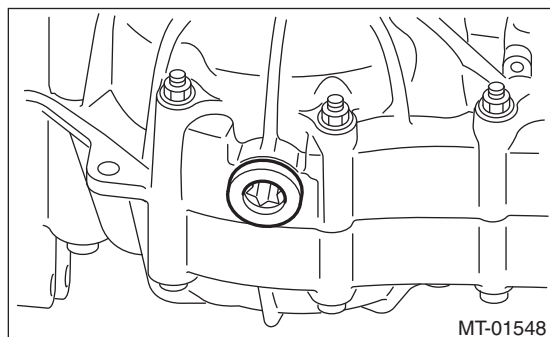

- 4) Remove the rear exhaust pipe and muffler. <Ref. to EX(H4SO)-8, REMOVAL, Rear Exhaust Pipe.> <Ref. to EX(H4SO)-10, REMOVAL, Muffler.>
- 5) Remove the heat shield cover.

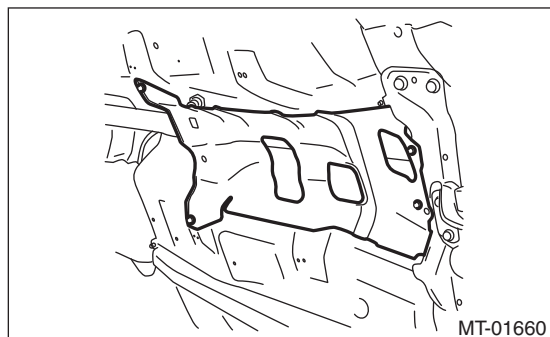

- 6) Remove the propeller shaft. <Ref. to DS-10, REMOVAL, Propeller Shaft.>

- 7) Using the ST, remove the oil seal.
ST 398527700 PULLER ASSY

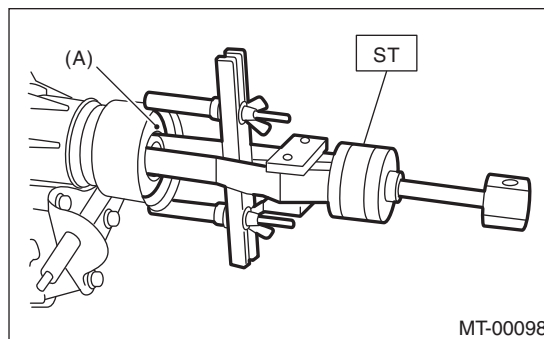

(A) Oil seal

- 8) Using the ST, install the oil seal.
ST 498057300 INSTALLER

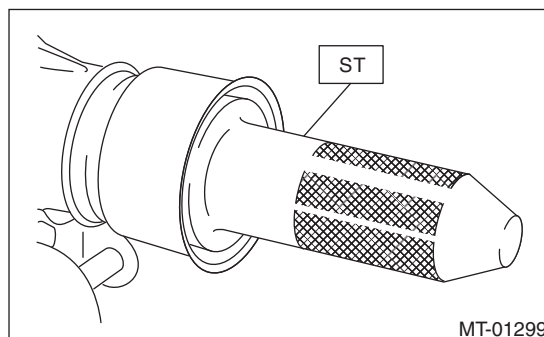

- 9) Install the propeller shaft. <Ref. to DS-11, INSTALLATION, Propeller Shaft.>
- 10) Install the heat shield cover.

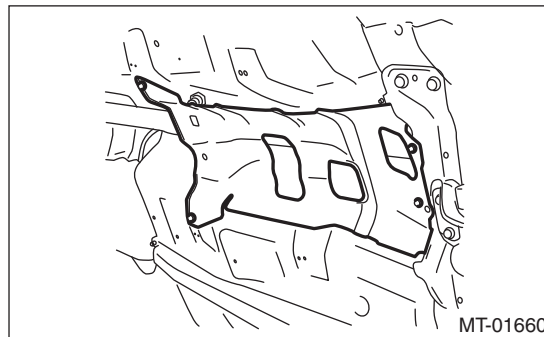

- 11) Install the rear exhaust pipe and muffler. <Ref. to EX(H4SO)-8, INSTALLATION, Rear Exhaust Pipe.> <Ref. to EX(H4SO)-10, INSTALLATION, Muffler.>
- 12) Pour in the transmission gear oil and check the oil level. <Ref. to 5MT-23, Transmission Gear Oil.>

Differential Side Retainer Oil Seal

6. Differential Side Retainer Oil Seal

A: INSPECTION

Check for leakage of gear oil from differential side retainer oil seal part. If there is oil leakage, replace the oil seal with the new part and check the drive shaft.

B: REPLACEMENT

- 1) Lift up the vehicle.
- 2) Remove the differential gear oil drain plug using TORX® bit T70, and drain the differential gear oil completely.

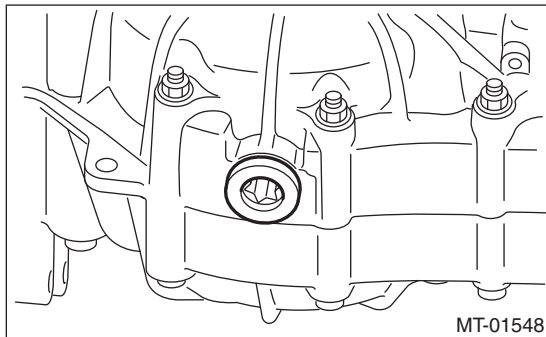

- 3) Replace the gasket with a new part and tighten the differential gear oil drain plug using the TORX® bit T70.

Tightening torque:

44 N·m (4.5 kgf·m, 32.5 ft·lb) (Aluminum gasket)

70 N·m (7.1 kgf·m, 51.6 ft·lb) (Copper gasket)

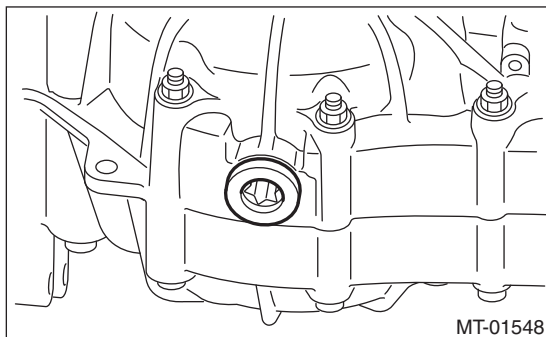

- 4) Remove the front and center exhaust pipe. <Ref. to EX(H4SO)-4, REMOVAL, Front Exhaust Pipe.>
- 5) Separate the front drive shaft from the transmission. <Ref. to DS-27, REMOVAL, Front Drive Shaft.>
- 6) Remove the differential side retainer oil seal.

NOTE:

- Be sure to replace the differential side retainer oil seal after the procedure of removing front drive shaft from transmission.
- To remove the oil seal, use ST 398527700 PULLER ASSY. When removing the part by using a flat tip screwdriver, be careful not to scratch the differential side retainer.

- 7) Using the ST, install the differential side retainer oil seal by lightly tapping with a plastic hammer.

ST 18675AA000 DIFFERENTIAL SIDE OIL SEAL INSTALLER

NOTE:

Apply oil to the oil seal lips.

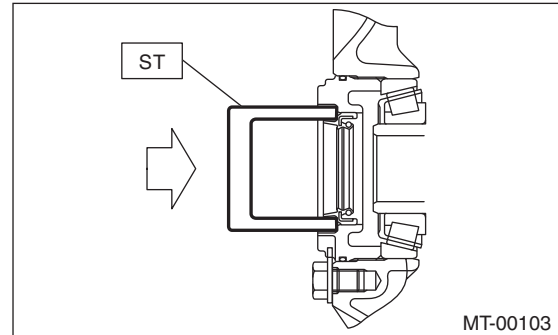

- 8) Install the front drive shaft. <Ref. to DS-28, INSTALLATION, Front Drive Shaft.>

ST 28399SA010 OIL SEAL PROTECTOR

- 9) Install the front and center exhaust pipe. <Ref. to EX(H4SO)-5, INSTALLATION, Front Exhaust Pipe.>

- 10) Lower the vehicle.

- 11) Fill the transmission gear oil through the oil level gauge hole. <Ref. to 5MT-23, REPLACEMENT, Transmission Gear Oil.>

7. Switches and Harness

A: REMOVAL

1. BACK-UP LIGHT SWITCH & NEUTRAL POSITION SWITCH

- 1) Disconnect the ground cable from battery.
- 2) Remove the air intake chamber and intake boot. <Ref. to IN(H4SO)-7, REMOVAL, Air Intake Chamber.>
- 3) Disconnect the connector back-up light switch & neutral position switch.

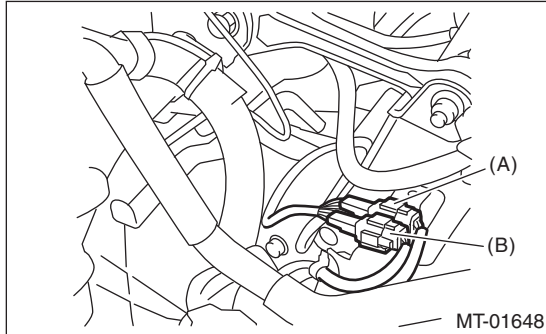

- (A) Neutral position switch connector (Brown)
- (B) Back-up light switch connector (Gray)

- 4) Lift up the vehicle.
- 5) Remove the back-up light switch & neutral position switch with the harness.

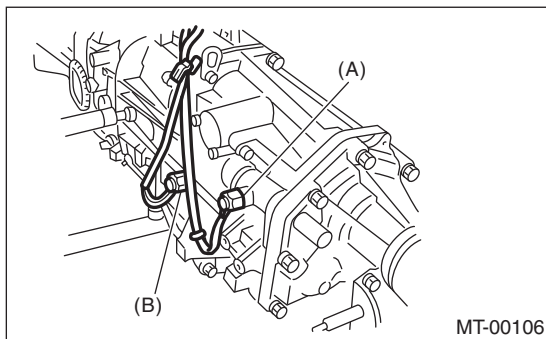

- (A) Neutral position switch
- (B) Back-up light switch

B: INSTALLATION

1. BACK-UP LIGHT SWITCH & NEUTRAL POSITION SWITCH

- 1) Install the back-up light switch & neutral position switch with the harness.

Tightening torque:

32.3 N·m (3.3 kgf·m, 23.8 ft·lb)

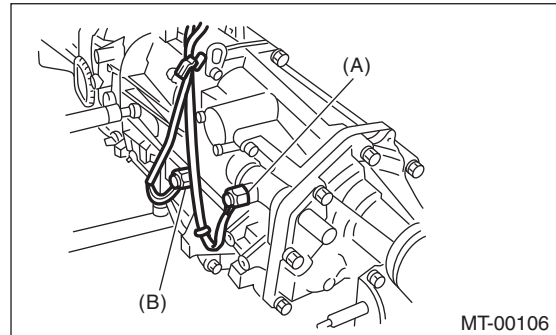

- (A) Neutral position switch
- (B) Back-up light switch

- 2) Connect the connectors of back-up light switch & neutral position switch.
- 3) Install the air intake chamber and intake boot. <Ref. to IN(H4SO)-7, INSTALLATION, Air Intake Chamber.>
- 4) Connect the battery ground cable to the battery.

C: INSPECTION

1. BACK-UP LIGHT SWITCH

Check the back-up light switch. <Ref. to LI-7, INSPECTION, Back-up Light System.>

2. NEUTRAL POSITION SWITCH

- 1) Turn the ignition switch to OFF.
- 2) Disconnect the connector of neutral position switch.
- 3) Measure the resistance between neutral position switch terminals.

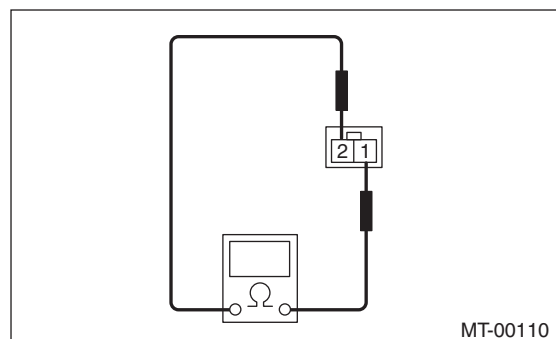

Gear shift position	Terminal No.	Specified resistance
Neutral position	1 and 2	Less than 1 Ω
Other positions		1 MΩ or more

- 4) Replace faulty parts.

Preparation for Overhaul

MANUAL TRANSMISSION AND DIFFERENTIAL

8. Preparation for Overhaul

A: PROCEDURE

- 1) Clean oil, grease, dirt and dust from the transmission.
- 2) Using the TORX® bit T70, remove the transmission gear oil drain plug, and drain the transmission gear oil completely.
- 3) Using the TORX® bit T70, tighten the transmission gear oil drain plug.

NOTE:

Use a new gasket.

Tightening torque:

44 N·m (4.5 kgf-m, 32.5 ft-lb) (Aluminum gasket)

70 N·m (7.1 kgf-m, 51.6 ft-lb) (Copper gasket)

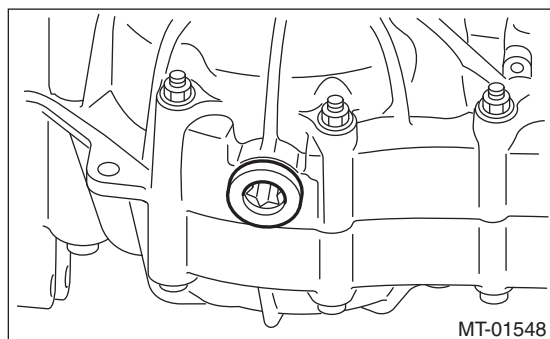

- 4) Attach the transmission to the ST.
ST 499937100 TRANSMISSION STAND

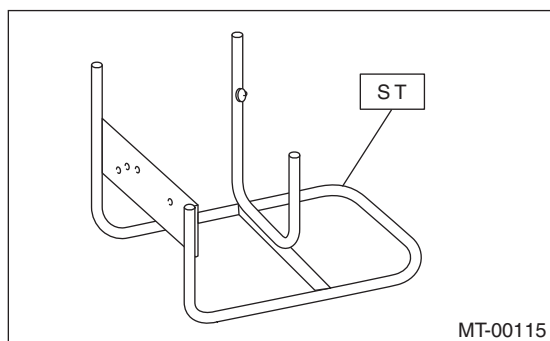

- 5) Apply oil to rotating parts before assembly.
- 6) All disassembled parts, if to be reused, should be reinstalled in the original positions and directions.
- 7) Gaskets, lock washers and lock nuts must be replaced with new parts.
- 8) Apply liquid gasket to the specified areas to prevent leakage.

9. Transfer Case and Extension Case Assembly

A: REMOVAL

- 1) Remove the manual transmission assembly from the vehicle. <Ref. to 5MT-24, REMOVAL, Manual Transmission Assembly.>
- 2) Remove the back-up light switch & neutral position switch. <Ref. to 5MT-35, REMOVAL, Switches and Harness.>
- 3) Remove the transfer case together with the extension case assembly.

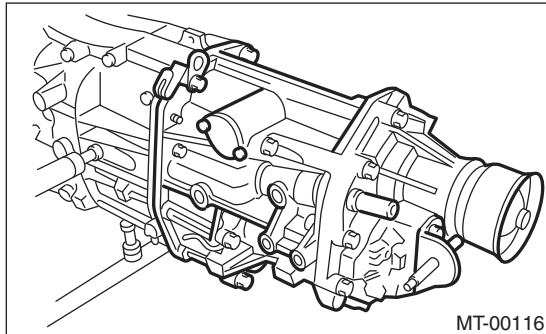

- 4) Remove the shifter arm.
- 5) Remove the extension case assembly.

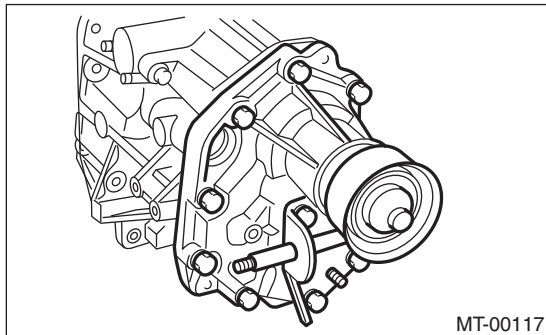

B: INSTALLATION

- 1) Install the center differential and transfer driven gear into the transfer case.

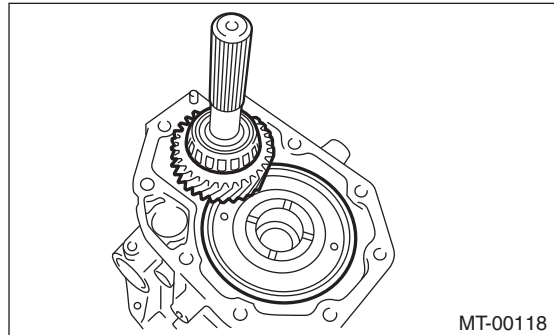

- 2) Remove the bearing outer race from the extension case.

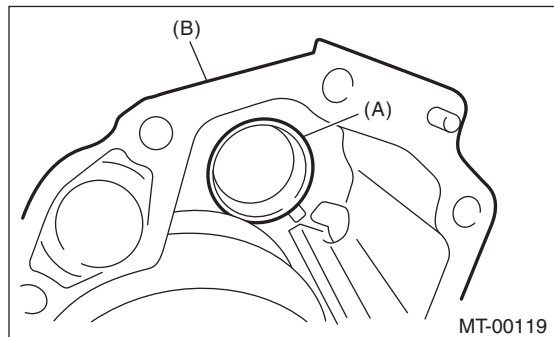

- (A) Bearing outer race
- (B) Extension case

- 3) While holding the bearing outer race horizontally, rotate the driven shaft for ten turns.
- 4) Measure the height "W" between transfer case and taper roller bearing on the transfer driven gear.

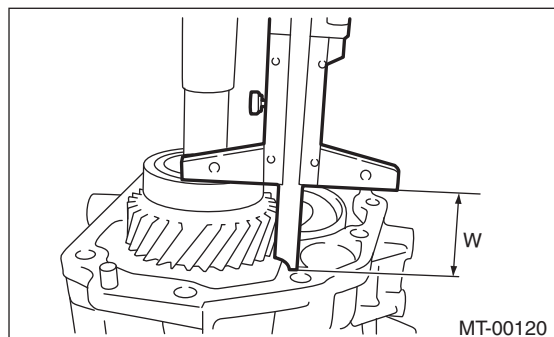

Transfer Case and Extension Case Assembly

MANUAL TRANSMISSION AND DIFFERENTIAL

5) Measure depth "X" on bearing insertion part of the extension case.

NOTE:

Measure with bearing outer race and thrust washer removed.

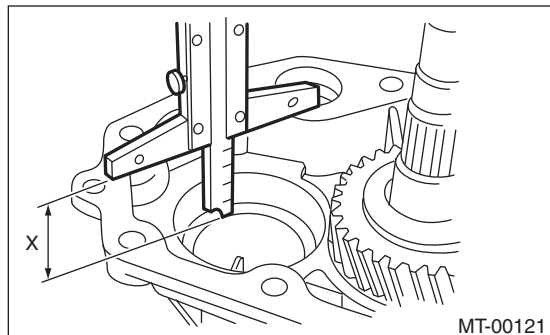

6) Calculate the thickness "t" of the thrust washer using following calculation.

$$t = X - W + (0.15 - 0.25 \text{ mm (0.006 - 0.010 in)})$$

7) Select the washer with the nearest value in the following table.

Preload of the taper roller bearing (amount of standard protrusion):

0.15 — 0.25 mm (0.006 — 0.010 in)

NOTE:

Be sure that the amount of preload is within the standard value.

Thrust washer (50 × 61 × t)	
Part number	Thickness mm (in)
803050060	0.50 (0.0197)
803050061	0.55 (0.0217)
803050062	0.60 (0.0236)
803050063	0.65 (0.0256)
803050064	0.70 (0.0276)
803050065	0.75 (0.0295)
803050066	0.80 (0.0315)
803050067	0.85 (0.0335)
803050068	0.90 (0.0354)
803050069	0.95 (0.0374)
803050070	1.00 (0.0394)
803050071	1.05 (0.0413)
803050072	1.10 (0.0433)
803050073	1.15 (0.0453)
803050074	1.20 (0.0472)
803050075	1.25 (0.0492)
803050076	1.30 (0.0512)
803050077	1.35 (0.0531)
803050078	1.40 (0.0551)
803050079	1.45 (0.0571)

8) Fit the thrust washers on the transfer drive shaft.

9) Install the bearing outer race into the extension case.

10) Measure the depth "S" between transfer case and center differential.

ST 398643600 GAUGE

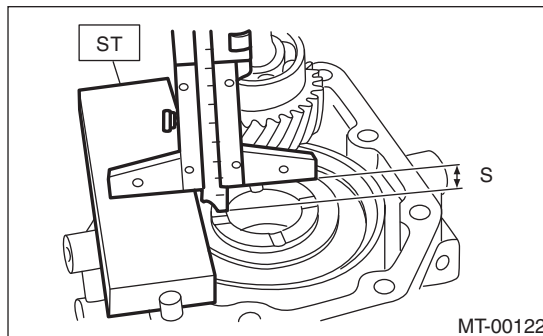

11) Measure the height "T" between the extension case and transfer drive gear.

ST 398643600 GAUGE

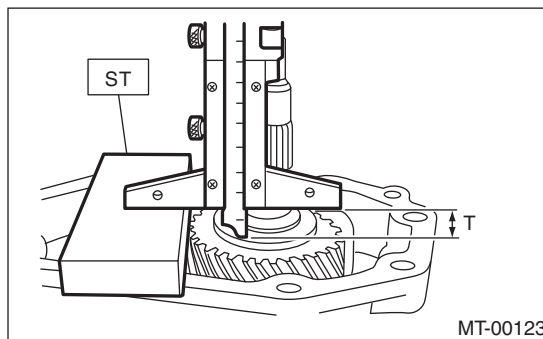

NOTE:

ST thickness [15 mm (0.59 in)]

12) Calculate the thickness "U" of the thrust washer using following calculation.

$$U = S + T - 30 \text{ mm (1.18 in) [Thickness of ST]}$$

13) Select a suitable washer in the following table.

Standard clearance:

0.15 — 0.35 mm (0.0059 — 0.0138 in)

Thrust washer	
Part number	Thickness mm (in)
803036050	0.9 (0.035)
803036054	1.0 (0.039)
803036051	1.1 (0.043)
803036055	1.2 (0.047)
803036052	1.3 (0.051)
803036056	1.4 (0.055)
803036053	1.5 (0.059)
803036057	1.6 (0.063)
803036058	1.7 (0.067)

14) Fit the thrust washer onto the center differential.

Transfer Case and Extension Case Assembly

MANUAL TRANSMISSION AND DIFFERENTIAL

15) Apply a proper amount of liquid gasket to the transfer case mating surface.

Liquid gasket:
THREE BOND 1215 (Part No. 004403007) or equivalent

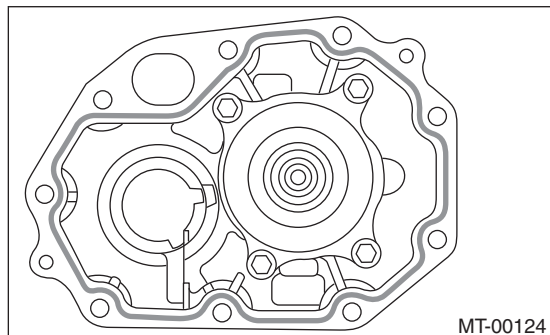

16) Install the extension assembly into the transfer case.

Tightening torque:
40 N·m (4.1 kgf-m, 29.5 ft-lb)

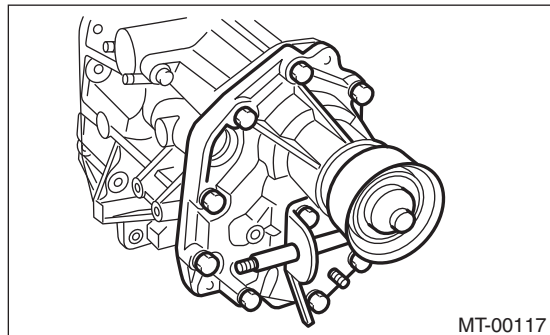

17) Attach the shifter arm to transfer case.

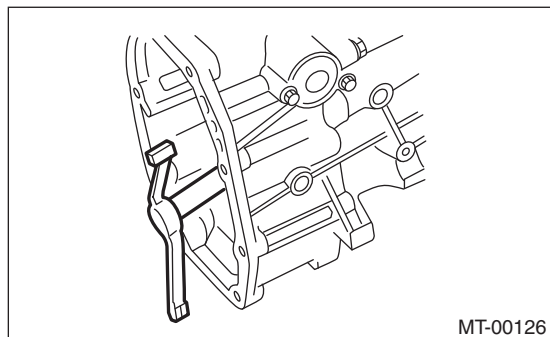

18) Hang the shifter arm on 3rd-4th fork rod.

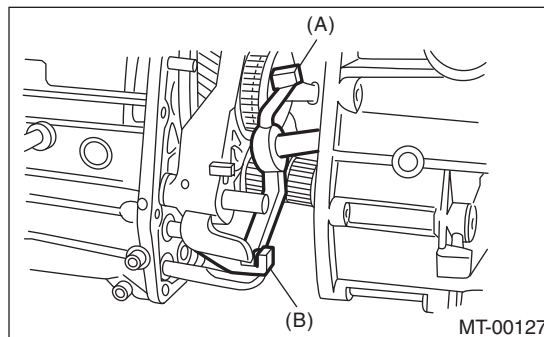

(A) Shifter arm
(B) 3rd-4th fork rod

19) Install the extension case assembly along with the transfer case to the transmission case.

Tightening torque:
24.5 N·m (2.5 kgf-m, 18.1 ft-lb)

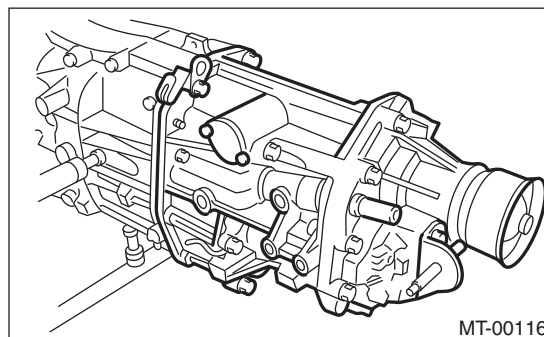

Transfer Case and Extension Case Assembly

MANUAL TRANSMISSION AND DIFFERENTIAL

C: DISASSEMBLY

1. TRANSFER CASE

- 1) Remove the reverse check sleeve assembly. <Ref. to 5MT-46, REMOVAL, Reverse Check Sleeve.>
- 2) Remove the oil guide.

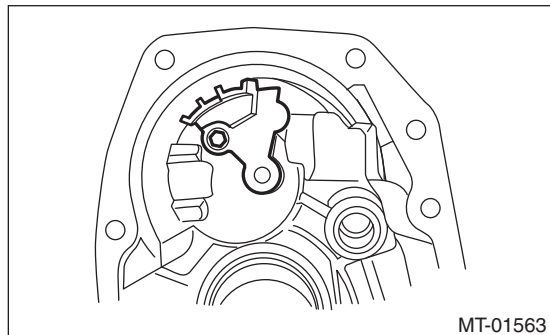

2. EXTENSION CASE

- 1) Remove the transfer drive gear assembly. <Ref. to 5MT-41, REMOVAL, Transfer Drive Gear.>
- 2) Remove the shift bracket.

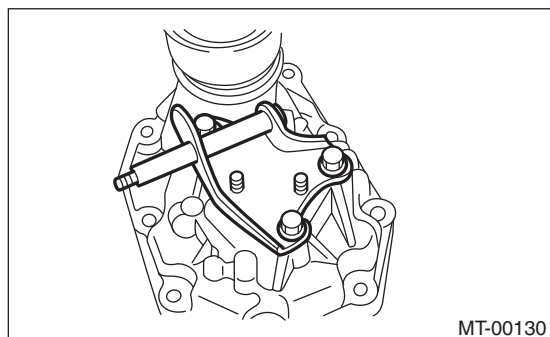

- 3) Remove the oil seal from the extension case. <Ref. to 5MT-33, Oil Seal.>

D: ASSEMBLY

1. EXTENSION CASE

- 1) Using the ST, install the oil seal to the extension case. <Ref. to 5MT-33, Oil Seal.>

NOTE:

Use a new oil seal.

- 2) Install the shift bracket to extension case.

Tightening torque:

24.5 N·m (2.5 kgf-m, 18.1 ft-lb)

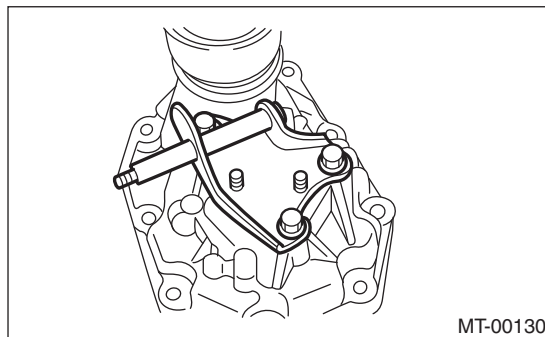

- 3) Install the transfer drive gear to the extension case. <Ref. to 5MT-41, INSTALLATION, Transfer Drive Gear.>

2. TRANSFER CASE

- 1) Install the oil guide to the transfer case.

Tightening torque:

6.4 N·m (0.7 kgf-m, 4.7 ft-lb)

NOTE:

Use a new installing bolt.

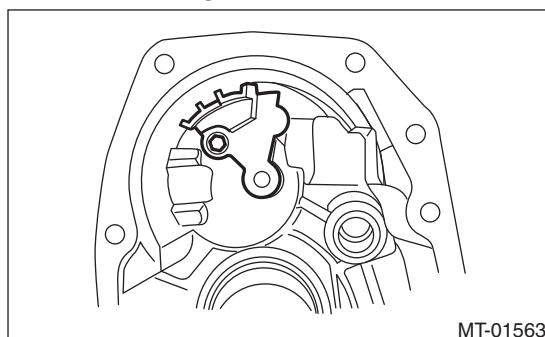

- 2) Install the reverse check sleeve assembly to the transfer case. <Ref. to 5MT-46, INSTALLATION, Reverse Check Sleeve.>

10. Transfer Drive Gear

A: REMOVAL

- 1) Remove the manual transmission assembly from the vehicle. <Ref. to 5MT-24, REMOVAL, Manual Transmission Assembly.>
- 2) Remove the back-up light switch & neutral position switch. <Ref. to 5MT-35, REMOVAL, Switches and Harness.>
- 3) Remove the transfer case together with the extension case assembly. <Ref. to 5MT-37, REMOVAL, Transfer Case and Extension Case Assembly.>
- 4) Remove the extension case assembly.
- 5) Remove the transfer driven gear.
- 6) Remove the transfer drive gear.

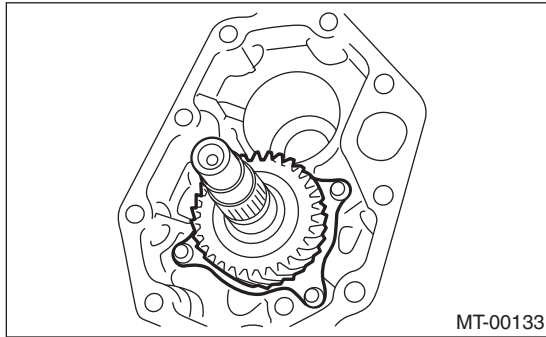

B: INSTALLATION

- 1) Install the transfer drive gear.

Tightening torque:

26 N·m (2.7 kgf·m, 19.2 ft·lb)

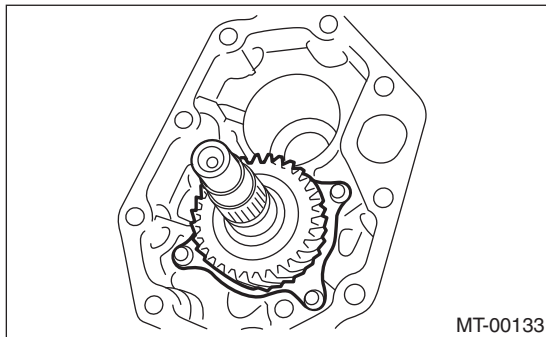

- 2) Install the transfer driven gear.
- 3) Install the extension case assembly.
- 4) Install the transfer case and the extension case assembly. <Ref. to 5MT-37, INSTALLATION, Transfer Case and Extension Case Assembly.>
- 5) Install the back-up light switch and the neutral position switch. <Ref. to 5MT-35, INSTALLATION, Switches and Harness.>
- 6) Install the manual transmission assembly to the vehicle. <Ref. to 5MT-27, INSTALLATION, Manual Transmission Assembly.>

C: DISASSEMBLY

- 1) Remove the snap ring.

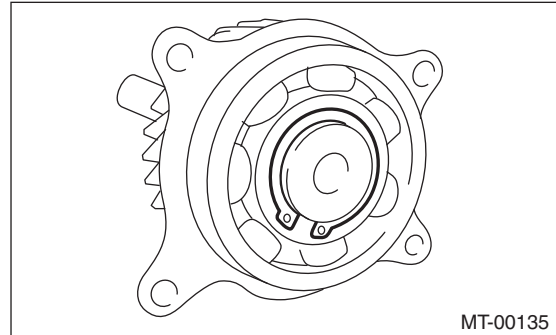

- 2) Remove the ball bearing.

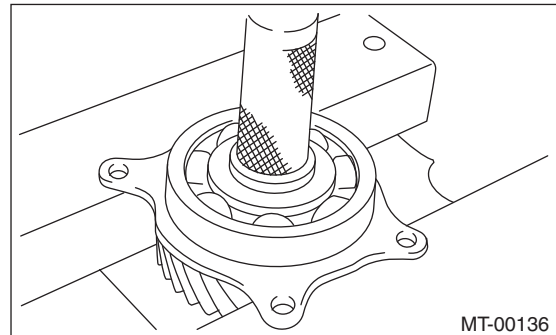

D: ASSEMBLY

- 1) Set the ST against the inner race of the bearing, and install the drive shaft.

ST 398177700 INSTALLER

CAUTION:

Do not apply a load in excess of 10 kN (1 ton, 1.1 US ton, 1.0 Imp ton).

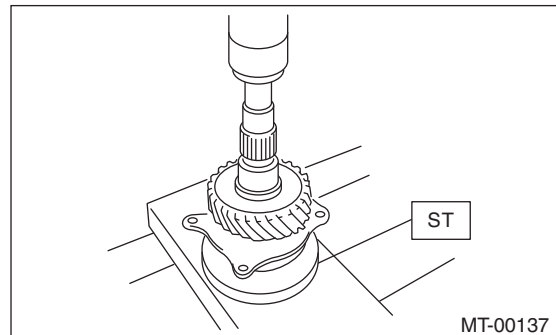

- 2) Install the snap ring on the transfer drive shaft.
- 3) Inspect the clearance between the snap ring and the ball bearing. <Ref. to 5MT-42, INSPECTION, Transfer Drive Gear.>

Transfer Drive Gear

MANUAL TRANSMISSION AND DIFFERENTIAL

E: INSPECTION

1) Bearing

Replace the bearings in the following cases.

- In case of broken or rusty bearings
- In case of worn or damaged bearings
- When the bearings fail to turn smoothly or emit noise in rotation after gear oil lubrication.

2) Drive gear

If the drive gear tooth surface and shaft are excessively broken or damaged, replace the drive gear.

3) Measure the clearance between snap ring and inner race of ball bearing with a thickness gauge.

Clearance:

0.01 — 0.15 mm (0.0004 — 0.0059 in)

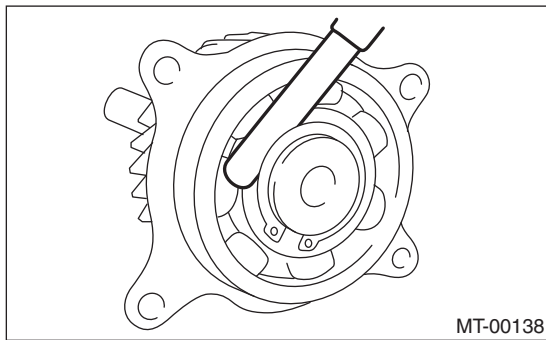

If the measurement is not within specification, select a suitable snap ring and replace it.

Snap ring (Outer-30)	
Part number	Thickness mm (in)
805030041	1.53 (0.0602)
805030042	1.65 (0.0650)
805030043	1.77 (0.0697)

11. Transfer Driven Gear

A: REMOVAL

- 1) Remove the manual transmission assembly from the vehicle. <Ref. to 5MT-24, REMOVAL, Manual Transmission Assembly.>
- 2) Remove the back-up light switch & neutral position switch. <Ref. to 5MT-35, REMOVAL, Switches and Harness.>
- 3) Remove the transfer case together with the extension case assembly. <Ref. to 5MT-37, REMOVAL, Transfer Case and Extension Case Assembly.>
- 4) Remove the extension case assembly.
- 5) Remove the transfer driven gear.

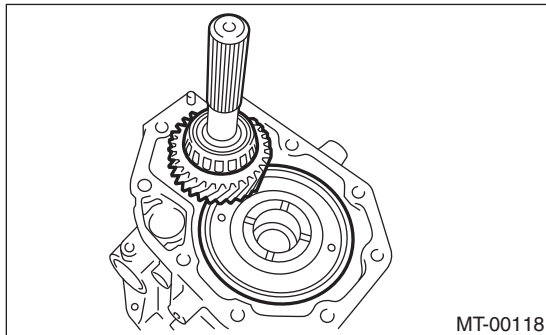

- 6) Remove bearing outer races from the extension case and transfer case.

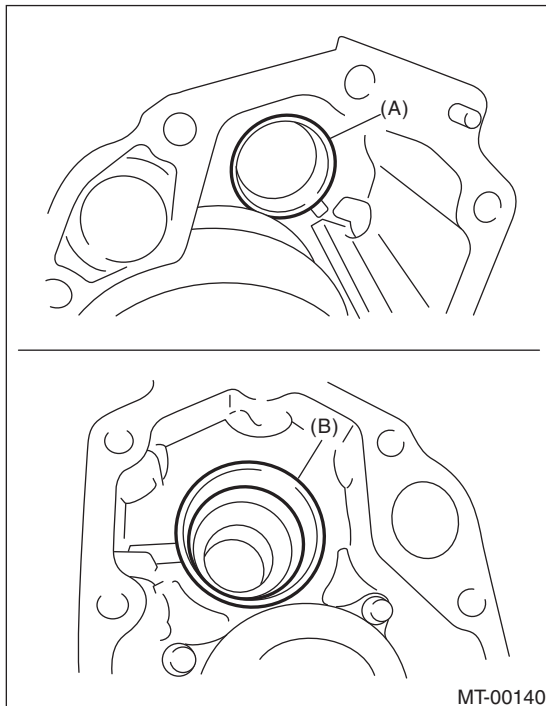

- (A) Bearing outer race (Transfer case side)
- (B) Bearing outer race (Extension case side)

B: INSTALLATION

- 1) Install the bearing outer races to extension case and transfer case.

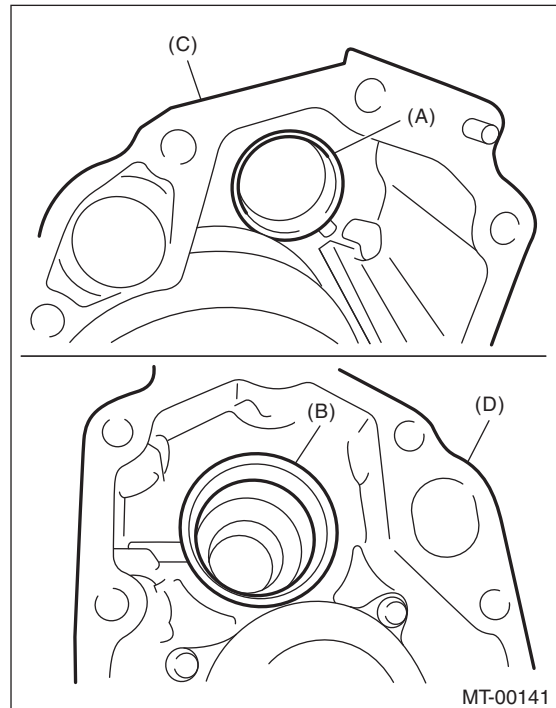

- (A) Bearing outer race
- (B) Bearing outer race
- (C) Transfer case
- (D) Extension case

- 2) Install the transfer driven gear.

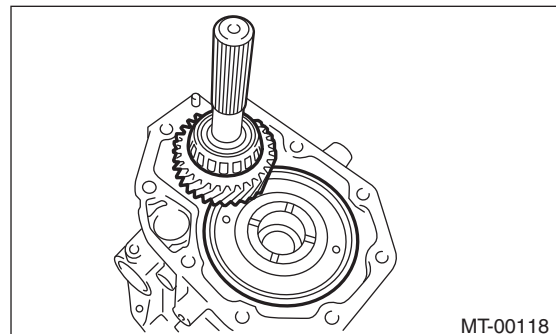

- 3) Install the transfer case and the extension case assembly. <Ref. to 5MT-37, INSTALLATION, Transfer Case and Extension Case Assembly.>
- 4) Install the back-up light switch and the neutral position switch. <Ref. to 5MT-35, INSTALLATION, Switches and Harness.>
- 5) Install the manual transmission assembly to the vehicle. <Ref. to 5MT-27, INSTALLATION, Manual Transmission Assembly.>

Transfer Driven Gear

MANUAL TRANSMISSION AND DIFFERENTIAL

C: DISASSEMBLY

1) Using the ST, remove the roller bearing (extension case side).

ST 498077000 REMOVER

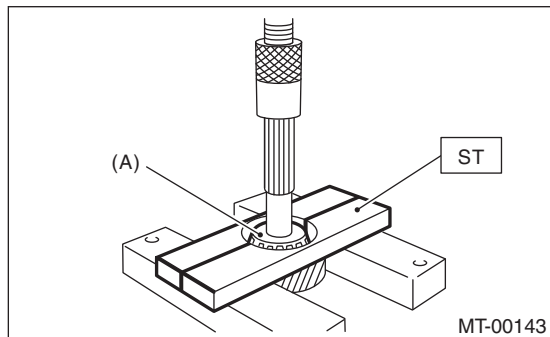

(A) Roller bearing

2) Using ST1 and ST2, remove the roller bearing (transfer case side).

ST1 498077000 REMOVER
ST2 899864100 REMOVER

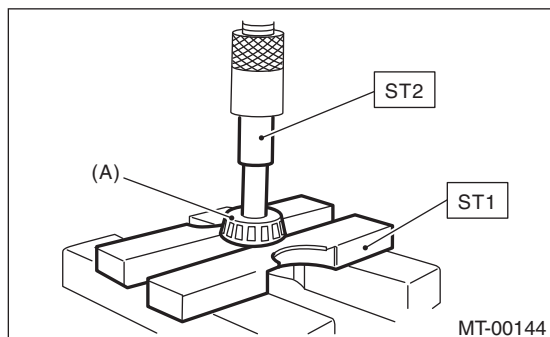

(A) Roller bearing

D: ASSEMBLY

1) Using the ST, install the roller bearing (extension case side).

ST1 398177700 INSTALLER
ST2 899864100 REMOVER

CAUTION:

Do not apply a load in excess of 10 kN (1 ton, 1.1 US ton, 1.0 Imp ton).

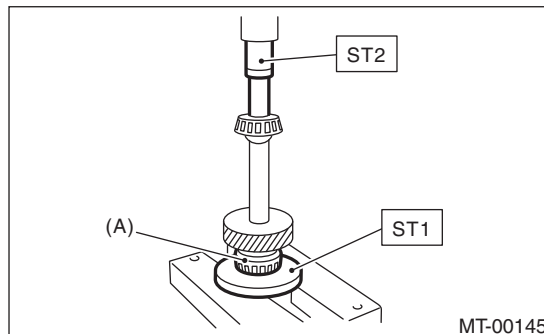

(A) Roller bearing

2) Using ST, install the roller bearing (transfer case side).

ST 499757002 INSTALLER

CAUTION:

Do not apply a load in excess of 10 kN (1 ton, 1.1 US ton, 1.0 Imp ton).

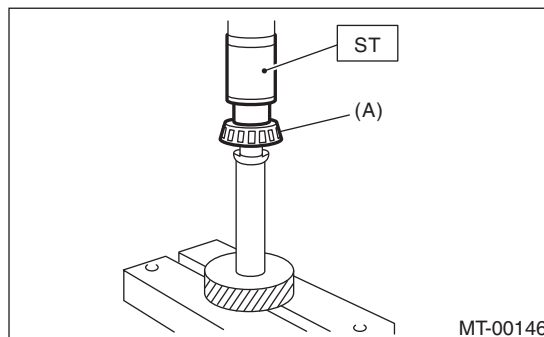

(A) Roller bearing

E: INSPECTION

1) Bearing

Replace the bearings in the following cases.

- In case of broken or rusty bearings
- In case of worn or damaged bearings
- When the bearings fail to turn smoothly or emit noise in rotation after gear oil lubrication.

2) Driven gear

If the driven gear tooth surface and shaft are excessively broken or damaged, replace the driven gear.

Center Differential

MANUAL TRANSMISSION AND DIFFERENTIAL

12.Center Differential

A: REMOVAL

- 1) Remove the manual transmission assembly from the vehicle. <Ref. to 5MT-24, REMOVAL, Manual Transmission Assembly.>
- 2) Remove the back-up light switch & neutral position switch. <Ref. to 5MT-35, REMOVAL, Switches and Harness.>
- 3) Remove the transfer case together with the extension case assembly. <Ref. to 5MT-37, REMOVAL, Transfer Case and Extension Case Assembly.>
- 4) Remove the extension case assembly. <Ref. to 5MT-37, REMOVAL, Transfer Case and Extension Case Assembly.>
- 5) Remove the transfer driven gear. <Ref. to 5MT-43, REMOVAL, Transfer Driven Gear.>
- 6) Remove the center differential.

B: INSTALLATION

- 1) Install the center differential into transfer case.
- 2) Install the transfer driven gear. <Ref. to 5MT-43, INSTALLATION, Transfer Driven Gear.>
- 3) Install the extension case assembly. <Ref. to 5MT-37, INSTALLATION, Transfer Case and Extension Case Assembly.>
- 4) Install the transfer case together with the extension case assembly. <Ref. to 5MT-37, INSTALLATION, Transfer Case and Extension Case Assembly.>
- 5) Install the back-up light switch and the neutral position switch. <Ref. to 5MT-35, INSTALLATION, Switches and Harness.>
- 6) Install the manual transmission assembly to the vehicle. <Ref. to 5MT-27, INSTALLATION, Manual Transmission Assembly.>

C: DISASSEMBLY

NOTE:

Center differential is a non-disassembled part which should not be disassembled.

Remove the ball bearing using ST.

NOTE:

Do not reuse the ball bearing.

ST 498077300 CENTER DIFFERENTIAL
BEARING REMOVER

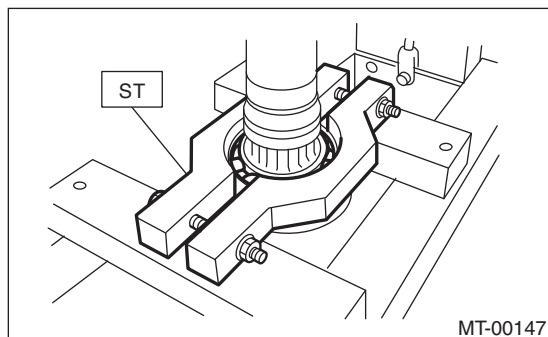

D: ASSEMBLY

Install the ball bearing into the center differential assembly.

CAUTION:

Do not apply a load in excess of 10 kN (1 ton, 1.1 US ton, 1.0 Imp ton).

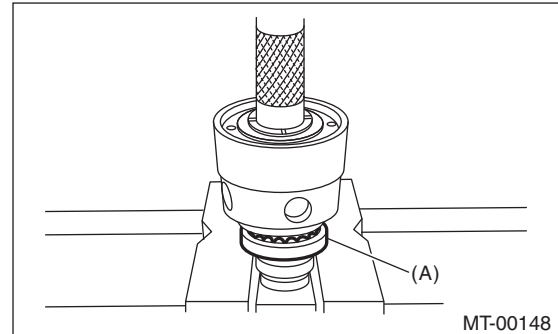

(A) Ball bearing

E: INSPECTION

1) Bearing

Replace the bearings in the following cases.

- In case of broken or rusty bearings
- In case of worn or damaged bearings
- When the bearings fail to turn smoothly or emit noise in rotation after gear oil lubrication.
- When bearing has other defects.

2) Center differential

Replace the center differential case assembly if worn or damaged.

Reverse Check Sleeve

MANUAL TRANSMISSION AND DIFFERENTIAL

13. Reverse Check Sleeve

A: REMOVAL

- 1) Remove the manual transmission assembly from the vehicle. <Ref. to 5MT-24, REMOVAL, Manual Transmission Assembly.>
- 2) Remove the transfer case together with the extension case assembly. <Ref. to 5MT-37, REMOVAL, Transfer Case and Extension Case Assembly.>
- 3) Remove the shifter arm.
- 4) Remove the plug, gasket, reverse accent spring, and reverse check ball.

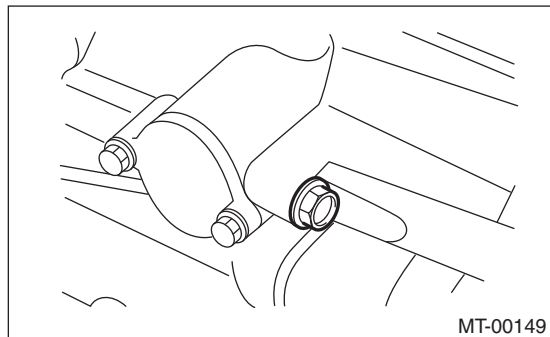

- 5) Remove the reverse check sleeve.

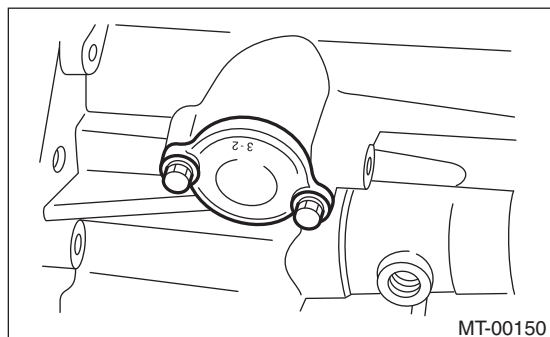

B: INSTALLATION

- 1) Install the reverse check sleeve.

Tightening torque:

6.4 N·m (0.7 kgf-m, 4.7 ft-lb)

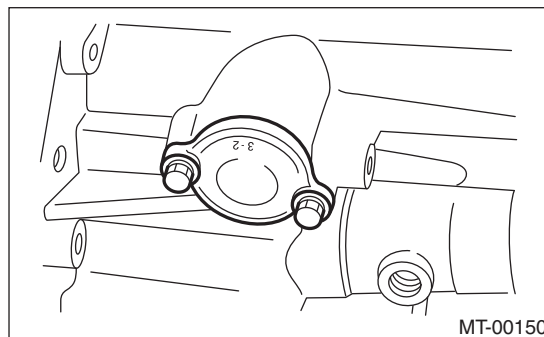

- 2) Reverse check ball, reverse accent spring, gasket and plug to the transfer case.

Tightening torque:

9.75 N·m (1.0 kgf-m, 7.2 ft-lb)

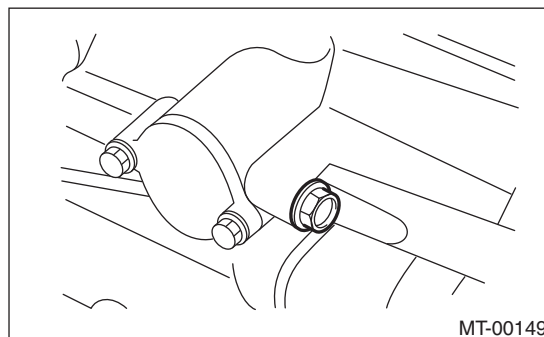

- 3) Attach the shifter arm to the transfer case assembly.
- 4) Install the transfer case together with the extension case assembly. <Ref. to 5MT-37, INSTALLATION, Transfer Case and Extension Case Assembly.>
- 5) Install the manual transmission assembly to the vehicle. <Ref. to 5MT-27, INSTALLATION, Manual Transmission Assembly.>

Reverse Check Sleeve

MANUAL TRANSMISSION AND DIFFERENTIAL

C: DISASSEMBLY

1) Cover the reverse check sleeve with a rag, and remove the snap ring using a screwdriver.

NOTE:

Replace the snap ring with a new part if it is deformed or spring force is weakened.

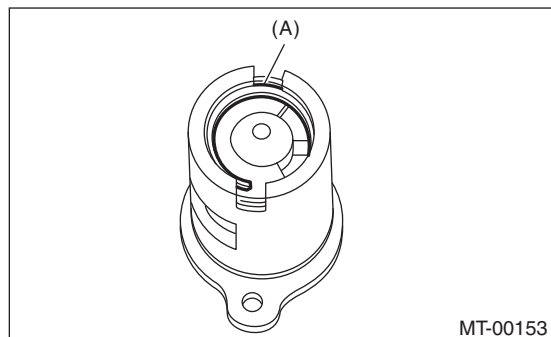

(A) Snap ring

2) Remove the reverse check plate, reverse check spring, reverse check cam, return spring (5th-Rev), reverse accent shaft, return spring cap and return spring (1st-2nd).

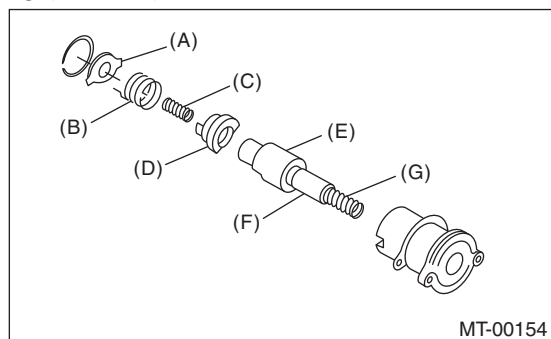

- (A) Reverse check plate
- (B) Reverse check spring
- (C) Return spring (5th-Rev)
- (D) Reverse check cam
- (E) Reverse accent shaft
- (F) Return spring cap
- (G) Return spring (1st-2nd)

3) Remove the O-ring.

NOTE:

- Visually check the O-ring. Replace if faulty.
- Be careful not to damage the adjusting shim between reverse check sleeve assembly and the case.

D: ASSEMBLY

1) Install the return spring (1st-2nd), return spring cap, reverse accent shaft, reverse check cam, return spring (5th-Rev) and reverse check spring to the reverse check sleeve.

NOTE:

Be sure to position the bent section of reverse check spring to fit in the groove of the check cam.

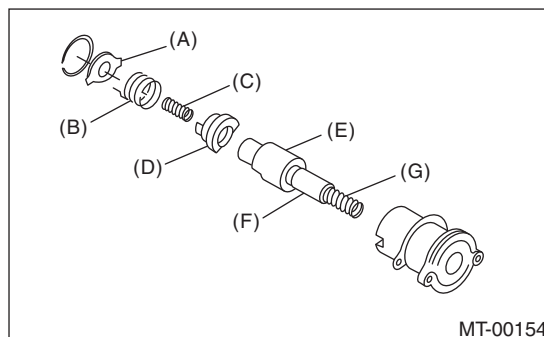

- (A) Reverse check plate
- (B) Reverse check spring
- (C) Return spring (5th-Rev)
- (D) Reverse check cam
- (E) Reverse accent shaft
- (F) Return spring cap
- (G) Return spring (1st-2nd)

2) Hook the curved section of the reverse check spring over the reverse check plate.

3) Rotate the cam so that the protrusion of the reverse check cam comes to the opening of the plate.

4) With cam held in that position, install the reverse check plate onto the reverse check sleeve and hold in place with the snap ring.

5) Position the new O-ring in the groove of sleeve.

Reverse Check Sleeve

MANUAL TRANSMISSION AND DIFFERENTIAL

E: INSPECTION

- Make sure the cutout of the reverse accent shaft is aligned with the opening in the reverse check sleeve.
- Turn the cam by hand to check for smooth rotation.
- Move the cam and shaft all the way toward the plate, and make sure it releases.

If the cam does not return properly, replace the reverse check spring. If the shaft does not return, check for scratches on the inner surface of sleeve. If the sleeve is in good order, replace the spring.

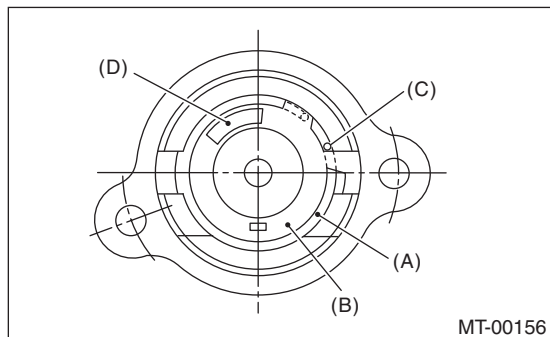

- (A) Snap ring
- (B) Reverse check plate
- (C) Reverse check spring
- (D) Reverse check cam

- Select a suitable reverse accent shaft and reverse check plate. <Ref. to 5MT-48, ADJUSTMENT, Reverse Check Sleeve.>

F: ADJUSTMENT

1. NEUTRAL POSITION ADJUSTMENT

- 1) Shift the gear into 3rd gear position.
- 2) Because of the return spring, until the arm contacts the stopper the shifter arm will feel lighter moving towards 1st/2nd gear and heavier towards the reverse gear.
- 3) Make adjustment so that the heavy stroke (reverse side) is a little heavier than the lighter stroke (1st/2nd side).
- 4) To adjust, remove the bolts holding the reverse check sleeve assembly to the case, and move the sleeve assembly outward, then place an adjustment shim between the sleeve assembly and the case to adjust the clearance.

CAUTION:

Be careful not to damage the O-ring when placing shims.

NOTE:

- When the shim is removed, the neutral position will move closer to reverse; when the shim is added, the neutral position will move closer to 1st gear.
- If it is not possible to adjust the clearance with only shims, replace the reverse accent shaft and re-adjust.

Adjusting shim	
Part number	Thickness mm (in)
32190AA000	0.15 (0.0059)
32190AA010	0.30 (0.0118)

Reverse accent shaft		
Part number	Mark	Remarks
32188AA130	S	Neutral position is closer to 1st gear.
32188AA140	T	Standard
32188AA150	U	Neutral position is closer to reverse gear.

2. REVERSE CHECK PLATE ADJUSTMENT

- 1) Shift the shifter arm to "5th" and then to reverse to see if the reverse check mechanism operates properly.
- 2) Also check to see if the arm returns to neutral when released from the reverse position. If the arm does not return properly, replace the reverse check plate.

Reverse check plate			
Part number	(A): No.	Angle θ	Remarks
32189AA001	0	28°	Arm stops closer to 5th gear.
32189AA011	1	31°	Arm stops closer to 5th gear.
32189AA021	2	34°	Arm stops in the center.
32189AA031	3	37°	Arm stops closer to reverse gear.
32189AA041	4	40°	Arm stops closer to reverse gear.

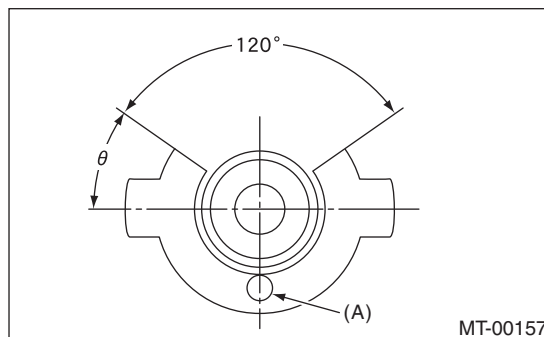

Transmission Case

MANUAL TRANSMISSION AND DIFFERENTIAL

14. Transmission Case

A: REMOVAL

- 1) Remove the manual transmission assembly from the vehicle. <Ref. to 5MT-24, REMOVAL, Manual Transmission Assembly.>
- 2) Remove the clutch release lever. <Ref. to CL-13, REMOVAL, Release Bearing and Lever.>
- 3) Remove the transfer case together with the extension case assembly. <Ref. to 5MT-37, REMOVAL, Transfer Case and Extension Case Assembly.>
- 4) Remove the bearing mounting bolt.

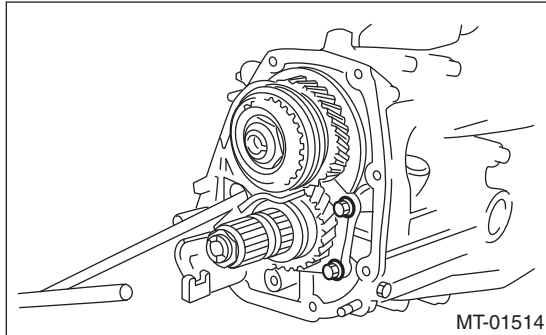

- 5) Remove the main shaft rear plate.

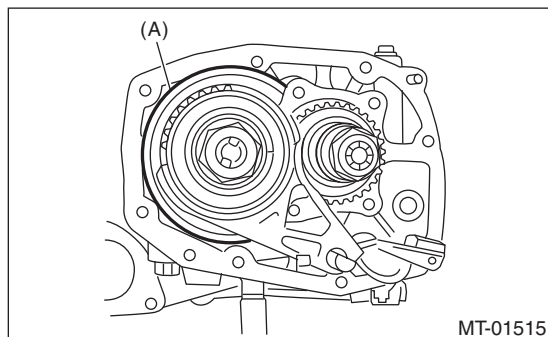

(A) Main shaft rear plate

- 6) Separate the transmission case into the right and left cases by loosening the coupling bolts and nuts.

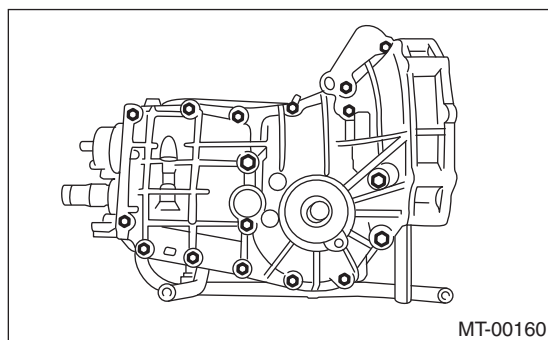

- 7) Remove the drive pinion shaft assembly from the left side of the transmission case.

NOTE:

Use a hammer handle, etc. to remove if too tight.

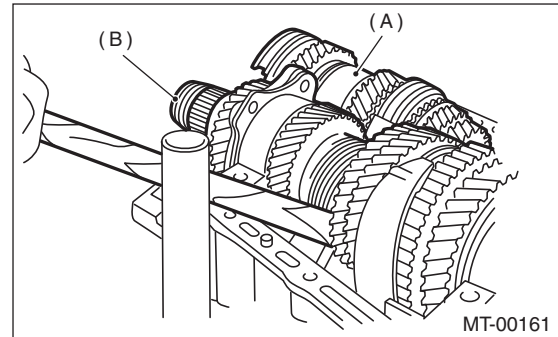

(A) Main Shaft ASSY for Single-Range
(B) Drive pinion shaft ASSY

- 8) Remove the main shaft assembly for single-range.
- 9) Remove the front differential assembly.

NOTE:

- Do not confuse the right and left roller bearing outer races.
- Be careful not to damage the oil seal of retainer.

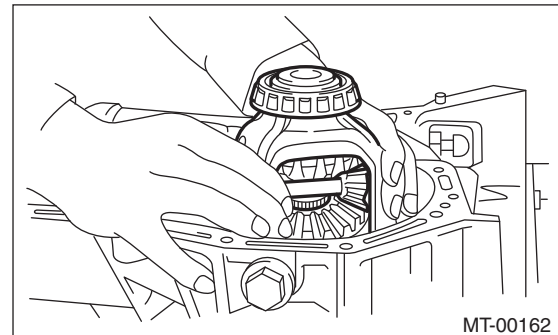

Transmission Case

MANUAL TRANSMISSION AND DIFFERENTIAL

B: INSTALLATION

- 1) Wipe off grease, oil and dust on the mating surfaces of transmission cases with cleaning solvent.
- 2) Install the front differential assembly.
- 3) Install the main shaft assembly for single-range. Install the transmission case knock pin into the knock pin hole of needle bearing.
- 4) Install the drive pinion shaft assembly. Install the transmission case knock pin into the roller bearing knock pin hole.
- 5) Apply liquid gasket, then join the right side and left side of the case together.

Liquid gasket:

THREE BOND 1215 (Part No. 004403007) or equivalent

- 6) With brackets and clips as shown in the figure, tighten the seventeen bolts.

NOTE:

- Insert the bolts from the bottom and tighten the nuts at the top.
- Put the cases together so that the drive pinion shim and input shaft holder shims are not caught between cases.

Tightening torque:

8 mm bolt

25 N·m (2.5 kgf·m, 18.4 ft·lb)

★ 10 mm bolt

39 N·m (4.0 kgf·m, 28.8 ft·lb)

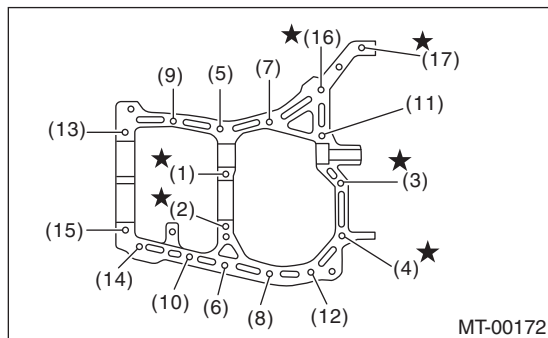

- 7) Tighten the ball bearing mounting bolts.

Tightening torque:

30 N·m (3.1 kgf·m, 22.1 ft·lb)

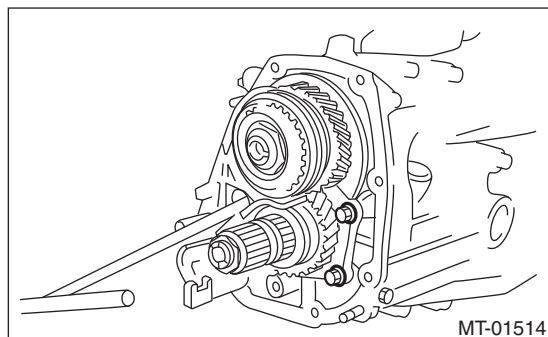

- 8) Perform backlash adjustment of the hypoid gear and preload measurement of the roller bearing:

NOTE:

Attach the ST on drive pinion assembly.

ST 498427100 STOPPER

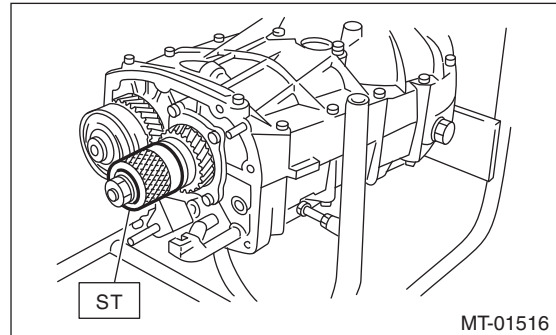

- 9) Place the transmission with the left side of case facing downward, and put ST1 on bearing cup.

- 10) Screw the retainer assembly from the bottom into left case using ST2. Fit the ST3 on transmission main shaft. Shift the gear into 4th or 5th, and turn the shaft several times. Screw in the retainer while rotating the ST3 until a slight resistance is felt on ST2.

This is the contact point of the hypoid gear and the drive pinion shaft. Repeat the above sequence several times to ensure the contact point.

ST1 399780104

WEIGHT

ST2 18630AA010

WRENCH COMPL

RETAINER

ST3 499927100

HANDLE

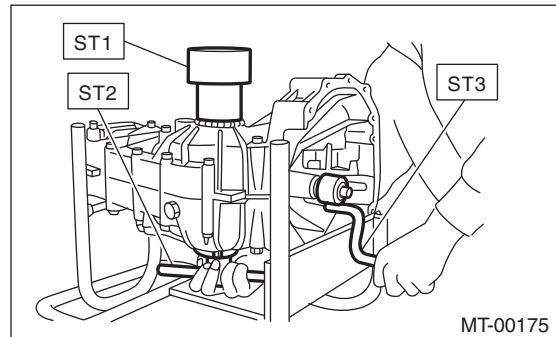

Transmission Case

MANUAL TRANSMISSION AND DIFFERENTIAL

11) Remove the weight, and screw in the retainer without the O-ring on the upper side, and stop at the point where a slight resistance is felt.

NOTE:

In this condition, the backlash between hypoid gear and drive pinion shaft is zero.

ST 18630AA010 WRENCH COMPL
RETAINER

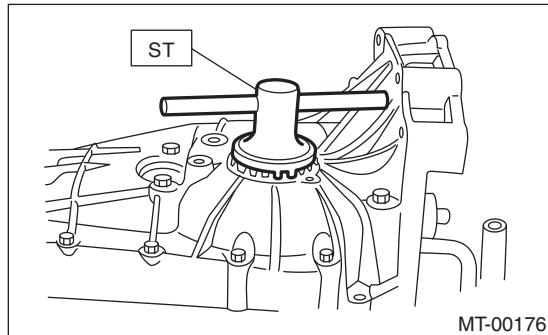

12) Loosen the retainer on the lower side by 3 notches and turn the retainer on the upper side by the same amount in order to apply backlash.

13) Rotate the retainer of the upper side additionally by 1 notch in order to apply preload on taper roller bearing.

14) Tighten temporarily both the upper and lower lock plates, and put marks both the holder and lock plate for later readjustment.

NOTE:

If it is hard to install the lock plates, reverse the sides and install them.

15) Turn the transmission main shaft several times while tapping around the retainer lightly with plastic hammer.

16) Inspect and adjust backlash and tooth contact of the hypoid gear. <Ref. to 5MT-70, INSPECTION, Front Differential Assembly.>

17) After checking the tooth contact of the hypoid gears, remove the lock plate. Then loosen the retainer until the O-ring groove appears. Fit the O-ring into the groove and tighten the retainer into the position where retainer was tightened previously. Install the lock plate.

NOTE:

- Count number of turns while loosening retainer and record it.
- Perform this for both upper and lower retainers.

Tightening torque:

T: 25 N·m (2.5 kgf-m, 18.4 ft-lb)

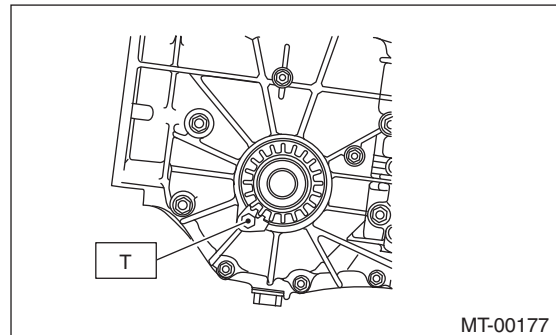

18) Select the main shaft rear plate. <Ref. to 5MT-56, ADJUSTMENT, Main Shaft Assembly for Single-range.>

19) Install the clutch release lever and bearing. <Ref. to CL-13, INSTALLATION, Release Bearing and Lever.>

20) Install the transfer case together with the extension case assembly. <Ref. to 5MT-37, INSTALLATION, Transfer Case and Extension Case Assembly.>

21) Install the manual transmission assembly to the vehicle. <Ref. to 5MT-27, INSTALLATION, Manual Transmission Assembly.>

C: INSPECTION

Check the transmission case for cracks, damage, or oil leaks.

Main Shaft Assembly for Single-range

MANUAL TRANSMISSION AND DIFFERENTIAL

15. Main Shaft Assembly for Single-range

A: REMOVAL

- 1) Remove the manual transmission assembly from the vehicle. <Ref. to 5MT-24, REMOVAL, Manual Transmission Assembly.>
- 2) Remove the transfer case together with the extension case assembly. <Ref. to 5MT-37, REMOVAL, Transfer Case and Extension Case Assembly.>
- 3) Remove the transmission case. <Ref. to 5MT-49, REMOVAL, Transmission Case.>
- 4) Remove the drive pinion shaft assembly. <Ref. to 5MT-57, REMOVAL, Drive Pinion Shaft Assembly.>
- 5) Remove the main shaft assembly for single-range.

B: INSTALLATION

- 1) Install the needle bearing and oil seal to the front of the transmission single-range main shaft assembly.

NOTE:

- Wrap the clutch splined section with vinyl tape to prevent damage to the oil seal.
- Apply KOPR-KOTE (or equivalent) to the sealing lip of the oil seal.
- Use a new oil seal.

- 2) Install the transmission case knock pin into the knock pin hole of the needle bearing outer race.

NOTE:

Align the end face of the seal with surface (A) when installing the oil seal.

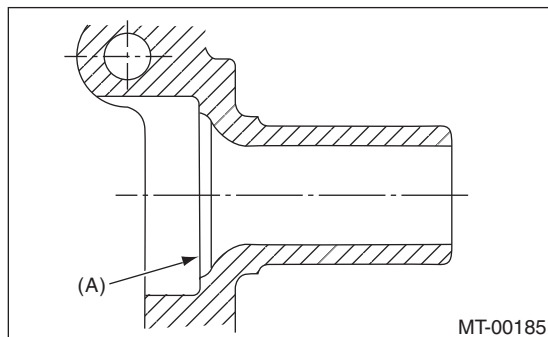

- 3) Install the drive pinion shaft assembly. <Ref. to 5MT-57, INSTALLATION, Drive Pinion Shaft Assembly.>
- 4) Install the transmission case. <Ref. to 5MT-50, INSTALLATION, Transmission Case.>
- 5) Install the transfer case together with the extension case assembly. <Ref. to 5MT-37, INSTALLATION, Transfer Case and Extension Case Assembly.>
- 6) Install the manual transmission assembly to the vehicle. <Ref. to 5MT-27, INSTALLATION, Manual Transmission Assembly.>

C: DISASSEMBLY

- 1) Put vinyl tape around main shaft spline to protect the oil seal from damage. Then pull out the oil seal and needle bearing by hand.
- 2) Remove the lock nut from transmission main shaft assembly for single range.

NOTE:

Flatten the lock nut tab before removing the lock nut.

- | | | |
|-----|-----------|---------------------|
| ST1 | 498937000 | TRANSMISSION HOLDER |
| ST2 | 499987003 | SOCKET WRENCH (35) |

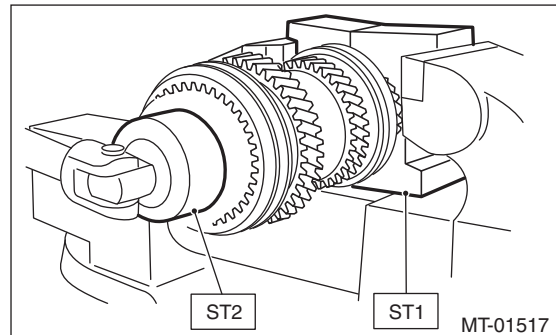

- 3) Remove the 5th hub & sleeve No. 2, baulk lever, baulk ring, 5th drive gear & needle bearing.

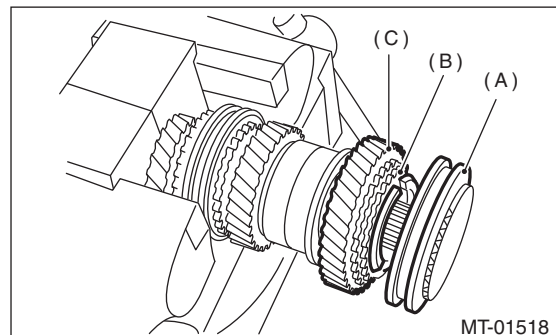

- (A) 5th hub & sleeve No. 2
- (B) Baulk ring
- (C) 5th drive gear

Main Shaft Assembly for Single-range

MANUAL TRANSMISSION AND DIFFERENTIAL

4) Using ST1 and ST2, remove the rest of the parts.

NOTE:

- When replacing the sleeve & hub, replace them as a set.
- Do not disassemble the sleeve & hub; the aligning position is pre-matched.
- If it is necessary to disassemble, mark the engaging points on the splines beforehand.

ST1 899864100 REMOVER

ST2 899714110 REMOVER

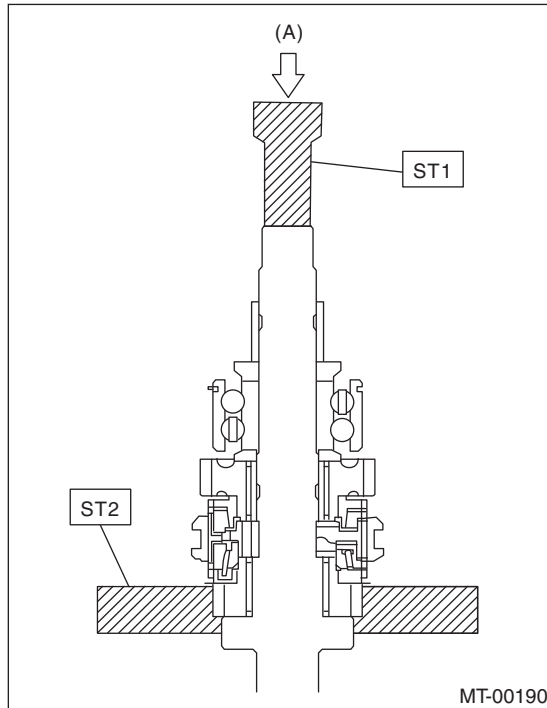

(A) Press

D: ASSEMBLY

1) When the sleeve & hub assemblies have been disassembled, reassemble by aligning the alignment marks.

NOTE:

Position the open ends of the spring 120° apart.

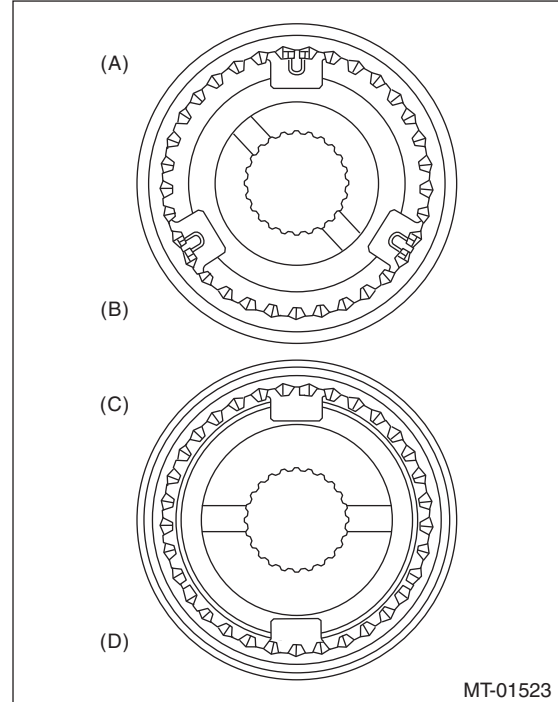

- (A) 3rd-4th hub ASSY
- (B) 3rd gear side
- (C) 5th hub & sleeve No. 2
- (D) 5th gear side

Main Shaft Assembly for Single-range

MANUAL TRANSMISSION AND DIFFERENTIAL

2) Install the 3rd drive gear, outer baulk ring, synchro cone, inner baulk ring, sleeve & hub assembly for the 3rd needle bearing, on the transmission main shaft.

NOTE:

Align the groove in baulk ring with the shifting insert.

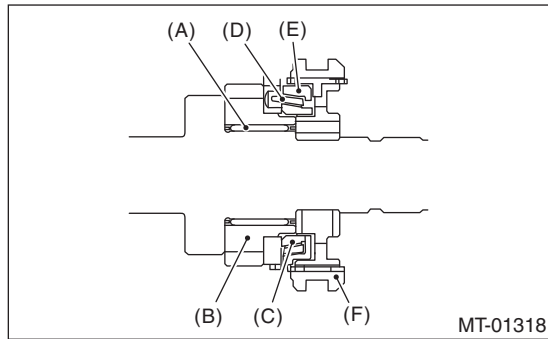

- (A) 3rd needle bearing
- (B) 3rd drive gear
- (C) Inner baulk ring
- (D) Synchro cone
- (E) Outer baulk ring
- (F) Sleeve & hub ASSY

3) Install the 4th needle bearing race onto transmission main shaft using ST1, ST2 and press.

CAUTION:

Do not apply a load in excess of 10 kN (1 ton, 1.1 US ton, 1.0 Imp ton).

- ST1 899714110 REMOVER
- ST2 499877000 RACE 4-5 INSTALLER

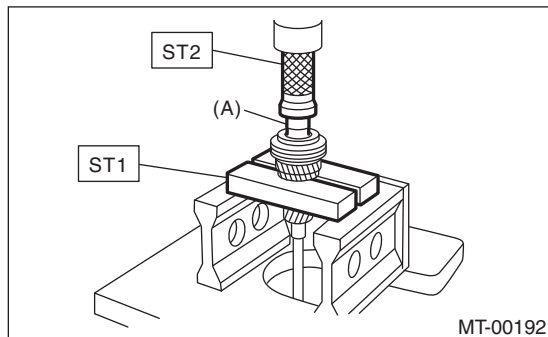

- (A) 4th needle bearing race

4) Install the baulk ring, needle bearing, 4th drive gear and 4th gear thrust washer to the transmission main shaft.

NOTE:

Align the baulk ring and gear & hub assembly with the key groove.

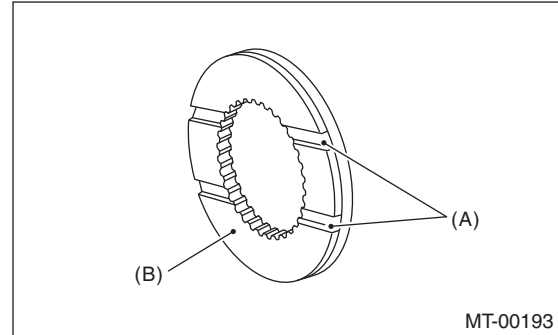

- (A) Groove
- (B) Face this surface to the 4th gear side.

5) Press-fit the ball bearing into the rear section of transmission main shaft using ST1, ST2 and a press.

CAUTION:

Do not apply a load in excess of 10 kN (1 ton, 1.1 US ton, 1.0 Imp ton).

- ST1 899714110 REMOVER
- ST2 499877000 RACE 4-5 INSTALLER

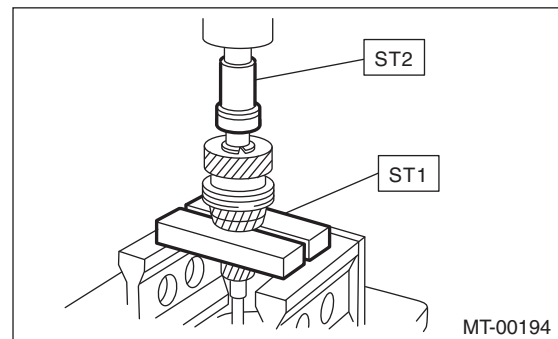

Main Shaft Assembly for Single-range

MANUAL TRANSMISSION AND DIFFERENTIAL

6) Using the ST1 and ST2, install the 5th gear thrust washer and 5th needle bearing race onto the rear section of transmission main shaft.

CAUTION:

Do not apply a load in excess of 10 kN (1 ton, 1.1 US ton, 1.0 Imp ton).

NOTE:

Make sure the thrust washer is oriented in the correct direction.

ST1 899714110 REMOVER
ST2 499877000 RACE 4-5 INSTALLER

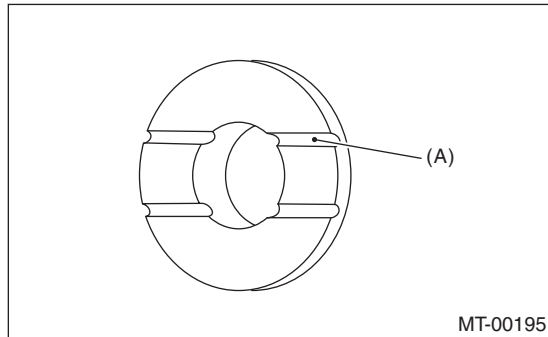

(A) Face this surface to the 5th gear side.

7) Install rest of the parts to the rear section of the transmission main shaft.

CAUTION:

• **Install the baulk lever so that the concave side faces toward the 5th hub.**

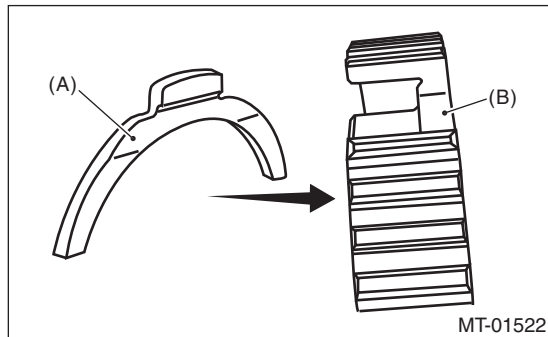

(A) Baulk lever
(B) 5th hub

• **Fit the convex portions of baulk ring with the gaps between baulk levers.**

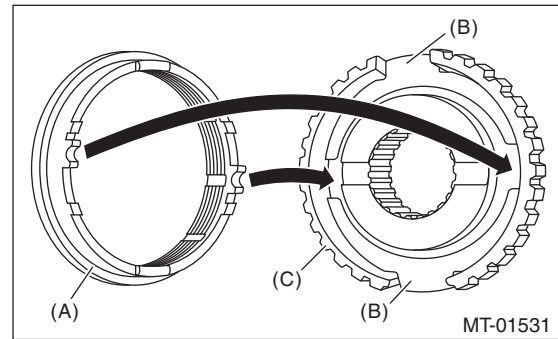

(A) Baulk ring
(B) Baulk lever
(C) 5th hub

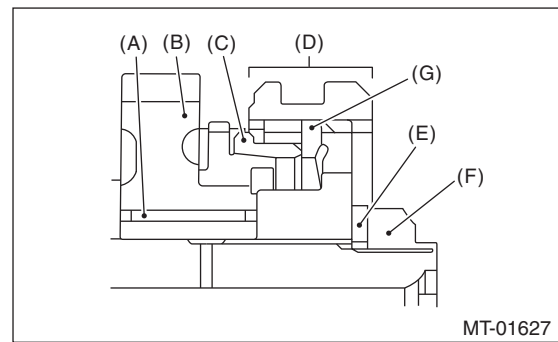

(A) Needle bearing
(B) 5th drive gear
(C) Baulk ring
(D) 5th hub & sleeve No. 2
(E) Lock washer
(F) Lock nut
(G) Baulk lever

8) Tighten the lock nuts to the specified torque using ST1 and ST2.

9) Crimp lock nuts in two locations after tightening.
ST1 499987003 SOCKET WRENCH (35)
ST2 498937000 TRANSMISSION HOLDER

Tightening torque:

120 N·m (12.2 kgf·m, 88.5 ft·lb)

Main Shaft Assembly for Single-range

MANUAL TRANSMISSION AND DIFFERENTIAL

E: INSPECTION

Disassembled parts should be washed clean first with cleaning solvent and then inspected carefully.

1) Bearing

Replace the bearings in the following cases.

- When the bearing balls, outer races and inner races are broken or rusty.
- When the bearing is worn.
- When the bearings fail to turn smoothly or emit noise in rotation after gear oil lubrication.
- When bearing has other defects.

2) Bushing (each gear)

Replace the bushing in following cases.

- When the sliding surface is damaged or abnormally worn.
- When the inner wall is abnormally worn.

3) Gear

Replace gears in the following cases.

- Replace gear with new part if its tooth surfaces are broken, damaged or excessively worn.
- Correct or replace if the cone that contacts the baulk ring is rough or damaged.
- Correct or replace if the inner surface or end face is damaged.

4) Baulk ring

Replace the baulk rings in the following cases.

- When the inner surface and end face are damaged.
- When the ring inner surface is abnormally or partially worn down.
- When the contact surface of synchronizer ring insert is cracked or abnormally worn.
- If the gap between the end faces of the ring and the gear splined part is excessively small, check the clearance (A) while pressing the ring against the cone.

Clearance (A):

0.5 mm (0.020 in) or more

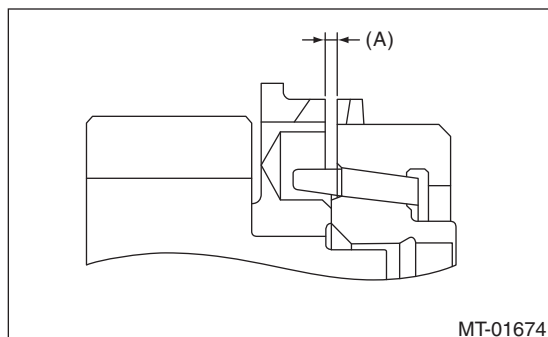

5) Shifting insert key

Replace the insert key if deformed, excessively worn or defective in any way.

6) Oil seal

Replace the oil seal if the lip is deformed, hardened, worn or defective in any way.

7) O-ring

Replace the O-ring if the sealing face is deformed, hardened, damaged, worn or defective in any way.

8) Gearshift mechanism

Repair or replace the gearshift mechanism if excessively worn, bent or defective in any way.

F: ADJUSTMENT

Selection of main shaft rear plate:

Using the ST, measure the protrusion amount (A) of ball bearing from transmission main case surface, and select a suitable plate in the following table.

NOTE:

Before measuring, tap the end of main shaft with a plastic hammer lightly in order to make the clearance zero between the main case surface and moving flange of bearing.

ST 498147001

DEPTH GAUGE

Dimension (A) mm (in)	Part number	Mark
4.00 — 4.13 (0.1575 — 0.1626)	32294AA041	1
3.87 — 4.00 (0.1524 — 0.1575)	32294AA051	2

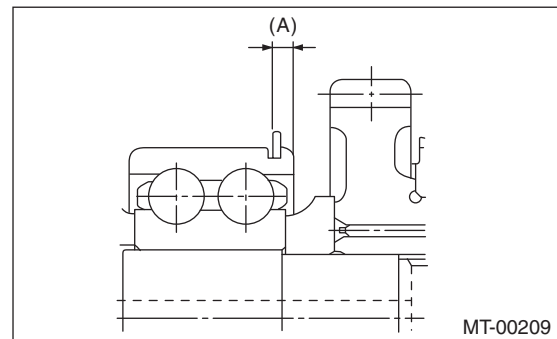

Drive Pinion Shaft Assembly

MANUAL TRANSMISSION AND DIFFERENTIAL

16. Drive Pinion Shaft Assembly

A: REMOVAL

- 1) Remove the manual transmission assembly from the vehicle. <Ref. to 5MT-24, REMOVAL, Manual Transmission Assembly.>
- 2) Remove the transfer case together with the extension case assembly. <Ref. to 5MT-37, REMOVAL, Transfer Case and Extension Case Assembly.>
- 3) Remove the transmission case. <Ref. to 5MT-49, REMOVAL, Transmission Case.>
- 4) Remove the drive pinion shaft assembly.

NOTE:

Use a hammer handle, etc. to remove if too tight.

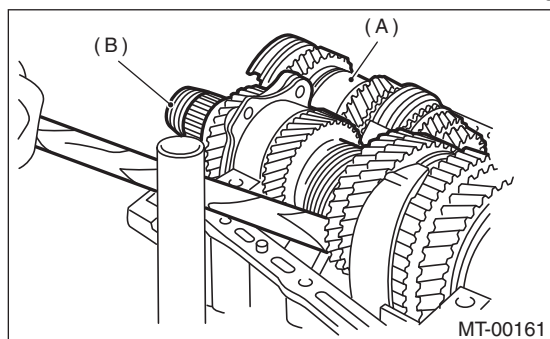

- (A) Main shaft ASSY for single-range
- (B) Drive pinion shaft ASSY

B: INSTALLATION

- 1) Remove the front differential assembly.
- 2) Alignment marks/numbers on hypoid gear set: The number (A) on top of the drive pinion, and the number on the hypoid driven gear are set numbers for the two gears. Use a pair having the same numbers.

The figure (B) below shows a number for shim adjustment. If no number is shown, the value is zero.

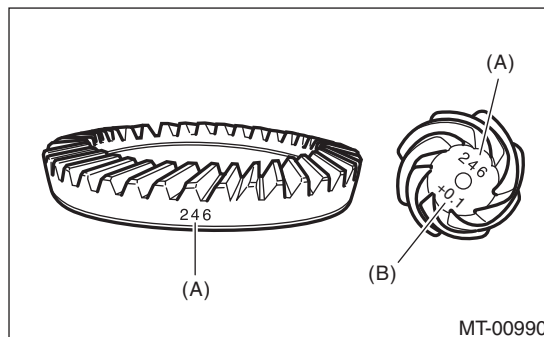

- (A) Set number
- (B) Number for shim adjustment

- 3) Place the drive pinion shaft assembly on transmission main case RH without shim and tighten the bearing mounting bolts.
- 4) Perform inspection and adjustment of ST.

NOTE:

- Loosen the two bolts and adjust so that the scale indicates 0.5 correctly when the plate end and the scale end are on the same level.
- Tighten the two bolts.

ST 499917500 DRIVE PINION GAUGE ASSY

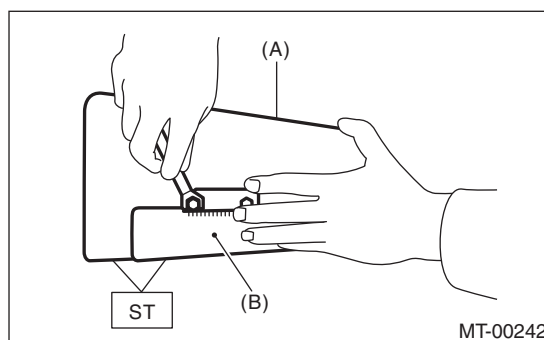

- (A) Plate
- (B) Scale

- 5) Position the ST by inserting the knock pin of ST into the knock hole of transmission case.

ST 499917500 DRIVE PINION GAUGE ASSY

Drive Pinion Shaft Assembly

MANUAL TRANSMISSION AND DIFFERENTIAL

6) Slide the drive pinion gauge scale with finger tip and read the value at the point where it matches with the end face of drive pinion.

ST 499917500 DRIVE PINION GAUGE ASSY

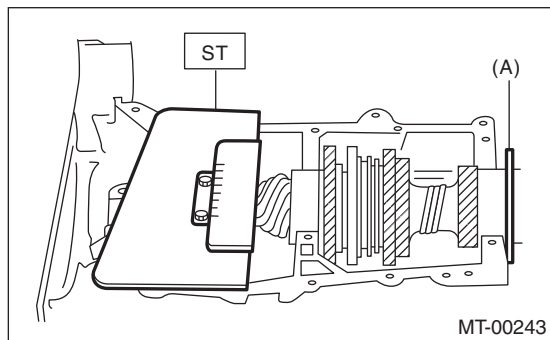

(A) Adjust the clearance to zero without shim.

7) The thickness of shim shall be determined by adding the value indicated on drive pinion to the value indicated on the ST. (Add if the number on drive pinion is prefixed by +, and subtract if the number is prefixed by -.)

ST 499917500 DRIVE PINION GAUGE ASSY

8) Select one to three shims in the following table for the value determined as described above, and take the shim(s) which thickness is closest to the said value.

Drive pinion shim	
Part number	Thickness mm (in)
32295AA031	0.150 (0.0059)
32295AA041	0.175 (0.0069)
32295AA051	0.200 (0.0079)
32295AA061	0.225 (0.0089)
32295AA071	0.250 (0.0098)
32295AA081	0.275 (0.0108)
32295AA091	0.300 (0.0118)
32295AA101	0.500 (0.0197)

9) Install the front differential assembly. <Ref. to 5MT-66, INSTALLATION, Front Differential Assembly.>

10) Set the transmission main shaft assembly for single range and drive pinion shaft assembly in the install location. (When doing so, there will be no clearance between the two when moved all the way to the front). Inspect a suitable 1st-2nd, 3rd-4th and 5th shifter fork so that the coupling sleeve and reverse driven gear are positioned in the center of the synchronizing mechanism. <Ref. to 5MT-63, INSPECTION, Drive Pinion Shaft Assembly.>

11) Install the transmission case. <Ref. to 5MT-50, INSTALLATION, Transmission Case.>

12) Install the transfer case together with the extension case assembly. <Ref. to 5MT-37, INSTALLATION, Transfer Case and Extension Case Assembly.>

13) Install the manual transmission assembly to the vehicle. <Ref. to 5MT-27, INSTALLATION, Manual Transmission Assembly.>

C: DISASSEMBLY

NOTE:

Attach a cloth to the end of driven shaft (on the frictional side of the thrust needle bearing) to prevent damage during disassembly or reassembly.

1) Flatten the tab of the axle nut. Remove the lock nut with ST1, ST2 and ST3.

ST1 899884100 HOLDER
ST2 498427100 STOPPER
ST3 899988608 SOCKET WRENCH (27)

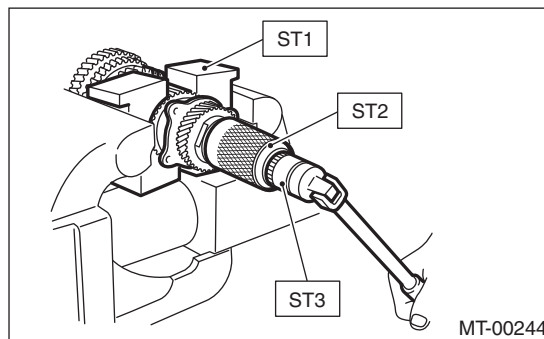

2) Draw out the drive pinion from driven shaft. Remove the differential bevel gear sleeve, adjusting washer No. 1, adjusting washer No. 2, thrust bearing, needle bearing and drive pinion collar.

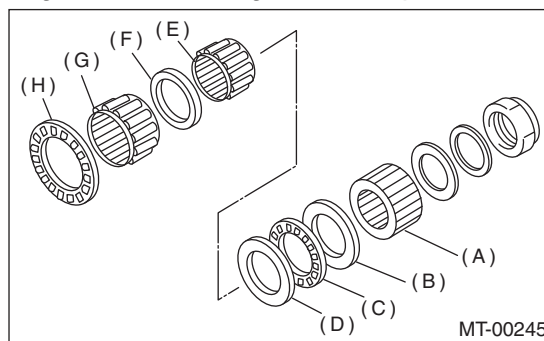

- (A) Differential bevel gear sleeve
- (B) Adjusting washer No. 1 (25 × 37.5 × t)
- (C) Thrust bearing (25 × 37.5 × 3)
- (D) Adjusting washer No. 2 (25 × 37.5 × 4)
- (E) Needle bearing (25 × 30 × 20)
- (F) Drive pinion collar
- (G) Needle bearing (30 × 37 × 23)
- (H) Thrust bearing (33 × 50 × 3)

Drive Pinion Shaft Assembly

MANUAL TRANSMISSION AND DIFFERENTIAL

3) Remove the roller bearing and washer using ST and a press.

NOTE:

Do not reuse the roller bearing.

ST 498077000 REMOVER

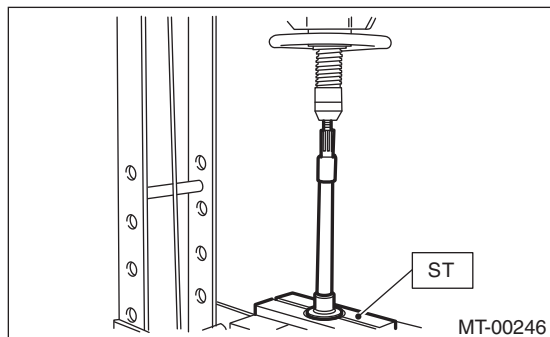

4) Flatten the tab of the lock nut. Remove the lock nut using ST1 and ST2.

ST1 499987300 SOCKET WRENCH (50)

ST2 899884100 HOLDER

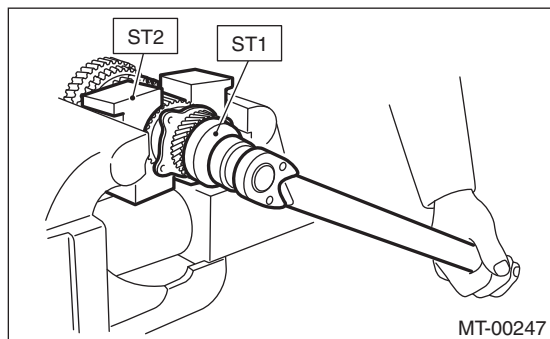

5) Remove the 5th driven gear using ST.

ST 499857000 5TH DRIVEN GEAR REMOVER

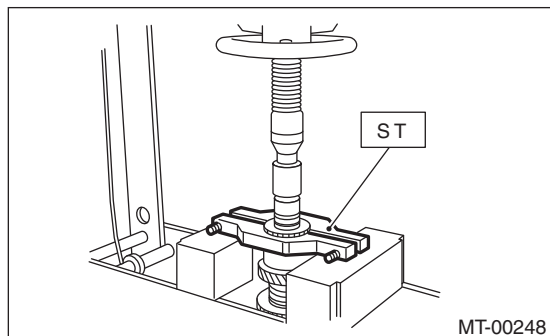

6) Remove the woodruff key.

7) Remove the roller bearing and 3rd-4th driven gear using ST1 and ST2.

ST1 499757002 INSTALLER

ST2 899714110 REMOVER

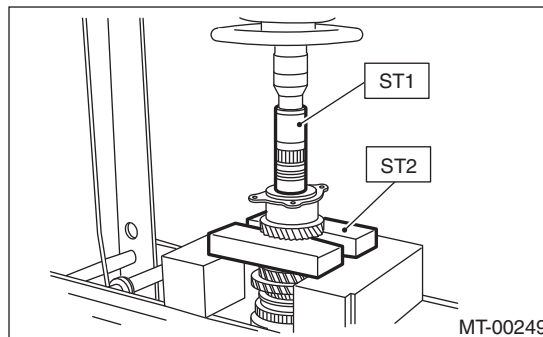

8) Remove the key.

9) Remove the 2nd driven gear, inner baulk ring, synchro cone and outer baulk ring.

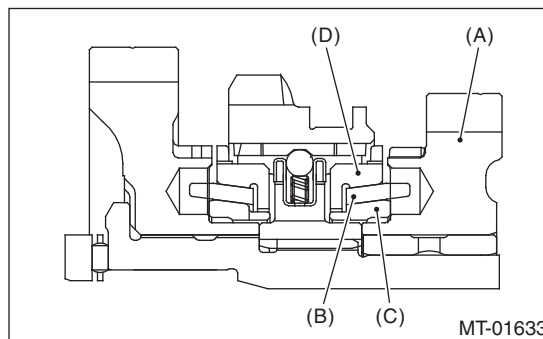

(A) 2nd driven gear

(B) Synchro cone

(C) Inner baulk ring

(D) Outer baulk ring

Drive Pinion Shaft Assembly

MANUAL TRANSMISSION AND DIFFERENTIAL

10) Remove the 1st driven gear, inner baulk ring, synchro cone, outer baulk ring, 2nd gear bushing, gear and hub using ST1 and ST2.

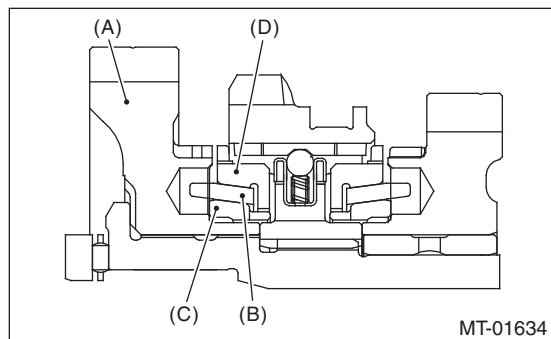

- (A) 1st driven gear
- (B) Synchro cone
- (C) Inner baulk ring
- (D) Outer baulk ring

NOTE:

If necessary, use the new gear & hub assembly, when replacing the gear or hub assembly. Because these must engage at the specified point, avoid disassembly as much as possible. If it must be disassembled, mark the engaging point on the spline beforehand.

ST1 499757002
ST2 899714110

INSTALLER
REMOVER

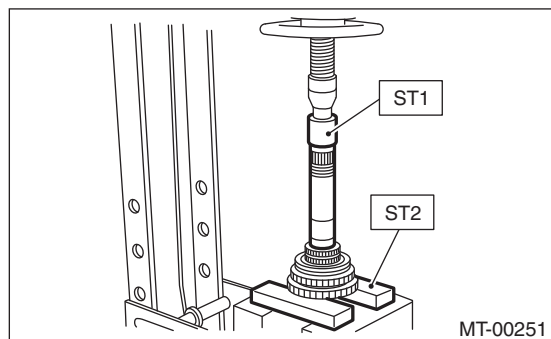

11) Remove the sub gear, washer, and snap ring (outer) for the 1st driven gear.

D: ASSEMBLY

1) Install the sleeve and gear & hub assembly by matching alignment marks.

NOTE:

• After installation, make sure there is no significant gap at both sides of the ball detent.

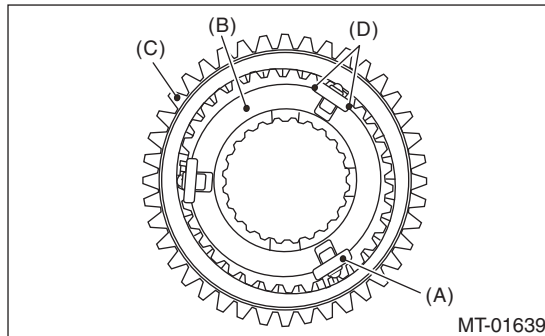

- (A) Ball detent
- (B) 1st-2nd synchronizer hub
- (C) Reverse driven gear
- (D) There is no significant gap at these points.

• Use the new gear & hub assembly, if replacing the gear or hub.

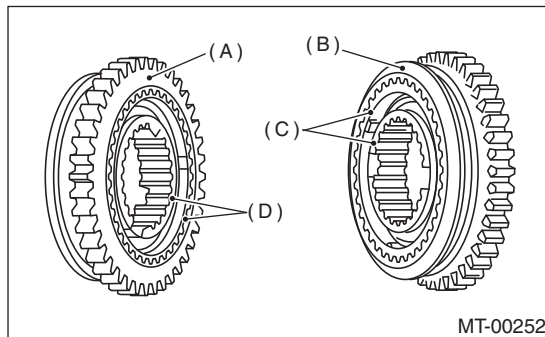

- (A) 1st gear side
- (B) 2nd gear side
- (C) Flush surface
- (D) Stepped surface

2) Install the washer, snap ring (outer) and sub gear onto the 1st driven gear.

Drive Pinion Shaft Assembly

MANUAL TRANSMISSION AND DIFFERENTIAL

3) Install the 1st driven gear, inner baulk ring, synchro cone, outer baulk ring onto driven shaft.

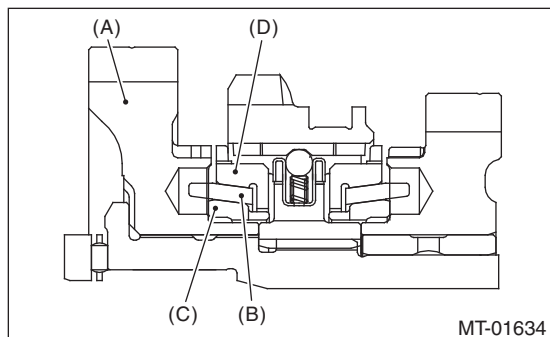

- (A) 1st driven gear
- (B) Synchro cone
- (C) Inner baulk ring
- (D) Outer baulk ring

5) Install the 2nd driven gear, inner baulk ring, synchro cone and outer baulk ring, and insert them onto driven shaft.

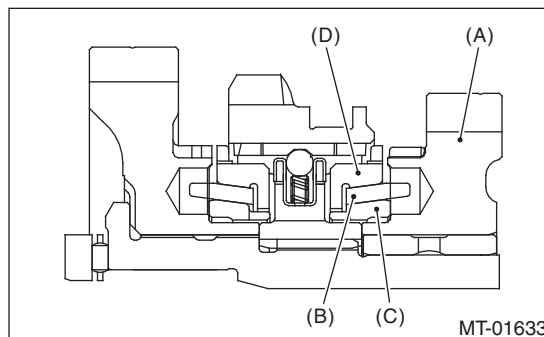

- (A) 2nd driven gear
- (B) Synchro cone
- (C) Inner baulk ring
- (D) Outer baulk ring

NOTE:

- Take care to install the gear & hub assembly in proper direction.
- Align the baulk ring and gear & hub assembly with the key groove.

4) Install the 2nd driven gear bushing onto the driven shaft using ST1, ST2 and a press.

CAUTION:

Do not apply a load in excess of 10 kN (1 ton, 1.1 US ton, 1.0 Imp ton).

NOTE:

- Attach a cloth to the end of the driven shaft to prevent damage.
- When press fitting, align the oil holes of the shaft and bushing

ST1 499277200 INSTALLER
ST2 499587000 INSTALLER

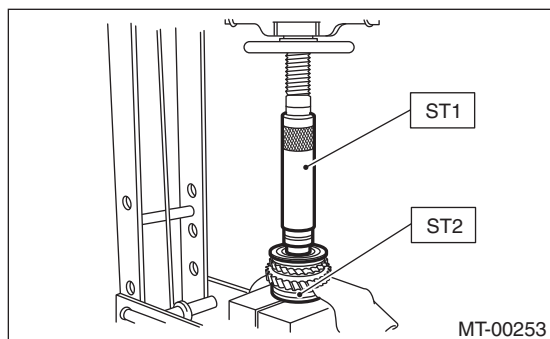

6) After installing key on driven shaft, install the 3rd-4th driven gear using an ST and a press.

CAUTION:

Do not apply a load in excess of 10 kN (1 ton, 1.1 US ton, 1.0 Imp ton).

NOTE:

Align the groove in baulk ring with the insert.

ST 499277200 INSTALLER

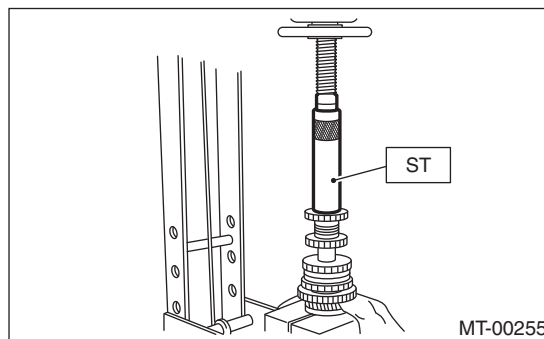

7) Install a set of roller bearings onto the driven shaft using the ST and a press.

CAUTION:

Do not apply a load in excess of 10 kN (1 ton, 1.1 US ton, 1.0 Imp ton).

ST 499277200 INSTALLER

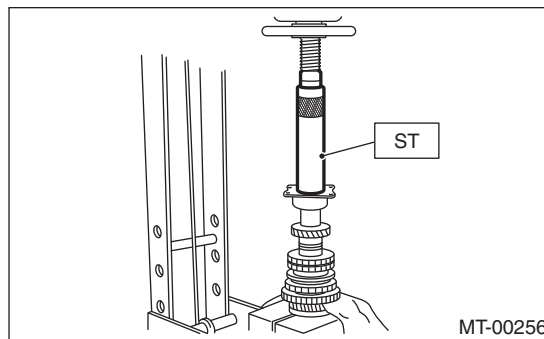

Drive Pinion Shaft Assembly

MANUAL TRANSMISSION AND DIFFERENTIAL

8) Position the woodruff key in groove of the rear of driven shaft. Install the 5th driven gear onto driven shaft using ST and a press.

CAUTION:

Do not apply a load in excess of 10 kN (1 ton, 1.1 US ton, 1.0 Imp ton).

ST 499277200 INSTALLER

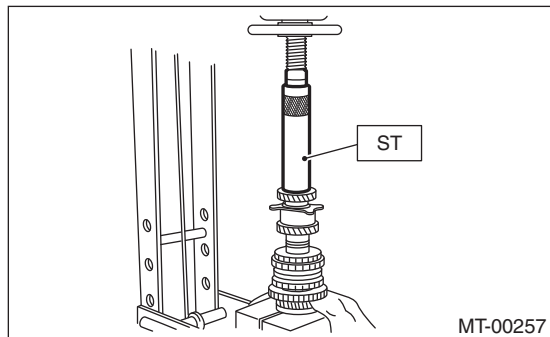

9) Install the lock washer. Install the lock nut and tighten to the specified torque using the ST.

ST 499987300 SOCKET WRENCH (50)

Tightening torque:

260 N·m (26.5 kgf·m, 191.8 ft·lb)

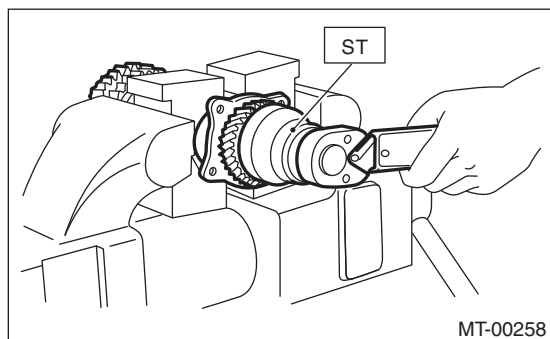

NOTE:

- Crimp the locknut in 2 locations.
- Using a spring scale, check that starting torque of the roller bearing is 0.1 to 1.5 N (0.01 to 0.15 kgf, 0.02 to 0.34 lbf).

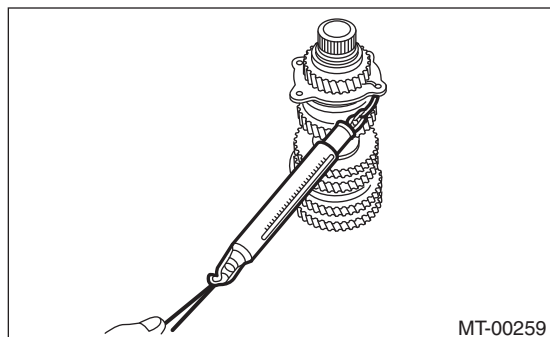

10) Install the roller bearing onto the drive pinion shaft.

NOTE:

When installing the roller bearing, note its directions (front and rear) because the knock pin hole of outer race is offset.

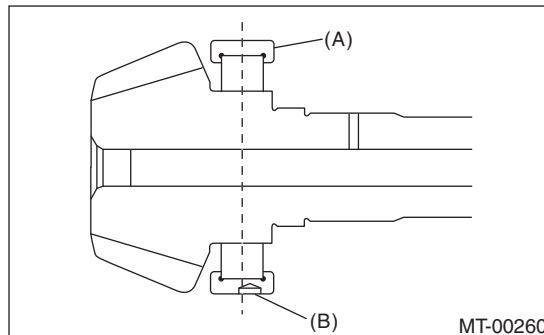

- (A) Roller bearing
- (B) Knock pin hole

11) Install the washer using ST1, ST2 and a press.

CAUTION:

Do not apply a load in excess of 10 kN (1 ton, 1.1 US ton, 1.0 Imp ton).

ST1 499277100 BUSHING 1-2 INSTALLER
ST2 499277200 INSTALLER

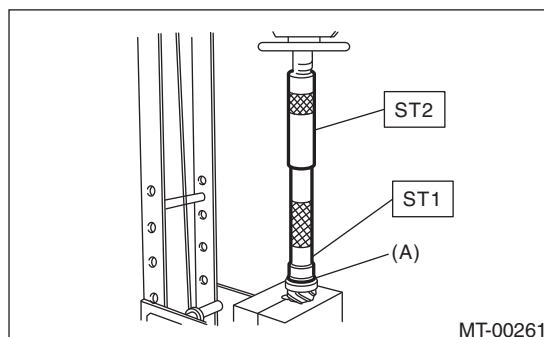

- (A) Washer

12) Install the thrust bearing and needle bearing. Install the driven shaft assembly.

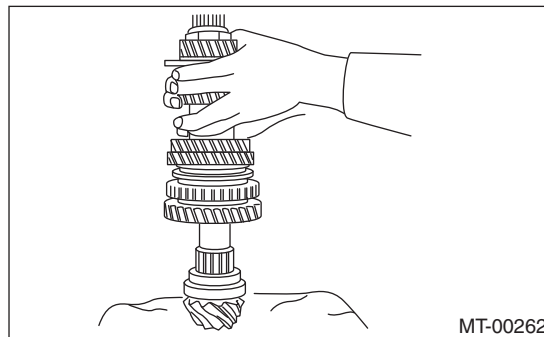

Drive Pinion Shaft Assembly

MANUAL TRANSMISSION AND DIFFERENTIAL

13) Install the drive pinion collar, needle bearing, adjusting washer No. 2, thrust bearing, adjusting washer No. 1 and differential bevel gear sleeve in this order.

NOTE:

Be careful to install the spacer in the proper direction.

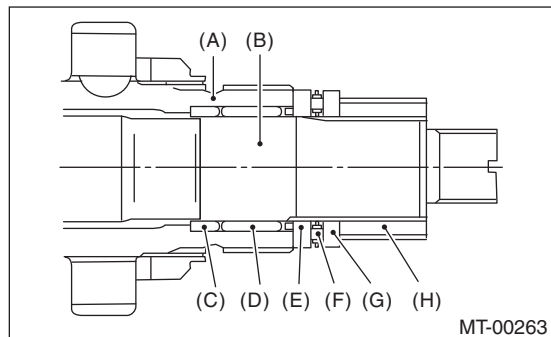

- (A) Driven shaft
- (B) Drive pinion shaft
- (C) Drive pinion collar
- (D) Needle bearing (25 × 30 × 20)
- (E) Adjusting washer No. 2 (25 × 36 × 4)
- (F) Thrust bearing (25 × 37.5 × 3)
- (G) Adjusting washer No. 1 (25 × 36 × t)
- (H) Differential bevel gear sleeve

14) Adjust the thrust bearing preload. <Ref. to 5MT-64, THRUST BEARING PRELOAD, ADJUSTMENT, Drive Pinion Shaft Assembly.>

E: INSPECTION

Disassembled parts should be washed clean first with cleaning solvent and then inspected carefully.

1) Bearing

Replace the bearings in the following cases.

- When the bearing balls, outer races and inner races are broken or rusty.
- When the bearing is worn.
- When the bearings fail to turn smoothly or emit noise in rotation after gear oil lubrication.
- The bearing on the rear side of the drive pinion shaft should be checked for smooth rotation before the drive pinion shaft assembly is disassembled. In this case, because a preload is working on the bearing, its rotation feels like it is slightly dragging unlike other bearings.

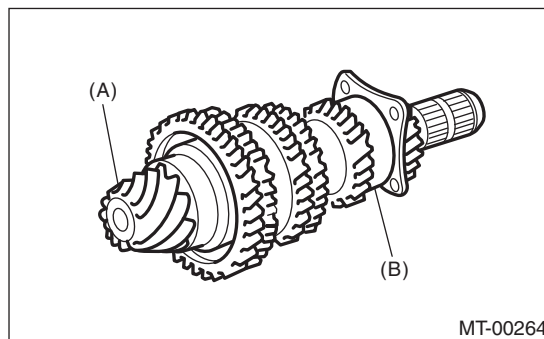

- (A) Drive pinion shaft
- (B) Ball bearing

- When bearing has other defects.

2) Bushing (each gear)

Replace the bushing in following cases.

- When the sliding surface is damaged or abnormally worn.
- When the inner wall is abnormally worn.

3) Gear

Replace gears in the following cases.

- Replace gear with new part if its tooth surfaces are broken, damaged or excessively worn.
- Correct or replace if the cone that contacts the baulk ring is rough or damaged.
- Correct or replace if the inner surface or end face is damaged.

Drive Pinion Shaft Assembly

MANUAL TRANSMISSION AND DIFFERENTIAL

4) Baulk ring

Replace the baulk rings in the following cases.

- When the inner surface and end face are damaged.
- When the ring inner surface is abnormally or partially worn down.
- When the contact surface of synchronizer ring insert is cracked or abnormally worn.
- If the gap between the end faces of the ring and the gear splined part is excessively small, check the clearance (A) while pressing the ring against the cone.

Clearance (A):

0.5 mm (0.020 in) or more

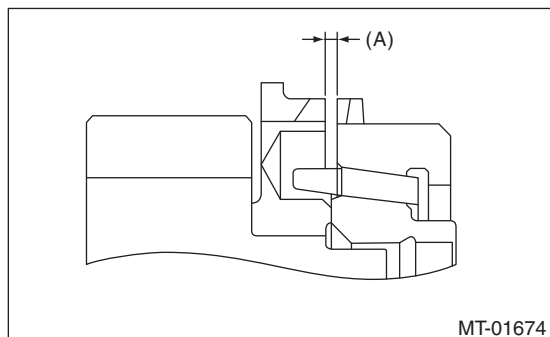

5) Ball detent

Replace the ball detent if deformed, excessively worn or defective in any way.

6) Oil seal

Replace the oil seal if the lip is deformed, hardened, worn or defective in any way.

7) O-ring

Replace the O-ring if the sealing face is deformed, hardened, damaged, worn or defective in any way.

F: ADJUSTMENT

1. THRUST BEARING PRELOAD

1) Select a suitable adjusting washer No. 1 to so that dimension (H) will be zero in a visual check. Position the washer (18.3 × 30 × 4) and lock washer (18 × 30 × 2) and install lock nut. (18 × 13.5)

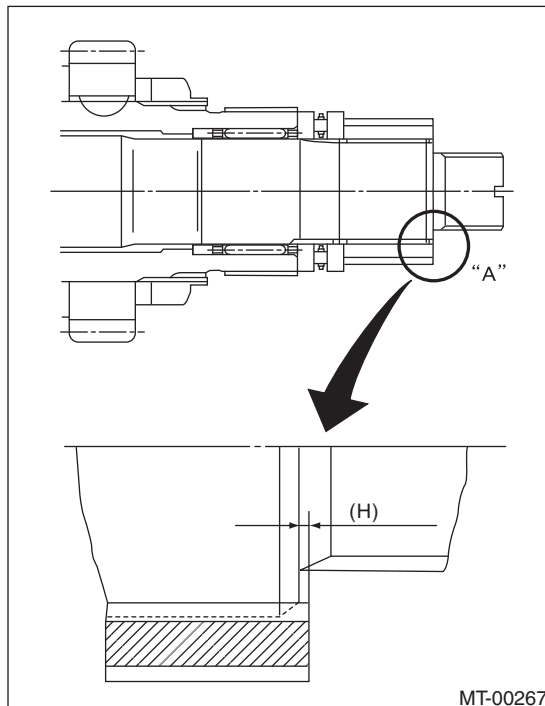

2) Using the ST1, ST2 and ST3, tighten the new lock nut to the specified torque.

ST1	899884100	HOLDER
ST2	498427100	STOPPER
ST3	899988608	SOCKET WRENCH (27)

Tightening torque:

120 N·m (12.2 kgf·m, 88.5 ft·lb)

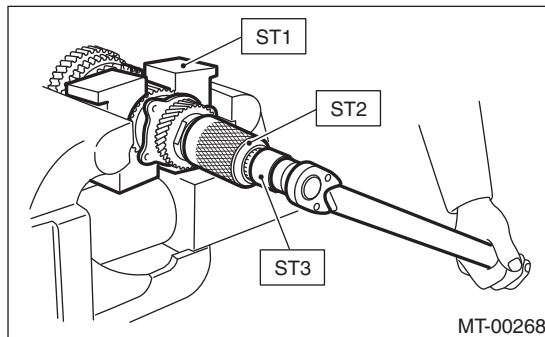

Drive Pinion Shaft Assembly

MANUAL TRANSMISSION AND DIFFERENTIAL

3) After removing the ST2, measure the starting torque using torque driver.

ST1 899884100 HOLDER
ST3 899988608 SOCKET WRENCH (27)

Starting torque:

0.3 — 0.8 N·m (0.03 — 0.08 kgf·m, 0.2 — 0.6 ft·lb)

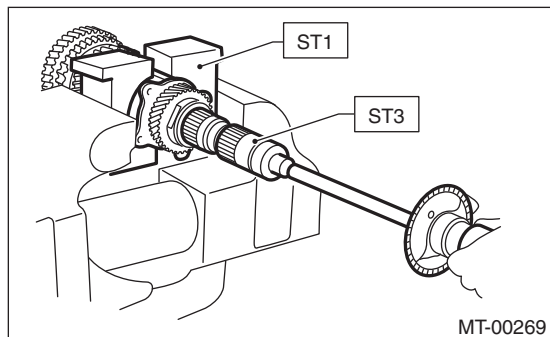

4) If the starting torque is not within the specified limit, select new adjusting washer No. 1 and recheck starting torque.

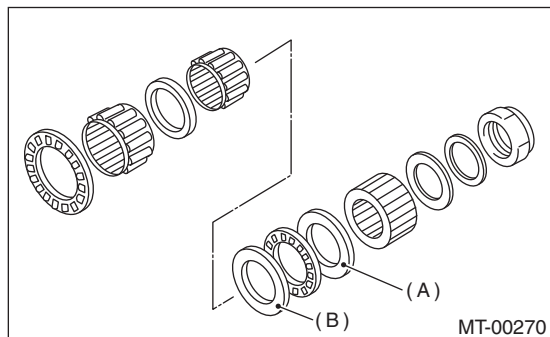

(A) Adjusting washer No. 1
(B) Adjusting washer No. 2

Adjusting washer No. 1	
Part number	Thickness mm (in)
803025051	3.925 (0.1545)
803025052	3.950 (0.1555)
803025053	3.975 (0.1565)
803025054	4.000 (0.1575)
803025055	4.025 (0.1585)
803025056	4.050 (0.1594)
803025057	4.075 (0.1604)

5) When the specified starting torque cannot be obtained by adjusting washer No. 1, select adjusting washer No. 2 from the following table. Repeat procedures 1) through 4) to adjust starting torque.

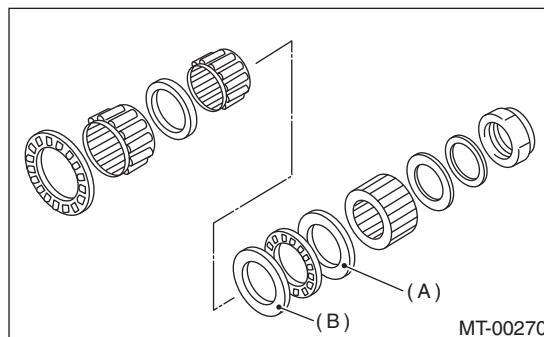

(A) Adjusting washer No. 1
(B) Adjusting washer No. 2

Starting torque	Dimension H	Adjusting washer No. 2
Low	Small	Select thicker one.
High	Large	Select thinner one.

Adjusting washer No. 2	
Part number	Thickness mm (in)
803025059	3.850 (0.1516)
803025054	4.000 (0.1575)
803025058	4.150 (0.1634)

6) Recheck that the starting torque is within the specified range, then crimp the lock nut at four positions.

Front Differential Assembly

MANUAL TRANSMISSION AND DIFFERENTIAL

17. Front Differential Assembly

A: REMOVAL

- 1) Remove the manual transmission assembly from the vehicle. <Ref. to 5MT-24, REMOVAL, Manual Transmission Assembly.>
- 2) Remove the transfer case together with the extension case assembly. <Ref. to 5MT-37, REMOVAL, Transfer Case and Extension Case Assembly.>
- 3) Remove the transmission case. <Ref. to 5MT-49, REMOVAL, Transmission Case.>
- 4) Remove the drive pinion shaft assembly. <Ref. to 5MT-57, REMOVAL, Drive Pinion Shaft Assembly.>
- 5) Remove the main shaft assembly for single-range. <Ref. to 5MT-52, REMOVAL, Main Shaft Assembly for Single-range.>
- 6) Remove the front differential assembly.

NOTE:

- Do not confuse the right and left roller bearing outer races.
- Be careful not to damage the oil seal of retainer.

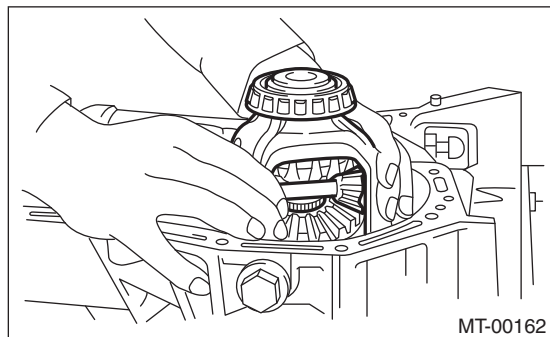

- 7) Remove the differential side retainers using ST. ST 18630AA010 WRENCH COMPL RETAINER

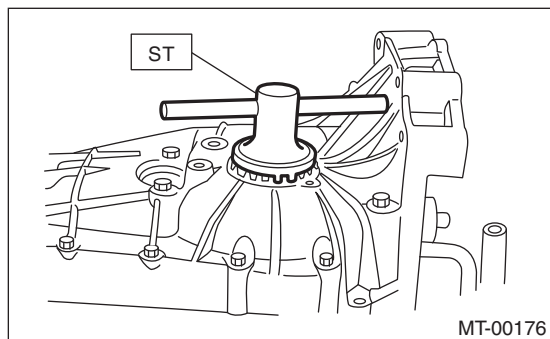

- 8) Remove the bearing outer race from the transmission case. ST 398527700 PULLER ASSY

B: INSTALLATION

- 1) Install the differential side retainers using ST. ST 18630AA010 WRENCH COMPL RETAINER
- 2) Install the bearing outer race to the transmission case.
- 3) Install the front differential assembly.

NOTE:

Be careful not to fold the sealing lip of oil seal.

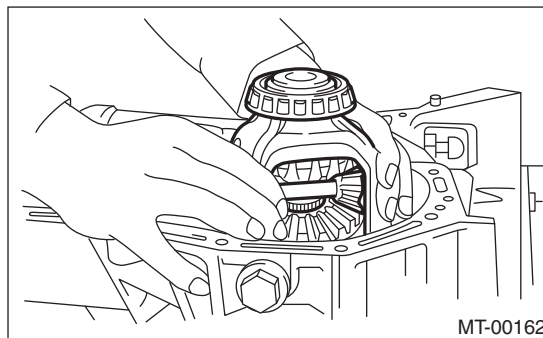

- 4) Install the main shaft assembly for single-range. <Ref. to 5MT-52, INSTALLATION, Main Shaft Assembly for Single-range.>
- 5) Install the drive pinion shaft assembly. <Ref. to 5MT-57, INSTALLATION, Drive Pinion Shaft Assembly.>
- 6) Install the transmission case. <Ref. to 5MT-50, INSTALLATION, Transmission Case.>
- 7) Install the transfer case together with the extension case assembly. <Ref. to 5MT-37, INSTALLATION, Transfer Case and Extension Case Assembly.>
- 8) Install the manual transmission assembly to the vehicle. <Ref. to 5MT-27, INSTALLATION, Manual Transmission Assembly.>

Front Differential Assembly

MANUAL TRANSMISSION AND DIFFERENTIAL

C: DISASSEMBLY

1. DIFFERENTIAL CASE ASSEMBLY

1) Loosen the twelve bolts and remove hypoid driven gear.

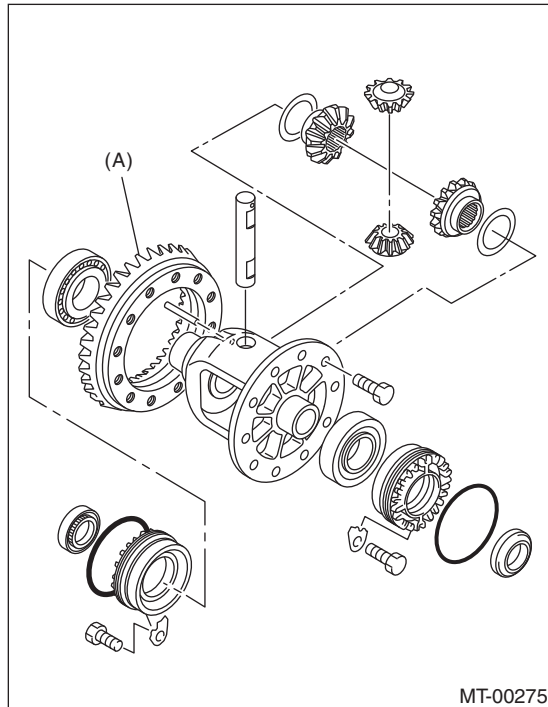

(A) Hypoid driven gear

2) Drive out the straight pin from differential assembly toward hypoid driven gear side.

ST 899904100 STRAIGHT PIN REMOVER

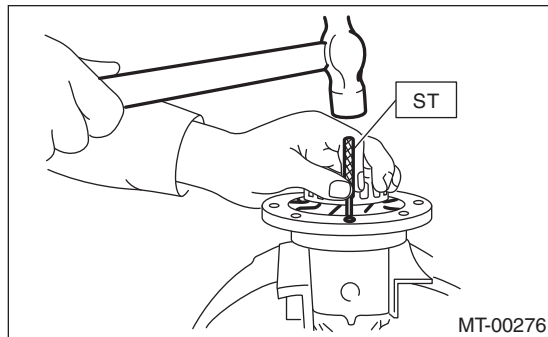

3) Pull out the pinion shaft, and remove the differential bevel pinion, differential bevel gear and washer.

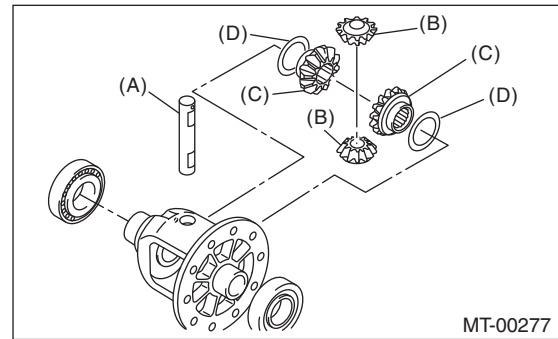

- (A) Pinion shaft
- (B) Differential bevel pinion
- (C) Differential bevel gear
- (D) Washer

4) Using the ST, remove the roller bearing.
ST 899524100 PULLER SET

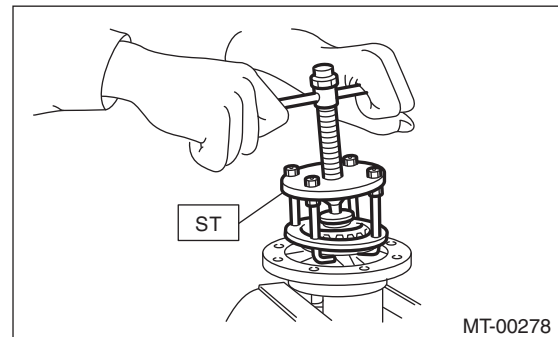

Front Differential Assembly

MANUAL TRANSMISSION AND DIFFERENTIAL

2. SIDE RETAINER

1) Remove the O-ring.

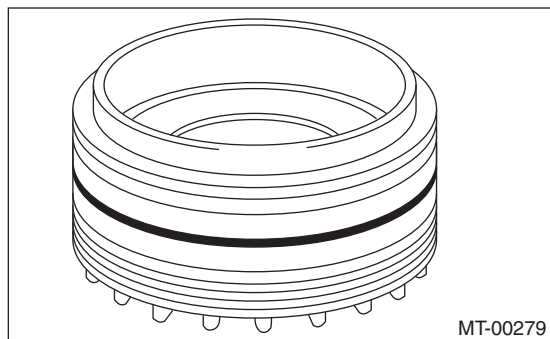

2) Remove the oil seal.

NOTE:

- Remove using the flat tip screwdriver.
- Do not reuse the oil seal. Replace the oil seal with a new part.

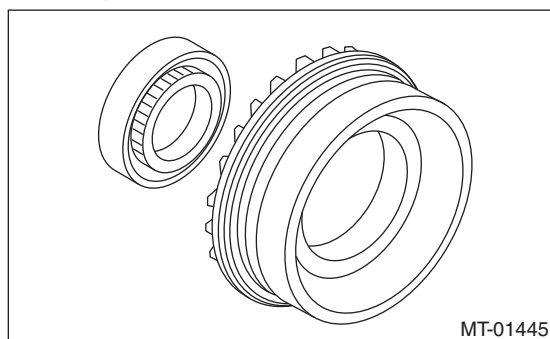

D: ASSEMBLY

1. DIFFERENTIAL CASE ASSEMBLY

1) Install the differential bevel gear and differential bevel pinion together with washers, and insert the pinion shaft.

NOTE:

Face the chamfered side of washer toward gear.

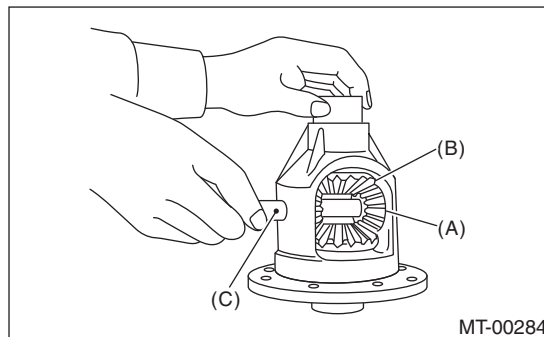

- (A) Differential bevel pinion
- (B) Differential bevel gear
- (C) Pinion shaft

2) Measure the backlash between differential bevel gear and differential bevel pinion. If backlash is not within specified value, install a suitable washer to adjust. <Ref. to 5MT-70, BEVEL PINION GEAR BACKLASH, INSPECTION, Front Differential Assembly.>

NOTE:

Be sure the pinion gear teeth contacts adjacent gear teeth during measurement.

- ST1 498247001 MAGNET BASE
- ST2 498247100 DIAL GAUGE

Standard backlash

0.13 — 0.18 mm (0.0051 — 0.0071 in)

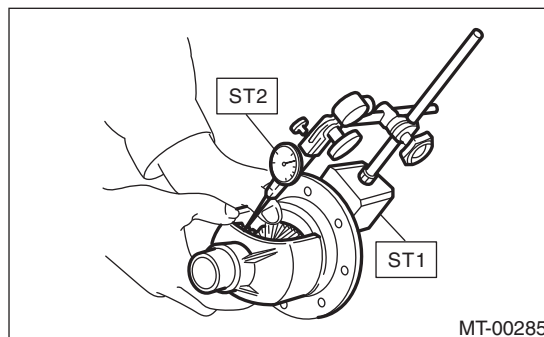

Front Differential Assembly

MANUAL TRANSMISSION AND DIFFERENTIAL

3) Align the pinion shaft and differential case with each hole, and drive the straight pin into the holes from the hypoid driven gear using the ST.

NOTE:

Lock the straight pin after installing.

ST 899904100 STRAIGHT PIN REMOVER

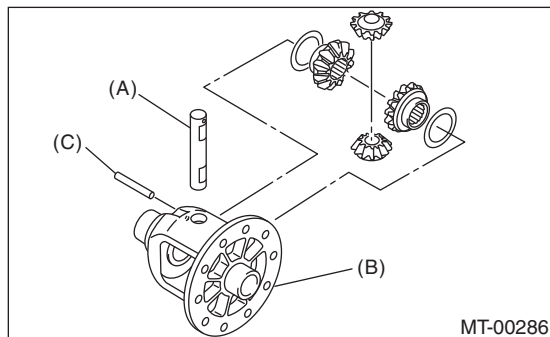

- (A) Pinion shaft
- (B) Differential case
- (C) Straight pin

4) Install the roller bearing to differential case.

CAUTION:

Do not apply a load in excess of 10 kN (1 ton, 1.1 US ton, 1.0 Imp ton).

NOTE:

Be careful because the roller bearing outer races are used as a set.

ST1 499277100 BUSHING 1-2 INSTALLER
ST2 398497701 ADAPTER

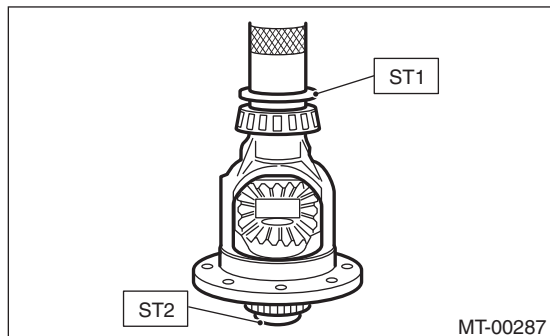

5) Install the hypoid driven gear to the differential case using twelve bolts.

Tightening torque:

T: 62 N·m (6.3 kgf-m, 45.7 ft-lb)

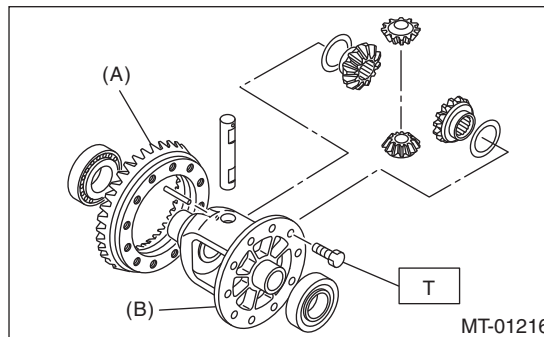

- (A) Hypoid driven gear
- (B) Differential case

2. SIDE RETAINER

1) Install a new oil seal.

ST 18675AA000 DIFFERENTIAL SIDE OIL SEAL INSTALLER

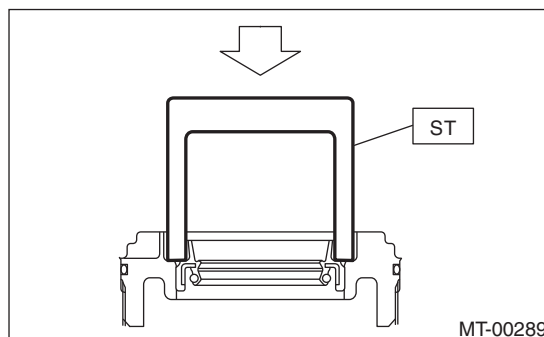

CAUTION:

- When press-fitting the oil seal to the side retainer, tap with a plastic hammer etc. to press in.
 - Never use a press.
- 2) Install a new O-ring.

NOTE:

Do not stretch or damage the O-ring.

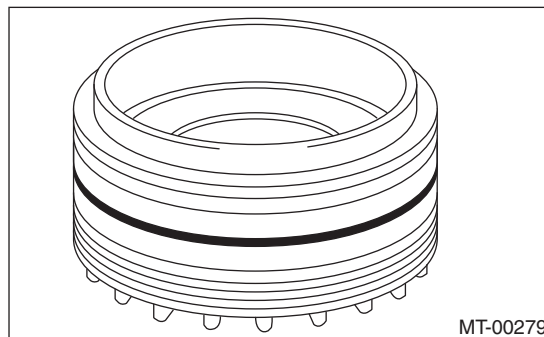

Front Differential Assembly

MANUAL TRANSMISSION AND DIFFERENTIAL

E: INSPECTION

Repair or replace the differential gear in the following cases:

- When the hypoid drive gear and drive pinion shaft tooth surfaces are damaged, excessively worn, or seized.
- When the roller bearing on the drive pinion shaft has a worn or damaged roller path.
- When there is damage, wear or seizure of the differential bevel pinion, differential bevel gear, washer, pinion shaft or straight pin.
- When the differential case has worn or damaged sliding surfaces.

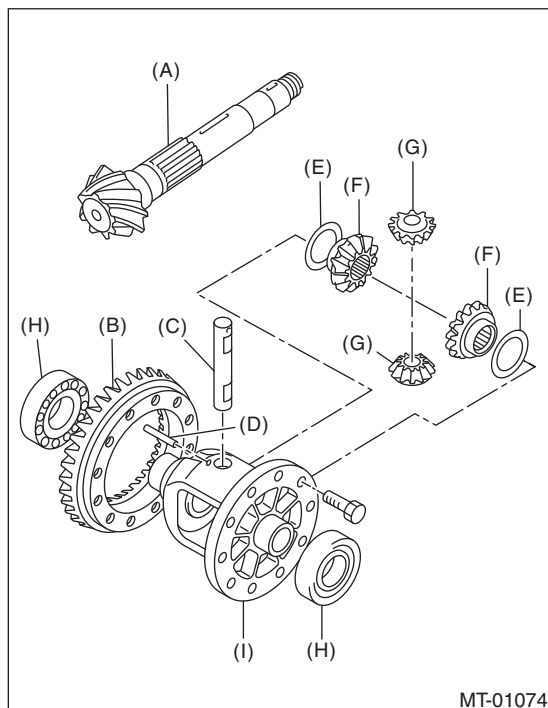

- (A) Drive pinion shaft
- (B) Hypoid driven gear
- (C) Pinion shaft
- (D) Straight pin
- (E) Washer
- (F) Differential bevel gear
- (G) Differential bevel pinion
- (H) Roller bearing
- (I) Differential case

1. BEVEL PINION GEAR BACKLASH

Measure the backlash between differential bevel gear and differential bevel pinion. If backlash is not within specified value, install a suitable washer to adjust. <Ref. to 5MT-71, ADJUSTMENT, Front Differential Assembly.>

NOTE:

Be sure the pinion gear teeth contacts adjacent gear teeth during measurement.

ST1 498247001 MAGNET BASE
ST2 498247100 DIAL GAUGE

Standard backlash

0.13 — 0.18 mm (0.0051 — 0.0071 in)

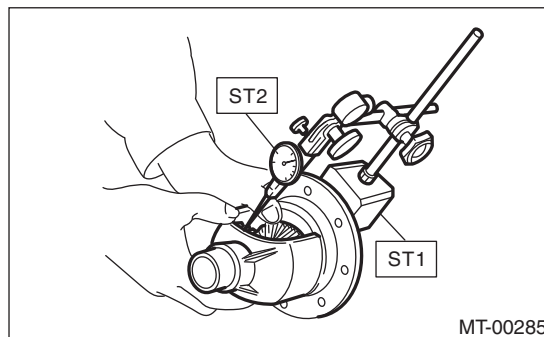

2. HYPOID GEAR BACKLASH

1) Set the ST1, ST2 and ST3. Insert the needle through transmission oil drain plug hole so that the needle comes in contact with the tooth surface on the right corner, and check the backlash.

ST1 498247001 MAGNET BASE
ST2 498247100 DIAL GAUGE
ST3 498255400 PLATE

2) Install SUBARU genuine axle shafts to both sides, rotate in the inversion direction so that the gauge contacts the tooth surface, and read the dial gauge

Part No. 38415AA100 AXLE SHAFT

Backlash

0.13 — 0.18 mm (0.0051 — 0.0071 in)

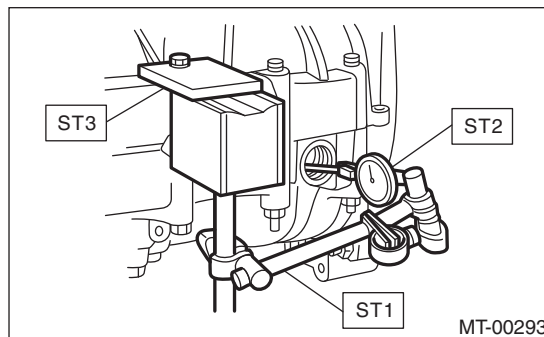

NOTE:

If the backlash is outside the specified range, adjust it by turning the side retainer in the right side case.

Front Differential Assembly

MANUAL TRANSMISSION AND DIFFERENTIAL

3. TOOTH CONTACT OF HYPOID GEAR

Check tooth contact of hypoid gear as follows: Apply a thin uniform coat of red lead on both teeth surfaces on 3 or 4 teeth of the hypoid gear. Move the hypoid gear back and forth by turning the transmission main shaft until a definite contact pattern is developed on the hypoid gear, and judge whether face contact is correct. When the contact pattern is not correct, adjust it. <Ref. to 5MT-71, ADJUSTMENT, Front Differential Assembly.>

- Tooth contact is correct.

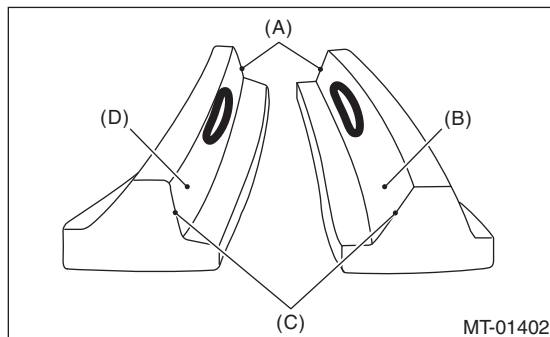

- (A) Toe
- (B) Coast side
- (C) Heel
- (D) Drive side

F: ADJUSTMENT

1. BEVEL PINION GEAR BACKLASH

- 1) Disassemble the front differential assembly. <Ref. to 5MT-67, DISASSEMBLY, Front Differential Assembly.>
- 2) Select a different washer from the table and install.

Washer	
Part number	Thickness mm (in)
803038021	0.925 — 0.950 (0.0364 — 0.0374)
803038022	0.975 — 1.000 (0.0384 — 0.0394)
803038023	1.025 — 1.050 (0.0404 — 0.0413)

- 3) Adjust until the standard value is obtained.

Backlash:

Standard

0.13 — 0.18 mm (0.0051 — 0.0071 in)

2. HYPOID GEAR BACKLASH

Adjust the backlash by turning the holder in the RH side case.

ST 18630AA010 WRENCH COMPL
RETAINER

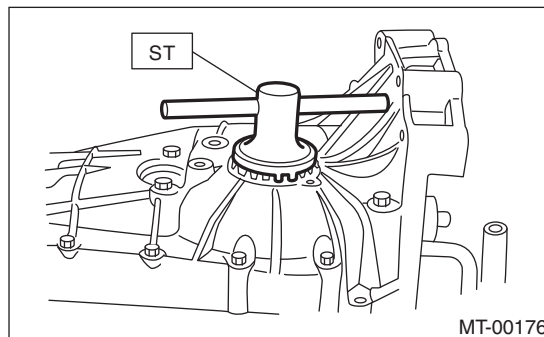

NOTE:

Each time side retainer rotates one tooth, backlash changes by 0.05 mm (0.020 in).

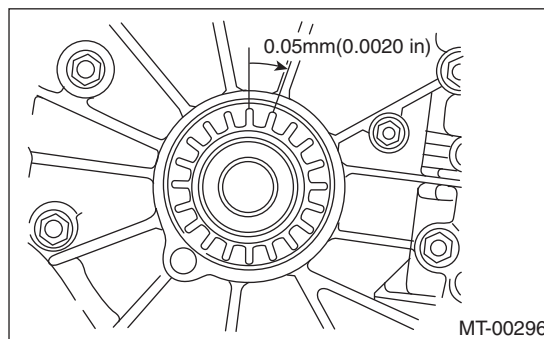

3. TOOTH CONTACT OF HYPOID GEAR

- 1) Adjust until correct teeth contact is obtained.
- 2) Check tooth contact, and perform the adjustment as follows.

- Tooth contact

Check item: Tooth contact surface is slightly shifted toward the toe side under a no-load condition. (When driving, it moves towards the heel side.)

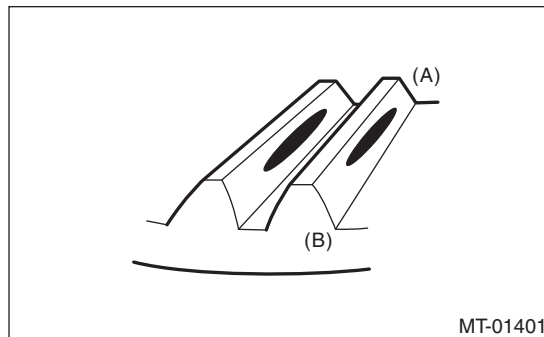

- (A) Toe side
- (B) Heel side

Front Differential Assembly

MANUAL TRANSMISSION AND DIFFERENTIAL

- Face contact

Check item: Backlash is too large.

Contact pattern

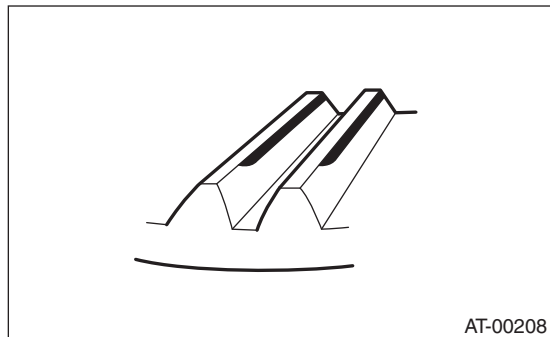

Corrective action: Tighten the side retainer to move the driven gear closer to the drive pinion.

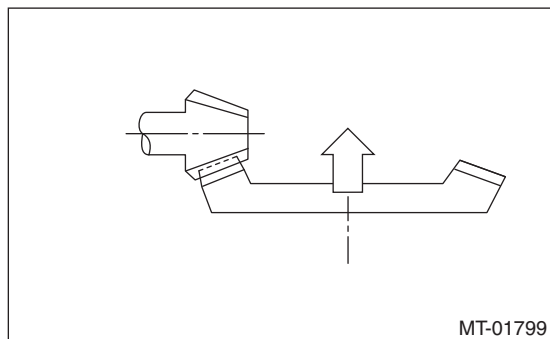

- Flank contact

Check item: Backlash is too small.

Contact pattern

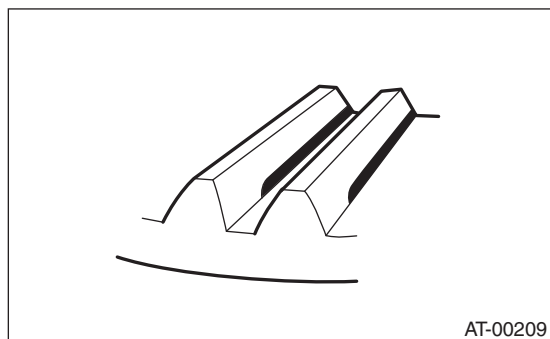

Corrective action: Loosen the side retainer to move the driven gear away from the drive pinion.

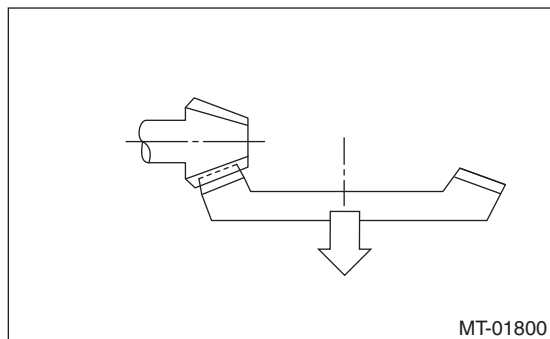

- Toe contact (inside contact)

Check item: Teeth contact area is too small.

Contact pattern

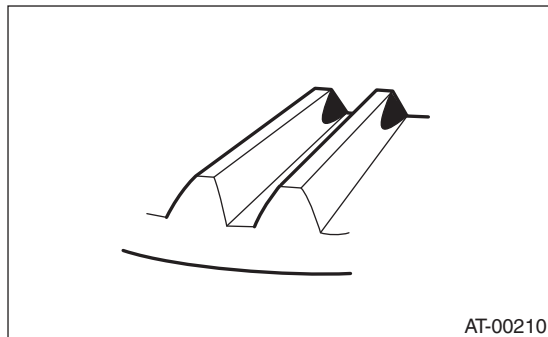

Corrective action: Increase the thickness of drive pinion shim according to the procedure for moving the drive pinion toward the driven gear side.

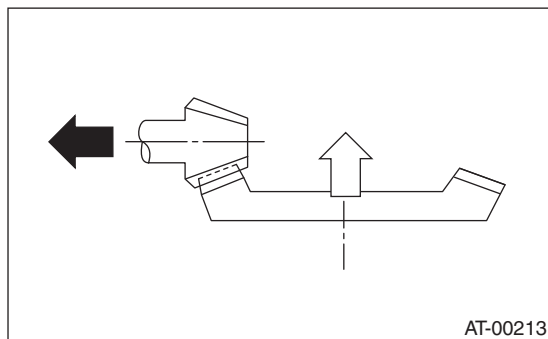

- Heel contact (outside end contact)

Check item: Teeth contact area is too small.

Contact pattern

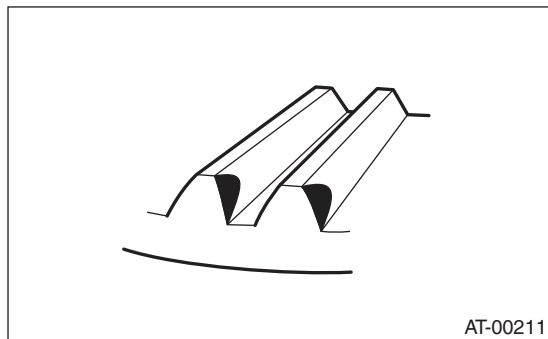

Corrective action: Reduce the thickness of drive pinion shim according to the procedure for moving the drive pinion closer to driven gear side.

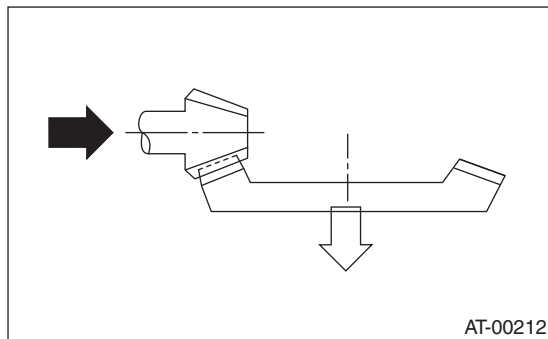

18. Reverse Idler Gear

A: REMOVAL

- 1) Remove the manual transmission assembly from the vehicle. <Ref. to 5MT-24, REMOVAL, Manual Transmission Assembly.>
- 2) Remove the back-up light switch & neutral position switch. <Ref. to 5MT-35, REMOVAL, Switches and Harness.>
- 3) Remove the transfer case together with the extension case assembly. <Ref. to 5MT-37, REMOVAL, Transfer Case and Extension Case Assembly.>
- 4) Remove the transmission case. <Ref. to 5MT-49, REMOVAL, Transmission Case.>
- 5) Remove the drive pinion shaft assembly. <Ref. to 5MT-57, REMOVAL, Drive Pinion Shaft Assembly.>
- 6) Remove the main shaft assembly for single-range. <Ref. to 5MT-52, REMOVAL, Main Shaft Assembly for Single-range.>
- 7) Remove the front differential assembly. <Ref. to 5MT-66, REMOVAL, Front Differential Assembly.>
- 8) Remove the shifter forks and rods. <Ref. to 5MT-75, REMOVAL, Shifter Fork and Rod.>
- 9) Pull out the straight pin, and remove the reverse idler gear shaft, washer, reverse idler gear and washer.

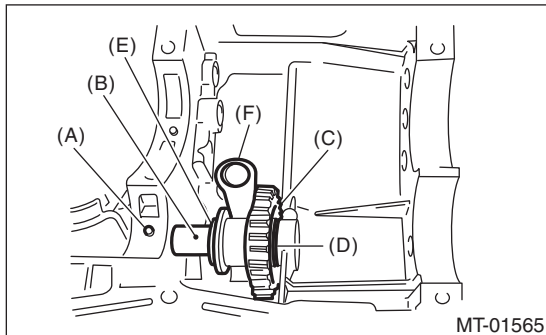

- (A) Straight pin
- (B) Reverse idler gear shaft
- (C) Reverse idler gear
- (D) Washer
- (E) Washer
- (F) Reverse shifter lever

- 10) Remove the reverse shifter lever.

B: INSTALLATION

- 1) Install the reverse shifter lever, washer, reverse idler gear, washer and reverse idler gear shaft, and secure them with the straight pin.

NOTE:

Be sure to install the reverse idler gear shaft from rear side.

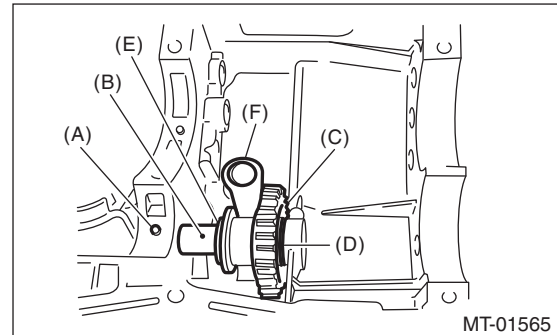

- (A) Straight pin
- (B) Reverse idler gear shaft
- (C) Reverse idler gear
- (D) Washer
- (E) Washer
- (F) Reverse shifter lever

- 2) Check and adjust clearance between the reverse idler gear and the timing case wall surface. <Ref. to 5MT-73, INSTALLATION, Reverse Idler Gear.> <Ref. to 5MT-74, ADJUSTMENT, Reverse Idler Gear.>
- 3) Install the shifter forks and rods. <Ref. to 5MT-76, INSTALLATION, Shifter Fork and Rod.>
- 4) Install the front differential assembly. <Ref. to 5MT-66, INSTALLATION, Front Differential Assembly.>
- 5) Install the main shaft assembly for single-range. <Ref. to 5MT-52, INSTALLATION, Main Shaft Assembly for Single-range.>
- 6) Install the drive pinion shaft assembly. <Ref. to 5MT-57, INSTALLATION, Drive Pinion Shaft Assembly.>
- 7) Install the transmission case. <Ref. to 5MT-50, INSTALLATION, Transmission Case.>
- 8) Install the transfer case together with the extension case assembly. <Ref. to 5MT-37, INSTALLATION, Transfer Case and Extension Case Assembly.>
- 9) Install the back-up light switch and the neutral position switch. <Ref. to 5MT-35, INSTALLATION, Switches and Harness.>
- 10) Install the manual transmission assembly to the vehicle. <Ref. to 5MT-27, INSTALLATION, Manual Transmission Assembly.>

Reverse Idler Gear

MANUAL TRANSMISSION AND DIFFERENTIAL

C: INSPECTION

1) Move the reverse shifter rod toward the reverse side. Check the clearance between the reverse idler gear and the timing case wall surface. If out of specification, select the appropriate reverse shifter lever and adjust.

Clearance A:
6.0 — 7.5 mm (0.236 — 0.295 in)

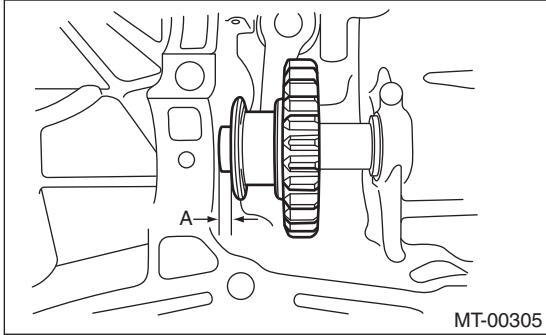

2) After installing a suitable reverse shifter lever, shift into neutral. Check the clearance between the reverse idler gear and the timing case wall surface. If out of specification, select the appropriate washer and adjust.

Clearance:
0 — 0.5 mm (0 — 0.020 in)

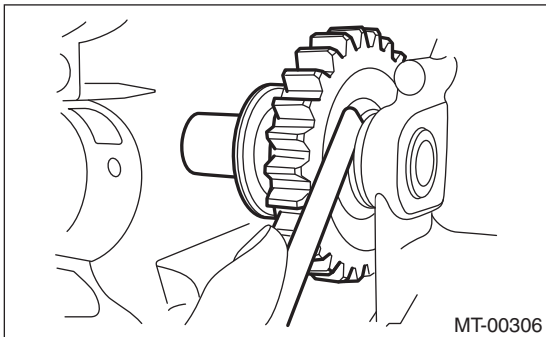

3) Check the reverse idler gear and shaft for damage. Replace if it is damaged.

D: ADJUSTMENT

1) Select the appropriate reverse shifter lever from the table below, and adjust until the clearance between the reverse idler gear and transmission case wall is within specification.

Clearance A:
6.0 — 7.5 mm (0.236 — 0.295 in)

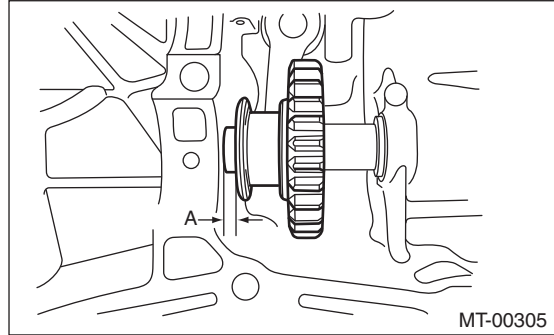

Reverse shifter lever		
Part number	Mark	Remarks
32820AA070	7	Far from case wall
32820AA080	8	Standard
32820AA090	9	Closer to case wall

2) Select the appropriate washer from the table below, and adjust until the clearance between the reverse idler gear and transmission case wall is within specification.

Clearance:
0 — 0.5 mm (0 — 0.020 in)

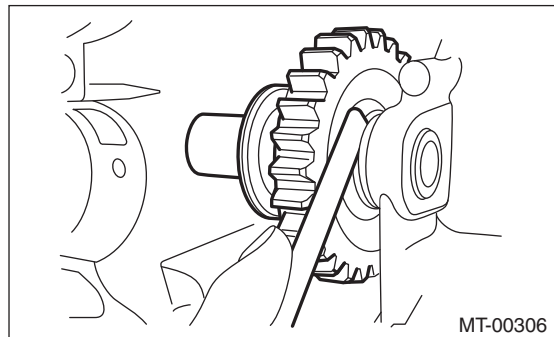

Washer	
Part number	Thickness mm (in)
803020151	0.4 (0.016)
803020152	1.1 (0.043)
803020153	1.5 (0.059)
803020154	1.9 (0.075)
803020155	2.3 (0.091)

Shifter Fork and Rod

MANUAL TRANSMISSION AND DIFFERENTIAL

19. Shifter Fork and Rod

A: REMOVAL

1) Remove the manual transmission assembly from the vehicle. <Ref. to 5MT-24, REMOVAL, Manual Transmission Assembly.>

2) Remove the back-up light switch & neutral position switch. <Ref. to 5MT-35, REMOVAL, Switches and Harness.>

3) Remove the transfer case together with the extension case assembly. <Ref. to 5MT-37, REMOVAL, Transfer Case and Extension Case Assembly.>

4) Remove the transmission case. <Ref. to 5MT-49, REMOVAL, Transmission Case.>

5) Remove the drive pinion shaft assembly. <Ref. to 5MT-57, REMOVAL, Drive Pinion Shaft Assembly.>

6) Remove the main shaft assembly for single-range. <Ref. to 5MT-52, REMOVAL, Main Shaft Assembly for Single-range.>

7) Remove the front differential assembly. <Ref. to 5MT-66, REMOVAL, Front Differential Assembly.>

8) Drive out the straight pin by tapping with the ST, and pull out the 5th shifter fork.

ST 398791700 STRAIGHT PIN REMOVER

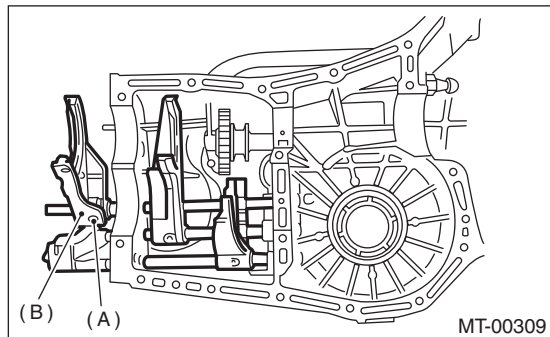

- (A) Straight pin
- (B) 5th shifter fork

9) Remove the plugs, springs and check balls.

10) Drive out the straight pin by tapping with the ST, and pull out the 3rd-4th fork rod and shifter fork.

NOTE:

When removing the rod, keep other rods in neutral. Also, when pulling out the straight pin, remove it toward the inside of case so that it does not hit against the case.

ST 398791700 STRAIGHT PIN REMOVER

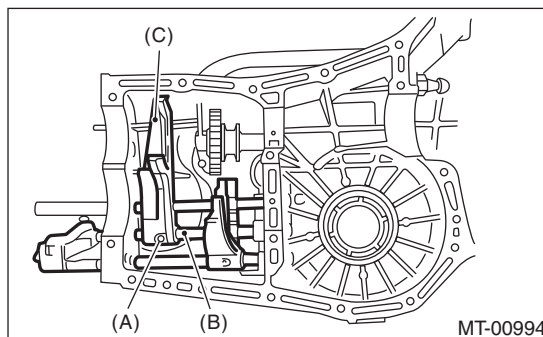

- (A) Straight pin
- (B) 3rd-4th fork rod
- (C) Shifter fork

11) Drive out the straight pin by tapping with the ST, and pull out the 1st-2nd fork rod and shifter fork.

ST 398791700 STRAIGHT PIN REMOVER

12) Remove the snap ring (outer), and pull out the reverse fork rod from reverse fork rod arm. Then take out the ball, spring and interlock plunger from the rod.

And then remove the rod.

NOTE:

When pulling out the reverse fork rod arm, be careful not to let the ball pop out of arm.

13) Remove the reverse shifter lever.

Shifter Fork and Rod

MANUAL TRANSMISSION AND DIFFERENTIAL

B: INSTALLATION

1) Install the reverse arm fork spring, ball and interlock plunger to the reverse fork rod arm. Insert the reverse fork rod into the hole of the reverse fork rod arm, and hold it with snap ring (outer) using ST.

NOTE:

Apply grease to plunger to prevent it from falling.
ST 399411700 ACCENT BALL INSTALLER

2) Position the ball, spring and new gasket in the reverse fork rod hole on the left side of transmission case, and tighten the checking ball plug.

3) Install the 1st-2nd fork rod into 1st-2nd shifter fork through the hole on the rear of transmission case.

4) Align the holes in the rod and the fork, and drive the new straight pin into these holes using the ST.

NOTE:

- Set other rods to neutral.
- Make sure the interlock plunger is on the 3rd-4th fork rod side.

ST 398791700 STRAIGHT PIN REMOVER

5) Attach the interlock plunger on 3rd-4th fork rod.

NOTE:

Apply grease to plunger to prevent it from falling.

6) Attach the 3rd-4th fork rod into 3rd-4th shifter fork through the hole on the rear of transmission case.

7) Align the holes in the rod and the fork, and drive the new straight pin into these holes.

NOTE:

- Set the reverse fork rod to neutral.
- Make sure the interlock plunger (before installation) is on the reverse fork rod side.

ST 398791700 STRAIGHT PIN REMOVER

8) Install the 5th shifter fork onto the rear of reverse fork rod. Align the holes in the two parts and drive new straight pin into the specified place.

ST 398791700 STRAIGHT PIN REMOVER

9) Position the balls, check ball springs and new gaskets into holes of the 3rd-4th fork rods and 1st-2nd fork rods, and install the plugs.

Tightening torque:

20 N·m (2.0 kgf·m, 14.8 ft·lb)

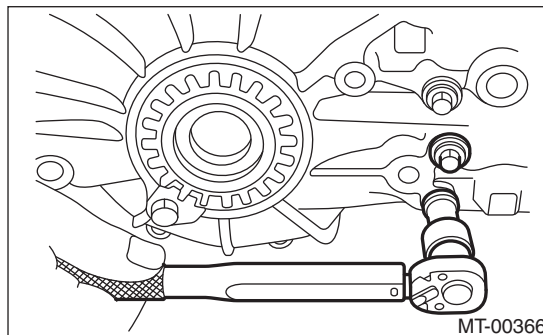

10) Install the front differential assembly. <Ref. to 5MT-66, INSTALLATION, Front Differential Assembly.>

11) Install the main shaft assembly for single-range. <Ref. to 5MT-52, INSTALLATION, Main Shaft Assembly for Single-range.>

12) Install the drive pinion shaft assembly. <Ref. to 5MT-57, INSTALLATION, Drive Pinion Shaft Assembly.>

13) Install the transmission case. <Ref. to 5MT-50, INSTALLATION, Transmission Case.>

14) Install the transfer case together with the extension case assembly. <Ref. to 5MT-37, INSTALLATION, Transfer Case and Extension Case Assembly.>

15) Install the back-up light switch and the neutral position switch. <Ref. to 5MT-35, INSTALLATION, Switches and Harness.>

16) Install the manual transmission assembly to the vehicle. <Ref. to 5MT-27, INSTALLATION, Manual Transmission Assembly.>

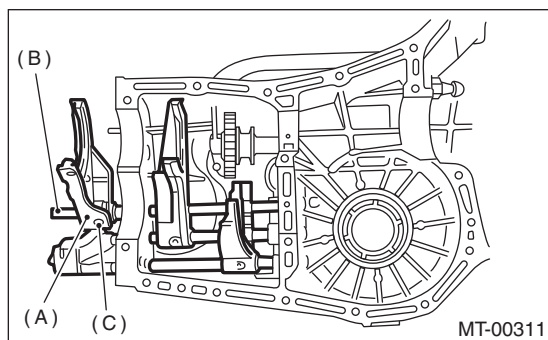

- (A) 5th shifter fork
- (B) Reverse fork rod
- (C) Straight pin

Shifter Fork and Rod

C: INSPECTION

1) Check the fork and rod for damage. Replace if it is damaged.

2) Gearshift mechanism

Repair or replace the gearshift mechanism if excessively worn, bent or defective in any way.

3) Inspect the clearance between 1st, 2nd driven gear and reverse driven gear. If any clearance is not within specifications, replace the shifter fork as required.

Clearance (a) and (b):
9.5 mm (0.374 in)

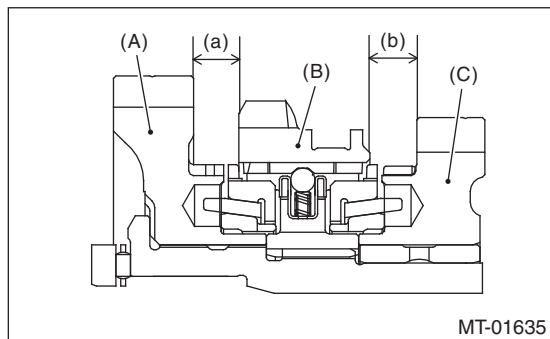

- (A) 1st driven gear
- (B) Reverse driven gear
- (C) 2nd driven gear

1st-2nd shifter fork		
Part number	Mark	Remarks
32804AA060	1	Approaches 1st gear by 0.2 mm (0.008 in).
32804AA070	No mark	Standard
32804AA080	3	Approaches 2nd gear by 0.2 mm (0.008 in)

4) Inspect the clearance between the 3rd, 4th drive gear and the coupling sleeve. If any clearance is not within specifications, replace the shifter fork as required.

Clearance (a) and (b):
9.3 mm (0.366 in)

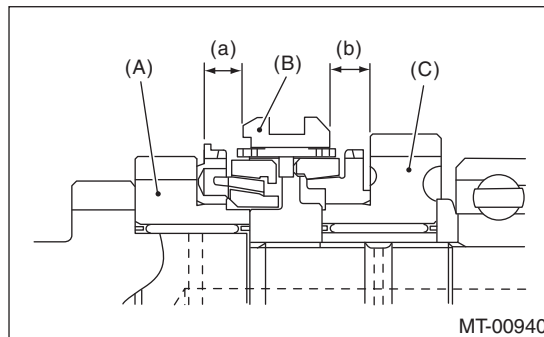

- (A) 3rd drive gear
- (B) Coupling sleeve
- (C) 4th drive gear

3rd-4th shifter fork		
Part number	Mark	Remarks
32810AA061	1	Approaches 4th gear by 0.2 mm (0.008 in).
32810AA071	No mark	Standard
32810AA101	3	Approaches 3rd gear by 0.2 mm (0.008 in)

Shifter Fork and Rod

MANUAL TRANSMISSION AND DIFFERENTIAL

5) Inspect the clearance between 5th drive gear and coupling sleeve. If any clearance is not within specifications, replace the shifter fork as required.

Clearance (a):

9.3 mm (0.366 in)

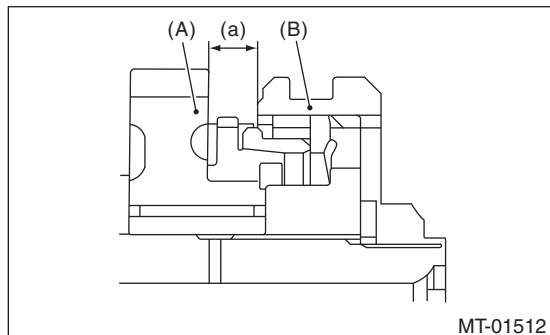

- (A) 5th drive gear
- (B) Coupling sleeve

5th shifter fork		
Part number	Mark	Remarks
32812AA201	7	Approaches 5th gear by 0.2 mm (0.008 in).
32812AA211	No mark	Standard
32812AA221	9	Moves away from 5th gear by 0.2 mm (0.008 in).

6) Inspect the rod end clearances (A) and (B). If any clearance is not within specifications, replace the rod or fork as required.

Clearance (A):

3rd-4th — 5th

0.5 — 1.3 mm (0.020 — 0.051 in)

Clearance (B):

1st-2nd — 3rd-4th

0.4 — 1.4 mm (0.016 — 0.055 in)

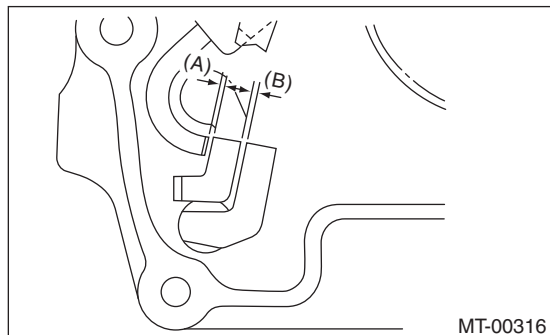

General Diagnostic Table

MANUAL TRANSMISSION AND DIFFERENTIAL

20. General Diagnostic Table

A: INSPECTION

1. MANUAL TRANSMISSION

Symptom	Possible cause	Corrective action
1. Gears are difficult to intermesh. NOTE: The cause for difficulty in shifting gears can be classified into two kinds: One is a defective gear shift system and the other is defective transmission. However, if the operation is heavy and engagement of the gears is difficult, a defective clutch disengagement may also be responsible. Check whether the clutch is correctly functioning, before checking the gear shift system and transmission.	(a) Worn, damaged or burred chamfer at internal spline of the sleeve and reverse driven gear	Replace.
	(b) Worn, damaged or burred chamfer of gear spline	Replace.
	(c) Worn or scratched bushings	Replace.
	(d) Incorrect contact or wear between synchronizer ring and gear cone	Correct or replace.
2. Gear slip-out <ul style="list-style-type: none"> • Gear slips out when coasting on rough road. • Gear slips out during acceleration. 	(a) Defective pitching stopper adjustment	Adjust.
	(b) Loose engine mounting bolts	Tighten or replace.
	(c) Worn fork shifter, broken shifter fork rail spring	Replace.
	(d) Worn or damaged ball bearing	Replace.
	(e) Excessive clearance between splines of synchronizer hub and synchronizer sleeve	Replace.
	(f) Worn tooth step of synchronizer hub (caused by slip-out of 3rd gear)	Replace.
	(g) Worn 1st driven gear and driven shaft	Replace.
	(h) Worn 2nd driven gear and bushing	Replace.
	(i) Worn 3rd drive gear and needle bearing	Replace.
	(j) Worn 4th drive gear and needle bearing	Replace.
	(k) Worn reverse idler gear and bushing	Replace.
3. Noise emitted from transmission NOTE: If a noise is heard when the vehicle is parked with its engine idling and if a noise ceases when the clutch is disengaged, it may be considered that the noise is coming from the transmission.	(a) Insufficient or improper lubrication	Lubricate with specified oil or replace.
	(b) Worn or damaged gears and bearings NOTE: If the trouble is only wear of the gear teeth surfaces, only a high whirring noise will occur at high speeds, but if any part is broken, rhythmical clicking sounds will be heard even at low speeds.	Replace.

General Diagnostic Table

MANUAL TRANSMISSION AND DIFFERENTIAL

2. DIFFERENTIAL

Symptoms	Possible cause	Corrective action
<p>1. Broken differential (case, gear, bearing, etc.)</p> <p>NOTE: Noise will occur, and eventually the differential will not be able to operate due to broken pieces obstructing the gear revolution.</p>	(a) Insufficient or improper oil	Disassemble the differential and replace broken components. At the same time check other components for any trouble, and replace if necessary.
	(b) Use of vehicle under severe conditions such as excessive load and improper use of the clutch	Readjust the preload and backlash of the bearing, and the contact surface of gear.
	(c) Improper adjustment of taper roller bearing	Adjust.
	(d) Improper adjustment of the drive pinion and the hypoid driven gear	Adjust.
	(e) Excessive backlash of a vehicle under severe operating conditions due to worn differential side gear, washer or differential pinion.	Add recommended oil to the specified level. Do not use vehicle under severe operating conditions.
	(f) Loose hypoid driven gear tightening bolts	Tighten.
<p>2. Differential and hypoid gear noises</p> <p>Troubles of the differential and hypoid gear always appear as noise problems. Therefore noise is the first indication of trouble. However, noises from the engine, muffler, tire, exhaust gas, bearing, body, etc. are easily mistaken for the differential noise. Pay special attention to the hypoid gear noise because it is easily confused with other gear noises. There are the following four kinds of noises.</p> <ul style="list-style-type: none"> • Gear noise when driving: If noise increases as the vehicle speed increases, it may be due to insufficient gear oil, incorrect gear engagement, damaged gears, etc. • Gear noise when coasting: Damaged gears due to misadjusted bearings and incorrect shim adjustment. • Bearing noise when driving or coasting: Cracked, broken or damaged bearings • Noise mainly when turning: Noise from differential side gear, differential pinion or differential pinion shaft, etc. 	(a) Insufficient oil	Lubricate.
	(b) Improper adjustment of hypoid driven gear and drive pinion	Check the tooth contact.
	(c) Worn teeth of hypoid driven gear and drive pinion	Replace as a set. Readjust the bearing preload.
	(d) Loose roller bearing	Readjust the backlash of the hypoid driven gear to drive pinion, and check the tooth contact.
	(e) Distorted hypoid driven gear or differential case	Replace.
	(f) Worn washer and differential pinion shaft	Replace.

CLUTCH SYSTEM

CL

	Page
1. General Description	2
2. Clutch Disc and Cover	9
3. Flywheel	12
4. Release Bearing and Lever	13
5. Operating Cylinder	15
6. Master Cylinder	17
7. Clutch Pipe and Hose	19
8. Clutch Fluid	20
9. Clutch Fluid Air Bleeding	21
10. Clutch Pedal	22
11. Clutch Switch	26
12. General Diagnostic Table	28

General Description

CLUTCH SYSTEM

1. General Description

A: SPECIFICATION

Model		2.5 L non-turbo		
Transmission type		5MT		
Clutch cover	Type	Push type		
	Diaphragm set load	N (kgf, lbf)	5,688 (580, 1,279)	
Clutch disc	Facing material		Woven (Non-asbestos)	
	O.D. × I.D. × thickness mm (in)	Clutch cover side	225 × 150 × 3.5 (8.86 × 5.91 × 0.138)	
		Flywheel side		
	Spline outer diameter		mm (in)	25.2 (0.992), (Number of teeth: 24)
	Depth of rivet head mm (in)	Clutch cover side	1.65 — 2.25 (0.065 — 0.089)	
		Flywheel side		
		Limit of sinking	0.3 (0.012)	
Deflection limit		mm (in)	0.7 (0.028) at R = 110 (4.33)	
Clutch release lever ratio		1.6		
Release bearing		Grease-packed self-aligning		
Clutch pedal	Full stroke	mm (in)	130 — 135 (5.12 — 5.31)	
	Free play	mm (in)	5 — 15 (0.20 — 0.59)	
Flywheel	Type	Flexible		

B: COMPONENT

1. CLUTCH ASSEMBLY

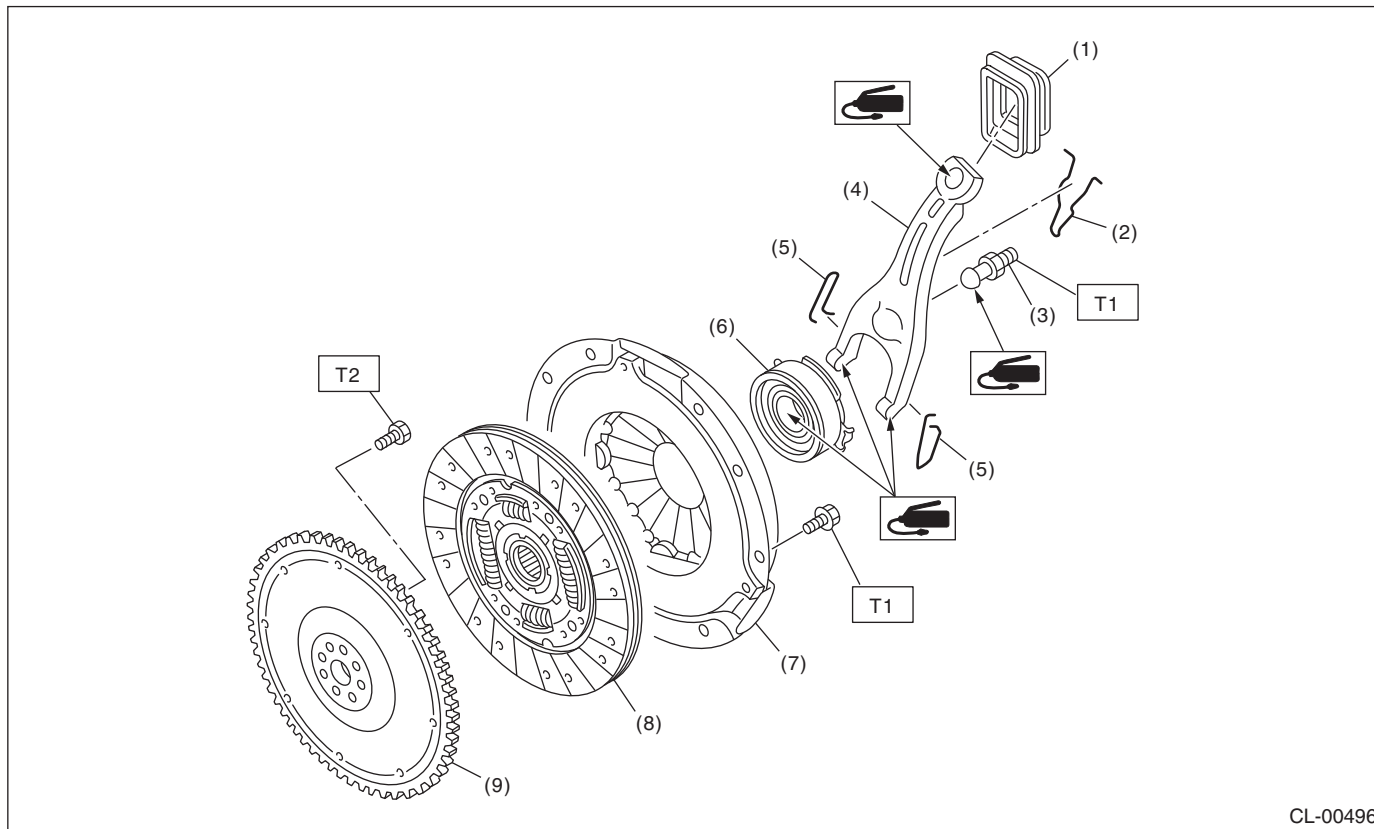

CL-00496

- | | |
|-------------------|---------------------|
| (1) Dust cover | (6) Release bearing |
| (2) Lever spring | (7) Clutch cover |
| (3) Pivot | (8) Clutch disc |
| (4) Release lever | (9) Flywheel |
| (5) Clip | |

Tightening torque: N·m (kgf-m, ft-lb)

T1: 16 (1.6, 11.8)

T2: 72 (7.3, 53.1)

General Description

CLUTCH SYSTEM

2. CLUTCH PIPE AND HOSE

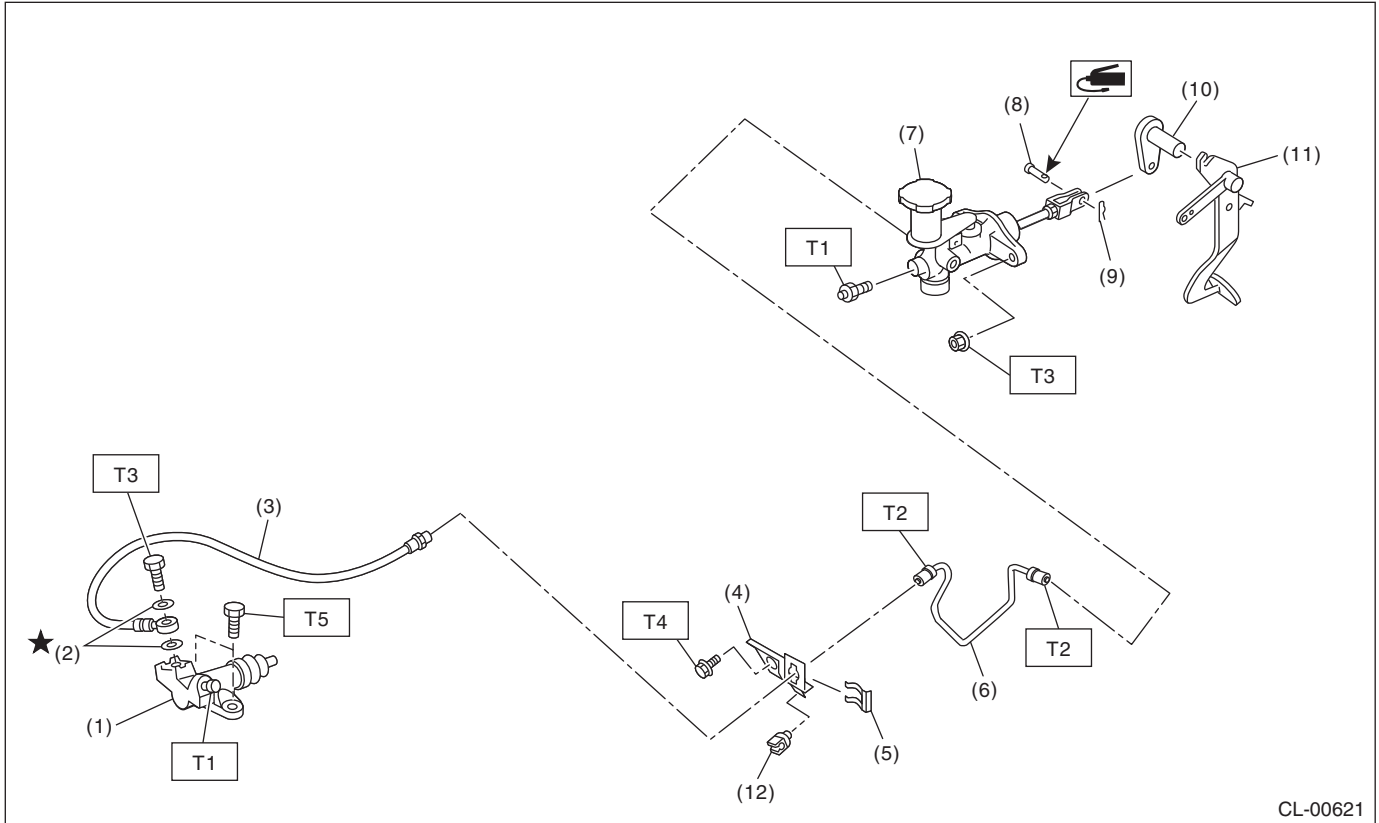

CL-00621

- | | |
|------------------------|--------------------------|
| (1) Operating cylinder | (7) Master cylinder ASSY |
| (2) Washer | (8) Clevis pin |
| (3) Clutch hose | (9) Snap pin |
| (4) Bracket | (10) Lever |
| (5) Clip | (11) Pedal |
| (6) Clutch pipe | (12) Clamp |

Tightening torque: N·m (kgf·m, ft·lb)

T1: 7.8 (0.8, 5.8)

T2: 15 (1.5, 11.1)

T3: 18 (1.8, 13.3)

T4: 25 (2.5, 18.4)

T5: 37 (3.8, 27.3)

3. MASTER CYLINDER

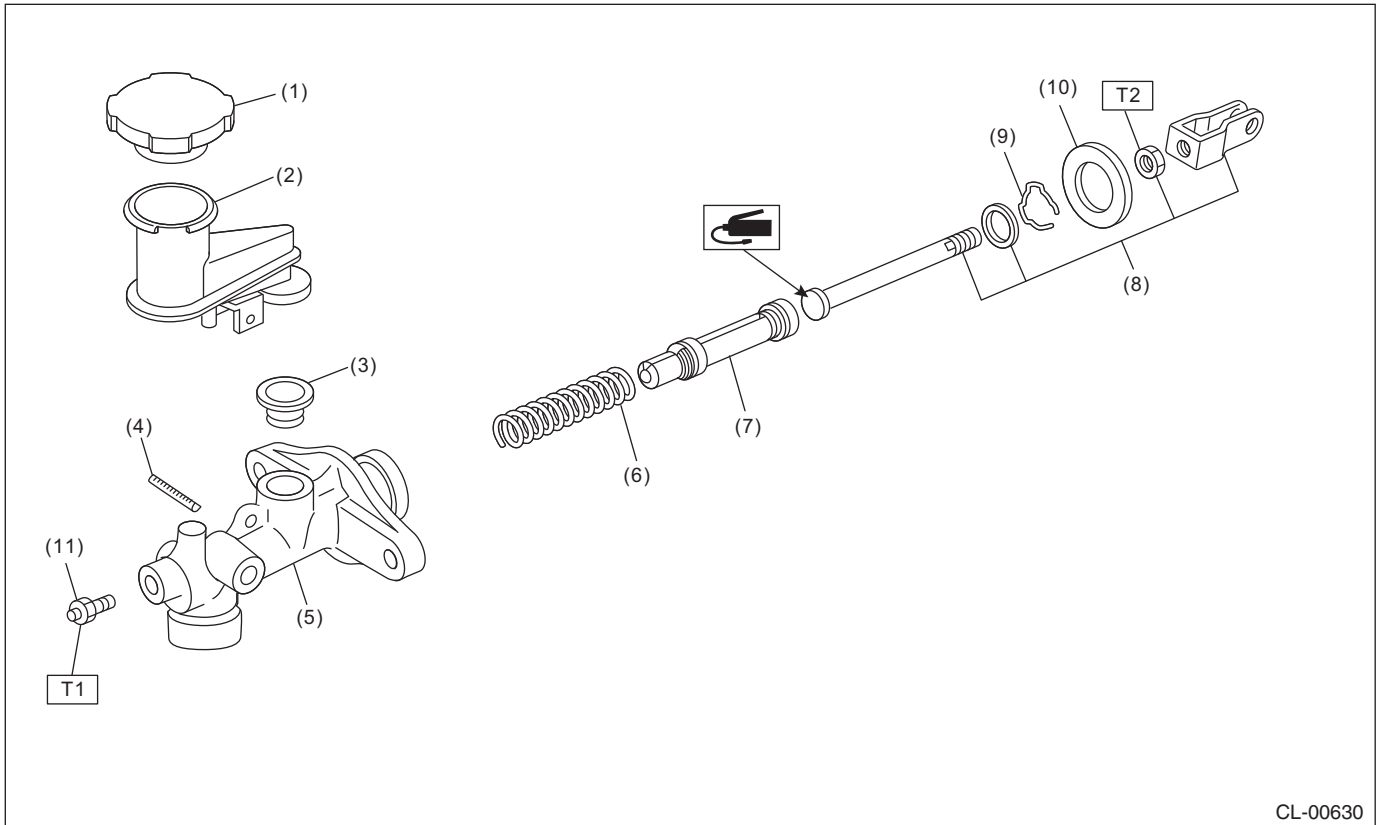

CL-00630

- (1) Reservoir cap
- (2) Reservoir tank
- (3) Oil seal
- (4) Straight pin
- (5) Master cylinder

- (6) Return spring
- (7) Piston
- (8) Push rod ASSY
- (9) Piston stop ring
- (10) Seat

- (11) Breather screw

Tightening torque: N·m (kgf·m, ft·lb)

T1: 7.8 (0.8, 5.8)

T2: 10 (1.0, 7.4)

General Description

CLUTCH SYSTEM

4. OPERATING CYLINDER

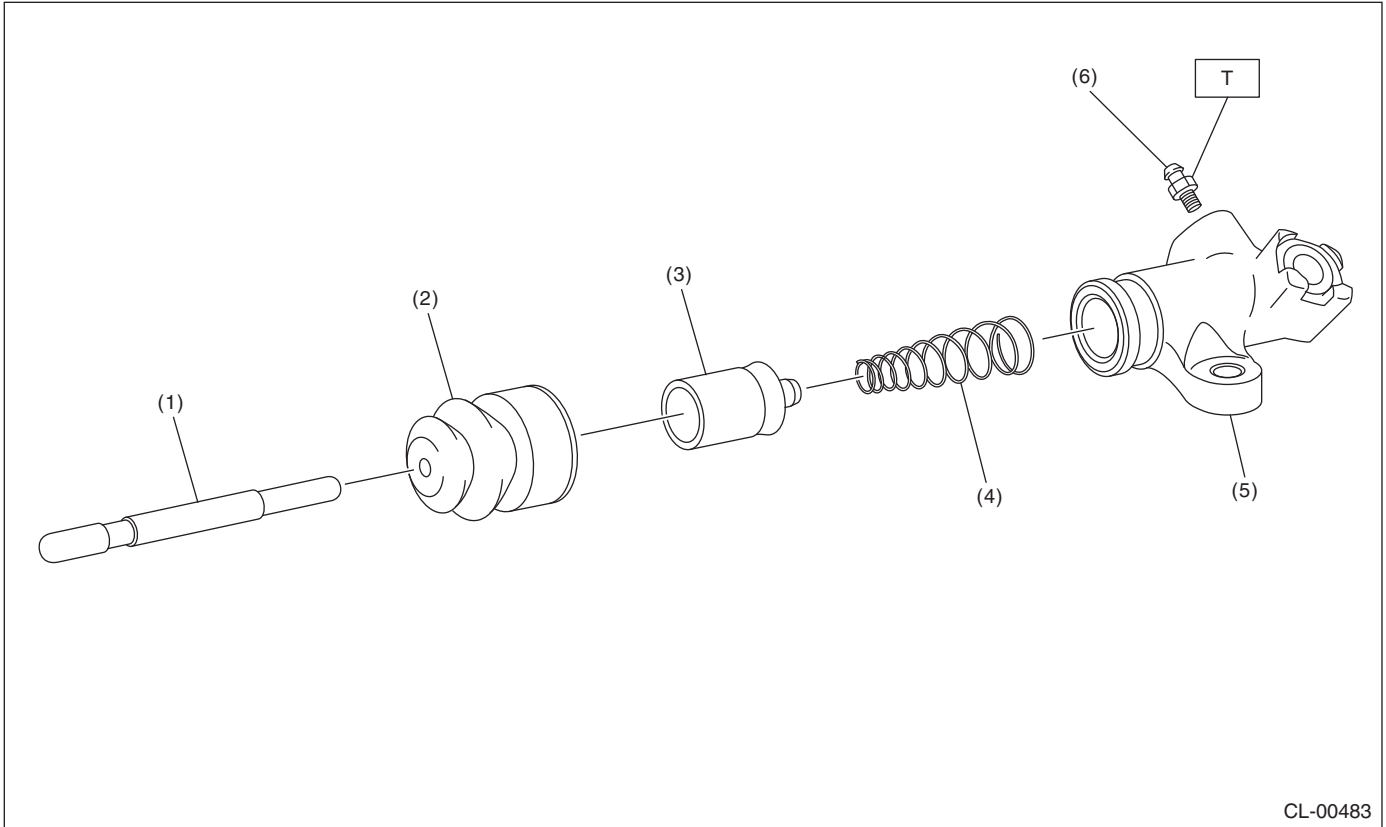

CL-00483

- | | |
|--------------|------------------------|
| (1) Push rod | (4) Piston spring |
| (2) Boot | (5) Operating cylinder |
| (3) Piston | (6) Breather screw |

Tightening torque: N·m (kgf·m, ft·lb)

T: 7.8 (0.8, 5.8)

5. CLUTCH PEDAL

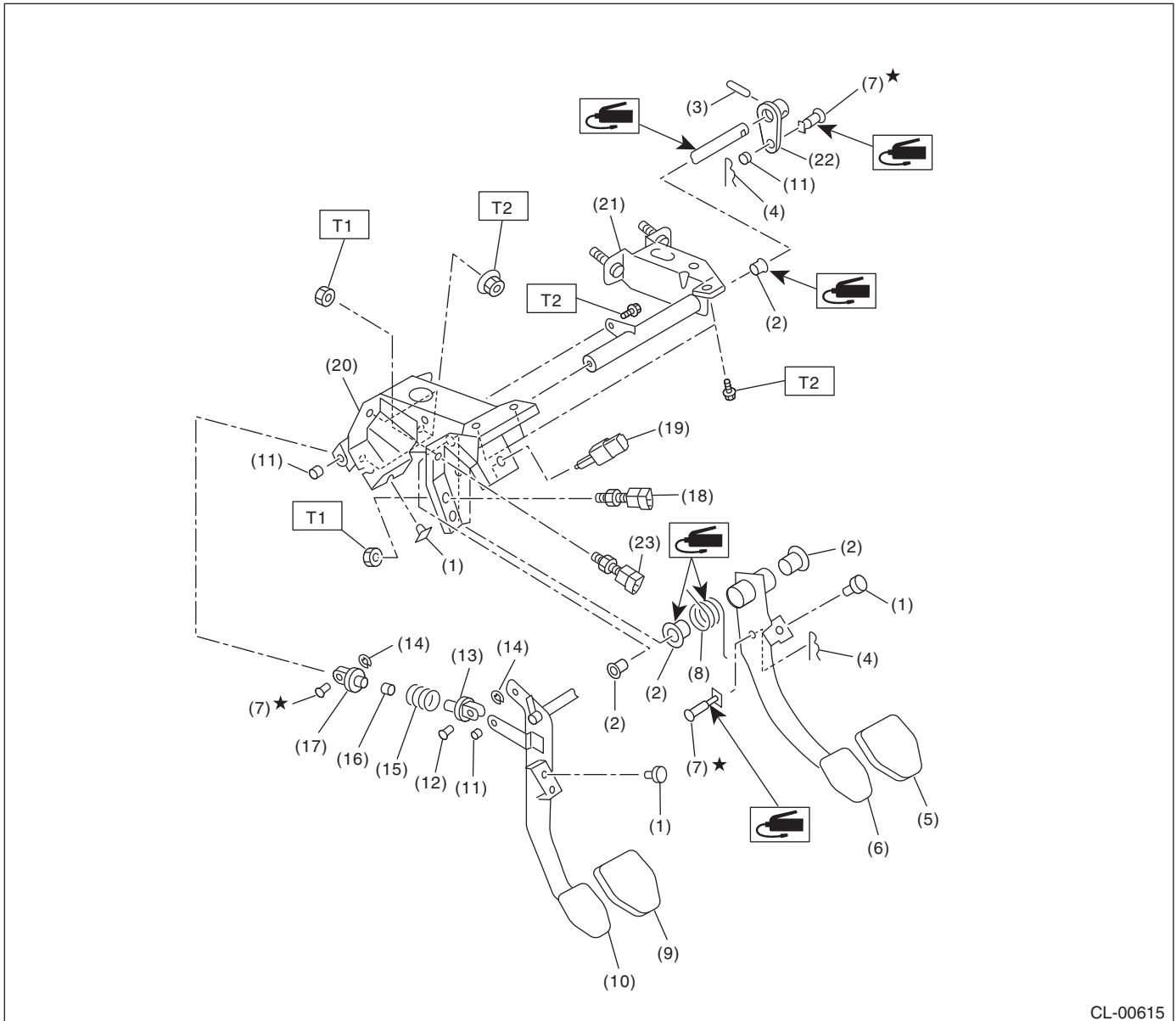

CL-00615

- | | | |
|------------------------|-------------------------------------|-------------------------------------|
| (1) Stopper | (10) Clutch pedal | (19) Stop light switch |
| (2) Bushing | (11) Bushing C | (20) Pedal bracket |
| (3) Spring pin | (12) Clutch clevis pin | (21) Clutch master cylinder bracket |
| (4) Snap pin | (13) Assist rod A | (22) Lever |
| (5) Brake pedal pad | (14) Clip | (23) Clutch switch (clutch start) |
| (6) Brake pedal | (15) Assist spring | |
| (7) Clevis pin | (16) Assist bushing | |
| (8) Brake pedal spring | (17) Assist rod B | |
| (9) Clutch pedal pad | (18) Clutch switch (Cruise control) | |

Tightening torque: N·m (kgf·m, ft·lb)

T1: 8 (0.8, 5.9)

T2: 18 (1.8, 13.3)

General Description

CLUTCH SYSTEM

C: CAUTION

- Wear appropriate work clothing, including a cap, protective goggles and protective shoes when performing any work.
- Remove contamination including dirt and corrosion before removal, installation or disassembly.
- Keep the disassembled parts in order and protect them from dust and dirt.
- Before removal, installation or disassembly, be sure to clarify the failure. Avoid unnecessary removal, installation, disassembly and replacement.
- Vehicle components are extremely hot after driving. Be wary of receiving burns from heated parts.
- Use SUBARU genuine fluid, grease etc. or equivalent. Do not mix fluid, grease, etc. of different grades or manufacturers.
- Be sure to tighten fasteners including bolts and nuts to the specified torque.
- Place shop jacks or rigid racks at the specified points.
- Apply grease onto sliding or revolving surfaces before installation.
- Before installing O-rings or snap rings, apply sufficient amount of fluid to avoid damage and deformation.
- Before securing a part in a vise, place cushioning material such as wood blocks, aluminum plate or cloth between the part and the vise.
- Keep fluids away from the vehicle body. If any fluid contacts the vehicle body, immediately flush the area with water.

D: PREPARATION TOOL

1. SPECIAL TOOL

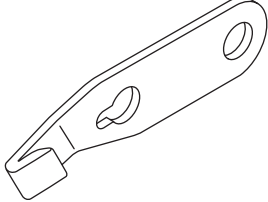
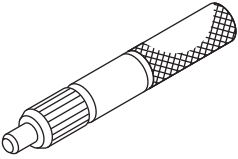
ILLUSTRATION	TOOL NUMBER	DESCRIPTION	REMARKS
 <p>ST-498497100</p>	498497100	CRANKSHAFT STOPPER	Used for stopping rotation of the flywheel when loosening/tightening bolts, etc.
 <p>ST-499747100</p>	499747100	CLUTCH DISC GUIDE	Used when installing the clutch disc to the flywheel.

2. GENERAL TOOL

TOOL NAME	REMARKS
Circuit tester	Used for measuring resistance, voltage and ampere.
Dial gauge	Used for measuring clutch disc run-out.
Depth gauge	Used for measuring clutch disc wear.

2. Clutch Disc and Cover

A: REMOVAL

1) Remove the transmission assembly from vehicle body.

<Ref. to 5MT-24, REMOVAL, Manual Transmission Assembly.>

2) Attach the ST on the flywheel.

ST 499747100 CLUTCH DISC GUIDE

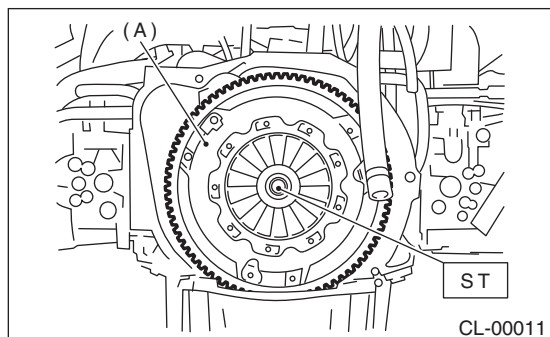

(A) Clutch cover

3) Remove the clutch cover and clutch disc.

NOTE:

- Take care not to allow oil to touch the clutch disc face.
- Do not disassemble the clutch cover or clutch disc.

B: INSTALLATION

1) Insert the ST into the clutch disc and attach to the flywheel by inserting the ST end into pilot bearing.

NOTE:

When installing the clutch disc, be careful to attach in the correct direction.

ST 499747100 CLUTCH DISC GUIDE

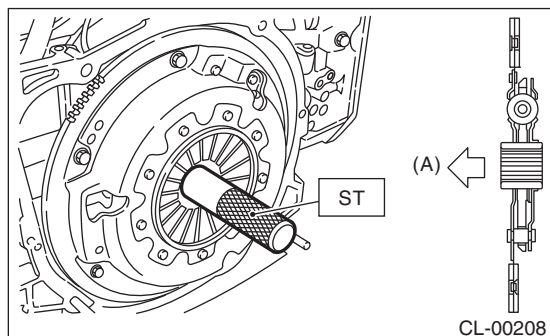

(A) Flywheel side

2) Install the clutch cover to the flywheel and tighten the bolts to the specified torque.

NOTE:

- When installing the clutch cover to the fly wheel, position the clutch cover so that the distance between unbalance marks (● paint marks) is at least 120°. (The unbalance marks ● indicate the directions of residual unbalance.)
- Note the front and rear of the clutch disc when installing.
- Temporarily tighten the bolts by hand. Each bolt should be tightened to the specified torque in a crisscross order.

Tightening torque:

16 N·m (1.6 kgf-m, 11.8 ft-lb)

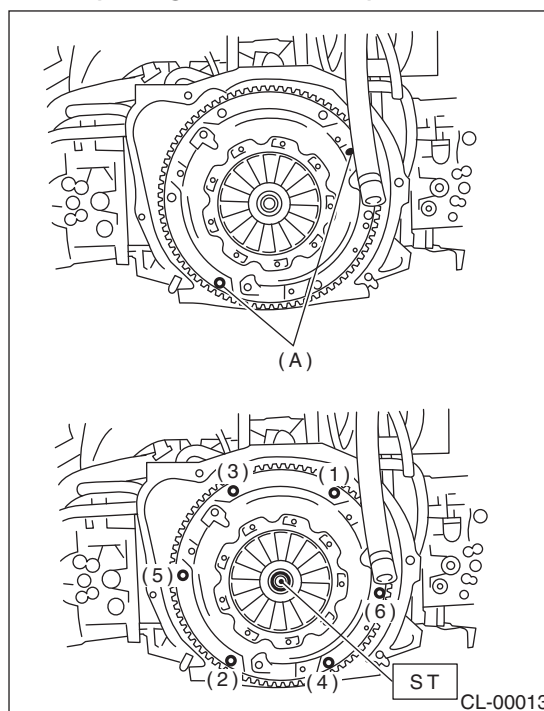

(A) Unbalance mark (paint)

3) Remove the ST.

ST 499747100 CLUTCH DISC GUIDE

4) Install the transmission assembly.

<Ref. to 5MT-27, INSTALLATION, Manual Transmission Assembly.>

Clutch Disc and Cover

CLUTCH SYSTEM

C: INSPECTION

1. CLUTCH DISC

1) Facing wear

Measure the depth from the facing surface to the rivet head. Replace if the face is worn locally or worn down to less than the specified value.

Depth to rivet head:

Limit of sinking

0.3 mm (0.012 in)

NOTE:

Do not wash the clutch disc with any type of cleaning fluid.

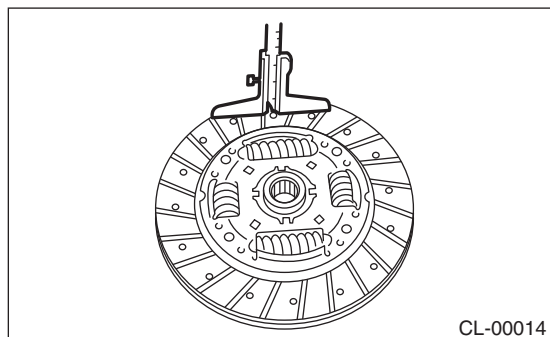

2) Hardened facing

Replace the clutch disc.

3) Oil soakage on facing

Replace the clutch disc and inspect the transmission front oil seal, transmission case mating surface, engine rear oil seal and other locations for oil leakage.

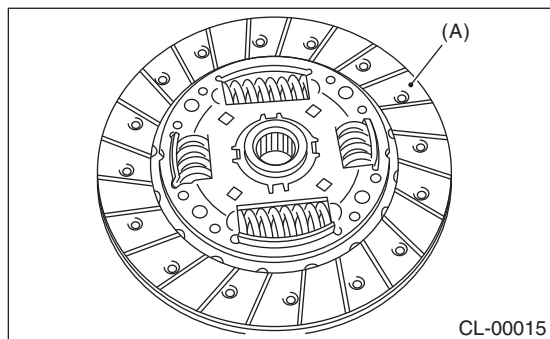

(A) Clutch facing

4) Deflection on facing:

If deflection exceeds the specified value at the outer circumference of the facing, replace the clutch disc.

ST 499747100 CLUTCH DISC GUIDE

Limit for deflection:

0.7 mm (0.028 in) at R = 110 mm (4.33 in)

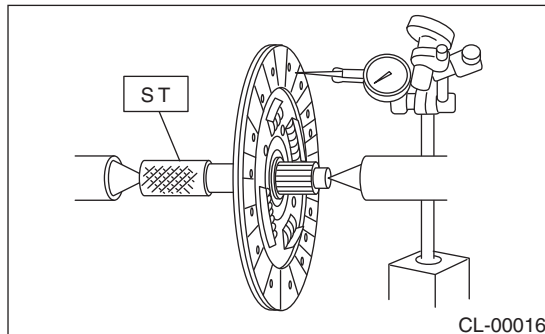

5) If there is spline wear, loose rivets, failed damper springs, etc., replace the clutch disc.

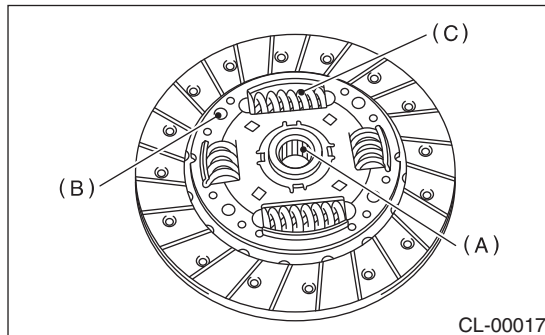

(A) Spline

(B) Rivet

(C) Damper spring

2. CLUTCH COVER

NOTE:

Visually check the following items without disassembling, and replace or repair if defective.

- 1) Loose thrust rivet
- 2) Damaged or worn bearing contact area at the center of diaphragm spring

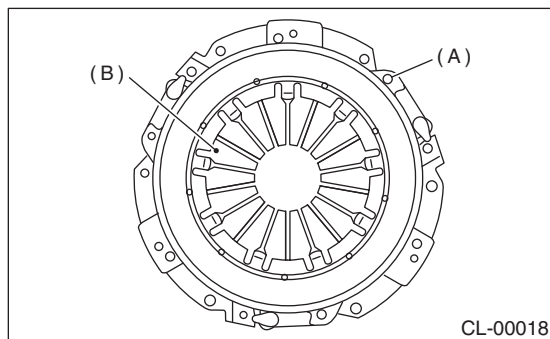

- (A) Thrust rivet
- (B) Diaphragm spring

- 3) Damaged or worn disc contact surface of the pressure plate
- 4) Loose strap plate installation area
- 5) Worn diaphragm sliding area

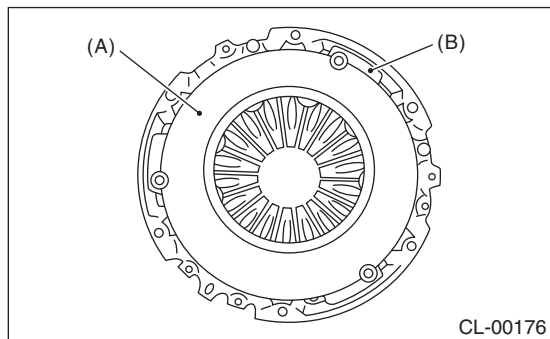

- (A) Pressure plate
- (B) Strap plate

Flywheel

CLUTCH SYSTEM

3. Flywheel

A: REMOVAL

- 1) Remove the transmission assembly.
<Ref. to 5MT-24, REMOVAL, Manual Transmission Assembly.>
- 2) Remove the clutch cover and clutch disc. <Ref. to CL-9, REMOVAL, Clutch Disc and Cover.>
- 3) Using the ST, remove the flywheel.
ST 498497100 CRANKSHAFT STOPPER

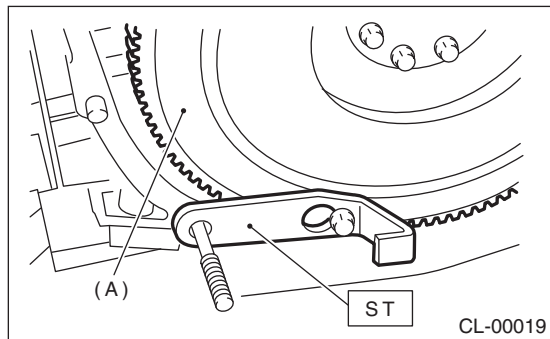

(A) Flywheel

B: INSTALLATION

- 1) Install the flywheel and ST.
ST 498497100 CRANKSHAFT STOPPER

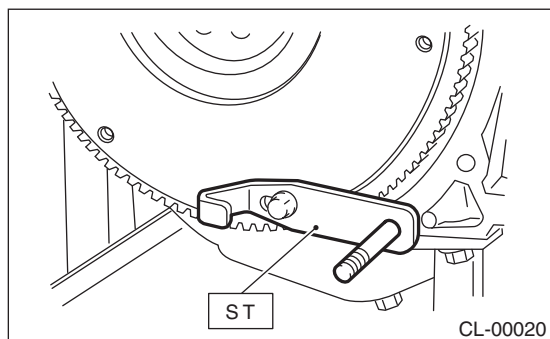

- 2) Tighten the flywheel mounting bolts to the specified torque.

NOTE:

Tighten the flywheel attachment bolts gradually. Each bolt should be tightened to the specified torque in crisscross order.

Tightening torque:

72 N·m (7.3 kgf-m, 53.1 ft-lb)

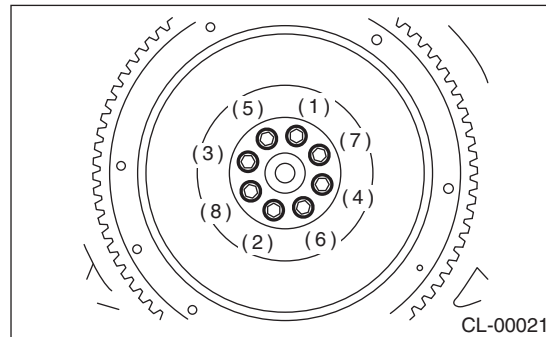

- 3) Install the clutch disc and cover. <Ref. to CL-9, INSTALLATION, Clutch Disc and Cover.>
- 4) Install the transmission assembly.
<Ref. to 5MT-27, INSTALLATION, Manual Transmission Assembly.>

C: INSPECTION

CAUTION:

Because this bearing is grease-sealed and is a non-lubrication type, do not wash with gasoline or solvents.

- 1) If there is damage or defectiveness in the facing sliding surface or ring gear, replace the flywheel.

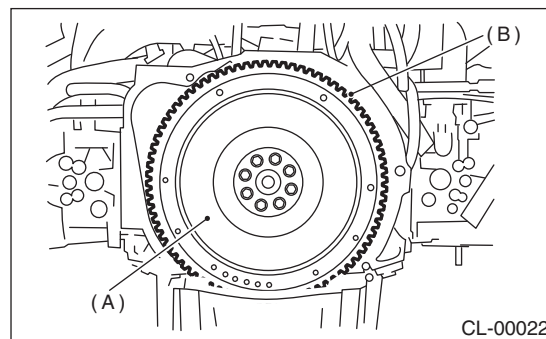

(A) Flywheel
(B) Ring gear

- 2) Smoothness of rotation
Rotate the ball bearing while applying pressure in the thrust direction.
- 3) If noise or excessive play is noted, replace the flywheel.

4. Release Bearing and Lever

A: REMOVAL

1) Remove the transmission assembly from vehicle body.

<Ref. to 5MT-24, REMOVAL, Manual Transmission Assembly.>

2) Remove the two clips from the release lever and remove the release bearing.

CAUTION:

Be careful not to deform the clips.

3) Remove the dust cover.

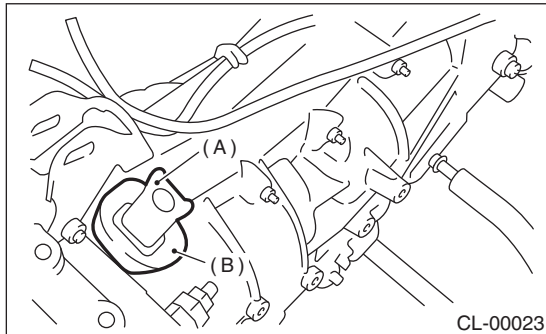

(A) Release lever
(B) Dust cover

4) Remove the lever spring from the pivot with a screwdriver by accessing it through the clutch housing release lever hole. Then remove the release lever.

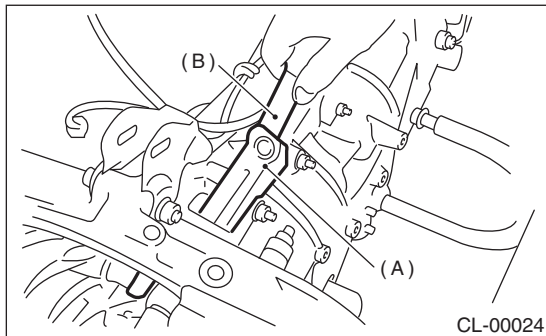

(A) Release lever
(B) Screwdriver

B: INSTALLATION

NOTE:

Apply the specified grease to lubricate the following points before installation.

- Contact surface of lever and pivot
- Contact surface of lever and bearing
- Transmission main shaft spline (Use grease containing molybdenum disulphide.)

1) Apply grease (KOPR-KOTE: Part No. 003603001) to the contact point of the release lever and operating cylinder.

2) While pushing the release lever to the pivot and twisting it to both sides, fit the lever spring onto the raised portion of the pivot.

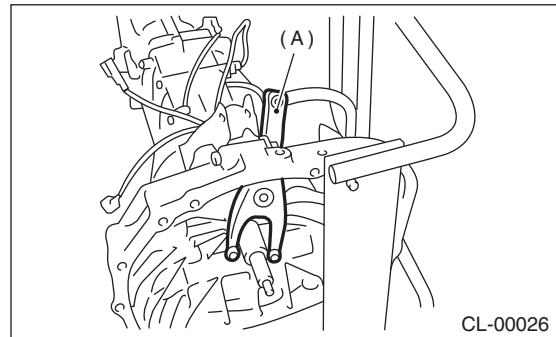

(A) Release lever

NOTE:

Observing from the main case hole, check that the lever spring is installed securely.

3) Install the release bearing and fasten it with two clips.

4) Install the dust cover.

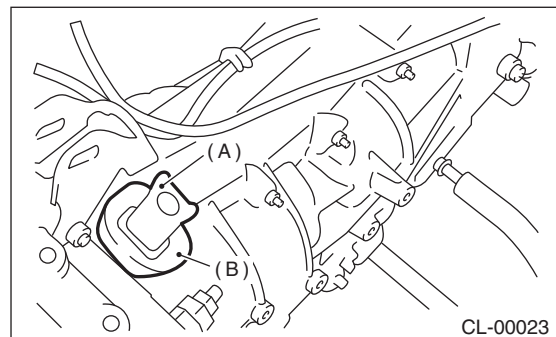

(A) Release lever
(B) Dust cover

5) Check the bearing for smooth movement by operating the release lever.

6) Install the transmission assembly.

<Ref. to 5MT-27, INSTALLATION, Manual Transmission Assembly.>

Release Bearing and Lever

CLUTCH SYSTEM

C: INSPECTION

1. RELEASE BEARING

CAUTION:

Since this bearing is grease-sealed and is a non-lubrication type, do not wash with gasoline or any other solvent when servicing the clutch.

1) Check the bearing for smooth movement by applying force to the bearing in the radial direction.

Radial direction stroke:

1.6 mm (0.063 in)

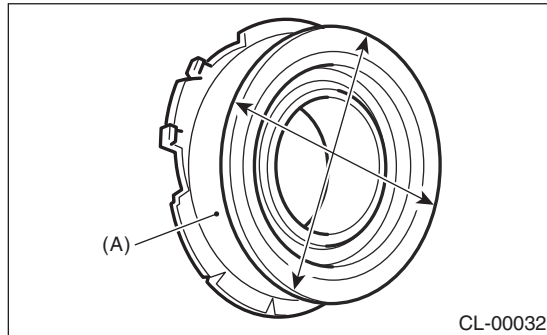

(A) Bearing case

2) While applying force to the bearing in the rotational direction, check the bearing for smooth rotation.

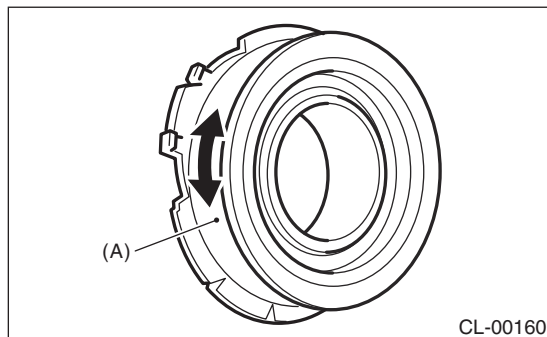

(A) Bearing case

3) Check for wear and damage at the bearing case surface in contact with the lever.

2. RELEASE LEVER

Check the pivot portion of the lever and the contact area with the release bearing case for wear.

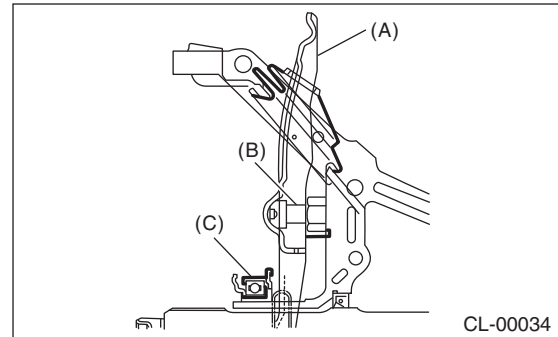

- (A) Release lever
- (B) Pivot
- (C) Release bearing

5. Operating Cylinder

A: REMOVAL

- 1) Remove the air intake chamber. <Ref. to IN(H4SO)-7, REMOVAL, Air Intake Chamber.>
- 2) Disconnect the clutch hose from the operating cylinder.

CAUTION:

Cover the hose joint to prevent the clutch fluid from flowing out.

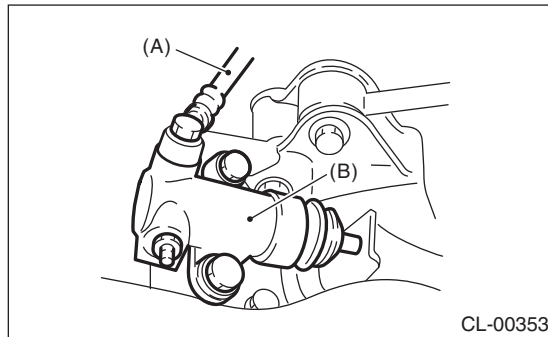

- (A) Clutch hose
(B) Operating cylinder

- 3) Remove the operating cylinder from the transmission.

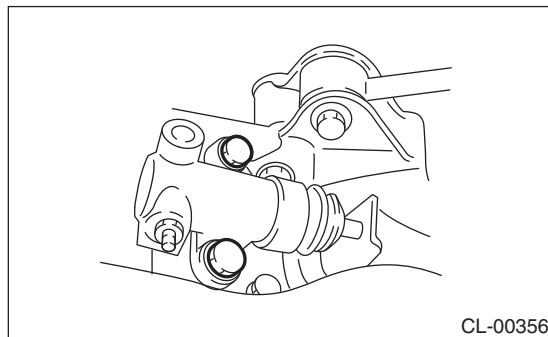

B: INSTALLATION

- 1) Install in the reverse order of removal.

NOTE:

Before installing the operating cylinder, apply grease (KOPR-KOTE: Part No. 003603001) to the contact point of the release lever and operating cylinder.

Tightening torque:

T1: 18 N·m (1.8 kgf-m, 13.3 ft-lb)

T2: 37 N·m (3.8 kgf-m, 27.3 ft-lb)

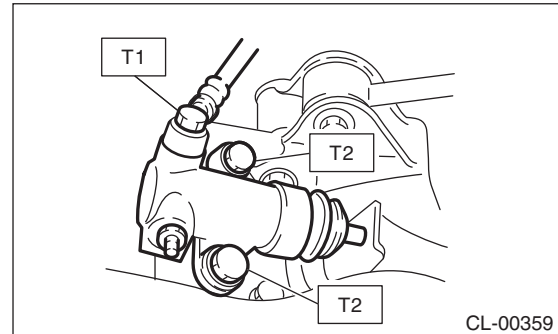

NOTE:

- Be sure to install the clutch hose with the mark side facing upward.
- Be careful not to twist the clutch hose during installation.

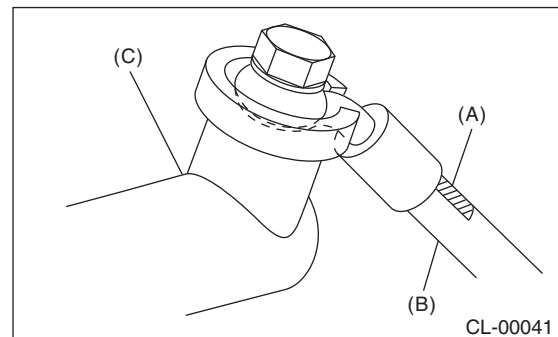

- (A) Mark
(B) Clutch hose
(C) Operating cylinder

- 2) After bleeding air from the operating cylinder, ensure that the clutch operates properly. <Ref. to CL-21, Clutch Fluid Air Bleeding.>

Operating Cylinder

CLUTCH SYSTEM

C: DISASSEMBLY

- 1) Remove the boots and push rod assembly.

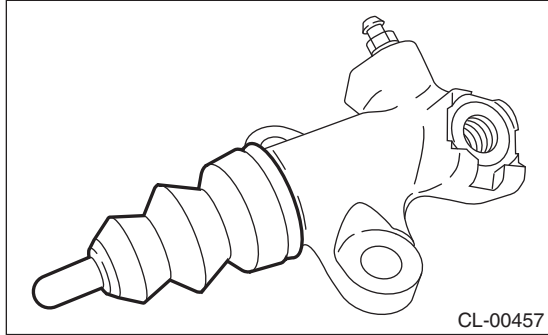

- 2) Apply compressed air through clutch hose attaching port.

NOTE:

Face the piston port down and place a piece of wood underneath to prevent the piston from popping out.

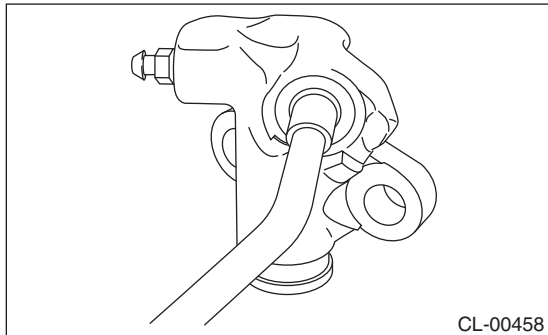

- 3) Separate the piston and piston spring.

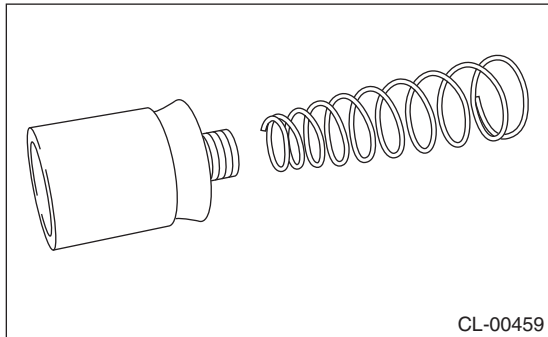

D: ASSEMBLY

NOTE:

During assembly, apply hydraulic oil to all parts.

Recommended clutch fluid:

New FMVSS No. 116 DOT3 brake fluid

- 1) Install the piston spring to the piston.

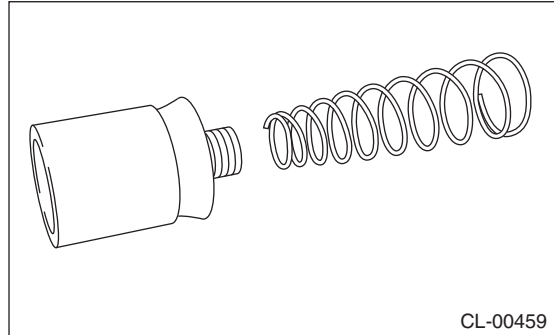

- 2) Insert piston to the operating cylinder.
- 3) Install push rod to the boot.
- 4) Install boot and push rod to the operating cylinder.

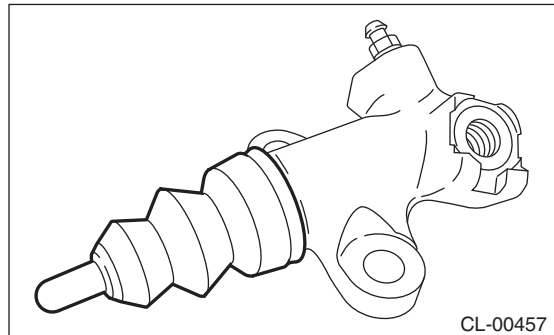

E: INSPECTION

- 1) Check the operating cylinder for damage. If operating cylinder is damaged, replace it.
- 2) Check the operating cylinder for fluid leakage or damage on the boot. If any leakage or damage is found, replace the operating cylinder.

6. Master Cylinder

A: REMOVAL

- 1) Thoroughly drain the brake fluid from the reservoir tank.
- 2) Remove the snap pin and clevis pin, and then separate the push rod of the master cylinder from clutch pedal.

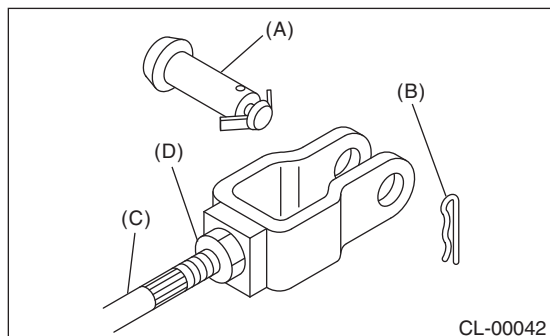

- (A) Clevis pin
- (B) Snap pin
- (C) Push rod
- (D) Lock nut

- 3) Remove the air intake chamber. <Ref. to IN(H4SO)-7, REMOVAL, Air Intake Chamber.>
- 4) Remove the clutch pipe from the master cylinder.
- 5) Remove the master cylinder and reservoir tank as a unit.

CAUTION:

Be careful not to spill the brake fluid. Brake fluid spilled on the vehicle body will harm the paint surface; wash it off with water and wipe clean quickly if spilled.

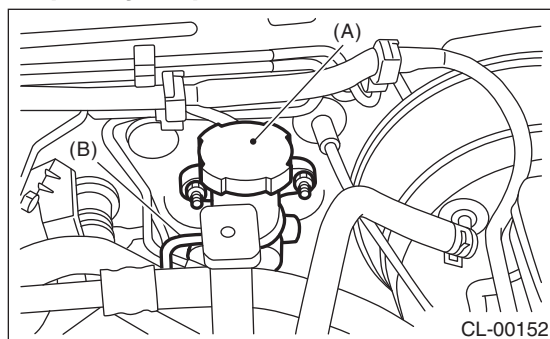

- (A) Master cylinder
- (B) Clutch pipe

B: INSTALLATION

- 1) Install the master cylinder to the vehicle body, and connect the clutch pipe to the master cylinder.

NOTE:

Check that the pipe is routed properly.

Tightening torque:

T1: 15 N·m (1.5 kgf-m, 11.1 ft-lb)

T2: 18 N·m (1.8 kgf-m, 13.3 ft-lb)

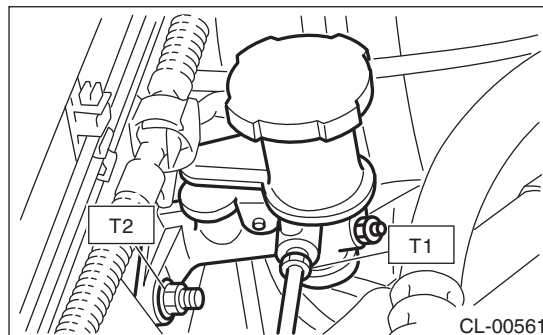

- 2) Connect the push rod of the master cylinder to the clutch pedal, and install the clevis pin and snap pin.

NOTE:

Apply grease to the clevis pin.

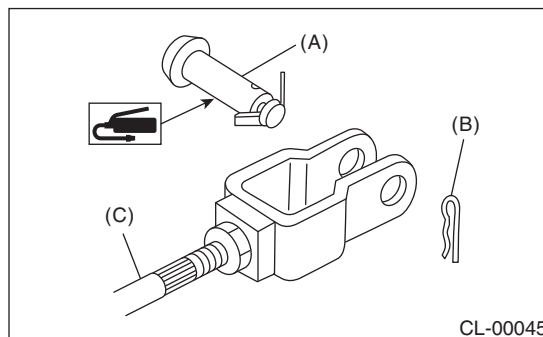

- (A) Clevis pin
- (B) Snap pin
- (C) Push rod

- 3) After bleeding air from the clutch system, ensure that the clutch operates properly.

<Ref. to CL-21, Clutch Fluid Air Bleeding.>

- 4) Install the air intake chamber. <Ref. to IN(H4SO)-7, INSTALLATION, Air Intake Chamber.>

Master Cylinder

CLUTCH SYSTEM

C: DISASSEMBLY

1) Remove the straight pin and reservoir tank.

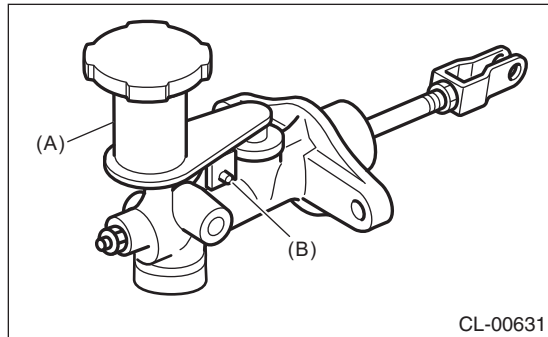

- (A) Reservoir tank
- (B) Straight pin

2) Remove the oil seal.

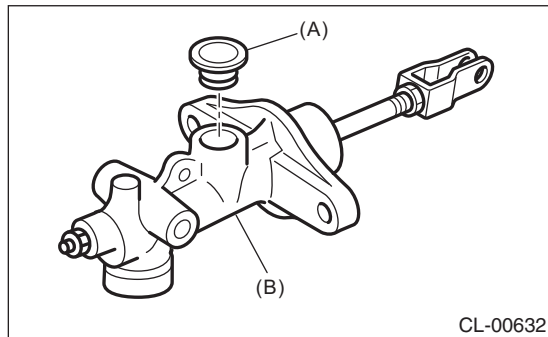

- (A) Oil seal
- (B) Master cylinder

3) Move the seat towards the rear.

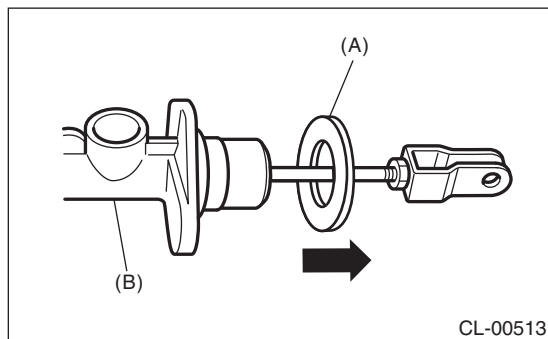

- (A) Seat
- (B) Master cylinder

4) Remove the piston stop ring.

CAUTION:

When removing the piston stop ring, be careful to prevent the rod, washer, piston and return spring from coming out.

D: ASSEMBLY

1) Apply a coat of grease to the contact surfaces of the push rod and piston before installation.

Grease:

SILICONE GREASE G-40M
(Part No. 004404003)

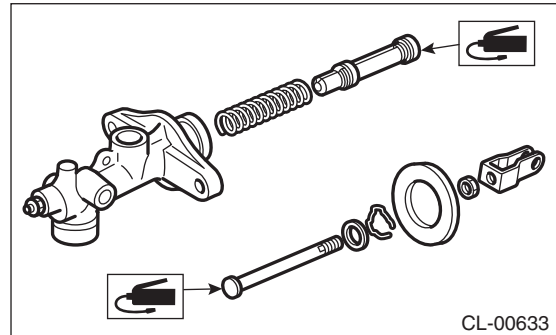

2) Assemble in the reverse order of disassembly.

Tightening torque:

10 N·m (1.0 kgf-m, 7.4 ft-lb)

E: INSPECTION

If any damage, deformation, wear, swelling, rust or other faults are found on the cylinder, piston, push rod, reservoir tank, return spring, seat or hose, replace the faulty part.

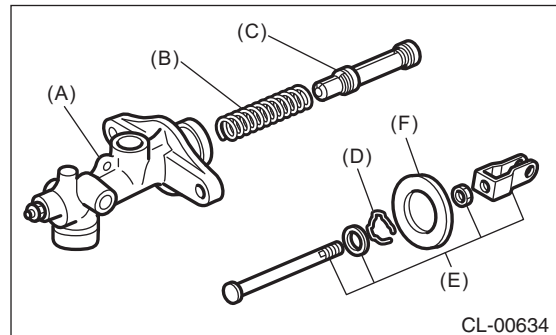

- (A) Master cylinder body
- (B) Return spring
- (C) Piston
- (D) Piston stop ring
- (E) Push rod ASSY
- (F) Seat

7. Clutch Pipe and Hose

A: REMOVAL

- 1) Remove the air intake chamber and air intake duct. <Ref. to IN(H4SO)-7, REMOVAL, Air Intake Chamber.> <Ref. to IN(H4SO)-8, REMOVAL, Air Intake Duct.>
- 2) Drain the clutch fluid. <Ref. to CL-20, Clutch Fluid.>
- 3) Disconnect the clutch pipe from the clutch hose and master cylinder.
- 4) Pull out the clamp, then disconnect the clutch hose from the bracket.

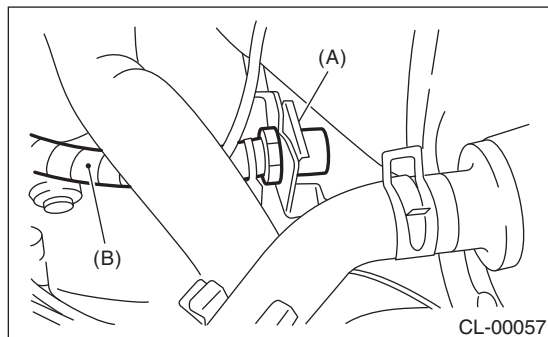

- (A) Clamp
(B) Clutch hose

- 5) Remove the hose from operating cylinder.
- 6) Remove the bracket.

B: INSTALLATION

Install in the reverse order of removal.

NOTE:

Bleed air from the clutch fluid. <Ref. to CL-21, Clutch Fluid Air Bleeding.>

Tightening torque:

T1: 15 N·m (1.5 kgf-m, 11.1 ft-lb)

T2: 18 N·m (1.8 kgf-m, 13.3 ft-lb)

T3: 25 N·m (2.5 kgf-m, 18.4 ft-lb)

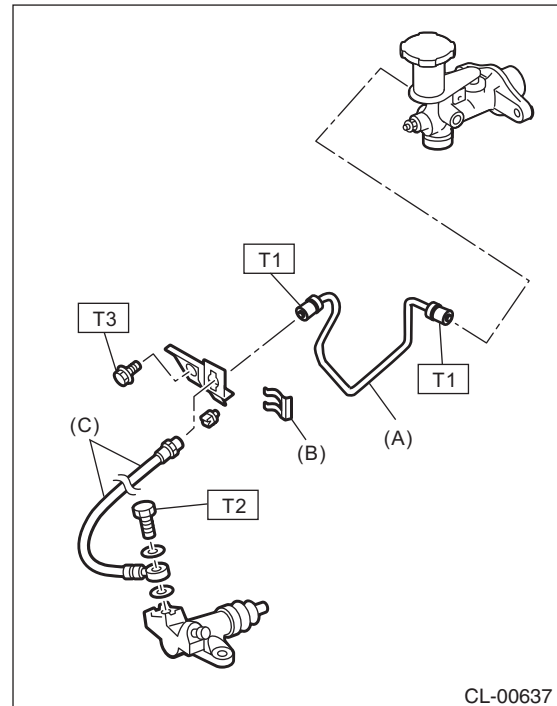

- (A) Clutch pipe
(B) Clip
(C) Clutch hose

C: INSPECTION

Check pipes and hoses for cracks, breakage or damage. Check joints for fluid leakage. If any cracks, breakage, damage or leakage is found, repair or replace the defective pipe or hose.

8. Clutch Fluid

A: INSPECTION

- 1) Park the vehicle on a level surface.
- 2) Inspect the fluid level using the scale on the outside of the reservoir tank. If the level is below "MIN", add fluid to bring it up to "MAX", and also inspect for leakage.

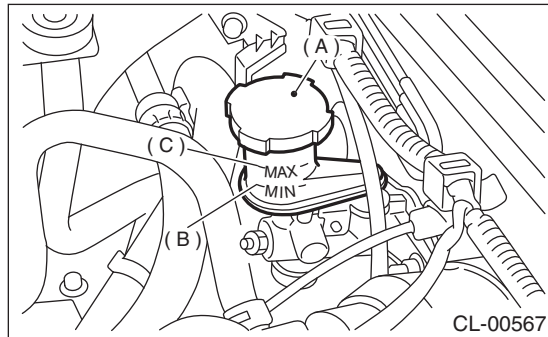

- (A) Reservoir tank
- (B) MIN. level
- (C) MAX. level

B: REPLACEMENT

CAUTION:

- Use new FMVSS No. 116 DOT3 brake fluid.
- Cover the breather with cloth to prevent brake fluid from being splashed on surrounding parts when loosening the breather.
- Avoid mixing different brands of brake fluid to prevent the quality of fluid from degrading.
- Be careful not to allow dirt or dust to enter the reservoir tank.

NOTE:

- During bleeding operation, keep the clutch reservoir tank filled with brake fluid to prevent entry of air.
 - Clutch pedal must be operated very slowly.
 - Bleed air from the oil line with help of a co-worker.
 - The amount of brake fluid required is approximately 70 m^l (2.4 US fl oz, 2.5 Imp fl oz) for total clutch system.
- 1) Remove the air intake chamber. <Ref. to IN(H4SO)-7, REMOVAL, Air Intake Chamber.>
 - 2) Drain the brake fluid from the reservoir tank.
 - 3) Refill the reservoir tank with recommended brake fluid.

Recommended brake fluid:

New FMVSS No. 116 DOT3 brake fluid

- 4) If necessary, bleed air from the clutch fluid. <Ref. to CL-21, Clutch Fluid Air Bleeding.>

9. Clutch Fluid Air Bleeding

A: PROCEDURE

NOTE:

Bleed air from the oil line with help of a co-worker.

1) Remove the air intake chamber. <Ref. to IN(H4SO)-7, REMOVAL, Air Intake Chamber.>

2) Fit one end of a vinyl tube into the air breather of the operating cylinder, and put the other end into a brake fluid container.

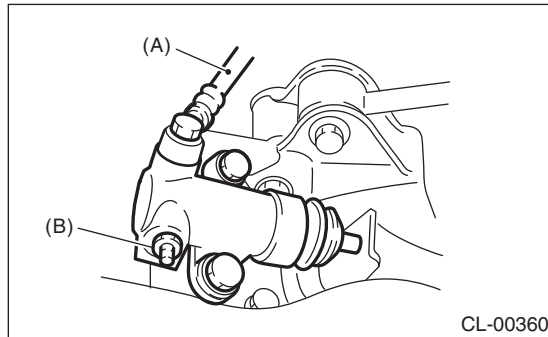

- (A) Clutch hose
- (B) Air breather

3) Slowly depress the clutch pedal and keep it depressed. Then open the air breather to discharge air together with the fluid.

Release the air breather for 1 or 2 seconds. Next, with the breather closed, slowly release the clutch pedal.

CAUTION:

Cover the breather with cloth to prevent brake fluid from being splashed on surrounding parts when loosening the breather.

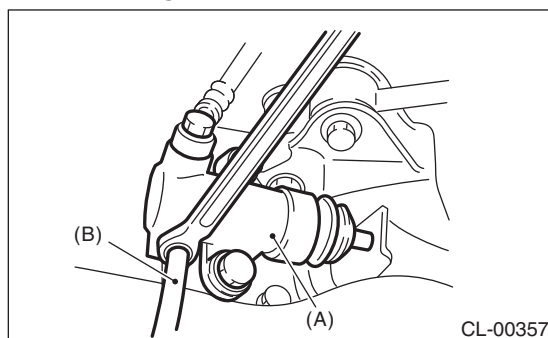

- (A) Operating cylinder
- (B) Vinyl tube

4) Repeat procedure 3), until there are no more air bubbles in the vinyl tube.

5) Tighten the air breather.

Tightening torque:

T: 7.8 N·m (0.8 kgf·m, 5.8 ft·lb)

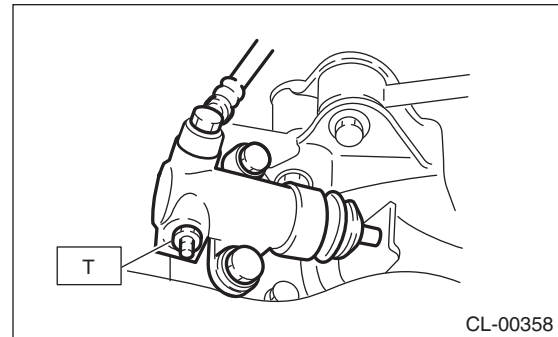

6) After stepping on the clutch pedal, make sure that there are no leaks evident in the entire clutch system.

7) After bleeding the air from clutch system, ensure that the clutch operates properly.

8) Install the air intake chamber. <Ref. to IN(H4SO)-7, INSTALLATION, Air Intake Chamber.>

Clutch Pedal

CLUTCH SYSTEM

10. Clutch Pedal

A: REMOVAL

- 1) Disconnect the ground cable from battery.
- 2) Remove the steering column. <Ref. to PS-15, REMOVAL, Steering Column.>
- 3) Disconnect the connector from the stop light switch and clutch switch.
- 4) Remove the snap pins from clevis pins which secure the lever to the push rod and operating rod.
- 5) Pull out the clevis pins which secures the lever to the push rod and operating rod.

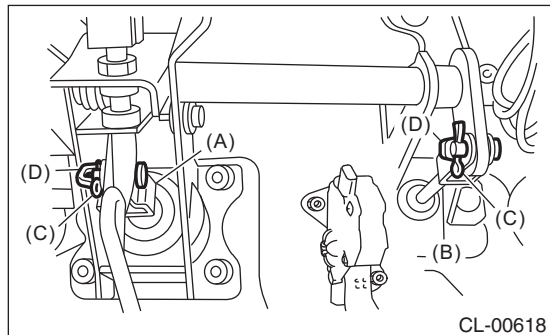

- (A) Operating rod
- (B) Push rod
- (C) Snap pin
- (D) Clevis pin

- 6) Remove the air intake chamber. <Ref. to IN(H4SO)-7, REMOVAL, Air Intake Chamber.>
- 7) Remove the nut which secures the clutch master cylinder.

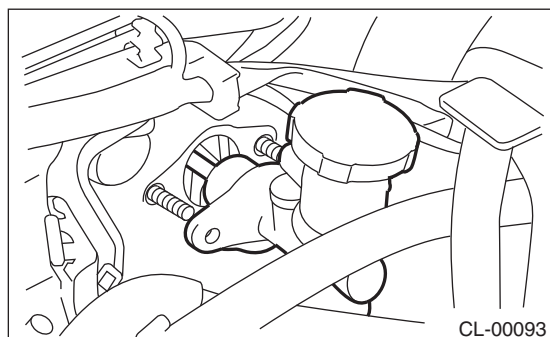

- 8) Remove the bolts and nuts which secure the brake pedal and clutch pedal, and remove the pedal assembly.

B: INSTALLATION

- 1) Install in the reverse order of removal.

CAUTION:

Always use a new clevis pin.

- 2) Adjust the clutch pedal after installation. <Ref. to CL-23, ADJUSTMENT, Clutch Pedal.>
- 3) Adjust the clutch switch (clutch start). <Ref. to CL-27, ADJUSTMENT, Clutch Switch.>

C: DISASSEMBLY

- 1) Remove the clip, assist spring, rod and bushing.

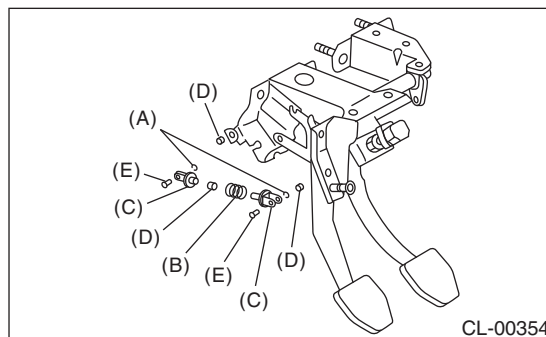

- (A) Clip
- (B) Assist spring
- (C) Assist rod
- (D) Bushing
- (E) Clevis pin

- 2) Remove the spring pin and lever.

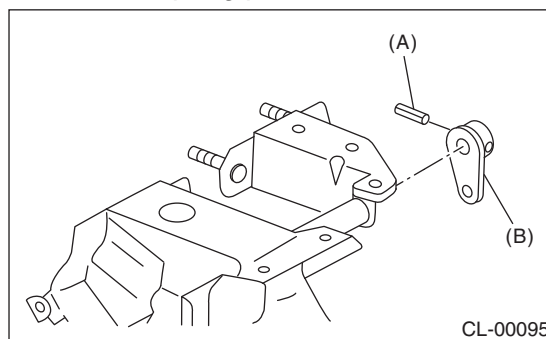

- (A) Pin
- (B) Lever

- 3) Remove the clutch pedal and bushings.

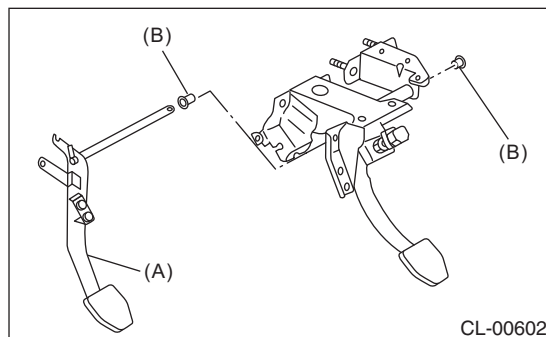

- (A) Clutch pedal
- (B) Bushing

4) Remove the stopper from the clutch pedal.

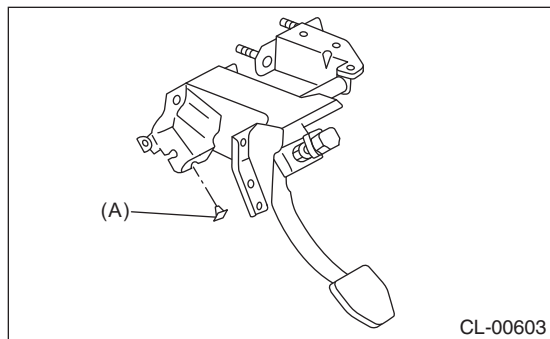

(A) Stopper

5) Remove the clutch pedal pad.

D: ASSEMBLY

1) Install the stopper, etc., temporarily to the pedal bracket.

2) Clean the clutch pedal and brake pedal bushing holes, apply grease, and install the bushings.

3) Align the holes of the pedal bracket, clutch pedal and brake pedal, and install the brake pedal return spring, assist rod, spring and bushing.

NOTE:

Clean the inside of the bushings and apply grease before installing the spacer.

E: INSPECTION

Move the clutch pedal pads in the lateral direction with a force of approximately 10 N (1 kgf, 2 lbf) to check that the clutch pedal deflection is within the service limit.

CAUTION:

If the play exceeds the service limit, replace the bushing with a new part.

Deflection of the clutch pedal:

Service limit

4.0 mm (0.157 in) or less

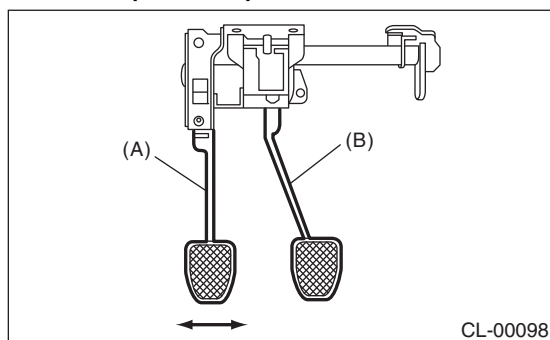

(A) Clutch pedal
(B) Brake pedal

F: ADJUSTMENT

1) Turn the lock nut until the full stroke of clutch pedal becomes within the specification.

CAUTION:

When adjusting the full stroke of clutch pedal, do not turn the clutch switch.

NOTE:

If the lock nut cannot adjust the full stroke of clutch pedal to the specified value, adjust it by turning the master cylinder push rod.

Clutch pedal full stroke A:

130 — 135 mm (5.12 — 5.31 in)

Tightening torque (Clutch switch lock nut):

T: 8 N·m (0.8 kgf-m, 5.9 ft-lb)

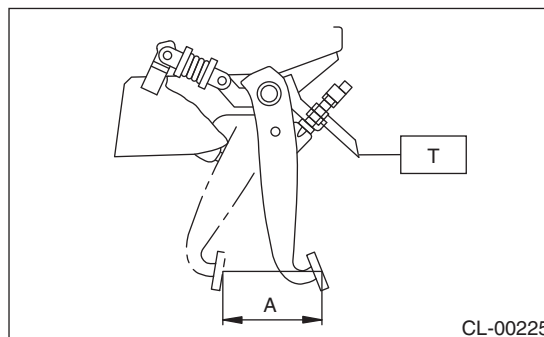

2) If the full stroke is not within the specified range, adjust it by loosening the clutch switch lock nut.

Tightening torque:

8 N·m (0.8 kgf-m, 5.9 ft-lb)

3) Loosen the push rod lock nuts.

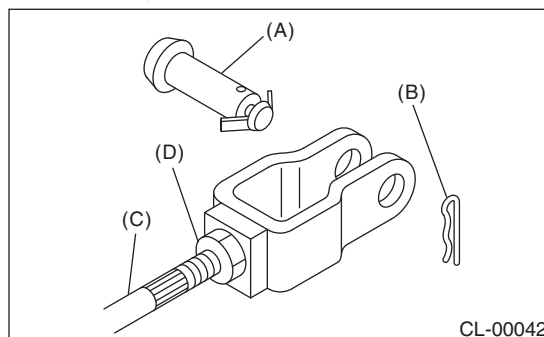

(A) Clevis pin
(B) Snap pin
(C) Push rod
(D) Push rod lock nut

Clutch Pedal

CLUTCH SYSTEM

4) Rotate the push rod to adjust.

(1) Make sure that the clutch pedal contacts the clutch switch side when the pedal is released.

(2) Make sure that the clutch pedal contacts the clutch pedal bracket stopper when the clutch pedal is at the maximum stroke position.

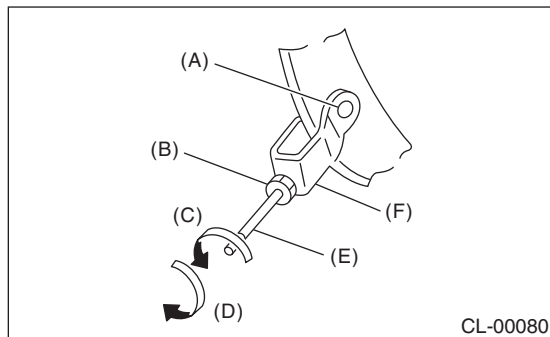

- (A) Clevis hole
- (B) Push rod lock nut
- (C) In the shorter direction
- (D) In the longer direction
- (E) Push rod
- (F) Clevis

5) Turn the push rod to shorten until a clearance is gained on the clutch switch side.

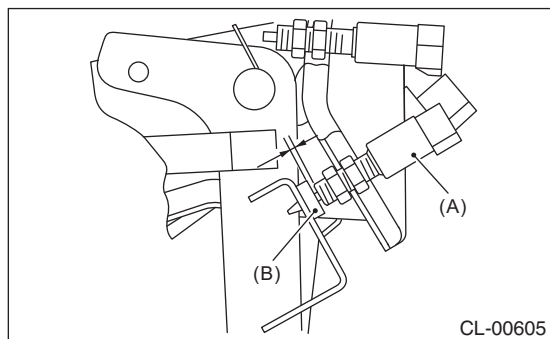

- (A) Clutch switch
- (B) Stopper

6) Turn the push rod to lengthen until the clutch pedal contacts the clutch switch.

7) Turn further in the direction that will shorten the push rod (arrow direction shown in figure) by 270°.

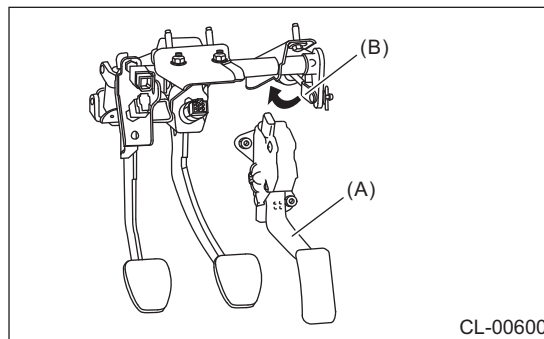

- (A) Accelerator pedal
- (B) Clevis

8) Check that the clevis pin moves smoothly by moving it in the left and right directions.

9) Tighten the push rod lock nut.

Tightening torque (Push rod lock nut):

T: 10 N·m (1.0 kgf-m, 7.4 ft-lb)

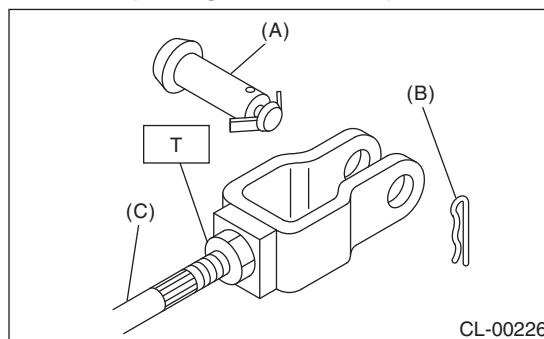

- (A) Clevis pin
- (B) Snap pin
- (C) Push rod

10) Depress and release the clutch pedal two or three times to ensure that the clutch pedal and release lever operate smoothly. If the clutch pedal and release lever do not operate smoothly, bleed air from the clutch hydraulic system. <Ref. to CL-21, Clutch Fluid Air Bleeding.>

11) Measure the clutch pedal full stroke length again to ensure that it is within specifications. If it is not within specifications, repeat adjustment procedures again from the beginning.

Clutch pedal full stroke:

130 — 135 mm (5.12 — 5.31 in)

12) Push the release lever until the operating cylinder push rod retracts. Make sure that the clutch fluid level in the reservoir tank increases. If the clutch fluid level increases, the hydraulic clutch is properly adjusted; If the fluid level does not increase or the push rod does not retract, replace the master cylinder with a new part. <Ref. to CL-17, Master Cylinder.>

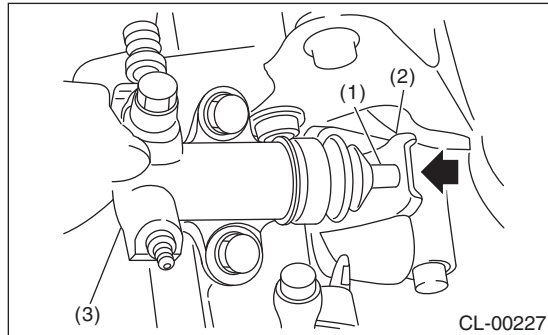

- (1) Push rod
- (2) Release lever
- (3) Operating cylinder

13) Push the release lever until the operating cylinder push rod retracts. Check that the clutch fluid level in the reservoir tank increases.

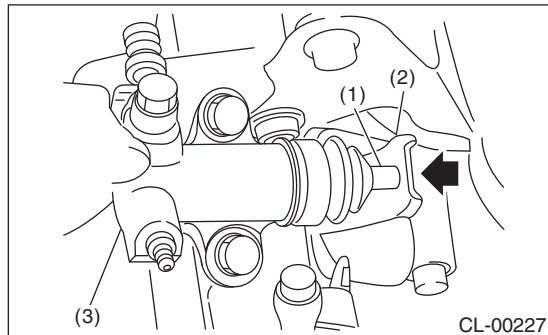

- (1) Push rod
- (2) Release lever
- (3) Operating cylinder

14) If the clutch fluid level increases, hydraulic clutch play is correct.

15) If the clutch fluid level does not increase or push rod does not retract, readjust the clutch pedal.

16) Check the fluid level using the scale on the outside of the reservoir tank. If the level is below "MIN", fill fluid up to "MAX" level.

Recommended clutch fluid:

New FMVSS No. 116 DOT3 brake fluid

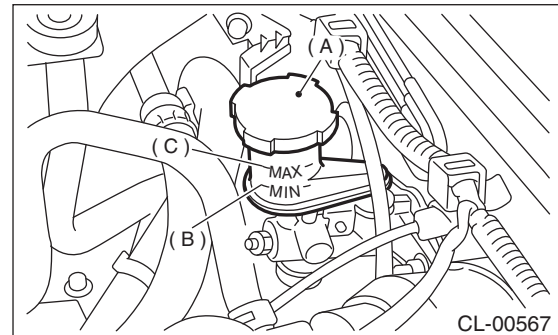

- (A) Reservoir tank
- (B) MIN. level
- (C) MAX. level

11. Clutch Switch

A: REMOVAL

- 1) Disconnect the ground cable from battery.
- 2) Remove the instrument panel lower cover.
- 3) Disconnect the connector of clutch switch.
- 4) Remove the clutch switches.

B: INSTALLATION

1. CLUTCH SWITCH (CRUISE CONTROL)

- 1) Move the clevis pin of push rod to left and right, retain it at the position where it moves smoothly, and measure the clutch pedal stroke.

Clutch pedal full stroke A:

130 — 135 mm (5.12 — 5.31 in)

Tightening torque:

T: 8 N·m (0.8 kgf·m, 5.9 ft·lb)

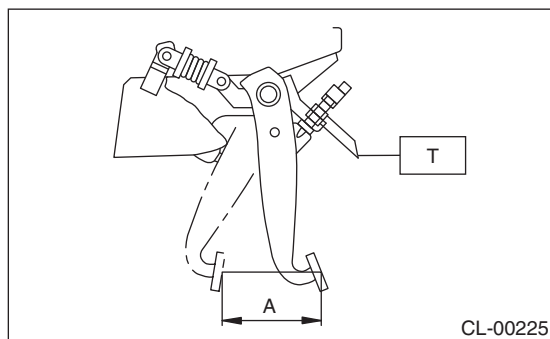

- 2) If the clutch pedal stroke is out of specification, adjust the stroke. <Ref. to CL-23, ADJUSTMENT, Clutch Pedal.>
- 3) Connect the clutch switch connector.

2. CLUTCH SWITCH (CLUTCH START)

- 1) Fully depress the clutch and hold it.
- 2) Install the clutch pedal plate and clutch switch so that the gap between them is 3.1 — 4.1 mm (0.12 — 0.16 in), and then tighten the lock nut.

Tightening torque:

8 N·m (0.8 kgf·m, 5.9 ft·lb)

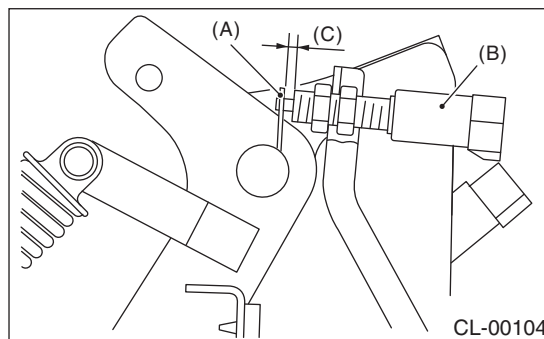

- (A) Plate
- (B) Clutch switch (Clutch start)
- (C) 3.1 — 4.1 mm (0.12 — 0.16 in)

- 3) Connect the clutch switch connector.
- 4) Make sure that engine does not start with clutch pedal not depressed.
- 5) Make sure that engine starts with clutch pedal fully depressed.

C: INSPECTION

- 1) If the clutch switch (cruise control) does not operate properly (or if it does not stop at the specified position), replace it with a new part.

Specified position L:

2+ 1.5 mm (0.079 + 0.059 in)

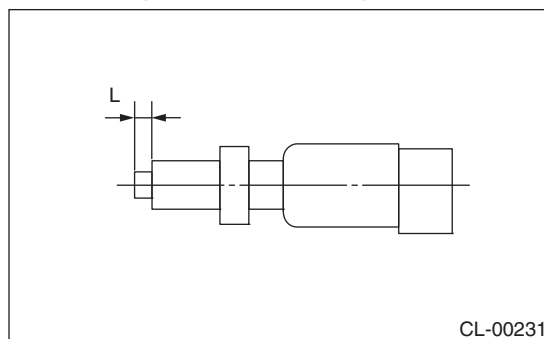

2) Check the clutch switch for continuity. If the resistance is not at the standard value, replace the switch.

- (1) Disconnect the clutch switch connector.
- (2) Measure the resistance between terminal 1 and 2 of the switch.

• Clutch switch (Cruise control)

Condition	Terminal No.	Specified resistance
When clutch pedal is depressed	No. 1 — No. 2	1 MΩ or more
When the clutch pedal is not depressed	No. 1 — No. 2	Less than 1 Ω

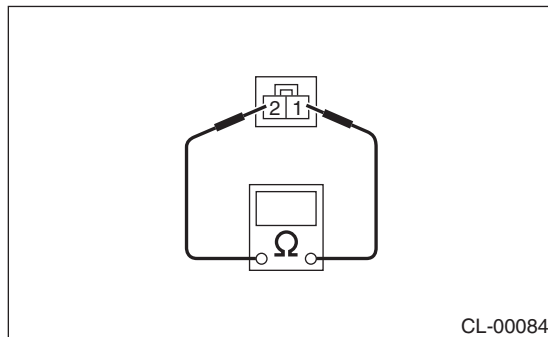

• Clutch switch (Clutch start)

Condition	Terminal No.	Specified resistance
When clutch pedal is depressed	No. 1 — No. 2	Less than 1 Ω
When the clutch pedal is not depressed	No. 1 — No. 2	1 MΩ or more

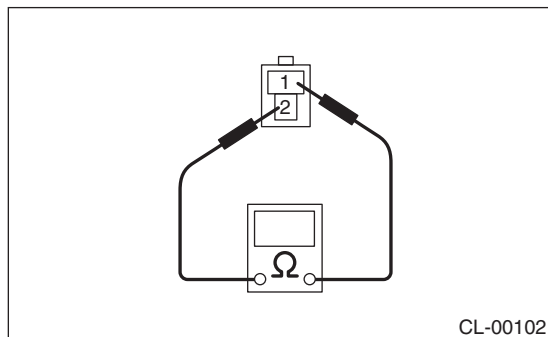

3) Make sure that engine does not start with clutch pedal not depressed. If the engine starts, adjust the clutch switch and inspect the clutch start circuit.

4) Make sure that engine starts with clutch pedal fully depressed. If the engine does not start, adjust the clutch switch and inspect the clutch start circuit.

D: ADJUSTMENT

1) Loosen the lock nut of clutch switch (clutch start).

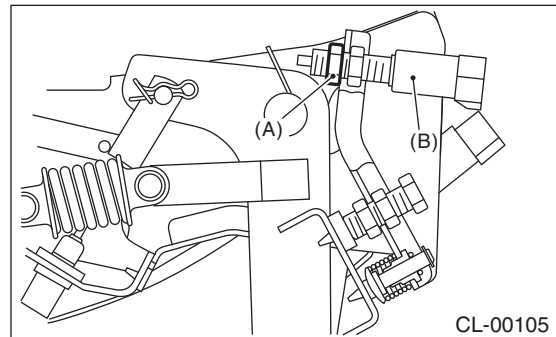

- (A) Lock nut
- (B) Clutch switch (Clutch start)

2) Fully depress the clutch and hold it.
3) Adjust the gap of the clutch pedal plate and the clutch switch to be 3.1 — 4.1 mm (0.12 — 0.16 in).

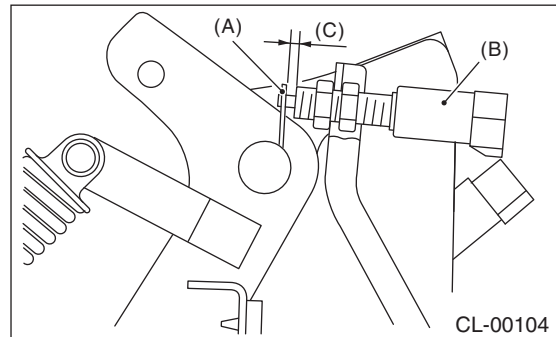

- (A) Plate
- (B) Clutch switch (Clutch start)
- (C) 3.1 — 4.1 mm (0.12 — 0.16 in)

4) Tighten the lock nut.

Tightening torque:
8 N·m (0.8 kgf·m, 5.9 ft·lb)

General Diagnostic Table

CLUTCH SYSTEM

12. General Diagnostic Table

A: INSPECTION

1. CLUTCH

Symptom	Possible cause	Corrective action
<p>1. Clutch slippage. It is hard to perceive clutch slippage in the early stage, but pay attention to the following symptoms.</p> <ul style="list-style-type: none"> • Engine speeds up when shifting. • High-speed driving is not possible; especially rapid acceleration is not possible and vehicle speed does not increase in proportion to the increase in engine speed. • Power drops particularly when ascending a slope, and there is a burning smell of the clutch plate. • Method of testing: Park the vehicle and fully apply the parking brake. Disengage the clutch and shift the transmission gear into the 1st. Gradually increase the engine speed while gradually allowing the clutch to engage. The clutch function is satisfactory if the engine stalls. However, the clutch is slipping if the vehicle does not move forward and the engine does not stall. 	(a) Oil on the clutch face	Replace.
	(b) Worn clutch face	Replace.
	(c) Deteriorated diaphragm spring	Replace.
	(d) Warped pressure plate or flywheel	Correct or replace.
	(e) Defective release bearing holder	Correct or replace.
<p>2. Clutch drags. As a symptom of this trouble, a harsh scratching noise occurs and control becomes difficult when shifting gears. The symptom becomes more apparent when shifting into the 1st gear. However, because most trouble of this sort is due to a defective synchronization mechanism, perform the following tests.</p> <ul style="list-style-type: none"> • Method of testing: <Ref. to CL-29, DIAGNOSTIC DIAGRAM OF CLUTCH DRAG, INSPECTION, General Diagnostic Table.> <p>The problem is caused by insufficient disengagement of the clutch if an abnormal noise occurs during this test.</p>	(a) Worn or rusty clutch disc hub spline	Replace the clutch disc.
	(b) Excessive deflection of clutch disc face	Correct or replace.
	(c) Stuck crankshaft pilot needle bearing	Replace.
	(d) Cracked clutch disc face	Replace.
	(e) Stuck clutch disc (smeared by oil or water)	Replace.
<p>3. Clutch chatters. Clutch chattering is an unpleasant vibration to the whole vehicle when the vehicle is just started with clutch partially engaged.</p>	(a) Adhesion of oil on the clutch face	Replace the clutch disc.
	(b) Weak or broken damper spring	Replace the clutch disc.
	(c) Poor contact of the disc surface or excessively worn disc	Replace the faulty clutch disc.
	(d) Warped pressure plate or flywheel	Correct or replace.
	(e) Loose disc rivets	Replace the clutch disc.
	(f) Loose engine mounting	Retighten or replace mounting.
	(g) Improper adjustment of the pitching stopper	Adjust.
<p>4. Noisy clutch Noise occurs when the clutch is disengaged, engaged, or partially engaged.</p>	(a) Broken, worn or insufficiently lubricated release bearing	Replace the release bearing.
	(b) Insufficient lubrication of the pilot bearing	Replace the pilot bearing.
	(c) Loose clutch disc hub	Replace the clutch disc.
	(d) Loose damper spring retainer	Replace the clutch disc.
	(e) Deteriorated or broken damper spring	Replace the clutch disc.

General Diagnostic Table

CLUTCH SYSTEM

Symptom	Possible cause	Corrective action
5. Clutch grabs suddenly. When starting the vehicle with the clutch partially engaged, the clutch engages suddenly and the vehicle jumps instead of making a smooth start.	(a) Grease or oil on facing	Replace the clutch disc.
	(b) Deteriorated cushioning spring	Replace the clutch disc.
	(c) Worn or rusted spline of clutch disc or main shaft	Take off rust, apply grease or replace clutch disc or main shaft.
	(d) Deteriorated or broken damper spring	Replace the clutch disc.
	(e) Loose engine mounting	Retighten or replace mounting.
	(f) Deteriorated diaphragm spring	Replace.

2. CLUTCH PEDAL

Symptom	Corrective action
Insufficient pedal play	Adjust the free play of the pedal.
Insufficient clutch pedal free play	Adjust the free play of the pedal.
Excessively worn and damaged pedal shaft and/or bushing	Replace the bushing or shaft with a new part.

3. DIAGNOSTIC DIAGRAM OF CLUTCH DRAG

Step	Check	Yes	No
1 CHECK GEAR NOISE. 1) Start the engine. 2) Disengage the clutch and shift quickly from neutral to reverse in idling condition.	Is there any abnormal noise from the transmission gear?	Go to step 2.	Clutch is normal.
2 CHECK GEAR NOISE. Disengage the clutch at idle and shift from neutral to reverse within 0.5 — 1.0 seconds.	Is there any abnormal noise from the transmission gear?	Go to step 3.	Defective transmission or excessive clutch drag torque. Inspect pilot bearing, clutch disc, transmission and clutch disc hub spline.
3 CHECK GEAR NOISE. 1) Disengage the clutch at idle and shift from neutral to reverse within 0.5 — 1.0 seconds. 2) With the clutch disengaged, shift from neutral to reverse, reverse to neutral several times.	Is there any abnormal noise from the transmission gear?	Inadequate clutch disengage. Inspect the clutch disc, clutch cover, clutch release, and clutch pedal free play.	Clutch and fly-wheel seizure. Inspect the clutch disc and the spline of the clutch disc hub.

General Diagnostic Table

CLUTCH SYSTEM

CHASSIS SECTION

This service manual has been prepared to provide SUBARU service personnel with the necessary information and data for the correct maintenance and repair of SUBARU vehicles.

This manual includes the procedures for maintenance, disassembling, reassembling, inspection and adjustment of components and diagnostics for guidance of experienced mechanics.

Please peruse and utilize this manual fully to ensure complete repair work for satisfying our customers by keeping their vehicle in optimum condition. When replacement of parts during repair work is needed, be sure to use SUBARU genuine parts.

All information, illustration and specifications contained in this manual are based on the latest product information available at the time of publication approval.

FRONT SUSPENSION	FS
REAR SUSPENSION	RS
WHEEL AND TIRE SYSTEM	WT
TIRE PRESSURE MONITORING SYSTEM (DIAGNOSTICS)	TPM(diag)
DIFFERENTIALS	DI
TRANSFER CASE	TC
DRIVE SHAFT SYSTEM	DS
VEHICLE DYNAMICS CONTROL (VDC)	VDC
VEHICLE DYNAMICS CONTROL (VDC) (DIAGNOSTICS)	VDC(diag)
BRAKE	BR
PARKING BRAKE	PB
POWER ASSISTED SYSTEM (POWER STEERING)	PS

FRONT SUSPENSION



	Page
1. General Description	2
2. Wheel Alignment	7
3. Front Crossmember Support Plate	15
4. Front Stabilizer	16
5. Front Ball Joint	17
6. Front Arm	19
7. Front Strut	22
8. Front Crossmember	26
9. General Diagnostic Table	28

General Description

FRONT SUSPENSION

1. General Description

A: SPECIFICATION

Model		All models	
Front	Wheel arch height (Tolerance: $+12\text{ mm}$ -24 mm ($+0.47\text{ in}$ -0.94 in))	mm (in) 445 (17.5)	
	Camber (Tolerance: $\pm 0^\circ 45'$ Differences between RH and LH: 45' or less)		
	Caster (Referential Value)		
	Steering angle (Tolerance: $\pm 1.5^\circ$)	Inner wheel	38.3°
		Outer wheel	33.8°
	Toe-in	mm (in)	0±3 (0±0.12) Toe angle (sum of both wheels): 0°±0°15'
Kingpin angle (Referential Value)		13°20'	
Rear	Wheel arch height (Tolerance: $+12\text{ mm}$ -24 mm ($+0.47\text{ in}$ -0.94 in))	mm (in) 448 (17.6)	
	Camber (Tolerance: $\pm 0^\circ 45'$ Differences between RH and LH: 45' or less)		
	Toe-in	mm (in)	0±3 (0±0.12) Toe angle (sum of both wheels): 0°±0°15'
	Thrust angle (Tolerance: $\pm 0^\circ 30'$)		0°

NOTE:

- Front and rear toe-in and front camber can be adjusted. Adjust if the toe-in or camber tolerance exceeds specifications.
- Other items indicated in the specifications is not equipped with adjustment mechanisms. If other items exceed specifications, check the suspension parts and connections for deformation, and replace with new parts as required.

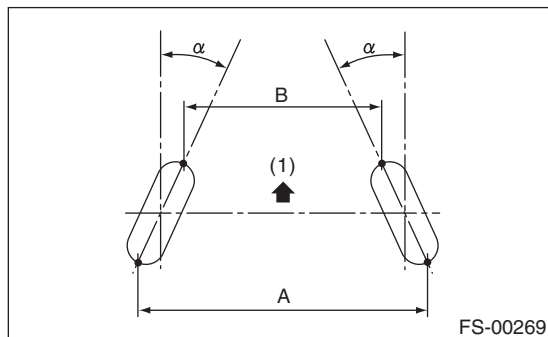

(1) Front

A – B = Positive: Toe-in, Negative: Toe-out

α = Individual toe angles

B: COMPONENT

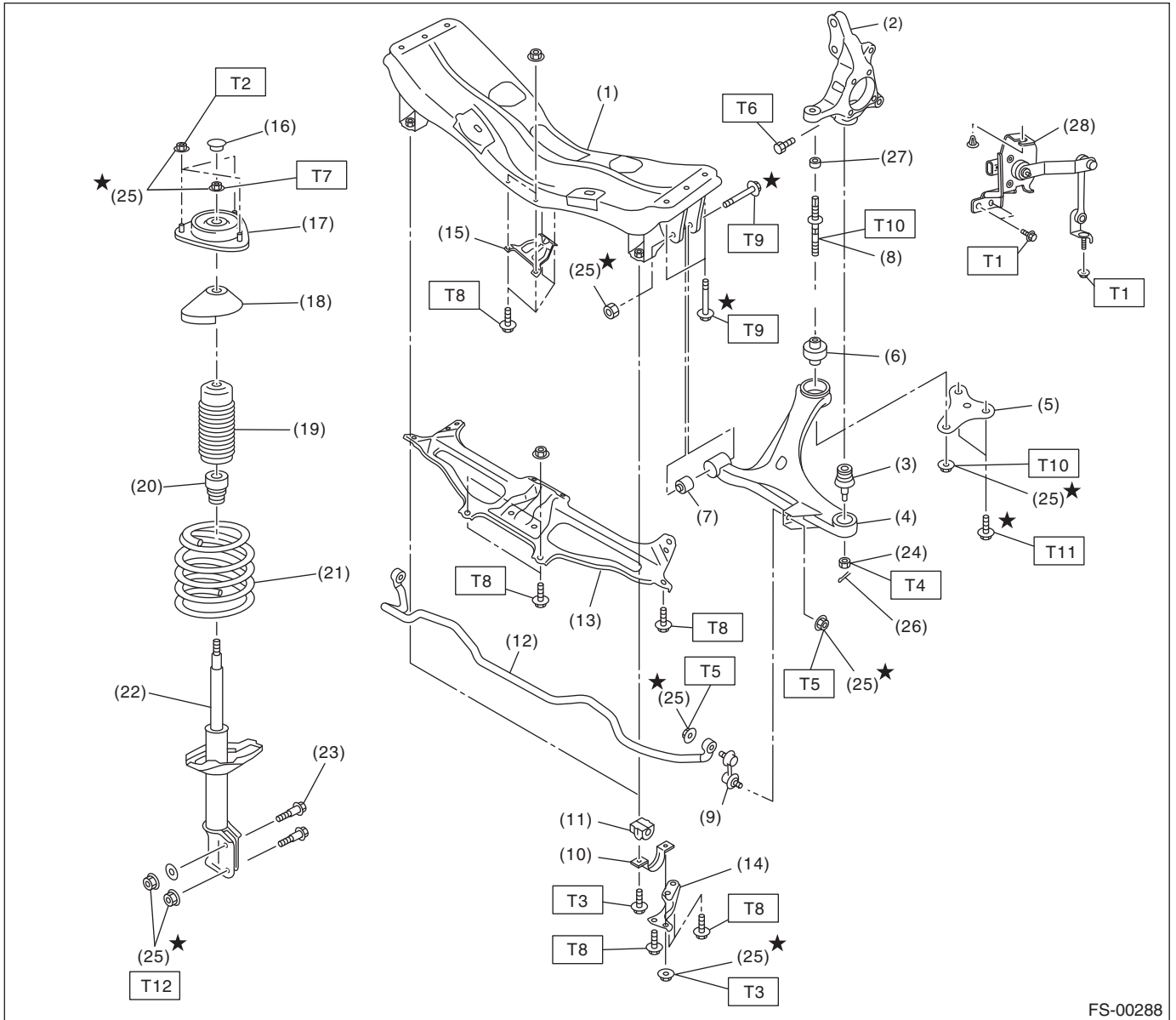

FS-00288

General Description

FRONT SUSPENSION

(1) Front crossmember	(15) Jack-up plate	Tightening torque: N·m (kgf-m, ft-lb) T1: 7.5 (0.76, 5.5) T2: 20 (2.0, 14.5) T3: 25 (2.5, 18.4) T4: 39 (4.0, 28.8) T5: 45 (4.6, 33.2) T6: 50 (5.1, 36.9) T7: 55 (5.6, 40.6) T8: 60 (6.1, 44.3) T9: 95 (9.7, 70.1) T10: 110 (11.2, 81.1) T11: 150 (15.3, 110.6) T12: 155 (15.8, 114.3)
(2) Housing	(16) Dust seal	
(3) Ball joint	(17) Strut mount	
(4) Front arm	(18) Upper spring seat	
(5) Support plate	(19) Dust cover	
(6) Rear bushing	(20) Helper	
(7) Front bushing	(21) Coil spring	
(8) Stud bolt	(22) Strut	
(9) Stabilizer link	(23) Adjusting bolt	
(10) Bracket	(24) Castle nut	
(11) Bushing	(25) Self-locking nut	
(12) Stabilizer	(26) Cotter pin	
(13) Crossmember support plate (Large type)	(27) Stopper	
(14) Crossmember support plate (Small type)	(28) Front vehicle height sensor (models with auto headlight beam leveler only)	

C: CAUTION

- Wear appropriate work clothing, including a cap, protective goggles and protective shoes when performing any work.
- Before removal, installation or disassembly, be sure to clarify the failure. Avoid unnecessary removal, installation, disassembly and replacement.
- Use SUBARU genuine grease etc. or equivalent. Do not mix grease etc. of different grades or manufacturers.
- Before securing a part on a vise, place cushioning material such as wood blocks, aluminum plate, or cloth between the part and the vise.
- Be sure to tighten fasteners including bolts and nuts to the specified torque.
- Place shop jacks or rigid racks at the specified points.

D: PREPARATION TOOL

1. SPECIAL TOOL

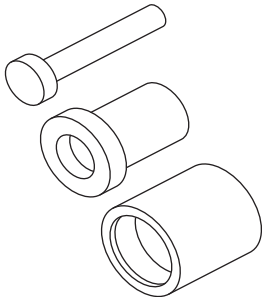
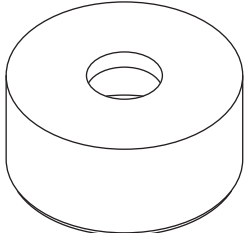
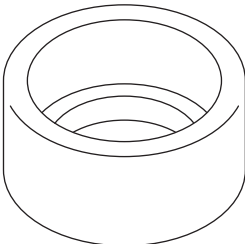
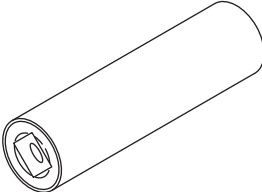
ILLUSTRATION	TOOL NUMBER	DESCRIPTION	REMARKS
 <p style="text-align: center;">ST-927680000</p>	927680000	INSTALLER & REMOVER SET	Used for replacing front arm front bushing.
 <p style="text-align: center;">ST20299AG000</p>	20299AG000	REMOVER	<ul style="list-style-type: none"> • Used for replacing front arm rear bushing. • Used together with BASE (20999AG010).
 <p style="text-align: center;">ST20299AG010</p>	20299AG010	BASE	<ul style="list-style-type: none"> • Used for replacing front arm rear bushing. • Used together with REMOVER (20999AG000).
 <p style="text-align: center;">ST20299AG020</p>	20299AG020	STUD BOLT SOCKET	Used for removing and installing the stud bolt for front arm installing portion.

General Description

FRONT SUSPENSION

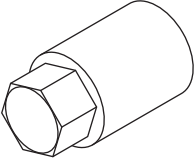
ILLUSTRATION	TOOL NUMBER	DESCRIPTION	REMARKS
 <p style="text-align: center;">ST20399AG000</p>	20399AG000	STRUT MOUNT SOCKET	Used for disassembling and assembling strut mount.

2. GENERAL TOOL

TOOL NAME	REMARKS
Alignment gauge	Used for measuring wheel alignment.
Alignment gauge adapter	Used for measuring wheel alignment.
Turning radius gauge	Used for measuring wheel alignment.
Toe-in gauge	Used for toe-in measurement.
Dial gauge	Used for damper strut measurement.
Coil spring compressor	Used for strut assembly/disassembly.
Side slip tester	Used for measuring side slip

2. Wheel Alignment

A: INSPECTION

Check the following items before performing the wheel alignment measurement.

- Tire inflation pressure
- Uneven wear of RH and LH tires, or difference of sizes
- Tire runout
- Excessive play and wear of ball joint
- Excessive play and wear of tie-rod end
- Excessive play of wheel bearing
- Right and left wheel base imbalance
- Deformation and excessive play of steering link
- Deformation and excessive play of suspension parts

Check, adjust and measure the wheel alignment in accordance with the procedures indicated in the figure.

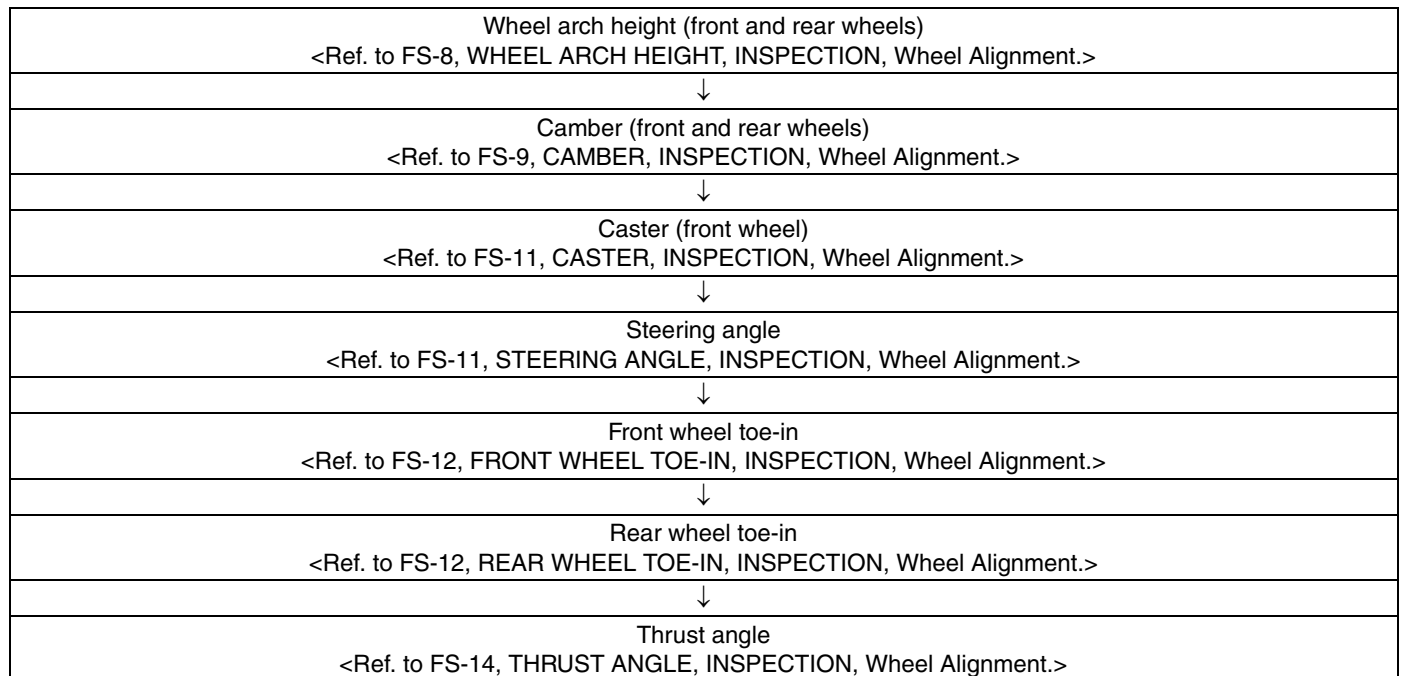

Wheel Alignment

FRONT SUSPENSION

1. WHEEL ARCH HEIGHT

- 1) Park the vehicle on a level surface.
- 2) Empty the vehicle so that it is at "curb weight". (Empty the luggage compartment, load the spare tire, jack and service tools, and fill up the fuel tank.)
- 3) Set the steering wheel in a straight-ahead position, and stabilize the suspensions by moving the vehicle in a straight line for 5 m (16 ft) or more.
- 4) Suspend a thread from the wheel arch (point "A" in the figure below) and affix at a position directly above the center of wheel.
- 5) Measure the distance between the point "A" and the center of wheel.

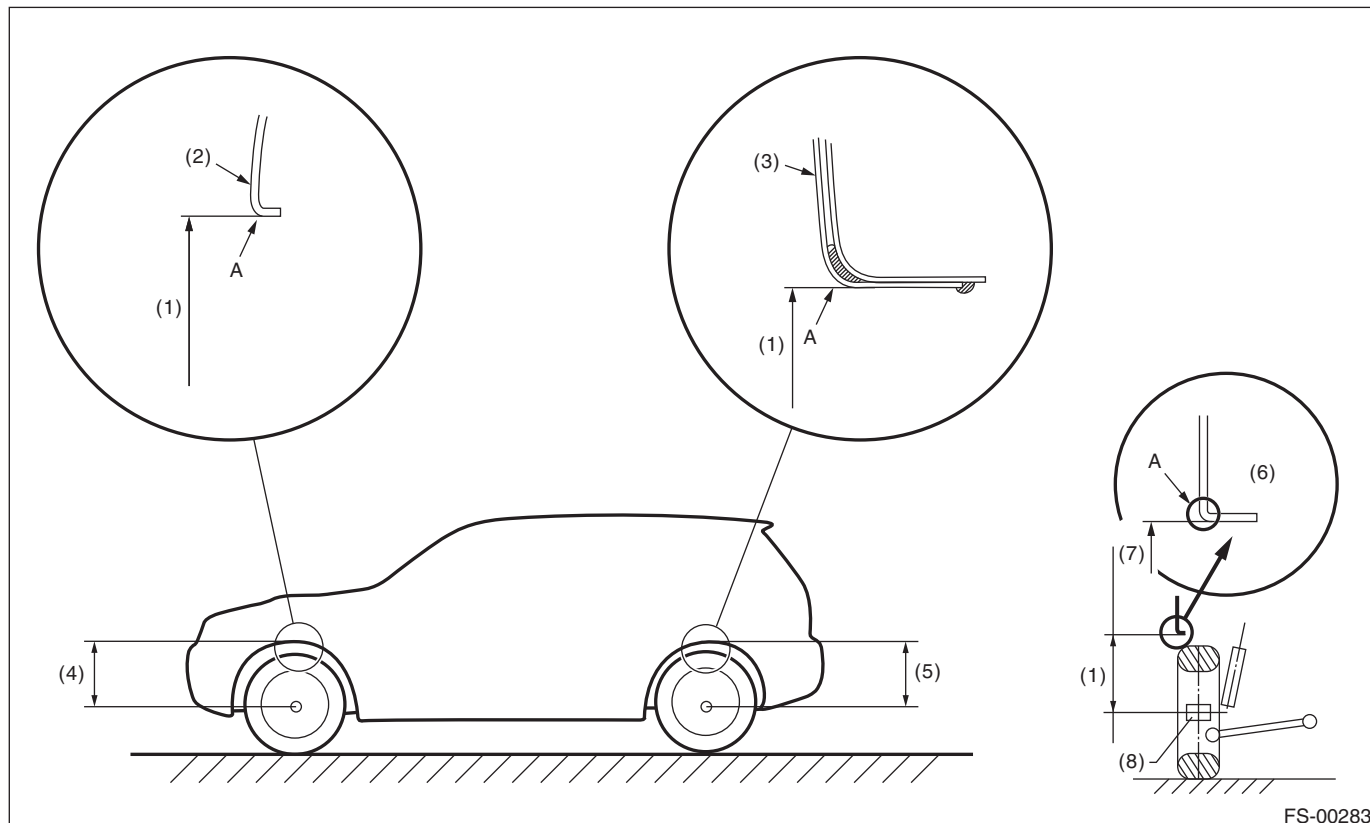

FS-00283

- | | | |
|-----------------------|-----------------------------|--------------------------|
| (1) Wheel arch height | (4) Front wheel arch height | (7) Point of measurement |
| (2) Front fender | (5) Rear wheel arch height | (8) End of spindle |
| (3) Rear quarter | (6) Flange bend line | |

Wheel arch height specification mm (in) (Tolerance: +12 mm -24 mm (+0.47 in -0.94 in))	
Model	All models
Front	445 (17.5)
Rear	448 (17.6)

2. CAMBER

• INSPECTION

- 1) Place the front wheel on the turning radius gauge. Make sure the ground contact surfaces of the front and rear wheels are at the same height.
- 2) Set the adapter into the center of wheel, and then set the wheel alignment gauge.

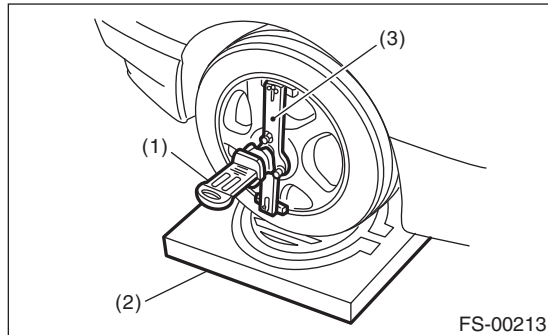

- (1) Alignment gauge
- (2) Turning radius gauge
- (3) Adapter

- 3) Measure the camber angle in accordance with the operation manual for wheel alignment gauge.

Model	Camber (Difference between RH and LH 45' or less)
All models	0°00'±0°45'

• FRONT CAMBER ADJUSTMENT

- 1) When adjusting the camber, adjust it to the following value.

Model	Camber (Difference between RH and LH 45' or less)
All models	0°00'±0°30'

- 2) Loosen the two self-locking nuts located at the front lower section of the strut.

NOTE:

When the adjusting bolt needs to be loosened or tightened, hold its head with a wrench and turn the self-locking nut.

- 3) Turn the camber adjusting bolt so that the camber is set at specification.

NOTE:

Moving the adjusting bolt by one scale changes the camber by approximately 0°15'.

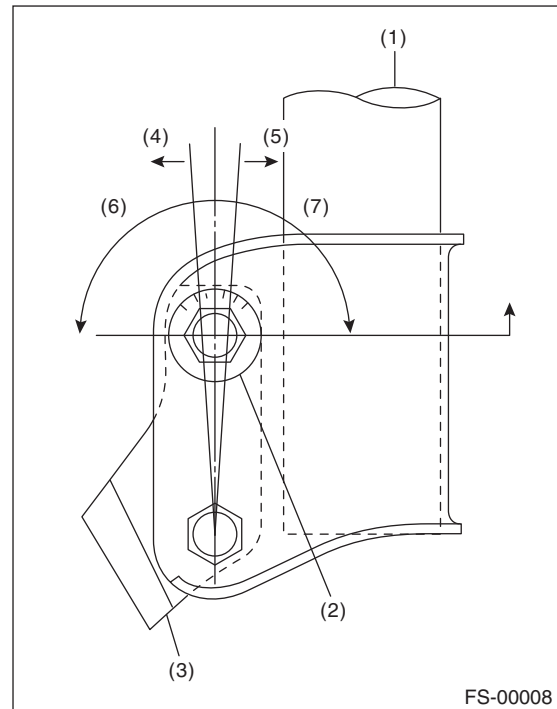

- (1) Strut
- (2) Adjusting bolt
- (3) Housing
- (4) Outer
- (5) Inner
- (6) Camber is increased.
- (7) Camber is decreased.

Wheel Alignment

FRONT SUSPENSION

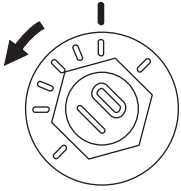
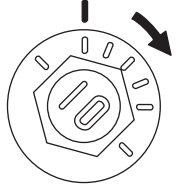
To increase camber.	
Rotate the left side counterclockwise.	Rotate the right side clockwise.
 <p>FS-00009</p>	 <p>FS-00010</p>

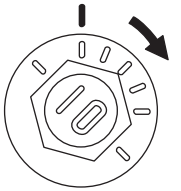
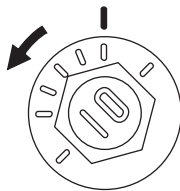
To decrease camber.	
Rotate the left side clockwise.	Rotate the right side counterclockwise.
 <p>FS-00010</p>	 <p>FS-00009</p>

4) Tighten two new self-locking nuts.

Tightening torque:

155 N·m (15.8 kgf·m, 114.3 ft·lb)

3. CASTER

• INSPECTION

- 1) Place the front wheel on the turning radius gauge. Make sure the ground contact surfaces of the front and rear wheels are at the same height.
- 2) Set the adapter into the center of wheel, and then set the wheel alignment gauge.

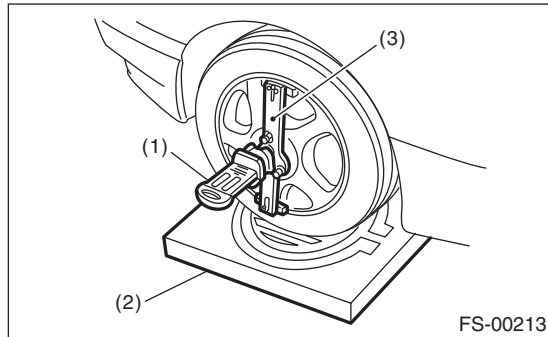

- (1) Alignment gauge
- (2) Turning radius gauge
- (3) Adapter

- 3) Measure the caster angle in accordance with the operation manual for wheel alignment gauge.

Model	Caster
All models	5°25'

4. STEERING ANGLE

• INSPECTION

- 1) Place the vehicle on turning radius gauge.
- 2) While depressing the brake pedal, turn the steering wheel fully to the left and right. With the steering wheel held at each fully turned position, measure both the inner and outer wheel steering angles.

Model	Inner wheel	Outer wheel
All models	38.3°±1.5°	33.8°±1.5°

• ADJUSTMENT

- 1) Turn the tie-rod to adjust the steering angle of both inner and outer wheels.
- 2) Check the toe-in.

NOTE:

Correct the boot if it is twisted.

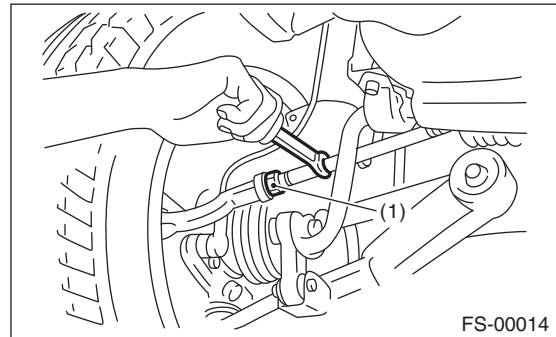

- (1) Lock nut

Wheel Alignment

FRONT SUSPENSION

5. FRONT WHEEL TOE-IN

• INSPECTION

Toe-in:

0 ± 3 mm (0 ± 0.12 in)

- 1) Set the toe-in gauge in the position at wheel axis center height behind the right and left front tires.
- 2) Place a mark at the center of both left and right tires, and measure distance "A" between the marks.
- 3) Move the vehicle forward to rotate the tires 180° .

NOTE:

Be sure to rotate the tires in the forward direction.
4) Measure the distance "B" between the left and right marks. Find toe-in using the following calculation:

$$A - B = \text{Toe-in}$$

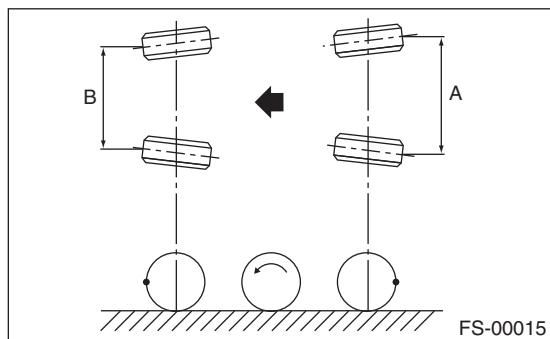

• ADJUSTMENT

When adjusting the toe-in, adjust it to the following value.

Toe-in:

0 ± 2 mm (0 ± 0.08 in)

- 1) Check that the left and right wheel steering angles are within specification.
- 2) Loosen the left and right side steering tie-rod lock nuts.
- 3) Turn the left and right tie-rods by equal amounts until the toe-in is at the specification.

Both the left and right tie-rods are right-hand threaded. To increase toe-in, turn both tie-rods clockwise by equal amount (viewing from the inside of vehicle).

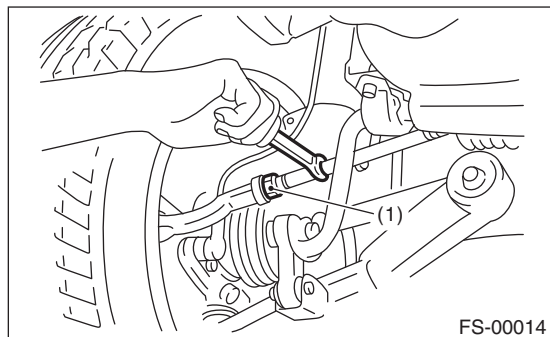

(1) Lock nut

- 4) Tighten the tie-rod lock nut.

Tightening torque:

85 N·m (8.7 kgf·m, 63 ft·lb)

NOTE:

Check and correct the tie-rod boot if twisted.

6. REAR WHEEL TOE-IN

• INSPECTION

Toe-in:

0 ± 3 mm (0 ± 0.12 in)

Refer to FRONT WHEEL TOE-IN for rear toe-in inspection procedures.

<Ref. to FS-12, FRONT WHEEL TOE-IN, INSPECTION, Wheel Alignment.>

• ADJUSTMENT

When adjusting, adjust it to the following value.

Toe-in:

0 ± 2 mm (0 ± 0.08 in)

- 1) Loosen the self-locking nut on the inner side of front lateral link.

NOTE:

When loosening or tightening the adjusting bolt, hold the bolt head and turn the self-locking nut.

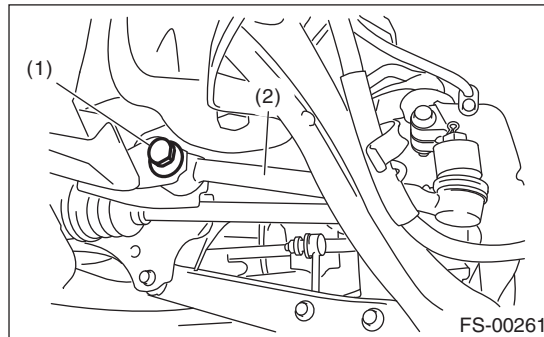

(1) Adjusting bolt

(2) Lateral link

- 2) Turn the adjusting bolt until toe-in is within the specification.

NOTE:

When the left and right wheels are adjusted for toe-in at the same time, the movement of one scale graduation changes toe-in by approx. 1.3 mm (0.05 in).

Wheel Alignment

FRONT SUSPENSION

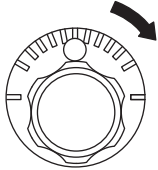
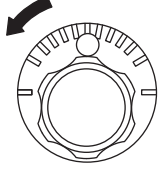
To increase toe-in.	
Rotate the left side clockwise.	Rotate the right side counterclockwise.
	
FS-00018	FS-00019

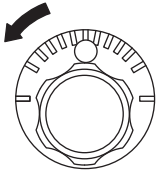
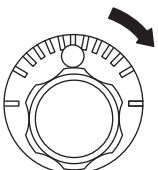
To decrease toe-in.	
Rotate the left side counterclockwise.	Rotate the right side clockwise.
	
FS-00019	FS-00018

3) Attach and tighten a new self-locking nut.

Tightening torque:

100 N·m (10.2 kgf·m, 73.8 ft·lb)

Wheel Alignment

FRONT SUSPENSION

7. THRUST ANGLE

• INSPECTION

- 1) Park the vehicle on a level surface.
- 2) Move the vehicle 3 to 4 meters (10 to 13 feet) straight forward.
- 3) Draw the center of loci for both the front and rear axles.
- 4) Measure distance "L" between the center lines of the axle loci.

Thrust angle:

$0^{\circ} \pm 30'$

Less than 30' when "L" is 23 mm (0.9 in) or less.

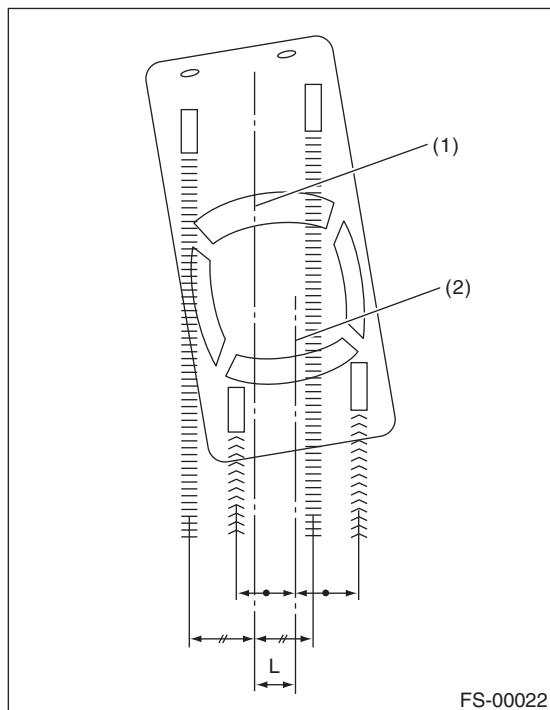

- (1) Center line of loci (front axle)
- (2) Center line of loci (rear axle)

• ADJUSTMENT

When adjusting, adjust it to the following value.

Thrust angle:

$0^{\circ} \pm 20'$

Less than 20' when "L" is 15 mm (0.6 in) or less.

- 1) Make thrust angle adjustments by turning the toe-in adjusting bolts of the rear suspension equally in the same direction.
- 2) When one rear wheel is adjusted in a toe-in direction, adjust the other rear wheel equally in toe-out direction, in order to make the thrust angle adjustment.

- 3) When the left and right adjusting bolts are turned by one graduation, the thrust angle will change approx. 15' ("L" is approx. 11 mm (0.43 in)).

NOTE:

Thrust angle is a mean value of left and right wheel toe angles in relation to the vehicle body center line. Vehicle is driven straight in the thrust angle direction while slanting in the oblique direction depending on the degree of the mean thrust angle.

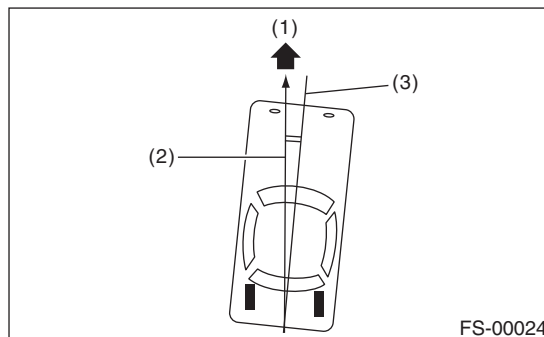

- (1) Front
- (2) Thrust angle
- (3) Body center line

Thrust angle: $r = (\alpha - \beta)/2$

α : Rear RH wheel toe-in angle

β : Rear LH wheel toe-in angle

Substitute only the positive toe-in values from each wheel into α and β in the calculation.

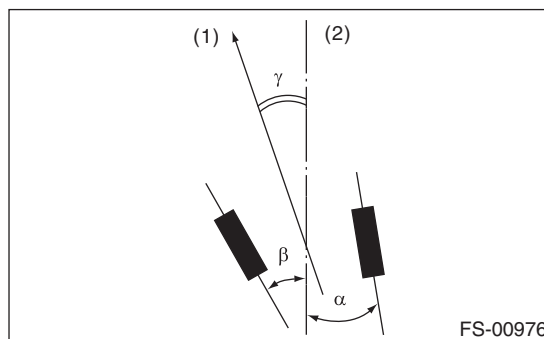

- (1) Front
- (2) Body center line

3. Front Crossmember Support Plate

A: REMOVAL

- 1) Lift up the vehicle
- 2) Remove the front under cover. <Ref. to EI-25, REMOVAL, Front Under Cover.>
- 3) Remove the bolt and remove front crossmember support plate.

- Large type

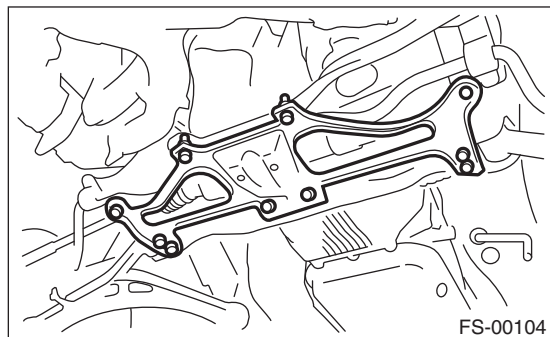

- Small type

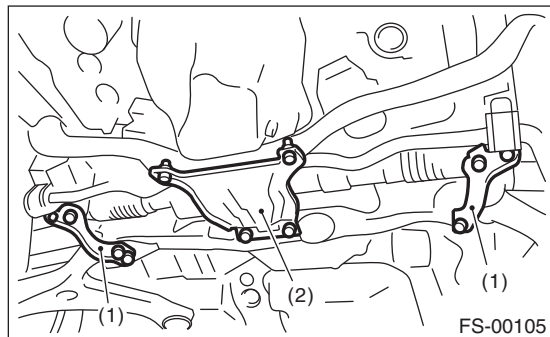

- (1) Crossmember support plate
- (2) Jack-up plate

B: INSTALLATION

Install in the reverse order of removal.

NOTE:

Tighten the small type crossmember support plate together with stabilizer bracket.

After installing the stabilizer bracket to the crossmember, tighten the crossmember support plate together.

Tightening torque:

Crossmember support plate:

60 N·m (6.1 kgf·m, 44.3 ft·lb)

Crossmember support plate (Tightened together with the stabilizer bracket):

25 N·m (2.5 kgf·m, 18.4 ft·lb)

Jack-up plate:

60 N·m (6.1 kgf·m, 44.3 ft·lb)

Front Stabilizer

FRONT SUSPENSION

4. Front Stabilizer

A: REMOVAL

- 1) Lift up the vehicle, and then remove the front wheels.
- 2) Remove the front under cover. <Ref. to EI-25, REMOVAL, Front Under Cover.>
- 3) Remove the front crossmember support plate. <Ref. to FS-15, REMOVAL, Front Crossmember Support Plate.>
- 4) Remove the stabilizer link.



- 5) Remove the stabilizer bracket.

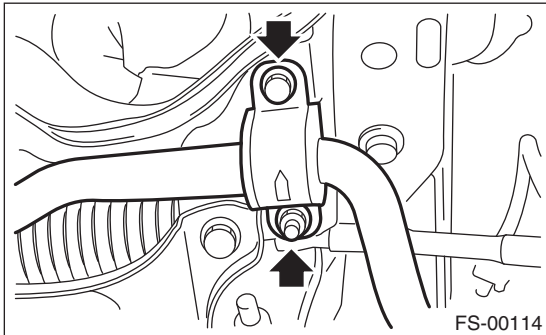

B: INSTALLATION

Install in the reverse order of removal.

CAUTION:

- Use a new self-locking nut.
- Ensure the stabilizer bushing and stabilizer have the same identification colors.
- Install the stabilizer bushing (front crossmember side) while aligning it with the paint mark on stabilizer.
- The stabilizer bracket has a set orientation. Install it with the arrow mark facing the upper side of the vehicle.

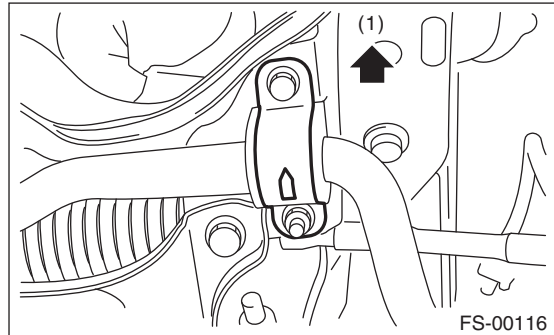

(1) Front side

Tightening torque:

Stabilizer link:

45 N·m (4.6 kgf·m, 33.2 ft·lb)

Stabilizer bracket:

25 N·m (2.5 kgf·m, 18.4 ft·lb)

C: INSPECTION

- 1) Check the bushing for abnormal cracks, fatigue or damages.
- 2) Check the stabilizer link for damage.

5. Front Ball Joint

A: REMOVAL

- 1) Disconnect the ground cable from the battery.
- 2) Lift up the vehicle, and remove the front wheels.
- 3) Disconnect the front vehicle height sensor connector (models with auto headlight beam leveler, left side only).

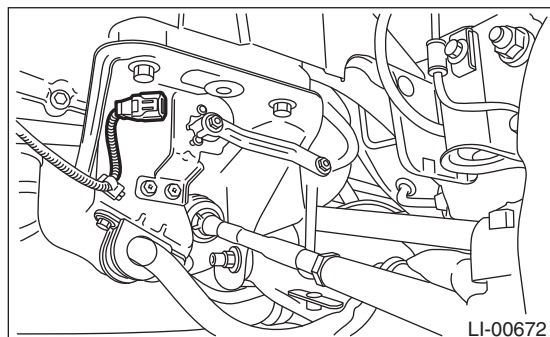

- 4) Remove the front vehicle height sensor (models with auto headlight beam leveler, left side only).

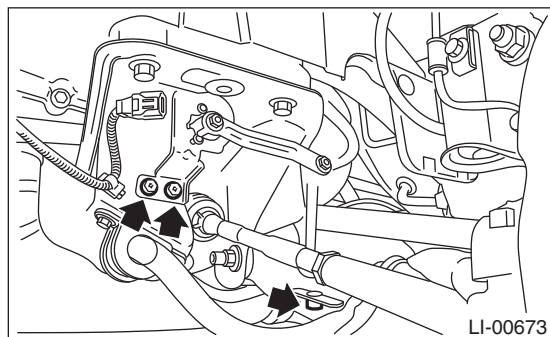

- 5) Remove the both sides of stabilizer bracket.

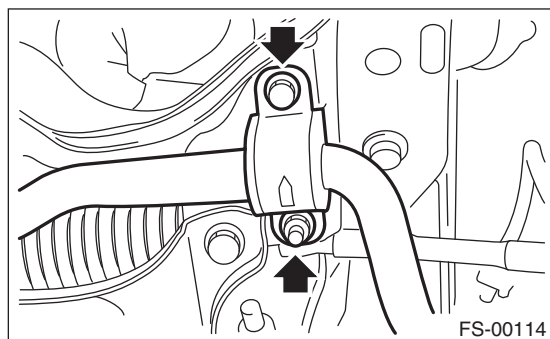

- 6) Pull out the pin from ball stud, remove the castle nut, and extract the ball stud from front arm.

- 7) Remove the bolt installing ball joint to housing.

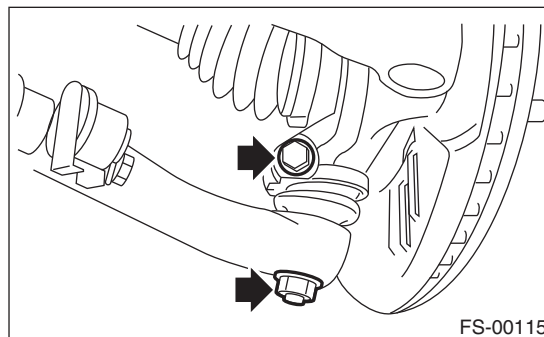

- 8) Extract the ball joint from housing.

Front Ball Joint

FRONT SUSPENSION

B: INSTALLATION

1) Insert the ball joint into housing.

Tightening torque (Bolt):

50 N·m (5.1 kgf·m, 36.9 ft·lb)

CAUTION:

Do not apply grease to the tapered portion of ball stud.

2) Install the ball joint into front arm.

Tightening torque (Castle nut):

39 N·m (4.0 kgf·m, 28.8 ft·lb)

3) Retighten the castle nut further up to 60° until the hole in the ball stud is aligned with a slot in castle nut. Then, insert a new cotter pin and bend it around the castle nut.

4) Install the stabilizer bracket.

NOTE:

The stabilizer bracket has a set orientation. Install it with the arrow mark facing the upper side of the vehicle.

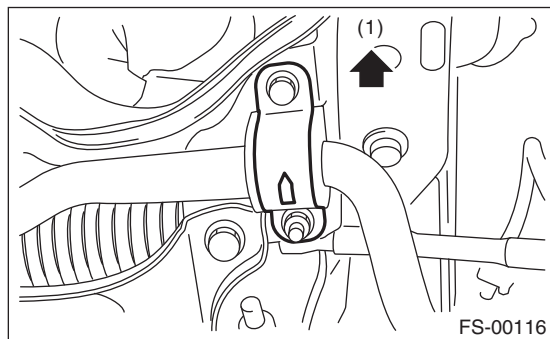

(1) Front side

Tightening torque:

25 N·m (2.5 kgf·m, 18.4 ft·lb)

5) Install the front vehicle height sensor (models with auto headlight beam leveler, left side only).

Tightening torque:

7.5 N·m (0.76 kgf·m, 5.5 ft·lb)

6) Install the front vehicle height sensor connector (models with auto headlight beam leveler, left side only).

7) Install the front wheels.

8) Connect the battery ground cable to the battery.

9) Re-initialize the auto headlight beam leveler system (models with auto headlight beam leveler).
<Ref. to LI-15, PROCEDURE, Auto Headlight Beam Leveler System.>

C: INSPECTION

1) Measure the play of the ball joint using the following procedures. Replace with a new part if the play exceeds specification.

(1) With 686 N (70 kgf, 154 lbf) loaded in direction shown in the figure, measure the length l_1 .

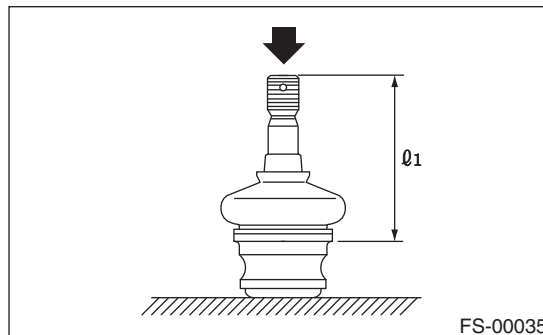

(2) With 686 N (70 kgf, 154 lbf) loaded in direction shown in the figure, measure the length l_2 .

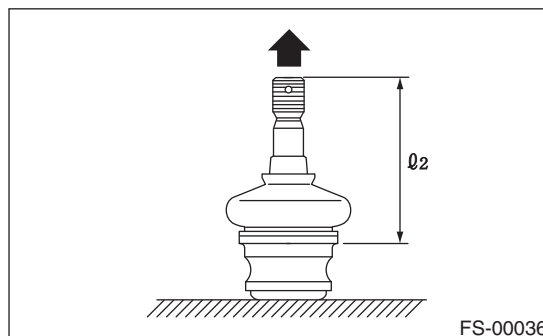

(3) Determine free play using the following formula.

$$S = l_2 - l_1$$

(4) Replace with a new part if the play exceeds specification.

Front ball joint

Specification for replacement S:

Less than 0.3 mm (0.012 in)

2) If the play is within specification, visually check the dust cover.

3) Remove the ball joint and cover, and check for wear, damage or cracks. If any damage is found, replace the corresponding part.

4) If the dust cover is damaged, replace with a new ball joint.

6. Front Arm

A: REMOVAL

- 1) Disconnect the ground cable from the battery.
- 2) Lift up the vehicle, and then remove the front wheels.
- 3) Disconnect the front vehicle height sensor connector (models with auto headlight beam leveler, left side only).

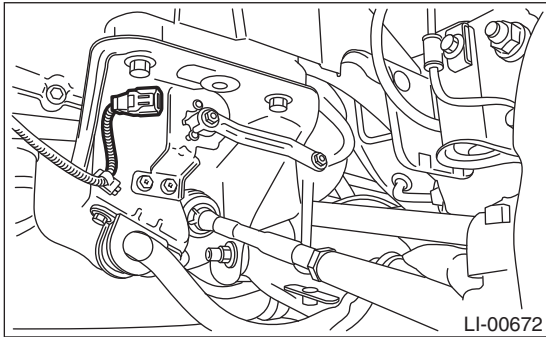

- 4) Remove the front vehicle height sensor (models with auto headlight beam leveler, left side only).

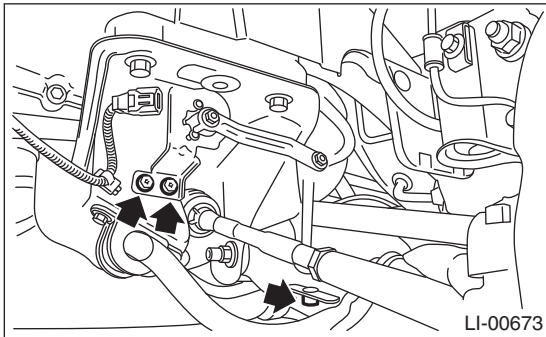

- 5) Remove the front crossmember support plate. <Ref. to FS-15, REMOVAL, Front Crossmember Support Plate.>
- 6) Remove the front stabilizer. <Ref. to FS-16, REMOVAL, Front Stabilizer.>
- 7) Remove the ball joint of front arm.

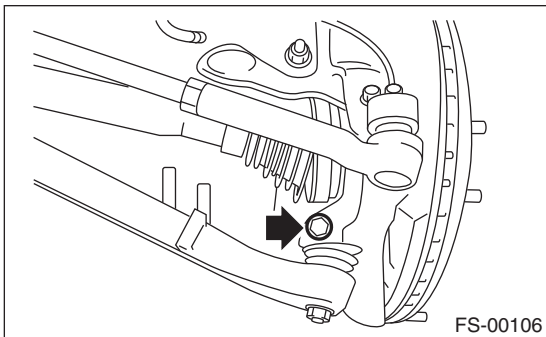

- 8) Remove the nut securing the front arm to crossmember. (Do not remove the bolt.)

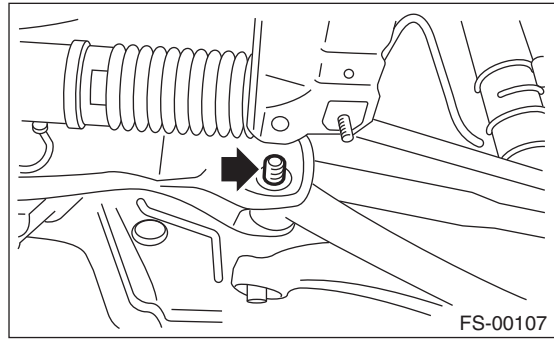

- 9) Remove the front arm support plate.

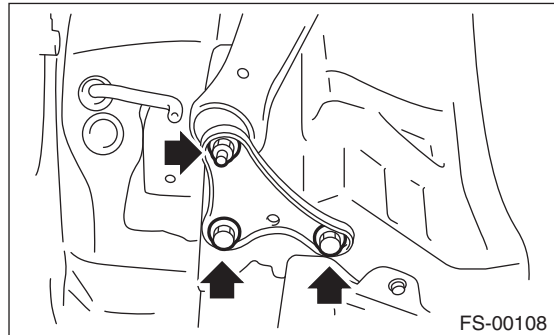

- 10) Remove the bolt securing front arm to crossmember and pull the front arm out of the crossmember.

- 11) To remove the stud bolt, use the ST.
ST 20299AG020 STUD BOLT SOCKET

CAUTION:

Do not remove the stud bolt without necessity. Always replace the parts with new parts when removed.

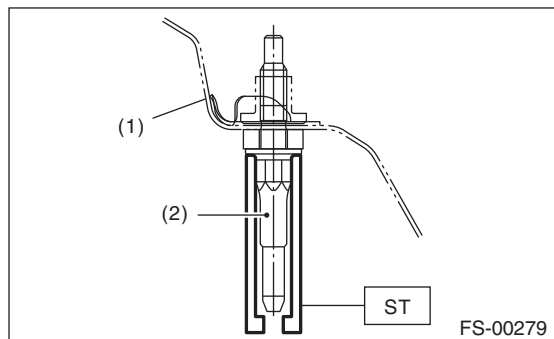

- (1) Vehicle body
- (2) Stud bolt

Front Arm

FRONT SUSPENSION

B: INSTALLATION

1) Using the ST, install the stud bolt.
ST 20299AG020 STUD BOLT SOCKET

Tightening torque:

110 N·m (11.2 kgf·m, 81.1 ft·lb)

- 2) Using new bolts and self-locking nuts, temporarily tighten the front arm to crossmember.
- 3) Secure the front arm to body, and then install the support plate with new bolts and self-locking nuts.

Tightening torque:

Support plate to Front arm:

110 N·m (11.2 kgf·m, 81.1 ft·lb)

Support plate to Body:

150 N·m (15.3 kgf·m, 110.6 ft·lb)

- 4) Install the ball joint into housing.

Tightening torque:

50 N·m (5.1 kgf·m, 36.9 ft·lb)

- 5) Install the stabilizer. <Ref. to FS-16, INSTALLATION, Front Stabilizer.>
- 6) Install the front vehicle height sensor (models with auto headlight beam leveler, left side only).

Tightening torque:

7.5 N·m (0.76 kgf·m, 5.5 ft·lb)

- 7) Install the front vehicle height sensor connector (models with auto headlight beam leveler, left side only).
- 8) Install the front wheels.
- 9) Lower the vehicle from lift, and tighten the bolt which secures the front arm to crossmember with wheels in full contact with the ground and the vehicle at curb weight.

Tightening torque:

95 N·m (9.7 kgf·m, 70.1 ft·lb)

- 10) Connect the battery ground cable to the battery.
- 11) Inspect the wheel alignment and adjust if necessary.
- 12) Re-initialize the auto headlight beam leveler system (models with auto headlight beam leveler). <Ref. to LI-15, PROCEDURE, Auto Headlight Beam Leveler System.>

C: DISASSEMBLY

1. FRONT BUSHING

Using the ST and a press, remove the front bushing.
ST 927680000 INSTALLER & REMOVER SET

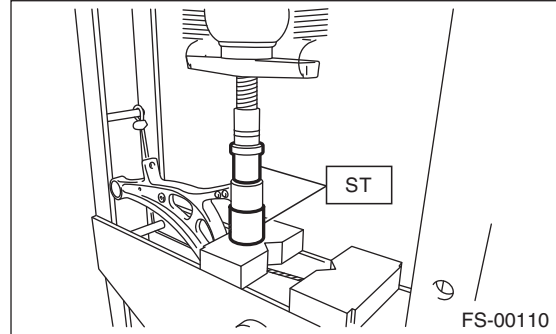

2. REAR BUSHING

1) Put an alignment mark on the front arm based on the center of rear bushing recess portion.

CAUTION:

Always put an alignment mark for aligning the position on bushing installation.

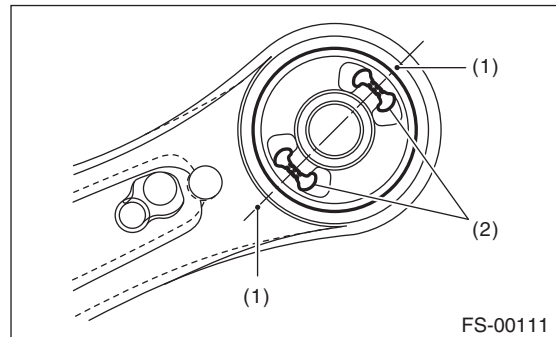

- (1) Put an alignment mark.
- (2) Recess section

2) Using the ST and a press, remove the rear bushing.

ST1 20299AG000 REMOVER
ST2 20299AG010 BASE

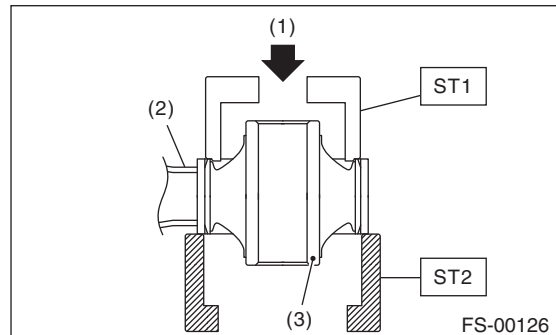

- (1) Press
- (2) Front arm
- (3) Rear bushing

D: ASSEMBLY

1. FRONT BUSHING

Assemble in the reverse order of disassembly.

CAUTION:

Install the front bushing in proper direction as shown in the figure.

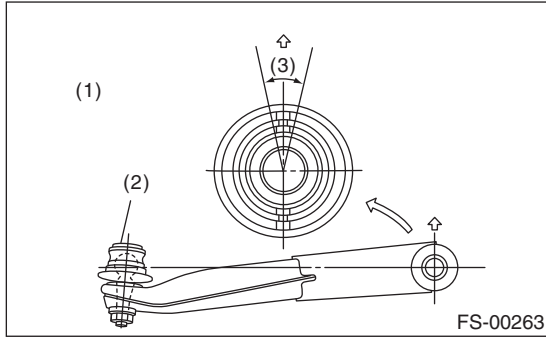

- (1) Face the bushing toward the center of ball joint.
- (2) Ball joint
- (3) $\pm 3^\circ$

2. REAR BUSHING

1) Install the rear bushing with its longer inner cylinder facing upward and the shorter facing downward and protruding part rearward as shown in the figure.

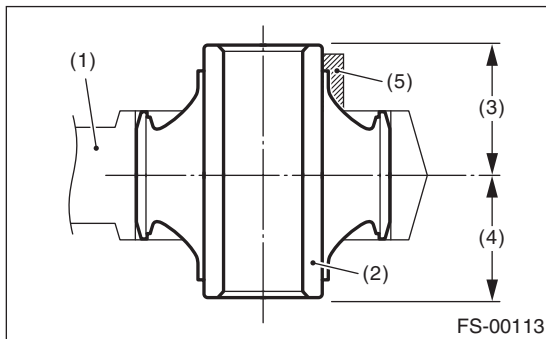

- (1) Front arm
- (2) Bushing inner cylinder
- (3) Longer
- (4) Shorter
- (5) Protrusion portion

2) Align the center of rear bushing recess portion with the aligning mark on the front arm.

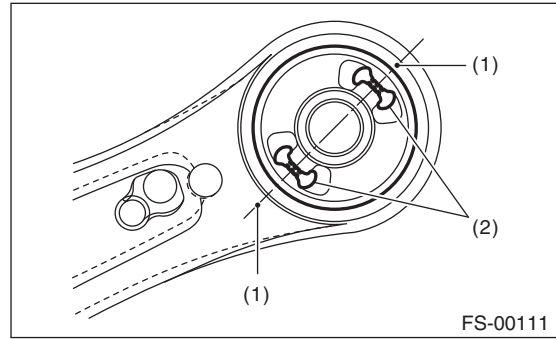

- (1) Alignment mark
- (2) Recess section

3) Using the ST and a press, install the rear bushing.

ST1 20299AG000 REMOVER
ST2 20299AG010 BASE

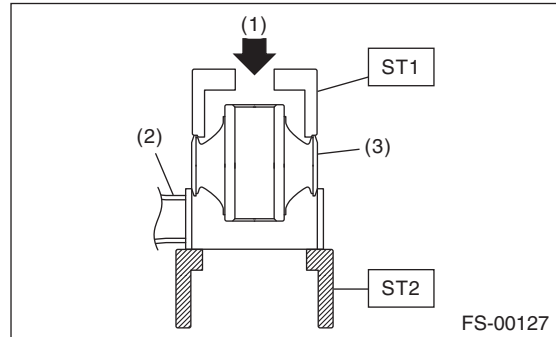

- (1) Press
- (2) Front arm
- (3) Rear bushing

E: INSPECTION

- 1) Check the front arm for damage or cracks, and correct or replace if defective.
- 2) Check the bushing for abnormal fatigue or damage.

Front Strut

FRONT SUSPENSION

7. Front Strut

A: REMOVAL

- 1) Disconnect the ground cable from the battery.
- 2) Lift up the vehicle, and then remove the front wheels.
- 3) Disconnect the front vehicle height sensor connector (models with auto headlight beam leveler, left side only).

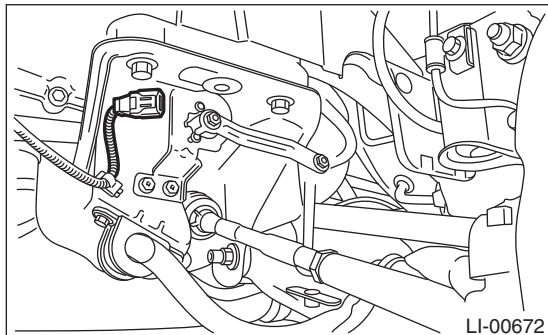

- 4) Remove the front vehicle height sensor (models with auto headlight beam leveler, left side only).

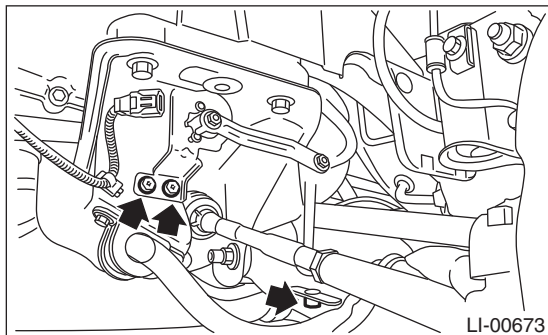

- 5) Place an alignment mark on the camber adjusting bolt and strut.
- 6) Remove the bolt securing the brake hose from the strut.

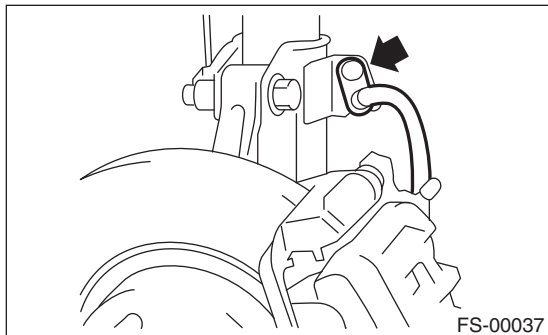

- 7) Remove the bolt securing the ABS wheel speed sensor harness.

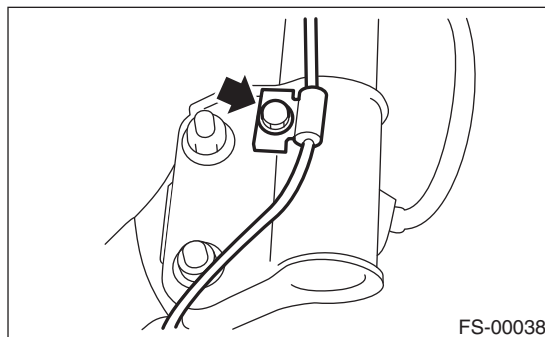

- 8) Remove the two bolts securing the housing to the strut.

NOTE:

While holding the head of the adjusting bolt, loosen the self-locking nut.

- 9) Remove the three nuts securing strut mount to body.

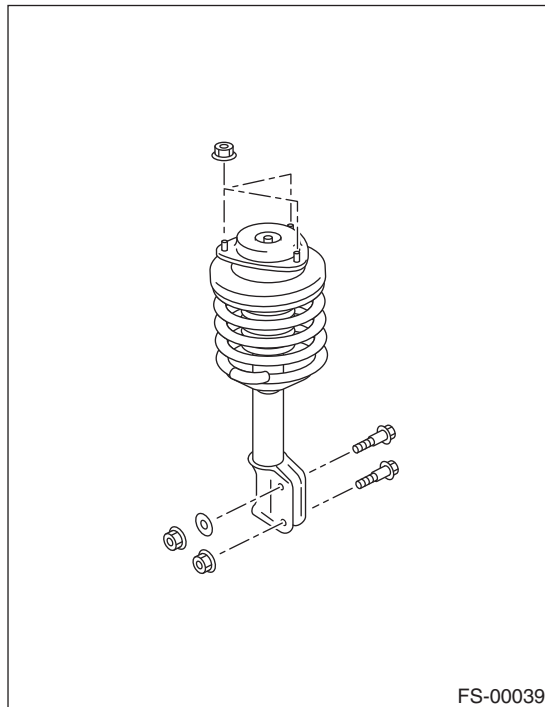

B: INSTALLATION

1) Install the strut mount at the upper side of strut to body, and tighten it with new self-locking nuts.

Tightening torque:

20 N·m (2.0 kgf·m, 14.5 ft·lb)

2) Align alignment marks on the camber adjusting bolt and strut.

Using new self-locking nuts, install the strut to the housing.

NOTE:

While holding the head of adjusting bolt, tighten the self-locking nut.

Tightening torque:

155 N·m (15.8 kgf·m, 114.3 ft·lb)

3) Secure the ABS wheel speed sensor harness to the strut.

Tightening torque:

33 N·m (3.4 kgf·m, 24.3 ft·lb)

4) Install the bolts which secure the brake hose to the strut.

Tightening torque:

33 N·m (3.4 kgf·m, 24.3 ft·lb)

5) Install the front vehicle height sensor (models with auto headlight beam leveler, left side only).

Tightening torque:

7.5 N·m (0.76 kgf·m, 5.5 ft·lb)

6) Install the front vehicle height sensor connector (models with auto headlight beam leveler, left side only).

7) Install the front wheels.

8) Connect the battery ground cable to the battery.

9) Inspect the wheel alignment and adjust if necessary.

10) Re-initialize the auto headlight beam leveler system (models with auto headlight beam leveler).

<Ref. to LI-15, PROCEDURE, Auto Headlight Beam Leveler System.>

C: DISASSEMBLY

1) Using a coil spring compressor, compress the coil spring.

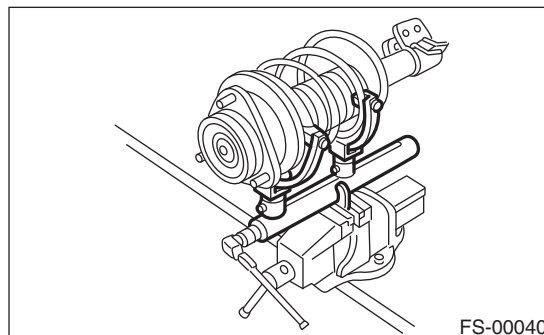

2) Using the ST, remove the self-locking nut.
ST 20399AG000 STRUT MOUNT SOCKET

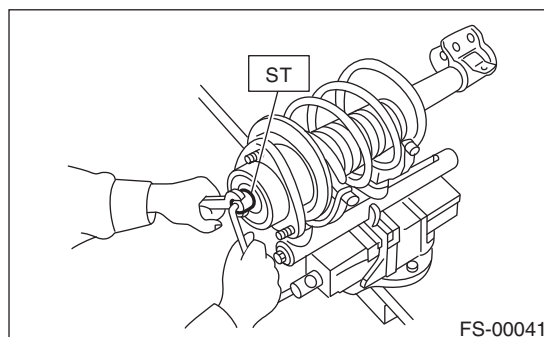

3) Remove the strut mount and upper spring seat from strut.

4) Gradually decrease the compression force of compressor, and remove the coil spring.

5) Remove the dust cover and helper spring.

Front Strut

FRONT SUSPENSION

D: ASSEMBLY

1) Before installing the coil spring, strut mount, etc. on strut, check for the presence of air in the dampening force generating mechanism of the strut since air prevents proper dampening force production.

2) Checking for presence of air

(1) Place the strut vertically with the piston rod facing up.

(2) Move the piston rod to the center of its entire stroke.

(3) While holding the piston rod end with fingers, move the rod up and down.

(4) If the piston rod moves 10 mm (0.39 in) or more in the former step, purge air from the strut.

3) Air purging procedure

(1) Place the strut vertically with the piston rod facing up.

(2) Fully extend the piston rod.

(3) With the piston rod fully extended, place the piston rod side down. The strut must stand vertically.

(4) Fully retract the piston rod.

(5) Repeat 3 or 4 times from the step (1).

NOTE:

After purging air from the strut, be sure to place the strut with the piston rod facing up. If the strut is laid down for any reason, check for the entry of air in accordance with "Checking for presence of air"

4) Using a coil spring compressor, compress the coil spring.

NOTE:

Make sure that the vertical install direction of the coil spring is as shown in the figure.

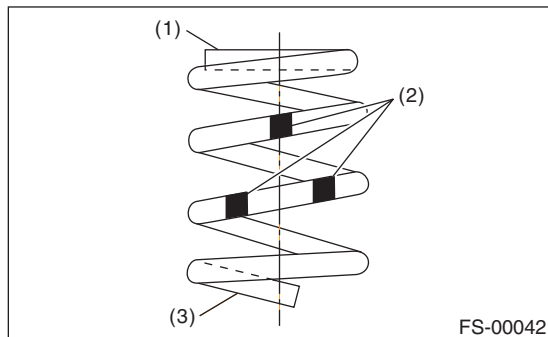

- (1) Diameter is small (Upper part)
- (2) Identification paint
- (3) Diameter is large (Bottom part)

5) Set the coil spring correctly so that its end face seats well in the spring seat as shown in the figure.

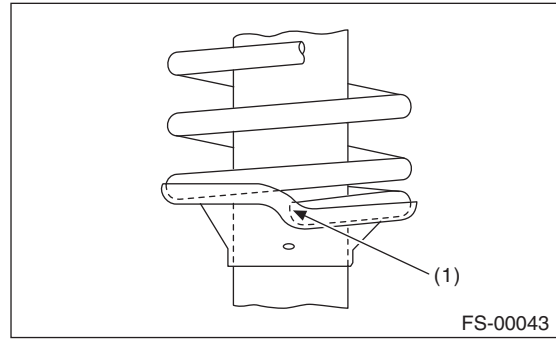

(1) Coil spring end face

6) Install the helper and dust cover to the piston rod.

7) Pull the piston rod fully upward, and install the spring seat.

NOTE:

Position the upper spring seat as shown in the figure.

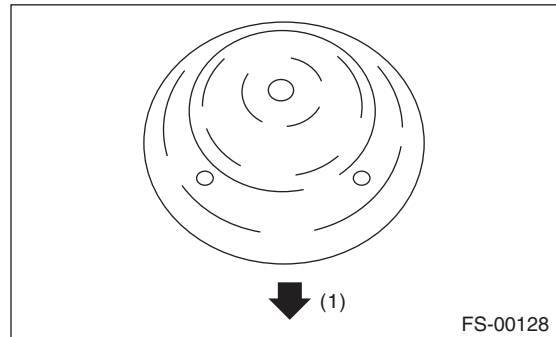

(1) Outside of body

8) Install the strut mount to piston rod, and temporarily attach and tighten a new self locking nut.

9) Using a hexagon wrench to prevent strut rod from turning, tighten the new self-locking nut with ST.

ST 20399AG000 STRUT MOUNT SOCKET

Tightening torque:

55 N·m (5.6 kgf·m, 40.6 ft·lb)

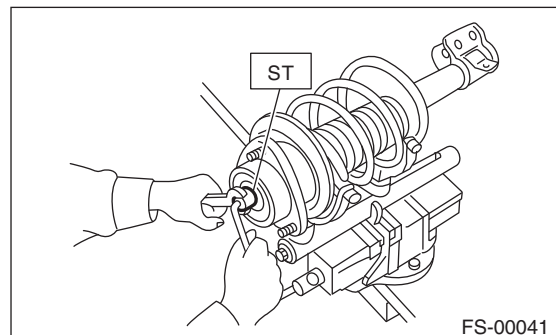

10) Loosen the coil spring compressor carefully.

E: INSPECTION

Check the removed part for wear, damage and cracks, and then repair or replace it if defective.

1. STRUT

- 1) Check for oil leaks.
- 2) Move the piston rod up and down to check that it operates smoothly without any hitch.
- 3) Piston rod play

- Measure the play as follows:

Fix the outer shell in place and fully extend the rod. Set a dial gauge at the end of rod L [10 mm (0.39 in)], and then read the dial gauge indication P_1 while applying a force of W [20 N (2 kgf, 4 lbf)] to the threaded portion. Apply a force of 20 N (2 kgf, 4 lbf) from the opposite direction of "W", and then read the dial gauge indication P_2 .

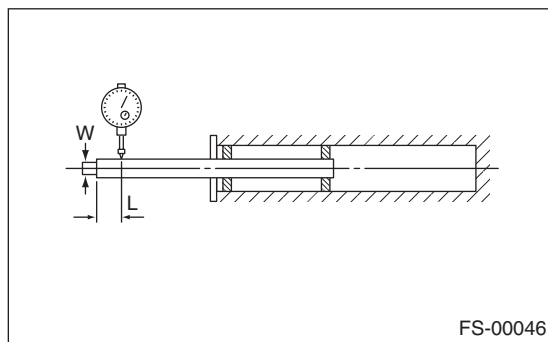

Play limit ($P_1 + P_2$):
0.8 mm (0.031 in)

If the play exceeds limit, replace the strut.

2. STRUT MOUNT

Check the rubber part for deformation, cracks or deterioration, and then replace it with a new part if defective.

3. DUST COVER

If major cracks or damage are found, replace it with a new part.

4. COIL SPRING

If a permanent strain is found, replace it with a new part.

5. HELPER

If major cracks or damage are found, replace it with a new part.

F: DISPOSAL

CAUTION:

- Before handling struts, be sure to wear goggles to protect eyes from gas, oil and cutting powder.
- Do not disassemble the strut damper or throw into flames.
- When discarding gas filled struts, drill holes in them to purge the gas.

- 1) Place the strut on a level surface with the piston rod fully expanded.
- 2) Using a 2 — 3 mm (0.08 — 0.12 in) dia. drill, make holes in areas shown in the figure.

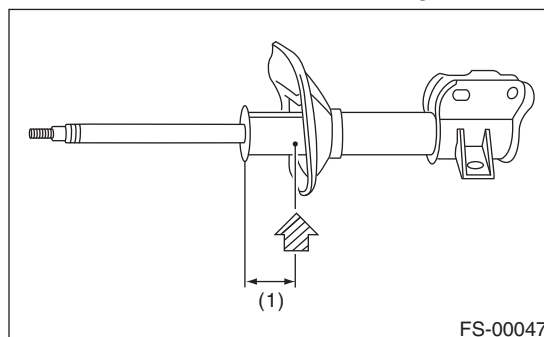

(1) 40 mm (1.57 in)

Front Crossmember

FRONT SUSPENSION

8. Front Crossmember

A: REMOVAL

- 1) Disconnect the ground cable from the battery.
- 2) Lift up the vehicle, and then remove the front wheels.
- 3) Disconnect the front vehicle height sensor connector (models with auto headlight beam leveler, left side only).

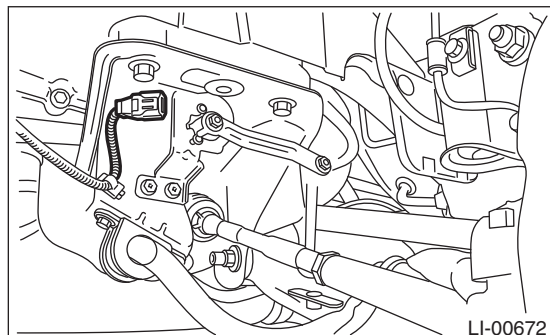

- 4) Remove the front vehicle height sensor (models with auto headlight beam leveler, left side only).

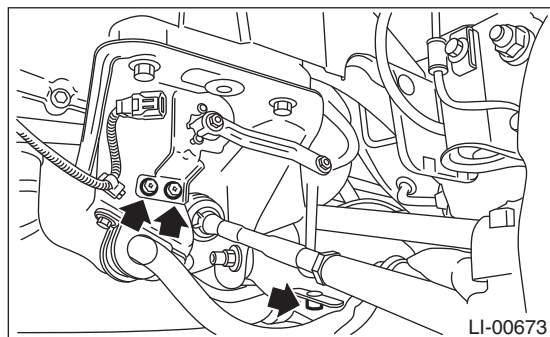

- 5) Remove the front exhaust pipe.
- 6) Remove the front crossmember support plate. <Ref. to FS-15, REMOVAL, Front Crossmember Support Plate.>
- 7) Remove the front stabilizer. <Ref. to FS-16, REMOVAL, Front Stabilizer.>
- 8) Disconnect the tie-rod end from housing.
- 9) Remove the front arm. <Ref. to FS-19, REMOVAL, Front Arm.>
- 10) Remove the nuts attaching the engine mount cushion rubber to crossmember.

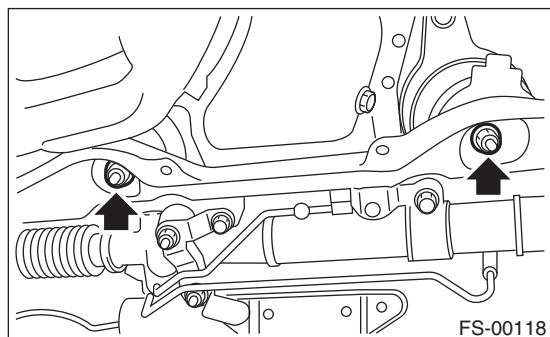

- 11) Remove the steering universal joint.

- 12) Disconnect the power steering hose from steering gearbox.
- 13) Lift the engine approx. 10 mm (0.39 in) using a chain block.
- 14) Support the crossmember with a jack, remove the bolts securing crossmember to body, and then gradually lower the crossmember with steering gearbox as a unit.

CAUTION:

When removing the crossmember downward, be careful that the tie-rod end does not interfere with drive shaft boot.

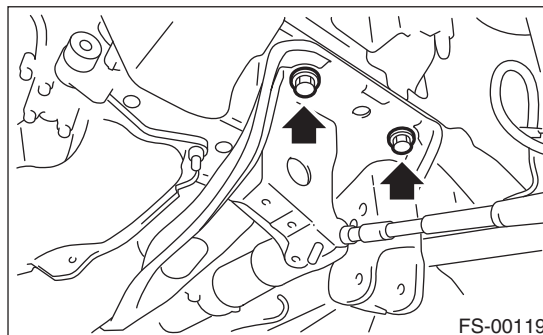

B: INSTALLATION

1) Install in the reverse order of removal.

CAUTION:

- Use a new bolt and self-locking nut. For parts which are not reusable, refer to “COMPONENT”. <Ref. to FS-3, COMPONENT, General Description.>
- Always tighten the stabilizer bushing in the state where the vehicle is at curb weight and the wheels are in full contact with the ground.

Tightening torque:

Crossmember to body:

95 N·m (9.7 kgf-m, 70.1 ft-lb)

Engine mounting to Crossmember:

85 N·m (8.7 kgf-m, 63 ft-lb)

Front arm to Crossmember:

95 N·m (9.7 kgf-m, 70.1 ft-lb)

Front arm to Support plate:

110 N·m (11.2 kgf-m, 81.1 ft-lb)

Support plate body:

150 N·m (15.3 kgf-m, 110.6 ft-lb)

Tie-rod end to Housing:

27.0 N·m (2.75 kgf-m, 19.9 ft-lb)

After tightening to the specified torque, tighten the castle nut further but within 60° until the hole in the ball stud is aligned with a slot in castle nut

Tightening torque:

Universal joint:

24 N·m (2.4 kgf-m, 17.4 ft-lb)

Stabilizer bracket:

25 N·m (2.5 kgf-m, 18.4 ft-lb)

Stabilizer link:

45 N·m (4.6 kgf-m, 33.2 ft-lb)

Power steering hose to Steering gearbox:

15 N·m (1.5 kgf-m, 10.8 ft-lb)

Front vehicle height sensor (models with auto headlight beam leveler, left side only):

7.5 N·m (0.76 kgf-m, 5.5 ft-lb)

2) Purge air from the power steering system.

3) Inspect the wheel alignment and adjust if necessary.

4) Re-initialize the auto headlight beam leveler system (models with auto headlight beam leveler). <Ref. to LI-15, PROCEDURE, Auto Headlight Beam Leveler System.>

C: INSPECTION

Check the crossmember for damage or cracks, and correct or replace if defective.

General Diagnostic Table

FRONT SUSPENSION

9. General Diagnostic Table

A: INSPECTION

1. IMPROPER VEHICLE POSTURE OR IMPROPER WHEEL ARCH HEIGHT

Possible cause	Corrective action
(1) Permanent distortion or damage of the coil spring	Replace.
(2) Rough operation of strut or shock absorber	Replace.
(3) Improper installation of strut or shock absorber	Replace with appropriate parts.
(4) Installation of the wrong coil spring	Replace with appropriate parts.

2. POOR RIDE COMFORT

- 1) Large rebound shock
- 2) Rocking of the vehicle continues too long after running over bump and hump.
- 3) Excessive shock in bumping

Possible cause	Corrective action
(1) Damaged coil spring	Replace.
(2) Overinflation of tires	Adjust.
(3) Improper wheel arch height	Adjust or replace the coil springs with new parts.
(4) Fault in operation of strut or shock absorber	Replace.
(5) Damage or deformation of strut mount or shock absorber mount	Replace.
(6) Unsuitable length (maximum or minimum) of strut or shock absorber	Replace with appropriate parts.
(7) Deformation or loss of bushing	Replace.
(8) Deformation or damage of helper in strut assembly or shock absorber	Replace.
(9) Oil leakage from the strut or shock absorber	Replace.

3. NOISE

Possible cause	Corrective action
(1) Wear or damage of strut or shock absorber component parts	Replace.
(2) Loosening of the suspension link installing bolt	Tighten to the specified torque.
(3) Deformation or loss of bushing	Replace.
(4) Unsuitable length (maximum or minimum) of strut or shock absorber	Replace with appropriate parts.
(5) Damaged coil spring	Replace.
(6) Wear or damage of the ball joint	Replace.
(7) Deformation of the stabilizer clamp	Replace.

REAR SUSPENSION

RS

	Page
1. General Description	2
2. Wheel Alignment	7
3. Rear Stabilizer	8
4. Rear Trailing Link	9
5. Upper Arm	11
6. Rear Shock Absorber	12
7. Front Lateral Link	13
8. Rear Lateral Link	14
9. Rear Sub Frame	15
10. General Diagnostic Table	17

General Description

REAR SUSPENSION

1. General Description

A: SPECIFICATION

Refer to "FS" section for rear suspension specifications. <Ref. to FS-2, SPECIFICATION, General Description.>

NOTE:

- Front and rear toe-in and front camber can be adjusted. Adjust if the toe-in or camber tolerance exceeds specifications.
- Other items indicated in the specifications table cannot be adjusted. If other items exceed specifications, check the suspension parts and connections for deformation. If defective, replace with new parts.

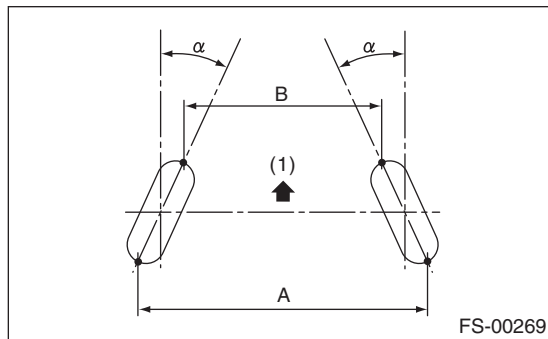

(1) Front

A – B = Positive: Toe-in, Negative: Toe-out
 α = Individual toe angles

B: COMPONENT

1. REAR SUSPENSION

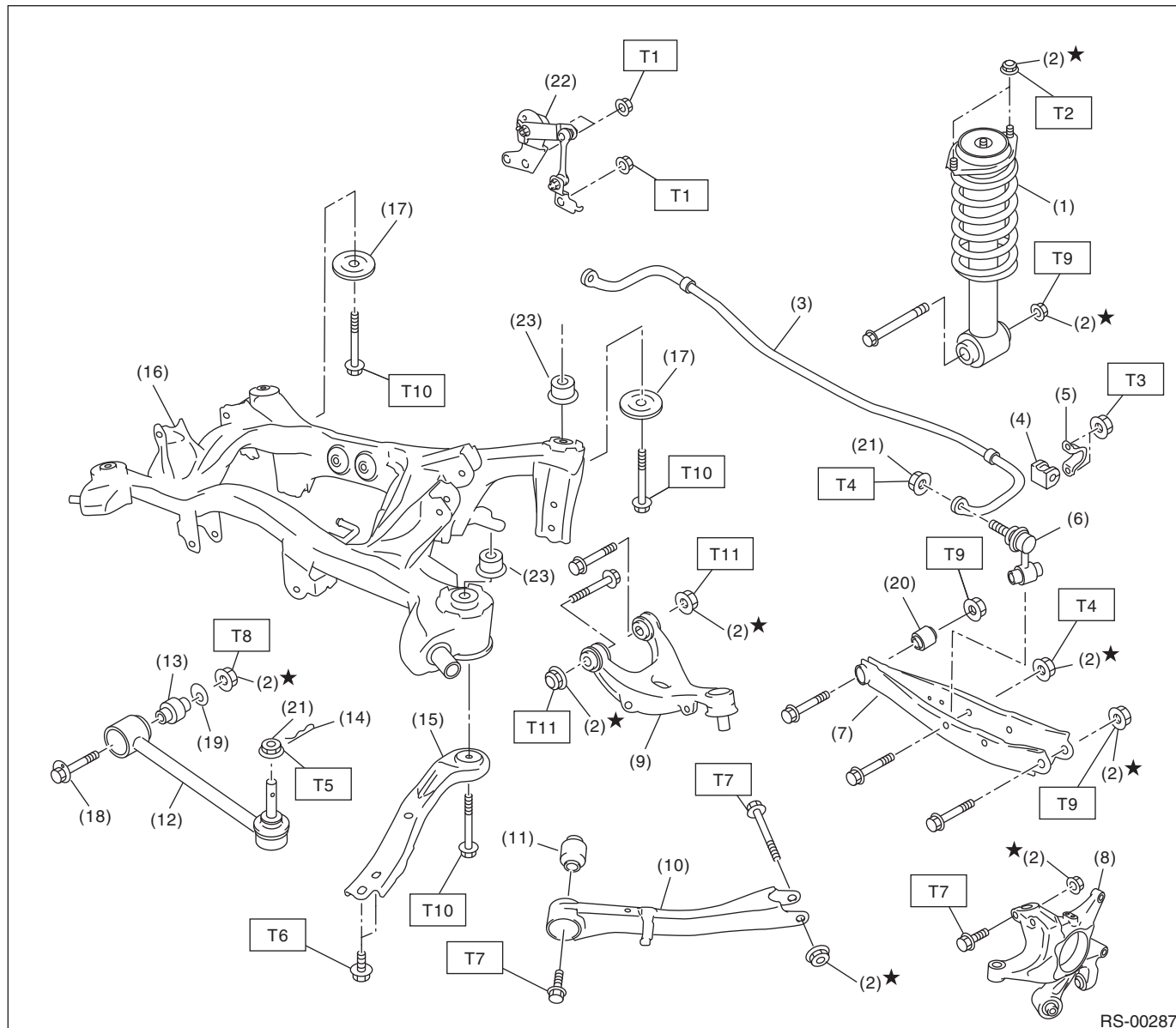

RS-00287

- | | |
|---------------------------------|--|
| (1) Shock absorber | (15) Front sub frame support plate |
| (2) Self-locking nut | (16) Rear sub frame |
| (3) Rear stabilizer | (17) Rear sub frame stopper plate (lower) |
| (4) Stabilizer bushing | (18) Adjusting bolt |
| (5) Stabilizer clamp | (19) Adjusting washer |
| (6) Stabilizer link | (20) Rear lateral link bushing |
| (7) Rear lateral link | (21) Flange nut |
| (8) Rear housing | (22) Rear vehicle height sensor (models with auto headlight beam leveler only) |
| (9) Upper arm | (23) Rear sub frame stopper plate (upper) |
| (10) Trailing link | |
| (11) Trailing link bushing | |
| (12) Front lateral link | |
| (13) Front lateral link bushing | |
| (14) Snap pin | |

Tightening torque: N·m (kgf·m, ft·lb)

- | | |
|-------------|-------------------------|
| T1: | 7.5 (0.76, 5.5) |
| T2: | 30 (3.1, 22.4) |
| T3: | 40 (4.1, 29.5) |
| T4: | 45 (4.6, 33.2) |
| T5: | 60 (6.1, 44) |
| T6: | 70 (7.1, 51.6) |
| T7: | 90 (9.2, 66.4) |
| T8: | 100 (10.2, 73.8) |
| T9: | 120 (12.2, 89) |
| T10: | 145 (14.8, 107) |
| T11: | 150 (15.3, 111) |

General Description

REAR SUSPENSION

2. SHOCK ABSORBER

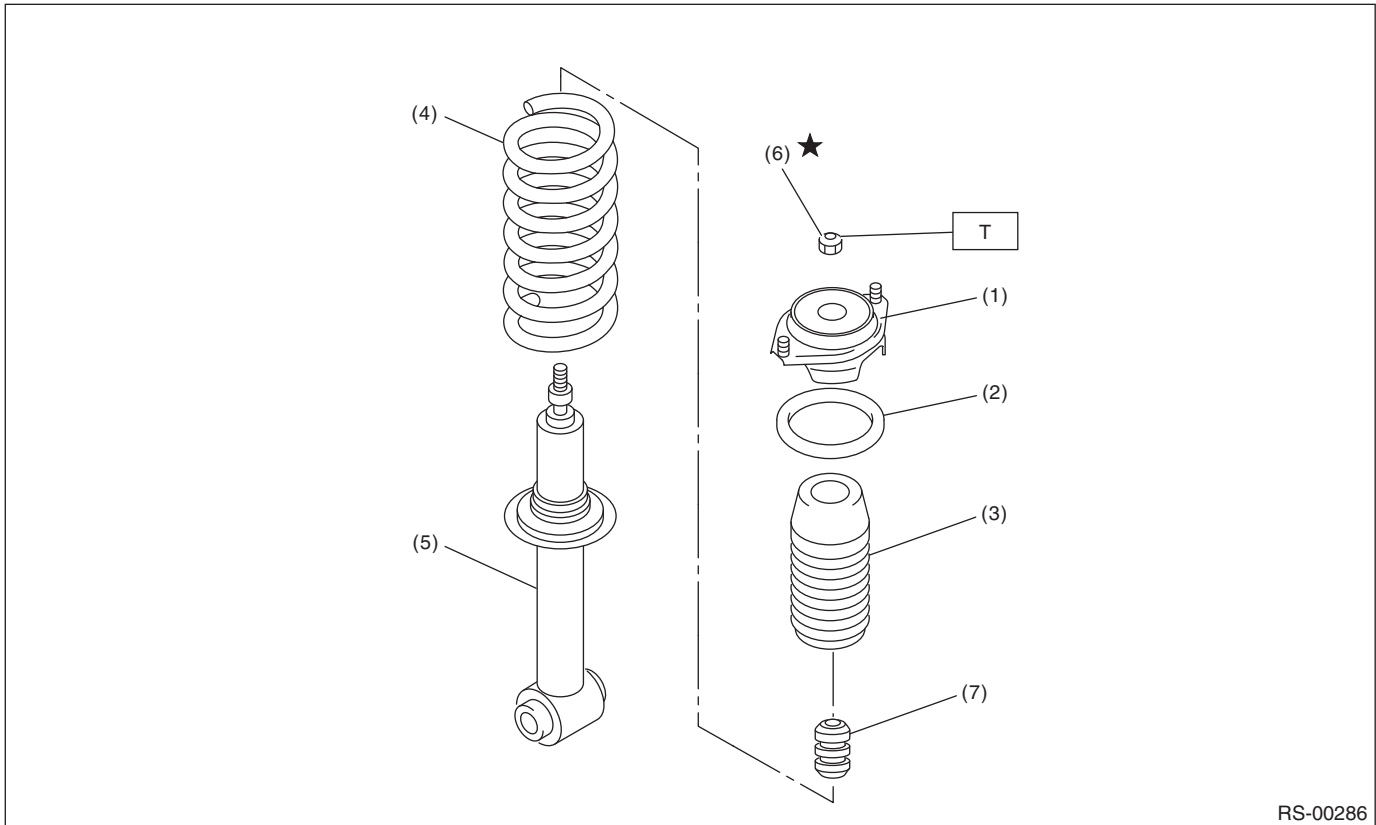

RS-00286

- | | |
|------------------------|----------------------|
| (1) Mount | (5) Shock absorber |
| (2) Upper rubber sheet | (6) Self-locking nut |
| (3) Dust cover | (7) Helper |
| (4) Coil spring | |

Tightening torque: N·m (kgf·m, ft·lb)

T: 25 (2.5, 18.4)

C: CAUTION

Please clearly understand and adhere to the following general precautions. They must be strictly followed to avoid minor or serious injury to the person doing the work or people in the area.

1. CAUTIONS

- Wear appropriate work clothing, including a cap, protective goggles and protective shoes when performing any work.
- Before disposing of shock absorbers, be sure to bleed the gas out completely. Also, do not expose to flames or fire.
- Before removal, installation or disassembly, be sure to clarify the failure. Avoid unnecessary removal, installation, disassembly and replacement.
- Use SUBARU genuine grease etc. or equivalent. Do not mix grease etc. of different grades or manufacturers.
- Before securing a part on a vise, place cushioning material such as wood blocks, aluminum plate, or cloth between the part and the vise.
- Be sure to tighten fasteners including bolts and nuts to the specified torque.
- Place shop jacks or rigid racks at the specified points.

2. OIL

When handling oil, carefully observe the following to prevent unexpected accidents.

- Prepare container and waste cloths when performing work which oil could possibly spill. If oil spills, wipe it off immediately to prevent from penetrating into floor or flowing outside, for environmental protection.
- Follow all government regulations concerning disposal of refuse when disposing.

General Description

REAR SUSPENSION

D: PREPARATION TOOL

1. SPECIAL TOOL

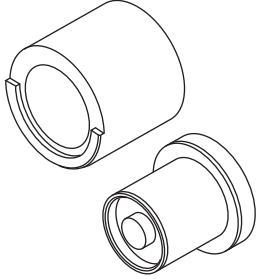
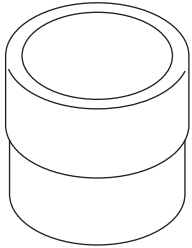
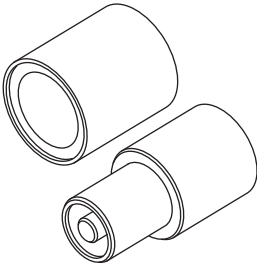
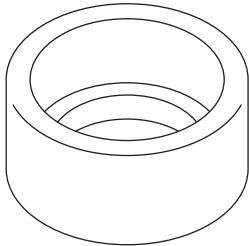
ILLUSTRATION	TOOL NUMBER	DESCRIPTION	REMARKS
 <p>ST20099AE000</p>	20099AE000	INSTALLER & REMOVER	Used for replacing the front lateral link bushing.
 <p>ST-499755602</p>	499755602	PRESS	Used for replacing the rear trailing link bushing.
 <p>ST20099AE010</p>	20099AE010	INSTALLER & REMOVER	Used for replacing the rear lateral link bushing.
 <p>ST20299AG010</p>	20299AG010	BASE	Used for replacing the rear trailing link bushing.

General Description

REAR SUSPENSION

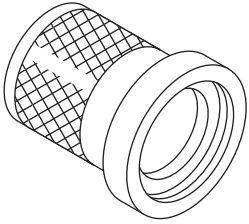
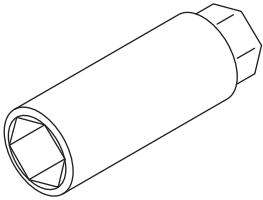
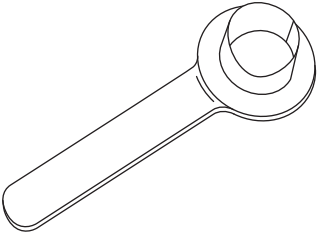
ILLUSTRATION	TOOL NUMBER	DESCRIPTION	REMARKS
 <p style="text-align: center;">ST-899874100</p>	899874100	INSTALLER	Used for replacing the rear trailing link bushing.
 <p style="text-align: center;">ST20399FG000</p>	20399FG000	STRUT MOUNT SOCKET	<ul style="list-style-type: none"> • Used for removing and installing shock mount. • Used for checking torque of shock mount center nut.
 <p style="text-align: center;">ST28099PA090</p>	28099PA090	OIL SEAL PROTECTOR	<ul style="list-style-type: none"> • Used for installing the rear drive shaft to the rear differential. • For oil seal protection

2. GENERAL TOOL

TOOL NAME	REMARKS
Alignment tester	Used for measuring wheel alignment.
Toe-in gauge	Used for toe-in measurement.
Jack	Used for removing and installing suspension.
Bearing puller	Used for removing bushings.
Coil spring compressor	Used for disassembling and assembling shock absorber.

2. Wheel Alignment

A: INSPECTION

NOTE:

Measure and adjust the front and rear wheel alignment at a time. Refer to "FS" section for measurement and adjustment of wheel alignment. <Ref. to FS-7, INSPECTION, Wheel Alignment.>

Rear Stabilizer

REAR SUSPENSION

3. Rear Stabilizer

A: REMOVAL

- 1) Lift up the vehicle, and then remove the rear wheels.
- 2) Remove the stabilizer link.

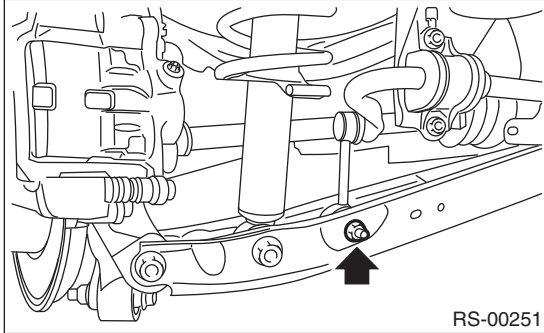

- 3) Remove the stabilizer clamp.

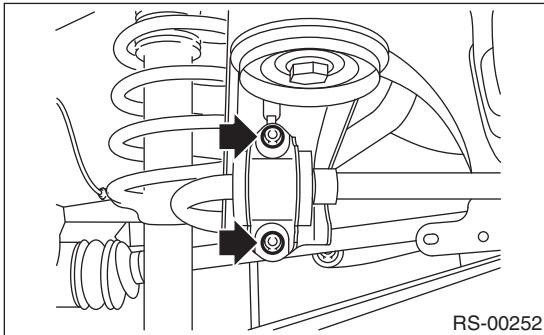

B: INSTALLATION

CAUTION:

- Be sure to use a new flange nut and self-locking nut.
- Always tighten the stabilizer bushing in the state where the vehicle is at curb weight and the wheels are in full contact with the ground.
- Align the paint mark end of stabilizer to the end of stabilizer bushing when installing.

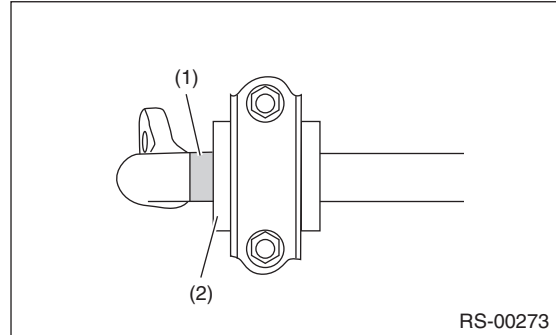

- (1) Identification paint
(2) Bushing

Install in the reverse order of removal.

Tightening torque:

Stabilizer link

45 N·m (4.6 kgf-m, 33.2 ft-lb)

Stabilizer clamp

40 N·m (4.1 kgf-m, 29.5 ft-lb)

C: INSPECTION

- 1) Check the bushing for abnormal cracks, fatigue or damage.
- 2) Check the stabilizer link for damage.

4. Rear Trailing Link

A: REMOVAL

- 1) Lift up the vehicle, and then remove the rear wheels.
- 2) Remove the bracket, and remove the parking brake cable from the guide.

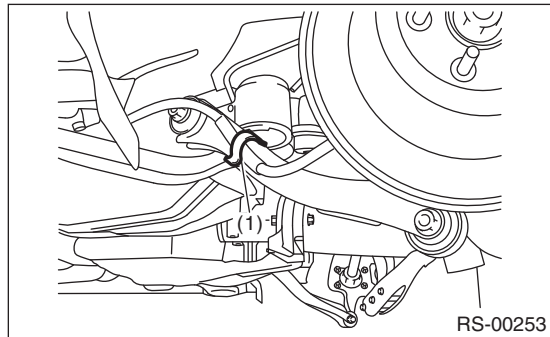

(1) Guide

- 3) Remove the trailing link.

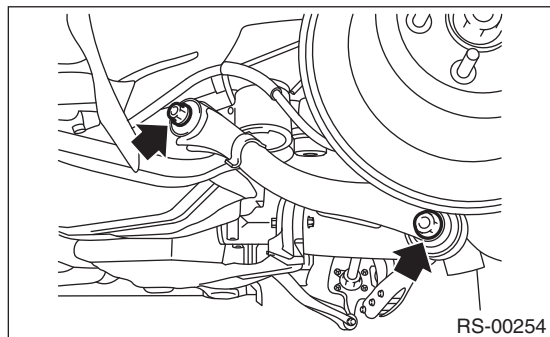

B: INSTALLATION

CAUTION:

- Be sure to use a new self-locking nut.
- Always tighten the bushing in the state where the vehicle is at curb weight and the wheels are in full contact with the ground.

Install in the reverse order of removal.

Tightening torque:

90 N·m (9.2 kgf·m, 66.4 ft·lb)

C: DISASSEMBLY

Using the ST A and ST B, press the bushing out.

STA 8998741000 INSTALLER

STB 499755602 PRESS

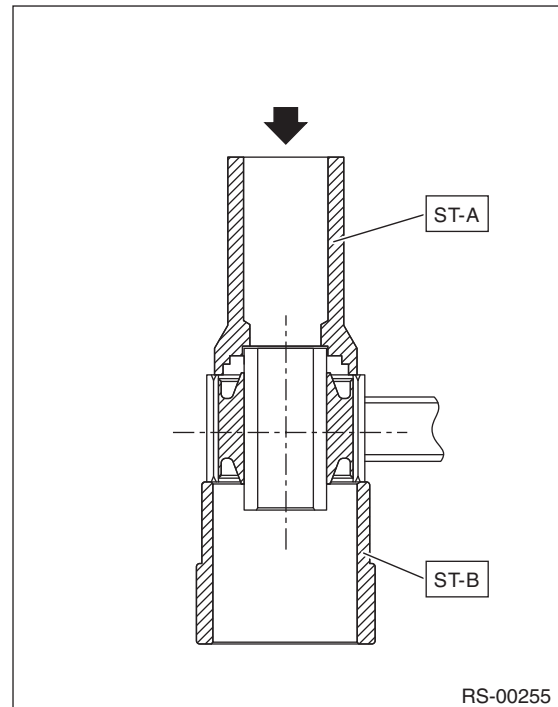

D: ASSEMBLY

Using the ST A and ST B, press-fit the bushing.

STA 8998741000 INSTALLER

STB 20299AG010 BASE

CAUTION:

Make sure to press the bushing straight in.

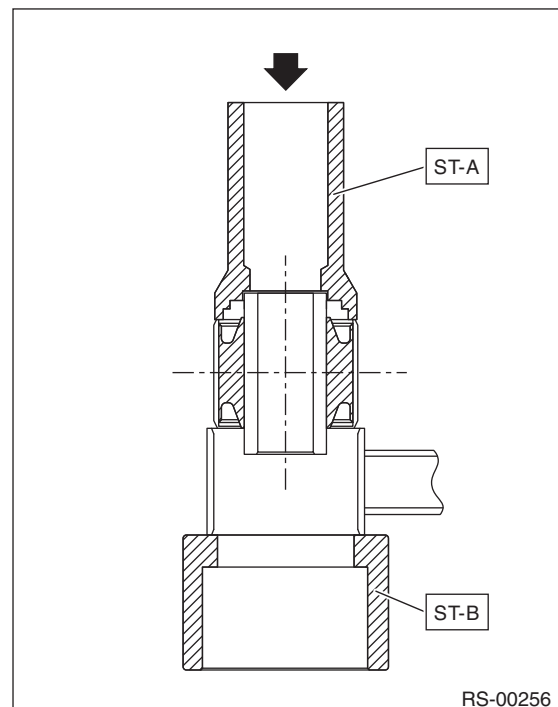

Rear Trailing Link

REAR SUSPENSION

E: INSPECTION

Visually check the trailing link for damage and deformation.

5. Upper Arm

A: REMOVAL

- 1) Disconnect the ground cable from the battery.
- 2) Lift up the vehicle, and then remove the rear wheels.
- 3) Remove the rear ABS wheel speed sensor bracket.

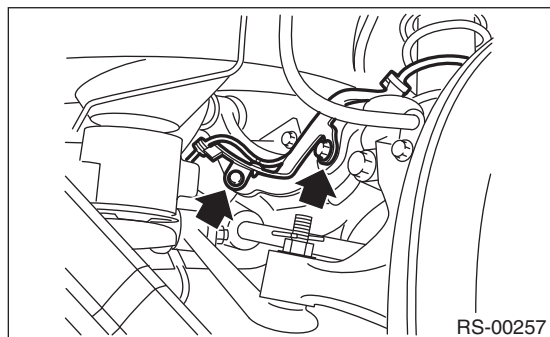

- 4) Remove the bolts, then remove the upper arm.

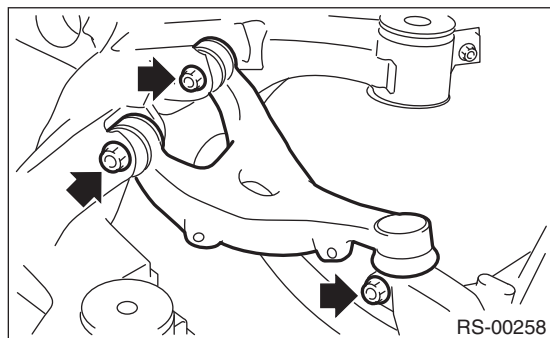

B: INSTALLATION

CAUTION:

- Use a new self-locking nut.
- Always tighten the bushing when the arm is positioned in the state where the vehicle is at curb weight and the wheels are in full contact with the ground.

- 1) Install in the reverse order of removal.
- 2) Inspect the wheel alignment and adjust if necessary.

Tightening torque:

Upper arm — Rear sub frame
 150 N·m (15.3 kgf·m, 111 ft·lb)

Upper arm — Rear housing
 90 N·m (9.2 kgf·m, 66.4 ft·lb)

Rear ABS wheel speed sensor bracket
 7.5 N·m (0.76 kgf·m, 5.5 ft·lb)

C: INSPECTION

- 1) Visually check the upper arm for damage and deformation.
- 2) Visually check the bushing for abnormal cracks, fatigue or damage.

Rear Shock Absorber

REAR SUSPENSION

6. Rear Shock Absorber

A: REMOVAL

- 1) Disconnect the ground cable from the battery.
- 2) Remove the luggage floor mat.
- 3) Remove the strut cap of the quarter trim.
- 4) Lift up the vehicle, and then remove the rear wheels.
- 5) Disconnect the connector, remove the nuts, and then remove the rear vehicle height sensor. (models with auto headlight beam leveler, left side only)

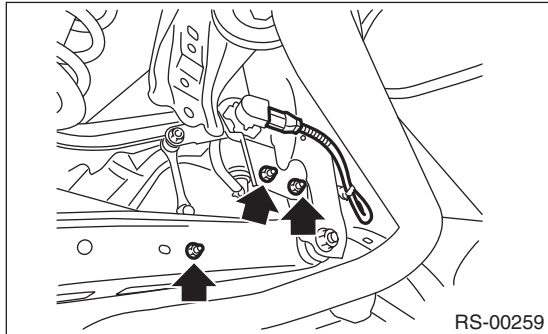

- 6) Remove the nut and disconnect the rear stabilizer link.
- 7) Remove the shock absorber lower bolt.
- 8) Disconnect the rear lateral link.

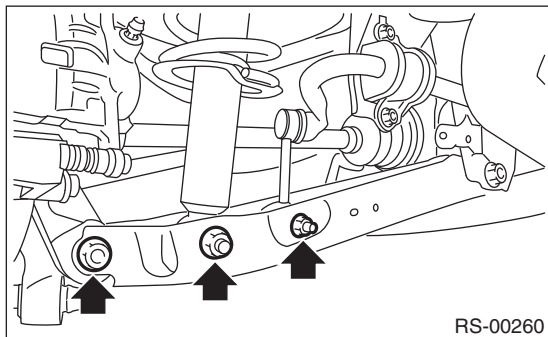

- 9) Remove the shock absorber mount nut.

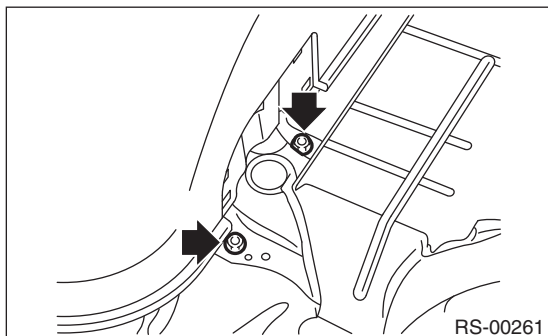

- 10) Remove the shock absorber.

B: INSTALLATION

CAUTION:

- Be sure to use a new self-locking nut.
- Always tighten the bushing in the state where the vehicle is at curb weight and the wheels are in full contact with the ground.

- 1) Install in the reverse order of removal.

Tightening torque:

Refer to “COMPONENT” of “General Description” for the tightening torque. <Ref. to RS-3, COMPONENT, General Description.>

- 2) Check the wheel alignment and adjust it if necessary.
- 3) Re-initialize the auto headlight beam leveler system (models with auto headlight beam leveler). <Ref. to LI-15, PROCEDURE, Auto Headlight Beam Leveler System.>

C: DISASSEMBLY

Refer to “Front Strut” for disassembly procedure. <Ref. to FS-23, DISASSEMBLY, Front Strut.>

D: ASSEMBLY

Refer to “Front Strut” for installation procedures. <Ref. to FS-24, ASSEMBLY, Front Strut.>

E: INSPECTION

Refer to “Front Strut” for inspection procedures. <Ref. to FS-25, INSPECTION, Front Strut.>

F: DISPOSAL

CAUTION:

- Before handling the shock absorber, be sure to wear goggles to protect eyes from gas, oil and cutting powder.
- Do not disassemble the shock absorber or place it into a fire.
- Drill a hole into shock absorbers in case of discarding shock absorbers filled with gas.

- 1) Place the shock absorber on a level surface with the piston rod fully expanded.
- 2) Make a hole into the specified position 30 mm (1.18 in) deep using a drill with 2 — 3 mm (0.08 — 0.12 in) diameter.

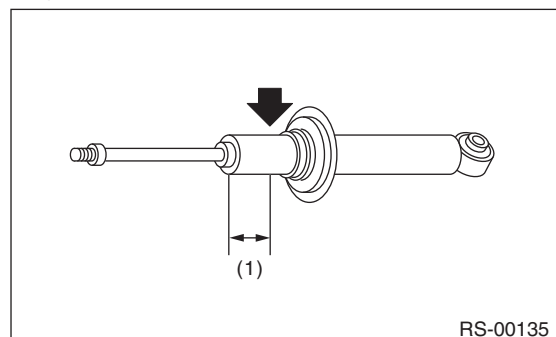

(1) 40 mm (1.57 in)

7. Front Lateral Link

A: REMOVAL

- 1) Lift up the vehicle, and then remove the rear wheels.
- 2) Remove the rear trailing link. <Ref. to RS-9, REMOVAL, Rear Trailing Link.>
- 3) Remove the snap pin and nut.

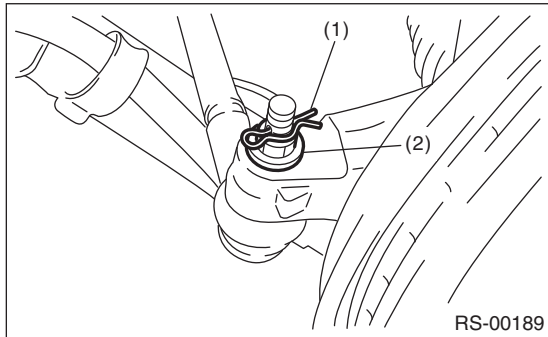

- (1) Snap pin
- (2) Nut

- 4) Using a puller, remove the ball joint.

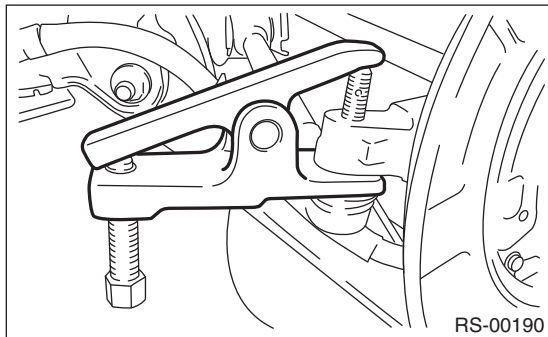

- 5) Scribe an alignment mark on the front lateral link adjusting bolt and rear sub frame.
- 6) Remove the adjusting bolt, and remove the front lateral link.

CAUTION:

When removing the adjusting bolt, make sure to fix the bolt head in place when loosening the nut.

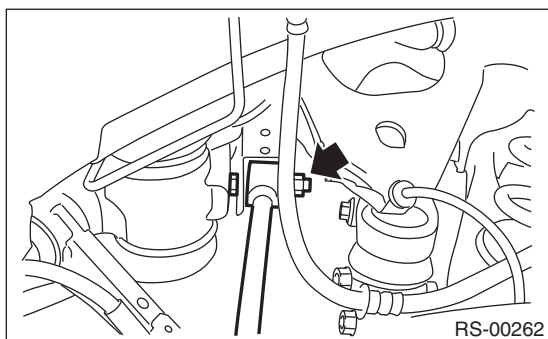

B: INSTALLATION

CAUTION:

- Be sure to use a new self-locking nut.
- Always tighten the bushing in the state where the vehicle is at curb weight and the wheels are in full contact with the ground.

- 1) Install in the reverse order of removal.

Tightening torque:

Front lateral link — Sub frame

100 N·m (10.2 kgf-m, 73.8 ft-lb)

Front lateral link — Rear axle housing

60 N·m (6.1 kgf-m, 44 ft-lb)

- 2) Inspect the wheel alignment and adjust if necessary.

C: INSPECTION

Visually check the front lateral link for damage and deformation.

D: DISASSEMBLY

Using the ST A and ST B, press the bushing out.
 STA 20099AE000 INSTALLER & REMOVER
 STB 20099AE000 INSTALLER & REMOVER

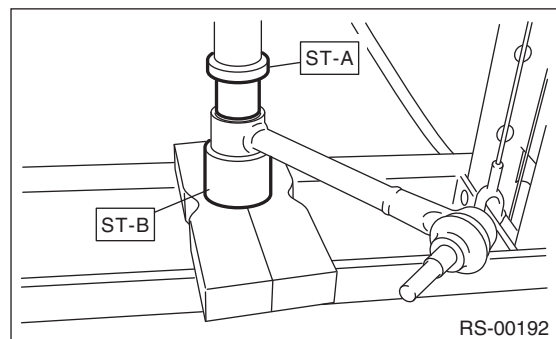

E: ASSEMBLY

Using the ST A and ST B, press-fit the bushing.
 STA 20099AE000 INSTALLER & REMOVER
 STB 20099AE000 INSTALLER & REMOVER

CAUTION:

Make sure to press the bushing straight in.

Rear Lateral Link

REAR SUSPENSION

8. Rear Lateral Link

A: REMOVAL

- 1) Disconnect the ground cable from the battery.
- 2) Lift up the vehicle, and then remove the rear wheels.
- 3) Disconnect the connector, and remove the rear vehicle height sensor (models with auto headlight beam leveler, left side only).

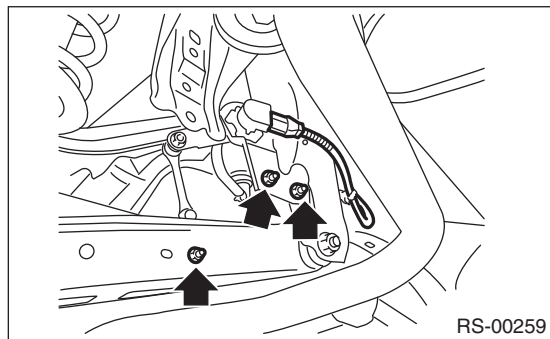

- 4) Remove the nut and disconnect the stabilizer link.
- 5) Remove the shock absorber lower bolt.
- 6) Remove the bolt, and remove rear lateral link.

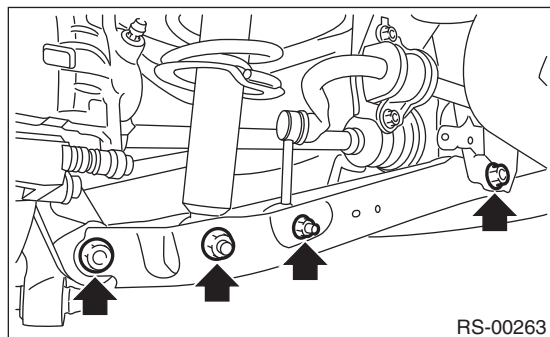

B: INSTALLATION

CAUTION:

- Be sure to use a new self-locking nut.
- Always tighten the bushing in the state where the vehicle is at curb weight and the wheels are in full contact with the ground.

- 1) Install in the reverse order of removal.

Tightening torque:

Rear lateral link

120 N·m (12.2 kgf·m, 89 ft·lb)

Shock absorber

120 N·m (12.2 kgf·m, 89 ft·lb)

Stabilizer link

45 N·m (4.6 kgf·m, 33.2 ft·lb)

Rear vehicle height sensor (models with auto headlight beam leveler, left side only)

7.5 N·m (0.76 kgf·m, 5.5 ft·lb)

- 2) Inspect the wheel alignment and adjust if necessary.
- 3) Re-initialize the auto headlight beam leveler system (models with auto headlight beam leveler).
<Ref. to LI-15, PROCEDURE, Auto Headlight Beam Leveler System.>

C: DISASSEMBLY

Using the ST A and ST B, press the bushing out.
STA 20099AE010 INSTALLER & REMOVER
STB 20099AE010 INSTALLER & REMOVER

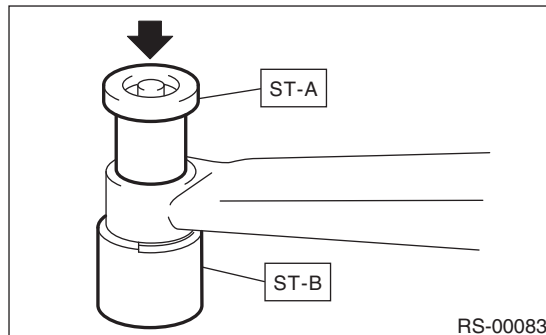

D: ASSEMBLY

Using the ST A and ST B, press-fit the bushing.
STA 20099AE010 INSTALLER & REMOVER
STB 20099AE010 INSTALLER & REMOVER

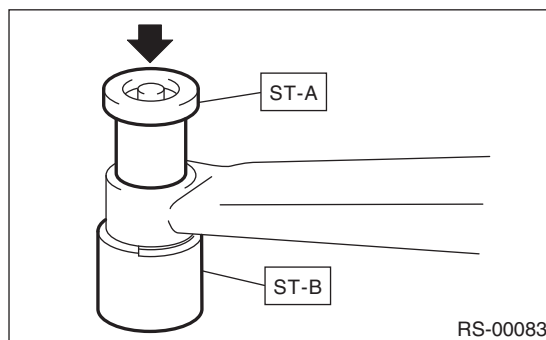

E: INSPECTION

Visually check the rear lateral link for damage and deformation.

9. Rear Sub Frame

A: REMOVAL

- 1) Disconnect the ground cable from the battery.
- 2) Lift up the vehicle, and then remove the rear wheels.
- 3) Disconnect the connector, and remove the rear vehicle height sensor (models with auto headlight beam leveler, left side only).

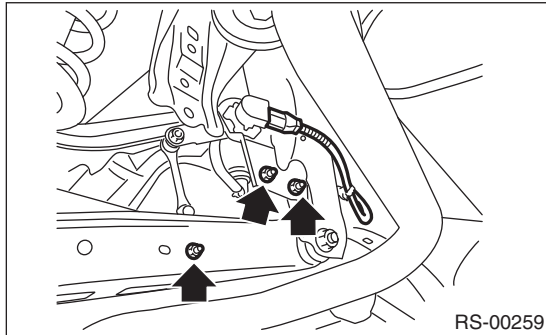

- 4) Separate the front exhaust pipe and rear exhaust pipe.
- 5) Remove the rear exhaust pipe and muffler.
- 6) Remove the propeller shaft.
<Ref. to DS-10, REMOVAL, Propeller Shaft.>
- 7) Remove the brake hose bracket.

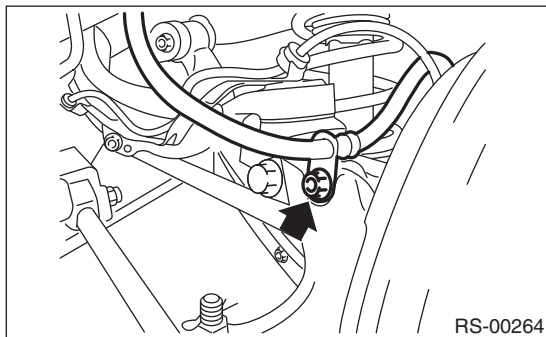

- 8) Remove the rear disc brake caliper and suspend it from the shock absorber.

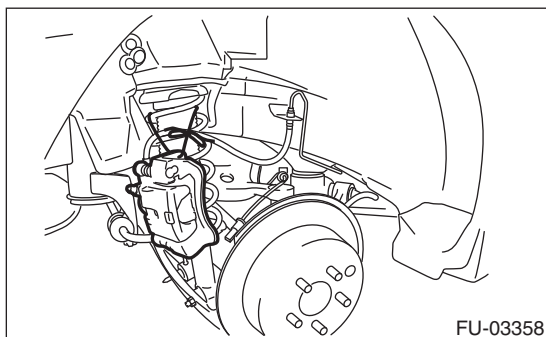

- 9) Remove the rear parking brake cable from the parking brake assembly. <Ref. to PB-6, REMOVAL, Parking Brake Assembly (Rear Disc Brake).>

- 10) Disconnect the ABS wheel speed sensor connector.

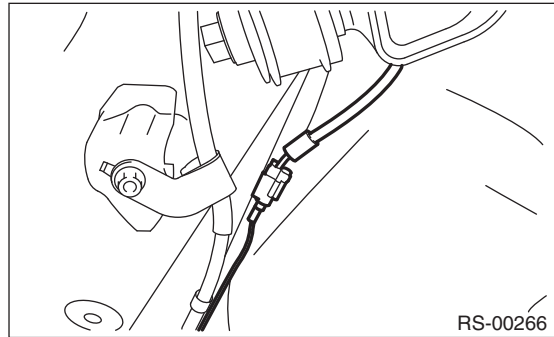

- 11) Disconnect the drain hose (B) from canister drain connector (A).

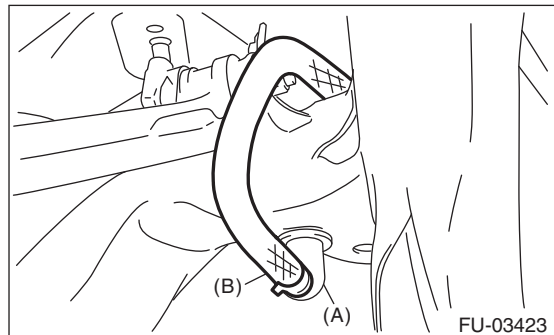

- 12) Remove the shock absorber lower bolt.

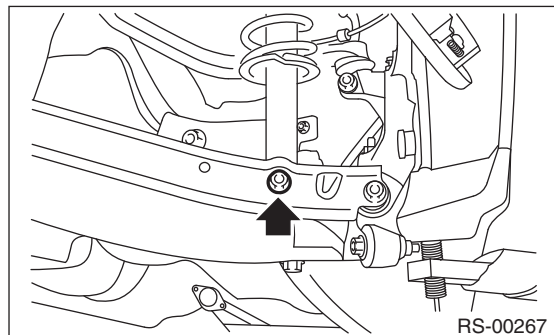

- 13) Support the sub frame using a jack.
- 14) Remove the support plate.

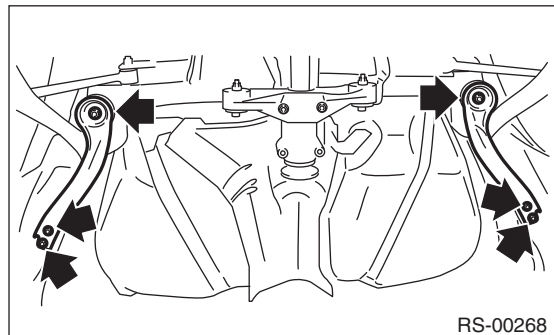

Rear Sub Frame

REAR SUSPENSION

15) Remove the rear sub frame.

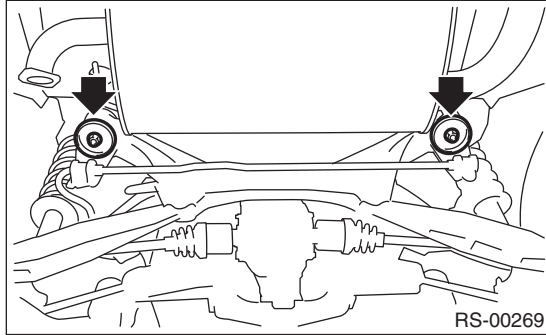

B: INSTALLATION

CAUTION:

- Be sure to use a new self-locking nut.
- Always tighten the bushing in the state where the vehicle is at curb weight and the wheels are in full contact with the ground.

1) Install in the reverse order of removal.

Tightening torque:

Refer to “COMPONENT” of “General Description” for the tightening torque. <Ref. to RS-3, COMPONENT, General Description.>

- 2) Bleed air from brake system.
- 3) Inspect the wheel alignment and adjust if necessary.
- 4) Re-initialize the auto headlight beam leveler system (models with auto headlight beam leveler). <Ref. to LI-15, PROCEDURE, Auto Headlight Beam Leveler System.>

C: INSPECTION

Check the removed parts for wear, damage and crack, and repair or replace them if faulty.

10. General Diagnostic Table

A: INSPECTION

1. IMPROPER VEHICLE POSTURE OR IMPROPER WHEEL ARCH HEIGHT

Possible cause	Corrective action
(1) Permanent distortion or damaged coil spring	Replace.
(2) Rough operation of strut or shock absorber	Replace.
(3) Improper installation of strut or shock absorber	Replace with proper parts.
(4) Installation of the wrong coil spring	Replace with proper parts.

2. POOR RIDE COMFORT

- 1) Large rebound shock
- 2) Rocking of the vehicle continues too long after running over bump and hump.
- 3) Excessive shock in bumping

Possible cause	Corrective action
(1) Damaged coil spring	Replace.
(2) Overinflation of tires	Adjust.
(3) Improper wheel arch height	Adjust or replace the coil springs with new parts.
(4) Fault in operation of strut or shock absorber	Replace.
(5) Damage or deformation of strut mount or shock absorber mount	Replace.
(6) Unsuitable length (maximum or minimum) of strut or shock absorber	Replace with appropriate parts.
(7) Deformation or loss of bushing	Replace.
(8) Deformation or damage of helper in strut assembly or shock absorber	Replace.
(9) Oil leakage from the strut or shock absorber	Replace.

3. NOISE

Possible cause	Corrective action
(1) Wear or damage of strut or shock absorber component parts	Replace.
(2) Loosening of the suspension link installing bolt	Tighten to the specified torque.
(3) Deformation or loss of bushing	Replace.
(4) Unsuitable length (maximum or minimum) of strut or shock absorber	Replace with appropriate parts.
(5) Damaged coil spring	Replace.
(6) Wear or damage of the ball joint	Replace.
(7) Deformation of the stabilizer clamp	Replace.

General Diagnostic Table

REAR SUSPENSION

WHEEL AND TIRE SYSTEM

WT

	Page
1. General Description	2
2. Tire	5
3. Aluminum Wheel	6
4. Steel Wheel	7
5. Wheel Balancing	8
6. "T-type" Tire	10
7. Full Wheel Cap	11
8. Tire Pressure Monitoring System	12
9. General Diagnostic Table	14

General Description

WHEEL AND TIRE SYSTEM

1. General Description

A: SPECIFICATION

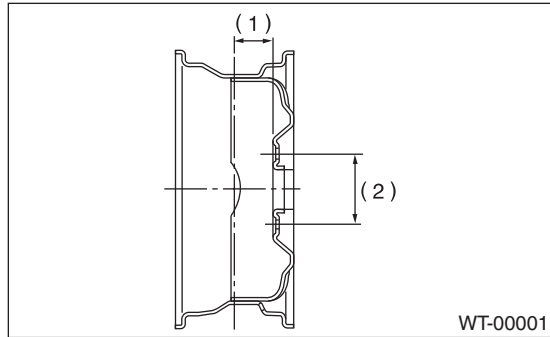

- (1) Offset
(2) P.C.D.

Model	Tire size	Wheel size	Offset mm (in)	P.C.D. mm (in)	Tire inflation pressure kPa (kgf/cm ² , psi)	
					Front wheel	Rear wheel
Non-turbo	P215/65R16 96H	16 × 6 ¹ / ₂ J 16 × 6 ¹ / ₂ JJ	48 (1.89)	100 (3.94)	210 (2.1, 30)	200 (2.0, 29)
Turbo	P225/55R17 95H	17 × 7JJ			220 (2.2, 32)	210 (2.1, 30)
Spare tire	T155/70D17 110M	17 × 4T	40 (1.57)		–	420 (4.2, 60)
	P215/65R16 96H (C4 only)	16 × 6 ¹ / ₂ JJ	48 (1.89)		–	200 (2.0, 29)
	P225/55R17 95H (C4 only)	17 × 7JJ			–	210 (2.1, 30)

NOTE:

- T-type tire is prepared for temporary use as a spare tire.
- The equipped spare tire differs depending on model destination.

General Description

WHEEL AND TIRE SYSTEM

1. SERVICE DATA

Part	Axial runout	Radial runout
Steel wheel	1.5 mm (0.059 in)	
Aluminum wheel	1.0 mm (0.039 in)	

2. ADJUSTING PARTS

Wheel balancing	Standard:	Service limit
Dynamic unbalance	5 g (0.18 oz) or less	

Balance weight part number (Knock-on type weight for steel wheels)	Weight
28101TC000	5 g (0.18 oz)
28101SA060	10 g (0.35 oz)
28101SA070	15 g (0.53 oz)
28101SA080	20 g (0.71 oz)
28101SA090	25 g (0.88 oz)
28101SA160	30 g (1.06 oz)
28101SA170	35 g (1.23 oz)
28101SA180	40 g (1.41 oz)
28101SA190	45 g (1.59 oz)
28101SA200	50 g (1.76 oz)
28101SA210	55 g (1.94 oz)
28101SA220	60 g (2.12 oz)

Balance weight part number (Knock-on type weight for aluminum wheel)	Weight
28101SA000	5 g (0.18 oz)
28101SA010	10 g (0.35 oz)
28101SA020	15 g (0.53 oz)
28101SA030	20 g (0.71 oz)
28101SA040	25 g (0.88 oz)
28101SA100	30 g (1.06 oz)
28101SA110	35 g (1.23 oz)
28101SA120	40 g (1.41 oz)
28101SA130	45 g (1.59 oz)
28101SA140	50 g (1.76 oz)
—	55 g (1.94 oz)
28101SA150	60 g (2.12 oz)

Balance weight part number (Adhesive type weight for aluminum wheel)	Weight
28101AG002	5 g (0.18 oz)
28101AG012	7.5 g (0.26 oz)
28101AG022	10 g (0.35 oz)
28101AG032	12.5 g (0.44 oz)
28101AG042	15 g (0.53 oz)
28101AG052	17.5 g (0.62 oz)
28101AG062	20 g (0.71 oz)
28101AG072	22.5 g (0.79 oz)
28101AG082	25 g (0.88 oz)
28101AG092	27.5 g (0.97 oz)
28101AG102	30 g (1.06 oz)
28101AG112	32.5 g (1.15 oz)
28101AG122	35 g (1.23 oz)
28101AG132	37.5 g (1.32 oz)
28101AG142	40 g (1.41 oz)
28101AG152	42.5 g (1.50 oz)
28101AG162	45 g (1.59 oz)
28101AG172	47.5 g (1.68 oz)
28101AG182	50 g (1.76 oz)
28101AG192	52.5 g (1.85 oz)
28101AG202	55 g (1.94 oz)
28101AG212	57.5 g (2.03 oz)
28101AG222	60 g (2.12 oz)
28101AG232	62.5 g (2.20 oz)
28101AG242	65 g (2.29 oz)
28101AG252	67.5 g (2.38 oz)
28101AG262	70 g (2.47 oz)
28101AG272	72.5 g (2.56 oz)
28101AG282	75 g (2.65 oz)
28101AG292	77.5 g (2.73 oz)
28101AG302	80 g (2.82 oz)
28101AG312	82.5 g (2.91 oz)
28101AG322	85 g (3.00 oz)
28101AG332	87.5 g (3.09 oz)
28101AG342	90 g (3.17 oz)
28101AG352	92.5 g (3.26 oz)
28101AG362	95 g (3.35 oz)
28101AG372	97.5 g (3.44 oz)
28101AG382	100 g (3.53 oz)
28101SA300	102.5 g (3.62 oz)
28101SA310	105 g (3.70 oz)
28101SA320	107.5 g (3.79 oz)
28101SA330	110 g (3.88 oz)
28101SA340	112.5 g (3.97 oz)
28101SA350	115 g (4.06 oz)
28101SA360	117.5 g (4.14 oz)
28101SA370	120 g (4.23 oz)

General Description

WHEEL AND TIRE SYSTEM

B: COMPONENT

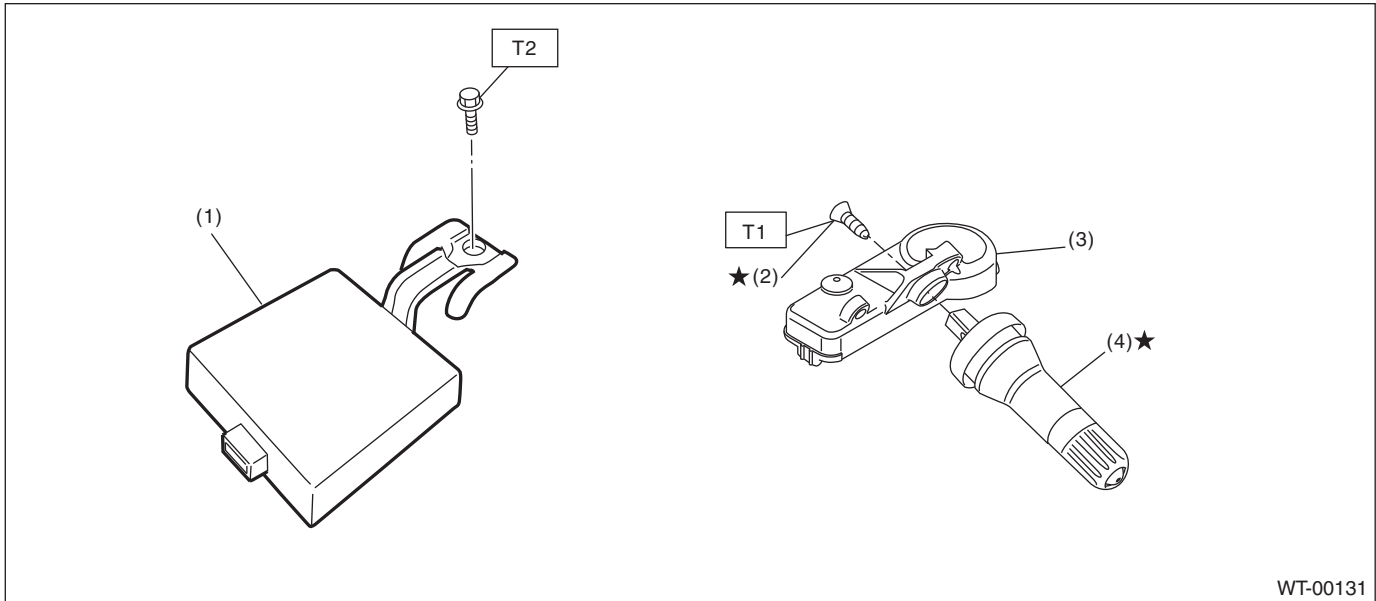

- (1) Tire pressure monitoring control module
(2) Screw
(3) Transmitter (Snap in type)
(4) Valve

Tightening torque:N-m (kgf-m, ft-lb)

T1: 1.4 (0.14, 1)

T2: 7.5 (0.76, 5.5)

C: PREPARATION TOOL

1. GENERAL TOOL

TOOL NAME	REMARKS
Air pressure gauge	Used for measuring tire air pressure.
Dial gauge	Used for measuring wheel runout.
Wheel balancer	Used for adjusting wheel balance.

2. Tire

A: INSPECTION

1) Take stones, glass, nails etc. out of the tread groove.

2) Replace tires in the following cases.

CAUTION:

- When replacing a tire, make sure to use only tires of the same size, construction and load range as originally installed.
- When the direction of tire rotation is specified, be careful not to install the tire to the wheel in the wrong direction.
- Use a tire changer when removing the tire from the wheel.
- On models equipped with tire pressure monitoring systems, do not use the bead breaker in a 90° area centered on the transmitter to prevent damaging the transmitter.

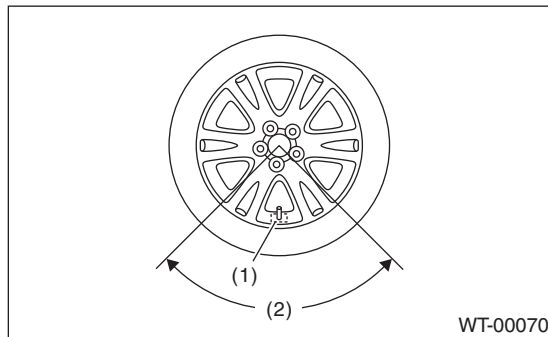

- (1) Transmitter
 (2) 90° (use of a bead breaker is prohibited in this area.)

- To prevent damaging the transmitter, set the tire changer boom in the position as shown in the figure.

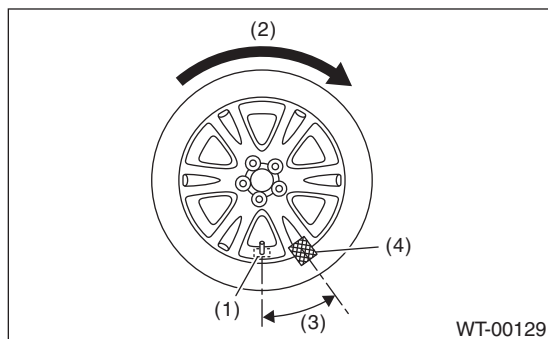

- (1) Transmitter
 (2) Direction of turn table rotation
 (3) 30°
 (4) Tire changer boom

(1) If large cracks on side wall, damage or cracks on the tread is found.

(2) When the “tread wear indicator” appears as a solid band across the tread.

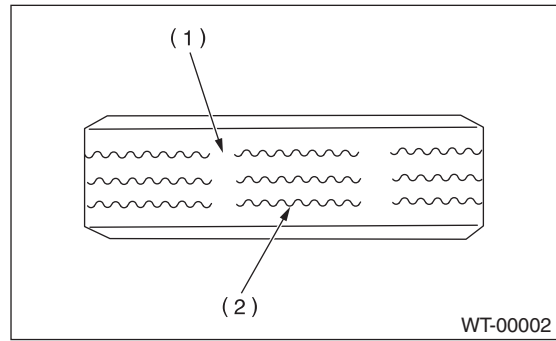

- (1) Tread wear indicator
 (2) Tire tread

3) When a crack on tire valve is found, replace the tire valve.

1. TIRE ROTATION

Rotate tires periodically (12,500 km/7,500 miles) as shown in the figure, in order to prevent them from uneven wear and to prolong their life.

- When the direction of tire rotation is not specified

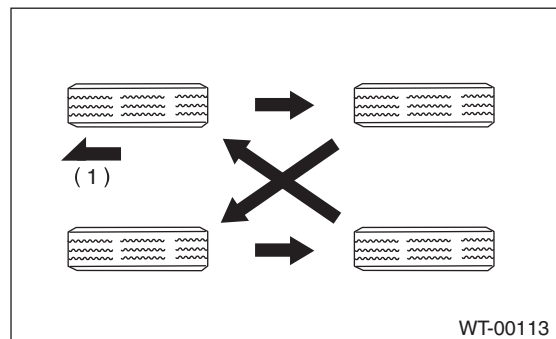

(1) Front

- When the direction of tire rotation is specified

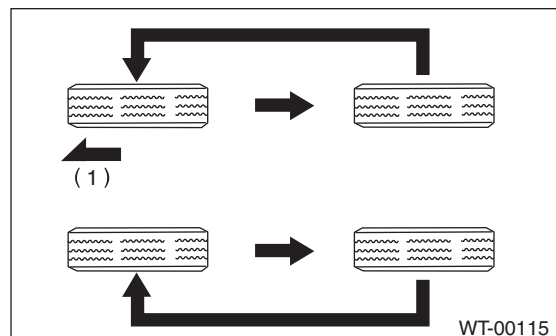

(1) Front

NOTE:

Vehicles equipped with tire pressure monitoring systems will require re-registration of transmitter ID. <Ref. to TPM(diag)-12, Register Transmitter (ID).>

Aluminum Wheel

WHEEL AND TIRE SYSTEM

3. Aluminum Wheel

A: REMOVAL

- 1) Apply the parking brake, and position select lever or shift lever to "P" range (AT model) or "1st gear" (MT model).
- 2) Set the shop jacks or a lift to the specified points, and support the vehicle with its wheels slightly contacting the floor.
- 3) Loosen the wheel nuts.
- 4) Raise the vehicle until its wheels are off the ground using the jack or a lift.
- 5) Remove the wheel nuts and wheels.

NOTE:

- When removing the wheels, be careful not to damage the hub bolts.
- Place the wheels with their outer sides facing upward to prevent wheels from being damaged.

B: INSTALLATION

- 1) Remove dirt from the mating surface of the wheel and brake rotor.
- 2) Attach the wheel to the hub by aligning the wheel bolt holes with the hub bolts.
- 3) Temporarily attach the wheel nuts to the hub bolts. (Use SUBARU genuine wheel nuts for aluminum wheels.)
- 4) Tighten the nuts by hand, making sure the wheel hub hole is aligned correctly to the guide portion of hub.
- 5) Tighten the wheel nuts in a diagonal selection to the specified torque. Use a wheel nut wrench.

Wheel nut tightening torque:

100 N·m (10.2 kgf·m, 73.8 ft·lb)

CAUTION:

- **Tighten the wheel nuts in two or three steps by gradually increasing the torque on opposing nuts, until they reach the specified torque.**
 - **Do not push the wrench by foot. Always use both hands when tightening the nuts.**
 - **Make sure the bolt, nut and the nut seating surface of the wheel are free from oil.**
- 6) If a wheel is removed for replacement or for repair of a puncture, retighten the wheel nuts to the specified torque after driving 1,000 km (600 miles).

C: INSPECTION

- 1) Deformation or damage to the rim may cause air leakage. Check the rim flange for deformation, cracks or damage, and repair or replace as necessary.
- 2) Jack-up the vehicle until wheels clear the floor.
- 3) Slowly rotate the wheel to check rim "runout" using a dial gauge.

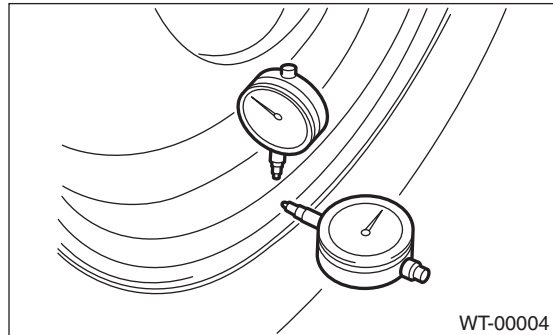

Axial runout limit	Radial runout limit
1.0 mm (0.039 in)	

- 4) If the rim runout exceeds specifications, replace the wheel.

D: CAUTION

Aluminum wheels are easily scratched. To maintain their appearance and safety, be careful of the following:

- 1) Be careful not to damage the aluminum wheels during removal, installation, wheel balancing, etc. After removing aluminum wheels, place them on a rubber mat etc.
- 2) When washing the aluminum wheel, use neutral synthetic detergent and water. Avoid using cleansers containing abrasives, hard brushes or an automatic car washer.

4. Steel Wheel

A: REMOVAL

Refer to “Aluminum Wheel” for removal procedure of steel wheels. <Ref. to WT-6, REMOVAL, Aluminum Wheel.>

B: INSTALLATION

Refer to “Aluminum Wheel” for installation procedure of steel wheels. <Ref. to WT-6, INSTALLATION, Aluminum Wheel.>

C: INSPECTION

Refer to “Aluminum Wheel” for inspection procedure of steel wheels. <Ref. to WT-6, INSPECTION, Aluminum Wheel.>

Rim runout

Axial runout limit	Radial runout limit
1.5 mm (0.059 in)	

Wheel Balancing

WHEEL AND TIRE SYSTEM

5. Wheel Balancing

A: ADJUSTMENT

NOTE:

Change the setting of wheel balancer to adhesive type weight if adhesive type weight is adopted.

1) Remove the balance weights.

CAUTION:

- Be careful not to damage the wheel.
- Completely remove the double-sided tape of the adhesive weight from the wheel.

2) Using the wheel balancer, measure wheel balance.

3) Select a weight close to the value measured by wheel balancer.

CAUTION:

Use SUBARU genuine balance weights.

Balance weight part number (Knock-on type weight for steel wheels)	Weight
28101TC000	5 g (0.18 oz)
28101SA060	10 g (0.35 oz)
28101SA070	15 g (0.53 oz)
28101SA080	20 g (0.71 oz)
28101SA090	25 g (0.88 oz)
28101SA160	30 g (1.06 oz)
28101SA170	35 g (1.23 oz)
28101SA180	40 g (1.41 oz)
28101SA190	45 g (1.59 oz)
28101SA200	50 g (1.76 oz)
28101SA210	55 g (1.94 oz)
28101SA220	60 g (2.12 oz)

Balance weight part number (Knock-on type weight for aluminum wheel)	Weight
28101SA000	5 g (0.18 oz)
28101SA010	10 g (0.35 oz)
28101SA020	15 g (0.53 oz)
28101SA030	20 g (0.71 oz)
28101SA040	25 g (0.88 oz)
28101SA100	30 g (1.06 oz)
28101SA110	35 g (1.23 oz)
28101SA120	40 g (1.41 oz)
28101SA130	45 g (1.59 oz)
28101SA140	50 g (1.76 oz)
—	55 g (1.94 oz)
28101SA150	60 g (2.12 oz)

Balance weight part number (Adhesive type weight for aluminum wheel)	Weight
28101AG002	5 g (0.18 oz)
28101AG012	7.5 g (0.26 oz)
28101AG022	10 g (0.35 oz)
28101AG032	12.5 g (0.44 oz)
28101AG042	15 g (0.53 oz)
28101AG052	17.5 g (0.62 oz)
28101AG062	20 g (0.71 oz)
28101AG072	22.5 g (0.79 oz)
28101AG082	25 g (0.88 oz)
28101AG092	27.5 g (0.97 oz)
28101AG102	30 g (1.06 oz)
28101AG112	32.5 g (1.15 oz)
28101AG122	35 g (1.23 oz)
28101AG132	37.5 g (1.32 oz)
28101AG142	40 g (1.41 oz)
28101AG152	42.5 g (1.50 oz)
28101AG162	45 g (1.59 oz)
28101AG172	47.5 g (1.68 oz)
28101AG182	50 g (1.76 oz)
28101AG192	52.5 g (1.85 oz)
28101AG202	55 g (1.94 oz)
28101AG212	57.5 g (2.03 oz)
28101AG222	60 g (2.12 oz)
28101AG232	62.5 g (2.20 oz)
28101AG242	65 g (2.29 oz)
28101AG252	67.5 g (2.38 oz)
28101AG262	70 g (2.47 oz)
28101AG272	72.5 g (2.56 oz)
28101AG282	75 g (2.65 oz)
28101AG292	77.5 g (2.73 oz)
28101AG302	80 g (2.82 oz)
28101AG312	82.5 g (2.91 oz)
28101AG322	85 g (3.00 oz)
28101AG332	87.5 g (3.09 oz)
28101AG342	90 g (3.17 oz)
28101AG352	92.5 g (3.26 oz)
28101AG362	95 g (3.35 oz)
28101AG372	97.5 g (3.44 oz)
28101AG382	100 g (3.53 oz)
28101SA300	102.5 g (3.62 oz)
28101SA310	105 g (3.70 oz)
28101SA320	107.5 g (3.79 oz)
28101SA330	110 g (3.88 oz)
28101SA340	112.5 g (3.97 oz)
28101SA350	115 g (4.06 oz)
28101SA360	117.5 g (4.14 oz)
28101SA370	120 g (4.23 oz)

4) Install the selected weight to the point designated by the wheel balancer.

CAUTION:

- Degrease the wheel surface where the adhesive type weight will be applied.
- Press the adhesive type weight by 25 N (2.5 kgf, 5.6 lbf) or more per 5 g (0.18 oz) for 2 seconds or more and attain full adhesion.
- Total application of the adhesive type weight should be 120 g (4.23 oz) or less.

5) Using the wheel balancer, measure the wheel balance again. Check that wheel balance is correctly adjusted.

B: INSPECTION

1) When a tire is replaced or worn, proper wheel balance may be lost. Check the tire dynamic balance and repair if necessary.

2) When checking the dynamic balance, use the wheel balancer. Insert the balance weights into the top and the rear side of rim.

3) With some types of balancer, wheels may be damaged. When adjusting the wheel balance, use a proper balancer.

4) Use Subaru genuine balance weights.

NOTE:

- Balance weights are not available in 55 g (1.94 oz) size for aluminum wheels.
- Balance weights can be used for any 15 to 18-inch wheels.

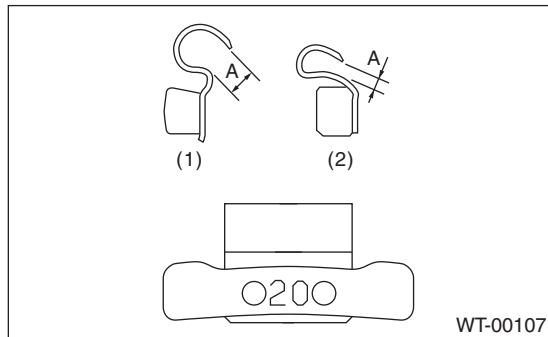

- (1) Knock-on type weight for aluminum wheel
- (2) Knock-on type weight for steel wheel

Service limit A:

Knock-on type weight for steel wheel:
2.0 mm (0.079 in)

Knock-on type weight for aluminum wheel:
5.0 mm (0.197 in)

6. “T-type” Tire

A: NOTE

“T-type” tire for temporary use is prepared as a spare tire.

CAUTION:

- Do not use tire chains for “T-type” tires. Because tire size is small, tire chains can not be installed and will damage the vehicle and tires.
- Do not drive at a speed greater than 80 km/h (50 MPH).
- Drive the vehicle as slowly as possible and avoid bumps on the road.

B: REPLACEMENT

Refer to “Removal/Installation of Steel Wheels” for removal and installation procedures of the “T-type” tire. <Ref. to WT-7, Steel Wheel.>

CAUTION:

The “T-type” tire is only for temporary use. Replace with a conventional tire as soon as possible.

C: INSPECTION

- 1) Check the tire air pressure.

Specifications:

420 kPa (4.2 kgf/cm², 60 psi)

- 2) Take stones, glass, nails etc. out of the tread groove.
- 3) Check the tires for deformation, cracks, partial wear, or wear.

7. Full Wheel Cap

A: REMOVAL

Insert a remover into the notch located diagonally to the valve hole, and remove the cap by prying the remover to the tire side.

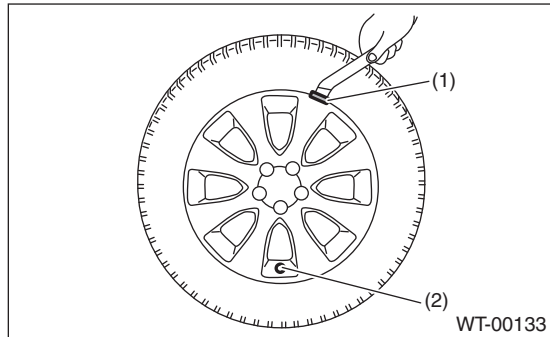

- (1) Cutout portion
- (2) Valve hole

B: INSTALLATION

- 1) Align the valve with the valve hole in the hubcap.
- 2) Install the hubcap by tapping it in the order from (1) to (3) described in the figure.

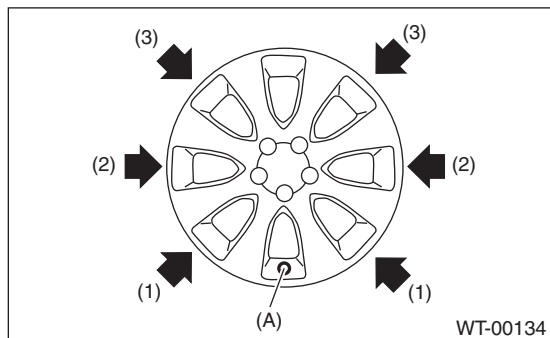

- (A) Valve hole

C: INSPECTION

Check the hubcap for damage.

Tire Pressure Monitoring System

WHEEL AND TIRE SYSTEM

8. Tire Pressure Monitoring System

A: REMOVAL

1. TRANSMITTER (SNAP IN TYPE)

- 1) Remove the wheels from the vehicle. <Ref. to WT-7, REMOVAL, Steel Wheel.>
- 2) Remove the tires from wheels.

CAUTION:

Use a tire changer when removing the tire from the wheel.

- 3) Loosen the screw to remove the transmitter from the valve stem.

NOTE:

Replace the valve and screw with a new part when reusing transmitter.

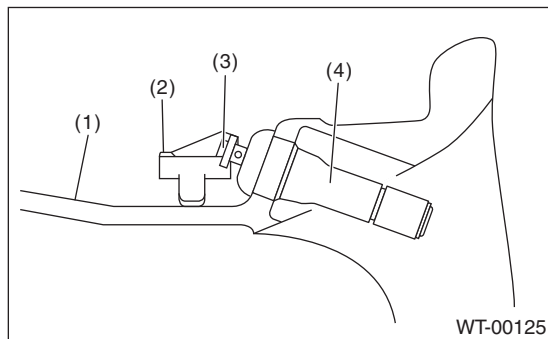

- (1) Wheel
- (2) Transmitter
- (3) Screw
- (4) Valve

- 4) Remove the valve from the wheel.

2. TIRE PRESSURE MONITORING CONTROL MODULE

- 1) Remove the canister. <Ref. to EC(H4SO)-5, REMOVAL, Canister.>
- 2) Remove the connector to remove tire pressure monitoring control module.

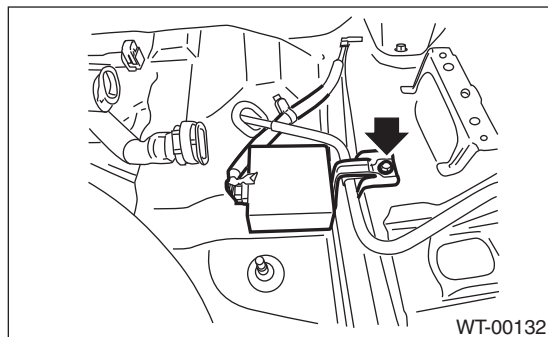

B: INSTALLATION

1. TRANSMITTER (SNAP IN TYPE)

CAUTION:

Use the new transmitter assembly or replace the new valve and screw, when installing.

- 1) Replace the valve and screw with a new part when reusing transmitter.

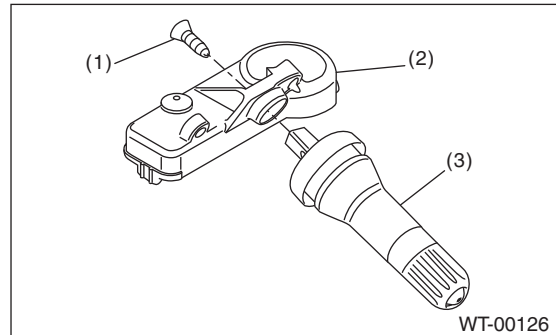

- (1) Screw
- (2) Transmitter
- (3) Valve

Tightening torque:

1.4 N·m (0.14 kgf·m, 1 ft·lb)

- 2) Install the transmitter to the wheel by aligning it with the valve hole.

NOTE:

When using the jig that pulls the valve cap by hooking its neck part, use another short-type cap.

- 3) Install the tires to wheels.

CAUTION:

- Use a tire changer when installing tire to wheel.
- To prevent damaging the transmitter, set the tire changer boom in the position as shown in the figure.

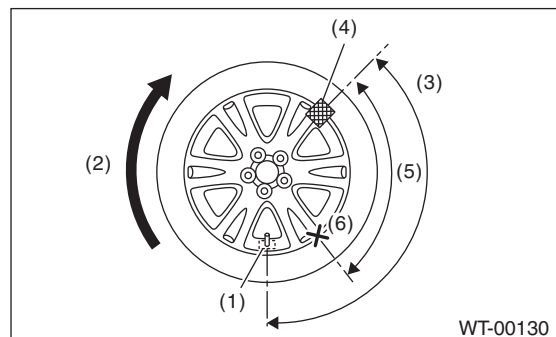

- (1) Transmitter
- (2) Direction of turn table rotation
- (3) 135°
- (4) Tire changer boom
- (5) 90°
- (6) Starting point for fitting the bead to the rim

4) Install the wheels to vehicle. <Ref. to WT-7, INSTALLATION, Steel Wheel.>

5) Register the transmitter ID to the tire pressure monitoring control module. <Ref. to TPM(diag)-12, Register Transmitter (ID).>

2. TIRE PRESSURE MONITORING CONTROL MODULE

Install in the reverse order of removal.

Tightening torque:

7.5 N·m (0.76 kgf-m, 5.5 ft-lb)

C: ADJUSTMENT

Re-register the transmitter ID when transmitter has been replaced. <Ref. to TPM(diag)-12, Register Transmitter (ID).>

General Diagnostic Table

WHEEL AND TIRE SYSTEM

9. General Diagnostic Table

A: INSPECTION

Symptoms	Possible cause	Corrective action
Wheel is out of balance.	Improperly inflated tire.	Adjust the tire pressure.
	Uneven wear	Check the tire referring to Abnormal tire wear in this table, carry out the procedure and replace the tire.
	Front wheel alignment	Check the front wheel alignment. <Ref. to FS-7, INSPECTION, Wheel Alignment.>
	Rear wheel alignment	Check the rear wheel alignment. <Ref. to RS-7, INSPECTION, Wheel Alignment.>
	Front strut	Check the front strut. <Ref. to FS-25, INSPECTION, Front Strut.>
	Rear shock absorber	Check the rear shock absorber. <Ref. to RS-12, INSPECTION, Rear Shock Absorber.>
	Front axle	Check the front axle. <Ref. to DS-17, INSPECTION, Front Axle.>
	Front hub unit bearing	Check the front hub unit bearing. <Ref. to DS-19, INSPECTION, Front Hub Unit Bearing.>
	Rear hub unit bearing	Check the rear hub unit bearing. <Ref. to DS-26, INSPECTION, Rear Hub Unit Bearing.>
Vehicle is abnormally out of balance.	Improperly inflated tire.	Adjust the tire pressure.
	Uneven wear	Check the tire referring to Abnormal tire wear in this table, carry out the procedure and replace the tire.
	Front stabilizer	Inspect the front stabilizer. <Ref. to FS-16, INSPECTION, Front Stabilizer.>
	Front wheel alignment	Check the front wheel alignment. <Ref. to FS-7, INSPECTION, Wheel Alignment.>
	Rear wheel alignment	Check the rear wheel alignment. <Ref. to RS-7, INSPECTION, Wheel Alignment.>
Abnormal wheel vibration	Improperly inflated tire.	Adjust the tire pressure.
	Uneven wear	Check the tire referring to Abnormal tire wear in this table, carry out the procedure and replace the tire.
	Improper wheel balancing	Check the wheel balance. <Ref. to WT-8, ADJUSTMENT, Wheel Balancing.>
	Front axle	Check the front axle. <Ref. to DS-17, INSPECTION, Front Axle.>
	Front hub unit bearing	Check the front hub unit bearing. <Ref. to DS-19, INSPECTION, Front Hub Unit Bearing.>
	Rear hub unit bearing	Check the rear hub unit bearing. <Ref. to DS-26, INSPECTION, Rear Hub Unit Bearing.>
Abnormal tire wear	Improperly inflated tire.	Adjust the tire pressure.
	Improper wheel balancing	Check the wheel balance. <Ref. to WT-8, ADJUSTMENT, Wheel Balancing.>
	Front wheel alignment	Check the front wheel alignment. <Ref. to FS-7, INSPECTION, Wheel Alignment.>
	Rear wheel alignment	Check the rear wheel alignment. <Ref. to RS-7, INSPECTION, Wheel Alignment.>

TIRE PRESSURE MONITORING SYSTEM (DIAGNOSTICS)

TPM(diag)

	Page
1. Basic Diagnostic Procedure	2
2. General Description	3
3. Electrical Component Location	5
4. Control Module I/O Signal	6
5. Subaru Select Monitor	8
6. Read Diagnostic Trouble Code (DTC)	9
7. Clear Memory Mode	10
8. Read Current Data	11
9. Register Transmitter (ID)	12
10. Display Transmitter (Id)	13
11. Inspection Mode	14
12. Tire Pressure Warning Light / Trouble Indicator Light Illumination Pattern	15
13. Diagnostic Procedure for Subaru Select Monitor Communication	22
14. List of Diagnostic Trouble Code (DTC)	25
15. Diagnostic Procedure with Diagnostic Trouble Code (DTC)	27
16. General Diagnostic Table	37

Basic Diagnostic Procedure

TIRE PRESSURE MONITORING SYSTEM (DIAGNOSTICS)

1. Basic Diagnostic Procedure

A: PROCEDURE

CAUTION:

Remove foreign matter (dust, water, oil etc.) from the tire pressure monitoring control module connector when removing or installing.

NOTE:

To check harness for open or short circuits, shake the suspected trouble spot or connector.

Step	Check	Yes	No
1 CHECK PRE-INSPECTION. 1) Check with the user regarding when the warning light lit or started blinking. 2) Before performing diagnostics, check all components which may adversely affect the tire pressure monitor system. <Ref. to TPM(diag)-3, INSPECTION, General Description.>	Is the component that might affect the tire pressure monitor system normal?	Go to step 2.	Repair or replace each component.
2 CHECK DIAGNOSTIC TROUBLE CODE (DTC). 1) Turn the ignition switch to OFF. 2) Connect the Subaru Select Monitor to data link connector. 3) Turn the ignition switch to ON and run the Subaru Select Monitor. NOTE: If the communication function of the Subaru Select Monitor cannot be executed normally, check the communication circuit. <Ref. to TPM(diag)-22, Diagnostic Procedure for Subaru Select Monitor Communication.> 4) Read the DTC. <Ref. to TPM(diag)-9, OPERATION, Read Diagnostic Trouble Code (DTC).>	Is DTC displayed?	Go to step 4.	Go to step 3.
3 PERFORM GENERAL DIAGNOSTICS. 1) Perform the inspection by referring to "General Diagnostic Table". <Ref. to TPM(diag)-37, General Diagnostic Table.> 2) Perform the Clear Memory Mode. <Ref. to TPM(diag)-10, Clear Memory Mode.> 3) Perform the Inspection Mode. <Ref. to TPM(diag)-14, Inspection Mode.> 4) Read the DTC. <Ref. to TPM(diag)-9, Read Diagnostic Trouble Code (DTC).> Check that there is no DTC displayed.	Does the tire pressure warning light illuminates for about 2 seconds and then goes off after turning on the ignition switch, and then go out?	Finish the diagnosis.	Check by referring to "Diagnostic Procedure for TPM". <Ref. to TPM(diag)-15, Tire Pressure Warning Light / Trouble Indicator Light Illumination Pattern.>
4 PERFORM DIAGNOSIS. 1) Refer to "List of Diagnostic Trouble Code (DTC)". 2) Correct the cause of trouble. 3) Perform the Clear Memory Mode. <Ref. to TPM(diag)-10, Clear Memory Mode.> 4) Perform the drive test. Drive the vehicle at 40 km/h (25 MPH) or faster for at least 10 minutes. 5) Read the DTC. <Ref. to TPM(diag)-9, Read Diagnostic Trouble Code (DTC).>	Is DTC displayed?	Repeat steps 1 to 4 until DTC is not shown.	Finish the diagnosis.

General Description

TIRE PRESSURE MONITORING SYSTEM (DIAGNOSTICS)

2. General Description

A: CAUTION

1. SUPPLEMENTAL RESTRAINT SYSTEM “AIRBAG”

Airbag system wiring harness is routed near the TPM control module.

CAUTION:

- All airbag system wiring harnesses are yellow. Do not use the electrical test equipment on these circuits.
- Be careful not to damage the airbag system wiring harness when servicing the tire pressure monitoring control module.

2. TIRE PRESSURE MONITORING CONTROL MODULE

- If the transmitter is replaced, ID registration for the transmitter is required. <Ref. to TPM(diag)-12, Register Transmitter (ID).>
- When adjusting tire pressure indoors in winter, there is a big temperature difference between the indoor facilities and outside. Once the car is outside where the temperature is lower, the air pressure in the tires will drop, causing the tire pressure warning light to illuminate, even if the pressure in the tires was adjusted to standard values indoors. To avoid this, it is necessary to adjust the tire pressure to the high side in consideration of the difference in temperature between inside and outside according to the following table.
- 215/65R16

Temperature °C (°F)	Indoor temperature	15.5 (60)		
	Ambient temperature	-1 (30)	-12 (10)	-23 (-10)
Air pressure kPa (psi)	Front	230 (33)	240 (35)	255 (37)
	Rear	220 (32)	235 (34)	250 (36)

- 225/55R17

Temperature °C (°F)	Indoor temperature	15.5 (60)		
	Ambient temperature	-1 (30)	-12 (10)	-23 (-10)
Air pressure kPa (psi)	Front	240 (32)	255 (37)	270 (39)
	Rear	230 (33)	240 (35)	255 (37)

B: INSPECTION

Before performing diagnosis, check the following item which might affect the quality of the tire pressure monitoring system.

1. TIRE

- Inspect that the tire pressure is within the specification while the tire is cool. (Refer to Tire Caution Label.)
- Check the tires for damage or the insertion of foreign matters.

2. BATTERY

Check that amount of battery fluid, gravity and voltage are within the specifications.

Standard voltage: 12 V or more

Specific gravity: 1.260 or more

General Description

TIRE PRESSURE MONITORING SYSTEM (DIAGNOSTICS)

C: PREPARATION TOOL

1. SPECIAL TOOL

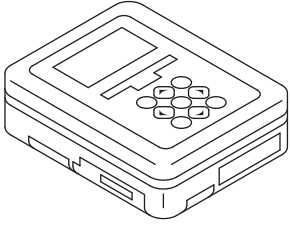
ILLUSTRATION	TOOL NUMBER	DESCRIPTION	REMARKS
 ST1B022XU0	1B022XU0 (Newly adopted tool)	SUBARU SELECT MONITOR III KIT	Used for troubleshooting the electrical system.

2. GENERAL TOOL

TOOL NAME	REMARKS
Circuit tester	Used for measuring resistance, voltage and current.
Transmitter registration tool	Used to register the transmitter ID. Manufacturer: Kent-Moore Item number: J45295

Electrical Component Location

TIRE PRESSURE MONITORING SYSTEM (DIAGNOSTICS)

3. Electrical Component Location

A: LOCATION

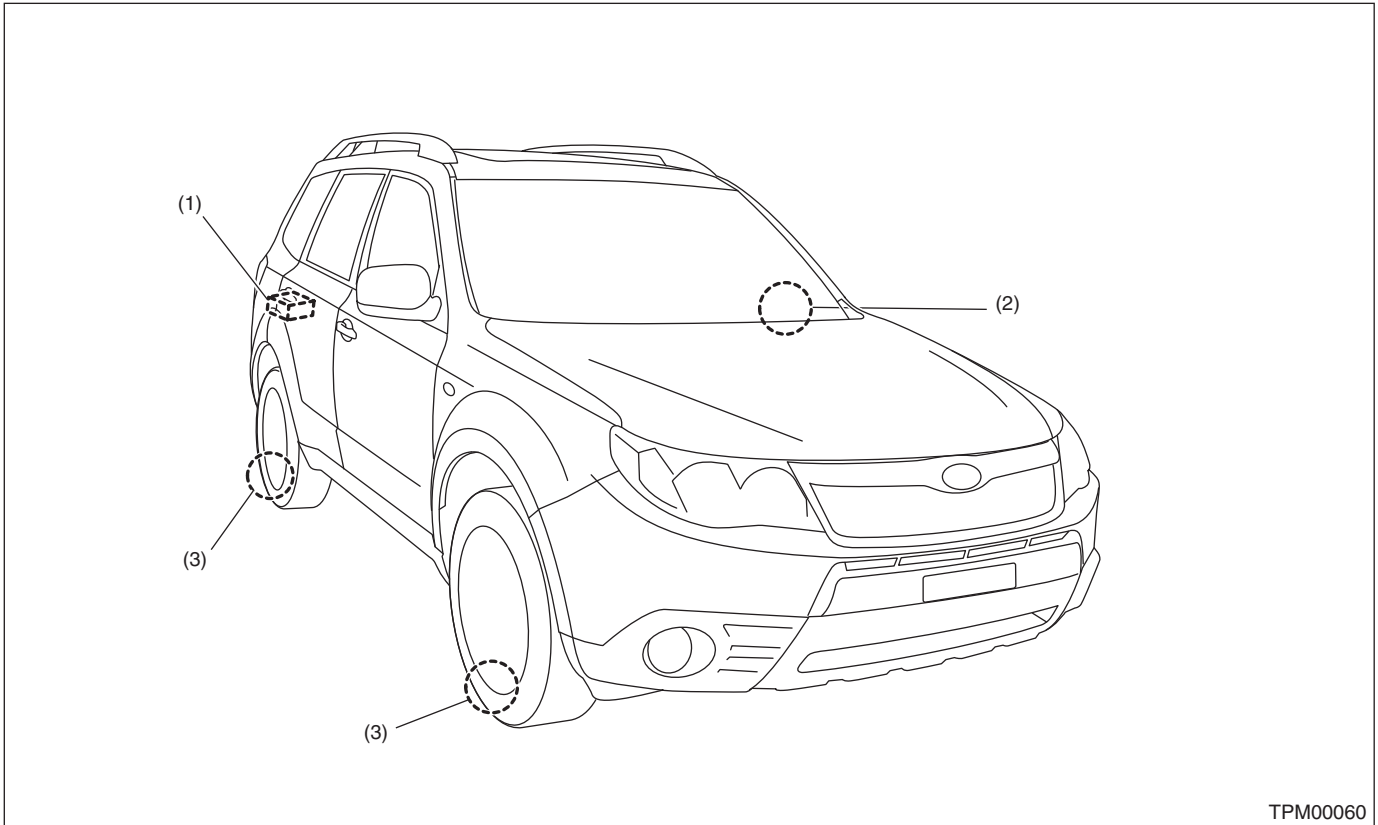

TPM00060

- (1) Tire pressure monitoring control module (2) Tire pressure warning light (3) Snap-in type transmitter

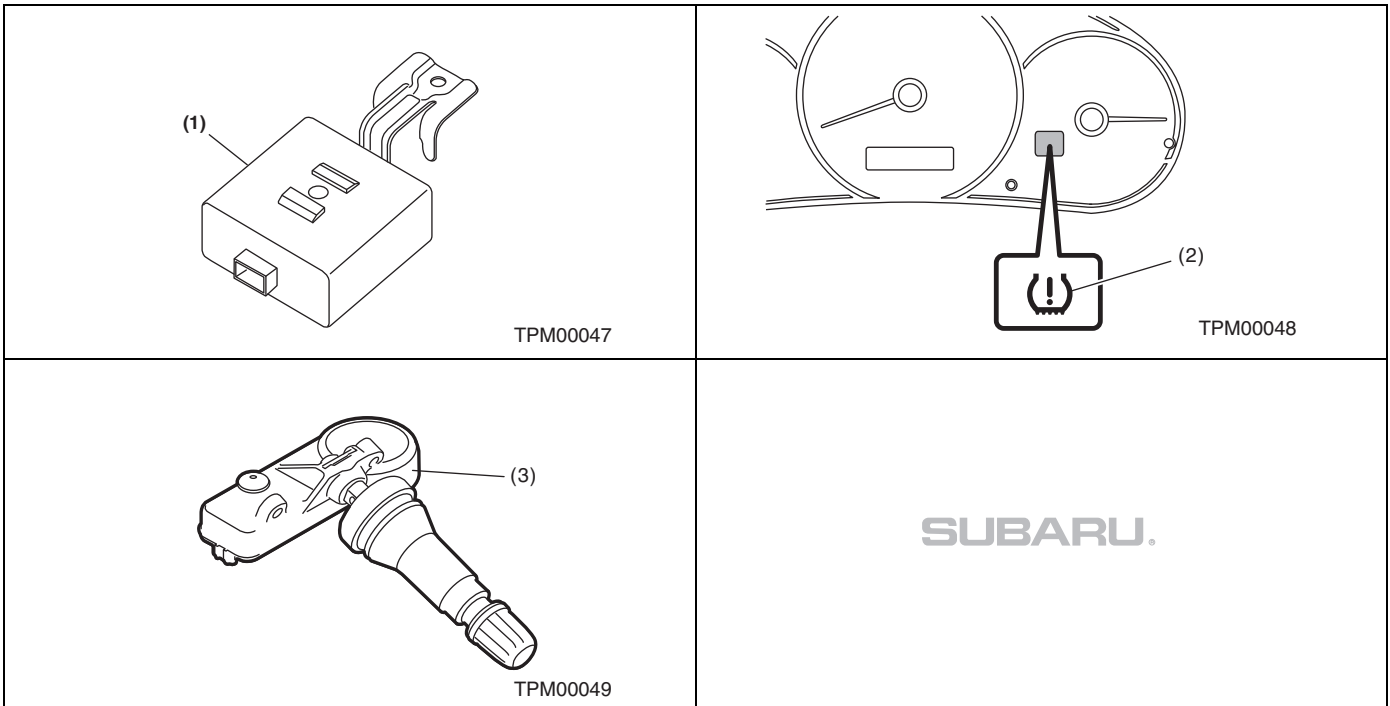

Control Module I/O Signal

TIRE PRESSURE MONITORING SYSTEM (DIAGNOSTICS)

4. Control Module I/O Signal

A: ELECTRICAL SPECIFICATION

Terminal No.	Measured value	Measuring condition	Remarks
1	Select monitor communication	Serial communication	—
2	Tire pressure warning light output	Illuminate when malfunction occurs, or tire pressure decreases	System failure: blinks 25 times → illuminates Tire pressure decreases: turns on
4	Speed sensor signal	While driving (Pulse signal)	Change according to vehicle speed
5	Ignition power supply	IG switch ON (Battery voltage)	—
6	Battery power supply	Battery voltage	Always
8	Body integrated unit (Hazard output signal).	—	When hazard turns on.
9	GND	0 V (Always)	Always

Control Module I/O Signal

TIRE PRESSURE MONITORING SYSTEM (DIAGNOSTICS)

B: WIRING DIAGRAM

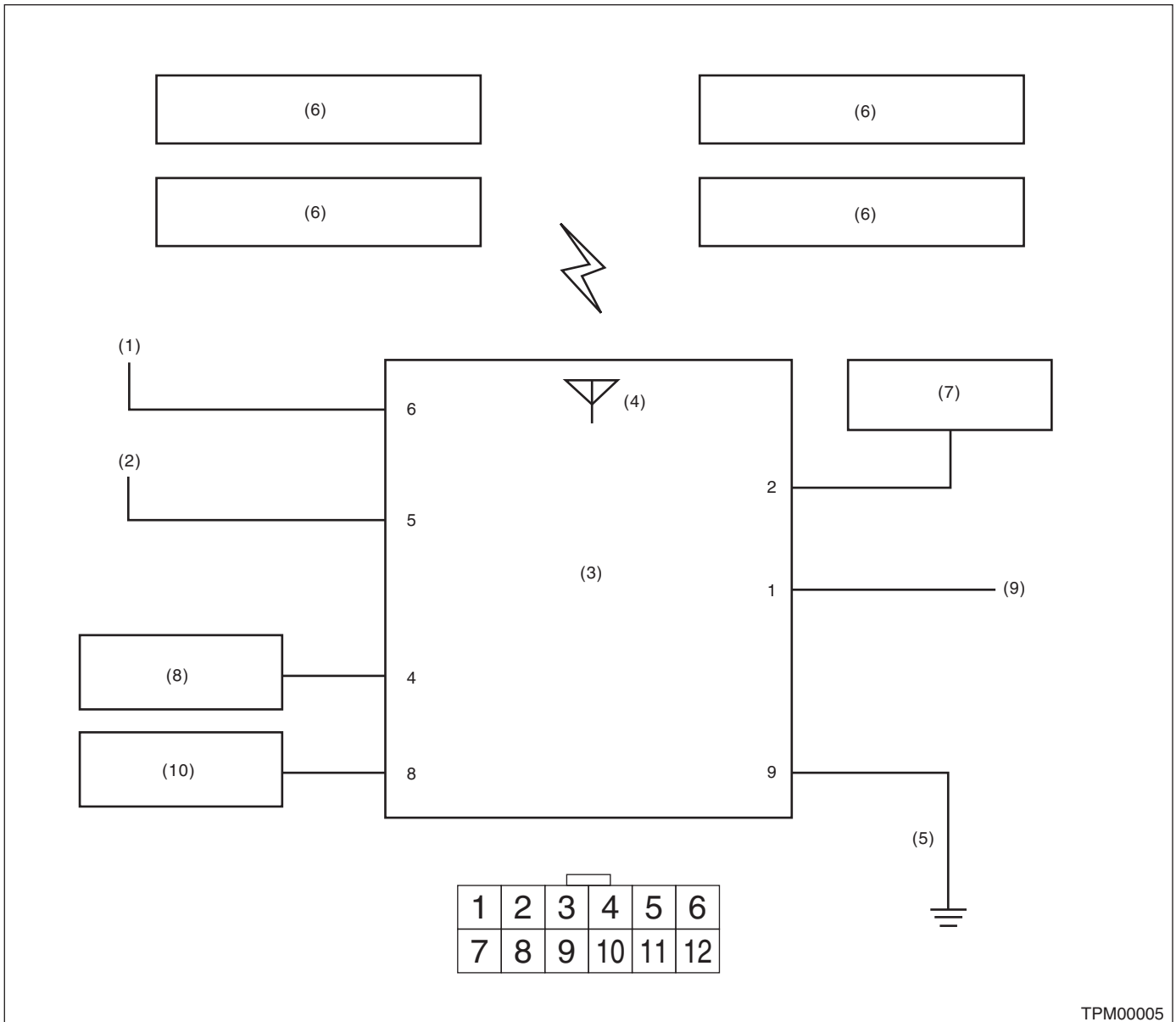

TPM00005

- | | | |
|---|-----------------------|---------------------------|
| (1) Battery power supply | (4) Antenna | (8) Vehicle speed signal |
| (2) Ignition power supply | (5) GND | (9) Subaru Select Monitor |
| (3) Tire pressure monitoring control module | (6) Transmitter | (10) Body integrated unit |
| | (7) Combination meter | |

Subaru Select Monitor

TIRE PRESSURE MONITORING SYSTEM (DIAGNOSTICS)

5. Subaru Select Monitor

A: OPERATION

1) Prepare the Subaru Select Monitor kit. <Ref. to TPM(diag)-4, SPECIAL TOOL, PREPARATION TOOL, General Description.>

2) Connect the diagnosis cable to the Subaru Select Monitor.

3) Connect the Subaru Select Monitor to the data link connector.

(1) The data link connector is located in the lower portion of the instrument panel (on the driver's side).

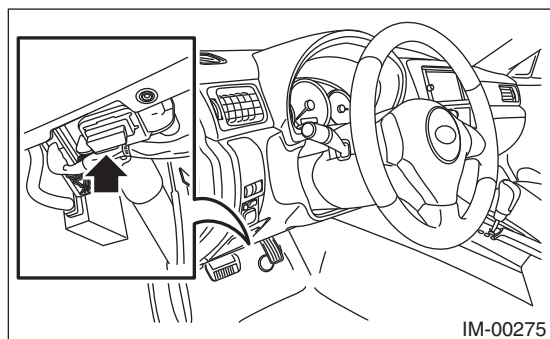

(2) Connect the diagnosis cable to the data link connector.

CAUTION:

Do not connect the scan tools other than the Subaru Select Monitor.

4) Turn the ignition switch to ON (engine OFF) and run the Subaru Select Monitor.

6. Read Diagnostic Trouble Code (DTC)

A: OPERATION

- 1) On the «Main Menu» display screen, select {Each System Check}.
- 2) On the «System Selection Menu», select {Tire pressure monitor}.
- 3) After {System Name} is displayed, select [OK].
- 4) On the «Tire pressure monitor diagnosis», select {Diagnostic Code(s) Display}.

NOTE:

- For details concerning the operation procedure, refer to the “PC application help for Subaru Select Monitor”.
 - For details concerning DTCs, refer to List of Diagnostic Trouble Codes (DTC). <Ref. to TPM(diag)-25, List of Diagnostic Trouble Code (DTC).>
 - All DTCs detected will be displayed.
 - If a particular DTC is not properly stored in memory (due to a voltage drop of the tire air pressure monitor control module power supply, etc.) when a problem occurs, a DTC suffixed with a question mark will appear on the Subaru Select Monitor display. This shows it may be an unreliable reading.
- 5) If communication is not possible between the tire pressure monitoring control module and the Subaru Select Monitor, check the communication circuit. <Ref. to TPM(diag)-22, Diagnostic Procedure for Subaru Select Monitor Communication.>
 - 6) When DTC is not displayed, check the indicator circuit and communication circuit. <Ref. to TPM(diag)-15, Tire Pressure Warning Light / Trouble Indicator Light Illumination Pattern.>

Clear Memory Mode

TIRE PRESSURE MONITORING SYSTEM (DIAGNOSTICS)

7. Clear Memory Mode

A: OPERATION

- 1) On the «Main Menu» display, select {2. Each System Check}.
- 2) On the «System Selection Menu», select {Tire Pressure Monitor}.
- 3) After the {Tire pressure monitor} is displayed, select [OK].
- 4) On the «Tire pressure monitor diagnosis», select {Clear Memory}.
- 5) When “Done” and “Turn Ignition Switch OFF” are shown on the display screen, end the Subaru Select Monitor and turn the ignition switch to OFF.

NOTE:

For details concerning the operation procedure, refer to the “PC application help for Subaru Select Monitor”.

Read Current Data

TIRE PRESSURE MONITORING SYSTEM (DIAGNOSTICS)

8. Read Current Data

A: OPERATION

- 1) On the «Main Menu», select {Each System Check}.
- 2) On the «System Selection Menu», select {Tire pressure monitor}.
- 3) After the {Tire pressure monitor} is displayed, select [OK].
- 4) On the «Tire pressure monitor diagnosis», select the {Data Display}, and then necessary data will be displayed.

B: LIST

Display	Contents to be monitored	Unit of measure
Tire 1 FN code	LEARN, LOW BAT, OFF, WAKE, RE ME, NORMAL	LEARN: Transmitted transmitter ID using the transmitter registration tool LOW BAT: Transmitter battery voltage running low OFF: Transmitter function stops (no data transmission) RE ME: Tire air changes ± 8.4 kPa WAKE: When data transmission is started from a stopped state. NORMAL: Conditions other than above
Tire 2 FN code		
Tire 3 FN code		
Tire 4 FN code		
Tire 1 air pressure	Value converted to tire pressure from data delivered from transmitter is displayed. (The figure may differ from the actual measured values.)	kPa, psig, mmHg, inHg
Tire 2 air pressure		kPa, psig, mmHg, inHg
Tire 3 air pressure		kPa, psig, mmHg, inHg
Tire 4 air pressure		kPa, psig, mmHg, inHg
Vehicle Speed	Vehicle speed signal which is input in control module.	km/h, MPH
Pressure warning	Threshold where tire pressure warning light illuminates	kPa, psig, mmHg, inHg
Return pressure	Threshold where tire pressure warning light goes out	kPa, psig, mmHg, inHg

Register Transmitter (ID)

TIRE PRESSURE MONITORING SYSTEM (DIAGNOSTICS)

9. Register Transmitter (ID)

A: OPERATION

Perform the procedures below to register the transmitter.

- Transmitter replaced.
- Replaced the tire pressure monitoring control module.

NOTE:

- If registration of the transmitter ID is not possible after 2 attempts, replace the tire pressure monitoring control module. <Ref. to WT-12, TIRE PRESSURE MONITORING CONTROL MODULE, REMOVAL, Tire Pressure Monitoring System.> <Ref. to WT-13, TIRE PRESSURE MONITORING CONTROL MODULE, INSTALLATION, Tire Pressure Monitoring System.>

- During the registration, turn the ignition switch to OFF and end the Subaru Select Monitor. Or if the registration is not performed for 5 minutes or more, the registration mode is cancelled.

- When rotating tires, there is no affect on the performance or functions of the tire pressure monitoring control module even if the transmitter (ID) is not registered, however, the tire position displayed on the Subaru Select Monitor will be incorrect.

1) Adjust all tire pressures to the specifications.

2) Connect Subaru Select Monitor and select {2. Each System Check} on the «Main Menu».

3) On the «System Selection Menu», select {Tire pressure monitor}.

4) After the {Tire pressure monitor} is displayed, select [OK].

5) On the «Tire pressure monitor diagnosis», select {Transmitter ID regist confirm}.

6) {ID registration mode when execute, Registered ID is deleted. Continue?} is displayed, select [OK].

7) Touch the transmitter registration tool to the side wall area near the air valve on the front left tire, and press the switch. The transmitter ID is sent to the tire pressure monitoring control module. (At that time, the tire pressure warning light blinks to confirm that the registration has started.)

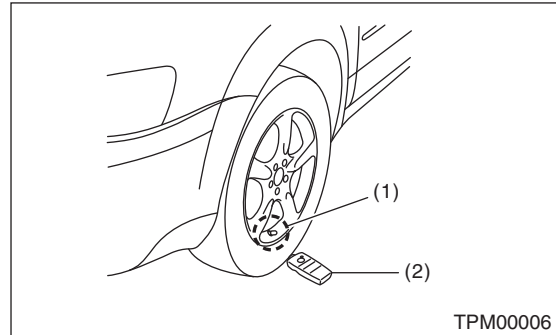

(1) Air valve (transmitter)

(2) Transmitter registration tool

NOTE:

- The registration order of transmitter ID is not specified.

- The transmitter registration tool is used by touching the side wall area near the transmitter.

- When registration of each tire is completed, the hazard light will blink and {ID registration completed} is displayed on the Select Monitor screen.

- If registration procedure stop in the halfway (turning ignition switch to OFF, wrong registration order, etc), proceed from step 5)

8) When ID registration is completed, the tire pressure warning light remains lit for approximately 2 seconds, to end the registration. Switch to the screen displaying the transmitter ID on the Subaru Select Monitor display. <Ref. to TPM(diag)-13, Display Transmitter (Id).>

9) Check the transmitter ID that was registered, then perform a driving test. <Ref. to TPM(diag)-14, Inspection Mode.>

10. Display Transmitter (Id)

A: OPERATION

- 1) On the «Main Menu», select {Each System Check}.
- 2) On the «System Selection Menu», select {Tire pressure monitor}.
- 3) After the {Tire pressure monitor} is displayed, select [OK].
- 4) On the «Tire pressure monitor diagnosis», select {Transmitter ID regist confirm}.
- 5) Select the {Transmitter ID data monitor} and then select [OK] to display the transmitter ID.

Inspection Mode

TIRE PRESSURE MONITORING SYSTEM (DIAGNOSTICS)

11. Inspection Mode

A: PROCEDURE

- Reproduce the malfunction occurrence condition as much as possible.
- Drive the vehicle at 40 km/h (25 MPH) or faster for approx. ten minutes.

Tire Pressure Warning Light / Trouble Indicator Light Illumination Pattern

TIRE PRESSURE MONITORING SYSTEM (DIAGNOSTICS)

12. Tire Pressure Warning Light / Trouble Indicator Light Illumination Pattern

A: INSPECTION

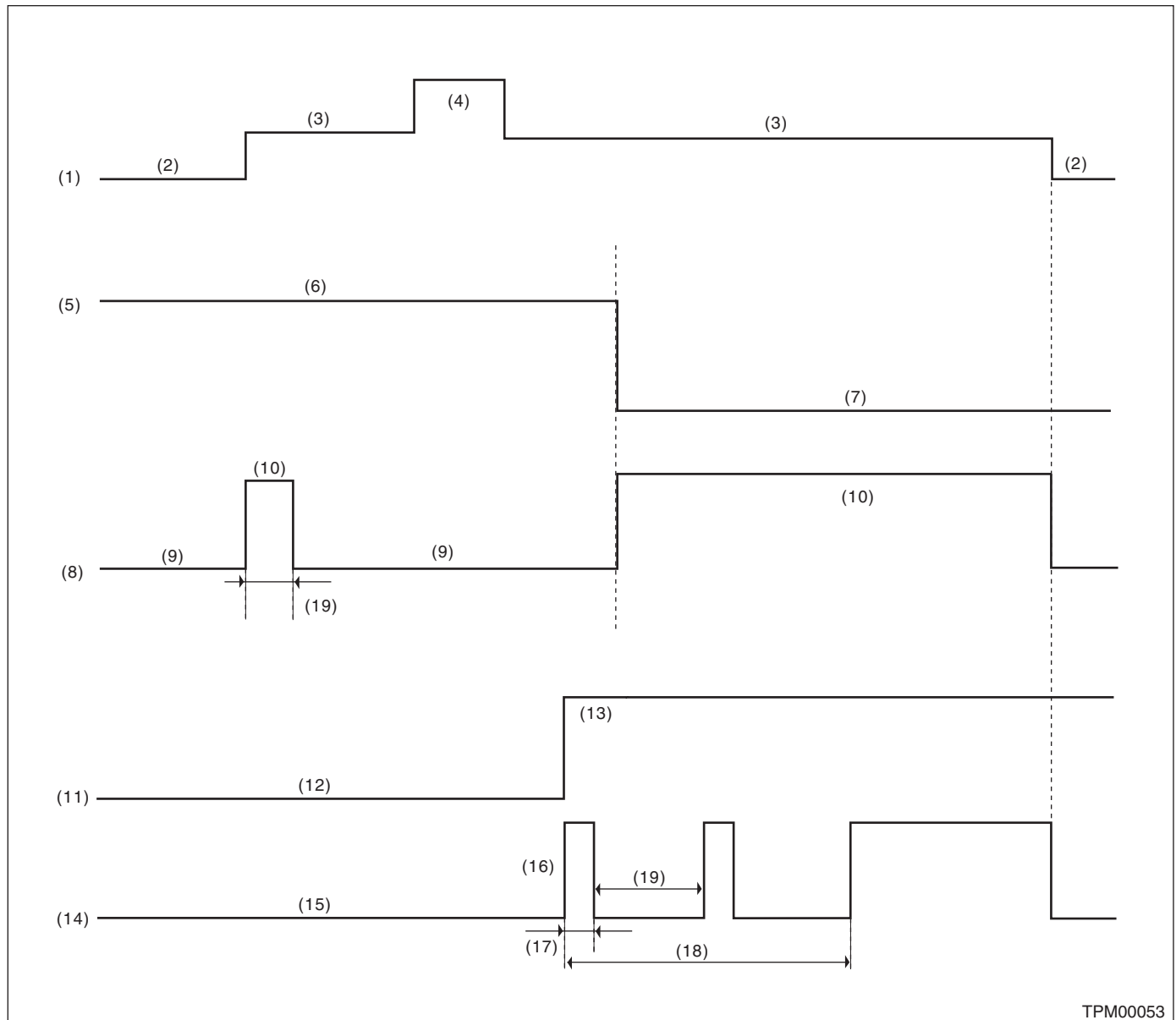

TPM00053

- | | | |
|---|---------------------------------|----------------------------------|
| (1) Ignition switch | (8) Tire pressure warning light | (14) Tire pressure warning light |
| (2) OFF | (9) Light OFF | (15) Light OFF |
| (3) ON | (10) Light ON | (16) Blink |
| (4) Start | (11) System status | (17) 1 second |
| (5) Tire pressure | (12) Normal | (18) Blinks 25 times |
| (6) Meet the specification | (13) Malfunction | (19) 2 seconds |
| (7) 186 kPa (1.86 kgf/cm ² , 27 psi) or less | | |

Tire Pressure Warning Light / Trouble Indicator Light Illumination Pattern

TIRE PRESSURE MONITORING SYSTEM (DIAGNOSTICS)

1) When the tire pressure warning light does not illuminate in accordance with this illumination pattern, there must be an electrical malfunction.

2) If the tire pressure warning light does not go off, check the tire pressure monitoring control module/warning light circuit and the combination meter circuit. <Ref. to TPM(diag)-18, TIRE PRESSURE WARNING LIGHT DOES NOT COME OFF, Tire Pressure Warning Light / Trouble Indicator Light Illumination Pattern.>

NOTE:

If the problem is fixed while driving at approximately 40 km/h (25 MPH) after the tire pressure warning light blinks/lights, the warning light goes out and the tire pressure monitor system operates normally. (If there is a decrease in tire pressure, or a malfunction of the system, the malfunction history is displayed.)

Tire Pressure Warning Light / Trouble Indicator Light Illumination Pattern

TIRE PRESSURE MONITORING SYSTEM (DIAGNOSTICS)

B: TIRE PRESSURE WARNING LIGHT DOES NOT COME ON

DETECTING CONDITION:

Defective combination meter

TROUBLE SYMPTOM:

When the ignition switch is turned to ON (engine OFF), the tire pressure warning light does not come on (for approximately 2 seconds).

WIRING DIAGRAM:

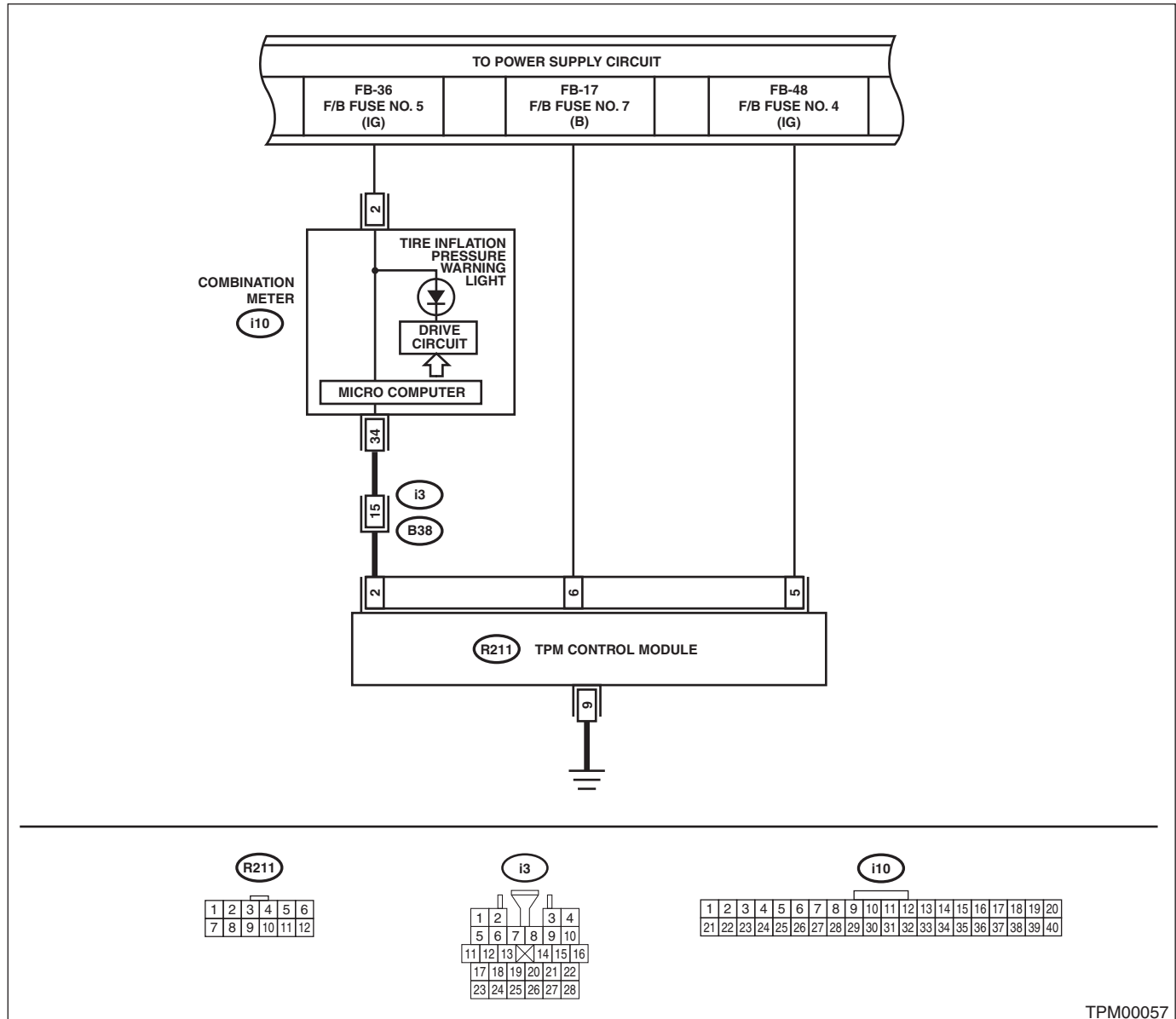

TPM00057

Step	Check	Yes	No	
1	<p>CHECK DIAGNOSTIC TROUBLE CODE (DTC). Connect the Subaru Select Monitor, and read the Diagnostic Trouble Code. <Ref. to TPM(diag)-9, Read Diagnostic Trouble Code (DTC).></p>	<p>Is diagnostics code (DTC) displayed?</p>	<p>Perform the diagnosis according to the DTC. <Ref. to TPM(diag)-25, List of Diagnostic Trouble Code (DTC).></p>	<p>Replace the combination meter. <Ref. to IDI-16, REMOVAL, Combination Meter.></p>

Tire Pressure Warning Light / Trouble Indicator Light Illumination Pattern

TIRE PRESSURE MONITORING SYSTEM (DIAGNOSTICS)

C: TIRE PRESSURE WARNING LIGHT DOES NOT COME OFF

DETECTING CONDITION:

- Defective combination meter
- Tires pressure drop
- Transmitter ID not registered

TROUBLE SYMPTOM:

Tire pressure warning light remains illuminating after engine starts.

WIRING DIAGRAM:

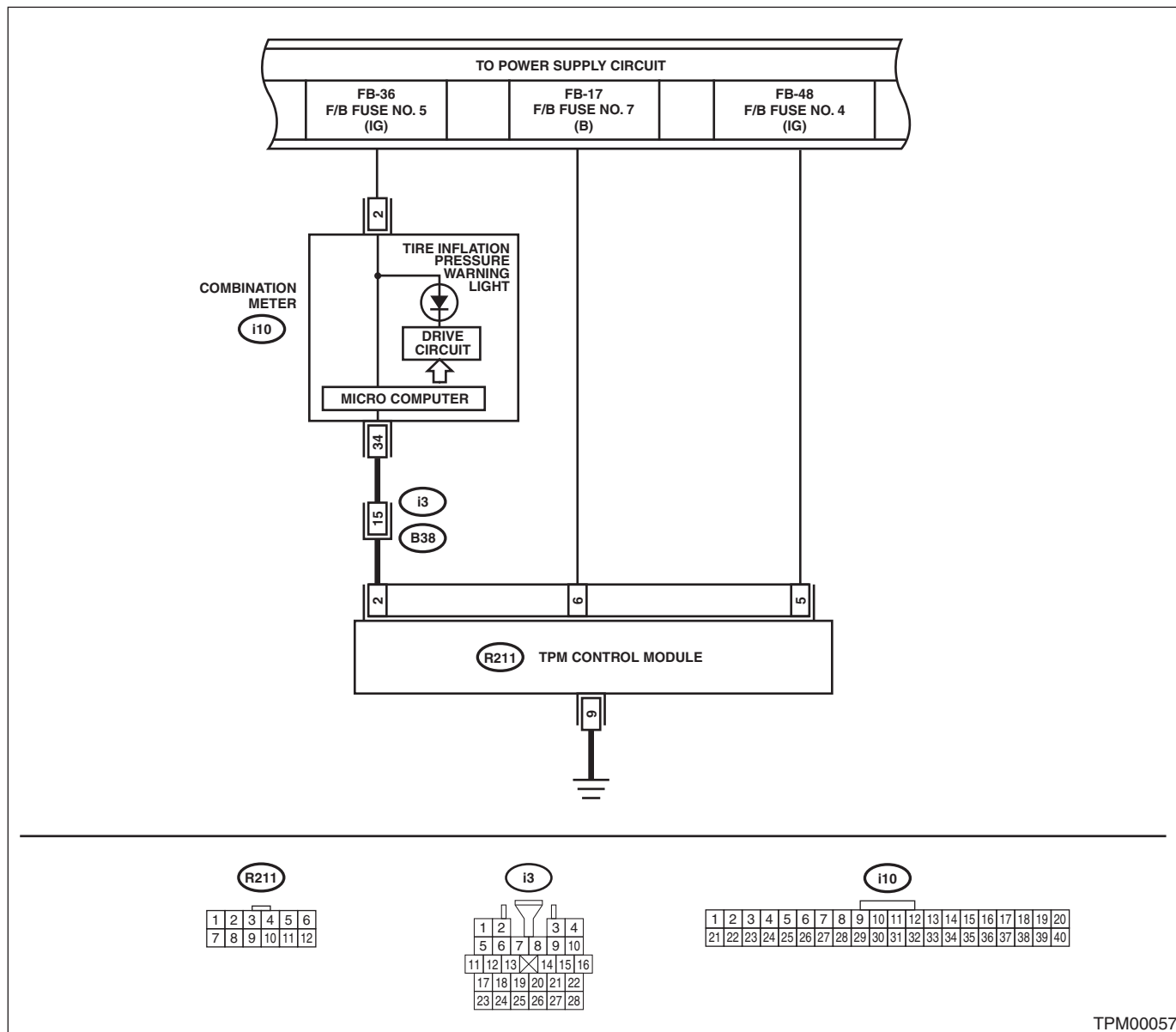

TPM00057

Tire Pressure Warning Light / Trouble Indicator Light Illumination Pattern

TIRE PRESSURE MONITORING SYSTEM (DIAGNOSTICS)

	Step	Check	Yes	No
1	CHECK DIAGNOSTIC TROUBLE CODE (DTC). Connect the Subaru Select Monitor, and read the Diagnostic Trouble Code. <Ref. to TPM(diag)-9, Read Diagnostic Trouble Code (DTC).>	Is DTC displayed?	Perform the diagnosis according to the DTC. <Ref. to TPM(diag)-25, List of Diagnostic Trouble Code (DTC).>	Go to step 2.
2	CHECK TRANSMITTER (ID). Display the transmitter ID of the tire pressure monitor system. <Ref. to TPM(diag)-13, Display Transmitter (Id).>	Is the transmitter ID registered?	Go to step 3.	Register the transmitter ID. <Ref. to TPM(diag)-12, Register Transmitter (ID).>
3	CHECK TRANSMITTER DATA OUTPUT. 1) Select data display of the tire pressure monitoring. 2) Start the engine and check the tire pressure warning light output.	Is the warning light output ON?	Replace the tire pressure monitoring control module. <Ref. to WT-12, TIRE PRESSURE MONITORING CONTROL MODULE, REMOVAL, Tire Pressure Monitoring System.>	Replace the combination meter. <Ref. to IDI-16, REMOVAL, Combination Meter.>

Tire Pressure Warning Light / Trouble Indicator Light Illumination Pattern

TIRE PRESSURE MONITORING SYSTEM (DIAGNOSTICS)

D: TIRE PRESSURE WARNING LIGHT IS 25 TIMES BLINKING AND TURN ON DETECTING CONDITION:

- Tire pressure monitoring control module is faulty.
- Defective harness
- Transmitter is faulty.

TROUBLE SYMPTOM:

Every time the engine starts, tire pressure warning light blinks 25 times and then illuminates.

WIRING DIAGRAM:

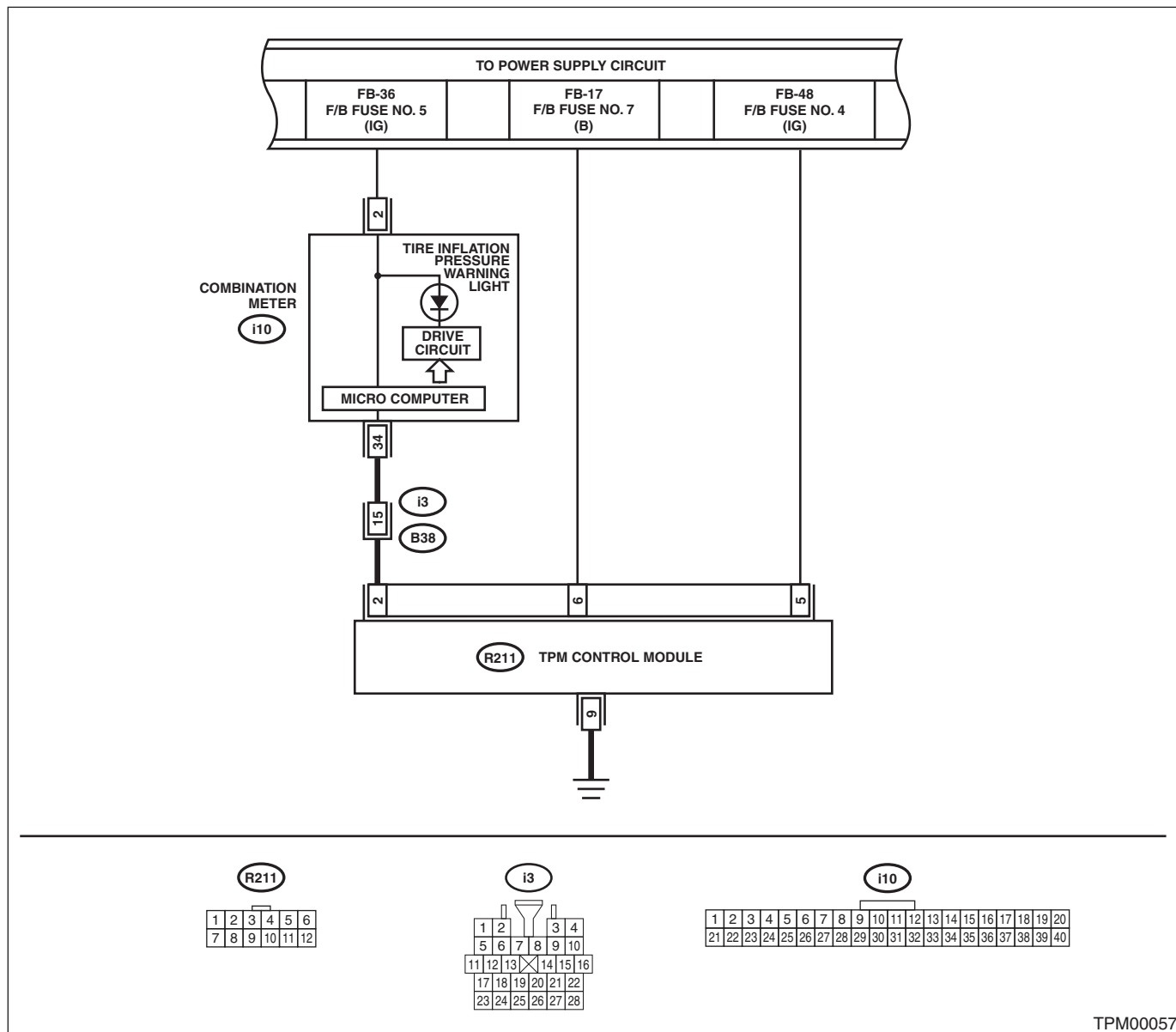

TPM00057

Tire Pressure Warning Light / Trouble Indicator Light Illumination Pattern

TIRE PRESSURE MONITORING SYSTEM (DIAGNOSTICS)

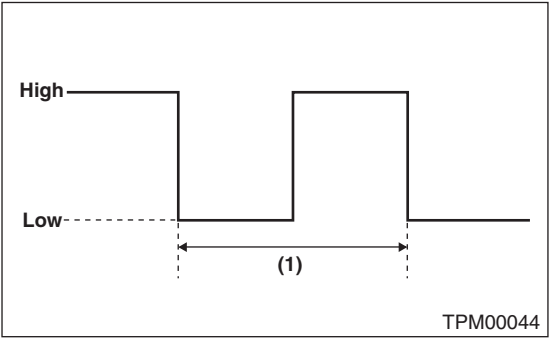
Step	Check	Yes	No
1 CHECK DIAGNOSTIC TROUBLE CODE (DTC). Connect the Subaru Select Monitor, and read the Diagnostic Trouble Code. <Ref. to TPM(diag)-9, Read Diagnostic Trouble Code (DTC).>	Is diagnostics code (DTC) displayed?	Perform the diagnosis according to the DTC. <Ref. to TPM(diag)-25, List of Diagnostic Trouble Code (DTC).>	Go to step 2.
2 CHECK HARNESS. 1) Connect the Subaru Select Monitor to the terminal No. 2 of the tire pressure monitoring control module connector (R211). Connector & terminal (R211) No. 2 (+) — Chassis ground (-): 2) Turn the ignition switch to ON, and select "Oscilloscope" from the Main Menu of Subaru Select Monitor. 3) Check the voltage displayed.	Is the voltage 10 V or more?	Go to step 3.	Go to step 4.
3 CHECK HARNESS. 1) Check the output waveform displayed in the oscilloscope of Subaru Select Monitor. 	Is the pattern the same output waveform as shown in the figure? (1) 400±20 ms Duty 50 % High: Battery voltage Low: 1.5 V or less	Check the combination meter.	Replace the tire pressure monitoring control module. <Ref. to WT-12, REMOVAL, Tire Pressure Monitoring System.>
4 CHECK HARNESS. 1) Disconnect the tire pressure monitoring control module connector. 2) Connect the Subaru Select Monitor to the terminal No. 2 of the tire pressure monitoring control module connector (R211). Connector & terminal (R211) No. 2 (+) — Chassis ground (-): 3) Turn the ignition switch to ON, and select "Oscilloscope" from the Main Menu of Subaru Select Monitor. 4) Check the voltage displayed.	Is the voltage 10 V or more?	Replace the tire pressure monitoring control module. <Ref. to WT-12, REMOVAL, Tire Pressure Monitoring System.>	The harness between the combination meter connector and the tire pressure monitoring control module connector is shorted or open. Repair or replace the harness.

Diagnostic Procedure for Subaru Select Monitor Communication

TIRE PRESSURE MONITORING SYSTEM (DIAGNOSTICS)

13. Diagnostic Procedure for Subaru Select Monitor Communication

A: INSPECTION

Communication for initializing impossible

DETECTING CONDITION:

Defective harness connector

TROUBLE SYMPTOM:

Communication is impossible between the tire pressure monitoring control module and the Subaru Select Monitor.

WIRING DIAGRAM:

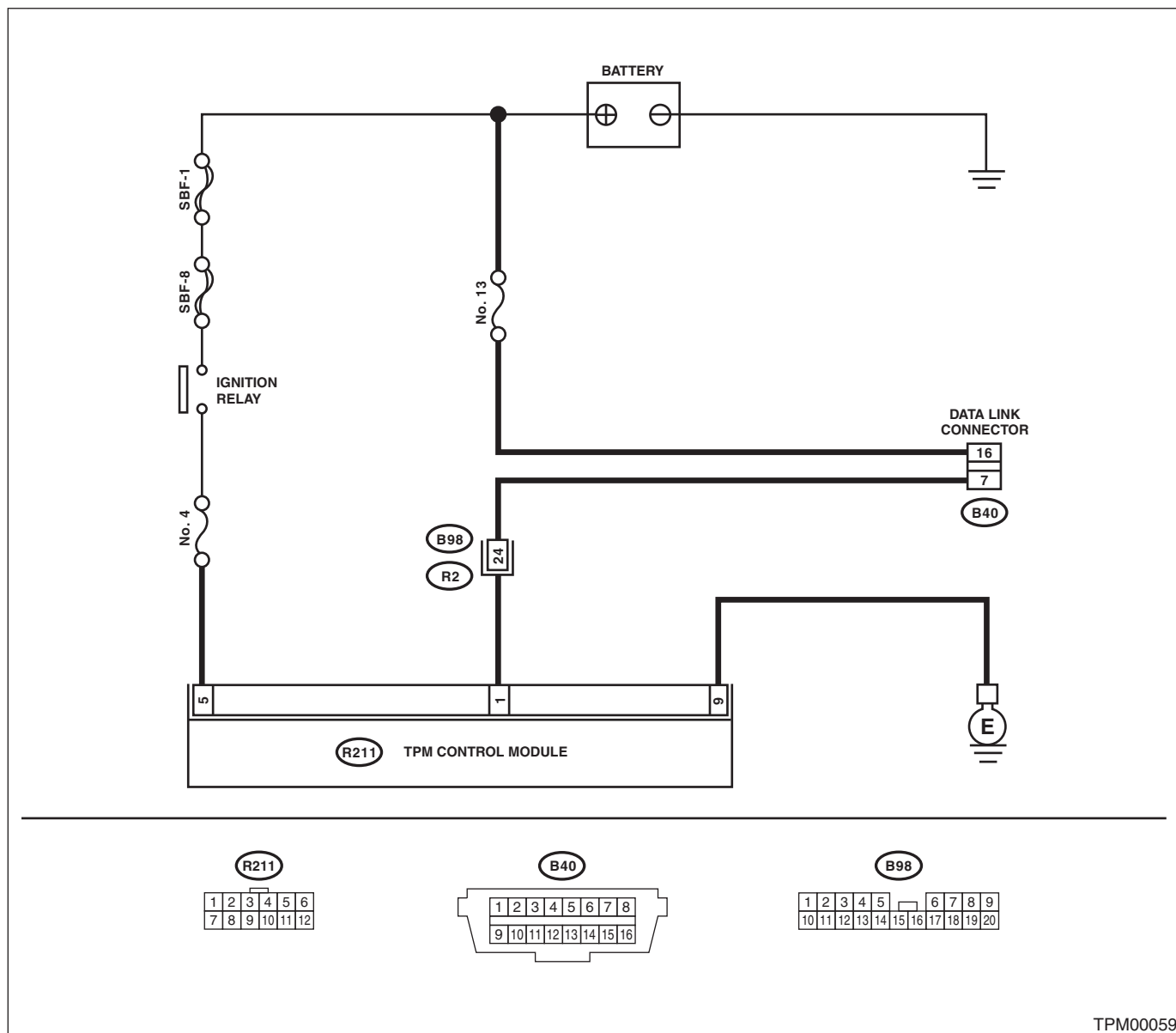

TPM00059

Diagnostic Procedure for Subaru Select Monitor Communication

TIRE PRESSURE MONITORING SYSTEM (DIAGNOSTICS)

Step	Check	Yes	No	
1	CHECK IGNITION SWITCH.	Is the ignition switch ON?	Go to step 2.	Turn the ignition switch to ON, and select TPM mode using Subaru Select Monitor.
2	CHECK BATTERY.	Is the voltage 11 V or more?	Go to step 3.	Charge or replace the battery.
3	CHECK BATTERY TERMINAL.	Is there poor contact at battery terminal?	Repair or tighten the battery terminal.	Go to step 4.
4	CHECK SUBARU SELECT MONITOR COMMUNICATION. 1) Turn the ignition switch to ON. 2) Using the Subaru Select Monitor, check whether communication to other systems can be performed normally.	Is the system name displayed on Subaru Select Monitor?	Go to step 8.	Go to step 5.
5	CHECK SUBARU SELECT MONITOR COMMUNICATION. 1) Turn the ignition switch to OFF. 2) Disconnect the tire pressure monitoring control module connector. 3) Turn the ignition switch to ON. 4) Check whether communication to other systems can be executed normally.	Is the system name displayed on Subaru Select Monitor?	Replace the tire pressure monitoring control module. <Ref. to WT-12, TIRE PRESSURE MONITORING CONTROL MODULE, REMOVAL, Tire Pressure Monitoring System.>	Go to step 6.
6	CHECK HARNESS CONNECTOR BETWEEN EACH CONTROL MODULE AND DATA LINK CONNECTOR. 1) Turn the ignition switch to OFF. 2) Disconnect the tire pressure monitoring control module. 3) Measure the resistance between data link connector and chassis ground. Connector & terminal (B40) No. 7 — Chassis ground:	Is the resistance 1 M Ω or more?	Go to step 7.	Repair the harness and connector between each control module and data link connector.
7	CHECK TIRE PRESSURE MONITORING CONTROL MODULE OUTPUT SIGNAL. 1) Turn the ignition switch to ON. 2) Measure the voltage between tire pressure monitoring control module and chassis ground. Connector & terminal (B40) No. 7 (+) — Chassis ground (-):	Is the voltage less than 1 V?	Go to step 8.	Repair the harness and connector between each control module and data link connector.
8	CHECK HARNESS CONNECTOR BETWEEN TIRE PRESSURE MONITORING CONTROL MODULE AND DATA LINK CONNECTOR. Measure the resistance between tire pressure monitoring control module and data link connector. Connector & terminal (R211) No. 1 — (B40) No. 7:	Is the resistance less than 0.5 Ω ?	Go to step 9.	Repair the harness and connector between tire pressure monitoring control module and data link connector.
9	CHECK TIRE PRESSURE MONITORING CONTROL MODULE CONNECTOR. Turn the ignition switch to OFF.	Is the tire pressure monitoring control module connector inserted in the tire pressure monitoring control module until it locks?	Go to step 10.	Insert the tire pressure monitoring control module connector into the tire pressure monitoring control module.

Diagnostic Procedure for Subaru Select Monitor Communication

TIRE PRESSURE MONITORING SYSTEM (DIAGNOSTICS)

Step	Check	Yes	No
10 CHECK POWER SUPPLY CIRCUIT. 1) Turn the ignition switch to ON. (engine OFF) 2) Measure the ignition power voltage between tire pressure monitoring control module connector and chassis ground. <i>Connector & terminal</i> <i>(R211) No. 5 (+) — Chassis ground (-):</i>	Is the voltage 10 — 15 V?	Go to step 11.	Repair open circuit of the harness between the tire pressure monitoring control module and battery.
11 CHECK HARNESS CONNECTOR BETWEEN TIRE PRESSURE MONITORING CONTROL MODULE AND CHASSIS GROUND. 1) Turn the ignition switch to OFF. 2) Disconnect the connector from the tire pressure monitoring control module. 3) Measure the resistance of harness between tire pressure monitoring control module and chassis ground. <i>Connector & terminal</i> <i>(R211) No. 9 — Chassis ground:</i>	Is the resistance less than 0.5 Ω ?	Go to step 12.	Repair open circuit of the harness of the tire pressure monitoring control module.
12 CHECK POOR CONTACT OF CONNECTOR.	Is there poor contact in tire pressure monitoring control module power supply, ground circuit and data link connector?	Repair the connector.	Replace the tire pressure monitoring control module. <Ref. to WT-12, TIRE PRESSURE MONITORING CONTROL MODULE, REMOVAL, Tire Pressure Monitoring System.>

List of Diagnostic Trouble Code (DTC)

TIRE PRESSURE MONITORING SYSTEM (DIAGNOSTICS)

14. List of Diagnostic Trouble Code (DTC)

A: LIST

DTC	Item	Contents of diagnosis	Remarks
11	Tire 1 air pressure decrease	Tire pressure of tire 1 is reduced.	<Ref. to TPM(diag)-27, DTC 11 TIRE 1 AIR PRESSURE DECREASE, Diagnostic Procedure with Diagnostic Trouble Code (DTC).>
12	Tire 2 air pressure decrease	Tire pressure of tire 2 is reduced.	<Ref. to TPM(diag)-27, DTC 12 TIRE 2 AIR PRESSURE DECREASE, Diagnostic Procedure with Diagnostic Trouble Code (DTC).>
13	Tire 3 air pressure decrease	Tire pressure of tire 3 is reduced.	<Ref. to TPM(diag)-27, DTC 13 TIRE 3 AIR PRESSURE DECREASE, Diagnostic Procedure with Diagnostic Trouble Code (DTC).>
14	Tire 4 air pressure decrease	Tire pressure of tire 4 is reduced.	<Ref. to TPM(diag)-27, DTC 14 TIRE 4 AIR PRESSURE DECREASE, Diagnostic Procedure with Diagnostic Trouble Code (DTC).>
21	Transmitter 1 no data	Data cannot be received from transmitter 1.	<Ref. to TPM(diag)-28, DTC 21 TRANSMITTER 1 NO DATA, Diagnostic Procedure with Diagnostic Trouble Code (DTC).>
22	Transmitter 2 no data	Data cannot be received from transmitter 2.	<Ref. to TPM(diag)-28, DTC 22 TRANSMITTER 2 NO DATA, Diagnostic Procedure with Diagnostic Trouble Code (DTC).>
23	Transmitter 3 no data	Data cannot be received from transmitter 3.	<Ref. to TPM(diag)-28, DTC 23 TRANSMITTER 3 NO DATA, Diagnostic Procedure with Diagnostic Trouble Code (DTC).>
24	Transmitter 4 no data	Data cannot be received from transmitter 4.	<Ref. to TPM(diag)-29, DTC 24 TRANSMITTER 4 NO DATA, Diagnostic Procedure with Diagnostic Trouble Code (DTC).>
31	Transmitter 1 pressure data abnormal	Transmitter 1 data contents are abnormal.	<Ref. to TPM(diag)-30, DTC 31 TRANSMITTER 1 PRESSURE DATA ABNORMAL, Diagnostic Procedure with Diagnostic Trouble Code (DTC).>
32	Transmitter 2 pressure data abnormal	Transmitter 2 data contents are abnormal.	<Ref. to TPM(diag)-30, DTC 32 TRANSMITTER 2 PRESSURE DATA ABNORMAL, Diagnostic Procedure with Diagnostic Trouble Code (DTC).>
33	Transmitter 3 pressure data abnormal	Transmitter 3 data contents are abnormal.	<Ref. to TPM(diag)-30, DTC 33 TRANSMITTER 3 PRESSURE DATA ABNORMAL, Diagnostic Procedure with Diagnostic Trouble Code (DTC).>
34	Transmitter 4 pressure data abnormal	Transmitter 4 data contents are abnormal.	<Ref. to TPM(diag)-31, DTC 34 TRANSMITTER 4 PRESSURE DATA ABNORMAL, Diagnostic Procedure with Diagnostic Trouble Code (DTC).>
41	Transmitter 1 function code abnormal	Function code has error.	<Ref. to TPM(diag)-32, DTC 41 TRANSMITTER 1 FUNCTION CODE ABNORMAL, Diagnostic Procedure with Diagnostic Trouble Code (DTC).>
42	Transmitter 2 function code abnormal	Function code has error.	<Ref. to TPM(diag)-32, DTC 42 TRANSMITTER 2 FUNCTION CODE ABNORMAL, Diagnostic Procedure with Diagnostic Trouble Code (DTC).>
43	Transmitter 3 function code abnormal	Function code has error.	<Ref. to TPM(diag)-32, DTC 43 TRANSMITTER 3 FUNCTION CODE ABNORMAL, Diagnostic Procedure with Diagnostic Trouble Code (DTC).>
44	Transmitter 4 function code abnormal	Function code has error.	<Ref. to TPM(diag)-33, DTC 44 TRANSMITTER 4 FUNCTION CODE ABNORMAL, Diagnostic Procedure with Diagnostic Trouble Code (DTC).>
51	Transmitter 1 battery voltage decrease	Transmitter battery voltage is low.	<Ref. to TPM(diag)-34, DTC 51 TRANSMITTER 1 BATTERY VOLTAGE DECREASE, Diagnostic Procedure with Diagnostic Trouble Code (DTC).>

List of Diagnostic Trouble Code (DTC)

TIRE PRESSURE MONITORING SYSTEM (DIAGNOSTICS)

DTC	Item	Contents of diagnosis	Remarks
52	Transmitter 2 battery voltage decrease	Transmitter battery voltage is low.	<Ref. to TPM(diag)-34, DTC 52 TRANSMITTER 2 BATTERY VOLTAGE DECREASE, Diagnostic Procedure with Diagnostic Trouble Code (DTC).>
53	Transmitter 3 battery voltage decrease	Transmitter battery voltage is low.	<Ref. to TPM(diag)-34, DTC 53 TRANSMITTER 3 BATTERY VOLTAGE DECREASE, Diagnostic Procedure with Diagnostic Trouble Code (DTC).>
54	Transmitter 4 battery voltage decrease	Transmitter battery voltage is low.	<Ref. to TPM(diag)-34, DTC 54 TRANSMITTER 4 BATTERY VOLTAGE DECREASE, Diagnostic Procedure with Diagnostic Trouble Code (DTC).>
61	Vehicle speed is abnormal	Vehicle speed signal is not input to the control module when the vehicle speed is 6 km/h (3.7 MPH) or more.	<Ref. to TPM(diag)-35, DTC 61 VEHICLE SPEED IS ABNORMAL, Diagnostic Procedure with Diagnostic Trouble Code (DTC).>

Diagnostic Procedure with Diagnostic Trouble Code (DTC)

TIRE PRESSURE MONITORING SYSTEM (DIAGNOSTICS)

15. Diagnostic Procedure with Diagnostic Trouble Code (DTC)

A: DTC 11 TIRE 1 AIR PRESSURE DECREASE

NOTE:

Refer to DTC 14 for diagnostic procedure. <Ref. to TPM(diag)-27, DTC 14 TIRE 4 AIR PRESSURE DECREASE, Diagnostic Procedure with Diagnostic Trouble Code (DTC).>

B: DTC 12 TIRE 2 AIR PRESSURE DECREASE

NOTE:

Refer to DTC 14 for diagnostic procedure. <Ref. to TPM(diag)-27, DTC 14 TIRE 4 AIR PRESSURE DECREASE, Diagnostic Procedure with Diagnostic Trouble Code (DTC).>

C: DTC 13 TIRE 3 AIR PRESSURE DECREASE

NOTE:

Refer to DTC 14 for diagnostic procedure. <Ref. to TPM(diag)-27, DTC 14 TIRE 4 AIR PRESSURE DECREASE, Diagnostic Procedure with Diagnostic Trouble Code (DTC).>

D: DTC 14 TIRE 4 AIR PRESSURE DECREASE

DTC DETECTING CONDITION:

Inflation pressure of tires dropped under specifications (186 kPa (1.86 kgf/cm², 27 psi) or less).

TROUBLE SYMPTOM:

Tire pressure warning light illuminates.

	Step	Check	Yes	No
1	CHECK TIRES. Lift up the vehicle and check for damage in the tires.	Are there cracks or damage?	Replace the tire. <Ref. to WT-5, Tire.>	Go to step 2.
2	CHECK TIRES. Check the tire air pressure.	Is the tire pressure in the specifications?	Go to step 3.	Adjust the air pressure.
3	CHECK TRANSMITTER. Drive the vehicle at 40 km/h (25 MPH) or faster and compare the data from the transmitter on the four wheels.	Is there a transmitter with different data?	Replace the transmitter (tire pressure sensor). <Ref. to WT-12, Tire Pressure Monitoring System.>	Go to step 4.
4	PERFORM DRIVING TEST. 1) Perform the Clear Memory Mode. <Ref. to TPM(diag)-10, Clear Memory Mode.> 2) Perform a driving test. <Ref. to TPM(diag)-14, PROCEDURE, Inspection Mode.> 3) Read the DTC. <Ref. to TPM(diag)-9, Read Diagnostic Trouble Code (DTC).>	Is DTC displayed?	Inspect using the "Diagnostic Procedure with Diagnostic Trouble Code (DTC)". <Ref. to TPM(diag)-27, Diagnostic Procedure with Diagnostic Trouble Code (DTC).>	Finish the diagnosis.

CAUTION:

When driving vehicle to perform driving test, there should be always 2 persons (driver and checker) to check.

Diagnostic Procedure with Diagnostic Trouble Code (DTC)

TIRE PRESSURE MONITORING SYSTEM (DIAGNOSTICS)

E: DTC 21 TRANSMITTER 1 NO DATA

NOTE:

Refer to DTC 24 for diagnostic procedure. <Ref. to TPM(diag)-29, DTC 24 TRANSMITTER 4 NO DATA, Diagnostic Procedure with Diagnostic Trouble Code (DTC).>

F: DTC 22 TRANSMITTER 2 NO DATA

NOTE:

Refer to DTC 24 for diagnostic procedure. <Ref. to TPM(diag)-29, DTC 24 TRANSMITTER 4 NO DATA, Diagnostic Procedure with Diagnostic Trouble Code (DTC).>

G: DTC 23 TRANSMITTER 3 NO DATA

NOTE:

Refer to DTC 24 for diagnostic procedure. <Ref. to TPM(diag)-29, DTC 24 TRANSMITTER 4 NO DATA, Diagnostic Procedure with Diagnostic Trouble Code (DTC).>

Diagnostic Procedure with Diagnostic Trouble Code (DTC)

TIRE PRESSURE MONITORING SYSTEM (DIAGNOSTICS)

H: DTC 24 TRANSMITTER 4 NO DATA

DTC DETECTING CONDITION:

Data from each transmitter is not received for 8 minutes.

TROUBLE SYMPTOM:

Tire pressure warning light blinks 25 times and then illuminates.

Step	Check	Yes	No
1 START FL TRANSMITTER. 1) Connect the Subaru Select Monitor and then turn the ignition switch to ON. 2) Select "Transmitter ID". <Ref. to TPM(diag)-13, Display Transmitter (Id).> 3) Use the transmitter registration tool and transmit the ID from the FL transmitter to check "Latest reception ID".	Is "Latest reception ID" updated?	Go to step 2.	Replace front left transmitter.
2 CHECK FL TRANSMITTER ID. Check the ID displayed in the updated ID display and the tire 1 registered ID.	Are the two IDs same?	Go to step 3.	Record the received ID update as the FL transmitter. Go to step 3.
3 START FR TRANSMITTER. Use the transmitter registration tool and transmit the ID from the FR transmitter to check "Latest reception ID".	Is "Latest reception ID" updated?	Go to step 4.	Replace the front right transmitter.
4 CHECK FR TRANSMITTER ID. Check the ID displayed in the updated ID display and the tire 2 registered ID.	Are the two IDs same?	Go to step 5.	Record the received ID update as the FR transmitter. Go to step 5.
5 START RR TRANSMITTER. Use the transmitter registration tool and transmit the ID from the RR transmitter to check "Latest reception ID".	Is "Latest reception ID" updated?	Go to step 6.	Replace the RR transmitter.
6 CHECK RR TRANSMITTER ID. Check the ID displayed in the updated ID display and the tire 3 registered ID.	Are the two IDs same?	Go to step 7.	Record the received ID update as the RR transmitter. Go to step 7.
7 START RL TRANSMITTER. Use the transmitter registration tool and transmit the ID from the RL transmitter to check "Latest reception ID".	Is "Latest reception ID" updated?	Go to step 8.	Replace the RL transmitter.
8 CHECK RL TRANSMITTER ID. Check the ID displayed in the updated ID display and the tire 4 registered ID.	Are the two IDs same?	Go to step 9.	Record the received ID update as the RL transmitter. Go to step 9.
9 CHECK MALFUNCTION TRANSMITTER.	Is ID recorded by this procedure?	Go to step 10.	Go to step 1.
10 CHECK MALFUNCTION TRANSMITTER. Check the registered ID of the transmitter indicated by DTC.	Is there checked ID in the record?	Replace the transmitter of the recorded position.	Replace the transmitter showing the latest ID that is not included in the registered IDs.

CAUTION:

When driving vehicle to perform driving test, there should be always 2 persons (driver and checker) to check.

Diagnostic Procedure with Diagnostic Trouble Code (DTC)

TIRE PRESSURE MONITORING SYSTEM (DIAGNOSTICS)

I: DTC 31 TRANSMITTER 1 PRESSURE DATA ABNORMAL

NOTE:

Refer to DTC 34 for diagnostic procedure. <Ref. to TPM(diag)-31, DTC 34 TRANSMITTER 4 PRESSURE DATA ABNORMAL, Diagnostic Procedure with Diagnostic Trouble Code (DTC).>

J: DTC 32 TRANSMITTER 2 PRESSURE DATA ABNORMAL

NOTE:

Refer to DTC 34 for diagnostic procedure. <Ref. to TPM(diag)-31, DTC 34 TRANSMITTER 4 PRESSURE DATA ABNORMAL, Diagnostic Procedure with Diagnostic Trouble Code (DTC).>

K: DTC 33 TRANSMITTER 3 PRESSURE DATA ABNORMAL

NOTE:

Refer to DTC 34 for diagnostic procedure. <Ref. to TPM(diag)-31, DTC 34 TRANSMITTER 4 PRESSURE DATA ABNORMAL, Diagnostic Procedure with Diagnostic Trouble Code (DTC).>

Diagnostic Procedure with Diagnostic Trouble Code (DTC)

TIRE PRESSURE MONITORING SYSTEM (DIAGNOSTICS)

L: DTC 34 TRANSMITTER 4 PRESSURE DATA ABNORMAL

DTC DETECTING CONDITION:

- When comparing the data from each transmitter to the previous data, the change is large.
- The pressure exceeds what the transmitter can measure. (Excessive pressure)

TROUBLE SYMPTOM:

Tire pressure warning light blinks 25 times and then illuminates.

	Step	Check	Yes	No
1	START FL TRANSMITTER. 1) Connect the Subaru Select Monitor and then turn the ignition switch to ON. 2) Select "Transmitter ID display". <Ref. to TPM(diag)-13, Display Transmitter (Id).> 3) Use the transmitter registration tool and transmit the ID from the FL transmitter to check "Latest reception ID".	Is "Latest reception ID" updated?	Go to step 2.	Replace front left transmitter.
2	CHECK FL TRANSMITTER ID. Check the ID displayed in the updated ID display and the tire 1 registered ID.	Are the two IDs same?	Go to step 3.	Record the received ID update as the FL transmitter. Go to step 3.
3	START FR TRANSMITTER. Use the transmitter registration tool and transmit the ID from the FR transmitter to check "Latest reception ID".	Is "Latest reception ID" updated?	Go to step 4.	Replace the front right transmitter.
4	CHECK FR TRANSMITTER ID. Check the ID displayed in the updated ID display and the tire 2 registered ID.	Are the two IDs same?	Go to step 5.	Record the received ID update as the FR transmitter. Go to step 5.
5	START RR TRANSMITTER. Use the transmitter registration tool and transmit the ID from the RR transmitter to check "Latest reception ID".	Is "Latest reception ID" updated?	Go to step 6.	Replace the RR transmitter.
6	CHECK RR TRANSMITTER ID. Check the ID displayed in the updated ID display and the tire 3 registered ID.	Are the two IDs same?	Go to step 7.	Record the received ID update as the RR transmitter. Go to step 7.
7	START RL TRANSMITTER. Use the transmitter registration tool and transmit the ID from the RL transmitter to check "Latest reception ID".	Is "Latest reception ID" updated?	Go to step 8.	Replace the RL transmitter.
8	CHECK RL TRANSMITTER ID. Check the ID displayed in the updated ID display and the tire 4 registered ID.	Are the two IDs same?	Go to step 9.	Record the received ID update as the RL transmitter. Go to step 9.
9	CHECK MALFUNCTION TRANSMITTER.	Is ID recorded by this procedure?	Go to step 10.	Go to step 1.
10	CHECK MALFUNCTION TRANSMITTER. Check the registered ID of the transmitter indicated by DTC.	Is there checked ID in the record?	Replace the transmitter of the recorded position.	Replace the transmitter showing the latest ID that is not included in the registered IDs.

Diagnostic Procedure with Diagnostic Trouble Code (DTC)

TIRE PRESSURE MONITORING SYSTEM (DIAGNOSTICS)

M: DTC 41 TRANSMITTER 1 FUNCTION CODE ABNORMAL

NOTE:

Refer to DTC 44 for diagnostic procedure. <Ref. to TPM(diag)-33, DTC 44 TRANSMITTER 4 FUNCTION CODE ABNORMAL, Diagnostic Procedure with Diagnostic Trouble Code (DTC).>

N: DTC 42 TRANSMITTER 2 FUNCTION CODE ABNORMAL

NOTE:

Refer to DTC 44 for diagnostic procedure. <Ref. to TPM(diag)-33, DTC 44 TRANSMITTER 4 FUNCTION CODE ABNORMAL, Diagnostic Procedure with Diagnostic Trouble Code (DTC).>

O: DTC 43 TRANSMITTER 3 FUNCTION CODE ABNORMAL

NOTE:

Refer to DTC 44 for diagnostic procedure. <Ref. to TPM(diag)-33, DTC 44 TRANSMITTER 4 FUNCTION CODE ABNORMAL, Diagnostic Procedure with Diagnostic Trouble Code (DTC).>

Diagnostic Procedure with Diagnostic Trouble Code (DTC)

TIRE PRESSURE MONITORING SYSTEM (DIAGNOSTICS)

P: DTC 44 TRANSMITTER 4 FUNCTION CODE ABNORMAL

DTC DETECTING CONDITION:

Unexpected function codes received from each transmitter.

TROUBLE SYMPTOM:

Tire pressure warning light blinks 25 times and then illuminates.

Step	Check	Yes	No
1 START FL TRANSMITTER. 1) Connect the Subaru Select Monitor and then turn the ignition switch to ON. 2) Select "Transmitter ID". <Ref. to TPM(diag)-13, Display Transmitter (Id).> 3) Use the transmitter registration tool and transmit the ID from the FL transmitter to check "Latest reception ID".	Is "Latest reception ID" updated?	Go to step 2.	Replace front left transmitter.
2 CHECK FL TRANSMITTER ID. Check the ID displayed in the updated ID display and the tire 1 registered ID.	Are the two IDs same?	Go to step 3.	Record the received ID update as the FL transmitter. Go to step 3.
3 START FR TRANSMITTER. Use the transmitter registration tool and transmit the ID from the FR transmitter to check "Latest reception ID".	Is "Latest reception ID" updated?	Go to step 4.	Replace the front right transmitter.
4 CHECK FR TRANSMITTER ID. Check the ID displayed in the updated ID display and the tire 2 registered ID.	Are the two IDs same?	Go to step 5.	Record the received ID update as the FR transmitter. Go to step 5.
5 START RR TRANSMITTER. Use the transmitter registration tool and transmit the ID from the RR transmitter to check "Latest reception ID".	Is "Latest reception ID" updated?	Go to step 6.	Replace the RR transmitter.
6 CHECK RR TRANSMITTER ID. Check the ID displayed in the updated ID display and the tire 3 registered ID.	Are the two IDs same?	Go to step 7.	Record the received ID update as the RR transmitter. Go to step 7.
7 START RL TRANSMITTER. Use the transmitter registration tool and transmit the ID from the RL transmitter to check "Latest reception ID".	Is "Latest reception ID" updated?	Go to step 8.	Replace the RL transmitter.
8 CHECK RL TRANSMITTER ID. Check the ID displayed in the updated ID display and the tire 4 registered ID.	Are the two IDs same?	Go to step 9.	Record the received ID update as the RL transmitter. Go to step 9.
9 CHECK MALFUNCTION TRANSMITTER.	Is ID recorded by this procedure?	Go to step 10.	Check again. Go to step 1.
10 CHECK MALFUNCTION TRANSMITTER. Check the registered ID of the transmitter indicated by DTC.	Is there checked ID in the record?	Replace the transmitter of the recorded position.	Replace the transmitter showing the latest ID that is not included in the registered IDs.

Diagnostic Procedure with Diagnostic Trouble Code (DTC)

TIRE PRESSURE MONITORING SYSTEM (DIAGNOSTICS)

Q: DTC 51 TRANSMITTER 1 BATTERY VOLTAGE DECREASE

NOTE:

Refer to DTC 54 for diagnostic procedure. <Ref. to TPM(diag)-34, DTC 54 TRANSMITTER 4 BATTERY VOLTAGE DECREASE, Diagnostic Procedure with Diagnostic Trouble Code (DTC).>

R: DTC 52 TRANSMITTER 2 BATTERY VOLTAGE DECREASE

NOTE:

Refer to DTC 54 for diagnostic procedure. <Ref. to TPM(diag)-34, DTC 54 TRANSMITTER 4 BATTERY VOLTAGE DECREASE, Diagnostic Procedure with Diagnostic Trouble Code (DTC).>

S: DTC 53 TRANSMITTER 3 BATTERY VOLTAGE DECREASE

NOTE:

Refer to DTC 54 for diagnostic procedure. <Ref. to TPM(diag)-34, DTC 54 TRANSMITTER 4 BATTERY VOLTAGE DECREASE, Diagnostic Procedure with Diagnostic Trouble Code (DTC).>

T: DTC 54 TRANSMITTER 4 BATTERY VOLTAGE DECREASE

DTC DETECTING CONDITION:

Low battery signals received 20 times from each transmitter.

TROUBLE SYMPTOM:

Tire pressure warning light blinks 25 times and then illuminates.

	Step	Check	Yes	No
1	CHECK TRANSMITTER. 1) Replace all transmitters and register their IDs. <Ref. to TPM(diag)-12, Register Transmitter (ID).> 2) Perform the Clear Memory Mode, and perform driving test.	Is the fault eliminated?	Internal battery of the transmitter had worn out.	Replace the tire pressure monitoring control module. <Ref. to WT-12, TIRE PRESSURE MONITORING CONTROL MODULE, REMOVAL, Tire Pressure Monitoring System.>

Diagnostic Procedure with Diagnostic Trouble Code (DTC)

TIRE PRESSURE MONITORING SYSTEM (DIAGNOSTICS)

U: DTC 61 VEHICLE SPEED IS ABNORMAL

DTC DETECTING CONDITION:

Vehicle speed function codes were received from the transmitter, but the vehicle speed signal was not input to the module.

TROUBLE SYMPTOM:

Tire pressure warning light blinks 25 times and then illuminates.

WIRING DIAGRAM:

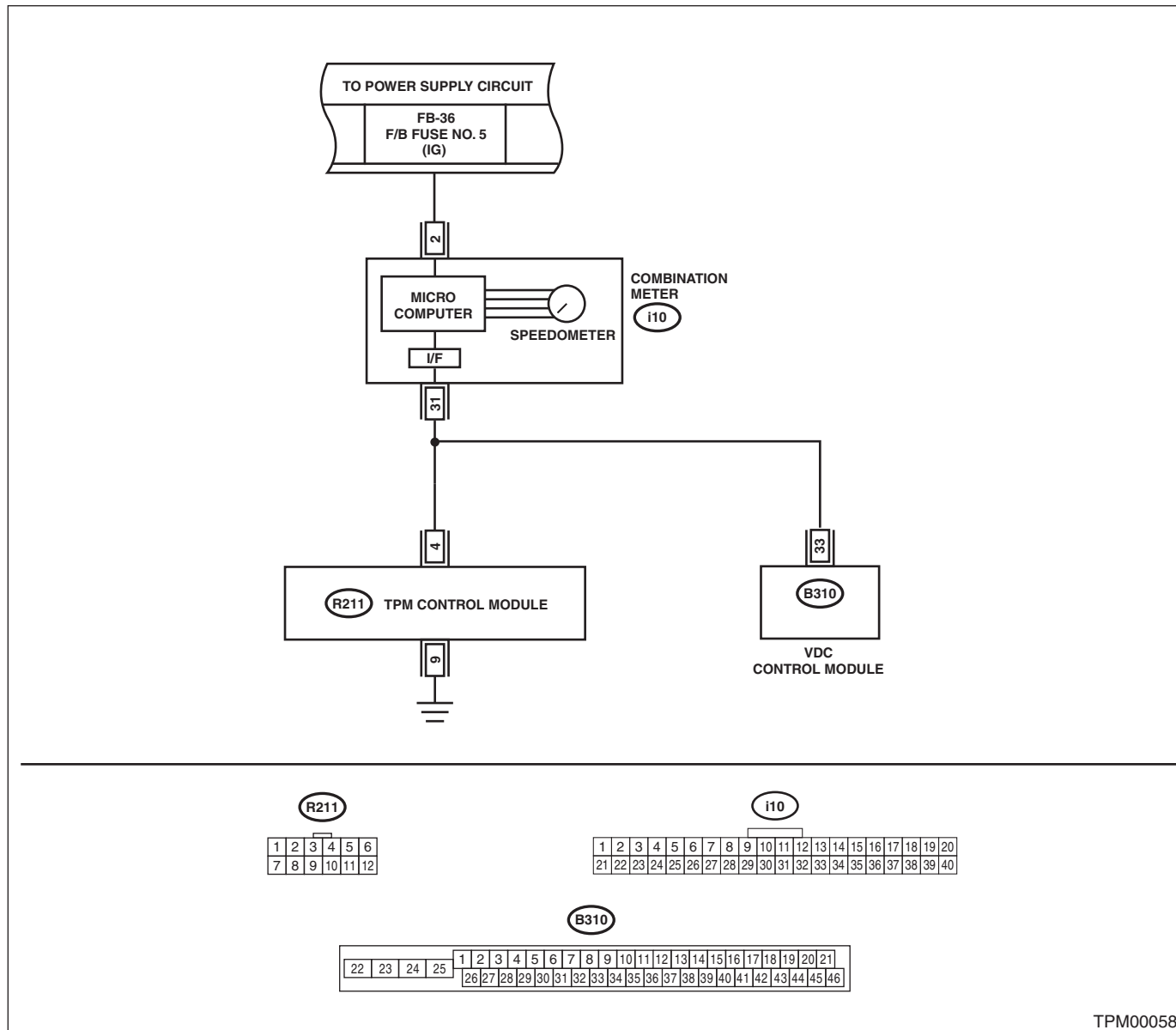

TPM00058

Diagnostic Procedure with Diagnostic Trouble Code (DTC)

TIRE PRESSURE MONITORING SYSTEM (DIAGNOSTICS)

Step	Check	Yes	No
1 CHECK TIRE PRESSURE MONITORING CONTROL MODULE. 1) Connect an oscilloscope to the terminal No. 4 of the tire pressure monitoring control module connector (R211). 2) Drive the vehicle at 40 km/h (25 MPH) and check the vehicle speed signal at that time.	Is the vehicle speed being input?	Replace the tire pressure monitoring control module. <Ref. to WT-12, TIRE PRESSURE MONITORING CONTROL MODULE, REMOVAL, Tire Pressure Monitoring System.>	Go to step 2.
2 CHECK HARNESS. 1) Disconnect the combination meter connector (i10). 2) Connect the tire pressure monitoring control module connector (R211) and combination meter connector (i10) and measure the resistance.	Is the resistance less than 0.5 Ω ?	Check the combination meter. <Ref. to IDI-16, REMOVAL, Combination Meter.>	Repair or replace the open circuit of the harness.

General Diagnostic Table

TIRE PRESSURE MONITORING SYSTEM (DIAGNOSTICS)

16. General Diagnostic Table

A: INSPECTION

Symptoms		Problem parts
Tire pressure warning light illuminates.	Tire pressure is reduced.	<ul style="list-style-type: none">• Improper tire pressure adjustment.• Punctured tire
Tire pressure warning light blinks 25 times and then illuminates.	Tire pressure monitoring system has malfunction.	<ul style="list-style-type: none">• Air pressure sensor malfunction• Air pressure sensor is out of battery.• Tire pressure monitoring control module is faulty.• Defective vehicle harness• Defective combination meter
Tire pressure is dropping but the warning light does not illuminate.	Tire pressure warning light does not illuminate.	<ul style="list-style-type: none">• Air pressure sensor is faulty.• Tire pressure monitoring control module is faulty.• Defective combination meter

General Diagnostic Table

TIRE PRESSURE MONITORING SYSTEM (DIAGNOSTICS)

DIFFERENTIALS

DI

	Page
1. General Description	2
2. Differential Gear Oil	14
3. Front Differential Assembly	15
4. Rear Differential	16
5. Rear Differential Front Oil Seal	35
6. Rear Differential Side Oil Seal	37
7. Rear Differential Front Member	40
8. General Diagnostic Table	41

General Description

DIFFERENTIALS

4. SERVICE DATA

Drive pinion bearing preload (For new bearing)	Measure with spring measurement. (Measured from the companion flange bolt)	N (kgf, lbf)	17.7 — 38.8 (1.8 — 4.0, 4.0 — 8.7)
	Measure with torque wrench	N·m(kgf·m, ft·lb)	0.67 — 1.47 (0.07 — 0.15, 0.49 — 1.08)
Side gear backlash		mm (in)	0.10 — 0.20 (0.004 — 0.008)
Side bearing standard width		mm (in)	20.00 (0.7874)
Hypoid driven gear to drive pinion backlash		mm (in)	0.10 — 0.20 (0.004 — 0.008)
Hypoid driven gear runout on its back surface		mm (in)	0.05 (0.002)

5. ADJUSTING PARTS

	Part No.	Length mm (in)
Preload adjusting spacer	383695201	56.2 (2.213)
	383695202	56.4 (2.220)
	383695203	56.6 (2.228)
	383695204	56.8 (2.236)
	383695205	57.0 (2.244)
	383695206	57.2 (2.252)

	Part No.	Thickness mm (in)
Preload adjusting washer	383705200	2.59 (0.1020)
	383715200	2.57 (0.1012)
	383725200	2.55 (0.1004)
	383735200	2.53 (0.0996)
	383745200	2.51 (0.0988)
	383755200	2.49 (0.0980)
	383765200	2.47 (0.0972)
	383775200	2.45 (0.0965)
	383785200	2.43 (0.0957)
	383795200	2.41 (0.0949)
	383805200	2.39 (0.0941)
	383815200	2.37 (0.0933)
	383825200	2.35 (0.0925)
	383835200	2.33 (0.0917)
	383845200	2.31 (0.0909)

General Description

DIFFERENTIALS

	Part No.	Thickness mm (in)	
Pinion height adjusting washer	383495200	3.09 (0.1217)	
	383505200	3.12 (0.1228)	
	383515200	3.15 (0.1240)	
	383525200	3.18 (0.1252)	
	383535200	3.21 (0.1264)	
	383545200	3.24 (0.1276)	
	383555200	3.27 (0.1287)	
	383565200	3.30 (0.1299)	
	383575200	3.33 (0.1311)	
	383585200	3.36 (0.1323)	
	383595200	3.39 (0.1335)	
	383605200	3.42 (0.1346)	
	383615200	3.45 (0.1358)	
	383625200	3.48 (0.1370)	
	383635200	3.51 (0.1382)	
	383645200	3.54 (0.1394)	
	383655200	3.57 (0.1406)	
	383665200	3.60 (0.1417)	
	383675200	3.63 (0.1429)	
383685200	3.66 (0.1441)		
Side gear thrust washer	383445201	0.75 — 0.80 (0.0295 — 0.0315)	
	383445202	0.80 — 0.85 (0.0315 — 0.0335)	
	383445203	0.85 — 0.90 (0.0335 — 0.0354)	
Side bearing retainer shim	383475201	0.20 (0.0079)	
	383475202	0.25 (0.0098)	
	383475203	0.30 (0.0118)	
	383475204	0.40 (0.0157)	
	383475205	0.50 (0.0197)	
Drive pinion bearing preload	Measure with spring measurement. (Measured from the companion flange bolt)	N (kgf, lb)	17.7 — 38.8 (1.8 — 4.0, 4.0 — 8.7)
	Measure with torque wrench	N·m(kgf-m, ft-lb)	0.67 — 1.47 (0.07 — 0.15, 0.49 — 1.08)
Side gear backlash	mm (in)	0.10 — 0.20 (0.004 — 0.008)	
Hypoid driven gear to drive pinion backlash limit	mm (in)	0.10 — 0.20 (0.004 — 0.008)	
Hypoid driven gear runout limit on its back surface	mm (in)	0.05 (0.002)	

B: COMPONENT

1. REAR DIFFERENTIAL (T-TYPE)

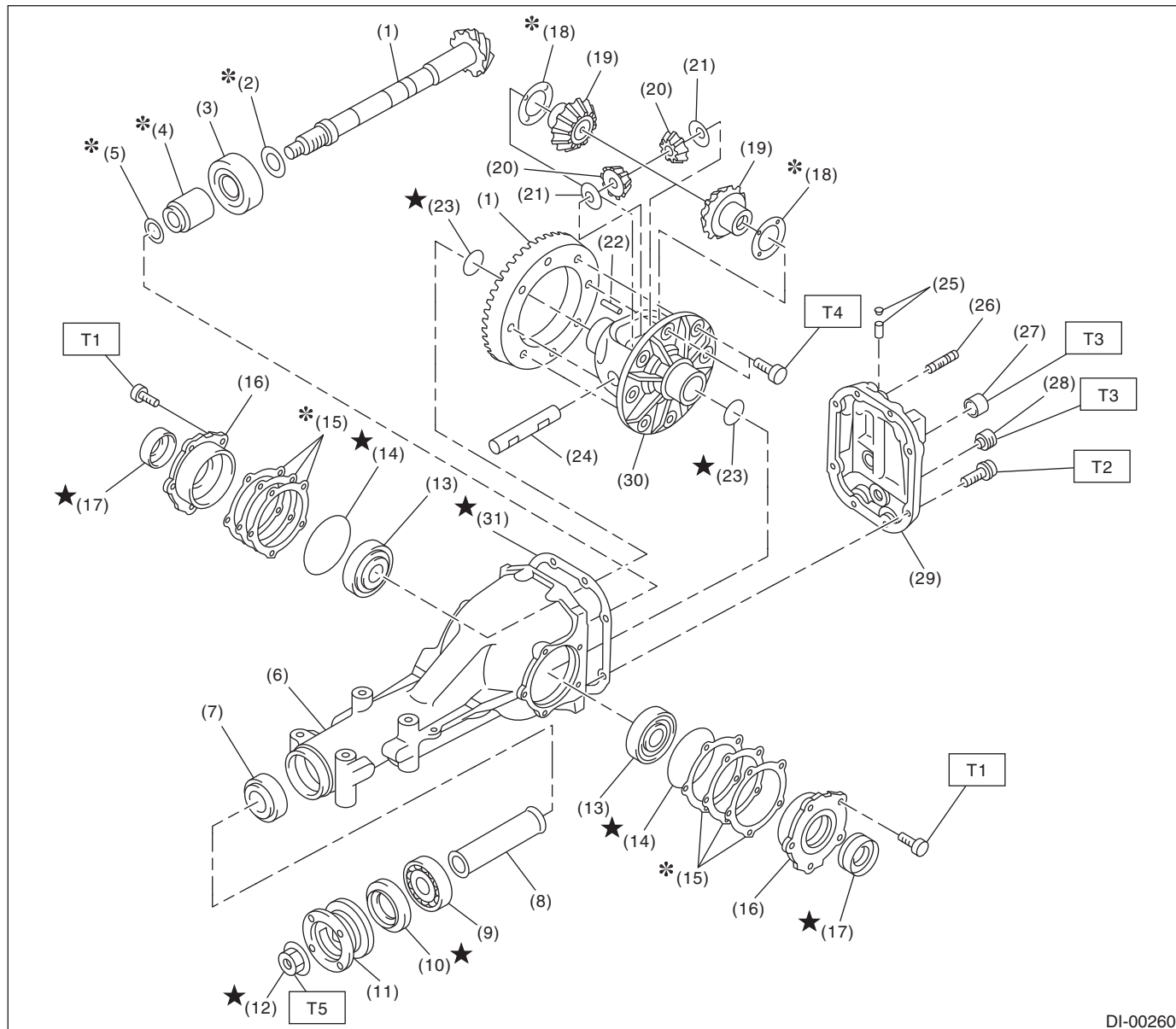

DI-00260

- | | | |
|---|------------------------------|------------------------|
| (1) Hypoid driven gear and drive pinion set | (13) Side bearing | (26) Stud bolt |
| (2) Pinion height adjusting washer | (14) O-ring | (27) Oil filler plug |
| (3) Rear bearing | (15) Side retainer shim | (28) Oil drain plug |
| (4) Bearing preload adjusting spacer | (16) Side retainer | (29) Rear cover |
| (5) Bearing preload adjusting washer | (17) Side oil seal | (30) Differential case |
| (6) Differential carrier | (18) Side gear thrust washer | (31) Gasket |
| (7) Front bearing | (19) Side gear | |
| (8) Spacer | (20) Pinion mate gear | |
| (9) Pilot bearing | (21) Pinion mate gear washer | |
| (10) Front oil seal | (22) Pinion shaft lock pin | |
| (11) Companion flange | (23) Snap ring | |
| (12) Self-locking nut | (24) Pinion mate shaft | |
| | (25) Air breather cap | |

Tightening torque: N-m (kgf-m, ft-lb)

T1: 10.5 (1.1, 7.7)

T2: 29.5 (3.0, 21.8)

T3: 49 (5.0, 36.1)

T4: 103 (10.5, 76.0)

T5: 181.5 (18.5, 133.9)

General Description

DIFFERENTIALS

2. REAR DIFFERENTIAL MOUNTING SYSTEM

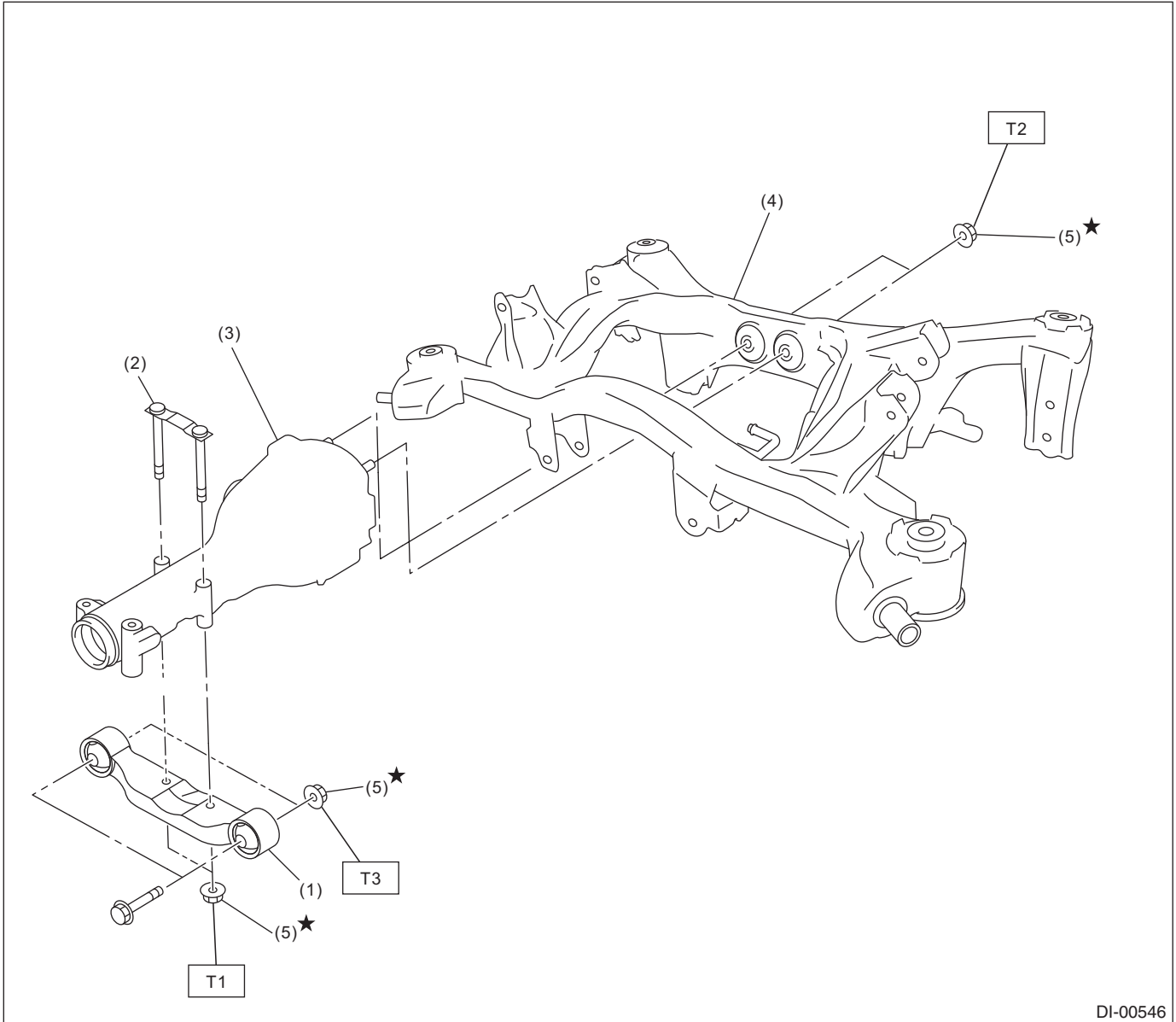

DI-00546

- | | |
|------------------------------------|----------------------|
| (1) Rear differential front member | (4) Sub frame |
| (2) Rear differential member plate | (5) Self-locking nut |
| (3) Rear differential ASSY | |

Tightening torque: N·m (kgf-m, ft-lb)

T1: 50 (5.1, 36.9)

T2: 70 (7.1, 51.6)

T3: 110 (11.2, 81.1)

C: CAUTION

- Wear appropriate work clothing, including a cap, protective goggles and protective shoes when performing any work.
- Remove contamination including dirt and corrosion before removal, installation or disassembly.
- Keep the disassembled parts in order and protect them from dust and dirt.
- Before removal, installation or disassembly, be sure to clarify the failure. Avoid unnecessary removal, installation, disassembly and replacement.
- Vehicle components are extremely hot after driving. Be wary of receiving burns from heated parts.
- Use SUBARU genuine gear oil, grease. Do not mix gear oil, grease, etc. of different grades or manufacturers.
- Be sure to tighten fasteners including bolts and nuts to the specified torque.
- Place shop jacks or rigid racks at the specified points.
- Apply gear oil onto sliding or revolving surfaces before installation.
- Before installing the O-ring or snap ring, apply a sufficient amount of gear oil to avoid damage and deformation.
- Before securing a part on a vise, place cushioning material such as wood blocks, aluminum plate, or cloth between the part and the vise.
- Avoid damaging the mating surface of the case.

General Description

DIFFERENTIALS

D: PREPARATION TOOL

1. SPECIAL TOOL

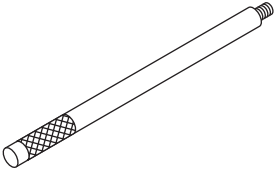
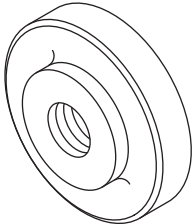
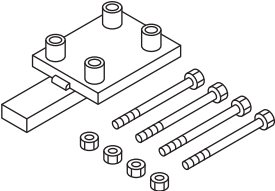
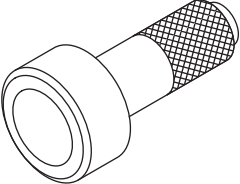
ILLUSTRATION	TOOL NUMBER	DESCRIPTION	REMARKS
 ST-398477701	398477701	HANDLE	Used for installing the front and rear bearing cones.
 ST-398477702	398477702	DRIFT	Used for press-fitting the bearing race (front) of the differential carrier.
 ST-398217700	398217700	ATTACHMENT SET	Stand for rear differential carrier disassembly and assembly.
 ST-498447120	498447120	INSTALLER	Used for installing the front oil seal.

General Description

DIFFERENTIALS

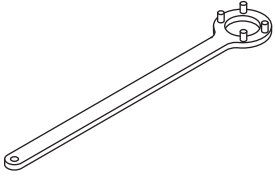
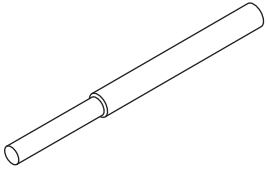
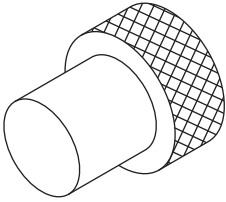
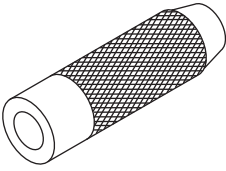
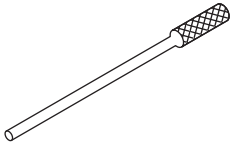
ILLUSTRATION	TOOL NUMBER	DESCRIPTION	REMARKS
 <p style="text-align: center;">ST-498427200</p>	498427200	FLANGE WRENCH	Used for preventing rotation of companion flange when loosening and tightening self-lock nut.
 <p style="text-align: center;">ST-398467700</p>	398467700	DRIFT	Used for removing pinion, pilot bearing and front bearing cone.
 <p style="text-align: center;">ST-399780104</p>	399780104	WEIGHT	Used for installing the front bearing cone and the pilot bearing companion flange.
 <p style="text-align: center;">ST-899580100</p>	899580100	INSTALLER	Used for press-fitting the front bearing cone and pilot bearing.
 <p style="text-align: center;">ST-899904100</p>	899904100	STRAIGHT PIN REMOVER	Used for driving out differential pinion shaft lock pin.

General Description

DIFFERENTIALS

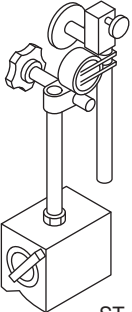
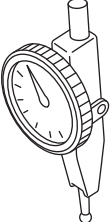
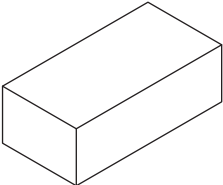
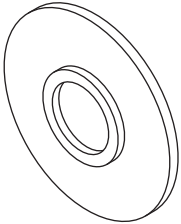
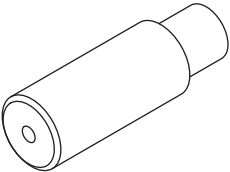
ILLUSTRATION	TOOL NUMBER	DESCRIPTION	REMARKS
 <p style="text-align: center;">ST-498247001</p>	498247001	MAGNET BASE	<ul style="list-style-type: none"> • Used for measuring backlash between side gear and pinion, and hypoid gear. • Used together with the DIAL GAUGE (498247100).
 <p style="text-align: center;">ST-498247100</p>	498247100	DIAL GAUGE	<ul style="list-style-type: none"> • Used for measuring backlash between side gear and pinion, and hypoid gear. • Used together with the MAGNET BASE (498247001).
 <p style="text-align: center;">ST-398507704</p>	398507704	BLOCK	Used for adjusting pinion height and preload.
 <p style="text-align: center;">ST-398177700</p>	398177700	INSTALLER	Used for installing the rear bearing cone.
 <p style="text-align: center;">ST-398457700</p>	398457700	ATTACHMENT	Used for removing the side retainer.

General Description

DIFFERENTIALS

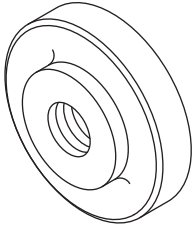
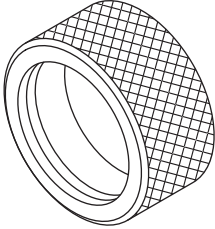
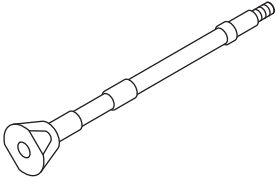
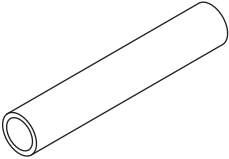
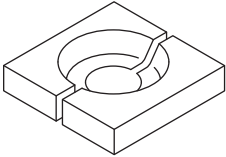
ILLUSTRATION	TOOL NUMBER	DESCRIPTION	REMARKS
 <p style="text-align: center;">ST-398477703</p>	398477703	DRIFT 2	Used for press-fitting bearing race (rear) of differential carrier.
 <p style="text-align: center;">ST-398437700</p>	398437700	DRIFT	Used for installing the side oil seal.
 <p style="text-align: center;">ST-398507702</p>	398507702	DUMMY SHAFT	Used for adjusting pinion height and preload.
 <p style="text-align: center;">ST-398507703</p>	398507703	DUMMY COLLAR	Used for adjusting pinion height and preload.
 <p style="text-align: center;">ST-398517700</p>	398517700	REPLACER	Used for removing rear bearing cone.

General Description

DIFFERENTIALS

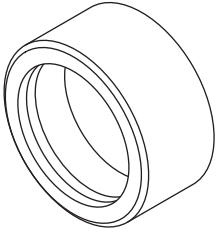
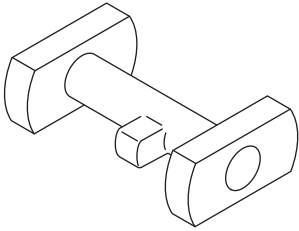
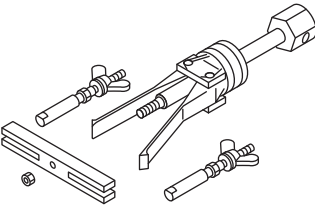
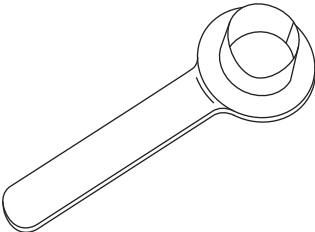
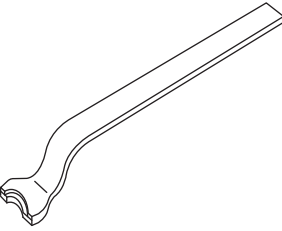
ILLUSTRATION	TOOL NUMBER	DESCRIPTION	REMARKS
 <p style="text-align: center;">ST-398487700</p>	398487700	DRIFT	Used for press-fitting side bearing cone.
 <p style="text-align: center;">ST-398507701</p>	398507701	DIFFERENTIAL CARRIER GAUGE	Used for adjusting pinion height.
 <p style="text-align: center;">ST-398527700</p>	398527700	PULLER ASSY	<ul style="list-style-type: none"> • Used for removing front oil seal. • Used for removing side bearing cup.
 <p style="text-align: center;">ST28099PA090</p>	28099PA090	OIL SEAL PROTECTOR	<ul style="list-style-type: none"> • Used for installing the rear drive shaft to the rear differential. • For oil seal protection
 <p style="text-align: center;">ST28099PA100</p>	28099PA100	DRIVE SHAFT REMOVER	Used for removing the rear drive shaft from rear differential.

General Description

DIFFERENTIALS

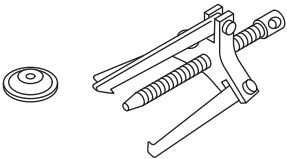
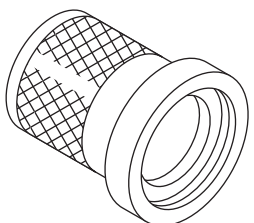
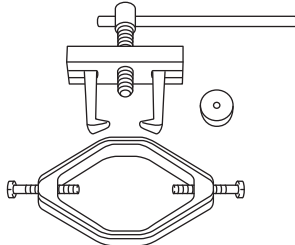
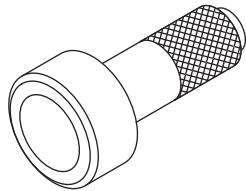
ILLUSTRATION	TOOL NUMBER	DESCRIPTION	REMARKS
 <p>ST-399703600</p>	399703600	PULLER ASSY	Used for removing companion flange.
 <p>ST-899874100</p>	899874100	INSTALLER	Used for installing the companion flange.
 <p>ST18759AA000</p>	18759AA000	PULLER ASSY	Used for removing the differential side bearing cone.
 <p>ST-398417700</p>	398417700	DRIFT	Used for installing side bearing race.

2. GENERAL TOOL

TOOL NAME	REMARKS
Transmission jack	Used for assembly/disassembly of the rear differential.
Puller	Used for removing the side bearing retainer.
Thickness gauge	Used for measuring clearance.

Differential Gear Oil

DIFFERENTIALS

2. Differential Gear Oil

A: INSPECTION

1) Remove the filler plug, and then check the gear oil. Replace the gear oil if it is contaminated or deteriorated. <Ref. to DI-14, REPLACEMENT, Differential Gear Oil.>

2) Check that the gear oil level is within -5 mm (-0.2 in) from the bottom of the filler plug hole. If the level is low, refill up to the bottom of filler plug.

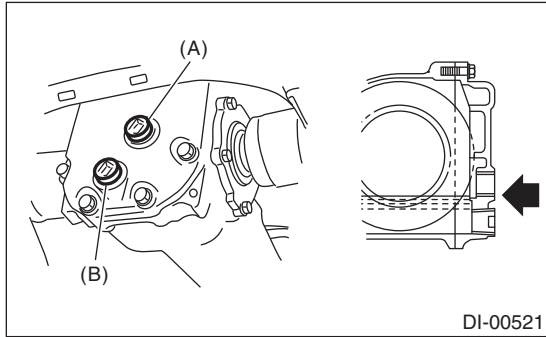

(A) Filler plug
(B) Oil drain plug

B: REPLACEMENT

1) Lift up the vehicle.
2) Remove the oil drain plug and filler plug, and drain the gear oil.

CAUTION:
Gear oil is extremely hot just after driving. Be wary of receiving burns.

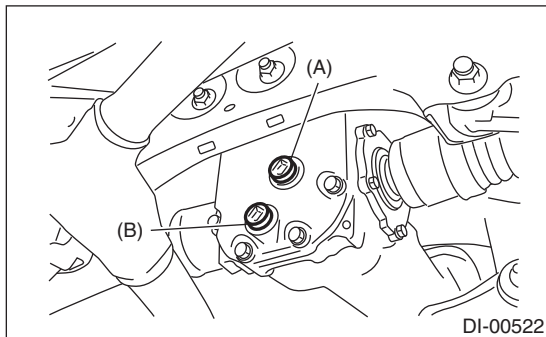

(A) Filler plug
(B) Oil drain plug

3) Tighten the oil drain plug.

NOTE:
Apply liquid gasket to the drain plug.

Liquid gasket:
THREE BOND 1105 (Part No. 004403010) or equivalent

Tightening torque:
49 N·m (5.0 kgf·m, 36.1 ft·lb)

4) Fill the differential carrier with gear oil to the bottom of filler plug.

NOTE:
Carefully refill oil while watching the level. Excessive or insufficient oil must be avoided.

Recommended gear oil:
<Ref. to DI-2, SPECIFICATION, General Description.>

Oil capacity:
0.8 ℓ (0.8 US qt, 0.7 Imp qt)

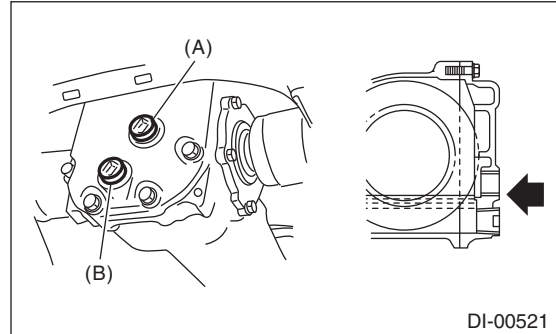

(A) Filler plug
(B) Oil drain plug

5) Install the filler plug.

NOTE:
Apply liquid gasket to the filler plug.

Liquid gasket:
THREE BOND 1105 (Part No. 004403010) or equivalent

Tightening torque:
49 N·m (5.0 kgf·m, 36.1 ft·lb)

3. Front Differential Assembly

A: NOTE

1. AT MODEL

For front differential of automatic transmissions, refer to the "4AT" section. <Ref. to 4AT-94, Front Differential Assembly.>

2. MT MODEL

For front differential of the manual transmission, refer to "5MT" section. <Ref. to 5MT-66, Front Differential Assembly.>

4. Rear Differential

A: REMOVAL

- 1) Set the vehicle on a lift.
- 2) Disconnect the ground cable from the battery.
- 3) Shift the select lever or gear shift lever to neutral.
- 4) Release the parking brake.
- 5) Loosen the wheel nuts.
- 6) Lift up the vehicle
- 7) Remove the wheels.
- 8) Remove the rear exhaust pipe and muffler.

- Non-turbo model

<Ref. to EX(H4SO)-8, REMOVAL, Rear Exhaust Pipe.> <Ref. to EX(H4SO)-10, REMOVAL, Muffler.>

- Turbo model

<Ref. to EX(H4DOTC)-12, REMOVAL, Rear Exhaust Pipe.> <Ref. to EX(H4DOTC)-14, REMOVAL, Muffler.>

- 9) Remove the heat shield cover.

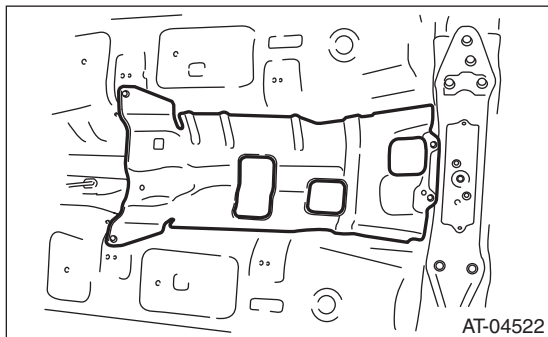

- 10) Separate the rear differential side of the propeller shaft.

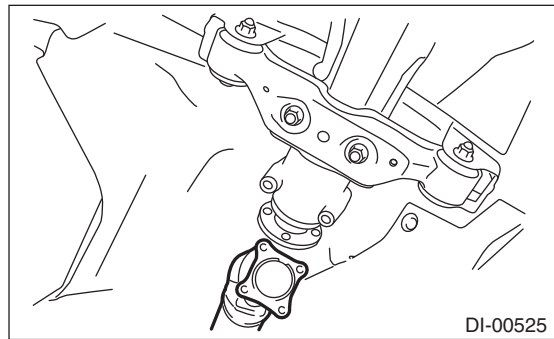

NOTE:

Make alignment marks on the flange yoke and rear differential before separating it.

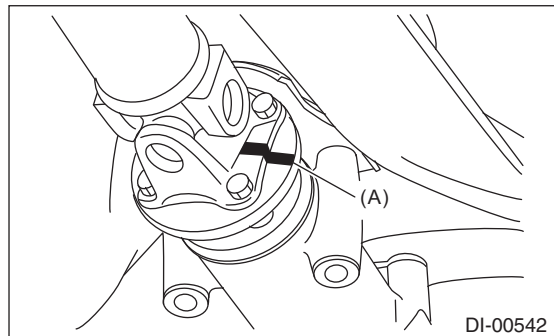

(A) Alignment mark

- 11) Remove the DOJ of rear drive shaft from rear differential.

- (1) Remove the ABS wheel speed sensor cable from the clamp.

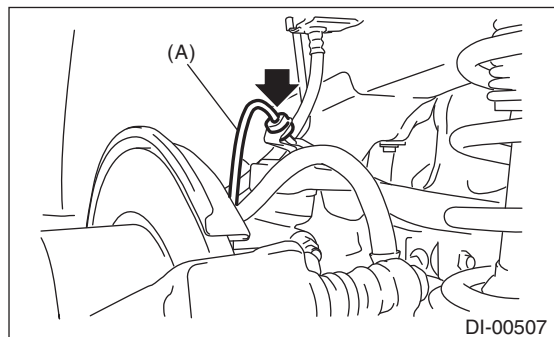

(A) ABS wheel speed sensor cable

(2) Disconnect the connector and remove the nut to remove the rear vehicle height sensor. (models with auto headlight beam leveler, left side only)

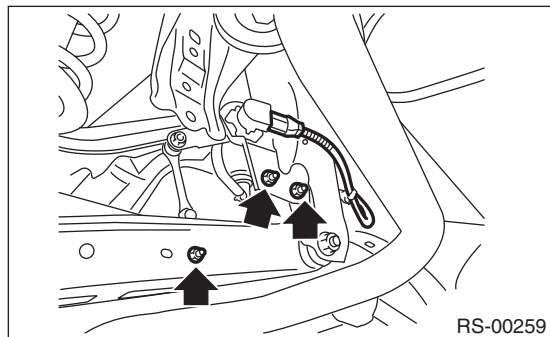

(3) Remove the bolts which secure the rear stabilizer link to the rear lateral link.

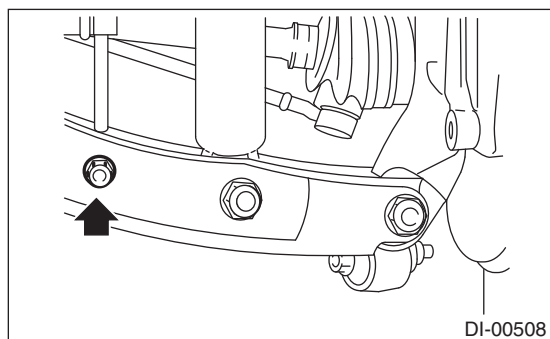

(4) Remove the bolts which secure the shock absorber to the rear lateral link.

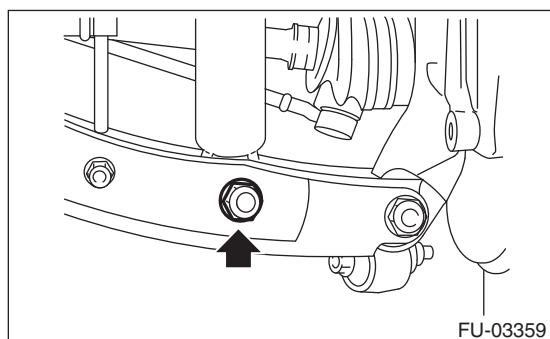

(5) Remove the bolts which secure the rear lateral link to the housing.

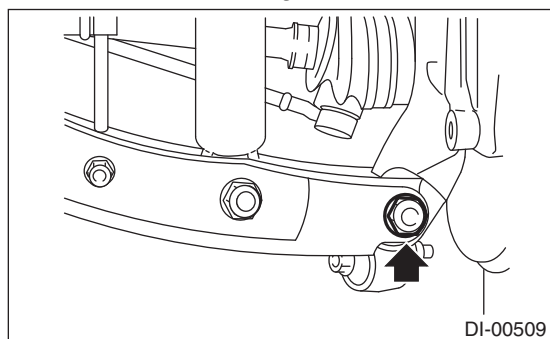

(6) Remove the bolts which secure the trailing link to the housing.

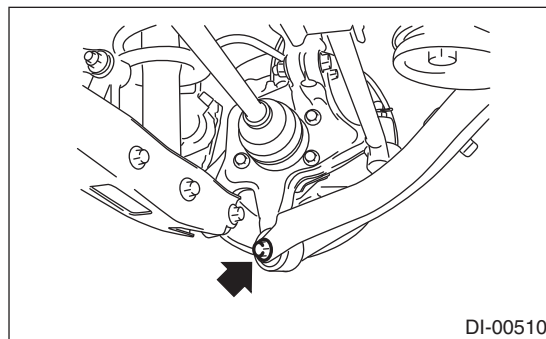

(7) Remove the DOJ from the rear differential by using ST.

NOTE:

When removing the DOJ from the rear differential, fit the ST to the bolts as shown in the figure so as not to damage the side retainer.

ST 28099PA100 DRIVE SHAFT REMOVER

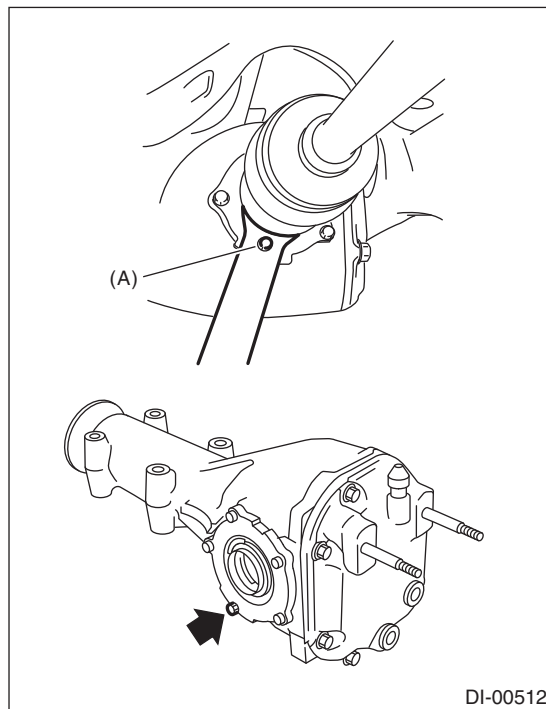

(A) Bolt

Rear Differential

DIFFERENTIALS

12) Suspend the rear drive shaft to the rear cross-member using wire.

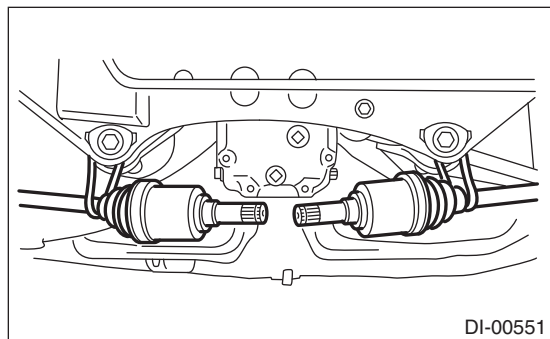

13) Remove the rear differential front member.

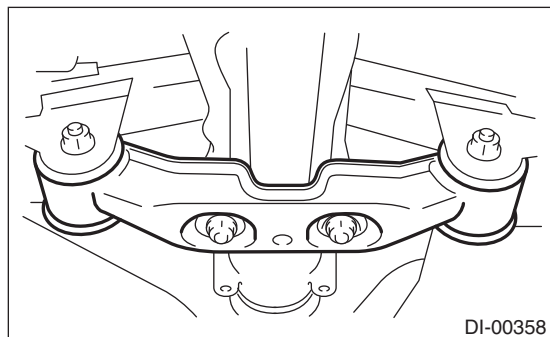

14) Support the rear differential with the transmission jack.

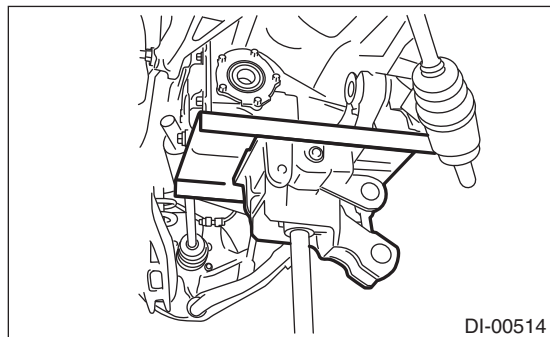

15) Remove the self-lock nuts which hold the rear differential to the rear crossmember.

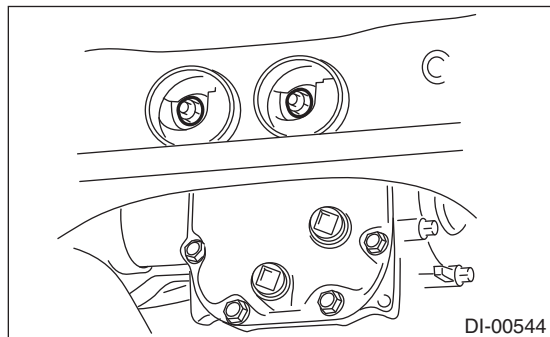

16) While slowly lowering the transmission jack, move the rear differential forward, and remove the rear differential from vehicle.

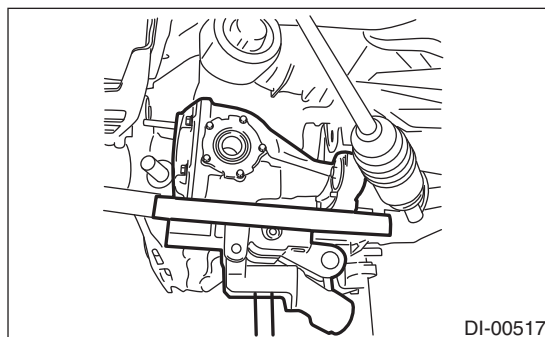

17) Remove the rear differential member plate from rear differential.

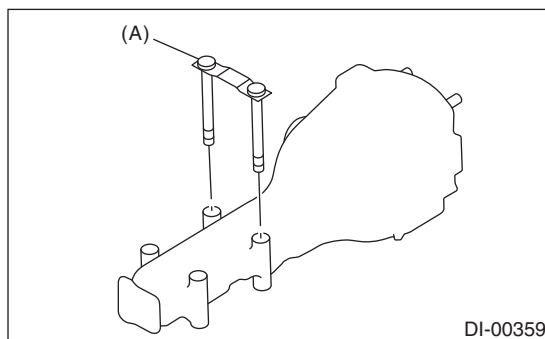

(A) Rear differential member plate

B: INSTALLATION

1) Install the rear differential member plate to the rear differential.

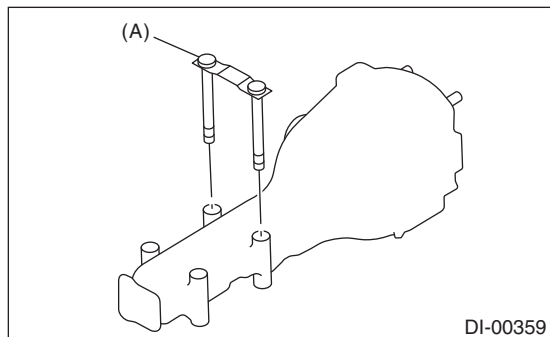

(A) Rear differential member plate

2) Set the rear differential to transmission jack.
3) Adjust the transmission jack, and insert the rear differential stud bolt into rear crossmember bushing properly.

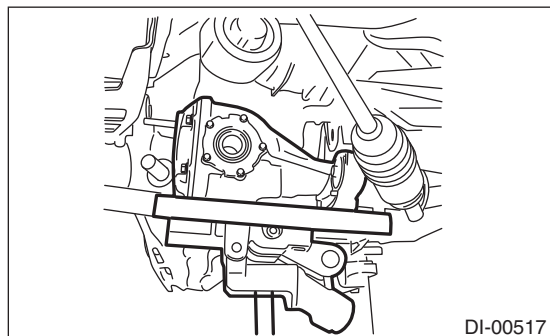

4) After inserting the rear differential stud bolt into the rear crossmember bushing, lift up the transmission jack and align the rear differential to its attachment position.

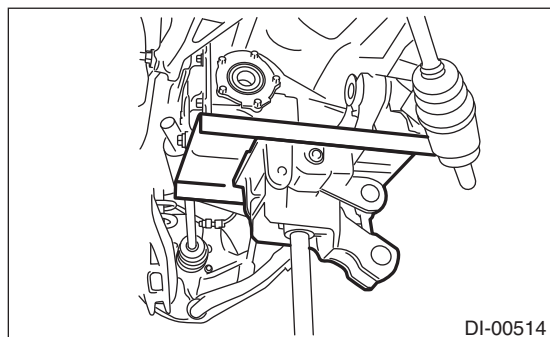

5) Tighten a new self-locking nut temporarily to rear crossmember.

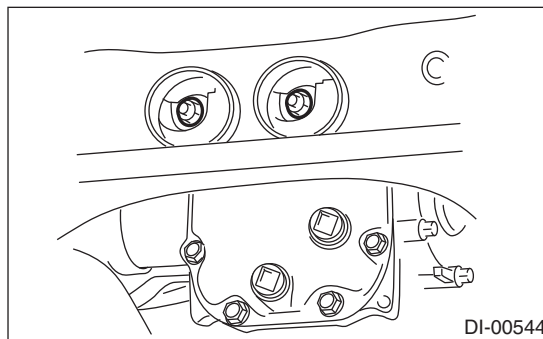

6) Install the rear differential front member with a new self-locking nut.

Tightening torque:

T1: 50 N·m (5.1 kgf-m, 36.9 ft-lb)

T2: 110 N·m (11.2 kgf-m, 81.1 ft-lb)

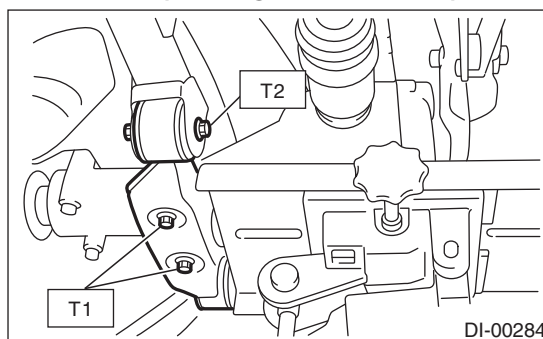

7) Tighten the self-locking nut.

Tightening torque:

70 N·m (7.1 kgf-m, 51.6 ft-lb)

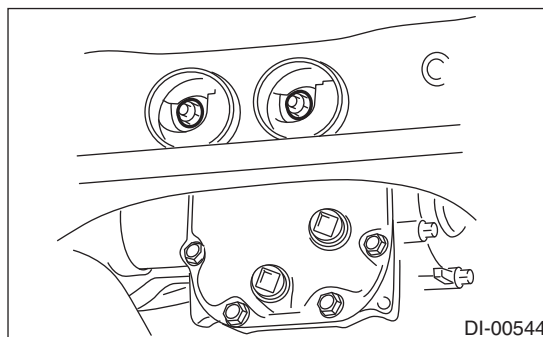

8) Attach the ST to rear differential.

ST 28099PA090 OIL SEAL PROTECTOR

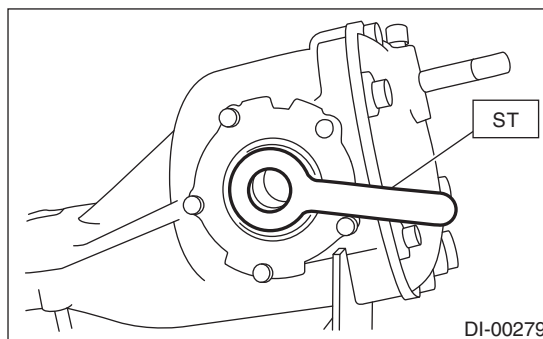

Rear Differential

DIFFERENTIALS

9) Insert the spline shaft until the spline portion comes inside the side oil seal.

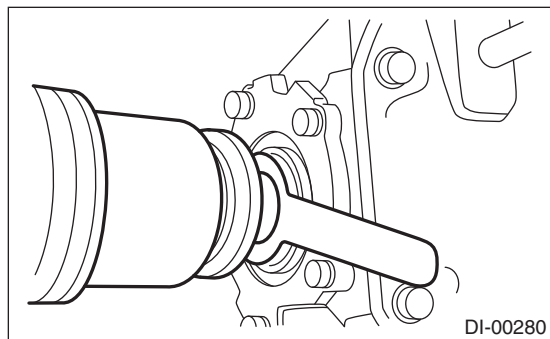

10) Remove ST from rear differential.
ST 28099PA090 OIL SEAL PROTECTOR

11) Push the housing to insert DOJ completely into rear differential.

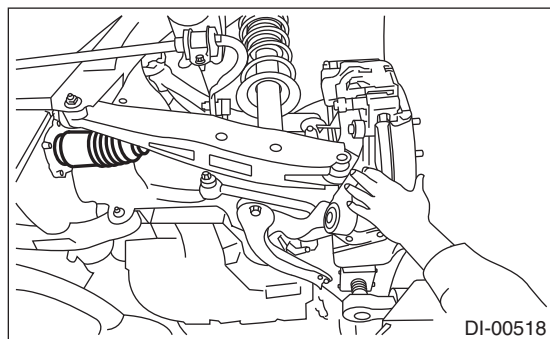

- 12) Lower the transmission jack.
- 13) Installing procedure hereafter is in the reverse order of removal.
- 14) After installing, fill the differential carrier with gear oil up to the bottom of the filler plug hole. <Ref. to DI-14, Differential Gear Oil.>
- 15) Inspect the wheel alignment and adjust if necessary.
- 16) Re-initialize the auto headlight beam leveler system. (models with auto headlight beam leveler) <Ref. to LI-15, PROCEDURE, Auto Headlight Beam Leveler System.>

C: DISASSEMBLY

To detect the real cause of trouble, inspect the following items before disassembling.

- Tooth contact and backlash between hypoid driven gear and drive pinion
- Hypoid driven gear runout on its back surface
- Total preload of drive pinion

1) Set the ST on vise and install the differential assembly to ST.

ST 398217700

ATTACHMENT SET

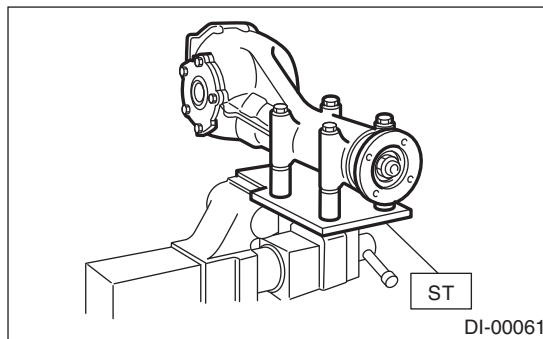

- 2) Remove the oil drain plug and filler plug, and drain the gear oil.
- 3) Remove the air breather cap.

NOTE:

- Do not attempt to replace the air breather cap unless necessary.
- Whenever the air breather cap is removed, replace it with a new part.

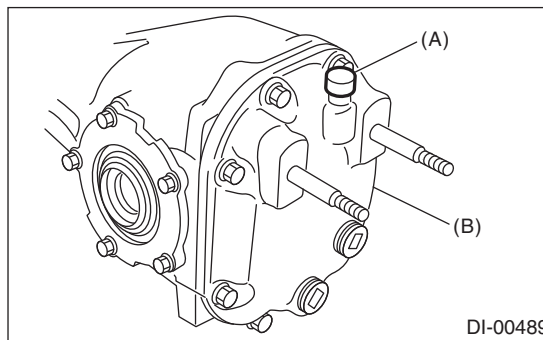

- (A) Air breather cap
- (B) Rear cover

4) Remove the bolts, and then remove the rear cover.

5) Keep the side retainers separate to make it possible to identify RH and LH sides. Remove the side retainer attaching bolts, set the ST to differential case, and extract the side retainers RH and LH with a puller.

NOTE:

Each side retainer shim of both sides should be kept together with its mating retainer.

ST 398457700 ATTACHMENT

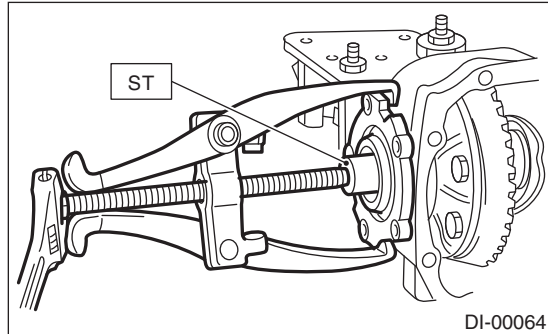

DI-00064

6) Pull out the differential case assembly from differential carrier.

NOTE:

Be careful so that the teeth do not hit against the case.

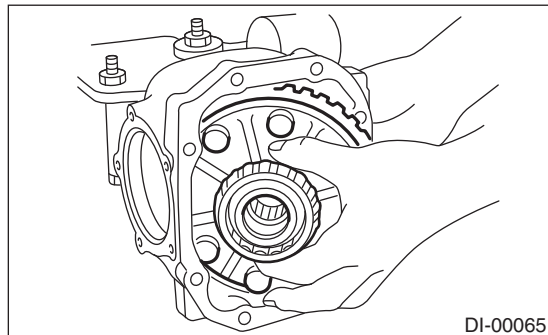

DI-00065

7) When replacing the side bearing, remove the bearing cup from the side retainer using ST.

ST 398527700 PULLER ASSY

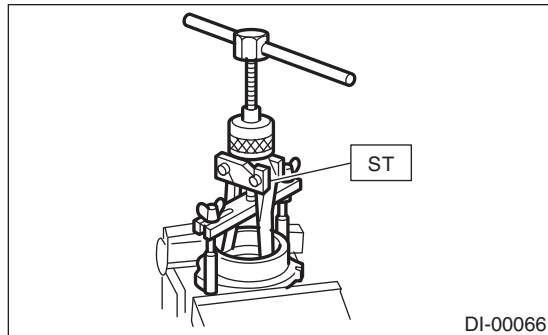

DI-00066

8) Remove the bearing cone with ST.

NOTE:

- Do not attempt to disassemble the parts unless necessary.
- Set the puller so that its claws catch the edge of the bearing cone.
- Never mix up the RH and LH bearing races and cones.

ST 18759AA000 PULLER ASSY

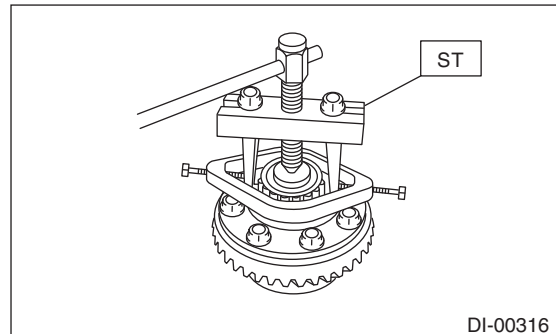

DI-00316

9) Remove the hypoid driven gear by loosening hypoid driven gear bolts.

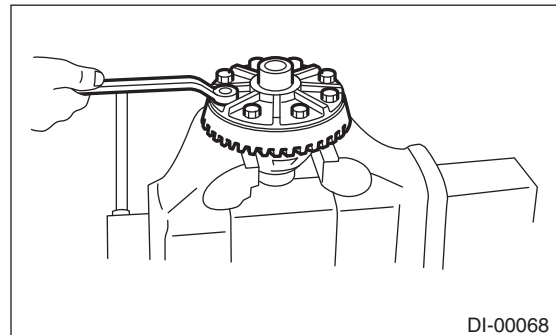

DI-00068

10) Drive out the pinion shaft lock pin from the hypoid driven gear side.

NOTE:

The lock pin is staked at the pin hole end on the differential carrier. Do not drive it out forcibly before removing the stake.

ST 899904100 STRAIGHT PIN REMOVER

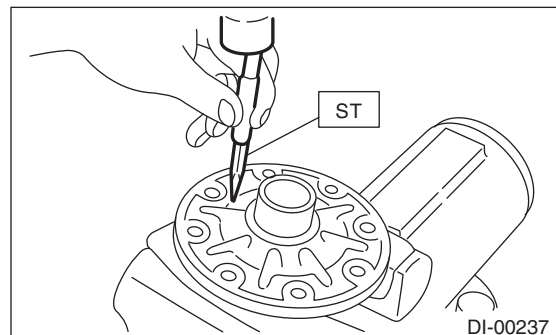

DI-00237

Rear Differential

DIFFERENTIALS

11) Draw out the pinion mate shaft and remove pinion mate gears, side gears and thrust washers.

NOTE:

The gears should be marked or kept separated right and left, and front and rear as well as thrust washers.

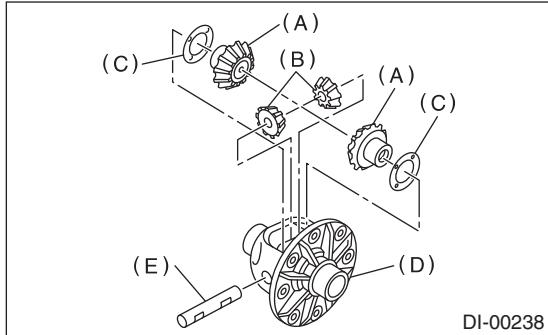

- (A) Side gear
- (B) Pinion mate gear
- (C) Thrust washer
- (D) Differential case
- (E) Pinion mate shaft

12) Remove the self-locking nut while holding the companion flange with ST.

ST 498427200 FLANGE WRENCH

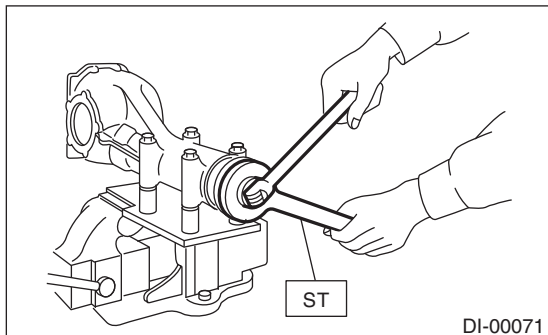

13) Extract the companion flange with a puller.

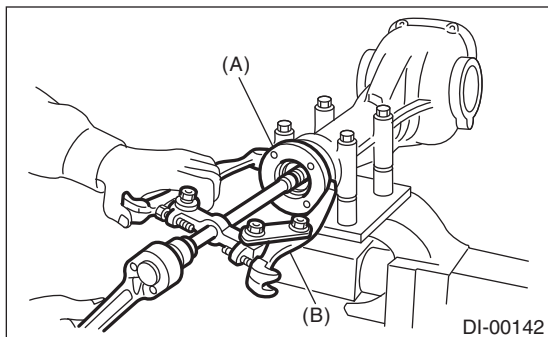

- (A) Companion flange
- (B) Puller

14) Press the end of drive pinion shaft and extract it together with rear bearing cone, pinion height adjusting washer and washer.

NOTE:

Hold the drive pinion so as not to drop it.

ST 398467700 DRIFT

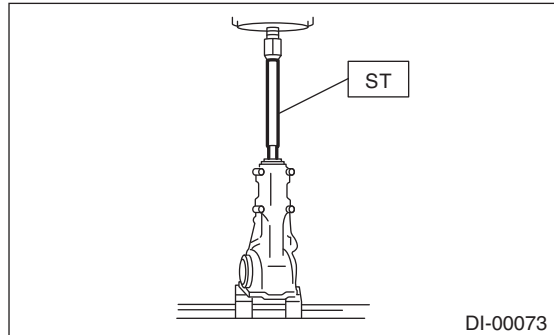

15) Remove the rear bearing cone from drive pinion by supporting the cone with ST.

NOTE:

Place the replacer so that its center-recessed side faces the pinion gear.

ST 398517700 REPLACER

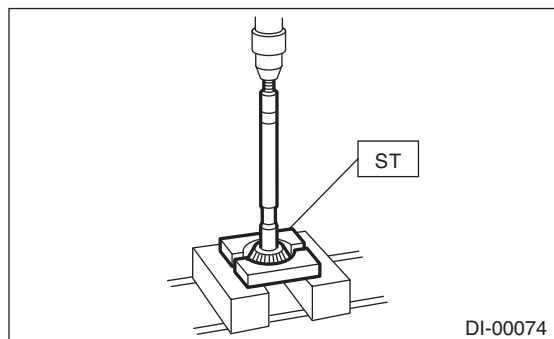

16) Remove the front oil seal from differential carrier using ST.

ST 398527700 PULLER ASSY

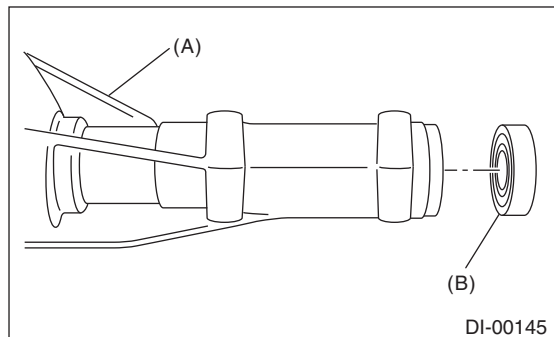

- (A) Differential carrier
- (B) Front oil seal

17) Remove the pilot bearing together with the front bearing cone and spacer using the ST.

ST 398467700 DRIFT

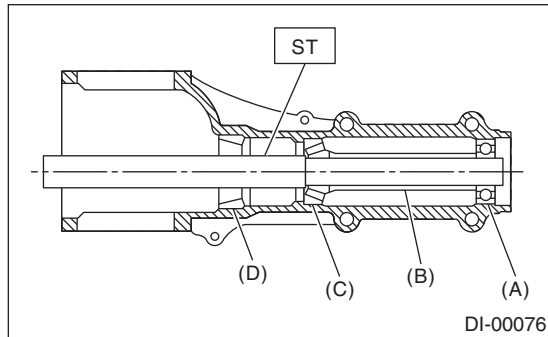

- (A) Pilot bearing
- (B) Spacer
- (C) Front bearing
- (D) Rear bearing cup

18) When replacing the bearings, hit out the front bearing cup and rear bearing cup in this order using a brass bar.

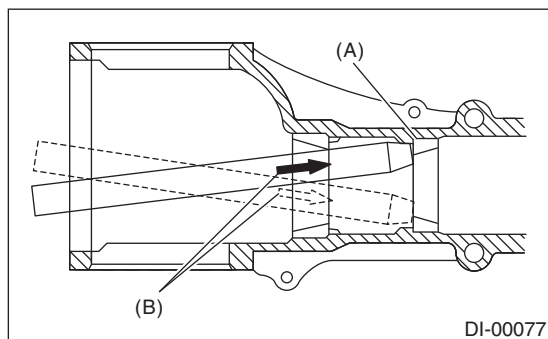

- (A) 2 cutout portions along diagonal lines
- (B) Tap alternately with brass bar.

D: ASSEMBLY

NOTE:

- Assemble in the reverse order of disassembly.
- Check and adjust each part during assembly.
- Keep the shims and washers in order, so that they are not improperly installed.
- Thoroughly clean the surfaces on which the shims, washers and bearings are to be installed.
- Apply differential gear oil when installing the bearings and thrust washers.
- Be careful not to mix up the RH and LH bearing races.
- Use a new O-ring and gasket.
- Replace the oil seal with a new part at every disassembly.
- Apply differential gear oil to the lips when installing the oil seal.
- Be careful not to mix up the oil seal RH and LH.

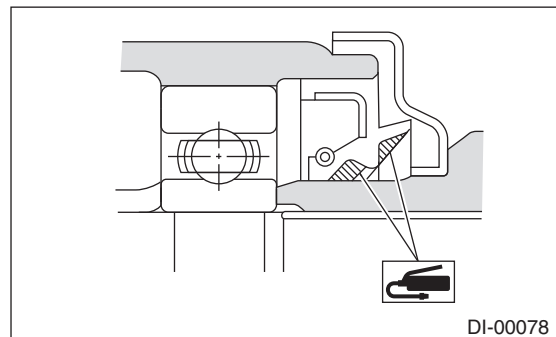

1) Adjusting preload for front and rear bearings

NOTE:

Adjust the bearing preload between front and rear bearings with spacer and washer. Pinion height adjusting washer is not affected by this adjustment. The adjustment must not be carried out with oil seal inserted.

(1) Install the rear bearing race into the differential carrier using ST1 and ST2.

ST1 398477701 HANDLE

ST2 398477703 DRIFT 2

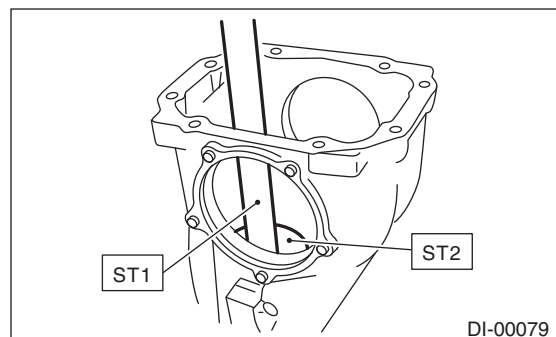

(2) Install the front bearing race to the differential carrier using ST1 and ST2.

ST1 398477701 HANDLE

ST2 398477702 DRIFT

Rear Differential

DIFFERENTIALS

(3) Insert the ST1 into carrier with the pinion height adjusting washer and rear bearing cone fitted onto it.

NOTE:

- If tooth contact (drive pinion, hypoid driven gear) is normal in the inspection before disassembling, verify that the washer is not deformed, and then reuse the used washer.
- Use new rear bearing cone.

(4) Install the preload adjusting spacer & washer, front bearing cone, ST2, companion flange, and washer & self-locking nut.

ST1 398507702 DUMMY SHAFT
ST2 398507703 DUMMY COLLAR

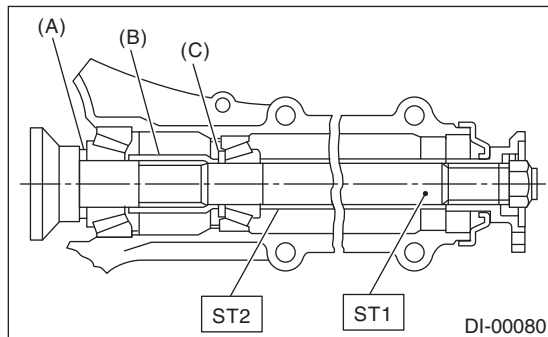

- (A) Pinion height adjusting washer
(B) Preload adjusting spacer
(C) Preload adjusting washer

(5) Turn the ST1 by hand to smooth the bearing, and tighten the self-locking nut while measuring the initial load or initial torque with a spring scale or torque wrench. Select the preload adjusting washer and spacer so that the specified preload is obtained when nut is tightened to the specified torque.

NOTE:

- Use a new self-locking nut.
- Measure the preload in direction of tangent to the flange.
- Be careful not to give excessive preload.
- When tightening the self-locking nut, lock ST1 with ST2 as shown in the figure.

ST1 398507702 DUMMY SHAFT
ST2 398507704 BLOCK

Tightening torque:

181.5 N·m (18.5 kgf·m, 133.9 ft·lb)

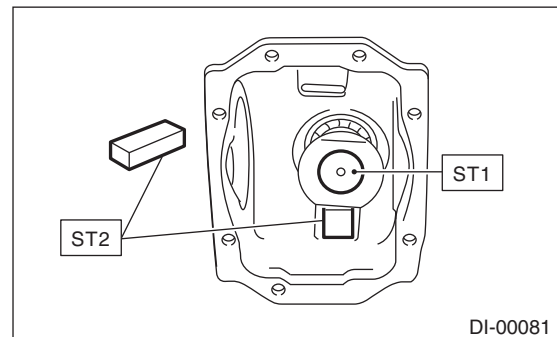

Initial load:

17.7 — 38.8 N (1.8 — 4.0 kgf, 4.0 — 8.7 lb)

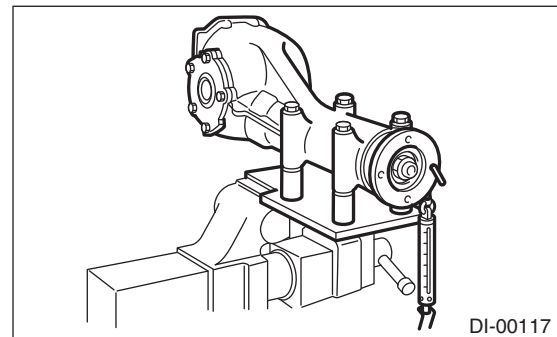

Initial torque:

**0.67 — 1.47 N·m (0.07 — 0.15 kgf·m,
0.49 — 1.08 ft·lb)**

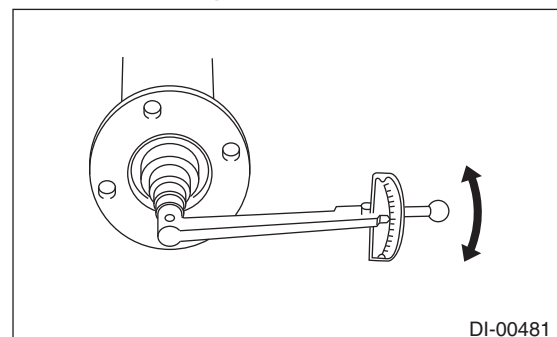

Preload adjusting washer	Part No.	Thickness mm (in)
	383705200	2.59 (0.1020)
	383715200	2.57 (0.1012)
	383725200	2.55 (0.1004)
	383735200	2.53 (0.0996)
	383745200	2.51 (0.0988)
	383755200	2.49 (0.0980)
	383765200	2.47 (0.0972)
	383775200	2.45 (0.0965)
	383785200	2.43 (0.0957)
	383795200	2.41 (0.0949)
	383805200	2.39 (0.0941)
	383815200	2.37 (0.0933)
	383825200	2.35 (0.0925)
	383835200	2.33 (0.0917)
383845200	2.31 (0.0909)	
Preload adjusting spacer	Part No.	Length mm (in)
	383695201	56.2 (2.213)
	383695202	56.4 (2.220)
	383695203	56.6 (2.228)
	383695204	56.8 (2.236)
	383695205	57.0 (2.244)
	383695206	57.2 (2.252)

2) Adjusting drive pinion height:
Adjust the drive pinion height with washer installed between the rear bearing cone and the back of pinion gear.

(1) Attach the ST2.

NOTE:

At this time, install a pinion height adjusting washer, temporarily selected, or the same as that used before. Measure and record the thickness.

- ST1 398507702 DUMMY SHAFT
- ST2 398507701 DIFFERENTIAL CARRIER GAUGE
- ST3 398507703 DUMMY COLLAR

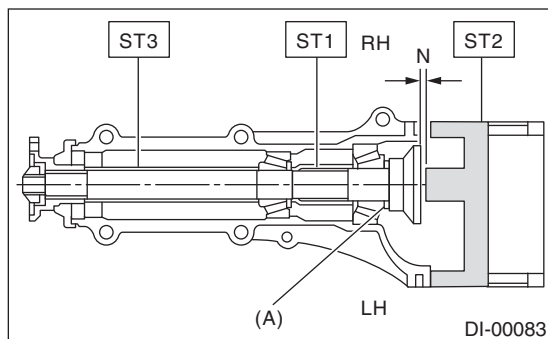

(A) Pinion height adjusting washer

(2) Measure the clearance N between the end of ST2 and the end surface of ST1 by using a thickness gauge.

NOTE:

Make sure there is no clearance between the case and ST2.

- ST1 398507702 DUMMY SHAFT
- ST2 398507701 DIFFERENTIAL CARRIER GAUGE

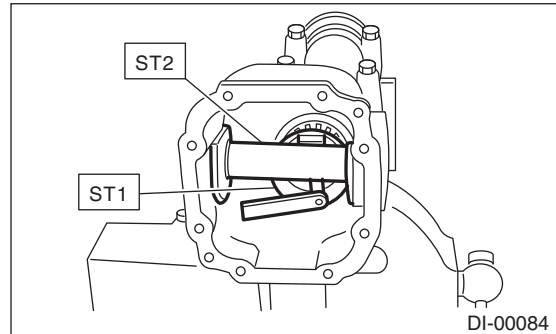

(3) Obtain the thickness of pinion height adjusting washer to be inserted from the following formula, and replace the temporarily installed washer with this one.

$$T = To + N - (H \times 0.01) - 0.20 \text{ mm (0.0079 in)}$$

NOTE:

Use copies of this page.

T	Thickness of pinion height adjusting washer mm (in)
To	Thickness of washer temporarily inserted mm (in)
N	Clearance of thickness gauge mm (in)
H	Figure marked on drive pinion head
Memo:	

(Example of calculation)

$$To = 2.20 \text{ mm (0.0866 in)} + 1.20 \text{ mm (0.0472 in)} = 3.40 \text{ mm (0.1339 in)}$$

$$N = 0.23 \text{ mm (0.0091 in)}$$

$$H = + 1$$

$$T = 3.40 \text{ mm (0.1339 in)} + 0.23 \text{ mm (0.0091 in)} - 0.01 \text{ mm (0.0004 in)} - 0.20 \text{ mm (0.0079 in)} = 3.42 \text{ mm (0.1346 in)}$$

$$\text{Thickness} = 3.42 \text{ mm (0.1346 in)}$$

Therefore use washer 383605200.

Rear Differential

DIFFERENTIALS

Pinion height adjusting washer	
Part No.	Thickness mm (in)
383495200	3.09 (0.1217)
383505200	3.12 (0.1228)
383515200	3.15 (0.1240)
383525200	3.18 (0.1252)
383535200	3.21 (0.1264)
383545200	3.24 (0.1276)
383555200	3.27 (0.1287)
383565200	3.30 (0.1299)
383575200	3.33 (0.1311)
383585200	3.36 (0.1323)
383595200	3.39 (0.1335)
383605200	3.42 (0.1346)
383615200	3.45 (0.1358)
383625200	3.48 (0.1370)
383635200	3.51 (0.1382)
383645200	3.54 (0.1394)
383655200	3.57 (0.1406)
383665200	3.60 (0.1417)
383675200	3.63 (0.1429)
383685200	3.66 (0.1441)

3) Install the selected pinion height adjusting washer on drive pinion, and press the rear bearing cone into position with ST.

ST 398177700 INSTALLER

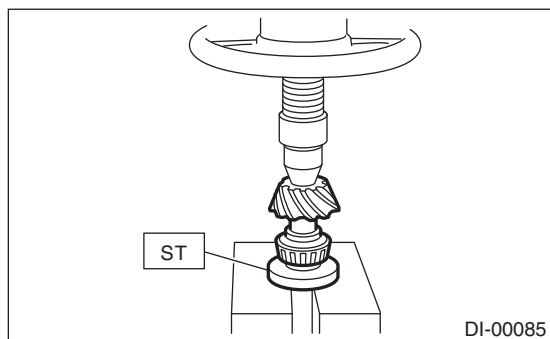

4) Insert the drive pinion into the differential carrier, and install the preselected bearing preload adjusting spacer and washer.

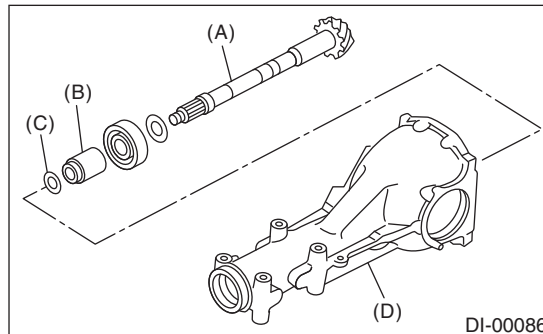

- (A) Drive pinion
- (B) Bearing preload adjusting spacer
- (C) Bearing preload adjusting washer
- (D) Differential carrier

5) Press-fit the front bearing cone into case with ST1, ST2 and ST3.

ST1 398507703 DUMMY COLLAR
 ST2 399780104 WEIGHT
 ST3 899580100 INSTALLER

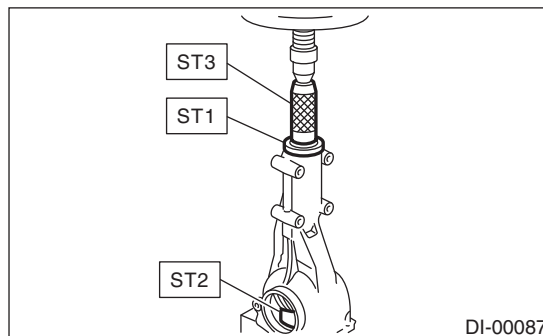

6) Insert the spacer, then press-fit the pilot bearing with ST1 and ST2.

ST1 399780104 WEIGHT
 ST2 899580100 INSTALLER

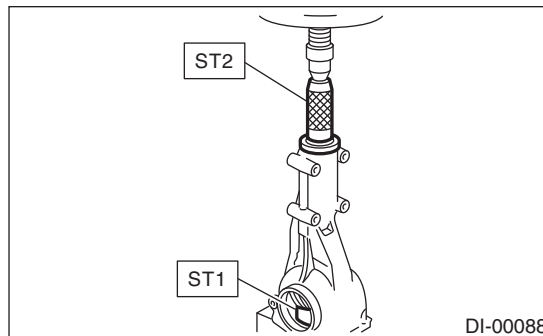

7) Fit a new oil seal with ST.

NOTE:

- Press-fit until the oil seal end comes 1 mm (0.04 in) inward from end of carrier.
- Apply differential gear oil to the oil seal lips.

ST 498447120 INSTALLER

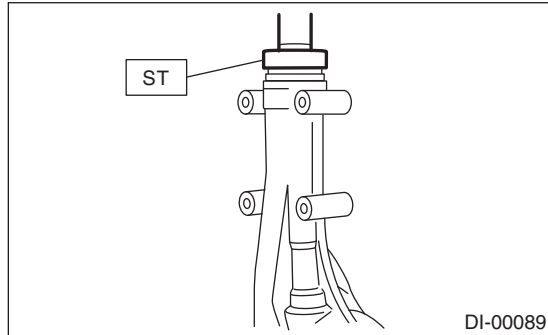

DI-00089

8) Press-fit the companion flange with ST1 and ST2.

NOTE:

Be careful not to damage the bearing.

ST1 899874100 INSTALLER

ST2 399780104 WEIGHT

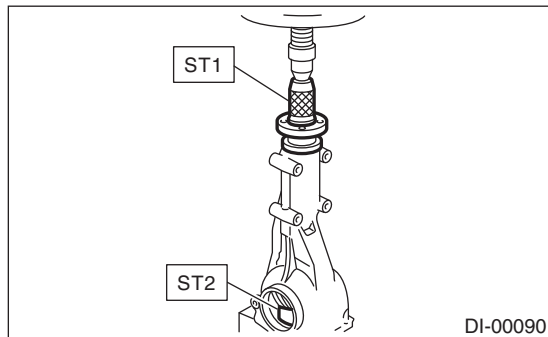

DI-00090

9) Apply seal material on the drive pinion shaft thread and new self-locking nut seat.

SEAL MATERIAL

THREE BOND 1324 (Part No. 004403042) or equivalent

10) Attach a new self-locking nut and tighten it with the ST.

ST 498427200 FLANGE WRENCH

Tightening torque:

181.5 N·m (18.5 kgf·m, 133.9 ft·lb)

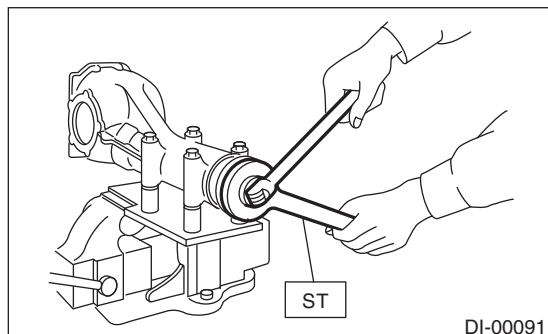

DI-00091

11) Assembling differential case

Install the side gears and pinion mate gears, with their thrust washers and pinion mate shaft, into the differential case.

NOTE:

- Apply gear oil on both sides of the washer and on the side gear shaft before installing.
- Insert the pinion mate shaft into the differential case by aligning the lock pin holes.

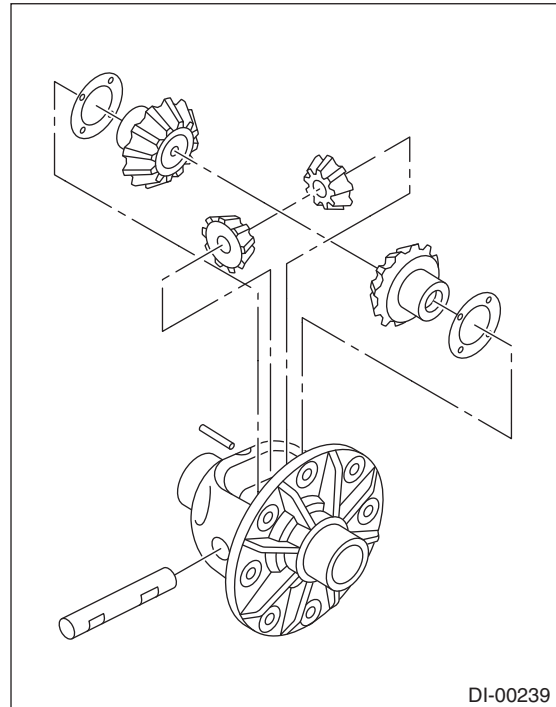

DI-00239

(1) Measure the side gear backlash.

Side gear backlash:

0.10 — 0.20 mm (0.004 — 0.008 in)

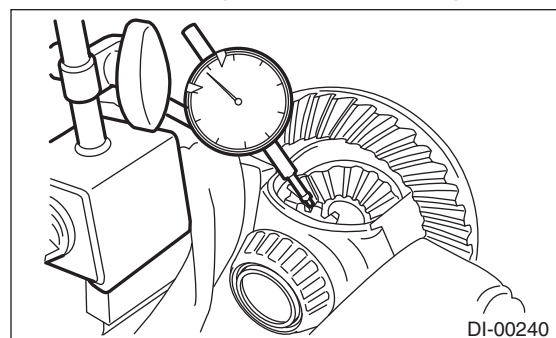

DI-00240

(2) Adjust the backlash as specified by selecting side gear thrust washer.

Side gear thrust washer	
Part No.	Thickness mm (in)
383445201	0.75 — 0.80 (0.0295 — 0.0315)
383445202	0.80 — 0.85 (0.0315 — 0.0335)
383445203	0.85 — 0.90 (0.0335 — 0.0354)

Rear Differential

DIFFERENTIALS

(3) Check the condition of rotation after applying differential gear oil to the gear tooth surfaces and thrust washer surfaces.

(4) After inserting the pinion shaft lock pin into differential case, stake the both sides of the hole to prevent pin from falling off.

12) Install the driven gear to the differential case.

NOTE:

- Before installing bolts, apply seal material to bolt threads.

SEAL MATERIAL

THREE BOND 1324 (Part No. 004403042) or equivalent

- Make sure there is no clearance between the differential case and driven gear.
- Tighten the bolts diagonally.

Tightening torque:

103 N·m (10.5 kgf-m, 76.0 ft-lb)

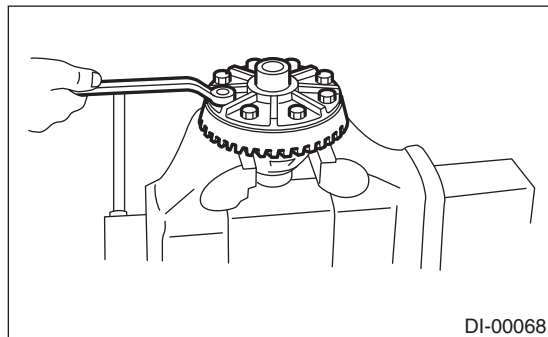

13) Press the side bearing into differential case using ST.

ST 398487700 DRIFT

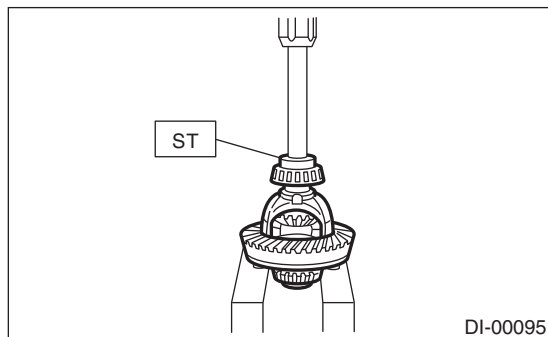

14) Press the side bearing outer race into side retainer using ST.

ST 398417700 DRIFT

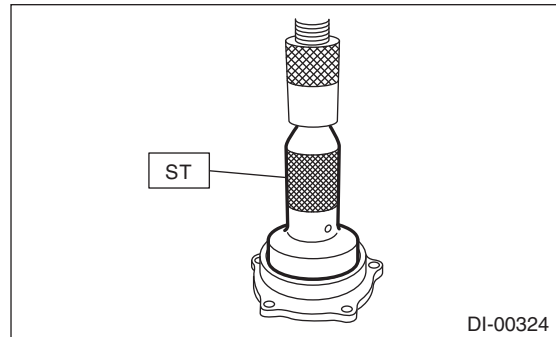

15) Side retainer shim adjustment

(1) The hypoid driven gear backlash and side bearing preload can be adjusted by the side retainer shim thickness.

(2) Install the differential case assembly into differential carrier in the reverse order of disassembly.

NOTE:

Be careful so that the teeth do not hit against the case.

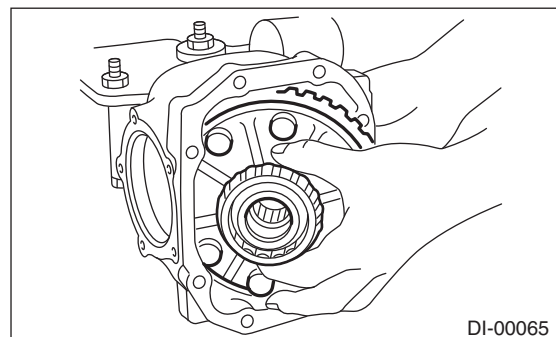

(3) Install the side retainer shims and O-ring to retainers RH and LH on which they were installed.

NOTE:

- Replace the O-ring with a new part.
- Replace broken or corroded side retainer shims with a new part of the same thickness.

Side retainer shim	
Part No.	Thickness mm (in)
383475201	0.20 (0.0079)
383475202	0.25 (0.0098)
383475203	0.30 (0.0118)
383475204	0.40 (0.0157)
383475205	0.50 (0.0197)

(4) Align the arrow mark on differential carrier with the arrow mark on side retainer during installation.

NOTE:

Be careful that side outer race is not damaged by the bearing roller.

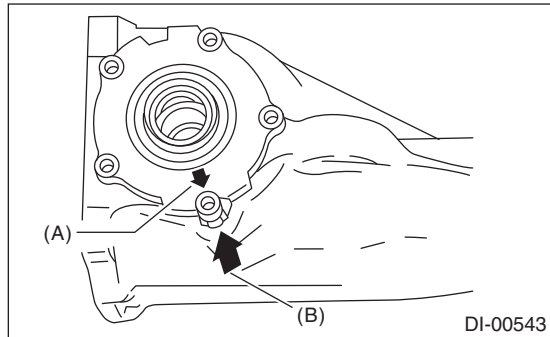

- (A) Arrow mark (on the side retainer)
- (B) Arrow mark (on the differential carrier)

(5) Tighten the side retainer bolts.

Tightening torque:

10.5 N·m (1.1 kgf·m, 7.7 ft·lb)

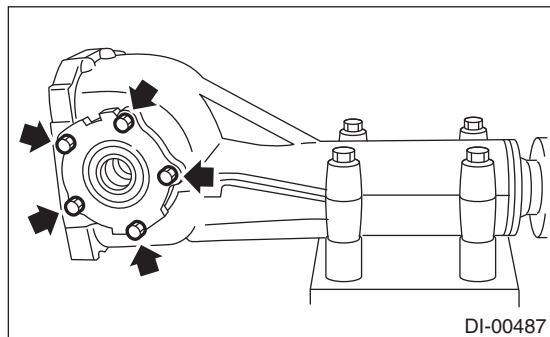

(6) Measure the backlash between the hypoid driven gear and drive pinion. Set the magnet base on differential carrier. Align the contact point of dial gauge with the tooth surface of hypoid driven gear, and move the hypoid driven gear while securing the drive pinion. Read the value indicated on dial gauge. If the backlash is not within the range of specifications, adjust the side retainer shim using the following procedures.

•When backlash is less than 0.1 mm (0.004 in): Reduce the hypoid driven gear rear face shim thickness and increase the hypoid driven gear tooth surface side shim thickness.

•When backlash exceeds 0.2 mm (0.008 in): Increase the hypoid driven gear rear face shim thickness and reduce the tooth surface side shim thickness.

Backlash:

0.10 — 0.20 mm (0.004 — 0.008 in)

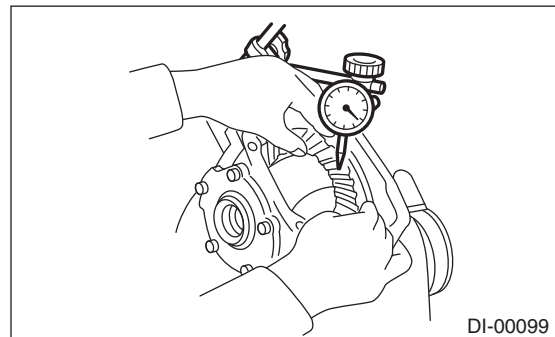

(7) At the same time, measure the total preload of the drive pinion. Compared with the resistance when differential case is not installed, if the total preload is not within specification, adjust the thickness of side retainer shims, increasing/reducing both shims by an even amount at a time.

Total preload:

20.7 — 54.4 N (2.1 — 5.5 kgf, 4.7 — 12.2 lbf)

16) Recheck the backlash between the hypoid driven gear and drive pinion.

Backlash:

0.10 — 0.20 mm (0.004 — 0.008 in)

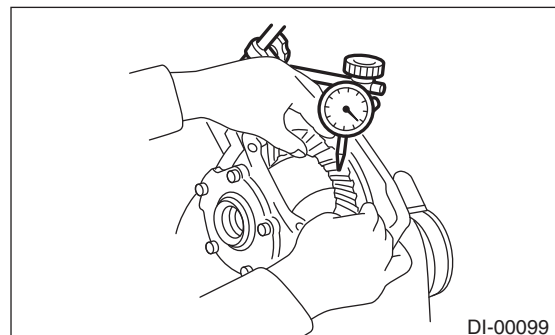

Rear Differential

DIFFERENTIALS

17) Check the driven gear runout on its back surface, and make sure that the pinion and driven gear rotate smoothly.

If the hypoid driven gear runout on its back surface exceeds the specification, check for any foreign objects between the hypoid driven gear and differential case, and for any deformation of the case or gear.

**Hypoid driven gear back surface runout:
0.05 mm (0.002 in)**

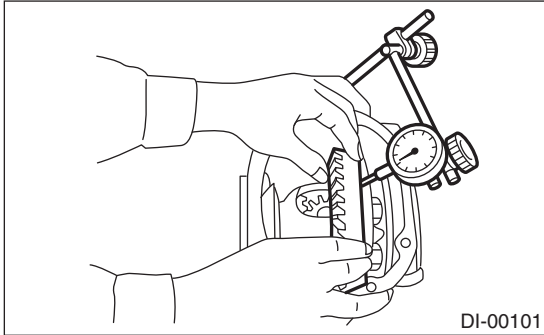

18) Checking and adjusting the tooth contact of hypoid driven gear

(1) Apply red lead evenly to the both side of three or four teeth on hypoid driven gear. Check the contact pattern after rotating the hypoid driven gear several revolutions back and forth until a definite contact pattern appears on the hypoid driven gear.

(2) When the contact pattern is not correct, re-adjust.

NOTE:

Be sure to wipe off the red lead after the adjustment is completed.

- Correct tooth contact

Check item: Tooth contact pattern is slightly shifted toward toe side under no-load rotation. (When driving, it moves towards the heel side.)

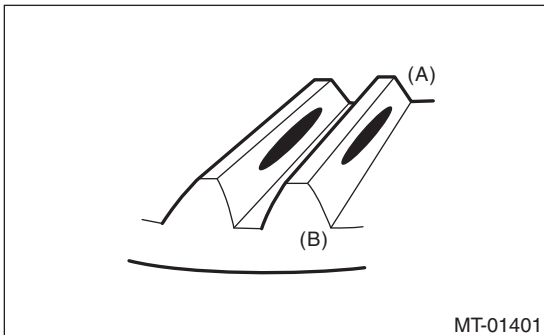

- (A) Toe side
- (B) Heel side

- Face contact

Check item: Backlash is too large.

Contact pattern

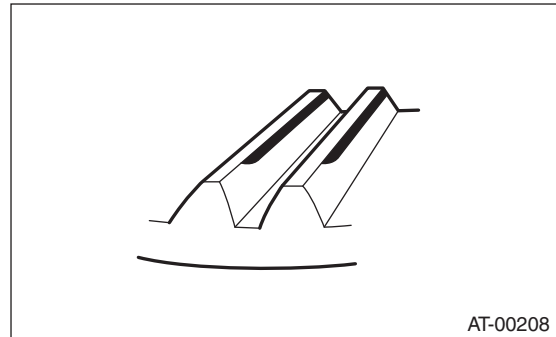

Corrective action: Increase thickness of drive pinion height adjusting washer in order to bring drive pinion close to hypoid driven gear.

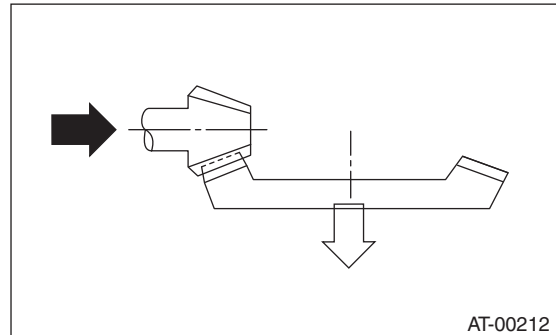

- Flank contact

Check item: Backlash is too small.

Contact pattern

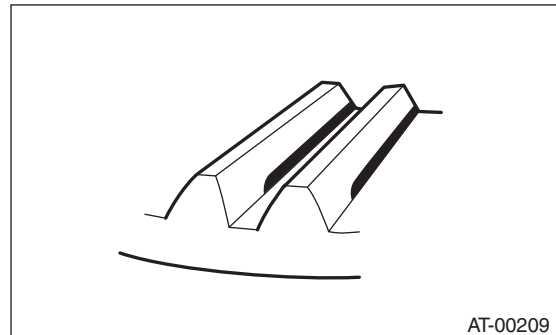

Adjustment: Reduce the thickness of pinion height adjusting washer according to the procedure for bringing the drive pinion away from hypoid driven gear.

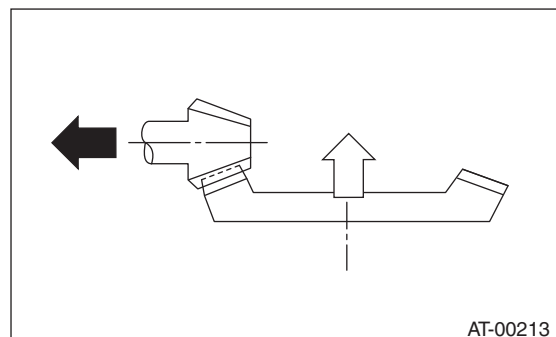

- Toe contact (inside contact)
Check item: Contact area is too small.
 Contact pattern

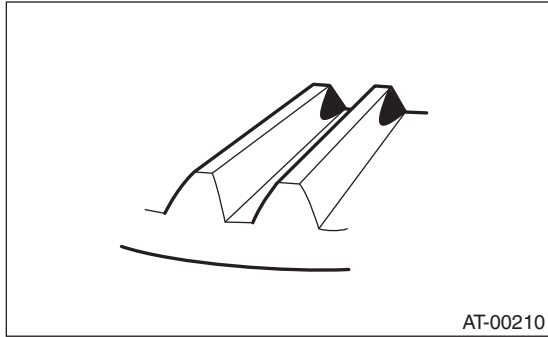

Adjustment: Reduce the thickness of pinion height adjusting washer according to the procedure for bringing the drive pinion away from hypoid driven gear.

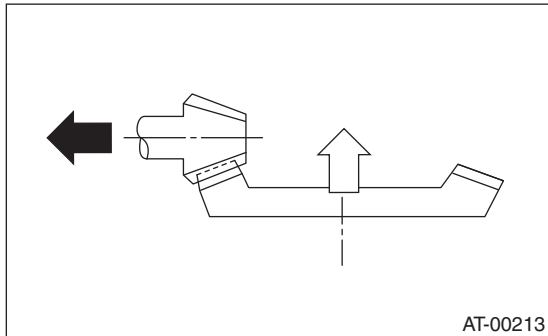

- Heel contact (outside end contact)
Check item: Contact area is too small.
 Contact pattern

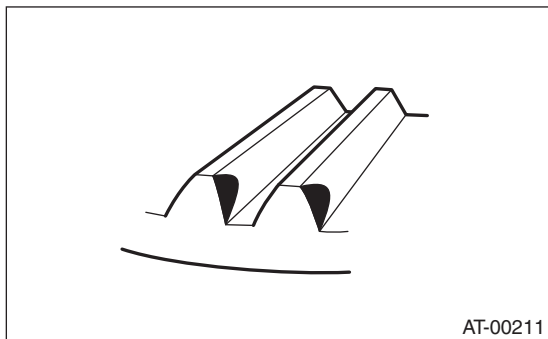

Corrective action: Increase thickness of drive pinion height adjusting washer in order to bring drive pinion close to hypoid driven gear.

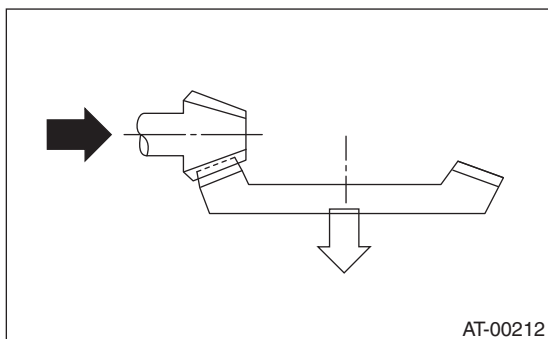

19) If proper tooth contact is not obtained, once again adjust the drive pinion height by changing the RH and LH side retainer shims and the hypoid gear backlash.

(1) Drive pinion height

- | | | |
|-----|-----------|----------------------------|
| ST1 | 398507702 | DUMMY SHAFT |
| ST2 | 398507701 | DIFFERENTIAL CARRIER GAUGE |

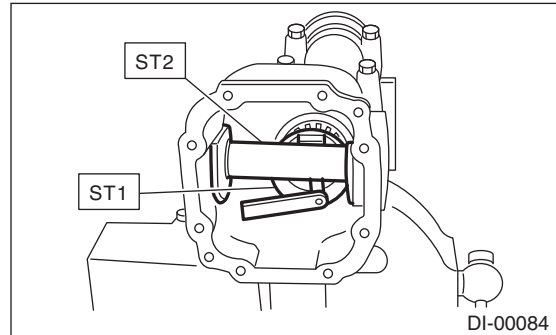

$$T = T_o + N - (H \times 0.01) - 0.20 \text{ (mm)}$$

Place:

T = Thickness of pinion height adjusting washer (mm)

T_o = Thickness of washer temporarily inserted (mm)

N = Clearance of thickness gauge (mm)

H = Figure marked on drive pinion head

(2) Hypoid gear backlash

Backlash:

0.10 — 0.20 mm (0.004 — 0.008 in)

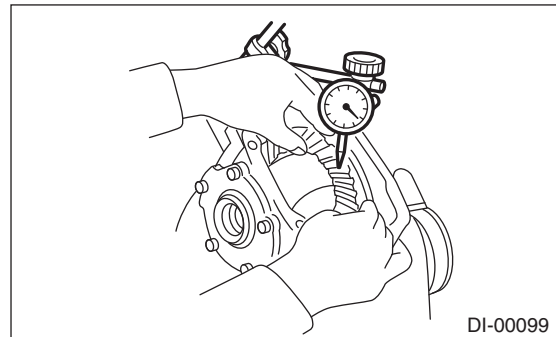

20) Remove the RH and LH side retainers.

21) Install new O-rings to side retainers of both sides.

22) Install oil seal to side retainers of both sides.
 <Ref. to DI-37, REPLACEMENT, Rear Differential Side Oil Seal.>

Rear Differential

DIFFERENTIALS

23) Align the arrow mark on differential carrier with the arrow mark on side retainer during installation.

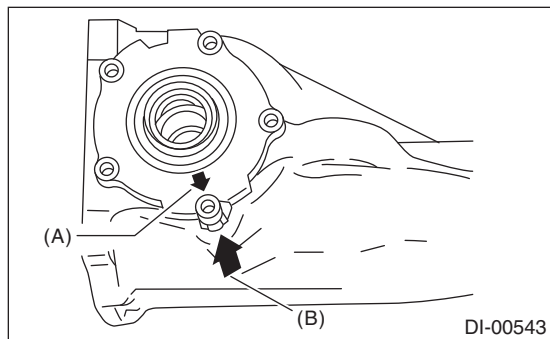

- (A) Arrow mark (on the side retainer)
- (B) Arrow mark (on the differential carrier)

24) Apply liquid gasket to the bolt with arrow marks, and install the side retainer.

Liquid gasket:
THREE BOND 1110B (Part No. K0879Y0020)
or equivalent

Tightening torque:
10.5 N·m (1.1 kgf-m, 7.7 ft-lb)

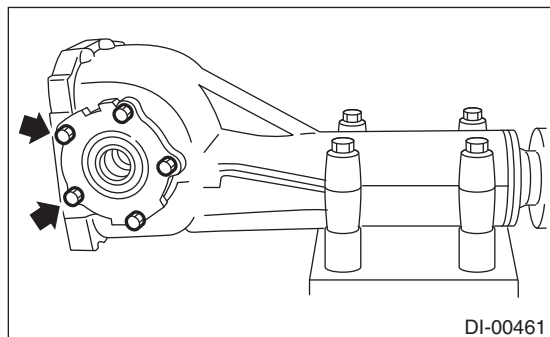

25) Install the new gasket and rear cover, and tighten the bolts to specified torque.

Tightening torque:
29.5 N·m (3.0 kgf-m, 21.8 ft-lb)

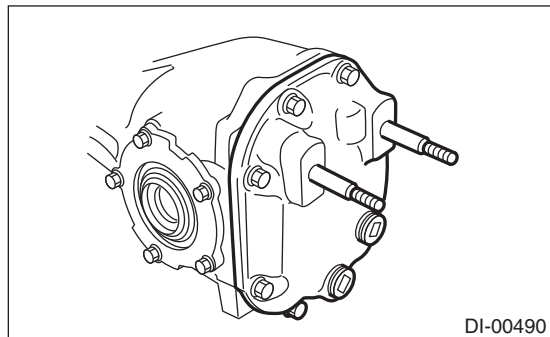

26) Install the air breather cap.

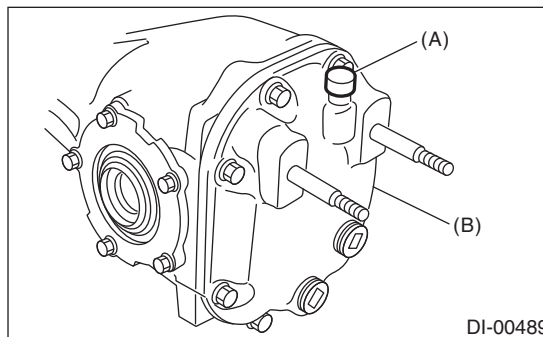

- (A) Air breather cap
- (B) Rear cover

27) Install the oil drain plug and filler plug.

Tightening torque:
49 N·m (5.0 kgf-m, 36.1 ft-lb)

E: INSPECTION

Wash all the disassembled parts clean, and examine them for wear, damage and other defects. Repair or replace the defective parts as necessary.

- 1) Hypoid driven gear and drive pinion
 - If there is evidently an abnormal tooth contact, find out the cause and adjust until the teeth contact correctly. Replace the gear if there is an excessive worn or an incapable adjustment.
 - If crack, cutout or seizure is found, replace the parts as a set. Slight damage of some teeth can be corrected by oil stone or the like.
- 2) Side gear and pinion mate gear
 - Replace if cracks, scoring or other defects are evident on the tooth surface.
 - Replace if thrust washer contact surface is worn or seized. Slight damages of the surface can be corrected by oil stones or equivalent.
- 3) Bearing
 - Replace if seizure, peeling, wear, rust, dragging during rotation, abnormal noise or other defect is evident.
- 4) Thrust washer of the side gear and pinion mate gear:
 - Replace if seized, flawed, abnormally worn or having other defects.
- 5) Oil seal
 - Replace if deformed or damaged, and at every disassembling.
- 6) Differential carrier
 - Replace if the bearing bores are worn or damaged.
- 7) Differential case
 - Replace if its sliding surfaces are abnormally worn, burned, or cracked.
- 8) Companion flange
 - Replace if the oil seal lip contact surface shows cracking.

1. SIDE GEAR BACKLASH

Using a dial gauge, check the backlash of side gear.

Side gear backlash:

0.10 — 0.20 mm (0.004 — 0.008 in)

If the side gear backlash is not within the specification, select the side gear thrust washer and adjust the side gear backlash as specified.

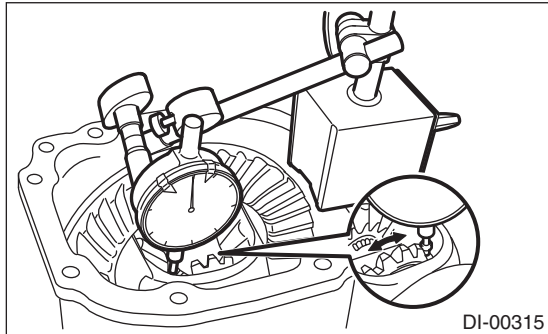

2. HYPOID DRIVEN GEAR BACKLASH

Using a dial gauge, check the backlash of hypoid driven gear.

Hypoid driven gear backlash:

0.10 — 0.20 mm (0.004 — 0.008 in)

If the hypoid driven gear backlash is not within the specification, adjust the side bearing preload or repair if necessary.

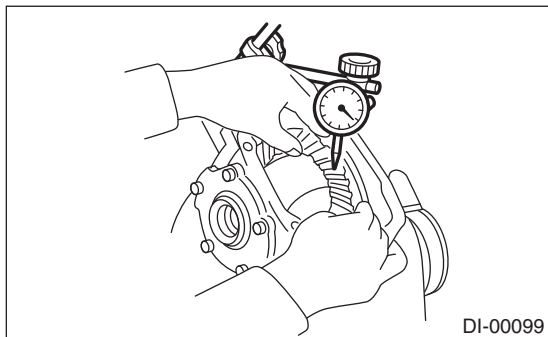

3. HYPOID DRIVEN GEAR RUNOUT ON ITS BACK SURFACE

Using a dial gauge, check the hypoid driven gear back surface runout.

Hypoid driven gear back surface runout:

0.05 mm (0.002 in)

If the hypoid driven gear runout exceeds 0.05 mm (0.002 in), replace the hypoid driven gear.

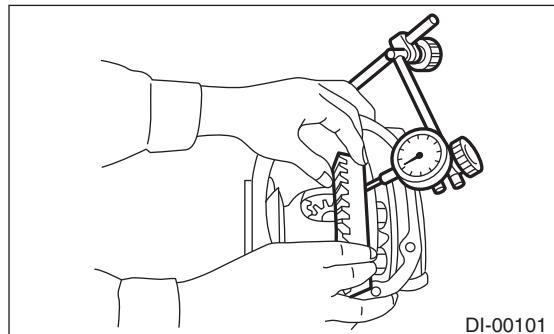

4. TOOTH CONTACT BETWEEN HYPOID DRIVEN GEAR AND DRIVE PINION

Inspect the tooth contact between the hypoid driven gear and drive pinion. <Ref. to DI-23, ASSEMBLY, Rear Differential.>

5. TOTAL PRELOAD

Using a spring scale, check the total preload.

Total preload:

20.7 — 54.4 N (2.1 — 5.5 kgf, 4.7 — 12.2 lbf)

If the total preload is not within the specification, adjust the side retainer shims.

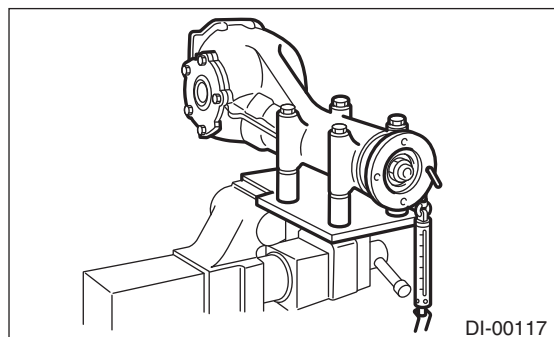

Rear Differential

DIFFERENTIALS

6. COMPANION FLANGE

- 1) If rust or dirt is attached to the companion flange, remove them.
- 2) Set a dial gauge at a companion flange surface (mating surface of propeller shaft and companion flange), and then measure the companion flange runout.

Limit of runout:

0.08 mm (0.003 in)

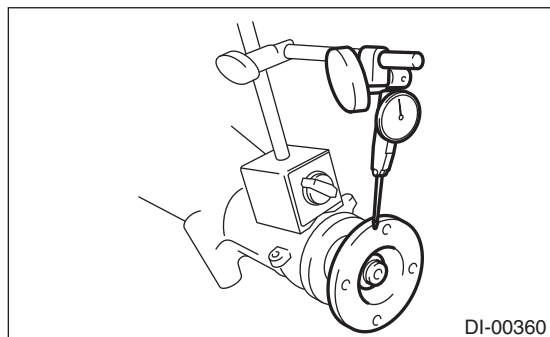

- 3) Set the gauge inside of the companion flange, and measure the runout.

Limit of runout:

0.08 mm (0.003 in)

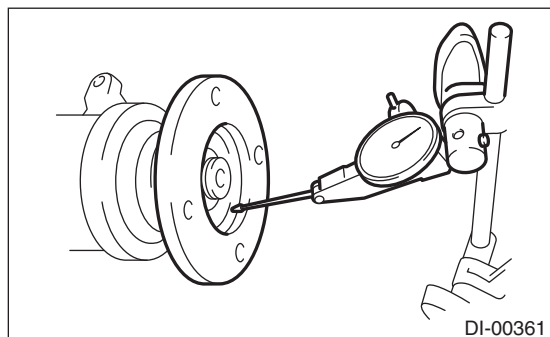

- 4) If either runout exceeds the limit, move the phase of companion flange and drive pinion 90° each, and find the point where the runout is within the limit.
- 5) If the runout exceeds the limit after changing the phase, replace the companion flange and recheck the runout.
- 6) If the runout exceeds the limit after replacing the companion flange, the drive pinion may be assembled incorrectly or bearing is faulty.

F: ADJUSTMENT

1. SIDE GEAR BACKLASH

Adjust the side gear backlash.

<Ref. to DI-23, ASSEMBLY, Rear Differential.>

2. HYPOID DRIVEN GEAR BACKLASH

Adjust hypoid driven gear backlash.

<Ref. to DI-23, ASSEMBLY, Rear Differential.>

3. TOOTH CONTACT BETWEEN HYPOID DRIVEN GEAR AND DRIVE PINION

Adjust the tooth contact between hypoid driven gear and drive pinion gear.

<Ref. to DI-23, ASSEMBLY, Rear Differential.>

4. TOTAL PRELOAD

Adjust the side retainer shim.

<Ref. to DI-23, ASSEMBLY, Rear Differential.>

5. Rear Differential Front Oil Seal

A: INSPECTION

Check that there is no leakage from front oil seal portion. If there is any leakage replace the oil seal and inspect the propeller shaft.

B: REPLACEMENT

- 1) Disconnect the ground cable from the battery.
- 2) Shift the select lever or gear shift lever to neutral.
- 3) Release the parking brake.
- 4) Remove the oil drain plug, and drain gear oil.

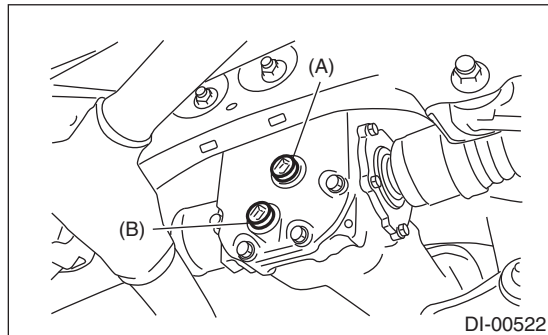

- (A) Filler plug
- (B) Oil drain plug

- 5) Install the oil drain plug.

NOTE:

Apply liquid gasket to the drain plug.

Liquid gasket:

THREE BOND 1105 (Part No. 004403010) or equivalent

Tightening torque:

49 N·m (5.0 kgf·m, 36.1 ft·lb)

- 6) Lift up the vehicle.
- 7) Remove the rear exhaust pipe and muffler.
 - Non-turbo model
<Ref. to EX(H4SO)-8, REMOVAL, Rear Exhaust Pipe.> <Ref. to EX(H4SO)-10, REMOVAL, Muffler.>
 - Turbo model
<Ref. to EX(H4DOTC)-12, REMOVAL, Rear Exhaust Pipe.> <Ref. to EX(H4DOTC)-14, REMOVAL, Muffler.>

- 8) Remove the heat shield cover.

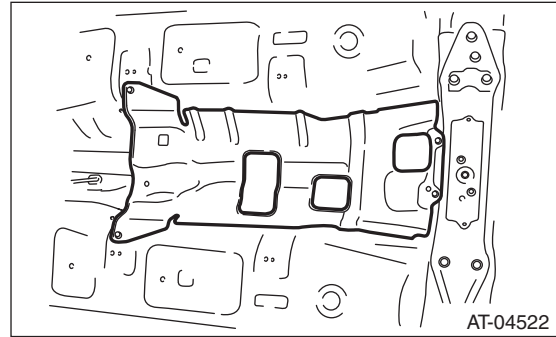

- 9) Remove the propeller shaft. <Ref. to DS-10, REMOVAL, Propeller Shaft.>

- 10) Remove the self-locking nut while holding the companion flange with ST.

ST 498427200 FLANGE WRENCH

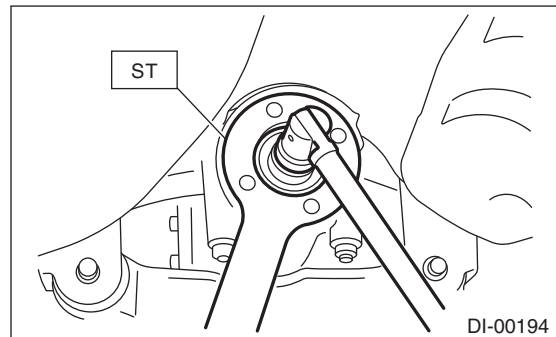

- 11) Extract the companion flange using ST.

ST 399703600 PULLER ASSY

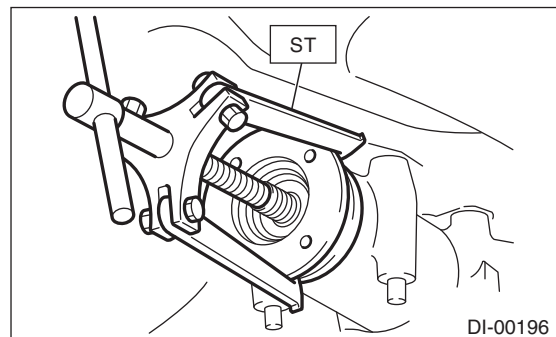

- 12) Remove the oil seal using ST or screwdriver.

ST 398527700 PULLER ASSY

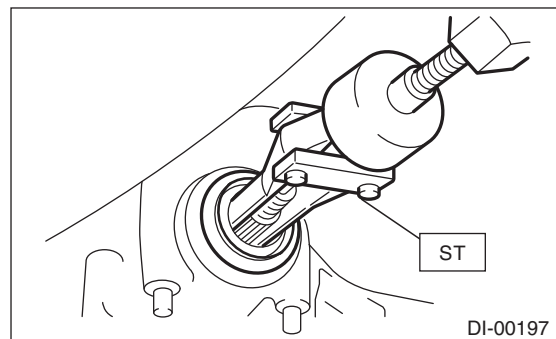

Rear Differential Front Oil Seal

DIFFERENTIALS

13) Install a new oil seal using ST.

NOTE:

Apply differential gear oil to the oil seal lips.

ST 498447120 INSTALLER

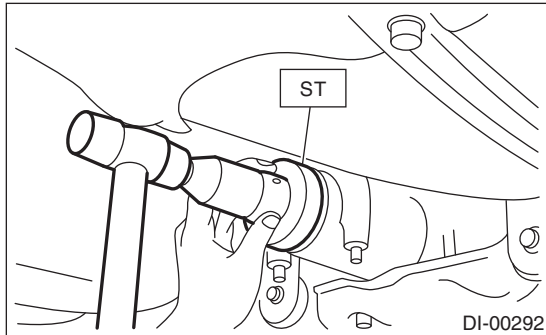

14) Install the companion flange.

NOTE:

Use a plastic hammer to install companion flange.

15) Tighten the self-locking nut to the specified torque so that rotating resistance of the companion flange becomes the same value as that before replacing the oil seal.

ST 498427200 FLANGE WRENCH

NOTE:

- Use a new self-locking nut.
- Before installing the self-locking nut, apply seal material to self-locking nut threads.

SEAL MATERIAL:

THREE BOND 1324 (Part No. 004403042) or equivalent

Tightening torque:

181.5 N·m (18.5 kgf-m, 133.9 ft-lb)

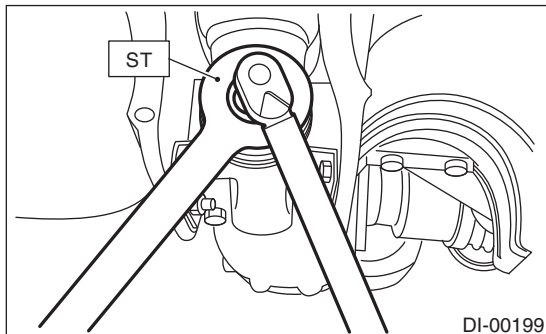

16) Hereafter, reassemble in the reverse order of disassembly.

17) After installing, fill the differential carrier with gear oil up to the bottom of the filler plug hole. <Ref. to DI-14, Differential Gear Oil.>

6. Rear Differential Side Oil Seal

A: INSPECTION

Inspect for oil leakage from the side oil seal.
If there is oil leakage, replace the oil seal.

B: REPLACEMENT

- 1) Shift the select lever or gear shift lever to neutral.
- 2) Release the parking brake.
- 3) Loosen the wheel nuts.
- 4) Lift up the vehicle
- 5) Remove the wheels.
- 6) Remove the rear exhaust pipe and muffler.

- Non-turbo model

<Ref. to EX(H4SO)-8, REMOVAL, Rear Exhaust Pipe.> <Ref. to EX(H4SO)-10, REMOVAL, Muffler.>

- Turbo model

<Ref. to EX(H4DOTC)-12, REMOVAL, Rear Exhaust Pipe.> <Ref. to EX(H4DOTC)-14, REMOVAL, Muffler.>

- 7) Remove the DOJ of rear drive shaft from rear differential.

- (1) Remove the ABS wheel speed sensor cable from the clamp.

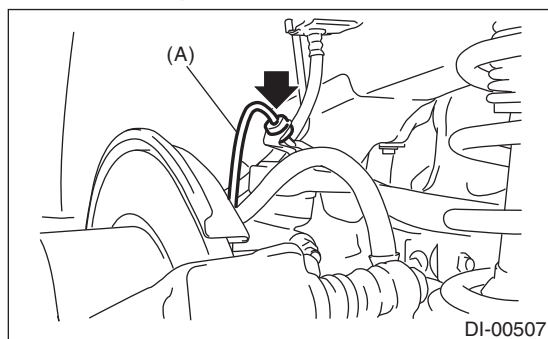

(A) ABS wheel speed sensor cable

- (2) Disconnect the connector and remove the nut to remove the rear vehicle height sensor. (models with auto headlight beam leveler, left side only)

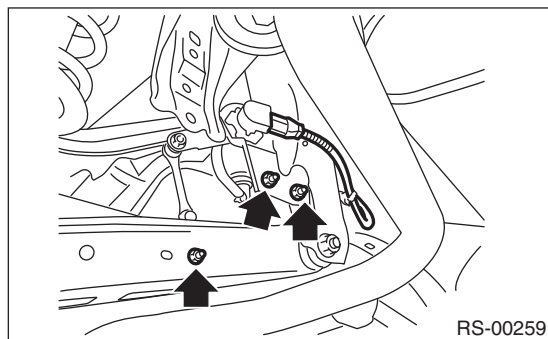

- (3) Remove the bolts which secure the rear stabilizer link to the rear lateral link.

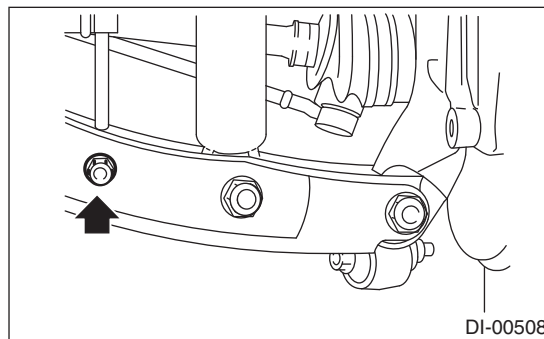

- (4) Remove the bolts which secure the shock absorber to the rear lateral link.

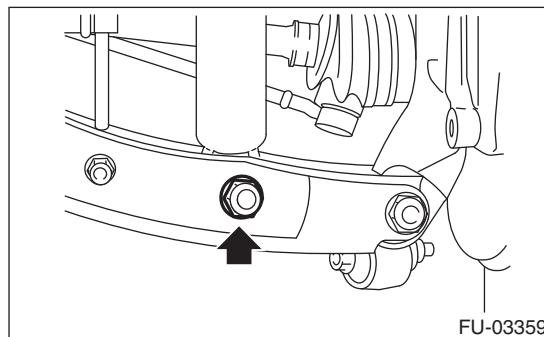

- (5) Remove the bolts which secure the rear lateral link to the housing.

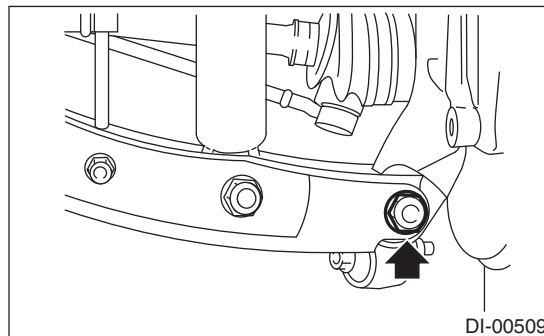

- (6) Remove the bolts which secure the trailing link to the housing.

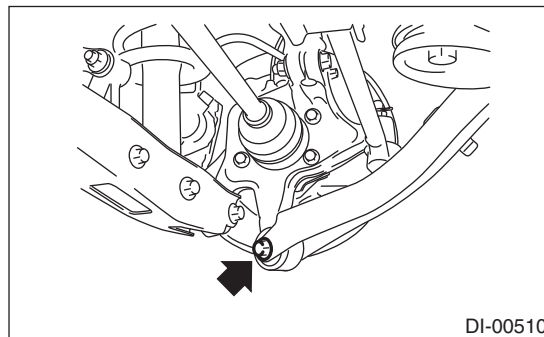

Rear Differential Side Oil Seal

DIFFERENTIALS

(7) Remove the DOJ from the rear differential by using ST.

NOTE:

When removing the DOJ from the rear differential, fit the ST to the bolts as shown in the figure so as not to damage the side retainer.

ST 28099PA100 DRIVE SHAFT REMOVER

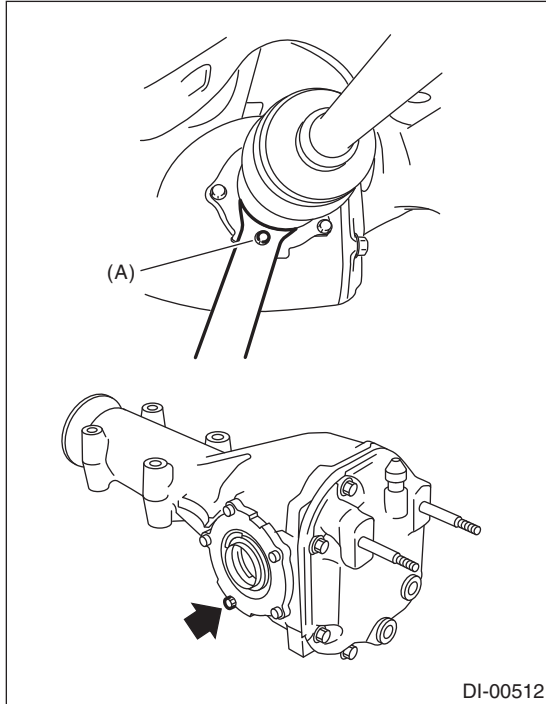

(A) Bolt

(8) Suspend the rear drive shaft to the rear cross-member using wire.

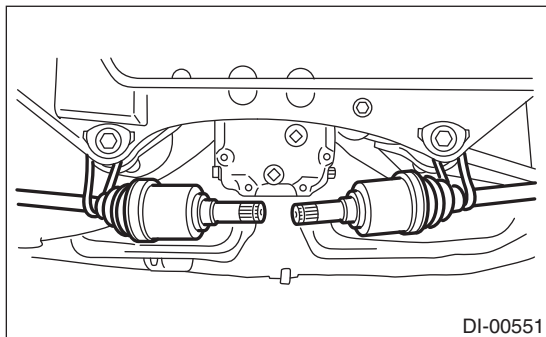

DI-00551

9) Remove the oil seal using ST.
ST 398527700 PULLER ASSY

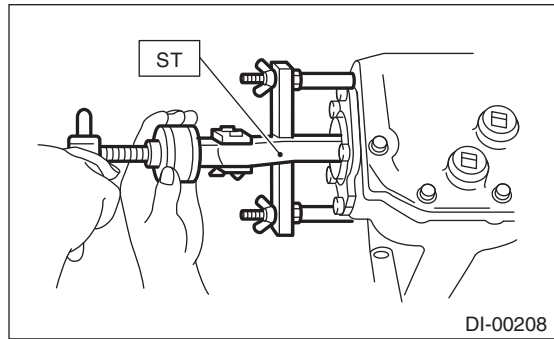

DI-00208

10) Install a new side oil seal using the ST.

NOTE:

Apply differential gear oil to the oil seal lips.

ST 398437700 DRIFT

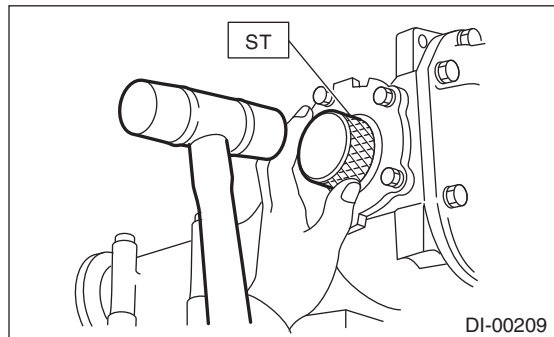

DI-00209

11) Insert the DOJ into rear differential.

(1) Attach the ST to rear differential.

ST 28099PA090 OIL SEAL PROTECTOR

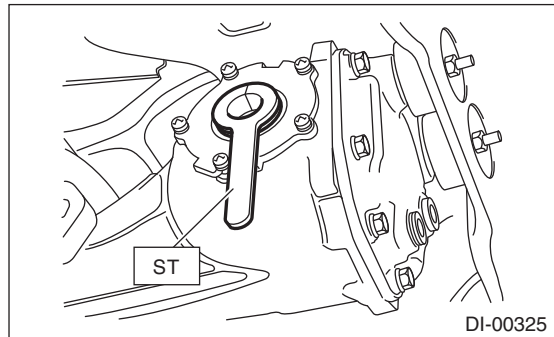

DI-00325

(2) Insert the spline shaft until the spline portion comes inside the side oil seal.

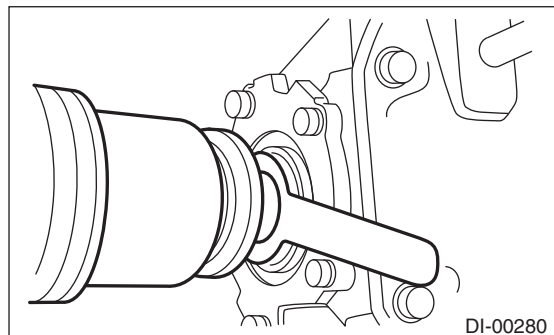

DI-00280

(3) Remove ST from rear differential.

ST 28099PA090 OIL SEAL PROTECTOR

(4) Push the housing to insert DOJ completely into rear differential.

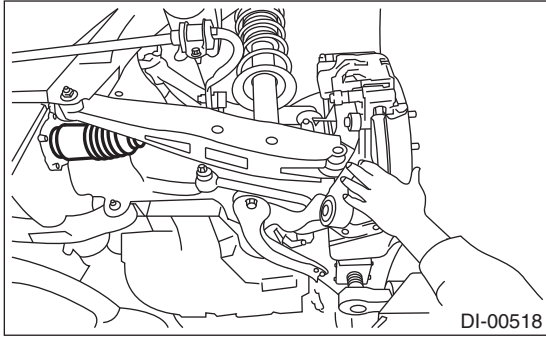

12) Installing procedure hereafter is in the reverse order of removal.

13) Inspect the wheel alignment and adjust if necessary.

14) Re-initialize the auto headlight beam leveler system. (models with auto headlight beam leveler) <Ref. to LI-15, PROCEDURE, Auto Headlight Beam Leveler System.>

7. Rear Differential Front Member

A: REMOVAL

- 1) Disconnect the ground cable from the battery.
- 2) Lift up the vehicle
- 3) Support the rear differential using transmission jack, and then remove the rear differential front member.

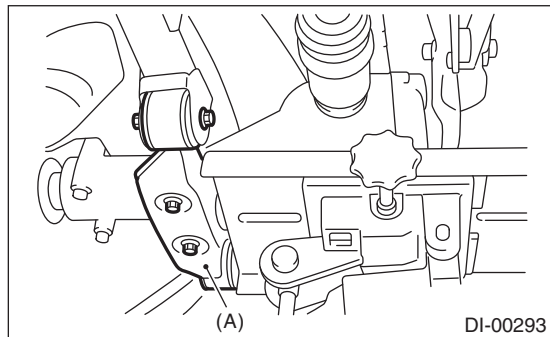

(A) Rear differential front member

B: INSTALLATION

Using new self-locking nuts, install the rear differential front member.

Tightening torque:

T1: 50 N·m (5.1 kgf-m, 36.9 ft-lb)

T2: 110 N·m (11.2 kgf-m, 81.1 ft-lb)

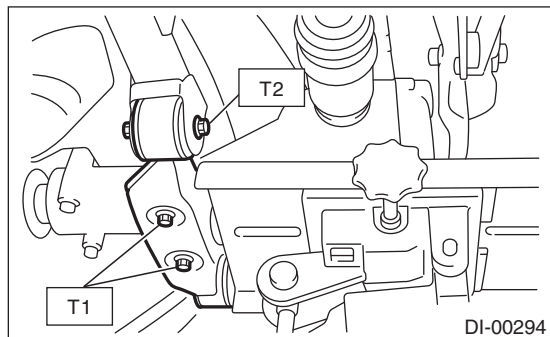

C: INSPECTION

- 1) Check the rear differential front member for damage, bend and corrosion.
If damage, bend or corrosion is excessive, replace the rear differential front member.
- 2) Check the bushings of rear differential member for cracking, hardening and damage.
If cracking, hardening or damage is excessive, replace rear differential front member.

8. General Diagnostic Table

A: INSPECTION

Symptom or trouble	Possible cause	Remedy
1. Oil leakage	(1) Worn, scratched, or incorrectly seated front or side oil seal. Scored, battered or excessively worn sliding surface of companion flange.	Correct or replace.
	(2) Clogged or damaged air breather cap.	Clean, repair or replace.
	(3) Loose bolts on differential spindle or side retainer, or incorrectly fitted O-ring.	Tighten the bolts to specified torque. Replace the O-ring.
	(4) Loose rear cover attaching bolts or damaged gasket.	Tighten the bolts to specified torque. Replace gasket and apply liquid gasket.
	(5) Loose oil filler or oil drain plug.	Retighten and apply liquid gasket.
	(6) Wear, damage or incorrect fitting of drive shaft, side retainer or oil seal.	Correct or replace.
2. Seizure NOTE: Seized or damaged parts should be replaced, and also other parts should be thoroughly checked for any defect and should be repaired or replaced as required.	(1) Insufficient backlash for hypoid gear.	Readjust or replace.
	(2) Excessive preload for side, rear or front bearing.	Readjust or replace.
	(3) Insufficient or improper oil used.	Add specified oil to the specified level.
3. Damage NOTE: Damaged parts should be replaced, and also other parts should be thoroughly checked for any defect and should be repaired or replaced as required.	(1) Improper backlash for hypoid gear.	Replace.
	(2) Insufficient or excessive preload for side, rear or front bearing.	Readjust or replace.
	(3) Excessive backlash for differential gear.	Replace gear or thrust washer.
	(4) Loose bolts and nuts such as hypoid driven gear bolt.	Retighten.
	(5) Damage due to overloading.	Replace.
4. Noises when starting or shifting gears NOTE: Noises may be caused by differential assembly, universal joint, wheel bearing, etc. Find out what is actually making noise before disassembling.	(1) Improper tooth contact of hypoid gear.	Readjust. (Drive pinion shim adjustment, backlash adjustment)
	(2) Excessive backlash for differential gear or hypoid gear.	Replace gear or thrust washer.
	(3) Insufficient preload for front or rear bearing.	Readjust.
	(4) Loose drive pinion nut.	Tighten to the specified torque.
	(5) Loose bolts and nuts such as side retainer attaching bolt.	Tighten to the specified torque.
5. Noises when cornering	(1) Damaged differential gear.	Replace.
	(2) Excessive wear or damage of thrust washer.	Replace.
	(3) Broken pinion mate shaft.	Replace.
	(4) Seized or damaged side bearing.	Replace.

General Diagnostic Table

DIFFERENTIALS

Symptom or trouble	Possible cause	Remedy
6. Gear noise NOTE: Since noises from engine, muffler, transmission, propeller shaft, wheel bearings, tires, and body are sometimes mistaken for noises from differential assembly, be careful in checking them. Inspection methods to locate noises include coasting, accelerating, cruising, and lift-up all four wheels. Perform these inspections according to the condition of trouble. When listening to noises, shift the gear into four wheel drive and fourth speed position, trying to pick up only differential noise.	(1) Improper tooth contact of hypoid gear.	Readjust or replace hypoid gear set.
	(2) Improper backlash of the hypoid gear.	Readjust.
	(3) Scored or chipped teeth of hypoid gear.	Replace hypoid gear set.
	(4) Seized hypoid gear.	Replace hypoid gear set.
	(5) Improper preload for front or rear bearings.	Readjust.
	(6) Seized, cut-away or chipped front or rear bearing.	Replace.
	(7) Seized, cut-away or chipped side bearing.	Replace.
	(8) Vibrating differential gear.	Replace.

TRANSFER CASE

TC

	Page
1. General Description	2
2. Transfer Case and Extension Case Assembly	3
3. Transfer Clutch	4
4. Extension Case	5
5. Oil Seal	6
6. Transfer Drive Gear	7
7. Transfer Driven Gear	8
8. Reduction Drive Gear	9
9. Reduction Driven Gear	10
10. Center Differential	11
11. Transfer Clutch Pressure Test	12

General Description

TRANSFER CASE

1. General Description

A: NOTE

For general description, refer to "4AT" or "5MT" section.

4AT model:

<Ref. to 4AT-2, General Description.>

5MT model:

<Ref. to 5MT-2, General Description.>

2. Transfer Case and Extension Case Assembly

A: NOTE

For removal, installation and inspection, refer to the "5MT" section. <Ref. to 5MT-37, Transfer Case and Extension Case Assembly.>

3. Transfer Clutch

A: NOTE

For removal, installation and inspection, refer to the "4AT" section. <Ref. to 4AT-70, Transfer Clutch.>

4. Extension Case

A: NOTE

For removal, installation and inspection, refer to the "4AT" section. <Ref. to 4AT-68, Extension Case.>

5. Oil Seal

A: NOTE

For removal, installation and inspection, refer to the "4AT" or "5MT" section.

4AT model:

<Ref. to 4AT-44, Extension Case Oil Seal.> <Ref. to 4AT-45, Differential Side Retainer Oil Seal.>

5MT model:

<Ref. to 5MT-33, Oil Seal.> <Ref. to 5MT-34, Differential Side Retainer Oil Seal.>

6. Transfer Drive Gear

A: NOTE

For removal, installation and inspection, refer to the "5MT" section. <Ref. to 5MT-41, Transfer Drive Gear.>

7. Transfer Driven Gear

A: NOTE

For removal, installation and inspection, refer to the "5MT" section. <Ref. to 5MT-43, Transfer Driven Gear.>

8. Reduction Drive Gear

A: NOTE

For removal, installation and inspection, refer to the "4AT" section. <Ref. to 4AT-77, Reduction Drive Gear.>

9. Reduction Driven Gear

A: NOTE

For removal, installation and inspection, refer to the "4AT" section. <Ref. to 4AT-75, Reduction Driven Gear.>

10.Center Differential

A: NOTE

For removal, installation and inspection, refer to the "5MT" section. <Ref. to 5MT-45, Center Differential.>

Transfer Clutch Pressure Test

TRANSFER CASE

11. Transfer Clutch Pressure Test

A: NOTE

For inspection, refer to the "4AT" section. <Ref. to 4AT-33, Transfer Clutch Pressure Test.>

DRIVE SHAFT SYSTEM

DS

	Page
1. General Description	2
2. Propeller Shaft	10
3. Front Axle	13
4. Front Hub Unit Bearing	18
5. Rear Axle	20
6. Rear Hub Unit Bearing	24
7. Front Drive Shaft	27
8. Rear Drive Shaft	33
9. General Diagnostic Table	38

General Description

DRIVE SHAFT SYSTEM

1. General Description

A: SPECIFICATION

1. PROPELLER SHAFT

Model	All models		
Propeller shaft type	EDJ		
Front propeller shaft Joint-to-joint length: L_1	mm (in)	AT	675.5 (26.59)
		MT	735.5 (28.96)
Rear propeller shaft Joint-to-Joint length: L_2	mm (in)	698 (27.48)	
Outer diameter of tube:	mm (in)	D_1	63.5 (2.500)
		D_2	57.5 (2.264)

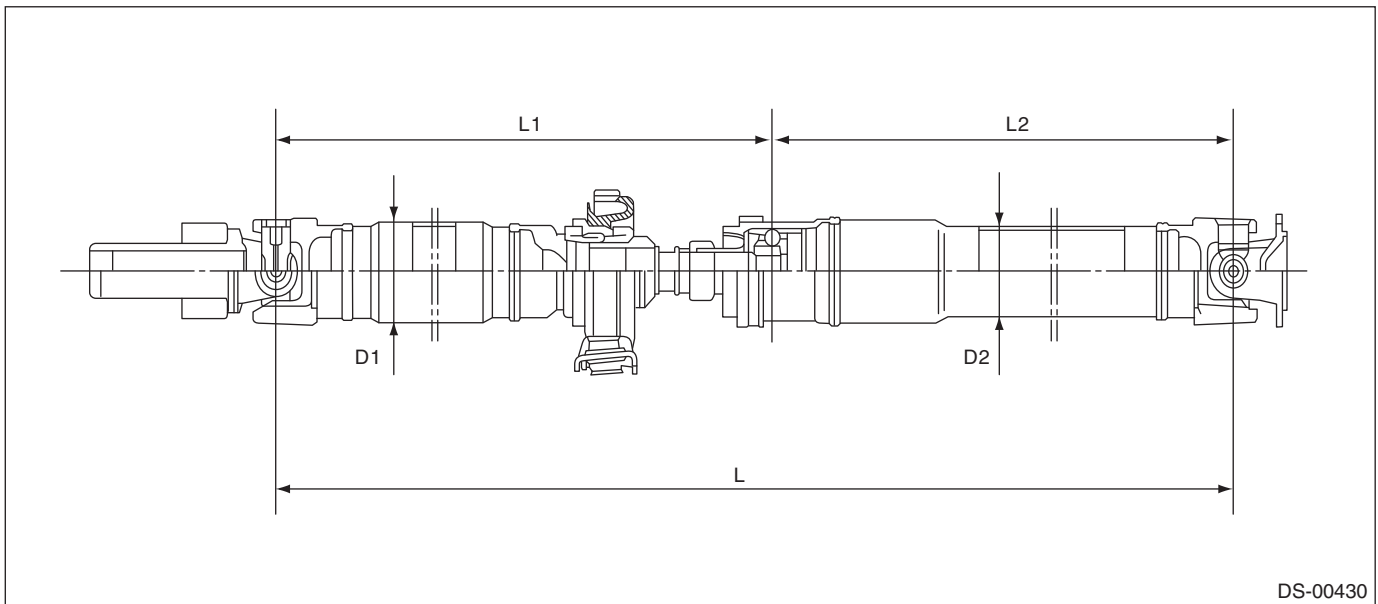

DS-00430

General Description

DRIVE SHAFT SYSTEM

2. FRONT DRIVE SHAFT ASSEMBLY

Model	Type of drive shaft	Axle diameter ϕ D mm (in)	Axle length L mm (in)
All models	EBJ + PTJ	26 (1.02)	347 (13.66)

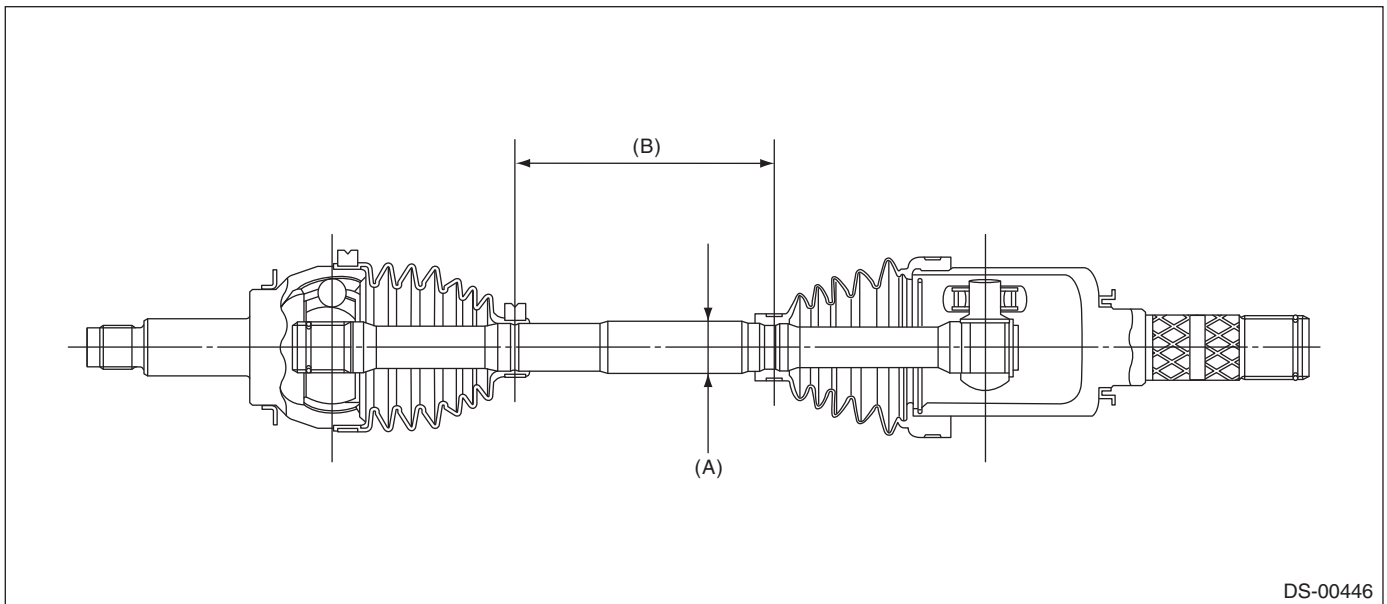

(A) Axle diameter

(B) Axle length

3. REAR DRIVE SHAFT ASSEMBLY

Model	Type of drive shaft	Axle diameter ϕ D mm (in)	Axle length L mm (in)
All models	EBJ + DOJ	22 (0.87)	383.1 (15.08)

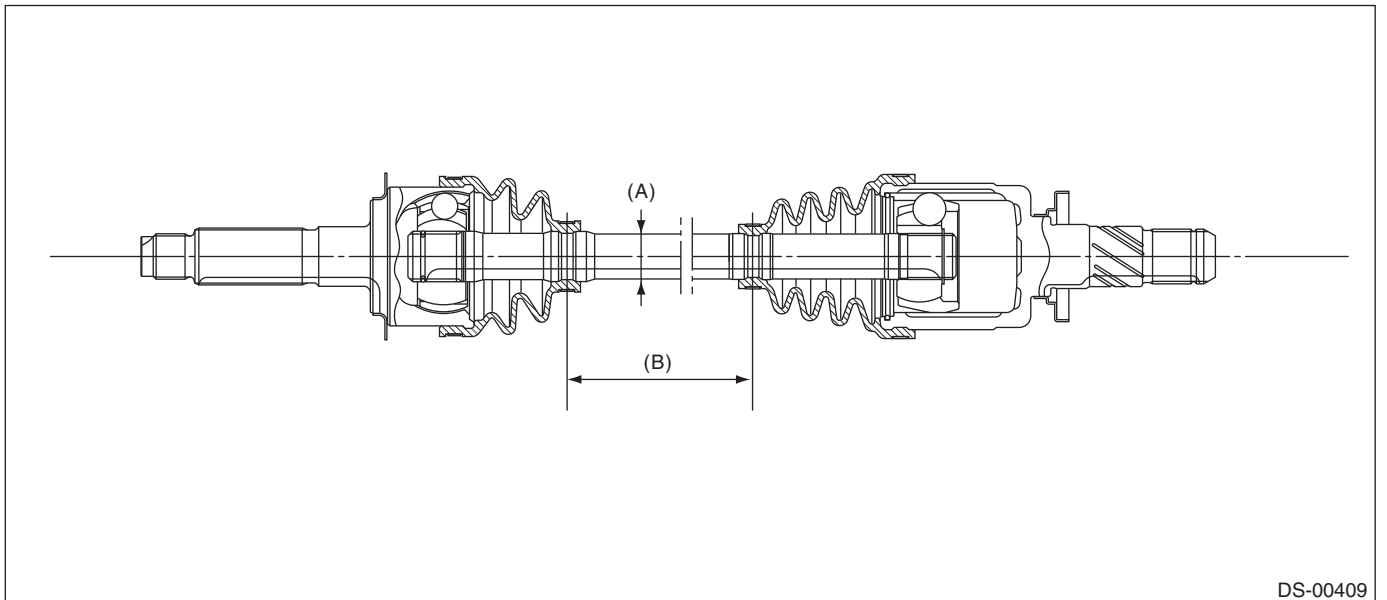

(A) Axle diameter

(B) Axle length

General Description

DRIVE SHAFT SYSTEM

B: COMPONENT

1. PROPELLER SHAFT

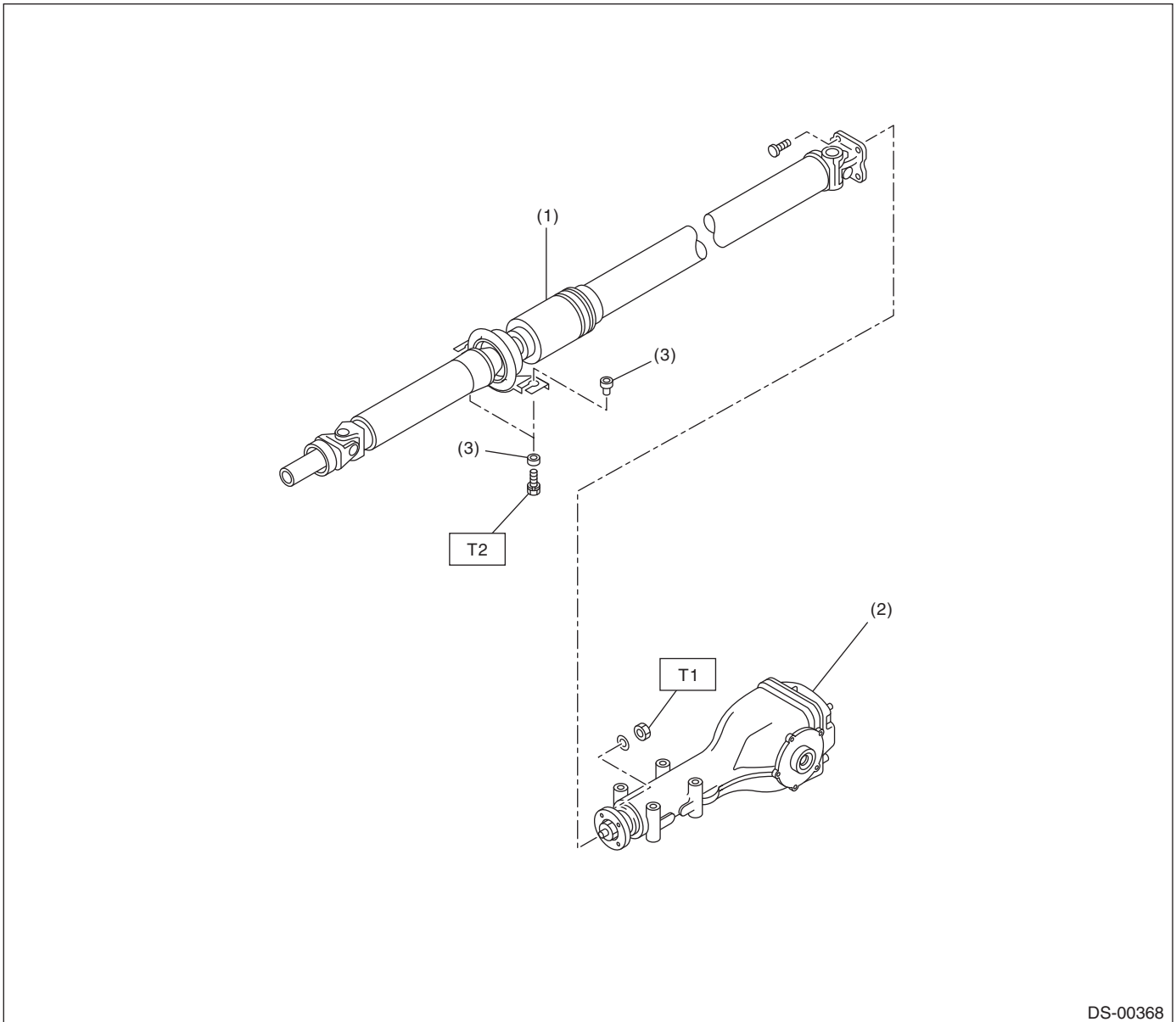

DS-00368

- (1) Propeller shaft
- (2) Rear differential

- (3) Bushing

Tightening torque: N·m (kgf·m, ft·lb)

T1: 31 (3.2, 23.1)

T2: 52 (5.3, 38.3)

2. FRONT AXLE

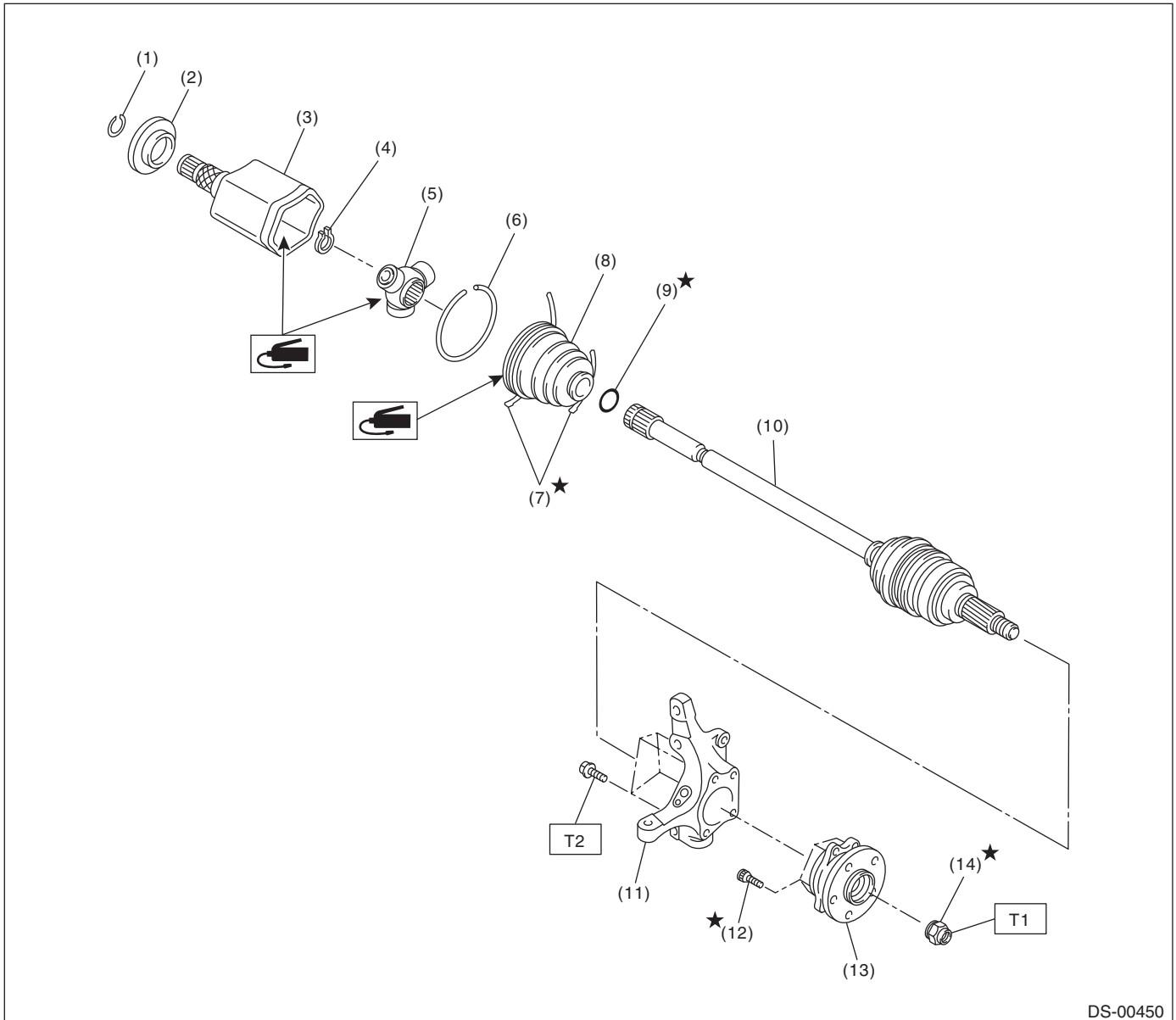

DS-00450

- | | | |
|----------------------|---------------------|-----------------------------|
| (1) Circlip | (7) Boot band | (13) Front hub unit bearing |
| (2) Baffle plate | (8) Boot (PTJ) | (14) Axle nut |
| (3) Outer race (PTJ) | (9) O-ring | |
| (4) Snap ring | (10) EBJ shaft ASSY | |
| (5) Trunnion | (11) Housing | |
| (6) Snap ring | (12) Hub bolt | |

Tightening torque: N·m (kgf·m, ft·lb)

T1: 220 (22.4, 162)

T2: 65 (6.6, 47.9)

General Description

DRIVE SHAFT SYSTEM

3. REAR AXLE

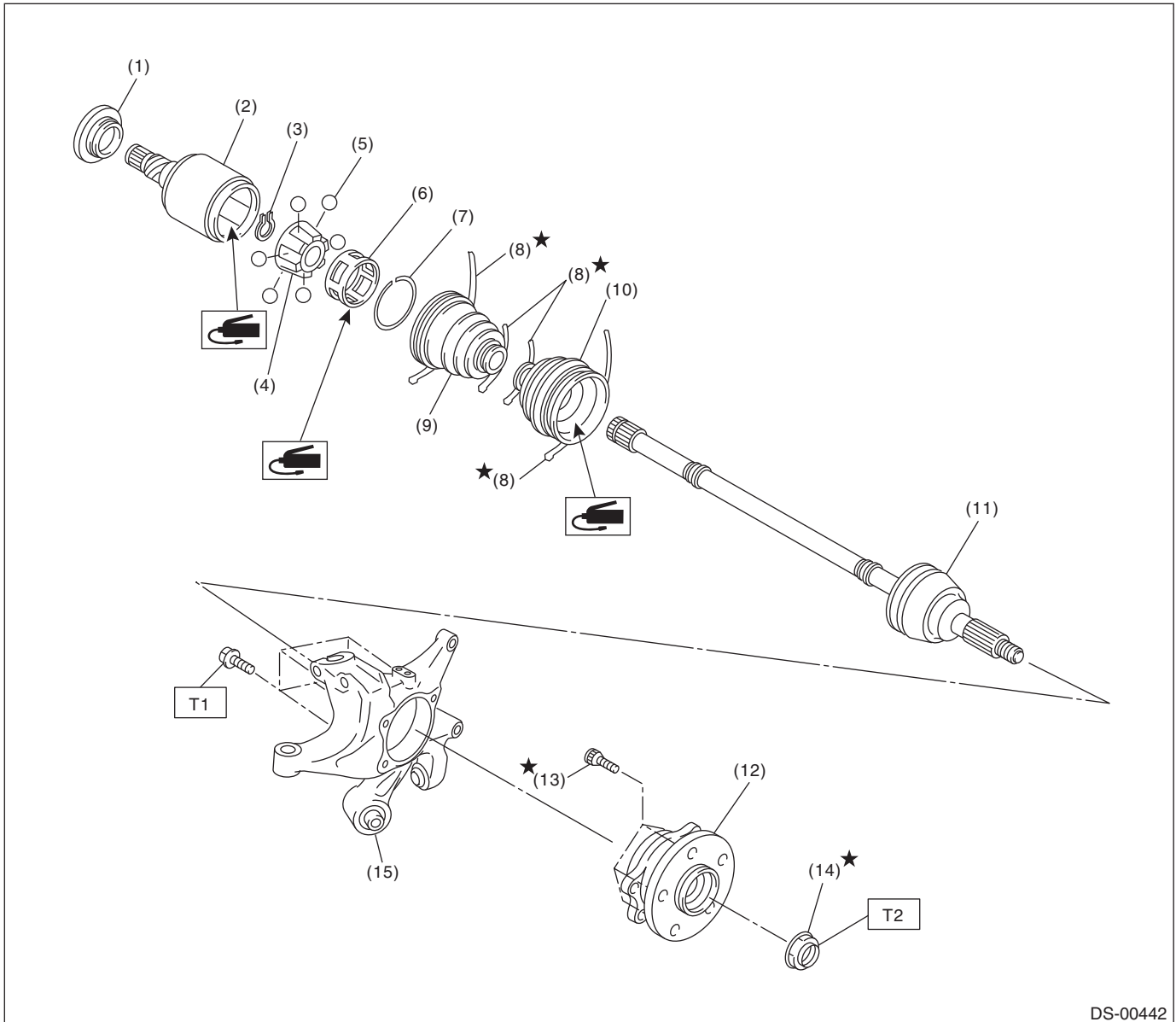

DS-00442

- | | | |
|----------------------|----------------------------|------------------------|
| (1) Baffle plate | (8) Boot band | (14) Axle nut |
| (2) Outer race (DOJ) | (9) Boot (DOJ) | (15) Rear axle housing |
| (3) Snap ring | (10) Boot (EBJ) | |
| (4) Inner race | (11) EBJ shaft ASSY | |
| (5) Ball | (12) Rear hub unit bearing | |
| (6) Cage | (13) Hub bolt | |
| (7) Snap ring | | |

Tightening torque: N·m (kgf·m, ft·lb)

T1: 65 (6.6, 47.9)

T2: 190 (19.4, 140)

C: CAUTION

- Wear appropriate work clothing, including a cap, protective goggles and protective shoes when performing any work.
- Remove contamination including dirt and corrosion before removal, installation or disassembly.
- Keep the disassembled parts in order and protect them from dust and dirt.
- Before removal, installation or disassembly, be sure to clarify the failure. Avoid unnecessary removal, installation, disassembly and replacement.
- Vehicle components are extremely hot after driving. Be wary of receiving burns from heated parts.
- Use SUBARU genuine grease etc. or equivalent. Do not mix grease etc. of different grades or manufacturers.
- Be sure to tighten fasteners including bolts and nuts to the specified torque.
- Place shop jacks or rigid racks at the specified points.
- Apply grease onto sliding or revolving surfaces before installation.
- Before installing snap rings, apply sufficient amount of grease to avoid damage and deformation.
- Before securing a part on a vise, place cushioning materials such as wood blocks, aluminum plates, or waste cloth between the part and the vise.

D: PREPARATION TOOL

1. SPECIAL TOOL

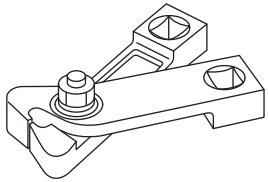
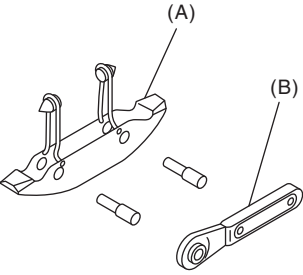
ILLUSTRATION	TOOL NUMBER	DESCRIPTION	REMARKS
 <p style="text-align: center;">ST28099AC000</p>	28099AC000	BOOT BAND PLIER	Used for tightening the boot band. (Front PTJ boot band)
 <p style="text-align: center;">ST-925091000</p>	925091000	BAND TIGHTENING TOOL	Used for tightening the boot band. (A) Jig for the band (B) Ratchet wrench

General Description

DRIVE SHAFT SYSTEM

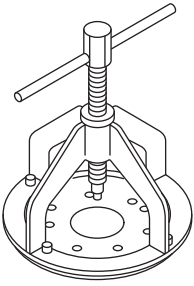
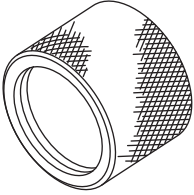
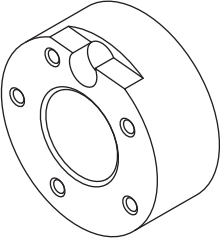
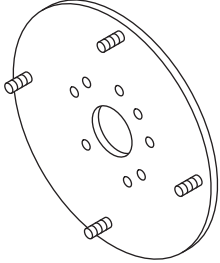
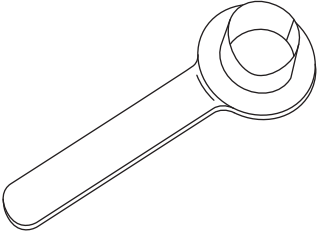
ILLUSTRATION	TOOL NUMBER	DESCRIPTION	REMARKS
 <p style="text-align: center;">ST-926470000</p>	926470000	AXLE SHAFT PULLER	<ul style="list-style-type: none"> • Used for removing the axle shaft. • Used together with AXLE SHAFT PULLER PLATE (28099PA110).
 <p style="text-align: center;">ST18675AA000</p>	18675AA000	DIFFERENTIAL SIDE OIL SEAL INSTALLER	Used for installing the differential side retainer oil seal.
 <p style="text-align: center;">ST-927080000</p>	927080000	HUB STAND	Used for assembling hub bolt in hub.
 <p style="text-align: center;">ST28099PA110</p>	28099PA110	AXLE SHAFT PULLER PLATE	Exchange with the plate of the AXLE SHAFT PULLER (926470000) to use.
 <p style="text-align: center;">ST28099PA090</p>	28099PA090	OIL SEAL PROTECTOR	<ul style="list-style-type: none"> • Used for installing the rear drive shaft to the rear differential. • For protecting the oil seal.

General Description

DRIVE SHAFT SYSTEM

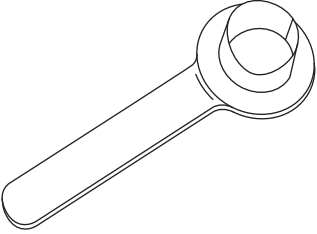
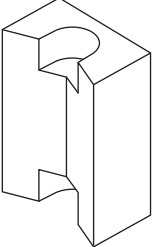
ILLUSTRATION	TOOL NUMBER	DESCRIPTION	REMARKS
 ST28399SA010	28399SA010	OIL SEAL PROTECTOR	<ul style="list-style-type: none"> • Used for installing front drive shaft into front differential. • For protecting the oil seal.
 ST28399AG000	28399AG000	HUB STAND	Used for extracting hub bolt.

2. GENERAL TOOL

TOOL NAME	REMARKS
Puller	Used for removing the ball joint from knuckle arm.
Dial gauge	Used for inspecting the propeller shaft run-out.
Extension cap	Used for preventing leakage of gear oil or ATF.
Bar	Used for extracting drive shaft.

Propeller Shaft

DRIVE SHAFT SYSTEM

2. Propeller Shaft

A: REMOVAL

NOTE:

- Before removing propeller shaft, wrap metal parts with a cloth or rubber material.
- In case of a EDJ type, wrap the metal parts at the rubber boot of center EDJ with a cloth or rubber material before removing propeller shaft, as shown in the figure. The rubber boot may be damaged due to interference with adjacent metal parts while bending the EDJ during removal.

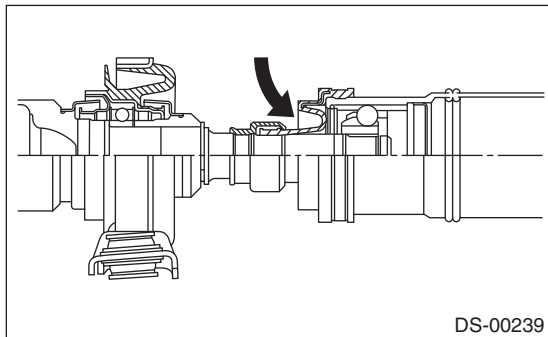

- 1) Disconnect the ground cable from the battery.
- 2) Shift the select lever or gear shift lever to neutral.
- 3) Release the parking brake.
- 4) Lift up the vehicle.
- 5) Remove the center exhaust pipe.
- 6) Remove the rear exhaust pipe and muffler.
- 7) Remove the heat shield cover.

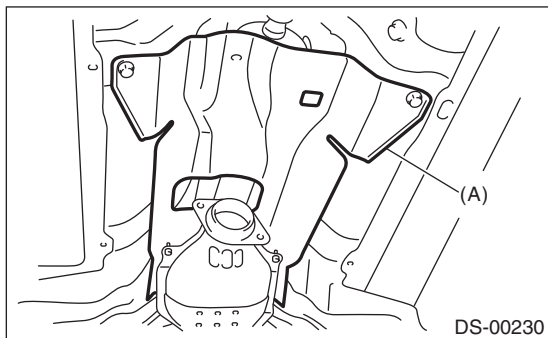

(A) Heat shield cover

- 8) Make alignment marks on the flange yoke and rear differential before removal.

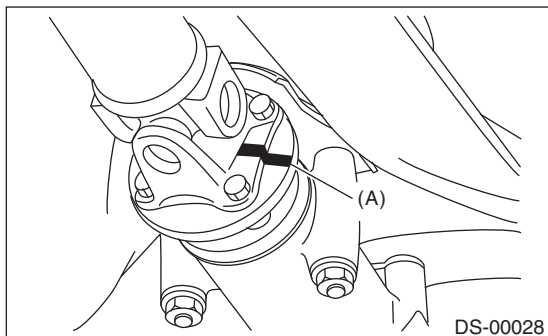

(A) Alignment mark

- 9) Remove the three bolts holding the propeller shaft to the rear differential.
- 10) Remove the remaining bolt.
- 11) Remove the two bolts which hold center bearing to vehicle body.

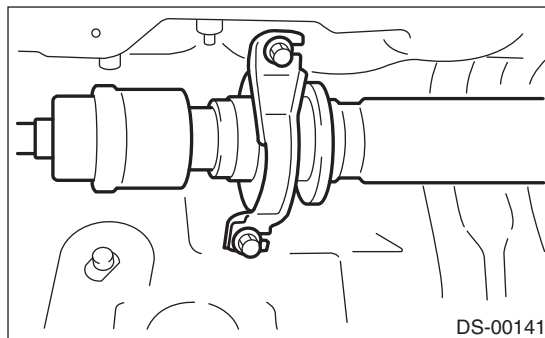

- 12) Remove the propeller shaft from transmission.

CAUTION:

- Be careful not to damage oil seals and contact surface of the sleeve yoke.
- Cover the center exhaust pipe with a cloth to keep off any ATF or oil spilled from transmission when removing propeller shaft.

NOTE:

Use a container to catch ATF or oil flowing from propeller shaft.

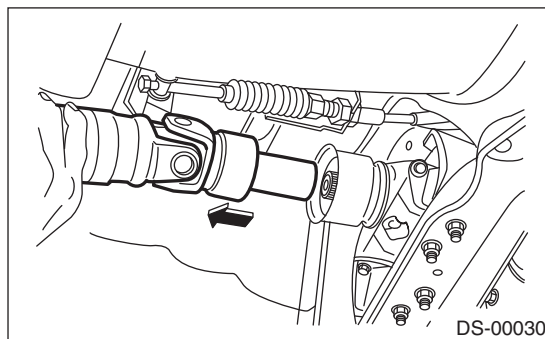

- 13) Install an extension cap to the transmission.

NOTE:

If extension cap is not available, place vinyl bag over opening and fasten with string to prevent gear oil or ATF from leaking.

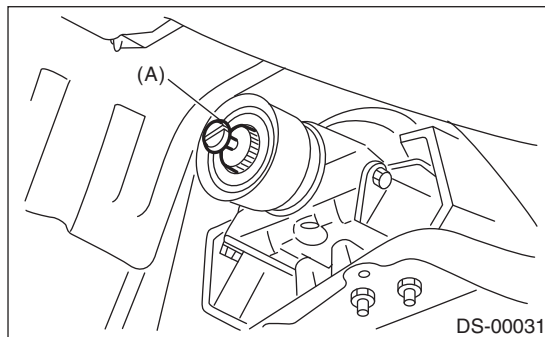

(A) Extension cap

B: INSTALLATION

1) Insert the sleeve yoke into the transmission and attach center bearing to body.

Tightening torque:

52 N·m (5.3 kgf-m, 38.3 ft-lb)

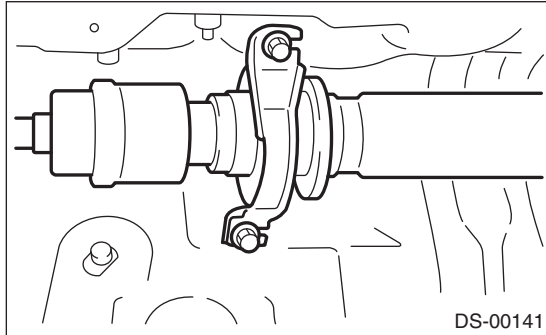

2) Align the alignment marks and connect the flange yoke and rear differential.

Tightening torque:

31 N·m (3.2 kgf-m, 23.1 ft-lb)

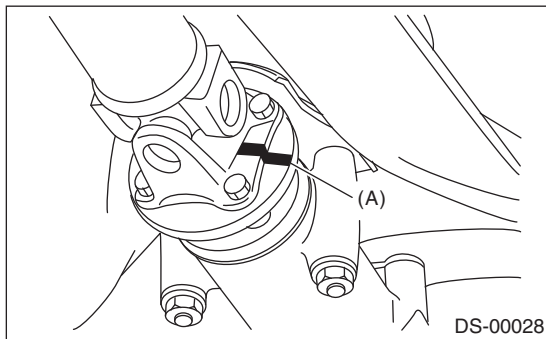

(A) Alignment mark

- 3) Install the heat shield cover.
- 4) Install the center exhaust pipe.
- 5) Install the rear exhaust pipe and muffler.
- 6) Lower the vehicle.
- 7) Connect the ground cable to the battery.

C: INSPECTION

NOTE:

Do not disassemble propeller shaft. Check the following and replace if necessary.

- Dents or cracks on the tube surface
- Splines for deformation or abnormal wear
- Unsmooth joint operation or abnormal noise
- Center bearing for free play, noise or non-smooth operation.
- Oil seals for abnormal wear or damage
- Damaged center bearing

Check the following points with propeller shaft installed in vehicle.

1. JOINTS AND CONNECTORS

- 1) Remove the center exhaust pipe.
- 2) Remove the heat shield cover.
- 3) Check for any looseness of the yoke flange mounting bolts which connect to the rear differential and center bearing bracket mounting bolts.

2. SPLINES AND BEARING

- 1) Remove the center exhaust pipe.
- 2) Remove the rear exhaust pipe and muffler.
- 3) Remove the heat shield cover.
- 4) Turn the propeller shaft by hand to see if abnormal free play exists at splines. Also move yokes to see if abnormal free play exists at spiders and bearings.

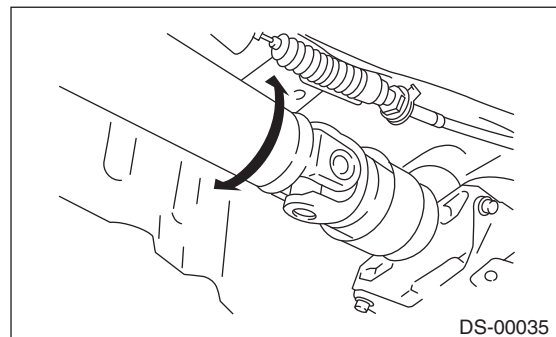

Propeller Shaft

DRIVE SHAFT SYSTEM

3. RUNOUT OF PROPELLER SHAFT

- 1) Remove the center exhaust pipe.
- 2) Remove the rear exhaust pipe and muffler.
- 3) Remove the heat shield cover.
- 4) Set the dial gauge with its indicator stem at the center of the propeller shaft tube.
- 5) Turn the propeller shaft slowly by hands to check for runout of the propeller shaft.

Runout:

Limit: 0.6 mm (0.024 in)

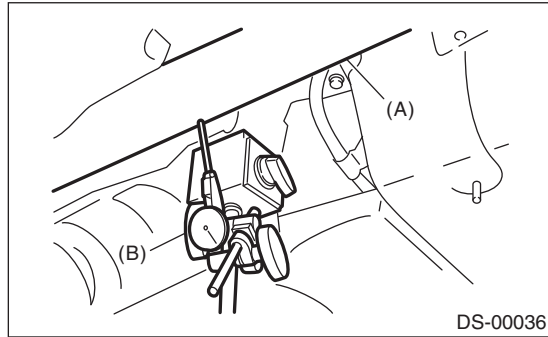

- (A) Propeller shaft
(B) Dial gauge

4. CENTER BEARING FREE PLAY

- 1) Remove the front and center exhaust pipes.
- 2) Remove the rear exhaust pipe and muffler.
- 3) Remove the heat shield cover.
- 4) Move the propeller shaft near the center bearing up, down, left, right by hand, to check for any abnormal free play of the bearings.

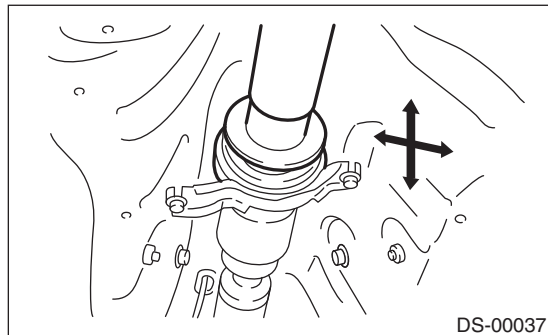

3. Front Axle

A: REMOVAL

- 1) Disconnect the ground cable from the battery.
- 2) Lift up the vehicle, and remove the front wheels.
- 3) Disconnect the front vehicle height sensor connector. (models with auto headlight beam leveler, left side only)

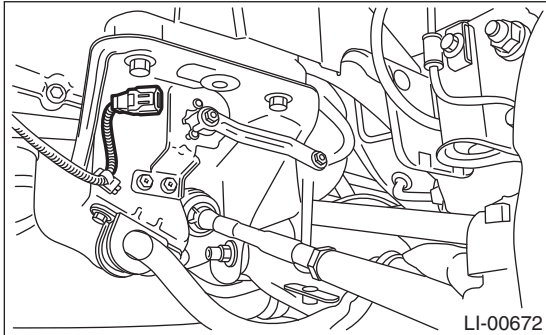

- 4) Remove the front vehicle height sensor. (models with auto headlight beam leveler, left side only)

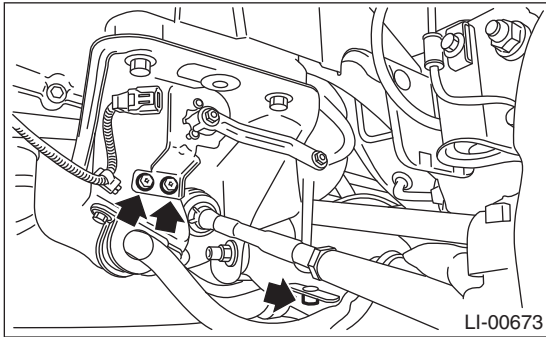

- 5) Lift the crimped section of axle nut.

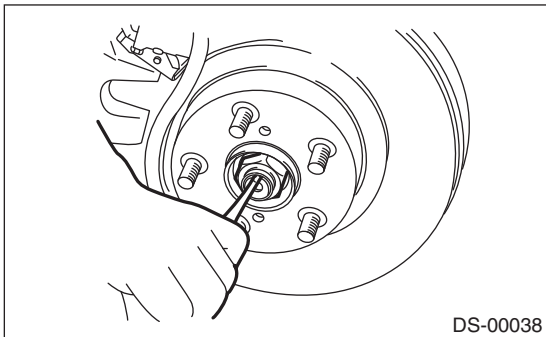

- 6) Remove the axle nut using a socket wrench while depressing the brake pedal.

CAUTION:

Remove the wheel before loosening the axle nut. Failure to follow this rule may damage the wheel bearings.

- 7) Remove the stabilizer link.

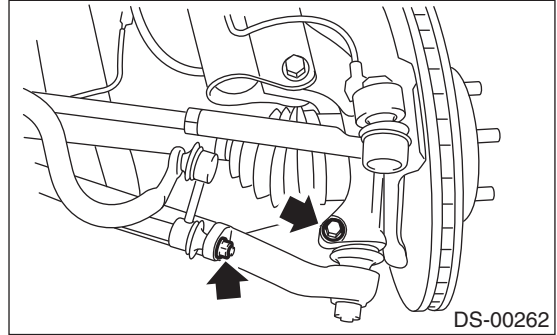

- 8) Remove the disc brake caliper from the housing, and suspend it from strut using a wire.

- 9) Remove the disc rotor from the hub.

NOTE:

If it is difficult to remove the disc rotor from the hub, drive the 8 mm bolt into the threaded end of rotor, and then remove the rotor.

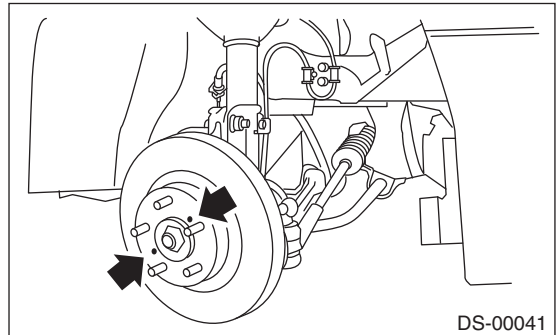

- 10) Remove the cotter pin and castle nut securing the tie-rod end to the housing knuckle arm.

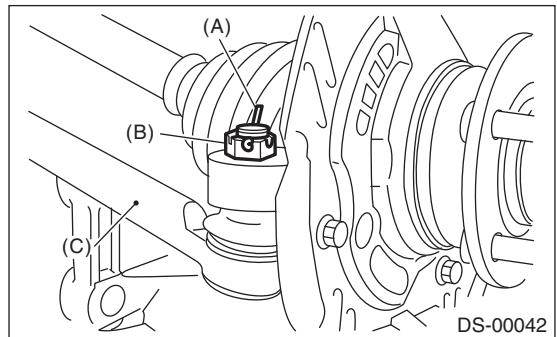

- (A) Cotter pin
- (B) Castle nut
- (C) Tie-rod

Front Axle

DRIVE SHAFT SYSTEM

11) Using a puller, remove the tie-rod ball joint from knuckle arm.

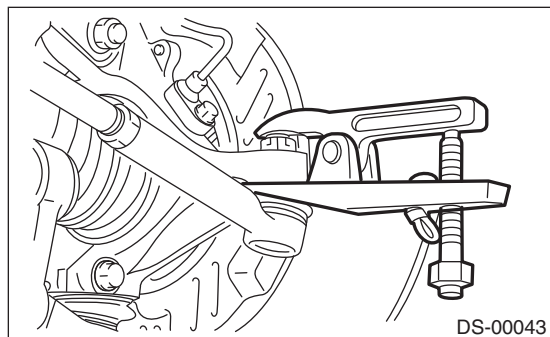

12) Remove the ABS wheel speed sensor assembly and harness.

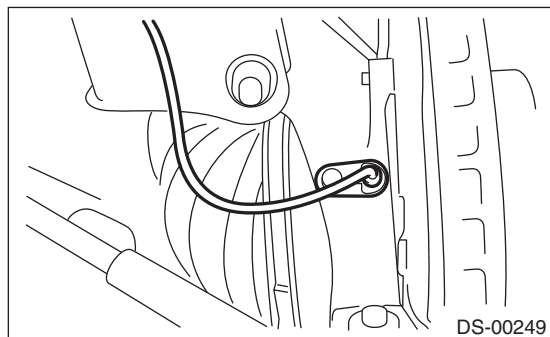

13) Remove the bolts which secure the sensor harness to the strut.

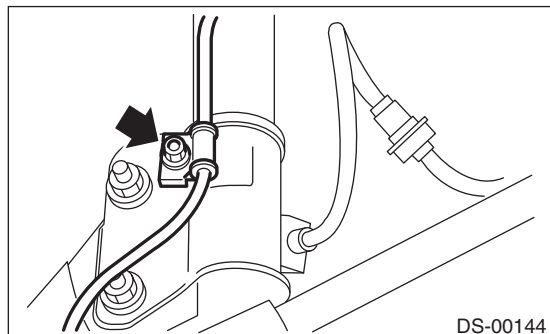

14) Remove the front arm ball joint from the housing.

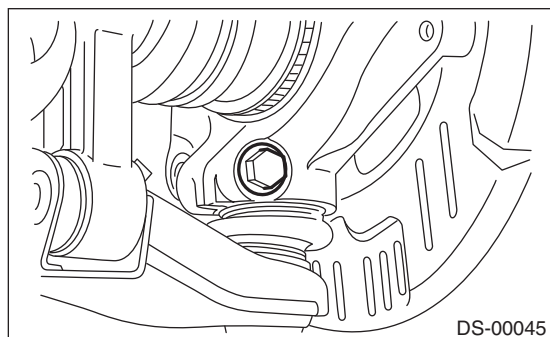

15) Remove the front drive shaft from the transmission.

16) Remove the front drive shaft assembly from the hub. If it is hard to remove, use the ST.

ST1 926470000 AXLE SHAFT PULLER
ST2 28099PA110 AXLE SHAFT PULLER PLATE

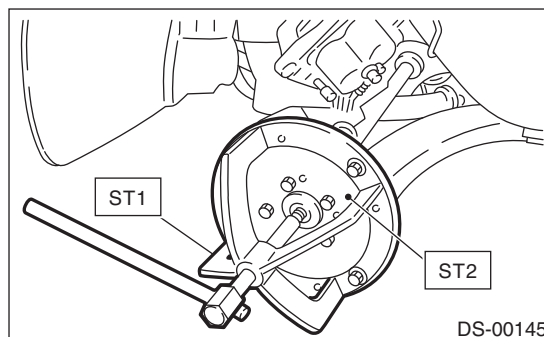

17) After scribing an alignment mark on camber adjusting bolt head, remove the bolts which connect the housing and strut, and disconnect the housing from strut.

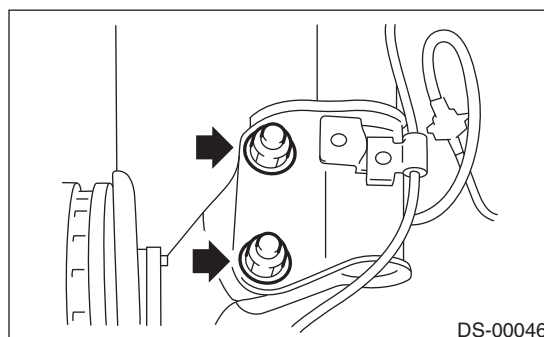

B: INSTALLATION

1) Align the alignment mark on the camber adjusting bolt head, and tighten the housing and strut using a new self-locking nut.

Tightening torque:

155 N·m (15.8 kgf-m, 114.3 ft-lb)

2) Install the front drive shaft. <Ref. to DS-28, INSTALLATION, Front Drive Shaft.>

3) Install the front arm ball joint to the housing.

Tightening torque:

50 N·m (5.1 kgf-m, 36.9 ft-lb)

4) Install the ABS sensor harness to the strut.

5) Install the ABS wheel speed sensor on the housing.

Tightening torque:

7.5 N·m (0.76 kgf-m, 5.5 ft-lb)

6) Install the disc rotor to hub.

7) Install the disc brake caliper on the housing.

Tightening torque:

80 N·m (8.2 kgf-m, 59 ft-lb)

8) Install the stabilizer link.

9) Connect the tie-rod end ball joint to the knuckle arm with a castle nut.

Tightening torque:

27.0 N·m (2.75 kgf-m, 19.9 ft-lb)

CAUTION:

When connecting the tie-rod, do not hit the cap at bottom of tie-rod end with a hammer.

10) Tighten the castle nut to specified torque and tighten further within 60° until the pin hole is aligned with the slot in the nut. Bend the cotter pin to lock.

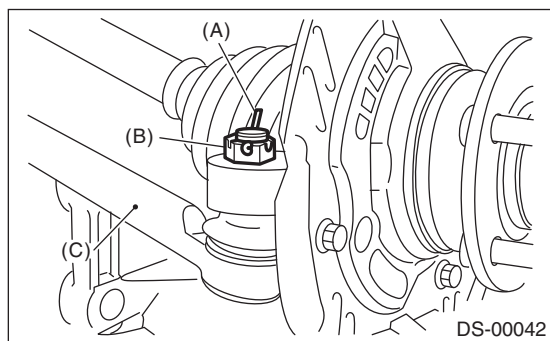

- (A) Cotter pin
- (B) Castle nut
- (C) Tie-rod

11) While depressing the brake pedal, tighten a new axle nut to the specified torque and lock it securely.

Tightening torque:

220 N·m (22.4 kgf-m, 162 ft-lb)

CAUTION:

- Do not install wheel and let it touch the ground before tightening the axle nut. Failure to follow this rule may damage the axle bearing.
- Do not overtighten the nuts as this may damage the axle bearing.

12) After tightening the axle nut, lock it securely.

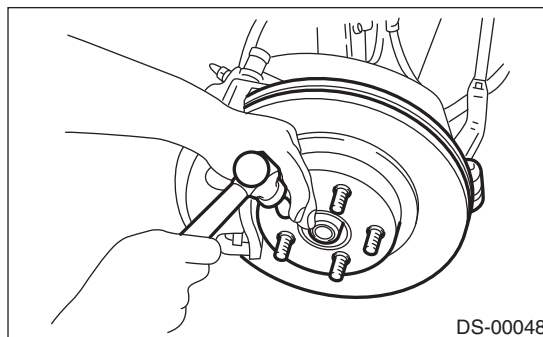

13) Install the front vehicle height sensor. (models with auto headlight beam leveler, left side only)

Tightening torque:

7.5 N·m (0.76 kgf-m, 5.5 ft-lb)

14) Attach the front vehicle height sensor connector. (models with auto headlight beam leveler, left side only)

15) Install the wheel.

Tightening torque:

100 N·m (10.2 kgf-m, 73.8 ft-lb)

16) Connect the ground cable to the battery.

17) Inspect the wheel alignment and adjust if necessary.

18) Perform reinitialization of the auto headlight beam leveler system. (models with auto headlight beam levelers) <Ref. to LI-15, PROCEDURE, Auto Headlight Beam Leveler System.>

Front Axle

DRIVE SHAFT SYSTEM

C: DISASSEMBLY

1) Remove the four bolts from the housing, and remove the front hub unit bearing and disc cover.

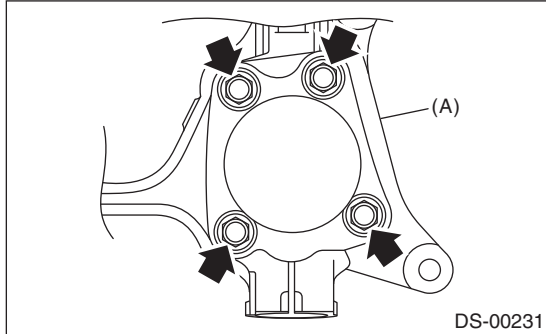

(A) Housing

CAUTION:

- Do not get closer the tool which charged magnetism to magnetic encoder.
- Be careful not to damage the magnetic encoder.

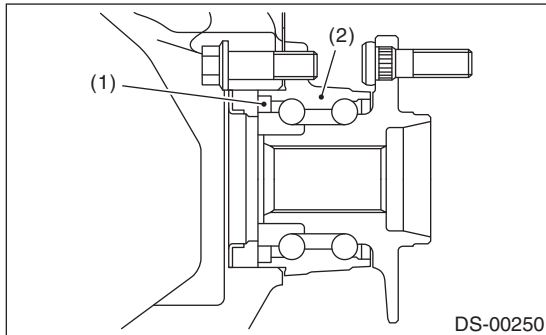

- (1) Magnetic encoder
(2) Front hub unit bearing

2) Disassemble the front hub unit bearing. <Ref. to DS-19, DISASSEMBLY, Front Hub Unit Bearing.>

D: ASSEMBLY

1) Assemble the front hub unit bearing. <Ref. to DS-19, ASSEMBLY, Front Hub Unit Bearing.>
2) Place the disc cover between housing and front hub unit, and tighten the four bolts.

Tightening torque:

65 N·m (6.6 kgf·m, 47.9 ft·lb)

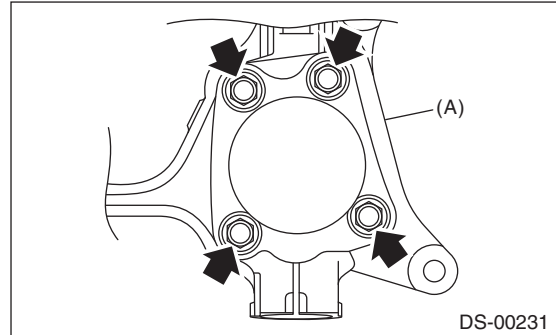

(A) Housing

CAUTION:

- Do not get closer the tool which charged magnetism to magnetic encoder.
- Be careful not to damage the magnetic encoder.

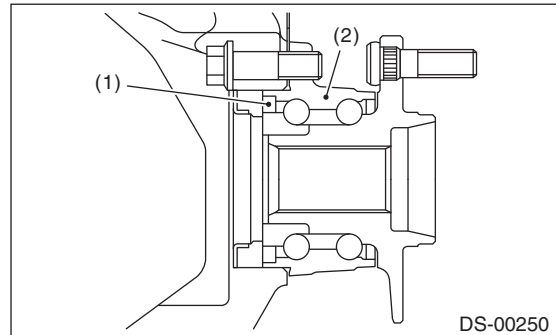

- (1) Magnetic encoder
(2) Front hub unit bearing

E: INSPECTION

1) Moving the front tire up and down by hand, check there is no play in bearing, and check the wheel rotates smoothly.

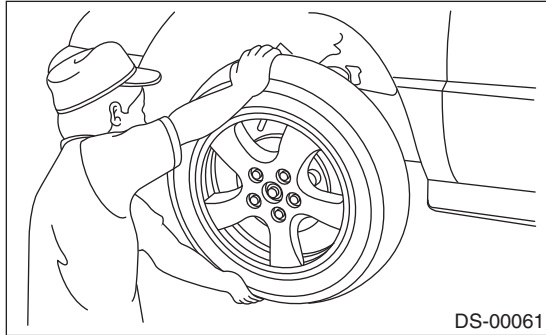

2) Inspect the lean of axis direction using a dial gauge. Replace the bearing if the load range exceeds the limitation.

Service limit:

Maximum: 0.05 mm (0.0020 in)

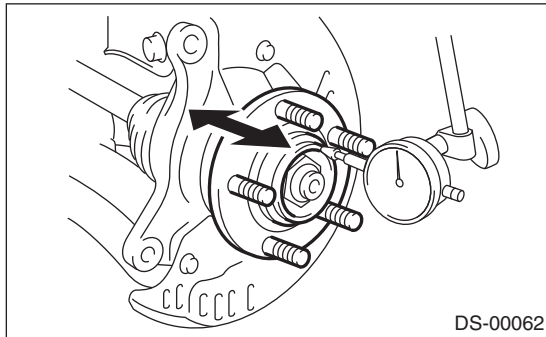

Front Hub Unit Bearing

4. Front Hub Unit Bearing

A: REMOVAL

- 1) Disconnect the ground cable from the battery.
- 2) Lift up the vehicle, and remove the front wheels.
- 3) Lift the crimped section of axle nut.

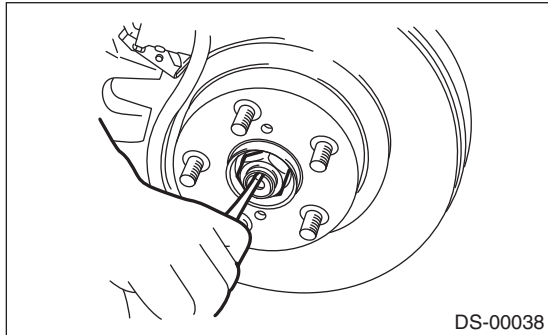

- 4) Remove the axle nut using a socket wrench while depressing the brake pedal.

CAUTION:

Remove the wheel before loosening the axle nut. Failure to follow this rule may damage the wheel bearings.

- 5) Remove the disc brake caliper from the housing, and suspend it from strut using a wire.
- 6) Remove the disc rotor from the hub.

NOTE:

If it is difficult to remove the disc rotor from the hub, drive the 8 mm bolt into the threaded end of rotor, and then remove the rotor.

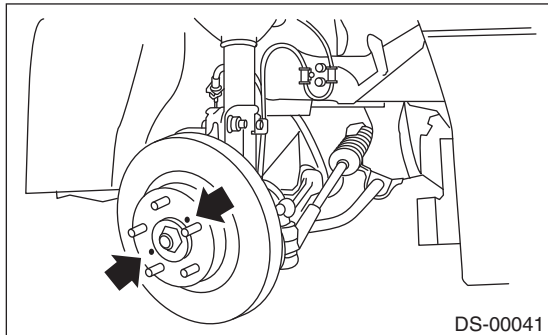

- 7) Remove the four bolts from the housing.

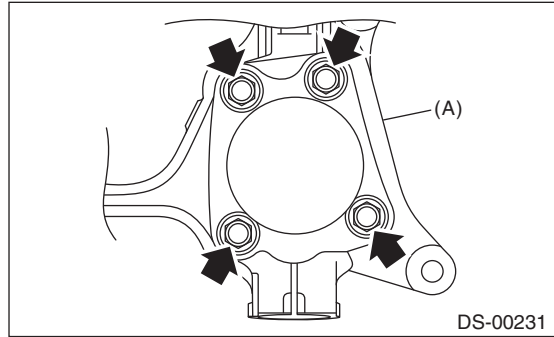

(A) Housing

CAUTION:

- Do not get closer the tool which charged magnetism to magnetic encoder.
- Be careful not to damage the magnetic encoder.

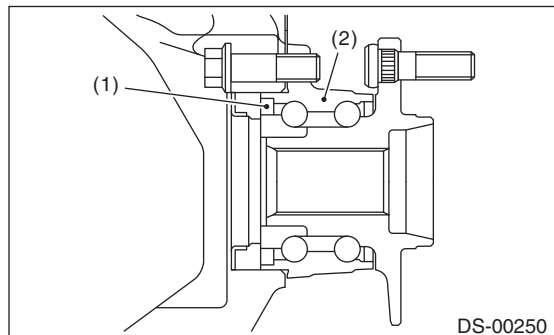

- (1) Magnetic encoder
- (2) Front hub unit bearing

- 8) Remove the front hub unit bearing. If it is hard to remove, use the ST.

ST1 926470000 AXLE SHAFT PULLER
ST2 28099PA110 AXLE SHAFT PULLER PLATE

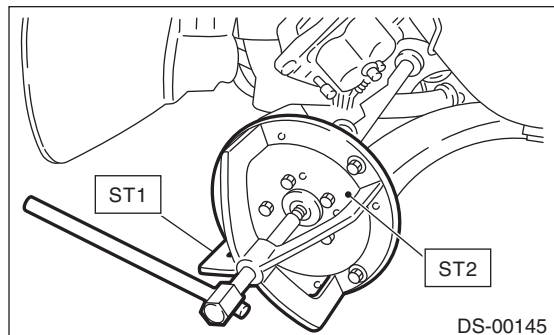

B: INSTALLATION

1) Place the disc cover between housing and front hub unit, and tighten the four bolts.

Tightening torque:

65 N·m (6.6 kgf·m, 47.9 ft·lb)

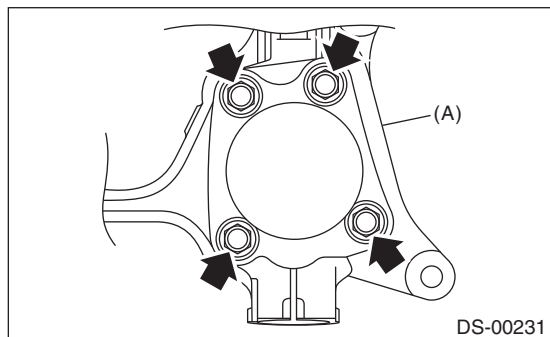

(A) Housing

2) Install the front drive shaft. <Ref. to DS-28, INSTALLATION, Front Drive Shaft.>

3) Tighten the axle nut temporarily.

4) Install the disc rotor to hub.

5) Install the disc brake caliper on the housing.

Tightening torque:

80 N·m (8.2 kgf·m, 59 ft·lb)

6) While depressing the brake pedal, tighten a new axle nut to the specified torque and lock it securely.

Tightening torque:

220 N·m (22.4 kgf·m, 162 ft·lb)

CAUTION:

- Do not install wheel and let it touch the ground before tightening the axle nut. Failure to follow this rule may damage the axle bearing.
- Do not overtighten the nuts as this may damage the axle bearing.

7) After tightening the axle nut, lock it securely.

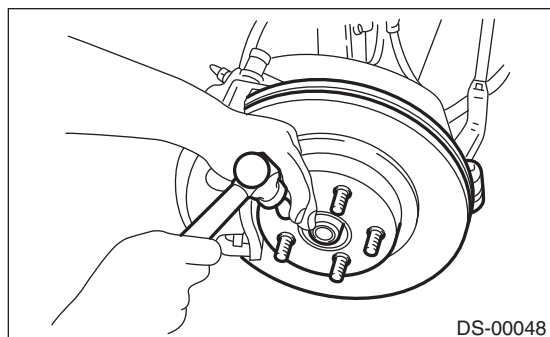

8) Install the wheel.

Tightening torque:

100 N·m (10.2 kgf·m, 73.8 ft·lb)

C: DISASSEMBLY

Using the ST and a hydraulic press, push out the hub bolts.

ST 28399AG000 HUB STAND

CAUTION:

- Be careful not to hammer the hub bolts. This may deform the hub.
- Do not reuse the hub bolt.

NOTE:

Since the hub unit bearing can not be disassembled, only hub bolts can be removed.

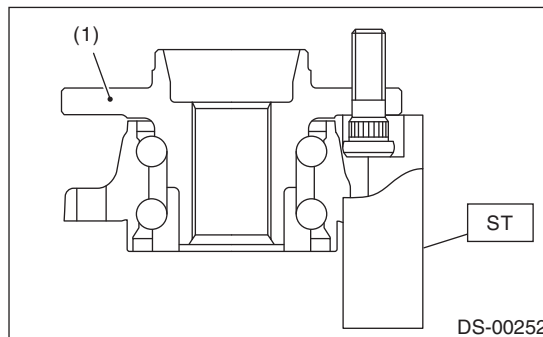

(1) Front hub unit bearing

D: ASSEMBLY

1) Attach the hub to the ST securely.

ST 927080000 HUB STAND

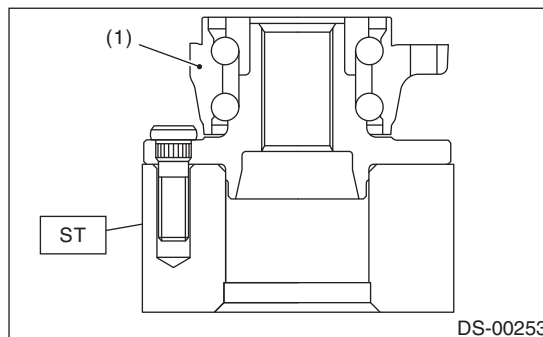

(1) Front hub unit bearing

2) Using a press, press the new hub bolts until their seating surfaces contact the hub.

NOTE:

Use the 12 mm (0.47 in) dia. holes in the HUB STAND to prevent bolts from tilting.

E: INSPECTION

Refer to "Front Axle" for inspection procedures. <Ref. to DS-17, INSPECTION, Front Axle.>

CAUTION:

If there is any fault in the bearing, replace hub unit bearing.

Rear Axle

DRIVE SHAFT SYSTEM

5. Rear Axle

A: REMOVAL

- 1) Disconnect the ground cable from the battery.
- 2) Lift up the vehicle, and then remove the rear wheels.
- 3) Lift the crimped section of axle nut.

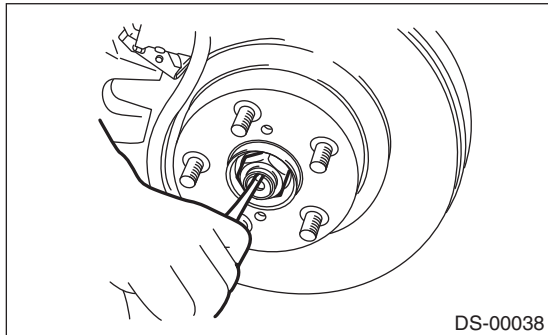

- 4) Remove the axle nut using a socket wrench while depressing the brake pedal.

CAUTION:

Remove the wheel before loosening the axle nut. Failure to follow this rule may damage the wheel bearings.

- 5) Disconnect the connector, remove the nut and remove the rear vehicle height sensor. (models with auto headlight beam leveler, left side only)

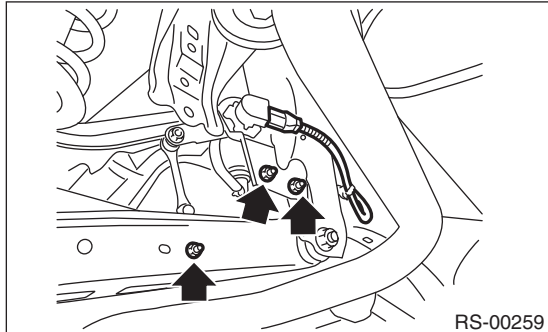

- 6) Remove the brake hose bracket and the rear ABS wheel speed sensor.

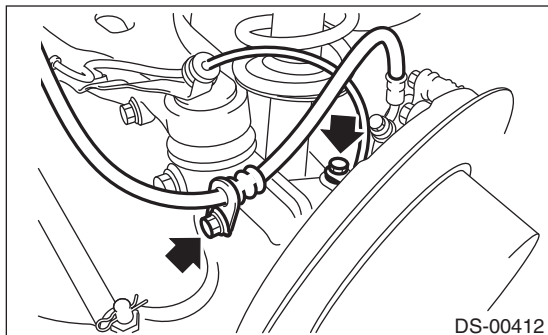

- 7) Remove the disc brake caliper from the rear housing, and suspend it from the vehicle using a string.

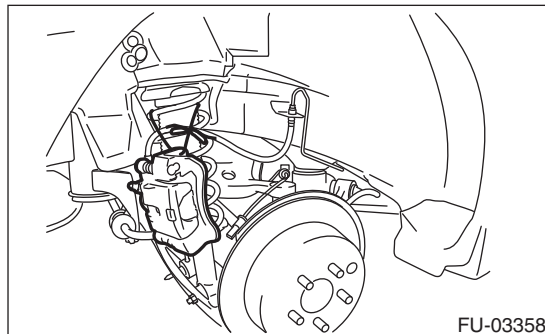

- 8) Remove the rear disc rotor.
- 9) Remove the four bolts from the rear housing.

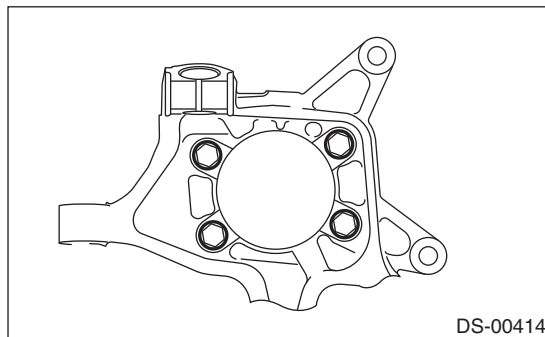

10) Remove the rear hub unit bearing.

CAUTION:

- Be careful not to damage the magnetic encoder.
- Do not get closer the tool which charged magnetism to magnetic encoder.

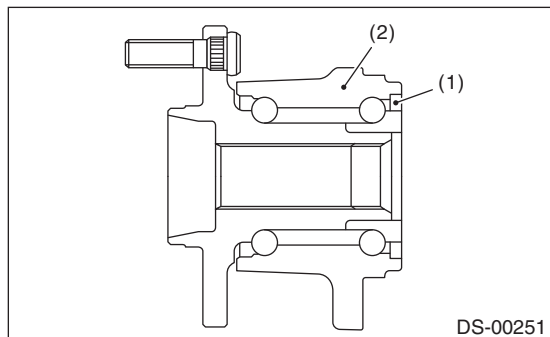

- (1) Magnetic encoder
- (2) Rear hub unit bearing

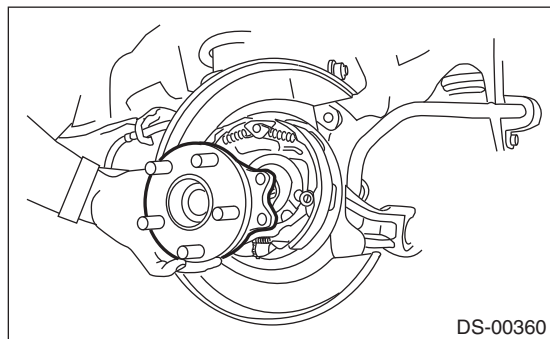

NOTE:

If it is hard to remove, use the ST.

- ST1 926470000 AXLE SHAFT PULLER
- ST2 28099PA110 AXLE SHAFT PULLER PLATE

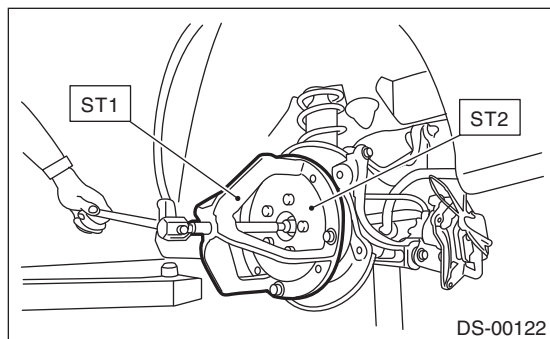

11) Remove the snap pin and nut from the front lateral link.

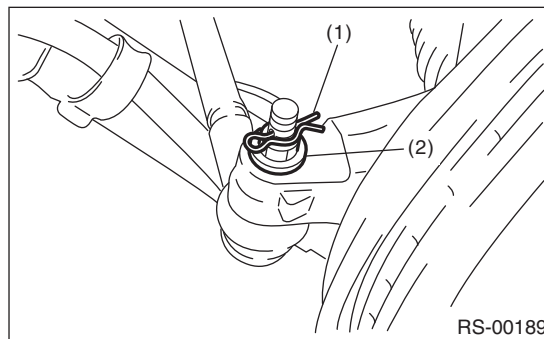

- (1) Snap pin
- (2) Nut

12) Using a puller, separate the rear housing and ball joint.

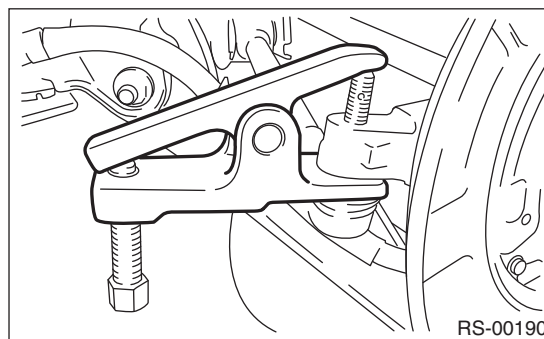

13) Separate the upper arm, trailing link, and rear lateral link from the rear housing.

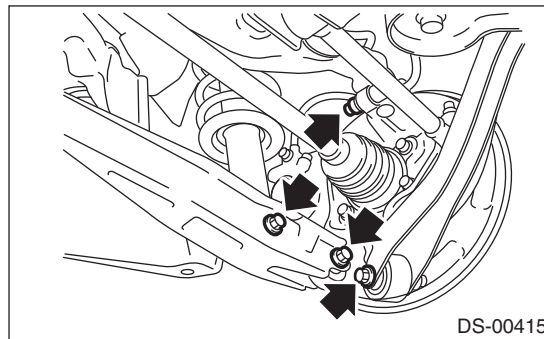

14) Remove the rear axle.

Rear Axle

DRIVE SHAFT SYSTEM

B: INSTALLATION

- 1) Temporarily tighten the rear housing to the upper arm.
- 2) Aligning with the mounting hole of the rear brake back plate, temporarily tighten the rear hub unit bearing to the rear housing.

CAUTION:

- Be careful not to damage the magnetic encoder.
- Do not get closer the tool which charged magnetism to magnetic encoder.

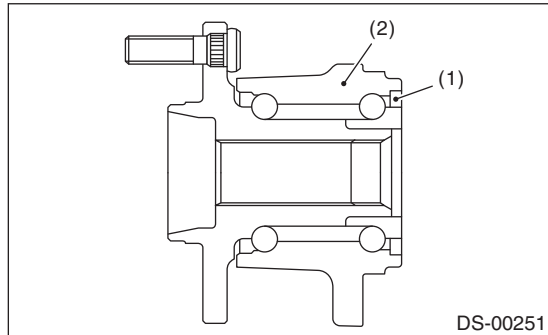

- (1) Magnetic encoder
- (2) Rear hub unit bearing

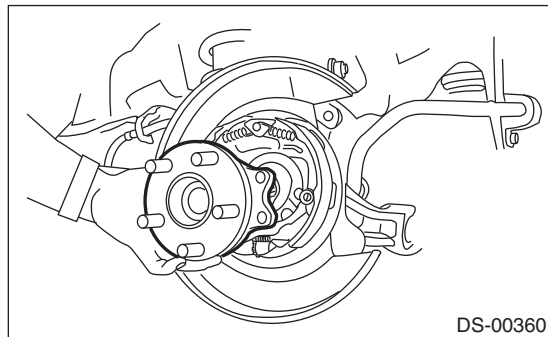

- 3) Attach the rear drive shaft to the rear hub unit bearing.
- 4) Tighten the new axle nut temporarily.

CAUTION:

Use new axle nuts.

- 5) Attach the links to the rear housing and tighten them to the specified torque.

Tightening torque:

Upper arm

90 N·m (9.2 kgf·m, 66.4 ft·lb)

Front lateral link

60 N·m (6.1 kgf·m, 44 ft·lb)

Rear lateral link

120 N·m (12.2 kgf·m, 89 ft·lb)

Trailing link

90 N·m (9.2 kgf·m, 66.4 ft·lb)

- 6) Tighten the four bolts of the rear housing.

Tightening torque:

65 N·m (6.6 kgf·m, 47.9 ft·lb)

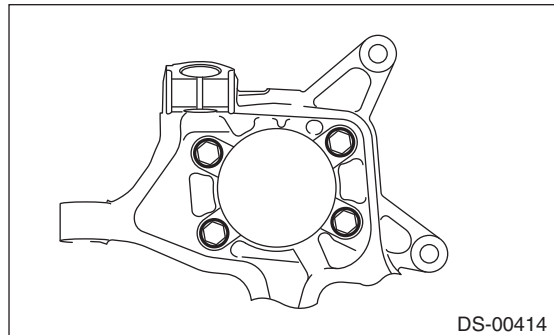

- 7) Install the rear disc rotor.
- 8) Install the rear disc brake caliper to the rear housing.

Tightening torque:

66 N·m (6.7 kgf·m, 48.7 ft·lb)

- 9) Install the brake hose bracket and rear ABS wheel speed sensor.

Tightening torque:

Brake hose bracket

33 N·m (3.4 kgf·m, 24.3 ft·lb)

Rear ABS wheel speed sensor

7.5 N·m (0.76 kgf·m, 5.5 ft·lb)

- 10) Attach the rear vehicle height sensor. (models with auto headlight beam leveler, left side only)

Tightening torque:

7.5 N·m (0.76 kgf·m, 5.5 ft·lb)

- 11) While pressing the brake pedal, tighten the new axle nuts to the specified torque.

Tightening torque:

190 N·m (19.4 kgf·m, 140 ft·lb)

CAUTION:

- Do not install wheel and let it touch the ground before tightening the axle nut. Failure to follow this rule may damage the axle bearing.
 - Do not overtighten the nuts as this may damage the axle bearing.
- 12) After tightening the axle nut, lock it securely.

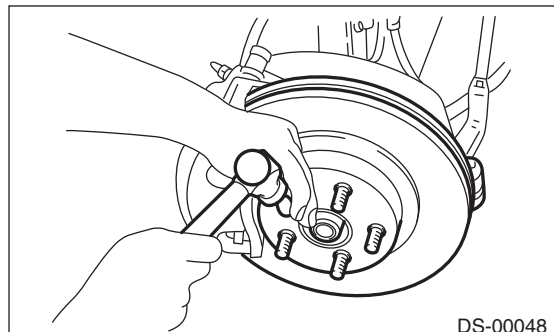

13) Install the rear wheels.

Tightening torque:

100 N·m (10.2 kgf-m, 73.8 ft-lb)

14) Connect the ground cable to the battery.

15) Inspect the wheel alignment and adjust if necessary.

16) Perform reinitialization of the auto headlight beam leveler system. <Ref. to LI-15, PROCEDURE, Auto Headlight Beam Leveler System.>

Rear Hub Unit Bearing

DRIVE SHAFT SYSTEM

6. Rear Hub Unit Bearing

A: REMOVAL

- 1) Disconnect the ground cable from the battery.
- 2) Lift up the vehicle, and then remove the rear wheels.
- 3) Lift the crimped section of axle nut.

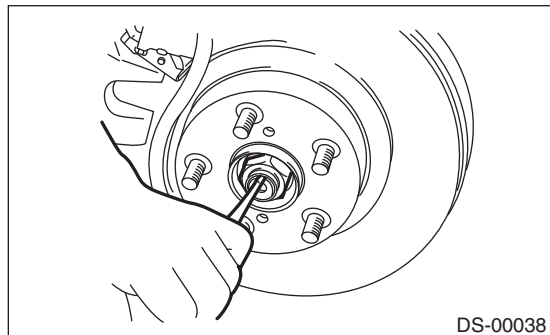

- 4) Remove the axle nut using a socket wrench while depressing the brake pedal.

CAUTION:

Remove the wheel before loosening the axle nut. Failure to follow this rule may damage the wheel bearings.

- 5) Remove the disc brake caliper from the rear housing, and suspend it from the vehicle using a string.

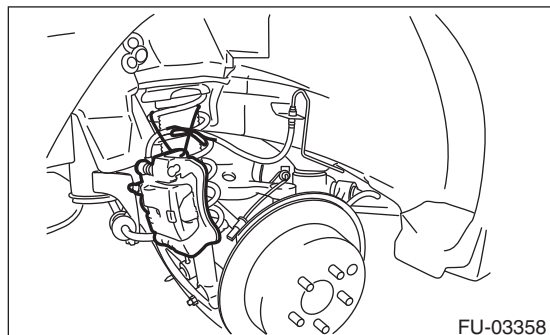

- 6) Remove the rear disc rotor.
- 7) Remove the four bolts from the rear housing.

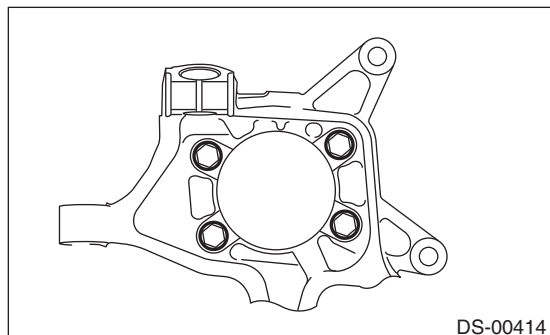

- 8) Remove the rear hub unit bearing.

CAUTION:

- Be careful not to damage the magnetic encoder.
- Do not get closer the tool which charged magnetism to magnetic encoder.

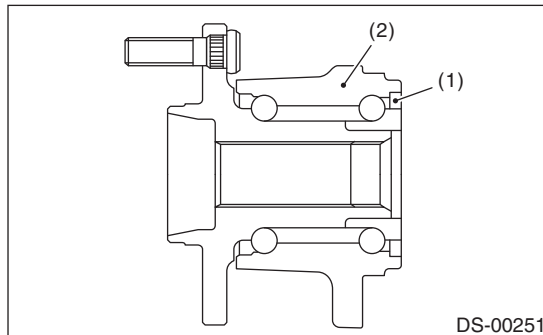

- (1) Magnetic encoder
- (2) Rear hub unit bearing

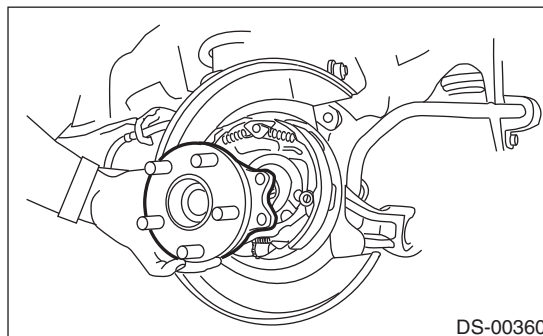

NOTE:

If it is hard to remove, use the ST.

- | | | |
|-----|------------|-------------------------|
| ST1 | 926470000 | AXLE SHAFT PULLER |
| ST2 | 28099PA110 | AXLE SHAFT PULLER PLATE |

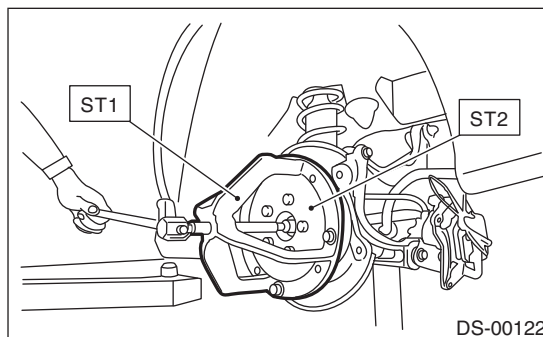

B: INSTALLATION

1) Aligning with the mounting hole of the rear brake back plate, temporarily tighten the rear hub unit bearing to the rear housing.

CAUTION:

- Be careful not to damage the magnetic encoder.
- Do not get closer the tool which charged magnetism to magnetic encoder.

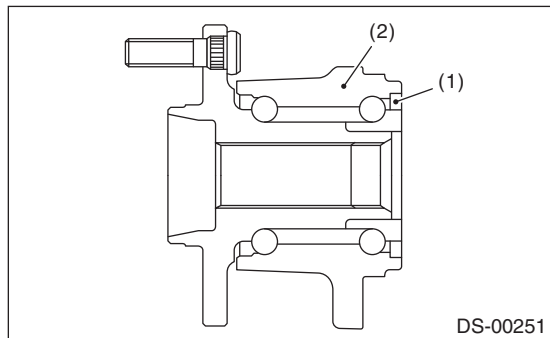

- (1) Magnetic encoder
(2) Rear hub unit bearing

2) Tighten the four bolts of the rear housing.

Tightening torque:

65 N·m (6.6 kgf-m, 47.9 ft-lb)

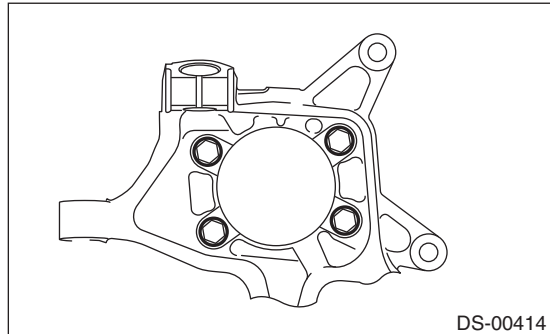

3) Tighten the new axle nut temporarily.

CAUTION:

Use new axle nuts.

- 4) Install the rear disc rotor.
5) Install the disc brake caliper to the rear housing.

Tightening torque:

66 N·m (6.7 kgf-m, 48.7 ft-lb)

6) While pressing the brake pedal, tighten the new axle nuts to the specified torque.

Tightening torque:

190 N·m (19.4 kgf-m, 140 ft-lb)

CAUTION:

- Do not install wheel and let it touch the ground before tightening the axle nut. Failure to follow this rule may damage the axle bearing.
- Do not overtighten the nuts as this may damage the axle bearing.

7) After tightening the axle nut, lock it securely.

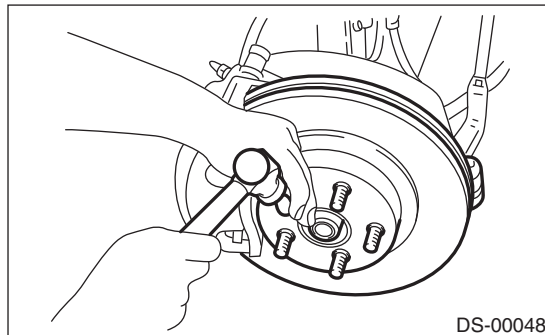

8) Install the rear wheels.

Tightening torque:

100 N·m (10.2 kgf-m, 73.8 ft-lb)

C: DISASSEMBLY

Using the ST and a hydraulic press, push out the hub bolts.

ST 28399AG000 HUB STAND

CAUTION:

- Be careful not to hammer the hub bolts. This may deform the hub.
- Do not reuse the hub bolt.

NOTE:

Since the hub unit bearing can not be disassembled, only hub bolts can be removed.

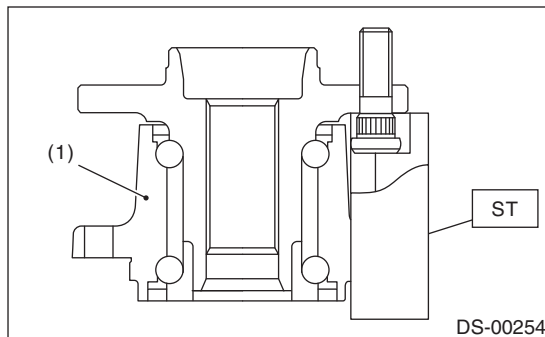

- (1) Rear hub unit bearing

Rear Hub Unit Bearing

DRIVE SHAFT SYSTEM

D: ASSEMBLY

- 1) Attach the hub to the ST securely.
ST 927080000 HUB STAND

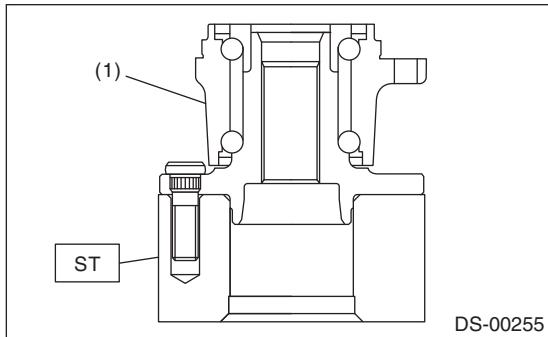

(1) Rear hub unit bearing

- 2) Using a press, press the new hub bolts until their seating surfaces contact the hub.

NOTE:

Use the 12 mm (0.47 in) dia. holes in the HUB STAND to prevent bolts from tilting.

E: INSPECTION

- 1) Moving the rear tire up and down by hand, check there is no backlash in bearing, and check the wheel rotates smoothly.

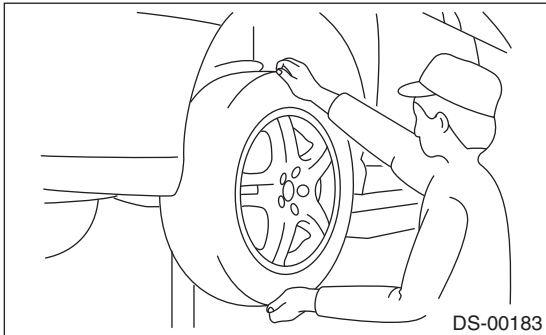

- 2) Inspect the lean of axis direction using a dial gauge. Replace the hub bearing if the play exceeds the limit value.

Service limit:

Maximum: 0.05 mm (0.0020 in)

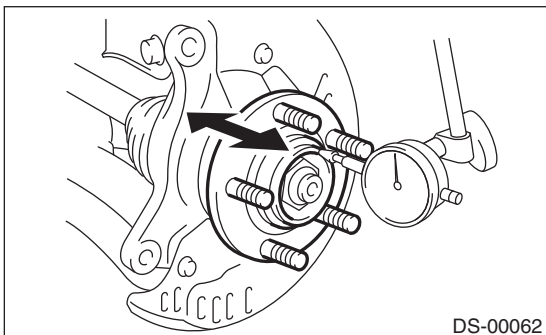

7. Front Drive Shaft

A: REMOVAL

- 1) Disconnect the ground cable from the battery.
- 2) Lift up the vehicle, and remove the front wheels.
- 3) Lift the crimped section of axle nut.

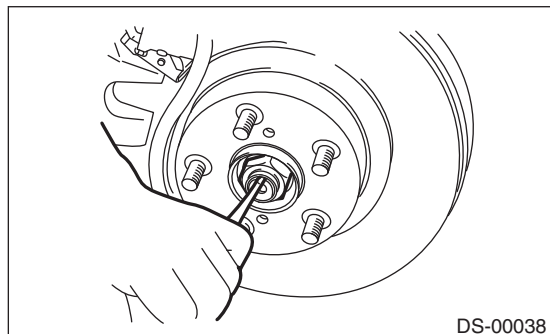

- 4) Remove the axle nut using a socket wrench while depressing the brake pedal.

CAUTION:

Remove the wheel before loosening the axle nut. Failure to follow this rule may damage the wheel bearings.

- 5) Drain the transmission gear oil. (MT model)
- 6) Drain the differential gear oil. (AT model)
- 7) Disconnect the front vehicle height sensor connector. (models with auto headlight beam leveler, left side only)

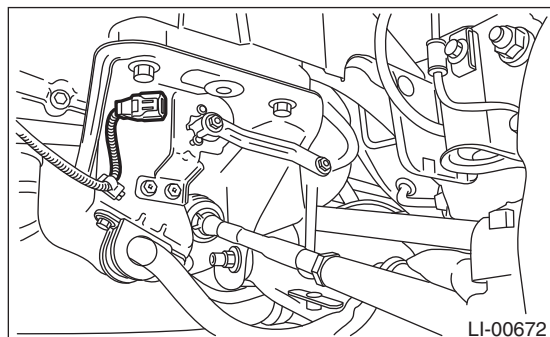

- 8) Remove the front vehicle height sensor. (models with auto headlight beam leveler, left side only)

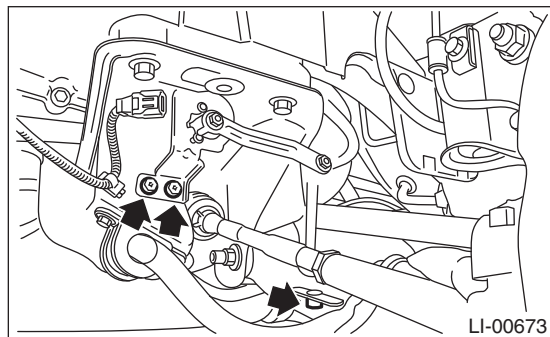

- 9) Remove the stabilizer link from front arm.

- 10) Disconnect the front arm ball joint from the housing.

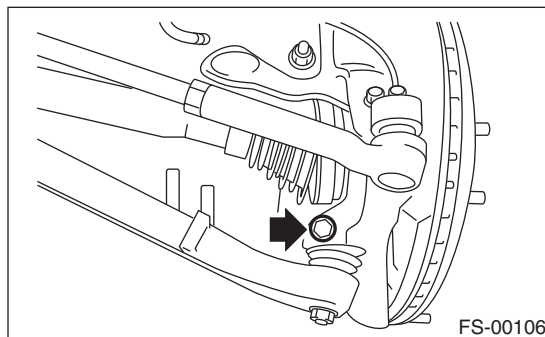

- 11) Remove the front drive shaft assembly. If it is hard to remove, use ST1 and ST2.

- | | | |
|-----|------------|-------------------------|
| ST1 | 926470000 | AXLE SHAFT PULLER |
| ST2 | 28099PA110 | AXLE SHAFT PULLER PLATE |

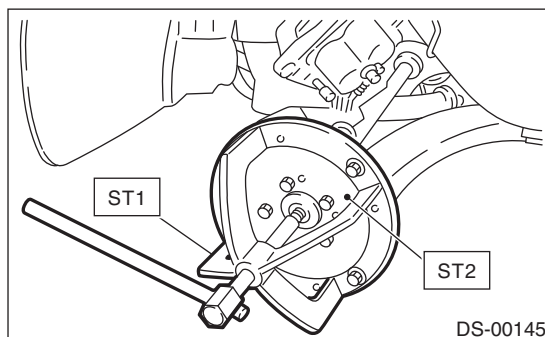

- 12) Using a bar, remove the front drive shaft from transmission.

CAUTION:

Be careful not to allow the bar to damage holder area.

Front Drive Shaft

DRIVE SHAFT SYSTEM

B: INSTALLATION

1) Replace the differential side retainer oil seal with a new part.

NOTE:

After pulling out the drive shaft, be sure to replace with a new oil seal.

4AT model <Ref. to 4AT-45, REPLACEMENT, Differential Side Retainer Oil Seal.>

5MT model <Ref. to 5MT-34, REPLACEMENT, Differential Side Retainer Oil Seal.>

2) Insert the EBJ into the hub spline.

3) Draw the drive shaft into specified position.

CAUTION:

Do not hammer drive shaft when installing it.

4) Tighten the axle nut temporarily.

5) Using the ST, install the front drive shaft to transmission.

ST 28399SA010 OIL SEAL PROTECTOR

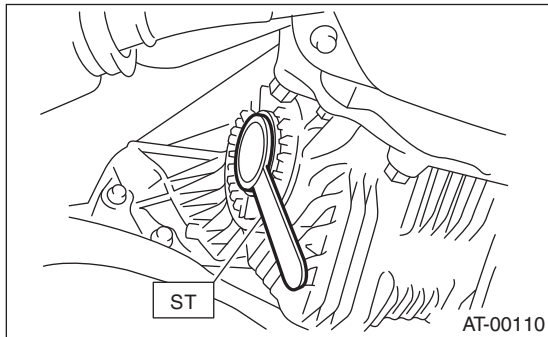

6) Connect the front arm ball joint to the housing.

Tightening torque:

50 N·m (5.1 kgf·m, 36.9 ft·lb)

7) Install the stabilizer link.

CAUTION:

Be sure to use a new self-locking nut.

Tightening torque:

45 N·m (4.6 kgf·m, 33.2 ft·lb)

8) While pressing the brake pedal, tighten the new axle nuts to the specified torque.

Tightening torque:

220 N·m (22.4 kgf·m, 162 ft·lb)

CAUTION:

- Do not install wheel and let it touch the ground before tightening the axle nut. Failure to follow this rule may damage the axle bearing.
- Do not overtighten the nuts as this may damage the axle bearing.

9) After tightening axle nut, lock it securely.

10) Fill the transmission gear oil. (MT model)

11) Fill the differential gear oil. (AT model)

12) Install the front vehicle height sensor. (models with auto headlight beam leveler, left side only)

Tightening torque:

7.5 N·m (0.76 kgf·m, 5.5 ft·lb)

13) Attach the front vehicle height sensor connector. (models with auto headlight beam leveler, left side only)

14) Install the front wheels.

Tightening torque:

100 N·m (10.2 kgf·m, 73.8 ft·lb)

15) Connect the ground cable to the battery.

16) Inspect the wheel alignment and adjust if necessary.

17) Perform reinitialization of the auto headlight beam leveler system. (models with auto headlight beam leveler) <Ref. to LI-15, PROCEDURE, Auto Headlight Beam Leveler System.>

C: DISASSEMBLY

1) Place alignment marks on the shaft and outer race.

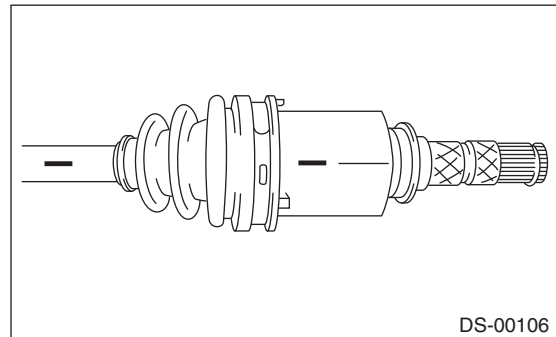

2) Remove the PTJ boot band and boot.

CAUTION:

Be careful not to damage the boot.

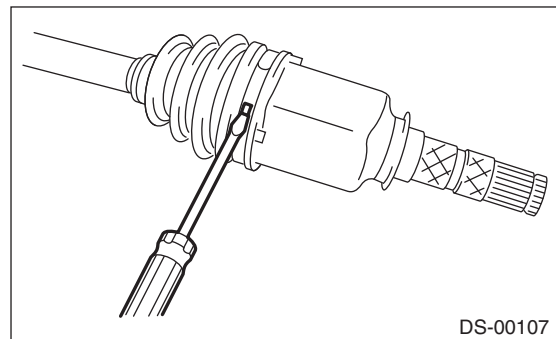

3) Remove the snap ring from the PTJ outer race.

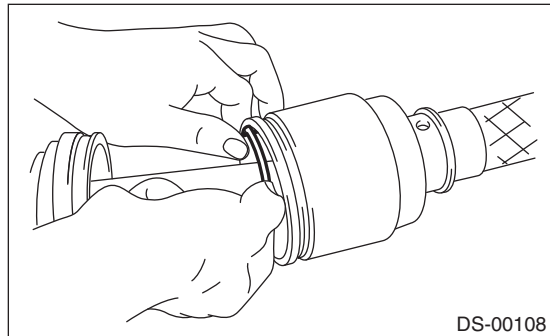

4) Remove the PTJ outer race from the shaft assembly.

5) Wipe off grease.

CAUTION:

The grease is a special type of grease. Do not mix with other grease.

6) Place alignment marks on the roller kit and trunnion.

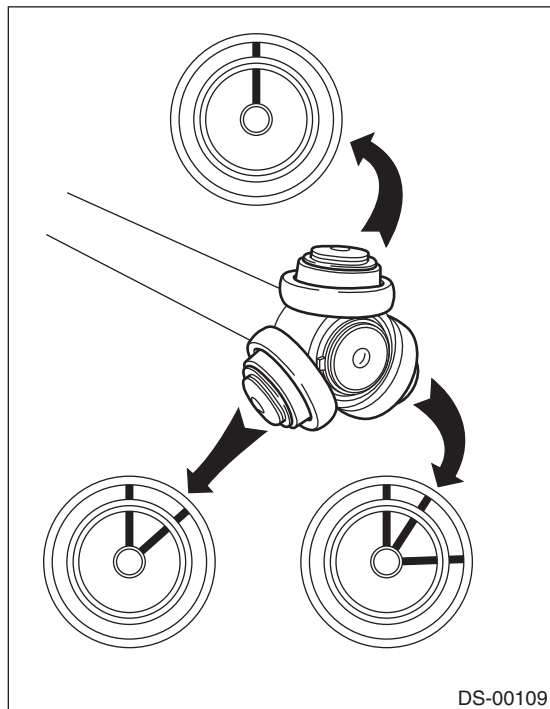

7) Remove the roller kit from trunnion.

CAUTION:

Be careful with the roller kit position.

8) Place alignment marks on the trunnion and shaft.

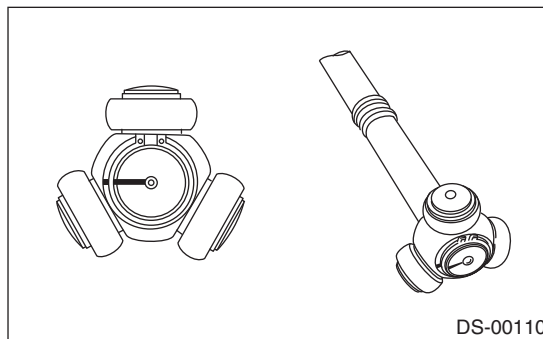

9) Remove the snap ring and trunnion.

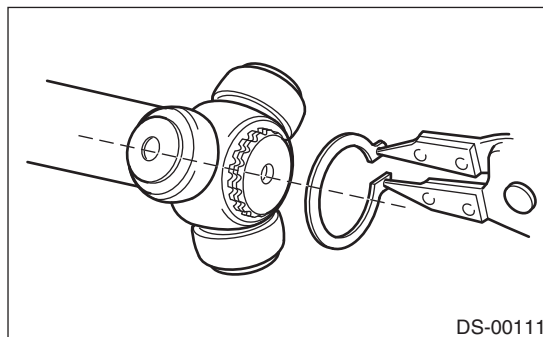

CAUTION:

Be sure to wrap shaft splines with vinyl tape to protect the boot from scratches.

10) Remove the PTJ boot.

11) Remove the O-ring in the shaft boot groove.

NOTE:

The EBJ is a non-disassembly part, so the axle disassembly stops here.

Front Drive Shaft

DRIVE SHAFT SYSTEM

D: ASSEMBLY

1) Roll up a thick sheet of paper, etc. to a size where the shaft can fit inside, and affix with tape to make a cylinder.

2) Attach a new O-ring on this cylinder.

CAUTION:

- Always use a new O-ring.
- Be careful that the O-ring does not become scratched and that there are no foreign objects attached to it.
- Make sure to install the O-ring so that it does not twist as much as possible.
- Do not stretch the O-ring to 30 mm (1.18 in) inner diameter or more.

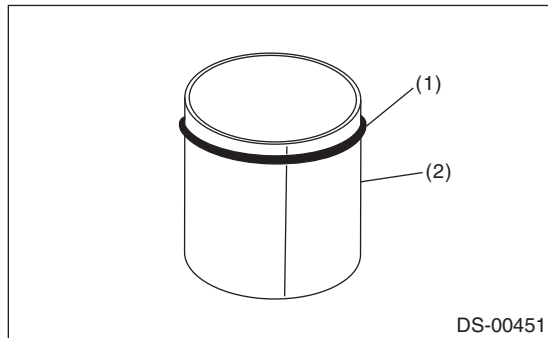

- (1) O-ring
- (2) Cylinder made with thick paper, etc.

3) Pass the cylinder material onto the shaft, and slide in the direction of the shaft axis.

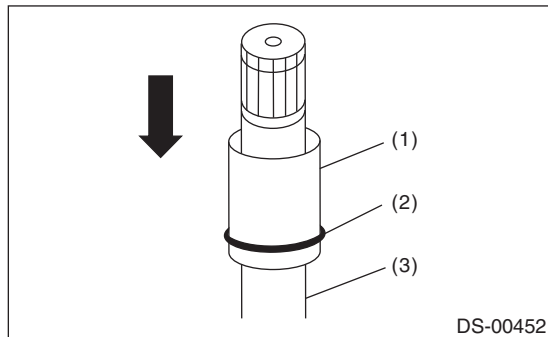

- (1) Cylinder material
- (2) O-ring
- (3) Shaft

4) Clean the shaft boot groove, and wipe off the grease.

5) Slide the cylinder material near the shaft boot groove, and move the O-ring from the cylinder material onto the shaft boot groove.

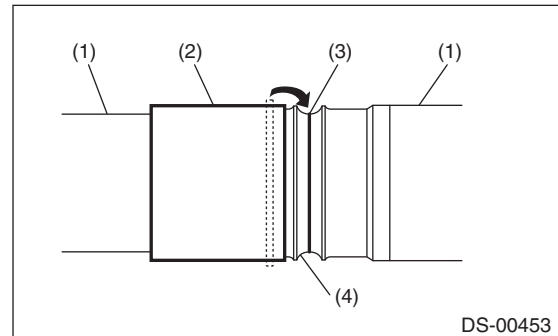

- (1) Shaft
- (2) Cylinder material
- (3) O-ring
- (4) Boot groove

CAUTION:

- Attach the O-ring to the shaft boot groove center.
- Be careful that the O-ring does not become scratched and that there are no foreign objects attached to it.
- Make sure to install the O-ring so that it does not twist as much as possible.
- With the O-ring attached, do not wash with kerosene, gasoline, etc.

6) Pass the PTJ small diameter boot band through the shaft.

7) Wrap vinyl tape around the splines of the shaft.

CAUTION:

To prevent damage to the boots, make sure to always wrap with vinyl tape for protection.

8) Install a new PTJ boot.

CAUTION:

Make sure to fit securely on the boot groove of the shaft.

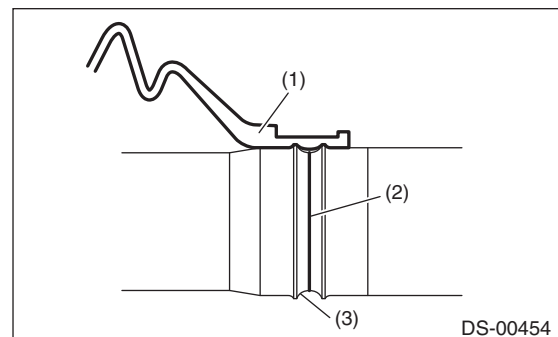

- (1) PTJ boot
- (2) O-ring
- (3) Boot groove

9) Match the alignment marks, and attach the trunnion onto the shaft.

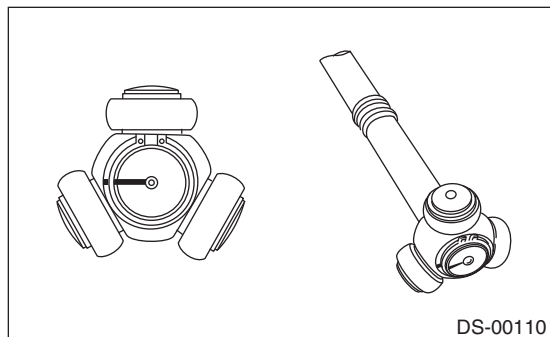

10) Attach the snap ring to the shaft.

CAUTION:

Confirm that the snap ring is completely fitted in the shaft groove.

11) Fill 100 to 110 g (3.53 to 3.88 oz) of specified grease into the interior of the PTJ outer race.

Grease:

NKG302

12) Apply a thin coat of specified grease to the roller kit and trunnion.

13) Match the alignment marks of the roller kit and trunnion, and attach the roller kit.

CAUTION:

Be careful with the roller kit position.

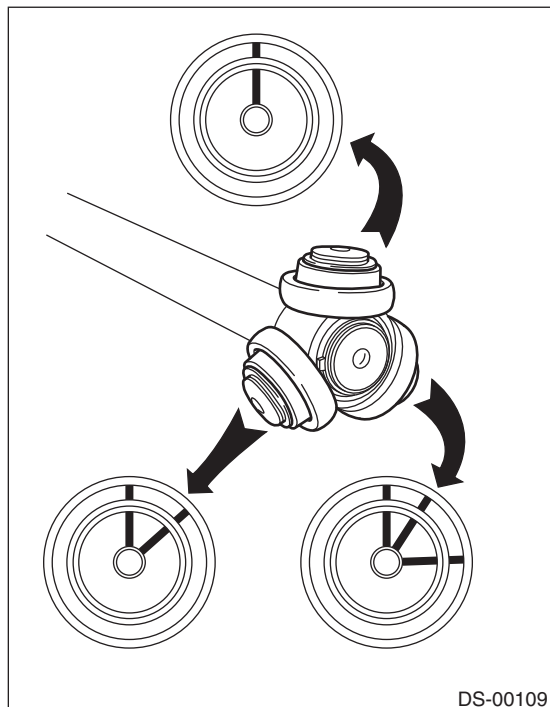

14) Match the alignment marks of the shaft and outer race, and attach the outer race.

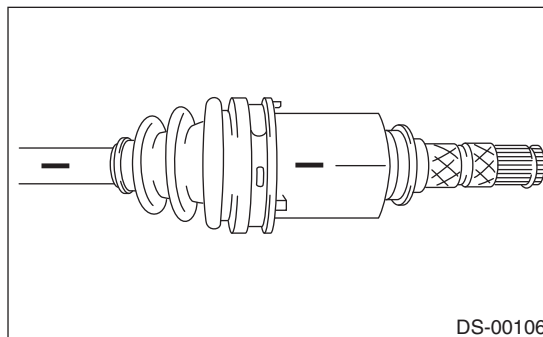

15) Install the snap ring in the groove of the PTJ outer race.

CAUTION:

Pull the shaft lightly and make sure that the snap ring is completely fitted in the groove.

16) Apply an even coat of the specified grease 30 to 40 g (1.06 to 1.41 oz) to the entire inner surface of boot.

17) Attach the PTJ boot taking care not to twist it.

CAUTION:

- **Clean the larger end of PTJ boot and the boot groove well, and remove the grease and other substances.**

- **When installing the PTJ boot, position the outer race of the PTJ at center of the stroke.**

18) Set the new boot band at the specified position.

Front Drive Shaft

DRIVE SHAFT SYSTEM

19) Tighten the boot bands using ST, torque wrench and socket flex handle.

ST 28099AC000 BOOT BAND PLIER

CAUTION:

The large boot band is to be tightened so that the omega shaped part is at the position indicated in the figure below.

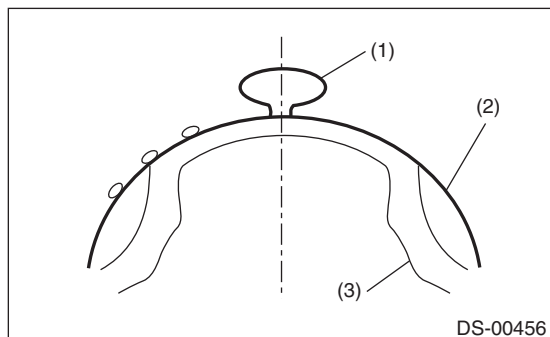

- (1) Omega shaped part
- (2) Boot band
- (3) Outer race

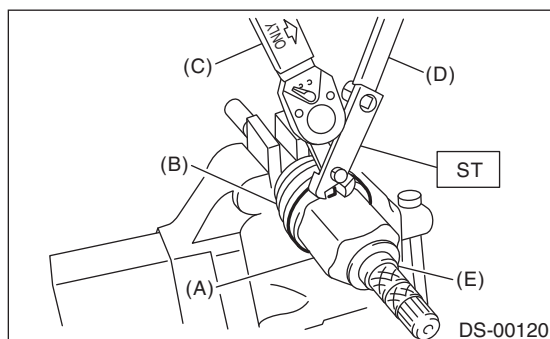

- (A) Large boot band
- (B) Boot
- (C) Torque wrench
- (D) Socket flex handle
- (E) Outer race

Tightening torque:

Large boot band

178 N·m (18.2 kgf·m, 131 ft·lb)

Small boot band

145 N·m (14.8 kgf·m, 107 ft·lb)

20) Extend and retract the PTJ repeatedly so that grease is spread evenly.

E: INSPECTION

Check the removed parts for damage, wear, corrosion etc. If faulty, repair or replace.

- PTJ (Pillow tripod joint)

Check for seizure, corrosion, damage, wear and excessive play.

- EBJ (high-efficiency compact ball fixed joint)

Check for seizure, corrosion, damage, or excessive play.

- Shaft

Check for excessive bending, twisting, damage and wear.

- Boot

Check for wear, warping, breakage and scratches.

- Grease

Check for discoloration and fluidity.

8. Rear Drive Shaft

A: REMOVAL

- 1) Disconnect the ground cable from the battery.
- 2) Lift up the vehicle, and then remove the rear wheels.
- 3) Lift the crimped section of axle nut.

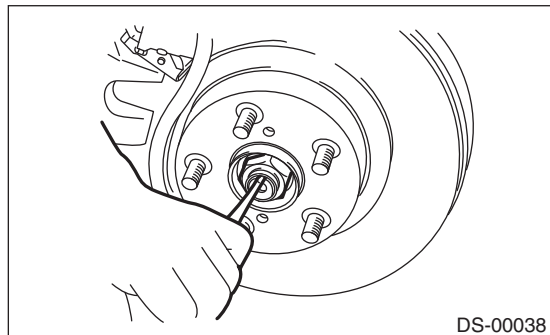

- 4) Remove the axle nut using a socket wrench while depressing the brake pedal.

CAUTION:

Remove the wheel before loosening the axle nut. Failure to follow this rule may damage the wheel bearings.

- 5) Drain the differential gear oil.
- 6) Disconnect the connector, remove the nut and remove the rear vehicle height sensor. (models with auto headlight beam leveler, left side only)

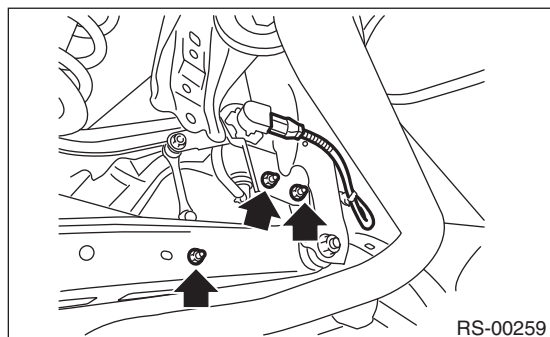

- 7) Remove the rear trailing link. <Ref. to RS-9, REMOVAL, Rear Trailing Link.>
- 8) Remove the rear lateral link. <Ref. to RS-14, REMOVAL, Rear Lateral Link.>

- 9) Remove the rear drive shaft from the rear differential by using the ST.

ST 28099PA100 DRIVE SHAFT REMOVER

NOTE:

Fit the ST to the bolts as shown in the figure to prevent damage of the side bearing retainer.

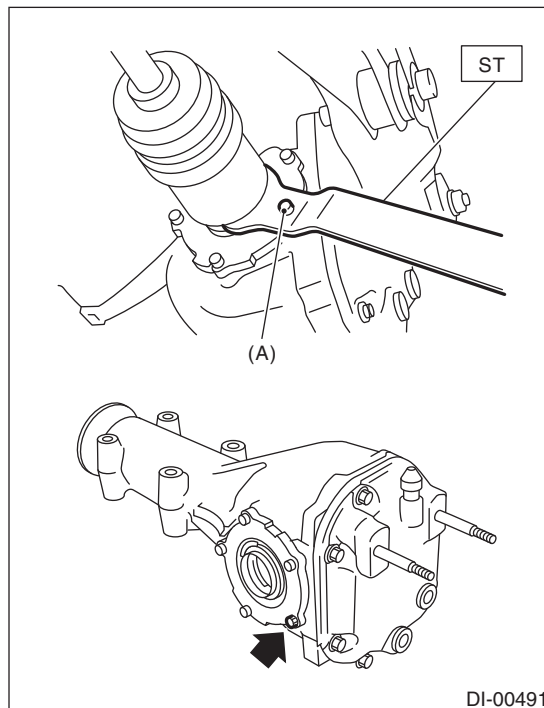

(A) Bolt

- 10) Remove the rear drive shaft from the rear axle. If it is hard to remove, use ST1 and ST2.

ST1 926470000 AXLE SHAFT PULLER

ST2 28099PA110 AXLE SHAFT PULLER PLATE

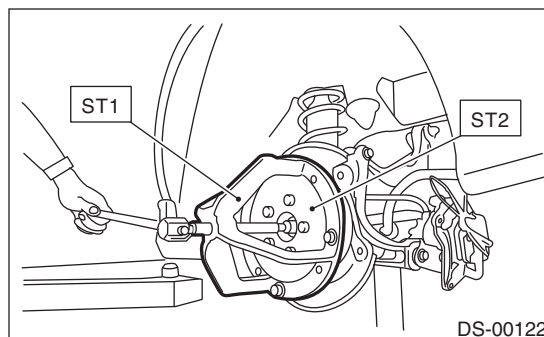

Rear Drive Shaft

DRIVE SHAFT SYSTEM

B: INSTALLATION

1) Replace the rear differential side oil seal. <Ref. to DI-37, REPLACEMENT, Rear Differential Side Oil Seal.>

NOTE:

After pulling out the drive shaft, be sure to replace with a new oil seal.

2) Insert the EBJ into rear hub splines.

CAUTION:

- Be careful not to damage the magnetic encoder.
- Do not get closer the tool which charged magnetism to magnetic encoder.

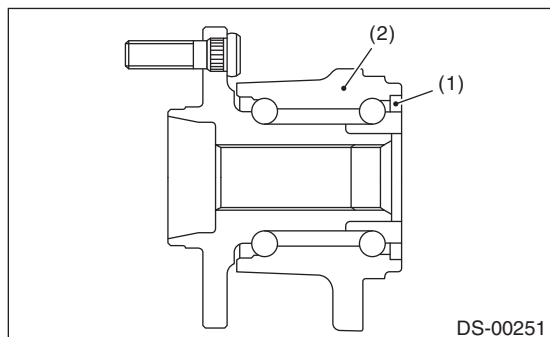

- (1) Magnetic encoder
- (2) Rear hub unit bearing

3) Draw the rear drive shaft into specified position.

CAUTION:

Do not hammer drive shaft when installing it.

4) Tighten the axle nut temporarily.

5) Using the ST, install the rear drive shaft to the rear differential.

ST 28099PA090 OIL SEAL PROTECTOR

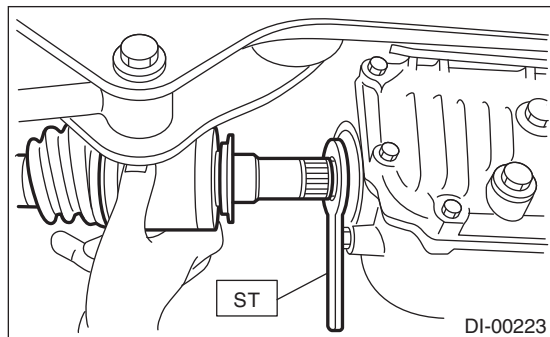

6) Attach the links to the rear housing and tighten them to the specified torque.

Tightening torque:

Stabilizer link

45 N·m (4.6 kgf-m, 33.2 ft-lb)

Shock absorber

120 N·m (12.2 kgf-m, 89 ft-lb)

Rear lateral link

120 N·m (12.2 kgf-m, 89 ft-lb)

Trailing link

90 N·m (9.2 kgf-m, 66.4 ft-lb)

7) While pressing the brake pedal, tighten the new axle nuts to the specified torque.

Tightening torque:

190 N·m (19.4 kgf-m, 140 ft-lb)

CAUTION:

- Do not install wheel and let it touch the ground before tightening the axle nut. Failure to follow this rule may damage the axle bearing.
- Do not overtighten the nuts as this may damage the axle bearing.

8) Lock the axle nut securely.

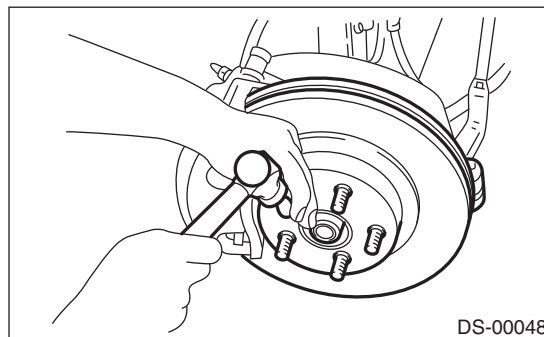

9) Attach the rear vehicle height sensor. (models with auto headlight beam leveler, left side only)

Tightening torque:

7.5 N·m (0.76 kgf-m, 5.5 ft-lb)

10) Fill the differential gear oil.

11) Install the rear wheels.

Tightening torque:

100 N·m (10.2 kgf-m, 73.8 ft-lb)

12) Connect the ground cable to the battery.

13) Inspect the wheel alignment and adjust if necessary.

14) Perform reinitialization of the auto headlight beam leveler system. (models with auto headlight beam levelers) <Ref. to LI-15, PROCEDURE, Auto Headlight Beam Leveler System.>

C: DISASSEMBLY

1) Using a flat tip screwdriver or plier, loosen the boot band on the large end of DOJ boot.

CAUTION:

Be careful not to damage the boot.

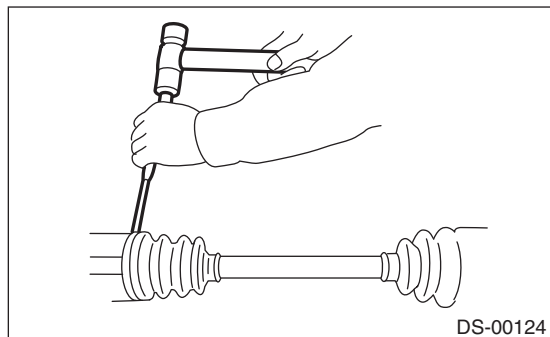

2) Remove the boot band on the small end of DOJ boot in the same manner.

3) Remove the larger end of DOJ boot from DOJ outer race.

4) Remove the round snap ring at the neck of DOJ outer race with a flat tip screwdriver.

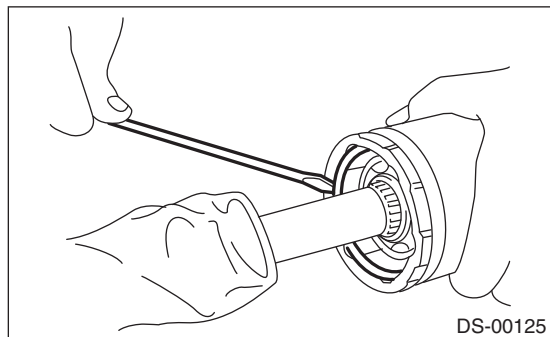

5) Take out the DOJ outer race from the shaft assembly.

6) Wipe off the grease and take out the ball bearings.

CAUTION:

The grease is a special grease (grease for constant velocity joints). Do not mix with other greases.

NOTE:

Disassemble exercising care not to lose balls (6 pcs).

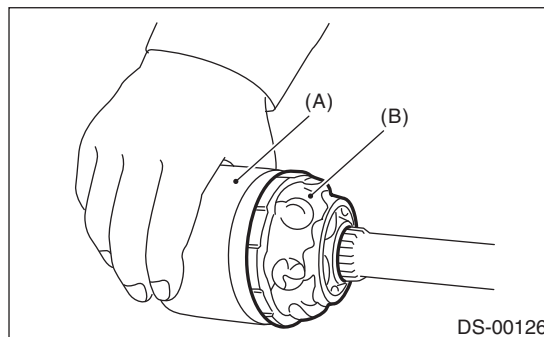

(A) Outer race

(B) Grease

7) To remove the cage from inner race, turn the cage by a half pitch to the track groove of inner race and shift the cage.

8) Using pliers, remove the snap ring fixing the inner race to the shaft.

9) Take out the DOJ inner race.

10) Take off the DOJ cage from shaft and remove the DOJ boot.

CAUTION:

Wrap shaft splines with vinyl tape to protect the boot from scratches.

11) Remove the EBJ boot using the same procedures as for the DOJ boot.

NOTE:

The EBJ is a non-disassembly part, so the drive shaft disassembly stops here.

Rear Drive Shaft

DRIVE SHAFT SYSTEM

D: ASSEMBLY

CAUTION:

Wrap shaft splines with vinyl tape to protect the boot from scratches.

NOTE:

Use specified grease.

Grease

EBJ side

NKG106

DOJ side:

NKG205

- 1) Install the EBJ boot to the specified position, and fill it with 50 to 60 g (1.76 to 2.12 oz) of specified grease.
- 2) Place the DOJ boot at the center of shaft.
- 3) Insert the DOJ cage onto shaft.

NOTE:

Insert the cage with the cutout portion facing the shaft end, since the cage has an orientation.

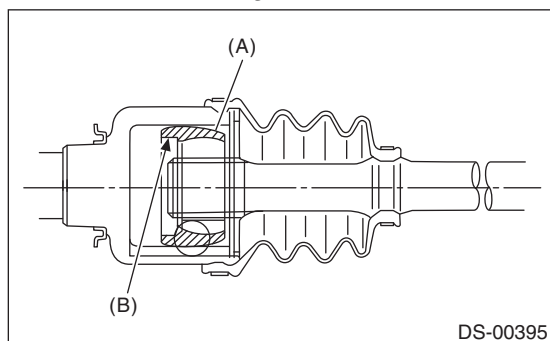

- (A) Cage
- (B) Cutout portion

- 4) Install the DOJ inner race on shaft and fix the snap ring in place with pliers.

NOTE:

Confirm that the snap ring is completely fitted in the shaft groove.

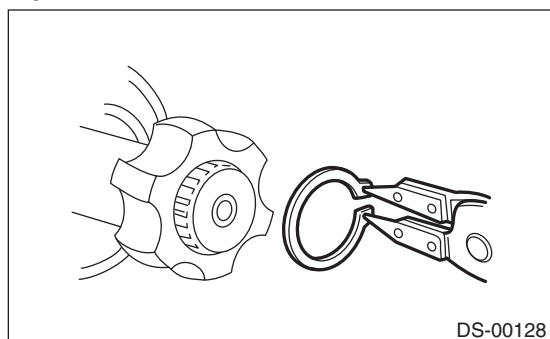

- 5) Install the cage to inner race fixed upon shaft.

NOTE:

Fit the cage with the protruding section aligned with the track on the inner race, and turn by a half pitch.

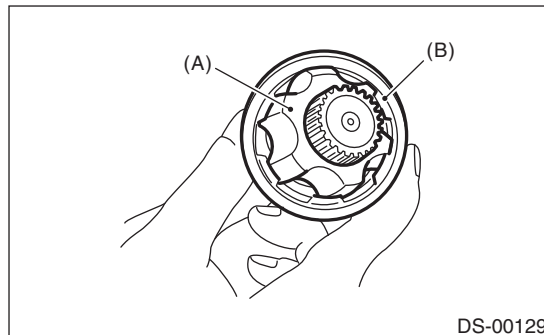

- (A) Inner race
- (B) Cage

- 6) Fill 80 to 90 g (2.82 to 3.17 oz) of specified grease into the inner side of the DOJ outer race.
- 7) Apply a thin coat of specified grease to the cage pocket and six ball bearings.
- 8) Insert the six ball bearings into the cage pocket.
- 9) Align the outer race track and ball positions, and place the shaft, inner race, cage and ball bearings in the original positions, and then fix outer race in place.

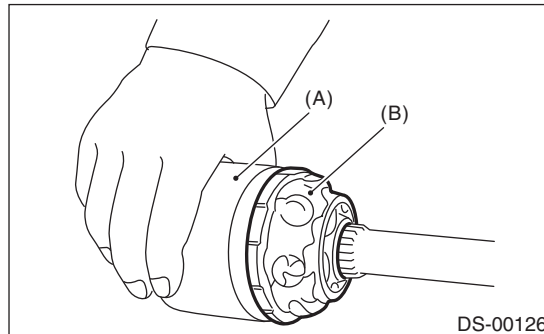

- (A) Outer race
- (B) Grease

10) Install the snap ring in the groove on the DOJ outer race.

NOTE:

- Assure that the balls, cage and inner race are completely fitted in the outer race of DOJ.
- Use care not to place the matched position of snap ring in the ball groove of outer race.
- Pull the shaft lightly and assure that the circlip is completely fitted in the groove.

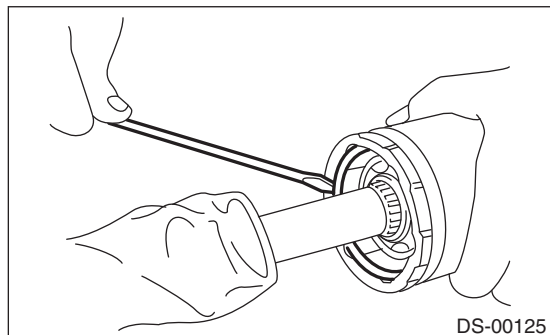

11) Apply an even coat of the specified grease [20 to 30 g (0.71 to 1.06 oz)] to the entire inner surface of boot. Also apply grease to the shaft.

12) Install the DOJ boot taking care not to twist it.

NOTE:

- The inside of the larger end of DOJ boot and the boot groove shall be cleaned so as to be free from grease and other substances.
- When installing the DOJ boot, position the outer race of DOJ at center of the stroke.

13) Put a new band through the clip and wind twice in the band groove of the boot.

14) Pinch the end of band with pliers. Hold the clip and tighten securely.

NOTE:

When tightening boot, use care so that the air within the boot is appropriate.

15) Tighten the band using the ST.

ST 925091000 BAND TIGHTENING TOOL

NOTE:

Tighten the band until it cannot be moved by hand.

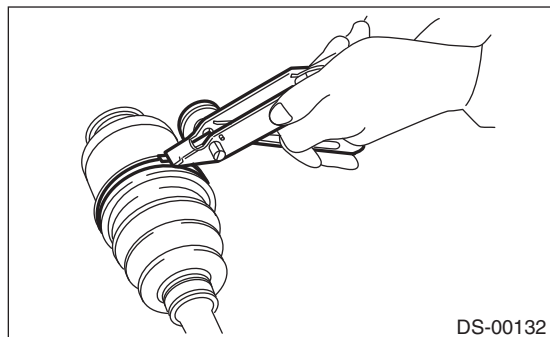

16) Tap the clip with the punch provided at the end of the ST.

ST 925091000 BAND TIGHTENING TOOL

NOTE:

Tap to an extent that the boot underneath is not damaged.

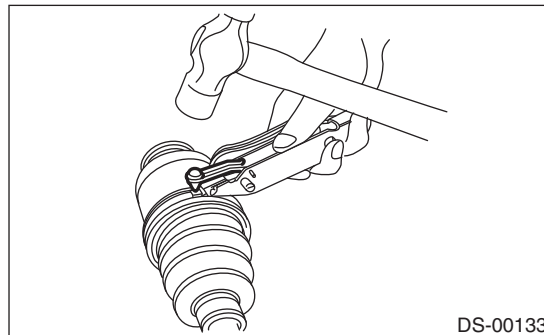

17) Cut off the band with an allowance of about 10 mm (0.39 in) left from the clip and bend this allowance over the clip.

NOTE:

Be careful so that the end of the band is in close contact with clip.

18) Install the EBJ boot using the same procedures as for the DOJ boot.

19) Extend and retract the DOJ repeatedly to provide an equal coating of grease.

E: INSPECTION

Check the removed parts for damage, wear, corrosion etc. Repair or replace if defective.

- DOJ (Double Offset Joint)

Check for seizure, corrosion, damage, wear and excessive play.

- EBJ (high-efficiency compact ball fixed joint)

Check for seizure, corrosion, damage, wear and excessive play.

- Shaft

Check for excessive bending, twisting, damage and wear.

- Boot

Check for wear, warping, breakage and scratches.

- Grease

Check for discoloration and fluidity.

General Diagnostic Table

DRIVE SHAFT SYSTEM

9. General Diagnostic Table

A: INSPECTION

NOTE:

Vibration while cruising may be caused by an unbalanced tire, improper tire inflation pressure, improper wheel alignment, etc.

Symptoms	Possible cause	Corrective action
Noise or vibration from propeller shaft	Center bearing	Check the center bearing. <Ref. to DS-12, CENTER BEARING FREE PLAY, INSPECTION, Propeller Shaft.>
	Runout of propeller shaft	Check for deflection of the propeller shaft. <Ref. to DS-12, RUNOUT OF PROPELLER SHAFT, INSPECTION, Propeller Shaft.>
	Loose or gap at connections	Check the joints and connectors. <Ref. to DS-11, JOINTS AND CONNECTORS, INSPECTION, Propeller Shaft.> Check the spline and bearing. <Ref. to DS-11, SPLINES AND BEARING, INSPECTION, Propeller Shaft.>
Abnormal wheel vibration	Wheel is out of balance.	Check the wheel balance. <Ref. to WT-8, ADJUSTMENT, Wheel Balancing.>
	Front wheel alignment	Check the front wheel alignment. <Ref. to FS-7, INSPECTION, Wheel Alignment.>
	Rear wheel alignment	Check the rear wheel alignment. <Ref. to RS-7, INSPECTION, Wheel Alignment.>
	Front strut	Check the front strut. <Ref. to FS-25, INSPECTION, Front Strut.>
	Rear shock absorber	Check the rear shock absorber. <Ref. to RS-12, INSPECTION, Rear Shock Absorber.>
	Front drive shaft	Check the front drive shaft. <Ref. to DS-32, INSPECTION, Front Drive Shaft.>
	Rear drive shaft	Check the rear drive shaft. <Ref. to DS-37, INSPECTION, Rear Drive Shaft.>
	Front hub unit bearing	Check the front hub unit bearing. <Ref. to DS-19, INSPECTION, Front Hub Unit Bearing.>
	Rear hub unit bearing	Check the rear hub unit bearing. <Ref. to DS-26, INSPECTION, Rear Hub Unit Bearing.>
Noise from the underbody	Wheel is out of balance.	Check the wheel balance. <Ref. to WT-8, ADJUSTMENT, Wheel Balancing.>
	Front wheel alignment	Check the front wheel alignment. <Ref. to FS-7, INSPECTION, Wheel Alignment.>
	Rear wheel alignment	Check the rear wheel alignment. <Ref. to RS-7, INSPECTION, Wheel Alignment.>
	Front strut	Check the front strut. <Ref. to FS-25, INSPECTION, Front Strut.>
	Rear shock absorber	Check the rear shock absorber. <Ref. to RS-12, INSPECTION, Rear Shock Absorber.>

VEHICLE DYNAMICS CONTROL (VDC)

VDC

	Page
1. General Description	2
2. VDC Control Module and Hydraulic Control Unit (VDCCM&H/U)	7
3. ABS Sequence Control	14
4. VDC Sequence Control	17
5. Yaw Rate and Lateral G Sensor	20
6. Steering Angle Sensor	22
7. Front ABS Wheel Speed Sensor	24
8. Rear ABS Wheel Speed Sensor	26
9. Front Magnetic Encoder	27
10. Rear Magnetic Encoder	28
11. VDC OFF Switch	29

General Description

VEHICLE DYNAMICS CONTROL (VDC)

1. General Description

A: SPECIFICATION

Item			Specification or identification	
ABS wheel speed sensor	ABS wheel speed sensor gap (for reference)	Front	0.77 — 1.43 mm (0.030 — 0.056 in)	
		Rear	0.64 — 1.56 mm (0.025 — 0.061 in)	
	Identifications of harness (marks, color)	Front	RH	K1 (White)
			LH	K2 (Yellow)
		Rear	RH	P3 (light blue)
			LH	P4 (brown)
VDCCM&H/U Identification	AT	Z1		
	MT	Z2		

B: COMPONENT

1. ABS WHEEL SPEED SENSOR

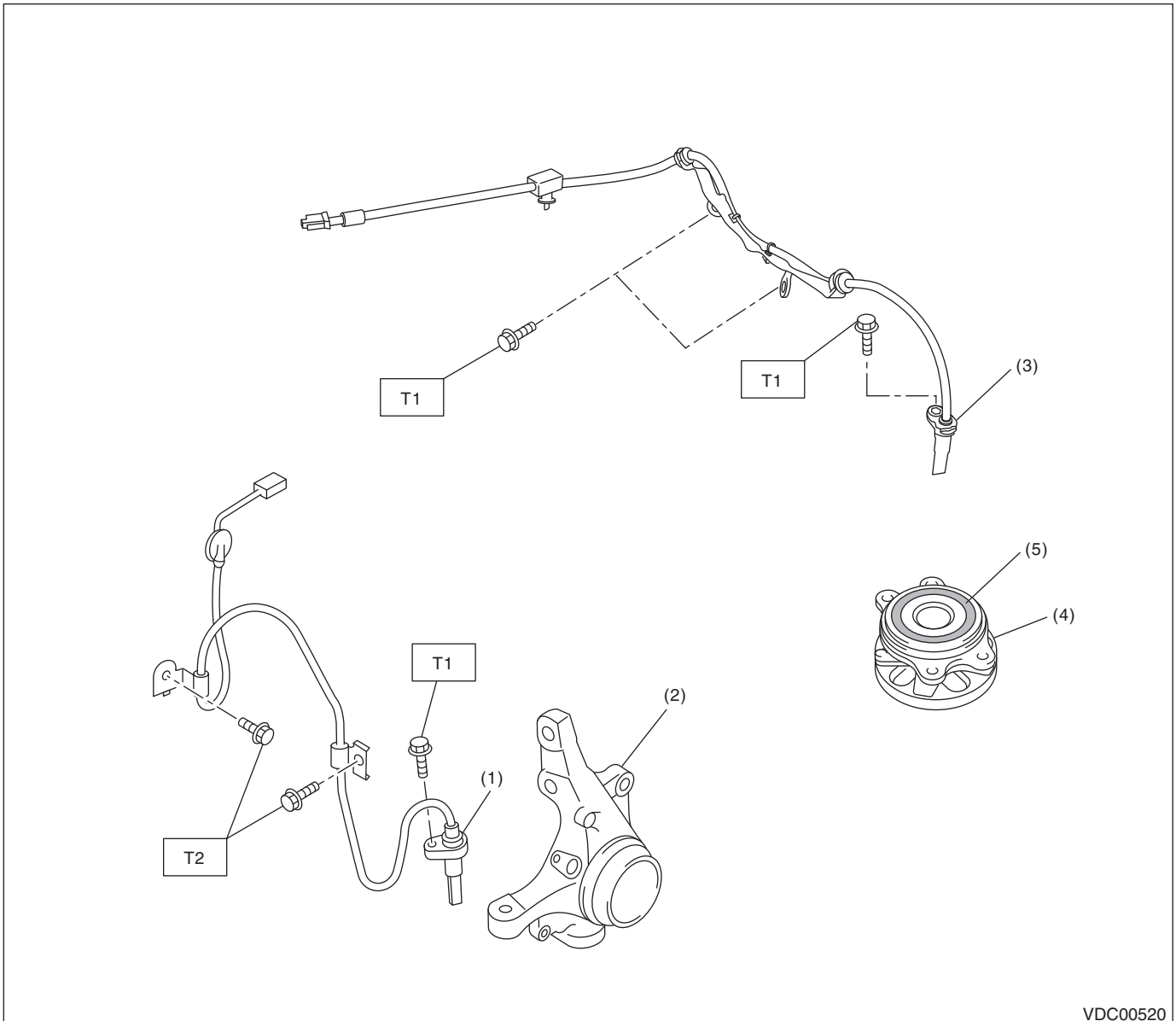

VDC00520

- | | |
|----------------------------------|----------------------|
| (1) Front ABS wheel speed sensor | (4) Hub unit bearing |
| (2) Front housing | (5) Magnetic encoder |
| (3) Rear ABS wheel speed sensor | |

Tightening torque: N·m (kgf·m, ft·lb)

T1: 7.5 (0.76, 5.5)

T2: 33 (3.4, 24.3)

General Description

VEHICLE DYNAMICS CONTROL (VDC)

2. YAW RATE & LATERAL G SENSOR

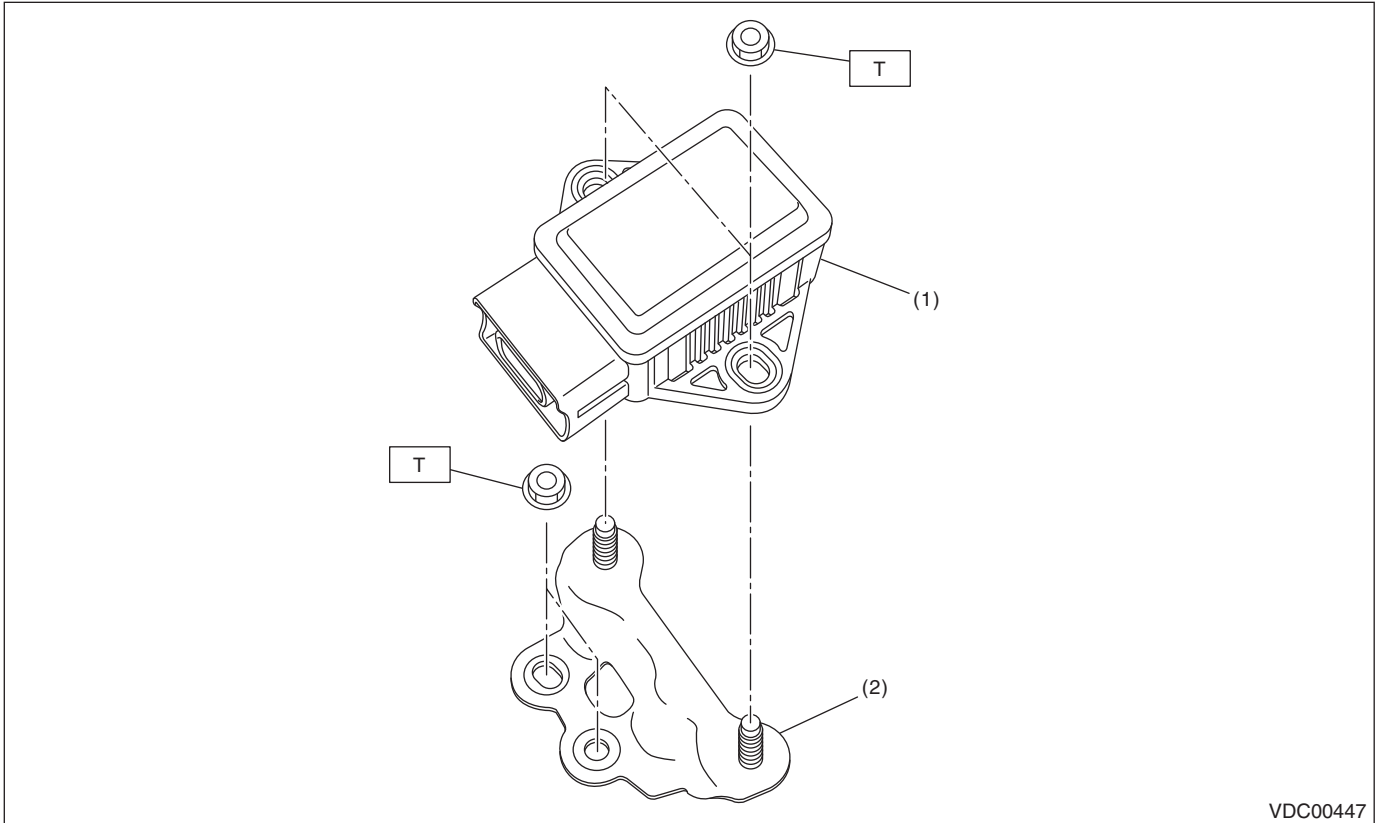

(1) Yaw rate & lateral G sensor

(2) Bracket

Tightening torque: N·m (kgf·m, ft·lb)

T: 7.5 (0.76, 5.5)

3. STEERING ANGLE SENSOR

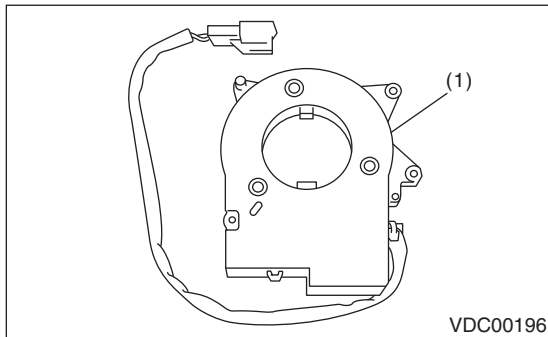

(1) Steering angle sensor

General Description

VEHICLE DYNAMICS CONTROL (VDC)

4. VDC CONTROL MODULE & HYDRAULIC CONTROL UNIT (VDCCM&H/U)

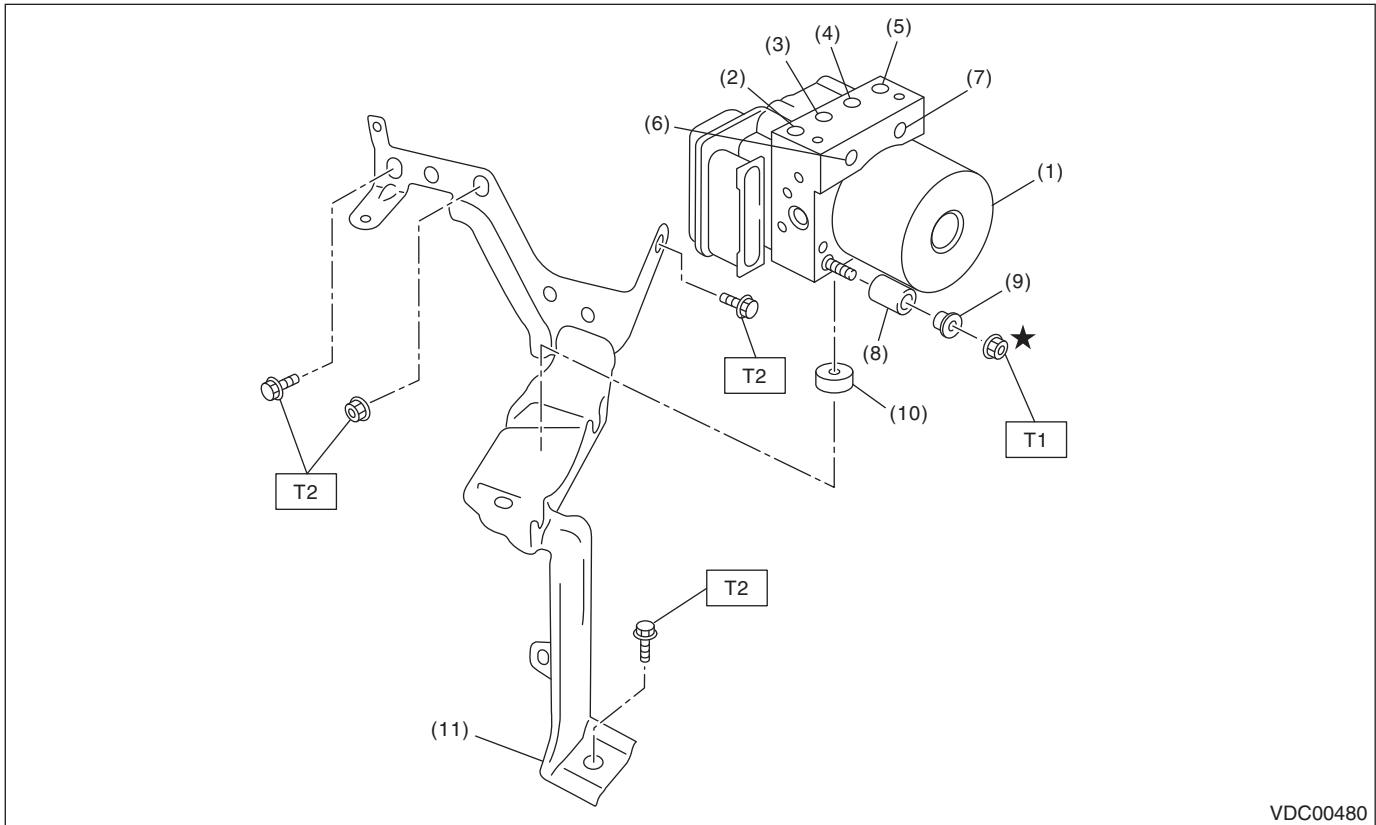

VDC00480

- | | | |
|---|---------------------|--------------|
| (1) VDC control module & hydraulic control unit (VDCCM&H/U) | (6) Primary inlet | (11) Bracket |
| (2) Front RH outlet | (7) Secondary inlet | |
| (3) Rear LH outlet | (8) Damper | |
| (4) Rear RH outlet | (9) Spacer | |
| (5) Front LH outlet | (10) Damper | |

Tightening torque: N·m (kgf·m, ft·lb)

T1: 7.5 (0.76, 5.5)

T2: 33 (3.4, 24.3)

General Description

VEHICLE DYNAMICS CONTROL (VDC)

C: CAUTION

- Wear appropriate work clothing, including a cap, protective goggles and protective shoes when performing any work.
- Remove contamination including dirt and corrosion before removal, installation or disassembly.
- Keep the disassembled parts in order and protect them from dust and dirt.
- Before disconnecting connectors of sensors or units, be sure to disconnect the ground cable from the battery.
- Before removal, installation or disassembly, be sure to clarify the failure. Avoid unnecessary removal, installation, disassembly and replacement.
- Vehicle components are extremely hot after driving. Be wary of receiving burns from heated parts.
- Be sure to tighten fasteners including bolts and nuts to the specified torque.
- Place shop jacks or rigid racks at the specified points.

D: PREPARATION TOOL

1. SPECIAL TOOL

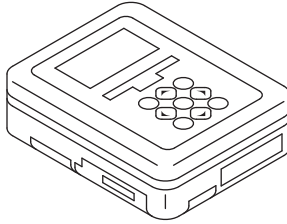
ILLUSTRATION	TOOL NUMBER	DESCRIPTION	REMARKS
 ST1B022XU0	1B022XU0 (Newly adopted tool)	SUBARU SELECT MONITOR III KIT	Used for troubleshooting the electrical system.

2. GENERAL TOOL

TOOL NAME	REMARKS
Circuit tester	Used for measuring resistance, voltage and current.
Pressure gauge	Used for measuring oil pressure.
Oscilloscope	Used for measuring the sensor.
TORX® bit E5	Used for replacing the VDC control module.

2. VDC Control Module and Hydraulic Control Unit (VDCCM&H/U)

A: REMOVAL

- 1) Disconnect the ground cable from the battery.
- 2) Use compressed air to remove moisture and dust around the VDCCM&H/U.

NOTE:

If the terminals become dirty, it may cause improper contact.

- 3) Lift the lock lever and disconnect the VDCCM&H/U connector.

CAUTION:

Do not pull on the harness when disconnecting the connector.

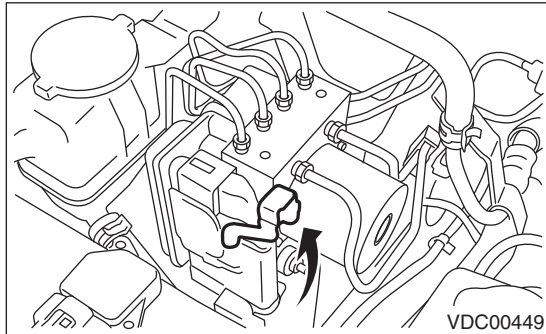

- 4) Disconnect the brake pipes from the VDCCM&H/U.
- 5) Wrap the brake pipe with a vinyl bag so as not to spill the brake fluid on the vehicle body.

CAUTION:

If brake fluid is spilled on the vehicle body, wash it off immediately with water and wipe clean.

- 6) Remove the nuts and remove the VDCCM&H/U.

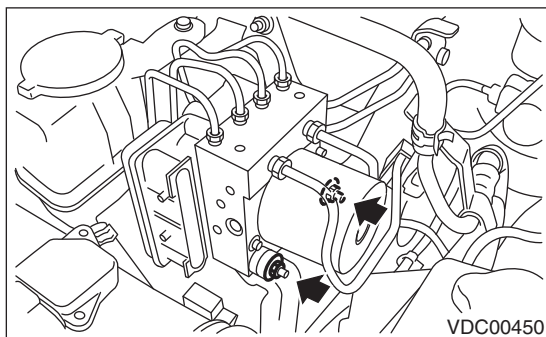

CAUTION:

- Do not drop or bump the VDCCM&H/U.
- Do not turn the VDCCM&H/U upside down or place it sideways for storage.
- Be careful not to let foreign matter enter the VDCCM&H/U.
- Be careful that no water enters the connectors.

- 7) Remove the VDCCM&H/U bracket.

B: INSTALLATION

- 1) Install the VDCCM&H/U bracket.

Tightening torque:

33 N·m (3.3 kgf·m, 24 ft·lb)

- 2) Install the VDCCM&H/U with a new nut (Part No. 023506000) by aligning the damper groove of the VDCCM&H/U to the bracket side claw.

Tightening torque:

7.5 N·m (0.76 kgf·m, 5.5 ft·lb)

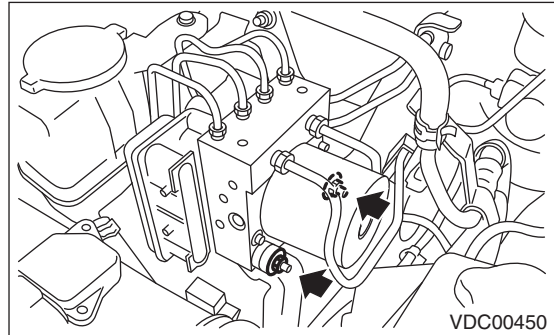

- 3) Connect the brake pipes to their correct VDCCM&H/U positions.

Tightening torque:

T1: 15 N·m (1.5 kgf·m, 11.1 ft·lb)

T2: 19 N·m (1.9 kgf·m, 14 ft·lb)

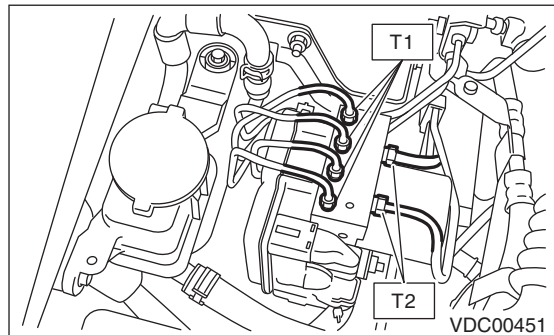

- 4) Connect the VDCCM&H/U connector.

NOTE:

- Be sure to remove all foreign matter from inside the connector before connecting.
- Make sure the VDCCM&H/U connector is securely locked.

- 5) Bleed air from the brake system.

- 6) Check the parameter to confirm that the applied models and grades of the relevant vehicle are included. <Ref. to VDC(diag)-18, PARAMETER CHECK, OPERATION, Subaru Select Monitor.>

VDC Control Module and Hydraulic Control Unit (VDCCM&H/U)

VEHICLE DYNAMICS CONTROL (VDC)

7) If the applied model and grade of the target vehicle are not included on the {Parameter Check} display screen, perform parameter selection and registration. <Ref. to VDC(diag)-17, PARAMETER SELECTION, OPERATION, Subaru Select Monitor.>

NOTE:

- When the VDCCM&H/U is replaced with a new part, be sure to perform the selection and registration operation.
- For the selection and registration of parameter, the Subaru Select Monitor is required.
- When no data is registered, ABS/EBD/VDC warning light illuminates and the DTC "Parameter selection failure" is detected.

C: INSPECTION

- 1) Check the condition of connection and settlement of connector.
- 2) Check the mark used for VDCCM&H/U identification.

Refer to "SPECIFICATION" for the identification mark. <Ref. to VDC-2, SPECIFICATION, General Description.>

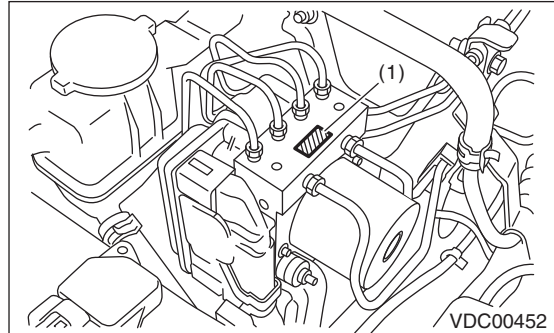

(1) Identification mark

1. CHECKING THE HYDRAULIC UNIT ABS OPERATION BY PRESSURE GAUGE

- 1) Lift up the vehicle, and remove the wheels.
- 2) Remove the air bleeder screws from FL and FR caliper bodies.
- 3) Connect two pressure gauges to FL and FR caliper bodies.

CAUTION:

- Use a pressure gauge used exclusively for brake fluid measurement.
- Do not use the pressure gauge used for the measurement of transmission oil. Doing so will cause the piston seal to expand and deform.

NOTE:

Wrap sealing tape around the pressure gauge.

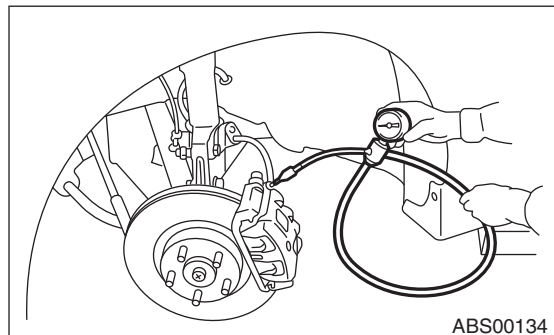

- 4) Bleed air from the pressure gauges and the FL and FR caliper bodies.
- 5) Perform ABS sequence control. <Ref. to VDC-14, ABS Sequence Control.>
- 6) When the hydraulic unit begins to work, first the FL side performs decompression, hold and compression, and then the FR side performs decompression, hold and compression.

VDC Control Module and Hydraulic Control Unit (VDCCM&H/U)

VEHICLE DYNAMICS CONTROL (VDC)

7) Read values indicated on the pressure gauge and check if the fluctuation of the values between decompression and compression meets the standard values. Depress the brake pedal and check that the kick-back is normal, and tightness is normal.

	Front wheel	Rear wheel
Initial value	3,500 kPa (36 kgf/cm ² , 511 psi)	3,500 kPa (36 kgf/cm ² , 511 psi)
When depressurized	500 kPa (5 kgf/cm ² , 73 psi) or less	500 kPa (5 kgf/cm ² , 73 psi) or less
When pressurized	3,500 kPa (36 kgf/cm ² , 511 psi) or more	3,500 kPa (36 kgf/cm ² , 511 psi) or more

8) Disconnect the pressure gauges from FL and FR caliper bodies.

9) Install the air bleeder screws of FL and FR caliper bodies.

10) Remove the air bleeder screws from RL and RR caliper bodies.

11) Connect two pressure gauges to RL and RR caliper bodies.

12) Bleed air from the brake system.

13) Bleed air from RL and RR caliper bodies, and pressure gauge.

14) Perform ABS sequence control.

<Ref. to VDC-14, ABS Sequence Control.>

15) When the hydraulic unit begins to work, first the RR side performs decompression, hold and compression, and then the RL side performs decompression, hold and compression.

16) Read values indicated on the pressure gauge and check if the fluctuation of the values between decompression and compression meets specification. Depress the brake pedal and check that the kick-back is normal, and tightness is normal.

17) Disconnect the pressure gauge from the RL and RR caliper bodies.

18) Install the air bleeder screws of RL and RR caliper bodies.

19) Bleed air from the brake system.

2. CHECKING THE HYDRAULIC UNIT ABS OPERATION BY BRAKE TESTER

- 1) Set wheels other than the one to measure free rollers.
- 2) Prepare for ABS sequence control operation.
<Ref. to VDC-14, ABS Sequence Control.>
- 3) Set the front wheels or rear wheels on the brake tester and set the gear to neutral.

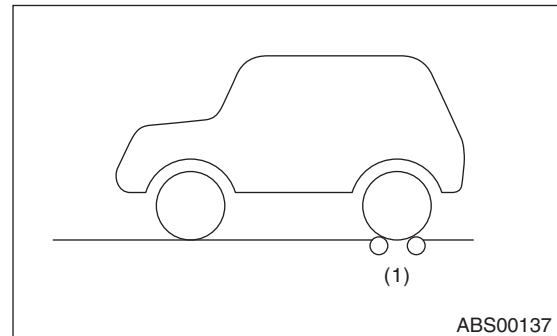
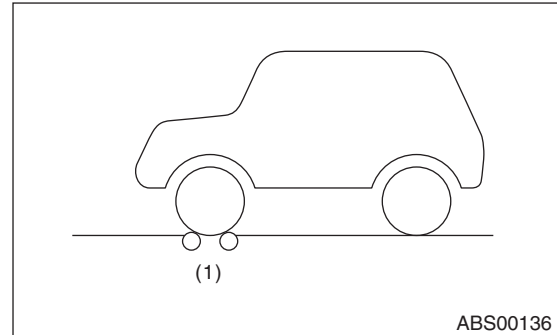

(1) Brake tester

4) Operate the brake tester.

5) Perform ABS sequence control.

<Ref. to VDC-14, ABS Sequence Control.>

6) When the hydraulic unit begins to work, check the following work sequence.

(1) The FL wheel performs decompression, hold and compression in sequence, and subsequently the FR wheel repeats the cycle.

(2) The RR wheel performs decompression, hold and compression in sequence, and subsequently the RL wheel repeats the cycle.

7) Read values indicated on the brake tester and check if the fluctuation of the values between decompression and compression meets specification.

	Front wheel	Rear wheel
Initial value	1,000 N (102 kgf, 225 lb)	1,000 N (102 kgf, 225 lb)
When depressurized	500 N (51 kgf, 112 lb) or less	500 N (51 kgf, 112 lb) or less
When pressurized	1,000 N (102 kgf, 225 lb) or more	1,000 N (102 kgf, 225 lb) or more

8) After the inspection, depress the brake pedal and check that it is not abnormally hard, and tightness is normal.

VDC Control Module and Hydraulic Control Unit (VDCCM&H/U)

VEHICLE DYNAMICS CONTROL (VDC)

3. CHECKING THE HYDRAULIC UNIT VDC OPERATION USING A PRESSURE GAUGE

- 1) Lift up the vehicle, and remove the wheels.
- 2) Remove the air bleeder screws from FL and FR caliper bodies.
- 3) Connect two pressure gauges to FL and FR caliper bodies.

CAUTION:

- Use a pressure gauge used exclusively for brake fluid measurement.
- Do not use the pressure gauge used for the measurement of transmission oil pressure. Doing so will cause the piston seal to expand and deform.

NOTE:

Wrap sealing tape around the pressure gauge.

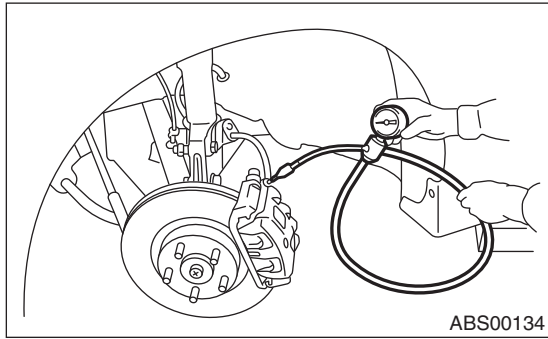

- 4) Bleed air from the pressure gauge.
- 5) Perform VDC sequence control.
<Ref. to VDC-17, VDC Sequence Control.>
- 6) When the hydraulic unit begins work, first the FL side performs compression, hold, and decompression, and then the FR side performs compression, hold, and decompression.
- 7) Read values indicated on the pressure gauge and check if the fluctuation of the values between decompression and compression meets specification. Also, step on the brake pedal and check for any abnormal hardness or softness of the brake.

	Front wheel	Rear wheel
When pressurized	3,000 kPa (31 kgf/cm ² , 441 psi) or more	3,000 kPa (31 kgf/cm ² , 441 psi) or more
When depressurized	500 kPa (5 kgf/cm ² , 73 psi) or less	500 kPa (5 kgf/cm ² , 73 psi) or less

- 8) Disconnect the pressure gauges from FL and FR caliper bodies.
- 9) Install the air bleeder screws of FL and FR caliper bodies.
- 10) Remove the air bleeder screws from RL and RR caliper bodies.
- 11) Connect two pressure gauges to RL and RR caliper bodies.

- 12) Bleed air from RL and RR caliper bodies, and pressure gauge.

- 13) Perform VDC sequence control.

<Ref. to VDC-17, VDC Sequence Control.>

- 14) When the hydraulic unit begins work, first the RR side performs compression, hold, and decompression, and then the RL side performs compression, hold, and decompression.

- 15) Read the values indicated on the pressure gauges and check if it is within specification. Also, step on the brake pedal and check for any abnormal hardness or softness of the brake.

- 16) Disconnect the pressure gauge from the RL and RR caliper bodies.

- 17) Install the air bleeder screws of RL and RR caliper bodies.

- 18) Bleed air from the brake line.

4. CHECKING THE HYDRAULIC UNIT VDC OPERATION WITH BRAKE TESTER

- 1) Set wheels other than the one to measure free rollers.
- 2) Prepare to operate the VDC sequence control.
<Ref. to VDC-17, VDC Sequence Control.>
- 3) Set the front wheels or rear wheels on the brake tester and set the gear to neutral.

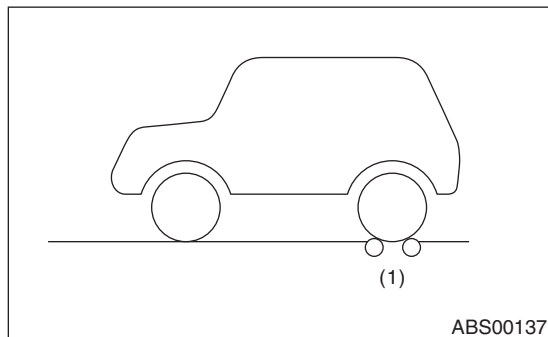
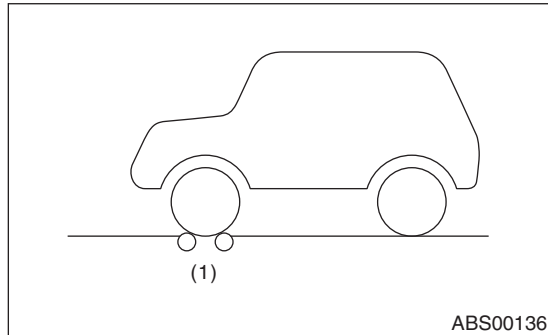

(1) Brake tester

- 4) Operate the brake tester.
- 5) Perform VDC sequence control.
<Ref. to VDC-17, VDC Sequence Control.>
- 6) When the hydraulic unit begins to work, check the following work sequence.
 - (1) The FL wheel performs compression, hold and decompression in sequence, and subsequently the FR wheel repeats the cycle.
 - (2) The RR wheel performs compression, hold and decompression in sequence, and subsequently the RL wheel repeats the cycle.
- 7) Read values indicated on the brake tester and check if the fluctuation of the values between decompression and compression meets specification.

	Front wheel	Rear wheel
When pressurized	2,000 N (204 kgf, 450 lbf) or more	2,000 N (204 kgf, 450 lbf) or more
When depressurized	500 N (51 kgf, 112 lbf) or less	500 N (51 kgf, 112 lbf) or less

- 8) After the inspection, depress the brake pedal and check that it is not abnormally hard, and tightness is normal.

D: REPLACEMENT

CAUTION:

- Because the pressure sensor built into the H/U is easily damaged by static electricity, start the operation after performing static electricity measures.
- Be careful not to touch the sensors in the H/U to prevent damage.
- Because the seal of the VDCCM cannot be replaced, do not pull or peel it by lifting it up.
- Because the screw of the H/U will become slightly worn in every replacement procedure, 5 times is the maximum number of times for replacement. If a problem is found such as not being able to torque the screw to specifications even before 5 replacement operations are performed, replace the H/U body.
- When installing the VDCCM, always use new screws.
- When the sealing surface of the VDCCM or H/U is dirty or damaged and it cannot be cleaned or repaired, replace with a new part.

- 1) Remove the VDCCM&H/U. <Ref. to VDC-7, REMOVAL, VDC Control Module and Hydraulic Control Unit (VDCCM&H/U).>
- 2) To prevent entry of foreign objects and brake fluid leakage, plug the oil pressure port of the VDCCM&H/U using a screw plug, etc.
- 3) Set the pump motor section of the removed VDCCM&H/U face down on a vise.

NOTE:

Before securing a part in a vise, place cushioning material such as wood blocks, aluminum plate or cloth between the part and the vise.

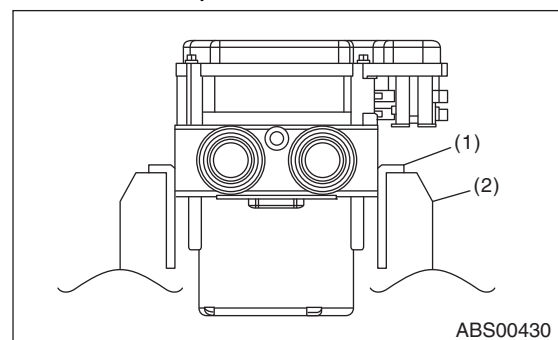

- (1) Aluminum plate, etc.
- (2) Vice

VDC Control Module and Hydraulic Control Unit (VDCCM&H/U)

VEHICLE DYNAMICS CONTROL (VDC)

4) Using TORX® bit E5, remove the four screws of VDCCM.

NOTE:

These screws cannot be reused.

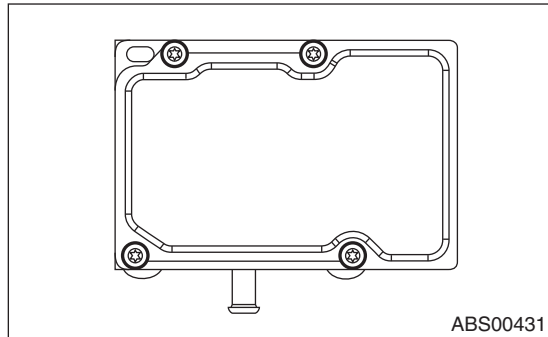

5) Slowly pull out the VDCCM upward from the H/U.

NOTE:

To prevent damaging of coil section, remove the VDCCM straight up from H/U without twisting.

6) Make sure there is no dirt or damage on the sealing surface of the H/U.

CAUTION:

- Do not clean the VDCCM&H/U by applying compressed air.
- Even if damage is found on the H/U seal, do not attempt repair by filing or with a metal scraper. To remove the seal residue, always use a plastic scraper. Do not use chemical such as paint thinner, etc., to clean.

7) Position the coil of the new VDCCM to align with the H/U valve.

8) To prevent deformation of the VDCCM housing cover, hold the corner of VDCCM and install it to the H/U without tilting.

9) Using a TORX® bit E5, attach/tighten new screws in the order of (1) through (4).

CAUTION:

Always use new screws.

Tightening torque:

1.5 N·m (0.15 kgf·m, 1.1 ft·lb)

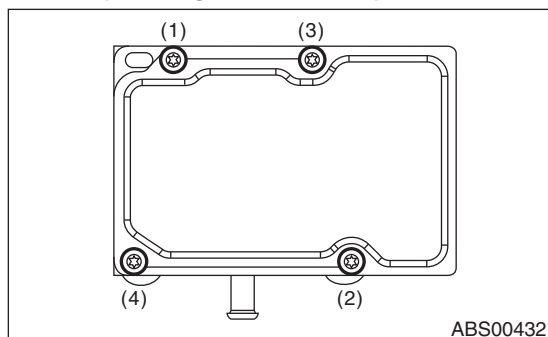

10) Check that there is no foreign matter in mating surface between the VDCCM&H/U.

11) Using a TORX® bit E5, tighten the screws in the order of (1) through (4) again.

Tightening torque:

3 N·m (0.3 kgf·m, 2.2 ft·lb)

12) Check that there is no gap in the mating surface between VDCCM&H/U.

13) Install the VDCCM&H/U to the vehicle.

14) Bleed air from the brake system.

15) Perform the selection and registration operation of parameter. <Ref. to VDC(diag)-17, PARAMETER SELECTION, OPERATION, Subaru Select Monitor.>

NOTE:

- After replacing the VDCCM, be sure to perform the selection and registration operation of parameter.

- For the selection and registration of parameter, the Subaru Select Monitor is required.

- When no data is registered, ABS/EBD/VDC warning light illuminates and the DTC “Parameter selection failure” is detected.

16) Check the parameters to confirm that the applied models and grades of the relevant vehicle are included. <Ref. to VDC(diag)-18, PARAMETER CHECK, OPERATION, Subaru Select Monitor.>

17) If the applied model and grade of the target vehicle are not included on the {Confirm on Parameter} display screen, perform parameter selection and registration again. <Ref. to VDC(diag)-17, PARAMETER SELECTION, OPERATION, Subaru Select Monitor.>

18) Execute Clear Memory after parameter selection and registration operations because the DTC for “Parameter selection failure” is memorized.

E: ADJUSTMENT

When the following replacement, removal and installation are performed, be sure to perform the centering of the steering angle sensor and zero point setting of yaw rate & lateral G sensor.

- VDCCM&H/U
- Steering angle sensor
- Yaw rate & lateral G sensor
- Steering wheel parts (Including airbag)
- Suspension parts
- Wheel alignment adjustment

1) Park the vehicle straight on a level surface. (Engine operation in the “P” or “N” range)

2) Check that steering wheel is positioned at the center. (When the center position is not correct, adjust the wheel alignment.)

3) Set the Subaru Select Monitor to the vehicle, and select {Set up mode for Neutral of Steering Angle Sensor & Lateral G Sensor 0 point} in the «Function check sequence» screen. (Follow the steps on the display.)

4) On the «Brake Control System» display screen, select {Current Data Display & Save}, and check that the steering angle sensor shows “0 deg”.

5) When the “0 deg” is not displayed, repeat the above steps and check that the “0 deg” is displayed.

6) Drive the vehicle for 10 minutes, and check that the ABS and VDC warning light is not illuminated.

7) Check that there is no unnecessary VDC operation or steering control loss. If NG, repeat the steps above.

3. ABS Sequence Control

A: OPERATION

- 1) While the ABS sequence control is being performed, the operation of the hydraulic unit can be checked using the brake tester or pressure gauge after the hydraulic unit solenoid valve operation.
- 2) ABS sequence control can be started by the Subaru Select Monitor.

1. ABS SEQUENCE CONTROL WITH SUBARU SELECT MONITOR

NOTE:

In the event of any trouble, the ABS sequence control will not operate.

- 1) Connect the Subaru Select Monitor to data link connector under the driver's side instrument panel lower cover.
- 2) Turn the ignition switch to ON.
- 3) Run the "PC application for Subaru Select Monitor".
- 4) Set the Subaru Select Monitor to "Brake Control System" mode.
- 5) When the "Function check sequence" is selected, the "ABS sequence control" will start.
- 6) Execute the following operations when the message "Press the brake pedal so that the brake pedal force is between 100 and 150 kgf" is displayed.
 - (1) When using a brake tester, press the brake pedal pad with a force of 1,000 N (102 kgf, 225 lbf).
 - (2) When using a pressure gauge, press the brake pedal so that the pressure gauge indicates 3,500 kPa (36 kgf/cm², 511 psi).
- 7) Press the [OK] after "Press OK" is displayed.
- 8) The brake system being operated is displayed on the Subaru Select Monitor.

ABS Sequence Control

2. CONDITIONS FOR ABS SEQUENCE CONTROL

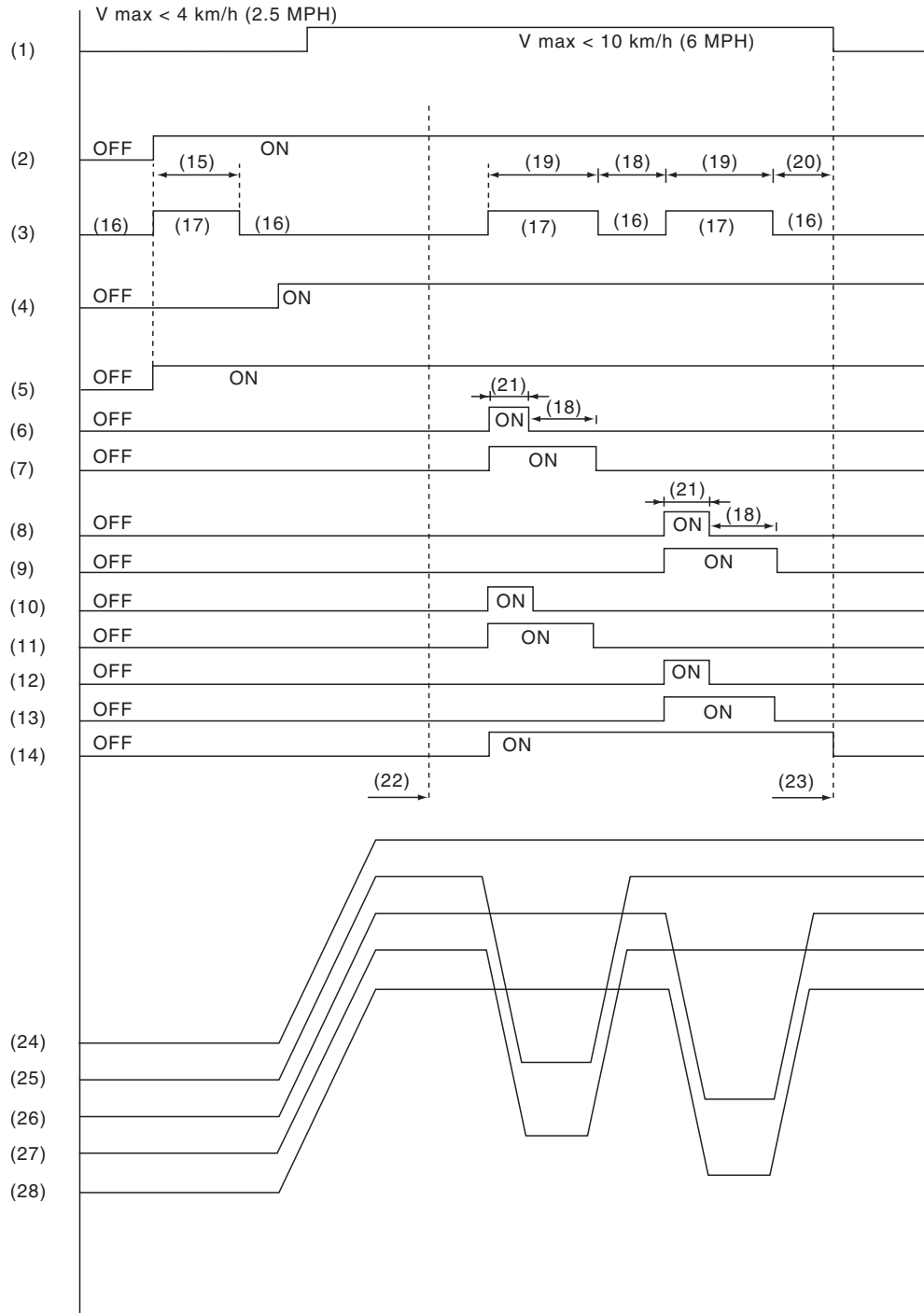

ABS00943

ABS Sequence Control

VEHICLE DYNAMICS CONTROL (VDC)

- | | | |
|-----------------------------|-----------------------------|---------------------------------|
| (1) All wheel speed | (11) RR compression valve | (20) 0.6 seconds |
| (2) Ignition key | (12) RL decompression valve | (21) 0.4 seconds |
| (3) ABS warning light | (13) RL compression valve | (22) Point A |
| (4) Stop light switch | (14) Pump motor | (23) Reset |
| (5) Valve relay | (15) 1.5 seconds | (24) Master cylinder pressure |
| (6) FL decompression valve | (16) Light OFF | (25) FL wheel cylinder pressure |
| (7) FL compression valve | (17) Light ON | (26) FR wheel cylinder pressure |
| (8) FR decompression valve | (18) 1.0 seconds | (27) RR wheel cylinder pressure |
| (9) FR compression valve | (19) 1.4 seconds | (28) RL wheel cylinder pressure |
| (10) RR decompression valve | | |

NOTE:

The control operation starts at point A.

B: SPECIFICATION

1. CONDITIONS FOR COMPLETION OF ABS SEQUENCE CONTROL

When the following conditions develop, the ABS sequence control stops and ABS operation is returned to the normal control mode.

- 1) When the speed of at least one wheel reaches 10 km/h (6 MPH).
- 2) When the brake pedal is released during ABS sequence control and the stop light switch becomes OFF.
- 3) After completion of ABS sequence control.
- 4) When a malfunction is detected.

4. VDC Sequence Control

A: OPERATION

- 1) While VDC sequence control is being performed, the operation of the hydraulic unit can be checked using the brake tester or pressure gauge after the hydraulic unit solenoid valve operation.
- 2) VDC sequence control can be started by the Subaru Select Monitor.

1. VDC SEQUENCE CONTROL WITH SUBARU SELECT MONITOR

NOTE:

In the event of any trouble, sequence control will not operate.

- 1) Connect the Subaru Select Monitor to data link connector under the driver's side instrument panel lower cover.
- 2) Turn the ignition switch to ON.
- 3) Run the "PC application for Subaru Select Monitor".
- 4) Set the Subaru Select Monitor to "Brake Control System" mode.
- 5) When the "VDC Inspection Mode" is selected from the "Function check sequence" menu, the "VDC sequence control" will start.
- 6) Press the [OK] after "Press OK" is displayed.
- 7) Operation points will be displayed on Subaru Select Monitor.

VDC Sequence Control

VEHICLE DYNAMICS CONTROL (VDC)

2. CONDITIONS FOR VDC SEQUENCE CONTROL

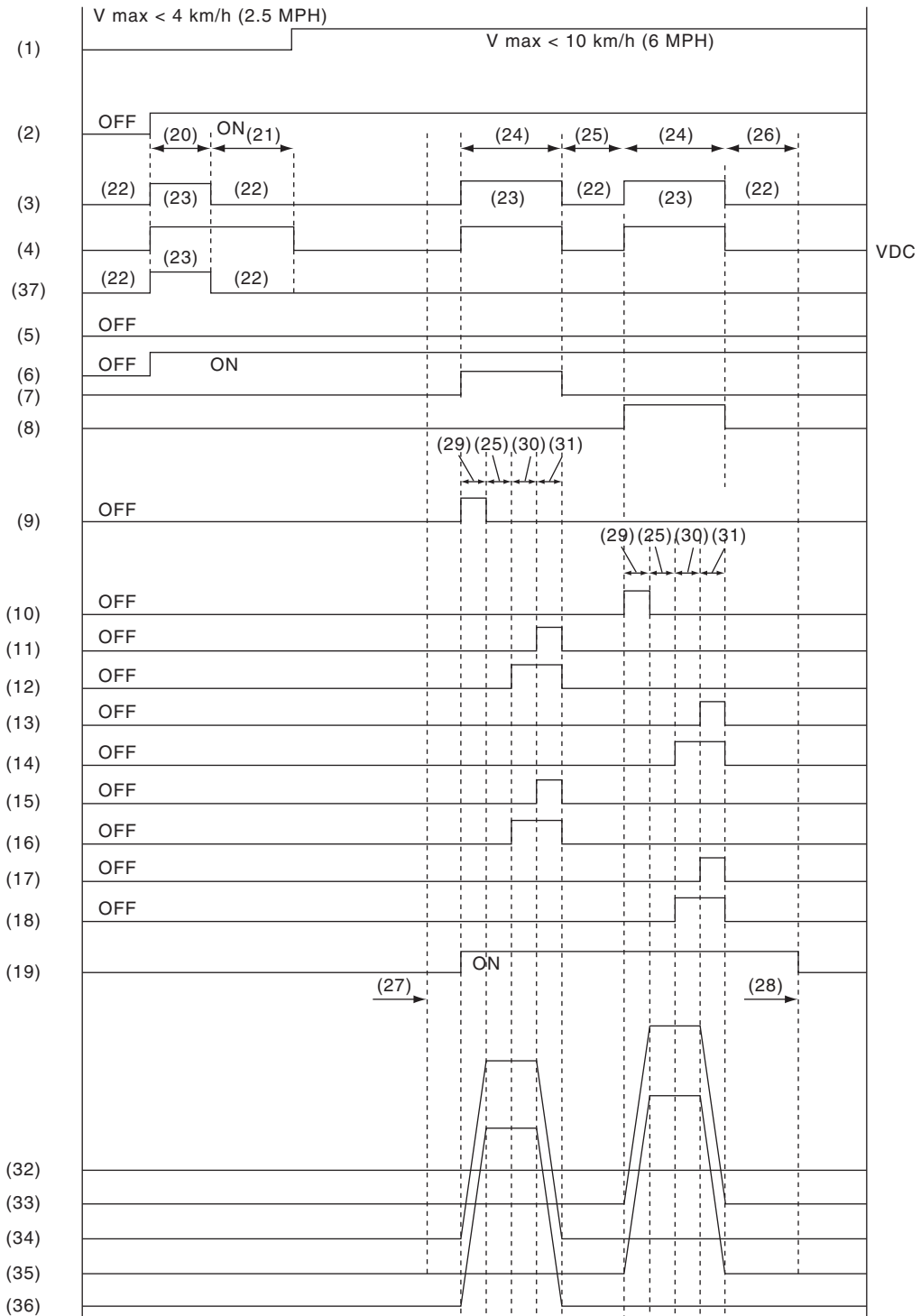

VDC00607

VDC Sequence Control

VEHICLE DYNAMICS CONTROL (VDC)

(1) All wheel speed	(14) FR compression valve	(27) Point A
(2) Ignition key	(15) RR decompression valve	(28) Reset
(3) ABS warning light	(16) RR compression valve	(29) 0.8 seconds
(4) VDC warning light	(17) RL decompression valve	(30) 1.2 seconds
(5) Stop light switch	(18) RL compression valve	(31) 0.4 seconds
(6) Valve relay	(19) Pump motor	(32) Master cylinder pressure
(7) VDC switching valve 1 FL	(20) 1.5 seconds	(33) FR wheel cylinder pressure
(8) VDC switching valve 1 FR	(21) Approx. 3 seconds	(34) FL wheel cylinder pressure
(9) VDC switching valve 2 FL	(22) Light OFF	(35) RL wheel cylinder pressure
(10) VDC switching valve 2 FR	(23) Light ON	(36) RR wheel cylinder pressure
(11) FL decompression valve	(24) 3.4 seconds	(37) Hill start assist warning light (MT vehicles only)
(12) FL compression valve	(25) 1 seconds	
(13) FR decompression valve	(26) 1.6 seconds	

NOTE:

The control operation starts from point A.

B: SPECIFICATION

1. CONDITIONS FOR COMPLETION OF VDC SEQUENCE CONTROL

When the following conditions develop, the VDC sequence control stops and VDC operation is returned to the normal control mode.

- 1) When the speed of at least one wheel reaches 10 km/h (6 MPH).
- 2) When the brake pedal is pressed during sequence control and the stop light switch is set to ON.
- 3) After completion of VDC sequence control.
- 4) When a malfunction is detected.

Yaw Rate and Lateral G Sensor

VEHICLE DYNAMICS CONTROL (VDC)

5. Yaw Rate and Lateral G Sensor

A: REMOVAL

- 1) Disconnect the ground cable from the battery.
- 2) Remove the console box.
<Ref. to EI-46, Console Box.>
- 3) Disconnect the connector from yaw rate & lateral G sensor.
- 4) Remove the yaw rate & lateral G sensor.

CAUTION:

Do not drop or bump the yaw rate & lateral G sensor.

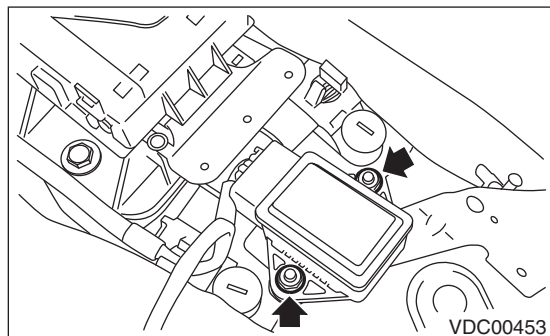

B: INSTALLATION

Install in the reverse order of removal.

Tightening torque:

7.5 N·m (0.76 kgf-m, 5.5 ft-lb)

CAUTION:

After completion of installation, set the following two positions.

- Positioning to the center of steering angle sensor
- Positioning of the yaw rate & lateral G sensor to zero

The procedures above are required for the VDCCM&H/U to identify the vehicle position later. For the setting procedures of the two steps above, refer to “VDC Control Module and Hydraulic Control Unit (VDCCM&H/U)”. <Ref. to VDC-13, ADJUSTMENT, VDC Control Module and Hydraulic Control Unit (VDCCM&H/U).>

Yaw Rate and Lateral G Sensor

VEHICLE DYNAMICS CONTROL (VDC)

C: INSPECTION

1. YAW RATE & LATERAL G SENSOR SIGNAL

Step	Check	Yes	No
1 CHECK YAW RATE & LATERAL G SENSOR. 1) Turn the ignition switch to OFF. 2) Connect the Subaru Select Monitor connector to the data link connector. 3) Turn the ignition switch to ON. 4) Set the Subaru Select Monitor to "Brake Control System" mode. 5) Select {Current Data Display & Save}. 6) Read the output of the yaw rate & lateral G sensor.	Are the indicated values when the vehicle is placed horizontally, Lateral G sensor: $-1.5 - 1.5 \text{ m/s}^2$, Yaw rate sensor: $-4 - 4 \text{ deg/s}$?	Go to step 2.	Repair the harness connector between yaw rate & lateral G sensor and VDCCM&H/U. Or replace the yaw rate & lateral G sensor.
2 CHECK VEHICLE.	Is the vehicle an AT model?	Go to step 5.	Go to step 3.
3 CHECK G SENSOR. 1) Remove the console box. 2) Remove the yaw rate & lateral G sensor from vehicle without disconnecting the connector. 3) Read the display of Subaru Select Monitor. NOTE: When the yaw rate & lateral G sensor is moved with its power supply on, DTC of yaw rate & lateral G sensor may be recorded.	When the yaw rate & lateral G sensor is inclined 90° forward, is the indicated value $6.8 - 12.8 \text{ m/s}^2$?	Go to step 4.	Repair the harness connector between yaw rate & lateral G sensor and VDCCM&H/U. Or replace the yaw rate & lateral G sensor.
4 CHECK G SENSOR. Read the display of Subaru Select Monitor. NOTE: When the yaw rate & lateral G sensor is moved with its power supply on, DTC of yaw rate & lateral G sensor may be recorded.	When the yaw rate & lateral G sensor is inclined 90° backward, is the indicated value $-6.8 - -12.8 \text{ m/s}^2$?	Go to step 5.	Repair the harness connector between yaw rate & lateral G sensor and VDCCM&H/U. Or replace the yaw rate & lateral G sensor.
5 CHECK G SENSOR. 1) Remove the console box. (AT model only) 2) Remove the yaw rate & lateral G sensor from vehicle without disconnecting the connector. (AT model only) 3) Read the display of Subaru Select Monitor. NOTE: When the yaw rate & lateral G sensor is moved with its power supply on, DTC of yaw rate & lateral G sensor may be recorded.	Is the value $6.8 - 12.8 \text{ m/s}^2$ when the yaw rate & lateral G sensor is inclined 90° to the right?	Go to step 6.	Repair the harness connector between yaw rate & lateral G sensor and VDCCM&H/U. Or replace the yaw rate & lateral G sensor.
6 CHECK G SENSOR. Read the display of Subaru Select Monitor. NOTE: When the yaw rate & lateral G sensor is moved with its power supply on, DTC of yaw rate & lateral G sensor may be recorded.	Is the value $-6.8 - -12.8 \text{ m/s}^2$ when the yaw rate & lateral G sensor is inclined 90° to the left?	Yaw rate & lateral G sensors are normal.	Repair the harness connector between yaw rate & lateral G sensor and VDCCM&H/U. Or replace the yaw rate & lateral G sensor.

Steering Angle Sensor

VEHICLE DYNAMICS CONTROL (VDC)

6. Steering Angle Sensor

A: REPLACEMENT

CAUTION:

- Do not remove unless replacing.
- If the sensor needs replacement, replace along with the combination replacement assembly once every three times for the protection of the threaded portion.

1) Set the steering wheel in a straight-ahead position.

2) Disconnect the ground cable from the battery.

3) Remove the airbag module.

<Ref. to AB-16, REMOVAL, Driver's Airbag Module.>

WARNING:

Always refer to "Airbag System" when performing the airbag module repair service.

<Ref. to AB-5, CAUTION, General Description.>

4) Remove the steering wheel.

<Ref. to PS-12, REMOVAL, Steering Wheel.>

5) Remove the screws, and remove the steering column lower cover.

6) Remove the two screws securing the steering column upper cover.

7) Disconnect the connectors of roll connector and steering angle sensor.

8) Remove the screws which secure the roll connector to steering column.

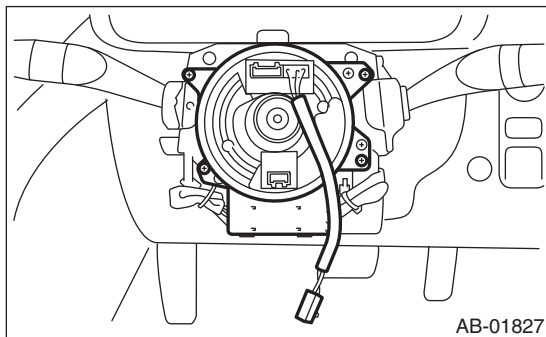

9) Remove the vinyl tape binding the harness, and remove the steering angle sensor from roll connector.

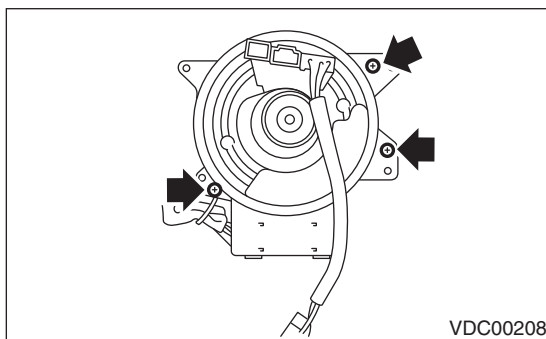

10) Turn the protrusion portion of new steering angle sensor to match the alignment mark of inspection hole.

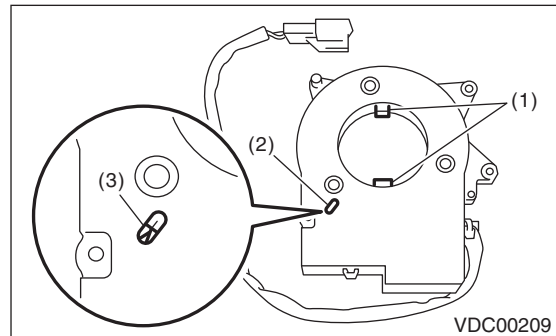

(1) Protrusion portion

(2) Inspection hole

(3) Alignment mark

CAUTION:

Be careful not to allow foreign matter to enter into inspection hole.

11) Align the center of roll connector.

<Ref. to AB-28, INSTALLATION, Roll Connector.>

12) Apply the grease provided with the new part on the four locations of the protrusion on the steering angle sensor.

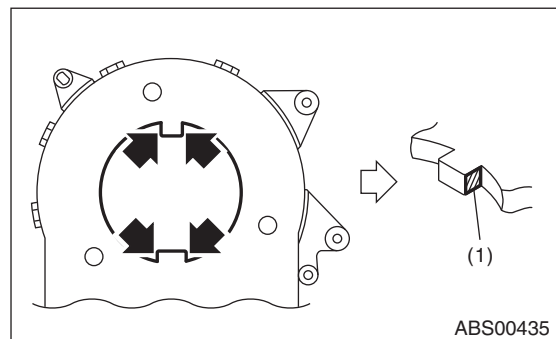

(1) Grease application location

13) Align the position of the protrusion and install roll connector to steering angle sensor.

Tightening torque:

0.5 N·m (0.05 kgf·m, 0.36 ft·lb)

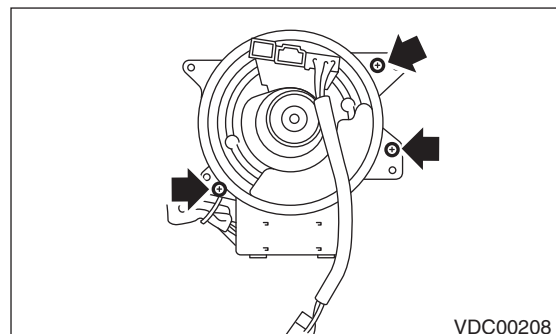

14) Install the roll connector to combination switch and bind the harness with vinyl tape as originally bound.

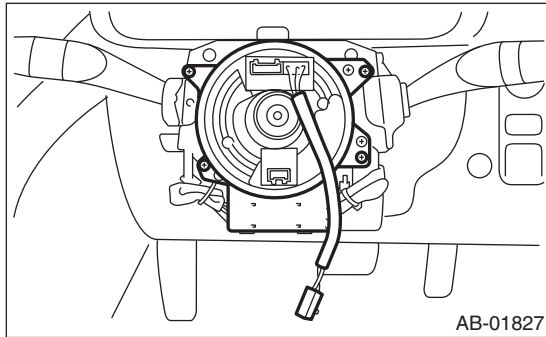

15) Install the steering wheel.
<Ref. to PS-12, INSTALLATION, Steering Wheel.>

Tightening torque:

39 N·m (4.0 kgf-m, 28.8 ft-lb)

16) Install the airbag module to the steering wheel.
<Ref. to AB-16, INSTALLATION, Driver's Airbag Module.>

WARNING:

Always refer to “Airbag System” before performing the service operation.

<Ref. to AB-5, CAUTION, General Description.>

17) Connect the ground cable to the battery.

CAUTION:

After completion of installation, adjust the following two positions.

- Positioning to the center of steering angle sensor
- Positioning of the yaw rate & lateral G sensor to zero

The procedures above are required for the VDCCM to identify the vehicle position later. For the setting procedures of the two steps above, refer to “VDC Control Module and Hydraulic Control Unit (VDCCM&H/U)”. <Ref. to VDC-13, ADJUSTMENT, VDC Control Module and Hydraulic Control Unit (VDCCM&H/U).>

Front ABS Wheel Speed Sensor

VEHICLE DYNAMICS CONTROL (VDC)

7. Front ABS Wheel Speed Sensor

A: REMOVAL

- 1) Disconnect the ground cable from the battery.
- 2) Disconnect the ABS wheel speed sensor connector located next to the front strut mounting house in the engine compartment.
- 3) Remove the sensor harness bracket.

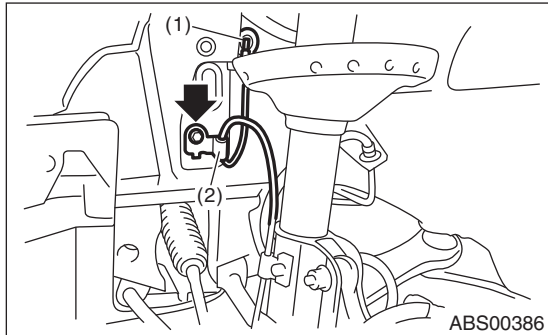

- (1) To the front ABS wheel speed sensor connector
- (2) Sensor harness bracket

- 4) Remove the bolts which secure the sensor harness to the front strut.
- 5) Remove the front ABS wheel speed sensor from housing.

CAUTION:

- Be careful not to damage the sensor.
- Do not apply excessive force to the sensor harness.

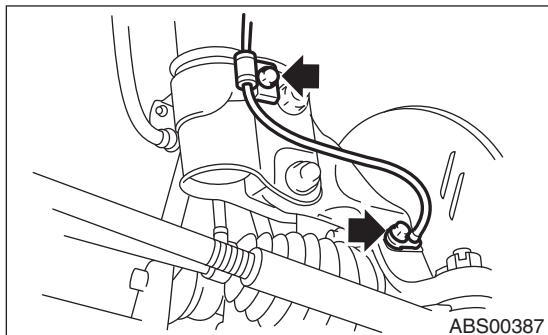

B: INSTALLATION

Install in the reverse order of removal.

Tightening torque:

Sensor:

7.5 N·m (0.76 kgf-m, 5.5 ft-lb)

Bracket:

33 N·m (3.4 kgf-m, 24.3 ft-lb)

CAUTION:

Be careful not to damage the sensor.

NOTE:

- Check the identification (mark) on the harness to make sure there is no warpage. (RH: K1 (White), LH: K2 (Yellow))
- Check if the harness is not pulled and does not come in contact with the suspension or body during steering wheel effort.

C: INSPECTION

1. CHECK WITH SUBARU SELECT MONITOR

- 1) Connect the Subaru Select Monitor to the data link connector.
- 2) Select {Current Data Display & Save}. Check if the speed indicated on the display changes in the same manner as the speedometer reading during acceleration/deceleration when the steering wheel is in the straight-ahead position.
- 3) If the speed indicated on the display does not change, check the ABS wheel speed sensor. <Ref. to VDC-25, ABS WHEEL SPEED SENSOR, INSPECTION, Front ABS Wheel Speed Sensor.>

2. ABS WHEEL SPEED SENSOR

- 1) Check the tip of the ABS wheel speed sensor for foreign particles or damage. If necessary, clean the tip or replace the ABS wheel speed sensor.
- 2) Connect a 12 V power supply to No. 2 terminal of sensor connector as shown in the figure, then attach resistance to the No. 1 terminal. Rotate the wheel at about 2.75 km/h (2 MPH), and measure the voltage using an oscilloscope.

Standard value of output voltage:

0.7 — 1.4 V

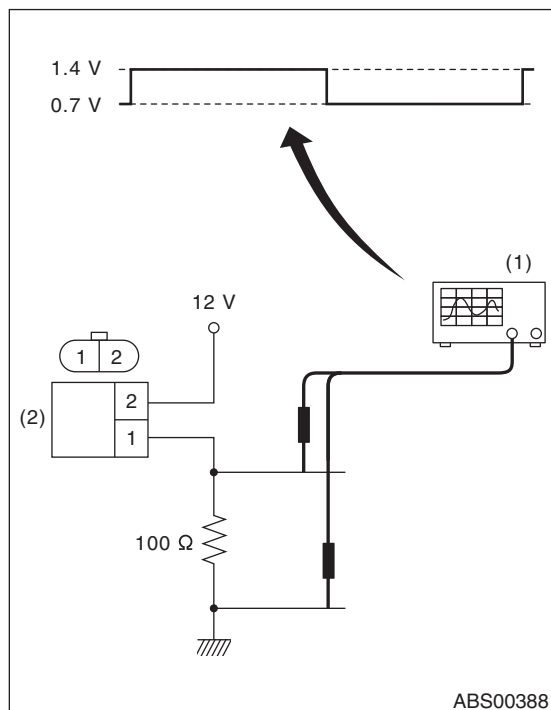

- (1) Oscilloscope
- (2) ABS wheel speed sensor

NOTE:

Check the ABS wheel speed sensor cable for discontinuity. If necessary, replace with a new part.

Rear ABS Wheel Speed Sensor

VEHICLE DYNAMICS CONTROL (VDC)

8. Rear ABS Wheel Speed Sensor

A: REMOVAL

- 1) Disconnect the ground cable from the battery.
- 2) Disconnect the connector from the rear ABS wheel speed sensor.

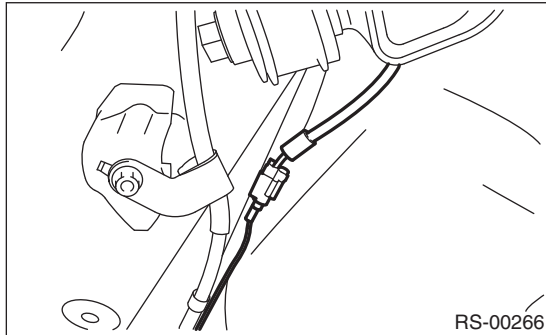

- 3) Remove the sensor harness clamp of the rear sub frame.

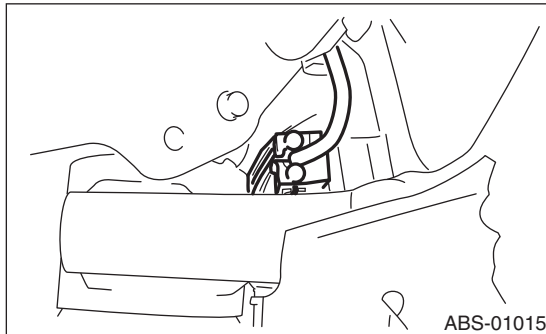

- 4) Remove the sensor harness bracket from the upper arm.

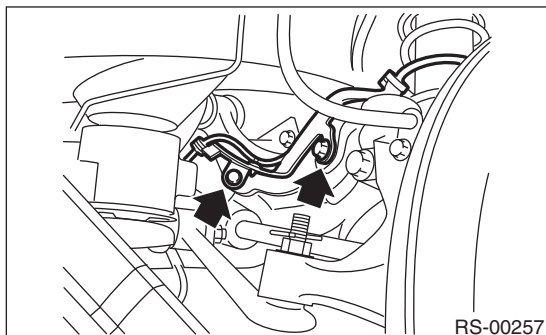

- 5) Remove the rear ABS wheel speed sensor from the rear axle.

CAUTION:

- Be careful not to damage the sensor.
- Do not apply excessive force to the sensor harness.

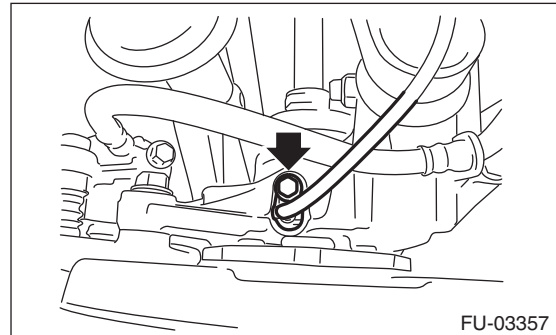

B: INSTALLATION

Install in the reverse order of removal.

CAUTION:

Be careful not to damage the sensor.

Tightening torque:

Sensor:

7.5 N·m (0.76 kgf·m, 5.5 ft·lb)

Bracket:

7.5 N·m (0.76 kgf·m, 5.5 ft·lb)

NOTE:

Check the identification (mark) on the harness to make sure there is no warpage. (RH: P3 (light blue), LH: P4 (brown))

C: INSPECTION

1. ABS WHEEL SPEED SENSOR

<Ref. to VDC-25, ABS WHEEL SPEED SENSOR, INSPECTION, Front ABS Wheel Speed Sensor.>

9. Front Magnetic Encoder

A: REMOVAL

Refer to “Front Hub Bearing” for removal, because the front magnetic encoder is integrated with front hub bearing.

<Ref. to DS-18, REMOVAL, Front Hub Unit Bearing.>

B: INSTALLATION

Refer to “Front Hub Bearing” for installation, because the front magnetic encoder is integrated with front hub bearing.

<Ref. to DS-19, INSTALLATION, Front Hub Unit Bearing.>

C: INSPECTION

Visually check the magnetic encoder for any damage. If necessary, replace with a new hub unit bearing.

NOTE:

Because the magnetic encoder is integrated with hub unit bearing assembly, replace the hub unit bearing with a new part if there is any defect found on the magnetic encoder.

10.Rear Magnetic Encoder

A: REMOVAL

Refer to “Rear Hub Unit Bearing” for removal, because the rear magnetic encoder is integrated with rear hub unit bearing.

<Ref. to DS-24, REMOVAL, Rear Hub Unit Bearing.>

B: INSTALLATION

Refer to “Rear Hub Unit Bearing” for installation, because the rear magnetic encoder is integrated with rear hub unit bearing.

<Ref. to DS-25, INSTALLATION, Rear Hub Unit Bearing.>

C: INSPECTION

Visually check the magnetic encoder parts for any damage. If necessary, replace with a new hub unit bearing.

NOTE:

Because the magnetic encoder is integrated with hub unit bearing assembly, replace the hub unit bearing with a new part if there is any defect found on the magnetic encoder.

11.VDC OFF Switch

A: REMOVAL

- 1) Remove the instrument panel lower cover.
- 2) Remove the screws, and then remove the VDC OFF switch.

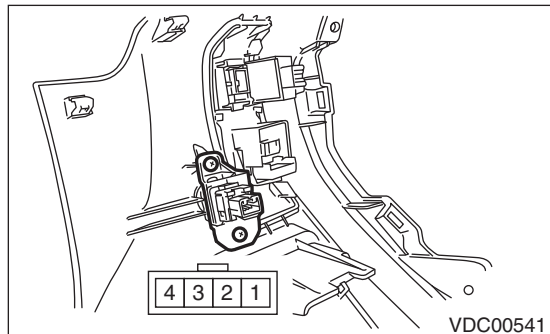

B: INSTALLATION

Install in the reverse order of removal.

C: INSPECTION

Measure the resistance between the VDC OFF switch terminals.

Switch position	Terminal No.	Standard
OFF	2 — 3	1 M Ω or more
ON	2 — 3	Less than 1 Ω

If it is not within the standard, replace the VDC OFF switch.

VDC OFF Switch

VEHICLE DYNAMICS CONTROL (VDC)

VEHICLE DYNAMICS CONTROL (VDC) (DIAGNOSTICS)

VDC(diag)

	Page
1. Basic Diagnostic Procedure	2
2. Check List for Interview	4
3. General Description	8
4. Electrical Component Location	10
5. Control Module I/O Signal	12
6. Subaru Select Monitor	15
7. Read Diagnostic Trouble Code (DTC)	22
8. Inspection Mode	23
9. Clear Memory Mode	24
10. Warning Light Illumination Pattern	25
11. List of Diagnostic Trouble Code (DTC)	32
12. Diagnostic Procedure with Diagnostic Trouble Code (DTC)	38
13. General Diagnostic Table	101

Basic Diagnostic Procedure

VEHICLE DYNAMICS CONTROL (VDC) (DIAGNOSTICS)

1. Basic Diagnostic Procedure

A: PROCEDURE

CAUTION:

Remove foreign matter (dust, water, oil etc.) from the VDCCM&H/U connector during removal and installation.

NOTE:

- To check the harness for broken wires or short circuits, shake problem spot or connector.
- Refer to "Check List for Interview". <Ref. to VDC(diag)-4, Check List for Interview.>

Step	Check	Yes	No
1 CHECK PRE-INSPECTION. 1) Ask the customer when and how the trouble occurred using the interview check list. <Ref. to VDC(diag)-4, Check List for Interview.> 2) Before performing diagnostics, check the component which might affect VDC problems. <Ref. to VDC(diag)-8, INSPECTION, General Description.>	Is the component that might influence the VDC problem normal?	Go to step 2.	Repair or replace each component.
2 CHECK INDICATION OF DTC. 1) Turn the ignition switch to OFF. 2) Connect the Subaru Select Monitor to the data link connector. 3) Turn the ignition switch to ON and run the Subaru Select Monitor. 4) Read the DTC using the Subaru Select Monitor. <Ref. to VDC(diag)-22, OPERATION, Read Diagnostic Trouble Code (DTC).> NOTE: If the communication function of the Subaru Select Monitor cannot be executed normally, check the communication circuit. <Ref. to VDC(diag)-19, COMMUNICATION FOR INITIALIZING IMPOSSIBLE, INSPECTION, Subaru Select Monitor.> 5) Record all DTCs and freeze frame data.	Is DTC displayed on the Subaru Select Monitor?	Go to step 4.	Go to step 3.
3 PERFORM GENERAL DIAGNOSTICS. 1) Perform the inspection by referring to "General Diagnostic Table". <Ref. to VDC(diag)-101, INSPECTION, General Diagnostic Table.> 2) Perform the Clear Memory Mode. <Ref. to VDC(diag)-24, OPERATION, Clear Memory Mode.> 3) Perform the Inspection Mode. <Ref. to VDC(diag)-23, PROCEDURE, Inspection Mode.> 4) Read the DTC. <Ref. to VDC(diag)-22, OPERATION, Read Diagnostic Trouble Code (DTC).> 5) Check the DTC is not displayed.	Do the VDC warning light and ABS warning light go off after starting the engine?	Finish the diagnosis.	Check the combination meter circuit. <Ref. to VDC(diag)-28, ABS WARNING LIGHT DOES NOT GO OFF, Warning Light Illumination Pattern.> <Ref. to VDC(diag)-29, VDC WARNING LIGHT AND VDC OFF INDICATOR LIGHT DO NOT GO OFF, Warning Light Illumination Pattern.>

Basic Diagnostic Procedure

VEHICLE DYNAMICS CONTROL (VDC) (DIAGNOSTICS)

	Step	Check	Yes	No
4	PERFORM DIAGNOSIS. 1) Refer to "List of Diagnostic Trouble Code (DTC)". NOTE: For the DTC list, refer to "List of Diagnostic Trouble Code (DTC)". <Ref. to VDC(diag)-32, LIST, List of Diagnostic Trouble Code (DTC).> 2) Correct the cause of trouble. 3) Perform the Clear Memory Mode. <Ref. to VDC(diag)-24, OPERATION, Clear Memory Mode.> 4) Perform the Inspection Mode. <Ref. to VDC(diag)-23, PROCEDURE, Inspection Mode.> 5) Read the DTC. <Ref. to VDC(diag)-22, OPERATION, Read Diagnostic Trouble Code (DTC).>	Is DTC displayed?	Repeat step 4 until DTC is not shown.	Finish the diagnosis.

Check List for Interview

VEHICLE DYNAMICS CONTROL (VDC) (DIAGNOSTICS)

2. Check List for Interview

A: CHECK

Check the following item about the vehicle's state.

1. STATE OF ABS WARNING LIGHT

ABS warning light illuminates.	<input type="checkbox"/> Always <input type="checkbox"/> Sometimes <input type="checkbox"/> Only once <input type="checkbox"/> Does not come on • When/How long does it illuminate?		
Ignition key position	<input type="checkbox"/> LOCK <input type="checkbox"/> ACC <input type="checkbox"/> ON (before starting engine) <input type="checkbox"/> START <input type="checkbox"/> ON (after starting engine, engine is running) <input type="checkbox"/> ON (after starting engine, engine is at a standstill)		
Timing	<input type="checkbox"/> Immediately after turning the ignition switch to ON <input type="checkbox"/> Immediately after turning the ignition switch to START		
	<input type="checkbox"/> While accelerating	—	km/h
		—	MPH
	<input type="checkbox"/> While driving at a constant speed	km/h	MPH
	<input type="checkbox"/> While decelerating	—	km/h
		—	MPH
	<input type="checkbox"/> When turning to the right	Steering angle:	deg
		Steering time:	Sec.
	<input type="checkbox"/> When turning to the left	Steering angle:	deg
		Steering time:	Sec.
	<input type="checkbox"/> When other electrical parts are operating		
	• Part name:		
	• Operating condition:		

Check List for Interview

VEHICLE DYNAMICS CONTROL (VDC) (DIAGNOSTICS)

2. STATE OF VDC WARNING LIGHT AND VDC OFF INDICATOR LIGHT

VDC warning light and VDC OFF indicator light illuminate.	<input type="checkbox"/> Always <input type="checkbox"/> Sometimes <input type="checkbox"/> Only once <input type="checkbox"/> Does not come on • When/How long does it illuminate?			
Ignition key position	<input type="checkbox"/> LOCK <input type="checkbox"/> ACC <input type="checkbox"/> ON (before starting engine) <input type="checkbox"/> START <input type="checkbox"/> ON (after starting engine, engine is running) <input type="checkbox"/> ON (after starting engine, engine is at a standstill)			
Timing	<input type="checkbox"/> Immediately after turning the ignition switch to ON <input type="checkbox"/> Immediately after turning the ignition switch to START			
	<input type="checkbox"/> While accelerating	—	km/h	
		—	MPH	
	<input type="checkbox"/> While driving at a constant speed	km/h	MPH	
	<input type="checkbox"/> While decelerating	—	km/h	
		—	MPH	
	<input type="checkbox"/> When turning to the right	Steering angle:	deg	
		Steering time:	Sec.	
	<input type="checkbox"/> When turning to the left	Steering angle:	deg	
		Steering time:	Sec.	
<input type="checkbox"/> When other electrical parts are operating				
• Part name:				
• Operating condition:				

3. STATE OF VDC INDICATOR LIGHT

VDC operation indicator light illuminate.	<input type="checkbox"/> Always <input type="checkbox"/> Sometimes <input type="checkbox"/> Only once <input type="checkbox"/> Does not come on • When/How long does it illuminate?			
Ignition key position	<input type="checkbox"/> LOCK <input type="checkbox"/> ACC <input type="checkbox"/> ON (before starting engine) <input type="checkbox"/> START <input type="checkbox"/> ON (after starting engine, engine is running) <input type="checkbox"/> ON (after starting engine, engine is at a standstill)			
Timing	<input type="checkbox"/> Immediately after turning the ignition switch to ON <input type="checkbox"/> Immediately after turning the ignition switch to START			
	<input type="checkbox"/> While accelerating	—	km/h	
		—	MPH	
	<input type="checkbox"/> While driving at a constant speed	km/h	MPH	
	<input type="checkbox"/> While decelerating	—	km/h	
		—	MPH	
	<input type="checkbox"/> When turning to the right	Steering angle:	deg	
		Steering time:	Sec.	
	<input type="checkbox"/> When turning to the left	Steering angle:	deg	
		Steering time:	Sec.	
<input type="checkbox"/> When other electrical parts are operating				
• Part name:				
• Operating condition:				

Check List for Interview

VEHICLE DYNAMICS CONTROL (VDC) (DIAGNOSTICS)

4. CONDITIONS UNDER WHICH TROUBLE OCCURS

Environment	a) Weather	<input type="checkbox"/> Fine <input type="checkbox"/> Cloudy <input type="checkbox"/> Rainy <input type="checkbox"/> Snowy <input type="checkbox"/> Others:
	b) Ambient temperature	°C (°F)
	c) Road	<input type="checkbox"/> Inner city <input type="checkbox"/> Suburbs <input type="checkbox"/> Highway <input type="checkbox"/> Local street <input type="checkbox"/> Uphill <input type="checkbox"/> Downhill <input type="checkbox"/> Paved road <input type="checkbox"/> Gravel road <input type="checkbox"/> Muddy road <input type="checkbox"/> Sandy place <input type="checkbox"/> Straight road <input type="checkbox"/> Sharp curve <input type="checkbox"/> Gentle curve <input type="checkbox"/> S-curve <input type="checkbox"/> Road with a slope on both sides <input type="checkbox"/> Others:
	d) Road surface	<input type="checkbox"/> Dry <input type="checkbox"/> Wet <input type="checkbox"/> Covered with fresh snow <input type="checkbox"/> Covered with hardened snow <input type="checkbox"/> Frozen slope <input type="checkbox"/> Others:

Check List for Interview

VEHICLE DYNAMICS CONTROL (VDC) (DIAGNOSTICS)

Condition	a) Brakes	Deceleration: G
		<input type="checkbox"/> Continuous / <input type="checkbox"/> Intermittent
	b) Accelerator	Acceleration: G
		<input type="checkbox"/> Continuous / <input type="checkbox"/> Intermittent
	c) Vehicle speed	km/h MPH
		<input type="checkbox"/> Advancing
		<input type="checkbox"/> While accelerating
		<input type="checkbox"/> While decelerating
		<input type="checkbox"/> At low speed
		<input type="checkbox"/> When turning
		<input type="checkbox"/> Others:
	d) Tire inflation pressure	Front RH tire: kPa
		Front LH tire: kPa
		Rear RH tire: kPa
		Rear LH tire: kPa
	e) Degree of wear	Front RH tire:
		Front LH tire:
		Rear RH tire:
		Rear LH tire:
	f) Steering wheel	<input type="checkbox"/> Sharp turning
	<input type="checkbox"/> Gentle turning	
	<input type="checkbox"/> Straight forward motion	
	<input type="checkbox"/> Gentle return	
	<input type="checkbox"/> Sharp return	
g) Tire/Wheel size	<input type="checkbox"/> Specified size	
	<input type="checkbox"/> Except specification ()	
h) Tire variation	<input type="checkbox"/> Summer tire	
	<input type="checkbox"/> Studless tire (Brand:)	
i) Tire chain is attached: <input type="checkbox"/> Yes / <input type="checkbox"/> No		
j) T-type tire is used: <input type="checkbox"/> Yes / <input type="checkbox"/> No		
k) Condition of suspension alignment:		
l) Loading state:		
m) Repair parts are used: <input type="checkbox"/> Yes / <input type="checkbox"/> No		
• Contents:		
n) Others:		

General Description

VEHICLE DYNAMICS CONTROL (VDC) (DIAGNOSTICS)

3. General Description

A: CAUTION

1. SUPPLEMENTAL RESTRAINT SYSTEM “AIRBAG”

Airbag system wiring harness is routed near the ABS wheel speed sensor and VDCCM&H/U.

CAUTION:

- All airbag system wiring harness and connectors are colored yellow. Do not use electrical test equipment on these circuits.
- Be careful not to damage the airbag system wiring harness when servicing the ABS wheel speed sensor and VDCCM&H/U.

B: INSPECTION

Before performing diagnosis, check the following items which might affect VDC problems.

1. BATTERY

Measure the battery voltage and check electrolyte.

Standard voltage:

12 V or more

Specific gravity:

1.260 or more

2. GROUND

Check the tightening torque of ground (GB-6) bolt of VDC.

Tightening torque:

13 N·m (1.3 kgf·m, 9.6 ft·lb)

3. BRAKE FLUID

- 1) Check the brake fluid level.
- 2) Check the brake fluid for leaks.

4. HYDRAULIC UNIT

Check the hydraulic unit.

- When using the brake tester <Ref. to VDC-9, CHECKING THE HYDRAULIC UNIT ABS OPERATION BY BRAKE TESTER, INSPECTION, VDC Control Module and Hydraulic Control Unit (VDCCM&H/U).>
- Without brake tester <Ref. to VDC-8, CHECKING THE HYDRAULIC UNIT ABS OPERATION BY PRESSURE GAUGE, INSPECTION, VDC Control Module and Hydraulic Control Unit (VDCCM&H/U).>

5. BRAKE DRAG

Check for brake drag.

6. BRAKE PAD AND ROTOR

Check the brake pad and rotor.

- Front <Ref. to BR-12, INSPECTION, Front Brake Pad.> <Ref. to BR-13, INSPECTION, Front Disc Rotor.>
- Rear <Ref. to BR-18, INSPECTION, Rear Brake Pad.> <Ref. to BR-20, INSPECTION, Rear Disc Rotor.>

7. TIRE

Check the tire specifications, tire wear and air pressure. <Ref. to WT-2, SPECIFICATION, General Description.>

General Description

VEHICLE DYNAMICS CONTROL (VDC) (DIAGNOSTICS)

C: PREPARATION TOOL

1. SPECIAL TOOL

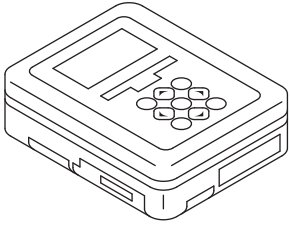
ILLUSTRATION	TOOL NUMBER	DESCRIPTION	REMARKS
 ST1B022XU0	1B022XU0 (Newly adopted tool)	SUBARU SELECT MONITOR III KIT	Used for troubleshooting the electrical system.

2. GENERAL TOOL

TOOL NAME	REMARKS
Circuit tester	Used for measuring resistance, voltage and current.
Oscilloscope	Used for measuring the sensor.

Electrical Component Location

VEHICLE DYNAMICS CONTROL (VDC) (DIAGNOSTICS)

4. Electrical Component Location

A: LOCATION

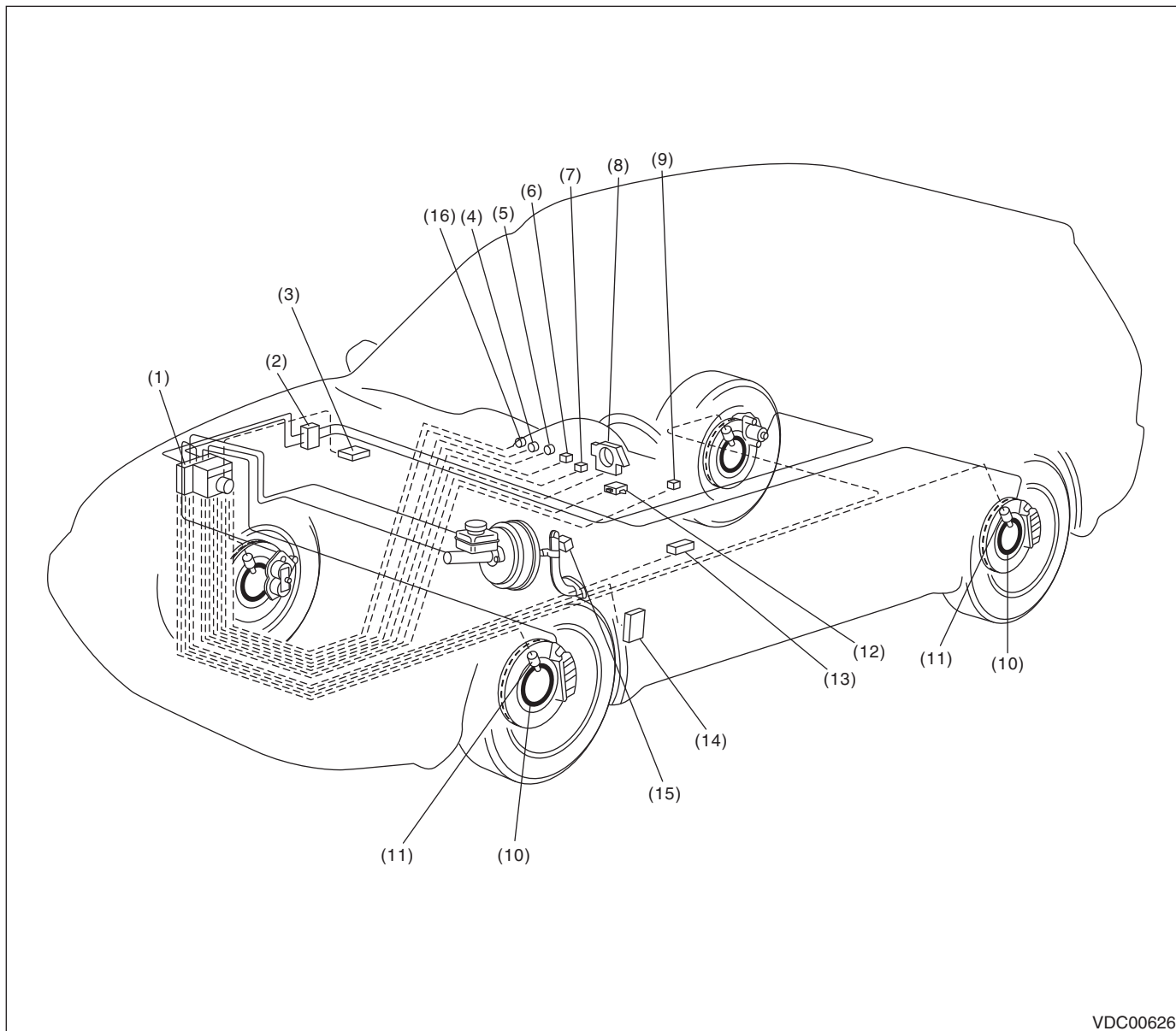

VDC00626

- | | | |
|---|---|--|
| (1) VDC control module and hydraulic control unit (VDCCM&H/U) | (5) ABS warning light | (11) ABS wheel speed sensor |
| (2) Connector | (6) VDC indicator light | (12) Yaw rate & lateral G sensor |
| (3) Transmission control module (TCM) | (7) VDC warning light and VDC OFF indicator light | (13) Data link connector |
| (4) Brake warning light (EBD warning light) | (8) Steering angle sensor | (14) Engine control module (ECM) |
| | (9) VDC OFF switch | (15) Stop light switch |
| | (10) Magnetic encoder | (16) Hill start assist warning light (MT model only) |

Electrical Component Location

VEHICLE DYNAMICS CONTROL (VDC) (DIAGNOSTICS)

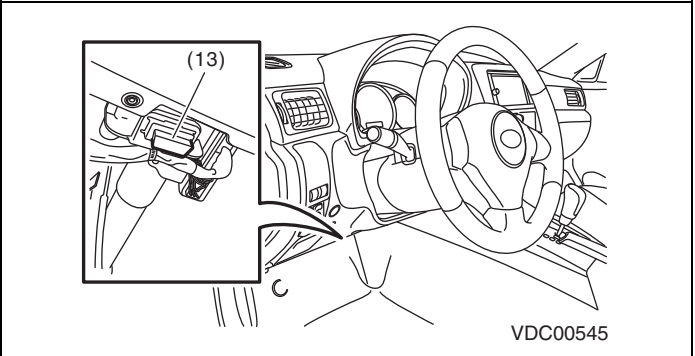
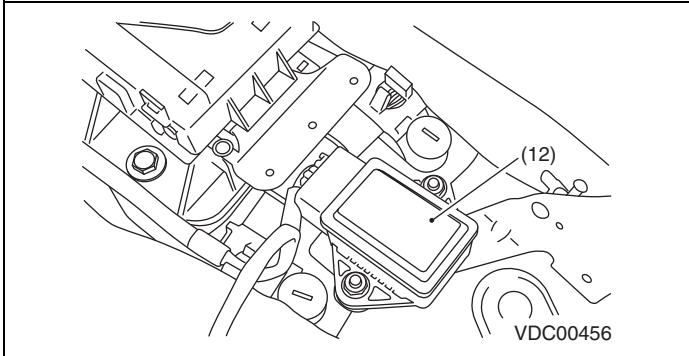
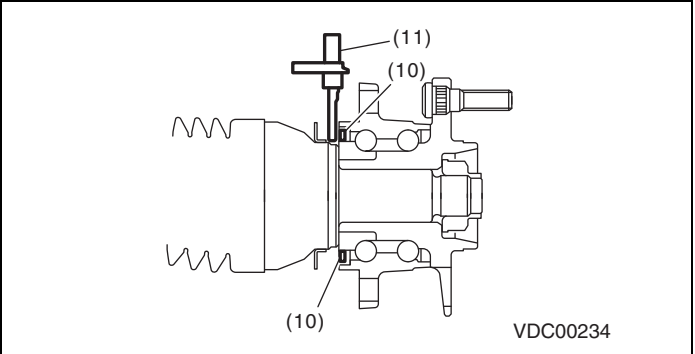
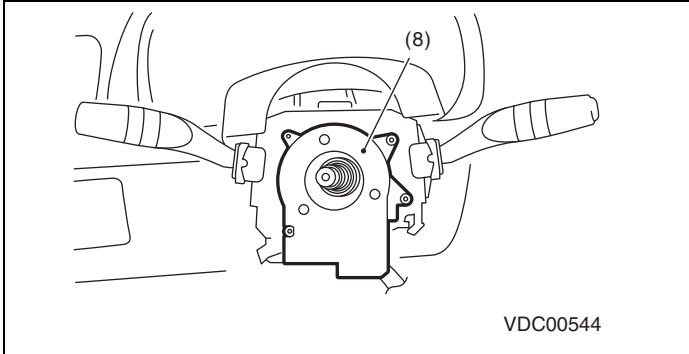
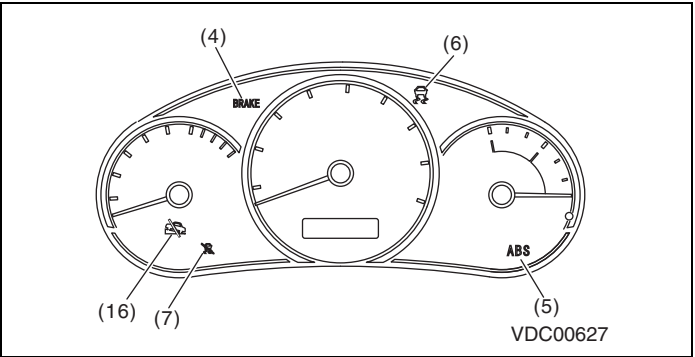
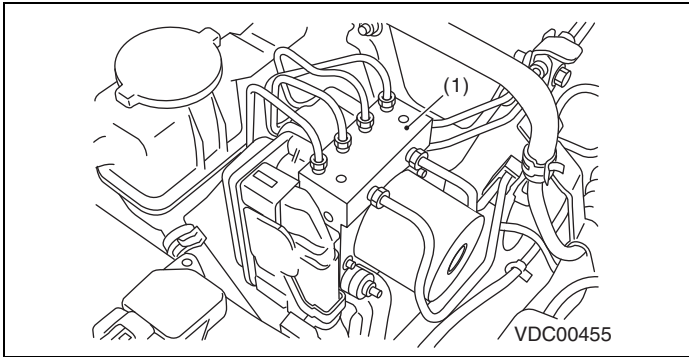

Control Module I/O Signal

VEHICLE DYNAMICS CONTROL (VDC) (DIAGNOSTICS)

5. Control Module I/O Signal

A: ELECTRICAL SPECIFICATION

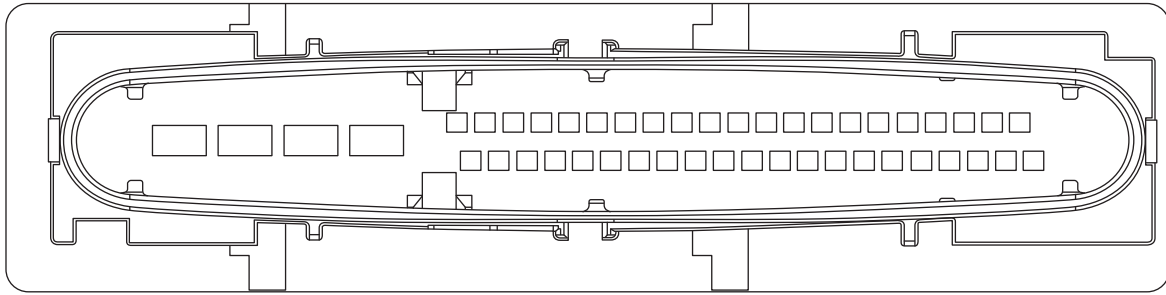

B310

22	23	24	25	1	2	3	4	5	6	7	8	9	10	11	12	13	14	15	16	17	18	19	20	21
				26	27	28	29	30	31	32	33	34	35	36	37	38	39	40	41	42	43	44	45	46

VDC00457

NOTE:

- Terminal numbers in VDCCM&H/U connector are shown in the figure.
- When the connector is removed from the VDCCM&H/U, the ABS warning light, VDC warning light, VDC OFF indicator light, and the hill start assist warning light illuminate.

Control Module I/O Signal

VEHICLE DYNAMICS CONTROL (VDC) (DIAGNOSTICS)

Content		Terminal No. (+) — (-)	Input/Output signal	
			Measured value and measuring conditions	
Power supply		28 — 25	10 — 15 V when the ignition switch is ON.	
ABS wheel speed sensor	Front LH wheel	Power supply	26 — 25	4.5 — 16.5 V
		Signal	1	5.9 — 16.8 mA: Rectangle waveform
	Front RH wheel	Power supply	5 — 25	4.5 — 16.5 V
		Signal	6	5.9 — 16.8 mA: Rectangle waveform
	Rear LH wheel	Power supply	2 — 25	4.5 — 16.5 V
		Signal	27	5.9 — 16.8 mA: Rectangle waveform
	Rear RH wheel	Power supply	3 — 25	4.5 — 16.5 V
		Signal	4	5.9 — 16.8 mA: Rectangle waveform
CAN communication line (+)		35	2.5 — 1.5 V pulse signal	
CAN communication line (-)		10	3.5 — 2.5 V pulse signal	
Valve relay power supply		24 — 25	10 — 15 V when the ignition switch is ON.	
Motor relay power supply		23 — 22	10 — 15 V when the ignition switch is ON.	
Stop light switch		30 — 25	1.5 V or less when the stop light is OFF; otherwise, 10 — 15 V when the stop light is ON.	
Subaru Select Monitor		7 — 25	0 ↔ 12 V pulse (in communication)	
Vehicle speed output signal		33	0 ↔ 12 V pulse	
Ground		25	—	

Control Module I/O Signal

VEHICLE DYNAMICS CONTROL (VDC) (DIAGNOSTICS)

B: WIRING DIAGRAM

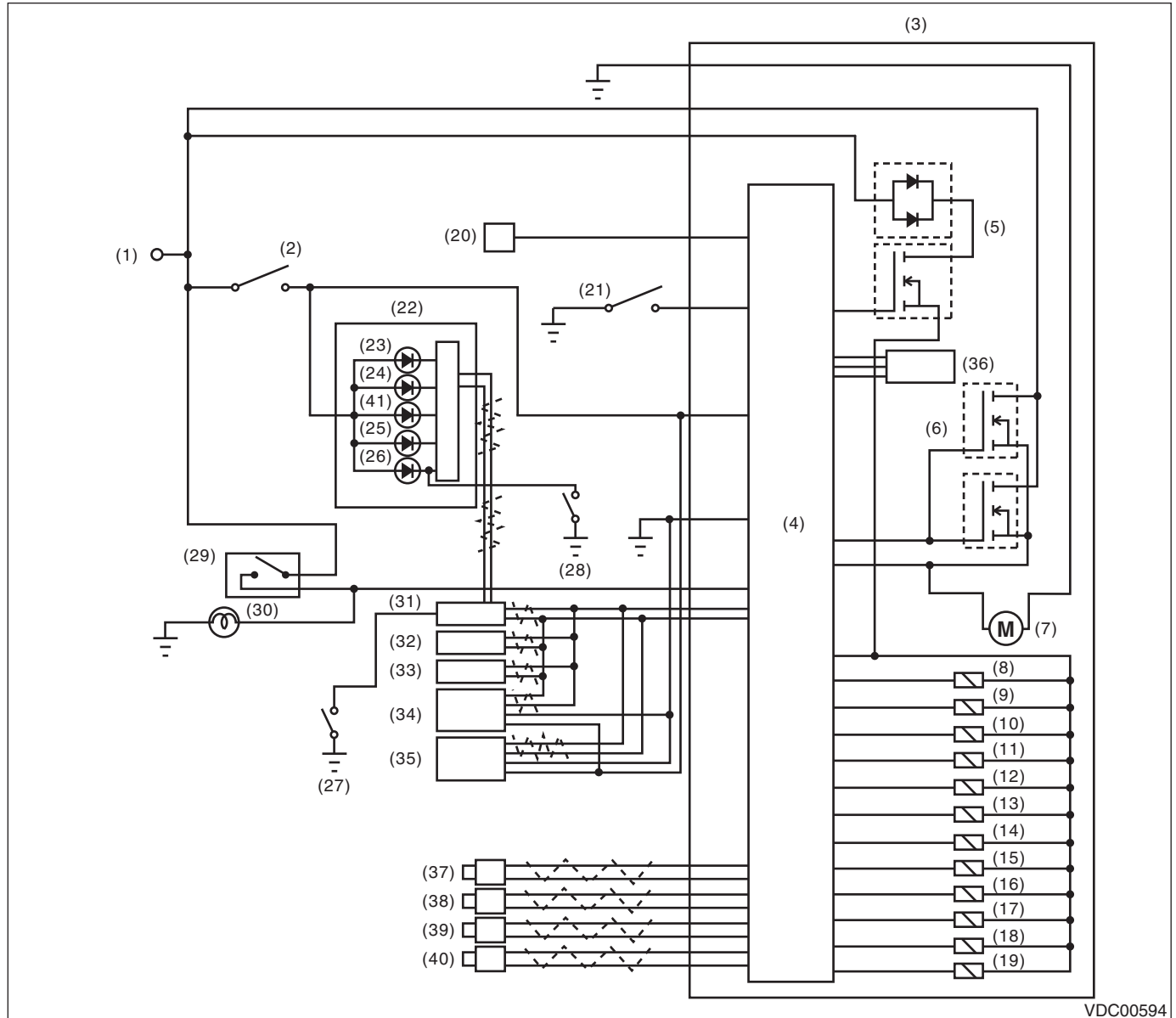

VDC00594

- | | | |
|---|--|--|
| (1) Battery | (15) Rear outlet solenoid valve RH | (29) Stop light switch |
| (2) Ignition switch | (16) Primary cut solenoid valve | (30) Stop light |
| (3) VDC control module and hydraulic control unit (VDCCM&H/U) | (17) Primary suction solenoid valve | (31) Body integrated unit |
| (4) VDC control module | (18) Secondary cut solenoid valve | (32) Engine control module (ECM) |
| (5) Valve relay | (19) Secondary suction solenoid valve | (33) Transmission control module (TCM) |
| (6) Motor relay | (20) Data link connector | (34) Steering angle sensor |
| (7) Motor | (21) VDC OFF switch | (35) Yaw rate & lateral G sensor |
| (8) Front inlet solenoid valve LH | (22) Combination meter | (36) Pressure sensor |
| (9) Front outlet solenoid valve LH | (23) VDC indicator light | (37) Front ABS wheel speed sensor LH |
| (10) Front inlet solenoid valve RH | (24) VDC warning light and VDC OFF indicator light | (38) Front ABS wheel speed sensor RH |
| (11) Front outlet solenoid valve RH | (25) ABS warning light | (39) Rear ABS wheel speed sensor LH |
| (12) Rear inlet solenoid valve LH | (26) Brake warning light | (40) Rear ABS wheel speed sensor RH |
| (13) Rear outlet solenoid valve LH | (27) Parking brake switch | (41) Hill start assist warning light (MT model only) |
| (14) Rear inlet solenoid valve RH | (28) Brake fluid level switch | |

6. Subaru Select Monitor

A: OPERATION

1. READ DIAGNOSTIC TROUBLE CODE (DTC)

1) Prepare the Subaru Select Monitor kit. <Ref. to VDC(diag)-9, SPECIAL TOOL, PREPARATION TOOL, General Description.>

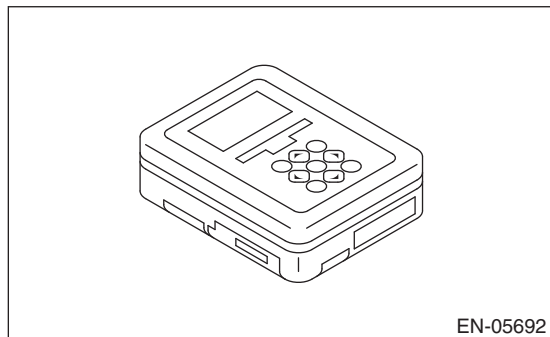

2) Prepare PC with Subaru Select Monitor installed.

3) Connect the SDI (Subaru Diagnostic Interface) to the PC USB port (exclusively for Subaru Selector Monitor) using a USB cable.

NOTE:

Port exclusively for Subaru Select Monitor refers to the USB port used when installing Subaru Select Monitor.

4) Connect the diagnosis cable to the SDI.

5) Connect the SDI to the data link connector located in the lower portion of the instrument panel (on the driver's side).

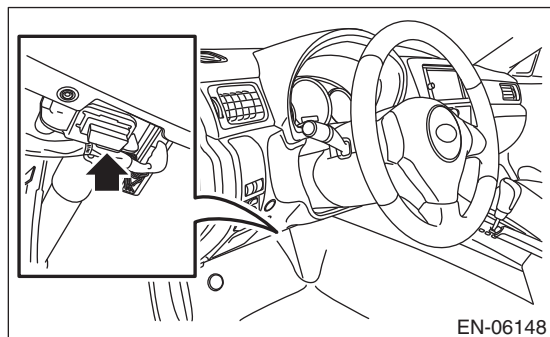

CAUTION:

Do not connect scan tools other than the Subaru Select Monitor.

6) Start the PC.

7) Turn the ignition switch to ON (engine OFF) and run the "PC application for Subaru Select Monitor".

8) Record the DTC and data.

NOTE:

For detailed operation procedure, refer to the "PC application help for Subaru Select Monitor".

9) If VDC and Subaru Select Monitor cannot communicate, check the communication circuit. <Ref. to VDC(diag)-19, COMMUNICATION FOR INITIALIZING IMPOSSIBLE, INSPECTION, Subaru Select Monitor.>

Subaru Select Monitor

VEHICLE DYNAMICS CONTROL (VDC) (DIAGNOSTICS)

2. READ CURRENT DATA

- 1) On the «Main Menu» display, select {Each System Check}.
 - 2) On the «System Selection Menu», select {Brake Control System}.
 - 3) Click the [OK] button after the {VDC} is displayed.
 - 4) On the «Brake Control Diagnosis» screen, select {Current Data Display & Save}.
 - 5) On the «Data Display Menu», select the data display method.
 - 6) Using the scroll key, scroll the display screen up or down until necessary data is shown.
- A list of the support data is shown in the following table.

Display	Contents to be monitored	Unit of measure
FR Wheel Speed	Wheel speed detected by front ABS wheel speed sensor RH is displayed.	km/h or MPH
FL Wheel Speed	Wheel speed detected by front ABS wheel speed sensor LH is displayed.	km/h or MPH
RR Wheel Speed	Wheel speed detected by rear ABS wheel speed sensor RH is displayed.	km/h or MPH
RL Wheel Speed	Wheel speed detected by rear ABS wheel speed sensor LH is displayed.	km/h or MPH
Steer Angle Sensor Op	Steering angle detected by steering angle sensor is displayed.	deg
Yaw Rate Sensor Output	Vehicle angular speed detected by yaw rate sensor is displayed.	deg/s
Pressure Sensor Output	Brake fluid pressure detected by pressure sensor is displayed.	bar
Abnormal Lateral G Sensor output	Vehicle lateral acceleration detected by lateral G sensor is displayed.	m/s (m/s ²)
ABS_CM Power Voltage	Voltage supplied to VDCCM&H/U is displayed.	V
E/G Control Stop Flag	Engine control command signal is displayed.	1 or 0
ABS Control Flag	ABS operation condition is displayed.	ON or OFF
EBD Control Flag	EBD operation condition is displayed.	ON or OFF
TCS Control Flag	TCS operation condition is displayed.	ON or OFF
VDC Control Flag	VDC operation condition is displayed.	ON or OFF
OFF Lamp	ON/OFF condition of VDC OFF indicator light is displayed.	ON or OFF
EBD Warning Light	ON operation of the EBD warning light is displayed.	ON or OFF
ABS Warning Light	ON operation of the ABS warning light is displayed.	ON or OFF
VDC Warning Light	ON operation of the VDC warning light is displayed.	ON or OFF
Valve Relay Signal	Valve relay operation signal is displayed.	ON or OFF
Motor Relay Signal	Motor relay operation signal is displayed.	ON or OFF
M. Relay monitor Voltage	Voltage applied to the motor relay is displayed.	V
OFF SW Signal	Operation condition of VDC OFF switch is displayed.	ON or OFF
Brake Switch	Brake ON/OFF is displayed.	ON or OFF
Fr Rr G sensor Output	Vehicle forward/reverse acceleration detected by the longitudinal G sensor is displayed. (MT vehicles only. AT vehicles are fixed at -0.1 m/s ² .)	m/s ²
Clutch Switch	Clutch ON/OFF is displayed. (MT vehicles only. AT vehicles fixed at OFF.)	ON or OFF
Reverse Signal	Reverse gear ON/OFF is displayed. (MT vehicles only. AT vehicles fixed at OFF.)	ON or OFF

NOTE:

For details concerning the operation procedure, refer to the “PC application help for Subaru Select Monitor”.

3. FUNCTION CHECK

Display	Contents of display	Index No.
ABS Sequence Control Mode	Operate the valve and pump motor continuously to perform the ABS sequence control.	<Ref. to VDC-14, ABS Sequence Control.>
VDC Check Mode	Operate the valve and pump motor continuously to perform the VDC sequence control.	<Ref. to VDC-17, VDC Sequence Control.>
Set mode Str.A.Sen.N&Lat.GSen.0p	Set the steering angle sensor neutral position and the lateral G sensor “0” point.	<Ref. to VDC-22, Steering Angle Sensor.>

Subaru Select Monitor

VEHICLE DYNAMICS CONTROL (VDC) (DIAGNOSTICS)

4. FREEZE FRAME DATA

NOTE:

- Data stored at the time of trouble occurrence is shown on the display.
- Each time a trouble occurs, the latest information is stored in the freeze frame data in memory.
- If a freeze frame data is not properly stored in memory (due to a drop in VDCCM power supply, etc.), a DTC suffixed with a question mark “?” appears on the Subaru Select Monitor display. This shows it may be an unreliable reading.

Display	Contents to be monitored
Steer Angle Sensor Op	Steering angle detected by steering angle sensor is displayed.
Yaw Rate Sensor Output	Vehicle angular speed detected by yaw rate sensor is displayed.
Abnormal Lateral G Sensor output	Vehicle lateral acceleration detected by lateral G sensor is displayed.
Pressure Sensor Output	Brake fluid pressure detected by pressure sensor is displayed.
Vehicle Speed	Vehicle speed calculated by VDC control module is displayed.
FR Wheel Speed	Wheel speed detected by front ABS wheel speed sensor RH is displayed in km/h or MPH.
FL Wheel Speed	Wheel speed detected by front ABS wheel speed sensor LH is displayed in km/h or MPH.
RR Wheel Speed	Wheel speed detected by rear ABS wheel speed sensor RH is displayed in km/h or MPH.
RL Wheel Speed	Wheel speed detected by rear ABS wheel speed sensor LH is displayed in km/h or MPH.
Accel. Opening Angle	Acceleration opening is displayed.
Engine Speed	Engine speed on malfunction occurrence is displayed.
Gear Position	Gear position on malfunction occurrence is displayed.
ABS_CM Power Voltage	Voltage supplied to VDC control module is displayed.
Steering angle flag	Whether the absolute angle of the steering angle sensor was determined is displayed.
E/G Control Stop Flag	Engine control command signal is displayed.
VDC Control Flag	VDC control condition is displayed.
EBD Control Flag	EBD control condition is displayed.
TCS Control Flag	TCS control condition is displayed.
ABS Control Flag	ABS control condition is displayed.
OFF Switch Detection	ON/OFF condition of the VDC operated by the driver is displayed.
Brake Switch	Brake ON/OFF is displayed.

Display	Contents to be monitored
Fr Rr G sensor Output	Vehicle forward/reverse acceleration detected by the longitudinal G sensor is displayed.(MT vehicles only. AT vehicles are fixed at -0.1 m/s^2 .)
Clutch Switch	Clutch ON/OFF is displayed.(MT vehicles only. AT vehicles fixed at OFF.)
Reverse Signal	Reverse gear ON/OFF is displayed.(MT vehicles only. AT vehicles fixed at OFF.)

5. PARAMETER SELECTION

CAUTION:

- **Subaru Select Monitor is required for parameter selection.**
- **This function can be used for the replacement VDCCM&H/U and VDCCM.**

NOTE:

- When a VDCCM is replaced with a replacement, use this function to select and register parameters to the VDCCM.
- For confirmation of applied models, refer to the “Model number plate” attached to the vehicles. <Ref. to ID-2, IDENTIFICATION, Identification.>
- If a wrong applied model is written, it can be re-written.
- When no data is registered, ABS/EBD/VDC warning light illuminates and the DTC “Parameter selection error” is detected.
 - 1) Connect the Subaru Select Monitor.
 - 2) On the «Main Menu» display, select {Each System Check}.
 - 3) On the «System Selection Menu», select {Brake Control System}.
 - 4) Click the [OK] button after the {VDC} is displayed.
 - 5) On the «Brake Control Diagnosis», select {Selection of Parameter}.
 - 6) Check the applied model indicated in the “Model number plate”. <Ref. to ID-2, IDENTIFICATION, Identification.>
 - 7) Enter the applied model of 7-digit alphanumeric characters and press the [Enter] key.
 - 8) When the confirmation screen indicating the vehicle information appears, check that the correct applied model and grade are displayed and click the [OK] button.

NOTE:

- When the displayed applied model and grade are different from those of the vehicle, perform registration operations again after clicking the [OK] button.
- 9) Execute Clear Memory after parameter selection and registration operations because the DTC for “Parameter selection error” is memorized.

Subaru Select Monitor

VEHICLE DYNAMICS CONTROL (VDC) (DIAGNOSTICS)

6. PARAMETER CHECK

NOTE:

The parameter data registered in the VDCCM is shown on the display.

- 1) Connect the Subaru Select Monitor.
- 2) On the «Main Menu» display, select {Each System Check}.
- 3) On the «System Selection Menu», select {Brake Control System}.
- 4) Click the [OK] button after the {VDC} is displayed.
- 5) On the «Brake Control Diagnosis», select {Confirm on parameter}.
- 6) On the {Confirm on parameter} display screen, check that the applied model and grade of the target vehicle are included, and click the [OK] button.
- 7) If the applied model and grade of the target vehicle are not included on the {Confirm on parameter} display screen, perform parameter selection and registration. <Ref. to VDC(diag)-17, PARAMETER SELECTION, OPERATION, Subaru Select Monitor.>

Subaru Select Monitor

VEHICLE DYNAMICS CONTROL (VDC) (DIAGNOSTICS)

B: INSPECTION

1. COMMUNICATION FOR INITIALIZING IMPOSSIBLE

DETECTING CONDITION:

Defective harness connector

TROUBLE SYMPTOM:

Communication is impossible between VDC and Subaru Select Monitor.

WIRING DIAGRAM:

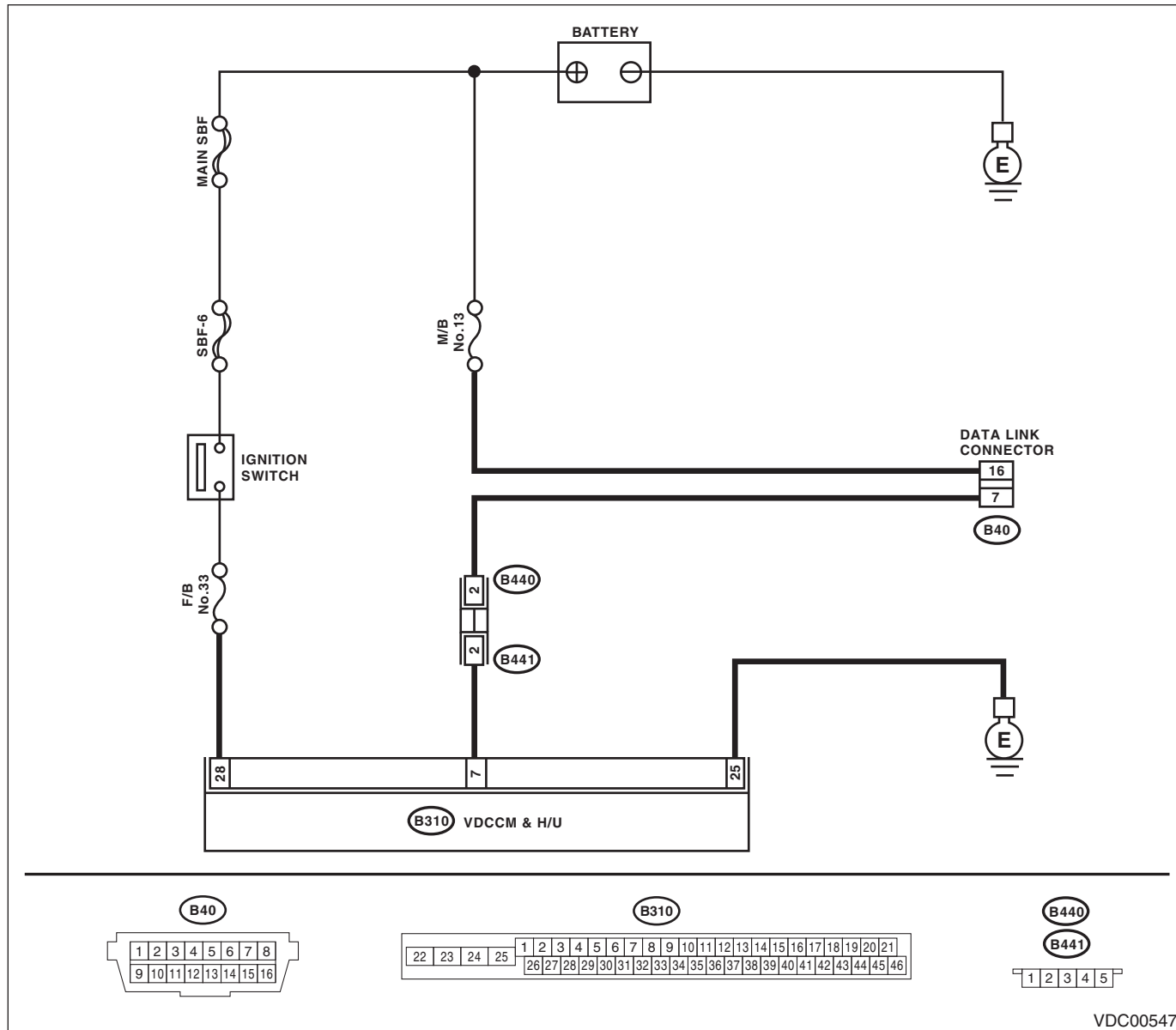

VDC00547

Subaru Select Monitor

VEHICLE DYNAMICS CONTROL (VDC) (DIAGNOSTICS)

Step	Check	Yes	No	
1	CHECK IGNITION SWITCH.	Is the ignition switch ON?	Go to step 2.	Turn the ignition switch to ON, and select VDC mode using Subaru Select Monitor.
2	CHECK BATTERY. 1) Turn the ignition switch to OFF. 2) Measure the battery voltage.	Is the voltage 11 V or more?	Go to step 3.	Charge or replace the battery.
3	CHECK BATTERY TERMINAL.	Is there poor contact at the battery terminal?	Repair or tighten the battery terminal.	Go to step 4.
4	CHECK SUBARU SELECT MONITOR COMMUNICATION. 1) Turn the ignition switch to ON. 2) Using the Subaru Select Monitor, check whether communication to other systems can be performed normally.	Is the system name displayed on the Subaru Select Monitor?	Go to step 8.	Go to step 5.
5	CHECK SUBARU SELECT MONITOR COMMUNICATION. 1) Turn the ignition switch to OFF. 2) Disconnect the VDCCM&H/U connector. 3) Turn the ignition switch to ON. 4) Check whether communication to other systems can be executed normally.	Is the system name displayed on Subaru Select Monitor?	Replace the VDCCM only. <Ref. to VDC-11, REPLACEMENT, VDC Control Module and Hydraulic Control Unit (VDCCM&H/U).>	Go to step 6.
6	CHECK HARNESS CONNECTOR BETWEEN EACH CONTROL MODULE AND DATA LINK CONNECTOR. 1) Turn the ignition switch to OFF. 2) Disconnect the VDCCM&H/U, ECM and TCM. 3) Measure the resistance between data link connector and chassis ground. Connector & terminal (B40) No. 7 — Chassis ground:	Is the resistance 1 MΩ or more?	Go to step 7.	Repair the harness and connector between each control module and data link connector.
7	CHECK OUTPUT SIGNAL FOR VDCCM&H/U. 1) Turn the ignition switch to ON. 2) Measure the voltage between data link connector and chassis ground. Connector & terminal (B40) No. 7 (+) — Chassis ground (-):	Is the voltage less than 1 V?	Go to step 8.	Repair the harness and connector between each control module and data link connector.
8	CHECK HARNESS CONNECTOR BETWEEN VDCCM&H/U AND DATA LINK CONNECTOR. Measure the resistance between VDCCM&H/U connector and data link connector. Connector & terminal (B310) No. 7 — (B40) No. 7:	Is the resistance less than 0.5 Ω?	Go to step 9.	Repair harness and connector between VDCCM&H/U and data link connector.
9	CHECK INSTALLATION OF VDCCM&H/U CONNECTOR. Turn the ignition switch to OFF.	Is the VDCCM&H/U connector inserted into VDCCM&H/U until the clamp locks onto it?	Go to step 10.	Insert VDCCM&H/U connector into VDCCM&H/U.
10	CHECK POWER SUPPLY CIRCUIT. 1) Turn the ignition switch to ON. (engine OFF) 2) Measure the ignition power supply voltage between VDCCM&H/U connector and chassis ground. Connector & terminal (B310) No. 28 (+) — Chassis ground (-):	Is the voltage 10 — 15 V?	Go to step 11.	Repair open circuit in harness between VDCCM&H/U and battery.

Subaru Select Monitor

VEHICLE DYNAMICS CONTROL (VDC) (DIAGNOSTICS)

Step	Check	Yes	No
11 CHECK HARNESS CONNECTOR BETWEEN VDCCM&H/U AND CHASSIS GROUND. 1) Turn the ignition switch to OFF. 2) Disconnect the connector from the VDCCM&H/U. 3) Measure the resistance of harness between VDCCM&H/U connector and chassis ground. Connector & terminal (B310) No. 25 — Chassis ground:	Is the resistance less than 0.5 Ω?	Go to step 12.	Repair the open circuit of VDCCM&H/U ground harness and poor contact of connector.
12 CHECK POOR CONTACT IN CONNECTOR.	Is there poor contact in control module power supply, ground circuit and data link connector?	Repair the connector.	Replace the VDCCM only. <Ref. to VDC-11, REPLACEMENT, VDC Control Module and Hydraulic Control Unit (VDCCM&H/U).>

Read Diagnostic Trouble Code (DTC)

VEHICLE DYNAMICS CONTROL (VDC) (DIAGNOSTICS)

7. Read Diagnostic Trouble Code (DTC)

A: OPERATION

- 1) On the «Main Menu» display, select {Each System Check}.
- 2) On the «System Selection Menu», select {Brake Control System}.
- 3) Click the [OK] button after the {VDC} is displayed.
- 4) On the «Brake Control Diagnosis» screen, select {Diagnostic Code(s) Display}.
- 5) Record the DTC and data.

NOTE:

- For detailed operation procedure, refer to the “PC application help for Subaru Select Monitor”.
- For details concerning DTCs, refer to “List of Diagnostic Trouble Code (DTC)”. <Ref. to VDC(diag)-32, List of Diagnostic Trouble Code (DTC).>
- Up to 3 DTCs are displayed in the order of detection.
- If a particular DTC is not stored in memory properly at the occurrence of problem (due to a drop in VDCCM&H/U power supply etc.), the DTC suffixed with a question mark “?” is displayed on Subaru Select Monitor display screen. This shows it may be an unreliable reading.

Display	Contents to be monitored
(Current)	The current DTC is displayed on Subaru Select Monitor display screen.
(Old)	The latest DTC in previous troubles is displayed on Subaru Select Monitor display screen.
(Older)	The second latest DTC in previous troubles is displayed on Subaru Select Monitor display screen.
(Before 3)	The third latest DTC in previous problems is displayed on Subaru Select Monitor display screen.

8. Inspection Mode

A: PROCEDURE

Reproduce the malfunction occurrence condition as much as possible.

Drive the vehicle at least ten minutes.

NOTE:

Make sure the vehicle is not dragged to one side under usual driving condition.

Clear Memory Mode

VEHICLE DYNAMICS CONTROL (VDC) (DIAGNOSTICS)

9. Clear Memory Mode

A: OPERATION

- 1) On the «Main Menu» display, select {Each System Check}.
- 2) On the «System Selection Menu», select {Brake Control System}.
- 3) Click the [OK] button after the {VDC} is displayed.
- 4) On the «Brake Control Diagnosis», select {Clear Memory}.
- 5) When the “Clear Memory?” is shown on the screen, click the [YES] button.
- 6) When “Done” and “Turn Ignition Switch OFF” are shown on the display screen, turn the ignition switch to OFF.

NOTE:

For detailed operation procedure, refer to the “PC application help for Subaru Select Monitor”.

Warning Light Illumination Pattern

VEHICLE DYNAMICS CONTROL (VDC) (DIAGNOSTICS)

10.Warning Light Illumination Pattern

A: INSPECTION

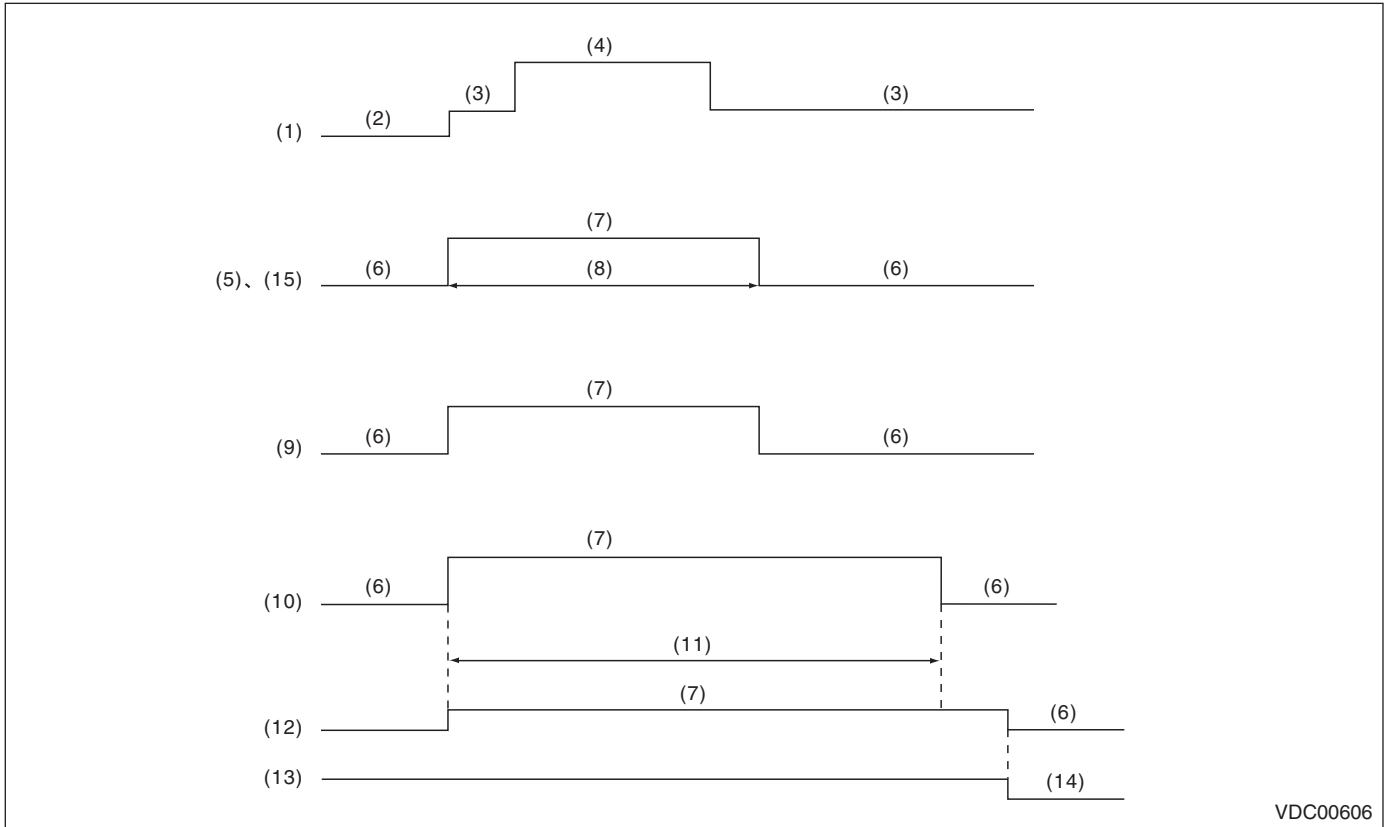

VDC00606

- | | | |
|-----------------------|---|---|
| (1) Ignition switch | (8) 2 sec. | (12) Brake warning light
(EBD warning light) |
| (2) OFF | (9) VDC indicator light | (13) Parking brake |
| (3) ON | (10) VDC warning light and VDC OFF
indicator light | (14) Released |
| (4) Engine start | (11) Several seconds (depending on
engine coolant temperature) | (15) Hill start assist warning light
(MT model only) |
| (5) ABS warning light | | |
| (6) Light OFF | | |
| (7) Light ON | | |

Warning Light Illumination Pattern

VEHICLE DYNAMICS CONTROL (VDC) (DIAGNOSTICS)

1) When warning lights or indicator lights do not illuminate in accordance with this illumination pattern, there must be an electrical malfunction.

2) When warning lights or indicator lights remain constantly OFF, check the combination meter circuit or CAN communication circuit. <Ref. to VDC(diag)-27, VDC WARNING LIGHT, VDC OFF INDICATOR LIGHT AND VDC INDICATOR LIGHT DO NOT COME ON, Warning Light Illumination Pattern.>

3) When the ABS warning light and the hill start assist warning light do not go off, check the combination meter circuit. <Ref. to VDC(diag)-28, ABS WARNING LIGHT DOES NOT GO OFF, Warning Light Illumination Pattern.>

4) When the VDC indicator light, VDC warning light and VDC OFF indicator light do not go off, check the combination meter circuit or CAN communication circuit. <Ref. to VDC(diag)-28, VDC INDICATOR LIGHT DOES NOT GO OFF, Warning Light Illumination Pattern.> <Ref. to VDC(diag)-29, VDC WARNING LIGHT AND VDC OFF INDICATOR LIGHT DO NOT GO OFF, Warning Light Illumination Pattern.>

NOTE:

- Even though the ABS warning light does not go off after 2 seconds from ABS warning light illumination, the ABS system operates normally when the warning light goes off while driving at approximately 12 km/h (7 MPH). However, the ABS system does not work while the ABS warning light is illuminated.
- It may take several minutes before VDC warning light and VDC OFF indicator light goes off if the vehicle is parked under low temperature for a specified time. This is not defective because it is resulted from low engine coolant temperature.
- With the vehicle jack-up/lift-up or set on free rollers, when the wheels lock or spin after starting the engine, ABS warning light, VDC warning light and VDC OFF indicator light may illuminate because VDCCM&H/U detects the abnormal conditions from ABS wheel speed sensors. In this case, this is not a malfunction. Perform the Clear Memory Mode.

Warning Light Illumination Pattern

VEHICLE DYNAMICS CONTROL (VDC) (DIAGNOSTICS)

B: VDC WARNING LIGHT, VDC OFF INDICATOR LIGHT AND VDC INDICATOR LIGHT DO NOT COME ON

DETECTING CONDITION:

- Defective combination meter
- Defective CAN communication

TROUBLE SYMPTOM:

When the ignition switch is turned to ON (engine OFF), VDC indicator light, VDC warning light and VDC OFF indicator light do not come on.

NOTE:

When pressing the VDC OFF switch for 10 seconds or more, the VDC OFF indicator light goes off and cannot operate any more. When turning the ignition switch from OFF to ON, the OFF operation enabled status is restored.

Step	Check	Yes	No	
1	CHECK OTHER INDICATOR LIGHT. Turn the ignition switch to ON.	Does other indicator light illuminate soon after "ON".	Go to step 2.	Perform the self-diagnosis of combination meter.
2	CHECK VDCCM. When the engine does not start, display the current data of VDCCM using Subaru Select Monitor.	Is "VDC Warning Light" output set to "ON"?	Go to step 3.	Replace the VDCCM only.
3	CHECK LAN SYSTEM. Perform the diagnosis for LAN system. <Ref. to LAN(diag)-15, OPERATION, Read Diagnostic Trouble Code (DTC).>	Is there any fault in LAN system?	Perform the diagnosis according to DTC for LAN system.	Go to step 4.
4	CHECK COMBINATION METER. Check the combination meter.	Is combination meter OK?	Replace the VDCCM only.	Repair the combination meter assembly.

C: ABS WARNING LIGHT DOES NOT COME ON

DETECTING CONDITION:

- Defective combination meter
- Defective CAN communication

TROUBLE SYMPTOM:

When the ignition switch is turned to ON (engine OFF), the ABS warning light and hill start assist warning light do not come on.

Step	Check	Yes	No	
1	CHECK OTHER LIGHTS TURN ON. Turn the ignition switch to ON.(engine OFF)	Do other warning lights illuminate?	Go to step 2.	Check the combination meter.
2	READ DTC. Read the DTC. <Ref. to VDC(diag)-22, Read Diagnostic Trouble Code (DTC).>	Is DTC displayed?	Perform the diagnosis according to DTC.	Go to step 3.
3	CHECK LAN SYSTEM. Perform the diagnosis for LAN system. <Ref. to LAN(diag)-15, OPERATION, Read Diagnostic Trouble Code (DTC).>	Is there any fault in LAN system?	Perform the diagnosis according to DTC for LAN system.	Go to step 4.
4	CHECK COMBINATION METER. Check the combination meter.	Is combination meter OK?	Replace the VDCCM only.	Repair the combination meter assembly.

Warning Light Illumination Pattern

VEHICLE DYNAMICS CONTROL (VDC) (DIAGNOSTICS)

D: HILL START ASSIST WARNING LIGHT DOES NOT COME ON

Refer to “ABS warning light does not illuminate” for diagnostic procedure. <Ref. to VDC(diag)-27, ABS WARNING LIGHT DOES NOT COME ON, Warning Light Illumination Pattern.>

E: ABS WARNING LIGHT DOES NOT GO OFF

DETECTING CONDITION:

- Defective combination meter
- Defective CAN communication

TROUBLE SYMPTOM:

When starting the engine, the ABS warning light and hill start assist warning light remains lit.

	Step	Check	Yes	No
1	READ DTC. Read the DTC. <Ref. to VDC(diag)-22, Read Diagnostic Trouble Code (DTC).>	Is DTC displayed?	Perform the diagnosis according to DTC.	Go to step 2.
2	CHECK LAN SYSTEM. Perform the diagnosis for LAN system. <Ref. to LAN(diag)-15, OPERATION, Read Diagnostic Trouble Code (DTC).>	Is there any fault in LAN system?	Perform the diagnosis according to DTC for LAN system.	Go to step 3.
3	CHECK COMBINATION METER. Check the combination meter.	Is combination meter OK?	Replace the VDCCM only.	Repair the combination meter.

F: HILL START ASSIST WARNING LIGHT DOES NOT GO OFF

Refer to “ABS warning light does not go off” for diagnostic procedure. <Ref. to VDC(diag)-28, ABS WARNING LIGHT DOES NOT GO OFF, Warning Light Illumination Pattern.>

G: VDC INDICATOR LIGHT DOES NOT GO OFF

DETECTING CONDITION:

- Defective combination meter
- Defective CAN communication

TROUBLE SYMPTOM:

When starting the engine, VDC indicator light is kept ON.

	Step	Check	Yes	No
1	READ DTC. Read the DTC. <Ref. to VDC(diag)-22, Read Diagnostic Trouble Code (DTC).>	Is DTC displayed?	Perform the diagnosis according to DTC.	Go to step 2.
2	CHECK LAN SYSTEM. Perform the diagnosis for LAN system. <Ref. to LAN(diag)-15, OPERATION, Read Diagnostic Trouble Code (DTC).>	Is there any fault in LAN system?	Perform the diagnosis according to DTC for LAN system.	Go to step 3.
3	CHECK COMBINATION METER. Check the combination meter.	Is combination meter OK?	Replace the VDCCM only.	Repair the combination meter.

Warning Light Illumination Pattern

VEHICLE DYNAMICS CONTROL (VDC) (DIAGNOSTICS)

H: VDC WARNING LIGHT AND VDC OFF INDICATOR LIGHT DO NOT GO OFF

DETECTING CONDITION:

- Defective combination meter
- Defective CAN communication
- Defective engine
- VDC OFF switch is shorted.

TROUBLE SYMPTOM:

When starting the engine, VDC OFF indicator light is kept ON.

NOTE:

When pressing the VDC OFF switch for 10 seconds or more, the VDC OFF indicator light goes off and cannot operate any more. When turning the ignition switch from OFF to ON, the OFF operation enabled status is restored.

	Step	Check	Yes	No
1	READ DTC. Read the DTC. <Ref. to VDC(diag)-22, Read Diagnostic Trouble Code (DTC).>	Is DTC displayed?	Perform the diagnosis according to DTC.	Go to step 2.
2	CHECK ENGINE.	Does the malfunction indicator light illuminate?	Repair the engine.	Go to step 3.
3	CHECK ENGINE COOLANT TEMPERATURE. Warm up the engine and check if VDC warning light and VDC OFF indicator light illumination condition changes.	When the engine coolant temperature is too low, VDC warning light and VDC OFF indicator light illuminate. Do the lights go off when the engine is warmed-up?	Normal operation	Go to step 4.
4	CHECK VDC OFF SWITCH. Remove and check VDC OFF switch. <Ref. to VDC-29, VDC OFF Switch.>	Is the VDC OFF switch normal?	Go to step 5.	Replace the VDC OFF switch.
5	CHECK LAN SYSTEM. Perform the diagnosis for LAN system. <Ref. to LAN(diag)-15, OPERATION, Read Diagnostic Trouble Code (DTC).>	Is there any fault in LAN system?	Perform the diagnosis according to DTC for LAN system.	Go to step 6.
6	CHECK COMBINATION METER. Check the combination meter.	Is combination meter OK?	Replace the VDCCM only.	Repair the combination meter.

Warning Light Illumination Pattern

VEHICLE DYNAMICS CONTROL (VDC) (DIAGNOSTICS)

I: BRAKE WARNING LIGHT DOES NOT GO OFF

DETECTING CONDITION:

- Brake warning light circuit is shorted.
- Defective sensor/connector

TROUBLE SYMPTOM:

After starting the engine, the brake warning light remains lit though the parking lever is released.

WIRING DIAGRAM:

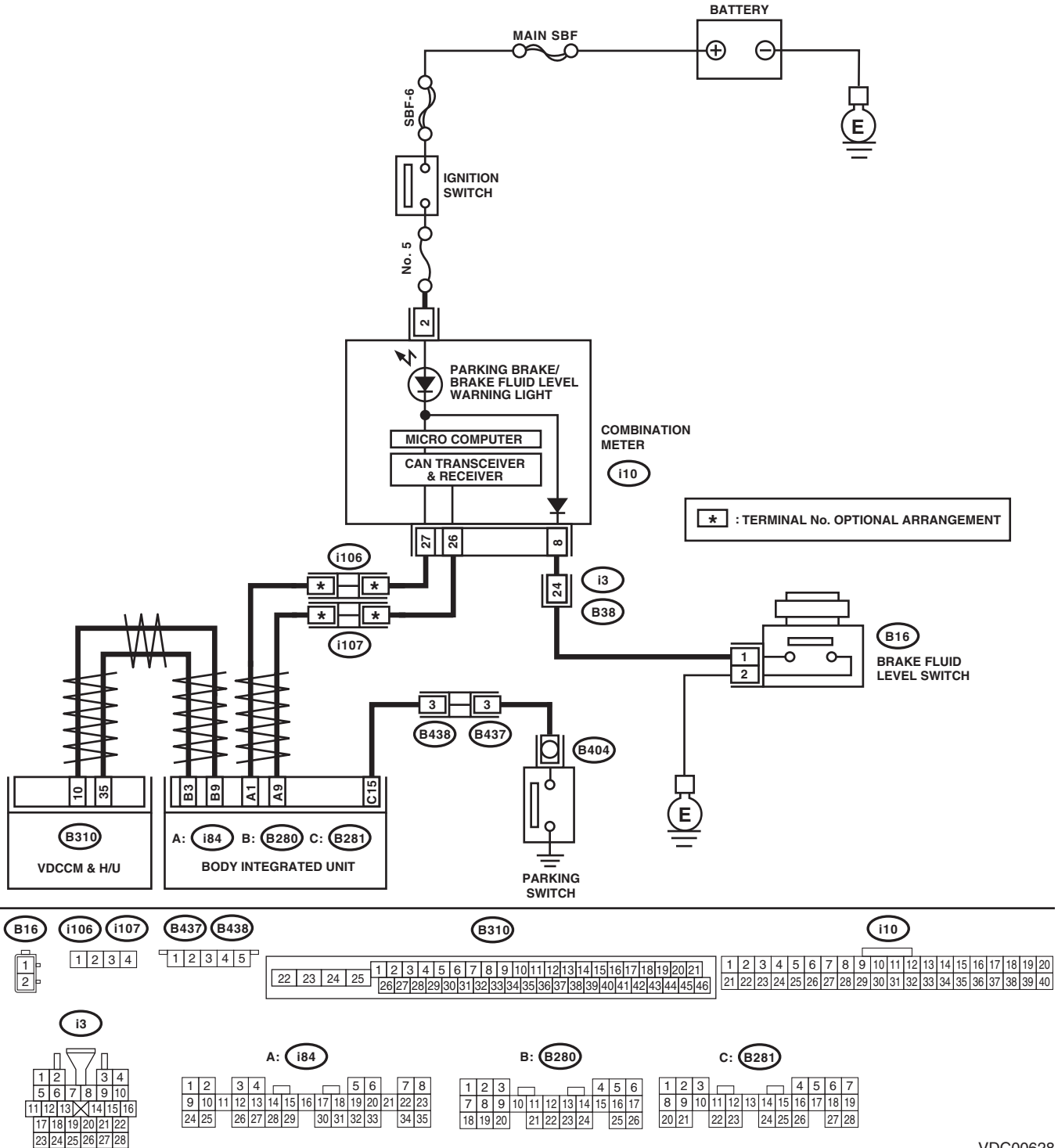

VDC00628

Warning Light Illumination Pattern

VEHICLE DYNAMICS CONTROL (VDC) (DIAGNOSTICS)

Step	Check	Yes	No
1 CHECK INSTALLATION OF VDCCM&H/U CONNECTOR. 1) Turn the ignition switch to OFF. 2) Check that the VDCCM&H/U connector is inserted until it is locked by clamp.	Is the connector firmly inserted?	Go to step 2.	Insert the VDCCM&H/U connector until it is locked by clamp.
2 READ DTC. Read the DTC. <Ref. to VDC(diag)-22, Read Diagnostic Trouble Code (DTC).>	Is DTC displayed?	Perform the diagnosis according to DTC.	Go to step 3.
3 CHECK BRAKE FLUID AMOUNT. Check the amount of brake fluid in the reservoir tank of master cylinder.	Is the amount of brake fluid between the lines of "MAX" and "MIN"?	Go to step 4.	Replenish brake fluid to the specified value.
4 CHECK BRAKE FLUID LEVEL SWITCH. 1) Turn the ignition switch to OFF. 2) Disconnect the level switch connector (B16) from master cylinder. 3) Measure the resistance of master cylinder terminals. <i>Terminals</i> <i>No. 1 — No. 2:</i>	Is the resistance 1 MΩ or more?	Go to step 5.	Replace the master cylinder.
5 CHECK GROUND SHORT OF HARNESS. 1) Disconnect the connector (i10) from the combination meter. 2) Measure the resistance between combination meter connector and chassis ground. <i>Connector & terminal</i> <i>(i10) No. 8 — Chassis ground:</i>	Is the resistance 1 MΩ or more?	Go to step 6.	Repair the harness connector between the combination meter and brake fluid level switch.
6 CHECK PARKING BRAKE SWITCH. 1) Disconnect the connector (B404) from parking brake switch. 2) Release the parking brake. 3) Measure the resistance between parking brake switch terminal and chassis ground.	Is the resistance 1 MΩ or more?	Go to step 7.	Replace the parking brake switch.
7 CHECK GROUND SHORT OF HARNESS. 1) Disconnect the connector (B281) from body integrated unit. 2) Measure the resistance between body integrated unit connector and chassis ground. <i>Connector & terminal</i> <i>(B281) No. 15 — Chassis ground:</i>	Is the resistance 1 MΩ or more?	Go to step 8.	Repair the harness between the body integrated unit and parking brake switch.
8 CHECK POOR CONTACT IN CONNECTOR. Check for poor contact in all connectors.	Is there poor contact?	Repair the connector.	Go to step 9.
9 CHECK LAN SYSTEM. Perform the diagnosis for LAN system. <Ref. to LAN(diag)-15, OPERATION, Read Diagnostic Trouble Code (DTC).>	Is there any fault in LAN system?	Perform the diagnosis according to DTC for LAN system.	Go to step 10.
10 CHECK COMBINATION METER. Check the combination meter.	Is combination meter OK?	Replace the VDCCM only.	Repair the combination meter.

List of Diagnostic Trouble Code (DTC)

VEHICLE DYNAMICS CONTROL (VDC) (DIAGNOSTICS)

11. List of Diagnostic Trouble Code (DTC)

A: LIST

DTC	Detailed code	Display	Content of diagnosis	Reference target
C0021	07B1H 07B2H 07C0H	Front Right ABS Sensor Circuit Open or Shorted Battery	Open/high input of front ABS wheel speed sensor RH	<Ref. to VDC(diag)-38, DTC C0021 FRONT RIGHT ABS SENSOR CIRCUIT OPEN OR SHORT, Diagnostic Procedure with Diagnostic Trouble Code (DTC).>
C0022	0720H 072FH 0736H 0737H 0738H 073AH 073CH	Front Right ABS Sensor Signal	Front ABS wheel speed sensor RH signal malfunction	<Ref. to VDC(diag)-41, DTC C0022 FRONT RIGHT ABS SENSOR SIGNAL, Diagnostic Procedure with Diagnostic Trouble Code (DTC).>
C0023	06B1H 06B2H 06C0H	Front Left ABS Sensor Circuit Open or Shorted Battery	Open/high input of front ABS wheel speed sensor LH	<Ref. to VDC(diag)-38, DTC C0023 FRONT LEFT ABS SENSOR CIRCUIT OPEN OR SHORT, Diagnostic Procedure with Diagnostic Trouble Code (DTC).>
C0024	0620H 062FH 0636H 0637H 0638H 063AH 063CH	Front Left ABS Sensor Signal	Front ABS wheel speed sensor LH signal malfunction	<Ref. to VDC(diag)-41, DTC C0024 FRONT LEFT ABS SENSOR SIGNAL, Diagnostic Procedure with Diagnostic Trouble Code (DTC).>
C0025	09B1H 09B2H 09C0H	Rear Right ABS Sensor Circuit Open or Shorted Battery	Open/high input of rear ABS wheel speed sensor RH	<Ref. to VDC(diag)-38, DTC C0025 REAR RIGHT ABS SENSOR CIRCUIT OPEN OR SHORT, Diagnostic Procedure with Diagnostic Trouble Code (DTC).>
C0026	0920H 092FH 0936H 0937H 0938H 093AH 093CH	Rear Right ABS Sensor Signal	Rear ABS wheel speed sensor RH signal malfunction	<Ref. to VDC(diag)-41, DTC C0026 REAR RIGHT ABS SENSOR SIGNAL, Diagnostic Procedure with Diagnostic Trouble Code (DTC).>
C0027	08B1H 08B2H 08C0H	Rear Left ABS Sensor Circuit Open or Shorted Battery	Open/high input of rear ABS wheel speed sensor LH	<Ref. to VDC(diag)-39, DTC C0027 REAR LEFT ABS SENSOR CIRCUIT OPEN OR SHORT, Diagnostic Procedure with Diagnostic Trouble Code (DTC).>
C0028	0820H 082FH 0836H 0837H 0838H 083AH 083CH	Rear Left ABS Sensor Signal	Rear ABS wheel speed sensor LH signal malfunction	<Ref. to VDC(diag)-42, DTC C0028 REAR LEFT ABS SENSOR SIGNAL, Diagnostic Procedure with Diagnostic Trouble Code (DTC).>
C0029	0A10H 0A41H 0A4BH 0A4DH 0A52H 0A56H 0A60H	Any One of Four ABS Sensors Signal	ABS wheel speed sensor signal malfunction in one of four wheels	<Ref. to VDC(diag)-45, DTC C0029 ANY OF WHEEL SENSORS SIGNAL, Diagnostic Procedure with Diagnostic Trouble Code (DTC).>

List of Diagnostic Trouble Code (DTC)

VEHICLE DYNAMICS CONTROL (VDC) (DIAGNOSTICS)

DTC	Detailed code	Display	Content of diagnosis	Reference target
C0031	0DB8H 0DC0H 0DC1H 0DD0H	FR Hold Valve malfunction	Front inlet solenoid valve RH malfunction in VDCCM&H/U	<Ref. to VDC(diag)-47, DTC C0031 FR HOLD VALVE MALFUNCTION, Diagnostic Procedure with Diagnostic Trouble Code (DTC).>
C0032	0EB8H 0EC0H 0EC1H 0ED0H	FR Pressure Reducing Valve malfunction	Front outlet solenoid valve RH malfunction in VDCCM&H/U	<Ref. to VDC(diag)-47, DTC C0032 FR PRESSURE REDUCING VALVE MALFUNCTION, Diagnostic Procedure with Diagnostic Trouble Code (DTC).>
C0033	0BB8H 0BC0H 0BC1H 0BD0H	FL Hold Valve malfunction	Front inlet solenoid valve LH malfunction in VDCCM&H/U	<Ref. to VDC(diag)-47, DTC C0033 FL HOLD VALVE MALFUNCTION, Diagnostic Procedure with Diagnostic Trouble Code (DTC).>
C0034	0CB8H 0CC0H 0CC1H 0CD0H	FL Pressure Reducing Valve malfunction	Front outlet solenoid valve LH malfunction in VDCCM&H/U	<Ref. to VDC(diag)-47, DTC C0034 FL PRESSURE REDUCING VALVE MALFUNCTION, Diagnostic Procedure with Diagnostic Trouble Code (DTC).>
C0035	11B8H 11C0H 11C1H 11D0H	RR Hold Valve malfunction	Rear inlet solenoid valve RH malfunction in VDCCM&H/U	<Ref. to VDC(diag)-47, DTC C0035 RR HOLD VALVE MALFUNCTION, Diagnostic Procedure with Diagnostic Trouble Code (DTC).>
C0036	12B8H 12C0H 12C1H 12D0H	RR Pressure Reducing Valve malfunction	Rear outlet solenoid valve RH malfunction in VDCCM&H/U	<Ref. to VDC(diag)-47, DTC C0036 RR PRESSURE REDUCING VALVE MALFUNCTION, Diagnostic Procedure with Diagnostic Trouble Code (DTC).>
C0037	0FB8H 0FC0H 0FC1H 0FD0H	RL Hold Valve malfunction	Rear inlet solenoid valve LH malfunction in VDCCM&H/U	<Ref. to VDC(diag)-48, DTC C0037 RL HOLD VALVE MALFUNCTION, Diagnostic Procedure with Diagnostic Trouble Code (DTC).>
C0038	10B8H 10C0H 10C1H 10D0H	RL Pressure Reducing Valve malfunction	Rear outlet solenoid valve LH malfunction in VDCCM&H/U	<Ref. to VDC(diag)-48, DTC C0038 RL PRESSURE REDUCING VALVE MALFUNCTION, Diagnostic Procedure with Diagnostic Trouble Code (DTC).>
C0039	0FB5H 11B5H	Any One of Four Solenoid Valves	Solenoid valve malfunction in one of four wheels	<Ref. to VDC(diag)-48, DTC C0039 ANY ONE OF FOUR SOLENOID VALVES, Diagnostic Procedure with Diagnostic Trouble Code (DTC).>
C0041	—	Electrical Control Module	VDC control module malfunction	<Ref. to VDC(diag)-51, DTC C0041 ECM, Diagnostic Procedure with Diagnostic Trouble Code (DTC).>
	1630H 1645H 16C0H	Parameter selection error	VDC control module parameter selection failure	<Ref. to VDC(diag)-53, DTC C0041 PARAMETER SELECTION ERROR, Diagnostic Procedure with Diagnostic Trouble Code (DTC).>
C0042	0316H 031CH 0322H 0324H	Power Supply Voltage Failure	Power voltage malfunction	<Ref. to VDC(diag)-54, DTC C0042 POWER SUPPLY VOLTAGE FAILURE, Diagnostic Procedure with Diagnostic Trouble Code (DTC).>
C0044	2921H	TCM Communication Circuit	CAN communication failure of transmission control module	<Ref. to VDC(diag)-56, DTC C0044 TCM COMMUNICATION CIRCUIT, Diagnostic Procedure with Diagnostic Trouble Code (DTC).>

List of Diagnostic Trouble Code (DTC)

VEHICLE DYNAMICS CONTROL (VDC) (DIAGNOSTICS)

DTC	Detailed code	Display	Content of diagnosis	Reference target
C0045	2922H 2932H	Incorrect VDC Control Module specifications	Different VDC control module specification	<Ref. to VDC(diag)-57, DTC C0045 INCORRECT VDC CONTROL MODULE SPECIFICATIONS, Diagnostic Procedure with Diagnostic Trouble Code (DTC).>
	2923H	TCM malfunction	AT control module malfunction	<Ref. to VDC(diag)-58, DTC C0045 TCM MALFUNCTION, Diagnostic Procedure with Diagnostic Trouble Code (DTC).>
C0047	1504H 1505H 1506H 1507H 1508H 150EH 1512H 1514H 1518H 1519H 151AH 151DH 151EH 151FH 1520H 1531H 1540H 15C0H	Improper CAN Communication	Improper CAN communication	<Ref. to VDC(diag)-59, DTC C0047 CAN COMMUNICATION, Diagnostic Procedure with Diagnostic Trouble Code (DTC).>
C0051	021FH 0220H 0221H 0280H 0281H 02B0H 02B1H 02C0H	Valve Relay	Valve Relay	<Ref. to VDC(diag)-61, DTC C0051 VALVE RELAY, Diagnostic Procedure with Diagnostic Trouble Code (DTC).>
C0052	0562H 0574H 0580H	Motor and Motor Relay OFF Failure	Motor/motor relay OFF malfunction	<Ref. to VDC(diag)-63, DTC C0052 MOTOR AND MOTOR RELAY OFF FAILURE, Diagnostic Procedure with Diagnostic Trouble Code (DTC).>
	05A0H	Motor and Motor Relay ON Failure	Motor/motor relay ON malfunction	<Ref. to VDC(diag)-65, DTC C0052 MOTOR AND MOTOR RELAY ON FAILURE, Diagnostic Procedure with Diagnostic Trouble Code (DTC).>
	0560H	Motor malfunction	Motor	<Ref. to VDC(diag)-66, DTC C0052 MOTOR MALFUNCTION, Diagnostic Procedure with Diagnostic Trouble Code (DTC).>
C0054	04B0H	BLS Circuit Open	BLS open circuit	<Ref. to VDC(diag)-67, DTC C0054 BLS CIRCUIT OPEN, Diagnostic Procedure with Diagnostic Trouble Code (DTC).>
	043CH	BLS ON malfunction	BLS ON malfunction	<Ref. to VDC(diag)-69, DTC C0054 BLS ON MALFUNCTION, Diagnostic Procedure with Diagnostic Trouble Code (DTC).>
	04C1H	BLS OFF Malfunction	BLS OFF malfunction	<Ref. to VDC(diag)-71, DTC C0054 BLS OFF MALFUNCTION, Diagnostic Procedure with Diagnostic Trouble Code (DTC).>

List of Diagnostic Trouble Code (DTC)

VEHICLE DYNAMICS CONTROL (VDC) (DIAGNOSTICS)

DTC	Detailed code	Display	Content of diagnosis	Reference target
C0056	1760H 1770H 1780H	Longitudinal G Sensor Signal	Abnormal longitudinal G sensor output signal	<Ref. to VDC(diag)-73, DTC C0056 G SENSOR SIGNAL, Diagnostic Procedure with Diagnostic Trouble Code (DTC).>
C0057	2931H	ECM Communication Circuit	CAN communication failure of engine control module	<Ref. to VDC(diag)-75, DTC C0057 ECM COMMUNICATION CIRCUIT, Diagnostic Procedure with Diagnostic Trouble Code (DTC).>
	2930H	ECM Control System	Coordinate control prohibition of engine control module	<Ref. to VDC(diag)-76, DTC C0057 ECM CONTROL SYSTEM, Diagnostic Procedure with Diagnostic Trouble Code (DTC).>
C0061	19B8H 19C0H 19C1H 19D0H	Normal Opening Valve 1 malfunction	Secondary cut valve malfunction in VDCCM&H/U	<Ref. to VDC(diag)-48, DTC C0061 NORMAL OPENING VALVE 1 MALFUNCTION, Diagnostic Procedure with Diagnostic Trouble Code (DTC).>
C0062	1AB8H 1AC0H 1AC1H 1AD0H	Normal Opening Valve 2 malfunction	Primary cut valve malfunction in VDCCM&H/U	<Ref. to VDC(diag)-48, DTC C0062 NORMAL OPENING VALVE 2 MALFUNCTION, Diagnostic Procedure with Diagnostic Trouble Code (DTC).>
C0063	1BB8H 1BC0H 1BC1H 1BD0H	Normal Closing Valve 1 malfunction	Secondary suction valve malfunction in VDCCM&H/U	<Ref. to VDC(diag)-48, DTC C0063 NORMAL CLOSING VALVE 1 MALFUNCTION, Diagnostic Procedure with Diagnostic Trouble Code (DTC).>
C0064	1CB8H 1CC0H 1CC1H 1CD0H	Normal Closing Valve 2 malfunction	Primary suction valve malfunction in VDCCM&H/U	<Ref. to VDC(diag)-49, DTC C0064 NORMAL CLOSING VALVE 2 MALFUNCTION, Diagnostic Procedure with Diagnostic Trouble Code (DTC).>
C0071	2130H	Steering Angle Sensor Offset is too big	Excessive steering angle sensor output offset	<Ref. to VDC(diag)-77, DTC C0071 STEERING ANGLE SENSOR OFFSET IS TOO BIG, Diagnostic Procedure with Diagnostic Trouble Code (DTC).>
	2134H	Change range of Steering Angle Sensor is too big	Excessive variation amount of steering angle sensor output	<Ref. to VDC(diag)-79, DTC C0071 CHANGE RANGE OF STEERING ANGLE SENSOR IS TOO BIG, Diagnostic Procedure with Diagnostic Trouble Code (DTC).>
	212EH 2132H 2136H 2138H 213CH 2150H 2151H 2152H 2153H 2154H 2155H 2156H 2157H 2158H 2159H 215AH	Steering Angle Sensor Op	Steering angle sensor output	<Ref. to VDC(diag)-81, DTC C0071 STEER ANGLE SENSOR OP, Diagnostic Procedure with Diagnostic Trouble Code (DTC).>
	2104H	Steering angle sensor malfunction	Steering angle sensor power supply malfunction	<Ref. to VDC(diag)-83, DTC C0071 STEERING ANGLE SENSOR MALFUNCTION, Diagnostic Procedure with Diagnostic Trouble Code (DTC).>

List of Diagnostic Trouble Code (DTC)

VEHICLE DYNAMICS CONTROL (VDC) (DIAGNOSTICS)

DTC	Detailed code	Display	Content of diagnosis	Reference target
C0072	1E1AH 1E1EH 1E22H 1E26H 1E28H 1E2CH 1E34H 1E38H 1E3AH 1E3FH	Abnormal Yaw Rate Sensor output	Yaw rate sensor output	<Ref. to VDC(diag)-85, DTC C0072 ABNORMAL YAW RATE SENSOR OUTPUT, Diagnostic Procedure with Diagnostic Trouble Code (DTC).>
	1EB6H	Voltage inputted to Yaw Rate Sensor exceeds specification	Yaw rate sensor power supply/output	<Ref. to VDC(diag)-87, DTC C0072 VOLTAGE INPUTTED TO YAW RATE SENSOR EXCEEDS SPECIFICATION, Diagnostic Procedure with Diagnostic Trouble Code (DTC).>
	1E30H	Change range of Yaw Rate Sensor Signal is too big	Excessive variation amount of yaw rate sensor output	<Ref. to VDC(diag)-89, DTC C0072 CHANGE RANGE OF YAW RATE SENSOR SIGNAL IS TOO BIG, Diagnostic Procedure with Diagnostic Trouble Code (DTC).>
	1EB7H 1EBFH 1EB5H 1EBCH 1EBDH 1EBEH 1EC0H 1EC2H 1EC3H 1EC4H 1EC6H 1ECEH 1ECFH 1ED0H 1ED3H 1ED4H 1ED5H	Yaw Rate Sensor Communication	Yaw rate sensor communication	<Ref. to VDC(diag)-91, DTC C0072 YAW RATE SENSOR COMMUNICATION, Diagnostic Procedure with Diagnostic Trouble Code (DTC).>
	1EB9H 1ED6H	Sensor type abnormal	Different yaw rate sensor specification	<Ref. to VDC(diag)-93, DTC C0072 SENSOR TYPE ABNORMAL, Diagnostic Procedure with Diagnostic Trouble Code (DTC).>
	C0073	1D46H 1D47H	Lateral G Sensor offset is too big	Excessive amount of lateral G sensor output offset
1D44H 1D45H		Abnormal Lateral G Sensor output	Lateral G sensor output	<Ref. to VDC(diag)-93, DTC C0073 ABNORMAL LATERAL G SENSOR OUTPUT, Diagnostic Procedure with Diagnostic Trouble Code (DTC).>
1D49H		Excessive Lateral G Sensor signal	Excessive lateral G sensor output	<Ref. to VDC(diag)-94, DTC C0073 EXCESSIVE LATERAL G SENSOR SIGNAL, Diagnostic Procedure with Diagnostic Trouble Code (DTC).>
C0074	1F4EH 1F4FH 1FB1H 1FC0H	Pressure Sensor	Pressure sensor	<Ref. to VDC(diag)-96, DTC C0074 PRESSURE SENSOR, Diagnostic Procedure with Diagnostic Trouble Code (DTC).>

List of Diagnostic Trouble Code (DTC)

VEHICLE DYNAMICS CONTROL (VDC) (DIAGNOSTICS)

DTC	Detailed code	Display	Content of diagnosis	Reference target
C0075	2510H 2520H	Reverse signal	Abnormal reverse signal	<Ref. to VDC(diag)-97, DTC C0075 REVERSE SIGNAL, Diagnostic Procedure with Diagnostic Trouble Code (DTC).>
C0076	2610H 2620H	Clutch signal	Abnormal clutch signal	<Ref. to VDC(diag)-99, DTC C0076 CLUTCH SIGNAL, Diagnostic Procedure with Diagnostic Trouble Code (DTC).>
C0081	2201H 2202H	System Failure	System malfunction	<Ref. to VDC(diag)-100, DTC C0081 SYSTEM FAILURE, Diagnostic Procedure with Diagnostic Trouble Code (DTC).>

Diagnostic Procedure with Diagnostic Trouble Code (DTC)

VEHICLE DYNAMICS CONTROL (VDC) (DIAGNOSTICS)

12. Diagnostic Procedure with Diagnostic Trouble Code (DTC)

A: DTC C0021 FRONT RIGHT ABS SENSOR CIRCUIT OPEN OR SHORT

NOTE:

For the diagnostic procedure, refer to DTC C0027 “RL WHEEL SPEED SENSOR CIRCUIT OPEN/HIGH INPUT”. <Ref. to VDC(diag)-39, DTC C0027 REAR LEFT ABS SENSOR CIRCUIT OPEN OR SHORT, Diagnostic Procedure with Diagnostic Trouble Code (DTC).>

B: DTC C0023 FRONT LEFT ABS SENSOR CIRCUIT OPEN OR SHORT

NOTE:

For the diagnostic procedure, refer to DTC C0027 “RL WHEEL SPEED SENSOR CIRCUIT OPEN/HIGH INPUT”. <Ref. to VDC(diag)-39, DTC C0027 REAR LEFT ABS SENSOR CIRCUIT OPEN OR SHORT, Diagnostic Procedure with Diagnostic Trouble Code (DTC).>

C: DTC C0025 REAR RIGHT ABS SENSOR CIRCUIT OPEN OR SHORT

NOTE:

For the diagnostic procedure, refer to DTC C0027 “RL WHEEL SPEED SENSOR CIRCUIT OPEN/HIGH INPUT”. <Ref. to VDC(diag)-39, DTC C0027 REAR LEFT ABS SENSOR CIRCUIT OPEN OR SHORT, Diagnostic Procedure with Diagnostic Trouble Code (DTC).>

Diagnostic Procedure with Diagnostic Trouble Code (DTC)

VEHICLE DYNAMICS CONTROL (VDC) (DIAGNOSTICS)

D: DTC C0027 REAR LEFT ABS SENSOR CIRCUIT OPEN OR SHORT

DTC DETECTING CONDITION:

- Defective ABS wheel speed sensor (broken wire, input voltage too high)
- Defective harness connector

TROUBLE SYMPTOM:

- ABS does not operate.
- VDC does not operate.

WIRING DIAGRAM:

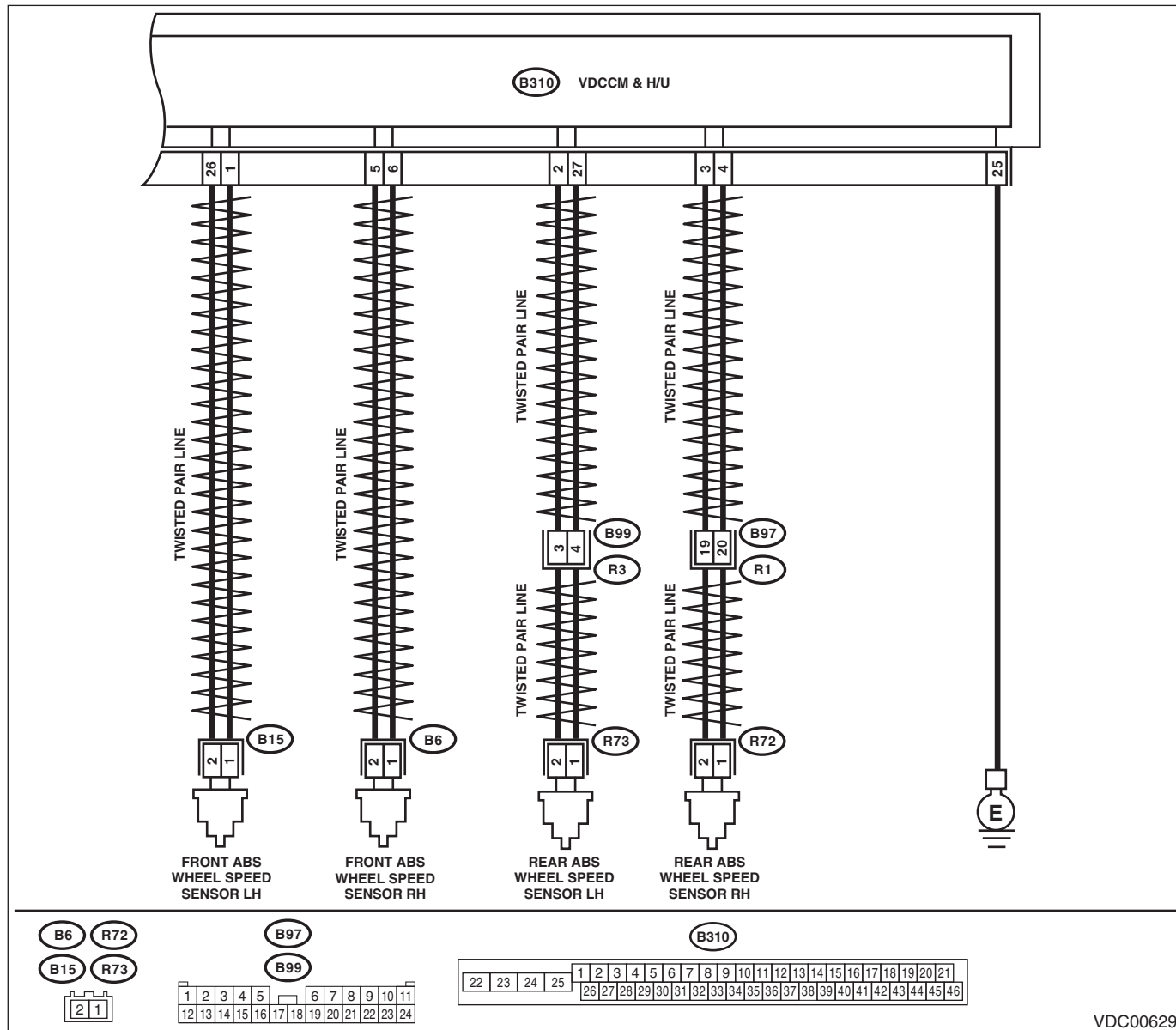

VDC00629

Diagnostic Procedure with Diagnostic Trouble Code (DTC)

VEHICLE DYNAMICS CONTROL (VDC) (DIAGNOSTICS)

Step	Check	Yes	No
1 CHECK POOR CONTACT IN CONNECTOR. Check if there is poor contact between VDCCM&H/U and ABS wheel speed sensor.	Is there poor contact?	Repair the connector.	Go to step 2.
2 CHECK HARNESS CONNECTOR BETWEEN VDCCM&H/U AND ABS WHEEL SPEED SENSOR. 1) Disconnect the connector (B310) from the VDCCM&H/U. 2) Disconnect the connector from the ABS wheel speed sensor. 3) Measure the resistance between VDCCM&H/U connector and ABS wheel speed sensor connector. <i>Connector & terminal</i> DTC C0021 (B310) No. 6 — (B6) No. 1: (B310) No. 5 — (B6) No. 2: DTC C0023 (B310) No. 1 — (B15) No. 1: (B310) No. 26 — (B15) No. 2: DTC C0025 (B310) No. 4 — (R72) No. 1: (B310) No. 3 — (R72) No. 2: DTC C0027 (B310) No. 27 — (R73) No. 1: (B310) No. 2 — (R73) No. 2:	Is the resistance less than 0.5 Ω?	Go to step 3.	Repair the harness connector between VDCCM&H/U and ABS wheel speed sensor.
3 CHECK GROUND SHORT OF HARNESS. Measure the resistance between VDCCM&H/U connector and chassis ground. <i>Connector & terminal</i> DTC C0021 (B310) No. 6 — Chassis ground: DTC C0023 (B310) No. 1 — Chassis ground: DTC C0025 (B310) No. 4 — Chassis ground: DTC C0027 (B310) No. 27 — Chassis ground:	Is the resistance 1 MΩ or more?	Go to step 4.	Repair the harness connector between VDCCM&H/U and ABS wheel speed sensor.
4 CHECK ABS WHEEL SPEED SENSOR POWER SUPPLY CIRCUIT. 1) Connect the VDCCM&H/U connector. 2) Turn the ignition switch to ON. 3) Measure the voltage between ABS wheel speed sensor connector and chassis ground. <i>Connector & terminal</i> DTC C0021 (B6) No. 2 (+) — Chassis ground (-): DTC C0023 (B15) No. 2 (+) — Chassis ground (-): DTC C0025 (R72) No. 2 (+) — Chassis ground (-): DTC C0027 (R73) No. 2 (+) — Chassis ground (-):	Is the voltage 5 — 16 V?	Go to step 6.	Go to step 5.

Diagnostic Procedure with Diagnostic Trouble Code (DTC)

VEHICLE DYNAMICS CONTROL (VDC) (DIAGNOSTICS)

Step	Check	Yes	No
5 CHECK VDCCM&H/U POWER SUPPLY CIRCUIT. 1) Turn the ignition switch to OFF. 2) Disconnect the VDCCM&H/U connector. 3) Turn the ignition switch to ON. 4) Measure the voltage between VDCCM&H/U connector terminals. Connector & terminal (B310) No. 28 (+) — (B310) No. 25 (-):	Is the voltage 10 — 15 V?	Go to step 6.	Check the generator, battery and VDCCM&H/U power supply circuit.
6 CHECK ABS WHEEL SPEED SENSOR SIGNAL. 1) Install the ABS wheel speed sensor. 2) Prepare an oscilloscope. 3) Check the ABS wheel speed sensor. <Ref. to VDC-25, ABS WHEEL SPEED SENSOR, INSPECTION, Front ABS Wheel Speed Sensor.>	Is the pattern the same waveform as shown in the figure?	Go to step 7.	Replace the ABS wheel speed sensor.
7 CHECK VDCCM&H/U. 1) Connect all connectors. 2) Erase the memory. 3) Perform the Inspection Mode. <Ref. to VDC(diag)-23, PROCEDURE, Inspection Mode.> 4) Read the DTC.	Is the same DTC displayed?	Replace the VDCCM only. <Ref. to VDC-11, REPLACEMENT, VDC Control Module and Hydraulic Control Unit (VDCCM&H/U).>	Go to step 8.
8 CHECK OTHER DTC DETECTION.	Is any other DTC displayed?	Perform the diagnosis according to DTC.	It results from a temporary noise interference.

E: DTC C0022 FRONT RIGHT ABS SENSOR SIGNAL

NOTE:

For the diagnostic procedure, refer to DTC C0028 "RL WHEEL SPEED SENSOR SIGNAL". <Ref. to VDC(diag)-42, DTC C0028 REAR LEFT ABS SENSOR SIGNAL, Diagnostic Procedure with Diagnostic Trouble Code (DTC).>

F: DTC C0024 FRONT LEFT ABS SENSOR SIGNAL

NOTE:

For the diagnostic procedure, refer to DTC C0028 "RL WHEEL SPEED SENSOR SIGNAL". <Ref. to VDC(diag)-42, DTC C0028 REAR LEFT ABS SENSOR SIGNAL, Diagnostic Procedure with Diagnostic Trouble Code (DTC).>

G: DTC C0026 REAR RIGHT ABS SENSOR SIGNAL

NOTE:

For the diagnostic procedure, refer to DTC C0028 "RL WHEEL SPEED SENSOR SIGNAL". <Ref. to VDC(diag)-42, DTC C0028 REAR LEFT ABS SENSOR SIGNAL, Diagnostic Procedure with Diagnostic Trouble Code (DTC).>

Diagnostic Procedure with Diagnostic Trouble Code (DTC)

VEHICLE DYNAMICS CONTROL (VDC) (DIAGNOSTICS)

H: DTC C0028 REAR LEFT ABS SENSOR SIGNAL

DTC DETECTING CONDITION:

- Defective ABS wheel speed sensor signal (noise, irregular signal, etc.)
- Defective harness connector

TROUBLE SYMPTOM:

- ABS does not operate.
- VDC does not operate.

WIRING DIAGRAM:

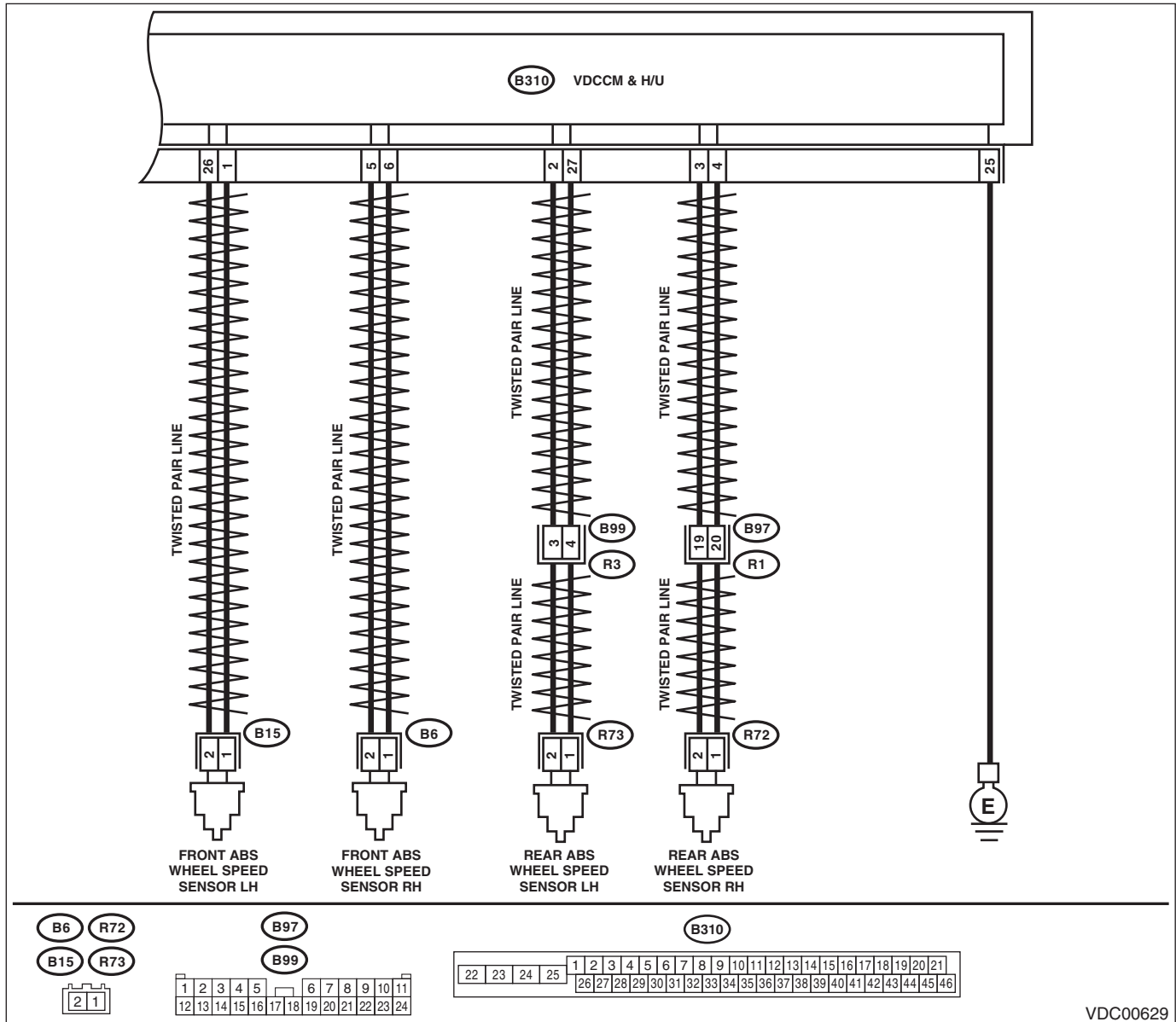

Diagnostic Procedure with Diagnostic Trouble Code (DTC)

VEHICLE DYNAMICS CONTROL (VDC) (DIAGNOSTICS)

Step	Check	Yes	No	
1	CHECK OUTPUT OF ABS WHEEL SPEED SENSOR USING SUBARU SELECT MONITOR. 1) Select {Current Data Display & Save} in Subaru Select Monitor. 2) Read the defective ABS wheel speed sensor output.	Does the speed indicated on the display change in response to the speedometer reading during acceleration/deceleration when the steering wheel is in the straight-ahead position?	Go to step 2.	Go to step 7.
2	CHECK POOR CONTACT IN CONNECTOR. Turn the ignition switch to OFF.	Is there poor contact in connectors between VDCCM&H/U and ABS wheel speed sensor?	Repair the connector.	Go to step 3.
3	CHECK CAUSE OF SIGNAL NOISE. Make sure the radio wave devices and electronic components are installed correctly.	Are the radio wave devices and electronic components installed correctly?	Go to step 4.	Install the radio wave devices and electronic components properly.
4	CHECK CAUSE OF SIGNAL NOISE. Check if the noise sources (such as an antenna) are installed near the sensor harness.	Are noise sources installed?	Install the noise sources apart from sensor harness.	Go to step 5.
5	CHECK VDCCM&H/U. 1) Connect all connectors. 2) Erase the memory. 3) Perform the Inspection Mode. <Ref. to VDC(diag)-23, PROCEDURE, Inspection Mode.> 4) Read the DTC.	Is the same DTC displayed?	Replace the VDCCM only. <Ref. to VDC-11, REPLACEMENT, VDC Control Module and Hydraulic Control Unit (VDCCM&H/U).>	Go to step 6.
6	CHECK OTHER DTC DETECTION.	Is any other DTC displayed?	Perform the diagnosis according to DTC.	It results from a temporary noise interference.
7	CHECK INSTALLATION OF ABS WHEEL SPEED SENSOR.	Is the ABS wheel speed sensor installation bolt tightened 7.5 N·m (0.76 kgf·m, 5.5 ft·lb)?	Go to step 8.	Tighten the ABS wheel speed sensor installation bolts.
8	CHECK ABS WHEEL SPEED SENSOR SIGNAL. 1) Install the ABS wheel speed sensor. 2) Prepare an oscilloscope. 3) Check the ABS wheel speed sensor. <Ref. to VDC-25, ABS WHEEL SPEED SENSOR, INSPECTION, Front ABS Wheel Speed Sensor.>	Does the oscilloscope indicate the waveform pattern like shown in the figure when the tire is slowly turned? Does the oscilloscope indication repeat the waveform pattern like shown in the figure when the tire is slowly turned in equal speed for one rotation or more?	Go to step 10.	Go to step 9.
9	CHECK ABS WHEEL SPEED SENSOR OR MAGNETIC ENCODER.	Are there foreign matter, breakage or damage at the tip of ABS wheel speed sensor or magnetic encoder?	Remove dirt thoroughly. Also replace the ABS wheel speed sensor or magnetic encoder as a unit with hub unit bearing if it is broken or damaged.	Go to step 10.
10	CHECK CAUSE OF SIGNAL NOISE. Make sure the radio wave devices and electronic components are installed correctly.	Are the radio wave devices and electronic components installed correctly?	Go to step 11.	Install the radio wave devices and electronic components properly.
11	CHECK CAUSE OF SIGNAL NOISE. Check if the noise sources (such as an antenna) are installed near the sensor harness.	Is the noise sources installed?	Go to step 12.	Install the noise sources apart from sensor harness.

Diagnostic Procedure with Diagnostic Trouble Code (DTC)

VEHICLE DYNAMICS CONTROL (VDC) (DIAGNOSTICS)

Step	Check	Yes	No
12 CHECK VDCCM&H/U. 1) Connect all connectors. 2) Erase the memory. 3) Perform the Inspection Mode. <Ref. to VDC(diag)-23, PROCEDURE, Inspection Mode.> 4) Read the DTC.	Is the same DTC displayed?	Replace the VDCCM only. <Ref. to VDC-11, REPLACEMENT, VDC Control Module and Hydraulic Control Unit (VDCCM&H/U).>	Go to step 13.
13 CHECK OTHER DTC DETECTION.	Is any other DTC displayed?	Perform the diagnosis according to DTC.	It results from a temporary noise interference. NOTE: Though the ABS warning light remains on at this time, this is normal. Drive the vehicle at 12 km/h (7 MPH) or more in order to turn ABS warning light off. Be sure to drive the vehicle and check that the warning light goes off.

Diagnostic Procedure with Diagnostic Trouble Code (DTC)

VEHICLE DYNAMICS CONTROL (VDC) (DIAGNOSTICS)

I: DTC C0029 ANY OF WHEEL SENSORS SIGNAL

DTC DETECTING CONDITION:

- Defective ABS wheel speed sensor signal (noise, irregular signal, etc.)
- Defective magnetic encoder
- When a wheel is turned freely for a long time

TROUBLE SYMPTOM:

- ABS does not operate.
- VDC does not operate.
- EBD may not operate.

NOTE:

Brake warning light illuminates as well as ABS warning light when EBD does not operate.

WIRING DIAGRAM:

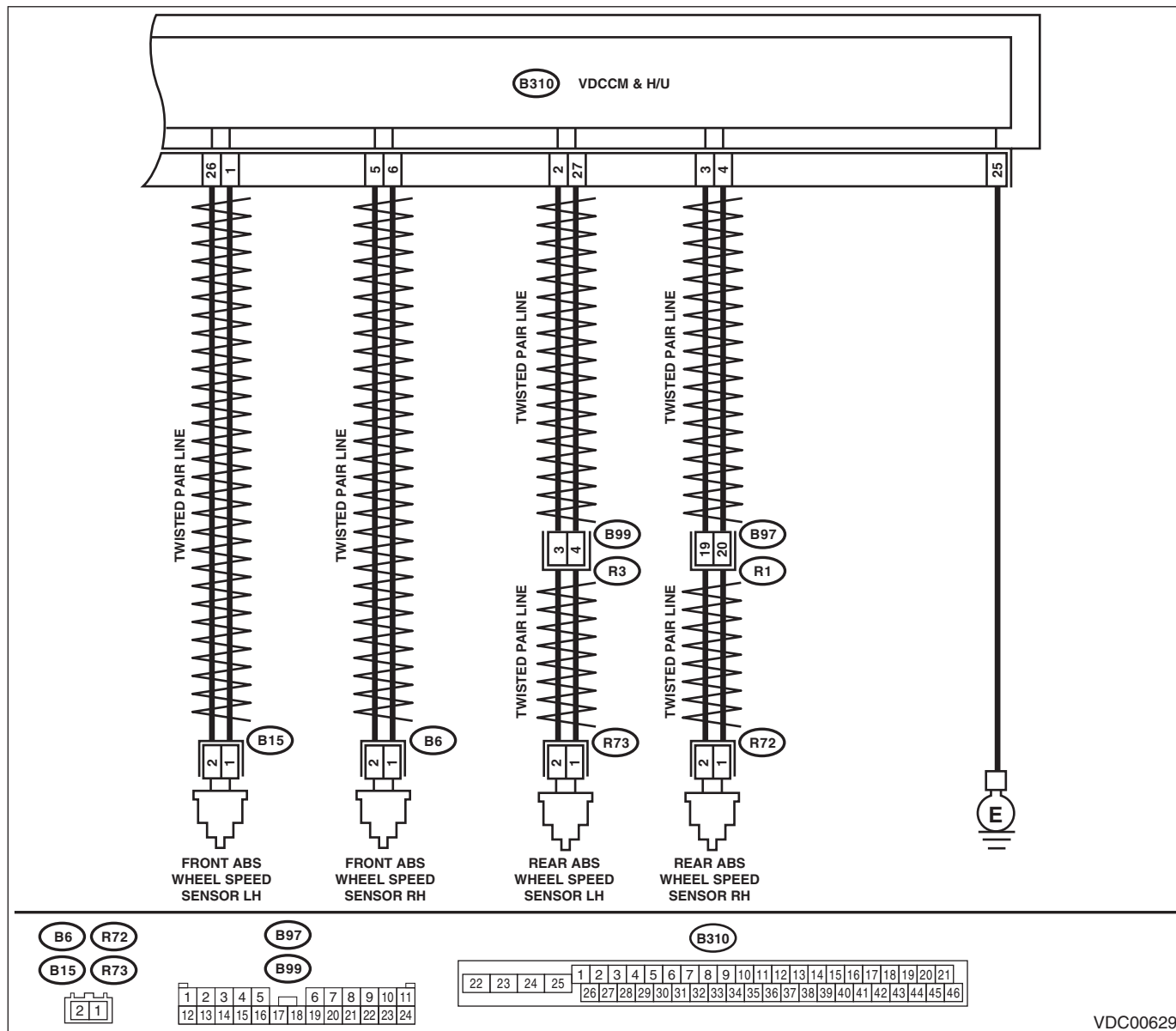

VDC00629

Diagnostic Procedure with Diagnostic Trouble Code (DTC)

VEHICLE DYNAMICS CONTROL (VDC) (DIAGNOSTICS)

Step	Check	Yes	No
1 WHETHER A WHEEL TURNED FREELY OR NOT. Check if the wheels have been turned freely for one minute or more, such as when the vehicle is jacked-up, under full-lock cornering or when the wheels are not in contact with road surface.	Did the wheels turn freely?	VDC is normal. Erase the memory. NOTE: This diagnostic trouble code may sometimes occur if the wheels turn freely for a long time, for example when the vehicle is towed or jacked-up, or when steering wheel is continuously turned all the way.	Go to step 2.
2 CHECK TIRE SPECIFICATIONS. Turn the ignition switch to OFF.	Are the tire specifications correct?	Go to step 3.	Replace the tire.
3 CHECK WEAR OF TIRE.	Is the tire worn excessively?	Replace the tire.	Go to step 4.
4 CHECK TIRE INFLATION PRESSURE.	Is the tire pressure correct?	Go to step 5.	Adjust the tire pressure.
5 CHECK INSTALLATION OF ABS WHEEL SPEED SENSOR.	Are the ABS wheel speed sensor installation bolts tightened 7.5 N·m (0.76 kgf-m, 5.5 ft-lb)? (For four wheels)	Go to step 6.	Tighten the ABS wheel speed sensor installation bolts.
6 CHECK ABS WHEEL SPEED SENSOR SIGNAL. 1) Install the ABS wheel speed sensor. 2) Prepare an oscilloscope. 3) Check the ABS wheel speed sensor. <Ref. to VDC-25, ABS WHEEL SPEED SENSOR, INSPECTION, Front ABS Wheel Speed Sensor.>	Does the oscilloscope indicate the waveform pattern like shown in the figure when the tire is slowly turned? Does the oscilloscope indication repeat the waveform pattern like shown in the figure when the tire is slowly turned in equal speed for one rotation or more?	Go to step 8.	Go to step 7.
7 CHECK ABS WHEEL SPEED SENSOR OR MAGNETIC ENCODER.	Are there foreign matter, breakage or damage at the tip of ABS wheel speed sensor or magnetic encoder?	Remove dirt thoroughly. Also replace the ABS wheel speed sensor or magnetic encoder as a unit with hub unit bearing if it is broken or damaged.	Go to step 8.
8 CHECK VDCCM&H/U. 1) Connect all connectors. 2) Erase the memory. 3) Perform the Inspection Mode. <Ref. to VDC(diag)-23, PROCEDURE, Inspection Mode.> 4) Read the DTC.	Is the same DTC displayed?	Replace the VDCCM only. <Ref. to VDC-11, REPLACEMENT, VDC Control Module and Hydraulic Control Unit (VDCCM&H/U).>	Go to step 9.

Diagnostic Procedure with Diagnostic Trouble Code (DTC)

VEHICLE DYNAMICS CONTROL (VDC) (DIAGNOSTICS)

Step	Check	Yes	No
9 CHECK OTHER DTC DETECTION.	Is any other DTC displayed?	Perform the diagnosis according to DTC.	It results from a temporary noise interference. NOTE: Though the ABS warning light remains on at this time, this is normal. Drive the vehicle at 12 km/h (7 MPH) or more in order to turn ABS warning light off. Be sure to drive the vehicle and check that the warning light goes off.

J: DTC C0031 FR HOLD VALVE MALFUNCTION

NOTE:

For the diagnostic procedure, refer to DTC C0064 "VDC SWITCHING VALVE 2 (P)". <Ref. to VDC(diag)-49, DTC C0064 NORMAL CLOSING VALVE 2 MALFUNCTION, Diagnostic Procedure with Diagnostic Trouble Code (DTC).>

K: DTC C0032 FR PRESSURE REDUCING VALVE MALFUNCTION

NOTE:

For the diagnostic procedure, refer to DTC C0064 "VDC SWITCHING VALVE 2 (P)". <Ref. to VDC(diag)-49, DTC C0064 NORMAL CLOSING VALVE 2 MALFUNCTION, Diagnostic Procedure with Diagnostic Trouble Code (DTC).>

L: DTC C0033 FL HOLD VALVE MALFUNCTION

NOTE:

For the diagnostic procedure, refer to C0064 "VDC SWITCHING VALVE 2 (P)". <Ref. to VDC(diag)-49, DTC C0064 NORMAL CLOSING VALVE 2 MALFUNCTION, Diagnostic Procedure with Diagnostic Trouble Code (DTC).>

M: DTC C0034 FL PRESSURE REDUCING VALVE MALFUNCTION

NOTE:

For the diagnostic procedure, refer to C0064 "VDC SWITCHING VALVE 2 (P)". <Ref. to VDC(diag)-49, DTC C0064 NORMAL CLOSING VALVE 2 MALFUNCTION, Diagnostic Procedure with Diagnostic Trouble Code (DTC).>

N: DTC C0035 RR HOLD VALVE MALFUNCTION

NOTE:

For the diagnostic procedure, refer to C0064 "VDC SWITCHING VALVE 2 (P)". <Ref. to VDC(diag)-49, DTC C0064 NORMAL CLOSING VALVE 2 MALFUNCTION, Diagnostic Procedure with Diagnostic Trouble Code (DTC).>

O: DTC C0036 RR PRESSURE REDUCING VALVE MALFUNCTION

NOTE:

For the diagnostic procedure, refer to C0064 "VDC SWITCHING VALVE 2 (P)". <Ref. to VDC(diag)-49, DTC C0064 NORMAL CLOSING VALVE 2 MALFUNCTION, Diagnostic Procedure with Diagnostic Trouble Code (DTC).>

Diagnostic Procedure with Diagnostic Trouble Code (DTC)

VEHICLE DYNAMICS CONTROL (VDC) (DIAGNOSTICS)

P: DTC C0037 RL HOLD VALVE MALFUNCTION

NOTE:

For the diagnostic procedure, refer to C0064 "VDC SWITCHING VALVE 2 (P)". <Ref. to VDC(diag)-49, DTC C0064 NORMAL CLOSING VALVE 2 MALFUNCTION, Diagnostic Procedure with Diagnostic Trouble Code (DTC).>

Q: DTC C0038 RL PRESSURE REDUCING VALVE MALFUNCTION

NOTE:

For the diagnostic procedure, refer to C0064 "VDC SWITCHING VALVE 2 (P)". <Ref. to VDC(diag)-49, DTC C0064 NORMAL CLOSING VALVE 2 MALFUNCTION, Diagnostic Procedure with Diagnostic Trouble Code (DTC).>

R: DTC C0039 ANY ONE OF FOUR SOLENOID VALVES

NOTE:

For the diagnostic procedure, refer to C0064 "VDC SWITCHING VALVE 2 (P)". <Ref. to VDC(diag)-49, DTC C0064 NORMAL CLOSING VALVE 2 MALFUNCTION, Diagnostic Procedure with Diagnostic Trouble Code (DTC).>

S: DTC C0061 NORMAL OPENING VALVE 1 MALFUNCTION

NOTE:

For the diagnostic procedure, refer to C0064 "VDC SWITCHING VALVE 2 (P)". <Ref. to VDC(diag)-49, DTC C0064 NORMAL CLOSING VALVE 2 MALFUNCTION, Diagnostic Procedure with Diagnostic Trouble Code (DTC).>

T: DTC C0062 NORMAL OPENING VALVE 2 MALFUNCTION

NOTE:

For the diagnostic procedure, refer to C0064 "VDC SWITCHING VALVE 2 (P)". <Ref. to VDC(diag)-49, DTC C0064 NORMAL CLOSING VALVE 2 MALFUNCTION, Diagnostic Procedure with Diagnostic Trouble Code (DTC).>

U: DTC C0063 NORMAL CLOSING VALVE 1 MALFUNCTION

NOTE:

For the diagnostic procedure, refer to C0064 "VDC SWITCHING VALVE 2 (P)". <Ref. to VDC(diag)-49, DTC C0064 NORMAL CLOSING VALVE 2 MALFUNCTION, Diagnostic Procedure with Diagnostic Trouble Code (DTC).>

Diagnostic Procedure with Diagnostic Trouble Code (DTC)

VEHICLE DYNAMICS CONTROL (VDC) (DIAGNOSTICS)

V: DTC C0064 NORMAL CLOSING VALVE 2 MALFUNCTION

DTC DETECTING CONDITION:

- Defective harness connector
- Defective VDCH/U solenoid valve

TROUBLE SYMPTOM:

- ABS does not operate.
- EBD does not operate.
- VDC does not operate.

WIRING DIAGRAM:

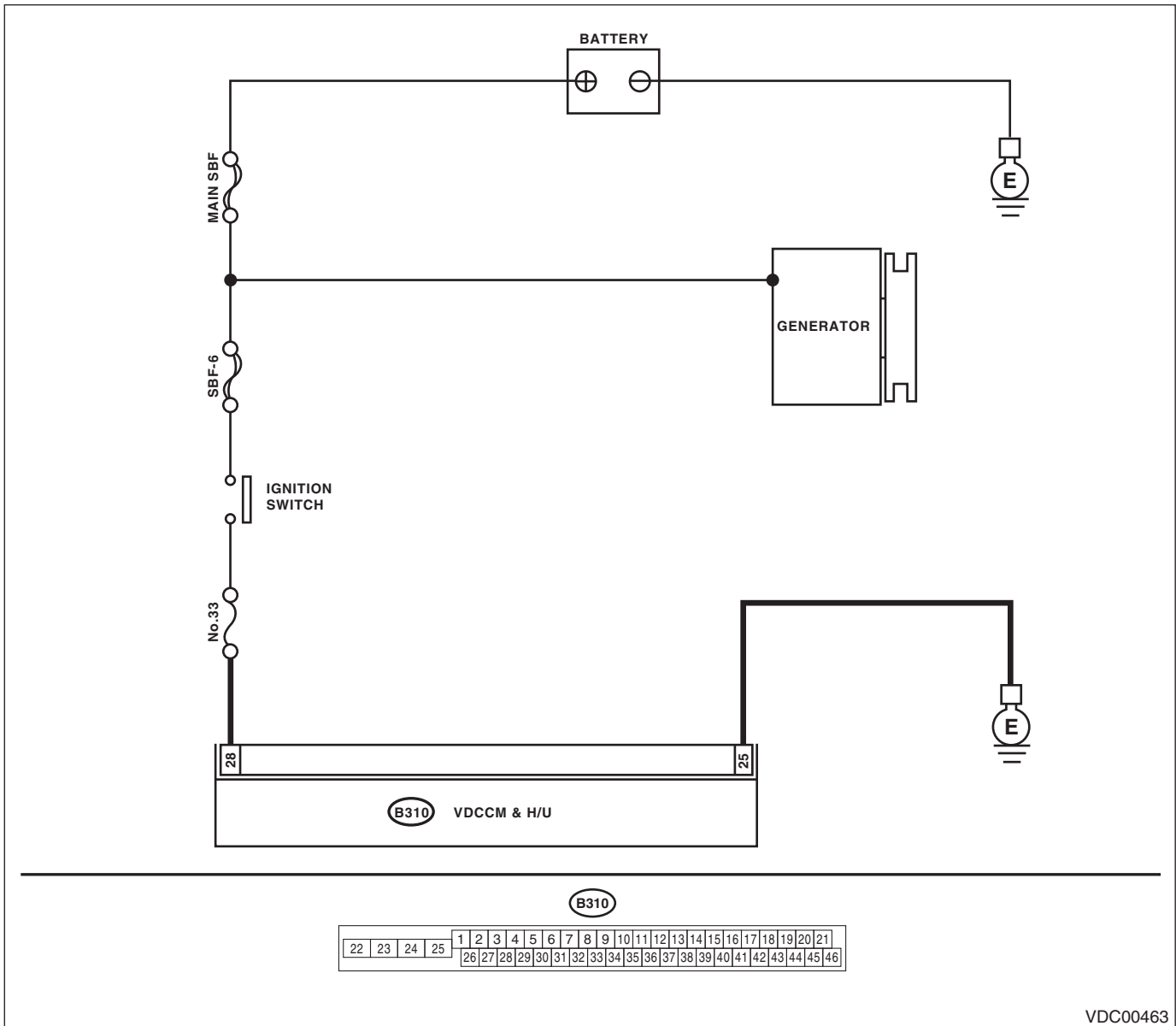

Diagnostic Procedure with Diagnostic Trouble Code (DTC)

VEHICLE DYNAMICS CONTROL (VDC) (DIAGNOSTICS)

Step	Check	Yes	No
1 CHECK VDCCM&H/U INPUT VOLTAGE. 1) Turn the ignition switch to OFF. 2) Disconnect the connector from the VDCCM&H/U. 3) Run the engine at idle. 4) Measure the voltage between VDCCM&H/U connector and chassis ground. Connector & terminal (B310) No. 28 (+) — Chassis ground (-):	Is the voltage 10 — 15 V?	Go to step 2.	Repair the power supply circuit.
2 CHECK VDCCM&H/U GROUND CIRCUIT. 1) Turn the ignition switch to OFF. 2) Measure the resistance between VDCCM&H/U connector and chassis ground. Connector & terminal (B310) No. 25 — Chassis ground:	Is the resistance less than 0.5 Ω?	Go to step 3.	Repair the VDCCM&H/U ground harness.
3 CHECK POOR CONTACT IN CONNECTORS.	Is there poor contact in connector between generator, battery and VDCCM&H/U?	Repair the connector.	Go to step 4.
4 CHECK VDCCM&H/U. 1) Connect all connectors. 2) Erase the memory. 3) Perform the Inspection Mode. 4) Read the DTC.	Is the same DTC displayed?	Replace the VDCCM&H/U. <Ref. to VDC-7, VDC Control Module and Hydraulic Control Unit (VDCCM&H/U).>	Go to step 5.
5 CHECK OTHER DTC DETECTION.	Is any other DTC displayed?	Perform the diagnosis according to DTC.	Temporary poor contact occurs.

Diagnostic Procedure with Diagnostic Trouble Code (DTC)

VEHICLE DYNAMICS CONTROL (VDC) (DIAGNOSTICS)

W: DTC C0041 ECM

DTC DETECTING CONDITION:

Defective VDCCM&H/U

TROUBLE SYMPTOM:

- ABS does not operate.
- EBD does not operate.
- VDC does not operate.

WIRING DIAGRAM:

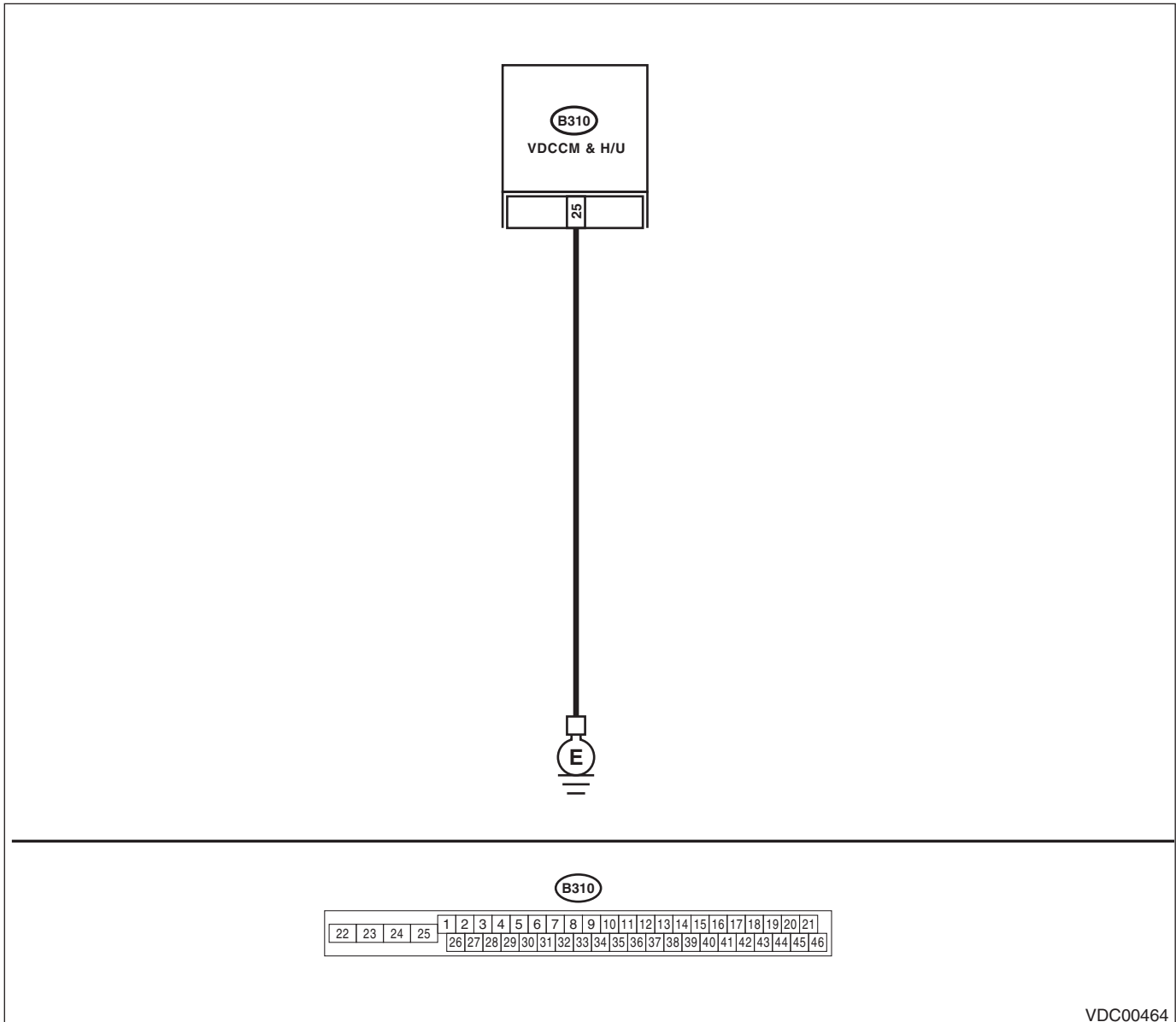

Diagnostic Procedure with Diagnostic Trouble Code (DTC)

VEHICLE DYNAMICS CONTROL (VDC) (DIAGNOSTICS)

Step	Check	Yes	No
1 CHECK VDCCM&H/U GROUND CIRCUIT. 1) Turn the ignition switch to OFF. 2) Disconnect the connector from the VDCCM&H/U. 3) Measure the resistance between VDCCM&H/U and chassis ground. <i>Connector & terminal</i> <i>(B310) No. 25 — Chassis ground:</i>	Is the resistance less than 0.5 Ω?	Go to step 2.	Repair the VDCCM&H/U ground harness.
2 CHECK POOR CONTACT IN CONNECTORS.	Is there poor contact of the connector between the battery, ignition switch and VDCCM&H/U?	Repair the connector.	Go to step 3.
3 CHECK CAUSE OF SIGNAL NOISE.	Are the radio wave devices and electronic components installed correctly?	Go to step 4.	Install the radio wave devices and electronic components properly.
4 CHECK CAUSE OF SIGNAL NOISE.	Is there a noise source (such as an antenna) installed near the sensor harness?	Install the noise sources apart from the sensor harness.	Go to step 5.
5 CHECK VDCCM&H/U. 1) Connect all connectors. 2) Erase the memory. 3) Perform the Inspection Mode. 4) Read the DTC.	Is the same DTC displayed?	Replace the VDCCM only. <Ref. to VDC-11, REPLACEMENT, VDC Control Module and Hydraulic Control Unit (VDCCM&H/U).>	Go to step 6.
6 CHECK OTHER DTC DETECTION.	Is any other DTC displayed?	Perform the diagnosis according to DTC. <Ref. to VDC(diag)-32, List of Diagnostic Trouble Code (DTC).>	Temporary poor contact occurs.

Diagnostic Procedure with Diagnostic Trouble Code (DTC)

VEHICLE DYNAMICS CONTROL (VDC) (DIAGNOSTICS)

X: DTC C0041 PARAMETER SELECTION ERROR

DTC DETECTING CONDITION:

VDCCM parameter selection failure

TROUBLE SYMPTOM:

- ABS does not operate.
- EBD does not operate.
- VDC does not operate.

NOTE:

When the VDCCM or VDCCM&H/U is replaced, this DTC may be memorized.

Step	Check	Yes	No
1	CHECK VDCCM&H/U REPLACEMENT HISTORY.	Go to step 2.	Go to step 3.
2	CHECK VDCCM IDENTIFICATION NUMBER. Check the identification number on the sticker attached on the VDCCM side.	Go to step 4.	Replace the VDCCM only.
3	CHECK VDCCM&H/U IDENTIFICATION NUMBER. Check the identification number stamped on the upper side of the H/U.	Go to step 4.	Replace the VDCCM&H/U.
4	CHECK PARAMETER SELECTED FOR VDC-CM. <Ref. to VDC(diag)-18, PARAMETER CHECK, OPERATION, Subaru Select Monitor.>	Replace the VDCCM only.	Select and register the correct parameter. <Ref. to VDC(diag)-17, PARAMETER SELECTION, OPERATION, Subaru Select Monitor.>

Diagnostic Procedure with Diagnostic Trouble Code (DTC)

VEHICLE DYNAMICS CONTROL (VDC) (DIAGNOSTICS)

Y: DTC C0042 POWER SUPPLY VOLTAGE FAILURE

DTC DETECTING CONDITION:

VDCCM&H/U power supply voltage error

TROUBLE SYMPTOM:

- ABS does not operate.
- EBD may not operate.
- VDC does not operate.

NOTE:

Warning lights go off if voltage returns.

WIRING DIAGRAM:

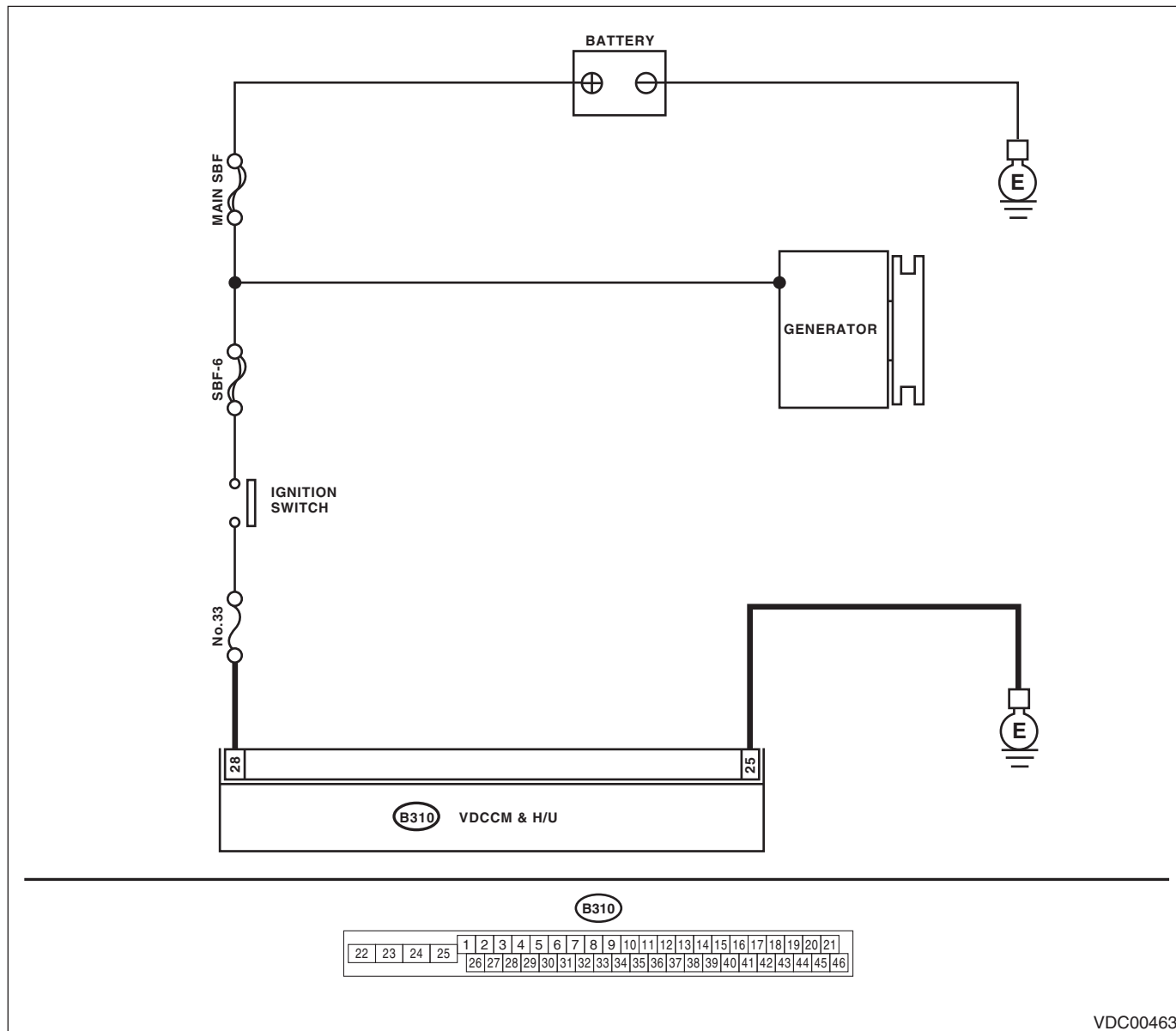

Diagnostic Procedure with Diagnostic Trouble Code (DTC)

VEHICLE DYNAMICS CONTROL (VDC) (DIAGNOSTICS)

	Step	Check	Yes	No
1	CHECK GENERATOR. 1) Start the engine. 2) Run the engine at idle after warming up. 3) Measure the voltage between generator terminal B and chassis ground. Terminals Generator B terminal (+) — Chassis ground (-):	Is the voltage 10 — 15 V?	Go to step 2.	Repair the generator.
2	CHECK BATTERY TERMINAL. Turn the ignition switch to OFF.	Are the positive and negative battery terminals clamped tightly?	Go to step 3.	Tighten the terminal.
3	CHECK VDCCM&H/U INPUT VOLTAGE. 1) Disconnect the connector from the VDCCM&H/U. 2) Run the engine at idle. 3) Operate devices such as headlights, air conditioner, defogger, etc. which produce an electrical load. 4) Measure the voltage between VDCCM&H/U connector and chassis ground. Connector & terminal (B310) No. 28 (+) — Chassis ground (-):	Is the voltage 10 — 15 V?	Go to step 4.	Repair the power supply circuit.
4	CHECK VDCCM&H/U GROUND CIRCUIT. 1) Turn the ignition switch to OFF. 2) Measure the resistance between VDCCM&H/U connector and chassis ground. Connector & terminal (B310) No. 25 — Chassis ground:	Is the resistance less than 0.5 Ω ?	Go to step 5.	Repair the VDCCM&H/U ground harness.
5	CHECK POOR CONTACT IN CONNECTORS.	Is there poor contact in connector between generator, battery and VDCCM&H/U?	Repair the connector.	Go to step 6.
6	CHECK VDCCM&H/U. 1) Connect all connectors. 2) Erase the memory. 3) Perform the Inspection Mode. 4) Read the DTC.	Is the same DTC displayed?	Replace the VDCCM only. <Ref. to VDC-11, REPLACEMENT, VDC Control Module and Hydraulic Control Unit (VDCCM&H/U).>	Go to step 7.
7	CHECK OTHER DTC DETECTION.	Is any other DTC displayed?	Perform the diagnosis according to DTC. <Ref. to VDC(diag)-32, List of Diagnostic Trouble Code (DTC).>	Temporary poor contact occurs.

Diagnostic Procedure with Diagnostic Trouble Code (DTC)

VEHICLE DYNAMICS CONTROL (VDC) (DIAGNOSTICS)

Z: DTC C0044 TCM COMMUNICATION CIRCUIT

DTC DETECTING CONDITION:

No CAN signal from TCM.

TROUBLE SYMPTOM:

- ABS does not operate.
- VDC does not operate.

Step	Check	Yes	No
1	CHECK LAN SYSTEM. Perform the diagnosis for LAN system. <Ref. to LAN(diag)-15, OPERATION, Read Diagnostic Trouble Code (DTC).>	Is there any fault in LAN system?	Perform the diagnosis according to DTC for LAN system. Go to step 2.
2	CHECK POOR CONTACT IN CONNECTORS.	Is there poor contact in TCM connector?	Repair the connector. Go to step 3.
3	CHECK TCM.	Is the TCM normal?	Go to step 4. Replace the TCM. <Ref. to 4AT-60, Transmission Control Module (TCM).>
4	CHECK VDCCM&H/U. 1) Connect all connectors. 2) Erase the memory. 3) Perform the Inspection Mode. 4) Read the DTC.	Is the same DTC displayed?	Replace the VDCCM only. Go to step 5.
5	CHECK OTHER DTC DETECTION.	Is any other DTC displayed?	Perform the diagnosis according to DTC. It results from a temporary noise interference.

Diagnostic Procedure with Diagnostic Trouble Code (DTC)

VEHICLE DYNAMICS CONTROL (VDC) (DIAGNOSTICS)

AA:DTC C0045 INCORRECT VDC CONTROL MODULE SPECIFICATIONS

DTC DETECTING CONDITION:

Different control module specification

TROUBLE SYMPTOM:

- ABS does not operate.
- VDC does not operate.

NOTE:

When parameter selection for VDCCM is improper, this DTC may be memorized.

Step	Check	Yes	No
1	CHECK VDCCM REPLACEMENT HISTORY. Is there replacement history of VDCCM alone?	Go to step 2.	Go to step 3.
2	CHECK VDCCM IDENTIFICATION NUMBER. Check the identification number on the sticker attached on the VDCCM side. AT: Z1 MT: Z2	Go to step 4.	Replace the VDCCM only.
3	CHECK VDCCM&H/U IDENTIFICATION NUMBER. Check the identification number stamped on the upper side of the H/U. AT: Z1 MT: Z2	Go to step 4.	Replace the VDCCM&H/U.
4	CHECK PARAMETER SELECTED FOR VDCCM. <Ref. to VDC(diag)-18, PARAMETER CHECK, OPERATION, Subaru Select Monitor.>	Go to step 5.	Select and register the correct parameter. <Ref. to VDC(diag)-17, PARAMETER SELECTION, OPERATION, Subaru Select Monitor.>
5	CHECK TCM SPECIFICATION. Check the TCM specification.	Go to step 6.	Replace the TCM. <Ref. to 4AT-60, Transmission Control Module (TCM).>
6	CHECK AT SYSTEM. 1) Start the engine. 2) Check the DTC in AT system.	Repair the AT system.	Go to step 7.
7	CHECK ECM SPECIFICATION. Check the ECM specification.	Go to step 8.	Replace the ECM. <Ref. to FU(H4SO)-39, Engine Control Module (ECM).> <Ref. to FU(H4DOTC)-46, Engine Control Module (ECM).>
8	CHECK VDCCM&H/U. 1) Connect all connectors. 2) Erase the memory. 3) Perform the Inspection Mode. 4) Read the DTC.	Replace the VDCCM only.	Go to step 9.
9	CHECK OTHER DTC DETECTION. Is any other DTC displayed?	Perform the diagnosis according to DTC.	It results from a temporary noise interference.

Diagnostic Procedure with Diagnostic Trouble Code (DTC)

VEHICLE DYNAMICS CONTROL (VDC) (DIAGNOSTICS)

AB:DTC C0045 TCM MALFUNCTION

DTC DETECTING CONDITION:

Defective TCM

TROUBLE SYMPTOM:

- ABS does not operate.
- VDC does not operate.

	Step	Check	Yes	No
1	CHECK AT SYSTEM. 1) Start the engine. 2) Check the DTC in AT system.	Is DTC of AT system displayed?	Repair the AT system.	Go to step 2.
2	CHECK VDCCM&H/U. 1) Connect all connectors. 2) Erase the memory. 3) Perform the Inspection Mode. 4) Read the DTC.	Is the same DTC displayed?	Replace the VDCCM only.	Go to step 3.
3	CHECK OTHER DTC DETECTION.	Is any other DTC displayed?	Perform the diagnosis according to DTC.	It results from a temporary noise interference.

Diagnostic Procedure with Diagnostic Trouble Code (DTC)

VEHICLE DYNAMICS CONTROL (VDC) (DIAGNOSTICS)

AC:DTC C0047 CAN COMMUNICATION

DTC DETECTING CONDITION:

CAN communication line circuit is open or shorted.

TROUBLE SYMPTOM:

- ABS does not operate.
- VDC does not operate.

WIRING DIAGRAM:

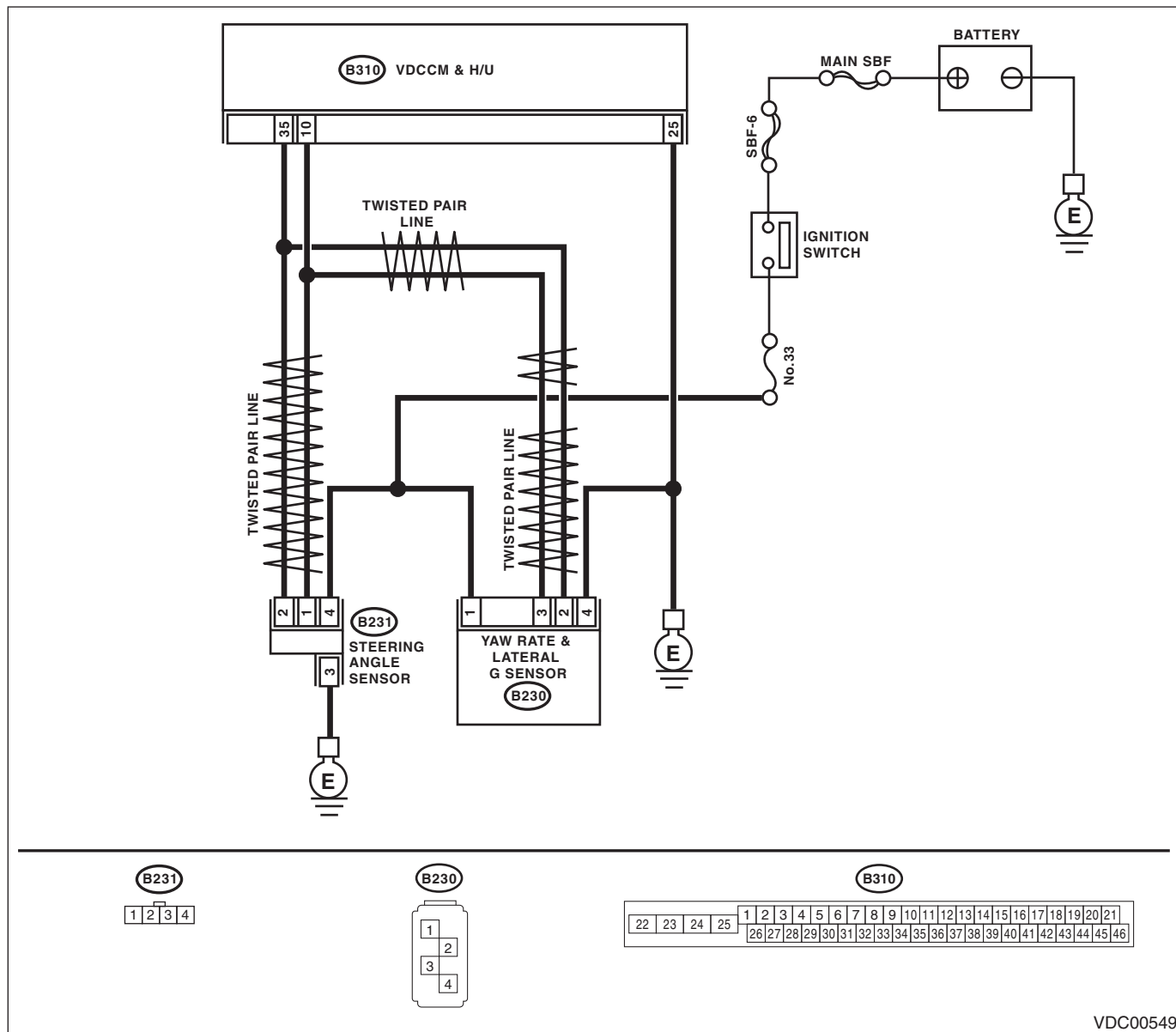

VDC00549

Diagnostic Procedure with Diagnostic Trouble Code (DTC)

VEHICLE DYNAMICS CONTROL (VDC) (DIAGNOSTICS)

	Step	Check	Yes	No
1	CHECK LAN SYSTEM. Perform the diagnosis for LAN system. <Ref. to LAN(diag)-15, OPERATION, Read Diagnostic Trouble Code (DTC).>	Is there any fault in LAN system?	Perform the diagnosis according to DTC for LAN system.	Go to step 2.
2	CHECK POOR CONTACT IN CONNECTORS.	Is there poor contact in VDCCM&H/U connector?	Repair the connector.	Go to step 3.
3	CHECK OUTPUT OF STEERING ANGLE SENSOR. Connect the Subaru Select Monitor and check output of the steering angle sensor.	Does the output signal change?	Go to step 4.	Check output of the steering angle sensor. <Ref. to VDC(diag)-81, DTC C0071 STEER ANGLE SENSOR OP, Diagnostic Procedure with Diagnostic Trouble Code (DTC).>
4	CHECK OUTPUT OF YAW RATE & LATERAL G SENSOR. Connect the Subaru Select Monitor and check output of the yaw rate & lateral G sensor.	Does the output signal change?	Go to step 5.	Check output of the yaw rate & lateral G sensor. <Ref. to VDC(diag)-91, DTC C0072 YAW RATE SENSOR COMMUNICATION, Diagnostic Procedure with Diagnostic Trouble Code (DTC).>
5	CHECK VDCCM&H/U. 1) Connect all connectors. 2) Erase the memory. 3) Perform the Inspection Mode. 4) Read the DTC.	Is the same DTC displayed?	Replace the VDCCM only. <Ref. to VDC-11, REPLACEMENT, VDC Control Module and Hydraulic Control Unit (VDCCM&H/U).>	Temporary poor contact occurs.

Diagnostic Procedure with Diagnostic Trouble Code (DTC)

VEHICLE DYNAMICS CONTROL (VDC) (DIAGNOSTICS)

AD:DTC C0051 VALVE RELAY

DTC DETECTING CONDITION:

Defective valve relay

TROUBLE SYMPTOM:

- ABS does not operate.
- EBD does not operate.
- VDC does not operate.

WIRING DIAGRAM:

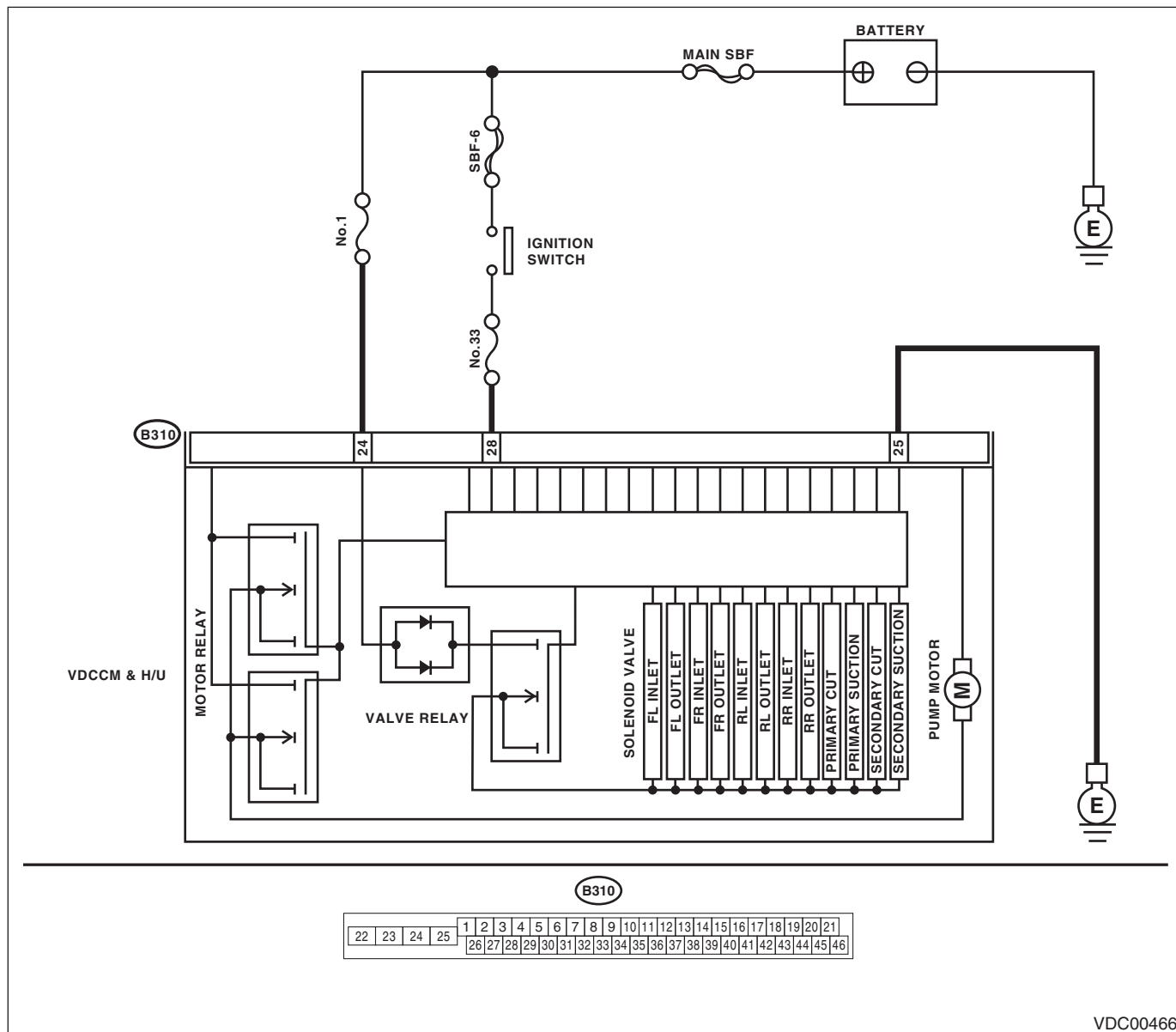

VDC00466

Diagnostic Procedure with Diagnostic Trouble Code (DTC)

VEHICLE DYNAMICS CONTROL (VDC) (DIAGNOSTICS)

	Step	Check	Yes	No
1	CHECK VDCCM&H/U INPUT VOLTAGE. 1) Turn the ignition switch to OFF. 2) Disconnect the connector from the VDCCM&H/U. 3) Run the engine at idle. 4) Measure the voltage between VDCCM&H/U connector and chassis ground. Connector & terminal (B310) No. 28 (+) — Chassis ground (-): (B310) No. 24 (+) — Chassis ground (-):	Is the voltage 10 — 15 V?	Go to step 2.	Repair the power supply circuit.
2	CHECK VDCCM&H/U INPUT VOLTAGE. Calculate the voltage difference measured in step 1. A: (B310) No. 28 (+) — Chassis ground (-): B: (B310) No. 24 (+) — Chassis ground (-):	Is the voltage difference between A and B 2 V or more?	Repair the power supply circuit.	Go to step 3.
3	CHECK VDCCM&H/U GROUND CIRCUIT. 1) Turn the ignition switch to OFF. 2) Measure the resistance between VDCCM&H/U connector and chassis ground. Connector & terminal (B310) No. 25 — Chassis ground:	Is the resistance less than 0.5 Ω?	Go to step 4.	Repair the VDCCM&H/U ground harness.
4	CHECK VDCCM&H/U VALVE RELAY. Measure the resistance between VDCCM&H/U connector terminals. Connector & terminal (B310) No. 24 — (B310) No. 25:	Is the resistance 1 MΩ or more?	Go to step 5.	Replace the VDCCM&H/U.
5	CHECK POOR CONTACT IN CONNECTORS.	Is there poor contact in connector between generator, battery and VDCCM&H/U?	Repair the connector.	Go to step 6.
6	CHECK VDCCM&H/U. 1) Connect all connectors. 2) Erase the memory. 3) Perform the Inspection Mode. 4) Read the DTC.	Is the same DTC displayed?	Replace the VDCCM only. <Ref. to VDC-11, REPLACEMENT, VDC Control Module and Hydraulic Control Unit (VDCCM&H/U).>	Go to step 7.
7	CHECK OTHER DTC DETECTION.	Is any other DTC displayed?	Perform the diagnosis according to DTC.	Temporary poor contact occurs.

Diagnostic Procedure with Diagnostic Trouble Code (DTC)

VEHICLE DYNAMICS CONTROL (VDC) (DIAGNOSTICS)

AE:DTC C0052 MOTOR AND MOTOR RELAY OFF FAILURE

DTC DETECTING CONDITION:

- Defective motor and motor relay
- Defective harness connector

TROUBLE SYMPTOM:

- ABS does not operate.
- VDC does not operate.
- EBD may not operate.

WIRING DIAGRAM:

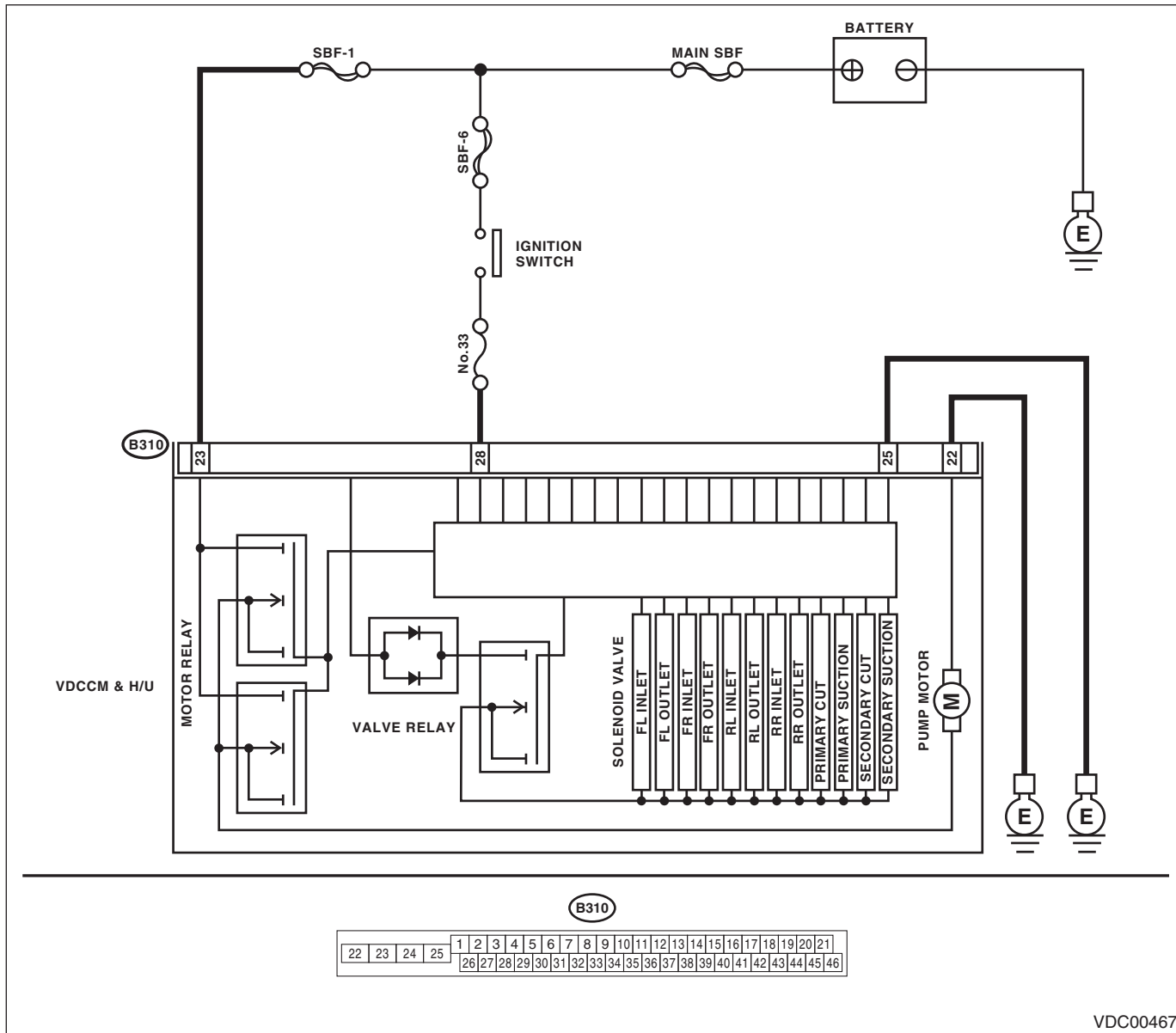

Diagnostic Procedure with Diagnostic Trouble Code (DTC)

VEHICLE DYNAMICS CONTROL (VDC) (DIAGNOSTICS)

Step	Check	Yes	No
1 CHECK VDCCM&H/U INPUT VOLTAGE. 1) Turn the ignition switch to OFF. 2) Disconnect the connector from the VDCCM&H/U. 3) Turn the ignition switch to ON. 4) Measure the voltage between VDCCM&H/U connector and chassis ground. Connector & terminal (B310) No. 23 (+) — Chassis ground (-): (B310) No. 28 (+) — Chassis ground (-):	Is the voltage 10 — 15 V?	Go to step 2.	Repair the VDCCM&H/U power supply circuit.
2 CHECK INSTALLATION OF MOTOR GROUND.	Is the motor ground terminal installation bolt tightened 33 N·m (3.4 kgf·m, 24.3 ft·lb)?	Go to step 3.	Tighten the motor ground terminal installation bolt.
3 CHECK VDCCM&H/U GROUND CIRCUIT. 1) Turn the ignition switch to OFF. 2) Measure the resistance between VDCCM&H/U connector and chassis ground. Connector & terminal (B310) No. 25 — Chassis ground: (B310) No. 22 — Chassis ground:	Is the resistance less than 0.5 Ω?	Go to step 4.	Repair the VDCCM&H/U ground harness.
4 CHECK VDCCM&H/U MOTOR RELAY. Measure the resistance between VDCCM&H/U connector terminals. Terminals No. 23 — No. 22:	Is the resistance 1 MΩ or more?	Go to step 5.	Replace the VDCCM&H/U.
5 CHECK POOR CONTACT IN CONNECTORS. Turn the ignition switch to OFF.	Is there poor contact in connector between generator, battery and VDCCM&H/U?	Repair the connector.	Go to step 6.
6 CHECK VDCCM&H/U. 1) Connect all connectors. 2) Erase the memory. 3) Perform the Inspection Mode. 4) Read the DTC.	Is the same DTC displayed?	Replace the VDCCM&H/U. <Ref. to VDC-7, VDC Control Module and Hydraulic Control Unit (VDCCM&H/U).>	Go to step 7.
7 CHECK OTHER DTC DETECTION.	Is any other DTC displayed?	Perform the diagnosis according to DTC. <Ref. to VDC(diag)-32, List of Diagnostic Trouble Code (DTC).>	Temporary poor contact occurs. NOTE: Though the ABS warning light remains on at this time, it is normal. Drive the vehicle at 12 km/h (7 MPH) or more in order to turn ABS warning light off. Be sure to drive the vehicle and check that the warning light goes off.

Diagnostic Procedure with Diagnostic Trouble Code (DTC)

VEHICLE DYNAMICS CONTROL (VDC) (DIAGNOSTICS)

AF:DTC C0052 MOTOR AND MOTOR RELAY ON FAILURE

DTC DETECTING CONDITION:

- Defective motor relay
- Defective harness connector

TROUBLE SYMPTOM:

- ABS does not operate.
- VDC does not operate.
- EBD may not operate.

WIRING DIAGRAM:

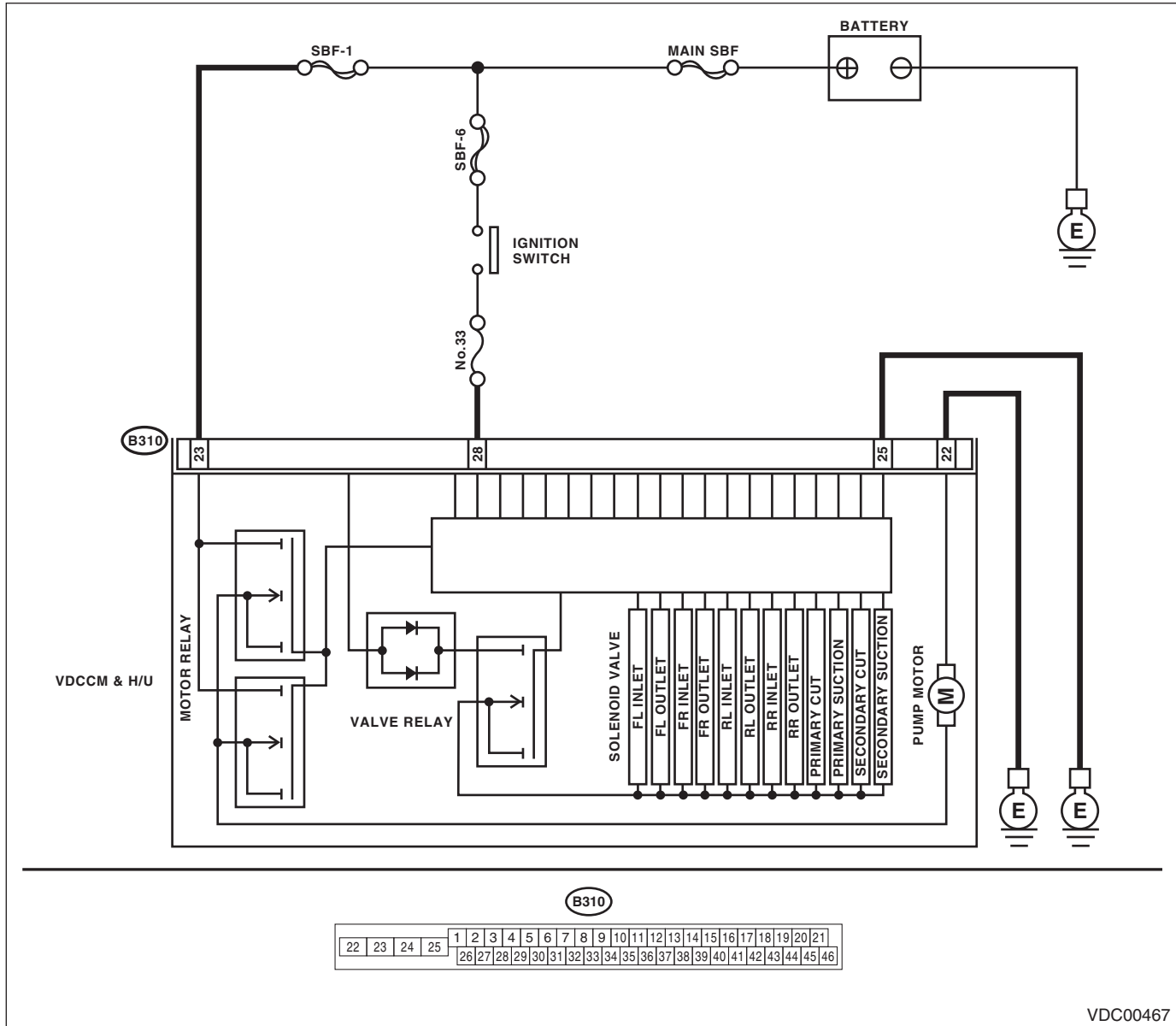

VDC00467

Step	Check	Yes	No
1	CHECK INSTALLATION OF MOTOR GROUND.	Go to step 2.	Tighten the motor ground installation bolt.

Diagnostic Procedure with Diagnostic Trouble Code (DTC)

VEHICLE DYNAMICS CONTROL (VDC) (DIAGNOSTICS)

Step	Check	Yes	No
2 CHECK VDCCM&H/U MOTOR RELAY. 1) Disconnect the connector from the VDCCM&H/U. 2) Measure the resistance between VDCCM&H/U connector terminals. Terminals No. 23 — No. 22:	Is the resistance 1 MΩ or more?	Go to step 3.	Replace the VDCCM&H/U. <Ref. to VDC-7, VDC Control Module and Hydraulic Control Unit (VDCCM&H/U).>
3 CHECK VDCCM&H/U. 1) Connect all connectors. 2) Erase the memory. 3) Perform the Inspection Mode. 4) Read the DTC.	Is the same DTC displayed?	Replace the VDCCM only. <Ref. to VDC-11, REPLACEMENT, VDC Control Module and Hydraulic Control Unit (VDCCM&H/U).>	Go to step 4.
4 CHECK OTHER DTC DETECTION.	Is any other DTC displayed?	Perform the diagnosis according to DTC. <Ref. to VDC(diag)-32, List of Diagnostic Trouble Code (DTC).>	Temporary poor contact occurs. NOTE: Though the ABS warning light remains on at this time, it is normal. Drive the vehicle at 12 km/h (7 MPH) or more in order to turn ABS warning light off. Be sure to drive the vehicle and check that the warning light goes off.

AG:DTC C0052 MOTOR MALFUNCTION

DTC DETECTING CONDITION:

- Defective motor
- Defective motor relay
- Defective harness connector

TROUBLE SYMPTOM:

- ABS does not operate.
- VDC does not operate.
- EBD may not operate.

NOTE:

For the diagnostic procedure, refer to DTC C0052 "MOTOR/MOTOR RELAY OFF FAILURE". <Ref. to VDC(diag)-63, DTC C0052 MOTOR AND MOTOR RELAY OFF FAILURE, Diagnostic Procedure with Diagnostic Trouble Code (DTC).>

Diagnostic Procedure with Diagnostic Trouble Code (DTC)

VEHICLE DYNAMICS CONTROL (VDC) (DIAGNOSTICS)

AH:DTC C0054 BLS CIRCUIT OPEN

DTC DETECTING CONDITION:

Defective stop light switch

TROUBLE SYMPTOM:

- ABS does not operate.
- VDC does not operate.

WIRING DIAGRAM:

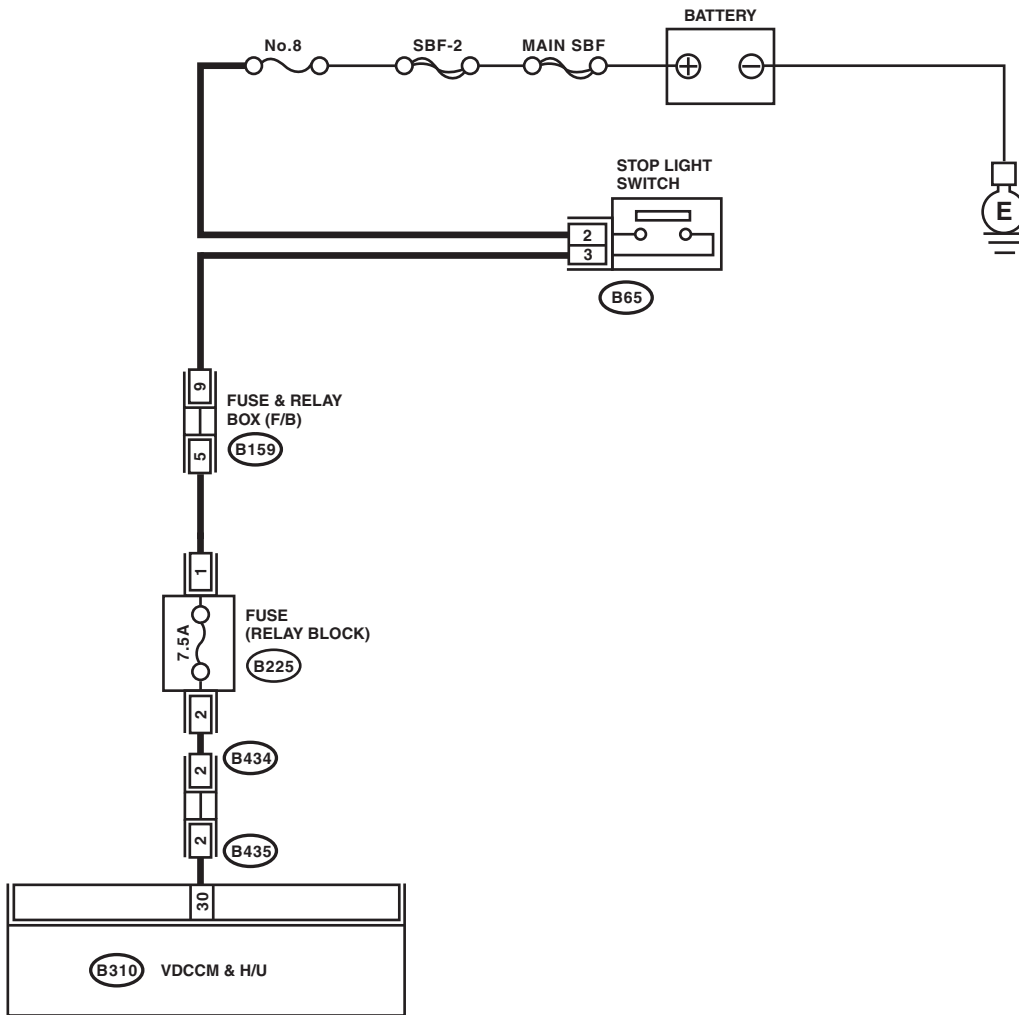

B65

1	2
3	4

B310

22	23	24	25	1	2	3	4	5	6	7	8	9	10	11	12	13	14	15	16	17	18	19	20	21
				26	27	28	29	30	31	32	33	34	35	36	37	38	39	40	41	42	43	44	45	46

B225

1	2	9	13	17	21				
3	4	10	14	18	22				
5	6	11	12	15	16	19	20	23	24
7	8	25	29	33	37				
		26	30	34	38				
		27	28	31	32	35	36	39	40

B159

1	2		3	4
5	6	7	8	9

B434

B435

1	2	3	4	5
---	---	---	---	---

VDC00718

Diagnostic Procedure with Diagnostic Trouble Code (DTC)

VEHICLE DYNAMICS CONTROL (VDC) (DIAGNOSTICS)

Step	Check	Yes	No
1 CHECK OUTPUT OF STOP LIGHT SWITCH WITH SUBARU SELECT MONITOR. 1) Select {Current Data Display & Save} in Subaru Select Monitor. 2) Release the brake pedal. 3) Read the stop light switch output in Subaru Select Monitor.	Is OFF displayed on the display screen?	Go to step 2.	Go to step 3.
2 CHECK OUTPUT OF STOP LIGHT SWITCH WITH SUBARU SELECT MONITOR. 1) Depress the brake pedal. 2) Read the stop light switch output in Subaru Select Monitor.	Is ON displayed on the display screen?	Go to step 6.	Go to step 3.
3 CHECK IF STOP LIGHTS COME ON. Depress the brake pedal.	Does the stop light illuminate?	Go to step 4.	Repair the stop light circuit.
4 CHECK FUSE. Check the relay block fuse (B225).	Is the fuse OK?	Go to step 5.	Replace the fuse.
5 CHECK OPEN CIRCUIT OF HARNESS. 1) Turn the ignition switch to OFF. 2) Disconnect the connector from the VDCCM&H/U. 3) Depress the brake pedal. 4) Measure the voltage between VDCCM&H/U connector and chassis ground. <i>Connector & terminal (B310) No. 30 (+) — Chassis ground (-):</i>	Is the voltage 10 — 15 V?	Go to step 6.	Repair the harness between stop light switch and VDCCM&H/U connector.
6 CHECK POOR CONTACT IN CONNECTORS.	Is there poor contact in connector between stop light switch and VDCCM&H/U?	Repair the connector.	Go to step 7.
7 CHECK VDCCM&H/U. 1) Connect all connectors. 2) Erase the memory. 3) Perform the Inspection Mode. 4) Read the DTC.	Is the same DTC displayed?	Replace the VDCCM only. <Ref. to VDC-11, REPLACEMENT, VDC Control Module and Hydraulic Control Unit (VDCCM&H/U).>	Go to step 8.
8 CHECK OTHER DTC DETECTION.	Is any other DTC displayed?	Perform the diagnosis according to DTC.	Temporary poor contact occurs.

Diagnostic Procedure with Diagnostic Trouble Code (DTC)

VEHICLE DYNAMICS CONTROL (VDC) (DIAGNOSTICS)

AI: DTC C0054 BLS ON MALFUNCTION

DTC DETECTING CONDITION:

Defective stop light switch

TROUBLE SYMPTOM:

- ABS does not operate.
- VDC does not operate.

WIRING DIAGRAM:

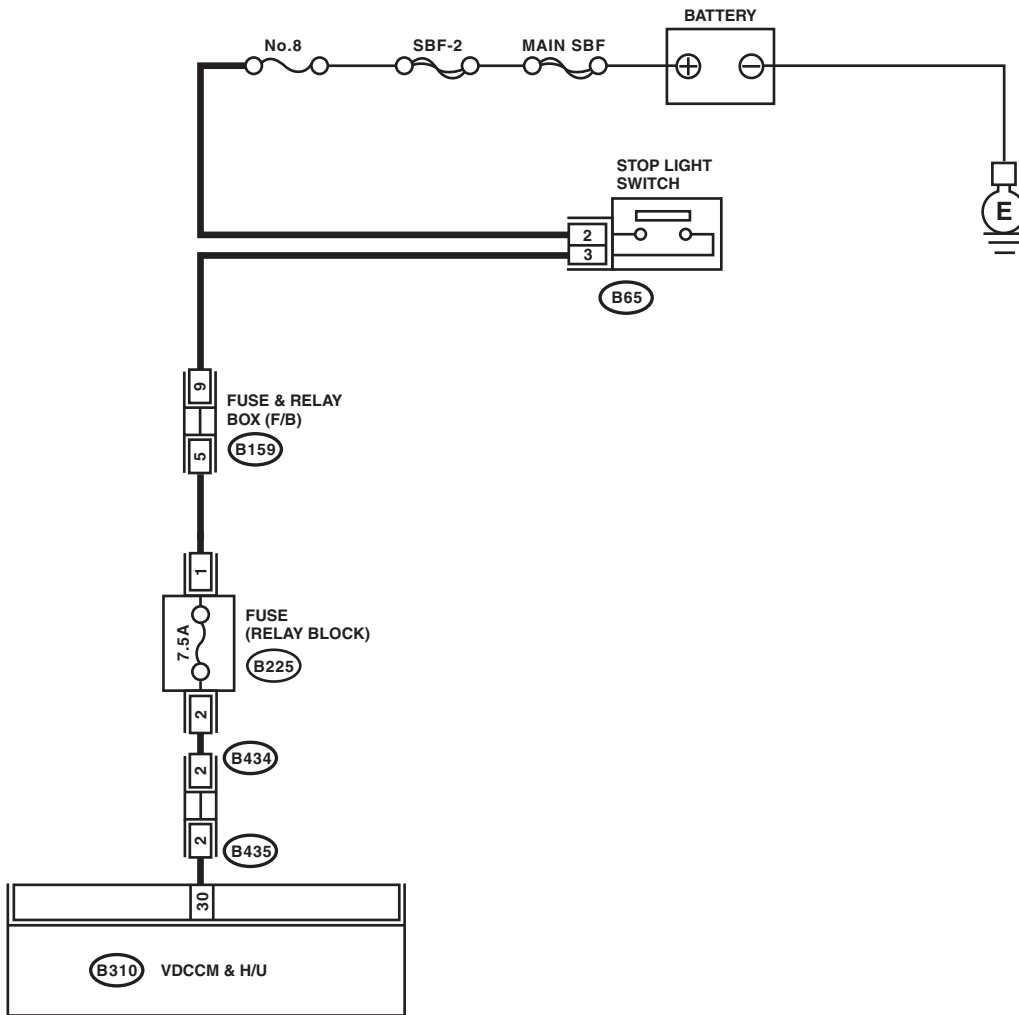

B65

1	2
3	4

B310

22	23	24	25	1	2	3	4	5	6	7	8	9	10	11	12	13	14	15	16	17	18	19	20	21
				26	27	28	29	30	31	32	33	34	35	36	37	38	39	40	41	42	43	44	45	46

B225

1	2	9	13	17	21				
3	4	10	14	18	22				
5	6	11	12	15	16	19	20	23	24
7	8	25	29	33	37				
		26	30	34	38				
		27	28	31	32	35	36	39	40

B159

1	2		3	4
5	6	7	8	9

B434

B435

1	2	3	4	5
---	---	---	---	---

VDC00718

Diagnostic Procedure with Diagnostic Trouble Code (DTC)

VEHICLE DYNAMICS CONTROL (VDC) (DIAGNOSTICS)

Step	Check	Yes	No
1 CHECK STOP LIGHT SWITCH. 1) Turn the ignition switch to OFF. 2) Disconnect the stop light switch connector. 3) Measure the resistance of stop light switch terminals.	Is the resistance 1 MΩ or more when switch is OFF (when pedal is not depressed)?	Go to step 2.	Replace the stop light switch.
2 INTERVIEWING CUSTOMERS. Make sure that the operation was performed in which accelerator pedal and brake pedal were depressed simultaneously (with depressing brake pedal with left foot).	Were the acceleration pedal and brake pedal depressed simultaneously?	System is normal. (DTC may be recorded while brake is applied during driving.)	Go to step 3.
3 CHECK VDCCM&H/U. 1) Connect all connectors. 2) Erase the memory. 3) Perform the Inspection Mode. 4) Read the DTC.	Is the same DTC displayed?	Replace the VDCCM only. <Ref. to VDC-11, REPLACEMENT, VDC Control Module and Hydraulic Control Unit (VDCCM&H/U).>	Go to step 4.
4 CHECK OTHER DTC DETECTION.	Is any other DTC displayed?	Perform the diagnosis according to DTC. <Ref. to VDC(diag)-32, List of Diagnostic Trouble Code (DTC).>	Temporary poor contact occurs.

Diagnostic Procedure with Diagnostic Trouble Code (DTC)

VEHICLE DYNAMICS CONTROL (VDC) (DIAGNOSTICS)

AJ:DTC C0054 BLS OFF MALFUNCTION

DTC DETECTING CONDITION:

Defective stop light switch

TROUBLE SYMPTOM:

- ABS does not operate.
- VDC does not operate.

WIRING DIAGRAM:

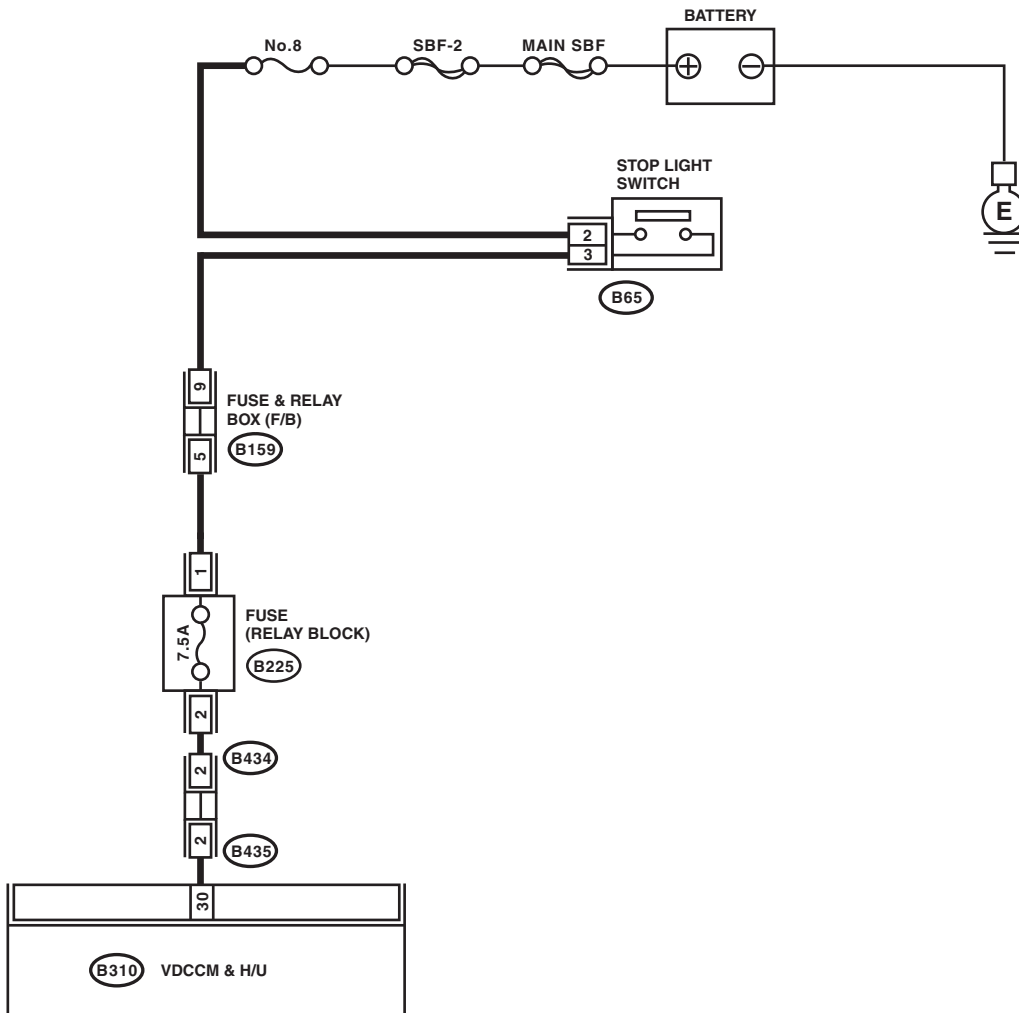

(B65)

1	2
3	4

(B310)

22	23	24	25	1	2	3	4	5	6	7	8	9	10	11	12	13	14	15	16	17	18	19	20	21
				26	27	28	29	30	31	32	33	34	35	36	37	38	39	40	41	42	43	44	45	46

(B225)

1	2	9	13	17	21				
3	4	10	14	18	22				
5	6	11	12	15	16	19	20	23	24
7	8	25	29	33	37				
		26	30	34	38				
		27	28	31	32	35	36	39	40

(B159)

1	2		3	4
5	6	7	8	9

(B434)

(B435)

1	2	3	4	5
---	---	---	---	---

VDC00718

Diagnostic Procedure with Diagnostic Trouble Code (DTC)

VEHICLE DYNAMICS CONTROL (VDC) (DIAGNOSTICS)

Step	Check	Yes	No
1 CHECK STOP LIGHT SWITCH. 1) Turn the ignition switch to OFF. 2) Disconnect the stop light switch connector. 3) Measure the resistance of stop light switch terminals.	Is the resistance 0.5 M Ω or less when the switch is ON (when pedal is depressed)?	Go to step 2.	Replace the stop light switch.
2 CHECK POWER SUPPLY OF STOP LIGHT SWITCH. Measure the voltage between the stop light switch terminal and chassis ground. <i>Connector & terminal</i> <i>(B65) No. 2 (+) — Chassis ground (-):</i>	Is the voltage 10 — 15 V?	Go to step 3.	Repair the power supply circuit of stop light.
3 CHECK STOP LIGHT SWITCH HARNESS. 1) Disconnect the connector from the VDCCM&H/U. 2) Measure the resistance between VDCCM&H/U and stop light switch. <i>Connector & terminal</i> <i>(B65) No. 3 — (B310) No. 30:</i>	Is the resistance less than 0.5 Ω ?	Go to step 4.	Repair the stop light switch circuit.
4 CHECK POOR CONTACT IN CONNECTORS.	Is there poor contact in connector between stop light switch and VDCCM&H/U?	Repair the connector.	Go to step 5.
5 CHECK VDCCM&H/U. 1) Connect all connectors. 2) Erase the memory. 3) Perform the Inspection Mode. 4) Read the DTC.	Is the same DTC displayed?	Replace the VDCCM only. <Ref. to VDC-11, REPLACEMENT, VDC Control Module and Hydraulic Control Unit (VDCCM&H/U).>	Go to step 6.
6 CHECK OTHER DTC DETECTION.	Is any other DTC displayed?	Perform the diagnosis according to DTC.	Temporary poor contact occurs.

Diagnostic Procedure with Diagnostic Trouble Code (DTC)

VEHICLE DYNAMICS CONTROL (VDC) (DIAGNOSTICS)

AK:DTC C0056 G SENSOR SIGNAL

DTC DETECTING CONDITION:

Defective longitudinal G sensor

TROUBLE SYMPTOM:

Hill start assist does not operate.

WIRING DIAGRAM:

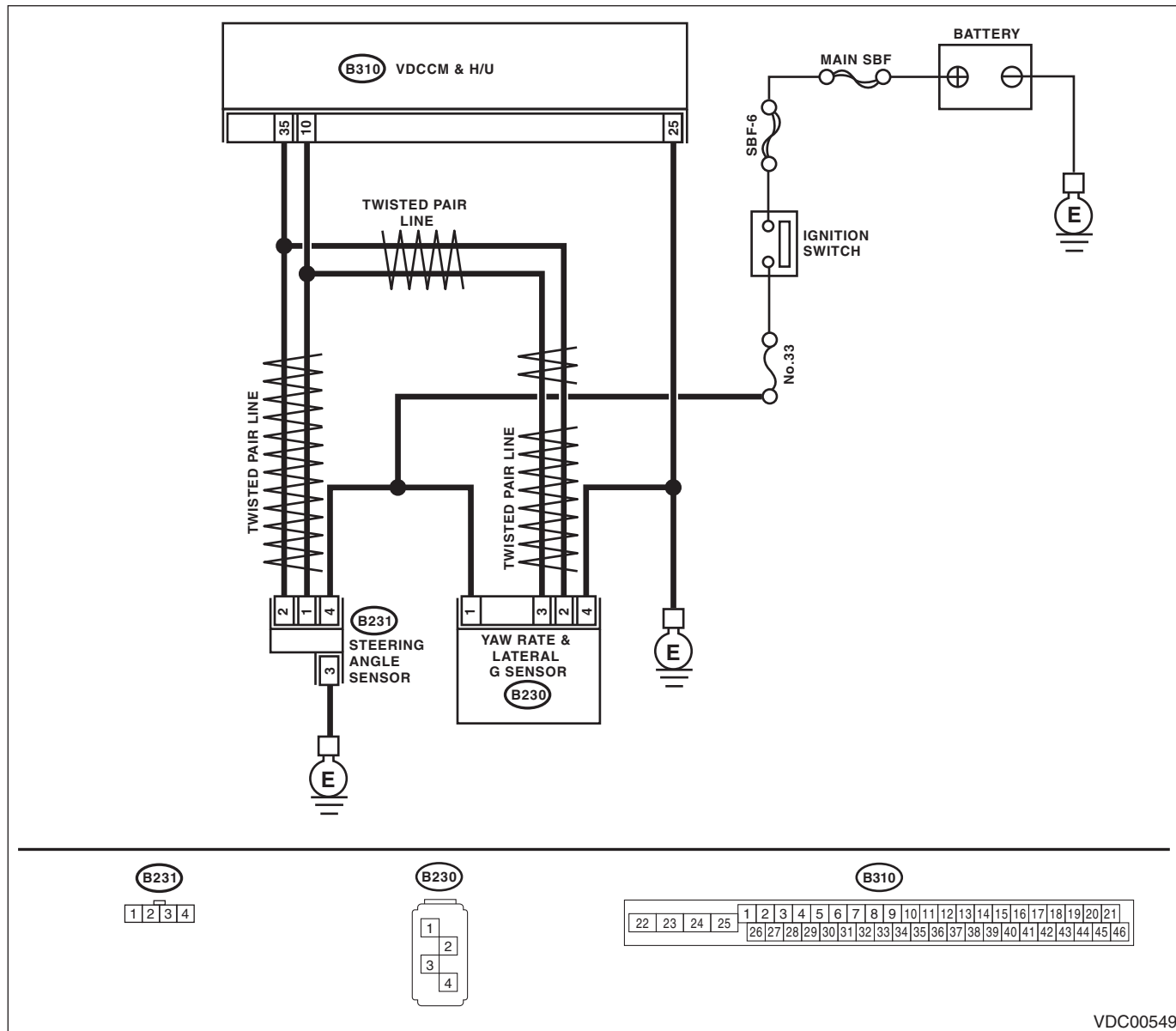

Diagnostic Procedure with Diagnostic Trouble Code (DTC)

VEHICLE DYNAMICS CONTROL (VDC) (DIAGNOSTICS)

Step	Check	Yes	No
1 WHETHER A WHEEL TURNED FREELY OR NOT. Check if the wheels have been turned freely for one minute or more, such as when the vehicle is jacked-up, under full-lock cornering or when the wheels are not in contact with road surface.	Did the wheels turn freely?	VDC is normal. Erase the memory.	Go to step 2.
2 CHECK OUTPUT OF LONGITUDINAL G SENSOR USING SUBARU SELECT MONITOR. 1) Park the vehicle on a level surface. 2) Select {Current Data Display & Save} in Subaru Select Monitor. 3) Read the display for the longitudinal G sensor output.	Is the indicated reading on the monitor display $-1.2 - 1.2 \text{ m/s}^2$?	Go to step 3.	Replace the yaw rate & lateral G sensor.
3 CHECK OUTPUT OF LONGITUDINAL G SENSOR USING SUBARU SELECT MONITOR. 1) Turn the ignition switch to OFF. 2) Remove the yaw rate & lateral G sensor from vehicle. 3) Turn the ignition switch to ON, and select {Current Data Display & Save} in Subaru Select Monitor. 4) Read the display for the longitudinal G sensor output.	When the yaw rate & lateral G sensor is inclined forward by 90° , is the indicated value $6.8 - 12.8 \text{ m/s}^2$?	Go to step 4.	Replace the yaw rate & lateral G sensor.
4 CHECK OUTPUT OF LONGITUDINAL G SENSOR USING SUBARU SELECT MONITOR. Read the display for the longitudinal G sensor output.	When the yaw rate & lateral G sensor is inclined backward by 90° , is the indicated value $-6.8 - -12.8 \text{ m/s}^2$?	Go to step 5.	Replace the yaw rate & lateral G sensor.
5 CHECK POOR CONTACT OF CONNECTORS. Turn the ignition switch to OFF.	Is there poor contact in connector between VDCCM&H/U and yaw rate & lateral G sensor?	Repair the connector.	Go to step 6.
6 CHECK VDCCM&H/U. 1) Connect all connectors. 2) Erase the memory. 3) Perform the Inspection Mode. 4) Read the DTC.	Is the same DTC displayed?	Replace the VDCCM only. <Ref. to VDC-11, REPLACEMENT, VDC Control Module and Hydraulic Control Unit (VDCCM&H/U).>	Go to step 7.
7 CHECK OTHER DTC DETECTION.	Is any other DTC displayed?	Perform the diagnosis according to DTC.	Temporary poor contact occurs.

Diagnostic Procedure with Diagnostic Trouble Code (DTC)

VEHICLE DYNAMICS CONTROL (VDC) (DIAGNOSTICS)

AL:DTC C0057 ECM COMMUNICATION CIRCUIT

DTC DETECTING CONDITION:

No CAN signal from ECM.

TROUBLE SYMPTOM:

- ABS does not operate.
- VDC does not operate.

Step	Check	Yes	No
1 CHECK LAN SYSTEM. Perform the diagnosis for LAN system. <Ref. to LAN(diag)-15, OPERATION, Read Diagnostic Trouble Code (DTC).>	Is there any fault in LAN system?	Perform the diagnosis according to DTC for LAN system.	Go to step 2.
2 CHECK POOR CONTACT IN CONNECTORS.	Is there poor contact in ECM connector?	Repair the connector.	Go to step 3.
3 CHECK ECM.	Is ECM normal?	Go to step 4.	Replace the ECM.
4 CHECK VDCCM&H/U. 1) Connect all connectors. 2) Erase the memory. 3) Perform the Inspection Mode. 4) Read the DTC.	Is the same DTC displayed?	Replace the VDCCM only. <Ref. to VDC-11, REPLACEMENT, VDC Control Module and Hydraulic Control Unit (VDCCM&H/U).>	Go to step 5.
5 CHECK OTHER DTC DETECTION.	Is any other DTC displayed?	Perform the diagnosis according to DTC.	It results from a temporary noise interference.

Diagnostic Procedure with Diagnostic Trouble Code (DTC)

VEHICLE DYNAMICS CONTROL (VDC) (DIAGNOSTICS)

AM:DTC C0057 ECM CONTROL SYSTEM

DTC DETECTING CONDITION:

ECM coordinate control prohibition

TROUBLE SYMPTOM:

- ABS does not operate.
- VDC does not operate.

NOTE:

Warning lights go off if ECM coordinate control is recovered.

Step	Check	Yes	No
1 CHECK WARNING LIGHT. Check whether the VDC warning light illuminates after driving for 1 minute or more at a speed of 10 km/h or more.	Does the VDC warning light illuminate?	Go to step 2.	VDC is normal. Perform the Clear Memory Mode. NOTE: If cranking operation is performed while driving, DTC may be memorized.
2 CHECK POOR CONTACT IN CONNECTORS.	Is there poor contact in ECM connector?	Repair the connector.	Go to step 3.
3 CHECK ECM.	Is ECM normal?	Go to step 4.	Replace the ECM.
4 CHECK VDCCM&H/U. 1) Connect all connectors. 2) Perform the Clear Memory Mode. 3) Perform the Inspection Mode. 4) Read the DTC.	Is the same DTC displayed?	Replace the VDCCM only. <Ref. to VDC-11, REPLACEMENT, VDC Control Module and Hydraulic Control Unit (VDCCM&H/U).>	Go to step 5.
5 CHECK OTHER DTC DETECTION.	Is any other DTC displayed?	Perform the diagnosis according to DTC.	It results from a temporary noise interference.

Diagnostic Procedure with Diagnostic Trouble Code (DTC)

VEHICLE DYNAMICS CONTROL (VDC) (DIAGNOSTICS)

AN:DTC C0071 STEERING ANGLE SENSOR OFFSET IS TOO BIG

DTC DETECTING CONDITION:

Defective steering angle sensor

TROUBLE SYMPTOM:

VDC does not operate.

WIRING DIAGRAM:

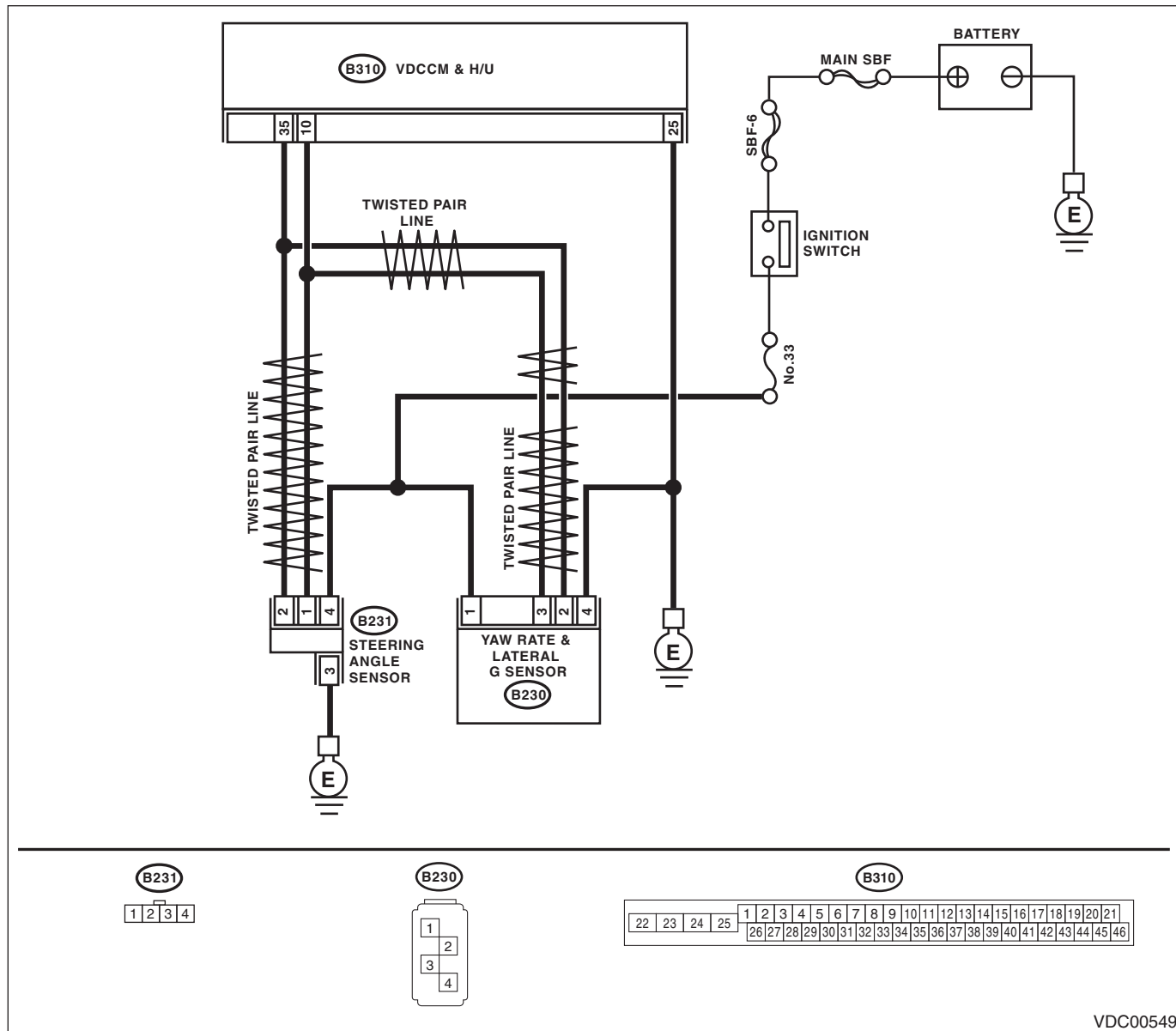

VDC00549

Diagnostic Procedure with Diagnostic Trouble Code (DTC)

VEHICLE DYNAMICS CONTROL (VDC) (DIAGNOSTICS)

Step	Check	Yes	No
1 CHECK STEERING WHEEL. 1) Drive the vehicle on a flat road. 2) Park the vehicle straight. 3) Check the steering wheel for deviation from center.	Is the deviation from the center of steering wheel less than 5°?	Go to step 2.	Perform the centering adjustment of steering wheel.
2 CHECK VDCCM&H/U. 1) Turn the ignition switch to OFF. 2) Connect all connectors. 3) Erase the memory. 4) Perform the Inspection Mode. 5) Read the DTC.	Is the same DTC displayed?	Replace the VDCCM only. <Ref. to VDC-11, REPLACEMENT, VDC Control Module and Hydraulic Control Unit (VDCCM&H/U).>	Go to step 3.
3 CHECK OTHER DTC DETECTION.	Is any other DTC displayed?	Perform the diagnosis according to DTC. <Ref. to VDC(diag)-32, List of Diagnostic Trouble Code (DTC).>	Temporary poor contact occurs.

Diagnostic Procedure with Diagnostic Trouble Code (DTC)

VEHICLE DYNAMICS CONTROL (VDC) (DIAGNOSTICS)

AO:DTC C0071 CHANGE RANGE OF STEERING ANGLE SENSOR IS TOO BIG

DTC DETECTING CONDITION:

Defective steering angle sensor

TROUBLE SYMPTOM:

VDC does not operate.

WIRING DIAGRAM:

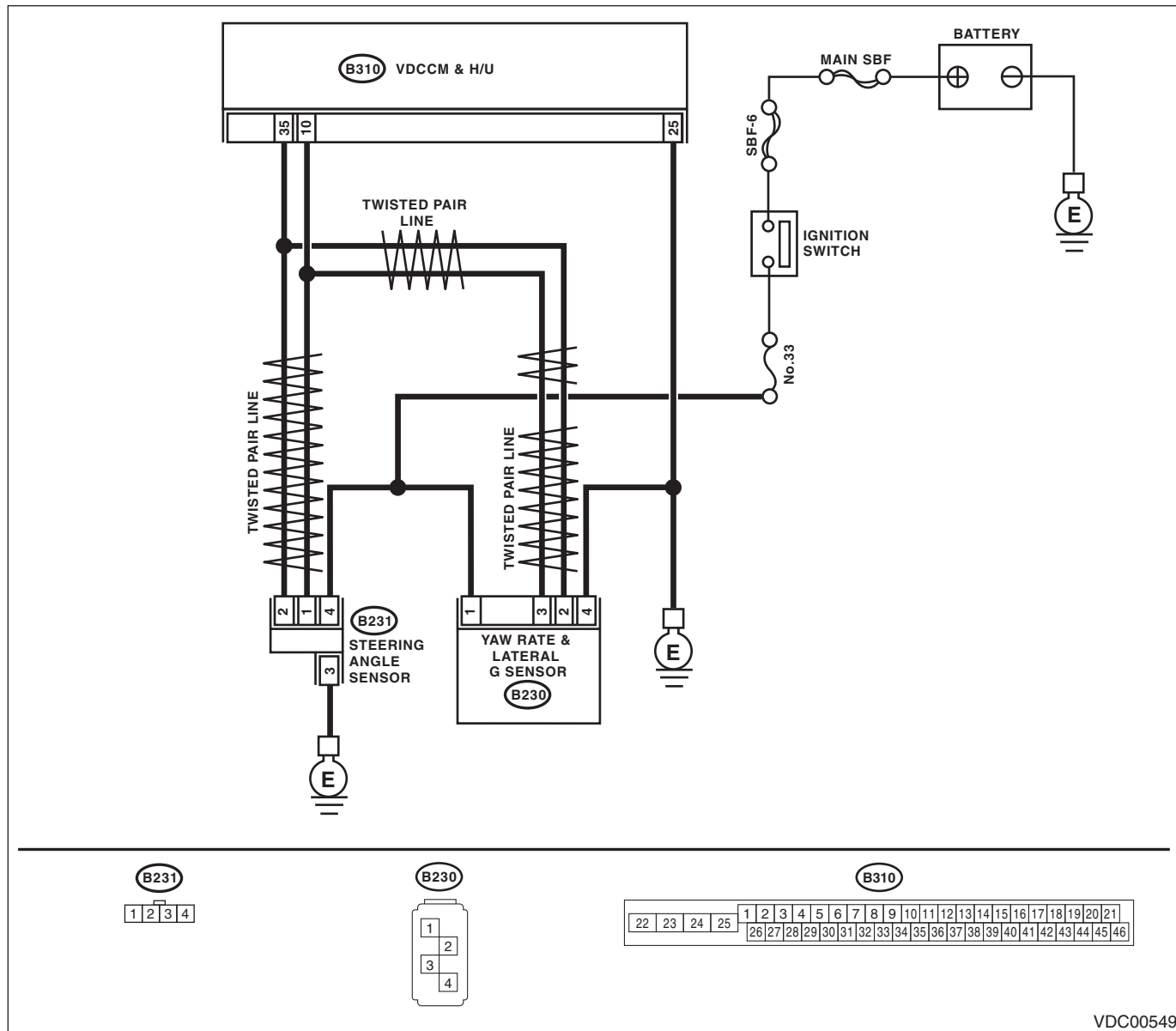

VDC00549

Diagnostic Procedure with Diagnostic Trouble Code (DTC)

VEHICLE DYNAMICS CONTROL (VDC) (DIAGNOSTICS)

Step	Check	Yes	No
1 CHECK VDCCM&H/U. 1) Turn the ignition switch to OFF. 2) Connect all connectors. 3) Erase the memory. 4) Perform the Inspection Mode. 5) Read the DTC.	Is the same DTC displayed?	Replace the VDCCM only. <Ref. to VDC-11, REPLACEMENT, VDC Control Module and Hydraulic Control Unit (VDCCM&H/U).>	Go to step 2.
2 CHECK OTHER DTC DETECTION.	Is any other DTC displayed?	Perform the diagnosis according to DTC. <Ref. to VDC(diag)-32, List of Diagnostic Trouble Code (DTC).>	Temporary poor contact occurs.

Diagnostic Procedure with Diagnostic Trouble Code (DTC)

VEHICLE DYNAMICS CONTROL (VDC) (DIAGNOSTICS)

Step	Check	Yes	No
1 CHECK POWER SUPPLY FOR STEERING ANGLE SENSOR. 1) Turn the ignition switch to OFF. 2) Disconnect the connector from steering angle sensor. 3) Turn the ignition switch to ON. 4) Measure the voltage between the steering angle sensor and chassis ground. <i>Connector & terminal</i> <i>(B231) No. 4 (+) — Chassis ground (-):</i>	Is the voltage 10 — 15 V?	Go to step 2.	Repair the power supply circuit of steering angle sensor.
2 CHECK GROUND CIRCUIT OF STEERING ANGLE SENSOR. Measure the resistance between steering angle sensor and chassis ground. <i>Connector & terminal</i> <i>(B231) No. 3 — Chassis ground:</i>	Is the resistance less than 0.5 Ω?	Go to step 3.	Repair ground circuit in the steering angle sensor.
3 CHECK STEERING ANGLE SENSOR HARNESS. 1) Disconnect the connector from the VDCCM&H/U. 2) Measure the resistance between VDCCM&H/U and steering angle sensor. <i>Connector & terminal</i> <i>(B231) No. 1 — (B310) No. 10:</i> <i>(B231) No. 2 — (B310) No. 35:</i>	Is the resistance less than 0.5 Ω?	Go to step 4.	Repair the harness between the steering angle sensor and VDCCM&H/U.
4 CHECK GROUND SHORT CIRCUIT OF STEERING ANGLE SENSOR HARNESS. Measure the resistance between steering angle sensor and chassis ground. <i>Connector & terminal</i> <i>(B231) No. 1 — Chassis ground:</i> <i>(B231) No. 2 — Chassis ground:</i>	Is the resistance 1 MΩ or more?	Go to step 5.	Repair the harness between the steering angle sensor and VDCCM&H/U.
5 CHECK STEERING ANGLE SENSOR. 1) Turn the ignition switch to OFF. 2) Connect all connectors. 3) Erase the memory. 4) Perform the Inspection Mode. 5) Read the DTC.	Is the same DTC displayed?	Go to step 6.	Go to step 7.
6 CHECK VDCCM&H/U. 1) Turn the ignition switch to OFF. 2) Replace the steering angle sensor. 3) Erase the memory. 4) Perform the Inspection Mode. 5) Read the DTC.	Is the same DTC displayed?	Replace the VDCCM only. <Ref. to VDC-11, REPLACEMENT, VDC Control Module and Hydraulic Control Unit (VDCCM&H/U).>	Go to step 8.
7 CHECK OTHER DTC DETECTION.	Is any other DTC displayed?	Perform the diagnosis according to DTC.	Temporary poor contact occurs.
8 CHECK OTHER DTC DETECTION.	Is any other DTC displayed?	Perform the diagnosis according to DTC.	Original steering angle sensor malfunction

Diagnostic Procedure with Diagnostic Trouble Code (DTC)

VEHICLE DYNAMICS CONTROL (VDC) (DIAGNOSTICS)

AQ:DTC C0071 STEERING ANGLE SENSOR MALFUNCTION

DTC DETECTING CONDITION:

Defective steering angle sensor

TROUBLE SYMPTOM:

- ABS does not operate.
- VDC does not operate.

NOTE:

- Warning light does not illuminate though problem is detected.
- The ABS and VDC operate normally if voltage returns.

WIRING DIAGRAM:

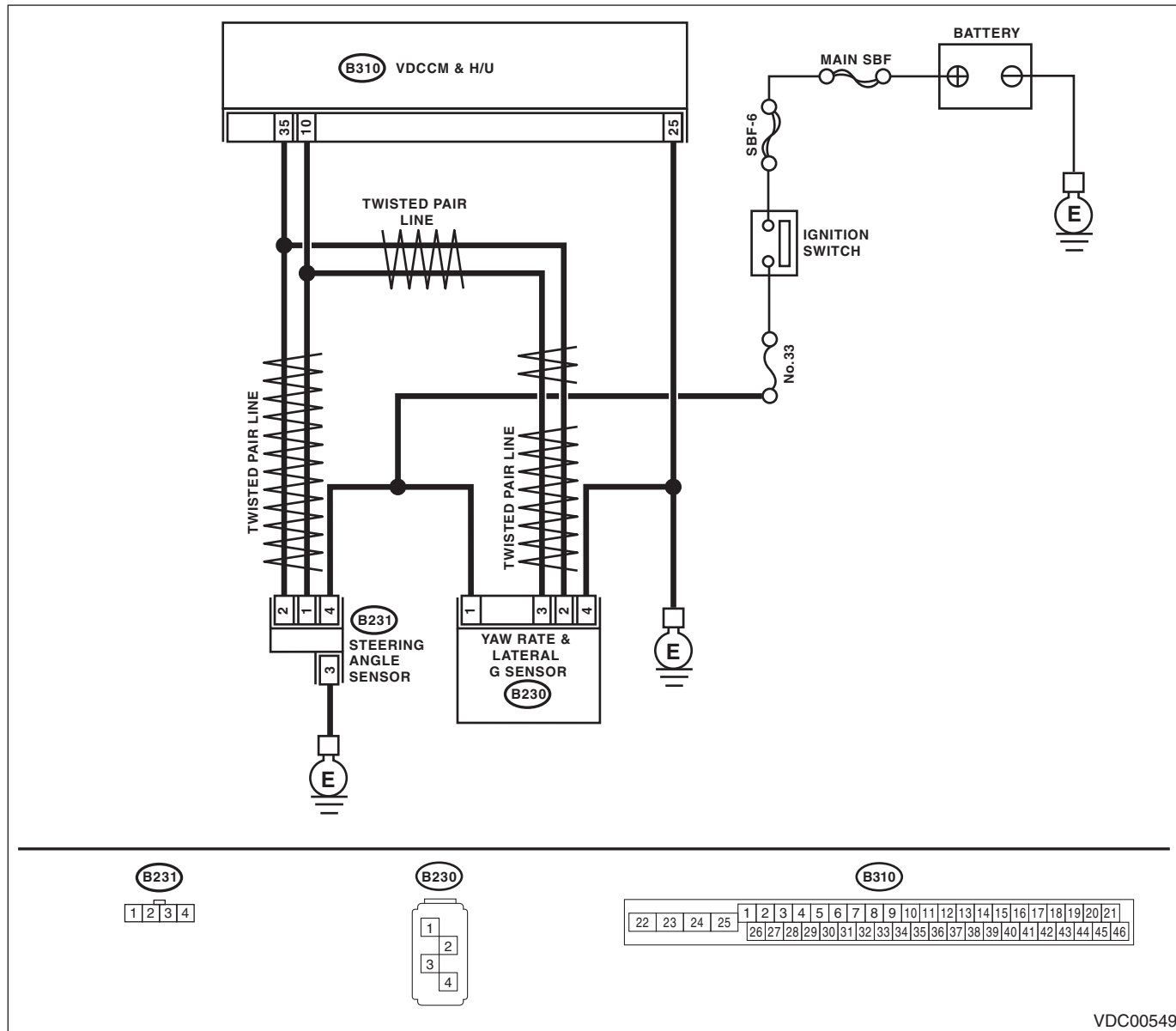

VDC00549

Diagnostic Procedure with Diagnostic Trouble Code (DTC)

VEHICLE DYNAMICS CONTROL (VDC) (DIAGNOSTICS)

Step	Check	Yes	No
1 CHECK POWER SUPPLY FOR STEERING ANGLE SENSOR. 1) Turn the ignition switch to OFF. 2) Disconnect the connector from steering angle sensor. 3) Turn the ignition switch to ON. 4) Measure the voltage between the steering angle sensor and chassis ground. Connector & terminal (B231) No. 4 (+) — Chassis ground (-):	Is the voltage 10 — 15 V?	Go to step 2.	Repair the power supply circuit of steering angle sensor.
2 CHECK GROUND CIRCUIT OF STEERING ANGLE SENSOR. Measure the resistance between steering angle sensor and chassis ground. Connector & terminal (B231) No. 3 — Chassis ground:	Is the resistance less than 0.5 Ω?	Go to step 3.	Repair ground circuit in the steering angle sensor.
3 CHECK STEERING ANGLE SENSOR. 1) Turn the ignition switch to OFF. 2) Connect all connectors. 3) Erase the memory. 4) Perform the Inspection Mode. 5) Read the DTC.	Is the same DTC displayed?	Go to step 4.	Go to step 5.
4 CHECK VDCCM&H/U. 1) Turn the ignition switch to OFF. 2) Replace the steering angle sensor. 3) Erase the memory. 4) Perform the Inspection Mode. 5) Read the DTC.	Is the same DTC displayed?	Replace the VDCCM only. <Ref. to VDC-11, REPLACEMENT, VDC Control Module and Hydraulic Control Unit (VDCCM&H/U).>	Go to step 6.
5 CHECK OTHER DTC DETECTION.	Is any other DTC displayed?	Perform the diagnosis according to DTC.	Temporary poor contact occurs.
6 CHECK OTHER DTC DETECTION.	Is any other DTC displayed?	Perform the diagnosis according to DTC.	Original steering angle sensor malfunction

Diagnostic Procedure with Diagnostic Trouble Code (DTC)

VEHICLE DYNAMICS CONTROL (VDC) (DIAGNOSTICS)

AR:DTC C0072 ABNORMAL YAW RATE SENSOR OUTPUT

DTC DETECTING CONDITION:

Defective yaw rate sensor

TROUBLE SYMPTOM:

VDC does not operate.

WIRING DIAGRAM:

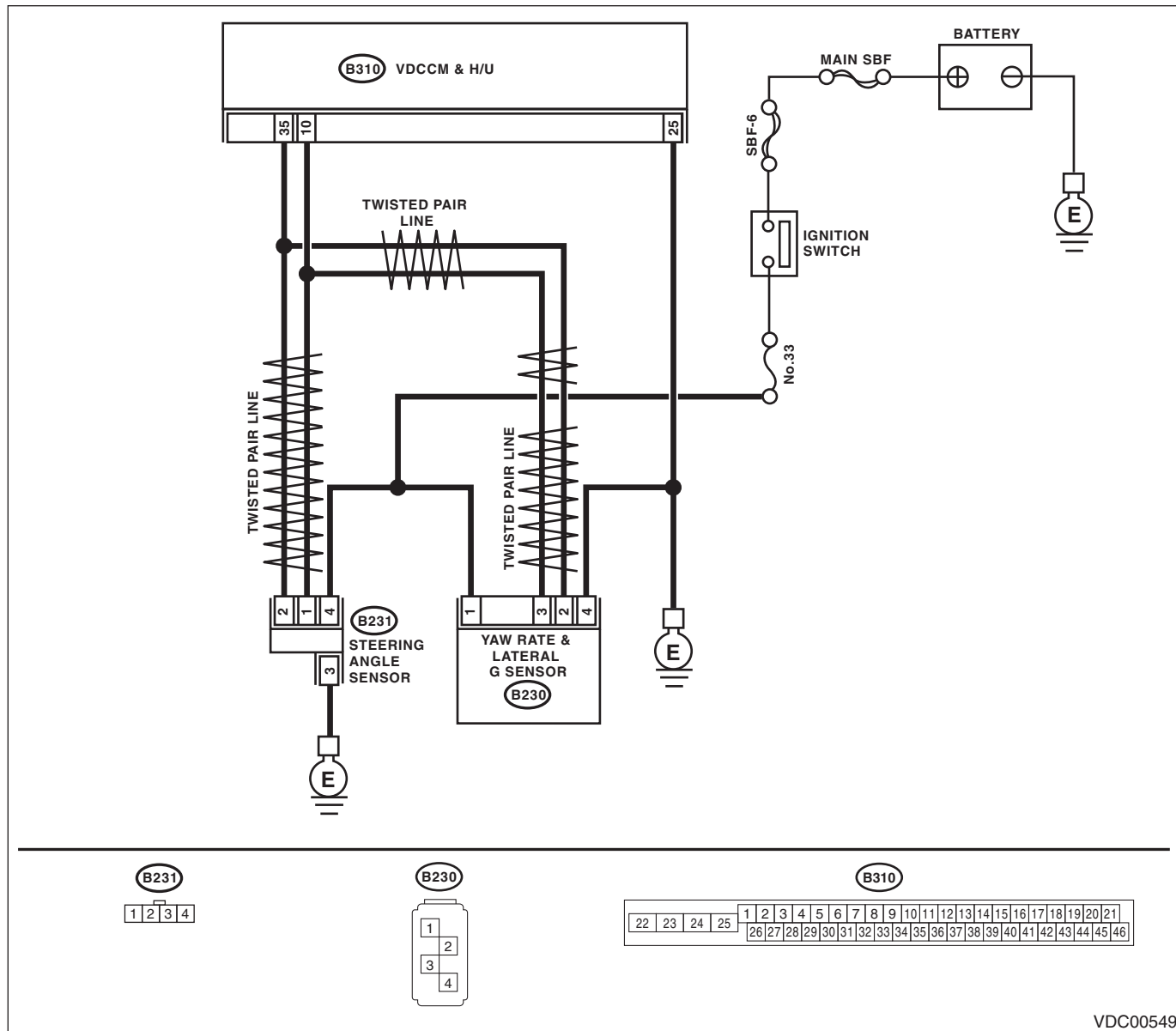

VDC00549

Diagnostic Procedure with Diagnostic Trouble Code (DTC)

VEHICLE DYNAMICS CONTROL (VDC) (DIAGNOSTICS)

Step	Check	Yes	No
1 CHECK DRIVING PLACE. Check if the vehicle ran the road with banks or sandy surface (which does not mean a dirt road).	Did the vehicle run the road with banks or sandy surface (which does not mean a dirt road)?	VDCCM&H/U may record DTC when the vehicle ran the road with banks or sandy surface (which does not mean a dirt road).	Go to step 2.
2 CHECK YAW RATE & LATERAL G SENSOR INSTALLATION.	Is the yaw rate & lateral G sensor installation bolt tightened to 7.5 N·m (0.76 kgf·m, 5.5 ft·lb)?	Go to step 3.	Tighten the yaw rate & lateral G sensor installation bolt.
3 CHECK OUTPUT OF YAW RATE & LATERAL G SENSOR WITH SUBARU SELECT MONITOR. 1) Drive the vehicle on a flat road. 2) Park the vehicle straight. 3) Select {Current Data Display & Save} in Subaru Select Monitor. 4) Read the yaw rate output displayed on display.	Is the reading indicated on monitor display -4 — 4 deg/s?	Go to step 4.	Replace the yaw rate & lateral G sensor.
4 CHECK OUTPUT OF STEERING ANGLE SENSOR WITH SUBARU SELECT MONITOR. 1) Drive the vehicle on a flat road. 2) Park the vehicle straight. 3) Select {Current Data Display & Save} in Subaru Select Monitor. 4) Read the steering angle sensor output displayed on display.	Is the reading indicated on monitor display -5 — 5°?	Go to step 5.	Perform the centering adjustment of steering wheel.
5 CHECK YAW RATE & LATERAL G SENSOR. 1) Turn the ignition switch to OFF. 2) Connect all connectors. 3) Erase the memory. 4) Perform the Inspection Mode. 5) Read the DTC.	Is the same DTC displayed?	Go to step 6.	Go to step 7.
6 CHECK VDCCM&H/U. 1) Turn the ignition switch to OFF. 2) Replace the yaw rate & lateral G sensor. 3) Erase the memory. 4) Perform the Inspection Mode. 5) Read the DTC.	Is the same DTC displayed?	Replace the VDCCM only. <Ref. to VDC-11, REPLACEMENT, VDC Control Module and Hydraulic Control Unit (VDCCM&H/U).>	Go to step 8.
7 CHECK OTHER DTC DETECTION.	Is any other DTC displayed?	Perform the diagnosis according to DTC.	Temporary poor contact occurs.
8 CHECK OTHER DTC DETECTION.	Is any other DTC displayed?	Perform the diagnosis according to DTC.	Malfunction is found in original yaw rate & lateral G sensor.

Diagnostic Procedure with Diagnostic Trouble Code (DTC)

VEHICLE DYNAMICS CONTROL (VDC) (DIAGNOSTICS)

AS:DTC C0072 VOLTAGE INPUTTED TO YAW RATE SENSOR EXCEEDS SPECIFICATION

DTC DETECTING CONDITION:

Defective yaw rate sensor

TROUBLE SYMPTOM:

VDC does not operate.

WIRING DIAGRAM:

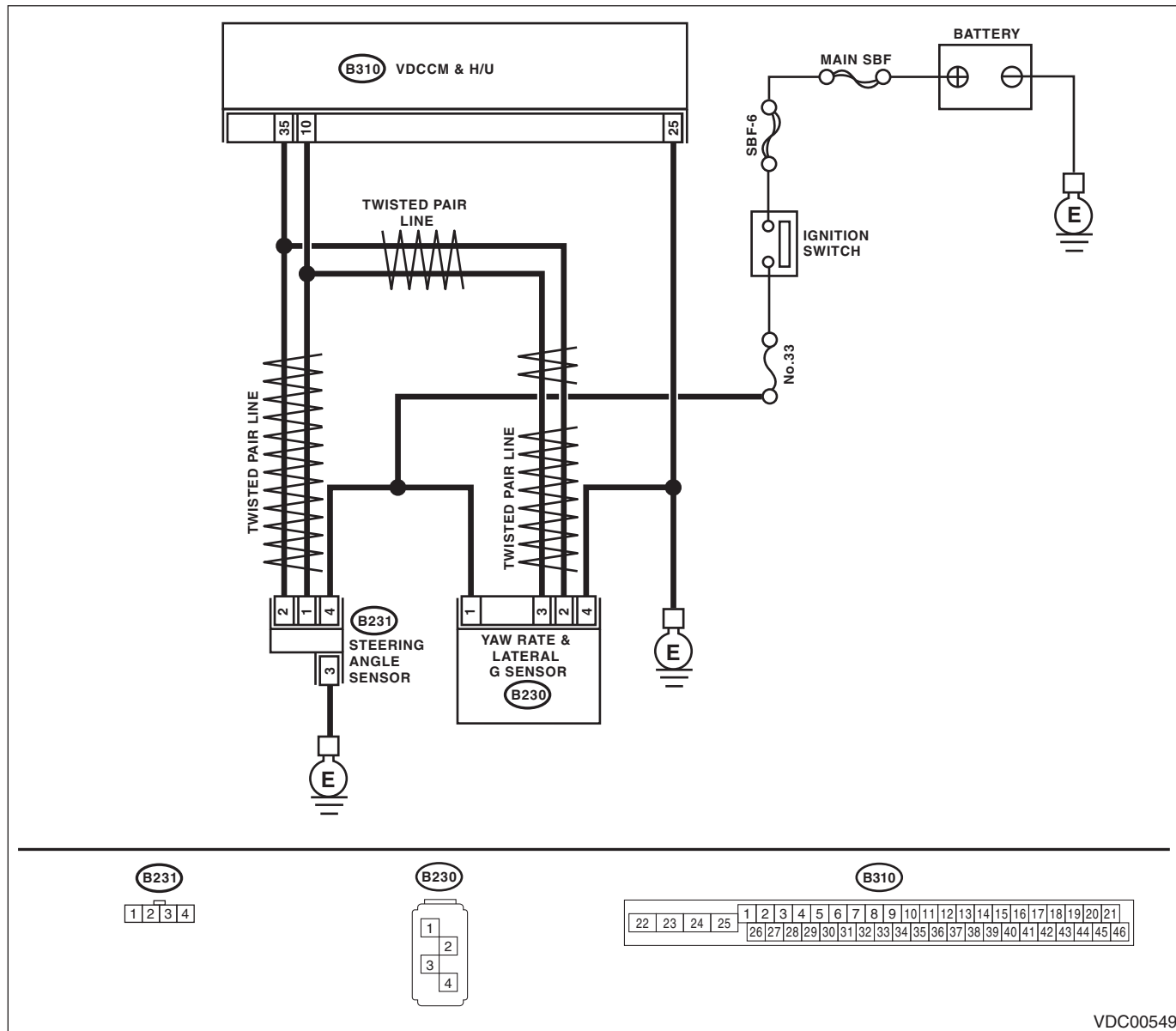

VDC00549

Diagnostic Procedure with Diagnostic Trouble Code (DTC)

VEHICLE DYNAMICS CONTROL (VDC) (DIAGNOSTICS)

Step	Check	Yes	No
1 CHECK YAW RATE & LATERAL G SENSOR POWER SUPPLY. 1) Turn the ignition switch to OFF. 2) Disconnect the connector from yaw rate & lateral G sensor. 3) Turn the ignition switch to ON. 4) Measure the voltage between yaw rate & lateral G sensor and chassis ground. <i>Connector & terminal</i> <i>(B230) No. 1 (+) — Chassis ground (-):</i>	Is the voltage 10 — 15 V?	Go to step 2.	Repair the power supply circuit of the yaw rate & lateral G sensor.
2 CHECK YAW RATE & LATERAL G SENSOR GROUND CIRCUIT. Measure the resistance between the yaw rate & lateral G sensor and chassis ground. <i>Connector & terminal</i> <i>(B230) No. 4 — Chassis ground:</i>	Is the resistance less than 0.5 Ω ?	Go to step 3.	Repair the ground circuit of the yaw rate & lateral G sensor.
3 CHECK YAW RATE & LATERAL G SENSOR. 1) Turn the ignition switch to OFF. 2) Connect all connectors. 3) Erase the memory. 4) Perform the Inspection Mode. 5) Read the DTC.	Is the same DTC displayed?	Replace the yaw rate & lateral G sensor.	Go to step 4.
4 CHECK OTHER DTC DETECTION.	Is any other DTC displayed?	Perform the diagnosis according to DTC.	Temporary poor contact occurs.

Diagnostic Procedure with Diagnostic Trouble Code (DTC)

VEHICLE DYNAMICS CONTROL (VDC) (DIAGNOSTICS)

AT:DTC C0072 CHANGE RANGE OF YAW RATE SENSOR SIGNAL IS TOO BIG

DTC DETECTING CONDITION:

Defective yaw rate sensor

TROUBLE SYMPTOM:

VDC does not operate.

WIRING DIAGRAM:

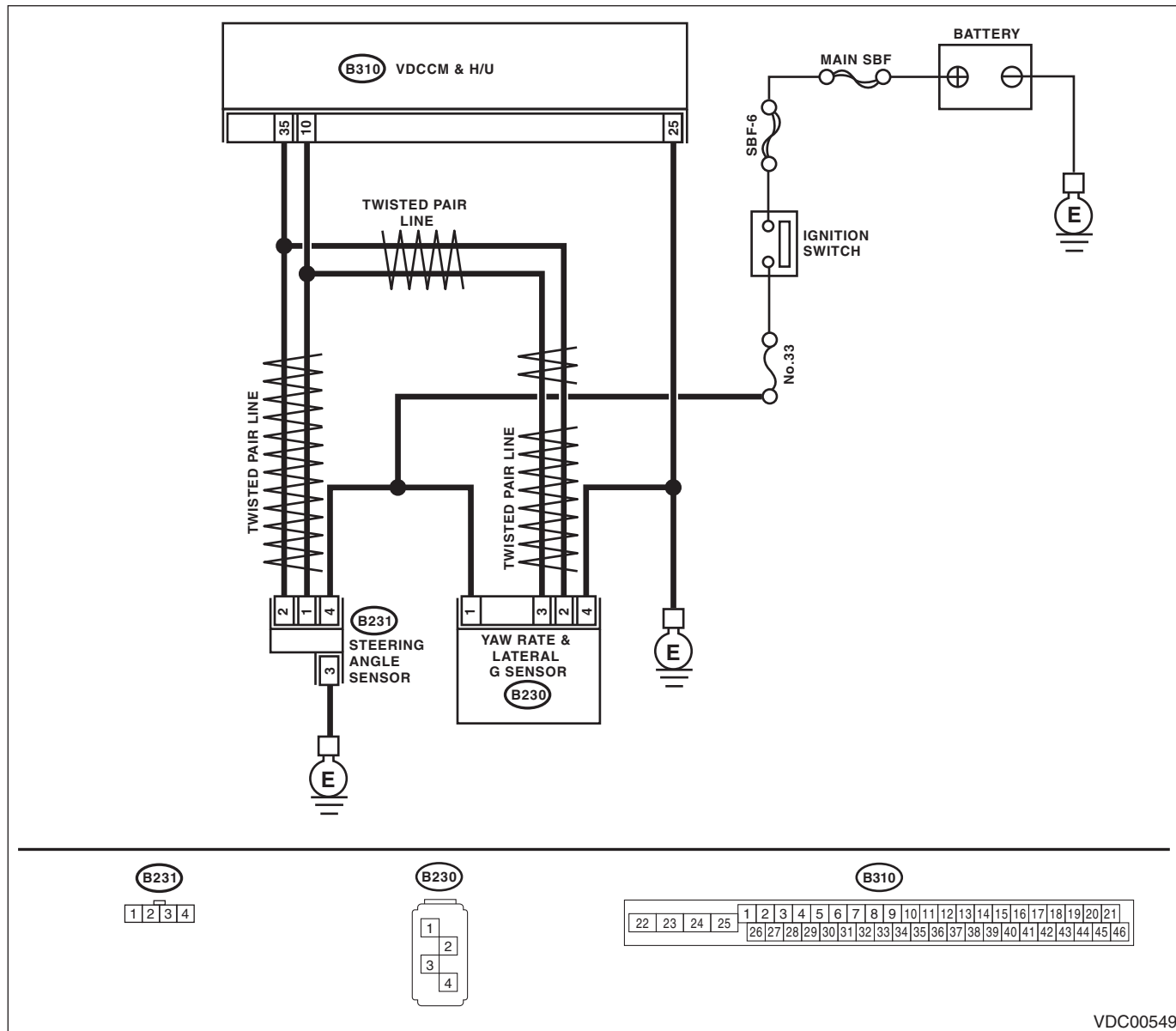

VDC00549

Diagnostic Procedure with Diagnostic Trouble Code (DTC)

VEHICLE DYNAMICS CONTROL (VDC) (DIAGNOSTICS)

Step	Check	Yes	No	
1	CHECK DRIVING PLACE. Check if the vehicle ran the road with banks or sandy surface (which does not mean a dirt road).	Did the vehicle run the road with banks or sandy surface (which does not mean a dirt road)?	VDCCM&H/U may record DTC when the vehicle ran the road with banks or sandy surface (which does not mean a dirt road).	Go to step 2.
2	CHECK YAW RATE & LATERAL G SENSOR INSTALLATION.	Is the yaw rate & lateral G sensor installation bolt tightened to 7.5 N·m (0.76 kgf·m, 5.5 ft·lb)?	Go to step 3.	Tighten the yaw rate & lateral G sensor installation bolt.
3	CHECK YAW RATE & LATERAL G SENSOR POWER SUPPLY. 1) Turn the ignition switch to OFF. 2) Disconnect the connector from yaw rate & lateral G sensor. 3) Turn the ignition switch to ON. 4) Measure the voltage between yaw rate & lateral G sensor and chassis ground. Connector & terminal (B230) No. 1 (+) — Chassis ground (-):	Is the voltage 10 — 15 V?	Go to step 4.	Repair the power supply circuit of the yaw rate & lateral G sensor.
4	CHECK YAW RATE & LATERAL G SENSOR GROUND CIRCUIT. Measure the resistance between the yaw rate & lateral G sensor and chassis ground. Connector & terminal (B230) No. 4 — Chassis ground:	Is the resistance less than 0.5 Ω?	Go to step 5.	Repair the ground circuit of the yaw rate & lateral G sensor.
5	CHECK OUTPUT OF YAW RATE & LATERAL G SENSOR WITH SUBARU SELECT MONITOR. 1) Drive the vehicle on a flat road. 2) Park the vehicle straight. 3) Select {Current Data Display & Save} in Subaru Select Monitor. 4) Read the yaw rate output displayed on display.	Is the reading indicated on monitor display -4 — 4 deg/s?	Go to step 6.	Replace the yaw rate & lateral G sensor.
6	CHECK YAW RATE & LATERAL G SENSOR. 1) Turn the ignition switch to OFF. 2) Connect all connectors. 3) Erase the memory. 4) Perform the Inspection Mode. 5) Read the DTC.	Is the same DTC displayed?	Go to step 7.	Go to step 8.
7	CHECK VDCCM&H/U. 1) Turn the ignition switch to OFF. 2) Replace the yaw rate & lateral G sensor. 3) Erase the memory. 4) Perform the Inspection Mode. 5) Read the DTC.	Is the same DTC displayed?	Replace the VDCCM only. <Ref. to VDC-11, REPLACEMENT, VDC Control Module and Hydraulic Control Unit (VDCCM&H/U).>	Go to step 9.
8	CHECK OTHER DTC DETECTION.	Is any other DTC displayed?	Perform the diagnosis according to DTC.	Temporary poor contact occurs.
9	CHECK OTHER DTC DETECTION.	Is any other DTC displayed?	Perform the diagnosis according to DTC.	Malfunction is found in original yaw rate & lateral G sensor.

Diagnostic Procedure with Diagnostic Trouble Code (DTC)

VEHICLE DYNAMICS CONTROL (VDC) (DIAGNOSTICS)

AU:DTC C0072 YAW RATE SENSOR COMMUNICATION

DTC DETECTING CONDITION:

Communication failure between yaw rate sensor and VDCCM

TROUBLE SYMPTOM:

- ABS does not operate.
- VDC does not operate.

WIRING DIAGRAM:

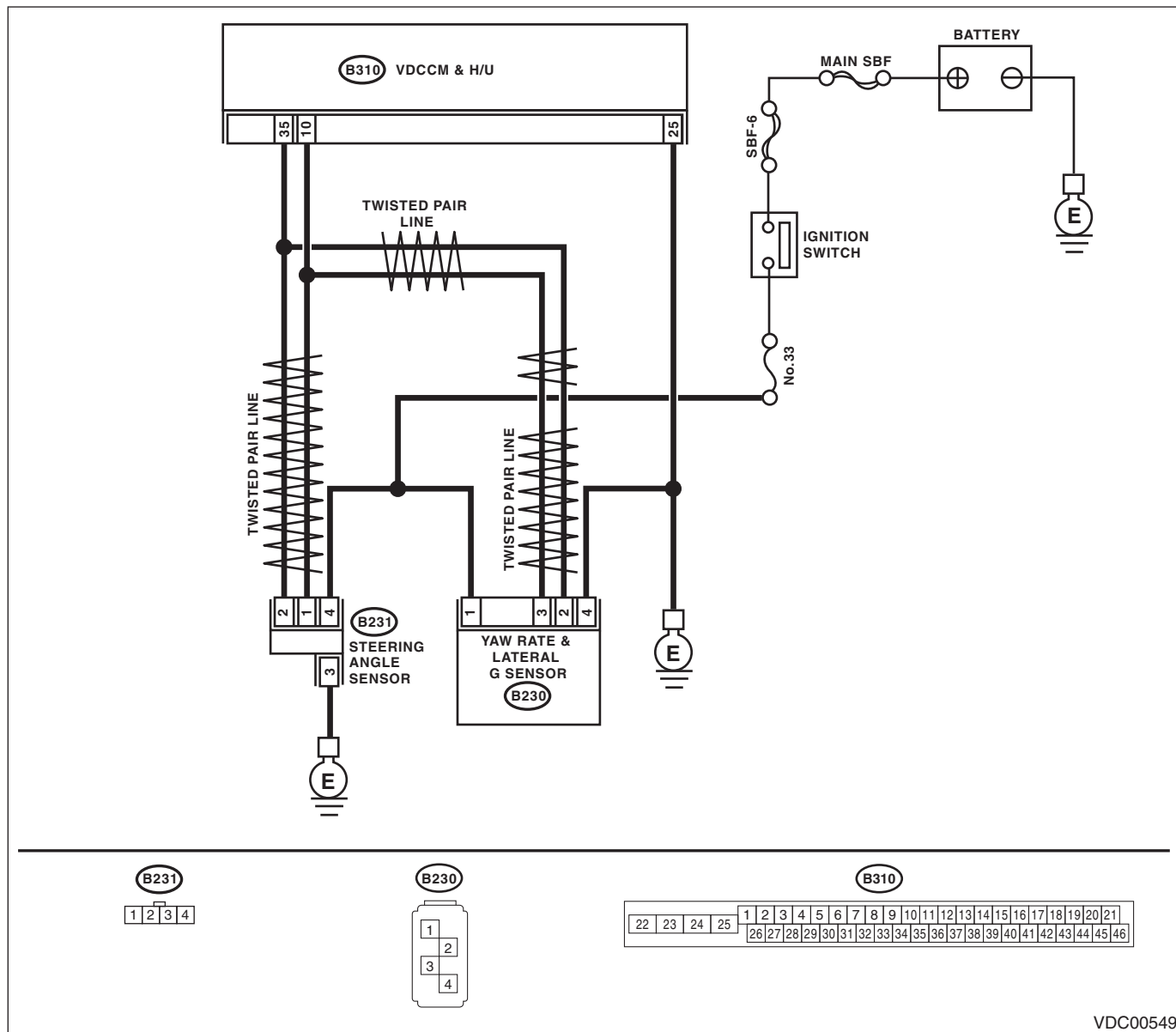

VDC00549

Diagnostic Procedure with Diagnostic Trouble Code (DTC)

VEHICLE DYNAMICS CONTROL (VDC) (DIAGNOSTICS)

Step	Check	Yes	No
1 CHECK POWER SUPPLY FOR YAW RATE & LATERAL G SENSOR. 1) Turn the ignition switch to OFF. 2) Disconnect the connector from yaw rate & lateral G sensor. 3) Turn the ignition switch to ON. 4) Measure the voltage between yaw rate & lateral G sensor and chassis ground. <i>Connector & terminal</i> <i>(B230) No. 1 (+) — Chassis ground (-):</i>	Is the voltage 10 — 15 V?	Go to step 2.	Repair the power supply circuit of the yaw rate & lateral G sensor.
2 CHECK YAW RATE & LATERAL G SENSOR GROUND CIRCUIT. Measure the resistance between the yaw rate & lateral G sensor and chassis ground. <i>Connector & terminal</i> <i>(B230) No. 4 — Chassis ground:</i>	Is the resistance less than 0.5 Ω?	Go to step 3.	Repair the ground circuit of the yaw rate & lateral G sensor.
3 CHECK YAW RATE & LATERAL G SENSOR HARNESS. 1) Disconnect the connector from the VDCCM&H/U. 2) Measure the resistance between VDCCM&H/U and yaw rate & lateral G sensor. <i>Connector & terminal</i> <i>(B230) No. 3 — (B310) No. 10:</i> <i>(B230) No. 2 — (B310) No. 35:</i>	Is the resistance less than 0.5 Ω?	Go to step 4.	Repair the harness between yaw rate & lateral G sensor and VDCCM&H/U.
4 CHECK GROUND SHORT CIRCUIT FOR YAW RATE & LATERAL G SENSOR HARNESS. Measure the resistance between the yaw rate & lateral G sensor and chassis ground. <i>Connector & terminal</i> <i>(B230) No. 2 — Chassis ground:</i> <i>(B230) No. 3 — Chassis ground:</i>	Is the resistance 1 MΩ or more?	Go to step 5.	Repair the harness between yaw rate & lateral G sensor and VDCCM&H/U.
5 CHECK YAW RATE & LATERAL G SENSOR. 1) Turn the ignition switch to OFF. 2) Connect all connectors. 3) Erase the memory. 4) Perform the Inspection Mode. 5) Read the DTC.	Is the same DTC displayed?	Go to step 6.	Go to step 7.
6 CHECK YAW RATE & LATERAL G SENSOR. 1) Turn the ignition switch to OFF. 2) Replace the yaw rate & lateral G sensor. 3) Erase the memory. 4) Perform the Inspection Mode. 5) Read the DTC.	Is the same DTC displayed?	Replace the VDCCM only. <Ref. to VDC-11, REPLACEMENT, VDC Control Module and Hydraulic Control Unit (VDCCM&H/U).>	Go to step 8.
7 CHECK OTHER DTC DETECTION.	Is any other DTC displayed?	Perform the diagnosis according to DTC.	Temporary poor contact occurs.
8 CHECK OTHER DTC DETECTION.	Is any other DTC displayed?	Perform the diagnosis according to DTC.	Malfunction is found in original yaw rate & lateral G sensor.

Diagnostic Procedure with Diagnostic Trouble Code (DTC)

VEHICLE DYNAMICS CONTROL (VDC) (DIAGNOSTICS)

AV:DTC C0072 SENSOR TYPE ABNORMAL

DTC DETECTING CONDITION:

Different yaw rate sensor specification

TROUBLE SYMPTOM:

- VDC does not operate.
- Hill start assist does not operate.

Step	Check	Yes	No
1 CHECK YAW RATE & LATERAL G SENSOR IDENTIFICATION NUMBER. Check the identification number on the sticker applied on the top of the yaw rate & lateral G sensor.	Is the identification number correct? MT:R AT:S	Go to step 2.	Replace the yaw rate & lateral G sensor with the proper product.
2 CHECK VDCCM&H/U IDENTIFICATION NUMBER. Check the identification number on the sticker printed on the upper side of the H/U.	Is the identification number correct? MT: Z2 AT: Z1	Replace the VDCCM only. <Ref. to VDC-11, REPLACEMENT, VDC Control Module and Hydraulic Control Unit (VDCCM&H/U).>	Replace the VDCCM&H/U. <Ref. to VDC-7, VDC Control Module and Hydraulic Control Unit (VDCCM&H/U).>

AW:DTC C0073 LATERAL G SENSOR OFFSET IS TOO BIG

NOTE:

For the diagnostic procedure, refer to DTC C0073 "EXCESSIVE LATERAL G SENSOR SIGNAL". <Ref. to VDC(diag)-94, DTC C0073 EXCESSIVE LATERAL G SENSOR SIGNAL, Diagnostic Procedure with Diagnostic Trouble Code (DTC).>

AX:DTC C0073 ABNORMAL LATERAL G SENSOR OUTPUT

NOTE:

For the diagnostic procedure, refer to DTC C0073 "EXCESSIVE LATERAL G SENSOR SIGNAL". <Ref. to VDC(diag)-94, DTC C0073 EXCESSIVE LATERAL G SENSOR SIGNAL, Diagnostic Procedure with Diagnostic Trouble Code (DTC).>

Diagnostic Procedure with Diagnostic Trouble Code (DTC)

VEHICLE DYNAMICS CONTROL (VDC) (DIAGNOSTICS)

AY:DTC C0073 EXCESSIVE LATERAL G SENSOR SIGNAL

DTC DETECTING CONDITION:

Lateral G sensor malfunction

TROUBLE SYMPTOM:

VDC does not operate.

WIRING DIAGRAM:

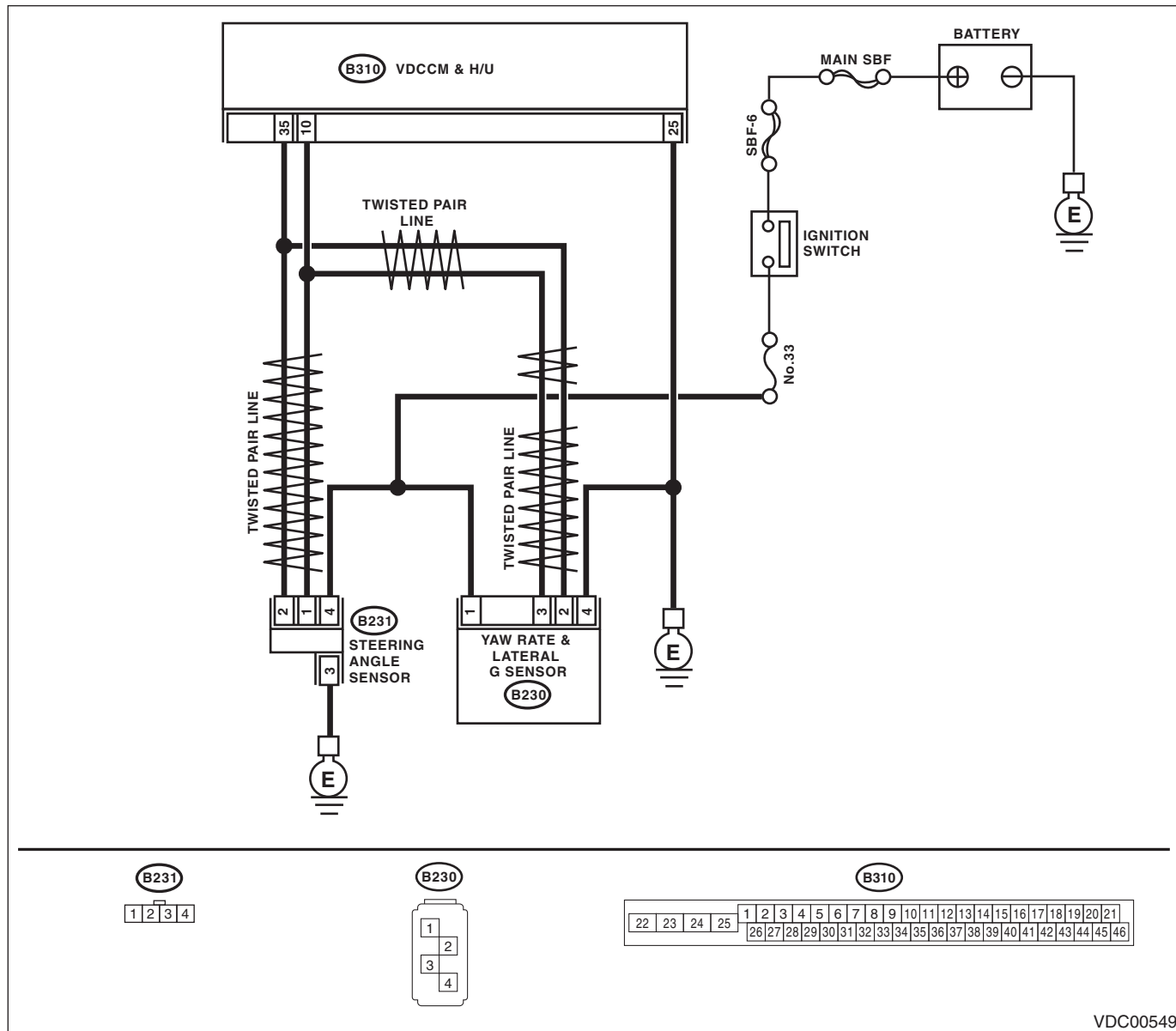

VDC00549

Diagnostic Procedure with Diagnostic Trouble Code (DTC)

VEHICLE DYNAMICS CONTROL (VDC) (DIAGNOSTICS)

Step	Check	Yes	No
1	CHECK YAW RATE & LATERAL G SENSOR INSTALLATION.	Go to step 2.	Tighten the yaw rate & lateral G sensor installation bolt.
2	CHECK LATERAL G SENSOR OUTPUT. 1) Park the vehicle on a level surface. 2) Select {Current Data Display & Save} in Subaru Select Monitor. 3) Read the lateral G sensor output displayed on screen.	Go to step 3.	Replace the yaw rate & lateral G sensor.
3	CHECK LATERAL G SENSOR OUTPUT. 1) Turn the ignition switch to OFF. 2) Remove the yaw rate & lateral G sensors from vehicle. 3) Turn the ignition switch to ON, and select {Current Data Display & Save} in Subaru Select Monitor. 4) Read the lateral G sensor output displayed on screen.	Go to step 4.	Replace the yaw rate & lateral G sensor.
4	CHECK LATERAL G SENSOR. Read the lateral G sensor output displayed on screen.	Go to step 5.	Replace the yaw rate & lateral G sensor.
5	CHECK POOR CONTACT IN CONNECTORS. Turn the ignition switch to OFF.	Repair the connector.	Go to step 6.
6	CHECK VDCCM&H/U. 1) Connect all connectors. 2) Erase the memory. 3) Perform the Inspection Mode. 4) Read the DTC.	Replace the VDCCM only. <Ref. to VDC-11, REPLACEMENT, VDC Control Module and Hydraulic Control Unit (VDCCM&H/U).>	Go to step 7.
7	CHECK OTHER DTC DETECTION.	Perform the diagnosis according to DTC.	Temporary poor contact occurs.

Diagnostic Procedure with Diagnostic Trouble Code (DTC)

VEHICLE DYNAMICS CONTROL (VDC) (DIAGNOSTICS)

AZ:DTC C0074 PRESSURE SENSOR

DTC DETECTING CONDITION:

Defective pressure sensor

TROUBLE SYMPTOM:

- ABS does not operate.
- VDC does not operate.

Step	Check	Yes	No	
1	CHECK STOP LIGHT SWITCH CIRCUIT. Check stop light switch open circuit.	Is the stop light switch circuit OK?	Go to step 2.	Repair the stop light switch circuit. NOTE: If there is malfunction in the stop light circuit, DTC may be memorized.
2	CHECK OUTPUT OF PRESSURE SENSOR WITH SUBARU SELECT MONITOR. 1) Select {Current Data Display & Save} in Subaru Select Monitor. 2) Read the pressure sensor output displayed on display.	When the brake pedal is released, is the displayed value -40 — 40 bar?	Go to step 3.	Replace the VDCCM&H/U. <Ref. to VDC-7, VDC Control Module and Hydraulic Control Unit (VDCCM&H/U).>
3	CHECK OUTPUT OF PRESSURE SENSOR WITH SUBARU SELECT MONITOR. 1) Select {Current Data Display & Save} in Subaru Select Monitor. 2) Read the pressure sensor output displayed on display.	When operating the brake pedal, does the pressure sensor output value on the display change according to the brake pedal operation?	Go to step 4.	Replace the VDCCM&H/U. <Ref. to VDC-7, VDC Control Module and Hydraulic Control Unit (VDCCM&H/U).>
4	CHECK PRESSURE SENSOR. 1) Erase the memory. 2) Perform the Inspection Mode. 3) Read the DTC.	Is the same DTC displayed?	Replace the VDCCM&H/U. <Ref. to VDC-7, VDC Control Module and Hydraulic Control Unit (VDCCM&H/U).>	Go to step 5.
5	CHECK OTHER DTC DETECTION.	Is any other DTC displayed?	Perform the diagnosis according to DTC. <Ref. to VDC(diag)-32, List of Diagnostic Trouble Code (DTC).>	It results from a temporary noise interference.

Diagnostic Procedure with Diagnostic Trouble Code (DTC)

VEHICLE DYNAMICS CONTROL (VDC) (DIAGNOSTICS)

BA:DTC C0075 REVERSE SIGNAL

DTC DETECTING CONDITION:

Reverse signal malfunction

TROUBLE SYMPTOM:

Hill start assist does not operate.

WIRING DIAGRAM:

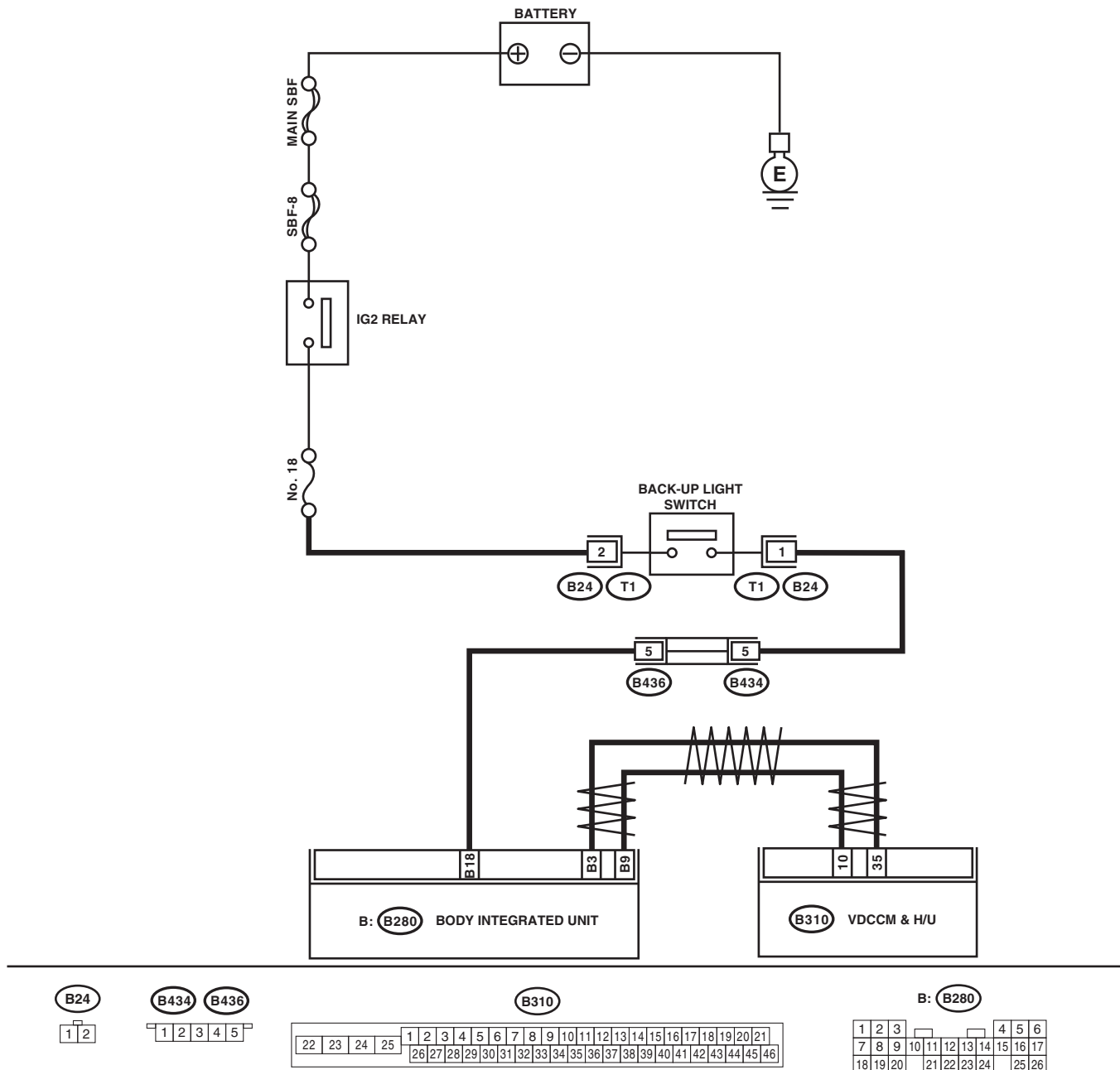

VDC00631

Diagnostic Procedure with Diagnostic Trouble Code (DTC)

VEHICLE DYNAMICS CONTROL (VDC) (DIAGNOSTICS)

Step	Check	Yes	No
1 CHECK LAN SYSTEM. Perform the diagnosis for LAN system. <Ref. to LAN(diag)-15, OPERATION, Read Diagnostic Trouble Code (DTC).>	Is there any fault in LAN system?	Perform the diagnosis according to DTC for LAN system.	Go to step 2.
2 CHECK REVERSE SIGNAL USING SUBARU SELECT MONITOR. 1) Select {Current Data Display & Save} in the Subaru Select Monitor. 2) Read the display of the reverse signal.	Is OFF displayed when the shift position is in a position other than reverse, and ON when it is placed in reverse?	Go to step 5.	Go to step 3.
3 CHECK LIGHTING OF BACK-UP LIGHT. 1) Turn the ignition switch to ON. 2) Set the shift lever to the reverse position.	Does the back-up light illuminate?	Go to step 4.	Repair the back-up light circuit.
4 CHECK HARNESS BETWEEN BODY INTEGRATED UNIT AND BACK-UP LIGHT SWITCH. 1) Turn the ignition switch to OFF. 2) Disconnect the connector from the body integrated unit and the back-up light switch. 3) Measure the resistance of the harness between the body integrated unit and back-up switch connector. <i>Connector & terminal (B280) No. 18 — (B24) No. 1:</i>	Is the resistance less than 0.5 Ω?	Replace the back-up light switch. <Ref. to 5MT-35, Switches and Harness.>	Repair the harness between the body integrated unit and back-up light switch connector.
5 CHECK VDCCM&H/U. 1) Connect all connectors. 2) Erase the memory. 3) Perform the Inspection Mode. 4) Read the DTC.	Is the same DTC displayed?	Replace the VDCCM only. <Ref. to VDC-11, REPLACEMENT, VDC Control Module and Hydraulic Control Unit (VDCCM&H/U).>	Go to step 6.
6 CHECK OTHER DTC DETECTION.	Is any other DTC displayed?	Perform the diagnosis according to DTC.	Temporary poor contact occurs.

Diagnostic Procedure with Diagnostic Trouble Code (DTC)

VEHICLE DYNAMICS CONTROL (VDC) (DIAGNOSTICS)

BB:DTC C0076 CLUTCH SIGNAL

DTC DETECTING CONDITION:

Clutch signal malfunction

TROUBLE SYMPTOM:

Hill start assist does not operate.

WIRING DIAGRAM:

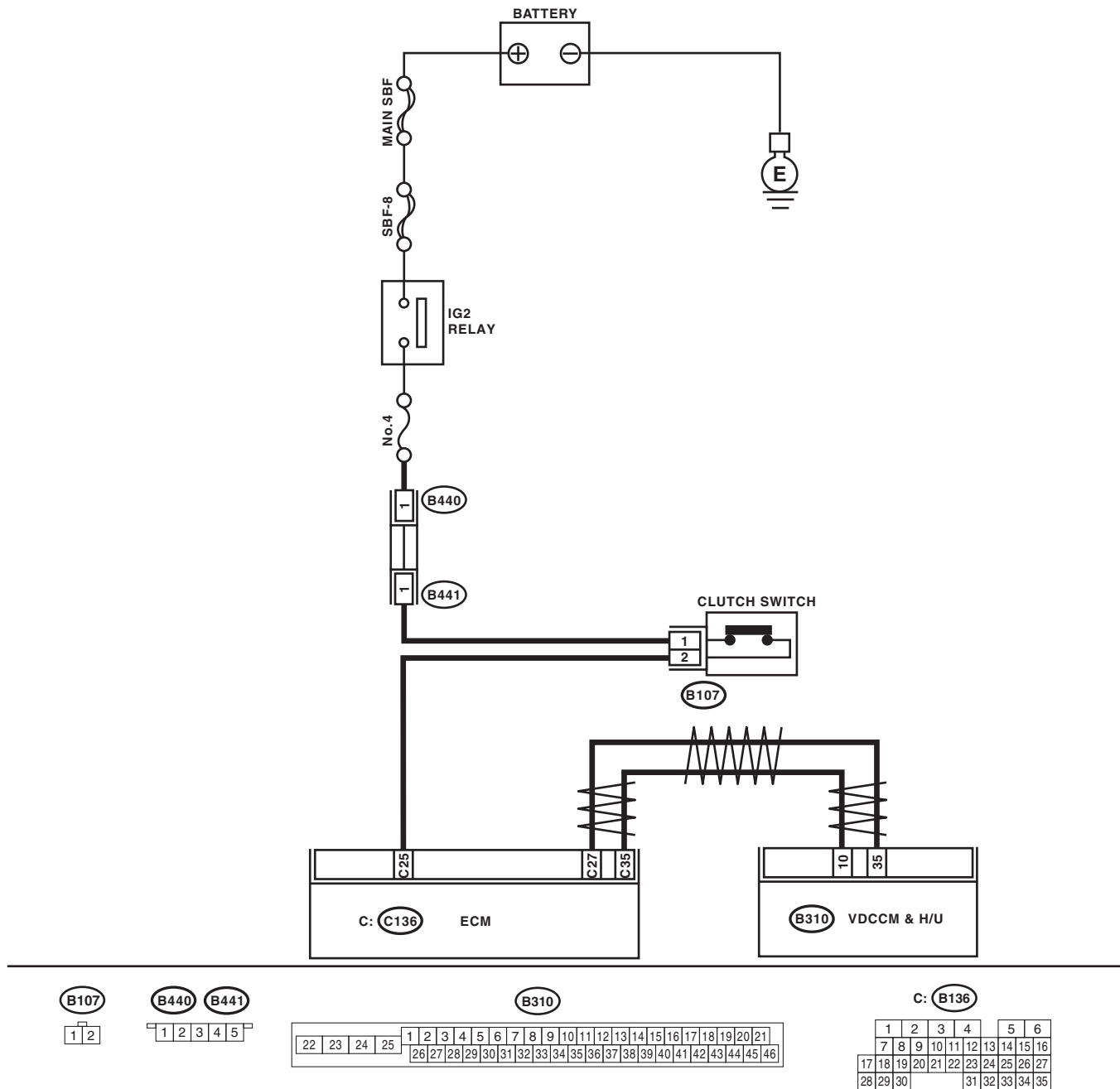

VDC00561

Diagnostic Procedure with Diagnostic Trouble Code (DTC)

VEHICLE DYNAMICS CONTROL (VDC) (DIAGNOSTICS)

	Step	Check	Yes	No
1	CHECK LAN SYSTEM. Perform the diagnosis for LAN system. <Ref. to LAN(diag)-15, OPERATION, Read Diagnostic Trouble Code (DTC).>	Is there any fault in LAN system?	Perform the diagnosis according to DTC for LAN system.	Go to step 2.
2	CHECK CLUTCH SIGNAL USING SUBARU SELECT MONITOR. 1) Select {Current Data Display & Save} in Subaru Select Monitor. 2) Read the display of the clutch switch signal.	Is OFF displayed while the clutch pedal is released, is ON displayed when it is depressed?	Go to step 5.	Go to step 3.
3	CHECK ECM CLUTCH SIGNAL USING SUBARU SELECT MONITOR. 1) Select {Current Data Display & Save} of the ECM in the Subaru Select Monitor. 2) Read the display of the clutch switch signal.	Is OFF displayed while the clutch pedal is released, is ON displayed when it is depressed?	Go to step 5.	Go to step 4.
4	CHECK HARNESS BETWEEN ECM AND CLUTCH SWITCH. 1) Turn the ignition switch to OFF. 2) Disconnect the connector from the ECM and the clutch switch. 3) Measure the resistance of harness between the ECM and clutch switch connector. Connector & terminal (B136) No. 25 — (B107) No. 2:	Is the resistance less than 0.5 Ω?	Repair the clutch switch power supply circuit. Or, replace the clutch switch. <Ref. to CL-26, Clutch Switch.>	Repair the harness between the ECM and clutch switch connector.
5	CHECK VDCCM&H/U. 1) Connect all connectors. 2) Erase the memory. 3) Perform the Inspection Mode. 4) Read the DTC.	Is the same DTC displayed?	Replace the VDCCM only. <Ref. to VDC-11, REPLACEMENT, VDC Control Module and Hydraulic Control Unit (VDCCM&H/U).>	Go to step 6.
6	CHECK OTHER DTC DETECTION.	Is any other DTC displayed?	Perform the diagnosis according to DTC.	Temporary poor contact occurs.

BC:DTC C0081 SYSTEM FAILURE

DTC DETECTING CONDITION:

VDC long time sequential control

TROUBLE SYMPTOM:

- ABS does not operate.
- VDC does not operate.

	Step	Check	Yes	No
1	CHECK POOR CONTACT IN CONNECTOR.	Is there poor contact in the VDCCM&H/U and yaw rate & lateral G sensor connector?	Repair the connector.	Go to step 2.
2	CHECK VDCCM&H/U. 1) Replace the yaw rate & lateral G sensor. 2) Connect all connectors. 3) Erase the memory. 4) Perform the Inspection Mode. 5) Read the DTC.	Is the same DTC displayed?	Replace the VDCCM&H/U.	Malfunction is found in original yaw rate & lateral G sensor.

General Diagnostic Table

VEHICLE DYNAMICS CONTROL (VDC) (DIAGNOSTICS)

13. General Diagnostic Table

A: INSPECTION

Symptom		Main probable cause	Other probable cause
Poor brake performance	Long braking/ stopping distance	<ul style="list-style-type: none"> • VDCCM&H/U • Brake pad • Aeration to brake line • Tire specifications, tire wear and air pressures • Incorrect wiring or piping connections 	<ul style="list-style-type: none"> • Defective ABS wheel speed sensor or sensor gap • Defective steering angle sensor or improper neutral position • Defective yaw rate & lateral G sensor or improper installation • Master cylinder • Brake caliper • Disc rotor • Brake pipe • Brake booster
	Wheel lock	<ul style="list-style-type: none"> • VDCCM&H/U • Defective ABS wheel speed sensor or sensor gap • Incorrect wiring or piping connections 	<ul style="list-style-type: none"> • Defective steering angle sensor or improper neutral position • Defective yaw rate & lateral G sensor or improper installation • Brake caliper • Brake pipe
	Brake drag	<ul style="list-style-type: none"> • VDCCM&H/U • Defective ABS wheel speed sensor or sensor gap • Master cylinder • Brake caliper • Parking brake • Axle and wheels • Brake pedal play 	<ul style="list-style-type: none"> • Defective steering angle sensor or improper neutral position • Defective yaw rate & lateral G sensor or improper installation • Brake pad • Brake pipe
	Long brake pedal stroke	<ul style="list-style-type: none"> • Aeration to brake line • Brake pedal play 	<ul style="list-style-type: none"> • VDCCM&H/U • Master cylinder • Brake caliper • Brake pad • Brake pipe • Brake booster
	Vehicle vertical pitching	<ul style="list-style-type: none"> • VDCCM&H/U • Road surface (uneven) • Suspension play or fatigue (poor damping) • Incorrect wiring or piping connections 	<ul style="list-style-type: none"> • Defective ABS wheel speed sensor or sensor gap • Defective steering angle sensor or improper neutral position • Defective yaw rate & lateral G sensor or improper installation
Poor brake performance	Unstable or uneven braking	<ul style="list-style-type: none"> • VDCCM&H/U • Defective ABS wheel speed sensor or sensor gap • Brake caliper • Brake pad • Road surface (uneven) • Tire specifications, tire wear and air pressures • Incorrect wiring or piping connections 	<ul style="list-style-type: none"> • Defective ABS wheel speed sensor or sensor gap • Defective steering angle sensor or improper neutral position • Defective yaw rate & lateral G sensor or improper installation • Master cylinder • Disc rotor • Brake pipe • Axle and wheels • Road with crowns or banks • Suspension play or fatigue (poor damping)

General Diagnostic Table

VEHICLE DYNAMICS CONTROL (VDC) (DIAGNOSTICS)

Symptom		Main probable cause	Other probable cause
Vibration or noise <ul style="list-style-type: none"> • When braking suddenly • When accelerating suddenly • While driving on a slippery road 	Excessive brake pedal vibration	<ul style="list-style-type: none"> • Road surface (uneven) • Incorrect wiring or piping connections 	<ul style="list-style-type: none"> • VDCCM&H/U • Brake booster • Suspension play or fatigue (poor damping)
	Noise from VDCH/U	<ul style="list-style-type: none"> • VDCCM&H/U (mount bushing) • Defective ABS wheel speed sensor or sensor gap • Brake pipe 	<ul style="list-style-type: none"> • VDCCM&H/U • Defective steering angle sensor or improper neutral position • Defective yaw rate & lateral G sensor or improper installation
	Noise from the front side of vehicle	<ul style="list-style-type: none"> • VDCCM&H/U (mount bushing) • Defective ABS wheel speed sensor or sensor gap • Master cylinder • Brake caliper • Brake pad • Disc rotor • Brake pipe • Brake booster • Suspension play or fatigue (poor damping) 	<ul style="list-style-type: none"> • Axle and wheels • Tire specifications, tire wear and air pressures
	Noise from the rear side of vehicle	<ul style="list-style-type: none"> • Defective ABS wheel speed sensor or sensor gap • Brake caliper • Brake pad • Disc rotor • Parking brake • Brake pipe • Suspension play or fatigue (poor damping) 	<ul style="list-style-type: none"> • Axle and wheels • Tire specifications, tire wear and air pressures
Engine does not accelerate or goes into a stall when accelerating suddenly or driving on a slippery surface.		<ul style="list-style-type: none"> • VDCCM&H/U • Defective ABS wheel speed sensor or sensor gap • Master cylinder • Brake caliper • Parking brake • Incorrect wiring or piping 	<ul style="list-style-type: none"> • Defective steering angle sensor or improper neutral position • Defective yaw rate & lateral G sensor or improper installation • Brake pad • Brake pipe

General Diagnostic Table

VEHICLE DYNAMICS CONTROL (VDC) (DIAGNOSTICS)

Symptom		Main probable cause	Other probable cause
Poor change-direction-operation stability of TCS	Deviation to right or left direction	<ul style="list-style-type: none"> • VDCCM&H/U • Defective ABS wheel speed sensor or sensor gap • Defective steering angle sensor or improper neutral position • Defective yaw rate & lateral G sensor or improper installation • Brake caliper • Brake pad • Wheel alignment • Road surface (uneven) • Road with crowns or banks • Tire specifications, tire wear and air pressures • Incorrect wiring or piping connections 	<ul style="list-style-type: none"> • Disc rotor • Brake pipe • Axle and wheels • Suspension play or fatigue (poor damping)
	Vehicle spin	<ul style="list-style-type: none"> • VDCCM&H/U • Defective ABS wheel speed sensor or sensor gap • Defective steering angle sensor or improper neutral position • Defective yaw rate & lateral G sensor or improper installation • Brake pad • Tire specifications, tire wear and air pressures • Incorrect wiring or piping connections 	<ul style="list-style-type: none"> • Brake caliper • Brake pipe
Steering wheel drag while driving		<ul style="list-style-type: none"> • VDCCM&H/U • Defective ABS wheel speed sensor or sensor gap • Defective steering angle sensor or improper neutral position • Defective yaw rate & lateral G sensor or improper installation • Incorrect wiring or piping connections • Power steering system 	<ul style="list-style-type: none"> • Brake caliper • Brake pad • Disc rotor • Wheel alignment • Road surface (uneven) • Road with crowns or banks • Suspension play or fatigue (poor damping) • Tire specifications, tire wear and air pressures
VDC operates while driving normally.		<ul style="list-style-type: none"> • VDCCM&H/U • Defective ABS wheel speed sensor or sensor gap • Defective steering angle sensor or improper neutral position • Defective yaw rate & lateral G sensor or improper installation • Wheel alignment • Road surface (uneven) • Road with crowns or banks • Suspension play or fatigue (poor damping) • Tire specifications, tire wear and air pressures • Incorrect wiring or piping connections • Power steering system 	
VDC OFF indicator light does not come on when the VDC OFF switch is depressed. NOTE: When pressing VDC OFF switch for 10 seconds or more, VDC OFF indicator light goes off and cannot operate any more. When turning the ignition switch from OFF to ON, the previous status is restored.		<ul style="list-style-type: none"> • Harness • Indicator light bulb • VDC OFF switch 	

General Diagnostic Table

VEHICLE DYNAMICS CONTROL (VDC) (DIAGNOSTICS)

BRAKE

BR

	Page
1. General Description	2
2. Front Brake Pad	12
3. Front Disc Rotor	13
4. Front Disc Brake Assembly	14
5. Rear Brake Pad	17
6. Rear Disc Rotor	19
7. Rear Disc Brake Assembly	21
8. Master Cylinder	24
9. Brake Booster	26
10. Brake Fluid	31
11. Air Bleeding	32
12. Brake Hose	34
13. Brake Pipe	36
14. Brake Pedal	37
15. Stop Light Switch	39
16. General Diagnostic Table	41

General Description

BRAKE

1. General Description

A: SPECIFICATION

Model		All models
Front disc brake	Size	16-inch type
	Type	Disc (Floating type, ventilated)
	Effective disc diameter	mm (in) 244 (9.61)
	Disc thickness × Diameter	mm (in) 24 × 294 (0.94 × 11.57)
	Effective cylinder diameter	mm (in) 42.8 (1.685) × 2
	Pad dimensions (Length × Width × Thickness)	mm (in) 117.8 × 50.5 × 11.0 (4.638 × 1.988 × 0.433)
	Clearance adjustment	Automatic adjustment
Rear disc brake	Size	15-inch type
	Type	Disc (Floating type, solid)
	Effective disc diameter	mm (in) 250 (9.84)
	Disc thickness × Diameter	mm (in) 10 × 286 (0.39 × 11.26)
	Effective cylinder diameter	mm (in) 38.1 (1.500)
	Pad dimensions (Length × Width × Thickness)	mm (in) 92.0 × 33.0 × 9.0 (3.622 × 1.299 × 0.354)
Clearance adjustment	Automatic adjustment	
Master cylinder	Type	Tandem
	Effective diameter	mm (in) 23.8 (15/16)
	Reservoir type	Sealed type
	Brake fluid reservoir capacity	cm ³ (cu in) 205 (12.51)
Brake booster	Type	Vacuum suspended
	Effective diameter	mm (in) 208 + 229 (8.19 + 9.02)
Brake line		Dual circuit system
Brake fluid CAUTION: <ul style="list-style-type: none"> • Avoid mixing brake fluid of different brands to prevent fluid performance from degrading. • When filling with brake fluid, be careful not to allow any dust to enter the reservoir. • Use new SUBARU genuine brake fluid when replacing or refilling the fluid. 		FMVSS No. 116, DOT3

General Description

BRAKE

NOTE:

Refer to "PB" section for parking brake specifications. <Ref. to PB-2, SPECIFICATION, General Description.>

Contents				Standard	Limit
Front brake	Pad thickness	mm (in)	All models	11 (0.43)	1.5 (0.059)
	Disc thickness	mm (in)	All models	24 (0.94)	22 (0.87)
	Disc runout	mm (in)		—	0.05 (0.0020)
Rear brake	Pad thickness	mm (in)	All models	9.0 (0.354)	1.5 (0.059)
	Disc thickness	mm (in)	All models	10 (0.39)	8.5 (0.335)
	Disc runout	mm (in)		—	0.05 (0.0020)
Parking brake	Inside diameter	mm (in)		190 (7.48)	191 (7.52)
	Lining thickness	mm (in)		2.8 (0.11)	1.5 (0.059)
	Lever stroke	7 — 8 notches/200 N (20 kgf, 45 lbf)			

		Brake pedal force N (kgf, lbf)	Fluid pressure kPa (kgf/cm ² , psi)
		All models	
Brake booster	Brake fluid pressure with engine stopped	147 (15, 33)	545 (6, 79)
		294 (30, 66)	1,564 (16, 227)
	Brake fluid pressure with engine running and vacuum pressure at 66.7 kPa (500 mmHg, 19.69 inHg)	147 (15, 33)	6,400 (65, 928)
		294 (30, 66)	11,273 (115, 1,635)

Brake pedal	Free play	mm (in)	0.5 — 2 (0.020 — 0.079) [When pulling the brake pedal upward with a force of less than 10 N (1 kgf, 2 lbf).]
-------------	-----------	---------	---

General Description

BRAKE

B: COMPONENT

1. FRONT DISC BRAKE

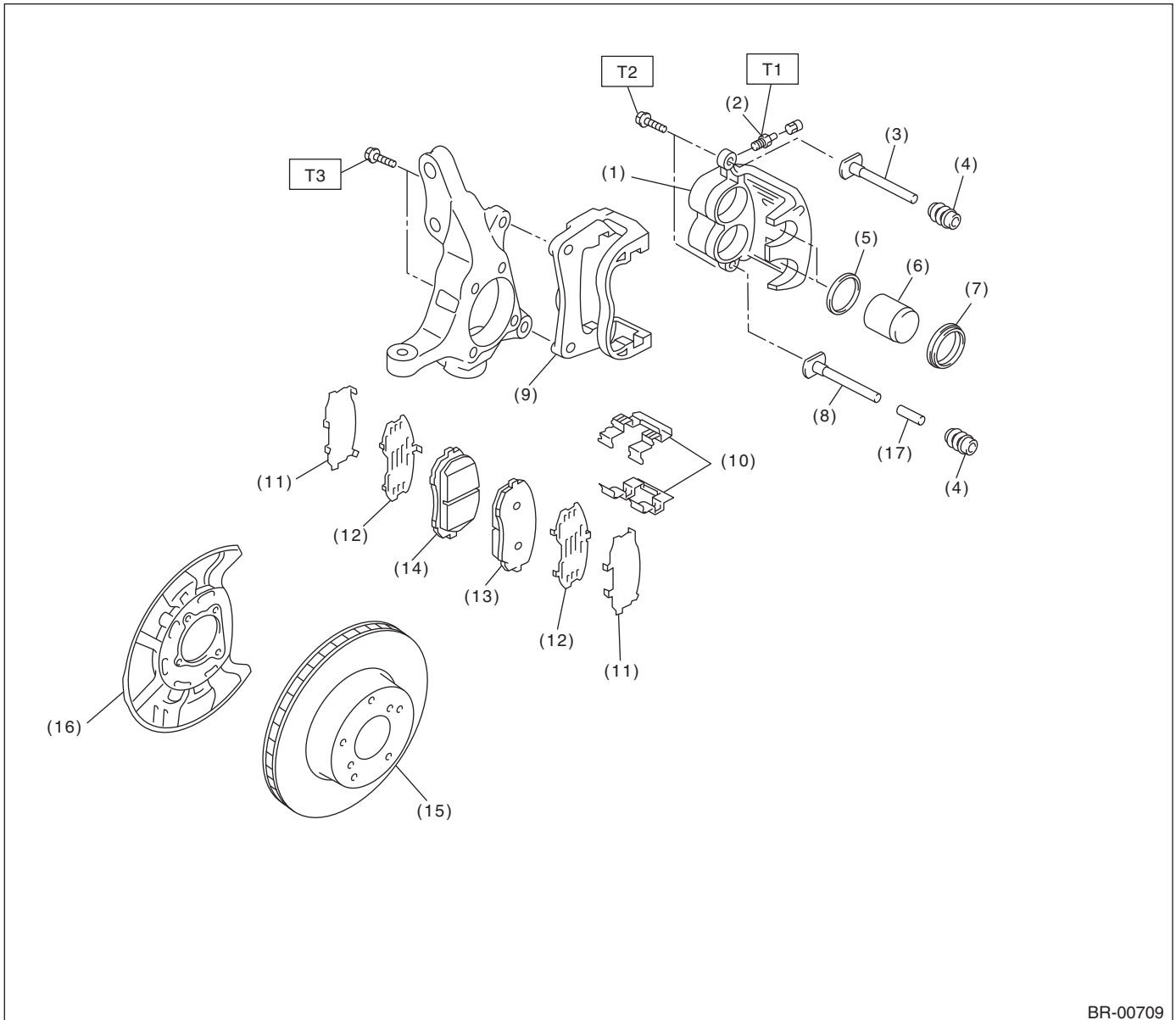

BR-00709

- | | | |
|-----------------------|--------------------|-----------------|
| (1) Caliper body | (9) Support | (16) Disc cover |
| (2) Air bleeder screw | (10) Pad clip | (17) Bushing |
| (3) Guide pin | (11) Outer shim | |
| (4) Pin boot | (12) Inner shim | |
| (5) Piston seal | (13) Pad (outside) | |
| (6) Piston | (14) Pad (inside) | |
| (7) Piston boot | (15) Disc rotor | |
| (8) Lock pin | | |

Tightening torque: N-m (kgf-m, ft-lb)

T1: 8 (0.8, 5.8)

T2: 27 (2.8, 19.9)

T3: 80 (8.2, 59)

General Description

BRAKE

3. MASTER CYLINDER

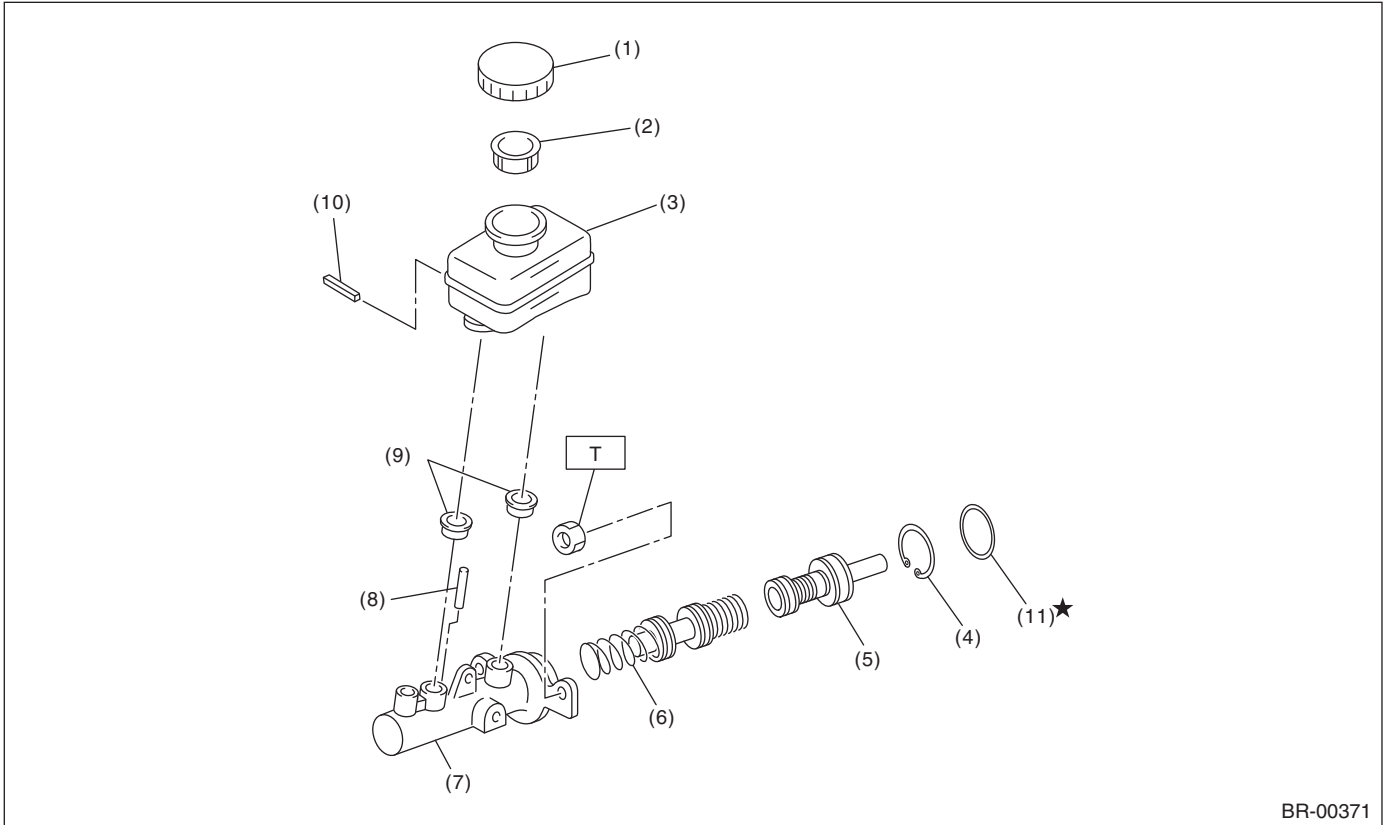

BR-00371

- (1) Cap
- (2) Filter
- (3) Reservoir tank
- (4) C-ring
- (5) Primary piston

- (6) Secondary piston
- (7) Cylinder body
- (8) Cylinder pin
- (9) Seal
- (10) Pin

- (11) O-ring

Tightening torque: N·m (kgf-m, ft-lb)

T: 13 (1.3, 9.6)

4. FRONT BRAKE PIPES AND HOSES

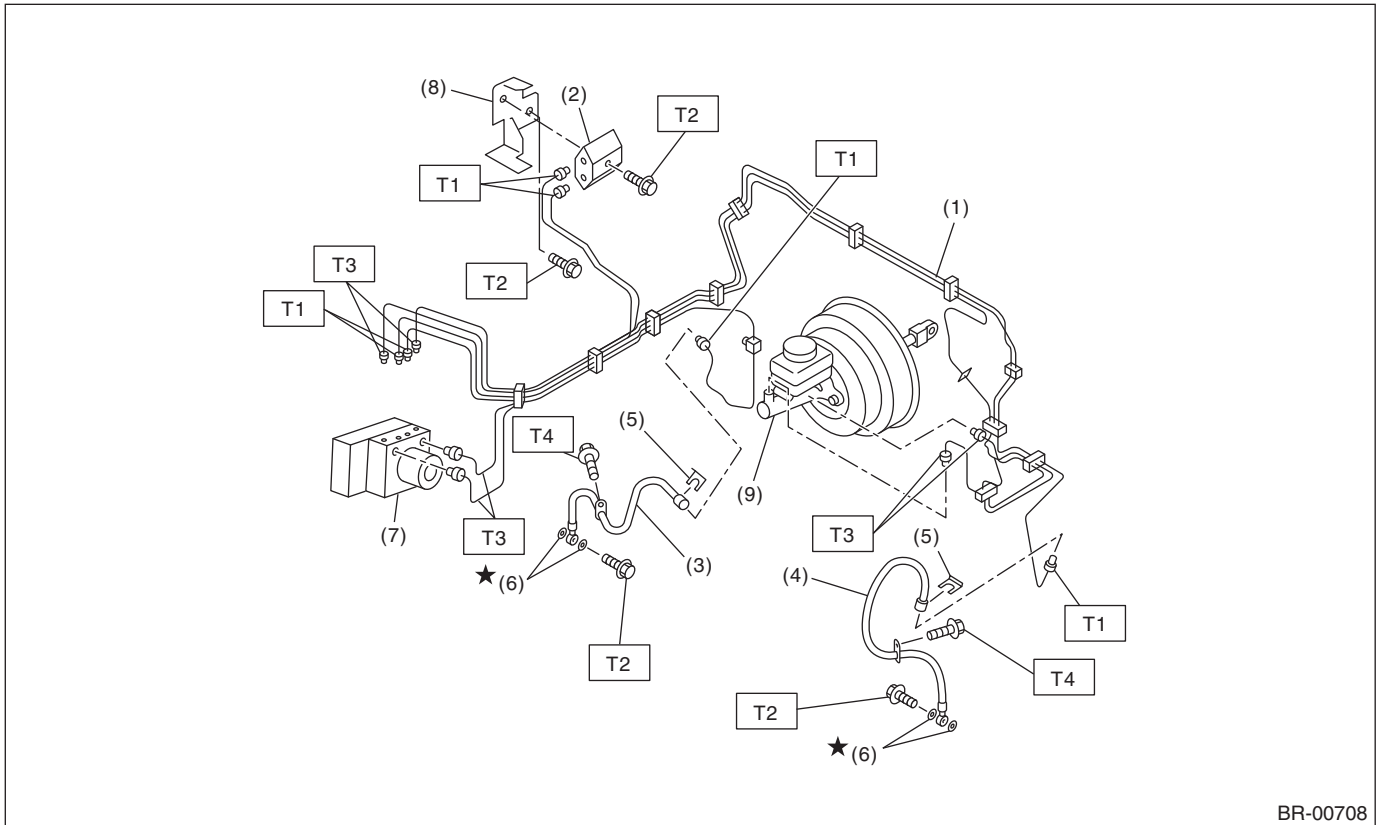

BR-00708

- | | |
|---------------------------|---|
| (1) Front brake pipe ASSY | (6) Gasket |
| (2) Two-way connector | (7) VDC control module & hydraulic control unit (VDCCM&H/U) |
| (3) Front brake hose RH | (8) Bracket |
| (4) Front brake hose LH | (9) Master cylinder |
| (5) Clamp | |

Tightening torque: N·m (kgf·m, ft·lb)

T1: 15 (1.5, 10.8)

T2: 18 (1.8, 13.0)

T3: 19 (1.9, 14.0)

T4: 33 (3.4, 24.3)

General Description

BRAKE

5. CENTER AND REAR BRAKE PIPES AND HOSES

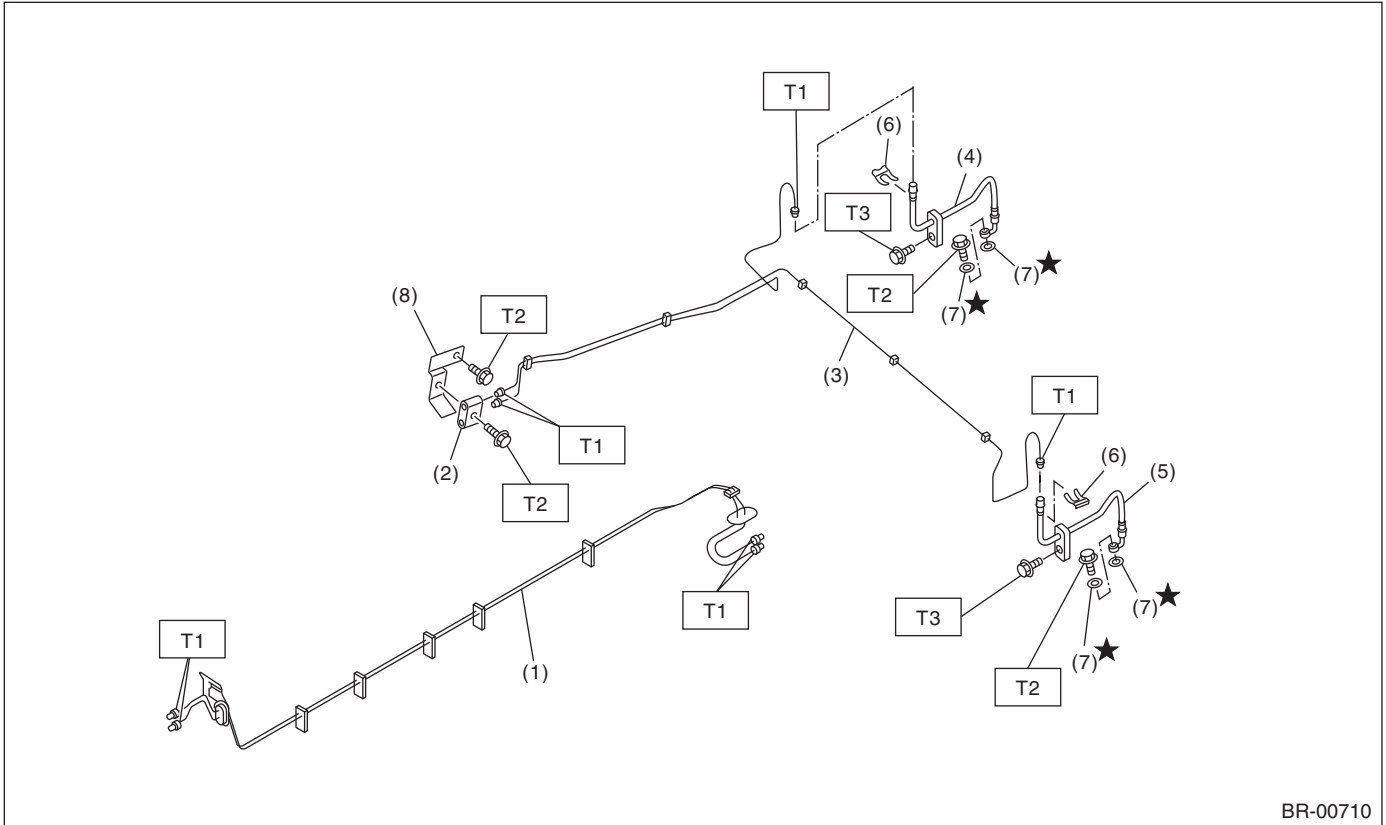

- | | |
|----------------------------|------------------------|
| (1) Center brake pipe ASSY | (5) Rear brake hose LH |
| (2) Two-way connector | (6) Clamp |
| (3) Rear brake pipe ASSY | (7) Gasket |
| (4) Rear brake hose RH | (8) Bracket |

Tightening torque: N·m (kgf·m, ft·lb)

T1: 15 (1.5, 10.8)

T2: 18 (1.8, 13.0)

T3: 33 (3.4, 24.3)

6. BRAKE BOOSTER

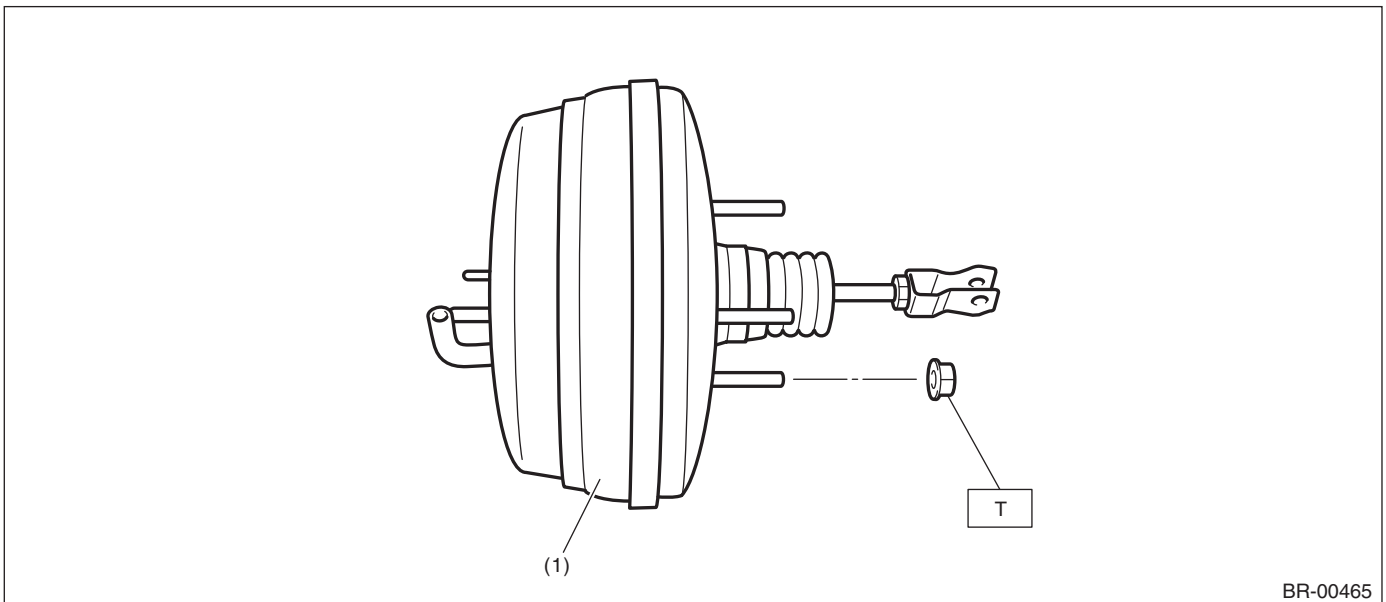

- (1) Brake booster

Tightening torque: N·m (kgf·m, ft·lb)

T: 18 (1.8, 13.0)

7. BRAKE PEDAL

- MT model

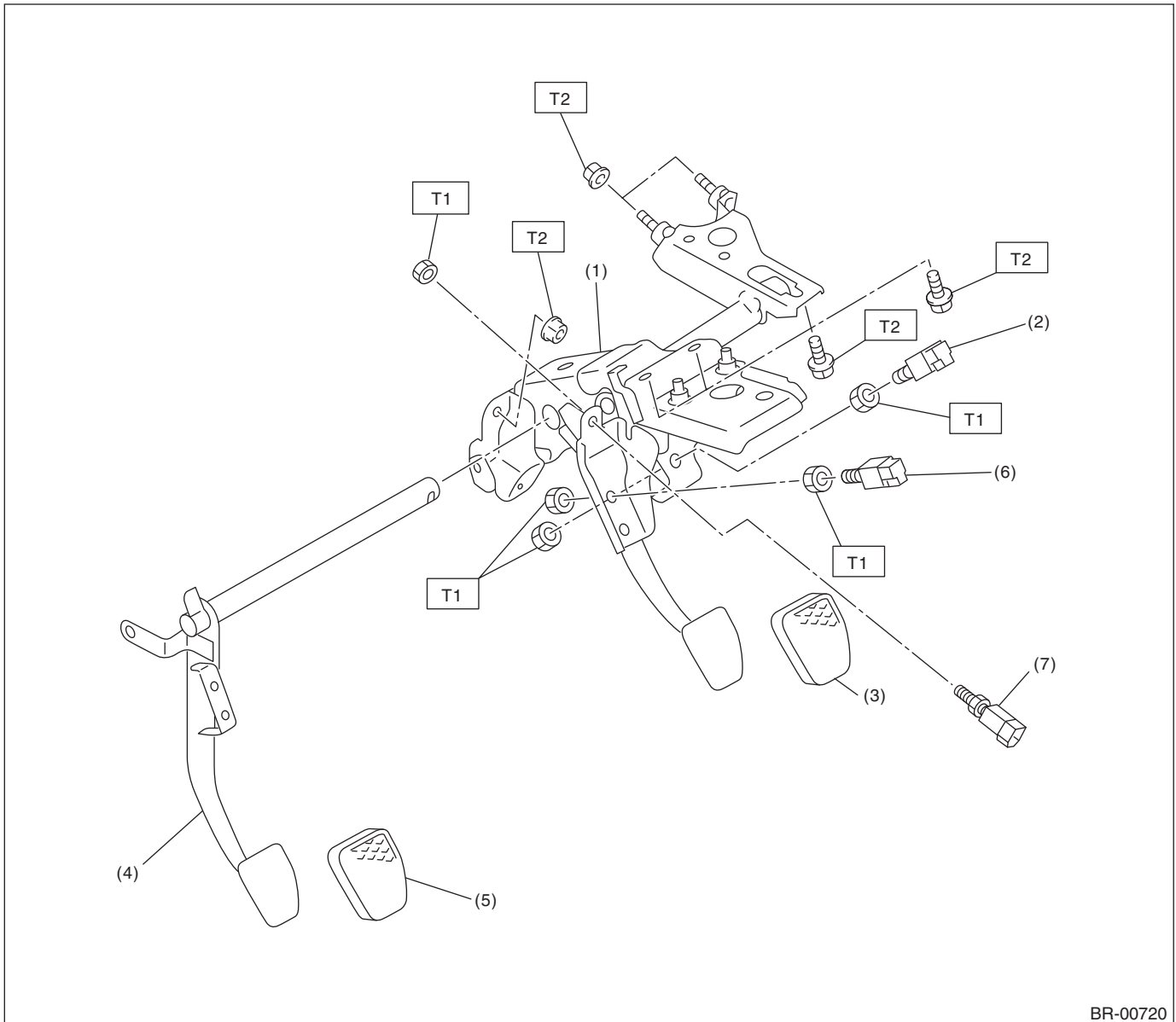

BR-00720

- | | |
|-----------------------|------------------------------------|
| (1) Brake pedal ASSY | (5) Clutch pedal pad |
| (2) Stop light switch | (6) Clutch switch (cruise control) |
| (3) Brake pedal pad | (7) Clutch switch (clutch start) |
| (4) Clutch pedal | |

Tightening torque: N·m (kgf·m, ft·lb)

T1: 8 (0.8, 5.8)

T2: 18 (1.8, 13.0)

General Description

BRAKE

- AT model

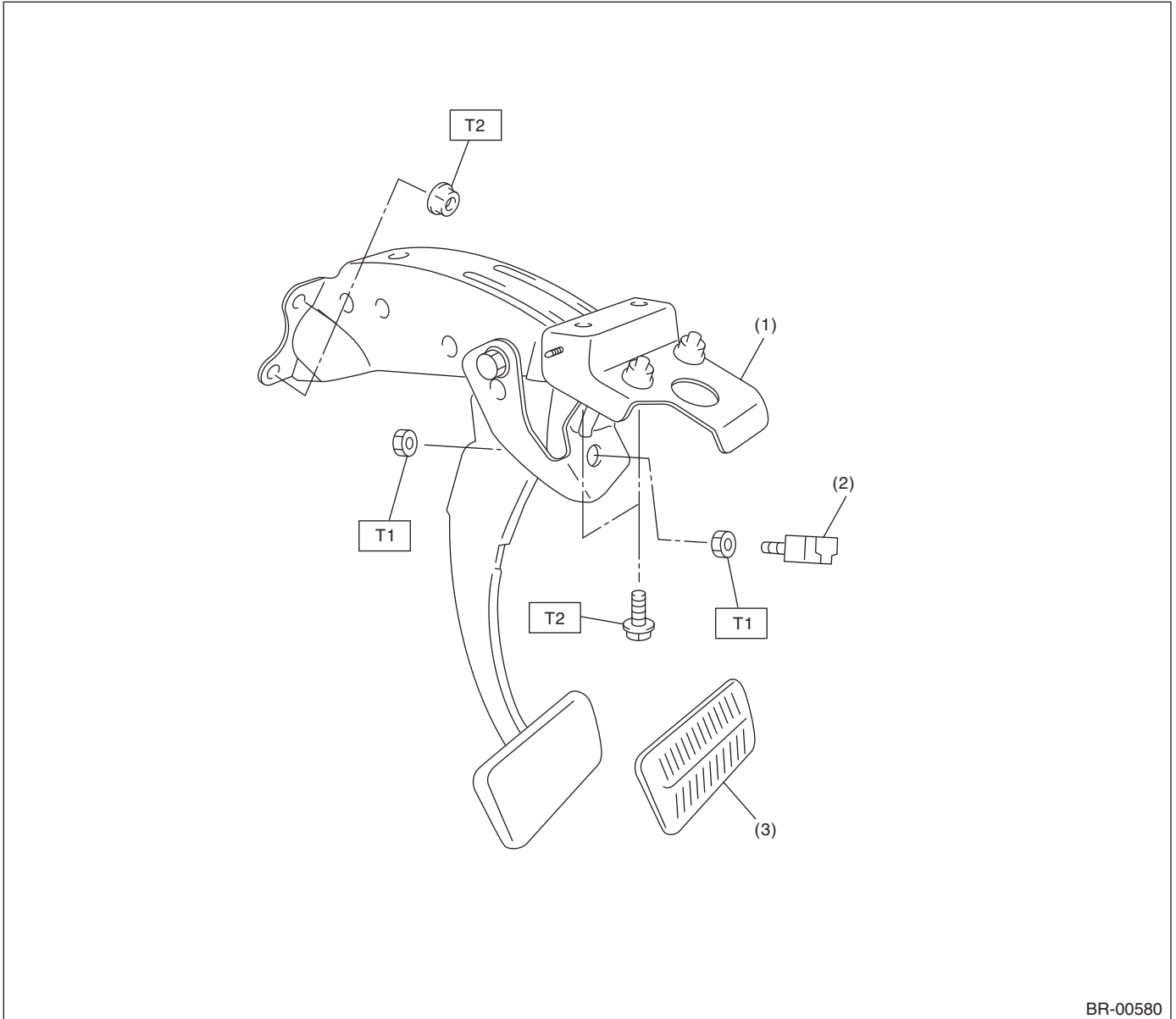

BR-00580

- (1) Brake pedal ASSY
(2) Stop light switch

- (3) Brake pedal pad

Tightening torque: N·m (kgf·m, ft·lb)

T1: 8 (0.8, 5.8)

T2: 18 (1.8, 13.0)

C: CAUTION

- Wear appropriate work clothing, including a cap, protective goggles and protective shoes when performing any work.
- Before removal, installation or disassembly, be sure to clarify the failure. Avoid unnecessary removal, installation, disassembly and replacement.
- Use SUBARU genuine grease etc. or equivalent. Do not mix grease etc. of different grades or manufacturers.
- Before securing a part in a vise, place cushioning material such as wood blocks, aluminum plate or cloth between the part and the vise.
- Be sure to tighten fasteners including bolts and nuts to the specified torque.
- Place shop jacks or rigid racks at the specified points.

D: PREPARATION TOOL

1. GENERAL TOOL

TOOL NAME	REMARKS
Snap ring pliers	Used for removing and installing snap rings.

Front Brake Pad

BRAKE

2. Front Brake Pad

A: REMOVAL

- 1) Lift up the vehicle, and remove the front wheels.
- 2) Remove the caliper bolt.

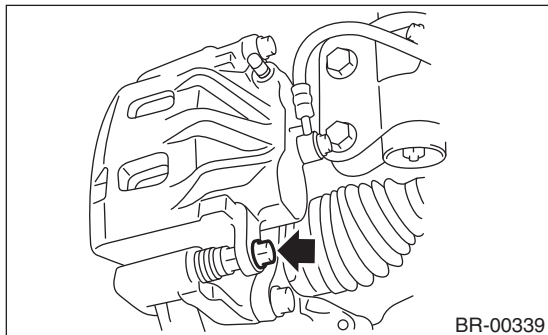

- 3) Raise the caliper body and support it.

NOTE:

Do not disconnect the brake hose from the caliper body.

- 4) Remove the pads.

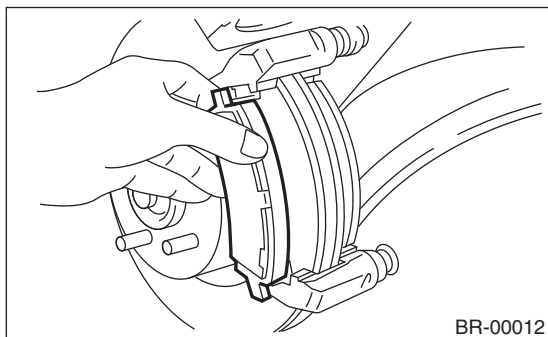

B: INSTALLATION

- 1) Apply a thin coat of Molykote M7439 (Part No. K0770YA000) or grease contained in the pad kit to the pad clip.

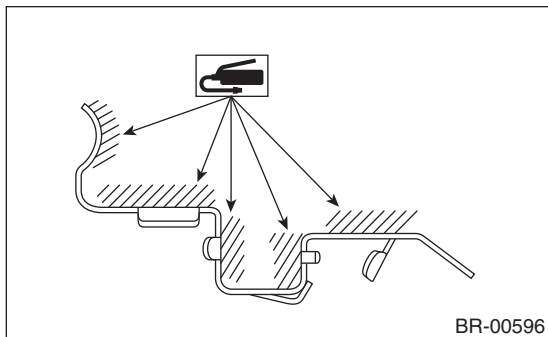

- 2) Apply a thin coat of Molykote AS880N (Part No. K0777YA010) or grease contained in the pad kit to both surfaces of the pad inner shim.

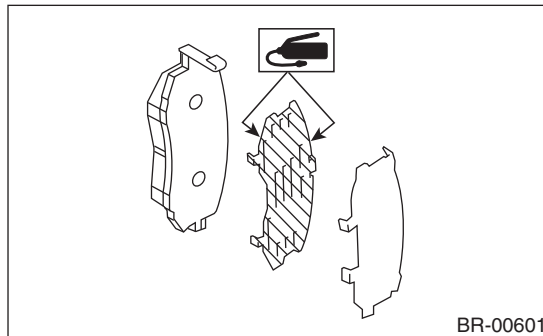

- 3) Install the pad to the support.
- 4) Install the caliper body to the support.

Tightening torque:

27 N·m (2.8 kgf·m, 19.9 ft·lb)

C: INSPECTION

Check the pad thickness A.

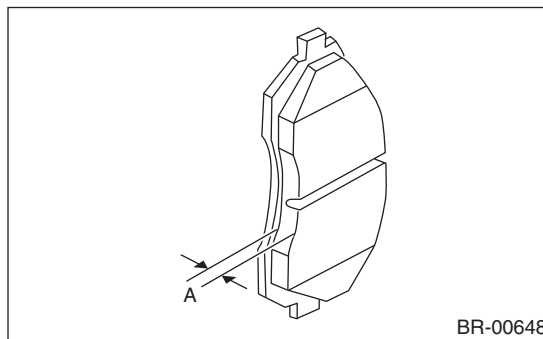

Pad thickness mm (in)	Standard	11 (0.43)
	Wear limit	1.5 (0.059)

NOTE:

- Always replace the pads of both sides as a set on both wheels.
- Replace pad clips if they are twisted or worn.
- A wear indicator is installed on the inner disc brake pad. If the pad is worn to the limit, the end of wear indicator contacts disc rotor, and a squeaking sound is heard as the wheel rotates. If the sound is heard, replace the pad.
- Replace the pad if there is oil or grease on it.

3. Front Disc Rotor

A: REMOVAL

- 1) Lift up the vehicle, and remove the front wheels.
- 2) Remove the caliper body and the support from housing, and suspend it from the strut using a wire.

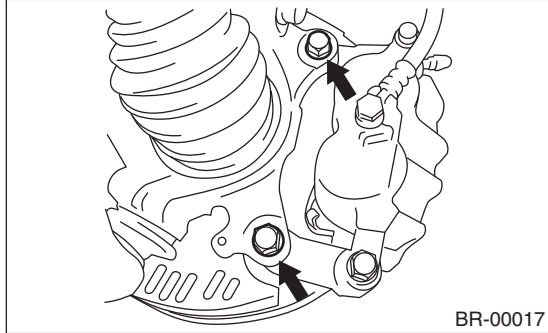

- 3) Remove the disc rotor.

NOTE:

If it is difficult to remove the disc rotor from the hub, drive an 8 mm bolt into the threaded section (B) of the rotor, then remove the rotor.

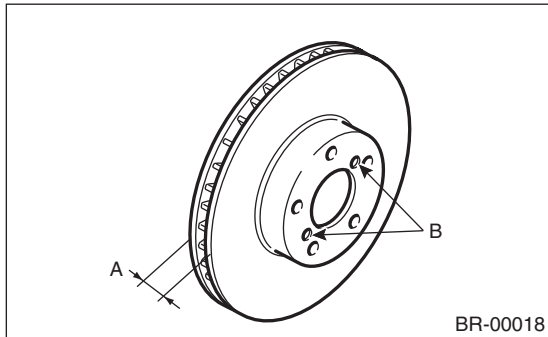

- 4) Remove mud and foreign matter from the caliper body assembly and the support.

B: INSTALLATION

- 1) Install the disc rotor.
- 2) Install the caliper body and the support to housing.

Tightening torque:

80 N·m (8.2 kgf·m, 59 ft·lb)

- 3) Install the front wheels.

C: INSPECTION

- 1) Check the front wheel bearing play and axle hub runout before the inspection of disc rotor runout limit. <Ref. to DS-17, INSPECTION, Front Axle.>
- 2) Secure the disc rotor by tightening the five wheel nuts.
- 3) Set a dial gauge 10 mm (0.39 in) inward from the disc rotor outer circumference. Rotate the disc rotor to check runout. If the runout of disc rotor exceeds the service limit, grind the disc rotor. After grinding, check the thickness of the disc rotor according to the procedure in step 4).

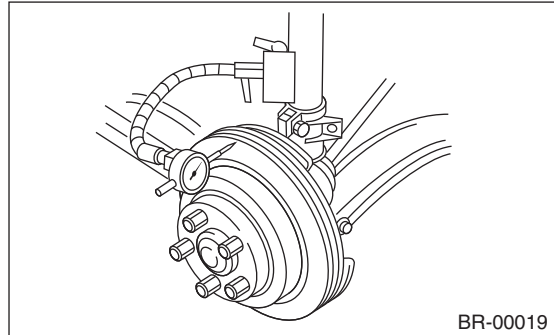

**Disc rotor runout limit:
0.05 mm (0.0020 in)**

- 4) Set a micrometer 10 mm (0.39 in) inward from the disc rotor outer perimeter, and then measure the disc rotor thickness. If the thickness of the disc rotor exceeds the service limit, replace with a new disc rotor.

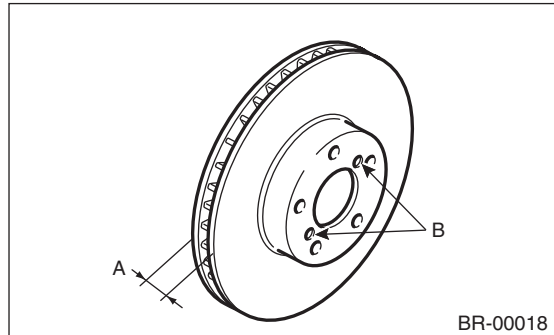

	Standard	Limit	Disc rotor outer diameter
Disc rotor thickness A mm (in)	24 (0.94)	22 (0.87)	294 (11.57)

Front Disc Brake Assembly

BRAKE

4. Front Disc Brake Assembly

A: REMOVAL

CAUTION:

Do not allow brake fluid to come in contact with vehicle body. If it does, wash off with water and wipe away completely.

- 1) Lift up the vehicle, and remove the front wheels.
- 2) Remove the union bolt, and disconnect the brake hose from the caliper body assembly.

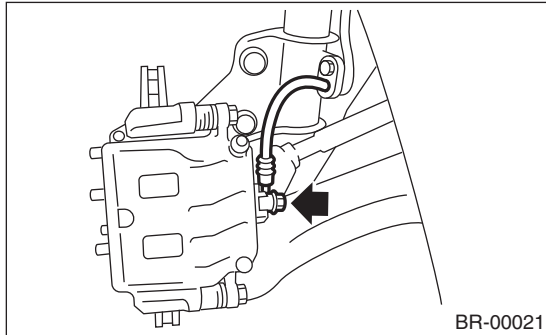

- 3) Remove the bolt which secures the caliper body.

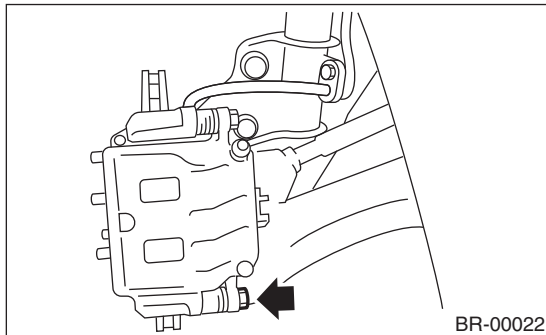

- 4) Raise the caliper body, and then move it toward vehicle center to separate it from the support.
- 5) Remove the support from housing.

NOTE:

Remove the support only when replacing the rotor or support. It is not necessary to remove it when servicing the caliper body assembly.

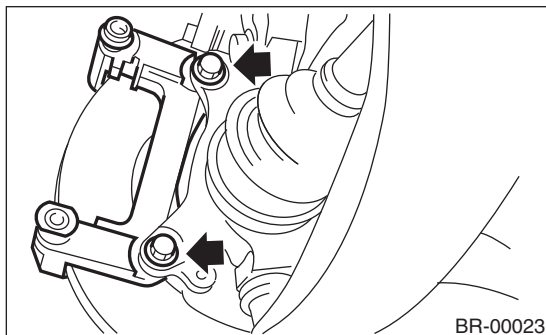

- 6) Remove mud and foreign matter from the caliper body assembly and the support.

B: INSTALLATION

- 1) Apply a thin coat of Molykote M7439 (Part No. K0770YA000) or grease contained in the pad kit to the support.

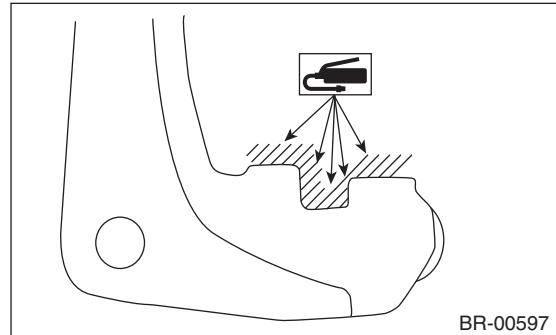

- 2) Install the support to the housing.

Tightening torque:

80 N·m (8.2 kgf·m, 59 ft·lb)

- 3) Apply a thin coat of Molykote M7439 (Part No. K0770YA000) or grease contained in the pad kit to the pad clip.

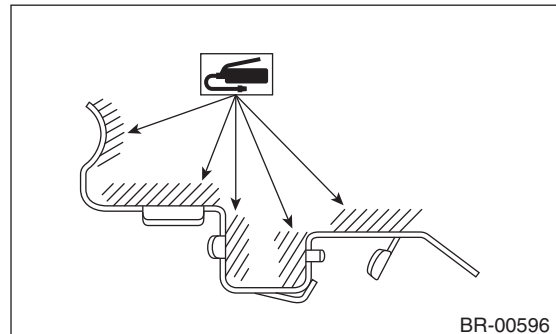

- 4) Apply a thin coat of Molykote AS880N (Part No. K0777YA010) or grease contained in the pad kit to both surfaces of the pad inner shim.

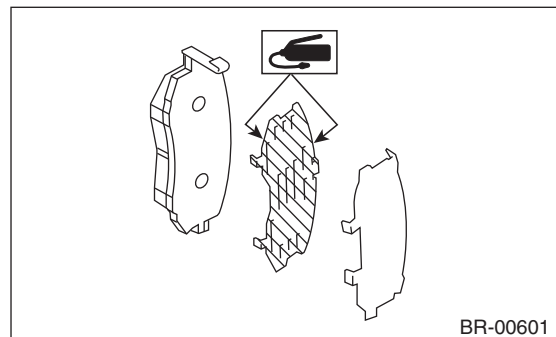

- 5) Install the pad to the support.
- 6) Install the caliper body to the support.

Tightening torque:

27 N·m (2.8 kgf·m, 19.9 ft·lb)

- 7) Connect the brake hose using a new brake hose gasket.

Tightening torque:

18 N·m (1.8 kgf·m, 13.0 ft·lb)

- 8) Bleed air from the brake system.

C: DISASSEMBLY

1) Remove mud and foreign matter from the caliper body assembly and the support.

CAUTION:

Be careful not to allow foreign matter to enter the brake hose connector.

2) Place a wooden block in the caliper body as shown in the figure to prevent the piston from jumping out and being damaged.

3) Gradually apply compressed air via the brake hose installation hole to push the piston out.

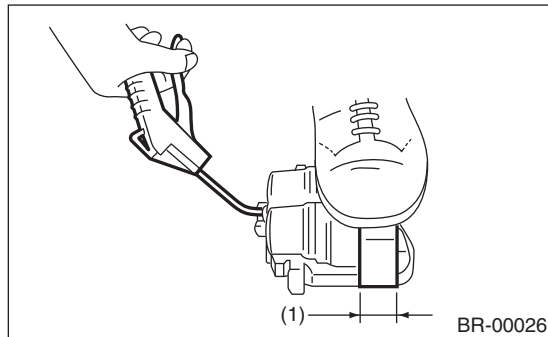

(1) Place a wooden block of 30 mm (1.18 in) width.

4) Remove the piston boot.

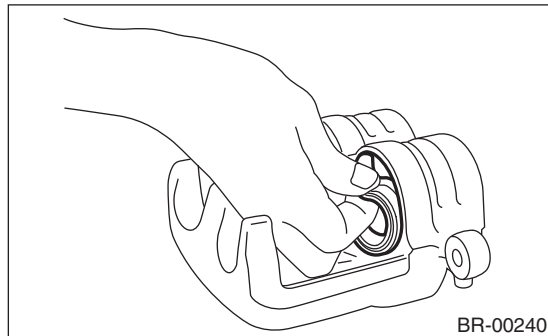

5) Remove the piston seal from the caliper body cylinder.

CAUTION:

Do not damage the cylinder and piston seal groove.

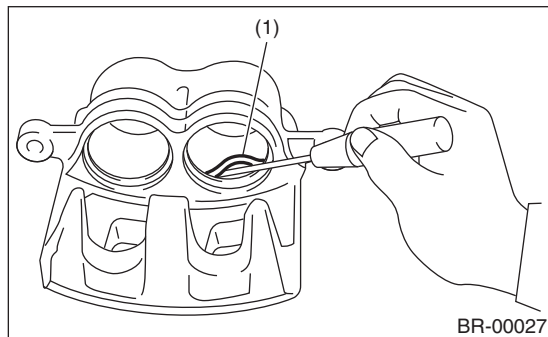

(1) Piston seal

6) Remove the guide pin and boot from caliper body.

D: ASSEMBLY

1) Clean the inside of the caliper body using brake fluid.

2) Apply a coat of brake fluid to piston seal and install the piston seal to the caliper body groove.

3) Apply a coat of brake fluid to the inner surface of cylinder and the entire outer surface of the piston.

4) Apply NIGLUBE RX-2 (Part No. 000041000) or grease contained in the piston seal kit to the boot, and install it to the groove at the end of the cylinder.

5) Insert the piston into the cylinder.

CAUTION:

Do not force the piston into cylinder.

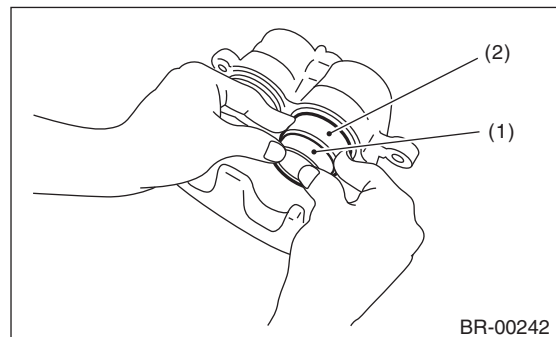

(1) Piston
(2) Piston boot

6) Position the boot in the grooves on cylinder and piston.

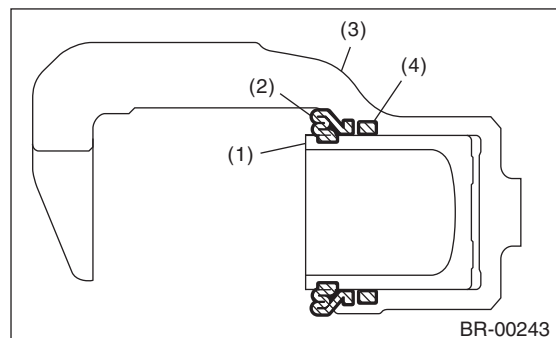

(1) Piston
(2) Piston boot
(3) Caliper body
(4) Piston seal

7) Apply NIGLUBE RX-2 (Part No. 000041000) or grease contained in the piston seal kit to the lock pin, guide pin outer surface, cylinder inner surface, and boot grooves.

Front Disc Brake Assembly

BRAKE

8) Insert the lock pin and guide pin boot into the support.

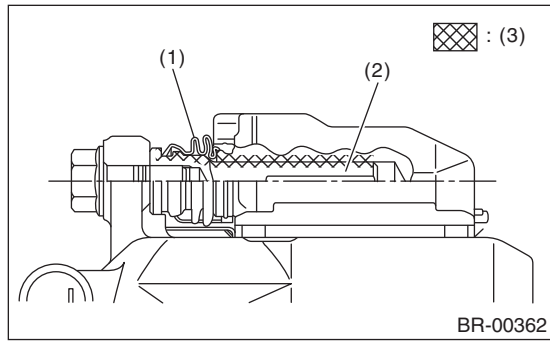

- (1) Pin boot
- (2) Lock pin or guide pin
- (3) Grease applied area

CAUTION:

Insert the lock pin and guide pin into position, and make sure that they slide and seat properly.

E: INSPECTION

- 1) Repair or replace the faulty parts.
- 2) Check the caliper body and piston for uneven wear, damage or rust.
- 3) Check the rubber parts for damage or deterioration.

5. Rear Brake Pad

A: REMOVAL

- 1) Lift up the vehicle, then remove the rear wheels.
- 2) Remove the brake hose bracket.

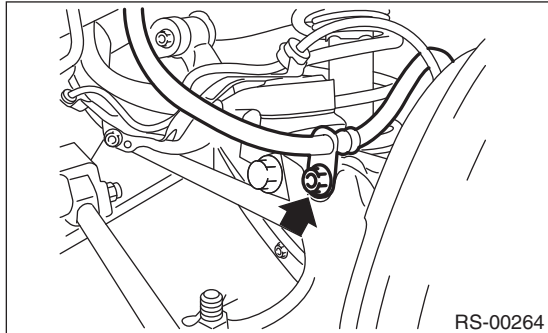

- 3) Remove the caliper bolt.

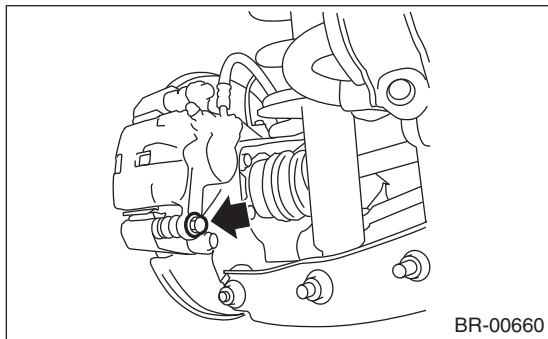

- 4) Raise the caliper body and support it.

NOTE:

Do not disconnect the brake hose from the caliper body.

- 5) Remove the pads.

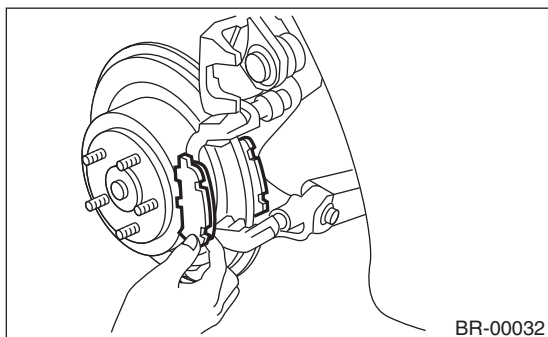

B: INSTALLATION

- 1) Apply a thin coat of Molykote M7439 (Part No. K0770YA000) or grease contained in the pad kit to the pad clip.

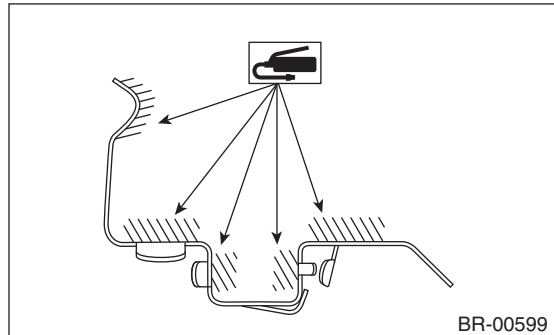

- 2) Apply a thin coat of Molykote AS880N (Part No. K0777YA010) or grease contained in the pad kit to the contact surface between the pad and shim.

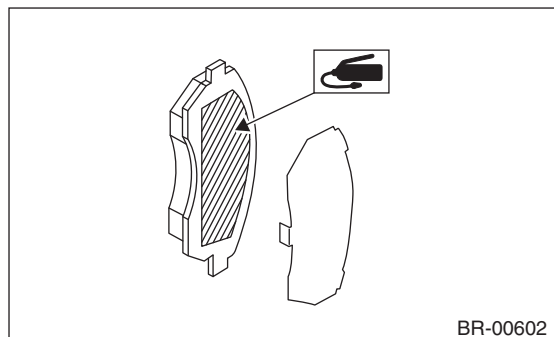

- 3) Apply a thin coat of Molykote AS880N (Part No. K0777YA010) or grease contained in the pad kit to both surfaces of the pad inner shim.

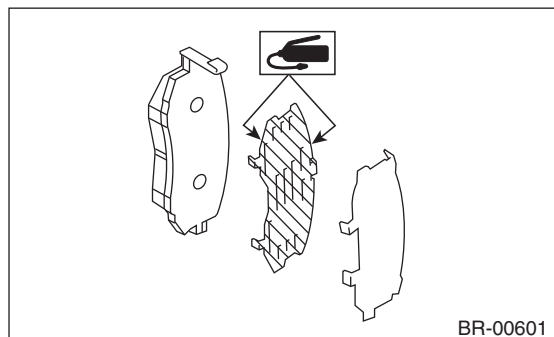

- 4) Install the pad to the support.
- 5) Install the caliper body to the support.

Tightening torque:

27 N·m (2.8 kgf-m, 19.9 ft-lb)

- 6) Install the brake hose bracket.

Tightening torque:

33 N·m (3.4 kgf-m, 24.3 ft-lb)

Rear Brake Pad

BRAKE

C: INSPECTION

Check the pad thickness A.

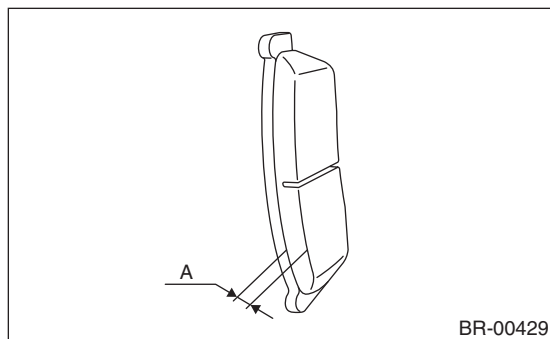

Pad thickness	Standard	9.0 (0.35)
mm (in)	Wear limit	1.5 (0.059)

NOTE:

- Always replace the pads of both sides as a set on both wheels.
- Replace pad clips if they are twisted or worn.
- A wear indicator is installed on the inner disc brake pad. If the pad is worn to the limit, the end of wear indicator contacts disc rotor, and a squeaking sound is heard as the wheel rotates. If the sound is heard, replace the pad.
- Replace the pad if there is oil or grease on it.

6. Rear Disc Rotor

A: REMOVAL

- 1) Lift up the vehicle, then remove the rear wheels.
- 2) Release the parking brake.
- 3) Remove the brake hose bracket.

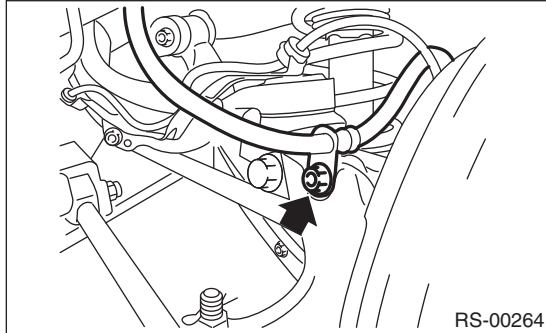

- 4) Remove the two mounting bolts, and remove the disc brake assembly.

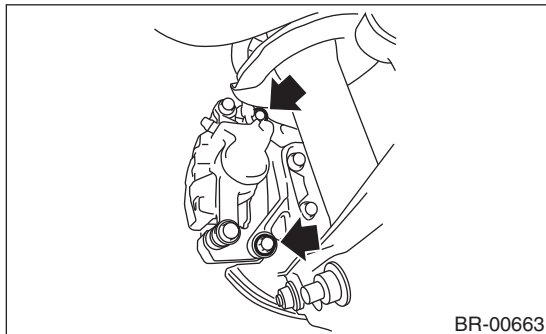

- 5) Suspend the disc brake assembly so that the hose is not stretched.
- 6) Remove the disc rotor.

NOTE:

If it is difficult to remove the disc rotor, perform the following two methods in order.

- (1) Turn the adjuster using a flat tip screwdriver until the brake shoe is far enough away to allow removal of the disc rotor.

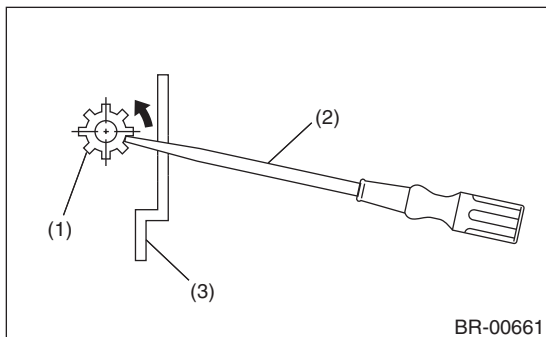

- (1) Adjuster
- (2) Flat tip screwdriver
- (3) Disc rotor

- (2) If it is difficult to remove the disc rotor from the hub, drive an 8 mm bolt into the threads B of the rotor, then remove the rotor.

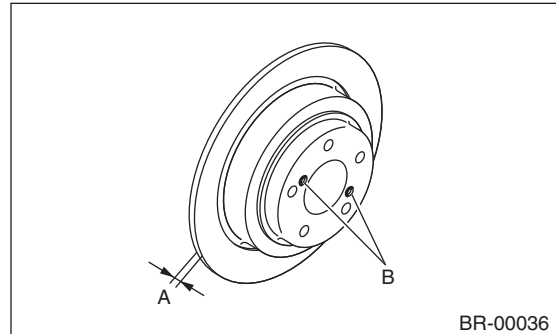

B: INSTALLATION

- 1) Install in the reverse order of removal.

Tightening torque:

<Ref. to BR-4, COMPONENT, General Description.>

- 2) Adjust the parking brake. <Ref. to PB-8, ADJUSTMENT, Parking Brake Assembly (Rear Disc Brake).>

Rear Disc Rotor

BRAKE

C: INSPECTION

- 1) Check the rear wheel bearing play and axle hub runout before inspecting the disc rotor runout. <Ref. to DS-26, INSPECTION, Rear Hub Unit Bearing.>
- 2) Secure the disc rotor by tightening the five wheel nuts.
- 3) Set a dial gauge 10 mm (0.39 in) inward from the disc rotor outer circumference. Rotate the disc rotor to check runout. If the runout of disc rotor exceeds the service limit, grind the disc rotor. After grinding, check the thickness of the disc rotor according to the procedure in step 4).

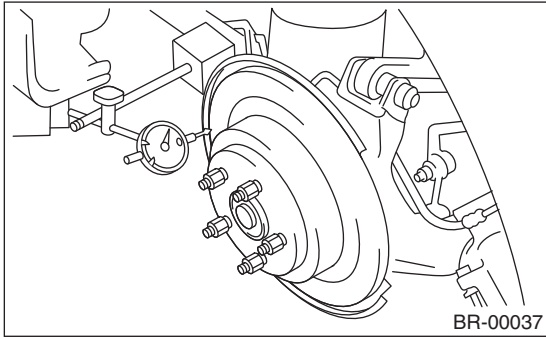

**Disc rotor runout limit:
0.05 mm (0.0020 in)**

- 4) Set a micrometer 10 mm (0.39 in) inward from the disc rotor outer perimeter, and then measure the disc rotor thickness. If the thickness of the disc rotor exceeds the service limit, replace with a new disc rotor.

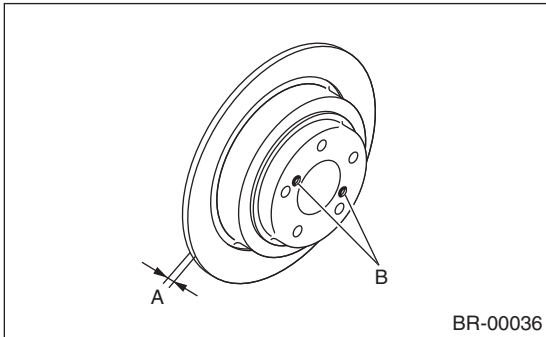

	Standard	Limit	Disc outer dia.
Disc rotor thickness A	10 (0.39)	8.5 (0.335)	286 (11.26)
	mm (in)		

7. Rear Disc Brake Assembly

A: REMOVAL

CAUTION:

Do not allow brake fluid to come in contact with vehicle body. If it does, wash off with water and wipe away completely.

- 1) Lift up the vehicle, then remove the rear wheels.
- 2) Disconnect the brake hose.

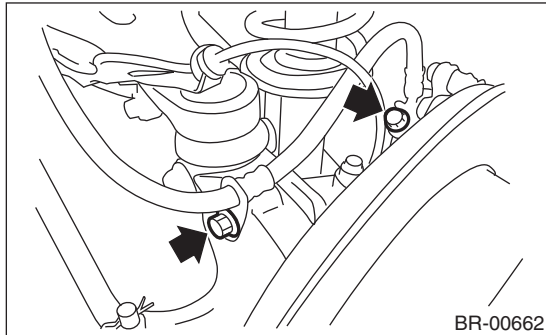

- 3) Remove the caliper mounting bolt.

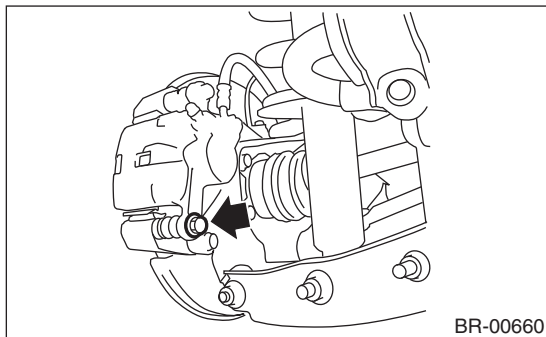

- 4) Raise the caliper body, and then move it toward vehicle center to separate it from the support.
- 5) Remove the support from housing.

NOTE:

Remove the support only when replacing the rotor or support. It is not necessary to remove it when servicing the caliper body assembly.

- 6) Remove mud and foreign matter from the caliper body assembly and the support.

CAUTION:

Be careful not to allow foreign matter to enter the brake hose connector.

B: INSTALLATION

- 1) Apply a thin coat of Molykote M7439 (Part No. K0770YA000) or grease contained in the pad kit to the support.

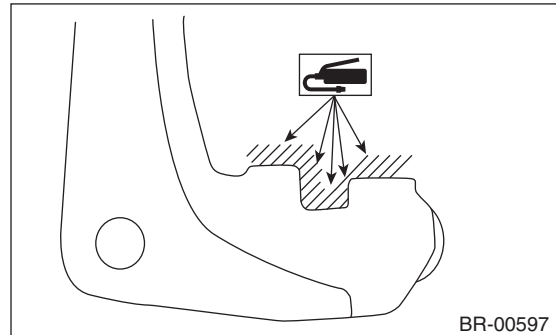

- 2) Install the support to the housing.

Tightening torque:

66 N·m (6.7 kgf·m, 48.7 ft·lb)

- 3) Apply a thin coat of Molykote M7439 (Part No. K0770YA000) or grease contained in the pad kit to the pad clip.

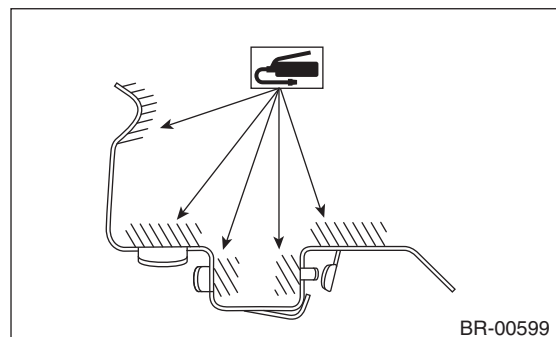

- 4) Apply a thin coat of Molykote AS880N (Part No. K0777YA010) or grease contained in the pad kit to the contact surface between the pad and shim.

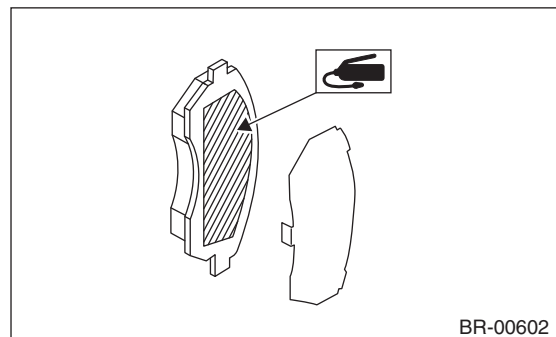

Rear Disc Brake Assembly

BRAKE

5) Apply a thin coat of Molykote AS880N (Part No. K0777YA010) or grease contained in the pad kit to both surfaces of the pad inner shim.

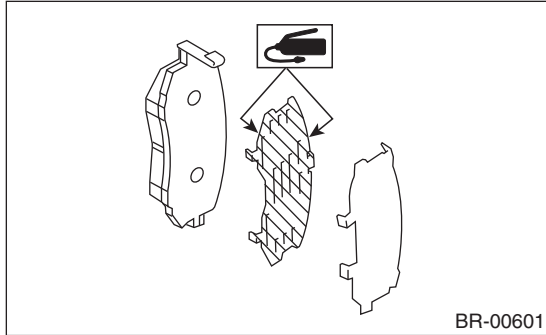

- 6) Install the pad to the support.
- 7) Install the caliper body to the support.

Tightening torque:

27 N·m (2.8 kgf-m, 19.9 ft-lb)

- 8) Install the brake hose bracket.

Tightening torque:

33 N·m (3.4 kgf-m, 24.3 ft-lb)

- 9) Connect the brake hose using a new brake hose gasket.

Tightening torque:

18 N·m (1.8 kgf-m, 13.0 ft-lb)

- 10) Bleed air from the brake system.

C: DISASSEMBLY

- 1) Remove the piston boot.

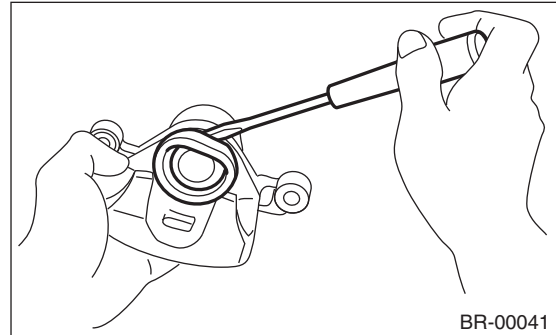

- 2) Place a wooden block in the caliper body as shown in the figure to prevent the piston from jumping out and being damaged.
- 3) Gradually apply compressed air via the brake hose installation hole to push the piston out.

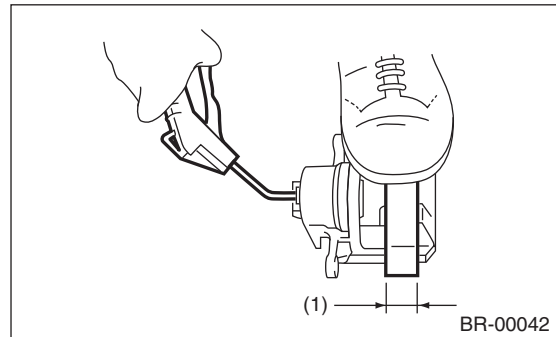

- (1) Place a wooden block of 30 mm (1.18 in) width.

- 4) Remove the piston seal from caliper body cylinder.

CAUTION:

Do not damage the cylinder and piston seal groove.

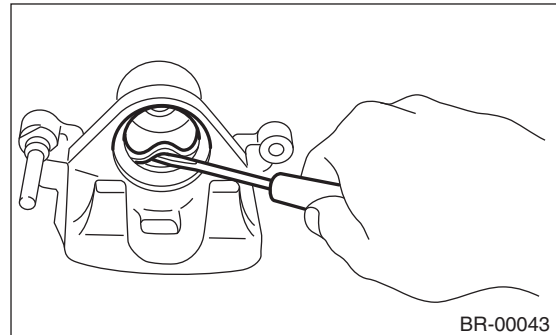

- 5) Remove the pin boot.

D: ASSEMBLY

- 1) Clean the inside of the caliper body using brake fluid.
- 2) Apply a coat of brake fluid to piston seal and install the piston seal to the caliper body groove.
- 3) Apply a coat of brake fluid to the inner surface of cylinder and the entire outer surface of the piston.
- 4) Apply NIGLUBE RX-2 (Part No. 000041000) or grease contained in the piston kit to the boot, and install it to the groove at the end of the cylinder.
- 5) Insert the piston into the cylinder.

CAUTION:

Do not force the piston into cylinder.

- 6) Position the boot in the grooves on piston and cylinder.

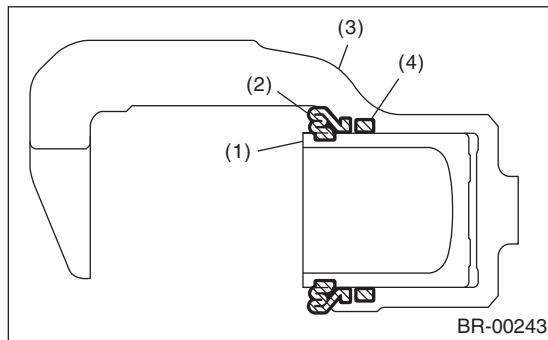

- (1) Piston
- (2) Piston boot
- (3) Caliper body
- (4) Piston seal

- 7) Apply NIGLUBE RX-2 (Part No. 000041000) or grease contained in the piston kit to cylinder inner surface, pin, bushing outer surface, and boot grooves.

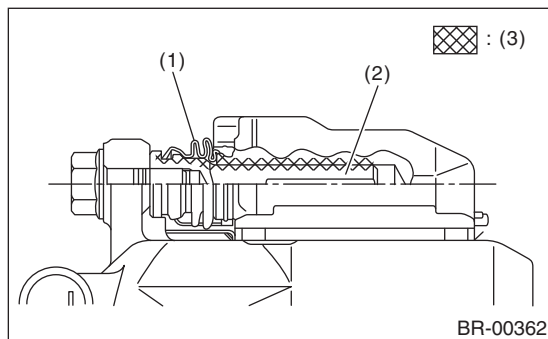

- (1) Pin boot
- (2) Lock pin or guide pin
- (3) Grease applied area

- 8) Insert the pin boot into the support.
- 9) Install the pin boot to the support, and then insert the pin into the specified position.

CAUTION:

Insert pin into position, and make sure that it slides and seats properly.

E: INSPECTION

- 1) Repair or replace the faulty parts.
- 2) Check the caliper body and piston for uneven wear, damage or rust.
- 3) Check the rubber parts for damage or deterioration.

8. Master Cylinder

A: REMOVAL

CAUTION:

Do not allow brake fluid to come in contact with vehicle body. If it does, wash off with water and wipe away completely.

- 1) Drain brake fluid from the reservoir tank completely.
- 2) Disconnect the harness connector of the fluid level gauge.
- 3) Remove the brake pipe from the master cylinder.
- 4) Remove the master cylinder mounting nuts, and carefully remove the master cylinder from the brake booster.

B: INSTALLATION

- 1) Replace the O-ring for the master cylinder with a new part.

CAUTION:

Be careful not to install the O-ring in the wrong location.

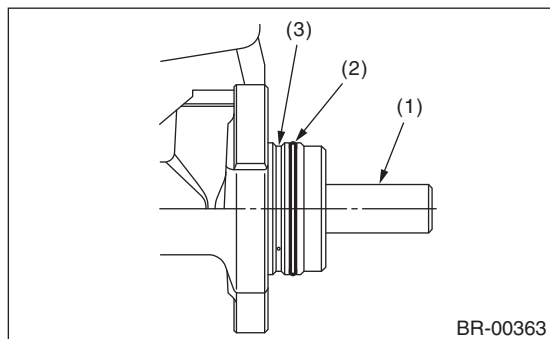

- (1) Primary piston
- (2) O-ring
- (3) Do not install the O-ring on this groove.

- 2) Install in the reverse order of removal.

Tightening torque:

Master cylinder mounting nut

13 N·m (1.3 kgf-m, 9.6 ft-lb)

Piping flare nut

15 N·m (1.5 kgf-m, 10.8 ft-lb)

CAUTION:

Be sure to use recommended brake fluid.

- 3) Bleed air from brake system. <Ref. to BR-32, PROCEDURE, Air Bleeding.>

C: REPLACEMENT

- 1) Remove mud and dirt from the surface of brake master cylinder.
- 2) Secure the master cylinder in a vise.

NOTE:

To avoid damaging the master cylinder, place between aluminum plates or other material when holding with a vise.

- 3) Remove the pin which secures the master cylinder and reservoir tank, then remove the reservoir tank and seal.

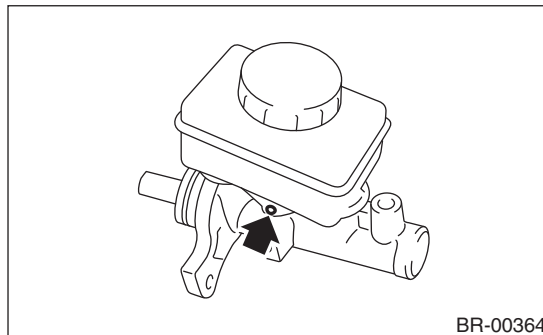

BR-00364

- 4) While pushing in the primary piston, remove the C-ring using pliers.

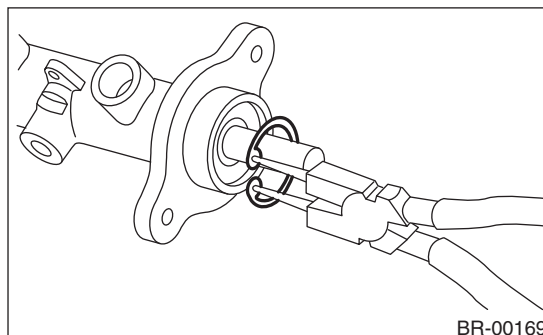

BR-00169

- 5) While pushing in the primary piston, remove the cylinder pin from the port on the reservoir tank attachment location using a magnet pick-up tool.

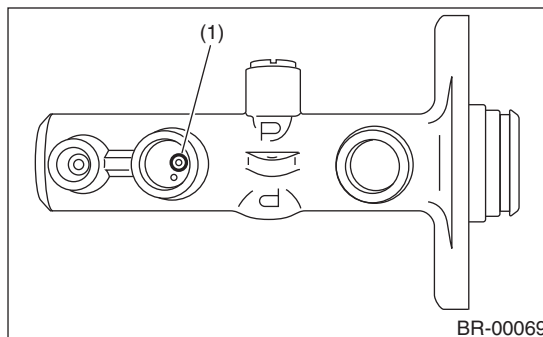

BR-00069

- (1) Cylinder pin

- 6) Extract the primary piston assembly and secondary piston assembly straight out while taking care not to scratch the inner surface of the cylinder.

7) Clean the inside of master cylinder with brake fluid. Check the inside of the cylinder for damage, deformation and wear. Replace the master cylinder as an assembly if faulty.

8) Apply brake fluid to the inner surface of master cylinder and piston assembly.

9) Make sure that the inner surface of master cylinder and the piston assembly are free of foreign matter. Install the primary piston assembly and the secondary piston assembly to master cylinder, while taking care not to scratch the master cylinder inner surface.

10) While pushing-in the primary piston, install the cylinder pin.

11) While pushing-in the primary piston, install the C-ring to the groove using pliers.

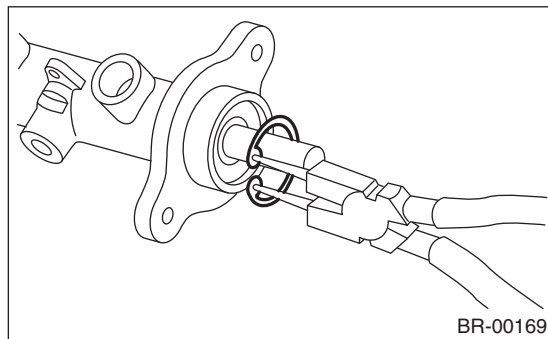

CAUTION:

Make sure the C-ring is installed to the groove securely.

12) Install the seal to reservoir tank.

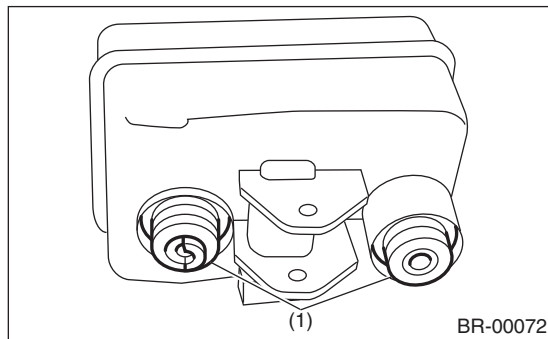

(1) Seal

13) Install the reservoir tank to the master cylinder, and secure with pin.

14) Replace the O-ring for the master cylinder with a new part.

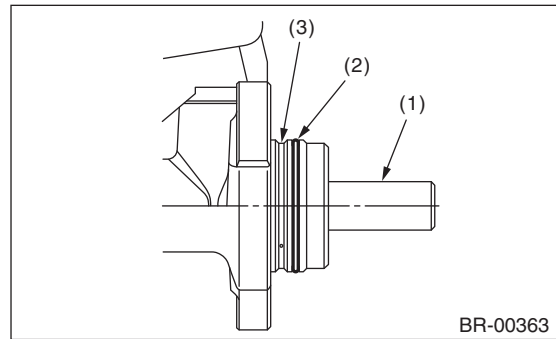

(1) Primary piston

(2) O-ring

(3) Do not install the O-ring on this groove.

D: INSPECTION

Inspect for brake fluid leakage from the master cylinder.

NOTE:

After replacing the piston kit, if a brake fluid leakage is found even though there is no damage or scratches on the inside of the cylinder, the master cylinder inner wall may be worn. In this case, replace the master cylinder as an assembly.

Brake Booster

BRAKE

9. Brake Booster

A: REMOVAL

1) Remove or disconnect the following parts in the engine compartment.

- (1) Disconnect the connector of brake fluid level gauge.
- (2) Remove the brake pipe from the master cylinder.
- (3) Remove the master cylinder installation nut.
- (4) Disconnect the vacuum hose from brake booster.

2) Remove the following parts from the pedal bracket.

- (1) Snap pin and clevis pin
- (2) Four brake booster installation nuts

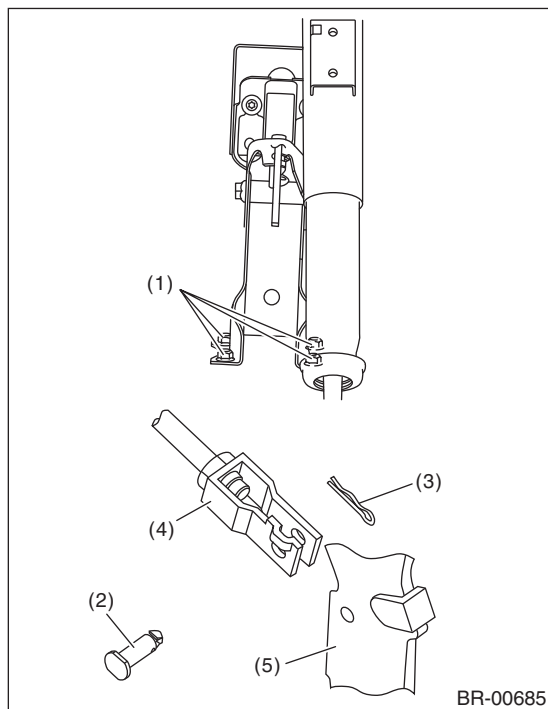

- (1) Nut
- (2) Clevis pin
- (3) Snap pin
- (4) Operating rod
- (5) Brake pedal

3) Remove the brake booster while avoiding the brake pipe.

NOTE:

- Make sure that the booster shell and vacuum pipe are not subject to strong impacts.
- Be careful not to drop the brake booster. If the booster is dropped, replace it.
- Use special care when handling the operating rod. If excessive force is applied to the operating rod, the angle may change by $\pm 3^\circ$, and it may result in damage to power piston cylinder.
- Be careful when placing the brake booster on floor.
- Do not change the push rod length.

CAUTION:

- Do not disassemble the brake booster.
- If external force is applied from above when brake booster is placed in this position, the resin portion as indicated by "P" may become damaged.

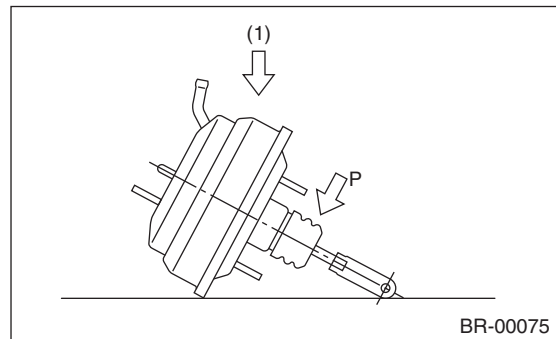

(1) Force

B: INSTALLATION

1) Check and adjust the operating rod of the brake booster.

Specification L:

136.3 mm (5.37 in)

If it is out of specification, adjust it with the brake booster operating rod.

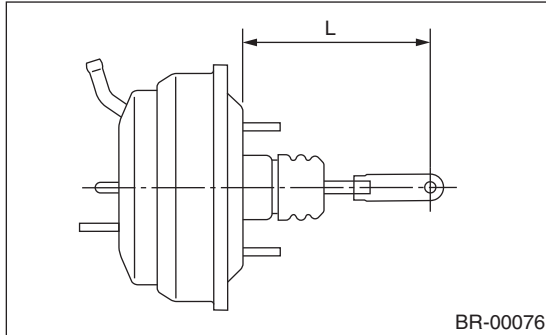

- 2) Mount the brake booster in position.
- 3) Install clevis pin and snap pin which secure the operating rod to the brake pedal.

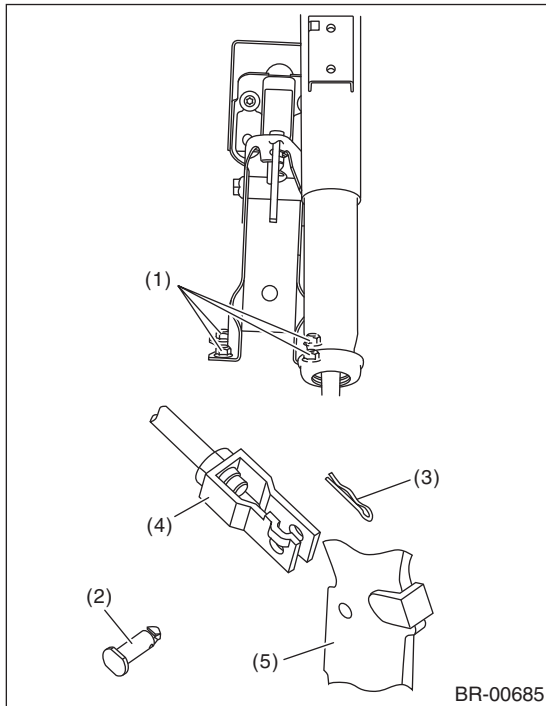

- (1) Nut
- (2) Clevis pin
- (3) Snap pin
- (4) Operating rod
- (5) Brake pedal

5) After replacing the O-ring, install the master cylinder to brake booster.

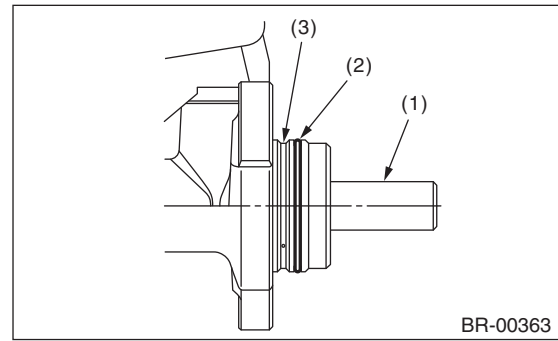

- (1) Primary piston
- (2) O-ring
- (3) Do not install the O-ring on this groove.

- 6) Connect the brake pipes to the master cylinder.
- 7) Connect the connector of the brake fluid level gauge.
- 8) Apply grease to the operating rod connecting pin to prevent it from wear.
- 9) Bleed air from brake system.

Tightening torque (air bleeder screw):

8 N·m (0.8 kgf-m, 5.8 ft-lb)

10) Perform a road test to make sure the brakes do not drag.

NOTE:

Apply a thin coat of KOPR-KOTE (Part No. 003603001) to the clevis pin.

4) Connect the vacuum hose to the brake booster.

C: INSPECTION

NOTE:

If the vehicle is equipped with a brake assist mechanism, the following may result when the brake pedal is depressed. They are normal conditions that occur when the mechanism is performing properly.

- Brake feel is soft when brake pedal is depressed hard or quicker than usual.
- A light crack is heard when brake pedal is depressed hard or quicker than usual.

1. OPERATION CHECK (WITHOUT GAUGES)

CAUTION:

When checking operation, be sure to apply the parking brake securely.

• CHECK WITHOUT GAUGES

This method can not determine exactly what part is defective. But it is possible to identify the outline of the defect by performing the check according to the following procedures.

• AIR TIGHTNESS CHECK

Start the engine, and idle it for 1 to 2 minutes, then turn it OFF. Depress the brake pedal several times applying the normal pedal force. The pedal stroke should be the longest at the 1st depression, and it should become shorter at each successive depression. If no change occurs in the pedal height when pressed, the brake booster is faulty.

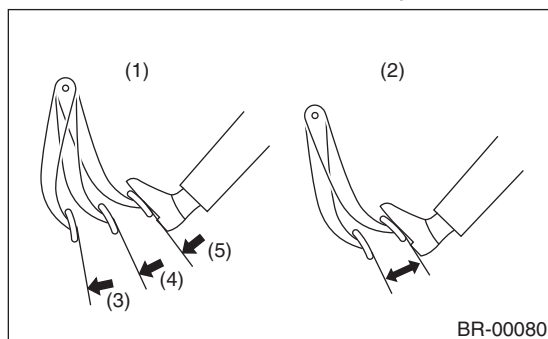

- (1) Normal operation
- (2) Not OK
- (3) 1st
- (4) 2nd
- (5) 3rd

NOTE:

- In case of defective operation, inspect the condition of the check valve and vacuum hose as well.
- Replace them if faulty, and perform the test again.
- If no improvement is observed, check precisely with gauges.

• OPERATION CHECK

- 1) While the engine is OFF, depress the brake pedal several times applying the same pedal force, to check for a change in pedal height.

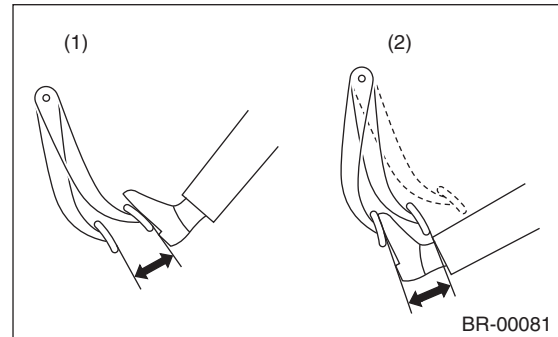

- (1) When engine is stopped
- (2) When engine is started

- 2) With the brake pedal depressed, start the engine.

- 3) As the engine starts, the brake pedal should move slowly toward the floor. If the pedal height does not change, the brake booster is faulty.

NOTE:

If faulty, check precisely with gauges.

• LOADED AIR TIGHTNESS CHECK

Depress the brake pedal while the engine is running, and turn the engine to OFF while the pedal is depressed. Keep the pedal depressed for 30 seconds. If the pedal height does not change, the function of brake booster is normal. If the pedal height increases, it is faulty.

NOTE:

If faulty, check precisely with gauges.

2. OPERATION CHECK (WITH GAUGE)

CAUTION:

When checking operation, be sure to apply the parking brake securely.

• CHECK WITH GAUGE

Connect the gauge as shown in the figure. After bleeding air from the pressure gauge, perform each check.

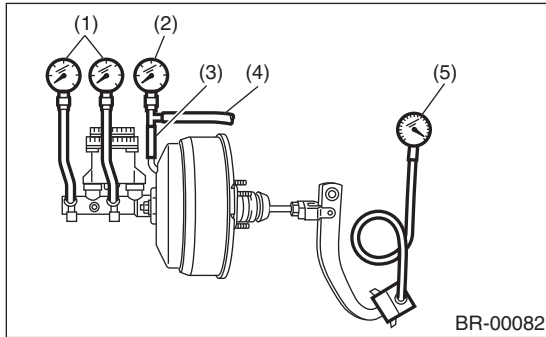

- (1) Pressure gauge
- (2) Vacuum gauge
- (3) Adapter hose
- (4) Vacuum hose
- (5) Pedal force gauge

• AIR TIGHTNESS CHECK

1) Start the engine and keep it running until vacuum pressure indicates point A of the vacuum gauge = 66.7 kPa (500 mmHg, 19.69 inHg). Do not depress the brake pedal at this time.

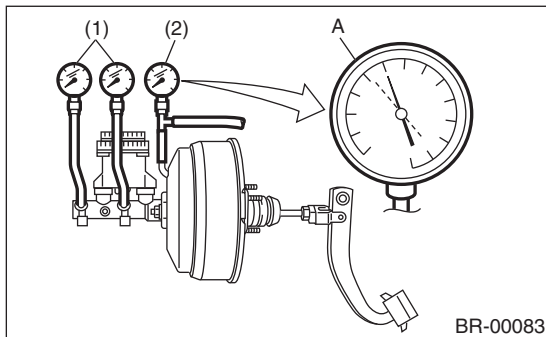

- (1) Pressure gauge
- (2) Vacuum gauge

2) Stop the engine and check the gauge. If the vacuum pressure drop within 15 seconds after stopping the engine is 3.3 kPa (25 mmHg, 0.98 inHg) or less, the function of brake booster is normal.

If faulty, the cause may be one of the following.

- Check valve malfunction
- Leak from vacuum hose
- Leak from shell joint section or stud bolt welded section
- Damaged diaphragm
- Leak from valve body seal and bearing section
- Leak from plate and seal assembly section
- Leak from poppet valve assembly section

• LOADED AIR TIGHTNESS CHECK

1) Start the engine and depress the brake pedal with a pedal force of 196 N (20 kgf, 44 lbf). Keep the engine running and keep the pedal pressed until a vacuum of point B = 66.7 kPa (500 mmHg, 19.69 inHg) is indicated on the vacuum gauge.

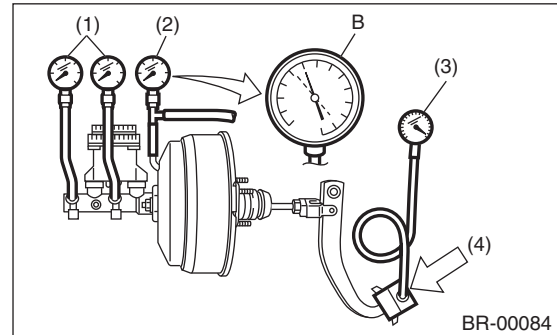

- (1) Pressure gauge
- (2) Vacuum gauge
- (3) Pedal force gauge
- (4) Depressed

2) Stop the engine and check the vacuum gauge. If the vacuum pressure drop within 15 seconds after stopping the engine is 3.3 kPa (25 mmHg, 0.98 inHg) or less, the function of brake booster is normal. If defective, refer to "AIR TIGHTNESS CHECK".

<Ref. to BR-28, INSPECTION, Brake Booster.>

3) If the brake booster is faulty, replace it with a new part.

• LACK OF BOOST ACTION CHECK

Turn the engine OFF, and set the value of the vacuum gauge to "0". Then, check the fluid pressure when the brake pedal is depressed. The pressure must be greater than the specification listed.

Brake pedal operation force N (kgf, lbf)	147 (15, 33)	294 (30, 66)
Fluid pressure kPa (kgf/cm ² , psi)	545 (6, 79)	1,564 (16, 227)

Brake Booster

BRAKE

• BOOSTING ACTION CHECK

Set the vacuum gauge reading to 66.7 kPa (500 mmHg, 19.69 inHg) with the engine running. Then, check the fluid pressure when the brake pedal is depressed. The pressure must be greater than the specification listed.

Brake pedal operation force N (kgf, lbf)	147 (15, 33)	294 (30, 66)
Fluid pressure kPa (kgf/cm ² , psi)	6,400 (65, 928)	11,273 (115, 1,635)

10.Brake Fluid

A: INSPECTION

1) Check that the brake fluid level is between “MIN” and “MAX”. If out of the specified range, refill or drain fluid. If the fluid level is close to “MIN”, check the brake pad for wear and refill the fluid.

2) Check the fluid for discoloration. If the fluid color has changed excessively, drain the fluid and refill with new fluid.

B: REPLACEMENT

CAUTION:

- Do not let brake fluid come into contact with the painted surface of the vehicle body. Wash away with water immediately and wipe off if it is spilled by accident.
- Avoid mixing brake fluid of different brands to prevent fluid performance from degrading.
- Be careful not to allow dirt or dust to enter the reservoir tank.

NOTE:

- During the operation, keep the reservoir tank filled with brake fluid to eliminate entry of air.
- Operate the brake pedal slowly.
- For convenience and safety, two people should work together.
- The required amount of brake fluid is approximately 500 ml (16.9 US fl oz, 17.6 Imp fl oz) for the entire brake system.

1) Lift up the vehicle and set rigid racks at the specified locations, or keep the vehicle lifted.

2) Remove both the front and rear wheels.

3) Drain brake fluid from the reservoir tank.

4) Refill the reservoir tank with the recommended brake fluid.

Recommended brake fluid:

Refer to “General Description”. <Ref. to BR-2, SPECIFICATION, General Description.>

Perform the same procedure as for bleeding the brake line, until new brake fluid comes out from vinyl tube. <Ref. to BR-32, PROCEDURE, Air Bleeding.>

11. Air Bleeding

A: PROCEDURE

CAUTION:

- Do not let brake fluid come into contact with the painted surface of the vehicle body. Wash away with water immediately and wipe off if it is spilled by accident.
- Avoid mixing brake fluid of different brands to prevent fluid performance from degrading.
- Be careful not to allow dirt or dust to enter the reservoir tank.

1. MASTER CYLINDER

NOTE:

- When the master cylinder is disassembled or the reservoir tank is empty, bleed the master cylinder.
- If bleeding of the master cylinder is not necessary, omit the following procedures, and perform bleeding of the brake line. <Ref. to BR-33, BRAKE LINE, PROCEDURE, Air Bleeding.>

1) Fill the reservoir tank of the master cylinder with brake fluid.

NOTE:

While bleeding air, keep the reservoir tank filled with brake fluid to prevent entry of air.

- 2) Disconnect the brake line at primary and secondary sides.
- 3) Wrap the master cylinder with a plastic bag.
- 4) Depress the brake pedal slowly and hold it.

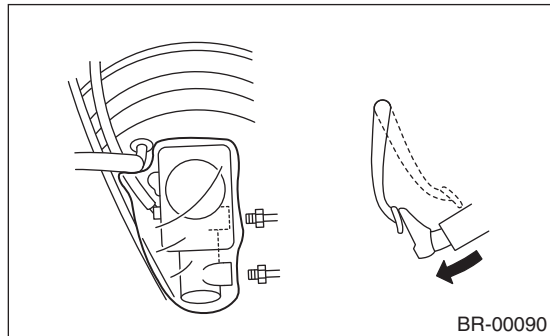

NOTE:

If the vehicle is equipped with a brake assist mechanism, the following may result when the brake pedal is depressed. They are normal conditions that occur when the mechanism is performing properly.

- Brake feel is soft when brake pedal is depressed hard or quicker than usual.
- A light crack is heard when brake pedal is depressed hard or quicker than usual.

5) Plug the outlet plug with your finger, and then release the brake pedal.

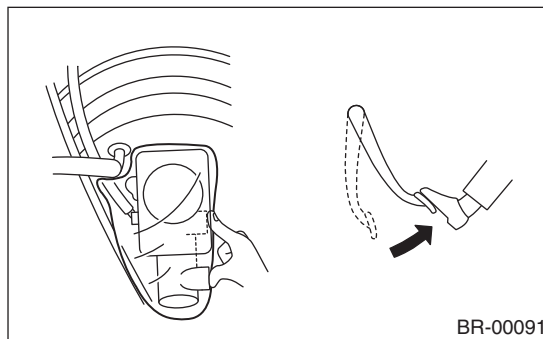

- 6) Repeat the step 4) and 5) several times.
- 7) Remove the plastic bag.
- 8) Install the brake pipe to the master cylinder.

Tightening torque:

19 N·m (1.9 kgf-m, 14.0 ft-lb)

9) Bleed air from the brake line. <Ref. to BR-33, BRAKE LINE, PROCEDURE, Air Bleeding.>

2. BRAKE LINE

1) When the master cylinder is disassembled or the reservoir tank is empty, bleed the master cylinder before bleeding the brake line. <Ref. to BR-32, MASTER CYLINDER, PROCEDURE, Air Bleeding.>

2) Fill the reservoir tank of the master cylinder with brake fluid.

NOTE:

While bleeding air, keep the reservoir tank filled with brake fluid to prevent entry of air.

3) Attach one end of the vinyl tube to the air bleeder and the other end to the brake fluid container.

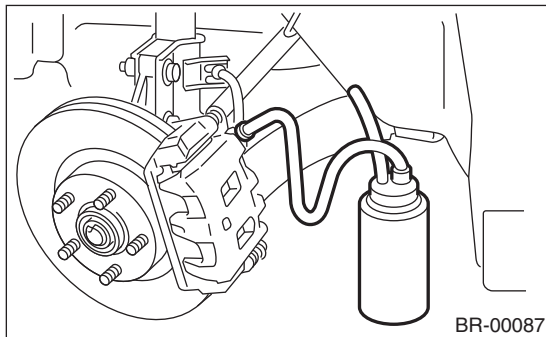

4) Depress the brake pedal several times, and hold it.

5) Loosen the air bleeder screw to drain brake fluid. Tighten the air bleeder quickly, and release the brake pedal.

6) Repeat the steps 4) to 5) until there are no more air bubbles in the vinyl tube.

7) Repeat the steps from 2) to 6) above to bleed air from each wheel.

NOTE:

Perform air bleed starting in the order from the farthest wheel cylinder from the master cylinder.

8) Securely tighten the air bleeder screws.

Tightening torque:

8 N·m (0.8 kgf·m, 5.8 ft·lb)

9) Check that there are no brake fluid leaks in the entire system.

10) Check the pedal stroke.

Run the engine at idle after warming up the engine, and depress the brake pedal with a force of 500 N (51 kgf, 112 lbf). Measure the distance between the brake pedal and steering wheel. Release the pedal, and measure the distance between pedal and steering wheel again.

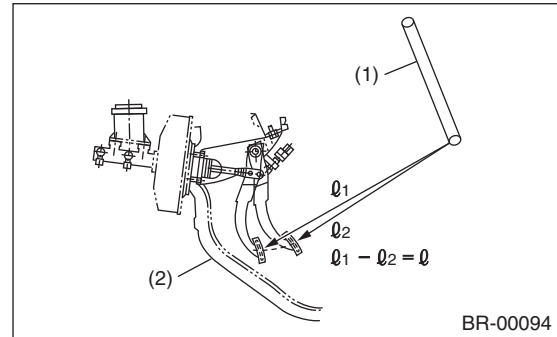

- (1) Steering wheel
- (2) Toe board

Specification of pedal stroke:

When depressing the pedal with a force of 500 N (51 kgf, 112 lbf).

95 mm (3.74 in) or less

11) If the distance is more than specification, there is a possibility of air being caught in the brake line. Bleed the brake line of all air until the pedal stroke meets the specification.

12) Operate the hydraulic control unit in the sequence control mode. <Ref. to VDC-14, ABS Sequence Control.>

13) Check the pedal stroke again.

14) If the distance is more than specification, there is a possibility of air being caught in the hydraulic unit. Repeat above steps 2) to 9) until the pedal stroke meets the specification.

15) Fill the reservoir tank with brake fluid up to the "MAX" level.

16) Test run the vehicle and ensure that the brakes operate normally.

12.Brake Hose

A: REMOVAL

1. FRONT BRAKE HOSE

- 1) Separate the brake pipe from brake hose using a flare nut wrench.
- 2) Remove the clamp, the strut mount bolts, and union bolt.

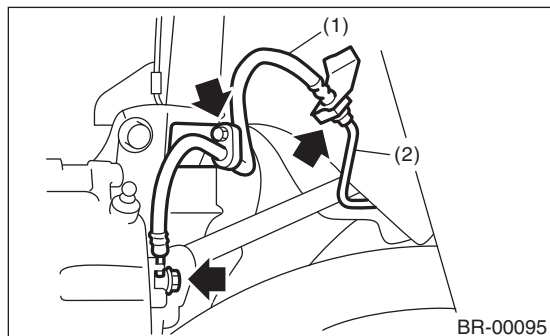

- (1) Brake hose
- (2) Brake pipe

2. REAR BRAKE HOSE

- 1) Remove union bolt and brake hose bracket bolt.

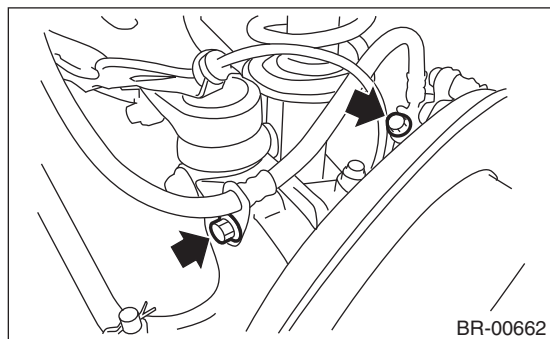

- 2) Separate the brake pipe from brake hose using a flare nut wrench.
- 3) Remove the clamp, and then remove the brake hose.

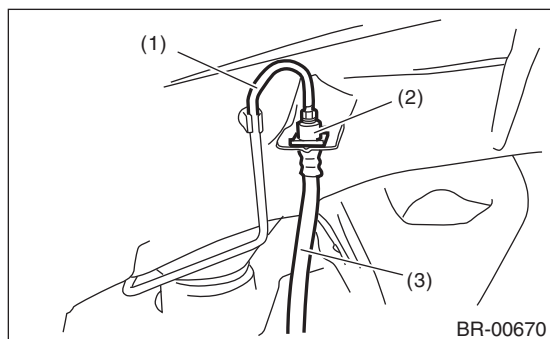

- (1) Brake pipe
- (2) Brake hose clamp
- (3) Brake hose

B: INSTALLATION

1. FRONT BRAKE HOSE

- 1) Secure the brake hose to strut mount.

Tightening torque:

33 N·m (3.4 kgf-m, 24.3 ft-lb)

- 2) Install the brake hose to the caliper using a new gasket.

Tightening torque (union bolt):

18 N·m (1.8 kgf-m, 13.0 ft-lb)

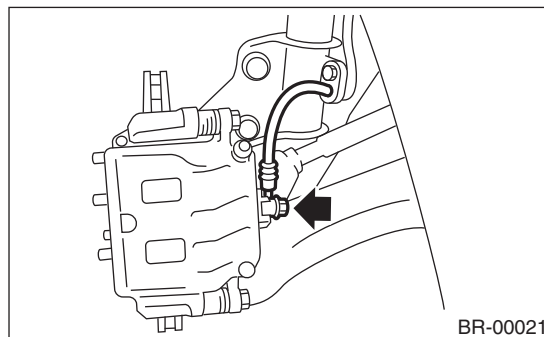

- 3) Position the disc in straight position and route the brake hose through the hole in the bracket on the wheel apron side.

CAUTION:

Do not twist the brake hose.

- 4) Temporarily tighten the flare nut which connects brake pipe and hose.
- 5) Secure the brake hose to wheel apron bracket with clamp.
- 6) Tighten the flare nut to the specified torque.

Tightening torque (brake pipe flare nut):

15 N·m (1.5 kgf-m, 10.8 ft-lb)

- 7) Bleed air from the brake system.

2. REAR BRAKE HOSE

- 1) Route the brake hose through the hole of bracket, and lightly tighten the flare nut to connect brake pipe.
- 2) Insert the clamp to secure brake hose.

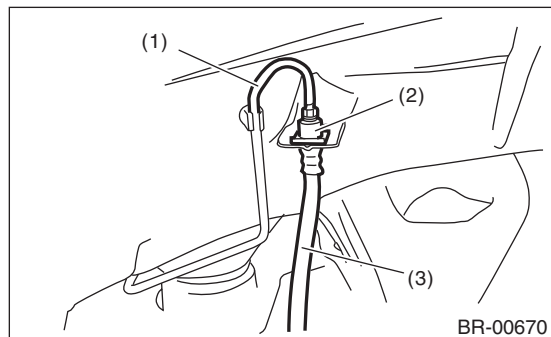

- (1) Brake pipe
- (2) Brake hose clamp
- (3) Brake hose

- 3) Install the brake hose to rear brake caliper using a new gasket.

Tightening torque:

Union bolt

18 N·m (1.8 kgf-m, 13.0 ft-lb)

Brake hose bracket

33 N·m (3.4 kgf-m, 24.3 ft-lb)

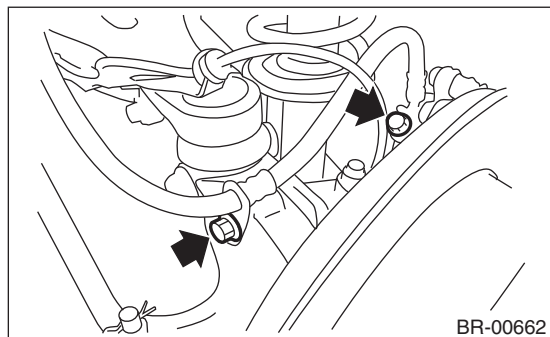

- 4) Tighten the flare nut to the specified torque.

Tightening torque (brake pipe flare nut):

15 N·m (1.5 kgf-m, 10.8 ft-lb)

- 5) Bleed air from the brake system.

C: INSPECTION

Make sure there are no cracks, breakage or damage on hoses. Check the joint for fluid leakage. If any cracks, breakage, damage or fluid leakage is found, repair or replace the hose.

13. Brake Pipe

A: REMOVAL

NOTE:

The airbag system wiring harness is routed near the center brake pipe.

CAUTION:

- Airbag system wiring harness and connectors are colored yellow. Do not use the electrical test equipment on these circuits.
- Be careful not to damage the airbag system wiring harness when servicing the center brake pipe.
- When removing the brake pipe, do not bend.

B: INSTALLATION

NOTE:

The airbag system wiring harness is routed near the center brake pipe.

CAUTION:

- Airbag system wiring harness and connectors are colored yellow. Do not use the electrical test equipment on these circuits.
- Be careful not to damage the airbag system wiring harness when servicing the center brake pipe.
- When installing the brake pipe, do not bend.
- After installing the brake pipe and hose, perform air bleed.
- After installing the brake hoses, make sure that they do not contact the tires or suspension assembly, etc.

Brake pipe tightening torque:

Refer to "COMPONENT" of "General Description". <Ref. to BR-7, FRONT BRAKE PIPES AND HOSES, COMPONENT, General Description.> <Ref. to BR-8, CENTER AND REAR BRAKE PIPES AND HOSES, COMPONENT, General Description.>

C: INSPECTION

Make sure there are no cracks, breakage or damage on hoses. Check the joint for fluid leakage. If any cracks, breakage, damage or fluid leakage is found, repair or replace the pipes.

NOTE:

Use a mirror when inspecting back sides and other locations which are hard to see.

14. Brake Pedal

A: REMOVAL

1. MT MODEL

- 1) Remove the steering column. <Ref. to PS-15, REMOVAL, Steering Column.>
- 2) Disconnect the connector from clutch switch.
- 3) Disconnect the connector from stop light switch.
- 4) Remove the clevis pin which secures the pedal and operating rod.

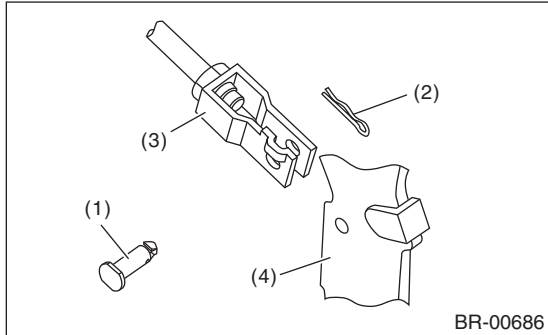

- (1) Clevis pin
- (2) Snap pin
- (3) Operating rod
- (4) Pedal

- 5) Remove the nut which secures the clutch master cylinder.
- 6) Remove the bolt and nut which secures the pedal bracket.

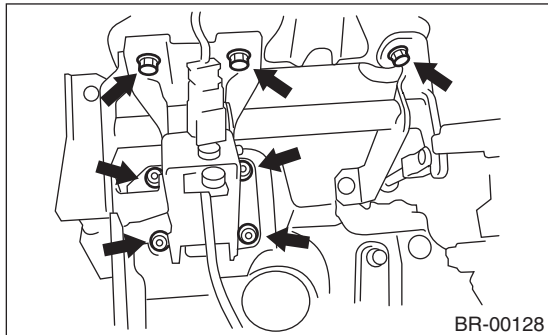

2. AT MODEL

- 1) Remove the steering column. <Ref. to PS-15, REMOVAL, Steering Column.>
- 2) Disconnect the connector from stop light switch.
- 3) Remove the clevis pin which secures the brake pedal and operating rod.

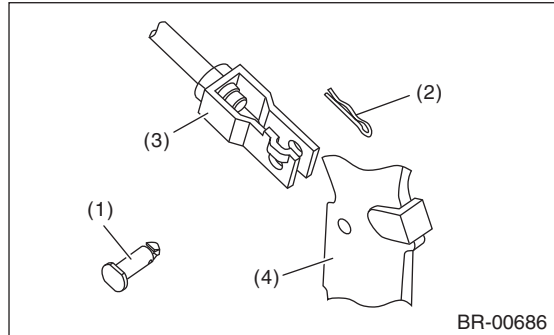

- (1) Clevis pin
- (2) Snap pin
- (3) Operating rod
- (4) Brake pedal

- 4) Remove the bolts and nuts which secure the brake pedal bracket.

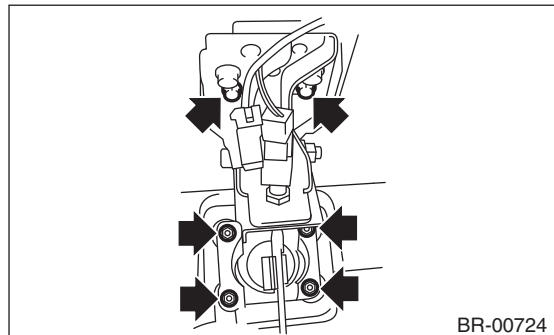

Brake Pedal

BRAKE

B: INSTALLATION

1) Install the bolt and nut which secure the brake pedal bracket.

Tightening torque:

18 N·m (1.8 kgf·m, 13.0 ft·lb)

2) Install clevis pin and snap pin which secure the operating rod to the brake pedal.

NOTE:

- Replace with a new clevis pin.
- Apply a thin coat of KOPR-KOTE (Part No. 003603001) to the clevis pin.

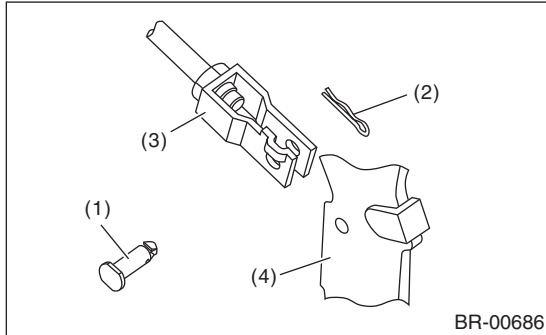

- (1) Clevis pin
- (2) Snap pin
- (3) Operating rod
- (4) Brake pedal

- 3) Connect the stop light switch connector.
- 4) Check that the brake light operate properly.
- 5) Check the brake pedal after installation. <Ref. to BR-38, INSPECTION, Brake Pedal.>

C: INSPECTION

1) Move the brake pedal pads in a horizontal direction with a force of approx. 10 N (1 kgf, 2 lbf), and check that the pedal deflection is in the range of specifications.

CAUTION:

If excessive deflection is noted, replace with a new bushing.

Deflection of brake pedal:

Service limit

5.0 mm (0.197 in) or less

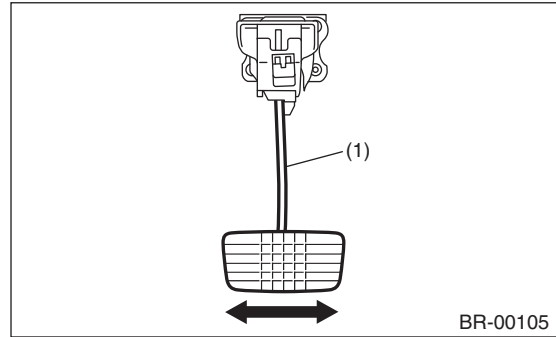

- (1) Brake pedal

2) Check the position of the pedal pad.

Pedal height L:

150 — 160 mm (5.91 — 6.29 in)

Brake pedal free play A:

0.5 — 2 mm (0.020 — 0.079 in) [When pulling the brake pedal upward with a force of less than 10 N (1 kgf, 2 lbf).]

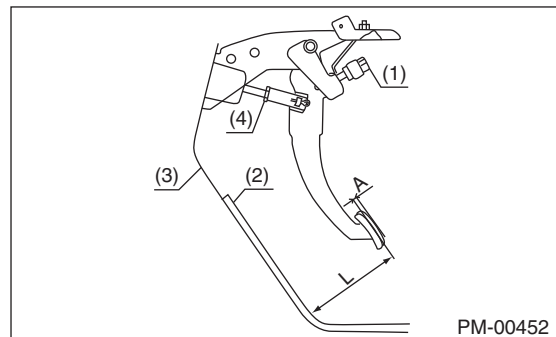

- (1) Stop light switch
- (2) Mat
- (3) Toe board
- (4) Brake booster operating rod

3) If it is not within the specification, loosen the lock nut of brake booster operating rod, and rotate the rod to adjust the pedal height L within the specification.

4) Tighten the lock nut.

Tightening torque:

22 N·m (2.2 kgf·m, 16.2 ft·lb)

15. Stop Light Switch

A: REMOVAL

- 1) Disconnect the battery ground cable from the battery.
- 2) Disconnect the stop light switch connector.
- 3) Loosen the nut, unscrew the stop light switch, and remove stop light switch.

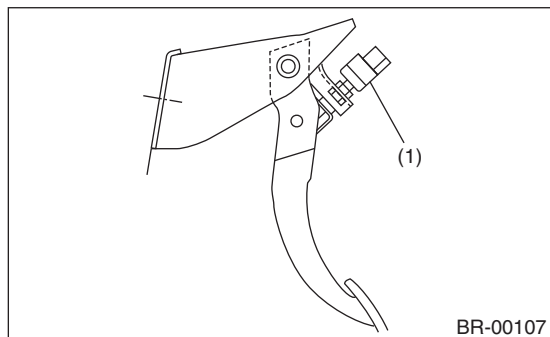

(1) Stop light switch

B: INSTALLATION

- 1) Install the stop light switch onto the bracket with screw and position it with the nut.
 - 2) Adjust the stop light switch position, and then tighten the nut.
- <Ref. to BR-40, ADJUSTMENT, Stop Light Switch.>

Tightening torque:

8 N·m (0.8 kgf·m, 5.8 ft·lb)

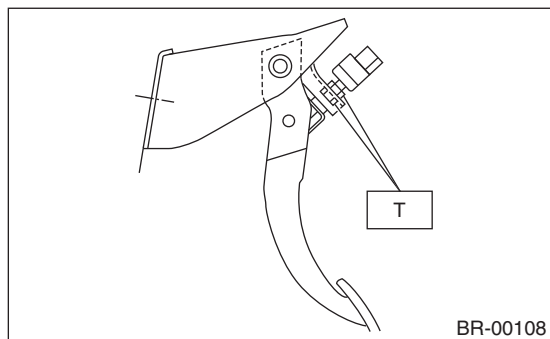

C: INSPECTION

1. INSPECT THE SPECIFIED POSITION

- 1) If the stop light switch does not operate properly (or if it is not secured at the specified position), replace with a new part.

Specified position L:

2 mm (0.079 in)

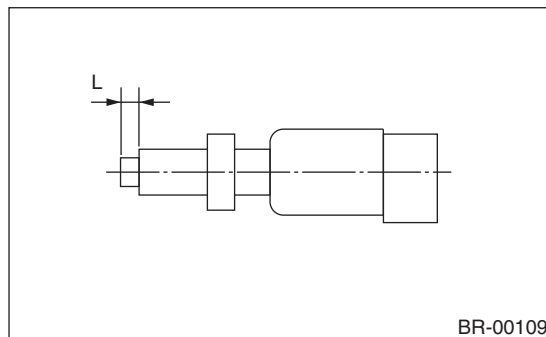

- 2) Measure the clearance between the threaded end of stop light switch and the stopper.

CAUTION:

Be careful not to rotate the stop light switch.

Stop light switch clearance A:

0.3 mm (0.012 in)

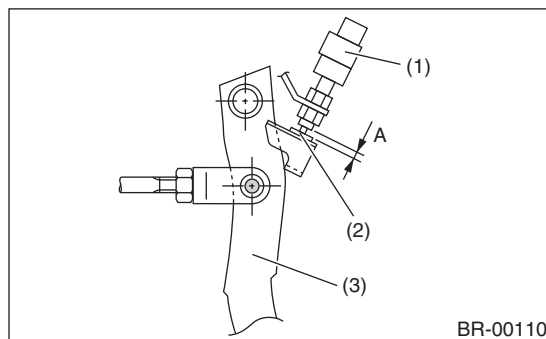

- (1) Stop light switch
- (2) Stopper
- (3) Brake pedal

- 3) If it is not within the specification, adjust the position of the stop light switch.

CAUTION:

Be careful not to rotate the stop light switch.

Stop Light Switch

BRAKE

2. INSPECT THE RESISTANCE

- 1) If the stop light switch does not operate properly, replace with a new part.
- 2) Measure the resistance of stop light switch.

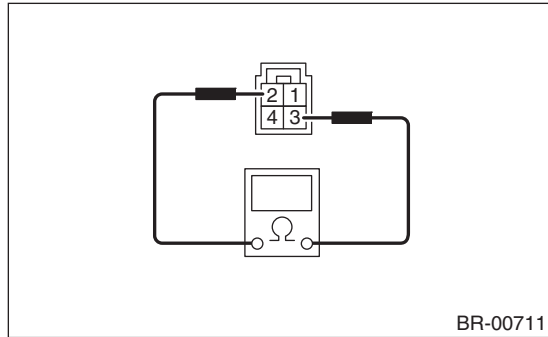

Switch	Pedal	Terminal No.	Standard
Stop light	Released	2 and 3	1 MΩ or more
	Depressed		Less than 1 Ω

D: ADJUSTMENT

Loosen the lock nut, and adjust the stop light switch position until the clearance (A) between the threaded end of the stop light switch and stopper becomes 0.3 mm (0.012 in). Then, tighten the lock nut.

Tightening torque:

8 N·m (0.8 kgf·m, 5.8 ft·lb)

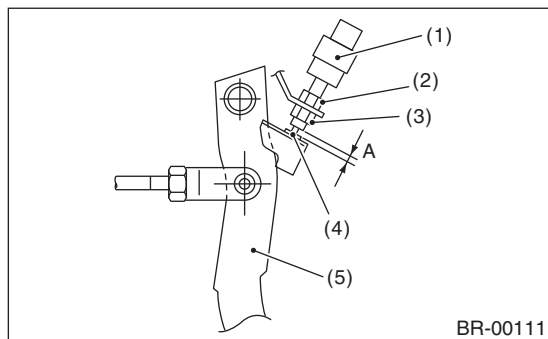

- (1) Stop light switch
- (2) Lock nut A
- (3) Lock nut B
- (4) Stopper
- (5) Brake pedal

NOTE:

Tighten lock nut B until the threaded end of switch contacts with stopper. Hold the switch so that it does not rotate, then loosen the lock nut B approx. 60°. The clearance (A) will become approximately 0.3 mm (0.012 in).

16. General Diagnostic Table

A: INSPECTION

	Trouble and possible cause	Corrective action
1. Insufficient braking	(1) Fluid leakage from the hydraulic mechanism	Correct or replace. (cup, piston seal, piston boot, master cylinder piston kit, pipe or hose)
	(2) Entry of air into the hydraulic mechanism	Bleed air.
	(3) Wear, deteriorated surface material, water or fluid on lining	Replace, grind or clean.
	(4) Improper operation of master cylinder, disc caliper, brake booster or check valve	Correct or replace.
2. Unstable or uneven braking	(1) Fluid on lining or rotor	Correct the cause of fluid leakage, and clean or replace.
	(2) Rotor defective	Repair or replace the rotor.
	(3) Improper lining contact, deteriorated surface, deteriorated or worn lining material	Repair by grinding, or replace.
	(4) Deformed back plate	Correct or replace.
	(5) Overinflation of tires	Adjust the air pressure.
	(6) Defective wheel alignment	Adjust alignment.
	(7) Loose back plate or support installation bolt	Tighten to the specified torque.
	(8) Faulty wheel bearing	Replace.
	(9) Defective hydraulic system	Replace the cylinder, brake pipe or hose.
	(10) Unstable performance of the parking brake	Check, adjust or replace the rear brake and cable system.
3. Excessive pedal stroke	(1) Entry of air into the hydraulic mechanism	Bleed air.
	(2) Excessive play in the master cylinder push rod	Adjust.
	(3) Fluid leakage from the hydraulic mechanism	Correct or replace. (cup, piston seal, piston boot, master cylinder piston kit, pipe or hose)
	(4) Improper lining contact or worn lining	Correct or replace.
4. Brake dragging or improper brake return	(1) Insufficient pedal play	Adjust play.
	(2) Improper master cylinder return	Clean or replace the cylinder.
	(3) Clogged hydraulic system	Replace.
	(4) Improper return or adjustment of parking brake	Repair or adjust.
	(5) Weakened spring tension or breakage of shoe return spring	Replace the spring.
	(6) Improper disc caliper operation	Correct or replace.
	(7) Faulty wheel bearing	Replace.
5. Brake noise (1) (creaking sound)	(1) Hardened or deteriorated brake pad	Replace the pad.
	(2) Worn brake pad	Replace the pad.
	(3) Loose back plate or support installation bolt	Tighten to the specified torque.
	(4) Loose wheel bearing	Tighten to the specified torque.
	(5) Dirty rotor	Clean the rotor, or clean and replace brake assembly.
6. Brake noise (2) (hissing sound)	(1) Worn brake pad	Replace the pad.
	(2) Improperly installed pad	Correct or replace the pad.
	(3) Loose or bent rotor	Retighten or replace.
7. Brake noise (3) (click sound)	Excessively worn pad or support	Replace the pad or the support.

General Diagnostic Table

BRAKE

PARKING BRAKE

PB

	Page
1. General Description	2
2. Parking Brake Lever	4
3. Parking Brake Cable	5
4. Parking Brake Assembly (Rear Disc Brake)	6
5. General Diagnostic Table	10

General Description

PARKING BRAKE

1. General Description

A: SPECIFICATION

Model		Rear disc brake
Type		Mechanical, drum in disc rear brakes
Effective drum diameter	mm (in)	190 (7.48)
Lining dimensions (Length x Width x Thickness)	mm (in)	165.8 x 30.0 x 2.8 (6.53 x 1.181 x 0.11)
Clearance adjustment		Manual adjustment
Lever stroke	Notches/N (kgf, lbf)	7 — 8/200 (20.4, 45)

B: COMPONENT

1. PARKING BRAKE (REAR DISC BRAKE)

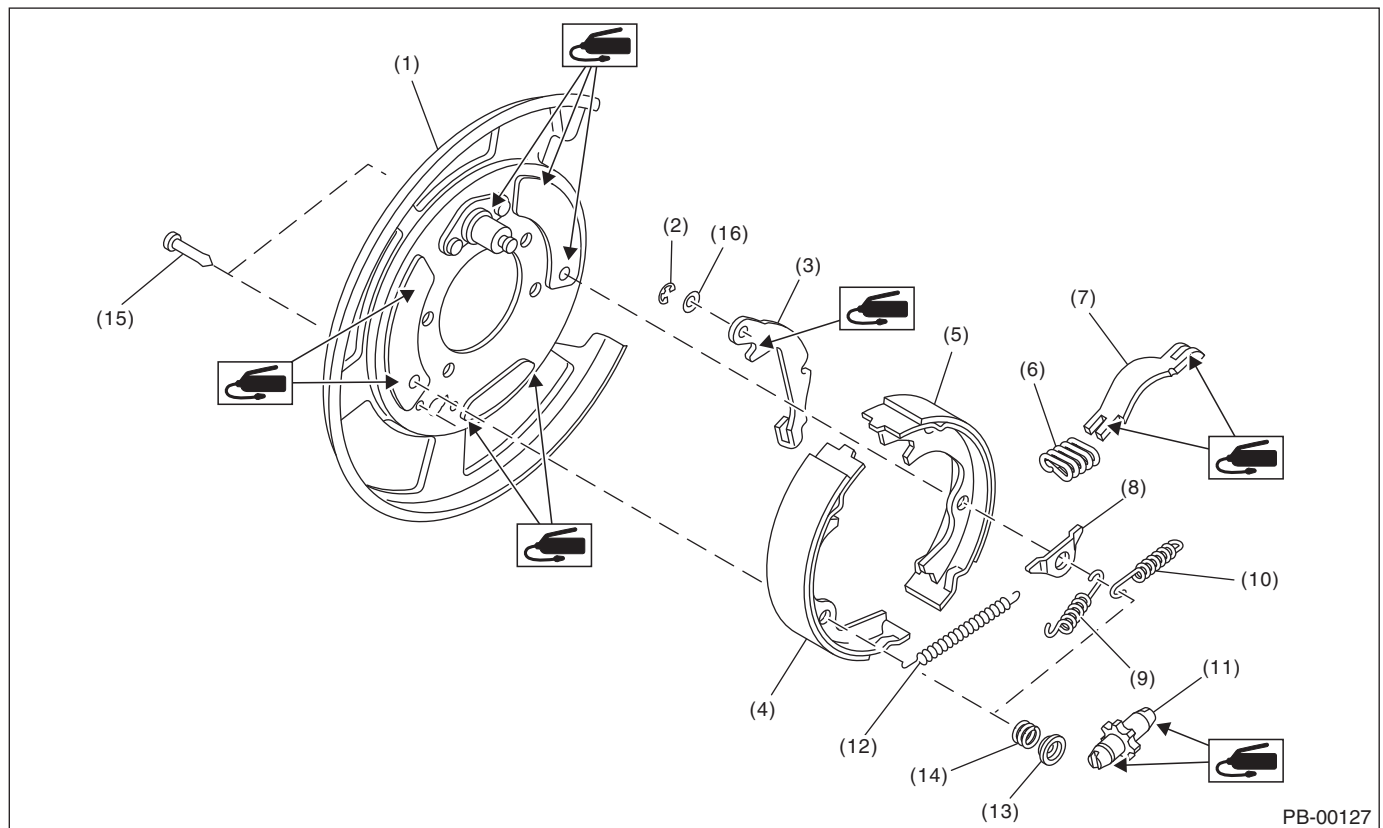

PB-00127

- | | | |
|------------------------------------|---------------------------------------|----------------------------|
| (1) Back plate | (7) Strut | (12) Adjusting spring |
| (2) Retainer | (8) Shoe guide plate | (13) Shoe hold-down cup |
| (3) Lever | (9) Primary return spring (Blue) | (14) Shoe hold-down spring |
| (4) Parking brake shoe (Primary) | (10) Secondary return spring (Yellow) | (15) Shoe hold-down pin |
| (5) Parking brake shoe (Secondary) | (11) Adjuster | (16) Wave washer |
| (6) Strut spring | | |

2. PARKING BRAKE LEVER AND CABLE

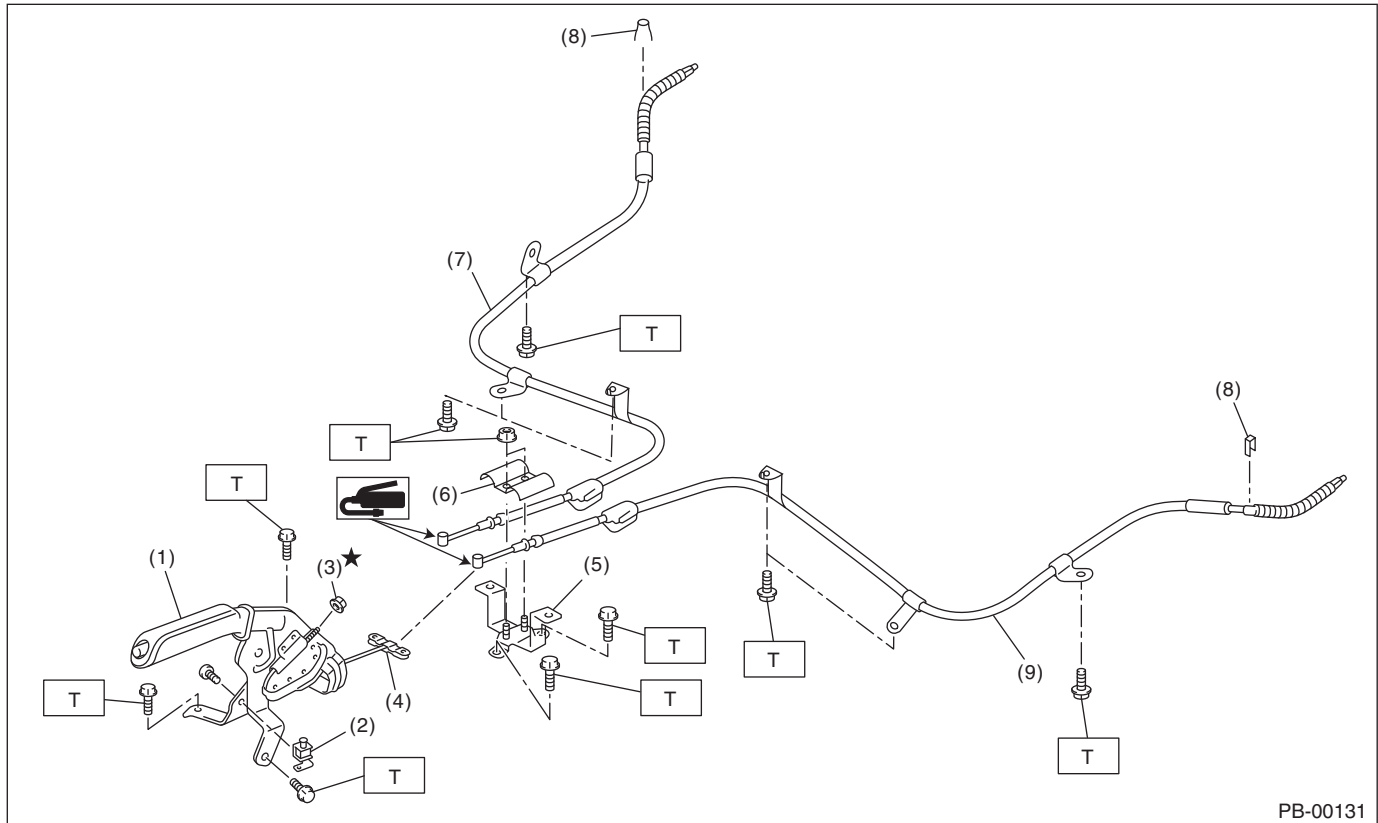

PB-00131

- | | | |
|--------------------------------------|----------------------------|----------------------------|
| (1) Parking brake lever | (5) Bracket | (9) Parking brake cable LH |
| (2) Parking brake switch | (6) Clamp | |
| (3) Adjusting nut (Self-locking nut) | (7) Parking brake cable RH | |
| (4) Equalizer | (8) Clamp | |

Tightening torque: N·m (kgf·m, ft·lb)

T: 18 (1.8, 13)

C: CAUTION

- Wear appropriate work clothing, including a cap, protective goggles and protective shoes when performing any work.
- Before removal, installation or disassembly, be sure to clarify the failure. Avoid unnecessary removal, installation, disassembly and replacement.
- Vehicle components are extremely hot after driving. Be wary of receiving burns from heated parts.
- Use SUBARU genuine grease etc. or equivalent. Do not mix grease etc. of different grades or manufacturers.
- Be sure to tighten fasteners including bolts and nuts to the specified torque.
- Place shop jacks or rigid racks at the specified points.
- Make sure grease does not come into contact with the parking shoes.

2. Parking Brake Lever

A: REMOVAL

- 1) Set the wheel stoppers to tires.
- 2) Remove the console box.
- 3) Disconnect the parking brake switch connector.
- 4) Remove the parking cable adjusting nut (self-locking nut).
- 5) Remove the parking brake lever.

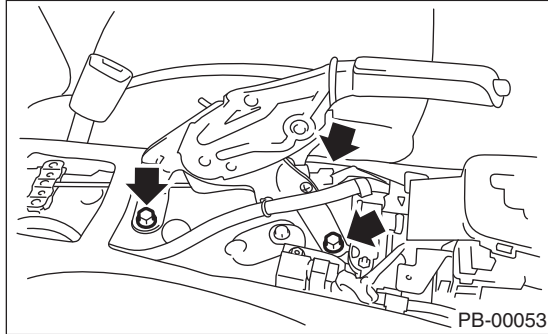

B: INSTALLATION

- 1) Install in the reverse order of removal.

Tightening torque:

Parking brake lever

18 N·m (1.8 kgf-m, 13 ft-lb)

- 2) Install a new adjusting nut (self-locking nut).
- 3) Be sure to adjust the lever stroke. <Ref. to PB-4, ADJUSTMENT, Parking Brake Lever.>

C: INSPECTION

- 1) Operate the parking brake lever 3 to 4 times and fully return the lever.
- 2) While slowly pulling the parking brake lever upward, count the notches.

Lever stroke:

7 to 8 notches when pulled with a force of 200 N (20.4 kgf, 45 lbf)

If it is not within the specified value, adjust the parking brake. <Ref. to PB-8, ADJUSTMENT, Parking Brake Assembly (Rear Disc Brake).>

D: ADJUSTMENT

Adjust the parking lever stroke. <Ref. to PB-9, LEVER STROKE, ADJUSTMENT, Parking Brake Assembly (Rear Disc Brake).>

3. Parking Brake Cable

A: REMOVAL

- 1) Remove the rear seat cushion.
- 2) Remove the console box.
- 3) Remove the parking cable adjusting nut (self-locking nut).
- 4) Remove the parking brake lever. <Ref. to PB-4, REMOVAL, Parking Brake Lever.>
- 5) Roll up the floor mat and remove the clamps.

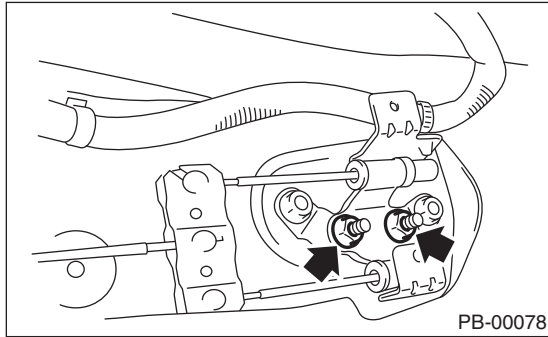

- 6) Remove the inner cable end from equalizer.

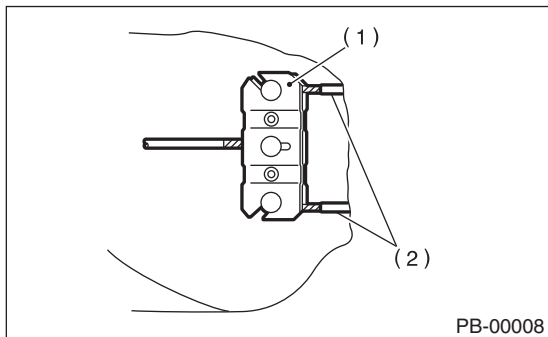

- (1) Equalizer
- (2) Inner cable end

- 7) Lift up the vehicle, and then remove the rear wheels.
- 8) Remove the parking brake cable from rear brake. <Ref. to PB-6, REMOVAL, Parking Brake Assembly (Rear Disc Brake).>
- 9) Remove the clamp from the rear brake.
- 10) Remove the cable clamp from the rear arm bracket.
- 11) Remove the cable clamp from rear floor.

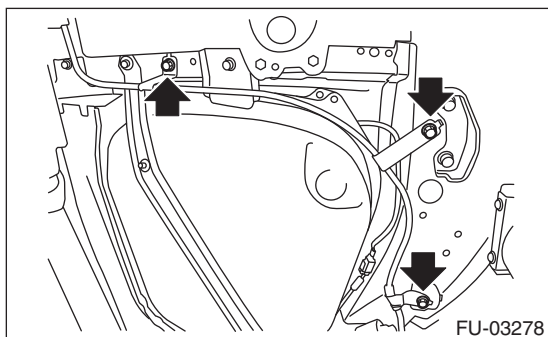

- 12) Remove the grommet from the rear floor, and remove the cable assembly.

B: INSTALLATION

- 1) Install in the reverse order of removal.

NOTE:

- Be sure to pass the cable through the tunnel in the cable guide.
- 2) Be sure to adjust the lever stroke. <Ref. to PB-4, ADJUSTMENT, Parking Brake Lever.>

C: INSPECTION

Check and replace the removed cable if damaged, rusty or faulty.

- 1) Check the cable for smooth operation.
- 2) Check the inner cable for damage and rust.
- 3) Check the outer cable for damage, bends and cracks.

Parking Brake Assembly (Rear Disc Brake)

PARKING BRAKE

4. Parking Brake Assembly (Rear Disc Brake)

A: REMOVAL

- 1) Release the parking brake.
- 2) Lift up the vehicle, and then remove the rear wheels.
- 3) Remove the brake hose bracket.

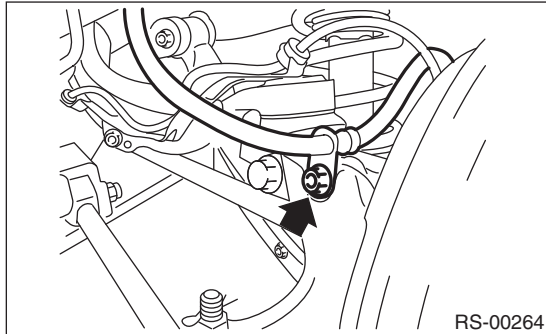

- 4) Remove the two mounting bolts and remove the rear disc brake caliper.

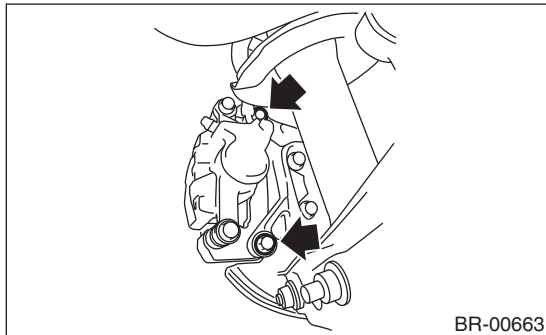

- 5) Suspend the rear disc brake caliper so that the brake hose is not stretched.
- 6) Remove the rear disc brake rotor.

NOTE:

If the disc rotor is difficult to remove, try the following two methods in order.

- (1) Turn the adjusting screw using a flat tip screwdriver until the brake shoe moves adequately away from the disc rotor.

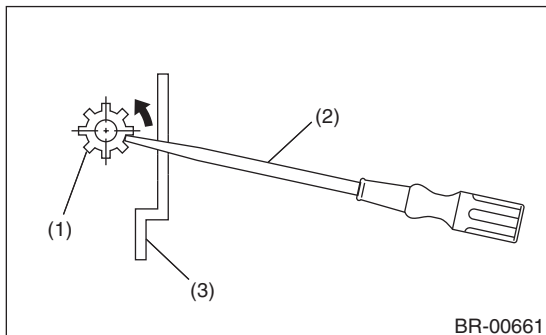

- (1) Adjuster
- (2) Flat tip screwdriver
- (3) Disc rotor

- (2) If disc rotor is seized on the hub, drive the disc rotor out by pushing two 8 mm bolts in holes B on the rotor.

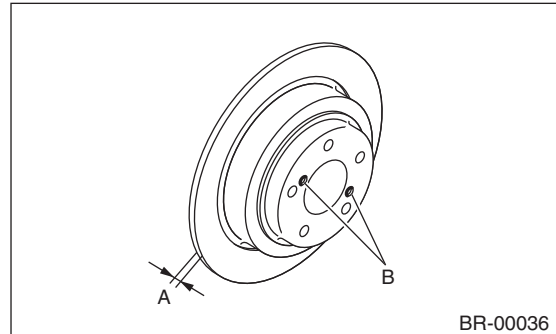

- 7) Remove the shoe return spring.

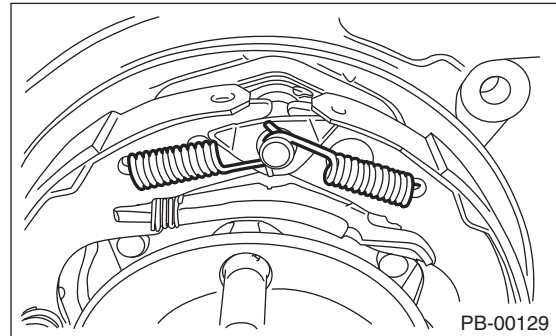

- 8) Remove the brake shoe cup and brake shoe spring, and remove the primary brake shoe.

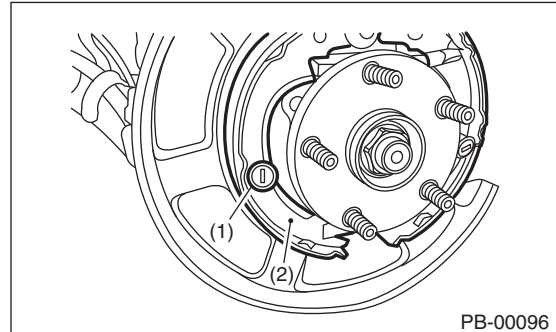

- (1) Brake shoe cup
- (2) Primary brake shoe

- 9) Remove the strut and strut spring.
- 10) Remove the adjuster.
- 11) Remove brake shoe cup and brake shoe spring, and remove the secondary brake shoe.

12) Remove the parking brake cable from lever.

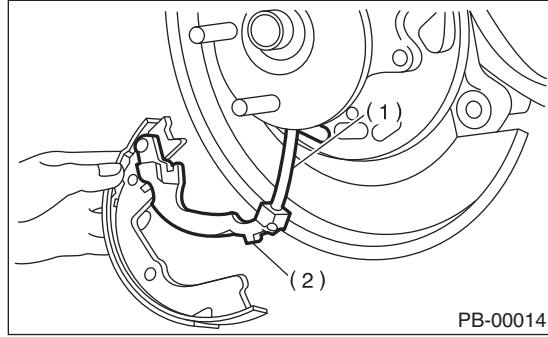

- (1) Parking brake cable
- (2) Lever

13) Remove a retainer from the secondary side brake shoe. Remove the lever from the brake shoe.

B: INSTALLATION

CAUTION:

Be sure the lining surface is free from brake fluid and grease.

1) Apply brake grease to the following locations.

Brake grease:

Brake Grease (Part No. 003602002)

- Six contact surfaces of the brake shoe rim and back plate gasket
- Contact surface of the brake shoe and the anchor pin
- Contact surface of the parking brake lever and strut
- Contact surface of the brake shoe and the adjuster
- Contact surface of the brake shoe and strut
- Contact surface of lever and brake shoe

2) Install the wave washer and lever to the secondary side brake shoe pin, and lock the retainer securely.

3) Install the parking brake cable to the lever.

4) Install the adjuster and adjusting spring to the brake shoe.

NOTE:

Install the adjuster with screw section in the direction shown below.

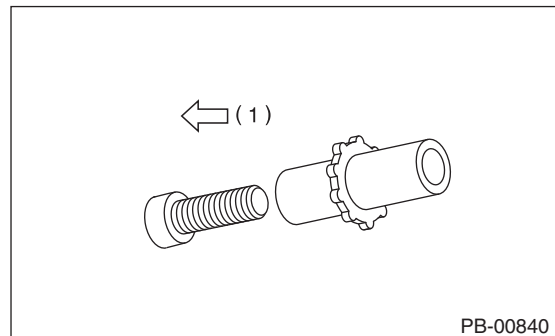

- (1) For left wheels, facing the front side of vehicle, for right wheels, facing the rear side of vehicle

5) Check that the parking brake cable does not fall from the cable guide.

6) Install the brake shoes to the back plate with shoe hold pins, brake shoe springs, and brake shoe cups.

7) Install the strut and strut spring to the brake shoes.

NOTE:

Install the strut springs on the front side of the vehicle.

8) Install the return springs; first the primary side (blue) then the secondary side (yellow).

9) Install the brake disc rotor and the brake caliper.

Parking Brake Assembly (Rear Disc Brake)

PARKING BRAKE

10) Install the brake hose bracket.

Tightening torque:

<Ref. to BR-4, COMPONENT, General Description.>

11) Adjust the parking brake. <Ref. to PB-8, ADJUSTMENT, Parking Brake Assembly (Rear Disc Brake).>

12) If new brake shoes are replaced, drive the vehicle to break-in the parking brake lining.

- (1) Drive the vehicle at about 35 km/h (22 MPH).
- (2) With the parking brake lever button pushed in, pull the parking brake lever gently.
- (3) Drive the vehicle for about 200 m (0.12 mile) in this condition.
- (4) Wait 5 to 10 minutes for the parking brake to cool down. Repeat steps (1) through (3) again.
- (5) After breaking-in, re-adjust the parking brakes.

C: INSPECTION

1) Measure the brake disc rotor inside diameter. If the disc is scored or worn, replace the brake disc rotor.

Disc rotor inside diameter:

Standard:

190 mm (7.48 in)

Service limit:

191 mm (7.52 in)

2) Measure the lining thickness. If it exceeds the limit, replace the brake shoes.

Lining thickness:

Standard:

2.8 mm (0.11 in)

Service limit:

1.5 mm (0.059 in)

NOTE:

Replace the right and left brake shoe as a set.

D: ADJUSTMENT

1. SHOE CLEARANCE

- 1) Return the parking brake lever fully.
- 2) Remove the adjusting hole cover from the disc rotor.
- 3) Turn the adjusting screw using a flat tip screwdriver until the brake shoe is in close contact with the disc rotor.

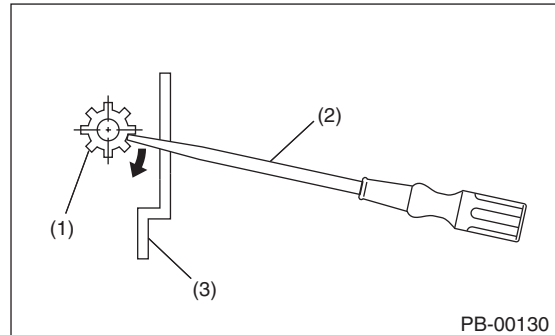

- (1) Adjusting screw
- (2) Flat tip screwdriver
- (3) Disc rotor

4) Turn back (upward) the adjusting screw 3 to 4 notches.

CAUTION:

Check there is no brake drag.

- 5) Install the adjusting hole cover to the disc rotor.
- 6) Adjust the parking lever stroke. <Ref. to PB-9, LEVER STROKE, ADJUSTMENT, Parking Brake Assembly (Rear Disc Brake).>

2. LEVER STROKE

- 1) Adjust the shoe clearance before adjusting lever stroke. <Ref. to PB-8, SHOE CLEARANCE, ADJUSTMENT, Parking Brake Assembly (Rear Disc Brake).>
- 2) Remove the parking lever cover.
- 3) Pull the parking brake lever hard 3 to 5 times.
- 4) Turn the adjusting nut until the lever stroke is at the specified value.

Lever stroke:

**7 to 8 notches when pulled with a force of 200 N
(20.4 kgf, 45 lbf)**

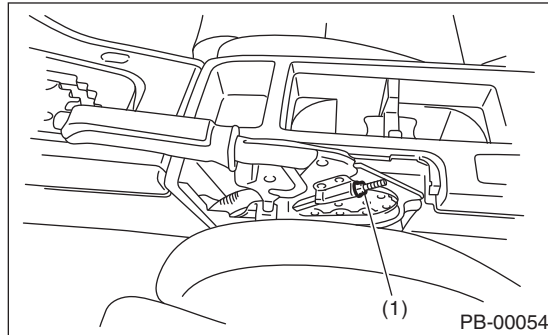

(1) Adjusting nut (Self-locking nut)

- 5) Check there is no brake drag.
- 6) Install the parking lever cover.

General Diagnostic Table

PARKING BRAKE

5. General Diagnostic Table

A: INSPECTION

Symptom	Possible cause	Corrective action
Brake drag	Parking brake lever is not adjusted correctly.	Adjust.
	Parking brake cable does not move.	Correct or replace.
	Parking brake shoe clearance is maladjusted.	Adjust.
	Return spring is faulty.	Replace.
Noise from brake	Return spring is faulty.	Replace.
	Shoe hold-down spring faulty.	Replace.

POWER ASSISTED SYSTEM (POWER STEERING)

PS

	Page
1. General Description	2
2. Steering Wheel	12
3. Universal Joint	13
4. Steering Column	15
5. Steering Gearbox	17
6. Pipe Assembly	36
7. Oil Pump	42
8. Reservoir Tank	49
9. Power Steering Fluid	50
10. General Diagnostic Table	51

General Description

POWER ASSISTED SYSTEM (POWER STEERING)

1. General Description

A: SPECIFICATION

Model		Non-turbo model	Turbo model	
Whole system	Minimum turning radius	m (ft)		
	Steering angle	Inner wheel	5.3 (17.4)	
		Outer wheel	38.3°±1.5°	
	Steering wheel diameter	mm (in)		
Lock to lock rotation	3.2			
Gearbox	Type	Rack and Pinion, Integral		
	Backlash	0 (Automatic adjusting)		
	Valve (Power steering system)	Rotary valve		
Pump (Power steering system)	Type	Vane pump		
	Oil tank	Installed on body		
	Specific output	cm ³ (cu in)/rev.	7.2 (0.439)	8.5 (0.519)
	Relief pressure	kPa (kgf/cm ² , psi)	7,350 — 8,050 (75 — 82, 1,066 — 1,167)	8,100 — 8,800 (83 — 90, 1,174 — 1,276)
	Hydraulic fluid control	Engine speed sensitive		
	Hydraulic fluid	ℓ (US qt, Imp qt)	1,000 rpm: 6.5 (6.9, 5.7) 3,000 rpm: 5 (5.3, 4.4)	1,000 rpm: 6.3 (6.7, 5.5) 3,000 rpm: 5.9 (6.2, 5.2)
	RPM range	rpm	680 — 9,800	680 — 9,600
Direction of rotation	Clockwise			
Hydraulic oil (Power steering system)	Capacity	Oil tank	0.2 (0.2, 0.2)	
		Whole system	0.7 (0.7, 0.6)	

Steering wheel	Free play	mm (in)	17 (0.67)	
Steering shaft	Clearance between the steering wheel and column cover	mm (in)	2 — 4 (0.08 — 0.16)	
Steering gearbox (Power steering system)	Sliding resistance	N (kgf, lbf)	314(32, 71) or less Difference between right and left sliding resistance: 20%	
	Rack shaft play in the radial direction	Right-turn steering	mm (in)	Deflection in the horizontal direction 0.6 (0.024) or less Deflection in the vertical direction. 0.4 (0.016) or less
		Left-turn steering	mm (in)	0.4 (0.016) or less
	Input shaft play	In radial direction	mm (in)	0.18 (0.0071) or less
		In axial direction	mm (in)	0.27 (0.0106) or less
Rotation resistance	N (kgf, lbf)	Maximum allowable value: 13 (1.3, 2.9) or less Difference between right and left sliding resistance: 20%		
Oil pump (Power steering system)	Pulley shaft	Radial play	mm (in)	0.4 (0.016) or less
		Axial play	mm (in)	0.9 (0.035) or less
	Pulley	Ditch deflection	mm (in)	1.0 (0.039) or less
		Rotation resistance	N (kgf, lbf)	9.22(0.94, 2.07) or less
Regular pressure (Unloaded)	kPa (kgf/cm ² , psi)	981(10, 142) or less		
Steering wheel effort (Power steering system)	At standstill with engine idling on paved road	N (kgf, lbf)	29.4 (3.0, 6.6) or less	
	At standstill with engine stalled on paved road	N (kgf, lbf)	294.2(30, 66.2) or less	

Recommended power steering fluid
SUBARU ATF or DEXRON III

General Description

POWER ASSISTED SYSTEM (POWER STEERING)

B: COMPONENT

1. STEERING WHEEL AND COLUMN

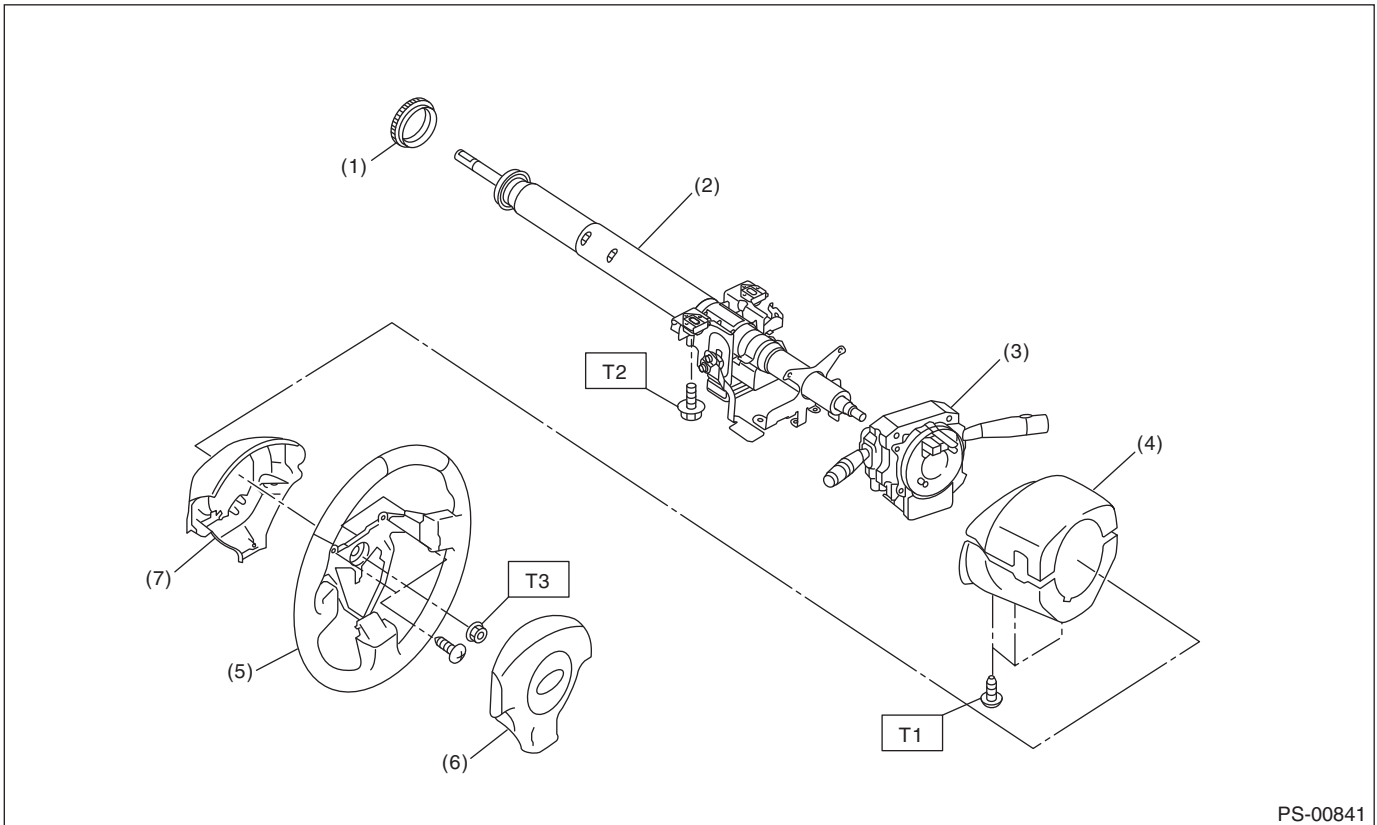

PS-00841

- | | |
|-----------------------------|--------------------------------|
| (1) Bushing | (5) Steering wheel |
| (2) Steering shaft | (6) Airbag module |
| (3) Steering roll connector | (7) Steering wheel lower cover |
| (4) Column cover | |

Tightening torque: N·m (kgf-m, ft-lb)

T1: 1.2 (0.12, 0.9)

T2: 25 (2.5, 18.4)

T3: 39 (4.0, 28.8)

General Description

POWER ASSISTED SYSTEM (POWER STEERING)

2. POWER ASSISTED SYSTEM

- Hose and tank

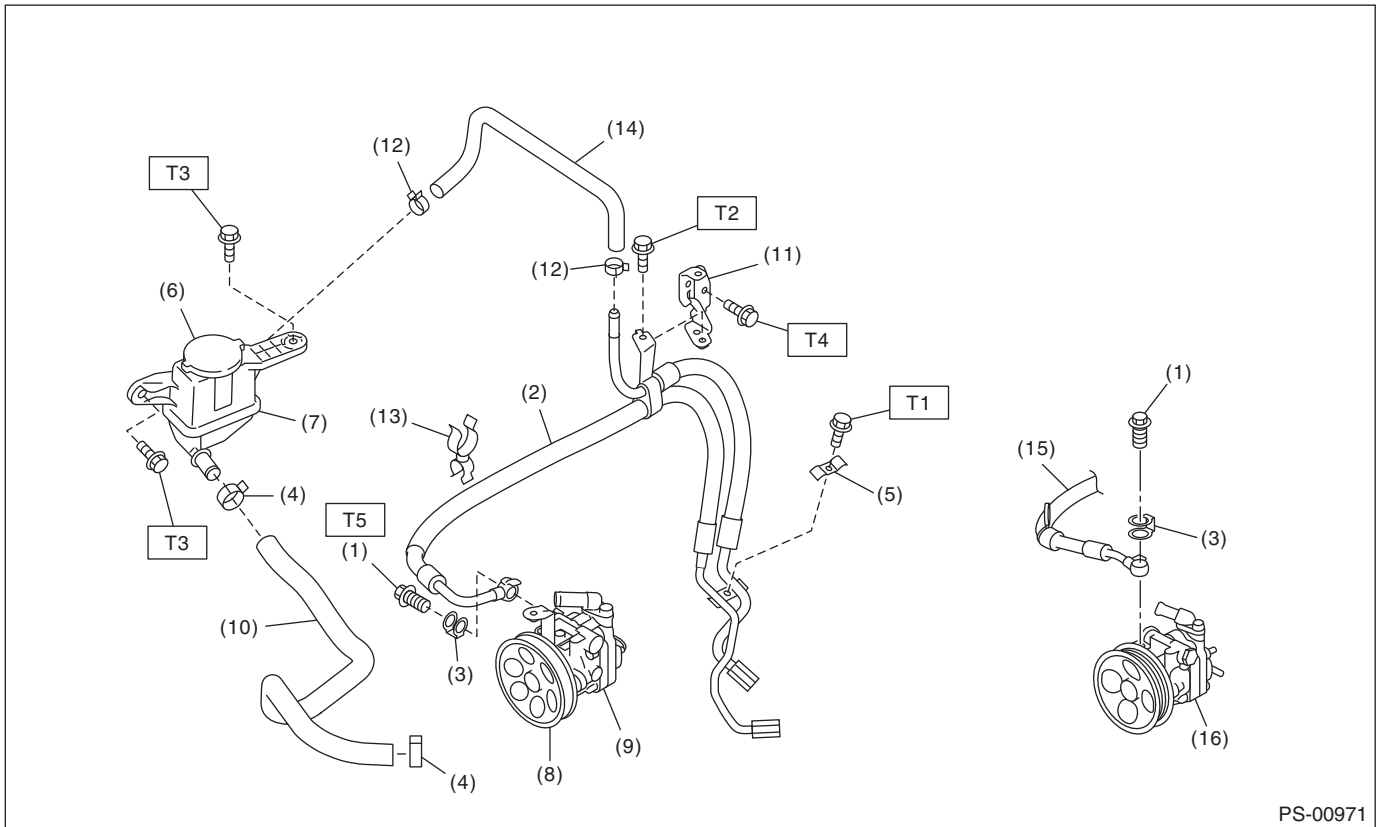

PS-00971

- | | |
|------------------------|---------------------------------|
| (1) Eye bolt | (9) Oil pump (Turbo model) |
| (2) Hose (Turbo model) | (10) Suction hose |
| (3) Eye bolt gasket | (11) Hose bracket |
| (4) Clip | (12) Clip |
| (5) Clamp E | (13) Clip |
| (6) Cap | (14) Return hose |
| (7) Reservoir tank | (15) Hose (Non-turbo model) |
| (8) Pulley | (16) Oil pump (Non-turbo model) |

Tightening torque: N·m (kgf-m, ft-lb)

T1: 7.5 (0.76, 5.53)

T2: 10 (1.02, 7.4)

T3: 13 (1.32, 9.6)

T4: 18 (1.84, 13.3)

T5: 40 (4.1, 29.5)

General Description

POWER ASSISTED SYSTEM (POWER STEERING)

• Gearbox

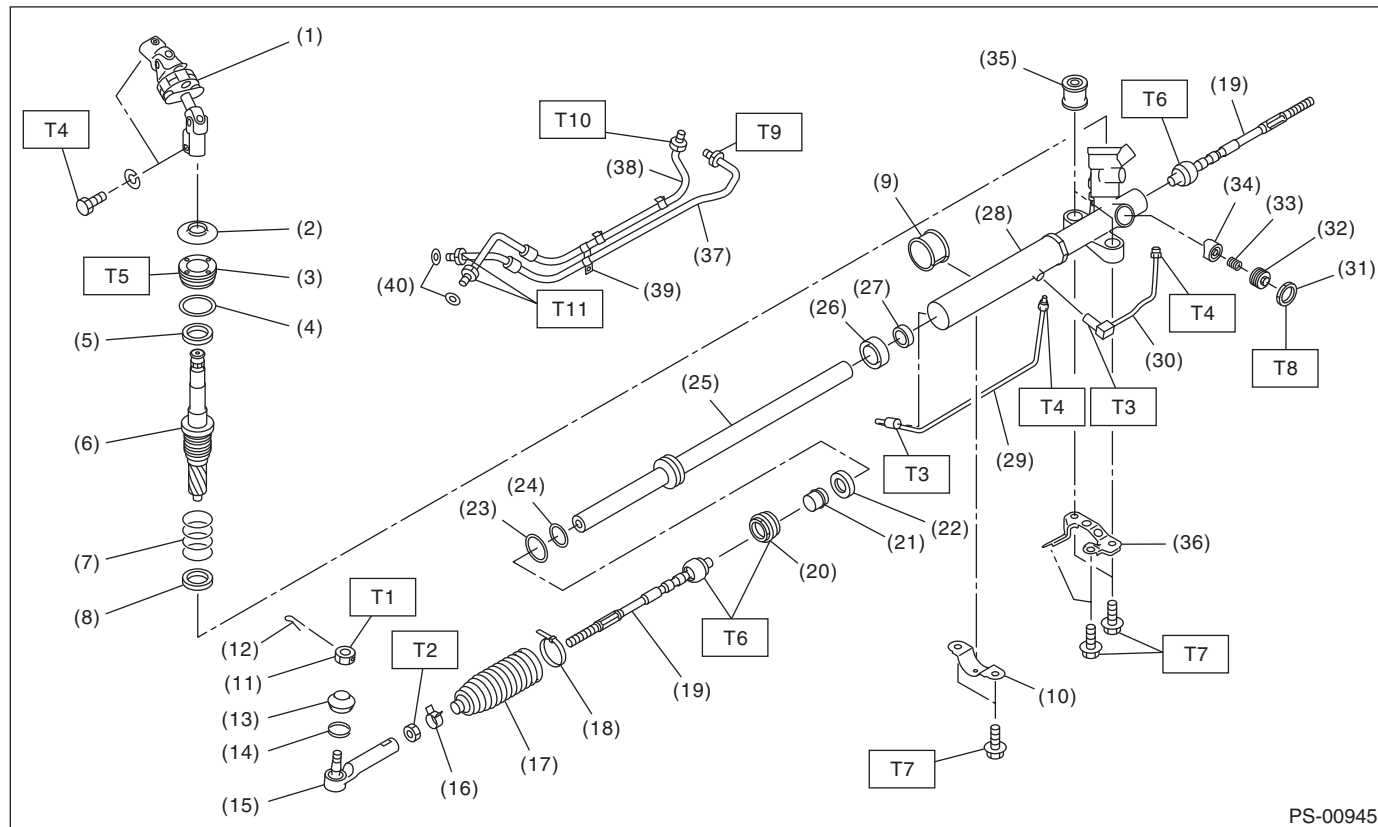

- (1) Universal joint
- (2) Dust cover
- (3) Plug
- (4) O-ring
- (5) Oil seal
- (6) Control valve
- (7) Seal ring
- (8) Oil seal
- (9) Adapter
- (10) Clamp
- (11) Castle nut
- (12) Cotter pin
- (13) Dust seal
- (14) Clip
- (15) Tie-rod end
- (16) Clip
- (17) Boot
- (18) Band

- (19) Tie-rod
- (20) Holder
- (21) Bushing
- (22) Oil seal
- (23) Seal ring
- (24) O-ring
- (25) Rack
- (26) Oil seal
- (27) Back-up washer
- (28) Steering body
- (29) Pipe A
- (30) Pipe B
- (31) Lock nut
- (32) Adjusting screw
- (33) Spring
- (34) Sleeve
- (35) Bushing
- (36) Stiffener

- (37) Pipe C
- (38) Pipe D
- (39) Clamp plate
- (40) O-ring

Tightening torque: N·m (kgf·m, ft·lb)

T1: 27 (2.75, 19.9)

T2: 85 (8.7, 63)

T3: 20 (2.0, 14.5)

T4: 24 (2.4, 17.4)

T5: 64 (6.5, 47.0)

T6: 90 (9.1, 65.7)

T7: 60 (6.1, 44.1)

T8: 39 (4.0, 28.9)

T9: 15 (1.5, 11.1)

T10: 25 (2.5, 18.4)

T11: 18 (1.8, 13.3)

General Description

POWER ASSISTED SYSTEM (POWER STEERING)

3. OIL PUMP

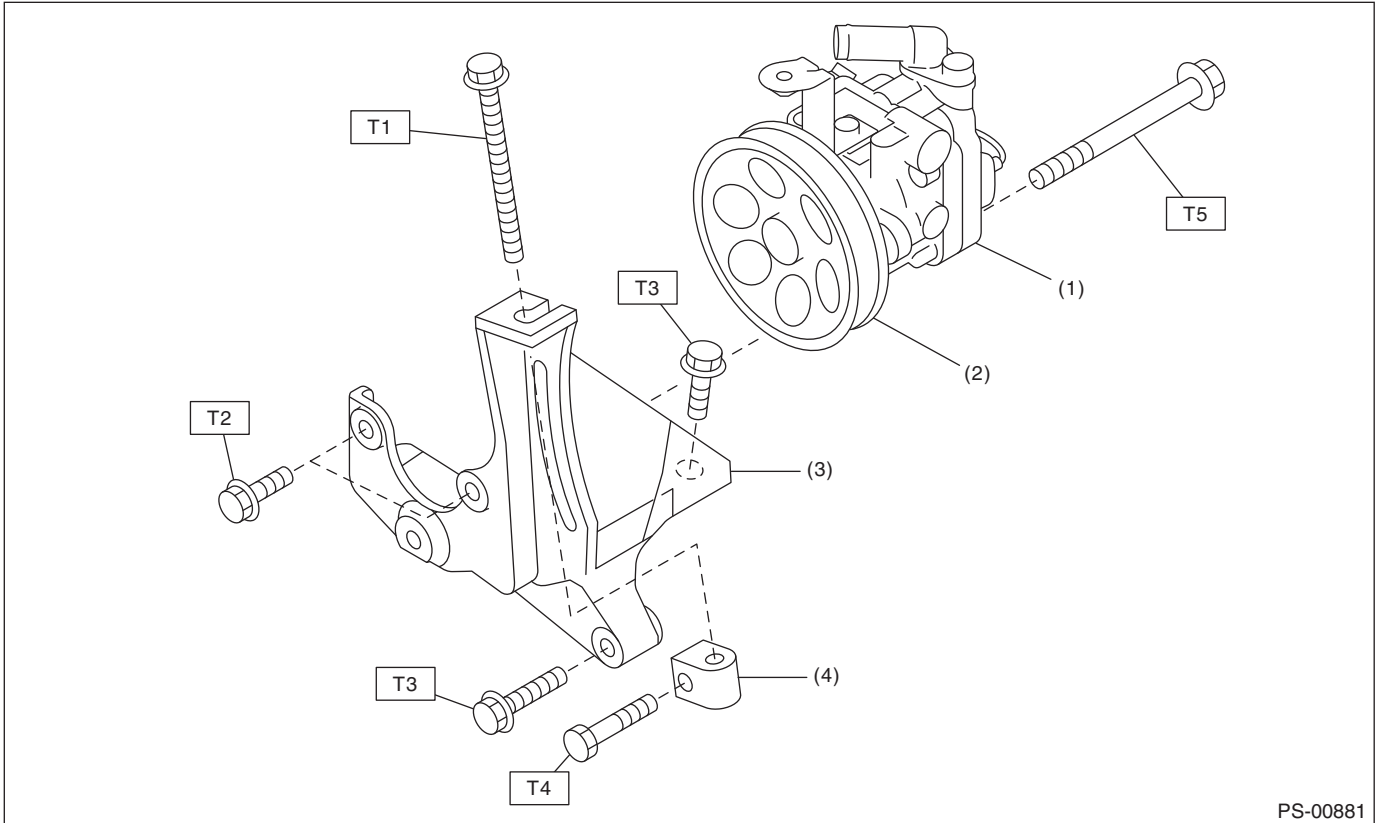

PS-00881

- (1) Oil pump
- (2) Pulley

- (3) Bracket
- (4) Belt tension nut

Tightening torque:N·m (kgf·m, ft·lb)

T1: 8 (0.8, 5.8)

T2: 16 (1.6, 11.8)

T3: 22 (2.2, 15.9)

T4: 25 (2.5, 18.4)

T5: 36 (3.7, 26.6) (Non-turbo model)

48 (4.9, 35.4) (Turbo model)

General Description

POWER ASSISTED SYSTEM (POWER STEERING)

C: CAUTION

- Wear appropriate work clothing, including a cap, protective goggles and protective shoes when performing any work.
- Before removal, installation or disassembly, be sure to clarify the failure. Avoid unnecessary removal, installation, disassembly and replacement.
- Vehicle components are extremely hot after driving. Be wary of receiving burns from heated parts.
- Use SUBARU genuine power steering fluid, grease etc. or the equivalent. Do not mix fluid, grease etc. of different grades or manufacturers.
- Be sure to tighten fasteners including bolts and nuts to the specified torque.
- Place shop jacks or rigid racks at the specified points.
- Before securing a part on a vise, place cushioning material such as wooden blocks, aluminum plate or cloth between the part and the vise.

D: PREPARATION TOOL

1. SPECIAL TOOL

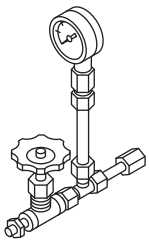
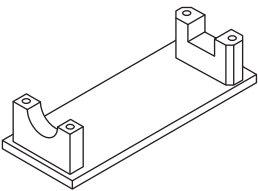
ILLUSTRATION	TOOL NUMBER	DESCRIPTION	REMARKS
 ST-925711000	925711000	PRESSURE GAUGE	Used for measuring oil pressure.
 ST-926200000	926200000	STAND	<ul style="list-style-type: none">• Used when inspecting characteristic of gear-box assembly and disassembling it.• Used together with BOSS D (34199AG000).

General Description

POWER ASSISTED SYSTEM (POWER STEERING)

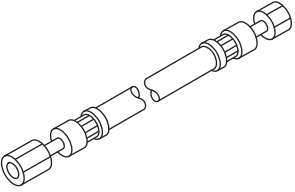
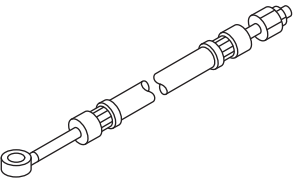
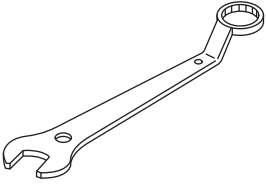
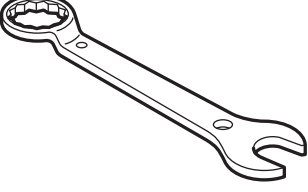
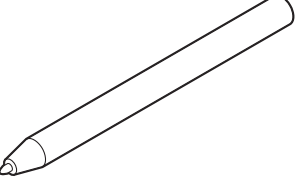
ILLUSTRATION	TOOL NUMBER	DESCRIPTION	REMARKS
 <p style="text-align: center;">ST34099AC010</p>	34099AC010	ADAPTER HOSE A	Used together with PRESSURE GAUGE (925711000).
 <p style="text-align: center;">ST34099AC020</p>	34099AC020	ADAPTER HOSE B	Used together with PRESSURE GAUGE (925711000).
 <p style="text-align: center;">ST-926230000</p>	926230000	SPANNER	For the lock nut when adjusting backlash of gearbox.
 <p style="text-align: center;">ST34099PA100</p>	34099PA100	SPANNER	Used when measuring the rotating resistance of gearbox assembly.
 <p style="text-align: center;">ST34099FA060</p>	34099FA060	PUNCH HOLDER	Used for crimping.

General Description

POWER ASSISTED SYSTEM (POWER STEERING)

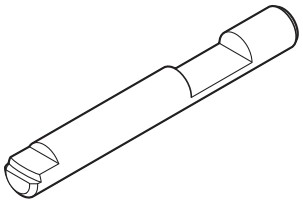
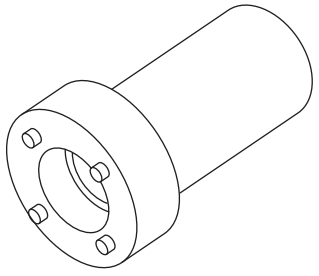
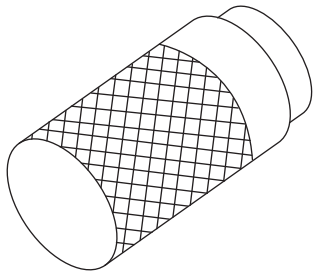
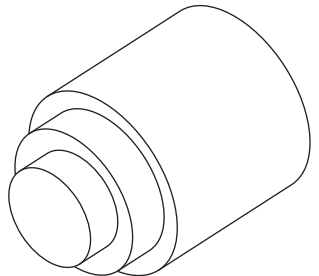
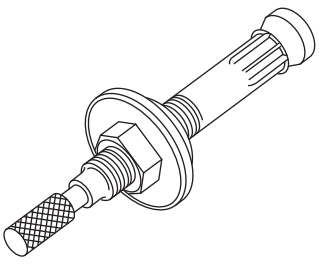
ILLUSTRATION	TOOL NUMBER	DESCRIPTION	REMARKS
 <p data-bbox="324 514 462 541">ST34099FA080</p>	34099FA080	PUNCH	Used to remove crimps.
 <p data-bbox="324 871 462 898">ST34199AE090</p>	34199AE090	PLUG WRENCH	Used for removing the plug.
 <p data-bbox="324 1228 462 1255">ST34199AE100</p>	34199AE100	OIL SEAL PLUG REMOVER	Used for removing oil seal plug.
 <p data-bbox="324 1585 462 1612">ST34199AE110</p>	34199AE110	OIL SEAL PLUG INSTALLER	Used for installing the oil seal plug.
 <p data-bbox="324 1942 462 1969">ST34199AE120</p>	34199AE120	GEAR BOX OIL SEAL REMOVER	Used to remove the oil seal of the gearbox.

General Description

POWER ASSISTED SYSTEM (POWER STEERING)

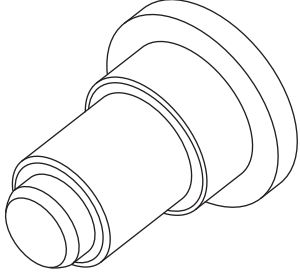
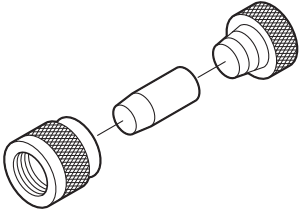
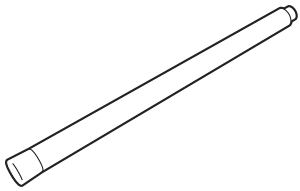
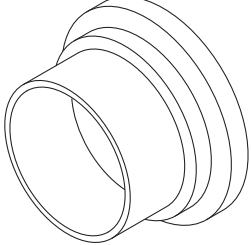
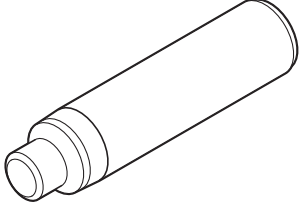
ILLUSTRATION	TOOL NUMBER	DESCRIPTION	REMARKS
 <p style="text-align: center;">ST34199AE130</p>	34199AE130	GEAR BOX OIL SEAL INSTALLER	Used for attaching the gear box oil seal.
 <p style="text-align: center;">ST34199FE040</p>	34199FE040	INSTALLER A, B, C	Used for installing the oil seal to the rack assembly.
 <p style="text-align: center;">ST34199FE010</p>	34199FE010	REMOVER	Used to remove the backup ring and oil seal.
 <p style="text-align: center;">ST34199FE050</p>	34199FE050	GUIDE	Used for installing the rack and seal to the housing assembly.
 <p style="text-align: center;">ST34199FE000</p>	34199FE000	INSTALLER & REMOVER	Used for removing and installing the rack oil seal (outer & inner).

General Description

POWER ASSISTED SYSTEM (POWER STEERING)

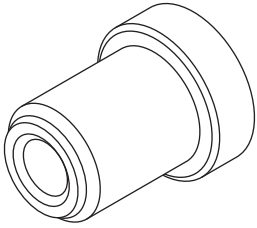
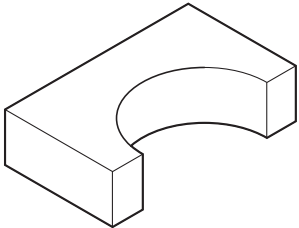
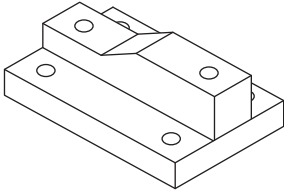
ILLUSTRATION	TOOL NUMBER	DESCRIPTION	REMARKS
 ST34199FE060	34199FE060	INSTALLER	Used for installing the rack oil seal (outer).
 ST34199FE020	34199FE020	BASE	Used for crimping.
 ST34199AG000	34199AG000	BOSS D	<ul style="list-style-type: none">• Used when inspecting characteristic of gear-box assembly and disassembling it.• Used together with STAND (926200000).

Steering Wheel

POWER ASSISTED SYSTEM (POWER STEERING)

2. Steering Wheel

A: REMOVAL

- 1) Disconnect the ground cable from the battery.
- 2) Set the tire to the straight-ahead position.
- 3) Remove the airbag module. <Ref. to AB-16, REMOVAL, Driver's Airbag Module.>

WARNING:

Always refer to "Airbag System" before performing service on the airbag modules. <Ref. to AB-5, CAUTION, General Description.>

- 4) Place alignment marks on the steering wheel and steering shaft.

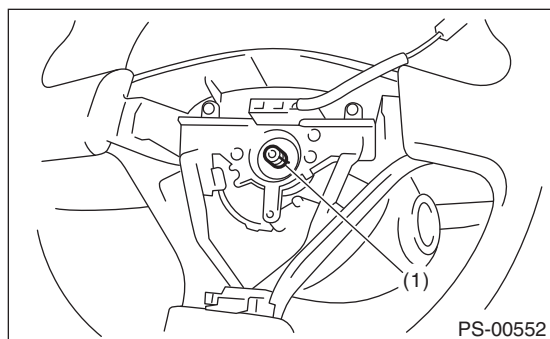

(1) Alignment mark

- 5) Remove the steering wheel nut, and then draw out the steering wheel from shaft using steering puller.

B: INSTALLATION

WARNING:

Always refer to "Airbag System" before performing service on the airbag modules. <Ref. to AB-5, CAUTION, General Description.>

- 1) Align the center position of the roll connector. <Ref. to AB-28, ADJUSTMENT, Roll Connector.>
- 2) Install in the reverse order of removal.

NOTE:

Align the alignment marks on the steering wheel and steering shaft.

Tightening torque:

39 N·m (4.0 kgf·m, 28.8 ft·lb)

Column cover-to-steering wheel clearance:

2 — 4 mm (0.08 — 0.16 in)

CAUTION:

Insert the roll connector guide pin into the guide hole on the lower end of the steering wheel surface. Avoid damaging the pin.

C: INSPECTION

- 1) Check the steering wheel for deformation. If the deformation is excessive, replace the steering wheel.
- 2) Check the splines on the steering wheel for damage. If the damage is excessive, replace the steering wheel.

Universal Joint

POWER ASSISTED SYSTEM (POWER STEERING)

3. Universal Joint

A: REMOVAL

- 1) Remove the steering wheel. <Ref. to PS-12, REMOVAL, Steering Wheel.>
- 2) Place alignment marks on universal joint.
- 3) Remove the universal joint bolt and remove the universal joint.

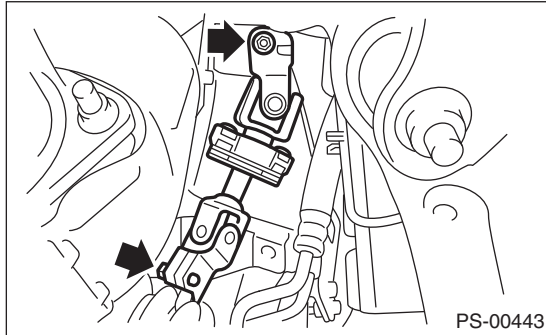

B: INSTALLATION

- 1) Align the cutout portion at serrated section of the column shaft and yoke, then install the universal joint into column shaft.

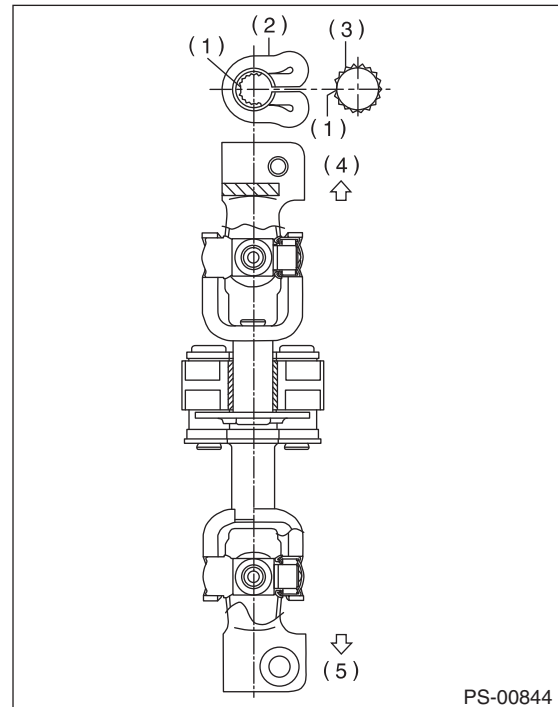

- (1) Cutout portion
- (2) Yoke
- (3) Column shaft
- (4) Column shaft side
- (5) Gearbox side

- 2) Install the universal joint to the serrations of gearbox assembly by matching alignment marks.
- 3) Tighten the bolts.

Tightening torque:

24 N·m (2.4 kgf·m, 17.4 ft·lb)

CAUTION:

Excessively large tightening torque of universal joint bolts may lead to heavy steering wheel operation.

Clearance between coupling of universal joint and turbo cover:

15 mm (0.59 in) or more

- 4) Align the center position of the roll connector. <Ref. to AB-28, ADJUSTMENT, Roll Connector.>
- 5) Install the steering wheel. <Ref. to PS-12, INSTALLATION, Steering Wheel.>

Universal Joint

POWER ASSISTED SYSTEM (POWER STEERING)

C: INSPECTION

1) Check for wear, damage or any other faults. Replace as necessary

Service limit:

Universal joint play: 0 mm (0 in)

Maximum swing torque: 0.3 N (0.03 kgf, 0.07 lbf)

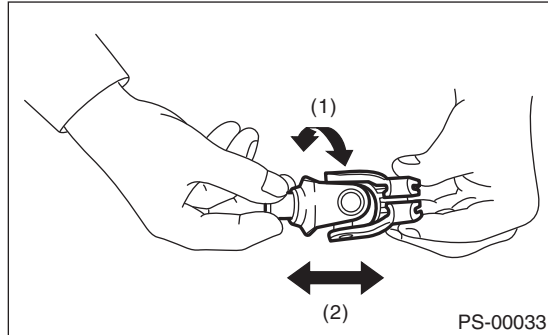

- (1) Swing torque
- (2) Play

2) Measure the swing torque of universal joint.

Service limit:

Maximum load: 3.8 N (0.39 kgf, 0.86 lbf) or less

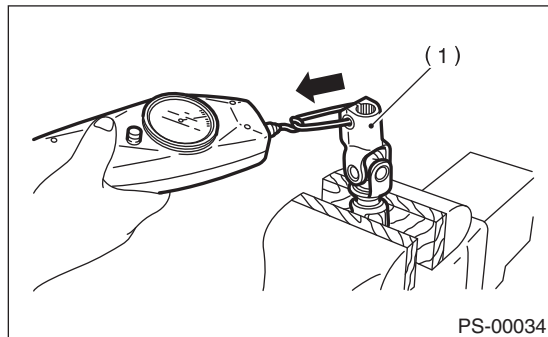

- (1) Yoke (Gearbox side)

Service limit:

Maximum load: 3.8 N (0.39 kgf, 0.86 lbf) or less

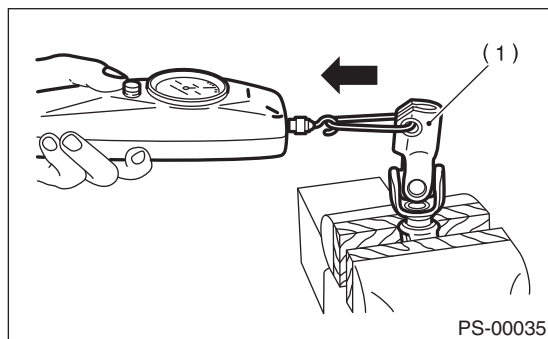

- (1) Yoke (Gearbox side)

Service limit:

Maximum load: 7.3 N (0.74 kgf, 1.64 lbf) or less

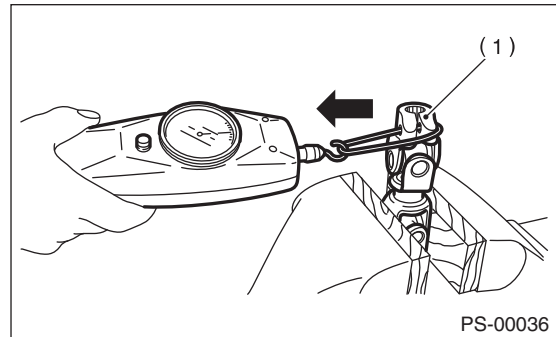

- (1) Yoke (Steering column side)

Service limit:

Maximum load: 7.3 N (0.74 kgf, 1.64 lbf) or less

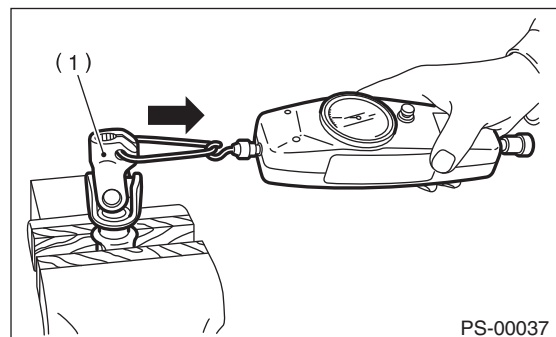

- (1) Yoke (Steering column side)

Steering Column

POWER ASSISTED SYSTEM (POWER STEERING)

4. Steering Column

A: REMOVAL

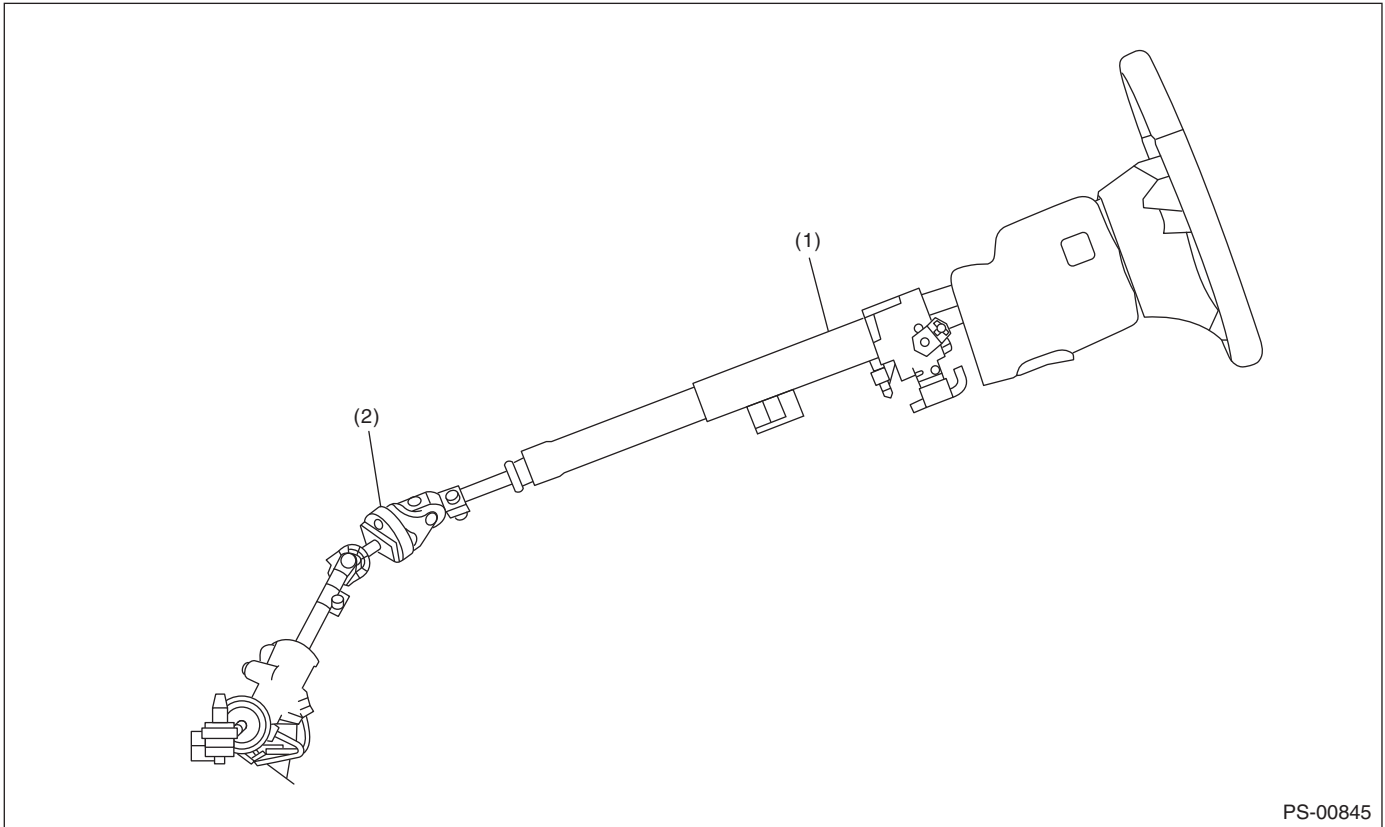

PS-00845

(1) Tilt & telescopic steering column (2) Universal joint

- 1) Remove the steering wheel. <Ref. to PS-12, REMOVAL, Steering Wheel.>
- 2) Remove the universal joint. <Ref. to PS-13, REMOVAL, Universal Joint.>
- 3) Remove the instrument panel lower cover under.
- 4) Remove the instrument panel lower cover upper.
- 5) Remove all connectors from the steering column.
- 6) Remove the two bolts under instrument panel securing the steering column.

- 7) Pull out the steering shaft assembly from the hole on toe board.

CAUTION:

- Be sure to remove the universal joint before removing steering shaft assembly installing bolts when removing steering shaft assembly or when lowering it for servicing other parts.
- Do not loosen the tilt lever when the steering column is not secured to the vehicle.

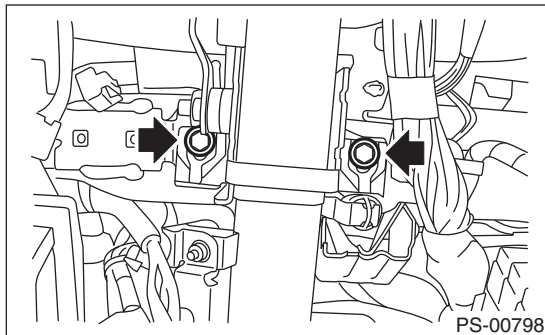

PS-00798

Steering Column

POWER ASSISTED SYSTEM (POWER STEERING)

B: INSTALLATION

- 1) Install the grommet to the toe board.

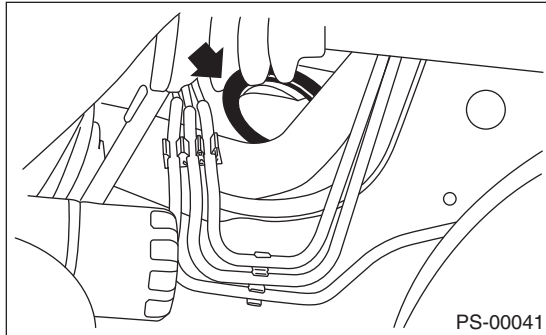

- 2) Insert the end of the steering shaft into the toe board grommet.
- 3) With the tilt lever secured, tighten the steering shaft mounting bolts under instrument panel.

Tightening torque:

25 N·m (2.5 kgf·m, 18.4 ft·lb)

- 4) Connect all the connectors under the instrument panel.
- 5) Connect the airbag system connector at the harness spool.

NOTE:

Make sure to apply double lock.

- 6) Install the instrument panel lower cover with tilt lever held in the lowered position.
- 7) Install the universal joint. <Ref. to PS-13, INSTALLATION, Universal Joint.>
- 8) Align the center position of the roll connector. <Ref. to AB-28, ADJUSTMENT, Roll Connector.>
- 9) Install the steering wheel. <Ref. to PS-12, INSTALLATION, Steering Wheel.>

CAUTION:

Insert the roll connector guide pin into the guide hole on lower end of steering wheel surface to prevent damage.

C: DISASSEMBLY

Remove the two screws securing the upper steering column covers, and the two screws securing the combination switch, and then remove related parts.

D: ASSEMBLY

Insert the combination switch to the upper column shaft, and install the upper column cover. Then route the ignition key harness and combination switch harness between the column cover mounting bosses.

Tightening torque:

1.2 N·m (0.12 kgf·m, 0.9 ft·lb)

CAUTION:

Do not overtorque the screw.

E: INSPECTION

1. BASIC INSPECTION

Measure the overall length of steering column. If not within specification, replace it.

Standard: Overall length L

Tilt column

$833.6^{+1.3}_{-0.3}$ mm ($32.82^{+0.051}_{-0.012}$ in)

Tilt & telescopic column

(measure while minimized)

$823.6^{+1.5}_{-1.5}$ mm ($32.43^{+0.059}_{-0.059}$ in)

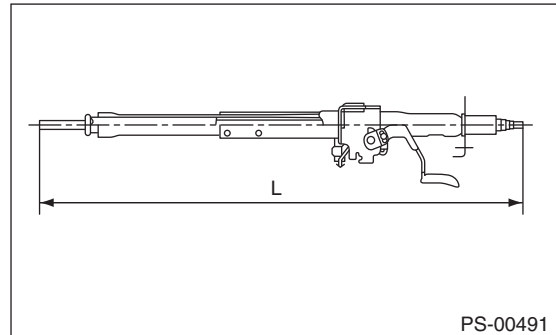

2. INSPECTION OF AIRBAG SYSTEM

Refer to "Airbag System" for airbag inspection procedure. <Ref. to AB-16, INSPECTION, Driver's Airbag Module.>

Steering Gearbox

POWER ASSISTED SYSTEM (POWER STEERING)

5. Steering Gearbox

A: REMOVAL

- 1) Set the vehicle on a lift.
- 2) Disconnect the ground cable from the battery.
- 3) Loosen the front wheel nuts.
- 4) Lift up the vehicle, and remove the front wheels.
- 5) Remove the under cover. <Ref. to EI-25, REMOVAL, Front Under Cover.>
- 6) Remove the front exhaust pipe assembly. (Non-turbo model) <Ref. to EX(H4SO)-4, REMOVAL, Front Exhaust Pipe.>

WARNING:

Be careful not to burn yourself because the exhaust pipe is hot.

- 7) Remove the cotter pin and castle nut securing the tie-rod end.

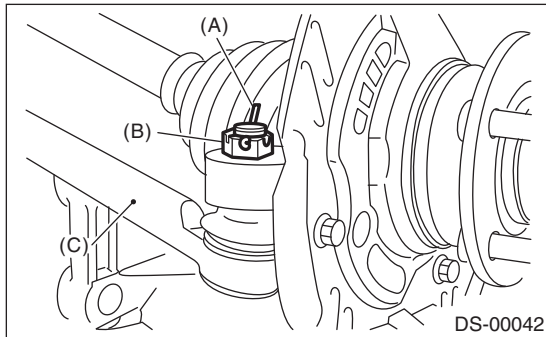

- (A) Cotter pin
- (B) Castle nut
- (C) Tie-rod end

- 8) Using a puller, remove the tie-rod.

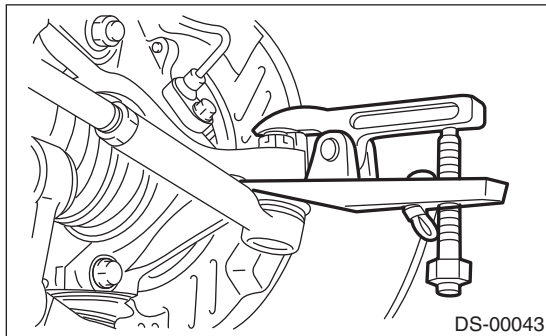

- 9) Remove the front crossmember support plate, jack-up plate and front stabilizer. <Ref. to FS-16, REMOVAL, Front Stabilizer.>

- Large type

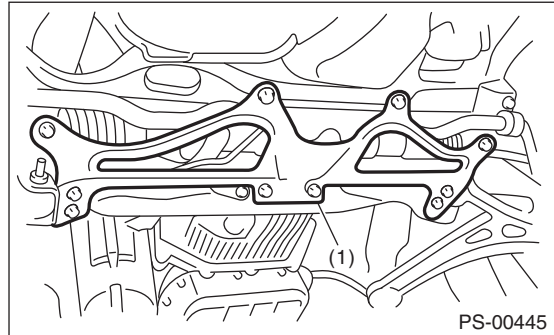

- (1) Front crossmember support plate

- Small type

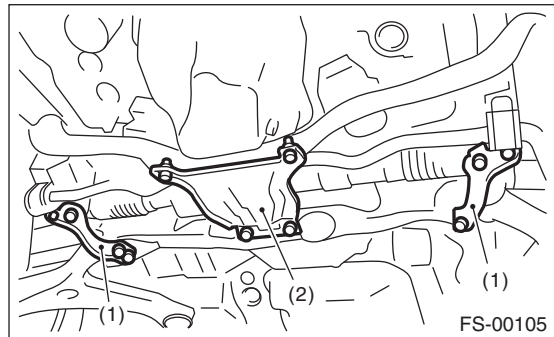

- (1) Crossmember support plate
- (2) Jack-up plate

- 10) Remove the one pipe joint at the center of the gearbox, and connect the vinyl hose to the pipe and the joint. Discharge the fluid by turning the steering wheel fully clockwise and counterclockwise. Discharge the fluid similarly from other pipes.

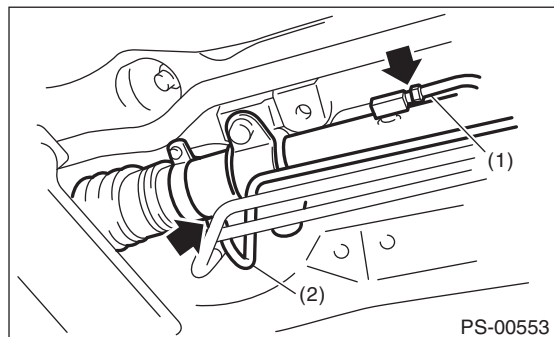

- (1) Pipe A
- (2) Pipe B

- 11) Remove the universal joint. <Ref. to PS-13, REMOVAL, Universal Joint.>

Steering Gearbox

POWER ASSISTED SYSTEM (POWER STEERING)

12) Disconnect the pipe C from pressure hose first, then disconnect pipe D from the return hose.

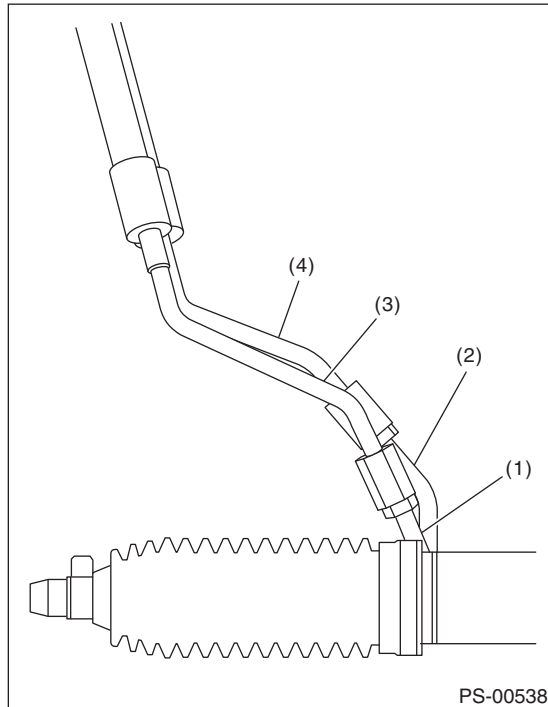

- (1) Pipe C
- (2) Pipe D
- (3) Pressure hose
- (4) Return hose

14) Remove the bolts securing the gearbox, and remove the stiffener and gear box.

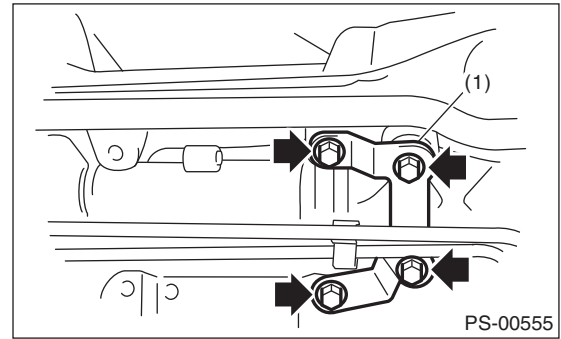

- (1) Stiffener

13) Remove the clamp bolts securing the gearbox to the crossmember, and remove the clamp.

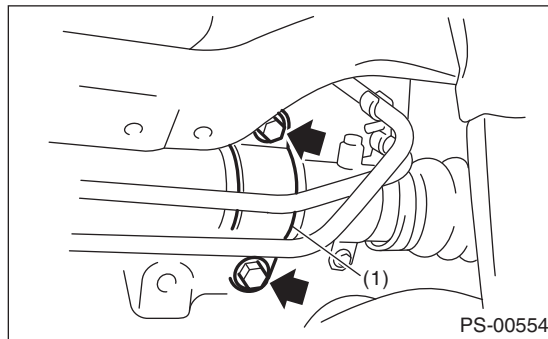

- (1) Clamp

Steering Gearbox

POWER ASSISTED SYSTEM (POWER STEERING)

B: INSTALLATION

- 1) Insert the gearbox into crossmember, being careful not to damage gearbox boot.
- 2) Install the gearbox and stiffener. Temporarily tighten the bolts.

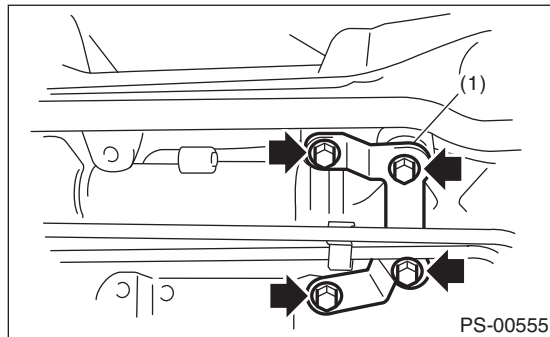

(1) Stiffener

- 3) Insert bolts through the clamp to temporarily tighten the gearbox to the crossmember bracket.

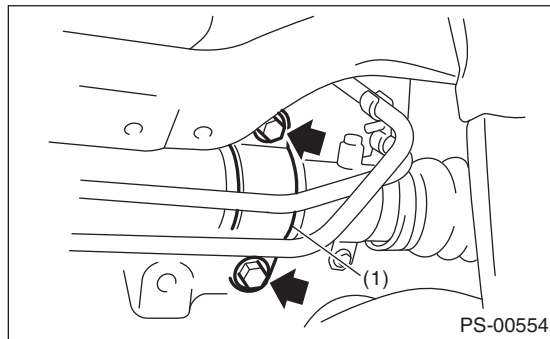

(1) Clamp

- 4) Tighten the bolts temporarily holding the gearbox clamp and bracket together to the specified torque.

Tightening torque:

60 N·m (6.1 kgf·m, 44.1 ft·lb)

- 5) Connect pipe D to the return hose, then connect pipe C to the pressure hose.

Tightening torque:

15 N·m (1.5 kgf·m, 10.8 ft·lb)

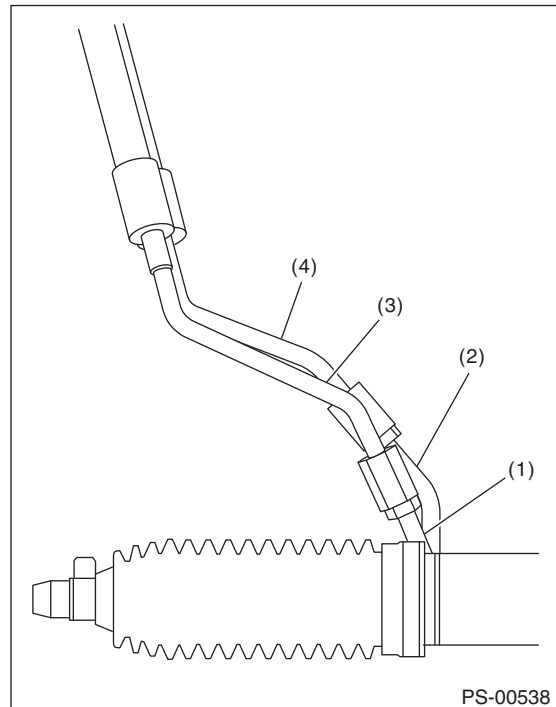

- (1) Pipe C
- (2) Pipe D
- (3) Pressure hose
- (4) Return hose

- 6) Install the universal joint. <Ref. to PS-13, INSTALLATION, Universal Joint.>

- 7) Connect the tie-rod end and knuckle arm, and tighten with castle nut.

Castle nut tightening torque:

27 N·m (2.75 kgf·m, 19.9 ft·lb)

CAUTION:

When connecting, do not hit the cap at the bottom of tie-rod end with hammer.

Steering Gearbox

POWER ASSISTED SYSTEM (POWER STEERING)

8) After tightening the castle nut to the specified tightening torque, tighten it further within 60° until the cotter pin hole is aligned with slot in the nut. Fit the cotter pin into the nut, and then bend the pin to lock.

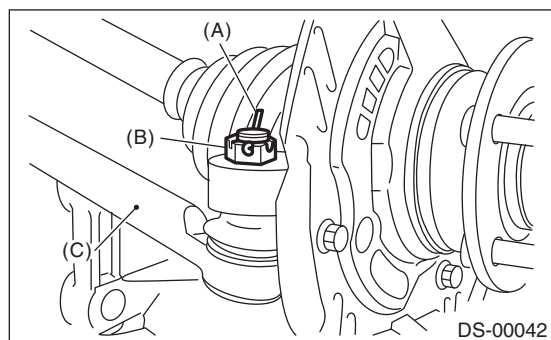

- (A) Cotter pin
- (B) Castle nut
- (C) Tie-rod end

9) Install the front stabilizer. <Ref. to FS-16, INSTALLATION, Front Stabilizer.>

10) Install the front crossmember support plate and jack-up plate.

11) Install the front exhaust pipe assembly. (Non-turbo model) <Ref. to EX(H4SO)-5, INSTALLATION, Front Exhaust Pipe.>

12) Install the under cover. <Ref. to EI-25, INSTALLATION, Front Under Cover.>

13) Install the front wheels.

14) Tighten the wheel nuts to the specified torque.

Tightening torque:

100 N·m (10.2 kgf·m, 73.8 ft·lb)

15) Lower the vehicle.

16) Remove the steering wheel. <Ref. to PS-12, REMOVAL, Steering Wheel.>

17) Align the center position of the roll connector. <Ref. to AB-28, ADJUSTMENT, Roll Connector.>

18) Install the steering wheel. <Ref. to PS-12, INSTALLATION, Steering Wheel.>

19) Connect the ground cable to the battery.

20) Pour fluid into the oil tank, and bleed air. <Ref. to PS-50, Power Steering Fluid.>

21) Check for fluid leaks.

22) Check the fluid level in oil tank.

23) After adjusting toe-in and steering angle, tighten the lock nut on tie-rod end.

Tightening torque:

85 N·m (8.7 kgf·m, 62.7 ft·lb)

NOTE:

When adjusting toe-in, hold the boot as shown to prevent it from being rotated or twisted. If it becomes twisted, straighten it.

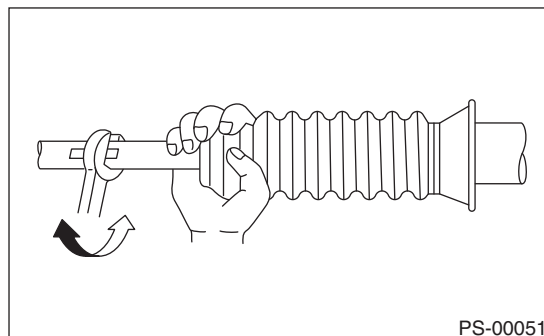

Steering Gearbox

POWER ASSISTED SYSTEM (POWER STEERING)

C: DISASSEMBLY

1) Disconnect the four pipes from the steering body and control valve housing.

2) Secure the gearbox removed from vehicle in a vise using ST.

ST1 92620000 STAND

ST2 34199AG000 BOSS D

CAUTION:

Using the ST, affix the gear box assembly to a vice as shown in the figure. Do not hold the gearbox on the vice without this ST.

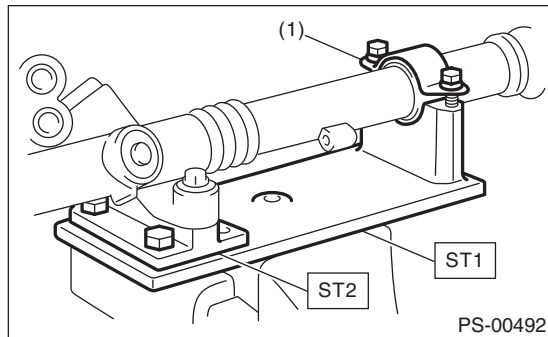

(1) Clamp

3) Remove the tie-rod end and lock nut from the gearbox.

4) Remove the clip on the outer side of the boot, and move the boot towards the tie-rod end.

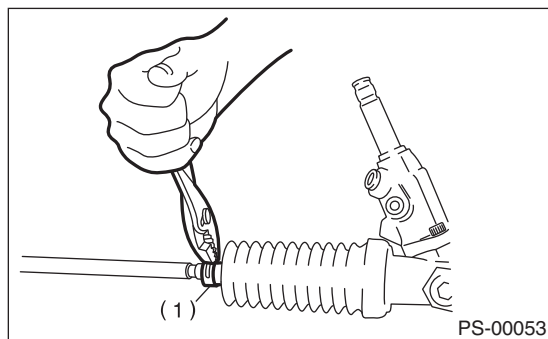

(1) Clip

5) Using a flat tip screwdriver, remove the band from boot.

NOTE:

Replace the boot if there is damage, cracks or deterioration.

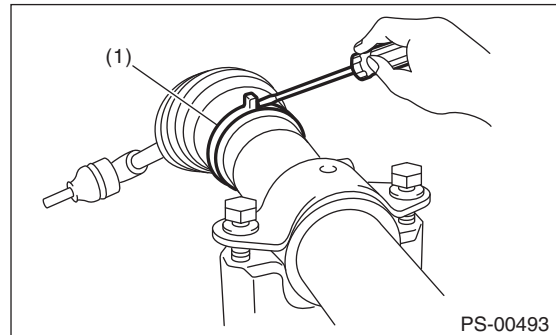

(1) Band

6) Using the ST, loosen the lock nut.

ST 926230000 SPANNER

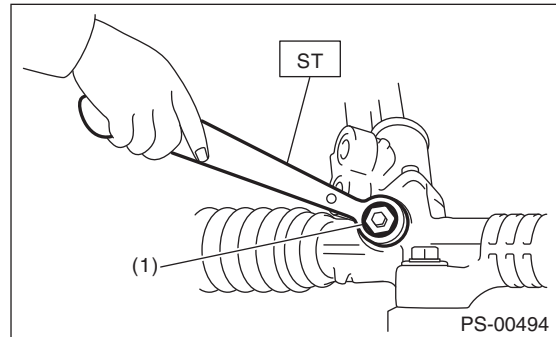

(1) Lock nut

7) Tighten the adjusting screw until it can no longer be tightened.

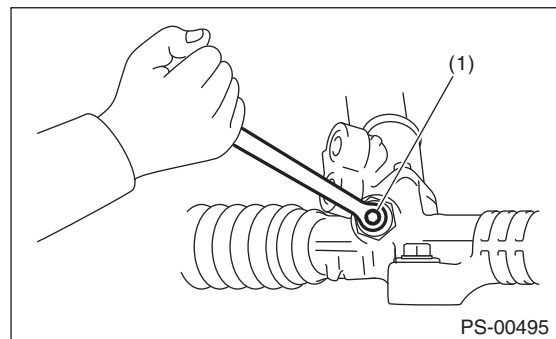

(1) Adjusting screw

8) Remove the tie-rod.

9) Loosen the adjusting screw, and remove the spring and sleeve.

Steering Gearbox

POWER ASSISTED SYSTEM (POWER STEERING)

10) Remove any soil on the input shaft. Being careful not to damage the housing and input shaft, and that no foreign objects enter the gear box, pull out the dust cover.

CAUTION:

Wrap tape around the input shaft splines to prevent damaging the dust cover.

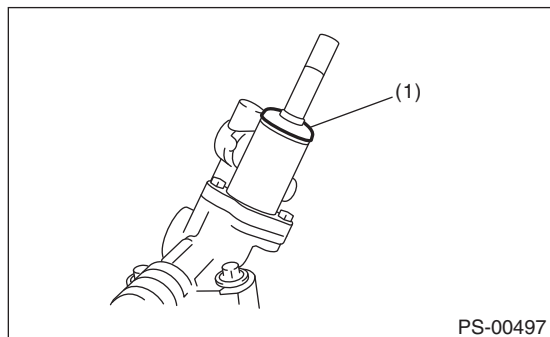

(1) Dust cover

11) Match the pin of the ST to the plug hole and attach. Turn the ST counterclockwise to remove the plug.

ST 34199AE090 PLUG WRENCH

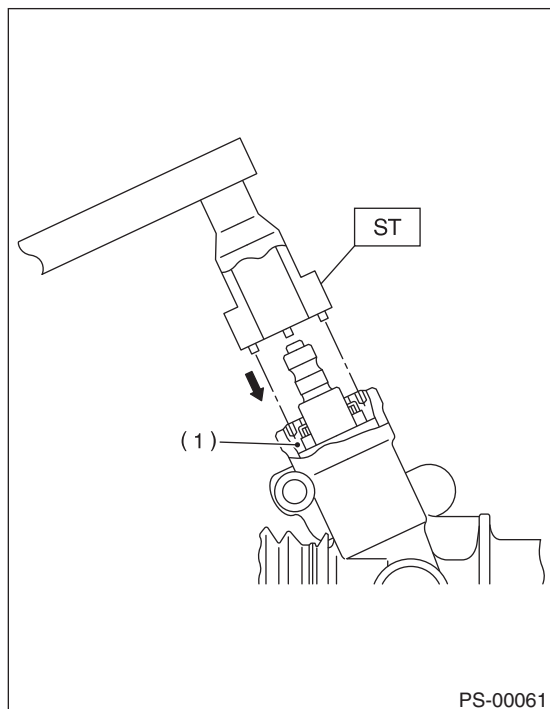

(1) Plug

12) Remove the valve assembly while being careful not to damage the seal rings and valve housing inner surfaces.

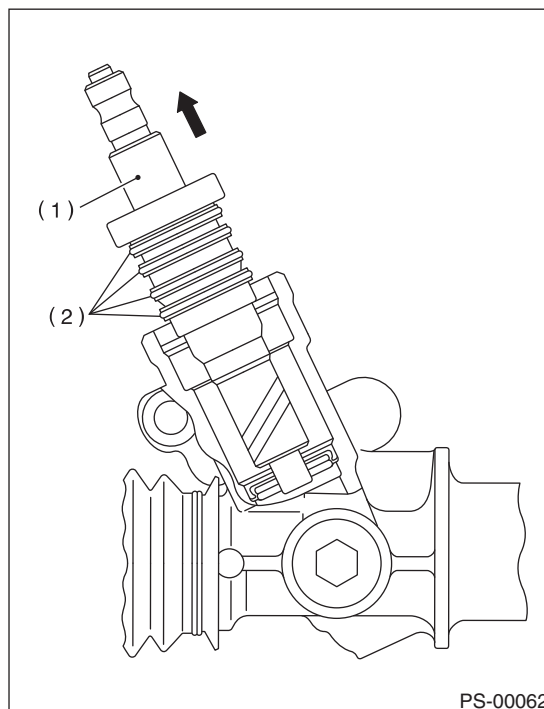

(1) Valve assembly

(2) Seal ring

13) Remove the holder.

Steering Gearbox

POWER ASSISTED SYSTEM (POWER STEERING)

14) Attach the ST to the rack pinion housing side, and push the rack out together with the outer side oil seal.

ST 34199FE000 INSTALLER & REMOVER

NOTE:

Plug the pipe connection of the steering body, so that fluid will not come pouring out.

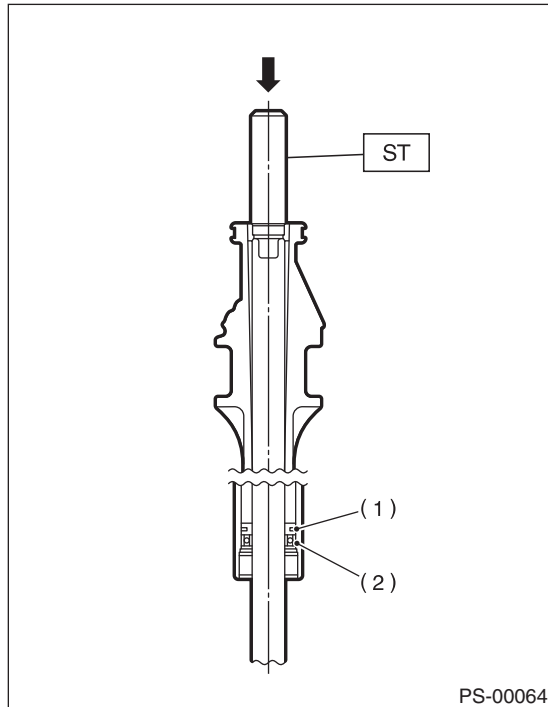

- (1) Rack piston
- (2) Outer side oil seal

15) Insert the ST from the valve side, and push out the backup ring and oil seal.

ST 34199FE010 REMOVER

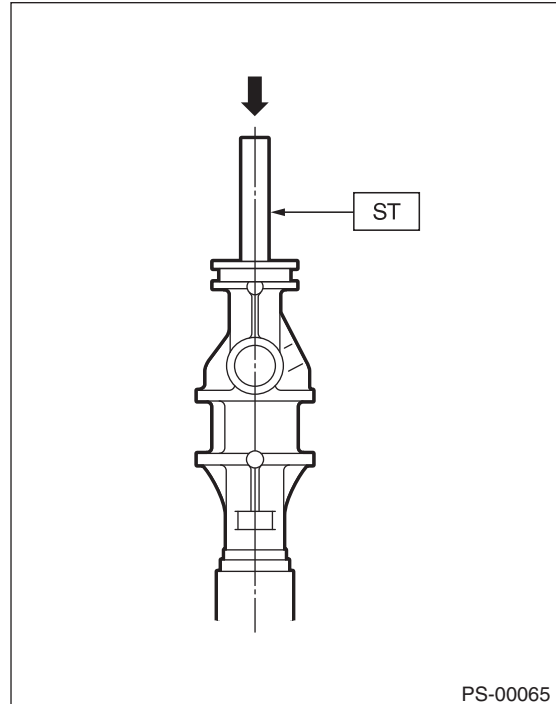

16) Correct the crimped area of the cylinder using ST1 and ST2.

ST1 34099FA080 PUNCH

ST2 34199FE020 BASE

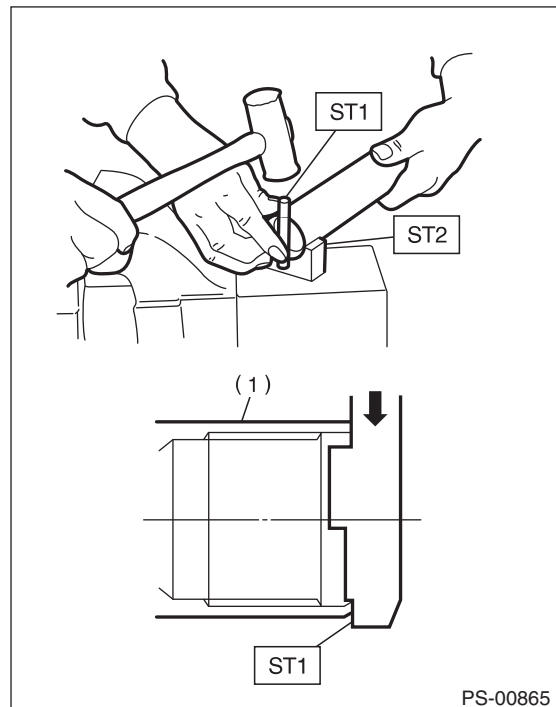

- (1) Cylinder

Steering Gearbox

POWER ASSISTED SYSTEM (POWER STEERING)

17) If the cylinder end is deformed to form a protrusion, use an oil stone to correct.

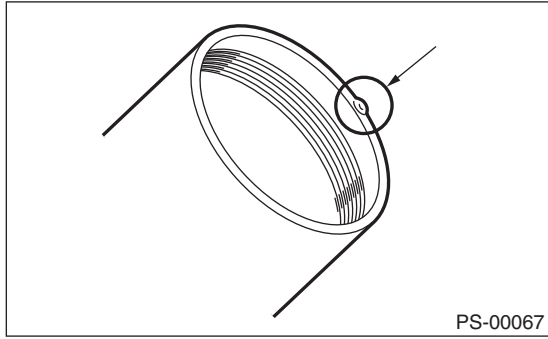

18) Using the ST, remove the oil seal and push out from the plug.

ST 34199AE100 OIL SEAL PLUG REMOVER

NOTE:

Do not apply a force to the end surface of a plug.

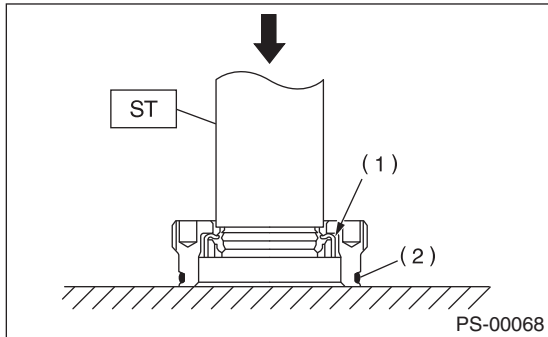

- (1) Oil seal
- (2) O-ring

19) Set the ST at the dimensions indicated in the figure.

ST 34199AE120 GEAR BOX OIL SEAL REMOVER

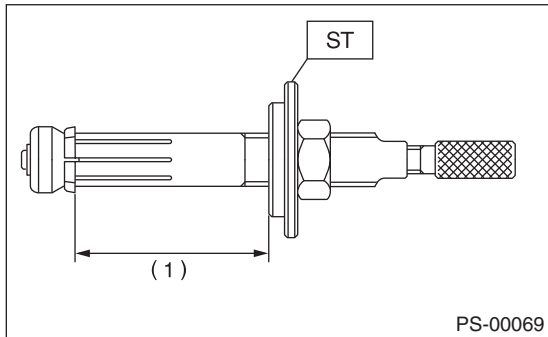

- (1) 70 mm (2.76 in)

20) Set the stopper in the gearbox body first, then insert the tip of the ST into the gearbox body.

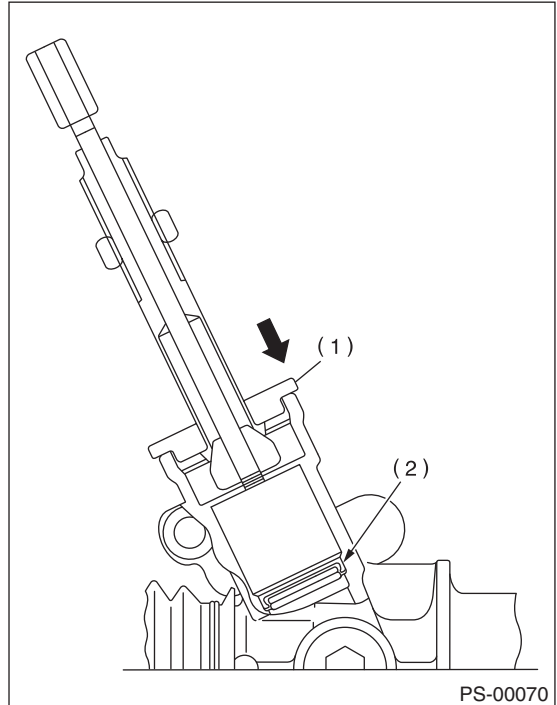

- (1) Stopper
- (2) Oil seal

21) Fix the width across flats in place, push in while rotating the rod, and hook the oil seal.

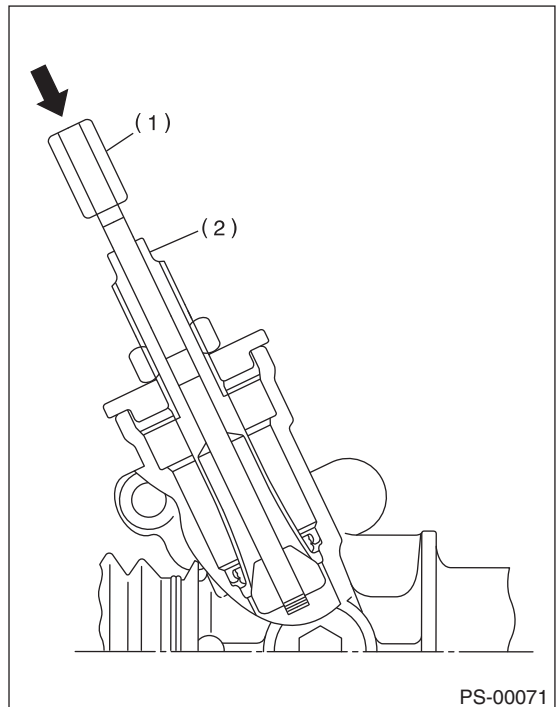

- (1) Rod
- (2) Width across flats

Steering Gearbox

POWER ASSISTED SYSTEM (POWER STEERING)

22) Fix the width across flats in place, turn the nut and pull out the oil seal.

CAUTION:

Be careful not to damage the inner surface of the gearbox.

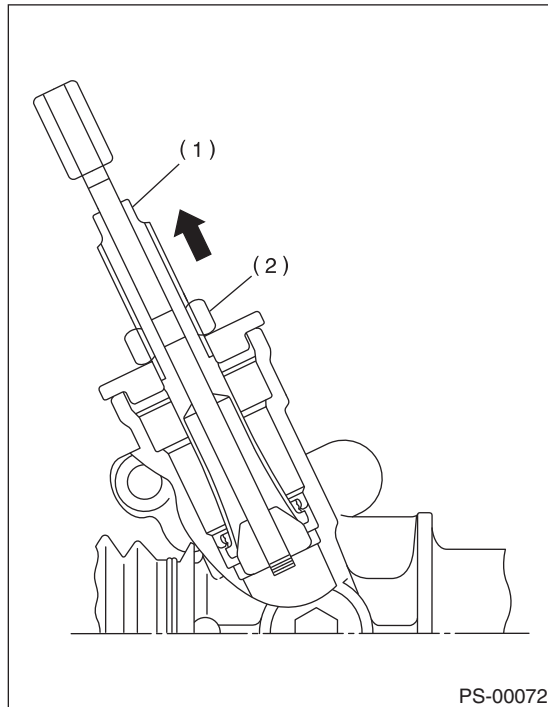

- (1) Width across flats
- (2) Nut

D: ASSEMBLY

1) Apply grease to the inside and outside of a new oil seal.

Steering grease:

VALIANT GREASE M2 (Part No 003608001)

2) Check the direction and attachment location of the oil seal. Using an ST and a press, press fit the oil seal into the gear box.

CAUTION:

- Make sure to press fit the oil seal in all the way.
- The gap between the gear box end face and the ST is to be approximately 4 mm (0.157 in) after press fitting.

ST 34199AE130 GEAR BOX OIL SEAL INSTALLER

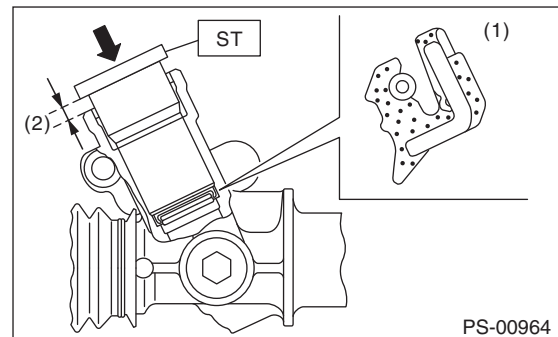

- (1) Oil seal
- (2) 4 mm (0.157 in)

3) Attach the steering body to the ST as shown in the figure. Apply grease to the needle bearing.

ST1 926200000 STAND

ST2 34199AG000 BOSS D

CAUTION:

Make sure that there are no problems with the needle bearing. If faulty, replace with a new steering body.

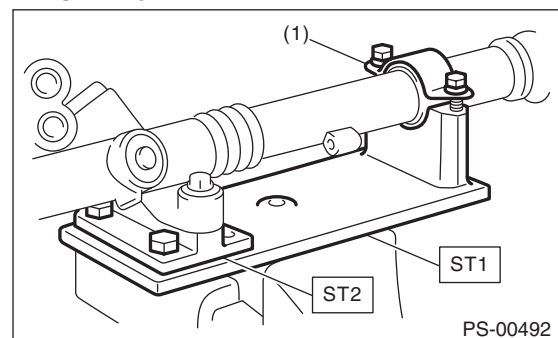

- (1) Clamp

Steering Gearbox

POWER ASSISTED SYSTEM (POWER STEERING)

4) Using the ST B and ST C, attach the oil seal to ST A.

ST 34199FE040 INSTALLER A, B, C

NOTE:

Face the oil seal in the direction as shown in the figure.

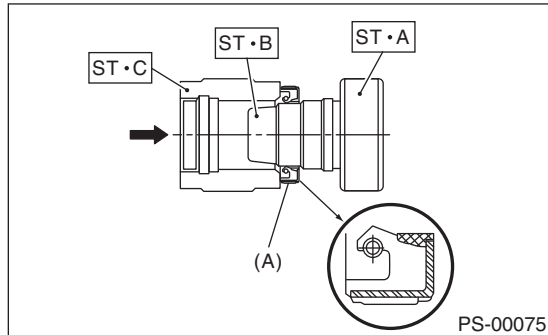

(A) Oil seal

5) Insert the ST A with oil seal assembled from the gear side of rack. Remove the oil seal from ST A near piston, and then remove the ST A from rack.

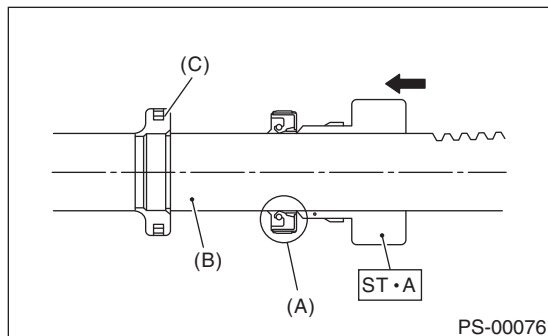

(A) Oil seal
(B) Rack
(C) Piston

6) Install the back-up washer from the gear side of rack.

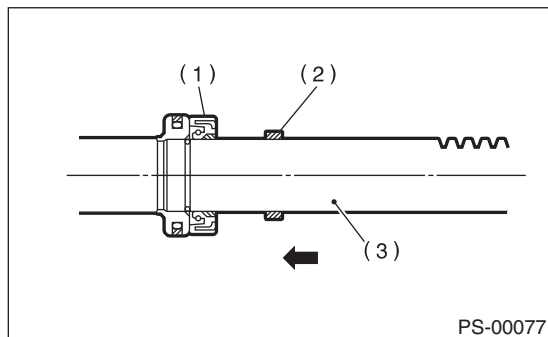

(1) Oil seal
(2) Back-up washer
(3) Rack

7) Apply a coat of grease to the grooves in rack, sliding surface of sleeve and sealing surface of piston. Then insert the rack into steering body from cylinder side.

8) Temporarily tighten the holder to gearbox cylinder.

9) Mark a position 9 mm (0.35 in) from the end of the ST as indicated in the figure.

ST 34199FE000 INSTALLER & REMOVER

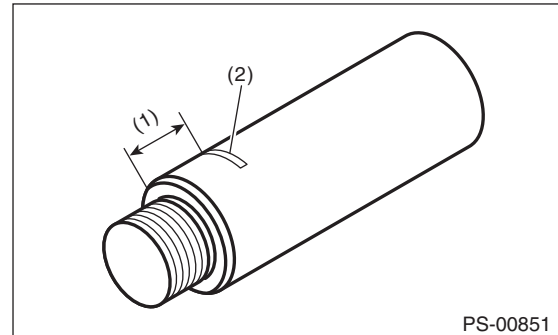

(1) 9 mm (0.35 in)
(2) Place a mark

10) Set the ST to the end of rack.

ST 34199FE000 INSTALLER & REMOVER

11) Using a press, press-fit until the mark placed on the ST is aligned to the end surface of the holder.

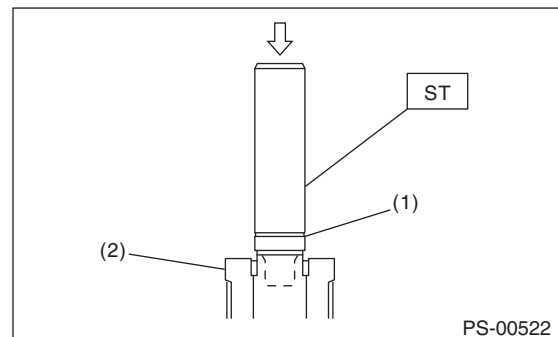

(1) Mark
(2) Holder

12) Remove the ST and holder.

13) Using the same procedures as steps 4)-5), insert the outer side oil seal to the rack.

ST 34199FE040 INSTALLER A, B, C

Steering Gearbox

POWER ASSISTED SYSTEM (POWER STEERING)

14) Place ST2 through the rack, and use the press to hold the rack and ST2.

Push in the outer side oil seal until ST1 and ST2 contact each other, and the rack end face is aligned with the end face of ST2.

ST1 34199FE050 GUIDE
ST2 34199FE060 INSTALLER

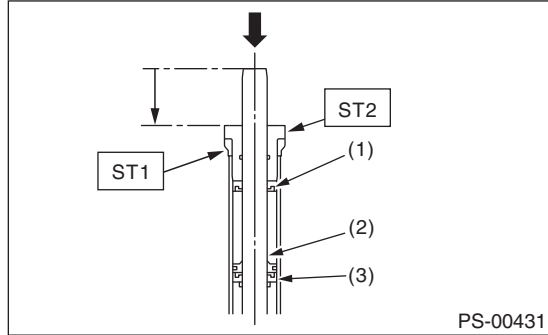

- (1) Outer side oil seal
- (2) Rack piston
- (3) Inner side oil seal

15) Attach a new holder on the cylinder side of the steering body.

Tightening torque:

90 N·m (9.1 kgf·m, 65.7 ft·lb)

16) Using the ST, crimp one location less than 3 mm (0.12 in) from the holder.

CAUTION:

Be careful not to deform the holder.

ST1 34099FA060 PUNCH HOLDER

ST2 34199FE020 BASE

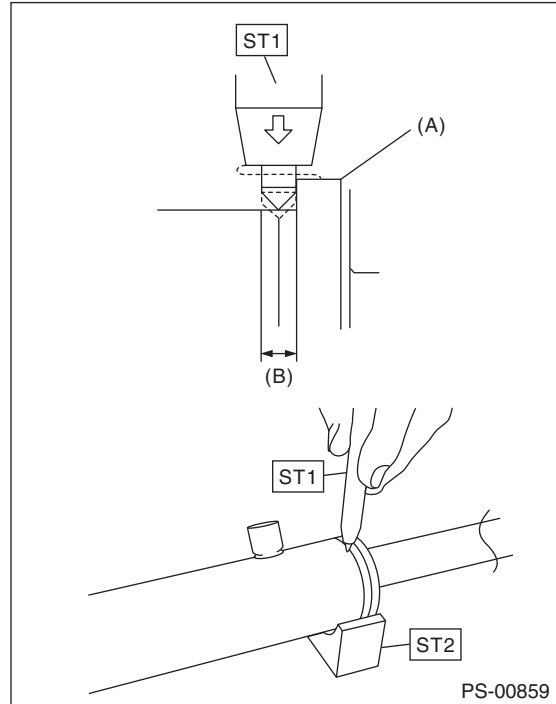

- (A) Holder
- (B) 3 mm (0.12 in)

17) Wrap the serrated part of the valve assembly with vinyl tape, and apply grease to the tape surface.

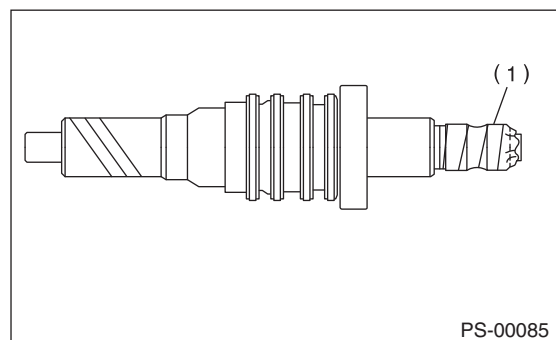

- (1) Vinyl tape

Steering Gearbox

POWER ASSISTED SYSTEM (POWER STEERING)

18) Apply grease to the gear teeth of the valve assembly, and while being careful not to damage the oil seals and seal rings, attach the valve assembly.

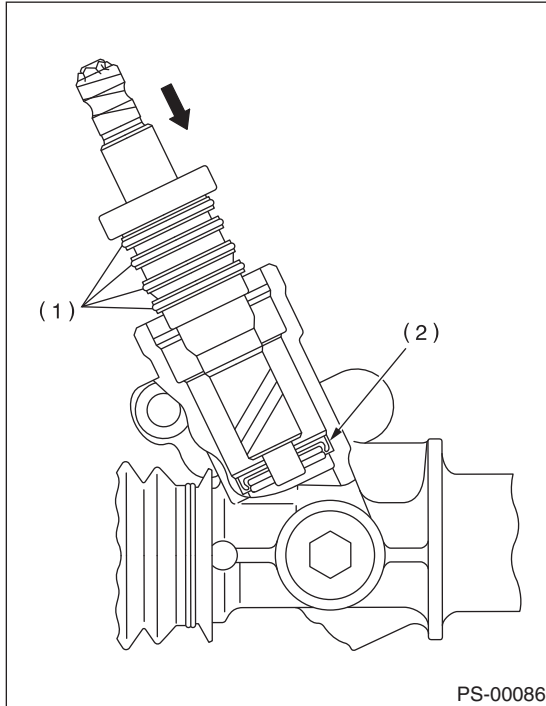

- (1) Seal ring
- (2) Oil seal

19) Replace the O-ring for the plug periphery with a new O-ring.

20) Apply grease around the oil seal, and use the ST and press to insert into the plug

ST 34199AE110 OIL SEAL PLUG INSTALLER

CAUTION:

- Attach the oil seal in the correct direction.
- To avoid compression of the oil seal, pressure insert with the plug and ST separated by 1 mm (0.039 in).

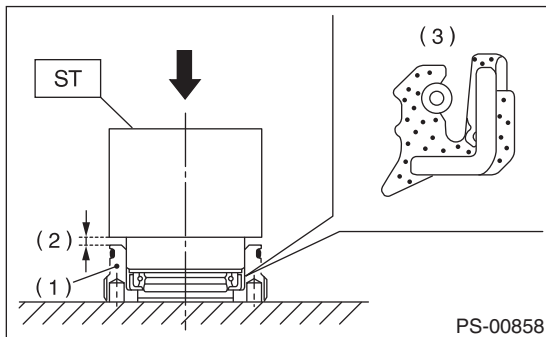

- (1) Plug
- (2) 1 mm (0.039 in)
- (3) Oil seal

21) Using the ST, attach the plug.
ST 34199AE090 PLUG WRENCH

Tightening torque:

64 N·m (6.5 kgf·m, 47.0 ft·lb)

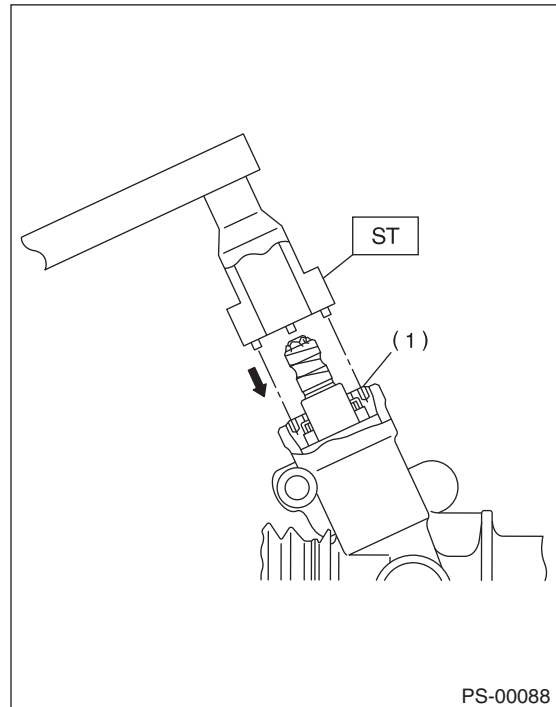

- (1) Plug

22) Attach the dust cover, and remove the vinyl tape.

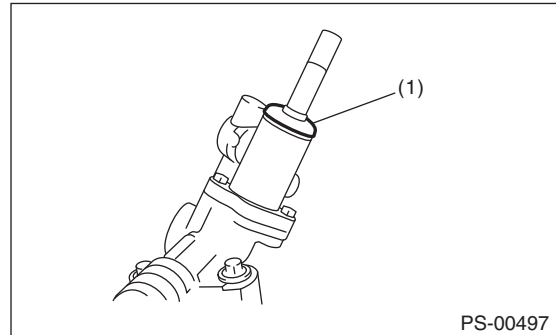

- (1) Dust cover

23) Temporarily attach the tie-rod to the rack end, and fully stroke the rack two or three times to the left and right to properly fit the rack.

CAUTION:

Moving the rack for across its full stroke without installing tie-rods may damage the oil seal. Always install the left and right tie-rods.

Steering Gearbox

POWER ASSISTED SYSTEM (POWER STEERING)

24) Apply liquid gasket to 1/3 or more of entire perimeter of adjusting screw thread.

Liquid gasket:

THREE BOND 1141 (Part No. 004403006)

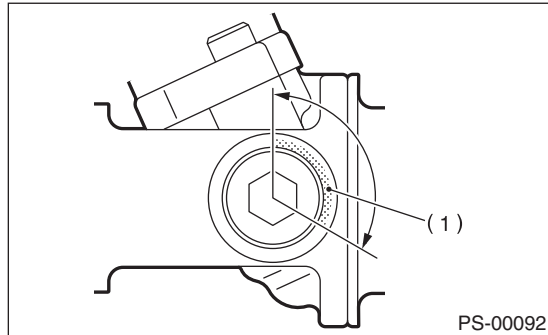

(1) Apply liquid gasket to 1/3 or more of the entire perimeter.

25) Apply a coat of grease to the sliding surface of sleeve and seating surface of spring, and then insert the sleeve into steering body.

Charge the adjusting screw with grease, and then insert the spring into adjusting screw. Then install on the steering body.

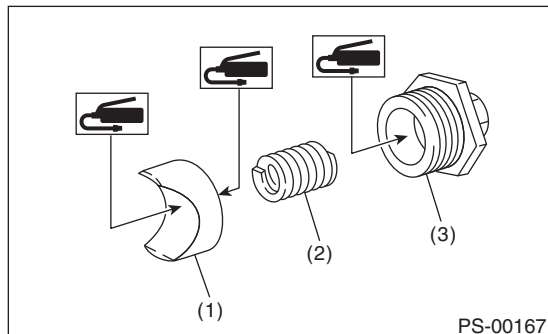

(1) Sleeve
(2) Spring
(3) Adjusting screw

26) Tighten the adjusting screw to the specified torque, then loosen it.

Tightening torque:

9.8 N-m (1.0 kgf-m, 7.2 ft-lb)

27) Tighten the adjusting screw to the specified torque, then loosen it.

Tightening torque:

4.9 N-m (0.50 kgf-m, 3.6 ft-lb)

28) Tighten the adjusting screw to the specified torque, then loosen it by approximately 30°.

CAUTION:

Do not loosen by more 37° or more.

Tightening torque:

4.9 N-m (0.50 kgf-m, 3.6 ft-lb)

29) Remove the tie-rod.

30) Check for whether play and looseness is within specifications. <Ref. to PS-32, SERVICE LIMIT, INSPECTION, Steering Gearbox.>

31) Install the lock nut. While holding the adjusting screw with wrench, tighten the lock nut using ST. ST 926230000 SPANNER

Tightening torque (lock nut):

39 N-m (4.0 kgf-m, 28.9 ft-lb)

NOTE:

Hold the adjusting screw with a wrench to prevent it from turning while tightening lock nut.

32) Attach the tie-rod to the rack.

Tightening torque:

90 N-m (9.1 kgf-m, 65.7 ft-lb)

NOTE:

Be careful that debris, dust, and other foreign objects do not become attached to the attachment surfaces of the rack and tie-rod.

33) Apply a coat of grease to the tie-rod groove, and then install the boot to the housing.

NOTE:

Make sure that the boot is installed without unusual inflation or deflation.

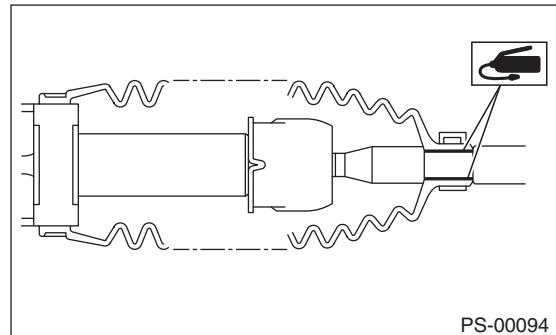

Steering Gearbox

POWER ASSISTED SYSTEM (POWER STEERING)

34) Using boot clamp pliers, crimp it so that the clearance of the boot band crimping section becomes 2 mm (0.08 in) or less.

NOTE:

Use a new boot band.

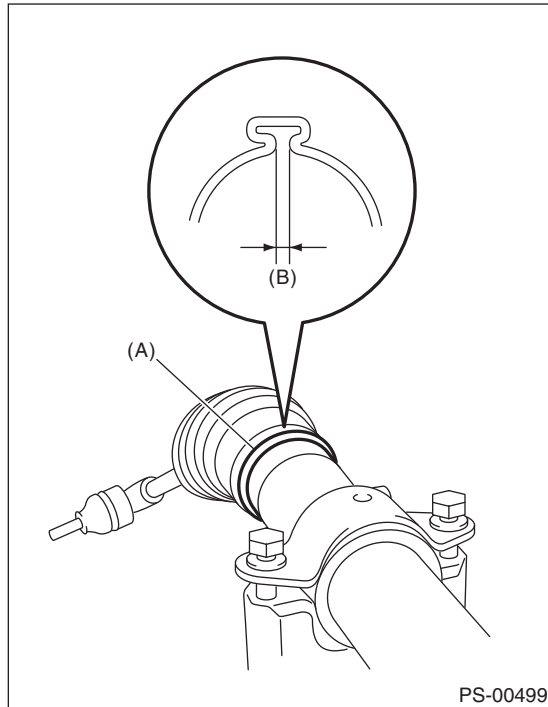

(A) Boot band

(B) 2 mm (0.08 in) or less

35) Fix the boot end with small clip.

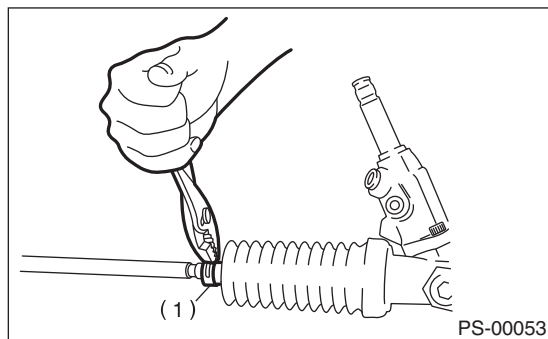

(1) Clip

36) After installing, check that the boot end is installed to the groove of the tie-rod.

37) If the tie-rod end has been removed, screw in lock nut and tie-rod end to the screwed portion of tie-rod, and tighten the lock nut temporarily in a position as shown in the figure.

**Installed tie-rod length L:
28 mm (1.1 in)**

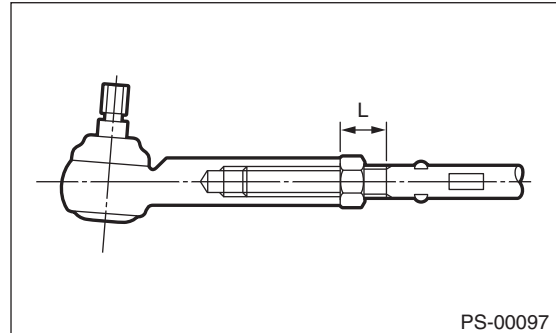

38) Inspect the gearbox as follows:

“A” Holding the tie-rod end, repeat lock to lock several times as quickly as possible.

“B” Holding the tie-rod end, turn it slowly at a radius several times as large as possible.

Finally, make sure that the boot is installed at the specified position without inflating.

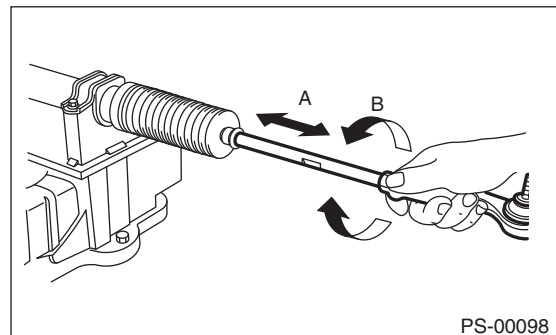

39) Remove the gearbox from ST.

ST1 926200000 STAND

ST2 34199AG000 BOSS D

40) Attach the four pipes to the steering body and control valve housing.

Steering Gearbox

POWER ASSISTED SYSTEM (POWER STEERING)

E: INSPECTION

1. BASIC INSPECTION

1) Clean all the disassembled parts, and check for wear, damage or any other faults, then repair or replace as necessary.

2) When disassembling, check the inside of gearbox for water. If any water is found, carefully check the boot for damage, input shaft dust seal, adjusting screw and boot clips for poor sealing. If faulty, replace with new parts.

No.	Parts	Inspection	Corrective action
1	Input shaft	(1) Bent input shaft (2) Damage on serration	If the bend or damage is excessive, replace the entire gearbox.
2	Dust seal	(1) Crack or damage (2) Wear	If the outer wall slips, the lip is worn out or damage is found, replace it with a new part.
3	Rack & pinion	Poor mating of rack with pinion	(1) Adjust the backlash properly. By measuring the turning torque of the gearbox and sliding resistance of rack, check if the rack & pinion engage uniformly and smoothly with each other. (Refer to "Service limit".) (2) Pull out the entire rack to allow viewing of the teeth, and check for damage. When the abnormality is found in either (1) or (2), replace the entire gearbox.
4	Gearbox unit	(1) Bending of the rack shaft (2) Bending of the cylinder portion (3) Crack or damage on the cast iron portion	Replace the gearbox with a new part.
		(4) Wear or damage on rack bushing	If the free play of rack shaft in radial direction is out of the specified range, replace the gearbox with new part. (Refer to "Service limit".)
		(5) Wear on input shaft bearing	If the free play of input shaft in radial and axial direction is out of the specified range, replace the gearbox with a new part. (Refer to "Service limit".)
5	Boot	Crack, damage or deterioration	Replace.
6	Tie-rod	(1) Looseness of ball joint (2) Bend of tie-rod	Replace.
7	Tie-rod end	Damage or deterioration of dust seal	Replace.
8	Adjusting screw spring	Deterioration	Replace.
9	Boot clip	Deterioration	Replace.
10	Sleeve	Damage	Replace.
11	Pipe	(1) Damage to flared surface (2) Damage to flare nut (3) Damage to pipe	Replace.

Steering Gearbox

POWER ASSISTED SYSTEM (POWER STEERING)

2. SERVICE LIMIT

Make a measurements as follows. If it exceeds the specified service limits, adjust or replace.

NOTE:

When making a measurement, vise the gearbox using ST. Never vise the gearbox by inserting aluminum plates etc. between vise and gearbox.

ST1 926200000 STAND
ST2 34199AG000 BOSS D

Rack shaft sliding resistance:

Service limit

314 N (32 kgf, 71 lbf) or less

Left/right differential of sliding resistance:

20% or less

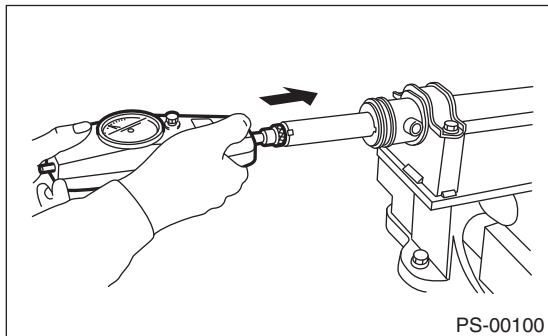
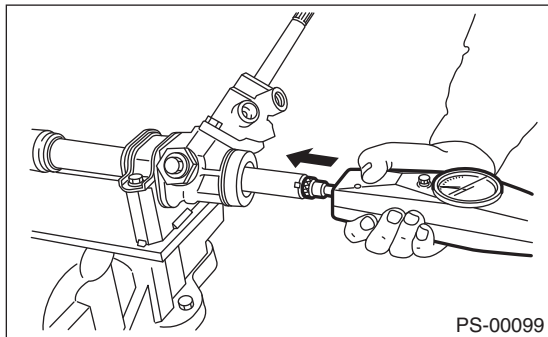

3. RACK SHAFT PLAY IN THE RADIAL DIRECTION

Right-turn steering:

Service limit

Direction \longleftrightarrow

0.4 mm (0.016 in) or less

Direction \longleftrightarrow

0.6 mm (0.024 in) or less

Condition

L: 5 mm (0.20 in)

P: 98 N (10 kgf, 22 lbf)

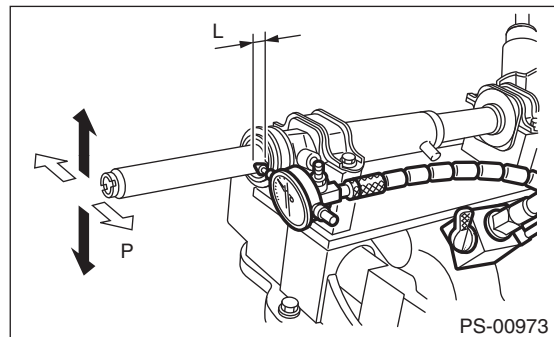

Left-turn steering:

Service limit

Direction \longleftrightarrow

0.4 mm (0.016 in) or less

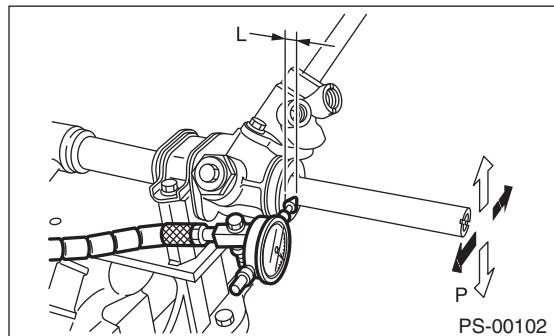

Steering Gearbox

POWER ASSISTED SYSTEM (POWER STEERING)

4. INPUT SHAFT PLAY

In radial direction:

Service limit

0.18 mm (0.0071 in) or less

Condition

P: 98 N (10 kgf, 22 lbf)

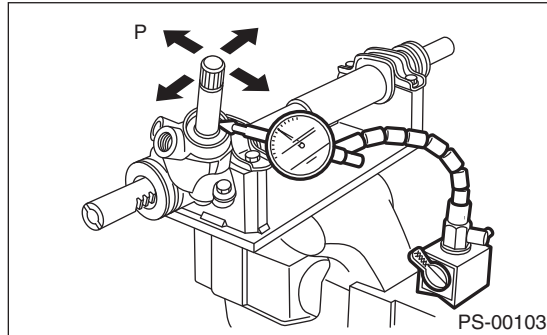

In axial direction:

Service limit

0.27 mm (0.0106 in) or less

Condition

P: 20 — 49 N (2 — 5 kgf, 4 — 11 lbf)



5. TURNING RESISTANCE OF GEARBOX

Using the ST, measure the gearbox turning resistance.

ST 34099PA100 SPANNER

Service limit:

Maximum allowable resistance:

13 N (1.3 kgf, 2.9 lbf) or less

Difference between right and left turning resistance:

20% or less

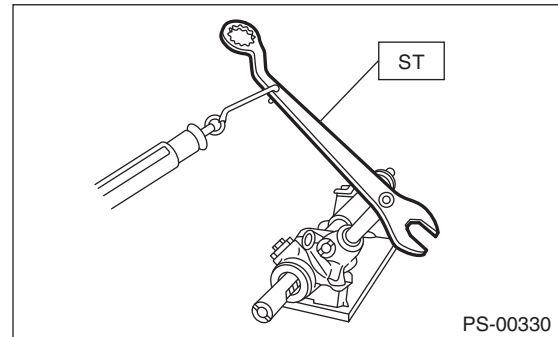

Steering Gearbox

POWER ASSISTED SYSTEM (POWER STEERING)

6. OIL LEAKAGE

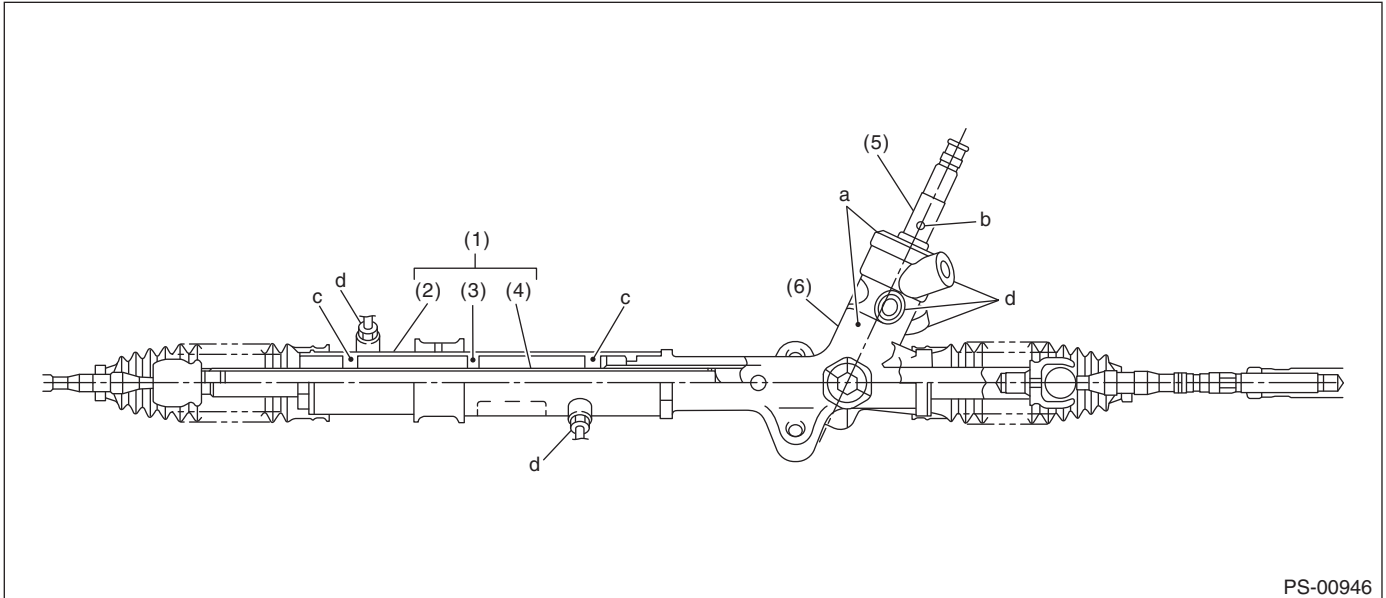

PS-00946

- | | | |
|--------------------|-----------------|-------------------|
| (1) Power cylinder | (3) Rack piston | (5) Input shaft |
| (2) Cylinder | (4) Rack axle | (6) Valve housing |

1) Lift up the vehicle.

2) If a fluid leak is found, clean the fluid completely from the suspect area, and turn the steering wheel 30 to 40 times to the left and right from lock to lock, with the engine running, and check again for leaks immediately, and also after a few hours have passed.

3) Cause and solution for oil leakage from "a"
The oil seal is damaged. Replace the valve assembly with a new part.

4) Cause and measure for oil leakage from "b".
The torsion bar O-ring is damaged. Replace the valve assembly with a new part.

5) Cause and measure for oil leakage from "c".
The oil seal is damaged. Replace the oil seal with a new part.

6) Cause and solution for oil leakage from "d".
The pipe is damaged. Replace the faulty pipe or O-ring.

F: ADJUSTMENT

1) Adjust the front toe.
 <Ref. to FS-12, FRONT WHEEL TOE-IN, INSPECTION, Wheel Alignment.>

Standard of front toe:

IN 3 — OUT 3 mm (IN 0.12 — OUT 0.12 in)

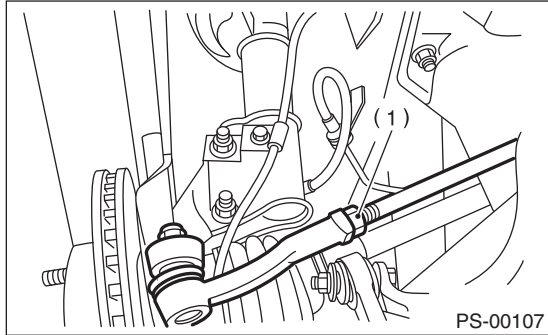

(1) Lock nut

2) Adjust the steering angle of the wheels.

Standard of steering angle:

Model	Inner wheel	Outer wheel
All models	$38.3^{\circ} \pm 1.5^{\circ}$	$33.8^{\circ} \pm 1.5^{\circ}$

3) If the steering wheel spokes are not horizontal when wheels are set in the straight ahead position, or error is more than 5° on the periphery of the steering wheel, correctly re-install the steering wheel.

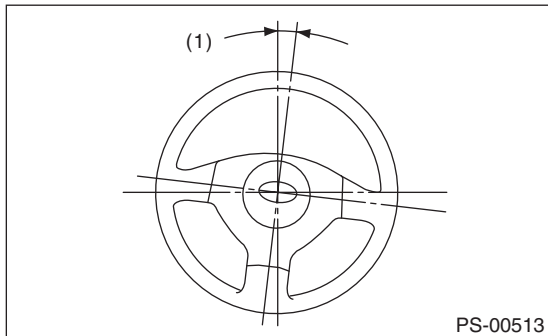

(1) 5° or less

4) If the steering wheel spokes are not horizontal with vehicle set in the straight ahead position after this adjustment, correct it by turning the right and left tie-rods in the opposite direction from each other by the same angle.

Pipe Assembly

POWER ASSISTED SYSTEM (POWER STEERING)

6. Pipe Assembly

A: REMOVAL

- 1) Disconnect the ground cable from the battery.
 - 2) Lift up the vehicle, and then remove the front crossmember support plate and jack-up plate.
- Large type

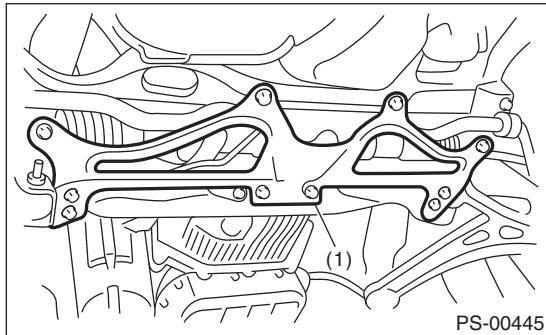

(1) Front crossmember support plate

- Small type

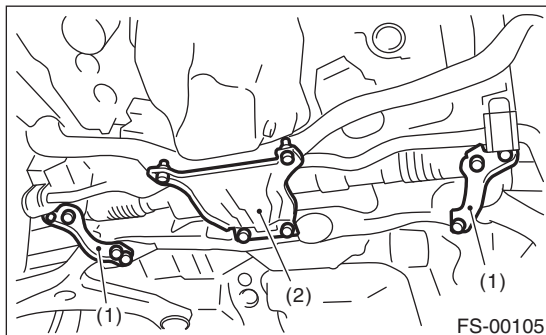

(1) Front crossmember support plate
(2) Jack-up plate

- 3) Remove the one pipe joint at the center of the gearbox, and connect the vinyl hose to the pipe and the joint. Discharge the fluid by turning the steering wheel fully clockwise and counterclockwise. Discharge the fluid similarly from other pipes.

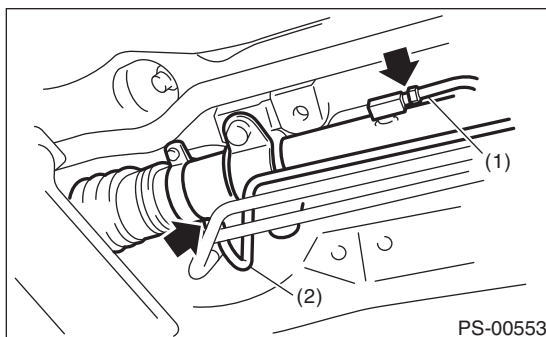

(1) Pipe A
(2) Pipe B

- 4) Remove the clamp E from return hose and pressure hose.

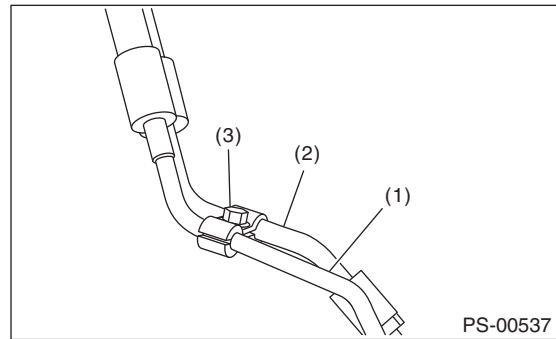

(1) Return hose
(2) Pressure hose
(3) Clamp E

- 5) Disconnect the pipe D from return hose and pipe C from pressure hose.

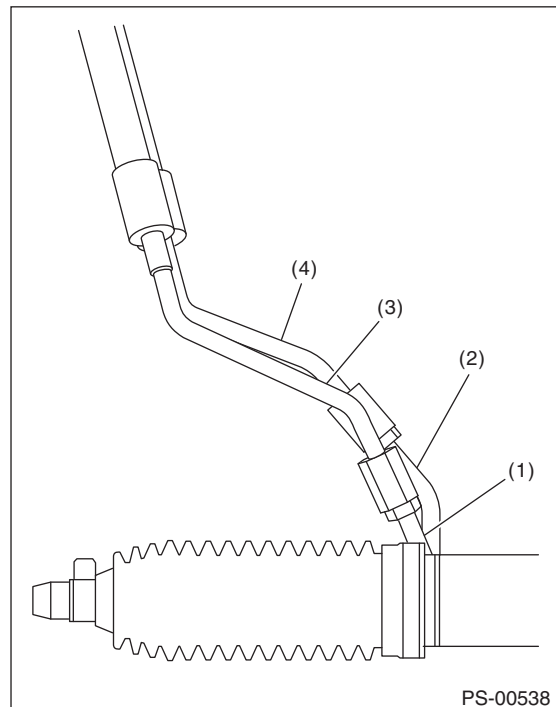

(1) Pipe C
(2) Pipe D
(3) Pressure hose
(4) Return hose

- 6) Remove the air intake duct.

Pipe Assembly

POWER ASSISTED SYSTEM (POWER STEERING)

7) Disconnect the suction hose and pressure hose from oil pump.

- Non-turbo model

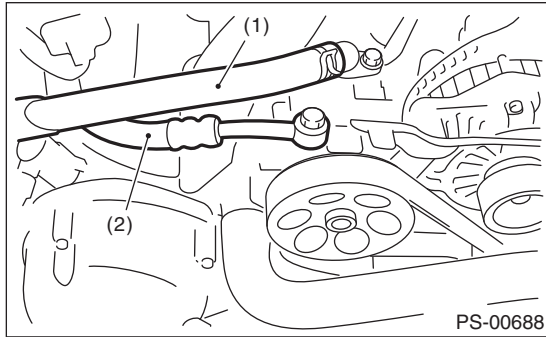

- (1) Suction hose
- (2) Pressure hose

9) Remove the hose bracket and take out the hose assembly from vehicle.

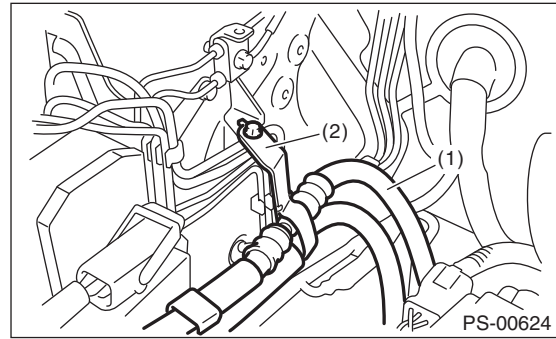

- (1) Hose ASSY
- (2) Hose bracket

- Turbo model

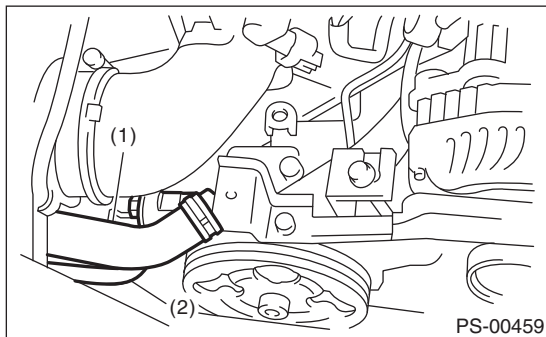

- (1) Suction hose
- (2) Pressure hose

8) Disconnect the suction hose and return hose from the reservoir tank.

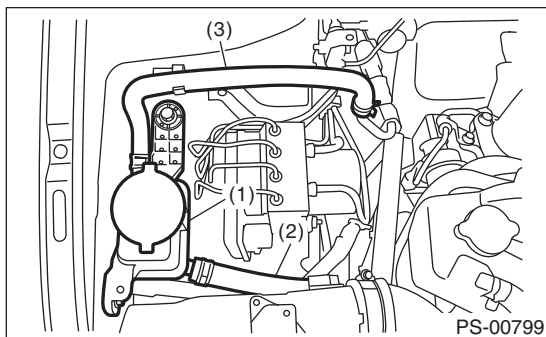

- (1) Reservoir tank
- (2) Suction hose
- (3) Return hose

Pipe Assembly

POWER ASSISTED SYSTEM (POWER STEERING)

B: INSTALLATION

- 1) Temporarily tighten the hose bracket bolt.

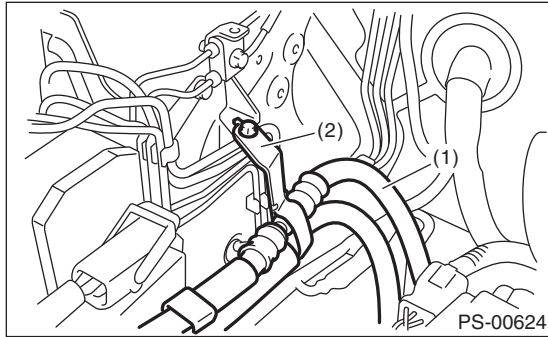

- (1) Hose ASSY
- (2) Hose bracket

- 2) Install the plastic clip to the pressure hose and suction hose.

CAUTION:

Align the installation position of the plastic clip with the protector edge of the suction hose.

- Non-turbo model

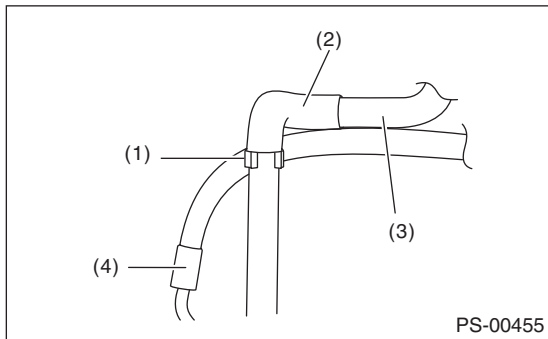

- (1) Plastic clip
- (2) Protector
- (3) Suction hose
- (4) Pressure hose

- Turbo model

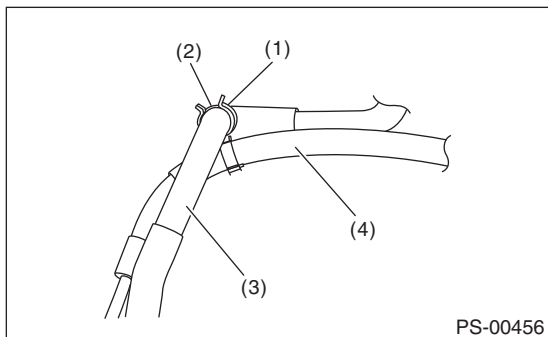

- (1) Plastic clip
- (2) Protector
- (3) Suction hose
- (4) Pressure hose

- 3) Connect the suction hose and return hose to the reservoir tank.

CAUTION:

Firmly insert the plastic clip of return hose to the bracket.

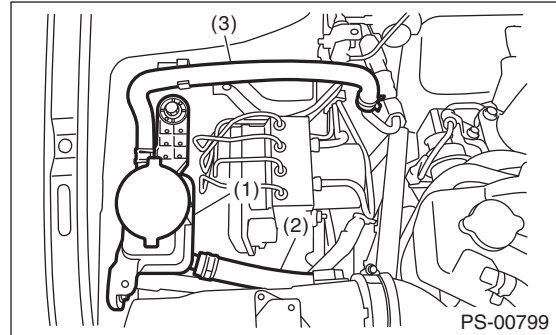

- (1) Reservoir tank
- (2) Suction hose
- (3) Return hose

- 4) Connect the suction hose and pressure hose to the oil pump. Tighten the eye bolt of pressure hose.

Tightening torque:

40 N·m (4.1 kgf·m, 29.5 ft·lb)

- Non-turbo model

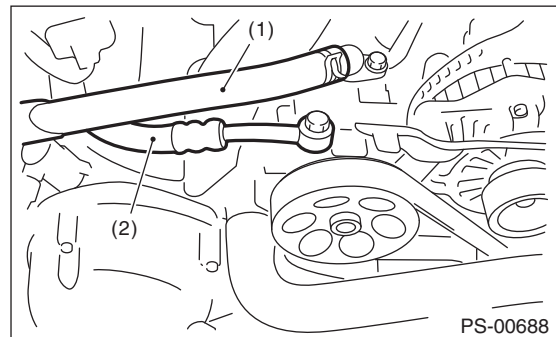

- (1) Suction hose
- (2) Pressure hose

- Turbo model

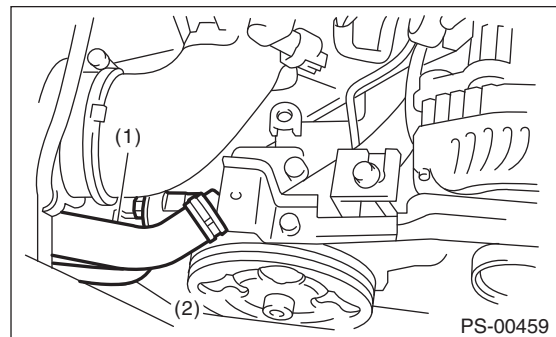

- (1) Suction hose
- (2) Pressure hose

Pipe Assembly

POWER ASSISTED SYSTEM (POWER STEERING)

5) Temporarily connect pressure hose and pipe C, and the return hose and pipe D. Temporarily tighten the bolt of clamp E.

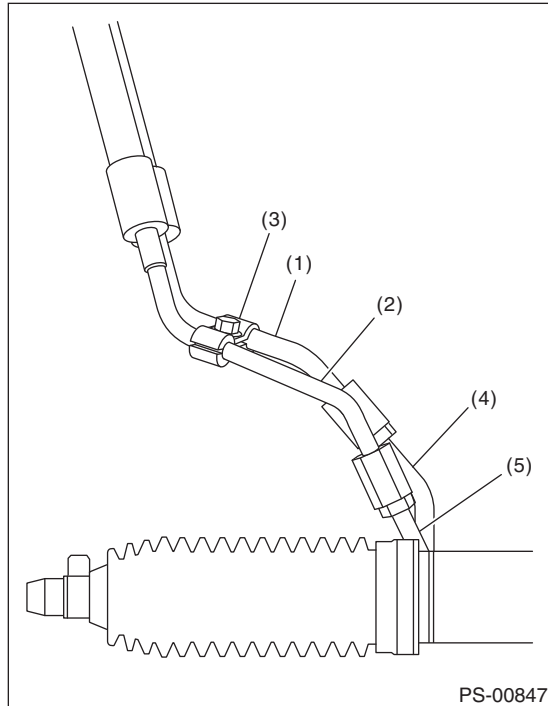

- (1) Return hose
- (2) Pressure hose
- (3) Clamp E
- (4) Pipe C
- (5) Pipe D

6) Tighten clamp E.

Tightening torque:

7.5 N·m (0.76 kgf-m, 5.53 ft-lb)

7) Tighten the pressure hose and pipe C, and the return hose and pipe D.

Tightening torque:

15 N·m (1.5 kgf-m, 10.8 ft-lb)

8) Connect pipes A and B to the four pipe joints of the gearbox.

Tightening torque:

Refer to "COMPONENT" of "General Description". <Ref. to PS-4, POWER ASSISTED SYSTEM, COMPONENT, General Description.>

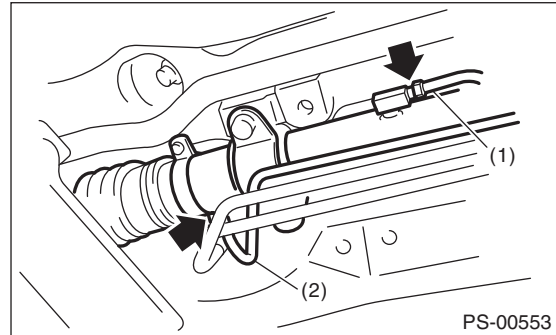

- (1) Pipe A
- (2) Pipe B

9) Install the front crossmember support plate and jack-up plate.

10) Lower the vehicle.

11) Tighten the bolts which hold the hose bracket.

Tightening torque:

10 N·m (1.02 kgf-m, 7.4 ft-lb)

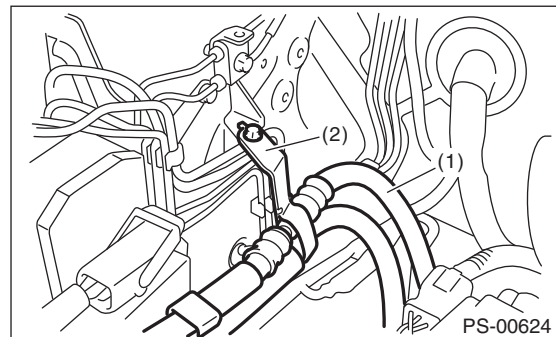

- (1) Hose ASSY
- (2) Hose bracket

12) Install the air intake duct.

13) Connect the ground cable to the battery.

14) Fill with the specified fluid.

CAUTION:

Never start the engine before filling with fluid; otherwise the vane pump may become seized.

15) Finally, check the clearance between pipes or hoses as shown in the figure indicated in "General Diagnostic Table". <Ref. to PS-55, INSPECTION OF CLEARANCE, INSPECTION, General Diagnostic Table.>

Pipe Assembly

POWER ASSISTED SYSTEM (POWER STEERING)

C: INSPECTION

Check all disassembled parts for wear, damage or other problems. Repair or replace the defective parts as necessary.

Part	Maintenance parts	Corrective action
Pipe	<ul style="list-style-type: none"> • O-ring fitting surface damage • Nut damage • Pipe damage 	Replace with a new part.
Clamp	<ul style="list-style-type: none"> • Loose clamps 	Replace with a new part.
Hose	<ul style="list-style-type: none"> • Flare surface damage • Flare nut damage • Outer surface cracks • Outer surface wear • Clip damage • End coupling or adapter deformation 	Replace with a new part.

CAUTION:

Although the surface layer materials of rubber hoses have excellent weathering resistance, heat resistance and resistance for low temperature brittleness, they are likely to be damaged chemically by brake fluid, battery electrolyte, engine oil and automatic transmission fluid and their service lives are to be very shortened. Wipe off hoses immediately if any of these come into contact with the hoses. Since resistances for heat or low temperature brittleness are gradually declining according to time accumulation of hot or cold conditions for the hoses and their service lives are shortening accordingly, it is necessary to perform careful inspection frequently when the vehicle is used in hot weather areas, cold weather areas and a driving condition in which many steering operations are required in short time.

Continuous discharge of the relief valve for 5 seconds or more will reduce the service lives of hoses, oil pump, fluid, etc., due to over heating.

Trouble	Possible cause	Corrective action
Pressure hose burst	Excessive holding time of relief status	Instruct customers.
	Malfunction of the relief valve	Replace the oil pump.
	Poor cold characteristic of fluid	Replace fluid.
Disconnection of the return hose	Improper connection	Repair.
	Loosening of the clip	Retighten.
	Poor cold characteristic of fluid	Replace fluid.
Fluid slightly leaking out of hose	Wrong layout, tensioned	Replace the hose.
	Excessive play of engine due to deterioration of engine mounting rubber	Replace the parts if defective.
	Improper stop position of pitching stopper	Replace the parts if defective.
Crack on hose	Excessive holding time of relief status	Replace. Instruct customers.
	Excessive tightening torque for return hose clip	Replace.
	Power steering fluid, engine oil, electrolyte adhere on the hose surface	Replace. Be careful during service work.
	Too many uses in extremely cold weather	Replace. Instruct customers.

Pipe Assembly

POWER ASSISTED SYSTEM (POWER STEERING)

NOTE:

There are conditions in which a fluid leak is diagnosed, but is not actually leaking. This is because the fluid spilt during the last maintenance was not completely wiped off. Be sure to wipe off spilt fluid thoroughly after maintenance.

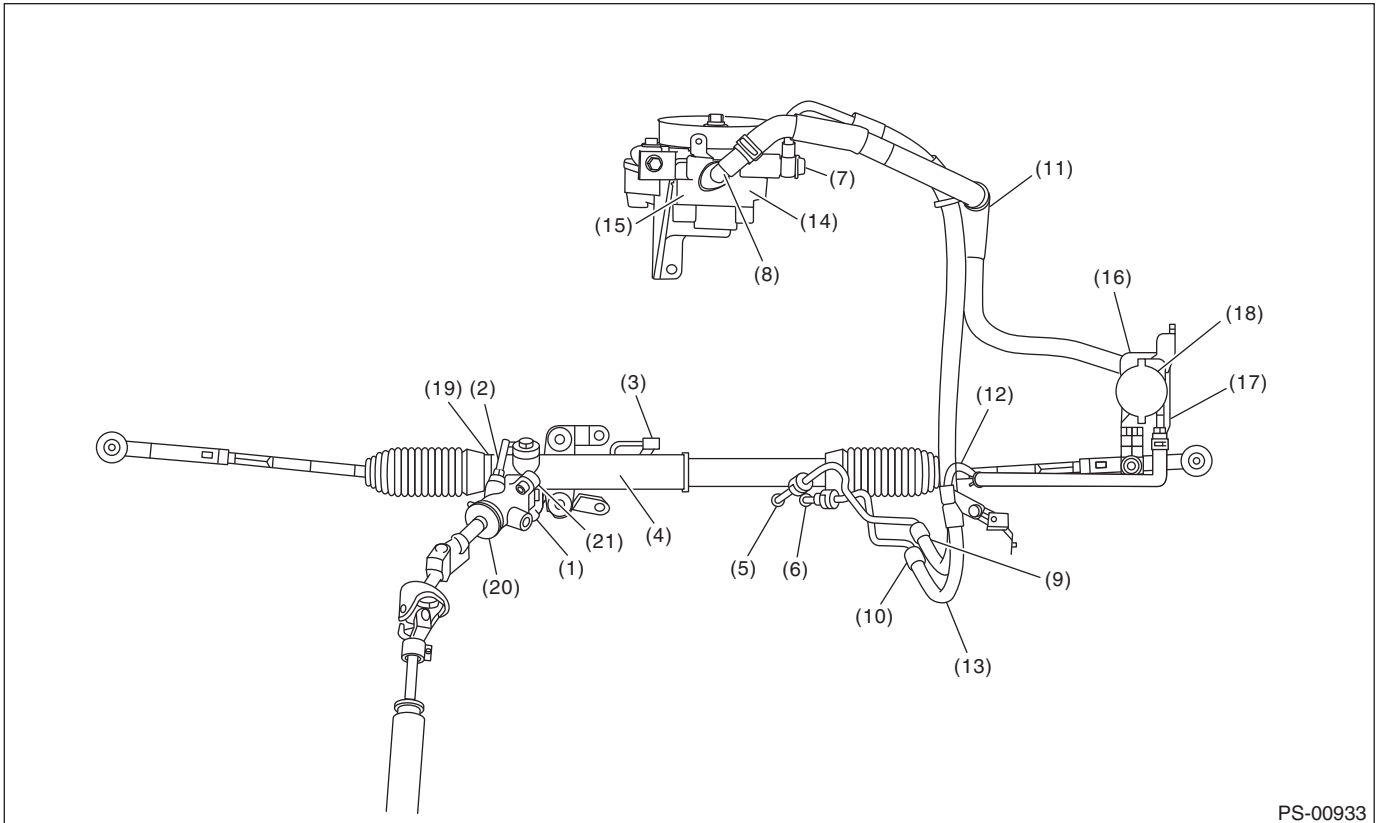

PS-00933

Fluid leaking area	Possible cause	Corrective action
Leakage from the connections of pipes and hoses, numbered (1) through (8) in the figure	Insufficient tightening of flare nut, adhesion of dirt, damage to flare or flare nut or eye bolt	Loosen and retighten. Replace if ineffective.
	Improper installation of hose or clamp	Retighten or replace the clamp.
	Damaged O-ring or gasket	Replace the O-ring, gasket pipe or hose with new part, if still no improvement, replace the gearbox as well.
Leakage from hose (9) through (13) in the figure	Crack or damage in hose	Replace with a new part.
	Crack or damage in hose hardware	Replace with a new part.
Leakage from surrounding of cast iron portion of oil pump, (14) and (15) in the figure	Damaged O-ring	Replace the oil pump.
	Damaged gasket	Replace the oil pump.
Leakage from oil tank, (16) and (17) in the figure	Crack in oil tank	Replace the oil tank.
Leakage from filler neck of (18)	Damaged cap gasket	Replace the cap.
	Crack in root of filler neck	Replace the oil tank.
	Fluid level too high	Adjust the fluid level.
Leakage from power cylinder of gearbox area (19) in the figure	Damaged oil seal	Replace the oil seal.
Leakage from (20), (21) in the figure and control valve of gearbox	Damaged gasket or oil seal	Replace the problem parts.
	Damage in control valve	Replace the control valve.

Oil Pump

POWER ASSISTED SYSTEM (POWER STEERING)

7. Oil Pump

A: REMOVAL

- 1) Disconnect the ground cable from the battery.
- 2) Remove the air intake duct.
- 3) Remove the pulley belt cover.
- 4) Loosen the belt tension securing bolt and generator securing bolt, then remove the power steering pump V-belt.

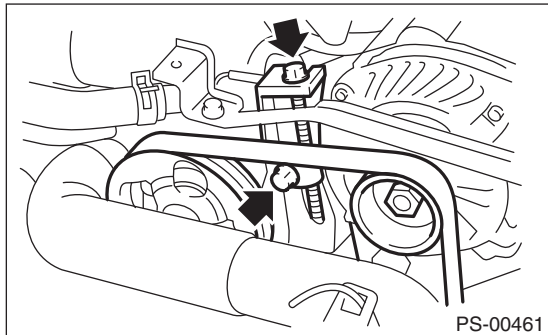

- 5) Disconnect the connector from power steering pump switch.

- 6) Disconnect the pressure hose and suction hose from the oil pump.

CAUTION:

- Do not allow fluid to come into contact with the pulley belt.
- To prevent foreign matter from entering the hose and pipe, cover the open ends with clean cloth.
- Non-turbo model

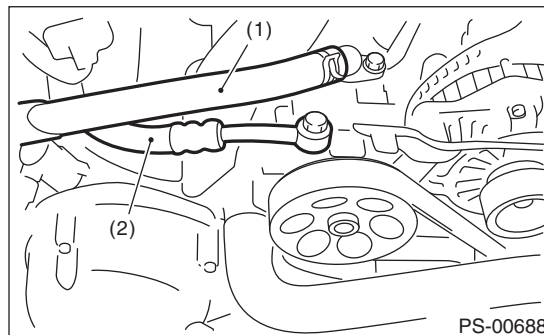

- (1) Suction hose
- (2) Pressure hose

- Turbo model

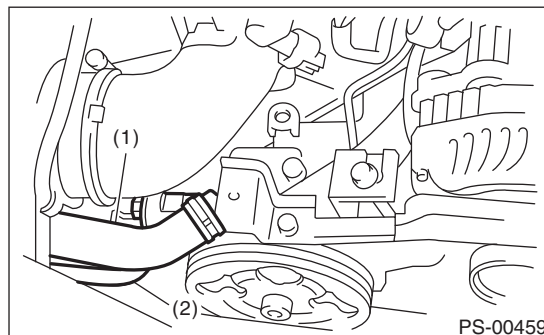

- (1) Suction hose
- (2) Pressure hose

- 7) Remove the installation bolt of the power steering pump bracket.

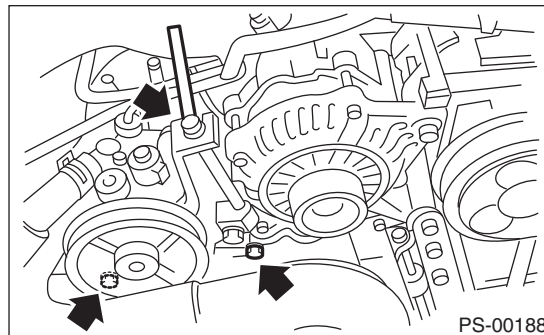

Oil Pump

POWER ASSISTED SYSTEM (POWER STEERING)

8) Place the oil pump bracket in a vise, and remove the two bolts from the front side of the oil pump.

CAUTION:

When securing the oil pump bracket in a vise, hold the oil pump bracket with the least possible force between two pieces of wood.

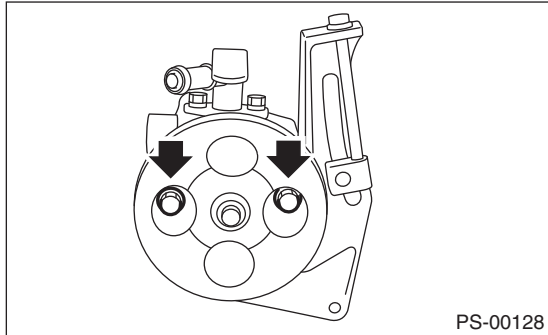

9) Remove the bolt from the rear side of oil pump.
10) Disassemble the oil pump and bracket by inserting a flat tip screwdriver as shown in the figure.

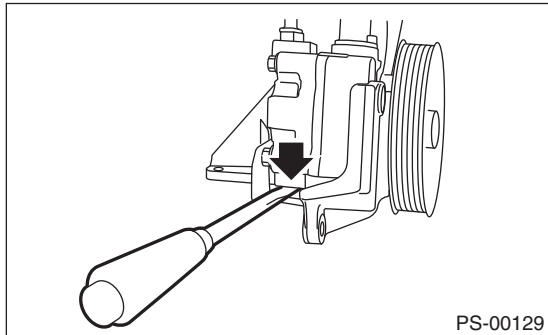

B: INSTALLATION

1) Install the oil pump to bracket.

Tightening torque:

16 N·m (1.6 kgf·m, 11.8 ft·lb)

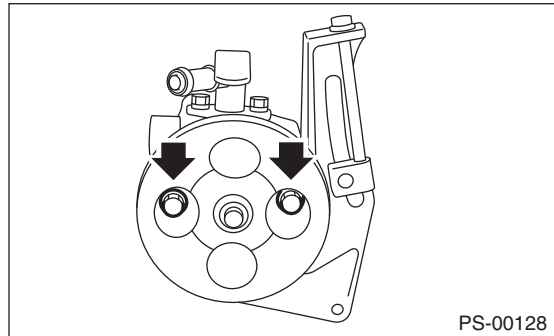

Tightening torque:

36 N·m (3.7 kgf·m, 26.6 ft·lb) (Non-turbo model)
48 N·m (4.9 kgf·m, 35.4 ft·lb) (Turbo model)

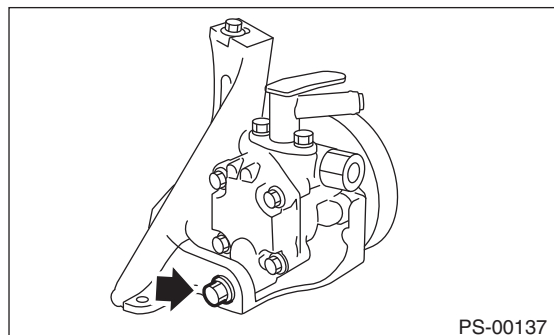

2) Attach the installation bolts of the power steering pump bracket.

Tightening torque:

<Ref. to PS-6, OIL PUMP, COMPONENT, General Description.>

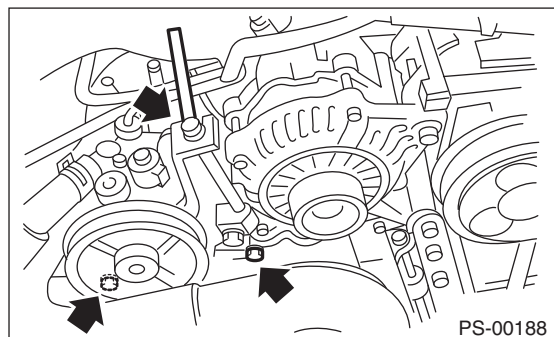

3) After installing the oil pump, fill the oil pump with fluid while rotating the pulley by hand and bleed the air from the oil pump.

CAUTION:

Always fill the oil pump with the fluid to prevent abnormal noise and seizure of the oil pump.

Oil Pump

POWER ASSISTED SYSTEM (POWER STEERING)

4) Connect the pressure hose and suction hose.

Tightening torque:

Eye bolt

40 N·m (4.1 kgf·m, 29.5 ft·lb)

CAUTION:

Be careful when installing; If the hose is twisted it may come into contact with other parts.

- Non-turbo model

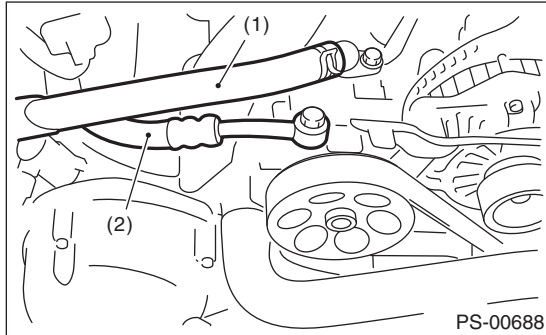

- (1) Suction hose
- (2) Pressure hose

- Turbo model

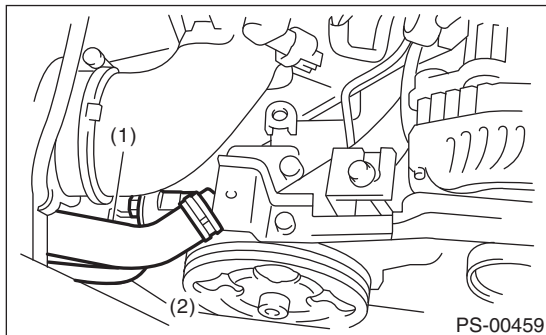

- (1) Suction hose
- (2) Pressure hose

5) Connect the connector to the power steering pump switch.

6) Install the V-belts to the oil pump.

7) Check the tension of the V-belt.

<Ref. to ME(H4SO)-48, INSPECTION, V-belt.>

8) Tighten the belt tension bolt.

Tightening torque:

25 N·m (2.5 kgf·m, 18.4 ft·lb)

9) Install the pulley belt cover.

10) Install the air intake duct.

11) Connect the ground cable to the battery.

12) Fill with the specified power steering fluid.

<Ref. to PS-50, Power Steering Fluid.>

CAUTION:

Never start the engine before filling with fluid; otherwise the vane pump may become seized.

Oil Pump

POWER ASSISTED SYSTEM (POWER STEERING)

C: INSPECTION

1. BASIC INSPECTION

Perform the following inspection procedures and replace faulty parts.

No.	Parts	Inspection	Corrective action
1	Oil pump (Exterior)	(1) Crack, damage or oil leakage	Replace the oil pump with a new part.
		(2) Play of pulley shaft	Measure the radial play and axial play. If any of these exceeds the service limit, replace the oil pump with a new part.
2	Pulley	(1) Damage	Replace with a new part.
		(2) Bend	Measure the V groove deflection. If it exceeds the service limit, replace the pulley with a new part.
3	Oil pump (Interior)	(1) Faulty or seized of vane pump	Check the rotating resistance of pulley. If it exceeds the service limit, replace the oil pump with a new part.
		(2) Bend in the shaft or damage to bearing	If the a string is wrapped on the pulley and rotated, and the oil pump emits a noise that is markedly different in tone and loudness from a sound of a new oil pump, replace the oil pump with a new part.
4	O-ring	Cracking or deterioration	Replace with a new part.
5	Bracket	Crack	Replace with a new part.

Oil Pump

POWER ASSISTED SYSTEM (POWER STEERING)

2. SERVICE LIMIT

Make a measurements as follows. If it exceeds the service limit, replace with a new part.

CAUTION:

- When securing the oil pump on a vise, hold the oil pump with the least possible force between two pieces of wood.
- Do not set the outside of flow control valve or pulley on a vise; otherwise outside or pulley might be deformed. Select properly sized wood pieces.

1) Play of the pulley shaft

Condition:

P: When applying the force of 9.8 N (1.0 kgf, 2.2 lbf)

Service limit:

Play in the radial direction (Direction ◀ ▶) 0.4 mm (0.016 in) or less

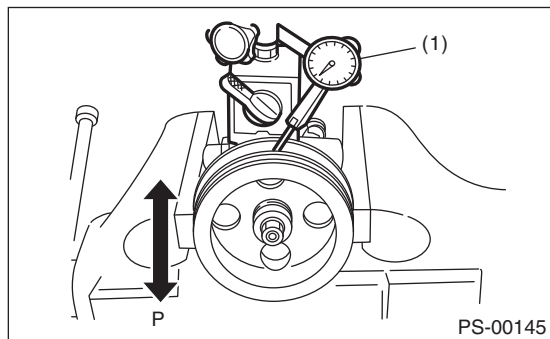

(1) Dial gauge

Axial play (Direction ◀ ▶) 0.9 mm (0.035 in) or less

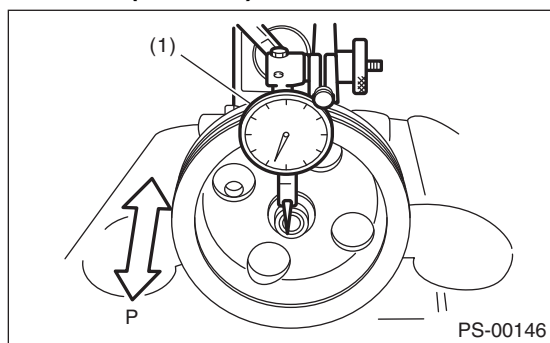

(1) Dial gauge

2) Deflection of the pulley groove

Service limit:

1.0 mm (0.039 in) or less

NOTE:

Read the value for one surface of V ditch, and then the value for another off the dial gauge.

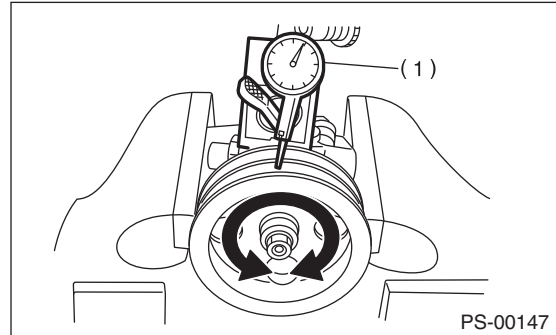

(1) Dial gauge

3) Rotating resistance of pulley

Service limit:

Maximum load: 9.22 N (0.94 kgf, 2.07 lbf) or less

NOTE:

- A rather higher value may be indicated when pulley starts turning.
- Measure the load during rotation to make a judgement.

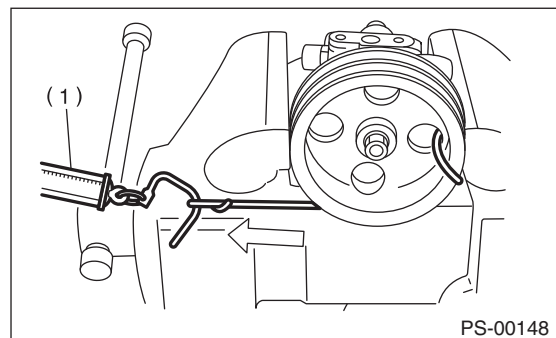

(1) Spring scale

Oil Pump

POWER ASSISTED SYSTEM (POWER STEERING)

3. HYDRAULIC PRESSURE

NOTE:

- To measure hydraulic pressure correctly, be sure to complete all the items in "INSPECTION", prior to performing the measurement. <Ref. to PS-51, INSPECTION, General Diagnostic Table.>
- Do not leave the valve of pressure gauge closed or hold the steering wheel at lock for 5 seconds or more in any case, this can damage the oil pump.
- Before attaching a pressure gauge, place cloth at locations where fluid is expected to spill. Wipe off any spill fluid completely after the measurement.

1) Regular pressure measurement

(1) Connect the ST1, ST2 and ST3.

ST1 925711000 PRESSURE GAUGE

ST2 34099AC020 ADAPTER HOSE B

ST3 34099AC010 ADAPTER HOSE A

(2) Remove the air intake duct.

(3) Disconnect the pipe C from pump.

(4) Using the gasket (Part No. 34621AC021) and bolt (Part No. 34620AC010), install the ST2 to pump instead of pressure hose.

- Non-turbo model

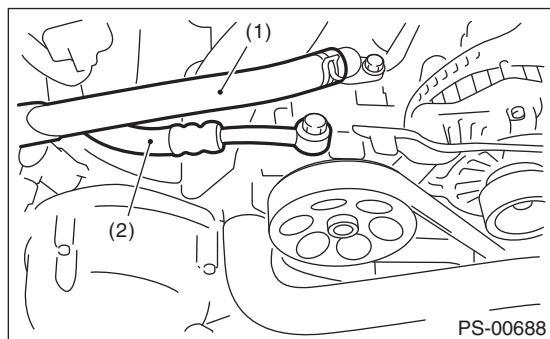

(1) Suction hose

(2) Pressure hose

- Turbo model

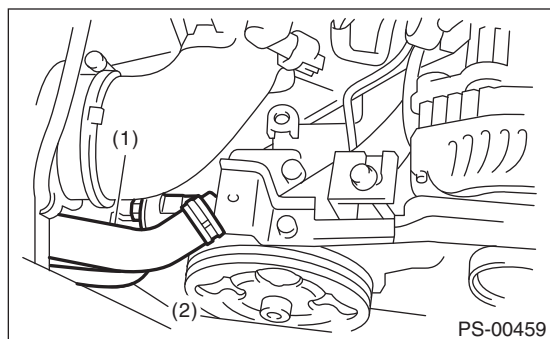

(1) Suction hose

(2) Pressure hose

(5) Attach the ST3 to the end of pressure hose which is removed from pump.

(6) Replenish power steering fluid up to the specified level.

(7) Open the valve, and start the engine.

(8) Measure the regular pressure.

ST1 925711000 PRESSURE GAUGE

ST2 34099AC020 ADAPTER HOSE B

ST3 34099AC010 ADAPTER HOSE A

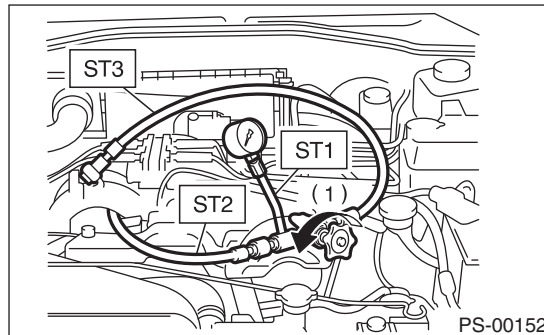

(1) Valve

Service limit:

981 kPa (10 kgf/cm², 142 psi) or less

(9) If it is not within the specification, replace the problem part for the following problems. (Pipe or hose clogged, leaks from fluid line, and mixture of foreign matter in fluid line)

2) Measure the relief pressure.

(1) Using the STs, measure the relief pressure.

(2) Close the valve.

(3) Measure the relief pressure.

ST1 925711000 PRESSURE GAUGE

ST2 34099AC020 ADAPTER HOSE B

ST3 34099AC010 ADAPTER HOSE A

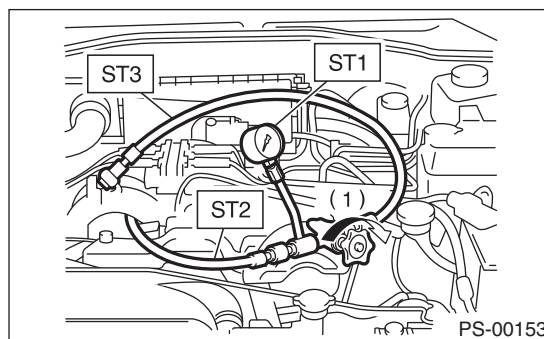

(1) Valve

Service limit:

Non-turbo model:

7,350 — 8,050 kPa

(75 — 82 kgf/cm², 1,066 — 1,167 psi)

Turbo model:

8,100 — 8,800 kPa

(83 — 90 kgf/cm², 1,174 — 1,276 psi)

(4) If it is not within the specification, replace the oil pump.

Oil Pump

POWER ASSISTED SYSTEM (POWER STEERING)

3) Measure the working pressure.

- (1) Using the ST, measure the working pressure.
- (2) Open the valve.
- (3) Measure the working pressure of control valve by turning steering wheel from stop to stop.

ST1 925711000 PRESSURE GAUGE
ST2 34099AC020 ADAPTER HOSE B
ST3 34099AC010 ADAPTER HOSE A

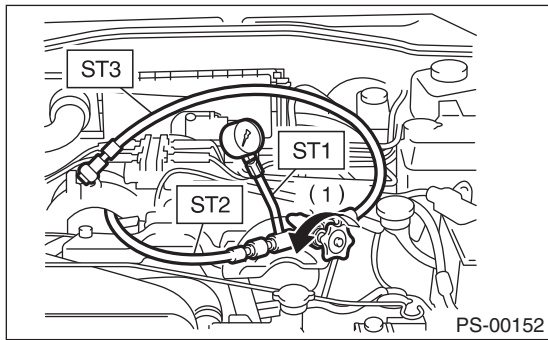

(1) Valve

Service limit:

Non-turbo model:

7,350 — 8,050 kPa

(75 — 82 kgf/cm², 1,066 — 1,167 psi)

Turbo model:

8,100 — 8,800 kPa

(83 — 90 kgf/cm², 1,174 — 1,276 psi)

- (4) If it is out of specification, measure the steering effort. <Ref. to PS-54, MEASUREMENT OF STEERING EFFORT, INSPECTION, General Diagnostic Table.> If it is not within specification, replace the control valve itself or control valve and pinion as a single unit, using new parts.

8. Reservoir Tank

A: REMOVAL

- 1) Drain fluid from the reservoir tank.
- 2) Disconnect the hose from reservoir tank.

CAUTION:

To prevent foreign matter from entering the hose and pipe, cover the open ends of them with clean cloth.

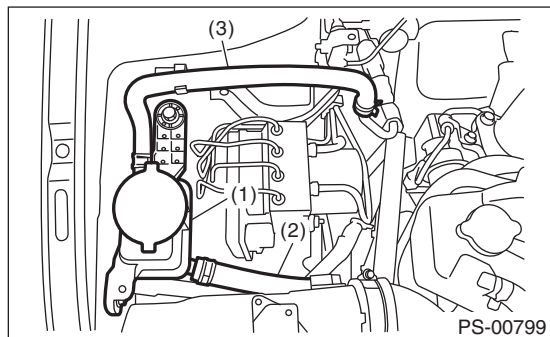

- (1) Reservoir tank
- (2) Suction hose
- (3) Return hose

- 3) Remove the reservoir tank from the body.

B: INSTALLATION

- 1) Install the reservoir tank to the body.

Tightening torque:

13 N·m (1.32 kgf·m, 9.6 ft·lb)

- 2) Connect the hose to the reservoir tank.

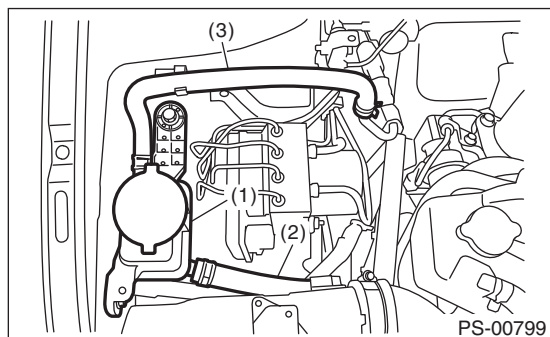

- (1) Reservoir tank
- (2) Suction hose
- (3) Return hose

- 3) Replenish power steering fluid up to the specified level. <Ref. to PS-50, INSPECTION, Power Steering Fluid.>

C: INSPECTION

Check the reservoir tank for cracks, breakage or damage. If a failure is found, replace the reservoir tank.

Power Steering Fluid

POWER ASSISTED SYSTEM (POWER STEERING)

9. Power Steering Fluid

A: SPECIFICATION

Recommended power steering fluid
SUBARU ATF or DEXRON III

B: INSPECTION

1) Check the power steering fluid for deterioration or contamination. If the fluid is highly deteriorated or contaminated, drain it and refill with new fluid.

2) Check the joints and units for oil leakage. If any oil leaks are found, repair or replace the applicable part.

3) Inspect the fluid level of reservoir tank with vehicle on level surface and engine stopped.

If the level is at "MIN." point or below, add fluid to keep the level in the specified range of the indicator. If at "MAX". point or above, drain fluid by using a syringe or the like.

(1) Check at power steering fluid temperature 20°C (68°F); read the fluid level on the "COLD" side.

(2) Check at power steering fluid temperature 80°C (176°F); read the fluid level on the "HOT" side.

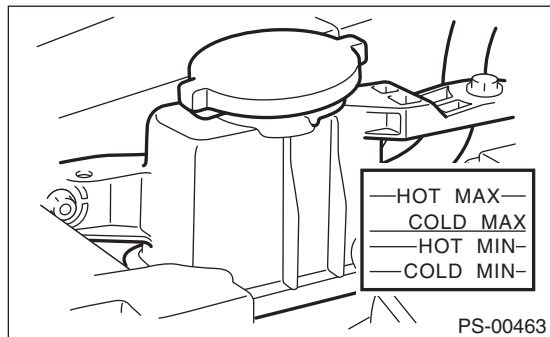

C: REPLACEMENT

1) Lift up the vehicle.
2) Remove the crossmember support.
3) Remove the pipe joint in the center of gearbox, and connect the vinyl hose to the pipe and joint. Wipe fluid off while turning the steering wheel.

4) Add the specified fluid to reservoir tank at "MAX" level.

5) Maintaining the fluid level of step 4), continue to turn the steering wheel slowly from lock to lock until the bubbles stop appearing on oil surface.

6) If the steering wheel is turned in a low fluid level condition, air will be sucked into the pipe. If air has entered, leave it for about half an hour and then repeat step 5) again.

7) Start the engine and let it idle.

8) Continue to turn the steering wheel slowly from lock to lock again until the bubbles stop appearing on oil surface, while keeping the fluid at the level in step 4).

Normally bubbles will stop appearing after turning the steering wheel from lock to lock three times.

9) In case bubbles do not stop appearing in the tank, leave it for about half an hour and then repeat step 4) again.

10) Lower the vehicle, and then idle the engine.

11) Continue to turn the steering wheel from lock to lock until the bubbles stop appearing and change of the fluid level is within 3 mm (0.12 in).

12) In case the following happens, leave it about half an hour and then do step 8) to 11) again.

(1) The fluid level changes 3 mm (0.12 in) or more.

(2) Bubbles remain on the upper surface of the fluid.

(3) Grinding noise is generated from oil pump.

13) Check the fluid leakage after turning steering wheel from lock to lock with engine running.

General Diagnostic Table

POWER ASSISTED SYSTEM (POWER STEERING)

10. General Diagnostic Table

A: INSPECTION

Trouble	Possible cause	Corrective action
<ul style="list-style-type: none"> Steering effort is heavy in all ranges. Steering effort is heavy at stand still. Steering wheel vibrates when turning. 	1. Pulley belt <ul style="list-style-type: none"> Unequal length of pulley belts Contact with oil or grease Looseness or damage of the pulley belt Poor uniformity of the pulley belt cross section Pulley belt touches to pulley bottom Poor revolution of pulleys (except oil pump pulley) Poor revolution of oil pump pulley 	Adjust or replace.
	2. Tire and wheel <ul style="list-style-type: none"> Improper tire out of specifications*1 Improper wheel out of specifications*1 Tires not properly inflated 	Replace or reinflate.
	3. Fluid <ul style="list-style-type: none"> Low fluid level Air entry in fluid Dust entry in fluid Fluid deterioration Inadequate warm-up of fluid*2 	Refill, bleed air, replace or instruct customer.
	4. Idle speed <ul style="list-style-type: none"> Lower idle speed Excessive drop of idle speed at start or when turning the steering wheel*3 	Adjust or instruct customer.
	5. Measure the hydraulic pressure. <Ref. to PS-45, INSPECTION, Oil Pump.>	Replace the problem parts.
	6. Measure the steering wheel effort. <Ref. to PS-54, MEASUREMENT OF STEERING EFFORT, INSPECTION, General Diagnostic Table.>	Adjust or replace.
<ul style="list-style-type: none"> Vehicle leads to one side or the other. Returning force of steering wheel to center is poor. Steering wheel vibrates when turning. 	1. Fluid line <ul style="list-style-type: none"> Folded hose Flattened pipe 	Correct or replace.
	2. Tire and wheel <ul style="list-style-type: none"> Flat tire Mixed use of different tires Mixed use of different wheels Abnormal wear of tire Unequal tread remaining Unequal pressure of tire 	Adjust, fix or replace.
	3. Front alignment <ul style="list-style-type: none"> Improper or unequal caster Improper or unequal toe-in Loose suspension connections 	Adjust or retighten.
	4. Others <ul style="list-style-type: none"> Damaged joint assembly Unbalanced height Unbalanced weight 	Replace, adjust or instruct customer.
	5. Measure the steering wheel effort. <Ref. to PS-54, MEASUREMENT OF STEERING EFFORT, INSPECTION, General Diagnostic Table.>	Adjust or replace.

*1 If the tires or wheels are wider than standard, the load to power steering system is increased. Accordingly, in a condition, for example before fluid warms-up, relief valve may work before reaching maximum turning angle. In this case, steering effort may be heavy. When the measured hydraulic pressure is normal, there is no abnormal thing.

*2 In cold weather, steering effort may be heavy due to increased flow resistance of cold fluid. After warming-up engine, turn the steering wheel from stop to stop several times to warm-up fluid. If steering effort reduces normally, function is normal.

*3 In cold weather or with insufficient warm-up of the engine, steering effort may be heavy due to excessive drop of idling when turning the steering wheel. In this case, start the vehicle with increasing engine speed than usual. If steering effort reduces normally, function is normal.

General Diagnostic Table

POWER ASSISTED SYSTEM (POWER STEERING)

1. NOISE AND VIBRATION

CAUTION:

Do not keep the relief valve operated for five seconds or more at any time or inner parts of the oil pump may be damaged due to rapid increase of fluid temperature.

NOTE:

- A screeching noise may be heard immediately after the engine start in extremely cold conditions. In this case, if the noise goes off during warm-up there is no abnormal function in the system. This is due to the fluid characteristics in extremely cold condition.
- The oil pump normally makes a small whining noise due to its mechanism. Even if a noise is heard when steering wheel is turned at stand still, there is no abnormal function in the system provided that the noise eliminates when the vehicle is driving.
- When turning the steering wheel with the brake applied when the vehicle is parked, a screeching noise may be generated by the brake disc and pads. This is not a fault in the steering system.
- There may be a small vibration around the steering devices when turning the steering wheel at standstill, even though the component parts are operating properly.

Hydraulic systems are likely to generate this kind of vibration as well as working noise and fluid noise because of combined conditions, i.e., road surface and tire surface, engine speed and turning speed of steering wheel, fluid temperature and braking condition.

These conditions do not indicate a problem in the system.

Confirm vibration for an AT model, by applying the parking brake on a concrete surface, shifting into the "D" range, and turning the steering wheel repeatedly from slow to rapid, step by step.

Trouble	Possible cause	Corrective action
Hiss noise (continuous) While engine is running.	Relief valve emits operating sound when steering wheel is completely turned in either direction. (Do not keep this condition for 5 seconds or more.)	Normal operation
	Relief valve emits operating sound when steering wheel is not turned. This means that the relief valve is defective.	Replace the oil pump.
Rattling noise (intermittent) While engine is running.	Interference with adjacent parts	Check the clearance. Correct if necessary. <Ref. to PS-55, INSPECTION OF CLEARANCE, INSPECTION, General Diagnostic Table.>
	Loosened installation of oil pump, oil tank, pump bracket, gearbox or crossmember	Retighten.
	Loose oil pump pulley or other pulley(s)	Retighten.
	Looseness of linkage, play of steering, improper tightening (looseness) of suspension joint or steering column	Retighten or replace.
	Sound generates from the inside of gearbox or oil pump.	Replace faulty parts in the gearbox or oil pump.
Knocking When turning steering wheel in both directions with small angle repeatedly at engine ON or OFF.	Excessive backlash Loosened lock nut for adjusting backlash	Adjust and retighten.
	Insufficient tightening or play in the tie-rod or tie-rod end	Retighten or replace.
Grinding noise (continuous) While engine is running.	Air in vane pump	Inspect and retighten the fluid line connection. Refill the fluid and vent air.
	Vane pump seizing	Replace the oil pump.
	Oil pump pulley bearing seized	Replace the oil pump.
	Folded hose, flattened pipe	Replace.
Squeal, squeak (intermittent or continuous) While engine is running.	Improper adjustment of pulley belt Damaged or over tensioned pulley belt Unequal length of pulley belts	Adjust or replace. (Replace two belts as a set.)
	Runout or dirty V-groove surface of oil pump pulley	Clean or replace.

General Diagnostic Table

POWER ASSISTED SYSTEM (POWER STEERING)

Trouble	Possible cause	Corrective action
Sizzling noise (continuous) While engine is running.	Fluid aeration	Fix the faulty part causing aeration. Replace the fluid and vent air.
	Damaged pipe of gearbox	Replace the pipe.
	Faulty inside of hose or pipe Flattened hose or pipe	Correct or replace.
	Abnormal inside of oil tank	Replace.
	Removed oil tank cap	Install cap.
Whistle (continuous) While engine is running.	Faulty pipe of gearbox or faulty hose	Replace the faulty parts of the gearbox or the hose.
Whine or growl (intermittent or continuous) While engine is running. (with/without steering operation)	Looseness of oil pump, oil pump bracket attachment	Retighten.
	Fault inside of oil pump or hose	Replace the oil pump or hose, if the noise can be heard when vehicle is running as well as being stopped.
	Torque converter growl, air conditioner compression growl	Remove the power steering pulley belt and check.
Grinding noise (continuous) While engine is running. (with steering operation)	Fault inside of gearbox	Replace the faulty parts of gearbox.
	Faulty steering shaft bearing	Apply grease or replace.
	Occurs when turning the steering wheel with brakes (service or parking) applied.	If the noise goes off when brake is released, it is normal.
Vibration While engine is running. (with/without steering operation)	Engine speed is too low.	Adjust, and notify customer.
	Air in vane pump	Repair faulty part Vent air.
	Damaged valve in oil pump or gearbox	Replace the faulty parts in gearbox and oil pump.
	Excessive play in steering, looseness of suspension parts	Retighten.

General Diagnostic Table

POWER ASSISTED SYSTEM (POWER STEERING)

2. MEASUREMENT OF STEERING EFFORT

Step	Check	Yes	No
1 CHECK STEERING EFFORT. 1) Stop the vehicle on paved road. 2) Start the engine. 3) Idle the engine. 4) Install a spring scale on the steering wheel. 5) Pull the spring scale at a right angle to the steering wheel, and measure both right and left steering wheel efforts. NOTE: When turning the steering more quickly than necessary from a direction to the other direction at an engine speed of 2,000 rpm or more, steering effort may be heavy. This is caused by flow characteristic of the fluid in the oil pump and is not a defect.	Is the steering effort less than 29.4 N (3.0 kgf, 6.6 lbf)?	Go to step 2.	Adjust the backlash.
2 CHECK STEERING EFFORT. 1) Stop the engine. 2) Pull the spring scale at a right angle to the steering wheel, and measure both right and left steering wheel efforts.	Is the steering effort less than 294.2 N (30 kgf, 66.2 lbf)?	Go to step 3.	Perform the adjustment.
3 CHECK STEERING WHEEL EFFORT. 1) Remove the universal joint. 2) Measure the steering wheel effort.	Is the steering effort less than 2.26 N (0.23 kgf, 0.51 lbf)?	Go to step 4.	Check, adjust and replace if necessary.
4 CHECK STEERING WHEEL EFFORT. Measure the steering wheel effort.	Is the difference of steering effort between right and left less than 20%?	Go to step 5.	Check, adjust and replace if necessary.
5 CHECK UNIVERSAL JOINT. Measure the swing torque of the joint. (Yoke of steering column side) <Ref. to PS-14, INSPECTION, Universal Joint.>	Is the swing torque of the universal joint less than 7.3 N (0.74 kgf, 1.64 lbf)?	Go to step 6.	Replace with a new part.
6 CHECK UNIVERSAL JOINT. Measure the swing torque of the joint. (Yoke of gearbox side) <Ref. to PS-14, INSPECTION, Universal Joint.>	Is the swing torque of the universal joint less than 3.8 N (0.39 kgf, 0.86 lbf)?	Go to step 7.	Replace with a new part.
7 CHECK FRONT WHEEL. Check the front wheels.	Does the front wheels have unsteady revolution or rattling, or does the brake drag?	Inspect, readjust and replace if necessary.	Go to step 8.
8 CHECK TIE-ROD ENDS. Remove the tie-rod ends.	If the tie-rod ends of suspension have unsteady revolution or rattling?	Inspect and replace if necessary.	Go to step 9.
9 BALL JOINT CHECK. Remove the ball joint.	If the ball joints of suspension have unsteady revolution or rattling?	Inspect and replace if necessary.	Go to step 10.
10 CHECK GEARBOX. Measure the rotating of gearbox. <Ref. to PS-33, TURNING RESISTANCE OF GEARBOX, INSPECTION, Steering Gearbox.>	Is the rotational resistance of the steering gearbox less than 13 N (1.3 kgf, 2.9 lbf)? Is the difference between clockwise and counter-clockwise less than 24 %?	Steering effort is normal.	Readjust the backlash, and if ineffective, replace the faulty parts.

General Diagnostic Table

POWER ASSISTED SYSTEM (POWER STEERING)

3. INSPECTION OF CLEARANCE

This table lists various clearances that must be correctly adjusted to ensure the normal vehicle driving without interfering noise, or any other faults.

Install locations	Minimum allowance mm (in)
(1) Crossmember to-Hose ASSY	3 (0.12)
(2) Front exhaust pipe to Hose ASSY	15 (0.59)
(3) Front frame side to Hose ASSY	10 (0.39)
(4) Turbo cover to Hose ASSY	10 (0.39)
(5) Master cylinder to Return hose	10 (0.39)
(6) Master cylinder to Hose clip	10 (0.39)
(7) VDC H/U to Hose ASSY	5 (0.20)
(8) Air cleaner to Hose ASSY	5 (0.20)
(9) Air boot to Hose ASSY	10 (0.39)
(10) Air cleaner hose to Hose ASSY	10 (0.39)
(11) Blow-by hose to Hose ASSY	8 (0.31)
(12) Over flow hose to Hose ASSY	8 (0.31)
(13) Brake pipe to Return hose	10 (0.39)
(14) Front suspension bracket to Return hose	5 (0.20)
(15) Front wheel apron to Return hose	5 (0.20)
(16) VDC H/U bracket to Suction hose	5 (0.20)
(17) Air cleaner case to Suction hose	5 (0.20)
(18) Air intake duct to Suction hose	10 (0.39)
(19) Air duct to Suction hose	10 (0.39)
(20) Front wheel apron to Reservoir tank	5 (0.20)
(21) VDC H/U to Reserve tank	5 (0.20)
(22) Valve housing to DOJ (5MT model)	12 (0.47)
(23) Valve housing to Crossmember (Hole)	1 (0.04)
(24) Cannon mount to Crossmember	There must be no contact
(25) Pipe to Crossmember	5 (0.20)
(26) Pipe to Stabilizer	15 (0.59)
(27) Pipe to Exhaust pipe	18 (0.71)
(28) Tie rod end to Brake dust cover	2.5 (0.10)
(29) Universal joint coupling to Turbo cover	15 (0.59)
(30) Universal joint column side yoke to Master cylinder (Closest point of approach when the universal joint turns by 360°)	5 (0.20)
(31) Universal joint coupling to ATF level gauge	10 (0.39)

General Diagnostic Table

POWER ASSISTED SYSTEM (POWER STEERING)

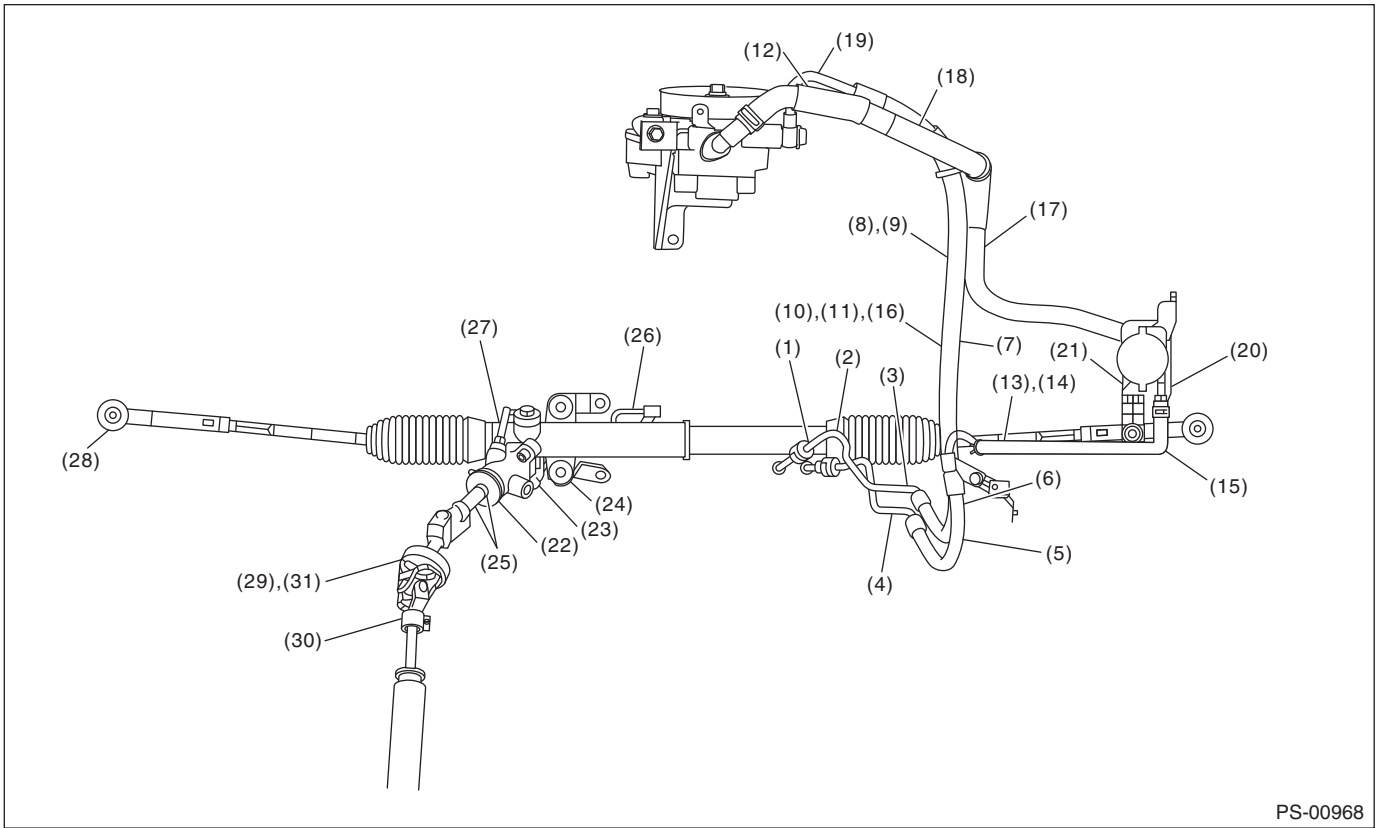

PS-00968

BODY SECTION

This service manual has been prepared to provide SUBARU service personnel with the necessary information and data for the correct maintenance and repair of SUBARU vehicles.

This manual includes the procedures for maintenance, disassembling, reassembling, inspection and adjustment of components and diagnostics for guidance of experienced mechanics.

Please peruse and utilize this manual fully to ensure complete repair work for satisfying our customers by keeping their vehicle in optimum condition. When replacement of parts during repair work is needed, be sure to use SUBARU genuine parts.

All information, illustration and specifications contained in this manual are based on the latest product information available at the time of publication approval.

**HVAC SYSTEM
(HEATER, VENTILATOR AND A/C)** AC

**HVAC SYSTEM (AUTO A/C)
(DIAGNOSTICS)** AC(diag)

AIRBAG SYSTEM AB

AIRBAG SYSTEM (DIAGNOSTICS) AB(diag)

**OCCUPANT DETECTION SYSTEM
(DIAGNOSTICS)** OD(diag)

SEAT BELT SYSTEM SB

LIGHTING SYSTEM LI

WIPER AND WASHER SYSTEMS WW

ENTERTAINMENT ET

COMMUNICATION SYSTEM COM

GLASS/WINDOWS/MIRRORS GW

BODY STRUCTURE BS

INSTRUMENTATION/DRIVER INFO IDI

SEATS SE

SECURITY AND LOCKS SL

**SUNROOF/T-TOP/CONVERTIBLE TOP
(SUNROOF)** SR

EXTERIOR/INTERIOR TRIM EI

BODY SECTION

EXTERIOR BODY PANELS

EB

CRUISE CONTROL SYSTEM

CC

**CRUISE CONTROL SYSTEM
(DIAGNOSTICS)**

CC(diag)

IMMOBILIZER (DIAGNOSTICS)

IM(diag)

LAN SYSTEM (DIAGNOSTICS)

LAN(diag)

HVAC SYSTEM (HEATER, VENTILATOR AND A/C)

AC

	Page
1. General Description	2
2. Refrigerant Pressure with Manifold Gauge Set	16
3. Refrigerant Recovery Procedure	17
4. Refrigerant Charging Procedure	18
5. Refrigerant Leak Check	21
6. Compressor Oil	22
7. Blower Motor Unit Assembly	23
8. Blower Motor	24
9. Power Transistor (Auto A/C Model)	25
10. Blower Resistor (Manual A/C Model)	26
11. Heater Core	27
12. Control Unit (Manual A/C Model)	28
13. Control Unit (Auto A/C Model)	29
14. Compressor	30
15. Condenser	31
16. Heater and Cooling Unit	32
17. Evaporator	33
18. Hose and Pipe	35
19. Relay and Fuse	36
20. Pressure Switch (Triple Pressure Switch)	37
21. Ambient Sensor (Auto A/C Model)	38
22. Sunload Sensor (Auto A/C Model)	39
23. In-vehicle Sensor (Auto A/C Model)	40
24. Air Vent Grille	41
25. Heater Duct	42
26. Heater Vent Duct	43
27. A/C Filter	44
28. General Diagnostic Table	45

General Description

HVAC SYSTEM (HEATER, VENTILATOR AND A/C)

1. General Description

A: SPECIFICATION

1. HEATER SYSTEM

Item		Specification	Condition
Heating capacity		5.0 kW (4,299 kcal/h, 17,059 BTU/h) or more	<ul style="list-style-type: none"> • Mode selector switch: HEAT • Temperature control switch: FULL HOT • Temperature difference between hot water and inlet air: 65°C (149°F) • How water flow rate: 360 ℓ (95.1 US gal, 79.2 Imp gal)/h
Air flow rate		290 m ³ (10,243 cu ft)/h	Heat mode (FRESH), FULL HOT at 12.5 V
Max air flow rate		480 m ³ (16,954 cu ft)/h	<ul style="list-style-type: none"> • Temperature control switch: FULL COLD • Blower fan speed: Auto A/C: 7th position Manual A/C: 4th position • Mode selector lever: RECIRC
Heater core size (height × length × width)		257.5 × 118.5 × 27 mm (10.1 × 4.67 × 1.06 in)	—
Blower motor	Type	Magnet motor 250 W or less	12 V
	Fan type and size (diameter × width)	Sirocco fan type 150 × 75 mm (5.91 × 2.95 in)	—

2. A/C SYSTEM

Item		Specification
Type of air conditioner		Reheat air-mix type
Cooling capacity		5.0 kW [at 480 m ³ (16,954 cu ft) /h] (4,299 kcal/h, 17,059 BTU/h)
Refrigerant		HFC-134a (CH ₂ FCF ₃) [0.5±0.03 kg (1.1±0.07 lb)]
Compressor	Type	Rotary, constant volume (DVK-10R)
	Discharge	105 cc (6.41 cu in)/rev
	Max. permissible speed	7,700 rpm
Magnet clutch	Type	Dry, single-disc type
	Power consumption	38.8 W
	Type of belt	V-belt 4 PK
	Pulley dia. (effective dia.)	100 mm (3.9 in)
	Pulley ratio	1.32
Condenser	Type	Sub cool type
	Core face area	0.188 m ² (2.002 sq ft)
	Core thickness	16 mm (0.63 in)
	Radiation area	4.5 m ² (48.44 sq ft)
Receiver drier	Effective inner capacity	177 cm ³ (10.8 cu in)
Expansion valve	Type	Block
Evaporator	Type	Double tank
	Dimensions (W × H × T)	290.1 × 172 × 39 mm (11.42 × 6.77 × 1.54 in)
Blower fan	Fan type	Sirocco fan
	Outer diameter × width	150 × 75 mm (5.91 × 2.95 in)
	Power consumption	250 W

General Description

HVAC SYSTEM (HEATER, VENTILATOR AND A/C)

Item		Specification	
Condenser fan (Sub fan)	Motor type	Magnet	
	Power consumption	Non-turbo model: 90 W Turbo model: 120 W	
	Fan outer diameter	Non-turbo model: 300 mm (11.8 in) Turbo model: 318.5 mm (12.5 in)	
Radiator fan (Main fan)	Motor type	Magnet	
	Power consumption	Non-turbo model: 90 W Turbo model: 120 W	
	Fan outer diameter	Non-turbo model: 300 mm (11.8 in) Turbo model: 318.5 mm (12.5 in)	
Idle speed	MPI model	Non-turbo MT model (no load): 650±100 rpm Non-turbo MT model (A/C on): 850±100 rpm Non-turbo AT model (no load): 700±100 rpm Non-turbo AT model (A/C on): 850±100 rpm Turbo model (no load): 700±100 rpm Turbo model (A/C on): 825±100 rpm	
Triple switch (Pressure switch)	Low-pressure switch operating pressure	ON → OFF	177±25 kPa (1.80±0.25 kgf/cm ² , 25.7±3.6 psi)
		OFF → ON	206±30 kPa (2.10±0.31 kgf/cm ² , 29.9±4.3 psi)
	High-pressure switch operating pressure	ON → OFF	2,940±200 kPa (29.98±2.04 kgf/cm ² , 426.3±29 psi)
		OFF → ON	2,350±200 kPa (24.00±2.04 kgf/cm ² , 340.7±29.0 psi)
	Middle-pressure switch operating pressure	ON → OFF	1,470±120 kPa (14.99±1.22 kgf/cm ² , 213.15±17.4 psi)
		OFF → ON	1,770±100 kPa (18.05±1.02 kgf/cm ² , 256.65±14.5 psi)
Thermo-control amplifier working temperature	<p style="text-align: right;">AC-00601</p> <p>(1) ON (2) OFF (3) 1.5±0.3°C (34.7±0.5°F) (4) 1.0±0.5°C (33.8±0.9°F)</p>		

General Description

HVAC SYSTEM (HEATER, VENTILATOR AND A/C)

B: COMPONENT

1. HEATER COOLING UNIT

- Auto A/C model

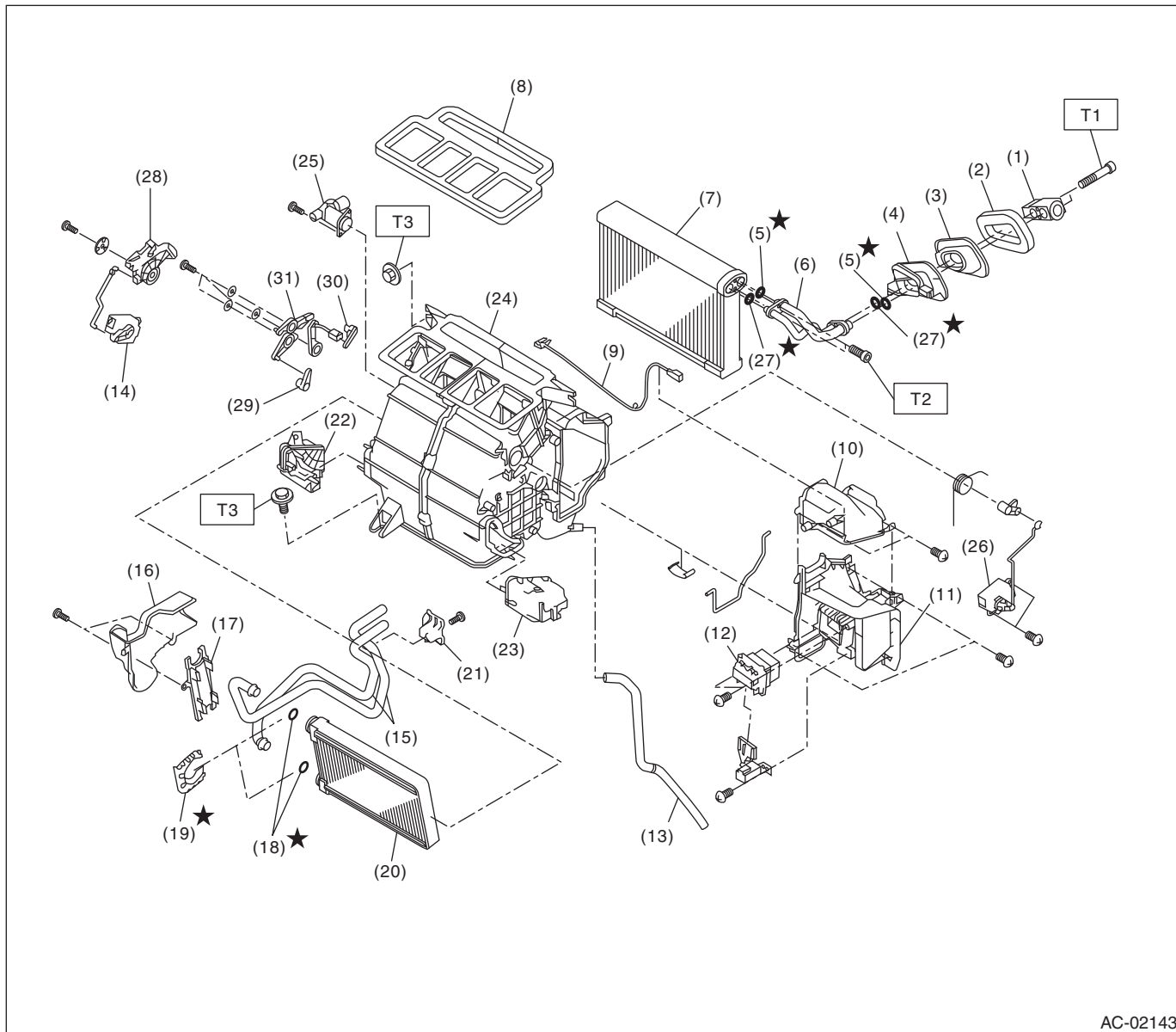

- | | | |
|----------------------------|------------------------|--------------------------|
| (1) Expansion valve | (13) Drain hose | (25) Aspirator |
| (2) Gasket | (14) Mode actuator | (26) Air mix actuator |
| (3) Grommet | (15) Heater core pipe | (27) O-ring |
| (4) Case | (16) Heater pipe cover | (28) Mode main lever |
| (5) O-ring | (17) Heater core cover | (29) Vent door link |
| (6) Evaporator pipe | (18) O-ring | (30) Defroster door link |
| (7) Evaporator | (19) Clamp | (31) Mode link |
| (8) Lining | (20) Heater core | |
| (9) Evaporator sensor | (21) Pipe clamp | |
| (10) Evaporator pipe cover | (22) Foot duct (LH) | |
| (11) Evaporator cover | (23) Foot duct (RH) | |
| (12) Power transistor | (24) Heater case | |

Tightening torque: N·m (kgf·m, ft·lb)

T1: 5.0 (0.5, 3.7)

T2: 6.68 (0.7, 4.9)

T3: 7.5 (0.76, 5.5)

General Description

HVAC SYSTEM (HEATER, VENTILATOR AND A/C)

- Manual A/C model

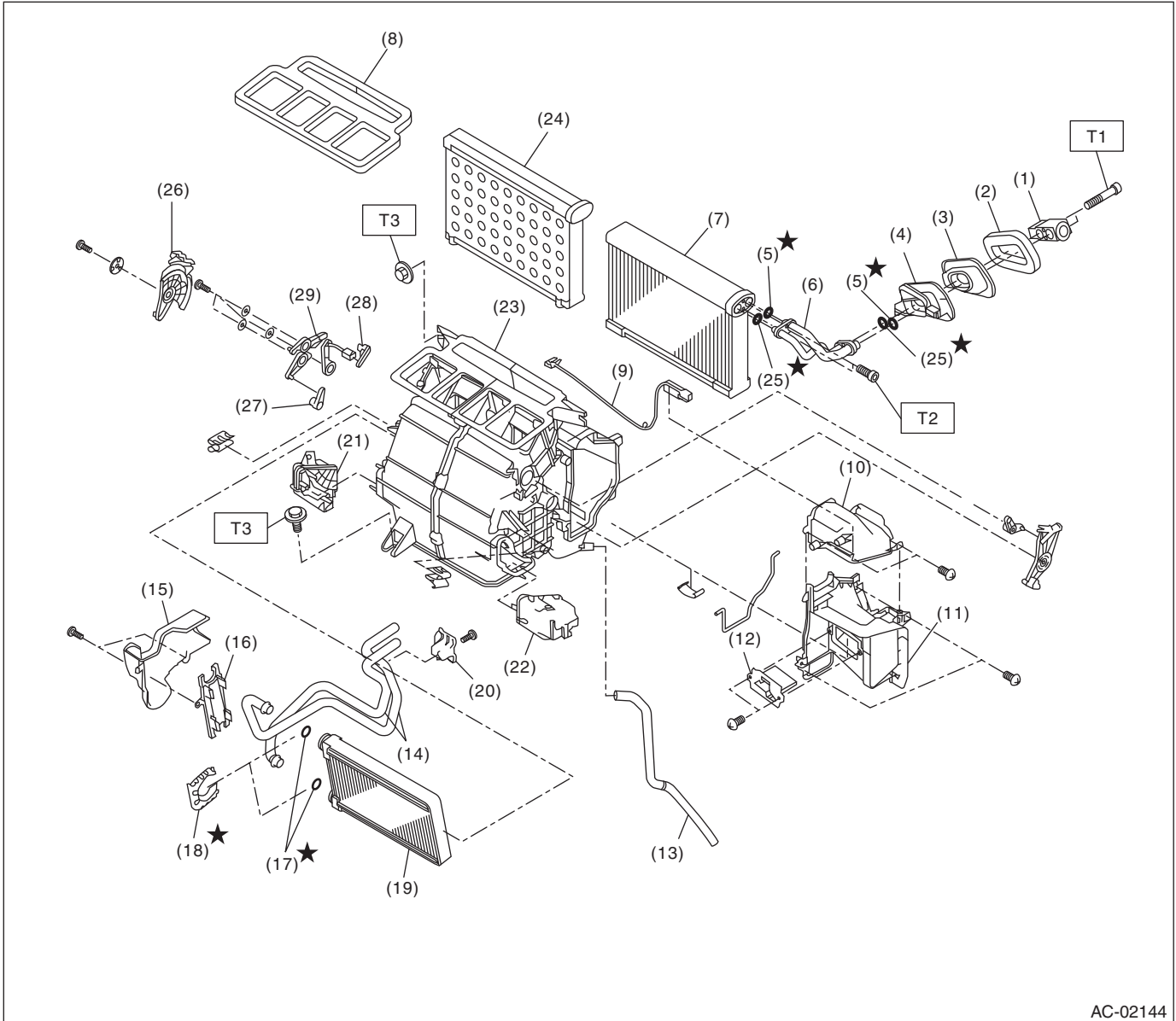

AC-02144

- | | | |
|----------------------------|------------------------|--------------------------------|
| (1) Expansion valve | (13) Drain hose | (24) Plate (Model without A/C) |
| (2) Gasket | (14) Heater core pipe | (25) O-ring |
| (3) Grommet | (15) Heater pipe cover | (26) Mode main lever |
| (4) Case | (16) Heater core cover | (27) Vent door link |
| (5) O-ring | (17) O-ring | (28) Defroster door link |
| (6) Evaporator pipe | (18) Clamp | (29) Mode link |
| (7) Evaporator | (19) Heater core | |
| (8) Lining | (20) Pipe clamp | |
| (9) Thermostat | (21) Foot duct (LH) | |
| (10) Evaporator pipe cover | (22) Foot duct (RH) | |
| (11) Evaporator cover | (23) Heater case | |
| (12) Resistor | | |

Tightening torque: N·m (kgf·m, ft·lb)

T1: 5.0 (0.5, 3.7)

T2: 6.68 (0.7, 4.9)

T3: 7.5 (0.76, 5.5)

General Description

HVAC SYSTEM (HEATER, VENTILATOR AND A/C)

2. BLOWER MOTOR UNIT

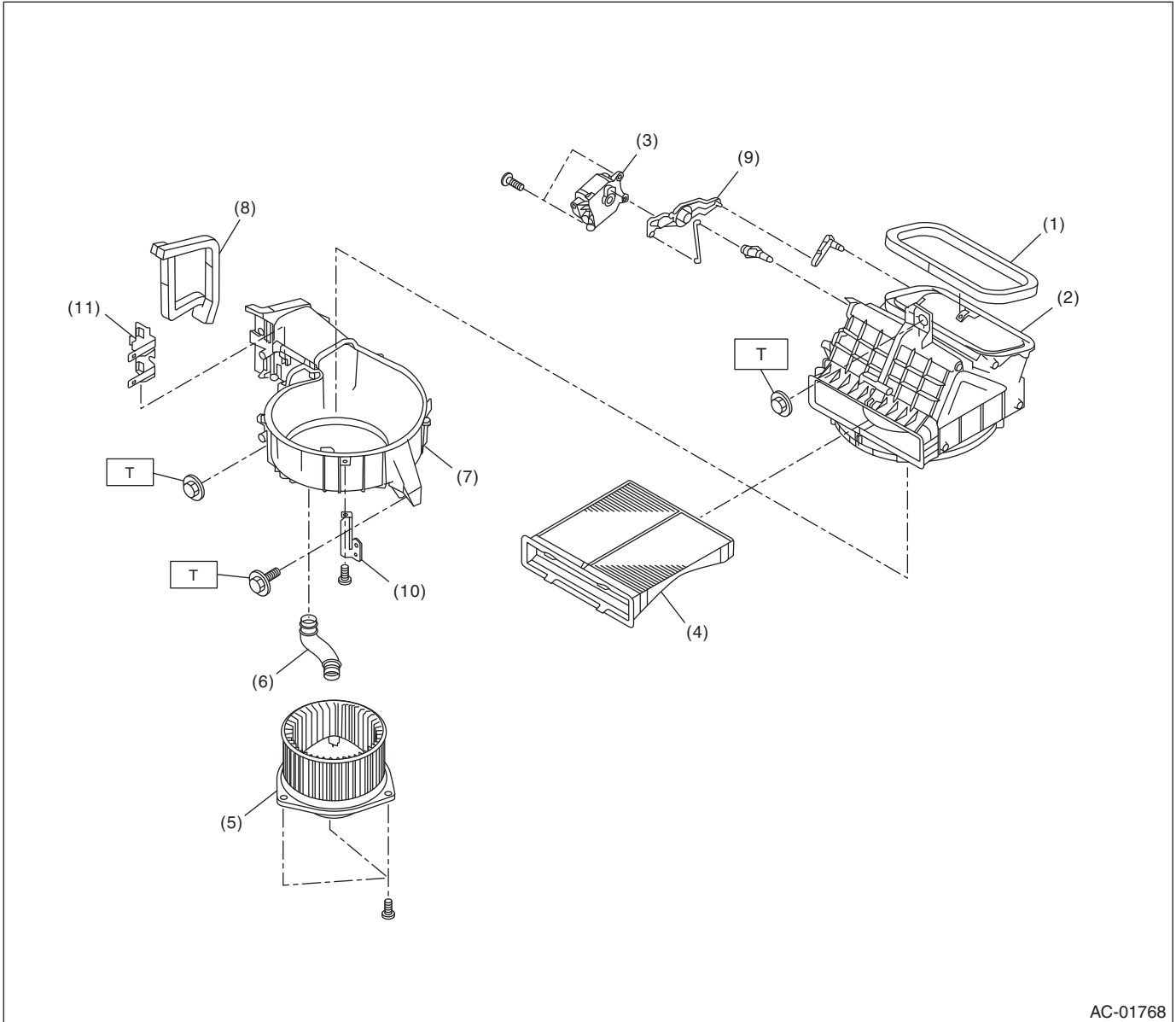

AC-01768

- | | | |
|--------------------------|----------------------|---------------------------|
| (1) Lining | (6) Hose | (11) Relay holder bracket |
| (2) Upper case | (7) Lower case | |
| (3) Intake door actuator | (8) Lining | |
| (4) Filter | (9) Intake door link | |
| (5) Blower motor ASSY | (10) Relay bracket | |

Tightening torque: N·m (kgf·m, ft·lb)
T: 7.5 (0.76, 5.5)

General Description

HVAC SYSTEM (HEATER, VENTILATOR AND A/C)

3. CONTROL MODULE

- Auto A/C model

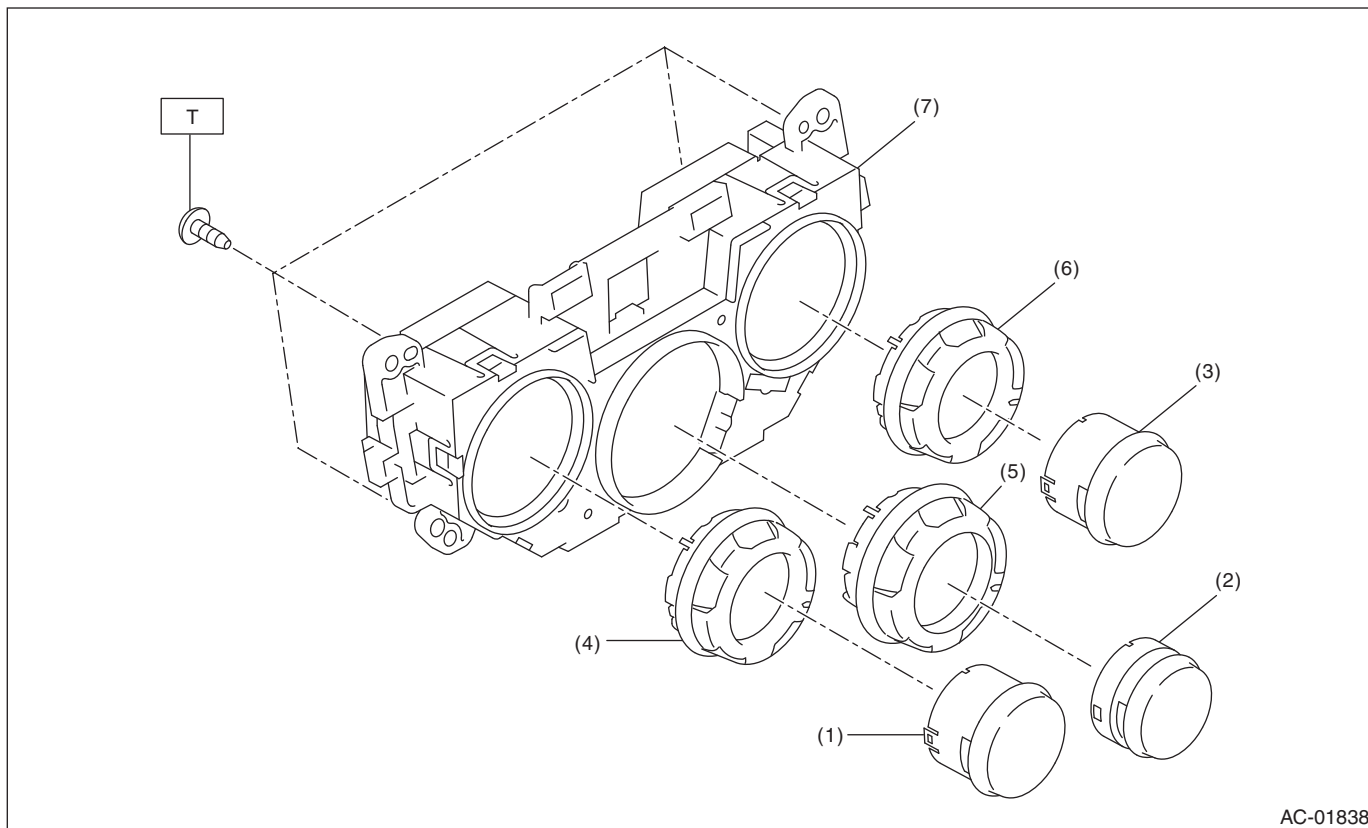

AC-01838

- (1) FRESH/RECIRC switch
- (2) Rear defogger switch
- (3) A/C switch
- (4) Fan speed control dial

- (5) Mode control dial
- (6) Temperature adjustment dial
- (7) Control case

Tightening torque: N·m (kgf-m, ft-lb)
T: 2 (0.2, 1.48)

General Description

HVAC SYSTEM (HEATER, VENTILATOR AND A/C)

- Manual A/C model

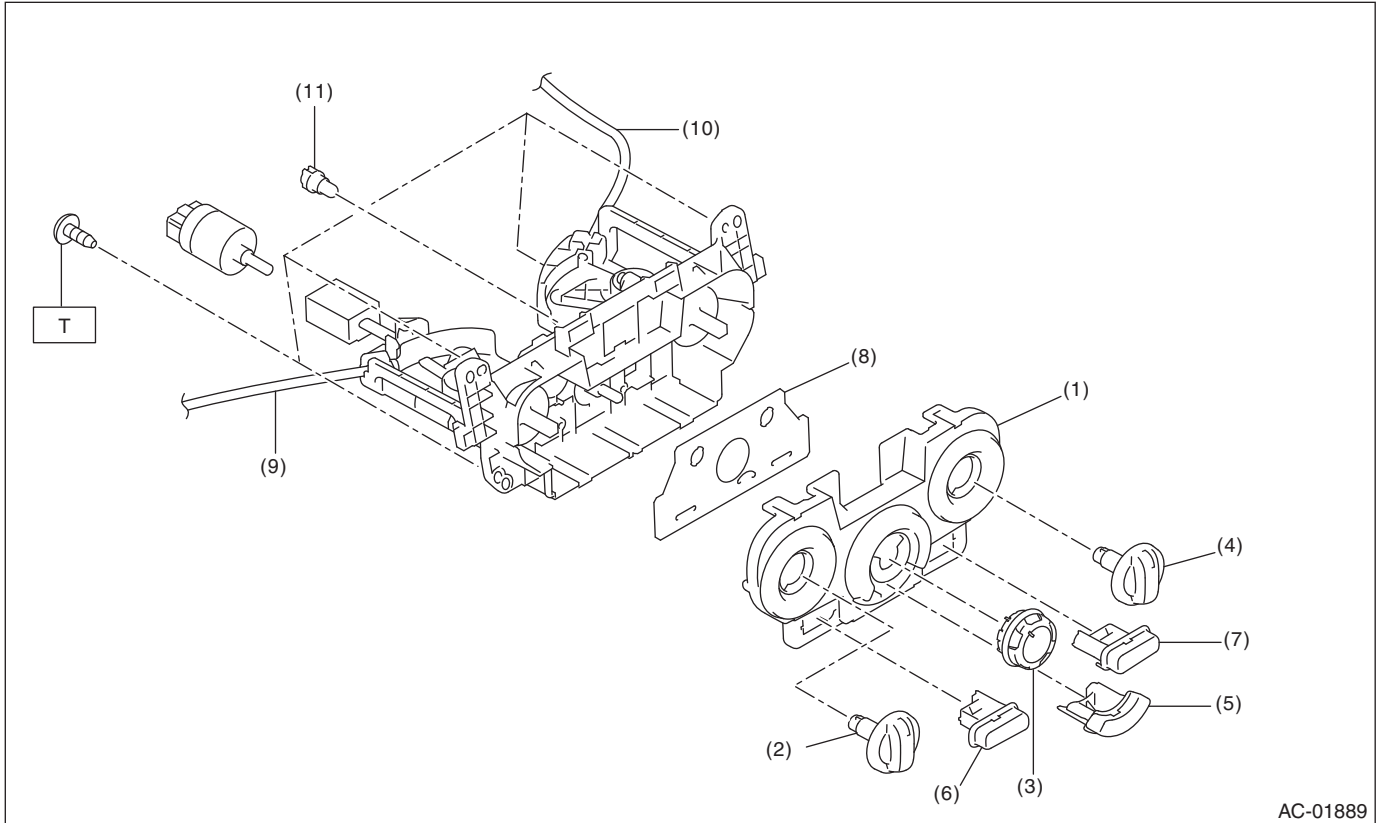

- | | |
|---------------------------------|--------------------------------|
| (1) Panel | (6) Rear defogger switch |
| (2) Air flow control dial | (7) FRESH/RECIRC switch |
| (3) Fan speed control dial | (8) Switch board |
| (4) Temperature adjustment dial | (9) Mode switch cable |
| (5) A/C switch | (10) Temperature control cable |

- (11) Valve

Tightening torque: N·m (kgf·m, ft·lb)

T: 2 (0.2, 1.48)

General Description

HVAC SYSTEM (HEATER, VENTILATOR AND A/C)

4. AIR CONDITIONING UNIT

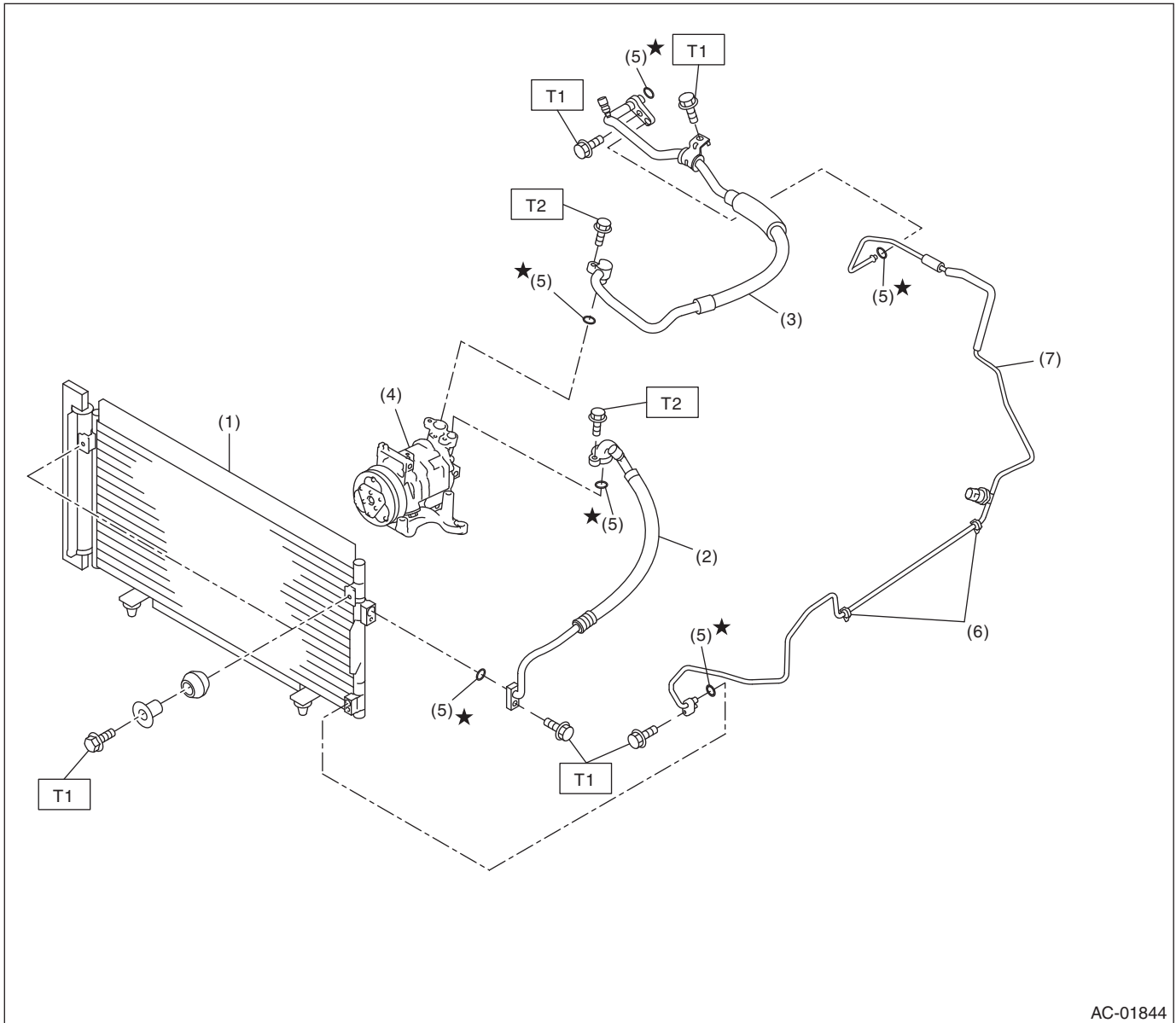

AC-01844

- | | |
|--------------------------|------------|
| (1) Condenser | (5) O-ring |
| (2) Hose (High-pressure) | (6) Clamp |
| (3) Hose (Low-pressure) | (7) Pipe |
| (4) Compressor | |

Tightening torque: N·m (kgf·m, ft·lb)

T1: 7.5 (0.76, 5.5)

T2: 10 (1.0, 7.4)

General Description

HVAC SYSTEM (HEATER, VENTILATOR AND A/C)

5. COMPRESSOR

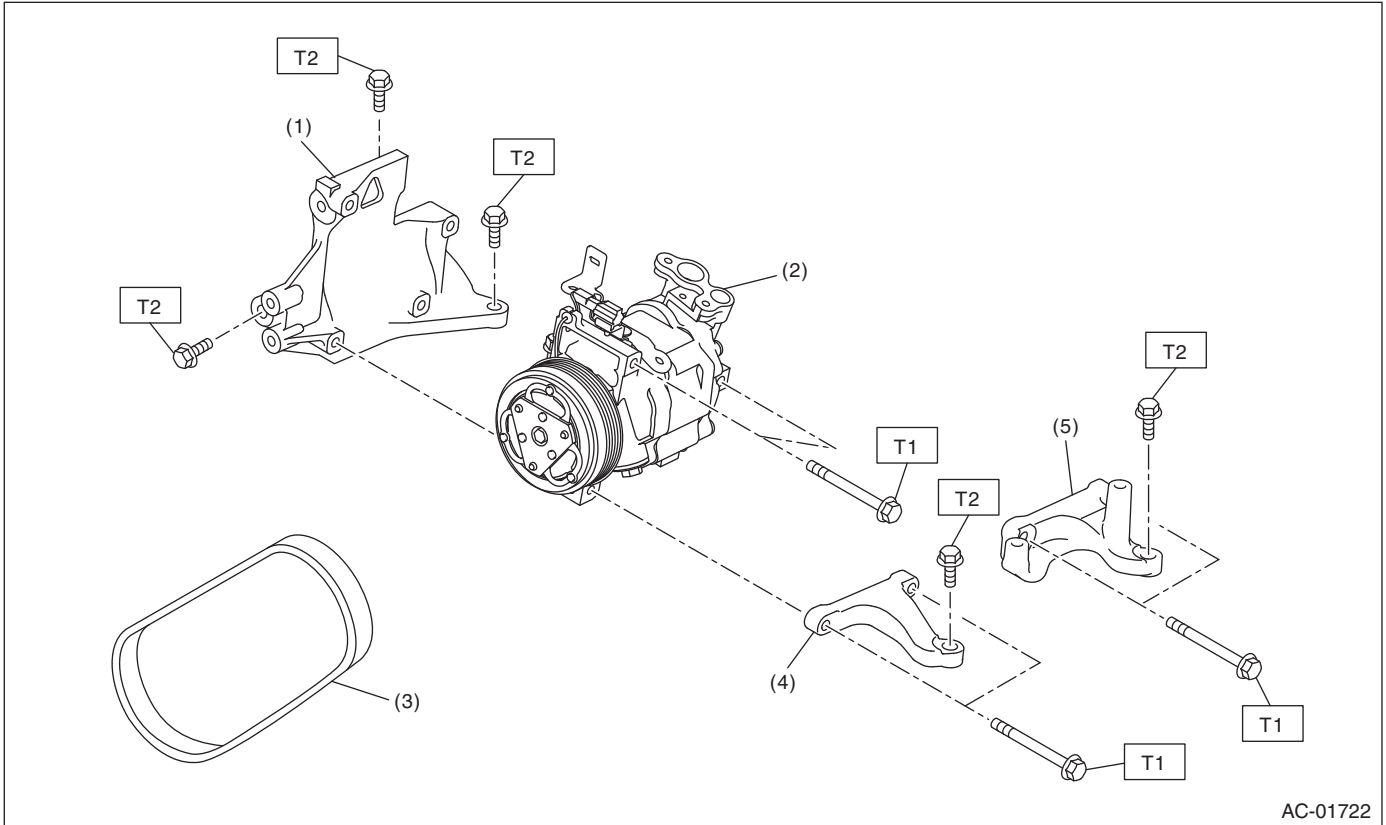

AC-01722

- (1) Compressor bracket
- (2) Compressor
- (3) V-belt

- (4) Compressor bracket (Non-turbo model)
- (5) Compressor bracket (Turbo model)

Tightening torque: N·m (kgf·m, ft·lb)

T1: 26.5 (2.7, 19.5)

T2: 36 (3.7, 26.6)

General Description

HVAC SYSTEM (HEATER, VENTILATOR AND A/C)

6. HEATER DUCT

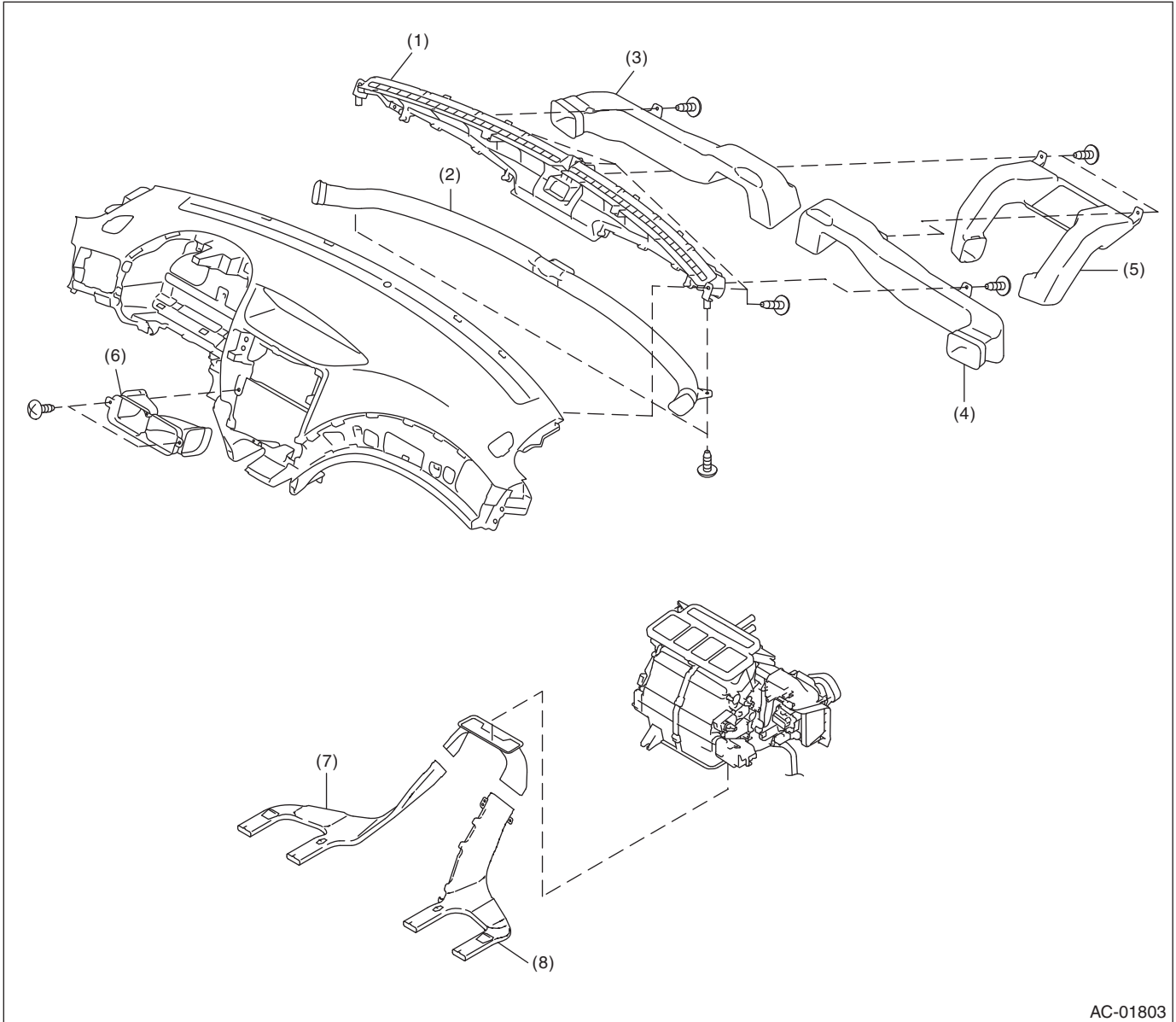

AC-01803

(1) Front defroster nozzle

(2) Side defroster duct

(3) Side ventilation duct (LH)

(4) Side ventilation duct (RH)

(5) Center ventilation duct (A)

(6) Center ventilation duct (B)

(7) Rear heater duct (LH)

(8) Rear heater duct (RH)

General Description

HVAC SYSTEM (HEATER, VENTILATOR AND A/C)

C: CAUTION

1. HFC-134A A/C SYSTEM

- The cooling system components for the HFC-134a system such as the refrigerant and compressor oil are different from the conventional CFC-12 system components and they are incompatible with each other.
- Vehicles with the HFC-134a system can be identified by the label (A) attached to the vehicle. Before maintenance, check which A/C system is installed to the vehicle.

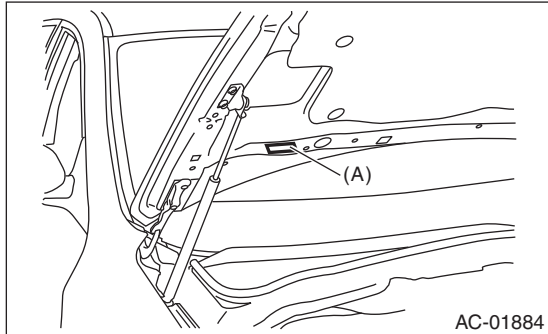

2. COMPRESSOR OIL

- HFC-134a compressor oil has no compatibility with that of CFC-12 system.
 - Use only the manufacturer-authorized compressor oil for the HFC-134a system; only use DH-PR (ZXL200PG).
 - Do not mix multiple compressor oils.
- If CFC-12 compressor oil is used in the HFC-134a A/C system, the compressor may become stuck due to poor lubrication, or the refrigerant may leak due to swelling of rubber parts.
- On the other hand, if HFC-134a compressor oil is used in a CFC-12 A/C system, the durability of the A/C system will be lowered.
- HFC-134a compressor oil is very hygroscopic. When replacing or installing/removing A/C parts, immediately isolate the oil from atmosphere using a plug or tape. In order to avoid moisture, store the oil in a container with its cap tightly closed.

3. REFRIGERANT

- CFC-12 refrigerant cannot be used in a HFC-134a A/C system. HFC-134a refrigerant, also cannot be used in a CFC-12 A/C system.
- If an incorrect or no refrigerant is used, it will result in poor lubrication and the compressor itself may be damaged.

4. HANDLING OF REFRIGERANT

- The refrigerant boils at approx. -30°C (-22°F). When handling it, be sure to wear protective goggles and protective gloves. Direct contact of the refrigerant with skin may cause frostbite. If the refrigerant gets into your eye, avoid rubbing your eyes with your hands. Wash your eye with plenty of water, and receive medical treatment from an eye doctor.
- Do not heat a service can. If a service can is directly heated, or put into boiling water, the inside pressure will become extremely high. This may cause the can to explode. If a service can must be warmed up, use warm water of 40°C (104°F) or less.
- Do not drop or impact a service can. (Observe the precautions and operation procedure described on the refrigerant can.)
- When the engine is running, do not open the high-pressure valve of the manifold gauge. High-pressure gas may backflow, causing the can to explode.
- Provide good ventilation and do not work in a closed area.
- In order to prevent global warming, avoid releasing HFC-134a into the atmosphere. Using a refrigerant recovery system, discharge and recycle the gas.

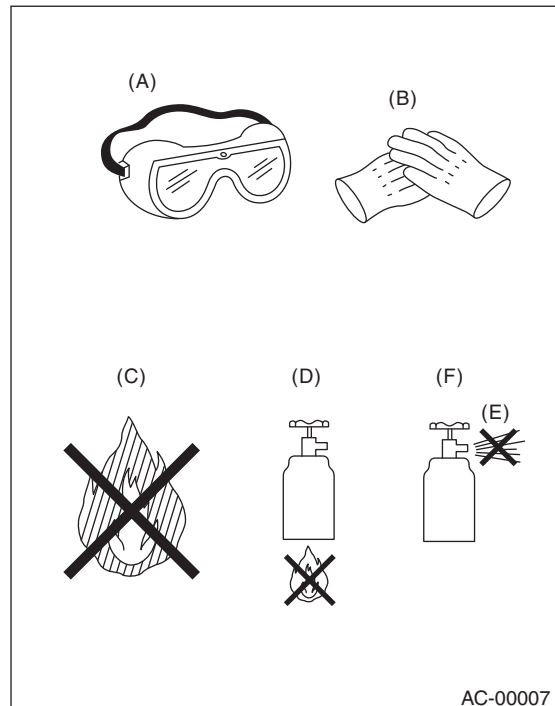

- (A) Goggles
- (B) Gloves
- (C) Avoid open flame
- (D) No direct heat on container
- (E) Do not discharge
- (F) Loosen

General Description

HVAC SYSTEM (HEATER, VENTILATOR AND A/C)

5. O-RING CONNECTIONS

- Always use a new O-ring.
- In order to keep the O-rings free of lint which will cause a refrigerant gas leak, perform work without using gloves or waste cloths.
- Apply compressor oil to O-rings to avoid sticking, before installation.
- Use a torque wrench to tighten the O-ring fittings. Over-tightening will result in damage of the O-ring and deformation of the pipe end.
- If the work is interrupted before completing pipe connections, recap the pipes, components and fittings with a plug or tape to prevent foreign matter from entering.

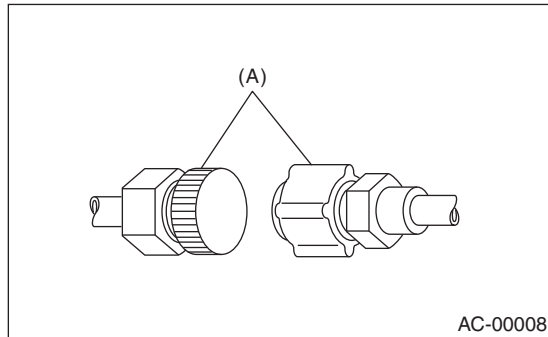

(A) Seal

- Visually check the surfaces and mating surfaces of O-rings, threads and connecting points. If a failure is found, replace the applicable parts.
- Install the O-rings straight against the groove of the pipe.

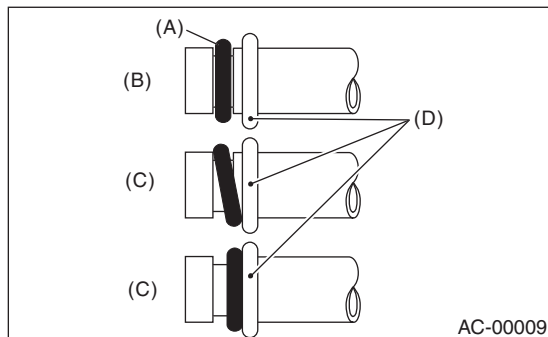

- (A) O-ring
- (B) OK
- (C) NG
- (D) Groove

- Use compressor oil specified in the service manual to lubricate the O-rings. Apply oil to the top and sides of O-rings before installation. Apply compressor oil to grooves of the pipe.

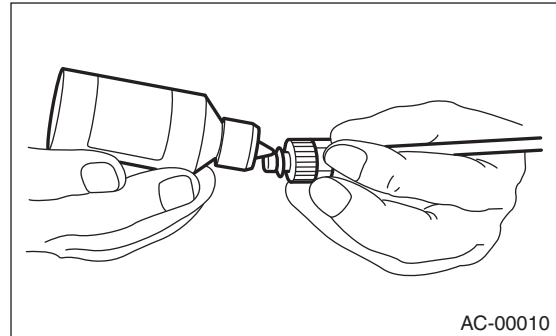

- After tightening, use a clean cloth to remove excess compressor oil from the connections and any oil which may have run on the vehicle body or other parts.
- If any leakage is suspected after tightening, do not tighten the connections further, but disconnect the connections, remove the O-rings, and check the O-rings, threads, and connections.

D: PREPARATION TOOL

CAUTION:

When working on vehicles with a HFC-134a system, only use HFC-134a specified tools and parts. Do not mix CFC-12 tools and parts. If HFC-134a and CFC-12 refrigerant or compressor oil is mixed, it will result in poor lubrication and the compressor itself may be damaged.

In order to prevent the mixing HFC-134a and CFC-12 parts and fluids, the type of tools, screw types, and replacement valves are different. The gas leak detectors for the HFC-134a and CFC-12 systems must also not be interchanged.

	HFC-134a	CFC-12
Tool & screw type	Millimeter size	Inch size
Valve type	Quick joint type	Screw-in type

General Description

HVAC SYSTEM (HEATER, VENTILATOR AND A/C)

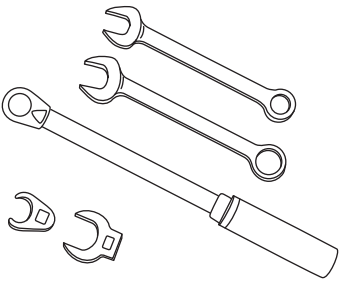
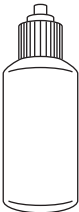
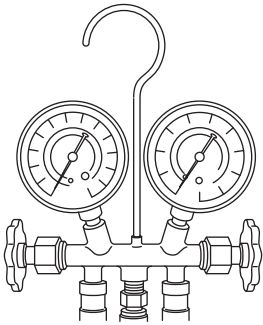
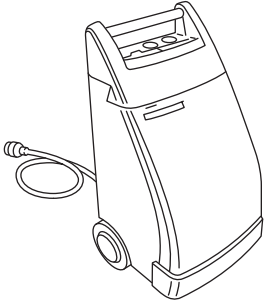
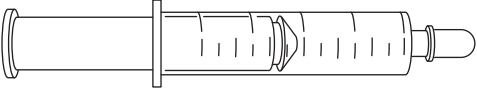
Illustration	Name and Function
 <p style="text-align: right;">AC-00213</p>	<p>Wrench</p> <p>Various WRENCHES will be required to service an A/C system. 7 — 40 N·m (0.7 to 4.1 kgf-m, 5 to 30 ft-lb) torque wrench and various crow-foot wrenches will be needed. Open end or flare nut wrenches will be needed to affix the pipe and hose fittings.</p>
 <p style="text-align: right;">AC-00012</p>	<p>Applicator bottle</p> <p>A small APPLICATOR BOTTLE is recommended to apply compressor oil to the various parts. It can be available at a hardware or drug store.</p>
 <p style="text-align: right;">AC-00013</p>	<p>Manifold gauge set</p> <p>A MANIFOLD GAUGE SET (with hoses) is available either from a refrigerant supplier or an automotive equipment supplier.</p>
 <p style="text-align: right;">AC-00014</p>	<p>Refrigerant recovery system</p> <p>A REFRIGERANT RECOVERY SYSTEM is used for the recovery and recycling of an A/C system refrigerant after contaminants and moisture have been removed from the refrigerant.</p>
 <p style="text-align: right;">AC-00015</p>	<p>Syringe</p> <p>A graduated plastic SYRINGE will be needed to add oil into the system again. A syringe can be available at a pharmacy or drug store.</p>

General Description

HVAC SYSTEM (HEATER, VENTILATOR AND A/C)

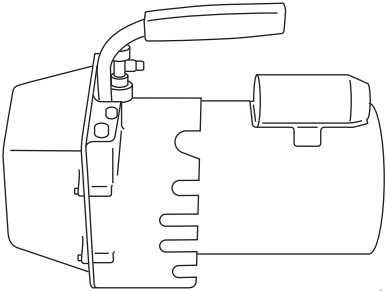
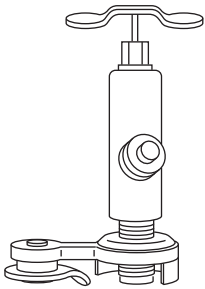
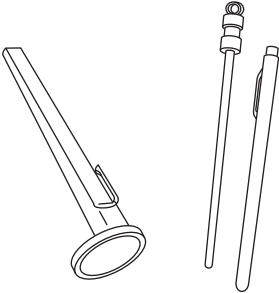
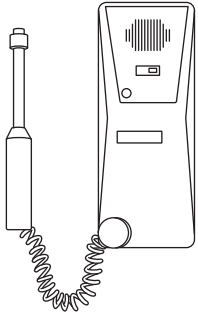
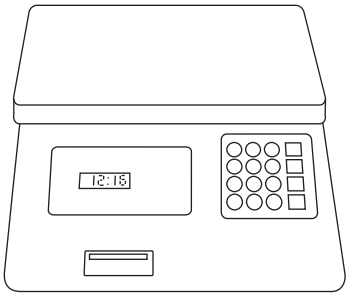
Illustration	Name and Function
 <p data-bbox="597 510 691 533">AC-00016</p>	<p data-bbox="743 201 899 226">Vacuum pump</p> <p data-bbox="743 233 1484 321">A VACUUM PUMP is necessary (for a good working condition), and is available either at a refrigerant supplier or an automotive equipment supplier.</p>
 <p data-bbox="597 863 691 886">AC-00017</p>	<p data-bbox="743 552 834 577">Can tap</p> <p data-bbox="743 583 1455 644">A CAN TAP for the 397 g (14 oz.) can is available at an automotive equipment supplier.</p>
 <p data-bbox="597 1213 691 1236">AC-00018</p>	<p data-bbox="743 903 889 928">Thermometer</p> <p data-bbox="743 934 1477 995">A Pocket THERMOMETER is available either at a industrial hardware store or a refrigerant supplier.</p>
 <p data-bbox="597 1564 691 1587">AC-00019</p>	<p data-bbox="743 1253 997 1278">Electronic leak detector</p> <p data-bbox="743 1285 1484 1346">An ELECTRONIC LEAK DETECTOR is available at either a specialty tool supplier or an A/C equipment supplier.</p>
 <p data-bbox="597 1913 691 1936">AC-00020</p>	<p data-bbox="743 1604 883 1629">Weight scale</p> <p data-bbox="743 1635 1490 1724">A WEIGHT SCALE such as an electronic charging scale or a bathroom scale with digital display will be needed, if a 13.6 kg (30 lb) refrigerant container is used.</p>

Refrigerant Pressure with Manifold Gauge Set

HVAC SYSTEM (HEATER, VENTILATOR AND A/C)

2. Refrigerant Pressure with Manifold Gauge Set

A: PROCEDURE

- 1) Place the vehicle in the shade and windless condition.
- 2) Open the front hood.
- 3) Connect the manifold gauge set.
- 4) Open the front windows and close all doors.
- 5) Increase the engine to 1,500 rpm.
- 6) Turn the A/C switch to ON.
- 7) Turn the temperature control switch to MAX COOL.
- 8) Put in RECIRC position.
- 9) Turn the blower control switch to HI.
- 10) Read the gauge.

Standard:

Low pressure: 127 — 196 kPa (1.3 — 2.0 kg/cm², 18 — 28 psi)

High pressure: 1,471 — 1,667 kPa (15 — 17 kg/cm², 213 — 242 psi)

Ambient temperature: 30 — 35°C (86 — 95°F)

B: INSPECTION

Symptom	Probable cause	Repair order
High-pressure side is unusually high.	<ul style="list-style-type: none">• Defective condenser fan motor• Clogged condenser fin• Too much refrigerant• Air inside the system• Defective receiver dryer	<ul style="list-style-type: none">• Replace the fan motor.• Clean the condenser fin.• Discharge refrigerant.• Replace the receiver dryer.• After evacuating again, charge an appropriate amount of refrigerant.
High-pressure side is unusually low.	<ul style="list-style-type: none">• Defective compressor• Not enough refrigerant• Clogged expansion valve• Expansion valve frozen temporarily by moisture.	<ul style="list-style-type: none">• Replace the compressor.• Check for leaks.• Replace the expansion valve.• Fully evacuate the expansion valve.
Low-pressure side is unusually high.	<ul style="list-style-type: none">• Defective compressor• Defective expansion valve• Too much refrigerant	<ul style="list-style-type: none">• Replace the compressor.• Replace the expansion valve.• Discharge refrigerant.
Low-pressure side is unusually low.	<ul style="list-style-type: none">• Not enough refrigerant• Clogged expansion valve• Expansion valve frozen temporarily by moisture.• Saturated receiver dryer	<ul style="list-style-type: none">• Check for leaks.• Replace the expansion valve.• Replace the receiver dryer.

Refrigerant Recovery Procedure

HVAC SYSTEM (HEATER, VENTILATOR AND A/C)

3. Refrigerant Recovery Procedure

A: PROCEDURE

CAUTION:

- During operation, be sure to wear protective goggles and protective gloves.
- Connect the refrigerant recovery system with the manifold gauge set set to discharge the refrigerant from the A/C system and recycle the gas.
- When recycling the discharged refrigerant, keep service cans on hand. Because the recovery rate with the recovery system is approx. 90%, service cans are necessary to charge the refrigerant.

• Follow the detailed operation procedure described in the operation manual attached to the refrigerant recovery system.

- 1) Perform the compressor oil return operation. <Ref. to AC-22, PROCEDURE, Compressor Oil.>
- 2) Stop the engine.
- 3) Make sure the valves on the low/high pressure sides of the manifold gauge set are fully closed.

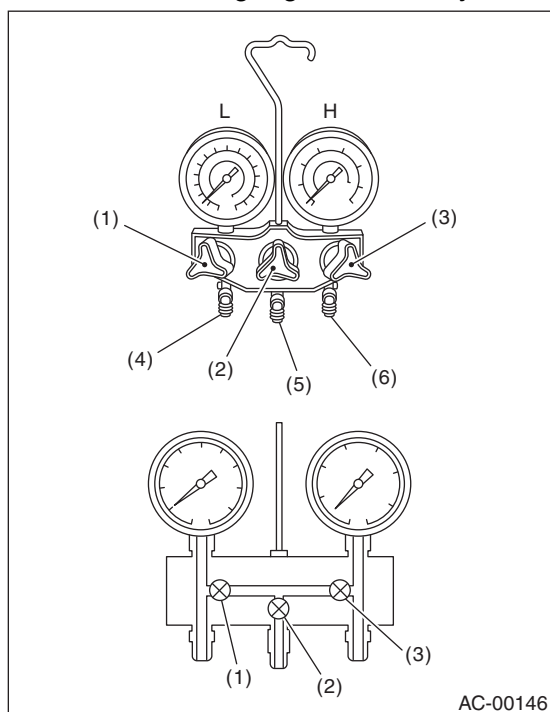

- L: Low pressure gauge
- H: High-pressure gauge
- (1) Low pressure valve
- (2) Vacuum pump valve
- (3) High pressure valve
- (4) For low pressure
- (5) For vacuum pump
- (6) For high pressure

- 4) Install the low/high pressure hoses to the low/high pressure side service ports of the vehicle respectively.

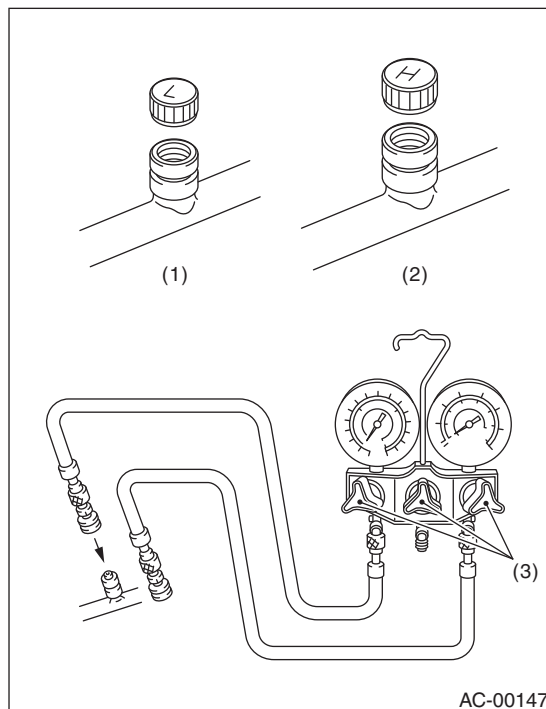

- (1) Low-pressure side service port
- (2) High-pressure side service port
- (3) Close

- 5) Connect the center hose to the refrigerant recovery system.
- 6) Follow the operation manual to activate the refrigerant recovery system.

Refrigerant Charging Procedure

HVAC SYSTEM (HEATER, VENTILATOR AND A/C)

4. Refrigerant Charging Procedure

A: PROCEDURE

CAUTION:

- When working, be sure to wear protective goggles and protective gloves.
- Air in the cycle will cause insufficient air conditioning, and water in the cycle will cause clogging (icing) and rusting inside the cycle. To remove this air and water, use a vacuum pump to perform evacuation before filling with refrigerant. By making the inside of the cycle a vacuum, moisture will boil and evaporate even at normal temperature, making it possible to remove.

1) Close all valves of the manifold gauge.

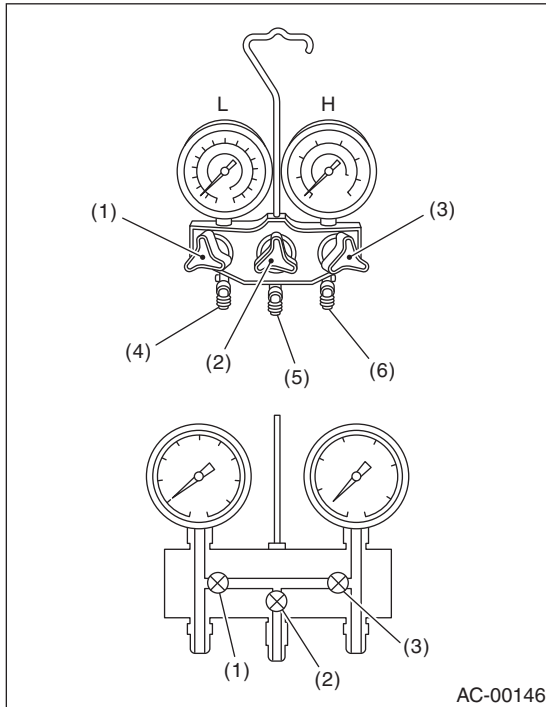

- L: Low pressure gauge
- H: High-pressure gauge
- (1) Low pressure valve
- (2) Vacuum pump valve
- (3) High pressure valve
- (4) For low pressure
- (5) For vacuum pump
- (6) For high pressure

2) Attach the low pressure side and high pressure side hoses to the vehicle service port.

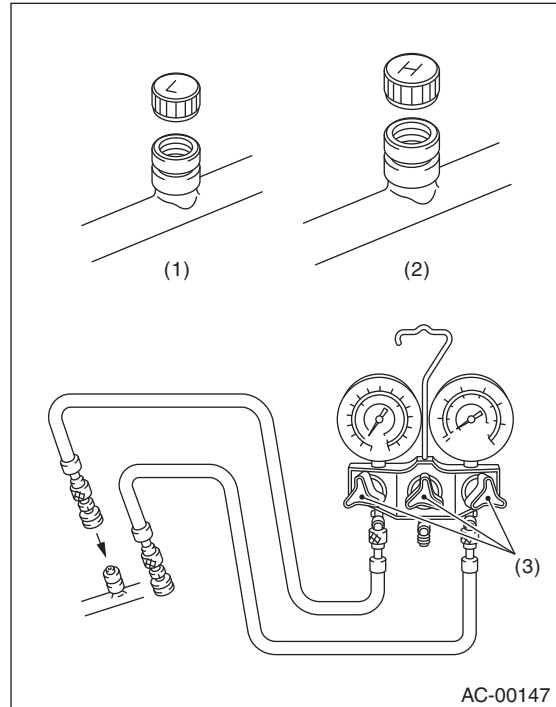

- (1) Low-pressure side service port
- (2) High-pressure side service port
- (3) Close

CAUTION:

Confirm that the connections are secure.

- 3) Connect the center manifold hose of the manifold gauge to the vacuum pump.
- 4) Operate the vacuum pump, and open the low pressure side and high pressure side valves. Open the center manifold hose valve, and start evacuation.

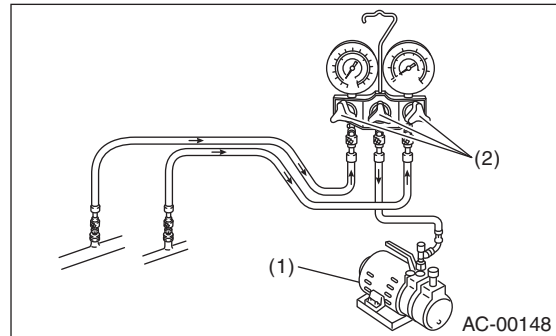

- (1) Vacuum pump
- (2) Open

CAUTION:

Always use a vacuum pump when performing evacuation.

Refrigerant Charging Procedure

HVAC SYSTEM (HEATER, VENTILATOR AND A/C)

5) After performing evacuation for over 5 minutes, when the low pressure gauge needle reaches above -100.0 kPa (-750 mmHg, -29.5 inHg), close the center manifold hose valve, and stop the vacuum pump.

6) After closing the low pressure side and high pressure side valves, leave for 5 to 10 minutes, and inspect for whether there is any change in the low pressure gauge needle. If the needle position changes, this indicates a leak. Check the connections of pipes and hoses, and repair the problem locations. In this case, repeat from step 1).

7) If there are no leaks, continue evacuation for 20-30 additional minutes.

8) Close all valves, and stop the vacuum pump.

9) Follow the can tap operation manual, and attach to the refrigerant can.

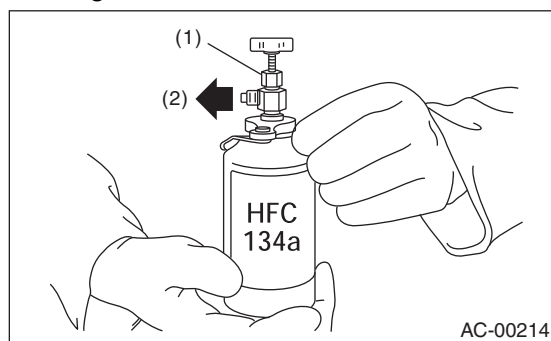

- (1) Tap valve
- (2) To the center manifold hose

10) Disconnect the center manifold hose from the vacuum pump, and connect the hose to the tap valve.

11) When a 13.6 kg (30 lb) refrigerant container is used, measure the weight of the refrigerant first on a scale, then connect to the center manifold hose.

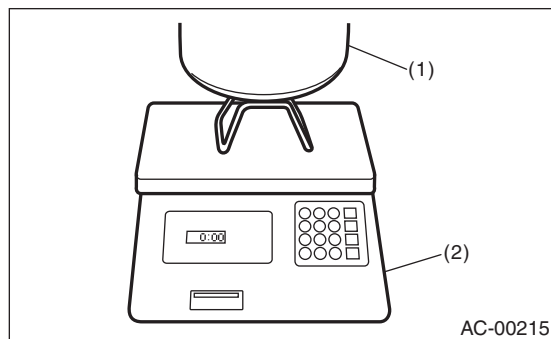

- (1) Refrigerant container (HFC-134a)
- (2) Weight scale

12) Open the valve on the HFC-134a source.

13) Loosen the center manifold hose connection on the manifold gauge for a few seconds (if there is a purge valve on the manifold gauge, press this instead) to force out the air in the center manifold hose using the refrigerant pressure.

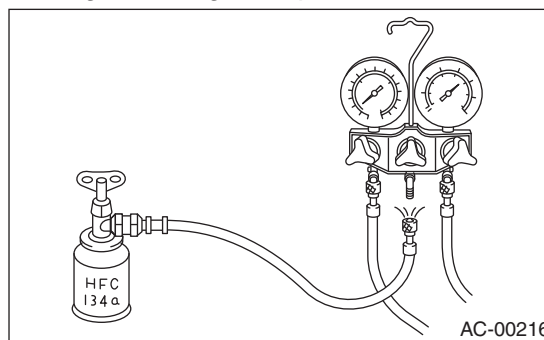

14) Open the high pressure side and low pressure side valves of the manifold gauge to fill with refrigerant.

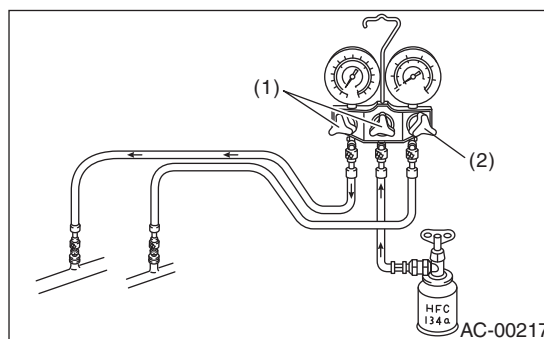

- (1) Open
- (2) Open

CAUTION:

When filling while running the engine, do not open the high pressure side valve. Always fill from the low pressure side.

15) When the gauge needle reaches approximately 200 kPa (1,500 mmHg, 59.1 inHg), close all valves.

16) Using a leak tester, check the system for refrigerant leaks.

17) After checking that there are no refrigerant leaks, fill with refrigerant up to the specified amount.

18) If the HFC-134a supply container becomes empty, close all valves, and close the can tap valve to replace the empty container. After replacing the HFC-134a supply container with a new container, air purge first, then restart the filling procedure.

19) When the refrigerant filling efficiency becomes low, close all valves.

20) Check that the low pressure and high pressure valves are closed. Start the engine with the A/C switch OFF.

Refrigerant Charging Procedure

HVAC SYSTEM (HEATER, VENTILATOR AND A/C)

21) To avoid damaging the compressor, press the A/C switch ON-OFF quickly several times.

22) Set up the vehicle to the following status:

CAUTION:

When filling while running the engine, do not open the high pressure side valve.

Always fill from the low pressure side valve.

- A/C switch ON
- Engine running at 1,500 rpm
- Blower speed setting to "HI"
- Temperature setting to "MAX COOL"
- Air inlet setting to "RECIRC"
- Window open

23) Open the low pressure side valve and fill with refrigerant up to the specified amount.

24) After filling with refrigerant, close all valves and disconnect the hose from the service port.

25) Attach the cap to the service port.

Refrigerant Leak Check

HVAC SYSTEM (HEATER, VENTILATOR AND A/C)

5. Refrigerant Leak Check

A: INSPECTION

1) Operate the A/C system for approx. 10 minutes, and check that the high-side pressure shows at least 690 kPa (7.03 kgf/cm², 100 psi). Then stop the engine to start the leak test.

2) Starting from the connection between high-pressure pipe and evaporator, check the system for leaks along the high-pressure side through the compressor. The following items must be checked thoroughly.

3) Check the joint and seam between pressure switch (triple pressure switch) and high-pressure pipe.

4) Check the connections between condenser and pipes, and welded joints on the condenser.

The leak tester may detect the oil on the condenser fins as a leak.

5) Check the joint between compressor and hoses.

6) Check the machined area of the compressor and other joints on the compressor.

7) Check the compressor shaft seal at the area near the center of compressor clutch pulley.

Shaft seals may show a slight amount of leakage, about 3 g (0.1 oz) per year. This is not a problem.

8) Starting from the connection between low-pressure pipe and evaporator, check the system for leakage along the low-pressure side through the compressor. The following items must be checked thoroughly.

- Connection between 2 parts
- Connection between pipe and plate

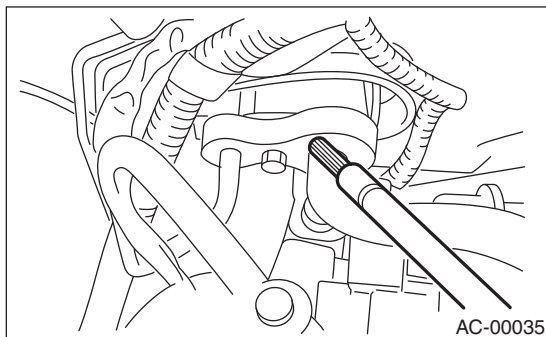

9) Visually check the rubber area of the flexible hose for cracks.

Check the entire length of the flexible hose, especially the connection with the metal hose end.

CAUTION:

Carefully check the external surface of hoses and pipes at approx. 25 mm (0.98 in) per second.

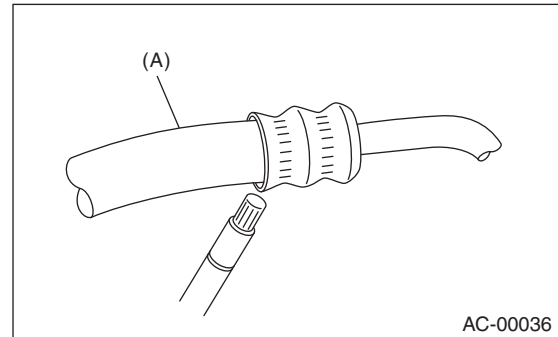

(A) Flexible hose

10) Disconnect the drain hose from the heater case, and check the hose end for at least 10 seconds.

After the test is finished, reconnect the drain hose.

11) Turn the ignition key to the ON position, and run the blower at high speed for approx. 1 minute. Stop the blower and check the ventilation grille on the instrument panel. While moving the tester closer to the grille, run the blower for 1 or 2 seconds, then stop it. Check the grille at that position for at least 10 seconds.

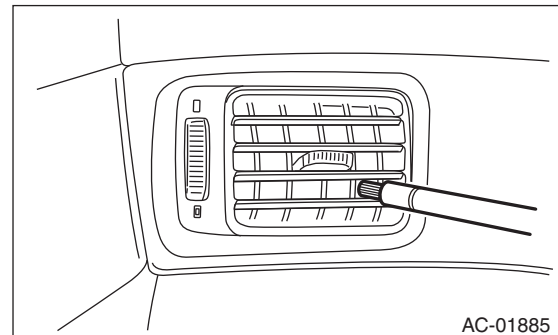

12) Check the valve in the service port.

13) Visually check the rubber seal in the service port cap.

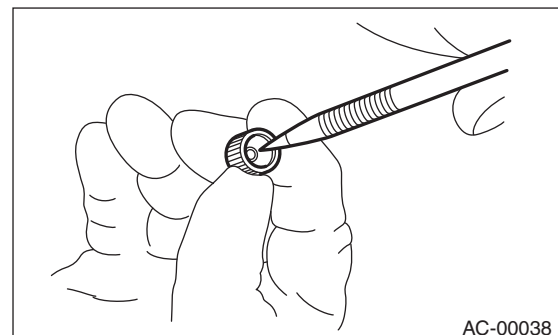

Compressor Oil

HVAC SYSTEM (HEATER, VENTILATOR AND A/C)

6. Compressor Oil

A: PROCEDURE

NOTE:

Before making repairs, perform the oil return operation to return the compressor oil in circulation with the refrigerant to the compressor.

- 1) Increase the engine to 1,500 rpm.
- 2) Turn the A/C switch to ON.
- 3) Turn the temperature control switch to MAX COOL.
- 4) Put in RECIRC position.
- 5) Turn the blower control switch to HI.
- 6) Leave in this condition for 10 minutes.

B: REPLACEMENT

NOTE:

- If a component has been replaced, add an appropriate amount of compressor oil (same as the amount of remaining oil in removed component).
- When replacing the compressor, the new compressor will already have the specified amount of oil in it. Adjust the oil amount (so that the amount remains the same as that of the removed compressor) and install the new compressor.
- Since the hygroscopicity of compressor oil is high, perform this series of works quickly.

Blower Motor Unit Assembly

HVAC SYSTEM (HEATER, VENTILATOR AND A/C)

7. Blower Motor Unit Assembly

A: REMOVAL

- 1) Disconnect the battery ground cable from the battery.
- 2) Remove the instrument panel lower cover. <Ref. to EI-49, INSTRUMENT PANEL LOWER, REMOVAL, Center Console.>
- 3) Remove the protect cover of ECM.

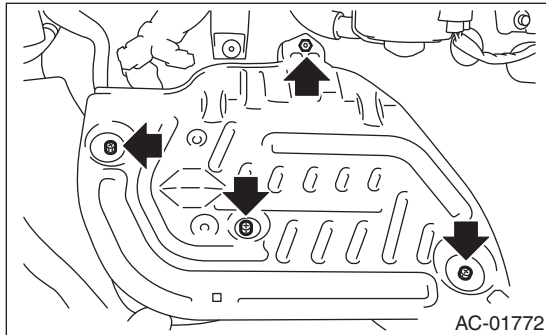

- 4) Disconnect the connectors of the intake door actuator and blower motor.
- 5) Remove the relay holder.
- 6) Loosen the bolt and nut to remove blower motor unit assembly.

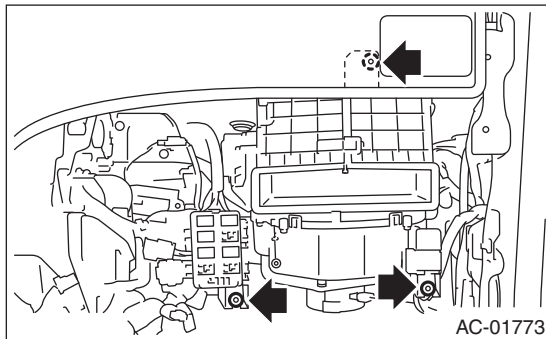

B: INSTALLATION

Install in the reverse order of removal.

Tightening torque:

Refer to “COMPONENT” of “General Description”. <Ref. to AC-4, HEATER COOLING UNIT, COMPONENT, General Description.>
<Ref. to AC-6, BLOWER MOTOR UNIT, COMPONENT, General Description.>

Blower Motor

HVAC SYSTEM (HEATER, VENTILATOR AND A/C)

8. Blower Motor

A: REMOVAL

- 1) Disconnect the battery ground cable from the battery.
- 2) Disconnect the connector of the blower motor.
- 3) Turn up the floor mat near the blower motor.
- 4) Loosen the screw to remove the blower motor.

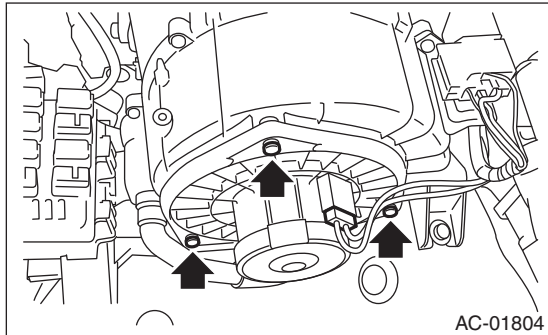

B: INSTALLATION

Install in the reverse order of removal.

C: INSPECTION

Connect the battery positive (+) terminal to terminal No. 2 of blower motor connector, and negative (-) terminal to terminal No. 1. Check the blower motor for smooth rotation.

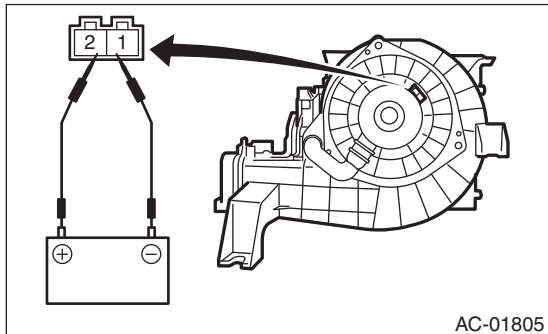

Power Transistor (Auto A/C Model)

HVAC SYSTEM (HEATER, VENTILATOR AND A/C)

9. Power Transistor (Auto A/C Model)

A: REMOVAL

- 1) Remove the instrument panel lower. <Ref. to EI-49, INSTRUMENT PANEL LOWER, REMOVAL, Center Console.>
- 2) Disconnect the power transistor connector.
- 3) Remove the two screws and remove the power transistor.

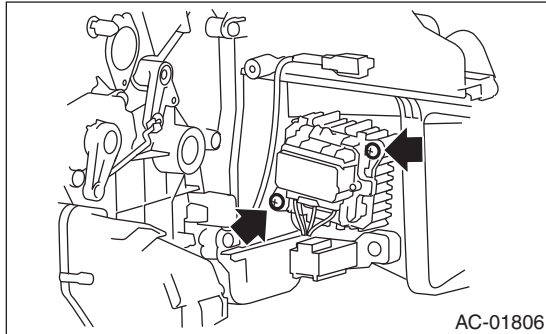

B: INSTALLATION

Install in the reverse order of removal.

Blower Resistor (Manual A/C Model)

HVAC SYSTEM (HEATER, VENTILATOR AND A/C)

10. Blower Resistor (Manual A/C Model)

A: REMOVAL

- 1) Remove the instrument panel lower cover. <Ref. to EI-49, INSTRUMENT PANEL LOWER, REMOVAL, Center Console.>
- 2) Disconnect the blower resistor connector.
- 3) Remove the two screws and remove the blower resistor.

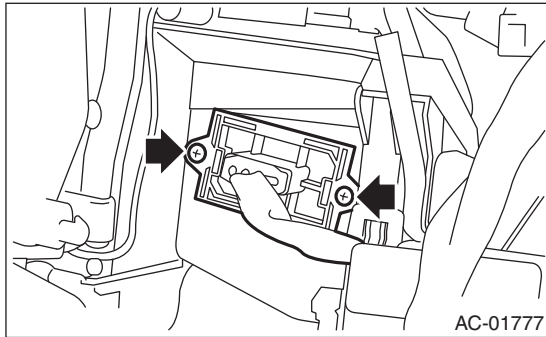

B: INSTALLATION

Install in the reverse order of removal.

C: INSPECTION

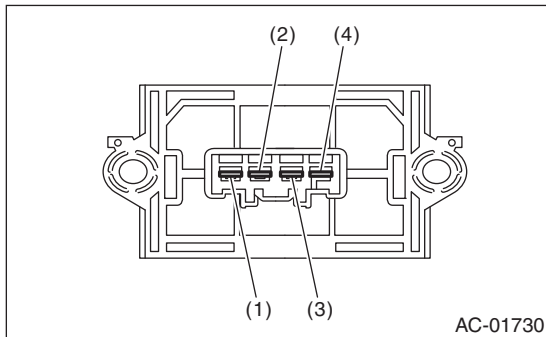

Measure the blower resistor resistance.

Terminal No.	Standard
4 and 3	Approx. 0.43 Ω
4 and 2	Approx. 1.03 Ω
4 and 1	Approx. 3.0 Ω

If NG, replace the blower resistor.

Heater Core

HVAC SYSTEM (HEATER, VENTILATOR AND A/C)

11.Heater Core

A: REMOVAL

- 1) Remove the heater and cooling unit. <Ref. to AC-32, REMOVAL, Heater and Cooling Unit.>
- 2) Remove the screws and detach the heater pipe cover.



- 3) Remove the screws and detach the clamp.

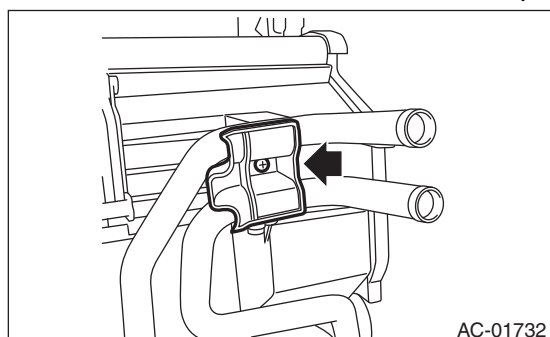

- 4) Remove the pipe clamp and detach the pipe.

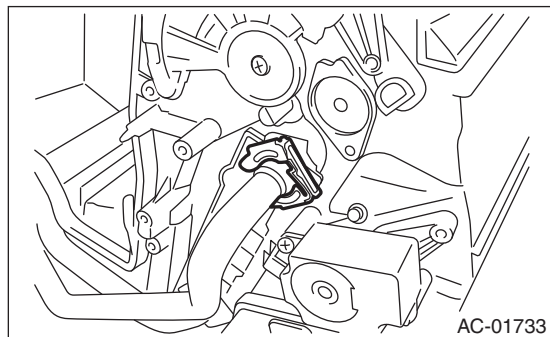

- 5) Remove the heater core cover.

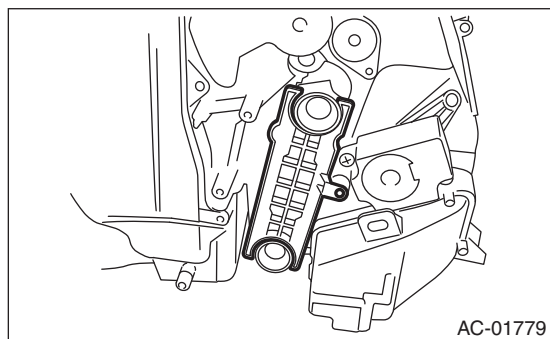

- 6) Remove the heater core.

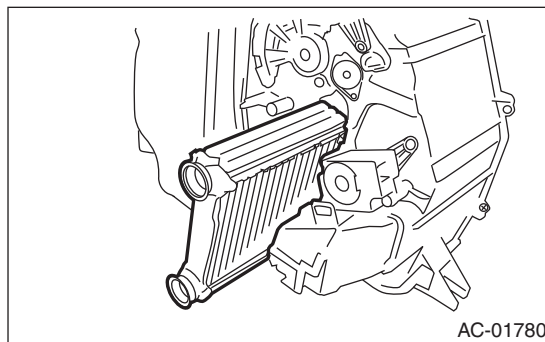

B: INSTALLATION

Install in the reverse order of removal.

CAUTION:

Replace the O-rings and pipe clamps with new parts, and attach securely.

Control Unit (Manual A/C Model)

HVAC SYSTEM (HEATER, VENTILATOR AND A/C)

12. Control Unit (Manual A/C Model)

A: REMOVAL

- 1) Disconnect the battery ground cable from the battery.
- 2) Remove the ornament panel. <Ref. to EI-48, ORNAMENT PANEL, REMOVAL, Center Console.>
- 3) Remove the knee guard panel.
- 4) Remove the control wires from both sides of the heater and cooling unit.

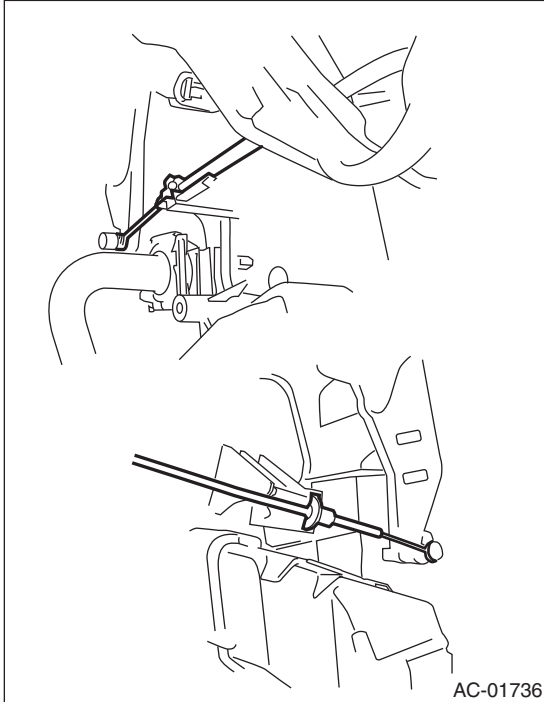

- 5) Remove the screw and claw to detach the control unit from the ornament panel RH.

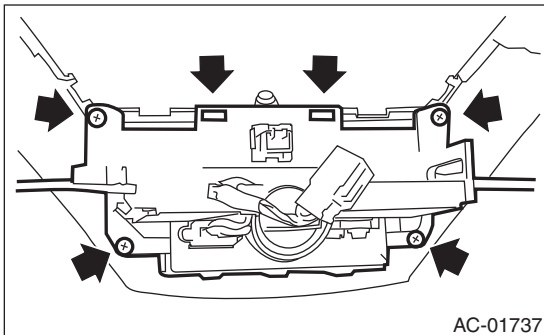

B: INSTALLATION

Install in the reverse order of removal.

NOTE:

Assemble the plate at the end of control wires to the heater case securely.

Control Unit (Auto A/C Model)

HVAC SYSTEM (HEATER, VENTILATOR AND A/C)

13. Control Unit (Auto A/C Model)

A: REMOVAL

- 1) Disconnect the battery ground cable from the battery.
- 2) Remove the ornament panel. <Ref. to EI-48, ORNAMENT PANEL, REMOVAL, Center Console.>
- 3) Remove the screw and claw and disconnect the connector to detach the control unit from the ornament panel RH.

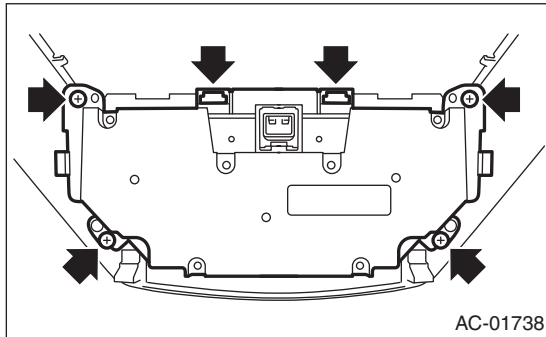

B: INSTALLATION

Install in the reverse order of removal.

Compressor

HVAC SYSTEM (HEATER, VENTILATOR AND A/C)

14. Compressor

A: INSPECTION

1. MAGNETIC CLUTCH CLEARANCE

Check the clearance of the entire circumference around the drive plate and pulley.

Standard:

0.3 — 0.6 mm (0.0118 — 0.0236 in)

2. MAGNETIC CLUTCH OPERATION

- 1) Disconnect the compressor connector.
 - 2) Connect the battery positive (+) terminal to the terminal of the compressor connector.
 - 3) Check the magnet clutch engagement.
- If there is a malfunction, replace the compressor.

B: REMOVAL

- 1) Perform the compressor oil return operation. <Ref. to AC-22, PROCEDURE, Compressor Oil.>
- 2) Turn the A/C switch to OFF and stop the engine.
- 3) Using the refrigerant recovery system, discharge refrigerant. <Ref. to AC-17, PROCEDURE, Refrigerant Recovery Procedure.>
- 4) Disconnect the ground cable from the battery.
- 5) Remove the V-belts. <Ref. to ME(H4SO)-42, REMOVAL, V-belt.> <Ref. to ME(H4DOTC)-39, REMOVAL, V-belt.>
- 6) Remove the generator. <Ref. to SC(H4SO)-15, REMOVAL, Generator.>
- 7) Remove the bolt and remove the low-pressure hose and high-pressure hose.

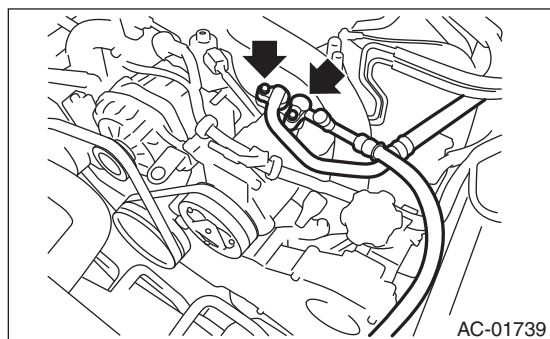

- 8) Disconnect the compressor harness from the body harness.

- 9) Remove the bolts and remove the compressor bracket.

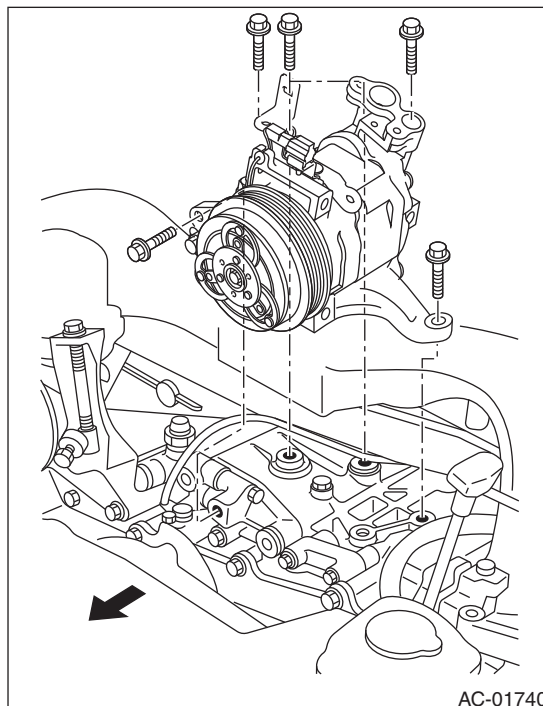

- 10) Remove the bolts, then remove the bracket from the compressor.

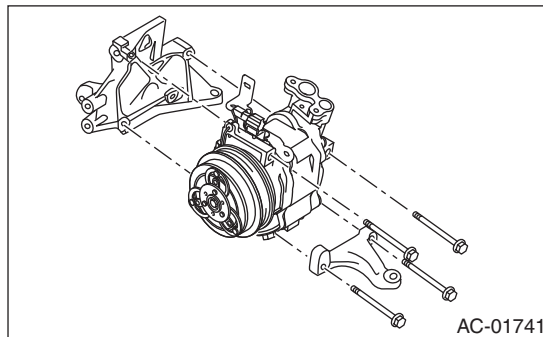

C: INSTALLATION

- 1) Install in the reverse order of removal.
- 2) Replace the O-rings on low-/high-pressure hoses with new parts, then apply compressor oil.
- 3) After replacing the compressor, adjust the amount of compressor oil. <Ref. to AC-22, PROCEDURE, Compressor Oil.>
- 4) Charge refrigerant. <Ref. to AC-18, PROCEDURE, Refrigerant Charging Procedure.>

Tightening torque:

Refer to "COMPONENT" of "General Description". <Ref. to AC-9, AIR CONDITIONING UNIT, COMPONENT, General Description.> <Ref. to AC-10, COMPRESSOR, COMPONENT, General Description.>

Condenser

HVAC SYSTEM (HEATER, VENTILATOR AND A/C)

15. Condenser

A: REMOVAL

- 1) Using the refrigerant recovery system, discharge refrigerant. <Ref. to AC-17, PROCEDURE, Refrigerant Recovery Procedure.>
- 2) Disconnect the ground cable from the battery.
- 3) Disconnect the high pressure hose and pipe from the condenser.

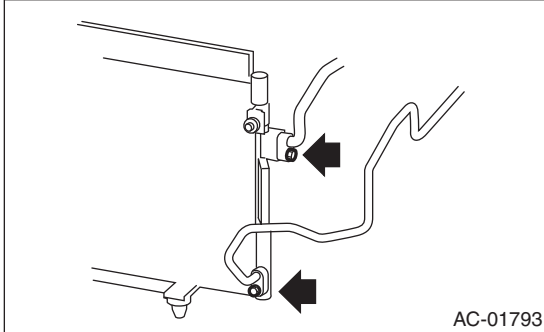

- 4) Remove the radiator brackets.

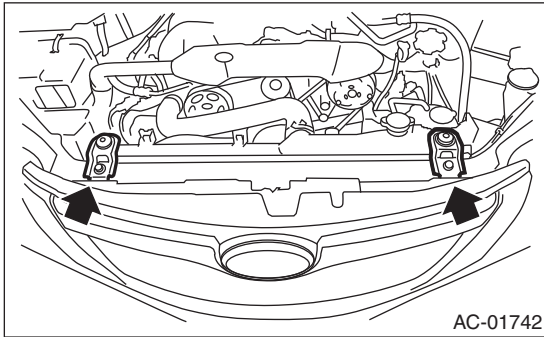

- 5) Remove the front bumper. <Ref. to EI-28, REMOVAL, Front Bumper.>
- 6) Remove two bolts. While lifting the condenser, pull out through space between the radiator and the radiator panel.

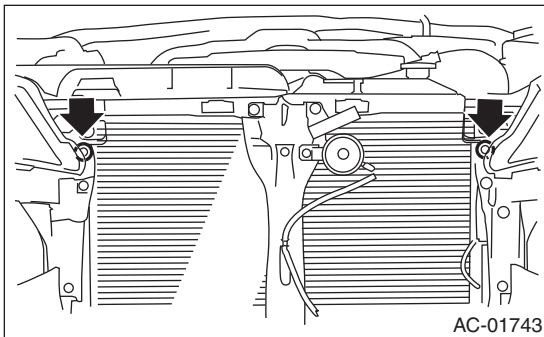

CAUTION:

- Be careful not to damage the condenser fins. If a damaged fin is found, repair it using a thin screwdriver.
- If the condenser is replaced, add an appropriate amount of compressor oil to the compressor. <Ref. to AC-22, REPLACEMENT, Compressor Oil.>

B: INSTALLATION

- 1) Install in the reverse order of removal.

CAUTION:

Replace the O-rings on hoses or pipes with new parts, and then apply compressor oil. Confirm that lower guide (A) of condenser fits into holes on radiator panel.

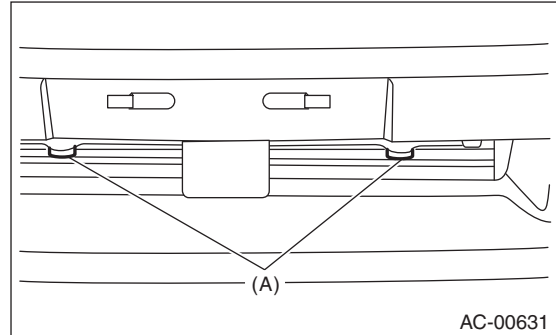

- 2) Charge refrigerant. <Ref. to AC-18, PROCEDURE, Refrigerant Charging Procedure.>

Tightening torque:

Refer to "COMPONENT" of "General Description". <Ref. to AC-9, AIR CONDITIONING UNIT, COMPONENT, General Description.>

C: INSPECTION

- 1) Check to see that the condenser fins are not clogged with debris or insects. Blow with compressed air or flush fins with water as needed.
- 2) Inspect for oil leakage from the condenser. If a failure is found, replace the condenser with a new part.

Heater and Cooling Unit

HVAC SYSTEM (HEATER, VENTILATOR AND A/C)

16.Heater and Cooling Unit

A: REMOVAL

- 1) Disconnect the ground cable from the battery.
- 2) Using the refrigerant recovery system, discharge refrigerant. <Ref. to AC-17, PROCEDURE, Refrigerant Recovery Procedure.>
- 3) Drain coolant from the radiator.
- 4) Remove the bolts securing expansion valve and pipe in engine compartment. Release the heater hose clamps in engine compartment to remove the hoses.



- 5) Remove the instrument panel. <Ref. to EI-50, REMOVAL, Instrument Panel Assembly.>
- 6) Remove the blower motor unit assembly. <Ref. to AC-23, REMOVAL, Blower Motor Unit Assembly.>
- 7) Disconnect the connectors of the actuator, thermo sensor, blower resistor, and power transistor.
- 8) Remove the bolt and nuts and remove the heater and cooling unit.

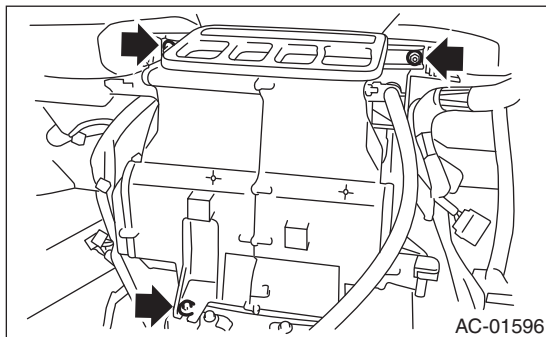

B: INSTALLATION

- 1) Install in the reverse order of removal.
- 2) Charge refrigerant. <Ref. to AC-18, PROCEDURE, Refrigerant Charging Procedure.>

Tightening torque:

Refer to “COMPONENT” of “General Description”. <Ref. to AC-4, HEATER COOLING UNIT, COMPONENT, General Description.>

Evaporator

HVAC SYSTEM (HEATER, VENTILATOR AND A/C)

17. Evaporator

A: REMOVAL

- 1) Disconnect the ground cable from battery.
- 2) Using the refrigerant recovery system, drain the refrigerant. <Ref. to AC-17, PROCEDURE, Refrigerant Recovery Procedure.>
- 3) Remove the bolt and detach the pipe from expansion valve.

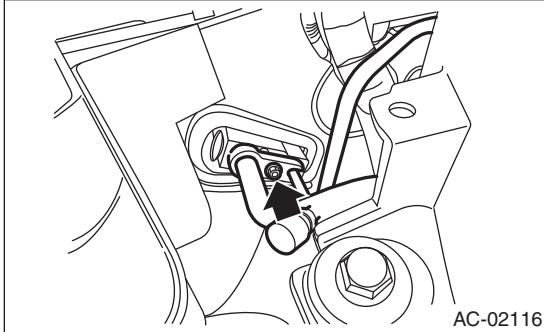

- 4) Remove the instrument panel lower. <Ref. to EI-49, INSTRUMENT PANEL LOWER, REMOVAL, Center Console.>
- 5) Remove the blower motor unit. <Ref. to AC-23, REMOVAL, Blower Motor Unit Assembly.>
- 6) Remove the two screws and remove the evaporator pipe cover.

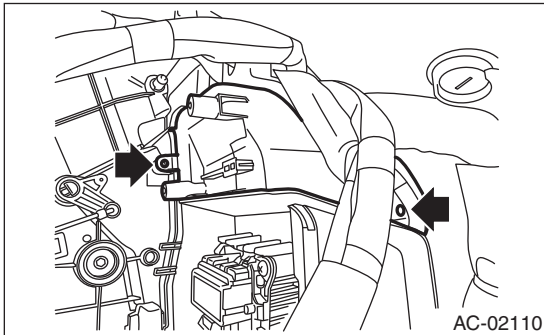

- 7) Remove the two evaporator pipe mounting bolts, two evaporator cover mounting screws and clip.

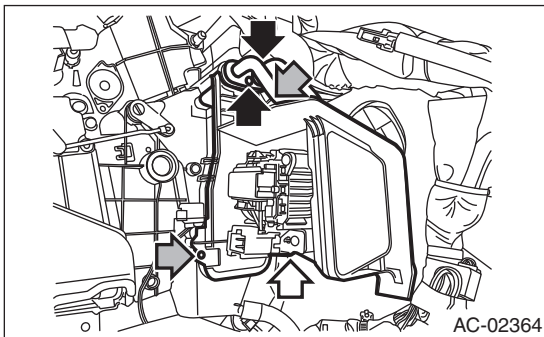

- 8) Remove the evaporator cover and evaporator pipe.

CAUTION:

Since the evaporator cover and evaporator pipe cannot be removed by itself, remove them as a unit.

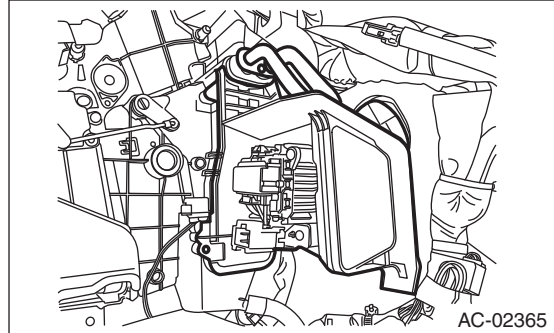

- (1) Release the connection of evaporator and pipe.
 - (2) Remove the evaporator pipe together with the evaporator cover.
- 9) Remove the evaporator.

CAUTION:

If the evaporator is replaced, add an appropriate amount of compressor oil to evaporator. <Ref. to AC-22, REPLACEMENT, Compressor Oil.>

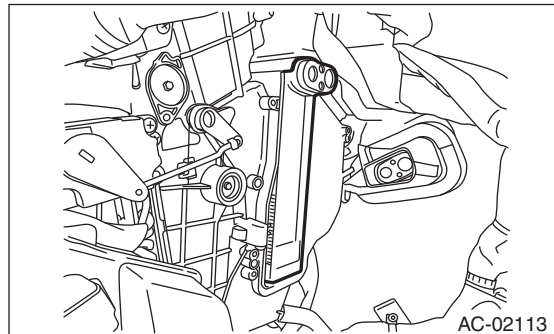

Evaporator

HVAC SYSTEM (HEATER, VENTILATOR AND A/C)

B: INSTALLATION

Install in the reverse order of removal.

CAUTION:

- Make sure that the water stop gasket of the cover attachment area is securely attached.
- Install the sensor at the position shown in the figure below.

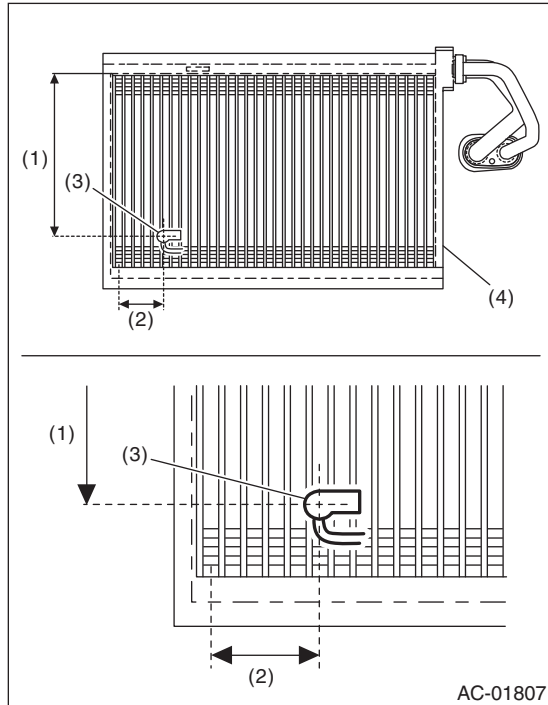

- (1) 148 mm (5.83 in) from the upper end of the fin
- (2) The 6th column fin from the left end
- (3) Sensor
- (4) Evaporator

18.Hose and Pipe

A: REMOVAL

CAUTION:

- When disconnecting hoses, do not apply excessive force. After installing, check that no torsion or excessive tension applied to the hoses.

- Seal the disconnected hose with a plug or vinyl tape to prevent foreign matter from entering.

- 1) Disconnect the ground cable from the battery.
- 2) Using the refrigerant recovery system, discharge refrigerant. <Ref. to AC-17, PROCEDURE, Refrigerant Recovery Procedure.>
- 3) Remove the bolt and detach the hoses and pipes.

B: INSTALLATION

CAUTION:

- Always replace with new O-rings.
- When connecting hoses, do not apply excessive force. After installing, check that no torsion or excessive tension applied to the hoses.

- 1) Install in the reverse order of removal.
- 2) Charge refrigerant. <Ref. to AC-18, PROCEDURE, Refrigerant Charging Procedure.>

Tightening torque:

Refer to "COMPONENT" of "General Description". <Ref. to AC-9, AIR CONDITIONING UNIT, COMPONENT, General Description.>

C: INSPECTION

Check the hoses for cracks, damage and expansion. If any fault is found, replace with new parts.

Relay and Fuse

HVAC SYSTEM (HEATER, VENTILATOR AND A/C)

19. Relay and Fuse

A: LOCATION

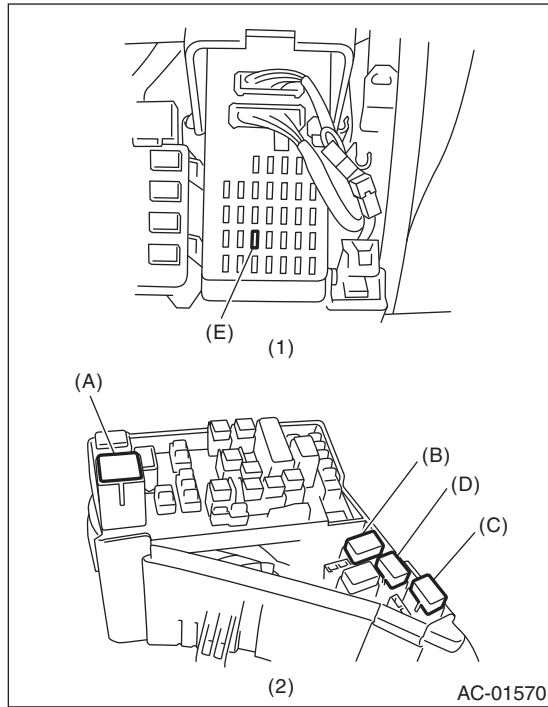

- (1) Joint box
- (2) Main fuse box

Main fan relay 1	(A)
Main fan relay 2	(B)
Sub fan relay	(C)
A/C relay	(D)
A/C Fuse	(E)

B: INSPECTION

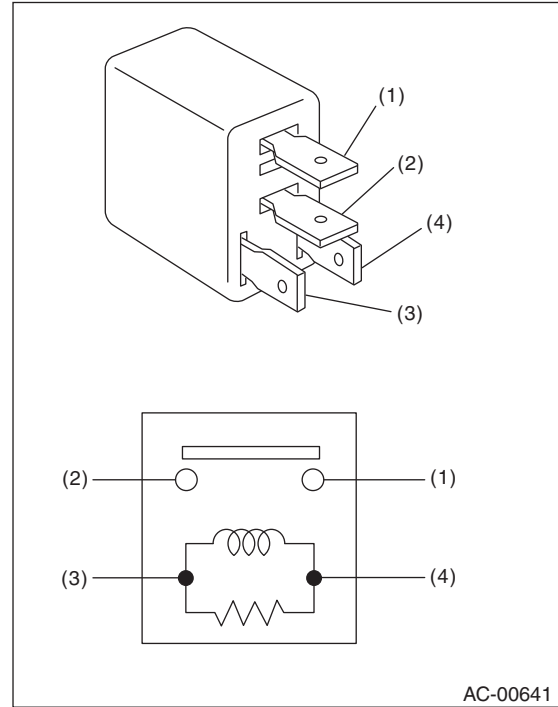

- (3) — (4): Continuity exists
- (1) — (2): Continuity does not exist

While applying battery voltage to the terminal between (3) and (4), check for continuity between (1) and (2).

If no continuity exists, replace the relay with a new part.

Pressure Switch (Triple Pressure Switch)

HVAC SYSTEM (HEATER, VENTILATOR AND A/C)

20. Pressure Switch (Triple Pressure Switch)

A: INSPECTION

- 1) Connect the manifold gauge to the service valve on the high-pressure side.
- 2) Disconnect the pressure switch harness connector.
- 3) Start the air conditioner, and check the operating pressure of switch by turning the compressor (magnet clutch) to ON/OFF. Operation of each switch is as follows.

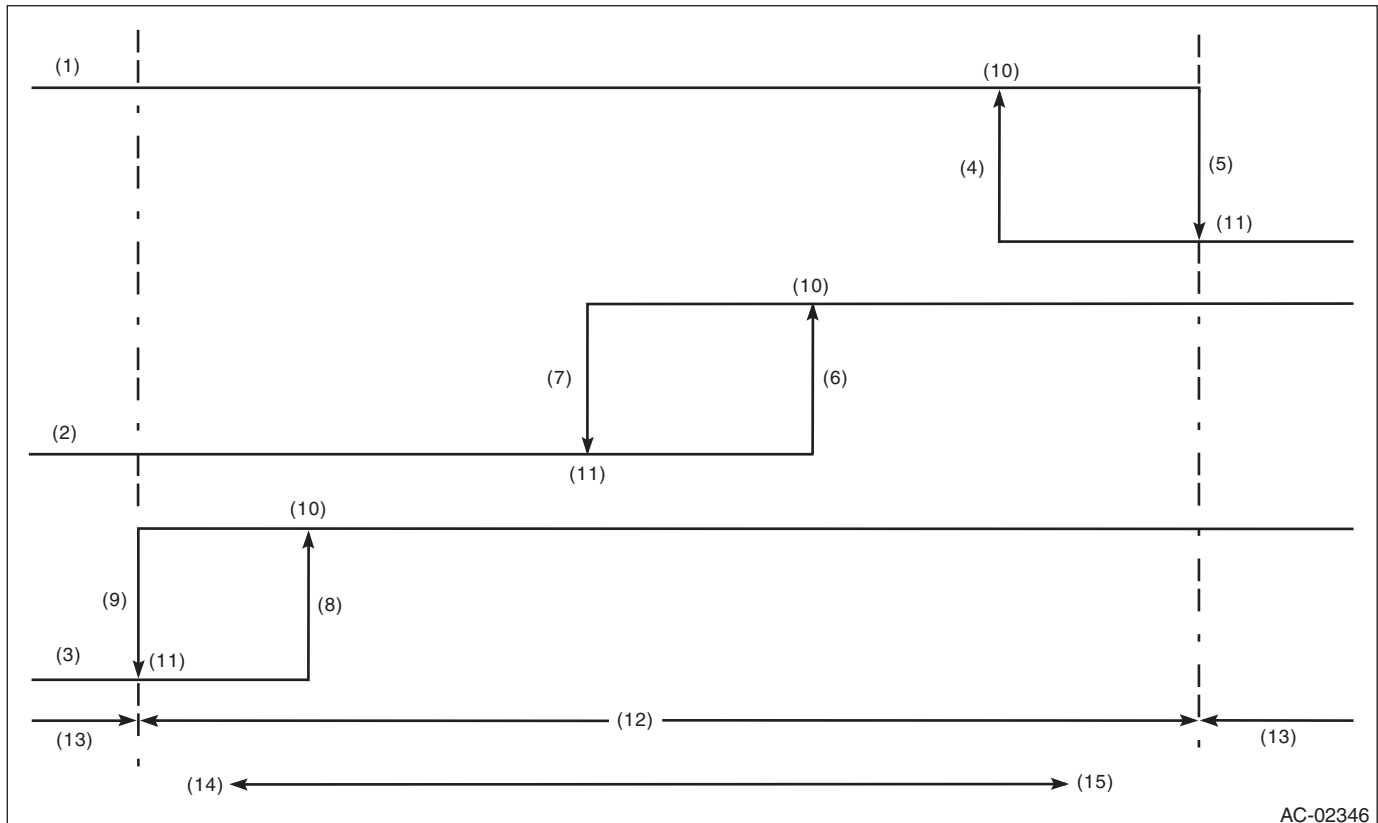

AC-02346

(1) High pressure switch	(6) 1,770±100 kPa (18.05±1.02 kg/cm ² , 256.65±14.5 psi)	(9) 177±25 kPa (1.80±0.25 kg/cm ² , 25.7±3.6 psi)
(2) Middle pressure switch	(7) 1,470±120 kPa (14.99±1.22 kg/cm ² , 213.15±17.4 psi)	(10) ON
(3) Low pressure switch	(8) 206±30 kPa (2.10±0.31 kg/cm ² , 29.9±4.3 psi)	(11) OFF
(4) 2,350±200 kPa (24.00±2.04 kg/cm ² , 340.7±29.0 psi)	(12) Operative range of compressor	(13) Inoperative range of compressor
(5) 2,940±200 kPa (29.98±2.04 kg/cm ² , 426.3±29.0 psi)	(14) Low pressure	(15) High pressure

NOTE:

- High pressure switch turns the compressor (magnet clutch) to OFF when the refrigerant pressure becomes extremely high to prevent the evaporator, air conditioner piping and expansion valve from getting damaged or frozen, etc.
- Middle pressure switch effectively controls the radiator fan output by judging high load/low load in normal range.
- If the refrigerant pressure is abnormally low, the low pressure switch determines that there is insufficient refrigerant, and turns the compressor (magnetic clutch) OFF since there is a possibility that the compressor will seize if it is continued to run.

Ambient Sensor (Auto A/C Model)

HVAC SYSTEM (HEATER, VENTILATOR AND A/C)

21. Ambient Sensor (Auto A/C Model)

A: REMOVAL

- 1) Disconnect the ground cable from the battery.
- 2) Disconnect the ambient sensor connector.
- 3) Remove the ambient sensor from the radiator lower panel.

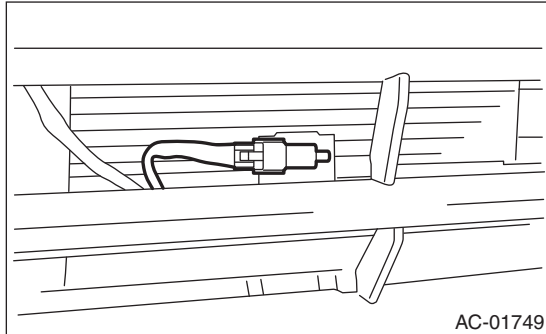

B: INSTALLATION

Install in the reverse order of removal.

C: INSPECTION

<Ref. to AC(diag)-29, AMBIENT SENSOR, Diagnostic Procedure for Sensors.>

Sunload Sensor (Auto A/C Model)

HVAC SYSTEM (HEATER, VENTILATOR AND A/C)

22. Sunload Sensor (Auto A/C Model)

A: REMOVAL

- 1) Disconnect the ground cable from the battery.
- 2) Remove the audio. <Ref. to ET-6, REMOVAL, Audio.>
- 3) Push out the sunload sensor from the back side of the instrument panel.

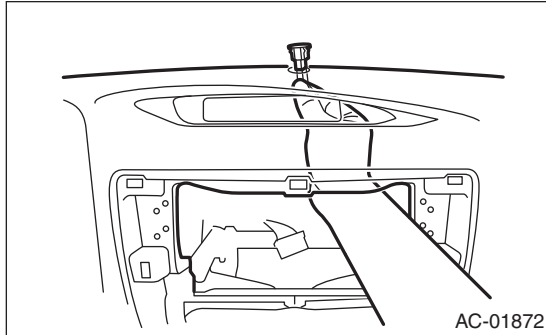

- 4) Disconnect the connector, and remove the sunload sensor.

CAUTION:

Be careful not to damage the interior trims when removing the sensor.

B: INSTALLATION

Install in the reverse order of removal.

C: INSPECTION

<Ref. to AC(diag)-35, SUNLOAD SENSOR, Diagnostic Procedure for Sensors.>

In-vehicle Sensor (Auto A/C Model)

HVAC SYSTEM (HEATER, VENTILATOR AND A/C)

23. In-vehicle Sensor (Auto A/C Model)

A: REMOVAL

- 1) Disconnect the ground cable from the battery.
- 2) Remove the instrument panel lower. <Ref. to EI-49, INSTRUMENT PANEL LOWER, REMOVAL, Center Console.>
- 3) Disconnect the connector and aspirator hose, remove the screw and remove the in-vehicle sensor from the instrument panel.

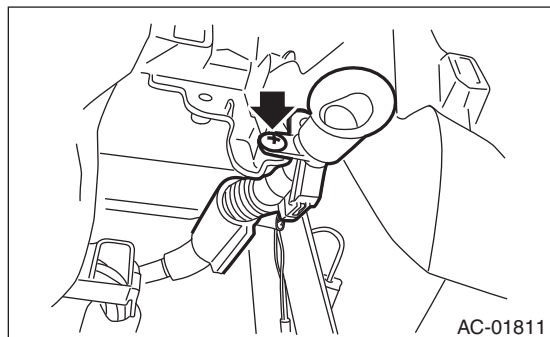

CAUTION:

Be careful not to damage the sensors and interior trims when removing.

B: INSTALLATION

Install in the reverse order of removal.

C: INSPECTION

<Ref. to AC(diag)-31, IN-VEHICLE SENSOR, Diagnostic Procedure for Sensors.>

24. Air Vent Grille

A: REMOVAL

1. CENTER GRILLE

- 1) Insert a plastic remover into the slit at the bottom edge of the center panel and lift the panel.
- 2) Disengage the tabs and plastic hooks, and remove the center panel.

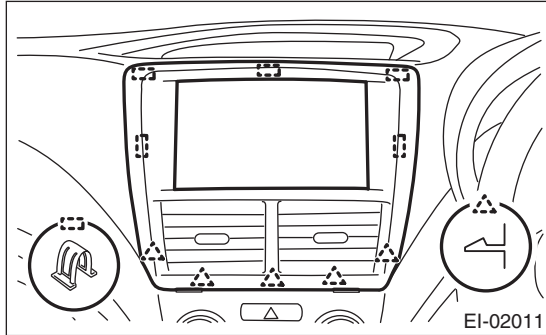

- 3) Remove the air vent center grille from the center panel.

2. SIDE GRILLE

- 1) Remove the ornament panel. <Ref. to EI-48, ORNAMENT PANEL, REMOVAL, Center Console.>
- 2) Remove the claws, and remove the air vent side grille.

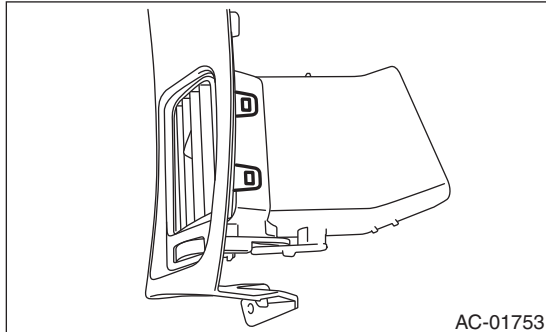

B: INSTALLATION

Install in the reverse order of removal.

C: INSPECTION

- 1) Check that the direction and amount of air can be adjusted smoothly.
- 2) Check that the adjustment can be maintained in each position.

Heater Duct

HVAC SYSTEM (HEATER, VENTILATOR AND A/C)

25.Heater Duct

A: REMOVAL

1. REAR HEATER DUCT

- 1) Remove the heater cooling unit. <Ref. to AC-32, REMOVAL, Heater and Cooling Unit.>
- 2) Remove the front seats. <Ref. to SE-8, REMOVAL, Front Seat.>
- 3) Remove the front side sill cover.
- 4) Pull off the floor mat to remove the rear center heater duct (A) and rear heater duct LH, RH (B).

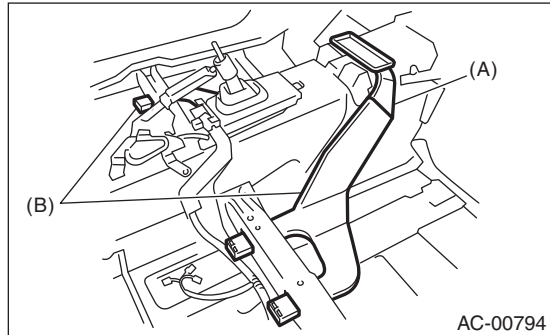

B: INSTALLATION

Install in the reverse order of removal.

Heater Vent Duct

HVAC SYSTEM (HEATER, VENTILATOR AND A/C)

26.Heater Vent Duct

A: REMOVAL

- 1) Remove the instrument panel. <Ref. to EI-50, REMOVAL, Instrument Panel Assembly.>
- 2) Remove the screws, and then remove the heater vent duct.

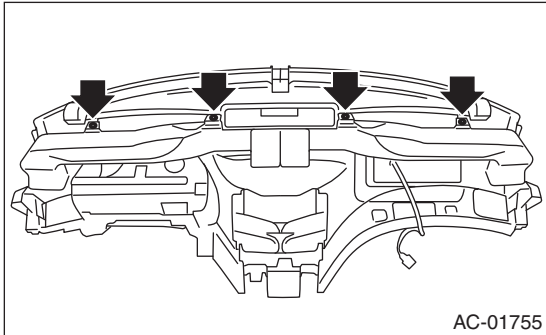

B: INSTALLATION

Install in the reverse order of removal.

27.A/C Filter

A: REPLACEMENT

1) Remove the glove box damper.

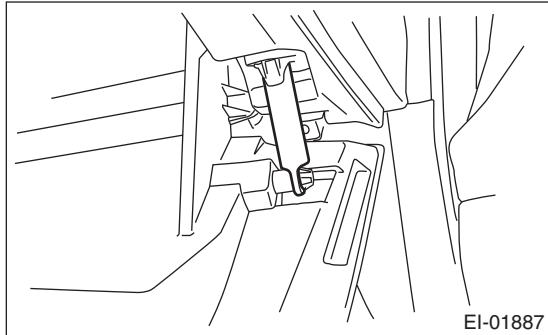

2) Disengage the stopper section and pull the glove box lid to remove it.

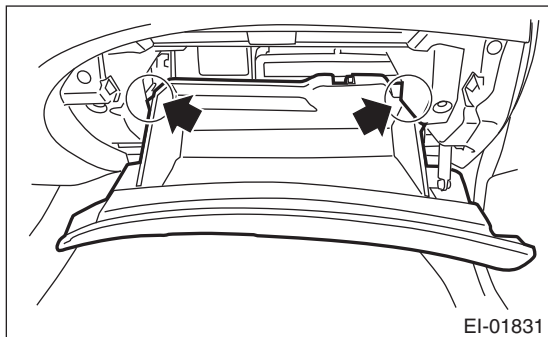

3) Pinch the claw to unlock and remove the A/C filter.

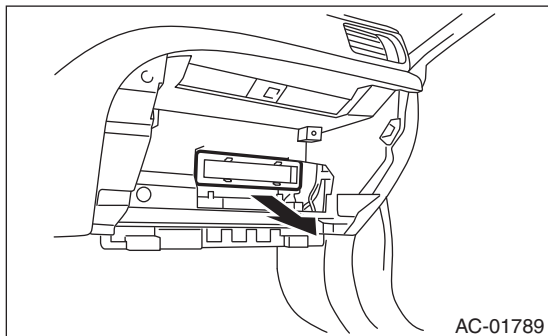

4) Install in the reverse order of removal.

General Diagnostic Table

HVAC SYSTEM (HEATER, VENTILATOR AND A/C)

28. General Diagnostic Table

A: INSPECTION

Symptom		Repair order
Blower motor	Does not operate.	Fuse
		Blower motor relay
		Blower motor
		Blower motor resistor (Manual A/C)
		Blower switch
		Wiring harness
	Noise	Blower motor
Compressor	Does not operate.	Refrigerant
		Fuse
		Air conditioning relay
		Magnet clutch
		Compressor
		Pressure switch
		A/C switch
		Blower switch
		Wiring harness
	Noise	V-belt
		Magnet clutch
		Compressor
		Refrigerant
		V-belt
Cold air not emitted.	Magnet clutch	
	Compressor	
	Pressure switch	
	Aspirator hose	
	Blower fan relay	
	Blower motor	
	A/C switch	
	Blower switch	
	Control module	
	Expansion valve	
	Evaporator	
	Air mix actuator (Auto A/C)	
	Temperature control cable (Manual A/C)	
	Wiring harness	
	Heater duct	
	Heater vent duct	
	Warm air not emitted.	Engine coolant
		Aspirator hose
		Air mix actuator (Auto A/C)
		Temperature control cable (Manual A/C)
Blower switch		
Heater core		

General Diagnostic Table

HVAC SYSTEM (HEATER, VENTILATOR AND A/C)

Symptom	Repair order
Temperature of air from vents does not change.	Engine coolant
	Air mix actuator (Auto A/C)
	Temperature control cable (Manual A/C)
	Temperature control switch
	Wiring harness (Auto A/C)
Unable to switch blow vents.	Mode actuator (Auto A/C)
	Mode switch cable (Manual A/C)
	Mode switch (Auto A/C)
	Wiring harness (Auto A/C)
Unable to switch suction vents.	FRESH/RECIRC switch (Auto A/C)
	Intake door actuator (Auto A/C)
	Wiring harness (Auto A/C)

HVAC SYSTEM (AUTO A/C) (DIAGNOSTICS)

AC(diag)

	Page
1. Basic Diagnostic Procedure	2
2. General Description	3
3. Electrical Component Location	5
4. Auto A/C Control Module I/O Signal	7
5. Diagnostic Chart for Self-diagnosis	9
6. Diagnostics for A/C System Malfunction	13
7. Diagnostic Procedure for Actuators	23
8. Diagnostic Procedure for Sensors	29
9. Diagnostics with Phenomenon	37

Basic Diagnostic Procedure

HVAC SYSTEM (AUTO A/C) (DIAGNOSTICS)

1. Basic Diagnostic Procedure

A: PROCEDURE

Step	Check	Yes	No
1 START INSPECTIONS. 1) Perform the pre-inspection. <Ref. to AC(diag)-3, INSPECTION, General Description.> 2) Perform the self-diagnosis. <Ref. to AC(diag)-9, OPERATION, Diagnostic Chart for Self-diagnosis.>	Does the self-diagnosis operate?	Go to step 2.	<Ref. to AC(diag)-13, A/C OR SELF-DIAGNOSIS SYSTEMS DO NOT OPERATE, Diagnostics for A/C System Malfunction.>
2 IDENTIFY MALFUNCTION PART. Identify the malfunction part with self-diagnosis.	Can the malfunction part be confirmed?	Repair the malfunctioning part in accordance with each diagnostic chart.	Go to step 3.
3 CHECK COMPARTMENT TEMPERATURE. 1) Turn the A/C switch to ON. 2) Turn the temperature control dial at maximum cool position. 3) Check the compartment temperature change.	Does the compartment temperature change?	Go to step 4.	<Ref. to AC(diag)-20, COMPARTMENT TEMPERATURE DOES NOT CHANGE, OR A/C SYSTEM DOES NOT RESPOND PROMPTLY, Diagnostics for A/C System Malfunction.>
4 CHECK A/C SYSTEM RESPONSE. Change the temperature setting, and check the response of A/C system.	Does the A/C system respond quickly?	A/C system is normal.	<Ref. to AC(diag)-20, COMPARTMENT TEMPERATURE DOES NOT CHANGE, OR A/C SYSTEM DOES NOT RESPOND PROMPTLY, Diagnostics for A/C System Malfunction.>

General Description

HVAC SYSTEM (AUTO A/C) (DIAGNOSTICS)

2. General Description

A: CAUTION

- 1) Never connect the battery in reverse polarity.
 - Doing so may immediately damage the auto A/C control module.
- 2) Do not disconnect the battery terminals while the engine is running.
 - A large counter electromotive force will be generated in the generator, and this voltage may damage electronic parts such as auto A/C control module etc.
- 3) Before disconnecting the connectors of sensors and the auto A/C control module, be sure to turn off the ignition switch.
 - Auto A/C control module may be damaged.
- 4) Every A/C-related part is a precision part. Do not drop them.
- 5) Airbag system wiring harness is routed near the A/C control panel and junction box.

CAUTION:

- Do not use electrical test equipment on the airbag system wiring harness and connector.
- Be careful not to damage the airbag system wiring harness when servicing the A/C control panel and junction box.

B: INSPECTION

Before performing the diagnosis, check the following items which may cause problems in the A/C system.

1. BATTERY

- 1) Measure the battery voltage and specific gravity of the electrolyte.

Standard voltage:

12 V

Specific gravity:

1.260 or more

- 2) Check the condition of the fuses for A/C system power supply and other fuses.
- 3) Check the condition of harness and harness connector connections.

2. ASPIRATOR HOSE

- 1) Turn the ignition switch to ON, and press the A/C switch.
- 2) Turn the temperature control dial to maximum hot position.
- 3) Set the outlet opening to the defroster position.
- 4) Turn the fan switch to MAX.
- 5) Put a thin strip of paper close to the front side of in-vehicle sensor suction port (A) at the instrument panel lower cover, and check whether the strip becomes drawn towards the port, indicating that air is being drawn in at the port.

NOTE:

Be careful not to let the paper get sucked into the port.

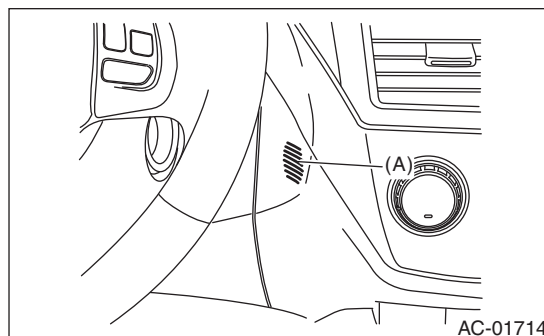

- 6) If the paper strip does not move at all, remove the center console <Ref. to EI-49, INSTRUMENT PANEL LOWER, REMOVAL, Center Console.>, and check for improper connection of the aspirator hose (A), in-vehicle sensor and heater unit, and repair them if necessary.

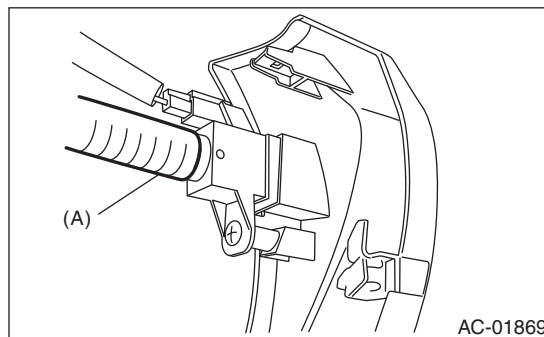

3. A/C LINE

Check the connection for A/C line (A) and lower side high-pressure pipe.

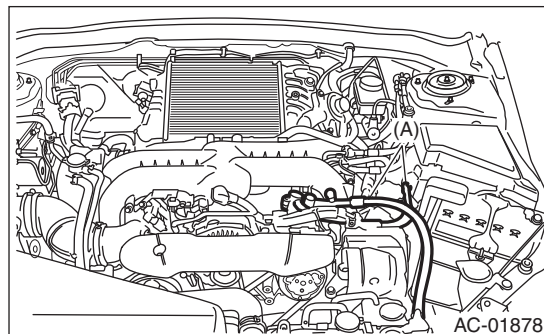

General Description

HVAC SYSTEM (AUTO A/C) (DIAGNOSTICS)

4. CONTROL LINKAGE

- 1) Check the state of mode door linkage.
- 2) Check the state of air mix door linkage.
- 3) Check the state of FRESH/RECIRC door linkage.

5. CONTROL SWITCHES

Start the engine and warm-up completely.

1) Inspection using switches

No.	Point to check	Switch operation	Judgement standard
1	Air flow control dial	Turn the dial to the right.	Outlet opening (mode) switches AUTO → VENT → BI-LEVEL → HEAT → DEF/HEAT → DEF each time turning the dial.
2	Fan speed control dial	Turn the dial to the right.	Fan speed switches OFF → AUTO → 1st → 2nd → 3rd → 4th → 5th → 6th → 7th each time the dial is turned.
3	FRESH/RECIRC switch	Press the FRESH/RECIRC switch.	Inlet opening switches RECIRC → FRESH → RECIRC each time pressing the switch. (LED illuminates at RECIRC)
		Set both of the air flow control dial and the fan dial to AUTO position.	The system switches to AUTO.
4	A/C switch	Turn the A/C switch to ON with the fan speed control dial set to except for OFF position.	The LED lights and the compressor operates.
		Set both of the air flow control dial and the fan dial to AUTO position.	The system switches to AUTO.
5	Auto function Operate in order starting from 1).	1) Set the following dial and switch to AUTO. • Air flow control dial • Fan speed control dial • FRESH/RECIRC switch • A/C switch 2) Turn the temperature control dial completely to the left, and set to the maximum cool position.	<ul style="list-style-type: none"> • Outlet air temperature: COOL • Fan speed: Max. • Outlet opening: VENT • Inlet opening: RECIRC • Compressor: AUTO
		3) Turn the temperature control dial to the right slowly up to the maximum hot position.	<ul style="list-style-type: none"> • Outlet air temperature: COOL → HOT • Fan speed: AUTO • Outlet opening: AUTO • Inlet opening: AUTO • Compressor: AUTO
		4) Turn the temperature control dial fully to the right, to the maximum hot position.	<ul style="list-style-type: none"> • Outlet air temperature: HOT • Fan speed: Max. • Outlet opening: HEAT • Inlet opening: FRESH • Compressor: AUTO
6	Defroster Interlock Function	Set the air flow control dial to the DEF or the DEF/HEAT position.	<ul style="list-style-type: none"> • Outlet air temperature: AUTO • Fan speed: AUTO • Outlet opening: DEF or DEF/HEAT • Inlet opening: FRESH • Compressor: ON
7	Rear defogger switch	Press the rear defogger switch.	LED illuminates

2) Compressor operation inspection

No.	Point to check	Switch operation	Judgement standard
1	Compressor	1) Turn the A/C switch to ON. 2) Set the FAN switch between LO and HI.	Compressor: ON

3) Inspection of illumination control

No.	Point to check	Switch operation	Judgement standard
1	Illumination	Turn the lighting switch to ON.	Illumination becomes lit. If the LED is lit, the LED will dim.

Electrical Component Location

HVAC SYSTEM (AUTO A/C) (DIAGNOSTICS)

3. Electrical Component Location

A: LOCATION

1. ENGINE COMPARTMENT

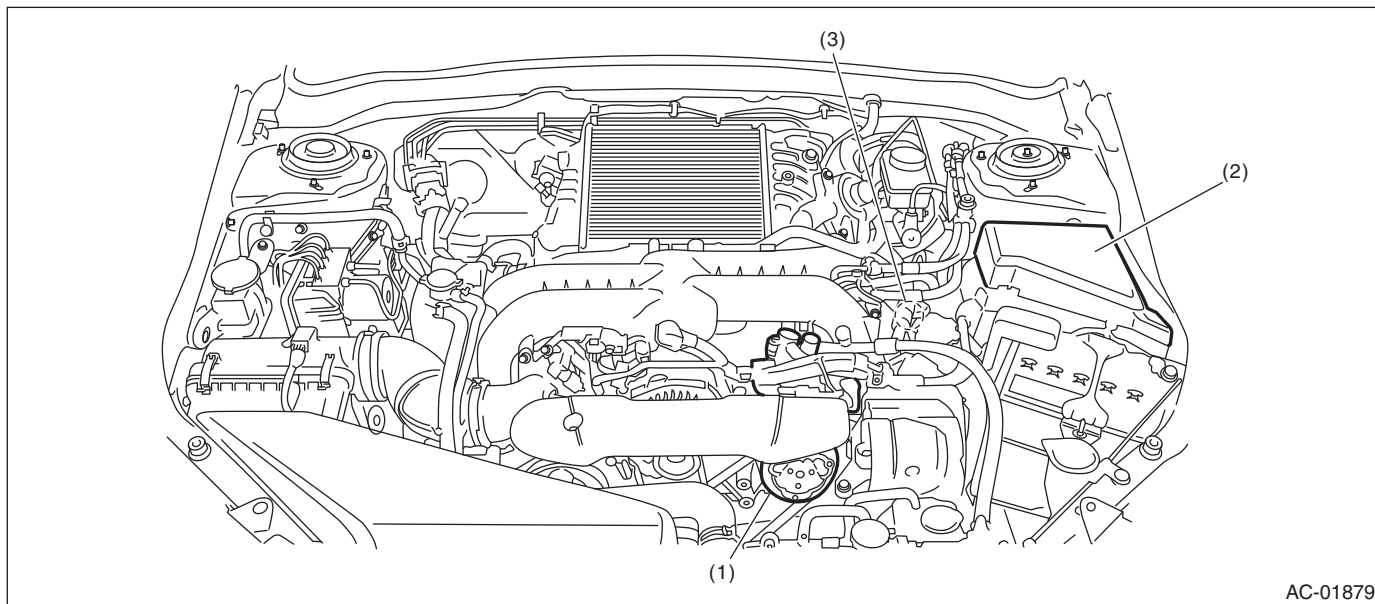

AC-01879

- (1) A/C compressor
- (2) A/C relay

- (3) Pressure switch

- (4) Ambient sensor

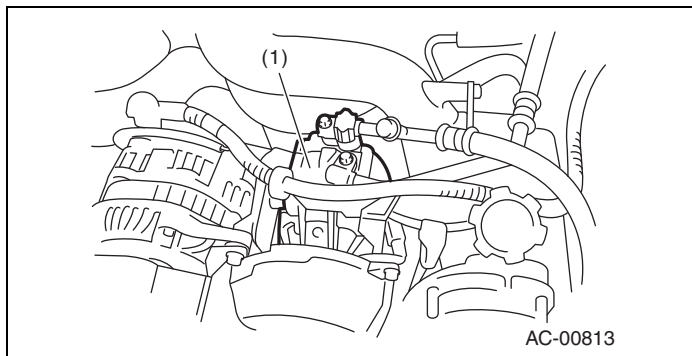

AC-00813

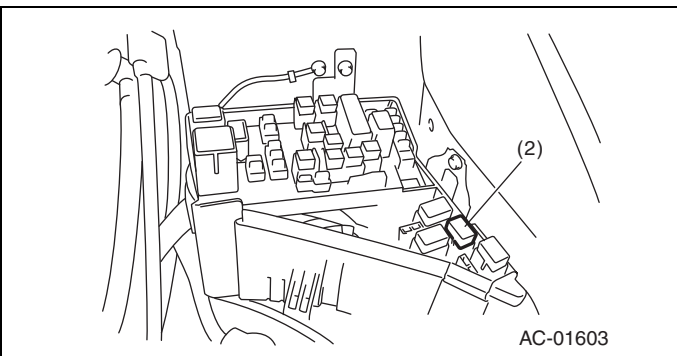

AC-01603

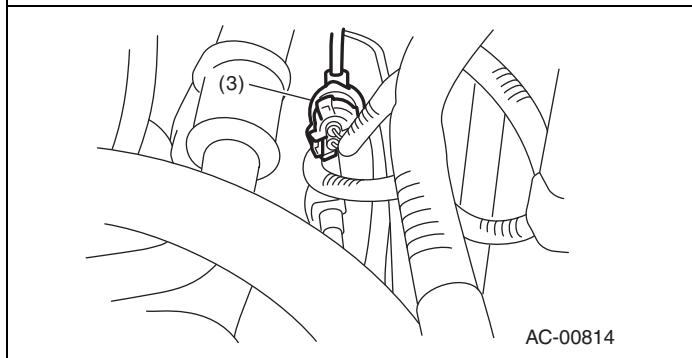

AC-00814

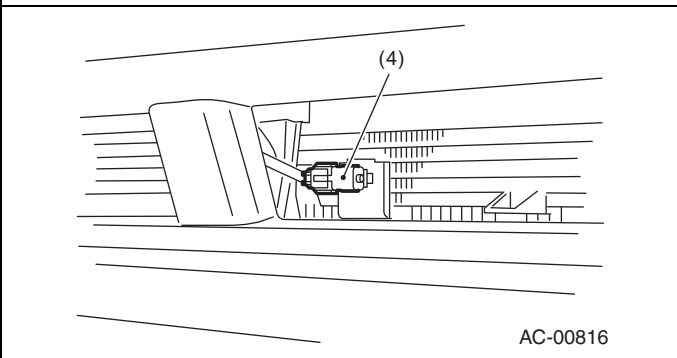

AC-00816

Electrical Component Location

HVAC SYSTEM (AUTO A/C) (DIAGNOSTICS)

2. COMPARTMENT

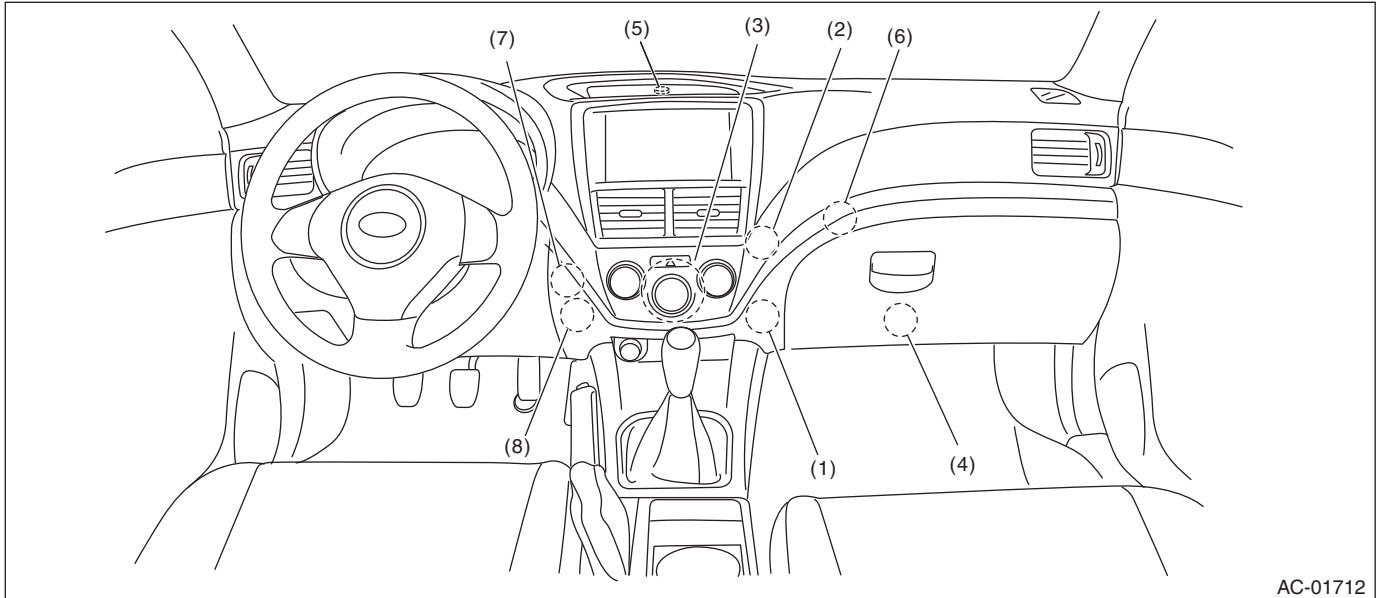

AC-01712

- | | | |
|-----------------------------|--------------------------|------------------------|
| (1) Evaporator sensor | (4) Blower motor | (7) Mode door actuator |
| (2) Air mix door actuator | (5) Sunload sensor | (8) In-vehicle sensor |
| (3) Auto A/C control module | (6) Intake door actuator | |

Auto A/C Control Module I/O Signal

HVAC SYSTEM (AUTO A/C) (DIAGNOSTICS)

4. Auto A/C Control Module I/O Signal

A: ELECTRICAL SPECIFICATION

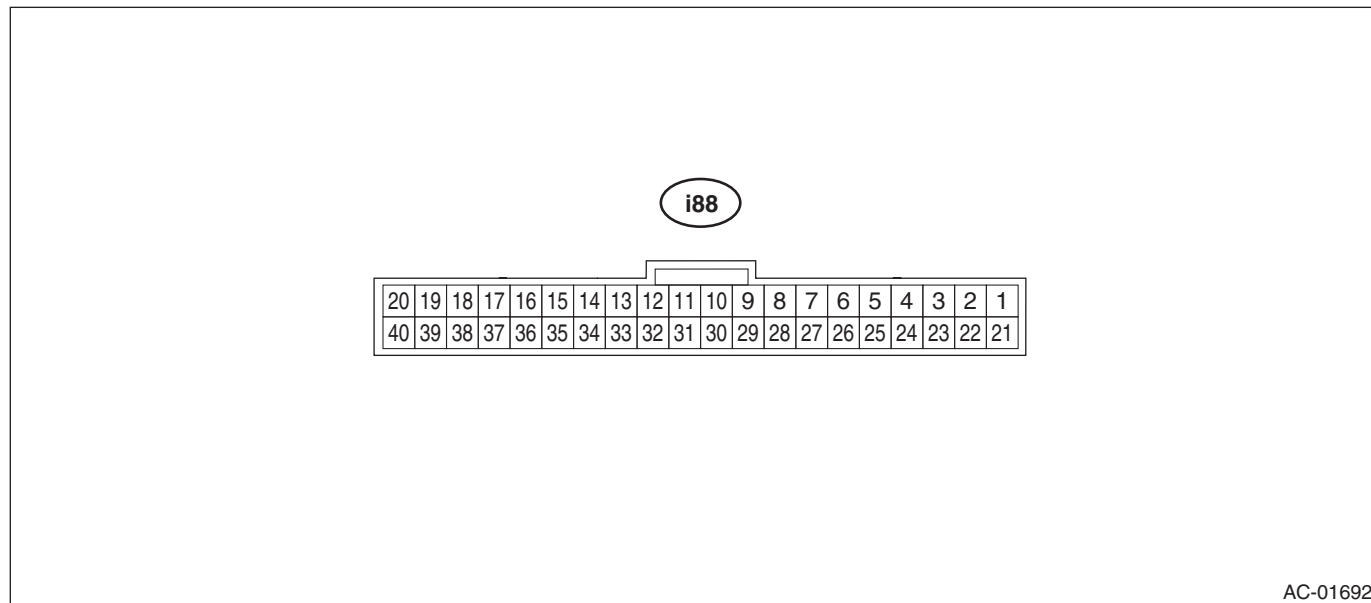

AC-01692

Terminal No.	Contents	Measuring condition	Standard
1	Mode actuator #4	Actuator active	8 V or more
2	Mode actuator #3	Actuator active	8 V or more
3	Mode actuator #2	Actuator active	8 V or more
4	Mode actuator #1	Actuator active	8 V or more
6	Intake door actuator (external air)	External air condition	1 V or less
7	Intake door actuator (MIX)	MIX condition	1 V or less
8	Intake door actuator (internal air)	Internal air condition	1 V or less
9	Blower fan ON signal	When blower fan is turned to ON.	1 V or less
10	Rr defogger operation signal input	When Rr defogger is active	10 V or more
11	A/C cut signal	When A/C is cut	1 V or less
14	Sensor GND	Always	1 V or less
15	ACC power supply	ACC ON	Battery voltage
16	Sunload sensor	When exposed to sunlight	1 — 4 V
17	RECIRC sensor	Ignition switch ON	25°C: 2.5 V
18	After evaporator sensor	Changes according to the temperature after passing through the evaporator	1 — 4.5 V
19	CAN Lo	Unable to measure the voltage for digital signal.	—
20	CAN Hi	Unable to measure the voltage for digital signal.	—
25	Air mix actuator #4	Air mix actuator active	8 V or more
26	Air mix actuator #3	Air mix actuator active	8 V or more
27	Air mix actuator #2	Air mix actuator active	8 V or more
28	Air mix actuator #1	Air mix actuator active	8 V or more
31	BATT	Always	Battery voltage
32	IGN	Ignition ON	Battery voltage
34	GND	Always	1 V or less
36	A/C ON signal	When A/C is active	8 V or more
35	ILL-	Illumination ON (measure between 37 — 35)	Battery voltage
37	ILL+		
39	Rr defogger switch output	When rear defogger relay is ON	Battery voltage
40	Fan control signal	Ignition switch ON, Blower switch ON	8 V or more

Auto A/C Control Module I/O Signal

HVAC SYSTEM (AUTO A/C) (DIAGNOSTICS)

B: WIRING DIAGRAM

1. AIR CONDITIONER AUTO A/C MODEL

<Ref. to WI-81, WIRING DIAGRAM, Air Conditioning System.>

Diagnostic Chart for Self-diagnosis

HVAC SYSTEM (AUTO A/C) (DIAGNOSTICS)

5. Diagnostic Chart for Self-diagnosis

A: OPERATION

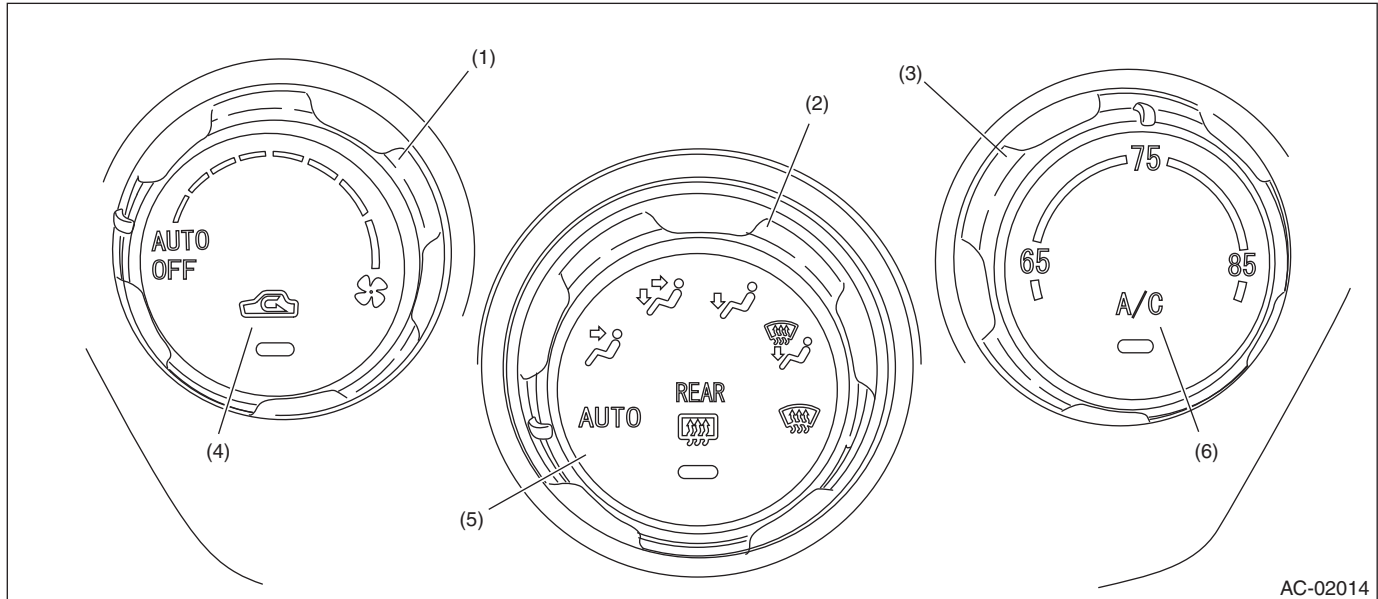

AC-02014

- | | | |
|---------------------------|---------------------------------|---------------------------------|
| (1) Fan dial | (3) Temperature adjustment dial | (5) Rear window defogger switch |
| (2) Air flow control dial | (4) FRESH/RECIRC switch | (6) A/C switch |

1. A/C CONTROL PANEL SELF-DIAGNOSIS

Step	Check	Yes	No
1 SELECT SELF-DIAGNOSIS MODE IN THE CONTROL PANEL. 1) Set the air flow control dial and fan dial to the AUTO position. 2) Start the engine with the A/C switch and the FRESH/RECIRC switch pressed.	Does the self-diagnosis mode operate?	Go to step 2.	<Ref. to AC(diag)-13, A/C OR SELF-DIAGNOSIS SYSTEMS DO NOT OPERATE, Diagnostics for A/C System Malfunction.>
2 CHECK THE LIGHTING OF THE LED. Make sure that all switch LEDs on the control panel illuminate.	Do all LEDs blink eight times?	Go to step 3.	Replace the control panel.
3 CHECK SENSOR MALFUNCTION. 1) Set the air flow control dial and fan dial to the AUTO position. 2) If the system has trouble for each sensor, the FRESH/RECIRC switch LED blinks or is turned off. 3) If the system has no trouble, the FRESH/RECIRC switch LED illuminates.	Does the FRESH/RECIRC switch LED illuminate?	Go to step 5.	Go to step 4.
4 CONFIRM MALFUNCTIONING SENSOR. 1) Set the air flow control dial to the AUTO position. 2) Turn the fan dial to each mode position, and check each switch LED illumination according to the sensor check table. <Ref. to AC(diag)-11, SENSOR CHECK TABLE, OPERATION, Diagnostic Chart for Self-diagnosis.>	When the fan dial is set to the individual mode positions, does the FRESH/RECIRC switch LED turn off?	Go to step 5.	Repair the defective sensor. <Ref. to AC(diag)-29, Diagnostic Procedure for Sensors.>

Diagnostic Chart for Self-diagnosis

HVAC SYSTEM (AUTO A/C) (DIAGNOSTICS)

Step	Check	Yes	No
5 CHECK AIR MIX DOOR AND MODE DOOR POSITION SIGNALS. 1) Set the air flow control dial to the FACE position. 2) Turn the fan dial to AUTO. 3) If the system has trouble for air mix door signal and mode door position signal, the FRESH/RECIRC switch LED is turned off or blinks. 4) If the system has no trouble, the FRESH/RECIRC switch LED illuminates.	Does the FRESH/RECIRC switch LED illuminate?	Go to step 8.	Go to step 6.
6 CHECK AIR MIX DOOR POSITION DRIVE SIGNALS. 1) Set the air flow control dial to the FACE position. 2) Set the fan dial to each position, and check the lighting conditions of each LED. <Ref. to AC(diag)-12, DRIVE SIGNAL CHECK TABLE, OPERATION, Diagnostic Chart for Self-diagnosis.>	Does the lighting conditions of the LED match the drive signal list?	Go to step 7.	Check the air mix door actuator circuit. <Ref. to AC(diag)-27, AIR MIX DOOR ACTUATOR, Diagnostic Procedure for Actuators.>
7 CHECK MODE DOOR POSITION DRIVE SIGNALS. 1) Press the A/C switch. 2) Set the fan dial to each position, and check the lighting conditions of each LED. <Ref. to AC(diag)-12, DRIVE SIGNAL CHECK TABLE, OPERATION, Diagnostic Chart for Self-diagnosis.>	Does the lighting conditions of the LED match the drive signal list?	Go to step 8.	Check the mode door actuator circuit. <Ref. to AC(diag)-25, MODE DOOR ACTUATOR, Diagnostic Procedure for Actuators.>
8 CHECK OPERATION OF EACH ACTUATOR, BLOWER FAN AND COMPRESSOR CLUTCH. 1) Set the air flow control dial to the B/L position. 2) Set the fan dial to AUTO — 7th position, and select the operating mode. 3) Check the operation of each mode according to operating mode table. <Ref. to AC(diag)-11, OPERATING MODE TABLE, OPERATION, Diagnostic Chart for Self-diagnosis.> <ul style="list-style-type: none"> • FRESH/RECIRC door • Air flow control door • Air mix door • Blower fan • A/C compressor 	Does the operation of each mode match to operating mode table?	Turn the fan dial to OFF or turn the ignition switch to OFF, to complete the self diagnosis.	Repair the malfunctioning part in accordance with each diagnostic chart.

Diagnostic Chart for Self-diagnosis

HVAC SYSTEM (AUTO A/C) (DIAGNOSTICS)

2. SENSOR CHECK TABLE

NOTE:

- When the sunload sensor check is performed indoors or in the shade, it could be diagnosed as having an open circuit. Always check the sunload sensor at a location exposed to direct sunlight.
- LED illuminates to warn the past malfunction if it was detected four times or more in the past.
- To clear the past malfunction, disconnect the ground cable from the battery, or press and hold the FRESH/RECIRC switch for five seconds or more when performing the self-diagnosis Step 3 to Step 7.

Air flow control dial position	Fan dial position	Sensor	No trouble	Short circuit	Open circuit	When currently malfunctioning	When having malfunctioned in the past
AUTO	AUTO	In-vehicle sensor	FRESH/RECIRC switch LED is turned off	FRESH/RECIRC switch LED blinks (Illuminates for 0.2 sec. ⇔ turns off for 0.2 sec.)	FRESH/RECIRC switch LED blinks (Illuminates for 1 sec. ⇔ turns off for 1 sec.)	Rear window defogger switch LED is turned off	Rear window defogger switch LED illuminates
	1st	Ambient sensor		FRESH/RECIRC switch LED blinks (Illuminates for 0.2 sec. ⇔ turns off for 0.2 sec.)			
	2nd	Evaporator sensor		FRESH/RECIRC switch LED blinks (Illuminates for 0.2 sec. ⇔ turns off for 0.2 sec.)			
	3rd	Engine coolant temperature sensor		—			
	4th	Sunload sensor		FRESH/RECIRC switch LED blinks (Illuminates for 0.2 sec. ⇔ turns off for 0.2 sec.)			
	5th — 7th	CAN communication		—			

3. OPERATING MODE TABLE

Operation	Fan dial position							
	AUTO	1st	2nd	3rd	4th	5th	6th	7th
Blower fan	4 V	4 V	4.9 V	5.9 V	7.0 V	8.3 V	9.8 V	14 V
FRESH/RECIRC door	RECIRC	RECIRC	MIX	FRESH	FRESH	FRESH	FRESH	FRESH
Air flow control door	FACE	FACE	FACE	B/L	HEAT	HEAT	D/H	DEF
Air mix door	0%	0%	0%	50%	50%	100%	100%	100%
A/C compressor	OFF	ON	ON	ON	ON	ON	ON	ON

Diagnostic Chart for Self-diagnosis

HVAC SYSTEM (AUTO A/C) (DIAGNOSTICS)

4. DRIVE SIGNAL CHECK TABLE

NOTE:

- LED illuminates to warn the past malfunction if it was detected four times or more in the past.
- To clear the past malfunction, disconnect the ground cable from the battery, or press and hold the FRESH/RECIRC switch for five seconds or more when performing the self-diagnosis Step 3 to Step 7.

Air flow control dial position	Fan dial position	Drive signal to check	A/C switch LED	No trouble	Short circuit	Open circuit	When currently malfunctioning	When having malfunctioned in the past
FACE	AUTO	MIX #1	Blinking (Illuminates for 0.2 sec. ⇔ turns off for 0.2 sec.)	FRESH/ RECIRC switch LED is turned off	FRESH/ RECIRC switch LED blinks (Illuminates for 0.2 sec. ⇔ turns off for 0.2 sec.)	FRESH/ RECIRC switch LED blinks (Illuminates for 1 sec. ⇔ turns off for 1 sec.)	Rear window defogger switch LED is turned off	Rear window defogger switch LED illuminates
	1st	MIX #2						
	2nd	MIX #3						
	3rd — 7th	MIX #4						
	AUTO	MODE #1	Blinking (Illuminates for 1 sec. ⇔ turns off for 1 sec.)					
	1st	MODE #2						
	2nd	MODE #3						
	3rd — 7th	MODE #4						

Diagnostics for A/C System Malfunction

HVAC SYSTEM (AUTO A/C) (DIAGNOSTICS)

6. Diagnostics for A/C System Malfunction

A: A/C OR SELF-DIAGNOSIS SYSTEMS DO NOT OPERATE

TROUBLE SYMPTOM:

- Set temperature is not indicated on the display, switch LEDs are faulty and switches do not operate.
- Self-diagnosis system does not operate.

WIRING DIAGRAM:

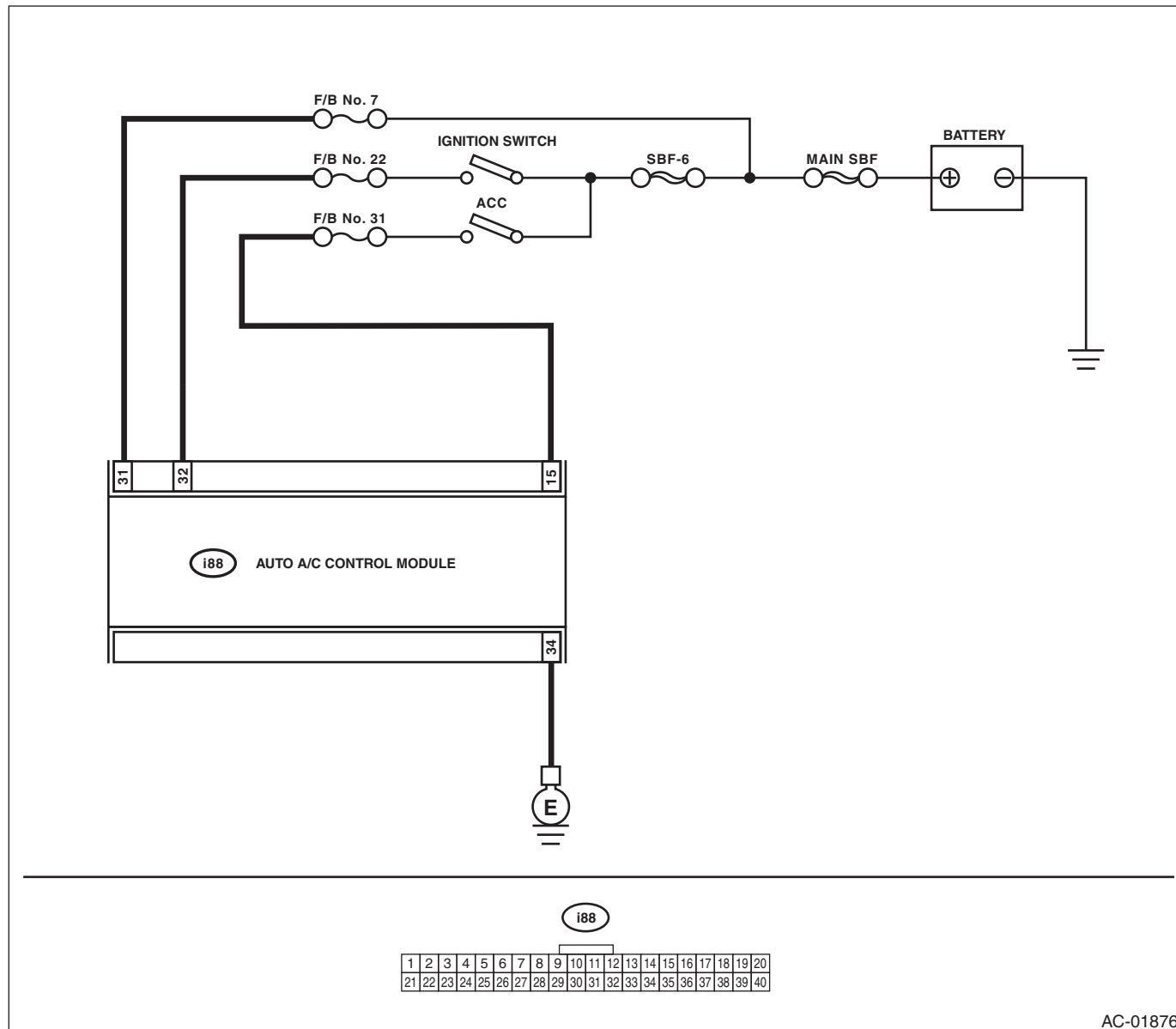

AC-01876

Diagnostics for A/C System Malfunction

HVAC SYSTEM (AUTO A/C) (DIAGNOSTICS)

Step	Check	Yes	No
1 CHECK FUSE. 1) Turn the ignition switch to OFF. 2) Remove the fuse No. 7 from fuse & relay box. 3) Check the condition of fuse.	Is the fuse blown out?	Replace the fuse.	Go to step 2.
2 CHECK FUSE. 1) Turn the ignition switch to OFF. 2) Remove the fuse No. 22 and No. 31 from fuse & relay box. 3) Check the condition of fuse.	Is the fuse blown out?	Replace the fuse.	Go to step 3.
3 CHECK A/C CONTROL UNIT POWER CIRCUIT. 1) Remove the A/C control panel. 2) Disconnect the A/C control panel harness connector. 3) Measure the voltage between A/C control panel harness connector terminal and chassis ground after turning the ignition switch to ACC. <i>Connector & terminal (i88) No. 15 (+) — Chassis ground (-):</i>	Is the voltage 10 V or more?	Go to step 4.	Check for open or short circuit in the harness between A/C control panel and fuse.
4 CHECK A/C CONTROL UNIT POWER CIRCUIT. Measure the voltage between A/C control panel harness connector terminal and chassis ground after turning the ignition switch to ON. <i>Connector & terminal (i88) No. 32 (+) — Chassis ground (-):</i>	Is the voltage 10 V or more?	Go to step 5.	Check for open or short circuit in the harness between A/C control panel and fuse.
5 CHECK A/C CONTROL PANEL GROUND POWER CIRCUIT. Measure the resistance of harness between A/C control panel and chassis ground after turning the ignition switch to OFF. <i>Connector & terminal (i88) No. 34 — Chassis ground:</i>	Is the resistance less than 1 Ω ?	Go to step 6.	Repair the harness for ground line.
6 CHECK POOR CONTACT. Check poor contact of auto A/C control module connector.	Is there poor contact in connector?	Repair the connector.	Replace the auto A/C control module.

Diagnostics for A/C System Malfunction

HVAC SYSTEM (AUTO A/C) (DIAGNOSTICS)

B: BLOWER MOTOR DOES NOT ROTATE

TROUBLE SYMPTOM:

- Blower motor does not rotate.
- Blower motor does not change speeds.

WIRING DIAGRAM:

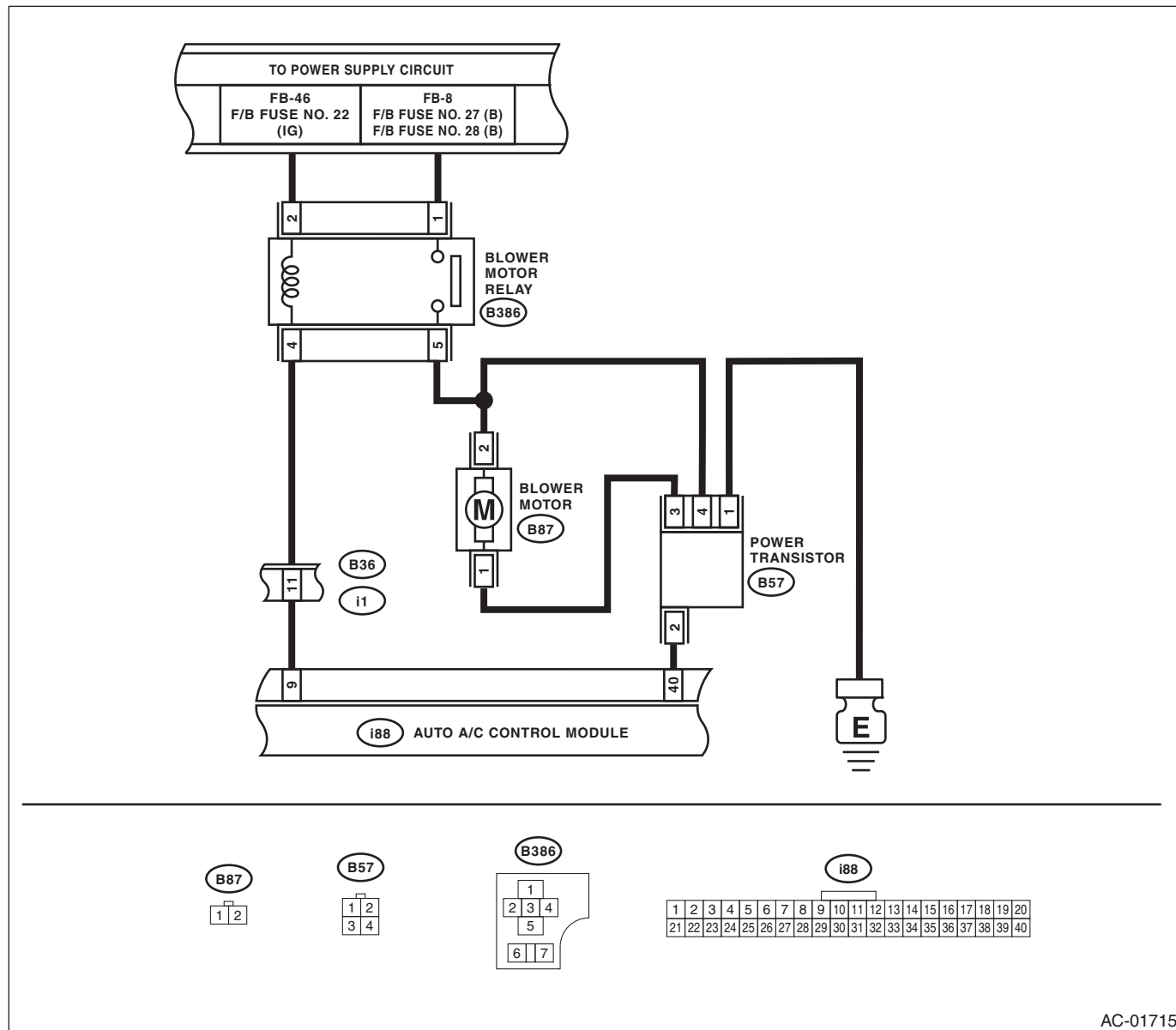

AC-01715

Diagnostics for A/C System Malfunction

HVAC SYSTEM (AUTO A/C) (DIAGNOSTICS)

Step	Check	Yes	No
1 CHECK FUSE. 1) Remove fuse No. 22, 27 and 28 from the fuse & relay box. 2) Check the condition of fuse.	Is any fuse blown out?	Replace the fuse.	Go to step 2.
2 CHECK BLOWER MOTOR RELAY POWER SUPPLY. 1) Turn the ignition switch to OFF. 2) Remove the blower motor relay. 3) Turn the ignition switch to ON. 4) Use a tester to measure the voltage between the blower motor relay connector and chassis ground. Connector & terminal (B386) No. 2 — Chassis ground:	Is the voltage 10 V or more?	Go to step 3.	Repair the open circuit of blower motor power supply line harness.
3 CHECK BLOWER MOTOR RELAY POWER SUPPLY. 1) Turn the ignition switch to ON. 2) Turn the blower switch to ON. 3) Use a tester to measure the voltage between the blower motor relay connectors. Connector & terminal (B386) No. 2 — No. 4:	Is the voltage 10 V or more?	Go to step 5.	Go to step 4.
4 CHECK HARNESS. 1) Turn the ignition switch to OFF. 2) Disconnect the auto A/C control module connector (i88). 3) Use a tester to measure the resistance between harness terminals. Connector & terminal (B386) No. 4 — (i88) No. 9:	Is the resistance less than 1 Ω ?	Go to step 5.	Repair or replace the open circuit of the harness.
5 CHECK BLOWER MOTOR RELAY. 1) Turn the ignition switch to OFF. 2) Remove the blower motor relay. 3) Connect the battery terminal to the blower motor relay. No. 2 (+) — No. 4 (-) 4) Measure the resistance between terminals. Terminals No. 1 — No. 5:	Is the resistance less than 1 Ω ?	Go to step 6.	Replace the blower motor relay.
6 CHECK BLOWER MOTOR POWER SUPPLY. 1) Turn the ignition switch to OFF. 2) Install the blower motor relay. 3) Disconnect the blower motor connector. 4) Turn the ignition switch to ON. 5) Turn the blower switch to ON. 6) Use a tester to measure the voltage between the blower motor connector and chassis ground. Connector & terminal (B87) No. 2 — Chassis ground:	Is the voltage 10 V or more?	Go to step 7.	Repair or replace the harness between the blower motor relay and the blower motor.
7 CHECK BLOWER MOTOR. 1) Disconnect the connector from the blower motor. 2) Connect the battery positive terminal to terminal No. 2 of blower motor connector, and negative terminal to terminal No. 1. 3) Make sure the blower motor runs.	Does the blower motor run?	Go to step 8.	Replace the blower motor.

Diagnostics for A/C System Malfunction

HVAC SYSTEM (AUTO A/C) (DIAGNOSTICS)

Step	Check	Yes	No
8 CHECK HARNESS. 1) Turn the ignition switch to OFF. 2) Disconnect the power transistor connector. 3) Disconnect the auto A/C control module connector. 4) Use a tester to measure the resistance between harness terminals. Connector & terminal <i>(B57) No. 1 — Chassis ground:</i> <i>(B57) No. 2 — (i88) No. 40:</i> <i>(B57) No. 3 — (B87) No. 1:</i> <i>(B57) No. 4 — (B87) No. 2:</i> <i>(B57) No. 4 — (B386) No. 5:</i>	Is the resistance less than 1 Ω ?	Go to step 9.	Repair or replace the harness.
9 CHECK FAN CONTROL SIGNAL. 1) Turn the ignition switch to OFF. 2) Connect the blower motor and auto A/C control module. 3) Turn the ignition switch to ON. 4) Set the fan dial to 1st — 7th. 5) Use a tester to measure the voltage between the power transistor connector and chassis ground. Connector & terminal <i>(B57) No. 2 (+) — Chassis ground (-):</i>	Is approx. 10 V detected in 1st, and 1 V at 7th?	Replace the power transistor. <Ref. to AC-25, REMOVAL, Power Transistor (Auto A/C Model).>	Go to step 10.
10 CHECK POOR CONTACT. Check poor contact of auto A/C control module connector.	Is there poor contact in connector?	Repair the connector.	Replace the auto A/C control module.

Diagnostics for A/C System Malfunction

HVAC SYSTEM (AUTO A/C) (DIAGNOSTICS)

C: BLOWER MOTOR TURNS AROUND EARLY

TROUBLE SYMPTOM:

- The blower turns even though the blower switch is not turned ON.
- The blower motor continues to turn at high speed. (Cannot be adjusted)

WIRING DIAGRAM:

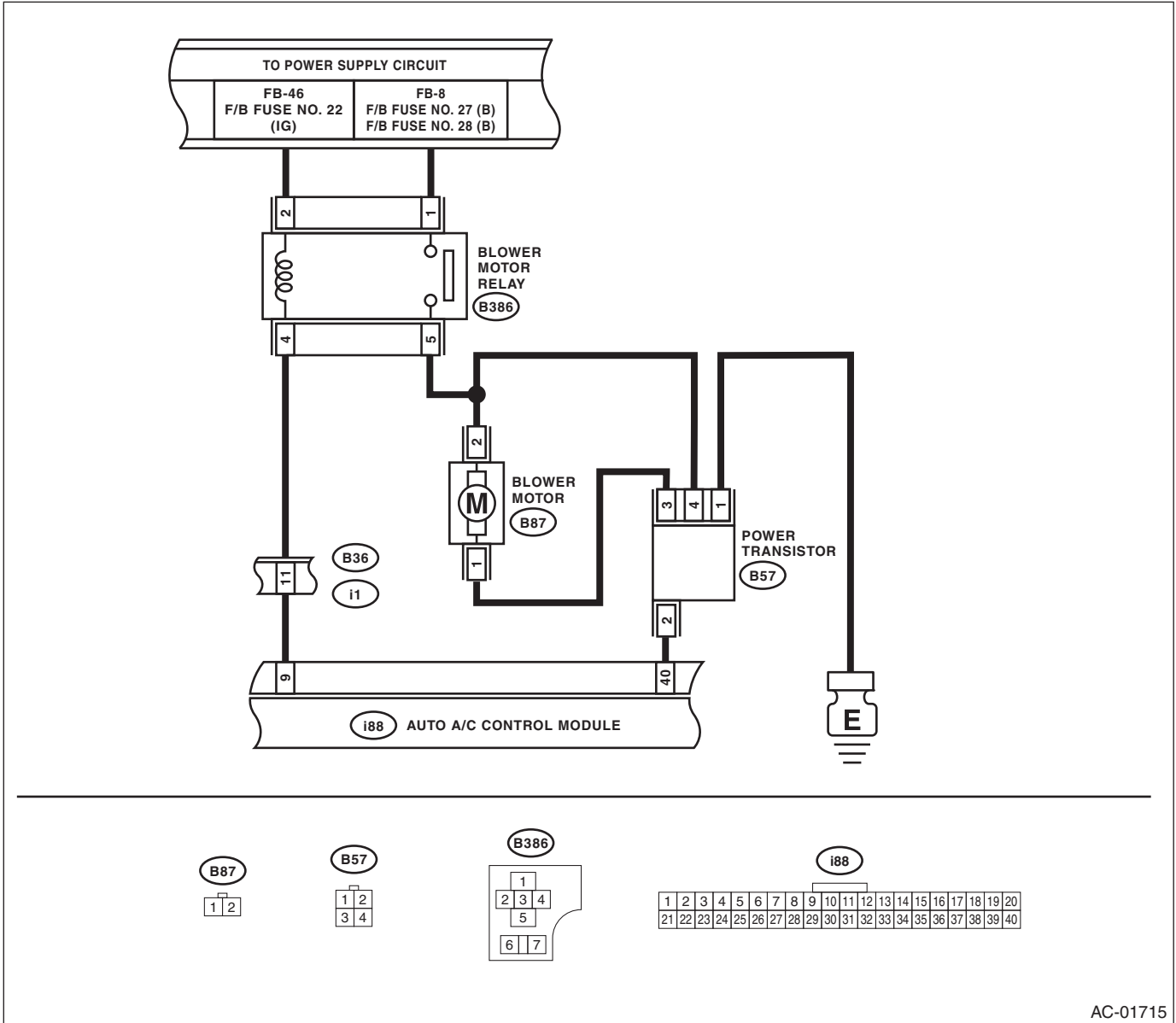

AC-01715

Diagnostics for A/C System Malfunction

HVAC SYSTEM (AUTO A/C) (DIAGNOSTICS)

Step	Check	Yes	No
1 CHECK BLOWER MOTOR CIRCUIT. 1) Turn the ignition switch to OFF. 2) Disconnect the power transistor connector. 3) Use a tester to measure the resistance between the power transistor connector and chassis ground. Connector & terminal (B57) No. 3 — Chassis ground:	Is there continuity?	Repair or replace the short circuit of the harness.	Go to step 2.
2 CHECK HARNESS. 1) Remove the auto A/C control module. 2) Use a tester to measure the resistance between the power transistor connector and chassis ground. Connector & terminal (B57) No. 2 — Chassis ground:	Is there continuity?	Repair or replace the short circuit of the harness.	Go to step 3.
3 CHECK POWER TRANSISTOR. 1) Connect the disconnected connectors. 2) Turn the ignition switch to ON. 3) Use a tester to measure the voltage between the power transistor connector and chassis ground. Connector & terminal (B57) No. 2 (+) — Chassis ground (-):	Is approx. 10 V detected when the fan dial is set to 1st, and approx. 1 V when it is set to 7th?	Replace the power transistor. <Ref. to AC-25, REMOVAL, Power Transistor (Auto A/C Model).>	Go to step 4.
4 CHECK AUTO A/C CONTROL MODULE. 1) Turn the fan dial to OFF. 2) Disconnect the power transistor connector. 3) Use a tester to measure the resistance between the power transistor connector and chassis ground. Connector & terminal (B57) No. 2 — Chassis ground:	Is the resistance changed between when the fan dial is OFF and otherwise?	Replace the power transistor. <Ref. to AC-25, REMOVAL, Power Transistor (Auto A/C Model).>	Replace the auto A/C control module. <Ref. to AC-29, REMOVAL, Control Unit (Auto A/C Model).>

Diagnostics for A/C System Malfunction

HVAC SYSTEM (AUTO A/C) (DIAGNOSTICS)

D: COMPARTMENT TEMPERATURE DOES NOT CHANGE, OR A/C SYSTEM DOES NOT RESPOND PROMPTLY

TROUBLE SYMPTOM:

- Compartment temperature does not change. (Cold air does not come out)
- The A/C system does not respond. (Response is extremely slow)

WIRING DIAGRAM:

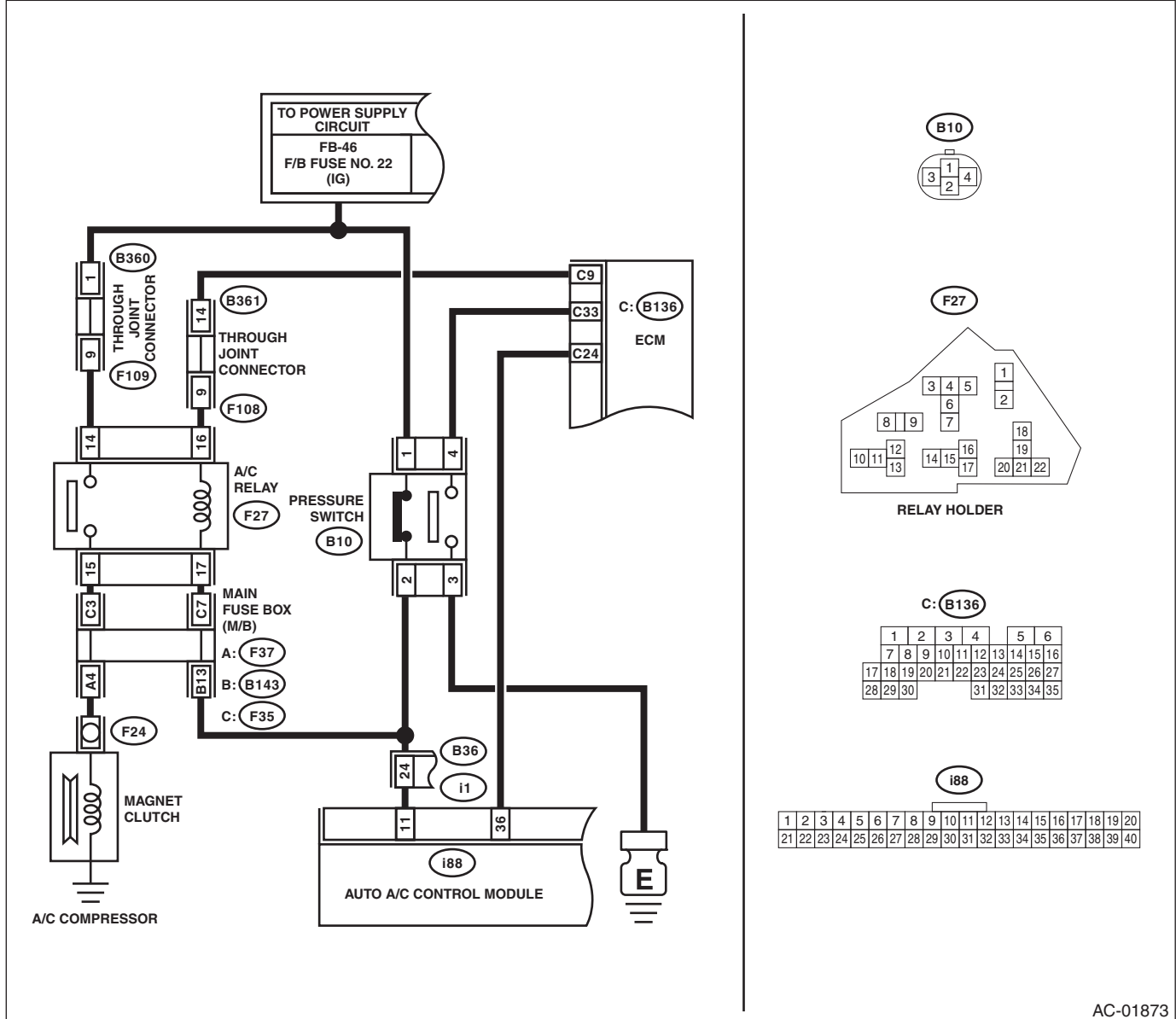

AC-01873

Diagnostics for A/C System Malfunction

HVAC SYSTEM (AUTO A/C) (DIAGNOSTICS)

Step	Check	Yes	No
1 CHECK FUSE. 1) Turn the ignition switch to OFF. 2) Remove the fuse No. 22 from fuse & relay box. 3) Check the condition of fuse.	Is the fuse blown out?	Replace the fuse.	Go to step 2.
2 CHECK SIGNAL TO A/C RELAY AND AUTO A/C CONTROL MODULE. 1) Disconnect the A/C relay and auto A/C control module harness connector. 2) Turn the ignition switch to ON. 3) Measure the voltage between A/C relay connector terminal and chassis ground. 4) Measure the voltage between auto A/C control module harness connector terminal and chassis ground. Connector & terminal <i>(F27) No. 17 (+) — Chassis ground (-):</i> <i>(i88) No. 11 (+) — Chassis ground (-):</i>	Is the voltage 10 V or more?	Go to step 5.	Go to step 3.
3 CHECK POWER SUPPLY FOR PRESSURE SWITCH. 1) Turn the ignition switch to OFF. 2) Disconnect the pressure switch harness connector. 3) Turn the ignition switch to ON. 4) Measure the voltage between pressure switch harness connector terminal and chassis ground. Connector & terminal <i>(B10) No. 2 (+) — Chassis ground (-):</i>	Is the voltage 10 V or more?	Go to step 4.	Check for open or short circuit in the harness between fuse and pressure switch.
4 CHECK HARNESS BETWEEN PRESSURE SWITCH AND A/C RELAY, AUTO A/C CONTROL MODULE. 1) Turn the ignition switch to OFF. 2) Measure the resistance of harness between pressure switch connector and A/C relay connector. 3) Measure the resistance of harness between pressure switch connector and auto A/C control module connector. Connector & terminal <i>(B10) No. 2 — (F27) No. 17:</i> <i>(B10) No. 2 — (i88) No. 11:</i>	Is the resistance less than 1 Ω ?	Check the pressure switch. <Ref. to AC-37, INSPECTION, Pressure Switch (Triple Pressure Switch).>	Repair the harness.
5 CHECK POWER SUPPLY FOR A/C RELAY. Measure the voltage between A/C relay connector terminal and chassis ground. Connector & terminal <i>(F27) No. 14 (+) — Chassis ground (-):</i>	Is the voltage 10 V or more?	Go to step 6.	Check open or short circuit of harness between fuse and A/C relay.
6 CHECK A/C RELAY. Check the A/C relay. <Ref. to AC-36, INSPECTION, Relay and Fuse.>	Is there a malfunction in the A/C relay?	Go to step 7.	Replace the A/C relay.

Diagnostics for A/C System Malfunction

HVAC SYSTEM (AUTO A/C) (DIAGNOSTICS)

Step	Check	Yes	No
7 CHECK A/C ON SIGNAL. 1) Turn the ignition switch to OFF. 2) Connect the A/C relay and all disconnected connectors. 3) Start the engine and turn the A/C switch to ON. 4) Turn the temperature control dial at maximum cool position. 5) Measure the voltage between auto A/C control module harness connector terminal and chassis ground. Connector & terminal (i88) No. 36 (+) — Chassis ground (-):	Is the voltage 5.5 V or more?	Go to step 9.	Go to step 8.
8 CHECK HARNESS BETWEEN AUTO A/C CONTROL MODULE AND ECM. 1) Turn the ignition switch to OFF. 2) Disconnect the harness connector of auto A/C control module and ECM. 3) Measure the resistance of harness between auto A/C control module connector and ECM connector. Connector & terminal (i88) No. 36 — (B136) No. 24:	Is the resistance less than 1 Ω ?	Replace the auto A/C control module.	Repair the harness.
9 CHECK MAGNET CLUTCH ON SIGNAL. 1) Stop the engine and turn the A/C switch to OFF. 2) Turn the ignition switch to ON. 3) Measure the voltage between ECM connector terminal and chassis ground. Connector & terminal (B136) No. 9 (+) — Chassis ground (-):	Is the voltage 10 V or more?	Go to step 10.	Check for open or short circuit in the harness between A/C relay and ECM.
10 CHECK MAGNET CLUTCH ON SIGNAL. 1) Start the engine and turn the A/C switch to ON. 2) Turn the temperature control dial at maximum cool position. 3) Measure the voltage between ECM connector terminal and chassis ground. Connector & terminal (B136) No. 9 (+) — Chassis ground (-):	Is the voltage 0 V?	Go to step 11.	Replace the ECM.
11 CHECK POWER SUPPLY FOR MAGNET CLUTCH. 1) Stop the engine and turn the A/C switch to OFF. 2) Disconnect the harness connector of magnet clutch. 3) Start the engine and turn the A/C switch to ON. 4) Turn the temperature control dial at maximum cool position. 5) Measure the voltage between magnet clutch harness connector terminal and chassis ground. Connector & terminal (F24) No. 1 (+) — Chassis ground (-):	Is the voltage 10 V or more?	Inspect the compressor. <Ref. to AC-30, INSPECTION, Compressor.>	Check for open or short circuit in the harness between A/C relay and magnet clutch.

Diagnostic Procedure for Actuators

7. Diagnostic Procedure for Actuators

A: INTAKE DOOR ACTUATOR

TROUBLE SYMPTOM:

FRESH/RECIRC mode is not changed.

WIRING DIAGRAM:

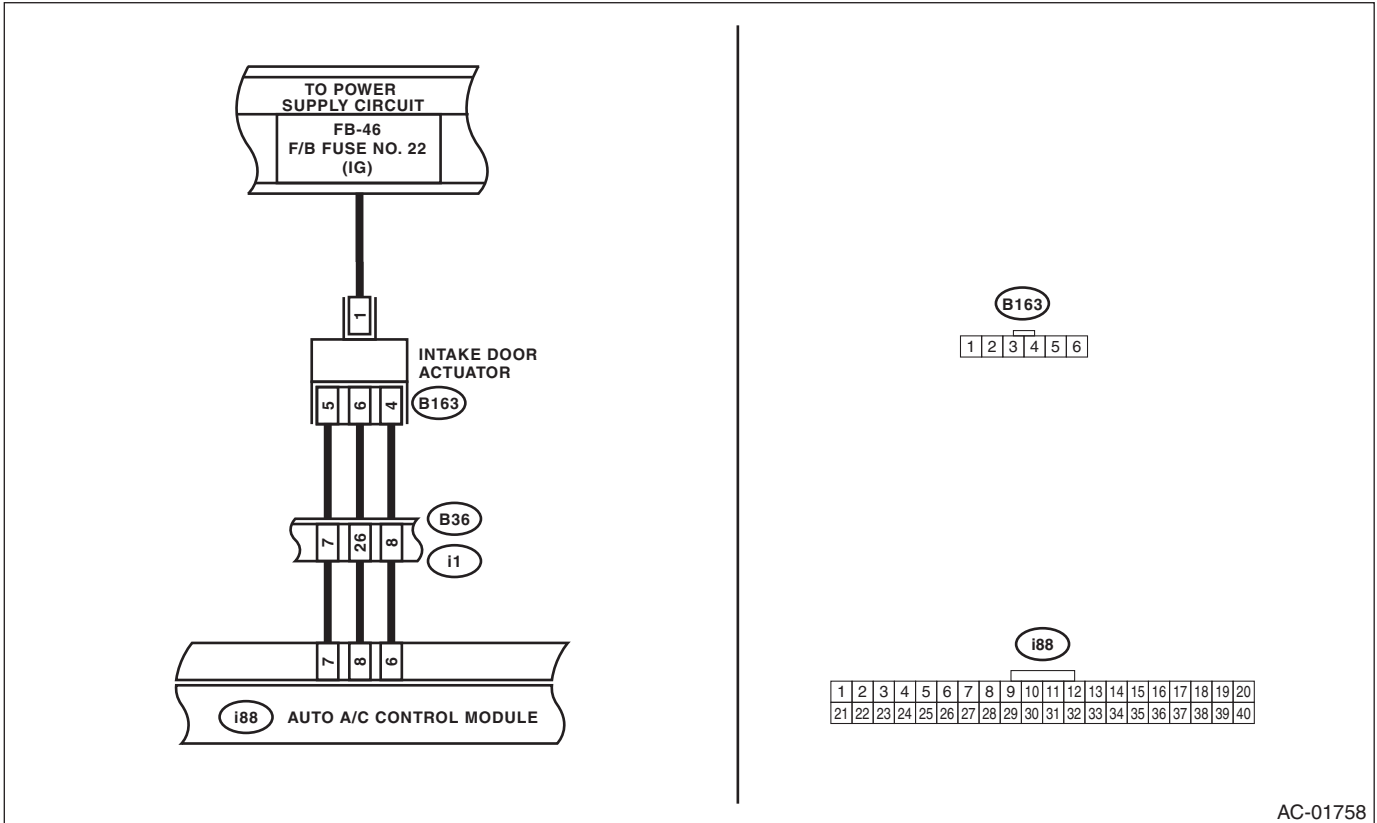

AC-01758

Diagnostic Procedure for Actuators

HVAC SYSTEM (AUTO A/C) (DIAGNOSTICS)

Step	Check	Yes	No
1 CHECK POWER SUPPLY FOR INTAKE DOOR ACTUATOR. 1) Turn the ignition switch to OFF. 2) Disconnect the intake door actuator connector. 3) Turn the ignition switch to ON. 4) Measure the voltage between intake door actuator connector and chassis ground. Connector & terminal (B163) No. 1 (+) — Chassis ground (-):	Is the voltage 7 V (at normal temperature)?	Go to step 2.	Check for open or short circuit in the harness between intake door actuator and fuse.
2 CHECK HARNESS BETWEEN AUTO A/C CONTROL MODULE AND INTAKE DOOR ACTUATOR. 1) Turn the ignition switch to OFF. 2) Disconnect the auto A/C control module connector. 3) Measure the resistance between intake door actuator connector and auto A/C control module connector. Connector & terminal (i88) No. 8 — (B163) No. 6: (i88) No. 7 — (B163) No. 5: (i88) No. 6 — (B163) No. 4:	Is the resistance less than 1 Ω ?	Go to step 3.	Repair the harness between auto A/C control module and intake door actuator.
3 CHECK OPERATION OF INTAKE DOOR ACTUATOR. 1) Connect the intake door actuator connector. 2) Ground the auto A/C control module connector with a suitable wire. 3) Turn the ignition switch to ON, and check the operation of intake door actuator. Connector & terminal (B163) No. 4 — Chassis ground:	Does the actuator move to the FRESH side?	Go to step 4.	Replace the intake door actuator.
4 CHECK OPERATION OF INTAKE DOOR ACTUATOR. 1) Turn the ignition switch to OFF. 2) Ground the auto A/C control module connector with a suitable wire. 3) Turn the ignition switch to ON, and check the operation of intake door actuator. Connector & terminal: (B163) No. 5 — Chassis ground:	Does the actuator move to the RECIRC side?	Replace the auto A/C control module.	Replace the intake door actuator.

Diagnostic Procedure for Actuators

HVAC SYSTEM (AUTO A/C) (DIAGNOSTICS)

B: MODE DOOR ACTUATOR

TROUBLE SYMPTOM:

Air flow outlet is not changed.

WIRING DIAGRAM:

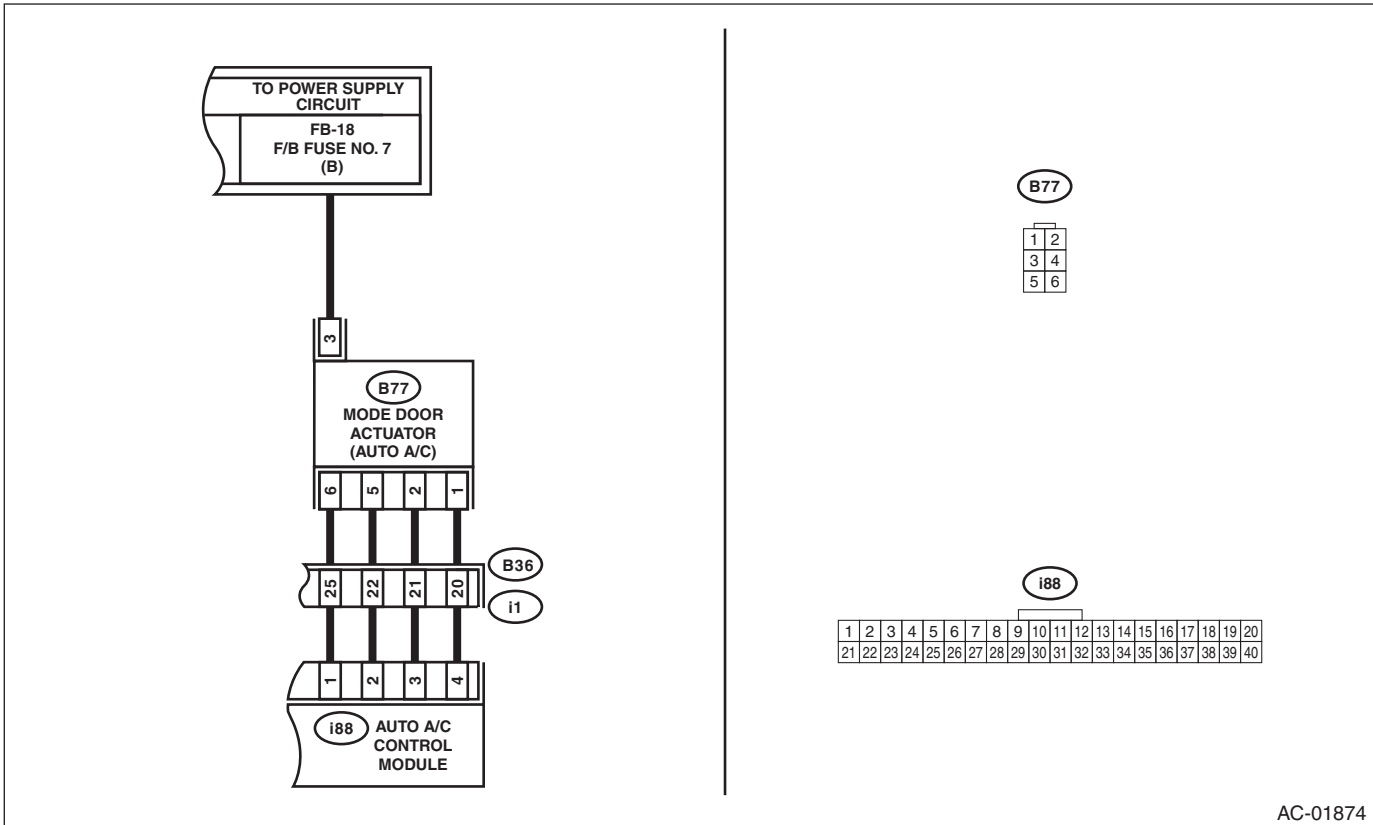

Diagnostic Procedure for Actuators

HVAC SYSTEM (AUTO A/C) (DIAGNOSTICS)

Step	Check	Yes	No
1 CHECK POWER SUPPLY FOR MODE DOOR ACTUATOR. 1) Turn the ignition switch to OFF. 2) Disconnect the mode door actuator connector. 3) Turn the ignition switch to ON. 4) Measure the voltage between the mode door actuator connector terminal and chassis ground. <i>Connector & terminal</i> <i>(B77) No. 3 (+) — Chassis ground (-):</i>	Is the voltage approx. 10 V or more?	Go to step 2.	Repair the DC power supply circuit.
2 CHECK MODE DOOR ACTUATOR. 1) Disconnect the mode door actuator connector. 2) Use a tester to measure the resistance between mode door actuator terminals. <i>Connector & terminal</i> <i>(B77) No. 3 — No. 1:</i> <i>(B77) No. 3 — No. 2:</i> <i>(B77) No. 3 — No. 5:</i> <i>(B77) No. 3 — No. 6:</i>	Is the resistance between 80 — 100 Ω ?	Go to step 3.	Replace the mode door actuator.
3 CHECK HARNESS BETWEEN AUTO A/C CONTROL MODULE AND MODE DOOR ACTUATOR. 1) Turn the A/C and ignition switch to OFF. 2) Disconnect the auto A/C control module connector. 3) Measure the resistance between auto A/C control module and mode door actuator connector. <i>Connector & terminal</i> <i>(B77) No. 1 — (i88) No. 4:</i> <i>(B77) No. 2 — (i88) No. 3:</i> <i>(B77) No. 5 — (i88) No. 2:</i> <i>(B77) No. 6 — (i88) No. 1:</i>	Is the resistance less than 1 Ω ?	Go to step 4.	Repair the harness between auto A/C control module and mode door actuator.
4 CHECK POOR CONTACT. Check poor contact of auto A/C control module and connector.	Is there poor contact in connector?	Repair the connector.	Replace the auto A/C control module.

Diagnostic Procedure for Actuators

HVAC SYSTEM (AUTO A/C) (DIAGNOSTICS)

C: AIR MIX DOOR ACTUATOR

TROUBLE SYMPTOM:

Outlet air temperature does not change.

WIRING DIAGRAM:

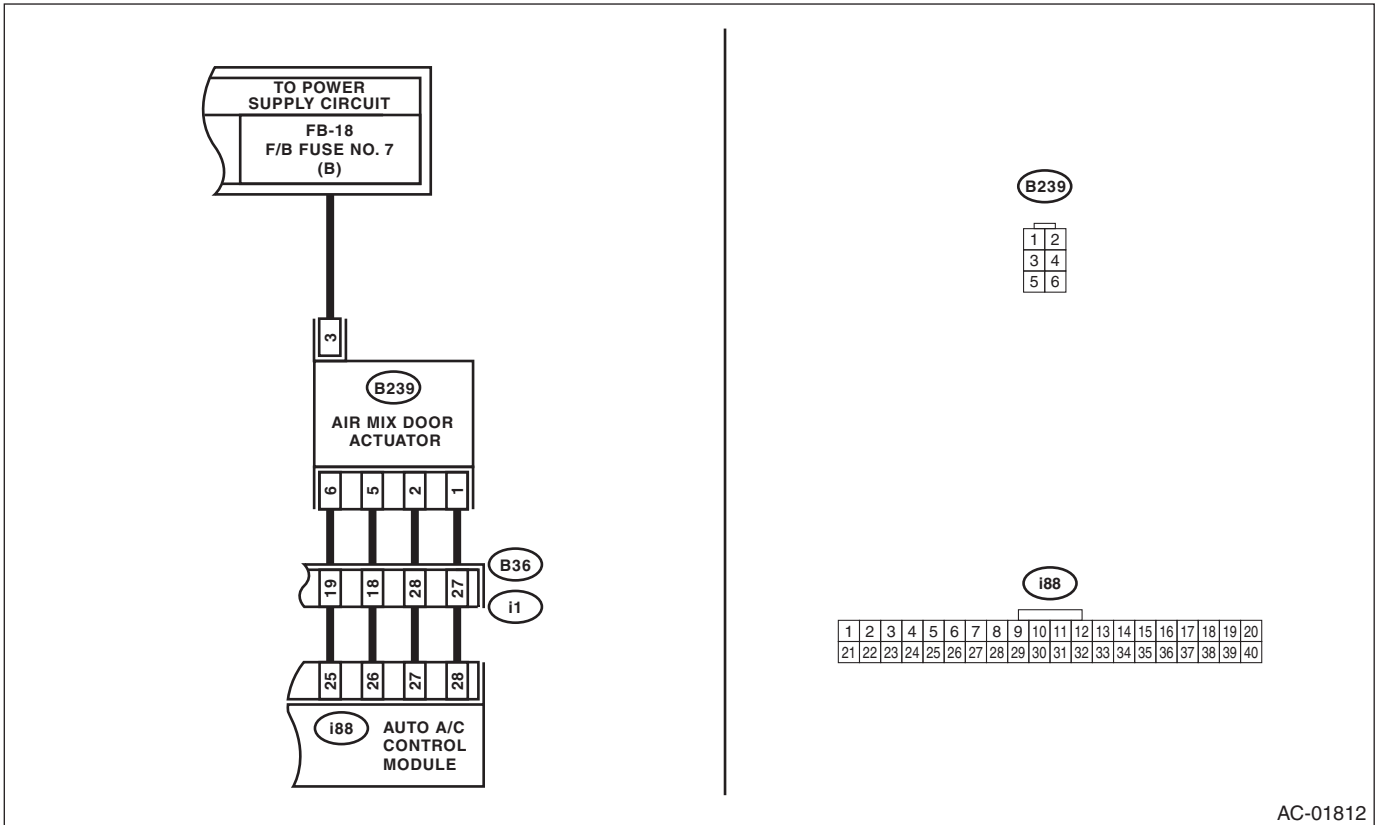

AC-01812

Diagnostic Procedure for Actuators

HVAC SYSTEM (AUTO A/C) (DIAGNOSTICS)

Step	Check	Yes	No
<p>1 CHECK AIR MIX DOOR ACTUATOR POWER SUPPLY.</p> <p>1) Turn the ignition switch to OFF. 2) Disconnect the air mix door actuator connector. 3) Turn the ignition switch to ON. 4) Measure the voltage between the air mix door actuator connector terminal and chassis ground.</p> <p>Connector & terminal (B239) No. 3 (+) — Chassis ground (-):</p>	Is the voltage approx. 10 V or more?	Go to step 2.	Repair the DC power supply circuit.
<p>2 CHECK AIR MIX DOOR ACTUATOR.</p> <p>1) Disconnect the air mix door actuator connector. 2) Use a tester to measure the resistance between the air mix actuator terminals.</p> <p>Connector & terminal (B239) No. 3 — No. 1: (B239) No. 3 — No. 2: (B239) No. 3 — No. 5: (B239) No. 3 — No. 6:</p>	Is the resistance between 80 — 100 Ω ?	Go to step 3.	Replace the air mix door actuator.
<p>3 CHECK HARNESS BETWEEN AUTO A/C CONTROL MODULE AND AIR MIX DOOR ACTUATOR.</p> <p>1) Turn the A/C and ignition switch to OFF. 2) Disconnect the auto A/C control module connector. 3) Measure the resistance between auto A/C control module and air mix door actuator connector.</p> <p>Connector & terminal (B239) No. 1 — (i88) No. 28: (B239) No. 2 — (i88) No. 27: (B239) No. 5 — (i88) No. 26: (B239) No. 6 — (i88) No. 25:</p>	Is the resistance less than 1 Ω ?	Go to step 4.	Repair the harness between auto A/C control module and air mix door actuator.
<p>4 CHECK POOR CONTACT.</p> <p>Check poor contact of auto A/C control module and connector.</p>	Is there poor contact in connector?	Repair the connector.	Replace the auto A/C control module.

Diagnostic Procedure for Sensors

HVAC SYSTEM (AUTO A/C) (DIAGNOSTICS)

8. Diagnostic Procedure for Sensors

A: AMBIENT SENSOR

TROUBLE SYMPTOM:

- Fan speed is not switched when the fan dial is in AUTO position.
- Failure related to the ambient sensor is indicated in self-diagnosis.

WIRING DIAGRAM:

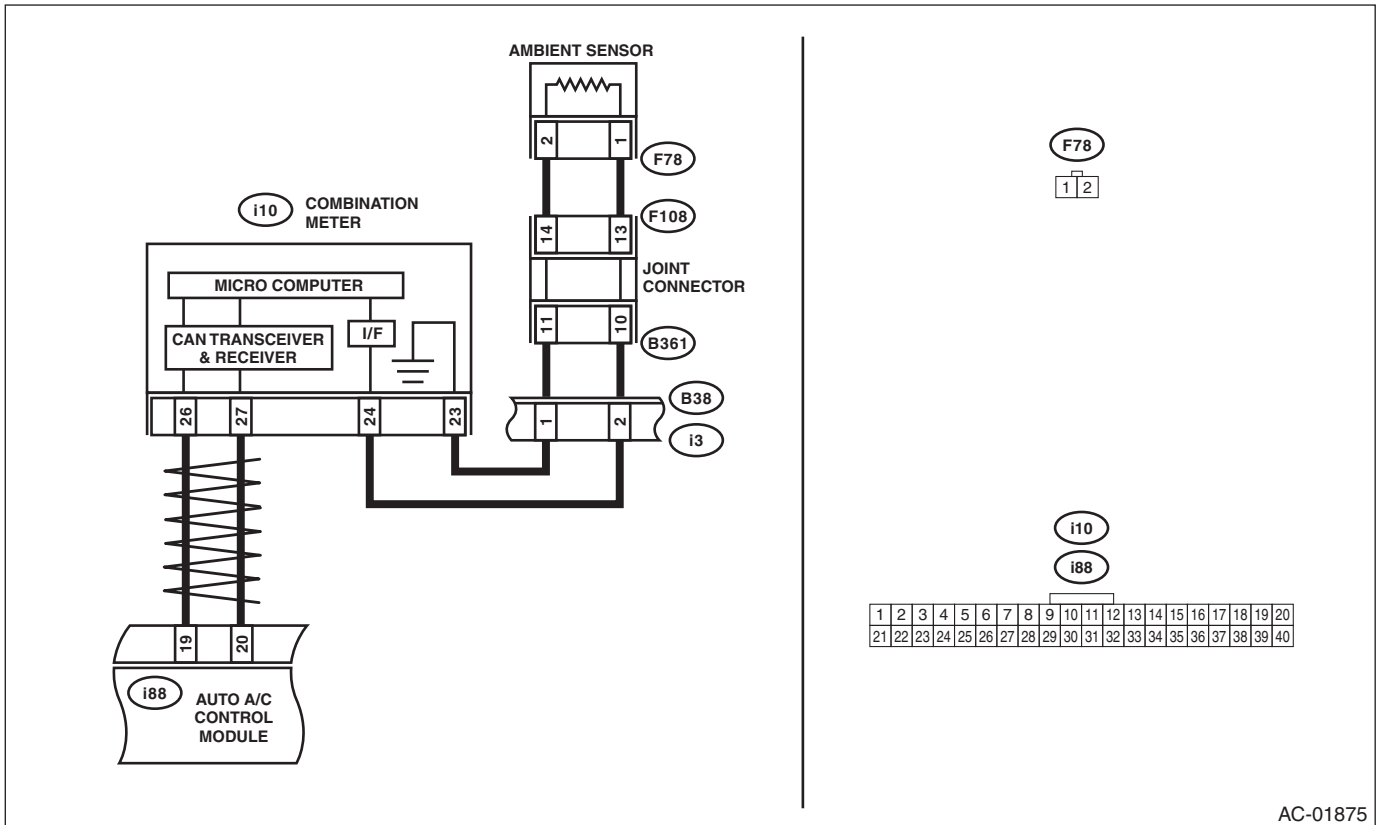

AC-01875

Step	Check	Yes	No
1 CHECK AMBIENT SENSOR. 1) Turn the ignition switch to OFF. 2) Disconnect the connector from ambient sensor. 3) Measure the resistance between terminals of ambient sensor. Terminals No. 1 — No. 2:	Is the resistance approximately 3 kΩ at 25°C (77°F)?	Go to step 2.	Replace the ambient sensor.
2 CHECK INPUT SIGNAL FOR AMBIENT SENSOR. 1) Turn the ignition to ON. 2) Measure the voltage between connector (F78) terminals. Connector & terminal (F78) No. 1 (+) — No. 2 (-):	Is the voltage approx. 5 V?	Go to step 6.	Go to step 3.

Diagnostic Procedure for Sensors

HVAC SYSTEM (AUTO A/C) (DIAGNOSTICS)

Step	Check	Yes	No
3 CHECK COMBINATION METER OUTPUT SIGNAL. 1) Turn the ignition switch to OFF. 2) Pull out the combination meter. 3) Disconnect the connector from ambient sensor. 4) Turn the ignition switch to ON. 5) Measure the voltage between the combination meter connector terminals. Connector & terminal <i>(i10) No. 24 (+) — No. 23 (-):</i>	Is the voltage approx. 5 V?	Go to step 4.	Go to step 6.
4 CHECK HARNESS CONNECTOR BETWEEN COMBINATION METER AND AMBIENT TEMPERATURE SENSOR. 1) Turn the ignition switch to OFF. 2) Disconnect the connector from combination meter. 3) Measure the resistance of the harness between the combination meter and ambient temperature sensor. Connector & terminal <i>(F78) No. 1 — (i10) No. 24:</i>	Is the resistance less than 1 Ω ?	Go to step 5.	Repair the open circuit in the harness between the combination meter and ambient temperature sensor.
5 CHECK HARNESS CONNECTOR BETWEEN COMBINATION METER AND AMBIENT TEMPERATURE SENSOR. Measure the resistance of the harness between the combination meter and ambient temperature sensor. Connector & terminal <i>(F78) No. 2 — (i10) No. 23:</i>	Is the resistance less than 1 Ω ?	Replace the combination meter.	Repair the open circuit in the harness between the combination meter and ambient temperature sensor.
6 CHECK HARNESS CONNECTOR BETWEEN COMBINATION METER AND AUTO A/C CONTROL MODULE. 1) Turn the ignition switch to OFF. 2) Disconnect the connector from the combination meter. 3) Disconnect the auto A/C control module connector. 4) Measure the resistance of the harness between the combination meter and auto A/C control module. Connector & terminal <i>(i88) No. 19 — (i10) No. 26:</i>	Is the resistance less than 1 Ω ?	Go to step 7.	Repair the open circuit in the harness between the combination meter and auto A/C control module.
7 CHECK HARNESS CONNECTOR BETWEEN COMBINATION METER AND AUTO A/C CONTROL MODULE. Measure the resistance of the harness between the combination meter and auto A/C control module. Connector & terminal <i>(i88) No. 20 — (i10) No. 27:</i>	Is the resistance less than 1 Ω ?	Go to step 8.	Repair the open circuit in the harness between the combination meter and auto A/C control module.
8 CHECK POOR CONTACT. Check poor contact of auto A/C control module connector.	Is there poor contact in connector?	Repair the connector.	Replace the auto A/C control module.

Diagnostic Procedure for Sensors

HVAC SYSTEM (AUTO A/C) (DIAGNOSTICS)

B: IN-VEHICLE SENSOR

TROUBLE SYMPTOM:

- Blower fan speed, air flow outlet and FRESH/RECIRC do not change after turning the AUTO switch to ON.
- Failure related to the in-vehicle sensor is indicated in self-diagnosis.

WIRING DIAGRAM:

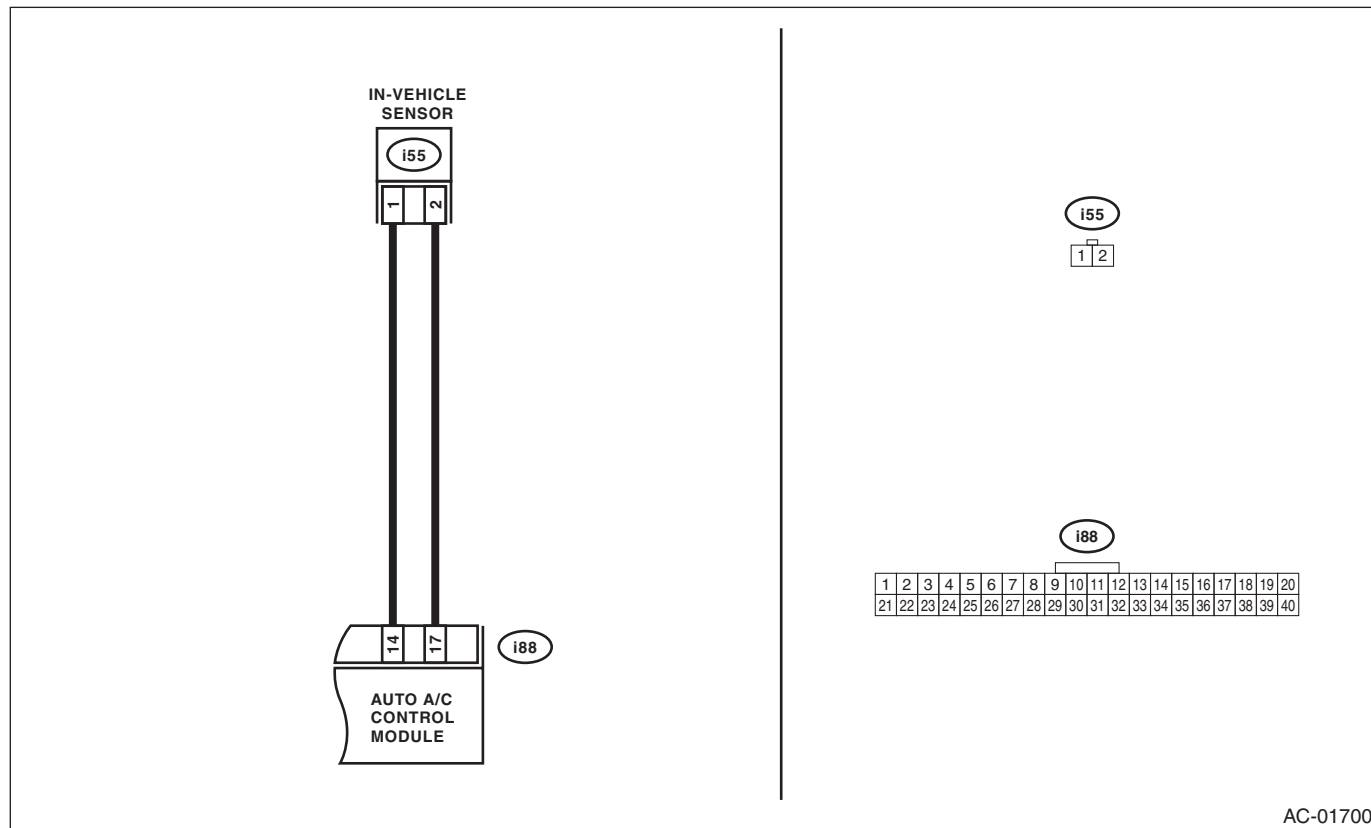

AC-01700

Diagnostic Procedure for Sensors

HVAC SYSTEM (AUTO A/C) (DIAGNOSTICS)

Step	Check	Yes	No
1 CHECK IN-VEHICLE SENSOR. 1) Turn the ignition switch to OFF. 2) Remove the driver's side lower cover. 3) Disconnect the connector from in-vehicle sensor. 4) Measure the resistance between terminals of in-vehicle sensor. Terminals No. 1 — No. 2:	Is the resistance approximately 2.2 k Ω at 25°C (77°F)?	Go to step 2.	Replace the in-vehicle sensor.
2 CHECK INPUT SIGNAL FOR IN-VEHICLE SENSOR. 1) Turn the ignition switch to ON. 2) Measure the voltage between in-vehicle sensor harness connector terminals. Connector & terminal (i55) No. 2 (+) — No. 1 (-):	Is the voltage approx. 5 V?	Go to step 6.	Go to step 3.
3 CHECK AUTO A/C CONTROL MODULE OUTPUT SIGNAL. 1) Turn the ignition switch to OFF. 2) Remove the auto A/C control module. 3) Turn the ignition switch to ON. 4) Measure the voltage between connector terminals of auto A/C control module. Connector & terminal (i88) No. 17 (+) — (i88) No. 14 (-):	Is the voltage approx. 5 V?	Go to step 4.	Go to step 6.
4 CHECK HARNESS BETWEEN AUTO A/C CONTROL MODULE AND IN-VEHICLE SENSOR. 1) Turn the ignition switch to OFF. 2) Disconnect the connector from the auto A/C control module. 3) Measure the resistance of harness between auto A/C control module and in-vehicle sensor. Connector & terminal (i55) No. 2 — (i88) No. 17:	Is the resistance less than 1 Ω ?	Go to step 5.	Repair the harness between auto A/C control module and in-vehicle sensor.
5 CHECK HARNESS BETWEEN AUTO A/C CONTROL MODULE AND IN-VEHICLE SENSOR. Measure the resistance of harness between auto A/C control module and in-vehicle sensor. Connector & terminal (i55) No. 1 — (i88) No. 14:	Is the resistance less than 1 Ω ?	Go to step 6.	Repair the harness between auto A/C control module and in-vehicle sensor.
6 CHECK POOR CONTACT. Check poor contact of auto A/C control module connector.	Is there poor contact in connector?	Repair the connector.	Replace the auto A/C control module.

Diagnostic Procedure for Sensors

HVAC SYSTEM (AUTO A/C) (DIAGNOSTICS)

C: EVAPORATOR SENSOR

WIRING DIAGRAM:

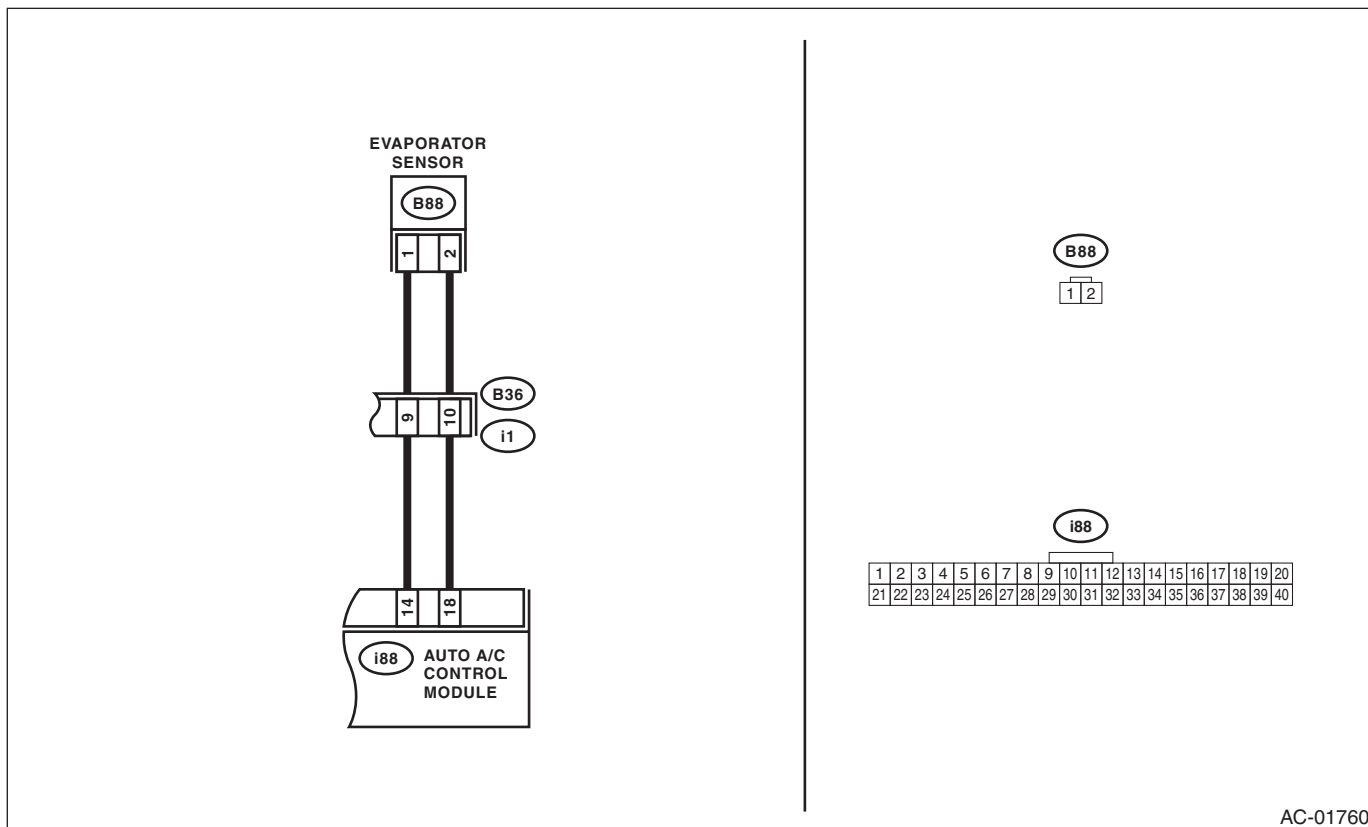

AC-01760

Diagnostic Procedure for Sensors

HVAC SYSTEM (AUTO A/C) (DIAGNOSTICS)

Step	Check	Yes	No
1 CHECK EVAPORATOR SENSOR. 1) Turn the ignition switch to OFF. 2) Remove the glove box. 3) Disconnect the connector from evaporator sensor. 4) Measure the resistance between terminals of the evaporator sensor. Terminals No. 1 — No. 2:	Is the resistance approximately 6.2 k Ω at 0°C (32°F), or approximately 3.3 k Ω at 15°C (59°F) ?	Go to step 2.	Replace the evaporator sensor.
2 CHECK INPUT SIGNAL FOR EVAPORATOR SENSOR. 1) Turn the ignition switch to ON. 2) Measure the voltage between connector (B88) terminals. Connector & terminal (B88) No. 2 (+) — No. 1 (-):	Is the voltage approx. 5 V?	Go to step 6.	Go to step 3.
3 CHECK AUTO A/C CONTROL MODULE OUTPUT SIGNAL. 1) Turn the ignition switch to OFF. 2) Remove the auto A/C control module. 3) Turn the ignition switch to ON. 4) Measure the voltage between connector terminals of auto A/C control module. Connector & terminal (i88) No. 18 (+) — (i88) No. 14 (-):	Is the voltage approx. 5 V?	Go to step 4.	Go to step 6.
4 CHECK HARNESS CONNECTOR BETWEEN AUTO A/C CONTROL MODULE AND EVAPORATOR SENSOR. 1) Turn the ignition switch to OFF. 2) Disconnect the connector from the auto A/C control module. 3) Measure the resistance of harness between auto A/C control module and evaporator sensor. Connector & terminal (B88) No. 2 — (i88) No. 18:	Is the resistance less than 1 Ω ?	Go to step 5.	Repair the open circuit of harness between auto A/C control module and evaporator sensor.
5 CHECK HARNESS CONNECTOR BETWEEN AUTO A/C CONTROL MODULE AND EVAPORATOR SENSOR. Measure the resistance of harness between auto A/C control module and evaporator sensor. Connector & terminal (B88) No. 1 — (i88) No. 14:	Is the resistance less than 1 Ω ?	Go to step 6.	Repair the open circuit of harness between auto A/C control module and evaporator sensor.
6 CHECK POOR CONTACT. Check poor contact of auto A/C control module connector.	Is there poor contact in connector?	Repair the connector.	Replace the auto A/C control module.

Diagnostic Procedure for Sensors

HVAC SYSTEM (AUTO A/C) (DIAGNOSTICS)

D: SUNLOAD SENSOR

TROUBLE SYMPTOM:

- Sensor identifies that sunlight is at maximum. Then, A/C system is controlled to COOL side.
- Sensor identifies that sunlight is at minimum. Then, A/C system is controlled to HOT side.

NOTE:

When the sunload sensor check is performed indoors or in the shade, it could be diagnosed as having an open circuit. Always check the sunload sensor with the sun shining on it.

WIRING DIAGRAM:

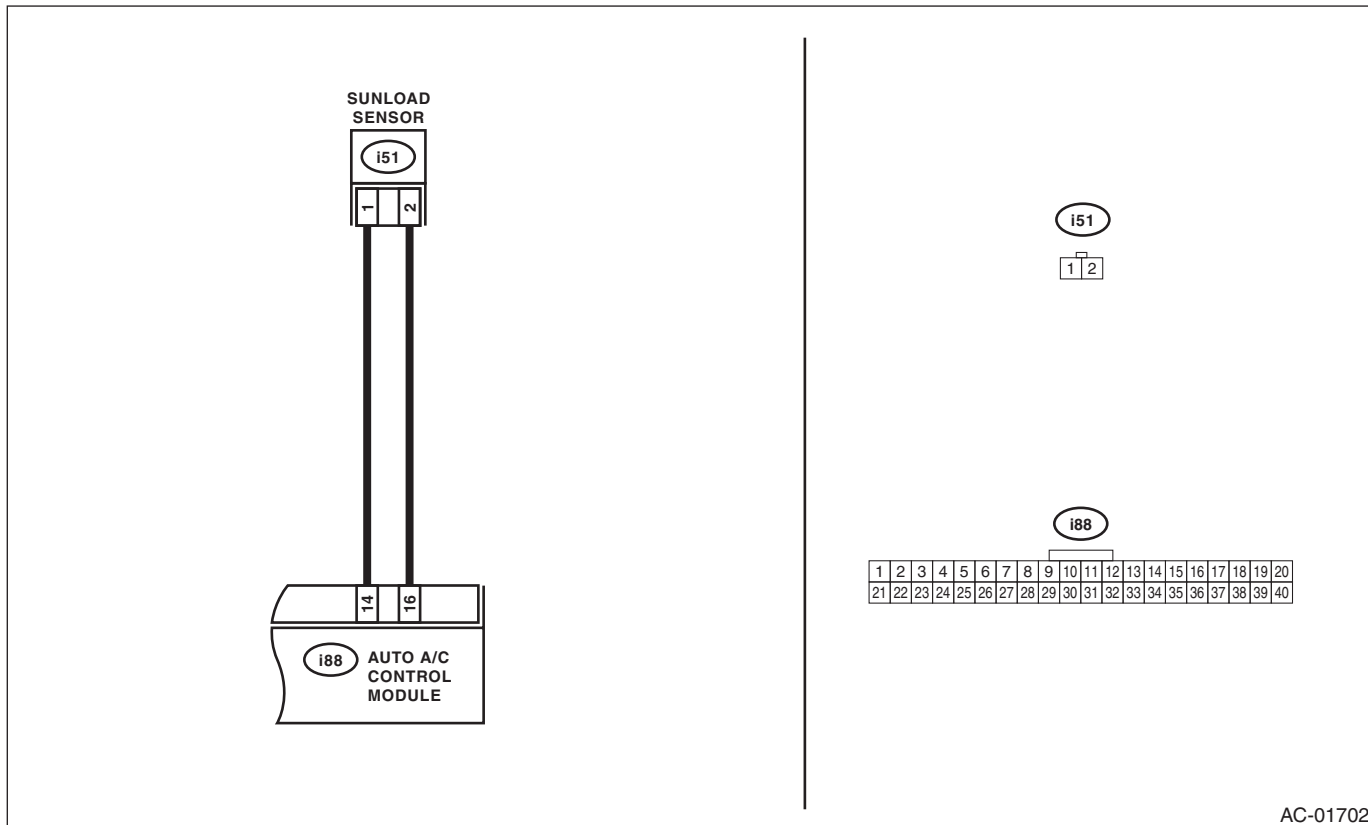

Diagnostic Procedure for Sensors

HVAC SYSTEM (AUTO A/C) (DIAGNOSTICS)

Step	Check	Yes	No
1 CHECK POWER SUPPLY VOLTAGE FOR SUNLOAD SENSOR. 1) Turn the ignition switch to OFF. 2) Disconnect the connector from sunload sensor. 3) Turn the ignition switch to ON. 4) Measure the power supply voltage for sunload sensor. Connector & terminal (i51) No. 2 (+) — No. 1 (-):	Is the voltage approx. 5 V?	Go to step 4.	Go to step 2.
2 CHECK HARNESS CONNECTOR BETWEEN AUTO A/C CONTROL MODULE AND SUNLOAD SENSOR. 1) Turn the ignition switch to OFF. 2) Disconnect the connector from the auto A/C control module. 3) Measure the resistance of the harness between the auto A/C control module and sunload sensor. Connector & terminal (i51) No. 2 — (i88) No. 16:	Is the resistance less than 1 Ω ?	Go to step 3.	Repair the harness between auto A/C control module and sunload sensor.
3 CHECK HARNESS CONNECTOR BETWEEN AUTO A/C CONTROL MODULE AND SUNLOAD SENSOR. Measure the resistance of the harness between the auto A/C control module and sunload sensor. Connector & terminal (i51) No. 1 — (i88) No. 14:	Is the resistance less than 1 Ω ?	Go to step 4.	Repair the harness between auto A/C control module and sunload sensor.
4 CHECK INPUT VOLTAGE FOR AUTO A/C CONTROL MODULE. 1) Connect the connectors of sunload sensor and auto A/C control module. 2) Turn the ignition switch to ON. 3) Measure the voltage between connector terminals of auto A/C control module. Connector & terminal (i88) No. 16 (+) — (i88) No. 14 (-):	Is the voltage within approximately 1.0 — 4.0 V?	Go to step 5.	Replace the sunload sensor.
5 CHECK POOR CONTACT. Check poor contact of auto A/C control module connector.	Is there poor contact in connector?	Repair the connector.	Replace the auto A/C control module.

Diagnostics with Phenomenon

HVAC SYSTEM (AUTO A/C) (DIAGNOSTICS)

9. Diagnostics with Phenomenon

A: INSPECTION

Symptoms	Problem parts
A/C system fails to operate.	<ul style="list-style-type: none"> • Fuse (M/B No. 8, F/B No. 22, 31) • Connector (Poor contact) • Ground • Auto A/C control module • Blower fan motor • Blower fan relay • A/C relay • Compressor (Magnet clutch) • Evaporator sensor
Fuse is blown out.	<ul style="list-style-type: none"> • Fuse (M/B No. 8, F/B No. 22, 31) • Connector (Poor contact)
Illumination cannot dim.	<ul style="list-style-type: none"> • Fuse (M/B No. 8, F/B No. 22, 31) • Connector (Poor contact) • Auto A/C control module
Blower fan does not rotate or fan speed cannot be controlled.	<ul style="list-style-type: none"> • Fuse (M/B No. 8, F/B No. 22, 31) • Connector (Poor contact) • Ground • Auto A/C control module • Blower fan motor • Blower fan relay
Unable to switch suction vents.	<ul style="list-style-type: none"> • Connector (Poor contact) • Auto A/C control module • Intake door actuator
Unable to switch vents.	<ul style="list-style-type: none"> • Connector (Poor contact) • Auto A/C control module • Mode door actuator
Compartment temperature does not rise. (Warm air does not come out)	<ul style="list-style-type: none"> • Connector (Poor contact) • Auto A/C control module • Air mix door actuator • In-vehicle sensor, ambient sensor, evaporator sensor and sunload sensor • In-vehicle sensor aspirator hose
Compartment temperature does not lower. (Cold air does not come out)	<ul style="list-style-type: none"> • Connector (Poor contact) • Auto A/C control module • Air mix door actuator • A/C relay • Compressor (Magnet clutch) • Radiator fan motor • Radiator fan relay • In-vehicle sensor, ambient sensor, evaporator sensor and sunload sensor • In-vehicle sensor aspirator hose
Compartment temperature is higher or lower than setting temperature.	<ul style="list-style-type: none"> • Auto A/C control module • Air mix door actuator • In-vehicle sensor, ambient sensor, evaporator sensor and sunload sensor • In-vehicle sensor aspirator hose
Compartment temperature does not quickly respond to setting temperature.	<ul style="list-style-type: none"> • Air mix door actuator • In-vehicle sensor, ambient sensor, evaporator sensor and sunload sensor • In-vehicle sensor aspirator hose
Radiator fan does not rotate during A/C operation.	<ul style="list-style-type: none"> • Radiator fan motor • Radiator fan relay

Diagnostics with Phenomenon

HVAC SYSTEM (AUTO A/C) (DIAGNOSTICS)

AIRBAG SYSTEM

AB

	Page
1. General Description	2
2. Airbag Connector	9
3. Inspection Locations After a Collision	13
4. Driver's Airbag Module	16
5. Passenger's Airbag Module	17
6. Side Airbag Module	18
7. Curtain Airbag Module	21
8. Airbag Control Module	23
9. Front Sub Sensor	24
10. Side Airbag Sensor	25
11. Curtain Airbag Sensor	26
12. Satellite Safing Sensor	27
13. Roll Connector	28

General Description

AIRBAG SYSTEM

1. General Description

A: COMPONENT

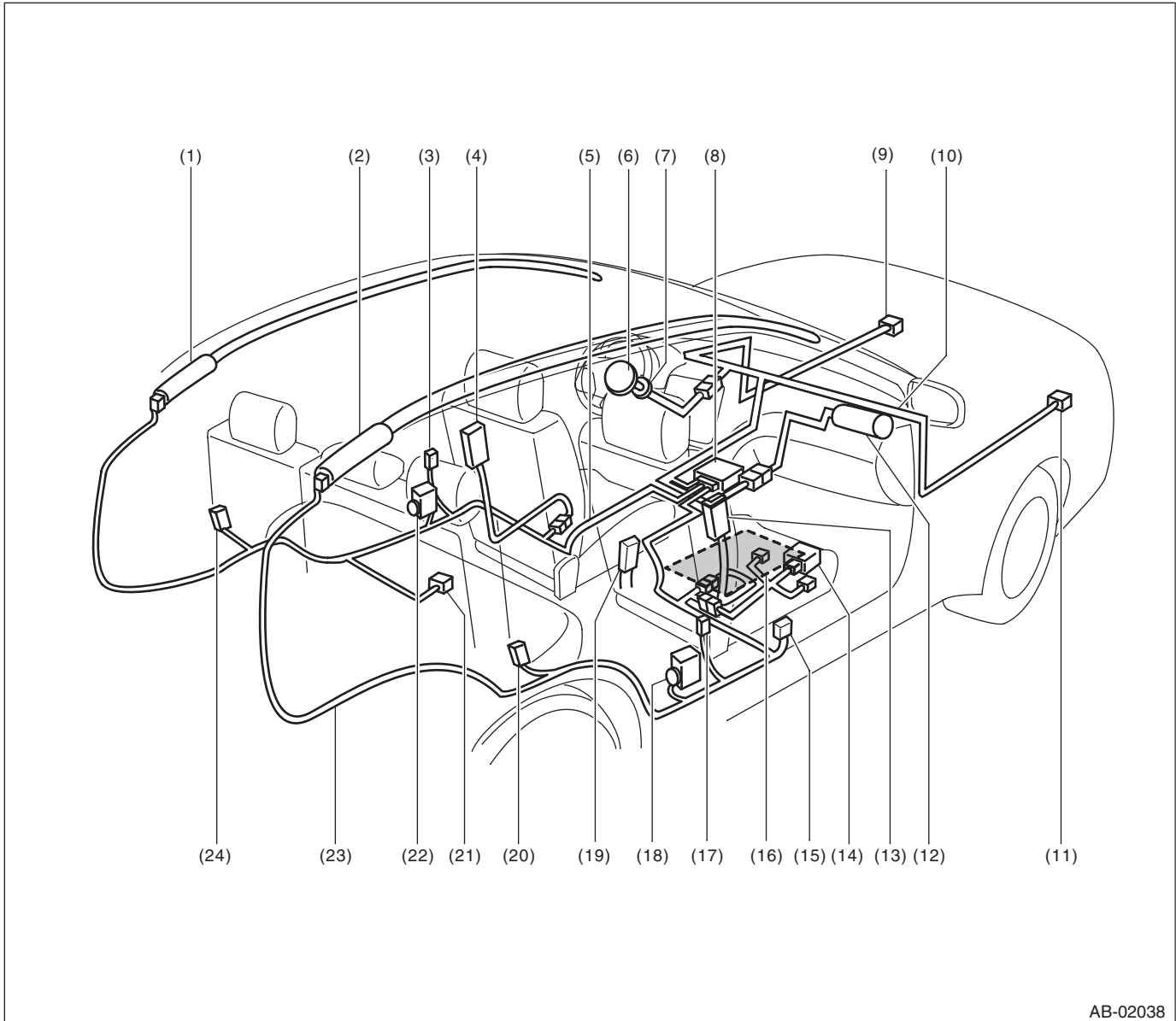

AB-02038

- | | | |
|---|--|--------------------------------|
| (1) Curtain airbag module LH | (9) Front sub sensor LH | (17) Side airbag sensor RH |
| (2) Curtain airbag module RH | (10) Front airbag harness | (18) Seat belt pretensioner RH |
| (3) Side airbag sensor LH | (11) Front sub sensor RH | (19) Buckle switch RH |
| (4) Side airbag module LH | (12) Airbag module ASSY (Passenger) | (20) Curtain airbag sensor RH |
| (5) Airbag rear harness LH | (13) Side airbag module RH | (21) Satellite safing sensor |
| (6) Airbag module ASSY (Driver) | (14) Occupant detection control module | (22) Seat belt pretensioner LH |
| (7) Combination switch ASSY with roll connector | (15) Belt tensioner sensor | (23) Airbag rear harness RH |
| (8) Airbag control module | (16) Occupant detection sensor | (24) Curtain airbag sensor LH |

1. DRIVER'S AIRBAG MODULE

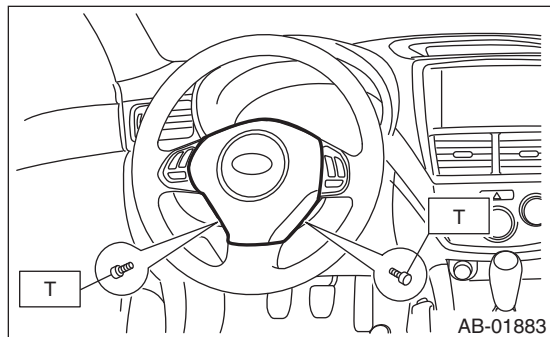

Tightening torque:
 10 N·m (1.0 kgf·m, 7.2 ft·lb)

2. PASSENGER'S AIRBAG MODULE

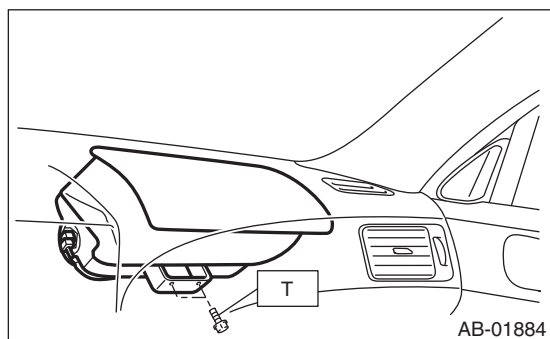

Tightening torque:
 7.5 N·m (0.76 kgf·m, 5.5 ft·lb)

3. SIDE AIRBAG MODULE

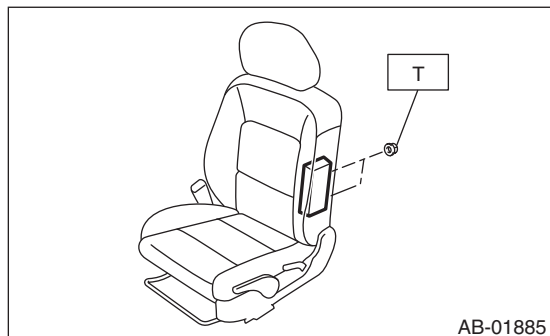

Tightening torque:
 6 N·m (0.61 kgf·m, 4.4 ft·lb)

4. CURTAIN AIRBAG MODULE

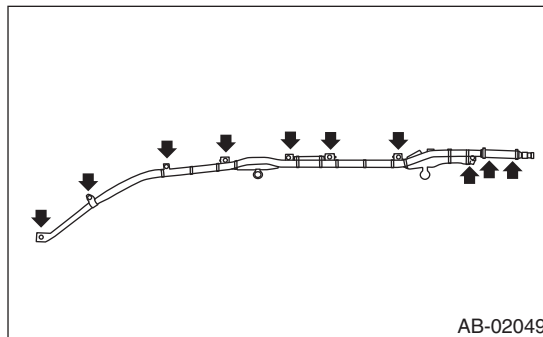

Tightening torque:
 7.5 N·m (0.76 kgf·m, 5.5 ft·lb)

5. AIRBAG CONTROL MODULE

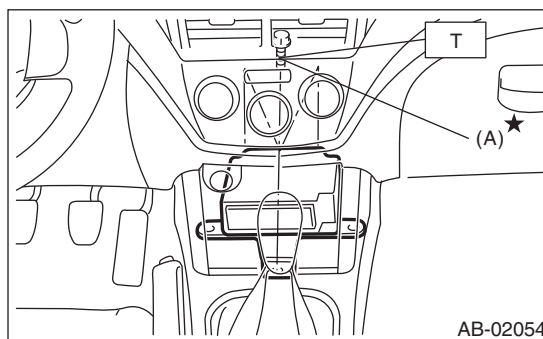

(A) Bolt

CAUTION:
 Do not reuse mounting bolts and nuts.

Tightening torque:
 25 N·m (2.5 kgf·m, 18.1 ft·lb)

6. FRONT SUB SENSOR

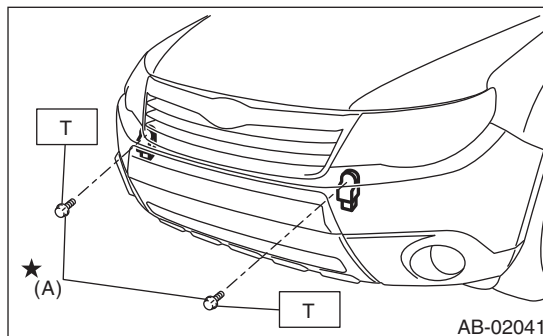

(A) Bolt

CAUTION:
 Do not reuse mounting bolts and nuts.

Tightening torque:
 13 N·m (1.32 kgf·m, 9.6 ft·lb)

General Description

AIRBAG SYSTEM

7. SIDE AIRBAG SENSOR

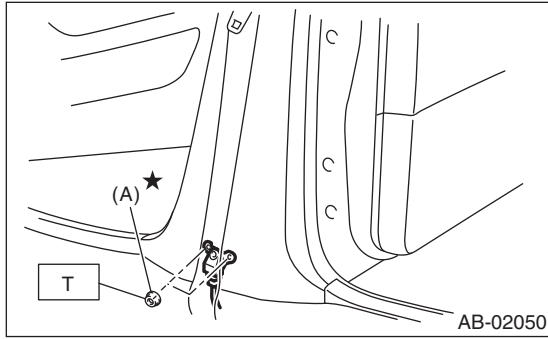

(A) Nut

CAUTION:
Do not reuse mounting bolts and nuts.

Tightening torque:
7.5 N·m (0.76 kgf-m, 5.5 ft-lb)

8. CURTAIN AIRBAG SENSOR

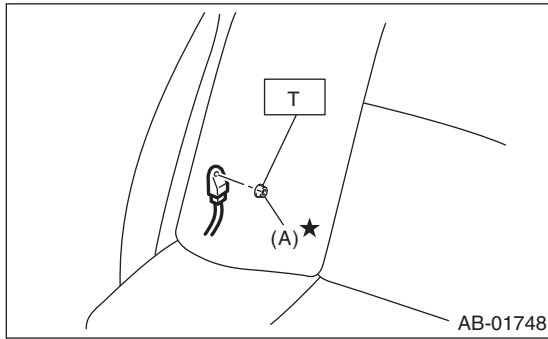

(A) Nut

CAUTION:
Do not reuse mounting bolts and nuts.

Tightening torque:
7.5 N·m (0.76 kgf-m, 5.5 ft-lb)

9. SATELLITE SAFING SENSOR

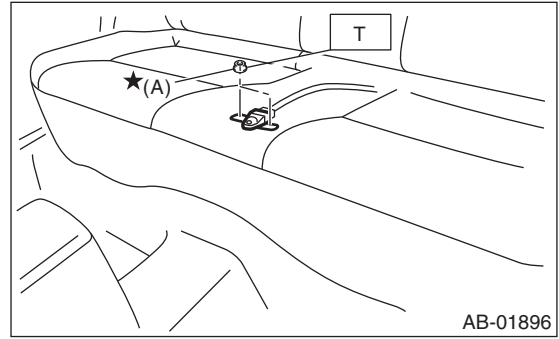

(A) Nut

CAUTION:
Do not reuse mounting bolts and nuts.

Tightening torque:
7.5 N·m (0.76 kgf-m, 5.5 ft-lb)

10. STEERING ROLL CONNECTOR

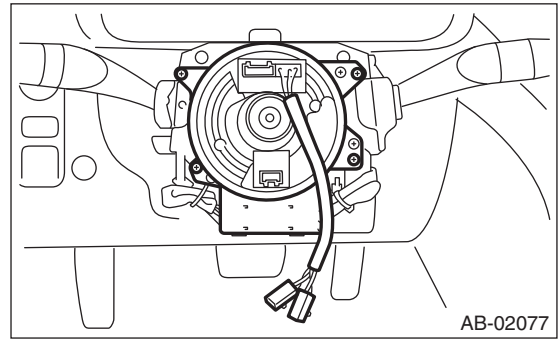

11. AIRBAG HARNESS

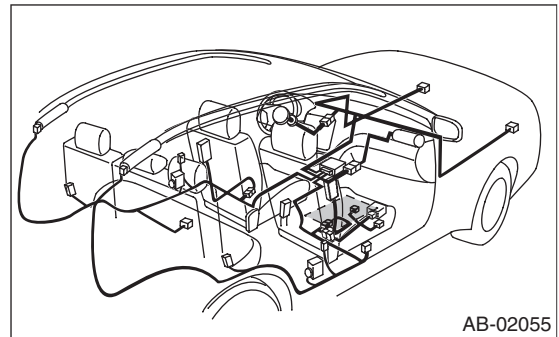

B: CAUTION

- When servicing a vehicle, be sure to turn the ignition switch to OFF, disconnect the ground cable from battery, and wait for 20 seconds or more before starting work.
- The airbag system is fitted with a backup power source. After disconnecting the battery ground cable, the airbag may deploy if you do not wait for 20 seconds or more before starting airbag system servicing.

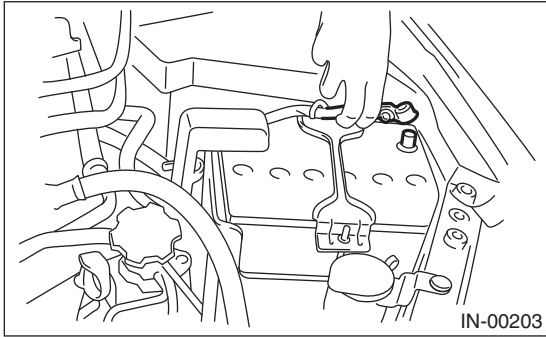

- If the airbag warning light illuminates, repair the vehicle immediately. Otherwise, the airbag or pretensioner may inflate incorrectly, or not inflate in collision.
- If each airbag sensor, airbag module, airbag control module, pretensioner, harness or satellite safing sensor is deformed or damaged, replace with a new part.

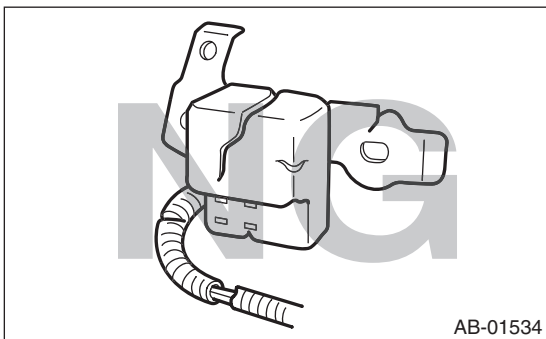

- When checking the airbag system, be sure to use a digital circuit tester. Use of an analog circuit tester may cause the airbag to activate erroneously due to a minimal current inside tester.

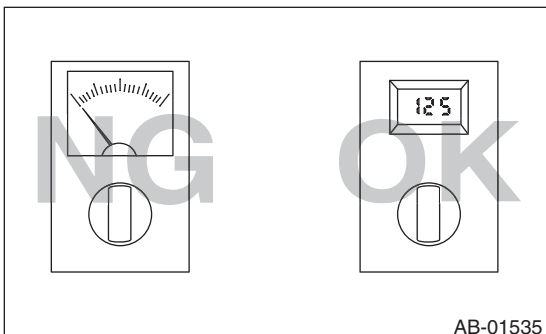

- When checking, use a test harness (1). Damage to connector terminal cause malfunction. Do not directly apply the tester probe to connector terminal of airbag.

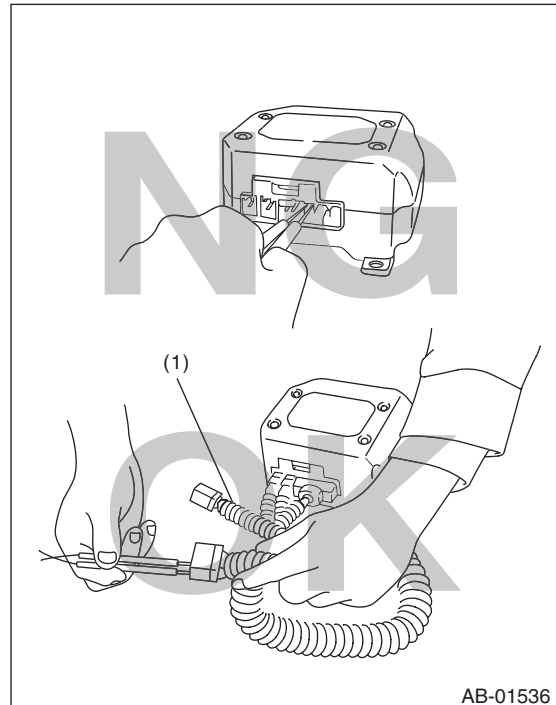

- Do not allow water or oil to come in contact with the connector terminals. Also do not touch the connector terminals.

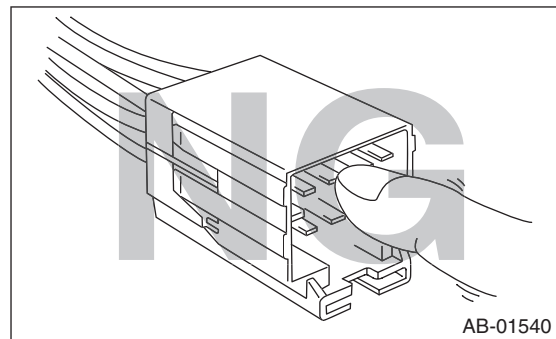

- Do not check continuity of the airbag modules for driver's side, passenger's side and curtain, or the pretensioner.

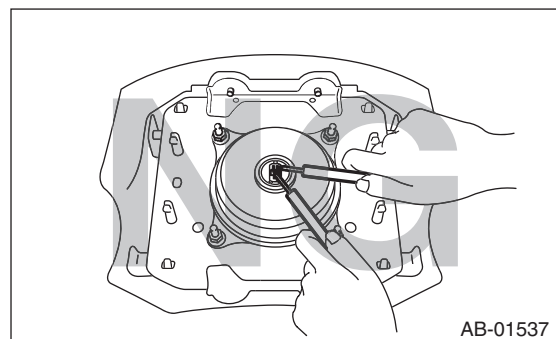

General Description

AIRBAG SYSTEM

- If damage, open circuit or rust is found on airbag system wiring harness, do not use a soldering equipment to repair. Replace the faulty harness with a new genuine part.

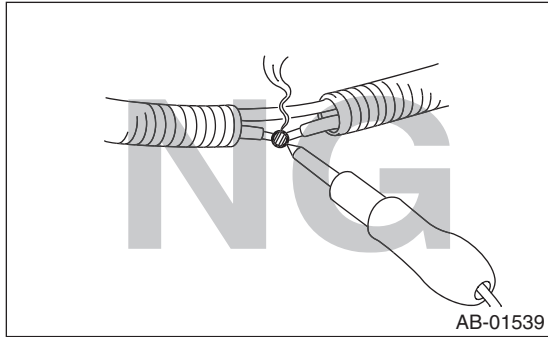

- Install the wiring harness securely with the specified clips to avoid interference or tangled with other parts.

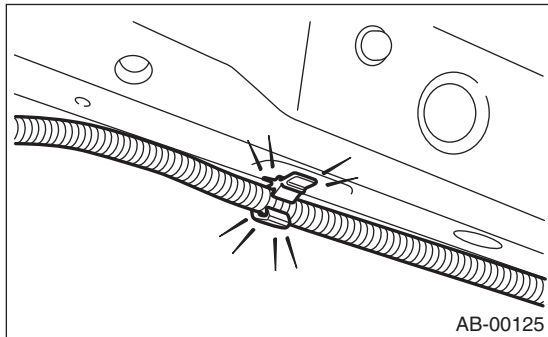

- When painting or performing sheet metal work on the front part of the vehicle, including the front wheel apron, front fender and front side frame, remove the front sub sensors and wiring harness of airbag system.
- When painting or performing sheet metal work on the side of the vehicle, including the side sill, center pillar and front and rear doors, or near the rear floorpan or rear crossmember, remove the side airbag sensors, curtain airbag sensors, satellite safing sensor and wiring harness of the airbag system.

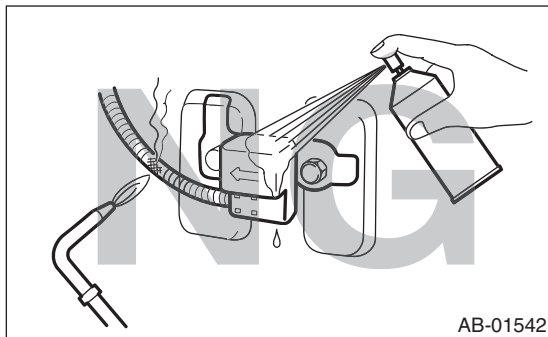

- Do not use the airbag or pretensioner parts from other vehicles. Always replace the defective parts with new parts.
- Never reuse a deployed airbag module and pretensioner.

- Do not discard undeployed airbag module or pretensioner.
- When airbag control module, front sub sensor, side airbag sensor, curtain airbag sensor and satellite safing sensor are removed, do not reuse the bolts and nuts. Always use new bolts and nuts for them.
- Do not drop each airbag module, airbag control module or sensor, subject them to high temperature of 85°C (185°F) or more, or let water, oil or grease get on them; otherwise, the internal parts may be damaged and reliability greatly lowered.

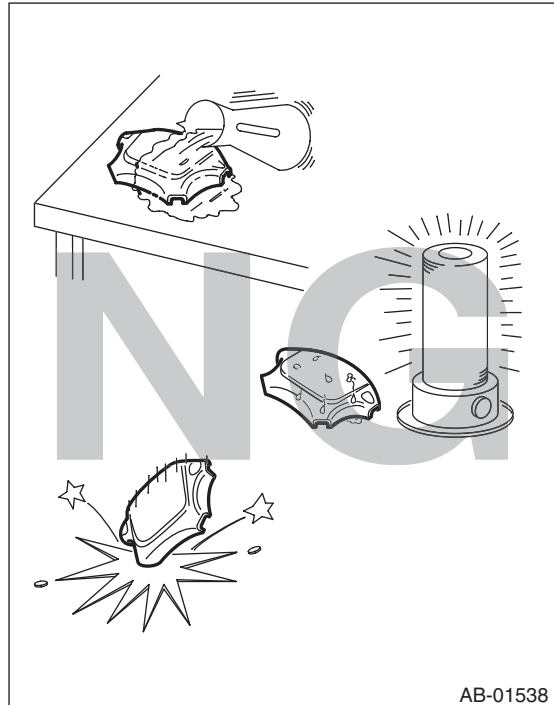

- After removing all the parts of airbag system, keep the airbag module with the pad side facing upward on a dry, clean and flat surface away from heat, light sources, moisture and dust.

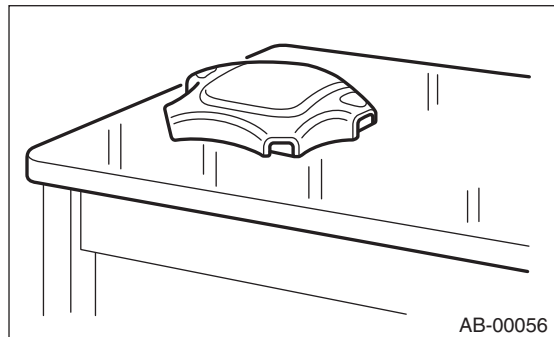

- Do not disassemble driver's, passenger's, side, curtain airbag modules, and the pretensioner.

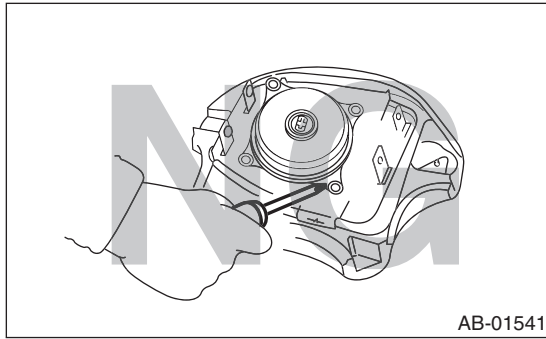

- When installing steering wheel and steering roll connector, be sure to adjust the steering roll connector.
- The removed front seat with airbag module must be kept at least 200 mm (8 in) away from walls and other objects.

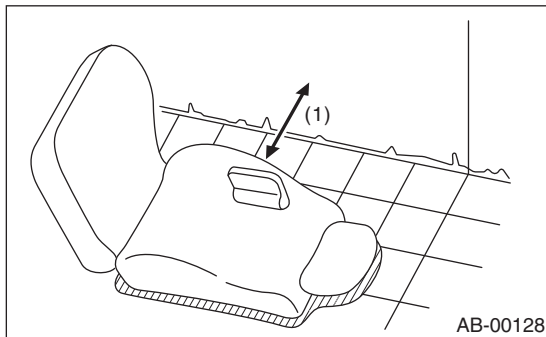

(1) 200 mm (8 in) or more

General Description

AIRBAG SYSTEM

- When storing a removed airbag module, do not place it with the pad side of airbag facing downward. Do not place any objects on the airbag module. Do not pile up the airbag module. If the airbag inflates for some reason when an airbag module pad is touching other objects, it may cause serious accident.

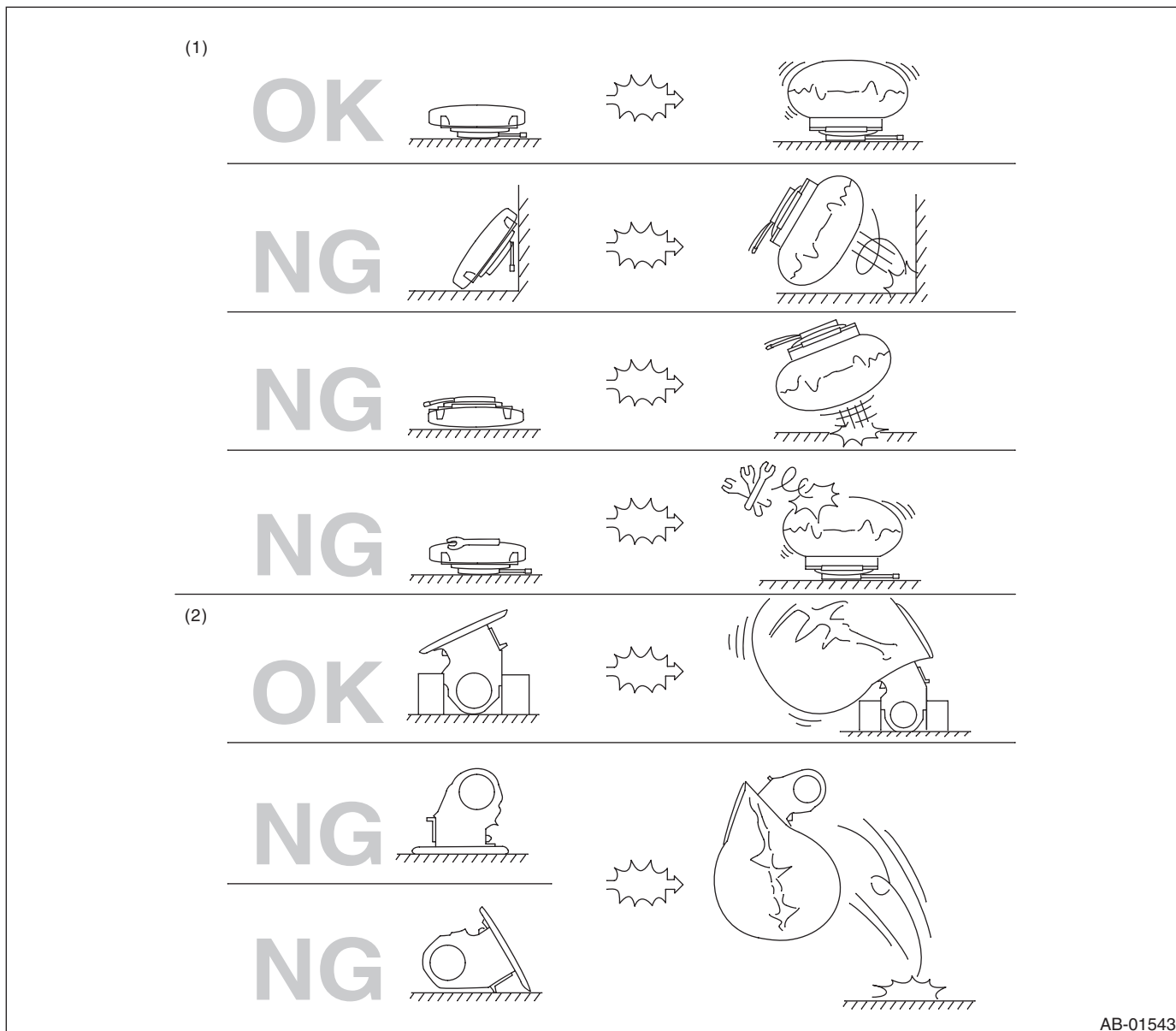

(1) Driver's airbag module

(2) Passenger's airbag module

C: PREPARATION TOOL

1. GENERAL TOOL

TOOL NAME	REMARKS
TORX® T30	Used for removal/installation of driver's airbag module

2. Airbag Connector

A: PROCEDURE

1. POWER SUPPLY

1) How to disconnect:
Push lock (A), then disconnect the connector.

CAUTION:
When pulling the slide lock or disconnecting connector, be sure to hold the connector, not the harness.

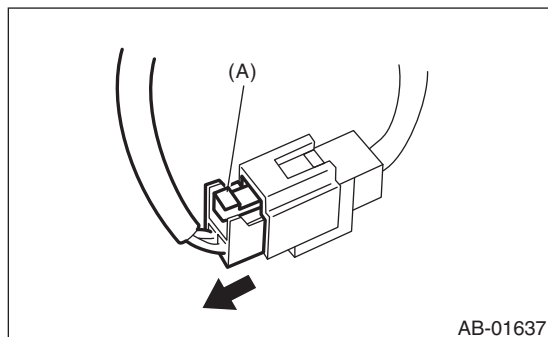

2) How to connect:
Holding the connector, push it in securely until a clicking sound is heard.

CAUTION:
Be sure to insert the connector in until it is locked. Then pull it gently to make sure that it is locked.

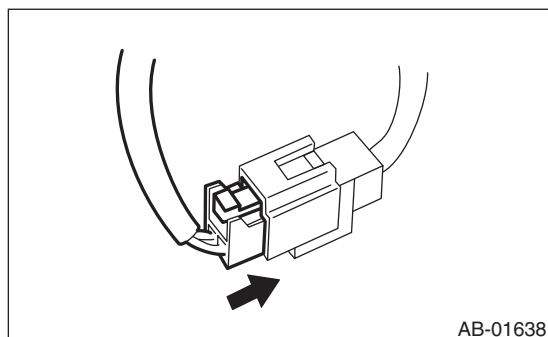

2. AIRBAG CONTROL MODULE

1) How to disconnect:
Press the lock lever plate (A) and pull out the lock lever.

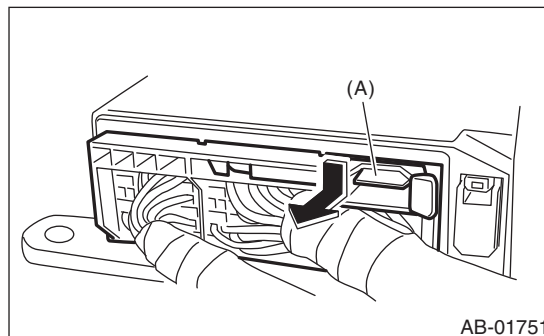

2) How to connect:
Insert the connector, push the lock lever in securely.

CAUTION:
Be sure to insert the connector in until it is locked. Then pull it lightly to make sure that it is locked.

Airbag Connector

AIRBAG SYSTEM

3. DRIVER'S AIRBAG MODULE (BETWEEN AIRBAG MAIN HARNESS AND ROLL CONNECTOR) AND PASSENGER'S AIRBAG MODULE

1) How to disconnect:

(1) Push the slide lock (A) in the direction of arrow.

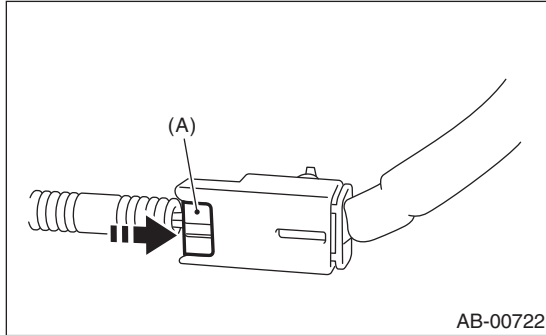

(2) With the slide lock pushed, disconnect the connector.

CAUTION:

When pulling the slide lock or disconnecting connector, be sure to hold the connector, not the harness.

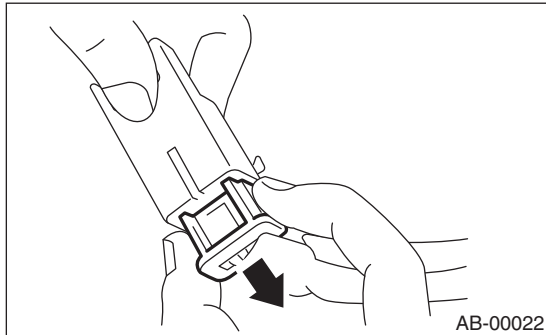

2) How to connect:

Holding the connector, push it in securely until a clicking sound is heard.

CAUTION:

Be sure to insert the connector in until it is locked. Then pull it gently to make sure that it is locked.

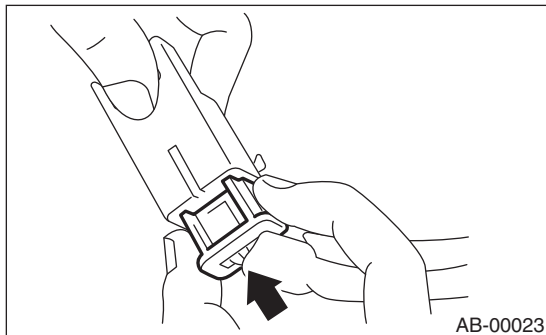

4. DRIVER'S AIRBAG MODULE, CURTAIN AIRBAG MODULE AND PRETENSIONER

1) How to disconnect:

(1) Using a flat tip screwdriver, pry the push lock upward to unlock.

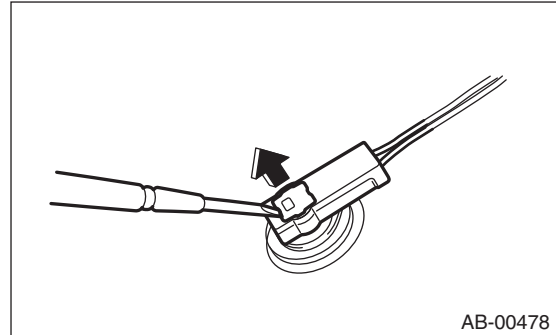

(2) Pull the connector to disconnect from the driver's airbag module assembly or the retractor assembly.

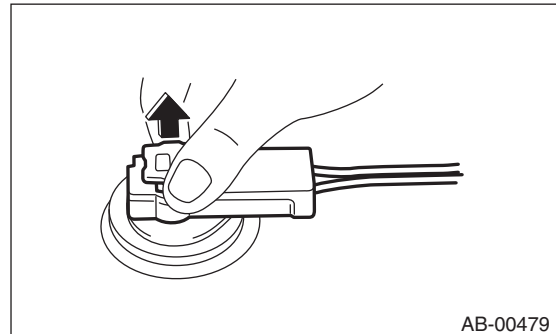

2) How to connect:

Connect the connector in the reverse order of disconnecting. At this time, be sure to insert until a clicking sound is heard.

CAUTION:

- Be sure to insert the connector in until it is locked.
- Be sure to push the push lock in securely. Then pull it gently to make sure that it is locked.

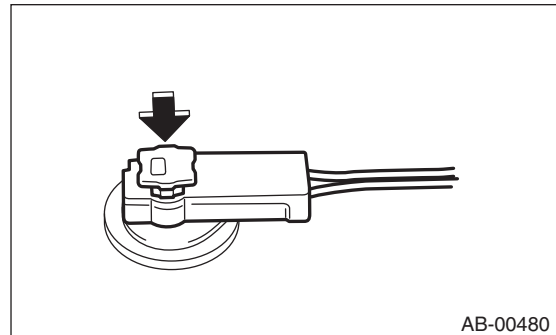

5. SIDE AIRBAG SENSOR, CURTAIN AIRBAG SENSOR AND SATELLITE SAFING SENSOR

1) How to disconnect:
Holding outer part (A), pull it in the direction of arrow.

CAUTION:
When pulling the slide lock or disconnecting connector, be sure to hold the connector, not the harness.

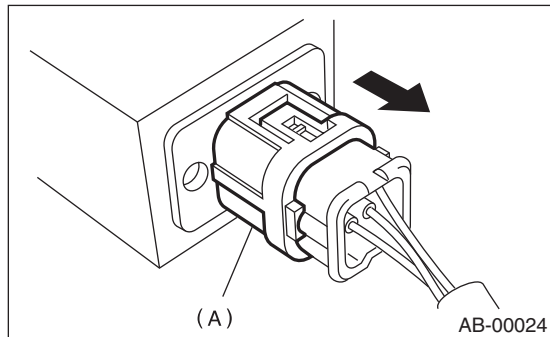

2) How to connect:
Holding the connector, push it in securely until a clicking sound is heard.

CAUTION:

- Do not touch the outer side section or else the outer side (A) will move back.
- Be sure to insert the connector in until it is locked. Then pull it gently to make sure that it is locked.

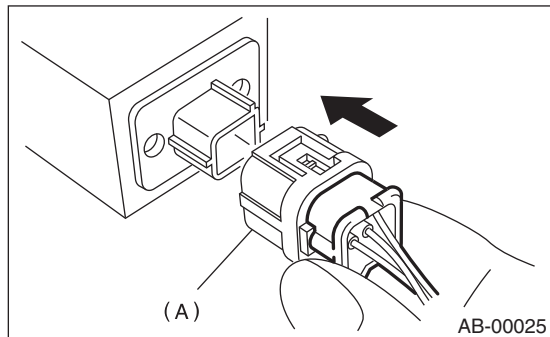

6. SIDE AIRBAG MODULE

1) How to disconnect:
(1) Move the slide lock (A) in the direction of arrow and hold it.
(2) With the slide lock (A) moved, pull the connector (B) in the direction of arrow.

CAUTION:
When pulling the slide lock or disconnecting connector, be sure to hold the connector, not the harness.

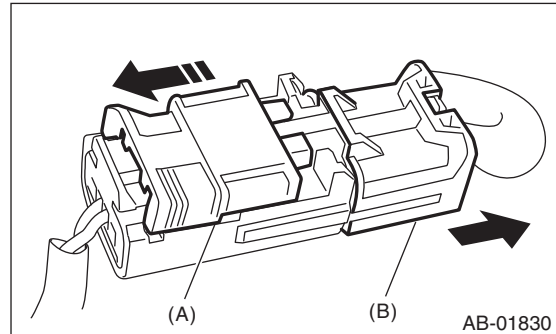

2) How to connect:
Holding the connector, push it in securely until a clicking sound is heard.

CAUTION:
Be sure to insert the connector in until it is locked. Then pull it gently to make sure that it is locked.

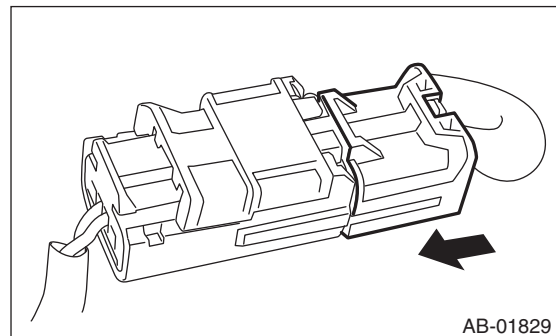

Airbag Connector

AIRBAG SYSTEM

7. BUCKLE SWITCH RH

1) How to disconnect:

(1) Move the slide lock (A) in the direction of arrow and hold it.

(2) With the slide lock (A) moved, pull the connector (B) in the direction of arrow.

CAUTION:

When pulling the slide lock or disconnecting connector, be sure to hold the connector, not the harness.

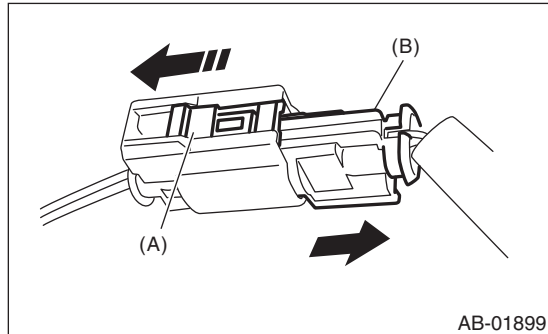

2) How to connect:

Holding the connector, push it in securely until a clicking sound is heard.

CAUTION:

Be sure to insert the connector in until it is locked. Then pull it gently to make sure that it is locked.

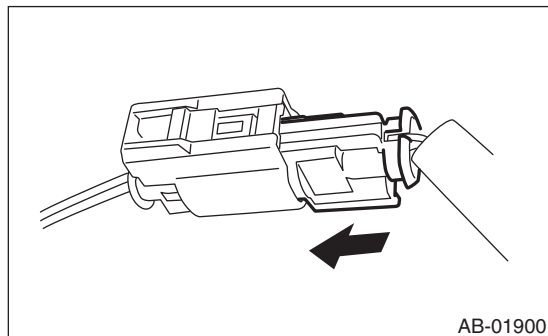

8. FRONT SUB SENSOR

1) How to disconnect:

CAUTION:

When pulling the slide lock or disconnecting connector, be sure to hold the connector, not the harness.

(1) Push the lock arm.

(2) Holding outer part, pull it for one level in the direction of arrow.

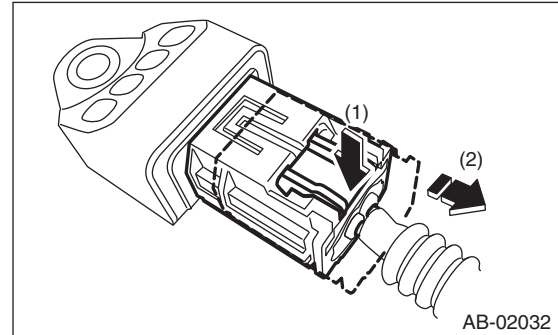

(3) Push the lock arm again.

(4) Holding outer part, pull it in the direction of arrow to separate the connector.

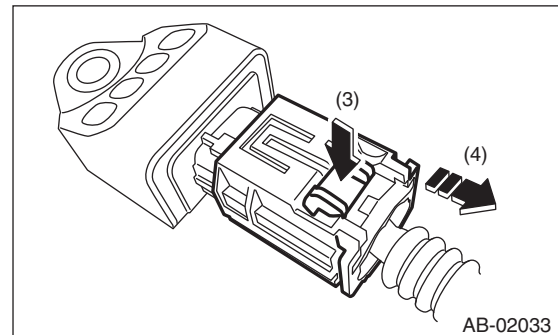

2) How to connect:

Holding the connector, push it in securely until a clicking sound is heard.

CAUTION:

Be sure to insert the connector in until it is locked. Then pull it gently to make sure that it is locked.

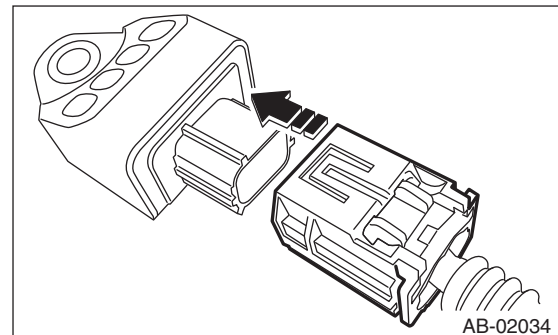

3. Inspection Locations After a Collision

A: REPLACEMENT

Replace the following parts when the airbag is deployed.

1. FRONT COLLISION

- 1) Driver's airbag module
- 2) Passenger's airbag module
- 3) Driver's seat belt (pretensioner)
- 4) Passenger's seat belt (pretensioner)
- 5) Airbag control module
- 6) Front sub sensor (right and left)
- 7) Roll connector
- 8) Passenger's side seat cushion pad and frame assembly
- 9) Instrument panel (for integrating with passenger's airbag module)

2. SIDE COLLISION

- 1) Airbag control module
- 2) Satellite safing sensor
- 3) Satellite safing sensor cover (model without rear seat center table)
- 4) Driver's seat belt (pretensioner)
- 5) Passenger's seat belt (pretensioner)
- 6) Side airbag module (operating side seat backrest)
- 7) Side airbag sensor (operating side)
- 8) Curtain airbag module (operating side)
- 9) Curtain airbag sensor (operating side)

3. INSPECTION OF OTHER PARTS

Check for the following parts, and replace the damaged parts with new parts.

- 1) Steering wheel and steering shaft

Check the steering shaft for mounting conditions and deflection of front and rear, upward and downward directions, and deflection of front and rear direction with tilt lever released. (After a collision, absorbing part of steering shaft may have been operated.)

- 2) Check the direct type connector of driver's airbag module, curtain airbag module, pretensioner, etc. for damage, and also check each harness for pinch and connector damage. Replace the main harness as a unit if damage is found.

- 3) Check the seat cushion, backrest, seat rail and headrest for installing condition and play.

- 4) For the passenger's seat, replace the seat cushion pad frame assembly with a new part if the seat cushion frame assembly is deformed or cracked.

- 5) If there are tears or loosening in the passenger side seat cushion cover, it may interfere with the proper operation of the passenger detection system. Replace with a new cushion cover.

- 6) Be sure to perform the system calibration for the occupant detection system after removing or replacing the passenger seat cushion cover. Failure to do so may cause improper operation of the occupant detection system. <Ref. to OD(diag)-19, OPERATION, System Calibration (Rezeroing).>

- 7) Use the Subaru Select Monitor to check whether the front right seat belt buckle switch is operating normally.

Inspection Locations After a Collision

AIRBAG SYSTEM

B: INSPECTION

If the vehicle is involved in a collision, even if it is a slight collision, be sure to check the following systems.

1. DRIVER'S AIRBAG MODULE

1) Check for the following, and replace the damaged parts with new parts.

- Airbag module is cracked or deformed.
- Harness and/or connector is cracked, deformed or open.
- Harness wire is exposed.
- The module surface is fouled with grease, oil, water or cleaning solvent.

2) When installing a new driver's airbag module, check for the following, and replace the damaged parts with new parts.

- The steering wheel is in the way, making it difficult to install the airbag module.
- The clearance between the driver's airbag module and steering wheel is not constant.
- When steering wheel deformation in axial and vertical directions exceed limits.

Standard:

Axial deflection A

Less than 6 mm (0.24 in)

Vertical deflection L

Less than 17 mm (0.68 in)

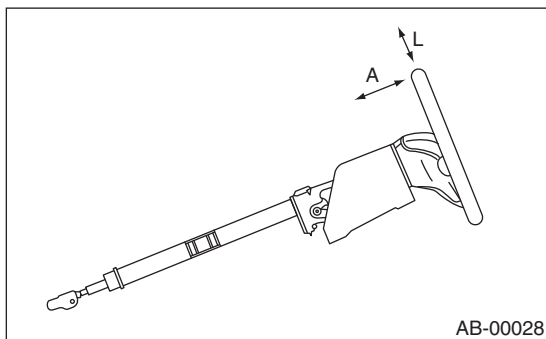

2. PASSENGER'S AIRBAG MODULE

Check for the following, and replace the damaged parts with new parts.

- Airbag module is cracked or deformed.
- Harness and/or connector is cracked, deformed or open.
- Harness wire is exposed.
- Mounting bracket is cracked or deformed.

3. SIDE AIRBAG MODULE

Check for the following, and replace the damaged parts with new parts.

- Front seat, airbag module and mounting bracket are damaged or deformed.
- Harness and/or connector is cracked, deformed or open.
- Harness wire is exposed.

4. CURTAIN AIRBAG MODULE

Check for the following, and replace the damaged parts with new parts.

- Airbag cover is scratched or torn.
- Harness and/or connector is cracked, deformed or open.
- Harness wire is exposed.
- Mounting bracket and securing clip are cracked or deformed.

5. AIRBAG CONTROL MODULE

Check for the following, and replace the damaged parts with new parts.

- Control module is cracked or deformed.
- Mounting bracket is cracked or deformed.
- Connector is scratched, cracked or deformed.
- Airbag is deployed.
- Side airbag is deployed.
- Curtain airbag is deployed.

6. FRONT SUB SENSOR

If the section of vehicle as shown in the figure is damaged, check the following items and replace the damaged parts with new parts.

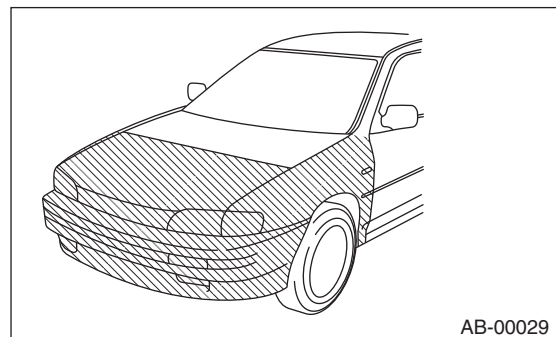

- Front sub sensor is cracked or deformed.
- Connector is scratched, cracked or deformed.
- Airbag is deployed.

7. SATELLITE SAFING SENSOR, SIDE AIRBAG SENSOR AND CURTAIN AIRBAG SENSOR

If the section of vehicle as shown in the figure is damaged, check the following items and replace the damaged parts with new parts.

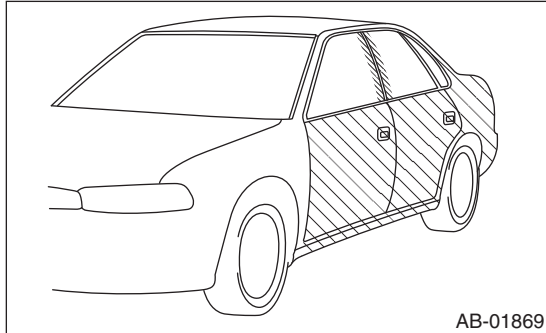

- Satellite safing sensor, side airbag sensor and curtain airbag sensor are cracked or deformed.
- Mounting bracket is cracked or deformed.
- Satellite safing sensor is cracked or deformed. (model without rear seat center table)
- Connector is scratched, cracked or deformed.
- Side airbag or curtain airbag is deployed. (operating side)

8. ROLL CONNECTOR

Check for the following, and replace the damaged parts such as cracks, deformation, etc. with new parts.

- Combination switch
- Steering roll connector

9. STEERING SHAFT

Measure the overall length of steering column. If the length is not within the specification, the steering column may be damaged. Replace it with a new part.

Standard: Overall length L

Tilt column

$$833.6^{+1.3}_{-0.3} \text{ mm } (32.82^{+0.051}_{-0.012} \text{ in})$$

**Tilt and telescopic column
(measure while minimized)**

$$823.6^{+1.5}_{-1.5} \text{ mm } (32.43^{+0.059}_{-0.059} \text{ in})$$

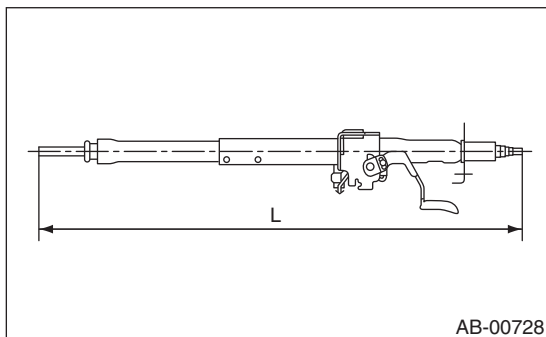

10. PASSENGER'S SEAT

1) Check for the following, and replace the damaged parts with new parts.

- Seat belt buckle body or bracket is scratched, cracked or deformed.
- Backrest frame for crack or deformation
- Headrest for deformation or play
- If the seat cushion cover and seat backrest cover is scratched or coming loose, replace with a new cover and readjust the system. <Ref. to OD(diag)-19, OPERATION, System Calibration (Rezeroing).>

CAUTION:

If any of the following applies, replace the seat cushion pad and frame assembly. Do not disassemble.

- Cracks or deformation found in the seat cushion frame or seat cushion pad.
- Scratches, cracks, or deformation found on the passenger detection system pressure sensor hoses or passenger detection control module, or attachment brackets of the control module.
- Harness and/or connector is cracked, deformed or open. Harness wire is exposed.

2) After checking the installing condition of passenger's seat, perform the system calibration of occupant detection system. <Ref. to OD(diag)-19, OPERATION, System Calibration (Rezeroing).>

11. BELT TENSION SENSOR

Check for the following, and replace the damaged parts with new parts.

- Belt tension sensor is scratched, cracked, or deformed.
- Harness and/or connector is cracked, deformed or open. Harness wire is exposed.

4. Driver's Airbag Module

A: REMOVAL

CAUTION:

Refer to "CAUTION" of "General Description" before handling the airbag module. <Ref. to AB-5, CAUTION, General Description.>

- 1) Position the front wheels straight ahead. (After moving a vehicle 5 m (16 ft) or more with front wheels positioned straight ahead, make sure that the vehicle moves straight ahead.)
- 2) Turn the ignition switch to OFF.
- 3) Disconnect the ground cable from battery and wait for at least 20 seconds before starting work.
- 4) Using TORX® bit T30 (1), remove the two TORX® bolts on the side of steering wheel.

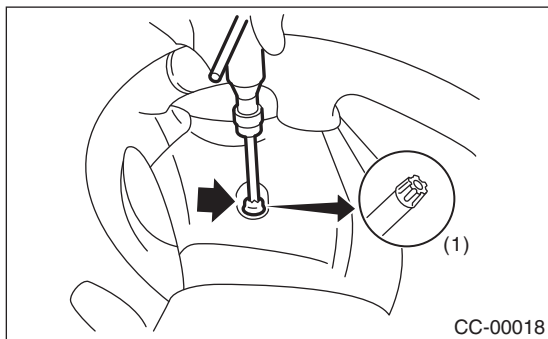

- 5) Disconnect the horn harness.
- 6) Disconnect the airbag connector on the back of airbag module, and then remove the airbag module. <Ref. to AB-9, PROCEDURE, Airbag Connector.>

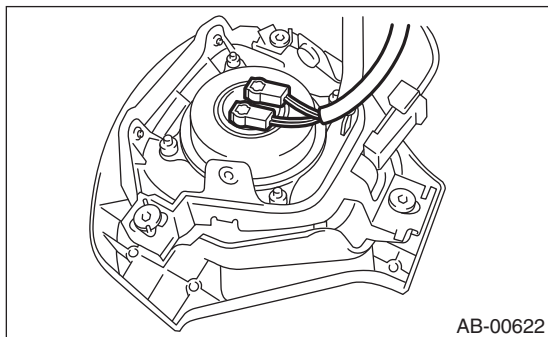

- 7) Refer to "CAUTION" for handling of a removed airbag module. <Ref. to AB-5, CAUTION, General Description.>

B: INSTALLATION

CAUTION:

- Refer to "CAUTION" of "General Description" before handling the airbag module. <Ref. to AB-5, CAUTION, General Description.>
 - Do not allow harness and connectors to interfere or get tangled up with other parts.
- Install in the reverse order of removal.

Tightening torque:

10 N·m (1.0 kgf-m, 7.2 ft-lb)

C: INSPECTION

CAUTION:

- Refer to "CAUTION" of "General Description" before handling the airbag module. <Ref. to AB-5, CAUTION, General Description.>
 - Do not allow harness and connectors to interfere or get tangled up with other parts.
- Check for the following, and replace the damaged parts with new parts. <Ref. to AB-14, DRIVER'S AIRBAG MODULE, INSPECTION, Inspection Locations After a Collision.>

- Airbag module
- Harness
- Connector
- Mounting bracket

5. Passenger's Airbag Module

A: REMOVAL

CAUTION:

Refer to "CAUTION" of "General Description" before handling the airbag module. <Ref. to AB-5, CAUTION, General Description.>

- 1) Turn the ignition switch to OFF.
- 2) Disconnect the ground cable from battery and wait for at least 20 seconds before starting work.
- 3) Remove the instrument panel. <Ref. to EI-50, REMOVAL, Instrument Panel Assembly.>
- 4) Remove the claw, and remove the passenger's airbag module.

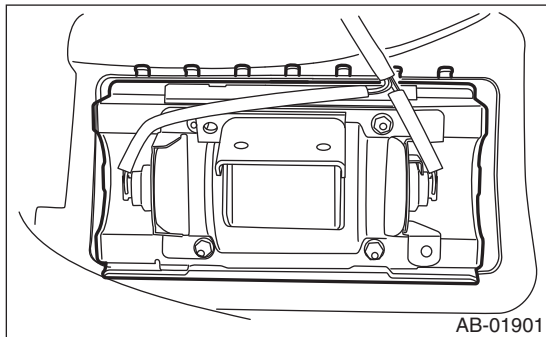

- 5) Refer to "CAUTION" for handling of a removed airbag module. <Ref. to AB-5, CAUTION, General Description.>

B: INSTALLATION

CAUTION:

Do not allow harness and connectors to interfere or get tangled up with other parts.

Install in the reverse order of removal.

Tightening torque:

7.5 N·m (0.76 kgf-m, 5.5 ft-lb)

C: INSPECTION

CAUTION:

Refer to "CAUTION" of "General Description" before handling the airbag module. <Ref. to AB-5, CAUTION, General Description.>

Check for the following, and replace the damaged parts with new parts. <Ref. to AB-14, PASSENGER'S AIRBAG MODULE, INSPECTION, Inspection Locations After a Collision.>

- Airbag module
- Harness
- Connector
- Mounting bracket

Side Airbag Module

AIRBAG SYSTEM

6. Side Airbag Module

A: REMOVAL

CAUTION:

Refer to “CAUTION” of “General Description” before handling the airbag module. <Ref. to AB-5, CAUTION, General Description.>

NOTE:

Remove the passenger’s side by referring to driver’s side.

- 1) Turn the ignition switch to OFF.
- 2) Disconnect the ground cable from battery and wait for at least 20 seconds before starting work.
- 3) Remove the front seat from the vehicle. <Ref. to SE-8, REMOVAL, Front Seat.>
- 4) Remove the clip from reverse side of seat cushion assembly and slide rail, and then remove the side airbag harness.
- 5) Remove the side airbag harness from backrest frame assembly.
- 6) Remove the plastic fastener at the bottom-back side of backrest.

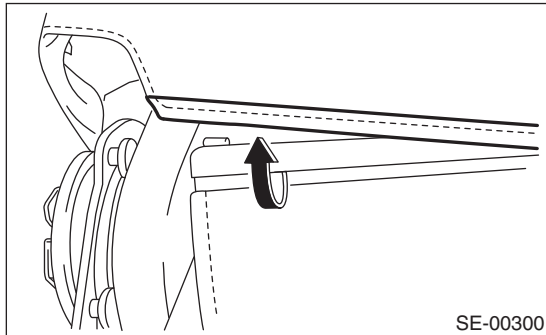

- 7) Open the fastener at the rear side of backrest.

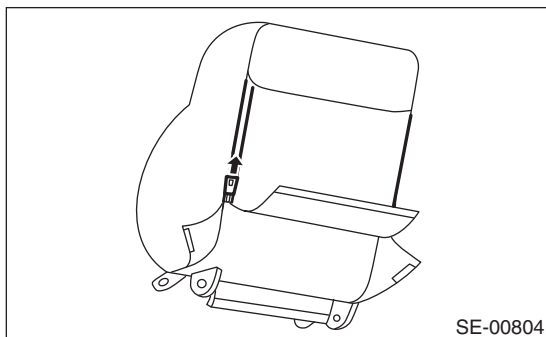

- 8) Remove the hog rings of backrest cover.

CAUTION:

When removing the hog rings, be careful not to tear the vinyl sheet within the seat. If the sheet has torn, replace it with a new sheet.

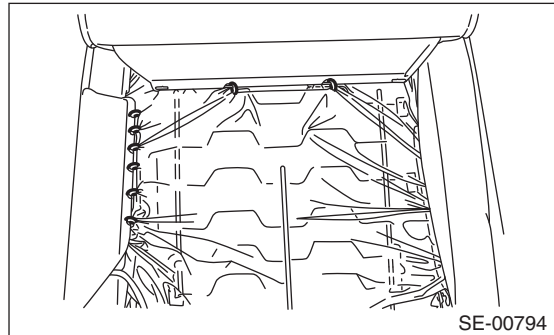

- 9) Remove the pad (A) and then remove the mounting nuts for side airbag module.

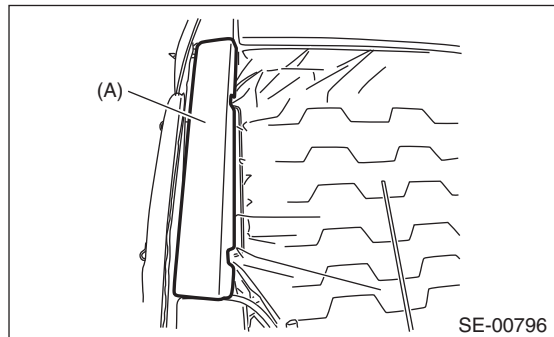

- 10) Remove the side airbag harness from backrest frame assembly.

B: INSTALLATION

CAUTION:

- Refer to “CAUTION” of “General Description” before handling the airbag module. <Ref. to AB-5, CAUTION, General Description.>
- Be sure to perform the system calibration for occupant detection system after passenger’s seat installation. <Ref. to OD(diag)-19, OPERATION, System Calibration (Rezeroing).>
- When installing the side airbag module assembly, be sure to install it by inserting the side airbag module between the backrest cover and airbag guide cloth.

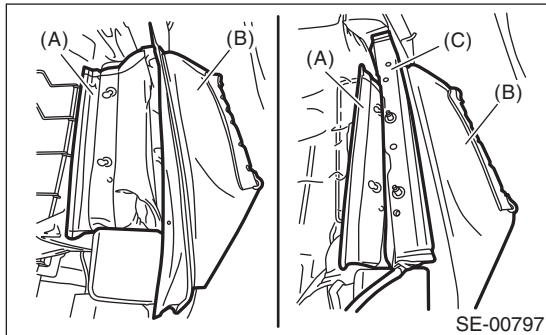

- (A) Airbag guide cloth
- (B) Backrest cover
- (C) Side airbag module ASSY

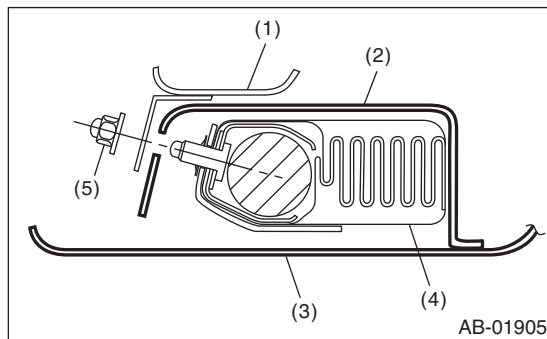

- (1) Backrest frame ASSY
- (2) Airbag guide cloth
- (3) Backrest cover
- (4) Side airbag module ASSY
- (5) Hexagon cap nut

When the backrest cover is not installed securely, the side airbag module may not be deployed properly, therefore keep strictly to the following procedure.

- Be careful not to stain or damage the backrest cover during assembly.
- Always use new hog rings.
- Secure the hog ring using hog ring pliers.
- Install the hog rings to the specified points securely and make sure that no wrinkle or twisting on backrest cover.

- 1) Make sure that there is no foreign matter on side airbag module.
- 2) Install the side airbag module (A) to backrest frame assembly.

Tightening torque:

6 N·m (0.61 kgf-m, 4.4 ft-lb)

- 3) Install the side airbag harness to backrest frame assembly.
- 4) Install the backrest cover.
- 5) Install the side airbag harness to the clips on the back of the seat cushion assembly and on the slide rail.
- 6) Recline the seat or slide it backward and forward, and check there is no contact between the seat backrest assembly, cushion cover assembly and side airbag harness.
- 7) Install the front seat to the vehicle body.

Tightening torque:

Refer to “COMPONENT” of “General Description”. <Ref. to SE-2, FRONT SEAT LH, COMPONENT, General Description.>

C: INSPECTION

CAUTION:

Refer to “CAUTION” of “General Description” before handling the airbag module. <Ref. to AB-5, CAUTION, General Description.>

Check for the following, and replace damaged parts with new parts. <Ref. to AB-14, SIDE AIRBAG MODULE, INSPECTION, Inspection Locations After a Collision.>

1) With side collision (when side airbag is deployed)

- Side airbag module assembly
- Satellite safing sensor
- Side airbag sensor
- Curtain airbag sensor
- Backrest pad assembly
- Backrest frame assembly
- Backrest cover assembly

2) When damage is found by visual check

- Headrest assembly
- Headrest lock bushing
- Outer slide rail
- Inner slide rail
- Seat hinge cover
- Seat lifter lever
- Reclining lever
- Side airbag harness and connector on body side
- Satellite safing sensor cover (model without rear seat center table)

3) With side collision (when side airbag is not deployed)

Check the seat, airbag module, sensor visually, and then replace them with new parts if damaged or cracked.

Specially inspect the damage of airbag module body, mounting bracket and harness connector.

4) Without side collision (dirt and damage of cover)

Replace the corresponding part with a new part.

7. Curtain Airbag Module

A: REMOVAL

CAUTION:

Refer to “CAUTION” of “General Description” before handling the airbag module. <Ref. to AB-5, CAUTION, General Description.>

- 1) Turn the ignition switch to OFF.
- 2) Disconnect the ground cable from battery and wait for at least 20 seconds before starting work.
- 3) Remove the upper inner trim. <Ref. to EI-53, REMOVAL, Upper Inner Trim.>
- 4) Remove the rear quarter trim. <Ref. to EI-55, REMOVAL, Rear Quarter Trim.>
- 5) Remove the roof trim. <Ref. to EI-59, REMOVAL, Roof Trim.>
- 6) Disconnect the curtain airbag module connector.

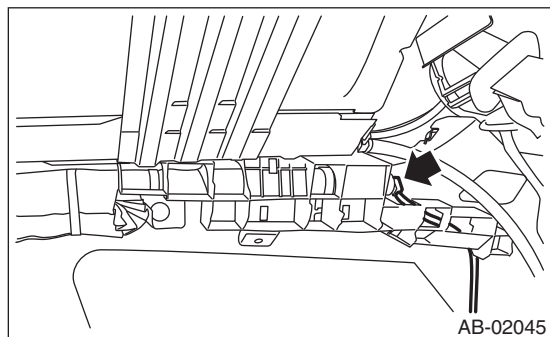

- 7) Remove the inflator pad.

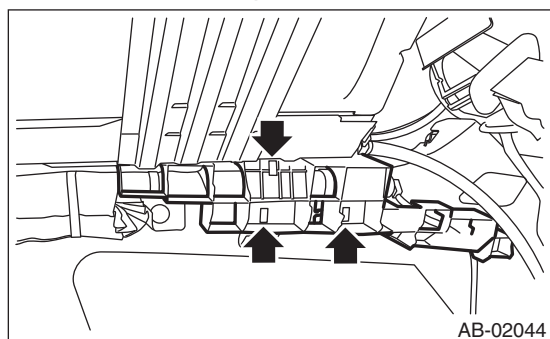

- 8) Remove the bolts and then remove the curtain airbag module.

CAUTION:

- Be careful not to damage the curtain airbag module during removal.
- Never open the curtain airbag module before deploying it. Never reuse the deployed curtain airbag module.

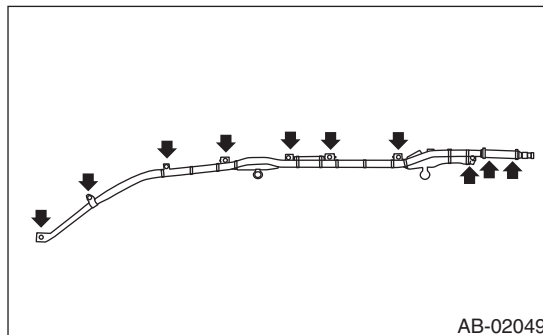

B: INSTALLATION

CAUTION:

- Refer to “CAUTION” of “General Description” before handling the airbag module. <Ref. to AB-5, CAUTION, General Description.>
- When installing the curtain airbag module, install a specified part at specified place.
- Be careful not to damage the curtain airbag module during removal.
- Never open the curtain airbag module before deploying it. Never reuse the deployed curtain airbag module.
- Make sure that there are no foreign matter on airbag module.

Install in the reverse order of removal.

Tightening torque:

7.5 N·m (0.76 kgf·m, 5.5 ft-lb)

C: INSPECTION

CAUTION:

Refer to “CAUTION” of “General Description” before handling the airbag module. <Ref. to AB-5, CAUTION, General Description.>

Check for the following, and replace the damaged parts with new parts. <Ref. to AB-14, CURTAIN AIRBAG MODULE, INSPECTION, Inspection Locations After a Collision.>

1) With side collision (when curtain airbag is deployed)

- Curtain airbag module assembly
- Satellite safing sensor
- Curtain airbag sensor
- Roof trim
- Front pillar upper trim
- Center pillar upper trim
- Rear quarter pillar trim
- Airbag guide

2) When damage is found by visual check

- Assist grip
- Assist grip bracket
- Curtain airbag harness and connector on body side
- Satellite safing sensor cover (model without rear seat center table)

3) With side collision (when curtain airbag is not deployed)

Check the roof trim, pillar trim, airbag module and sensor visually, and then replace them with new parts if damaged or cracked.

Specially inspect the damage of airbag module body, mounting bracket and harness connector.

4) Without side collision (dirt and damage of cover)
Replace the corresponding part with a new part.

8. Airbag Control Module

A: REMOVAL

CAUTION:

- Do not disassemble the airbag control module.
- If the airbag control module is deformed or if the damage from water is suspected, replace the airbag control module with a new part.
- Do not drop the airbag control module.
- After removal, keep the airbag control module on a dry, clean surface away from moisture, heat and dust.

- 1) Turn the ignition switch to OFF.
- 2) Disconnect the ground cable from battery and wait for at least 20 seconds before starting work.
- 3) Remove the console box. <Ref. to EI-46, REMOVAL, Console Box.>
- 4) Remove the console front panel. <Ref. to EI-47, CONSOLE FRONT PANEL, REMOVAL, Center Console.>
- 5) Remove the audio.
- 6) Disconnect the connector from airbag control module.
- 7) Remove the three bolts and remove airbag control module.

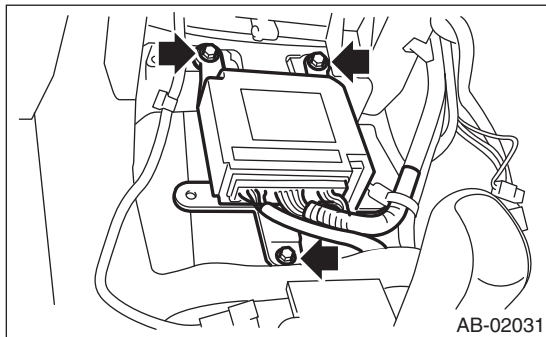

AB-02031

B: INSTALLATION

CAUTION:

- Do not reuse the bolt and nut.
- Always use new bolts and nuts for them.
- Before installing the audio, check that the heater duct is connected securely.
- Install in the reverse order of removal.

Tightening torque:

25 N·m (2.5 kgf·m, 18.1 ft·lb)

C: INSPECTION

Check for the following, and replace the damaged parts with new parts.

- Control module, connector, and mounting bracket are damaged.
- Airbag is deployed.
- Side airbag is deployed.
- Curtain airbag is deployed.

9. Front Sub Sensor

A: REMOVAL

- 1) Turn the ignition switch to OFF.
- 2) Disconnect the ground cable from battery and wait for at least 20 seconds before starting work.
- 3) Remove the front bumper face. <Ref. to EI-28, REMOVAL, Front Bumper.>
- 4) Remove the headlight assembly. <Ref. to LI-17, REMOVAL, Headlight Assembly.>
- 5) Remove the bolt, and then detach the front sub sensor.

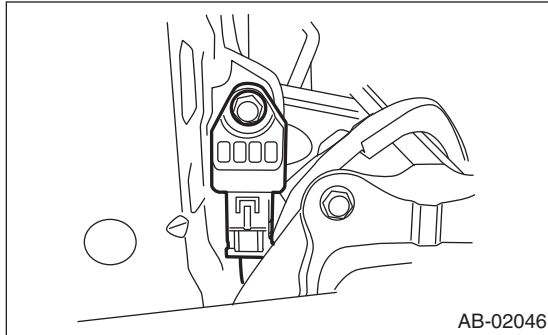

- 6) Disconnect the connector from front sub sensor.

B: INSTALLATION

Install in the reverse order of removal.

CAUTION:

- Do not reuse the bolt and nut.
Always use new bolts and nuts for them.
- When installing the sensor, securely insert the arrest pin on the back side of sensor into the body side hole.
- After attaching the headlight assembly, always perform headlight beam level adjustment.

Tightening torque:

13 N·m (1.32 kgf·m, 9.6 ft·lb)

C: INSPECTION

Check for the following, and replace the damaged parts with new parts.

- Front sub sensor or connector is damaged.
- Airbag is deployed.

10.Side Airbag Sensor

A: REMOVAL

- 1) Turn the ignition switch to OFF.
- 2) Disconnect the ground cable from battery and wait for at least 20 seconds before starting work.
- 3) Remove the front outer seat belt. <Ref. to SB-17, OUTER SEAT BELT ASSEMBLY, REMOVAL, Front Seat Belt.>
- 4) Remove the nuts to remove the side airbag sensor.

CAUTION:

- Do not separate the side airbag sensor and bracket. It causes the airbag system malfunction.
- If the sensor is removed from the bracket, replace them with new parts.

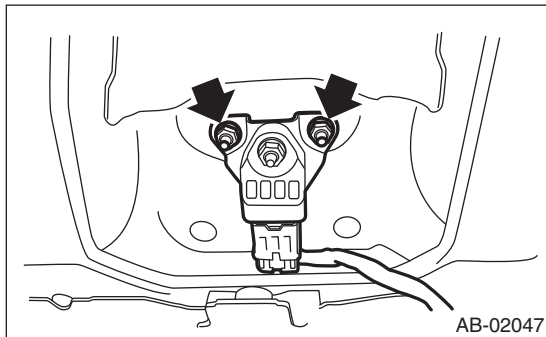

- 5) Disconnect the airbag connector.

B: INSTALLATION

CAUTION:

- Do not reuse the bolt and nut.**
Always use new bolts and nuts for them.
Install in the reverse order of removal.

Tightening torque:

7.5 N·m (0.76 kgf-m, 5.5 ft-lb)

C: INSPECTION

Check for the following, and replace the damaged parts with new parts.

- The bracket or connector of side airbag sensor is damaged.
- Side airbag is deployed.

11. Curtain Airbag Sensor

A: REMOVAL

- 1) Turn the ignition switch to OFF.
- 2) Disconnect the ground cable from battery and wait for at least 20 seconds before starting work.
- 3) Remove the rear seat cushion assembly and backrest shoulder. <Ref. to SE-15, REMOVAL, Rear Seat.>
- 4) Remove the nuts to remove the curtain airbag sensor.

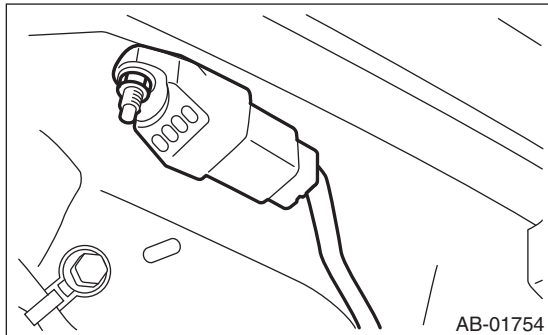

- 5) Disconnect the airbag connector.

B: INSTALLATION

CAUTION:

- Do not reuse the bolt and nut. Always use new bolts and nuts for them.
- When installing the sensor, securely insert the arrest pin on the back side of sensor into the body side hole.

Install in the reverse order of removal.

Tightening torque:

7.5 N·m (0.76 kgf-m, 5.5 ft-lb)

C: INSPECTION

Check for the following, and replace the damaged parts with new parts.

- Curtain airbag sensor or connector is damaged.
- Curtain airbag is deployed.

12.Satellite Safing Sensor

A: REMOVAL

- 1) Turn the ignition switch to OFF.
- 2) Disconnect the ground cable from battery and wait for at least 20 seconds before starting work.
- 3) Remove the rear seat cushion. <Ref. to SE-15, REMOVAL, Rear Seat.>
- 4) Remove the satellite safing sensor cover. (model without rear seat center table)

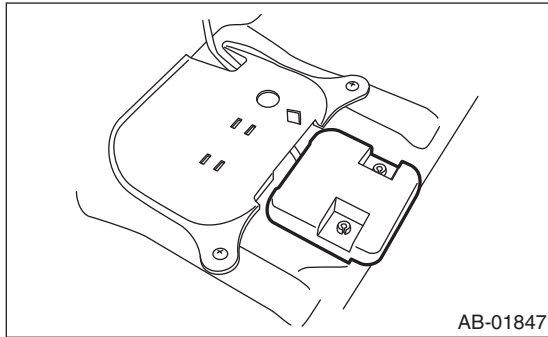

- 5) Remove the nuts to remove the satellite safing sensor.

CAUTION:

- Do not separate the satellite safing sensor and bracket. It causes the airbag system malfunction.
- If the sensor is removed from the bracket, replace them with new parts.

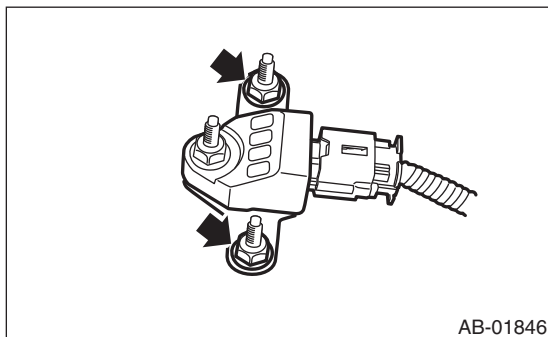

- 6) Disconnect the airbag connector.

B: INSTALLATION

CAUTION:

- Do not reuse the bolt and nut.
- Always use new bolts and nuts for them.
- When installing the satellite safing sensor cover, push the cover securely until it contacts the floor panel.
- When the installation of the satellite safing sensor cover becomes loose and it can be removed easily, replace the cover with a new part.
- After installing the satellite safing sensor cover, check that the sensor harness is not pinched.

Install in the reverse order of removal.

Tightening torque:

7.5 N·m (0.76 kgf·m, 5.5 ft·lb)

C: INSPECTION

Check for the following, and replace the damaged parts with new parts.

- Mounting bracket or connector of satellite safing sensor is damaged.
- The satellite safing sensor cover is damaged
- Side airbag or curtain airbag is deployed.

13. Roll Connector

A: REMOVAL

- 1) Turn the ignition switch to OFF.
- 2) Disconnect the ground cable from battery and wait for at least 20 seconds before starting work.
- 3) Remove the driver's airbag module. <Ref. to AB-16, Driver's Airbag Module.>
- 4) Remove the steering wheel. <Ref. to PS-12, REMOVAL, Steering Wheel.>
- 5) Remove the steering column cover.
- 6) Remove the screws, and then remove the roll connector.

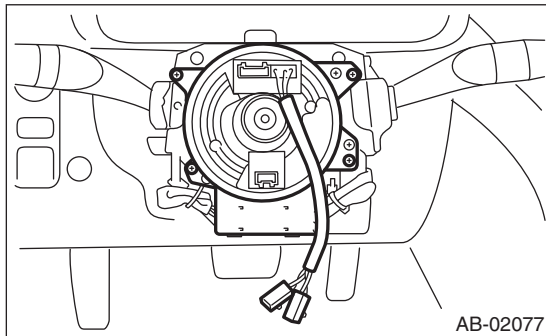

B: INSTALLATION

- 1) Install in the reverse order of removal.
- 2) Before installing steering wheel, be sure to adjust the direction of roll connector with steering. <Ref. to AB-28, ADJUSTMENT, Roll Connector.>

C: INSPECTION

Check for the following, and replace the damaged parts with new parts.

- Combination switch and roll connector are cracked or deformed.

D: ADJUSTMENT

- 1) Check that front wheels are positioned in straight ahead direction.
- 2) Turn the roll connector pin (A) clockwise until it stops.
- 3) Turn the roll connector pins (A) approx. 3.25 turns until "▲" marks are aligned.

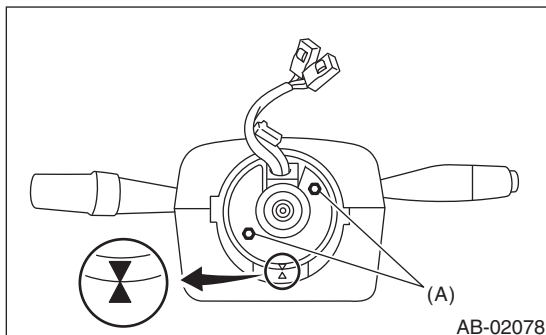

AIRBAG SYSTEM (DIAGNOSTICS)

AB(diag)

	Page
1. Basic Diagnostic Procedure	2
2. Check List for Interview	3
3. General Description	4
4. Electrical Component Location	22
5. Airbag Connector	23
6. Airbag Control Module I/O Signal	24
7. Subaru Select Monitor	26
8. Read Diagnostic Trouble Code (DTC)	30
9. Inspection Mode	31
10. Clear Memory Mode	32
11. Display of Status Information	33
12. Airbag Warning Light Illumination Pattern	34
13. Airbag Warning Light Failure	35
14. List of Diagnostic Trouble Code (DTC)	40
15. Diagnostic Chart with Trouble Code	46

Basic Diagnostic Procedure

AIRBAG SYSTEM (DIAGNOSTICS)

1. Basic Diagnostic Procedure

A: PROCEDURE

	Step	Check	Yes	No
1	CHECK WARNING LIGHT. Check whether the airbag warning light in the combination meter is lit.	Does the airbag warning light illuminate?	Go to step 2.	Perform the diagnosis according to phenomenon of the problem.
2	READ DTC. 1) Turn the ignition switch to OFF. 2) Connect the Subaru Select Monitor to the data link connector. 3) Turn the ignition switch to ON and run the Subaru Select Monitor. 4) Read the DTC. <Ref. to AB(diag)-30, OPERATION, Read Diagnostic Trouble Code (DTC).> NOTE: If the communication function of the Subaru Select Monitor cannot be executed normally, check the communication circuit. <Ref. to AB(diag)-27, COMMUNICATION FOR INITIALIZING IMPOSSIBLE, INSPECTION, Subaru Select Monitor.> 5) Record all DTCs and freeze frame data.	Is DTC displayed?	Go to step 3.	Move to "Airbag Warning Light Failure". <Ref. to AB(diag)-35, Airbag Warning Light Failure.>
3	PERFORM DIAGNOSIS. 1) Judge the possible cause from "List of Diagnostic Trouble Code (DTC)". <Ref. to AB(diag)-40, List of Diagnostic Trouble Code (DTC).> 2) Inspect the DTC using "List of Diagnostic Trouble Code (DTC)". 3) Repair the trouble cause. 4) Perform the Clear Memory Mode. <Ref. to AB(diag)-32, Clear Memory Mode.> 5) Perform the Inspection Mode. <Ref. to AB(diag)-31, Inspection Mode.> 6) Read any other DTCs displayed.	Is DTC displayed?	Perform the procedure 1) to 5) in step 3.	Finish the diagnosis.

Check List for Interview

AIRBAG SYSTEM (DIAGNOSTICS)

2. Check List for Interview

A: CHECK

Customer's name		Inspector's name	
Date vehicle brought in	/ /	Registration No.	
Odometer reading	km miles	V.I.N.	
Date problem occurred	/ /	Registration year	/ /
Weather	<input type="checkbox"/> Fine <input type="checkbox"/> Cloudy <input type="checkbox"/> Rainy <input type="checkbox"/> Snowy <input type="checkbox"/> Others:		
Temperature	°C (°F)		
Road condition	<input type="checkbox"/> Flat road <input type="checkbox"/> Uphill <input type="checkbox"/> Downhill <input type="checkbox"/> Gravel road <input type="checkbox"/> Others:		
Vehicle operation	<input type="checkbox"/> Starting <input type="checkbox"/> Idling <input type="checkbox"/> Driving <input type="checkbox"/> Constant speed <input type="checkbox"/> Accelerating <input type="checkbox"/> Decelerating <input type="checkbox"/> Turning <input type="checkbox"/> Others:		
Details of problem			
Airbag warning light operation	<input type="checkbox"/> Normal (After turning the ignition switch to ON, lit for approximately 6 seconds and goes off.) <input type="checkbox"/> Remains ON <input type="checkbox"/> Remains OFF		
DTC output	<input type="checkbox"/> OK code <input type="checkbox"/> DTC: (Code:)		

General Description

AIRBAG SYSTEM (DIAGNOSTICS)

3. General Description

A: CAUTION

- When servicing a vehicle, be sure to turn the ignition switch to OFF, disconnect the ground terminal from the battery, and wait for 20 seconds or more before starting work.
- The airbag system is fitted with a backup power source. After disconnecting the battery ground cable, the airbag may deploy if you do not wait for 20 seconds or more before starting airbag system servicing.

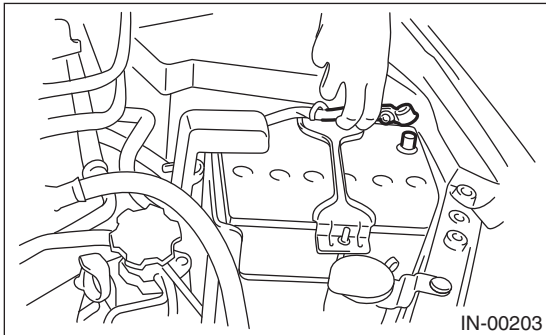

- If sensors, airbag module, airbag control module, pretensioner or harness is deformed or damaged, replace with new parts.

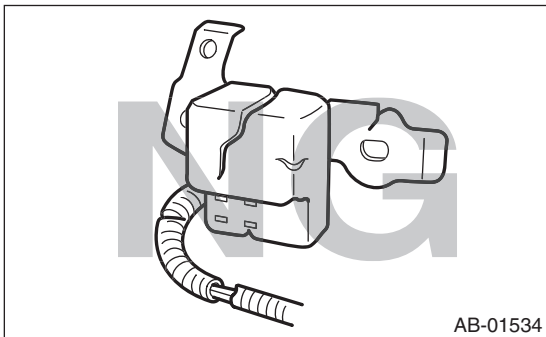

- Do not use the airbag system and pretensioners on other vehicles. When replacing parts, be sure to replace them with new parts.
- When checking the airbag system, be sure to use a digital circuit tester. Use of an analog circuit tester may cause the airbag to activate erroneously due to a minimal current inside tester.

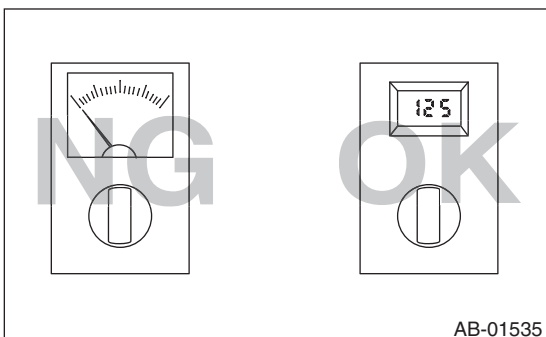

- When checking, use a test harness (1). Damage to connector terminal causes malfunction. Do not directly put the tester probe on airbag connector terminal.

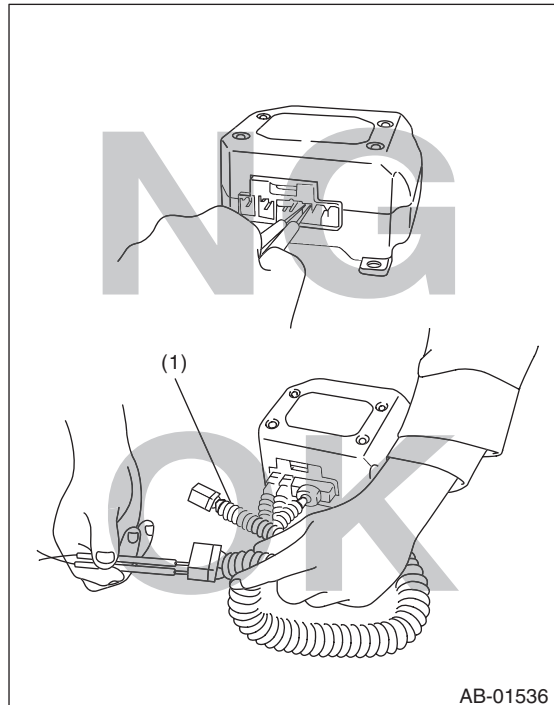

- Do not drop the airbag system parts, or keep them at high temperature of 85°C (153°F) or more, or let water, oil or grease get on them; the internal parts may be damaged and reliability greatly lowered.

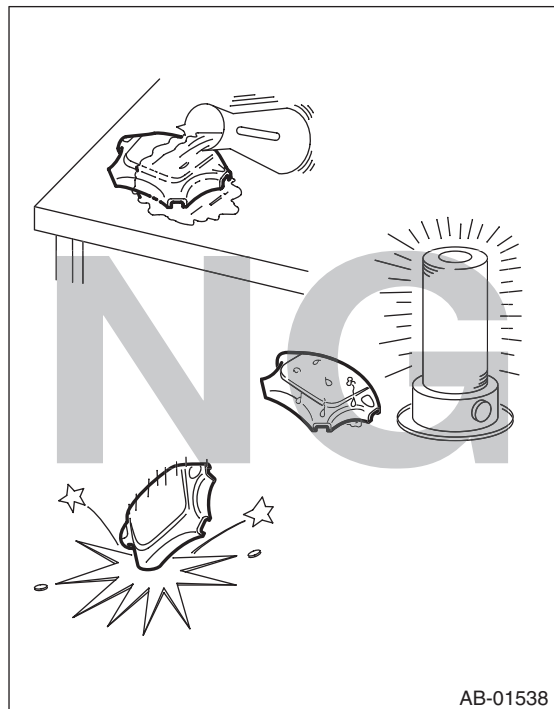

General Description

AIRBAG SYSTEM (DIAGNOSTICS)

- If damage, open circuit or rust is found on airbag system wiring harness, do not use a soldering equipment to repair. Replace the faulty harness with a new genuine part.

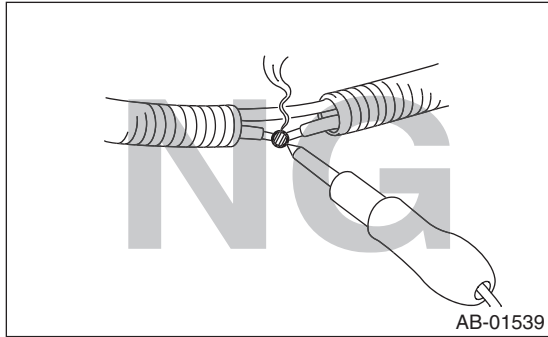

- Install the wiring harness securely with the specified clips to avoid interference or tangled with other parts.

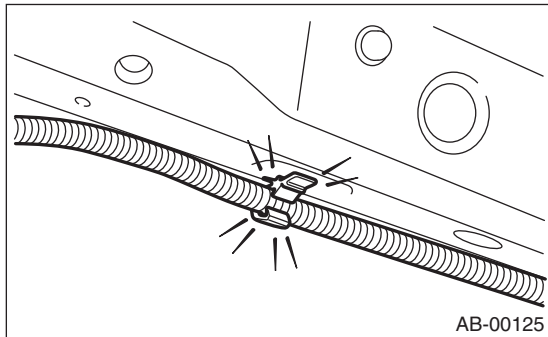

- Do not allow water or oil to come in contact with the connector terminals. Also, do not touch the connector terminals.

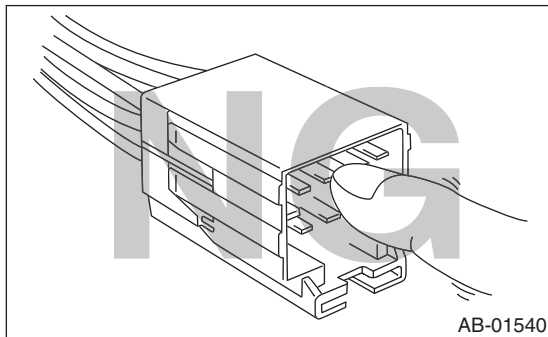

- Do not disassemble driver's airbag module, passenger's airbag module, side or curtain airbag modules, or pretensioner.

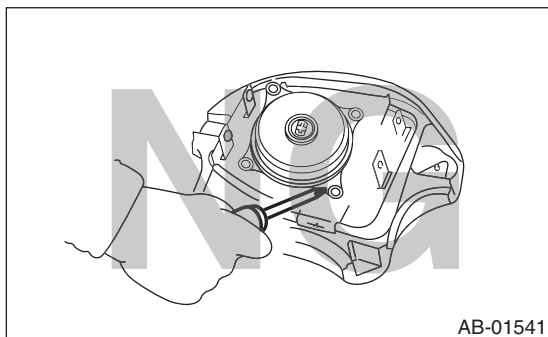

- The airbag module cannot be used again if deployed once.
- After removal, keep the airbag module with the pad side facing upward on a dry, clean and flat surface away from heat, light sources, moisture and dust.

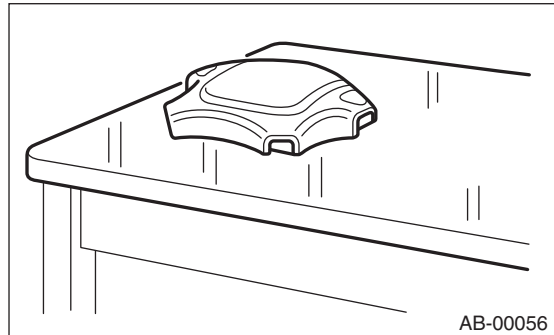

- Do not check continuity of the airbag modules for driver's side, passenger's side and curtain, or the pretensioner.

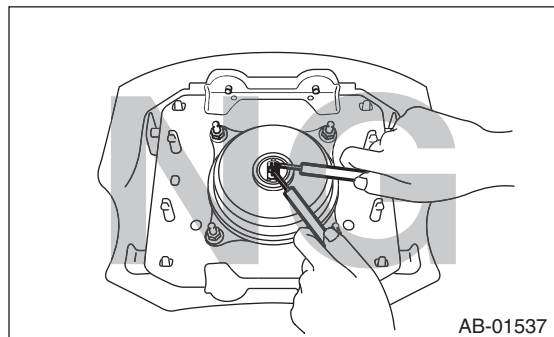

- The removed front seat with airbag module must be kept at least 200 mm (8 in) away from walls and other objects.

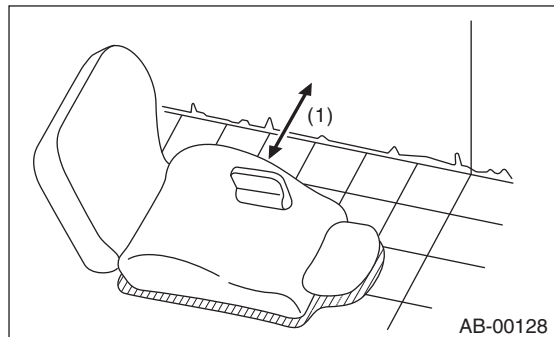

(1) 200 mm (8 in) or more

- When painting or performing sheet metal work on the front part of the vehicle, including the front wheel apron, front fender and front side frame, remove the front sub sensors and wiring harness of airbag system.

General Description

AIRBAG SYSTEM (DIAGNOSTICS)

- When painting or repairing sheet metal work on the side of the vehicle, including the side sill, center pillar, front and rear doors, rear crossmember and rear floorpan, remove the side airbag sensors, satellite safing sensor and wiring harness of the airbag system.

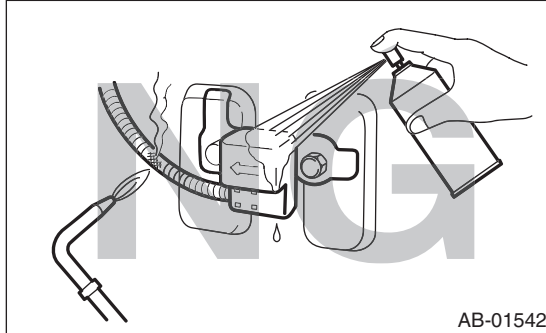

- Do not discard undeployed airbag modules. They could easily cause a serious accident if accidentally deployed.

General Description

AIRBAG SYSTEM (DIAGNOSTICS)

- When storing a removed airbag module, do not place it with the pad side facing downward. Do not place any objects on the airbag module. Do not pile up the airbag module. If the airbag inflates for some reason when an airbag module pad is touching other objects, it may cause serious accident.

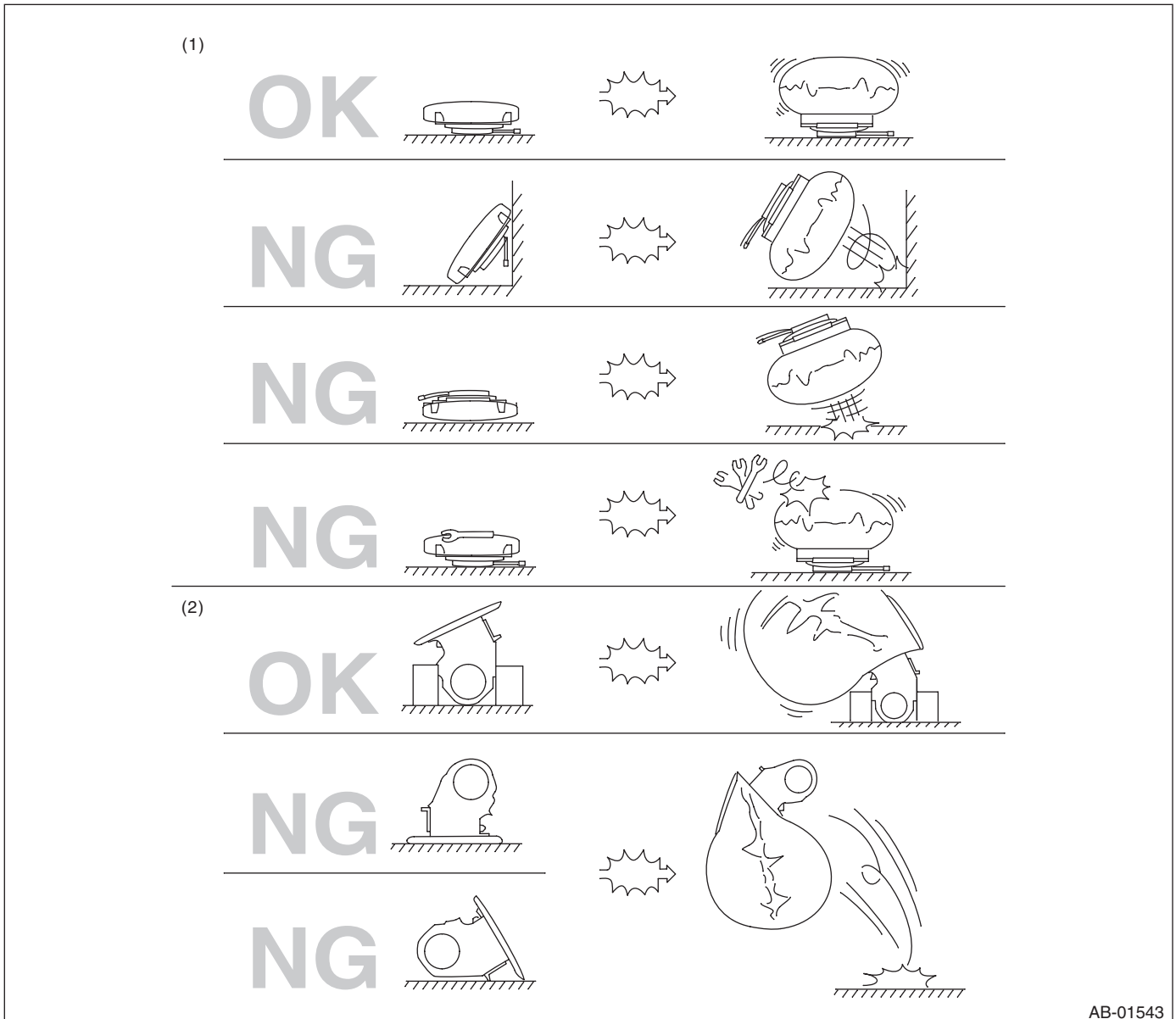

AB-01543

(1) Driver's airbag module

(2) Passenger's airbag module

B: INSPECTION

Measure the battery voltage and check electrolyte.

Standard voltage: 12 V

Specific gravity: 1.260 or more

General Description

AIRBAG SYSTEM (DIAGNOSTICS)

C: PREPARATION TOOL

CAUTION:

To measure the voltage and resistance of airbag system component, be sure to use the specified test harness.

1. SPECIAL TOOL

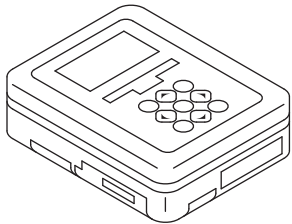
ILLUSTRATION	TOOL NUMBER	DESCRIPTION	REMARKS
 <p>ST1B022XU0</p>	1B022XU0 (Newly adopted tool)	SUBARU SELECT MONITOR III KIT	Used for troubleshooting the electrical system.

• TEST HARNESS H

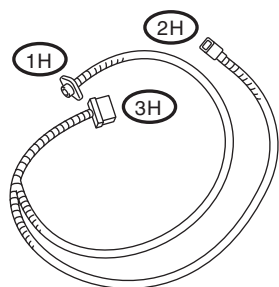
ILLUSTRATION	TOOL NUMBER	DESCRIPTION	REMARKS
 <p>ST98299FA030</p>	98299FA030	TEST HARNESS H	Used when measuring voltage and resistance of front sub sensor and satellite safing sensor.

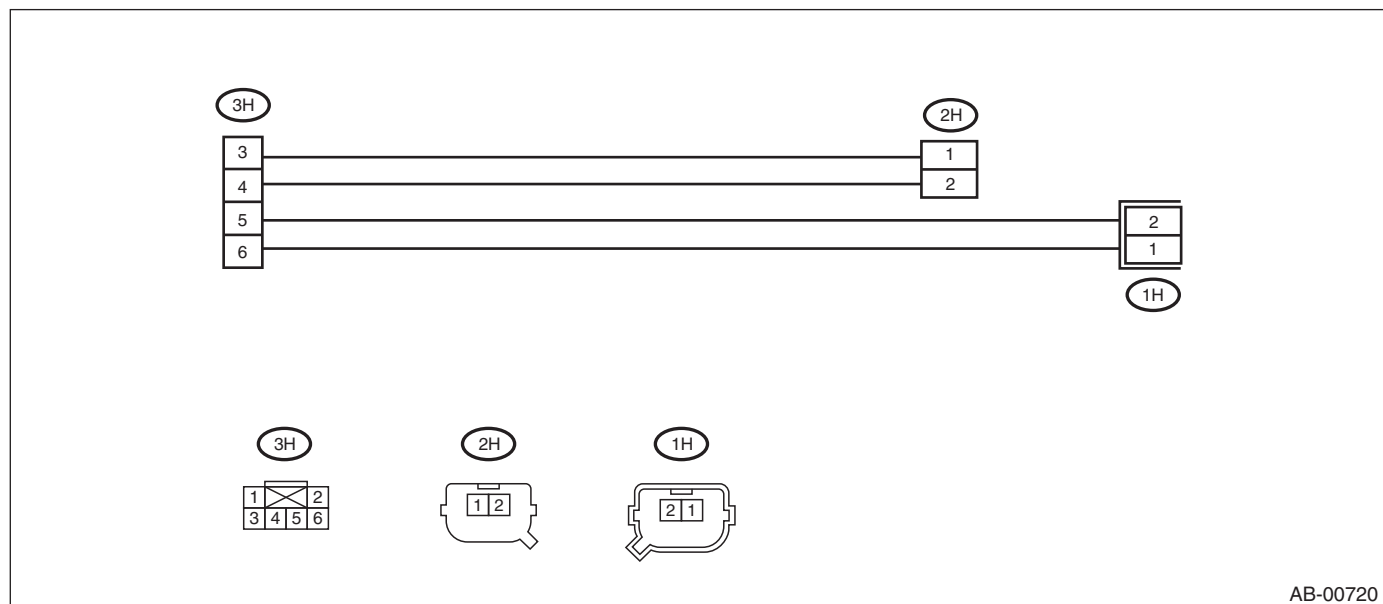

General Description

AIRBAG SYSTEM (DIAGNOSTICS)

- TEST HARNESS N

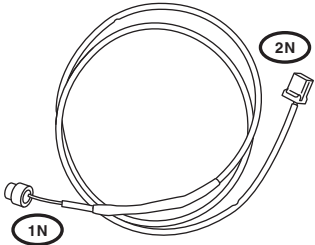
ILLUSTRATION	TOOL NUMBER	DESCRIPTION	REMARKS
 <p data-bbox="326 554 467 575">ST98299SA000</p>	98299SA000	TEST HARNESS N	Used when measuring voltage and resistance of driver's airbag module and seat belt pretensioner.

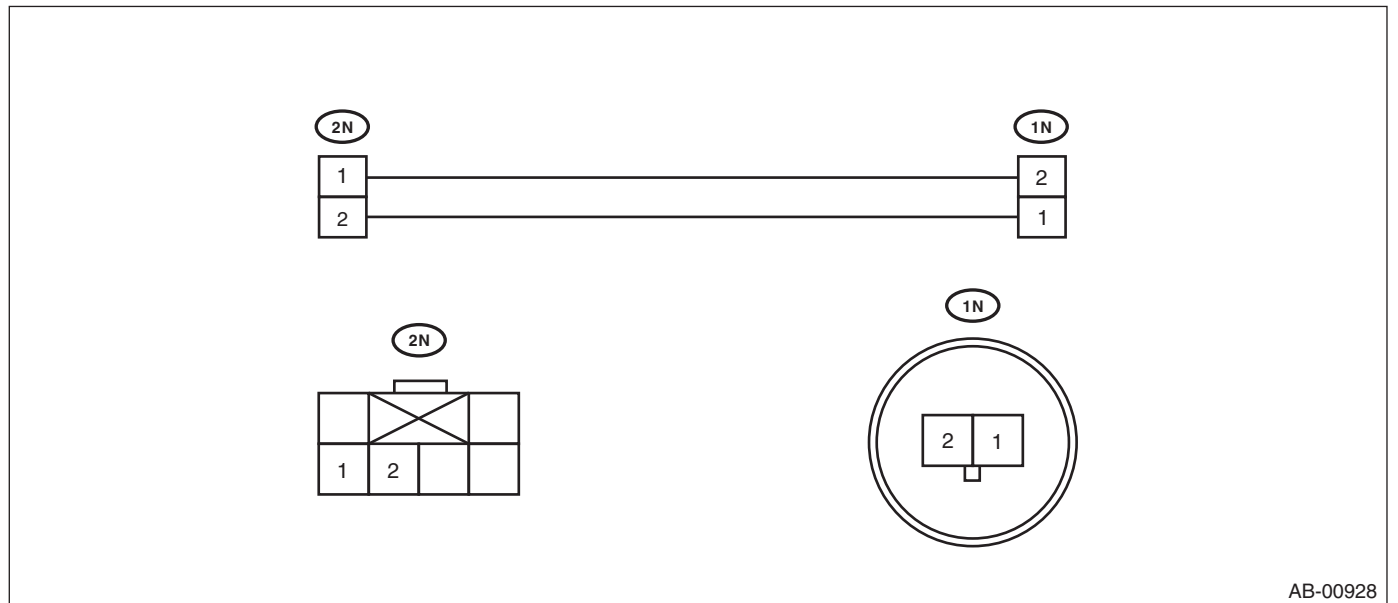

General Description

AIRBAG SYSTEM (DIAGNOSTICS)

- TEST HARNESS P

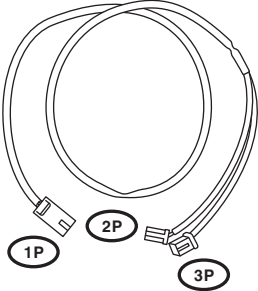
ILLUSTRATION	TOOL NUMBER	DESCRIPTION	REMARKS
 <p>ST98299SA020</p>	98299SA020	TEST HARNESS P	Used when measuring voltage and resistance of driver's airbag module harness.

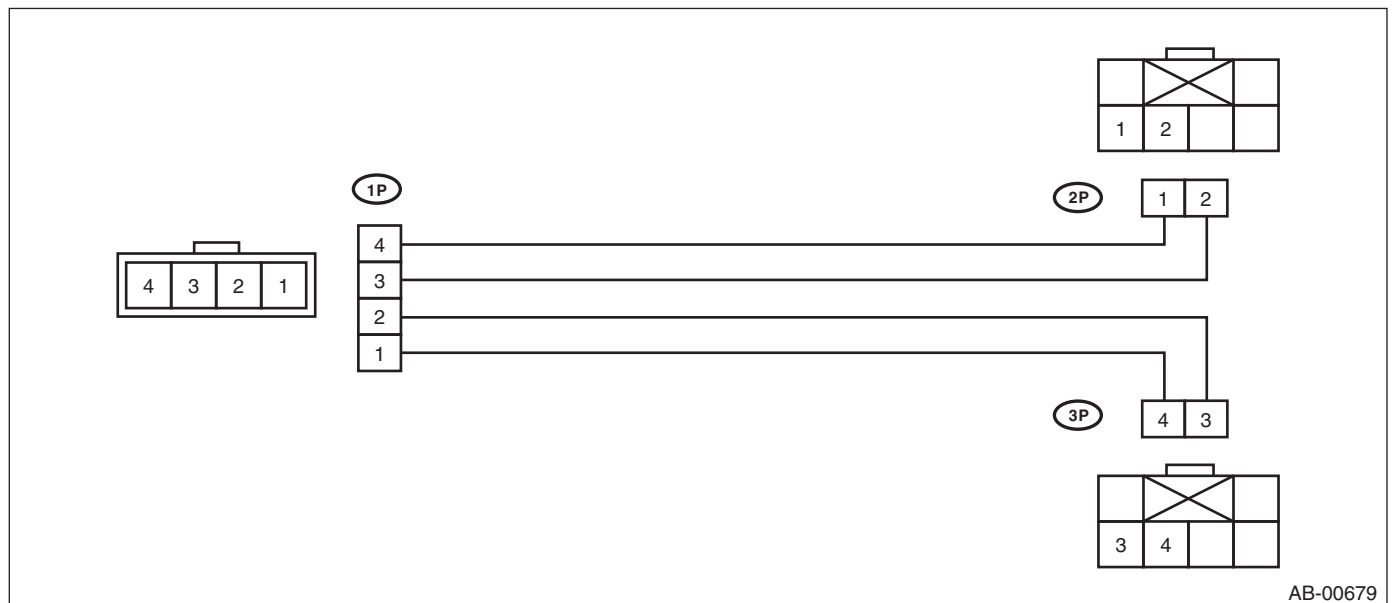

General Description

AIRBAG SYSTEM (DIAGNOSTICS)

- TEST HARNESS Q

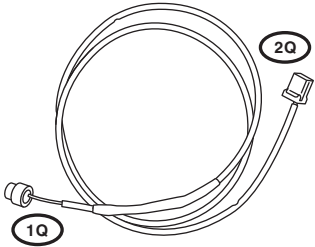
ILLUSTRATION	TOOL NUMBER	DESCRIPTION	REMARKS
 <p>ST98299SA040</p>	98299SA040	TEST HARNESS Q	Used when measuring voltage and resistance of driver's airbag module.

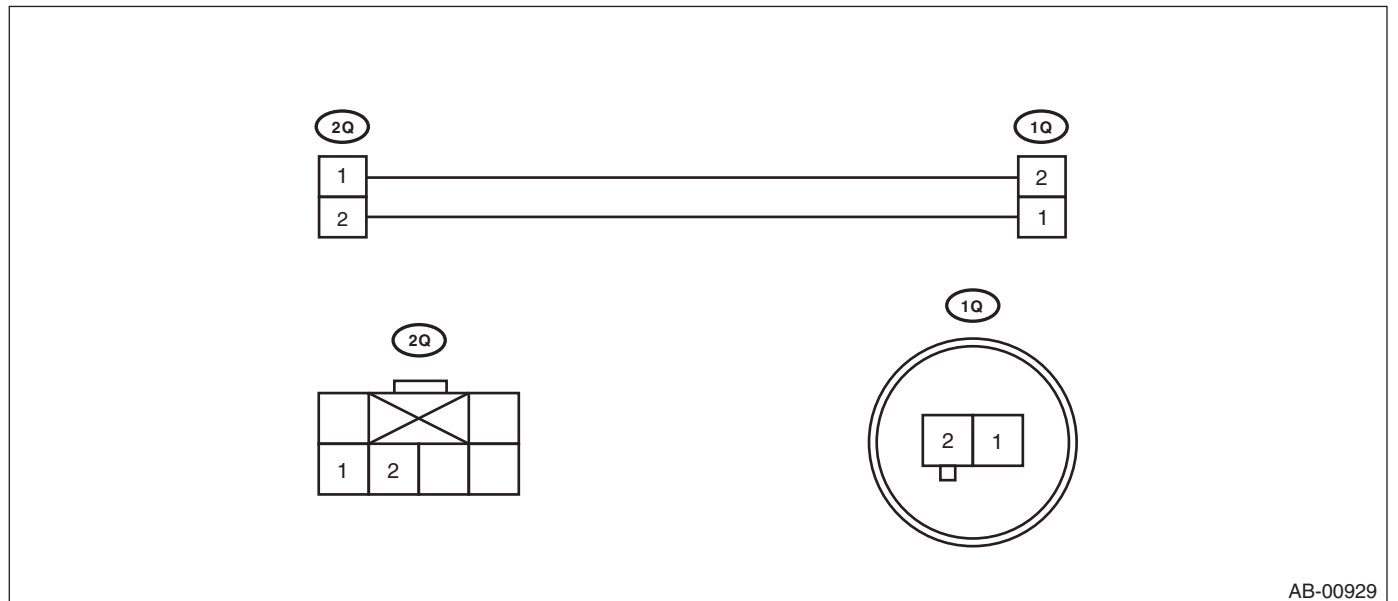

General Description

AIRBAG SYSTEM (DIAGNOSTICS)

- TEST HARNESS AG

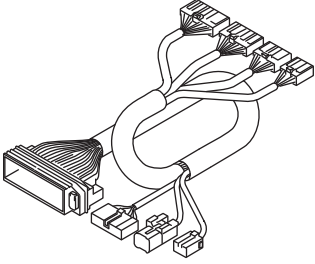
ILLUSTRATION	TOOL NUMBER	DESCRIPTION	REMARKS
 <p>ST98299AG070</p>	98299AG070	TEST HARNESS AG	Used when measuring voltage and resistance of airbag control module.

General Description

AIRBAG SYSTEM (DIAGNOSTICS)

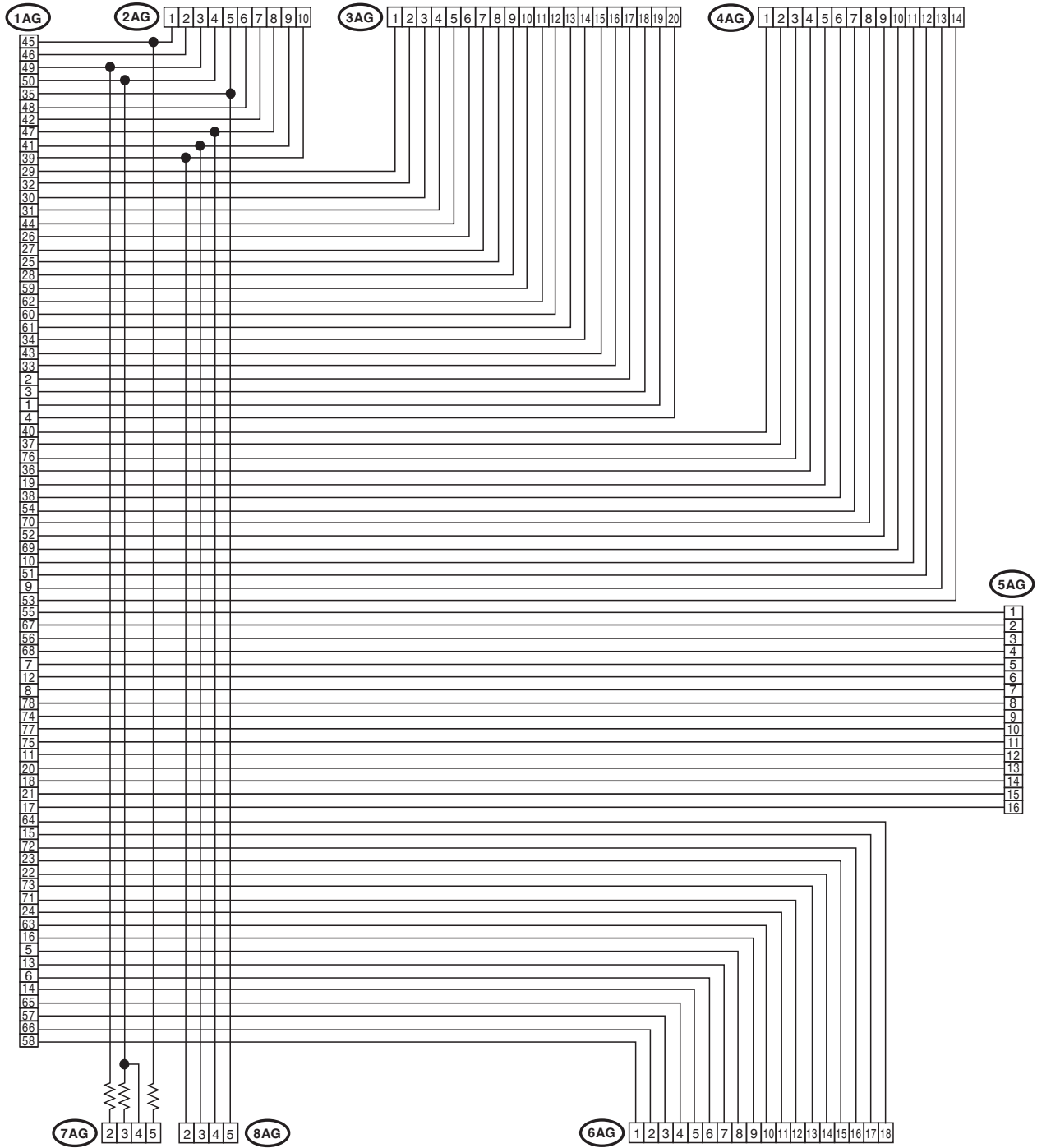

AB-01902

General Description

AIRBAG SYSTEM (DIAGNOSTICS)

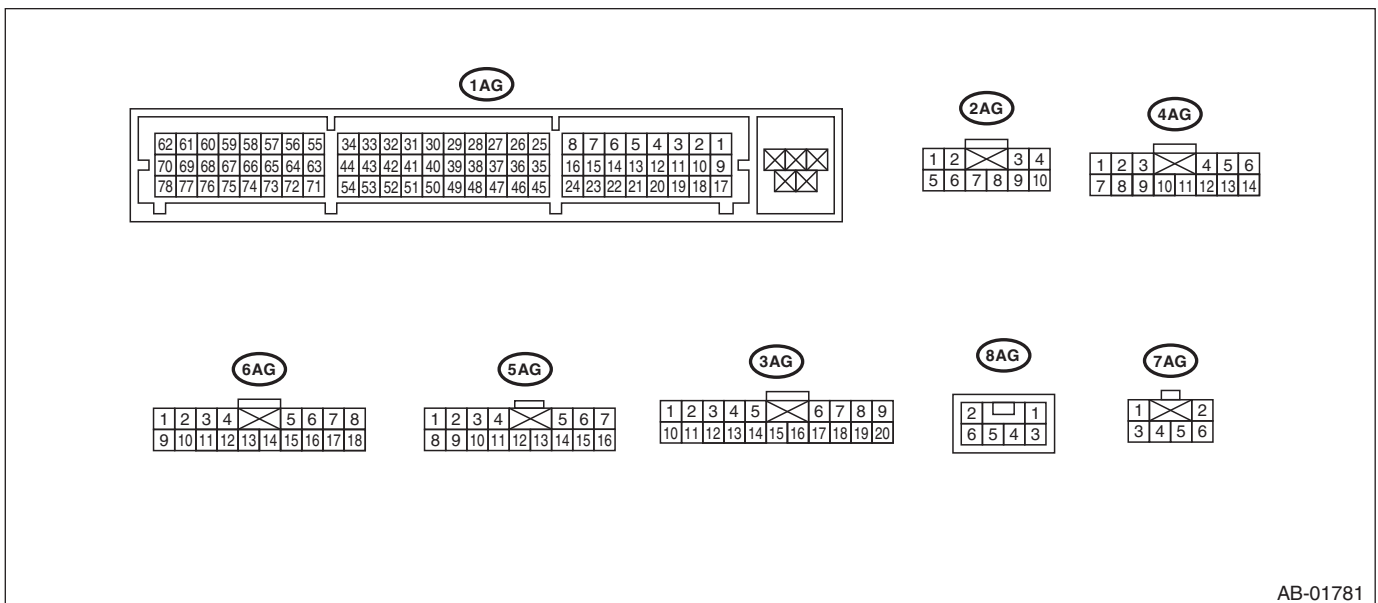

• TEST HARNESS AJ

ILLUSTRATION	TOOL NUMBER	DESCRIPTION	REMARKS
<p>ST98299FG000</p>	98299FG000	TEST HARNESS AJ	Used when measuring power supply and resistance of side airbag harness.

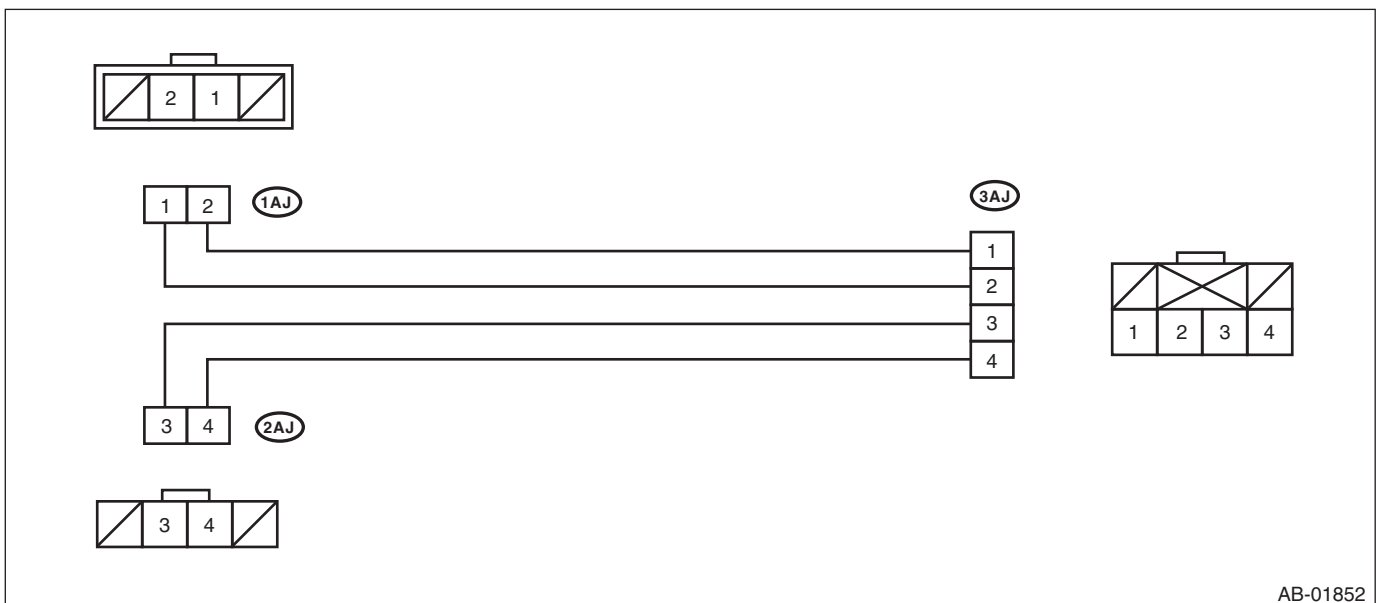

General Description

- TEST HARNESS V

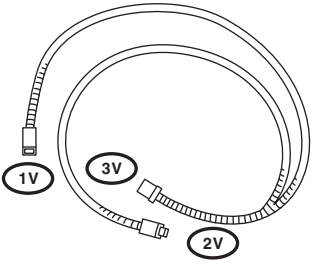
ILLUSTRATION	TOOL NUMBER	DESCRIPTION	REMARKS
 <p>ST98299AG010</p>	98299AG010	TEST HARNESS V	Used when measuring voltage and resistance of side airbag sensor and curtain airbag sensor.

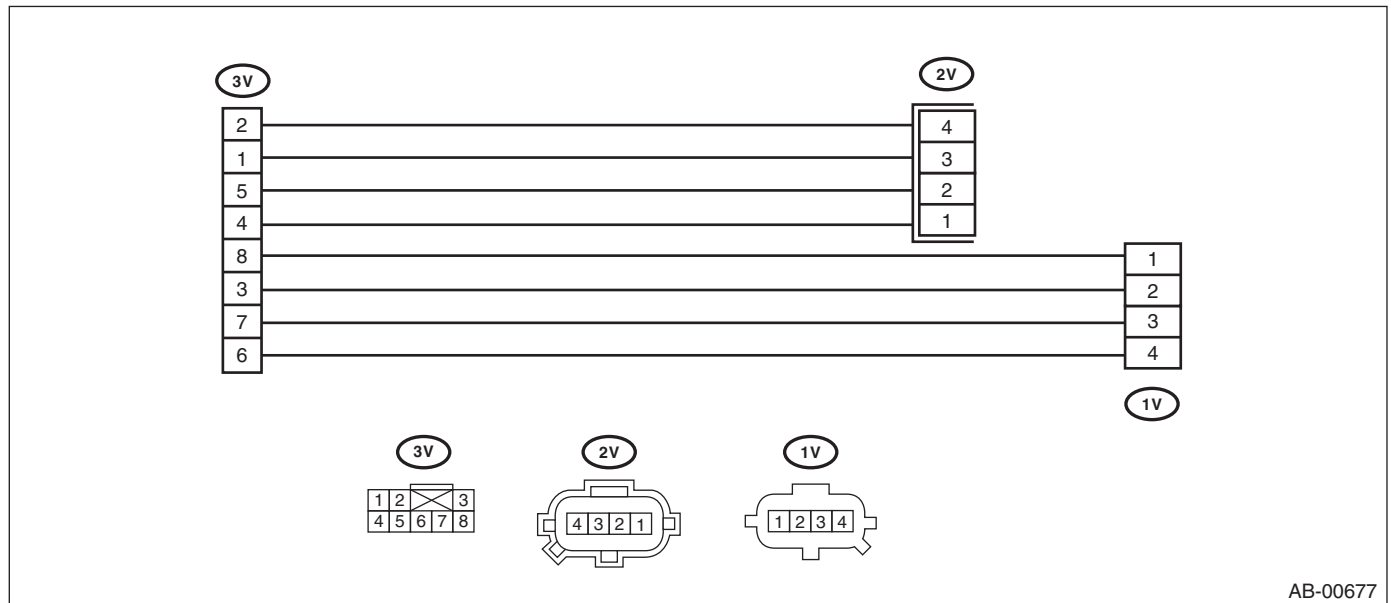

General Description

AIRBAG SYSTEM (DIAGNOSTICS)

- TEST HARNESS AB

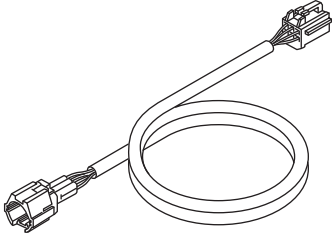
ILLUSTRATION	TOOL NUMBER	DESCRIPTION	REMARKS
 <p>ST98299XA000</p>	98299XA000	TEST HARNESS AB	Used when measuring voltage and resistance of occupant detection system.

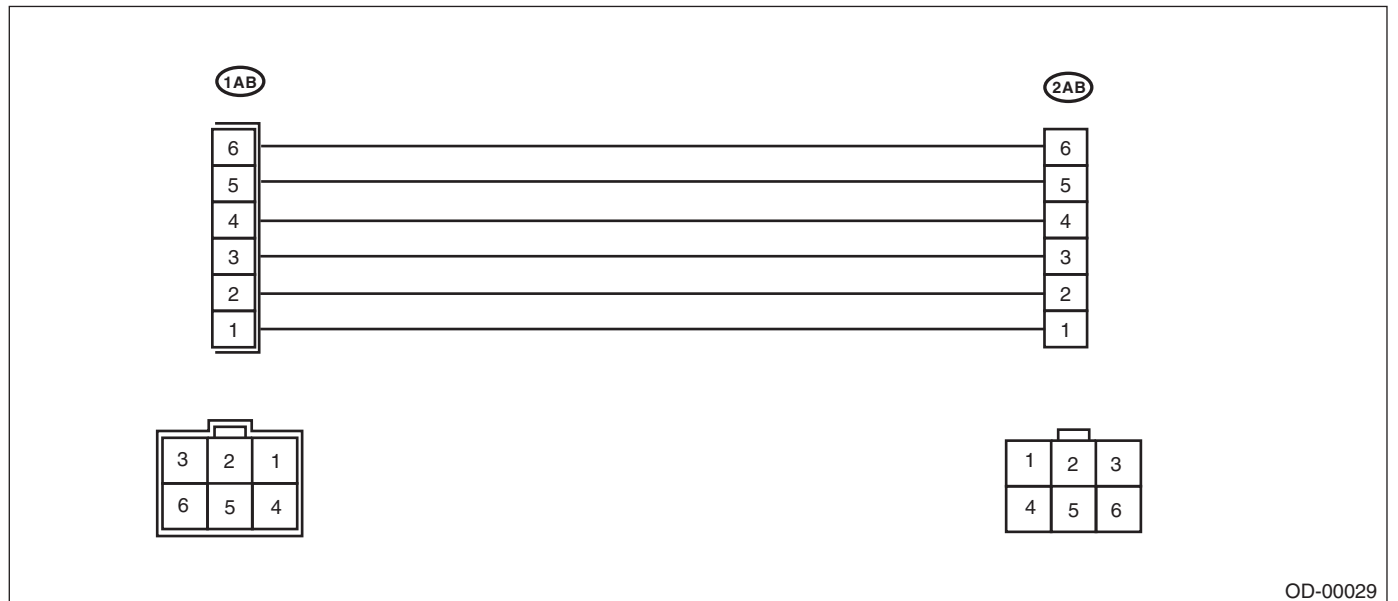

General Description

- TEST HARNESS AC

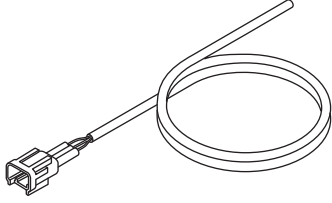
ILLUSTRATION	TOOL NUMBER	DESCRIPTION	REMARKS
 <p>ST98299XA010</p>	98299XA010	TEST HARNESS AC	Used for diagnosing seat belt tension sensor.

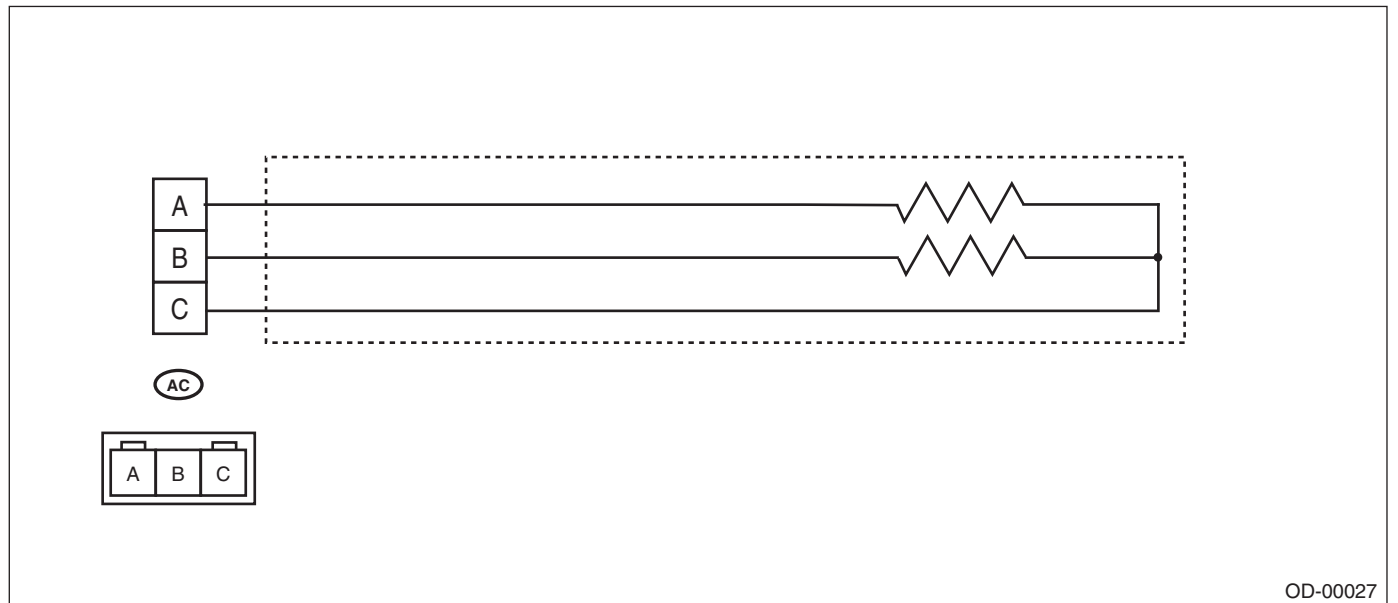

General Description

AIRBAG SYSTEM (DIAGNOSTICS)

- TEST HARNESS AD

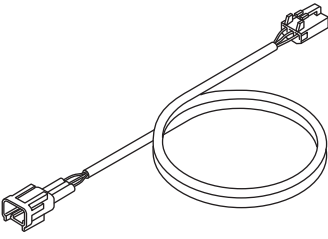
ILLUSTRATION	TOOL NUMBER	DESCRIPTION	REMARKS
 ST98299XA020	98299XA020	TEST HARNESS AD	Used when measuring voltage and resistance of the seat belt tension sensor.

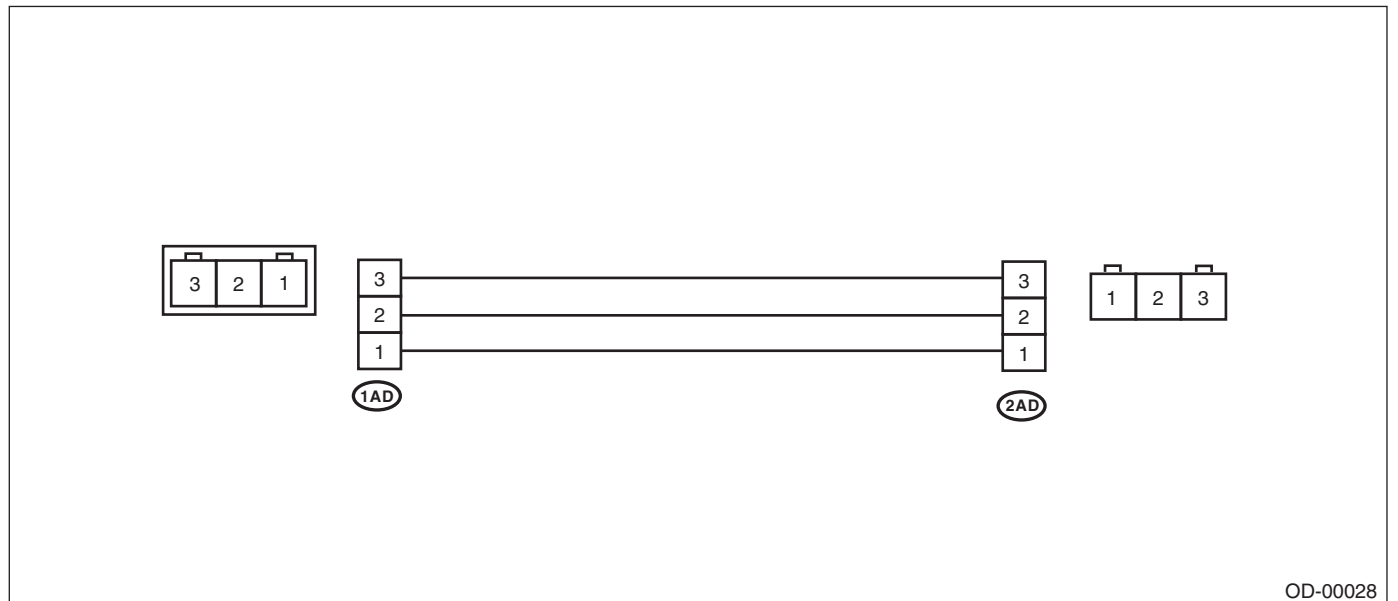

General Description

AIRBAG SYSTEM (DIAGNOSTICS)

• TEST HARNESS AE

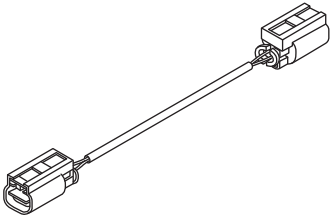
ILLUSTRATION	TOOL NUMBER	DESCRIPTION	REMARKS
 ST98299XA030	98299XA030	TEST HARNESS AE	<ul style="list-style-type: none">• Used for diagnosing seat belt tension sensor.• Used together with the test harness Y.

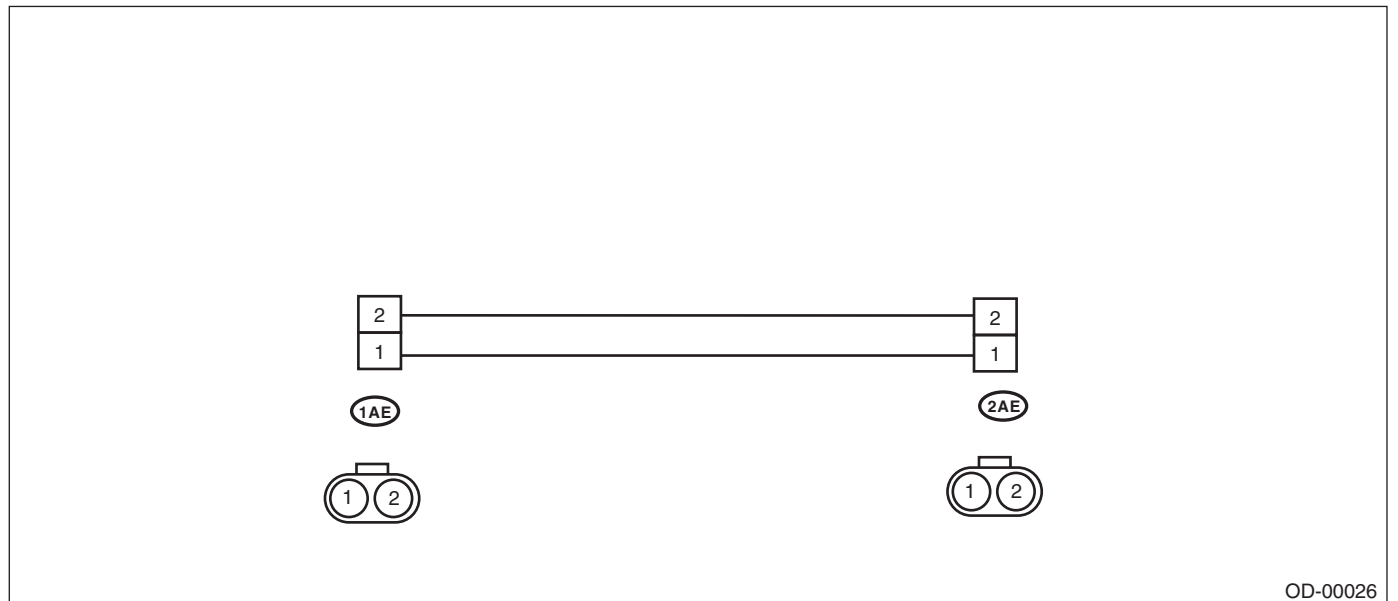

General Description

AIRBAG SYSTEM (DIAGNOSTICS)

- AIRBAG RESISTOR

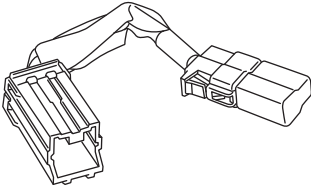
ILLUSTRATION	TOOL NUMBER	DESCRIPTION	REMARKS
 ST98299PA040	98299PA040	AIRBAG RESISTOR	Used in replacement of airbag module for which resistance value is same as airbag module. Two ST are required for diagnosis of two-stage inflator type airbag module.

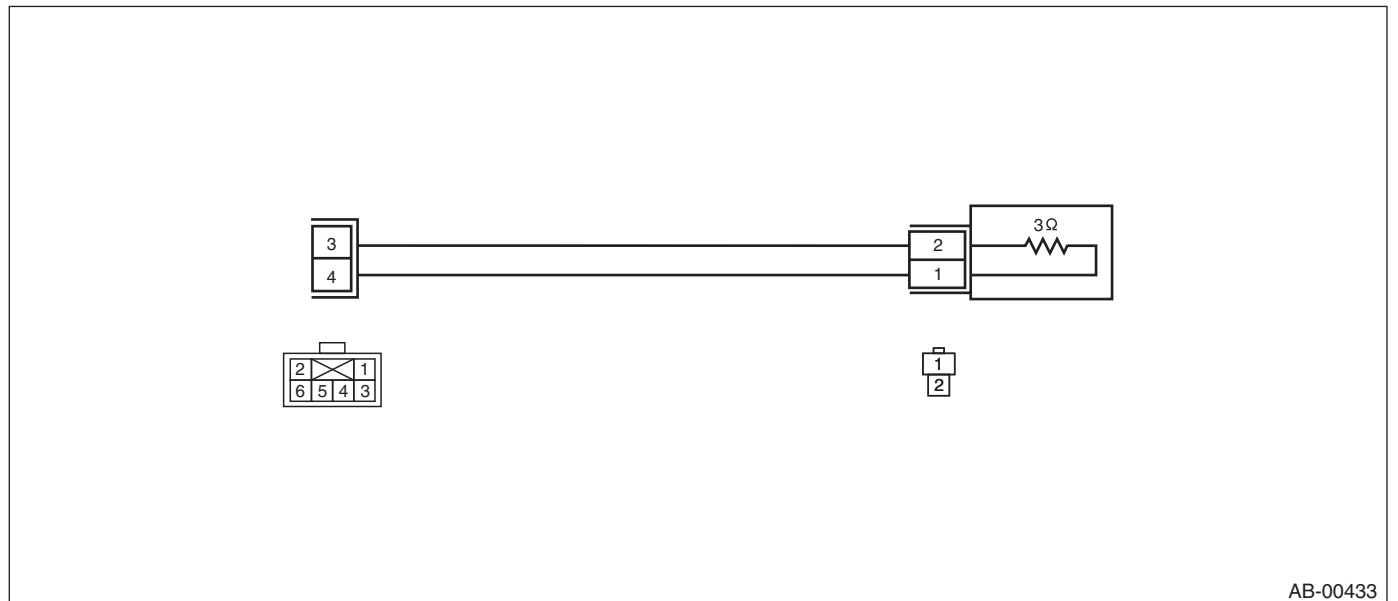

General Description

• TEST HARNESS AI

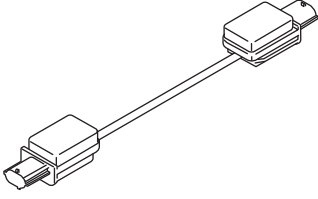
ILLUSTRATION	TOOL NUMBER	DESCRIPTION	REMARKS
 <p>ST98299AG090</p>	98299AG090	TEST HARNESS AI	<ul style="list-style-type: none"> Used when diagnosing the side airbag sensor and curtain airbag sensor. Used together with the test harness V.

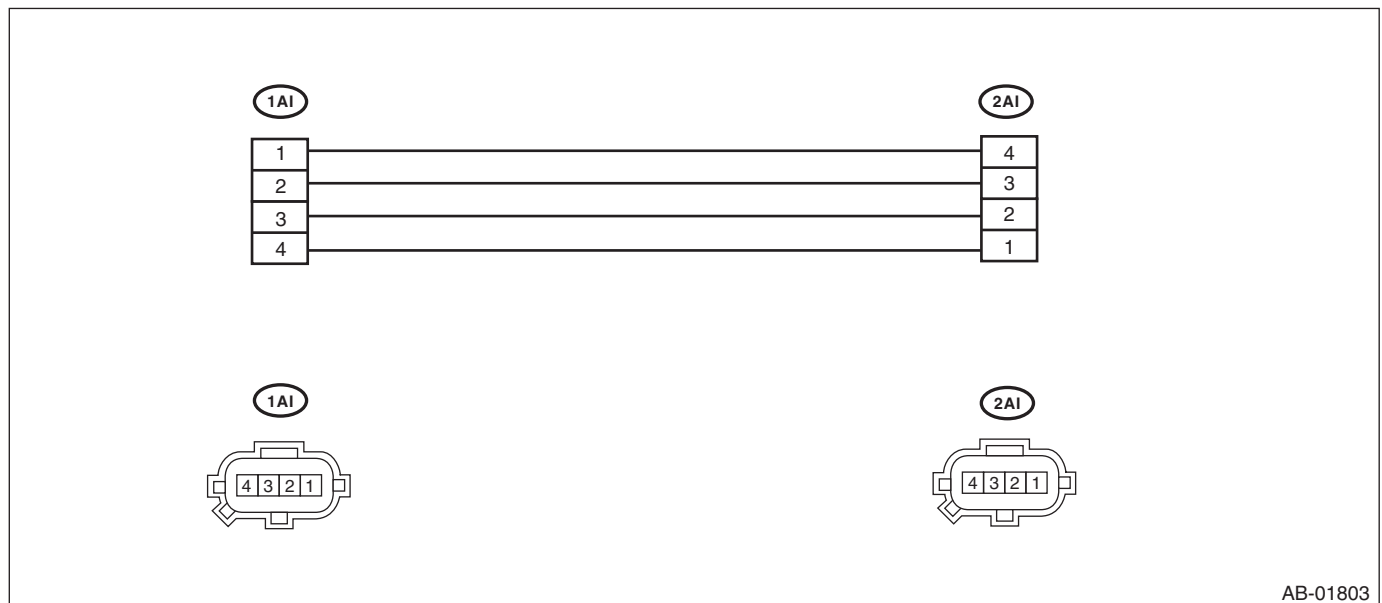

2. GENERAL TOOL

TOOL NAME	REMARKS
Circuit tester	Used for measuring resistance, voltage and current.
Oscilloscope	Used for measuring the sensor.

Electrical Component Location

AIRBAG SYSTEM (DIAGNOSTICS)

4. Electrical Component Location

A: LOCATION

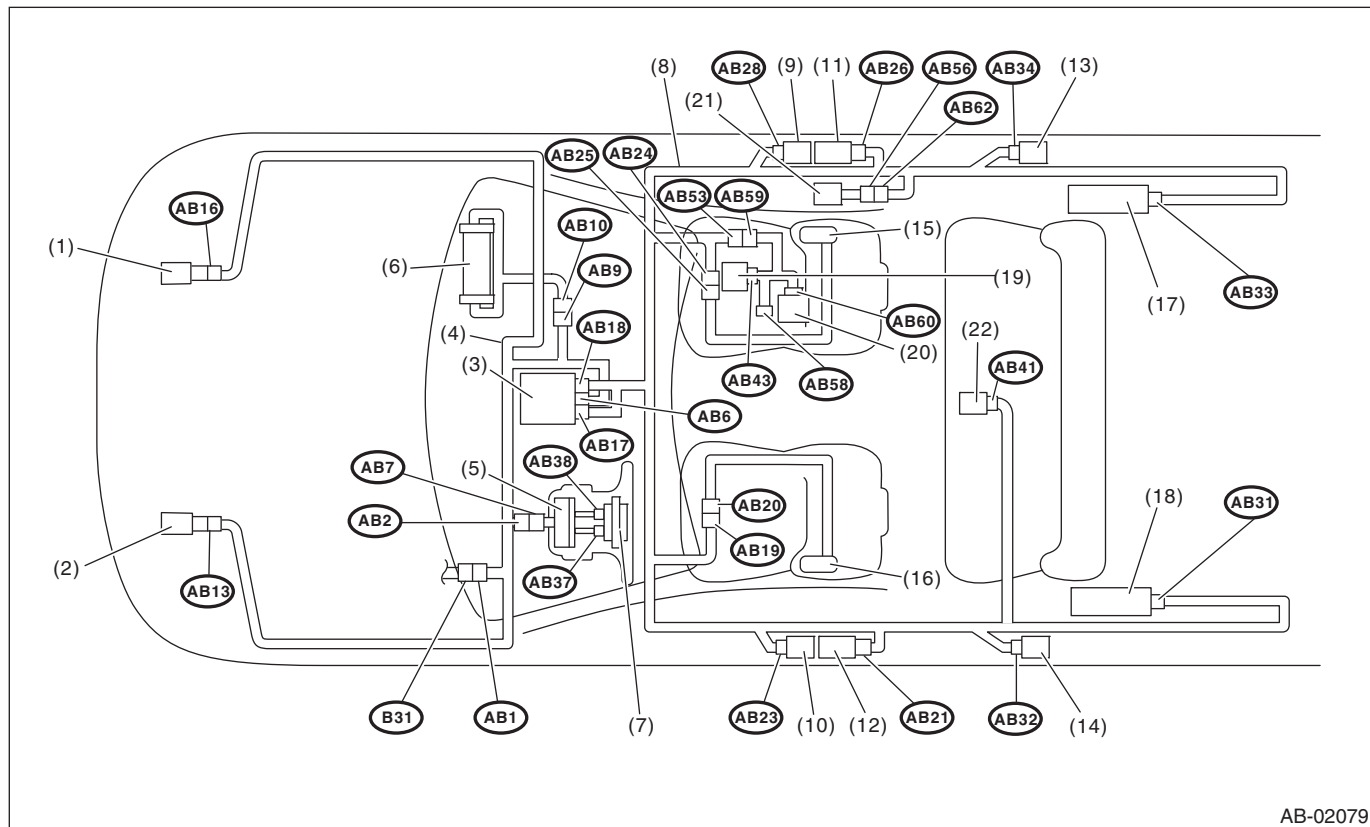

AB-02079

- | | | |
|---------------------------------|----------------------------------|--|
| (1) Front sub sensor (RH) | (9) Side airbag sensor (RH) | (16) Side airbag inflator (LH) |
| (2) Front sub sensor (LH) | (10) Side airbag sensor (LH) | (17) Curtain airbag inflator (RH) |
| (3) Airbag control module | (11) Seat belt pretensioner (RH) | (18) Curtain airbag inflator (LH) |
| (4) Airbag main harness | (12) Seat belt pretensioner (LH) | (19) Occupant detection control module |
| (5) Roll connector | (13) Curtain airbag sensor (RH) | (20) Buckle switch (RH) |
| (6) Passenger's airbag inflator | (14) Curtain airbag sensor (LH) | (21) Belt tension sensor |
| (7) Driver's airbag inflator | (15) Side airbag inflator (RH) | (22) Satellite safing sensor |
| (8) Airbag rear harness | | |

Connector No.	(AB1)	(AB2)	(AB6)	(AB7)	(AB9)	(AB10)	(AB13)	(AB16)	(AB17)	(AB18)	(AB19)	(AB20)
Pin	6	4	30	4	4	4	2	2	20	20	2	2
Color	Yellow	Yellow	Yellow	Yellow	Yellow	Yellow	Yellow	Yellow	Yellow	Yellow	Yellow	Yellow
Male/Female	Female	Female	Female	Male	Female	Male	Female	Female	Female	Female	Female	Male
Connector No.	(AB21)	(AB23)	(AB24)	(AB25)	(AB26)	(AB28)	(AB31)	(AB32)	(AB33)	(AB34)	(AB37)	(AB38)
Pin	2	4	2	2	2	4	2	4	2	4	2	2
Color	Black	Yellow	Yellow	Yellow	Black	Yellow	Black	Yellow	Black	Yellow	Orange	Black
Male/Female	Female	Female	Female	Male	Female	Female	Female	Female	Female	Female	Female	Female
Connector No.	(AB41)	(AB43)	(AB53)	(AB56)	(AB58)	(AB59)	(AB60)	(AB62)				
Pin	2	18	6	3	3	6	2	3				
Color	Yellow	Black	Gray	Brown	Gray	Gray	Yellow	Brown				
Male/Female	Female	Female	Female	Male	Female	Male	Male	Female				

5. Airbag Connector

A: PROCEDURE

<Ref. to AB-9, Airbag Connector.>

Airbag Control Module I/O Signal

AIRBAG SYSTEM (DIAGNOSTICS)

6. Airbag Control Module I/O Signal

A: ELECTRICAL SPECIFICATION

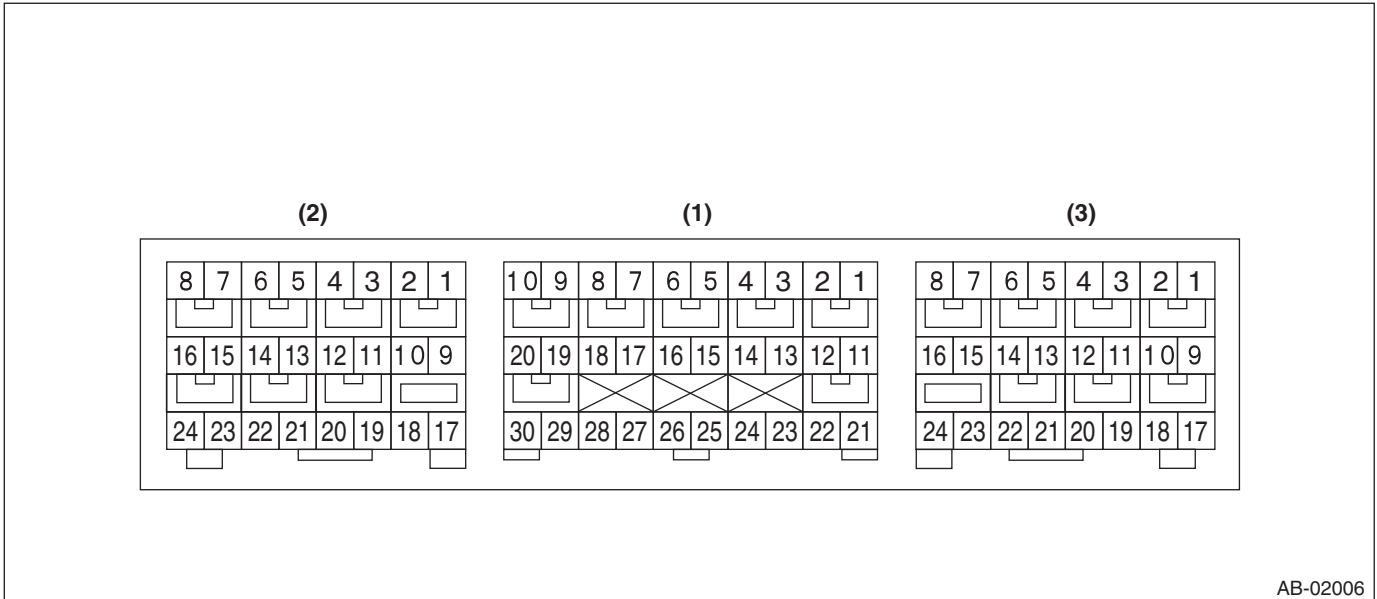

AB-02006

- Terminal numbers in airbag control module connector are shown in the figure.
- Airbag warning light illuminates when the connector is removed from airbag control module.

Airbag Control Module I/O Signal

AIRBAG SYSTEM (DIAGNOSTICS)

Item		Control module terminal No.
Data link connector		(1) — 16
Combination meter		(1) — 11
Battery power supply	Dedicated fuse	(1) — 21
Passenger's airbag module level one	+	(1) — 4
	-	(1) — 3
Passenger's airbag module level two	+	(1) — 1
	-	(1) — 2
Driver's airbag module level one	+	(1) — 5
	-	(1) — 6
Driver's airbag module level two	+	(1) — 8
	-	(1) — 7
Front sub sensor LH	+	(1) — 30
	-	(1) — 28
Front sub sensor RH	+	(1) — 29
	-	(1) — 27
Ground line (GND)		(1) — 25
		(1) — 26
Passenger's airbag OFF indicator		(1) — 17
Passenger's airbag ON indicator		(1) — 23
Passenger's seat belt warning light (integrated module)		(1) — 15
Seat belt pretensioner LH	+	(2) — 5
	-	(2) — 6
Side airbag sensor LH Curtain airbag sensor LH	+	(2) — 24
	-	(2) — 23
Side airbag module LH	+	(2) — 1
	-	(2) — 2
Curtain airbag module LH	+	(2) — 4
	-	(2) — 3
Seat belt pretensioner RH	+	(3) — 4
	-	(3) — 3
Side airbag sensor RH Curtain airbag sensor RH	+	(3) — 17
	-	(3) — 18
Side airbag module RH	+	(3) — 8
	-	(3) — 7
Curtain airbag module RH	+	(3) — 5
	-	(3) — 6
Satellite safing sensor	+	(2) — 20
	-	(2) — 21
Occupant detection control module	+	(3) — 16
	-	(3) — 24

B: WIRING DIAGRAM

Refer to the WI section wiring diagram. <Ref. to WI-90, WIRING DIAGRAM, Airbag System.>

7. Subaru Select Monitor

A: OPERATION

1) Prepare the Subaru Select Monitor kit. <Ref. to AB(diag)-8, SPECIAL TOOL, PREPARATION TOOL, General Description.>

2) Connect the diagnosis cable to the Subaru Select Monitor.

3) Connect the Subaru Select Monitor to the data link connector.

(1) Data link connector is located in the lower portion of instrument panel (on the driver's side).

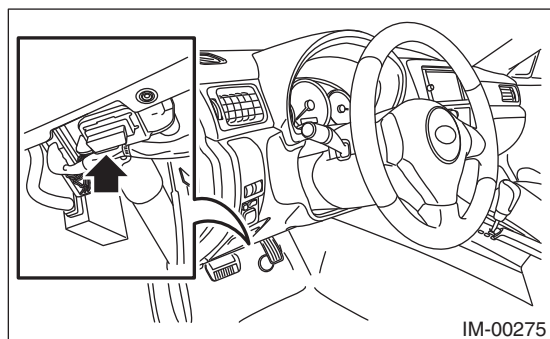

(2) Connect the diagnosis cable to the data link connector.

CAUTION:

Do not connect scan tools other than the Subaru Select Monitor.

4) Turn the ignition switch to ON (engine OFF) and run the Subaru Select Monitor.

B: INSPECTION

1. COMMUNICATION FOR INITIALIZING IMPOSSIBLE

DETECTING CONDITION:

Defective harness connector

TROUBLE SYMPTOM:

Communication is impossible between the airbag control module and the Subaru Select Monitor.

WIRING DIAGRAM:

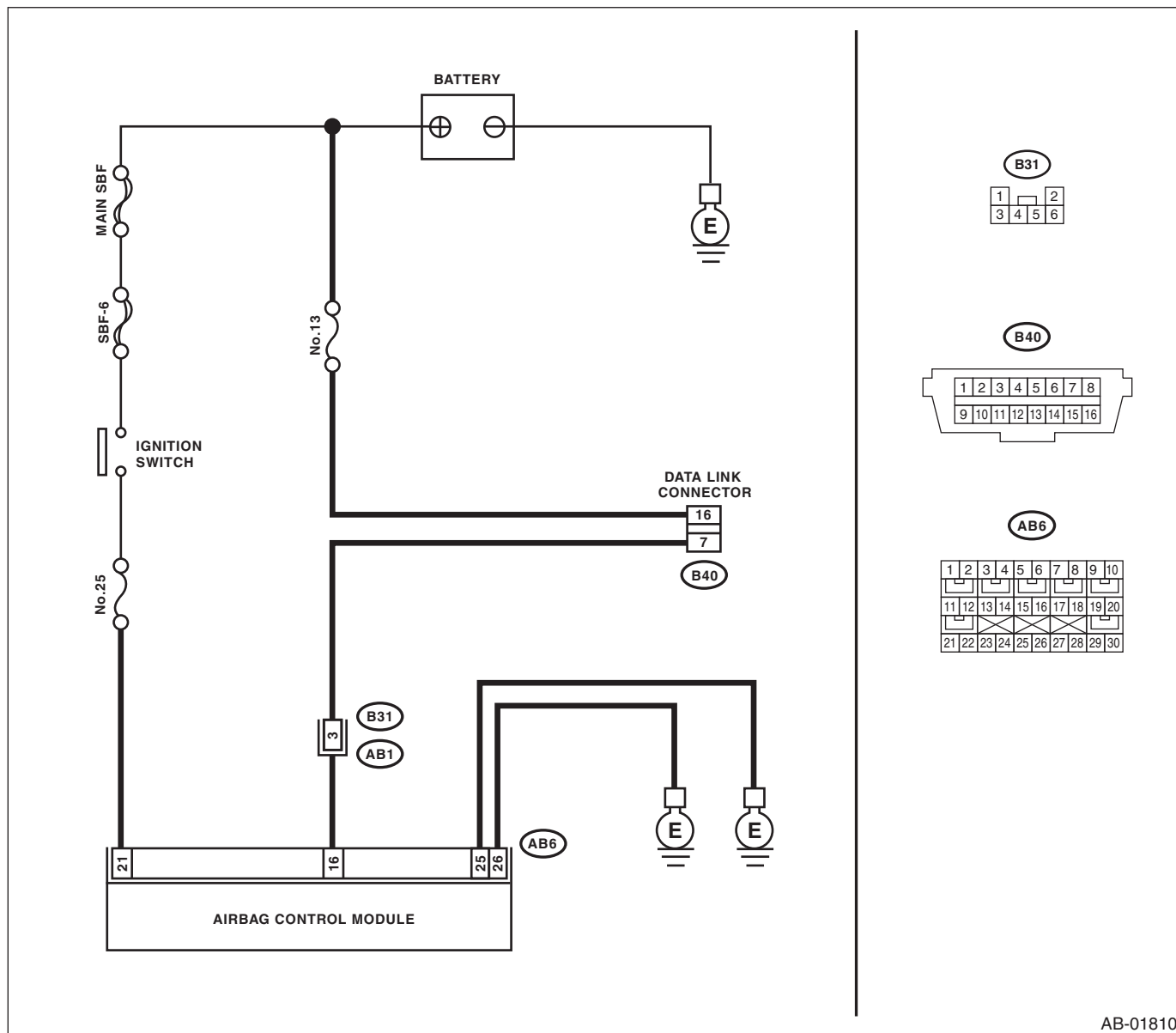

AB-01810

Subaru Select Monitor

AIRBAG SYSTEM (DIAGNOSTICS)

Step	Check	Yes	No	
1	CHECK IGNITION SWITCH.	Is the ignition switch ON?	Go to step 2.	Turn the ignition switch to ON, and select the airbag mode using the Subaru Select Monitor.
2	CHECK BATTERY. 1) Turn the ignition switch to OFF. 2) Measure the battery voltage.	Is the voltage 11 V or more?	Go to step 3.	Charge or replace the battery.
3	CHECK BATTERY TERMINAL.	Is there poor contact at battery terminal?	Tighten the battery terminal or replace it.	Go to step 4.
4	CHECK SUBARU SELECT MONITOR COMMUNICATION. 1) Turn the ignition switch to ON. 2) Using the Subaru Select Monitor, check whether communication to other systems can be performed normally.	Is the system name displayed on Subaru Select Monitor?	Go to step 10.	Go to step 5.
5	CHECK FUSE NO. 25 (IN FUSE & RELAY BOX). Remove the fuse No. 25 and perform visual inspection.	Is the fuse No. 25 (in fuse & relay box) blown out?	Replace the fuse No. 25. If fuse No. 25 is blown out again, check the power supply circuit.	Go to step 6.
6	CHECK AIRBAG CONTROL MODULE CONNECTOR. 1) Turn the ignition switch to OFF, disconnect the battery ground cable, and wait 20 seconds or more. 2) Confirm that the connectors of airbag control module (AB6, AB17, and AB18) are securely connected.	Is the connector of the airbag control module securely connected?	Go to step 7.	Connect the connector of the airbag control module.
7	CHECK SUBARU SELECT MONITOR COMMUNICATION. 1) Turn the ignition switch to OFF. 2) Disconnect the airbag control module connector. 3) Turn the ignition switch to ON. 4) Check whether communication to other systems can be executed normally.	Is the system name displayed on Subaru Select Monitor?	Replace the airbag control module. <Ref. to AB-23, Airbag Control Module.>	Go to step 8.
8	CHECK HARNESS CONNECTOR BETWEEN EACH CONTROL MODULE AND DATA LINK CONNECTOR. 1) Turn the ignition switch to OFF. 2) Disconnect the airbag control module, ABSCM&H/U, ECM and TCM. 3) Measure the resistance between data link connector and chassis ground. Connector & terminal (B40) No. 7 — Chassis ground:	Is the resistance 1 M Ω or more?	Go to step 9.	Repair the harness and connector between each control module and data link connector. (Replace the entire harness if repair is necessary for airbag harness.)

Subaru Select Monitor

AIRBAG SYSTEM (DIAGNOSTICS)

Step	Check	Yes	No
<p>9 CHECK OUTPUT SIGNAL TO THE AIRBAG CONTROL MODULE.</p> <p>1) Turn the ignition switch to ON in the condition of step 8.</p> <p>2) Measure the voltage between data link connector and chassis ground.</p> <p>Connector & terminal (B40) No. 7 (+) — Chassis ground (-):</p>	Is the voltage less than 1 V?	Go to step 10.	Repair the harness and connector between each control module and data link connector. (Replace the entire harness if repair is necessary for airbag harness.)
<p>10 CHECK THE HARNESS BETWEEN THE AIRBAG CONTROL MODULE AND DATA LINK CONNECTOR.</p> <p>1) Turn the ignition switch to OFF, disconnect the battery ground cable, and wait for 20 seconds or more.</p> <p>2) Disconnect the connectors (AB6, AB17, and AB18) from airbag control module.</p> <p>3) Connect the connector (1AG) in the test harness AG to the connectors (AB6, AB17, and AB18).</p> <p>4) Measure the resistance between connector (4AG) in the test harness AG and the data link connector.</p> <p>Connector & terminal (4AG) No. 1 — (B40) No. 7:</p>	Is the resistance less than 10 Ω?	Go to step 11.	Repair the harness between the airbag control module and the data link connector. Or replace the airbag main harness along with the bulkhead harness.
<p>11 CHECK POWER SUPPLY CIRCUIT.</p> <p>1) Turn the ignition switch to ON.</p> <p>2) Measure the voltage between connector (2AG) in the test harness AG and chassis ground.</p> <p>Connector & terminal (2AG) No. 1 — Chassis ground:</p>	Is the voltage 10 V or more?	Go to step 12.	Repair the harness between the airbag control module and the battery. Or replace the airbag main harness along with the bulkhead harness.
<p>12 CHECK BETWEEN THE AIRBAG CONTROL MODULE AND CHASSIS GROUND.</p> <p>1) Turn the ignition switch to OFF.</p> <p>2) Measure the resistance between connector (2AG) in the test harness AG and chassis ground.</p> <p>Connector & terminal (2AG) No. 4 — Chassis ground: (2AG) No. 3 — Chassis ground:</p>	Is the resistance less than 10 Ω?	Go to step 13.	Repair the harness between the airbag control module and the chassis ground. Or replace the airbag main harness along with the bulkhead harness.
<p>13 CHECK POOR CONTACT IN CONNECTOR.</p>	Is there poor contact in the control module power supply, ground circuit and data link connector?	Repair the connector. (For airbag system connectors, do not repair but replace the entire harness.)	Replace the airbag control module only. <Ref. to AB-23, REMOVAL, Airbag Control Module.>

Read Diagnostic Trouble Code (DTC)

AIRBAG SYSTEM (DIAGNOSTICS)

8. Read Diagnostic Trouble Code (DTC)

A: OPERATION

When malfunction of airbag system occurs, the DTC stored in airbag control module will be read out.

- 1) On the «Main Menu», select {Each System Check}.
- 2) On the «System Selection Menu», select {Airbag System}.
- 3) After {Airbag System} is displayed, select [OK].
- 4) Select the {Diagnostic Code(s) Display} in «Airbag System».
- 5) Record the DTC displayed.

NOTE:

- For details concerning the operation procedure, refer to the “PC application help for Subaru Select Monitor”.
- For details concerning DTCs, refer to “List of Diagnostic Trouble Code (DTC)”. <Ref. to AB(diag)-40, List of Diagnostic Trouble Code (DTC).>
- If “No diagnostic Code Present” is displayed, the combination meter fault or the open circuit of harness is possible. For the diagnostic procedure, refer to <Ref. to AB(diag)-35, Airbag Warning Light Failure.>.
- When the airbag warning light is OFF and “No diagnostic Code Present” is displayed on Subaru Select Monitor, the airbag system is operating properly.

9. Inspection Mode

A: PROCEDURE

Recreate the circumstance by referring to the conditions described in the checklist.

10. Clear Memory Mode

A: OPERATION

Clear the DTC stored in the airbag control module after repairing the airbag system. (After the breakdown is recovered, the breakdown code for completed recoveries are read out when the next breakdown occurs if the memory clear work is not performed.)

- 1) On the «Main Menu», select {Each System Check}.
- 2) On the «System Selection Menu», select {Airbag System}.
- 3) Select the {Clear Memory} in «Airbag System».
- 4) When the “Clear Memory?” is shown on the screen, select the [OK].
- 5) When “Done” is displayed, end the Subaru Select Monitor.
- 6) When “Done” and “Turn OFF the ignition switch” are shown on the display screen, turn the ignition switch to OFF.

NOTE:

- For details concerning the operation procedure, refer to the “PC application help for Subaru Select Monitor”.
- After the memory is cleared, initial diagnosis of the electronic throttle control is performed. Therefore, start the engine 10 seconds or more after have turning the ignition switch to ON.

11. Display of Status Information

A: OPERATION

Check the operating condition of each sensor in the event of malfunction in the seat belt buckle switch, or when the seat belt buckle switch has been replaced.

- 1) On the «Main Menu», select {Each System Check}.
- 2) On the «System Selection Menu», select {Airbag System}.
- 3) Select the {Status Data} in «Airbag System».

The following table is for support data.

Item	Display
Seat position sensor LH	— ^{*5}
Seat position sensor RH	— ^{*5}
Seat belt buckle switch LH	— ^{*9}
Seat belt buckle switch RH	Belted ^{*6} /Unbelted ^{*7} /Other ^{*8} /Initial Setting ^{*4} /— ^{*9}
Passenger's airbag control status	ON ^{*10} /OFF ^{*11} /Initial Setting ^{*4}

*1: The seat position is forward.

*2: The seat position is rearward.

*3: Displayed when data other than before and behind the seat, such as the breakdown etc, is input.

*4: Displayed when it is initial.

*5: Seat position sensor not supported

*6: Seat belt fastened

*7: Seat belt not fastened

*8: Displayed when data other than belt fastened or not fastened, such as breakdowns is input.

*9: Seat belt buckle switch not supported

*10: Passenger's airbag operating state

*11: Passenger's airbag non-operating state

NOTE:

For details concerning the operation procedure, refer to the "PC application help for Subaru Select Monitor".

Airbag Warning Light Illumination Pattern

AIRBAG SYSTEM (DIAGNOSTICS)

12. Airbag Warning Light Illumination Pattern

A: INSPECTION

Turn the ignition switch to ON, and confirm that the airbag warning light remains on for approx. 6 seconds and then goes off afterwards.

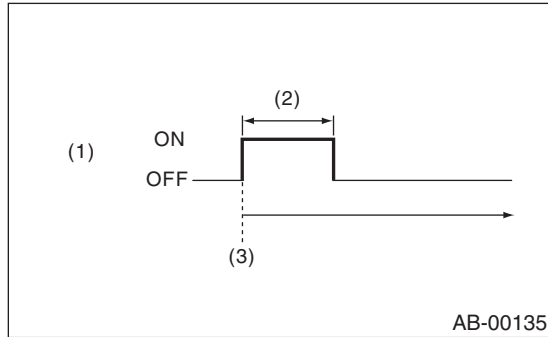

- (1) Airbag warning light
- (2) Approx. 6 sec.
- (3) Ignition switch ON

13. Airbag Warning Light Failure

A: AIRBAG WARNING LIGHT REMAINS ON

DETECTING CONDITION:

- Airbag warning light is faulty.
- Airbag control module to airbag warning light circuit is shorted or open.
- Grounding circuit is faulty.
- Airbag control module is faulty.
- Connection of (AB1) and (B31) is improper.
- Connection of (AB6, AB17, and AB18) to airbag control module is improper.

CAUTION:

- Before diagnosing the airbag system, be sure to turn the ignition switch to OFF, disconnect the ground terminal from the battery, and wait 20 seconds or more before starting to work.
- When replacing the airbag module, seat belt pretensioner, roll connector, control module and sensor, reconnect each part and check that the warning light operates properly.
- When inspecting the airbag main harness, disconnect the airbag module connectors of the driver's and passenger's seats for safety.
- When inspecting the airbag rear harness, disconnect the side airbag module connector, curtain airbag module connector and seat belt pretensioner connector for safety reasons.

WIRING DIAGRAM:

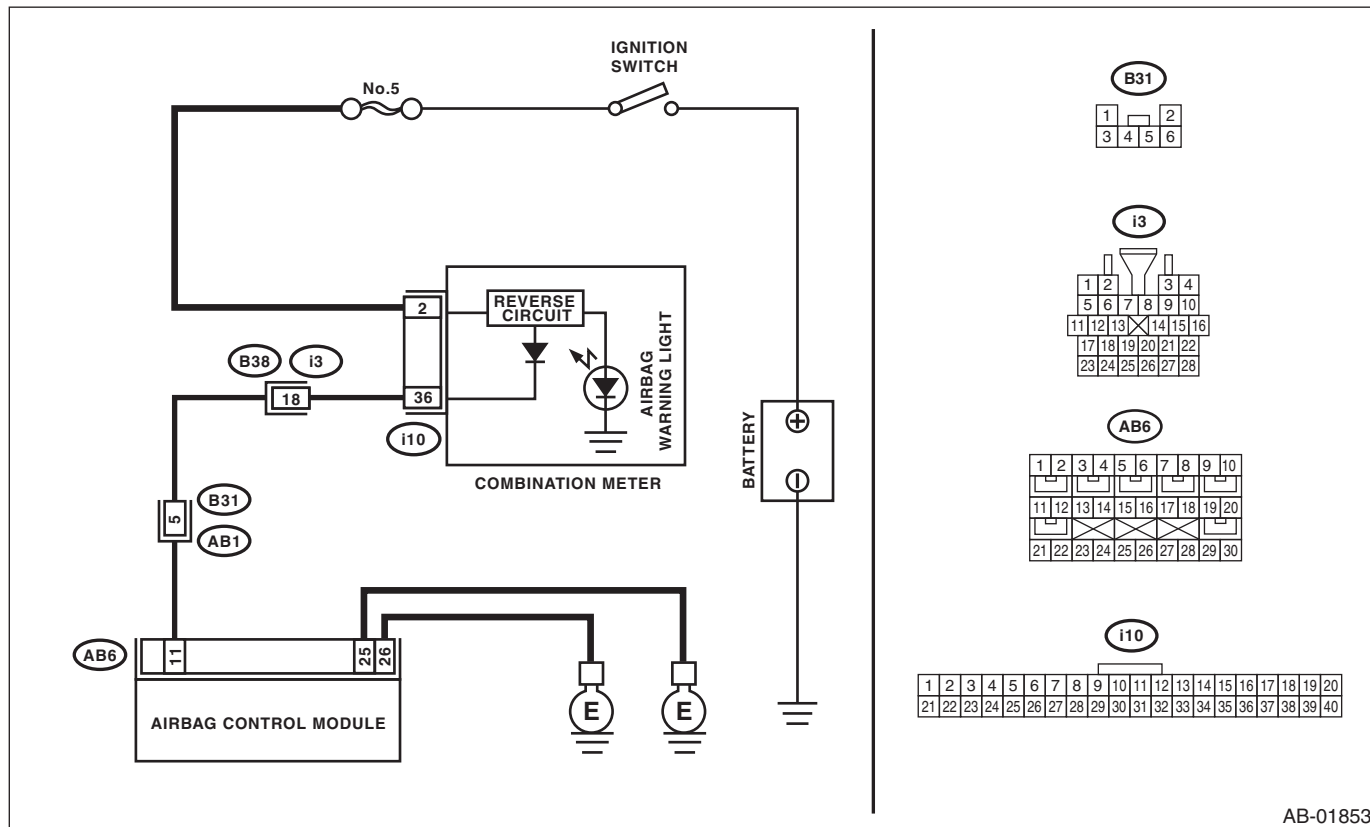

AB-01853

Airbag Warning Light Failure

AIRBAG SYSTEM (DIAGNOSTICS)

Step	Check	Yes	No
1 READ DTC. Read the DTC. <Ref. to AB(diag)-30, OPERATION, Read Diagnostic Trouble Code (DTC).>	Is DTC displayed?	Perform the diagnosis according to DTC.	Go to step 2.
2 CHECK POOR CONTACT. 1) Turn the ignition switch to OFF, disconnect the battery ground cable, and wait for 20 seconds or more. 2) Confirm that the connectors of airbag control module (AB6, AB17, and AB18) are securely connected.	Is there poor contact in connectors (AB6, AB17, and AB18)?	If the poor contact of the connector is not fixed, replace the airbag main harness along with body harness or replace the airbag control module. <Ref. to AB-23, Airbag Control Module.>	Go to step 3.
3 CHECK AIRBAG MAIN HARNESS. 1) Remove the instrument panel lower cover and disconnect the connectors (AB7) and (AB2). 2) Remove the console front panel and disconnect the connectors (AB10) and (AB9). 3) Disconnect the connectors (AB6, AB17, and AB18) from the airbag control module, and connect the connector (1AG) in the test harness AG. 4) Connect the battery ground terminal and turn the ignition switch to ON. 5) Connect the connectors (7AG) and (8AG) in the test harness AG. NOTE: After the fault has been cleared, disconnect the connectors (7AG) and (8AG).	Does the airbag warning light go off?	Go to step 4.	Go to step 5.
4 CHECK GROUND CIRCUIT. 1) Turn the ignition switch to OFF, disconnect the battery ground cable, and wait for 20 seconds or more. 2) Disconnect the connectors (AB6, AB17, and AB18) from airbag control module. 3) Connect the connector (1AG) in the test harness AG to the body harness connectors (AB6, AB17, and AB18). 4) Measure the resistance between connector (2AG) in the test harness AG and chassis ground. <i>Connector & terminal</i> <i>(2AG) No. 4 — Chassis ground:</i> <i>(2AG) No. 3 — Chassis ground:</i>	Is the resistance less than 10 Ω?	Replace the airbag control module. <Ref. to AB-23, Airbag Control Module.>	Repair the chassis ground circuit.
5 CHECK AIRBAG MAIN HARNESS AND BULKHEAD HARNESS. 1) Disconnect the connectors (7AG) and (8AG). 2) Remove the combination meter. 3) Measure the resistance between the combination meter connector and test harness AG connector (2AG). <i>Connector & terminal</i> <i>(2AG) No. 5 — (i10) No. 36:</i>	Is the resistance less than 10 Ω?	Check the combination meter.	Go to step 6.

Airbag Warning Light Failure

AIRBAG SYSTEM (DIAGNOSTICS)

Step	Check	Yes	No
6 CHECK POOR CONTACT OF CONNECTORS (AB1) AND (B31). 1) Turn the ignition switch to OFF, disconnect the battery ground terminal, and wait 20 seconds or more. 2) Confirm that there is a firm contact between connectors (AB1) and (B31).	Is there poor contact in connectors (AB1) and (B31)?	Repair the bulkhead harness or replace the airbag main harness along with body harness.	Go to step 7.
7 CHECK AIRBAG MAIN HARNESS. Check the airbag main harness for defect.	Is there any defect in the airbag main harness?	Replace the airbag main harness along with bulkhead harness.	Repair the bulkhead harness.

Airbag Warning Light Failure

AIRBAG SYSTEM (DIAGNOSTICS)

B: AIRBAG WARNING LIGHT REMAINS OFF

DETECTING CONDITION:

- Fuse No. 5 (in fuse box) is blown out.
- Body harness circuit is open.
- Airbag warning light is faulty.
- Airbag main harness is faulty.
- Airbag control module is faulty.

CAUTION:

- Before diagnosing the airbag system, be sure to turn the ignition switch to OFF, disconnect the ground terminal from the battery, and wait 20 seconds or more before starting to work.
- When replacing the airbag module, seat belt pretensioner, roll connector, control module and sensor, reconnect each part and check that the warning light operates properly.
- When inspecting the airbag main harness, disconnect the airbag module connectors of the driver's and passenger's seats for safety.
- When inspecting the airbag rear harness, disconnect the side airbag module connector, curtain airbag module connector and seat belt pretensioner connector for safety reasons.

WIRING DIAGRAM:

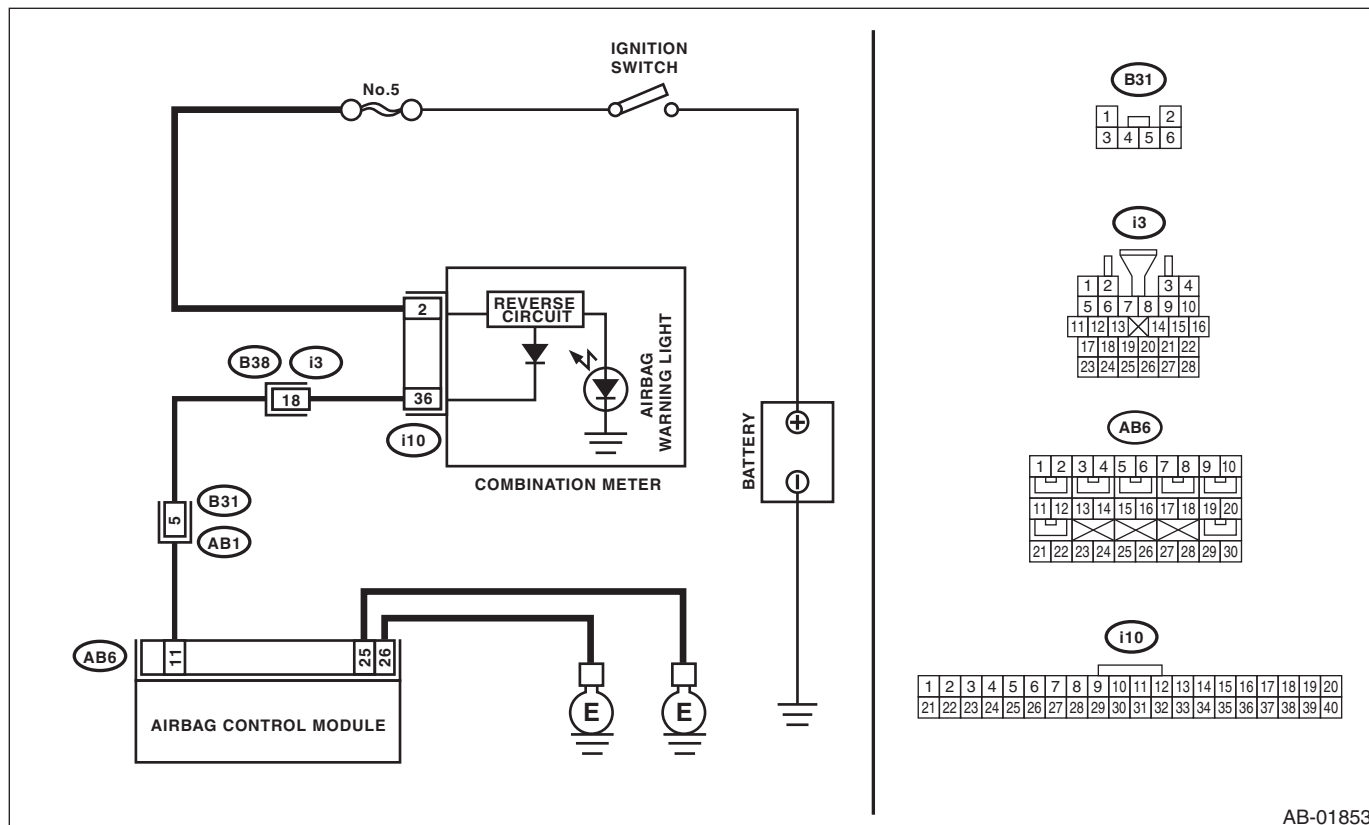

AB-01853

Airbag Warning Light Failure

AIRBAG SYSTEM (DIAGNOSTICS)

Step	Check	Yes	No
1 CHECK COMBINATION METER. Turn the ignition switch to ON, and confirm that warning light of combination meter illuminates.	Do warning lights except for airbag illuminate?	Go to step 2.	Check the combination meter.
2 CHECK DTC. Read the DTC. <Ref. to AB(diag)-30, OPERATION, Read Diagnostic Trouble Code (DTC).>	Is DTC displayed?	Perform the diagnosis according to DTC.	Go to step 3.
3 CHECK FUSE NO. 5 (IN MAIN FUSE BOX). Remove the fuse No. 5 and perform visual inspection.	Is the fuse No. 5 (in main fuse box) blown out?	Replace the fuse No. 5. If the fuse No. 5 is blown out again, go to step 4.	Go to step 4.
4 CHECK AIRBAG WARNING LIGHT CIRCUIT (IN COMBINATION METER). 1) Turn the ignition switch to OFF, disconnect the battery ground cable, and wait for 20 seconds or more. 2) Disconnect the connectors (AB1) and (B31). 3) Connect the battery ground terminal and turn the ignition switch to ON.	Does airbag warning light illuminate?	Go to step 5.	Check the combination meter.
5 CHECK AIRBAG MAIN HARNESS. 1) Turn the ignition switch to OFF, disconnect the battery ground cable, and wait for 20 seconds or more. 2) Connect the connector (AB1) and (B31). 3) Disconnect the connectors (AB6, AB17, and AB18) from airbag control module. 4) Connect the battery ground terminal and turn the ignition switch to ON.	Does airbag warning light illuminate?	Replace the airbag control module. <Ref. to AB-23, Airbag Control Module.>	Replace the airbag main harness along with bulkhead harness.

List of Diagnostic Trouble Code (DTC)

AIRBAG SYSTEM (DIAGNOSTICS)

14. List of Diagnostic Trouble Code (DTC)

A: LIST

DTC	Display	Diagnosis content	Reference
11	Driver's Airbag failure	<ul style="list-style-type: none"> • Airbag main harness circuit is open, shorted or shorted to ground. • Airbag module harness (Driver's side) circuit is open, shorted or shorted to ground. • Roll connector circuit is open, shorted or shorted to ground. • Airbag control module is faulty. • Driver's airbag module is faulty. 	<Ref. to AB(diag)-46, DTC 11 DRIVER'S AIRBAG FAILURE, Diagnostic Chart with Trouble Code.>
12	Passenger's Airbag failure	<ul style="list-style-type: none"> • Airbag main harness circuit is open, shorted or shorted to ground. • Airbag module harness (Passenger's side) circuit is open, shorted or shorted to ground. • Airbag control module is faulty. • Passenger's airbag module is faulty. 	<Ref. to AB(diag)-49, DTC 12 PASSENGER'S AIRBAG FAILURE, Diagnostic Chart with Trouble Code.>
15	Driver's Airbag failure	<ul style="list-style-type: none"> • Airbag main harness circuit (Driver's side) is shorted to power supply. • Airbag module harness circuit (Driver's side) is shorted to power supply. • Roll connector is shorted to power supply. • Airbag control module is faulty. • Driver's airbag module is faulty. 	<Ref. to AB(diag)-51, DTC 15 DRIVER'S AIRBAG FAILURE, Diagnostic Chart with Trouble Code.>
16	Passenger's Airbag failure	<ul style="list-style-type: none"> • Airbag main harness circuit (Passenger's side) is shorted to power supply. • Airbag module harness circuit (Passenger's side) is shorted to power supply. • Airbag control module is faulty. • Passenger's airbag module is faulty. 	<Ref. to AB(diag)-54, DTC 16 PASSENGER'S AIRBAG FAILURE, Diagnostic Chart with Trouble Code.>
21	Airbag ECU failure	Airbag control module is faulty.	<Ref. to AB(diag)-56, DTC 21 AIRBAG ECM FAILURE, Diagnostic Chart with Trouble Code.>
22	Front Airbag: Firing output	Front airbag module and seat belt pretensioner (LH/RH) are inflated.	<Ref. to AB(diag)-57, DTC 22 FRONT AIRBAG FIRING OUTPUT, Diagnostic Chart with Trouble Code.>
26	Passenger's Airbag indicator failure	<ul style="list-style-type: none"> • Passenger's airbag indicator is faulty. • Airbag control module is faulty. • Airbag main harness circuit is open, shorted or shorted to ground. • Body harness circuit is open. 	<Ref. to AB(diag)-58, DTC 26 PASSENGER'S AIRBAG INDICATOR FAILURE, Diagnostic Chart with Trouble Code.>
27	ODS Communication error	<ul style="list-style-type: none"> • Occupant detection control module communication is faulty. • Airbag rear harness circuit is open, shorted, shorted to ground or shorted to power supply. • Occupant detection harness is faulty. • Airbag control module is faulty. • Occupant detection system is faulty. 	<Ref. to AB(diag)-60, DTC 27 ODS COMMUNICATION ERROR, Diagnostic Chart with Trouble Code.>
29	ODS failure	<ul style="list-style-type: none"> • Occupant detection sensor is faulty. • Occupant detection control module is faulty. • Occupant detection harness is faulty. • Fuse No. 25 (in joint box) is blown. 	Refer to "Occupant Detection System" for details on DTC 29. <Ref. to OD(diag)-26, DTC 29 ODS FAILURE, Diagnostic Procedure with Diagnostic Trouble Code (DTC).>

List of Diagnostic Trouble Code (DTC)

AIRBAG SYSTEM (DIAGNOSTICS)

DTC	Display	Diagnosis content	Reference
2A	ODS Calibration error	System calibration (Rezeroing) of the occupant detection system was not ended normally.	Refer to "Occupant Detection System" for details on DTC 2A. <Ref. to OD(diag)-23, DTC 2A ODS CALIBRATION ERROR, Diagnostic Procedure with Diagnostic Trouble Code (DTC).>
2B	ODS System wrong parts	<ul style="list-style-type: none"> • Wrong airbag control module was installed. • Wrong occupant detection system was installed. • Occupant detection system is faulty. 	Refer to "Occupant Detection System" for details on DTC 2B. <Ref. to OD(diag)-23, DTC 2B ODS SYSTEM WRONG PARTS, Diagnostic Procedure with Diagnostic Trouble Code (DTC).>
2C	Belt tension Sensor failure	<ul style="list-style-type: none"> • Passenger's seat belt tension sensor is faulty. • Occupant detection system is faulty. • Airbag rear harness circuit is open, shorted, shorted to ground or shorted to power supply. • Occupant detection harness is faulty. 	Refer to "Occupant Detection System" for details on DTC 2C. <Ref. to OD(diag)-24, DTC 2C BELT TENSION SENSOR FAILURE, Diagnostic Procedure with Diagnostic Trouble Code (DTC).>
33	Front Sub Sensor RH failure	Front sub sensor (RH) is faulty.	<Ref. to AB(diag)-61, DTC 33 FRONT SUB SENSOR RH FAILURE, Diagnostic Chart with Trouble Code.>
34	Front Sub Sensor LH failure	Front sub sensor (LH) is faulty.	<Ref. to AB(diag)-61, DTC 34 FRONT SUB SENSOR LH FAILURE, Diagnostic Chart with Trouble Code.>
37	Buckle Switch RH failure	<ul style="list-style-type: none"> • Passenger's buckle switch circuit is open, shorted or shorted to ground. • Occupant detection system is faulty. • Occupant detection harness is faulty. 	Refer to "Occupant Detection System" for details on DTC 37. <Ref. to OD(diag)-27, DTC 37 BUCKLE SWITCH RH FAILURE, Diagnostic Procedure with Diagnostic Trouble Code (DTC).>
39	Seatbelt Warning failure	<ul style="list-style-type: none"> • Airbag control module is faulty. • Body integrated unit is faulty. • Harness circuits between body integrated unit and airbag control module are open, shorted or shorted to ground. 	<Ref. to AB(diag)-62, DTC 39 SEAT BELT WARNING FAILURE, Diagnostic Chart with Trouble Code.>
41	Side Airbag RH failure	<ul style="list-style-type: none"> • Side airbag harness (RH) circuit is faulty. • Side airbag module (RH) is faulty. • Airbag control module is faulty. 	<Ref. to AB(diag)-64, DTC 41 SIDE AIRBAG RH FAILURE, Diagnostic Chart with Trouble Code.>
42	Side Airbag LH failure	<ul style="list-style-type: none"> • Side airbag harness (LH) circuit is faulty. • Side airbag module (LH) is faulty. • Airbag control module is faulty. 	<Ref. to AB(diag)-66, DTC 42 SIDE AIRBAG LH FAILURE, Diagnostic Chart with Trouble Code.>
45	Side Airbag RH failure	<ul style="list-style-type: none"> • Side airbag harness (RH) is shorted to power supply. • Airbag control module is faulty. 	<Ref. to AB(diag)-68, DTC 45 SIDE AIRBAG RH FAILURE, Diagnostic Chart with Trouble Code.>
46	Side Airbag LH failure	<ul style="list-style-type: none"> • Side airbag harness (LH) is shorted to power supply. • Airbag control module is faulty. 	<Ref. to AB(diag)-70, DTC 46 SIDE AIRBAG LH FAILURE, Diagnostic Chart with Trouble Code.>

List of Diagnostic Trouble Code (DTC)

AIRBAG SYSTEM (DIAGNOSTICS)

DTC	Display	Diagnosis content	Reference
53	Side Airbag Sensor RH failure	Side airbag sensor (RH) is faulty.	<Ref. to AB(diag)-72, DTC 53 SIDE AIRBAG SENSOR RH FAILURE, Diagnostic Chart with Trouble Code.>
54	Side Airbag Sensor LH failure	Side airbag sensor (LH) is faulty.	<Ref. to AB(diag)-72, DTC 54 SIDE AIRBAG SENSOR LH FAILURE, Diagnostic Chart with Trouble Code.>
55	Side/Curtain Airbag: Firing output	<ul style="list-style-type: none"> • Side airbag module and curtain airbag module are deployed. • Curtain airbag module is deployed. 	<Ref. to AB(diag)-72, DTC 55 SIDE CURTAIN AIRBAG FIRING OUTPUT, Diagnostic Chart with Trouble Code.>
58	Curtain Airbag Sensor RH failure	Curtain airbag sensor (RH) is faulty.	<Ref. to AB(diag)-72, DTC 58 CURTAIN AIRBAG SENSOR RH FAILURE, Diagnostic Chart with Trouble Code.>
59	Curtain Airbag Sensor LH failure	Curtain airbag sensor (LH) is faulty.	<Ref. to AB(diag)-72, DTC 59 CURTAIN AIRBAG SENSOR LH FAILURE, Diagnostic Chart with Trouble Code.>
61	Belt Pretensioner RH failure	<ul style="list-style-type: none"> • Seat belt pretensioner (RH) circuit is open, shorted or shorted to ground. • Airbag control module is faulty. • Pretensioner is faulty. • Pretensioner harness is faulty. 	<Ref. to AB(diag)-73, DTC 61 BELT PRETENSIONER RH FAILURE, Diagnostic Chart with Trouble Code.>
62	Belt Pretensioner LH failure	<ul style="list-style-type: none"> • Seat belt pretensioner (LH) circuit is open, shorted or shorted to ground. • Airbag control module is faulty. • Pretensioner is faulty. • Pretensioner harness is faulty. 	<Ref. to AB(diag)-75, DTC 62 BELT PRETENSIONER LH FAILURE, Diagnostic Chart with Trouble Code.>
65	Belt Pretensioner RH failure	<ul style="list-style-type: none"> • Seat belt pretensioner (RH) circuit is shorted to power supply. • Pretensioner is faulty. • Pretensioner harness is faulty. • Airbag control module is faulty. 	<Ref. to AB(diag)-77, DTC 65 BELT PRETENSIONER RH FAILURE, Diagnostic Chart with Trouble Code.>
66	Belt Pretensioner LH failure	<ul style="list-style-type: none"> • Seat belt pretensioner (LH) circuit is shorted to power supply. • Pretensioner is faulty. • Pretensioner harness is faulty. • Airbag control module is faulty. 	<Ref. to AB(diag)-79, DTC 66 BELT PRETENSIONER LH FAILURE, Diagnostic Chart with Trouble Code.>
71	Driver's Airbag failure	<ul style="list-style-type: none"> • Airbag main harness circuit is open, shorted or shorted to ground. • Airbag module harness (Driver's side) circuit is open, shorted or shorted to ground. • Roll connector circuit is open, shorted or shorted to ground. • Airbag control module is faulty. • Driver's airbag module is faulty. 	<Ref. to AB(diag)-81, DTC 71 DRIVER'S AIRBAG FAILURE, Diagnostic Chart with Trouble Code.>
72	Passenger's Airbag failure	<ul style="list-style-type: none"> • Airbag main harness circuit is open, shorted or shorted to ground. • Airbag module harness (Passenger's side) circuit is open, shorted or shorted to ground. • Airbag control module is faulty. • Passenger's airbag module is faulty. 	<Ref. to AB(diag)-84, DTC 72 PASSENGER'S AIRBAG FAILURE, Diagnostic Chart with Trouble Code.>

List of Diagnostic Trouble Code (DTC)

AIRBAG SYSTEM (DIAGNOSTICS)

DTC	Display	Diagnosis content	Reference
75	Driver's Airbag failure	<ul style="list-style-type: none"> Airbag main harness circuit (Driver's side) is shorted to power supply. Airbag module harness circuit (Driver's side) is shorted to power supply. Roll connector is shorted to power supply. Airbag control module is faulty. Driver's airbag module is faulty. 	<Ref. to AB(diag)-86, DTC 75 DRIVER'S AIRBAG FAILURE, Diagnostic Chart with Trouble Code.>
76	Passenger's Airbag failure	<ul style="list-style-type: none"> Airbag main harness circuit (Passenger's side) is shorted to power supply. Airbag module harness circuit (Passenger's side) is shorted to power supply. Airbag control module is faulty. Passenger's airbag module is faulty. 	<Ref. to AB(diag)-89, DTC 76 PASSENGER'S AIRBAG FAILURE, Diagnostic Chart with Trouble Code.>
91	Curtain Airbag Module RH Failure	<ul style="list-style-type: none"> Curtain airbag harness (RH) circuit is faulty. Curtain airbag module (RH) is faulty. Airbag control module is faulty. 	<Ref. to AB(diag)-91, DTC 91 CURTAIN AIRBAG MODULE RH FAILURE, Diagnostic Chart with Trouble Code.>
92	Curtain Airbag Module LH Failure	<ul style="list-style-type: none"> Curtain airbag harness (LH) circuit is faulty. Curtain airbag module (LH) is faulty. Airbag control module is faulty. 	<Ref. to AB(diag)-93, DTC 92 CURTAIN AIRBAG MODULE LH FAILURE, Diagnostic Chart with Trouble Code.>
95	Curtain Airbag Module RH Failure	<ul style="list-style-type: none"> Curtain airbag harness (RH) is shorted to power supply. Curtain airbag module (RH) is faulty. Airbag control module is faulty. 	<Ref. to AB(diag)-95, DTC 95 CURTAIN AIRBAG MODULE RH FAILURE, Diagnostic Chart with Trouble Code.>
96	Curtain Airbag Module LH Failure	<ul style="list-style-type: none"> Curtain airbag harness (LH) is shorted to power supply. Curtain airbag module (LH) is faulty. Airbag control module is faulty. 	<Ref. to AB(diag)-97, DTC 96 CURTAIN AIRBAG MODULE LH FAILURE, Diagnostic Chart with Trouble Code.>
BB	Roll Over: Firing output	Curtain airbag module (LH/RH) and seat belt pretensioner (LH/RH) are inflated.	<Ref. to AB(diag)-99, DTC BB ROLL OVER: FIRING OUTPUT, Diagnostic Chart with Trouble Code.>
E2 E3 E4	Front Sensor Bus RH Communication error	<ul style="list-style-type: none"> Open or short circuit in harness (RH) between airbag control module and front sub sensor. Front sub sensor (RH) is faulty. Airbag control module is faulty. 	<Ref. to AB(diag)-99, DTC E2 FRONT SENSOR BUS RH COMMUNICATION ERROR, Diagnostic Chart with Trouble Code.> <Ref. to AB(diag)-99, DTC E3 FRONT SENSOR BUS RH COMMUNICATION ERROR, Diagnostic Chart with Trouble Code.> <Ref. to AB(diag)-100, DTC E4 FRONT SENSOR BUS RH COMMUNICATION ERROR, Diagnostic Chart with Trouble Code.>
E6 E7 E8	Front Sensor Bus LH Communication error	<ul style="list-style-type: none"> Open or short circuit in harness (LH) between airbag control module and front sub sensor. Front sub sensor (LH) is faulty. Airbag control module is faulty. 	<Ref. to AB(diag)-102, DTC E6 FRONT SENSOR BUS LH COMMUNICATION ERROR, Diagnostic Chart with Trouble Code.> <Ref. to AB(diag)-102, DTC E7 FRONT SENSOR BUS LH COMMUNICATION ERROR, Diagnostic Chart with Trouble Code.> <Ref. to AB(diag)-103, DTC E8 FRONT SENSOR BUS LH COMMUNICATION ERROR, Diagnostic Chart with Trouble Code.>

List of Diagnostic Trouble Code (DTC)

AIRBAG SYSTEM (DIAGNOSTICS)

DTC	Display	Diagnosis content	Reference
E9 EA EB EC	Side Sensor Bus RH Communication error	<ul style="list-style-type: none"> • Open or short circuit in harness (RH) between airbag control module and side sensor. • Side airbag sensor (RH) or curtain airbag sensor (RH) is faulty. • Airbag control module is faulty. 	<p><Ref. to AB(diag)-105, DTC E9 SIDE SENSOR BUS RH COMMUNICATION ERROR, Diagnostic Chart with Trouble Code.> <Ref. to AB(diag)-105, DTC EA SIDE SENSOR BUS RH COMMUNICATION ERROR, Diagnostic Chart with Trouble Code.> <Ref. to AB(diag)-105, DTC EB SIDE SENSOR BUS RH COMMUNICATION ERROR, Diagnostic Chart with Trouble Code.> <Ref. to AB(diag)-106, DTC EC SIDE SENSOR BUS RH COMMUNICATION ERROR, Diagnostic Chart with Trouble Code.></p>
ED EE	Side Sensor Bus RH Communication error	<ul style="list-style-type: none"> • Open or short circuit in harness (RH) between airbag control module and side sensor. • Side airbag sensor (RH) or curtain airbag sensor (RH) is faulty. • Airbag control module is faulty. 	<p><Ref. to AB(diag)-108, DTC ED SIDE SENSOR BUS RH COMMUNICATION ERROR, Diagnostic Chart with Trouble Code.> <Ref. to AB(diag)-109, DTC EE SIDE SENSOR BUS RH COMMUNICATION ERROR, Diagnostic Chart with Trouble Code.></p>
F1 F2 F3 F4	Side Sensor Bus LH Communication error	<ul style="list-style-type: none"> • Open or short circuit in harness (LH) between airbag control module and side sensor. • Side airbag sensor (LH) or curtain airbag sensor (LH) is faulty. • Airbag control module is faulty. 	<p><Ref. to AB(diag)-112, DTC F1 SIDE SENSOR BUS LH COMMUNICATION ERROR, Diagnostic Chart with Trouble Code.> <Ref. to AB(diag)-112, DTC F2 SIDE SENSOR BUS LH COMMUNICATION ERROR, Diagnostic Chart with Trouble Code.> <Ref. to AB(diag)-112, DTC F3 SIDE SENSOR BUS LH COMMUNICATION ERROR, Diagnostic Chart with Trouble Code.> <Ref. to AB(diag)-113, DTC F4 SIDE SENSOR BUS LH COMMUNICATION ERROR, Diagnostic Chart with Trouble Code.></p>
F5 F6	Side Sensor Bus LH Communication error	<ul style="list-style-type: none"> • Open or short circuit in harness (LH) between airbag control module and side sensor. • Side airbag sensor (LH) or curtain airbag sensor (LH) is faulty. • Airbag control module is faulty. 	<p><Ref. to AB(diag)-115, DTC F5 SIDE SENSOR BUS LH COMMUNICATION ERROR, Diagnostic Chart with Trouble Code.> <Ref. to AB(diag)-116, DTC F6 SIDE SENSOR BUS LH COMMUNICATION ERROR, Diagnostic Chart with Trouble Code.></p>

List of Diagnostic Trouble Code (DTC)

AIRBAG SYSTEM (DIAGNOSTICS)

DTC	Display	Diagnosis content	Reference
F8 F9 FA	Satellite Sensor Bus Communication error	<ul style="list-style-type: none"> • Open or short circuit in harness between airbag control module and satellite safing sensor. • Satellite safing sensor is faulty. • Airbag control module is faulty. 	<Ref. to AB(diag)-119, DTC F8 SATELLITE SENSOR BUS COMMUNICATION ERROR, Diagnostic Chart with Trouble Code.> <Ref. to AB(diag)-119, DTC F9 SATELLITE SENSOR BUS COMMUNICATION ERROR, Diagnostic Chart with Trouble Code.> <Ref. to AB(diag)-120, DTC FA SATELLITE SENSOR BUS COMMUNICATION ERROR, Diagnostic Chart with Trouble Code.>
3A	Front Sub Sensor RH false installation	<ul style="list-style-type: none"> • Front sensor (RH) is misinstalled. • Airbag control module is faulty. 	<Ref. to AB(diag)-122, DTC 3A FRONT SUB SENSOR RH FALSE INSTALLATION, Diagnostic Chart with Trouble Code.>
3B	Front Sub Sensor LH false installation	<ul style="list-style-type: none"> • Front sensor (LH) is misinstalled. • Airbag control module is faulty. 	<Ref. to AB(diag)-122, DTC 3B FRONT SUB SENSOR LH FALSE INSTALLATION, Diagnostic Chart with Trouble Code.>
3C	Satellite Sensor Bus failure	Satellite safing sensor is faulty.	<Ref. to AB(diag)-122, DTC 3C SATELLITE SENSOR BUS FAILURE, Diagnostic Chart with Trouble Code.>
3D	Satellite Sensor false installation	<ul style="list-style-type: none"> • Satellite safing sensor is misinstalled. • Airbag control module is faulty. 	<Ref. to AB(diag)-122, DTC 3D SATELLITE SENSOR FALSE INSTALLATION, Diagnostic Chart with Trouble Code.>
5A	Side Airbag Sensor RH false installation	<ul style="list-style-type: none"> • Side A/B sensor is misinstalled. • Airbag control module is faulty. 	<Ref. to AB(diag)-123, DTC 5A SIDE AIRBAG SENSOR RH FALSE INSTALLATION, Diagnostic Chart with Trouble Code.>
5B	Side Airbag Sensor LH false installation	<ul style="list-style-type: none"> • Side A/B sensor is misinstalled. • Airbag control module is faulty. 	<Ref. to AB(diag)-123, DTC 5B SIDE AIRBAG SENSOR LH FALSE INSTALLATION, Diagnostic Chart with Trouble Code.>
5C	Curtain Airbag Sensor RH false installation	<ul style="list-style-type: none"> • Curtain A/B sensor is misinstalled. • Airbag control module is faulty. 	<Ref. to AB(diag)-123, DTC 5C CURTAIN AIRBAG SENSOR RH FALSE INSTALLATION, Diagnostic Chart with Trouble Code.>
5D	Curtain Airbag Sensor LH false installation	<ul style="list-style-type: none"> • Curtain A/B sensor is misinstalled. • Airbag control module is faulty. 	<Ref. to AB(diag)-123, DTC 5D CURTAIN AIRBAG SENSOR LH FALSE INSTALLATION, Diagnostic Chart with Trouble Code.>

Diagnostic Chart with Trouble Code

AIRBAG SYSTEM (DIAGNOSTICS)

15. Diagnostic Chart with Trouble Code

A: DTC 11 DRIVER'S AIRBAG FAILURE

DTC DETECTING CONDITION:

- Airbag main harness circuit is open, shorted or shorted to ground.
- Airbag module harness (driver's side) circuit is open, shorted or shorted to ground.
- Roll connector circuit is open, shorted or shorted to ground.
- Driver's airbag module is faulty.
- Airbag control module is faulty.

CAUTION:

- Before diagnosing the airbag system, be sure to turn the ignition switch to OFF, disconnect the ground terminal from the battery, and wait 20 seconds or more before starting to work.
- When replacing the airbag module, seat belt pretensioner, roll connector, control module and sensor, reconnect each part and check that the warning light operates properly.
- When inspecting the airbag main harness, disconnect the airbag module connectors of the driver's and passenger's seats for safety.
- When inspecting the airbag rear harness, disconnect the side airbag module connector, curtain airbag module connector and seat belt pretensioner connector for safety reasons.

NOTE:

Prior to starting work, prepare two airbag resistors (98299PA040).

WIRING DIAGRAM:

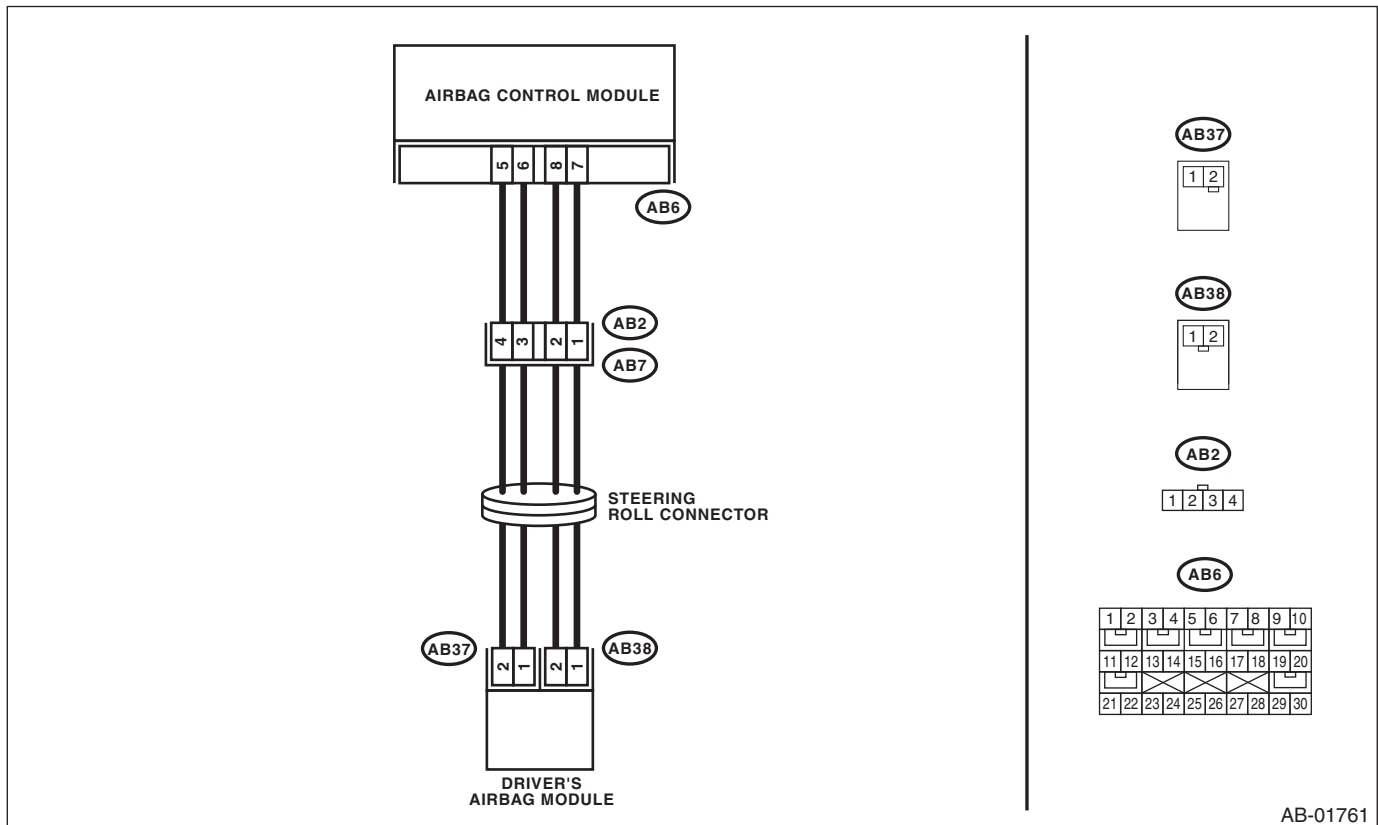

AB-01761

Diagnostic Chart with Trouble Code

AIRBAG SYSTEM (DIAGNOSTICS)

Step	Check	Yes	No
1 CHECK POOR CONTACT IN CONNECTORS. Check for poor contact of the connectors between the airbag control module and the driver's airbag module.	Is there poor contact?	Replace the airbag harness.	Go to step 2.
2 CHECK DRIVER'S AIRBAG MODULE. 1) Turn the ignition switch to OFF, disconnect the battery ground cable, and wait for 20 seconds or more. 2) Remove the driver's airbag module. 3) Connect the connector (1N) in the test harness N to the connector (AB38). 4) Connect the airbag resistor to the connector (2N) of test harness N. 5) Connect the connector (1Q) in the test harness Q to connector (AB37). 6) Connect the airbag resistor to the connector (2Q) in the test harness Q. 7) Connect the battery ground terminal and turn the ignition switch to ON.	Does the airbag warning light illuminate for 6 seconds and go off?	Replace the driver's airbag module. <Ref. to AB-16, Driver's Airbag Module.>	Go to step 3.
3 CHECK ROLL CONNECTOR. 1) Turn the ignition switch to OFF, disconnect the battery ground cable, and wait for 20 seconds or more. 2) Disconnect the test harness N from connector (AB38). 3) Disconnect the test harness Q from connector (AB37). 4) Remove the instrument panel lower cover and disconnect the connector (AB7) from (AB2). 5) Connect the connector (1P) in the test harness P to connector (AB2). 6) Connect the airbag resistor to the connectors (2P) and (3P) of test harness P. 7) Connect the battery ground terminal and turn the ignition switch to ON.	Does the airbag warning light illuminate for 6 seconds and go off?	Replace the roll connector. <Ref. to AB-28, Roll Connector.>	Go to step 4.
4 CHECK AIRBAG MAIN HARNESS (DRIVER'S AIRBAG HARNESS). 1) Turn the ignition switch to OFF, disconnect the battery ground cable, and wait for 20 seconds or more. 2) Disconnect the airbag resistor from the connectors (2P) and (3P) of test harness P. 3) Remove the console front panel and disconnect the connectors (AB10) and (AB9). 4) Disconnect the connectors (AB6, AB17, and AB18) from the airbag control module, and connect the connector (1AG) in the test harness AG. 5) Measure the resistance between connector (3AG) in the test harness AG and connectors (2P) and (3P) in the test harness P. Connector & terminal (3AG) No. 1 — (2P) No. 1: (3AG) No. 3 — (2P) No. 2:	Is the resistance less than 10 Ω?	Go to step 5.	Replace the airbag main harness along with body harness.

Diagnostic Chart with Trouble Code

AIRBAG SYSTEM (DIAGNOSTICS)

Step	Check	Yes	No
5 CHECK AIRBAG MAIN HARNESS (DRIVER'S AIRBAG HARNESS). Measure the resistance between connector (3AG) terminals in the test harness AG. Connector & terminal <i>(3AG) No. 1 — (3AG) No. 3:</i> <i>(3AG) No. 3 — Chassis ground:</i> <i>(3AG) No. 1 — Chassis ground:</i> <i>(3AG) No. 2 — (3AG) No. 4:</i> <i>(3AG) No. 2 — Chassis ground:</i> <i>(3AG) No. 4 — Chassis ground:</i> <i>(3AG) No. 1 — (3AG) No. 2:</i> <i>(3AG) No. 1 — (3AG) No. 4:</i> <i>(3AG) No. 2 — (3AG) No. 3:</i> <i>(3AG) No. 3 — (3AG) No. 4:</i>	Is the resistance 1 MΩ or more?	Go to step 6.	Replace the airbag main harness along with body harness.
6 CHECK AIRBAG CONTROL MODULE. 1) Connect all connectors. 2) Erase the memory. 3) Perform the Inspection Mode. 4) Read the DTC.	Is the same DTC displayed?	Replace the airbag control module. <Ref. to AB-23, Airbag Control Module.>	Go to step 7.
7 CHECK FOR ANY OTHER DTC ON DISPLAY.	Is any other DTC displayed?	Check DTC using "List of Diagnostic Trouble Code (DTC)". <Ref. to AB(diag)-40, List of Diagnostic Trouble Code (DTC).>	Finish the diagnosis.

Diagnostic Chart with Trouble Code

AIRBAG SYSTEM (DIAGNOSTICS)

B: DTC 12 PASSENGER'S AIRBAG FAILURE

DTC DETECTING CONDITION:

- Airbag main harness circuit is open, shorted or shorted to ground.
- Airbag module harness (Passenger's side) circuit is open, shorted or shorted to ground.
- Passenger's airbag module is faulty.
- Airbag control module is faulty.

CAUTION:

- Before diagnosing the airbag system, be sure to turn the ignition switch to OFF, disconnect the ground terminal from the battery, and wait 20 seconds or more before starting to work.
- When replacing the airbag module, seat belt pretensioner, roll connector, control module and sensor, reconnect each part and check that the warning light operates properly.
- When inspecting the airbag main harness, disconnect the airbag module connectors of the driver's and passenger's seats for safety.
- When inspecting the airbag rear harness, disconnect the side airbag module connector, curtain airbag module connector and seat belt pretensioner connector for safety reasons.

NOTE:

Prior to starting work, prepare two airbag resistors (98299PA040).

WIRING DIAGRAM:

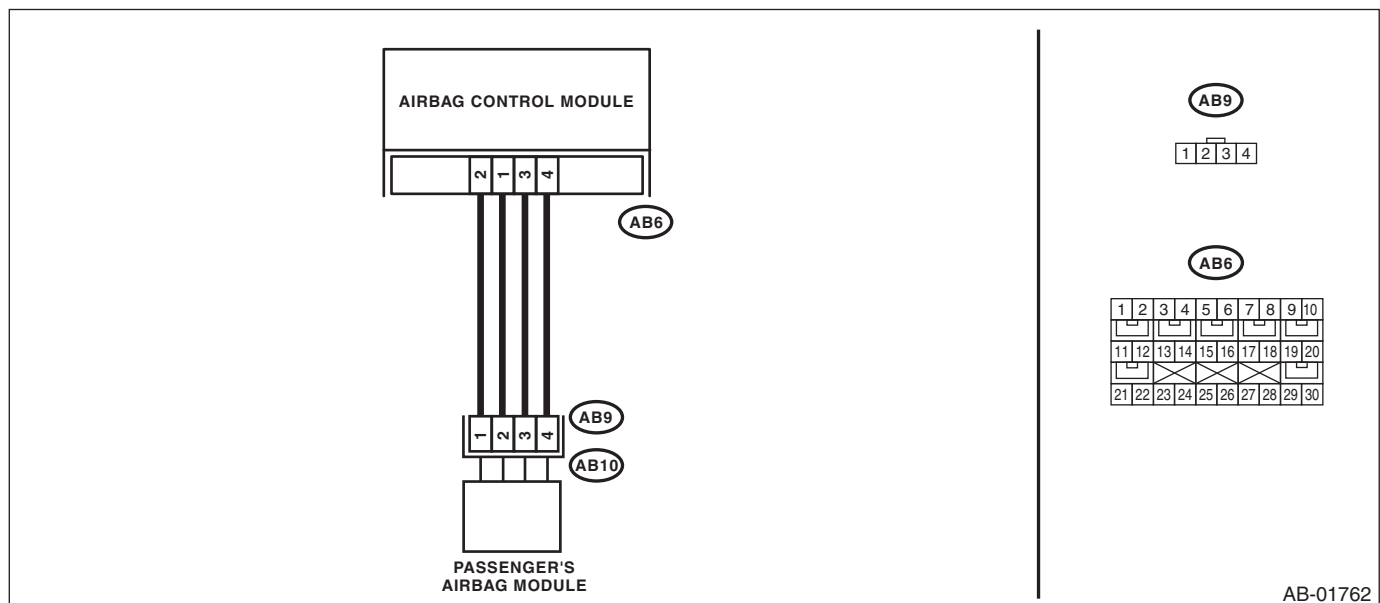

AB-01762

Step	Check	Yes	No
1 CHECK POOR CONTACT IN CONNECTORS. Check for poor contact of the connectors between the airbag control module and the passenger's airbag module.	Is there poor contact?	Replace the airbag harness.	Go to step 2.
2 CHECK PASSENGER'S AIRBAG MODULE. 1) Turn the ignition switch to OFF, disconnect the battery ground cable, and wait for 20 seconds or more. 2) Remove the console front panel and disconnect the connectors (AB10) from (AB9). 3) Connect the connector (1P) in the test harness P to connector (AB9). 4) Connect the airbag resistor to the connectors (2P) and (3P) of test harness P. 5) Connect the battery ground terminal and turn the ignition switch to ON.	Does the airbag warning light illuminate for 6 seconds and go off?	Replace the passenger's airbag module. <Ref. to AB-17, Passenger's Airbag Module.>	Go to step 3.

Diagnostic Chart with Trouble Code

AIRBAG SYSTEM (DIAGNOSTICS)

Step	Check	Yes	No
3 CHECK AIRBAG MAIN HARNESS (PASSENGER'S AIRBAG HARNESS). 1) Turn the ignition switch to OFF, disconnect the battery ground cable, and wait for 20 seconds or more. 2) Disconnect the airbag resistor from the connectors (2P) and (3P) of test harness P. 3) Remove the instrument panel lower cover and disconnect the connector (AB7) from (AB2). 4) Disconnect the connectors (AB6, AB17, and AB18) from the airbag control module, and connect the connector (1AG) in the test harness AG. 5) Measure the resistance between connector (3AG) in the test harness AG and connectors (2P) and (3P) in the test harness P. Connector & terminal (3AG) No. 9 — (2P) No. 1: (3AG) No. 7 — (2P) No. 2:	Is the resistance less than 10 Ω?	Go to step 4.	Replace the airbag main harness along with body harness.
4 CHECK AIRBAG MAIN HARNESS (PASSENGER'S AIRBAG HARNESS). Measure the resistance between connectors (3AG) in the test harness AG, and between connector (3AG) and chassis ground. Connector & terminal (3AG) No. 9 — (3AG) No. 7: (3AG) No. 9 — Chassis ground: (3AG) No. 7 — Chassis ground: (3AG) No. 8 — (3AG) No. 6: (3AG) No. 8 — Chassis ground: (3AG) No. 6 — Chassis ground: (3AG) No. 7 — (3AG) No. 6: (3AG) No. 6 — (3AG) No. 9: (3AG) No. 7 — (3AG) No. 8: (3AG) No. 8 — (3AG) No. 9:	Is the resistance 1 MΩ or more?	Go to step 5.	Replace the airbag main harness along with body harness.
5 CHECK AIRBAG CONTROL MODULE. 1) Connect all connectors. 2) Erase the memory. 3) Perform the Inspection Mode. 4) Read the DTC.	Is the same DTC displayed?	Replace the airbag control module. <Ref. to AB-23, Airbag Control Module.>	Go to step 6.
6 CHECK FOR ANY OTHER DTC ON DISPLAY.	Is any other DTC displayed?	Check DTC using "List of Diagnostic Trouble Code (DTC)". <Ref. to AB(diag)-40, List of Diagnostic Trouble Code (DTC).>	Finish the diagnosis.

Diagnostic Chart with Trouble Code

C: DTC 15 DRIVER'S AIRBAG FAILURE

DTC DETECTING CONDITION:

- Airbag main harness circuit (Driver's side) is shorted to power supply.
- Airbag module harness circuit (Driver's side) is shorted to power supply.
- Roll connector is shorted to power supply.
- Driver's airbag module is faulty.
- Airbag control module is faulty.

CAUTION:

- Before diagnosing the airbag system, be sure to turn the ignition switch to OFF, disconnect the ground terminal from the battery, and wait 20 seconds or more before starting to work.
- When replacing the airbag module, seat belt pretensioner, roll connector, control module and sensor, reconnect each part and check that the warning light operates properly.
- When inspecting the airbag main harness, disconnect the airbag module connectors of the driver's and passenger's seats for safety.
- When inspecting the airbag rear harness, disconnect the side airbag module connector, curtain airbag module connector and seat belt pretensioner connector for safety reasons.

NOTE:

Prior to starting work, prepare two airbag resistors (98299PA040).

WIRING DIAGRAM:

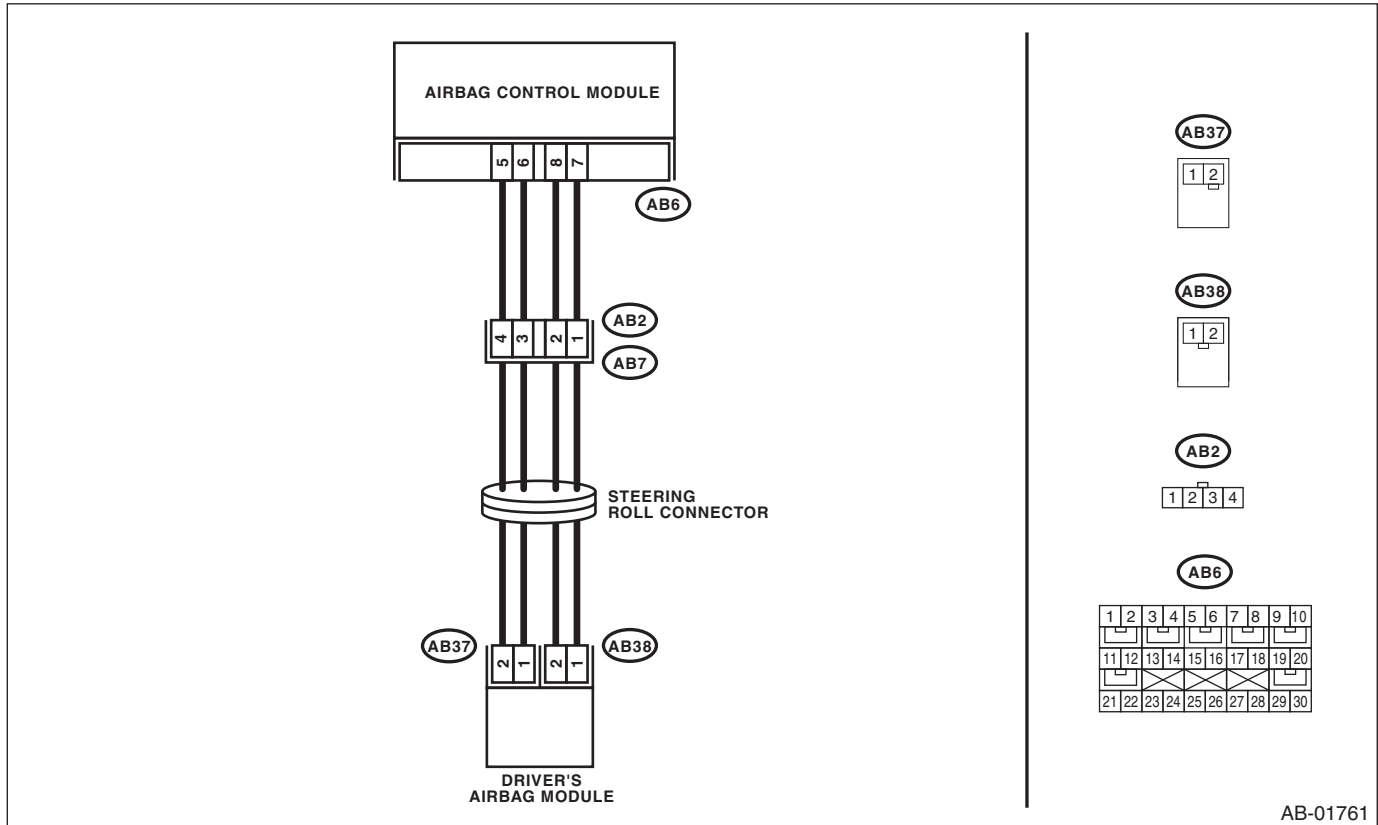

AB-01761

Diagnostic Chart with Trouble Code

AIRBAG SYSTEM (DIAGNOSTICS)

Step	Check	Yes	No
1 CHECK POOR CONTACT IN CONNECTORS. Check for poor contact of the connectors between the airbag control module and the driver's airbag module.	Is there poor contact?	Replace the airbag harness.	Go to step 2.
2 CHECK DRIVER'S AIRBAG MODULE. 1) Turn the ignition switch to OFF, disconnect the battery ground cable, and wait for 20 seconds or more. 2) Remove the driver's airbag module. 3) Connect the connector (AB38) to the connector (1N) in the test harness N. 4) Connect the airbag resistor to the connector (2N) of test harness N. 5) Connect the connector (1Q) in the test harness Q to connector (AB37). 6) Connect the airbag resistor to the connector (2Q) in the test harness Q. 7) Connect the battery ground terminal and turn the ignition switch to ON.	Does the airbag warning light illuminate for 6 seconds and go off?	Replace the driver's airbag module. <Ref. to AB-16, Driver's Airbag Module.>	Go to step 3.
3 CHECK ROLL CONNECTOR. 1) Turn the ignition switch to OFF, disconnect the battery ground cable, and wait for 20 seconds or more. 2) Disconnect the test harness N from connector (AB38). 3) Disconnect the test harness Q from connector (AB37). 4) Remove the instrument panel lower cover and disconnect the connector (AB7) from (AB2). 5) Connect the connector (1P) in the test harness P to connector (AB2). 6) Connect the airbag resistor to the connectors (2P) and (3P) of test harness P. 7) Connect the battery ground terminal and turn the ignition switch to ON.	Does the airbag warning light illuminate for 6 seconds and go off?	Replace the roll connector. <Ref. to AB-28, Roll Connector.>	Go to step 4.
4 CHECK AIRBAG MAIN HARNESS (DRIVER'S AIRBAG HARNESS). 1) Turn the ignition switch to OFF, disconnect the battery ground cable, and wait for 20 seconds or more. 2) Disconnect the airbag resistor from the connectors (2P) and (3P) of test harness P. 3) Remove the console front panel and disconnect the connectors (AB10) and (AB9). 4) Disconnect the connectors (AB6, AB17, and AB18) from the airbag control module, and connect the connector (1AG) in the test harness AG. 5) Connect the battery ground terminal and turn the ignition switch to ON. (engine OFF) 6) Measure the voltage between connector (3AG) in the test harness AG and chassis ground. Connector & terminal (3AG) No. 3 (+) — Chassis ground (-): (3AG) No. 1 (+) — Chassis ground (-):	Is the voltage less than 1 V?	Go to step 5.	Replace the airbag main harness along with body harness.

Diagnostic Chart with Trouble Code

AIRBAG SYSTEM (DIAGNOSTICS)

Step	Check	Yes	No
5 CHECK AIRBAG CONTROL MODULE. 1) Connect all connectors. 2) Erase the memory. 3) Perform the Inspection Mode. 4) Read the DTC.	Is the same DTC displayed?	Replace the airbag control module. <Ref. to AB-23, Airbag Control Module.>	Go to step 6 .
6 CHECK FOR ANY OTHER DTC ON DISPLAY.	Is any other DTC displayed?	Check DTC using "List of Diagnostic Trouble Code (DTC)". <Ref. to AB(diag)-40, List of Diagnostic Trouble Code (DTC).>	Finish the diagnosis.

Diagnostic Chart with Trouble Code

AIRBAG SYSTEM (DIAGNOSTICS)

D: DTC 16 PASSENGER'S AIRBAG FAILURE

DTC DETECTING CONDITION:

- Airbag main harness circuit (Passenger's side) is shorted to power supply.
- Airbag module harness circuit (Passenger's side) is shorted to power supply.
- Passenger's airbag module is faulty.
- Airbag control module is faulty.

CAUTION:

- Before diagnosing the airbag system, be sure to turn the ignition switch to OFF, disconnect the ground terminal from the battery, and wait 20 seconds or more before starting to work.
- When replacing the airbag module, seat belt pretensioner, roll connector, control module and sensor, reconnect each part and check that the warning light operates properly.
- When inspecting the airbag main harness, disconnect the airbag module connectors of the driver's and passenger's seats for safety.
- When inspecting the airbag rear harness, disconnect the side airbag module connector, curtain airbag module connector and seat belt pretensioner connector for safety reasons.

NOTE:

Prior to starting work, prepare two airbag resistors (98299PA040).

WIRING DIAGRAM:

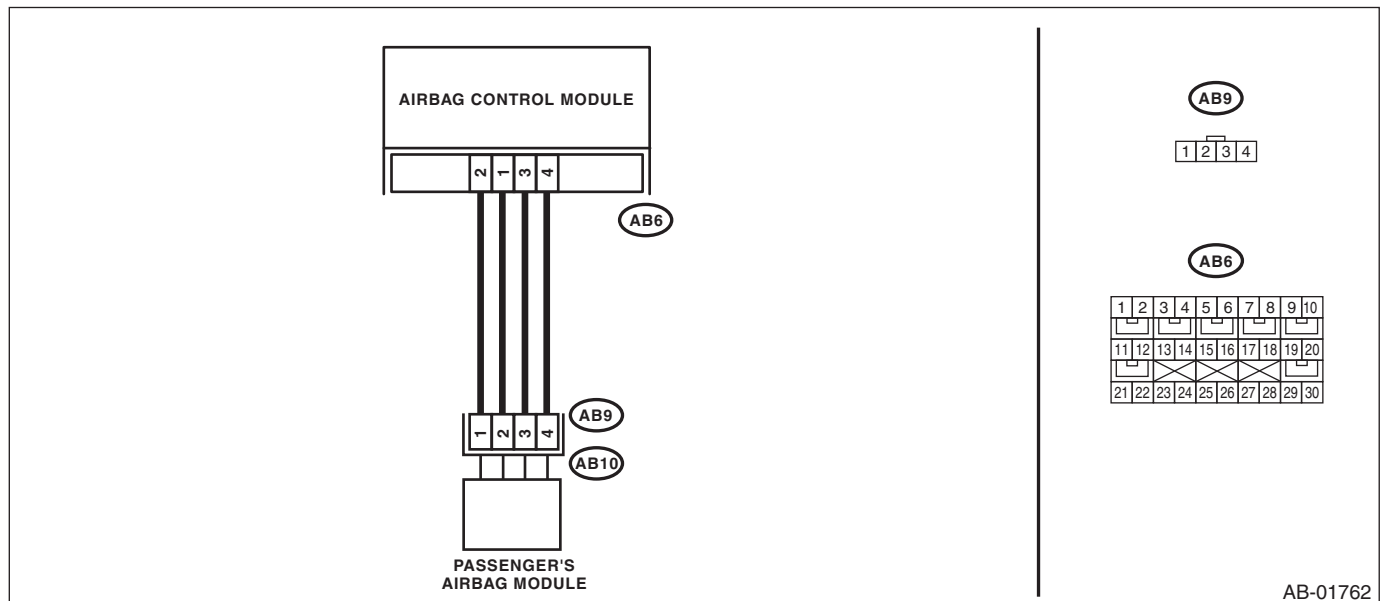

Diagnostic Chart with Trouble Code

AIRBAG SYSTEM (DIAGNOSTICS)

Step	Check	Yes	No
1 CHECK POOR CONTACT IN CONNECTORS. Check for poor contact of the connectors between the airbag control module and the passenger's airbag module.	Is there poor contact?	Replace the airbag harness along with chassis harness.	Go to step 2.
2 CHECK PASSENGER'S AIRBAG MODULE. 1) Turn the ignition switch to OFF, disconnect the battery ground cable, and wait for 20 seconds or more. 2) Remove the console front panel and disconnect the connectors (AB10) from (AB9). 3) Connect the connector (1P) in the test harness P to connector (AB9). 4) Connect the airbag resistor to the connectors (2P) and (3P) of test harness P. 5) Connect the battery ground terminal and turn the ignition switch to ON.	Does the airbag warning light illuminate for 6 seconds and go off?	Replace the passenger's airbag module. <Ref. to AB-17, Passenger's Airbag Module.>	Go to step 3.
3 CHECK AIRBAG MAIN HARNESS (PASSENGER'S AIRBAG HARNESS). 1) Turn the ignition switch to OFF, disconnect the battery ground cable, and wait for 20 seconds or more. 2) Disconnect the airbag resistor from the connectors (2P) and (3P) of test harness P. 3) Remove the instrument panel lower cover and disconnect the connector (AB7) from (AB2). 4) Disconnect the connectors (AB6, AB17, and AB18) from the airbag control module, and connect the connector (1AG) in the test harness AG. 5) Connect the battery ground terminal and turn the ignition switch to ON. (engine OFF) 6) Measure the voltage between connector (3AG) in the test harness AG and chassis ground. Connector & terminal (3AG) No. 9 (+) — Chassis ground (-): (3AG) No. 7 (+) — Chassis ground (-):	Is the voltage less than 1 V?	Go to step 4.	Replace the airbag main harness along with body harness.
4 CHECK AIRBAG CONTROL MODULE. 1) Connect all connectors. 2) Erase the memory. 3) Perform the Inspection Mode. 4) Read the DTC.	Is the same DTC displayed?	Replace the airbag control module. <Ref. to AB-23, Airbag Control Module.>	Go to step 5.
5 CHECK FOR ANY OTHER DTC ON DISPLAY.	Is any other DTC displayed?	Check DTC using "List of Diagnostic Trouble Code (DTC)". <Ref. to AB(diag)-40, List of Diagnostic Trouble Code (DTC).>	Finish the diagnosis.

Diagnostic Chart with Trouble Code

AIRBAG SYSTEM (DIAGNOSTICS)

E: DTC 21 AIRBAG ECM FAILURE

DTC DETECTING CONDITION:

Airbag control module is faulty.

CAUTION:

- Before diagnosing the airbag system, be sure to turn the ignition switch to OFF, disconnect the ground terminal from the battery, and wait 20 seconds or more before starting to work.
- When replacing the airbag module, seat belt pretensioner, roll connector, control module and sensor, reconnect each part and check that the warning light operates properly.

	Step	Check	Yes	No
1	CHECK IF DTC 21 IS INDICATED. Read the DTC. <Ref. to AB(diag)-30, OPERATION, Read Diagnostic Trouble Code (DTC).>	Does the Subaru Select Monitor display DTC21?	Replace the airbag control module. <Ref. to AB-23, Airbag Control Module.>	Perform the Clear Memory Mode. <Ref. to AB(diag)-32, OPERATION, Clear Memory Mode.>

Diagnostic Chart with Trouble Code

AIRBAG SYSTEM (DIAGNOSTICS)

F: DTC 22 FRONT AIRBAG FIRING OUTPUT

WIRING DIAGRAM:

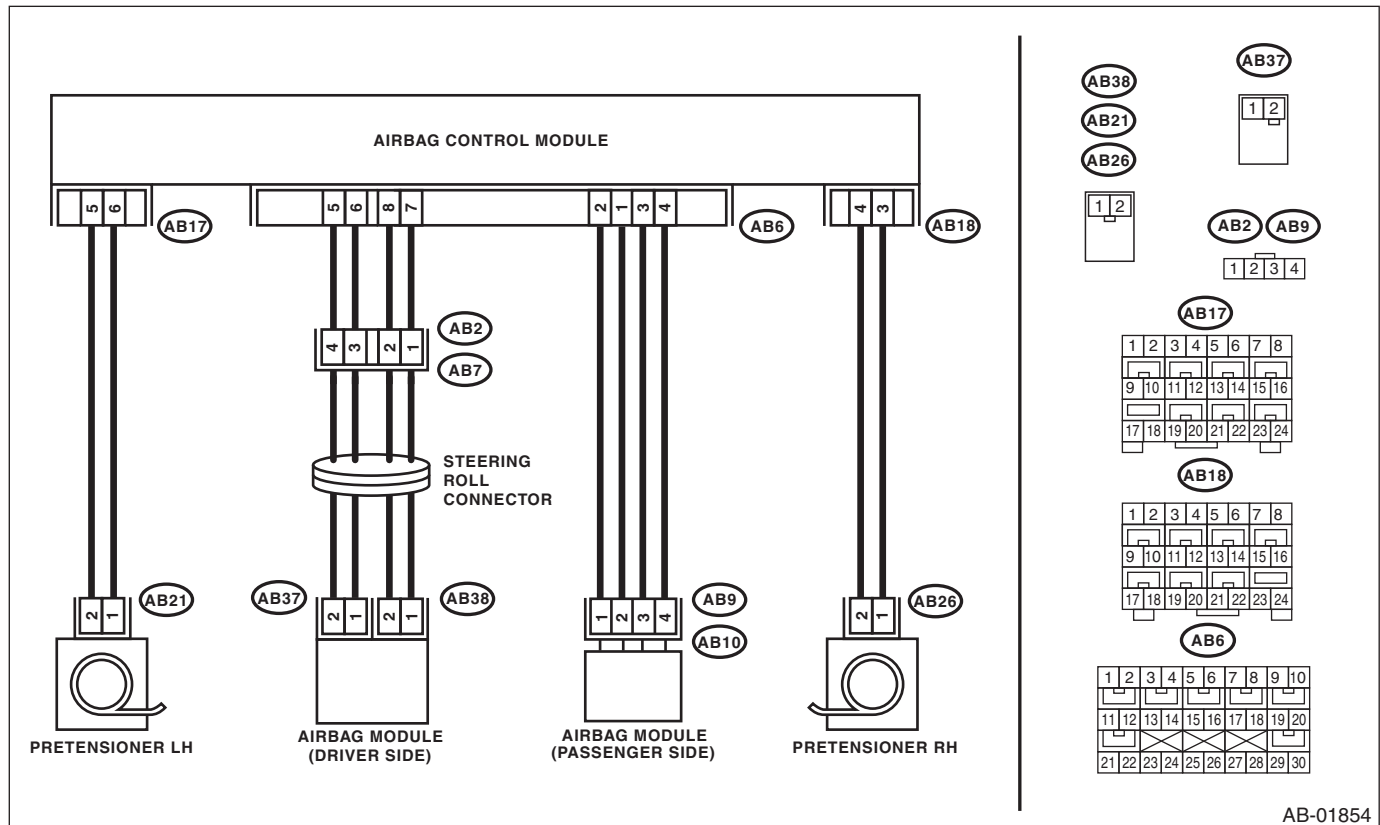

AB-01854

This DTC is indicated when the front airbag module and the pretensioner are deployed.

Once this DTC is displayed, the memory cannot be cleared. Therefore replace the following parts.

- Airbag control module <Ref. to AB-23, Airbag Control Module.>
- Driver's airbag module <Ref. to AB-16, Driver's Airbag Module.>
- Passenger's airbag module <Ref. to AB-17, Passenger's Airbag Module.>
- Front sub sensor of both sides <Ref. to AB-24, Front Sub Sensor.>
- Front outer seat belt with pretensioner of both sides <Ref. to SB-17, Front Seat Belt.>
- Steering roll connector <Ref. to AB-28, Roll Connector.>
- Occupant detection system (passenger's seat cushion & frame assembly) <Ref. to SE-8, Front Seat.>

Diagnostic Chart with Trouble Code

AIRBAG SYSTEM (DIAGNOSTICS)

G: DTC 26 PASSENGER'S AIRBAG INDICATOR FAILURE

DTC DETECTING CONDITION:

- Passenger's airbag indicator is faulty.
- Airbag control module is faulty.
- Airbag main harness circuit is open.
- Body harness circuit is open.

CAUTION:

- Before diagnosing the airbag system, be sure to turn the ignition switch to OFF, disconnect the ground terminal from the battery, and wait 20 seconds or more before starting to work.
- When replacing the airbag module, seat belt pretensioner, roll connector, control module and sensor, reconnect each part and check that the warning light operates properly.
- When inspecting the airbag main harness, disconnect the airbag module connectors of the driver's and passenger's seats for safety.
- When inspecting the airbag rear harness, disconnect the side airbag module connector, curtain airbag module connector and seat belt pretensioner connector for safety reasons.

WIRING DIAGRAM:

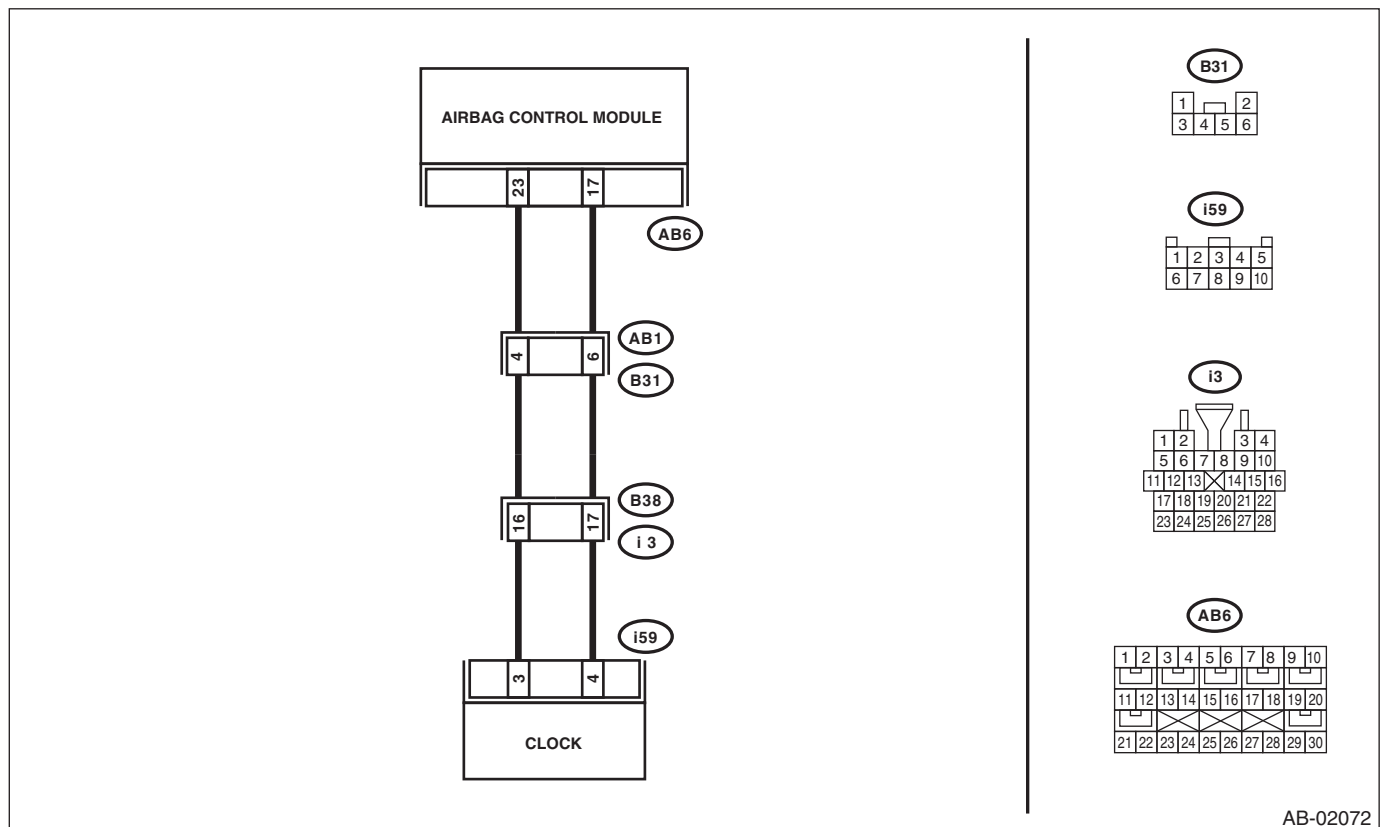

AB-02072

Diagnostic Chart with Trouble Code

AIRBAG SYSTEM (DIAGNOSTICS)

Step	Check	Yes	No
1 CHECK POOR CONTACT. 1) Turn the ignition switch to OFF, disconnect the battery ground cable, and wait for 20 seconds or more. 2) Confirm that firm contact is secured for the connector between the airbag control module and the clock.	Is there poor contact in any connector?	Replace the airbag harness connector.	Go to step 2.
2 CHECK AIRBAG MAIN HARNESS. 1) Disconnect the connectors (AB6, AB17, and AB18) from airbag control module. 2) Connect the battery ground terminal and turn the ignition switch to ON. NOTE: Neither of ON/OFF illuminates when it is normal.	Does the passenger's airbag indicator illuminate?	Go to step 3.	Go to step 4.
3 CHECK AIRBAG MAIN HARNESS. 1) Turn the ignition switch to OFF. 2) Remove the clock and disconnect the connector (i59). 3) Connect the connector (1AG) in the test harness AG to the connectors (AB6, AB17, and AB18). 4) Measure the resistance between connector (2AG) in the test harness AG and chassis ground. Connector & terminal (2AG) No. 9 — (2AG) No. 8: (2AG) No. 9 — Chassis ground: (2AG) No. 8 — Chassis ground:	Is the resistance 1 M Ω or more?	Replace the clock. <Ref. to IDI-21, REMOVAL, Clock.>	Repair the bulkhead harness. Or replace the airbag main harness along with body harness.
4 CHECK AIRBAG HARNESS. 1) Connect the connectors (7AG) and (8AG) in the test harness AG. 2) Connect the battery ground terminal and turn the ignition switch to ON.	Does the passenger's airbag indicator illuminate?	Replace the airbag control module. <Ref. to AB-23, Airbag Control Module.>	Go to step 5.
5 CHECK AIRBAG HARNESS. 1) Turn the ignition switch to OFF. 2) Connect the connector (1AG) in the test harness AG to the connectors (AB6, AB17, and AB18). 3) Measure the resistance between connector (2AG) in the test harness AG and connector (i59). Connector & terminal (2AG) No. 9 — (i59) No. 4: (2AG) No. 8 — (i59) No. 3:	Is the resistance less than 10 Ω ?	Go to step 6.	Repair the bulkhead harness. Or replace the airbag main harness along with body harness.
6 CHECK BODY HARNESS. 1) Turn the ignition switch to ON. 2) Measure the voltage between connector (i59) and chassis ground. Connector & terminal (i59) No. 8 — Chassis ground:	Is the voltage 10 V or more?	Replace the clock. <Ref. to IDI-21, REMOVAL, Clock.>	Repair the clock power supply line.

Diagnostic Chart with Trouble Code

AIRBAG SYSTEM (DIAGNOSTICS)

H: DTC 27 ODS COMMUNICATION ERROR

DTC DETECTING CONDITION:

- Communication to the occupant detection control module is faulty.
- Airbag rear harness circuit is open, shorted, shorted to ground or shorted to power supply.
- Occupant detection harness (seat harness) is faulty.
- Occupant detection system is faulty.
- Airbag control module is faulty.

Step	Check	Yes	No
1 CHECK POOR CONTACT IN CONNECTORS. Check for poor contact of the connectors between the airbag control module and the occupant detection control module.	Is there poor contact?	Reconnect the connector. If defective is not improved, replace the airbag rear harness along with the body harness or the occupant detection harness (seat harness).	Go to step 2.
2 CHECK AIRBAG HARNESS. 1) Turn the ignition switch to OFF, disconnect the battery ground cable, and wait for 20 seconds or more. 2) Disconnect the connectors (AB6, AB17, and AB18) from airbag control module. 3) Disconnect the connectors (AB59) and (AB53) under the passenger's seat. 4) Connect the connector (1AG) in the test harness AG to the connectors (AB6, AB17, and AB18). 5) Connect the connector (1AB) in the test harness AB to the connector (AB53). 6) Measure the resistance between connector (6AG) in the test harness AG and connector (2AB) in the test harness AB. <i>Connector & terminal</i> <i>(6AG) No. 9 — (2AB) No. 1:</i> <i>(6AG) No. 11 — (2AB) No. 2:</i>	Is the resistance less than 10 Ω?	Go to step 3.	Replace the airbag rear harness along with body harness.
3 CHECK AIRBAG HARNESS. Measure the resistance between connector (6AG) in the test harness AG and chassis ground. <i>Connector & terminal</i> <i>(6AG) No. 9 — Chassis ground:</i> <i>(6AG) No. 9 — (6AG) No. 11:</i> <i>(6AG) No. 11 — Chassis ground:</i>	Is the resistance less than 1 MΩ?	Go to step 4.	Replace the airbag rear harness along with body harness.
4 CHECK AIRBAG HARNESS. 1) Turn the ignition switch to ON. 2) Measure the voltage between connector (2AB) in the test harness AB and chassis ground. <i>Connector & terminal</i> <i>(2AB) No. 3 — Chassis ground:</i>	Is the voltage 9 V or more?	Replace the occupant detection harness (seat harness). If defective is not improved, replace the occupant detection system (seat cushion & frame assembly), and then the airbag control module in this order.	Check the battery voltage and fuse. If there is no fault, replace the airbag rear harness along with body harness or replace the body harness.

Diagnostic Chart with Trouble Code

AIRBAG SYSTEM (DIAGNOSTICS)

I: DTC 29 ODS FAILURE

NOTE:

Refer to “Occupant Detection System” for details on DTC 29. <Ref. to OD(diag)-26, DTC 29 ODS FAILURE, Diagnostic Procedure with Diagnostic Trouble Code (DTC).>

J: DTC 2A ODS CALIBRATION ERROR

NOTE:

Refer to “Occupant Detection System” for details on DTC 2A. <Ref. to OD(diag)-23, DTC 2A ODS CALIBRATION ERROR, Diagnostic Procedure with Diagnostic Trouble Code (DTC).>

K: DTC 2B ODS SYSTEM WRONG PARTS

NOTE:

Refer to “Occupant Detection System” for details on DTC 2B. <Ref. to OD(diag)-23, DTC 2B ODS SYSTEM WRONG PARTS, Diagnostic Procedure with Diagnostic Trouble Code (DTC).>

L: DTC 2C BELT TENSION SENSOR FAILURE

NOTE:

Refer to “Occupant Detection System” for details on DTC 2C. <Ref. to OD(diag)-24, DTC 2C BELT TENSION SENSOR FAILURE, Diagnostic Procedure with Diagnostic Trouble Code (DTC).>

M: DTC 33 FRONT SUB SENSOR RH FAILURE

DTC DETECTING CONDITION:

Front sub sensor (RH) is faulty.

If DTC 33 is displayed, the circuit within the front sub sensor (RH) is faulty.

Replace the front sub sensor (RH). <Ref. to AB-24, Front Sub Sensor.>

N: DTC 34 FRONT SUB SENSOR LH FAILURE

DTC DETECTING CONDITION:

Front sub sensor (LH) is faulty.

If DTC 34 is displayed, the circuit within the front sub sensor (LH) is faulty.

Replace the front sub sensor (LH). <Ref. to AB-24, Front Sub Sensor.>

O: DTC 37 BUCKLE SWITCH RH FAILURE

NOTE:

Refer to “Occupant Detection System” for details on DTC 37. <Ref. to OD(diag)-27, DTC 37 BUCKLE SWITCH RH FAILURE, Diagnostic Procedure with Diagnostic Trouble Code (DTC).>

Diagnostic Chart with Trouble Code

AIRBAG SYSTEM (DIAGNOSTICS)

P: DTC 39 SEAT BELT WARNING FAILURE

DTC DETECTING CONDITION:

- Airbag control module is faulty.
- Body integrated unit is faulty.
- Harness circuits between body integrated unit and airbag control module are open, shorted or shorted to ground.

CAUTION:

- Before diagnosing the airbag system, be sure to turn the ignition switch to OFF, disconnect the ground terminal from the battery, and wait 20 seconds or more before starting to work.
- When replacing the airbag module, seat belt pretensioner, roll connector, control module and sensor, reconnect each part and check that the warning light operates properly.
- When inspecting the airbag main harness, disconnect the airbag module connectors of the driver's and passenger's seats for safety.
- When inspecting the airbag rear harness, disconnect the side airbag module connector, curtain airbag module connector and seat belt pretensioner connector for safety reasons.

WIRING DIAGRAM:

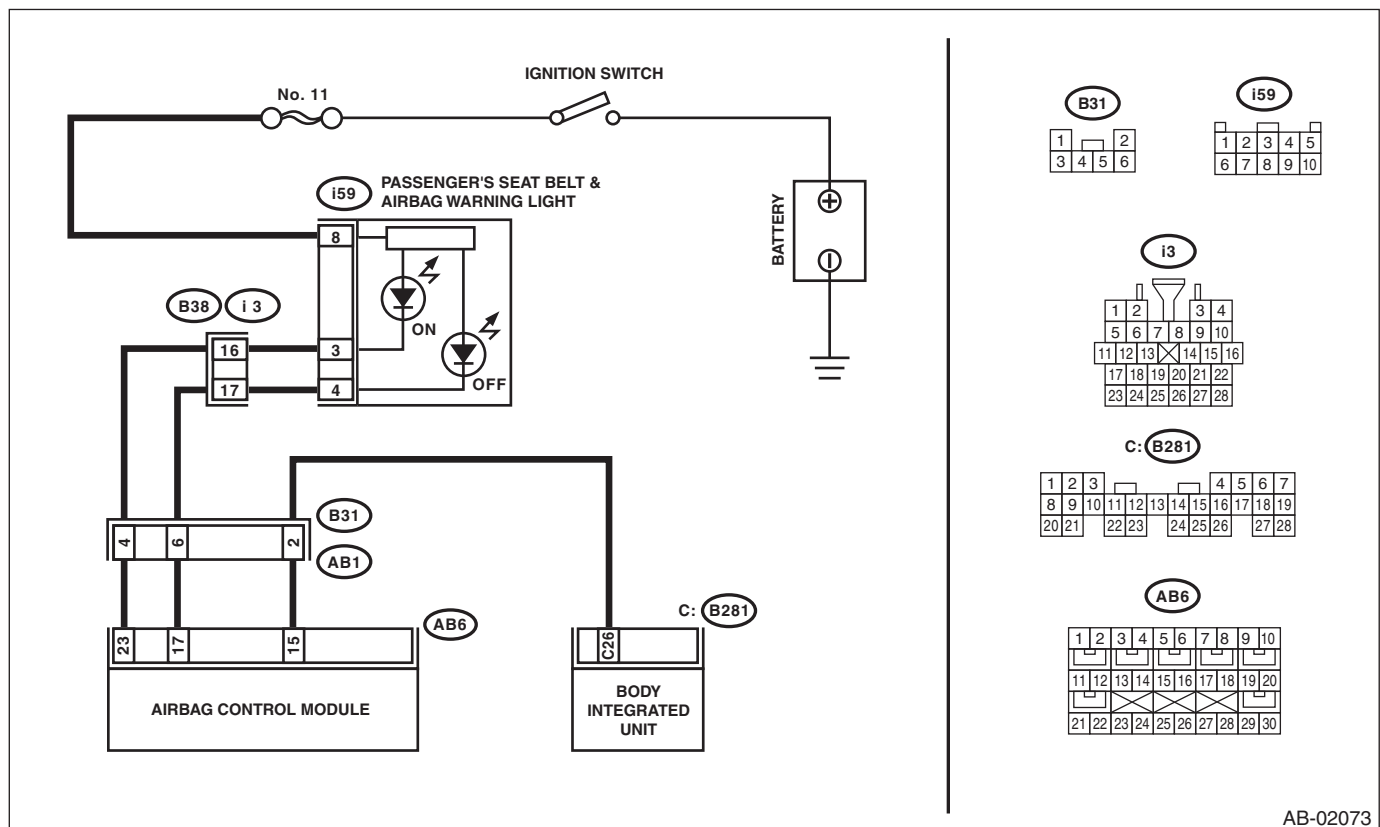

AB-02073

Diagnostic Chart with Trouble Code

AIRBAG SYSTEM (DIAGNOSTICS)

Step	Check	Yes	No
1 CHECK AIRBAG HARNESS. 1) Turn the ignition switch to OFF, disconnect the battery ground cable, and wait for 20 seconds or more. 2) Disconnect the connectors (AB6, AB17, and AB18) from airbag control module. 3) Connect the battery ground terminal and turn the ignition switch to ON.	Does the passenger's seat belt warning light blink for 6 seconds and go off?	Go to step 3.	Go to step 2.
2 CHECK AIRBAG HARNESS. 1) Turn the ignition switch to OFF. 2) Connect the connector (1AG) in the test harness AG to the connectors (AB6, AB17, and AB18). 3) Measure the resistance between connector (2AG) in the test harness AG and chassis ground. <i>Connector & terminal (2AG) No. 10 — Chassis ground:</i>	Is the resistance 1 M Ω or more?	Replace the body integrated unit.	Repair the bulk-head harness. Or replace the airbag main harness along with body harness.
3 CHECK AIRBAG HARNESS. 1) Connect the connectors (7AG) and (8AG) in the test harness AG in the condition of step 2. 2) Turn the ignition switch to ON.	Does the passenger's seat belt warning light blink for 6 seconds, then repeatedly light and go off?	Replace the airbag control module. <Ref. to AB-23, Airbag Control Module.>	Go to step 4.
4 CHECK AIRBAG HARNESS. 1) Disconnect the connectors (7AG) and (8AG) in the test harness AG in the condition of step 3. 2) Measure the resistance between connector (2AG) in the test harness AG and connector (B281). <i>Connector & terminal (2AG) No. 10 — (B281) No. 26:</i>	Is the resistance less than 10 Ω ?	Replace the body integrated unit.	Repair the bulk-head harness. Or replace the airbag main harness along with body harness.

Diagnostic Chart with Trouble Code

AIRBAG SYSTEM (DIAGNOSTICS)

Q: DTC 41 SIDE AIRBAG RH FAILURE

DTC DETECTING CONDITION:

- Side airbag harness (RH) is faulty.
- Side airbag module (RH) is faulty.
- Airbag control module is faulty.

CAUTION:

- Before diagnosing the airbag system, be sure to turn the ignition switch to OFF, disconnect the ground terminal from the battery, and wait 20 seconds or more before starting to work.
- When replacing the airbag module, seat belt pretensioner, roll connector, control module and sensor, reconnect each part and check that the warning light operates properly.
- When inspecting the airbag main harness, disconnect the airbag module connectors of the driver's and passenger's seats for safety.
- When inspecting the airbag rear harness, disconnect the side airbag module connector, curtain airbag module connector and seat belt pretensioner connector for safety reasons.

WIRING DIAGRAM:

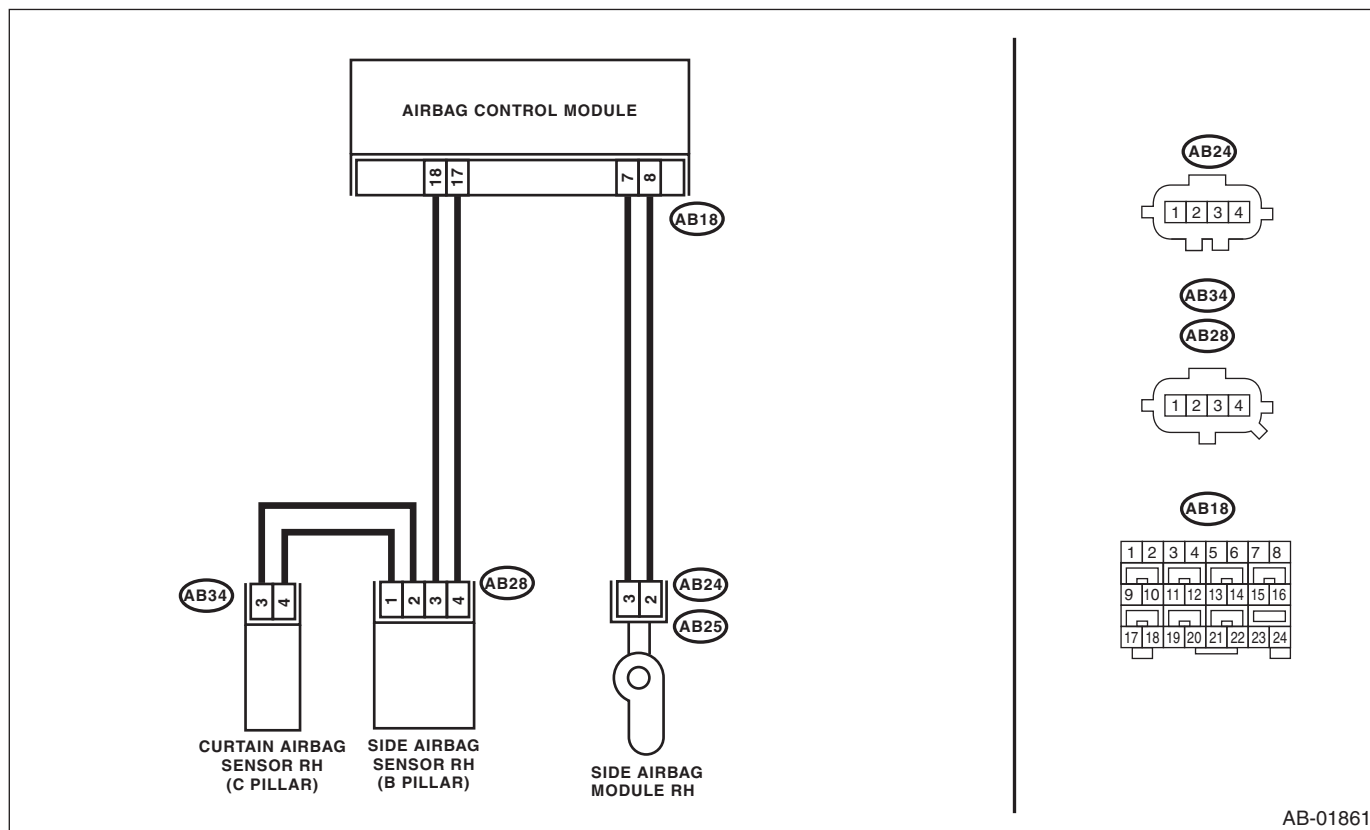

Step	Check	Yes	No	
1	CHECK POOR CONTACT IN CONNECTORS. Check for poor contact of the connectors between the airbag control module, side airbag module RH and the side airbag sensor RH.	Is there poor contact?	Replace the airbag rear harness along with body harness.	Go to step 2.

Diagnostic Chart with Trouble Code

AIRBAG SYSTEM (DIAGNOSTICS)

Step	Check	Yes	No
2 CHECK SIDE AIRBAG MODULE. 1) Turn the ignition switch to OFF, disconnect the battery ground cable, and wait for 20 seconds or more. 2) Disconnect the connectors (AB25) and (AB24), and connect the connector (1AJ) in test harness AJ to connector (AB24). 3) Connect the airbag resistor to the connector (3AJ) of test harness AJ. 4) Connect the battery ground terminal and turn the ignition switch to ON.	Does the airbag warning light illuminate for 6 seconds and go off?	Replace the side airbag module (RH). <Ref. to AB-18, REMOVAL, Side Airbag Module.>	Go to step 3.
3 CHECK AIRBAG REAR HARNESS (SIDE AIRBAG MODULE HARNESS RH). 1) Turn the ignition switch to OFF, disconnect the battery ground cable, and wait for 20 seconds or more. 2) Disconnect the connector (AB26) from seat belt pretensioner (RH). 3) Disconnect the connector (AB33) from curtain airbag module (RH). 4) Disconnect the airbag resistor from test harness AJ. 5) Disconnect the connectors (AB6, AB17, and AB18) from airbag control module. 6) Connect the connector (1AG) in the test harness AG to the connectors (AB6, AB17, and AB18). 7) Measure the resistance between connector (5AG) in the test harness AG and connector (3AJ) in the test harness AJ. <i>Connector & terminal</i> <i>(5AG) No. 5 — (3AJ) No. 2:</i> <i>(5AG) No. 7 — (3AJ) No. 1:</i>	Is the resistance less than 10 Ω?	Go to step 4.	Replace the airbag rear harness along with body harness.
4 CHECK AIRBAG REAR HARNESS (SIDE AIRBAG MODULE HARNESS RH). Measure the resistance between connector (5AG) terminals in the test harness AG. <i>Connector & terminal</i> <i>(5AG) No. 5 — (5AG) No. 7:</i>	Is the resistance 1 MΩ or more?	Go to step 5.	Replace the airbag rear harness along with body harness.
5 CHECK AIRBAG REAR HARNESS (SIDE AIRBAG MODULE HARNESS RH). Measure the resistance between connector (5AG) in the test harness AG and chassis ground. <i>Connector & terminal</i> <i>(5AG) No. 5 — Chassis ground:</i> <i>(5AG) No. 7 — Chassis ground:</i>	Is the resistance 1 MΩ or more?	Go to step 6.	Replace the airbag rear harness along with body harness.
6 CHECK AIRBAG CONTROL MODULE. 1) Connect all connectors. 2) Erase the memory. 3) Perform the Inspection Mode. 4) Read the DTC.	Is the same DTC displayed?	Replace the airbag control module. <Ref. to AB-23, Airbag Control Module.>	Go to step 7.
7 CHECK FOR ANY OTHER DTC ON DISPLAY.	Is any other DTC displayed?	Check DTC using "List of Diagnostic Trouble Code (DTC)". <Ref. to AB(diag)-40, List of Diagnostic Trouble Code (DTC).>	Finish the diagnosis.

Diagnostic Chart with Trouble Code

AIRBAG SYSTEM (DIAGNOSTICS)

R: DTC 42 SIDE AIRBAG LH FAILURE

DTC DETECTING CONDITION:

- Side airbag harness (LH) is faulty.
- Side airbag module (LH) is faulty.
- Airbag control module is faulty.

CAUTION:

- Before diagnosing the airbag system, be sure to turn the ignition switch to OFF, disconnect the ground terminal from the battery, and wait 20 seconds or more before starting to work.
- When replacing the airbag module, seat belt pretensioner, roll connector, control module and sensor, reconnect each part and check that the warning light operates properly.
- When inspecting the airbag main harness, disconnect the airbag module connectors of the driver's and passenger's seats for safety.
- When inspecting the airbag rear harness, disconnect the side airbag module connector, curtain airbag module connector and seat belt pretensioner connector for safety reasons.

WIRING DIAGRAM:

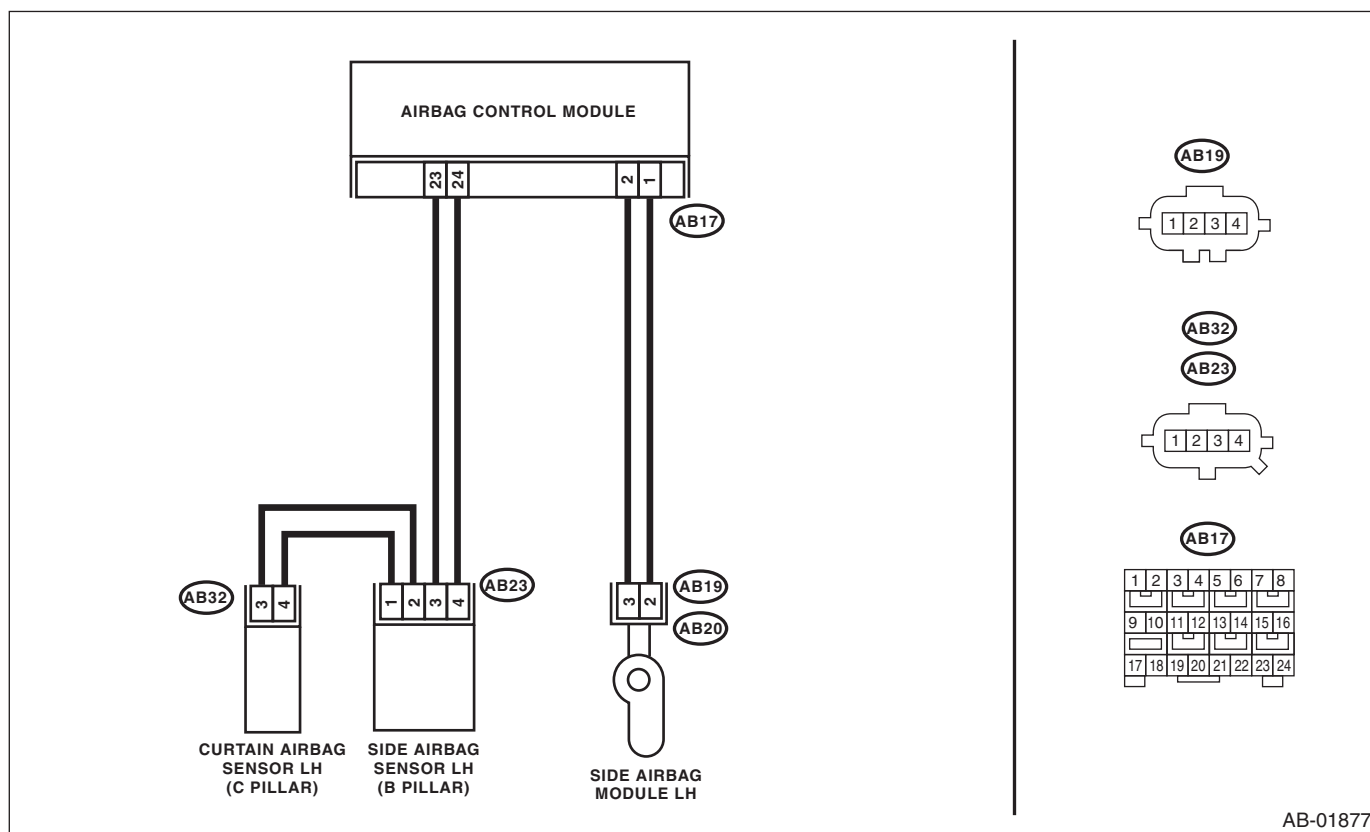

Step	Check	Yes	No
1 CHECK POOR CONTACT IN CONNECTORS. Check for poor contact of the connectors between the airbag control module, side airbag module LH and the side airbag sensor LH.	Is there poor contact?	Replace the airbag rear harness along with body harness.	Go to step 2.

Diagnostic Chart with Trouble Code

AIRBAG SYSTEM (DIAGNOSTICS)

Step	Check	Yes	No
2 CHECK SIDE AIRBAG MODULE. 1) Turn the ignition switch to OFF, disconnect the battery ground cable, and wait for 20 seconds or more. 2) Disconnect the connectors (AB20) and (AB19), and connect the connector (1AJ) in test harness AJ to connector (AB19). 3) Connect the airbag resistor to the connector (3AJ) of test harness AJ. 4) Connect the battery ground terminal and turn the ignition switch to ON.	Does the airbag warning light illuminate for 6 seconds and go off?	Replace the side airbag module (LH). <Ref. to AB-18, REMOVAL, Side Airbag Module.>	Go to step 3.
3 CHECK AIRBAG REAR HARNESS (SIDE AIRBAG MODULE HARNESS LH). 1) Turn the ignition switch to OFF, disconnect the battery ground cable, and wait for 20 seconds or more. 2) Disconnect the connector (AB21) from seat belt pretensioner (LH). 3) Disconnect the connector (AB31) from curtain airbag module (LH). 4) Disconnect the airbag resistor from test harness. 5) Disconnect the connectors (AB6, AB17, and AB18) from airbag control module. 6) Connect the connector (1AG) in the test harness AG to the connectors (AB6, AB17, and AB18). 7) Measure the resistance between connector (5AG) in the test harness AG and connector (3AJ) in the test harness AJ. Connector & terminal (5AG) No. 1 — (3AJ) No. 1: (5AG) No. 3 — (3AJ) No. 2:	Is the resistance less than 10 Ω?	Go to step 4.	Replace the airbag rear harness along with body harness.
4 CHECK AIRBAG REAR HARNESS (SIDE AIRBAG MODULE HARNESS LH). Measure the resistance between connector (5AG) terminals in the test harness AG. Connector & terminal (5AG) No. 1 — (5AG) No. 3:	Is the resistance 1 MΩ or more?	Go to step 5.	Replace the airbag rear harness along with body harness.
5 CHECK AIRBAG REAR HARNESS (SIDE AIRBAG MODULE HARNESS LH). Measure the resistance between connector (5AG) in the test harness AG and chassis ground. Connector & terminal (5AG) No. 1 — Chassis ground: (5AG) No. 3 — Chassis ground:	Is the resistance 1 MΩ or more?	Go to step 6.	Replace the airbag rear harness along with body harness.
6 CHECK AIRBAG CONTROL MODULE. 1) Connect all connectors. 2) Erase the memory. 3) Perform the Inspection Mode. 4) Read the DTC.	Is the same DTC displayed?	Replace the airbag control module. <Ref. to AB-23, Airbag Control Module.>	Go to step 7.
7 CHECK FOR ANY OTHER DTC ON DISPLAY.	Is any other DTC displayed?	Check DTC using "List of Diagnostic Trouble Code (DTC)". <Ref. to AB(diag)-40, List of Diagnostic Trouble Code (DTC).>	Finish the diagnosis.

Diagnostic Chart with Trouble Code

AIRBAG SYSTEM (DIAGNOSTICS)

S: DTC 45 SIDE AIRBAG RH FAILURE

DTC DETECTING CONDITION:

- Side airbag harness (RH) is shorted to power supply.
- Airbag control module is faulty.

CAUTION:

- Before diagnosing the airbag system, be sure to turn the ignition switch to OFF, disconnect the ground terminal from the battery, and wait 20 seconds or more before starting to work.
- When replacing the airbag module, seat belt pretensioner, roll connector, control module and sensor, reconnect each part and check that the warning light operates properly.
- When inspecting the airbag main harness, disconnect the airbag module connectors of the driver's and passenger's seats for safety.
- When inspecting the airbag rear harness, disconnect the side airbag module connector, curtain airbag module connector and seat belt pretensioner connector for safety reasons.

WIRING DIAGRAM:

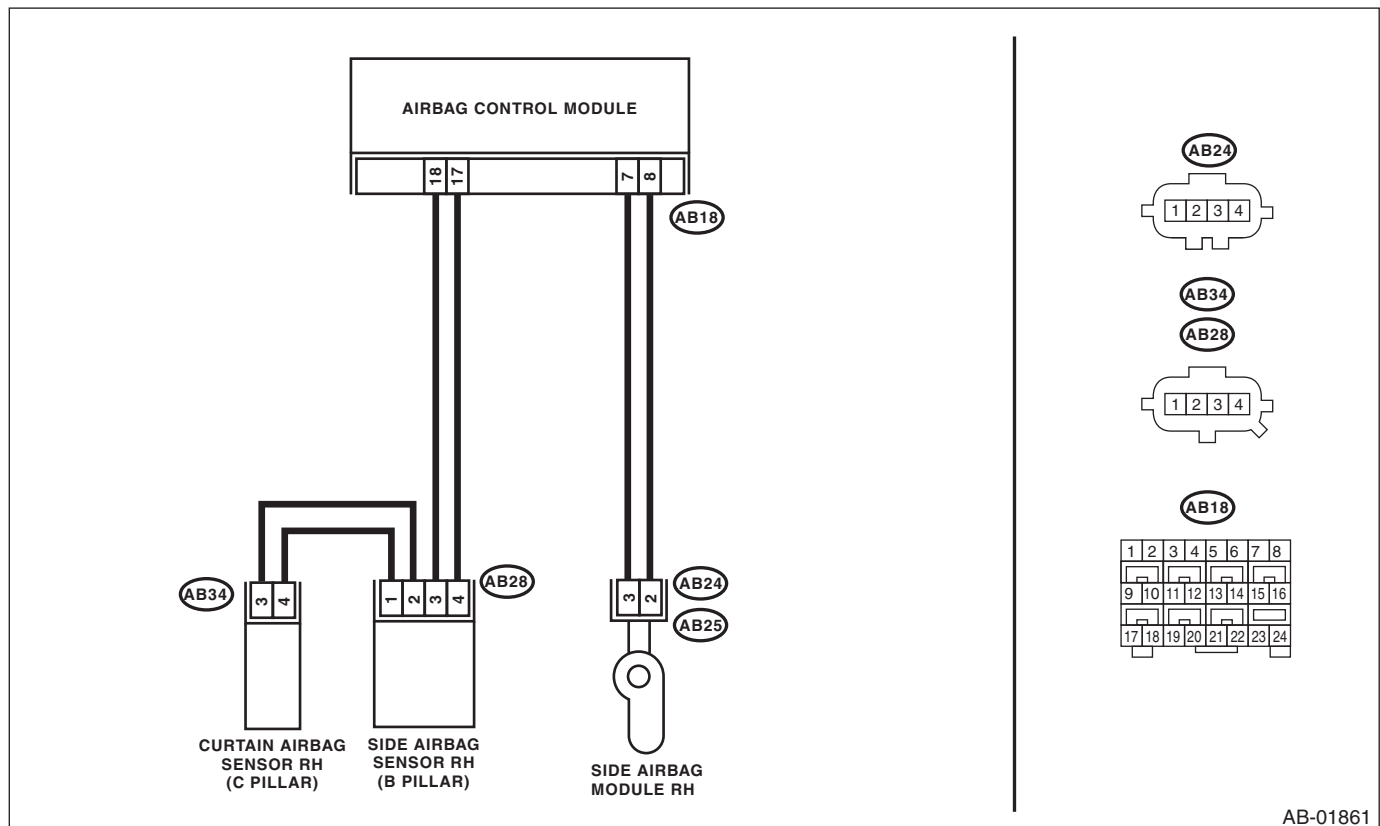

AB-01861

Diagnostic Chart with Trouble Code

AIRBAG SYSTEM (DIAGNOSTICS)

Step	Check	Yes	No
1 CHECK POOR CONTACT IN CONNECTORS. Check for poor contact of the connectors between the airbag control module, side airbag module RH and the side airbag sensor RH.	Is there poor contact?	Replace the airbag rear harness along with body harness.	Go to step 2.
2 CHECK SIDE AIRBAG MODULE. 1) Turn the ignition switch to OFF, disconnect the battery ground cable, and wait for 20 seconds or more. 2) Disconnect the connectors (AB25) and (AB24), and connect the connector (1AJ) in test harness AJ to connector (AB24). 3) Connect the airbag resistor to the connector (3AJ) of test harness AJ. 4) Connect the battery ground terminal and turn the ignition switch to ON.	Does the airbag warning light illuminate for 6 seconds and go off?	Replace the side airbag module (RH). <Ref. to AB-18, REMOVAL, Side Airbag Module.>	Go to step 3.
3 CHECK AIRBAG REAR HARNESS (SIDE AIRBAG MODULE HARNESS RH). 1) Turn the ignition switch to OFF, disconnect the battery ground cable, and wait for 20 seconds or more. 2) Disconnect the connector (AB26) from seat belt pretensioner (RH). 3) Disconnect the connector (AB33) from curtain airbag module (RH). 4) Disconnect the airbag resistor from test harness. 5) Disconnect the connectors (AB6, AB17, and AB18) from airbag control module. 6) Connect the connector (1AG) in the test harness AG to the connectors (AB6, AB17, and AB18). 7) Connect the battery ground terminal and turn the ignition switch to ON. 8) Measure the voltage between connector (5AG) in the test harness AG and chassis ground. Connector & terminal (5AG) No. 5 (+) — Chassis ground (-): (5AG) No. 7 (+) — Chassis ground (-):	Is the voltage less than 1 V?	Go to step 4.	Replace the airbag rear harness along with body harness.
4 CHECK AIRBAG CONTROL MODULE. 1) Connect all connectors. 2) Erase the memory. 3) Perform the Inspection Mode. 4) Read the DTC.	Is the same DTC displayed?	Replace the airbag control module. <Ref. to AB-23, Airbag Control Module.>	Go to step 5.
5 CHECK FOR ANY OTHER DTC ON DISPLAY.	Is any other DTC displayed?	Check DTC using "List of Diagnostic Trouble Code (DTC)". <Ref. to AB(diag)-40, List of Diagnostic Trouble Code (DTC).>	Finish the diagnosis.

Diagnostic Chart with Trouble Code

AIRBAG SYSTEM (DIAGNOSTICS)

T: DTC 46 SIDE AIRBAG LH FAILURE

DTC DETECTING CONDITION:

- Side airbag harness (LH) is shorted to power supply.
- Airbag control module is faulty.

CAUTION:

- Before diagnosing the airbag system, be sure to turn the ignition switch to OFF, disconnect the ground terminal from the battery, and wait 20 seconds or more before starting to work.
- When replacing the airbag module, seat belt pretensioner, roll connector, control module and sensor, reconnect each part and check that the warning light operates properly.
- When inspecting the airbag main harness, disconnect the airbag module connectors of the driver's and passenger's seats for safety.
- When inspecting the airbag rear harness, disconnect the side airbag module connector, curtain airbag module connector and seat belt pretensioner connector for safety reasons.

WIRING DIAGRAM:

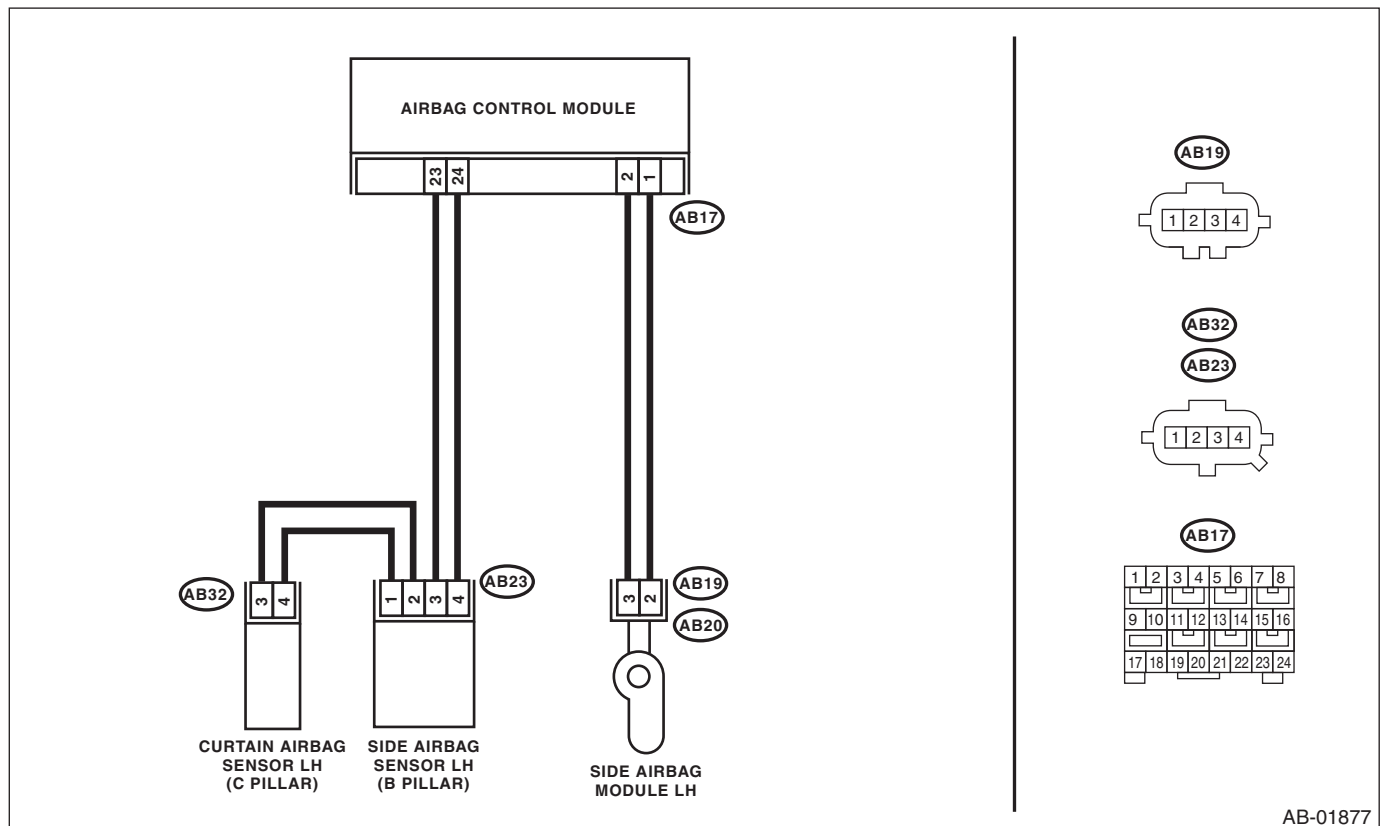

AB-01877

Diagnostic Chart with Trouble Code

AIRBAG SYSTEM (DIAGNOSTICS)

Step	Check	Yes	No
1 CHECK POOR CONTACT IN CONNECTORS. Check for poor contact of the connectors between the airbag control module, side airbag module LH and the side airbag sensor LH.	Is there poor contact?	Replace the airbag rear harness along with body harness.	Go to step 2.
2 CHECK SIDE AIRBAG MODULE. 1) Turn the ignition switch to OFF, disconnect the battery ground cable, and wait for 20 seconds or more. 2) Disconnect the connectors (AB20) and (AB19), and connect the connector (1AJ) in test harness AJ to connector (AB19). 3) Connect the airbag resistor to the connector (3AJ) of test harness AJ. 4) Connect the battery ground terminal and turn the ignition switch to ON.	Does the airbag warning light illuminate for 6 seconds and go off?	Replace the side airbag module (LH). <Ref. to AB-18, REMOVAL, Side Airbag Module.>	Go to step 3.
3 CHECK AIRBAG REAR HARNESS (SIDE AIRBAG MODULE HARNESS LH). 1) Turn the ignition switch to OFF, disconnect the battery ground cable, and wait for 20 seconds or more. 2) Disconnect the connector (AB21) from seat belt pretensioner (LH). 3) Disconnect the connector (AB31) from curtain airbag module (LH). 4) Disconnect the airbag resistor from test harness. 5) Disconnect the connectors (AB6, AB17, and AB18) from airbag control module. 6) Connect the connector (1AG) in the test harness AG to the connectors (AB6, AB17, and AB18). 7) Connect the battery ground terminal and turn the ignition switch to ON. 8) Measure the voltage between connector (5AG) in the test harness AG and chassis ground. Connector & terminal (5AG) No. 3 (+) — Chassis ground (-): (5AG) No. 1 (+) — Chassis ground (-):	Is the voltage less than 1 V?	Go to step 4.	Replace the airbag rear harness along with body harness.
4 CHECK AIRBAG CONTROL MODULE. 1) Connect all connectors. 2) Erase the memory. 3) Perform the Inspection Mode. 4) Read the DTC.	Is the same DTC displayed?	Replace the airbag control module. <Ref. to AB-23, Airbag Control Module.>	Go to step 5.
5 CHECK FOR ANY OTHER DTC ON DISPLAY.	Is any other DTC displayed?	Check DTC using "List of Diagnostic Trouble Code (DTC)". <Ref. to AB(diag)-40, List of Diagnostic Trouble Code (DTC).>	Finish the diagnosis.

Diagnostic Chart with Trouble Code

AIRBAG SYSTEM (DIAGNOSTICS)

U: DTC 53 SIDE AIRBAG SENSOR RH FAILURE

DTC DETECTING CONDITION:

Side airbag sensor (RH) is faulty.

When DTC 53 is displayed, the circuit within the side airbag sensor (RH) is faulty.

Replace the side airbag sensor (RH). <Ref. to AB-25, Side Airbag Sensor.>

V: DTC 54 SIDE AIRBAG SENSOR LH FAILURE

DTC DETECTING CONDITION:

Side airbag sensor (LH) is faulty.

When DTC 54 is displayed, the circuit within the side airbag sensor (LH) is faulty.

Replace the side airbag sensor (LH). <Ref. to AB-25, Side Airbag Sensor.>

W: DTC 55 SIDE CURTAIN AIRBAG FIRING OUTPUT

This DTC is displayed when the side airbag module and curtain airbag module are deployed.

Once this DTC is displayed, the memory cannot be cleared. Replace the following parts.

- Airbag control module <Ref. to AB-23, Airbag Control Module.>
- Front seat with side airbag module (Operating side) <Ref. to SE-8, Front Seat.>
- Side airbag sensor (Operating side) <Ref. to AB-25, Side Airbag Sensor.>
- Curtain airbag module (Operating side) <Ref. to AB-21, Curtain Airbag Module.>
- Curtain airbag sensor (Operating side) <Ref. to AB-26, Curtain Airbag Sensor.>
- Satellite safing sensor <Ref. to AB-27, Satellite Safing Sensor.>

X: DTC 58 CURTAIN AIRBAG SENSOR RH FAILURE

DTC DETECTING CONDITION:

Curtain airbag sensor (RH) is faulty.

If DTC 58 is displayed, the circuit within the curtain airbag sensor (RH) is faulty.

Replace the curtain airbag sensor (RH). <Ref. to AB-26, Curtain Airbag Sensor.>

Y: DTC 59 CURTAIN AIRBAG SENSOR LH FAILURE

DTC DETECTING CONDITION:

Curtain airbag sensor (LH) is faulty.

If DTC 59 is displayed, the circuit within the curtain airbag sensor (LH) is faulty.

Replace the curtain airbag sensor (LH). <Ref. to AB-26, Curtain Airbag Sensor.>

Diagnostic Chart with Trouble Code

AIRBAG SYSTEM (DIAGNOSTICS)

Z: DTC 61 BELT PRETENSIONER RH FAILURE

DTC DETECTING CONDITION:

- Seat belt pretensioner (RH) circuit is open, shorted or shorted to ground.
- Airbag control module is faulty.
- Pretensioner is faulty.
- Pretensioner harness is faulty.

CAUTION:

- Before diagnosing the airbag system, be sure to turn the ignition switch to OFF, disconnect the ground terminal from the battery, and wait 20 seconds or more before starting to work.
- When replacing the airbag module, seat belt pretensioner, roll connector, control module and sensor, reconnect each part and check that the warning light operates properly.
- When inspecting the airbag main harness, disconnect the airbag module connectors of the driver's and passenger's seats for safety.
- When inspecting the airbag rear harness, disconnect the side airbag module connector, curtain airbag module connector and seat belt pretensioner connector for safety reasons.

WIRING DIAGRAM:

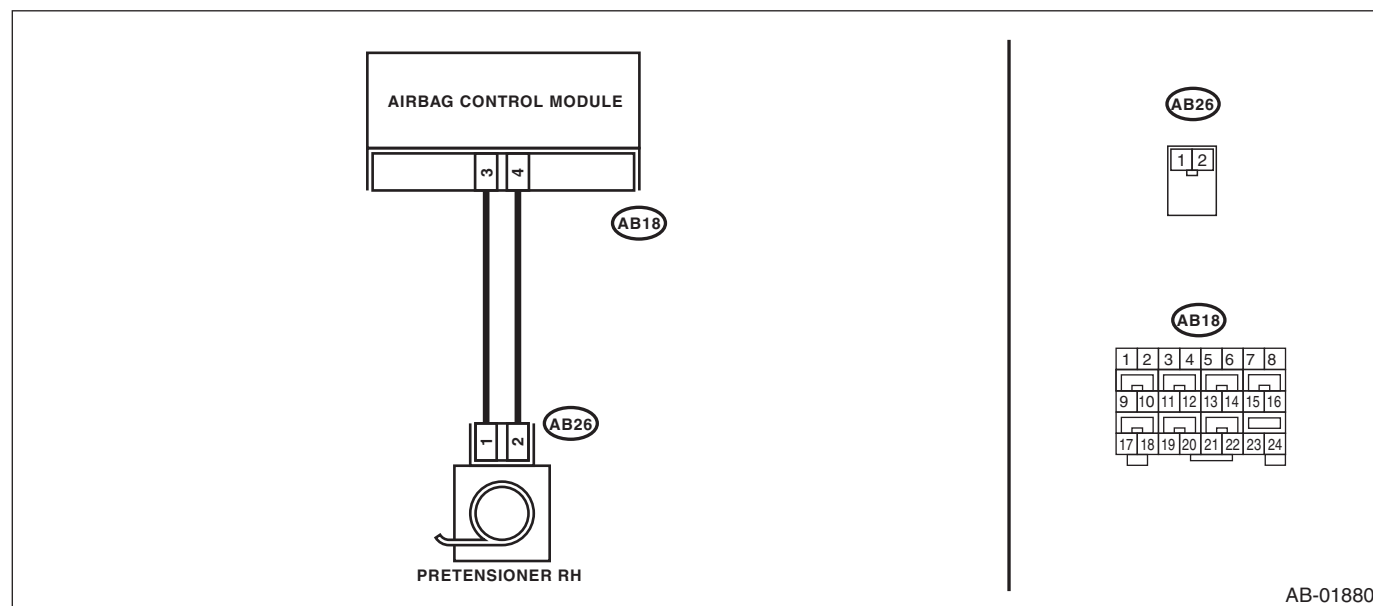

Step	Check	Yes	No
1 CHECK POOR CONTACT IN CONNECTORS. Check for poor contact of the connectors between the airbag control module and the seat belt pretensioner RH.	Is there poor contact?	Replace the airbag rear harness along with body harness.	Go to step 2.
2 CHECK SEAT BELT PRETENSIONER. 1) Turn the ignition switch to OFF, disconnect the battery ground cable, and wait for 20 seconds or more. 2) Disconnect the connector (AB26) from seat belt pretensioner (RH). 3) Connect the connector (1N) in the test harness N to the connector (AB26). 4) Connect the airbag resistor to the connector (2N) of test harness N. 5) Connect the battery ground terminal and turn the ignition switch to ON.	Does the airbag warning light illuminate for 6 seconds and go off?	Replace the seat belt pretensioner (RH). <Ref. to SB-17, Front Seat Belt.>	Go to step 3.

Diagnostic Chart with Trouble Code

AIRBAG SYSTEM (DIAGNOSTICS)

Step	Check	Yes	No
3 CHECK AIRBAG REAR HARNESS (PRE-TENSIONER HARNESS RH). 1) Turn the ignition switch to OFF, disconnect the battery ground cable, and wait for 20 seconds or more. 2) Disconnect the airbag resistor from test harness. 3) Disconnect connector (AB24) from side airbag module (RH). 4) Disconnect the connector (AB33) from curtain airbag module (RH). 5) Disconnect the connectors (AB6, AB17, and AB18) from airbag control module. 6) Connect the connector (1AG) in the test harness AG to the connectors (AB6, AB17, and AB18). 7) Measure the resistance between connector (3AG) in the test harness AG and connector (2N) in the test harness N. <i>Connector & terminal</i> <i>(3AG) No. 18 — (2N) No. 2:</i> <i>(3AG) No. 20 — (2N) No. 1:</i>	Is the resistance less than 10 Ω?	Go to step 4.	Replace the airbag rear harness along with body harness.
4 CHECK AIRBAG REAR HARNESS (PRE-TENSIONER HARNESS RH). Measure the resistance between connector (3AG) terminals in the test harness AG. <i>Connector & terminal</i> <i>(3AG) No. 18 — (3AG) No. 20:</i>	Is the resistance 1 MΩ or more?	Go to step 5.	Replace the airbag rear harness along with body harness.
5 CHECK AIRBAG REAR HARNESS (PRE-TENSIONER HARNESS RH). Measure the resistance between connector (3AG) in the test harness AG and chassis ground. <i>Connector & terminal</i> <i>(3AG) No. 18 — Chassis ground:</i> <i>(3AG) No. 20 — Chassis ground:</i>	Is the resistance 1 MΩ or more?	Go to step 6.	Replace the airbag rear harness along with body harness.
6 CHECK AIRBAG CONTROL MODULE. 1) Connect all connectors. 2) Erase the memory. 3) Perform the Inspection Mode. 4) Read the DTC.	Is the same DTC displayed?	Replace the airbag control module. <Ref. to AB-23, Airbag Control Module.>	Go to step 7.
7 CHECK FOR ANY OTHER DTC ON DISPLAY.	Is any other DTC displayed?	Check DTC using "List of Diagnostic Trouble Code (DTC)". <Ref. to AB(diag)-40, List of Diagnostic Trouble Code (DTC).>	Finish the diagnosis.

Diagnostic Chart with Trouble Code

AIRBAG SYSTEM (DIAGNOSTICS)

AA:DTC 62 BELT PRETENSIONER LH FAILURE

DTC DETECTING CONDITION:

- Seat belt pretensioner (LH) circuit is open, shorted or shorted to ground.
- Airbag control module is faulty.
- Pretensioner is faulty.
- Pretensioner harness is faulty.

CAUTION:

- Before diagnosing the airbag system, be sure to turn the ignition switch to OFF, disconnect the ground terminal from the battery, and wait 20 seconds or more before starting to work.
- When replacing the airbag module, seat belt pretensioner, roll connector, control module and sensor, reconnect each part and check that the warning light operates properly.
- When inspecting the airbag main harness, disconnect the airbag module connectors of the driver's and passenger's seats for safety.
- When inspecting the airbag rear harness, disconnect the side airbag module connector, curtain airbag module connector and seat belt pretensioner connector for safety reasons.

WIRING DIAGRAM:

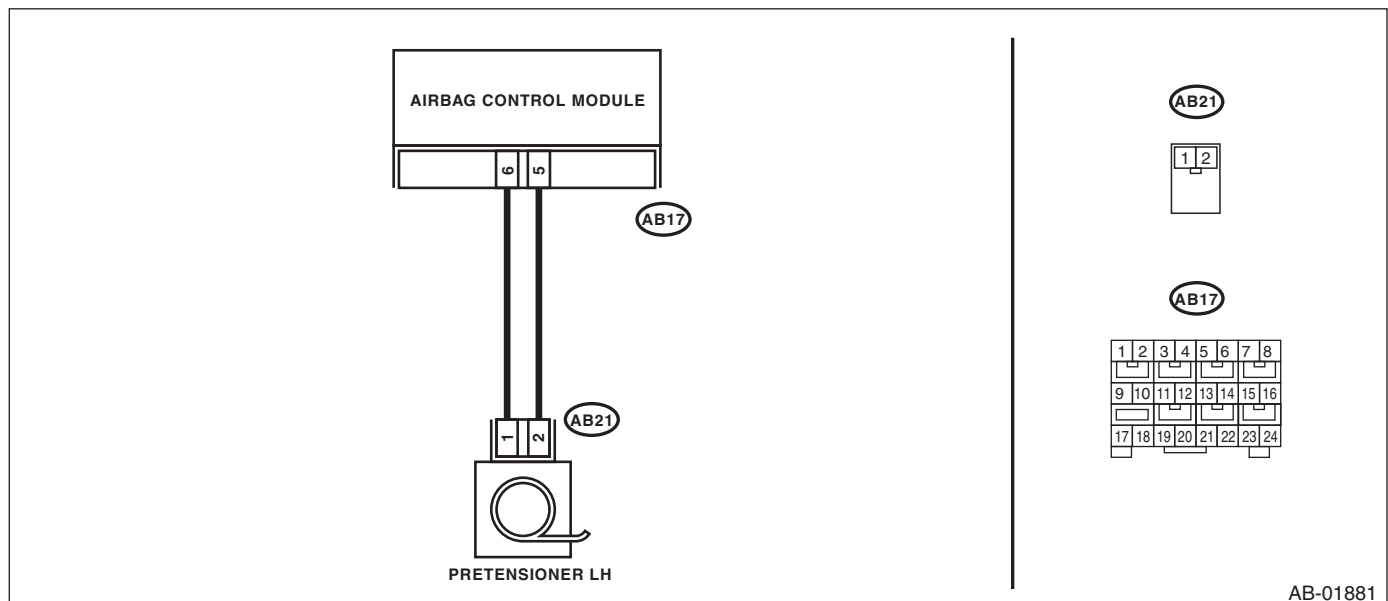

AB-01881

Step	Check	Yes	No
1 CHECK POOR CONTACT IN CONNECTORS. Check for poor contact of the connectors between the airbag control module and the seat belt pretensioner LH.	Is there poor contact?	Replace the airbag rear harness along with body harness.	Go to step 2.
2 CHECK SEAT BELT PRETENSIONER. 1) Turn the ignition switch to OFF, disconnect the battery ground cable, and wait for 20 seconds or more. 2) Disconnect the connector (AB21) from seat belt pretensioner (LH). 3) Connect the connector (1N) in the test harness N to the connector (AB21). 4) Connect the airbag resistor to the connector (2N) of test harness N. 5) Connect the battery ground terminal and turn the ignition switch to ON.	Does the airbag warning light illuminate for 6 seconds and go off?	Replace the seat belt pretensioner (LH). <Ref. to SB-17, Front Seat Belt.>	Go to step 3.

Diagnostic Chart with Trouble Code

AIRBAG SYSTEM (DIAGNOSTICS)

Step	Check	Yes	No
3 CHECK AIRBAG REAR HARNESS (PRE-TENSIONER HARNESS LH). 1) Turn the ignition switch to OFF, disconnect the battery ground cable, and wait for 20 seconds or more. 2) Disconnect the airbag resistor from test harness. 3) Disconnect connector (AB19) from side airbag module (LH). 4) Disconnect the connector (AB31) from curtain airbag module (LH). 5) Disconnect the connectors (AB6, AB17, and AB18) from airbag control module. 6) Connect the connector (1AG) in the test harness AG to the connectors (AB6, AB17, and AB18). 7) Measure the resistance between connector (3AG) in the test harness AG and connector (2N) in the test harness N. <i>Connector & terminal</i> <i>(3AG) No. 12 — (2N) No. 2:</i> <i>(3AG) No. 10 — (2N) No. 1:</i>	Is the resistance less than 10 Ω?	Go to step 4.	Replace the airbag rear harness along with body harness.
4 CHECK AIRBAG REAR HARNESS (PRE-TENSIONER HARNESS LH). Measure the resistance between connector (3AG) terminals in the test harness AG. <i>Connector & terminal</i> <i>(3AG) No. 10 — (3AG) No. 12:</i>	Is the resistance 1 MΩ or more?	Go to step 5.	Replace the airbag rear harness along with body harness.
5 CHECK AIRBAG REAR HARNESS (PRE-TENSIONER HARNESS LH). Measure the resistance between connector (3AG) in the test harness AG and chassis ground. <i>Connector & terminal</i> <i>(3AG) No. 10 — Chassis ground:</i> <i>(3AG) No. 12 — Chassis ground:</i>	Is the resistance 1 MΩ or more?	Go to step 6.	Replace the airbag rear harness along with body harness.
6 CHECK AIRBAG CONTROL MODULE. 1) Connect all connectors. 2) Erase the memory. 3) Perform the Inspection Mode. 4) Read the DTC.	Is the same DTC displayed?	Replace the airbag control module. <Ref. to AB-23, Airbag Control Module.>	Go to step 7.
7 CHECK FOR ANY OTHER DTC ON DISPLAY.	Is any other DTC displayed?	Check DTC using "List of Diagnostic Trouble Code (DTC)". <Ref. to AB(diag)-40, List of Diagnostic Trouble Code (DTC).>	Finish the diagnosis.

Diagnostic Chart with Trouble Code

AIRBAG SYSTEM (DIAGNOSTICS)

AB:DTC 65 BELT PRETENSIONER RH FAILURE

DTC DETECTING CONDITION:

- Seat belt pretensioner (RH) circuit is shorted to power supply.
- Pretensioner is faulty.
- Pretensioner harness is faulty.
- Airbag control module is faulty.

CAUTION:

- Before diagnosing the airbag system, be sure to turn the ignition switch to OFF, disconnect the ground terminal from the battery, and wait 20 seconds or more before starting to work.
- When replacing the airbag module, seat belt pretensioner, roll connector, control module and sensor, reconnect each part and check that the warning light operates properly.
- When inspecting the airbag main harness, disconnect the airbag module connectors of the driver's and passenger's seats for safety.
- When inspecting the airbag rear harness, disconnect the side airbag module connector, curtain airbag module connector and seat belt pretensioner connector for safety reasons.

WIRING DIAGRAM:

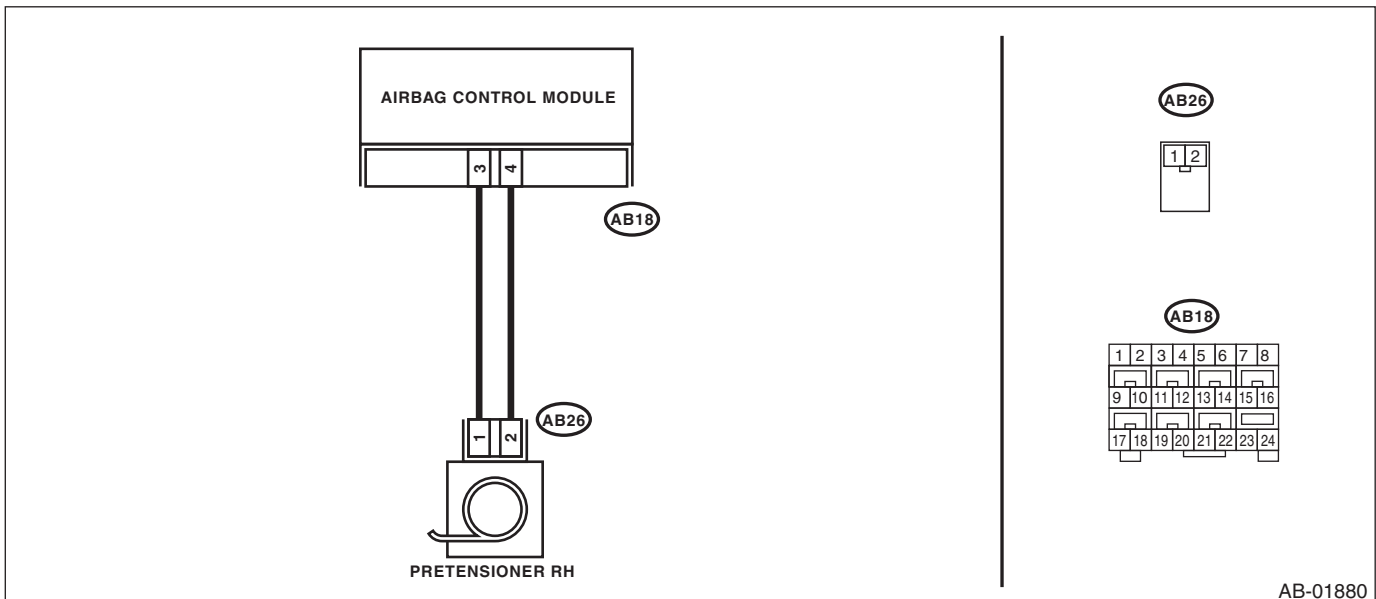

AB-01880

Diagnostic Chart with Trouble Code

AIRBAG SYSTEM (DIAGNOSTICS)

Step	Check	Yes	No
1 CHECK POOR CONTACT IN CONNECTORS. Check for poor contact of the connectors between the airbag control module and the seat belt pretensioner RH.	Is there poor contact?	Replace the airbag rear harness along with body harness.	Go to step 2.
2 CHECK SEAT BELT PRETENSIONER. 1) Turn the ignition switch to OFF, disconnect the battery ground cable, and wait for 20 seconds or more. 2) Disconnect the connector (AB26) from seat belt pretensioner (RH). 3) Connect the connector (1N) in the test harness N to the connector (AB26). 4) Connect the airbag resistor to the connector (2N) of test harness N. 5) Connect the battery ground terminal and turn the ignition switch to ON.	Does the airbag warning light illuminate for 6 seconds and go off?	Replace the seat belt pretensioner (RH). <Ref. to SB-17, Front Seat Belt.>	Go to step 3.
3 CHECK AIRBAG REAR HARNESS (PRETENSIONER HARNESS RH). 1) Turn the ignition switch to OFF, disconnect the battery ground cable, and wait for 20 seconds or more. 2) Disconnect the airbag resistor from test harness. 3) Disconnect connector (AB24) from side airbag module (RH). 4) Disconnect the connector (AB33) from curtain airbag module (RH). 5) Disconnect the connectors (AB6, AB17, and AB18) from airbag control module. 6) Connect the connector (1AG) in the test harness AG to the connectors (AB6, AB17, and AB18). 7) Connect the battery ground terminal and turn the ignition switch to ON. 8) Measure the voltage between connector (3AG) in the test harness AG and chassis ground. Connector & terminal (3AG) No. 20 (+) — Chassis ground (-): (3AG) No. 18 (+) — Chassis ground (-):	Is the voltage less than 1 V?	Go to step 4.	Replace the airbag rear harness along with body harness.
4 CHECK AIRBAG CONTROL MODULE. 1) Connect all connectors. 2) Erase the memory. 3) Perform the Inspection Mode. 4) Read the DTC.	Is the same DTC displayed?	Replace the airbag control module. <Ref. to AB-23, Airbag Control Module.>	Go to step 5.
5 CHECK FOR ANY OTHER DTC ON DISPLAY.	Is any other DTC displayed?	Check DTC using "List of Diagnostic Trouble Code (DTC)". <Ref. to AB(diag)-40, List of Diagnostic Trouble Code (DTC).>	Finish the diagnosis.

Diagnostic Chart with Trouble Code

AIRBAG SYSTEM (DIAGNOSTICS)

AC:DTC 66 BELT PRETENSIONER LH FAILURE

DTC DETECTING CONDITION:

- Seat belt pretensioner (LH) circuit is shorted to power supply.
- Pretensioner is faulty.
- Pretensioner harness is faulty.
- Airbag control module is faulty.

CAUTION:

- Before diagnosing the airbag system, be sure to turn the ignition switch to OFF, disconnect the ground terminal from the battery, and wait 20 seconds or more before starting to work.
- When replacing the airbag module, seat belt pretensioner, roll connector, control module and sensor, reconnect each part and check that the warning light operates properly.
- When inspecting the airbag main harness, disconnect the airbag module connectors of the driver's and passenger's seats for safety.
- When inspecting the airbag rear harness, disconnect the side airbag module connector, curtain airbag module connector and seat belt pretensioner connector for safety reasons.

WIRING DIAGRAM:

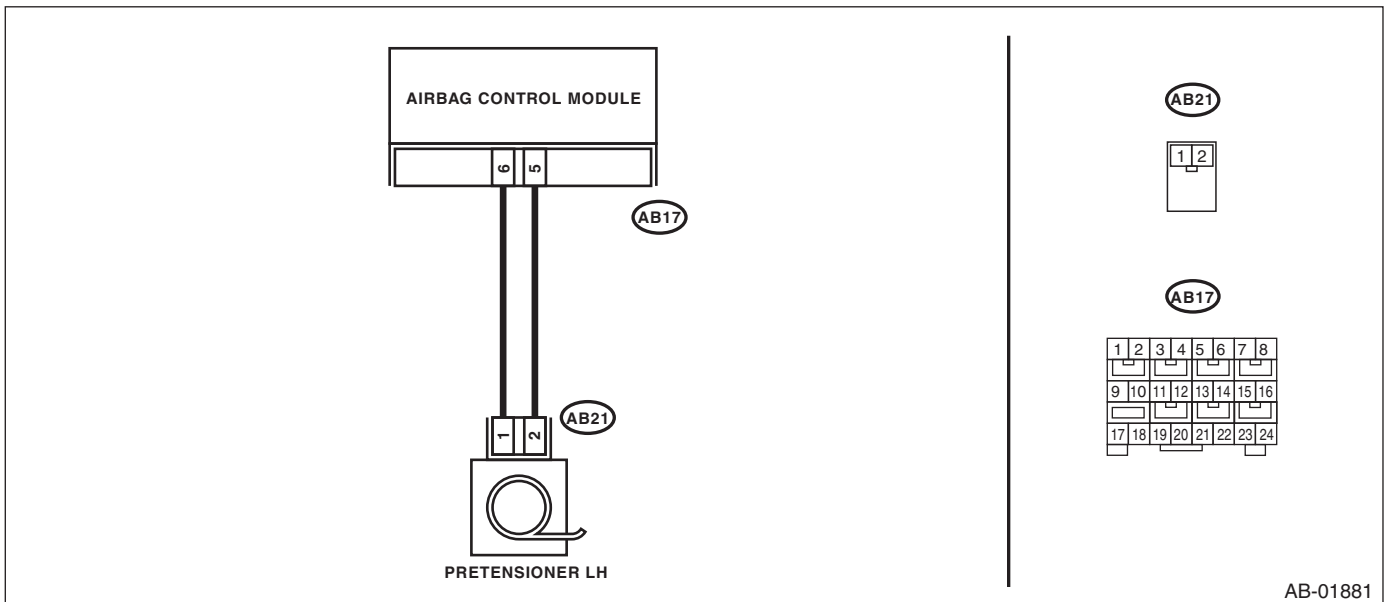

Diagnostic Chart with Trouble Code

AIRBAG SYSTEM (DIAGNOSTICS)

Step	Check	Yes	No
1 CHECK POOR CONTACT IN CONNECTORS. Check for poor contact of the connectors between the airbag control module and the seat belt pretensioner LH.	Is there poor contact?	Replace the airbag rear harness along with body harness.	Go to step 2.
2 CHECK SEAT BELT PRETENSIONER. 1) Turn the ignition switch to OFF, disconnect the battery ground cable, and wait for 20 seconds or more. 2) Disconnect the connector (AB21) from seat belt pretensioner (LH). 3) Connect the connector (1N) in the test harness N to the connector (AB21). 4) Connect the airbag resistor to the connector (2N) of test harness N. 5) Connect the battery ground terminal and turn the ignition switch to ON.	Does the airbag warning light illuminate for 6 seconds and go off?	Replace the seat belt pretensioner (LH). <Ref. to SB-17, Front Seat Belt.>	Go to step 3.
3 CHECK AIRBAG REAR HARNESS (PRETENSIONER HARNESS LH). 1) Turn the ignition switch to OFF, disconnect the battery ground cable, and wait for 20 seconds or more. 2) Disconnect the airbag resistor from test harness. 3) Disconnect connector (AB19) from side airbag module (LH). 4) Disconnect the connector (AB31) from curtain airbag module (LH). 5) Disconnect the connectors (AB6, AB17, and AB18) from airbag control module. 6) Connect the connector (1AG) in the test harness AG to the connectors (AB6, AB17, and AB18). 7) Connect the battery ground terminal and turn the ignition switch to ON. 8) Measure the voltage between connector (3AG) in the test harness AG and chassis ground. Connector & terminal (3AG) No. 10 (+) — Chassis ground (-): (3AG) No. 12 (+) — Chassis ground (-):	Is the voltage less than 1 V?	Go to step 4.	Replace the airbag rear harness along with body harness.
4 CHECK AIRBAG CONTROL MODULE. 1) Connect all connectors. 2) Erase the memory. 3) Perform the Inspection Mode. 4) Read the DTC.	Is the same DTC displayed?	Replace the airbag control module. <Ref. to AB-23, Airbag Control Module.>	Go to step 5.
5 CHECK FOR ANY OTHER DTC ON DISPLAY.	Is any other DTC displayed?	Check DTC using "List of Diagnostic Trouble Code (DTC)". <Ref. to AB(diag)-40, List of Diagnostic Trouble Code (DTC).>	Finish the diagnosis.

Diagnostic Chart with Trouble Code

AIRBAG SYSTEM (DIAGNOSTICS)

AD:DTC 71 DRIVER'S AIRBAG FAILURE

DTC DETECTING CONDITION:

- Airbag main harness circuit is open, shorted or shorted to ground.
- Airbag module harness (driver's side) circuit is open, shorted or shorted to ground.
- Roll connector circuit is open, shorted or shorted to ground.
- Driver's airbag module is faulty.
- Airbag control module is faulty.

CAUTION:

- Before diagnosing the airbag system, be sure to turn the ignition switch to OFF, disconnect the ground terminal from the battery, and wait 20 seconds or more before starting to work.
- When replacing the airbag module, seat belt pretensioner, roll connector, control module and sensor, reconnect each part and check that the warning light operates properly.
- When inspecting the airbag main harness, disconnect the airbag module connectors of the driver's and passenger's seats for safety.
- When inspecting the airbag rear harness, disconnect the side airbag module connector, curtain airbag module connector and seat belt pretensioner connector for safety reasons.

NOTE:

Prior to starting work, prepare two airbag resistors (98299PA040).

WIRING DIAGRAM:

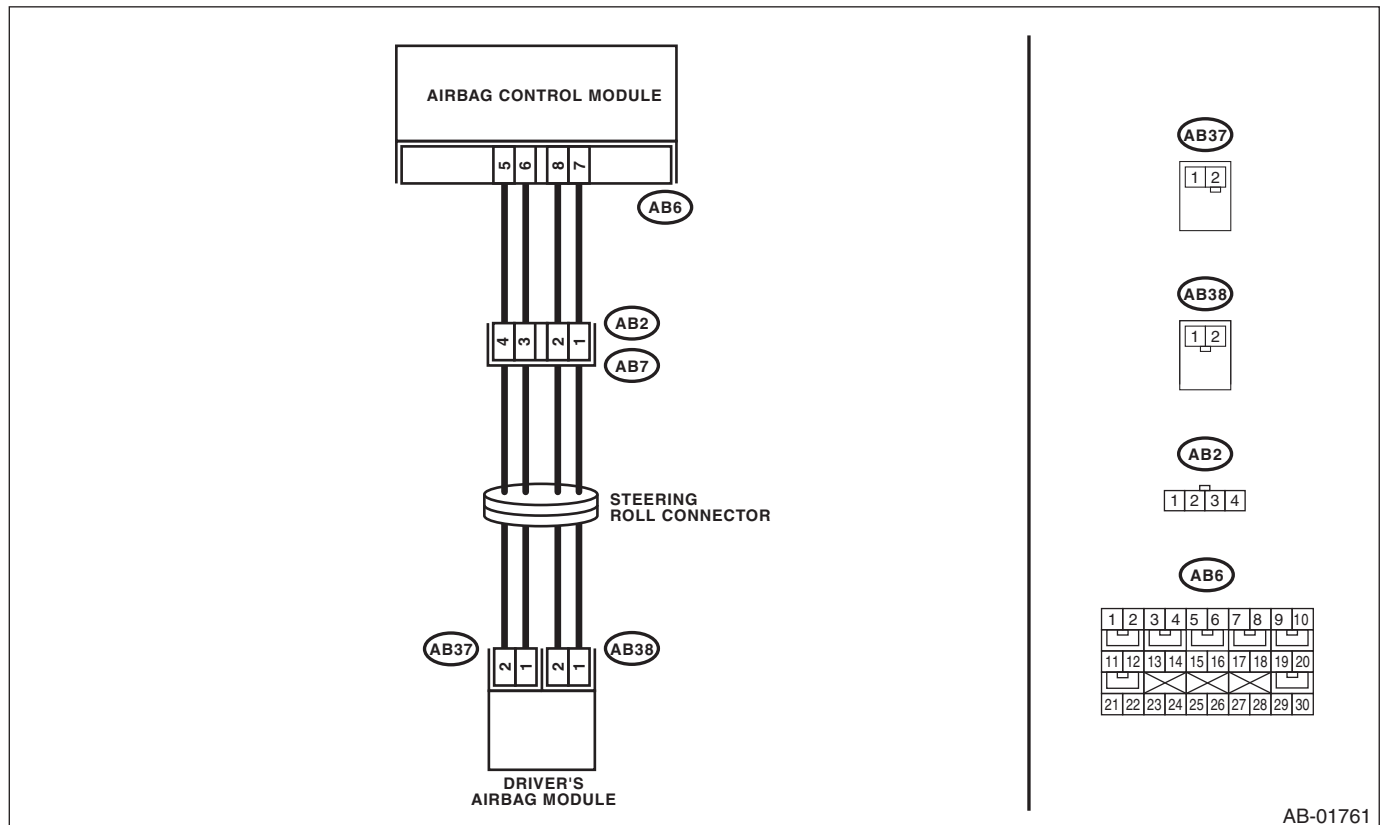

AB-01761

Diagnostic Chart with Trouble Code

AIRBAG SYSTEM (DIAGNOSTICS)

Step	Check	Yes	No
1 CHECK POOR CONTACT IN CONNECTORS. Check for poor contact of the connectors between the airbag control module and the driver's airbag module.	Is there poor contact?	Replace the airbag main harness along with body harness.	Go to step 2.
2 CHECK DRIVER'S AIRBAG MODULE. 1) Turn the ignition switch to OFF, disconnect the battery ground cable, and wait for 20 seconds or more. 2) Remove the driver's airbag module. 3) Connect the connector (1N) in the test harness N to the connector (AB38). 4) Connect the airbag resistor to the connector (2N) of test harness N. 5) Connect the connector (1Q) in the test harness Q to connector (AB37). 6) Connect the airbag resistor to the connector (2Q) in the test harness Q. 7) Connect the battery ground terminal and turn the ignition switch to ON.	Does the airbag warning light illuminate for 6 seconds and go off?	Replace the driver's airbag module. <Ref. to AB-16, Driver's Airbag Module.>	Go to step 3.
3 CHECK ROLL CONNECTOR. 1) Turn the ignition switch to OFF, disconnect the battery ground cable, and wait for 20 seconds or more. 2) Disconnect the test harness N from connector (AB38). 3) Disconnect the test harness Q from connector (AB37). 4) Remove the instrument panel lower cover and disconnect the connector (AB7) from (AB2). 5) Connect the connector (1P) in the test harness P to connector (AB2). 6) Connect the airbag resistor to the connectors (2P) and (3P) of test harness P. 7) Connect the battery ground terminal and turn the ignition switch to ON.	Does the airbag warning light illuminate for 6 seconds and go off?	Replace the roll connector. <Ref. to AB-28, Roll Connector.>	Go to step 4.
4 CHECK AIRBAG MAIN HARNESS (DRIVER'S AIRBAG HARNESS). 1) Turn the ignition switch to OFF, disconnect the battery ground cable, and wait for 20 seconds or more. 2) Disconnect the airbag resistor from the connectors (2P) and (3P) of test harness P. 3) Remove the console front panel and disconnect the connectors (AB10) and (AB9). 4) Disconnect the connectors (AB6, AB17, and AB18) from the airbag control module, and connect the connector (1AG) in the test harness AG. 5) Measure the resistance between connector (3AG) in the test harness AG and connectors (2P) and (3P) in the test harness P. Connector & terminal (3AG) No. 2 — (3P) No. 3: (3AG) No. 4 — (3P) No. 4:	Is the resistance less than 10 Ω?	Go to step 5.	Replace the airbag main harness along with body harness.

Diagnostic Chart with Trouble Code

AIRBAG SYSTEM (DIAGNOSTICS)

Step	Check	Yes	No
5 CHECK AIRBAG MAIN HARNESS (DRIVER'S AIRBAG HARNESS). Measure the resistance between connectors (3AG) in the test harness AG, and between connector (3AG) and chassis ground. Connector & terminal (3AG) No. 1 — (3AG) No. 3: (3AG) No. 3 — Chassis ground: (3AG) No. 1 — Chassis ground: (3AG) No. 2 — (3AG) No. 4: (3AG) No. 2 — Chassis ground: (3AG) No. 4 — Chassis ground: (3AG) No. 1 — (3AG) No. 2: (3AG) No. 1 — (3AG) No. 4: (3AG) No. 2 — (3AG) No. 3: (3AG) No. 3 — (3AG) No. 4:	Is the resistance 1 MΩ or more?	Go to step 6.	Replace the airbag main harness along with body harness.
6 CHECK AIRBAG CONTROL MODULE. 1) Connect all connectors. 2) Erase the memory. 3) Perform the Inspection Mode. 4) Read the DTC.	Is the same DTC displayed?	Replace the airbag control module. <Ref. to AB-23, Airbag Control Module.>	Go to step 7.
7 CHECK FOR ANY OTHER DTC ON DISPLAY.	Is any other DTC displayed?	Check DTC using "List of Diagnostic Trouble Code (DTC)". <Ref. to AB(diag)-40, List of Diagnostic Trouble Code (DTC).>	Finish the diagnosis.

Diagnostic Chart with Trouble Code

AIRBAG SYSTEM (DIAGNOSTICS)

AE:DTC 72 PASSENGER'S AIRBAG FAILURE

DTC DETECTING CONDITION:

- Airbag main harness circuit is open, shorted or shorted to ground.
- Airbag module harness (Passenger's side) circuit is open, shorted or shorted to ground.
- Passenger's airbag module is faulty.
- Airbag control module is faulty.

CAUTION:

- **Before diagnosing the airbag system, be sure to turn the ignition switch to OFF, disconnect the ground terminal from the battery, and wait 20 seconds or more before starting to work.**
- **When replacing the airbag module, seat belt pretensioner, roll connector, control module and sensor, reconnect each part and check that the warning light operates properly.**
- **When inspecting the airbag main harness, disconnect the airbag module connectors of the driver's and passenger's seats for safety.**
- **When inspecting the airbag rear harness, disconnect the side airbag module connector, curtain airbag module connector and seat belt pretensioner connector for safety reasons.**

NOTE:

Prior to starting work, prepare two airbag resistors (98299PA040).

WIRING DIAGRAM:

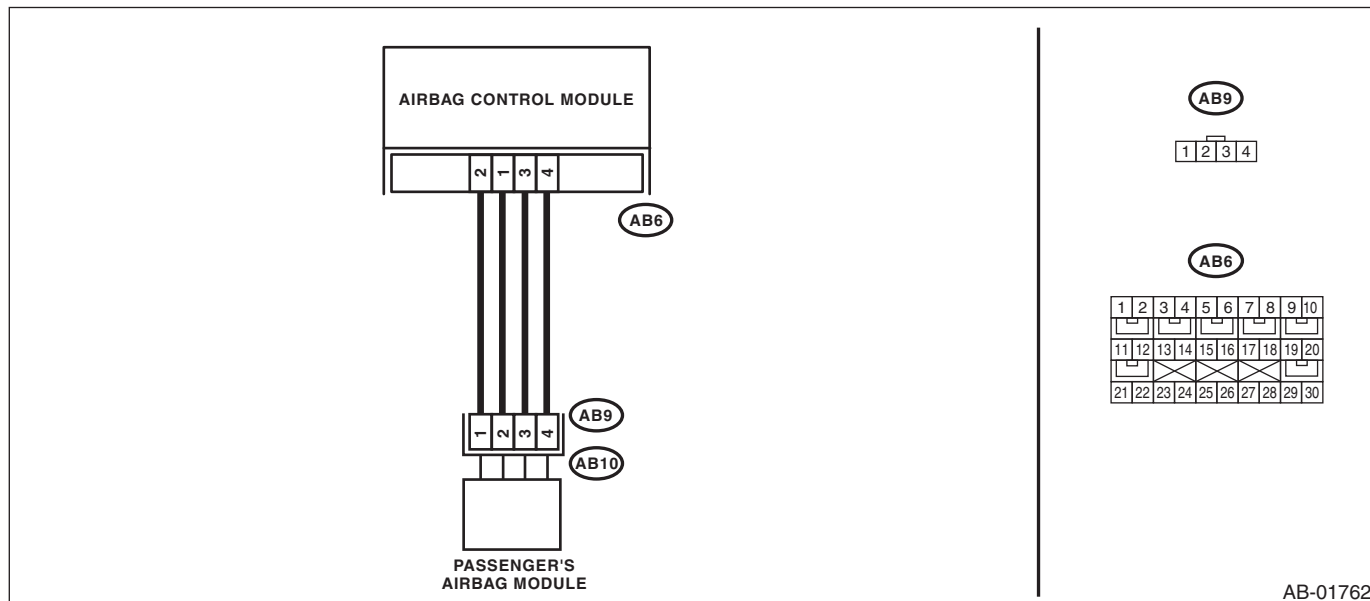

AB-01762

Step	Check	Yes	No
1 CHECK POOR CONTACT IN CONNECTORS. Check for poor contact of the connectors between the airbag control module and the passenger's airbag module.	Is there poor contact?	Replace the airbag main harness along with body harness.	Go to step 2.
2 CHECK PASSENGER'S AIRBAG MODULE. 1) Turn the ignition switch to OFF, disconnect the battery ground cable, and wait for 20 seconds or more. 2) Remove the console front panel and disconnect the connectors (AB10) from (AB9). 3) Connect the connector (1P) in the test harness P to connector (AB9). 4) Connect the airbag resistor to the connectors (2P) and (3P) of test harness P. 5) Connect the battery ground terminal and turn the ignition switch to ON.	Does the airbag warning light illuminate for 6 seconds and go off?	Replace the passenger's airbag module. <Ref. to AB-17, Passenger's Airbag Module.>	Go to step 3.

Diagnostic Chart with Trouble Code

AIRBAG SYSTEM (DIAGNOSTICS)

Step	Check	Yes	No
3 CHECK AIRBAG MAIN HARNESS (PASSENGER'S AIRBAG HARNESS). 1) Turn the ignition switch to OFF, disconnect the battery ground cable, and wait for 20 seconds or more. 2) Disconnect the airbag resistor from the connectors (2P) and (3P) of test harness P. 3) Remove the instrument panel lower cover and disconnect the connector (AB7) from (AB2). 4) Disconnect the connectors (AB6, AB17, and AB18) from the airbag control module, and connect the connector (1AG) in the test harness AG. 5) Measure the resistance between connector (3AG) in the test harness AG and connectors (2P) and (3P) in the test harness P. Connector & terminal (3AG) No. 8 — (3P) No. 3: (3AG) No. 6 — (3P) No. 4:	Is the resistance less than 10 Ω?	Go to step 4.	Replace the airbag main harness along with body harness.
4 CHECK AIRBAG MAIN HARNESS (PASSENGER'S AIRBAG HARNESS). Measure the resistance between connectors (3AG) in the test harness AG, and between connector (3AG) and chassis ground. Connector & terminal (3AG) No. 9 — (3AG) No. 7: (3AG) No. 9 — Chassis ground: (3AG) No. 7 — Chassis ground: (3AG) No. 8 — (3AG) No. 6: (3AG) No. 8 — Chassis ground: (3AG) No. 6 — Chassis ground: (3AG) No. 6 — (3AG) No. 7: (3AG) No. 6 — (3AG) No. 9: (3AG) No. 7 — (3AG) No. 8: (3AG) No. 8 — (3AG) No. 9:	Is the resistance 1 MΩ or more?	Go to step 5.	Replace the airbag main harness along with body harness.
5 CHECK AIRBAG CONTROL MODULE. 1) Connect all connectors. 2) Erase the memory. 3) Perform the Inspection Mode. 4) Read the DTC.	Is the same DTC displayed?	Replace the airbag control module. <Ref. to AB-23, Airbag Control Module.>	Go to step 6.
6 CHECK FOR ANY OTHER DTC ON DISPLAY.	Is any other DTC displayed?	Check DTC using "List of Diagnostic Trouble Code (DTC)". <Ref. to AB(diag)-40, List of Diagnostic Trouble Code (DTC).>	Finish the diagnosis.

Diagnostic Chart with Trouble Code

AIRBAG SYSTEM (DIAGNOSTICS)

AF:DTC 75 DRIVER'S AIRBAG FAILURE

DTC DETECTING CONDITION:

- Airbag main harness circuit (Driver's side) is shorted to power supply.
- Airbag module harness circuit (Driver's side) is shorted to power supply.
- Roll connector is shorted to power supply.
- Driver's airbag module is faulty.
- Airbag control module is faulty.

CAUTION:

- Before diagnosing the airbag system, be sure to turn the ignition switch to OFF, disconnect the ground terminal from the battery, and wait 20 seconds or more before starting to work.
- When replacing the airbag module, seat belt pretensioner, roll connector, control module and sensor, reconnect each part and check that the warning light operates properly.
- When inspecting the airbag main harness, disconnect the airbag module connectors of the driver's and passenger's seats for safety.
- When inspecting the airbag rear harness, disconnect the side airbag module connector, curtain airbag module connector and seat belt pretensioner connector for safety reasons.

NOTE:

Prior to starting work, prepare two airbag resistors (98299PA040).

WIRING DIAGRAM:

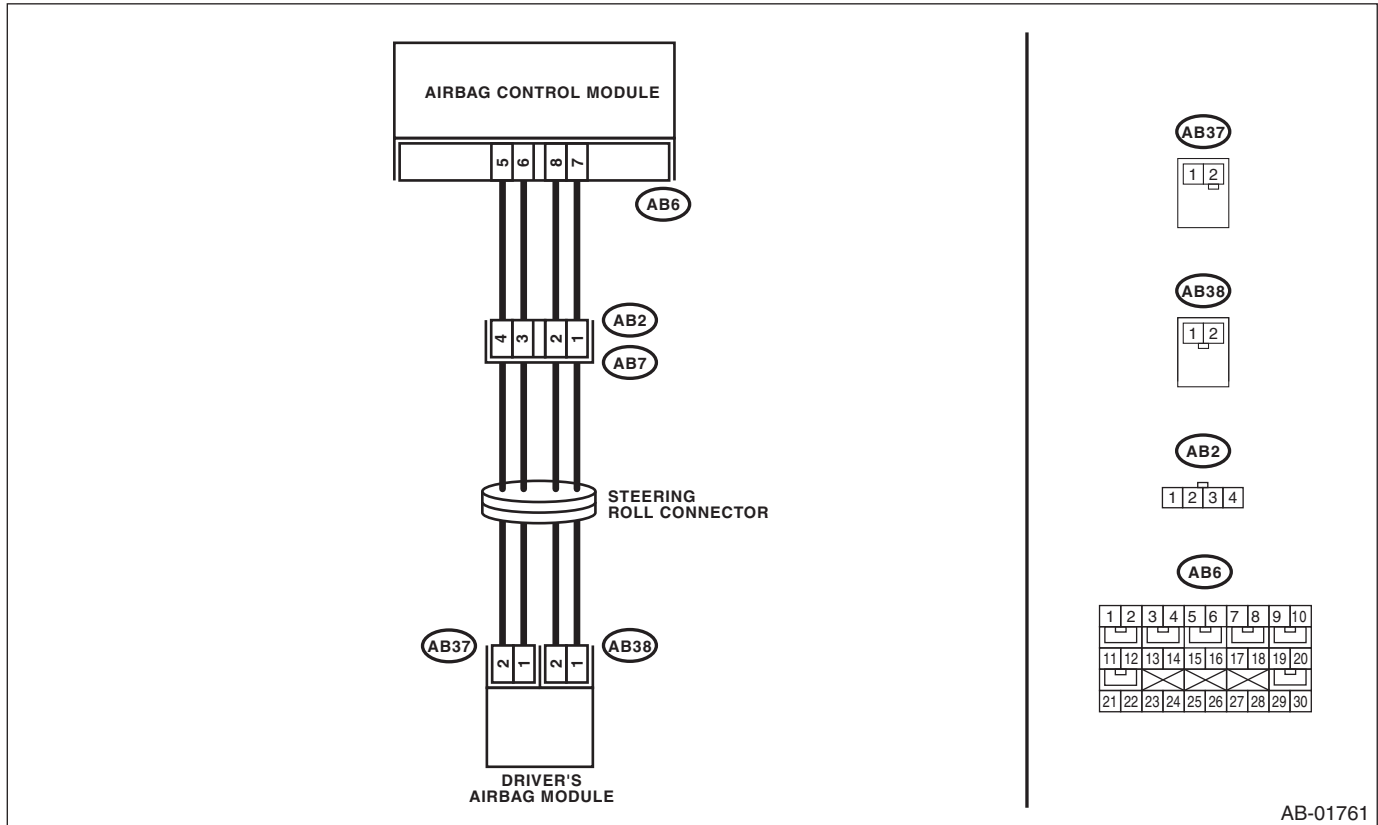

AB-01761

Diagnostic Chart with Trouble Code

AIRBAG SYSTEM (DIAGNOSTICS)

Step	Check	Yes	No
1 CHECK POOR CONTACT IN CONNECTORS. Check for poor contact of the connectors between the airbag control module and the driver's airbag module.	Is there poor contact?	Replace the airbag main harness along with body harness.	Go to step 2.
2 CHECK DRIVER'S AIRBAG MODULE. 1) Turn the ignition switch to OFF, disconnect the battery ground cable, and wait for 20 seconds or more. 2) Remove the driver's airbag module. 3) Connect the connector (AB38) to the connector (1N) in the test harness N. 4) Connect the airbag resistor to the connector (2N) of test harness N. 5) Connect the connector (1Q) in the test harness Q to connector (AB37). 6) Connect the airbag resistor to the connector (2Q) in the test harness Q. 7) Connect the battery ground terminal and turn the ignition switch to ON.	Does the airbag warning light illuminate for 6 seconds and go off?	Replace the driver's airbag module. <Ref. to AB-16, Driver's Airbag Module.>	Go to step 3.
3 CHECK ROLL CONNECTOR. 1) Turn the ignition switch to OFF, disconnect the battery ground cable, and wait for 20 seconds or more. 2) Disconnect the test harness N from connector (AB38). 3) Disconnect the test harness Q from connector (AB37). 4) Remove the instrument panel lower cover and disconnect the connector (AB7) from (AB2). 5) Connect the connector (1P) in the test harness P to connector (AB2). 6) Connect the airbag resistor to the connectors (2P) and (3P) of test harness P. 7) Connect the battery ground terminal and turn the ignition switch to ON.	Does the airbag warning light illuminate for 6 seconds and go off?	Replace the roll connector. <Ref. to AB-28, Roll Connector.>	Go to step 4.
4 CHECK AIRBAG MAIN HARNESS (DRIVER'S AIRBAG HARNESS). 1) Turn the ignition switch to OFF, disconnect the battery ground cable, and wait for 20 seconds or more. 2) Disconnect the airbag resistor from the connectors (2P) and (3P) of test harness P. 3) Remove the console front panel and disconnect the connectors (AB10) and (AB9). 4) Disconnect the connectors (AB6, AB17, and AB18) from the airbag control module, and connect the connector (1AG) in the test harness AG. 5) Connect the battery ground terminal and turn the ignition switch to ON. (engine OFF) 6) Measure the voltage between connector (3AG) in the test harness AG and chassis ground. Connector & terminal (3AG) No. 2 (+) — Chassis ground (-): (3AG) No. 4 (+) — Chassis ground (-):	Is the voltage less than 1 V?	Go to step 5.	Replace the airbag main harness along with body harness.

Diagnostic Chart with Trouble Code

AIRBAG SYSTEM (DIAGNOSTICS)

Step	Check	Yes	No
5 CHECK AIRBAG CONTROL MODULE. 1) Connect all connectors. 2) Erase the memory. 3) Perform the Inspection Mode. 4) Read the DTC.	Is the same DTC displayed?	Replace the airbag control module. <Ref. to AB-23, Airbag Control Module.>	Go to step 6 .
6 CHECK FOR ANY OTHER DTC ON DISPLAY.	Is any other DTC displayed?	Check DTC using "List of Diagnostic Trouble Code (DTC)". <Ref. to AB(diag)-40, List of Diagnostic Trouble Code (DTC).>	Finish the diagnosis.

Diagnostic Chart with Trouble Code

AIRBAG SYSTEM (DIAGNOSTICS)

AG:DTC 76 PASSENGER'S AIRBAG FAILURE

DTC DETECTING CONDITION:

- Airbag main harness circuit (Passenger's side) is shorted to power supply.
- Airbag module harness circuit (Passenger's side) is shorted to power supply.
- Passenger's airbag module is faulty.
- Airbag control module is faulty.

CAUTION:

- Before diagnosing the airbag system, be sure to turn the ignition switch to OFF, disconnect the ground terminal from the battery, and wait 20 seconds or more before starting to work.
- When replacing the airbag module, seat belt pretensioner, roll connector, control module and sensor, reconnect each part and check that the warning light operates properly.
- When inspecting the airbag main harness, disconnect the airbag module connectors of the driver's and passenger's seats for safety.
- When inspecting the airbag rear harness, disconnect the side airbag module connector, curtain airbag module connector and seat belt pretensioner connector for safety reasons.

NOTE:

Prior to starting work, prepare two airbag resistors (98299PA040).

WIRING DIAGRAM:

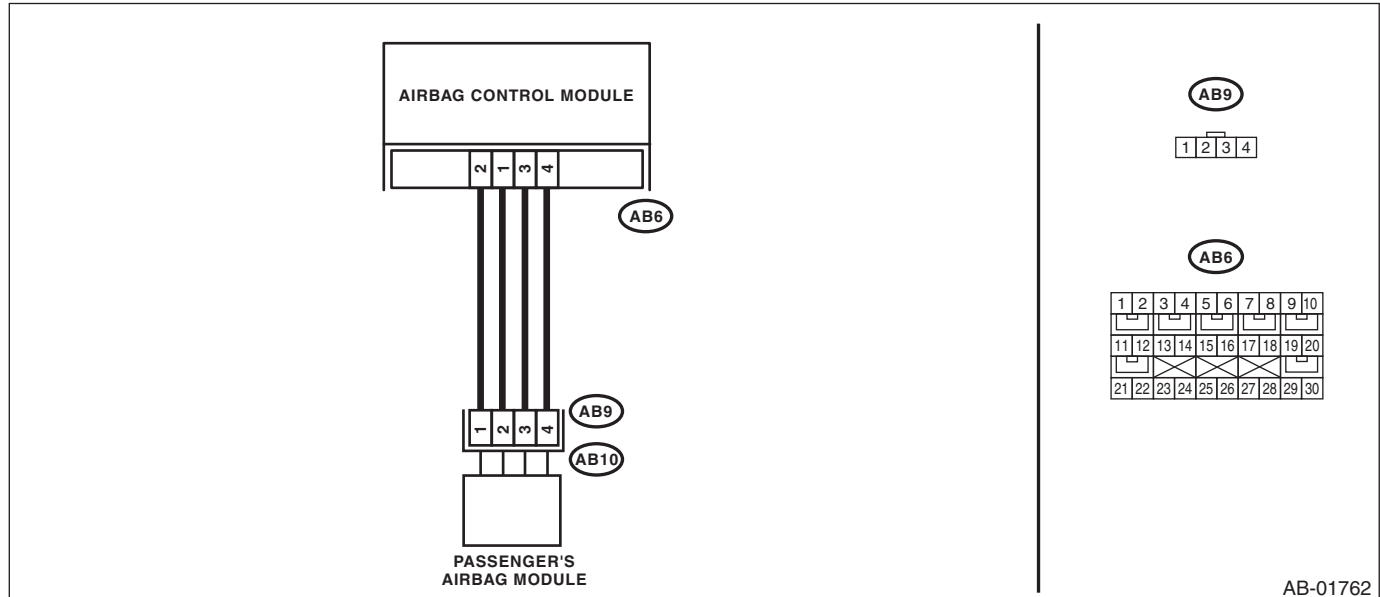

Diagnostic Chart with Trouble Code

AIRBAG SYSTEM (DIAGNOSTICS)

Step	Check	Yes	No
1 CHECK POOR CONTACT IN CONNECTORS. Check for poor contact of the connectors between the airbag control module and the passenger's airbag module.	Is there poor contact?	Replace the airbag main harness along with body harness.	Go to step 2.
2 CHECK PASSENGER'S AIRBAG MODULE. 1) Turn the ignition switch to OFF, disconnect the battery ground cable, and wait for 20 seconds or more. 2) Remove the console front panel and disconnect the connectors (AB10) from (AB9). 3) Connect the connector (1P) in the test harness P to connector (AB9). 4) Connect the airbag resistor to the connectors (2P) and (3P) of test harness P. 5) Connect the battery ground terminal and turn the ignition switch to ON.	Does the airbag warning light illuminate for 6 seconds and go off?	Replace the passenger's airbag module. <Ref. to AB-17, Passenger's Airbag Module.>	Go to step 3.
3 CHECK AIRBAG MAIN HARNESS (PASSENGER'S AIRBAG HARNESS). 1) Turn the ignition switch to OFF, disconnect the battery ground cable, and wait for 20 seconds or more. 2) Disconnect the airbag resistor from the connectors (2P) and (3P) of test harness P. 3) Remove the instrument panel lower cover and disconnect the connector (AB7) from (AB2). 4) Disconnect the connectors (AB6, AB17, and AB18) from the airbag control module, and connect the connector (1AG) in the test harness AG. 5) Measure the voltage between connector (3AG) in the test harness AG and chassis ground. <i>Connector & terminal</i> <i>(3AG) No. 8 (+) — Chassis ground (-):</i> <i>(3AG) No. 6 (+) — Chassis ground (-):</i>	Is the voltage less than 1 V?	Go to step 4.	Replace the airbag main harness along with body harness.
4 CHECK AIRBAG CONTROL MODULE. 1) Connect all connectors. 2) Erase the memory. 3) Perform the Inspection Mode. 4) Read the DTC.	Is the same DTC displayed?	Replace the airbag control module. <Ref. to AB-23, Airbag Control Module.>	Go to step 5.
5 CHECK FOR ANY OTHER DTC ON DISPLAY.	Is any other DTC displayed?	Check DTC using "List of Diagnostic Trouble Code (DTC)". <Ref. to AB(diag)-40, List of Diagnostic Trouble Code (DTC).>	Finish the diagnosis.

Diagnostic Chart with Trouble Code

AIRBAG SYSTEM (DIAGNOSTICS)

AH:DTC 91 CURTAIN AIRBAG MODULE RH FAILURE

DTC DETECTING CONDITION:

- Curtain airbag harness (RH) is faulty.
- Curtain airbag module (RH) is faulty.
- Airbag control module is faulty.

CAUTION:

- Before diagnosing the airbag system, be sure to turn the ignition switch to OFF, disconnect the ground terminal from the battery, and wait 20 seconds or more before starting to work.
- When replacing the airbag module, seat belt pretensioner, roll connector, control module and sensor, reconnect each part and check that the warning light operates properly.
- When inspecting the airbag main harness, disconnect the airbag module connectors of the driver's and passenger's seats for safety.
- When inspecting the airbag rear harness, disconnect the side airbag module connector, curtain airbag module connector and seat belt pretensioner connector for safety reasons.

WIRING DIAGRAM:

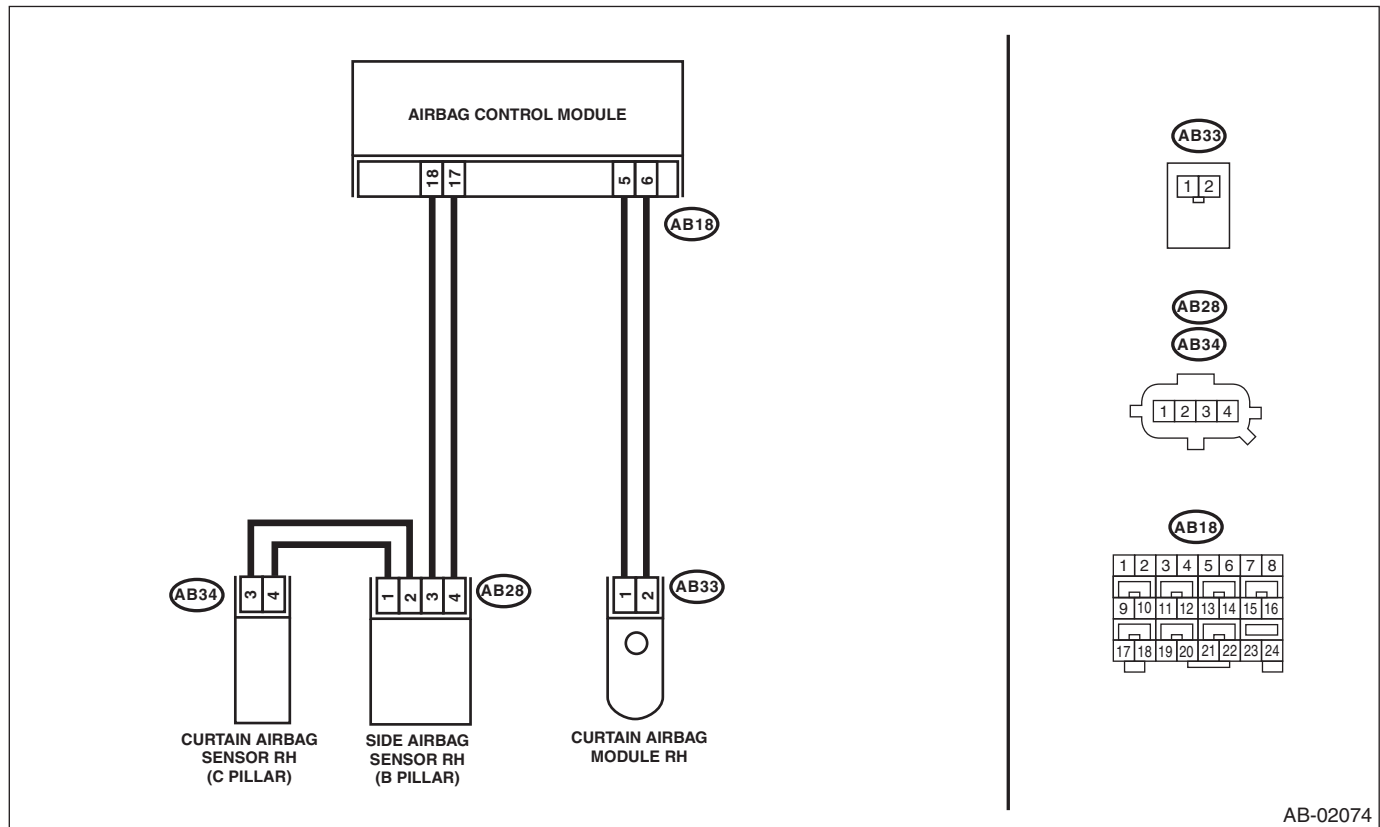

AB-02074

Step	Check	Yes	No	
1	CHECK POOR CONTACT IN CONNECTORS. Check for poor contact of the connectors between the airbag control module, curtain airbag module RH and the curtain airbag sensor RH.	Is there poor contact?	Replace the airbag rear harness along with body harness.	Go to step 2.

Diagnostic Chart with Trouble Code

AIRBAG SYSTEM (DIAGNOSTICS)

Step	Check	Yes	No
2 CHECK CURTAIN AIRBAG MODULE. 1) Turn the ignition switch to OFF, disconnect the battery ground cable, and wait for 20 seconds or more. 2) Disconnect the connector (AB33), and connect the connector (1N) in test harness N to connector (AB33). 3) Connect the airbag resistor to the connector (2N) of test harness N. 4) Connect the battery ground terminal and turn the ignition switch to ON.	Does the airbag warning light illuminate for 6 seconds and go off?	Replace the curtain airbag module (RH). <Ref. to AB-21, Curtain Airbag Module.>	Go to step 3.
3 CHECK AIRBAG REAR HARNESS (CURTAIN AIRBAG MODULE HARNESS RH). 1) Turn the ignition switch to OFF, disconnect the battery ground cable, and wait for 20 seconds or more. 2) Disconnect the connector (AB26) from seat belt pretensioner (RH). 3) Disconnect connector (AB24) from side airbag module (RH). 4) Disconnect the airbag resistor from test harness N. 5) Disconnect the connectors (AB6, AB17, and AB18) from airbag control module. 6) Connect the connector (1AG) in the test harness AG to the connectors (AB6, AB17, and AB18). 7) Measure the resistance between connector (6AG) in the test harness AG and connector (2N) in the test harness N. <i>Connector & terminal</i> <i>(6AG) No. 6 — (2N) No. 1:</i> <i>(6AG) No. 8 — (2N) No. 2:</i>	Is the resistance less than 10 Ω?	Go to step 4.	Replace the airbag rear harness along with body harness.
4 CHECK AIRBAG REAR HARNESS (CURTAIN AIRBAG MODULE HARNESS RH). Measure the resistance between connector (6AG) terminals in the test harness AG. <i>Connector & terminal</i> <i>(6AG) No. 6 — (6AG) No. 8:</i>	Is the resistance 1 MΩ or more?	Go to step 5.	Replace the airbag rear harness along with body harness.
5 CHECK AIRBAG REAR HARNESS (CURTAIN AIRBAG MODULE HARNESS RH). Measure the resistance between connector (6AG) in the test harness AG and chassis ground. <i>Connector & terminal</i> <i>(6AG) No. 6 — Chassis ground:</i> <i>(6AG) No. 8 — Chassis ground:</i>	Is the resistance 1 MΩ or more?	Go to step 6.	Replace the airbag rear harness along with body harness.
6 CHECK AIRBAG CONTROL MODULE. 1) Connect all connectors. 2) Erase the memory. 3) Perform the Inspection Mode. 4) Read the DTC.	Is the same DTC displayed?	Replace the airbag control module. <Ref. to AB-23, Airbag Control Module.>	Go to step 7.
7 CHECK FOR ANY OTHER DTC ON DISPLAY.	Is any other DTC displayed?	Check DTC using "List of Diagnostic Trouble Code (DTC)". <Ref. to AB(diag)-40, List of Diagnostic Trouble Code (DTC).>	Finish the diagnosis.

Diagnostic Chart with Trouble Code

AIRBAG SYSTEM (DIAGNOSTICS)

AI: DTC 92 CURTAIN AIRBAG MODULE LH FAILURE

DTC DETECTING CONDITION:

- Curtain airbag harness (LH) is faulty.
- Curtain airbag module (LH) is faulty.
- Airbag control module is faulty.

CAUTION:

- Before diagnosing the airbag system, be sure to turn the ignition switch to OFF, disconnect the ground terminal from the battery, and wait 20 seconds or more before starting to work.
- When replacing the airbag module, seat belt pretensioner, roll connector, control module and sensor, reconnect each part and check that the warning light operates properly.
- When inspecting the airbag main harness, disconnect the airbag module connectors of the driver's and passenger's seats for safety.
- When inspecting the airbag rear harness, disconnect the side airbag module connector, curtain airbag module connector and seat belt pretensioner connector for safety reasons.

WIRING DIAGRAM:

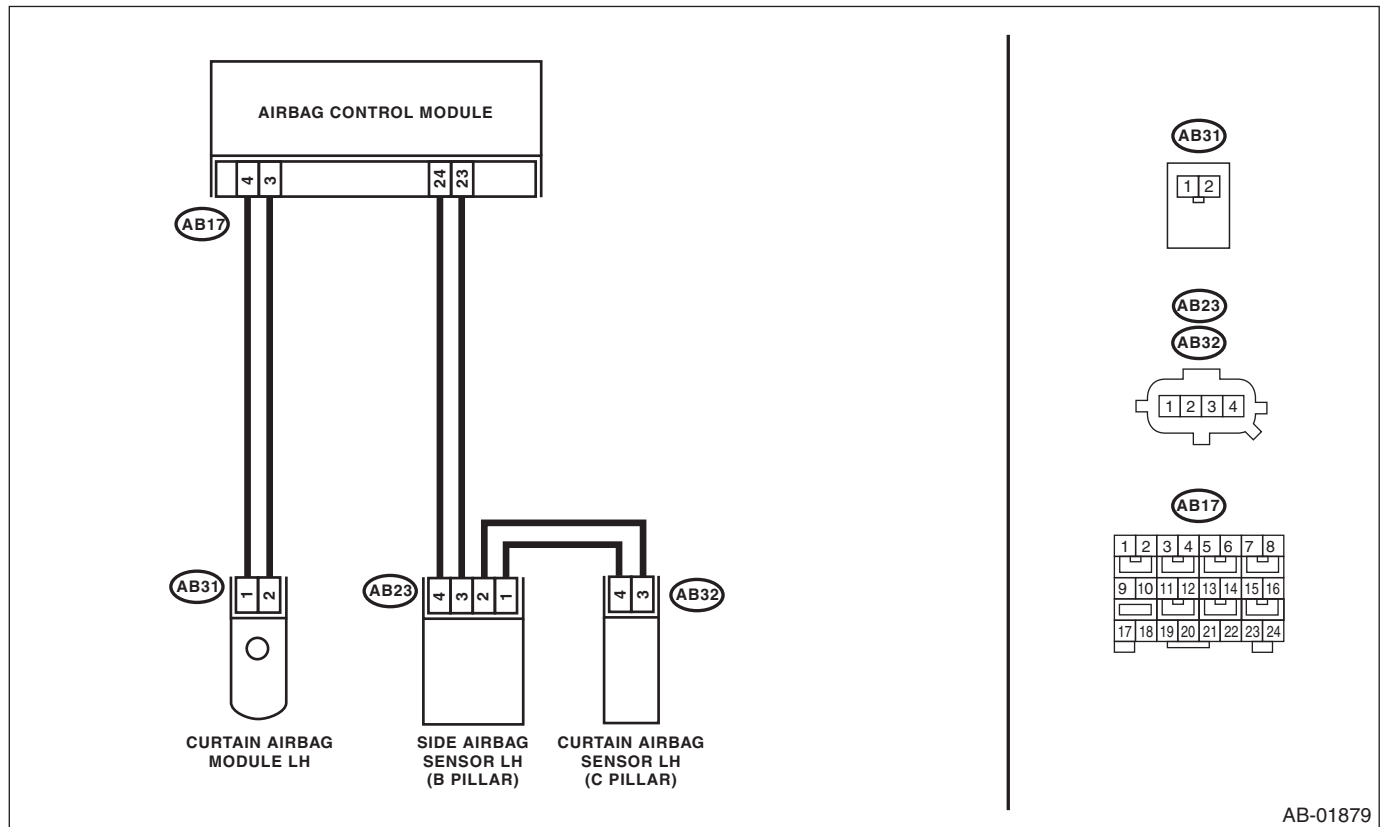

Step	Check	Yes	No	
1	CHECK POOR CONTACT IN CONNECTORS. Check for poor contact of the connectors between the airbag control module, curtain airbag module LH and the curtain airbag sensor LH.	Is there poor contact?	Replace the airbag rear harness along with body harness.	Go to step 2.

Diagnostic Chart with Trouble Code

AIRBAG SYSTEM (DIAGNOSTICS)

Step	Check	Yes	No
2 CHECK CURTAIN AIRBAG MODULE. 1) Turn the ignition switch to OFF, disconnect the battery ground cable, and wait for 20 seconds or more. 2) Disconnect the connector (AB31), and connect the connector (1N) in test harness N to connector (AB31). 3) Connect the airbag resistor to the connector (2N) of test harness N. 4) Connect the battery ground terminal and turn the ignition switch to ON.	Does the airbag warning light illuminate for 6 seconds and go off?	Replace the curtain airbag module (LH). <Ref. to AB-21, Curtain Airbag Module.>	Go to step 3.
3 CHECK AIRBAG REAR HARNESS (CURTAIN AIRBAG MODULE HARNESS LH). 1) Turn the ignition switch to OFF, disconnect the battery ground cable, and wait for 20 seconds or more. 2) Disconnect the connector (AB21) from seat belt pretensioner (LH). 3) Disconnect connector (AB19) from side airbag module (LH). 4) Disconnect the airbag resistor from test harness N. 5) Disconnect the connectors (AB6, AB17, and AB18) from airbag control module. 6) Connect the connector (1AG) in the test harness AG to the connectors (AB6, AB17, and AB18). 7) Measure the resistance between connector (6AG) in the test harness AG and connector (2N) in the test harness N. Connector & terminal (6AG) No. 1 — (2N) No. 2: (6AG) No. 3 — (2N) No. 1:	Is the resistance less than 10 Ω?	Go to step 4.	Replace the airbag rear harness along with body harness.
4 CHECK AIRBAG REAR HARNESS (CURTAIN AIRBAG MODULE HARNESS LH). Measure the resistance between connector (6AG) terminals in the test harness AG. Connector & terminal (6AG) No. 1 — (6AG) No. 3:	Is the resistance 1 MΩ or more?	Go to step 5.	Replace the airbag rear harness along with body harness.
5 CHECK AIRBAG REAR HARNESS (CURTAIN AIRBAG MODULE HARNESS LH). Measure the resistance between connector (6AG) in the test harness AG and chassis ground. Connector & terminal (6AG) No. 1 — Chassis ground: (6AG) No. 3 — Chassis ground:	Is the resistance 1 MΩ or more?	Go to step 6.	Replace the airbag rear harness along with body harness.
6 CHECK AIRBAG CONTROL MODULE. 1) Connect all connectors. 2) Erase the memory. 3) Perform the Inspection Mode. 4) Read the DTC.	Is the same DTC displayed?	Replace the airbag control module. <Ref. to AB-23, Airbag Control Module.>	Go to step 7.
7 CHECK FOR ANY OTHER DTC ON DISPLAY.	Is any other DTC displayed?	Check DTC using "List of Diagnostic Trouble Code (DTC)". <Ref. to AB(diag)-40, List of Diagnostic Trouble Code (DTC).>	Finish the diagnosis.

Diagnostic Chart with Trouble Code

AIRBAG SYSTEM (DIAGNOSTICS)

AJ:DTC 95 CURTAIN AIRBAG MODULE RH FAILURE

DTC DETECTING CONDITION:

- Curtain airbag harness (RH) is shorted to power supply.
- Airbag control module is faulty.

CAUTION:

- Before diagnosing the airbag system, be sure to turn the ignition switch to OFF, disconnect the ground terminal from the battery, and wait 20 seconds or more before starting to work.
- When replacing the airbag module, seat belt pretensioner, roll connector, control module and sensor, reconnect each part and check that the warning light operates properly.
- When inspecting the airbag main harness, disconnect the airbag module connectors of the driver's and passenger's seats for safety.
- When inspecting the airbag rear harness, disconnect the side airbag module connector, curtain airbag module connector and seat belt pretensioner connector for safety reasons.

WIRING DIAGRAM:

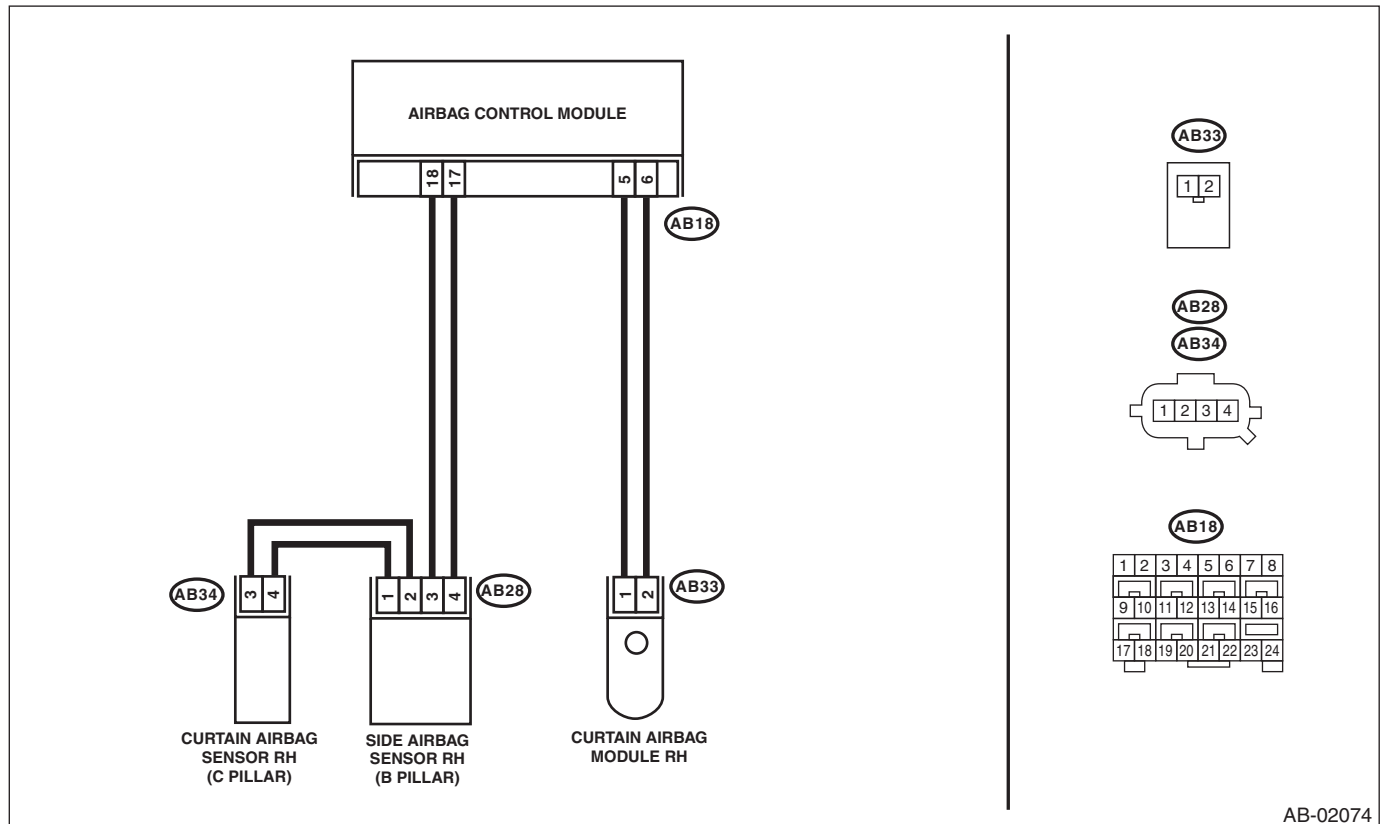

AB-02074

Diagnostic Chart with Trouble Code

AIRBAG SYSTEM (DIAGNOSTICS)

Step	Check	Yes	No
1 CHECK POOR CONTACT IN CONNECTORS. Check for poor contact of the connectors between the airbag control module, curtain airbag module RH and the curtain airbag sensor RH.	Is there poor contact?	Replace the airbag rear harness along with body harness.	Go to step 2.
2 CHECK CURTAIN AIRBAG MODULE. 1) Turn the ignition switch to OFF, disconnect the battery ground cable, and wait for 20 seconds or more. 2) Disconnect the connector (AB33), and connect the connector (1N) in test harness N to connector (AB33). 3) Connect the airbag resistor to the connector (2N) of test harness N. 4) Connect the battery ground terminal and turn the ignition switch to ON.	Does the airbag warning light illuminate for 6 seconds and go off?	Replace the curtain airbag module (RH). <Ref. to AB-21, Curtain Airbag Module.>	Go to step 3.
3 CHECK AIRBAG REAR HARNESS (CURTAIN AIRBAG MODULE HARNESS RH). 1) Turn the ignition switch to OFF, disconnect the battery ground cable, and wait for 20 seconds or more. 2) Disconnect the connector (AB26) from seat belt pretensioner (RH). 3) Disconnect connector (AB24) from side airbag module (RH). 4) Disconnect the airbag resistor from test harness N. 5) Disconnect the connectors (AB6, AB17, and AB18) from airbag control module. 6) Connect the connector (1AG) in the test harness AG to the connectors (AB6, AB17, and AB18). 7) Connect the battery ground terminal and turn the ignition switch to ON. 8) Measure the voltage between connector (6AG) in the test harness AG and chassis ground. Connector & terminal (6AG) No. 6 (+) — Chassis ground (-): (6AG) No. 8 (+) — Chassis ground (-):	Is the voltage less than 1 V?	Go to step 4.	Replace the airbag rear harness along with body harness.
4 CHECK AIRBAG CONTROL MODULE. 1) Connect all connectors. 2) Erase the memory. 3) Perform the Inspection Mode. 4) Read the DTC.	Is the same DTC displayed?	Replace the airbag control module. <Ref. to AB-23, Airbag Control Module.>	Go to step 5.
5 CHECK FOR ANY OTHER DTC ON DISPLAY.	Is any other DTC displayed?	Check DTC using "List of Diagnostic Trouble Code (DTC)". <Ref. to AB(diag)-40, List of Diagnostic Trouble Code (DTC).>	Finish the diagnosis.

Diagnostic Chart with Trouble Code

AIRBAG SYSTEM (DIAGNOSTICS)

AK:DTC 96 CURTAIN AIRBAG MODULE LH FAILURE

DTC DETECTING CONDITION:

- Curtain airbag harness (LH) is shorted to power supply.
- Airbag control module is faulty.

CAUTION:

- Before diagnosing the airbag system, be sure to turn the ignition switch to OFF, disconnect the ground terminal from the battery, and wait 20 seconds or more before starting to work.
- When replacing the airbag module, seat belt pretensioner, roll connector, control module and sensor, reconnect each part and check that the warning light operates properly.
- When inspecting the airbag main harness, disconnect the airbag module connectors of the driver's and passenger's seats for safety.
- When inspecting the airbag rear harness, disconnect the side airbag module connector, curtain airbag module connector and seat belt pretensioner connector for safety reasons.

WIRING DIAGRAM:

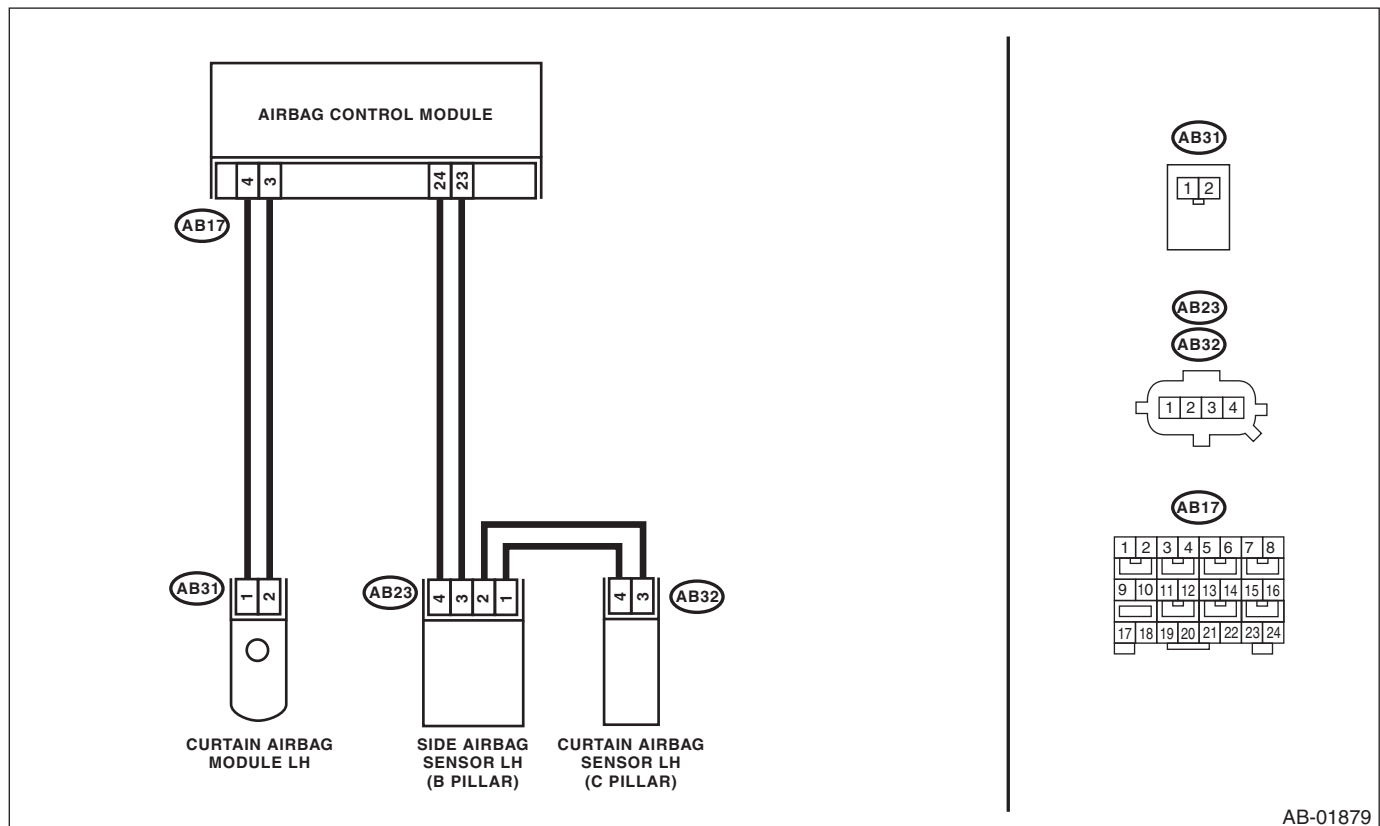

AB-01879

Diagnostic Chart with Trouble Code

AIRBAG SYSTEM (DIAGNOSTICS)

Step	Check	Yes	No
1 CHECK POOR CONTACT IN CONNECTORS. Check for poor contact of the connectors between the airbag control module, curtain airbag module LH and the curtain airbag sensor LH.	Is there poor contact?	Replace the airbag rear harness along with body harness.	Go to step 2.
2 CHECK SIDE AIRBAG MODULE. 1) Turn the ignition switch to OFF, disconnect the battery ground cable, and wait for 20 seconds or more. 2) Disconnect the connector (AB31), and connect the connector (1N) in test harness N to connector (AB31). 3) Connect the airbag resistor to the connector (2N) of test harness N. 4) Connect the battery ground terminal and turn the ignition switch to ON.	Does the airbag warning light illuminate for 6 seconds and go off?	Replace the curtain airbag module (LH). <Ref. to AB-21, Curtain Airbag Module.>	Go to step 3.
3 CHECK AIRBAG REAR HARNESS (CURTAIN AIRBAG MODULE HARNESS LH). 1) Turn the ignition switch to OFF, disconnect the battery ground cable, and wait for 20 seconds or more. 2) Disconnect the connector (AB21) from seat belt pretensioner (LH). 3) Disconnect connector (AB19) from side airbag module (LH). 4) Disconnect the airbag resistor from test harness N. 5) Disconnect the connectors (AB6, AB17, and AB18) from airbag control module. 6) Connect the connector (1AG) in the test harness AG to the connectors (AB6, AB17, and AB18). 7) Connect the battery ground terminal and turn the ignition switch to ON. 8) Measure the voltage between connector (3AG) in the test harness AG and chassis ground. Connector & terminal (3AG) No. 1 (+) — Chassis ground (-): (3AG) No. 3 (+) — Chassis ground (-):	Is the voltage less than 1 V?	Go to step 4.	Replace the airbag rear harness along with body harness.
4 CHECK AIRBAG CONTROL MODULE. 1) Connect all connectors. 2) Erase the memory. 3) Perform the Inspection Mode. 4) Read the DTC.	Is the same DTC displayed?	Replace the airbag control module. <Ref. to AB-23, Airbag Control Module.>	Go to step 5.
5 CHECK FOR ANY OTHER DTC ON DISPLAY.	Is any other DTC displayed?	Check DTC using "List of Diagnostic Trouble Code (DTC)". <Ref. to AB(diag)-40, List of Diagnostic Trouble Code (DTC).>	Finish the diagnosis.

Diagnostic Chart with Trouble Code

AIRBAG SYSTEM (DIAGNOSTICS)

AL:DTC BB ROLL OVER: FIRING OUTPUT

This DTC is indicated when the curtain airbag module and the seat belt pretensioner are deployed. Once this DTC is displayed, the memory cannot be cleared. Replace the following parts.

- Airbag control module <Ref. to AB-23, Airbag Control Module.>
- Curtain airbag module (Operating side) <Ref. to AB-21, Curtain Airbag Module.>
- Curtain airbag sensor (Operating side) <Ref. to AB-26, Curtain Airbag Sensor.>
- Front outer seat belt with pretensioner (Operating side) <Ref. to SB-17, Front Seat Belt.>

AM:DTC E2 FRONT SENSOR BUS RH COMMUNICATION ERROR

NOTE:

Refer to DTC E4 for details on DTC E2. <Ref. to AB(diag)-100, DTC E4 FRONT SENSOR BUS RH COMMUNICATION ERROR, Diagnostic Chart with Trouble Code.>

AN:DTC E3 FRONT SENSOR BUS RH COMMUNICATION ERROR

NOTE:

Refer to DTC E4 for details on DTC E3. <Ref. to AB(diag)-100, DTC E4 FRONT SENSOR BUS RH COMMUNICATION ERROR, Diagnostic Chart with Trouble Code.>

Diagnostic Chart with Trouble Code

AIRBAG SYSTEM (DIAGNOSTICS)

AO:DTC E4 FRONT SENSOR BUS RH COMMUNICATION ERROR

DTC DETECTING CONDITION:

- Open or short circuit in harness of front sensor bus (RH).
- Front sub sensor (RH) is faulty.
- Airbag control module is faulty.

CAUTION:

- Before diagnosing the airbag system, be sure to turn the ignition switch to OFF, disconnect the ground terminal from the battery, and wait 20 seconds or more before starting to work.
- When replacing the airbag module, seat belt pretensioner, roll connector, control module and sensor, reconnect each part and check that the warning light operates properly.
- When inspecting the airbag main harness, disconnect the airbag module connectors and seat belt pretensioners of the driver's and passenger's seats for safety reasons.

WIRING DIAGRAM:

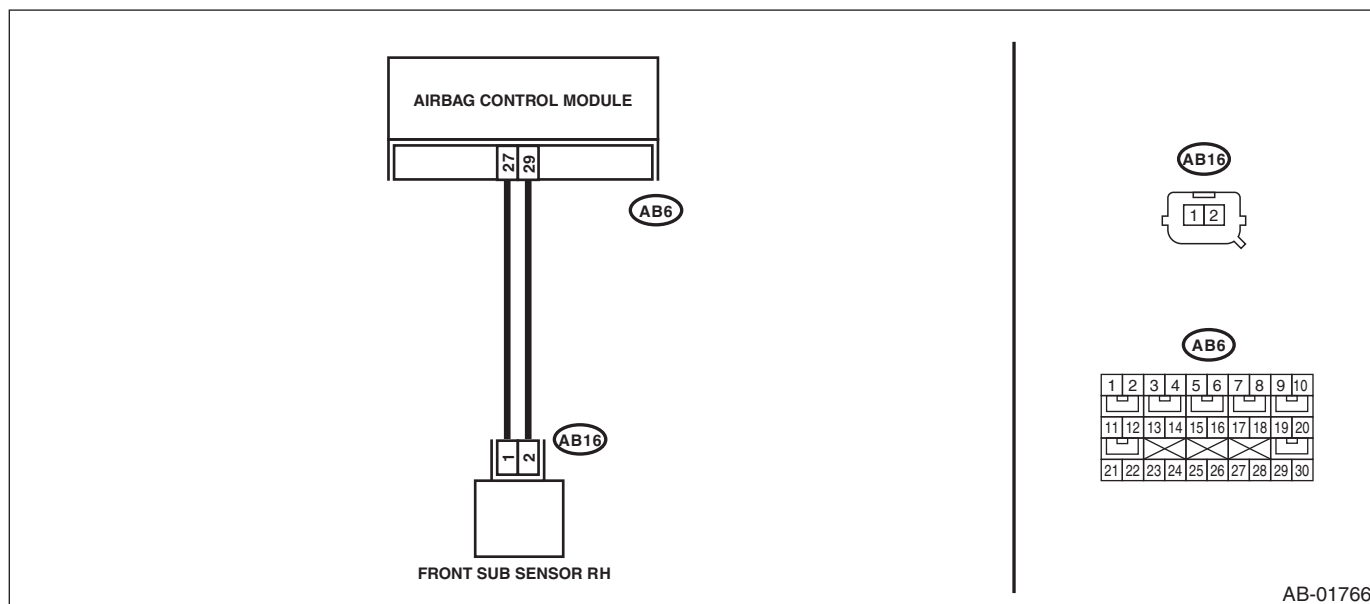

Step	Check	Yes	No
1	<p>CHECK POOR CONTACT OF CONNECTORS.</p> <p>Check for poor contact of the connectors (AB6, AB16) between the airbag control module and the front sub sensor (RH).</p>	Is there poor contact?	<p>Replace the airbag main harness along with body harness.</p> <p>Go to step 2.</p>

Diagnostic Chart with Trouble Code

AIRBAG SYSTEM (DIAGNOSTICS)

Step	Check	Yes	No
<p>2 CHECK AIRBAG MAIN HARNESS (FRONT SENSOR BUS RH).</p> <p>1) Turn the ignition switch to OFF, disconnect the battery ground cable, and wait for 20 seconds or more.</p> <p>2) Remove the instrument panel lower cover and disconnect the connectors (AB7) and (AB2).</p> <p>3) Remove the console front panel and disconnect the connectors (AB10) and (AB9).</p> <p>4) Disconnect the connectors (AB17, AB6, AB18) from airbag control module.</p> <p>5) Connect the connector (1AG) in the test harness AG to the connectors (AB17, AB6, AB18).</p> <p>6) Disconnect the front sub sensor (RH), and then connect the connector (1H) in the test harness H to connector (AB16).</p> <p>7) Measure the resistance between connector (4AG) in the test harness AG and connector (3H) in the test harness H.</p> <p>Connector & terminal (4AG) No. 14 — (3H) No. 5: (4AG) No. 12 — (3H) No. 6:</p>	Is the resistance less than 10 Ω?	Go to step 3.	Replace the airbag main harness along with body harness.
<p>3 CHECK AIRBAG MAIN HARNESS (FRONT SENSOR BUS RH).</p> <p>Measure the resistance between connector (4AG) in the test harness AG and chassis ground, and the resistance between connector (4AG) in the test harness AG and connector (3H) in test harness H.</p> <p>Connector & terminal (4AG) No. 14 — Chassis ground: (4AG) No. 12 — Chassis ground: (4AG) No. 14 — (4AG) No. 12:</p>	Is the resistance 1 MΩ or more?	Go to step 4.	Replace the airbag main harness along with body harness.
<p>4 CHECK AIRBAG CONTROL MODULE.</p> <p>1) Connect all connectors.</p> <p>2) Erase the memory.</p> <p>3) Perform the Inspection Mode.</p> <p>4) Read the DTC.</p>	Is the same DTC displayed?	Replace the front sub sensor (RH). <Ref. to AB-24, REMOVAL, Front Sub Sensor.> Replace the airbag control module if not operating normally even after replacing the sensor. <Ref. to AB-23, REMOVAL, Airbag Control Module.>	Go to step 5.
<p>5 CHECK FOR ANY OTHER DTC ON DISPLAY.</p>	Is any other DTC displayed?	Check DTC using “List of Diagnostic Trouble Code”. <Ref. to AB(diag)-40, LIST, List of Diagnostic Trouble Code (DTC).>	Finish the diagnosis.

Diagnostic Chart with Trouble Code

AIRBAG SYSTEM (DIAGNOSTICS)

AP:DTC E6 FRONT SENSOR BUS LH COMMUNICATION ERROR

NOTE:

Refer to DTC E8 for details on DTC E6. <Ref. to AB(diag)-103, DTC E8 FRONT SENSOR BUS LH COMMUNICATION ERROR, Diagnostic Chart with Trouble Code.>

AQ:DTC E7 FRONT SENSOR BUS LH COMMUNICATION ERROR

NOTE:

Refer to DTC E8 for details on DTC E7. <Ref. to AB(diag)-103, DTC E8 FRONT SENSOR BUS LH COMMUNICATION ERROR, Diagnostic Chart with Trouble Code.>

Diagnostic Chart with Trouble Code

AIRBAG SYSTEM (DIAGNOSTICS)

AR:DTC E8 FRONT SENSOR BUS LH COMMUNICATION ERROR

DTC DETECTING CONDITION:

- Open or short circuit in harness of front sensor bus (LH).
- Front sub sensor (LH) is faulty.
- Airbag control module is faulty.

CAUTION:

- Before diagnosing the airbag system, be sure to turn the ignition switch to OFF, disconnect the ground terminal from the battery, and wait 20 seconds or more before starting to work.
- When replacing the airbag module, seat belt pretensioner, roll connector, control module and sensor, reconnect each part and check that the warning light operates properly.
- When inspecting the airbag main harness, disconnect the airbag module connectors and seat belt pretensioners of the driver's and passenger's seats for safety reasons.

WIRING DIAGRAM:

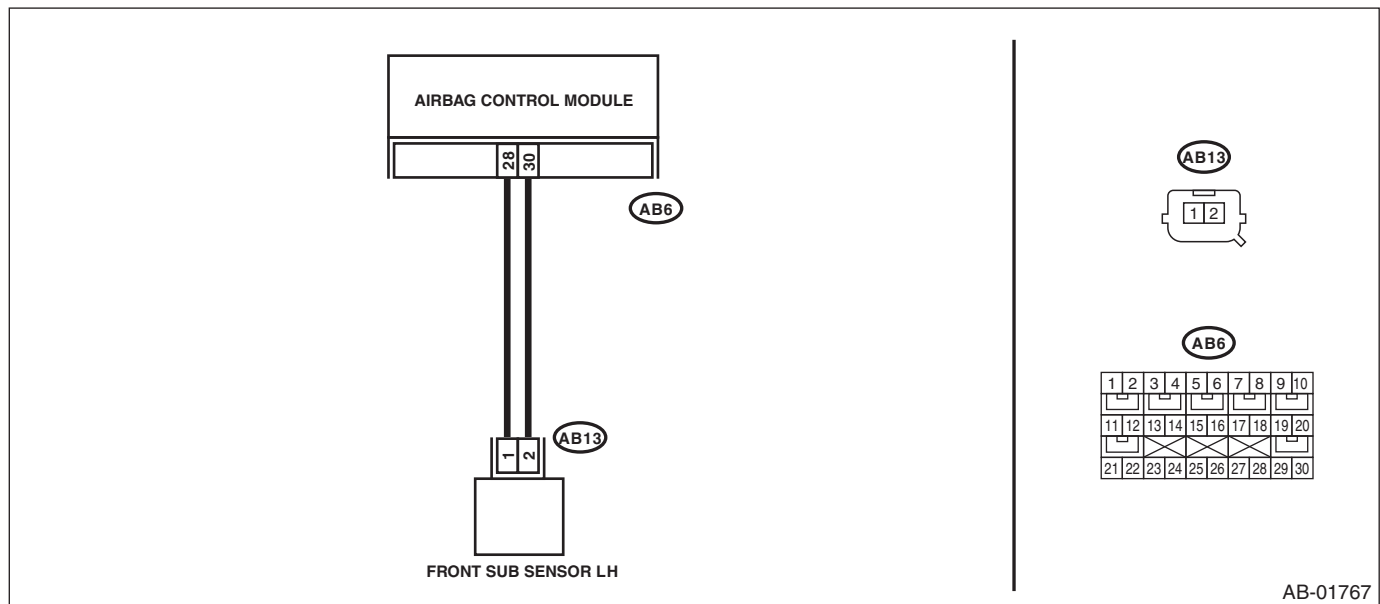

Step	Check	Yes	No
1	<p>CHECK POOR CONTACT OF CONNECTORS.</p> <p>Check for poor contact of the connectors (AB6, AB13) between the airbag control module and the front sub sensor (LH).</p>	Is there poor contact?	<p>Replace the airbag main harness along with body harness.</p> <p>Go to step 2.</p>

Diagnostic Chart with Trouble Code

AIRBAG SYSTEM (DIAGNOSTICS)

Step	Check	Yes	No
<p>2 CHECK AIRBAG MAIN HARNESS (FRONT SENSOR BUS LH).</p> <p>1) Turn the ignition switch to OFF, disconnect the battery ground cable, and wait for 20 seconds or more.</p> <p>2) Remove the instrument panel lower cover and disconnect the connectors (AB7) and (AB2).</p> <p>3) Remove the console front panel and disconnect the connectors (AB9) and (AB10).</p> <p>4) Disconnect the connectors (AB17, AB6, AB18) from airbag control module.</p> <p>5) Connect the connector (1AG) in the test harness AG to the connectors (AB17, AB6, AB18).</p> <p>6) Disconnect the front sub sensor (LH), and then connect the connector (1H) in the test harness H to connector (AB13).</p> <p>7) Measure the resistance between connector (4AG) in the test harness AG and connector (3H) in the test harness H.</p> <p>Connector & terminal (4AG) No. 7 — (3H) No. 5: (4AG) No. 9 — (3H) No. 6:</p>	Is the resistance less than 10 Ω?	Go to step 3.	Replace the airbag main harness along with body harness.
<p>3 CHECK AIRBAG MAIN HARNESS (FRONT SENSOR BUS LH).</p> <p>Measure the resistance between connector (4AG) in the test harness AG and chassis ground, and the resistance between connector (4AG) in the test harness AG and connector (3H) in test harness H.</p> <p>Connector & terminal (4AG) No. 7 — Chassis ground: (4AG) No. 9 — Chassis ground: (4AG) No. 7 — (4AG) No. 9:</p>	Is the resistance 1 MΩ or more?	Go to step 4.	Replace the airbag main harness along with body harness.
<p>4 CHECK AIRBAG CONTROL MODULE.</p> <p>1) Connect all connectors.</p> <p>2) Erase the memory.</p> <p>3) Perform the Inspection Mode.</p> <p>4) Read the DTC.</p>	Is the same DTC displayed?	Replace the front sub sensor (LH). <Ref. to AB-24, REMOVAL, Front Sub Sensor.> Replace the airbag control module if not operating normally even after replacing the sensor. <Ref. to AB-23, REMOVAL, Airbag Control Module.>	Go to step 5.
<p>5 CHECK FOR ANY OTHER DTC ON DISPLAY.</p>	Is any other DTC displayed?	Check DTC using “List of Diagnostic Trouble Code”. <Ref. to AB(diag)-40, LIST, List of Diagnostic Trouble Code (DTC).>	Finish the diagnosis.

Diagnostic Chart with Trouble Code

AIRBAG SYSTEM (DIAGNOSTICS)

AS:DTC E9 SIDE SENSOR BUS RH COMMUNICATION ERROR

NOTE:

Refer to DTC EC for details on DTC E9. <Ref. to AB(diag)-106, DTC EC SIDE SENSOR BUS RH COMMUNICATION ERROR, Diagnostic Chart with Trouble Code.>

AT:DTC EA SIDE SENSOR BUS RH COMMUNICATION ERROR

NOTE:

Refer to DTC EC for details on DTC EA. <Ref. to AB(diag)-106, DTC EC SIDE SENSOR BUS RH COMMUNICATION ERROR, Diagnostic Chart with Trouble Code.>

AU:DTC EB SIDE SENSOR BUS RH COMMUNICATION ERROR

NOTE:

Refer to DTC EC for details on DTC EB. <Ref. to AB(diag)-106, DTC EC SIDE SENSOR BUS RH COMMUNICATION ERROR, Diagnostic Chart with Trouble Code.>

Diagnostic Chart with Trouble Code

AIRBAG SYSTEM (DIAGNOSTICS)

AV:DTC EC SIDE SENSOR BUS RH COMMUNICATION ERROR

DTC DETECTING CONDITION:

- Open or short circuit in harness of side sensor bus (RH).
- Side airbag sensor (RH) and curtain airbag sensor (RH) is faulty.
- Airbag control module is faulty.

CAUTION:

- Before diagnosing the airbag system, be sure to turn the ignition switch to OFF, disconnect the ground terminal from the battery, and wait 20 seconds or more before starting to work.
- When replacing the airbag module, seat belt pretensioner, roll connector, control module and sensor, reconnect each part and check that the warning light operates properly.
- When inspecting the airbag main harness, disconnect the airbag module connectors and seat belt pretensioners of the driver's and passenger's seats for safety reasons.
- When inspecting the airbag rear harness, disconnect the side airbag module connector, curtain airbag module connector and seat belt pretensioner connector for safety reasons.

WIRING DIAGRAM:

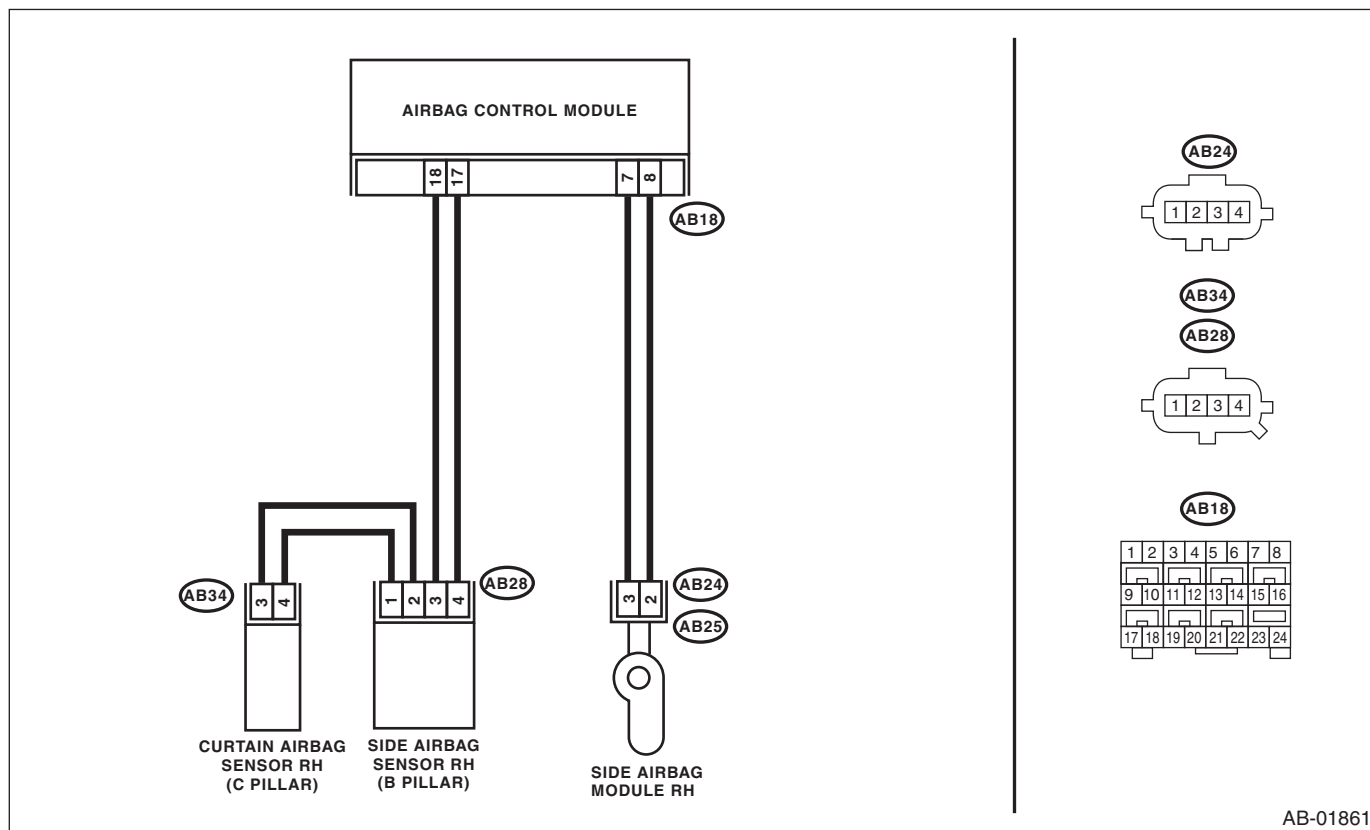

	Step	Check	Yes	No
1	CHECK POOR CONTACT IN CONNECTORS. Check for poor contact of the connectors (AB18, AB28, AB34) between the airbag control module and the curtain airbag sensor (RH).	Is there poor contact?	Replace the airbag rear harness along with body harness.	Go to step 2.

Diagnostic Chart with Trouble Code

AIRBAG SYSTEM (DIAGNOSTICS)

Step	Check	Yes	No
<p>2 CHECK AIRBAG REAR HARNESS (BETWEEN AIRBAG CONTROL MODULE AND SIDE AIRBAG SENSOR RH).</p> <p>1) Turn the ignition switch to OFF, disconnect the battery ground cable, and wait for 20 seconds or more.</p> <p>2) Disconnect the connector (AB26) from seat belt pretensioner (RH).</p> <p>3) Disconnect the connector (AB33) from curtain airbag module (RH).</p> <p>4) Disconnect connectors (AB25) and (AB24) from side airbag module (RH).</p> <p>5) Disconnect the connectors (AB17, AB6, AB18) from airbag control module.</p> <p>6) Connect the connector (1AG) in the test harness AG to the connectors (AB17, AB6, AB18).</p> <p>7) Disconnect the connector (AB28) from side airbag sensor (RH), and connect the connector (2V) in test harness V to connector (AB28).</p> <p>8) Measure the resistance between connector (5AG) in the test harness AG and connector (3V) in the test harness V.</p> <p>Connector & terminal (5AG) No. 16 — (3V) No. 2: (5AG) No. 14 — (3V) No. 1:</p>	Is the resistance less than 10 Ω?	Go to step 3.	Replace the airbag rear harness along with body harness.
<p>3 CHECK AIRBAG REAR HARNESS (BETWEEN AIRBAG CONTROL MODULE AND SIDE AIRBAG SENSOR RH).</p> <p>Measure the resistance between connector (5AG) in the test harness AG and chassis ground, and the resistance between connector (5AG) in the test harness AG and connector (3V) in test harness V.</p> <p>Connector & terminal (5AG) No. 16 — Chassis ground: (5AG) No. 14 — Chassis ground: (5AG) No. 16 — (5AG) No. 14:</p>	Is the resistance 1 MΩ or more?	Go to step 4.	Replace the airbag rear harness along with body harness.
<p>4 CHECK AIRBAG REAR HARNESS (BETWEEN SIDE AIRBAG SENSOR AND CURTAIN AIRBAG SENSOR RH).</p> <p>1) Disconnect the connector (2V) in the test harness V from the connector (AB28) of side airbag sensor (RH).</p> <p>2) Connect the connector (AB28) of side airbag sensor (RH) and the connector (1AI) in the test harness AI.</p> <p>3) Connect the connector (2AI) in the test harness AI and the connector (1V) in the test harness V.</p> <p>4) Disconnect the connector (AB34) from curtain airbag sensor (RH), and connect the connector (2V) in test harness V to connector (AB34).</p> <p>5) Measure the resistance between connector (3V) terminals in the test harness V.</p> <p>Connector & terminal (3V) No. 2 — (3V) No. 6: (3V) No. 1 — (3V) No. 7:</p>	Is the resistance less than 10 Ω?	Go to step 5.	Replace the airbag rear harness along with body harness.

Diagnostic Chart with Trouble Code

AIRBAG SYSTEM (DIAGNOSTICS)

Step	Check	Yes	No
5 CHECK AIRBAG REAR HARNESS (BETWEEN SIDE AIRBAG SENSOR AND CURTAIN AIRBAG SENSOR RH). Measure the resistance between connector (3V) in test harness V and chassis ground, and the resistance between connector (3V) in test harness V. <i>Connector & terminal</i> <i>(3V) No. 2 — Chassis ground:</i> <i>(3V) No. 1 — Chassis ground:</i> <i>(3V) No. 2 — (3V) No. 1:</i>	Is the resistance 1 MΩ or more?	Go to step 6.	Replace the airbag rear harness along with body harness.
6 CHECK AIRBAG CONTROL MODULE. 1) Connect all connectors. 2) Erase the memory. 3) Perform the Inspection Mode. 4) Read the DTC.	Is the same DTC displayed?	Go to step 7.	Go to step 8.
7 REPLACE SIDE AIRBAG SENSOR (RH) AND CHECK AIRBAG CONTROL MODULE AFTER REPLACEMENT. <Ref. to AB-25, REMOVAL, Side Airbag Sensor.> 1) Connect all connectors. 2) Erase the memory. 3) Perform the Inspection Mode. 4) Read the DTC.	Is the system normal?	Go to step 8.	Replace the curtain airbag sensor (RH). <Ref. to AB-26, REMOVAL, Curtain Airbag Sensor.> Replace the airbag control module if not operating normally even after replacing the sensor. <Ref. to AB-23, REMOVAL, Airbag Control Module.>
8 CHECK FOR ANY OTHER DTC ON DISPLAY.	Is any other DTC displayed?	Check DTC using "List of Diagnostic Trouble Code (DTC)". <Ref. to AB(diag)-40, List of Diagnostic Trouble Code (DTC).>	Finish the diagnosis.

AW:DTC ED SIDE SENSOR BUS RH COMMUNICATION ERROR

NOTE:

Refer to DTC EE for details on DTC ED. <Ref. to AB(diag)-109, DTC EE SIDE SENSOR BUS RH COMMUNICATION ERROR, Diagnostic Chart with Trouble Code.>

Diagnostic Chart with Trouble Code

AIRBAG SYSTEM (DIAGNOSTICS)

AX:DTC EE SIDE SENSOR BUS RH COMMUNICATION ERROR

DTC DETECTING CONDITION:

- Open or short circuit in harness of side sensor bus (RH).
- Side airbag sensor (RH) or curtain airbag sensor (RH) is faulty.
- Airbag control module is faulty.

CAUTION:

- Before diagnosing the airbag system, be sure to turn the ignition switch to OFF, disconnect the ground terminal from the battery, and wait 20 seconds or more before starting to work.
- When replacing the airbag module, seat belt pretensioner, roll connector, control module and sensor, reconnect each part and check that the warning light operates properly.
- When inspecting the airbag main harness, disconnect the airbag module connectors and seat belt pretensioners of the driver's and passenger's seats for safety reasons.
- When inspecting the airbag rear harness, disconnect the side airbag module connector, curtain airbag module connector and seat belt pretensioner connector for safety reasons.

WIRING DIAGRAM:

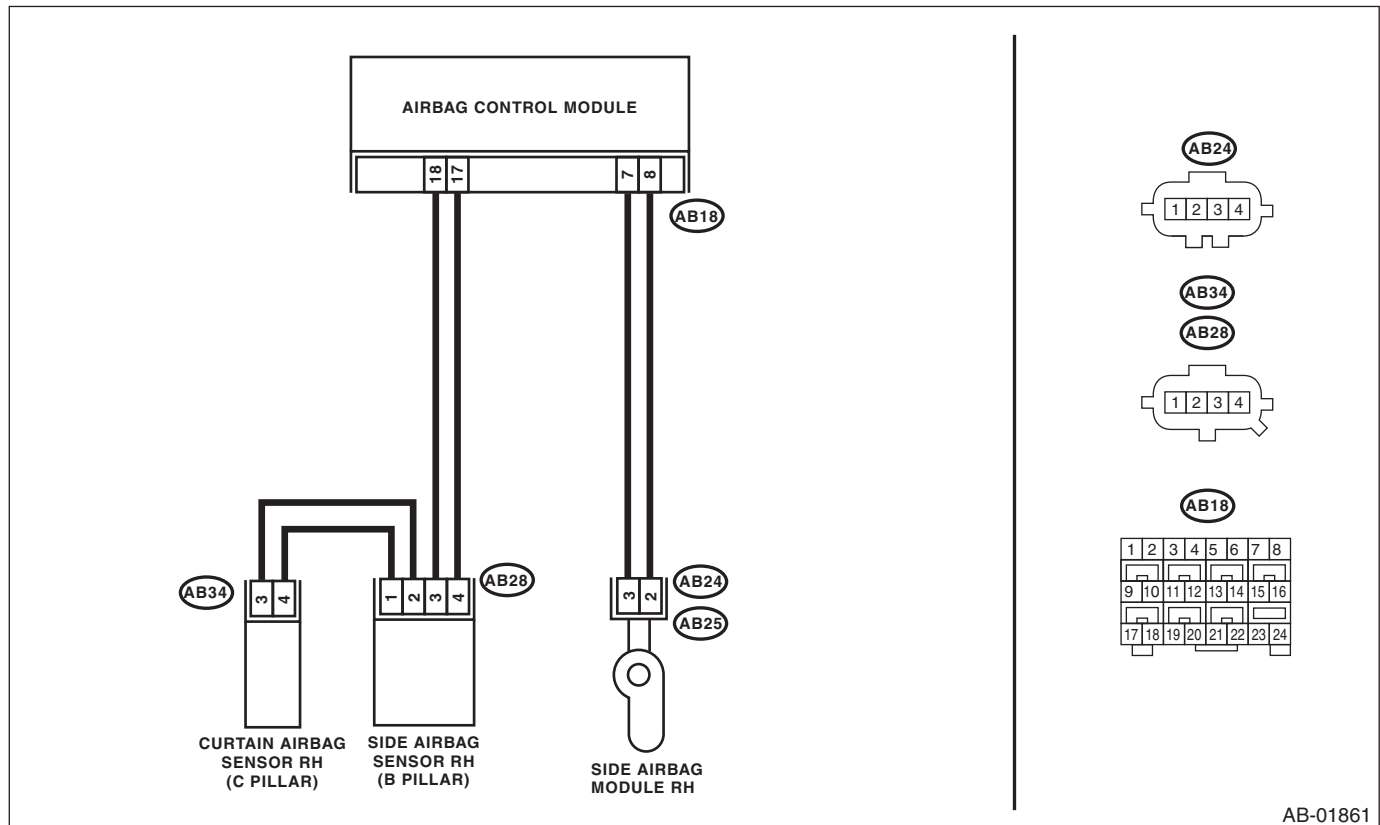

Diagnostic Chart with Trouble Code

AIRBAG SYSTEM (DIAGNOSTICS)

Step	Check	Yes	No
1 CHECK POOR CONTACT IN CONNECTORS. Check for poor contact of the connectors (AB18, AB28, AB34) between the airbag control module and the curtain airbag sensor (RH).	Is there poor contact?	Replace the airbag rear harness along with body harness.	Go to step 2.
2 CHECK AIRBAG REAR HARNESS (BETWEEN SIDE AIRBAG SENSOR (RH) AND CURTAIN AIRBAG SENSOR (RH)). 1) Turn the ignition switch to OFF, disconnect the battery ground cable, and wait for 20 seconds or more. 2) Disconnect the connector (AB26) from seat belt pretensioner (RH). 3) Disconnect the connector (AB33) from curtain airbag module (RH). 4) Disconnect connectors (AB25) and (AB24) from side airbag module (RH). 5) Disconnect connector (AB28) from side airbag sensor (RH). 6) Connect the connector (AB28) of side airbag sensor (RH) and the connector (1A1) in the test harness A1. 7) Connect the connector (2A1) in the test harness A1 and the connector (1V) in the test harness V. 8) Disconnect the connector (AB34) from curtain airbag sensor (RH), and connect the connector (2V) in test harness V to connector (AB34). 9) Measure the resistance between connector (3V) terminals in the test harness V. Connector & terminal <i>(3V) No. 2 — (3V) No. 6:</i> <i>(3V) No. 1 — (3V) No. 7:</i>	Is the resistance less than 10 Ω?	Go to step 3.	Replace the airbag rear harness along with body harness.
3 CHECK AIRBAG REAR HARNESS (BETWEEN SIDE AIRBAG SENSOR AND CURTAIN AIRBAG SENSOR RH). Measure the resistance between connector (3V) in test harness V and chassis ground, and the resistance between connector (3V) in test harness V. Connector & terminal <i>(3V) No. 2 — Chassis ground:</i> <i>(3V) No. 1 — Chassis ground:</i> <i>(3V) No. 2 — (3V) No. 1:</i>	Is the resistance 1 MΩ or more?	Go to step 4.	Replace the airbag rear harness along with body harness.

Diagnostic Chart with Trouble Code

AIRBAG SYSTEM (DIAGNOSTICS)

Step	Check	Yes	No
<p>4 CHECK AIRBAG REAR HARNESS (BETWEEN AIRBAG CONTROL MODULE AND SIDE AIRBAG SENSOR (RH)).</p> <p>1) Disconnect the connectors (AB17, AB6, AB18) from airbag control module.</p> <p>2) Connect the connector (1AG) in the test harness AG to the connectors (AB17, AB6, AB18).</p> <p>3) Disconnect the connector (AB28) in the side airbag sensor (RH) from the connector (1AI) in the test harness AI.</p> <p>4) Disconnect the connector (2AI) in the test harness AI from the connector (1V) in the test harness V.</p> <p>5) Connect the connector (AB28) of side airbag sensor (RH) and the connector (2V) in the test harness V to the connector (AB28).</p> <p>6) Measure the resistance between connector (5AG) in the test harness AG and connector (3V) in the test harness V.</p> <p>Connector & terminal (5AG) No. 16 — (3V) No. 2: (5AG) No. 14 — (3V) No. 1:</p>	Is the resistance less than 10 Ω?	Go to step 5.	Replace the airbag rear harness along with body harness.
<p>5 CHECK AIRBAG REAR HARNESS (BETWEEN AIRBAG CONTROL MODULE AND SIDE AIRBAG SENSOR RH).</p> <p>Measure the resistance between connector (5AG) in the test harness AG and chassis ground, and the resistance between connector (5AG) in the test harness AG and connector (3V) in test harness V.</p> <p>Connector & terminal (5AG) No. 16 — Chassis ground: (5AG) No. 14 — Chassis ground: (5AG) No. 16 — (5AG) No. 14:</p>	Is the resistance 1 MΩ or more?	Go to step 6.	Replace the airbag rear harness along with body harness.
<p>6 CHECK AIRBAG CONTROL MODULE.</p> <p>1) Connect all connectors.</p> <p>2) Erase the memory.</p> <p>3) Perform the Inspection Mode.</p> <p>4) Read the DTC.</p>	Is the same DTC displayed?	Go to step 7.	Go to step 8.
<p>7 REPLACE SIDE AIRBAG SENSOR (RH) AND CHECK AIRBAG CONTROL MODULE AFTER REPLACEMENT.</p> <p><Ref. to AB-25, REMOVAL, Side Airbag Sensor.></p> <p>1) Connect all connectors.</p> <p>2) Erase the memory.</p> <p>3) Perform the Inspection Mode.</p> <p>4) Read the DTC.</p>	Is the system normal?	Go to step 8.	Replace the curtain airbag sensor (RH). <Ref. to AB-26, REMOVAL, Curtain Airbag Sensor.> Replace the airbag control module if not operating normally even after replacing the sensor. <Ref. to AB-23, REMOVAL, Airbag Control Module.>
<p>8 CHECK FOR ANY OTHER DTC ON DISPLAY.</p>	Is any other DTC displayed?	Check DTC using "List of Diagnostic Trouble Code (DTC)". <Ref. to AB(diag)-40, List of Diagnostic Trouble Code (DTC).>	Finish the diagnosis.

Diagnostic Chart with Trouble Code

AIRBAG SYSTEM (DIAGNOSTICS)

AY:DTC F1 SIDE SENSOR BUS LH COMMUNICATION ERROR

NOTE:

Refer to DTC F4 for details on DTC F1. <Ref. to AB(diag)-113, DTC F4 SIDE SENSOR BUS LH COMMUNICATION ERROR, Diagnostic Chart with Trouble Code.>

AZ:DTC F2 SIDE SENSOR BUS LH COMMUNICATION ERROR

NOTE:

Refer to DTC F4 for details on DTC F2. <Ref. to AB(diag)-113, DTC F4 SIDE SENSOR BUS LH COMMUNICATION ERROR, Diagnostic Chart with Trouble Code.>

BA:DTC F3 SIDE SENSOR BUS LH COMMUNICATION ERROR

NOTE:

Refer to DTC F4 for details on DTC F3. <Ref. to AB(diag)-113, DTC F4 SIDE SENSOR BUS LH COMMUNICATION ERROR, Diagnostic Chart with Trouble Code.>

Diagnostic Chart with Trouble Code

AIRBAG SYSTEM (DIAGNOSTICS)

BB:DTC F4 SIDE SENSOR BUS LH COMMUNICATION ERROR

DTC DETECTING CONDITION:

- Open or short circuit in harness of side sensor bus (LH).
- Side airbag sensor (LH) and curtain airbag sensor (LH) is faulty.
- Airbag control module is faulty.

CAUTION:

- Before diagnosing the airbag system, be sure to turn the ignition switch to OFF, disconnect the ground terminal from the battery, and wait 20 seconds or more before starting to work.
- When replacing the airbag module, seat belt pretensioner, roll connector, control module and sensor, reconnect each part and check that the warning light operates properly.
- When inspecting the airbag main harness, disconnect the airbag module connectors and seat belt pretensioners of the driver's and passenger's seats for safety reasons.
- When inspecting the airbag rear harness, disconnect the side airbag module connector, curtain airbag module connector and seat belt pretensioner connector for safety reasons.

WIRING DIAGRAM:

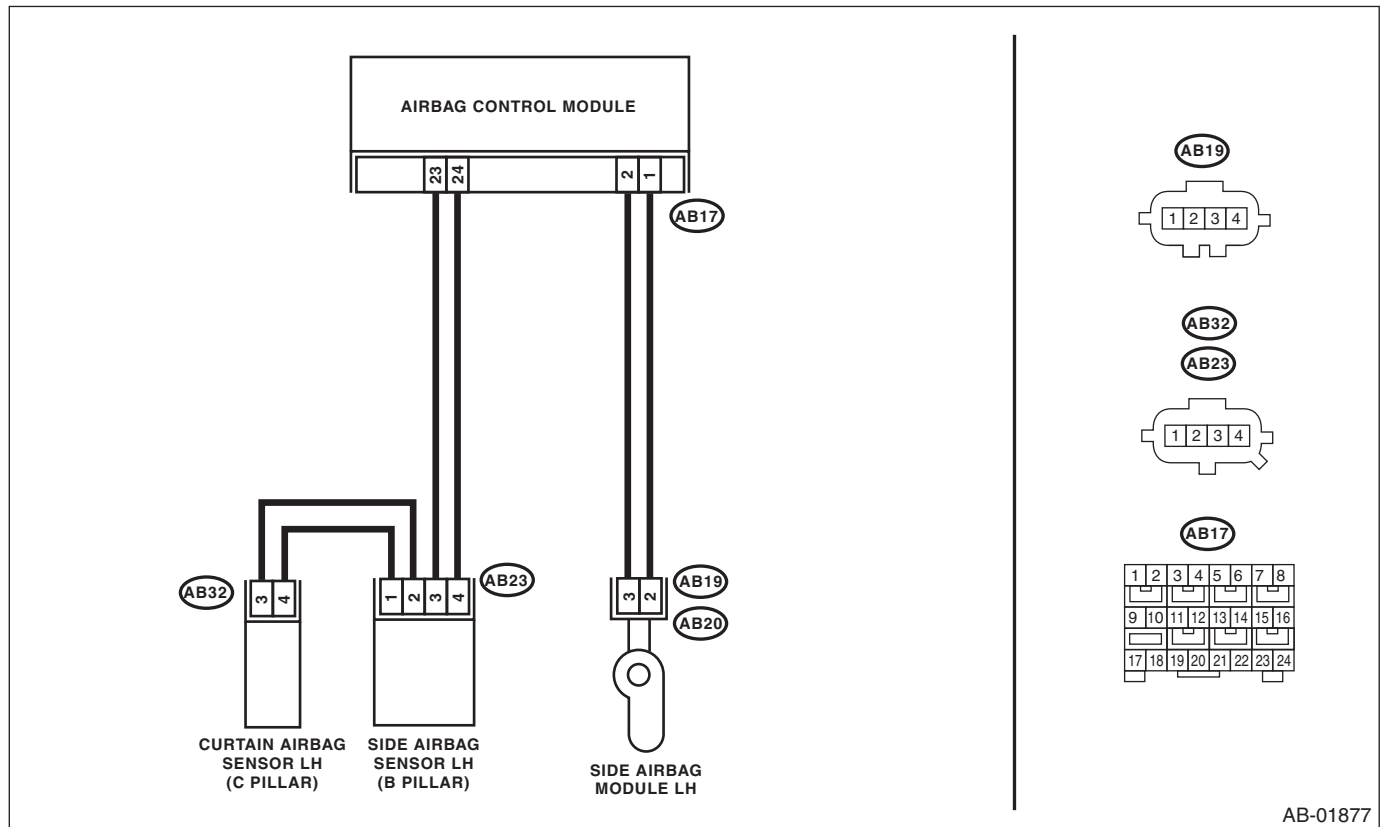

Step	Check	Yes	No
1	CHECK POOR CONTACT IN CONNECTORS. Check for poor contact of the connectors (AB17, AB23, AB32) between the airbag control module and the curtain airbag sensor (LH).	Is there poor contact?	Replace the airbag rear harness along with body harness. Go to step 2.

Diagnostic Chart with Trouble Code

AIRBAG SYSTEM (DIAGNOSTICS)

Step	Check	Yes	No
<p>2</p> <p>CHECK AIRBAG REAR HARNESS (BETWEEN AIRBAG CONTROL MODULE AND SIDE AIRBAG SENSOR LH).</p> <p>1) Turn the ignition switch to OFF, disconnect the battery ground cable, and wait for 20 seconds or more.</p> <p>2) Disconnect the connector (AB21) from seat belt pretensioner (LH).</p> <p>3) Disconnect the connector (AB31) from curtain airbag module (LH).</p> <p>4) Disconnect connectors (AB19) and (AB20) from side airbag module (LH).</p> <p>5) Disconnect the connectors (AB17, AB6, AB18) from airbag control module.</p> <p>6) Connect the connector (1AG) in the test harness AG to the connectors (AB17, AB6, AB18).</p> <p>7) Disconnect the connector (AB23) from side airbag sensor (LH), and connect the connector (2V) in test harness V to connector (AB23).</p> <p>8) Measure the resistance between connector (5AG) in the test harness AG and connector (3V) in the test harness V.</p> <p>Connector & terminal (5AG) No. 10 — (3V) No. 1: (5AG) No. 8 — (3V) No. 2:</p>	Is the resistance less than 10 Ω?	Go to step 3.	Replace the airbag rear harness along with body harness.
<p>3</p> <p>CHECK AIRBAG REAR HARNESS (BETWEEN AIRBAG CONTROL MODULE AND SIDE AIRBAG SENSOR LH).</p> <p>Measure the resistance between connector (5AG) in the test harness AG and chassis ground, and the resistance between connector (5AG) in the test harness AG and connector (3V) in test harness V.</p> <p>Connector & terminal (5AG) No. 10 — Chassis ground: (5AG) No. 8 — Chassis ground: (5AG) No. 10 — (5AG) No. 8:</p>	Is the resistance 1 MΩ or more?	Go to step 4.	Replace the airbag rear harness along with body harness.
<p>4</p> <p>CHECK AIRBAG REAR HARNESS (BETWEEN SIDE AIRBAG SENSOR (LH) AND CURTAIN AIRBAG SENSOR (LH)).</p> <p>1) Disconnect the connector (2V) in the test harness V from the connector (AB23) of side airbag sensor (LH).</p> <p>2) Connect the connector (AB23) of side airbag sensor (LH) and the connector (1AI) in the test harness AI.</p> <p>3) Connect the connector (2AI) in the test harness AI and the connector (1V) in the test harness V.</p> <p>4) Disconnect the connector (AB32) from curtain airbag sensor (LH), and connect the connector (2V) in test harness V to connector (AB32).</p> <p>5) Measure the resistance between connector (3V) terminals in the test harness V.</p> <p>Connector & terminal (3V) No. 2 — (3V) No. 6: (3V) No. 1 — (3V) No. 7:</p>	Is the resistance less than 10 Ω?	Go to step 5.	Replace the airbag rear harness along with body harness.

Diagnostic Chart with Trouble Code

AIRBAG SYSTEM (DIAGNOSTICS)

Step	Check	Yes	No
5 CHECK AIRBAG REAR HARNESS (BETWEEN SIDE AIRBAG SENSOR (LH) AND CURTAIN AIRBAG SENSOR (LH)). Measure the resistance between connector (3V) in test harness V and chassis ground, and the resistance between connector (3V) in test harness V. <i>Connector & terminal</i> <i>(3V) No. 2 — Chassis ground:</i> <i>(3V) No. 1 — Chassis ground:</i> <i>(3V) No. 2 — (3V) No. 1:</i>	Is the resistance 1 MΩ or more?	Go to step 6.	Replace the airbag rear harness along with body harness.
6 CHECK AIRBAG CONTROL MODULE. 1) Connect all connectors. 2) Erase the memory. 3) Perform the Inspection Mode. 4) Read the DTC.	Is the same DTC displayed?	Go to step 7.	Go to step 8.
7 REPLACE SIDE AIRBAG SENSOR (LH) AND CHECK AIRBAG CONTROL MODULE AFTER REPLACEMENT. <Ref. to AB-25, REMOVAL, Side Airbag Sensor.> 1) Connect all connectors. 2) Erase the memory. 3) Perform the Inspection Mode. 4) Read the DTC.	Is the system normal?	Go to step 8.	Replace the curtain airbag sensor (LH). <Ref. to AB-26, REMOVAL, Curtain Airbag Sensor.> Replace the airbag control module if not operating normally even after replacing the sensor. <Ref. to AB-23, REMOVAL, Airbag Control Module.>
8 CHECK FOR ANY OTHER DTC ON DISPLAY.	Is any other DTC displayed?	Check DTC using "List of Diagnostic Trouble Code (DTC)". <Ref. to AB(diag)-40, List of Diagnostic Trouble Code (DTC).>	Finish the diagnosis.

BC:DTC F5 SIDE SENSOR BUS LH COMMUNICATION ERROR

NOTE:

Refer to DTC F6 for details on DTC F5. <Ref. to AB(diag)-116, DTC F6 SIDE SENSOR BUS LH COMMUNICATION ERROR, Diagnostic Chart with Trouble Code.>

Diagnostic Chart with Trouble Code

AIRBAG SYSTEM (DIAGNOSTICS)

BD:DTC F6 SIDE SENSOR BUS LH COMMUNICATION ERROR

DTC DETECTING CONDITION:

- Open or short circuit in harness of side sensor bus (LH).
- Side airbag sensor (LH) or curtain airbag sensor (LH) is faulty.
- Airbag control module is faulty.

CAUTION:

- Before diagnosing the airbag system, be sure to turn the ignition switch to OFF, disconnect the ground terminal from the battery, and wait 20 seconds or more before starting to work.
- When replacing the airbag module, seat belt pretensioner, roll connector, control module and sensor, reconnect each part and check that the warning light operates properly.
- When inspecting the airbag main harness, disconnect the airbag module connectors and seat belt pretensioners of the driver's and passenger's seats for safety reasons.
- When inspecting the airbag rear harness, disconnect the side airbag module connector, curtain airbag module connector and seat belt pretensioner connector for safety reasons.

WIRING DIAGRAM:

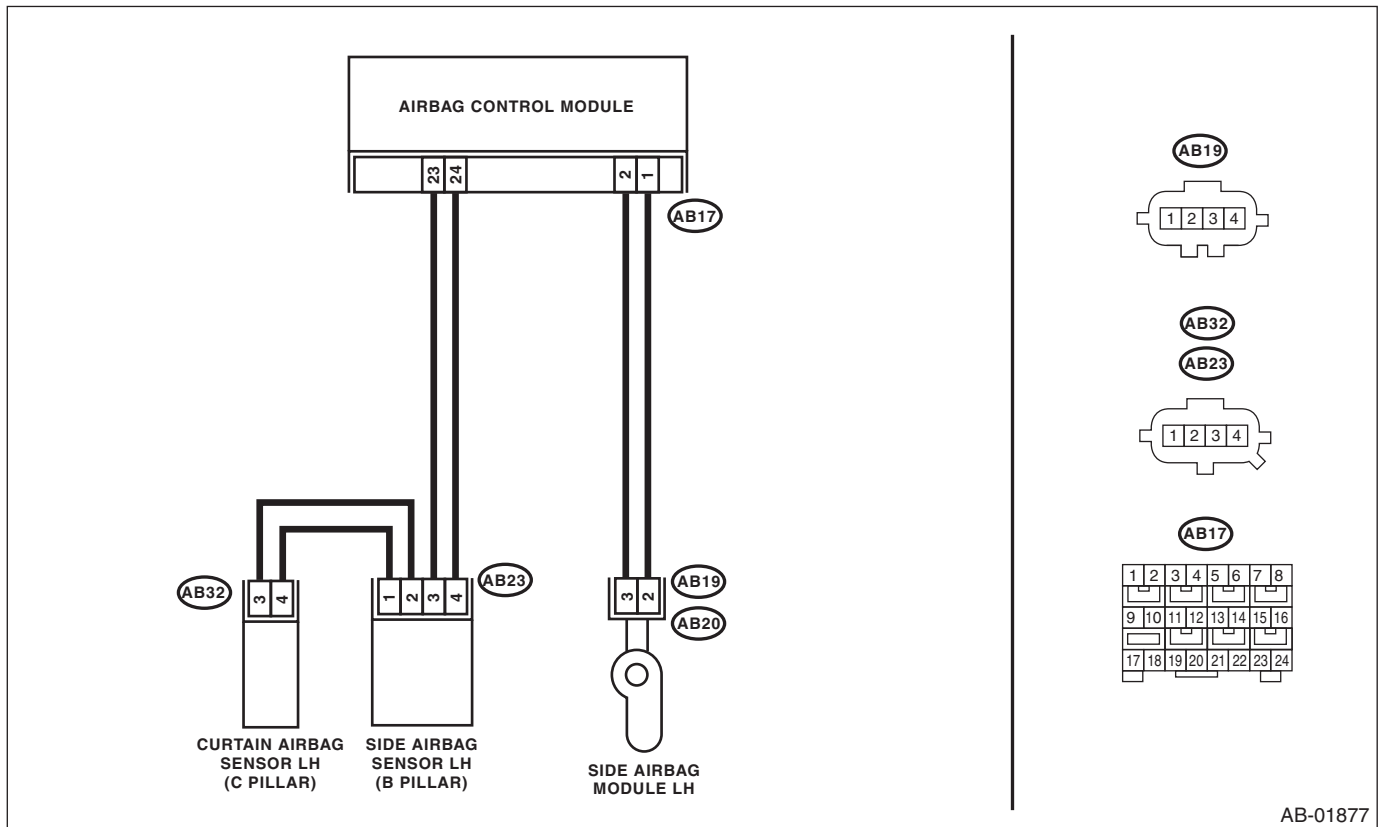

Diagnostic Chart with Trouble Code

AIRBAG SYSTEM (DIAGNOSTICS)

Step	Check	Yes	No
1 CHECK POOR CONTACT IN CONNECTORS. Check for poor contact of the connectors (AB17, AB23, AB32) between the airbag control module and the curtain airbag sensor (LH).	Is there poor contact?	Replace the airbag rear harness along with body harness.	Go to step 2.
2 CHECK AIRBAG REAR HARNESS (BETWEEN SIDE AIRBAG SENSOR (LH) AND CURTAIN AIRBAG SENSOR (LH)). 1) Turn the ignition switch to OFF, disconnect the battery ground cable, and wait for 20 seconds or more. 2) Disconnect the connector (AB21) from seat belt pretensioner (LH). 3) Disconnect the connector (AB31) from curtain airbag module (LH). 4) Disconnect connectors (AB19) and (AB20) from side airbag module (LH). 5) Disconnect the connector (AB23) in the side airbag sensor (LH). 6) Connect the connector (AB23) of side airbag sensor (LH) and the connector (1A1) in the test harness A1. 7) Connect the connector (2A1) in the test harness A1 and the connector (1V) in the test harness V. 8) Disconnect the connector (AB32) from curtain airbag sensor (LH), and connect the connector (2V) in test harness V to connector (AB32). 9) Measure the resistance between connector (3V) terminals in the test harness V. Connector & terminal <i>(3V) No. 2 — (3V) No. 6:</i> <i>(3V) No. 1 — (3V) No. 7:</i>	Is the resistance less than 10 Ω?	Go to step 3.	Replace the airbag rear harness along with body harness.
3 CHECK AIRBAG REAR HARNESS (BETWEEN SIDE AIRBAG SENSOR AND CURTAIN AIRBAG SENSOR LH). Measure the resistance between connector (3V) in test harness V and chassis ground, and the resistance between connector (3V) in test harness V. Connector & terminal <i>(3V) No. 6 — Chassis ground:</i> <i>(3V) No. 7 — Chassis ground:</i> <i>(3V) No. 2 — (3V) No. 1:</i>	Is the resistance 1 MΩ or more?	Go to step 4.	Replace the airbag rear harness along with body harness.

Diagnostic Chart with Trouble Code

AIRBAG SYSTEM (DIAGNOSTICS)

Step	Check	Yes	No
<p>4 CHECK AIRBAG REAR HARNESS (BETWEEN AIRBAG CONTROL MODULE AND SIDE AIRBAG SENSOR (LH)).</p> <p>1) Disconnect the connectors (AB17, AB6, AB18) from airbag control module.</p> <p>2) Connect the connector (1AG) in the test harness AG to the connectors (AB17, AB6, AB18).</p> <p>3) Disconnect the connector (AB23) in the side airbag sensor (LH) from the connector (1AI) in the test harness AI.</p> <p>4) Disconnect the connector (2AI) in the test harness AI from the connector (1V) in the test harness V.</p> <p>5) Connect the connector (2V) in the test harness V to the connector (AB23).</p> <p>6) Measure the resistance between connector (5AG) in the test harness AG and connector (3V) in the test harness V.</p> <p>Connector & terminal (5AG) No. 10 — (3V) No. 1: (5AG) No. 8 — (3V) No. 2:</p>	Is the resistance less than 10 Ω?	Go to step 5.	Replace the airbag rear harness along with body harness.
<p>5 CHECK AIRBAG REAR HARNESS (BETWEEN SIDE AIRBAG SENSOR (LH) AND CURTAIN AIRBAG SENSOR (LH)).</p> <p>Measure the resistance between connector (3V) in the test harness V and chassis ground, and the resistance between connector (5AG) in the test harness AG and connector (3V) in test harness V.</p> <p>Connector & terminal (3V) No. 2 — Chassis ground: (3V) No. 1 — Chassis ground: (5AG) No. 10 — (5AG) No. 8:</p>	Is the resistance 1 MΩ or more?	Go to step 6.	Replace the airbag rear harness along with body harness.
<p>6 CHECK AIRBAG CONTROL MODULE.</p> <p>1) Connect all connectors.</p> <p>2) Erase the memory.</p> <p>3) Perform the Inspection Mode.</p> <p>4) Read the DTC.</p>	Is the same DTC displayed?	Go to step 7.	Go to step 8.
<p>7 REPLACE SIDE AIRBAG SENSOR (LH) AND CHECK AIRBAG CONTROL MODULE AFTER REPLACEMENT.</p> <p><Ref. to AB-25, REMOVAL, Side Airbag Sensor.></p> <p>1) Connect all connectors.</p> <p>2) Erase the memory.</p> <p>3) Perform the Inspection Mode.</p> <p>4) Read the DTC.</p>	Is the system normal?	Go to step 8.	Replace the curtain airbag sensor (LH). <Ref. to AB-26, REMOVAL, Curtain Airbag Sensor.> Replace the airbag control module if not operating normally even after replacing the sensor. <Ref. to AB-23, REMOVAL, Airbag Control Module.>
<p>8 CHECK FOR ANY OTHER DTC ON DISPLAY.</p>	Is any other DTC displayed?	Check DTC using “List of Diagnostic Trouble Code (DTC)”. <Ref. to AB(diag)-40, List of Diagnostic Trouble Code (DTC).>	Finish the diagnosis.

Diagnostic Chart with Trouble Code

AIRBAG SYSTEM (DIAGNOSTICS)

BE:DTC F8 SATELLITE SENSOR BUS COMMUNICATION ERROR

NOTE:

Refer to DTC FA for details on DTC F8. <Ref. to AB(diag)-120, DTC FA SATELLITE SENSOR BUS COMMUNICATION ERROR, Diagnostic Chart with Trouble Code.>

BF:DTC F9 SATELLITE SENSOR BUS COMMUNICATION ERROR

NOTE:

Refer to DTC FA for details on DTC F9. <Ref. to AB(diag)-120, DTC FA SATELLITE SENSOR BUS COMMUNICATION ERROR, Diagnostic Chart with Trouble Code.>

Diagnostic Chart with Trouble Code

AIRBAG SYSTEM (DIAGNOSTICS)

BG:DTC FA SATELLITE SENSOR BUS COMMUNICATION ERROR

DTC DETECTING CONDITION:

- Open or short circuit in harness of satellite safing sensor.
- Satellite safing sensor is faulty.
- Airbag control module is faulty.

CAUTION:

- Before diagnosing the airbag system, be sure to turn the ignition switch to OFF, disconnect the ground terminal from the battery, and wait 20 seconds or more before starting to work.
- When replacing the airbag module, seat belt pretensioner, roll connector, control module and sensor, reconnect each part and check that the warning light operates properly.
- When inspecting the airbag main harness, disconnect the airbag module connectors and seat belt pretensioners of the driver's and passenger's seats for safety reasons.
- When inspecting the airbag rear harness, disconnect the side airbag module connector, curtain airbag module connector and seat belt pretensioner connector for safety reasons.

WIRING DIAGRAM:

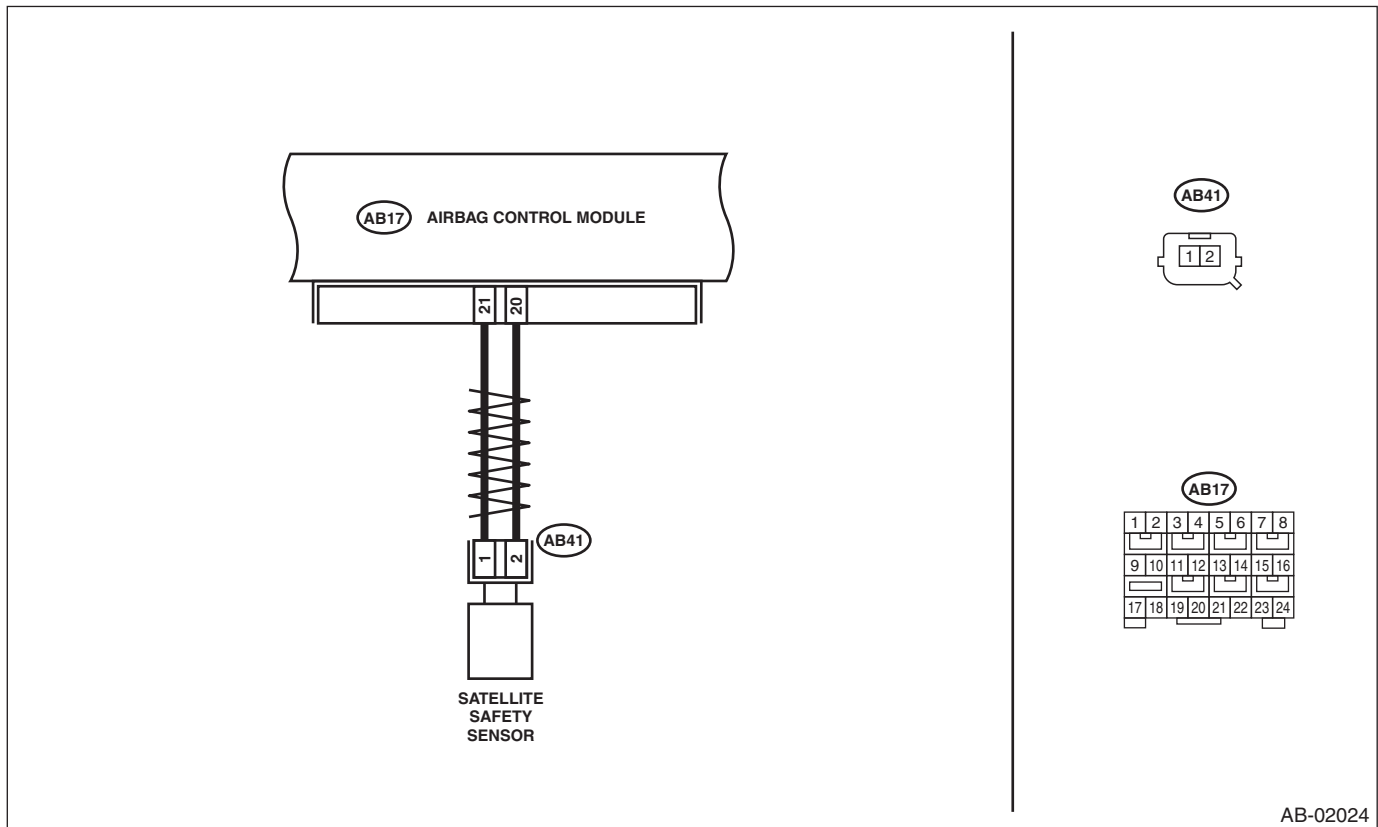

Step	Check	Yes	No
1 CHECK POOR CONTACT OF CONNECTORS. Check for poor contact of the connectors (AB17, AB41) between the airbag control module and the satellite safing sensor.	Is there poor contact?	Replace the airbag rear harness along with body harness.	Go to step 2.

Diagnostic Chart with Trouble Code

AIRBAG SYSTEM (DIAGNOSTICS)

Step	Check	Yes	No
<p>2 CHECK AIRBAG REAR HARNESS (BETWEEN AIRBAG CONTROL MODULE AND SATELLITE SAFING SENSOR).</p> <p>1) Turn the ignition switch to OFF, disconnect the battery ground cable, and wait for 20 seconds or more.</p> <p>2) Disconnect the connectors (AB21, AB26) from seat belt pretensioner.</p> <p>3) Disconnect the connectors (AB31, AB33) from curtain airbag module.</p> <p>4) Disconnect the connectors (AB19), (AB20), (AB24) and (AB25) from the side airbag module.</p> <p>5) Disconnect the connectors (AB17, AB6, AB18) from airbag control module.</p> <p>6) Connect the connector (1AG) in the test harness AG to the connectors (AB17, AB6, AB18).</p> <p>7) Disconnect the connector (AB41) from satellite safing sensor, and then connect the connector (1H) in the test harness H to connector (AB41).</p> <p>8) Measure the resistance between connector (5AG) in the test harness AG and connector (3H) in the test harness H.</p> <p>Connector & terminal (5AG) No. 9 — (3H) No. 5: (5AG) No. 11 — (3H) No. 6:</p>	Is the resistance less than 10 Ω?	Go to step 3.	Replace the airbag rear harness along with body harness.
<p>3 CHECK AIRBAG REAR HARNESS (BETWEEN AIRBAG CONTROL MODULE AND SATELLITE SAFING SENSOR).</p> <p>Measure the resistance between connector (5AG) in the test harness AG and chassis ground, and the resistance between connector (5AG) in the test harness AG and connector (3H) in test harness H.</p> <p>Connector & terminal (5AG) No. 9 — Chassis ground: (5AG) No. 11 — Chassis ground: (5AG) No. 9 — (5AG) No. 11:</p>	Is the resistance 1 MΩ or more?	Go to step 4.	Replace the airbag rear harness along with body harness.
<p>4 CHECK AIRBAG CONTROL MODULE.</p> <p>1) Connect all connectors.</p> <p>2) Erase the memory.</p> <p>3) Perform the Inspection Mode.</p> <p>4) Read the DTC.</p>	Is the same DTC displayed?	Replace the satellite safing sensor. <Ref. to AB-27, REMOVAL, Satellite Safing Sensor.> Replace the airbag control module if not operating normally even after replacing the sensor. <Ref. to AB-23, REMOVAL, Airbag Control Module.>	Go to step 5.
<p>5 CHECK FOR ANY OTHER DTC ON DISPLAY.</p>	Is any other DTC displayed?	Check DTC using "List of Diagnostic Trouble Code (DTC)". <Ref. to AB(diag)-40, List of Diagnostic Trouble Code (DTC).>	Finish the diagnosis.

Diagnostic Chart with Trouble Code

AIRBAG SYSTEM (DIAGNOSTICS)

BH:DTC 3A FRONT SUB SENSOR RH FALSE INSTALLATION

DTC DETECTING CONDITION:

Front sub sensor (RH) is misinstalled.

Step	Check	Yes	No	
1	REPLACE THE FRONT SUB SENSOR. 1) Turn the ignition switch to OFF, disconnect the battery ground cable, and wait for 20 seconds or more. 2) Replace the front sub sensor (RH) with a genuine sensor. <Ref. to AB-24, REMOVAL, Front Sub Sensor.>	Does the warning light go off?	Finish the diagnosis.	Replace the airbag control module. <Ref. to AB-23, REMOVAL, Airbag Control Module.>

BI: DTC 3B FRONT SUB SENSOR LH FALSE INSTALLATION

DTC DETECTING CONDITION:

Front sub sensor (LH) is misinstalled.

Step	Check	Yes	No	
1	REPLACE THE FRONT SUB SENSOR. 1) Turn the ignition switch to OFF, disconnect the battery ground cable, and wait for 20 seconds or more. 2) Replace the front sub sensor (LH) with a genuine sensor. <Ref. to AB-24, REMOVAL, Front Sub Sensor.>	Does the warning light go off?	Finish the diagnosis.	Replace the airbag control module. <Ref. to AB-23, REMOVAL, Airbag Control Module.>

BJ:DTC 3C SATELLITE SENSOR BUS FAILURE

DTC DETECTING CONDITION:

Satellite safing sensor is faulty.

Step	Check	Yes	No	
1	REPLACE SATELLITE SAFING SENSOR. 1) Turn the ignition switch to OFF, disconnect the battery ground cable, and wait for 20 seconds or more. 2) Replace the satellite safing sensor with a genuine sensor. <Ref. to AB-27, REMOVAL, Satellite Safing Sensor.>	Does the warning light go off?	Finish the diagnosis.	Replace the airbag control module. <Ref. to AB-23, REMOVAL, Airbag Control Module.>

BK:DTC 3D SATELLITE SENSOR FALSE INSTALLATION

DTC DETECTING CONDITION:

Satellite safing sensor is misinstalled.

Step	Check	Yes	No	
1	REPLACE SATELLITE SAFING SENSOR. 1) Turn the ignition switch to OFF, disconnect the battery ground cable, and wait for 20 seconds or more. 2) Replace the satellite safing sensor with a genuine sensor. <Ref. to AB-27, REMOVAL, Satellite Safing Sensor.>	Does the warning light go off?	Finish the diagnosis.	Replace the airbag control module. <Ref. to AB-23, REMOVAL, Airbag Control Module.>

Diagnostic Chart with Trouble Code

AIRBAG SYSTEM (DIAGNOSTICS)

BL:DTC 5A SIDE AIRBAG SENSOR RH FALSE INSTALLATION

DTC DETECTING CONDITION:

Side A/B sensor RH is misinstalled.

Step	Check	Yes	No
1 REPLACE SIDE AIRBAG SENSOR (RH). 1) Turn the ignition switch to OFF, disconnect the battery ground cable, and wait for 20 seconds or more. 2) Replace the side airbag sensor (RH) with a genuine sensor. <Ref. to AB-25, REMOVAL, Side Airbag Sensor.>	Does the warning light go off?	Finish the diagnosis.	Replace the airbag control module. <Ref. to AB-23, REMOVAL, Airbag Control Module.>

BM:DTC 5B SIDE AIRBAG SENSOR LH FALSE INSTALLATION

DTC DETECTING CONDITION:

Side A/B sensor LH is misinstalled.

Step	Check	Yes	No
1 REPLACE SIDE AIRBAG SENSOR (LH). 1) Turn the ignition switch to OFF, disconnect the battery ground cable, and wait for 20 seconds or more. 2) Replace the side airbag sensor (LH) with a genuine sensor. <Ref. to AB-25, REMOVAL, Side Airbag Sensor.>	Does the warning light go off?	Finish the diagnosis.	Replace the airbag control module. <Ref. to AB-23, REMOVAL, Airbag Control Module.>

BN:DTC 5C CURTAIN AIRBAG SENSOR RH FALSE INSTALLATION

DTC DETECTING CONDITION:

Curtain A/B sensor RH is misinstalled.

Step	Check	Yes	No
1 REPLACE CURTAIN AIRBAG SENSOR (RH). 1) Turn the ignition switch to OFF, disconnect the battery ground cable, and wait for 20 seconds or more. 2) Replace the curtain airbag sensor (RH) with a genuine sensor. <Ref. to AB-26, REMOVAL, Curtain Airbag Sensor.>	Does the warning light go off?	Finish the diagnosis.	Replace the airbag control module. <Ref. to AB-23, REMOVAL, Airbag Control Module.>

BO:DTC 5D CURTAIN AIRBAG SENSOR LH FALSE INSTALLATION

DTC DETECTING CONDITION:

Curtain A/B sensor RH is misinstalled.

Step	Check	Yes	No
1 REPLACE CURTAIN AIRBAG SENSOR (LH). 1) Turn the ignition switch to OFF, disconnect the battery ground cable, and wait for 20 seconds or more. 2) Replace the curtain airbag sensor (LH) with a genuine sensor. <Ref. to AB-26, REMOVAL, Curtain Airbag Sensor.>	Does the warning light go off?	Finish the diagnosis.	Replace the airbag control module. <Ref. to AB-23, REMOVAL, Airbag Control Module.>

Diagnostic Chart with Trouble Code

AIRBAG SYSTEM (DIAGNOSTICS)

OCCUPANT DETECTION SYSTEM (DIAGNOSTICS)

OD(diag)

	Page
1. Basic Diagnostic Procedure	2
2. Check List for Interview	3
3. General Description	4
4. Electrical Component Location	11
5. Airbag Connector	12
6. Control Module I/O Signal	13
7. Subaru Select Monitor	14
8. Read Diagnostic Trouble Code (DTC)	15
9. Inspection Mode	16
10. Clear Memory Mode	17
11. Display of Status Information	18
12. System Calibration (Rezeroing)	19
13. Airbag Warning Light Illumination Pattern	20
14. Passenger's Airbag ON/OFF Indicator Light Illumination Pattern	21
15. List of Diagnostic Trouble Code (DTC)	22
16. Diagnostic Procedure with Diagnostic Trouble Code (DTC)	23

Basic Diagnostic Procedure

OCCUPANT DETECTION SYSTEM (DIAGNOSTICS)

1. Basic Diagnostic Procedure

A: PROCEDURE

	Step	Check	Yes	No
1	CHECK WARNING LIGHT. Check whether the airbag warning light in the combination meter is lit.	Does the airbag warning light illuminate?	Go to step 2.	Perform the diagnosis according to phenomenon of the problem.
2	READ DTC. 1) Turn the ignition switch to OFF. 2) Connect the Subaru Select Monitor to the data link connector. 3) Turn the ignition switch to ON and run the Subaru Select Monitor. 4) Read the DTC. <Ref. to OD(diag)-15, Read Diagnostic Trouble Code (DTC).> NOTE: If the communication function of the Subaru Select Monitor cannot be executed normally, check the communication circuit. <Ref. to AB(diag)-27, COMMUNICATION FOR INITIALIZING IMPOSSIBLE, INSPECTION, Subaru Select Monitor.> 5) Record all DTCs and freeze frame data.	Is DTC displayed?	Go to step 3.	Go to "Airbag Warning Light Failure". <Ref. to AB(diag)-35, Airbag Warning Light Failure.>
3	PERFORM DIAGNOSIS. 1) Determine the possible cause from "List of Diagnostic Trouble Code (DTC)". <Ref. to OD(diag)-22, List of Diagnostic Trouble Code (DTC).> 2) Inspect the DTC using "List of Diagnostic Trouble Code (DTC)". 3) Repair the trouble cause. 4) Perform the Clear Memory Mode. <Ref. to OD(diag)-17, Clear Memory Mode.> 5) Perform the Inspection Mode. <Ref. to OD(diag)-16, Inspection Mode.> 6) Read any other DTCs displayed.	Is DTC displayed?	Perform the procedure 1) to 5) in step 3.	Finish the diagnosis.

Check List for Interview

OCCUPANT DETECTION SYSTEM (DIAGNOSTICS)

2. Check List for Interview

A: CHECK

Customer's name		Inspector's name	
Date vehicle brought in	/ /	Registration No.	
Odometer reading	km miles	V.I.N.	
Date problem occurred	/ /	Registration year	/ /
Weather	<input type="checkbox"/> Fine <input type="checkbox"/> Cloudy <input type="checkbox"/> Rainy <input type="checkbox"/> Snowy <input type="checkbox"/> Others:		
Temperature	°C (°F)		
Road condition	<input type="checkbox"/> Flat road <input type="checkbox"/> Uphill <input type="checkbox"/> Downhill <input type="checkbox"/> Gravel road <input type="checkbox"/> Others:		
Vehicle operation	<input type="checkbox"/> Starting <input type="checkbox"/> Idling <input type="checkbox"/> Driving <input type="checkbox"/> Constant speed <input type="checkbox"/> Accelerating <input type="checkbox"/> Decelerating <input type="checkbox"/> Turning <input type="checkbox"/> Others:		
Details of problem			
Airbag warning light operation	<input type="checkbox"/> Normal (After turning the ignition switch to ON, illuminates for 6 seconds then goes off.) <input type="checkbox"/> Remains ON <input type="checkbox"/> Remains OFF		
Passengers airbag ON/OFF indicator operation	<input type="checkbox"/> Normal (After turning the ignition switch to ON, illuminates for 6 seconds then goes off for 2 seconds; Lights ON (adult) or OFF (children/unoccupied).) <input type="checkbox"/> Both remain ON <input type="checkbox"/> Both remain OFF		
DTC output	<input type="checkbox"/> OK code <input type="checkbox"/> DTC: (Code:)		

General Description

OCCUPANT DETECTION SYSTEM (DIAGNOSTICS)

3. General Description

A: CAUTION

1) If the seat cushion cover is removed or replaced, make sure to perform passenger detection system adjustment after installing the seat to the vehicle. <Ref. to OD(diag)-19, System Calibration (Rezeroing).>

Failure to do so may cause improper operation of the passenger detection system.

2) The passenger detection system (passenger seat only) control unit and the passenger detection sensor are fixed to the seat cushion frame. Never remove the passenger detection control unit or the pressure sensor from the seat cushion frame.

3) Do not replace the seat cushion pad by itself. Always replace the seat cushion pad and frame assembly as a set. The seat cushion pad and cushion frame are adjusted as a set at the time of manufacture. If cushion pads and cushion frames are combined from those of other vehicles or other sets, the passenger detection system may not operate properly.

4) If the seat cushion cover is removed, make sure to replace the hang wire on the seat cushion side with a new wire.

5) Never connect the battery in reverse polarity. Occupant detection system may be destroyed instantly.

6) Do not disconnect the battery terminals while the engine is running.

A large counter electromotive force will be generated in the generator, and this voltage may damage electronic parts such as occupant detection control module.

7) Before disconnecting the connectors of each sensor and control module, be sure to turn the ignition switch to OFF and wait for 20 seconds or more. Occupant detection control module may be damaged.

8) All passenger detection system parts are precision components. Do not drop them.

CAUTION:

- Do not use electrical test equipment on the airbag system wiring harness and connector circuit.
- Be careful not to damage the airbag system wiring harness when servicing the occupant detection system.
- Refer to Airbag System when repairing the occupant detection system. <Ref. to AB(diag)-4, CAUTION, General Description.>

B: INSPECTION

Measure the battery voltage and check electrolyte.

Standard voltage:

12 V

Specific gravity:

1.260 or more

Fluid level:

Between the upper level and lower level

General Description

OCCUPANT DETECTION SYSTEM (DIAGNOSTICS)

C: PREPARATION TOOL

CAUTION:

To measure the voltage and resistance of airbag system and occupant detection system components, be sure to use the specified test harness.

1. SPECIAL TOOL

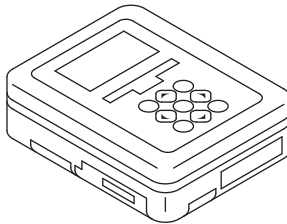
ILLUSTRATION	TOOL NUMBER	DESCRIPTION	REMARKS
 <p>ST1B022XU0</p>	1B022XU0 (Newly adopted tool)	SUBARU SELECT MONITOR III KIT	Used for troubleshooting the electrical system.

• TEST HARNESS D

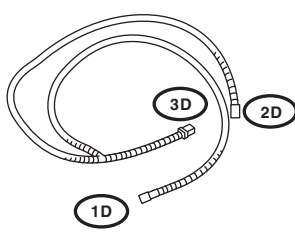
ILLUSTRATION	TOOL NUMBER	DESCRIPTION	REMARKS
 <p>ST98299AG060</p>	98299AG060	TEST HARNESS D	Used when measuring voltage and resistance of the front seat belt buckle switch.

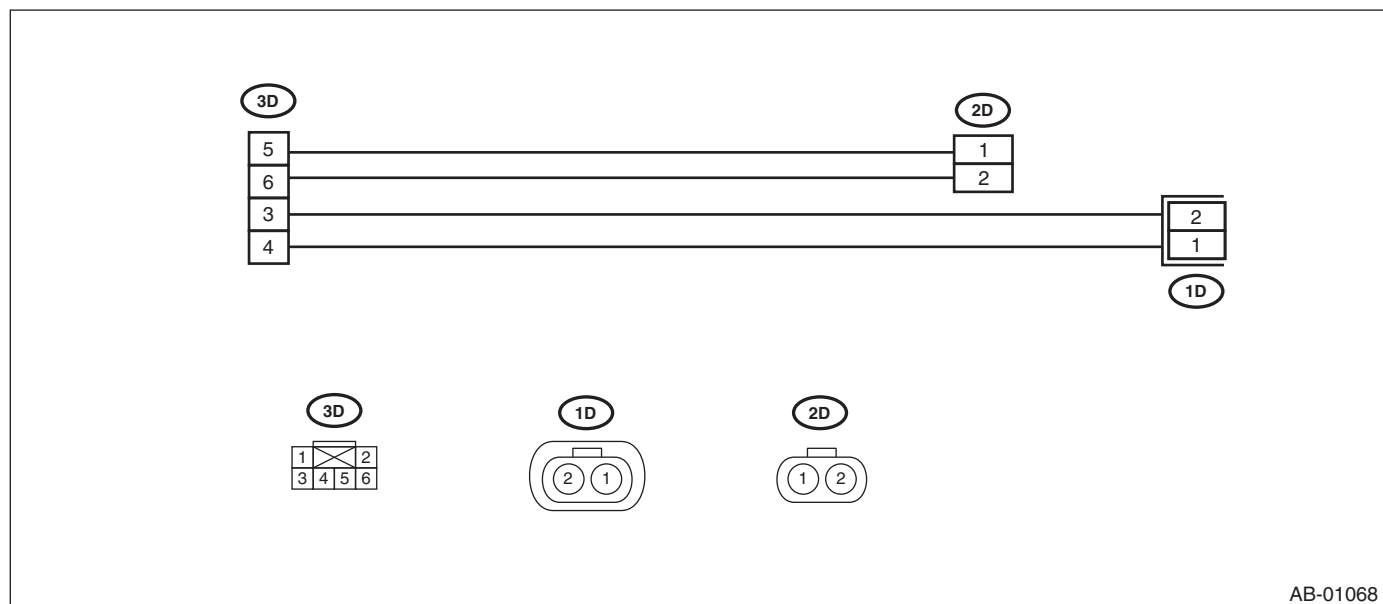

AB-01068

General Description

OCCUPANT DETECTION SYSTEM (DIAGNOSTICS)

- TEST HARNESS Y

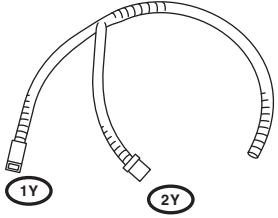
ILLUSTRATION	TOOL NUMBER	DESCRIPTION	REMARKS
 <p data-bbox="321 554 467 575">ST98299AG040</p>	98299AG040	TEST HARNESS Y	Used for diagnosing seat belt buckle switch.

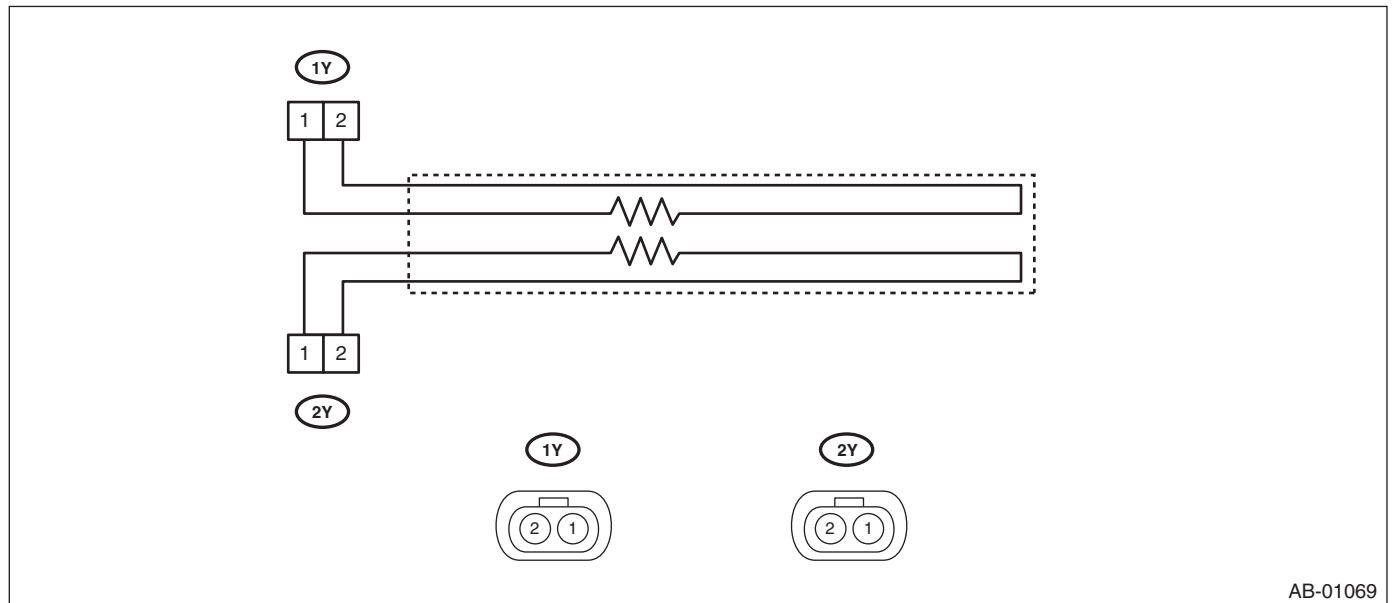

General Description

OCCUPANT DETECTION SYSTEM (DIAGNOSTICS)

- TEST HARNESS AB

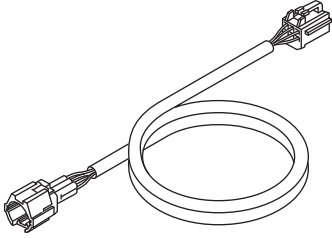
ILLUSTRATION	TOOL NUMBER	DESCRIPTION	REMARKS
 <p>ST98299XA000</p>	98299XA000	TEST HARNESS AB	Used when measuring voltage and resistance of occupant detection system.

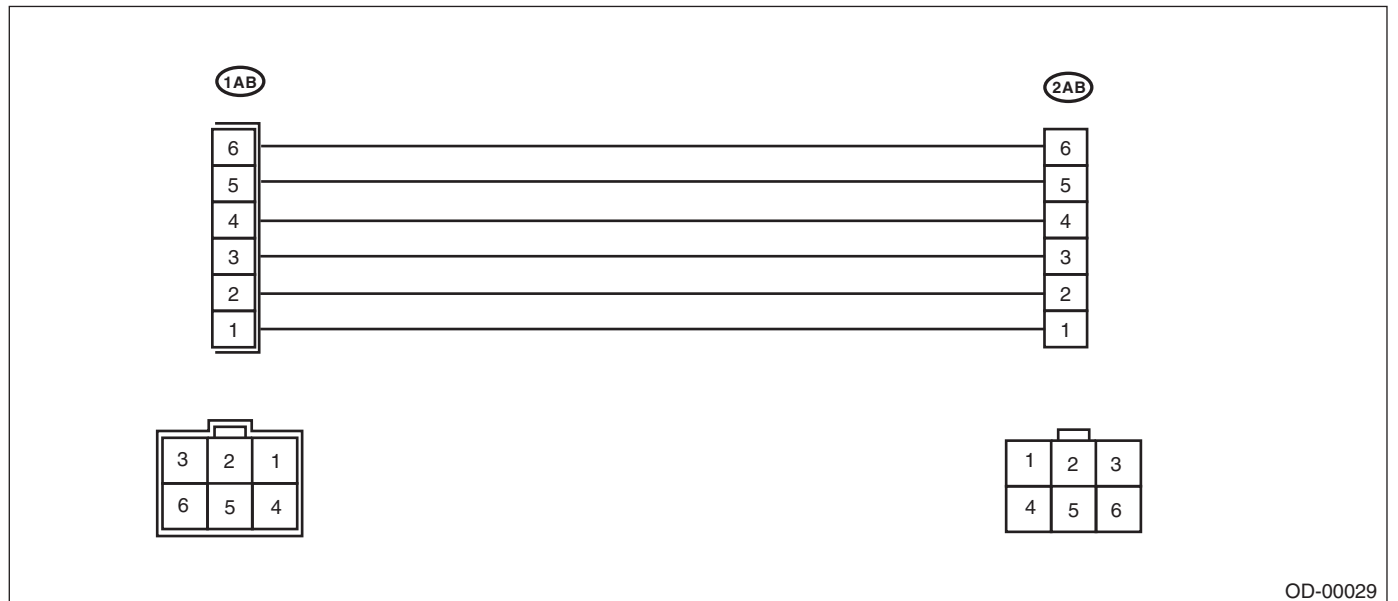

General Description

OCCUPANT DETECTION SYSTEM (DIAGNOSTICS)

- TEST HARNESS AE

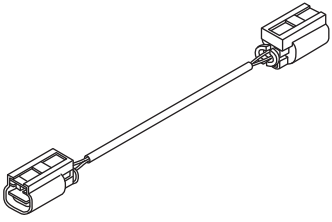
ILLUSTRATION	TOOL NUMBER	DESCRIPTION	REMARKS
 ST98299XA030	98299XA030	TEST HARNESS AE	TEST HARNESS Y ADAPTER HARNESS Used for diagnosing seat belt buckle switch.

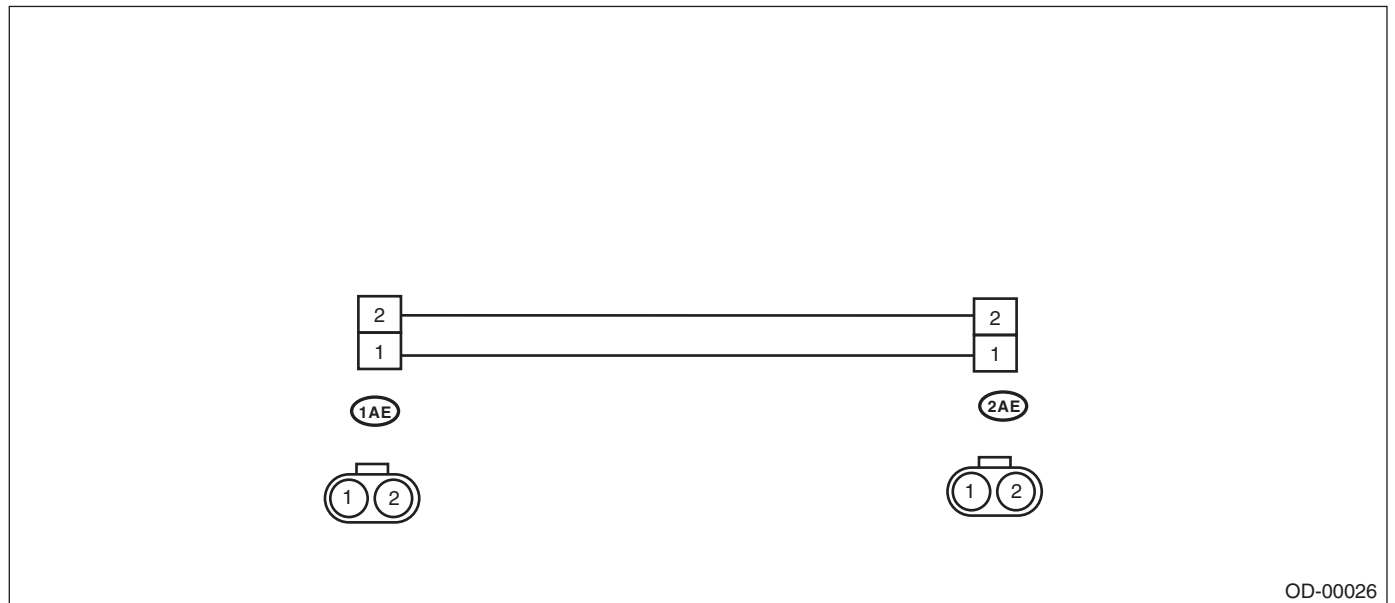

General Description

OCCUPANT DETECTION SYSTEM (DIAGNOSTICS)

- TEST HARNESS AC

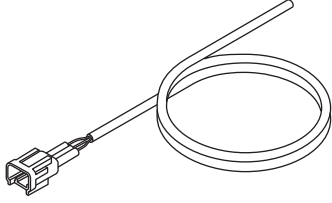
ILLUSTRATION	TOOL NUMBER	DESCRIPTION	REMARKS
 ST98299XA010	98299XA010	TEST HARNESS AC	Used for diagnosing the seat belt tension sensor.

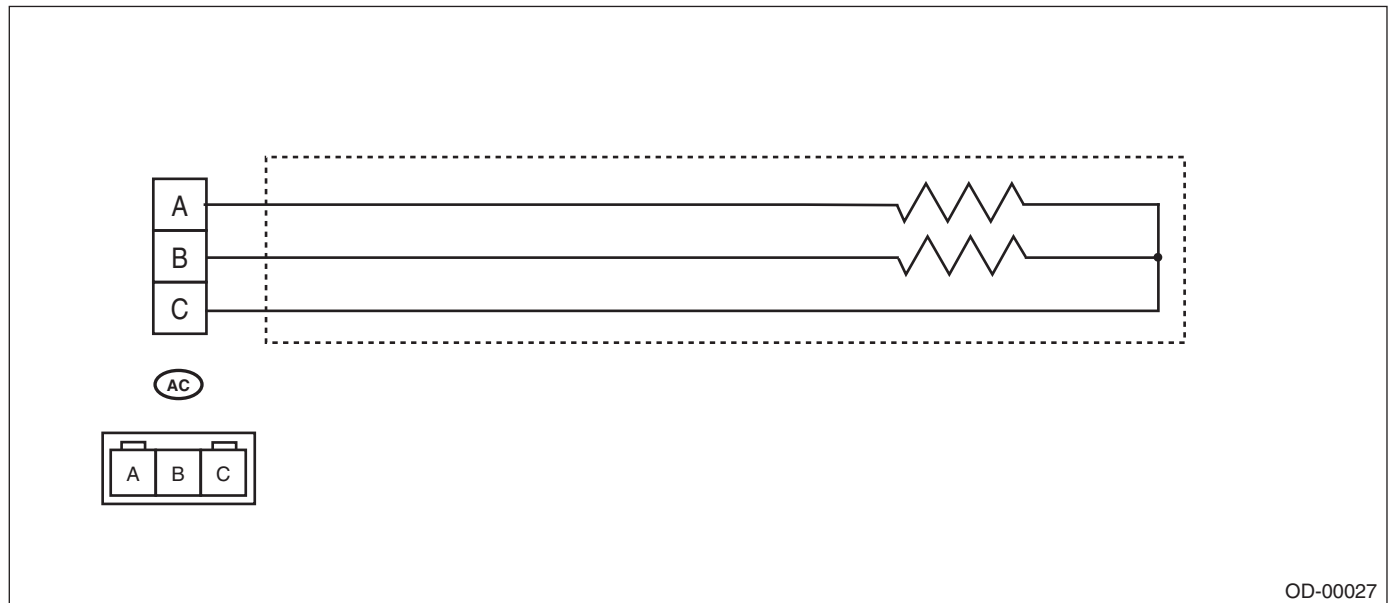

General Description

OCCUPANT DETECTION SYSTEM (DIAGNOSTICS)

- TEST HARNESS AD

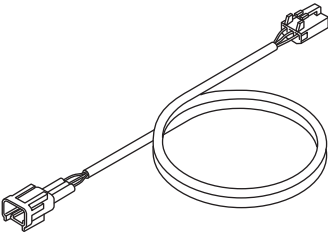
ILLUSTRATION	TOOL NUMBER	DESCRIPTION	REMARKS
 <p style="text-align: center;">ST98299XA020</p>	98299XA020	TEST HARNESS AD	Used when measuring voltage and resistance of the seat belt tension sensor.

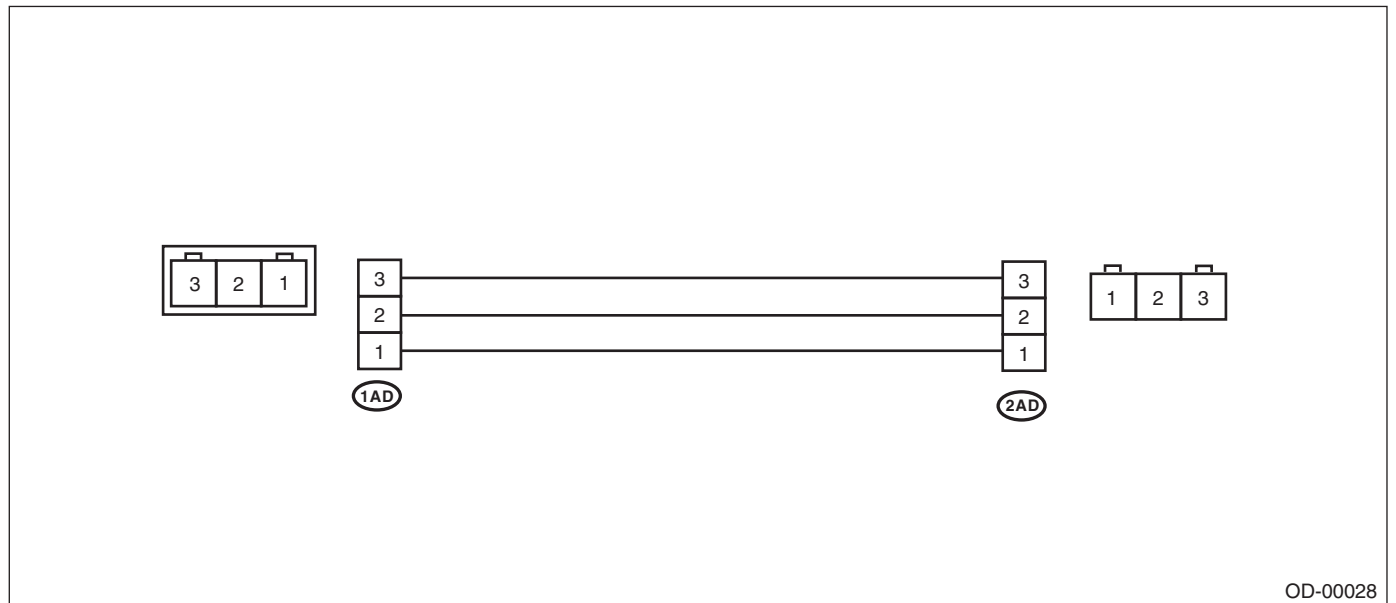

2. GENERAL TOOL

TOOL NAME	REMARKS
Circuit tester	Used for measuring resistance, voltage and current.

Electrical Component Location

OCCUPANT DETECTION SYSTEM (DIAGNOSTICS)

4. Electrical Component Location

A: LOCATION

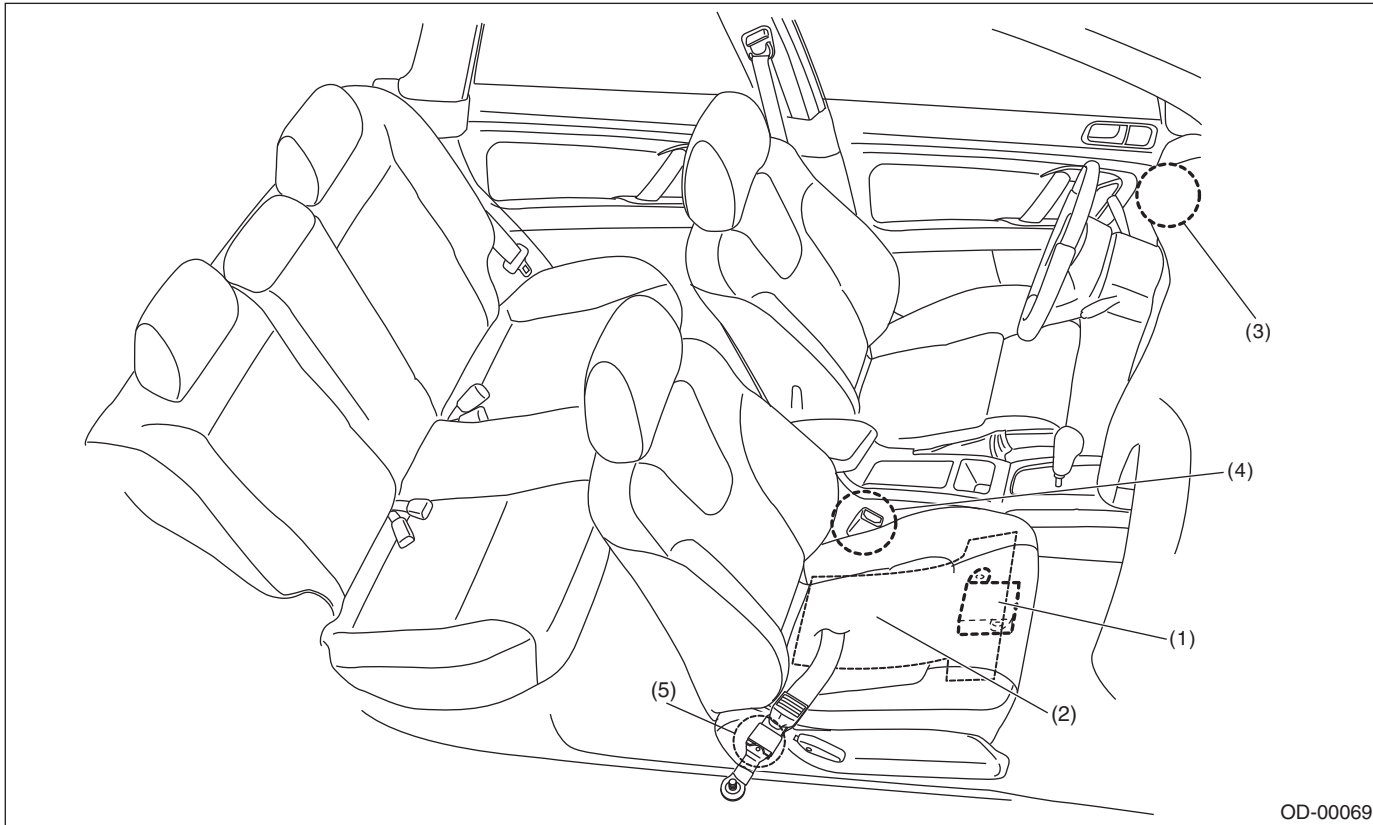

- (1) Occupant detection control module
- (2) Occupant detection sensor
- (3) Airbag ON/OFF indicator light
- (4) Buckle switch (Passenger's seat)
- (5) Seat belt tension sensor

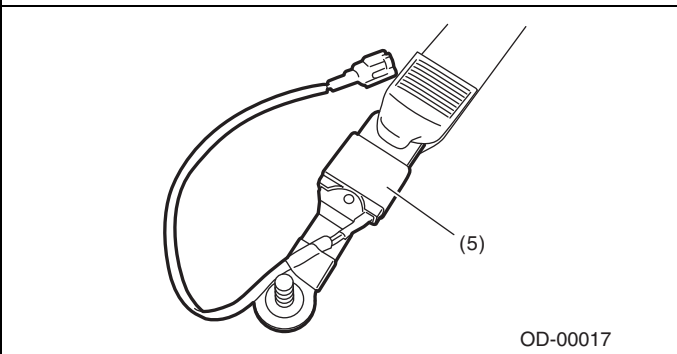
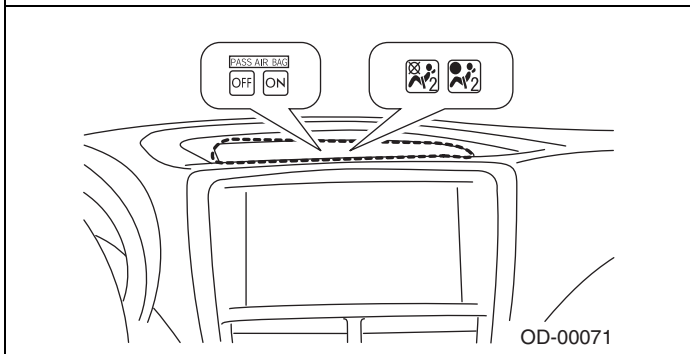
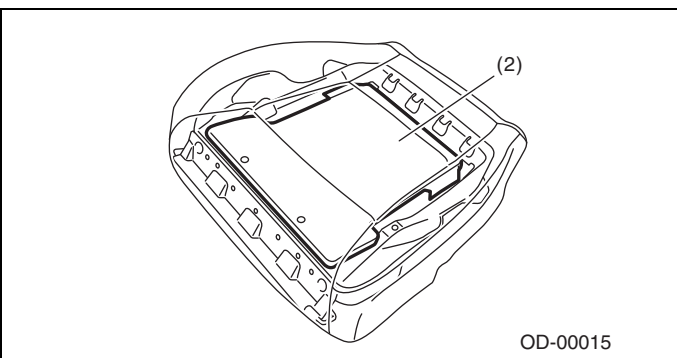
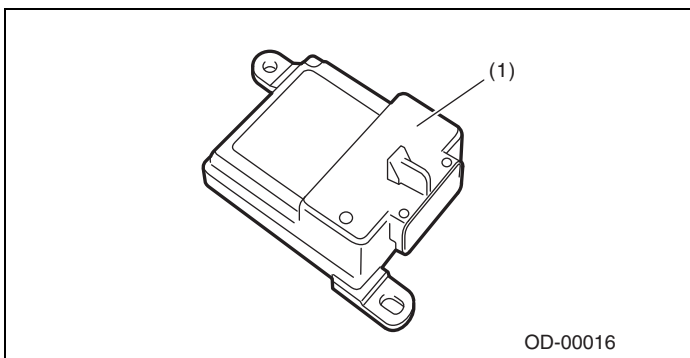

Airbag Connector

OCCUPANT DETECTION SYSTEM (DIAGNOSTICS)

5. Airbag Connector

A: PROCEDURE

<Ref. to AB-9, PROCEDURE, Airbag Connector.>

Control Module I/O Signal

OCCUPANT DETECTION SYSTEM (DIAGNOSTICS)

6. Control Module I/O Signal

A: ELECTRICAL SPECIFICATION

CAUTION:

Never remove the occupant detection control module, occupant detection sensor or seat frame because they are integrated into one unit.

Terminal name	Terminal No.	Input/Output value	Remarks	
IG – power supply	9	9 – 16 V	When ignition switch ON	
Airbag control module communication (COM)	10	Open collector terminal	Communication line	
Airbag control module communication (GND)	5	0 V	Ground	
Belt tension sensor	(Vcc)	4	0 – 5 V	Belt tension sensor power supply
	(Vout)	16	0.5 – 4.5 V	Sensor output voltage
	(GND)	14	0 V	Sensor ground
Occupant detection sensor	(Vcc)	6	0 – 5 V	Pressure sensor power supply
	(Vout)	7	0.5 – 4.5 V	Sensor output voltage
	(GND)	15	0 V	Sensor ground
Buckle switch	1	0 – IG voltage	Ignition voltage when switch ON	
Buckle switch (GND)	2	0 V	Switch ground	

B: WIRING DIAGRAM

Refer to the electrical wiring diagram. <Ref. to WI-95, WIRING DIAGRAM, Occupant Detection System.>

Subaru Select Monitor

OCCUPANT DETECTION SYSTEM (DIAGNOSTICS)

7. Subaru Select Monitor

A: OPERATION

1) Prepare the Subaru Select Monitor kit. <Ref. to AB(diag)-8, SPECIAL TOOL, PREPARATION TOOL, General Description.>

2) Connect the diagnosis cable to the Subaru Select Monitor.

3) Connect the Subaru Select Monitor to the data link connector.

(1) The data link connector is located in the lower portion of the instrument panel (on the driver's side).

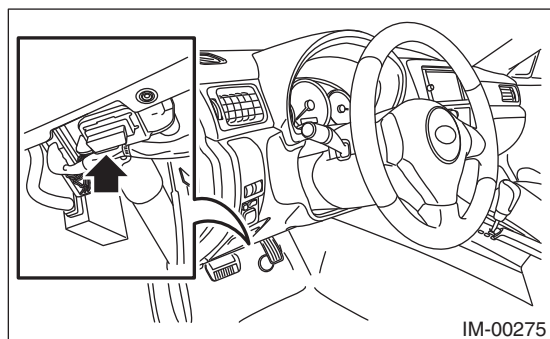

(2) Connect the diagnosis cable to the data link connector.

CAUTION:

Do not connect scan tools other than the Subaru Select Monitor.

4) Turn the ignition switch to ON (engine OFF) and run the Subaru Select Monitor.

B: INSPECTION

1. COMMUNICATION FOR INITIALIZING IMPOSSIBLE

DETECTING CONDITION:

Defective harness connector

TROUBLE SYMPTOM:

Communication is impossible between the airbag control module and the Subaru Select Monitor.

Refer to "COMMUNICATION FOR INITIALIZING IMPOSSIBLE" in the DTC of the airbag system (diag). <Ref. to AB(diag)-27, COMMUNICATION FOR INITIALIZING IMPOSSIBLE, INSPECTION, Subaru Select Monitor.>

2. WITHOUT DTC

DETECTING CONDITION:

- Defective combination meter
- Open circuit of harness

TROUBLE SYMPTOM:

- Airbag warning light remains on.
- "No diagnostic Code Present" will be displayed on the Subaru Select Monitor.

NOTE:

• For detailed operation procedures, refer to "Airbag Warning Light Failure". <Ref. to AB(diag)-35, Airbag Warning Light Failure.>

• When the airbag warning light is OFF and "No diagnostic Code Present" is displayed on Subaru Select Monitor, the system is operating properly.

8. Read Diagnostic Trouble Code (DTC)

A: OPERATION

- 1) Using the Subaru Select Monitor, on the «Main Menu», select {Each System Check}.
- 2) On the «System Selection Menu», select {Airbag System}.
- 3) After {Airbag System} is displayed, select [OK].
- 4) Select the {Diagnostic Code(s) Display} in «Airbag System».
- 5) Record the displayed DTC.

NOTE:

- For details concerning the operation procedure, refer to the “PC Application Help for Subaru Select Monitor”.
- For details concerning DTCs, refer to the List of Diagnostic Trouble Code (Airbag system, Occupant detection system). <Ref. to AB(diag)-40, List of Diagnostic Trouble Code (DTC).> <Ref. to OD(diag)-22, List of Diagnostic Trouble Code (DTC).>

Inspection Mode

OCCUPANT DETECTION SYSTEM (DIAGNOSTICS)

9. Inspection Mode

A: PROCEDURE

Recreate the circumstance by referring to the conditions described in the checklist.

10. Clear Memory Mode

A: OPERATION

Clear the DTC stored in the airbag control module after repairing the airbag system and occupant detection system. (After the breakdown is recovered, the breakdown code for completed recoveries are read out when the next breakdown occurs if the memory clear work is not performed.)

- 1) Select {Each System Check} in «Main Menu».
- 2) On the «System Selection Menu» display screen, select the {Airbag System}.
- 3) On the «Airbag System» display screen, select the {Clear Memory}.
- 4) When the «Clear Memory»? is shown on the screen, select the [OK].
- 5) When «Done» is displayed, terminate the Subaru Select Monitor and turn the ignition switch to OFF.

NOTE:

For details concerning the operation procedure, refer to the “PC Application Help for Subaru Select Monitor”.

Display of Status Information

OCCUPANT DETECTION SYSTEM (DIAGNOSTICS)

11. Display of Status Information

A: OPERATION

Check the operating condition of each sensor in the event of malfunction in the seat belt buckle switch and seat position sensor, or when the seat belt buckle switch and seat position sensor has been replaced.

1) Select {Each System Check} in «Main Menu».

2) On the «System Selection Menu» display screen, select the {Airbag System}.

3) On the «Airbag System» display screen, select the {Status Data}.

The following table is for support data.

Contents	Display Contents
Seat position sensor LH	— ^{*5}
Seat position sensor RH	— ^{*5}
Seat belt buckle switch LH	— ^{*9}
Seat belt buckle switch RH	Belted ^{*6} /Unbelted ^{*7} /Other ^{*8} /Initial Setting ^{*4} /— ^{*9}
Passenger's airbag control status	ON ^{*10} /OFF ^{*11} /Initial Setting ^{*4}

*1: The seat position is forward.

*2: The seat position is rearward.

*3: Displayed when data other than before and behind the seat, such as the breakdown etc, is input.

*4: Displayed when it is initial.

*5: Seat position sensor not supported

*6: Seat belt fastened

*7: Seat belt not fastened

*8: Displayed when data other than belt fastened or not fastened, such as breakdowns is input.

*9: Seat belt buckle switch not supported

*10: Passenger's airbag operating state

*11: Passenger's airbag non-operating state

NOTE:

For details concerning the operation procedure, refer to the "PC Application Help for Subaru Select Monitor".

System Calibration (Rezeroing)

OCCUPANT DETECTION SYSTEM (DIAGNOSTICS)

12. System Calibration (Rezeroing)

A: OPERATION

NOTE:

When replacing the occupant detection system, or removing and disassembling the passenger's seat, always perform the system calibration after installing a seat in the vehicle.

CAUTION:

When the trouble occurs in the system during calibration process, "Occupant detection calibration failure" is detected in the DTC 2A of the airbag system and the airbag warning light lights. In this case, after turning the ignition switch to OFF once, redo the system calibration (Rezeroing), or after clearing the cause of the failure, perform the system calibration again.

- 1) Park empty vehicle on a level surface.
- 2) Select {Each System Check} in «Main Menu».
- 3) On the «System Selection Menu» display screen, select the {Occupant Detection System}.
- 4) On the «Occupant Detection System» display screen, select the {Rezeroing}.
- 5) «See service manual. And check vehicle condition for successfully completing the rezeroing». is displayed. Check the following to adjust the condition of the vehicle.
 - Adjust the seat backrest to be fully upright. (For models with power seats, press the power seat button until the backrest comes to a stop.)
 - Adjust the seat slide position all the way back. (For models with power seats, press the power seat button until the seat slide does not move any further.)
 - Do not place anything on the top of the seat cushion.
 - Sit on the seat cushion to smooth the seat surface.
 - Check that the passenger's seat belt is not inserted into the buckle, not tense or not stuck.
 - Check that ambient temperature is in a range from 0 to 40°C.

- 6) When the «Re-zeroing Adjust the passenger seat to the condition shown in service manual» is displayed, slide the passenger seat all the way to the back, check that the backrest is adjusted to all the way up, and select the [OK].

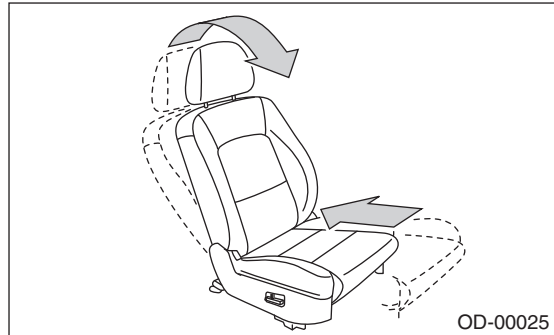

- 7) When the «Re-zeroing Unbelt the Passenger seatbelt Continue: OK, Quit: NO» is displayed, make sure the passenger's seatbelt is disconnected from the buckle and select the [OK].
- 8) When the «Re-zeroing Empty the passenger seat Continue: OK, Quit: NO» is displayed, make sure that the passenger's seat is empty, airbag OFF indicator illuminates and airbag ON indicator does not illuminate, and select the [OK].

NOTE:

- After selecting the [OK], «In process.... Please wait for a while without touching vehicle» is displayed. Do not touch or rock the vehicle while the message is displayed.
 - During the system calibration process, if the «Re-zeroing is unsuccessful See service manual Press "OK" to END» is displayed, go to step 10).
- 9) When the «re-zeroing is ended normally, the Re-zeroing is successfully completed Press "OK" to END» is displayed. And then turn the ignition switch to OFF to finish the diagnosis.
 - 10) During the system calibration process, if «Re-zeroing is unsuccessful See service manual Press "OK" to END» is displayed, turn the ignition switch to OFF once and turn it ON again, then read the DTC of the airbag system. <Ref. to OD(diag)-15, Read Diagnostic Trouble Code (DTC).> When DTC is input, fix the fault and then perform the system calibration. When DTC is not input, check the seat and vehicle status and then perform the system calibration again. <Ref. to OD(diag)-19, System Calibration (Rezeroing).>

NOTE:

When the re-zeroing is unsuccessful, there could be occupant detection system failure or improper seat and vehicle status. When the airbag warning light illuminates, read the DTC of the airbag system, and perform the diagnosis while referring to List of Diagnostic Trouble Code. <Ref. to OD(diag)-15, Read Diagnostic Trouble Code (DTC).> <Ref. to AB(diag)-40, LIST, List of Diagnostic Trouble Code (DTC).>

Airbag Warning Light Illumination Pattern

OCCUPANT DETECTION SYSTEM (DIAGNOSTICS)

13. Airbag Warning Light Illumination Pattern

A: INSPECTION

Turn the ignition switch to ON, and confirm that the airbag warning light remains on for approx. 6 seconds and then goes off afterwards.

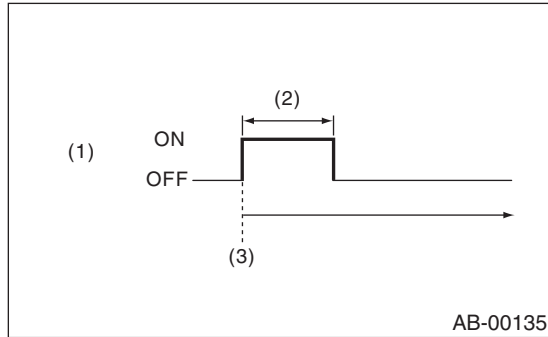

- (1) Airbag warning light
- (2) Approx. 6 sec.
- (3) Ignition switch ON

Passenger's Airbag ON/OFF Indicator Light Illumination Pattern

OCCUPANT DETECTION SYSTEM (DIAGNOSTICS)

14. Passenger's Airbag ON/OFF Indicator Light Illumination Pattern

A: INSPECTION

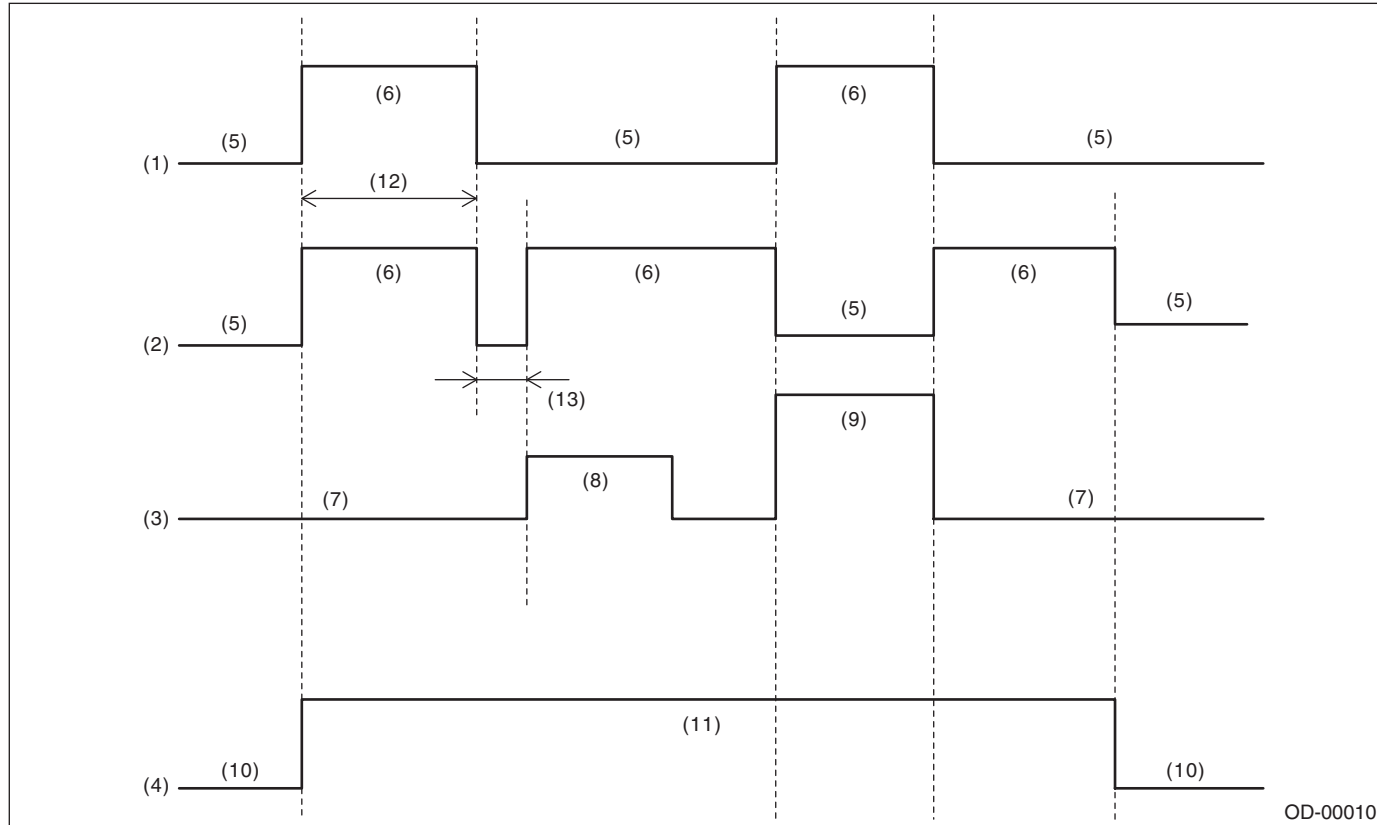

OD-00010

- | | | |
|--|---------------------|---------------------|
| (1) Passenger's airbag ON indicator light | (4) Ignition switch | (9) Adult |
| (2) Passenger's airbag OFF indicator light | (5) Light OFF | (10) OFF |
| (3) Occupant seating | (6) Light ON | (11) ON |
| | (7) Empty | (12) Approx. 6 sec. |
| | (8) Child | (13) Approx. 2 sec. |

List of Diagnostic Trouble Code (DTC)

OCCUPANT DETECTION SYSTEM (DIAGNOSTICS)

15. List of Diagnostic Trouble Code (DTC)

A: LIST

DTC	Display	Diagnosis content	Reference
2A	ODS Calibration error	System calibration (Rezeroing) was not completed normally.	<Ref. to OD(diag)-23, DTC 2A ODS CALIBRATION ERROR, Diagnostic Procedure with Diagnostic Trouble Code (DTC).>
2B	ODS System wrong parts	<ul style="list-style-type: none"> • Wrong airbag control module was installed. • Wrong occupant detection system was installed. • Occupant detection system is faulty. 	<Ref. to OD(diag)-23, DTC 2B ODS SYSTEM WRONG PARTS, Diagnostic Procedure with Diagnostic Trouble Code (DTC).>
2C	Belt tension Sensor failure	<ul style="list-style-type: none"> • Passenger's seat belt tension sensor is faulty. • Airbag main harness circuit is open or shorted. • Occupant detection system is faulty. • Occupant detection harness is faulty. 	<Ref. to OD(diag)-24, DTC 2C BELT TENSION SENSOR FAILURE, Diagnostic Procedure with Diagnostic Trouble Code (DTC).>
27	ODS Communication error	<ul style="list-style-type: none"> • Occupant detection control module and airbag control module communication is faulty. • Airbag rear harness circuit is open, shorted, shorted to ground or shorted to power supply. • Occupant detection harness is faulty. • Occupant detection system is faulty. • Airbag control module is faulty. 	<Ref. to OD(diag)-26, DTC 27 ODS COMMUNICATION ERROR, Diagnostic Procedure with Diagnostic Trouble Code (DTC).>
29	ODS failure	<ul style="list-style-type: none"> • Occupant detection sensor is faulty. • Occupant detection control module is faulty. • Occupant detection harness is faulty. • Fuse No. 25 (in joint box) is blown. 	<Ref. to OD(diag)-26, DTC 29 ODS FAILURE, Diagnostic Procedure with Diagnostic Trouble Code (DTC).>
37	Buckle Switch RH failure	<ul style="list-style-type: none"> • Passenger's buckle switch circuit is open, shorted or shorted to ground. • Occupant detection system is faulty. • Occupant detection harness is faulty. 	<Ref. to OD(diag)-27, DTC 37 BUCKLE SWITCH RH FAILURE, Diagnostic Procedure with Diagnostic Trouble Code (DTC).>

Diagnostic Procedure with Diagnostic Trouble Code (DTC)

OCCUPANT DETECTION SYSTEM (DIAGNOSTICS)

16. Diagnostic Procedure with Diagnostic Trouble Code (DTC)

A: DTC 2A ODS CALIBRATION ERROR

DTC DETECTING CONDITION:

System calibration (Rezeroing) was not completed properly.

	Step	Check	Yes	No
1	PERFORM RE-ZEROING. Perform system calibration using the Subaru Select Monitor. <Ref. to OD(diag)-19, System Calibration (Rezeroing).>	Did the system calibration complete properly?	Finish the diagnosis.	Follow the system calibration procedures. <Ref. to OD(diag)-19, System Calibration (Rezeroing).>

B: DTC 2B ODS SYSTEM WRONG PARTS

DTC DETECTING CONDITION:

- Wrong airbag control module is installed.
- Wrong occupant detection system is installed.

	Step	Check	Yes	No
1	CHECK OCCUPANT DETECTION SYSTEM. 1) Turn the ignition switch to OFF, disconnect the battery ground cable, and wait for 20 seconds or more. 2) Replace the passenger's seat cushion pad frame assembly. <Ref. to SE-8, REMOVAL, Front Seat.> <Ref. to SE-11, DRIVER'S SEAT (POWER SEAT), DISASSEMBLY, Front Seat.> 3) Connect the ground cable to the battery. 4) Connect Subaru Select Monitor to the vehicle and perform the system calibration. <Ref. to OD(diag)-19, System Calibration (Rezeroing).>	Did the system calibration complete properly?	Finish the diagnosis.	Go to step 2.
2	CHECK AIRBAG CONTROL SYSTEM. 1) Turn the ignition switch to OFF, disconnect the battery ground cable, and wait for 20 seconds or more. 2) Replace the airbag control module. <Ref. to AB-23, REMOVAL, Airbag Control Module.> 3) Connect the ground cable to the battery. 4) Connect Subaru Select Monitor to the vehicle and perform the system calibration. <Ref. to OD(diag)-19, System Calibration (Rezeroing).>	Did the system calibration complete properly?	Finish the diagnosis.	Check between the occupant detection control module and airbag control module.

Diagnostic Procedure with Diagnostic Trouble Code (DTC)

OCCUPANT DETECTION SYSTEM (DIAGNOSTICS)

C: DTC 2C BELT TENSION SENSOR FAILURE

DTC DETECTING CONDITION:

- Passenger's seat belt tension sensor is faulty.
- Airbag main harness circuit is open or shorted.
- Occupant detection control module is faulty.

WIRING DIAGRAM:

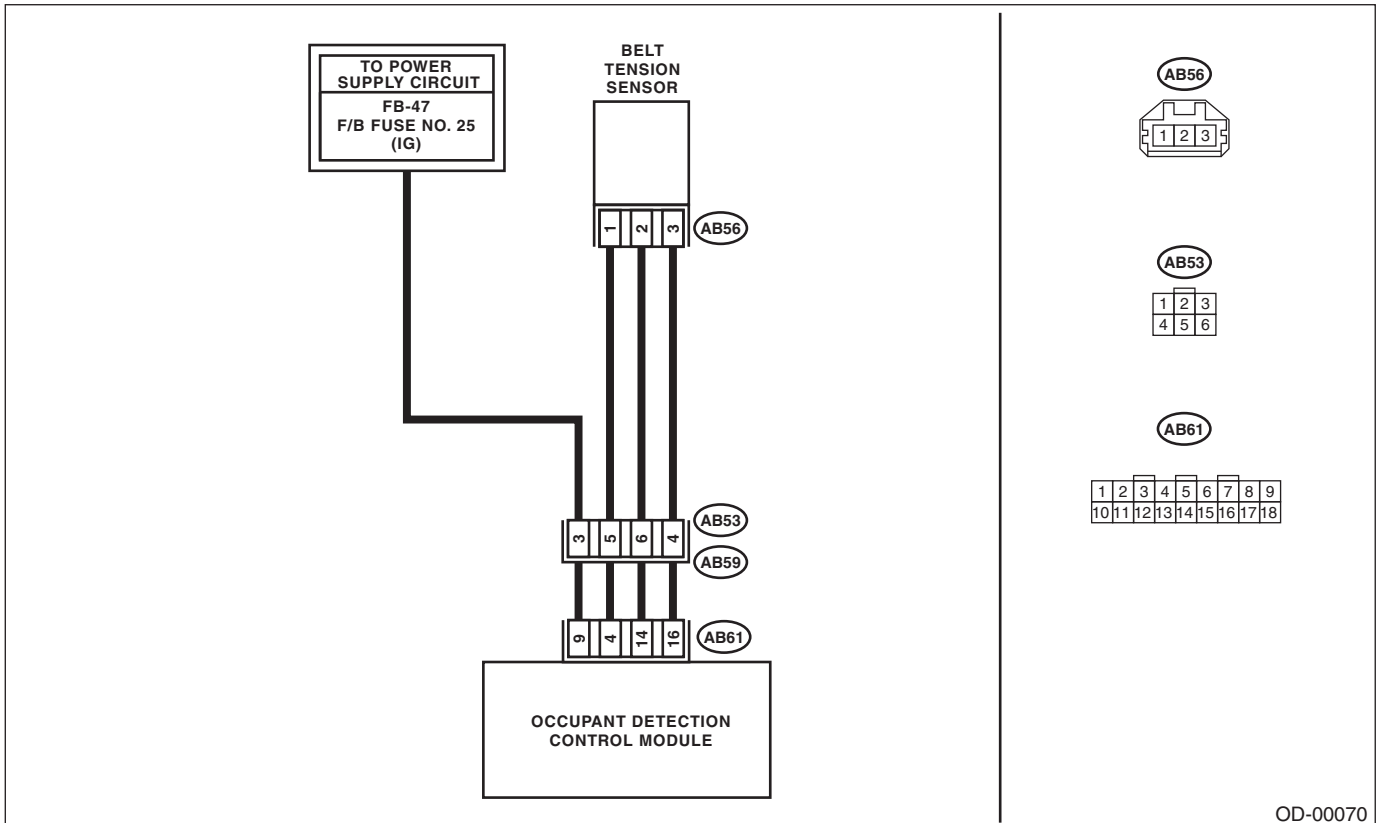

Diagnostic Procedure with Diagnostic Trouble Code (DTC)

OCCUPANT DETECTION SYSTEM (DIAGNOSTICS)

Step	Check	Yes	No
1 CHECK POOR CONTACT IN CONNECTORS. Check for poor contact of the connectors between the occupant detection control module and belt tension sensor.	Is there poor contact?	Reconnect the connector. If the fault is not fixed, replace the airbag harness.	Go to step 2.
2 CHECK THE BELT TENSION SENSOR. 1) Turn the ignition switch to OFF, disconnect the battery ground cable, and wait for 20 seconds or more. 2) Disconnect the belt tension sensor connector (AB56) from the airbag harness. 3) Connect the test harness AC to the connector (AB56). 4) Connect the battery ground terminal and turn the ignition switch to ON.	Does the airbag warning light illuminate for approximately 6 seconds and go off?	Replace the seat belt outer. <Ref. to SB-17, OUTER SEAT BELT ASSEMBLY, REMOVAL, Front Seat Belt.>	Go to step 3.
3 CHECK AIRBAG HARNESS. 1) Turn the ignition switch to OFF, disconnect the battery ground cable, and wait for 20 seconds or more. 2) Disconnect the test harness AC from the belt tension sensor connector (AB56). 3) Connect the test harness AD (1AD) to the connector (AB56). 4) Disconnect the airbag harness connector (AB53), and connect connector (1AB) of test harness AB. 5) Measure the resistance between test harness terminals. Connector & terminal (2AB) No. 5 — (2AD) No. 1: (2AB) No. 4 — (2AD) No. 3: (2AB) No. 6 — (2AD) No. 2:	Is the resistance less than 10 Ω?	Go to step 4.	Replace the airbag harness along with chassis harness.
4 CHECK AIRBAG HARNESS. Measure the resistance between test harness terminals, and between test harness terminal and chassis ground. Connector & terminal (2AB) No. 4 — (2AD) No. 1: (2AB) No. 4 — (2AD) No. 2: (2AB) No. 4 — Chassis ground: (2AB) No. 5 — (2AD) No. 2: (2AB) No. 5 — Chassis ground:	Is the resistance 1 MΩ or more?	Go to step 5.	Replace the airbag harness along with chassis harness.
5 CHECK AIRBAG HARNESS. 1) Connect the battery ground terminal and turn the ignition switch to ON. 2) Measure the voltage between test harness and chassis ground. Connector & terminal (2AD) No. 1 — Chassis ground: (2AD) No. 3 — Chassis ground:	Is the voltage 1 V or less?	Replace the airbag harness along with chassis harness.	Check the seat harness, and if any fault is found, replace the seat harness. If no fault is found in the seat harness, replace the seat cushion frame assembly. <Ref. to SE-11, DRIVER'S SEAT (POWER SEAT), DISASSEMBLY, Front Seat.>

Diagnostic Procedure with Diagnostic Trouble Code (DTC)

OCCUPANT DETECTION SYSTEM (DIAGNOSTICS)

D: DTC 27 ODS COMMUNICATION ERROR

Perform the diagnosis following diagnostic procedures for the airbag system. <Ref. to AB(diag)-60, DTC 27 ODS COMMUNICATION ERROR, Diagnostic Chart with Trouble Code.>

E: DTC 29 ODS FAILURE

DTC DETECTING CONDITION:

- Occupant detection sensor is faulty.
- Occupant detection control module is faulty.
- Occupant detection harness is faulty.
- Rear airbag harness is faulty.
- Fuse No. 25 (in joint box) is blown.

Step	Check	Yes	No
1 CHECK POOR CONTACT IN CONNECTORS. Check for poor contact of the connectors between the occupant detection control module and airbag control module.	Is there poor contact?	Reconnect the connector. If the fault is not fixed, replace the airbag harness.	Go to step 2.
2 CHECK DIAGNOSTIC TROUBLE CODE (DTC). Read diagnostic trouble code (DTC) for the airbag system.	Is "2C Belt Tension Sensor failure or 37 Buckle Switch failure" displayed in the diagnostics code?	Perform the diagnosis according to each DTC.	Check the seat harness, and if any fault is found, replace the seat harness. If the fault is not fixed, replace the occupant detection system. <Ref. to SE-11, DRIVER'S SEAT (POWER SEAT), DISASSEMBLY, Front Seat.>

Diagnostic Procedure with Diagnostic Trouble Code (DTC)

OCCUPANT DETECTION SYSTEM (DIAGNOSTICS)

F: DTC 37 BUCKLE SWITCH RH FAILURE

DTC DETECTING CONDITION:

- Passenger's buckle switch circuit is open, shorted or shorted to ground.
- Seat harness circuit is open, shorted or shorted to ground.
- Occupant detection control module is faulty.

WIRING DIAGRAM:

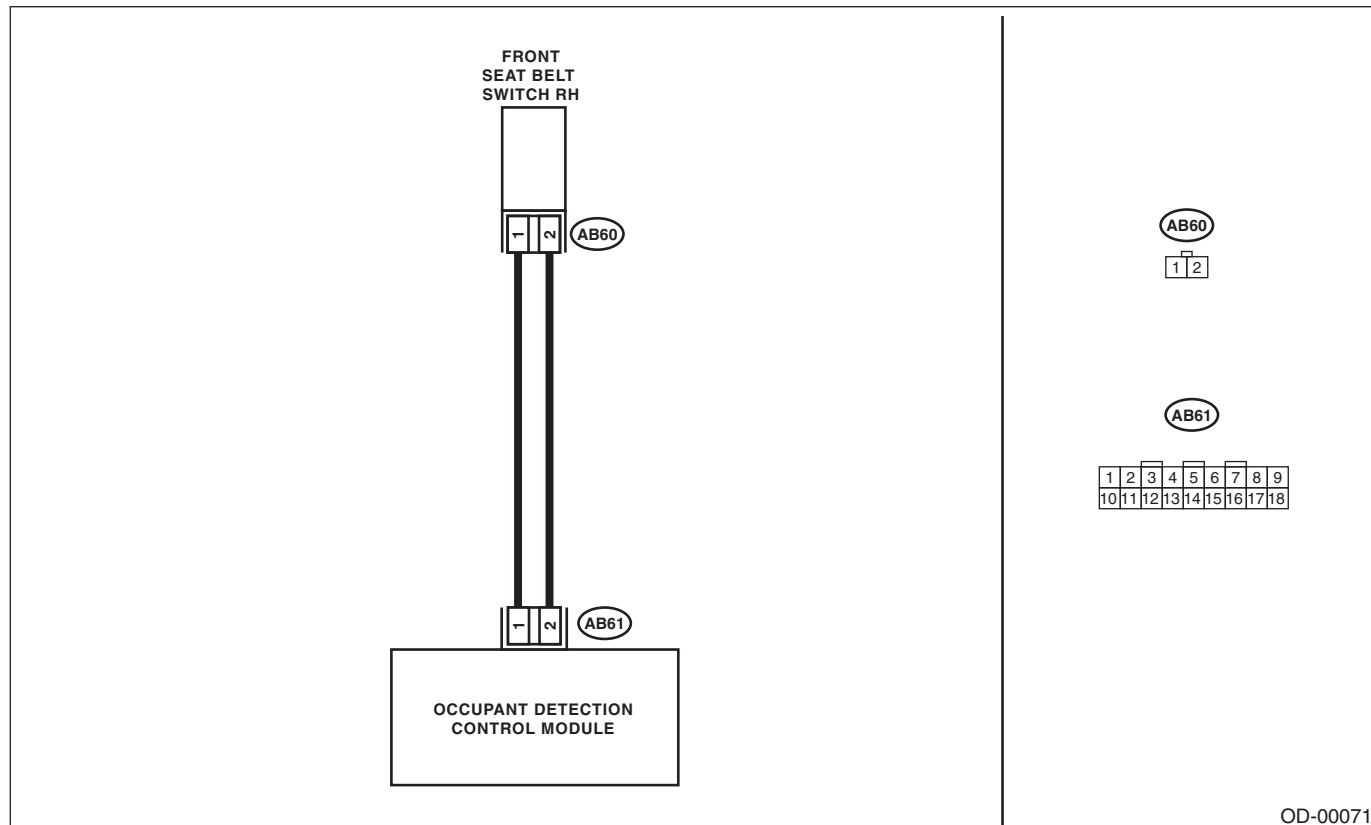

OD-00071

Step	Check	Yes	No
1 CHECK POOR CONTACT IN CONNECTORS. Check for poor contact of the connectors between the occupant detection control module and buckle switch.	Is there poor contact?	Reconnect the connector. If the fault is not fixed, replace the airbag harness.	Go to step 2.
2 CHECK THE BUCKLE SWITCH. 1) Turn the ignition switch to OFF, disconnect the battery ground terminal, and wait for 20 seconds. 2) Disconnect the buckle switch connector (AB60). 3) Connect the test harness AE1 and test harness connector Y to the buckle switch connector (AB60). 4) Connect the battery ground terminal and turn the ignition switch to ON.	Does the airbag warning light illuminate for 6 seconds and go off?	Replace the buckle switch. <Ref. to SB-17, INNER SEAT BELT ASSEMBLY, REMOVAL, Front Seat Belt.>	Check the seat harness, and if any fault is found, replace the seat harness. If the fault is not fixed, replace the occupant detection system.

Diagnostic Procedure with Diagnostic Trouble Code (DTC)

OCCUPANT DETECTION SYSTEM (DIAGNOSTICS)

SEAT BELT SYSTEM

SB

	Page
1. General Description	2
2. Pretensioner Connector	11
3. Inspection Locations After a Collision	12
4. Seat Belt Warning System	13
5. Front Seat Belt	17
6. Rear Seat Belt	18

General Description

SEAT BELT SYSTEM

1. General Description

A: COMPONENT

1. FRONT SEAT BELT

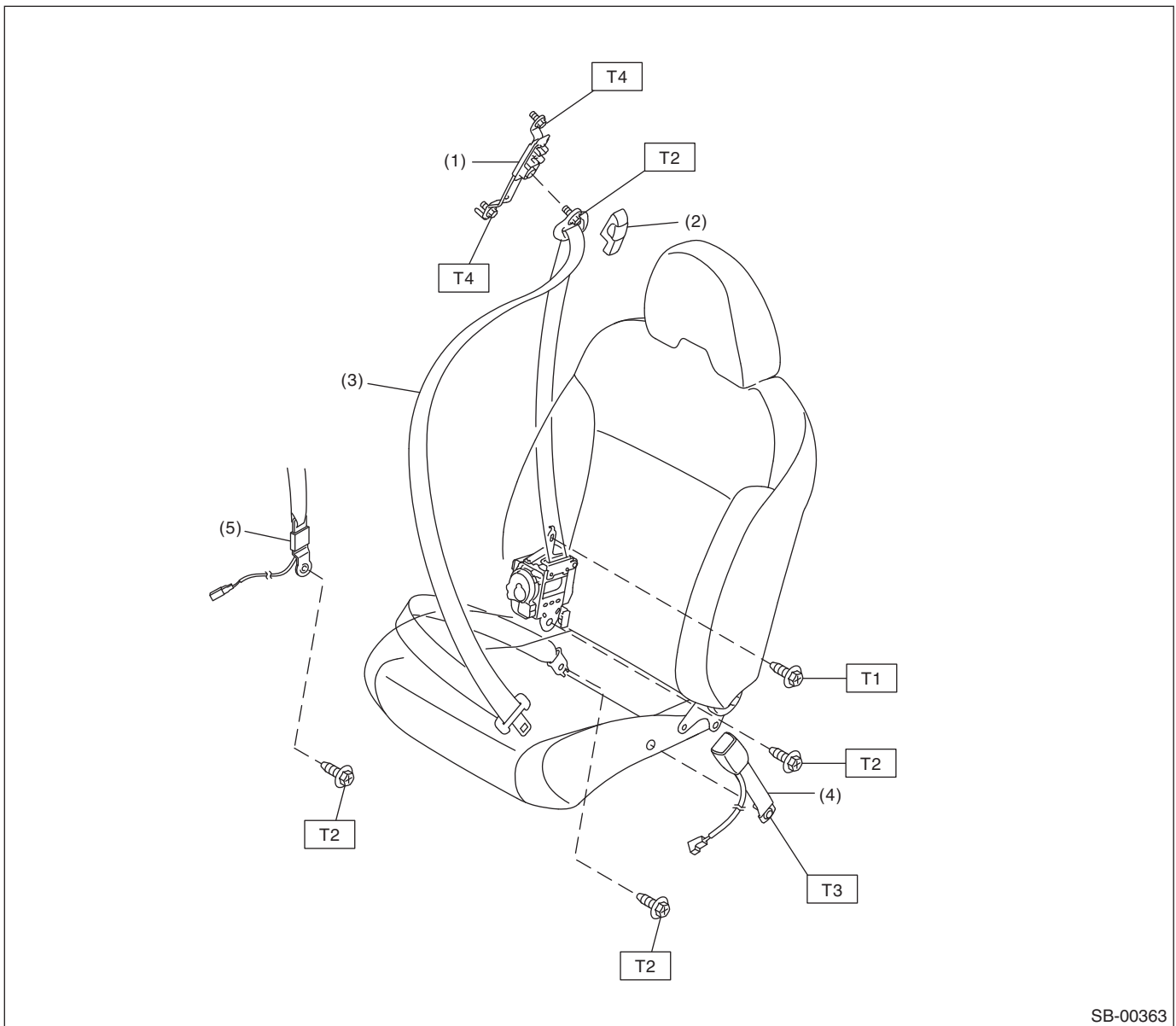

SB-00363

- | | |
|----------------------------|--|
| (1) Adjustable anchor ASSY | (4) Inner seat belt ASSY |
| (2) Anchor cover | (5) Belt tension sensor
(Passenger's side only) |
| (3) Outer belt ASSY | |

Tightening torque: N·m (kgf·m, ft·lb)

T1: 7.5 (0.76, 5.5)

T2: 30 (3.1, 22)

T3: 38 (3.9, 28)

T4: 53 (5.4, 39)

2. REAR SEAT BELT

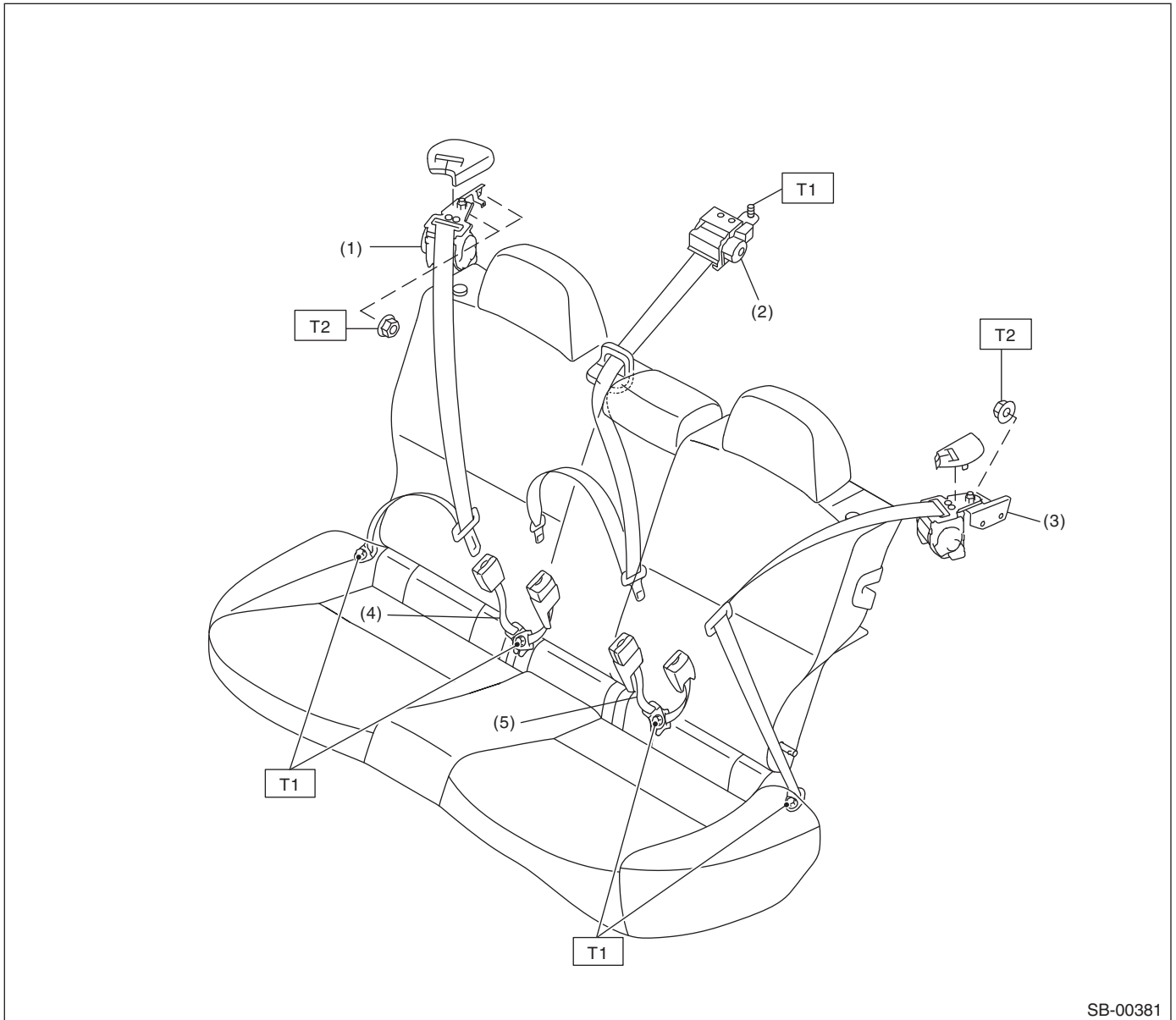

SB-00381

- | | |
|---------------------------------|------------------------------|
| (1) Outer seat belt ASSY RH | (4) Center seat belt ASSY RH |
| (2) Outer seat belt center ASSY | (5) Center seat belt ASSY LH |
| (3) Outer seat belt ASSY LH | |

Tightening torque: N·m (kgf·m, ft·lb)

T1: 30 (3.1, 22)

T2: 53 (5.4, 39)

General Description

SEAT BELT SYSTEM

B: CAUTION

- Before starting the work, turn the ignition switch to OFF, disconnect the battery ground cable and wait for 20 seconds or more.
- The pretensioner system has a backup power source. Be aware that the pretensioner might deploy if you do not wait for 20 seconds or more before starting work.
- Do not drop or apply any impact to the pretensioner.
- If oil, grease or water gets on the pretensioner, wipe it off immediately with a dry cloth.
- Do not expose the pretensioner to high temperature or flame.
- Do not allow current to flow through or voltage to reach the pretensioner. Do not use a circuit tester to check resistance of the pretensioner.
- Do not disassemble or attempt to repair the pretensioner. If it is dented, cracked or deformed, replace it with a new part.
- Do not use the airbag or pretensioner parts from other vehicles. Always perform any replacement with new parts.
- When handling a seat belt with deployed pretensioner, wear gloves and goggles. Wash your hands afterwards.
- Do not reuse a seat belt with deployed pretensioner.

C: PREPARATION TOOL

1. SPECIAL TOOL

- Subaru Select Monitor

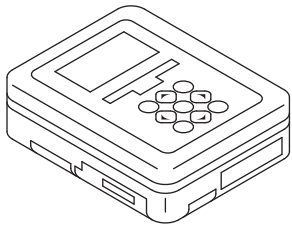
ILLUSTRATION	TOOL NUMBER	DESCRIPTION	REMARKS
 ST1B022XU0	1B022XU0 (Newly adopted tool)	SUBARU SELECT MONITOR III KIT	Used for setting of each function and trouble-shooting for electrical system.

- TEST HARNESS AB

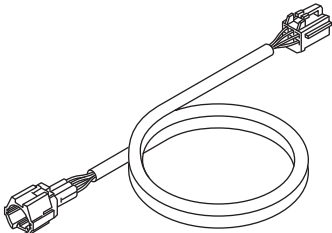
ILLUSTRATION	TOOL NUMBER	DESCRIPTION	REMARKS
 ST98299XA000	98299XA000	TEST HARNESS AB	Used when measuring voltage and resistance of occupant detection system.

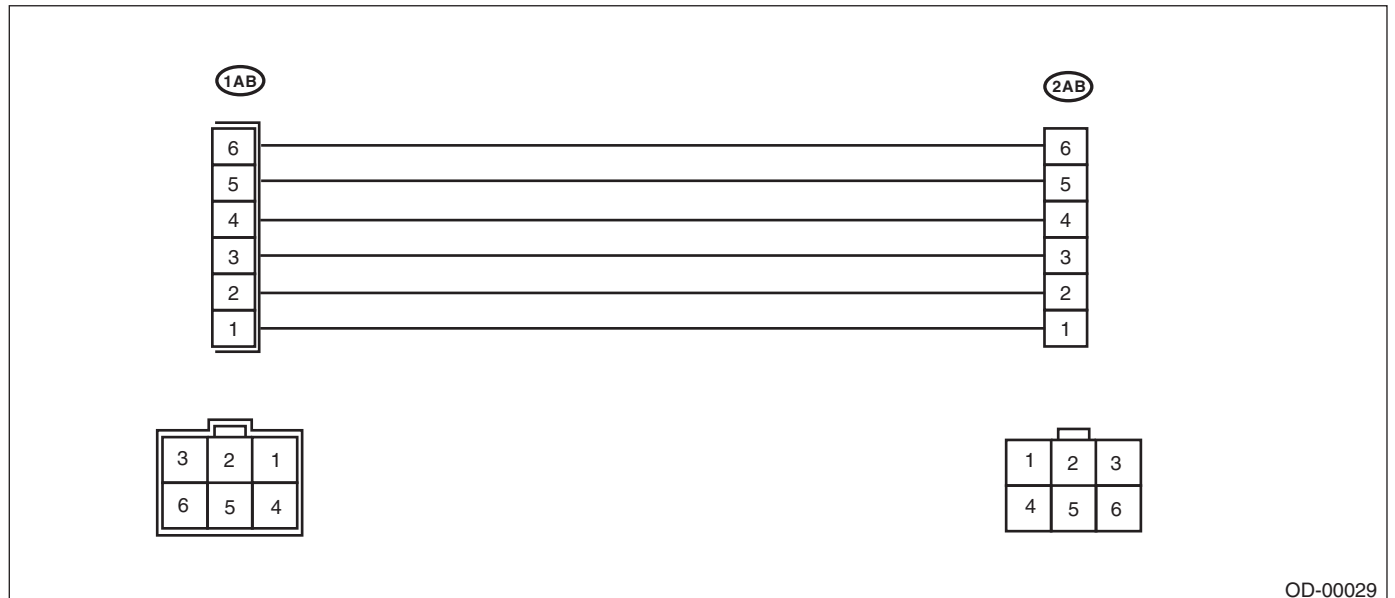

OD-00029

General Description

SEAT BELT SYSTEM

- TEST HARNESS AE

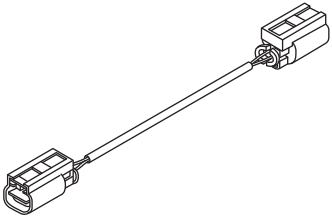
ILLUSTRATION	TOOL NUMBER	DESCRIPTION	REMARKS
 <p data-bbox="324 556 467 577">ST98299XA030</p>	98299XA030	TEST HARNESS AE	<ul style="list-style-type: none"> Used for diagnosing seat belt tension sensor. Used together with the test harness Y.

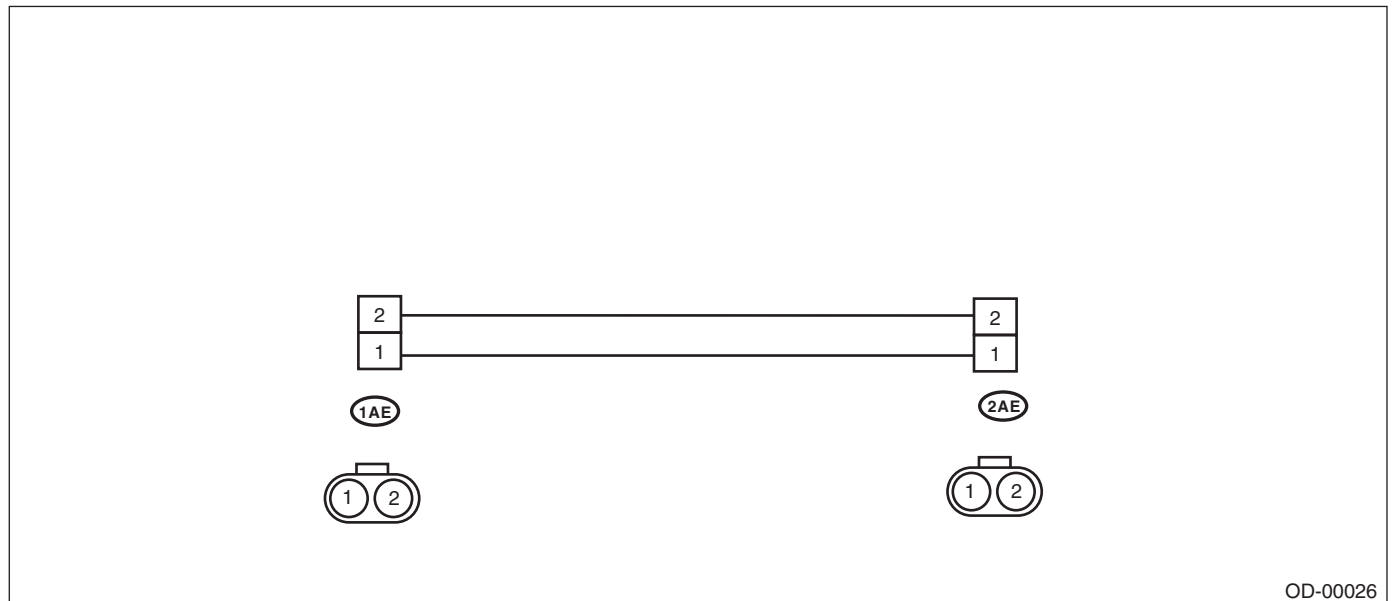

General Description

• TEST HARNESS AG

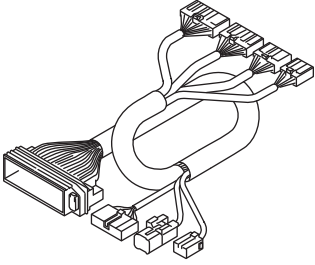
ILLUSTRATION	TOOL NUMBER	DESCRIPTION	REMARKS
 <p data-bbox="321 556 467 577">ST98299AG070</p>	98299AG070	TEST HARNESS AG	Used when measuring voltage and resistance of airbag control module.

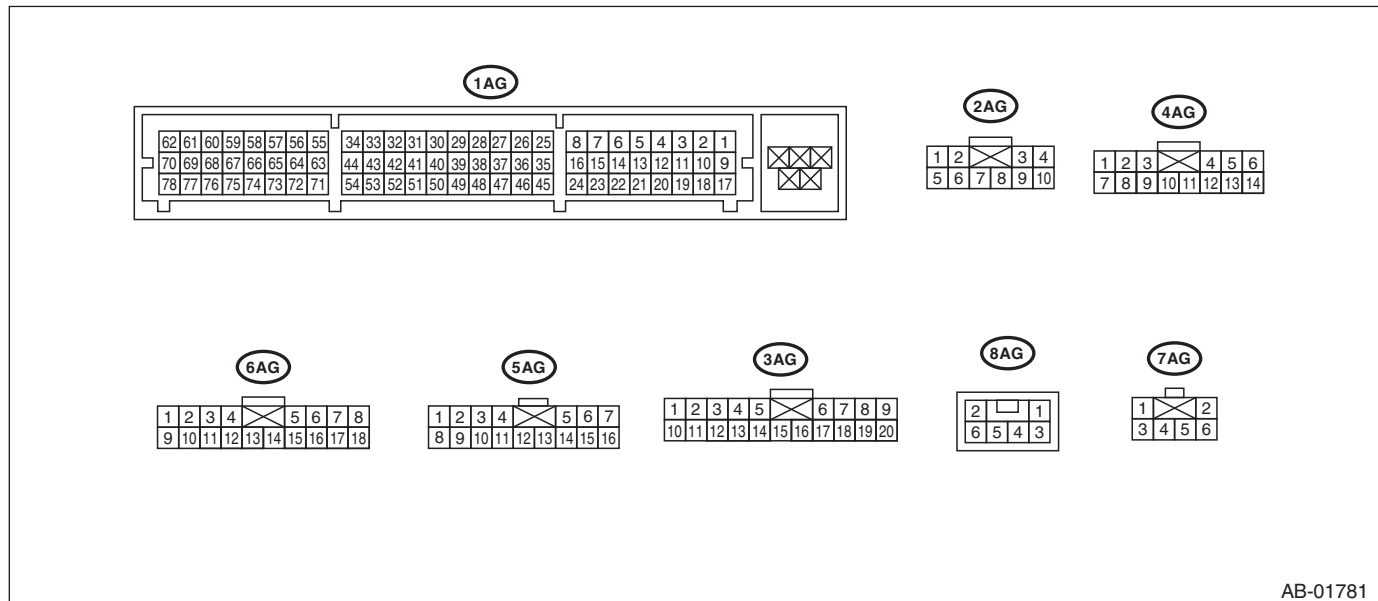

AB-01781

General Description

SEAT BELT SYSTEM

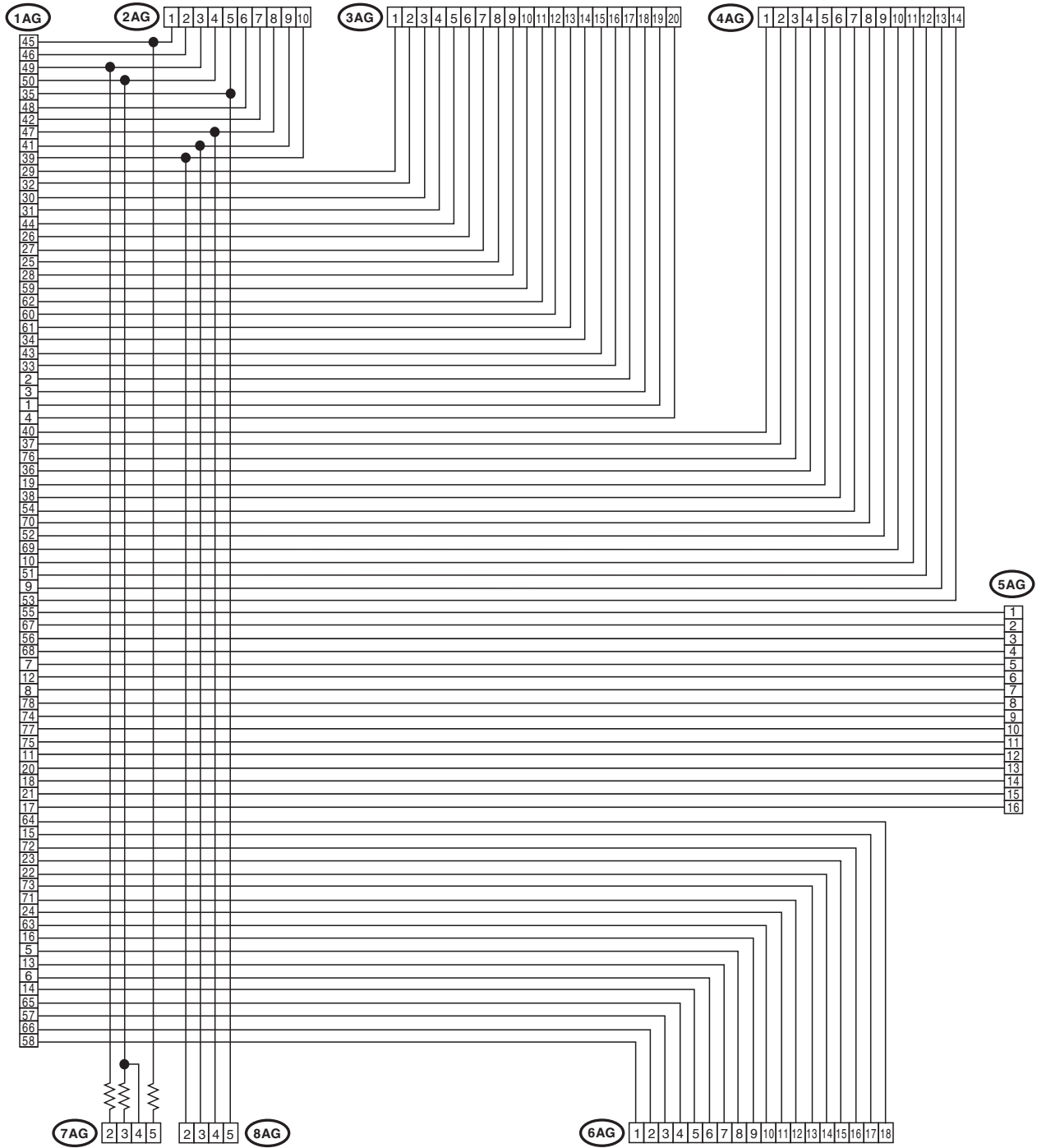

AB-01902

General Description

SEAT BELT SYSTEM

- TEST HARNESS Y

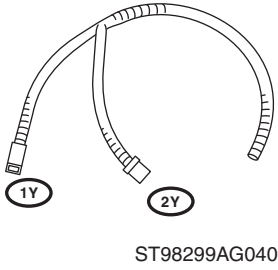
ILLUSTRATION	TOOL NUMBER	DESCRIPTION	REMARKS
 <p>ST98299AG040</p>	98299AG040	TEST HARNESS Y	Used for diagnosing seat belt buckle switch.

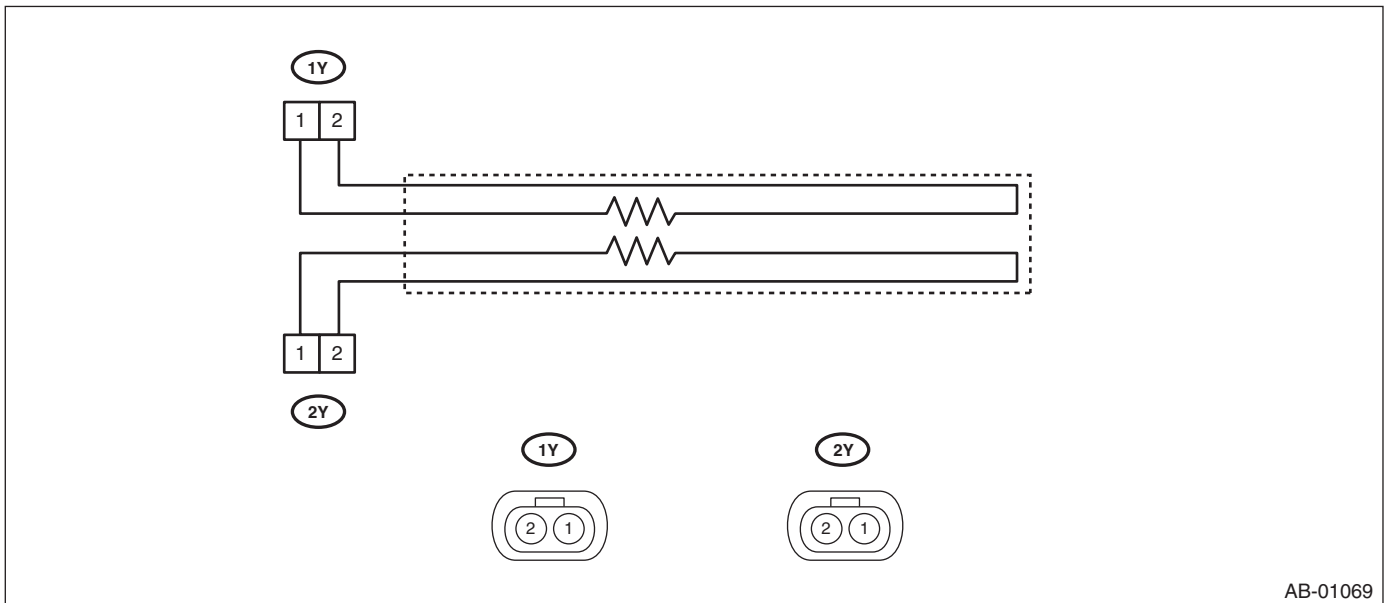

General Description

SEAT BELT SYSTEM

• AIRBAG RESISTOR

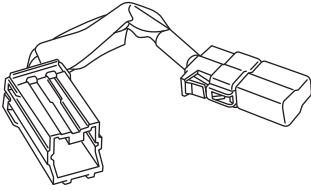
ILLUSTRATION	TOOL NUMBER	DESCRIPTION	REMARKS
 <p style="text-align: center;">ST98299PA040</p>	98299PA040	AIRBAG RESISTOR	Used in replacement of airbag module for which resistance value is same as airbag module. Two ST are required for diagnosis of two-stage inflator type airbag module.

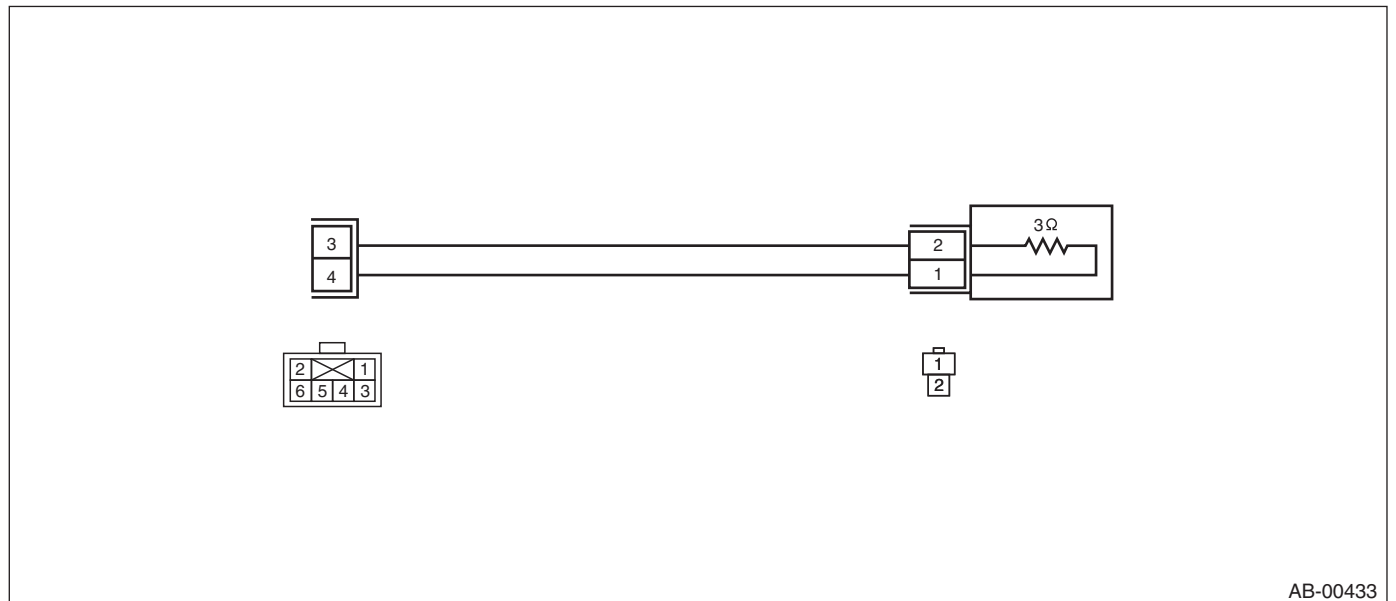

2. GENERAL TOOL

TOOL NAME	REMARKS
Circuit tester	Used for measuring resistance and voltage.

2. Pretensioner Connector

A: PROCEDURE

Refer to "Airbag Connector" of Airbag section for the connectors of the seat belt pretensioners and buckle switch RH. <Ref. to AB-9, PROCEDURE, Airbag Connector.>

Inspection Locations After a Collision

SEAT BELT SYSTEM

3. Inspection Locations After a Collision

A: INSPECTION

Refer to “Inspection Locations After a Collision” of Airbag section. <Ref. to AB-13, Inspection Locations After a Collision.>

4. Seat Belt Warning System

A: WIRING DIAGRAM

<Ref. to WI-94, WIRING DIAGRAM, Seat Belt Warning System.>

B: INSPECTION

CAUTION:

- Before diagnosing the airbag system, be sure to turn the ignition switch to OFF, disconnect the ground cable from the battery, and wait 20 seconds or more before starting to work.
- When replacing the airbag module, seat belt pretensioner, roll connector, control module and sensor, reconnect each part and check that the warning light operates properly.
- When inspecting the airbag main harness, disconnect the airbag module connectors of the driver's and passenger's seats for safety.
- When inspecting the airbag rear harness, disconnect the side airbag module connector, curtain airbag module connector and seat belt pretensioner connector for safety reasons.

TROUBLE SYMPTOM:

- Driver's side seat belt warning light does not turn on or off.
- Warning buzzer does not beep.

Step	Check	Yes	No
1 CHECK CURRENT SETTINGS. 1) Prepare the Subaru Select Monitor. 2) Turn the ignition switch to ON (engine OFF), and run the "PC application for Subaru Select Monitor". 3) Select "Current Data Display" and read the data of "Belt Warning Switch".	Is the belt warning display ON?	Go to step 2.	Turn the belt warning ON with unit customizing.
2 CHECK CURRENT DATA. 1) Select "Current Data Display" and read the data of "IG power supply voltage". 2) Turn the ignition switch ON ↔ OFF.	Does the voltage change between 10 V or higher ↔ less than 1.5 V, matching the ignition switch ON ↔ OFF operation?	Go to step 3.	Check the ignition switch circuit.
3 CHECK FUNCTION. 1) Sit in the driver's seat and passenger's seat, and disconnect the seat belts of both seats. 2) Turn the ignition switch to ON (engine OFF). 3) Check the illumination of the driver's seat belt warning light in the combination meter and the passenger's seat belt warning light in the clock unit, and the sounding of the buzzer.	Do the driver's and passenger's warning lights flash, and does the buzzer sound while the warning lights are flashing?	Go to step 4.	<ul style="list-style-type: none"> • Malfunction of the driver's seat belt warning light →Go to step 10. • Malfunction of the passenger's seat belt warning light →Go to step 16. • The buzzer does not sound. → Go to step 6.
4 CHECK FUNCTION. 1) Wait until the buzzer sound stops in step 3. (Approximately 6 seconds from starting to sound) 2) Fasten and detach the driver's and passenger's seat belts. 3) Check the illumination of the driver's seat belt warning light in the combination meter, and the passenger's seat belt warning light in the clock unit, and the sounding of the buzzer.	Do each seat belt warning light illuminate ↔ turn off according to the action?	Go to step 5.	<ul style="list-style-type: none"> • Malfunction of the driver's seat belt warning light →Go to step 6. • Malfunction of the passenger's seat belt warning light →Go to step 12.

Seat Belt Warning System

SEAT BELT SYSTEM

Step	Check	Yes	No
5 CHECK FUNCTION. 1) Wait until the buzzer sound stops in step 3. (Approximately 6 seconds from starting to sound) 2) Start the engine, and set the vehicle speed to 15 km/h (9 MPH) or faster. 3) Check the driver's and passenger's seat belt warning lights, and sounding of the alarm buzzer.	Do the driver's and passenger's warning lights flash, and does the buzzer sound while the warning lights are flashing?	The seat belt warning system is normal.	Go to step 19.
6 CHECK CURRENT DATA. 1) Select "Current Data Display" and read the data of the driver's seat belt switch. 2) Fasten and detach the seat belt buckle.	Does the seat belt SW display turn ON ←→ OFF according to the operation?	Go to step 10.	Go to step 7.
7 CHECK HARNESS. 1) Disconnect the negative terminal from the battery, and wait for 20 seconds or more. 2) Disconnect the connectors of the body integrated unit and the seat belt buckle switch. 3) Check for a short circuit to battery, open circuit or short circuit to ground between the body integrated unit and the seat belt buckle switch LH. Connector & terminal (B281) No. 16 — (R108) No. 3:	Is the harness normal?	Go to step 8.	Repair or replace the harness.
8 CHECK HARNESS. Measure the resistance between the seat belt buckle switch LH and chassis ground. Connector & terminal (R108) No. 1 — Chassis ground:	Is the resistance less than 10 Ω?	Go to step 9.	Repair or replace the harness.
9 CHECK SEAT BELT BUCKLE SWITCH LH. Measure the resistance between the connector terminals of the driver's seat belt switch when the driver's seat belt is fastened and detached. Connector & terminal (R108) No. 1 — (R108) No. 3:	Is the resistance when the belt is fastened 1 MΩ or higher, and less than 10 Ω when the belt is detached?	Replace the body integrated unit. <Ref. to SL-42, REMOVAL, Body Integrated Unit.>	Replace the inner belt assembly LH. <Ref. to SB-17, INNER SEAT BELT ASSEMBLY, REMOVAL, Front Seat Belt.>
10 CHECK DTC. Read the DTC using the Subaru Select Monitor.	Are any body CAN related DTC detected?	Check the CAN according to DTC.	Go to step 11.
11 CHECK COMBINATION METER. Perform self-diagnosis of the combination meter. <Ref. to IDI-4, SELF-DIAGNOSIS, INSPECTION, Combination Meter System.>	At the start of combination meter self diagnosis, did the buzzer sound and the seat belt warning light illuminate?	Replace the body integrated unit or the combination meter. Or, replace both. There may be a communication malfunction of the body integrated unit, or a reception malfunction of the combination meter.	Replace the combination meter. <Ref. to IDI-16, REMOVAL, Combination Meter.>
12 CHECK CURRENT DATA. 1) Sit in the passenger's seat. 2) Select "Current Data Display" and display the data of "P seatbelt SW input". 3) Fasten and detach the passenger's side seat belt buckle, and read the data of the seat belt switch. <Ref. to LAN(diag)-17, OPERATION, Read Current Data.>	Does the seat belt switch display turn ON ←→ OFF according to the operation of the seat belt buckle?	Go to step 16.	Go to step 13.

Seat Belt Warning System

SEAT BELT SYSTEM

Step	Check	Yes	No
13 CHECK AIRBAG SYSTEM AND OCCUPANT DETECTION SYSTEM. Perform the check in accordance with the diagnostic procedure DTC 27 of the airbag system. <Ref. to AB(diag)-60, DTC 27 ODS COMMUNICATION ERROR, Diagnostic Chart with Trouble Code.>	Is there any problem on the inspection result?	Go to step 14.	Repair or replace the harness.
14 CHECK BUCKLE SWITCH RH. Perform the check in accordance with the diagnostic procedure DTC 37 of the occupant detection system. <Ref. to OD(diag)-27, DTC 37 BUCKLE SWITCH RH FAILURE, Diagnostic Procedure with Diagnostic Trouble Code (DTC).>	Is there any problem on the inspection result?	Go to step 15.	Repair or replace the harness.
15 CHECK AIRBAG CONTROL MODULE AND BODY INTEGRATED UNIT. Check the airbag control module, occupant detection sensor and seat belt buckle switch RH. Perform the check in accordance with the diagnostic procedure DTC 39 of the airbag system. <Ref. to AB(diag)-62, DTC 39 SEAT BELT WARNING FAILURE, Diagnostic Chart with Trouble Code.>	Is there any problem on the inspection result?	Replace the body integrated unit. <Ref. to SL-42, REMOVAL, Body Integrated Unit.>	Repair or replace the harness.
16 CHECK HARNESS. 1) Disconnect the clock connector. 2) Turn the ignition switch to ON. 3) Measure the voltage between the body integrated unit and the clock. Connector & terminal (i59) No. 8 (+) — Chassis ground (-):	Is the voltage 10 V or higher?	Go to step 17.	Repair or replace the harness.
17 CHECK HARNESS. 1) Turn the ignition switch to ON. 2) Disconnect the connector of body integrated unit. 3) Check for a short circuit to battery, open circuit or short circuit to ground between the body integrated unit and the clock. Connector & terminal (i84) No. 25 — (i59) No. 2:	Is the harness normal?	Go to step 19.	Repair or replace the harness.
18 CHECK CLOCK. 1) Connect the clock connector. 2) Turn the ignition switch to ON. 3) Use an appropriate wiring harness to create a short between the body integrated unit and the clock. Connector & terminal (i84) No. 25 — Chassis ground: (i59) No. 2 — Chassis ground:	Does passenger's seat belt warning light in the clock illuminate?	Replace the body integrated unit. <Ref. to SL-42, REMOVAL, Body Integrated Unit.>	Replace the clock. <Ref. to IDI-21, REMOVAL, Clock.>
19 CHECK DTC. Read the DTCs for all systems using the Subaru Select Monitor.	Is a DTC detected?	Perform a check according to the DTC.	Go to step 20.

Seat Belt Warning System

SEAT BELT SYSTEM

Step	Check	Yes	No
20 CHECK CURRENT DATA. Select "Current Data Display" and read the data of the "Front Wheel Speed". <Ref. to LAN(diag)-17, OPERATION, Read Current Data.>	Does the data indicate the normal vehicle speed?	Go to step 11.	Check the following items. • LAN system <Ref. to LAN(diag)-62, DTC U1223 CAN-HS VDC/ABS NO-RECEIVE DATA, Diagnostic Procedure with Diagnostic Trouble Code (DTC).> • VDC <Ref. to VDC(diag)-2, Basic Diagnostic Procedure.>

5. Front Seat Belt

A: REMOVAL

1. OUTER SEAT BELT ASSEMBLY

CAUTION:

- Do not drop or subject the pretensioner to any impact.
- Since the pretensioner and bracket are integrated as a unit, do not disassemble them.

- 1) Before working, turn the ignition switch to OFF, disconnect the battery ground cable, and wait for 20 seconds or more.
- 2) Fold the backrest all the way forward, and then move the front seat all the way forward.
- 3) Remove the center pillar lower trim. <Ref. to EI-52, REMOVAL, Lower Inner Trim.>
- 4) Remove the anchor cover (A).
- 5) Loosen the shoulder anchor bolt (B), and then detach the shoulder anchor from center pillar.

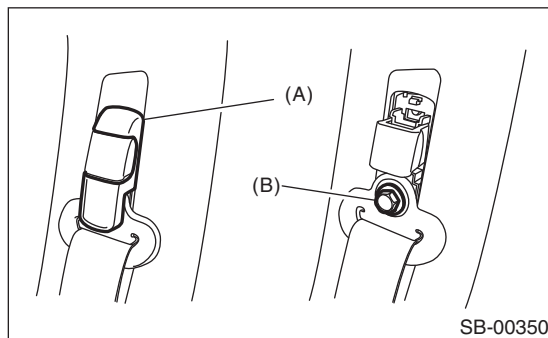

- 6) Disconnect the belt tension sensor connector on the passenger's seat.
- 7) Turn over the floor mat to disconnect the belt tension sensor connector.
- 8) Loosen the three bolts to remove the front outer belt.

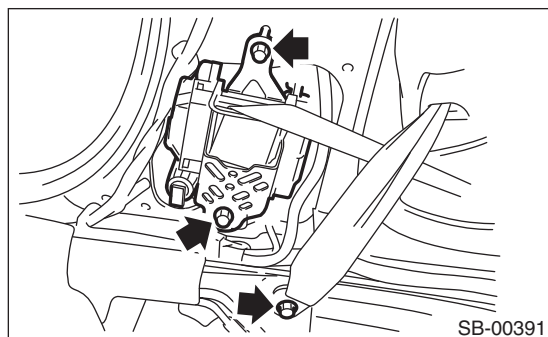

- 9) Remove the center pillar upper trim. <Ref. to EI-53, REMOVAL, Upper Inner Trim.>

- 10) Remove the two bolts to remove the adjustable anchor assembly.

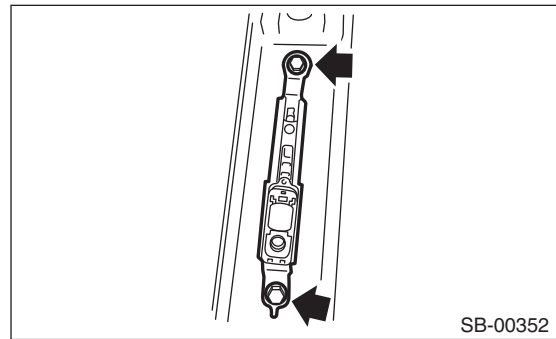

2. INNER SEAT BELT ASSEMBLY

- 1) Turn the ignition switch to OFF, disconnect the battery ground cable, and wait for 20 seconds or more.
- 2) Remove the console box. <Ref. to EI-46, REMOVAL, Console Box.>
- 3) Disconnect the seat belt warning light connector under the seat.
- 4) Remove the harness clips from slide rail.
- 5) Remove the bolt and remove the inner seat belt assembly.

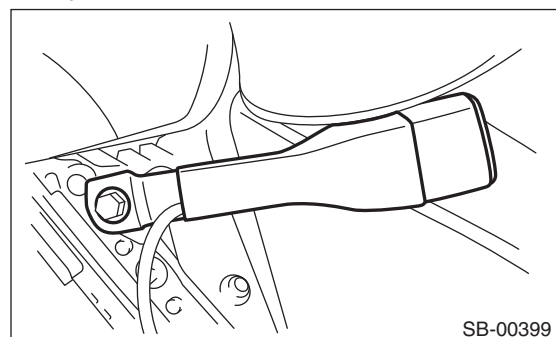

B: INSTALLATION

CAUTION:

- The parts of driver's seat and those of passenger's seat are not the same. Before installation, make sure that the correct part is used.
- Be careful not to twist the seat belts during installation.

Install in the reverse order of removal.

Tightening torque:

<Ref. to SB-2, FRONT SEAT BELT, COMPONENT, General Description.>

C: INSPECTION

Check for the following, and replace with new parts if necessary.

- Pretensioner is cracked or deformed.
- Seat belt is slackened, bent or worn.
- Seat belt is abnormally wound or extended.
- Inner seat belt assembly is deformed or damaged.
- Seat belt buckle cannot be engaged properly.

Rear Seat Belt

SEAT BELT SYSTEM

6. Rear Seat Belt

A: REMOVAL

1. OUTER SEAT BELT ASSEMBLY RH & LH

- 1) Remove the luggage floor mat.
- 2) Remove the rear seat cushion assembly and seat back shoulder. <Ref. to SE-15, REMOVAL, Rear Seat.>
- 3) Remove the seat belt lower anchor bolt.

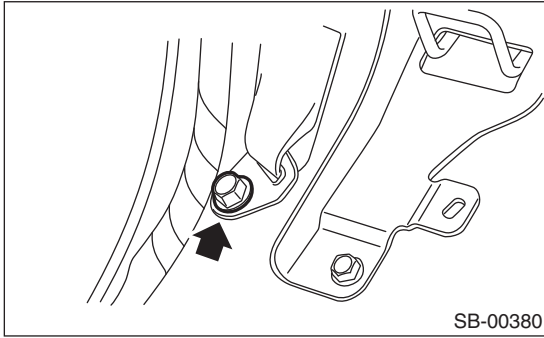

- 4) Remove the rear quarter trim. <Ref. to EI-55, REMOVAL, Rear Quarter Trim.>
- 5) Remove the nuts, and remove the outer belt assembly.

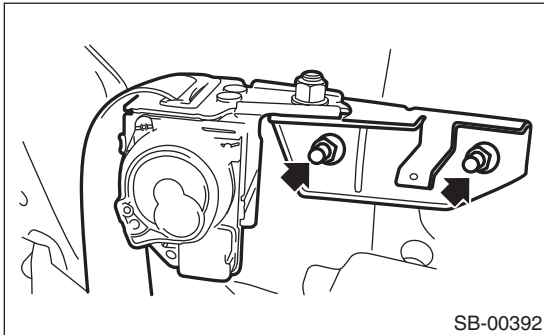

CAUTION:
Do not remove the bolt and nut securing the retractor and bracket.

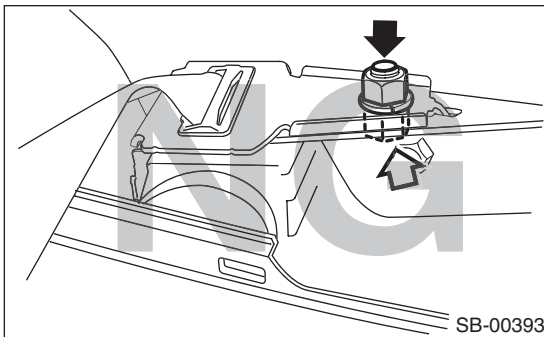

2. OUTER SEAT BELT CENTER ASSY

- 1) Carefully remove the snap lock, and remove cover (B). Pull the outer seat belt center tongue (A) from the hole towards the trim.

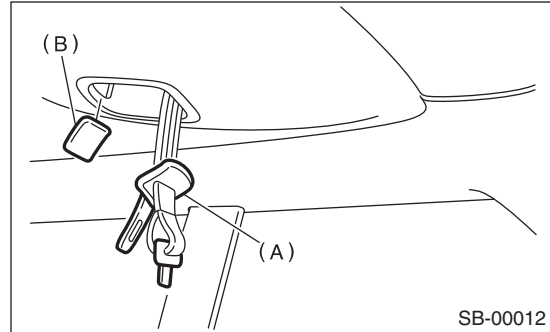

- 2) Remove the clip and drop the rear end of the roof trim from the roof.
- 3) Remove the bolts, then remove the outer seat belt center assembly.

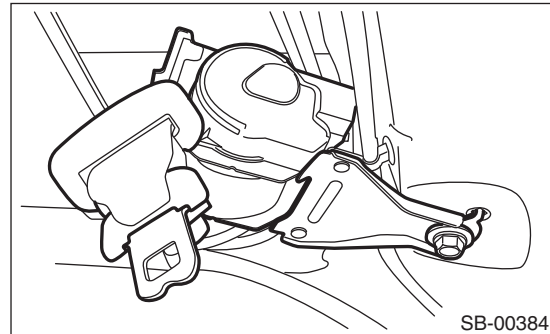

3. CENTER SEAT BELT ASSEMBLY

- 1) Remove the rear seat cushion. <Ref. to SE-15, REMOVAL, Rear Seat.>
- 2) Remove the bolts, then remove the center seat belt assembly.

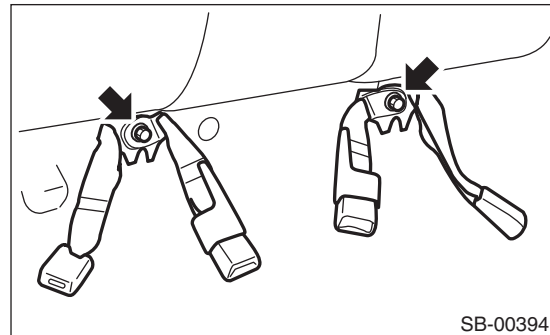

B: INSTALLATION

CAUTION:

- During installation, make sure that the seat belts are not twisted.
- After installation, make sure that the seat belts are smoothly extended and wound.
- Check that the center seat belt is not assembled wrongly.

1) Install in the reverse order of removal.

Tightening torque:

<Ref. to SB-3, REAR SEAT BELT, COMPONENT, General Description.>

2) Route the seat belt as shown in the figure below, and affix with Velcro tape.

- LH side

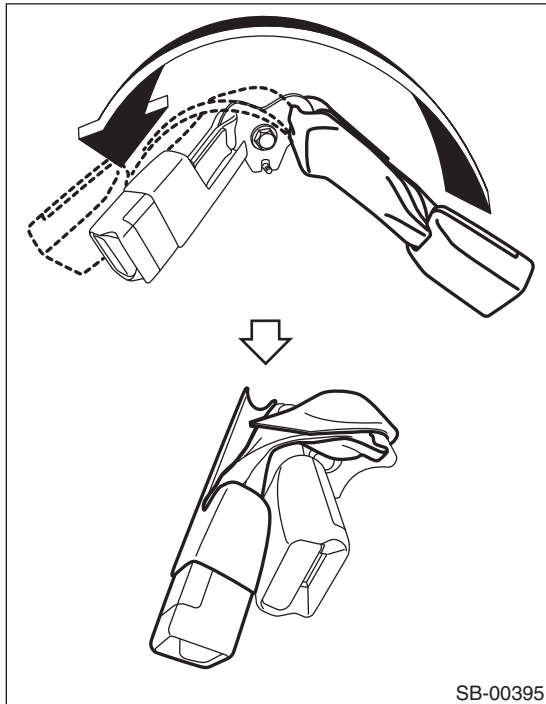

- RH side

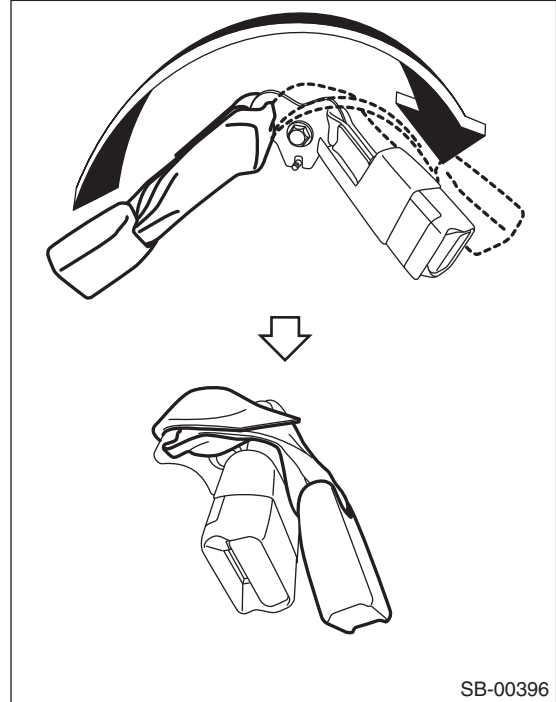

3) Attach the seat cushion, and pull out the center seat belt assembly.

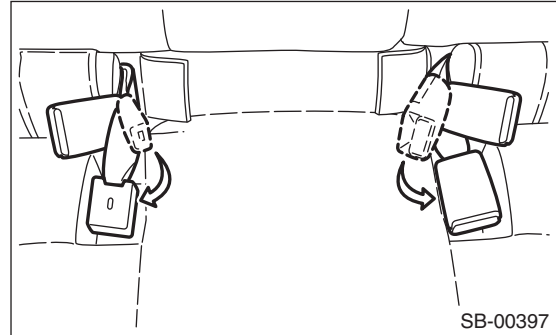

C: INSPECTION

Check for the following, and replace with new parts if necessary.

- Seat belt is slackened, bent or worn.
- Seat belt is abnormally wound or extended.
- Inner seat belt is deformed or damaged.
- Seat belt buckle cannot be engaged properly.

Rear Seat Belt

SEAT BELT SYSTEM

LIGHTING SYSTEM



	Page
1. General Description	2
2. Headlight and Tail Light System	3
3. Day Time Running Light System	4
4. Front Fog Light System	5
5. Turn Signal Light and Hazard Light System	6
6. Back-up Light System	7
7. Stop Light System	8
8. Room Light System	9
9. Combination Switch (Light)	10
10. Auto Headlight Beam Leveler System	11
11. Combination Base Switch Assembly	16
12. Headlight Assembly	17
13. Headlight Bulb	20
14. Front Turn Signal Light Bulb	22
15. Clearance/Parking Light Bulb	23
16. Front Side Marker Light Bulb	24
17. Front Fog Light Assembly	25
18. Front Fog Light Bulb	27
19. Rear Combination Light Assembly	28
20. Tail/Stop Light Bulb	29
21. Rear Turn Signal Light Bulb	30
22. Back-up Light Bulb	31
23. License Plate Light	32
24. High-mounted Stop Light	33
25. Spot Map Light	34
26. Room Light	35
27. Luggage Room Light	36
28. Door Step Light	37
29. Ignition Switch Illumination	38
30. Auto Headlight Beam Leveler Control Module	39
31. Front Height Sensor	40
32. Rear Height Sensor	41
33. Day Time Running Resistor	42
34. Reflex Reflector	43
35. Door Switch	44

General Description

LIGHTING SYSTEM

1. General Description

A: SPECIFICATION

Headlight	Halogen type low beam	12 V — 55 W
	HID type low beam	12 V — 35 W
	Halogen type high beam	12 V — 60 W
Front turn signal light		12 V — 21 W
Clearance / Parking light		12 V — 5 W
Front fog light		12 V — 51 W
Front side marker light		12 V — 5 W
Rear combination light	Tail / stop light	12 V — 5/21 W
	Turn signal light	12 V — 21 W
	Back-up light	12 V — 21 W
License plate light		12 V — 5 W
High-mounted stop light		12 V — 3.8 W (LED)
Room light		12 V — 8 W
Spot map light		12 V — 8 W
Luggage room light		12 V — 5 W
Door step light		12 V — 5 W

B: CAUTION

- Before removing or installing parts, always disconnect the battery ground cable from battery. When replacing the audio, control module and other parts provided with memory functions, record the memory contents before disconnecting the battery ground cable. Otherwise, the memory is cleared.
- Reassemble the parts in the reverse order of disassembly procedure unless otherwise indicated.
- Adjust parts to the given specifications.
- Connect the connectors securely during reassembly.
- After reassembly, make sure functional parts operate smoothly.

WARNING:

- The airbag system wiring harness is routed near electrical parts and switches. Do not use electrical test equipment on any airbag system wiring harnesses or connector circuits.
- Be careful not to damage the airbag system wiring harness when servicing electrical parts and switches.

C: PREPARATION TOOL

1. SPECIAL TOOL

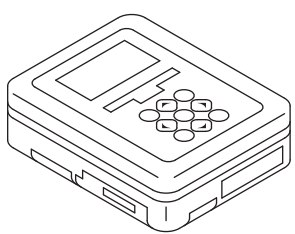
ILLUSTRATION	TOOL NUMBER	DESCRIPTION	REMARKS
 <p>ST1B022XU0</p>	1B022XU0 (Newly adopted tool)	SUBARU SELECT MONITOR III KIT	Used for diagnosis of the electrical system.

2. GENERAL TOOL

TOOL NAME	REMARKS
Circuit tester	Used for measuring resistance and voltage.

2. Headlight and Tail Light System

A: WIRING DIAGRAM

1. HALOGEN TYPE HEADLIGHT

<Ref. to WI-97, WIRING DIAGRAM, Headlight System.>

2. HID TYPE HEADLIGHT

<Ref. to WI-97, WIRING DIAGRAM, Headlight System.>

3. CLEARANCE LIGHT AND ILLUMINATION LIGHT

<Ref. to WI-106, WIRING DIAGRAM, Clearance Light and Illumination Light System.>

B: INSPECTION

1. HEADLIGHT SWITCH

<Ref. to LI-10, INSPECTION, Combination Switch (Light).>

2. HEADLIGHT RELAY

Measure the headlight relay resistance between terminals when connecting terminal No. 4 to the battery positive terminal and terminal No. 3 to the battery ground terminal.

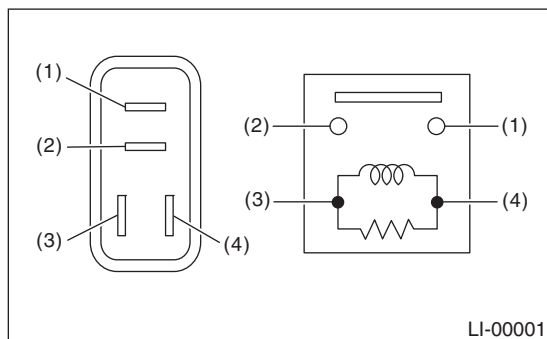

Continuity	Terminal No.	Standard
Yes	1 and 2	Less than 1 Ω
No		1 MΩ or more

3. TAIL AND ILLUMINATION RELAY

Measure the resistance between the tail and illumination relay terminals when connecting terminal No. 4 to the battery positive terminal and terminal No. 3 to the battery ground terminal.

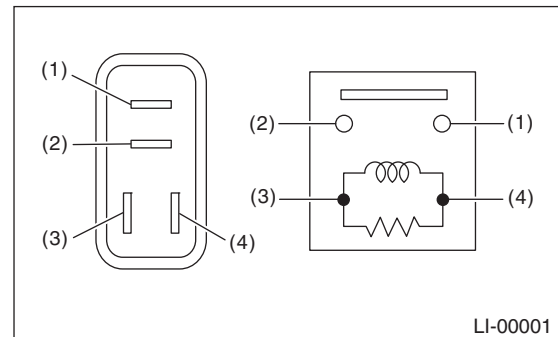

Continuity	Terminal No.	Standard
Yes	1 and 2	Less than 1 Ω
No		1 MΩ or more

Day Time Running Light System

LIGHTING SYSTEM

3. Day Time Running Light System

A: WIRING DIAGRAM

<Ref. to WI-97, WIRING DIAGRAM, Headlight System.>

B: INSPECTION

1. DAYTIME RUNNING LIGHT MODULE CHECK

Step	Check	Yes	No
1 CHECK DTC. 1) Connect the Subaru Select Monitor. 2) Read the DTC of the body integrated unit.	Is DTC displayed?	Perform the diagnosis according to DTC.	Go to step 2.
2 CHECK INPUT SIGNAL. 1) Display the current data of the body integrated unit. 2) Check the following input signals. (1) Parking brake switch (2) Shift position (3) Light 2	Is the input signal normal?	Go to step 3.	Check the defective part.
3 CHECK RELAY. Check the daytime running light relay.	Is the relay OK?	Go to step 4.	Replace the relay.
4 CHECK HARNESS.	Is the harness OK?	Replace the body integrated unit. <Ref. to SL-42, REMOVAL, Body Integrated Unit.>	Repair the harness.

2. DAYTIME RUNNING LIGHT RELAY

Measure the resistance between the daytime running relay terminals when connecting terminal No. 3 to the battery positive terminal and terminal No. 5 to the battery ground terminal.

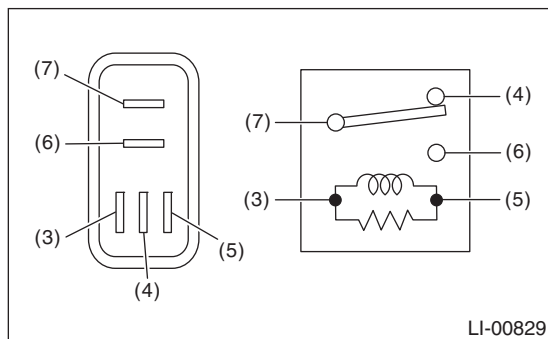

Continuity	Terminal No.	Standard
Yes	7 and 6	Less than 1 Ω
No		1 M Ω or more
Yes	7 and 4	1 M Ω or more
No		Less than 1 Ω

4. Front Fog Light System

A: WIRING DIAGRAM

1. FRONT FOG LIGHT

<Ref. to WI-102, WIRING DIAGRAM, Front Fog Light System.>

B: INSPECTION

1. FRONT FOG LIGHT SWITCH

Measure the resistance between front fog light switch terminals.

<Ref. to LI-10, INSPECTION, Combination Switch (Light).>

2. FRONT FOG LIGHT RELAY

Connect terminal No. 4 to battery positive terminal and terminal No. 3 to battery ground terminal, and measure the front fog light relay resistance between terminals.

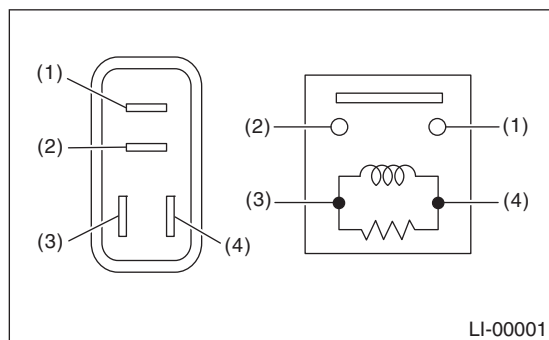

Continuity	Terminal No.	Standard
Yes	1 and 2	Less than 1 Ω
No		1 MΩ or more

Turn Signal Light and Hazard Light System

LIGHTING SYSTEM

5. Turn Signal Light and Hazard Light System

A: WIRING DIAGRAM

1. TURN SIGNAL LIGHT AND HAZARD LIGHT

<Ref. to WI-111, WIRING DIAGRAM, Turn Signal Light and Hazard Light System.>

B: INSPECTION

1. TURN SIGNAL SWITCH

<Ref. to LI-10, INSPECTION, Combination Switch (Light).>

2. HAZARD SWITCH

Measure the resistance between hazard switch terminals.

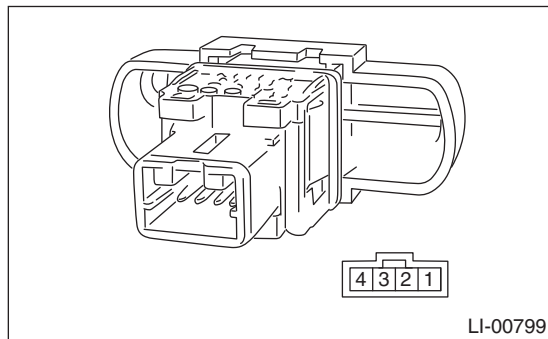

Switch position	Terminal No.	Standard
OFF	2 and 3	1 M Ω or more
ON		Less than 1 Ω

3. TURN SIGNAL AND HAZARD MODULE

Connect the battery and turn signal light bulb to the module. The module is properly functioning if it blinks when power is supplied to the circuit.

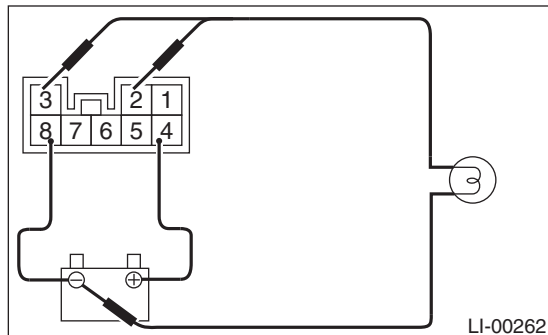

6. Back-up Light System

A: WIRING DIAGRAM

1. BACK-UP LIGHT

<Ref. to WI-104, WIRING DIAGRAM, Back-up Light System.>

B: INSPECTION

1. BACK-UP LIGHT SWITCH (MT MODEL)

Measure the resistance between the back-up light switch terminals.

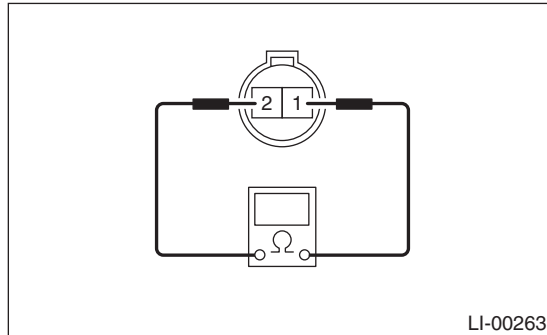

Switch position	Terminal No.	Standard
When shift lever is set in reverse position	1 and 2	Less than 1 Ω
Other positions		1 MΩ or more

2. INHIBITOR SWITCH (AT MODEL)

Measure the resistance between the inhibitor switch terminals.

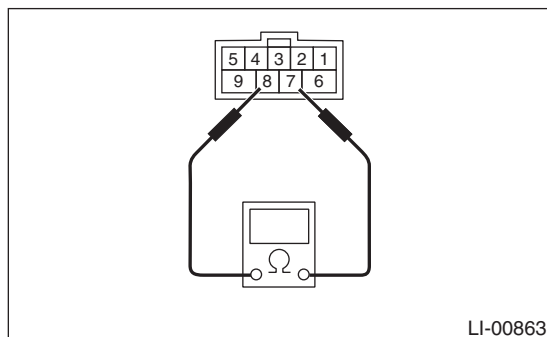

Switch position	Terminal No.	Standard
When the selector lever is in the "R" range	7 and 8	Less than 1 Ω
Other positions		1 MΩ or more

Stop Light System

LIGHTING SYSTEM

7. Stop Light System

A: WIRING DIAGRAM

1. STOP LIGHT

<Ref. to WI-105, WIRING DIAGRAM, Stop Light System.>

B: INSPECTION

1. STOP LIGHT SWITCH

Measure the resistance between stop light switch terminals.

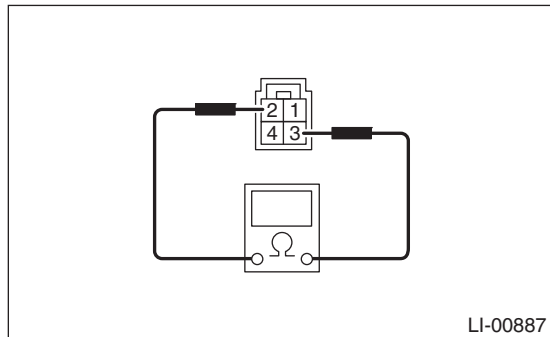

Switch position	Terminal No.	Standard
When brake pedal is depressed	2 and 3	Less than 1 Ω
When brake pedal is released		1 M Ω or more

8. Room Light System

A: WIRING DIAGRAM

1. ROOM LIGHT

<Ref. to WI-114, WIRING DIAGRAM, Interior Light System.>

B: INSPECTION

1. DOOR SWITCH

Measure the resistance between door switch terminals.

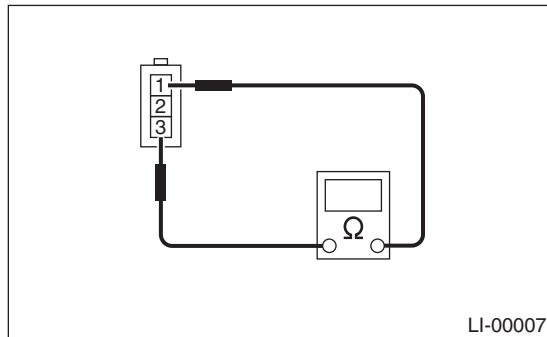

Switch position	Terminal No.	Standard
When door is opened	1 and 3	Less than 1 Ω
When door is closed		1 MΩ or more

2. REAR GATE LATCH SWITCH

Measure the resistance between rear gate latch switch terminals.

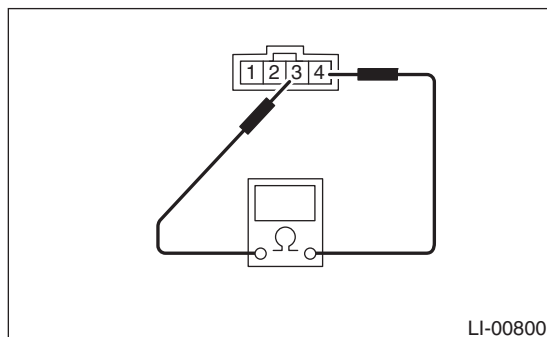

Switch position	Terminal No.	Standard
When rear gate is opened	3 and 4	Less than 1 Ω
When rear gate is closed		1 MΩ or more

Combination Switch (Light)

LIGHTING SYSTEM

9. Combination Switch (Light)

A: REMOVAL

- 1) Disconnect the ground cable from the battery.
- 2) Remove the screws, and remove the steering column lower cover.

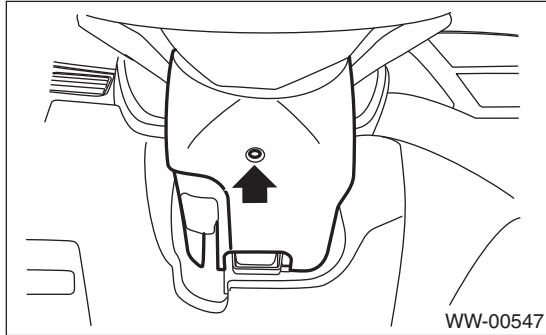

- 3) Remove the screws and steering column upper cover.

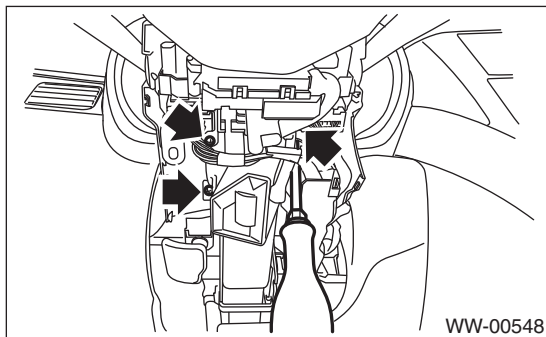

- 4) Disconnect the connector from the combination switch.

- 5) Remove the screws which secure the switch, then remove the combination switch.

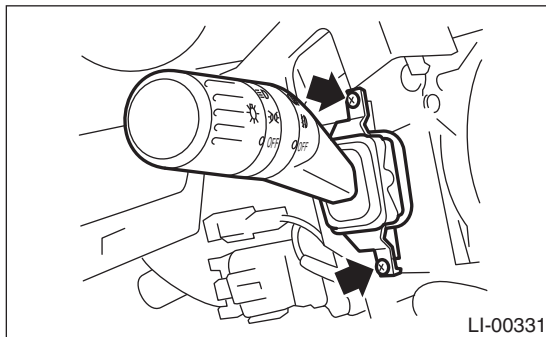

B: INSTALLATION

Install in the reverse order of removal.

C: INSPECTION

Measure the resistance between combination switch terminals.

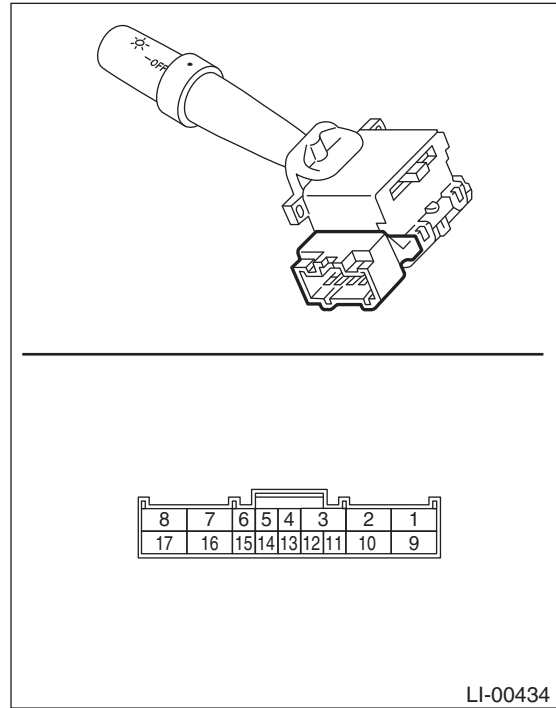

1. LIGHTING SWITCH

Switch position	Terminal No.	Standard
OFF	—	1 MΩ or more
Tail	14 and 16	Less than 1 Ω
Head	13, 14 and 16	Less than 1 Ω

2. DIMMER & PASSING SWITCH

Switch position	Terminal No.	Standard
Passing	7, 8 and 16	Less than 1 Ω
High beam	7 and 16	Less than 1 Ω

3. TURN SIGNAL SWITCH

Switch position	Terminal No.	Standard
Left	1 and 2	Less than 1 Ω
Neutral	—	1 MΩ or more
Right	3 and 2	Less than 1 Ω

4. FRONT FOG LIGHT SWITCH

Switch position	Terminal No.	Standard
OFF	11 and 10	1 MΩ or more
ON		Less than 1 Ω

10. Auto Headlight Beam Leveler System

A: WIRING DIAGRAM

<Ref. to WI-100, WIRING DIAGRAM, Headlight Beam Leveler System.>

B: SPECIFICATION

1. ECM CONNECTOR TERMINAL LAYOUT

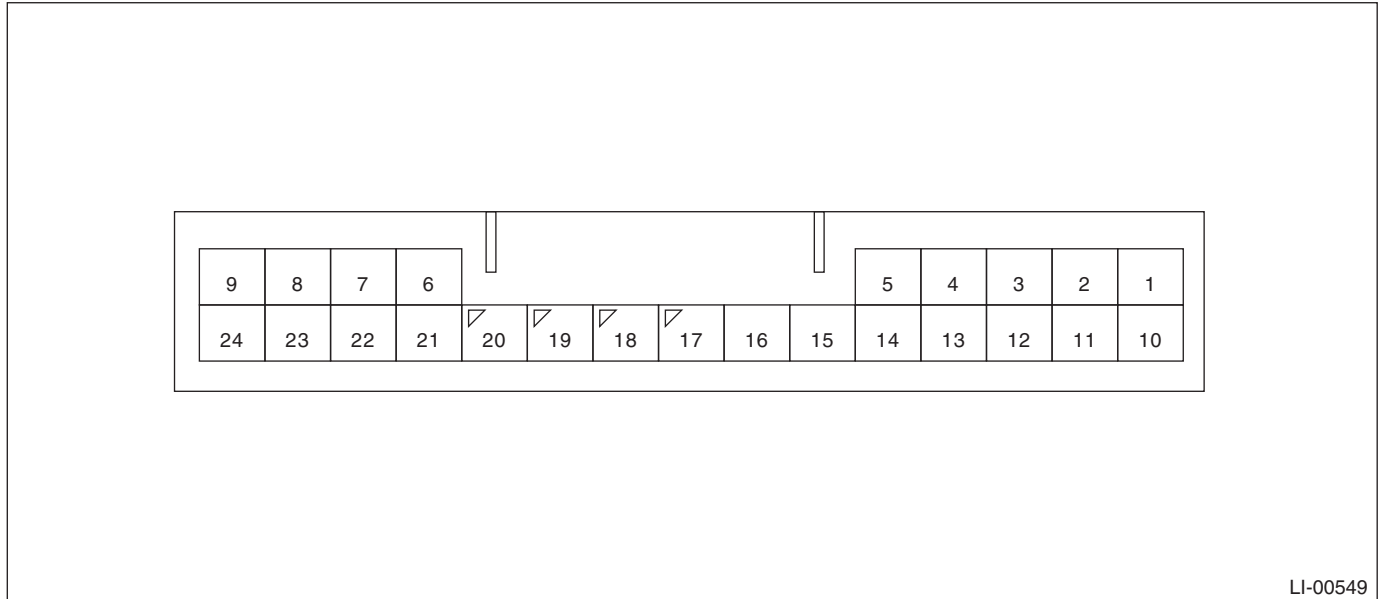

- | | | |
|--------------------------|--------------------------------|-------------------------------------|
| (1) IG power supply | (9) GND | (17) Actuator control signal output |
| (2) Not used | (10) Actuator power supply | (18) Not used |
| (3) Headlights ON signal | (11) Not used | (19) Rear sensor input |
| (4) Not used | (12) Rear sensor power supply | (20) Front sensor input |
| (5) Not used | (13) Front sensor power supply | (21) Rear sensor GND |
| (6) Indicator output | (14) Not used | (22) Front sensor GND |
| (7) Not used | (15) Not used | (23) Actuator GND |
| (8) Not used | (16) Vehicle speed pulse input | (24) Not used |

2. VEHICLE HEIGHT SENSOR UNIT TERMINAL LAYOUT

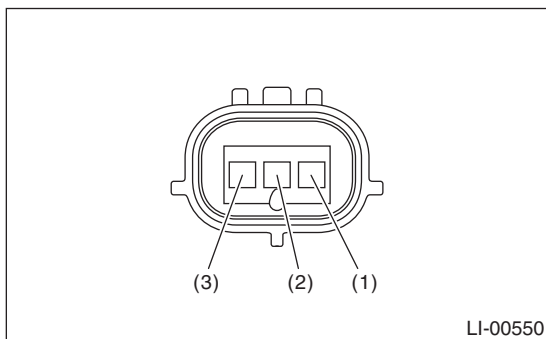

- (1) GND
- (2) Output
- (3) Power supply

Auto Headlight Beam Leveler System

LIGHTING SYSTEM

C: INSPECTION

1. SYMPTOM CHART

- No beam level control

Step	Check	Yes	No	
1	CHECK INDICATOR OUTPUT. Turn the ignition switch to ON.	Does the warning indicator illuminate for three seconds?	Go to step 2.	Go to step 5.
2	CHECK INDICATOR OUTPUT. Turn the ignition switch to ON and hold there for at least 10 seconds.	Does the warning indicator light turn off?	Go to step 10.	Go to step 3.
3	CHECK OUTPUT VOLTAGE BETWEEN HEADLIGHT LEVELER CONTROL MODULE AND VEHICLE HEIGHT SENSOR. 1) Disconnect the vehicle height sensor connector. (Front, rear) 2) Turn the ignition switch to ON. 3) Measure the voltage between the vehicle height sensor and chassis ground. Connector & terminal • Front vehicle height sensor: (F8) No. 3 (+) — Chassis ground (-): • Rear vehicle height sensor: (R29) No. 3 (+) — Chassis ground (-):	Is the voltage 5±0.25 V?	Go to step 8.	Go to step 4.
4	CHECK HARNESS BETWEEN HEADLIGHT LEVELER CONTROL MODULE AND VEHICLE HEIGHT SENSOR. 1) Turn the ignition switch to OFF. 2) Disconnect the ECM connector. 3) Check for continuity between headlight leveler control module and vehicle height sensor. Connector & terminal • Front vehicle height sensor: (B150) No. 22 — (F8) No. 1: (B150) No. 20 — (F8) No. 2: (B150) No. 13 — (F8) No. 3: • Rear vehicle height sensor: (B150) No. 21 — (R29) No. 1: (B150) No. 19 — (R29) No. 2: (B150) No. 12 — (R29) No. 3:	Is there continuity?	Replace the headlight leveler control module.	Repair the open circuit or poor contact of the connector in the harness between the headlight leveler control module and vehicle height sensor.
5	CHECK HARNESS BETWEEN BATTERY — INDICATOR BULB — ECM. 1) Disconnect the connector of ECM. 2) Turn the ignition switch to ON. 3) Measure the voltage between the indicator bulb and chassis ground. Connector & terminal (B150) No. 6 (+) — Chassis ground (-):	Is the voltage 12 V?	Replace the headlight leveler control module.	Go to step 6.
6	CHECK INDICATOR BULB. Check indicator bulb for open circuit or poor contact.	Is there an open circuit or poor contact?	Go to step 7.	Replace the indicator bulb.

Auto Headlight Beam Leveler System

LIGHTING SYSTEM

Step	Check	Yes	No
<p>7 CHECK HARNESS BETWEEN HEADLIGHT LEVELER CONTROL MODULE AND INDICATOR BULB.</p> <p>1) Turn the ignition switch to OFF. 2) Disconnect the connector of ECM. 3) Disconnect the combination meter connector. 4) Check for continuity between headlight leveler control module and combination meter.</p> <p>Connector & terminal <i>(B150) No. 6 — (i10) No. 7:</i></p>	Is there continuity?	Replace the headlight leveler control module.	Repair the open circuit or poor contact of the connector in the harness between the headlight leveler control module and indicator.
<p>8 CHECK OUTPUT SIGNAL OF VEHICLE HEIGHT SENSOR.</p> <p>1) Connect three batteries (1.5 V) in series. 2) Connect the No. 3 terminal of the sensor unit to the (+) side of the batteries and the No. 1 terminal to the (-) side of the batteries, applying 4.5 V between No. 3 — No. 1. 3) With the voltage applied, slowly move the sensor unit link up and down, and use a tester to measure the voltage between terminal No. 2 — No. 1.</p> <p>Connector & terminal <i>Sensor unit No. 2 (+) — No. 1 (-):</i></p>	Is the voltage 0.5 — 4.1 V?	Go to step 9.	Replace the vehicle height sensor.
<p>9 CHECK HARNESS BETWEEN HEADLIGHT LEVELER CONTROL MODULE AND VEHICLE HEIGHT SENSOR.</p> <p>1) Turn the ignition switch to OFF. 2) Disconnect the ECM connector. 3) Check for continuity between headlight leveler control module and vehicle height sensor.</p> <p>Connector & terminal</p> <ul style="list-style-type: none"> • Front vehicle height sensor: <i>(B150) No. 22 — (F8) No. 1:</i> <i>(B150) No. 20 — (F8) No. 2:</i> <i>(B150) No. 13 — (F8) No. 3:</i> • Rear vehicle height sensor: <i>(B150) No. 21 — (R29) No. 1:</i> <i>(B150) No. 19 — (R29) No. 2:</i> <i>(B150) No. 12 — (R29) No. 3:</i> 	Is there continuity?	Replace the headlight leveler control module.	Repair the open circuit or poor contact of the connector in the harness between the headlight leveler control module and vehicle height sensor.
<p>10 CHECK HEADLIGHT ON SIGNAL.</p> <p>1) Disconnect the headlight leveler control module connector. 2) Turn the ignition switch to ON. 3) Turn the headlight switch to ON. 4) Measure the voltage between the headlight relay and chassis ground.</p> <p>Connector & terminal <i>(B150) No. 3 (+) — Chassis ground (-):</i></p>	Is the voltage 12 V?	Go to step 11.	Repair the open circuit or poor contact of the connector in the harness between the headlight relay and headlight leveler control module.
<p>11 CHECK HEADLIGHT ASSEMBLY (LEVELING ACTUATOR) MOTOR.</p> <p>1) Stop the vehicle completely. 2) Turn the ignition switch to ON, and, within 10 seconds, turn the headlight switch OFF ⇒ ON five successive times. 3) Check that the headlight beam returns to the original position after lowering once. 4) While keeping the ignition ON, wait 30 seconds or more after the previous step, and turn the ignition switch to OFF.</p>	Does the headlight beam go completely down once and then return to the original position?	Replace the headlight leveler control module.	Go to step 12.

Auto Headlight Beam Leveler System

LIGHTING SYSTEM

Step	Check	Yes	No
<p>12 CHECK OUTPUT VOLTAGE BETWEEN HEADLIGHT LEVELER CONTROL MODULE AND HEADLIGHT ASSEMBLY (LEVELING ACTUATOR).</p> <p>1) Disconnect the headlight assembly (leveling actuator) connector. 2) Turn the ignition switch to ON. 3) Measure the voltage between the leveling actuator and chassis ground.</p> <p>Connector & terminal (B150) No. 10 (+) — Chassis ground (-):</p>	Is the voltage 12 V?	Replace the headlight assembly.	Go to step 13.
<p>13 CHECK HARNESS BETWEEN HEADLIGHT LEVELER CONTROL MODULE AND HEADLIGHT ASSEMBLY (LEVELING ACTUATOR).</p> <p>Check for continuity between the headlight leveler control module and headlight assembly (leveling actuator).</p> <p>Connector & terminal</p> <ul style="list-style-type: none"> • Headlight leveler RH: (B150) No. 10 — (F59) No. 3: (B150) No. 17 — (F59) No. 2: (B150) No. 23 — (F59) No. 1: • Headlight leveler LH: (B150) No. 10 — (F58) No. 3: (B150) No. 17 — (F58) No. 2: (B150) No. 23 — (F58) No. 1: 	Is there continuity?	Replace the headlight leveler control module.	Repair the open circuit or poor contact of the connector in the harness between the headlight assembly and headlight leveler control module.

D: PROCEDURE

When parts related to the auto headlight beam leveling system are removed or replaced, perform the following procedures to initialize or reinitialize.

NOTE:

Before performing initialization or reinitialization, check the following:

- Vehicle is parked on a level surface.
- The inflation pressure of tires is correct.
- Unload any cargo from the vehicle.
- Vehicle's fuel tank is fully filled.
- When determining whether to perform initialization or reinitialization, refer to the following:

Initialization	<ul style="list-style-type: none"> • When the headlight leveler control module has been replaced with a new part.
Reinitialization	<ul style="list-style-type: none"> • When the headlight leveler control module has been replaced with a part from a different vehicle. • When suspension parts have been removed or replaced. (Crossmember, transverse link, lateral link, strut) • When the vehicle height sensor has been replaced or removed.

1. INITIALIZATION

- 1) Confirm that the indicator in the meter is repeatedly flashing twice.
- 2) Bounce the vehicle several times to normalize the suspension.
- 3) Make certain that someone is seated in the driver's seat.
- 4) Turn the ignition ON, and within a period over 1.5 seconds and under 20 seconds, repeat headlight switch OFF ⇒ ON 3 times or more.
- 5) Confirm that the indicator in the meter flashes 3 times and turns OFF, completing the initialization. (At this time, the headlight beam adjustment is lowered, and then returns to the original position.)
- 6) Perform beam adjustment for the headlight. <Ref. to LI-18, ADJUSTMENT, Headlight Assembly.>

2. REINITIALIZATION

- 1) Bounce the vehicle several times to normalize the suspension.
- 2) Make certain that someone is seated in the driver's seat.
- 3) Turn the ignition ON, and within a period over 1.5 seconds and under 10 seconds, repeat headlight switch OFF ⇒ ON 5 times or more.
- 4) Check that the headlight beam drops once, then returns to normal.
- 5) After confirming 4), turn the ignition switch to OFF within 30 seconds.
- 6) Turn the ignition switch to ON again, and within a period over 1.5 seconds and under 10 seconds, repeat headlight switch OFF ⇒ ON 5 times or more.
- 7) Confirm that the indicator in the meter flashes 3 times and turns OFF, completing the reinitialization. (At this time, the headlight beam adjustment is lowered, and then returns to the original position.)
- 8) Perform beam adjustment for the headlight. <Ref. to LI-18, ADJUSTMENT, Headlight Assembly.>

CAUTION:

If the indicator does not flash 3 times or the headlight beam does not operate, there is a possibility of an open circuit or faulty connection in the harness between the headlight leveler control module, front and rear vehicle height sensors and headlight assembly. Perform inspection and repair according to the inspection results, then perform initialization/reinitialization again. <Ref. to LI-12, INSPECTION, Auto Headlight Beam Leveler System.> <Ref. to LI-15, PROCEDURE, Auto Headlight Beam Leveler System.>

Combination Base Switch Assembly

LIGHTING SYSTEM

11. Combination Base Switch Assembly

A: REMOVAL

- 1) Remove the driver's airbag module. <Ref. to AB-16, REMOVAL, Driver's Airbag Module.>
- 2) Remove the steering wheel. <Ref. to PS-12, REMOVAL, Steering Wheel.>
- 3) Remove the screws, and remove the steering column lower cover.

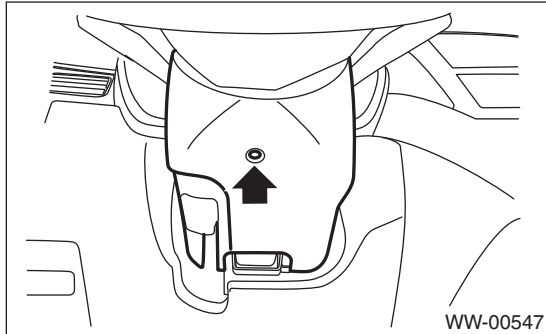

- 4) Remove the screws and steering column upper cover.

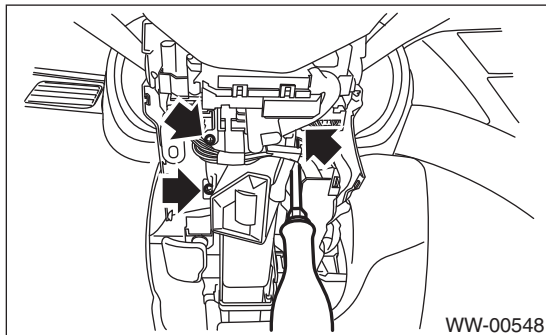

- 5) Remove the combination switch. <Ref. to LI-10, REMOVAL, Combination Switch (Light).> <Ref. to WW-8, REMOVAL, Combination Switch (Wiper).>
- 6) Remove the four screws and remove the roll connector.
- 7) Remove the three screws.

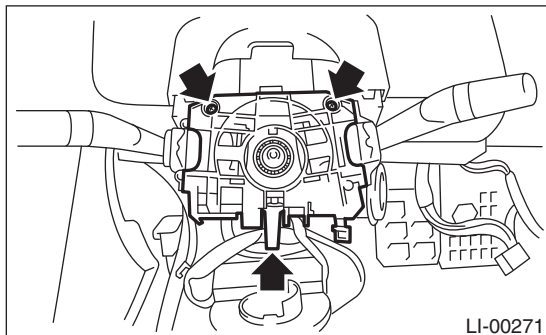

- 8) Disconnect the connector and remove the combination base switch assembly.

B: INSTALLATION

- 1) Install in the reverse order of removal.
- 2) Before installing steering wheel, be sure to adjust the direction of roll connector with steering. <Ref. to AB-28, ADJUSTMENT, Roll Connector.>

C: INSPECTION

1. COMBINATION BASE SWITCH ASSEMBLY

Inspect the combination base switch assembly and roll connector for cracks or deformation. If any damage is found, replace with a new part.

12. Headlight Assembly

A: REMOVAL

CAUTION:

- Do not work with wet hands.
 - Because the lighting circuit on the HID headlights uses high voltage, be sure to confirm that the power supply is turned off before operation.
- 1) Disconnect the ground cable from the battery.
 - 2) Remove the air intake duct (rear). (When removing the headlight RH).

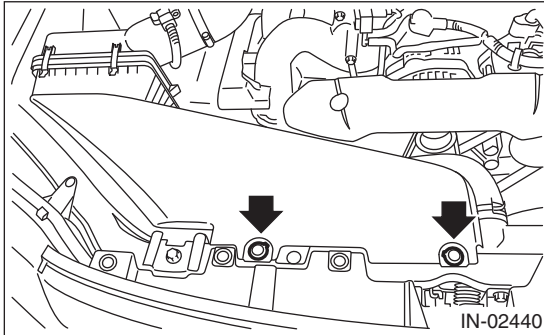

- 3) Remove the front bumper. <Ref. to EI-28, REMOVAL, Front Bumper.>
- 4) Disconnect harness connectors.
- 5) Remove the three bolts, disengage the clip, then detach the headlight assembly.

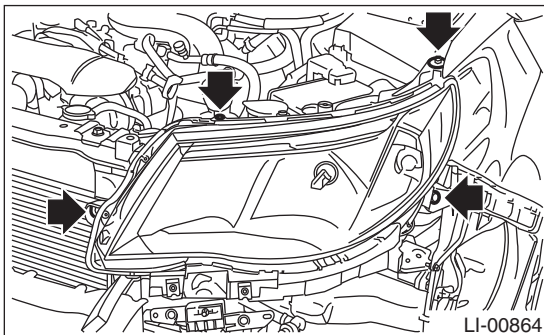

B: INSTALLATION

Install in the reverse order of removal.

Tightening torque:

7.5 N·m (0.76 kgf-m, 5.5 ft-lb)

C: DISASSEMBLY

1. HID HEADLIGHT BALLAST

CAUTION:

- Do not work with wet hands.
- Because the lighting circuit on the HID headlights uses high voltage, be sure to confirm that the power supply is turned off before operation.
- Do not leave the headlight without a ballast for extended periods of time. Dust, moisture, etc. entering the headlight may affect its performance.

- 1) Disconnect the ground cable from the battery.
- 2) Remove the headlight assembly. <Ref. to LI-17, REMOVAL, Headlight Assembly.>
- 3) Remove the back cover.

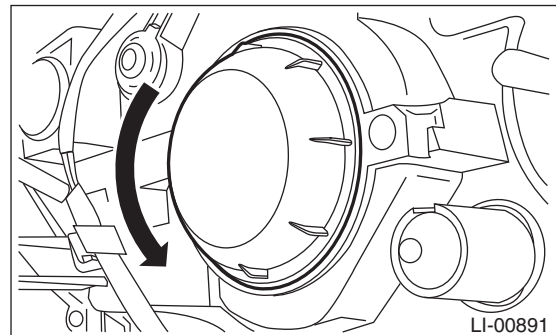

- 4) Disconnect the harness connector.

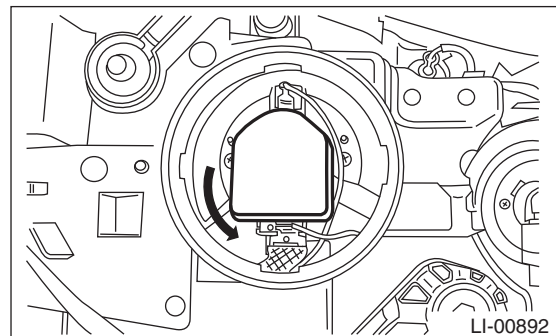

Headlight Assembly

LIGHTING SYSTEM

5) Disconnect the harness connector, loosen the screws, and remove the headlight ballast.

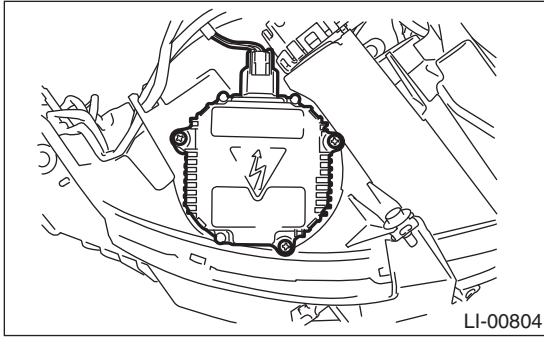

6) Disconnect the connector from the headlight ballast.

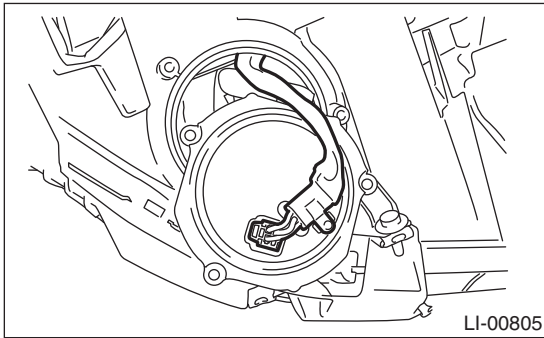

D: ASSEMBLY

1. HID HEADLIGHT BALLAST

Install in the reverse order of removal.

Tightening torque:

1.3 N·m (0.13 kgf-m, 0.96 ft-lb)

CAUTION:

- When installing the ballast cover, be sure to install the gasket.
- After installing the ballast to the vehicle, be sure to perform beam adjustment

NOTE:

Adjust the projector lens to near the center of the extension opening before installing the ballast. This makes the beam adjustment work easier.

E: ADJUSTMENT

1. HEADLIGHT BEAM ADJUSTMENT

CAUTION:

Turn off the light before adjusting the headlight beam level. If it is necessary to inspect the beam level, do not keep the light on for two minutes or more.

NOTE:

Before checking the headlight beam level, be sure of the following:

- Check the area around the headlight for any scratches, damage or other types of deformation.
 - Make sure that the vehicle is parked on a level surface.
 - Make sure that the inflation pressure of tires are correct.
 - Make sure that the vehicle fuel tank is full.
- 1) Bounce the vehicle two to three times to normalize the suspension.
 - 2) Make certain that someone is seated in the driver's seat.
 - 3) Measure the distance between the low beam bulb centers, and the height of the bulb center.

4) Turn the headlights on and then adjust the low beam pattern.

NOTE:

- First adjust the vertical beam level (A), then the horizontal beam level (B).

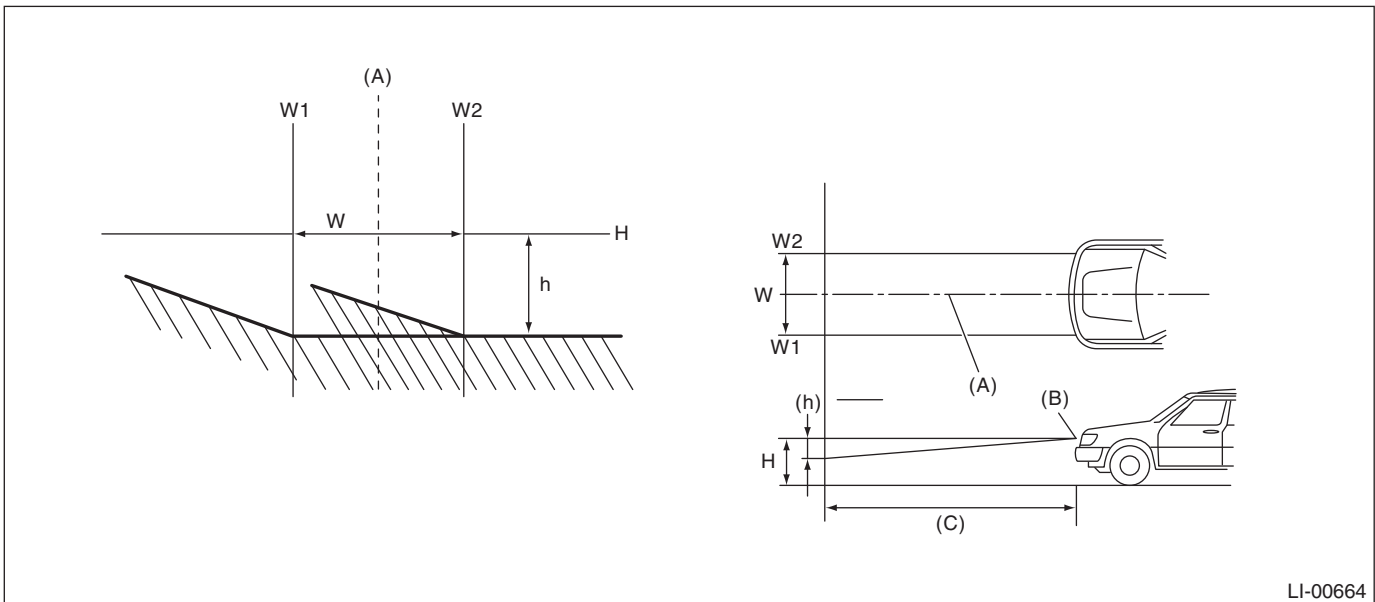
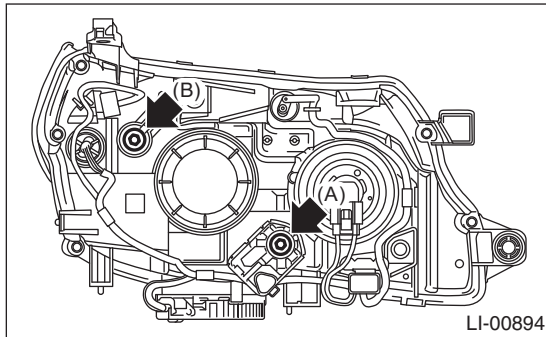

(A) Vehicle center

(B) Bulb center marking

(C) 3 m (10 ft)

W mm (in)	h mm (in) when C is 3 m (10 ft)
1,210 (47.64)	30 (1.19)

CAUTION:

Check the bulb center mark on the inner side of the lens since the low beam bulb center will differ according to bulb shape.

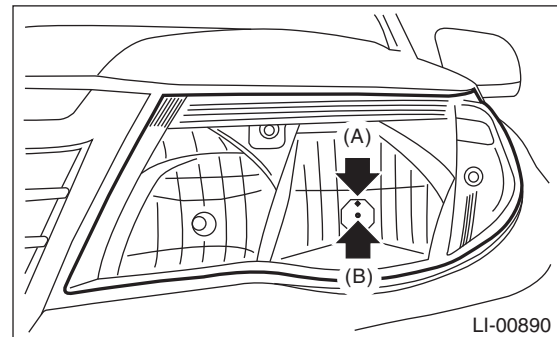

(A) HID type

(B) Halogen type

Headlight Bulb

LIGHTING SYSTEM

13. Headlight Bulb

A: REMOVAL

1. HIGH BEAM & HALOGEN TYPE LOW BEAM

CAUTION:

- Because the halogen bulb operates at a high temperature, dirt and oil on the bulb surface reduces the bulb's service life. Hold the flange portion when replacing the bulb. Never touch the glass portion.
 - Do not leave the headlight without a bulb for a long time. Dust, moisture, etc. entering the headlight may affect its performance.
- 1) Disconnect the ground cable from the battery.
 - 2) Remove the air intake duct (rear). (When removing the headlight bulb RH).

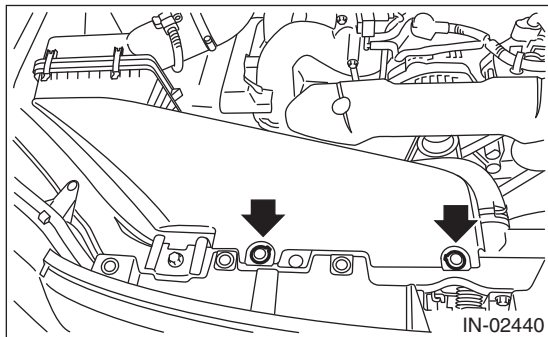

- 3) Disconnect the harness connector.
- 4) Remove the bulb assembly (A) then remove the high beam. To remove the low beam, remove the back cover (B), and then go to Step 5.

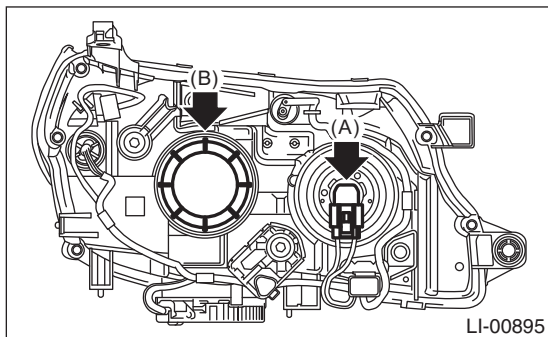

- 5) Disconnect the connector, and remove the bulb.

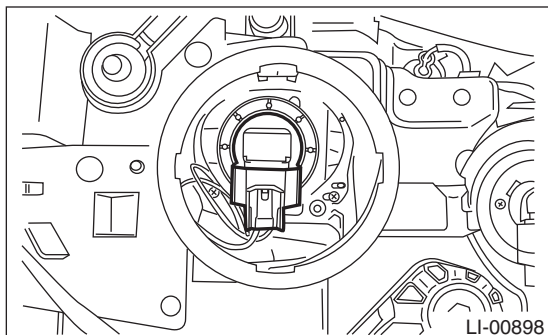

2. HID TYPE LOW BEAM

CAUTION:

- Do not work with wet hands.
 - Because the lighting circuit uses high voltage, be sure to confirm that the power supply is turned off before operation.
 - When replacing the bulb, hold the flange portion, and never touch the glass.
 - Do not leave the headlight without a bulb for a long time. Dust, moisture, etc. entering the headlight may affect its performance.
- 1) Disconnect the ground cable from the battery.
 - 2) Remove the headlight assembly. <Ref. to LI-17, REMOVAL, Headlight Assembly.>
 - 3) Remove the back cover.

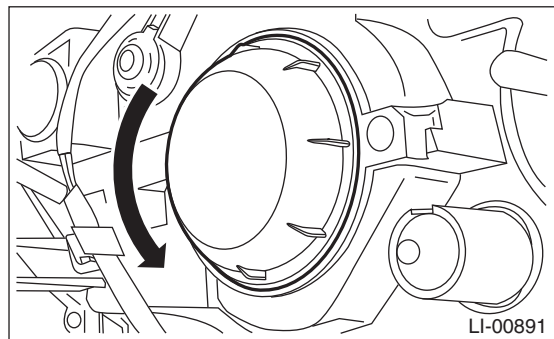

- 4) Disconnect the harness connector.

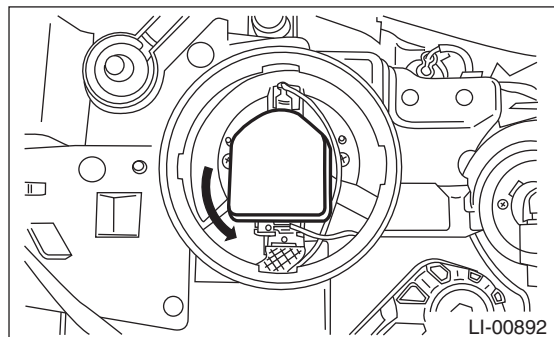

- 5) Remove the light bulb retaining spring, and remove the bulb.

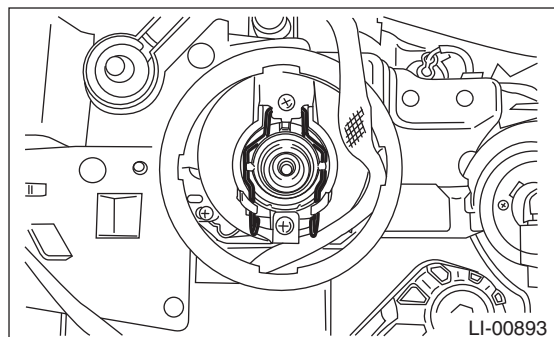

B: INSTALLATION

Install in the reverse order of removal.

C: INSPECTION

1. HALOGEN TYPE

- 1) Visually check the bulb for blow out.
- 2) Check the bulb specification.
<Ref. to LI-2, SPECIFICATION, General Description.>
- 3) If NG, replace the bulb with a new part.

2. HID TYPE

CAUTION:

- **Do not work with wet hands.**
- **Do not touch the harness, inner headlight, or any metallic portion of the headlight when the light is illuminated (when the lighting switch is turned on).**
- **When performing a lighting test, make sure that the headlight is mounted on the vehicle, and that the power supply is connected to the connector on the vehicle side.**

- 1) Check the bulb specification.
<Ref. to LI-2, SPECIFICATION, General Description.>
- 2) Install a SUBARU genuine HID bulb to test whether it lights properly.
- 3) If the headlight does not illuminate, replace the bulb with a new part.
- 4) Check the HID ballast.
Check the ballast in the following methods, and judge whether or not it can be reused.

(1) Perform the cold start (turning on the lights after the headlights have been off for 10 minutes or more) and hot start (turning on the headlights for 15 minutes or more → turning off the lights for one minute → turning on the lights again) several times and check if the headlights illuminate properly.

(2) Check the lighting condition immediately after the cold start until stable (approx. 5 min.), to make sure that an unstable condition (flicker etc.) does not occur.

(3) Attach two bulbs with equal amounts of operating hours to the right and left headlights, and light the headlights for approx. 30 minutes. Check to make sure that there is no difference in brightness between the right and left headlights.

- 5) If NG, replace the ballast with a new part.

Front Turn Signal Light Bulb

LIGHTING SYSTEM

14. Front Turn Signal Light Bulb

A: REMOVAL

- 1) Disconnect the ground cable from the battery.
- 2) Turn socket (A) and remove the bulb.

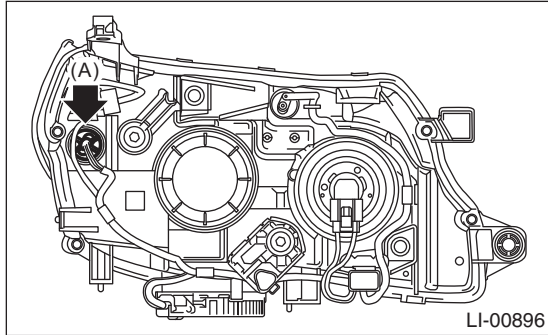

LI-00896

B: INSTALLATION

Install in the reverse order of removal.

C: INSPECTION

- 1) Visually check the bulb for blow out.
- 2) Check the bulb specification.
<Ref. to LI-2, SPECIFICATION, General Description.>
- 3) If NG, replace the bulb with a new part.

15. Clearance/Parking Light Bulb

A: REMOVAL

- 1) Disconnect the ground cable from the battery.
- 2) Turn socket (A) and remove the bulb.

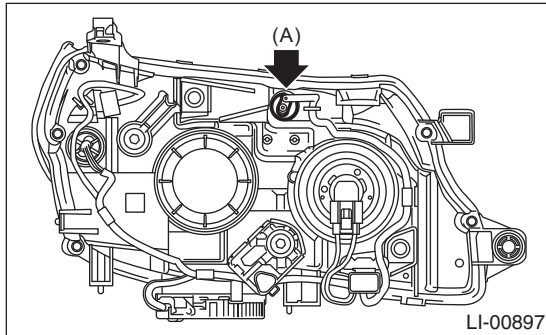

B: INSTALLATION

Install in the reverse order of removal.

C: INSPECTION

- 1) Visually check the bulb for blow out.
- 2) Check the bulb specification. <Ref. to LI-2, SPECIFICATION, General Description.>
- 3) If NG, replace the bulb with a new part.

Front Side Marker Light Bulb

LIGHTING SYSTEM

16. Front Side Marker Light Bulb

A: REMOVAL

- 1) Disconnect the ground cable from the battery.
- 2) Turn socket (A) and remove the bulb.

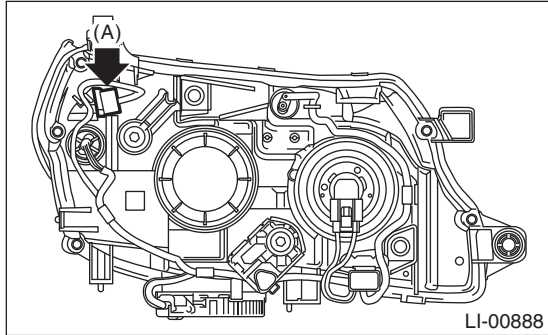

B: INSTALLATION

Install in the reverse order of removal.

C: INSPECTION

- 1) Visually check the bulb for blow out.
- 2) Check the bulb specification. <Ref. to LI-2, SPECIFICATION, General Description.>
- 3) If NG, replace with a new bulb.

17. Front Fog Light Assembly

A: REMOVAL

- 1) Disconnect the ground cable from the battery.
- 2) Remove the fog light cover.

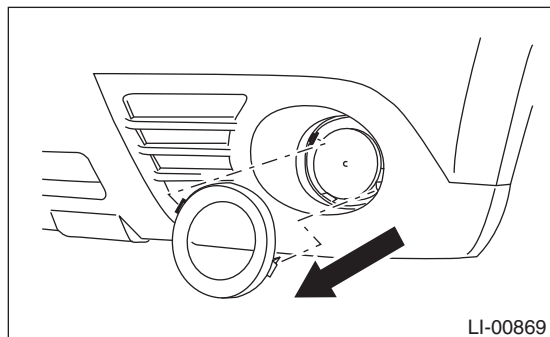

- 3) Disengage the three clips, then peel the mud guard.

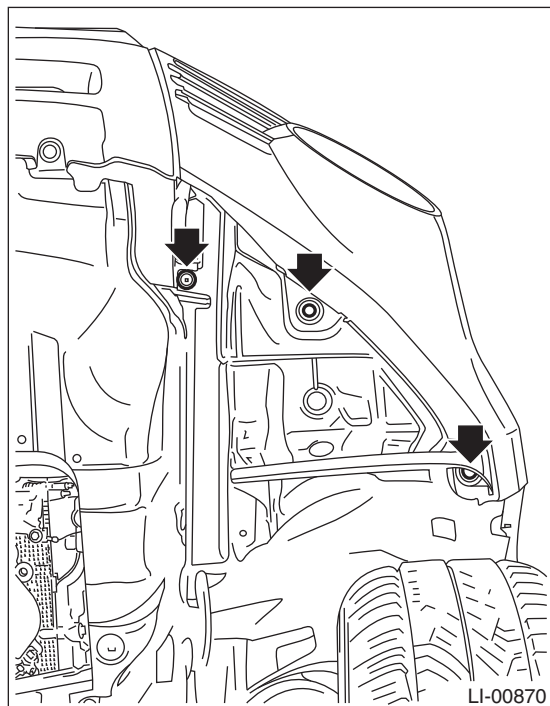

- 4) Disconnect the harness connector.
- 5) Remove the plastic nut and bolt, and remove the fog light assembly.

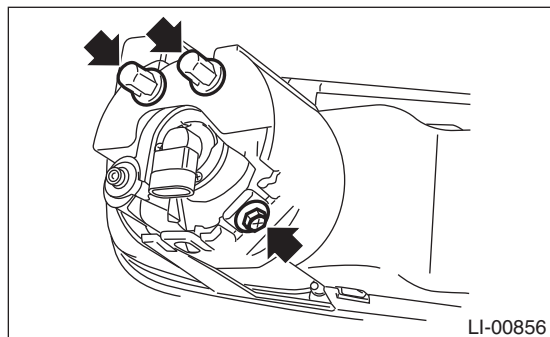

B: INSTALLATION

Install in the reverse order of removal.

Tightening torque:

7.5 N·m (0.76 kgf·m, 5.5 ft·lb)

C: ADJUSTMENT

1. FOG LIGHT AIMING

NOTE:

Before checking the fog light beam level, make sure the following:

- The area around the fog light has not sustained any accident, damage or other type of deformation.
- Make sure that the vehicle is parked on a level surface.
- Make sure that the inflation pressure of tires are correct.
- Make sure that the vehicle fuel tank is full.

- 1) Bounce the vehicle two to three times to normalize the suspension.
- 2) Make certain that someone is seated in the driver's seat.
- 3) Disengage the three clips, and then turn over the mud guard.

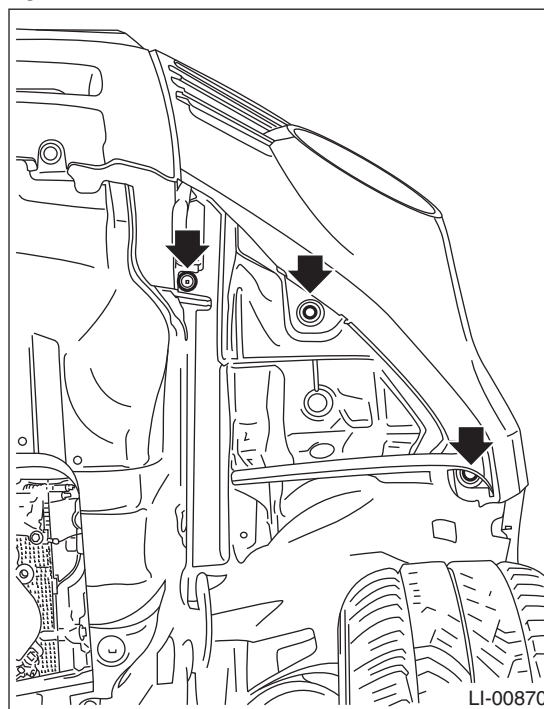

Front Fog Light Assembly

LIGHTING SYSTEM

4) Adjust the front fog light pattern by inserting a Philips screwdriver to the adjusting hole.

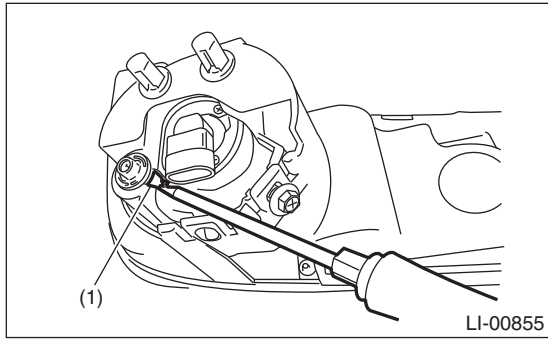

(1) Adjusting hole

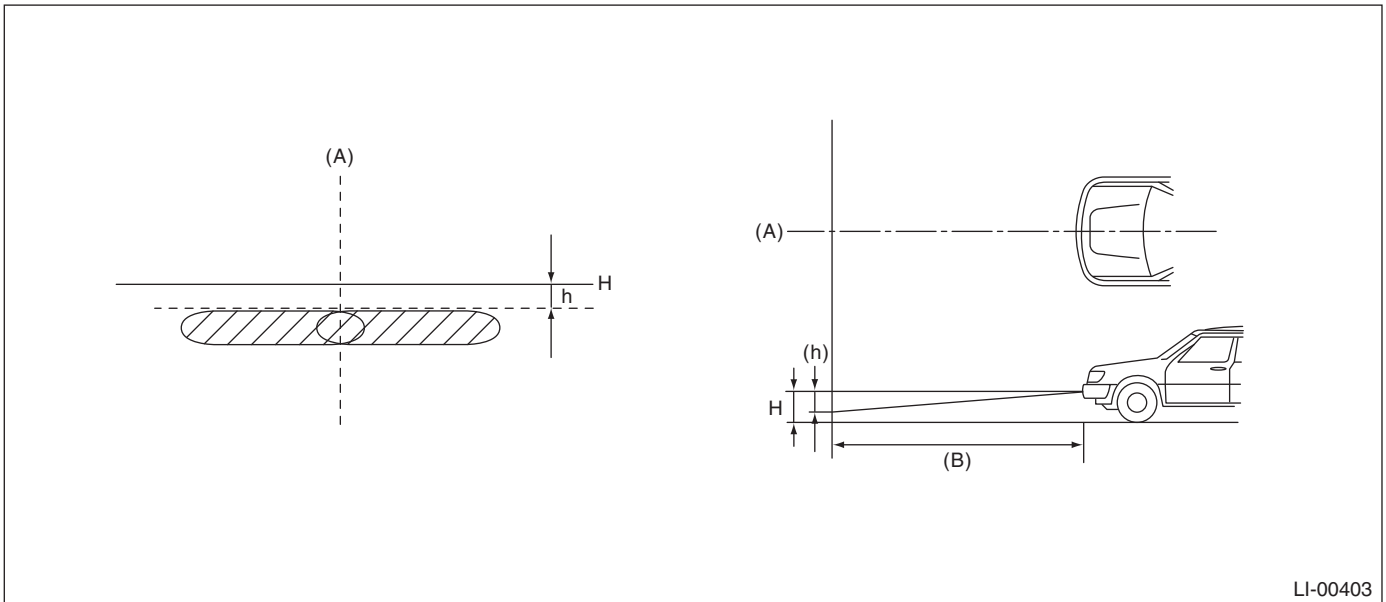

(A) Vehicle center

(B) 3 m (10 ft)

(H) Height of fog light center

h mm (in) at 3 m (10 ft)
60 (2.38)

18. Front Fog Light Bulb

A: REMOVAL

- 1) Disconnect the ground cable from the battery.
- 2) Disengage the three clips, and then turn over the mud guard.

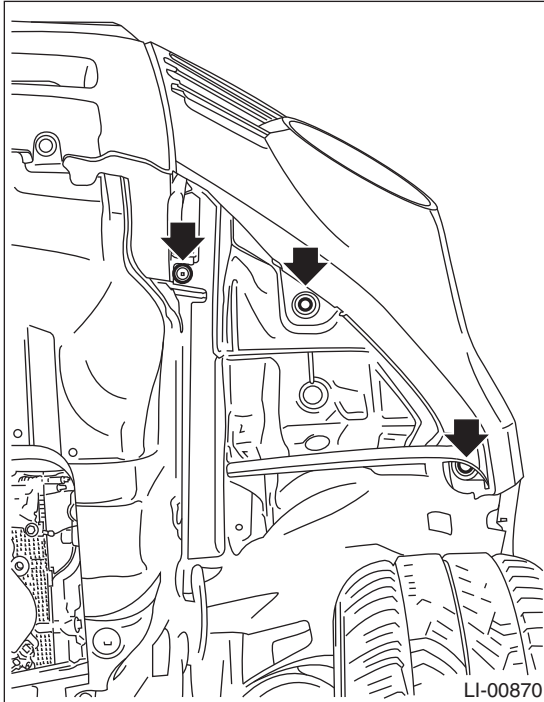

- 3) Disconnect the harness connector.
- 4) Rotate the bulb then detach the fog light bulb.

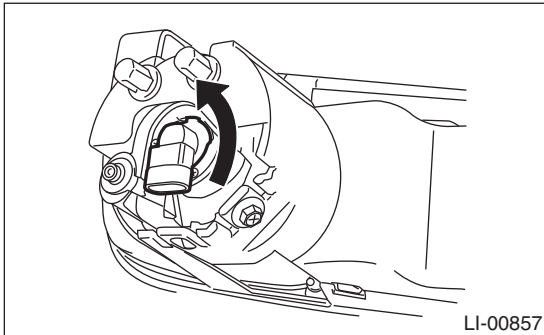

B: INSTALLATION

Install in the reverse order of removal.

C: INSPECTION

- 1) Visually check the bulb for blow out.
- 2) Check the bulb specification. <Ref. to LI-2, SPECIFICATION, General Description.>
- 3) If NG, replace the bulb with a new part.

19. Rear Combination Light Assembly

A: REMOVAL

- 1) Disconnect the ground cable from the battery.
- 2) Remove the two bolts, and then detach the rear combination light by pulling it to the rear side of vehicle.

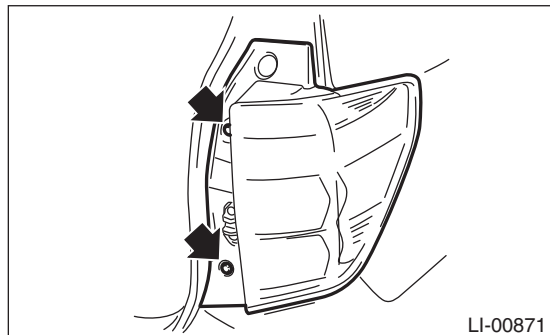

- 3) Disconnect the harness connector and rear combination light.

B: INSTALLATION

Install in the reverse order of removal.

Tightening torque:

7.5 N·m (0.76 kgf-m, 5.5 ft-lb)

C: INSPECTION

- 1) Visually check the bulb for blow out.
- 2) Check the bulb specification. <Ref. to LI-2, SPECIFICATION, General Description.>
- 3) If defective, replace with a new bulb.

20. Tail/Stop Light Bulb

A: REMOVAL

- 1) Remove the rear combination light assembly.
<Ref. to LI-28, REMOVAL, Rear Combination Light Assembly.>
- 2) Turn socket (A) and remove the bulb.

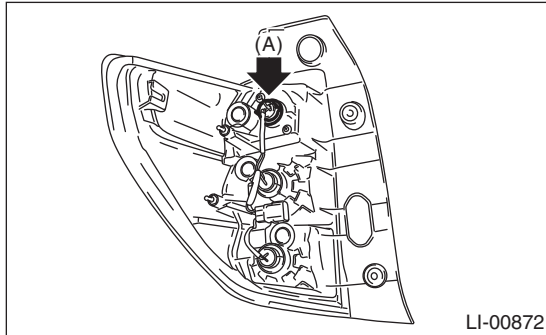

B: INSTALLATION

Install in the reverse order of removal.

C: INSPECTION

- 1) Visually check the bulb for blow out.
- 2) Check the bulb specification.
<Ref. to LI-2, SPECIFICATION, General Description.>
- 3) If NG, replace with a new bulb.

Rear Turn Signal Light Bulb

LIGHTING SYSTEM

21.Rear Turn Signal Light Bulb

A: REMOVAL

- 1) Remove the rear combination light assembly.
<Ref. to LI-28, REMOVAL, Rear Combination Light Assembly.>
- 2) Turn socket (A) and remove the bulb.

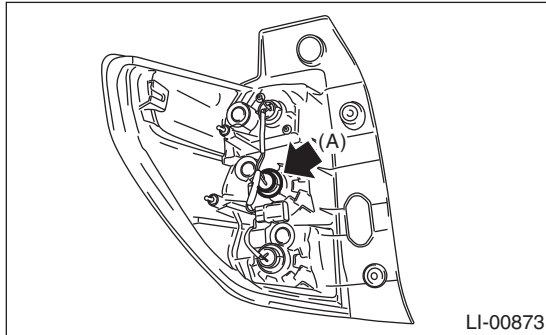

B: INSTALLATION

Install in the reverse order of removal.

C: INSPECTION

- 1) Visually check the bulb for blow out.
- 2) Check the bulb specification. <Ref. to LI-2, SPECIFICATION, General Description.>
- 3) If NG, replace the bulb with a new part.

22.Back-up Light Bulb

A: REMOVAL

- 1) Remove the rear combination light assembly.
<Ref. to LI-28, REMOVAL, Rear Combination Light Assembly.>
- 2) Turn socket (A) and remove the bulb.

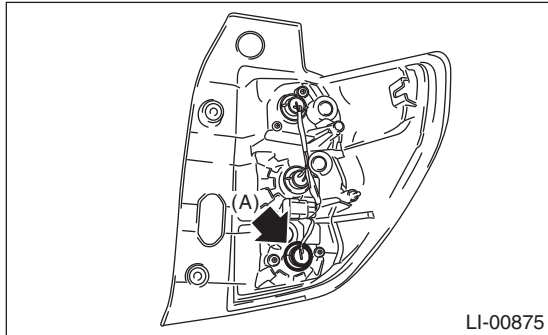

B: INSTALLATION

Install in the reverse order of removal.

C: INSPECTION

- 1) Visually check the bulb for blow out.
- 2) Check the bulb specification. <Ref. to LI-2, SPECIFICATION, General Description.>
- 3) If NG, replace the bulb with a new part.

23. License Plate Light

A: REMOVAL

- 1) Disconnect the ground cable from the battery.
- 2) Remove the screws and remove the license plate light.

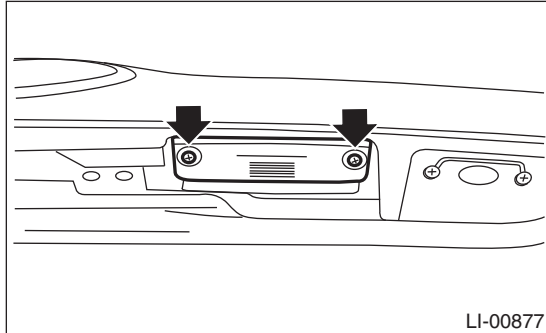

- 3) Remove the bulb.

B: INSTALLATION

Install in the reverse order of removal.

Tightening torque:

1.5 N·m (0.15 kgf-m, 1.1 ft-lb)

C: INSPECTION

- 1) Visually check the bulb for blow out.
- 2) Check the bulb specification. <Ref. to LI-2, SPECIFICATION, General Description.>
- 3) If NG, replace with a new bulb.

24. High-mounted Stop Light

A: REMOVAL

- 1) Disconnect the ground cable from the battery.
- 2) Remove the caps and screws, then detach the high-mounted stop light cover.

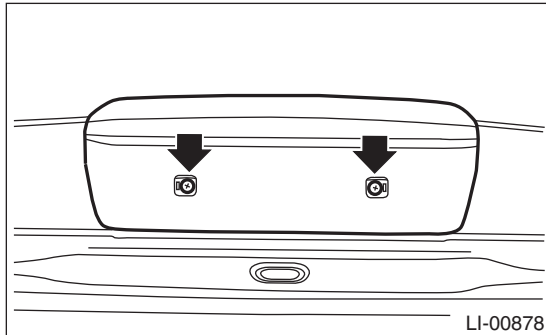

- 3) Remove the screws, then detach the high-mounted stop light.

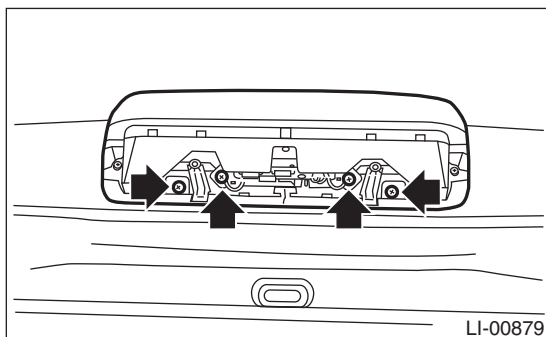

B: INSTALLATION

Install in the reverse order of removal.

Tightening torque:

1.5 N·m (0.15 kgf·m, 1.1 ft·lb)

C: INSPECTION

- 1) Install the high-mounted stop light to test if it illuminates normally.
- 2) If the high-mounted stop light does not illuminate, replace it with a new part.

NOTE:

Since LEDs (Light Emitting Diode) are used for the high-mounted stop light, replace the high-mounted stop light assembly if the LED burns out.

Spot Map Light

25. Spot Map Light

A: REMOVAL

- 1) Disconnect the ground cable from the battery.
- 2) Push open the rear end of the overhead console lid, and remove the screws.

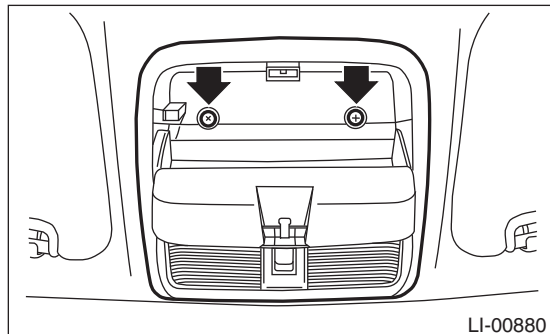

- 3) Disconnect the harness connectors and remove the spot map light.

NOTE:

The spot map light is a single unit with the overhead console.

B: INSTALLATION

Install in the reverse order of removal.

C: INSPECTION

1. SPOT MAP LIGHT BULB

- 1) Visually check the bulb for blow out.
- 2) Check the bulb specification. <Ref. to LI-2, SPECIFICATION, General Description.>
- 3) If NG, replace the bulb with a new part.

2. SPOT MAP LIGHT SWITCH

Measure the spot map light resistance.

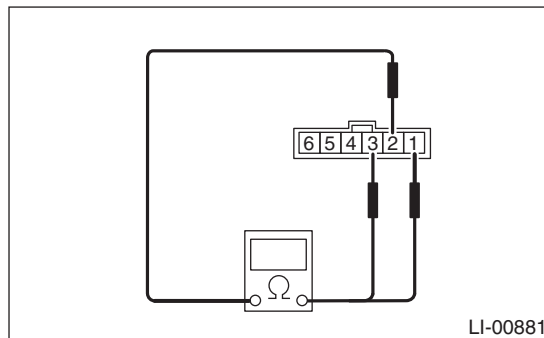

Switch position	Terminal No.	Standard
OFF	—	1 MΩ or more
ON	1 and 2	1.5±0.5 Ω
DOOR	2 and 3	1.5±0.5 Ω

3. OVERHEAD CONSOLE ILLUMINATION LIGHT BULB

NOTE:

Since LEDs (Light Emitting Diode) are used for the overhead console illumination light bulb, replace the overhead console assembly if the LED burns out.

26. Room Light

A: REMOVAL

- 1) Disconnect the ground cable from the battery.
 - 2) Remove the lens (A) and mounting screws (B).
- Model without sunroof

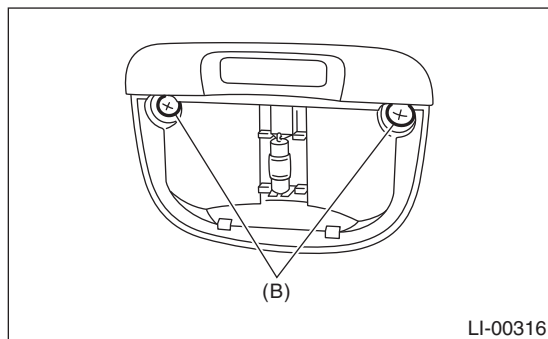
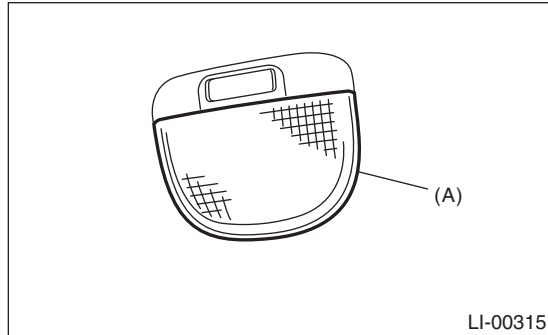

- Model with sunroof

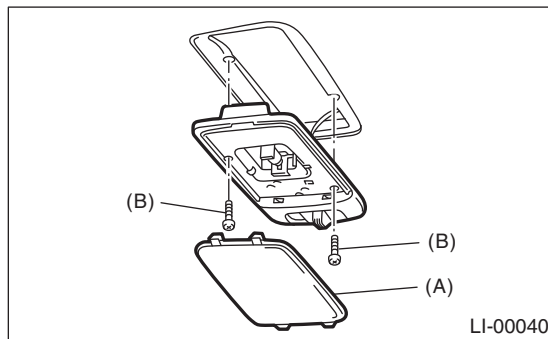

- 3) Disconnect the harness connector and remove the room light.

B: INSTALLATION

Install in the reverse order of removal.

C: INSPECTION

1. ROOM LIGHT BULB

- 1) Visually check the bulb for blow out.
- 2) Check the bulb specification. <Ref. to LI-2, SPECIFICATION, General Description.>
- 3) If NG, replace the bulb with a new part.

2. ROOM LIGHT SWITCH

Measure the resistance between room light switch terminals.

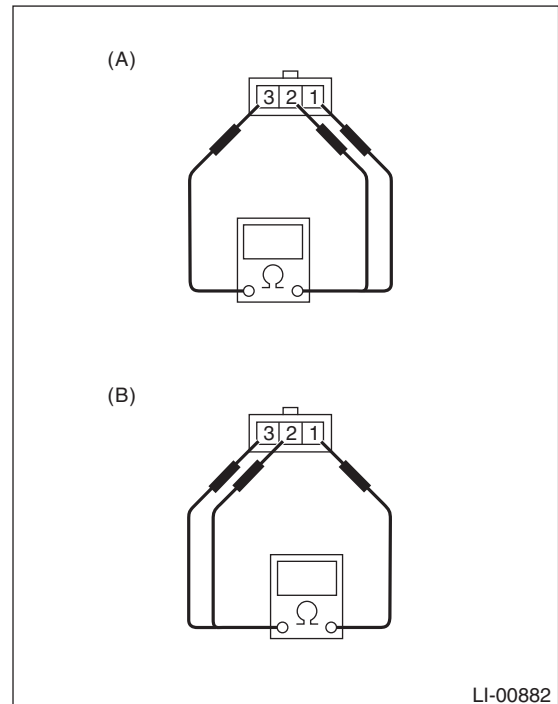

(A) Model without sunroof

(B) Model with sunroof

Switch position	Terminal No.	Standard
OFF	—	1 MΩ or more
ON	1 and 3	1.5±0.5 Ω
DOOR	2 and 3: Model without sunroof 1 and 2: Model with sunroof	1.5±0.5 Ω

Luggage Room Light

LIGHTING SYSTEM

27.Luggage Room Light

A: REMOVAL

- 1) Disconnect the ground cable from the battery.
- 2) Insert a flat tip screwdriver into the edge of the luggage room light body to remove the luggage room light.

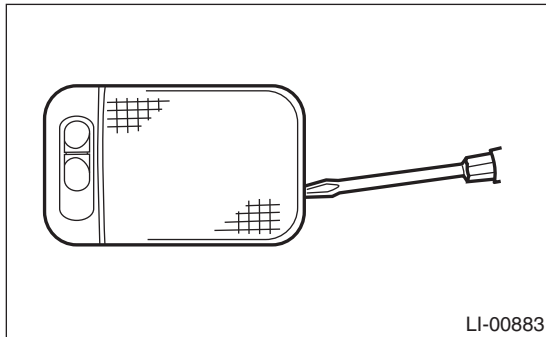

- 3) Disconnect the harness connector and remove the lens.

B: INSTALLATION

Install in the reverse order of removal.

C: INSPECTION

1. LUGGAGE ROOM LIGHT BULB

- 1) Visually check the bulb for blow out.
- 2) Check the bulb specification. <Ref. to LI-2, SPECIFICATION, General Description.>
- 3) If NG, replace the bulb with a new part.

2. LUGGAGE ROOM LIGHT SWITCH

Measure the resistance between luggage room light switch terminals.

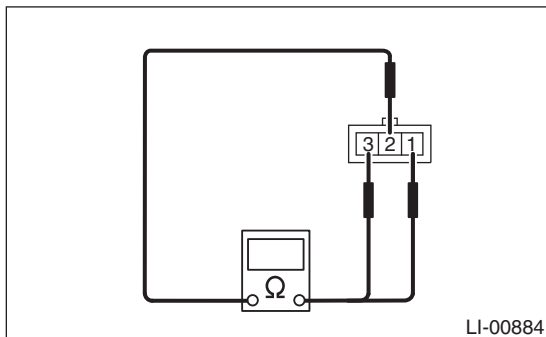

Switch position	Terminal No.	Standard
OFF	—	1 M Ω or more
ON	1 and 2	Less than 1 Ω
DOOR	2 and 3	Less than 1 Ω

28. Door Step Light

A: REMOVAL

- 1) Disconnect the ground cable from the battery.
- 2) Insert a flat tip screwdriver into the edge of the door step light body to remove the door step light.

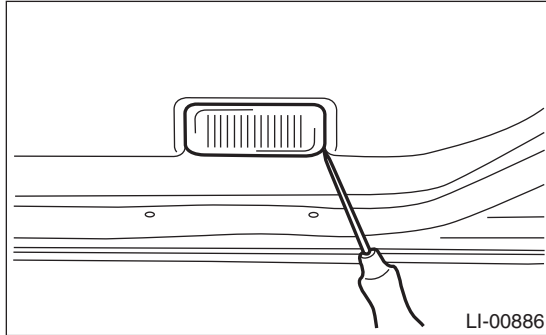

- 3) Disconnect the harness connector.

B: INSTALLATION

Install in the reverse order of removal.

C: INSPECTION

- 1) Visually check the bulb for blow out.
- 2) Check the bulb specification.
<Ref. to LI-2, SPECIFICATION, General Description.>
- 3) If NG, replace with a new bulb.

Ignition Switch Illumination

LIGHTING SYSTEM

29. Ignition Switch Illumination

A: REMOVAL

- 1) Disconnect the ground cable from the battery.
- 2) Remove the screw and steering lower cover.

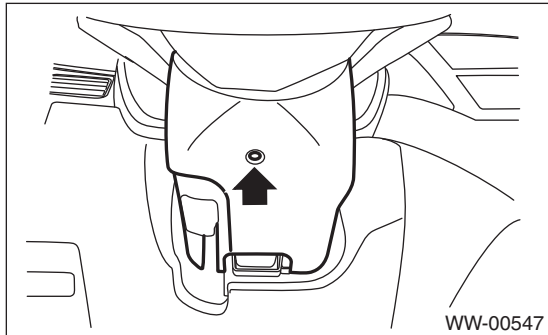

- 3) Remove the screws and steering upper cover.

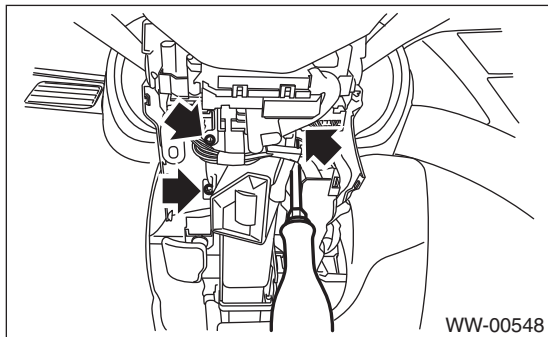

- 4) Remove the instrument panel lower cover. <Ref. to EI-44, REMOVAL, Instrument Panel Lower Cover.>
- 5) Disconnect the ignition switch illumination connector (A).
- 6) Turn the ignition switch illumination connector to the left and disconnect it.

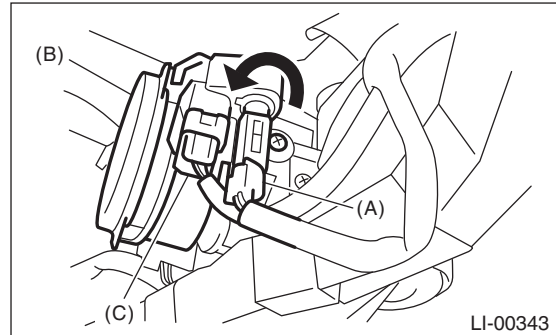

- (A) Ignition switch illumination connector
- (B) Ignition switch illumination
- (C) Immobilizer antenna connector

B: INSTALLATION

Install in the reverse order of removal.

C: INSPECTION

Step	Check	Yes	No	
1	CHECK IGNITION SWITCH ILLUMINATION. Make sure the ignition switch illumination illuminates when driver's side door is open.	Does the ignition switch illumination illuminate?	Ignition switch illumination is normal.	Go to step 2.
2	CHECK IGNITION SWITCH ILLUMINATION. Make sure the ignition switch illumination blinks when the ignition switch is turned to ON.	Does the ignition switch illumination blink?	Check the function setting of the body integrated unit. <Ref. to LAN(diag)-2, Basic Diagnostic Procedure.>	Check the ignition switch illumination circuit. <Ref. to SL-21, CHECK IGNITION SWITCH ILLUMINATION, INSPECTION, Keyless Entry System.>

30. Auto Headlight Beam Leveler Control Module

A: REMOVAL

- 1) Disconnect the ground cable from the battery.
- 2) Disconnect the connector, and remove the unit.

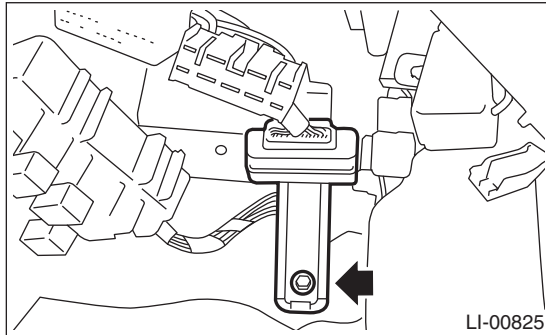

B: INSTALLATION

Install in the reverse order of removal.

Tightening torque:

7.5 N·m (0.76 kgf·m, 5.5 ft·lb)

NOTE:

Perform reinitialization if the auto head light leveler control module was removed. <Ref. to LI-15, PROCEDURE, Auto Headlight Beam Leveler System.>

31. Front Height Sensor

A: REMOVAL

CAUTION:

Always remove the vehicle height sensor before removing any parts related to the suspension.

- 1) Disconnect the ground cable from the battery.
- 2) Lift up the vehicle and remove the left front wheel.
- 3) Remove the under cover.
- 4) Disconnect the sensor connector.

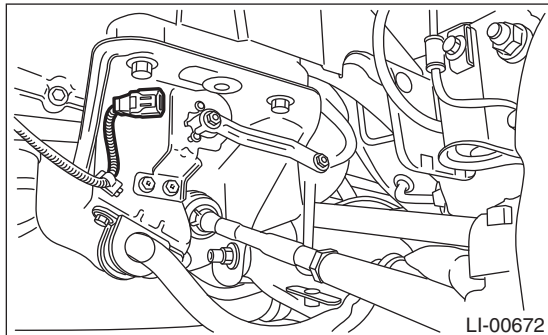

- 5) Remove the bracket from the front crossmember.

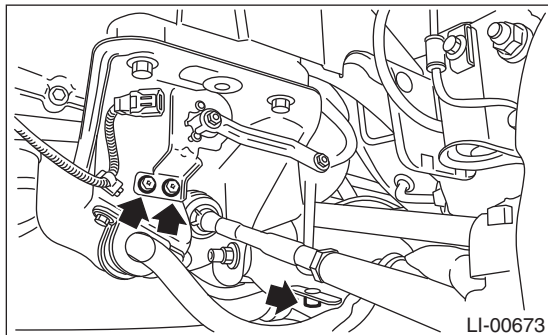

- 6) Remove the bracket from the transverse link.

CAUTION:

Do not disassemble the sensor and lever.

B: INSTALLATION

- 1) Align the bracket clip with the front crossmember installation hole, and install the bracket.
- 2) Install in the reverse order of removal.

Tightening torque:

7.5 N·m (0.76 kgf-m, 5.5 ft-lb)

NOTE:

Perform reinitialization if the front vehicle height sensor was removed. <Ref. to LI-15, PROCEDURE, Auto Headlight Beam Leveler System.>

32.Rear Height Sensor

A: REMOVAL

CAUTION:

Always remove the vehicle height sensor before removing any parts related to the suspension.

- 1) Disconnect the negative terminal of the battery.
- 2) Lift up the vehicle and remove the left rear wheel.
- 3) Disconnect the sensor connector, remove the nut and remove the rear vehicle height sensor.

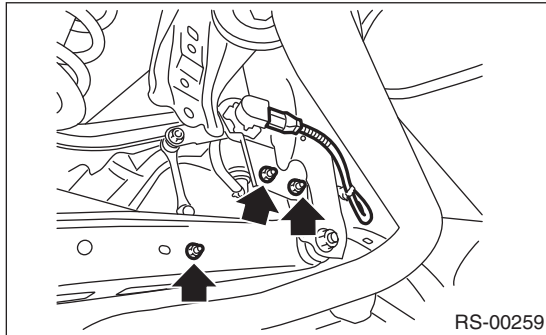

CAUTION:

Do not disassemble the sensor and lever.

B: INSTALLATION

Install in the reverse order of removal.

Tightening torque:

7.5 N·m (0.76 kgf-m, 5.5 ft-lb)

NOTE:

Perform reinitialization if the rear vehicle height sensor was removed. <Ref. to LI-15, PROCEDURE, Auto Headlight Beam Leveler System.>

Day Time Running Resistor

LIGHTING SYSTEM

33. Day Time Running Resistor

A: REMOVAL

- 1) Remove the front bumper. <Ref. to EI-28, REMOVAL, Front Bumper.>
- 2) Disconnect the harness connector.
- 3) Remove the mounting nut, then remove the day-time running resistor.

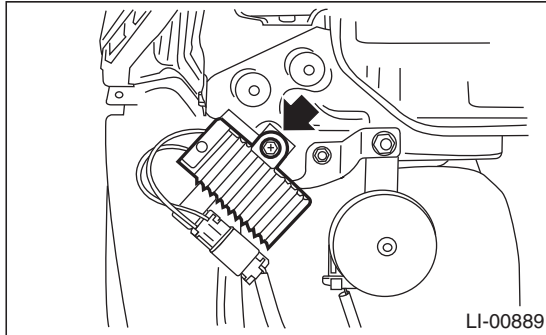

B: INSTALLATION

Install in the reverse order of removal.

34. Reflex Reflector

A: REMOVAL

- 1) Remove the plastic nut (A) of the reflex reflector from the backside of the bumper.
- 2) Press the tabs (B) to remove the reflex reflector.

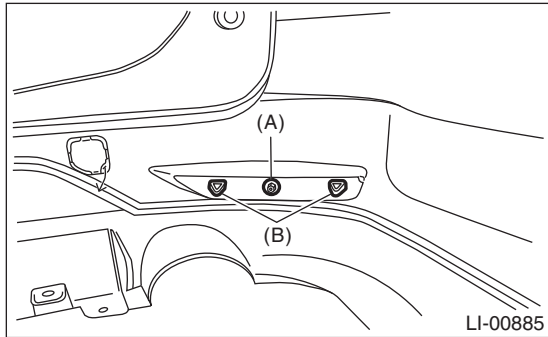

B: INSTALLATION

Install in the reverse order of removal.

35. Door Switch

A: REMOVAL

- 1) Disconnect the ground cable from the battery.
- 2) Remove the screw, and pull out the door switch.

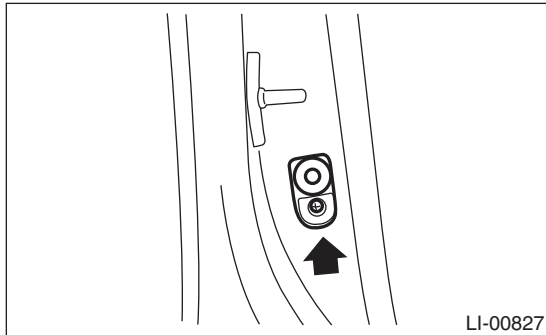

- 3) Disconnect the harness connector.

B: INSTALLATION

Install in the reverse order of removal.

C: INSPECTION

Refer to the door switch inspection of the room light system. <Ref. to LI-9, DOOR SWITCH, INSPECTION, Room Light System.>

WIPER AND WASHER SYSTEMS

WW

	Page
1. General Description	2
2. Wiper and Washer System	7
3. Combination Switch (Wiper)	8
4. Wiper Blade	12
5. Washer Tank and Motor	14
6. Front Wiper Arm	15
7. Front Wiper Motor and Link	16
8. Front Washer Nozzle	18
9. Rear Wiper Arm	19
10. Rear Wiper Motor	20
11. Rear Washer	21

General Description

WIPER AND WASHER SYSTEMS

1. General Description

A: SPECIFICATION

Front wiper motor	Input	12 V — 72 W or less
Rear wiper motor	Input	12 V — 42 W or less
Front washer motor	Pump type	Centrifugal
	Input	12 V — 36 W or less
Rear washer motor	Pump type	Centrifugal
	Input	12 V — 36 W or less

B: COMPONENT

1. FRONT WIPER

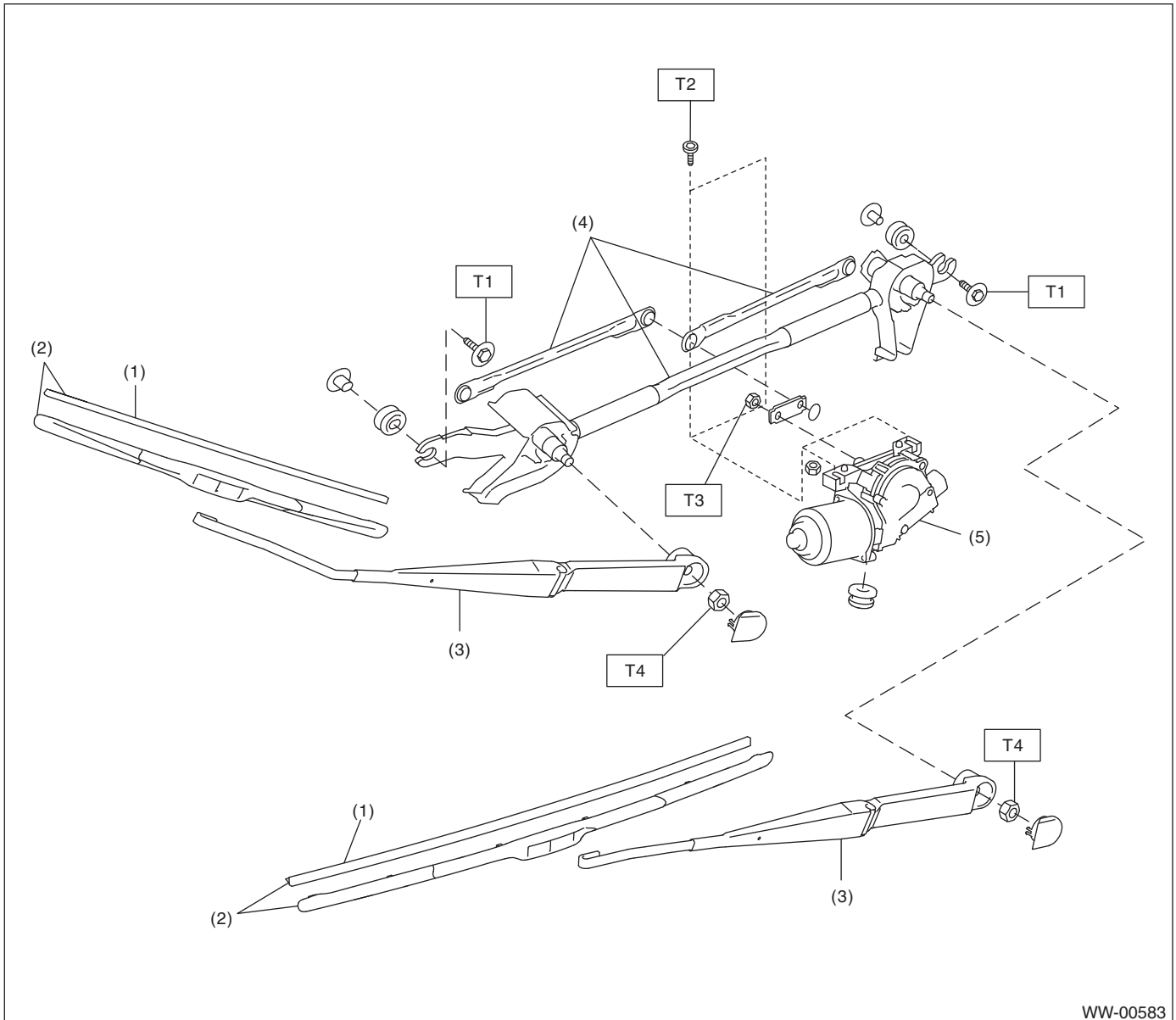

WW-00583

- (1) Wiper rubber
- (2) Wiper blade ASSY
- (3) Wiper arm

- (4) Wiper link
- (5) Wiper motor

Tightening torque:N-m (kgf-m, ft-lb)

T1: 6.0 (0.61, 4.4)

T2: 7.5 (0.76, 5.5)

T3: <Ref. to WW-16, INSTALLATION, Front Wiper Motor and Link.>

T4: 20 (2.0, 14.5)

General Description

WIPER AND WASHER SYSTEMS

2. REAR WIPER

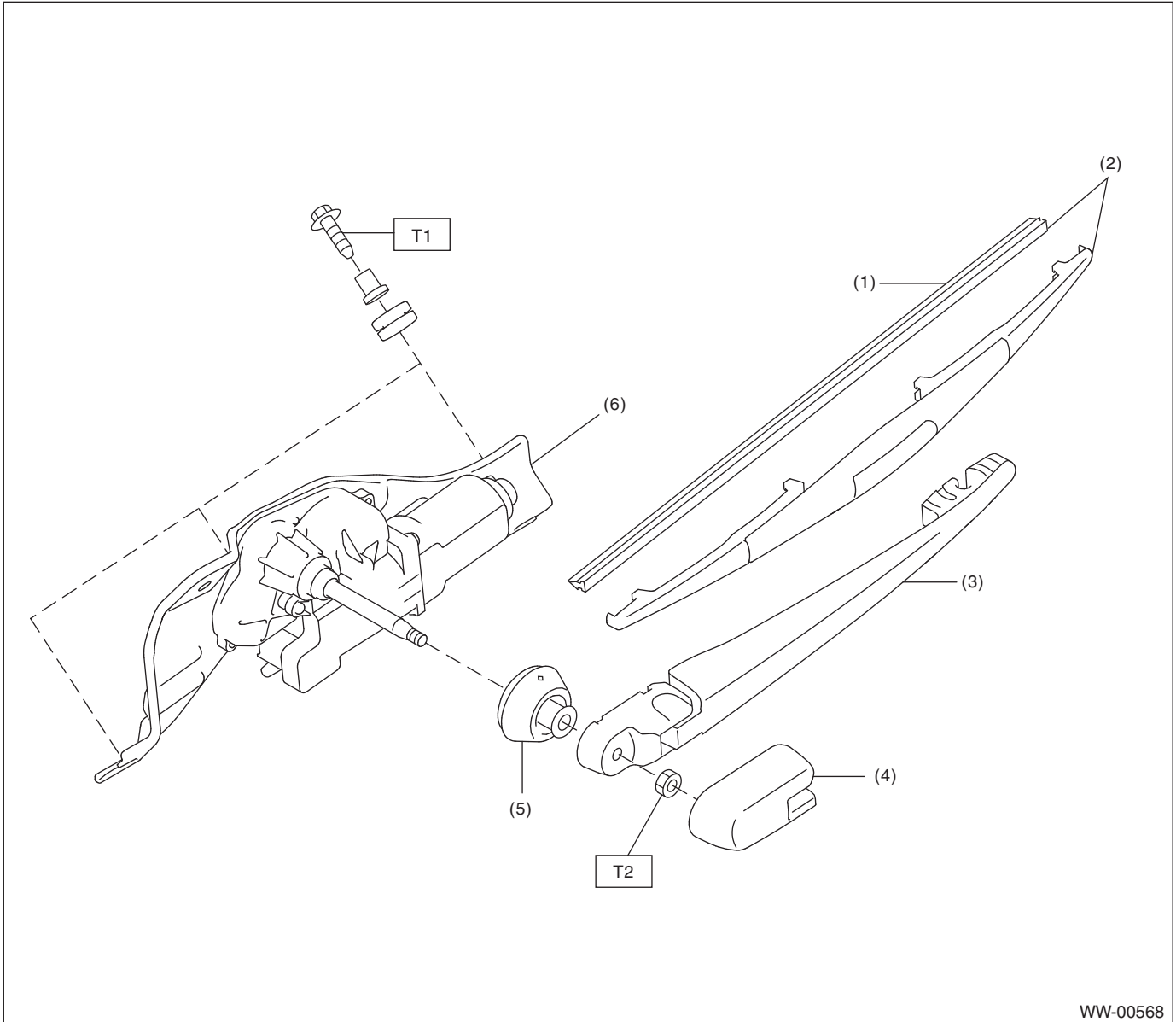

WW-00568

- (1) Wiper rubber
- (2) Wiper blade ASSY
- (3) Wiper arm

- (4) Wiper arm cover
- (5) Pivot cap
- (6) Wiper motor

Tightening torque: N·m (kgf-m, ft-lb)

T1: 6.0 (0.61, 4.4)

T2: 8.0 (0.82, 5.9)

3. WASHER TANK

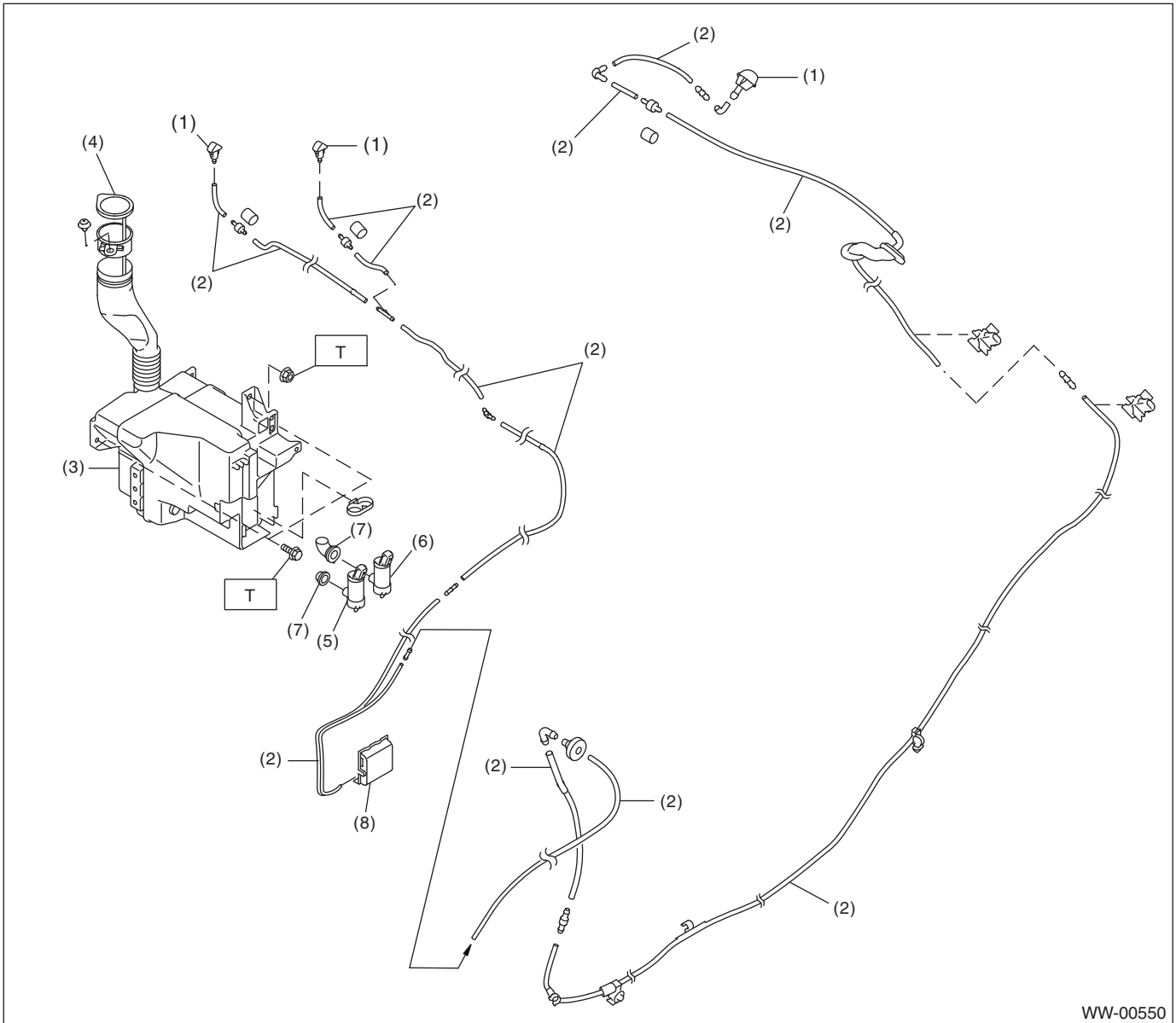

WW-00550

- | | |
|-------------------------------------|------------------------|
| (1) Washer nozzle | (5) Front washer motor |
| (2) Washer hose | (6) Rear washer motor |
| (3) Washer tank | (7) Grommet |
| (4) Washer tank cap and level gauge | (8) Washer motor cover |

Tightening torque: N·m (kgf·m, ft·lb)

T: 6.0 (0.61, 4.4)

General Description

WIPER AND WASHER SYSTEMS

C: CAUTION

- Connect the connectors and hoses securely during reassembly.
- After reassembly, make sure all features operate properly.
- Be careful with the airbag system wiring harness which passes near electrical parts and switches.
- Airbag system connectors are yellow. Do not use a tester equipment on these circuits.
- Care must be taken when connecting the pipe hose so that there are no bends or blockage.
- If even a small amount of silicon oil or grease enters the tank and washer fluid passages, an oil film will be formed on the glass and will cause the wiper to chatter and judder. Make sure that no oil comes into contact with the system.

D: PREPARATION TOOL

1. SPECIAL TOOL

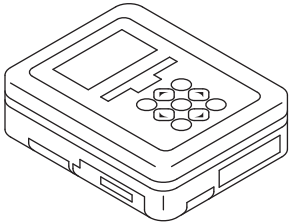
ILLUSTRATION	TOOL NUMBER	DESCRIPTION	REMARKS
 ST1B022XU0	1B022XU0 (Newly adopted tool)	SUBARU SELECT MONITOR III KIT	Used for setting of each function and troubleshooting for electrical system.

2. GENERAL TOOL

TOOL NAME	REMARKS
TORX® T50	Used for removing and installing the wiper motor assembly.
Circuit tester	Used for checking voltage and continuity.

2. Wiper and Washer System

A: WIRING DIAGRAM

1. WIPER AND WASHER (FRONT)

<Ref. to WI-118, WIRING DIAGRAM, Front Wiper and Washer System.>

2. WIPER AND WASHER (REAR)

<Ref. to WI-119, WIRING DIAGRAM, Rear Wiper and Washer System.>

B: INSPECTION

Symptom	Repair order
Wiper and washers do not operate.	<ol style="list-style-type: none"> 1. Wiper fuse (F/B No. 14, 15) 2. Combination switch 3. Wiper motor assembly 4. Wiring harness
Wipers do not operate in LO or HI.	<ol style="list-style-type: none"> 1. Combination switch 2. Wiper motor assembly 3. Wiring harness
Wipers do not operate in INT.	<ol style="list-style-type: none"> 1. Combination switch 2. Wiper motor assembly 3. Wiring harness
Washer motor does not operate.	<ol style="list-style-type: none"> 1. Washer switch 2. Washer motor 3. Wiring harness
Wipers do not operate when washer switch is ON.	<ol style="list-style-type: none"> 1. Wiper motor assembly 2. Wiring harness
Washer fluid spray does not operate properly.	<ol style="list-style-type: none"> 1. Washer motor 2. Washer hose and nozzle

C: NOTE

For removal of each component of the wiper and washer system, refer to the respective sections.

- Combination switch (wiper) <Ref. to WW-8, Combination Switch (Wiper).>
- Wiper blade <Ref. to WW-12, Wiper Blade.>
- Front wiper arm <Ref. to WW-15, Front Wiper Arm.>
- Front wiper motor and link <Ref. to WW-16, Front Wiper Motor and Link.>
- Rear wiper arm <Ref. to WW-19, Rear Wiper Arm.>
- Rear wiper motor <Ref. to WW-20, Rear Wiper Motor.>
- Washer tank and motor <Ref. to WW-14, Washer Tank and Motor.>
- Front washer nozzle <Ref. to WW-18, Front Washer Nozzle.>
- Rear washer nozzle <Ref. to WW-21, Rear Washer.>

Combination Switch (Wiper)

WIPER AND WASHER SYSTEMS

3. Combination Switch (Wiper)

A: REMOVAL

- 1) Disconnect the ground cable from the battery.
- 2) Loosen the screw to remove the steering column cover, lower.

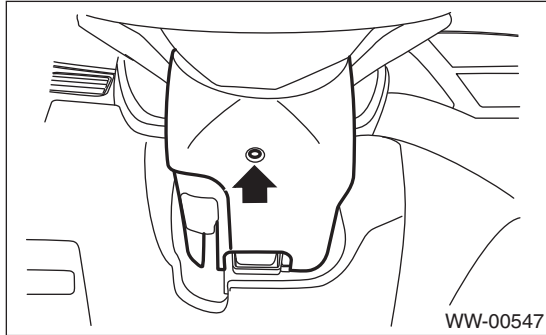

- 3) Remove the three screws securing the steering column cover, upper.

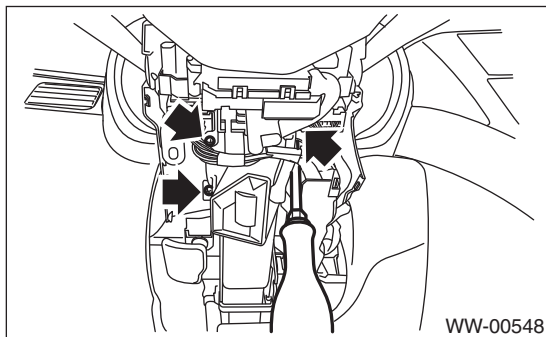

- 4) Disconnect the connector from the wiper switch.
- 5) Loosen the screws and remove the wiper switch.

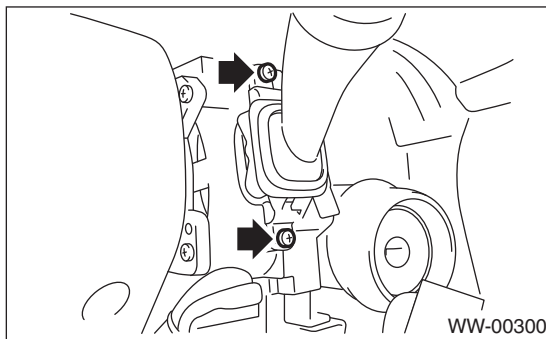

B: INSTALLATION

Install in the reverse order of removal.

C: INSPECTION

- Inspect the continuity between each connector terminal.

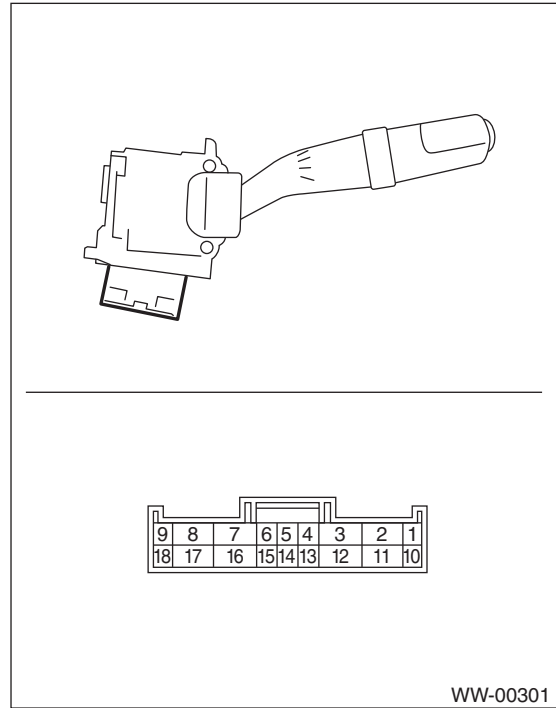

	Switch position	Terminal No.	Standard
Front	OFF	7 and 16	Less than 1 Ω
	INT	7 and 16	Less than 1 Ω
	LO	7 and 17	Less than 1 Ω
	HI	8 and 17	Less than 1 Ω
	Washer ON	2 and 11	Less than 1 Ω
Rear	OFF	2 and 10 10 and 12 2 and 12	1 MΩ or more
	INT	2 and 13	Less than 1 Ω
	ON	2 and 10	Less than 1 Ω
	Washer ON	2 and 12	Less than 1 Ω

If continuity is not as specified, replace the switch.

1. FRONT WIPER

1) Check with Subaru Select Monitor

When the front wiper switch is operated, check the input signal using the Subaru Select Monitor.

- (1) Prepare the Subaru Select Monitor kit.
- (2) Turn the ignition switch to ON.
- (3) On the "System Selection Menu", select {Integ. unit mode}.
- (4) Select the {Current Data Display & Save}.
- (5) Check the input signal when the front wiper switch is set to LO or HI.

Is the input signal normal?

- Yes → Finish the diagnosis.
- No →
 1. Check the harness.
 2. Check the ACC input voltage of the body integrated unit.

Connector & terminal

(B280) No. 7 (+) — Chassis ground (-):

3. Replace the body integrated unit. <Ref. to SL-42, Body Integrated Unit.>

2) Check the intermittent operation. (inspection of the wiper switch alone)

- (1) Set voltmeter between the terminal No. 7 (+) — No. 2 (-).
- (2) Connect the battery to connectors. (Terminal No. 17 (+), terminal No. 2 & 16 (-))
- (3) Turn the front wiper switch to INT.
- (4) Connect the battery (+) to the terminal No. 16 for 5 seconds.
- (5) Connect the battery (-) to the terminal No. 16, and check the voltage between terminal No. 7 — No. 2 when performing the intermittent operation.
- (6) Perform step 1) to 5) when intermittent control switch is in MIN or MAX, and replace the switch if the operation is not as specified.

Intermittent stationary time

MIN: Approx. 4 seconds

MAX: Approx. 19 seconds

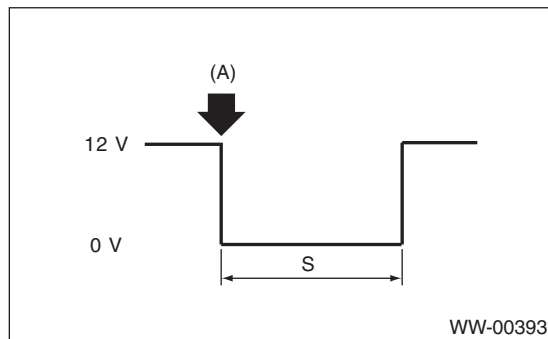

- (A): Connect the battery (-) to the terminal No. 16
 S: Intermittent stationary time (sec.)

Combination Switch (Wiper)

WIPER AND WASHER SYSTEMS

2. REAR WIPER

1) Check with Subaru Select Monitor

	Step	Check	Yes	No
1	<p>CHECK INPUT OF REAR WIPER SWITCH. Check the input from body integrated unit using the Subaru Select Monitor.</p> <ol style="list-style-type: none"> 1) Prepare the Subaru Select Monitor kit. 2) Turn the ignition switch to ON. 3) On the "System Selection Menu", select {Integ. unit mode}. 4) Select the {Current Data Display & Save}. 5) Check the input of the rear wiper switch. 	Is the input normal?	Go to step 4.	Go to step 2.
2	<p>CHECK HARNESS.</p> <ol style="list-style-type: none"> 1) Disconnect the ground cable from the battery. 2) Disconnect the connector of body integrated unit. 3) Disconnect the wiper switch connector. 4) Measure the resistance between the body integrated unit and wiper switch. <p>Connector & terminal (B281) No. 18 — (B70) No. 10: (B281) No. 27 — (B70) No. 13: (B281) No. 28 — (B70) No. 12:</p>	Is the resistance less than 10 Ω?	Go to step 3.	Repair the harness between the body integrated unit and wiper switch.
3	<p>CHECK INPUT VOLTAGE OF BODY INTEGRATED UNIT.</p> <ol style="list-style-type: none"> 1) Connect the ground cable to the battery. 2) Turn the ignition switch to ACC. 3) Measure the input voltage to the body integrated unit. <p>Connector & terminal (B280) No. 7 (+) — Chassis ground (-):</p>	Is the voltage 10 V or more?	Go to step 4.	Check the harness and fuse.
4	<p>CHECK OUTPUT OF BODY INTEGRATED UNIT.</p> <p>When the rear wiper switch is operated, check the output using the Subaru Select Monitor.</p> <ol style="list-style-type: none"> 1) Turn the ignition switch to ON. 2) Operate the rear wiper switch and set to each position of ON and INT. 3) At this time, check the body integrated unit output. 	When set to ON, is there continuous ON output? When set to INT, does it repeat ON/OFF output? (INT OFF time (when vehicle is parked): 12 seconds)	Check the rear wiper motor circuit.	Replace the body integrated unit. <Ref. to SL-42, Body Integrated Unit.>

Combination Switch (Wiper)

2) Check rear wiper motor circuit

Step	Check	Yes	No
1 CHECK POWER SUPPLY CIRCUIT OF THE REAR WIPER MOTOR. 1) Disconnect the harness connector of the rear wiper motor. 2) Turn the ignition switch to ACC. 3) Measure the voltage between the rear wiper motor harness connector terminal and chassis ground. Connector & terminal (D43) No. 3 (+) — Chassis ground (-):	Is the voltage 10 V or more?	Go to step 2.	<ul style="list-style-type: none"> • Check the fuse (No. 23 in fuse & relay box). • Check the fusible link (No. 7 in main fuse box).
2 CHECK GROUND CIRCUIT OF REAR WIPER MOTOR. 1) Turn the ignition switch to OFF. 2) Measure the resistance between the rear wiper motor harness connector terminal and chassis ground. Connector & terminal (D43) No. 3 — Chassis ground:	Is the resistance less than 10 Ω?	Go to step 3.	Repair the open circuit of the rear wiper motor ground circuit.
3 CHECK HARNESS BETWEEN BODY INTEGRATED UNIT AND REAR WIPER MOTOR. 1) Turn the ignition switch to OFF. 2) Disconnect the harness connector of body integrated unit. 3) Disconnect the harness connector of the rear wiper motor. 4) Measure the resistance between the harness connector terminals of the body integrated unit and rear wiper motor. Connector & terminal (B279) No. 8 — (D43) No. 1: (B279) No. 9 — (D43) No. 2:	Is the resistance less than 10 Ω?	Go to step 4.	Repair the open circuit of the harness between body integrated unit and rear wiper motor.
4 CHECK INPUT VOLTAGE OF BODY INTEGRATED UNIT. 1) Turn the ignition switch to ACC. 2) Measure the input voltage to the body integrated unit. Connector & terminal (B279) No. 21 (+) — Chassis ground (-):	Is the voltage 10 V or more?	Go to step 5.	Check the harness and fuse.
5 CHECK OUTPUT OF BODY INTEGRATED UNIT. 1) Connect the harness connector of the body integrated unit. 2) Disconnect the connector of the rear wiper motor. 3) Turn the ignition switch to ACC. 4) Measure the voltage between the rear wiper motor connector and chassis ground. Connector & terminal (B279) No. 9 (+) — Chassis ground (-):	With the rear wiper switch OFF, is the voltage less than 1.5 V, and with the rear wiper switch ON, is the voltage 10 V or higher?	Go to step 6.	Replace the body integrated unit. <Ref. to SL-42, Body Integrated Unit.>
6 CHECK OPERATION OF REAR WIPER MOTOR. 1) Remove the rear wiper motor. 2) Check the rear wiper motor. <Ref. to WW-20, INSPECTION, Rear Wiper Motor.>	Does the rear wiper motor rotate normally?	End.	Replace the rear wiper motor.

Wiper Blade

WIPER AND WASHER SYSTEMS

4. Wiper Blade

A: REMOVAL

1. FRONT

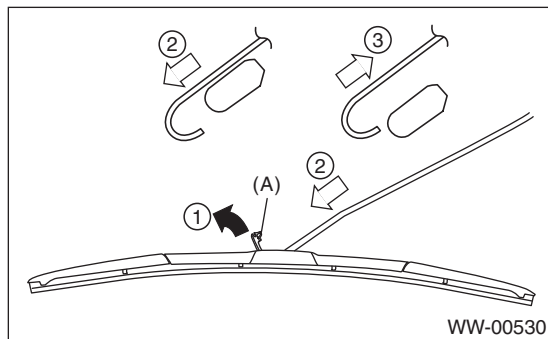

- 1) Pull up locking clip (A), and push the arm into the blade assembly side. (Arrow 2)
- 2) While lifting the arm, pull out (Arrow 3), and remove the blade assembly from the arm.

2. REAR

Turn the blade in the direction of arrow (A) and remove it from arm.

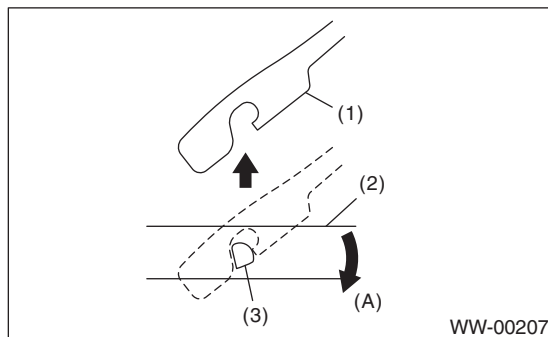

(A) Turn the wiper blade.

- (1) Wiper arm
- (2) Wiper blade
- (3) Wiper blade attachment section

B: INSTALLATION

- 1) Install in the reverse order of removal.
- 2) Confirm that the clip is locked securely.

C: DISASSEMBLY

1. FRONT

Pull side (A) of the wiper rubber stopper and remove the rubber from the blade assembly.

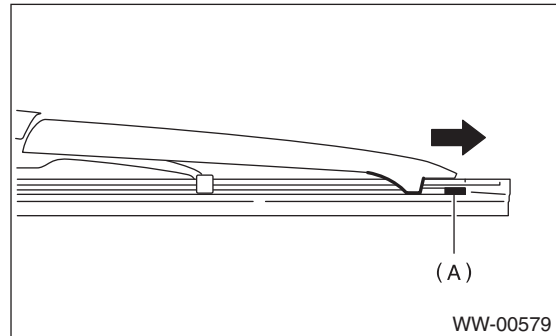

2. REAR

Pull the wiper rubber top slightly from stopper (A) and pull out completely.

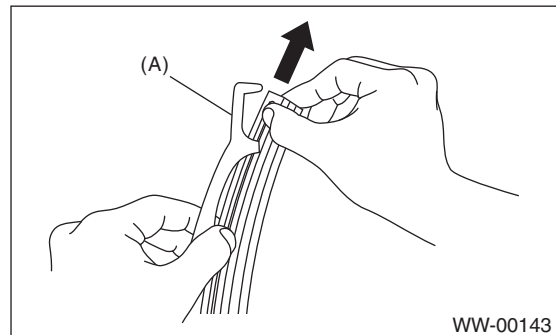

D: ASSEMBLY

1. FRONT

1) Insert the wiper rubber onto the blade so that the stopper is in the position shown in the figure.

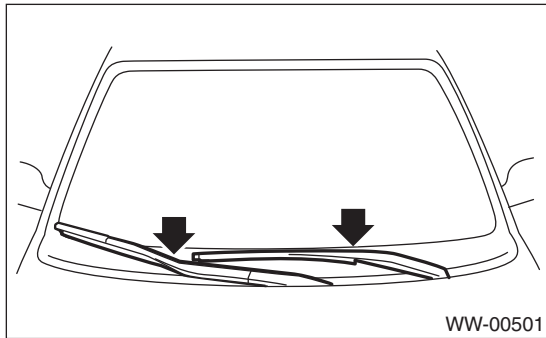

2) Make sure the wiper rubber is securely fastened to the pull stopper (A).

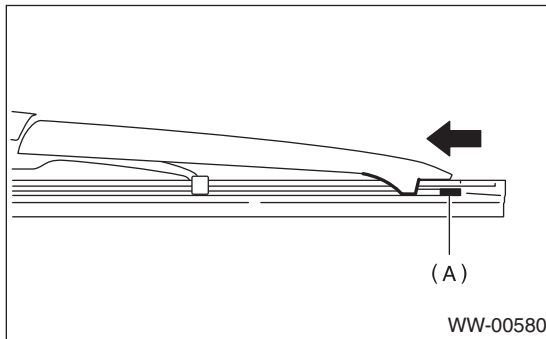

2. REAR

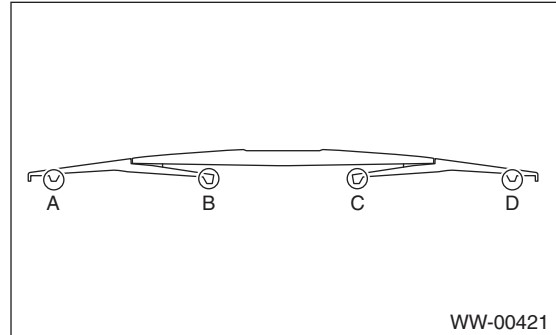

1) Insert the wiper rubber through claw (B).

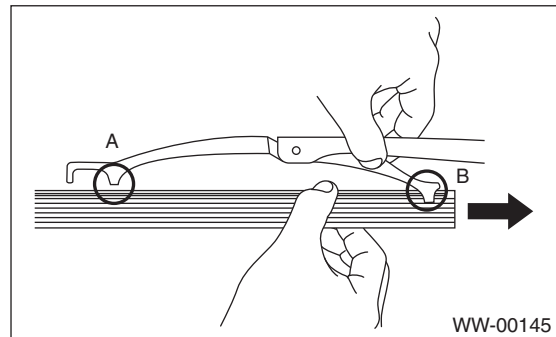

2) Insert the wiper rubber until its top end protrudes approx. 20 mm (0.79 in) from stopper (D).

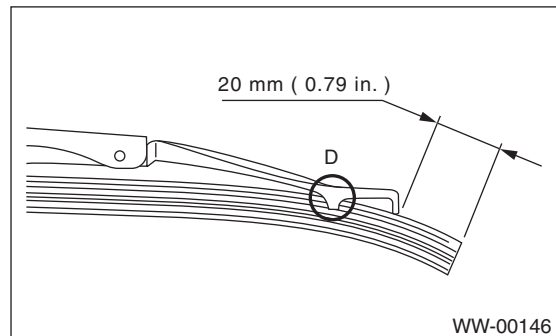

3) Insert the wiper rubber into claw (A).

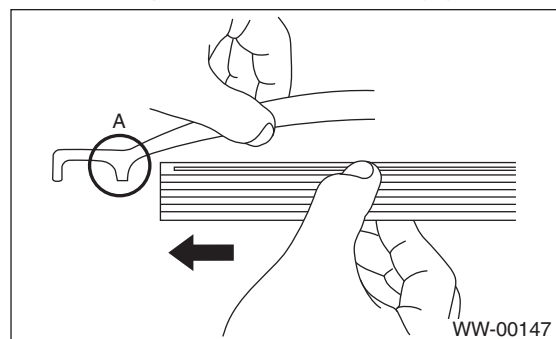

E: INSPECTION

1) When the wiper does not operate properly, inspect the following item.

- Make sure the movable part of blade assembly moves smoothly.
- Make sure the wiper rubber is not deformed or damaged.

2) Replace with a new part if damage is found.

Washer Tank and Motor

WIPER AND WASHER SYSTEMS

5. Washer Tank and Motor

A: REMOVAL

- 1) Open the front hood.
- 2) Disconnect the ground cable from the battery.
- 3) Remove the front bumper. <Ref. to EI-28, REMOVAL, Front Bumper.>
- 4) Remove the clip of the washer tank duct.

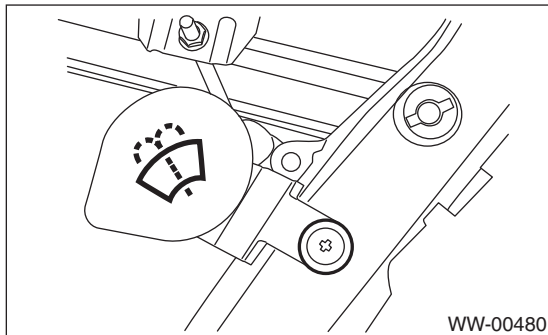

- 5) Remove the washer motor cover, and disconnect the connector.

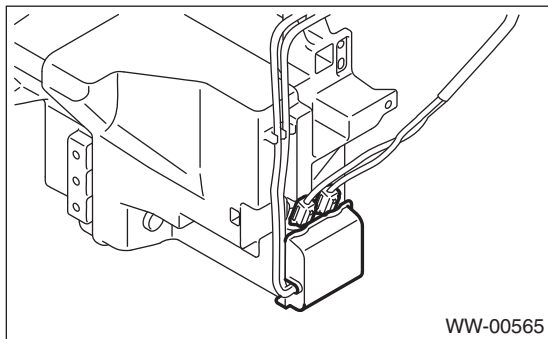

- 6) Disconnect the hose.

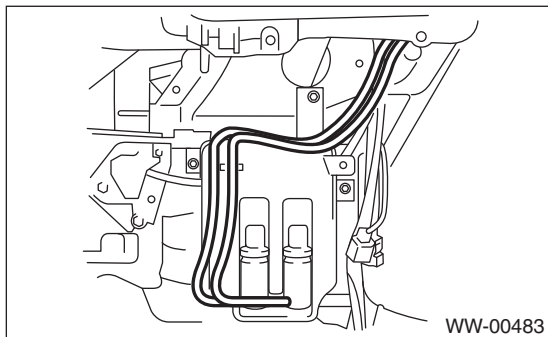

- 7) Remove the bolts and nuts and remove the washer tank.

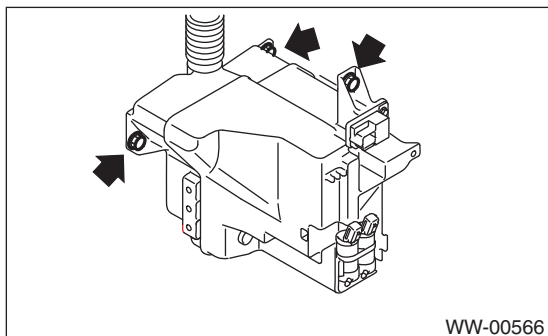

B: INSTALLATION

Install in the reverse order of removal.

Tightening torque:

6.0 N·m (0.61 kgf·m, 4.4 ft·lb)

C: DISASSEMBLY

Pull out the washer motor from the tank.

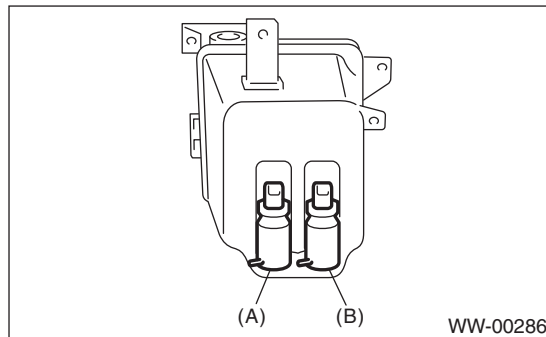

(A) Front

(B) Rear

D: ASSEMBLY

- 1) Assemble in the reverse order of disassembly.
- 2) Confirm that water does not leak from installation area of motor.

E: INSPECTION

Apply battery voltage to the connector terminal of the washer motor and make sure that the motor operates.

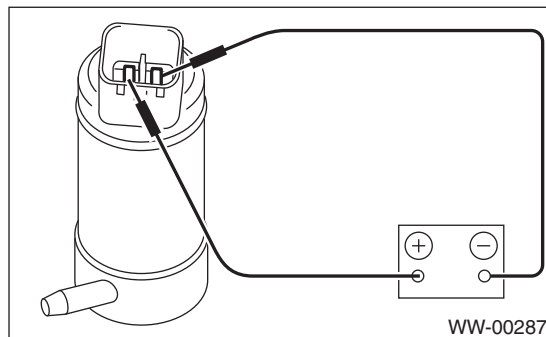

6. Front Wiper Arm

A: REMOVAL

- 1) Open the front hood.
- 2) Remove the cap.
- 3) Remove the nut, and remove the arm.

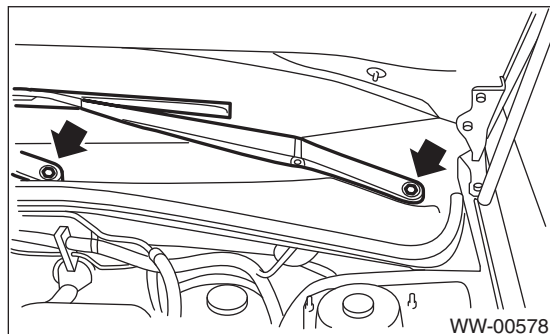

B: INSTALLATION

- 1) Install in the reverse order of removal.
- 2) Operate the wiper once.
- 3) Align the wiper blade to ceramic print point mark (A) of front window panel.

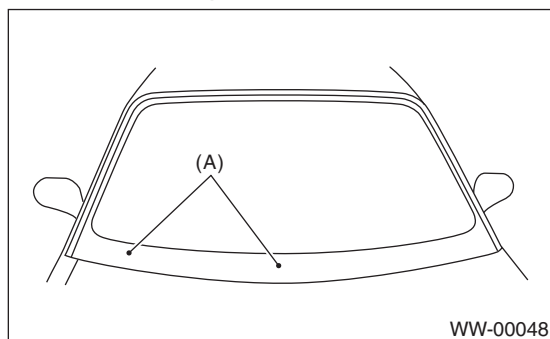

Tightening torque:

Refer to "COMPONENT" of "General Description".

<Ref. to WW-3, FRONT WIPER, COMPONENT, General Description.>

C: ADJUSTMENT

Operate the wiper once. Align the wiper blade to ceramic print point mark (A) of front window panel.

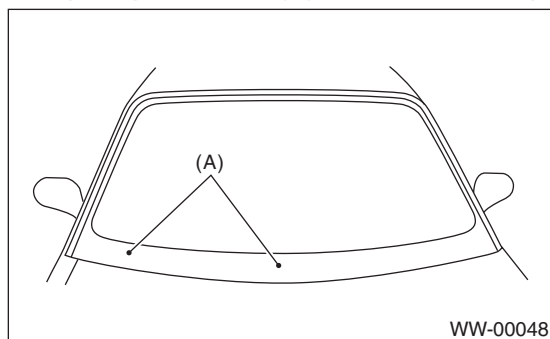

Front Wiper Motor and Link

WIPER AND WASHER SYSTEMS

7. Front Wiper Motor and Link

A: REMOVAL

- 1) Disconnect the ground cable from the battery.
- 2) Remove the cowl panel. <Ref. to EI-37, REMOVAL, Cowl Panel.>
- 3) Disconnect the connector of motor.
- 4) Remove the bolt, and remove the wiper link.

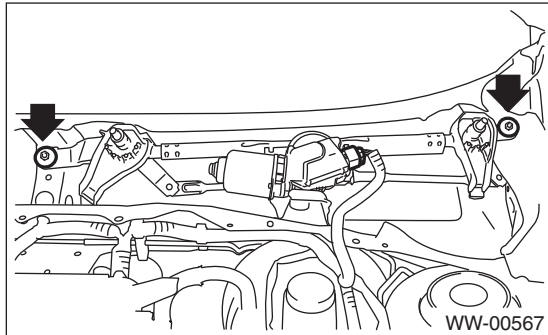

- 5) Remove the TORX® bolt and nuts, and remove the wiper motor assembly.

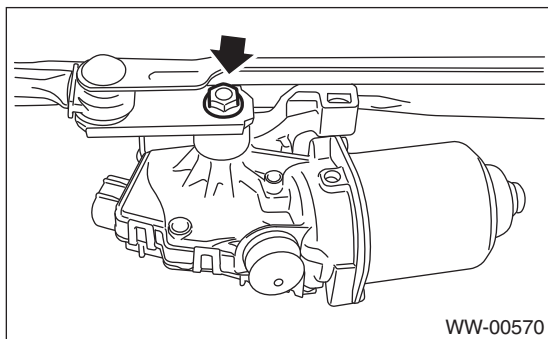
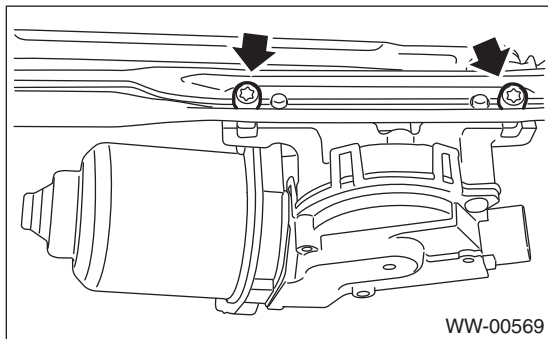

B: INSTALLATION

- 1) Connect the battery ground cable to the battery.
- 2) To confirm that the motor is at the auto stop position, connect the harness to the motor, and turn the wiper switch ON/OFF.
- 3) Disconnect the ground cable from the battery.
- 4) Install the wiper motor assembly.

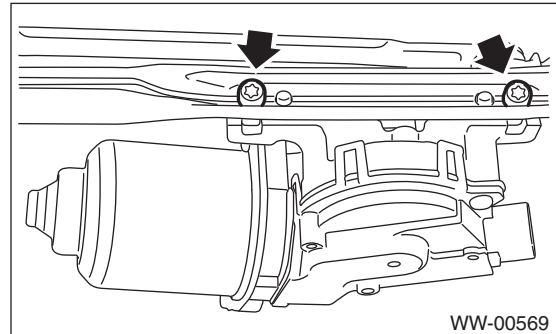

Tightening torque:

Refer to "COMPONENT" of "General Description".

<Ref. to WW-3, FRONT WIPER, COMPONENT, General Description.>

- 5) Tighten the nut of the link plate and motor assembly.

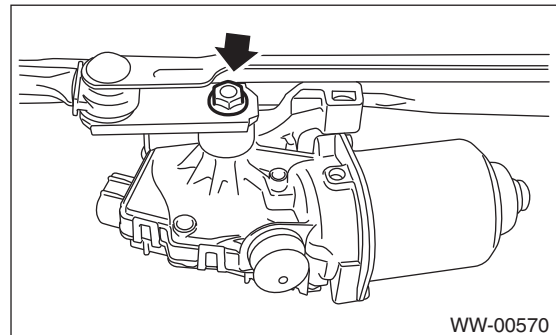

Tightening torque:

Tighten at 8.5 N·m (0.87 kgf·m, 6.3 ft·lb) for 115°.

CAUTION:

Tighten the nut where rod (A) and link plate (B) is aligned in a straight line.

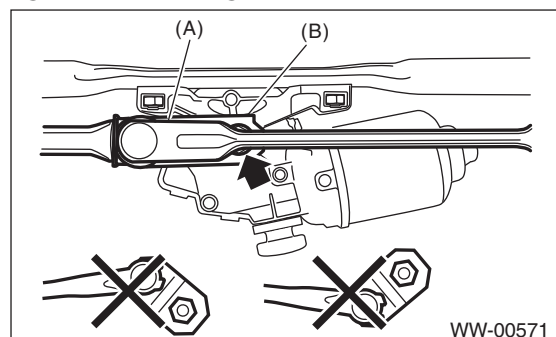

6) Install in the reverse order of removal.

Tightening torque:

Refer to "COMPONENT" of "General Description".

<Ref. to WW-3, FRONT WIPER, COMPONENT, General Description.>

C: INSPECTION

1) Check that the following operations perform normally.

CAUTION:

Fix the motor to prevent the motor from being shorted by moving during operation.

- (1) When the battery is connected to the terminal of connectors, confirm that the motor operates at low speed.
- (2) When the battery is connected to the terminal of connectors, confirm that the motor operates at high speed.
- (3) Connect the battery to terminals of the connector, and remove the terminal connection with motor rotating at low speed, and stop the motor assembly - windshield wiper in mid-operation.
- (4) Connect the battery and check that the motor stops at the automatic stop position after the motor operates at low speed again.

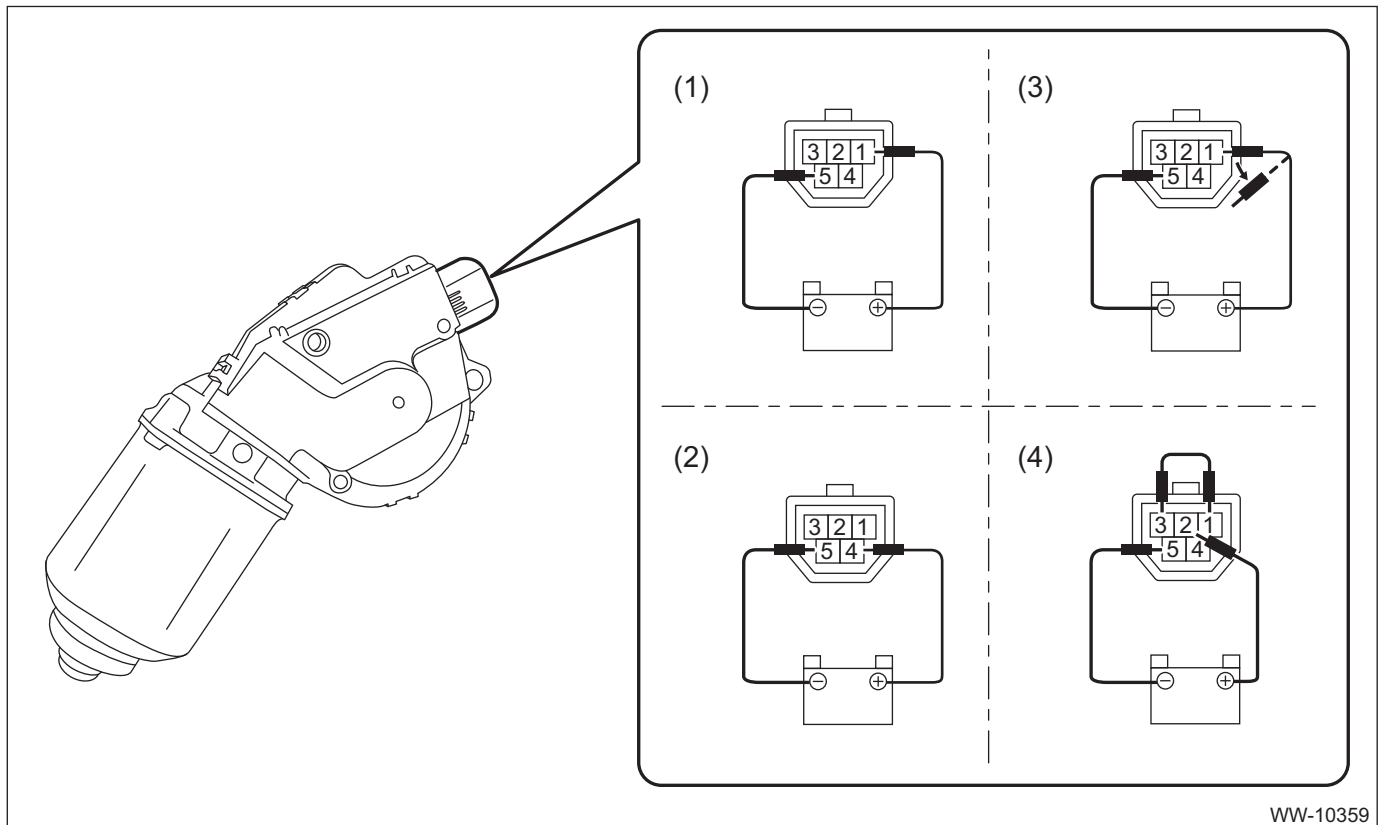

2) Replace the motor assembly - windshield wiper if it is found defective.

8. Front Washer Nozzle

A: REMOVAL

- 1) Remove the cowl panel. <Ref. to EI-37, REMOVAL, Cowl Panel.>
- 2) Remove the washer hose from the washer nozzle.
- 3) Using a driver with a narrow tip, etc., remove the washer nozzle from the cowl panel.

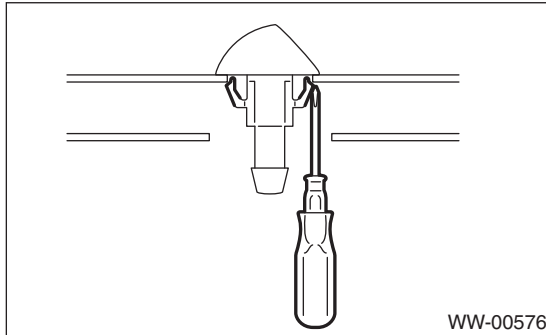

B: INSTALLATION

- 1) Install in the reverse order of removal.
- 2) Adjust the washer nozzle position. <Ref. to WW-18, ADJUSTMENT, Front Washer Nozzle.>

C: INSPECTION

- Make sure the nozzle and hose are not clogged.
- Make sure the hose is not bent.

D: ADJUSTMENT

- 1) Turn the wiper switch to OFF position.
- 2) While the vehicle is stopped, adjust the washer spray position as shown in the figure.

Spray position:

A: 250 mm (9.84 in)

B: 117 mm (4.6 in)

C: 264 mm (10.4 in)

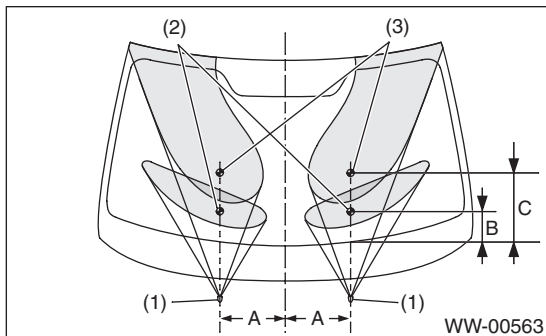

- (1) Washer nozzle
- (2) Center of upper nozzle
- (3) Center of lower nozzle

9. Rear Wiper Arm

A: REMOVAL

- 1) Detach the wiper arm cover (A).

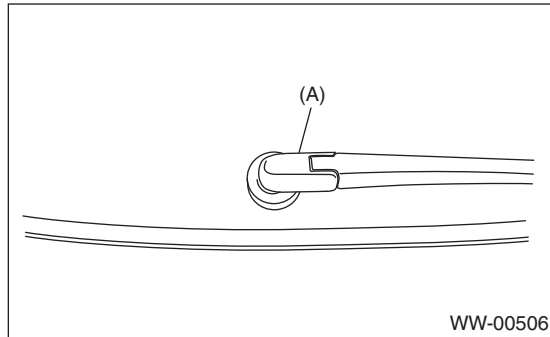

- 2) Remove the nut and remove the wiper arm.

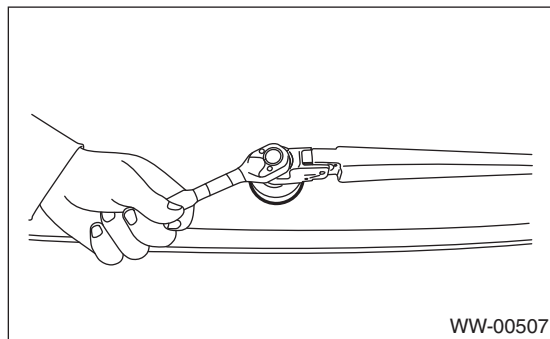

B: INSTALLATION

- 1) Install in the reverse order of removal.
- 2) Operate the rear wiper once.
- 3) Align the blade with the marking (A) of the glass.

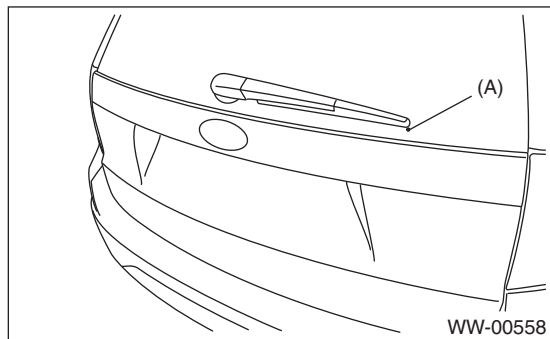

Tightening torque:

Refer to "COMPONENT" of "General Description".

<Ref. to WW-4, REAR WIPER, COMPONENT, General Description.>

C: ADJUSTMENT

- 1) Operate the rear wiper once.
- 2) Align the blade with the marking (A) of the glass.

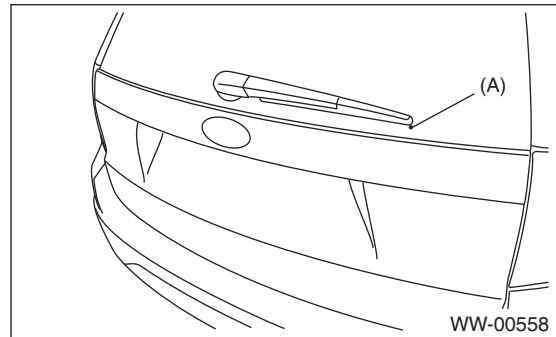

Rear Wiper Motor

WIPER AND WASHER SYSTEMS

10.Rear Wiper Motor

A: REMOVAL

- 1) Disconnect the ground cable from the battery.
- 2) Remove the rear wiper arm. <Ref. to WW-19, REMOVAL, Rear Wiper Arm.>
- 3) Remove the rear gate lower trim. <Ref. to EI-60, REMOVAL, Rear Gate Trim.>
- 4) Disconnect the harness connector of wiper motor assembly.
- 5) Remove the bolt, and then remove the wiper assembly.

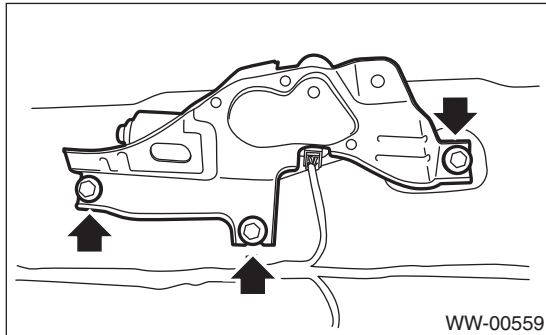

B: INSTALLATION

- 1) Install in the reverse order of removal.
- 2) As shown in the figure, make sure that the diamond mark of the pivot cap is facing upward.

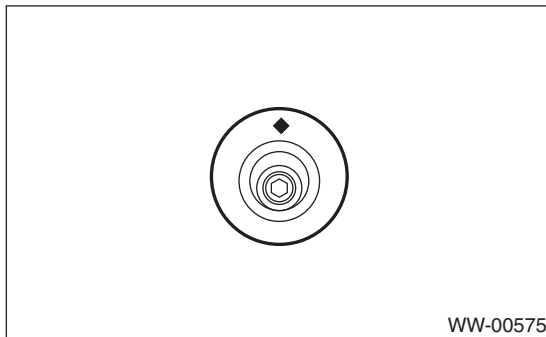

Tightening torque:

Refer to "COMPONENT" of "General Description".

<Ref. to WW-4, REAR WIPER, COMPONENT, General Description.>

C: INSPECTION

- 1) Connect the battery to the wiper motor connector and confirm that wiper motor operates.

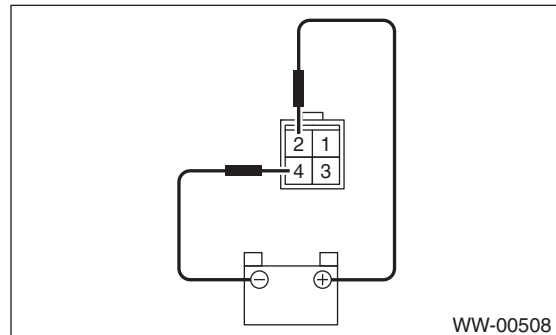

- 2) Connect the battery to the connector terminal, run the motor and disconnect the terminal connection, and stop the wiper motor in mid motion.

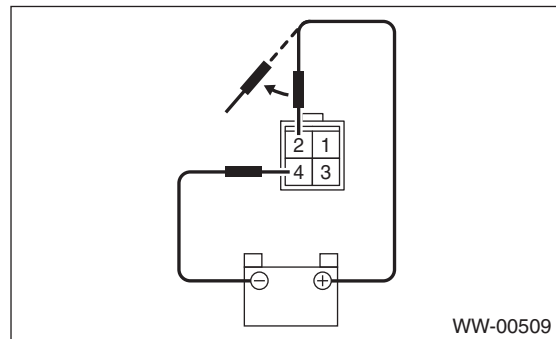

- 3) Connect the battery and confirm that the motor stops at the automatic stop position after the motor operates at low speed.

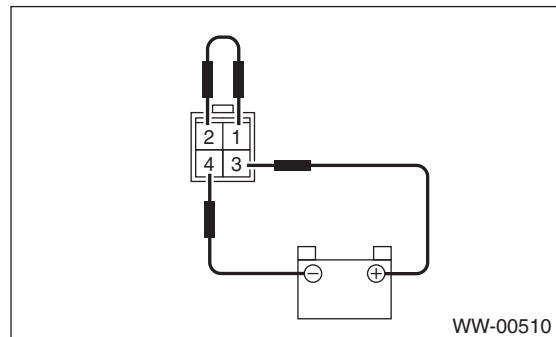

11.Rear Washer

A: REMOVAL

- 1) Remove the roof spoiler. (Model with roof spoiler) <Ref. to EI-38, REMOVAL, Roof Spoiler.>
- 2) Hold the claw of the washer nozzle from the outer side of the rear gate, and remove the washer nozzle.

CAUTION:

Be careful not to scratch the rear gate panel during removal.

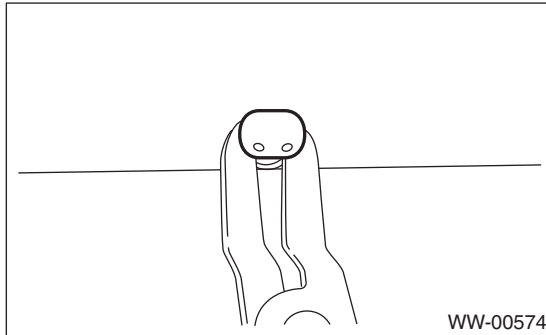

- 3) Remove the washer hose (B) from washer nozzle (A).

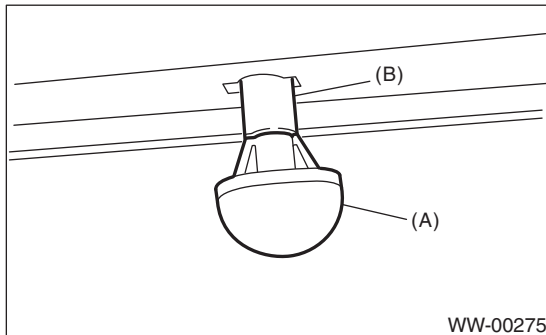

B: INSTALLATION

- 1) Install in the reverse order of removal.
- 2) Adjust the washer nozzle position. <Ref. to WW-21, ADJUSTMENT, Rear Washer.>

C: INSPECTION

- Make sure the nozzle and hose are not clogged.
- Make sure the hose is not bent.

D: ADJUSTMENT

- 1) Turn the wiper switch to OFF position.
- 2) While the vehicle is stopped, adjust the washer spray position as shown in the figure.

Spray position:

A: 72°

B: 45 mm (1.8 in)

C: 36 mm (1.4 in)

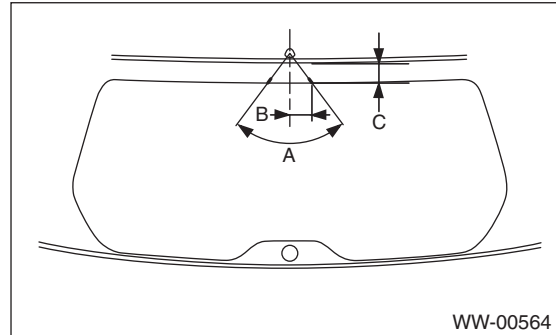

Rear Washer

WIPER AND WASHER SYSTEMS

ENTERTAINMENT

ET

	Page
1. General Description	2
2. Audio System	3
3. Navigation System	4
4. Audio	6
5. Front Speaker	7
6. Tweeter	8
7. Rear Speaker	9
8. Antenna	10
9. Steering Satellite Switch	11
10. Navigation Body	12
11. GPS Antenna	13
12. Front Accessory Power Supply Socket	14
13. Rear Accessory Power Supply Socket	15
14. AUX Input Terminal	16

1. General Description

A: CAUTION

- Before disassembling or reassembling parts, always disconnect the battery ground cable from battery. When replacing the audio, control module and other parts provided with memory functions, record the memory contents before disconnecting the battery ground cable. Otherwise, the memory is cleared.
- Reassemble the parts in the reverse order of disassembly procedure unless otherwise indicated.
- Adjust parts to the given specifications.
- Connect the connectors securely during reassembly.
- After reassembly, make sure functional parts operate smoothly.

B: PREPARATION TOOL

1. GENERAL TOOL

TOOL NAME	REMARKS
Circuit tester	Used for measuring resistance and voltage.

2. Audio System

A: WIRING DIAGRAM

1. AUDIO

<Ref. to WI-122, WIRING DIAGRAM, Audio System.>

B: INSPECTION

Symptom	Repair order
No power coming in. (No display and no sound from speakers)	<ol style="list-style-type: none"> 1. Check the fuse and power supply for audio. 2. Check the audio ground. 3. Remove the audio for repair.
A specific speaker does not operate.	<ol style="list-style-type: none"> 1. Check the speaker. 2. Check the output circuit between audio and speaker.
Audio generates noise with engine is running.	<ol style="list-style-type: none"> 1. Check the audio ground. 2. Check the generator. 3. Check the ignition coil. 4. Remove the audio for repair.
Volume is low in AM and FM modes or interference noise occurs.	<ol style="list-style-type: none"> 1. Check the antenna. 2. Check the audio ground. 3. Remove the audio for repair.

C: NOTE

For removal of each component of the audio system, refer to the respective section.

- Audio unit <Ref. to ET-6, Audio.>
- Front speaker <Ref. to ET-7, Front Speaker.>
- Tweeter <Ref. to ET-8, Tweeter.>
- Rear speaker <Ref. to ET-9, Rear Speaker.>
- Antenna <Ref. to ET-10, Antenna.>

3. Navigation System

A: WIRING DIAGRAM

<Ref. to WI-126, WIRING DIAGRAM, Navigation System.>

B: INSPECTION

1. CHECK THE OPERATION OF THE NAVIGATION

Start the engine, and then inspect that the opening screen is displayed.

Standard value: The opening screen should be displayed.

OK: Normal

NG: When not displayed, check the connecting lines for the power supply connector at the back side of the audio unit. If there are no problems in the connecting lines or the lines were repaired, check that the opening screen is displayed.

At this point, if the display is not viewable, the unit is defective.

2. CHECK THE DVD-ROM

An opening screen is displayed, then it switches to the map screen by pressing the «Agree» key.

When a screen other than the opening screen is displayed, press the «MAP» key.

Standard value: The map screen should be displayed.

OK: Normal

NG: If the map screen is not displayed, the following causes are possible.

- The DVD-ROM is not set in the navigation system unit.
- The DVD-ROM is inserted with its wrong side.
- The type of DVD-ROM is wrong.
- The DVD-ROM has scratches etc.

If there are no problems on the DVD-ROM, the main body is defective.

3. CHECK EACH CONNECTION

If there are no problems in “CHECK THE OPERATION OF THE NAVIGATION” and “CHECK THE DVD-ROM” above, check the circuit of the navigation system. <Ref. to WI-126, WIRING DIAGRAM, Navigation System.>

4. SWITCHING TO CONNECTION INSPECTION MODE

1) Press «Audio» key to display the AUDIO OFF screen.

2) Touch the screen in the order of (1) to (6) shown in the figure.

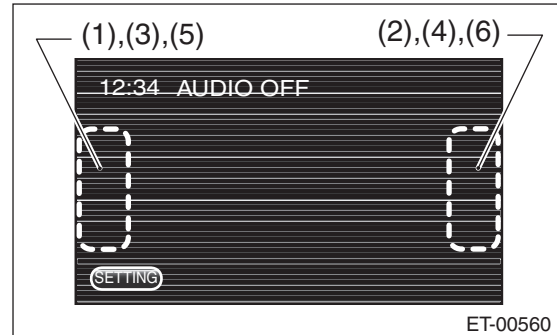

3) The display will switch to the Dealer Diag Menu screen.

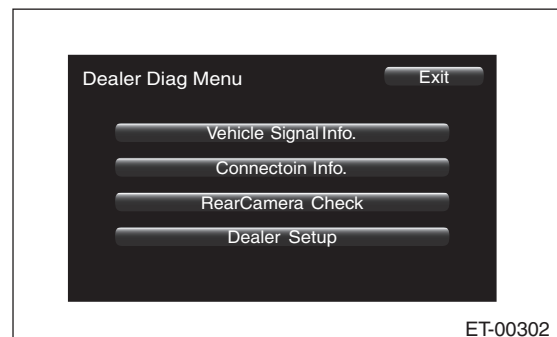

• CHECK THE GPS ANTENNA

NOTE:

When checking the GPS antenna, perform the check operation outdoors to improve the receiver sensitivity.

1) Touch {Vehicle Signal Info.} on the «Dealer Diag Menu» screen.

2) Check that “Connect” is displayed in the GPS Antenna item.

Connect: Normal.

NC: Abnormal. Check the GPS antenna connection.

• CHECK THE BACK SENSOR

NOTE:

Before starting inspections, check the safety around the rear end of the vehicle and then turn the ignition switch to ON.

1) Touch {Vehicle Signal Info.} on the «Dealer Diag Menu» screen.

2) Pull the parking brake and depress the brake, then put the gear in reverse.

3) Make sure that “ON” is displayed in the Reverse item.

ON: Normal.

OFF: Abnormal. Check the signal line connection. If there are no problems, the unit could be faulty.

• CHECK THE ILLUMINATION

NOTE:

Before starting inspections, turn the ignition switch to ON.

1) Touch {Vehicle Signal Info.} on the «Dealer Diag Menu» screen.

2) Turn the lighting switch to level 1.

Make sure that the bright switch is not turned ON at this time.

3) Make sure that “ON” lights in the Illumination item and then the screen fades out.

ON: Normal.

OFF: Abnormal. Check the signal line connection. If there are no problems, the unit could be faulty.

• CHECK SPEED SENSOR

NOTE:

- Before starting inspections, check the safety around the vehicle.

- Lift up the vehicle as necessary.

- When the diagnostic trouble code is input in the VDCCM, perform the Clear Memory operation.

1) Touch {Vehicle Signal Info.} on the «Dealer Diag Menu» screen.

2) Move the vehicle 2 to 3 meters (6.6 to 9.8 ft).

3) Check that “ON” is displayed in the Speed item.

ON: Normal.

OFF: Abnormal. Check the signal line connection. If there are no problems, the unit could be faulty.

C: NOTE

Refer to each section for removal of each component of the navigation system.

- Navigation unit <Ref. to ET-12, Navigation Body.>

- GPS antenna <Ref. to ET-13, GPS Antenna.>

4. Audio

A: REMOVAL

- 1) Disconnect the ground cable from the battery.
- 2) Remove the center panel. <Ref. to EI-47, CENTER PANEL, REMOVAL, Center Console.>
- 3) Remove the fitting screws, and slightly pull the audio out from the center console.

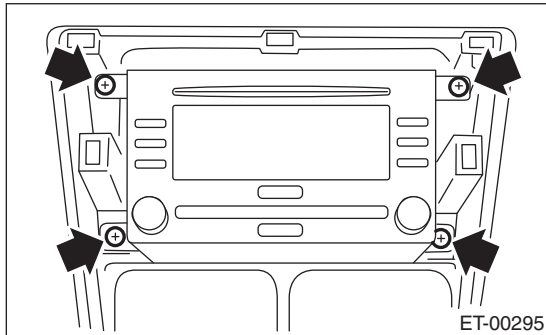

- 4) Disconnect the harness connectors and antenna feeder cord.
- 5) Remove the audio.
- 6) Remove the mounting screws and detach the satellite radio unit.

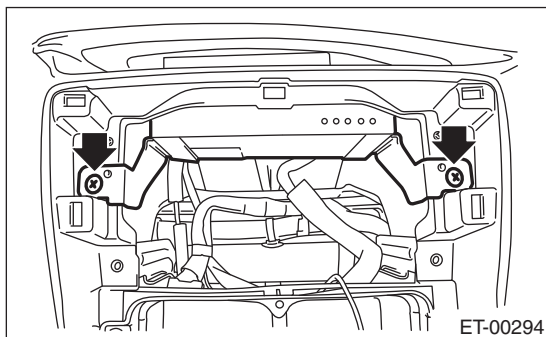

B: INSTALLATION

Install in the reverse order of removal.

5. Front Speaker

A: REMOVAL

- 1) Disconnect the ground cable from the battery.
- 2) Remove the front door trim. <Ref. to EI-42, REMOVAL, Door Trim.>
- 3) Remove the front speaker mounting screws.

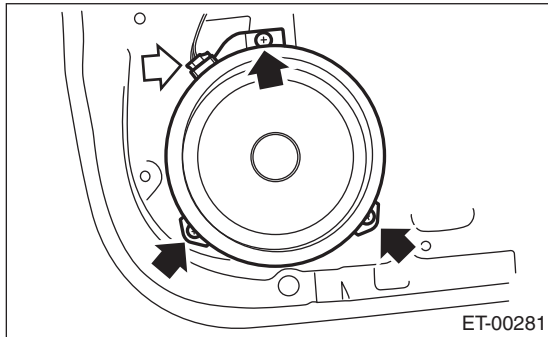

- 4) Disconnect the harness connector and remove the front speaker.

B: INSTALLATION

Install in the reverse order of removal.

6. Tweeter

A: REMOVAL

- 1) Disconnect the ground cable from the battery.
- 2) Disconnect the harness connector and remove the front door gusset cover.
- 3) Remove the claws and detach the tweeter.

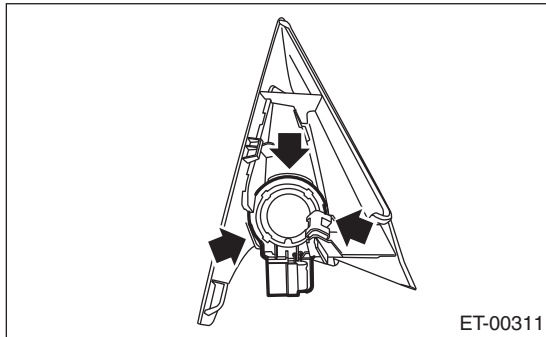

B: INSTALLATION

Install in the reverse order of removal.

7. Rear Speaker

A: REMOVAL

- 1) Disconnect the ground cable from the battery.
- 2) Remove the rear door trim. <Ref. to EI-42, REMOVAL, Door Trim.>
- 3) Remove the rear speaker mounting screws.

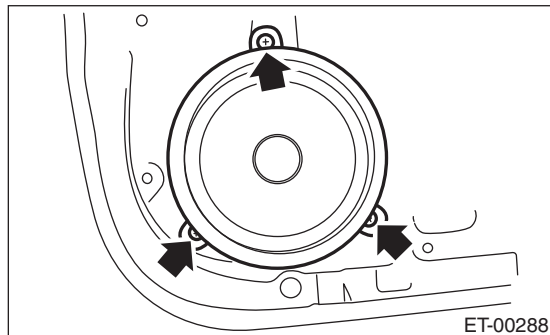

- 4) Disconnect the harness connector and remove the rear speaker.

B: INSTALLATION

Install in the reverse order of removal.

8. Antenna

A: REMOVAL

- 1) Remove the roof trim. <Ref. to EI-59, REMOVAL, Roof Trim.>
- 2) Disconnect the harness connectors and terminals and remove the fitting nut (A).

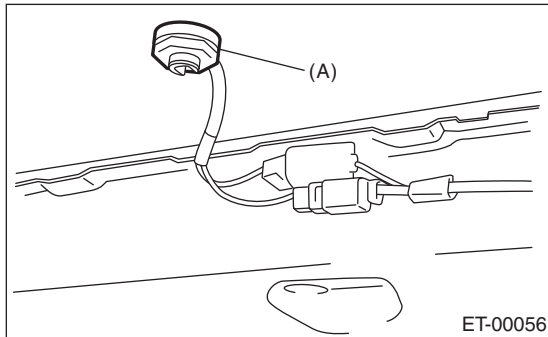

- 3) Pull off the antenna from the roof.

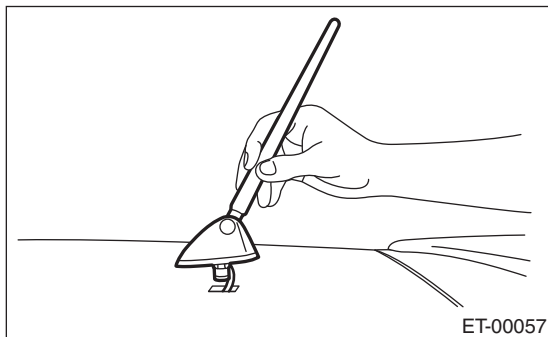

B: INSTALLATION

Install in the reverse order of removal.

C: INSPECTION

Check for cracks or damages.
If any cracks or damages, replace the antenna.

9. Steering Satellite Switch

A: REMOVAL

WARNING:

Before servicing, be sure to read the notes in the “AB” section for proper handling of the driver’s airbag module. <Ref. to AB-5, CAUTION, General Description.>

- 1) Set the front wheels in straight ahead position.
- 2) Turn the ignition switch to OFF.
- 3) Disconnect the ground cable from battery and wait for at least 20 seconds before starting work.
- 4) Using TORX® bit T30 (1), loosen two TORX® bolts which secure the driver’s airbag module.

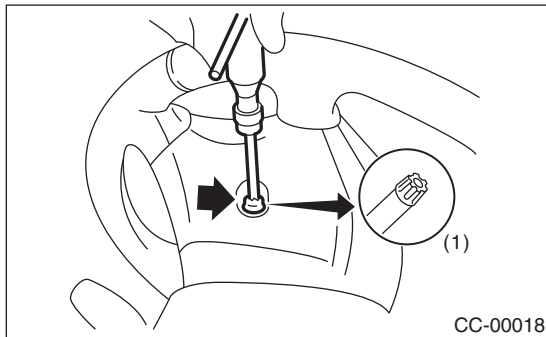

- 5) Disconnect the airbag module connector on back of the airbag module. <Ref. to AB-9, PROCEDURE, Airbag Connector.>
- 6) Remove the steering wheel. <Ref. to PS-12, REMOVAL, Steering Wheel.>
- 7) Remove the screws to remove the lower cover from steering wheel.

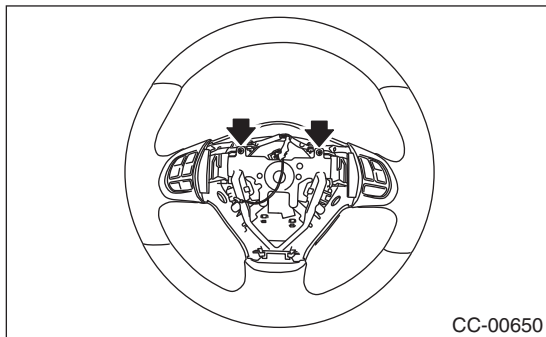

- 8) Loosen the screws on the backside of the steering wheel and remove the satellite switch.

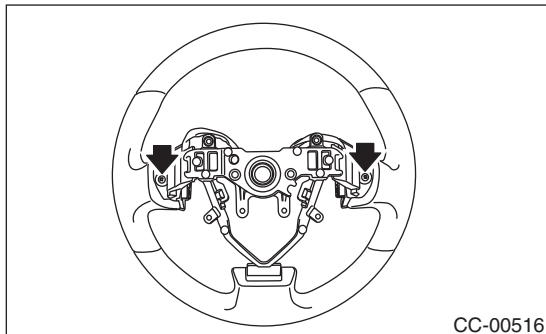

B: INSTALLATION

Install in the reverse order of removal.

C: INSPECTION

Measure the resistance between satellite switch connector terminals.

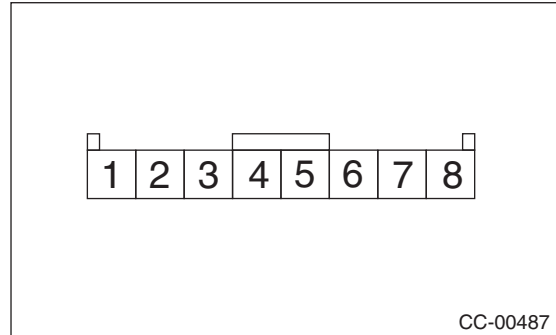

Switch	Position	Terminal No.	Standard
Mute Volume (+) Volume (-) Mode Seek (∧) Seek (∨)	All OFF	4 and 5	Approx. 4.7 kΩ
Mute	ON	4 and 5	Approx. 22 Ω
Volume (+)	ON	4 and 5	Approx. 90 Ω
Volume (-)	ON	4 and 5	Approx. 200 Ω
Mode	ON	4 and 5	Approx. 360 Ω
Preset CH UP/ Seek (∧)	ON	4 and 5	Approx. 690 Ω
Preset CH DOWN/Seek (∨)	ON	4 and 5	Approx. 1.15 kΩ

If NG, replace the cruise control command switch.

10.Navigation Body

A: PROCEDURE

For the removal and installation operation procedures of navigation unit, refer to the removal and installation procedures of the audio unit. <Ref. to ET-6, Audio.>

11. GPS Antenna

A: REMOVAL

- 1) Disconnect the ground cable from the battery.
- 2) Remove the center panel. <Ref. to EI-47, CENTER PANEL, REMOVAL, Center Console.>
- 3) Remove the navigation body. <Ref. to ET-12, PROCEDURE, Navigation Body.>
- 4) Disconnect the connector (green) of GPS antenna.

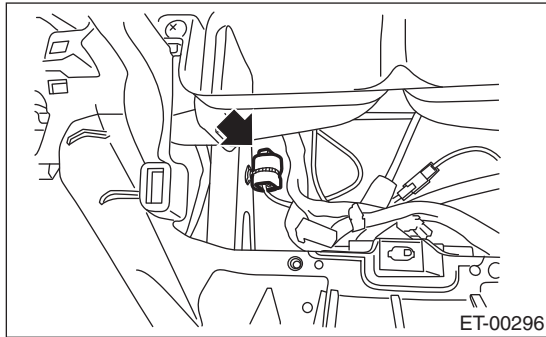

NOTE:

- Attach a string of about 50 cm in length, etc. to the GPS antenna connector for easy installation work.
- 5) Remove the combination meter assembly. <Ref. to IDI-16, REMOVAL, Combination Meter.>
 - 6) Remove the screw and harness clamp to remove the GPS antenna.

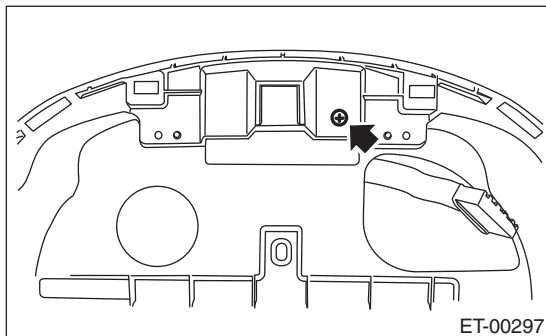

NOTE:

When the GPS antenna harness connector is pulled out, remove the string attached to the connector in step 4).

B: INSTALLATION

Install in the reverse order of removal.

Front Accessory Power Supply Socket

ENTERTAINMENT

12. Front Accessory Power Supply Socket

A: WIRING DIAGRAM

<Ref. to WI-124, WIRING DIAGRAM, Front Accessory Power Supply Socket System.>

B: REMOVAL

- 1) Disconnect the ground cable from the battery.
- 2) Remove the instrument panel lower cover. <Ref. to EI-49, INSTRUMENT PANEL LOWER, REMOVAL, Center Console.>
- 3) Disconnect the harness connectors and remove the front accessory power supply socket.

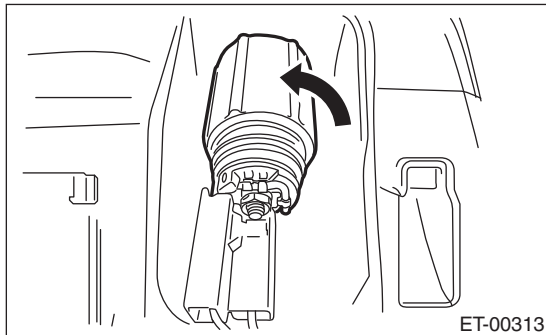

C: INSTALLATION

Install in the reverse order of removal.

13. Rear Accessory Power Supply Socket

A: WIRING DIAGRAM

<Ref. to WI-125, WIRING DIAGRAM, Rear Accessory Power Supply Socket System.>

B: REMOVAL

- 1) Disconnect the ground cable from the battery.
- 2) Remove the console box. <Ref. to EI-46, REMOVAL, Console Box.>
- 3) Disconnect the harness connector, and remove the accessory power supply socket.

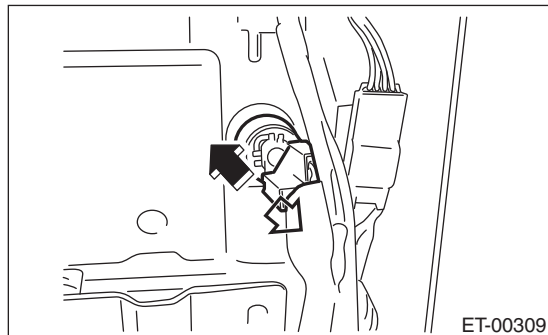

NOTE:

Remove the accessory power supply socket by pushing out from the backside.

C: INSTALLATION

Install in the reverse order of removal.

14.AUX Input Terminal

A: REMOVAL

- 1) Disconnect the ground cable from the battery.
- 2) Remove the console box. <Ref. to EI-46, REMOVAL, Console Box.>
- 3) Disconnect the harness connector.
- 4) Remove the claws to remove the AUX input terminal assembly by pushing it into the console box.

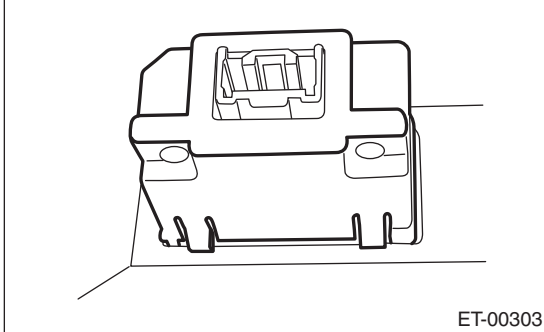

B: INSTALLATION

Install in the reverse order of removal.

COMMUNICATION SYSTEM

COM

	Page
1. General Description	2
2. Horn System	3
3. Horn	4
4. Horn Switch	5

General Description

COMMUNICATION SYSTEM

1. General Description

A: CAUTION

- Before disassembling or reassembling parts, always disconnect the battery ground cable from battery. When replacing the radio, control unit, and other parts provided with memory functions, record the memory contents before disconnecting the battery ground cable. Otherwise, the memory is cleared.
- Reassemble the parts in the reverse order of disassembly procedure unless otherwise indicated.
- Adjust parts to the given specifications.
- Connect the connectors and hoses securely during reassembly.
- After reassembly, make sure functional parts operate smoothly.

B: PREPARATION TOOL

1. GENERAL TOOL

TOOL NAME	REMARKS
Circuit tester	Used for measuring resistance and voltage.
TORX® T30	Used for removal/installation of driver's airbag module

2. Horn System

A: WIRING DIAGRAM

1. HORN

<Ref. to WI-130, WIRING DIAGRAM, Horn System.>

B: INSPECTION

1. HORN RELAY

Measure the security horn relay resistance between terminals (indicated in the table below) when connecting terminal No. 4 to battery positive terminal and terminal No. 3 to battery ground terminal.

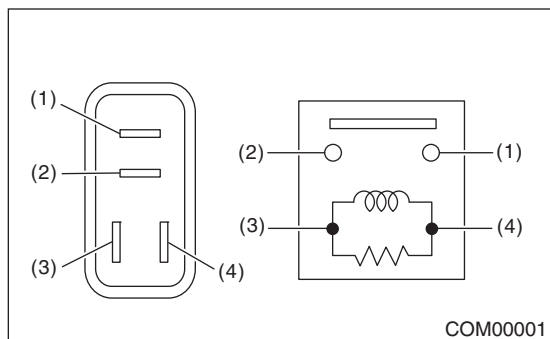

Continuity	Terminal No.	Standard
Yes	1 and 2	Less than 1 Ω
No		1 M Ω or more

C: NOTE

For removal procedure of each component in the horn system, refer to the respective section.

- Horn assembly <Ref. to COM-4, Horn.>
- Horn switch <Ref. to COM-5, Horn Switch.>

3. Horn

A: REMOVAL

- 1) Disconnect the ground cable from battery.
- 2) Remove the front bumper. <Ref. to EI-28, REMOVAL, Front Bumper.>
- 3) Disconnect the harness connector.
- 4) Remove the horn bracket mounting bolt to remove the horn assembly.

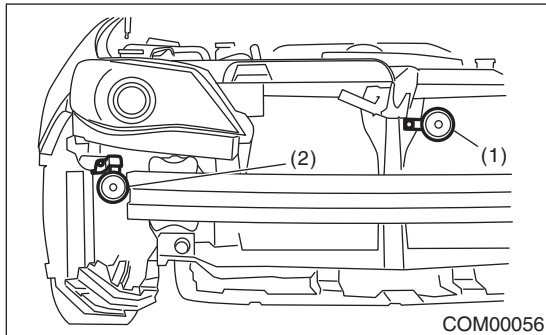

- (1) Low side horn
(2) High side horn

B: INSTALLATION

Install in the reverse order of removal.

C: INSPECTION

With 12 V direct current supply between horn terminal and case ground, check that the horn sounds properly.

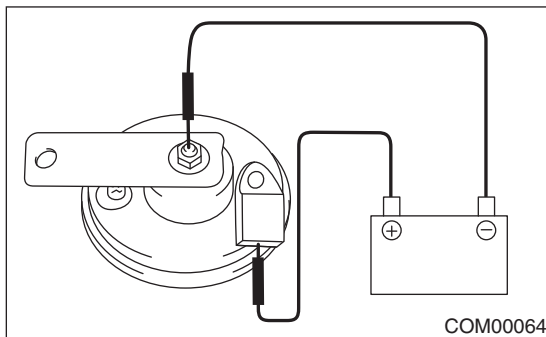

4. Horn Switch

A: REMOVAL

WARNING:

Before servicing, be sure to read the notes in the AB section for proper handling of the driver's airbag module. <Ref. to AB-5, CAUTION, General Description.>

NOTE:

Horn switch is a unit with the driver's airbag module.

- 1) Disconnect the ground cable from battery.
- 2) Remove the driver's airbag module. <Ref. to AB-16, REMOVAL, Driver's Airbag Module.>

B: INSTALLATION

Install in the reverse order of removal.

C: INSPECTION

Measure the resistance between horn switch terminal and airbag module bracket.

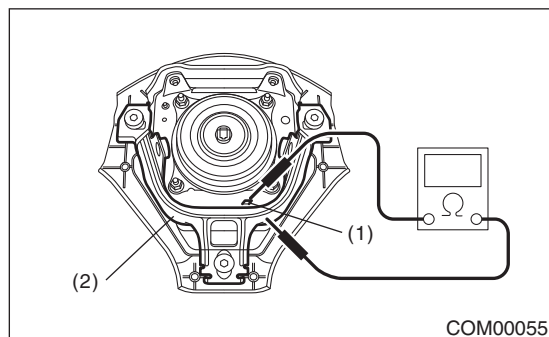

- (1) Horn switch terminal
- (2) Airbag module bracket

Switch position	Terminal No.	Resistance
The airbag module bracket being pushed	Horn switch terminal and airbag module bracket	Less than 1 Ω
The airbag module bracket being separated		1 M Ω or more

Horn Switch

COMMUNICATION SYSTEM

GLASS/WINDOWS/MIRRORS

GW

	Page
1. General Description	2
2. Power Window System	7
3. Power Window Control Switch	8
4. Front Door Glass	10
5. Front Regulator and Motor Assembly	11
6. Remote Control Mirror System	12
7. Scalp Cap	13
8. Outer Mirror Assembly	14
9. Outer Mirror	15
10. Remote Control Mirror Switch	16
11. Rear Door Glass	17
12. Rear Regulator and Motor Assembly	18
13. Windshield Glass	19
14. Rear Gate Glass	24
15. Rear Window Defogger	27
16. Rear Quarter Glass	29
17. Rearview Mirror	31
18. Wiper Deicer System	32

General Description

GLASS/WINDOWS/MIRRORS

1. General Description

A: COMPONENT

1. FIXED GLASS

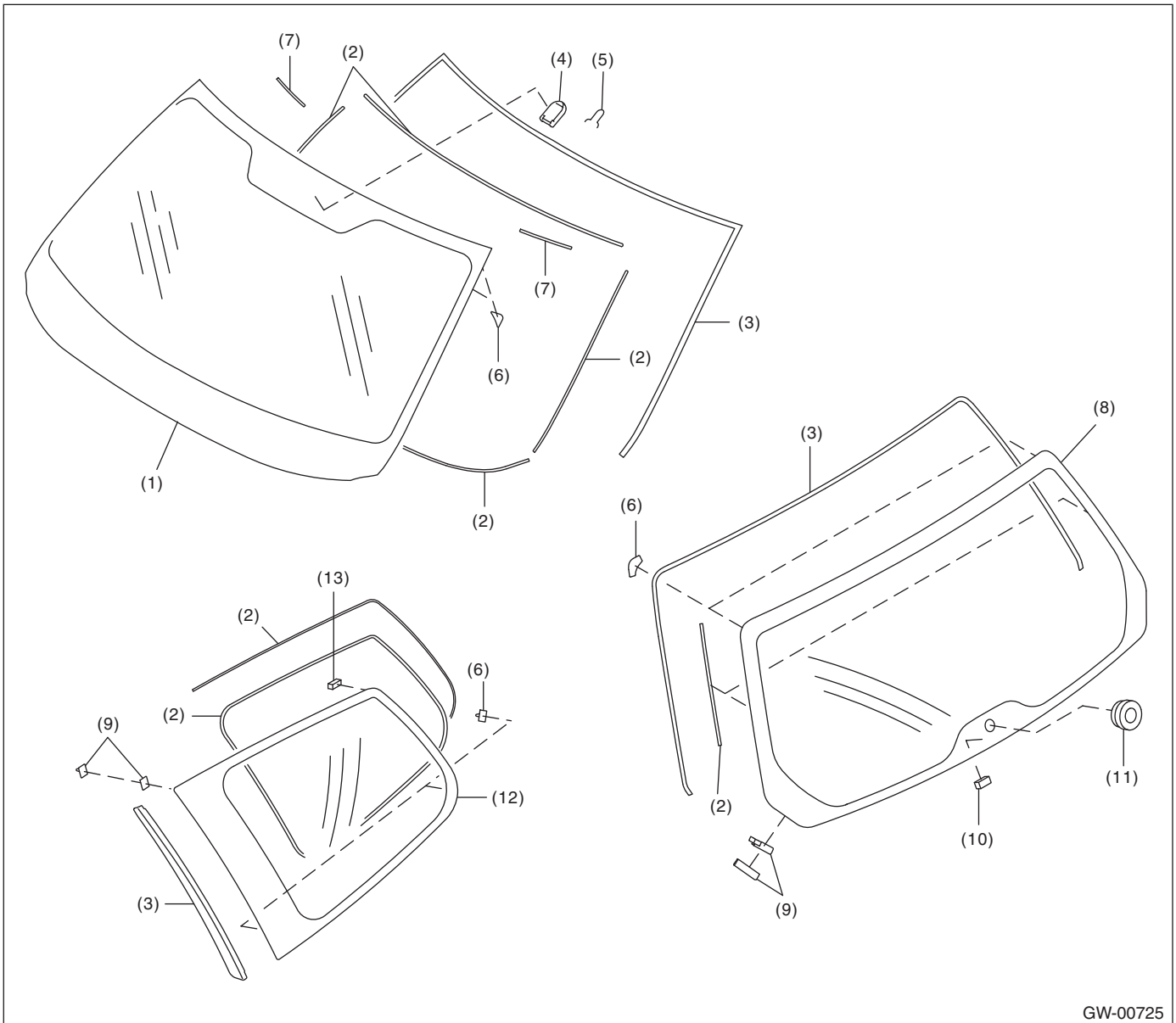

GW-00725

- | | | |
|---------------------------|---------------------|-------------------------|
| (1) Windshield glass | (6) Locating pin | (10) Rubber spacer |
| (2) Dam rubber | (7) Seal | (11) Pivot |
| (3) Molding | (8) Rear gate glass | (12) Rear quarter glass |
| (4) Rearview mirror mount | (9) Fastener | (13) Spacer |
| (5) Spring | | |

2. FRONT DOOR GLASS

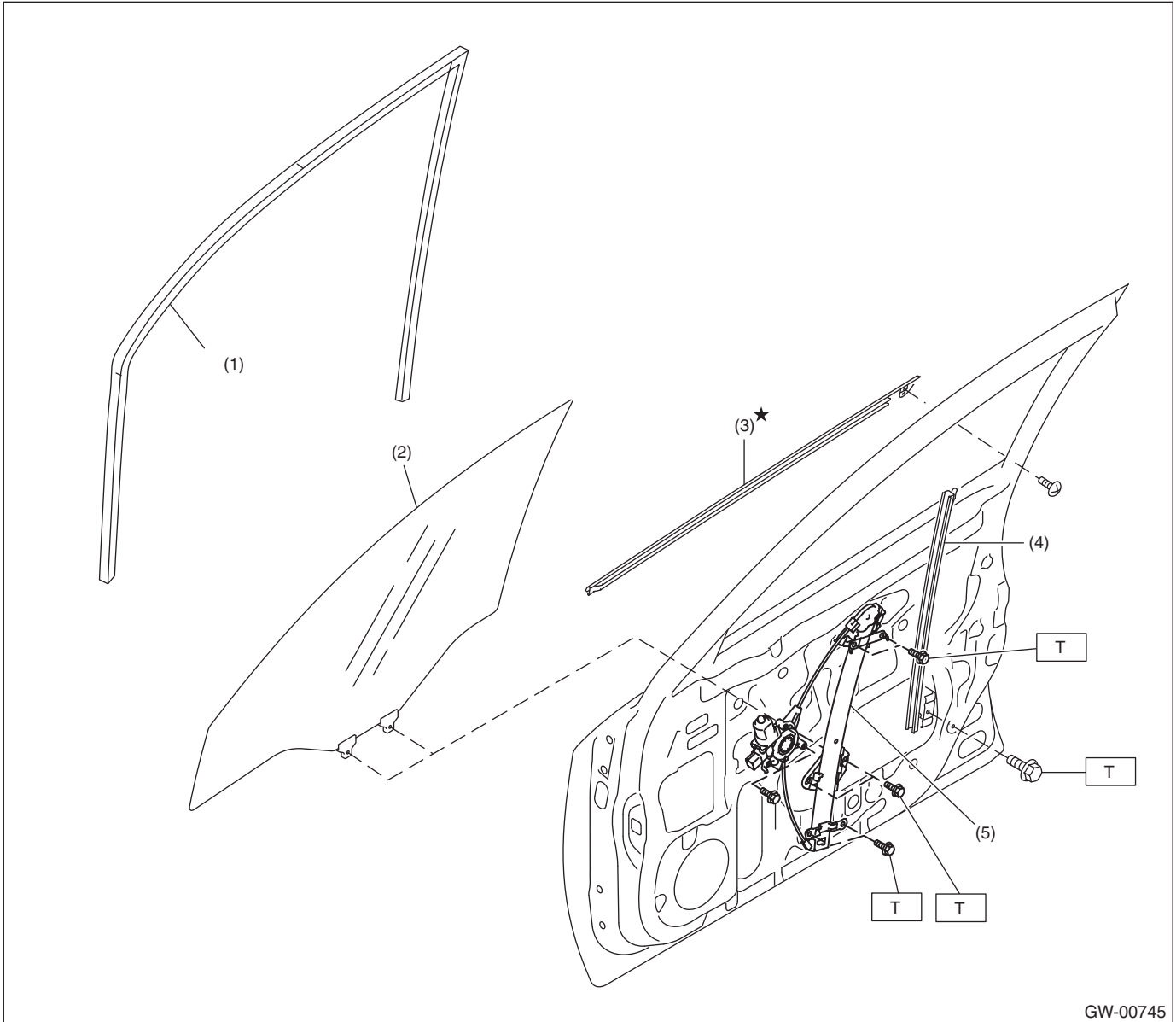

- | | |
|-------------------------|------------------------------|
| (1) Glass run rubber | (4) Door sash |
| (2) Glass | (5) Regulator and motor ASSY |
| (3) Weather strip outer | |

Tightening torque: N·m (kgf-m, ft-lb)

T: 7.5 (0.76, 5.5)

General Description

GLASS/WINDOWS/MIRRORS

3. REAR DOOR GLASS

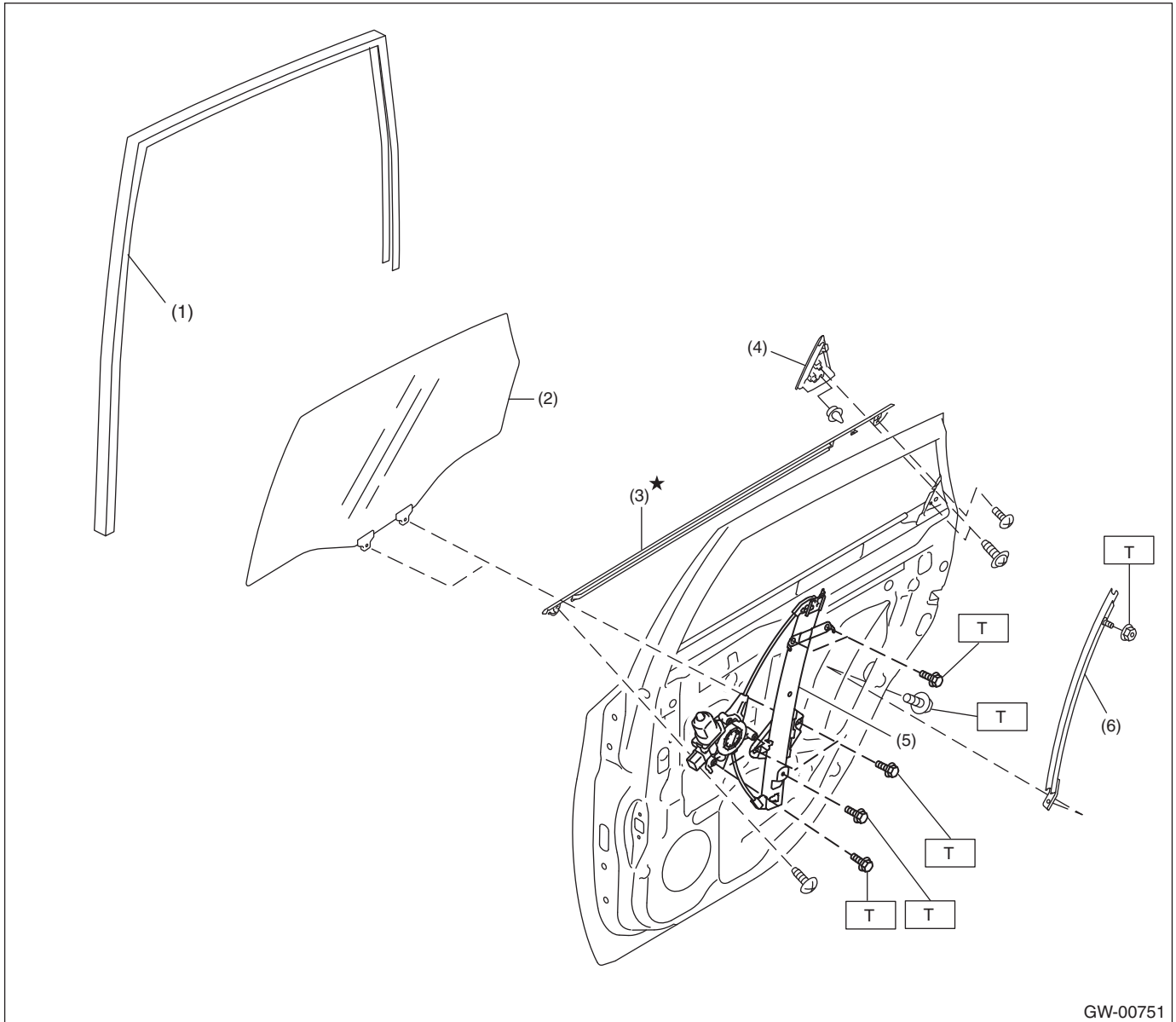

GW-00751

- | | |
|-------------------------|------------------------------|
| (1) Glass run rubber | (4) Rear outer gusset cover |
| (2) Glass | (5) Regulator and motor ASSY |
| (3) Weather strip outer | (6) Door sash |

Tightening torque: N·m (kgf·m, ft·lb)

T: 7.5 (0.76, 5.5)

4. MIRROR

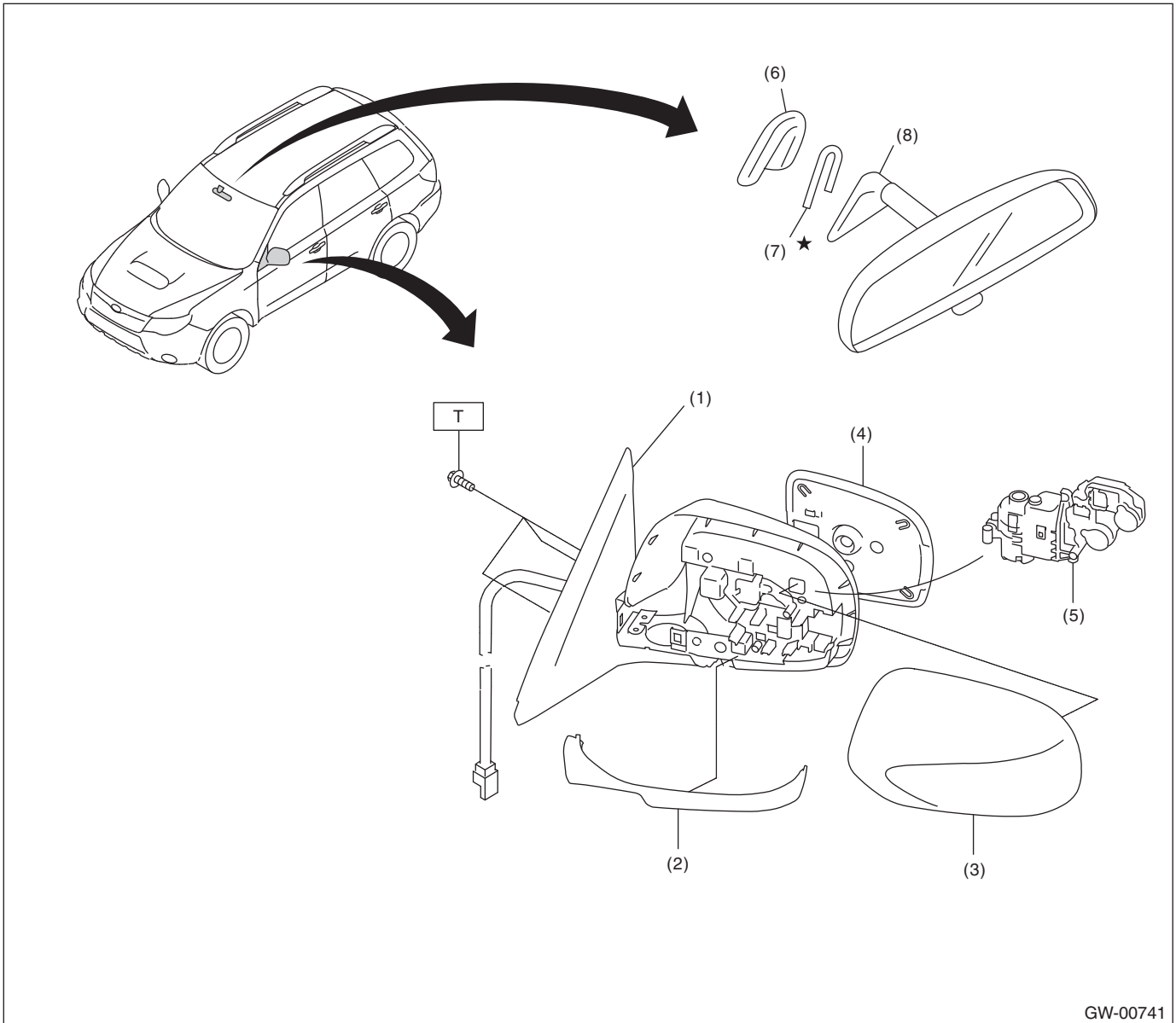

- | | |
|------------------------------|---------------------------|
| (1) Outer mirror case ASSY | (5) Mirror motor ASSY |
| (2) Outer mirror lower cover | (6) Mount |
| (3) Scalp cap | (7) Spring |
| (4) Outer mirror | (8) Rear view mirror ASSY |

Tightening torque: N·m (kgf·m, ft·lb)

T: 4.5 (0.46, 3.3)

B: CAUTION

- When electrical connectors are disconnected, always conduct an operational check after connecting them again.
- Avoid impact and damage to the glass.

General Description

GLASS/WINDOWS/MIRRORS

C: PREPARATION TOOL

1. SPECIAL TOOL

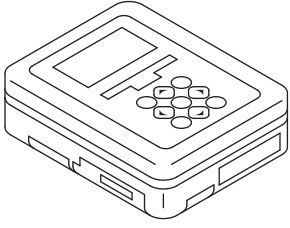
ILLUSTRATION	TOOL NUMBER	DESCRIPTION	REMARKS
 ST1B022XU0	1B022XU0 (Newly adopted tool)	SUBARU SELECT MONITOR III KIT	Used for setting of each function and trouble-shooting for electrical system.

2. GENERAL TOOL

TOOL NAME	REMARKS
Circuit tester	Used for checking voltage and continuity.
Piano wire	Used for removing the window glass.
Cutter knife	Used for removing the window glass.
Windshield glass knife	Used for removing the window glass.

2. Power Window System

A: WIRING DIAGRAM

<Ref. to WI-131, WIRING DIAGRAM, Power Window System.>

B: INSPECTION

Symptom	Repair order
All power windows do not operate.	<ol style="list-style-type: none"> 1. Fuse (SBF-4) 2. Power window circuit breaker 3. Power window relay 4. Wiring harness
Particular window does not operate.	<ol style="list-style-type: none"> 1. Power window main switch 2. Power window sub-switch 3. Power window motor 4. Wiring harness
"Window Lock" does not operate.	Power window main switch

C: NOTE

Refer to the respective sections for removal of power window system components.

- Power window control switch <Ref. to GW-8, Power Window Control Switch.>
- Front door glass <Ref. to GW-10, Front Door Glass.>
- Front regulator and motor ASSY <Ref. to GW-11, Front Regulator and Motor Assembly.>
- Rear door glass <Ref. to GW-17, Rear Door Glass.>
- Rear regulator and motor ASSY <Ref. to GW-18, Rear Regulator and Motor Assembly.>

Power Window Control Switch

GLASS/WINDOWS/MIRRORS

3. Power Window Control Switch

A: REMOVAL

1. MAIN SWITCH

- 1) Disconnect the ground cable from the battery.
- 2) Open the cover and remove the screws, then remove the power window main switch panel.

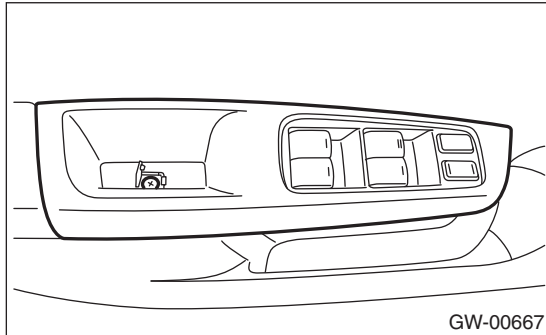

NOTE:
Remove it from the cutout portion at the tip of the switch panel.

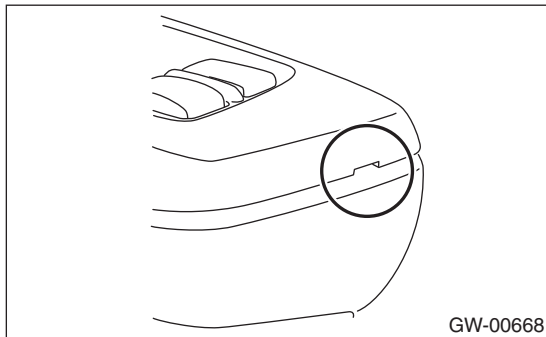

- 3) Disconnect the connector.
- 4) Remove the screws and remove the power window main switch assembly.

2. SUB-SWITCH

- 1) Open the cover and remove the screws, then remove the power window sub-switch panel.

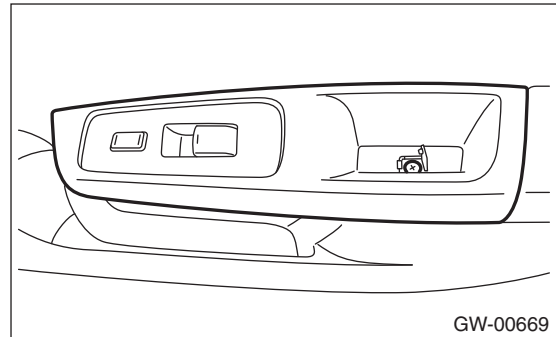

NOTE:
Remove from the notched part at the edge of the switch panel.

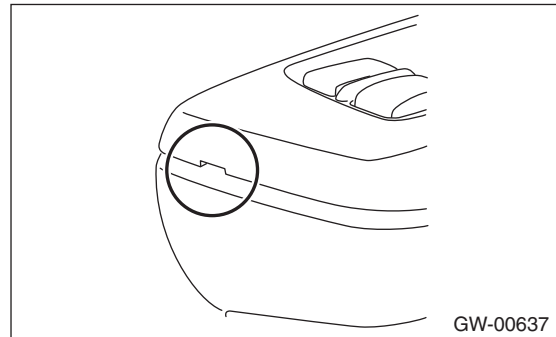

- 2) Disconnect the connector.
- 3) Remove the screws and remove the power window sub-switch assembly.

B: INSTALLATION

Install in the reverse order of removal.

C: INSPECTION

1. MAIN SWITCH

- 1) Remove the main switch. <Ref. to GW-8, MAIN SWITCH, REMOVAL, Power Window Control Switch.>
- 2) Measure the switch resistance.

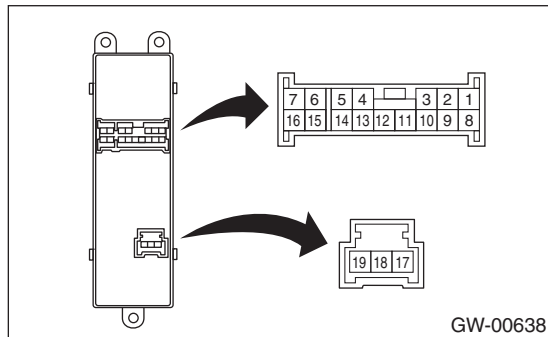

2. SUB-SWITCH

- 1) Remove the sub-switch. <Ref. to GW-8, SUB-SWITCH, REMOVAL, Power Window Control Switch.>
- 2) Measure the sub-switch resistance.

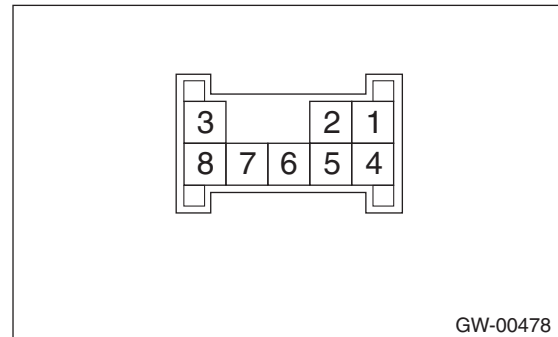

	Switch position	Terminal No.	Standard
Driver's side	UP	14 and 16 13 and 19	Less than 1 Ω
	OFF	14 and 13 14 and 16	1 MΩ or more
		17 and 18	Less than 1 Ω
	DOWN	14 and 13 16 and 19	Less than 1 Ω
	AUTO DOWN	14 and 13 16 and 19	Less than 1 Ω
Passenger's side	UP	14 and 8 12 and 19	Less than 1 Ω
	OFF	14 and 12 14 and 8	1 MΩ or more
		8 and 12 8 and 19 12 and 19	Less than 1 Ω
		DOWN	14 and 12 8 and 19
Rear LH	UP	14 and 7 5 and 19	Less than 1 Ω
	OFF	14 and 7 14 and 5	1 MΩ or more
		19 and 7 19 and 5 7 and 5	Less than 1 Ω
	DOWN	14 and 5 7 and 19	Less than 1 Ω
Rear RH	UP	14 and 1 3 and 19	Less than 1 Ω
	OFF	14 and 1 14 and 3	1 MΩ or more
		19 and 3 19 and 1 3 and 1	Less than 1 Ω
	DOWN	14 and 3 1 and 19	Less than 1 Ω

	Switch position	Terminal No.	Standard
Passenger seat, rear	UP	4 and 5 6 and 7	Less than 1 Ω
	OFF	7 and 4 8 and 4	1 MΩ or more
		5 and 8 6 and 7	Less than 1 Ω
	DOWN	4 and 6 5 and 8	Less than 1 Ω

Replace the sub-switch if faulty.

Replace the main switch if faulty.

4. Front Door Glass

A: REMOVAL

- 1) Remove the front door trim. <Ref. to EI-42, REMOVAL, Door Trim.>
- 2) Remove the sealing cover. <Ref. to EB-19, REMOVAL, Front Sealing Cover.>
- 3) Remove the pad.
- 4) Operate the power window switch to move the glass, and remove the two bolts.

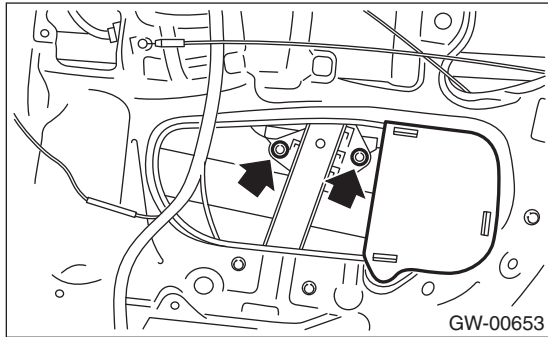

- 5) Tilt the door glass forward, and remove from the glass run rubber.
- 6) Remove the door glass.

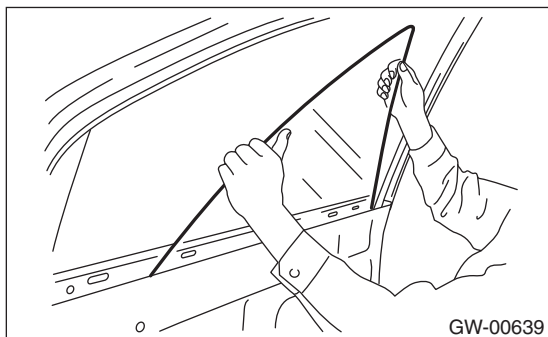

CAUTION:
Avoid impact and damage to the glass.

B: INSTALLATION

Install in the reverse order of removal.

CAUTION:
Make sure that the glass run rubber is affixed securely to the door frame and sash.

Tightening torque:
Refer to "COMPONENT" of "General Description". <Ref. to GW-3, FRONT DOOR GLASS, COMPONENT, General Description.>

5. Front Regulator and Motor Assembly

A: REMOVAL

- 1) Remove the front door glass. <Ref. to GW-10, REMOVAL, Front Door Glass.>
- 2) Disconnect the motor connector.
- 3) Remove the seven bolts, and remove the regulator and motor assembly.

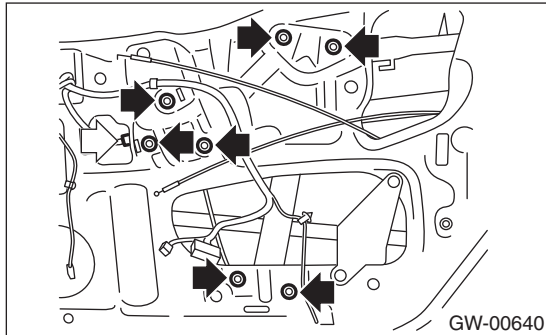

B: INSTALLATION

Install in the reverse order of removal.

Tightening torque:

Refer to “COMPONENT” of “General Description”. <Ref. to GW-3, FRONT DOOR GLASS, COMPONENT, General Description.>

C: INSPECTION

- 1) Check that the power window motor rotates properly when the battery voltage is applied to the terminals of the motor connector.
- 2) Change polarity of the battery connection to the terminals to check that the motor rotates in reverse direction.

Remote Control Mirror System

GLASS/WINDOWS/MIRRORS

6. Remote Control Mirror System

A: WIRING DIAGRAM

<Ref. to WI-135, WIRING DIAGRAM, Remote Control Mirror System.>

B: INSPECTION

Symptom	Repair order
All function does not operate.	1. Fuse (F/B No. 6) 2. Mirror switch 3. Wiring harness
One side of the mirror motor does not operate.	1. Mirror switch 2. Mirror motor 3. Wiring harness
Mirror heater does not operate.	1. Defogger switch 2. Mirror heater 3. Wiring harness

C: NOTE

Refer to the respective sections for removal of remote control mirror system components.

- Scalp cap <Ref. to GW-13, Scalp Cap.>
- Outer mirror ASSY <Ref. to GW-14, Outer Mirror Assembly.>
- Outer mirror <Ref. to GW-15, Outer Mirror.>
- Remote control mirror switch <Ref. to GW-16, Remote Control Mirror Switch.>

7. Scalp Cap

A: REPLACEMENT

- 1) Remove the mirror. <Ref. to GW-15, REPLACEMENT, Outer Mirror.>
- 2) Press-in the clips (A) from inside of outer mirror.

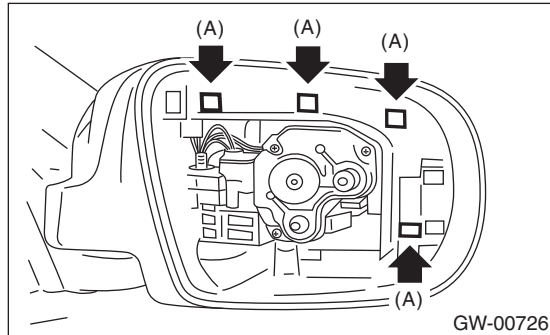

- 3) Pull the scalp cap towards the front of the outer mirror, then remove the scalp cap.
- 4) Align clip (A) on the reverse side of the scalp cap and the clip attachment hole of the outer mirror, and push the scalp cap in.

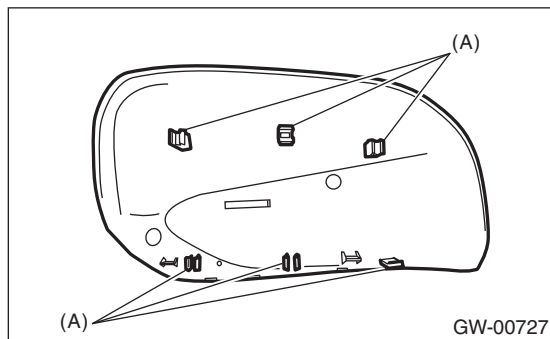

- 5) Install the scalp cap securely.

CAUTION:

Be careful and do not force when removing the scalp cap, as the lower hooks may become damaged.

Outer Mirror Assembly

GLASS/WINDOWS/MIRRORS

8. Outer Mirror Assembly

A: REMOVAL

- 1) Remove the front door trim. <Ref. to EI-42, REMOVAL, Door Trim.>
- 2) Disconnect the outer mirror connector.
- 3) Remove the bolts, then remove the outer mirror assembly.

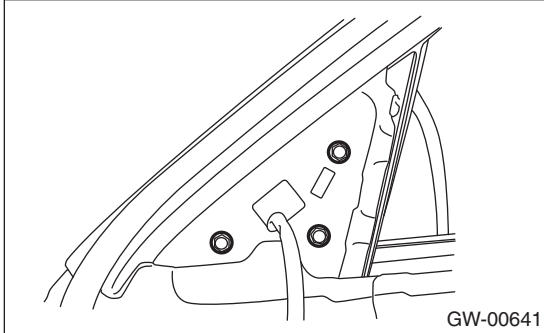

B: INSTALLATION

Install in the reverse order of removal.

Tightening torque:

4.5 N·m (0.46 kgf·m, 3.3 ft·lb)

C: INSPECTION

Check to ensure that the outer mirror moves properly when the battery voltage is applied to terminals.

Model without mirror heater

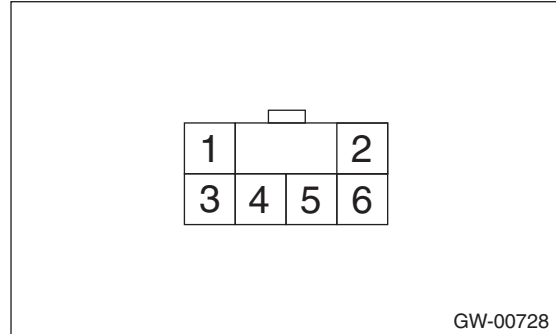

Switch position	Terminal No.
OFF	—
UP	4 (+) and 6 (-)
DOWN	6 (+) and 4 (-)
LEFT	5 (+) and 6 (-)
RIGHT	6 (+) and 5 (-)

If defective, replace the outer mirror.

Model with mirror heater

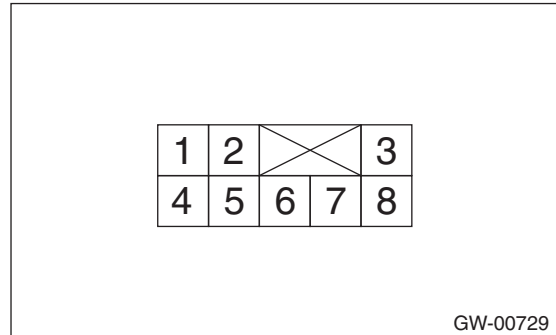

Switch position	Terminal No.
OFF	—
UP	6 (+) and 8 (-)
DOWN	8 (+) and 6 (-)
LEFT	7 (+) and 8 (-)
RIGHT	8 (+) and 7 (-)

If defective, replace the outer mirror.

9. Outer Mirror

A: REPLACEMENT

- 1) Face the mirror upward.
- 2) Lift the lower part and the outer side of the mirror, and remove the connections (1) and (2).

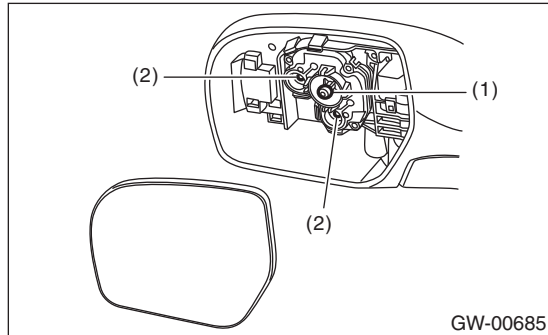

- 3) Disconnect the mirror heater connector. (Model with mirror heater)

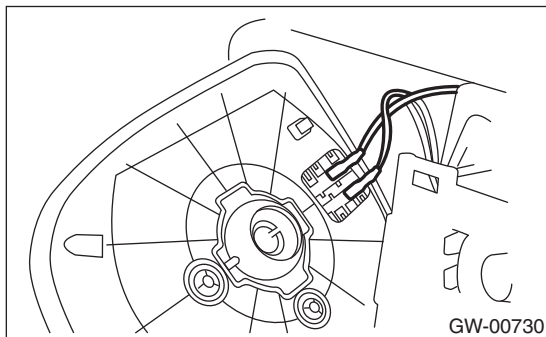

- 4) Attach the mirror to the connection (1), and attach the worm to the connection (2).

CAUTION:

When installing the mirror, insert the worm securely.

10. Remote Control Mirror Switch

A: REMOVAL

- 1) Remove the instrument panel lower cover. <Ref. to EI-44, REMOVAL, Instrument Panel Lower Cover.>
- 2) Remove the remote control mirror switch from instrument panel lower cover.

B: INSTALLATION

Install in the reverse order of removal.

C: INSPECTION

Move the remote control mirror switch to each position and check continuity between terminals.

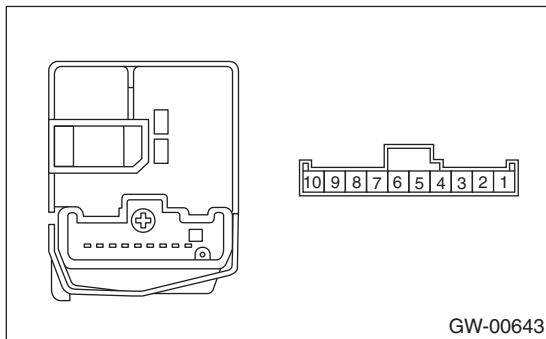

- Switch the change over switch to the right side:

Switch position	Terminal No.	Standard
OFF	—	1 MΩ or more
UP	8 and 3, 6 and 7	Less than 1 Ω
DOWN	8 and 6, 3 and 7	Less than 1 Ω
LEFT	8 and 2, 6 and 7	Less than 1 Ω
RIGHT	8 and 6, 2 and 7	Less than 1 Ω

- Switch the change over switch to the left side:

Switch position	Terminal No.	Standard
OFF	—	1 MΩ or more
UP	8 and 4, 6 and 7	Less than 1 Ω
DOWN	8 and 6, 4 and 7	Less than 1 Ω
LEFT	8 and 5, 6 and 7	Less than 1 Ω
RIGHT	8 and 6, 5 and 7	Less than 1 Ω

If NG, replace the switch.

11. Rear Door Glass

A: REMOVAL

- 1) Remove the rear door trim. <Ref. to EI-42, REMOVAL, Door Trim.>
- 2) Remove the sealing cover. <Ref. to EB-22, REMOVAL, Rear Sealing Cover.>
- 3) Operate the power window switch to move the glass, and remove the two bolts.

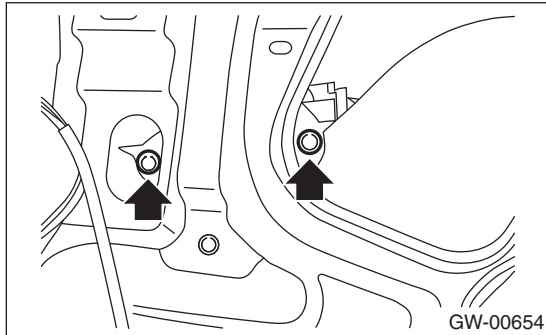

- 4) Remove the glass from the carrier plate, and while holding the glass, lower the carrier plate alone to the lowest position.

CAUTION:

Until the carrier plate is lowered to the lowest position, do not lower the glass alone to the lowest position in the door panel.

Otherwise the glass may come off of the sash and become damaged.

- 5) Carefully lower the glass to the lowest position of the door panel
- 6) Remove the bolt and nuts and remove the sash. (Remove the upper attachment point first.)

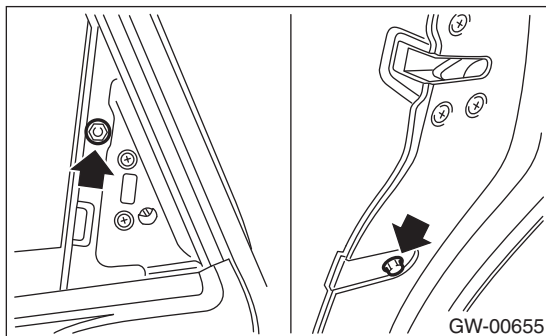

- 7) Remove the glass run rubber.
- 8) Tilt the glass, and take out the door glass.

CAUTION:

Avoid impact and damage to the glass.

B: INSTALLATION

Install in the reverse order of removal.

CAUTION:

Make sure that the glass run rubber is affixed securely to the door frame and sash.

Tightening torque:

Refer to "COMPONENT" of "General Description". <Ref. to GW-4, REAR DOOR GLASS, COMPONENT, General Description.>

12. Rear Regulator and Motor Assembly

A: REMOVAL

- 1) Remove the rear door glass. <Ref. to GW-17, REMOVAL, Rear Door Glass.>
- 2) Disconnect the motor connector.
- 3) Remove the six bolts, and remove the regulator assembly.

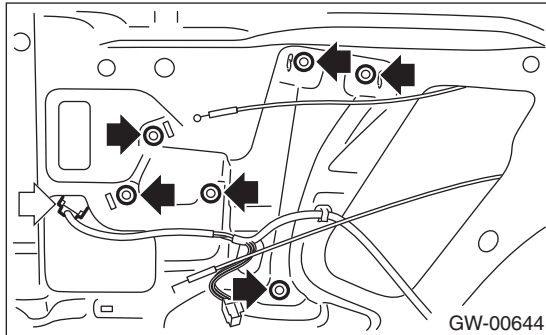

B: INSTALLATION

Install in the reverse order of removal.

Tightening torque:

Refer to “COMPONENT” of “General Description”. <Ref. to GW-4, REAR DOOR GLASS, COMPONENT, General Description.>

C: INSPECTION

- 1) Check that the power window motor rotates properly when the battery voltage is applied to the terminals of the motor connector.
- 2) Change polarity of the battery connection to the terminals to check that the motor rotates in reverse direction.

13. Windshield Glass

A: REMOVAL

1. WHEN USING WINDSHIELD GLASS KNIFE

- 1) Remove the front pillar trim of the passenger's side, and disconnect the wiper deicer connector. (Model with wiper deicer)
- 2) Remove the cowl panel. <Ref. to EI-37, REMOVAL, Cowl Panel.>
- 3) Remove the glass molding.
- 4) Tape the body side of the circumference of windshield glass for protection.
- 5) Apply sufficient amount of soapy water to the adhesive part.
- 6) Using a razor blade, cut a notch so that the windshield glass knife will be easier to insert.
- 7) Insert the windshield glass knife into the adhesive part.

8) While holding the knife edge and windshield glass edge at a right angle, move the windshield glass knife in parallel to the windshield glass edge along the surface and edge of windshield glass to cut the adhesive part.

NOTE:

- Do not twist the windshield glass knife.
- Cutting of adhesive part shall be started with wider gap between windshield glass and body.
- The locating pins are bonded to the corners of glass. Use piano wire to disconnect the pins.

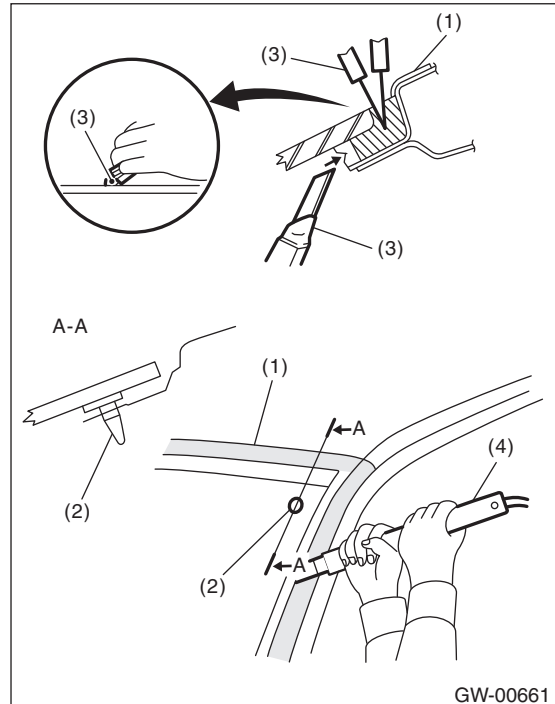

- (1) Tape for protection
- (2) Locating pin
- (3) Cutter knife
- (4) Windshield glass knife

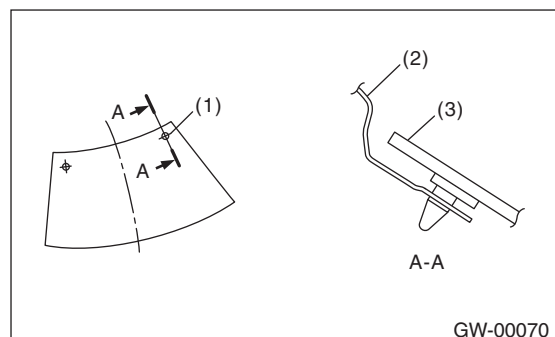

- (1) Locating pin
- (2) Body panel
- (3) Windshield glass

Windshield Glass

GLASS/WINDOWS/MIRRORS

2. WHEN USING PIANO WIRE

CAUTION:

- Do not tightly pull the piano wire against the windshield glass edge.
- Apply protective tape, etc., and be careful not to damage interior and exterior parts.
- Do not cross piano wires. Otherwise they may be cut.

1) Remove the front pillar trim of the passenger's side, and disconnect the wiper deicer connector. (Model with wiper deicer)

2) Remove the cowl panel. <Ref. to EI-37, REMOVAL, Cowl Panel.>

3) Remove the glass molding.

4) Tape the body side of the circumference of windshield glass for protection.

5) Using a drill or razor blade, make a hole in the adhesive part.

6) Pass the piano wire through the hole, and attach both the wire ends securely to pieces of wood.

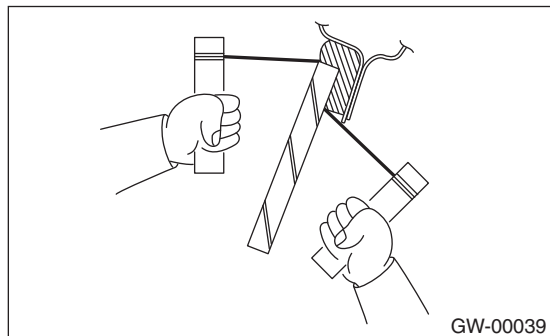

7) Pull the wire ends alternately to cut off the adhesive part.

B: INSTALLATION

1) Process the cartridge nozzle tip as shown in the figure, and set the adhesive in the sealant gun.

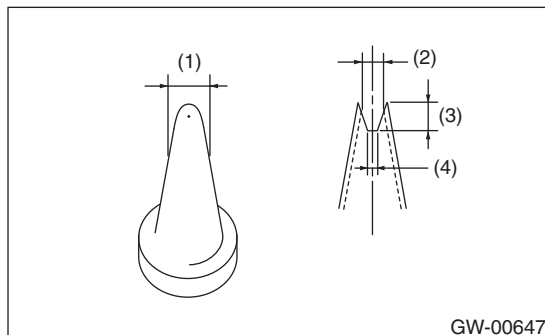

(1) 10 mm (0.39 in)

(2) 8 mm (0.31 in)

(3) 9 mm (0.35 in)

(4) 2 mm (0.08 in)

2) Clean the external circumference of windshield glass with alcohol or white gasoline.

3) Remove the adhesive layer on the body using cutter knife to obtain smooth face of 2 mm (0.08 in) thick.

CAUTION:

Be careful not to damage the body and paint surface.

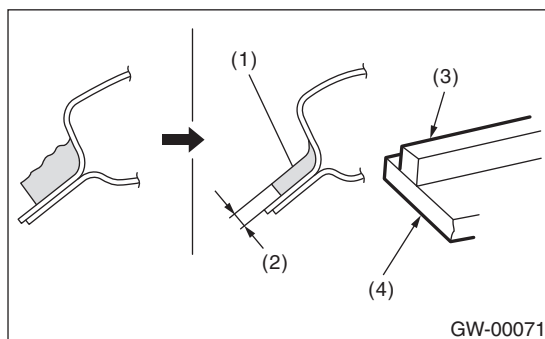

(1) Adhesive

(2) 2 mm (0.08 in)

(3) Dam rubber

(4) Glass

4) Clean the body with alcohol or white gasoline to eliminate cutting powder, dust and dirt completely from body.

5) Install the dam rubber.

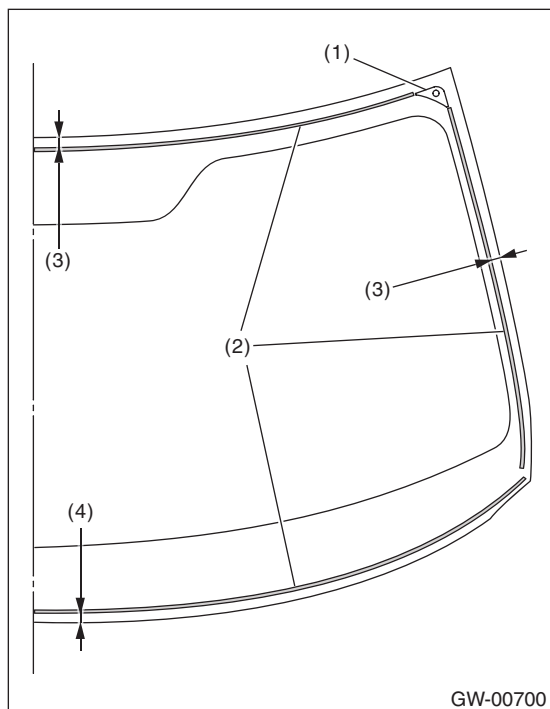

- (1) Locating pin
- (2) Dam rubber
- (3) 11 mm (0.433 in)
- (4) 13.5 mm (0.531 in)

6) Attach the molding to the glass.

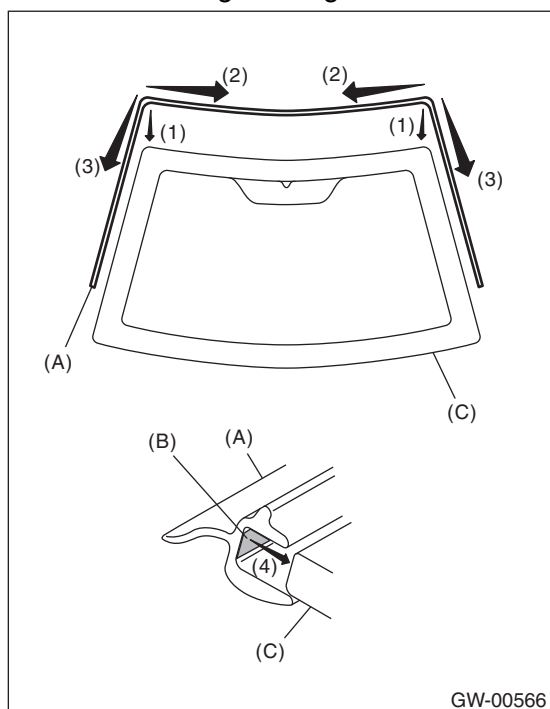

- (1) Align the molding (A) to the upper ends of the windshield glass (C).
- (2) Attach the molding from the upper corners towards the center.
- (3) Attach the molding from the upper corners downward.
- (4) Firmly apply the double sided tape (B) of the molding evenly to the end face of the glass.

7) Apply the sticker to the molding

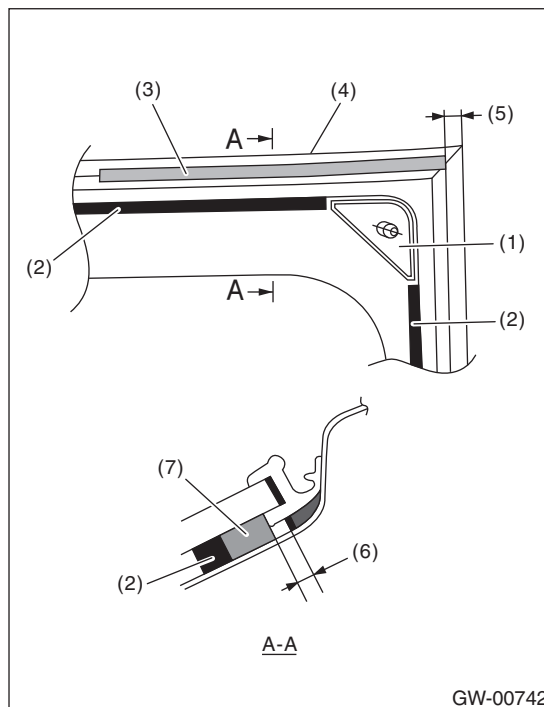

- (1) Locating pin
- (2) Dam rubber
- (3) Seal
- (4) Molding
- (5) 10 mm (0.39 in)
- (6) 1.5 mm (0.06 in)
- (7) Adhesive

NOTE:

Apply so that the sticker does not overlap out to the adhesive side (6).

Windshield Glass

GLASS/WINDOWS/MIRRORS

8) Using a sponge, apply primer to the glass side and body side adhesive surfaces.

Glass primer:

**Dow Automotive
ESSEX U-401, U-402 or equivalent**

Painted surface primer:

**Dow Automotive
ESSEX U-413 or equivalent**

NOTE:

- Primer once attached to the painted surface of the body and internal trim is hard to wipe off. Mask the circumference of such area.
- Let primer dry for about ten minutes before installing the glass.
- Do not touch the surface coated with primer.

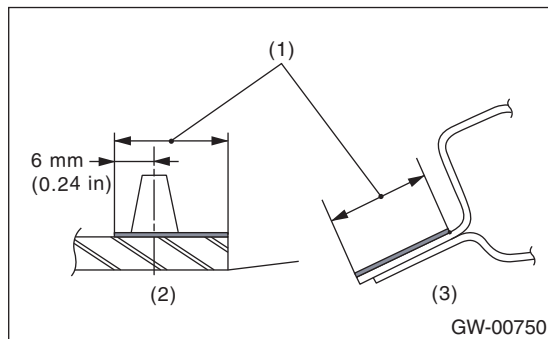

- (1) Application of primer
- (2) Glass side
- (3) Body side

9) Apply adhesive to the glass end surface as shown in the figure.

Adhesive:

**Dow Automotive
ESSEX U-400HV or equivalent**

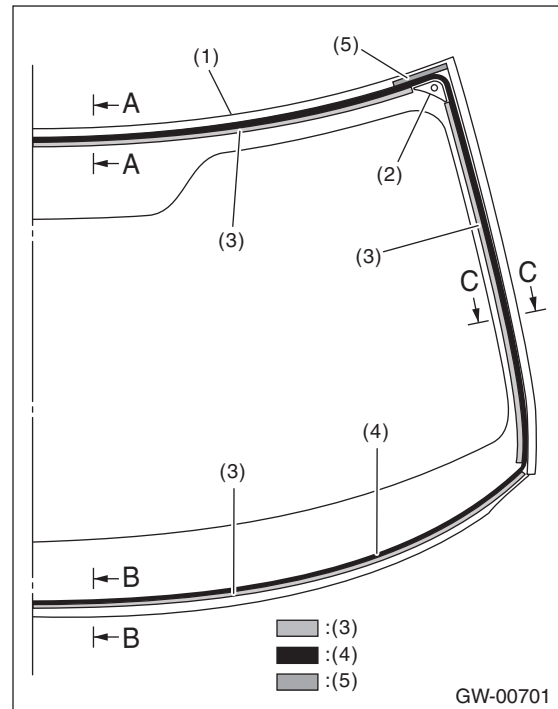

- (1) Molding
- (2) Locating pin
- (3) Dam rubber
- (4) Adhesive
- (5) Seal

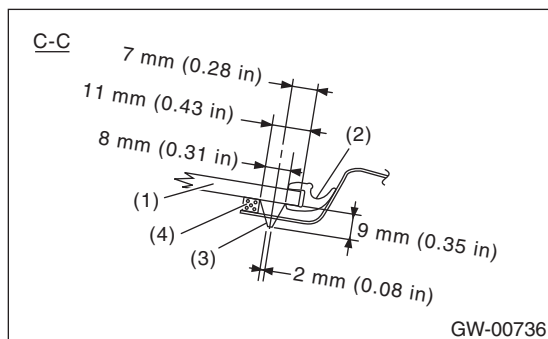
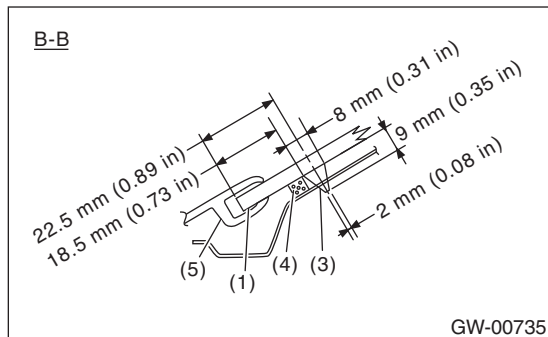
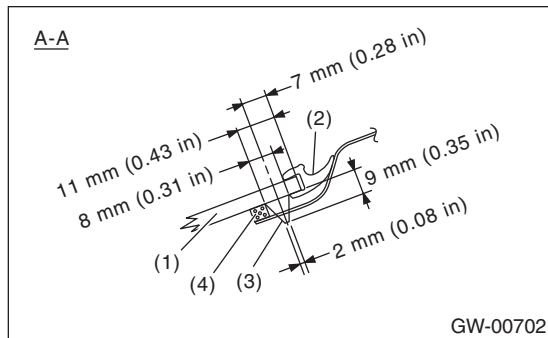

A-A Upper end area

B-B Lower end area

C-C Side area

- (1) Glass
- (2) Molding
- (3) Adhesive
- (4) Dam rubber
- (5) Cowl panel

10) Using suction rubber cups, fit the locator pins into the body side, and attach the windshield glass.

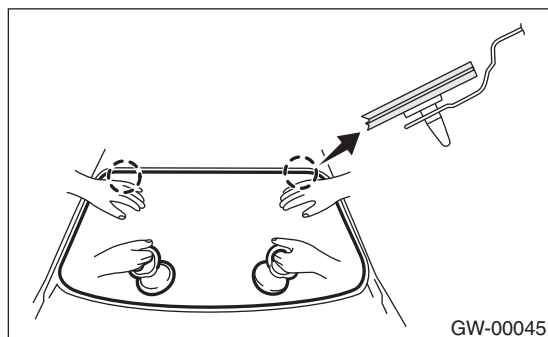

- 11) Lightly press the windshield glass for tight fit.
- 12) Make flush the adhesive surface juttred out using spatula.
- 13) Connect the wiper deicer connector. (Model with wiper deicer)
- 14) After completion of all work, allow the vehicle to stand for about 24 hours.

NOTE:

- When door is opened/closed after glass is bonded, always lower the door glass first, and then open/close it carefully.
- Move the vehicle slowly.
- For minimum drying time and vehicle standing time before driving after bonding, follow instructions or instruction manual from the adhesive manufacturer.

15) After curing of adhesive, pour the water on external surface of vehicle to check that there are no water leaks.

NOTE:

When a vehicle is returned to the user, tell him or her that the vehicle should not be subjected to heavy impact for at least three days.

16) Install the cowl panel. <Ref. to EI-37, INSTALLATION, Cowl Panel.>

14. Rear Gate Glass

A: REMOVAL

- 1) Remove the rear spoiler. <Ref. to EI-38, REMOVAL, Roof Spoiler.>
- 2) Remove the rear wiper motor. <Ref. to WW-20, REMOVAL, Rear Wiper Motor.>
- 3) Disconnect the electrical connectors from rear defogger terminal.
- 4) Remove the glass in the same procedures as for the windshield glass. <Ref. to GW-19, REMOVAL, Windshield Glass.>

B: INSTALLATION

- 1) Process the cartridge nozzle tip as shown in the figure, and set the adhesive in the sealant gun.

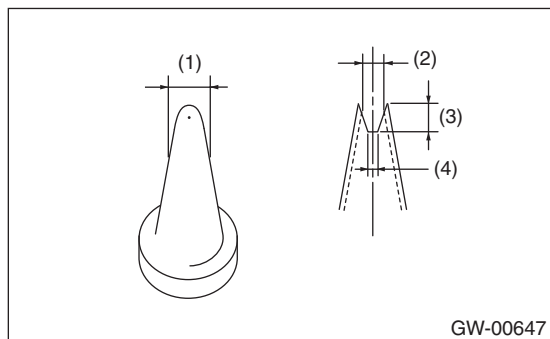

- (1) 10 mm (0.39 in)
- (2) 8 mm (0.31 in)
- (3) 10 mm (0.39 in)
- (4) 4 mm (0.16 in)

- 2) Prepare and clean the adhesion surfaces of the glass and body using the same procedures as for the windshield glass. <Ref. to GW-20, INSTALLATION, Windshield Glass.>

- 3) Install the dam rubber.

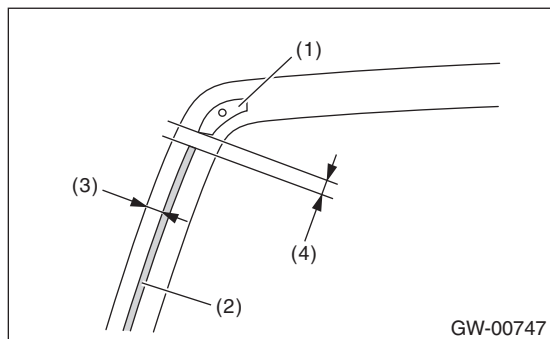

- (1) Locating pin
- (2) Dam rubber
- (3) 16 mm (0.63 in)
- (4) 15 mm (0.59 in)

- 4) Install the molding.

(1) Align the molding and glass corners, and adhere together.

(2) Because the lower end of the molding can become removed easily, affix the contact surfaces of the glass and molding with an adhesive agent.

Adhesive:

Cemedine

Cemedine 3000 (jelly type) or equivalent

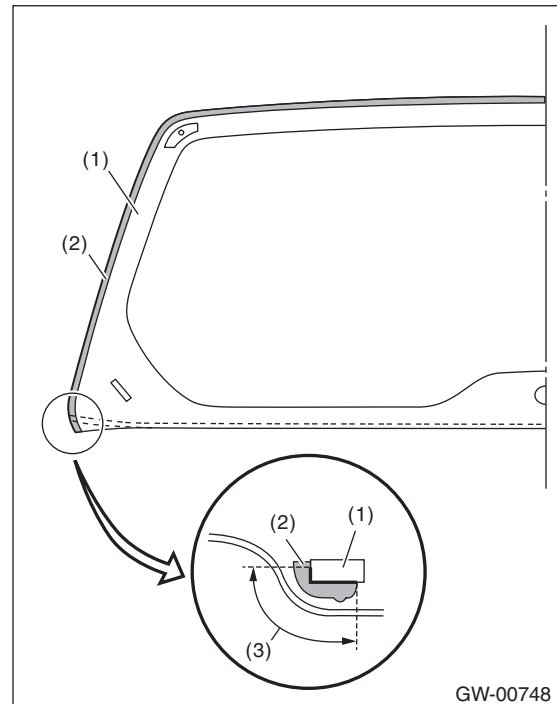

- (1) Rear gate glass
- (2) Molding
- (3) Adhesive application area

- 5) Using the same procedures as for the windshield glass, apply primer to the glass and body. <Ref. to GW-20, INSTALLATION, Windshield Glass.>

Rear Gate Glass

6) Apply adhesive in the same procedure as for the windshield glass. <Ref. to GW-20, INSTALLATION, Windshield Glass.>

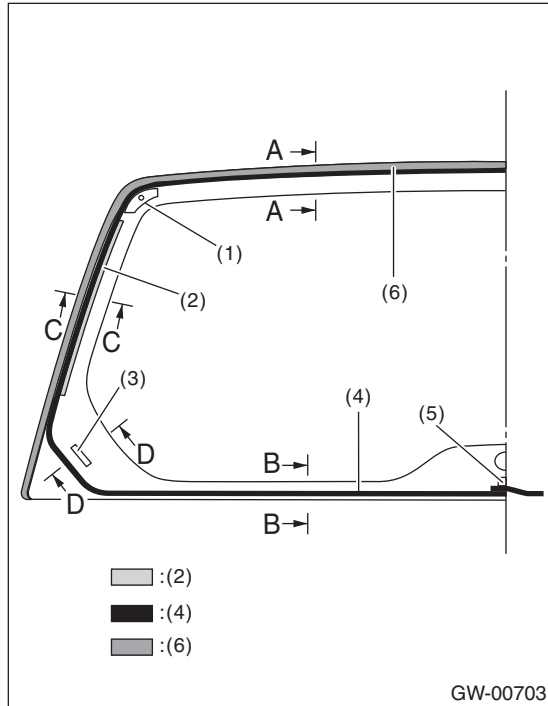

- (1) Locating pin
- (2) Dam rubber
- (3) Fastener
- (4) Adhesive
- (5) Rubber spacer
- (6) Molding

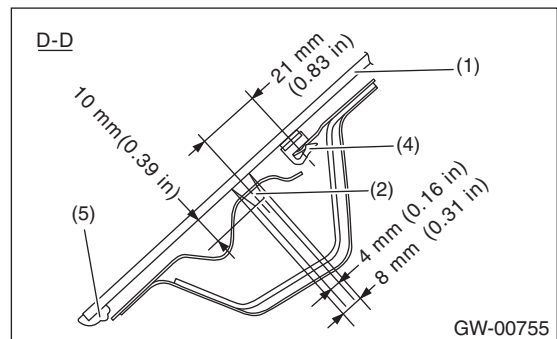
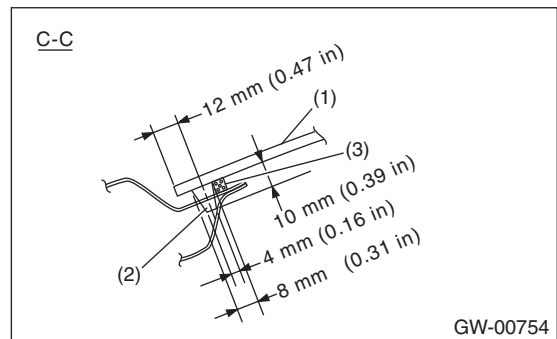
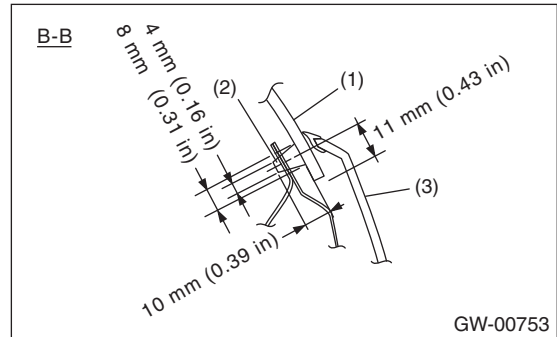
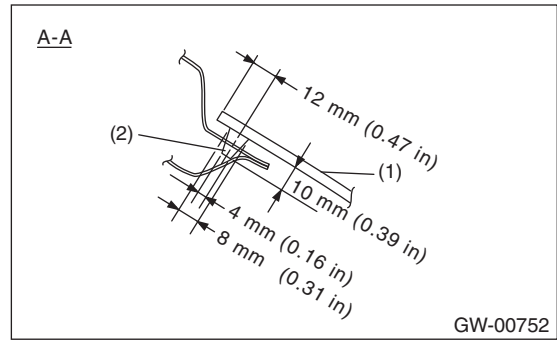

- A-A Upper end area
- B-B Lower end area
- C-C Side area
- D-D Lower end area

- (1) Glass
- (2) Adhesive
- (3) Dam rubber
- (4) Fastener
- (5) Molding

Rear Gate Glass

GLASS/WINDOWS/MIRRORS

- 7) Attach the fastener to the rear gate panel.
- 8) Insert the glass locating pins in the rear gate panel holes, and push the area around the locating pins to affix in place.
- 9) Push lightly on the area around the fastener and spacer to seal.
- 10) After completion of all work, allow the vehicle to stand for about 24 hours.

NOTE:

- When door is opened/closed after glass is bonded, always lower the door glass first, and then open/close it carefully.
 - Move the vehicle slowly.
 - For minimum drying time and vehicle standing time before driving after bonding, follow instructions or instruction manual from the adhesive manufacturer.
 - When a vehicle is returned to the user, tell him or her that the vehicle should not be subjected to heavy impact for at least three days.
- 11) After curing of adhesive, pour the water on external surface of vehicle to check that there are no water leaks.
 - 12) Connect the rear defogger terminals.
 - 13) Install the rear wiper. <Ref. to WW-20, INSTALLATION, Rear Wiper Motor.>

15. Rear Window Defogger

A: WIRING DIAGRAM

<Ref. to WI-136, WIRING DIAGRAM, Rear Defogger System.>

B: INSPECTION

1. SYSTEM INSPECTION

Symptoms	Repair order
Rear window defogger does not operate.	<ol style="list-style-type: none"> 1. Check the fuse. 2. Check the rear defogger relay. 3. Check the rear defogger switch. 4. Check the heat wire. 5. Check the wiring harness. 6. Check body integrated unit.

NOTE:

Rear window defogger system can be customized on the Subaru Select Monitor, when the body integrated unit customize setting {A/C ECM setting} is "support". (Auto A/C model)

System name	Initial setting	Customize setting
Rr defogger op. mode	OFF after 15 min.	Repeat 15 min. operation and 2 min. stop.

2. CHECK WITH SUBARU SELECT MONITOR

CAUTION:

Check whether the "Rr defogger op. mode" setting is in initial setting or customize setting before performing inspection.

1) Check the input signal when the rear window defogger switch is operated using Subaru Select Monitor.

(1) Prepare the Subaru Select Monitor. <Ref. to GW-6, PREPARATION TOOL, General Description.>

(2) Turn the ignition switch to ON (engine OFF) and run the "PC application for Subaru Select Monitor".

(3) On «System Selection Menu» display, select {Integ. unit mode}.

(4) Select the {Rr defogger output} on {Current Data Display & Save}.

(5) Check the displayed data (ON/OFF) by operating the rear window defogger switch.

2) Check the operation with rear window defogger switch ON.

- When customize setting is set as "Continuous", it is normal if the 15-minute operation and 2-minute stop repeats.

- When customize setting is "Normal", it is normal if the operation lasts for 15 minutes and then turns OFF.

3) When the operation in 2) above fails, replace the body integrated unit.

3. HEAT WIRE INSPECTION

CAUTION:

When wiping off the stain on glass with cloth, use a dry and soft cloth and move it in the direction of the heat wire extension to avoid damage to the heat wire.

1) Turn the ignition switch to ON.

2) Turn the defogger switch to ON.

3) Wrap the tips of tester probe with aluminum foil to avoid damage to heat wire.

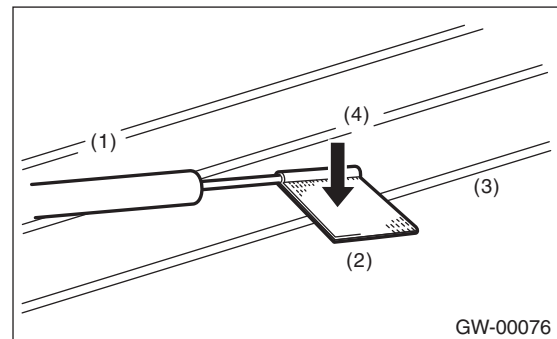

- (1) Tester probe
- (2) Aluminum foil
- (3) Heat wire
- (4) Press

4) Measure the voltage at heat wire center (1) with DC voltmeter.

Standard voltage:

Approx. 6 V

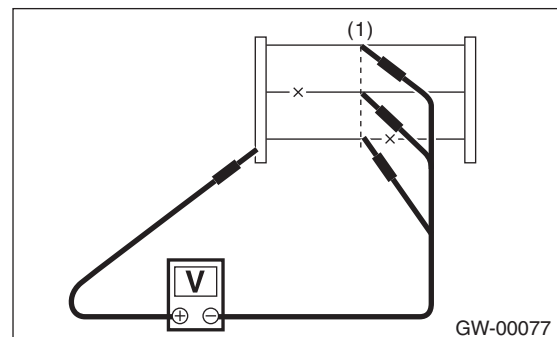

Voltage	Criteria
Approx. 6 V	Normal operation
Approx. 12 V or 0 V	Open

NOTE:

- If the measured value is 12 V, heat wire is open between heat wire center and positive (+) terminal of tester probe.

- If it is 0 V, the circuit is open between heat wire center and ground.

Rear Window Defogger

GLASS/WINDOWS/MIRRORS

5) Connect the tester probe of positive lead of voltmeter to positive terminal of heat wire and move tester probe of negative lead along the heat wire up to the negative terminal end. If voltage changes from zero to several volts during movement of tester probe, heat wire is open at the voltage change point.

C: REPAIR

1) Clean the broken portion with alcohol or white gasoline.

2) Mask both side of wire with thin film.

3) Apply conductive silver composition (DUPONT No. 4817) to the broken area.

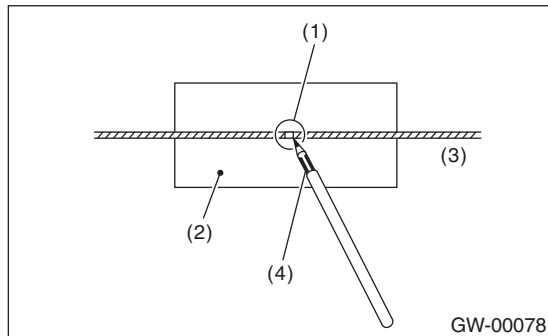

- (1) Broken portion
- (2) Thin film
- (3) Broken wire
- (4) Conductive silver composition
(DUPONT No. 4817)

4) After repair, check the wire.

16.Rear Quarter Glass

A: REMOVAL

Remove the glass in the same procedures as for the windshield glass. <Ref. to GW-19, REMOVAL, Windshield Glass.>

B: INSTALLATION

1) Process the cartridge nozzle tip as shown in the figure, and set the adhesive in the sealant gun.

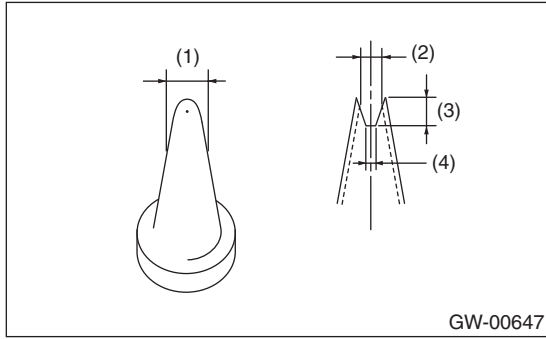

- (1) 10 mm (0.39 in)
- (2) 8 mm (0.31 in)
- (3) 9 mm (0.35 in)
- (4) 2 mm (0.08 in)

2) Prepare and clean the adhesion surfaces of the glass and body using the same procedures as for the windshield glass. <Ref. to GW-20, INSTALLATION, Windshield Glass.>

3) Attach the fastener to the body.

4) Attach the outer dam rubber at a position 4 mm from the glass end.

5) On the front end, attach the inner periphery dam rubber at a position 13 mm from the border of the glass ceramic gradation, and for other locations 17 mm from the end of the glass.

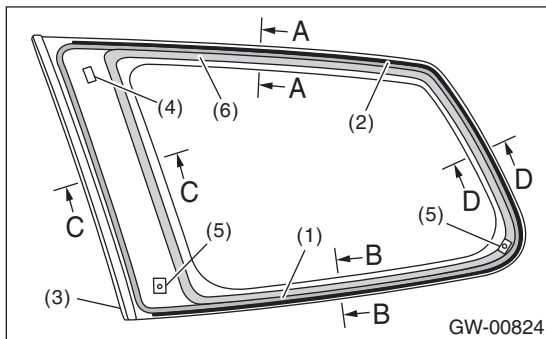

- (1) Adhesive
- (2) Outer periphery dam rubber
- (3) Molding
- (4) Fastener
- (5) Locating pin
- (6) Inner periphery dam rubber

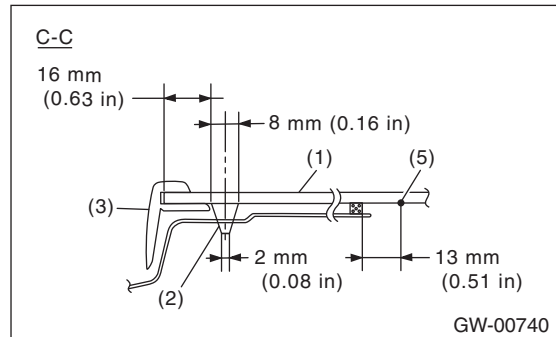
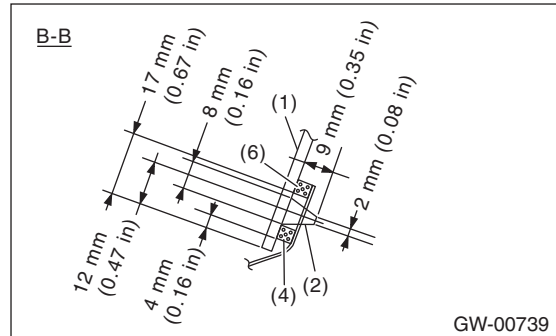
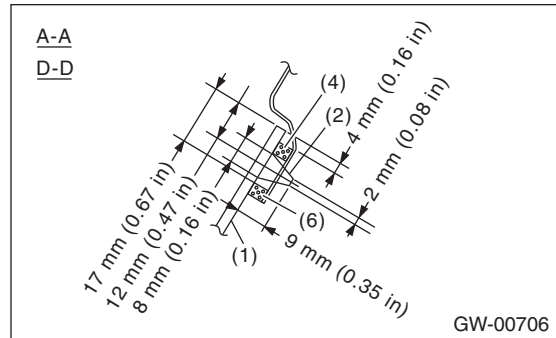

- A-A Upper end area
- B-B Lower end area
- C-C Front end area
- D-D Rear end area

- (1) Glass
- (2) Adhesive
- (3) Molding
- (4) Outer periphery dam rubber
- (5) Glass ceramic gradation border
- (6) Inner periphery dam rubber

Rear Quarter Glass

GLASS/WINDOWS/MIRRORS

6) Using the same procedures as for the front glass, apply primer to the glass and body. <Ref. to GW-20, INSTALLATION, Windshield Glass.>

7) Apply adhesive in the same procedure as for the windshield glass. <Ref. to GW-20, INSTALLATION, Windshield Glass.>

8) Insert the glass locating pins in the holes of the side panel, and push the area around the locating pins to affix in place.

After this, push lightly on the surrounding area to seal.

9) After completion of all work, allow the vehicle to stand for about 24 hours.

NOTE:

- When door is opened/closed after glass is bonded, always lower the door glass first, and then open/close it carefully.
- Move the vehicle slowly.
- For minimum drying time and vehicle standing time before driving after bonding, follow instructions or instruction manual from the adhesive manufacturer.

10) After curing of adhesive, pour the water on external surface of vehicle to check that there are no water leaks.

NOTE:

When a vehicle is returned to the user, tell him or her that the vehicle should not be subjected to heavy impact for at least three days.

17. Rearview Mirror

A: REMOVAL

CAUTION:

- Never reuse the spring. If the rear view mirror assembly is removed from the mirror base, the holding strength of the spring will become reduced and the rear view mirror assembly may fall off.
- Be careful not to damage the mirror surface and windshield glass.

1) Turn the mirror base 90° clockwise or counter-clockwise to remove it.

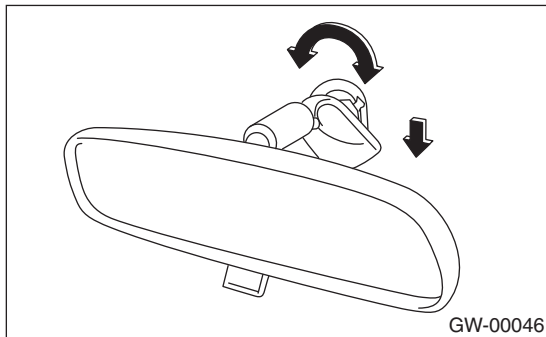

2) Remove the spring from the mirror base.

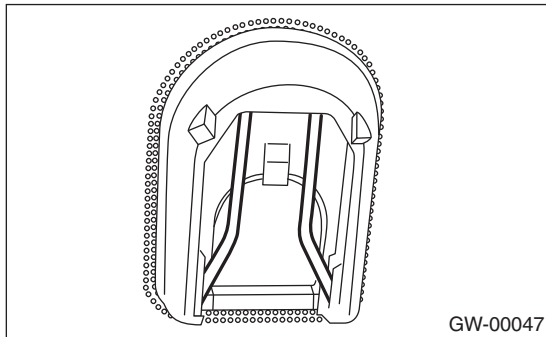

3) If the mirror base is damaged, use piano wire or a spatula to remove.

B: INSTALLATION

Install in the reverse order of removal.

NOTE:

When the mirror base is removed, it is attached according to the following procedures.

1. Remove the old adhesive completely.
2. Attach the mirror base by matching with the mark on the front glass.
3. Make sure the mirror base is securely attached and then install the spring to it.

Adhesive:

REPAIR KIT IN MR (Part No. 65029FC000) or equivalent

C: INSPECTION

- Make sure that the mirror is not damaged.
- Make sure that the spring is not damaged.
- Make sure that the mirror base is not damaged.

Wiper Deicer System

GLASS/WINDOWS/MIRRORS

18. Wiper Deicer System

A: WIRING DIAGRAM

<Ref. to WI-121, WIRING DIAGRAM, Wiper Deicer System.>

B: INSPECTION

1. SYSTEM INSPECTION

NOTE:

The wiper deicer operates with the rear window defogger at the same time.

Symptoms	Repair order
Wiper deicer does not operate.	1. Check the fuse. 2. Check the wiper deicer relay. 3. Check the rear defogger switch. 4. Check the heat wire. 5. Check the wiring harness. 6. Check body integrated unit.

NOTE:

Wiper deicer system can be customized on the Subaru Select Monitor, when the body integrated unit customize setting {A/C ECM setting} is "support". (Auto A/C model)

System name	Initial setting	Customize setting
Wiper deicer op. mode	OFF after 15 min.	Continuous operation*

*: When one of the following conditions occurs, continuous operation is suspended and turned off after 15 minutes.

- Ambient temperature at 5°C (41°F) or more continues for 10 seconds.
- Malfunction occurs on ambient sensor.
- Vehicle speed of 15 km/h (9 MPH) or less continues 15 minutes. (OFF when conditions are met)
- Malfunction occurs in CAN communication.
- Battery voltage (10 V or less) continues for 30 seconds.

2. CHECK WITH SUBARU SELECT MONITOR

CAUTION:

Before performing the inspection, check the following settings.

- Is the "wiperdeicer" setting "support"? If "no support", set to "support" using customize setting.
- "Wiper deicer op. mode" setting → Initial setting or customize setting

1) Check the input signal when the rear window defogger switch is operated using Subaru Select Monitor.

(1) Prepare the Subaru Select Monitor. <Ref. to GW-6, PREPARATION TOOL, General Description.>

(2) Turn the ignition switch to ON (engine OFF) and run the "PC application for Subaru Select Monitor".

(3) On «System Selection Menu» display, select {Integ. unit mode}.

(4) Select the {Wiper deicer output} on {Current Data Display & Save}.

(5) Check the displayed data (ON/OFF) by operating the rear window defogger switch.

2) Check the operation with rear window defogger switch ON.

- When customize setting is "Continuous", it is normal if the operation lasts without any termination conditions.

- When customize setting is «Normal», it is normal if the operation lasts for 15 minutes and then turns OFF.

3) When the operation in 2) above fails, replace the body integrated unit.

3. HEAT WIRE INSPECTION

Refer to "HEAT WIRE INSPECTION" of "Rear Window Defogger". <Ref. to GW-27, HEAT WIRE INSPECTION, INSPECTION, Rear Window Defogger.>

C: REPAIR

Refer to "REPAIR" of "Rear Window Defogger". <Ref. to GW-28, REPAIR, Rear Window Defogger.>

BODY STRUCTURE

BS

	Page
1. General Description	2



1. General Description

A: SPECIFICATION

Refer to “Body Repair Manual” for general description of body structure, reference points and reference dimensions.

INSTRUMENTATION/DRIVER INFO

IDI

	Page
1. General Description	2
2. Combination Meter System	4
3. Clock System	12
4. Combination Meter	16
5. Speedometer	18
6. Tachometer	19
7. Fuel Gauge	20
8. Clock	21

General Description

INSTRUMENTATION/DRIVER INFO

1. General Description

A: SPECIFICATION

Combination meter	Speedometer	Stepping motor type
	Tachometer	
	Fuel gauge	
	Malfunction indicator light	LED
	Oil pressure indicator light	
	AT oil temperature warning light	
	Tire pressure warning light	
	ABS warning light	
	Engine coolant temperature indicator light	
	Engine coolant temperature warning light	
	Airbag warning light	
	Seat belt warning light	
	Door open warning light	
	Brake fluid and parking brake warning light	
	Low fuel warning light	
	Charge warning light	
	Automatic headlight beam leveler warning light	
	AWD warning light (AT model)	
	Hill start assist warning light (MT model)	
	Vehicle dynamics control (VDC) warning light and VDC OFF indicator light	
	Vehicle dynamics control (VDC) indicator light	
	Turn signal indicator light	
	HI-beam indicator light	
	Security and immobilizer indicator light	
	Cruise indicator light	
	Cruise set indicator light	
	Front fog light indicator light	
	Sports indicator light (AT model)	
	Light illumination indicator light	
	Meter illumination light	
LCD back light		
Odo/trip indicator	LCD	
Sports indicator light (AT model)		
AT select lever position indicator		
Clock	Average fuel economy, Ambient air temperature, Current time, Malfunction warning display	VFD
	Passenger's airbag ON indicator	LED
	Passenger's airbag OFF indicator	
	Passenger' seat belt warning light	

B: CAUTION

- Be careful not to damage the meters and instrument panel.
- Be careful not to damage the meter glass.
- Make sure the electrical connector is connected securely.
- After installation, make sure that each meter operates normally.
- Use gloves to avoid damage and getting fingerprints on the glass surface and meter surfaces.
- Do not apply an excessive force on the printed circuit.
- Do not drop or otherwise apply impact.
- When the combination meter of model with immobilizer has been replaced, be sure to perform the registration of immobilizer.

C: PREPARATION TOOL

1. SPECIAL TOOL

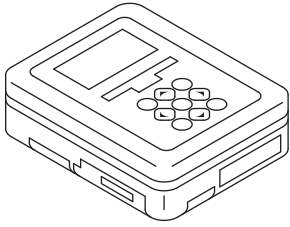
ILLUSTRATION	TOOL NUMBER	DESCRIPTION	REMARKS
 <p style="text-align: center; margin-top: 10px;">ST1B022XU0</p>	<p>1B022XU0 (Newly adopted tool)</p>	<p>SUBARU SELECT MONITOR III KIT</p>	<p>Used for troubleshooting the electrical system.</p>

2. GENERAL TOOL

TOOL NAME	REMARKS
Circuit tester	Used for measuring resistance and voltage.

Combination Meter System

INSTRUMENTATION/DRIVER INFO

2. Combination Meter System

A: WIRING DIAGRAM

1. COMBINATION METER

<Ref. to WI-137, WIRING DIAGRAM, Combination Meter System.>

B: INSPECTION

1. SELF-DIAGNOSIS

The self-diagnosis (checking of each meter, warning light, indicator, illumination, LCD) of combination meter can be performed in the following procedure.

NOTE:

Perform the steps described in 2) through 4) within 10 seconds.

- 1) Within 3 seconds after turning the ignition switch to ON, set the lighting switch to tail light or headlight position.
- 2) Press the odo/trip meter knob three times.
- 3) Turn the lighting switch to OFF, and press the odo/trip meter knob three times.
- 4) Set the lighting switch to tail light or headlight position again, and press the odo/trip meter knob three times.

NOTE:

- If the odo/trip meter knob is pressed four times in the step, it will switch to the DTC display mode. <Ref. to IDI-11, DTC DISPLAY MODE, INSPECTION, Combination Meter System.>
 - When the self-diagnosis function operates, the warning light, indicator, and LCD display checks are performed. After this, the buzzer will sound for 0.5 seconds every time the odo/trip meter knob is pressed, and operation checks are performed in the order of meter indicator needle operation, meter indicator needle indication, and LCD. Turn the ignition switch to OFF to cancel the self-diagnosis function.
 - When the engine starts during diagnosis, the self-diagnosis function is not cancelled, however, once the vehicle starts driving, the self-diagnosis function is deactivated automatically for safety.
- 5) Move on to the "Meter Indicator Needle Operation Check".
Check meter operation, warning light, indicator light, and LCD.

Meter indicator needle	LCD display, illumination	Warning lights, indicator lights
MIN indication ↓ MAX indication	ILL1 (lowest brightness) ↓ (Display each level for 1 second) ILL6 (highest brightness)	Light ON The engine coolant temperature warning light illuminates in red.
MAX indication ↓ MIN indication	ILL6 (highest brightness) ↓ (Display each level for 1 second) ILL1 (lowest brightness)	

6) Press the odo/tripmeter knob once.

7) Move on to the "Meter Indicator Needle Indication Check".

Check meter operation, warning light, indicator light, and LCD.

NOTE:

- The meter indicator needle will switch every 1.5 seconds.
- The ILL illumination level will be at the brightness it was set to when switching to the "Meter Indicator Needle Indication Check".

Speedometer (km/h)	Tachometer (rpm)	Fuel gauge	Engine coolant temperature gauge	Low fuel warning light	Warning lights, indicator lights
0	0	Lowest position	Lowest position	Light ON	Light OFF The engine coolant temperature indicator light illuminates in blue.
0	0	E	C	Light ON	
40	1000	1/2	1/2	Light OFF	
100	4000	F	H	Light OFF	
40	1000	1/2	1/2	Light OFF	
0	0	E	C	Light ON	

Combination Meter System

INSTRUMENTATION/DRIVER INFO

- 8) Press the odo/tripmeter knob once.
 9) Move on to the "LCD Display Check".
 Check the LCD.

NOTE:

- All warning lights and indicator lights turn off.
- The meter indicator needle maintains its position in the "Meter Indicator Needle Indication Check".
- The ILL illumination level is lit at ILL6 (highest brightness).

Illuminating order	1	2	3	4	5	6	7	8	9	10	11	12	13	Go back to 1 and repeat
ODO, TRIP A/B	All lights ON	All lights OFF	ODO	All lights OFF	TRIP A	All lights OFF	TRIP B	All lights OFF	All lights OFF	All lights OFF	TRIP A	All lights OFF	TRIP B	
Odo/trip meter	88888.8	111111	22222.2	333333	44444.4	555555	66666.6	777777	88888.8	999999	00000.0	888888	88888.8	
AT shift indicator	All lights ON	1	2	3	4	5	6	7	P	R	N	D	E	
	▲ ▼	▲ ▼	All lights OFF	▲	All lights OFF	▼	All lights OFF	▲	All lights OFF	▼	All lights OFF	▲	All lights OFF	

2. SYMPTOM CHART

Symptoms	Repair order	Reference
Combination meter assembly does not operate.	1. Power supply 2. Ground circuit 3. Combination meter	<Ref. to IDI-6, CHECK POWER SUPPLY AND GROUND CIRCUIT, INSPECTION, Combination Meter System.>
Speedometer does not operate.	1. VDC C/U 2. Harness 3. Combination meter	<Ref. to IDI-6, CHECK VDC CONTROL MODULE, INSPECTION, Combination Meter System.>
Tachometer does not operate.	1. ECM 2. Harness 3. Combination meter	<Ref. to IDI-7, CHECK ENGINE CONTROL MODULE (ECM), INSPECTION, Combination Meter System.>
Fuel gauge does not operate.	1. Combination meter 2. Communication circuit 3. Harness 4. Body integrated unit 5. Fuel level sensor	<Ref. to IDI-8, CHECK FUEL LEVEL SENSOR, INSPECTION, Combination Meter System.>
Warning buzzer for key left in ignition does not sound.	1. Communication circuit 2. Combination meter	<Ref. to IDI-10, CHECK WARNING BUZZER FOR KEY LEFT IN IGNITION, INSPECTION, Combination Meter System.>

CAUTION:

When measuring the voltage and resistance of each control module or sensor, use a tapered pin with a diameter of less than 0.64 mm (0.025 in) in order to avoid poor contact. Do not insert the pin more than 2 mm (0.08 in).

Combination Meter System

INSTRUMENTATION/DRIVER INFO

3. CHECK POWER SUPPLY AND GROUND CIRCUIT

Step	Check	Yes	No
1 CHECK POWER SUPPLY FOR COMBINATION METER. 1) Remove the combination meter. <Ref. to IDI-16, REMOVAL, Combination Meter.> 2) Disconnect the combination meter harness connector. 3) Turn the ignition switch to ON. 4) Measure the voltage between combination meter connector and chassis ground. Connector & terminal (i10) No. 2 (+) — Chassis ground (-):	Is the voltage 10 V or more?	Go to step 2.	Check the harness for open or short between the ignition switch and combination meter.
2 CHECK POWER SUPPLY FOR COMBINATION METER. Measure the voltage between combination meter connector and chassis ground. Connector & terminal (i10) No. 1 (+) — Chassis ground (-):	Is the voltage 10 V or more?	Go to step 3.	Check the harness for open or short between the fuse and combination meter.
3 CHECK GROUND CIRCUIT OF COMBINATION METER. 1) Turn the ignition switch to OFF. 2) Measure the resistance of harness between combination meter connector and chassis ground. Connector & terminal (i10) No. 21 — Chassis ground: (i10) No. 22 — Chassis ground:	Is the resistance less than 10 Ω?	Replace the meter case assembly.	Repair the wiring harness.

4. CHECK VDC CONTROL MODULE

Step	Check	Yes	No
1 CHECK VEHICLE SPEED SIGNAL. 1) Lift up the vehicle and support it with rigid racks. 2) Drive the vehicle faster than 10 km/h (6 MPH). WARNING: Be careful not to get caught in the running wheels. 3) Measure the voltage between combination meter connector and chassis ground. Connector & terminal (i10) No. 31 (+) — Chassis ground (-):	Is the voltage less than 1 V ←→ 5 V or more?	Replace the meter case assembly.	Go to step 2.
2 CHECK HARNESS BETWEEN VDC CONTROL MODULE AND COMBINATION METER. 1) Turn the ignition switch to OFF. 2) Disconnect the connectors from the VDC control module and combination meter. 3) Measure the resistance between VDC control module harness connector and combination meter harness connector. Connector & terminal (B310) No. 33 — (i10) No. 31:	Is the resistance less than 10 Ω?	Check the VDC control module. <Ref. to VDC(diag)-2, Basic Diagnostic Procedure.>	Repair the wiring harness.

Combination Meter System

INSTRUMENTATION/DRIVER INFO

5. CHECK ENGINE CONTROL MODULE (ECM)

Step	Check	Yes	No
<p>1</p> <p>CHECK ECM SIGNAL.</p> <p>1) Start the engine.</p> <p>2) Measure the voltage between ECM connector and chassis ground.</p> <p>Connector & terminal (B136) No. 22 (+) — Chassis ground (-):</p>	<p>Is the voltage 0 ↔ 14 V or more?</p>	<p>Go to step 2.</p>	<p>Inspect the ECM. <Ref. to EN(H4SO)(diag)-2, Basic Diagnostic Procedure.> <Ref. to EN(H4DOTC)(diag)-2, Basic Diagnostic Procedure.></p>
<p>2</p> <p>CHECK HARNESS BETWEEN COMBINATION METER AND ECM.</p> <p>1) Turn the ignition switch to OFF.</p> <p>2) Disconnect the connector from ECM and combination meter.</p> <p>3) Measure the resistance between ECM harness connector and combination meter harness connector.</p> <p>Connector & terminal (B136) No. 22 — (i10) No. 32:</p>	<p>Is the resistance less than 10 Ω?</p>	<p>Replace the meter case assembly.</p>	<p>Repair the wiring harness.</p>

Combination Meter System

INSTRUMENTATION/DRIVER INFO

6. CHECK FUEL LEVEL SENSOR

Step	Check	Yes	No	
1	CHECK COMBINATION METER. Check combination meter fuel gauge indication status.	Does the fuel gauge indicate EMPTY and is the remaining fuel or similar warning light blinking?	Go to step 4.	Go to step 2.
2	CHECK COMBINATION METER. Perform self-diagnosis of the combination meter. <Ref. to IDI-4, SELF-DIAGNOSIS, INSPECTION, Combination Meter System.>	Is operation normal?	Go to step 3.	Replace the meter case assembly.
3	CHECK THE COMMUNICATION STATUS. 1) Prepare the Subaru Select Monitor kit. 2) Turn the ignition switch to ON (engine OFF), and run the "PC application for Subaru Select Monitor". 3) Read the DTC of body integrated unit using Subaru Select Monitor. <Ref. to LAN(diag)-14, OPERATION, Subaru Select Monitor.>	Is DTC being displayed?	Perform the diagnosis according to DTC. <Ref. to LAN(diag)-28, LIST, List of Diagnostic Trouble Code (DTC).>	Go to step 4.
4	CHECK HARNESS. 1) Disconnect the harness connector of body integrated unit. 2) Measure the resistance between the body integrated unit harness connector terminal and chassis ground. Connector & terminal (B281) No. 7 — Chassis ground:	Is the resistance less than 2 — 96 Ω?	Go to step 5. When "Yes" was chosen in step 1, Go to step 9.	Repair the wiring harness.
5	CHECK COMMUNICATION BETWEEN THE BODY INTEGRATED UNIT AND METER. 1) Remove the fuel sub level sensor. <Ref. to FU(H4SO)-60, REMOVAL, Fuel Sub Level Sensor.> <Ref. to FU(H4DOTC)-67, REMOVAL, Fuel Sub Level Sensor.> 2) Short the fuel sub level sensor connector terminal to the chassis ground using a suitable lead wire with 100 Ω resistance connected between connector terminal and chassis ground. 3) Turn the ignition switch to ON. Terminal (R59) No. 1 — Chassis ground:	Does the meter needle indicate EMPTY?	Go to step 7.	Go to step 6.
6	CHECK BODY INTEGRATED UNIT. Under the same conditions as step 5, read the data of "Fuel Level Sensor Resistance" of the body integrated unit using the Subaru Select Monitor. <Ref. to LAN(diag)-14, OPERATION, Subaru Select Monitor.>	Is the data displayed as 100 Ω?	Go to step 11.	Replace the body integrated unit. <Ref. to SL-42, REMOVAL, Body Integrated Unit.>
7	CHECK COMMUNICATION BETWEEN THE BODY INTEGRATED UNIT AND METER. 1) Remove the fuel sub level sensor. <Ref. to FU(H4SO)-60, REMOVAL, Fuel Sub Level Sensor.> <Ref. to FU(H4DOTC)-67, REMOVAL, Fuel Sub Level Sensor.> 2) Short the fuel sub level sensor connector terminal to the chassis ground using a suitable lead wire with 2 — 6 Ω resistance connected between connector terminal and chassis ground. 3) Turn the ignition switch to ON. Terminal (R59) No. 1 — Chassis ground:	Does the meter needle indicate FULL?	Go to step 9.	Go to step 8.

Combination Meter System

INSTRUMENTATION/DRIVER INFO

Step	Check	Yes	No
8 CHECK BODY INTEGRATED UNIT. Under the same conditions as step 7, read the data of "Fuel Level Sensor Resistance" of the body integrated unit using the Subaru Select Monitor. <Ref. to LAN(diag)-14, OPERATION, Subaru Select Monitor.>	Is it approximately 2 — 6 Ω?	Go to step 11.	Replace the body integrated unit. <Ref. to SL-42, REMOVAL, Body Integrated Unit.>
9 CHECK FUEL SUB LEVEL SENSOR. 1) Remove the fuel sub level sensor. <Ref. to FU(H4SO)-60, REMOVAL, Fuel Sub Level Sensor.> <Ref. to FU(H4DOTC)-67, REMOVAL, Fuel Sub Level Sensor.> 2) Measure the resistance between fuel sub level sensor connector terminals when the float is in FULL or EMPTY position. Connector & terminal (R59) No. 1 — No. 2:	Is the resistance 1.0 — 3.0 Ω (FULL), and 61 — 63 Ω (EMPTY)?	Go to step 10.	Replace the fuel sub level sensor.
10 CHECK FUEL LEVEL SENSOR. 1) Remove the fuel level sensor. <Ref. to FU(H4SO)-58, REMOVAL, Fuel Level Sensor.> <Ref. to FU(H4DOTC)-66, REMOVAL, Fuel Level Sensor.> 2) Measure the resistance between fuel level sensor connector terminals when the float is in FULL or EMPTY position. Connector & terminal (R58) No. 1 — No. 4:	Is the resistance 1.0 — 3.0 Ω (FULL), and 31 — 33 Ω (EMPTY)?	Check the harness and connector for possible intermittent poor contact.	Replace the fuel level sensor.
11 CHECK COMBINATION METER OPERATION. 1) Remove the combination meter. 2) Install the combination meter to another vehicle with a normally operating fuel meter and check meter operation.	Is the fuel meter OK?	Replace the body integrated unit. <Ref. to SL-42, REMOVAL, Body Integrated Unit.>	Replace the meter case assembly.

7. CHECK ENGINE COOLANT TEMPERATURE SENSOR

Step	Check	Yes	No
1 CHECK THE COMMUNICATION STATUS. 1) Connect the Subaru Select Monitor and then turn the ignition switch and Subaru Select Monitor to ON. 2) Read the DTC of the body integrated unit. <Ref. to LAN(diag)-14, OPERATION, Subaru Select Monitor.>	Is DTC being displayed?	Perform the diagnosis according to DTC. <Ref. to LAN(diag)-28, LIST, List of Diagnostic Trouble Code (DTC).>	Go to step 2.
2 CHECK ENGINE COOLANT TEMPERATURE SENSOR. Check the engine coolant temperature sensor. <Ref. to EN(H4SO)(diag)-2, Basic Diagnostic Procedure.> <Ref. to EN(H4DOTC)(diag)-2, Basic Diagnostic Procedure.>	Is the engine coolant temperature sensor OK?	Replace the meter case assembly.	Replace the engine coolant temperature sensor.

Combination Meter System

INSTRUMENTATION/DRIVER INFO

8. CHECK WARNING BUZZER FOR KEY LEFT IN IGNITION

Step	Check	Yes	No
1 CHECK WARNING BUZZER FOR KEY LEFT IN IGNITION. 1) Insert the key into the ignition key lock. 2) Open the driver's side door.	Does the buzzer from the meter sound?	Normal operation.	Go to step 2.
2 CHECK THE COMMUNICATION STATUS. 1) Prepare the Subaru Select Monitor. 2) On the "System Selection Menu" display screen, select the {Integ. unit mode}. 3) Display the current data display and display "Key Warning Switch Input". 4) Remove and insert the key.	Does display switch between ON ⇔ OFF?	Go to step 3.	Check the ignition switch circuit. <Ref. to SL-36, INSPECTION, Ignition Key Lock.>
3 CHECK THE COMMUNICATION STATUS. 1) Display the current data display and display "Driver's Door Switch Input". 2) Open and close the door.	Does display switch between ON ⇔ OFF?	Go to step 4.	Check the door switch circuit. <Ref. to SL-9, CHECK DOOR LOCK SWITCH, INSPECTION, Door Lock Control System.>
4 CHECK THE COMMUNICATION STATUS. 1) Turn the ignition switch to ON (engine OFF), and start "Application for Subaru Select Monitor". 2) Read the DTC of the body integrated unit. <Ref. to LAN(diag)-14, OPERATION, Subaru Select Monitor.>	Is DTC being displayed?	Perform the diagnosis according to DTC. <Ref. to LAN(diag)-28, LIST, List of Diagnostic Trouble Code (DTC).>	Go to step 5.
5 CHECK COMBINATION METER. Perform the self-diagnosis of combination meter. <Ref. to IDI-4, SELF-DIAGNOSIS, INSPECTION, Combination Meter System.>	Did the buzzer sound?	Go to step 6.	Replace the meter case assembly.
6 CHECK COMBINATION METER. 1) Remove the combination meter. 2) Install the combination meter to another vehicle with a normally operating buzzer and check buzzer operation.	Did the buzzer sound?	Replace the body integrated unit. <Ref. to SL-42, REMOVAL, Body Integrated Unit.>	Replace the meter case assembly.

9. DTC DISPLAY MODE

It is possible to display the DTC of the combination meter through the following procedures.

- 1) Within 3 seconds after turning the ignition switch to ON, set the lighting switch to tail light or headlight position.
- 2) Press the odo/tripmeter knob four times.
- 3) Turn the lighting switch to OFF, and press the odo/trip meter knob four times.
- 4) Set the lighting switch to tail light or headlight position again, and press the odo/tripmeter knob four times.

NOTE:

- Perform the steps described in 2) and 4) within 10 seconds.
- When the engine starts during diagnosis, the self-diagnosis function is not cancelled, however, once turning the ignition switch to OFF or the vehicle starts driving, DTC display mode is cancelled automatically for safety.
- When the DTC display mode operates, {ECM}, {TCM}, {VDC} is displayed cyclically in this order for every three seconds or every press of the trip knob. DTC is displayed in the following table according to type of control module, receiving DTC, DTC detected, No DTC.
- When the DTCs of individual control modules change from current malfunctions to past malfunctions, and the trouble is cleared, when the engine is started three or more times, the DTC will no longer be displayed in the combination meter. In this case, read the DTC using Subaru Select Monitor.

Control module	Condition	Display
ECM	Receiving DTC	Trip "A" + "P (Blink)"
	DTC detected	Trip "A" + "P xxxx"
	No DTC	Trip "A" + "P ----"
TCM	Receiving DTC	Trip "B" + "P (Blink)"
	DTC detected	Trip "B" + "P xxxx"
	No DTC	Trip "B" + "P ----"
VDC CM	Receiving DTC	Trip "A" + "C (Blink)"
	DTC detected	Trip "A" + "C xxxx"
	No DTC	Trip "A" + "C ----"
When CAN communication error is occurred	—	"-----"

NOTE:

Only receiving DTC is displayed because the MT model is not equipped with a TCM.

Clock System

INSTRUMENTATION/DRIVER INFO

3. Clock System

A: WIRING DIAGRAM

1. CLOCK

<Ref. to WI-143, WIRING DIAGRAM, Clock System.>

B: INSPECTION

1. SYMPTOM CHART

Symptom	Repair order	Reference
No display is shown.	1. Power supply 2. Clock body	<Ref. to IDI-12, CHECK POWER SUPPLY AND GROUND CIRCUIT, INSPECTION, Clock System.>
The brightness does not change even when the night illumination control switch is operated.	1. Check combination meter DTC. 2. Check clock illumination circuit. 3. Check communication circuit between combination meter and clock.	<Ref. to IDI-13, CHECK ILLUMINATION CIRCUIT, INSPECTION, Clock System.>
Ambient air temperature/fuel economy displays do not appear.	1. Communication circuit between combination meter and clock 2. Clock body	<Ref. to IDI-13, CHECK CLOCK SYSTEM COMMUNICATION CIRCUIT, INSPECTION, Clock System.>
"Err" is displayed at the ambient air temperature display.	1. Check communication circuit between combination meter and ambient air temperature sensor. 2. Check combination meter DTC. 3. Check communication circuit between combination meter and clock.	<Ref. to IDI-14, CHECK AMBIENT TEMPERATURE METER SYSTEM COMMUNICATION CIRCUIT, INSPECTION, Clock System.>
"Err" is displayed at the average fuel economy display.	1. Check communication circuit between combination meter and each module. 2. Check communication circuit between combination meter and clock.	<Ref. to IDI-15, CHECK AVERAGE FUEL ECONOMY SYSTEM COMMUNICATION CIRCUIT, INSPECTION, Clock System.>

2. CHECK POWER SUPPLY AND GROUND CIRCUIT

Step	Check	Yes	No
1 CHECK CLOCK POWER SUPPLY. 1) Disconnect the clock harness connector. 2) Measure the voltage between the clock harness connector and chassis ground. Connector & terminal (i59) No. 10 (+) — Chassis ground (-):	Is the voltage 10 V or more?	Go to step 2.	Check the harness for a open or short between the fuse and clock.
2 CHECK CLOCK GROUND CIRCUIT. 1) Turn the ignition switch to OFF. 2) Measure the resistance between the clock harness connector and chassis ground. Connector & terminal (i59) No. 6 — Chassis ground:	Is the resistance less than 10 Ω?	Replace the clock body.	Repair the wiring harness.

3. CHECK ILLUMINATION CIRCUIT

Step	Check	Yes	No
1 CHECK BODY INTEGRATED UNIT OUTPUT DATA. Connect the Subaru Select Monitor, and check the illumination ON/OFF data at the data monitor of the integrated unit.	Is it operating properly?	Go to step 2.	Follow the diagnosis for the integrated unit. <Ref. to LAN(diag)-2, Basic Diagnostic Procedure.>
2 CHECK COMBINATION METER BRIGHTNESS CHANGE. 1) Turn the ignition switch to ON. 2) Turn the lighting switch to ON, and check for whether the combination meter brightness changes or not.	Does the brightness of the combination meter change?	Go to step 3.	Replace the meter case assembly.
3 CHECK CLOCK ILLUMINATION POWER SUPPLY. 1) Turn the ignition switch to OFF. 2) Disconnect the clock harness connector. 3) Turn the ignition switch and lighting switch to ON. 4) Measure the voltage between the clock harness connector and chassis ground. <i>Connector & terminal</i> <i>(i59) No. 1 (+) — Chassis ground (-):</i>	Is the voltage 10 V or more?	Go to step 4.	Check the harness for an open circuit between the fuse and clock.
4 CHECK COMBINATION METER. 1) Turn the ignition switch to OFF. 2) Disconnect the connector from the clock, and install a properly operating clock.	Does the brightness change?	Replace the clock body.	Replace the meter case assembly.

4. CHECK CLOCK SYSTEM COMMUNICATION CIRCUIT

Step	Check	Yes	No
1 CHECK THE HARNESS BETWEEN CLOCK AND COMBINATION METER. 1) Turn the ignition switch to OFF. 2) Disconnect the harness connector of the clock and the combination meter. 3) Measure the resistance between the harness connector of the clock and the combination meter. <i>Connector & terminal</i> <i>(i59) No. 5 — (i10) No. 29:</i>	Is the resistance less than 10 Ω ?	Replace the clock body.	Repair the wiring harness.

Clock System

INSTRUMENTATION/DRIVER INFO

5. CHECK AMBIENT TEMPERATURE METER SYSTEM COMMUNICATION CIRCUIT

Step	Check	Yes	No
1 CHECK POWER SUPPLY FOR AMBIENT SENSOR. 1) Turn the ignition switch to OFF. 2) Disconnect the ambient temperature sensor harness connector. 3) Turn the ignition switch to ON. 4) Measure the voltage between the ambient temperature sensor harness connector terminal and chassis ground. Connector & terminal (F78) No. 1 (+) — Chassis ground (-):	Is the voltage 4 V or more?	Go to step 2.	Check the harness for a open or short between the fuse and clock.
2 CHECK HARNESS BETWEEN AMBIENT TEMPERATURE SENSOR AND COMBINATION METER. 1) Turn the ignition switch to OFF. 2) Disconnect the connector from the combination meter. 3) Measure the resistance between the ambient temperature sensor harness connector terminal and combination meter harness connector terminal. Connector & terminal (F78) No. 1 (+) — (i10) No. 24: (F78) No. 2 (+) — (i10) No. 23:	Is the resistance less than 10 Ω?	Go to step 3.	Repair the wiring harness.
3 CHECK AMBIENT SENSOR. 1) Remove the ambient temperature sensor. 2) Check the ambient temperature sensor. <Ref. to AC(diag)-29, AMBIENT SENSOR, Diagnostic Procedure for Sensors.>	Is the ambient temperature sensor operating properly?	Go to step 4.	Replace the ambient sensor.
4 CHECK AMBIENT TEMPERATURE DISPLAY. 1) Connect the harness connector of the combination meter. 2) Connect a resistance of 3 Ω between the harness connector terminals of the ambient temperature sensor. 3) Turn the ignition switch to ON, and check the ambient air temperature display.	Is the ambient air temperature indicator showing 25°C (77°F)?	Repair the poor contact between the ambient air temperature sensor and harness connector.	Go to step 5.
5 CHECK AMBIENT AIR TEMPERATURE OUTPUT DATA. Connect the Subaru Select Monitor, and check the ambient temperature data in the data monitor of the integrated unit.	Is the ambient air temperature indicator showing 25°C (77°F)?	Go to step 6.	Replace the meter case assembly.
6 CHECK COMBINATION METER. 1) Turn the ignition switch to OFF. 2) Disconnect the connector from the clock, and install a properly operating clock.	Is the ambient air temperature indicator showing 25°C (77°F)?	Replace the clock.	Replace the meter case assembly.

Clock System

INSTRUMENTATION/DRIVER INFO

6. CHECK AVERAGE FUEL ECONOMY SYSTEM COMMUNICATION CIRCUIT

	Step	Check	Yes	No
1	CHECK OUTPUT DATA OF INTEGRATED UNIT. Read the DTC of integrated unit using Subaru Select Monitor. <Ref. to LAN(diag)-14, OPERATION, Subaru Select Monitor.>	Is DTC displayed?	Go to step 2.	Replace the meter case assembly.
2	CHECK THE COMMUNICATION STATUS. 1) Turn the ignition switch to OFF. 2) Disconnect the connector from the clock, and install a properly operating clock.	Is the displayed fuel economy correct?	Replace the clock body.	Replace the meter case assembly.

4. Combination Meter

A: REMOVAL

- 1) Disconnect the ground cable from battery.
- 2) Set the tilt steering at the lowest position. Pull out steering wheels with telescopic functions all the way.
- 3) Remove the instrument panel lower cover. <Ref. to EI-44, REMOVAL, Instrument Panel Lower Cover.>
- 4) Remove the plastic hook (A), and detach the meter visor.

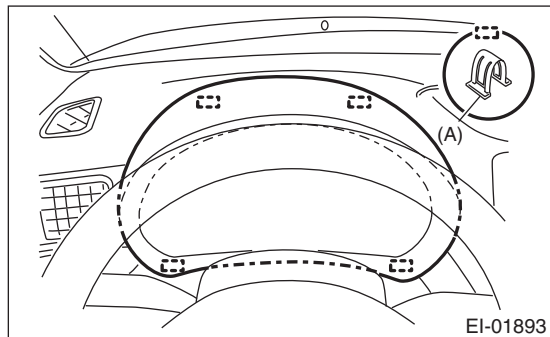

- 5) Remove the screws of the combination meter, and pull on the meter while tipping it towards yourself.

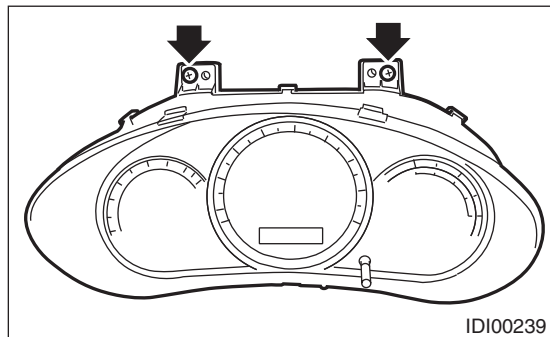

- 6) Disconnect the connector in the rear side of combination meter to remove meter.

CAUTION:

- Be careful not to damage the meter or instrument panel.
- Pay particular attention to avoid damaging the meter glass.

B: INSTALLATION

Install in the reverse order of removal.

CAUTION:

- Make sure the electrical connector is connected securely.
- Make sure that each meter operates normally.
- When the combination meter of model with immobilizer has been replaced, be sure to perform the registration of immobilizer.

C: DISASSEMBLY

CAUTION:

- Use gloves to avoid damage and getting fingerprints on the glass surface and meter surfaces.
- Be careful not to apply excessive force to the trip knob.
- Be sure not to touch the meter indicator needle.

Disengage claw (A), and remove the meter glass assembly (B) and meter visor (C) from meter case assembly (D).

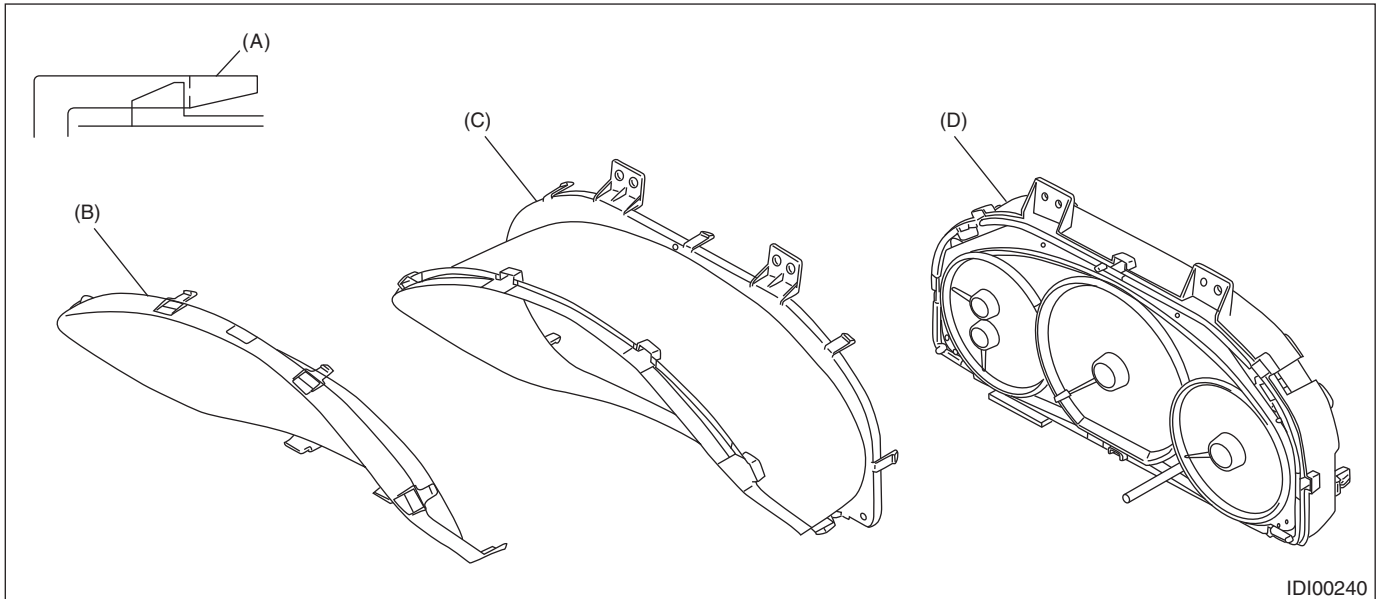

1. BULB REPLACEMENT

LEDs are used for all of warning lights and indicator lights of combination meters, replace the meter case assembly if faulty.

D: ASSEMBLY

Assemble in the reverse order of disassembly.

5. Speedometer

A: SPECIFICATION

Since the meter case assembly cannot be disassembled, do not remove or inspect the speedometer alone. (Do not remove the cover on the back surface.)

6. Tachometer

A: SPECIFICATION

Since the meter case assembly cannot be disassembled, do not remove or inspect the tachometer alone. (Do not remove the cover on the back surface.)

7. Fuel Gauge

A: SPECIFICATION

Since the meter case assembly cannot be disassembled, do not remove or inspect the fuel gauge alone. (Do not remove the cover on the back surface.)

8. Clock

A: REMOVAL

- 1) Disconnect the ground cable from battery.
- 2) Remove the audio. <Ref. to ET-6, REMOVAL, Audio.>
- 3) Insert your hands from the audio space, disengage the tabs of the bracket on the back side of the instrument panel, and push the clock

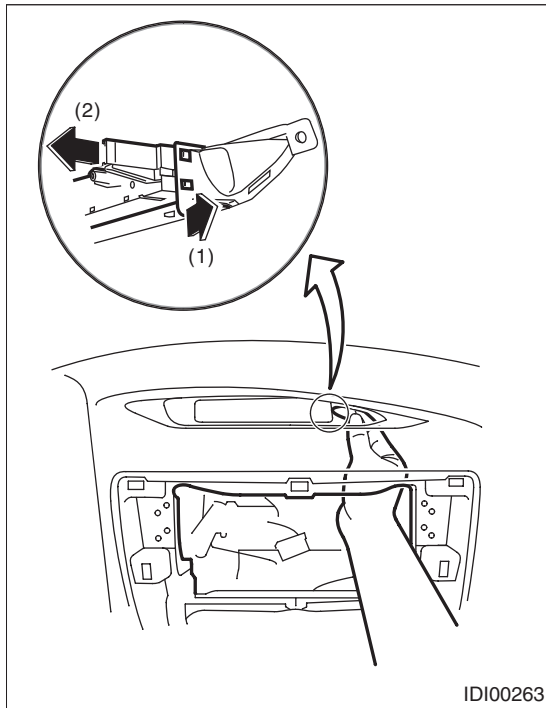

IDI00263

- 4) Disconnect the harness connector and remove the clock.

B: INSTALLATION

Install in the reverse order of removal.

SEATS

SE

	Page
1. General Description	2
2. Front Seat	8
3. Rear Seat	15
4. Power Seat System	19
5. Seat Heater System	24
6. Rear Seat Reclining System	26

General Description

SEATS

1. General Description

A: COMPONENT

1. FRONT SEAT LH

- Normal seat

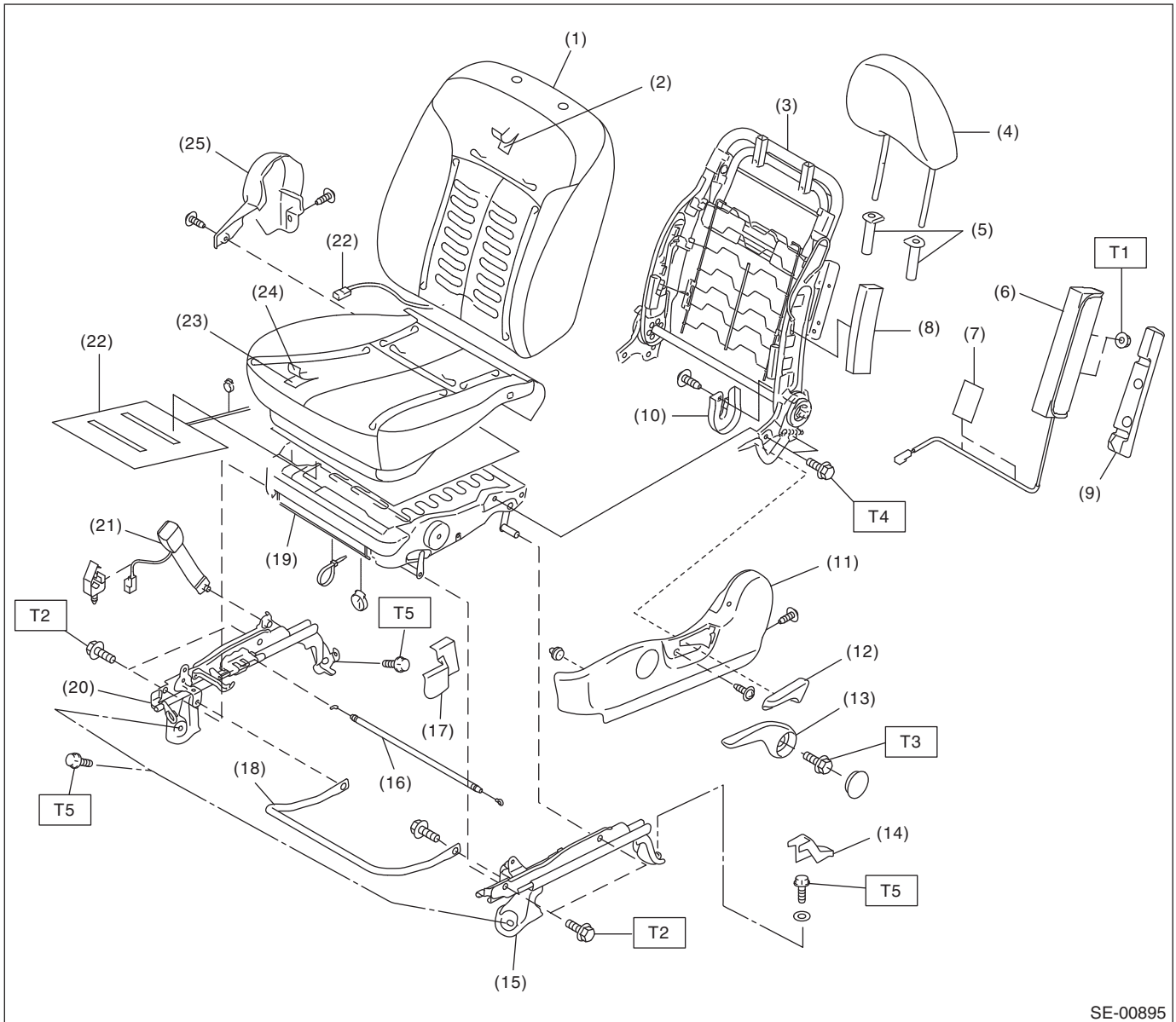

General Description

SEATS

(1) Backrest cover	(11) Seat side cover outside	(23) Seat cushion pad
(2) Backrest pad	(12) Reclining lever	(24) Seat cushion cover
(3) Backrest frame ASSY	(13) Lifter lever	(25) Seat side cover inside
(4) Headrest ASSY	(14) Rear bolt cover outside	
(5) Headrest lock bushing	(15) Outer slide rail	
(6) Side airbag module ASSY	(16) Connecting cable	
(7) Tape	(17) Rear bolt cover inside	
(8) Pad A (Only models without side airbags)	(18) Seat slide bar	
(9) Pad B (Only models with side airbags)	(19) Seat cushion frame ASSY	
(10) Seat hinge inner cover	(20) Inner slide rail	
	(21) Inner seat belt ASSY	
	(22) Seat heater module ASSY	

Tightening torque:N·m (kgf·m, ft·lb)

T1: 6 (0.61, 4.43)

T2: With lifter: 9.8 (1.0, 7.23)

Without lifter: 17.6 (1.8, 13.0)

T3: 17.6 (1.8, 13.0)

T4: 52 (5.30, 38.4)

T5: 53 (5.40, 39.1)

General Description

SEATS

• Power seat

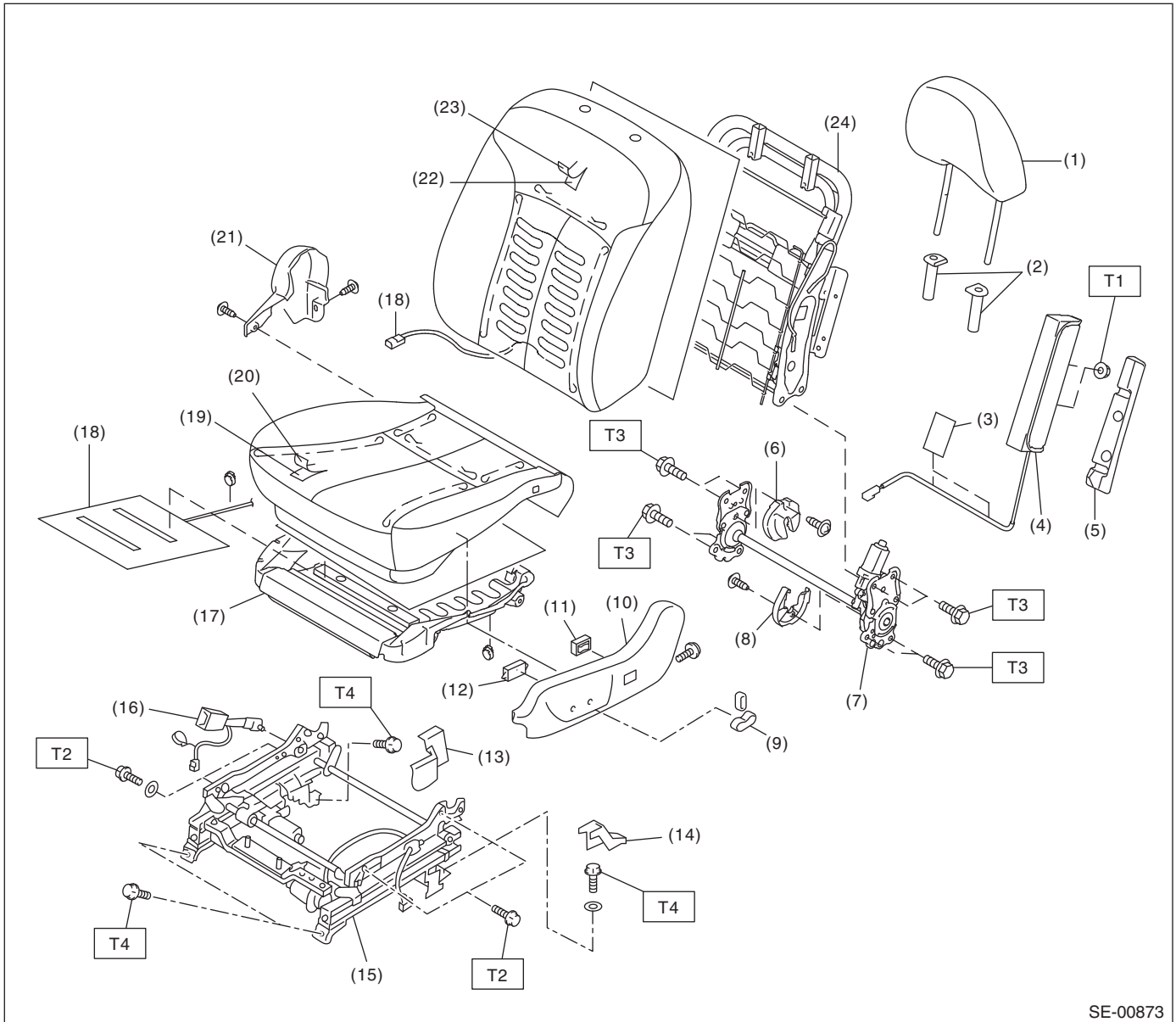

SE-00873

- | | | |
|------------------------------|------------------------------|-----------------------------|
| (1) Headrest ASSY | (11) Lumbar switch unit | (21) Seat side cover inside |
| (2) Headrest lock bushing | (12) Power seat switch unit | (22) Backrest pad |
| (3) Tape | (13) Rear bolt cover inside | (23) Backrest cover |
| (4) Side airbag module ASSY | (14) Rear bolt cover outside | (24) Backrest frame ASSY |
| (5) Pad | (15) Slide rail ASSY | |
| (6) Hinge inner cover RH | (16) Inner seat belt ASSY | |
| (7) Reclining hinge ASSY | (17) Seat cushion frame ASSY | |
| (8) Hinge inner cover LH | (18) Seat heater module ASSY | |
| (9) Power seat switch knob | (19) Seat cushion pad | |
| (10) Seat side cover outside | (20) Seat cushion cover | |

Tightening torque: N·m (kgf·m, ft·lb)

T1: 6 (0.61, 4.43)

T2: 17.6 (1.8, 13.0)

T3: 52 (5.30, 38.4)

T4: 53 (5.40, 39.1)

2. FRONT SEAT RH

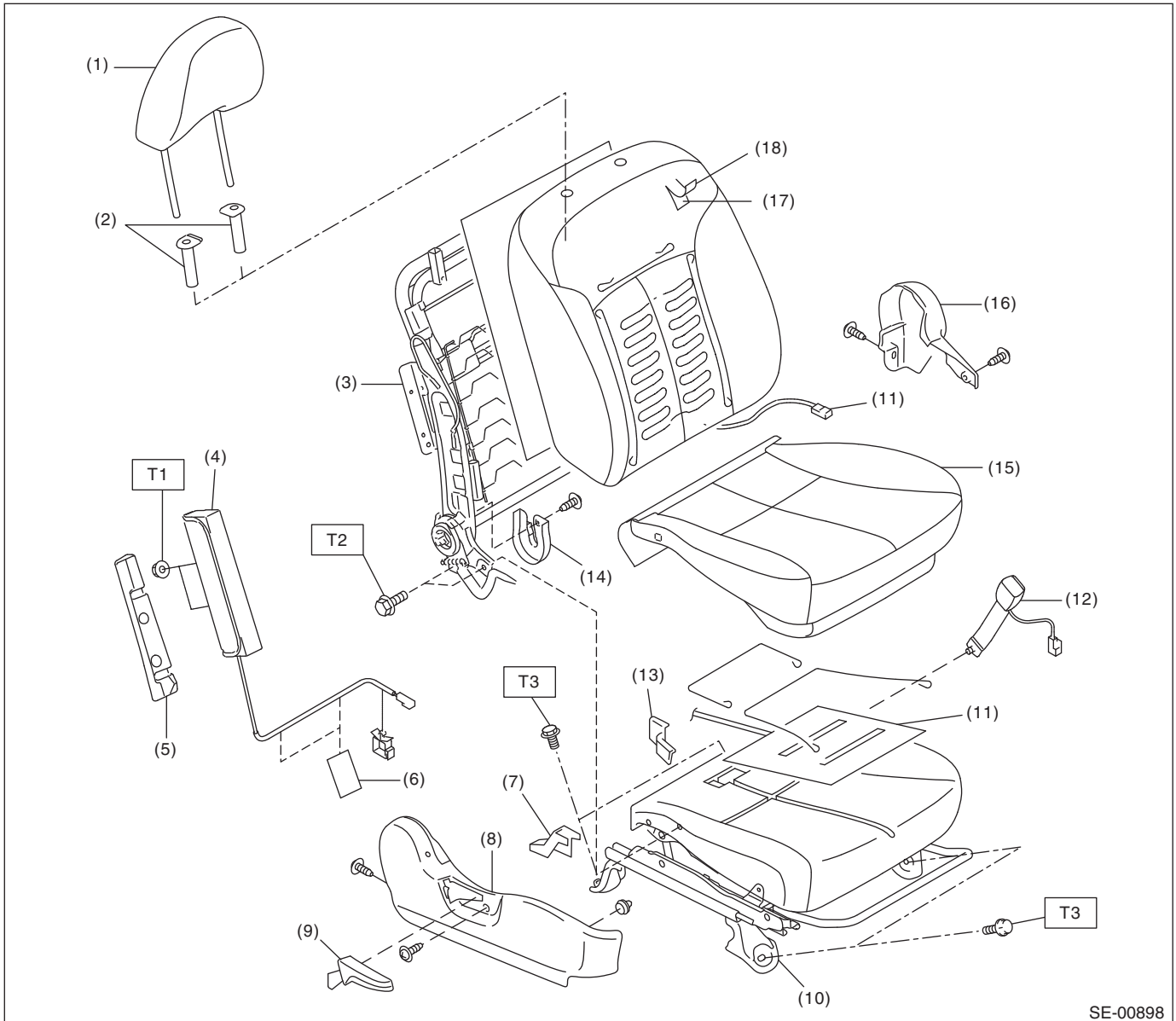

SE-00898

- | | | |
|-----------------------------|--------------------------------------|---------------------|
| (1) Headrest ASSY | (9) Reclining lever | (17) Backrest pad |
| (2) Headrest lock bushing | (10) Seat cushion pad and frame ASSY | (18) Backrest cover |
| (3) Backrest frame ASSY | (11) Seat heater unit | |
| (4) Side airbag module ASSY | (12) Inner seat belt ASSY | |
| (5) Pad | (13) Rear bolt cover inside | |
| (6) Tape | (14) Hinge inner cover RH | |
| (7) Rear bolt cover outside | (15) Seat cushion cover | |
| (8) Seat side cover outside | (16) Seat side cover inside | |

Tightening torque: N·m (kgf·m, ft·lb)

T1: 6 (0.61, 4.43)

T2: 52 (5.30, 38.4)

T3: 53 (5.40, 39.1)

General Description

SEATS

3. REAR SEAT

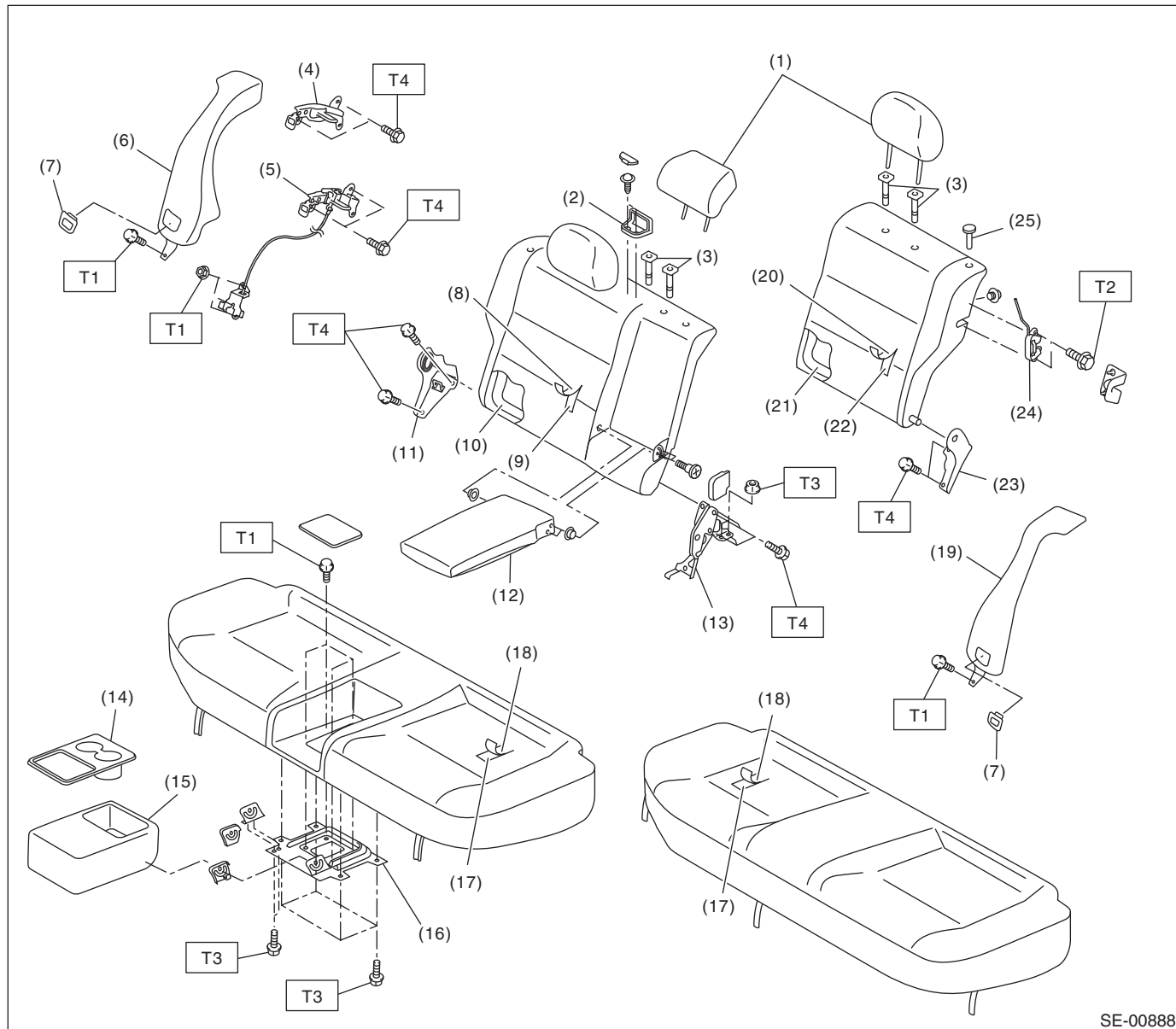

SE-00888

- | | | |
|-------------------------------|--|--------------------------|
| (1) Headrest ASSY | (13) Hinge ASSY center | (21) Backrest frame LH |
| (2) Seat belt guide | (14) Seat table plate
(Models with seat tables) | (22) Backrest pad LH |
| (3) Headrest bushing | (15) Seat table
(Models with seat tables) | (23) Hinge ASSY LH |
| (4) Striker | (16) Seat table frame
(Models with seat tables) | (24) Seat backrest latch |
| (5) Striker (Reclining type) | (17) Seat cushion pad | (25) Backrest knob |
| (6) Seat backrest shoulder RH | (18) Seat cushion cover | |
| (7) Reclining button | (19) Seat backrest shoulder LH | |
| (8) Backrest cover RH | (20) Backrest cover LH | |
| (9) Backrest pad RH | | |
| (10) Backrest frame RH | | |
| (11) Hinge ASSY RH | | |
| (12) Armrest ASSY | | |

Tightening torque: N·m (kgf·m, ft·lb)

T1: 7.5 (0.76, 5.5)

T2: 17.6 (1.8, 13.0)

T3: 24.5 (2.5, 18.1)

T4: 33 (3.3, 24.3)

B: CAUTION

- If the seat cushion cover is removed or replaced, make sure to perform passenger detection system adjustment after installing the seat to the vehicle. <Ref. to OD(diag)-19, OPERATION, System Calibration (Rezeroing).>

If system adjustment is not performed, the occupant detection system may not function properly.

- The passenger detection system (passenger seat only) control unit and the passenger detection sensor are fixed to the seat cushion frame. Never remove the passenger detection control unit or the pressure sensor from the seat cushion frame.

- Do not replace the seat cushion pad by itself. Always replace the seat cushion pad and frame assembly as a set. The seat cushion pad and cushion frame are adjusted as a set at the time of manufacture. If cushion pads and cushion frames are combined from those of other vehicles or other sets, the passenger detection system may not operate properly.

- If the seat cushion cover is removed, make sure to replace the hang wire on the seat cushion side with a new wire.

C: PREPARATION TOOL

1. GENERAL TOOL

TOOL NAME	REMARKS
Long nose plier	Used for removing the hog ring.
Hog ring pliers	Used for installing the hog ring.
Circuit tester	Used for checking voltage and continuity.

2. Front Seat

A: REMOVAL

1. DRIVER'S SEAT

CAUTION:

The airbag system is fitted with a backup power source. After disconnecting the battery ground cable, the airbag may deploy if you do not wait for 20 seconds before starting the service of airbag system.

1) Disconnect the ground cable from battery, and wait for 20 seconds or more before starting work.

NOTE:

Remove the front and rear bolts from the slide rail of the power seat before removing the battery ground.

2) Remove the headrest.

3) Tilt the backrest forward.

4) Move the seat to the full forward position.

5) Remove the rear bolt cover at the rear end of the slide rail, and remove the two bolts.

6) Move the seat to the rearmost position.

7) Remove the two bolts at the front side of the slide rail.

8) Disconnect the connector under the seat.

- Seat belt warning light connector (Driver's seat)
- Side airbag connector
- Seat heater connector (Model with seat heater)
- Power seat connector (Model with power seats)

9) Remove the front seat from vehicle.

2. PASSENGER'S SEAT

CAUTION:

Refer to "CAUTION" of "General Description" before starting the work. <Ref. to SE-7, CAUTION, General Description.>

1) Disconnect the ground cable from battery, and wait for 20 seconds or more before starting work.

2) Remove the headrest.

3) Tilt the backrest forward, and move the seat forward.

4) Remove the rear bolt cover, and then remove the rear side of slide rail.

5) Move the seat backward, remove the front bolt cover, and then remove the bolt at the front side of slide rail.

6) Disconnect all the connectors of connector holder in the backside of seat cushion.

- Harness connector of occupant detection control module
- Side airbag connector
- Seat heater connector (Models with seat heaters)

7) Remove the seat from vehicle.

B: INSTALLATION

Install in the reverse order of removal.

NOTE:

Tighten the slide rail installing bolt gradually in two or three steps to the specified torque in the order as shown in the figure.

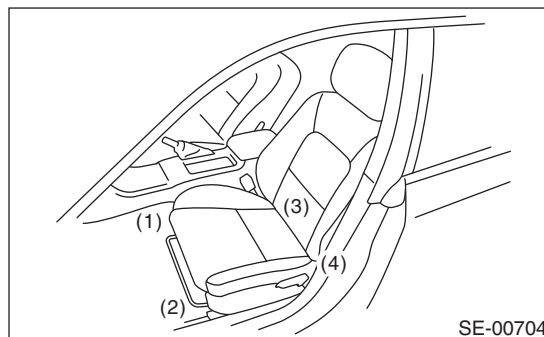

Tightening torque:

Refer to "COMPONENT" of "General Description". <Ref. to SE-2, FRONT SEAT LH, COMPONENT, General Description.>

C: DISASSEMBLY

1. DRIVER'S SEAT (NORMAL)

CAUTION:

Before assembly, check that the routing of harnesses such as those for the side airbag and inner seat belt harnesses, and make sure to route correctly during assembly. Incorrect harness routing during assembly can result in pinched harnesses or short circuits.

1) Remove the seat from vehicle. <Ref. to SE-8, REMOVAL, Front Seat.>

2) Remove the seat lifter cover using a flat tip screwdriver and loosen the inner bolt to remove the seat lifter lever.

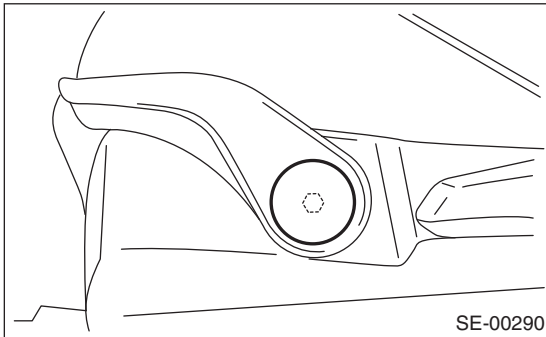

3) Disengage the tab while pulling the reclining lever, and remove the reclining lever cover.

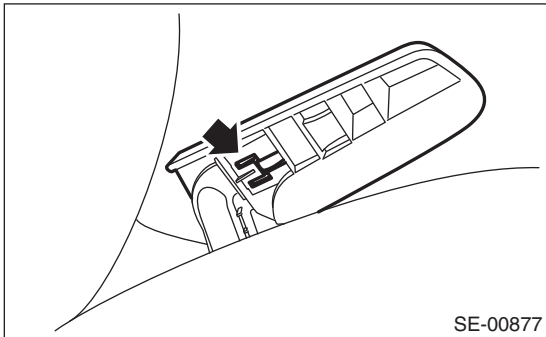

4) Remove screws (A) and clips (B), and then detach the seat side cover outside.

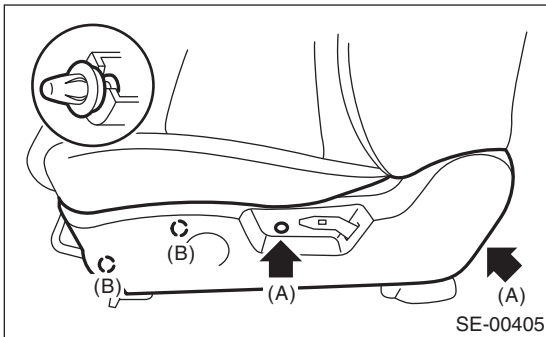

5) Remove the bolts and remove the inner seat belt assembly.

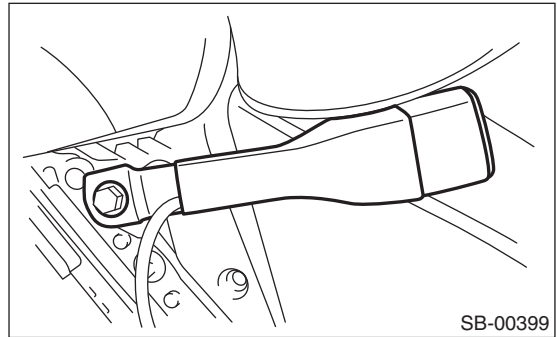

6) Remove the screws to detach the seat side cover inside.

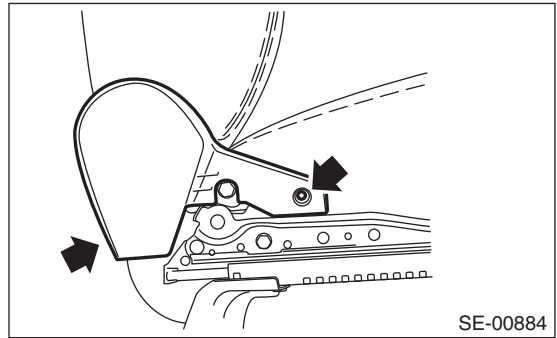

7) Remove the bolts on the seat cushion assembly side, and remove the slide rail. (Right and left)

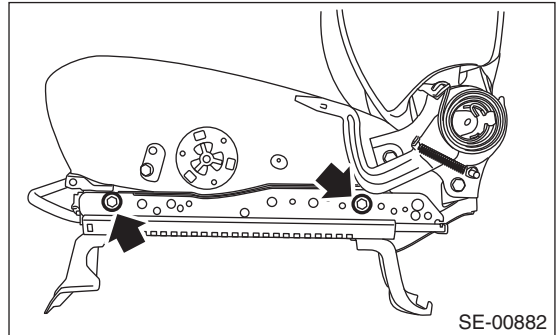

Front Seat

SEATS

8) Remove the bolts from the right and left reclining hinges.

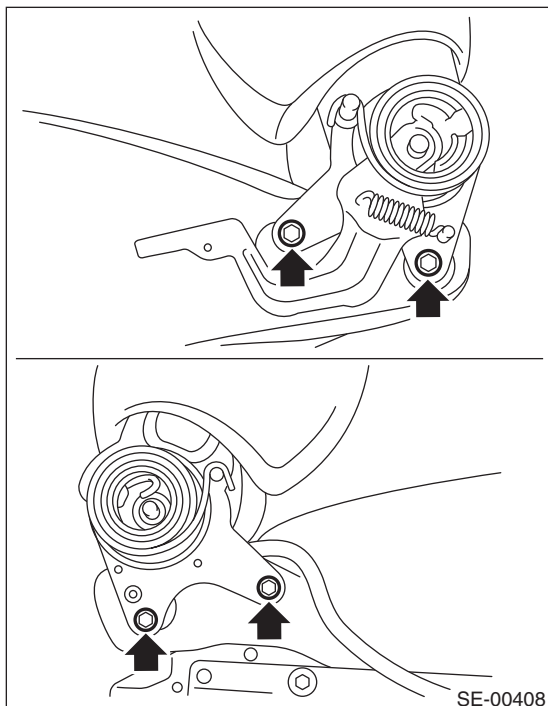

9) Remove the plastic fastener at the bottom-back side of backrest.

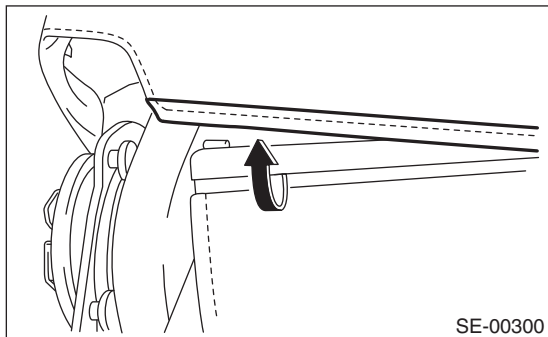

10) Open the fastener at the rear side of backrest.

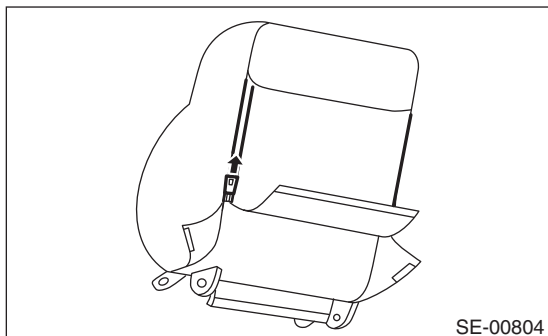

11) Remove the hog rings of backrest cover.

CAUTION:

When removing the hog rings, be careful not to tear the vinyl sheet within the seat.
If the sheet has torn, replace it with a new sheet.

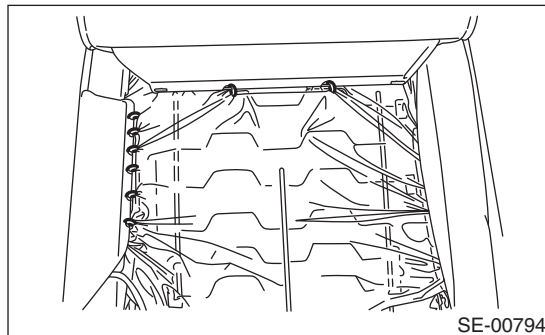

12) Remove the pad (A) and then remove the mounting nuts for side airbag module.

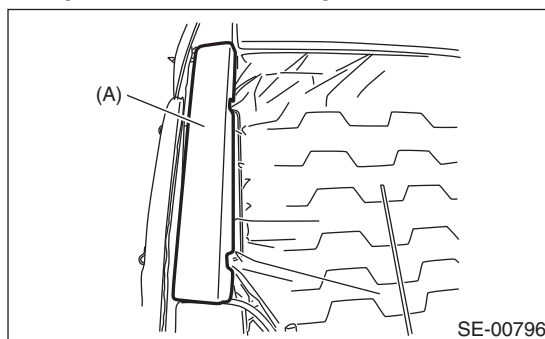

13) Remove the headrest bushing.

NOTE:

Push outside to remove it from the inside of seat.

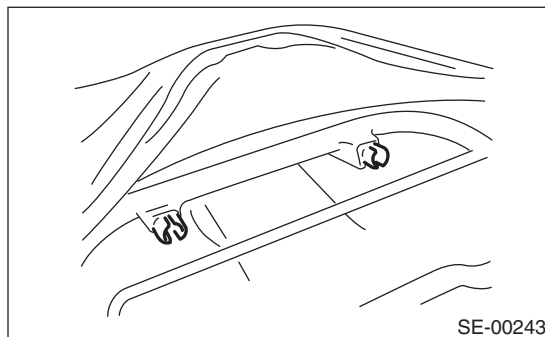

14) Pull out the backrest frame.

15) Remove all of the hog rings on the front side of the backrest, and then remove the backrest cover from backrest.

16) Remove the plastic hooks (A) of the seat cushion cover, and then remove the seat cushion assembly.

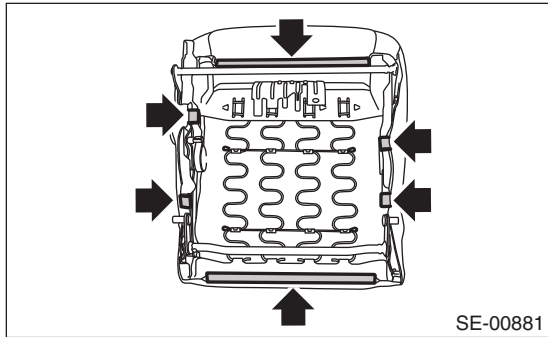

17) Remove all the hog rings, and then remove the seat cushion cover from the seat cushion pad.

18) Open the fastener on the bottom of the headrest, then remove the headrest cover from the headrest.

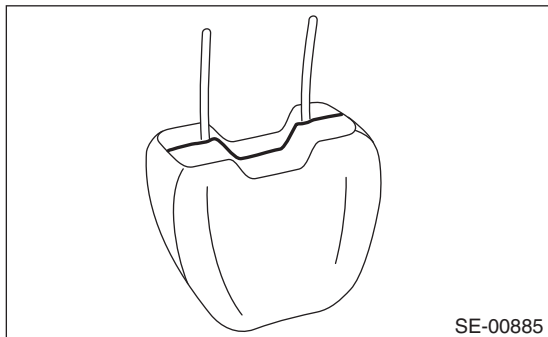

2. DRIVER'S SEAT (POWER SEAT)

CAUTION:

- Before assembly, check that the routing of harnesses such as those for the side airbag and inner seat belt harnesses, and make sure to route correctly during assembly. Incorrect harness routing during assembly can result in pinched harnesses or short circuits.

- Do not disassemble the backrest assembly, and seat cushion frame and slide rail assembly.

1) Remove the seat from vehicle. <Ref. to SE-8, REMOVAL, Front Seat.>

2) Remove the power seat switch knob.

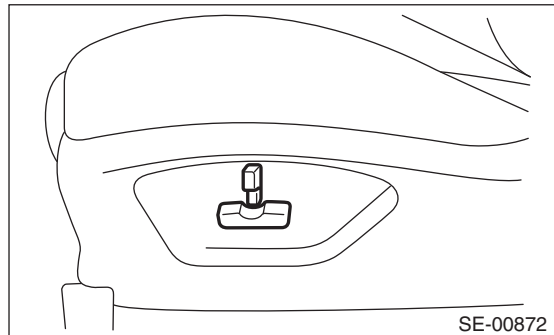

3) Disconnect the connector for reclining motor from the backside of seat cushion.

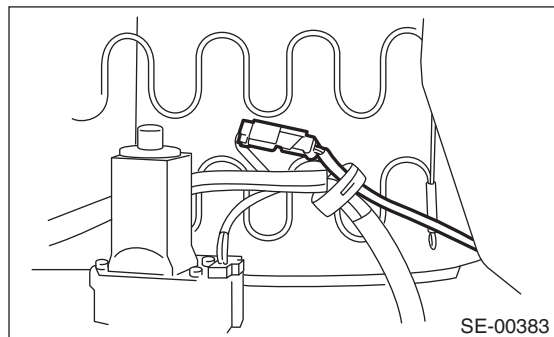

4) Remove the screw (A) and clips (B), and then disconnect the seat switch connector to remove seat side cover outside.

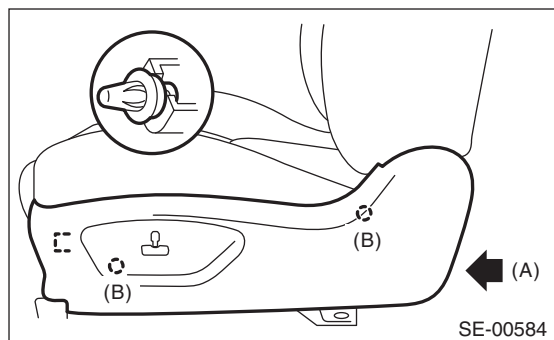

Front Seat

SEATS

5) Remove the bolts and remove the inner seat belt assembly.

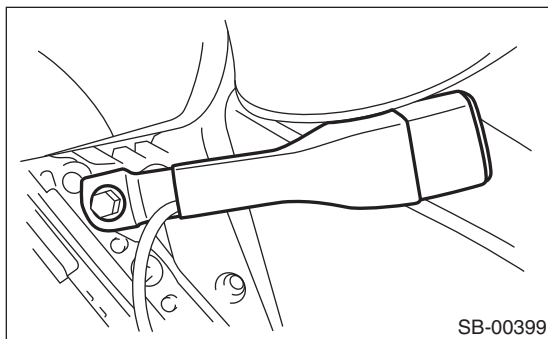

8) Remove the plastic fastener at the bottom-back side of backrest.

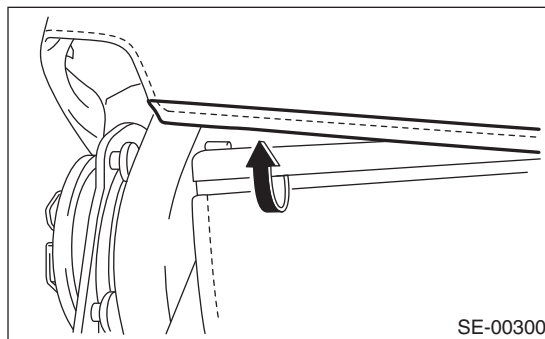

6) Remove the screw (A) and clip (B), and then remove the seat side cover inside.

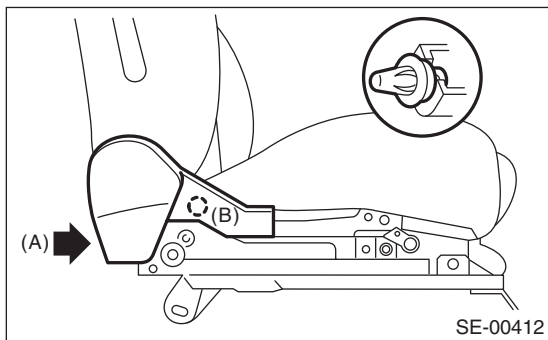

9) Open the fastener at the rear side of backrest.

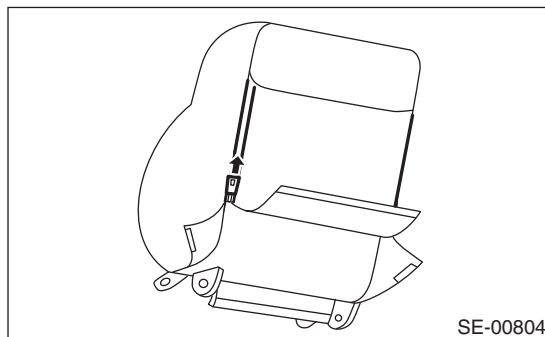

7) Remove the two bolts from the reclining hinge on each left and right side.

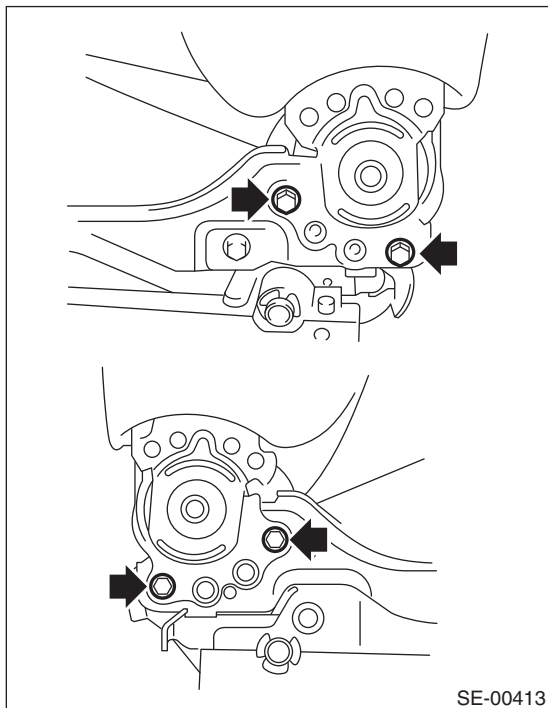

10) Remove the hog rings of backrest cover.

CAUTION:
When removing the hog rings, be careful not to tear the vinyl sheet within the seat.
If the sheet has torn, replace it with a new sheet.

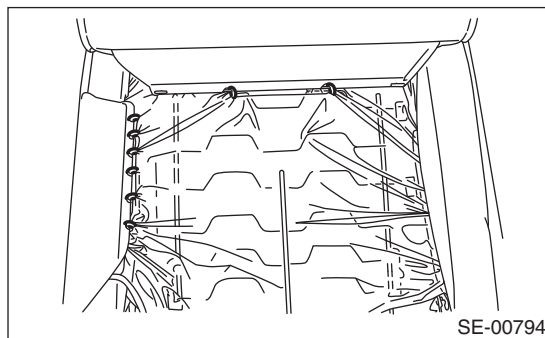

11) Remove the pad (A) and then remove the mounting nuts for side airbag module.

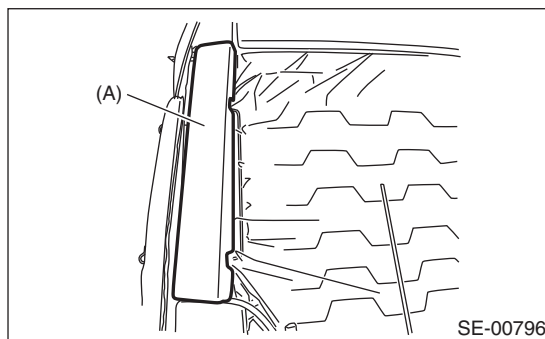

12) Remove the headrest bushing.

NOTE:

Push outside to remove it from the inside of seat.

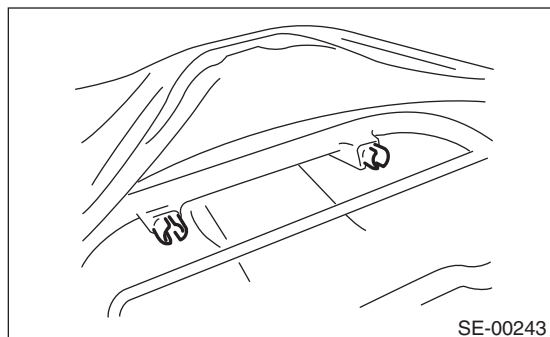

13) Pull out the backrest frame.

14) Remove all of the hog rings on the front side of the backrest, and then remove the backrest cover from backrest.

15) Remove the clip (A) and straps (B) on the back of seat cushion.

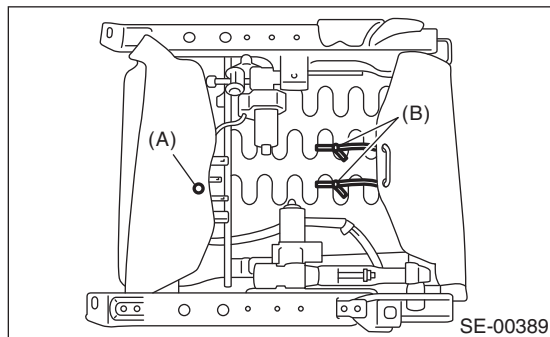

16) Remove the bolts on both the left and right sides, and then remove the seat cushion frame from the slide rail assembly.

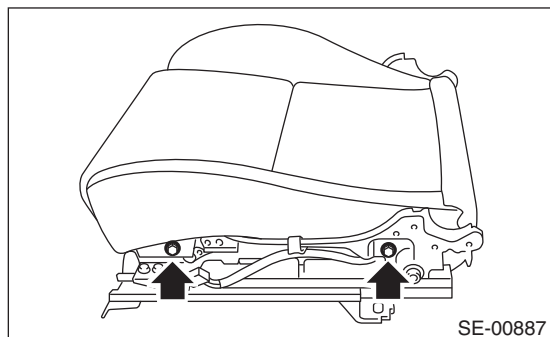

17) Remove the hooks (A), and then remove the seat cushion from seat cushion frame.

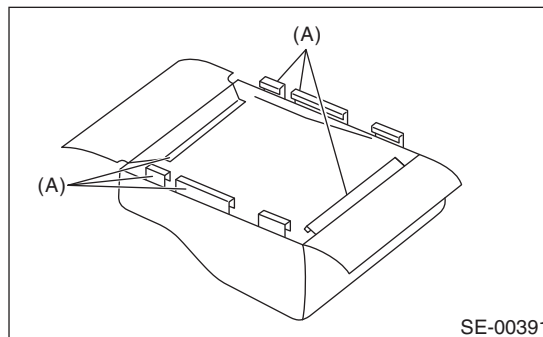

18) Remove the hog rings, and then remove the seat cushion cover from the seat cushion pad.

19) Open the fastener on the bottom of the headrest, then remove the headrest cover from the headrest.

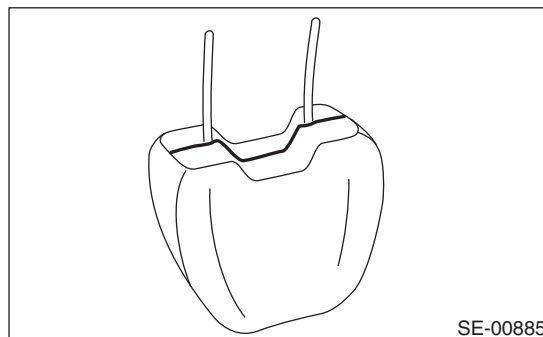

3. PASSENGER'S SEAT

CAUTION:

- If the seat cushion cover is removed or replaced, make sure to perform passenger detection system adjustment after installing the seat to the vehicle. <Ref. to OD(diag)-19, OPERATION, System Calibration (Rezeroing).> Failure to do so may prevent the passenger's airbag from operating properly.
- The passenger detection system (passenger seat only) control unit, passenger detection sensor, seat cushion pad and seat cushion frame are considered as a single seat cushion pad and frame assembly. Never remove the passenger detection control unit or the pressure sensor from the seat cushion frame.
- If the seat cushion cover is removed, make sure to replace the hang wire on the seat cushion side with a new wire.

- 1) Remove the seat from the vehicle. <Ref. to SE-8, PASSENGER'S SEAT, REMOVAL, Front Seat.>
- 2) Refer to the disassembly procedures for the driver's seat. <Ref. to SE-9, DRIVER'S SEAT (NORMAL), DISASSEMBLY, Front Seat.>

D: ASSEMBLY

CAUTION:

- Make sure there are no mistakes in the routing of harnesses such as those for the side airbag and inner seat belt harnesses. Incorrect harness routing during assembly can result in pinched harnesses or short circuits.
- When installing the side airbag module assembly, be sure to install it by inserting the side airbag module between the backrest cover and airbag guide cloth.

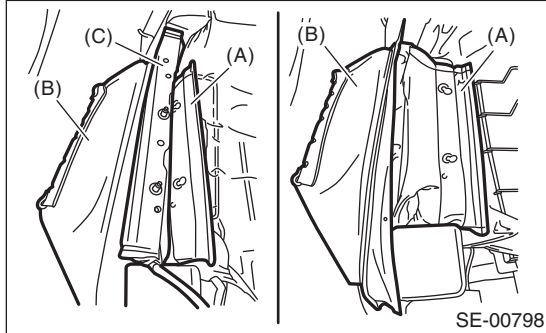

- (A) Airbag guide cloth
- (B) Backrest cover
- (C) Side airbag module ASSY

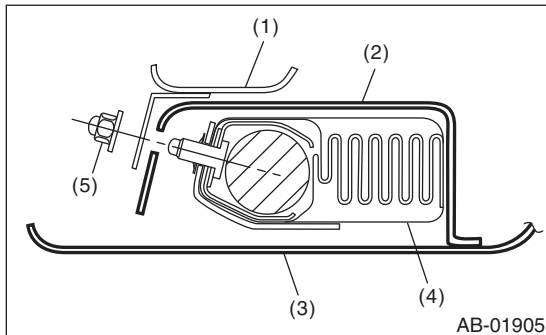

- (1) Backrest frame ASSY
- (2) Airbag guide cloth
- (3) Backrest cover
- (4) Side airbag module ASSY
- (5) Hexagon cap nut

When the backrest cover is not installed securely, the side airbag module may not be deployed properly, therefore keep strictly to the following procedure.

- Be careful not to stain or damage the backrest cover during assembly.
- Always use new hog rings.
- Secure the hog ring using hog ring pliers.
- Install the hog rings to the specified points securely and make sure that no wrinkle or twisting on backrest cover.

Assemble in the reverse order of disassembly.

Tightening torque:

Refer to "COMPONENT" of "General Description". <Ref. to SE-2, FRONT SEAT LH, COMPONENT, General Description.> <Ref. to SB-2, FRONT SEAT BELT, COMPONENT, General Description.>

E: INSPECTION

Check that no tear or fray on the backrest cover and seat cushion cover.

NOTE:

If the door side of the backrest cover is torn or frayed, the side airbag may not be deployed properly. In this case, replace the backrest cover.

3. Rear Seat

A: REMOVAL

CAUTION:

The satellite safing sensor of the airbag system is installed under the center of the rear seat cushion. Read the cautions and warnings indicated in the AB section before removing the rear seat. <Ref. to AB-5, CAUTION, General Description.>

- 1) Remove the cap behind the seat table and disconnect the connector. (Models with seat table)
- 2) Remove the bolt. (Models with seat table)

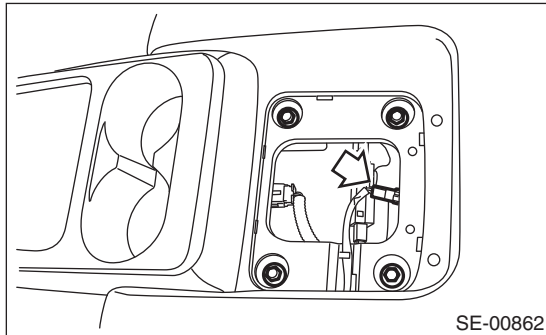

- 3) Remove the three hooks while lifting up the rear seat cushion.

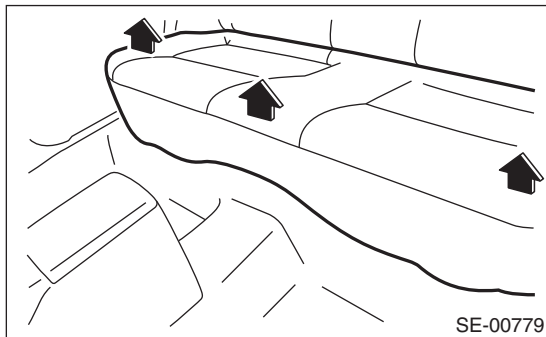

NOTE:

There are two hook locations on the seat table.

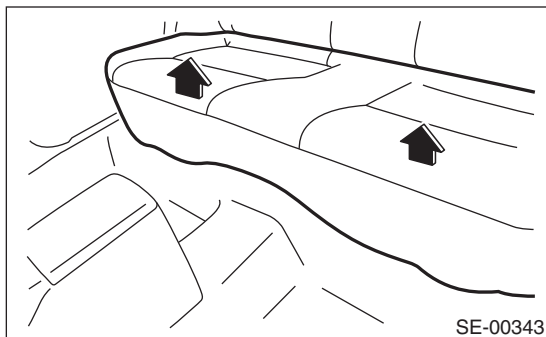

- 4) Remove the hook (A) by pushing it back while lifting the front side of the seat cushion, and remove the seat cushion.

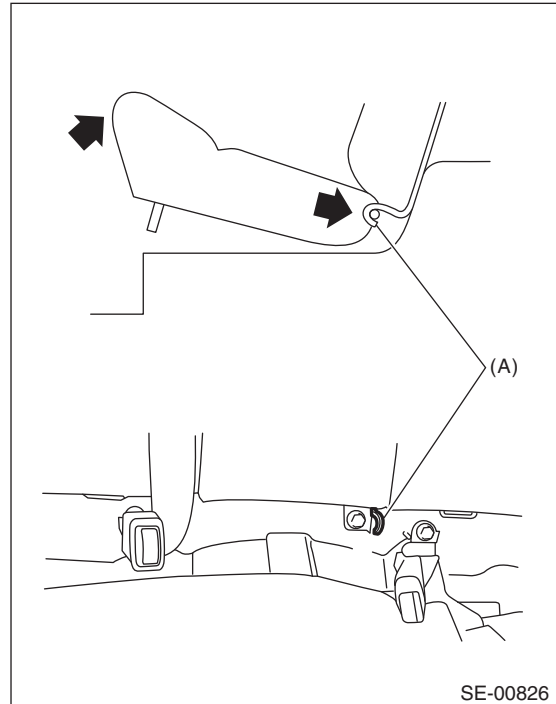

- 5) Remove the headrest, and then tilt the backrest forward.
- 6) Remove the luggage floor mat.
- 7) Turn over the mat and remove the bolts.

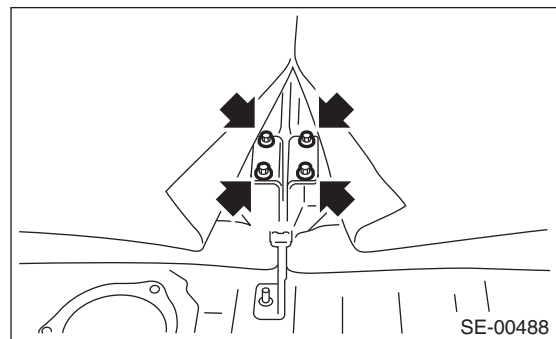

- 8) Remove the backrest from hinge assembly LH (hinge assembly RH).

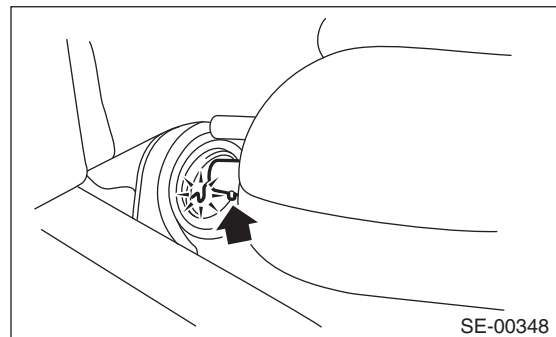

NOTE:

The backrest cannot be detached while the hinge assembly side and the backrest pin are not aligned.

Rear Seat

SEATS

9) Remove the reclining button.

CAUTION:

Use the following procedures to remove the reclining button. Damage to the reclining button may result if the procedures are not followed correctly.

- (1) Remove the weather strip, and insert a flat-head screwdriver into the rear of the rear seat backrest shoulder.
- (2) Press the tab on the rear side of the reclining button downwards and remove the reclining button.

CAUTION:

Do not press strongly on the button tab. Pressing with excessive force may break the tab.

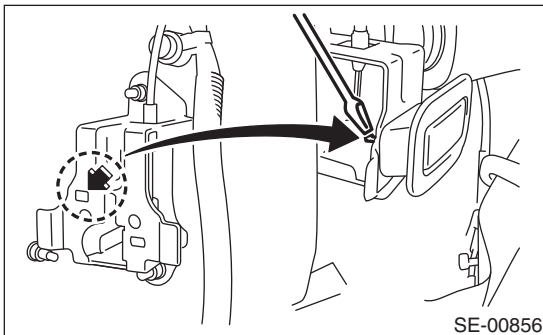
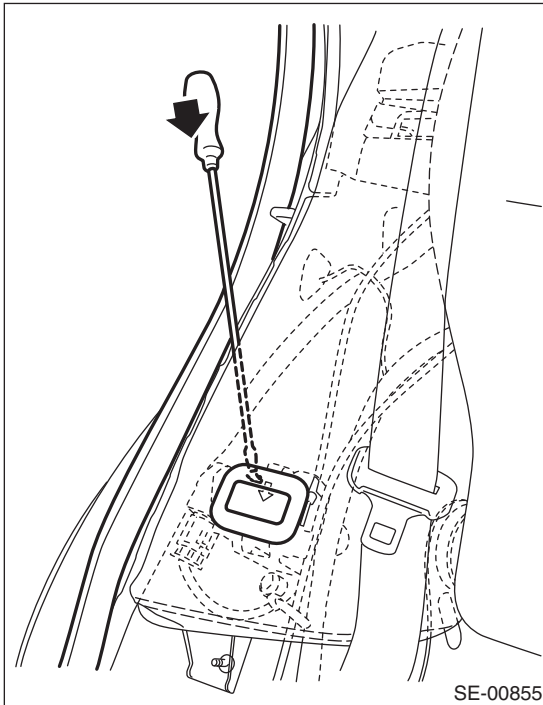

NOTE:

- Direct a light from under the rear seat backrest shoulder to easily identify the tab position.
- The LH side is left and right symmetrical.

10) Remove the nut, and remove the rear seat backrest shoulder.

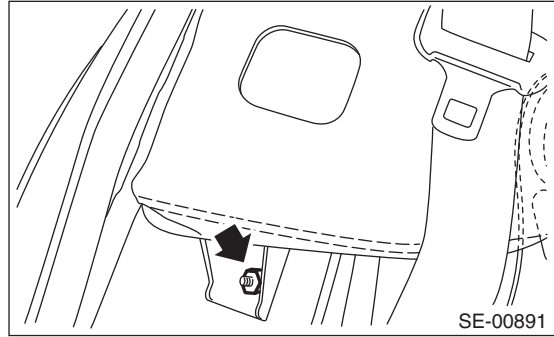

B: INSTALLATION

1) Install in the reverse order of removal.

Tightening torque:

Refer to "COMPONENT" of "General Description". <Ref. to SE-6, REAR SEAT, COMPONENT, General Description.>

2) Check the routing of the seat belt. <Ref. to SB-19, INSTALLATION, Rear Seat Belt.>

C: DISASSEMBLY

- 1) Remove the rear seat. <Ref. to SE-15, REMOV-AL, Rear Seat.>
- 2) Remove the armrest hinge cover in the direction of the black arrow, and loosen the screws to remove the armrest.

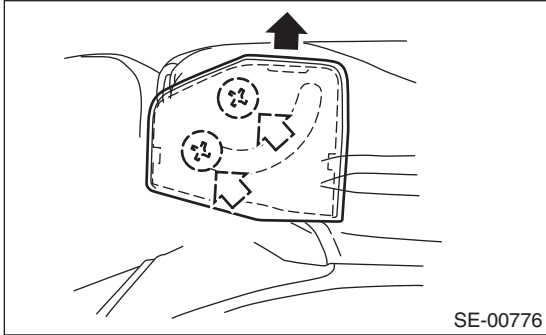

NOTE:

The armrests cannot be detached while the backrest assembly RH and armrest side pin positions are not aligned.

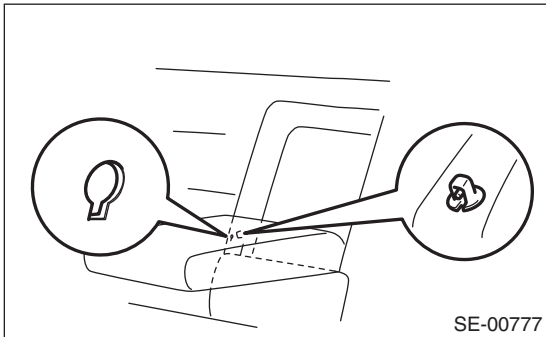

- 3) Remove the backrest knob. (Screw-in type)

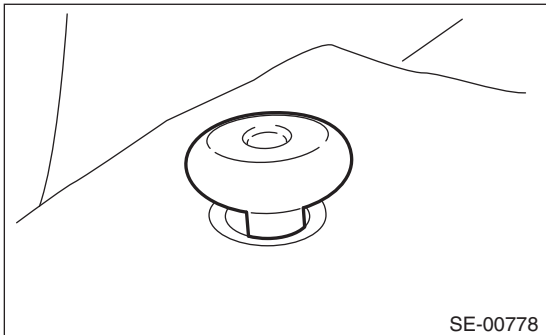

- 4) Remove the seat backrest latch cover.

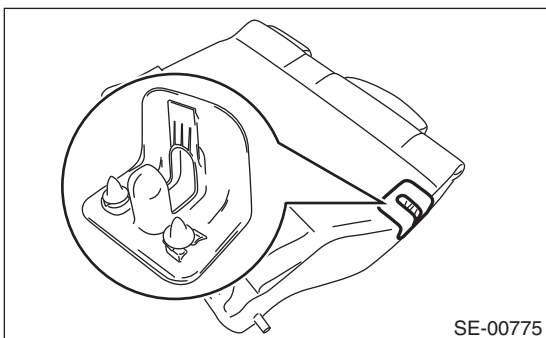

- 5) Turn over the backrest cover to remove the hog rings.

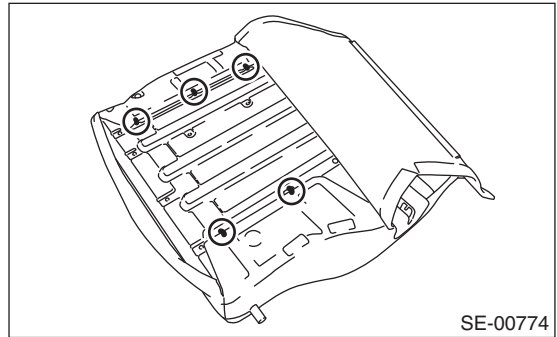

- 6) Remove all the hog rings securing the backrest frame and backrest pad.
- 7) Remove the headrest bushing.
- 8) Remove the backrest pad and backrest cover from the backrest frame.
- 9) Disassemble the backrest assembly LH by referring to above procedures.
- 10) Remove the bolts on the backside of the seat cushion, and remove the seat table assembly.

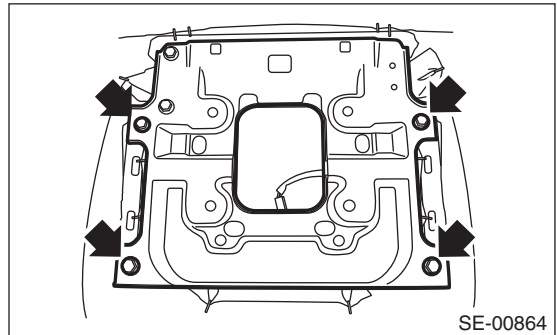

- 11) Remove the bolts on the right and left sides, and remove the seat table assembly.

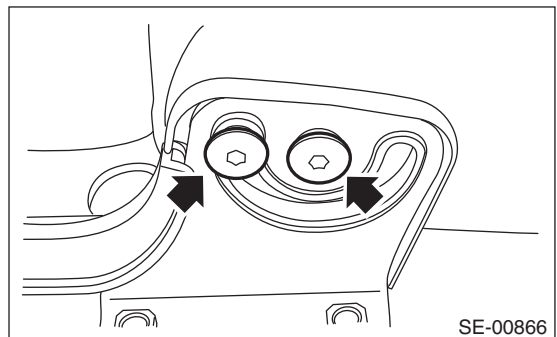

Rear Seat

SEATS

12) Remove the bolts and the seat table hinge.

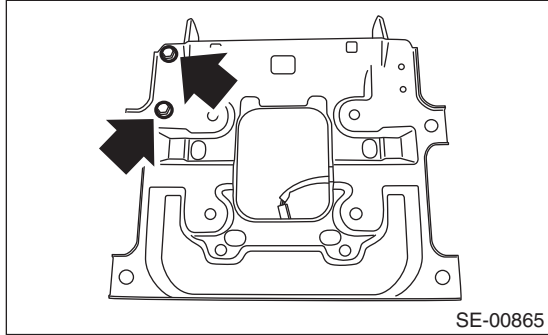

13) Remove the hooks and the seat table plate.

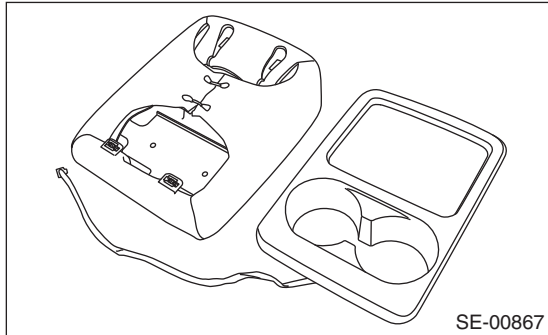

14) Remove all the hog rings on the backside of the seat cushion, and disassemble the seat cushion cover and seat cushion pad.

15) Open the plastic fastener and remove the headrest cover from the headrest.

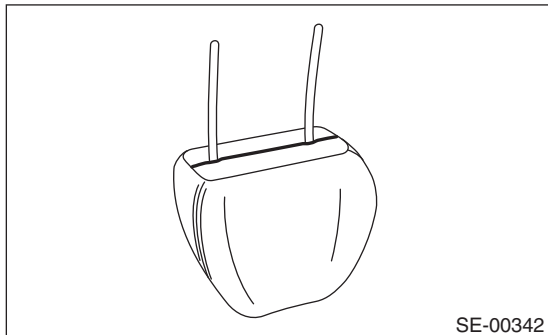

16) Detach the plastic fastener and hog ring, and then remove the armrest cover.

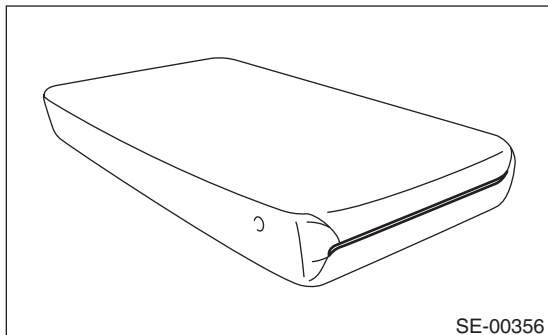

D: ASSEMBLY

CAUTION:

- Always use new hog rings.
- Secure the hog ring using hog ring pliers.
- Install the hog rings to the specified points securely and make sure that no wrinkle or twisting on backrest cover.

Assemble in the reverse order of disassembly.

NOTE:

- Do not contaminate or damage the cover.
- While installing the hog rings, prevent the seat from getting wrinkled.

4. Power Seat System

A: REMOVAL

CAUTION:

When it is necessary to remove the front seat, disconnect the ground cable from battery and wait for 20 seconds before disconnecting the side airbag module harness connector.

1. POWER SEAT SWITCH

1) Detach the connectors and remove the seat side cover outside. <Ref. to SE-9, DISASSEMBLY, Front Seat.>

2) Remove the screws to remove the power seat switch assembly.

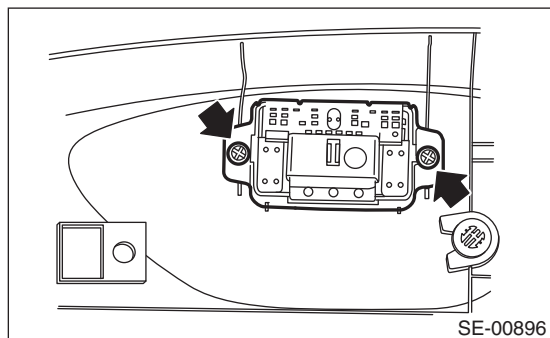

2. LUMBAR SWITCH

1) Detach the connectors and remove the seat side cover outside. <Ref. to SE-9, DISASSEMBLY, Front Seat.>

2) Disconnect the lumbar switch connector and remove the lumbar switch assembly.

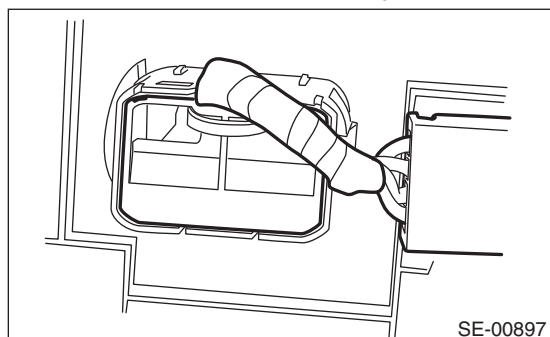

B: INSTALLATION

Install in the reverse order of removal.

C: INSPECTION

1. WIRING DIAGRAM

<Ref. to WI-89, WIRING DIAGRAM, Power Seat System.>

2. TROUBLE SYMPTOM

- Driver's side

Symptom	Criteria
All function fails to operate. <Ref. to SE-21, ALL FUNCTION FAILS TO OPERATE, INSPECTION, Power Seat System.>	<ul style="list-style-type: none"> • Power seat switch • Lumbar switch • Power seat harness • Body harness
A part of function does not operate. <Ref. to SE-21, SOME OF THE MOTORS DO NOT OPERATE (DRIVER'S SEAT), INSPECTION, Power Seat System.>	<ul style="list-style-type: none"> • Power seat switch • Lumbar switch • Power seat harness • Relevant motor

3. CHECK SWITCH

Move each switch and measure the resistance between connector terminals.

- Power seat switch

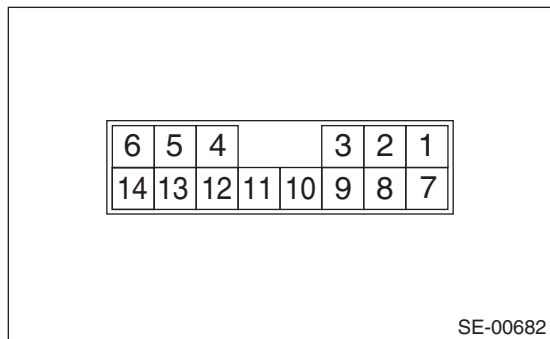

Switch position	Terminal No.	Standard
Slide forward	7 and 14 8 and 13	Less than 10 Ω
Slide backward	7 and 13 8 and 14	Less than 10 Ω
Tilt up	7 and 2 8 and 1	Less than 10 Ω
Tilt down	7 and 1 8 and 2	Less than 10 Ω
Lifter up	7 and 5 8 and 6	Less than 10 Ω
Lifter down	7 and 6 8 and 5	Less than 10 Ω
Reclining forward	7 and 3 8 and 4	Less than 10 Ω
Reclining backward	7 and 4 8 and 3	Less than 10 Ω

- Lumbar switch

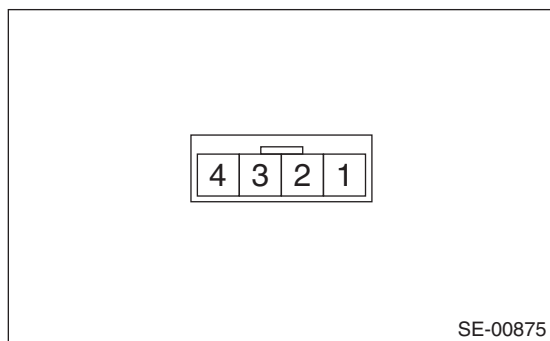

Switch position	Terminal No.	Standard
Lumbar forward	1 and 3 2 and 4	Less than 10 Ω
Lumbar backward	1 and 4 2 and 3	Less than 10 Ω

4. ALL FUNCTION FAILS TO OPERATE

Step	Check	Yes	No
1 CHECK SEAT FUNCTION. Operate each power seat switch and check that each power seat function operates normally.	Does all function fails to operate?	Go to step 2.	Check the motor which does not operate. <Ref. to SE-21, SOME OF THE MOTORS DO NOT OPERATE (DRIVER'S SEAT), INSPECTION, Power Seat System.>
2 CHECK FUSE. Check the power seat fuse inside the fuse box.	Is the fuse blown out?	Replace the appropriate fuse.	Go to step 3.
3 CHECK POWER SUPPLY CIRCUIT. 1) Disconnect the connectors of the power seat switch and lumbar switch. 2) Measure the voltage between harness connector and chassis ground. <i>Connector & terminal</i> <i>(R190) No. 7 (+) — Chassis ground (-):</i> <i>(R195) No. 1 (+) — Chassis ground (-):</i>	Is the voltage 10 V or more?	Go to step 4.	Check body harness.
4 CHECK POWER SUPPLY CIRCUIT. Measure the resistance between the power seat switch and lumbar switch harness connectors and chassis ground. <i>Connector & terminal</i> <i>(R190) No. 8 — Chassis ground:</i> <i>(R195) No. 2 — Chassis ground:</i>	Is the resistance less than 10 Ω?	Replace the faulty switch assembly.	Check body harness.

5. SOME OF THE MOTORS DO NOT OPERATE (DRIVER'S SEAT)

- Malfunction of slide operation

Step	Check	Yes	No
1 CHECK SWITCH. 1) Disconnect the connector of power seat switch assembly. 2) Measure the resistance between connector terminals when moving the switch to slide forward and slide backward. <Ref. to SE-20, CHECK SWITCH, INSPECTION, Power Seat System.>	Is there any problem on the inspection result?	Go to step 2.	Replace the power seat switch assembly.
2 CHECK HARNESS. 1) Disconnect the power seat switch connector and slide motor connector. 2) Measure the resistance between the power seat switch connector and slide motor connector. <i>Connector & terminal</i> <i>(R192) No. 1 — (R190) No. 14:</i> <i>(R192) No. 2 — (R190) No. 13:</i>	Is the resistance less than 10 Ω?	Go to step 3.	Check power seat harness.
3 CHECK SLIDE MOTOR. 1) Connect the power seat switch connector and slide motor connector. 2) Apply 12 V to the slide motor and check the motor rotation. <i>Connector & terminal</i> <i>(R190) No. 14 (+) — (R190) No. 13 (-):</i> <i>(R190) No. 13 (+) — (R190) No. 14 (-):</i>	Does the motor rotate normally?	Check for temporary poor contact or mechanical trouble in slide rail.	Slide motor problem. Replace the slide rail assembly.

Power Seat System

SEATS

• Malfunction of tilt operation

Step	Check	Yes	No
1 CHECK SWITCH. 1) Disconnect the connector of power seat switch assembly. 2) Measure the resistance between connector terminals when moving the switch to tilt up and tilt down. <Ref. to SE-20, CHECK SWITCH, INSPECTION, Power Seat System.>	Is there any problem on the inspection result?	Go to step 2.	Replace the power seat switch assembly.
2 CHECK HARNESS. 1) Disconnect the power seat switch connector and tilt motor connector. 2) Measure the resistance between power seat switch connector and tilt motor connector. Connector & terminal (R193) No. 2 — (R190) No. 2: (R193) No. 3 — (R190) No. 1:	Is the resistance less than 10 Ω?	Go to step 3.	Check power seat harness.
3 CHECK TILT MOTOR. 1) Connect the power seat switch connector and tilt motor connector. 2) Apply 12 V to the tilt motor and check the motor rotation. Connector & terminal (R190) No. 2 (+) — (R190) No. 1 (-): (R190) No. 1 (+) — (R190) No. 2 (-):	Does the motor rotate normally?	Check for temporary poor contact or mechanical trouble in tilt mechanism.	Tilt motor problem. Replace the slide rail assembly.

• Malfunction of lifter operation

Step	Check	Yes	No
1 CHECK SWITCH. 1) Disconnect the connector of power seat switch assembly. 2) Measure the resistance between connector terminals when moving the switch to lifter up and lifter down. <Ref. to SE-20, CHECK SWITCH, INSPECTION, Power Seat System.>	Is there any problem on the inspection result?	Go to step 2.	Replace the power seat switch assembly.
2 CHECK HARNESS. 1) Disconnect the power seat switch connector and lifter motor connector. 2) Measure the resistance between the power seat switch connector and lifter motor connector. Connector & terminal (R194) No. 4 — (R190) No. 5: (R194) No. 3 — (R190) No. 6:	Is the resistance less than 10 Ω?	Go to step 3.	Check power seat harness.
3 CHECK LIFTER MOTOR. 1) Connect the power seat switch connector and lifter motor connector. 2) Apply 12 V to the lifter motor and check the motor rotation. Connector & terminal (R190) No. 5 (+) — (R190) No. 6 (-): (R190) No. 6 (+) — (R190) No. 5 (-):	Does the motor rotate normally?	Check for temporary poor contact or mechanical trouble in lifter mechanism.	Lifter motor problem. Replace the slide rail assembly.

• Malfunction of reclining operation

Step	Check	Yes	No
1 CHECK SWITCH. 1) Disconnect the connector of power seat switch assembly. 2) Measure the resistance between connector terminals when moving the switch to reclining forward and reclining backward. <Ref. to SE-20, CHECK SWITCH, INSPECTION, Power Seat System.>	Is there any problem on the inspection result?	Go to step 2.	Replace the power seat switch assembly.
2 CHECK HARNESS. 1) Disconnect the power seat switch connector and reclining motor connector. 2) Measure the resistance between the power seat switch connector and reclining motor connector. Connector & terminal (R191) No. 2 — (R190) No. 3: (R191) No. 1 — (R190) No. 4:	Is the resistance less than 10 Ω?	Go to step 3.	Check power seat harness.
3 CHECK RECLINING MOTOR. 1) Connect the power seat switch connector and reclining motor connector. 2) Apply 12 V to the reclining motor and check the motor rotation. Connector & terminal (R190) No. 3 (+) — (R190) No. 4 (-): (R190) No. 4 (+) — (R190) No. 3 (-):	Does the motor rotate normally?	Check for temporary poor contact or mechanical trouble in reclining hinge.	Reclining motor problem. Replace the backrest hinge and motor assembly.

• Malfunction of lumbar operation

Step	Check	Yes	No
1 CHECK SWITCH. 1) Disconnect the connector of the lumbar switch assembly. 2) Measure the resistance between connector terminals when moving the switch to lumbar forward and lumbar backward. <Ref. to SE-20, CHECK SWITCH, INSPECTION, Power Seat System.>	Is there any problem on the inspection result?	Go to step 2.	Replace the lumbar switch assembly.
2 CHECK HARNESS. 1) Disconnect the lumbar switch connector and lumbar motor connector. 2) Measure the resistance between the lumbar switch connector and lumbar motor connector. Connector & terminal (R198) No. 1 — (R195) No. 3: (R198) No. 2 — (R195) No. 4:	Is the resistance less than 10 Ω?	Go to step 3.	Check power seat harness.
3 CHECK LUMBAR MOTOR. 1) Disconnect the lumbar switch connector and lumbar motor connector. 2) Apply 12 V to the lumbar motor and check the motor rotation. Connector & terminal (R195) No. 3 (+) — (R195) No. 4 (-): (R195) No. 4 (+) — (R195) No. 3 (-):	Does the motor rotate normally?	Check for temporary poor contact or mechanical trouble in the lumbar section.	Lumbar motor problem. Replace the lumbar motor assembly.

5. Seat Heater System

A: REMOVAL

1. SEAT HEATER UNIT

- 1) Remove the front seats. <Ref. to SE-8, REMOVAL, Front Seat.>
- 2) Remove the backrest cover of front seat and seat cushion cover. <Ref. to SE-9, DISASSEMBLY, Front Seat.>
- 3) Remove the hog rings, and then remove the seat heater unit.

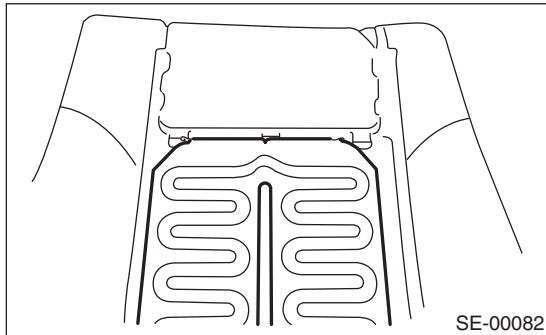

2. SEAT HEATER SWITCH

- 1) Remove the console box. <Ref. to EI-46, REMOVAL, Console Box.>
- 2) Remove the seat heater switch from the console box.

B: INSTALLATION

Install in the reverse order of removal.

C: INSPECTION

1. WIRING DIAGRAM

<Ref. to WI-96, WIRING DIAGRAM, Seat Heater System.>

2. DIAGNOSIS CHART

Symptom	Repair order
Seat heater does not operate.	1. Check the fuses. <Ref. to SE-24, CHECK SEAT HEATER FUSE, INSPECTION, Seat Heater System.>
	2. Check the power supply and ground circuit for the seat heater system. <Ref. to SE-24, CHECK POWER SUPPLY AND GROUND CIRCUIT, INSPECTION, Seat Heater System.>
	3. Check the thermistor circuit. <Ref. to SE-24, CHECK THERMISTOR CIRCUIT, INSPECTION, Seat Heater System.>
	4. Check the seat heater switch circuit. <Ref. to SE-25, CHECK SEAT HEATER SWITCH, INSPECTION, Seat Heater System.>

3. CHECK SEAT HEATER FUSE

Remove the seat heater fuse and inspect visually. Is the fuse blown out?

- Yes → Replace the fuse.
- No → Check the power supply and ground circuit.

4. CHECK POWER SUPPLY AND GROUND CIRCUIT

1) CHECK POWER SUPPLY CIRCUIT

- (1) Disconnect the seat heater switch.
- (2) Turn the ignition switch to ON.
- (3) Measure the voltage between harness connector terminal and chassis ground.

Connector & terminal

(AD8) No. 12 (+) — Chassis ground (-):

Is the voltage 12 V or more?

- Yes → Go to step 2.
- No → Check the harness between the seat heater switch and fuse.

2) CHECK GROUND CIRCUIT

Measure the resistance between harness connector terminal and chassis ground.

Connector & terminal

(AD8) No. 2 — Chassis ground:

Is the resistance less than 10 Ω?

- Yes → Go to step 3.
- No → Repair the harness.

3) CHECK GROUND CIRCUIT

Measure the resistance between harness connector terminals.

Connector & terminal

(AD8) No. 1 — (AD8) No. 2:

(AD8) No. 3 — (AD8) No. 2:

Is the resistance less than 10 Ω?

- Yes → The power supply and ground circuit are normal.
- No → Repair the harness.

5. CHECK THERMISTOR CIRCUIT

- 1) Disconnect the seat heater switch connector.
- 2) Measure the resistance between harness connector terminals.

Connector & terminal

Check LHD side

(AD8) No. 8 — (AD8) No. 3:

Check RHD side

(AD8) No. 6 — (AD8) No. 1:

Is the resistance between 1 KΩ to 200 KΩ?

- Yes → The thermistor circuit is normal.
- No → The harness or thermistor is faulty.

6. CHECK SEAT HEATER SWITCH

1) CHECK THERMISTOR OUTPUT VOLTAGE

- (1) Turn the ignition switch to ON.
- (2) Measure the voltage between the seat heater switch and chassis ground.

Connector & terminal

LHD side seat

(AD8) No. 8 (+) — Chassis ground (-):

RHD side seat

(AD8) No. 6 (+) — Chassis ground (-):

Is the voltage 1.5 V or more?

- Yes → Go to step 2.
- No → Replace the seat heater switch.

2) CHECK OUTPUT VOLTAGE

- (1) Turn the ignition switch to ON.
- (2) Measure the voltage between the seat heater switch and chassis ground when turning the switch to a position other than OFF.

Connector & terminal

LHD side seat

(AD8) No. 9 (+) — Chassis ground (-):

RHD side seat

(AD8) No. 7 (+) — Chassis ground (-):

Does the voltage fluctuate between 12 V ↔ 0 V?

- Yes → The harness or thermistor is faulty, or the heater has an open circuit.
- No → Replace the seat heater switch.

6. Rear Seat Reclining System

A: REMOVAL

- 1) Disconnect the ground cable from the battery.
- 2) Remove the backrest shoulder. <Ref. to SE-15, REMOVAL, Rear Seat.>
- 3) Remove the rear quarter lower trim. <Ref. to EI-55, REMOVAL, Rear Quarter Trim.>
- 4) Remove the bolts and the wire, and remove the rear seat backrest striker assembly.

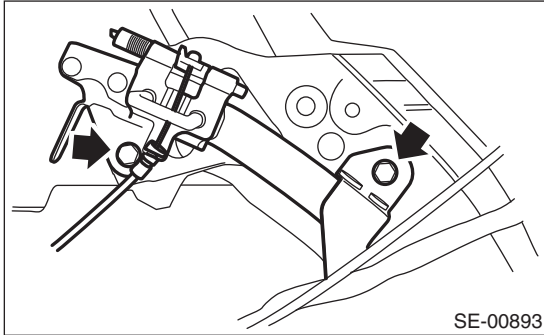

- 5) Remove the nuts and remove the reclining button bracket.

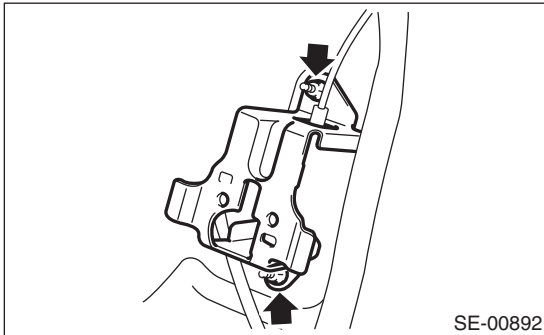

B: INSTALLATION

Install in the reverse order of removal.

SECURITY AND LOCKS

SL

	Page
1. General Description	2
2. Door Lock Control System	8
3. Keyless Entry System	13
4. Security System	22
5. Front Inner Remote	26
6. Front Outer Handle	27
7. Front Door Latch and Door Lock Actuator Assembly	28
8. Rear Inner Remote	29
9. Rear Outer Handle	30
10. Rear Door Latch and Door Lock Actuator Assembly	31
11. Rear Gate Opener Button	32
12. Rear Gate Latch and Actuator Assembly	33
13. Front Hood Lock Assembly	34
14. Remote Openers	35
15. Ignition Key Lock	36
16. Key Lock Cylinders	37
17. Security Control Module	38
18. Impact Sensor	39
19. Keyless Entry Control Module	40
20. Keyless Buzzer	41
21. Body Integrated Unit	42
22. Transmitter	43
23. Immobilizer Control Module	44
24. Immobilizer Antenna	45

General Description

SECURITY AND LOCKS

1. General Description

A: COMPONENT

1. DOOR LOCK ASSEMBLY

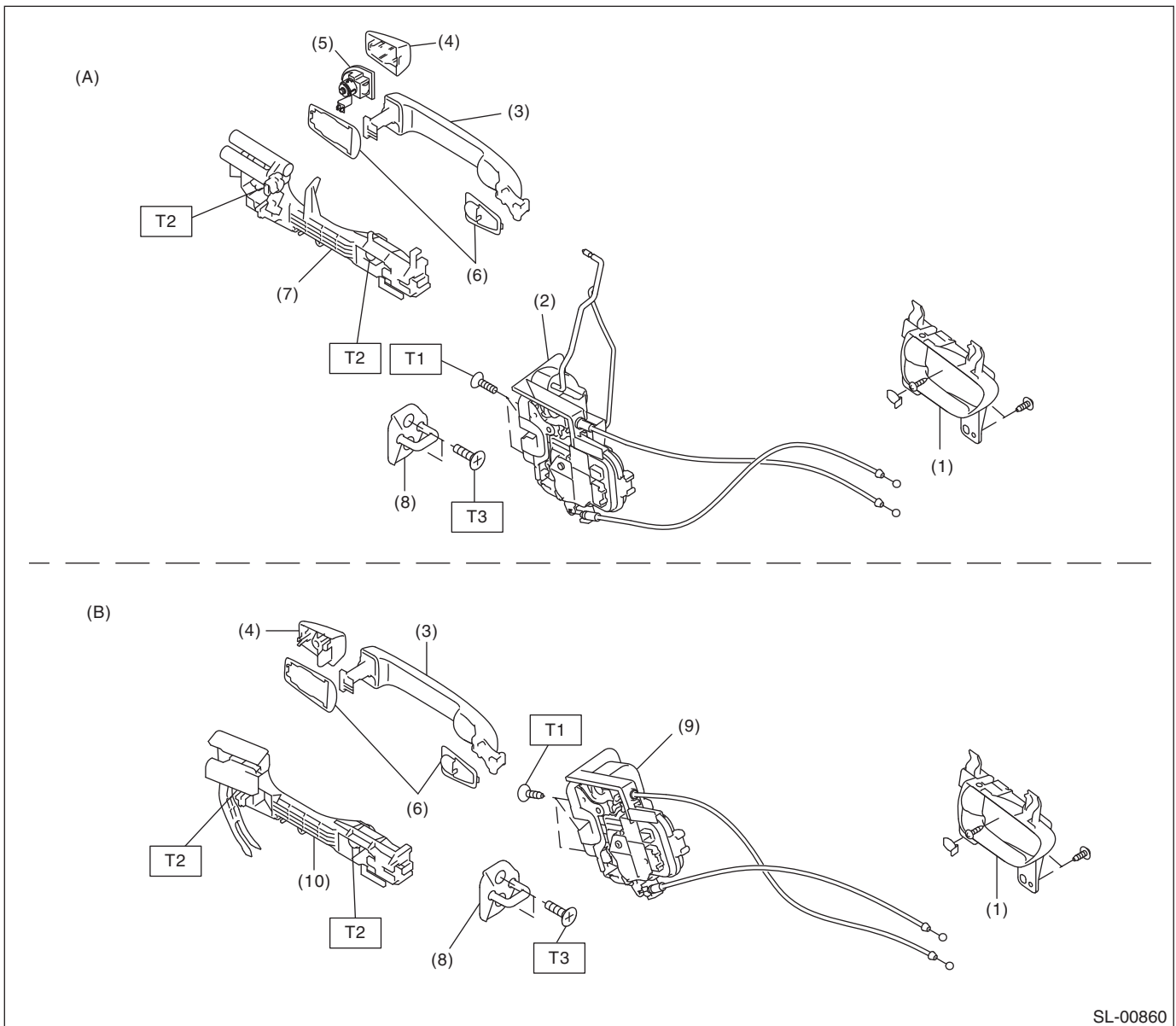

SL-00860

(A) Front

(B) Rear

- | | |
|--|---|
| (1) Inner remote ASSY | (7) Front door outer handle frame ASSY |
| (2) Front door latch and door lock actuator ASSY | (8) Striker |
| (3) Door outer handle | (9) Rear door latch and door lock actuator ASSY |
| (4) Door outer handle cover | (10) Rear door outer handle frame ASSY |
| (5) Key cylinder (Driver's side only) | |
| (6) Door outer handle spacer | |

Tightening torque: N·m (kgf·m, ft·lb)

T1: 6.5 (0.66, 4.8)

T2: 7.5 (0.76, 5.5)

T3: 18 (1.8, 13.3)

2. REAR GATE LOCK

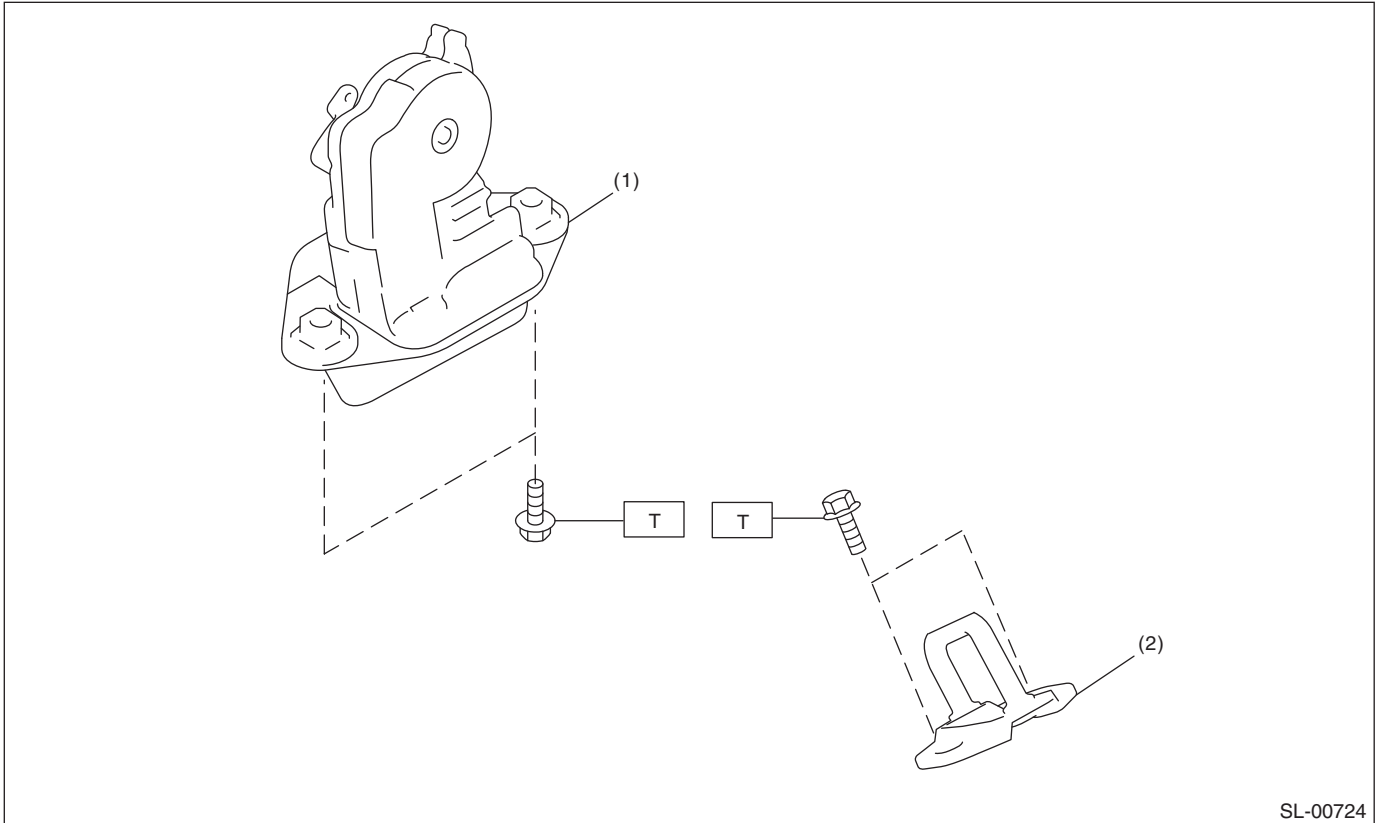

- (1) Rear gate latch and actuator ASSY (2) Rear gate striker

Tightening torque: N·m (kgf·m, ft·lb)
T: 25 (2.5, 18.4)

General Description

SECURITY AND LOCKS

3. FRONT HOOD LOCK AND REMOTE OPENERS

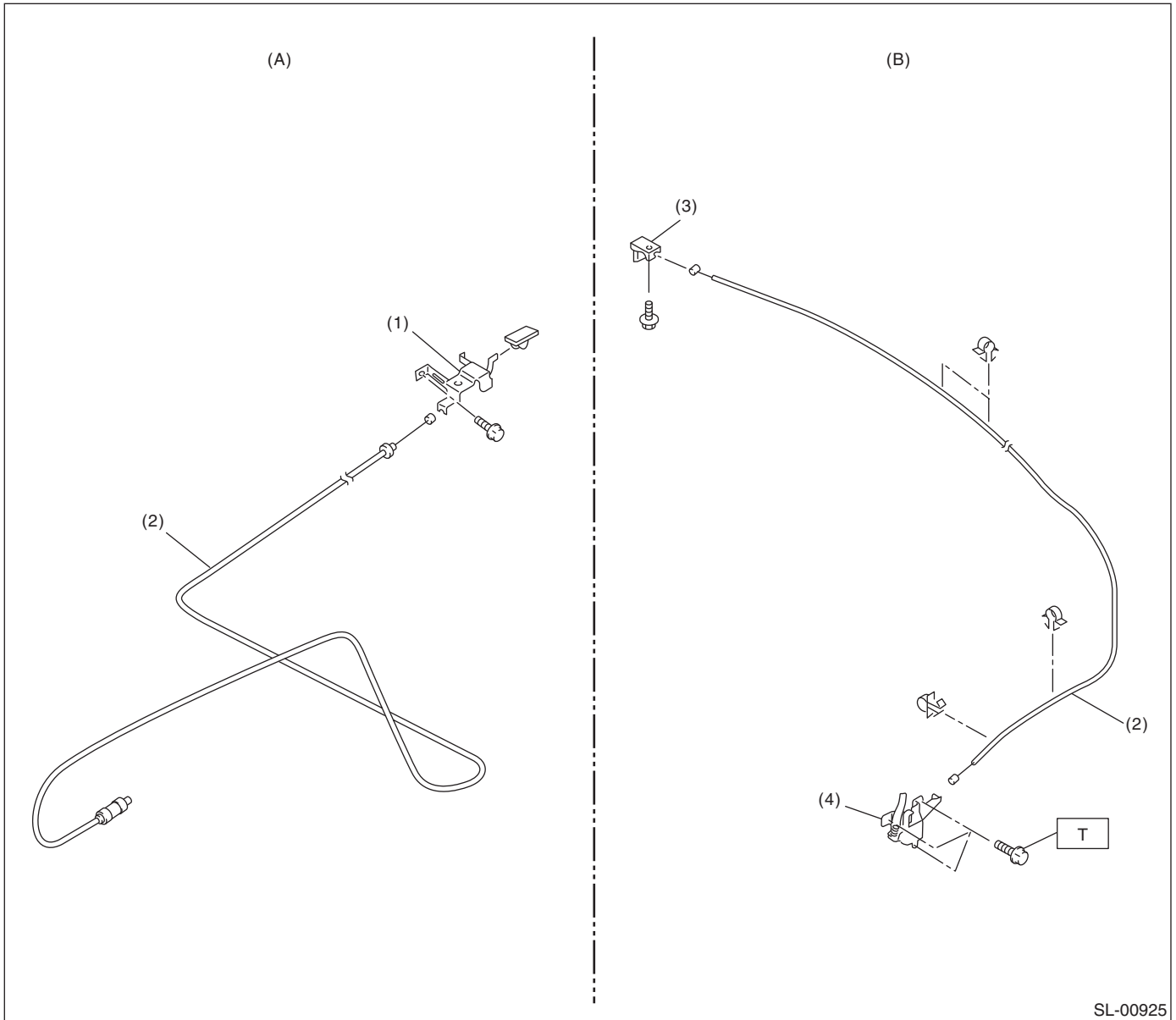

(A) Fuel lock release

(B) Hood lock release

(1) Pull handle ASSY

(3) Lever ASSY

(2) Cable

(4) Front hood lock ASSY

Tightening torque: N·m (kgf·m, ft·lb)

T: 33 (3.36, 24.2)

4. KEYLESS ENTRY SYSTEM

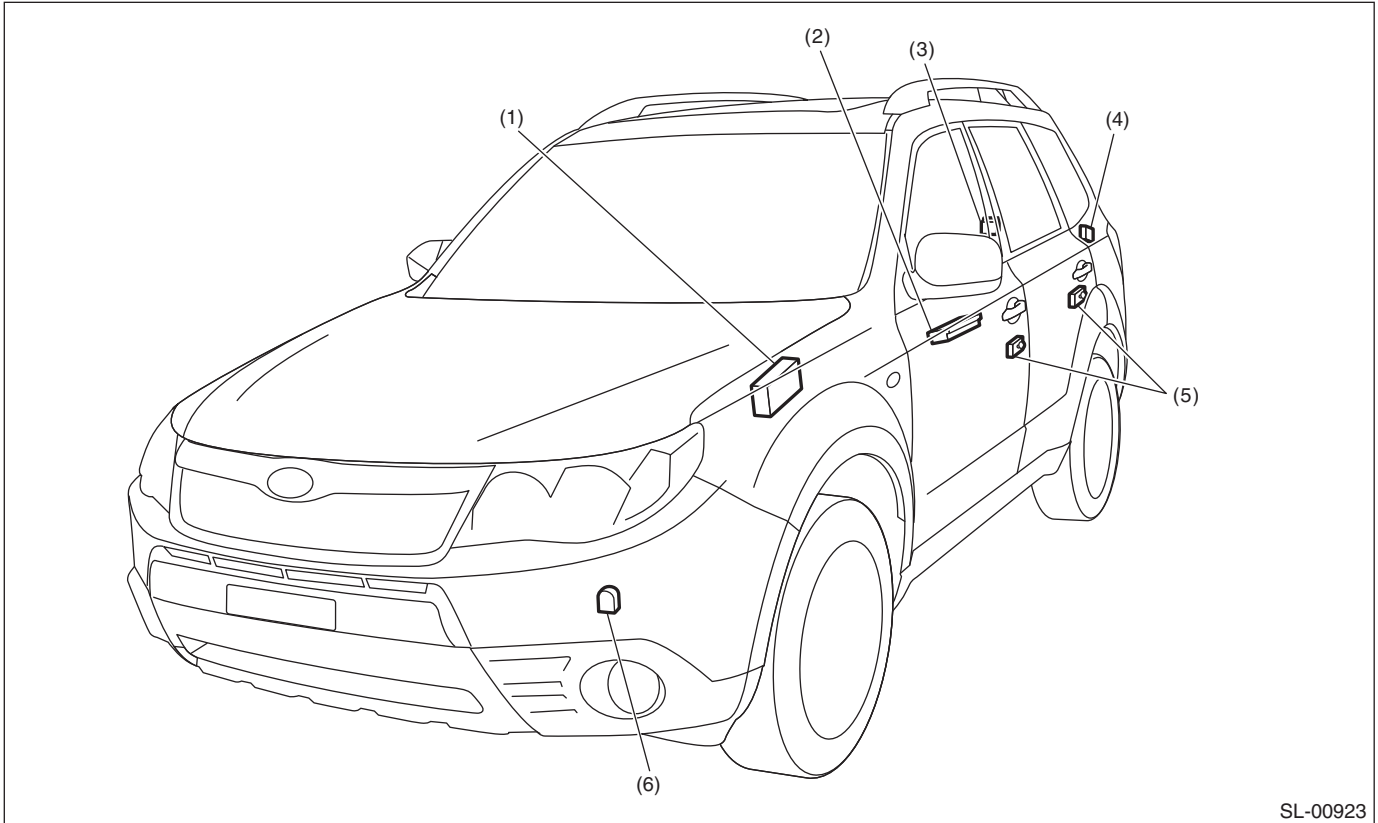

SL-00923

(1) Body integrated unit

(3) Rear gate latch switch

(5) Door switch

(2) Power window main switch

(4) Keyless entry control module

(6) Keyless buzzer

General Description

SECURITY AND LOCKS

5. SECURITY SYSTEM

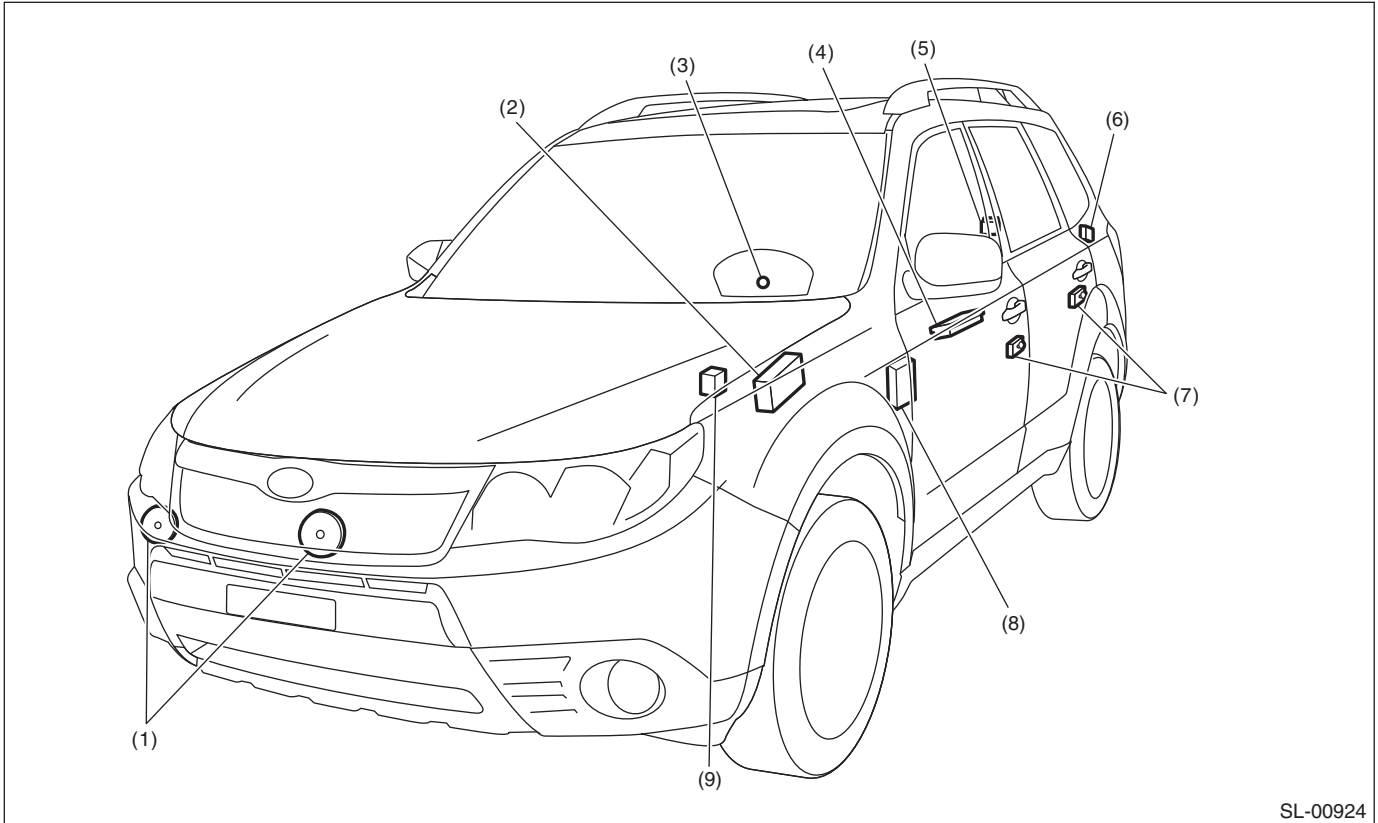

SL-00924

- | | | |
|---|----------------------------------|--|
| (1) Horn | (4) Power window main switch | (8) Impact sensor (Side of instrument panel on driver's seat side) (Dealer option) |
| (2) Body integrated unit | (5) Rear gate latch switch | (9) Horn relay (in main fuse box) |
| (3) Security indicator light (in combination meter) | (6) Keyless entry control module | |
| | (7) Door switch | |

B: CAUTION

- Before disassembling or reassembling parts, always disconnect the battery ground cable from battery. When repairing the audio, control module, etc. which are provided with memory functions, record the memory contents before disconnecting the ground cable from battery. Otherwise, these contents are erased upon disconnection.
- After disconnecting the battery or after restoring from a dead battery condition, turn the ignition to ON and OFF, and perform after opening and closing the driver's side door a few times.
- Reassemble the parts in the reverse order of disassembly unless otherwise indicated.
- Adjust the parts to the specifications described in this manual if so designated.
- Connect the connectors securely during reassembly.
- After reassembly, make sure all the functional parts operate smoothly.
- The airbag system wiring harness is routed near electrical parts and switches.
- Do not use the electrical test equipment on the airbag system wiring harnesses and connector circuits.
- Be careful not to damage the airbag system wiring harness when servicing the ignition key cylinder and steering lock CM.

C: PREPARATION TOOL

1. SPECIAL TOOL

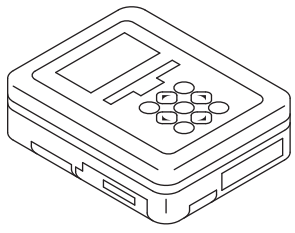
ILLUSTRATION	TOOL NUMBER	DESCRIPTION	REMARKS
 <p style="text-align: center;">ST1B022XU0</p>	1B022XU0 (Newly adopted tool)	SUBARU SELECT MONITOR III KIT	Used for diagnosis of the electrical system.

2. GENERAL TOOL

TOOL NAME	REMARKS
Circuit tester	Used for measuring resistance and voltage.
Drill	Used for replacing the ignition key lock or steering lock CM.
Clip remover	Used for removing trim clip

Door Lock Control System

SECURITY AND LOCKS

2. Door Lock Control System

A: WIRING DIAGRAM

For wiring diagrams related to the door lock control system, refer to “Keyless Entry System” in Section WI. <Ref. to WI-154, WIRING DIAGRAM, Keyless Entry System.>

B: ELECTRICAL SPECIFICATION

1. BODY INTEGRATED UNIT

Refer to the “Control Module I/O Signal” of the LAN system (diag). <Ref. to LAN(diag)-10, ELECTRICAL SPECIFICATION, Control Module I/O Signal.>

C: INSPECTION

1. SYMPTOM CHART

Symptom	Repair order	Reference
The door lock control system does not operate.	1. Remove the following fuses and inspect visually. <ul style="list-style-type: none">• No. 3 (In fuse & relay box)• No. 7 (In fuse & relay box)• No. 8 (in main fuse box)	If the fuse is blown out, replace the fuse with a new part. Check the power supply and ground circuit, if the fuse has no abnormality. <Ref. to SL-9, CHECK POWER SUPPLY AND GROUND CIRCUIT, INSPECTION, Door Lock Control System.>
	2. Check the power supply and ground circuit for body integrated unit.	<Ref. to SL-9, CHECK POWER SUPPLY AND GROUND CIRCUIT, INSPECTION, Door Lock Control System.>
	3. Check the door lock switch and the circuit.	<Ref. to SL-9, CHECK DOOR LOCK SWITCH, INSPECTION, Door Lock Control System.>
	4. Check the rear gate opener button and circuit.	<Ref. to SL-11, CHECK REAR GATE OPENER BUTTON CIRCUIT, INSPECTION, Door Lock Control System.>
	5. Check the door lock actuator and the circuit.	<Ref. to SL-11, CHECK DOOR LOCK ACTUATOR AND CIRCUIT, INSPECTION, Door Lock Control System.>
A specific door lock actuator does not operate.	Check the door lock actuator and circuit.	<Ref. to SL-11, CHECK DOOR LOCK ACTUATOR AND CIRCUIT, INSPECTION, Door Lock Control System.>

2. CHECK POWER SUPPLY AND GROUND CIRCUIT

Step	Check	Yes	No
1 CHECK POWER SUPPLY. 1) Disconnect the harness connector of body integrated unit. 2) Measure the voltage between harness connector terminal and chassis ground. <i>Connector & terminal</i> <i>(i84) No. 34 (+) — Chassis ground (-):</i> <i>(B280) No. 6 (+) — Chassis ground (-):</i> <i>(B281) No. 2 (+) — Chassis ground (-):</i>	Is the voltage 10 V or more?	Go to step 2.	Check the harness for open or short circuit between body integrated unit and fuse.
2 CHECK GROUND CIRCUIT. Measure the resistance between harness connector terminal and chassis ground. <i>Connector & terminal</i> <i>(i84) No. 28 — Chassis ground:</i> <i>(B280) No. 17 — Chassis ground:</i> <i>(B281) No. 20 — Chassis ground:</i> <i>(B279) No. 27 — Chassis ground:</i>	Is the resistance less than 10 Ω?	The power supply and ground circuit are OK.	Repair or replace the harness.

3. CHECK DOOR LOCK SWITCH

Step	Check	Yes	No
1 CHECK DOOR LOCK SWITCH Check the input from door lock switch to body integrated unit using Subaru Select Monitor. 1) Prepare the Subaru Select Monitor kit. 2) Turn the ignition switch to ON (engine OFF), and run the “PC application for Subaru Select Monitor”. 3) On the “System Selection Menu”, select {Integ. unit mode}. 4) On the “System Selection Menu”, select {Integ. unit mode}. Select the {Current Data Display & Save}. 5) On the “System Selection Menu”, select {Integ. unit mode}. Select the {Current Data Display & Save}. Check the {Manual lock switch input} input by operating each door lock switch (driver’s and passenger’s) in the LOCK direction.	Does the display switch between OFF ⇔ ON when each door lock switch is moved to LOCK?	Go to step 2.	Go to step 3.
2 CHECK DOOR LOCK SWITCH. From the condition in step 1), check the {Manual unlock switch input} input by operating each door unlock switch (driver’s and passenger’s) in the UNLOCK direction.	Does the display switch between OFF ⇔ ON when each door lock switch is moved to UNLOCK?	The door lock switch is OK.	Go to step 4.
3 CHECK DOOR LOCK SWITCH. 1) Disconnect the door lock switch harness connector. 2) Use a tester and check the continuity when the door lock switch is operated to the LOCK side. <i>Connector & terminal</i> <i>Driver’s side:</i> <i>(D102) No. 2 — (D102) No. 3:</i> <i>Passenger’s side:</i> <i>(D125) No. 4 — (D125) No. 5:</i>	Did the indicator change from “No continuity” (1 MΩ or more) to “Continuity exists” (less than 10 Ω)?	Go to step 4.	Replace the power window main switch and door lock switch.

Door Lock Control System

SECURITY AND LOCKS

Step	Check	Yes	No
4 CHECK DOOR LOCK SWITCH. Use a tester and check the continuity when the door lock switch is operated to the UNLOCK side. Connector & terminal Driver's side: (D102) No. 1 — (D102) No. 3: Passenger's side: (D125) No. 2 — (D125) No. 5:	Did the indicator change from "No continuity" (1 M Ω or more) to "Continuity exists" (less than 10 Ω)?	Go to step 5.	Replace the power window main switch and door lock switch.
5 CHECK HARNESS. Use a tester to measure the resistance between the door lock switch harness connector and chassis ground. Connector & terminal Driver's side: (D102) No. 3 — Chassis ground: Passenger's side: (D125) No. 5 — Chassis ground:	Is the resistance less than 10 Ω ?	Go to step 6.	Repair or replace the harness.
6 CHECK HARNESS. 1) Disconnect the harness connector of body integrated unit. 2) Measure the resistance between the body integrated unit and each door lock switch. Connector & terminal Driver's side: (D102) No. 2 — (i84) No. 15: (D102) No. 1 — (i84) No. 29: Passenger's side: (D125) No. 4 — (i84) No. 15: (D125) No. 2 — (i84) No. 29:	Is the resistance less than 10 Ω ?	Replace the body integrated unit. <Ref. to SL-42, Body Integrated Unit.>	Repair or replace the harness.

4. CHECK REAR GATE OPENER BUTTON CIRCUIT

Step	Check	Yes	No
1 CHECK REAR GATE OPENER BUTTON. Check the input from the rear gate opener button to body integrated unit using the Subaru Select Monitor. 1) Prepare the Subaru Select Monitor kit. 2) Turn the ignition switch to ON (engine OFF), and run the "PC application for Subaru Select Monitor". 3) On the "System Selection Menu", select {Integ. unit mode}. 4) On the "System Selection Menu", select {Integ. unit mode}. Select the {Current Data Display & Save}. 5) On the "System Selection Menu", select {Integ. unit mode}. Select the {Current Data Display & Save}. Check the {R Gate Release SW input} input by operating the rear gate opener button.	Does the display switch between OFF ⇔ ON when the rear gate opener button is operated?	The rear gate opener button is normal.	Go to step 2.
2 CHECK HARNESS. Measure the resistance between the body integrated unit and rear gate opener button. <i>Connector & terminal</i> <i>(B281) No. 24 — (D99) No. 5:</i>	Is the resistance less than 10 Ω?	Go to step 3.	Repair or replace the harness.
3 CHECK HARNESS. Measure the resistance between the rear gate opener button and chassis ground. <i>Connector & terminal</i> <i>(D99) No. 6 — Chassis ground:</i>	Is the resistance less than 10 Ω?	Go to step 4.	Repair or replace the harness.
4 CHECK REAR GATE OPENER BUTTON. Measure the resistance between connector terminals both when the rear gate opener button is pressed and when not pressed. <i>Connector & terminal</i> <i>(D99) No. 5 — (D99) No. 6:</i>	Is the resistance less than 10 MΩ when the switch is pressed and 1 MΩ or more when not pressed?	Replace the body integrated unit. <Ref. to SL-42, Body Integrated Unit.>	Replace the rear gate opener button. <Ref. to SL-32, Rear Gate Opener Button.>

5. CHECK DOOR LOCK ACTUATOR AND CIRCUIT

Step	Check	Yes	No
1 CHECK HARNESS (DOOR LOCK). Measure the resistance between the body integrated unit and each door lock actuator. <i>Connector & terminal</i> <i>(i84) No. 7 — (D18) No. 1: (front door LH)</i> <i>(i84) No. 7 — (D72) No. 1: (front door RH)</i> <i>(i84) No. 7 — (D26) No. 1: (rear door LH)</i> <i>(i84) No. 7 — (D32) No. 1: (rear door RH)</i>	Is the resistance less than 10 Ω?	Go to step 2.	Repair or replace the harness.
2 CHECK HARNESS (DOOR UNLOCK). Measure the resistance between the body integrated unit and each door lock actuator. <i>Connector & terminal</i> <i>(i84) No. 23 — (D18) No. 2: (front door LH)</i> <i>(i84) No. 8 — (D72) No. 2: (front door RH)</i> <i>(i84) No. 8 — (D26) No. 2: (rear door LH)</i> <i>(i84) No. 8 — (D32) No. 2: (rear door RH)</i>	Is the resistance less than 10 Ω?	Go to step 3.	Repair or replace the harness.

Door Lock Control System

SECURITY AND LOCKS

Step	Check	Yes	No
3 CHECK HARNESS (REAR GATE UNLOCK). Measure the resistance between the body integrated unit and rear gate lock actuator. <i>Connector & terminal</i> <i>(i84) No. 22 — (D46) No. 1:</i>	Is the resistance less than 10 Ω?	Go to step 4.	Repair or replace the harness.
4 CHECK HARNESS (REAR GATE UNLOCK). Measure the resistance between the rear gate lock actuator and chassis ground. <i>Connector & terminal</i> <i>(D46) No. 2 — Chassis ground:</i>	Is the resistance less than 10 Ω?	Go to step 5.	Repair or replace the harness.
5 CHECK BODY INTEGRATED UNIT. Measure the voltage between the connector terminals of the body integrated unit when moving the door lock switch to LOCK. <i>Connector & terminal</i> <i>Except for front door LH</i> <i>(i84) No. 7 (+) — (i84) No. 8 (-):</i> <i>Front door LH</i> <i>(i84) No. 7 (+) — (i84) No. 23 (-):</i>	Does the voltage change from less than 1.5 V → 10 V or more? (During lock output)	Go to step 6.	Replace the body integrated unit. <Ref. to SL-42, Body Integrated Unit.>
6 CHECK BODY INTEGRATED UNIT. Measure the voltage between the connector terminals of the body integrated unit when moving the door lock switch to UNLOCK. <i>Connector & terminal</i> <i>Except for front door LH</i> <i>(i84) No. 8 (+) — (i84) No. 7 (-):</i> <i>Front door LH</i> <i>(i84) No. 23 (+) — (i84) No. 7 (-):</i>	Does the voltage change from less than 1.5 V to 10 V or more? (During unlock output)	Go to step 7.	Replace the body integrated unit. <Ref. to SL-42, Body Integrated Unit.>
7 CHECK BODY INTEGRATED UNIT. Measure the voltage between the body integrated unit and chassis ground when the rear gate opener button is operated. <i>Connector & terminal</i> <i>(i84) No. 22 (+) — Chassis ground (-):</i>	Does the voltage change from less than 1.5 V to 10 V or more? (During unlock output)	Go to step 8.	Replace the body integrated unit. <Ref. to SL-42, Body Integrated Unit.>
8 CHECK DOOR LOCK ACTUATOR. Check the door lock actuator. <ul style="list-style-type: none"> • Front door lock actuator <Ref. to SL-28, INSPECTION, Front Door Latch and Door Lock Actuator Assembly.> • Rear door lock actuator <Ref. to SL-31, INSPECTION, Rear Door Latch and Door Lock Actuator Assembly.> 	Is the door lock actuator OK?	Go to step 9.	Replace the door latch and door lock actuator assembly.
9 CHECK REAR GATE LOCK ACTUATOR. Check the rear gate lock actuator. <Ref. to SL-33, Rear Gate Latch and Actuator Assembly.>	Is the rear gate lock actuator normal?	Check the harness for open or short circuits between the body integrated unit and rear gate lock actuator.	Replace the rear gate latch and actuator assembly.

3. Keyless Entry System

A: WIRING DIAGRAM

1. KEYLESS ENTRY

<Ref. to WI-154, WIRING DIAGRAM, Keyless Entry System.>

B: ELECTRICAL SPECIFICATION

1. KEYLESS ENTRY CONTROL MODULE

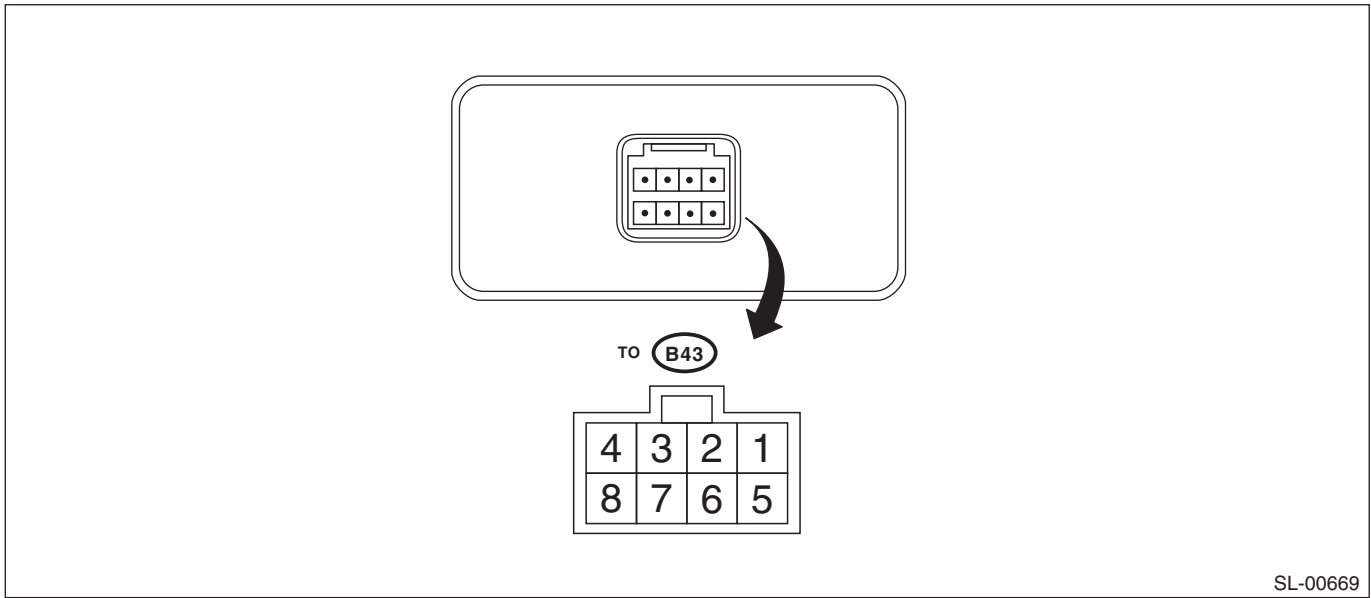

Remarks	Terminal No.	Measuring condition
—	1	—
—	2	—
Body integrated unit	3 (OUTPUT)	Battery voltage cannot be measured because of digital signal.
Power supply (Backup)	4	Battery voltage is constantly present.
—	5	—
—	6	—
Ground	7	0 V is constantly present.

2. BODY INTEGRATED UNIT

Refer to the “Control Module I/O Signal” of the LAN system (diag). <Ref. to LAN(diag)-10, ELECTRICAL SPECIFICATION, Control Module I/O Signal.>

Keyless Entry System

SECURITY AND LOCKS

C: INSPECTION

1. SYMPTOM CHART

Symptom	Repair order	Reference
None of the functions of the keyless entry system operate.	1. Check the keyless transmitter battery.	<Ref. to SL-15, CHECK KEYLESS TRANSMITTER BATTERY AND FUNCTION, INSPECTION, Keyless Entry System.>
	2. Remove and visually check the fuse No. 31 (in the fuse & relay box) and No. 7 (in the fuse & relay box).	If the fuse is blown out, replace the fuse with a new part. Check the power supply and ground circuit, if the fuse has no abnormality. <Ref. to SL-9, CHECK POWER SUPPLY AND GROUND CIRCUIT, INSPECTION, Door Lock Control System.>
	3. Check the keyless entry control module.	<Ref. to SL-16, CHECK KEYLESS ENTRY CONTROL MODULE, INSPECTION, Keyless Entry System.>
	4. Check the power supply and ground circuit for body integrated unit.	<Ref. to SL-16, CHECK BODY INTEGRATED UNIT POWER SUPPLY AND GROUND CIRCUIT, INSPECTION, Keyless Entry System.>
	5. Check the key warning switch.	<Ref. to SL-18, CHECK KEY WARNING SWITCH, INSPECTION, Keyless Entry System.>
	6. Check the door switch.	<Ref. to SL-17, CHECK DOOR SWITCH, INSPECTION, Keyless Entry System.>
	7. Check the body integrated unit.	<Ref. to LAN(diag)-2, Basic Diagnostic Procedure.>
The keyless transmitter cannot be registered.	1. Check the keyless transmitter battery.	<Ref. to SL-15, CHECK KEYLESS TRANSMITTER BATTERY AND FUNCTION, INSPECTION, Keyless Entry System.>
	2. Check the key warning switch.	<Ref. to SL-18, CHECK KEY WARNING SWITCH, INSPECTION, Keyless Entry System.>
	3. Check the door lock switch signal.	<Ref. to SL-20, CHECK DOOR LOCK SWITCH, INSPECTION, Keyless Entry System.>
	4. Check the body integrated unit.	<Ref. to LAN(diag)-2, Basic Diagnostic Procedure.>
Door lock or unlock does not operate. NOTE: If the door lock control system does not operate when using the door lock switch, check the door lock control system. <Ref. to SL-8, INSPECTION, Door Lock Control System.>	1. Check the keyless transmitter battery.	<Ref. to SL-15, CHECK KEYLESS TRANSMITTER BATTERY AND FUNCTION, INSPECTION, Keyless Entry System.>
	2. Check the keyless entry control module.	<Ref. to SL-16, CHECK KEYLESS ENTRY CONTROL MODULE, INSPECTION, Keyless Entry System.>
	3. Check the key warning switch.	<Ref. to SL-18, CHECK KEY WARNING SWITCH, INSPECTION, Keyless Entry System.>
	4. Check the door switch.	<Ref. to SL-17, CHECK DOOR SWITCH, INSPECTION, Keyless Entry System.>
	5. Check the body integrated unit.	<Ref. to LAN(diag)-2, Basic Diagnostic Procedure.>
Buzzer and hazard light do not operate.	1. Check the buzzer operation.	<Ref. to SL-20, CHECK KEYLESS BUZZER, INSPECTION, Keyless Entry System.>
	2. Check the hazard light operation.	<Ref. to SL-19, CHECK HAZARD LIGHT OPERATION, INSPECTION, Keyless Entry System.>
	3. Check the body integrated unit.	<Ref. to LAN(diag)-2, Basic Diagnostic Procedure.>
Room light does not operate.	1. Check the room light operation.	<Ref. to SL-19, CHECK ROOM LIGHT OPERATION, INSPECTION, Keyless Entry System.>
	2. Check the body integrated unit.	<Ref. to LAN(diag)-2, Basic Diagnostic Procedure.>
Ignition switch illumination does not operate.	1. Check the ignition switch illumination.	<Ref. to SL-21, CHECK IGNITION SWITCH ILLUMINATION, INSPECTION, Keyless Entry System.>
	2. Check the body integrated unit.	<Ref. to LAN(diag)-2, Basic Diagnostic Procedure.>

2. CHECK KEYLESS TRANSMITTER BATTERY AND FUNCTION

Step	Check	Yes	No
1 CHECK KEYLESS TRANSMITTER BATTERY. 1) Remove the battery from the keyless transmitter. <Ref. to SL-43, REMOVAL, Transmitter.> 2) Check the battery voltage. <Ref. to SL-43, INSPECTION, Transmitter.>	Is the voltage 2.5 V or more?	Go to step 2.	Replace the keyless transmitter battery. <Ref. to SL-43, Transmitter.>
2 CHECK KEYLESS TRANSMITTER. Register the keyless transmitter which operates normally on other vehicles to the inspection target vehicle. <Ref. to SL-43, REGISTRATION OF KEYLESS TRANSMITTER WITH SUBARU SELECT MONITOR, REPLACEMENT, Transmitter.> 1) Close all the doors and the rear gate of vehicle to be checked. 2) Using the keyless transmitter, lock and unlock the doors and rear gate of the vehicle.	Can all doors of the car being checked be locked and unlocked normally.	Go to step 3.	Due to vehicle malfunction, continue the keyless entry system diagnosis.
3 CHECK KEYLESS TRANSMITTER. Register the keyless transmitter of inspection target vehicle to the another vehicle on which the keyless system operates normally. <Ref. to SL-43, REGISTRATION OF KEYLESS TRANSMITTER WITH SUBARU SELECT MONITOR, REPLACEMENT, Transmitter.>	Is the keyless transmitter registered correctly?	Go to step 4.	Replace the keyless transmitter. <Ref. to SL-43, REGISTRATION OF KEYLESS TRANSMITTER WITH SUBARU SELECT MONITOR, REPLACEMENT, Transmitter.>
4 CHECK KEYLESS TRANSMITTER. Check the registered keyless transmitter. 1) Close all the doors and the rear gate of the vehicle which operates keyless system normally. 2) Using the keyless transmitter, lock and unlock the doors and rear gate of the vehicle.	Can the vehicle be locked and unlocked correctly?	The keyless transmitter is working properly.	Replace the keyless transmitter. <Ref. to SL-43, REGISTRATION OF KEYLESS TRANSMITTER WITH SUBARU SELECT MONITOR, REPLACEMENT, Transmitter.>

CAUTION:

Be sure to reset keyless transmitters from other vehicles that were registered to the inspection target vehicle, and the vehicle to which keyless transmitters were registered for the inspection, to the condition before performing the inspection. (Register the keyless transmitters again.)

Keyless Entry System

SECURITY AND LOCKS

3. CHECK KEYLESS ENTRY CONTROL MODULE

Step	Check	Yes	No
1 CHECK DIAGNOSTIC TROUBLE CODE (DTC). 1) Prepare the Subaru Select Monitor kit. 2) Turn the ignition switch to ON (engine OFF), and run the "PC application for Subaru Select Monitor". 3) On the "System Selection Menu", select {Integ. unit mode}. 4) Select the {Diagnostic Code(s) Display}. 5) Check if the DTC is displayed.	Is DTC B1500 "Keyless UART com. Malfunction" displayed?	Go to step 2.	Keyless entry control module is normal.
2 CHECK POWER SUPPLY. 1) Disconnect the keyless entry control module harness connector. 2) Measure the voltage between harness connector terminal and chassis ground. Connector & terminal (R80) No. 4 (+) — Chassis ground (-):	Is the voltage 10 V or more?	Go to step 3.	Check the harness for open circuits and shorts between the keyless entry control module and fuse.
3 CHECK GROUND CIRCUIT. Measure the resistance between harness connector terminal and chassis ground. Connector & terminal (iR80) No. 7 — Chassis ground:	Is the resistance less than 10 Ω?	Go to step 4.	Repair or replace the harness.
4 CHECK KEYLESS ENTRY CONTROL MODULE CIRCUIT. 1) Disconnect the harness connector of body integrated unit. 2) Measure the resistance between harness connector terminals. Connector & terminal (i84) No. 24 — (R80) No. 3:	Is the resistance less than 10 Ω?	Replace the keyless entry control module. <Ref. to SL-40, Keyless Entry Control Module.>	Repair or replace the harness.

4. CHECK BODY INTEGRATED UNIT POWER SUPPLY AND GROUND CIRCUIT

Step	Check	Yes	No
1 CHECK POWER SUPPLY OF BODY INTEGRATED UNIT. 1) Disconnect the harness connector of body integrated unit. 2) Measure the voltage between harness connector terminal and chassis ground. Connector & terminal (i84) No. 34 (+) — Chassis ground (-): (B280) No. 6 (+) — Chassis ground (-): (B281) No. 2 (+) — Chassis ground (-):	Is the voltage 10 V or more?	Go to step 2.	Check the harness between the body integrated unit and fuse for open or short circuits.
2 CHECK BODY INTEGRATED UNIT GROUND CIRCUIT. 1) Disconnect the harness connector of body integrated unit. 2) Measure the resistance between harness connector terminal and chassis ground. Connector & terminal (i84) No. 28 — Chassis ground: (B280) No. 17 — Chassis ground: (B281) No. 20 — Chassis ground: (B279) No. 27 — Chassis ground:	Is the resistance less than 10 Ω?	Check the body integrated unit. <Ref. to LAN(diag)-2, Basic Diagnostic Procedure.>	Repair or replace the harness.

5. CHECK DOOR SWITCH

Step	Check	Yes	No
<p>1 CHECK INPUT FROM EACH DOOR SWITCH. 1) Prepare the Subaru Select Monitor kit. 2) Turn the ignition switch to ON (engine OFF), and run the “PC application for Subaru Select Monitor”. 3) On the “System Selection Menu”, select {Integ. unit mode}. 4) Select the {Current Data Display & Save}. 5) Check the input of the doors and rear gate latch switches to the body integrated unit when opening each door (front RH and LH, rear RH and LH, and rear gate).</p>	<p>Is the input signal detected when opening the each door (front RH and LH, rear RH and LH, and rear gate)?</p>	<p>The door and rear gate latch switch circuits are normal.</p>	<p>If there is a door switch or rear gate latch switch where the input signal cannot be detected, Go to step 2.</p>
<p>2 CHECK DOOR SWITCH CIRCUIT. 1) Turn the ignition switch to OFF. 2) Disconnect the harness connector of body integrated unit. 3) Disconnect the harness connector of the faulty door or rear gate latch switch. 4) Measure the resistance between harness connector terminals. Connector & terminal <i>(i84) No. 19 — (R12) No. 1: (front door RH)</i> <i>(i84) No. 32 — (R9) No. 1: (front door LH)</i> <i>(i84) No. 6 — (R16) No. 1: (rear door RH)</i> <i>(i84) No. 20 — (R22) No. 1: (rear door LH)</i> <i>(i84) No. 33 — (D46) No. 3: (rear gate)</i></p>	<p>Is the resistance less than 10 Ω?</p>	<p>Go to step 3.</p>	<p>Repair or replace the harness.</p>
<p>3 CHECK GROUND CIRCUIT OF DOOR SWITCH. 1) Disconnect the harness connector of the faulty door or rear gate latch switch. 2) Measure the resistance of harness connector and chassis ground. Connector & terminal <i>(R12) No. 3 — Chassis ground: (front door RH)</i> <i>(R9) No. 3 — Chassis ground: (front door LH)</i> <i>(R16) No. 3 — Chassis ground: (rear door RH)</i> <i>(R22) No. 3 — Chassis ground: (rear door LH)</i> <i>(D46) No. 4 — Chassis ground: (rear gate)</i></p>	<p>Is the resistance less than 10 Ω?</p>	<p>Go to step 4.</p>	<p>Repair or replace the harness.</p>
<p>4 CHECK DOOR SWITCH. 1) Disconnect the harness connector of the faulty door or rear gate latch switch. 2) Measure the resistance between door switch and rear gate latch switch terminals. Terminals <i>No. 1 — No. 3: (except rear gate)</i> <i>No. 3 — No. 4: (rear gate)</i></p>	<p>Is the resistance 1 MΩ or more when the door switch is pushed and the rear gate is closed?</p>	<p>Go to step 5.</p>	<p>Replace the door switch, or rear gate latch and actuator assembly.</p>
<p>5 CHECK DOOR SWITCH. Measure the resistance between door switch and rear gate latch switch terminals. Terminals <i>No. 1 — No. 3: (except rear gate)</i> <i>No. 3 — No. 4: (rear gate)</i></p>	<p>Is the resistance less than 1 Ω when door switch is released and the rear gate is opened?</p>	<p>Check the body integrated unit. <Ref. to LAN(diag)-2, Basic Diagnostic Procedure.></p>	<p>Replace the door switch, or rear gate latch and actuator assembly.</p>

Keyless Entry System

SECURITY AND LOCKS

6. CHECK KEY WARNING SWITCH

	Step	Check	Yes	No
1	CHECK KEY WARNING SWITCH. Check the input signal from the key warning switch to the body integrated unit using the Subaru Select Monitor. 1) Prepare the Subaru Select Monitor kit. 2) On the "System Selection Menu", select {Integ. unit mode}. 3) Select the {Current Data Display & Save}. 4) Check the input signal to the body integrated unit by operating the ignition switch.	Is the normal input signal displayed when the key is inserted in/removed from the ignition switch?	The key warning switch is OK.	Go to step 2.
2	CHECK FUSE. Remove and visually check the fuse No. 14 (in the main fuse box).	Is the fuse blown out?	Replace the fuse with a new part.	Go to step 3.
3	CHECK KEY WARNING SWITCH CIRCUIT. 1) Disconnect the harness connector of body integrated unit. 2) Insert the key into ignition switch. (LOCK position) 3) Measure the voltage between harness connector terminal and chassis ground. Connector & terminal (B279) No. 2 (+) — Chassis ground (-):	Is the voltage 10 V or more?	Go to step 4.	Go to step 5.
4	CHECK KEY WARNING SWITCH CIRCUIT. 1) Remove the key from ignition switch. 2) Measure the voltage between harness connector terminal and chassis ground. Connector & terminal (B279) No. 2 (+) — Chassis ground (-):	Is the voltage 0 V?	Replace the body integrated unit. <Ref. to SL-42, Body Integrated Unit.>?	Go to step 5.
5	CHECK KEY WARNING SWITCH. 1) Disconnect the key warning switch harness connector. 2) Insert the key into ignition switch. (LOCK position) 3) Measure the resistance between key warning switch terminals. Connector & terminal (B350) No. 3 — No. 4:	Is the resistance less than 1 Ω?	Go to step 6.	Replace the key warning switch.
6	CHECK KEY WARNING SWITCH. 1) Remove the key from ignition switch. 2) Measure the resistance between key warning switch terminals. Connector & terminal (B350) No. 3 — No. 4:	Is the resistance 1 MΩ or more?	Check the following: <ul style="list-style-type: none"> • Harness for open circuits and shorts between the key warning switch and fuse • Harness for open or short between the body integrated unit and key warning switch 	Replace the key warning switch.

7. CHECK ROOM LIGHT OPERATION

Step	Check	Yes	No
1 CHECK ROOM LIGHT OPERATION. Make sure the room light illuminates when the room light switch is turned to ON.	Does the room light illuminate?	Go to step 2.	Check the room light circuit.
2 CHECK HARNESS BETWEEN ROOM LIGHT AND BODY INTEGRATED UNIT. 1) Disconnect the body integrated unit harness connector and room light harness connector. 2) Measure the resistance between the body integrated unit harness connector terminal and room light harness connector terminal. Connector & terminal (B279) No. 5 — (R52) No. 2:	Is the resistance less than 10 Ω?	The room light operation circuit is OK.	Check the harness for open or short between body integrated unit and room light.

8. CHECK HAZARD LIGHT OPERATION

Step	Check	Yes	No
1 CHECK HAZARD LIGHT OPERATION. Make sure the hazard light blinks when hazard switch is turned to ON.	Does the hazard light blink?	Go to step 2.	Check the hazard light circuit.
2 CHECK OUTPUT TO HAZARD LIGHT. 1) Turn the ignition switch to OFF. 2) Disconnect the key warning switch harness connector. 3) Prepare the Subaru Select Monitor kit. 4) Turn the ignition switch to ON (engine OFF), and run the "PC application for Subaru Select Monitor". 5) On the "System Selection Menu", select {Integ. unit mode}. 6) Select {ECM customizing}. 7) Check {Hazard answer-back setup}, and then switch to ON setting if necessary. 8) Select the {Current Data Display & Save}. 9) Remove the key from ignition switch. 10) When operating the LOCK/UNLOCK button of the transmitter, check the hazard output signal of the body integrated unit.	Is output signal present when operating the transmitter LOCK/UNLOCK button?	Go to step 3.	Check the body integrated unit. <Ref. to LAN(diag)-2, Basic Diagnostic Procedure.>
3 CHECK CIRCUIT OF HAZARD LIGHT. 1) Disconnect the harness connector of body integrated unit. 2) Disconnect the turn signal and hazard unit harness connector. 3) Measure the resistance between harness connector terminals. Connector & terminal (B281) No. 22 — (B32) No. 8:	Is the resistance less than 10 Ω?	Check the body integrated unit. <Ref. to LAN(diag)-2, Basic Diagnostic Procedure.>	Repair or replace the harness.

Keyless Entry System

SECURITY AND LOCKS

9. CHECK KEYLESS BUZZER

Step	Check	Yes	No
1 CHECK FUNCTION. Using the Subaru Select Monitor, check the {Answer-back buzzer setup}. <Ref. to LAN(diag)-17, Read Current Data.>	Is it ON?	Go to step 2.	Change the setting to ON. <Ref. to LAN(diag)-22, Function Setting (Customize).>
2 CHECK OUTPUT TO KEYLESS BUZZER. 1) Remove the key from ignition switch. 2) Read the {Keyless Buzzer Output} of the body integrated unit using the Subaru Select Monitor. <Ref. to LAN(diag)-14, Subaru Select Monitor.> 3) Press the LOCK/UNLOCK button of the keyless transmitter. NOTE: Due to the screen refresh timing of the Subaru Select Monitor, repeat the operation a few times to confirm, as there may be no change of OFF → ON at first.	Does display change from OFF → ON?	Go to step 3.	Replace the body integrated unit. <Ref. to SL-42, Body Integrated Unit.>
3 CHECK KEYLESS BUZZER. 1) Remove the keyless buzzer. 2) Install the keyless buzzer to another vehicle with a normally operating buzzer and check buzzer operation.	Does the keyless buzzer sound?	Go to step 4.	Replace the keyless buzzer.
4 CHECK HARNESS. 1) Disconnect the harness connector of body integrated unit. 2) Disconnect the keyless buzzer harness connector. 3) Measure the resistance between harness connector terminals. Connector & terminal (B279) No. 24 — (B164) No. 1:	Is the resistance less than 10 Ω?	Go to step 5.	Repair or replace the harness.
5 CHECK HARNESS. Measure the resistance between the keyless buzzer harness connector and chassis ground. Connector & terminal (B164) No. 2 — Chassis ground:	Is the resistance less than 10 Ω?	Replace the body integrated unit. <Ref. to SL-42, Body Integrated Unit.>	Repair or replace the harness.

10.CHECK DOOR LOCK SWITCH

Refer to the “CHECK DOOR LOCK SWITCH” of the Door Lock Control System. <Ref. to SL-9, CHECK DOOR LOCK SWITCH, INSPECTION, Door Lock Control System.>

11.CHECK IGNITION SWITCH ILLUMINATION

Step	Check	Yes	No
1 CHECK FUSE. Remove and visually check the fuse No. 14 (in the main fuse box).	Is the fuse blown out?	Replace the fuse with a new part.	Go to step 2.
2 CHECK POWER SUPPLY. 1) Disconnect the ignition switch illumination harness connector. 2) Measure the voltage between harness connector terminal and chassis ground. <i>Connector & terminal</i> <i>(B224) No. 2 (+) — Chassis ground (-):</i>	Is the voltage 10 V or more?	Go to step 3.	Check the harness for open circuits and shorts between the ignition switch illumination and fuse.
3 CHECK IGNITION SWITCH ILLUMINATION CIRCUIT. 1) Disconnect the harness connector of body integrated unit and ignition switch illumination harness connector. 2) Measure the resistance between body integrated unit harness connector terminal and ignition switch illumination harness connector terminal. <i>Connector & terminal</i> <i>(B281) No. 23 — (B224) No. 1:</i>	Is the resistance less than 10 Ω?	Replace the ignition switch illumination bulb with a new bulb. <Ref. to LI-38, REMOVAL, Ignition Switch Illumination.>	Check the harness for open circuits and shorts between the body integrated unit and ignition switch illumination.

Security System

SECURITY AND LOCKS

4. Security System

A: WIRING DIAGRAM

<Ref. to WI-150, WIRING DIAGRAM, Security System.>

B: ELECTRICAL SPECIFICATION

1. BODY INTEGRATED UNIT

Refer to the "Control Module I/O Signal" of the LAN system (diag). <Ref. to LAN(diag)-10, ELECTRICAL SPECIFICATION, Control Module I/O Signal.>

C: INSPECTION

1. BASIC DIAGNOSTIC PROCEDURE

Step	Check	Yes	No
1 INITIAL CHECK. Check keyless entry system.	Does the keyless entry system operate normally?	Go to step 2.	Check keyless entry system. <Ref. to SL-14, INSPECTION, Keyless Entry System.>
2 CHECK SECURITY ON/OFF SETTING. 1) Remove the key from ignition switch or turn the ignition to OFF, and close all doors. 2) Press the UNLOCK button of the keyless transmitter. 3) Check the flashing of the security indicator light.	Does the security indicator light blink in three second intervals?	Go to step 3.	Check the security indicator light circuit. <Ref. to SL-24, CHECK SECURITY INDICATOR LIGHT CIRCUIT, INSPECTION, Security System.>
3 CHECK SECURITY ON/OFF SETTING. 1) Press the LOCK button of the keyless transmitter. 2) Check the security indicator light flashing patterns.	Is the flashing pattern of the security indicator light as follows? / When monitoring lag is set to 0 seconds: flashes twice within 0.5 seconds, in 2 second intervals / When monitoring lag is set to 30 seconds: flashes 3 times per second, in 0.4 second intervals.	Go to step 6.	Go to step 4.
4 CHANGE THE SETTING OF SECURITY SYSTEM. Change the setting of the security system to ON. <Ref. to SL-24, SECURITY SYSTEM ON/OFF SETTING, INSPECTION, Security System.>	Is setting change completed correctly?	Go to step 5.	<ul style="list-style-type: none"> • Check the ignition switch circuit. <Ref. to SL-25, CHECK IGNITION SWITCH CIRCUIT, INSPECTION, Security System.> • Check the door lock switch circuit. <Ref. to SL-20, CHECK DOOR LOCK SWITCH, INSPECTION, Keyless Entry System.>
5 CHECK THE SETTING CHANGE OF SECURITY SYSTEM. 1) Remove the key from ignition switch, and then close all doors. 2) Press the LOCK button of the keyless transmitter. 3) Check the security indicator light flashing patterns.	Is the flashing pattern of the security indicator light as follows? / When monitoring lag is set to 0 seconds: flashes twice within 0.5 seconds, in 2 second intervals / When monitoring lag is set to 30 seconds: flashes 3 times per second, in 0.4 second intervals.	Go to step 6.	Replace the body integrated unit. <Ref. to SL-42, Body Integrated Unit.>

Security System

SECURITY AND LOCKS

Step	Check	Yes	No
6 CHECK SECURITY SYSTEM OPERATION. Press the LOCK button of keyless transmitter, and wait for 30 seconds.	Is the blinking pattern of security indicator light blink twice within 0.5 seconds in 2 second cycles?	Go to step 7.	Replace the body integrated unit. <Ref. to SL-42, Body Integrated Unit.>
7 CHECK SECURITY ALARM OPERATION. 1) Unlock all doors using the door lock switch on driver's door. 2) Open any door or the rear gate.	Does the security alarm operate when opening any door or the rear gate?	Go to step 8.	<ul style="list-style-type: none"> • Check the door switch. <Ref. to SL-24, CHECK DOOR SWITCH, INSPECTION, Security System.> • Check the rear gate latch switch. <Ref. to SL-33, Rear Gate Latch and Actuator Assembly.>
8 CHECK SECURITY ALARM OPERATION. Check the security alarm operation.	Do all security alarms operate? / Horn sound / Hazard lights flash / Security indicator light illuminates	Go to step 9.	<ul style="list-style-type: none"> • Check the horn. <Ref. to SL-24, CHECK HORN, INSPECTION, Security System.> • Check the hazard light. <Ref. to SL-25, CHECK HAZARD LIGHT OPERATION, INSPECTION, Security System.>
9 CHECK SECURITY ALARM CANCEL OPERATION. Press any button of transmitter while the security alarm is operating. Or turn the ignition switch to ON.	Do all security alarms stop? / Horn / Hazard lights	Go to step 10.	Check the ignition switch circuit. <Ref. to SL-25, CHECK IGNITION SWITCH CIRCUIT, INSPECTION, Security System.>
10 CHECK SECURITY SYSTEM CONDITION MEMORY. Check that the system functions properly when the battery is not connected temporarily. <Ref. to SL-24, CHECK SECURITY SYSTEM CONDITION MEMORY, INSPECTION, Security System.>	Does the system function properly when the battery is not connected temporarily?	Go to step 11.	Replace the body integrated unit. <Ref. to SL-42, Body Integrated Unit.>
11 CHECK IMPACT SENSOR (DEALER OPTION). Check the sensitivity of the impact sensor. <Ref. to SL-39, CHECK IMPACT SENSOR, ADJUSTMENT, Impact Sensor.>	Is the sensitivity set properly?	Press the UNLOCK button of keyless transmitter, and finish the diagnosis.	Adjust the sensitivity. <Ref. to SL-39, IMPACT SENSITIVITY ADJUSTMENT, ADJUSTMENT, Impact Sensor.>

NOTE:

Check the function setting of body integrated unit if any of the following symptoms appear. <Ref. to LAN(diag)-2, Basic Diagnostic Procedure.>

- The horn does not sound even when the security alarm is triggered and operating. As a cause, it is possible that the siren ON/OFF setting is set to ON in the customization function.
- The horn sounds when setting the security to ON (Monitoring condition) using the keyless transmitter. As a cause, it is possible that the impact sensor present (ON) / not present (OFF) setting is set to ON in the customization function though there is no impact sensor.

Security System

SECURITY AND LOCKS

2. CHECK SECURITY SYSTEM CONDITION MEMORY

- 1) Pull out the key from the ignition switch, or turn the ignition to OFF.
- 2) Close all the doors and the rear gate.
- 3) Open the front hood.
- 4) Press the LOCK button of the keyless transmitter.

NOTE:

Wait until the security indicator light blinks twice within 0.5 seconds at 2 second intervals.

If the 30 second monitoring lag has been set, wait 30 seconds.

5) Disconnect the ground cable from the battery.

6) Connect the ground cable to the battery.

7) Check that the security indicator light blinks twice within 0.5 seconds at 2 second intervals. When it does not blink, replace the body integrated unit.

3. SECURITY SYSTEM ON/OFF SETTING

1) Close all doors and the rear gate, and sit in the driver's seat. Press the UNLOCK button of the keyless transmitter.

2) Turn the ignition switch to ON.

3) Push the centralized door lock switch down and open the driver's side door at the same time, and hold in this condition for 10 seconds.

4) If the security system is ON, it will turn OFF. If OFF, it will turn ON.

4. CHECK DOOR SWITCH

Refer to the "CHECK DOOR LOCK SWITCH" of the Keyless Entry System. <Ref. to SL-17, CHECK DOOR SWITCH, INSPECTION, Keyless Entry System.>

5. CHECK SECURITY INDICATOR LIGHT CIRCUIT

Refer to the "CHECK SECURITY INDICATOR LIGHT CIRCUIT" of Immobilizer (diag). <Ref. to IM(diag)-11, CHECK SECURITY INDICATOR LIGHT CIRCUIT, INSPECTION, Diagnostics Chart for Security Indicator Light.>

6. CHECK HORN

	Step	Check	Yes	No
1	CHECK HORN OPERATION. Check the horn sounds when the horn switch is pushed.	Does the horn sound?	Go to step 2.	Check the horn circuit.
2	CHECK OUTPUT TO HORN RELAY. 1) Connect the Subaru Select Monitor Kit. 2) Turn the ignition switch to ON (engine OFF), and run the "PC application for Subaru Select Monitor". 3) On the "System Selection Menu", select {Integ. unit mode}. 4) Select {Function Check}. 5) Select {Horn Output} and execute	Does the horn sound?	Horn circuit is OK.	Go to step 3.
3	CHECK HORN RELAY CIRCUIT. 1) Turn the ignition switch to OFF. 2) Disconnect the harness connector of body integrated unit. 3) Disconnect the main fuse box harness connector (B186). 4) Measure the resistance between harness connector terminals. Connector & terminal (B279) No. 29 — (B186) No. 1:	Is the resistance less than 10 Ω?	Check the body integrated unit. <Ref. to LAN(diag)-2, Basic Diagnostic Procedure.>	Repair or replace the harness.

7. CHECK HAZARD LIGHT OPERATION

Refer to the “CHECK HAZARD LIGHT OPERATION” of the Keyless Entry System. <Ref. to SL-19, CHECK HAZARD LIGHT OPERATION, INSPECTION, Keyless Entry System.>

8. CHECK IGNITION SWITCH CIRCUIT

Step	Check	Yes	No
1 CHECK IGNITION SWITCH VOLTAGE. 1) Prepare the Subaru Select Monitor kit. 2) Turn the ignition switch to ON (engine OFF), and run the “PC application for Subaru Select Monitor”. 3) On the “System Selection Menu”, select {Integ. unit mode}. 4) Select the {Current Data Display & Save}. 5) Check the {BATT voltage} and {IG power supply voltage}.	Is the {IG power supply voltage} within ± 1 V against {BATT voltage}?	The ignition switch input circuit is OK.	Go to step 2.
2 CHECK IGNITION SWITCH CIRCUIT. 1) Turn the ignition switch to OFF. 2) Disconnect the harness connector of body integrated unit. 3) Turn the ignition switch to ON. 4) Measure the voltage between harness connector terminal and chassis ground. Connector & terminal (B280) No. 1 (+) — Chassis ground (-):	Is the voltage 10 V or more?	Check the body integrated unit. <Ref. to LAN(diag)-2, Basic Diagnostic Procedure.>	Check the harness for open or short circuit between the body integrated unit and fuse.

5. Front Inner Remote

A: REMOVAL

- 1) Remove the door trim. <Ref. to EI-42, REMOVAL, Door Trim.>
- 2) Remove the cable from the cable holder.
- 3) Remove the screws, and remove the inner remote handle.

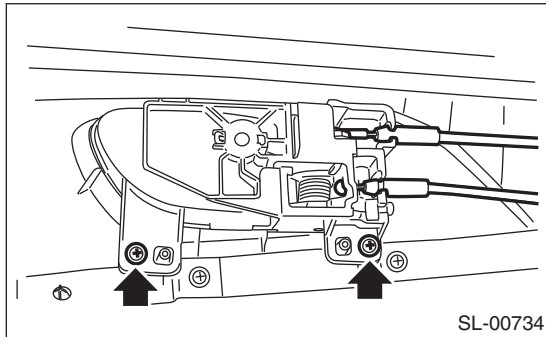

B: INSTALLATION

Install in the reverse order of removal.

C: INSPECTION

- 1) Check the cable of the door opener and door lock for deformation. When it is deformed, straighten it because failure operations may occur. When it is unrepairable, replace the front door latch and door lock actuator assembly.
- 2) Check the lever, rod and wire for smooth operation.

6. Front Outer Handle

A: REMOVAL

- 1) Raise the front door glass to the top position.
- 2) Remove the door trim. <Ref. to EI-42, REMOVAL, Door Trim.>
- 3) Remove the sealing cover. <Ref. to EB-19, REMOVAL, Front Sealing Cover.>
- 4) Remove the rod clamp.
- 5) Remove the plug at the rear of the door panel and loosen the TORX[®] bolt (1).

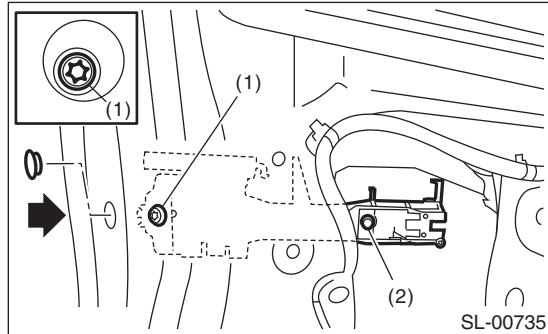

- 6) Remove the door outer handle cover.
- 7) Move the front outer handle towards the rear, and remove the front outer handle.

CAUTION:

Do not apply excessive force to remove the handle from the door panel. The door panel may become deformed.

- 8) remove the outer side spacer.
- 9) Loosen the TORX[®] bolt (2).
- 10) Remove the frame assembly from inside of the door panel.

B: INSTALLATION

Install in the reverse order of removal.

Tightening torque:

<Ref. to SL-2, DOOR LOCK ASSEMBLY, COMPONENT, General Description.>

C: INSPECTION

- 1) Check the rod for deformation.
- 2) Check the lever and rod for smooth operation.

Front Door Latch and Door Lock Actuator Assembly

SECURITY AND LOCKS

7. Front Door Latch and Door Lock Actuator Assembly

A: REMOVAL

- 1) Raise the front door glass to the top position.
- 2) Disconnect the ground cable from the battery.
- 3) Remove the front door trim. <Ref. to EI-42, REMOVAL, Door Trim.>
- 4) Remove the sealing cover. <Ref. to EB-19, REMOVAL, Front Sealing Cover.>
- 5) Partially remove the glass run rubber (A).

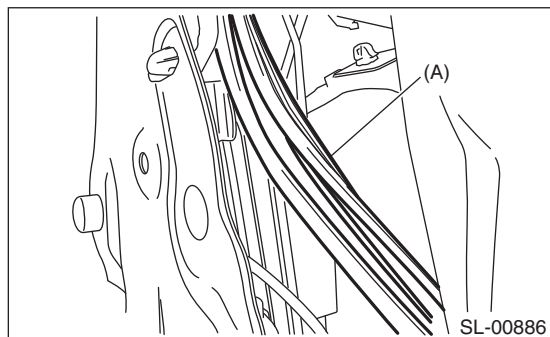

- 6) Remove the rear sash.
- 7) Remove the rod from the outer handle rod clamp.
- 8) Disconnect the connector.
- 9) Remove the three screws, and remove the front door latch and door lock actuator assembly.

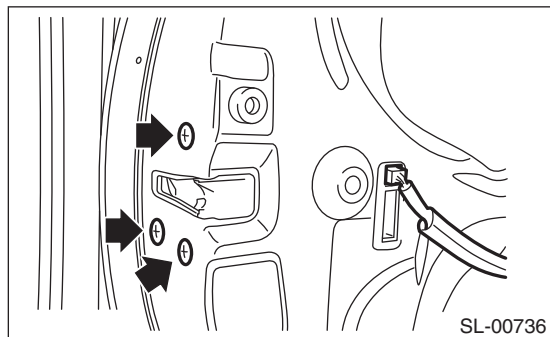

B: INSTALLATION

Install in the reverse order of removal.

Tightening torque:

<Ref. to SL-2, DOOR LOCK ASSEMBLY, COMPONENT, General Description.>

C: INSPECTION

1. DOOR LATCH

- 1) Check the rod, door opener and door lock cable for deformation. When it is deformed, straighten it because failure operations may occur. When it is unrepairable, replace the front door latch and door lock actuator assembly.
- 2) Check the lever, rod and wire for smooth operation.

2. LOCK ACTUATOR

- 1) Disconnect the door lock actuator harness connector.
- 2) Connect the battery to door lock actuator terminals.

If defective, replace the front door latch and door lock actuator assembly.

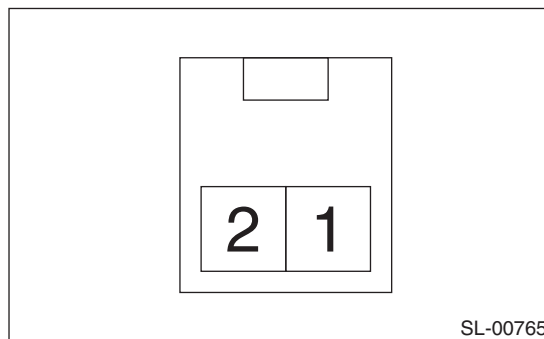

Actuator operation	Terminals	
	No. 1	No. 2
Lock → Unlock	-	+
Unlock → Lock	+	-

8. Rear Inner Remote

A: REMOVAL

Refer to “Front Inner Remote” for the removal procedure. <Ref. to SL-26, REMOVAL, Front Inner Remote.>

B: INSTALLATION

Install in the reverse order of removal.

C: INSPECTION

1) Check the cable of the door opener and door lock for deformation. When it is deformed, straighten it because failure operations may occur. When it is unrepairable, replace the rear door latch and door lock actuator assembly.

2) Check the lever, rod and wire for smooth operation.

3) Check the child safety lock for correct operations.

Rear Outer Handle

SECURITY AND LOCKS

9. Rear Outer Handle

A: REMOVAL

- 1) Raise the rear door glass to the top position.
- 2) Remove the rear door trim. <Ref. to EI-42, REMOVAL, Door Trim.>
- 3) Remove the sealing cover. <Ref. to EB-22, REMOVAL, Rear Sealing Cover.>
- 4) Remove the three screws, and move aside the rear door latch and door lock actuator assembly.

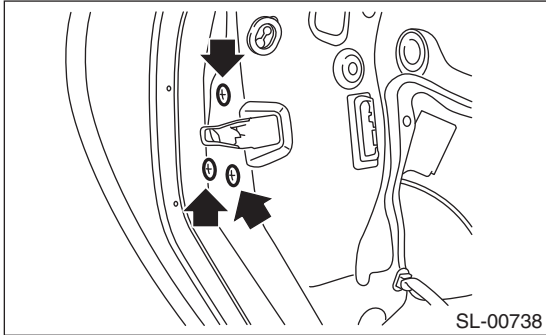

- 5) Remove the child protector cover, and loosen the TORX® bolt.

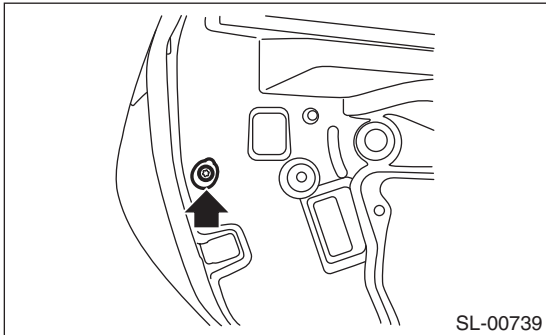

- 6) Remove the outer handle cover.
- 7) Move the rear outer handle towards the rear, and remove the rear outer handle.
- 8) Remove the outer side spacer.
- 9) Remove the TORX® bolt.

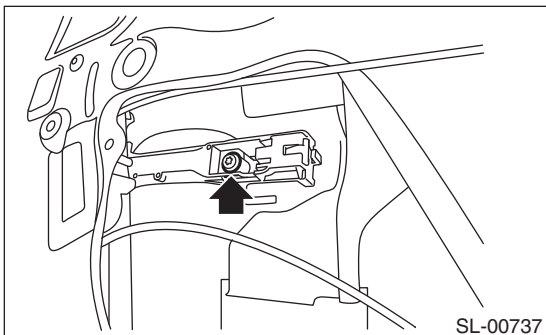

- 10) Remove the frame assembly from inside of the door panel.

CAUTION:

Do not apply excessive force to remove the handle from the door panel. The door panel may become deformed.

B: INSTALLATION

Install in the reverse order of removal.

Tightening torque:

<Ref. to SL-2, DOOR LOCK ASSEMBLY, COMPONENT, General Description.>

C: INSPECTION

- 1) Check that the latch joins securely.
- 2) Check the handle and wire for smooth operation.

10. Rear Door Latch and Door Lock Actuator Assembly

A: REMOVAL

- 1) Disconnect the ground cable from the battery.
- 2) Remove the rear door trim. <Ref. to EI-42, REMOVAL, Door Trim.>
- 3) Remove the wire from the rear inner remote. <Ref. to SL-29, REMOVAL, Rear Inner Remote.>
- 4) Remove the sealing cover. <Ref. to EB-22, REMOVAL, Rear Sealing Cover.>
- 5) Remove the rear door glass. <Ref. to GW-17, REMOVAL, Rear Door Glass.>
- 6) Disconnect the connector.
- 7) Remove the three screws, and remove the rear door latch and door lock actuator assembly.

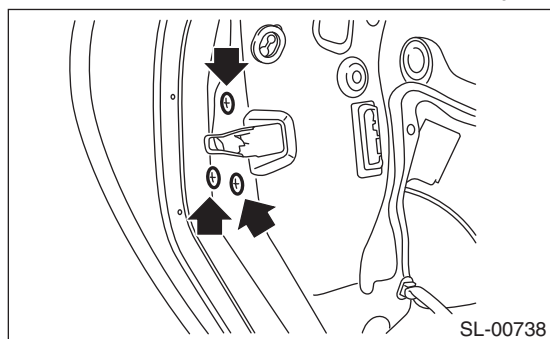

B: INSTALLATION

Install in the reverse order of removal.

Tightening torque:

<Ref. to SL-2, DOOR LOCK ASSEMBLY, COMPONENT, General Description.>

C: INSPECTION

1. DOOR LATCH

- 1) Check the cable for deformation. When it is deformed, straighten it because failure operations may occur. When it is unrepairable, replace the rear door latch and door lock actuator assembly.
- 2) Check the lever and wire for smooth operation.

2. LOCK ACTUATOR

- 1) Disconnect the door lock actuator harness connector.
- 2) Connect the battery to door lock actuator terminals.

If defective, replace the rear door latch and door lock actuator assembly.

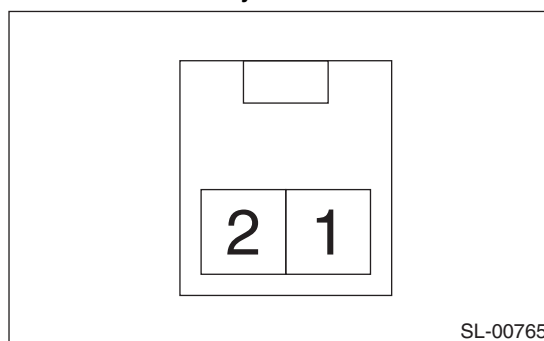

Actuator operation	Terminals	
	No. 1	No. 2
Lock → Unlock	-	+
Unlock → Lock	+	-

Rear Gate Opener Button

SECURITY AND LOCKS

11. Rear Gate Opener Button

A: REMOVAL

NOTE:

The rear gate opener button is integrated into the license plate light assembly harness.

- 1) Remove the rear gate trim. <Ref. to EI-60, REMOVAL, Rear Gate Trim.>
- 2) Remove the rear gate garnish. <Ref. to EI-62, REMOVAL, Rear Gate Garnish.>
- 3) Disconnect the harness connectors of the rear gate opener button and license plate light assembly.
- 4) Loosen four screws to remove the rear gate garnish lower cover.

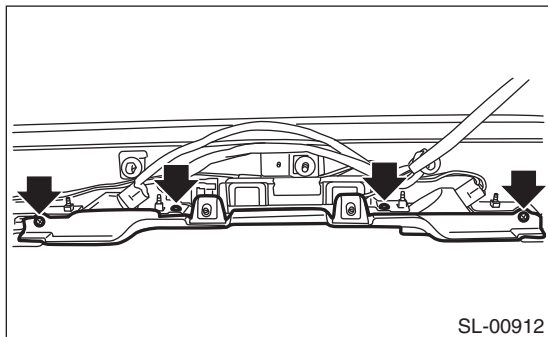

- 5) Hold down the hook of the rear gate opener button, and remove the rear gate opener button.

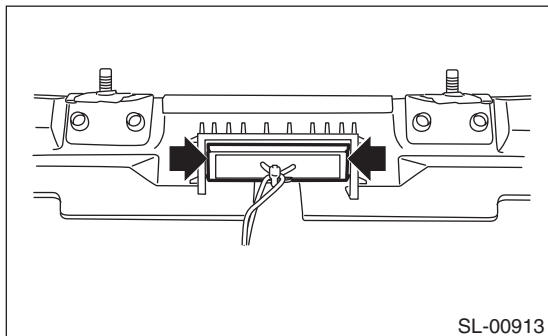

- 6) Remove the license plate light. <Ref. to LI-32, REMOVAL, License Plate Light.>
- 7) Remove the license plate light assembly harness.

B: INSTALLATION

CAUTION:

- Install with the protrusion of the switch harness clip facing towards the vehicle
- Make sure that the harness grommets are installed securely.

Failure to install securely may result in entry of water.

Install in the reverse order of removal.

C: INSPECTION

- 1) Disconnect the rear gate opener button harness connector.
- 2) Inspect the continuity between the rear gate opener button connector terminals.

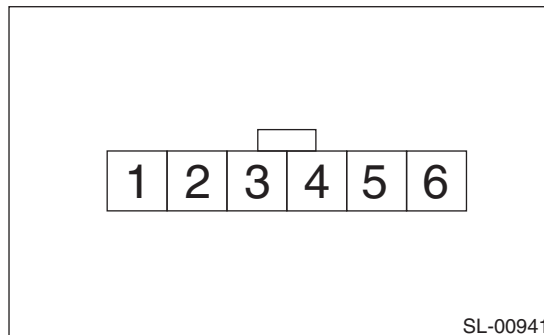

Switch	Terminal	Standard
Open	No. 5 and No. 6	Less than 1 Ω
Close		1 M Ω or more

If defective, replace the rear gate opener button.

12. Rear Gate Latch and Actuator Assembly

A: REMOVAL

- 1) Disconnect the ground cable from the battery.
- 2) Remove the rear gate trim. <Ref. to EI-60, REMOVAL, Rear Gate Trim.>
- 3) Remove two bolts.

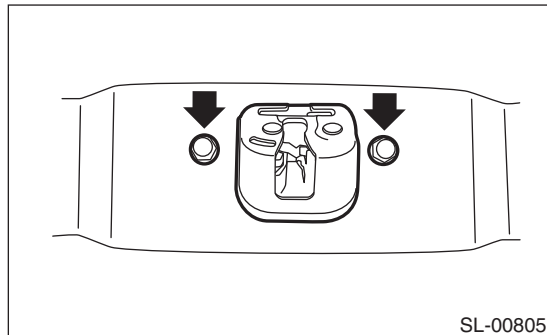

- 4) Disconnect the connector, and remove the rear gate latch and actuator assembly.

B: INSTALLATION

Install in the reverse order of removal.

C: INSPECTION

1. CHECK LOCK ACTUATOR

- 1) Disconnect the harness connector of the rear gate latch and actuator assembly.
- 2) Connect the battery to the rear gate latch and actuator assembly terminals.

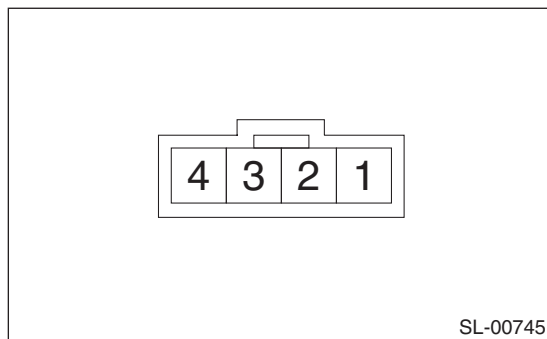

Actuator operation	Terminal	
	No. 1	No. 2
Lock → Unlock	+	-

If defective, replace the rear gate latch and actuator assembly.

13. Front Hood Lock Assembly

A: REMOVAL

- 1) Open the front hood.
- 2) Remove the front bumper. <Ref. to EI-28, REMOVAL, Front Bumper.>
- 3) Remove the bolts, and then detach the front hood lock assembly.
- 4) Remove the release cable from the lock assembly.

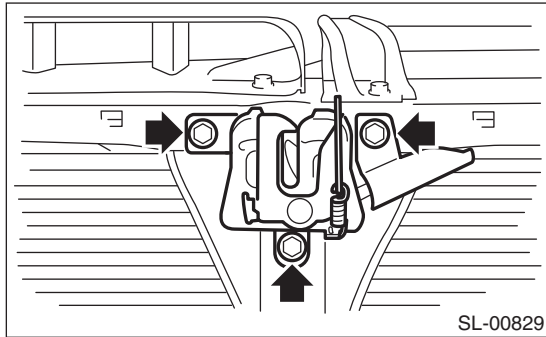

B: INSTALLATION

Install in the reverse order of removal.

Tightening torque:

<Ref. to SL-4, FRONT HOOD LOCK AND REMOTE OPENERS, COMPONENT, General Description.>

NOTE:

Apply grease to the movable part.

C: ADJUSTMENT

Loosen the bolt, and adjust the lock assembly while moving it up and down.

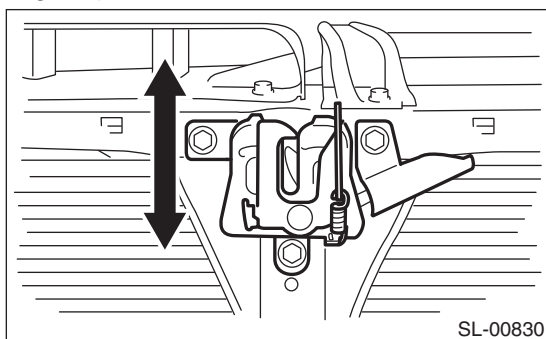

D: INSPECTION

- 1) Check the striker for deformation or abnormal wear.
- 2) Check the safety lever for improper movement.
- 3) Check other levers and springs for rust formation or unsmooth movement.

14. Remote Openers

A: REMOVAL

1. FRONT HOOD OPENER

- 1) Remove the cable from the front hood lock.
- 2) Remove the bolt, and then detach the opener lever.

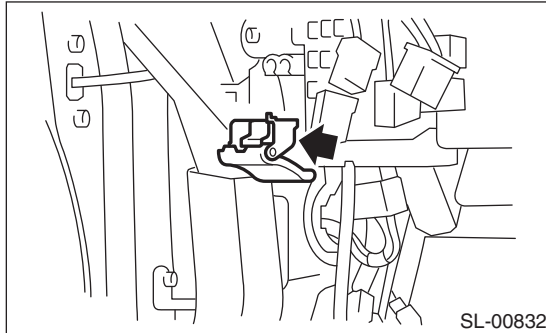

2. FUEL FILLER LID OPENER

- 1) Remove the rear seat. <Ref. to SE-15, REMOVAL, Rear Seat.>
- 2) Remove the driver's side lower inner trim, rear quarter trim and floor mat.
Remove the clip holding the cable.
- 3) Remove the bolt and nut, and remove the opener pull handle (B).
- 4) Remove cable (A) from the opener pull handle (B).

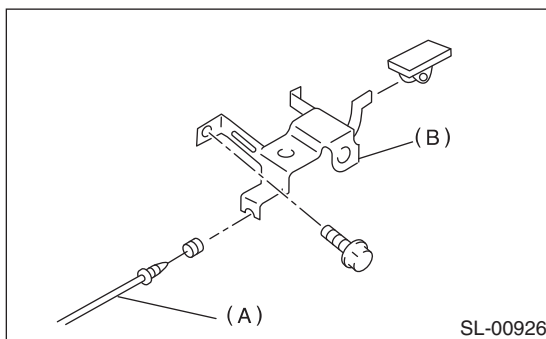

- 5) Remove the rear quarter trim RH. <Ref. to EI-55, REMOVAL, Rear Quarter Trim.>
- 6) Rotate the fuel lock inside the quarter panel to 90° and remove. (Either right or left turn)

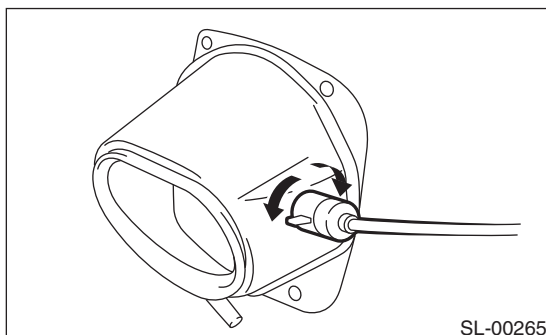

B: INSTALLATION

Install in the reverse order of removal.

C: INSPECTION

Make sure that the front hood and fuel flap open and close smoothly.

Ignition Key Lock

SECURITY AND LOCKS

15. Ignition Key Lock

A: REPLACEMENT

- 1) Disconnect the ground cable from the battery.
- 2) Remove the steering column. <Ref. to PS-15, REMOVAL, Steering Column.>
- 3) Secure the steering column in a vise. Remove the bolt with a drill.

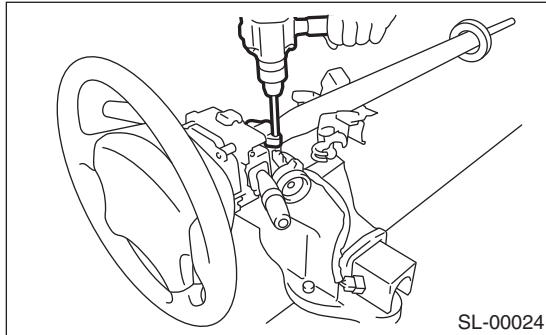

- 4) Remove the ignition key lock.
- 5) Using a new bolt, tighten the bolt until the bolt head is sheered off.

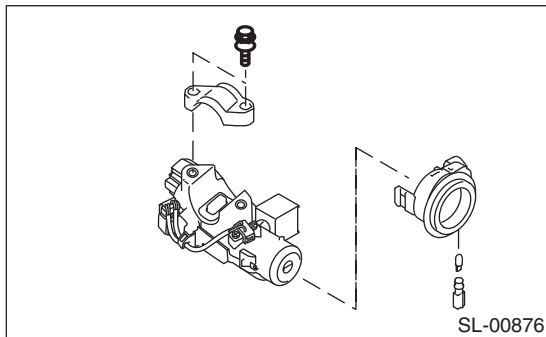

B: INSPECTION

- 1) Remove the instrument panel lower cover.
- 2) Remove the lower column cover.
- 3) Unfasten the fixing clip which secures harness, and then disconnect the connector of the ignition switch from body harness.
- 4) Turn the ignition key plate to each position and check the continuity between terminals of ignition connector.

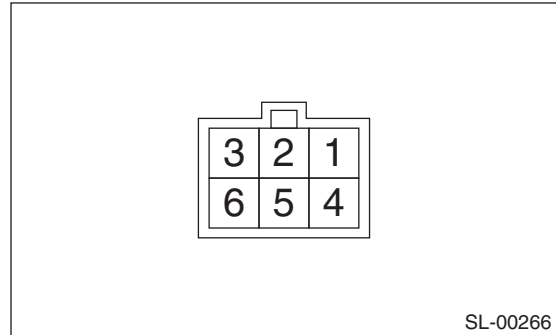

Switch position	Terminal	Standard
LOCK	—	—
ACC	No. 3 and No. 5	Less than 1 Ω
ON	No. 3 and No. 1 and No. 4 No. 3 and No. 5	Less than 1 Ω
ST	No. 3 and No. 2 No. 3 and No. 1 and No. 6	Less than 1 Ω

If NG, replace the ignition switch.

16. Key Lock Cylinders

A: REPLACEMENT

- 1) Raise the front door glass to the top position.
- 2) Remove the door trim. <Ref. to EI-42, REMOVAL, Door Trim.>
- 3) Remove the sealing cover. <Ref. to EB-19, REMOVAL, Front Sealing Cover.>
- 4) Remove the rod clamp.
- 5) Remove the plug to the rear of the door panel.
- 6) Loosen the TORX® bolt (1).

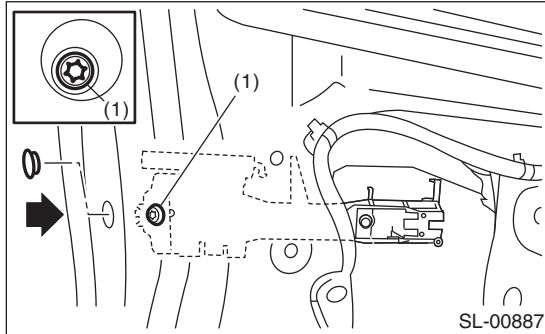

- 7) Remove the key cylinder along with the handle cover.
- 8) Remove the key cylinder from the cover, and replace the key cylinder.

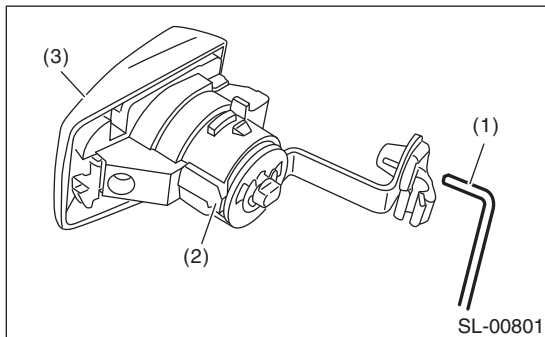

- (1) Latch connection rod
- (2) Key cylinder
- (3) Door outer handle cover

17.Security Control Module

A: NOTE

The control of security system is carried out in body integrated unit. Refer to the section of body integrated unit for work.

<Ref. to SL-42, Body Integrated Unit.>

18. Impact Sensor

A: REMOVAL

- 1) Remove the key from ignition switch.
- 2) Close all the doors and the rear gate.
- 3) Press the UNLOCK button of the keyless transmitter.
- 4) Disconnect the ground cable from the battery.
- 5) Remove the impact sensor.
- 6) Change the setting of impact sensor using Subaru Select Monitor.

B: INSTALLATION

- 1) Remove the key from ignition switch.
- 2) Close all the doors and the rear gate.
- 3) Press the UNLOCK button of the keyless transmitter.
- 4) Disconnect the ground cable from the battery.
- 5) Install the impact sensor.
- 6) Change the setting of impact sensor using Subaru Select Monitor.

C: OPERATION

1. IMPACT SENSOR SETTING USING SUBARU SELECT MONITOR

- 1) Connect the Subaru Select Monitor to the data link connector.
- 2) Turn the ignition switch to ON.
- 3) On the "System Selection Menu", select {Integ. unit mode}.
- 4) Select {ECM customizing}.
- 5) Make a impact monitor setting.
 - When installing: ON
 - When removing: OFF
- 6) Make a impact monitor ON/OFF setting.
 - When installing: ON
 - When removing: OFF
- 7) Turn the ignition switch to OFF, and then remove the Subaru Select Monitor.

D: ADJUSTMENT

1. CHECK IMPACT SENSOR

- 1) Remove the key from ignition switch.
- 2) Close all the windows.
- 3) Close all the doors and the rear gate. Leave open the front hood.
- 4) Press the LOCK button of the keyless transmitter from outside of vehicle.
- 5) Check that the security indicator light blinks twice within 0.5 seconds in 2 second cycles after 30 seconds.

- 6) Hit all windows with the palm with force repeatedly, to check for whether the security alarm operates. Lift up the front hood approx. 12 cm (4.7 in) or more, and then drop it off to check the operation of security alarm.
- 7) If NG, adjust the impact sensitivity.

2. IMPACT SENSITIVITY ADJUSTMENT

- 1) Connect the Subaru Select Monitor to the data link connector.
- 2) Turn the ignition switch to ON.
- 3) On the "System Selection Menu", select {Impact Sensor}.
- 4) Make a {Sensitivity Adjustment Mode}.
 - Sensitivity can be adjusted in 11 levels (0 to 10).
 - Initial setting is 5.
 - Smaller number means more sensitive.
 - Larger number means less sensitive.
- 5) Turn the ignition switch to OFF, and then remove the Subaru Select Monitor.

NOTE:

- Set the sensor so as not to let the alarm on normal vibration (reclining to the door, hit the ball and etc.).
- Set the sensor to operate the alarm with hitting the door or window glass, etc. continuously like a mayhem by robbery.
- Even if there is no burglary attempt, if there is vibration (road construction, elevated parking lots, passage of trains or boarding of ferries), the alarm can be triggered. Because of this, ask the customer about their parking conditions, and set an appropriate sensitivity level after discussion.
- The impact sensitivity can also be adjusted on the manufacturer's optional display, and it can be set in 11 levels from 0 to 10. The sensitivity is set to 5 by default. (Unlike the specification of the Subaru Select Monitor, the setting becomes duller as the setting value becomes smaller, and more sensitive as the number becomes larger.)
- If the sensitivity setting was not performed properly, a buzzer will sound four times. In this case, check the following:
 - Is there an error in CAN communication?
 - Is there an open circuit in the harness between the body integrated unit and the impact sensor?
 - Is there a malfunction in the display, body integrated unit or impact sensor?

Keyless Entry Control Module

SECURITY AND LOCKS

19. Keyless Entry Control Module

A: REMOVAL

- 1) Disconnect the ground cable from the battery.
- 2) Remove the left rear quarter trim. <Ref. to EI-55, REMOVAL, Rear Quarter Trim.>
- 3) Remove the bolt, disconnect the connector and remove the keyless entry control module.

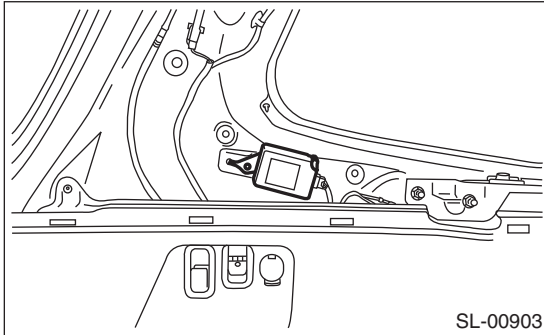

B: INSTALLATION

Install in the reverse order of removal.

20. Keyless Buzzer

A: REMOVAL

- 1) Disconnect the ground cable from the battery.
- 2) Remove the front bumper. <Ref. to EI-28, REMOVAL, Front Bumper.>
- 3) Remove the bolt, and then remove the keyless buzzer.

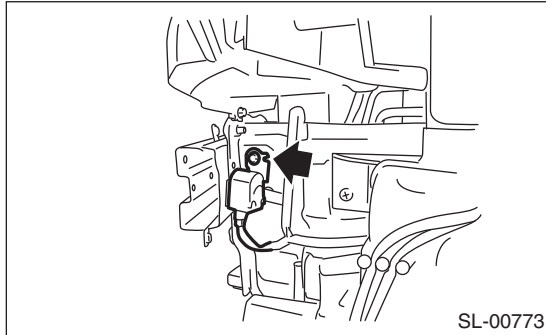

B: INSTALLATION

Install in the reverse order of removal.

C: INSPECTION

Using the Subaru Select Monitor, perform forced operation of the keyless buzzer. <Ref. to LAN(diag)-27, Function Check.>

NOTE:

If it does not sound, replace the buzzer.

21. Body Integrated Unit

A: REMOVAL

NOTE:

1. When replacing the body integrated unit
 - Prepare the security ID plate.
 - For models with immobilizers, prepare the required number of new immobilizer keys (unregistered).
 - When replacing the body integrated unit, check the current settings and record it. <Ref. to LAN(diag)-17, Read Current Data.>
 2. After replacing the body integrated unit with immobilizer
 - Register the immobilizer. For detailed operation procedures, refer to the “PC application help for Subaru Select Monitor”.
 - Set the current settings according to what was recorded.
- 1) Disconnect the ground cable from the battery.
 - 2) Remove the driver’s side instrument panel lower cover. <Ref. to EI-44, REMOVAL, Instrument Panel Lower Cover.>
 - 3) Remove the knee guard panel.
 - 4) Disconnect the connector of body integrated unit.

CAUTION:

Be careful to keep water and other foreign materials away from body integrated unit.

- 5) Remove two mounting nuts for body integrated unit bracket, and remove the body integrated unit.

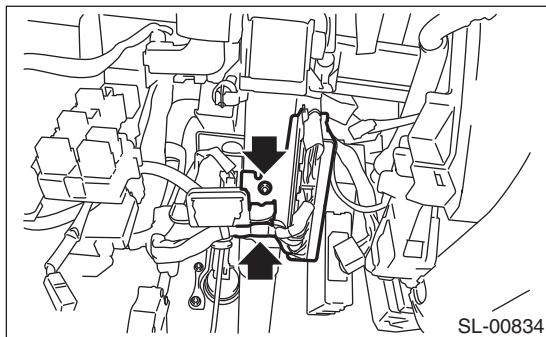

B: INSTALLATION

Install in the reverse order of removal.

NOTE:

Make sure that there are no differences from the contents of the current settings after installation. <Ref. to LAN(diag)-17, Read Current Data.>

22. Transmitter

A: REMOVAL

1. TRANSMITTER BATTERY

Remove the battery (1) from the transmitter.

NOTE:

To prevent static electricity damage to the transmitter printed circuit board, touch the steel area of building with hand to discharge static electricity carried on body or clothes before disassembling the transmitter.

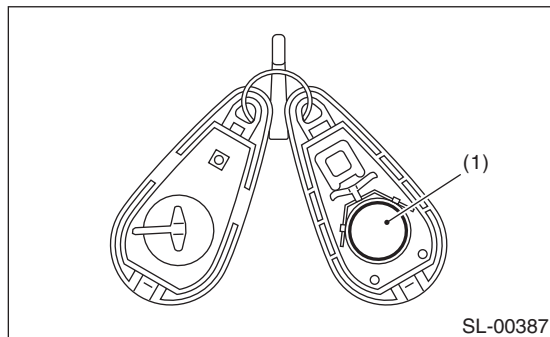

B: INSTALLATION

1. TRANSMITTER BATTERY

Install in the reverse order of removal.

C: INSPECTION

1. TRANSMITTER BATTERY

Measure the voltage between the keyless transmitter battery (+) terminal and (-) terminal.

NOTE:

Battery discharge occurs during the measurement. Complete the measurement within 5 seconds.

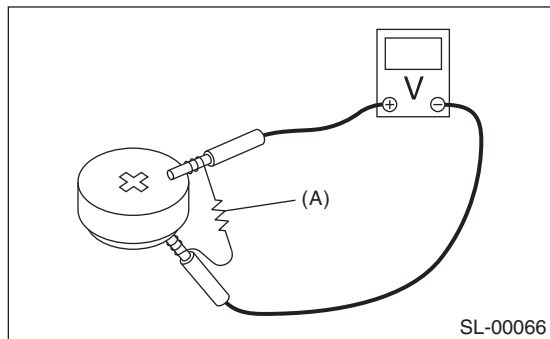

(A) Resistance (47 Ω)

Tester connection		Standard
(+)	(-)	
Battery Positive terminal	Battery Ground terminal	2.5 — 3.0 V

If NG, replace the battery. (Use CR2025 or equivalent.)

D: REPLACEMENT

1. REGISTRATION OF KEYLESS TRANSMITTER WITH SUBARU SELECT MONITOR

NOTE:

- A maximum of four keyless transmitter can be registered for each individual vehicle.
- When replacing or adding the keyless transmitter, new registration of transmitter is necessary.

1) Connect the Subaru Select Monitor to the vehicle.

2) Turn the ignition switch to ON.

3) From the «System Selection Menu» of the Subaru Select Monitor, select {2. Each System Check} → {7. Integ. unit mode} → {8. Keyless ID registration}.

4) Input the 8-digit ID number attached to the plastic bag of the keyless transmitter or inside the transmitter, from left to right, then press the [Enter] key.

NOTE:

Press the [▲] key on the Subaru Select Monitor to increase the number, and the [▼] key to decrease. Press the [<] key to move to the digit in the left, and [>] to the right.

5) The ID number you have entered will be shown. Make sure that the ID number shown is the same as that of plastic bag or inside of transmitter.

6) Press the [OK] key if the ID number is correct. If the ID number is incorrect, select [NO] to return to the step 3) and reenter the ID number.

7) «ID is being registered...» is displayed and registration starts.

8) «ID registration completed» will be displayed when the registration process is done.

9) To exit, select «END: NO» to return to {8. Keyless ID registration}. If there are additional keyless transmitters to be registered, select «The following are registered: OK» to return to the step 4).

NOTE:

• If the registration fails, «ID cannot register. Please try again.» will be displayed. Select the [OK] key to return to the {8. Keyless ID registration}. And retry from the step 3).

• «END: NO» is shown on the Subaru Select Monitor when fourth keyless transmitter has been registered. Select the [NO] key to return to {8. Keyless ID registration}.

23. Immobilizer Control Module

A: NOTE

The control of immobilizer system is carried out in body integrated unit. Refer to the section of body integrated unit for work.

<Ref. to SL-42, Body Integrated Unit.>

24. Immobilizer Antenna

A: REMOVAL

- 1) Disconnect the ground cable from the battery.
- 2) Remove the screw and steering lower cover.

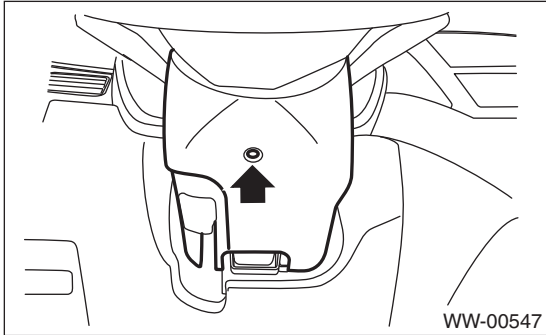

- 3) Remove the screws and steering upper cover.

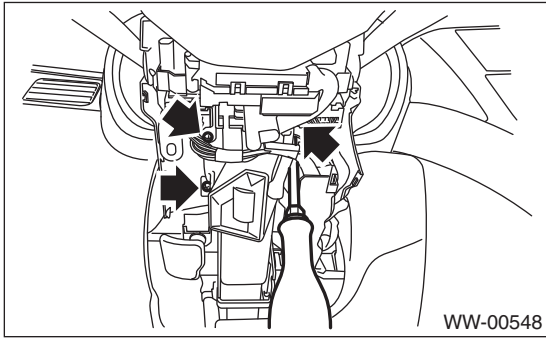

- 4) Remove the instrument panel lower cover. <Ref. to EI-44, REMOVAL, Instrument Panel Lower Cover.>
- 5) Disconnect the immobilizer antenna connector (A) and ignition switch lighting connector (B).

- 6) Loosen the screw and release the lock (D) at opposite side using flat-tip screwdriver (1), and then detach the immobilizer antenna (C).

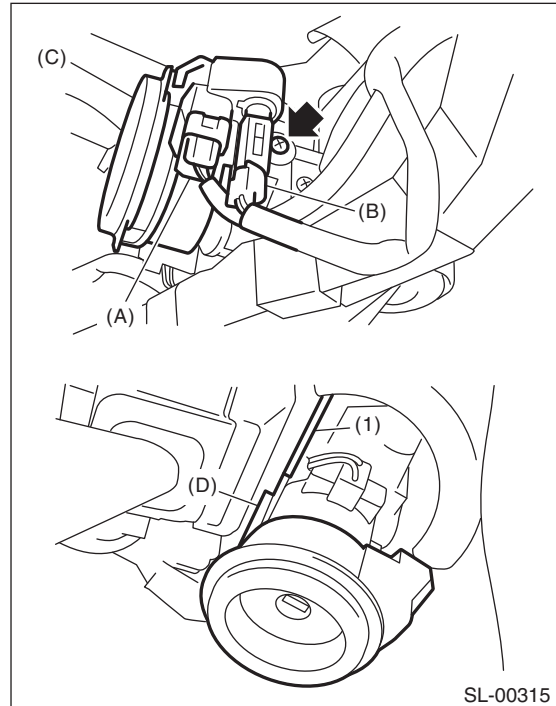

CAUTION:

Do not apply excessive force to remove the immobilizer antenna and lock. Otherwise they may be broken because those parts are the products made of a plastic.

B: INSTALLATION

Install in the reverse order of removal.

Immobilizer Antenna

SECURITY AND LOCKS

SUNROOF/T-TOP/CONVERTIBLE TOP (SUNROOF)

SR

	Page
1. General Description	2
2. Sunroof Control System	4
3. Sunroof Lid	5
4. Sunroof Assembly	6
5. Sunroof Motor	8
6. Sunroof Switch	9

General Description

SUNROOF/T-TOP/CONVERTIBLE TOP (SUNROOF)

1. General Description

A: COMPONENT

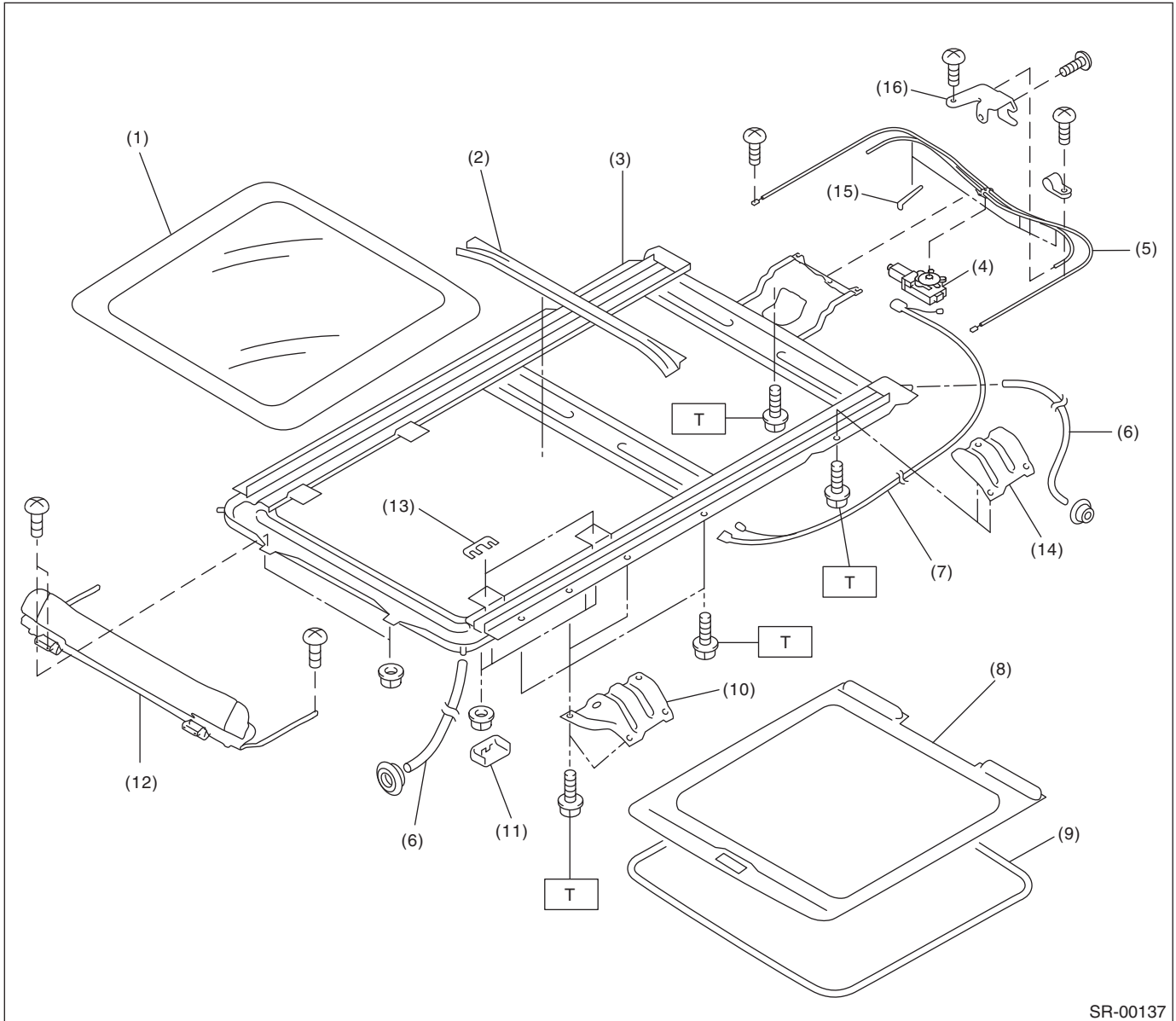

SR-00137

- (1) Sunroof lid
- (2) Rear drain ASSY
- (3) Frame ASSY
- (4) Motor ASSY
- (5) Drive unit
- (6) Drain tube
- (7) Harness

- (8) Sunshade
- (9) Garnish
- (10) Frame bracket
- (11) Cover
- (13) Shim

- (14) Sunroof bracket
- (15) Band
- (16) Shade stopper

Tightening torque: N·m (kgf·m, ft·lb)

T: 7.5 (0.76, 5.5)

General Description

SUNROOF/T-TOP/CONVERTIBLE TOP (SUNROOF)

B: CAUTION

- Before disassembling or reassembling parts, always disconnect the battery ground cable from battery. When replacing the radio, control unit, and other parts provided with memory functions, record the memory contents before disconnecting the battery ground cable in order to prevent memory deletion.
- Reassemble the parts in the reverse order of disassembly unless otherwise indicated.
- Adjust parts to the given specifications.
- Connect the connectors and hoses securely during reassembly.
- After reassembly, make sure functional parts operate smoothly.

C: PREPARATION TOOL

1. GENERAL TOOL

TOOL NAME	REMARKS
Circuit tester	Used for measuring resistance and voltage.

Sunroof Control System

SUNROOF/T-TOP/CONVERTIBLE TOP (SUNROOF)

2. Sunroof Control System

A: WIRING DIAGRAM

<Ref. to WI-149, WIRING DIAGRAM, Sunroof Control System.>

B: INSPECTION

Symptom	Inspection order
Water leakage	<ol style="list-style-type: none">1. Check roof panel and sunroof lid for improper or poor sealing.2. Check drain tube for clogging.3. Check sunroof frame seal and body for improper fit.
Wind noise	<ol style="list-style-type: none">1. Check the deflector upright position without binding.2. Check sunroof lid and roof panel for improper clearance.3. Check sunshade and roof trim for improper clearance.
Abnormal motor noise	<ol style="list-style-type: none">1. Check the motor mounting screws for looseness.2. Check gears and bearings for wear.3. Check cable for wear.4. Check cable pipe for deformities.
Failure of sunroof (Motor operates properly.)	<ol style="list-style-type: none">1. Check guide rail for foreign particles.2. Check guide rail for improper installation.3. Check parts for mutual interference.4. Check cable slider for improper clinching.5. Check cable for improper installation.
Motor does not rotate or it rotates improperly.	<ol style="list-style-type: none">1. Check fuse for blown out.2. Check switch for improper function.3. Check motor for incorrect terminal voltage.4. Check the relay for improper operation.5. Check poor grounding system.6. Check harness for open or short and terminals for poor connections.

Sunroof Lid

SUNROOF/T-TOP/CONVERTIBLE TOP (SUNROOF)

3. Sunroof Lid

A: REMOVAL

- 1) Completely close the sunroof lid, and then open the sunshade.
- 2) Remove the four covers (A), and then remove the eight nuts.

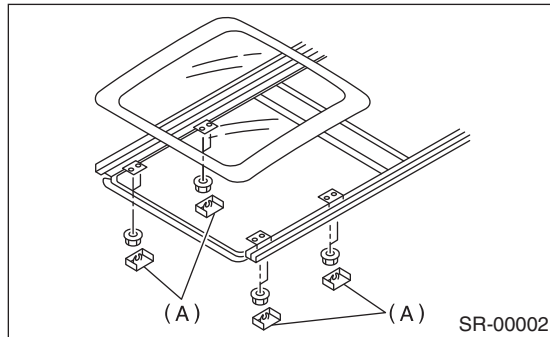

- 3) Remove the sunroof lid carefully.

B: INSTALLATION

Install in the reverse order of removal.

C: ADJUSTMENT

Adjust the height between sunroof lid and roof panel.

Loosen the sunroof lid nuts, and then adjust the height by adding (max: four pieces) or extracting (min: zero pieces) shims (normally two pieces) which are installed between the sunroof lid and the roof panel.

Difference in height between sunroof and roof panel

2.0 ± 1.0 mm (0.079 ± 0.039 in)

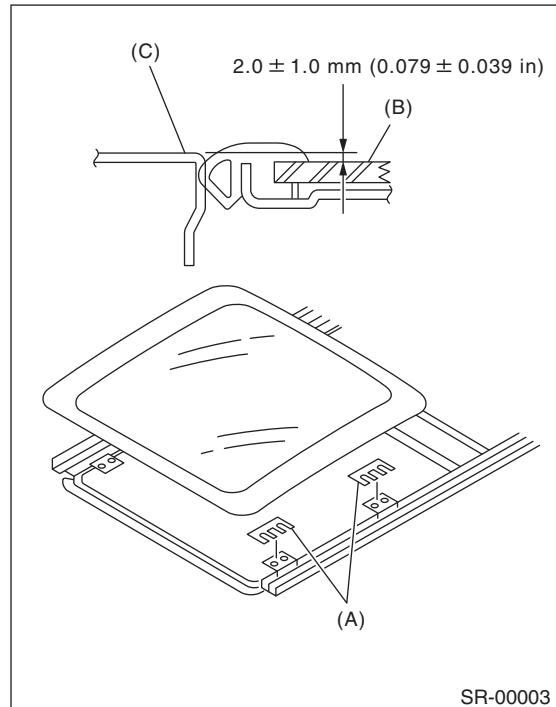

- (A) Shim
- (B) Sunroof lid
- (C) Roof panel

Sunroof Assembly

SUNROOF/T-TOP/CONVERTIBLE TOP (SUNROOF)

4. Sunroof Assembly

A: REMOVAL

- 1) Disconnect the ground cable from the battery.
- 2) Remove the roof trim. <Ref. to EI-59, REMOVAL, Roof Trim.>
- 3) Remove the sunroof lid. <Ref. to SR-5, REMOVAL, Sunroof Lid.>
- 4) Disconnect the sunroof harness connector.
- 5) Remove the bolts and then move the curtain air-bag module.
- 6) Remove the bolts and then remove the frame bracket.

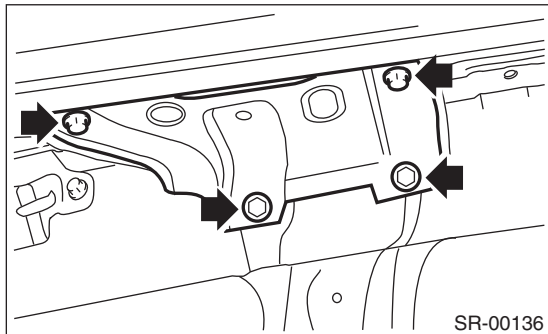

- 7) Remove the four drain tubes (A) from the sunroof frame.
- 8) Remove the nuts and bolts to remove the sunroof frame.

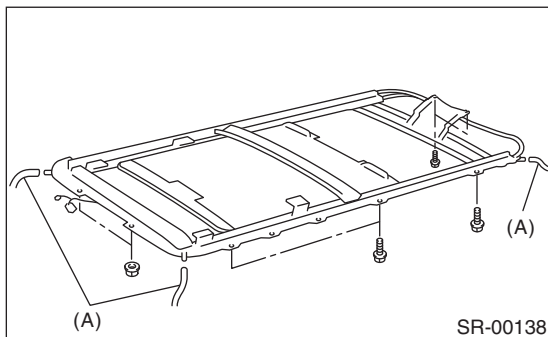

B: INSTALLATION

Install in the reverse order of removal.

CAUTION:

Be careful not to snag the harness.

NOTE:

- Be sure to connect the harness connector.
- When installing the drain tube, insert it securely into drain pipe.

Length A:

15 mm (0.59 in) or more

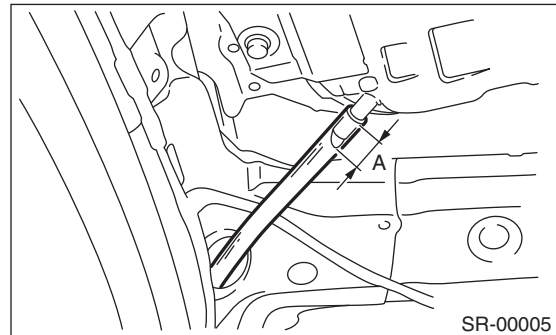

Sunroof Assembly

SUNROOF/T-TOP/CONVERTIBLE TOP (SUNROOF)

C: DISASSEMBLY

- 1) Remove the sunroof frame.
- 2) Remove the shade stopper (A).
- 3) Remove the motor bracket screw (B).
- 4) Remove the guide pipe screw (C), slightly pull out the guide pipe from the guide rail and then lower the motor bracket.

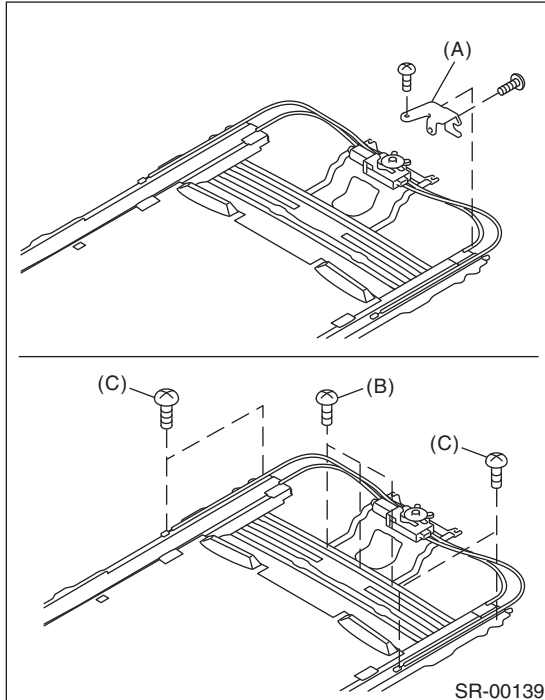

- 5) Pull out the sunshade (D) from sunroof frame.

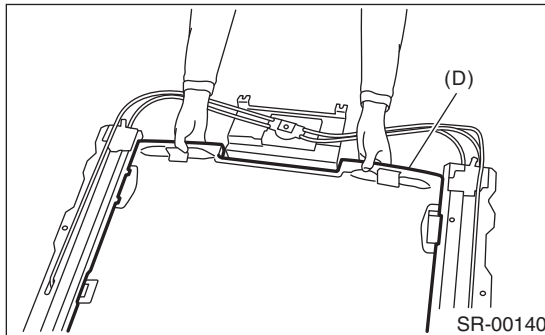

D: ASSEMBLY

Assemble in the reverse order of disassembly.

E: INSPECTION

Inspect moving load of the sunshade.

- 1) Attach a spring scale to sunshade edge using a cloth.

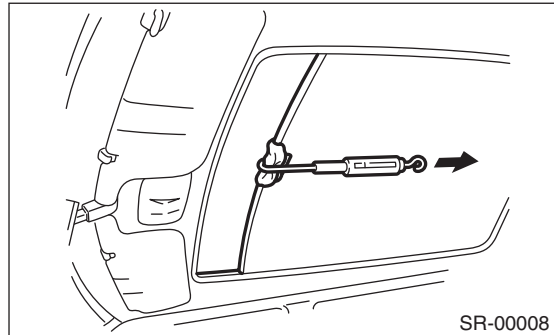

- 2) Pull the spring scale to measure moving load of the sunshade.

Moving load of sunshade:
20 N (2.0 kgf, 4.5 lb) or less

NOTE:

Moving load is larger at the beginning of pulling a spring scale, so take a spring scale reading while sunshade sliding smoothly.

- 3) If moving load exceeds specifications, check the sunroof lid, sunshade, deflector and guide rail assembly for improper installation.

Sunroof Motor

SUNROOF/T-TOP/CONVERTIBLE TOP (SUNROOF)

5. Sunroof Motor

A: REMOVAL

CAUTION:

- When removing the sunroof motor, completely close the sunroof.
- When removing the clip, use great care not to damage the roof trim.

- 1) Completely close the sunroof.
- 2) Disconnect the ground cable from the battery.
- 3) Remove the roof trim. <Ref. to EI-59, REMOVAL, Roof Trim.>
- 4) Disconnect the harness connector (A), and then remove the sunroof motor mounting screws (B) and nuts (C).

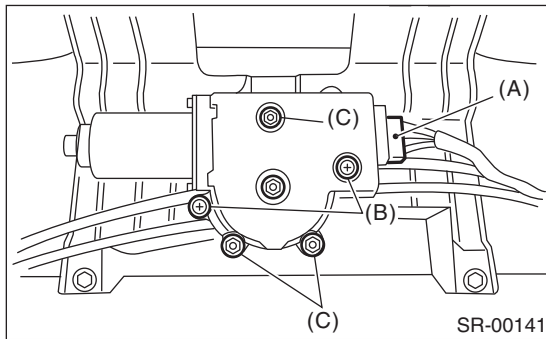

B: INSTALLATION

CAUTION:

When installing the sunroof motor assembly, be careful not to move the sunroof cable.

- 1) Install the sunroof motor.
- 2) Connect the sunroof motor harness connector of motor, and then connect the battery ground cable to battery.
- 3) Reset the sunroof motor. <Ref. to SR-8, ADJUSTMENT, Sunroof Motor.>
- 4) Check the sunroof operation as follows:

Inspection order	Switch position
(1) Sunroof closes completely.	Close
(2) Sunroof opens 500 mm (19.7 in) away from completely closed position.	Open
(3) Sunroof opens completely.	Open
(4) Sunroof closes 200 mm (7.87 in) in front of the completely closed position.	Close
(5) Sunroof closes completely.	Close

- 5) Install the roof trim. <Ref. to EI-59, INSTALLATION, Roof Trim.>

C: ADJUSTMENT

Reset the sunroof motor.

- 1) Completely close the sunroof lid, then continue pushing the switch for more than one second to the CLOSE side. (At this time, it operates intermittently in 50 mm (1.97 in) amounts. The switch must be pressed several times.)
- 2) Open the sunroof lid approximately 400 mm (15.75 in) out.
- 3) Completely close the sunroof lid, then continue pushing the switch for more than one second to the CLOSE side. (This operation enables the auto operation.)

D: INSPECTION

Inspect the sunroof lid auto-reverse mechanism.

- 1) Open the sunroof lid.
- 2) Forcefully push the sunroof lid in the opening direction while auto-closing, to check whether the window auto-reverse mechanism functions.
- 3) Check whether the window auto-reverse mechanism operates and the roof moves back 150 mm (5.91 in) in the opening direction.

CAUTION:

Do not place objects in the way to check the auto-reverse mechanism.

NOTE:

- The auto-function is cancelled when the window auto-reverse mechanism is activated more than five times.
- If the auto function is cancelled, reset it. <Ref. to SR-8, ADJUSTMENT, Sunroof Motor.>

6. Sunroof Switch

A: REMOVAL

- 1) Disconnect the ground cable from the battery.
- 2) Remove the spot map light. <Ref. to LI-34, REMOVAL, Spot Map Light.>
- 3) Disconnect the harness connector, and then remove the sunroof switch (A).

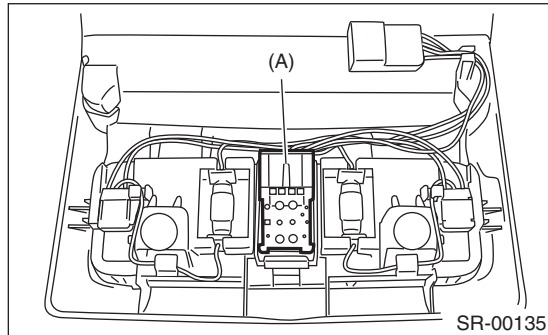

B: INSTALLATION

Install in the reverse order of removal.

C: INSPECTION

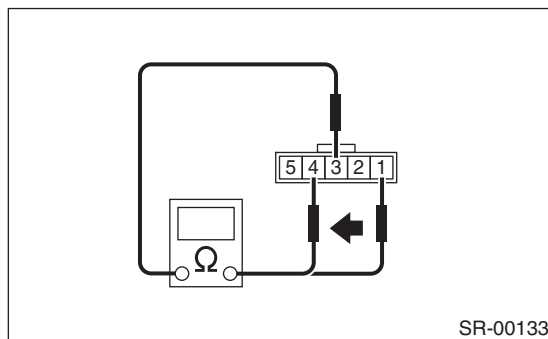

Inspect the continuity between each terminal during operation of the switches.

Switch	Terminal No.	Standard
Open	1 and 3	Less than 1 Ω
Close	4 and 3	Less than 1 Ω

Sunroof Switch

SUNROOF/T-TOP/CONVERTIBLE TOP (SUNROOF)

EXTERIOR/INTERIOR TRIM



	Page
1. General Description	2
2. Front Grille	23
3. Front Hood Grille	24
4. Front Under Cover	25
5. Fuel Tank Protector	26
6. Mud Guard	27
7. Front Bumper	28
8. Rear Bumper	35
9. Cowl Panel	37
10. Roof Spoiler	38
11. Side Sill Spoiler	39
12. Roof Molding	40
13. Roof Rail	41
14. Door Trim	42
15. Instrument Panel Lower Cover	44
16. Glove Box	45
17. Console Box	46
18. Center Console	47
19. Instrument Panel Assembly	50
20. Lower Inner Trim	52
21. Upper Inner Trim	53
22. Rear Quarter Trim	55
23. Sun Visor	57
24. Assist Grip	58
25. Roof Trim	59
26. Rear Gate Trim	60
27. Floor Mat	61
28. Rear Gate Garnish	62
29. Heat Shield Cover	63
30. Trailer Hitch	64
31. Ornament	65

General Description

EXTERIOR/INTERIOR TRIM

1. General Description

A: COMPONENT

1. FRONT GRILLE

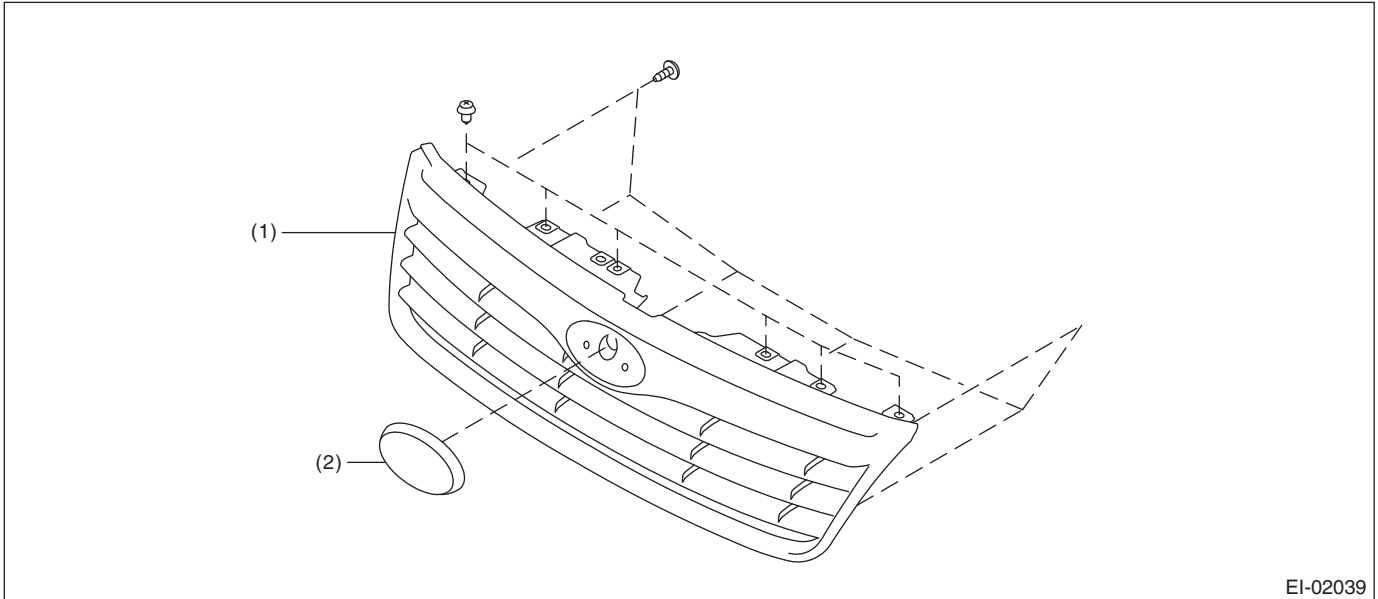

EI-02039

(1) Front grille ASSY

(2) Front grille emblem

2. UNDER COVER

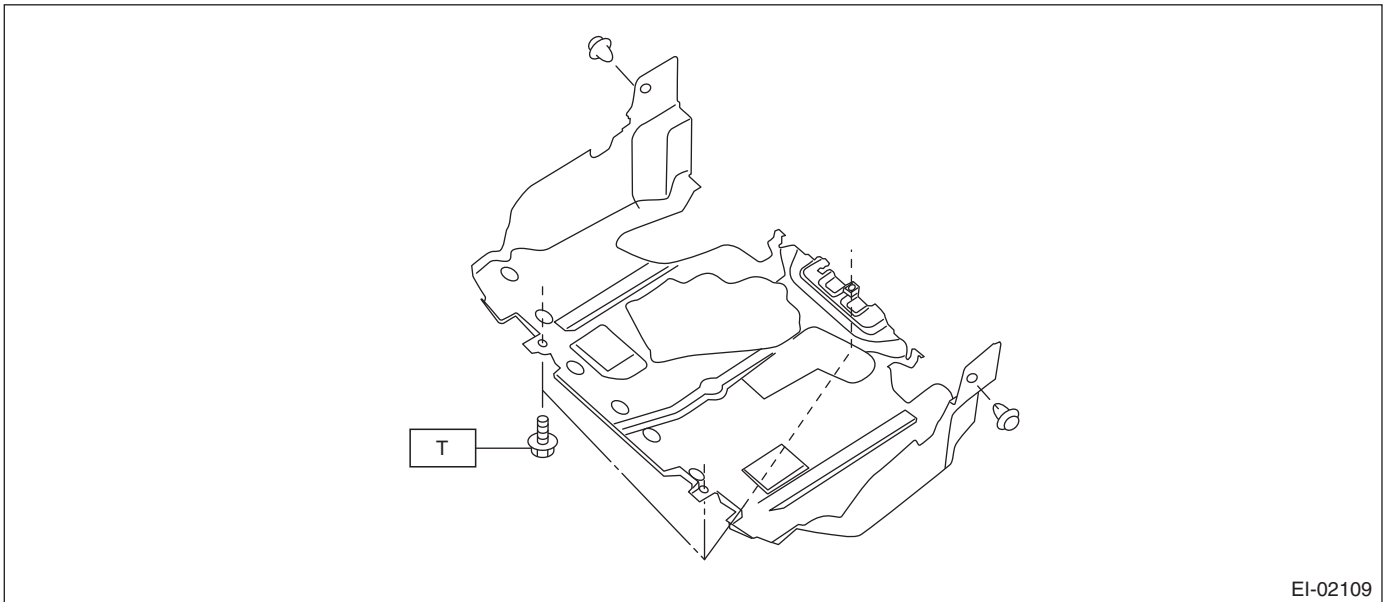

EI-02109

Tightening torque:N-m (kgf-m, ft-lb)

T: 14 (1.42, 10.3)

3. UNDER PROTECTOR

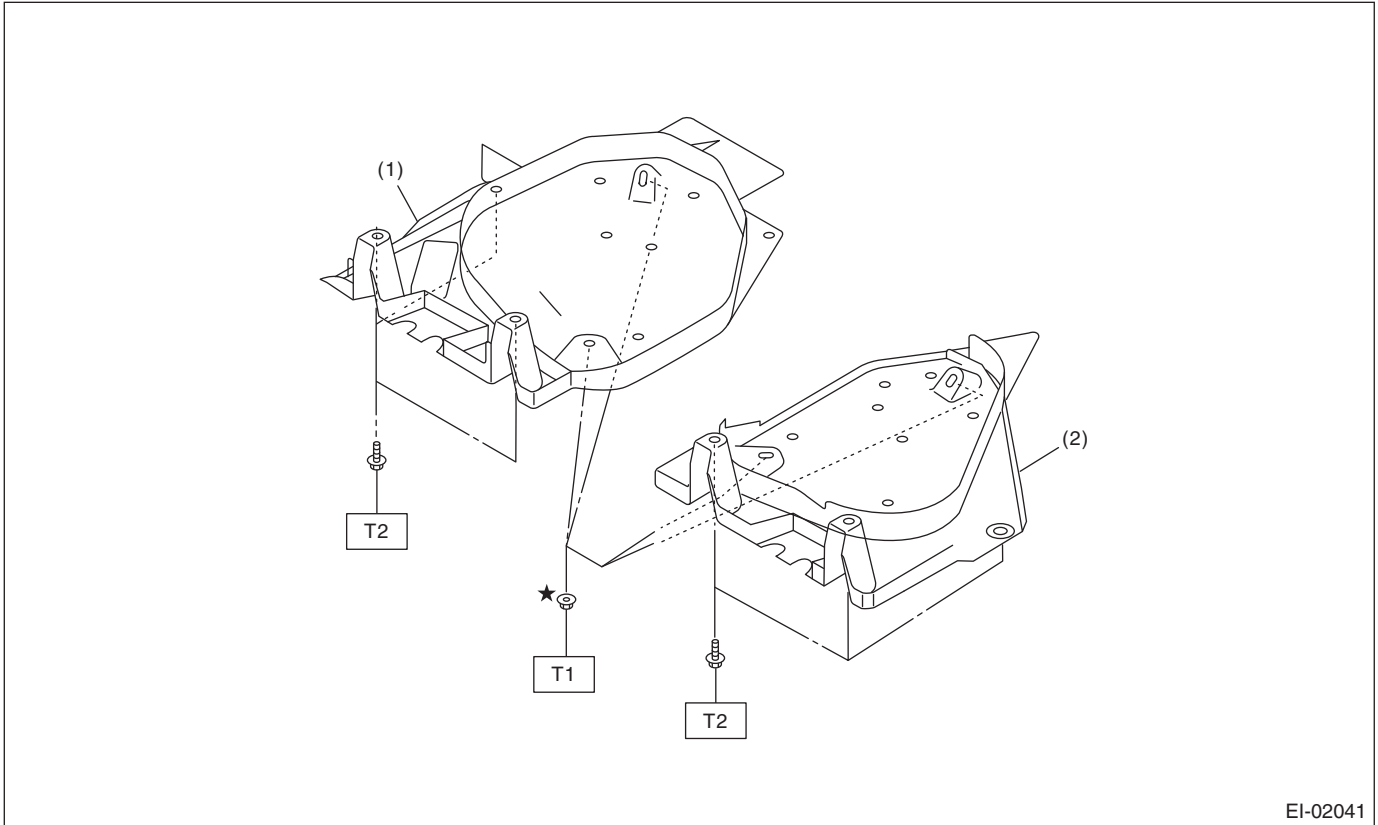

(1) Fuel tank protector RH

(2) Fuel tank protector LH

Tightening torque: N·m (kgf·m, ft·lb)

T1: 9 (0.92, 6.5)

T2: 18 (1.84, 13.3)

General Description

EXTERIOR/INTERIOR TRIM

4. FRONT HOOD GRILLE

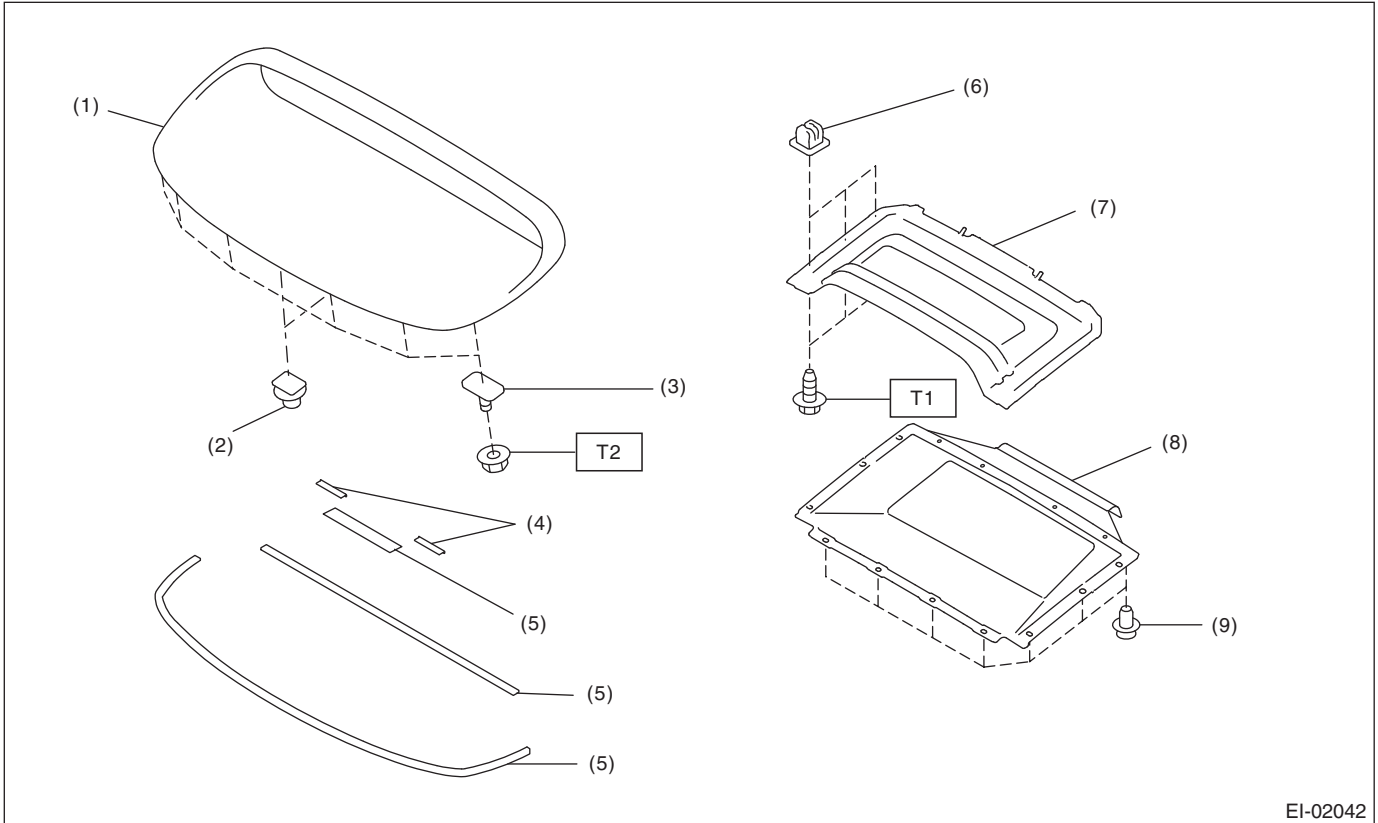

- | | |
|-----------------------|---------------------|
| (1) Front hood grille | (6) Grommet |
| (2) Clip anchor | (7) Hood duct |
| (3) Bolt | (8) Hood duct inner |
| (4) Protector | (9) Clip |
| (5) Gasket | |

Tightening torque: N·m (kgf·m, ft·lb)

T1: 1.0 (0.1, 0.74)

T2: 4.5 (0.46, 3.3)

5. FRONT BUMPER

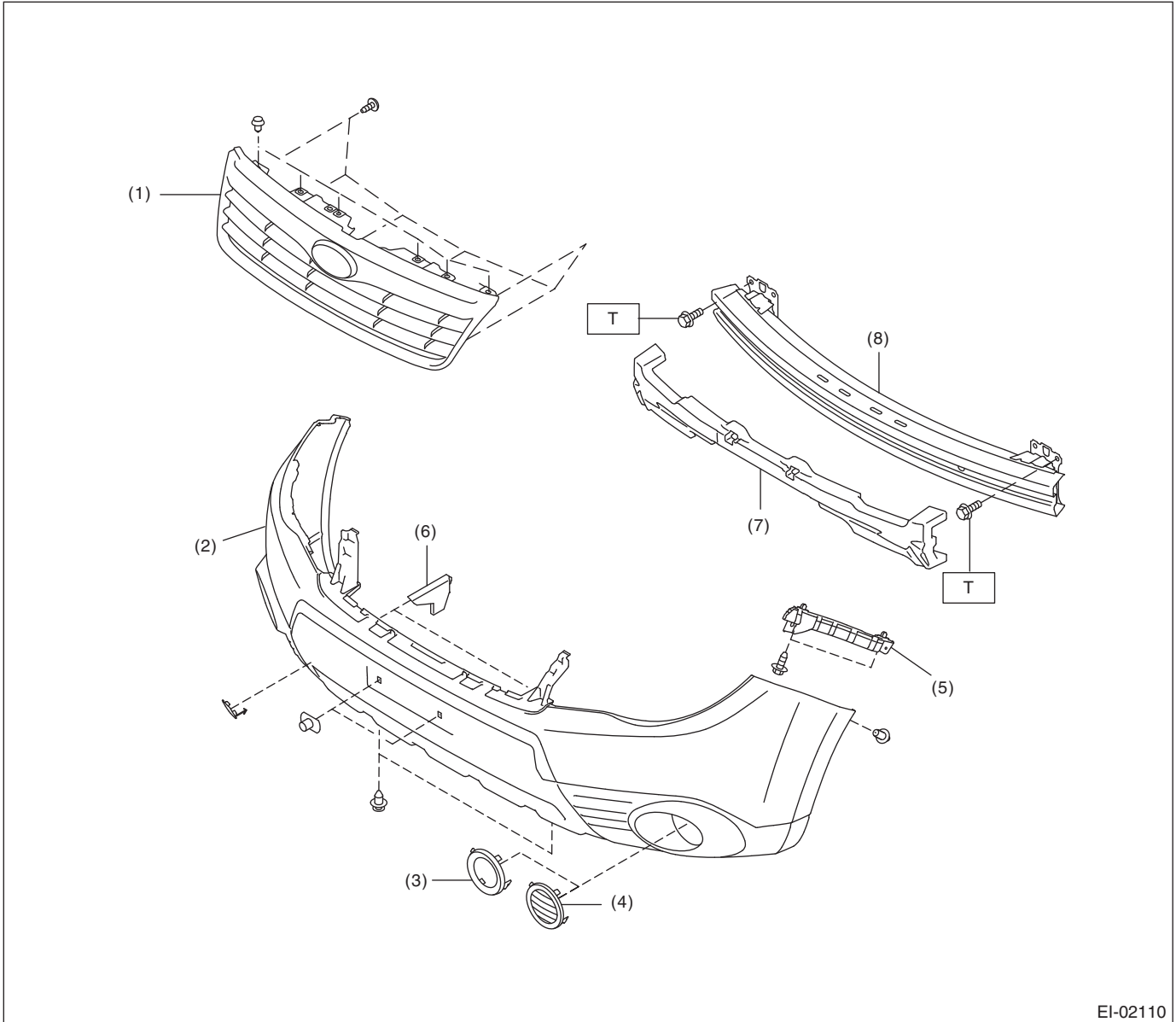

EI-02110

- | | |
|--|-------------------------------|
| (1) Front grille ASSY | (5) Front side bracket |
| (2) Bumper face | (6) Radiator gasket |
| (3) Fog light cover | (7) Energy absorber foam |
| (4) Front cover
(Models without fog lights) | (8) Bumper beam reinforcement |

Tightening torque: N·m (kgf·m, ft·lb)

T: 32 (3.3, 23.6)

General Description

EXTERIOR/INTERIOR TRIM

6. REAR BUMPER

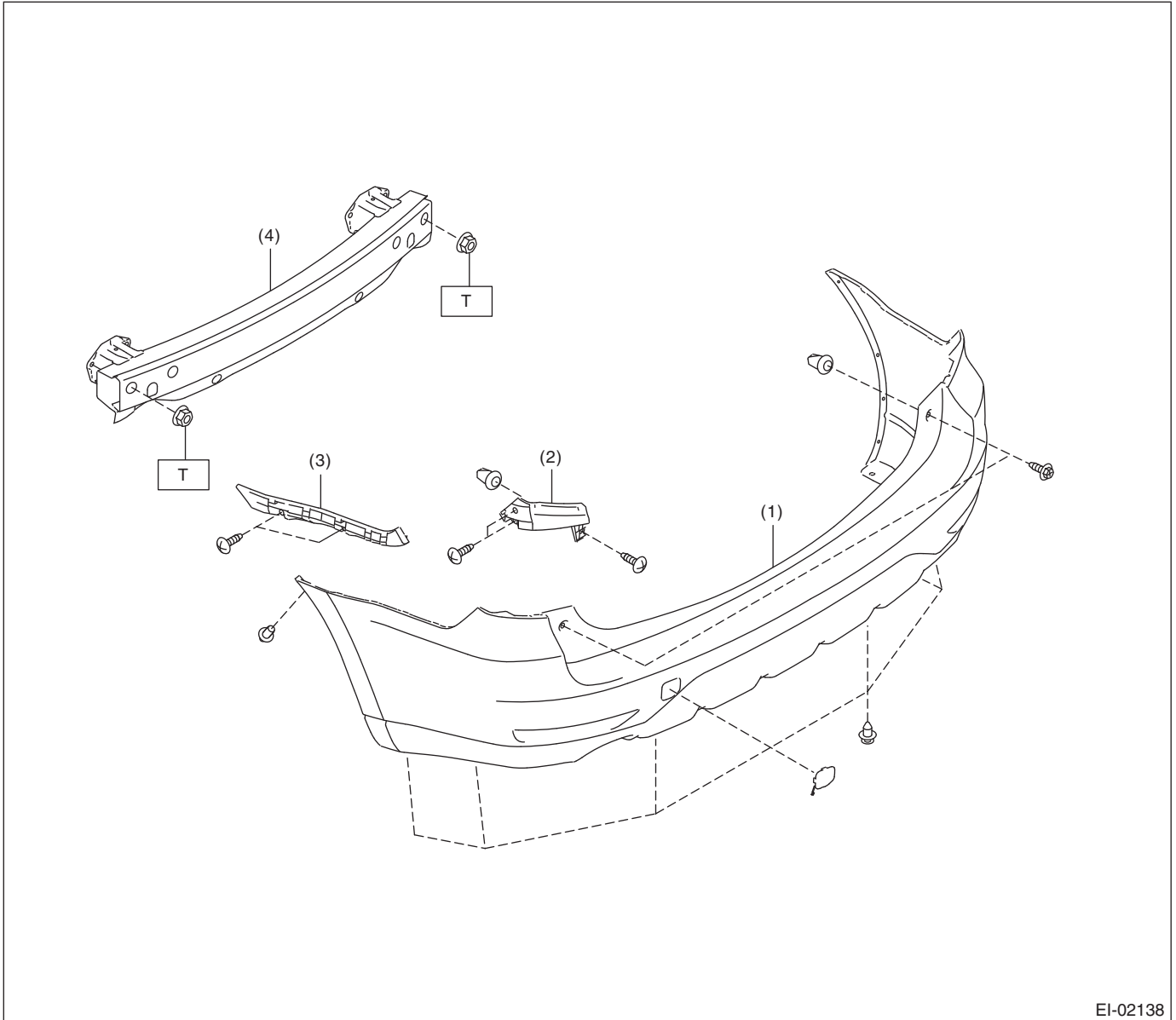

EI-02138

- | | |
|-------------------------|-------------------------------|
| (1) Bumper face | (3) Rear bracket side |
| (2) Rear bracket corner | (4) Bumper beam reinforcement |

Tightening torque: N·m (kgf·m, ft·lb)

T: 45 (4.6, 33.2)

7. MUD GUARD

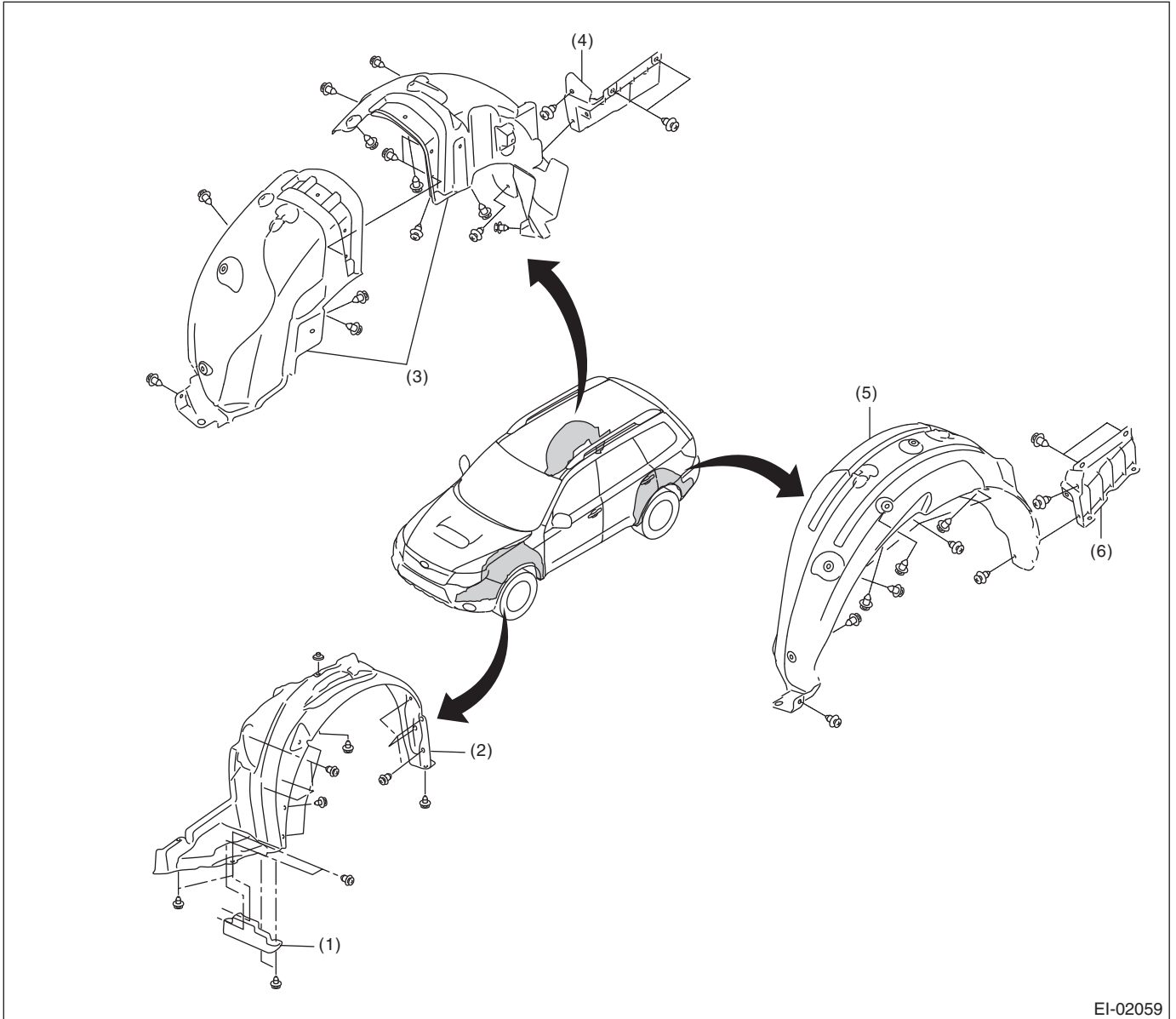

EI-02059

- (1) Air flap
- (2) Front mud guard

- (3) Rear mud guard RH
- (4) Mud guard rear RH

- (5) Rear mud guard LH
- (6) Mud guard rear LH

General Description

EXTERIOR/INTERIOR TRIM

8. COWL PANEL

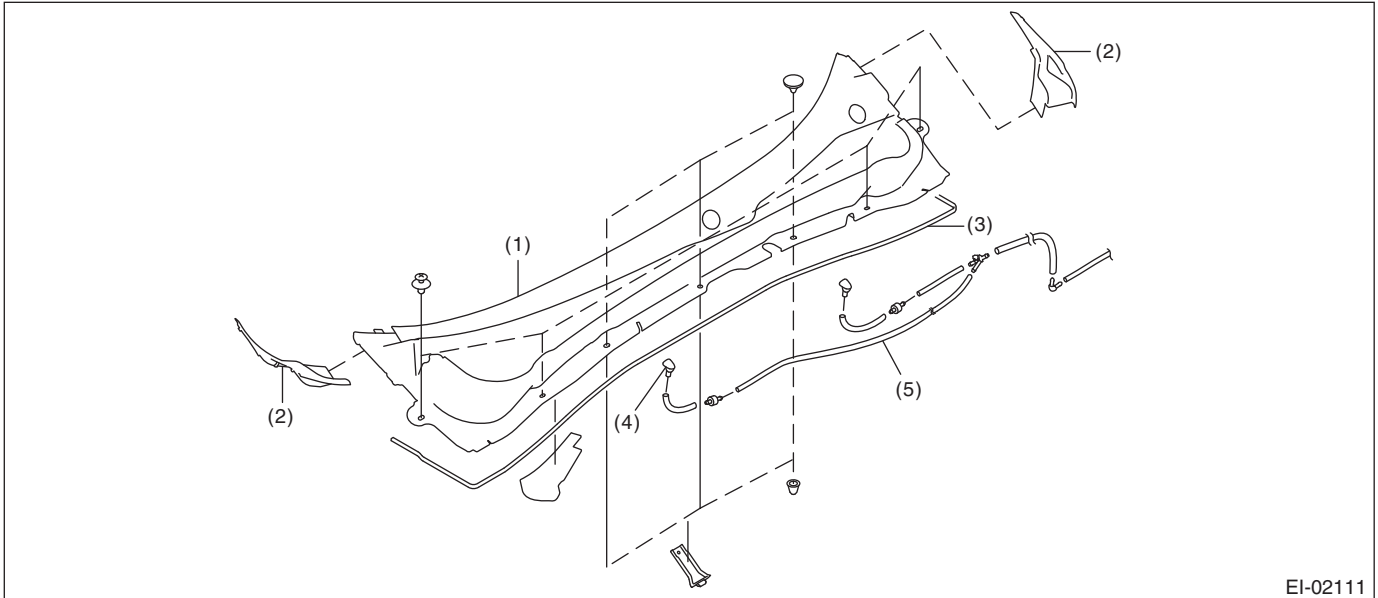

EI-02111

- (1) Cowl panel
- (2) Cowl panel, side
- (3) Gasket
- (4) Washer nozzle
- (5) Hose

9. ROOF SPOILER

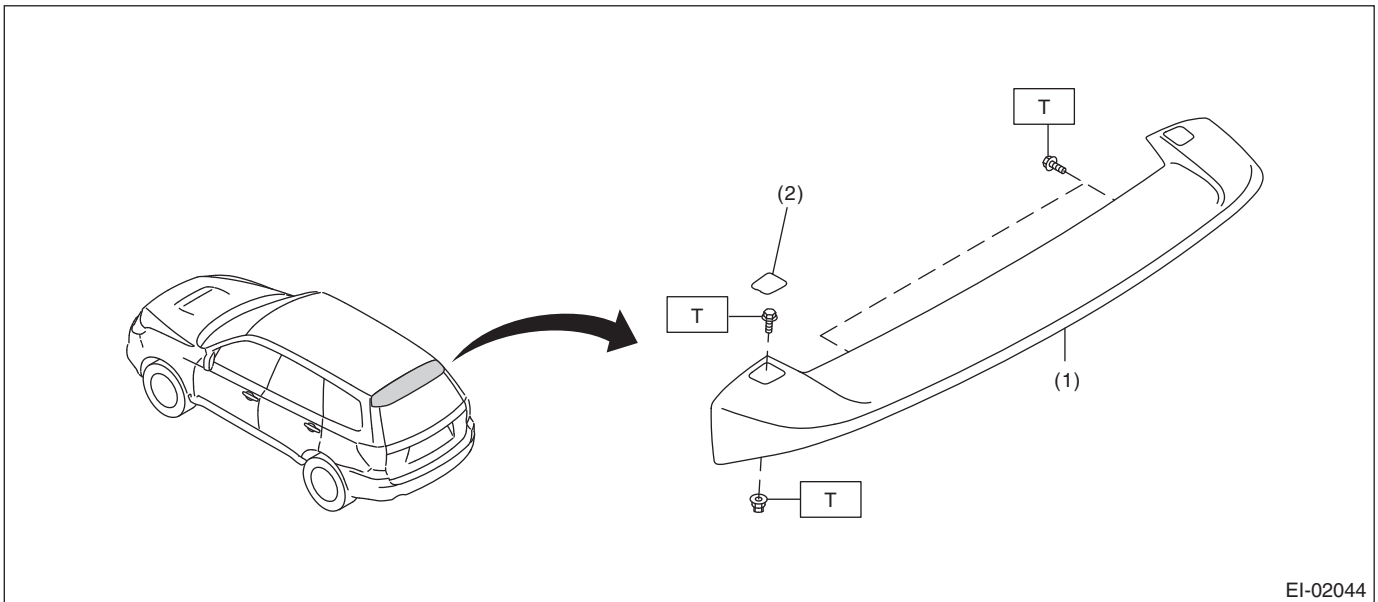

EI-02044

- (1) Roof spoiler
- (2) Cap

Tightening torque: N·m (kgf·m, ft·lb)
T: 7.5 (0.76, 5.5)

10. SIDE SILL SPOILER

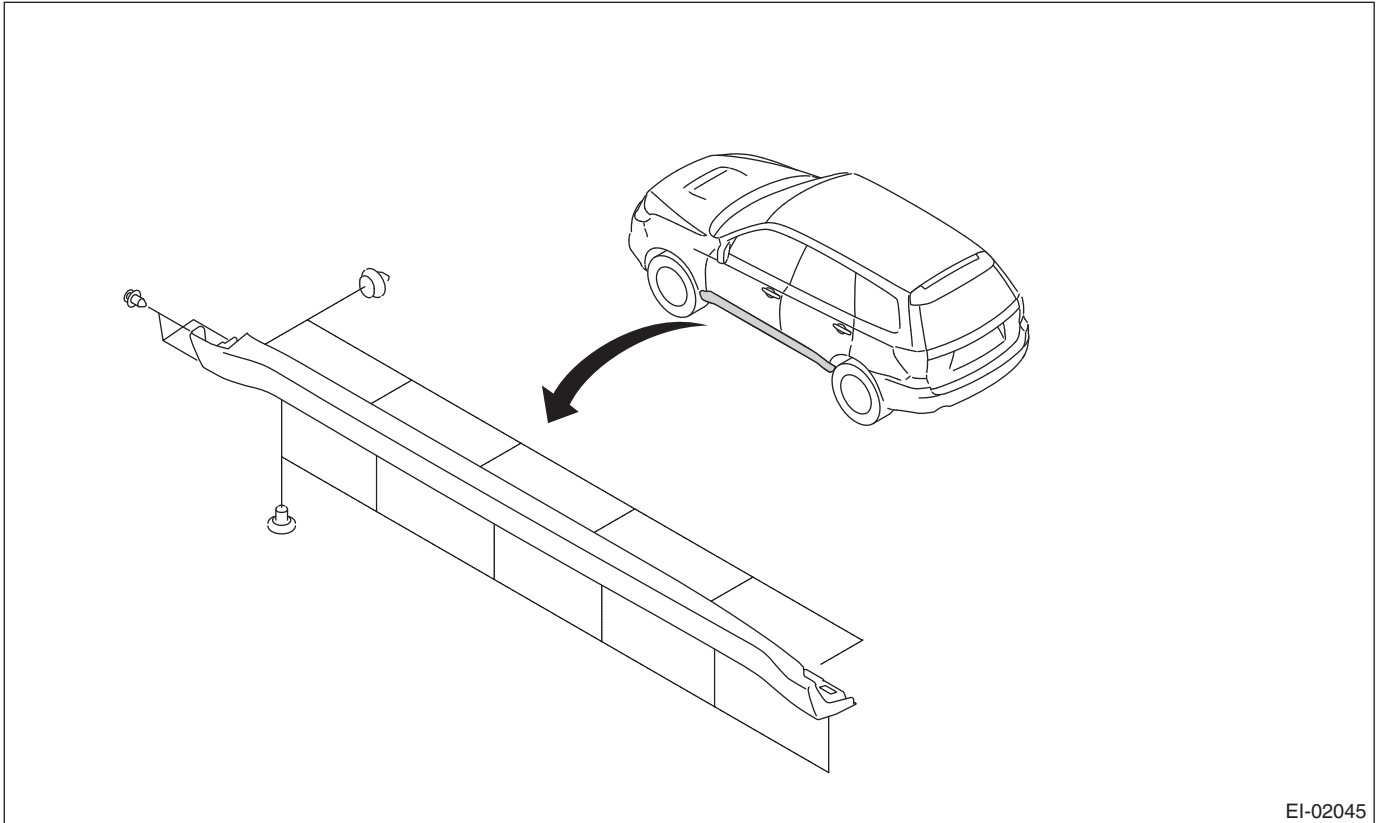

EI-02045

11. ROOF MOLDING

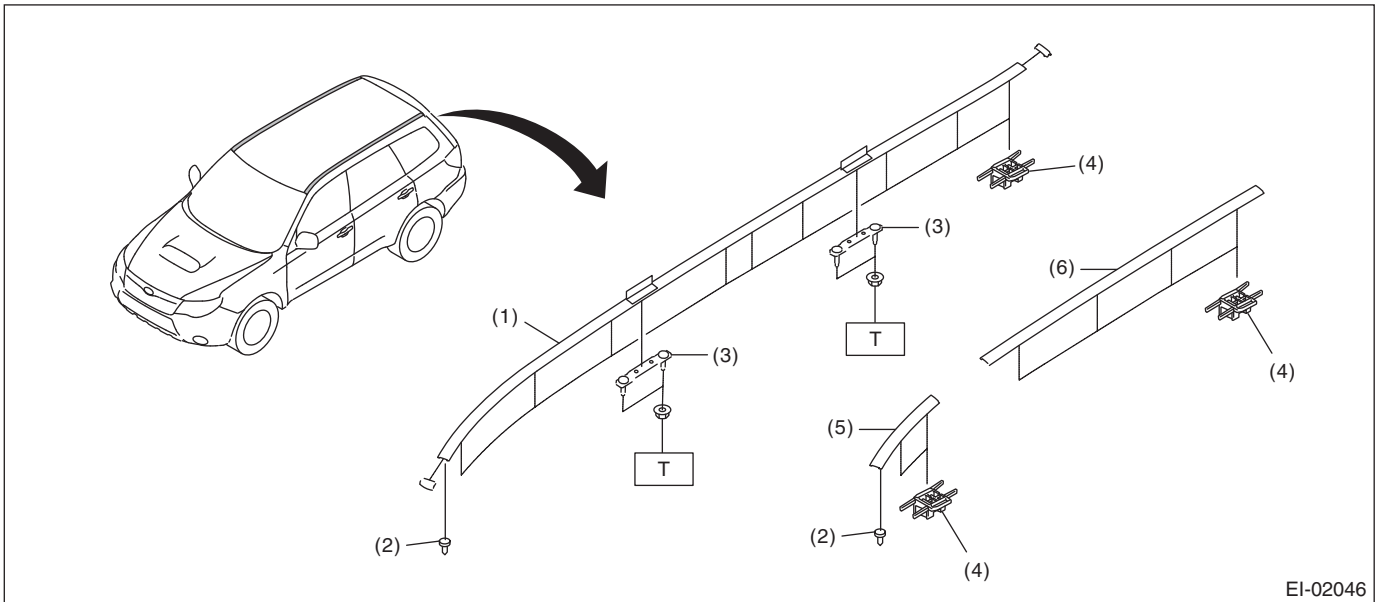

EI-02046

- | | |
|-------------------------------------|---|
| (1) Roof molding | (5) Roof molding, front
(Models with roof molding) |
| (2) Rivet | (6) Roof molding, rear
(Models with roof molding) |
| (3) Roof carrier attachment bracket | |
| (4) Clip | |

Tightening torque: N·m (kgf·m, ft·lb)
T: 7.5 (0.76, 5.5)

General Description

EXTERIOR/INTERIOR TRIM

12. ROOF RAIL

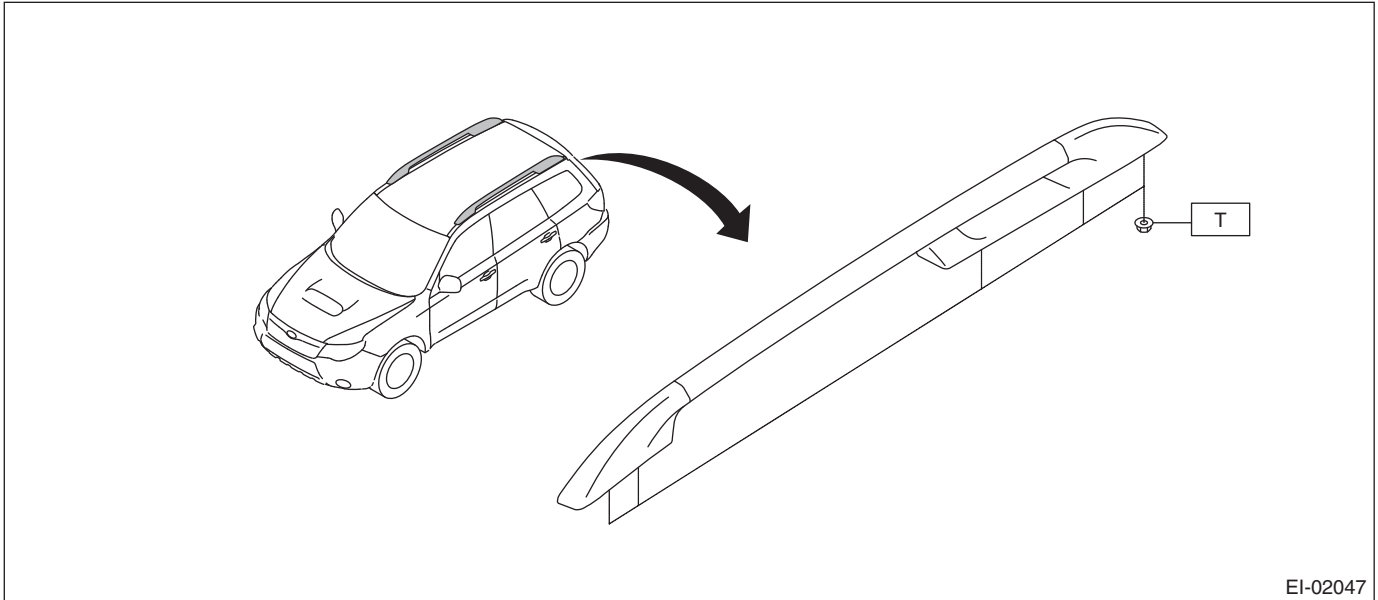

EI-02047

Tightening torque: N·m (kgf·m, ft·lb)

T: 7.5 (0.76, 5.5)

13. REAR GATE GARNISH

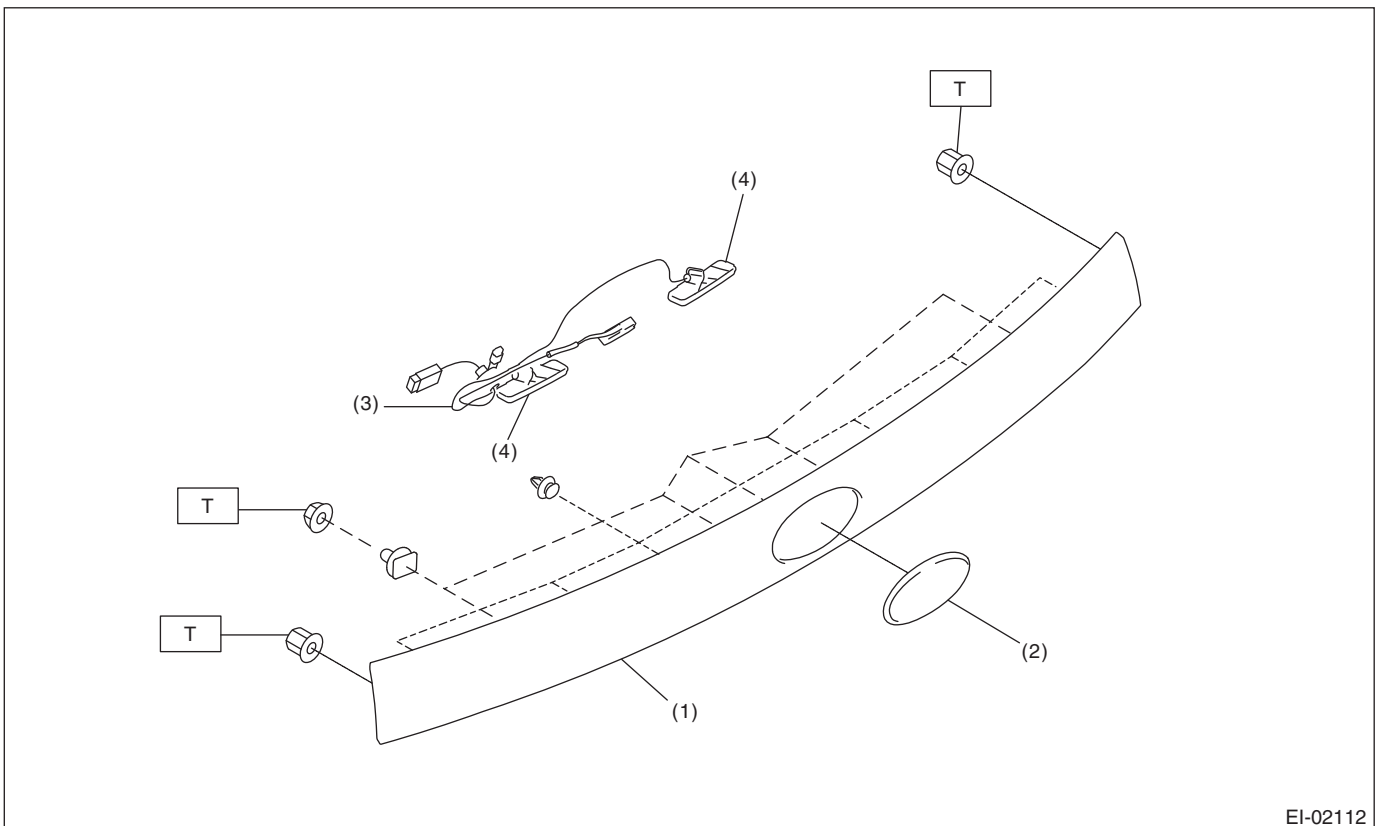

EI-02112

- (1) Rear gate garnish
- (2) Ornament

- (3) License plate light ASSY harness
- (4) License plate light

Tightening torque: N·m (kgf·m, ft·lb)

T: 4.5 (0.46, 3.32)

14.DOOR TRIM

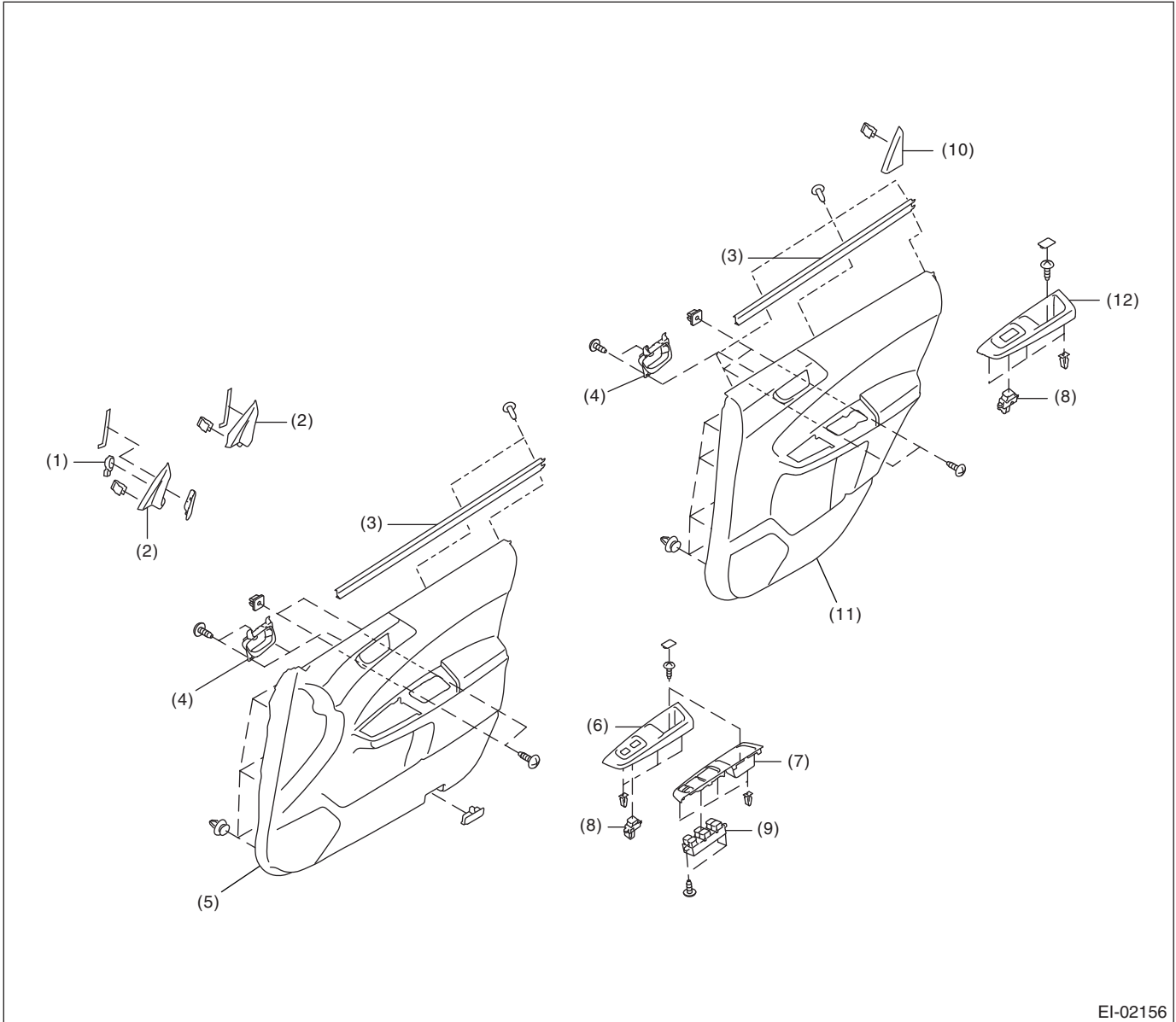

EI-02156

- | | | |
|-------------------------|---|--------------------------------------|
| (1) Tweeter | (6) Power window switch panel, front RH | (9) Power window main switch ASSY |
| (2) Gusset cover, front | (7) Power window switch panel, front LH | (10) Gusset cover, rear |
| (3) Upper weather strip | (8) Power window sub-switch | (11) Rear door trim |
| (4) Inner remote | | (12) Power window switch panel, rear |
| (5) Front door trim | | |

General Description

EXTERIOR/INTERIOR TRIM

15. CONSOLE BOX

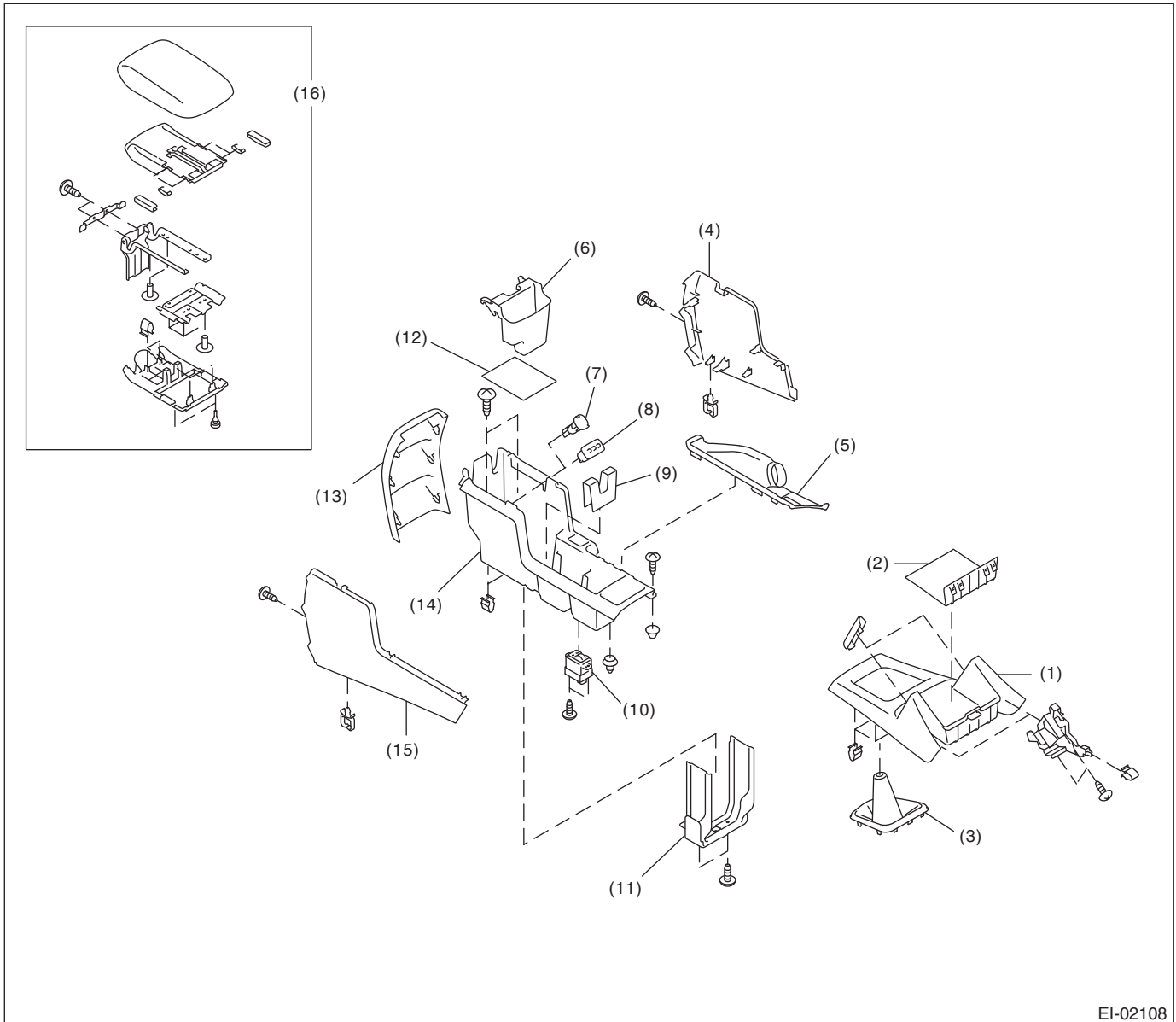

EI-02108

- | | | |
|-------------------------------|-----------------------------------|--------------------------------|
| (1) Console front panel | (7) Accessory power supply socket | (12) Console mat |
| (2) Console front mat | (8) AUX input terminal | (13) Console box, rear |
| (3) Shift boot (MT model) | (9) Cup holder partition | (14) Console cover |
| (4) Console box side cover LH | (10) Seat heater switch | (15) Console box side cover RH |
| (5) Parking brake lever boot | (11) Console box reinforcement | (16) Console lid ASSY |
| (6) Console pocket | | |

16. INSTRUMENT PANEL

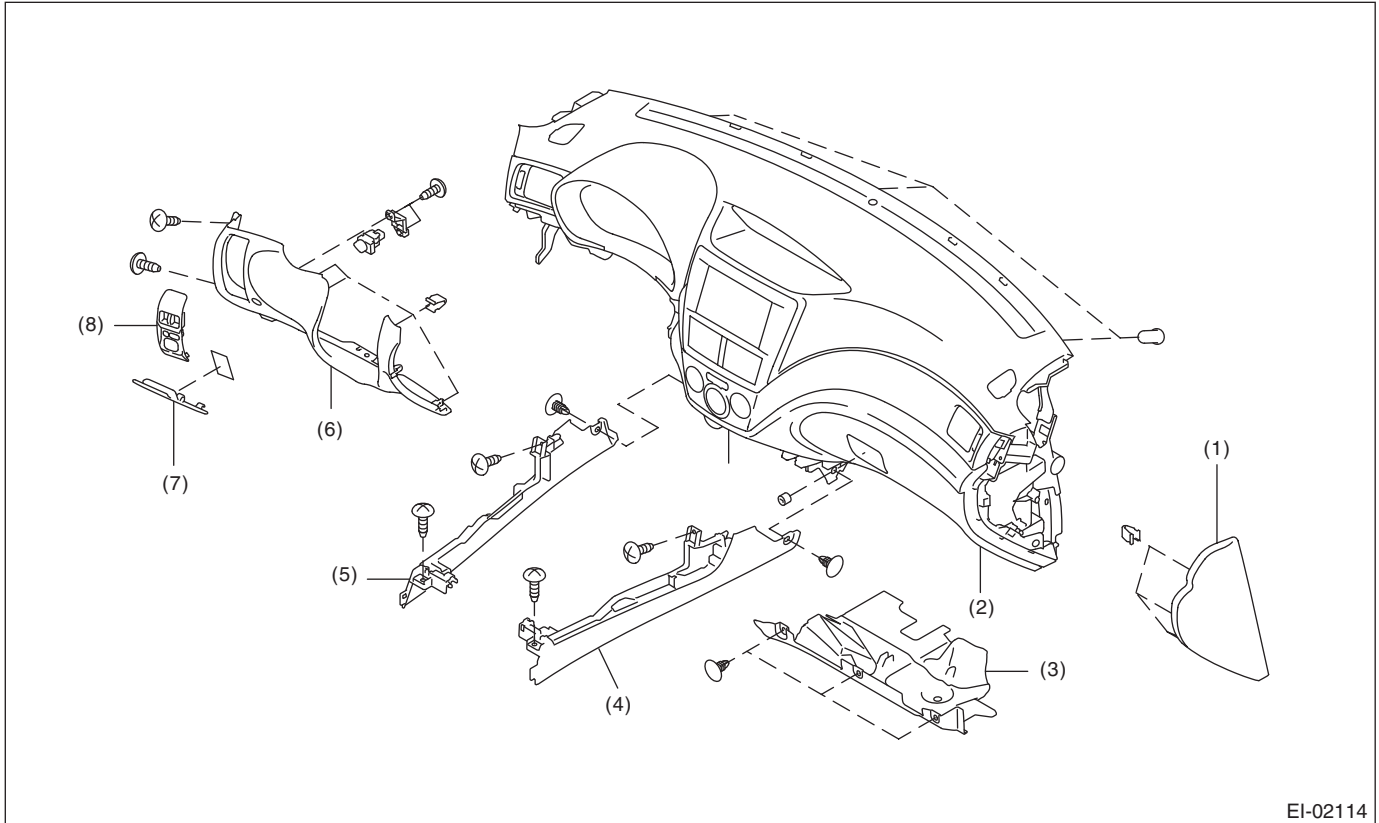

EI-02114

- | | | |
|---------------------------------|----------------------------------|-----------------------|
| (1) Instrument panel side cover | (4) Console side panel RH | (7) Fuse box lid |
| (2) Instrument panel ASSY | (5) Console side panel LH | (8) Switch panel ASSY |
| (3) Glove box lower cover | (6) Instrument panel lower cover | |

General Description

EXTERIOR/INTERIOR TRIM

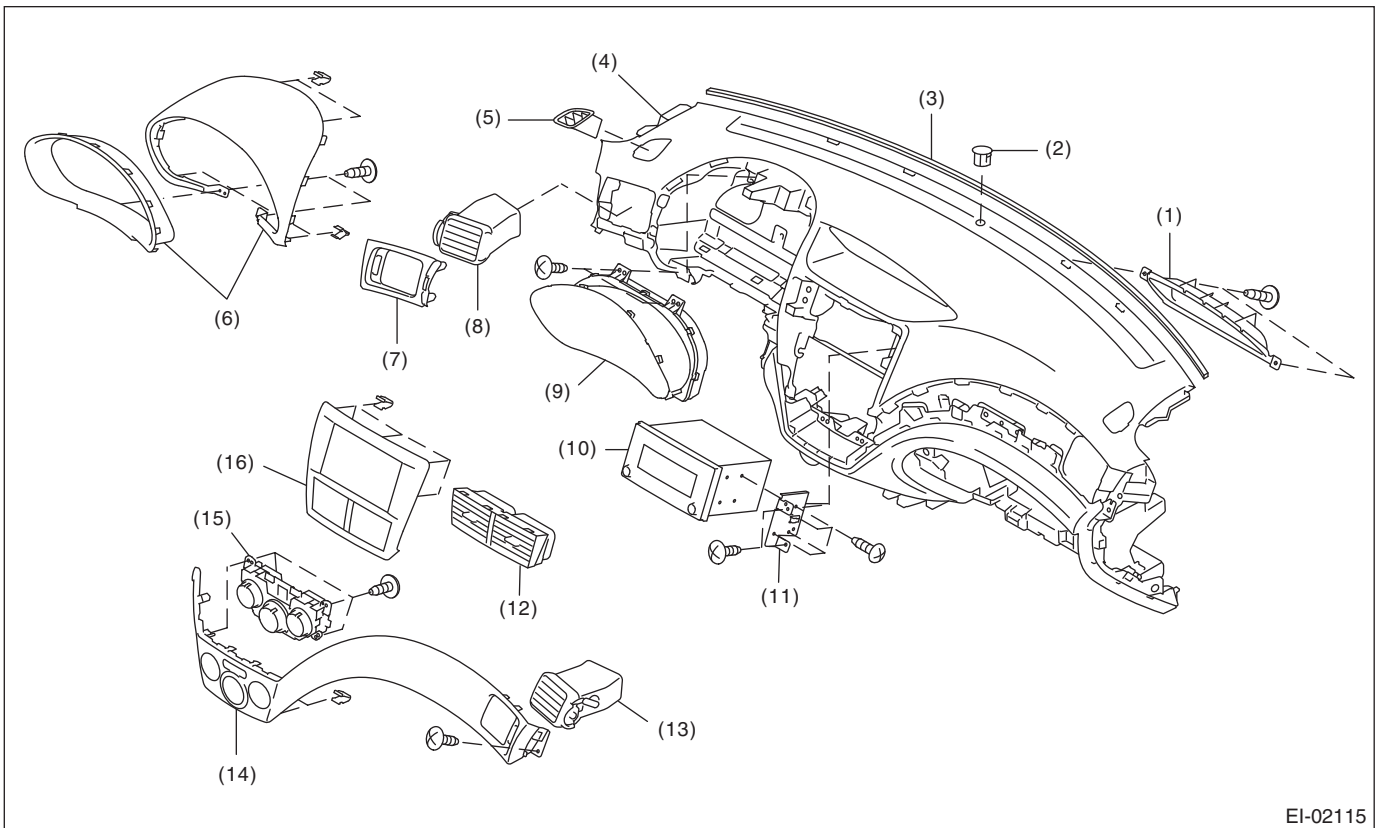

EI-02115

- | | | |
|---------------------------|-----------------------------|-------------------------------|
| (1) Clock panel | (7) Ornament panel LH | (12) Air vent side grille CTR |
| (2) Sunload sensor | (8) Air vent side grille LH | (13) Air vent grille RH |
| (3) Cushion | (9) Combination meter ASSY | (14) Ornament panel RH |
| (4) Instrument panel ASSY | (10) Audio | (15) Control module |
| (5) Defroster side grille | (11) Audio bracket | (16) Center panel |
| (6) Meter visor ASSY | | |

General Description

EXTERIOR/INTERIOR TRIM

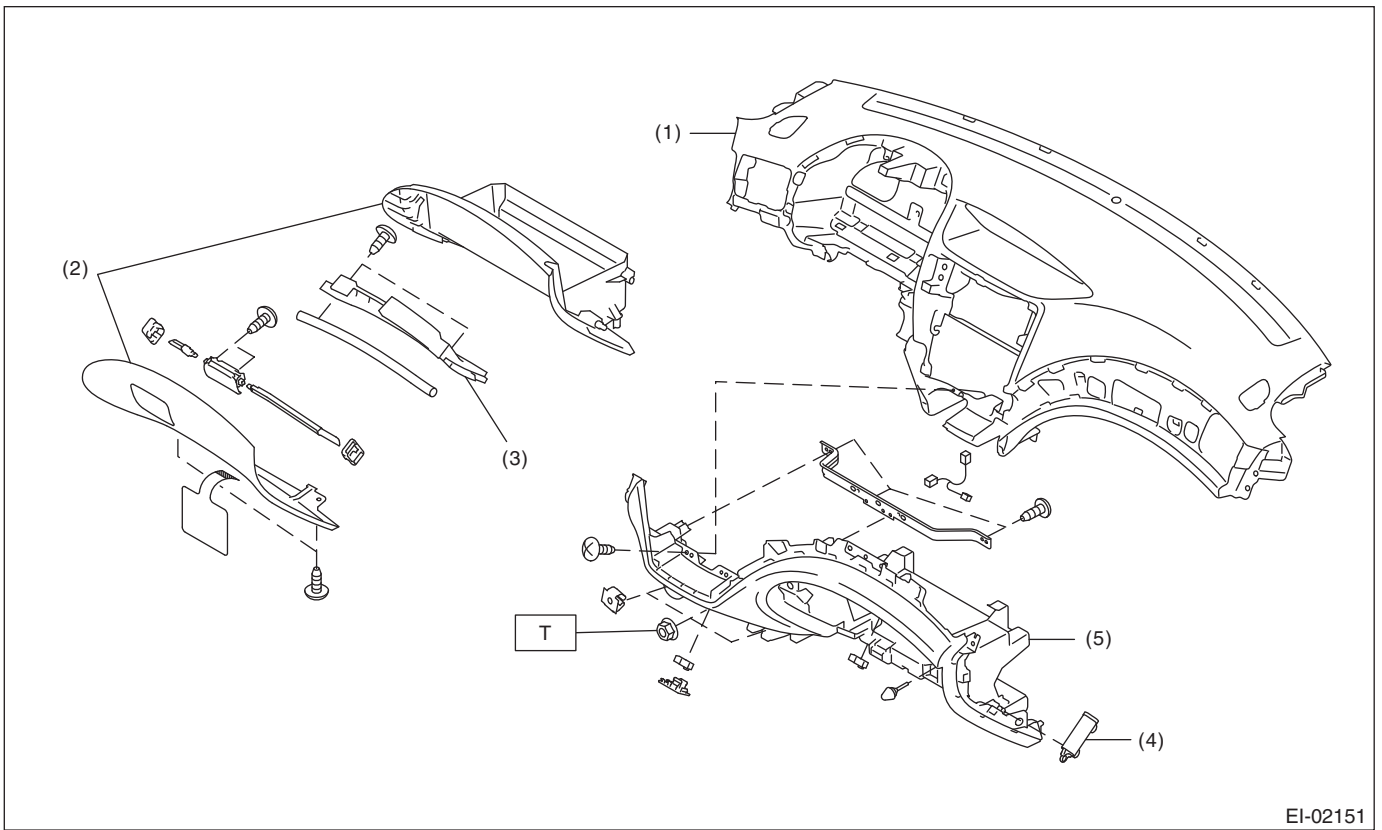

- (1) Instrument panel pad & frame ASSY
- (2) Glove box lid ASSY

- (3) Glove box pad
- (4) Glove box damper
- (5) Instrument panel lower

Tightening torque: N·m (kgf·m, ft·lb)
T: 7.5 (0.76, 5.5)

General Description

EXTERIOR/INTERIOR TRIM

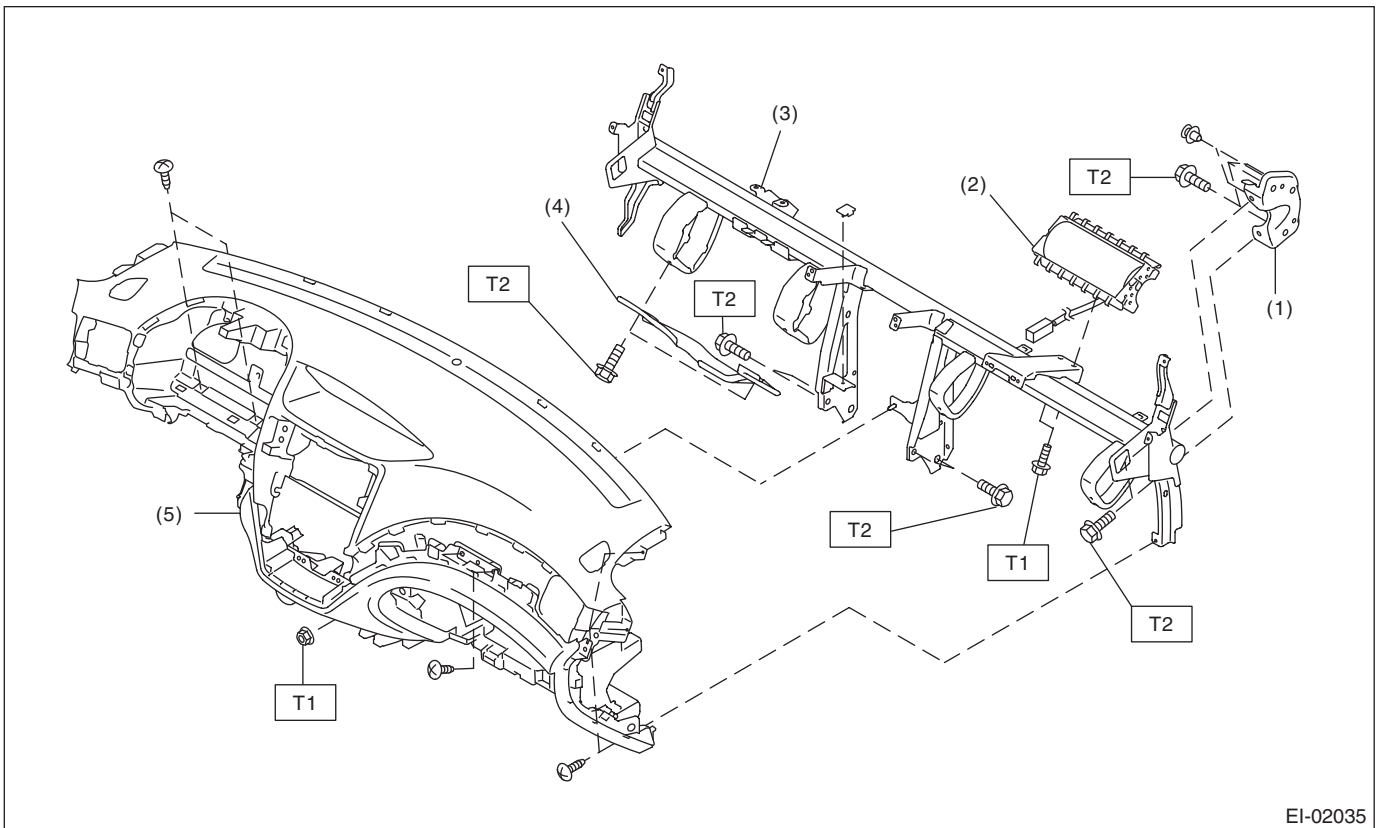

EI-02035

- | | |
|------------------------------------|---------------------------|
| (1) Steering support beam bracket | (4) Knee guard panel |
| (2) Passenger's airbag module ASSY | (5) Instrument panel ASSY |
| (3) Steering support beam ASSY | |

Tightening torque: N·m (kgf·m, ft·lb)

T1: 7.5 (0.76, 5.5)

T2: 25 (2.55, 18.4)

General Description

EXTERIOR/INTERIOR TRIM

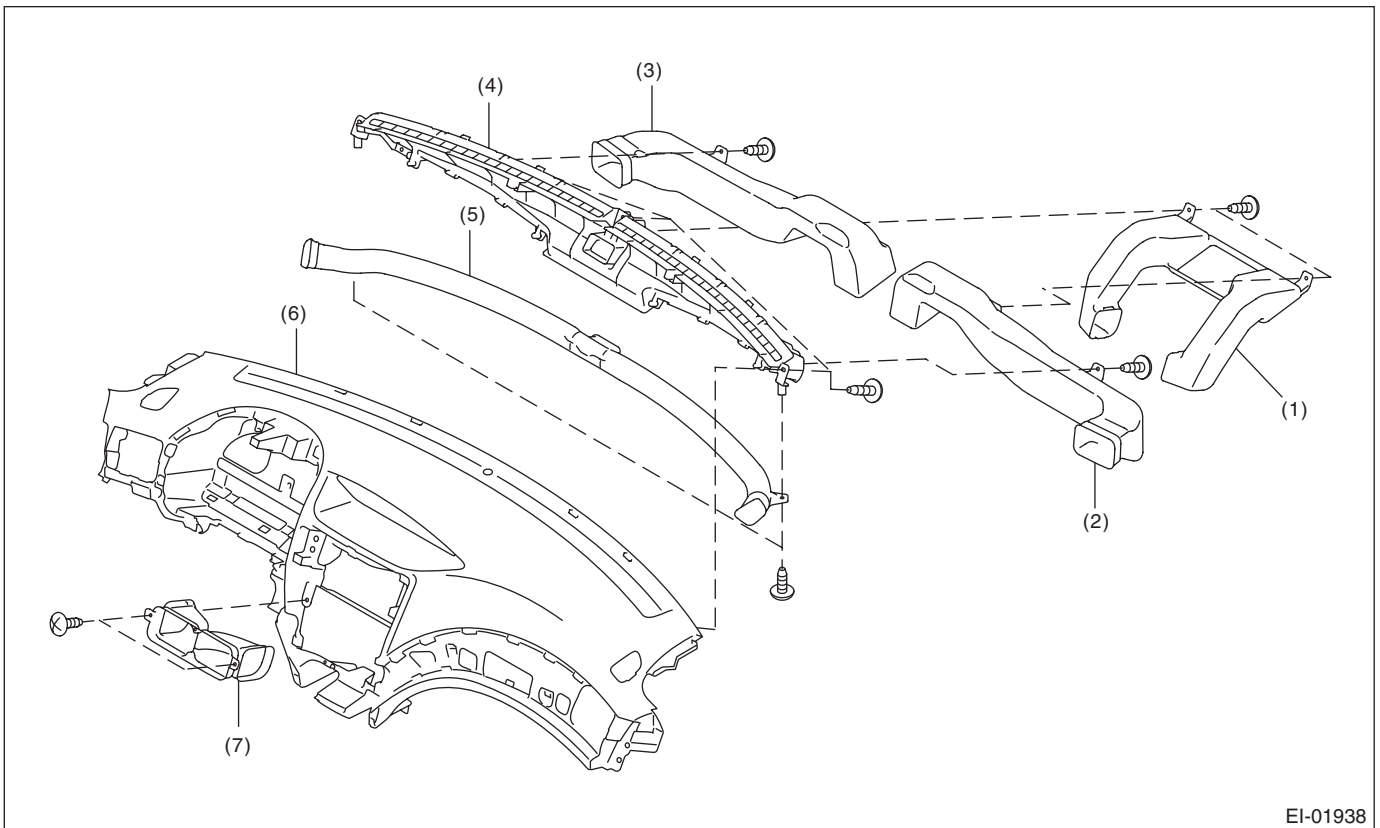

EI-01938

- | | | |
|--------------------------------|---------------------------------------|----------------------------|
| (1) Center vent duct | (5) Side defroster | (7) Center vent duct front |
| (2) Side vent duct RH | (6) Instrument panel pad & frame ASSY | |
| (3) Side ventilation duct (LH) | | |
| (4) Defroster nozzle ASSY | | |

General Description

EXTERIOR/INTERIOR TRIM

17.INNER TRIM

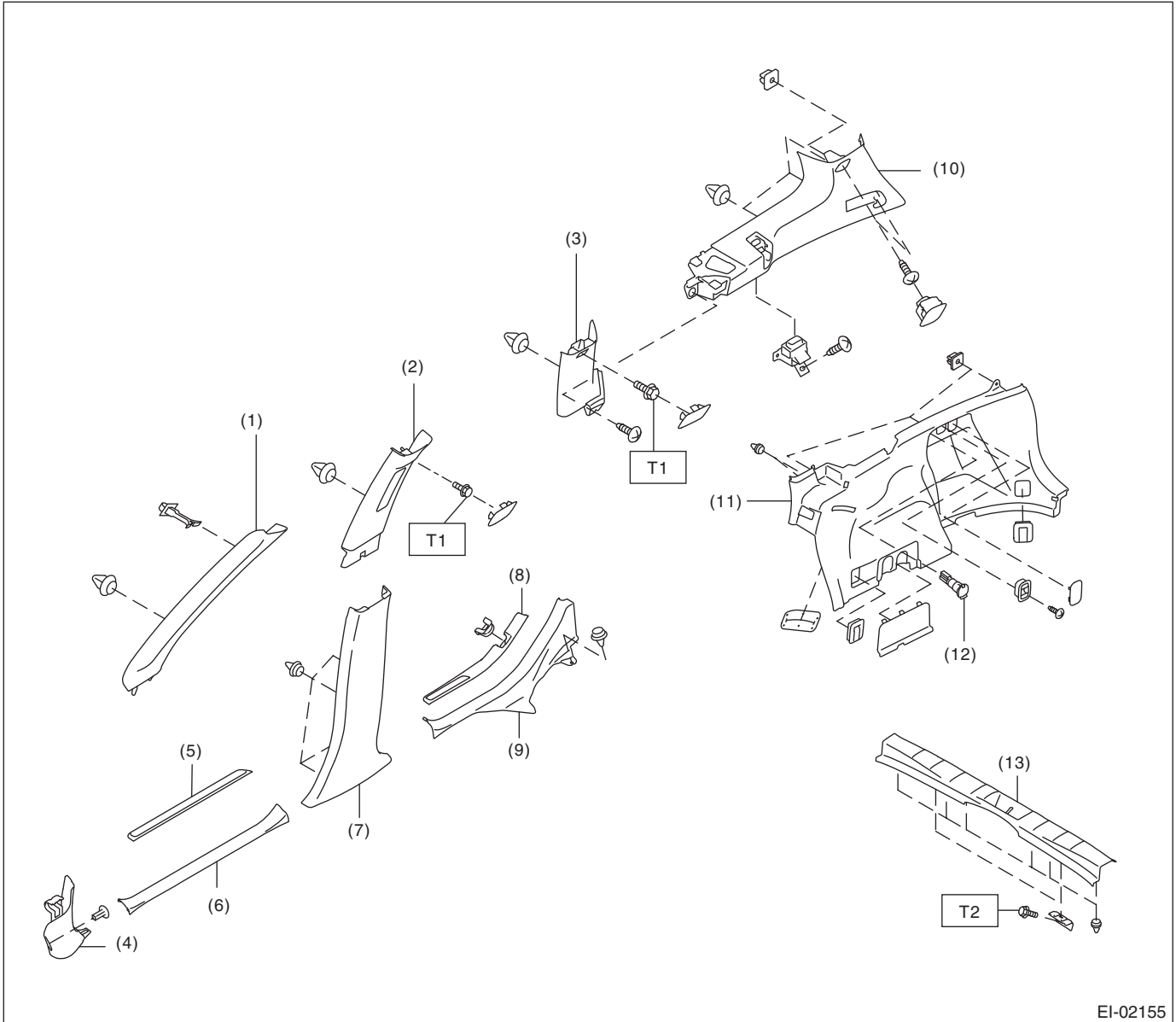

EI-02155

- | | |
|------------------------------------|------------------------------------|
| (1) Front pillar upper trim | (7) Center pillar lower trim |
| (2) Center pillar upper trim | (8) Rear outside scuff plate |
| (3) Rear quarter pillar front trim | (9) Rear inside scuff plate |
| (4) Front pillar lower trim | (10) Rear quarter upper trim |
| (5) Front outside scuff plate | (11) Rear quarter lower trim |
| (6) Front inside scuff plate | (12) Accessory power supply socket |

- (13) Luggage room end cover

Tightening torque: N·m (kgf·m, ft·lb)

T1: 7.5 (0.76, 5.5)

T2: 25 (2.55, 18.4)

18. REAR GATE TRIM

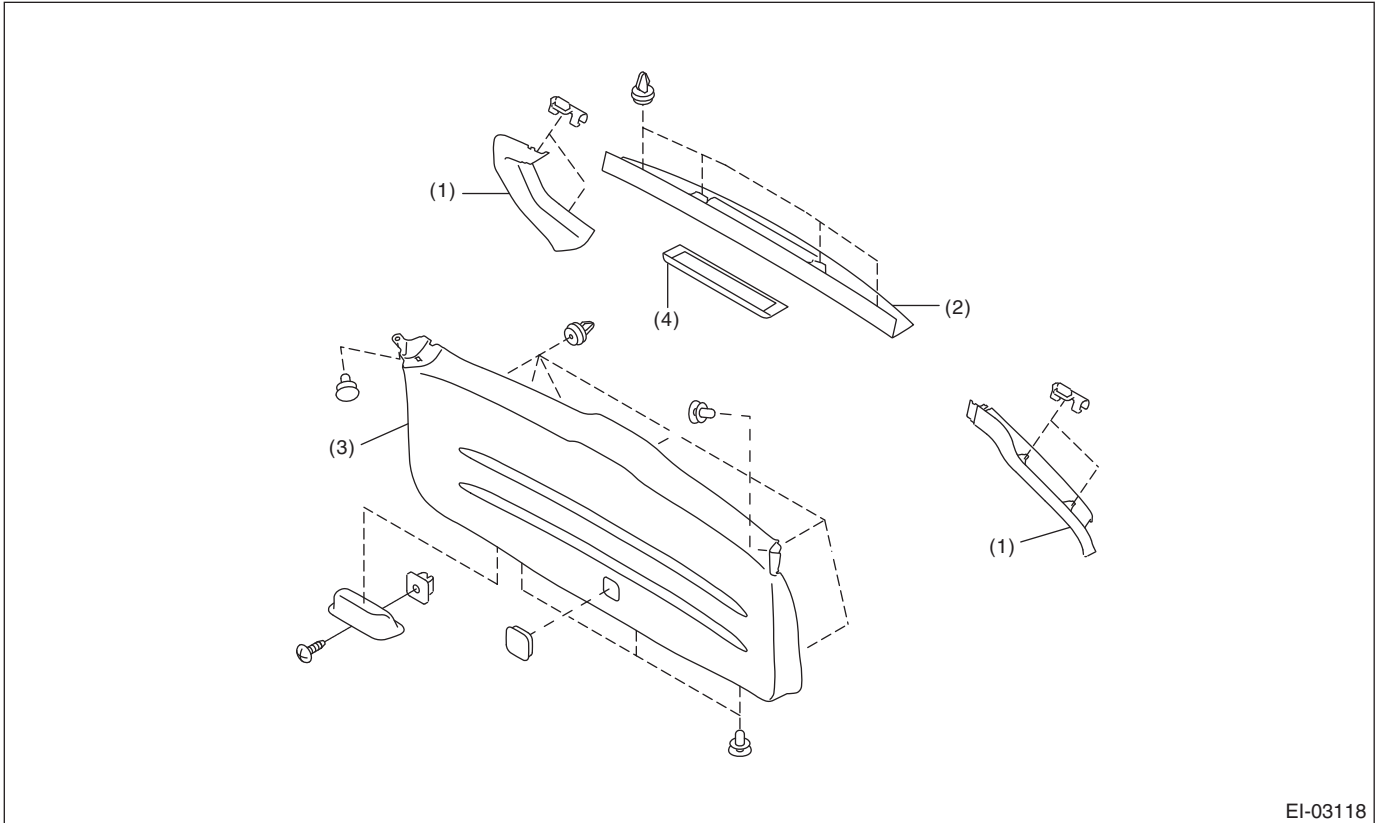

EI-03118

- (1) Rear gate pillar trim
- (2) Rear gate upper trim
- (3) Rear gate lower trim
- (4) High-mounted stop light

19. ROOF TRIM

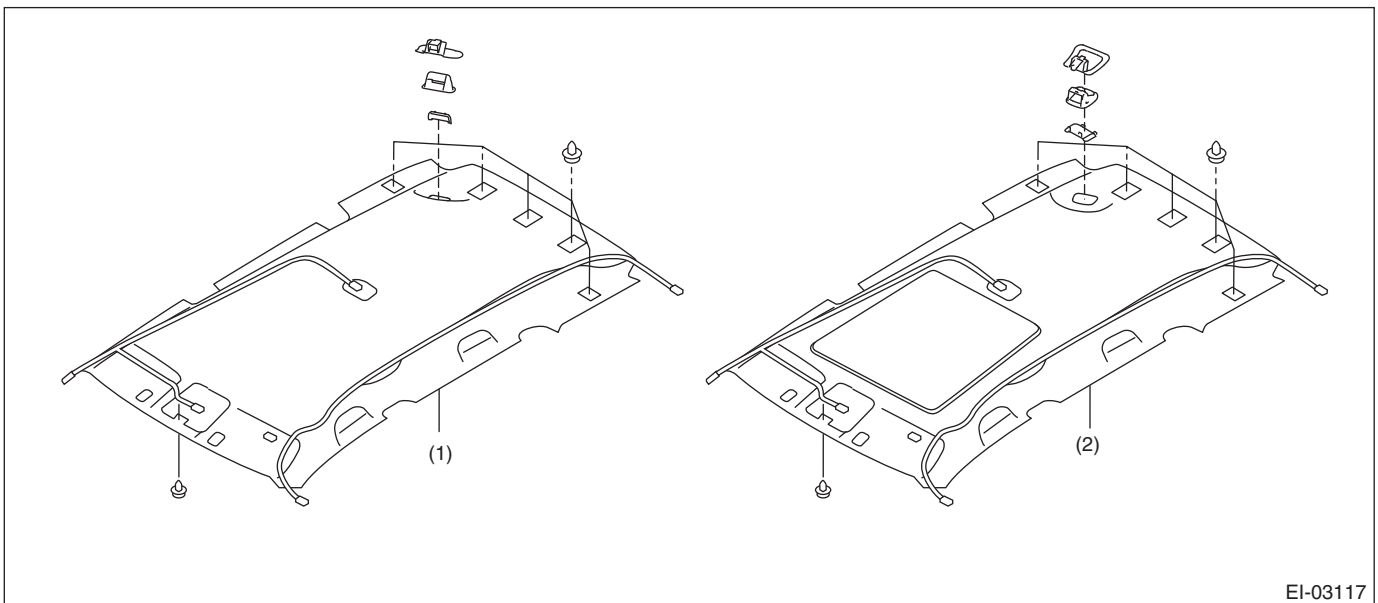

EI-03117

- (1) Models without sunroof
- (2) Models with sunroof

General Description

EXTERIOR/INTERIOR TRIM

20.ROOM INNER PARTS

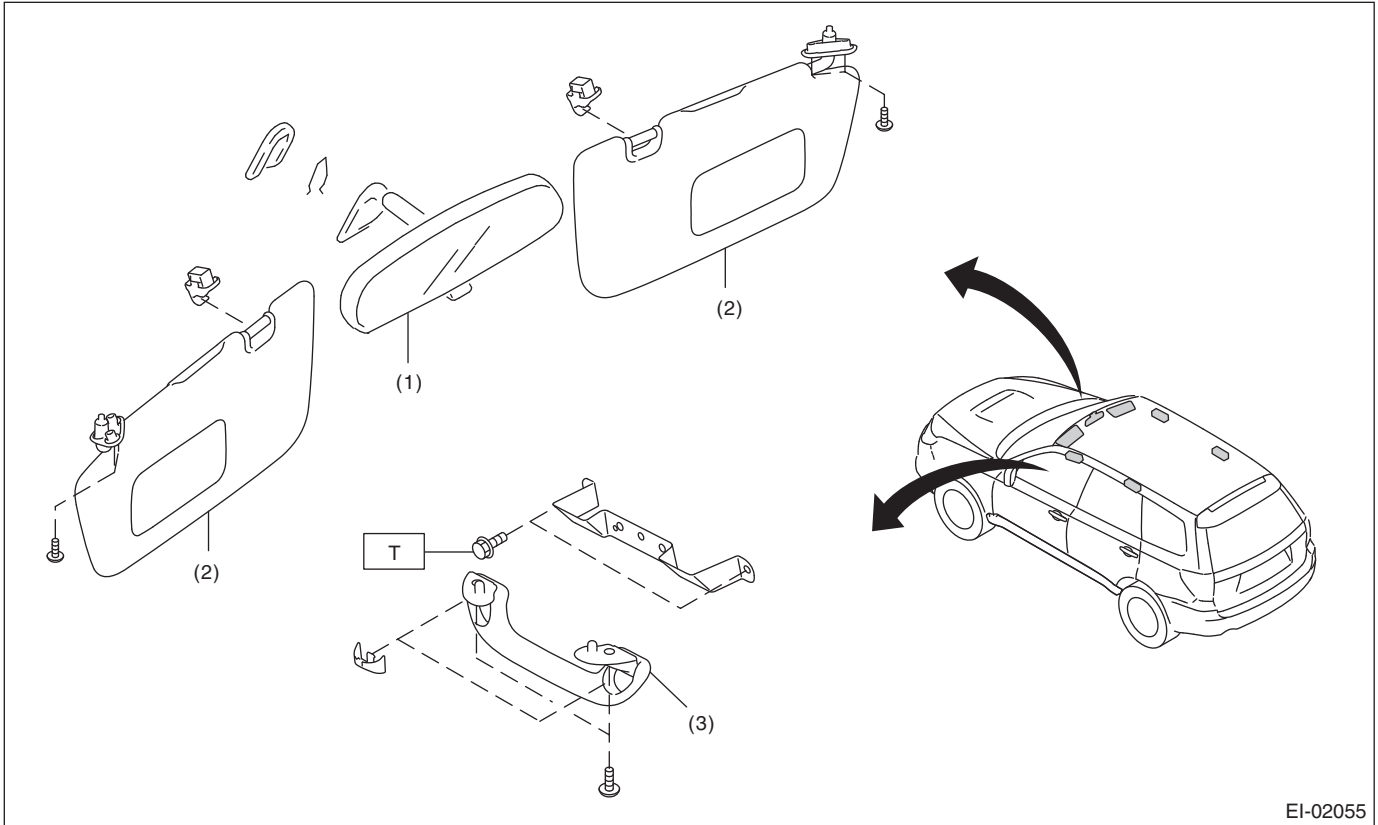

EI-02055

- (1) Room mirror
- (2) Sun visor

- (3) Assist grip

Tightening torque: N·m (kgf·m, ft·lb)
T: 7.5 (0.76, 5.5)

21.LUGGAGE ROOM PARTS

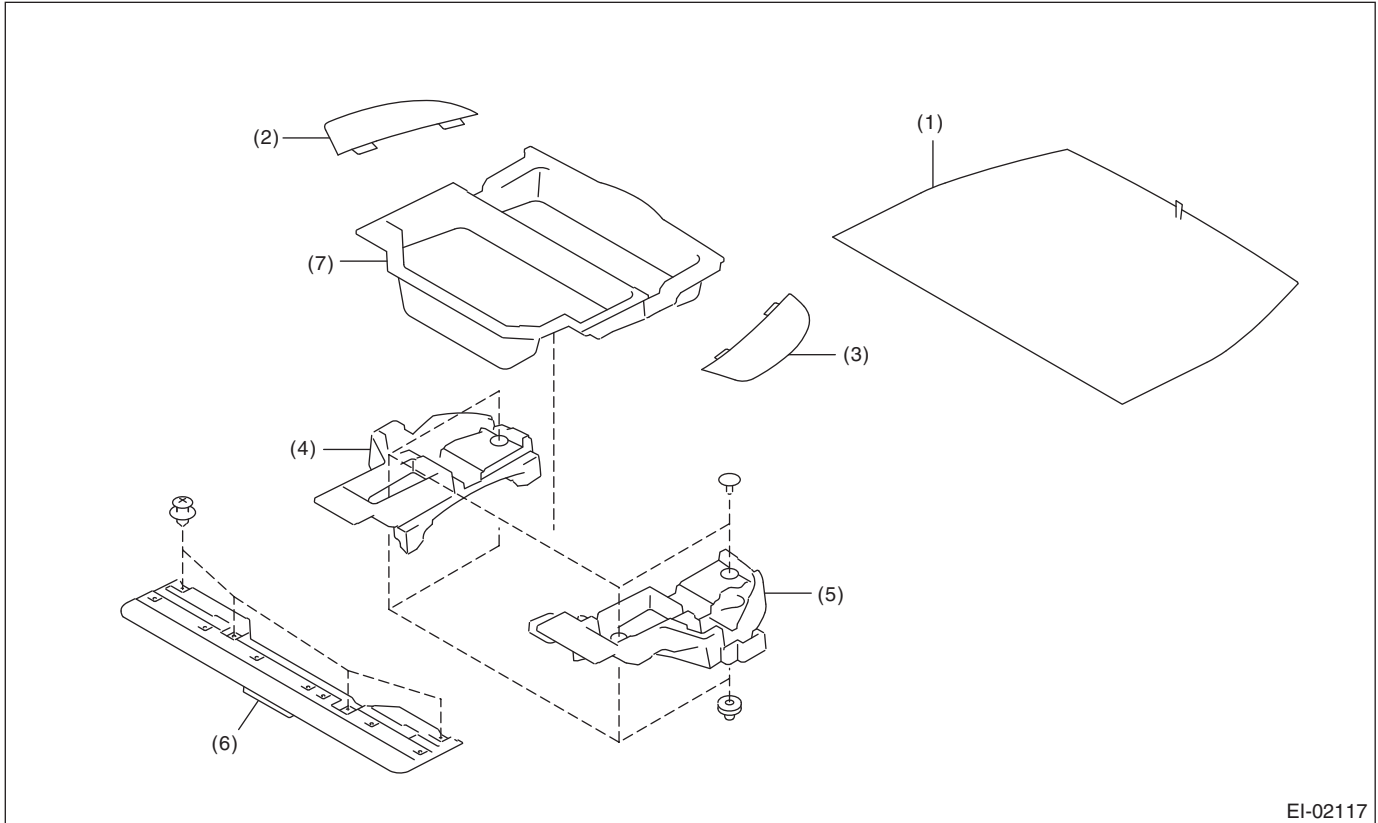

EI-02117

- | | | |
|---------------------------|-------------------------------|-----------------------------|
| (1) Luggage floor mat CTR | (4) Rear floor spacer side RH | (6) Rear floor spacer front |
| (2) Luggage floor mat RH | (5) Rear floor spacer side LH | (7) Trunk cover |
| (3) Luggage floor mat LH | | |

22.HEAT SHIELD COVER

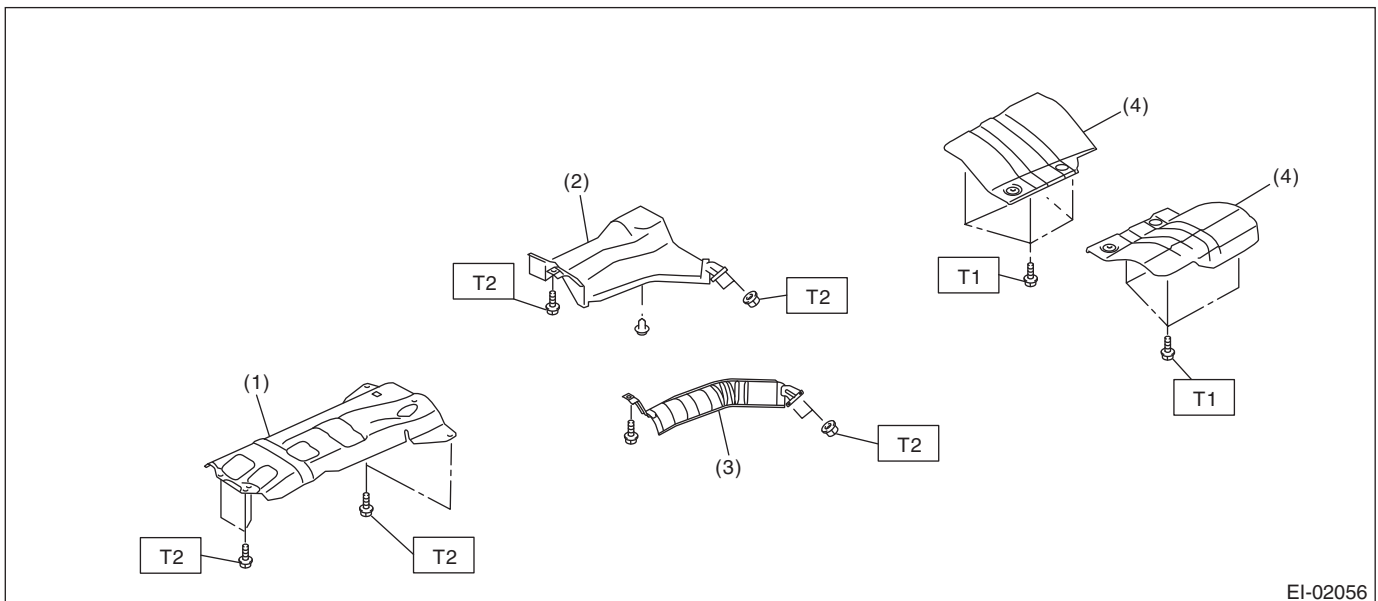

EI-02056

- | | |
|---|---|
| (1) Front heat shield cover | (3) Center heat shield cover
(Non-turbo model) |
| (2) Center heat shield cover
(Turbo model) | (4) Rear heat shield cover |

Tightening torque:N·m (kgf·m, ft·lb)
T1: 7.5 (0.76, 5.5)
T2: 18 (1.84, 13.3)

General Description

EXTERIOR/INTERIOR TRIM

23. TRAILER HITCH

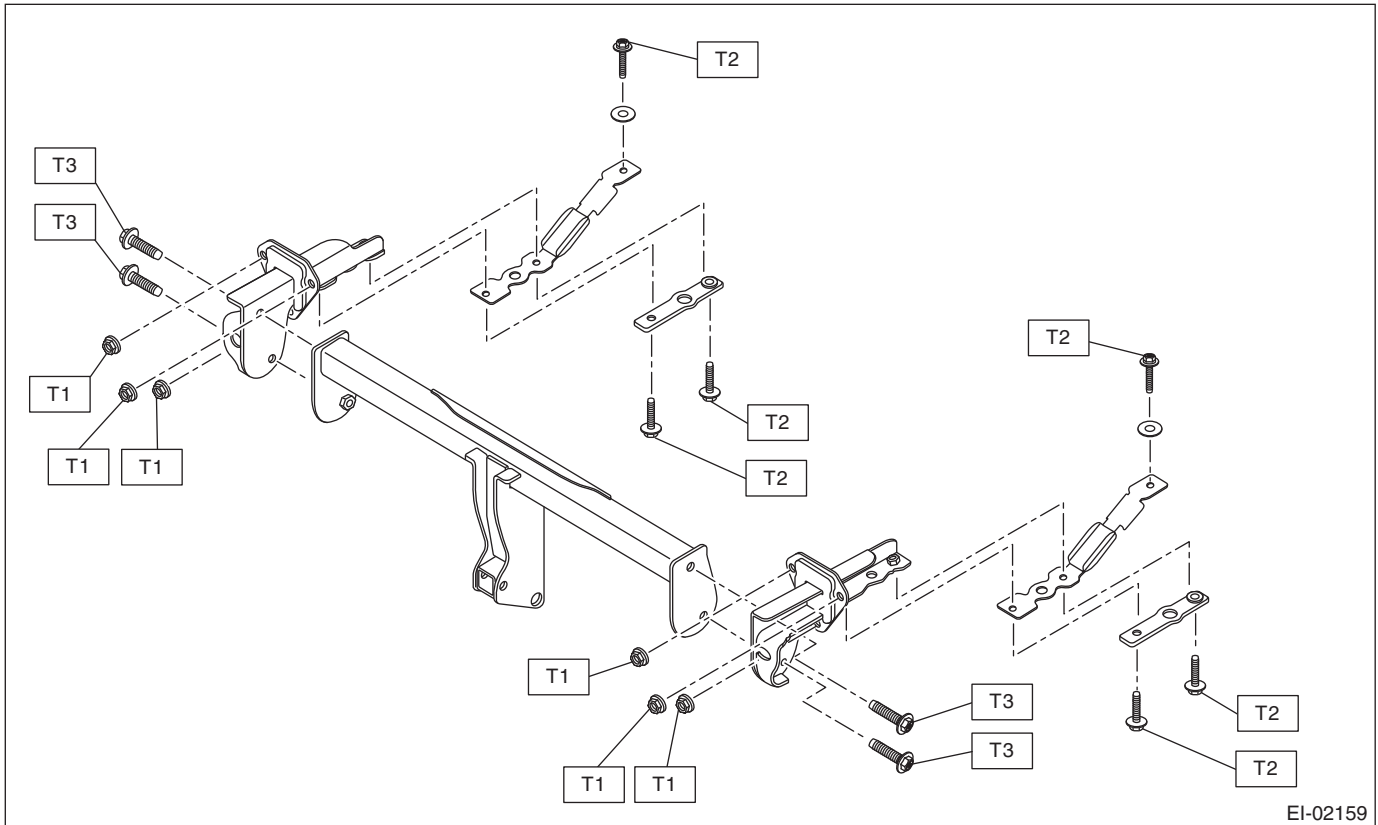

Tightening torque: N·m (kgf·m, ft·lb)

T1: 75 (7.6, 55.3)

T2: 90 (9.2, 66.4)

T3: 180 (18.4, 132.8)

B: PREPARATION TOOL

TOOL NAME	REMARKS
Clip remover	Used for removing trim. <ul style="list-style-type: none"> • KTC AP201-10A • KTC AP201-N • KTC AP203-10A • KTC AP20L-10B Or equivalent.
Clip clamp pliers	Used for removal of various clips and clamps. <ul style="list-style-type: none"> • KTC CCP-190 Or equivalent.

2. Front Grille

A: REMOVAL

- 1) Remove the front bumper face. <Ref. to EI-28, FRONT BUMPER FACE, REMOVAL, Front Bumper.>
- 2) Remove the screws (A) from the backside of the bumper face.
- 3) Detach the tabs (B) and remove the front grille assembly.

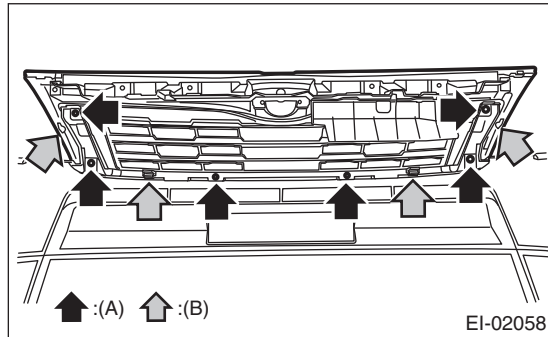

B: INSTALLATION

Install in the reverse order of removal.

Front Hood Grille

EXTERIOR/INTERIOR TRIM

3. Front Hood Grille

A: REMOVAL

- 1) Open the front hood.
- 2) Remove screws (A) and clip (B), and remove the hood duct assembly.

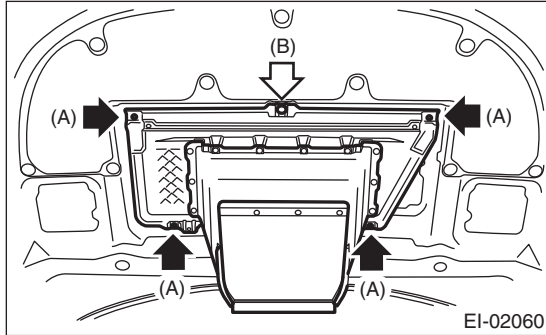

- 3) Release the clips to remove the front hood insulator.

CAUTION:

Do not reuse any clips damaged during removal. Always replace with new clips.

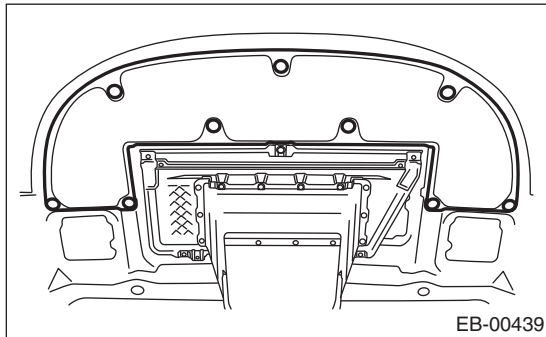

- 4) Loosen the nuts (A), remove the clip (B), and then remove the front hood grille.

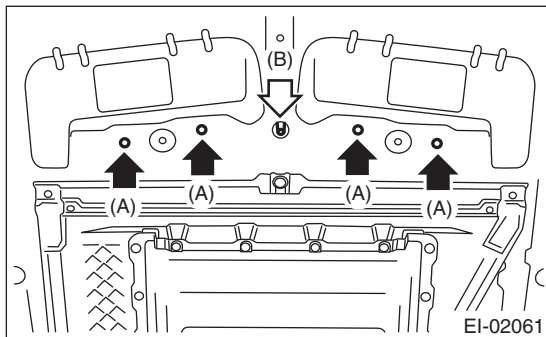

B: INSTALLATION

Install in the reverse order of removal.

NOTE:

Insert the hooks (B) of the front hood duct into holes (A) of the front hood.

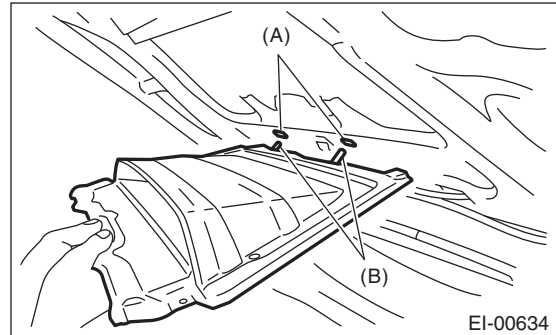

Tightening torque:

4.5 N·m (0.46 kgf·m, 3.32 ft·lb)

4. Front Under Cover

A: REMOVAL

- 1) Lift up the vehicle.
- 2) Remove clips (A) in front fender and bolts (B), then remove the front under cover.

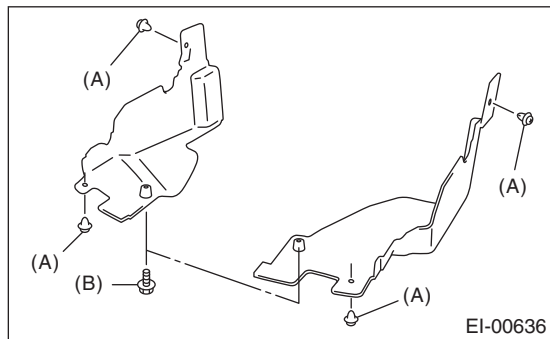
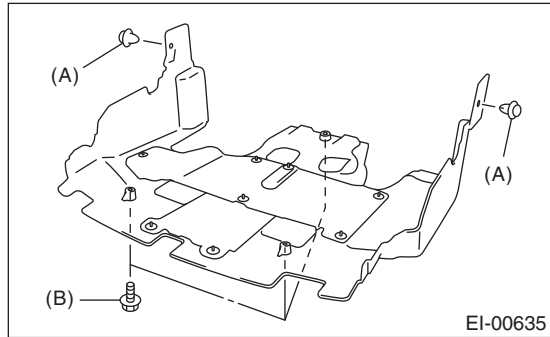

B: INSTALLATION

Install in the reverse order of removal.

Tightening torque:

14 N·m (1.42 kgf·m, 10.3 ft·lb)

5. Fuel Tank Protector

A: REMOVAL

- 1) Lift up the vehicle.
- 2) Remove the bolts (A) and nuts (B), and then remove the fuel tank protector.

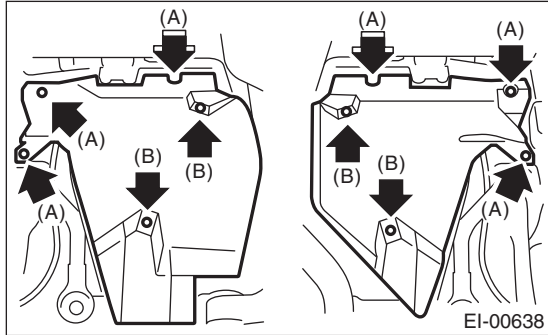

B: INSTALLATION

CAUTION:

Do not reuse the nuts (self-locking nuts). Always replace with new parts.

Install in the reverse order of removal.

Tightening torque:

Refer to "COMPONENT" of "General Description". <Ref. to EI-3, UNDER PROTECTOR, COMPONENT, General Description.>

6. Mud Guard

A: REMOVAL

1. FRONT MUD GUARD

- 1) Jack-up the vehicle.
- 2) Remove the front wheels.
- 3) Remove the clips, then remove the mud guard.

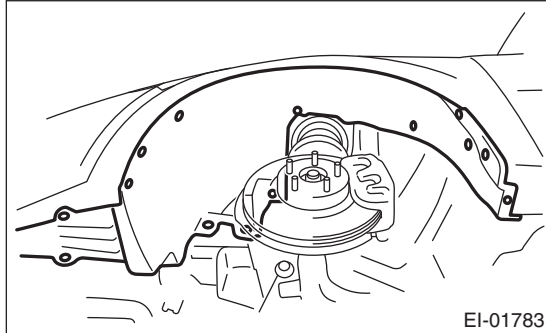

2. REAR MUD GUARD

- 1) Jack-up the vehicle.
- 2) Remove the rear wheels.
- 3) Remove the clips and screw (RH one location), and remove the mud guard.

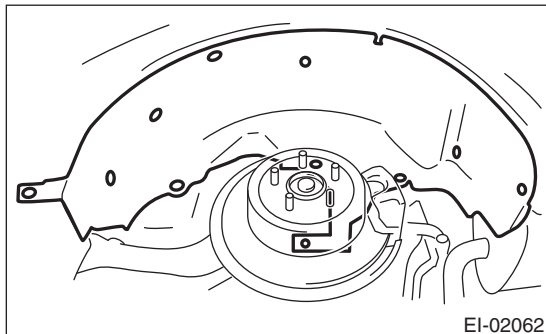

B: INSTALLATION

Install in the reverse order of removal.

Front Bumper

EXTERIOR/INTERIOR TRIM

7. Front Bumper

A: REMOVAL

1. FRONT BUMPER FACE

- 1) Disconnect the ground cable from the battery.
- 2) Remove the clips at the upper side of the bumper.

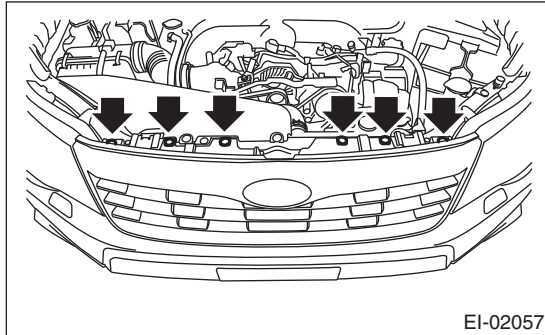

- 3) Remove the clips from the fender.

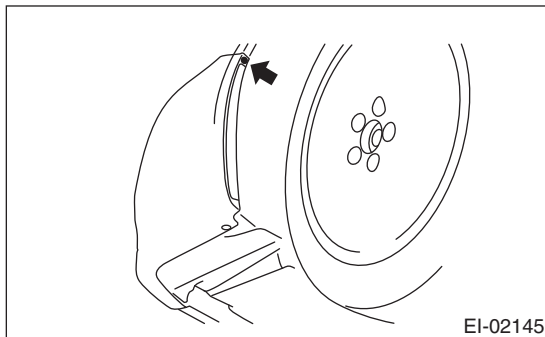

- 4) Remove the clips at the lower side of bumper.

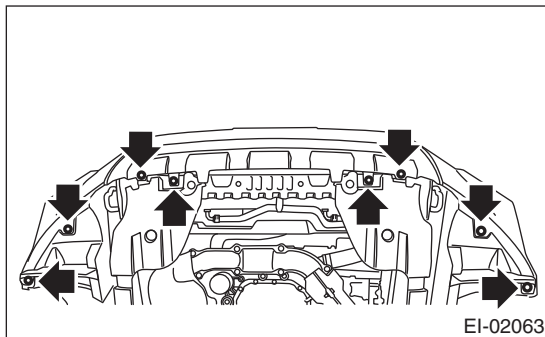

- 5) Disconnect the fog light connectors. (Model with fog light)

- 6) Detach the flange section on the bumper face side from the front side bracket.

CAUTION:

Do not pull forcibly. Doing so may damage the flange sections on the bumper face side.

NOTE:

It is easier to detach them from the fender side in the order from (1) to (3), while pulling up the bumper face to the direction of arrow (B) (upward).

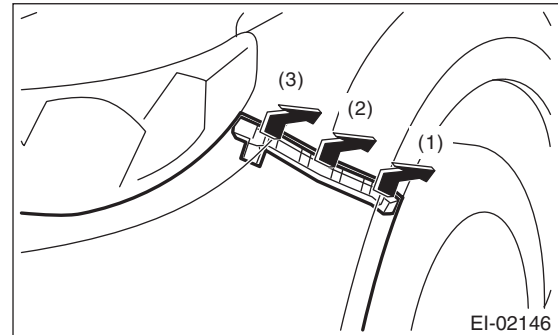

- 7) Remove the bumper face from vehicle body.
- 8) Remove the front grille from the bumper face. <Ref. to EI-23, REMOVAL, Front Grille.>
- 9) Remove the fog light from bumper face. <Ref. to LI-25, REMOVAL, Front Fog Light Assembly.>

2. FRONT BUMPER BEAM ASSEMBLY

- 1) Disconnect the ground cable from the battery.
- 2) Remove the front bumper face. <Ref. to EI-28, FRONT BUMPER FACE, REMOVAL, Front Bumper.>
- 3) Remove the energy absorber foam from the bumper beam assembly.

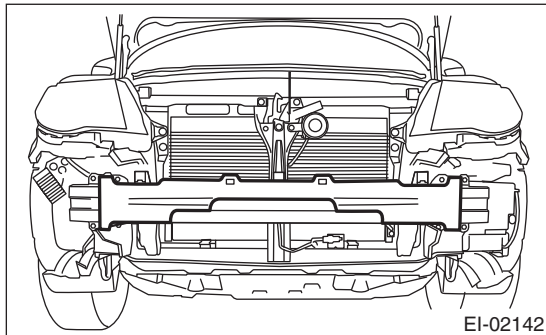

- 4) Remove the bolts, and remove the bumper beam assembly from vehicle body.

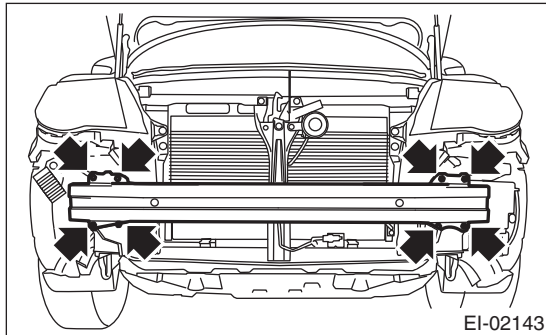

NOTE:

After all bolts are removed, raise the whole bumper beam a little to remove it from vehicle body.

B: INSTALLATION

1. FRONT BUMPER FACE

- 1) Install in the reverse order of removal.
- 2) Securely attach the bumper tabs (A) to the plastic bracket (B).

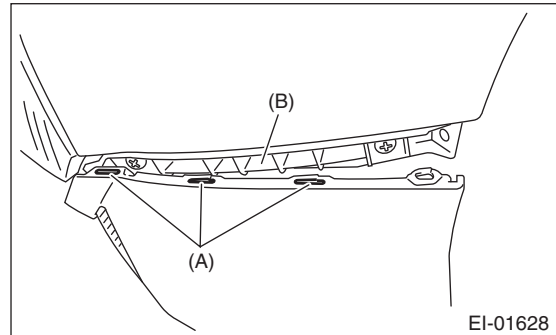

2. FRONT BUMPER BEAM ASSEMBLY

Install in the reverse order of removal.

Tightening torque:

Refer to "COMPONENT" of "General Description". <Ref. to EI-5, FRONT BUMPER, COMPONENT, General Description.>

Front Bumper

EXTERIOR/INTERIOR TRIM

C: REPAIR

1. COATING METHOD FOR PP BUMPER

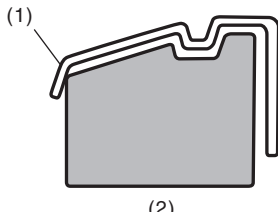
Process No.	Process name	Job contents	
1	Bumper installation	Place the bumper on a paint worktable as required. Use the paint worktable conforming to inner shape of bumper if possible.	 <p>(1) Bumper (2) Set bumper section</p> <p style="text-align: right;">EI-00234</p>
2	Masking	Mask specified part (black base) with masking tape. Use masking tape for PP (for example, Nichiban No. 533, etc.).	
3	Degreasing/cleaning	Clean all parts to be painted with white gasoline, normal alcohol, etc. to remove dirt, oil, fat, etc.	
4	Primer paint	Apply primer to all parts to be painted, using spray gun. Use primer (clear).	
5	Drying	Dry at normal temperature [10 to 15 min. at 20°C (68°F)]. In half-dried condition, PP primer paint is dissolved by solvent, e.g. thinner, etc. Therefore, if dust or dirt must be removed, use ordinary alcohol etc.	
6	Top coat paint (I)	Non-colored	Metallic paint
		Use section (block) paint for top coat. • Paint to be used (for each color): Solid paint Hardener PB Thinner T-301 • Mixture ratio: Main agent : Hardener = 4 : 1 • Viscosity: 10 — 13 sec./20°C (68°F) • Film thickness: 35 — 45 μ • Spraying pressure: 245 — 343 kPa (2.5 — 3.5 kgf/cm ² , 36 — 50 psi)	Use section (block) paint for top coat. • Paint to be used (for each color): Metallic paint Hardener PB Thinner T-306 • Mixture ratio: Main agent : Hardener = 10 : 1 • Viscosity: 10 — 13 sec./20°C (68°F) • Film thickness: 15 — 20 μ • Spraying pressure: 245 — 343 kPa (2.5 — 3.5 kgf/cm ² , 36 — 50 psi)
7	Drying	Not required.	Dry at normal temperature [at least 10 min. at 20°C (68°F)]. In half-dried condition, avoid dust, dirt.
8	Top coat paint (II)	Not required.	After top coating (I) three times at 5 — 7 minutes intervals, apply an additional clear coat to the part. • Paint to be used: Metallic paint Hardener PB Thinner T-301 • Mixture ratio: Clear coat : Hardener = 6 : 1 • Viscosity: 14 — 16 sec./20°C (68°F) • Film thickness: 25 — 30 μ • Spraying pressure: 245 — 343 kPa (2.5 — 3.5 kgf/cm ² , 36 — 50 psi)
9	Drying	60°C (140°F), 60 min. or 80°C (176°F), 30 min. If higher than 80°C (176°F), PP may become be deformed. Keep maximum temperature 80°C (176°F) or less.	
10	Inspection	Check paint.	
11	Removal of masking	Remove the masking tape applied in procedure 2.	

2. REPAIR INSTRUCTIONS FOR COLORED PP BUMPER

NOTE:

All PP bumpers are provided with a grained surface, and if the surface is damaged, it cannot normally be restored to its former condition. Damages limited to the shallow scratches that cause only a change in the luster of the base material or coating, can be almost fully restored. Before repairing a damaged area, explain this point to the customer and obtain an understanding about the matter.

Repair methods are outlined below, based on a classification of the extent of damage.

1) Minor damage causing only a change in the luster of the bumper due to a light touch
Almost restorable.

Process No.	Process name	Job contents	
1	Cleaning	Clean the area to be repaired using water.	
2	Sanding	Grind the repairing area with #500 sand paper in a "feathering" motion.	
3	Finish	Resin section	Coated section
		Repeatedly apply wax to the affected area using soft cloth (such as flannel). Recommended wax: NITTO KASEI Soft 99 TIRE WAX BLACK, or equivalent.	Perform either the same process as for the resin section or process No. 18 and subsequent in the 3) section, depending on the degree and nature of damage.
		Polish the waxed area with clean cloth after 5 — 10 minutes.	

2) Deep damage caused by scratching with fences etc.

A dent cannot be repaired but a whitened or swelled part can be removed.

Process No.	Process name	Job contents	
1	Cleaning	Clean the damaged area with water.	
2	Removal of damaged area	Cut off protruding area, if any, due to collision, using a putty knife.	
3	Sanding	Grind the affected area with #100 — #500 sand paper.	
4	Finish	Resin section	Coated section
		Same as step 3 in the "1)" section.	Perform step 12 and subsequent operations in the "3)" section.

Front Bumper

EXTERIOR/INTERIOR TRIM

3) Deep damage such as a break or hole that requires filling

Much of the peripheral grained surface must be sacrificed for repair. The degree of restoration is not really worth the expense. (The surface, however, will become almost flush with adjacent areas.)

Recommended repair kit: PP Part Repair Kit (NRM)

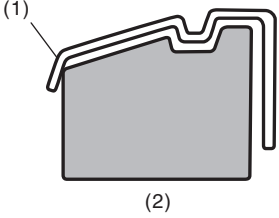
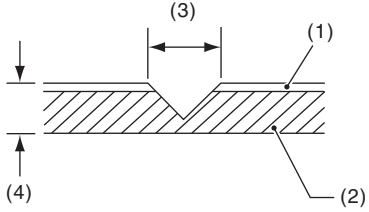
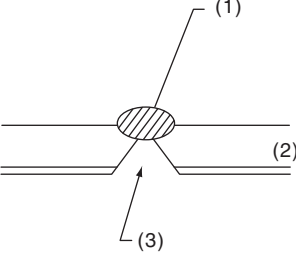
Process No.	Process name	Job contents	
1	Bumper removal	Remove the bumper as required.	
2	Removal of parts	Remove the parts built into bumper as required.	
3	Bumper placement	Place the bumper on a paint worktable as required. It is recommended to use the paint worktable conforming to internal shape of bumper.	 <p style="text-align: right;">EI-00234</p> <p>(1) Bumper (2) Set bumper section</p>
4	Surface preparation	Remove dust, oil, etc. from areas to be repaired and surrounding areas, using a suitable solvent (NRM No. 900 Precleno, white gasoline, or alcohol, etc.).	
5	Cutting	If nature of damage are cracks or holes, cut a guide slit of 20 to 30 mm (0.79 to 1.18 in) in length along the crack or hole up to the bumpers base surface. Next, use a knife or grinder to carve a V-shaped groove in the area for repair.	 <p style="text-align: right;">EI-00235</p> <p>(1) Paint surface (2) PP base surface (3) 20 — 30 mm (0.79 — 1.18 in) (4) 3 mm (0.12 in)</p>
6	Sanding (I)	Grind beveled surface with sand paper (#40 — #60) to smooth finish.	
7	Cleaning	Clean the sanded surface with the same solvent as used in Procedure 4.	
8	Temporary welding	Grind the side just opposite the beveled area with sand paper (#40 — #60) and clean using a solvent. Temporarily spot-weld the side, using PP welding rod and heater gun.	 <p style="text-align: right;">EI-00236</p> <p>(1) Welded point (Use heater gun and PP welding rod) (2) PP base surface (3) Beveled section</p> <p>NOTE:</p> <ul style="list-style-type: none"> • Do not melt welding rod until it flows out. This results in reduced strength. • Leave the welded spot unattended until it cools completely.

Front Bumper

EXTERIOR/INTERIOR TRIM

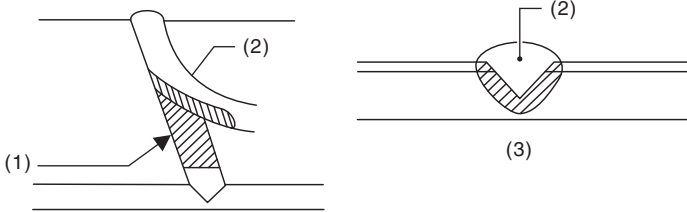
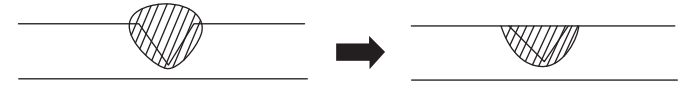
Process No.	Process name	Job contents
9	Welding	<p>Using a heater gun and PP welding rod, weld the beveled spot while melting both the rod and damaged area.</p>  <p>(1) Welding rod (2) Melt hatched area (3) Section</p> <p>NOTE:</p> <ul style="list-style-type: none"> • Melt the sections indicated by hatched area. • Do not melt the welding rod until it flows out, in order to provide strength. • Always keep the heater gun 1 to 2 cm (0.4 to 0.8 in) away from the welding spot. • Leave the welded spot unattended until it cools completely. <p>EI-00237</p>
10	Sanding (II)	<p>Remove excess part of weld with a putty knife. If a drill or disc wheel is used instead of the knife, operate it at a rate lower than 1,500 rpm and grind the excess part little by little. A higher rpm will cause the PP substrate to melt from the heat.</p>  <p>EI-00042</p> <p>Sand the welded spot smooth with #240 sand paper.</p>
11	Masking	Mask the black substrate section using masking tape. Recommended masking tape: Nichiban No. 533 or equivalent
12	Cleaning/ degreasing	Completely clean the entire coated area, using solvent similar to that used in Procedure 4.
13	Primer coating	Apply a coat of primer to the repaired surface and its surrounding areas. Mask these areas, if necessary. Recommended primer: Mp/ 364 PP Primer NOTE: Be sure to apply a coat of primer using a spray gun at a pressure of 245 — 343 kPa (2.5 — 3.5 kgf/cm ² , 36 — 50 psi).
14	Leave unattended	Leave the repaired area unattended at 20°C (68°F) for 10 to 15 minutes until primer is half-dry. NOTE: If dirt or dust comes in contact with the coated area, wipe it off with a cloth dampened with alcohol. (Do not use thinner since the coated area tends to melt.)
15	Primer surfacer coating	Apply primer surfacer to the repaired area two or three times at an interval of 3 — 5 minutes. Recommended surfacer: <ul style="list-style-type: none"> • UPS 300 Flex Primer • No. 303 UPS 300 Exclusive hardener • NPS 725 Exclusive Reducer (thinner) • Mixture ratio: 2 : 1 (UPS 300 : No. 303) • Viscosity: 12 — 14 sec./20°C (68°F) • Coating film thickness: 40 — 50 μ
16	Drying	Allow the coated surface to dry for 20 minutes at 20°C (68°F) [or 30 minutes at 60°C (140°F)].

Front Bumper

EXTERIOR/INTERIOR TRIM

Process No.	Process name	Job contents	
17	Sanding (III)	Sand the coated surface and its surrounding areas using #400 sand paper and water.	
18	Cleaning/ degreasing	Same as Process No. 12.	
19	Top coat (I)	Non-colored	Metallic paint
		Use a "block" coating method. • Recommended paint: Suncryl (SC) No. 307 Flex Hardener SC Reducer (thinner) • Mixture ratio: Suncryl (SC) : No. 307 Flex Hardener = 3 : 1 • Viscosity: 11 — 13 sec./20°C (68°F) • Coating film thickness: 40 — 50 μ • Spraying pressure: 245 — 343 kPa (2.5 — 3.5 kgf/cm ² , 36 — 50 psi)	Use a "block" coating method. • Recommended paint: Suncryl (SC) No. 307 Flex Hardener SC Reducer (thinner) • Mixture ratio: Suncryl (SC) : No. 307 Flex Hardener = 3 : 1 • Viscosity: 11 — 13 sec./20°C (68°F) • Coating film thickness: 20 — 30 μ • Spraying pressure: 245 — 343 kPa (2.5 — 3.5 kgf/cm ² , 36 — 50 psi)
20	Leave unattended	Not required.	Leave unattended at 20°C (68°F) for at least 10 minutes until the topcoated area is half-dry. NOTE: Be careful to keep dust or dirt from coming in contact with the affected area.
21	Top coat (II)	Not required.	Apply a clear coat three times at an interval of 3 to 5 minutes. • Recommended paint: SC710 Overlay Clear No. 307 Flex Hardener SC Reducer (thinner) • Mixture ratio: Suncryl (SC) : No. 307 Flex Hardener = 3 : 1 • Viscosity: 10 — 13 sec./20°C (68°F) • Coating film thickness: 20 — 30 μ • Spraying pressure: 245 — 343 kPa (2.5 — 3.5 kgf/cm ² , 36 — 50 psi)
22	Drying	Allow the coated surface to dry for two hours at 20°C (68°F) or 30 minutes at 60°C (140°F)]. NOTE: Do not allow the temperature to exceed 80°C (176°F) since this will deform the PP substrate.	
23	Inspection	Carefully check the condition of the repaired area.	
24	Removal of masking	Remove the masking tape applied in Process No. 11 and 13.	
25	Parts installation	Install parts on the bumper in reverse order of removal.	
26	Bumper installation	Install the bumper.	

8. Rear Bumper

A: REMOVAL

1. REAR BUMPER FACE

1) Remove the clips inside the wheel house.

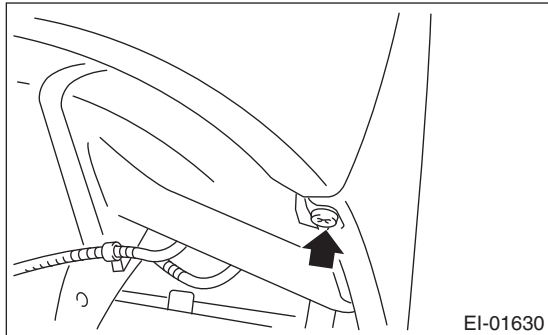

2) Remove the bolts.

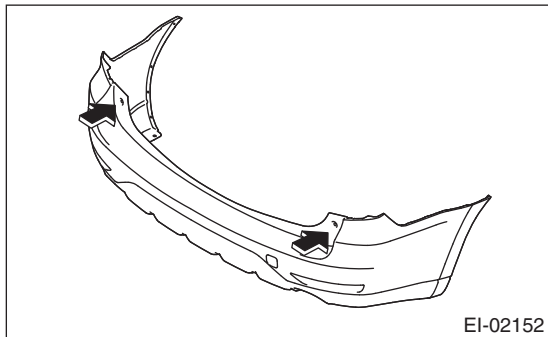

3) Remove the clips on the lower side of rear bumper.

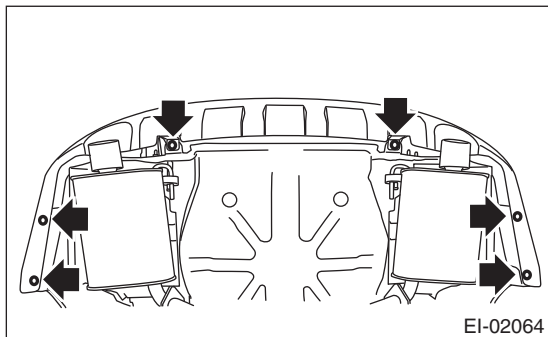

- 4) Remove the rear bumper from vehicle body.
 (1) Detach from the fender side in order from (1) to (3) while pulling up on the bumper face and twisting it towards you. (Both sides)
 (2) Detach in order from (4) to (6) while pulling up on the center part of the bumper face.

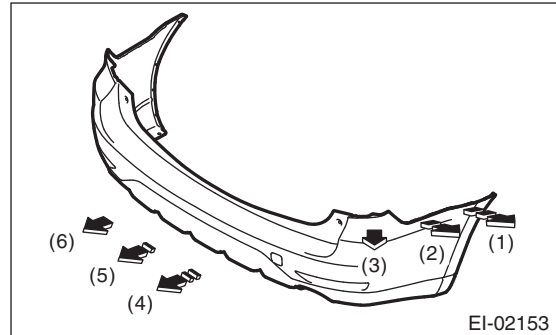

CAUTION:

Do not pull with a excessive force. Otherwise the bracket installation area may be damaged.

5) Remove the reflectors.

2. REAR BUMPER BEAM ASSEMBLY

- 1) Disconnect the ground cable from the battery.
 2) Remove the rear bumper face. <Ref. to EI-35, REAR BUMPER FACE, REMOVAL, Rear Bumper.>
 3) Remove the nuts, and remove the bumper beam assembly from the vehicle body.

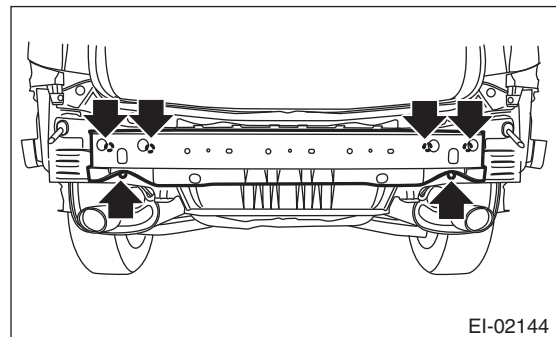

NOTE:

After all nuts are removed, raise the whole bumper beam a little to remove it from the vehicle body.

3. REAR BUMPER BRACKET

Remove the rear bumper face from vehicle body, and remove each bumper bracket.

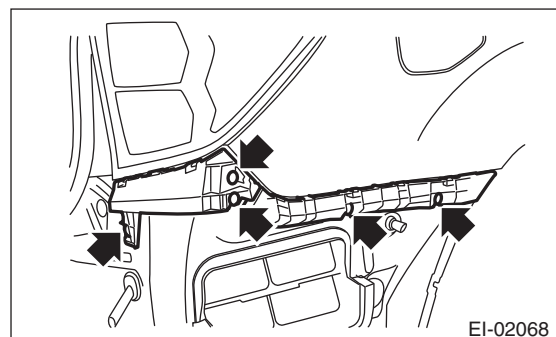

Rear Bumper

EXTERIOR/INTERIOR TRIM

B: INSTALLATION

Install in the reverse order of removal.

NOTE:

If the bumper face comes off easily from the beam upper rear, adjust the hook of the bracket side.

Tightening torque:

Refer to “COMPONENT” of “General Description”.

<Ref. to EI-6, REAR BUMPER, COMPONENT, General Description.>

C: REPAIR

Refer to front bumper repair. <Ref. to EI-30, REPAIR, Front Bumper.>

9. Cowl Panel

A: REMOVAL

- 1) Open the front hood.
- 2) Remove the wiper arm. <Ref. to WW-15, REMOVAL, Front Wiper Arm.>
- 3) Detach the tabs and remove the cowl panel, side.

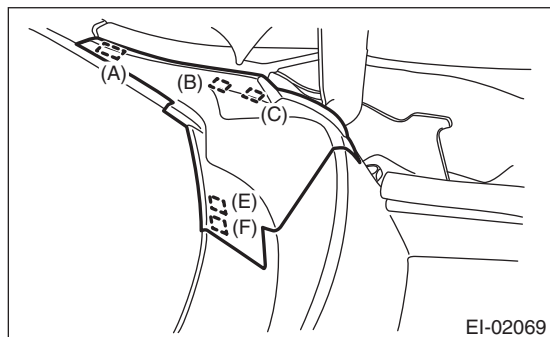

- (1) Detach tabs (A), (B), and (C) from the vehicle exterior.
- (2) Detach tabs (E) and (F).
- 4) Pull out and disconnect the washer hose.

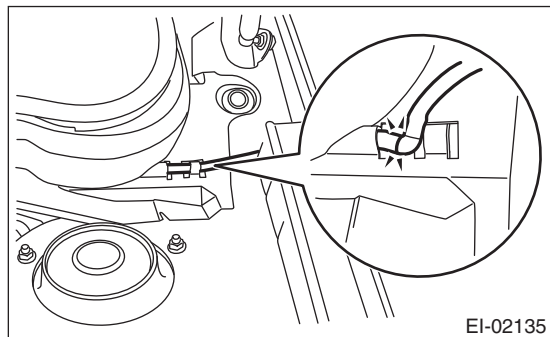

- 5) Remove clips (A) and (B), and remove the cowl panel.

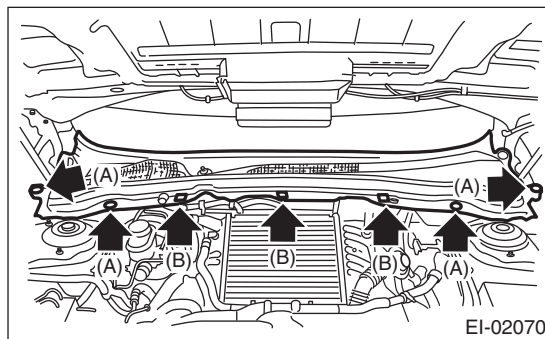

CAUTION:
 Press on the clip tabs from the left and right when removing clips (B).
 Do not pull forcibly on the clips to prevent damaging them.

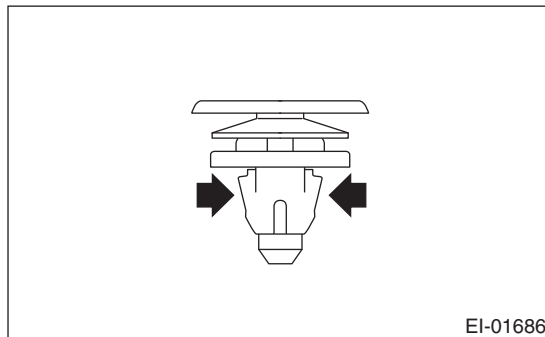

B: INSTALLATION

Install in the reverse order of removal.

NOTE:
 Hook the cowl panel tabs along the bottom edge of the wind shield.

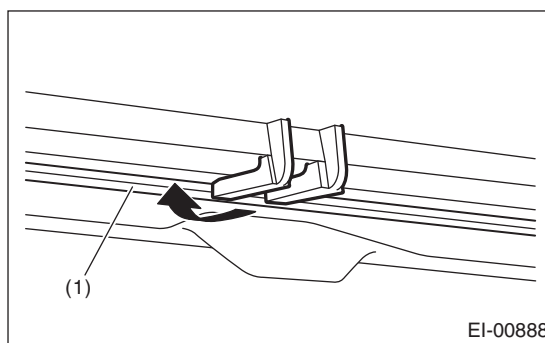

- (1) Wind shield cross-section

10. Roof Spoiler

A: REMOVAL

- 1) Disconnect the ground cable from the battery.
- 2) Remove the high-mounted stop light. <Ref. to LI-33, REMOVAL, High-mounted Stop Light.>
- 3) Remove the rear gate trim. <Ref. to EI-60, REMOVAL, Rear Gate Trim.>
- 4) Remove the bolt.

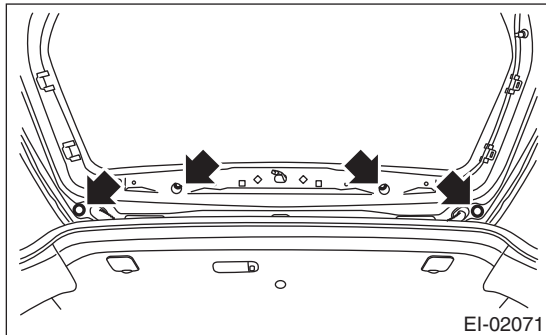

- 5) Open the caps (1), and remove the bolt inside, to remove the roof spoiler.

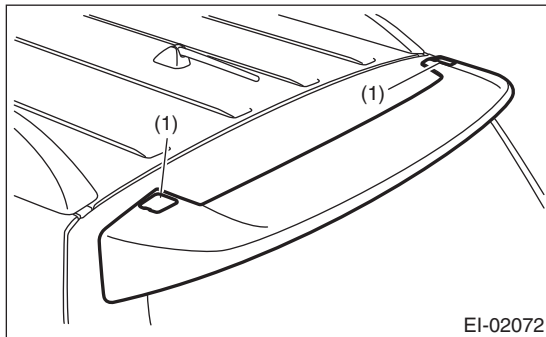

B: INSTALLATION

CAUTION:

Make sure that the bolts are securely attached, as insecure installation can cause water leaks.

Install in the reverse order of removal.

Tightening torque:

7.5 N·m (0.76 kgf-m, 5.5 ft-lb)

11.Side Sill Spoiler

A: REMOVAL

Remove the clips, and remove the side spoiler.

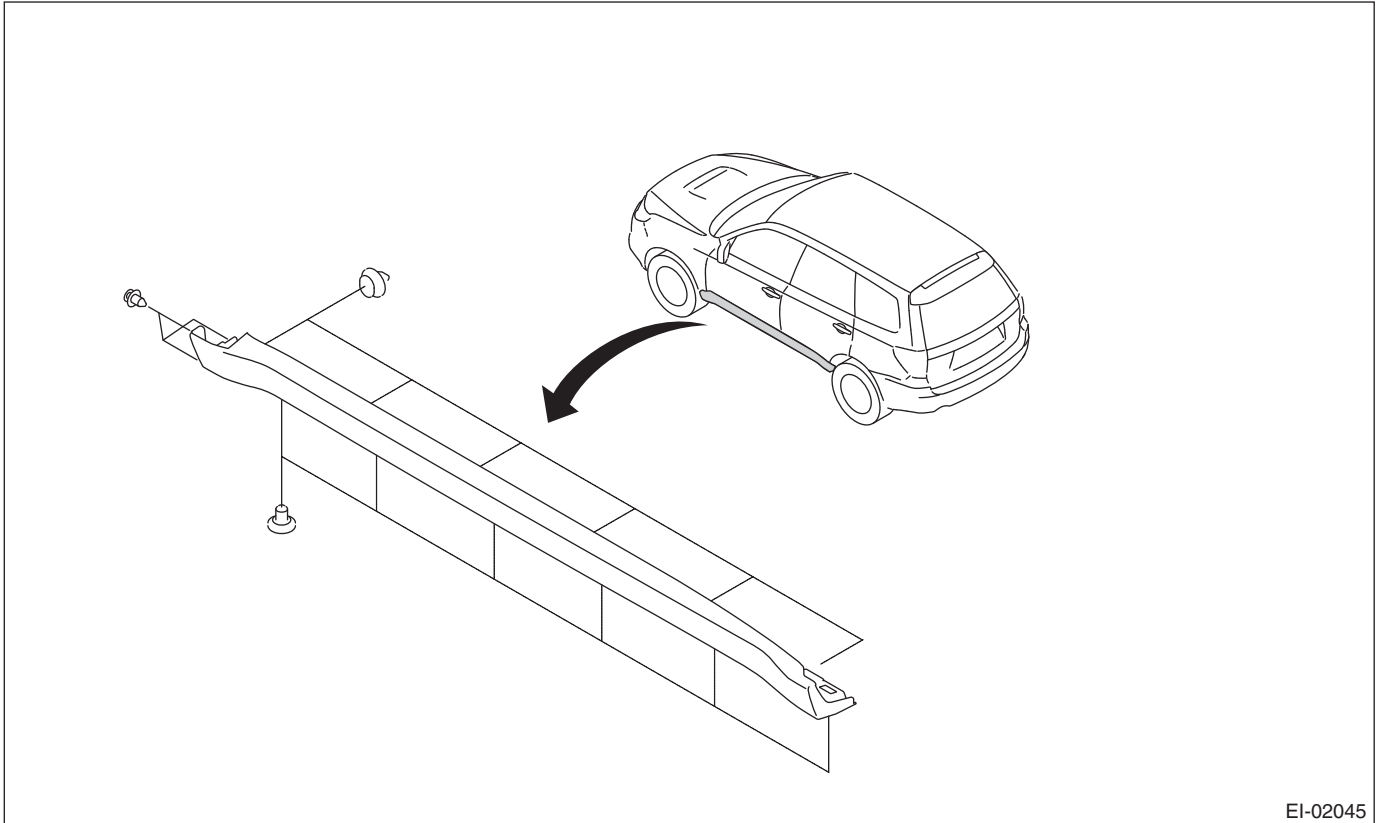

EI-02045

B: INSTALLATION

Install in the reverse order of removal.

Roof Molding

EXTERIOR/INTERIOR TRIM

12. Roof Molding

A: REMOVAL

1) Peel back the edge of the roof molding, slide the inner clips in the direction shown by the arrow using a flat tip screwdriver to remove the clips from the vehicle body studs.

RH: Slide towards the front of the vehicle.

LH: Slide towards the rear of the vehicle.

CAUTION:

Be careful not to damage the vehicle body.

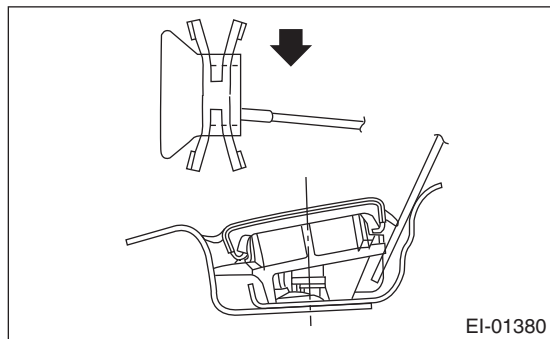
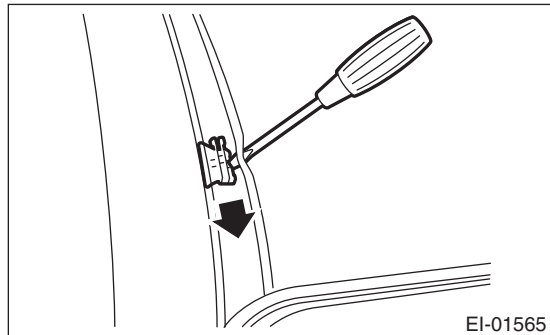

2) Lift up the roof molding and remove from the vehicle.

3) Remove the roof trim. <Ref. to EI-59, REMOVAL, Roof Trim.>

4) Remove the nuts and remove the roof carrier bracket.

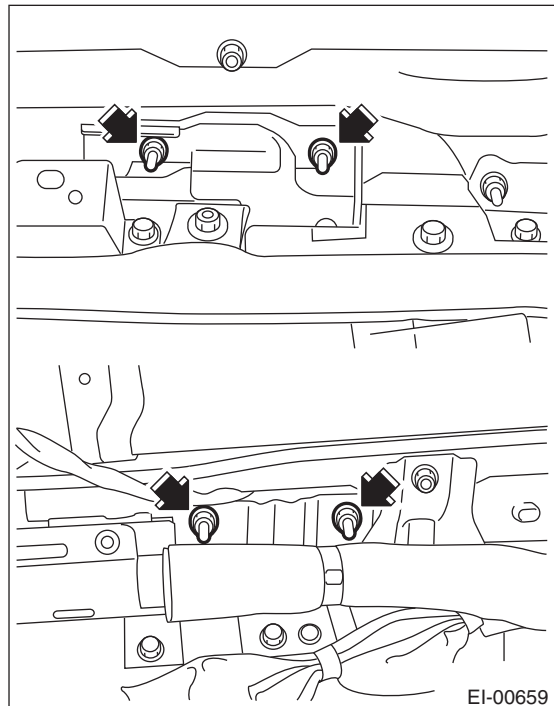

B: INSTALLATION

1) Install the roof carrier bracket.

Tightening torque:

7.5 N-m (7.6 kgf-m, 5.5 ft-lb)

2) Remove all clips from the roof molding and attach them to the vehicle body.

CAUTION:

Always replace any clips damaged when removing the roof molding with new clips.

3) Press the front edge of the roof molding against the front window, and attach the front positioning clip to the rivet on the body.

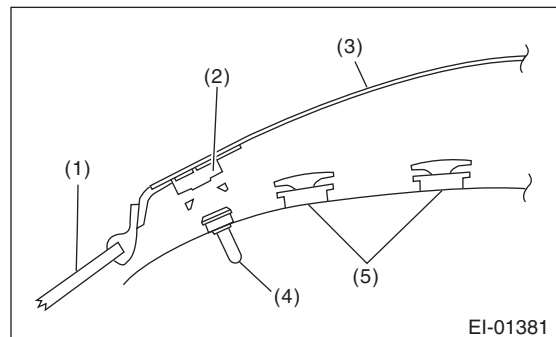

- (1) Windshield
- (2) Positioning clip
- (3) Roof molding
- (4) Rivet
- (5) Clip

4) While pushing down on the roof molding from above, engage the roof molding and clips.

13. Roof Rail

A: REMOVAL

- 1) Remove the roof trim. <Ref. to EI-59, REMOVAL, Roof Trim.>
- 2) Remove the front installation nuts.

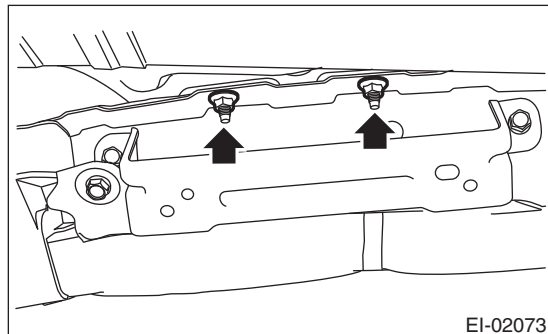

- 3) Remove the inflator pad (1) and then remove the rear mounting nuts.

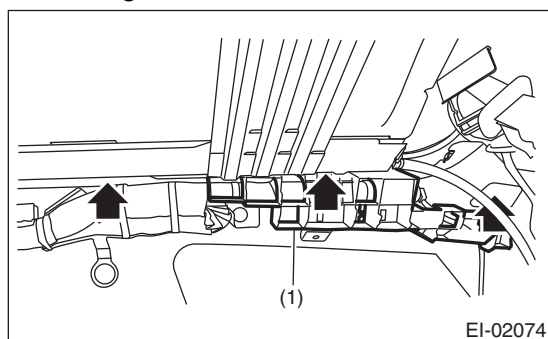

B: INSTALLATION

Install in the reverse order of removal.

CAUTION:

When removing or installing the roof rail, be careful not to scratch the body panel with the stud bolt of the roof rail.

Tightening torque:

7.5 N·m (0.76 kgf-m, 5.5 ft-lb)

Door Trim

EXTERIOR/INTERIOR TRIM

14. Door Trim

A: REMOVAL

- 1) Disconnect the ground cable from the battery.
- 2) Remove clip (A) and the gusset cover

- Front

For models with tweeters, disconnect the connector.

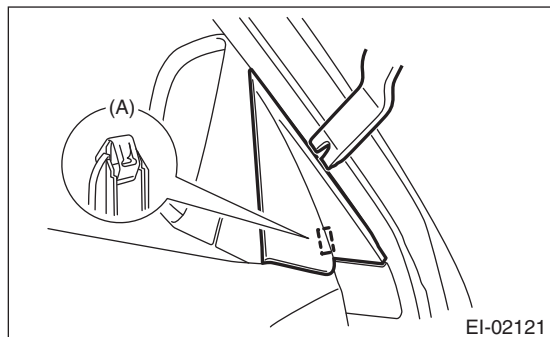

- Rear

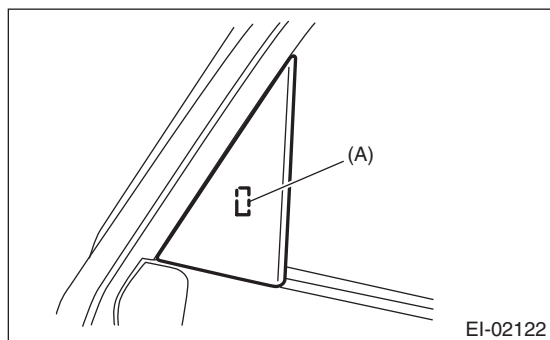

- 3) Open the inner remote cover and remove the screw.

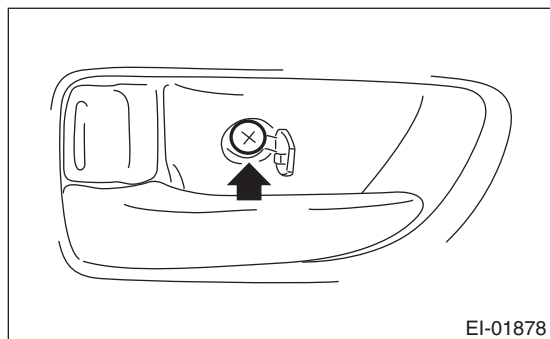

- 4) Open the cover, remove the screw, and remove the power window switch panel.

- Front door

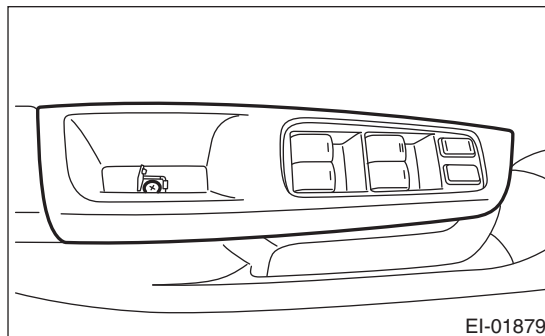

- Rear door

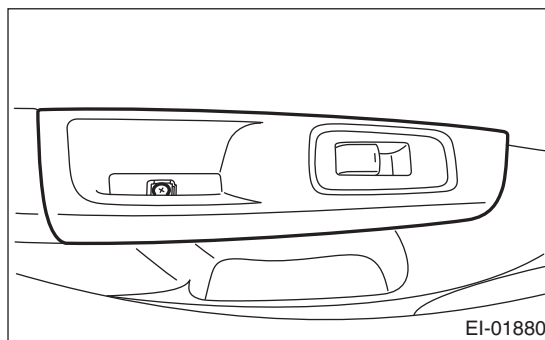

NOTE:

Remove from the notched part at the edge of the switch panel.

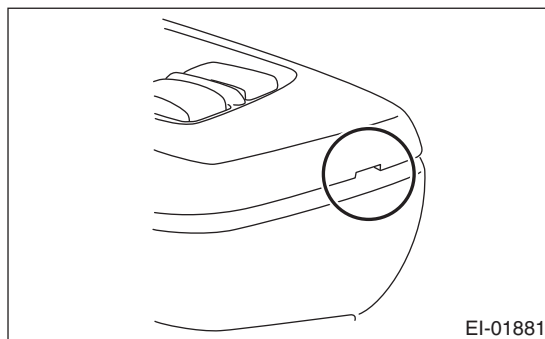

Door Trim

EXTERIOR/INTERIOR TRIM

5) Remove the door trim screws.

- Front

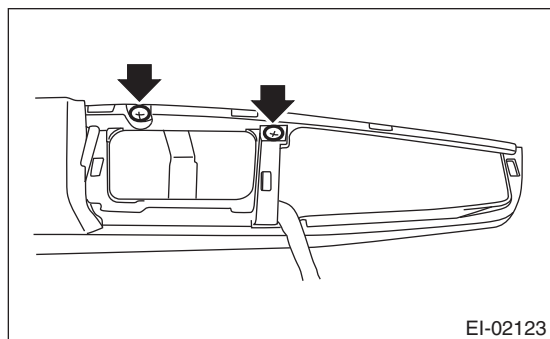

- Rear

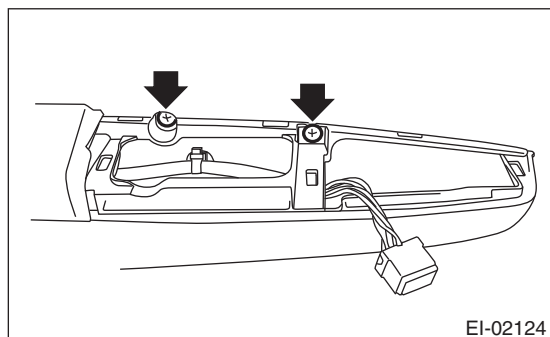

6) Remove the clips and disconnect the wire cables to remove the door trim.

NOTE:

Insert a plastic clip remover into the slit of the trim and lift the trim.

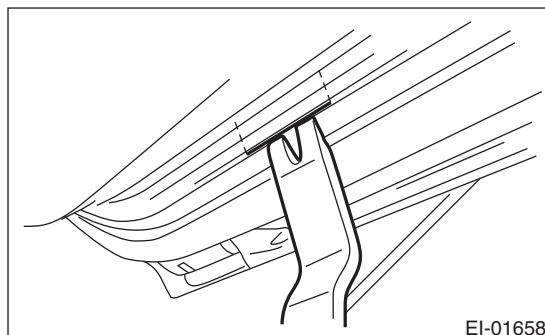

- Front door trim

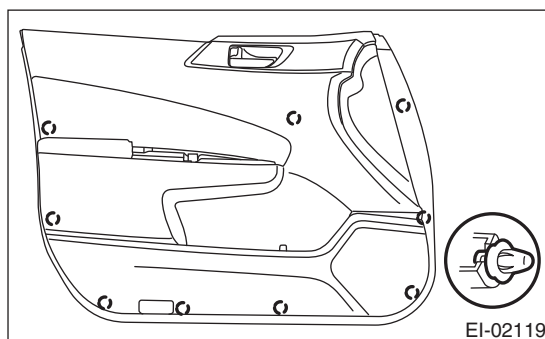

- Rear door trim

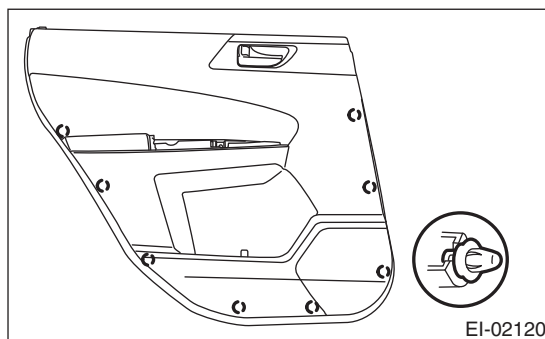

B: INSTALLATION

Install in the reverse order of removal.

Instrument Panel Lower Cover

EXTERIOR/INTERIOR TRIM

15. Instrument Panel Lower Cover

A: REMOVAL

- 1) Disconnect the ground cable from the battery.
- 2) Detach the plastic hooks (A) and remove the instrument panel side cover LH.

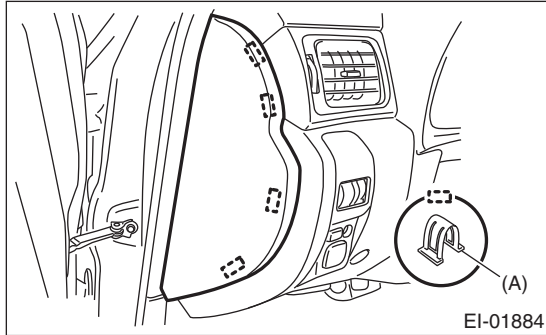

- 3) Remove the screws.

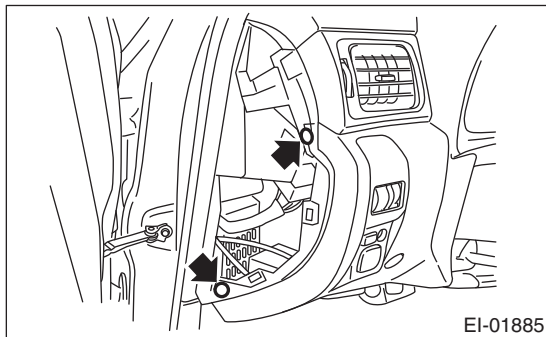

- 4) Disconnect the connectors and remove the instrument panel lower cover.

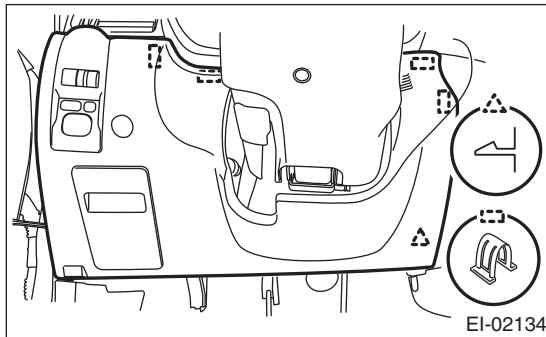

B: INSTALLATION

Install in the reverse order of removal.

16. Glove Box

A: REMOVAL

- 1) Disconnect the ground cable from the battery.
- 2) Remove the glove box damper.

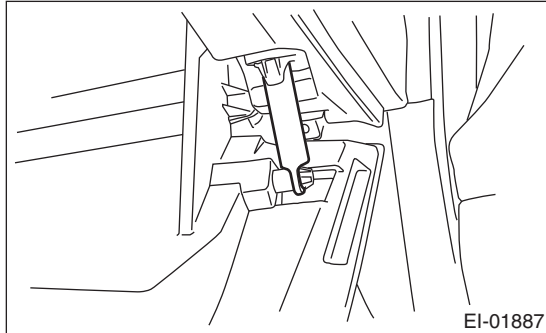

- 3) Disengage the stopper and pull the glove box lid assembly towards yourself to remove it.

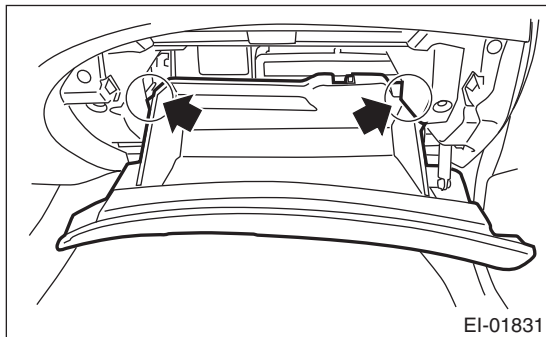

- 4) Remove the clips, and remove the glove box lower cover.

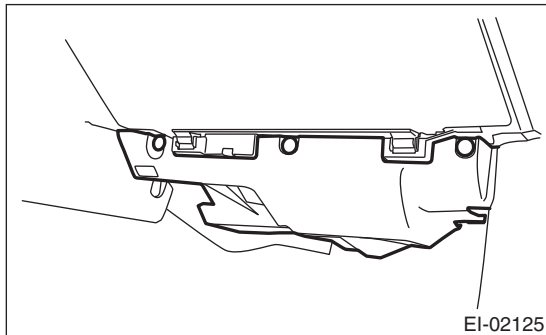

- 5) Remove the instrument panel lower cover. <Ref. to EI-49, INSTRUMENT PANEL LOWER, REMOVAL, Center Console.>

B: INSTALLATION

Install in the reverse order of removal.

17. Console Box

A: REMOVAL

- 1) Disconnect the ground cable from the battery.
- 2) Remove the parking brake lever boot.

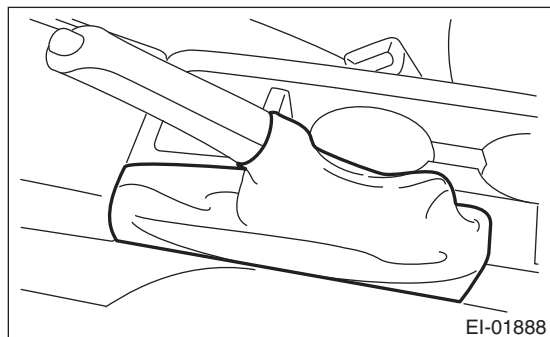

- 3) Remove bolts (A), screw (B), and clips (C).

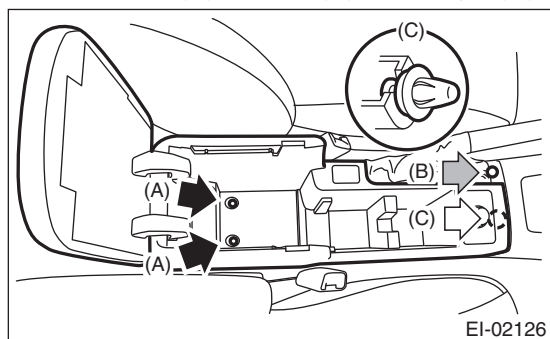

- 4) Disconnect the connectors and remove the console box.

B: INSTALLATION

Install in the reverse order of removal.

18.Center Console

A: REMOVAL

1. CENTER PANEL

- 1) Insert a plastic clip remover into the slit at the bottom edge of the center panel, and lift the panel.
- 2) Disengage the tabs and plastic hooks, and remove the center panel.

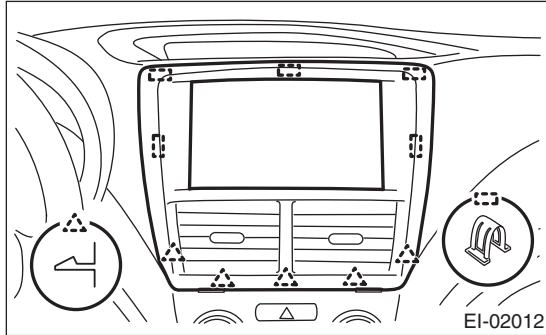

2. CONSOLE FRONT PANEL

- 1) Remove the console box. <Ref. to EI-46, REMOVAL, Console Box.>
- 2) Remove the shift knob. (MT model)
- 3) Detach the plastic hooks (A) and pull up on the console front panel.

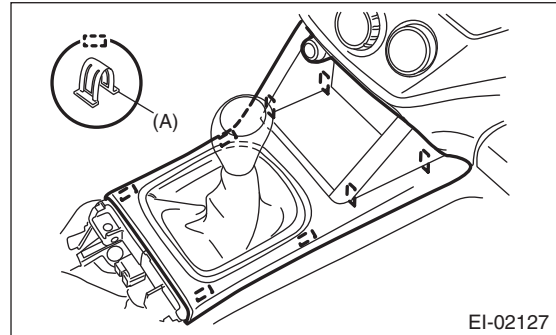

NOTE:

Pull up towards the rear of the vehicle to remove.

- 4) Remove the clips and screws, and remove the console side panel.

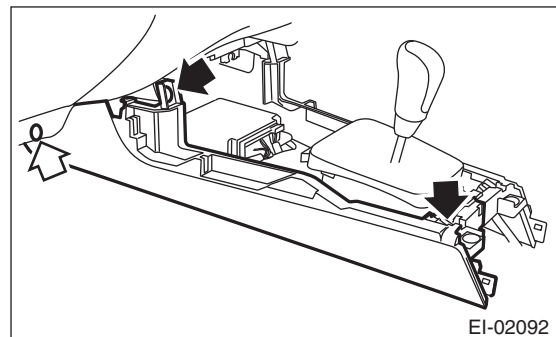
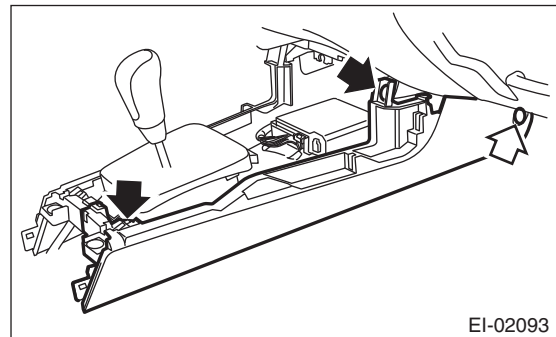

NOTE:

Pull towards the rear of the vehicle to remove.

Center Console

EXTERIOR/INTERIOR TRIM

3. ORNAMENT PANEL

• DRIVER'S SIDE

1) Detach the plastic hooks (A) and remove the instrument panel side cover LH.

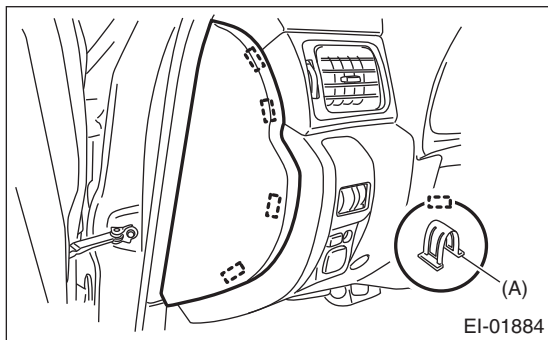

2) Remove the plastic hook (A), and detach the meter visor.

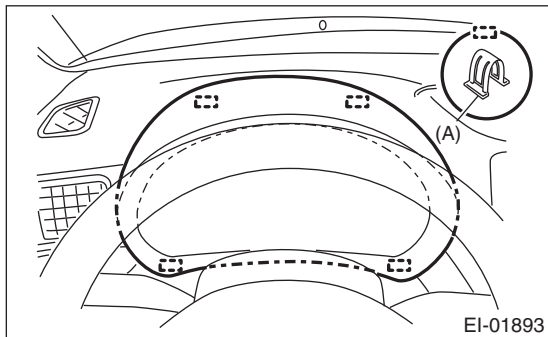

NOTE:

Pull the plastic hooks at the bottom of the meter visor towards you to remove.

3) Loosen the screws and detach the tabs to remove the ornament panel LH.

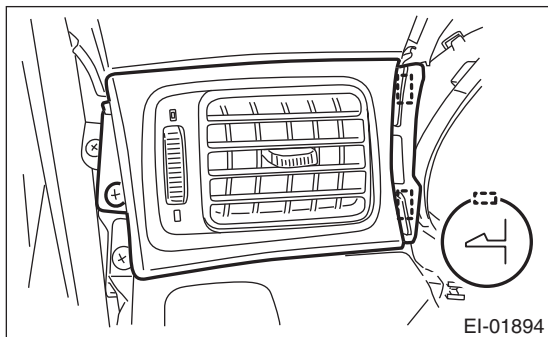

• PASSENGER'S SIDE

1) Remove the instrument panel lower cover. <Ref. to EI-44, REMOVAL, Instrument Panel Lower Cover.>

2) Remove the plastic hook (A), and detach the meter visor.

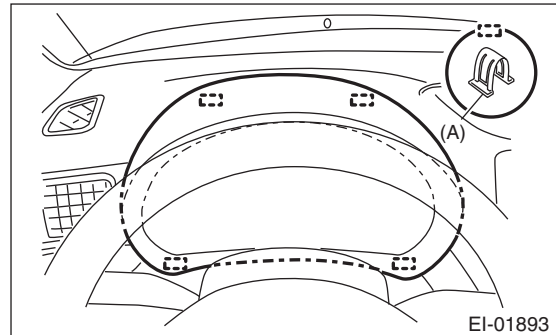

NOTE:

Pull the plastic hooks at the bottom of the meter visor towards you to remove.

3) Insert a plastic clip remover into the slit at the bottom edge of the center panel and lift the panel.

4) Disengage the tabs and plastic hooks, and remove the center panel.

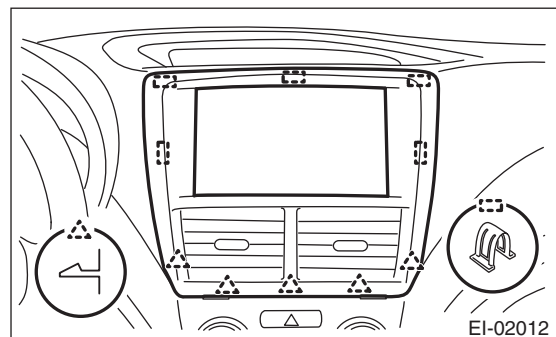

5) Detach the plastic hooks (A) and remove the instrument panel side cover RH.

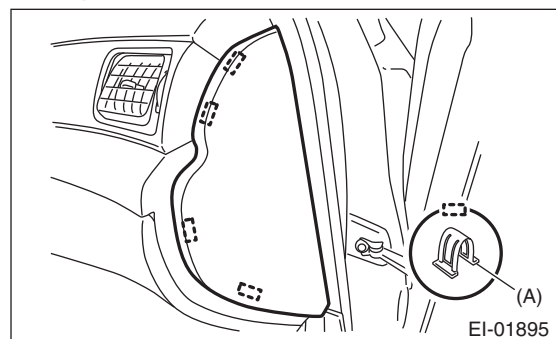

6) Remove the glove box lid. (Manual air conditioning model) <Ref. to EI-45, REMOVAL, Glove Box.>

7) On manual air conditioning models, remove the control cable.

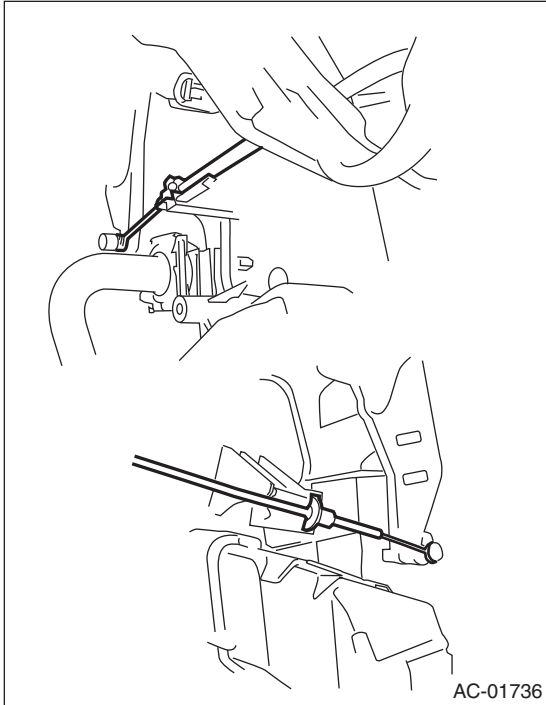

8) Loosen the screws and detach the plastic hooks to remove the ornament panel RH.

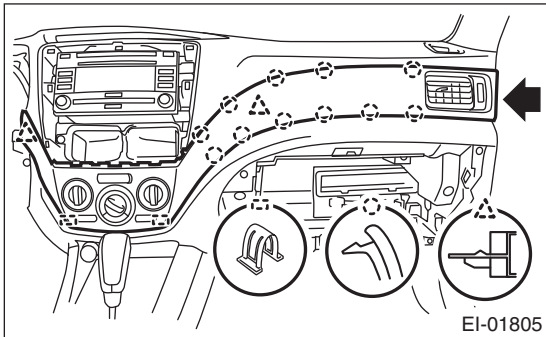

9) Disconnect the connectors.

4. INSTRUMENT PANEL LOWER

- 1) Remove the console box. <Ref. to EI-46, REMOVAL, Console Box.>
- 2) Remove the center panel. <Ref. to EI-47, CENTER PANEL, REMOVAL, Center Console.>
- 3) Remove the console front panel. <Ref. to EI-47, CONSOLE FRONT PANEL, REMOVAL, Center Console.>
- 4) Remove the ornament panel RH. <Ref. to EI-48, ORNAMENT PANEL, REMOVAL, Center Console.>
- 5) Remove the instrument panel lower cover. <Ref. to EI-44, REMOVAL, Instrument Panel Lower Cover.>
- 6) Remove the glove box lid and glove box lower cover. <Ref. to EI-45, REMOVAL, Glove Box.>
- 7) Remove the screws and nuts to remove the instrument panel lower.

NOTE:

The screw indicated by the white arrow is installed on the reverse face.

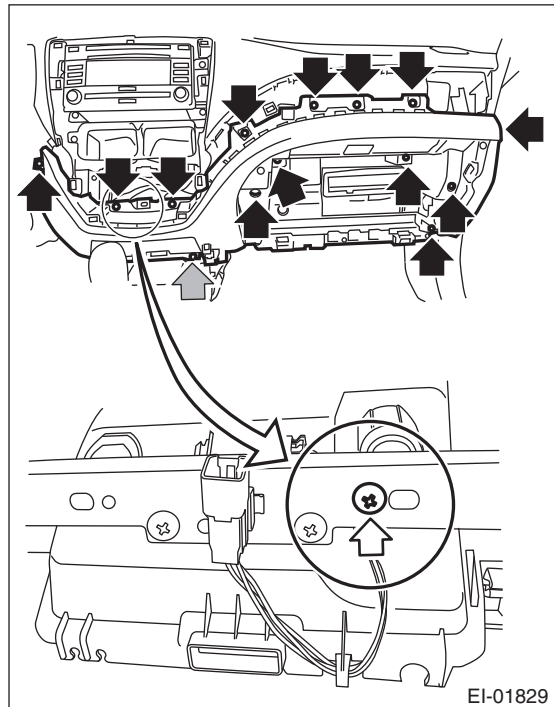

B: INSTALLATION

Install in the reverse order of removal.

Instrument Panel Assembly

EXTERIOR/INTERIOR TRIM

19. Instrument Panel Assembly

A: REMOVAL

CAUTION:

Be careful not to damage the airbag system harness when servicing the instrument panel. Damage may cause the system to malfunction.

- 1) Disconnect the ground cable from the battery.
- 2) Remove the front pillar upper trim. <Ref. to EI-53, REMOVAL, Upper Inner Trim.>
- 3) Detach the plastic hooks (A) and remove the instrument panel side cover LH.

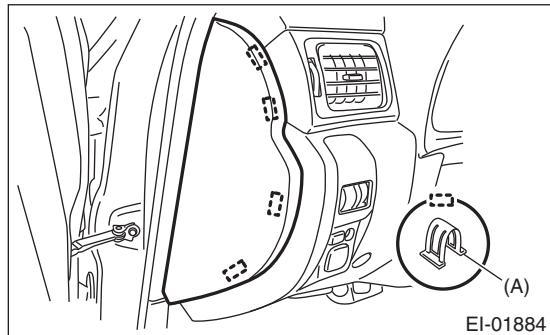

- 4) Detach the plastic hooks (A) and remove the instrument panel side cover RH.

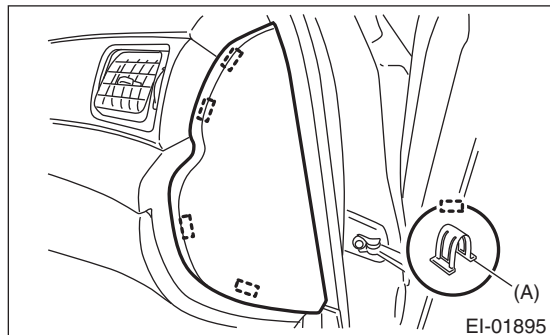

- 5) Remove the clips, and remove the glove box lower cover.

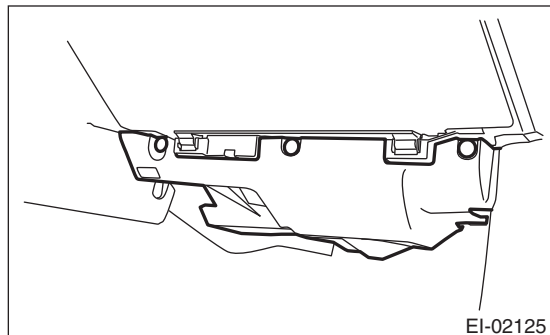

- 6) Remove the console box. <Ref. to EI-46, REMOVAL, Console Box.>
- 7) Remove the console front panel. <Ref. to EI-47, CONSOLE FRONT PANEL, REMOVAL, Center Console.>
- 8) Remove the instrument panel lower cover. <Ref. to EI-44, REMOVAL, Instrument Panel Lower Cover.>

- 9) Remove the glove box lid. (Manual air conditioning model) <Ref. to EI-45, REMOVAL, Glove Box.>
- 10) For manual air conditioning models, remove the control cable.

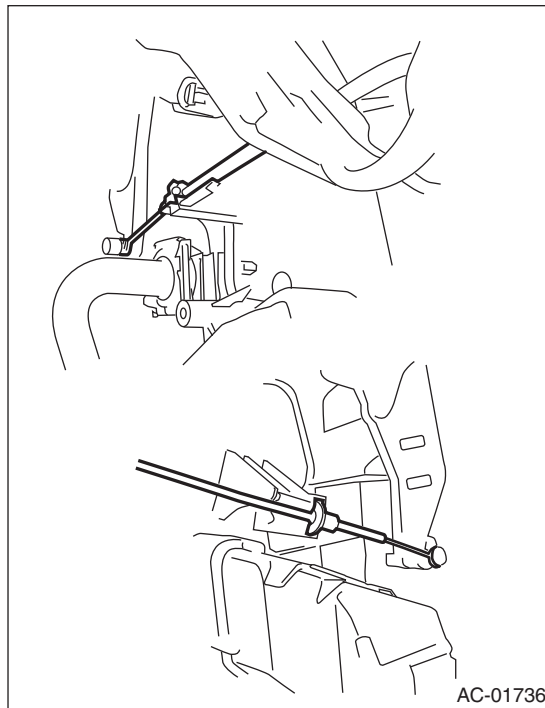

- 11) Remove the steering shaft assembly. <Ref. to PS-15, REMOVAL, Steering Column.>
- 12) Disconnect the connectors.

NOTE:

If necessary, make alignment marks for easy re-connection of connectors.

- 13) Remove the bolts on the driver's side and fuse box.

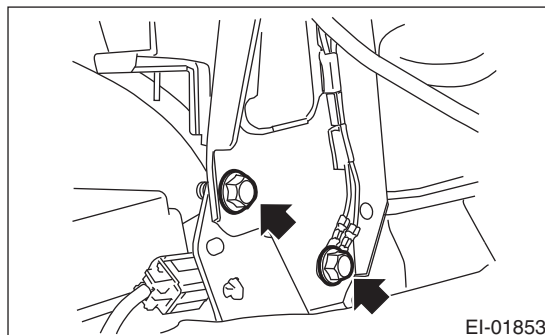
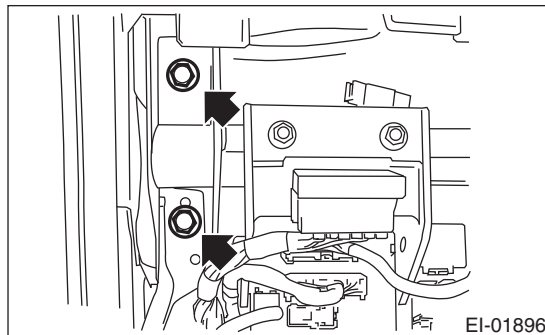

14) Remove the bolts on the passenger's side.

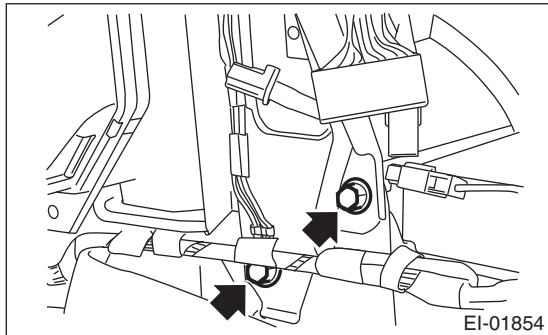
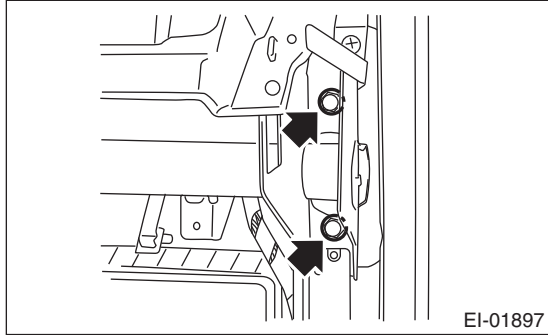

15) Check that the connectors are disconnected, and remove the instrument panel from the vehicle.

16) Remove the combination meter assembly. <Ref. to IDI-16, REMOVAL, Combination Meter.>

17) Remove the audio. <Ref. to ET-6, REMOVAL, Audio.>

18) Remove the GPS antenna. <Ref. to ET-13, REMOVAL, GPS Antenna.>

19) Remove the heater vent duct. <Ref. to AC-43, REMOVAL, Heater Vent Duct.>

20) Remove the bolts securing the passenger's airbag module to the steering support beam.

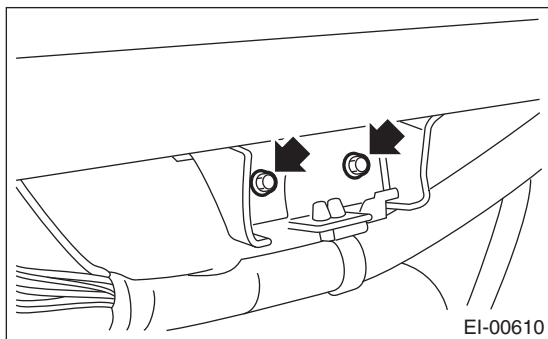

21) Remove the claw, and remove the passenger's airbag module.

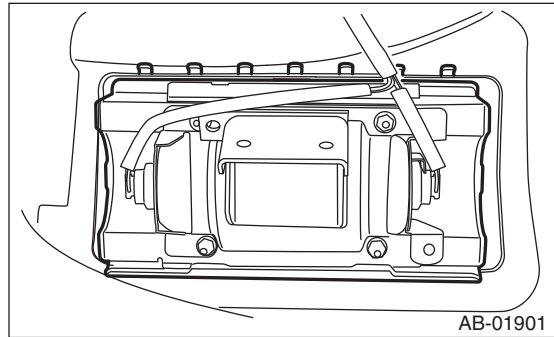

22) Remove the steering support beam bracket.

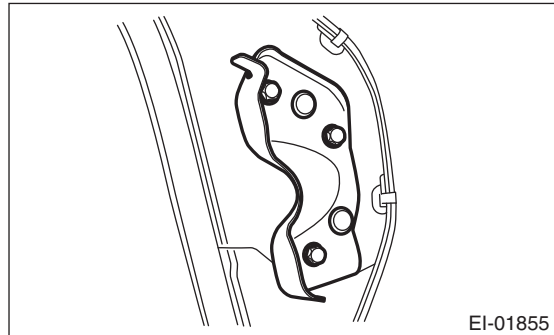

B: INSTALLATION

1) Install the parts in the reverse order of removal until the instrument panel assembly is formed.

NOTE:

Insulator installation procedures

- Adhesive

Use polyurethane adhesive. When assembling the instrument panel assembly, wait until the adhesive has evaporated to prevent filling of the smell in the compartment.

- Double-sided tape

Use commercial double-sided tape. (Use strong double-sided adhesive tape.)

2) Insert the matching pins (three locations) into the instrument panel assembly.

3) Check that the matching pins are inserted securely, and then route the harness.

4) Install in the reverse order of removal.

Tightening torque:

25 N·m (25.5 kgf·m, 18.4 ft·lb)

Lower Inner Trim

EXTERIOR/INTERIOR TRIM

20. Lower Inner Trim

A: REMOVAL

1) Remove the hook, and remove the inside scuff plate.

CAUTION:

Do not pull with excessive force. There is the possibility of the scuff plate being damaged.

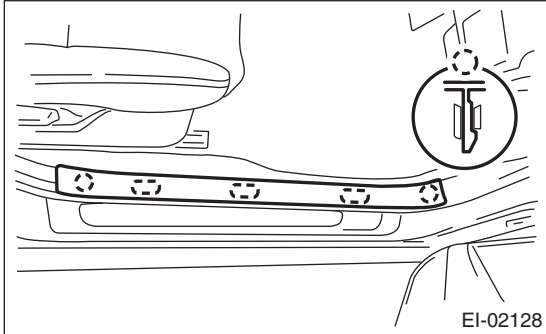

2) Remove the door molding (A), and remove the outside scuff plate.

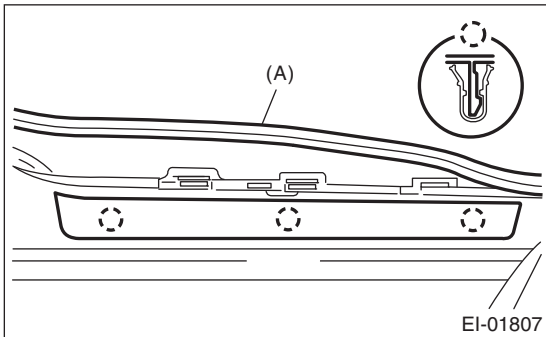

3) Remove clip (A), and remove the front pillar lower trim.

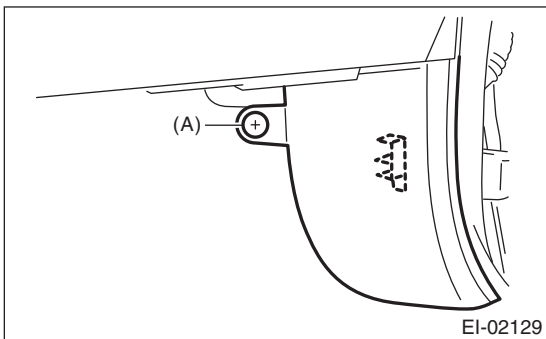

4) Remove the rear seat cushion. <Ref. to SE-15, REMOVAL, Rear Seat.>

5) Remove clip (A), and remove the inside scuff plate.

CAUTION:

Do not pull with excessive force. There is the possibility of the scuff plate being damaged.

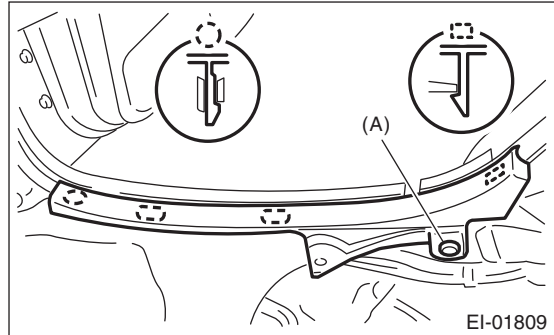

6) Remove door molding (A) and door catcher cover (B), then remove the outside scuff plate.

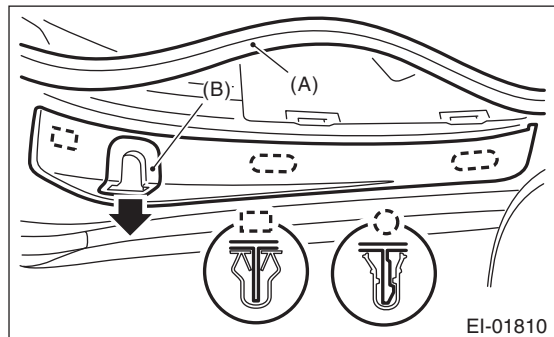

7) Spread the lower trim tab outward to disengage and pull the upper trim to remove.

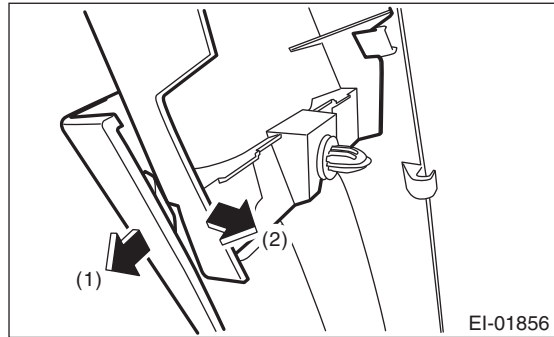

8) Remove the clips of the center pillar lower trim.

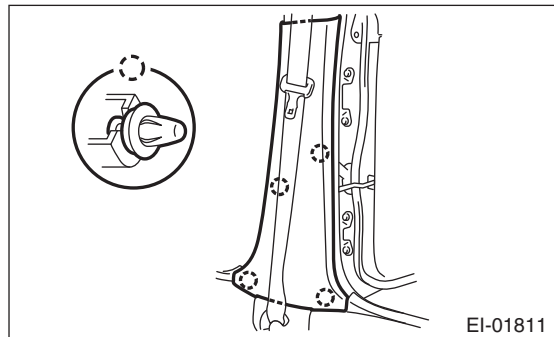

B: INSTALLATION

Install in the reverse order of removal.

21.Upper Inner Trim

A: REMOVAL

1) Pull the upper part of the front pillar upper trim towards the center of the vehicle.

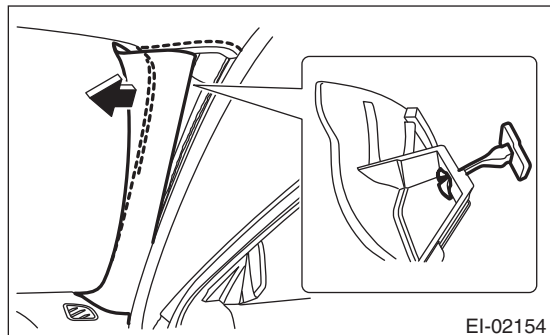

2) Insert long-nose pliers into the top part of the trim, grip the clip with the pliers and twist 90° in that position.

CAUTION:

Be careful not to damage the pillar trim surface and curtain airbag module when inserting the pliers.

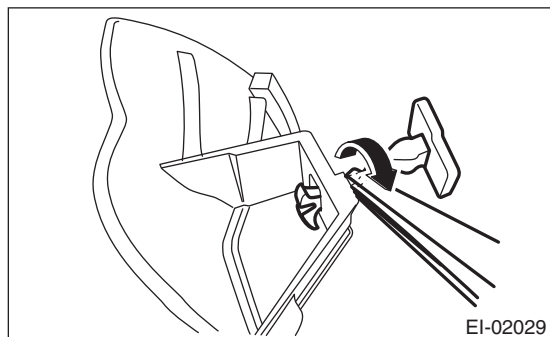

3) Holding the clip twisted as in the previous step, remove the front pillar upper trim from the clip.

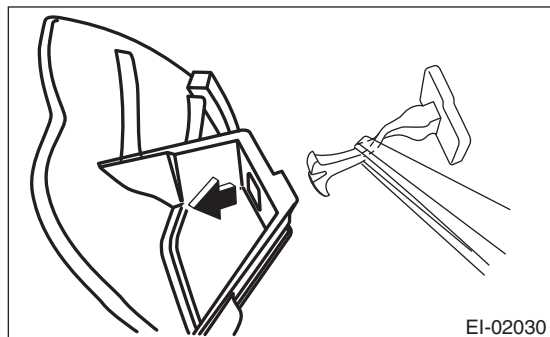

4) Remove the clip and the front pillar upper trim.

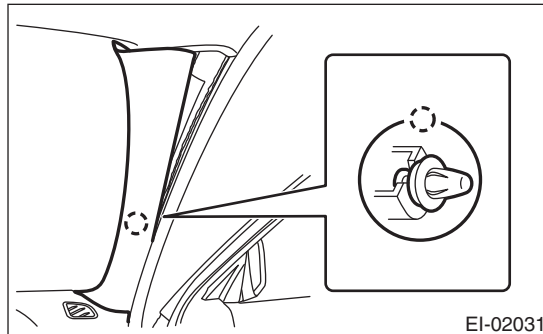

5) Remove the front inside scuff plate, rear inside scuff plate and center pillar lower trim. <Ref. to EI-52, REMOVAL, Lower Inner Trim.>

6) Remove the anchor bolt cover (A).

7) Loosen the shoulder anchor bolt (B), and then detach the shoulder anchor from center pillar.

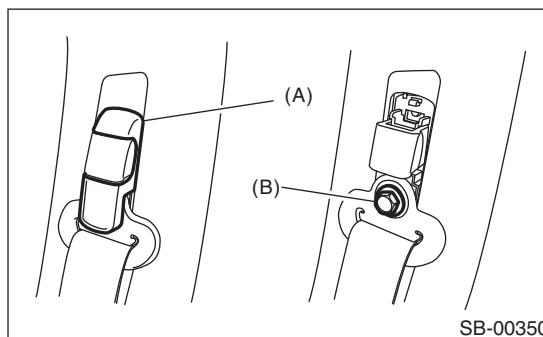

8) Remove the cap (B) on the upper side of the pillar trim, and remove the bolt.

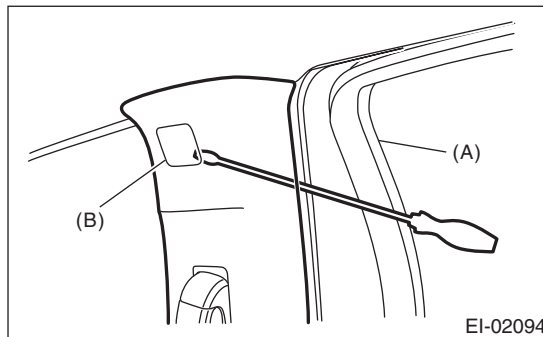

NOTE:

Remove molding (A), and remove the cap from the backside of the pillar trim being careful not to damage the trim.

Upper Inner Trim

EXTERIOR/INTERIOR TRIM

9) Pull the upper trim clip part of the center pillar towards yourself along with the entire lower trim.

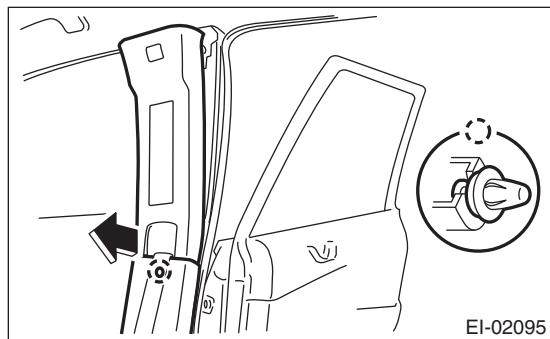

10) Spread the lower trim tab outward to disengage and pull the upper trim to remove.

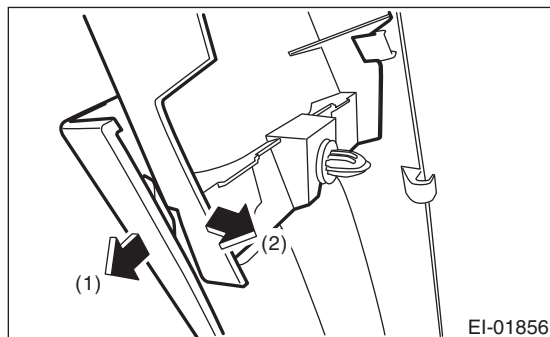

B: INSTALLATION

CAUTION:

- Do not reuse the pillar trim upper clips. The securing strength of the clips is reduced once they are removed from the pillar trim. Reuse might result in the pillar trim falling off. Always use new clips with installing the pillar trim.
- Before installing the pillar trim, check the condition of the protective fabric (white) of the curtain airbags. Replace the curtain airbag module assembly with a new module if the protective fabric is damaged (if the pink fabric of the airbag module can be seen).

1) Remove the remaining clips from the vehicle body.

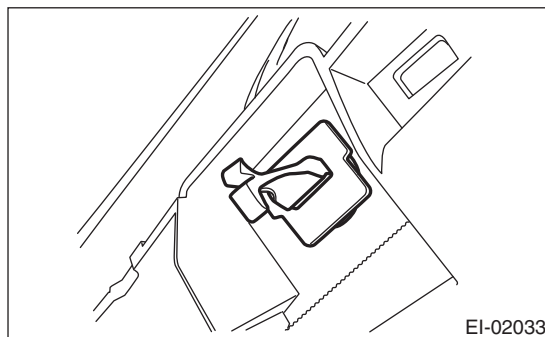

2) Prepare new clips and install the front pillar trim.

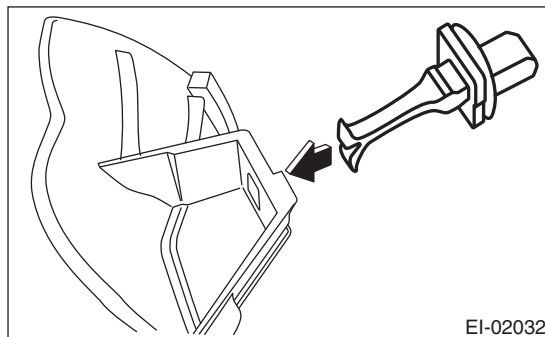

3) Install the front pillar trim.

4) Install in the reverse order of removal.

Tightening torque

Refer to "COMPONENT" of "General Description". <Ref. to EI-18, INNER TRIM, COMPONENT, General Description.>

Refer to "COMPONENT" of "General Description". <Ref. to SB-2, FRONT SEAT BELT, COMPONENT, General Description.>

22.Rear Quarter Trim

A: REMOVAL

- 1) Remove the rear seat. <Ref. to SE-15, REMOVAL, Rear Seat.>
- 2) Remove the seat belt lower anchor bolt.

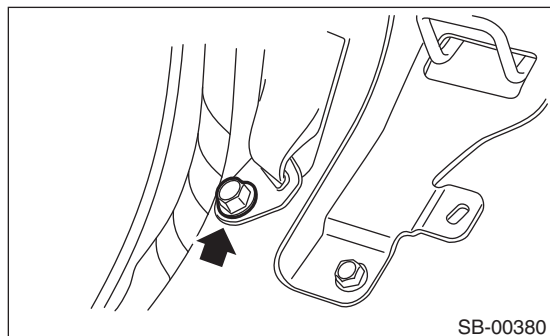

- 3) Remove cap (B) on the upper side of the rear quarter pillar front trim.

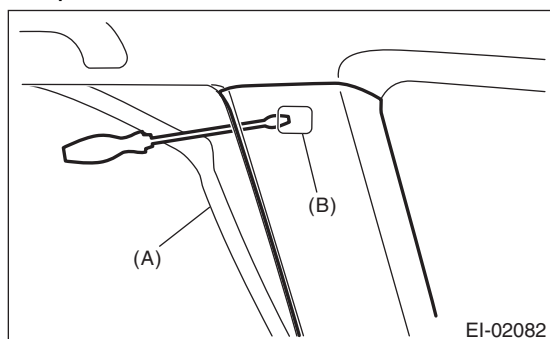

NOTE:

Remove molding (A), and remove the cap from the backside of the pillar trim being careful not to damage the trim.

- 4) Remove the bolt and screw, and remove the rear quarter pillar front trim.

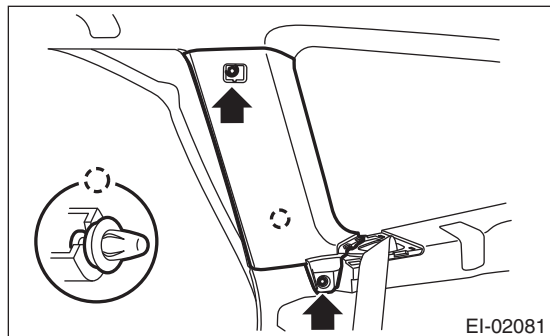

- 5) Remove covers (A) and (B).

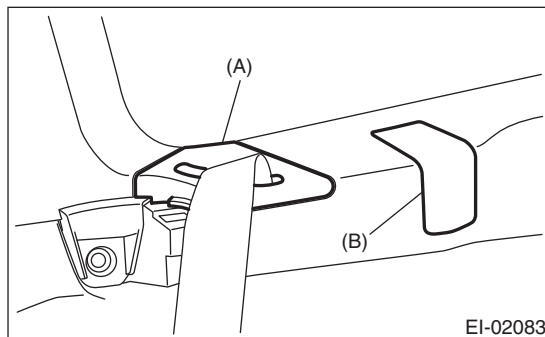

- 6) Remove the clips and screws, and remove the rear quarter upper trim.

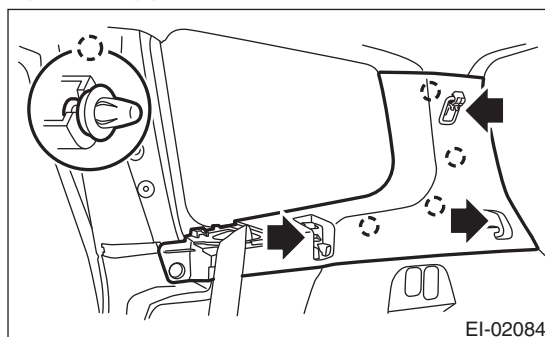

- 7) Remove the rear floor spacer.

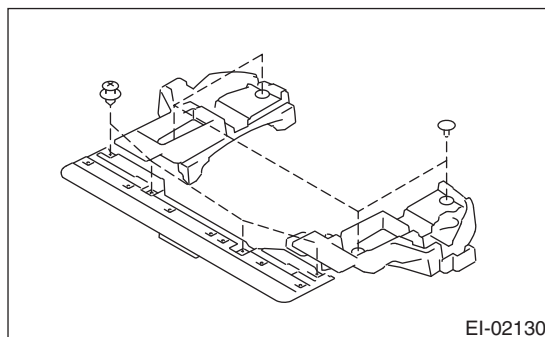

- 8) Remove the luggage room end covers.

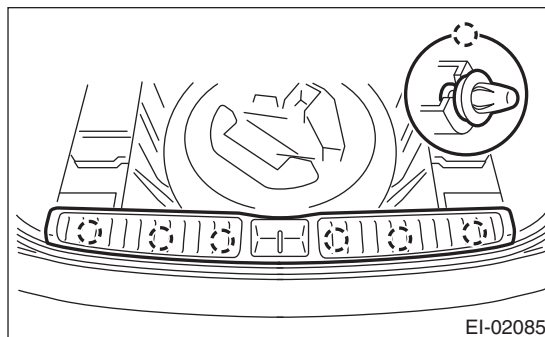

Rear Quarter Trim

EXTERIOR/INTERIOR TRIM

9) Remove the bolt and screws, and remove the rear quarter lower trim.

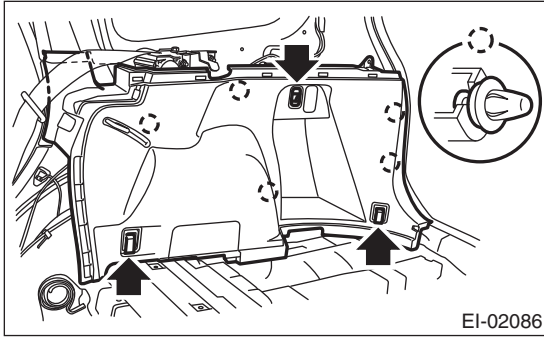

B: INSTALLATION

Install in the reverse order of removal.

Tightening torque

Refer to “COMPONENT” of “General Description”. <Ref. to EI-18, INNER TRIM, COMPONENT, General Description.>

Refer to “COMPONENT” of “General Description”. <Ref. to SB-3, REAR SEAT BELT, COMPONENT, General Description.>

23.Sun Visor

A: REMOVAL

1) Loosen the screws and remove the sun visor.

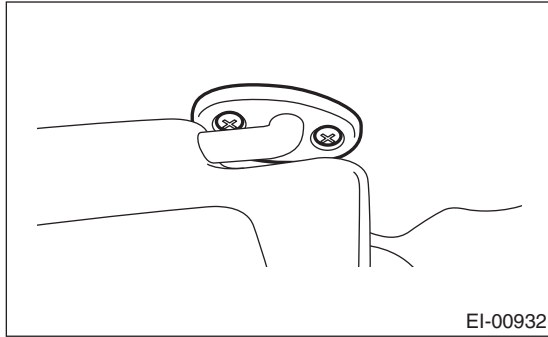

2) While pressing the (A) on the both side using flat tip screwdriver, pull the sun visor hook to remove it.

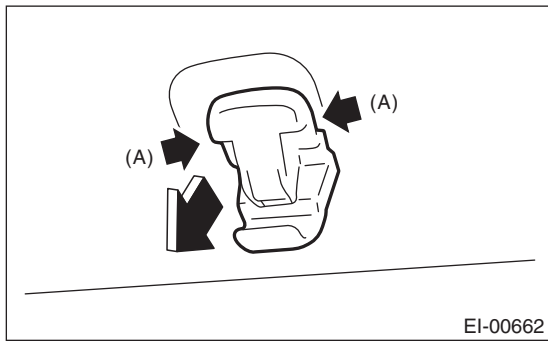

B: INSTALLATION

Install in the reverse order of removal.

24. Assist Grip

A: REMOVAL

- 1) Remove the screw cover, and remove the screw inside.
- 2) Pull the left side of assist grip, and rotate the right side of it counterclockwise to remove.

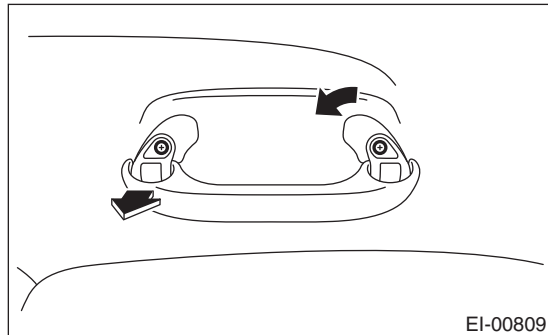

- 3) Remove the roof trim. <Ref. to EI-59, REMOVAL, Roof Trim.>
- 4) Remove the bolts, and remove the assist grip bracket.

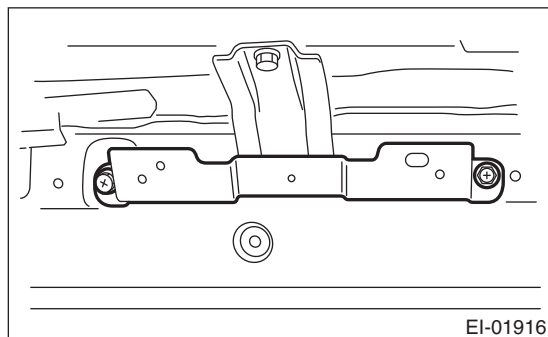

B: INSTALLATION

Install in the reverse order of removal.

Tightening torque

7.5 N·m (0.76 kgf·m, 5.5 ft·lb)

25. Roof Trim

A: REMOVAL

- 1) Disconnect the ground cable from the battery.
- 2) Remove the spot map light. <Ref. to LI-34, REMOVAL, Spot Map Light.>
- 3) Remove the room light. <Ref. to LI-35, REMOVAL, Room Light.>
- 4) Remove the sun visor. <Ref. to EI-57, REMOVAL, Sun Visor.>
- 5) Remove the assist grip. <Ref. to EI-58, REMOVAL, Assist Grip.>
- 6) Remove the upper inner trim. <Ref. to EI-53, REMOVAL, Upper Inner Trim.>
- 7) Remove the rear quarter trim. <Ref. to EI-55, REMOVAL, Rear Quarter Trim.>
- 8) Remove the sunroof opening trim. (Model with sunroof)

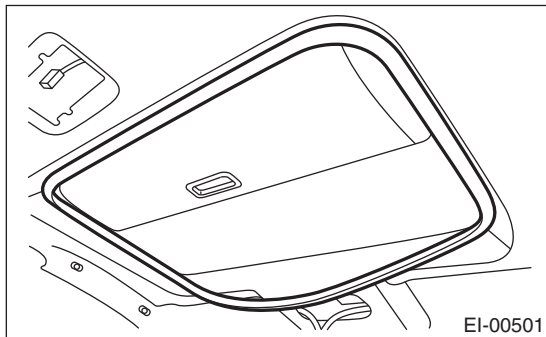

- 9) Disconnect the harness connectors of the left and right front pillar and rear quarter (LH).
- 10) Remove the clips, and then remove the roof trim.

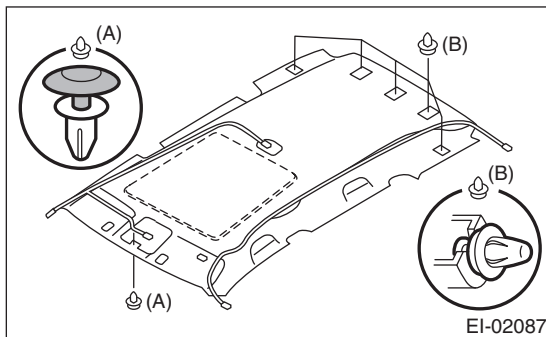

B: INSTALLATION

Install in the reverse order of removal.

Rear Gate Trim

EXTERIOR/INTERIOR TRIM

26.Rear Gate Trim

A: REMOVAL

- 1) Remove the high-mounted stop light. <Ref. to LI-33, REMOVAL, High-mounted Stop Light.>
- 2) Remove the clips, and remove the rear gate upper trim.

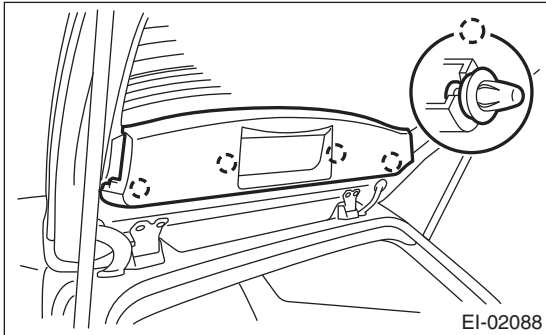

- 3) Using a plastic clip remover, disengage the trim tabs and remove the rear gate pillar trim.

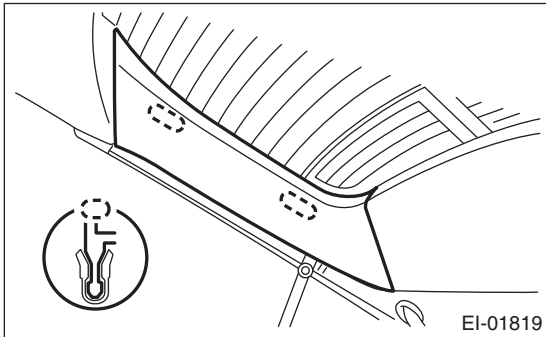

- 4) Remove the clips and the handle screws.

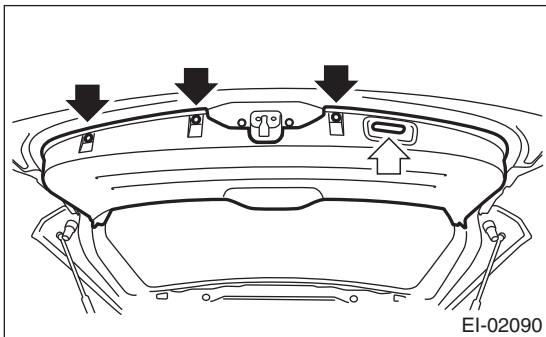

- 5) Remove the clips and rear gate lower trim.

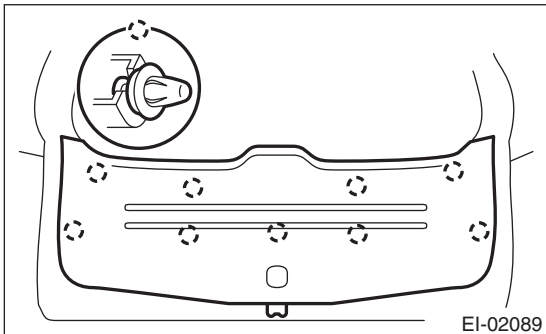

B: INSTALLATION

Install in the reverse order of removal.

27. Floor Mat

A: REMOVAL

- 1) Remove the front seats. <Ref. to SE-8, REMOVAL, Front Seat.>
- 2) Remove the rear seat cushion. <Ref. to SE-15, REMOVAL, Rear Seat.>
- 3) Remove the console box. <Ref. to EI-46, Console Box.>
- 4) Remove the console side panel. <Ref. to EI-47, CONSOLE FRONT PANEL, REMOVAL, Center Console.>
- 5) Remove the lower inner trim. <Ref. to EI-52, REMOVAL, Lower Inner Trim.>
- 6) Remove the footrest.
- 7) Remove the clips from the floor mat.
- 8) Remove the mat hook on both sides.
- 9) Remove the mat from toe board area.
- 10) Remove the mat from rear heater duct.
- 11) Roll the mat, and then take it out of opened rear door.

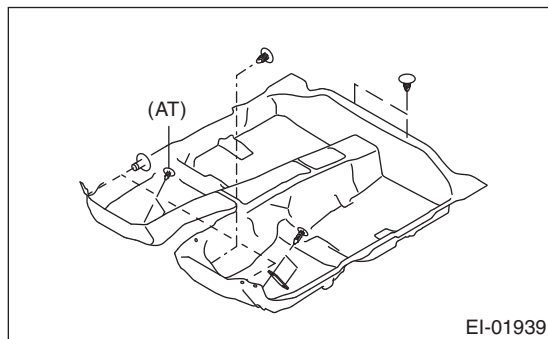

(AT) Automatic transmission model

B: INSTALLATION

Install in the reverse order of removal.

NOTE:

- Secure the mat firmly with hook and clip.
- Insert the mat edge firmly into the groove of side sill cover.

28.Rear Gate Garnish

A: REMOVAL

- 1) Remove the rear gate trim. <Ref. to EI-60, REMOVAL, Rear Gate Trim.>
- 2) Remove the rear wiper motor. <Ref. to WW-20, Rear Wiper Motor.>
- 3) Disconnect the connectors (white arrows).
- 4) Remove the nuts (black and gray arrows).

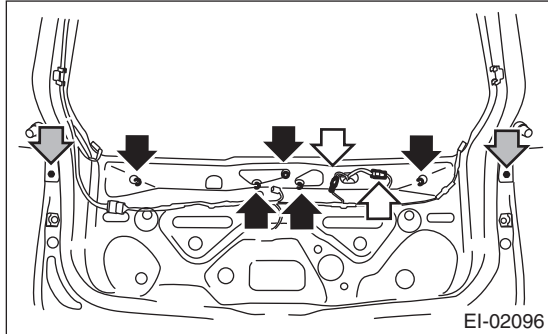

- 5) Remove the clips and rear gate garnish.

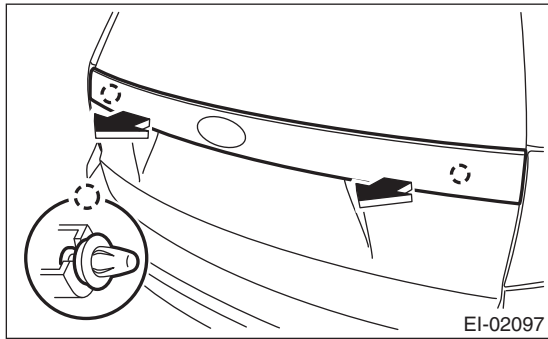

B: INSTALLATION

CAUTION:

Make sure that the harness grommets are installed securely.

Failure to install securely may result in water leaks inside.

Install in the reverse order of removal.

Tightening torque

7.5 N·m (0.76 kgf-m, 5.5 ft-lb)

29. Heat Shield Cover

A: REMOVAL

1. FRONT HEAT SHIELD COVER

Remove the four bolts to remove the front heat shield cover.

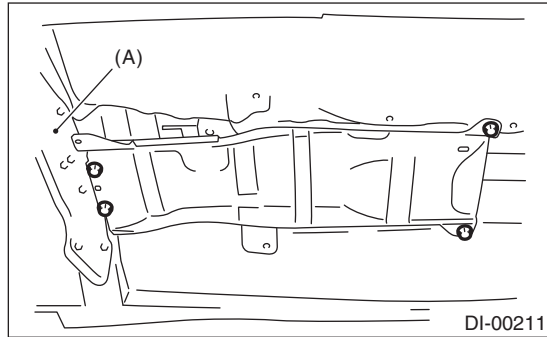

(A) Transmission mount

2. CENTER HEAT SHIELD COVER

Remove the bolt (A), nuts (B), and clip (C), and remove the center heat shield cover.

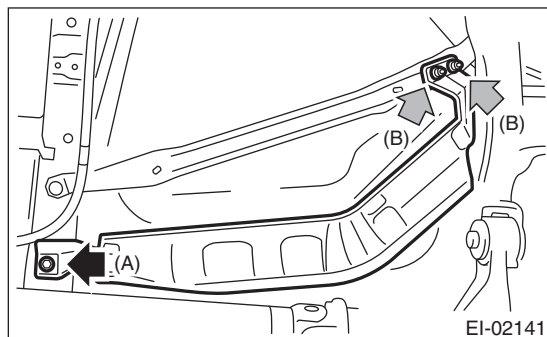
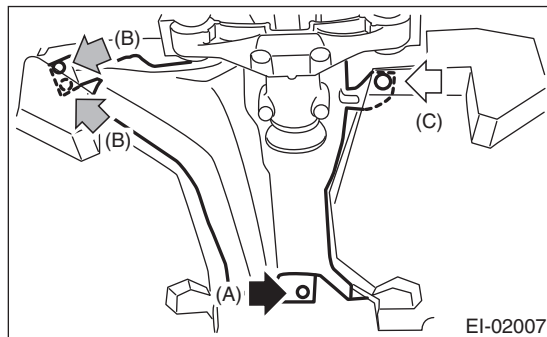

3. REAR HEAT SHIELD COVER

- 1) Remove the muffler. <Ref. to EX(H4SO)-10, REMOVAL, Muffler.> <Ref. to EX(H4DOTC)-14, REMOVAL, Muffler.>
- 2) Remove the bolts and rear heat shield cover.

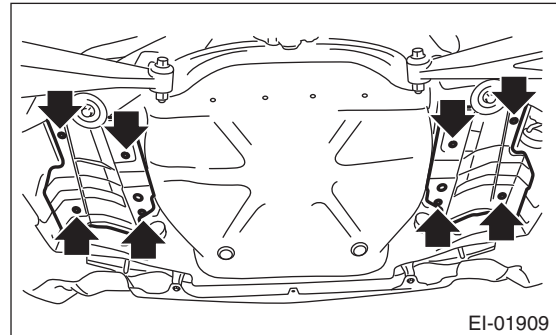

B: INSTALLATION

Install in the reverse order of removal.

Tightening torque:

Refer to "COMPONENT" of "General Description". <Ref. to EI-21, HEAT SHIELD COVER, COMPONENT, General Description.>

30.Trailer Hitch

A: REMOVAL

- 1) Remove the muffler. <Ref. to EX(H4SO)-10, REMOVAL, Muffler.> <Ref. to EX(H4DOTC)-14, REMOVAL, Muffler.>
- 2) Remove the trailer hitch harness.

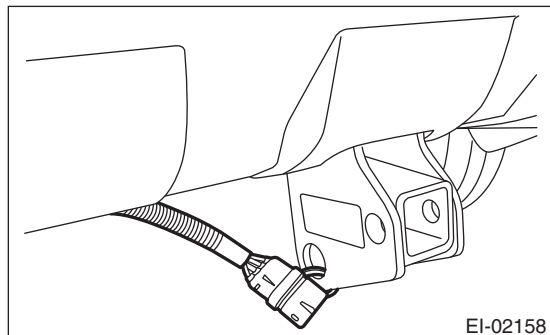

- 3) Remove the rear bumper face. <Ref. to EI-35, REAR BUMPER FACE, REMOVAL, Rear Bumper.>
- 4) Remove the bolts and side plate lower.

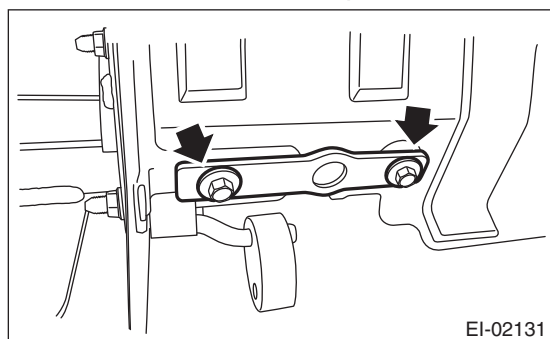

- 5) Remove the nuts and trailer hitch main frame assembly.

CAUTION:

The trailer hitch main frame assembly is very heavy. Be careful when removing.

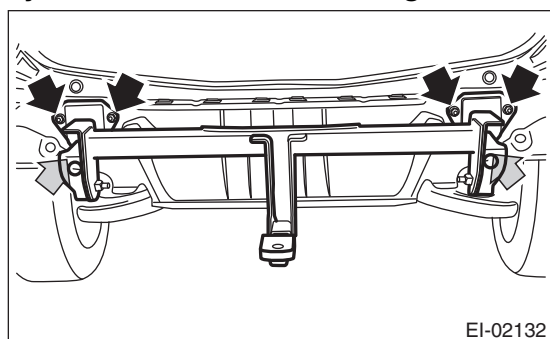

- 6) Remove the side plate upper from the vehicle body.

B: INSTALLATION

Install in the reverse order of removal.

Tightening torque:

Refer to "COMPONENT" of "General Description". <Ref. to EI-22, TRAILER HITCH, COMPONENT, General Description.>

31.Ornament

A: INSTALLATION

1. LETTER MARK

Adhere the letter mark according to the following measurements.

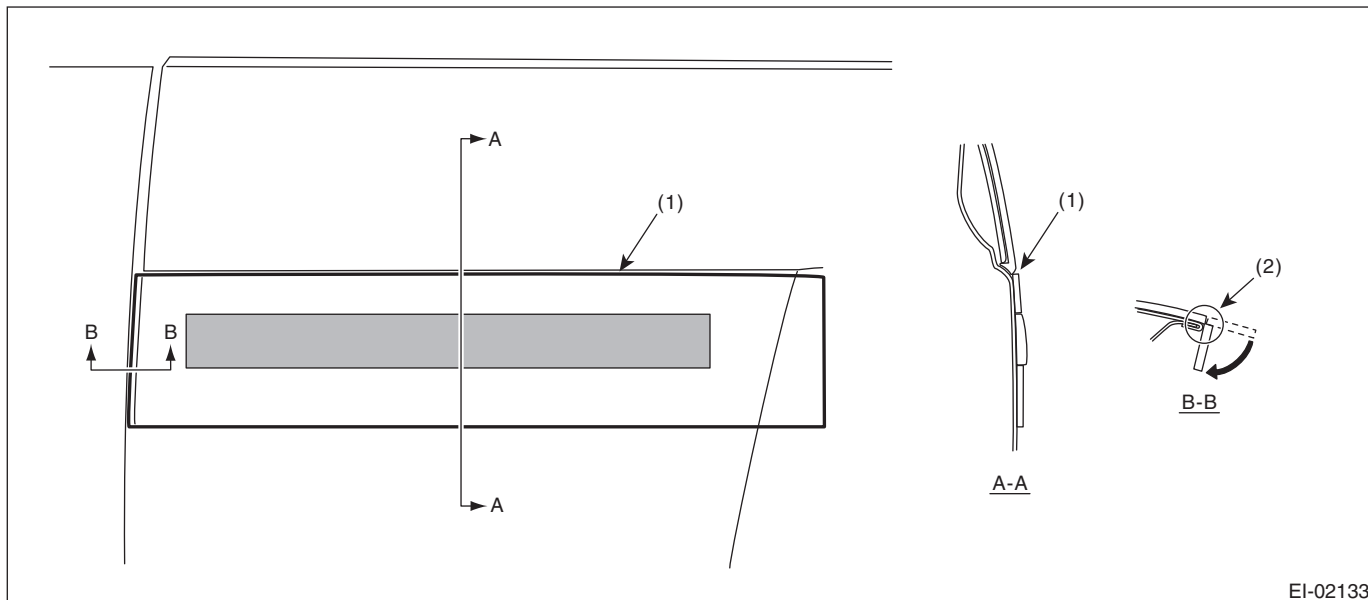

EI-02133

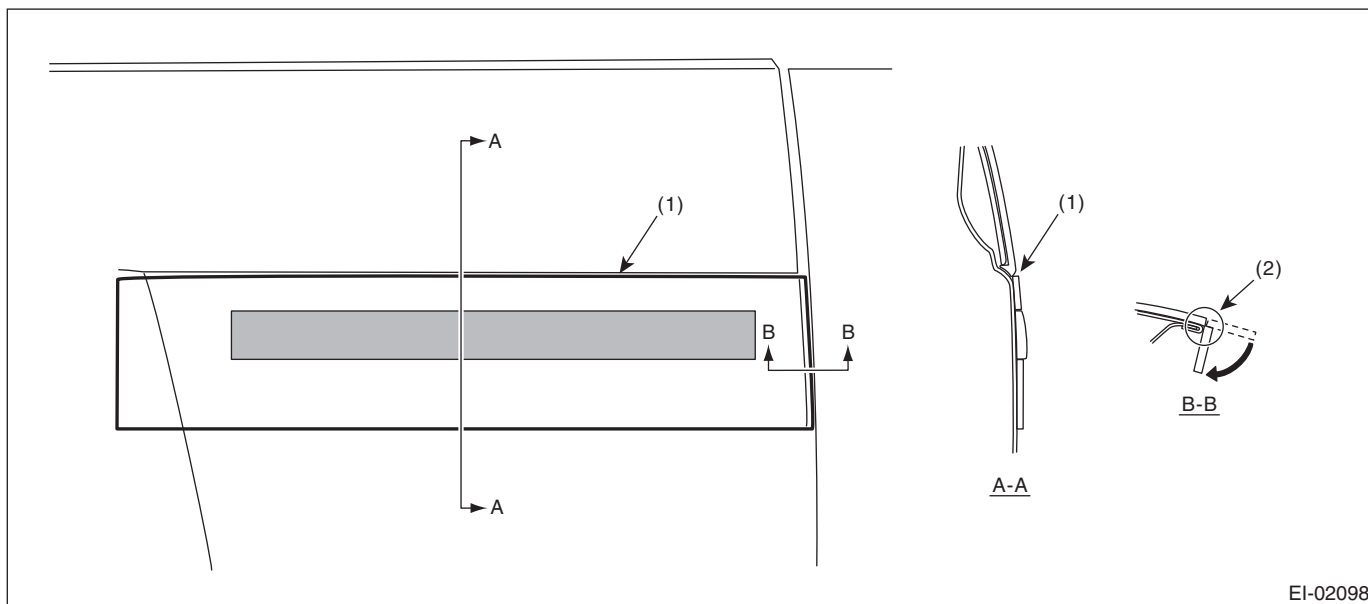

EI-02098

- (1) Align the upper edge of the application tape with the rear gate garnish. (2) Align the slit of the application tape with the edge of the rear gate panel, and break off the application tape.

Ornament

EXTERIOR/INTERIOR TRIM

EXTERIOR BODY PANELS



	Page
1. General Description	2
2. Front Hood	12
3. Front Fender	15
4. Front Performance Stay	16
5. Front Door	17
6. Front Sealing Cover	19
7. Rear Door	20
8. Rear Sealing Cover	22
9. Door Sash Tape	23
10. Rear Gate	29

General Description

EXTERIOR BODY PANELS

1. General Description

A: SPECIFICATION

1. FRONT

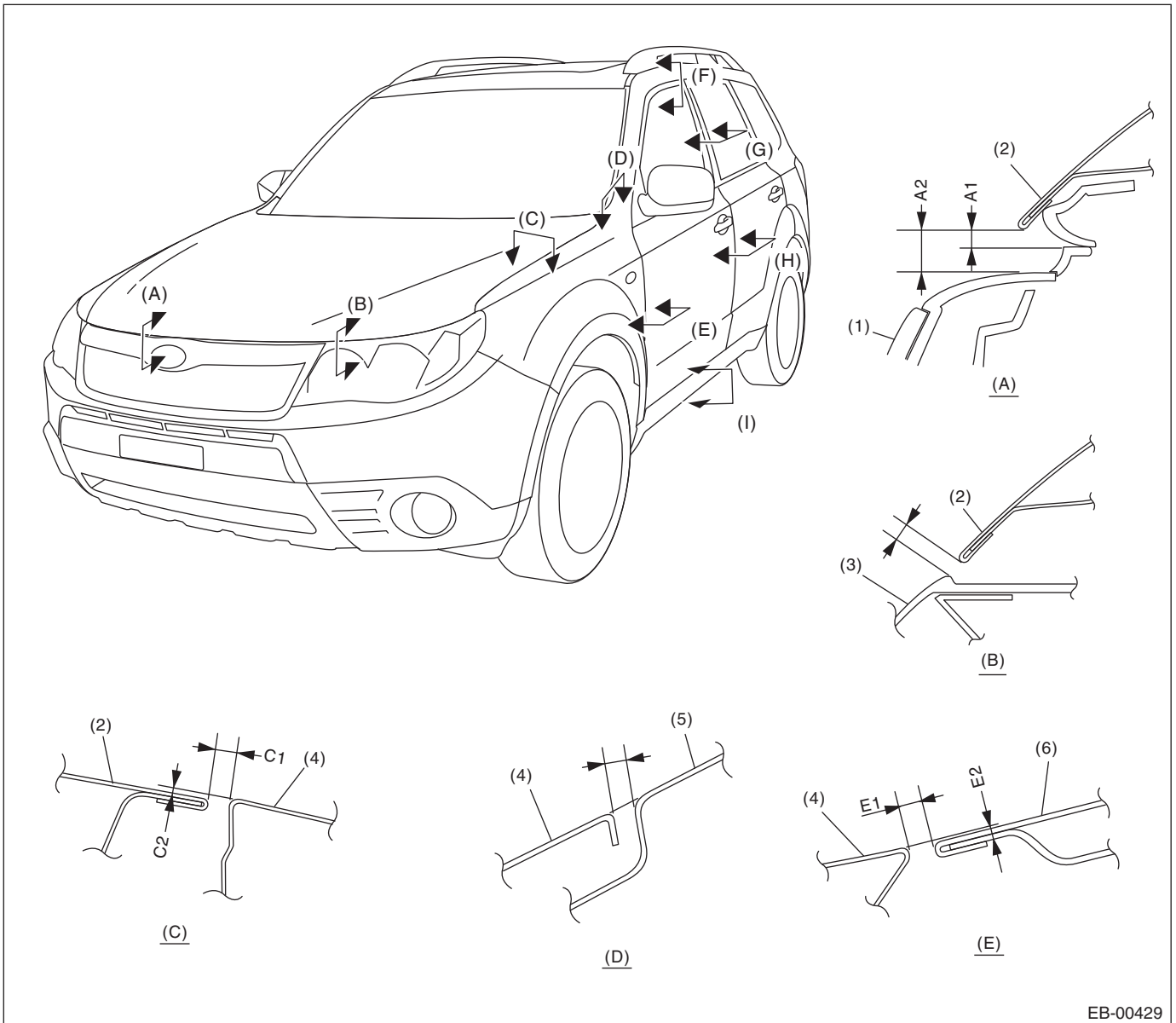

EB-00429

General Description

EXTERIOR BODY PANELS

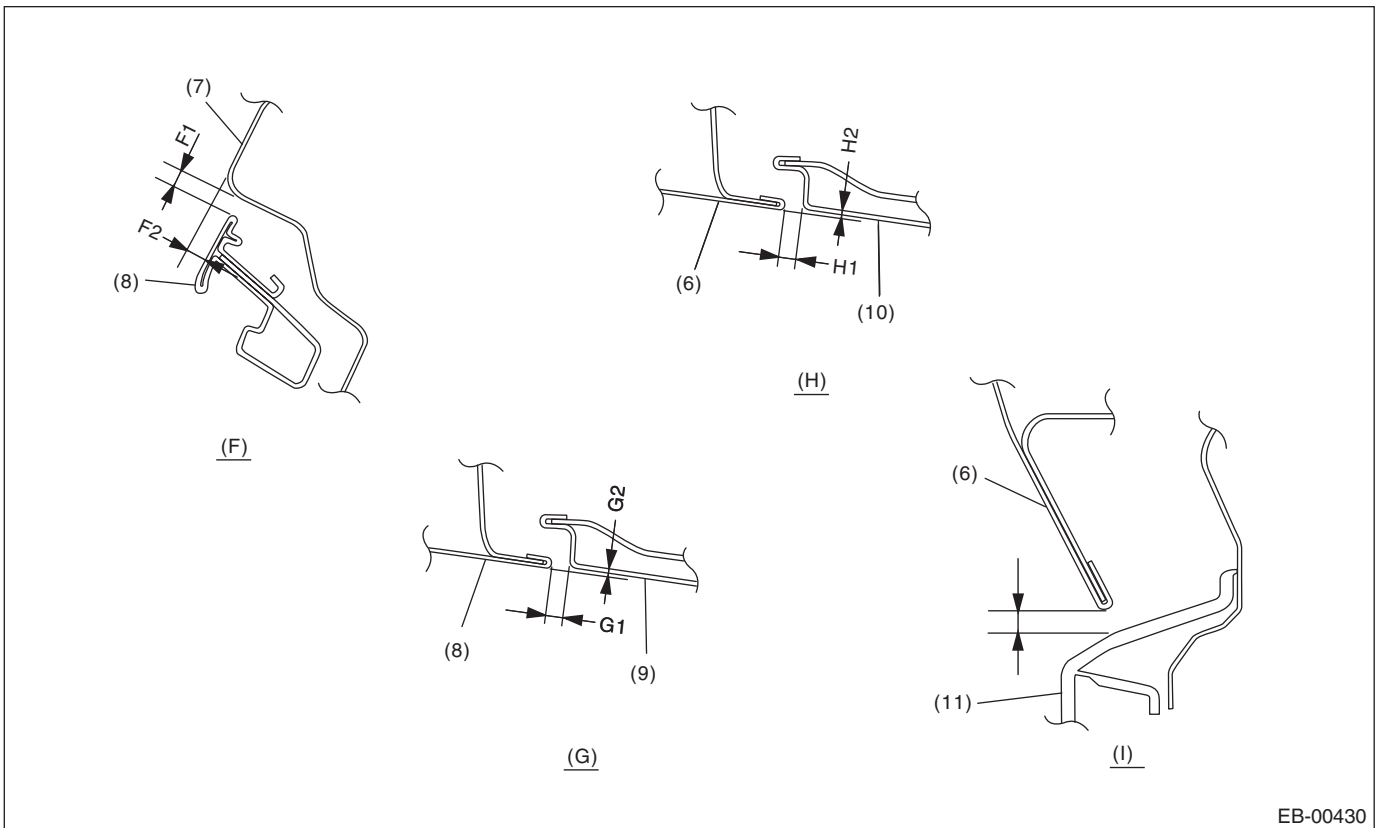

- | | | |
|------------------------|------------------------|------------------------|
| (1) Front grille | (5) Front pillar panel | (9) Rear door sash |
| (2) Front hood panel | (6) Front door panel | (10) Rear door panel |
| (3) Headlight | (7) Roof panel | (11) Side sill spoiler |
| (4) Front fender panel | (8) Front door sash | |

Section	Part	Standard value
(A)	Front hood panel to Front grille	A1: 2.2±1.0 mm (0.09±0.04 in) A2: 7.6±1.0 mm (0.3±0.04 in)
(B)	Front hood panel to Headlight	5.5±1.0 mm (0.22±0.04 in)
(C)	Front hood panel to Front fender panel	C1: 3.5±1.0 mm (0.14±0.04 in) C2: -0.5, +0.5 — -1.0 mm (-0.02, +0.02 — -0.04 in)
(D)	Front fender panel to Front pillar panel	3.0±1.0 mm (0.12±0.04 in)
(E)	Front fender panel to Front door panel	E1: 4.0±1.0 mm (0.16±0.04 in) E2: 0+1.0, -0.5 mm (0+0.04, -0.02 in)
(F)	Roof panel to Front door sash	F1: 5.0±1.0 mm (0.20±0.04 in) F2: 3.8±1.0 mm (0.15±0.04 in)
(G)	Front door sash to Rear door sash	G1: 5.5±1.0 mm (0.22±0.04 in) G2: 0+1.0, -0.5 mm (0+0.04, -0.02 in)
(H)	Front door panel to Rear door panel	H1: 4.5±1.0 mm (0.18±0.04 in) H2: 0+1.0, -0.5 mm (0+0.04, -0.02 in)
(I)	Front door panel to Side sill spoiler	5.7±1.0 mm (0.22±0.04 in)

General Description

EXTERIOR BODY PANELS

2. REAR

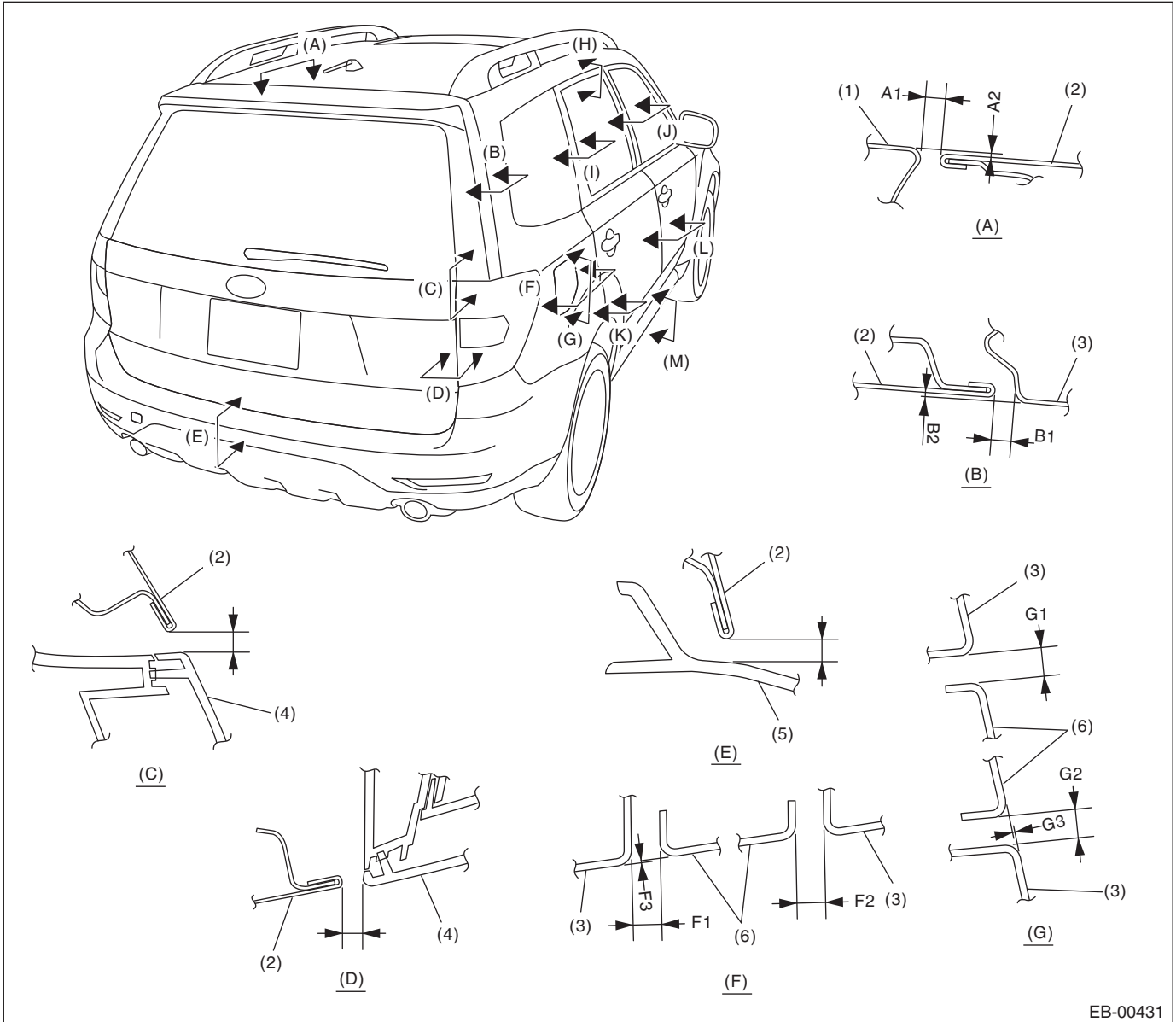

EB-00431

General Description

EXTERIOR BODY PANELS

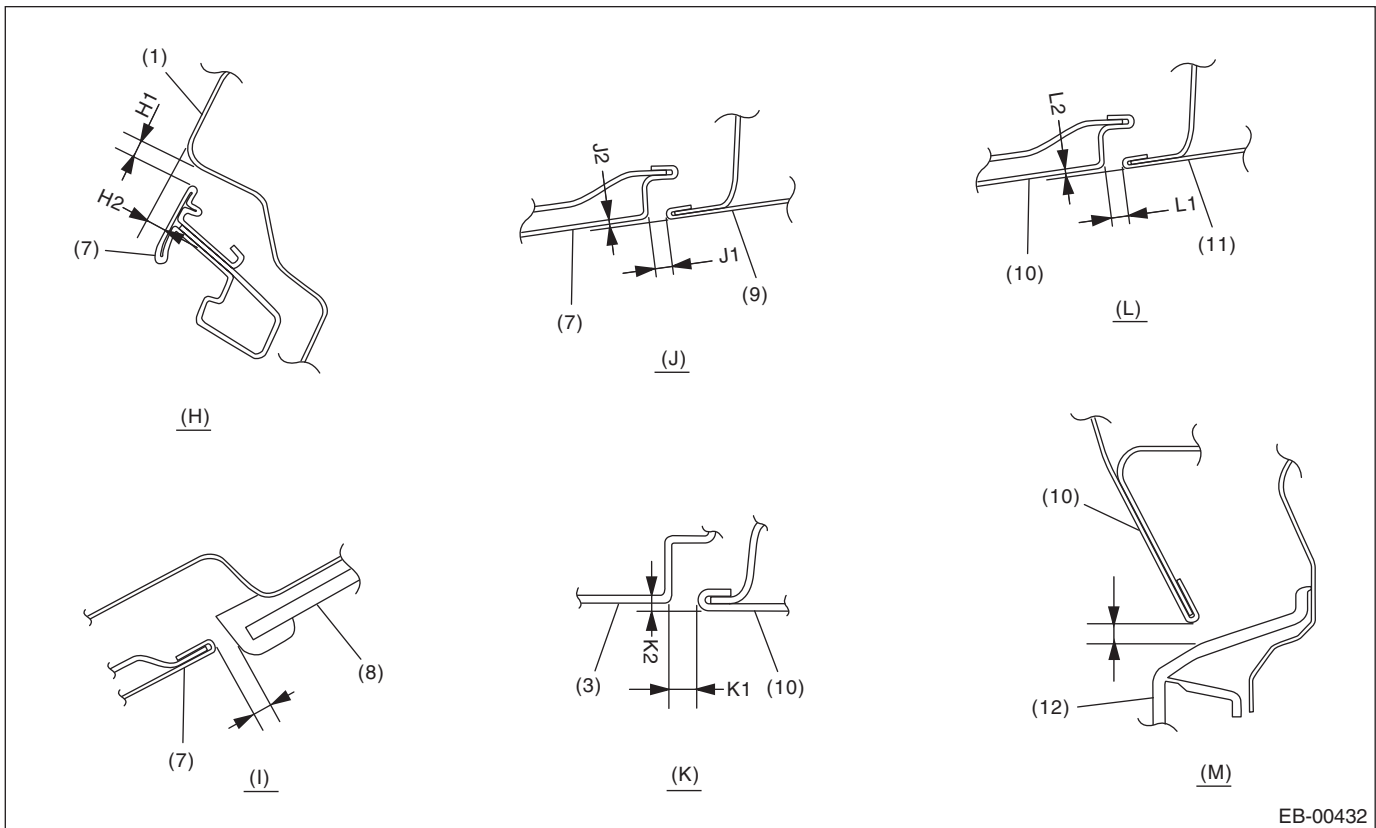

EB-00432

- | | | |
|----------------------------|------------------------|------------------------|
| (1) Roof panel | (5) Rear bumper | (9) Front door sash |
| (2) Rear gate panel | (6) Fuel filler lid | (10) Rear door panel |
| (3) Rear quarter panel | (7) Rear door sash | (11) Front door panel |
| (4) Rear combination light | (8) Rear quarter glass | (12) Side sill spoiler |

Section	Part	Standard value
(A)	Roof panel to Rear gate panel	A1: 6.5±1.0, -0.5 mm (0.26±0.04, -0.02 in) A2: 1.5±1.0 mm (0.06±0.04 in)
(B)	Rear gate panel to Rear quarter panel	B1: 6.8±1.0 mm (0.27±0.04 in) B2: 0-1.5 mm (0-0.06 in)
(C)	Rear combination light to Rear gate panel	5.4±1.0 mm (0.21±0.04 in)
(D)	Rear combination light to Rear gate panel	5.1±1.0 mm (0.20±0.04 in)
(E)	Rear gate panel to Rear bumper	7.1±1.0 mm (0.28±0.04 in)
(F)	Rear quarter panel to Fuel filler lid	F1: 3.5±0.5 mm (0.14±0.06 in) F2: 3.5±0.5 mm (0.14±0.06 in) F3: -0.2±0.4 mm (0.01±0.02 in)
(G)	Rear quarter panel to Fuel filler lid	G1: 3.5±0.5 mm (0.14±0.06 in) G2: 3.5±0.5 mm (0.14±0.06 in) G3: -0.2±0.4 mm (0.01±0.02 in)
(H)	Roof panel to Rear door sash	H1: 5.0±1.0 mm (0.20±0.04 in) H2: 3.8±1.0 mm (0.15±0.04 in)
(I)	Rear door sash to Rear quarter glass	5.5±1.0 mm (0.22±0.04 in)
(J)	Rear door sash to Front door sash	J1: 5.5±1.0 mm (0.22±0.04 in) J2: 0+1.0, -0.5 mm (0+0.04, -0.02 in)
(K)	Rear door panel to Rear quarter panel	K1: 4.0±1.0 mm (0.16±0.04 in) K2: 0±1.0 mm (0±0.04 in) (Vehicle body standard)
(L)	Front door panel to Rear door panel	L1: 4.5±1.0 mm (0.18±0.04 in) L2: 0+1.0, -0.5 mm (0+0.04, -0.02 in)
(M)	Front door panel to Side sill spoiler	5.7±1.0 mm (0.22±0.04 in)

General Description

EXTERIOR BODY PANELS

B: COMPONENT

1. FRONT HOOD

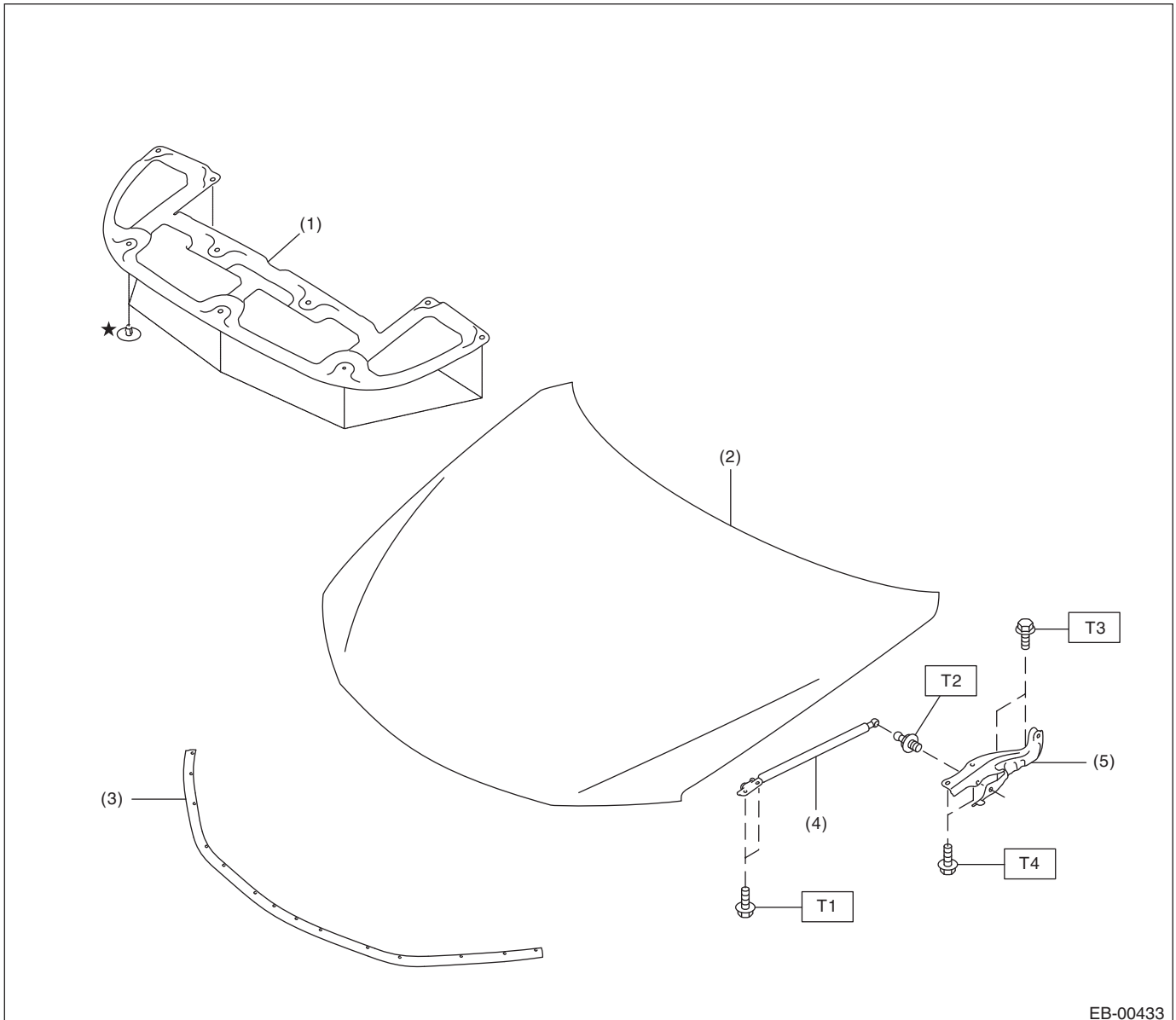

- (1) Insulator
- (2) Front hood panel ASSY
- (3) Seal

- (4) Damper stay
- (5) Hinge

Tightening torque: N·m (kgf·m, ft·lb)

T1: 7.5 (0.76, 5.5)

T2: 20 (2.04, 14.5)

T3: 25 (2.5, 18.4)

T4: 37 (3.8, 27.3)

2. FRONT FENDER

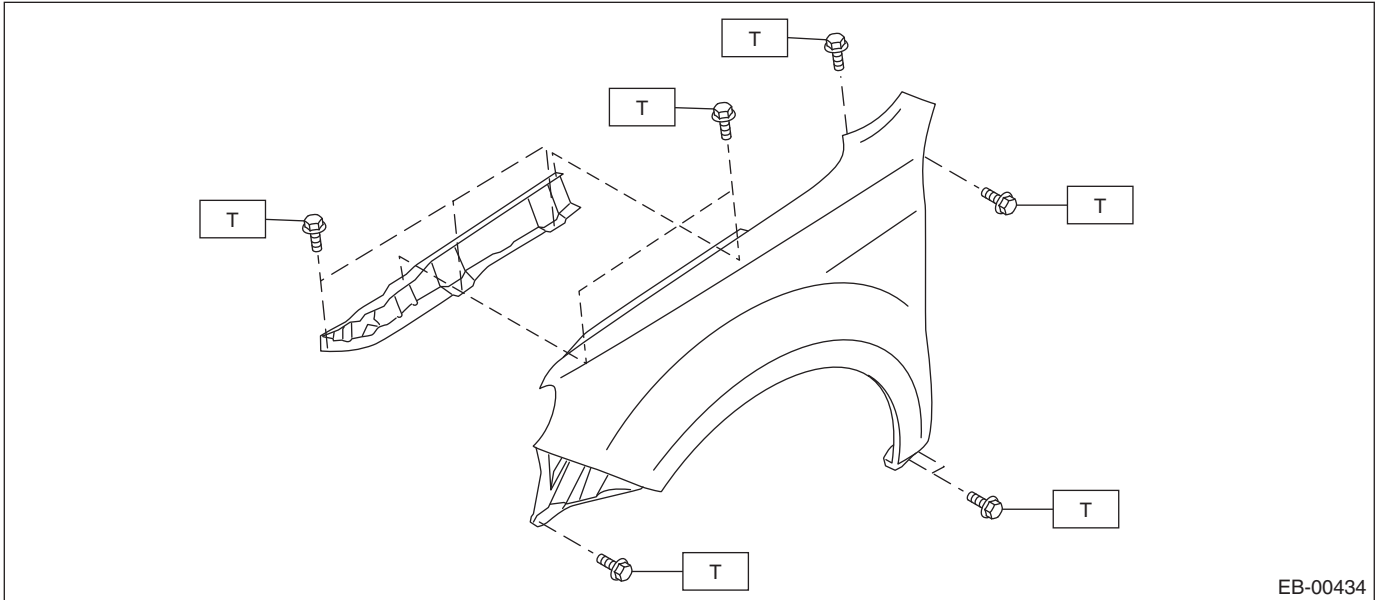

EB-00434

Tightening torque: N·m (kgf·m, ft·lb)

T: 7.5 (0.76, 5.5)

General Description

EXTERIOR BODY PANELS

3. FRONT DOOR

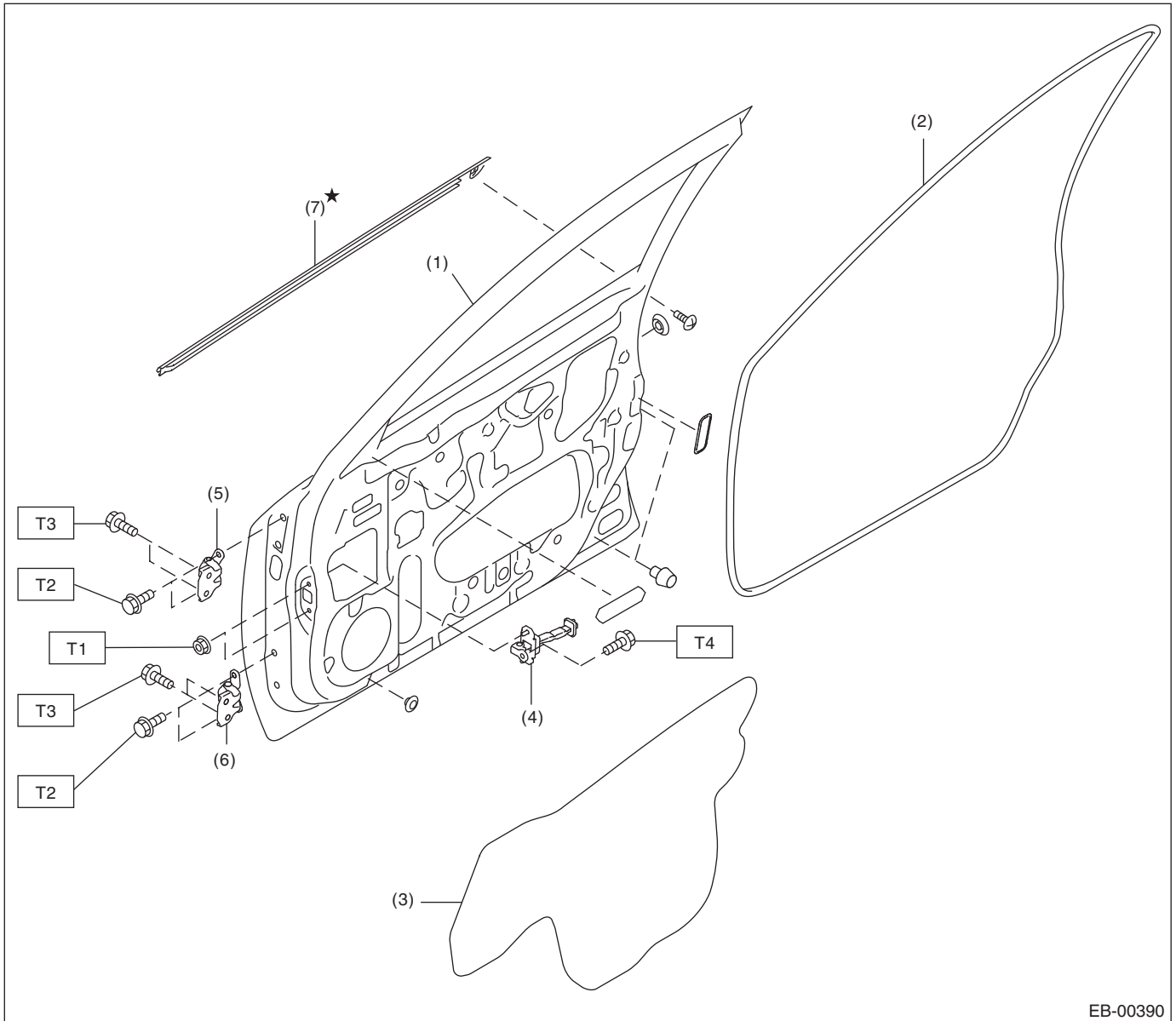

EB-00390

- | | |
|------------------------------|-------------------------------------|
| (1) Front door panel | (5) Upper hinge |
| (2) Front door weather strip | (6) Lower hinge |
| (3) Sealing cover | (7) Front door weather strip, outer |
| (4) Checker | |

Tightening torque: N·m (kgf-m, ft-lb)

T1: 7.5 (0.76, 5.5)

T2: 25 (2.5, 18.4)

T3: 30 (3.1, 22.1)

T4: 33 (3.4, 24.3)

4. REAR DOOR

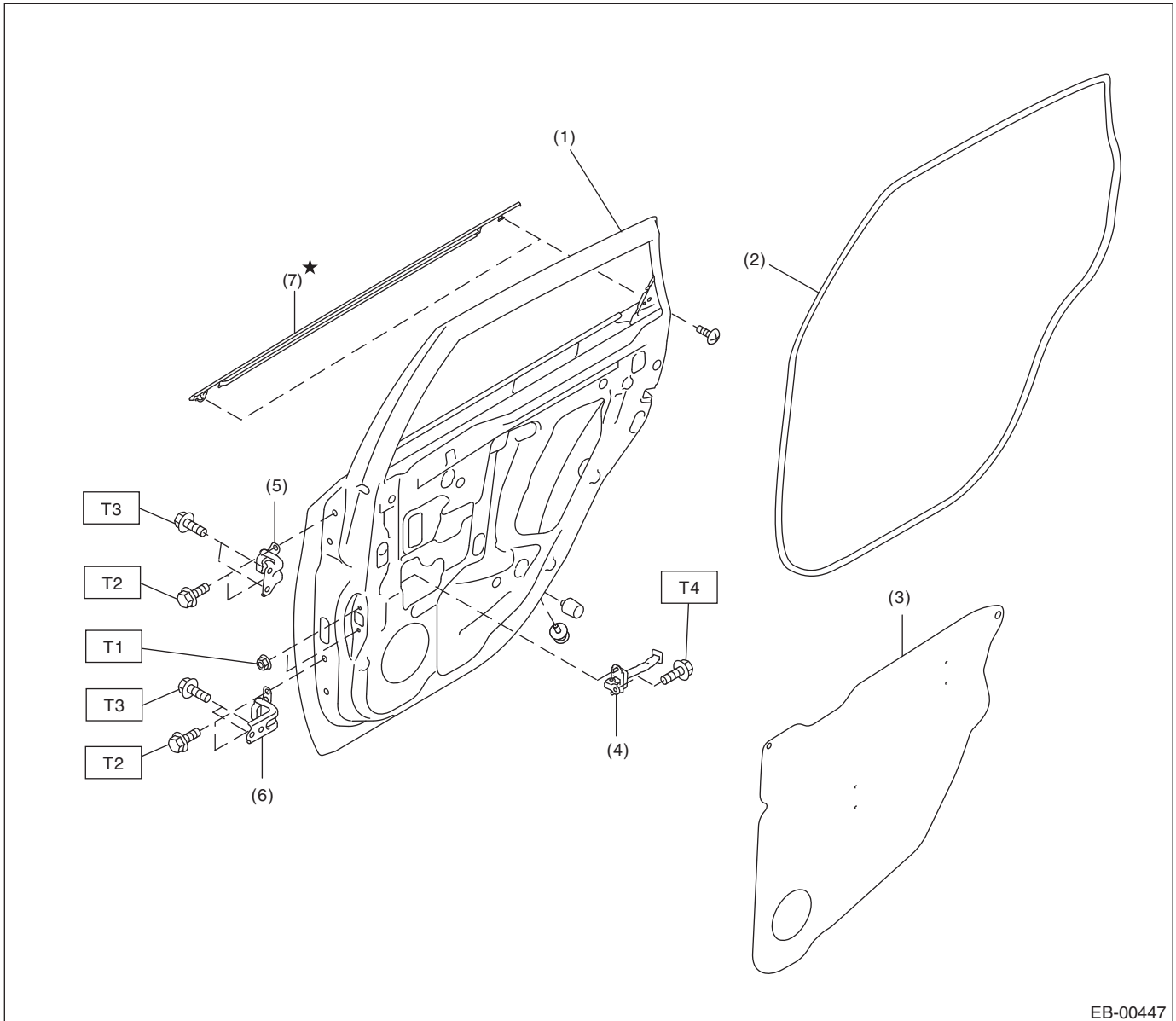

EB-00447

- | | |
|-----------------------------|------------------------------------|
| (1) Rear door panel | (5) Upper hinge |
| (2) Rear door weather strip | (6) Lower hinge |
| (3) Sealing cover | (7) Rear door weather strip, outer |
| (4) Checker | |

Tightening torque: N·m (kgf·m, ft·lb)

T1: 7.5 (0.76, 5.5)

T2: 25 (2.5, 18.4)

T3: 30 (3.1, 22.1)

T4: 33 (3.4, 24.3)

General Description

EXTERIOR BODY PANELS

5. REAR GATE

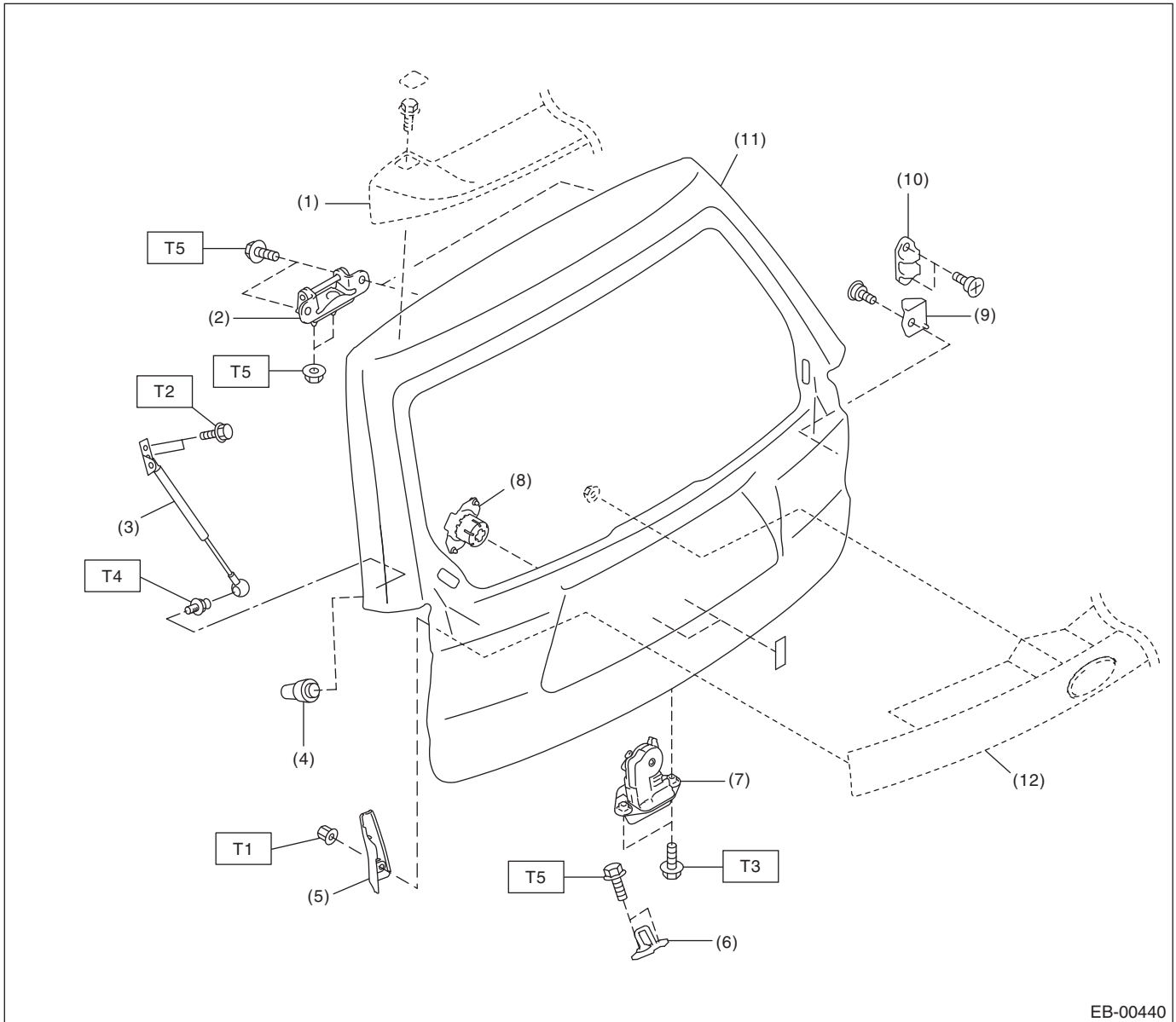

EB-00440

(1) Rear spoiler	(7) Rear gate latch and actuator ASSY	Tightening torque: N·m (kgf·m, ft·lb)
(2) Hinge	(8) Dynamic damper	T1: 4.5 (0.46, 3.32)
(3) Rear gate damper stay	(9) Buffer (Rear gate side)	T2: 10 (1.02, 7.4)
(4) Stopper rubber	(10) Buffer (Body side)	T3: 18 (1.8, 13.3)
(5) Rear gate cover	(11) Rear gate panel	T4: 20 (2.04, 14.5)
(6) Striker	(12) Rear gate garnish	T5: 25 (2.6, 18.4)

C: CAUTION

- The exterior body panel is very heavy. Be careful not to damage the panel by dropping it. During removal and installation, do not damage the panel painting surface.
- While removing mounting bolts, using assistance devices such as a support jack will help support the panel.
- Be careful not to lose small parts.

D: PREPARATION TOOL

1. SPECIAL TOOL

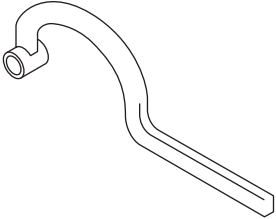
ILLUSTRATION	TOOL NUMBER	DESCRIPTION	REMARKS
 <p style="text-align: center;">ST-925610000</p>	925610000	WRENCH	Used for removing and installing door hinge.

2. GENERAL TOOL

TOOL NAME	REMARKS
Support jack	Used for supporting door panel.
Clip remover	Used for removing various types of clips

Front Hood

EXTERIOR BODY PANELS

2. Front Hood

A: REMOVAL

1. FRONT HOOD INSULATOR

Release the clips to remove the front hood insulator.

CAUTION:

Do not reuse any clips damaged during removal. Always replace with new clips.

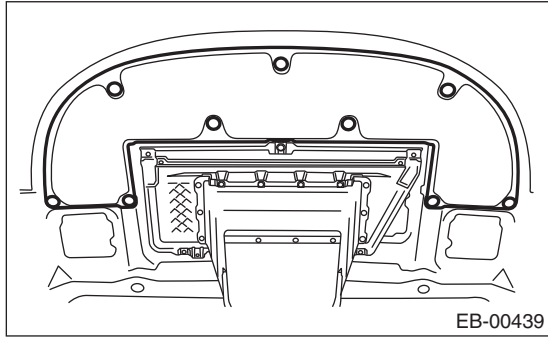

2. FRONT HOOD SEAL

Remove the seal.

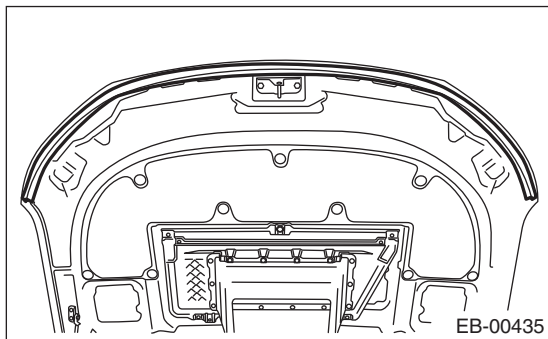

3. FRONT HOOD DAMPER

CAUTION:

The front hood panel is very heavy. Always work with two persons when removing/installing the damper stay and hood hinges.

1) Remove the mounting bolts and the damper stay.

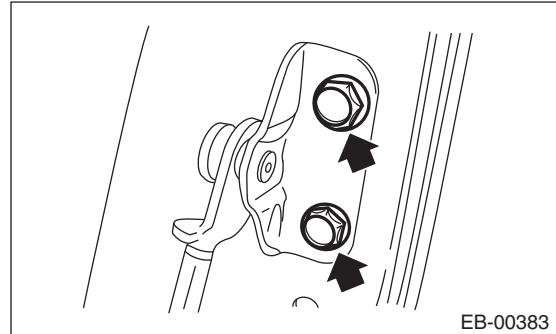

2) Remove the mounting bolts of the front hood damper stay.

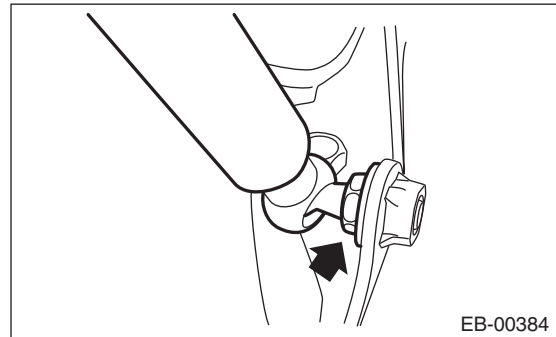

4. FRONT HOOD HINGE

CAUTION:

The front hood panel is heavy. Always work with two persons when removing/installing the damper stay and hood hinges.

- 1) Remove the front hood damper.
- 2) Remove the bolts and front hood panel.

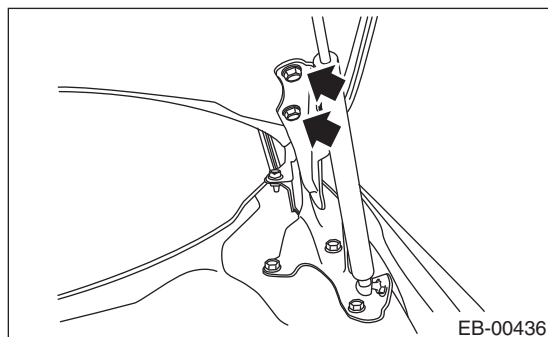

- 3) Detach the tabs and remove the cowl side panel front.

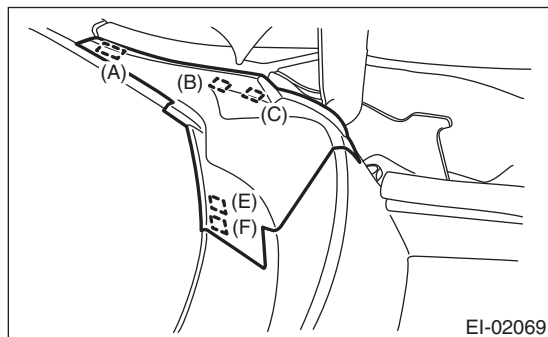

- (1) Detach tabs (A), (B), and (C) from the vehicle exterior.
- (2) Detach tabs (E) and (F).
- 4) Remove the front hood hinge bolts.

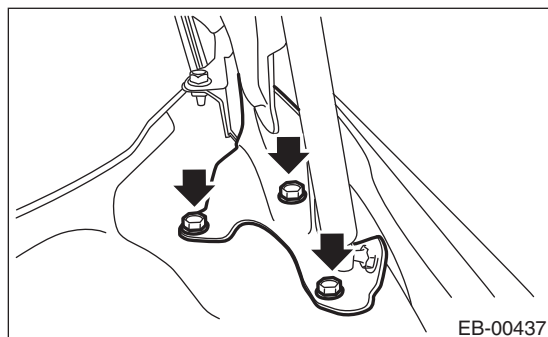

5. FRONT HOOD PANEL

CAUTION:

The front hood panel is heavy. Always work with two persons when removing/installing the damper stay and hood hinges.

- 1) Remove the front hood insulator.
- 2) Remove the front hood seal.
- 3) Remove the window washer hose and nozzle. <Ref. to WW-18, REMOVAL, Front Washer Nozzle.>
- 4) Remove the front hood damper.
- 5) Remove the bolt, and remove the front hood panel from the front hood hinge.

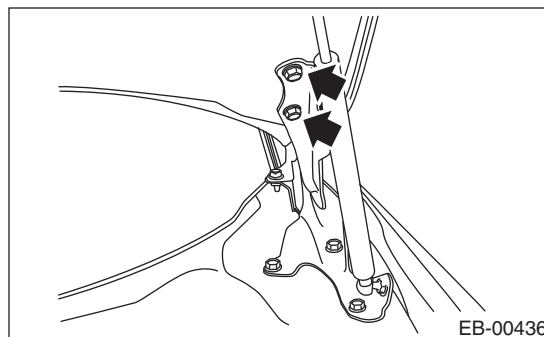

B: INSTALLATION

Install in the reverse order of removal.

NOTE:

- Make sure that the window washer hose does not get pinched by the insulator.
- Install while paying attention to maintaining a uniform clearance around the front hood panel. For the dimension of clearances, refer to "SPECIFICATION" in "General Description". <Ref. to EB-2, SPECIFICATION, General Description.>

Tightening torque:

Refer to "COMPONENT" of "General Description". <Ref. to EB-6, FRONT HOOD, COMPONENT, General Description.>

Front Hood

EXTERIOR BODY PANELS

C: ADJUSTMENT

- 1) Adjust the clearance between front hood panel and front fender panel. Clearance must be equal at both sides. For the dimension of clearances, refer to "SPECIFICATION" in "General Description". <Ref. to EB-2, SPECIFICATION, General Description.>
- 2) Use the hinge mounting bolts to align the front hood longitudinal and lateral position.

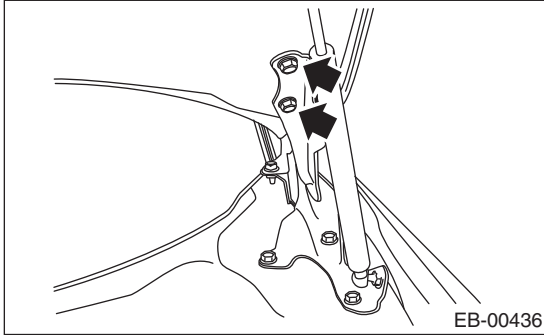

- 3) Adjust the height at the front end of the hood. <Ref. to SL-34, ADJUSTMENT, Front Hood Lock Assembly.>
- 4) Rotate the hood buffer to adjust lateral height.

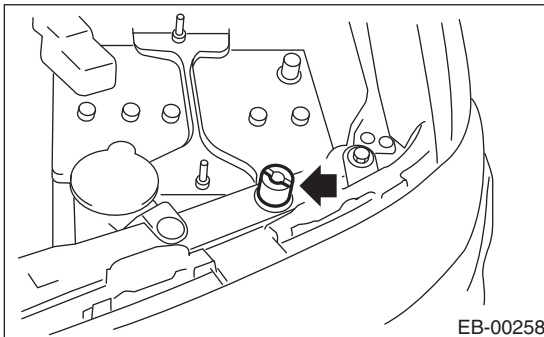

D: DISPOSAL

Refer to the disposal procedures for the rear gate damper stay for disposal procedures of the front hood tamper stay. <Ref. to EB-31, REAR GATE DAMPER STAY, DISPOSAL, Rear Gate.>

3. Front Fender

A: REMOVAL

- 1) Disconnect the ground cable from the battery.
- 2) Remove the side sill spoilers. <Ref. to EI-39, REMOVAL, Side Sill Spoiler.>
- 3) Remove the front bumper. <Ref. to EI-28, REMOVAL, Front Bumper.>
- 4) Remove the headlight assembly. <Ref. to LI-17, REMOVAL, Headlight Assembly.>
- 5) Remove the mud guard. <Ref. to EI-27, REMOVAL, Mud Guard.>
- 6) Detach the tabs and remove the cowl panel, side.

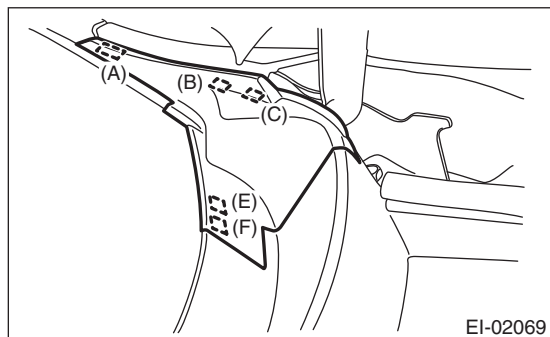

- (1) Detach tabs (A), (B), and (C) from the vehicle exterior.
 - (2) Detach tabs (E) and (F).
- 7) Remove the bolt, and remove the front fender panel.

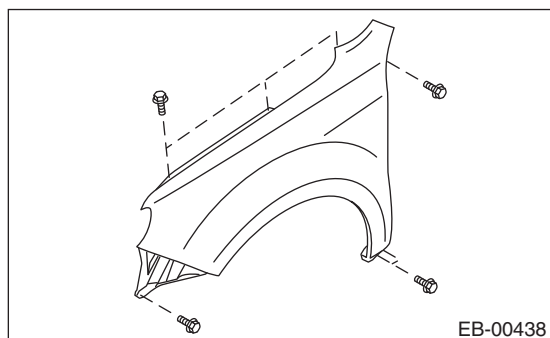

B: INSTALLATION

CAUTION:

- When replace double sided tape with new tape.
 - After attaching the front fender panel, always perform headlight beam level adjustment.
- Install in the reverse order of removal.

Tightening torque:

7.5 N·m (0.76 kgf·m, 5.5 ft·lb)

NOTE:

Install while paying attention to maintaining a uniform clearance around the front fender panel. For the dimension of clearances, refer to "SPECIFICATION" in "General Description". <Ref. to EB-2, SPECIFICATION, General Description.>

4. Front Performance Stay

A: REMOVAL

- 1) Remove the front fender. <Ref. to EB-15, REMOVAL, Front Fender.>
- 2) Remove the bolts and harness clip, and remove the front performance stay.

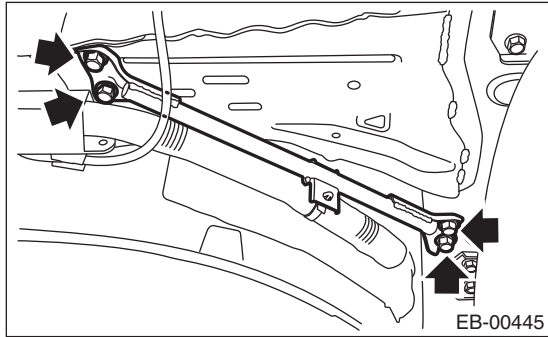

B: INSTALLATION

Install in the reverse order of removal.

Tightening torque:

70 N·m (7.1 kgf-m, 51.6 ft-lb)

5. Front Door

A: REMOVAL

- 1) Disconnect the ground cable from the battery.
- 2) Remove the front door trim. <Ref. to EI-42, REMOVAL, Door Trim.>
- 3) Remove the outer mirror assembly. <Ref. to GW-14, REMOVAL, Outer Mirror Assembly.>
- 4) Remove the front door speaker. <Ref. to ET-7, REMOVAL, Front Speaker.>
- 5) Remove the sealing cover. <Ref. to EB-19, REMOVAL, Front Sealing Cover.>
- 6) Remove the front door glass. <Ref. to GW-10, REMOVAL, Front Door Glass.>
- 7) Remove the front door regulator and motor. <Ref. to GW-11, REMOVAL, Front Regulator and Motor Assembly.>
- 8) Remove the front door latch assembly. <Ref. to SL-28, REMOVAL, Front Door Latch and Door Lock Actuator Assembly.>
- 9) Remove the front outer handle. <Ref. to SL-27, REMOVAL, Front Outer Handle.>
- 10) Remove the front door weather strip.

NOTE:

If the weather strip clip is removed with excessive force, the weather strip may be damaged. Be sure to use clip remover to remove.

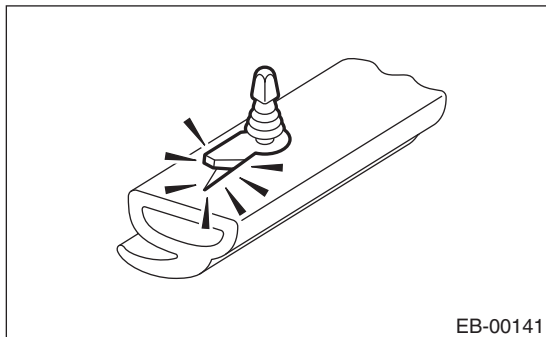

- 11) Remove the bolts and nuts to remove the door checker.

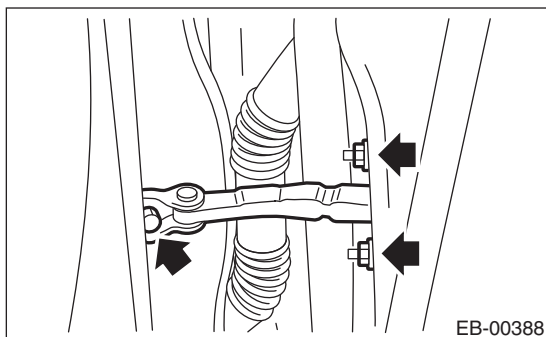

- 12) Remove the front pillar lower trim. <Ref. to EI-52, REMOVAL, Lower Inner Trim.>

- 13) Disconnect the connector of door harness from body harness.

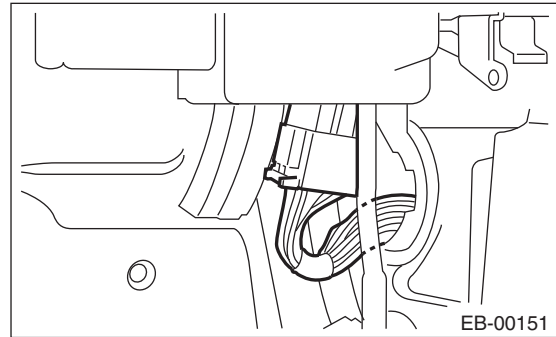

- 14) Put a wooden block on jack and place jack under the front door. Support the door with a jack to protect it from damage.

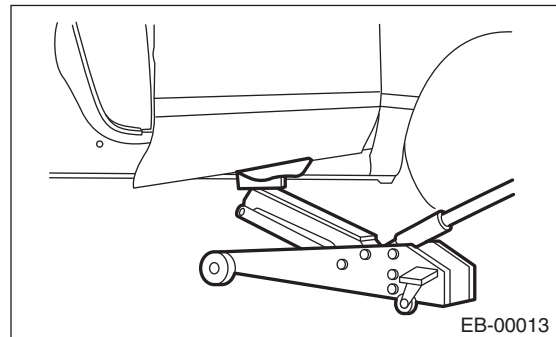

- 15) Remove the door-side bolts for upper and lower hinges to remove front door panel.

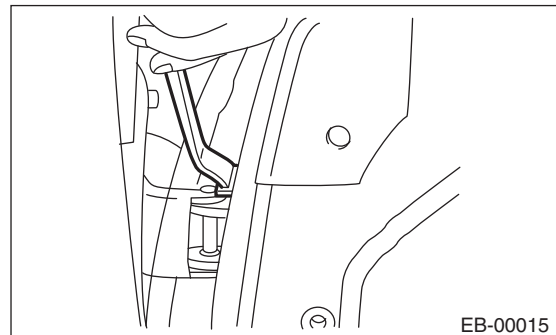

- 16) Remove the door hinge from vehicle.

Front Door

EXTERIOR BODY PANELS

B: INSTALLATION

1) Put a wooden block on jack and place the front door on that.

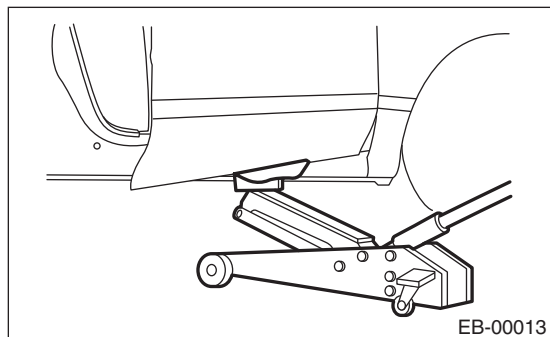

- 2) Apply grease to the sliding area of door hinges, and install the door hinge to vehicle.
- 3) Install the front door to upper hinge and lower hinge adjusting by jack.
- 4) Tighten bolt of door checker.
- 5) Connect door harness connector, and install the instrument panel lower cover.
- 6) Install the front pillar lower trim.

Tightening torque:

Refer to "COMPONENT" of "General Description".

<Ref. to EB-9, REAR DOOR, COMPONENT, General Description.>

NOTE:

Install while paying attention to maintaining a uniform clearance around the front door panel. For the dimension of clearances, refer to "SPECIFICATION" in "General Description". <Ref. to EB-2, SPECIFICATION, General Description.>

C: ADJUSTMENT

1) Using the ST, loosen the body-side bolts of upper and lower hinges to align the position for vertical and horizontal directions of the front door panel.
ST 925610000 WRENCH

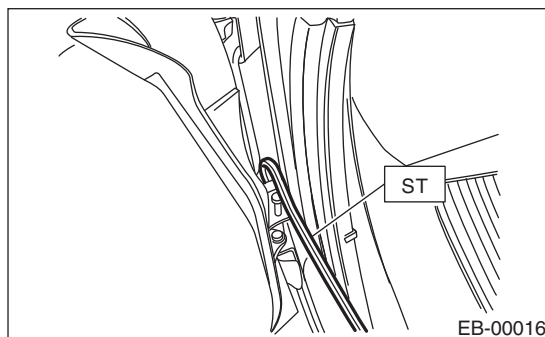

2) Loosen the screw (A) and tap striker (B) using plastic hammer to adjust the gap between rear end surface of front door panel and front end surface of rear door.

CAUTION:

Do not use an impact wrench. Welding area on the striker nut plate is easily broken.

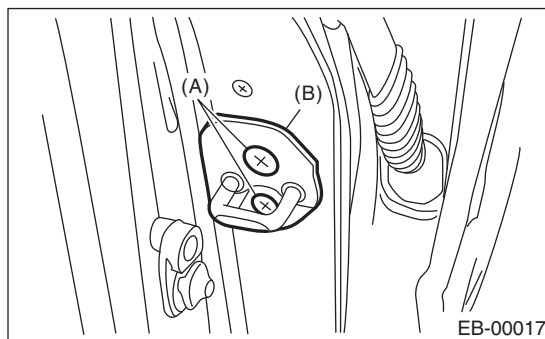

6. Front Sealing Cover

A: REMOVAL

- 1) Disconnect the ground cable from the battery.
- 2) Remove the front door trim. <Ref. to EI-42, REMOVAL, Door Trim.>
- 3) Remove the sealing cover.

NOTE:

- Carefully remove the butyl tape. Excessive force will easily break the cover.
- If cover gets broken, replace it with a new part.

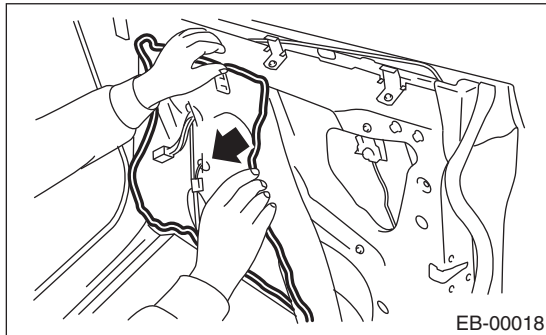

B: INSTALLATION

- 1) Install in the reverse order of removal.
- 2) When replacing the sealing cover, use the butyl tape.
- 3) Press the butyl tape-applied area firmly to prevent any floating on surface.

Butyl tape:

3M8626 or equivalent

NOTE:

- Apply a uniform bead of butyl tape.
- Attach the sealing cover, keeping it from becoming wrinkled.
- Breaks in the bead will allow water leakage and contamination.

C: INSPECTION

If the sealing cover gets damaged, replace it with a new part.

Rear Door

EXTERIOR BODY PANELS

7. Rear Door

A: REMOVAL

- 1) Disconnect the ground cable from the battery.
- 2) Remove the rear door trim. <Ref. to EI-42, REMOVAL, Door Trim.>
- 3) Remove the rear speaker. <Ref. to ET-9, REMOVAL, Rear Speaker.>
- 4) Remove the sealing cover. <Ref. to EB-22, REMOVAL, Rear Sealing Cover.>
- 5) Remove the door sash and rear door glass. <Ref. to GW-17, REMOVAL, Rear Door Glass.>
- 6) Remove the rear door regulator and motor assembly. <Ref. to GW-18, REMOVAL, Rear Regulator and Motor Assembly.>
- 7) Remove the rear door latch. <Ref. to SL-31, REMOVAL, Rear Door Latch and Door Lock Actuator Assembly.>
- 8) Remove the rear outer handle. <Ref. to SL-30, REMOVAL, Rear Outer Handle.>
- 9) Remove the rear door weather strip.

NOTE:

If the weather strip clip is removed with excessive force, the weather strip may be damaged. Be sure to use clip remover to remove.

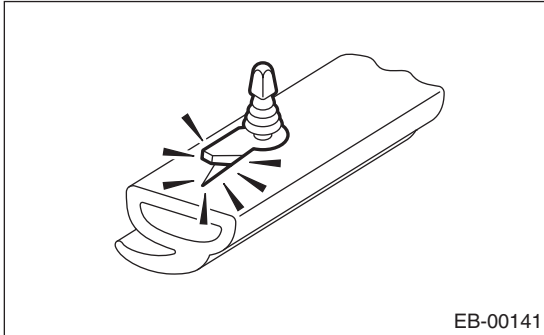

- 10) Remove the bolts and nuts to remove the door checker.

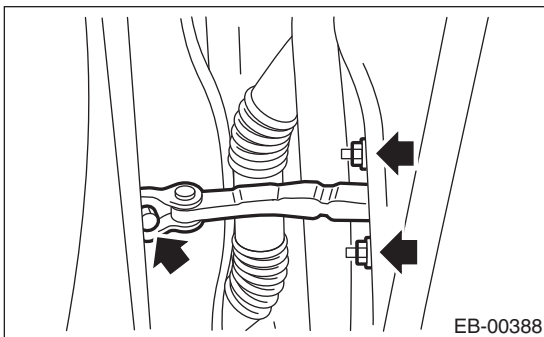

- 11) Pull the door harness connector inside the center pillar, then disconnect the connector.

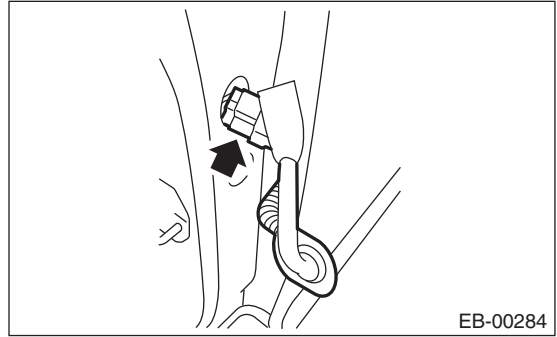

- 12) Put a wooden block on jack and place jack under the rear door. Support the rear door with a jack to protect it from damage.

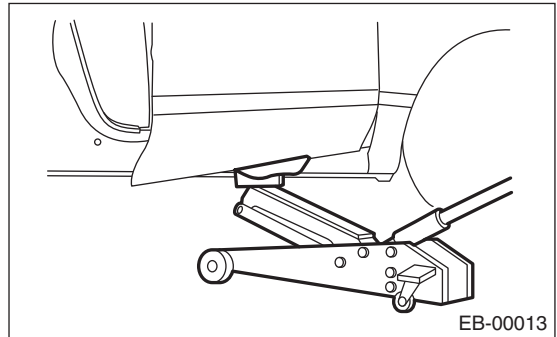

- 13) Remove the door-side bolts for upper and lower hinges to remove the rear door panel.

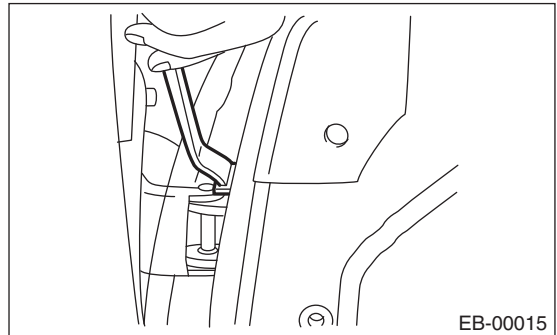

- 14) Remove the door hinge from vehicle.

B: INSTALLATION

1) Put a wooden block on jack and place the rear door on that.

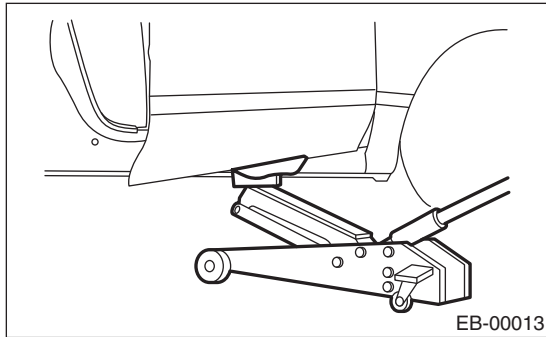

- 2) Apply grease to the moving part of door hinges.
- 3) Install the rear door to upper hinge and lower hinge adjusting by jack.
- 4) Tighten bolt of door checker.
- 5) Connect the door harness connectors.

Tightening torque:

Refer to “**COMPONENT**” of “**General Description**”.

<Ref. to EB-9, REAR DOOR, COMPONENT, General Description.>

NOTE:

Install while paying attention to make a uniform clearance around the rear door panel. For the dimension of clearances, refer to “**SPECIFICATION**” in “**General Description**”. <Ref. to EB-2, SPECIFICATION, General Description.>

C: ADJUSTMENT

1) Open the rear door, loosen the door-side bolts of upper and lower hinges to align the position for vertical and horizontal direction of rear door panel.

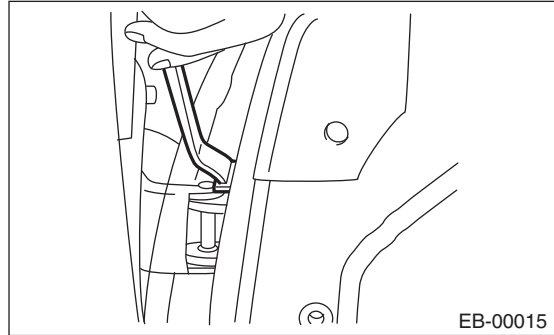

- 2) Loosen the screw (A) and tap striker (B) using plastic hammer to adjust the gap between rear end surface of rear door panel and body surface.

CAUTION:

Do not use an impact wrench. Welding area on the striker nut plate is easily broken.

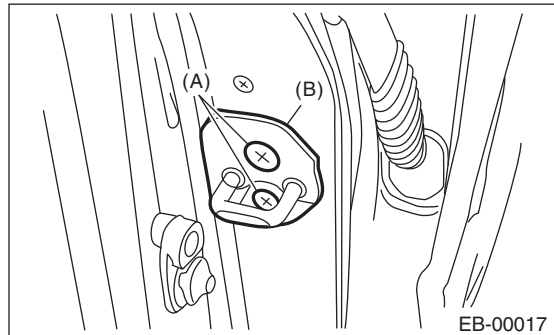

8. Rear Sealing Cover

A: REMOVAL

- 1) Disconnect the ground cable from the battery.
- 2) Remove the rear door trim. <Ref. to EI-42, REMOVAL, Door Trim.>
- 3) Remove the rear speaker. <Ref. to ET-9, REMOVAL, Rear Speaker.>
- 4) Remove the sealing cover.

NOTE:

- Carefully remove the butyl tape. Excessive force will easily break the cover.
- If cover gets broken, replace it with a new part.

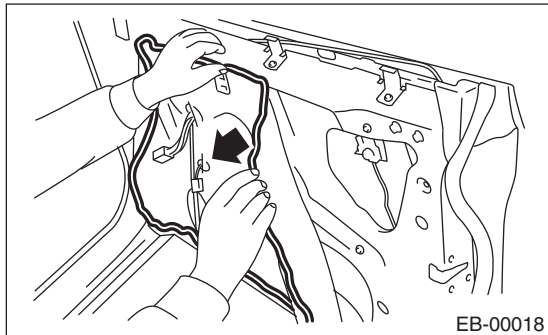

B: INSTALLATION

- 1) Install in the reverse order of removal.
- 2) When replacing the sealing cover, use the butyl tape.
- 3) Press the butyl tape-applied area firmly to prevent any floating on surface.

Butyl tape:

3M8626 or equivalent

NOTE:

- Apply a uniform bead of butyl tape.
- Attach the sealing cover, keeping it from becoming wrinkled.
- Breaks in the bead will allow water leakage and contamination.

C: INSPECTION

If the sealing cover gets damaged, replace it with a new part.

9. Door Sash Tape

A: REMOVAL

1. FRONT DOOR

- 1) Disconnect the ground cable from the battery.
- 2) Remove the front door trim. <Ref. to EI-42, REMOVAL, Door Trim.>
- 3) Remove the outer mirror assembly. <Ref. to GW-14, REMOVAL, Outer Mirror Assembly.>
- 4) Remove the sealing cover. <Ref. to EB-19, REMOVAL, Front Sealing Cover.>
- 5) Remove the front door glass. <Ref. to GW-10, REMOVAL, Front Door Glass.>
- 6) Remove the glass run rubber.
- 7) Remove the clip at the top of the B-pillar and the front door weather strip.

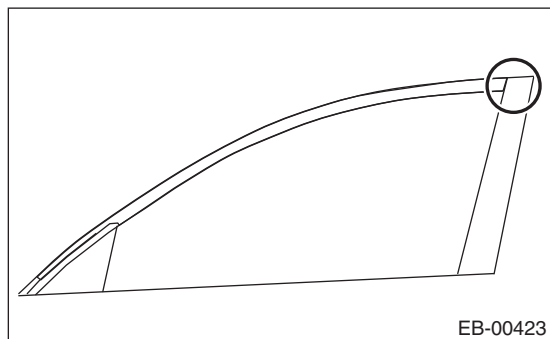

- 8) Remove the screw to remove the front door weather strip, outer.

CAUTION:

- Be careful not to scratch the vehicle when removing the weather strip, outer.
- Always replace the weather strip, outer with a new part if it appears to be deformed.

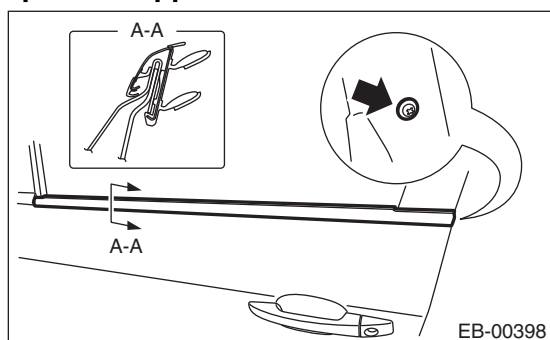

- 9) Remove the door sash tape from the door sash.

NOTE:

- If the tape is difficult to remove, heat with a hair dryer or similar device to make removal easier. Use a household dryer. Do not use an industrial dryer.
- Completely clean off any tape that has remained adhered to the door sash.

2. REAR DOOR

- 1) Disconnect the ground cable from the battery.
- 2) Remove the rear door trim. <Ref. to EI-42, REMOVAL, Door Trim.>
- 3) Remove the sealing cover. <Ref. to EB-22, REMOVAL, Rear Sealing Cover.>
- 4) Remove the rear door glass. <Ref. to GW-17, REMOVAL, Rear Door Glass.>
- 5) Remove the glass run rubber.
- 6) Remove the clip at the top of the B-pillar and the rear door weather strip.

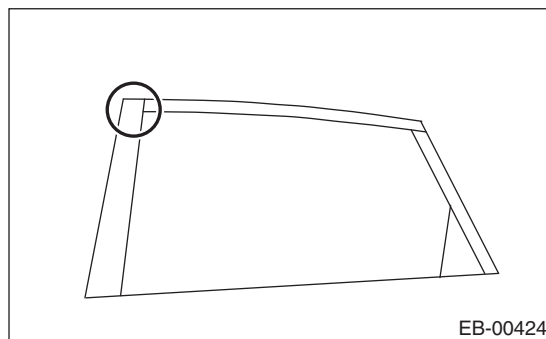

- 7) Remove the screws and clip to remove the gusset cover, outer.

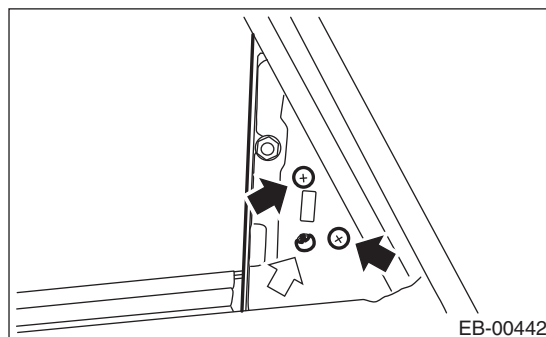

- 8) Remove the rear door weather strip, outer.

CAUTION:

- Be careful not to scratch the vehicle when removing the weather strip, outer.
- Always replace the weather strip, outer with a new part if it appears to be deformed.

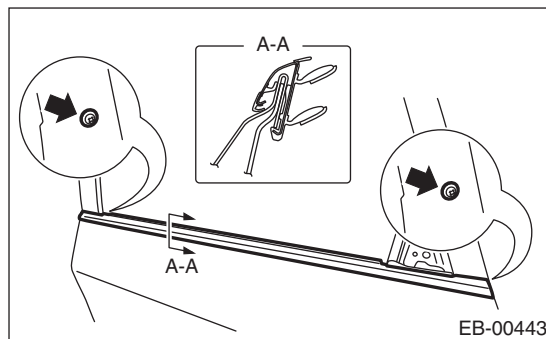

Door Sash Tape

EXTERIOR BODY PANELS

9) Remove the door sash tape from the door sash.

NOTE:

- If the tape is difficult to remove, heat with a hair dryer or similar device to make removal easier. Use a household dryer. Do not use an industrial dryer.
- Completely clean off any tape that has remained adhered to the door sash.

B: INSTALLATION

CAUTION:

- Press evenly along the sash when applying the tape using a spatula or similar object to make sure no bubbles are formed. If any bubbles are formed, replace the tape.
- If any wrinkles form in the tape while applying, replace the tape with new tape.
- Be sure to press the ends of the tape firmly to adhere securely. If the tape comes off at the ends or where folded, the adhesive strength is weakened and the tape may peel off.
- There are locations at the ends of the tape where it will overlap. Be sure to check the application order when applying the tape.

- Front

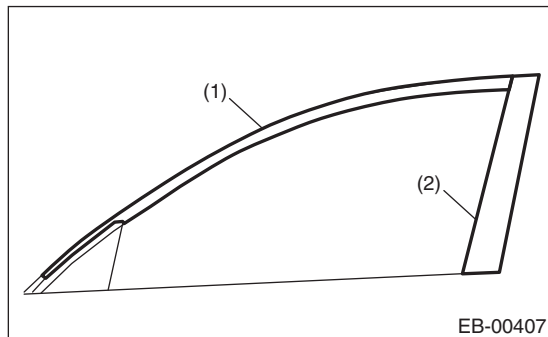

- Rear

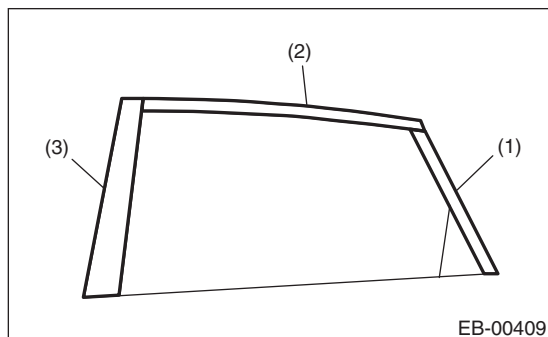

1. FRONT DOOR

1) Align the cutout of the tape with the top of the gusset as shown in the figure. (Position indicated by the arrow)

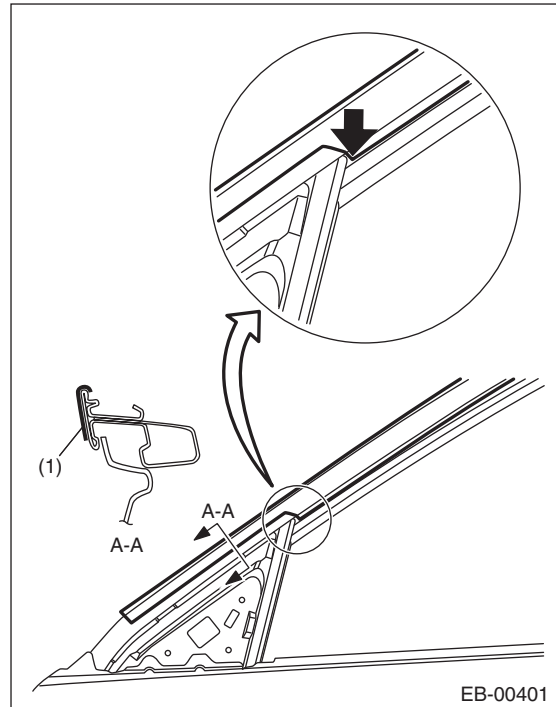

(1) Front door sash tape - front

2) Apply the tape from the front of the vehicle towards the rear.

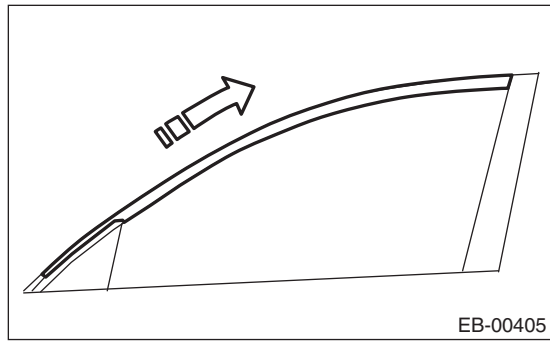

NOTE:

Apply the tape so that the end of the tape is within 2.5 ± 1.5 mm (0.1 ± 0.06 in) from a line extending from the front door rear sash.

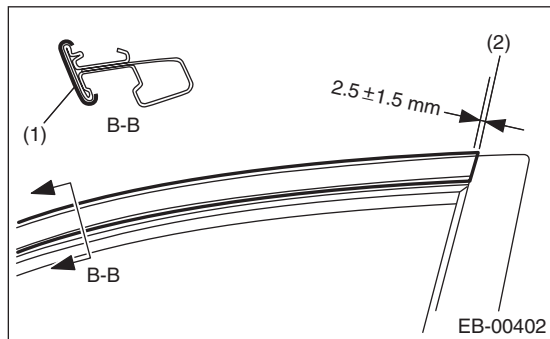

- (1) Front door sash tape - front
- (2) Line extending from the front door rear sash

3) Cut away both ends of the front door sash tape - rear.

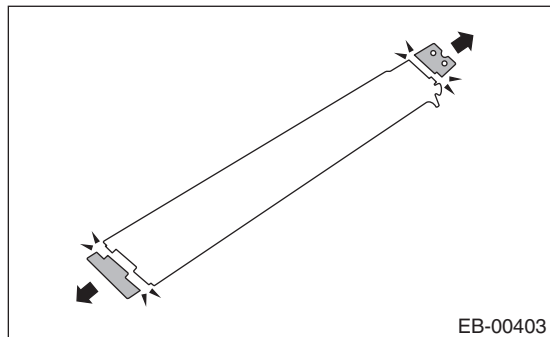

4) Align the cutaway portion of the tape with the corner of the sash as shown in the figure. (Position indicated by the arrow)

5) Position the tape so that there is a clearance of 3.7 mm (0.15 in) at the bottom end of the tape and it is not blocking the outer weather strip installation hole. (Position indicated by the arrow)

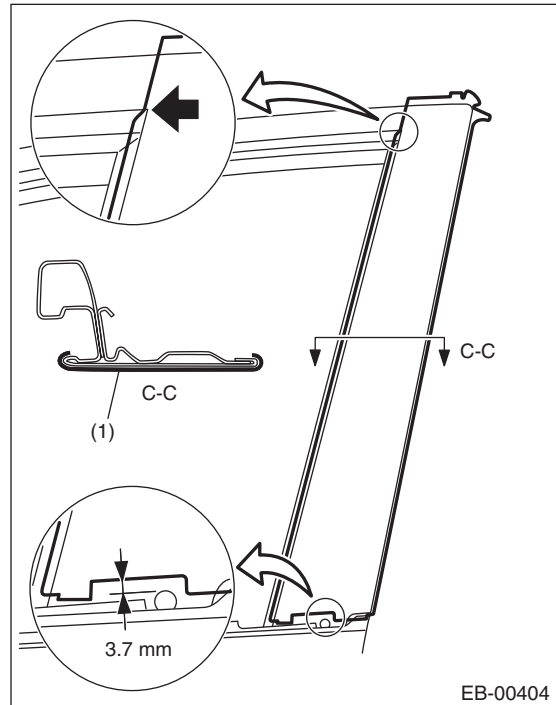

(1) Front door sash tape - rear

6) Apply the tape from the top of the vehicle towards the bottom.

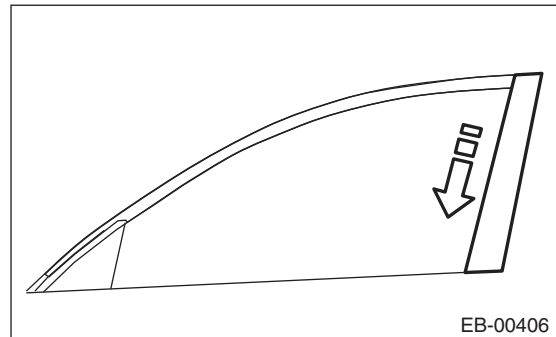

7) Fold the door upper end in order of (1) to (3).

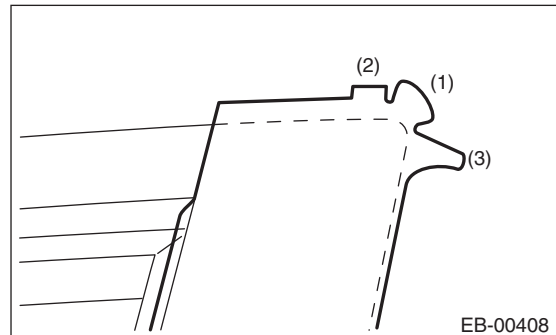

8) Install the door parts in the reverse order of removal.

Door Sash Tape

EXTERIOR BODY PANELS

9) Install while paying attention to maintaining a uniform clearance around the front door panel. For the dimension of clearances, refer to "SPECIFICATION" in "General Description". <Ref. to EB-2, SPECIFICATION, General Description.>

2. REAR DOOR

1) Cut away both ends of the rear door sash tape-rear.

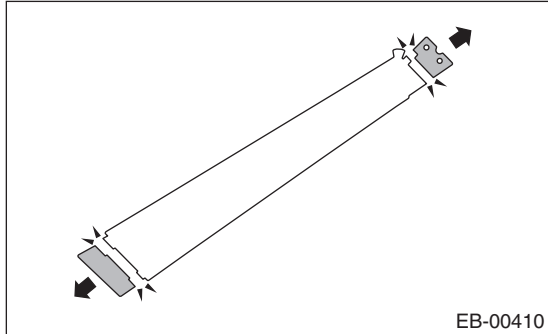

2) Apply the tape so that the end of the tape is within 2.5 ± 1.5 mm (0.1 ± 0.06 in) from a line extending from the rear door front sash.

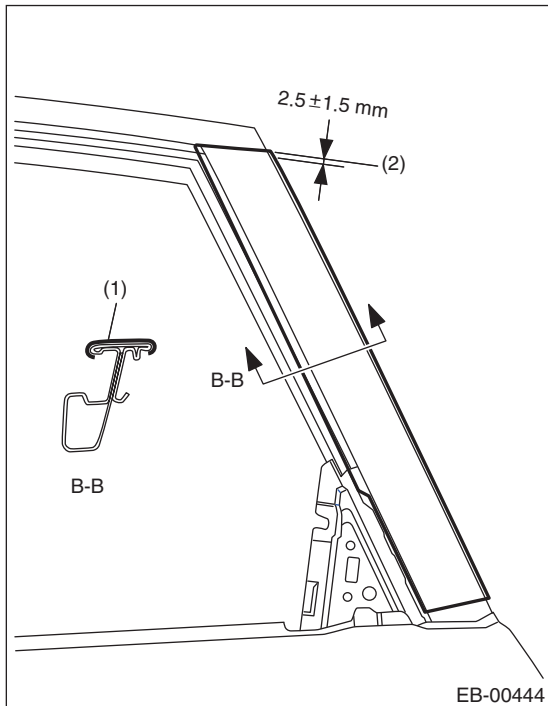

- (1) Rear door sash tape - rear
- (2) Line extending from the rear door upper sash

3) Apply the tape from the top of the vehicle towards the bottom.

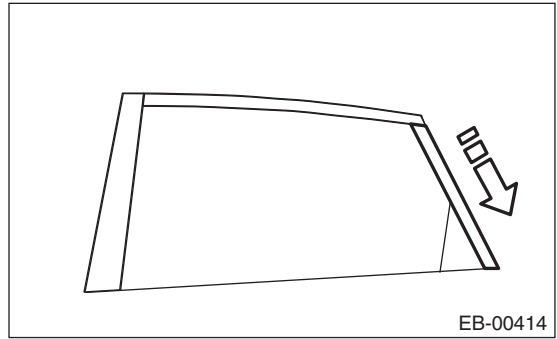

4) Align the cutout of the tape with the corner of the rear door upper sash as shown in the figure. (Position indicated by the arrow)

NOTE:

Apply the tape so that the end of the tape is within 2.5 ± 1.5 mm (0.1 ± 0.06 in) of a line extending from the rear door front sash.

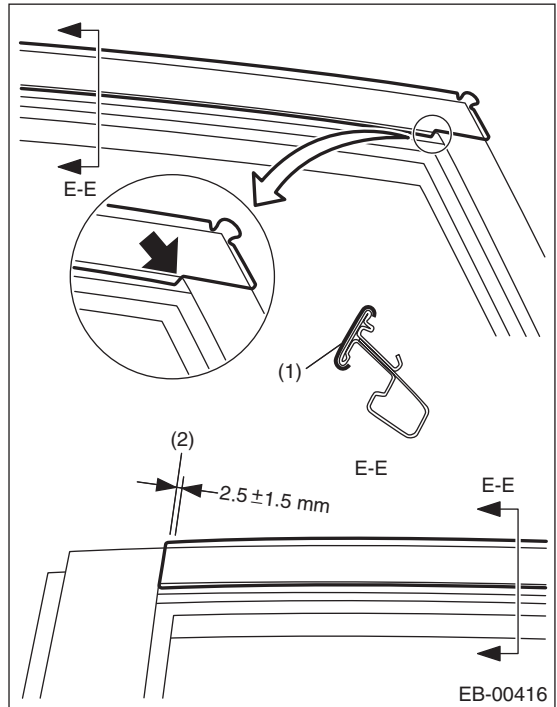

- (1) Rear door sash tape - medium
- (2) Line extending from the front sash of the rear door

Door Sash Tape

5) Apply the tape from the rear of the vehicle towards the front.

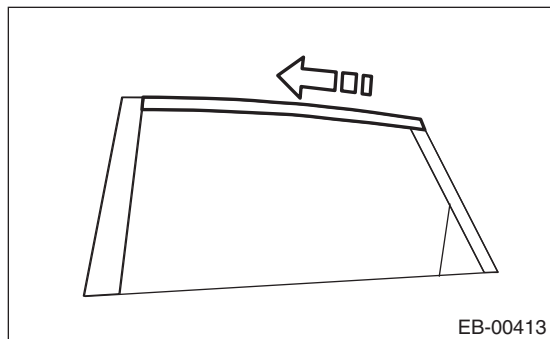

6) Fold the door upper end in order of (1) to (3).

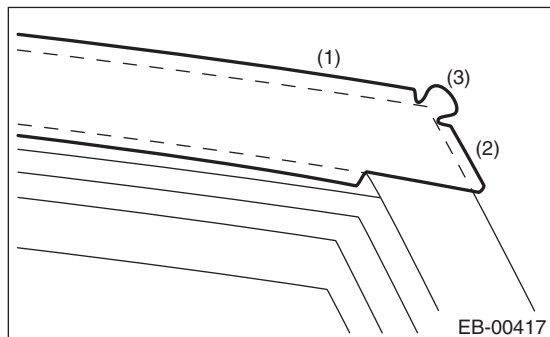

7) Cut away both ends of the rear door sash tape - front.

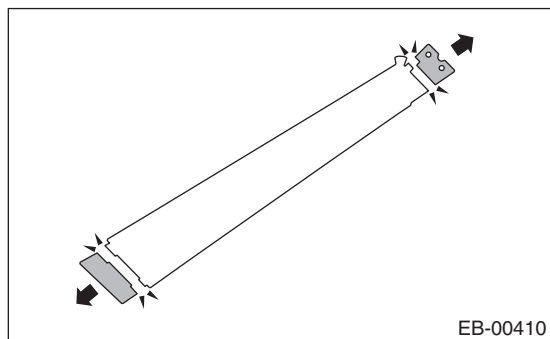

8) Align the cutaway portion of the tape with the corner of the sash as shown in the figure. (Position indicated by the arrow)

9) Position the tape so that there is a clearance of 3.7 mm (0.15 in) at the bottom end of the tape and it is not blocking the outer weather strip installation hole. (Position indicated by the arrow)

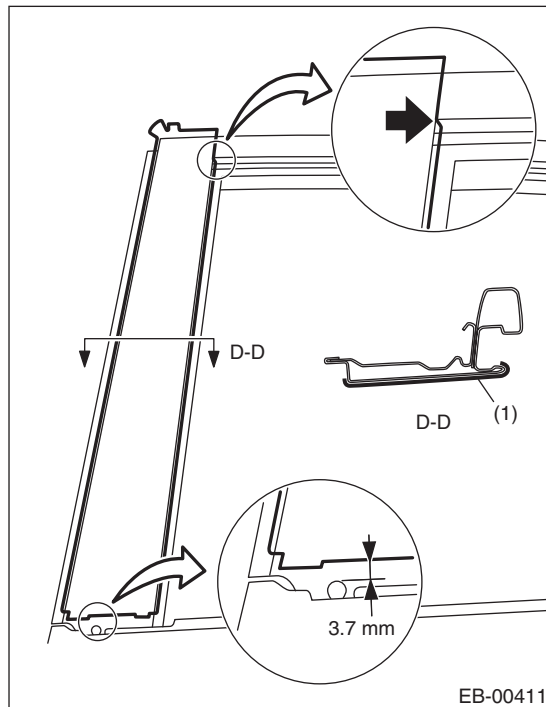

(1) Rear door sash tape - front

10) Apply the tape from the top of the vehicle towards the bottom.

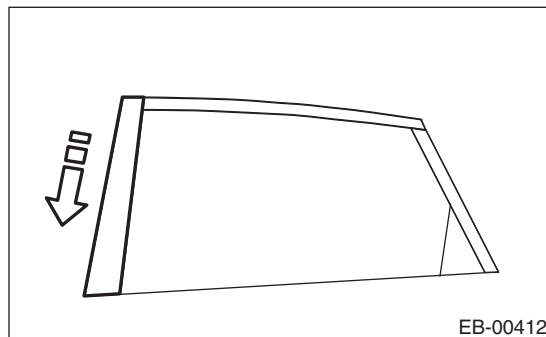

11) Fold the door upper end in order from (1) to (2).

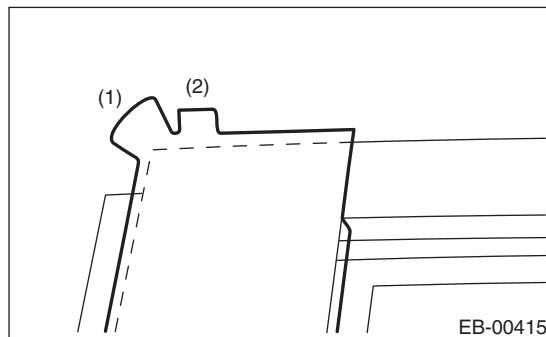

12) Install the door parts in the reverse order of removal.

Door Sash Tape

EXTERIOR BODY PANELS

13) Install while paying attention to make a uniform clearance around the rear door panel. For the dimension of clearances, refer to "SPECIFICATION" in "General Description". <Ref. to EB-2, SPECIFICATION, General Description.>

10. Rear Gate

A: REMOVAL

1. REAR GATE PANEL

- 1) Disconnect the ground cable from the battery.
- 2) Remove the rear gate trim. <Ref. to EI-60, REMOVAL, Rear Gate Trim.>
- 3) Remove the rear gate garnish. <Ref. to EI-62, REMOVAL, Rear Gate Garnish.>
- 4) Remove the rear wiper arm. <Ref. to WW-19, REMOVAL, Rear Wiper Arm.>
- 5) Remove the rear wiper motor. <Ref. to WW-20, REMOVAL, Rear Wiper Motor.>
- 6) Remove the rear gate latch and actuator assembly. <Ref. to SL-33, REMOVAL, Rear Gate Latch and Actuator Assembly.>
- 7) Remove the roof spoiler. <Ref. to EI-38, REMOVAL, Roof Spoiler.>
- 8) Remove the connecting part of rubber duct (A).

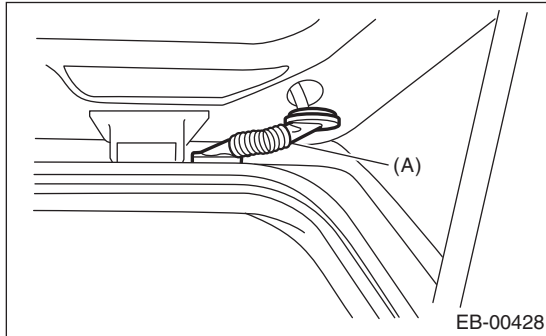

- 9) Pull off the harness and washer hose from the rear gate.
- 10) Remove harness clip of each connector from the rear gate panel.
- 11) Before removing the rear gate damper stay, prevent the rear gate from closing using prop or the like.

CAUTION:

If the prop comes off, operators may get injured and vehicle may get damaged. Make sure to support the rear gate with secure material to prevent injury or damage.

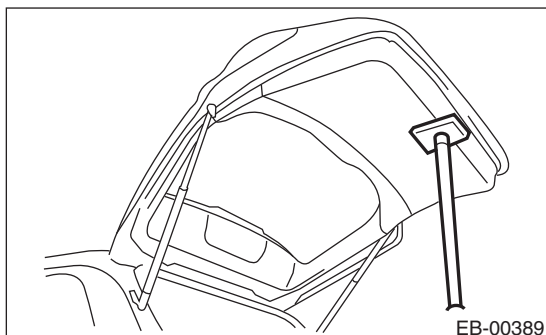

- 12) Remove the mounting bolt of rear gate damper stay.

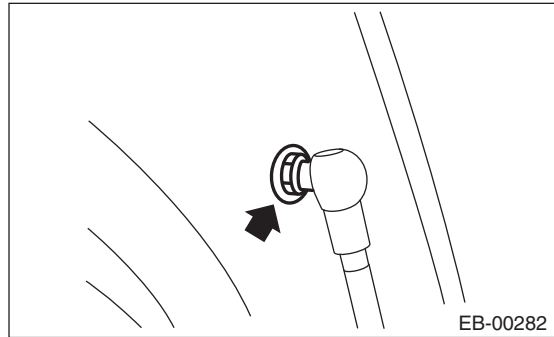

- 13) Remove the rear gate hinge bolt, and remove the rear gate panel.

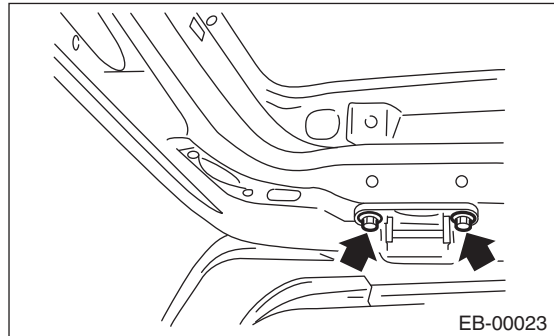

- 14) Remove the rear gate hinge from the vehicle.

Rear Gate

EXTERIOR BODY PANELS

2. REAR GATE DAMPER STAY

CAUTION:

- Do not damage piston rods and oil seals.
- Never disassemble cylinders: They contain gas.

1) Before removing the rear gate damper stay, prevent the rear gate from closing using prop or the like.

CAUTION:

If the prop comes off, operators may get injured and vehicle may get damaged. Make sure to support the rear gate with secure material to prevent injury or damage.

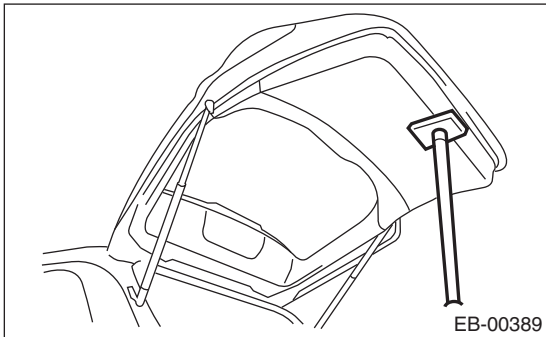

2) Remove the mounting bolt of rear gate damper stay.

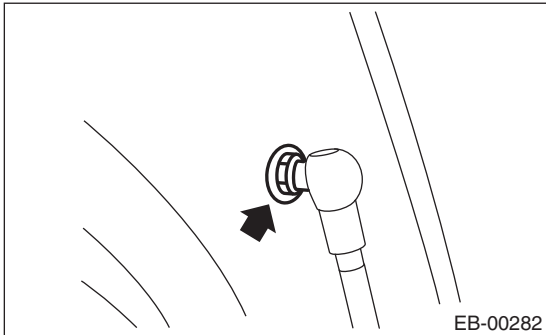

3) Remove the mounting bolts and the damper stay.

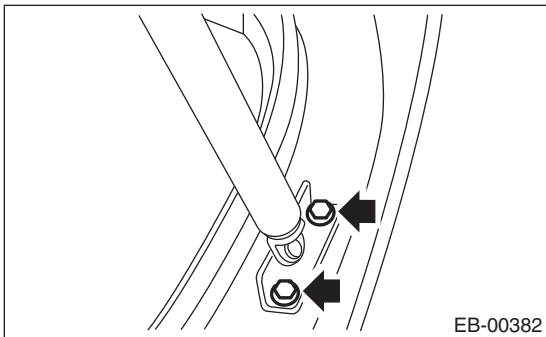

B: INSTALLATION

1. REAR GATE PANEL

Install in the reverse order of removal.

Tightening torque:

25 N·m (2.6 kgf-m, 18.4 ft-lb)

NOTE:

Install while paying attention to maintain a uniform clearance around the rear gate panel. For the dimension of clearances, refer to "SPECIFICATION" in "General Description". <Ref. to EB-2, SPECIFICATION, General Description.>

2. REAR GATE DAMPER STAY

1) Prevent the rear gate from closing using prop or the like.

CAUTION:

If the prop comes off, operators may get injured and vehicle may get damaged. Make sure to support the rear gate with secure material to prevent injury or damage.

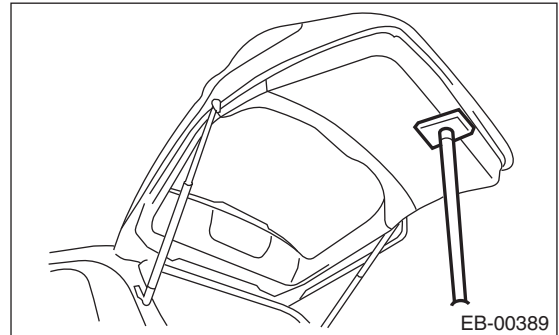

2) Install in the reverse order of removal.

Tightening torque:

Refer to "COMPONENT" of "General Description".

<Ref. to EB-10, REAR GATE, COMPONENT, General Description.>

C: DISPOSAL**1. REAR GATE DAMPER STAY****CAUTION:**

Gas is colorless, odorless, and harmless. However, gas pressure may spray cutting powder or oil. Be sure to wear dust-resistant goggles.

1) Cover with a vinyl sack as shown in the figure.

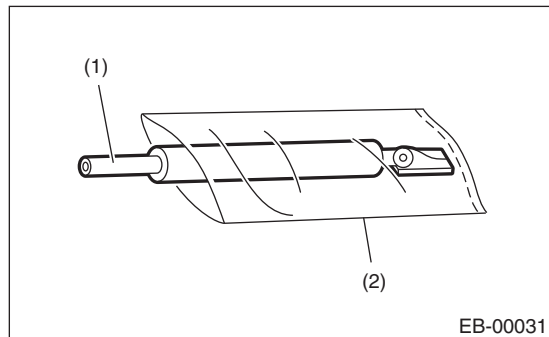

- (1) Rear gate damper stay
- (2) Vinyl sack

NOTE:

Prevent the vinyl sack from being caught by drill cutting edge

2) Lift the body side slightly with piston rods fully extended, and secure the body side with vise.

Drill a hole of 2 to 3 mm (0.08 to 0.12 in) diameter at a point 10 to 200 mm (0.39 to 7.87 in) from the body side, and bleed the rear gate damper stay gas completely.

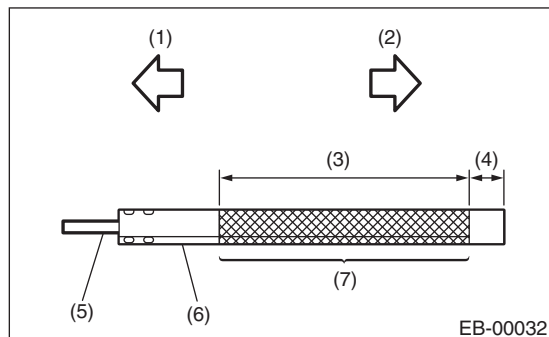

- (1) Door side
- (2) Body side
- (3) 190 mm (7.48 in)
- (4) 10 mm (0.39 in)
- (5) Piston rod
- (6) Cylinder
- (7) Portion to be drilled

Rear Gate

EXTERIOR BODY PANELS

CRUISE CONTROL SYSTEM

CC

	Page
1. General Description	2
2. Cruise Control Module	4
3. Cruise Control Command Switch	5
4. Combination Meter	6
5. Stop Light & Brake Switch	7
6. Transmission Control Module (TCM)	8
7. Inhibitor Switch	9

General Description

CRUISE CONTROL SYSTEM

1. General Description

A: COMPONENT

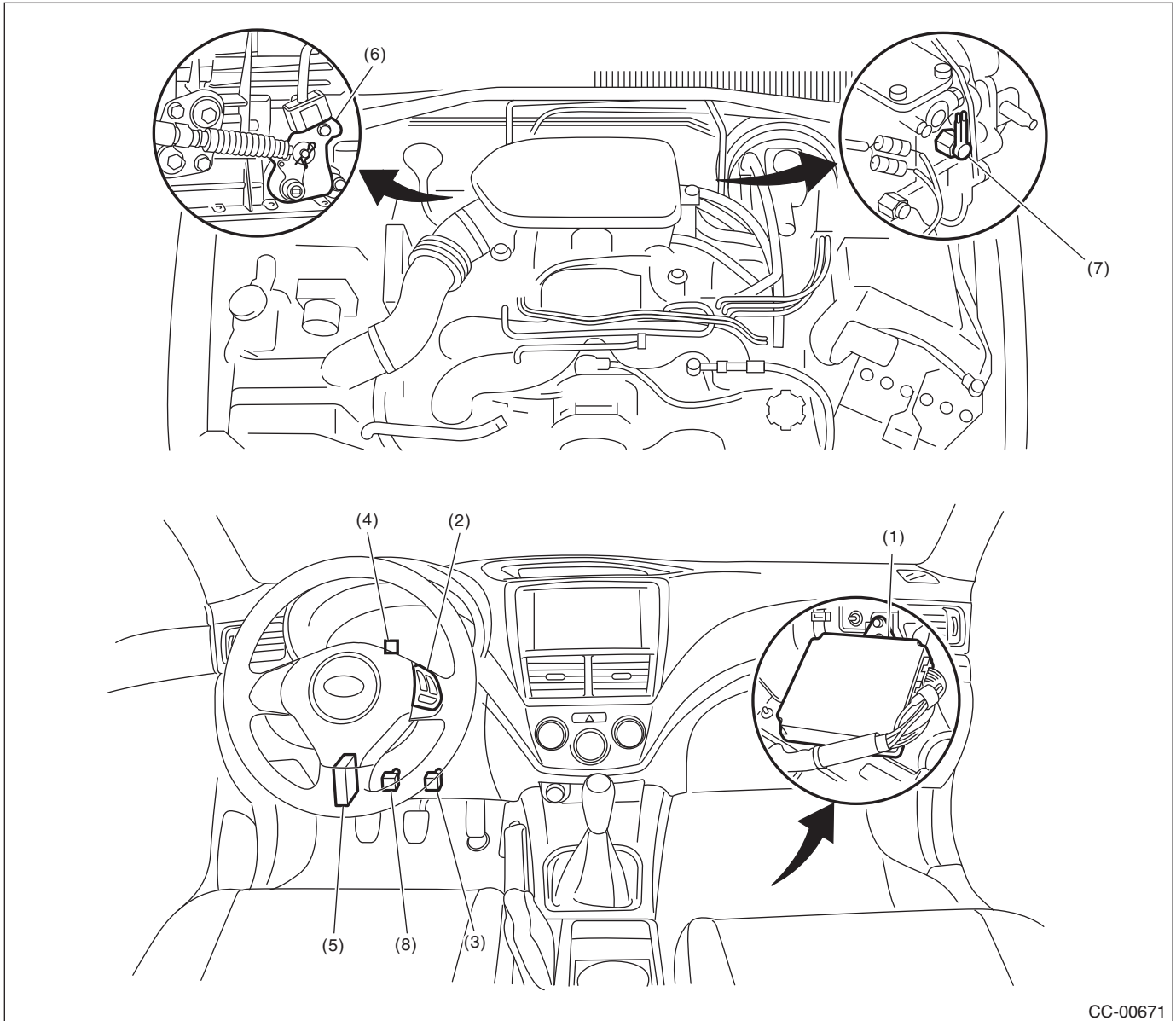

CC-00671

- | | | |
|---|--|--|
| (1) Engine control module (ECM) | (5) Transmission control module (TCM) (AT model) | (7) Neutral position switch (MT model) |
| (2) Cruise control command switch | (6) Inhibitor switch (AT model) | (8) Clutch switch (MT model) |
| (3) Stop light & brake switch | | |
| (4) Cruise indicator light and cruise set indicator light | | |

B: CAUTION

- Before disassembling or reassembling parts, always disconnect the battery ground cable from battery. When repairing the audio, control module, etc. which are provided with memory functions, record the memory contents before disconnecting the ground cable from battery. Otherwise, the memory will be cleared.
- Reassemble the parts in the reverse order of disassembly unless otherwise indicated.
- Adjust the parts to specifications specified in this manual.
- Connect the connectors securely during reassembly.
- After reassembly, ensure functional parts operate properly.

C: PREPARATION TOOL

TOOL NAME	REMARKS
Circuit tester	Used for measuring resistance and voltage.
TORX® bit T30	Used for removing/installing driver's airbag module

2. Cruise Control Module

A: NOTE

The control of cruise control system is carried out in engine control module (ECM).

Refer to “Engine Section” for removal/installation procedures of the control module.

B: REMOVAL

- 2.5 L turbo model <Ref. to FU(H4DOTC)-46, REMOVAL, Engine Control Module (ECM).>
- 2.5 L non-turbo model <Ref. to FU(H4SO)-39, REMOVAL, Engine Control Module (ECM).>

C: INSTALLATION

- 2.5 L turbo model <Ref. to FU(H4DOTC)-46, INSTALLATION, Engine Control Module (ECM).>
- 2.5 L non-turbo model <Ref. to FU(H4SO)-39, INSTALLATION, Engine Control Module (ECM).>

3. Cruise Control Command Switch

A: REMOVAL

WARNING:

Before servicing, be sure to read the notes in the “AB” section for proper handling of the driver’s airbag module. <Ref. to AB-5, CAUTION, General Description.>

- 1) Set the front wheels in straight ahead position.
- 2) Turn the ignition switch to OFF.
- 3) Disconnect the ground cable from battery and wait for at least 20 seconds before starting work.
- 4) Using TORX® bit T30 (1), loosen two TORX® bolts which secure the driver’s airbag module.

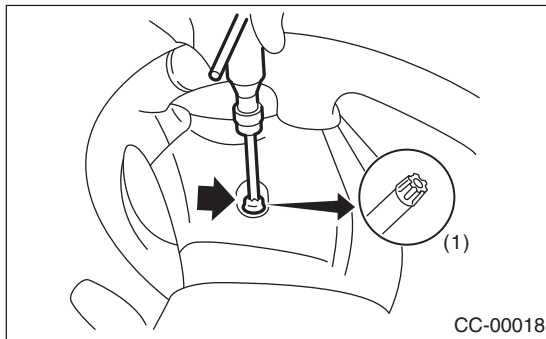

- 5) Disconnect the airbag module connector on back of the airbag module. <Ref. to AB-9, PROCEDURE, Airbag Connector.>
- 6) Remove the steering wheel. <Ref. to PS-12, REMOVAL, Steering Wheel.>
- 7) Remove the screws to remove the lower cover from steering wheel.

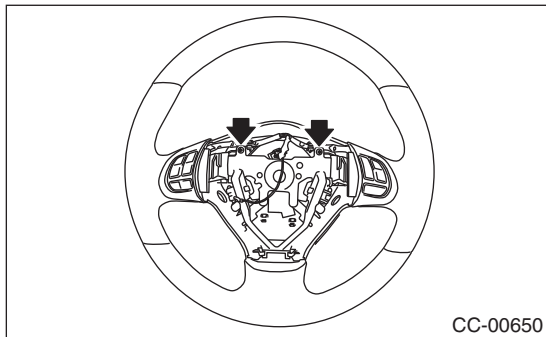

- 8) Remove the screws on the backside of the steering wheel and remove the cruise control command switch.

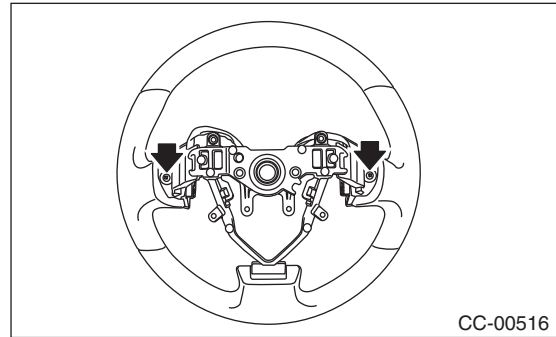

B: INSTALLATION

Install in the reverse order of removal.

C: INSPECTION

Measure the cruise control command switch resistance.

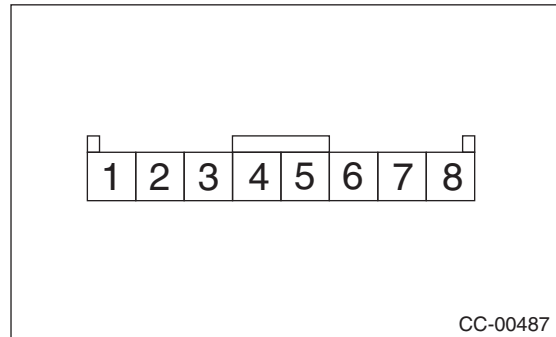

Switch	Position	Terminal No.	Standard value
CANCEL SET/COAST RESUME/ ACCEL	All OFF	7 and 6	Approx. 4 kΩ
CANCEL	ON	7 and 6	Less than 1 Ω
SET/COAST	ON	7 and 6	Approx. 250 Ω
RESUME/ ACCEL	ON	7 and 6	Approx. 1500 Ω
MAIN (CRUISE)	OFF	8 and 6	1 MΩ or more
	ON	8 and 6	Less than 1 Ω

If NG, replace the cruise control command switch.

4. Combination Meter

A: NOTE

For combination meter, refer to the "IDI". <Ref. to IDI-16, Combination Meter.>

5. Stop Light & Brake Switch

A: NOTE

Refer to "BR section" for stop light & brake switch.
<Ref. to BR-39, INSPECTION, Stop Light Switch.>

Transmission Control Module (TCM)

CRUISE CONTROL SYSTEM

6. Transmission Control Module (TCM)

A: NOTE

For transmission control module (TCM), refer to the following section. <Ref. to 4AT-60, Transmission Control Module (TCM).>

7. Inhibitor Switch

A: NOTE

Refer to "4AT section" for inhibitor switch. <Ref. to 4AT-46, INSPECTION, Inhibitor Switch.>

Inhibitor Switch

CRUISE CONTROL SYSTEM

CRUISE CONTROL SYSTEM (DIAGNOSTICS)

CC(diag)

	Page
1. Basic Diagnostic Procedure	2
2. General Description	4
3. Electrical Component Location	5
4. Engine Control Module (ECM) I/O Signal	6
5. Subaru Select Monitor	7
6. Read Cancel Code	8
7. Diagnostics with Phenomenon	10
8. List of Cancel Code	12
9. Diagnostic Procedure without Diagnostic Trouble Code (DTC)	15

Basic Diagnostic Procedure

CRUISE CONTROL SYSTEM (DIAGNOSTICS)

1. Basic Diagnostic Procedure

A: PROCEDURE

	Step	Check	Yes	No
1	CHECK MALFUNCTION INDICATOR LIGHT. Make sure the malfunction indicator light illuminates.	Does the malfunction indicator light illuminate?	Go to step 5.	Go to step 2.
2	CHECK CRUISE INDICATOR LIGHT. Make sure the cruise indicator light blinks.	Does the cruise indicator light blink?	Go to step 5.	Go to step 3.
3	CHECK CRUISE CONTROL MAIN SWITCH OPERATION. Check cruise control main switch operation. (Ensure the cruise indicator light illuminates.)	Is the cruise control main switch turned on? (Does the cruise indicator light illuminate?)	Go to step 4.	Go to phenomenon 1. <Ref. to CC(diag)-10, DIAGNOSTIC PROCEDURE WITH PHENOMENON, Diagnostics with Phenomenon.>
4	CHECK CRUISE CONTROL SET OPERATION. Check the cruise control setting operation.	Can the cruise control be set while driving at 40 km/h (25 MPH) or more?	Go to step 7.	Go to step 6.
5	CHECK CANCEL CODE. Read the cancel code using Subaru Select Monitor. NOTE: • Do not turn the ignition switch to OFF after the cruise control is deactivated. • Do not operate the cruise control command switch after the cruise control is deactivated. If the above is performed, the cancel code will be cleared.	Is it possible to read the cancel codes?	Perform the diagnosis according to the cancel code. <Ref. to CC(diag)-12, LIST, List of Cancel Code.>	Go to step 6.
6	CHECK CRUISE SET INDICATOR LIGHT. Make sure the cruise set indicator light illuminates.	Does the cruise set indicator light illuminate?	Go to step 7.	Go to phenomenon 3. <Ref. to CC(diag)-10, DIAGNOSTIC PROCEDURE WITH PHENOMENON, Diagnostics with Phenomenon.>
7	CHECK VEHICLE SPEED IS HELD WITHIN SET SPEED. Make sure the vehicle speed is held within set speed.	Is the vehicle speed kept within setting speed ± 3 km/h (± 2 MPH) ? (Make sure that on a level road.)	Go to step 8.	Go to phenomenon 4. <Ref. to CC(diag)-10, DIAGNOSTIC PROCEDURE WITH PHENOMENON, Diagnostics with Phenomenon.>
8	CHECK RESUME/ACCEL OPERATION. Check the RESUME/ACCEL switch operation.	Does the vehicle speed increase or return to set speed after RESUME/ACCEL switch has been pressed?	Go to step 9.	Go to phenomenon 5. <Ref. to CC(diag)-10, DIAGNOSTIC PROCEDURE WITH PHENOMENON, Diagnostics with Phenomenon.>

Basic Diagnostic Procedure

CRUISE CONTROL SYSTEM (DIAGNOSTICS)

Step	Check	Yes	No
9 CHECK SET/COAST OPERATION. Check the SET/COAST switch operation.	Does the vehicle speed decrease after SET/COAST switch has been pressed?	Go to step 10.	Go to phenomenon 6. <Ref. to CC(diag)-10, DIAGNOSTIC PROCEDURE WITH PHENOMENON, Diagnostics with Phenomenon.>
10 CANCEL OPERATION CHECK. Check the CANCEL switch operation.	Is the cruise control released after CANCEL switch has been pressed?	Go to step 11.	Go to phenomenon 7. <Ref. to CC(diag)-10, DIAGNOSTIC PROCEDURE WITH PHENOMENON, Diagnostics with Phenomenon.>
11 CHECK CRUISE CONTROL RELEASE OPERATION. Check the cruise control release operation.	Is the cruise control released after brake pedal has been depressed?	Go to step 12.	Go to phenomenon 8. <Ref. to CC(diag)-10, DIAGNOSTIC PROCEDURE WITH PHENOMENON, Diagnostics with Phenomenon.>
12 CHECK CRUISE CONTROL RELEASE OPERATION. Check the cruise control release operation.	Is the cruise control released after shifting to the neutral position?	Go to step 13.	Go to phenomenon 9. <Ref. to CC(diag)-10, DIAGNOSTIC PROCEDURE WITH PHENOMENON, Diagnostics with Phenomenon.>
13 CHECK CRUISE CONTROL RELEASE OPERATION. Check the cruise control release operation.	Is the cruise control released after depressing the clutch pedal?	Finish the diagnosis.	Go to phenomenon 10. <Ref. to CC(diag)-10, DIAGNOSTIC PROCEDURE WITH PHENOMENON, Diagnostics with Phenomenon.>

General Description

CRUISE CONTROL SYSTEM (DIAGNOSTICS)

2. General Description

A: CAUTION

Airbag system wiring harness is routed near the cruise control command switch.

CAUTION:

- Airbag system wiring harnesses and connectors are yellow. Do not use electrical test equipment on these circuits.
- Be careful not to damage the airbag system wiring harness when servicing the cruise control command switch. Airbag system wiring harness is routed near the cruise control command switch.

B: PREPARATION TOOL

1. SPECIAL TOOL

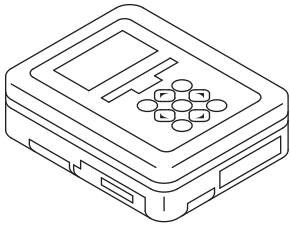
ILLUSTRATION	TOOL NUMBER	DESCRIPTION	REMARKS
 ST1B022XU0	1B022XU0 (Newly adopted tool)	SUBARU SELECT MONITOR III KIT	Used for troubleshooting the electrical system.

2. GENERAL TOOL

TOOL NAME	REMARKS
Circuit tester	Used for measuring resistance, voltage and current.

C: INSPECTION

Measure the battery voltage and specific gravity of electrolyte.

Standard voltage:

12 V or more

Specific gravity:

1.260 or more

Electrical Component Location

CRUISE CONTROL SYSTEM (DIAGNOSTICS)

3. Electrical Component Location

A: LOCATION

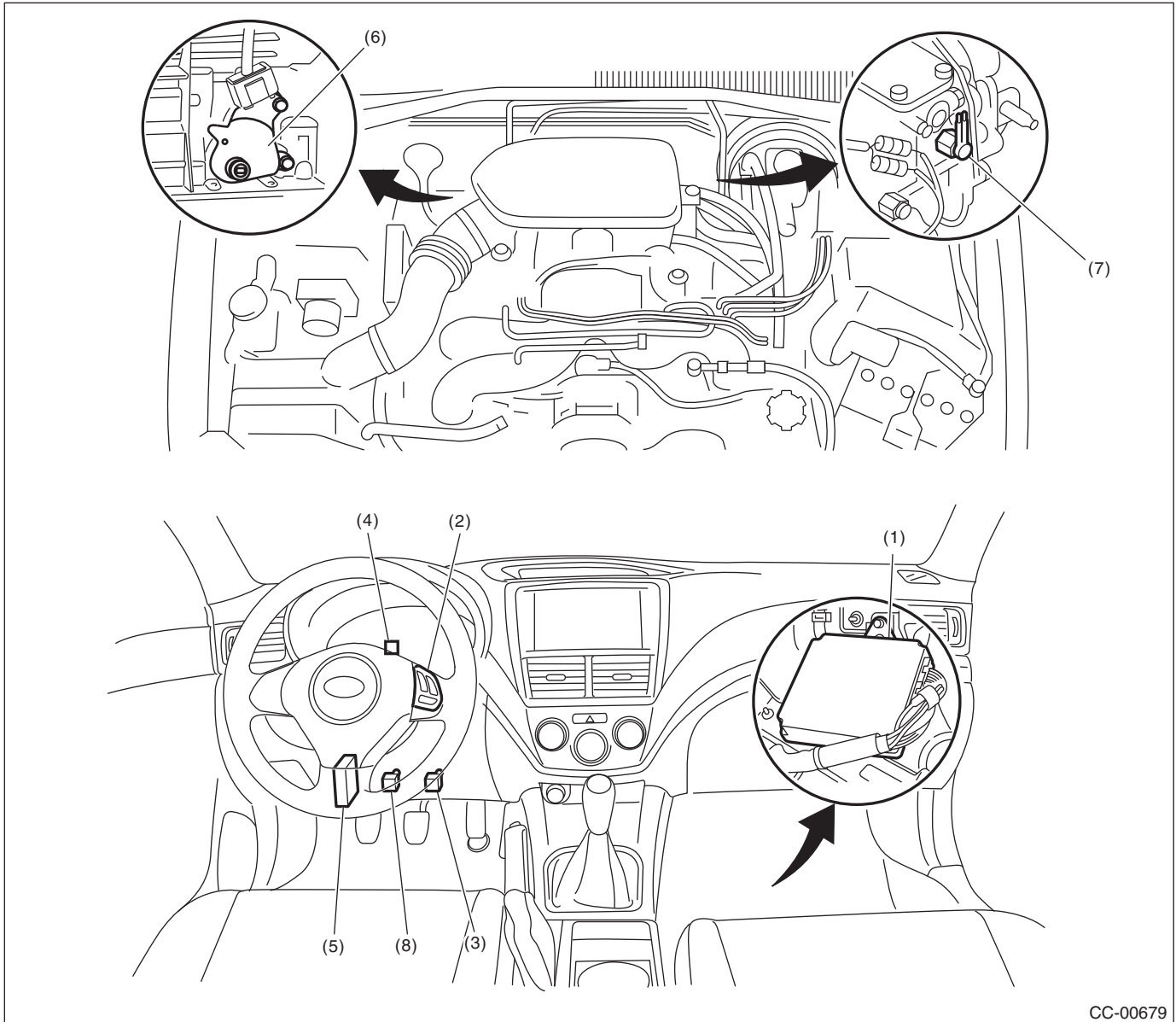

CC-00679

- | | | |
|---|--|--|
| (1) Engine control module (ECM) | (5) Transmission control module (TCM) (AT model) | (7) Neutral position switch (MT model) |
| (2) Cruise control command switch | (6) Inhibitor switch (AT model) | (8) Clutch switch (MT model) |
| (3) Stop light & brake switch | | |
| (4) Cruise indicator light and cruise set indicator light | | |

Engine Control Module (ECM) I/O Signal

CRUISE CONTROL SYSTEM (DIAGNOSTICS)

4. Engine Control Module (ECM) I/O Signal

A: ELECTRICAL SPECIFICATION

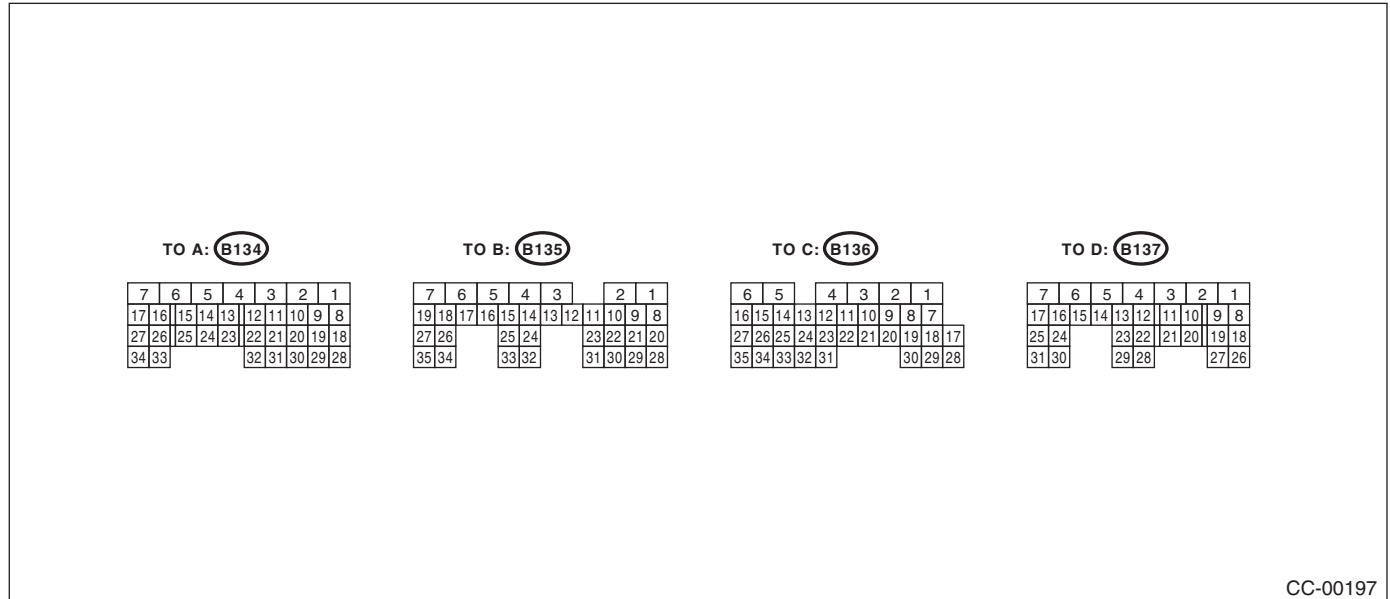

CC-00197

Contents		Terminal No.	Measurement condition and I/O signal (Idling with ignition ON: Except cruise set light)
Main power supply	VB (Control 1) VB (Control 2)	A7, B2	<ul style="list-style-type: none"> Battery voltage is detected when the main power is turned ON. "0 V" is detected when the main power is turned OFF.
Command switch		B24	<ul style="list-style-type: none"> "0 V" is detected when the command switch is in CANCEL position. "Approx. 1 V" is present when the command switch is in SET/COAST position. "Approx. 3 V" is detected when the command switch is in RESUME/ACCEL position. "Approx. 4 V" is detected when the command switch is released.
Brake switch 1 (Brake switch)		B20	<ul style="list-style-type: none"> Battery voltage is detected when the brake pedal is released. "0 V" is present when brake pedal is depressed.
Brake switch 2 (Stop light switch)		B28	<ul style="list-style-type: none"> Battery voltage is present when brake pedal is depressed. "0 V" is detected when the brake pedal is released.
Main switch		B12	<ul style="list-style-type: none"> "0 V" is present while the main switch is pressed or turned on. Approx. "5 V" is detected when the main switch is OFF.
Ground	GND (Control 1) GND (Control 2)	A5 C15 (Non-turbo model only)	—
Ignition switch		B19	<ul style="list-style-type: none"> Battery voltage is detected when the ignition switch is turned ON. "0 V" is detected when the ignition switch is turned OFF.
Clutch switch (MT model)		C25	<ul style="list-style-type: none"> "0 V" is present when brake pedal is depressed. Battery voltage is detected when the clutch pedal is released.
Neutral position switch (MT model)		C31	<ul style="list-style-type: none"> Battery voltage is present when the shift lever is set in any position other than neutral. "Approx. 0 V" is detected when the shift lever is in neutral position.
Neutral signal (AT model)		C31	<ul style="list-style-type: none"> Battery voltage is present when the shift lever is set in any position other than "P" or "N" position. "0 V" is detected when the shift lever is in "P" or "N" position.

B: WIRING DIAGRAM

<Ref. to WI-158, WIRING DIAGRAM, Cruise Control System.>

5. Subaru Select Monitor

A: OPERATION

- 1) Prepare the Subaru Select Monitor kit.
- 2) Prepare PC with Subaru Select Monitor installed.
- 3) Connect the SDI (Subaru Diagnostic Interface) to the PC USB port (exclusively for Subaru Selector Monitor) using a USB cable.

NOTE:

Port exclusively for Subaru Select Monitor refers to the USB port used when installing Subaru Select Monitor.

- 4) Connect the diagnosis cable to the SDI.
- 5) Connect the SDI to data link connector located in the lower portion of the instrument panel (on the driver's side).

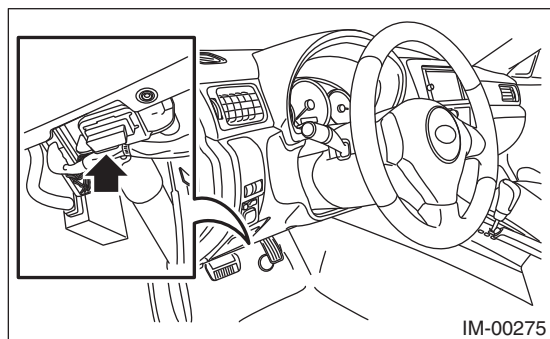

CAUTION:

Do not connect scan tools other than the Subaru Select Monitor.

- 6) Turn the ignition switch to ON.
- 7) Start the PC.
- 8) Run the "PC application for Subaru Select Monitor".

Read Cancel Code

CRUISE CONTROL SYSTEM (DIAGNOSTICS)

6. Read Cancel Code

A: OPERATION

1. GENERAL DESCRIPTION

The on-board diagnosis function operates in two categories, which are used depending on the type of problems;

1) Cruise Control Cancel Conditions Diagnosis:

(1) This category of diagnosis requires actual vehicle driving in order to determine the cause, as when cruise speed is cancelled during driving although cruise cancel condition is not entered.

(2) Cruise control memory in ECM stores the cancel code which occurred during driving. When there are multiple cancel code, they are shown on the Subaru Select Monitor.

CAUTION:

- **The cruise control memory stores not only the cruise “cancel” which occurred (although “cancel” operation is not entered by the driver), but also the “cancel” condition input by the driver.**

- **The latest memory content (latest code) is cleared when ignition switch is turned to OFF. However, the memory content by the diagnosis of faulty switches relating to the system and cruise control is retained as the fault history (memory code) after the ignition switch is turned OFF.**

2) Real-time Diagnosis:

Real-time diagnosis function is used to determine whether or not the input signal system is in good order, according to signal emitted from switches, sensors, etc.

(1) Vehicle cannot be driven at cruise speed when the problem occurs in the cruise control system or relevant circuits.

(2) Monitor the signal conditions from switches and sensors.

2. CRUISE CONTROL CANCEL CONDITIONS DIAGNOSIS

1) Run the Subaru Select Monitor.

2) On the «Main Menu», select {2. Each System Check}.

On the system selection display screen, select the {Engine Control System} and the [OK]. Select the [OK] after the information of engine type is displayed.

3) Drive vehicle at 40 km/h (25 MPH) or more and set the cruise control.

CAUTION:

- **When performing diagnosis, observe the legal speed limit on the road.**

- **Cancel code will be also displayed when cruise control is cancelled by the driver's operation. Do not confuse them.**

- **Be sure to get an assistant to support the diagnosis while driving, and have him/her operate the select monitor.**

4) When the set speed is canceled by itself (without any cancel operations such as applying brake) or when the cruise control could not be set by performing the setting operation, selecting the {Cancel Code(s) Display} on the engine malfunction diagnosis screen will display the cancel code on the select monitor display.

NOTE:

There are {Latest Diagnostic Code(s)} and {Memorized Diagnostic Code(s)} in cancel code. The latest code recognized during current test drive is displayed in {Latest Diagnostic Code(s)}. Cancel codes by the diagnosis of faulty switches relating to the system and cruise control are displayed in {Memorized Diagnostic Code(s)}.

5) Perform Engine DTC Clear Memory operation. <Ref. to EN(H4SO)(diag)-51, OPERATION, Clear Memory Mode.> <Ref. to EN(H4DOTC)(diag)-52, OPERATION, Clear Memory Mode.>

Cancel codes of switches relating to the system and cruise control are deleted by clearing memory on the engine side.

NOTE:

The latest code will be cleared by turning ignition switch to OFF.

3. REAL-TIME DIAGNOSIS

1) Select {Current Data Display & Save} in «Engine Diagnosis» display screen.

2) Make sure that normal display is shown when operated as follows:

- Depress and release the brake pedal. (Stop light switch and brake switch are turned ON.)
- Turn the main switch to ON.
- Turn the “CANCEL” switch to ON.
- Turn the “SET/COAST” switch to ON.
- Turn the “RESUME/ACCEL” switch to ON.
- Depress or release the clutch pedal.
- Place the shift lever in any position other than neutral.

NOTE:

- For details concerning the operation procedure, refer to the “PC application help for Subaru Select Monitor”.
- For detailed concerning cancel code, refer to the “List of Cancel Codes”. <Ref. to CC(diag)-12, List of Cancel Code.>

Diagnostics with Phenomenon

CRUISE CONTROL SYSTEM (DIAGNOSTICS)

7. Diagnostics with Phenomenon

A: DIAGNOSTIC PROCEDURE WITH PHENOMENON

Phenomenon		Check item	Reference
1	Cruise control main switch is not turned to ON. (Cruise indicator light does not illuminate.)	(1) Perform cruise cancel conditions diagnosis.	Perform the diagnosis according to displayed cancel code.
		(2) Perform the real-time diagnosis.	Check the input signal of cruise control system.
		(3) Check the cruise control command switch.	<Ref. to CC(diag)-15, DTC 11, Diagnostic Procedure without Diagnostic Trouble Code (DTC).>
		(4) Check the cruise indicator light.	<Ref. to CC(diag)-11, CHECK CRUISE INDICATOR LIGHT AND CRUISE SET INDICATOR LIGHT, Diagnostics with Phenomenon.>
2	Cruise control cannot be set.	(1) Perform cruise cancel conditions diagnosis.	Perform the diagnosis according to displayed cancel code.
		(2) Perform the real-time diagnosis.	Check the input signal of cruise control system.
		(3) Check the cruise control command switch.	<Ref. to CC(diag)-15, DTC 11, Diagnostic Procedure without Diagnostic Trouble Code (DTC).>
		(4) Check stop light switch and brake switch.	<Ref. to BR-37, Brake Pedal.> <Ref. to CC(diag)-17, DTC 12, Diagnostic Procedure without Diagnostic Trouble Code (DTC).>
		(5) Check clutch switch.	<Ref. to CL-26, Clutch Switch.> <Ref. to CC(diag)-19, DTC 13, Diagnostic Procedure without Diagnostic Trouble Code (DTC).>
		(6) Check the neutral position switch.	<Ref. to CC(diag)-21, DTC 14, Diagnostic Procedure without Diagnostic Trouble Code (DTC).> <Ref. to CC(diag)-25, DTC 62, Diagnostic Procedure without Diagnostic Trouble Code (DTC).>
		(7) Check vehicle speed sensor.	<Ref. to CC(diag)-24, DTC 22, Diagnostic Procedure without Diagnostic Trouble Code (DTC).>
3	Cruise set indicator light does not illuminate.	Check the cruise set indicator light.	<Ref. to CC(diag)-11, CHECK CRUISE INDICATOR LIGHT AND CRUISE SET INDICATOR LIGHT, Diagnostics with Phenomenon.>
4	Vehicle speed is not held within set speed ± 3 km/h (± 2 MPH).	Check the vehicle speed sensor.	<Ref. to CC(diag)-24, DTC 22, Diagnostic Procedure without Diagnostic Trouble Code (DTC).>
5	Vehicle speed does not increase or does not return to set speed after RESUME/ACCEL switch has been pressed.	(1) Perform the real-time diagnosis.	Check the input signal of cruise control system.
		(2) Check the RESUME/ACCEL switch.	<Ref. to CC(diag)-15, DTC 11, Diagnostic Procedure without Diagnostic Trouble Code (DTC).>
6	Vehicle speed does not decrease after SET/COAST switch has been pressed.	(1) Perform the real-time diagnosis.	Check the input signal of cruise control system.
		(2) Check the SET/COAST switch.	<Ref. to CC(diag)-15, DTC 11, Diagnostic Procedure without Diagnostic Trouble Code (DTC).>
7	Cruise control is not released after CANCEL switch has been pressed.	(1) Perform the real-time diagnosis.	Check the input signal of cruise control system.
		(2) Check the CANCEL switch.	<Ref. to CC(diag)-15, DTC 11, Diagnostic Procedure without Diagnostic Trouble Code (DTC).>
8	Cruise control is not released after brake pedal has been depressed.	(1) Perform the real-time diagnosis.	Check the input signal of cruise control system.
		(2) Check stop light switch and brake switch.	<Ref. to CC(diag)-17, DTC 12, Diagnostic Procedure without Diagnostic Trouble Code (DTC).> <Ref. to BR-39, INSTALLATION, Stop Light Switch.>

Diagnostics with Phenomenon

CRUISE CONTROL SYSTEM (DIAGNOSTICS)

Phenomenon		Check item	Reference
9	Cruise control is not released after shifting to the neutral position.	(1) Perform the real-time diagnosis.	Check the input signal of cruise control system.
		(2) Check the neutral position switch.	<Ref. to CC(diag)-21, DTC 14, Diagnostic Procedure without Diagnostic Trouble Code (DTC).> <Ref. to 4AT-46, INSPECTION, Inhibitor Switch.>
10	Cruise control is not released after clutch pedal has been depressed.	(1) Perform the real-time diagnosis.	Check the input signal of cruise control system.
		(2) Check clutch switch.	<Ref. to CC(diag)-19, DTC 13, Diagnostic Procedure without Diagnostic Trouble Code (DTC).> <Ref. to CL-26, CLUTCH SWITCH (CRUISE CONTROL), INSTALLATION, Clutch Switch.>

B: CHECK CRUISE INDICATOR LIGHT AND CRUISE SET INDICATOR LIGHT

TROUBLE SYMPTOM:

Cruise control can be set, but the cruise indicator light and cruise set indicator light do not illuminate.

Step	Check	Yes	No	
1	CHECK CRUISE INDICATOR LIGHT AND CRUISE SET INDICATOR LIGHT. 1) Perform the self-diagnosis of combination meter. <Ref. to IDI-4, SELF-DIAGNOSIS, INSPECTION, Combination Meter System.> 2) Check the cruise indicator light and cruise set indicator light if they illuminate.	Do the cruise indicator light and cruise set indicator light illuminate?	Go to step 2.	Replace the meter case assembly. <Ref. to IDI-16, Combination Meter.>
2	CHECK DTC OF LAN COMMUNICATION CIRCUIT. 1) Complete self-diagnosis, and turn the ignition switch to ON again. 2) Read the DTC of body integrated unit using Subaru Select Monitor.	Is DTC of Low-speed CAN displayed?	Check the LAN communication circuit.	Replace the ECM. <Ref. to FU(H4DOTC)-46, Engine Control Module (ECM).>

List of Cancel Code

CRUISE CONTROL SYSTEM (DIAGNOSTICS)

8. List of Cancel Code

A: LIST

NOTE:

- The cancel code is registered even when cancel is performed intentionally by the driver.
- Cancel codes are cleared if the ignition switch is turned to OFF.
- If a different cancel code is input after a cancel code (latest code) has been input, the latest code is overwritten.
- If the cruise indicator light is flashing, a malfunction is occurring in the system or cruise control related switch. The cancel code at this time is saved even after ignition switch OFF as a memory code of a past malfunction.
- To display a cancel code, use the Subaru Select Monitor to read the code after the cruise control is deactivated during a driving test.

Cancel code	Item	Contents of diagnosis	Reference
11	Main Switch	Main switch of cruise control command switch is turned to OFF, and then the cruise control is released.	This code is displayed without operating the main switch. <Ref. to CC(diag)-15, DTC 11, Diagnostic Procedure without Diagnostic Trouble Code (DTC).>
12	Stop Light & Brake Switch	Stop light switch or brake switch is turned to ON, and then the cruise control is released.	This code is displayed without depressing the brake pedal. <Ref. to CC(diag)-17, DTC 12, Diagnostic Procedure without Diagnostic Trouble Code (DTC).>
13	Clutch Switch	Clutch switch is turned to ON, and then the cruise control is released.	This code is displayed without depressing the clutch pedal. <Ref. to CC(diag)-19, DTC 13, Diagnostic Procedure without Diagnostic Trouble Code (DTC).>
14	Neutral Position Switch	Neutral position switch is turned to ON, and then the cruise control is released.	This code is displayed without shifting to neutral position. <Ref. to CC(diag)-21, DTC 14, Diagnostic Procedure without Diagnostic Trouble Code (DTC).>
15	Cancel Switch	Cancel switch is turned to ON, and then the cruise control is released.	This code is displayed without operating the cancel switch. <Ref. to CC(diag)-22, DTC 15, Diagnostic Procedure without Diagnostic Trouble Code (DTC).>
16	Ignition Switch	Ignition switch is turned to OFF, and then the cruise control is released.	This code is displayed without operating the ignition switch. <Ref. to CC(diag)-23, DTC 16, Diagnostic Procedure without Diagnostic Trouble Code (DTC).>

List of Cancel Code

CRUISE CONTROL SYSTEM (DIAGNOSTICS)

Cancel code	Item	Contents of diagnosis	Reference
21	Cruise control switch malfunction when ignition switch is turned to ON	When the ignition switch is turned to ON, each switch of cruise control command switch is already turned to ON.	This code is displayed when the ignition switch is turned to ON without operating the cruise control command switch. <Ref. to CC(diag)-23, DTC 21, Diagnostic Procedure without Diagnostic Trouble Code (DTC).>
22	Abnormality of change in vehicle speed	Malfunction of vehicle speed signal variation is detected.	<Ref. to CC(diag)-24, DTC 22, Diagnostic Procedure without Diagnostic Trouble Code (DTC).>
24	Cruise Control Related Switch Malfunction	Open circuit of cruise control switch is detected during cruise driving. (The system is judged as model without cruise control.)	This code is displayed with normal operation. <Ref. to CC(diag)-24, DTC 24, Diagnostic Procedure without Diagnostic Trouble Code (DTC).>
25	Brake Switch Input Circuit Malfunction	Malfunction of brake switch input circuit in ECM is detected.	<Ref. to CC(diag)-24, DTC 25, Diagnostic Procedure without Diagnostic Trouble Code (DTC).>
31	Abnormal engine speed Signal	<ul style="list-style-type: none"> Abnormal increase of engine speed is detected. Gear is placed in Neutral, 1st or Reverse position. 	Cruise in 2nd shift position or more. <Ref. to CC(diag)-24, DTC 31, Diagnostic Procedure without Diagnostic Trouble Code (DTC).>
32	Out of vehicle speed range of cruise control operation	<ul style="list-style-type: none"> Controlled vehicle speed decreased under the limit during cruising. Set operation was performed at vehicle speed unavailable for setting. RESUME operation was performed without memorized vehicle speed. 	This code is displayed, though the vehicle speed is increased to the speed available for cruise set and set operation was performed again. <Ref. to CC(diag)-24, DTC 32, Diagnostic Procedure without Diagnostic Trouble Code (DTC).>
34	Prohibition of cruise control at continuing big Accel. angle	The vehicle has been driven at higher speed than set vehicle speed for an abnormally long time (approximately 10 minutes) during cruise driving.	This code is displayed when driving for a long period of time at higher speed than appropriate cruise set vehicle speed by operating accelerator pedal. In this case, the cruise setting is deactivated. <Ref. to CC(diag)-24, DTC 34, Diagnostic Procedure without Diagnostic Trouble Code (DTC).>

List of Cancel Code

CRUISE CONTROL SYSTEM (DIAGNOSTICS)

Cancel code	Item	Contents of diagnosis	Reference
35	Prohibition when vehicle speed feedback is impossible	Set vehicle speed cannot be kept because of some reasons (steep uphill, parking brake, abnormal decrease of engine output, etc.) during cruise driving.	This code is displayed when driving condition is not suitable for cruise control. Perform cruise set operation again after clearing the possible cause. <Ref. to CC(diag)-25, DTC 35, Diagnostic Procedure without Diagnostic Trouble Code (DTC).>
41	VDC/TCS Operating	Vehicle dynamics control (VDC) or TCS is operated during cruise driving or cruise setting.	This code is displayed when driving condition is not suitable for cruise control. Perform cruise set operation again after clearing the possible cause. <Ref. to CC(diag)-25, DTC 41, Diagnostic Procedure without Diagnostic Trouble Code (DTC).>
43	ABS/VDC Failure	ABS or Vehicle dynamics control (VDC) system malfunction is detected during cruise driving or cruise setting.	<Ref. to CC(diag)-25, DTC 43, Diagnostic Procedure without Diagnostic Trouble Code (DTC).>
44	Body Integrated unit Failure	Body integrated unit system malfunction is detected during cruise driving or cruise setting.	<Ref. to CC(diag)-25, DTC 44, Diagnostic Procedure without Diagnostic Trouble Code (DTC).>
45	Meter Failure	Combination meter malfunction is detected during cruise driving or cruise setting.	<Ref. to CC(diag)-25, DTC 45, Diagnostic Procedure without Diagnostic Trouble Code (DTC).>
61	Brake switch abnormal	Malfunction in the stop light & brake switch is detected.	<Ref. to CC(diag)-25, DTC 61, Diagnostic Procedure without Diagnostic Trouble Code (DTC).>
62	Neutral switch Failure	Neutral position switch malfunction is detected.	<Ref. to CC(diag)-25, DTC 62, Diagnostic Procedure without Diagnostic Trouble Code (DTC).>
63	Abnormality 1 of change in vehicle speed	Malfunction of vehicle speed signal variation is detected.	<Ref. to CC(diag)-25, DTC 63, Diagnostic Procedure without Diagnostic Trouble Code (DTC).>
64	Engine Sensor Failure	Malfunction related to engine is detected.	<Ref. to CC(diag)-25, DTC 64, Diagnostic Procedure without Diagnostic Trouble Code (DTC).>
65	Abnormality 1 of switches related to cruise control 1	Cruise control command switch malfunction is detected. (While the switch is pressed ON for a long time (approximately two minutes), stuck ON condition is detected.)	<Ref. to CC(diag)-26, DTC 65, Diagnostic Procedure without Diagnostic Trouble Code (DTC).>
66	Cruise Control Calculation Error	Cruise control calculation (microcomputer) malfunction is detected.	<Ref. to CC(diag)-26, DTC 66, Diagnostic Procedure without Diagnostic Trouble Code (DTC).>

Diagnostic Procedure without Diagnostic Trouble Code (DTC)

CRUISE CONTROL SYSTEM (DIAGNOSTICS)

9. Diagnostic Procedure without Diagnostic Trouble Code (DTC)

A: DTC 11

The malfunction is detected when the main switch is pressed or problem relating to the main switch occurs.

TROUBLE SYMPTOM:

- Cruise control cannot be set. (Cancelled immediately.)
- Cruise control cannot be released.

WIRING DIAGRAM:

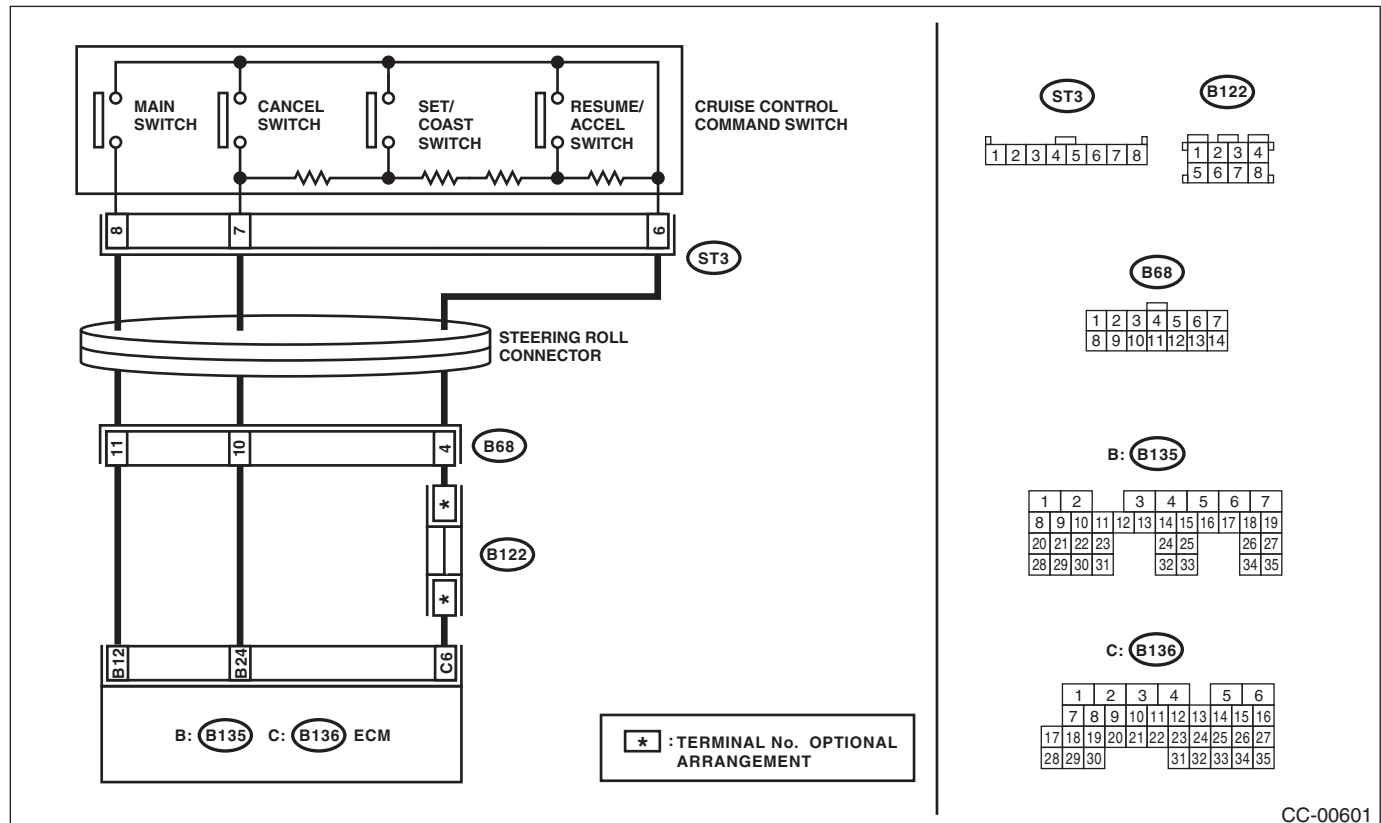

CC-00601

Diagnostic Procedure without Diagnostic Trouble Code (DTC)

CRUISE CONTROL SYSTEM (DIAGNOSTICS)

	Step	Check	Yes	No
1	<p>CHECK CRUISE CONTROL COMMAND SWITCH CIRCUIT.</p> <p>1) Remove the driver's airbag module. <Ref. to AB-16, REMOVAL, Driver's Airbag Module.></p> <p>2) Disconnect the harness connector of cruise control command switch.</p> <p>3) Turn the ignition switch to ON.</p> <p>4) Measure the voltage between harness connector terminal and chassis ground.</p> <p>Connector & terminal (ST3) No. 8 (+) — Chassis ground (-): (ST3) No. 7 (+) — Chassis ground (-):</p>	Is the voltage 5 V or more?	Go to step 2.	Check the harness between cruise control command switch and ECM, and the steering roll connector for open or short circuit, or for poor contact.
2	<p>CHECK CRUISE CONTROL COMMAND SWITCH CIRCUIT.</p> <p>1) Turn the ignition switch to OFF.</p> <p>2) Remove the cruise control command switch. <Ref. to CC-5, REMOVAL, Cruise Control Command Switch.></p> <p>3) Measure the resistance between harness connector terminal and chassis ground.</p> <p>Connector terminal (ST3) No. 6 — Chassis ground:</p>	Is the resistance less than 10 Ω?	Go to step 3.	Check for open between cruise control command switch and ECM and chassis ground, and check the ECM.
3	<p>CHECK CRUISE CONTROL COMMAND SWITCH.</p> <p>Measure the resistance between switch terminals when the cruise control command switch is not being pressed.</p> <p>Terminals No. 6 — No. 7:</p>	Is the resistance approx. 4 kΩ?	Go to step 4.	Replace the cruise control command switch. <Ref. to CC-5, Cruise Control Command Switch.>
4	<p>CHECK CANCEL SWITCH.</p> <p>1) Turn the ignition switch to OFF.</p> <p>2) Remove the cruise control command switch. <Ref. to CC-5, REMOVAL, Cruise Control Command Switch.></p> <p>3) Measure the resistance between switch terminals when the CANCEL switch is pressed.</p> <p>Terminals No. 6 — No. 7:</p>	Is the resistance approx. less than 1 Ω when the CANCEL switch is pressed?	Go to step 5.	Replace the cruise control command switch. <Ref. to CC-5, Cruise Control Command Switch.>
5	<p>CHECK SET/COAST SWITCH.</p> <p>Measure the resistance between switch terminals when the SET/COAST switch is pressed.</p> <p>Terminals No. 6 — No. 7:</p>	Is the resistance approx. 250 Ω when SET/COAST switch is pressed?	Go to step 6.	Replace the cruise control command switch. <Ref. to CC-5, Cruise Control Command Switch.>
6	<p>CHECK RESUME/ACCEL SWITCH CIRCUIT.</p> <p>Measure the resistance between switch terminals when the RESUME/ACCEL switch is pressed.</p> <p>Terminals No. 6 — No. 7:</p>	Is the resistance approx. 1,500 Ω when RESUME/ACCEL switch is pressed?	Replace the ECM. <Ref. to FU(H4DOTC)-46, Engine Control Module (ECM).>	Replace the cruise control command switch. <Ref. to CC-5, Cruise Control Command Switch.>

Diagnostic Procedure without Diagnostic Trouble Code (DTC)

CRUISE CONTROL SYSTEM (DIAGNOSTICS)

B: DTC 12

The DTC is detected when the brake pedal is pressed or problem relating to stop light & brake switch occurs.

TROUBLE SYMPTOM:

- Cruise control cannot be set.
- Cruise control cannot be released.

WIRING DIAGRAM:

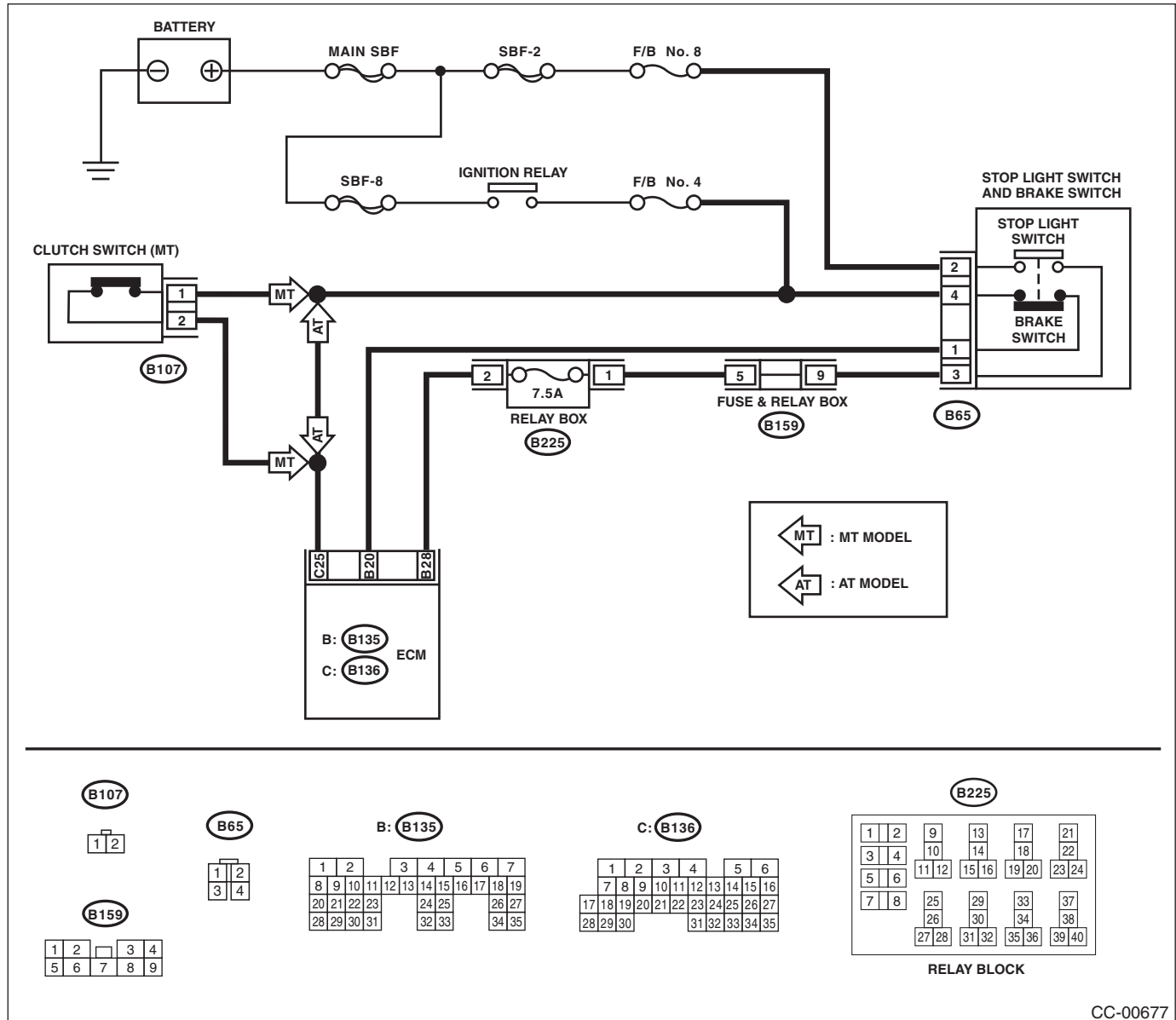

CC-00677

Diagnostic Procedure without Diagnostic Trouble Code (DTC)

CRUISE CONTROL SYSTEM (DIAGNOSTICS)

Step	Check	Yes	No
1 CHECK STOP LIGHT & BRAKE SWITCH CIRCUIT. 1) Turn the ignition switch to OFF. 2) Disconnect the stop light & brake switch harness connector. 3) Turn the ignition switch to ON. 4) Measure the voltage between harness connector terminal and chassis ground. Connector & terminal (B65) No. 2 (+) — Chassis ground (-):	Is the voltage 10 V or more?	Go to step 2.	<ul style="list-style-type: none"> • Check fuse No. 8 (in fuse & relay box). • Check for open or short in the harness between stop light & brake switch and fuse & relay box.
2 CHECK STOP LIGHT & BRAKE SWITCH CIRCUIT. Measure the voltage between harness connector terminal and chassis ground. Connector & terminal (B65) No. 4 (+) — Chassis ground (-):	Is the voltage 10 V or more?	Go to step 3.	<ul style="list-style-type: none"> • Check fuse No. 4 (in fuse & relay box). • Check for open or short in the harness between stop light & brake switch and fuse & relay box.
3 CHECK STOP LIGHT & BRAKE SWITCH CIRCUIT. 1) Turn the ignition switch to OFF. 2) Disconnect the harness connector of ECM. 3) Measure the resistance between ECM harness connector terminal and stop light & brake switch harness connector terminal. Connector & terminal (B135) No. 20 — (B65) No. 1: (B135) No. 28 — (B65) No. 3:	Is the resistance less than 10 Ω?	Go to step 4.	Repair the harness.
4 CHECK STOP LIGHT & BRAKE SWITCH CIRCUIT. Remove and check the stop light & brake switch. <Ref. to CC-7, Stop Light & Brake Switch.>	Is the stop light & brake switch OK?	Replace the ECM. <Ref. to FU(H4DOTC)-46, Engine Control Module (ECM).>	Replace the stop light & brake switch.

Diagnostic Procedure without Diagnostic Trouble Code (DTC)

CRUISE CONTROL SYSTEM (DIAGNOSTICS)

C: DTC 13

The DTC is detected when the clutch pedal is depressed or problem relating to the clutch switch occurs.

TROUBLE SYMPTOM:

- Cruise control cannot be set.
- Cruise control cannot be released.

WIRING DIAGRAM:

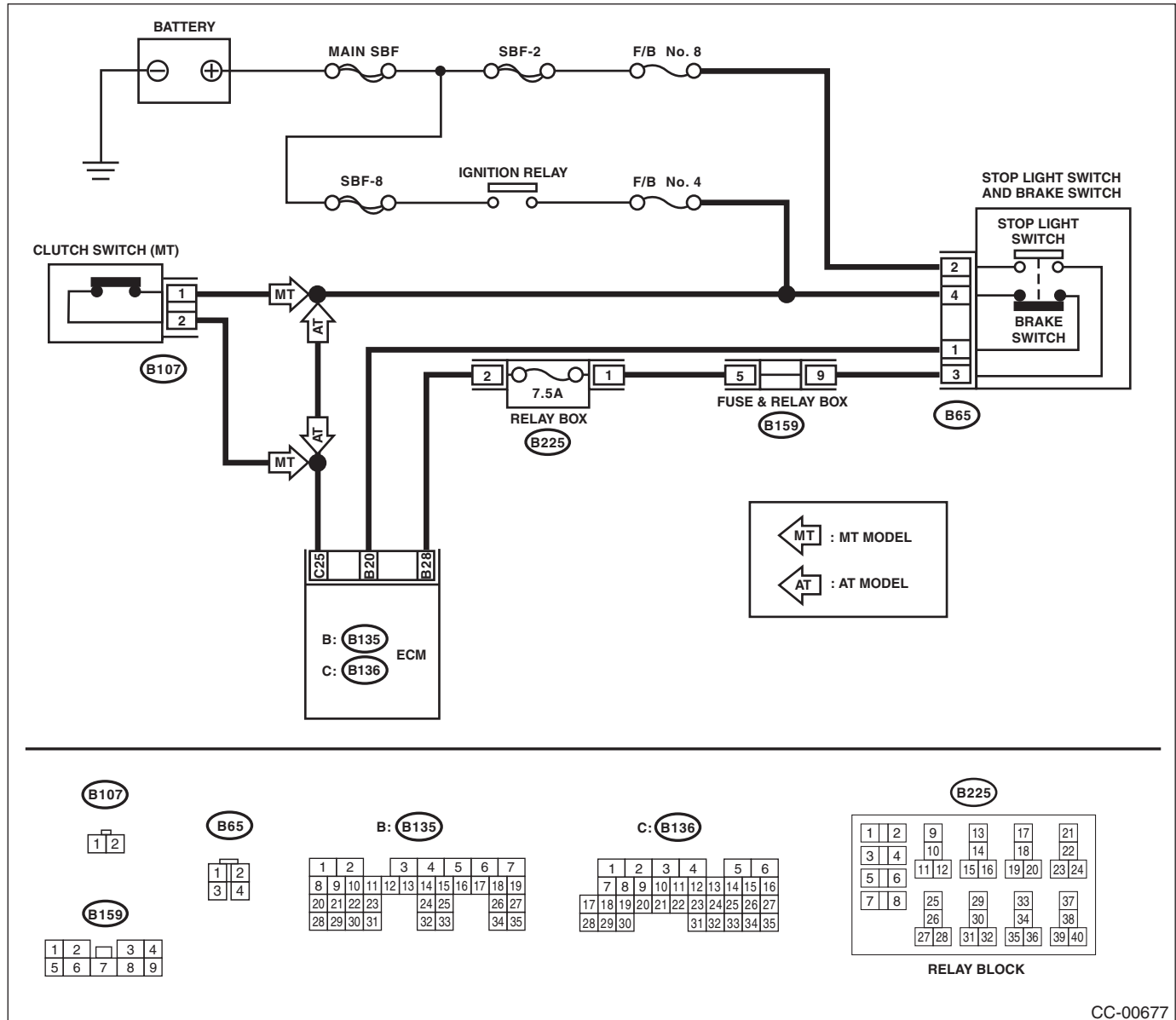

CC-00677

Diagnostic Procedure without Diagnostic Trouble Code (DTC)

CRUISE CONTROL SYSTEM (DIAGNOSTICS)

	Step	Check	Yes	No
1	CHECK CLUTCH SWITCH CIRCUIT. 1) Turn the ignition switch to OFF. 2) Disconnect the clutch switch harness connector. 3) Turn the ignition switch to ON. 4) Measure the voltage between harness connector terminal and chassis ground. Connector & terminal (B107) No. 1 (+) — Chassis ground (-):	Is the voltage 10 V or more?	Go to step 2.	<ul style="list-style-type: none"> • Check fuse No. 4 (in fuse & relay box). • Check open or shorted circuit of harness between clutch switch and fuse & relay box.
2	CHECK CLUTCH SWITCH CIRCUIT. 1) Turn the ignition switch to OFF. 2) Disconnect the harness connector of ECM. 3) Measure the resistance between clutch switch harness connector terminal and ECM harness connector terminal. Connector & terminal (B107) No. 2 — (B136) No. 25:	Is the resistance less than 10 Ω?	Go to step 3.	Repair the harness.
3	CHECK CLUTCH SWITCH. Remove and check the clutch switch. <Ref. to CL-26, INSPECTION, Clutch Switch.>	Is clutch switch OK?	Replace the ECM. <Ref. to FU(H4DOTC)-46, Engine Control Module (ECM).>	Replace the clutch switch.

Diagnostic Procedure without Diagnostic Trouble Code (DTC)

CRUISE CONTROL SYSTEM (DIAGNOSTICS)

D: DTC 14

The DTC is detected when the select lever is placed in neutral position or problem relating to the neutral position switch occurs.

TROUBLE SYMPTOM:

Cruise control cannot be set.

WIRING DIAGRAM:

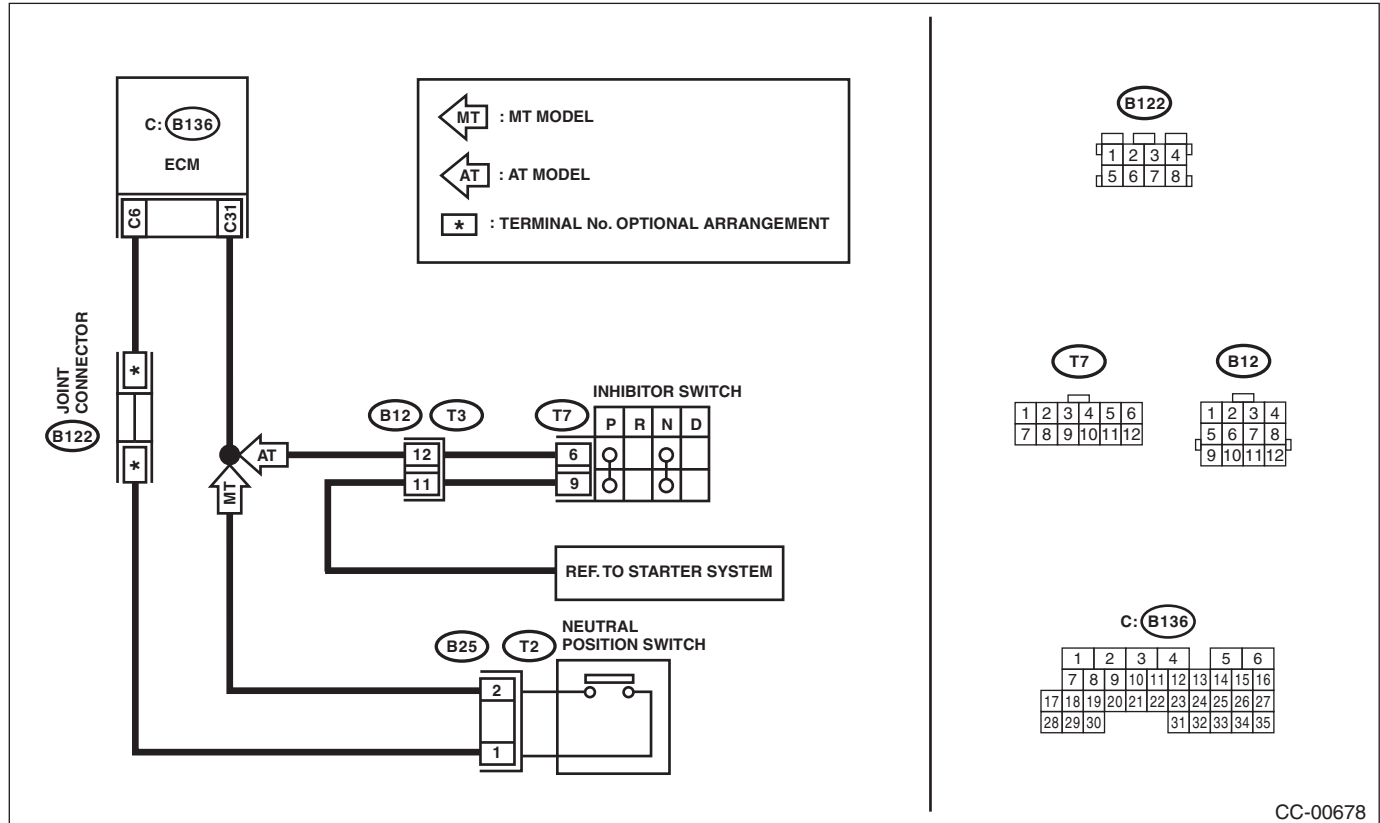

CC-00678

Diagnostic Procedure without Diagnostic Trouble Code (DTC)

CRUISE CONTROL SYSTEM (DIAGNOSTICS)

	Step	Check	Yes	No
1	CHECK TRANSMISSION TYPE.	Is the transmission type MT?	Go to step 5.	Go to step 2.
2	CHECK INHIBITOR SWITCH. 1) Turn the ignition switch to OFF. 2) Disconnect the inhibitor switch harness connector. 3) Turn the ignition switch to ON. 4) Measure the voltage between harness connector terminal and chassis ground. Connector & terminal (T7) No. 6 (+) — Chassis ground (-):	Is the voltage 5 V or more?	Go to step 3.	Check for open or short in the harness between inhibitor switch and ECM.
3	CHECK INHIBITOR SWITCH CIRCUIT. 1) Turn the ignition switch to OFF. 2) Disconnect the starter motor connector. 3) Turn the ignition switch to ON. 4) Measure the resistance between inhibitor switch harness connector terminal and starter motor. Connector & terminal (T7) No. 9 — Starter motor:	Is the resistance less than 10 Ω?	Repair the harness.	Go to step 4.
4	CHECK INHIBITOR SWITCH. Remove and check the inhibitor switch. <Ref. to 4AT-46, INSPECTION, Inhibitor Switch.>	Is the inhibitor switch OK?	Replace the ECM. <Ref. to FU(H4DOTC)-46, Engine Control Module (ECM).>	Replace the inhibitor switch.
5	CHECK NEUTRAL POSITION SWITCH CIRCUIT. 1) Turn the ignition switch to OFF. 2) Disconnect the neutral position switch harness connector. 3) Turn the ignition switch to ON. 4) Measure the voltage between harness connector terminal and chassis ground. Connector & terminal (B25) No. 1 (+) — Chassis ground (-):	Is the voltage approx. 10 V or more?	Go to step 6.	Check for open or short in the harness between neutral position switch and ECM.
6	CHECK NEUTRAL POSITION SWITCH CIRCUIT. 1) Turn the ignition switch to OFF. 2) Measure resistance between harness connector terminal of neutral position switch and chassis ground. Connector & terminal (B25) No. 2 — Chassis ground:	Is the resistance less than 10 Ω?	Go to step 7.	Repair the harness.
7	CHECK NEUTRAL POSITION SWITCH. Remove and check the neutral position switch.	Is the neutral position switch OK?	Replace the ECM. <Ref. to FU(H4DOTC)-46, Engine Control Module (ECM).>	Replace the neutral position switch.

E: DTC 15

This DTC is detected when the cancel switch is pressed or problem relating to the main switch occurs.

TROUBLE SYMPTOM:

- Cruise control cannot be set. (Cancelled immediately.)
- Cruise control cannot be released.

Refer to DTC 11 for diagnostic procedure.

<Ref. to CC(diag)-15, DTC 11, Diagnostic Procedure without Diagnostic Trouble Code (DTC).>

Diagnostic Procedure without Diagnostic Trouble Code (DTC)

CRUISE CONTROL SYSTEM (DIAGNOSTICS)

F: DTC 16

This DTC is detected when the ignition switch is turned OFF or problem relating to the ignition switch occurs.

TROUBLE SYMPTOM:

Cruise control cannot be set.

WIRING DIAGRAM:

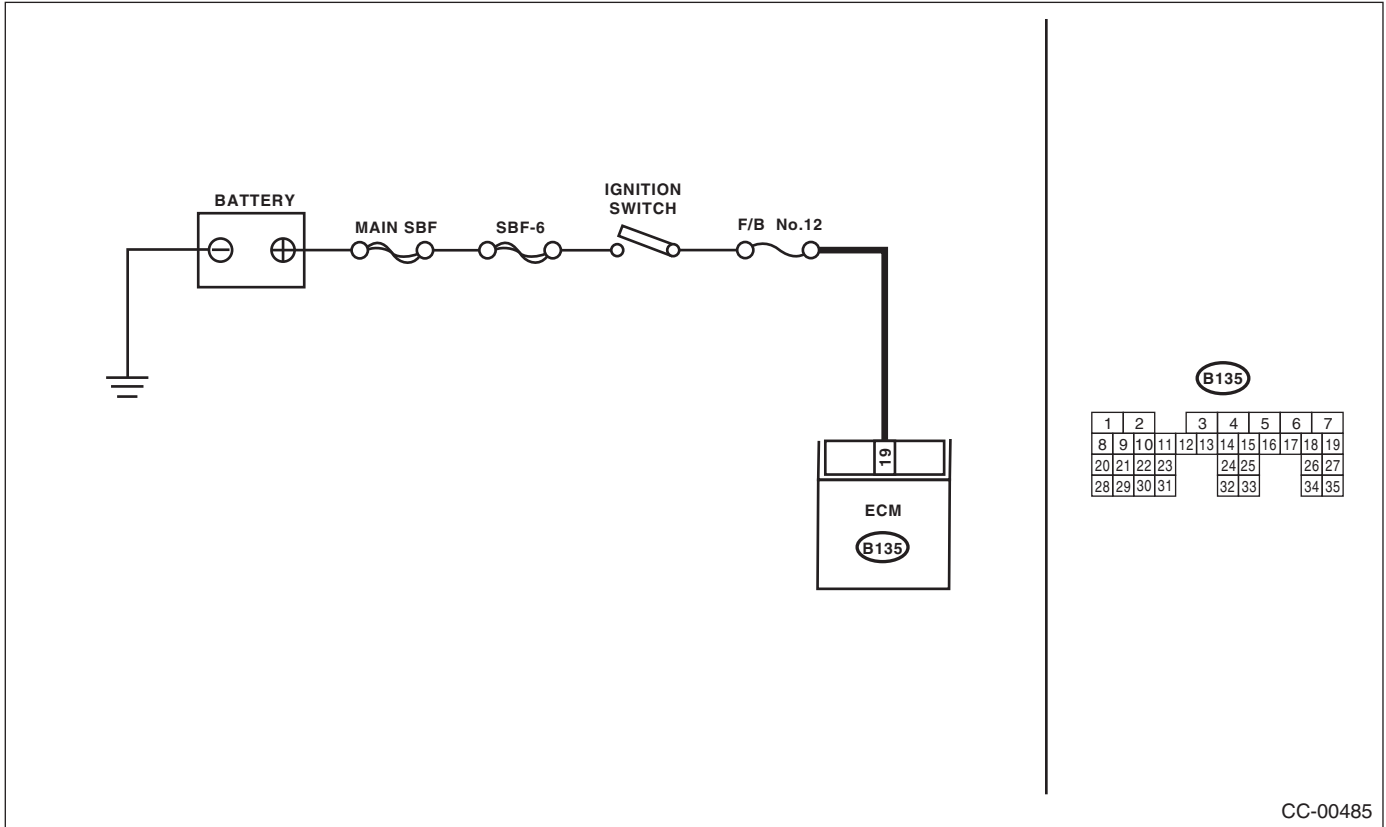

Step	Check	Yes	No
1 CHECK IGNITION SWITCH CIRCUIT. 1) Turn the ignition switch to OFF. 2) Disconnect the ECM harness connector. 3) Turn the ignition switch to ON. 4) Measure the voltage between harness connector terminal and chassis ground. Connector & terminal <i>Turbo model</i> (B135) No. 19 (+) — Chassis ground (-): <i>Non-turbo model</i> (B135) No. 10 (+) — Chassis ground (-):	Is the voltage 10 V or more?	Check for poor contact of the ECM connector.	<ul style="list-style-type: none"> Check fuse No. 12 (in fuse & relay box). Check the harness for open or short circuit between ignition switch and ECM.

G: DTC 21

Cruise control command switch malfunction is detected.

TROUBLE SYMPTOM:

- Cruise control cannot be set. (Cancelled immediately.)
- Cruise control cannot be released.

Refer to DTC 11 for diagnostic procedure. <Ref. to CC(diag)-15, DTC 11, Diagnostic Procedure without Diagnostic Trouble Code (DTC).>

Diagnostic Procedure without Diagnostic Trouble Code (DTC)

CRUISE CONTROL SYSTEM (DIAGNOSTICS)

H: DTC 22

Malfunction related to vehicle speed sensor is detected.

DIAGNOSIS:

Open or shorted circuit in vehicle speed sensor system.

TROUBLE SYMPTOM:

Cruise control cannot be set. (Cancelled immediately.)

	Step	Check	Yes	No
1	CHECK ABS OR VDC WARNING LIGHT. 1) Turn the ignition switch to ON. 2) After the initial operation of combination meter is completed, check if VDC warning light continues to illuminate.	Does the warning light continue to illuminate?	Check VDCCM. <Ref. to VDC(diag)-2, Basic Diagnostic Procedure.>	Go to step 2.
2	CHECK DTC OF LAN COMMUNICATION CIRCUIT. Read the DTC of body integrated unit using Subaru Select Monitor.	Is DTC of Low-speed CAN displayed?	Check the LAN communication circuit.	Replace the ECM. <Ref. to FU(H4DOTC)-46, Engine Control Module (ECM).>

I: DTC 24

Malfunction in cruise control-related switch is detected.

TROUBLE SYMPTOM:

- Cruise control cannot be set. (Cancelled immediately.)
- Cruise control cannot be released.

Refer to DTC 11 for diagnostic procedure.

<Ref. to CC(diag)-15, DTC 11, Diagnostic Procedure without Diagnostic Trouble Code (DTC).>

J: DTC 25

Malfunction of brake input circuit in ECM is detected.

Refer to the Engine Diagnostic Procedure for diagnostic procedure. <Ref. to EN(H4DOTC)(diag)-2, PROCEDURE, Basic Diagnostic Procedure.> <Ref. to EN(H4SO)(diag)-2, PROCEDURE, Basic Diagnostic Procedure.>

K: DTC 31

Malfunction of the engine speed signal is detected.

Abnormal increase of engine speed is detected.

Gear is set to 1st or Reverse position.

After driving at the 2nd gear position or more, perform the cruise setting again. If the cancel code is not detected, it is normal.

L: DTC 32

This DTC is detected out of vehicle speed range.

Increase vehicle speed high enough to allow the cruise control to function, and then perform setting operation again.

If the cancel code is detected after performing the setting operation, perform DTC 22 diagnosis.

Refer to DTC 22 for diagnostic procedure.

<Ref. to CC(diag)-24, DTC 22, Diagnostic Procedure without Diagnostic Trouble Code (DTC).>

M: DTC 34

The vehicle has been driven at a speed higher than set speed for a long time (approximately 10 minutes) during cruise driving.

Cancel code is detected when driving for a long period of time at higher speed than appropriate cruise speed by operating accelerator pedal.

Perform the cruise control setting operation again. If the cancel code is not detected, it is normal.

Diagnostic Procedure without Diagnostic Trouble Code (DTC)

CRUISE CONTROL SYSTEM (DIAGNOSTICS)

N: DTC 35

Detected when it is impossible to perform the vehicle speed feedback.

Set vehicle speed cannot be kept for some reasons (steep uphill, unreleased parking brake, etc.) during cruise driving.

Cancel code is detected when driving condition is not suitable for cruise control.

Perform cruise set operation again after clearing the possible cause.

O: DTC 41

VDC/TCS has operated.

Vehicle dynamics control (VDC) or TCS is operated during cruise driving or cruise setting.

<Ref. to VDC(diag)-2, PROCEDURE, Basic Diagnostic Procedure.>

P: DTC 43

ABS/VDC malfunction is detected.

VDC malfunction is detected during cruise driving or cruise setting.

<Ref. to VDC(diag)-2, PROCEDURE, Basic Diagnostic Procedure.>

Q: DTC 44

Body integrated unit malfunction is detected.

Body integrated unit system malfunction is detected during cruise driving or cruise setting.

R: DTC 45

Malfunction of the combination meter is detected.

Combination meter malfunction is detected during cruise driving or cruise setting.

S: DTC 61

Malfunction in the stop light & brake switch is detected.

TROUBLE SYMPTOM:

- Cruise control cannot be set.
- Cruise control cannot be released.

Refer to DTC 12 for diagnostic procedure. <Ref. to CC(diag)-17, DTC 12, Diagnostic Procedure without Diagnostic Trouble Code (DTC).>

T: DTC 62

Neutral position switch malfunction is detected.

TROUBLE SYMPTOM:

Cruise control cannot be set.

Refer to DTC 14 for diagnostic procedure. <Ref. to CC(diag)-21, DTC 14, Diagnostic Procedure without Diagnostic Trouble Code (DTC).>

U: DTC 63

Malfunction of vehicle speed signal variation is detected.

TROUBLE SYMPTOM:

Cruise control cannot be set. (Cancelled immediately.)

Refer to DTC 22 for diagnostic procedure. <Ref. to CC(diag)-24, DTC 22, Diagnostic Procedure without Diagnostic Trouble Code (DTC).>

V: DTC 64

Malfunction related to engine is detected.

Refer to the Engine Diagnostic Procedure for diagnostic procedure. <Ref. to EN(H4DOTC)(diag)-2, PROCEDURE, Basic Diagnostic Procedure.> <Ref. to EN(H4SO)(diag)-2, PROCEDURE, Basic Diagnostic Procedure.>

Diagnostic Procedure without Diagnostic Trouble Code (DTC)

CRUISE CONTROL SYSTEM (DIAGNOSTICS)

W: DTC 65

Cruise control command switch malfunction is detected.

While the command switch is pressed ON for a long time (approximately two minutes), stuck ON condition is detected.

TROUBLE SYMPTOM:

- Cruise control cannot be set. (Cancelled immediately.)
- Cruise control cannot be released.

Refer to DTC 11 for diagnostic procedure. <Ref. to CC(diag)-15, DTC 11, Diagnostic Procedure without Diagnostic Trouble Code (DTC).>

X: DTC 66

Cruise control calculation malfunction is detected.

Refer to the Engine Diagnostic Procedure for diagnostic procedure. <Ref. to EN(H4DOTC)(diag)-2, PROCEDURE, Basic Diagnostic Procedure.> <Ref. to EN(H4SO)(diag)-2, PROCEDURE, Basic Diagnostic Procedure.>

IMMOBILIZER (DIAGNOSTICS)

IM(diag)

	Page
1. Basic Diagnostic Procedure	2
2. General Description	3
3. Electrical Component Location	5
4. Immobilizer Control Module I/O Signal	6
5. Subaru Select Monitor	7
6. Read Diagnostic Trouble Code (DTC)	8
7. Clear Memory Mode	9
8. System Operation Check Mode	10
9. Diagnostics Chart for Security Indicator Light	11
10. List of Diagnostic Trouble Code (DTC)	15
11. Diagnostic Procedure with Diagnostic Trouble Code (DTC)	16

Basic Diagnostic Procedure

IMMOBILIZER (DIAGNOSTICS)

1. Basic Diagnostic Procedure

A: PROCEDURE

Step	Check	Yes	No
1 CHECK SECURITY INDICATOR LIGHT. 1) Turn the ignition switch to "OFF" or "ACC". 2) Wait at least 60 seconds.	Does the security indicator light blink?	Go to step 2.	Check the security indicator light circuit. <Ref. to IM(diag)-11, CHECK SECURITY INDICATOR LIGHT CIRCUIT, INSPECTION, Diagnostics Chart for Security Indicator Light.>
2 CHECK KEY SWITCH. Remove the key from ignition switch.	Does the security indicator light blink within 1 second after removing the key?	Go to step 3.	Check the key switch circuit. <Ref. to IM(diag)-13, CHECK KEY SWITCH CIRCUIT, INSPECTION, Diagnostics Chart for Security Indicator Light.>
3 CHECK SECURITY INDICATOR LIGHT. Turn the ignition switch to ON.	Does the security indicator light go off?	Go to step 5.	Go to step 4.
4 CHECK ENGINE START. Turn the ignition switch to START.	Does the starter operate?	Check the LAN communication circuit. <Ref. to LAN(diag)-2, Basic Diagnostic Procedure.>	Check the DTC display (body integrated unit). Go to step 7.
5 CHECK ENGINE START. Turn the ignition switch to START.	Does the starter operate?	Go to step 6.	Check the LAN communication circuit. <Ref. to LAN(diag)-2, Basic Diagnostic Procedure.>
6 CHECK ENGINE START. Turn the ignition switch to START.	Does the engine start?	Immobilizer system is normal.	Check the DTC display (ECM). Go to step 7.
7 CHECK FOR ANY OTHER DTC ON DISPLAY. 1) Turn the ignition switch to OFF. 2) Connect the Subaru Select Monitor to data link connector. <Ref. to IM(diag)-7, Subaru Select Monitor.> 3) Turn the ignition switch and Subaru Select Monitor switch to ON. 4) Read DTC's on the display.	Is the DTC displayed on screen?	Go to step 8.	Repair the related parts.
8 PERFORM DIAGNOSIS. 1) Inspect using the "Diagnostic Procedure with Diagnostic Trouble Code (DTC)". <Ref. to IM(diag)-16, Diagnostic Procedure with Diagnostic Trouble Code (DTC).> 2) Repair the trouble cause. 3) Perform the Clear Memory Mode. 4) Read DTC's again.	Is the DTC displayed on screen?	Inspect using the "Diagnostic Procedure with Diagnostic Trouble Code (DTC)". <Ref. to IM(diag)-16, Diagnostic Procedure with Diagnostic Trouble Code (DTC).>	Finish the diagnosis.

2. General Description

A: CAUTION

CAUTION:

- Do not use the electrical test equipment on the airbag system wiring harnesses and connector circuits.
- Be careful not to damage the airbag system wiring harness.
- While diagnostic items are being checked, do not operate radios, portable telephones, etc. which emit electromagnetic waves near or inside the vehicle.

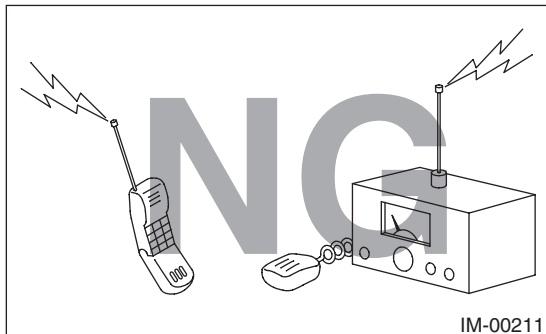

- When turning the ignition switch to ON or OFF while diagnostic items are being checked, do not allow keys with different ID codes close to the ignition switch. If the ignition key is on a key holder, remove it from the key holder before performing diagnoses.

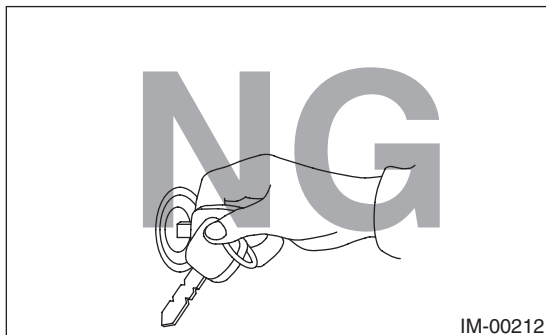

- When repeatedly turning the ignition switch to ON or OFF while diagnostic items are being checked, it should be switched in cycles of "ON" for at least 5 seconds → "OFF" for at least 8 seconds.

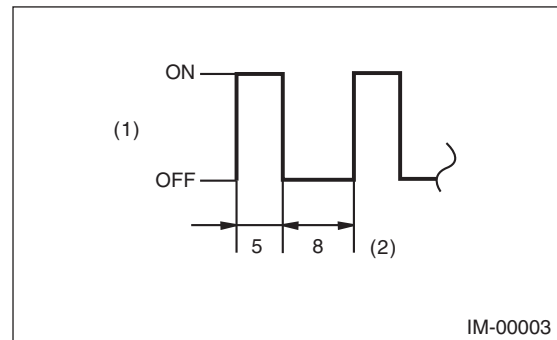

- (1) Ignition switch position
- (2) Sec.

- If the engine fails to start with a registered ignition key, detach the ignition key from ignition switch and wait for approx. 1 second until security indicator light begins to flash. And then start the engine again.
- Before performing the diagnostics, obtain all keys for the vehicle from the owner.
- Do not install or register a body integrated unit already registered to another vehicle to diagnose failures or inspect functions.

General Description

IMMOBILIZER (DIAGNOSTICS)

B: PREPARATION TOOL

1. SPECIAL TOOL

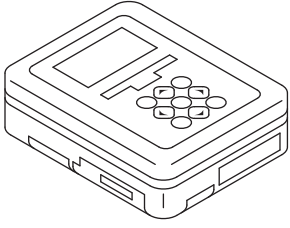
ILLUSTRATION	TOOL NUMBER	DESCRIPTION	REMARKS
 ST1B022XU0	1B022XU0 (Newly adopted tool)	SUBARU SELECT MONITOR III KIT	Used for troubleshooting for electrical system.

2. GENERAL TOOL

TOOL NAME	REMARKS
Circuit tester	Used for measuring resistance, voltage and current.

3. Electrical Component Location

A: LOCATION

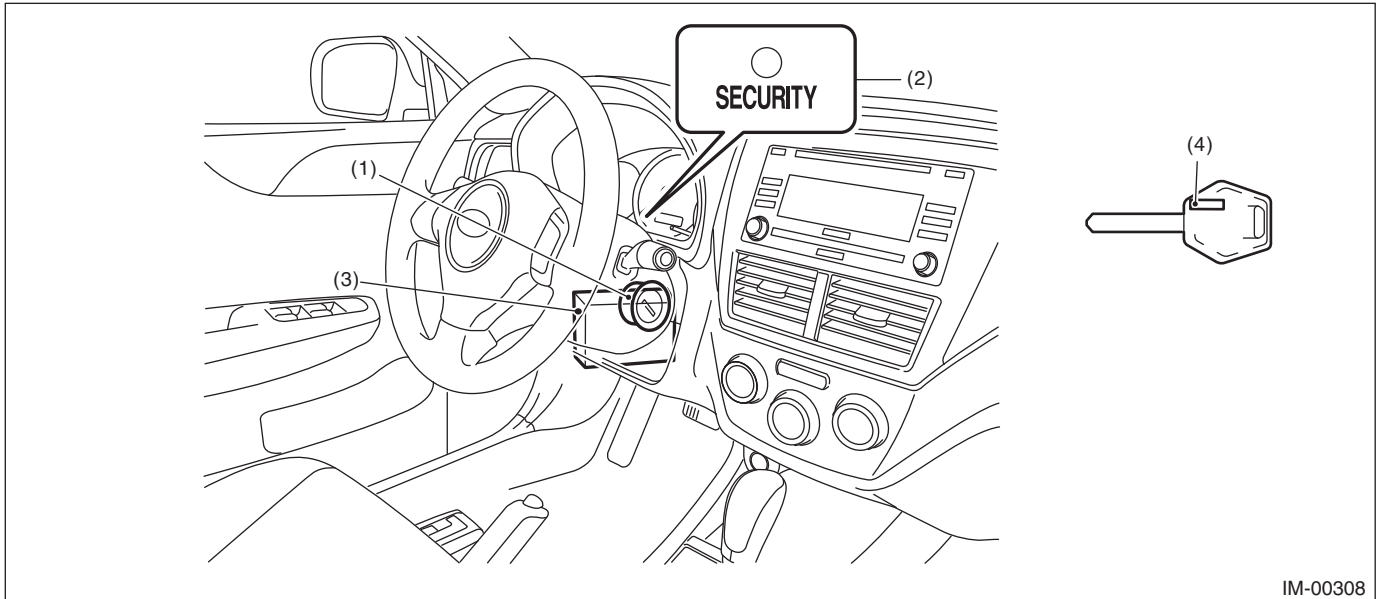

IM-00308

(1) Antenna

(3) Body integrated unit

(4) Transponder

(2) Security indicator light (LED bulb)

Immobilizer Control Module I/O Signal

IMMOBILIZER (DIAGNOSTICS)

4. Immobilizer Control Module I/O Signal

A: WIRING DIAGRAM

1. IMMOBILIZER

<Ref. to WI-153, WIRING DIAGRAM, Immobilizer
System.>

5. Subaru Select Monitor

A: OPERATION

- 1) Prepare the Subaru Select Monitor kit.
- 2) Connect the diagnosis cable to the Subaru Select Monitor.
- 3) Connect the Subaru Select Monitor to the data link connector.

(1) Data link connector is located in the lower portion of the instrument panel (on the driver's side).

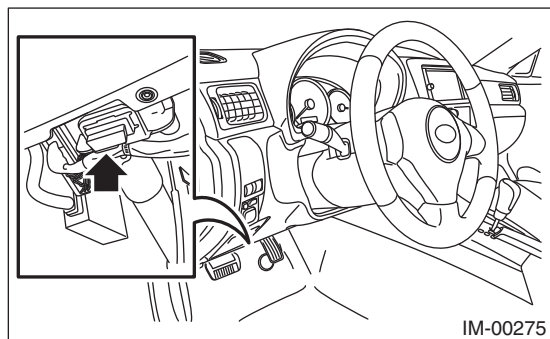

(2) Connect the diagnosis cable to the data link connector.

CAUTION:

Do not connect scan tools other than the Subaru Select Monitor.

- 4) Turn the ignition switch to ON (engine OFF) and run the Subaru Select Monitor.
- 5) Using the Subaru Select Monitor, call up DTCs and various data, then record them.

Read Diagnostic Trouble Code (DTC)

IMMOBILIZER (DIAGNOSTICS)

6. Read Diagnostic Trouble Code (DTC)

A: OPERATION

1. ECM

- 1) On the «Main Menu», select {Each System Check}.
- 2) On the «System Selection Menu» display, select {Engine Control System}.
- 3) After engine type information is displayed, select [OK].
- 4) On the «Engine Diagnosis», select {Diagnostic Code(s) Display}.
- 5) On the «Diagnostic Code(s) Display», select {Current DTC} or {Past DTC}.

NOTE:

- For detailed operation procedure, refer to the “PC application help for Subaru Select Monitor”.
- For detailed concerning DTC, refer to the List of Diagnostic Trouble Codes (DTC). <Ref. to IM(diag)-15, LIST, List of Diagnostic Trouble Code (DTC).>

2. BODY INTEGRATED UNIT

- 1) On the «Main Menu», select {Each System Check}.
- 2) On the «System Selection Menu», select {Integ. Unit}.
- 3) After {Integ. Unit} is displayed, select [OK].
- 4) On the «Integ. unit mode failure diag», select {Diagnostic Code(s) Display}.

NOTE:

- For detailed operation procedure, refer to the “PC application help for Subaru Select Monitor”.
- For detailed concerning DTC, refer to the List of Diagnostic Trouble Codes (DTC). <Ref. to IM(diag)-15, LIST, List of Diagnostic Trouble Code (DTC).>

7. Clear Memory Mode

A: OPERATION

1. ECM

- 1) On the «Main Menu», select {Each System Check}.
- 2) On the «System Selection Menu» display, select {Engine Control System}.
- 3) After engine type information is displayed, select [OK].
- 4) On the «Engine Diagnosis», select {Clear Memory}.
- 5) When “Done” is displayed on the display screen, end the Subaru Select Monitor and turn the ignition switch to OFF.

NOTE:

- After the memory has been cleared, the idle air control solenoid valve must be initialized. To execute this procedure, turn the ignition switch to ON. Wait for three seconds before starting the engine.
- For detailed operation procedure, refer to the “PC application help for Subaru Select Monitor”.

2. BODY INTEGRATED UNIT

- 1) On the «Main Menu», select {Each System Check}.
- 2) On the «System Selection Menu», select {Integ. Unit}.
- 3) After {Integ. Unit} is displayed, select [OK].
- 4) On the «Integ. unit mode», select {Clear Memory}.
- 5) When “Done” is displayed on the display screen, end the Subaru Select Monitor and turn the ignition switch to OFF.

NOTE:

For detailed operation procedure, refer to the “PC application help for Subaru Select Monitor”.

8. System Operation Check Mode

A: OPERATION

1. COMMUNICATION LINE CHECK

- 1) On the «Main Menu» display, select {Each System Check}.
- 2) On the «System Selection Menu» display, select {Engine Control System}.
- 3) After engine type information is displayed, select [OK].
- 4) On the «Engine Diagnosis» display, select {System Operation Check Mode}.
- 5) On the «System Operation Check Mode» display, select the {Immobilizer System}.
- 6) Start the communication line check.
- 7) Is «OK» displayed on screen?
If displayed, go to step 9).
If not, go to step 10).
- 8) After diagnostic results, it is determined that the circuit is not shorted. Finish the communication line check.
- 9) If a problem is detected, repair the trouble cause. <Ref. to IM(diag)-20, DTC P1572 IMM CIRCUIT FAILURE (EXCEPT ANTENNA CIRCUIT), Diagnostic Procedure with Diagnostic Trouble Code (DTC).>

NOTE:

For detailed operation procedure, refer to the “PC application help for Subaru Select Monitor”.

Diagnostics Chart for Security Indicator Light

IMMOBILIZER (DIAGNOSTICS)

9. Diagnostics Chart for Security Indicator Light

A: INSPECTION

1. CHECK SECURITY INDICATOR LIGHT CIRCUIT

WIRING DIAGRAM:

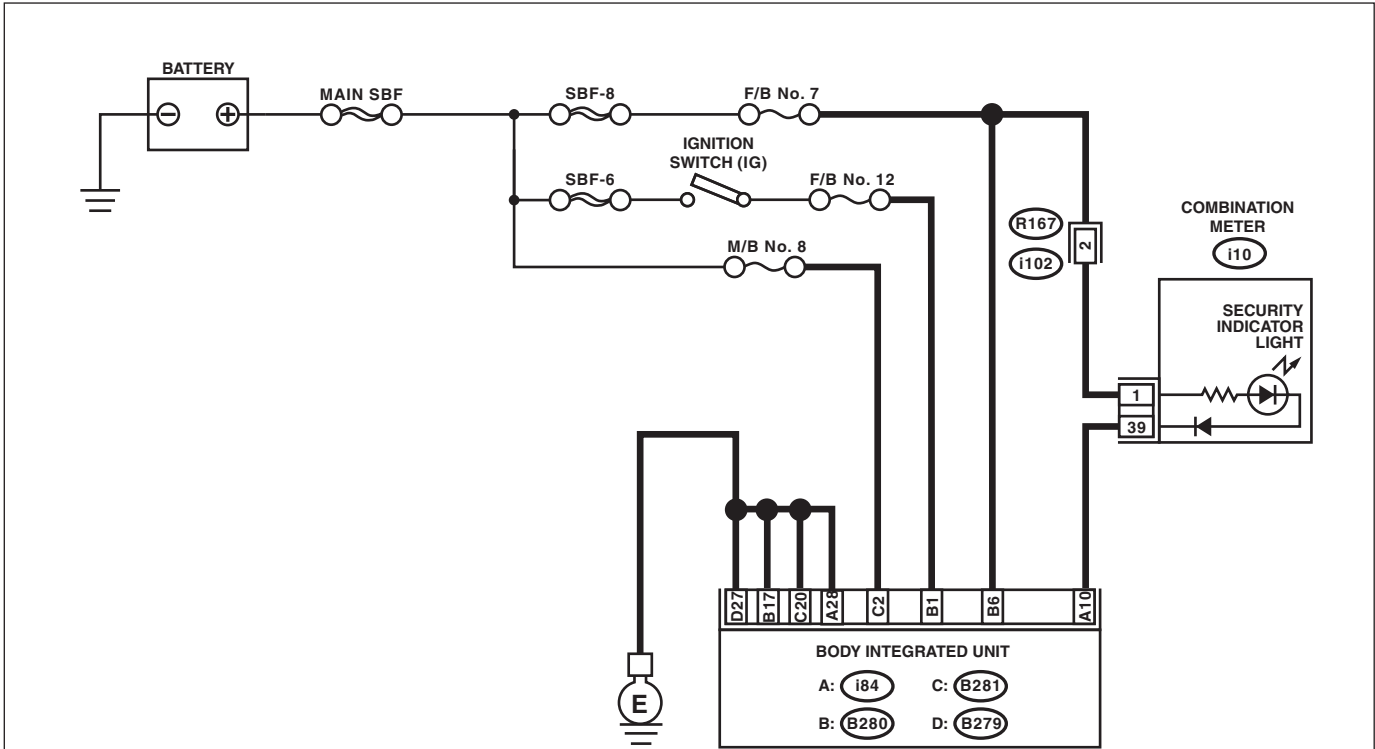

C: (B281)

1	2	3		4	5	6	7				
8	9	10	11	12	13	14	15	16	17	18	19
20	21	22	23	24	25	26	27	28			

D: (B279)

1	2	3		4	5	6	7					
8	9	10	11	12	13	14	15	16	17	18	19	20
21	22	23	24	25	26	27	28	29	30			

B: (B280)

1	2	3		4	5	6					
7	8	9	10	11	12	13	14	15	16	17	
18	19	20	21	22	23	24	25	26			

A: (i84)

1	2	3	4		5	6	7	8						
9	10	11	12	13	14	15	16	17	18	19	20	21	22	23
24	25	26	27	28	29	30	31	32	33	34	35			

i10

1	2	3	4	5	6	7	8	9	10	11	12	13	14	15	16	17	18	19	20
21	22	23	24	25	26	27	28	29	30	31	32	33	34	35	36	37	38	39	40

IM-00306

Diagnostics Chart for Security Indicator Light

IMMOBILIZER (DIAGNOSTICS)

Step	Check	Yes	No
1 CHECK SECURITY INDICATOR LIGHT. 1) Turn the ignition switch to OFF. 2) Disconnect the harness connector from the body integrated unit. 3) Connect a resistor (100 Ω) between the body integrated unit harness connector terminal (i84) No. 10 and chassis ground.	Does the security indicator light illuminate?	Go to step 2.	Go to step 5.
2 CHECK BODY INTEGRATED UNIT GROUND CIRCUIT. Measure the resistance between the body integrated unit harness connector terminal and chassis ground. Connector & terminal <i>(i84) No. 28 — Chassis ground:</i> <i>(B280) No. 17 — Chassis ground:</i> <i>(B281) No. 20 — Chassis ground:</i> <i>(B279) No. 27 — Chassis ground:</i>	Is the resistance less than 10 Ω?	Go to step 3.	Repair the open circuit of the body integrated unit ground circuit.
3 CHECK BODY INTEGRATED UNIT IGNITION CIRCUIT. 1) Turn the ignition switch to ON. (engine OFF) 2) Measure the voltage between the body integrated unit harness connector terminal and chassis ground. Connector & terminal <i>(B280) No. 1 (+) — Chassis ground (-):</i>	Is the voltage 10 V or more?	Go to step 4.	Check the harness for open or short circuit between the body integrated unit and ignition switch.
4 CHECK BODY INTEGRATED UNIT POWER SUPPLY CIRCUIT. 1) Turn the ignition switch to OFF. 2) Measure the voltage between the body integrated unit harness connector terminal and chassis ground. Connector & terminal <i>(B280) No. 6 (+) — Chassis ground (-):</i> <i>(B281) No. 2 (+) — Chassis ground (-):</i>	Is the voltage 10 V or more?	Replace the body integrated unit <Ref. to SL-42, Body Integrated Unit.> and replace all the ignition keys (including transponder). Execute the registration procedure next. Refer to the “PC application help for Subaru Select Monitor”.	Check the harness for open or short circuit between the body integrated unit and fuse.
5 CHECK COMBINATION METER CIRCUIT. 1) Remove the combination meter. <Ref. to IDI-16, Combination Meter.> 2) Measure the voltage between combination meter harness connector terminal and chassis ground. Connector & terminal <i>(i10) No. 1 (+) — Chassis ground (-):</i>	Is the voltage 10 V or more?	Go to step 6.	Check for an open or short circuit in the harness between the combination meter and fuse.
6 CHECK COMBINATION METER CIRCUIT. Measure the resistance between the body integrated unit harness connector terminal and combination meter harness connector terminals. Connector & terminal <i>(i84) No. 10 — (i10) No. 39:</i>	Is the resistance less than 10 Ω?	LED bulb is defective. Replace the combination meter case assembly. <Ref. to IDI-17, DISASSEMBLY, Combination Meter.>	Repair the harness or connector.

Diagnostics Chart for Security Indicator Light

IMMOBILIZER (DIAGNOSTICS)

2. CHECK KEY SWITCH CIRCUIT

WIRING DIAGRAM:

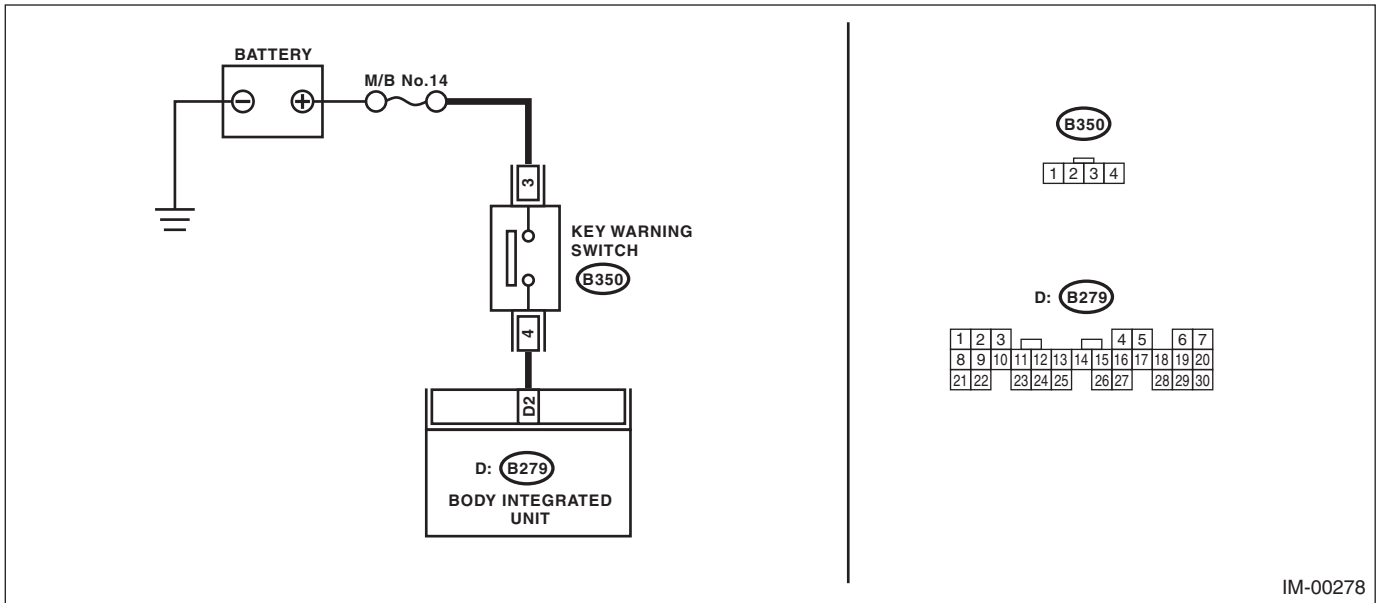

IM-00278

Diagnostics Chart for Security Indicator Light

IMMOBILIZER (DIAGNOSTICS)

Step	Check	Yes	No
1 CHECK POWER SUPPLY CIRCUIT. 1) Disconnect the key warning switch harness connector. 2) Set the ignition switch to ACC or LOCK (with key inserted). 3) Measure the voltage between the key warning switch harness connector terminal and chassis ground. Connector & terminal (B350) No. 3 (+) — Chassis ground (-):	Is the voltage 10 V or more?	Go to step 2.	Check for an open or short circuit in the harness between the key warning switch and fuse.
2 CHECK KEY WARNING SWITCH. 1) Insert the ignition key in the ignition switch. (OFF or ACC) 2) Measure the resistance between key warning switch connector terminals. Connector & terminal No. 3 — No. 4:	Is the resistance less than 1 Ω ?	Go to step 3.	Replace the key warning switch.
3 CHECK KEY WARNING SWITCH. 1) Remove the ignition key from the ignition switch. 2) Measure the resistance between key warning switch connector terminals. Connector & terminal No. 3 — No. 4:	Is the resistance 1 $M\Omega$ or more?	Go to step 4.	Replace the key warning switch.
4 CHECK HARNESS BETWEEN KEY WARNING SWITCH AND BODY INTEGRATED UNIT. 1) Disconnect the key warning switch harness connector. 2) Disconnect the harness connector from the body integrated unit. 3) Measure the resistance between the key warning switch harness connector and body integrated unit harness connector terminals. Connector & terminal (B350) No. 4 — (B279) No. 2:	Is the resistance less than 10 Ω ?	Replace the body integrated unit <Ref. to SL-42, Body Integrated Unit.> and replace all the ignition keys (including transponder). Execute the registration procedure next. Refer to the "PC application help for Subaru Select Monitor".	Repair the harness between the key warning switch and body integrated unit.

List of Diagnostic Trouble Code (DTC)

IMMOBILIZER (DIAGNOSTICS)

10. List of Diagnostic Trouble Code (DTC)

A: LIST

1. ECM

DTC	Item	Contents of diagnosis	Index No.
P0513	Incorrect Immobilizer Key	Incorrect immobilizer key (Use of unregistered key in body integrated unit)	<Ref. to IM(diag)-16, DTC P0513 INCORRECT IMMOBILIZER KEY, Diagnostic Procedure with Diagnostic Trouble Code (DTC).>
P1570	Antenna	Faulty antenna	<Ref. to IM(diag)-17, DTC P1570 ANTENNA, Diagnostic Procedure with Diagnostic Trouble Code (DTC).>
P1571	Reference Code Incompatibility	Reference code incompatibility between body integrated unit and ECM	<Ref. to IM(diag)-19, DTC P1571 REFERENCE CODE INCOMPATIBILITY, Diagnostic Procedure with Diagnostic Trouble Code (DTC).>
P1572	IMM Circuit Failure (Except Antenna Circuit)	<ul style="list-style-type: none"> Communication failure between body integrated unit and ECM Failed registration between the body integrated unit and the combination meter. 	<Ref. to IM(diag)-20, DTC P1572 IMM CIRCUIT FAILURE (EXCEPT ANTENNA CIRCUIT), Diagnostic Procedure with Diagnostic Trouble Code (DTC).>
P1574	Key Communication Failure	Communication failure between key and the body integrated unit	<Ref. to IM(diag)-22, DTC P1574 KEY COMMUNICATION FAILURE, Diagnostic Procedure with Diagnostic Trouble Code (DTC).>
P1576	EGI Control Module EEPROM	ECM malfunctioning	<Ref. to IM(diag)-23, DTC P1576 EGI CONTROL MODULE EEPROM, Diagnostic Procedure with Diagnostic Trouble Code (DTC).>
P1577	IMM Control Module EEPROM	Body integrated unit malfunctioning	<Ref. to IM(diag)-23, DTC P1577 IMM CONTROL MODULE EEPROM, Diagnostic Procedure with Diagnostic Trouble Code (DTC).>
P1578	Meter Failure	<ul style="list-style-type: none"> Reference code incompatibility between body integrated unit and combination meter Communication failure between body integrated unit and ECM 	<Ref. to IM(diag)-24, DTC P1578 METER FAILURE, Diagnostic Procedure with Diagnostic Trouble Code (DTC).>

NOTE:

Perform diagnosis of engine DTC when a DTC other than an immobilizer DTC is detected. <Ref. to EN(H4DOTC)(diag)-80, List of Diagnostic Trouble Code (DTC).>

2. BODY INTEGRATED UNIT

DTC	Item	Contents of diagnosis	Index No.	Relation between ECM and DTC
B1401	M collation NG	Reference code incompatibility between body integrated unit and combination meter	<Ref. to IM(diag)-24, DTC B1401 M COLLATION NG, Diagnostic Procedure with Diagnostic Trouble Code (DTC).>	P1578
B1402	Immobilizer Key collation NG	<ul style="list-style-type: none"> Incorrect immobilizer key (Use of unregistered key in body integrated unit) Faulty antenna 	<Ref. to IM(diag)-24, DTC B1402 IMMOBILIZER KEY COLLATION NG, Diagnostic Procedure with Diagnostic Trouble Code (DTC).>	<ul style="list-style-type: none"> P0513 P1570 P1574
B1403	E/G request NG	Communication failure between body integrated unit and ECM	<Ref. to IM(diag)-24, DTC B1403 E/G REQUEST NG, Diagnostic Procedure with Diagnostic Trouble Code (DTC).>	P1572

NOTE:

In immobilizer system, performing the starter relay control. When the body integrated unit detect the inconformity of reference code, immediately out put the starter relay cut signal to ECM, and then ECM stop the starter relay operation. In this case, engine does not start, and DTC is not recorded in ECM. Check that the engine does not start on the DTC of body integrated unit.

Diagnostic Procedure with Diagnostic Trouble Code (DTC)

IMMOBILIZER (DIAGNOSTICS)

11. Diagnostic Procedure with Diagnostic Trouble Code (DTC)

A: DTC P0513 INCORRECT IMMOBILIZER KEY

DTC DETECTING CONDITION:

Incorrect immobilizer key (Use of unregistered key in body integrated unit)

	Step	Check	Yes	No
1	PERFORM REGISTRATION ON IGNITION KEY. Perform registration on all keys of the vehicle. Refer to the "PC application help for Subaru Select Monitor".	Is registration for all keys complete?	END	Replace ignition keys (including transponder) which cannot be registered. Go to step 2.
2	PERFORM REGISTRATION ON IGNITION KEY. Perform registration on all keys of the vehicle. Refer to the "PC application help for Subaru Select Monitor".	Is registration for all keys complete?	END	Replace the body integrated unit <Ref. to SL-42, Body Integrated Unit.> and replace all the ignition keys (including transponder). Execute the registration procedure next. Refer to the "PC application help for Subaru Select Monitor".

Diagnostic Procedure with Diagnostic Trouble Code (DTC)

IMMOBILIZER (DIAGNOSTICS)

B: DTC P1570 ANTENNA

DTC DETECTING CONDITION:

Faulty antenna

WIRING DIAGRAM:

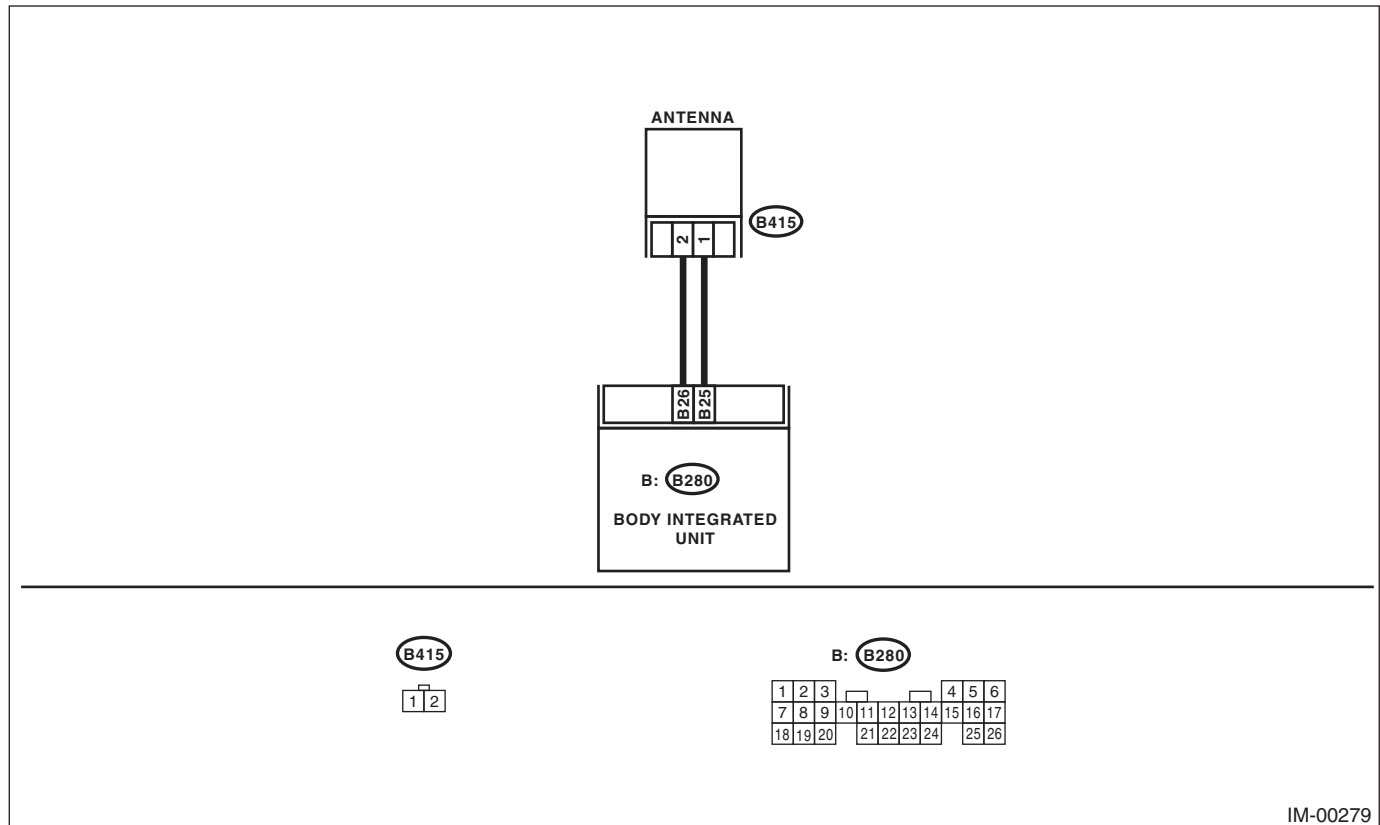

Step	Check	Yes	No
1 CHECK ANTENNA CIRCUIT. 1) Turn the ignition switch to OFF. 2) Disconnect the harness connector from the antenna. <Ref. to SL-45, Immobilizer Antenna.> 3) Measure the resistance of the antenna circuit. <i>Connector & terminal</i> <i>(B415) No. 1 — No. 2:</i>	Is the resistance less than 10 Ω?	Go to step 2.	Replace the antenna. <Ref. to SL-45, Immobilizer Antenna.>
2 CHECK ANTENNA CIRCUIT. 1) Disconnect the harness connector from the body integrated unit. 2) Measure the resistance between harness connector and chassis ground. <i>Connector & terminal</i> <i>(B280) No. 26 — Chassis ground:</i>	Is the resistance less than 10 Ω?	Repair the harness.	Go to step 3.
3 CHECK ANTENNA CIRCUIT. Measure the resistance between harness connector and chassis ground. <i>Connector & terminal</i> <i>(B280) No. 25 — Chassis ground:</i>	Is the resistance less than 10 Ω?	Repair the harness.	Go to step 4.

Diagnostic Procedure with Diagnostic Trouble Code (DTC)

IMMOBILIZER (DIAGNOSTICS)

Step	Check	Yes	No
4 CHECK ANTENNA CIRCUIT. 1) Turn the ignition switch to ON. (engine OFF) 2) Measure the voltage between harness connector and chassis ground. Connector & terminal (B280) No. 26 (+) — Chassis ground (-):	Is the voltage 0 V?	Go to step 5.	Repair the harness.
5 CHECK ANTENNA CIRCUIT. Measure the voltage between harness connector and chassis ground. Connector & terminal (B280) No. 25 (+) — Chassis ground (-):	Is the voltage 0 V?	Go to step 6.	Because the battery voltage or ignition switch "ON" circuit is shorted, repair the harness between the body integrated unit and antenna.
6 CHECK BODY INTEGRATED UNIT FUNCTION. 1) Turn the ignition switch to OFF. 2) Connect the harness connector to the body integrated unit. 3) Insert the key into the ignition switch, then measure changes in voltage between the antenna harness connectors. Connector & terminal (B280) No. 25 (+) — No. 26 (-):	Is the voltage -30 — 30 V? (Approx. 0.1 second after inserting the key) Is the voltage 0 V? (Approx. 1 second after inserting the key)	Go to step 7.	Replace the body integrated unit <Ref. to SL-42, Body Integrated Unit.> and replace all the ignition keys (including transponder). Execute the registration procedure next. Refer to the "PC application help for Subaru Select Monitor".
7 CHECK IGNITION KEY (TRANSPONDER). 1) Remove the key from ignition switch. 2) Start the engine using other key which is already registered.	Does the engine start?	Replace the ignition key (including the transponder). Execute the registration procedure next. Refer to the "PC application help for Subaru Select Monitor".	Replace the body integrated unit <Ref. to SL-42, Body Integrated Unit.> and replace all the ignition keys (including transponder). Execute the registration procedure next. Refer to the "PC application help for Subaru Select Monitor".

Diagnostic Procedure with Diagnostic Trouble Code (DTC)

IMMOBILIZER (DIAGNOSTICS)

C: DTC P1571 REFERENCE CODE INCOMPATIBILITY

DTC DETECTING CONDITION:

Reference code incompatibility between body integrated unit and ECM

Step	Check	Yes	No
1 PERFORM REGISTRATION ON IGNITION KEY. Perform registration on all keys of the vehicle. Refer to the "PC application help for Subaru Select Monitor".	Is registration for all keys complete?	END	Go to step 2.
2 CHECK FOR ANY OTHER DTC ON DISPLAY.	Is any other immobilizer DTC displayed?	Check the appropriate DTC using the "List of Diagnostic Trouble Code (DTC)". <Ref. to IM(diag)-15, List of Diagnostic Trouble Code (DTC).> Execute the registration procedure next. Refer to the "PC application help for Subaru Select Monitor".	Replace the ECM. <Ref. to FU(H4DOTC)-46, Engine Control Module (ECM).> Replace the body integrated unit <Ref. to SL-42, Body Integrated Unit.> and replace all the ignition keys (including transponder). Execute the registration procedure next. Refer to the "PC application help for Subaru Select Monitor".

Diagnostic Procedure with Diagnostic Trouble Code (DTC)

IMMOBILIZER (DIAGNOSTICS)

D: DTC P1572 IMM CIRCUIT FAILURE (EXCEPT ANTENNA CIRCUIT)

DTC DETECTING CONDITION:

Communication failure between body integrated unit and ECM

WIRING DIAGRAM:

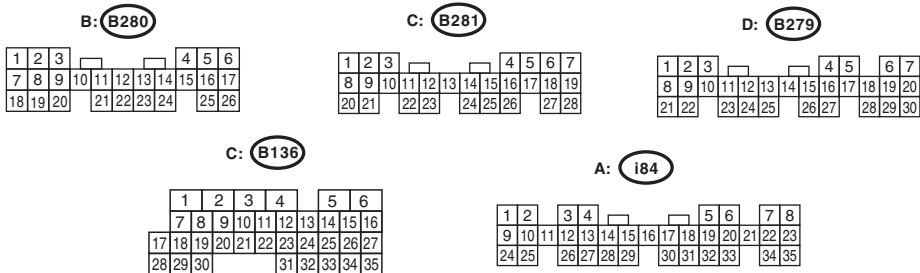
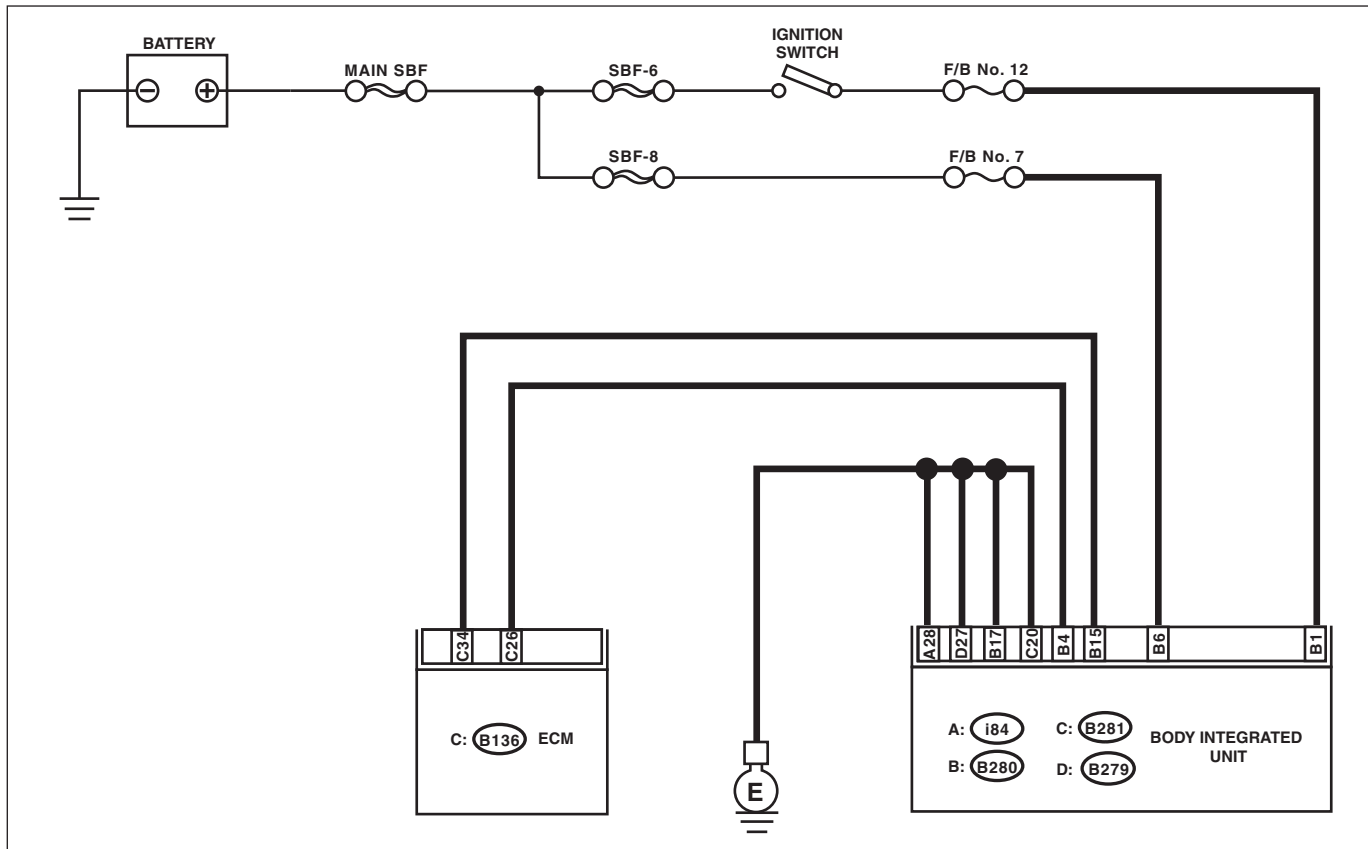

IM-00307

Diagnostic Procedure with Diagnostic Trouble Code (DTC)

IMMOBILIZER (DIAGNOSTICS)

Step	Check	Yes	No
<p>1 CHECK BODY INTEGRATED UNIT POWER SUPPLY CIRCUIT.</p> <p>1) Turn the ignition switch to OFF. 2) Disconnect the harness connector from the body integrated unit. 3) Measure the voltage between the body integrated unit harness connector terminal and chassis ground.</p> <p>Connector & terminal (B280) No. 6 (+) — Chassis ground (-):</p>	Is the voltage 10 V or more?	Go to step 2.	Check the harness for open or short circuit between the body integrated unit and fuse.
<p>2 CHECK BODY INTEGRATED UNIT POWER SUPPLY CIRCUIT.</p> <p>1) Turn the ignition switch to ON. (engine OFF) 2) Measure the voltage between the body integrated unit harness connector terminal and chassis ground.</p> <p>Connector & terminal (B280) No. 1 (+) — Chassis ground (-):</p>	Is the voltage 10 V or more?	Go to step 3.	Check the harness for open or short circuit between the body integrated unit and ignition switch.
<p>3 CHECK BODY INTEGRATED UNIT GROUND CIRCUIT.</p> <p>1) Turn the ignition switch to OFF. 2) Measure the resistance between the body integrated unit harness connector terminal and chassis ground.</p> <p>Connector & terminal (i84) No. 28 — Chassis ground: (B280) No. 17 — Chassis ground: (B281) No. 20 — Chassis ground: (B279) No. 27 — Chassis ground:</p>	Is the resistance less than 10 Ω?	Go to step 4.	Repair the open circuit of the body integrated unit ground circuit.
<p>4 CHECK GROUND CIRCUIT FOR ECM. Measure the resistance between the ECM ground terminal and engine ground.</p>	Is the resistance less than 10 Ω?	Go to step 5.	Repair ground circuit of ECM.
<p>5 CHECK HARNESS BETWEEN BODY INTEGRATED UNIT AND ECM.</p> <p>1) Disconnect the harness connector from the ECM and body integrated unit. 2) Measure the resistance between the body integrated unit harness connector and ECM harness connector terminals.</p> <p>Connector & terminal (B280) No. 4 — (B136) No. 26:</p>	Is the resistance less than 10 Ω?	Go to step 6.	Repair the open circuit of the harness between the body integrated unit and ECM.
<p>6 CHECK HARNESS BETWEEN BODY INTEGRATED UNIT AND ECM. Measure the resistance between the body integrated unit harness connector and ECM harness connector terminals.</p> <p>Connector & terminal (B280) No. 15 — (B136) No. 34:</p>	Is the resistance less than 10 Ω?	Go to step 7.	Repair the open circuit of the harness between the body integrated unit and ECM.
<p>7 CHECK COMMUNICATION CIRCUIT HARNESS.</p> <p>1) Turn the ignition switch to ON. (engine OFF) 2) Measure the voltage between the body integrated unit harness connector terminal and chassis ground.</p> <p>Connector & terminal (B280) No. 4 (+) — Chassis ground (-): (B280) No. 15 (+) — Chassis ground (-):</p>	Is the voltage 0 V?	Go to step 8.	Because the battery voltage or ignition switch "ON" circuit is shorted, repair the harness between the body integrated unit and ECM.

Diagnostic Procedure with Diagnostic Trouble Code (DTC)

IMMOBILIZER (DIAGNOSTICS)

Step	Check	Yes	No
8 CHECK COMMUNICATION CIRCUIT HARNESS. Measure the voltage between the ECM harness connector terminal and engine ground. Connector & terminal (B136) No. 26 (+) — Engine ground (-): (B136) No. 34 (+) — Engine ground (-):	Is the voltage 0 V?	Go to step 9.	Because the battery voltage or ignition switch "ON" circuit is shorted, repair the harness between the body integrated unit and ECM.
9 CHECK ECM BY COMMUNICATION SHORT CHECK. 1) Connect the harness connector to the ECM. 2) Disconnect the harness connector from the body integrated unit. 3) Start the communication short check. <Ref. to IM(diag)-10, System Operation Check Mode.>	Is the communication short check OK?	Replace the body integrated unit <Ref. to SL-42, Body Integrated Unit.> and replace all the ignition keys (including transponder). Execute the registration procedure next. Refer to the "PC application help for Subaru Select Monitor".	Replace the ECM. <Ref. to FU(H4DOTC)-46, Engine Control Module (ECM).> Next, execute the registration procedure. Refer to the "PC application help for Subaru Select Monitor".

E: DTC P1574 KEY COMMUNICATION FAILURE

DTC DETECTING CONDITION:

Communication failure between key and the body integrated unit

Step	Check	Yes	No
1 CHECK BODY INTEGRATED UNIT FUNCTION. Insert the key into the ignition switch (LOCK position), then measure changes in voltage between the antenna connectors. Connector & terminal (B415) No. 1 (+) — No. 2 (-):	Is the voltage -30 — 30 V? (Approx. 0.1 second after inserting the key) Is the voltage 0 V? (Approx. 1 second after inserting the key)	Go to step 2.	Replace the body integrated unit <Ref. to SL-42, Body Integrated Unit.> and replace all the ignition keys (including transponder). Execute the registration procedure next. Refer to the "PC application help for Subaru Select Monitor".
2 CHECK IGNITION KEY (TRANSPONDER). 1) Remove the key from ignition switch. 2) Start the engine using other key which is already registered.	Does the engine start?	Replace the ignition key (including the transponder). Execute the registration procedure next. Refer to the "PC application help for Subaru Select Monitor".	Replace the body integrated unit <Ref. to SL-42, Body Integrated Unit.> and replace all the ignition keys (including transponder). Execute the registration procedure next. Refer to the "PC application help for Subaru Select Monitor".

Diagnostic Procedure with Diagnostic Trouble Code (DTC)

IMMOBILIZER (DIAGNOSTICS)

F: DTC P1576 EGI CONTROL MODULE EEPROM

DTC DETECTING CONDITION:

- ECM malfunctioning
- Inaccessible ROM in ECM during key registration.

Step	Check	Yes	No
1 PERFORM REGISTRATION ON IGNITION KEY. Perform registration on all keys of the vehicle. Refer to the "PC application help for Subaru Select Monitor".	Is registration for all keys complete?	Make sure it is possible to start the engine with all keys that have been taught. This completes the work.	Go to step 2.
2 PERFORM REGISTRATION ON IGNITION KEY. Perform registration on all keys of the vehicle. Refer to the "PC application help for Subaru Select Monitor".	Is registration for all keys complete?	Make sure it is possible to start the engine with all keys that have been taught. This completes the work.	Go to step 3.
3 PERFORM REGISTRATION ON IGNITION KEY. Perform registration on all keys of the vehicle. Refer to the "PC application help for Subaru Select Monitor".	Is registration for all keys complete?	Make sure it is possible to start the engine with all keys that have been taught. This completes the work.	Replace the ECM. <Ref. to FU(H4DOTC)-46, Engine Control Module (ECM).>

G: DTC P1577 IMM CONTROL MODULE EEPROM

DTC DETECTING CONDITION:

- Body integrated unit malfunctioning
- Failed to access the ROM inside the body integrated unit.

Step	Check	Yes	No
1 PERFORM REGISTRATION ON IGNITION KEY. Perform registration on all keys of the vehicle. Refer to the "PC application help for Subaru Select Monitor".	Is registration for all keys complete?	Make sure it is possible to start the engine with all keys that have been taught. This completes the work.	Go to step 2.
2 PERFORM REGISTRATION ON IGNITION KEY. Perform registration on all keys of the vehicle. Refer to the "PC application help for Subaru Select Monitor".	Is registration for all keys complete?	Make sure it is possible to start the engine with all keys that have been taught. This completes the work.	Go to step 3.
3 PERFORM REGISTRATION ON IGNITION KEY. Perform registration on all keys of the vehicle. Refer to the "PC application help for Subaru Select Monitor".	Is registration for all keys complete?	Make sure it is possible to start the engine with all keys that have been taught. This completes the work.	Replace the body integrated unit. <Ref. to SL-42, Body Integrated Unit.>

Diagnostic Procedure with Diagnostic Trouble Code (DTC)

IMMOBILIZER (DIAGNOSTICS)

H: DTC P1578 METER FAILURE

DTC DETECTING CONDITION:

Reference code incompatibility between combination meter and body integrated unit

Step	Check	Yes	No
1 CHECK DIAGNOSTIC TROUBLE CODE (DTC). Read the DTC of body integrated unit using Subaru Select Monitor.	Is B1401 detected?	Go to step 2.	<Ref. to IM(diag)-20, DTC P1572 IMM CIRCUIT FAILURE (EXCEPT ANTENNA CIRCUIT), Diagnostic Procedure with Diagnostic Trouble Code (DTC).>
2 CHECK LAN COMMUNICATION SYSTEM. Inspect LAN communication system. <Ref. to LAN(diag)-2, Basic Diagnostic Procedure.>	DTC U1300, U1301, U1302, B1100 or B1101 of the body integrated unit is displayed.	Perform the diagnosis according to DTC. <Ref. to LAN(diag)-28, List of Diagnostic Trouble Code (DTC).>	Go to step 3.
3 CHECK COMBINATION METER. 1) Make a registration of immobilizer. Refer to the "PC application help for Subaru Select Monitor". 2) Start the engine.	Does the engine start?	System is normal.	Replace the combination meter. <Ref. to IDI-16, REMOVAL, Combination Meter.>

I: DTC B1401 M COLLATION NG

NOTE:

For the diagnostic procedure, refer to DTC P1578 "METER FAILURE". <Ref. to IM(diag)-24, DTC P1578 METER FAILURE, Diagnostic Procedure with Diagnostic Trouble Code (DTC).>

J: DTC B1402 IMMOBILIZER KEY COLLATION NG

NOTE:

Refer to the following inspection for diagnostic procedure.

- DTC P0513 "INCORRECT IMMOBILIZER KEY". <Ref. to IM(diag)-16, DTC P0513 INCORRECT IMMOBILIZER KEY, Diagnostic Procedure with Diagnostic Trouble Code (DTC).>
- DTC P1570 "ANTENNA". <Ref. to IM(diag)-17, DTC P1570 ANTENNA, Diagnostic Procedure with Diagnostic Trouble Code (DTC).>
- DTC P1574 "KEY COMMUNICATION FAILURE". <Ref. to IM(diag)-22, DTC P1574 KEY COMMUNICATION FAILURE, Diagnostic Procedure with Diagnostic Trouble Code (DTC).>

K: DTC B1403 E/G REQUEST NG

NOTE:

For the diagnostic procedure, refer to DTC P1572 "IMM CIRCUIT FAILURE (EXCEPT ANTENNA CIRCUIT)". <Ref. to IM(diag)-20, DTC P1572 IMM CIRCUIT FAILURE (EXCEPT ANTENNA CIRCUIT), Diagnostic Procedure with Diagnostic Trouble Code (DTC).>

LAN SYSTEM (DIAGNOSTICS)

LAN(diag)

	Page
1. Basic Diagnostic Procedure	2
2. Check List for Interview	3
3. General Description	6
4. Electrical Component Location	8
5. Control Module I/O Signal	10
6. Subaru Select Monitor	14
7. Read Diagnostic Trouble Code (DTC)	15
8. Clear Memory Mode	16
9. Read Current Data	17
10. Function Setting (Customize)	22
11. Registration Body Integrated Unit	24
12. Function Check	27
13. List of Diagnostic Trouble Code (DTC)	28
14. Diagnostic Procedure with Diagnostic Trouble Code (DTC)	31
15. General Diagnostic Table	78

Basic Diagnostic Procedure

LAN SYSTEM (DIAGNOSTICS)

1. Basic Diagnostic Procedure

A: PROCEDURE

1. WITH SUBARU SELECT MONITOR

CAUTION:

- Subaru Select Monitor is required for reading DTC, performing diagnosis and reading current data.
- Remove foreign matter (dust, water, oil, etc.) from the body integrated unit connector during removal and installation.
- For model with immobilizer, registration of immobilizer may be needed after the replacement of controller etc. For detailed procedure, refer to the “REGISTRATION MANUAL FOR IMMOBILIZER”.

NOTE:

- To check harness for open or short circuits, shake the suspected trouble spot or connector.
- Check List for Interview <Ref. to LAN(diag)-3, Check List for Interview.>

	Step	Check	Yes	No
1	CHECK PRE-INSPECTION. Ask the customer when and how the trouble occurred using the interview check list. <Ref. to LAN(diag)-3, Check List for Interview.>	Did you interview the customer?	Go to step 2.	Interview the customer.
2	BASIC INSPECTION. Check the components which might affect body control. <Ref. to LAN(diag)-6, INSPECTION, General Description.>	Is the component that might influence the body control problem normal?	Go to step 3.	Repair or replace each component.
3	CHECK DTC. 1) Read the DTC. <Ref. to LAN(diag)-15, Read Diagnostic Trouble Code (DTC).> NOTE: If the communication function of the Subaru Select Monitor cannot be executed normally, check the communication circuit. <Ref. to LAN(diag)-31, COMMUNICATION FOR INITIALIZING IMPOSSIBLE, Diagnostic Procedure with Diagnostic Trouble Code (DTC).> 2) Record all DTCs and freeze frame data.	Is DTC displayed on the Subaru Select Monitor?	Go to step 5.	Go to step 4.
4	PERFORM GENERAL DIAGNOSTICS. Inspect using “General Diagnostics Table”. <Ref. to LAN(diag)-78, General Diagnostic Table.>	Is result of inspection OK?	LAN system is normal.	Go to step 5.
5	PERFORM DIAGNOSIS. 1) Correct the cause of trouble. 2) Perform the Clear Memory Mode. <Ref. to LAN(diag)-16, Clear Memory Mode.> 3) Read the DTC. <Ref. to LAN(diag)-15, Read Diagnostic Trouble Code (DTC).>	Is DTC displayed on the Subaru Select Monitor?	Repeat step 5 until DTC is not shown.	Finish the diagnosis.

Check List for Interview

LAN SYSTEM (DIAGNOSTICS)

2. Check List for Interview

A: CHECK

Inspect the following item about the vehicle's state.

1. DISPLAY STATUS IN THE COMBINATION METER

Display status in the combination meter	a) Engine coolant temperature gauge display	<input type="checkbox"/> OK / <input type="checkbox"/> NG
	b) Fuel gauge display	<input type="checkbox"/> OK / <input type="checkbox"/> NG
Display of other indicators	c) Malfunction indicator light	<input type="checkbox"/> ON / <input type="checkbox"/> OFF
	d) SPORT indicator light (AT warning light)	<input type="checkbox"/> ON / <input type="checkbox"/> Blink / <input type="checkbox"/> OFF
	e) ABS warning light/Vehicle dynamics control (VDC) warning light	<input type="checkbox"/> ON / <input type="checkbox"/> Blink / <input type="checkbox"/> OFF
	f) Engine coolant temperature warning light	<input type="checkbox"/> ON / <input type="checkbox"/> Blink / <input type="checkbox"/> OFF
	g) Fuel level warning light	<input type="checkbox"/> ON / <input type="checkbox"/> Blink / <input type="checkbox"/> OFF
	h) ATF temperature warning light	<input type="checkbox"/> ON / <input type="checkbox"/> Blink / <input type="checkbox"/> OFF
	i) EBD warning light	<input type="checkbox"/> ON / <input type="checkbox"/> Blink / <input type="checkbox"/> OFF
	j) ABS warning light	<input type="checkbox"/> ON / <input type="checkbox"/> Blink / <input type="checkbox"/> OFF
	k) VDC warning light	<input type="checkbox"/> ON / <input type="checkbox"/> Blink / <input type="checkbox"/> OFF
	l) Hill start assist warning light	<input type="checkbox"/> ON / <input type="checkbox"/> Blink / <input type="checkbox"/> OFF
	m) Immobilizer indicator	<input type="checkbox"/> ON / <input type="checkbox"/> Blink / <input type="checkbox"/> OFF

Check List for Interview

LAN SYSTEM (DIAGNOSTICS)

2. SYMPTOM

Vehicle condition	a) Clearance light does not illuminate.	<input type="checkbox"/> Yes / <input type="checkbox"/> No
	b) Clearance light indicator does not illuminate.	<input type="checkbox"/> Yes / <input type="checkbox"/> No
	c) Low beam does not illuminate.	<input type="checkbox"/> Yes / <input type="checkbox"/> No
	d) Hi beam does not illuminate.	<input type="checkbox"/> Yes / <input type="checkbox"/> No
	e) High beam indicator does not illuminate.	<input type="checkbox"/> Yes / <input type="checkbox"/> No
	f) Front fog light does not illuminate.	<input type="checkbox"/> Yes / <input type="checkbox"/> No
	g) Front fog light indicator does not illuminate.	<input type="checkbox"/> Yes / <input type="checkbox"/> No
	h) Key cannot be removed from key cylinder.	<input type="checkbox"/> Yes / <input type="checkbox"/> No
	i) Key can be removed from any other than parking range.	<input type="checkbox"/> Yes / <input type="checkbox"/> No
	j) Shift lever can not be operated.	<input type="checkbox"/> Yes / <input type="checkbox"/> No
	k) Shift lock does not operate.	<input type="checkbox"/> Yes / <input type="checkbox"/> No
	l) Key warning switch alarm does not sound.	<input type="checkbox"/> Yes / <input type="checkbox"/> No
	m) Reverse warning alarm does not sound.	<input type="checkbox"/> Yes / <input type="checkbox"/> No
	n) Driver's seat belt warning light does not illuminate.	<input type="checkbox"/> Yes / <input type="checkbox"/> No
	o) Seat belt warning alarm does not sound.	<input type="checkbox"/> Yes / <input type="checkbox"/> No
	p) Wiper deicer does not operate.	<input type="checkbox"/> Yes / <input type="checkbox"/> No
	q) Rear defogger does not operate.	<input type="checkbox"/> Yes / <input type="checkbox"/> No
	r) Illumination volume control is not available.	<input type="checkbox"/> Yes / <input type="checkbox"/> No
	s) Combination meter does not dim when headlights are ON.	<input type="checkbox"/> Yes / <input type="checkbox"/> No
	t) Rear wiper does not operate.	<input type="checkbox"/> Yes / <input type="checkbox"/> No
	u) Doors can not be locked/unlocked with central door lock switch.	<input type="checkbox"/> Yes / <input type="checkbox"/> No
	v) Doors can not be locked/unlocked with keyless entry system.	<input type="checkbox"/> Yes / <input type="checkbox"/> No
	w) Rear gate can not be opened when rear gate opener button is pressed.	<input type="checkbox"/> Yes / <input type="checkbox"/> No
	x) Rear gate/trunk can not be opened with keyless entry system.	<input type="checkbox"/> Yes / <input type="checkbox"/> No
	y) Hazard answer-back does not operate.	<input type="checkbox"/> Yes / <input type="checkbox"/> No
	z) Ignition key illumination does not light.	<input type="checkbox"/> Yes / <input type="checkbox"/> No
	aa) Ignition key illumination blinks.	<input type="checkbox"/> Yes / <input type="checkbox"/> No
	ab) Room light does not operate in accordance with door open/close operations.	<input type="checkbox"/> Yes / <input type="checkbox"/> No
	ac) Room light blinks.	<input type="checkbox"/> Yes / <input type="checkbox"/> No
	ad) Foot light does not operate in accordance with door open/close operations.	<input type="checkbox"/> Yes / <input type="checkbox"/> No
	ae) Foot light blinks.	<input type="checkbox"/> Yes / <input type="checkbox"/> No
	af) Indicator does not illuminate when parking brake is operated.	<input type="checkbox"/> Yes / <input type="checkbox"/> No
	ag) Security monitor condition does not occur.	<input type="checkbox"/> Yes / <input type="checkbox"/> No
	ah) Security condition can not be canceled.	<input type="checkbox"/> Yes / <input type="checkbox"/> No
	ai) Hazard light does not blink during security operation.	<input type="checkbox"/> Yes / <input type="checkbox"/> No
	aj) Horn does not sound during security operation.	<input type="checkbox"/> Yes / <input type="checkbox"/> No
	ak) Alarm operates as soon as security monitor condition occurs.	<input type="checkbox"/> Yes / <input type="checkbox"/> No
	al) Security alarm does not operate even when impact is applied (model with impact sensor).	<input type="checkbox"/> Yes / <input type="checkbox"/> No
	am) DRL does not illuminate.	<input type="checkbox"/> Yes / <input type="checkbox"/> No
	an) Passenger's seat belt warning light does not illuminate.	<input type="checkbox"/> Yes / <input type="checkbox"/> No
ao) Engine does not start.	<input type="checkbox"/> Yes / <input type="checkbox"/> No	

Check List for Interview

LAN SYSTEM (DIAGNOSTICS)

3. CONDITIONS UNDER WHICH TROUBLE OCCURS

Driving condition	<input type="checkbox"/> At standstill (While idling)	
	<input type="checkbox"/> When the vehicle is running	Vehicle speed km/h (MPH)
	<input type="checkbox"/> While accelerating	Acceleration km/h (MPH) to km/h (MPH)
	<input type="checkbox"/> Decelerating (With braking)	Deceleration km/h (MPH) to km/h (MPH)
	<input type="checkbox"/> Decelerating (Without braking)	Deceleration km/h (MPH) to km/h (MPH)
	<input type="checkbox"/> Flat road	
	<input type="checkbox"/> Uphill	
	<input type="checkbox"/> Downhill	
	<input type="checkbox"/> Gravel road	
	<input type="checkbox"/> Bumpy road	
	<input type="checkbox"/> Snowy road	
	Does it occur when operating any part? Operated part: TROUBLE SYMPTOM:	
	Are there any other troubles occurred? From where: TROUBLE SYMPTOM:	

General Description

LAN SYSTEM (DIAGNOSTICS)

3. General Description

A: CAUTION

1. SUPPLEMENTAL RESTRAINT SYSTEM “AIRBAG”

Airbag system wiring harness is routed near the body integrated unit and twisted pair line.

CAUTION:

- Do not use electric test equipment on any wiring harnesses and connectors in the airbag system.
- Be careful not to damage the airbag system wiring harness when servicing the body integrated unit and LAN system.

2. LAN SYSTEM

- Bus line of LAN system is twisted pair line. Be careful not to bypass or partly unbind the twisted pair line.
- Do not make clearance between bus lines (CAN High, CAN Low).
- Difference of bus line length should be within 10 cm (3.94 in).
- Fray near the connector should be within 8 cm (3.14 in).

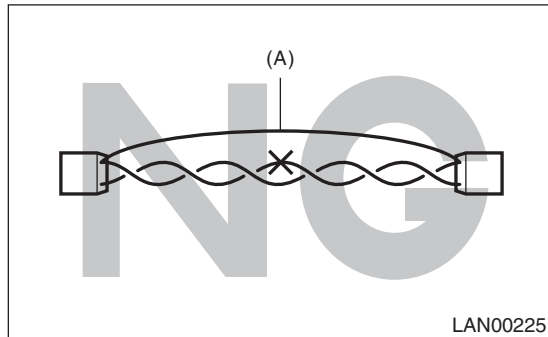

(A) Bypass wire connection

- If the characteristics of the twisted pair line are changed, it may extremely weaken against noise.
- When repairing the harness, connect the wires using soldering and protect it with insulating tape etc.

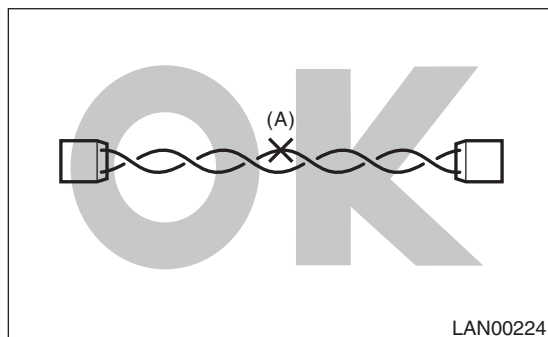

(A) Soldering and protection with insulating tape

B: INSPECTION

Before performing diagnostics, check the following item which might affect body integrated unit malfunctions.

- 1) Measure the battery voltage and check electrolyte.

Standard voltage: 12 V or more

Specific gravity: Above 1.260

- 2) Check the fuse condition.

Make sure that ampere of the fuse is setting value, and it is not blown out.

(Be sure to check the back-up fuse also.)

- 3) Check the connecting condition of harness and harness connector.

- 4) Confirm settings of body integrated unit are corresponded to vehicle equipment. <Ref. to LAN(diag)-24, Registration Body Integrated Unit.>

- 5) Make sure that a setting that does not match the vehicle equipment, is not set in the function setting (ECM customizing) of the body integrated unit. <Ref. to LAN(diag)-22, Function Setting (Customize).>

- 6) Confirm “Factory or Market setting” of body integrated unit registrations is “Market”.

- 7) Confirm key illumination does not blink with ignition switch turned to ON.

General Description

LAN SYSTEM (DIAGNOSTICS)

C: PREPARATION TOOL

1. SPECIAL TOOL

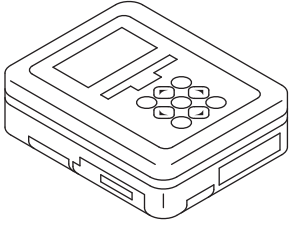
ILLUSTRATION	TOOL NUMBER	DESCRIPTION	REMARKS
 ST1B022XU0	1B022XU0 (Newly adopted tool)	SUBARU SELECT MONITOR III KIT	Used for troubleshooting the electrical system.

2. GENERAL TOOL

TOOL NAME	REMARKS
Circuit tester	Used for measuring resistance, voltage and current.

Electrical Component Location

LAN SYSTEM (DIAGNOSTICS)

4. Electrical Component Location

A: LOCATION

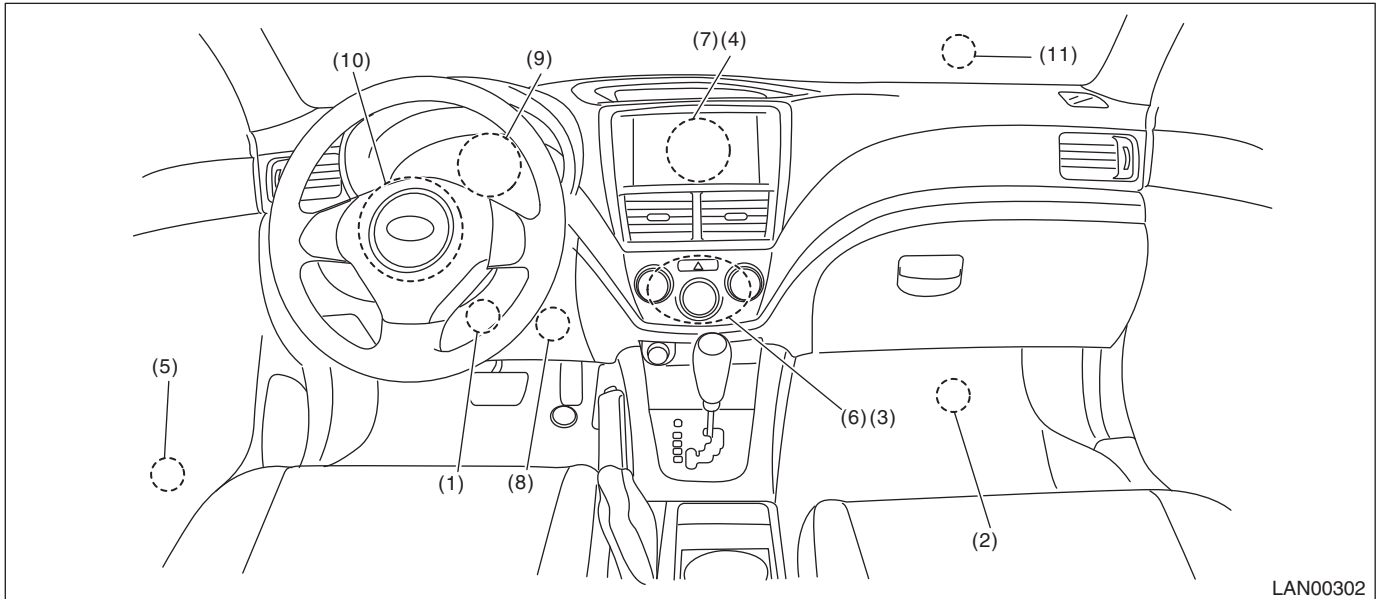

- | | | |
|----------------------------------|---------------------------------------|--|
| (1) Body integrated unit | (6) A/C control panel | (9) Combination meter |
| (2) Engine control module (ECM) | (7) Center display | (10) Steering angle sensor |
| (3) Auto A/C control module | (8) Transmission control module (TCM) | (11) VDCCM&H/U (In engine compartment) |
| (4) Navigation unit | | |
| (5) Keyless entry control module | | |

Electrical Component Location

LAN SYSTEM (DIAGNOSTICS)

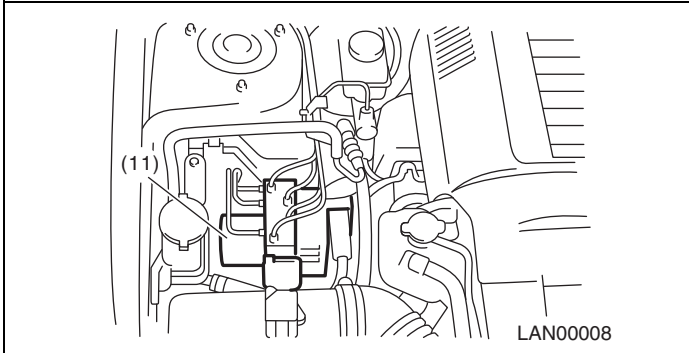
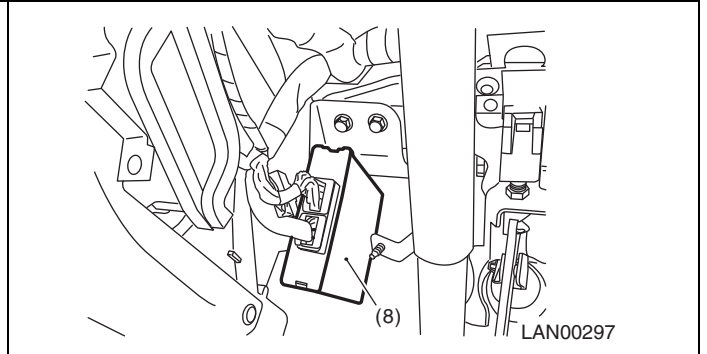
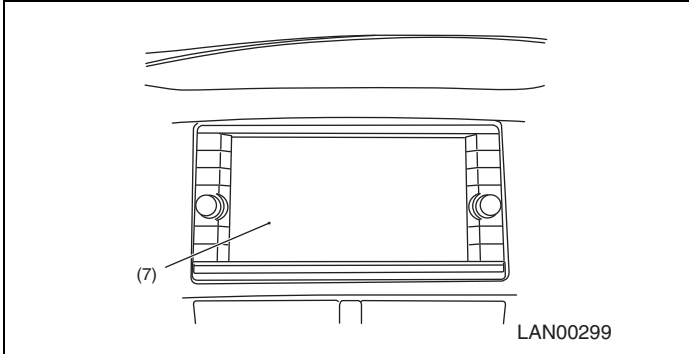
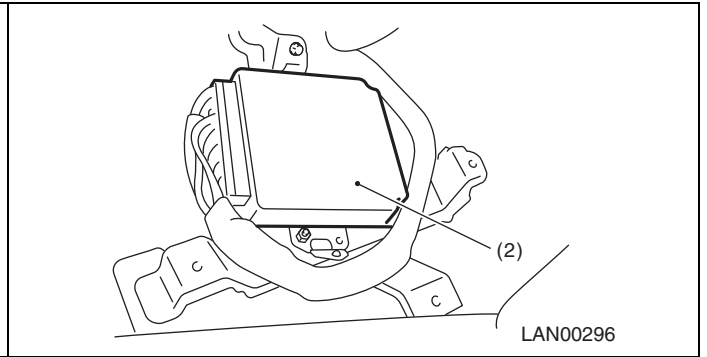
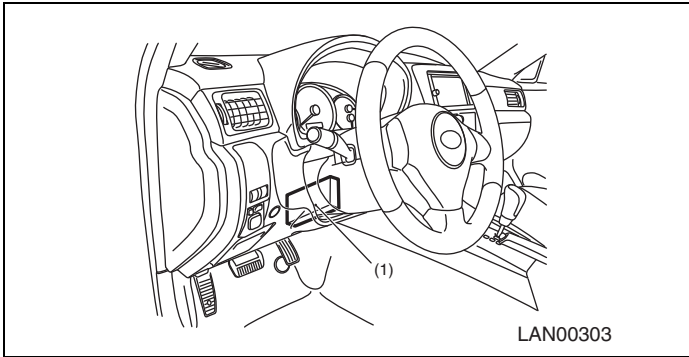

Control Module I/O Signal

LAN SYSTEM (DIAGNOSTICS)

5. Control Module I/O Signal

A: ELECTRICAL SPECIFICATION

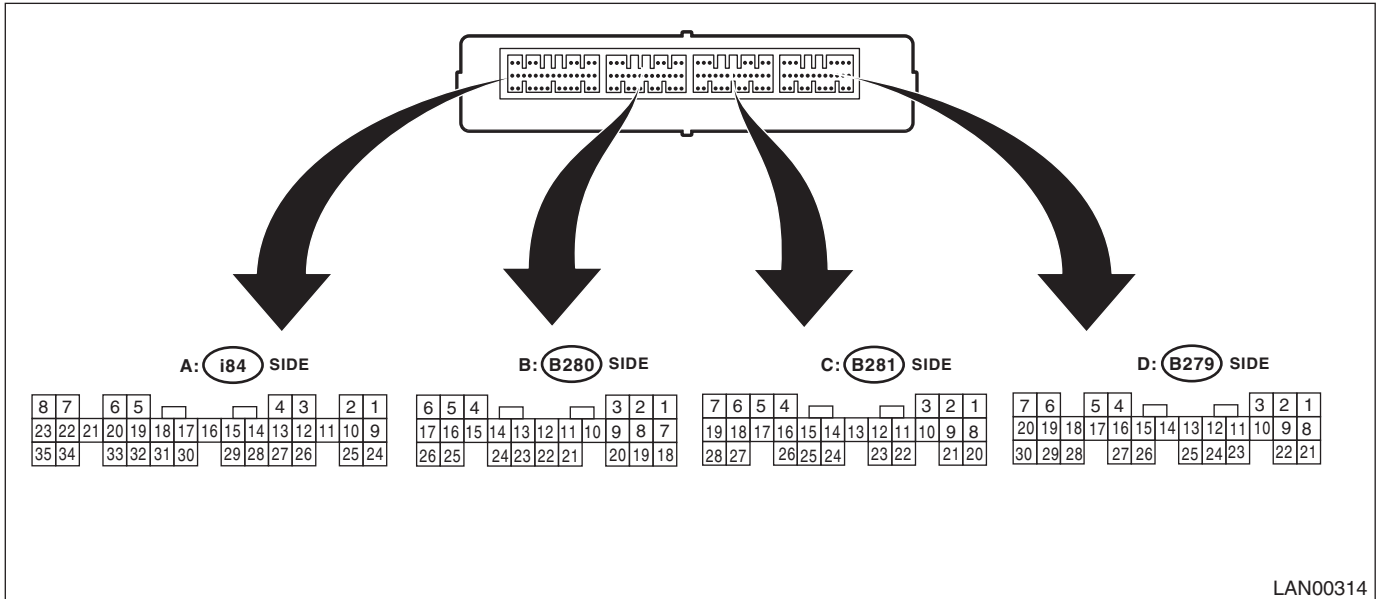

LAN00314

Contents	Terminal No.	Standard value	Measuring conditions
BAT (control)	B6 ← → chassis ground	10 — 14 V	Always
BAT (backup)	C2 ← → chassis ground	10 — 14 V	Always
BAT (door lock)	A34 ← → chassis ground	10 — 14 V	Always
BAT (shift lock/key lock)	D22 ← → chassis ground	10 — 14 V	Always
ACC (rear wiper)	D21 ← → chassis ground	10 — 15 V	When ACC is ON
Ground	A28 ← → chassis ground	Less than 1.5 V	Always
Ground	B17 ← → chassis ground	Less than 1.5 V	Always
Ground	C20 ← → chassis ground	Less than 1.5 V	Always
Ground	D27 ← → chassis ground	Less than 1.5 V	Always
Key warning switch	D2 ← → chassis ground	Less than 1.5 V → 10 — 15 V	With key removed → inserted
ACC	B7 ← → chassis ground	Less than 1.5 V → 10 — 15 V	IGN OFF → ACC ON
IGN	B1 ← → chassis ground	Less than 1.5 V → 10 — 15 V	IGN OFF → IGN ON
P range switch	C4 ← → chassis ground	Less than 1.5 V → 8 V or more	P range → other than P range
Stop light switch	B2 ← → chassis ground	Less than 1.5 V → 8 V or more	With brake pedal released → depressed
Door switch, driver's seat	A19 ← → chassis ground	8 V or more → less than 1.5 V	With driver's door closed → opened
Door switch, passenger's seat	A32 ← → chassis ground	8 V or more → less than 1.5 V	With passenger's door closed → opened

Control Module I/O Signal

LAN SYSTEM (DIAGNOSTICS)

Contents	Terminal No.	Standard value	Measuring conditions
Door switch, rear RH seat	A6 ← → chassis ground	8 V or more → less than 1.5 V	With rear RH seat door closed → opened
Door switch, rear LH seat	A20 ← → chassis ground	8 V or more → less than 1.5 V	With rear LH seat door closed → opened
Door switch, trunk/rear gate	A33 ← → chassis ground	8 V or more → less than 1.5 V	With trunk/rear gate closed → opened
rear gate opener button	C24 ← → chassis ground	8 V or more → less than 1.5 V	Switch OFF → ON
Manual switch (LOCK)	A15 ← → chassis ground	8 V or more → less than 1.5 V	Switch OFF → ON
Manual switch (UNLOCK)	A29 ← → chassis ground	8 V or more → less than 1.5 V	Switch OFF → ON
Delivery (test) mode connector	A17 ← → chassis ground	8 V or more → less than 1.5 V	When delivery (test) mode connector is connected
Front wiper input RTN	C5 ← → chassis ground	8 V or more → less than 1.5 V	When front wiper is reversed
Rear wiper switch ON	C18 ← → chassis ground	8 V or more → less than 1.5 V	Switch OFF → ON
Rear wiper switch (INT)	C27 ← → chassis ground	8 V or more → less than 1.5 V	Switch OFF → ON
Rear wiper switch, washer	C28 ← → chassis ground	8 V or more → less than 1.5 V	Switch OFF → ON
Lighting I switch	B11 ← → chassis ground	8 V or more → less than 1.5 V	Switch OFF → ON
Lighting II switch	C8 ← → chassis ground	8 V or more → less than 1.5 V	Switch OFF → ON
	D6 ← → chassis ground	8 V or more → less than 1.5 V	Key warning switch ON and lighting switch OFF → ON
Dimmer switch, Hi beam	B12 ← → chassis ground	8 V or more → less than 1.5 V	Switch OFF → ON
Dimmer switch, passing	B22 ← → chassis ground	8 V or more → less than 1.5 V	Switch OFF → ON
Front fog light switch	B24 ← → chassis ground	8 V or more → less than 1.5 V	Switch OFF → ON
TPMS answer-back request input	B13 ← → chassis ground	8 V or more → less than 1.5 V	When TPMS transmitter registration answer-back is output
MT reverse switch	B18 ← → chassis ground	8 V or more → less than 1.5 V	Other than reverse → reverse
Parking brake switch	C15 ← → chassis ground	8 V or more → less than 1.5 V	With parking brake not operated → operated
Bright switch	A14 ← → chassis ground	8 V or more → less than 1.5 V	Switch OFF → ON
Illumination (Vi1)	A12 ← → chassis ground	Approx. 5 V	While clearance light illuminates
Illumination (Vi2)	A3 ← → chassis ground	0.5 V — 4.5 V	While clearance light illuminates
Illumination (Vi3)	A26 ← → chassis ground	Less than 1.5 V	Always
Fuel level sensor	C7 ← → chassis ground	Approx. 2 — 96 Ω	Ignition ON
Wiper deicer & rear defogger switch	A16 ← → chassis ground	8 V or more → less than 1.5 V	Switch OFF → ON
Seat belt switch (driver's seat)	C16 ← → chassis ground	Less than 1.5 V → 8 V or more	With seat belt unbuckled → buckled

Control Module I/O Signal

LAN SYSTEM (DIAGNOSTICS)

Contents	Terminal No.	Standard value	Measuring conditions
Impact sensor	B8 ← → chassis ground	Less than 1.5 V ⇔ 8 V or more → 8 V or more	When impact is applied
Key lock solenoid output	D11 ← → chassis ground	Less than 1.5 V → 6 V or more	While key is inserted in other than P range
Shift lock solenoid output	D12 ← → chassis ground	Less than 1.5 V → 10 V or more	When vehicle stopped, IGN ON, other than P range, brake pedal depressed
Rear wiper output ON	D9 ← → chassis ground	Less than 1.5 V → 10 V or more	When rear wiper operates
Rear wiper output RTN	D8 ← → chassis ground	Less than 1.5 V → 10 V or more	When rear wiper reversed
Door lock output	A7 ← → A8	Less than 1.5 V → 10 V or more	While lock output
Door unlock output	A8 ← → A7	Less than 1.5 V → 10 V or more	While unlock output
Driver's door unlock output	A23 ← → chassis ground	Less than 1.5 V → 10 V or more	While unlock output
Trunk/rear gate UNLOCK output	A22 ← → chassis ground	Less than 1.5 V → 10 V or more	Sedan: While trunk UNLOCK output Wagon: While rear gate UNLOCK output
Lighting power supply	C1 ← → chassis ground	Less than 1.5 V → 10 V or more	With back-up fuse inserted, ACC ON or IGN ON
	D1 ← → chassis ground	Less than 1.5 V → 10 V or more	When key warning switch is ON
Clearance light relay output	D19 ← → chassis ground	8 V or more → less than 1.5 V	Small light ON
Lo beam relay output	C3 ← → chassis ground	8 V or more → less than 1.5 V	Headlight switch ON
	D7 ← → chassis ground	8 V or more → less than 1.5 V	Headlight switch ON
Hi beam relay output	D20 ← → chassis ground	8 V or more → less than 1.5 V	Headlight switch ON and Hi beam ON Passing switch ON
Front fog light relay output	D17 ← → chassis ground	8 V or more → less than 1.5 V	Headlight switch ON, and front fog light switch ON
DRL cancel output	D18 ← → chassis ground	8 V or more → less than 1.5 V	When Hi beam 100 % illuminates
Room light output	D5	Pulse control	Illumination is adjusted through PWM control
Key ring illumination output	C23	Pulse control	Illumination is adjusted through PWM control
Illumination output	A2	Pulse control	Illumination is adjusted through PWM control
Foot light output	D4 ← → chassis ground	Pulse control	Illumination is adjusted through PWM control
Seat belt warning light (passenger's seat)	A25 ← → chassis ground	8 V or more → less than 1.5 V	Indicator go off → illuminate
Answer-back buzzer output	D24 ← → chassis ground	Less than 1.5 V → 10 V or more	When LOCK/UNLOCK is operated with keyless entry
Rear defogger relay output	D16 ← → chassis ground	8 V or more → less than 1.5 V	While rear defogger output
Wiper deicer relay output	D15 ← → chassis ground	8 V or more → less than 1.5 V	While wiper deicer output
Seat belt warning light (passenger's seat)	A25 ← → chassis ground	8 V or more → less than 1.5 V	Indicator go off → illuminate
Answer-back buzzer output	D24 ← → chassis ground	Can not be measured because of high speed ON/OFF	Door lock → unlock with keyless entry system
Turn & hazard output	C22 ← → chassis ground	8 V or more → less than 1.5 V	Door lock or unlock with keyless entry system

Control Module I/O Signal

LAN SYSTEM (DIAGNOSTICS)

Contents	Terminal No.	Standard value	Measuring conditions
Horn relay output	D29 ← → chassis ground	8 V or more → less than 1.5 V	While security alarm operates
Security indicator output	A10 ← → chassis ground	8 V or more → less than 1.5 V	While indicator in combination meter blinks
Immobilizer antenna 1	B26 ← → B25	-30 — +30 V	While key secret code is verified
Immobilizer antenna 2	B25 ← → B26		
Immobilizer communication_1	B4	Can not be measured because of digital communication	Serial communication line
Immobilizer communication_2	B15	Can not be measured because of digital communication	Serial communication line
Keyless entry control module communication	A24	Can not be measured because of digital communication	Serial communication line
SSM communication (K line)	B20	Can not be measured because of digital communication	Serial communication line
Body system CAN_Hi	A1 ← → chassis ground	Can not be measured because of digital communication	Serial communication line
Body system CAN_Lo	A9 ← → chassis ground	Can not be measured because of digital communication	Serial communication line
Driving system CAN_Hi	B3 ← → chassis ground	Can not be measured because of digital communication	Serial communication line
Driving system CAN_Lo	B9 ← → chassis ground	Can not be measured because of digital communication	Serial communication line

B: WIRING DIAGRAM

<Ref. to WI-166, WIRING DIAGRAM, CAN Communication System.>

6. Subaru Select Monitor

A: OPERATION

1) Prepare the Subaru Select Monitor kit. <Ref. to LAN(diag)-7, PREPARATION TOOL, General Description.>

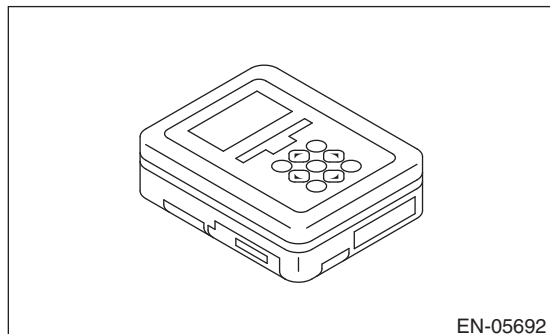

2) Prepare the personal computer which has been installed the Subaru Select Monitor.

3) Connect the USB cable between SDI (Subaru Diagnosis Interface) and USB port on the personal computer (dedicated port for the Subaru Select Monitor).

NOTE:

The dedicated port for the Subaru Select Monitor means the USB port which was used to install the Subaru Select Monitor.

4) Connect the diagnosis cable to SDI.

5) Connect the SDI to data link connector located in the lower portion of the instrument panel (on the driver's side).

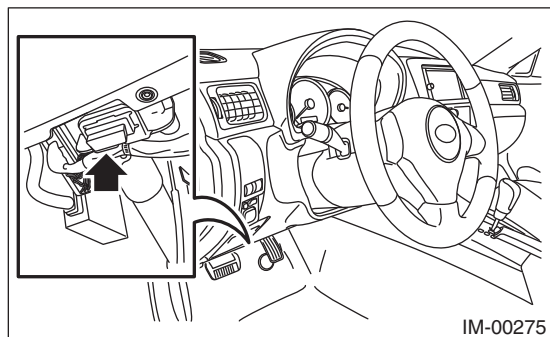

6) Start a PC.

7) Turn the ignition switch to ON (engine OFF), and run the "PC application for Subaru Select Monitor".

7. Read Diagnostic Trouble Code (DTC)

A: OPERATION

- 1) On the «Main Menu» display screen, select {Each System Check}.
- 2) On the «Each System Check» menu display screen, select the {Integ. unit mode}.
- 3) Select the [OK] after the information of body integrated unit type is displayed.
- 4) On the «Integ. unit mode» display screen, select the {Diagnostic Code(s) Display}.
- 5) Record the DTC displayed.

NOTE:

- For details concerning the operation procedure, refer to the “PC application help for Subaru Select Monitor”.
- For details concerning DTC, refer to “List of Diagnostic Trouble Code (DTC)”. <Ref. to LAN(diag)-28, List of Diagnostic Trouble Code (DTC).>

Clear Memory Mode

LAN SYSTEM (DIAGNOSTICS)

8. Clear Memory Mode

A: OPERATION

- 1) On the «Main Menu» display screen, select the {2. Each System Check}.
- 2) On the «System Selection Menu» display screen, select the {Integ. unit mode}.
- 3) Press the [OK] key after the information of body integrated unit type is displayed.
- 4) On the «Integ. unit mode failure diag» display screen, select {Clear Memory} and press the [OK] key.

Display	Contents to be monitored
Clear Memory ?	Clear function of DTC and freeze frame data

- 5) When “Done” is shown on the display screen, turn the ignition switch to OFF.

NOTE:

For details concerning the operation procedure, refer to the “PC application help for Subaru Select Monitor”.

9. Read Current Data

A: OPERATION

- 1) On the «Main Menu» display screen, select {Each System Check}.
- 2) On the «System Selection Menu» display screen, select the {Integ. unit mode}.
- 3) On the «Integ. unit mode failure diag» display screen, select the {Current Data Display & Save}.
- 4) Using the scroll key, scroll the display screen up or down until the desired data is shown.

B: LIST

Items to be displayed	Unit of measure	Remarks	Note
BATT voltage (control)	10 — 15 V	Body integrated unit input value	Always
BATT voltage (BACKUP)	10 — 15 V	Body integrated unit input value	Always
IG Power Supply Voltage	10 — 15 V	Body integrated unit input value	Ignition switch ON
ACC voltage	10 — 15 V	Body integrated unit input value	Ignition switch ACC
Illumination VR Voltage	0 — 5 V	Body integrated unit output value	Input value from illumination volume
Illumi. output d-ratio	0 — 100%	Body integrated unit input value	Small light ON Illumination volume is other than bright.
Ambient Temperature	-40 — 87.5°C	Body integrated unit output value	Ignition switch ON
Fuel level voltage	0 — 10 V	Body integrated unit input value	Ignition switch ON
Fuel level resistance	0 — 102.3 Ω	Body integrated unit input value	Ignition switch ON
key-lock solenoid V	6 — 15 V	Body integrated unit output value	Key warning switch ON, other than parking range Ignition ON
number of regist.	0 — 4	Number of keyless key registered	Number of transmitter registered is displayed
Front Wheel Speed	km/h	CAN data input value	Reception from VDC unit
VDC/ABS latest f-code	DTC display (Temporarily)	CAN data input value	It is normal when DTC is not been input even if this code is displayed. Received from VDC (displayed by hexadecimal number system)
Blower Fan Steps	0 — 2 levels	CAN data input value	0: OFF, 1: Low, 2: 2 levels or more Reception from air conditioner ECM
Fuel level resistance 2	0 — 102.3 Ω	CAN data output value	Reception from body integrated unit
Fuel consumption	cc/s	CAN data input value	Reception from ECM and transmission to center monitor
Coolant Temp.	-40 — 130°C	CAN data input value	Reception from ECM
Vehicle lateral G	m/s ²	CAN data input value	Reception from VDC unit
SPORT Shift Stages	0 — 7 levels	CAN data input value	(0: Light OFF; 1 — 5: Gear display; 6: Fail; 7: ATF temperature High/Low) Reception from TCM
Shift Position	0 — 7 levels	CAN data input value	0: 1; 1: 2; 2: 3; 3: 4; 4: D; 5: N; 6: R; 7: P shift position (There is no 8 input.) 8 is displayed in manual mode Reception from TCM
VDC/ABS condition	0 — 4	CAN data input value	
Destination Code	0 — 16	CAN data input value	
Touch SW	0 — 64	CAN data input value	
key-lock warning SW	ON/OFF	Body integrated unit input value	ON when ignition key is inserted
Stop Light Switch	ON/OFF	Body integrated unit input value	ON when brake pedal is depressed
Front fog lamp SW input	ON/OFF	Body integrated unit input value	When front fog light switch is ON
TPMS input	ON/OFF	Body integrated unit input value	Registration done signal
Door key-lock SW input	ON/OFF	Body integrated unit input value	Not supported
Door unlock SW input	ON/OFF	Body integrated unit input value	Not supported
Driver's door SW input	ON/OFF	Body integrated unit input value	ON when driver's door is open

Read Current Data

LAN SYSTEM (DIAGNOSTICS)

Items to be displayed	Unit of measure	Remarks	Note
P-door SW input	ON/OFF	Body integrated unit input value	ON when passenger's door is open
Rear right door SW input	ON/OFF	Body integrated unit input value	ON when rear right door is open
Rear left door SW input	ON/OFF	Body integrated unit input value	ON when rear left door is open
R Gate SW input	ON/OFF	Body integrated unit input value	ON when trunk/rear gate is open
Manual lock SW input	ON/OFF	Body integrated unit input value	Manual lock switch ON
Manual unlock SW input	ON/OFF	Body integrated unit input value	Manual unlock switch ON
Lock SW	ON/OFF	Body integrated unit input value	Not supported
Bright SW input	ON/OFF	Body integrated unit input value	ON when bright switch is ON
P SW	ON/OFF	Body integrated unit input value	ON when shift range is in parking Shift lever P SW signal
MT Reverse Switch	ON/OFF	Body integrated unit input value	Shift lever is at reverse position
R wiper ON SW input	ON/OFF	Body integrated unit input value	Rear wiper switch ON
R wiper INT SW input	ON/OFF	Body integrated unit input value	Rear wiper switch INT ON
R washer SW input	ON/OFF	Body integrated unit input value	Rear washer switch ON
wiper deicer SW input	ON/OFF	Body integrated unit input value	Wiper deicer switch ON
Rear Defogger SW	ON/OFF	Body integrated unit input value	Rear defogger switch ON (only manual A/C)
Driver's Seat SW input	ON/OFF	Body integrated unit input value	Driver's seat buckle switch ON
P seatbelt SW input	ON/OFF	Body integrated unit input value	With passenger's seat occupied and buckle switch ON
Fr wiper input	ON/OFF	Body integrated unit input value	ON when front wiper is operating
Parking Brake Switch Input	ON/OFF	Body integrated unit input value	When parking brake locked
Registration SW input	ON/OFF	Body integrated unit input value	When keyless registration connector is connected
Identification SW input	ON/OFF	Body integrated unit input value	ON with wagon
Driver's seat lock status SW input	ON/OFF	Body integrated unit input value	ON with door locked condition
Passenger's seat lock status SW input	ON/OFF	Body integrated unit input value	ON with door locked condition
R gate lock status SW input	ON/OFF	Body integrated unit input value	ON with door locked condition
R Gate Release SW input	ON/OFF	Body integrated unit input value	When rear gate opener button is ON
Rr defogger output	ON/OFF	Body integrated unit output value	ON when rear defogger relay is operating
lock actuat. LOCK output	ON/OFF	Body integrated unit output value	ON when lock signal is output
All seat UNLOCK output	ON/OFF	Body integrated unit output value	ON when unlock signal is output
D-seat UNLOCK output	ON/OFF	Body integrated unit output value	ON when unlock signal is output
R gate/trunk UNLK output	ON/OFF	Body integrated unit output value	ON when rear gate/trunk unlock signal is output
R wiper output	ON/OFF	Body integrated unit output value	ON when rear wiper motor is operating
Shift Lock Solenoid	ON/OFF	Body integrated unit output value	ON when shift lock solenoid is ON (only AT)
Key locking output	ON/OFF	Body integrated unit output value	With ignition switch ON and in other than the shift P range, with key in switch ON
wiper deicer output	ON/OFF	Body integrated unit output value	ON when wiper deicer relay is operating
Hazard Output	ON/OFF	Body integrated unit output value	ON when answer-back signal is received or when hazard is operating
Keyless Buzzer Output	ON/OFF	Body integrated unit output value	ON when lock/unlock signal is received
Horn Output	ON/OFF	Body integrated unit output value	ON when security warning is operating
P-belt warning light O/P	ON/OFF	Body integrated unit output value	ON when Ignition switch is turned to ON, occupant is seated, and buckle switch is turned off

Read Current Data

LAN SYSTEM (DIAGNOSTICS)

Items to be displayed	Unit of measure	Remarks	Note
Illumination lamp O/P	ON/OFF	Body integrated unit output value	ON when illumination is illuminated
Room lamp output	ON/OFF	Body integrated unit output value	ON when keyless lock/unlock signal is received (when keyless switch connector is removed)
key illumi. lamp o/p	ON/OFF	Body integrated unit output value	ON when key illumination light is illuminated
Immobilizer lamp output	ON/OFF	Body integrated unit output value	ON when immobilizer pilot light blinks
CC Main Lamp	ON/OFF	CAN data input value	Cruise control switch ON Reception from ECM and transmission to combination meter
CC Set Lamp	ON/OFF	CAN data input value	ON when cruise control vehicle speed is set Reception from ECM and transmission to combination meter
SPORT Lamp	ON/OFF	CAN data input value	SPORT mode switch ON Reception from TCM and transmission to combination meter (only AT)
SPORT Blink	Blink/OFF	CAN data input value	Blinks when there is an AT failure Reception from TCM and transmission to combination meter (only AT)
ATF Temperature Lamp	ON/OFF	CAN data input value	When ATF temperature rise (only AT)
ATF Blink	Blink/OFF	CAN data input value	Blinks when there is an AT failure Reception from TCM and transmission to combination meter (only AT)
Tire diameter abnormal 1	ON/OFF	CAN data input value	Lit when FWD fuse is connected (4AT only)
Tire diameter abnormal 2	Blink/OFF	CAN data input value	Blinks when the difference in rotation between front and rear wheels is 4% or more Reception from TCM and transmission to combination meter (only AT)
Shift Up Indication	UP/OFF	Body integrated unit input value	ON when shift lever can be operated up (only AT)
Shift Down Indication	DOWN/OFF	Body integrated unit input value	ON when shift lever can be operated down (only AT)
SPORT Shift (buzzer 1)	ON/OFF	CAN data input value	ON while the shift change prohibited warning buzzer is operating Reception from TCM and transmission to combination meter (only AT)
SPORT Shift (buzzer 2)	ON/OFF	CAN data input value	ON when the ATF high temperature warning buzzer is operating Reception from TCM and transmission to combination meter (only AT)
ABS/VDC Judging	ABS/VDC	CAN data input value	Transmission from vehicle dynamic control (VDC) to high speed control module
Lh Turn	ON/OFF	CAN data input value	Not supported
Rh Turn	ON/OFF	CAN data input value	Not supported
Rr Defogger SW	ON/OFF	CAN data input value	Rear defogger switch ON From A/C ECM

Read Current Data

LAN SYSTEM (DIAGNOSTICS)

Items to be displayed	Unit of measure	Remarks	Note
Australia Judging Flag	Australia/Others	Body integrated unit output value	North American specifications have others
large Diameter Tire	Large Tire/Others	Body integrated unit output value	Large Tire when standard tire is 18 in. Reception from combination meter
Number of cylinders	4 cylinders/6 cylinders	CAN data input value	Display engine equipped
Cam shaft specification	SOHC/DOHC	CAN data input value	Display engine equipped
Turbo	TURBO/Non-turbo	CAN data input value	Display engine equipped
E/G displacement (2.5 L)	2.5 L/ OFF	CAN data input value	Display engine equipped
E/G displacement (3.0 L)	3.0 L/ OFF	CAN data input value	Display engine equipped
AT Vehicle ID Signal	AT model / MT model	CAN data input value	Display transmission equipped
Blower fan information	ON/OFF	CAN data input value	ON when blower fan is operating (always OFF for auto A/C equipped models)
Door lock SW (Open)	ON/OFF	CAN data input value	
Door lock SW (Close)	ON/OFF	CAN data input value	
Door Key SW (Open)	ON/OFF	CAN data input value	
Door Key SW (Close)	ON/OFF	CAN data input value	
Under hook registration	ON/OFF	CAN data input value	
Hook registration end	ON/OFF	CAN data input value	
Unlock request	ON/OFF	CAN data input value	
Center display failure	OK/NG	CAN data input value	NG when there is a center display failure Reception from center display (NAVI monitor)
NAVI Failure	OK/NG	CAN data input value	NG when there is a navigation system failure Reception from Center Display
IE Bus failure	Can not use	CAN data input value	Reception from Center Display
Auto A/C failure	OK/NG	CAN data input value	NG when there is a failure in auto air conditioning system Reception from auto A/C module
EBD Warning Light	OK/OFF	CAN data input value	OK when EBD warning light is illuminated Reception from VDC/ABS and transmission to combination meter
ABS Warning Light	OK/OFF	CAN data input value	OK when ABS warning light is illuminated Reception from VDC/ABS and transmission to combination meter
VDC OFF flag	ON/OFF	CAN data input value	Vehicle dynamics control OFF SW is ON Reception from VDC/ABS and transmission to combination meter
VDC/ABS OK B	OK/NG	CAN data input value	NG when there is an error in VDC/ABS system Reception from VDC/ABS
Lighting I Switch Input	ON/OFF	Body integrated unit input value	ON when lighting switch, illumination is ON
Lighting II Switch Input	ON/OFF	Body integrated unit input value	ON when lighting switch, headlight is ON
Dimmer Hi Switch Input	ON/OFF	Body integrated unit input value	ON when dimmer switch is Hi beam position
Dimmer Pass Switch Input	ON/OFF	Body integrated unit input value	ON when dimmer switch is passing position
Lighting I Lamp Output	ON/OFF	Body integrated unit output value	ON when small light is illuminated
Lighting II Lamp Output	ON/OFF	Body integrated unit output value	ON when headlight is illuminated
Lighting Hi Lamp Output	ON/OFF	Body integrated unit output value	ON when Hi beam is illuminated
Front Fog Lamp Output	ON/OFF	Body integrated unit output value	ON when Front fog light is ON.
DRL Cancel Output	ON/OFF	Body integrated unit output value	When lighting switch is "Head" or dimmer & passing switch is "passing", parking switch is ON, ignition switch is "ACC", engine speed is 500 rpm or less

Read Current Data

LAN SYSTEM (DIAGNOSTICS)

Items to be displayed	Unit of measure	Remarks	Note
Power Supply Tr	ON/OFF	Body integrated unit output value	ON when lighting switch is "Head" position without inserting key in key cylinder
Foot Lamp Output	ON/OFF	Body integrated unit output value	ON when foot light RH, foot light LH is illuminated
Front Fog Lamp Output	ON/OFF	Body integrated unit output value	When fog light illuminates
Lighting I Switch Input	ON/OFF	Body integrated unit input value	ON when small light is illuminated
Lighting II Switch Input	ON/OFF	Body integrated unit input value	When headlight LO is ON
Dimmer Hi Switch Input	ON/OFF	Body integrated unit input value	When headlight HI is ON
Dimmer Pass Switch Input	ON/OFF	Body integrated unit input value	When headlight Pass is ON
Lighting I Lamp Output	ON/OFF	Body integrated unit output value	ON when tail & illumination relay is operated
Lighting II Lamp Output	ON/OFF	Body integrated unit output value	ON when headlight Lo relay is operated
Lighting Hi Lamp Output	ON/OFF	Body integrated unit output value	ON when headlight Hi relay is operated
Power Supply Tr	ON/OFF	Body integrated unit output value	Headlight auxiliary power supply ON
Foot Lamp Output	ON/OFF	Body integrated unit output value	ON when foot light is illuminated
Rr defogger op. mode	Continuous/Normal	Body integrated unit setting items	Customize setting
Wiper deicer op. mode	Continuous/Normal	Body integrated unit setting items	Customize setting
Security Alarm Setup	ON/OFF	Body integrated unit setting items	Customize setting
Impact Sensor Setup	ON/OFF	Body integrated unit setting items	Customize setting
Alarm delay setup	ON/OFF	Body integrated unit setting items	Customize setting
Lockout prevention	ON/OFF	Body integrated unit setting items	Customize setting
Impact sensor	ON/OFF	Body integrated unit setting items	Customize setting
Hazard answer-back setup	ON/OFF	Body integrated unit setting items	Customize setting
Automatic locking setup	ON/OFF	Body integrated unit setting items	Customize setting
Auto locking	ON/OFF	Body integrated unit setting items	Customize setting
Door open warning	ON/OFF	Body integrated unit setting items	Customize setting
Dome Light Alarm Setting	ON/OFF	Body integrated unit setting items	Customize setting
Belt Warning Switch	ON/OFF	Body integrated unit setting items	Customize setting
A/C ECM setting	ON/OFF	Body integrated unit setting items	Customize setting
wiperdeicer	ON/OFF	Body integrated unit setting items	Customize setting
Rear fog light setting	ON/OFF	Body integrated unit setting items	Customize setting
Illumination Control On/Off	ON/OFF	Body integrated unit setting items	Customize setting
Sedan/Wagon Setting	Sedan/wagon	Body integrated unit setting items	Customize setting
MT/AT Setting	MT/AT	Body integrated unit setting items	Customize setting
6MT Setting	6MT/Other than 6MT	Body integrated unit setting items	Customize setting
Destination Setting	0 — 16	Body integrated unit setting items	—
Factory or Market setting	Factory/Market	Body integrated unit setting items	Customize setting

NOTE:

For details concerning the operation procedure, refer to the "PC application help for Subaru Select Monitor".

Function Setting (Customize)

LAN SYSTEM (DIAGNOSTICS)

10.Function Setting (Customize)

A: OPERATION

- 1) On the «Main Menu» display screen, select {Each System Check}.
- 2) On the «System Selection Menu» display screen, select the {Integ. unit mode}.
- 3) On the «Integ. unit mode failure diag» display screen, select the {ECM customizing}.
- 4) Change the setting with UP/DOWN key and set with the [OK] key.

- List of function setting item (ECM customizing)

Data	Initial setting value	Customize setting	Remarks	
Off delay time	Normal		Delay time below can be selected by setting.	
			After door closed	After keyless unlock
		OFF	0 seconds	0 seconds
		Short	10 seconds	10 seconds
		Normal	20 seconds	20 seconds
		Long	30 seconds	30 seconds
Auto lock time	30 seconds	0 — 60 sec.	Workable when Auto locking is set to "ON" and Automatic locking setup is "ON". Time can be changed by 10 seconds: 0 (OFF) — 60 (maximum).	
Rr defogger op. mode	15 min.	15 min.	Wiper deicer stops in 15 minutes automatically after switch is turned to ON.	
		Continuous	The wiper deicer activates for 15 minutes and turns inactive for 2 minutes repeatedly until the switch is turned OFF.	
Wiper deicer op. mode	15 min.	15 min.	Wiper deicer stops in 15 minutes automatically after switch is turned to ON.	
		Continuous	The wiper deicer activates for 15 minutes and turns inactive for 2 minutes repeatedly until the switch is turned OFF.	
Security Alarm Setup	OFF	ON	Security alarm (hazard, horn or siren) in active condition	
		OFF	Security alarm in inactive condition	
Impact Sensor Setup	OFF	ON	Workable when Impact Sensor Setup is set to "ON". Impact sensor function becomes activated.	
		OFF	Impact sensor in inactive condition (Set to "OFF" in models without sensors.)	
Alarm delay setup	ON		After the keyless lock operation, the alarm monitor starts after the following delay time has passed.	
		ON	Delay time is 30 seconds.	
		OFF	Delay time is 0 seconds.	
Lockout prevention	ON	ON	Lockout prevention in inactive condition (The function does not operate if safety knob is locked by hand.)	
		OFF	Lockout prevention in inactive condition	
Impact sensor (OP)	OFF	ON	Vehicle is controlled in impact sensor equipped mode. (Make sure to set to OFF for models without the impact sensor. When set to ON, hazard, the horn or siren will operate after doors are locked by the keyless entry system operation (Alarm monitor start).	
		OFF	Vehicle is controlled in no impact sensor mode.	
Siren setting (OP)	OFF	ON	Make sure to set to OFF for models without the siren.	
		OFF		
Answer-back buzzer setup	ON	ON	Workable when answer-back buzzer setup is set to "ON". When lock/unlock is selected by keyless entry system operated, hazard answer-back buzzer operates.	
		OFF	When lock/unlock is selected by keyless entry system operated, answer-back buzzer does not sound.	

Function Setting (Customize)

LAN SYSTEM (DIAGNOSTICS)

Data	Initial setting value	Customize setting	Remarks
Hazard answer-back setup	ON	ON	Workable when hazard answer-back setup is set to "ON" When lock/unlock is selected by keyless entry system operated, hazard answer-back buzzer operates.
		OFF	When lock/unlock is selected by keyless entry system operated, hazard answer-back does not operate.
Automatic locking setup	ON	ON	Not supported
		OFF	
Ans.-back Buzzer	ON	ON	Vehicle is controlled in answer-back buzzer equipped mode.
		OFF	Vehicle is controlled in answer-back buzzer non-equipped mode. (Make sure to set to "OFF" in models without answer back buzzers.)
Auto locking	ON	ON	Not supported
		OFF	
Initial keyless setting	—	—	—
		Execution	Settings of keyless entry system are initialized. (No. 2: 30 sec., No. 11: ON, No. 12: ON, No. 13: ON, No. 14: ON)
Initial button setting	—	—	—
		Execution	Settings of each function are initialized. (No. 1: Normal, No. 3: 15 min., No. 4: 15 min., No. 8: ON)
Initial Security setting	—	—	Not supported
		Execution	
Passive Alarm	OFF	ON	Setting only for North American models
		OFF	
Door open warning	OFF	ON	If detecting door open for 30 minutes, room light, key ring illumination are turned off to prevent battery run-out.
		OFF	Room light, key illumination and door warning light is not turned off.
Belt Warning Switch	ON	ON	When using normally
		OFF	Stop the belt warning buzzer beep and warning light illumination.

5) After setting, make sure that vehicle equipment is same as the setting changed in the {Current Data Display & Save}.

CAUTION:

- **The above settings must match the actual vehicle equipment.**
- **Do not change settings other than the above while setting the functions.**
- **Be sure not to change Factory or Market setting except installation of new body integrated unit.**

NOTE:

For details concerning the operation procedure, refer to the "PC application help for Subaru Select Monitor".

Registration Body Integrated Unit

LAN SYSTEM (DIAGNOSTICS)

11.Registration Body Integrated Unit

A: OPERATION

1. CONFIRMATION OF CURRENT SETTING

- 1) On the «Main Menu» display screen, select {Each System Check}.
- 2) On the «System Selection Menu» display screen, select the {Integ. unit mode}.
- 3) On the «Integ. unit mode failure diag» display screen, select the {Current Data Display & Save}.
- 4) Using the scroll key, scroll the display screen up or down until the desired data is shown.
- 5) Display the following item and record the settings.

Required items for new registration (Except for system not equipped)

Contents	Item to confirm				Remarks
	1	2	3	4	
Key No. to register					Registered ID type
Off delay	OFF	Long	Normal	Short	Setting for lighting off time
Auto lock	60, 50, 40, 30, 20		OFF		(Unit: seconds)
Rr defogger op. mode	Normal		Continuous		
Wiper deicer op. mode	Normal		Continuous		Option setting
Security Alarm Setup	ON		OFF		
Impact Sensor Setup	ON		OFF		Option setting
Alarm delay setup	ON		OFF		
Lockout prevention	ON		OFF		
Impact sensor	support		no support		Option setting
Answer-back buzzer setup	ON		OFF		
Hazard answer-back setup	ON		OFF		
Automatic locking setup	ON		OFF		
Ans.-back Buzzer	support		no support		
Auto locking	support		no support		
Initial button setting	Execution		-		
Initial Security setting	Execution		-		
Select unlock switch	Selection		ALL		
Passive Alarm	ON		OFF		
Door open warning (prevention of battery run-out)	support		no support		
Dome Light Alarm Setting	ON		OFF		
Belt Warning Switch	ON		OFF		Switch the belt warning lighting and the buzzer sound.
A/C ECM setting	support		no support		Model with auto A/C
wiperdeicer	support		no support		Option setting
Rear fog light setting	support		no support		Not supported
Illumination Control On/Off	support		no support		Not supported
Sedan/Wagon Setting	Sedan		Wagon		
MT/AT Setting	AT		MT		
6MT Setting	6MT		Other than 6MT		
Destination Setting					
Factory or Market setting	Factory		Market		Do not change to factory mode.

2. REGISTRATION BODY INTEGRATED UNIT (EQUIPMENT SETTING)

CAUTION:

Body integrated unit is core of LAN system, and also can select the function of all vehicle system control. It is possible to control the original functions of vehicle when registrations of body integrated unit and function setting are corresponded to vehicle equipment.

If registrations and function setting are different from vehicle equipment, vehicle system does not operate normally and diagnosis cannot be performed correctly. Pay attention to following item.

- Be sure to correspond registrations and function settings to vehicle equipment.
 - Do not change the settings of vehicle improperly.
 - Confirm key illumination does not blink or “Factory or Market setting” of body integrated unit registrations is “Market”. If “Factory or Market setting” is set to “Factory,” key illumination blinks when ignition key is turned ON, to notify that the settings are unconfirmed.
 - Key illumination does not blink with ignition switch turned to ON and go off with door closed.
 - Be sure to register immobilizer if body integrated unit is replaced with a new part. (models with immobilizer)
 - Make a registration of immobilizer when the parts related to immobilizer have been replaced. Refer to the “PC application help for Subaru Select Monitor”.
- 1) On the «Main Menu» display screen, select {Each System Check}.
 - 2) On the «System Selection Menu» display screen, select the {Integ. unit mode}.
 - 3) Click the [OK] button after the control module name {Integ. Unit} is displayed.
 - 4) On the «Integ. unit mode failure diag» display screen, select the {ECM customizing}.
 - 5) Change the setting with UP/DOWN key.
- List of body integrated unit registration item

NOTE:

Setting is different depending on the grade of vehicle.

Data	Initial setting	Registration	Remarks
A/C ECM setting	OFF	ON	Illumination control does not operate if A/C ECM setting is set to “OFF” in case of model with auto A/C.
		OFF	If A/C ECM setting is set to “ON” in case of model without auto A/C, illumination change to night illumination and it is difficult to be recognized.
wiperdeicer (manufacturer option)	OFF	ON	ON signal does not output with operation of wiper deicer switch if wiper deicer is set to “OFF” in models with a wiper deicer.
		OFF	
Rear fog light setting	OFF	ON	Can not set to ON.
		OFF	Vehicle is controlled in rear fog light non-equipped mode. (Always set to “OFF” for vehicles not equipped with the rear fog light.)
Illumination Control On/Off	ON	ON	Lighting adjustment is not possible when “OFF” is set for the model with illumination volume control.
		OFF	
Sedan/Wagon Setting	Wagon	Wagon	Door lock/unlock is controlled with wagon setting.
		Sedan	Door lock/unlock is controlled with sedan setting.
MT/AT Setting	AT	MT	Shift lock solenoid and key lock solenoid are not controlled.
		AT	Shift lock solenoid and key lock solenoid are controlled.
6MT Setting	Other than 6MT	6MT	Change to 6MT is possible when MT is set.
		Other than 6MT	
Factory or Market setting (Reset of body integrated unit)	Factory	Factory (Reset)	If Factory or Market setting is set to “Factory”, registrations of items above is changed to “OFF”. Be sure to set to “Market”.
		Market (Confirmed)	

Registration Body Integrated Unit

LAN SYSTEM (DIAGNOSTICS)

CAUTION:

- To perform normal operation of vehicle and diagnosis, the above settings must match the actual vehicle equipment.
- When body integrated unit is a new part or “Factory” mode, key illumination blinks to show equipment settings have not been completed. Check the detailed procedures of function setting.
- Be sure not to change Factory or Market setting except installation of new body integrated unit.

NOTE:

“Factory” mode:

- Body integrated unit has not been set yet. It can be recognized by key illumination blinking with ignition switch turned to ON.
- All replacement body integrated units are set to Factory mode. When replacing a body integrated unit, be sure to perform the registration operation.

“Market” mode:

- Each settings have been set. It can be recognized by key ring illumination coming on in concocting with room light and going off with ignition switch turned to ON.

6) Perform the Factory or Market setting. On the «ECM customizing» display screen of Subaru Select Monitor, select the {Factory or Market setting}.

7) Change the mode from Factory to Market.

8) Change the Subaru Select Monitor system selection to «Immobilizer» to register the immobilizer key.

9) Perform the operation according to the “PC application help for Subaru Select Monitor”.

10) When key registration is completed, “Do you want to register remote engine start?” is displayed. Perform registration only for equipped models.

11) Perform the function setting (ECM customizing). <Ref. to LAN(diag)-22, OPERATION, Function Setting (Customize).>

NOTE:

For details concerning the operation procedure, refer to the “PC application help for Subaru Select Monitor”.

12. Function Check

A: OPERATION

NOTE:

In order to check the body integrated unit function, inspect the body integrated unit and actuator using Subaru Select Monitor without operating switches.

- 1) On the «Main Menu» display screen, select {Each System Check}.
- 2) On the «System Selection Menu» display screen, select the {Integ. unit mode}.
- 3) On the «Integ. unit mode failure diag» display screen, select the {Function check}.
- 4) Select the item to be operated on the «Function check» display screen with «UP/Down key» and press the [Next] button.

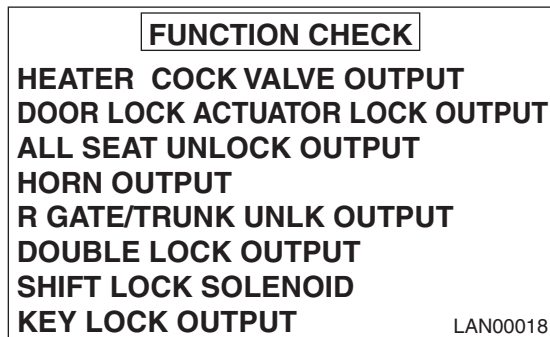

- 5) Pressing [Next] starts, [End] cancels the operation and [OK] returns to the System Operation Check Mode display screen.

NOTE:

- If not equipped (based on area or condition), process will not go on.
- For details concerning the operation procedure, refer to the “PC application help for Subaru Select Monitor”.

List of Diagnostic Trouble Code (DTC)

LAN SYSTEM (DIAGNOSTICS)

13. List of Diagnostic Trouble Code (DTC)

A: LIST

DTC	Item	Diagnosis content	Index
None	Communication for Initializing Impossible	<ul style="list-style-type: none"> • Open or short in Subaru Select Monitor communication line • Back-up power supply circuit malfunction 	<Ref. to LAN(diag)-31, COMMUNICATION FOR INITIALIZING IMPOSSIBLE, Diagnostic Procedure with Diagnostic Trouble Code (DTC).>
B1100	Integ. Unit System Error	Body integrated unit internal error	<Ref. to LAN(diag)-33, DTC B1100 INTEG. UNIT SYSTEM ERROR, Diagnostic Procedure with Diagnostic Trouble Code (DTC).>
B1101	BATT p/supply malfunction cont.	<ul style="list-style-type: none"> • Open or short in battery power supply control circuit • Voltage malfunction caused by poor contact 	<Ref. to LAN(diag)-34, DTC B1101 BATT P/ SUPPLY MALFUNCTION CONT, Diagnostic Procedure with Diagnostic Trouble Code (DTC).>
B1102	BATT p/supply malfunction backup	Voltage malfunction caused by poor contact of battery power supply backup circuits	<Ref. to LAN(diag)-36, DTC B1102 BATT P/ SUPPLY MALFUNCTION BACKUP, Diagnostic Procedure with Diagnostic Trouble Code (DTC).>
B1103	Ignition power failure	Voltage malfunction caused by poor contact of IGN power supply circuits	<Ref. to LAN(diag)-38, DTC B1103 IGNITION POWER FAILURE, Diagnostic Procedure with Diagnostic Trouble Code (DTC).>
B1104	ACC power failure	Voltage malfunction caused by poor contact of ACC power supply circuits	<Ref. to LAN(diag)-40, DTC B1104 ACC POWER FAILURE, Diagnostic Procedure with Diagnostic Trouble Code (DTC).>
B1105	Key interlock circuit abnormal	Ground short of key interlock circuit	<Ref. to LAN(diag)-42, DTC B1105 KEY INTERLOCK CIRCUIT ABNORMAL, Diagnostic Procedure with Diagnostic Trouble Code (DTC).>
B1106	shift lock circuit Failure	Open or short in shift lock circuit	<Ref. to LAN(diag)-44, DTC B1106 SHIFT LOCK CIRCUIT FAILURE, Diagnostic Procedure with Diagnostic Trouble Code (DTC).>
U1201	CAN-HS counter abnormal	Communication is unstable because of high speed CAN communication error.	<Ref. to LAN(diag)-46, DTC U1201 CAN-HS COUNTER ABNORMAL, Diagnostic Procedure with Diagnostic Trouble Code (DTC).>
U1202	CAN-HS bus off	<ul style="list-style-type: none"> • Open or power supply-output short, GND-output short occurs in CAN line. • End resistance malfunction • Internal error in each control module 	<Ref. to LAN(diag)-49, DTC U1202 CAN-HS BUS OFF, Diagnostic Procedure with Diagnostic Trouble Code (DTC).>
U1211	CAN-HS ECM FRC abnormal	Received error data from ECM.	<Ref. to LAN(diag)-52, DTC U1211 CAN-HS ECM DATA ABNORMAL, Diagnostic Procedure with Diagnostic Trouble Code (DTC).>
U1212	CAN-HS TEM FRC abnormal	Received error data from TCM.	<Ref. to LAN(diag)-54, DTC U1212 CAN-HS TCM DATA ABNORMAL, Diagnostic Procedure with Diagnostic Trouble Code (DTC).>
U1213	CAN-HS VDC/ABS data abnormal	Received error data from VDC/ABS module.	<Ref. to LAN(diag)-56, DTC U1213 CAN-HS VDC/ABS DATA ABNORMAL, Diagnostic Procedure with Diagnostic Trouble Code (DTC).>
U1221	CAN-HS ECM no-receive data	Not received error data from ECM.	<Ref. to LAN(diag)-58, DTC U1221 CAN-HS ECM NO-RECEIVE DATA, Diagnostic Procedure with Diagnostic Trouble Code (DTC).>
U1222	CAN-HS TCM no-receive data	Not received error data from TCM.	<Ref. to LAN(diag)-60, DTC U1222 CAN-HS TCM NO-RECEIVE DATA, Diagnostic Procedure with Diagnostic Trouble Code (DTC).>
U1223	CAN-HS VDC/ABS no-receive data	Not received error data from VDC/ABS CM.	<Ref. to LAN(diag)-62, DTC U1223 CAN-HS VDC/ABS NO-RECEIVE DATA, Diagnostic Procedure with Diagnostic Trouble Code (DTC).>

List of Diagnostic Trouble Code (DTC)

LAN SYSTEM (DIAGNOSTICS)

DTC	Item	Diagnosis content	Index
U1300	CAN-LS malfunction	Open or short in CAN-LS circuit, on ether side	<Ref. to LAN(diag)-64, DTC U1300 CAN-LS MALFUNCTION, Diagnostic Procedure with Diagnostic Trouble Code (DTC).>
U1301	CAN-LS counter abnormal	Communication is unstable because of low speed CAN communication error.	<Ref. to LAN(diag)-67, DTC U1301 CAN-LS COUNTER ABNORMAL, Diagnostic Procedure with Diagnostic Trouble Code (DTC).>
U1302	CAN-LS bus off	<ul style="list-style-type: none"> • Open or power supply-output short, GND-output short occurs in both CAN line. • Internal error in each control module 	<Ref. to LAN(diag)-70, DTC U1302 CAN-LS BUS OFF, Diagnostic Procedure with Diagnostic Trouble Code (DTC).>
U1311	CAN-LS meter unit FRC abnormal	Received error data from meter.	<Ref. to LAN(diag)-73, DTC U1311 CAN-LS METER UNIT DATA ABNORMAL, Diagnostic Procedure with Diagnostic Trouble Code (DTC).>
U1321	CAN-LS meter no-receive data	Not received error data from meter.	<Ref. to LAN(diag)-74, DTC U1321 CAN-LS METER NO-RECEIVE DATA, Diagnostic Procedure with Diagnostic Trouble Code (DTC).>
B1401	M collation NG	Malfunction related immobilizer	<Ref. to IM(diag)-15, List of Diagnostic Trouble Code (DTC).>
B1402	Immobilizer Key collation NG	Malfunction related immobilizer	<Ref. to IM(diag)-15, List of Diagnostic Trouble Code (DTC).>
B1403	E/G request NG	Malfunction related immobilizer	<Ref. to IM(diag)-15, List of Diagnostic Trouble Code (DTC).>
B1500	Keyless UART com. Malfunction	Open or short circuit in keyless UART circuit	<Ref. to LAN(diag)-76, DTC B1500 KEYLESS UART COM. MALFUNCTION, Diagnostic Procedure with Diagnostic Trouble Code (DTC).>

List of Diagnostic Trouble Code (DTC)

LAN SYSTEM (DIAGNOSTICS)

1. DTC TABLE

NOTE:

When more than two DTC codes are recorded, referring to their combination will make it easy to identify the possible cause. Refer to the list for typical examples.

DTC to Check	Diagnostic Code that was displayed.				Probable cause
	Body integrated unit	ECM	TCM	VDC/ABS CM	
B1100 <Ref. to LAN(diag)-33, DTC B1100 INTEG. UNIT SYSTEM ERROR, Diagnostic Procedure with Diagnostic Trouble Code (DTC).>	B1100	—	—	—	There could be a problem in the body integrated unit.
U1221 <Ref. to LAN(diag)-58, DTC U1221 CAN-HS ECM NO-RECEIVE DATA, Diagnostic Procedure with Diagnostic Trouble Code (DTC).>	U1221	—	P1718	C0057	It is possible that the ECM is faulty.
U1222 <Ref. to LAN(diag)-60, DTC U1222 CAN-HS TCM NO-RECEIVE DATA, Diagnostic Procedure with Diagnostic Trouble Code (DTC).>	U1222	P0600	—	C0057	It is possible that the TCM is faulty.
U1223 <Ref. to LAN(diag)-62, DTC U1223 CAN-HS VDC/ABS NO-RECEIVE DATA, Diagnostic Procedure with Diagnostic Trouble Code (DTC).>	U1223	P0600	P1718	—	It is possible that the VDC/ABS CM is faulty.
U1321 <Ref. to LAN(diag)-74, DTC U1321 CAN-LS METER NO-RECEIVE DATA, Diagnostic Procedure with Diagnostic Trouble Code (DTC).>	U1321	—	—	—	It is possible that the combination meter is faulty.
B1500 <Ref. to LAN(diag)-76, DTC B1500 KEYLESS UART COM. MALFUNCTION, Diagnostic Procedure with Diagnostic Trouble Code (DTC).>	B1500	—	—	—	It's possible that there is an internal problem in the keyless entry control module, or a open circuit in the communication line.

14. Diagnostic Procedure with Diagnostic Trouble Code (DTC)

A: COMMUNICATION FOR INITIALIZING IMPOSSIBLE

DIAGNOSIS:

- Subaru Select Monitor communication line is open or shorted.
- Back-up power supply circuit malfunction

TROUBLE SYMPTOM:

Not communicable with Subaru Select Monitor.

WIRING DIAGRAM:

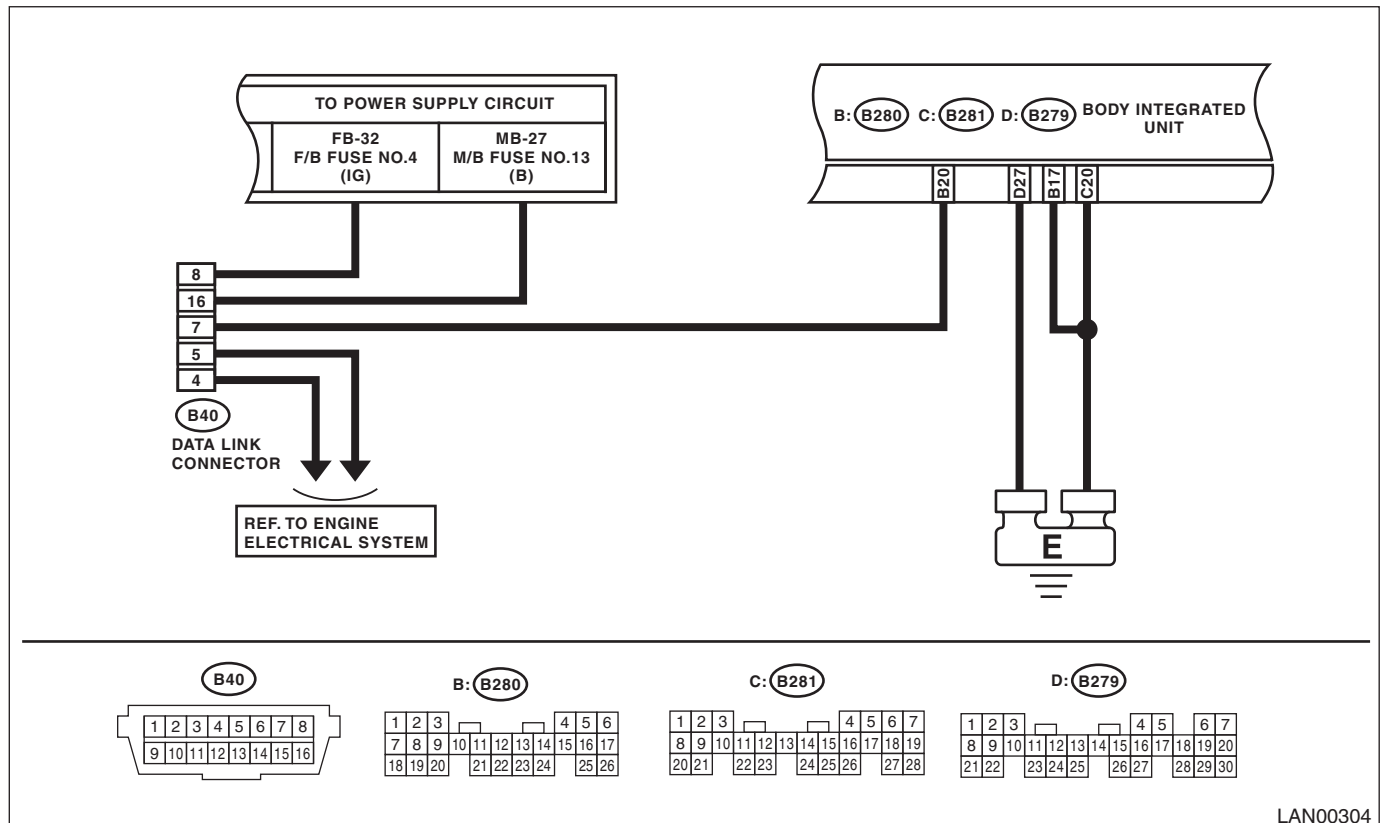

LAN00304

Step	Check	Yes	No	
1	CHECK IGNITION SWITCH.	Is the ignition switch ON?	Go to step 2.	Turn the ignition switch to ON, and select Integ. Unit mode using Subaru Select Monitor.
2	CHECK BATTERY. 1) Turn the ignition switch to OFF. 2) Measure the battery voltage.	Is the voltage 11 V or more?	Go to step 3.	Charge or replace the battery.
3	CHECK BATTERY TERMINAL.	Is there poor contact at the battery terminal?	Repair or tighten the battery terminal.	Go to step 4.
4	CHECK COMMUNICATION OF SUBARU SELECT MONITOR. 1) Turn the ignition switch to ON. 2) Using the Subaru Select Monitor, check whether communication to other systems can be executed normally.	Is the system name displayed?	Go to step 7.	Go to step 5.

Diagnostic Procedure with Diagnostic Trouble Code (DTC)

LAN SYSTEM (DIAGNOSTICS)

Step	Check	Yes	No
5 CHECK COMMUNICATION OF SUBARU SELECT MONITOR. 1) Turn the ignition switch to OFF. 2) Disconnect the body integrated unit connector. 3) Turn the ignition switch to ON. 4) Check whether communication to other systems can be executed normally.	Is the system name displayed?	Go to step 7.	Go to step 6.
6 CHECK HARNESS CONNECTOR BETWEEN EACH CONTROL MODULE AND SUBARU SELECT MONITOR. 1) Turn the ignition switch to ON. 2) Disconnect the body integrated unit connector. 3) Measure the resistance between data link connector and chassis ground. Connector & terminal (B40) No. 7 — Chassis ground:	Is the resistance 1 MΩ or more?	Go to step 7.	Repair the harness and connector between each control module and Subaru Select Monitor.
7 CHECK OUTPUT SIGNAL TO BODY INTEGRATED UNIT. 1) Turn the ignition switch to ON. 2) Measure the voltage between body integrated unit and chassis ground. Connector & terminal (B40) No. 7 (+) — Chassis ground (-):	Is the voltage less than 1 V?	Go to step 8.	Repair the harness and connector between each control module and Subaru Select Monitor.
8 CHECK HARNESS CONNECTOR BETWEEN BODY INTEGRATED UNIT AND DATA LINK CONNECTOR. Measure the resistance between body integrated unit and data link connector. Connector & terminal (B40) No. 7 — (B280) No. 20:	Is the resistance less than 1 Ω?	Go to step 9.	Repair the harness and connector between body integrated unit and Subaru Select Monitor.
9 CHECK BACK-UP FUSE. Check that back-up fuse is not blown out, or check that it is inserted.	Is back-up fuse OK?	Go to step 10.	Replace the back-up fuse, or insert it into the fuse holder.
10 CHECK POWER SUPPLY CIRCUIT. 1) Turn the ignition switch to ON (engine OFF). 2) Measure the ignition voltage between body integrated unit connector and chassis ground. Connector & terminal (B280) No. 1 (+) — Chassis ground (-):	Is the voltage 10 V or more?	Go to step 11.	Repair the open circuit of harness between body integrated unit and battery.
11 CHECK HARNESS CONNECTOR BETWEEN BODY INTEGRATED UNIT AND CHASSIS GROUND. 1) Turn the ignition switch to OFF. 2) Disconnect the connector from body integrated unit. 3) Measure the resistance of harness between the body integrated unit and chassis ground. Connector & terminal (B280) No. 20 — Chassis ground:	Is the resistance 1 MΩ or more?	Go to step 12.	Repair the poor contact of harness between body integrated unit and ground.
12 CHECK POOR CONTACT IN CONNECTOR.	Is there poor contact at control module ground and Subaru Select Monitor?	Replace the body integrated unit. <Ref. to SL-42, Body Integrated Unit.>	Repair the poor contact of connector.

CAUTION:

When replacing body integrated unit on the model with immobilizer system, refer to the “REGISTRATION MANUAL FOR IMMOBILIZER”.

Diagnostic Procedure with Diagnostic Trouble Code (DTC)

LAN SYSTEM (DIAGNOSTICS)

B: DTC B1100 INTEG. UNIT SYSTEM ERROR

DTC DETECTING CONDITION:

Memory read out error in body integrated unit

TROUBLE SYMPTOM:

- Check light comes on in the combination meter.
- LAN communication immobilizer function may not be executed normally.

	Step	Check	Yes	No
1	CHECK DTC. Check the DTC displayed in the body integrated unit.	Is the DTC B1100 displayed current malfunction?	Go to step 2.	Temporary EEPROM access error occurred.
2	CHECK CONNECTOR. 1) Turn the ignition switch to OFF. 2) Disconnect the body integrated unit connector. 3) Connect the disconnected connectors. 4) Read the DTC of body integrated unit using Subaru Select Monitor.	Is the DTC B1100 displayed current malfunction?	Replace the body integrated unit. <Ref. to SL-42, Body Integrated Unit.>	Temporary EEPROM access error occurred.

Diagnostic Procedure with Diagnostic Trouble Code (DTC)

LAN SYSTEM (DIAGNOSTICS)

C: DTC B1101 BATT P/SUPPLY MALFUNCTION CONT

DTC DETECTING CONDITION:

- Battery power supply backup circuit is open or shorted.
- Battery voltage is too high or too low.

TROUBLE SYMPTOM:

Each function stops operation.

NOTE:

- When B1102 BATT p/supply (backup) malfunction is output at the same time, all the function of body integrated unit may not operate.
- B1101 may input when the battery run-out occurs.

WIRING DIAGRAM:

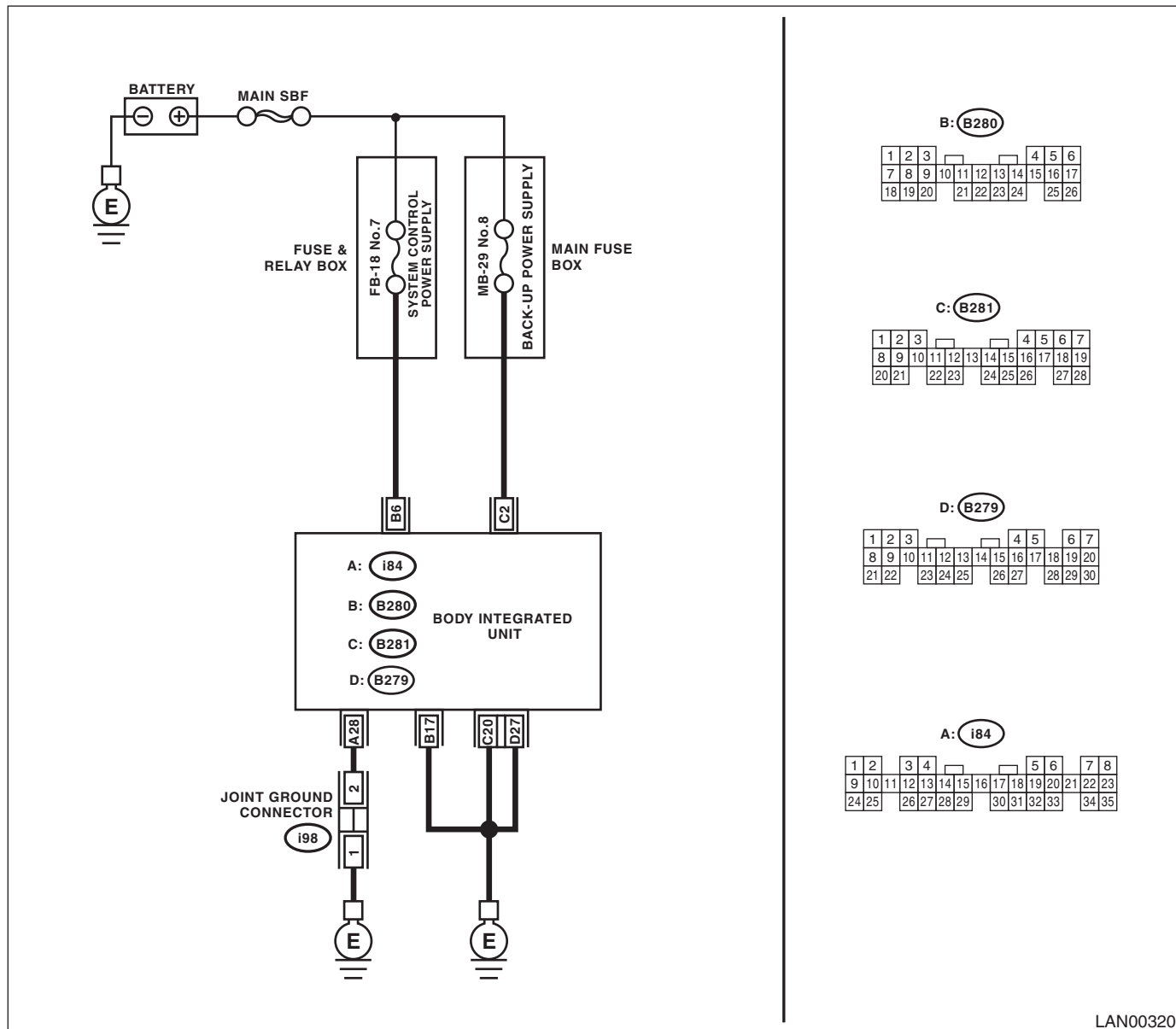

LAN00320

Diagnostic Procedure with Diagnostic Trouble Code (DTC)

LAN SYSTEM (DIAGNOSTICS)

Step	Check	Yes	No
1 CHECK DTC. Read the DTC of body integrated unit using Subaru Select Monitor.	Is B1101 current malfunction?	Go to step 2.	Go to step 5.
2 CHECK DTC. 1) Turn the ignition switch to OFF. 2) Disconnect the connector from body integrated unit and reconnect. 3) Wait approx. 2 minutes. 4) Read the DTC of body integrated unit using Subaru Select Monitor.	Is B1101 current malfunction?	Go to step 3.	Go to step 5.
3 CHECK FUSE. 1) Turn the ignition switch to OFF. 2) Inspect the fuse.	Is the fuse OK?	Go to step 4.	Replace the defective fuse.
4 CHECK HARNESS. 1) Disconnect the body integrated unit connector (B280). 2) Measure the voltage between body integrated unit connector and chassis ground using tester. <i>Connector & terminal (B280) No. 6 (+) — Chassis ground (-):</i>	Is the voltage 8.5 — 16.5 V?	Replace the body integrated unit. <Ref. to SL-42, Body Integrated Unit.>	Repair or replace the open or shorted circuit between body integrated unit and fuse.
5 CHECK CONNECTOR. 1) Turn the ignition switch to OFF. 2) Disconnect the body integrated unit connector (B280).	Is there poor contact in connector?	Repair or replace the poor contact of connector.	A temporary change of voltage occurred.

Diagnostic Procedure with Diagnostic Trouble Code (DTC)

LAN SYSTEM (DIAGNOSTICS)

D: DTC B1102 BATT P/SUPPLY MALFUNCTION BACKUP

DTC DETECTING CONDITION:

Back-up power supply circuit input voltage is too high or too low.

TROUBLE SYMPTOM:

No influence.

NOTE:

- When some B1101 BATT p/supply (control) malfunction cont. are output at the same time, all function of body integrated unit may not function.
- B1101 may input when the battery run-out occurs.

WIRING DIAGRAM:

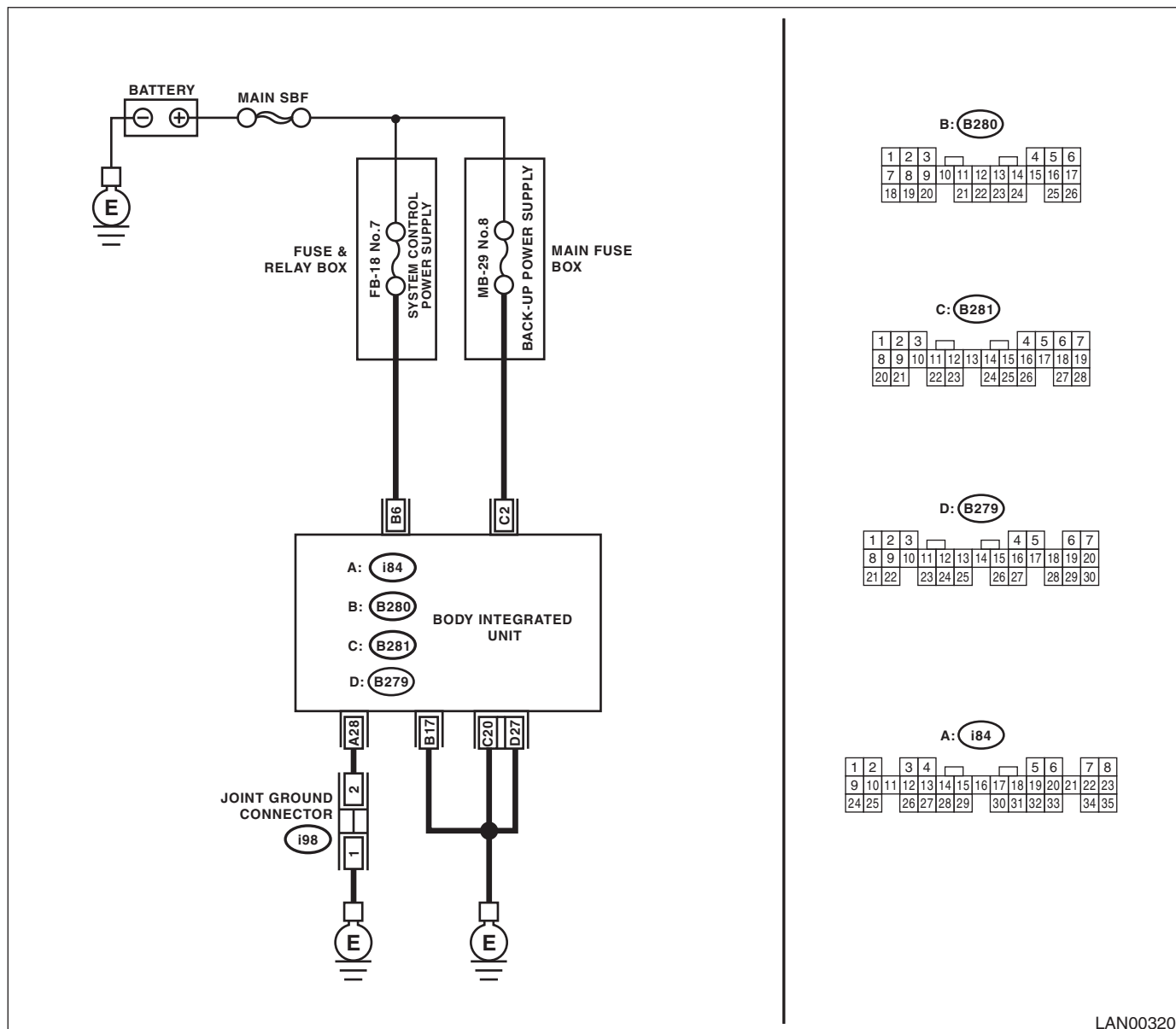

LAN00320

Diagnostic Procedure with Diagnostic Trouble Code (DTC)

LAN SYSTEM (DIAGNOSTICS)

Step	Check	Yes	No
1 CHECK DTC. Read the DTC of body integrated unit using Subaru Select Monitor.	Is B1102 current malfunction?	Go to step 2.	Go to step 5.
2 CHECK DTC. 1) Turn the ignition switch to OFF. 2) Disconnect the connector from body integrated unit and reconnect. 3) Wait approx. 2 minutes. 4) Read the DTC of body integrated unit using Subaru Select Monitor.	Is B1102 current malfunction?	Go to step 3.	Go to step 5.
3 CHECK FUSE. 1) Turn the ignition switch to OFF. 2) Inspect the fuse.	Is the fuse OK?	Go to step 4.	Replace the defective fuse.
4 CHECK HARNESS. 1) Disconnect the body integrated unit connector (B281). 2) Measure the voltage between body integrated unit connector and chassis ground using tester. <i>Connector & terminal (B281) No. 2 (+) — Chassis ground (-):</i>	Is the voltage 8.5 — 16.5 V?	Replace the body integrated unit. <Ref. to SL-42, Body Integrated Unit.>	Repair or replace the open or shorted circuit between body integrated unit and fuse.
5 CHECK CONNECTOR. 1) Turn the ignition switch to OFF. 2) Disconnect the body integrated unit connector (B280).	Is there poor contact in connector?	Repair or replace the poor contact of connector.	A temporary change of voltage occurred.

Diagnostic Procedure with Diagnostic Trouble Code (DTC)

LAN SYSTEM (DIAGNOSTICS)

E: DTC B1103 IGNITION POWER FAILURE

DTC DETECTING CONDITION:

IGN power supply circuit voltage is too high or too low.

TROUBLE SYMPTOM:

Error related to LAN system will not be detected.

NOTE:

B1103 may output when the ignition switch turns to ON with the weak battery condition.

WIRING DIAGRAM:

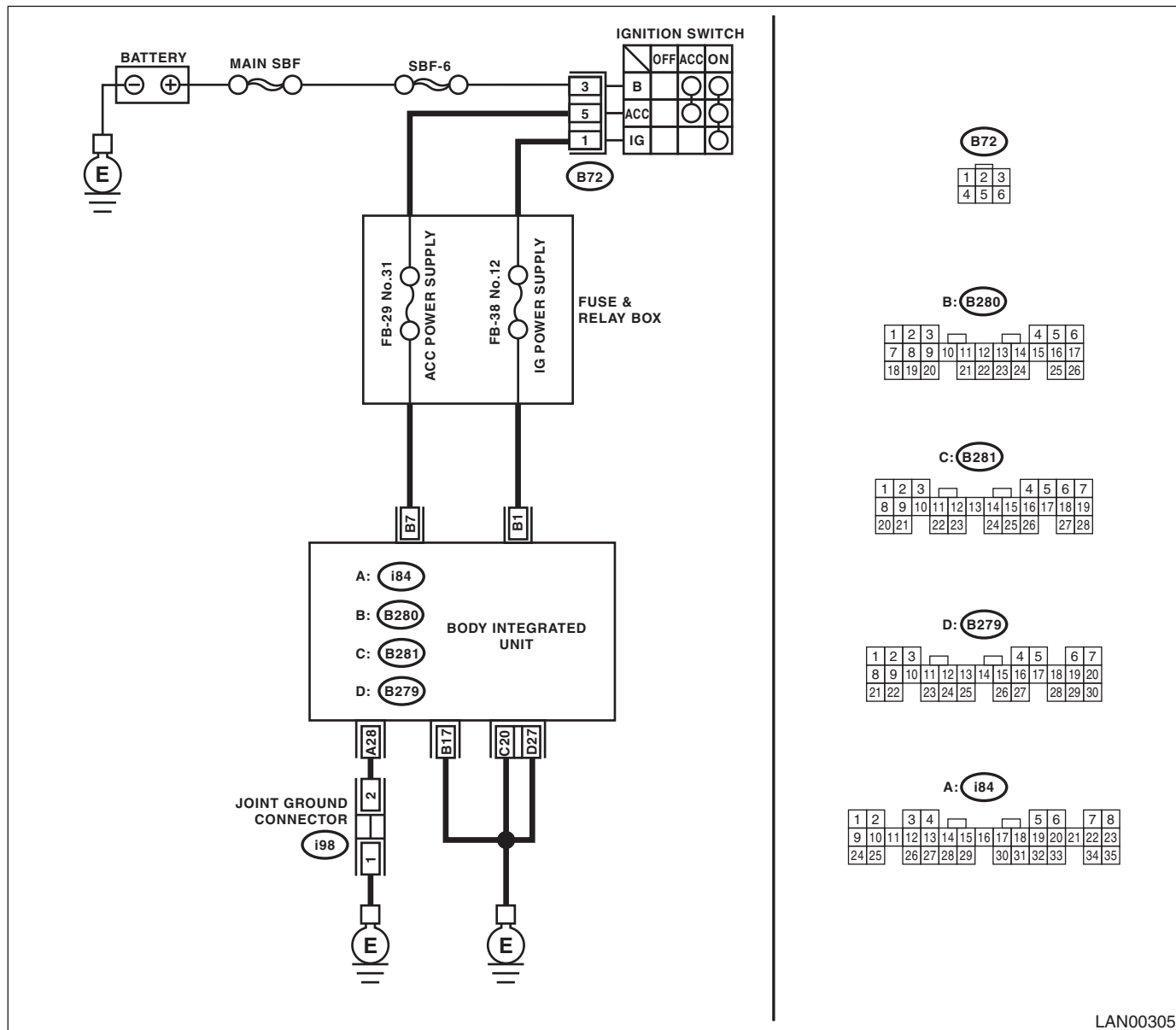

LAN00305

Diagnostic Procedure with Diagnostic Trouble Code (DTC)

LAN SYSTEM (DIAGNOSTICS)

Step	Check	Yes	No
1 CHECK DTC. Read the DTC of body integrated unit using Subaru Select Monitor.	Is B1103 current malfunction?	Go to step 2.	Go to step 5.
2 CHECK DTC. 1) Turn the ignition switch to OFF. 2) Disconnect the connector from body integrated unit and reconnect. 3) Turn the ignition switch to ON. 4) Wait approx. 2 minutes. 5) Read the DTC of body integrated unit using Subaru Select Monitor.	Is B1103 current malfunction?	Go to step 3.	Go to step 5.
3 CHECK FUSE. 1) Turn the ignition switch to OFF. 2) Inspect the fuse.	Is the fuse OK?	Go to step 4.	Replace the defective fuse.
4 CHECK HARNESS. 1) Disconnect the body integrated unit connector (B280). 2) Measure the voltage between body integrated unit connector and chassis ground using tester. <i>Connector & terminal (B280) No. 1 (+) — Chassis ground (-):</i>	Is the voltage 8.5 — 16.5 V?	Replace the body integrated unit. <Ref. to SL-42, Body Integrated Unit.>	Repair or replace the open or shorted circuit between body integrated unit and fuse.
5 CHECK CONNECTOR. 1) Turn the ignition switch to OFF. 2) Disconnect the body integrated unit connector (B280).	Is there poor contact in connector?	Repair or replace the poor contact of connector.	A temporary change of voltage occurred.

Diagnostic Procedure with Diagnostic Trouble Code (DTC)

LAN SYSTEM (DIAGNOSTICS)

F: DTC B1104 ACC POWER FAILURE

DTC DETECTING CONDITION:

ACC power supply circuit voltage is too high or too low.

TROUBLE SYMPTOM:

Does not exist.

NOTE:

B1104 may output when the ignition switch turns to ACC with the weak battery condition.

WIRING DIAGRAM:

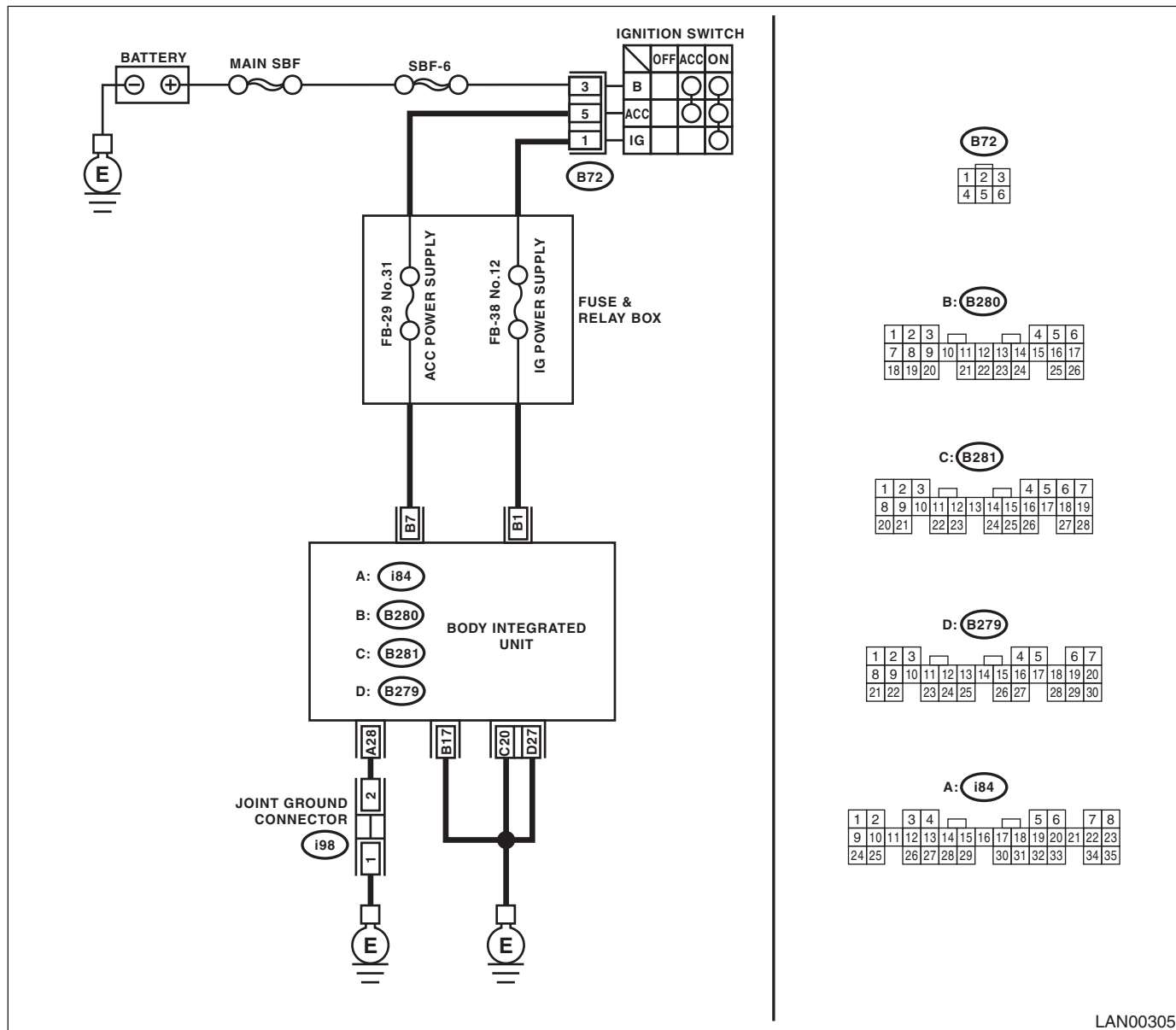

LAN00305

Diagnostic Procedure with Diagnostic Trouble Code (DTC)

LAN SYSTEM (DIAGNOSTICS)

Step	Check	Yes	No
1 CHECK DTC. Read the DTC of body integrated unit using Subaru Select Monitor.	Is B1104 current malfunction?	Go to step 2.	Go to step 5.
2 CHECK DTC. 1) Turn the ignition switch to OFF. 2) Disconnect the connector from body integrated unit and reconnect. 3) Turn the ignition switch to ACC. 4) Wait approx. 2 minutes. 5) Read the DTC of body integrated unit using Subaru Select Monitor.	Is B1104 current malfunction?	Go to step 3.	Go to step 5.
3 CHECK FUSE. 1) Turn the ignition switch to OFF. 2) Inspect the fuse.	Is the fuse OK?	Go to step 4.	Replace the defective fuse.
4 CHECK HARNESS. 1) Disconnect the body integrated unit connector (B279). 2) Measure the voltage between body integrated unit connector and chassis ground using tester. <i>Connector & terminal (B280) No. 7 (+) — Chassis ground (-):</i>	Is the voltage 8.5 — 16.5 V?	Replace the body integrated unit. <Ref. to SL-42, Body Integrated Unit.>	Repair or replace the open or shorted circuit between body integrated unit and fuse.
5 CHECK CONNECTOR. 1) Turn the ignition switch to OFF. 2) Disconnect the body integrated unit connector (B280).	Is there poor contact in connector?	Repair or replace the poor contact of connector.	A temporary change of voltage occurred.

Diagnostic Procedure with Diagnostic Trouble Code (DTC)

LAN SYSTEM (DIAGNOSTICS)

G: DTC B1105 KEY INTERLOCK CIRCUIT ABNORMAL

DTC DETECTING CONDITION:

Key interlock circuit is shorted to ground.

TROUBLE SYMPTOM:

Key interlock does not keep lock condition.

WIRING DIAGRAM:

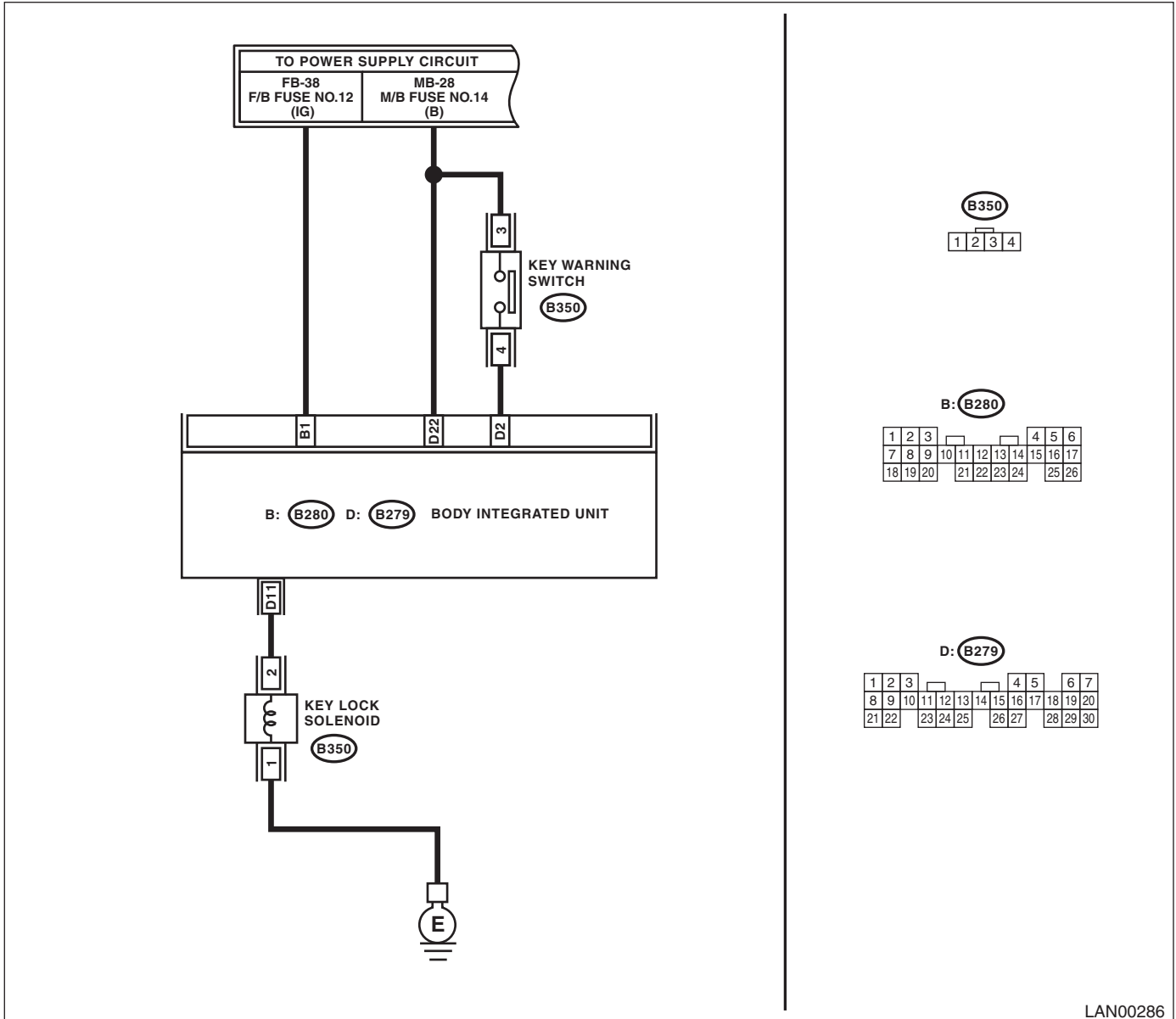

LAN00286

Diagnostic Procedure with Diagnostic Trouble Code (DTC)

LAN SYSTEM (DIAGNOSTICS)

Step	Check	Yes	No
1 CHECK DTC. 1) Insert the ignition key. 2) Shift to the Neutral range. 3) Read the DTC of body integrated unit using Subaru Select Monitor.	Is B1105 current malfunction?	Go to step 2.	Go to step 8.
2 CHECK DTC. 1) Remove the ignition key. 2) Disconnect the key lock solenoid connector (B350) and body integrated unit connector (B279). 3) Connect the disconnected connectors. 4) Insert the key and shift into Neutral. 5) Read the DTC of body integrated unit using Subaru Select Monitor.	Is B1105 current malfunction?	Go to step 3.	Go to step 8.
3 CHECK KEY LOCK SOLENOID. 1) Disconnect the key lock solenoid connector (B350). 2) Measure the resistance between the key lock solenoid connector. Connector & terminal (B350) No. 1 — No. 2:	Is the resistance between 12 — 14.5 Ω?	Go to step 4.	Replace the key lock solenoid.
4 CHECK KEY LOCK SOLENOID. 1) Turn the ignition switch to OFF. 2) Disconnect the key lock solenoid connector. 3) Connect the battery terminal to key lock solenoid. Terminals (B350) No. 2 — positive terminal: (B350) No. 1 — ground terminal:	Is the solenoid activated and then key locked?	Go to step 5.	Replace the key lock solenoid.
5 CHECK HARNESS. 1) Disconnect the body integrated unit connector (B279). 2) Measure the resistance between body integrated unit and key lock solenoid using tester. Connector & terminal (B350) No. 2 — (B279) No. 11:	Is the resistance less than 10 Ω?	Go to step 6.	Repair or replace the open circuit of harness.
6 CHECK HARNESS. Measure the resistance between body integrated unit and chassis ground using tester. Connector & terminal (B279) No. 11 — Chassis ground:	Is the resistance 1 MΩ or more?	Go to step 7.	Repair or replace the short circuit of the harness.
7 CHECK HARNESS. 1) Turn the ignition switch to ON. 2) Measure the voltage between body integrated unit and chassis ground using tester. Connector & terminal (B279) No. 11 — Chassis ground:	Is the voltage 1.5 V or more?	Repair or replace the short circuit of the harness.	Replace the body integrated unit. <Ref. to SL-42, Body Integrated Unit.>
8 CHECK CONNECTOR. 1) Turn the ignition switch to OFF. 2) Disconnect the body integrated unit connector (B279) and key lock solenoid connector (B350).	Is there poor contact at disconnected connector terminal?	Repair the terminal where poor contact exists, or replace harness.	It is possible that temporary poor contact occurs.

Diagnostic Procedure with Diagnostic Trouble Code (DTC)

LAN SYSTEM (DIAGNOSTICS)

H: DTC B1106 SHIFT LOCK CIRCUIT FAILURE

DTC DETECTING CONDITION:

Shift lock circuit is open or shorted.

TROUBLE SYMPTOM:

Shift lock does not be released or remain locked.

WIRING DIAGRAM:

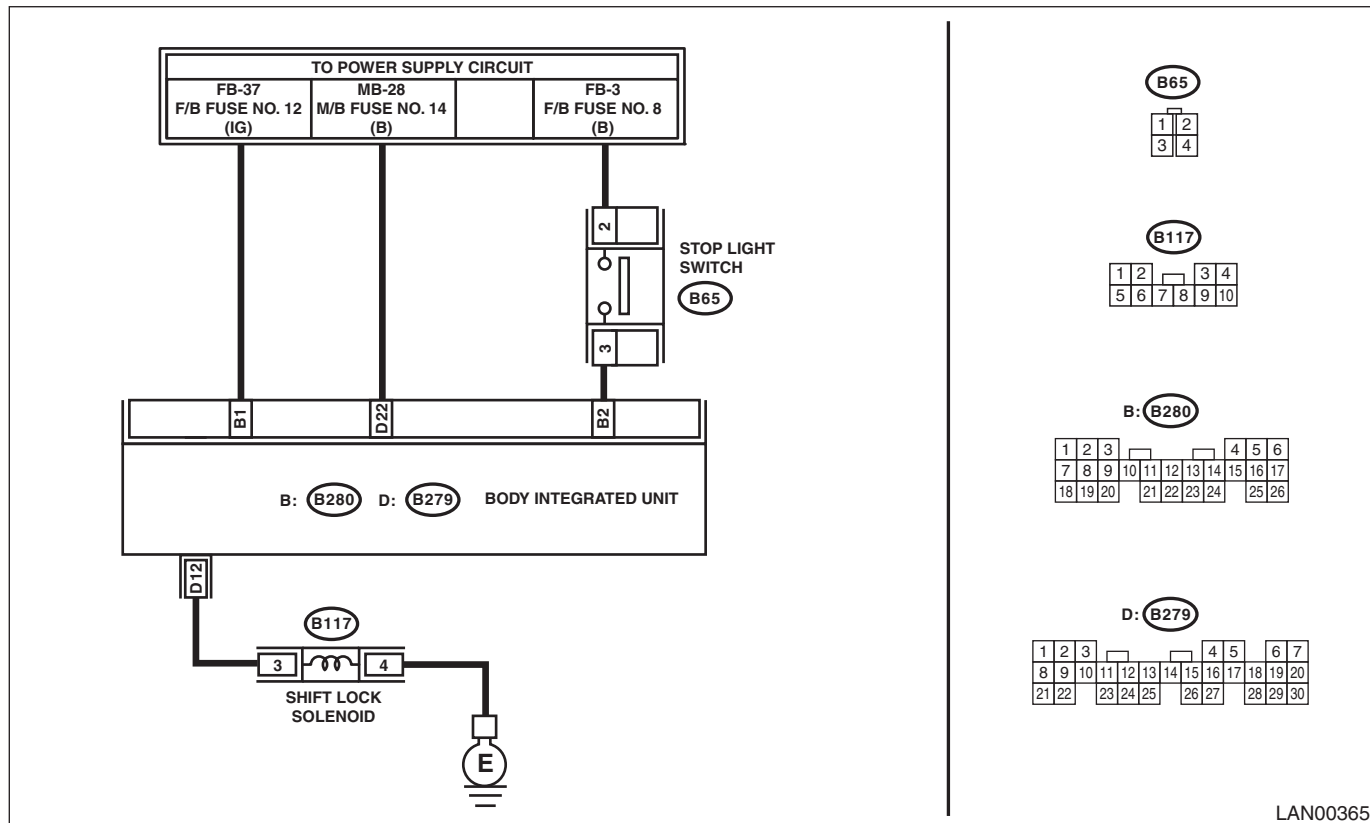

LAN00365

Step	Check	Yes	No
1 CHECK DTC. 1) Turn the ignition switch to ON. 2) Keep the Parking range for approx. 5 seconds. 3) Read the DTC of body integrated unit using Subaru Select Monitor.	Is B1106 current malfunction?	Go to step 2.	Go to step 7.
2 CHECK DTC. 1) Disconnect the body integrated unit connector (B279) and shift lock solenoid connector (B117). 2) Connect the disconnected connectors. 3) Turn the ignition switch to ON, then keep the Parking range for approx. 5 seconds. 4) Read the DTC of body integrated unit using Subaru Select Monitor.	Is B1106 current malfunction?	Go to step 3.	Go to step 7.
3 CHECK HARNESS. 1) Disconnect the shift lock solenoid connector (B117). 2) Measure the resistance between shift lock solenoid unit and chassis ground using tester. Connector & terminal (B117) No. 4 — Chassis ground:	Is the resistance less than 10 Ω?	Go to step 4.	Replace the shift lock solenoid.

Diagnostic Procedure with Diagnostic Trouble Code (DTC)

LAN SYSTEM (DIAGNOSTICS)

Step	Check	Yes	No
4 CHECK SHIFT LOCK SOLENOID. 1) Disconnect the shift lock solenoid connector. 2) Measure the resistance between the shift lock solenoid connector. Connector & terminal (B117) No. 4 — No. 3:	Is the resistance between 19 — 25 Ω ?	Go to step 5.	Replace the shift lock solenoid.
5 CHECK SHIFT LOCK SOLENOID. 1) Turn the ignition switch to OFF. 2) Disconnect the shift lock solenoid connector. 3) Connect the battery terminal to shift lock solenoid. Terminals (B117) No. 3 — positive terminal: (B117) No. 4 — ground terminal:	Is the solenoid activated, and then the shift lock released?	Go to step 6.	Replace the shift lock solenoid.
6 CHECK HARNESS. 1) Disconnect the body integrated unit connector (B279). 2) Measure the resistance between body integrated unit connector (B279) and chassis ground. Connector & terminal (B279) No. 12 — Chassis ground:	Is the resistance 1 M Ω or more?	Replace the body integrated unit. <Ref. to SL-42, Body Integrated Unit.>	Repair the short circuit of harness or replace harness.
7 CHECK DTC. 1) Turn the ignition switch to ON. 2) With Parking range, depress the brake pedal and keep it at depressed condition. 3) Read the DTC of body integrated unit using Subaru Select Monitor.	Is B1106 current malfunction?	Go to step 8.	Go to step 9.
8 CHECK DTC. 1) Turn the ignition switch to OFF. 2) Disconnect the body integrated unit connector (B279) and shift lock solenoid connector (B117). 3) Connect the disconnected connectors. 4) Turn the ignition switch to ON. 5) Shift into Parking range, then depress the brake pedal. 6) Read the DTC of body integrated unit using Subaru Select Monitor.	Is B1106 current malfunction?	Go to step 4.	Go to step 9.
9 CHECK CONNECTOR. 1) Turn the ignition switch to OFF. 2) Disconnect the body integrated unit connector (B279) and shift lock solenoid connector (B117).	Is there poor contact in connector terminal?	Repair the poor contact of the terminal or replace the harness.	It is possible that temporary poor contact occurs.

Diagnostic Procedure with Diagnostic Trouble Code (DTC)

LAN SYSTEM (DIAGNOSTICS)

I: DTC U1201 CAN-HS COUNTER ABNORMAL

DTC DETECTING CONDITION:

High speed CAN communication becomes unstable.

TROUBLE SYMPTOM:

Malfunction indicator light illuminates.

WIRING DIAGRAM:

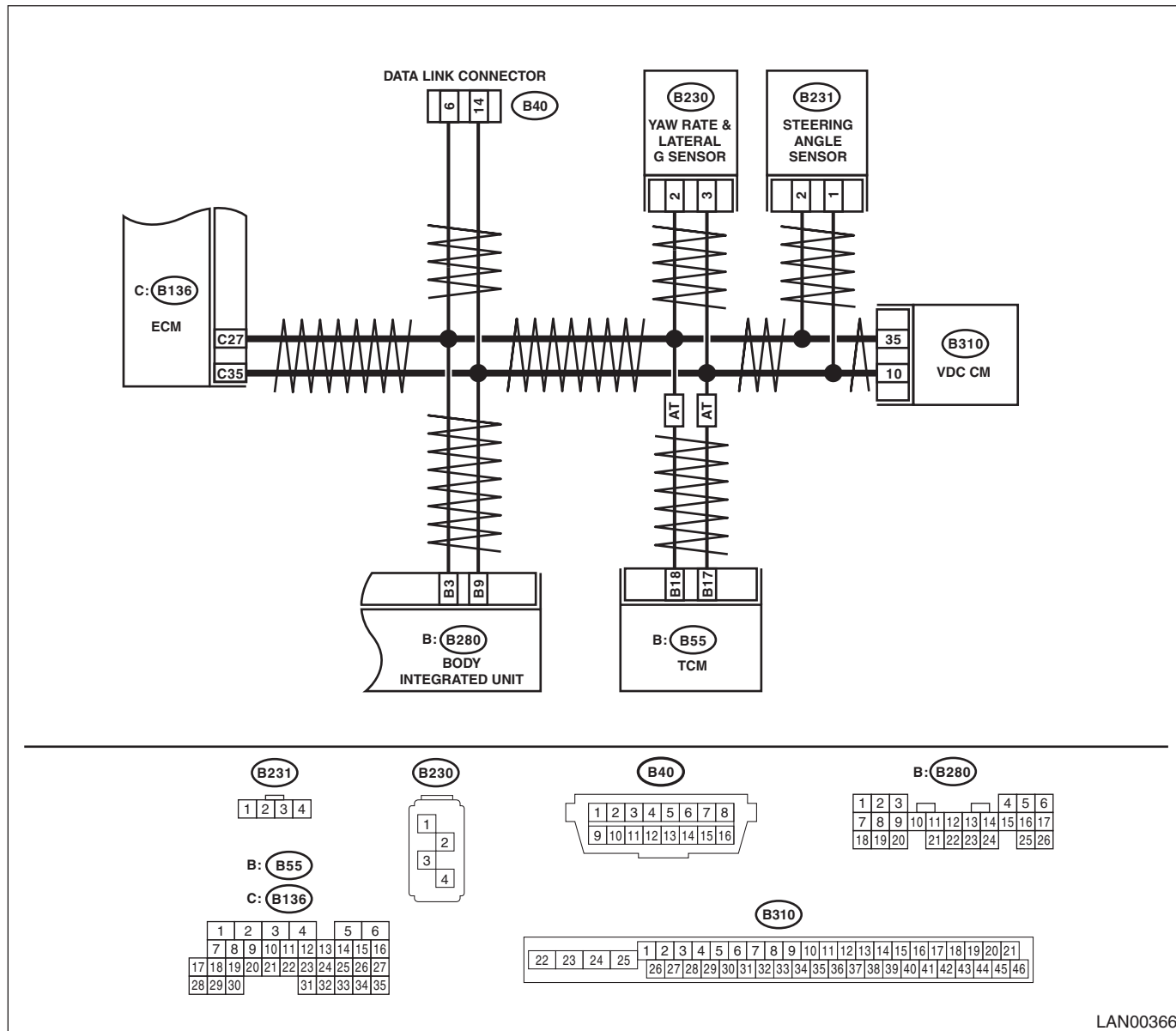

LAN00366

Diagnostic Procedure with Diagnostic Trouble Code (DTC)

LAN SYSTEM (DIAGNOSTICS)

Step	Check	Yes	No
1	CHECK DTC. Using the Subaru Select Monitor, read all DTCs.	Is there DTC U1202?	Perform the diagnosis according to DTC. Go to step 2.
2	CHECK DTC. Check DTC indicated by body integrated unit.	Is U1201 a current malfunction?	Go to step 3. Go to step 14.
3	CHECK DTC. 1) Turn the ignition switch to OFF. 2) Disconnect all connectors (B280, B310, B55, B136, B230, B231) that are connected to high speed CAN communication line. 3) Connect all the disconnected connectors. 4) Read the DTC of body integrated unit using Subaru Select Monitor.	Is U1201 a current malfunction?	Go to step 4. Go to step 14.
4	CHECK TCM. 1) Turn the ignition switch to OFF. 2) Disconnect the TCM connector (B55). 3) Read the DTC of body integrated unit using Subaru Select Monitor.	Is U1201 a current malfunction?	Go to step 5. Go to step 16.
5	CHECK STEERING ANGLE SENSOR. 1) Turn the ignition switch to OFF. 2) Connect the TCM connector. 3) Disconnect the steering angle sensor connector (B231). 4) Read the DTC of body integrated unit using Subaru Select Monitor.	Is U1201 a current malfunction?	Go to step 6. Go to step 17.
6	CHECK YAW RATE SENSOR. 1) Turn the ignition switch to OFF. 2) Connect the steering angle sensor connector. 3) Disconnect the yaw rate sensor connector (B230). 4) Read the DTC of body integrated unit using Subaru Select Monitor.	Is U1201 a current malfunction?	Go to step 7. Go to step 18.
7	CHECK VDC/ABS CM HARNESS. 1) Turn the ignition switch to OFF. 2) Connect the yaw rate sensor connector. 3) Disconnect the VDC/ABS CM connector (B310). 4) Install the 120 Ω resistance to VDC/ABS CM connector terminals. Terminals (B310) No. 10 — No. 35: 5) Using the tester, measure the resistance between terminals of data link connector. Terminals (B40) No. 6 — No. 14:	Is the resistance 60 Ω?	Go to step 8. Go to step 10.
8	CHECK DTC. Read the DTC of body integrated unit using Subaru Select Monitor.	Is U1201 a current malfunction?	Go to step 16. Go to step 9.
9	CHECK DTC. Read the DTC of body integrated unit using Subaru Select Monitor.	Is U1202 a current malfunction?	Replace the VDC/ABS CM. <Ref. to VDC-7, REMOVAL, VDC Control Module and Hydraulic Control Unit (VDCCM&H/U).> Go to step 10.

Diagnostic Procedure with Diagnostic Trouble Code (DTC)

LAN SYSTEM (DIAGNOSTICS)

Step	Check	Yes	No
10 CHECK ECM. 1) Turn the ignition switch to OFF. 2) Connect the VDC/ABS CM. 3) Disconnect the ECM connector (B136). 4) Install the 120 Ω resistance to ECM connector. Terminals (B136) No. 27 — No. 35: 5) Using the tester, measure the resistance between terminals of data link connector. Connector & terminal (B40) No. 6 — No. 14:	Is the resistance 60 Ω?	Go to step 11.	Repair or replace the open circuit of harness.
11 CHECK DTC. Read the DTC of body integrated unit using Subaru Select Monitor.	Is U1201 a current malfunction?	Go to step 12.	Repair or replace the open circuit of measured related harness.
12 CHECK DTC. Read the DTC of body integrated unit using Subaru Select Monitor.	Is U1202 a current malfunction?	Replace the ECM.	Go to step 13.
13 CHECK DTC. 1) Reconnect all the disconnected connectors. 2) Read the DTC of body integrated unit using Subaru Select Monitor.	Is U1201 a current malfunction?	Replace the body integrated unit. <Ref. to SL-42, REMOVAL, Body Integrated Unit.>	Go to step 14.
14 CHECK HARNESS. 1) Shake the instrument harness and bulkhead harness, rear harness. 2) Read the DTC of body integrated unit using Subaru Select Monitor.	Is U1201 a current malfunction?	Repair or replace the harness.	Go to step 15.
15 CHECK CONNECTOR. Connect the tester to ECM terminal, and measure the resistance. Connector & terminal (B136) No. 27 — No. 35: 1) Disconnect the connector used for CAN circuit. 2) Check the connector terminal.	Is there poor contact in connector terminal?	Repair the connector terminal where poor contact exists, or replace harness.	Replace the ECM. <Ref. to FU(H4DOTC)-46, Engine Control Module (ECM).>
16 CHECK HARNESS. Using the tester, measure the resistance between terminals of data link connector and TCM. Connector & terminal (B40) No. 14 — (B55) No. 17: (B40) No. 6 — (B55) No. 18:	Is the resistance less than 10 Ω?	Go to step 17.	Repair or replace the harness.
17 CHECK HARNESS. Using the tester, measure the resistance between terminals of data link connector and steering angle sensor. Connector & terminal (B40) No. 14 — (B231) No. 1: (B40) No. 6 — (B231) No. 2:	Is the resistance less than 10 Ω?	Go to step 18.	Repair or replace the harness.
18 CHECK HARNESS. Using the tester, measure the resistance between terminals of data link connector and yaw rate sensor. Connector & terminal (B40) No. 14 — (B230) No. 3: (B40) No. 6 — (B230) No. 2:	Is the resistance less than 10 Ω?	Replace the yaw rate sensor.	Repair or replace the harness.

Diagnostic Procedure with Diagnostic Trouble Code (DTC)

LAN SYSTEM (DIAGNOSTICS)

J: DTC U1202 CAN-HS BUS OFF

DTC DETECTING CONDITION:

- Open or power supply-output short, GND-output short occurs in CAN line.
- End resistance malfunction
- Internal error in each control module

TROUBLE SYMPTOM:

Each warning light illuminate because the CAN communication (sending and receiving) is not normal.

WIRING DIAGRAM:

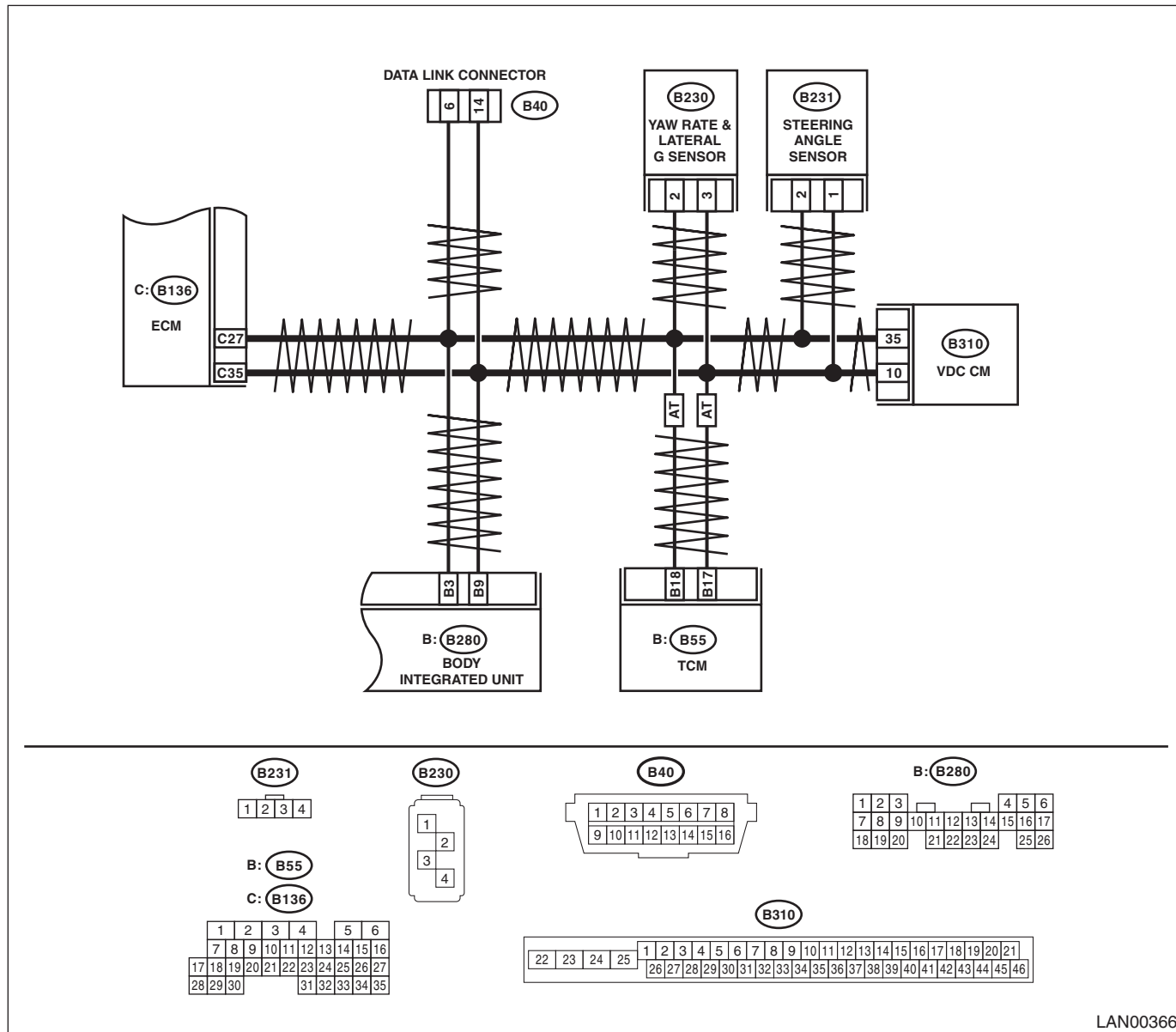

LAN00366

Diagnostic Procedure with Diagnostic Trouble Code (DTC)

LAN SYSTEM (DIAGNOSTICS)

Step	Check	Yes	No
1 CHECK DTC. Using the Subaru Select Monitor, confirm all DTCs.	Is any DTC other than for the body integrated unit displayed?	Perform the diagnosis according to displayed DTC.	Go to step 2.
2 CHECK DTC. 1) Turn the ignition switch to OFF. 2) Read the DTC of body integrated unit using Subaru Select Monitor.	Is U1202 a current malfunction?	Go to step 3.	Go to step 10.
3 CHECK DTC. 1) Turn the ignition switch to OFF. 2) Disconnect all connectors (B280, B310, B55, B136, B230, B231) that are connected to high speed CAN communication line. 3) Connect the disconnected connectors. 4) Read the DTC of body integrated unit using Subaru Select Monitor.	Is U1202 a current malfunction?	Go to step 4.	Go to step 10.
4 CHECK HARNESS. 1) Disconnect all connectors (B280, B310, B55, B136, B230, B231) that are connected to high speed CAN communication line. 2) Using the tester, measure the resistance between terminals of harness. Connector & terminal (B40) No. 6 — (B136) No. 27: (B40) No. 6 — (B310) No. 35: (B40) No. 6 — (B230) No. 2: (B40) No. 6 — (B231) No. 2: (B40) No. 6 — (B55) No. 18: (B40) No. 6 — (B280) No. 3:	Is the resistance less than 10 Ω?	Go to step 5.	Repair or replace the open circuit of harness.
5 CHECK HARNESS. Using the tester, measure the resistance between terminals of harness. Connector & terminal (B40) No. 14 — (B136) No. 35: (B40) No. 14 — (B310) No. 10: (B40) No. 14 — (B230) No. 3: (B40) No. 14 — (B231) No. 1: (B40) No. 14 — (B55) No. 17: (B40) No. 14 — (B280) No. 9:	Is the resistance less than 10 Ω?	Go to step 6.	Repair or replace the open circuit of harness.
6 CHECK ECM. 1) Connect the ECM. 2) Using the tester, measure the resistance between terminals of data link connector. Connector & terminal (B40) No. 6 — No. 14:	Is the resistance 120±5Ω?	Go to step 7.	Inspect the ECM. <Ref. to VDC(diag)-15, READ DIAGNOSTIC TROUBLE CODE (DTC), OPERATION, Subaru Select Monitor.>
7 CHECK VDC/ABS CM. 1) Disconnect the ECM connector (B136). 2) Connect the VDC/ABS CM. 3) Using the tester, measure the resistance between terminals of data link connector. Connector & terminal (B40) No. 6 — No. 14:	Is the resistance 120±5Ω?	Go to step 8.	Replace the VDC/ABS CM.

Diagnostic Procedure with Diagnostic Trouble Code (DTC)

LAN SYSTEM (DIAGNOSTICS)

Step	Check	Yes	No
8 CHECK HARNESS. 1) Connect the disconnected connectors. 2) Using the tester, measure the resistance between terminals of data link connector and chassis ground. Connector & terminal (B40) No. 6 — Chassis ground: (B40) No. 14 — Chassis ground:	Is the resistance 1 MΩ or more?	Go to step 9.	Go to step 12.
9 CHECK HARNESS. 1) Turn the ignition switch to ON. 2) Using the tester, measure the voltage between terminals of data link connector and chassis ground. Connector & terminal (B40) No. 6 — Chassis ground: (B40) No. 14 — Chassis ground:	Is the voltage 6 V or more?	Go to step 13.	Replace the body integrated unit.
10 CHECK HARNESS. 1) Shake the harness. 2) Read the DTC of body integrated unit using Subaru Select Monitor.	Is U1202 a current malfunction?	Repair or replace the harness.	Go to step 11.
11 CHECK CONNECTOR. Disconnect the connector used for high speed CAN circuit.	Is there poor contact in connector terminal?	Repair the connector terminal, or replace harness.	It is possible that temporary poor contact occurs.
12 CHECK CONTROL MODULE. With the tester connected, disconnect each control module connector.	Is there any control module whose resistance has changed?	Replace the control module whose resistance has changed.	Repair or replace the open or short circuit of the harness.
13 CHECK ECM. With the tester connected, disconnect each control module connector.	Is there any control module whose voltage has changed?	Replace the control module whose voltage has changed.	Repair or replace the short circuit of the harness.

Diagnostic Procedure with Diagnostic Trouble Code (DTC)

LAN SYSTEM (DIAGNOSTICS)

K: DTC U1211 CAN-HS ECM DATA ABNORMAL

DTC DETECTING CONDITION:

Received error data from ECM.

TROUBLE SYMPTOM:

It is possible that engine control error may occur.

WIRING DIAGRAM:

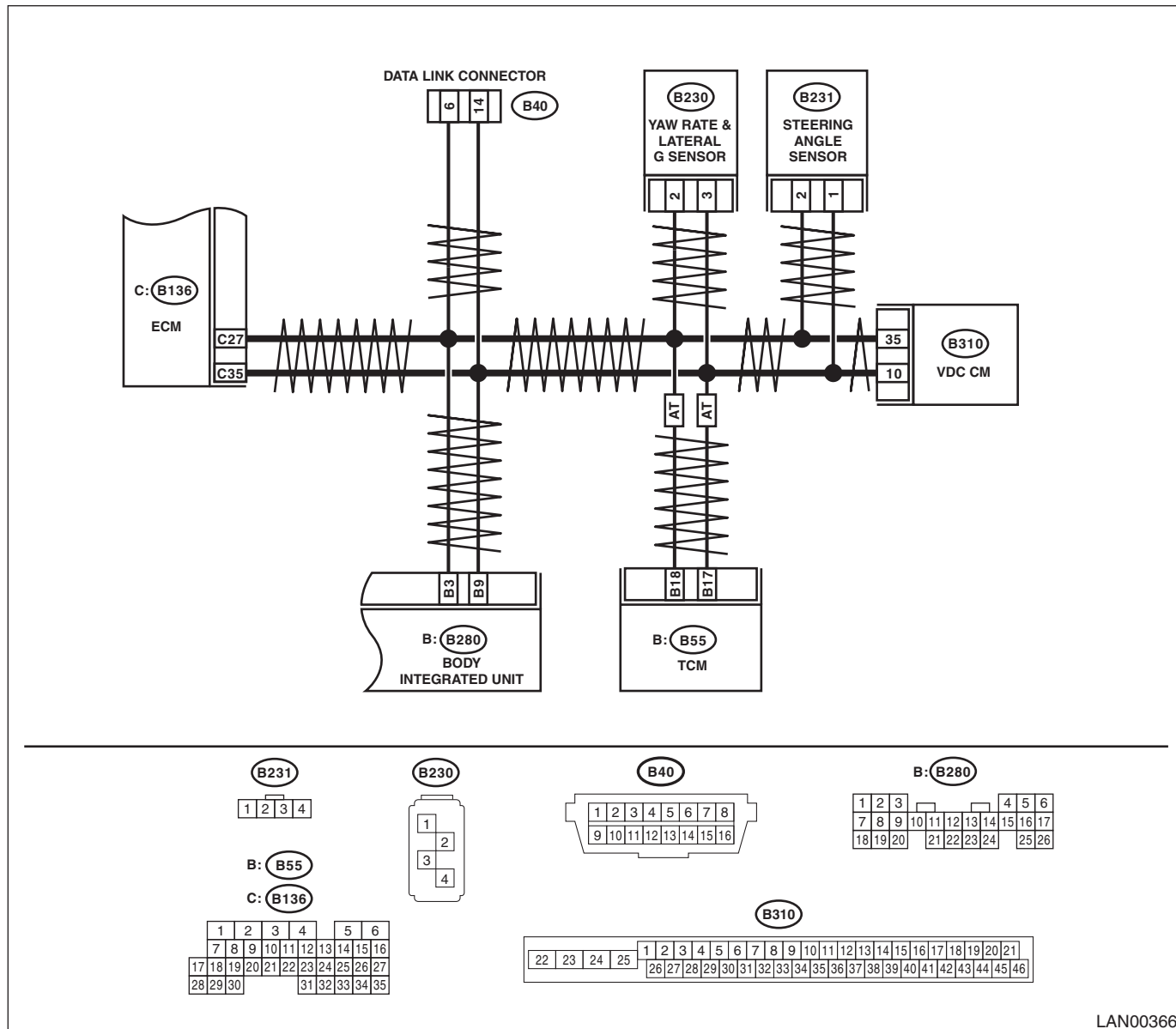

LAN00366

Diagnostic Procedure with Diagnostic Trouble Code (DTC)

LAN SYSTEM (DIAGNOSTICS)

Step	Check	Yes	No
1 CHECK DTC. Using the Subaru Select Monitor, read all DTCs.	Are there any U1201, U1202, DTCs other than for the body integrated unit?	Perform the diagnosis according to DTC.	Go to step 2.
2 CHECK DTC. Read the DTC of body integrated unit using Subaru Select Monitor.	Is U1211 a current malfunction?	Go to step 3.	Go to step 4.
3 CHECK ECM. 1) Turn the ignition switch to OFF. 2) Disconnect the connector from ECM. 3) Connect the disconnected connectors. 4) Read the DTC of body integrated unit using Subaru Select Monitor.	Is U1211 a current malfunction?	Replace the ECM. <Ref. to FU(H4DOTC)-46, Engine Control Module (ECM).>	Go to step 4.
4 CHECK HARNESS. 1) Shake the harness used for CAN communication circuit. 2) Read the DTC of body integrated unit using Subaru Select Monitor.	Is U1211 a current malfunction?	Repair the poor contact or temporary open circuit of harness.	Go to step 5.
5 CHECK CONNECTOR. 1) Turn the ignition switch to OFF. 2) Disconnect the connector that is connected to high speed CAN circuit.	Is there poor contact in connector?	Repair the connector terminal where poor contact exists, or replace harness.	It is possible that temporary poor contact occurs.

Diagnostic Procedure with Diagnostic Trouble Code (DTC)

LAN SYSTEM (DIAGNOSTICS)

L: DTC U1212 CAN-HS TCM DATA ABNORMAL

DTC DETECTING CONDITION:

Received error data from TCM.

TROUBLE SYMPTOM:

It is possible that transmission control error may occur.

WIRING DIAGRAM:

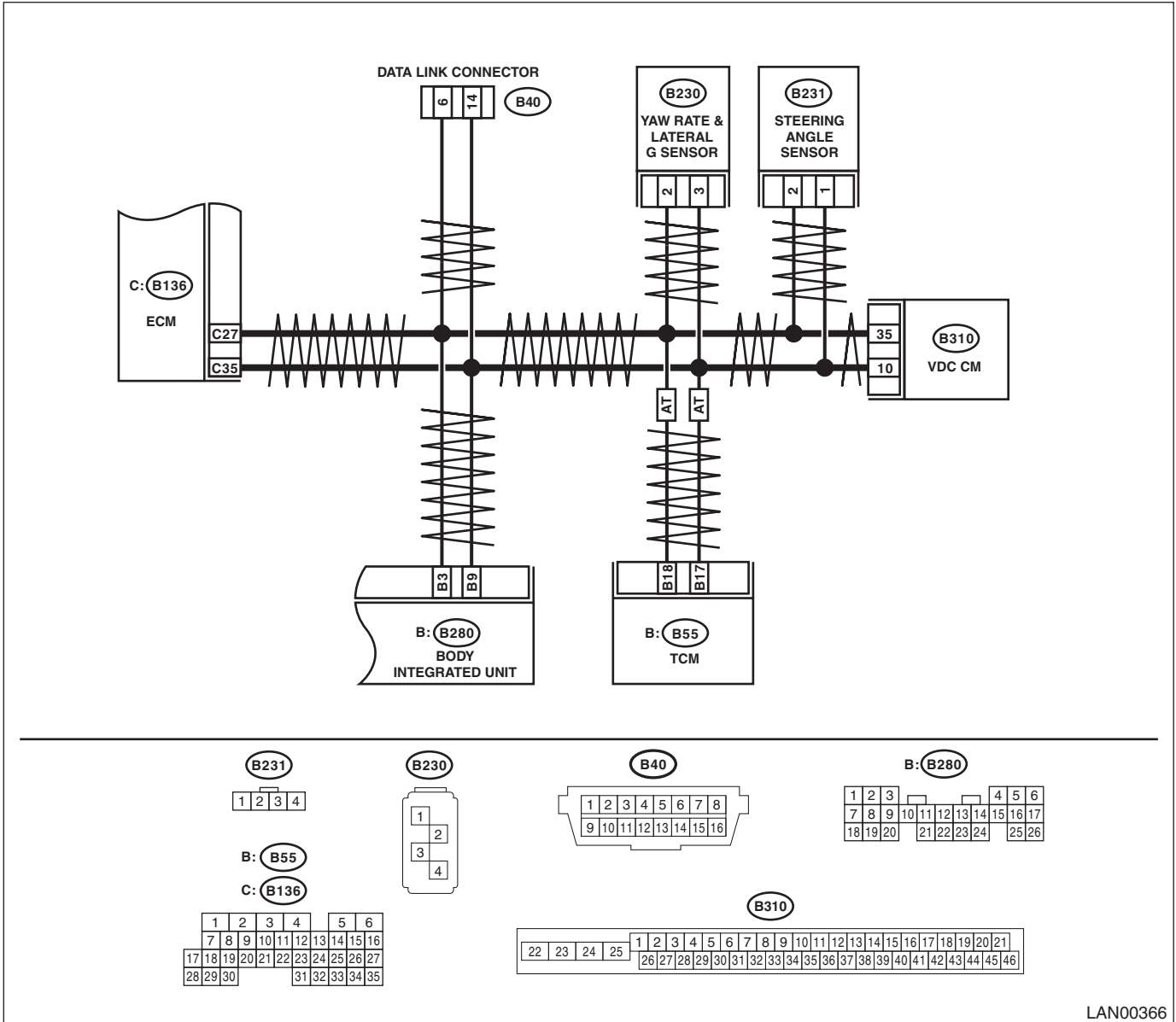

LAN00366

Diagnostic Procedure with Diagnostic Trouble Code (DTC)

LAN SYSTEM (DIAGNOSTICS)

	Step	Check	Yes	No
1	CHECK DTC. Using the Subaru Select Monitor, read all DTCs.	Are there any U1201, U1202, DTCs other than for the body integrated unit?	Perform the diagnosis according to DTC.	Go to step 2.
2	CHECK DTC. Read the DTC of body integrated unit using Subaru Select Monitor.	Is U1212 a current malfunction?	Go to step 3.	Go to step 4.
3	CHECK DTC. 1) Turn the ignition switch to OFF. 2) Disconnect the connector from TCM. 3) Connect the disconnected connectors. 4) Read the DTC of body integrated unit using Subaru Select Monitor.	Is U1212 a current malfunction?	Replace the TCM. <Ref. to 4AT-60, Transmission Control Module (TCM).>	Go to step 4.
4	CHECK HARNESS. 1) Turn the ignition switch to OFF. 2) Shake the harness used for CAN communication circuit. 3) Read the DTC of body integrated unit using Subaru Select Monitor.	Is U1212 a current malfunction?	Repair or replace the harness.	Go to step 5.
5	CHECK CONNECTOR. 1) Turn the ignition switch to OFF. 2) Disconnect the connector that is connected to high speed CAN circuit.	Is there poor contact in connector terminal?	Repair the connector terminal, or replace harness.	Temporary poor contact occurs.

Diagnostic Procedure with Diagnostic Trouble Code (DTC)

LAN SYSTEM (DIAGNOSTICS)

M: DTC U1213 CAN-HS VDC/ABS DATA ABNORMAL

DTC DETECTING CONDITION:

Received error data from VDC/ABS CM.

TROUBLE SYMPTOM:

It is possible that brake control error may occur.

WIRING DIAGRAM:

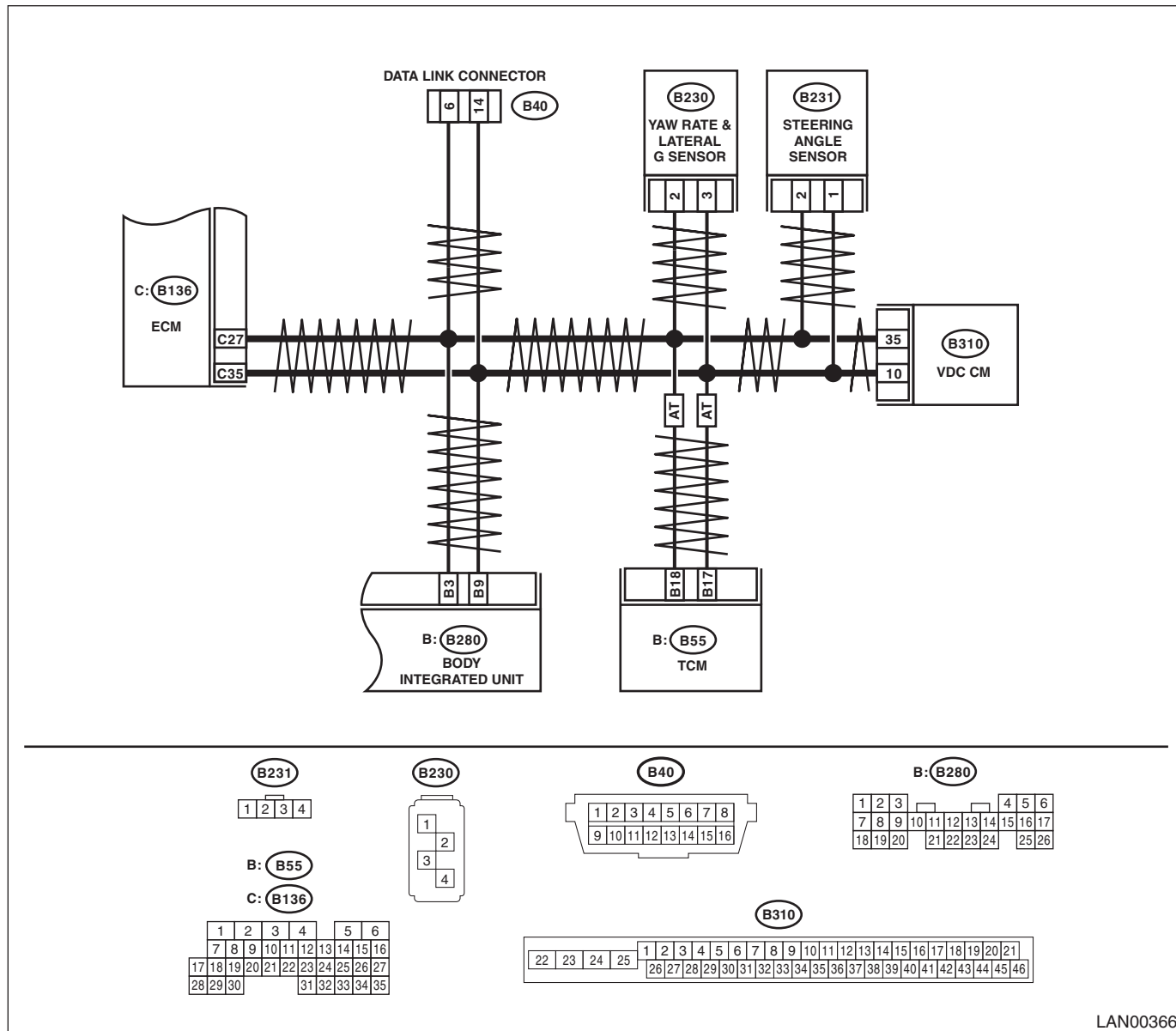

LAN00366

Diagnostic Procedure with Diagnostic Trouble Code (DTC)

LAN SYSTEM (DIAGNOSTICS)

Step	Check	Yes	No
1 CHECK DTC. Using the Subaru Select Monitor, read all DTCs.	Are there any U1201, U1202, DTCs other than for the body integrated unit?	Perform the diagnosis according to DTC.	Go to step 2.
2 CHECK DTC. Read the DTC of body integrated unit using Subaru Select Monitor.	Is U1213 a current malfunction?	Go to step 3.	Go to step 4.
3 CHECK DTC. 1) Turn the ignition switch to OFF. 2) Disconnect the VDC/ABS CM connector. 3) Connect the disconnected connectors. 4) Read the DTC of body integrated unit using Subaru Select Monitor.	Is U1213 a current malfunction?	Replace the VDC/ABS CM. <Ref. to VDC-7, VDC Control Module and Hydraulic Control Unit (VDCCM&H/U).>	Go to step 4.
4 CHECK HARNESS. 1) Turn the ignition switch to OFF. 2) Shake the harness used for CAN communication circuit. 3) Read the DTC of body integrated unit using Subaru Select Monitor.	Is U1213 a current malfunction?	Repair or replace the harness.	Go to step 5.
5 CHECK CONNECTOR. 1) Turn the ignition switch to OFF. 2) Disconnect the connector that is connected to high speed CAN circuit.	Is there poor contact in connector terminal?	Repair the connector terminal, or replace harness.	It is possible that temporary poor contact occurs.

Diagnostic Procedure with Diagnostic Trouble Code (DTC)

LAN SYSTEM (DIAGNOSTICS)

N: DTC U1221 CAN-HS ECM NO-RECEIVE DATA

DTC DETECTING CONDITION:

Not received error data from ECM. (If error is in the main harness, DTC P0600 CAN communication link is input.)

TROUBLE SYMPTOM:

Malfunction indicator light illuminates.

WIRING DIAGRAM:

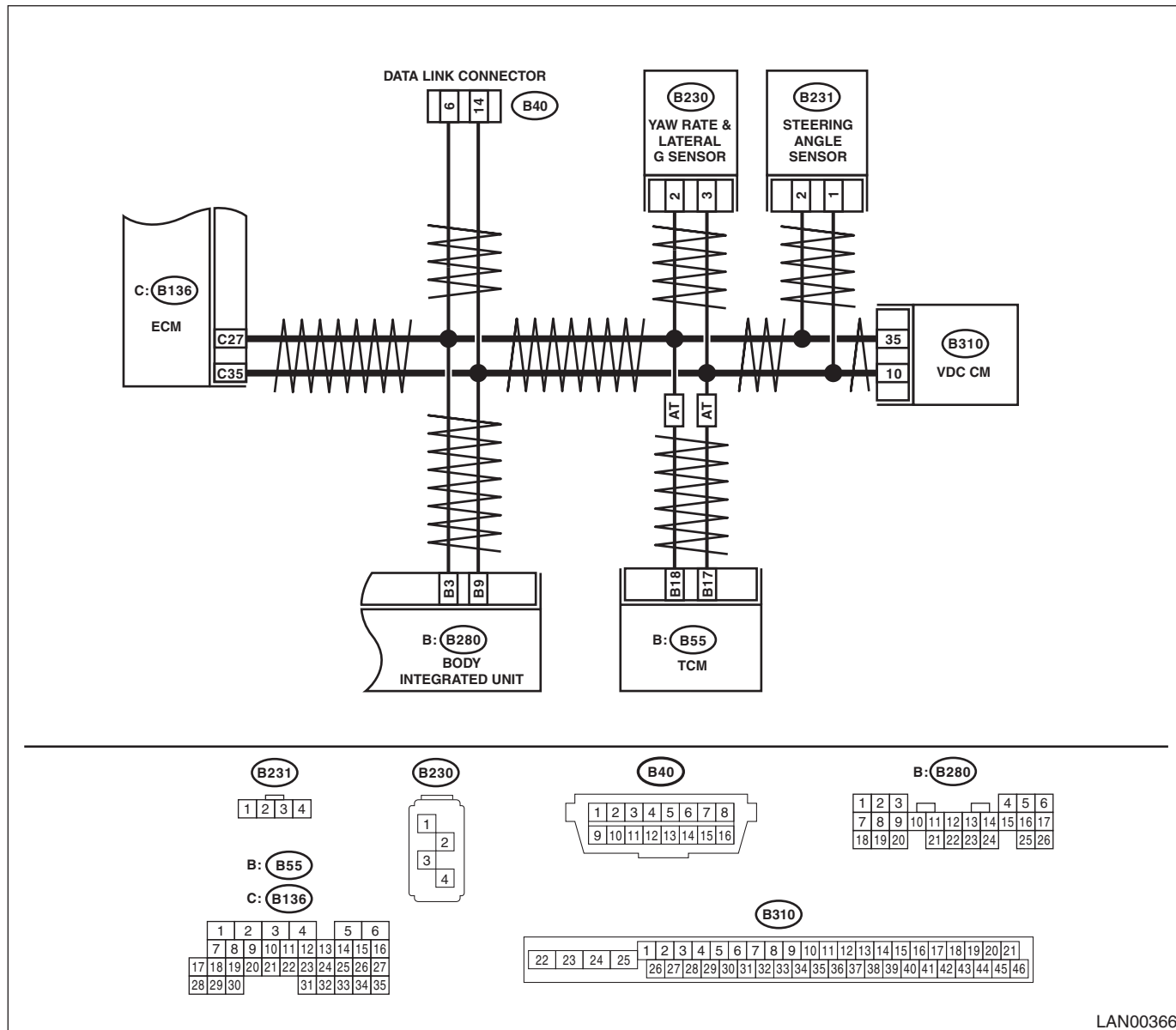

LAN00366

Diagnostic Procedure with Diagnostic Trouble Code (DTC)

LAN SYSTEM (DIAGNOSTICS)

Step	Check	Yes	No	
1	CHECK DTC. Using the Subaru Select Monitor, read all DTCs.	Are there any U1201, U1202, DTCs other than for the body integrated unit?	Perform the diagnosis according to DTC.	Go to step 2.
2	CHECK DTC. Read the DTC of body integrated unit using Subaru Select Monitor.	Is U1221 a current malfunction?	Go to step 3.	Go to step 8.
3	CHECK DTC. 1) Turn the ignition switch to OFF. 2) Disconnect all connectors (B280, B310, B55, B136, B230, B231) that are connected to high speed CAN communication line. 3) Connect the disconnected connectors. 4) Read the DTC of body integrated unit using Subaru Select Monitor.	Is U1221 a current malfunction?	Go to step 4.	Go to step 8.
4	CHECK CURRENT DATA. 1) Turn the ignition switch to OFF. 2) Disconnect all connectors (B280, B310, B55, B136, B230, B231) that are connected to high speed CAN communication line. 3) Using the tester, measure the resistance between terminals of harness. Connector & terminal (B40) No. 6 — (B136) No. 27: (B40) No. 6 — (B310) No. 35: (B40) No. 6 — (B230) No. 2: (B40) No. 6 — (B231) No. 2: (B40) No. 6 — (B55) No. 18: (B40) No. 6 — (B280) No. 3:	Is the resistance less than 10 Ω?	Go to step 5.	Repair or replace the open circuit of the harness.
5	CHECK HARNESS. Using the tester, measure the resistance between terminals of harness. Connector & terminal (B40) No. 14 — (B136) No. 35: (B40) No. 14 — (B310) No. 10: (B40) No. 14 — (B230) No. 3: (B40) No. 14 — (B231) No. 1: (B40) No. 14 — (B55) No. 17: (B40) No. 14 — (B280) No. 9:	Is the resistance less than 10 Ω?	Go to step 6.	Repair or replace the open circuit of the harness.
6	CHECK DTC. 1) Turn the ignition switch to OFF. 2) Connect the disconnected connectors. 3) Start the engine. 4) Read the DTC of body integrated unit using Subaru Select Monitor.	Is U1221 a current malfunction?	Go to step 7.	Go to step 8.
7	CHECK DTC. Using the Subaru Select Monitor, read all DTCs.	Are DTCs P1718 or P0044, P0045, P0140 detected?	Replace the ECM.	Replace the body integrated unit.
8	CHECK HARNESS. 1) Turn the ignition switch to OFF. 2) Shake the harness used for CAN communication circuit. 3) Read the DTC of body integrated unit using Subaru Select Monitor.	Is U1221 a current malfunction?	Repair or replace the harness.	Go to step 9.
9	CHECK CONNECTOR. 1) Turn the ignition switch to OFF. 2) Disconnect all the connector that is connected to high speed CAN circuit.	Is there poor contact in connector terminal?	Repair the connector terminal where poor contact exists, or replace harness.	Temporary poor contact occurs.

Diagnostic Procedure with Diagnostic Trouble Code (DTC)

LAN SYSTEM (DIAGNOSTICS)

O: DTC U1222 CAN-HS TCM NO-RECEIVE DATA

DTC DETECTING CONDITION:

Not received error data from TCM.

TROUBLE SYMPTOM:

Malfunction indicator light illuminates.

WIRING DIAGRAM:

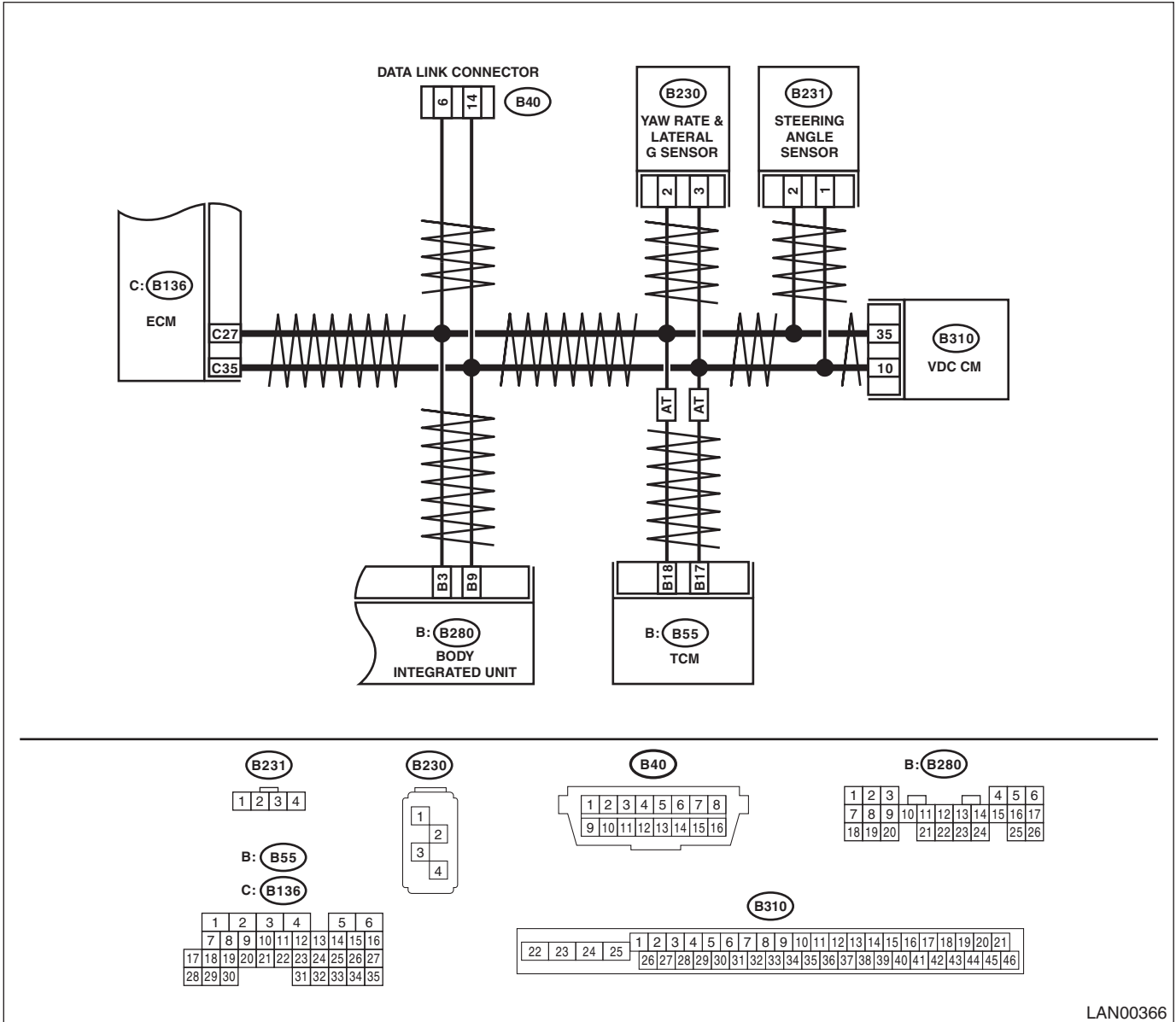

LAN00366

Diagnostic Procedure with Diagnostic Trouble Code (DTC)

LAN SYSTEM (DIAGNOSTICS)

Step	Check	Yes	No	
1	CHECK DTC. Using the Subaru Select Monitor, read all DTCs.	Are there any U1201, U1202, DTCs other than for the body integrated unit?	Perform the diagnosis according to DTC.	Go to step 2.
2	CHECK DTC. Read the DTC of body integrated unit using Subaru Select Monitor.	Is U1222 a current malfunction?	Go to step 3.	Go to step 7.
3	CHECK DTC. 1) Turn the ignition switch to OFF. 2) Disconnect all connectors (B280, B310, B55, B136, B230, B231) that are connected to high speed CAN communication line. 3) Connect the disconnected connectors. 4) Read the DTC of body integrated unit using Subaru Select Monitor.	Is U1222 a current malfunction?	Go to step 4.	Go to step 7.
4	CHECK HARNESS. 1) Disconnect all connectors (B280, B310, B55, B136, B230, B231) that are connected to high speed CAN communication line. 2) Using the tester, measure the resistance between terminals of harness. Connector & terminal (B55) No. 17 — (B40) No. 14: (B55) No. 18 — (B40) No. 6:	Is the resistance less than 10 Ω?	Go to step 5.	Repair or replace the harness.
5	CHECK DTC. 1) Connect the disconnected connectors. 2) Start the engine. 3) Read the DTC of body integrated unit using Subaru Select Monitor.	Is U1222 a current malfunction?	Go to step 6.	Go to step 7.
6	CHECK DTC. Using the Subaru Select Monitor, read all DTCs.	Are DTCs P0600 or P0044, P0045, C0140 displayed?	Replace the TCM. <Ref. to 4AT-60, Transmission Control Module (TCM).>	Replace the body integrated unit. <Ref. to SL-42, REMOVAL, Body Integrated Unit.>
7	CHECK HARNESS. 1) Shake the harness used for CAN communication circuit. 2) Read the DTC of body integrated unit using Subaru Select Monitor.	Is U1222 a current malfunction?	Repair or replace the harness.	Go to step 8.
8	CHECK CONNECTOR. 1) Turn the ignition switch to OFF. 2) Disconnect all the connector that is connected to high speed CAN circuit.	Is there poor contact in connector terminal?	Repair the connector terminal where poor contact exists, or replace harness.	Temporary poor contact occurs.

Diagnostic Procedure with Diagnostic Trouble Code (DTC)

LAN SYSTEM (DIAGNOSTICS)

P: DTC U1223 CAN-HS VDC/ABS NO-RECEIVE DATA

DTC DETECTING CONDITION:

Not received error data from VDC/ABS CM.

TROUBLE SYMPTOM:

ABS warning light and VDC warning light illuminate.

WIRING DIAGRAM:

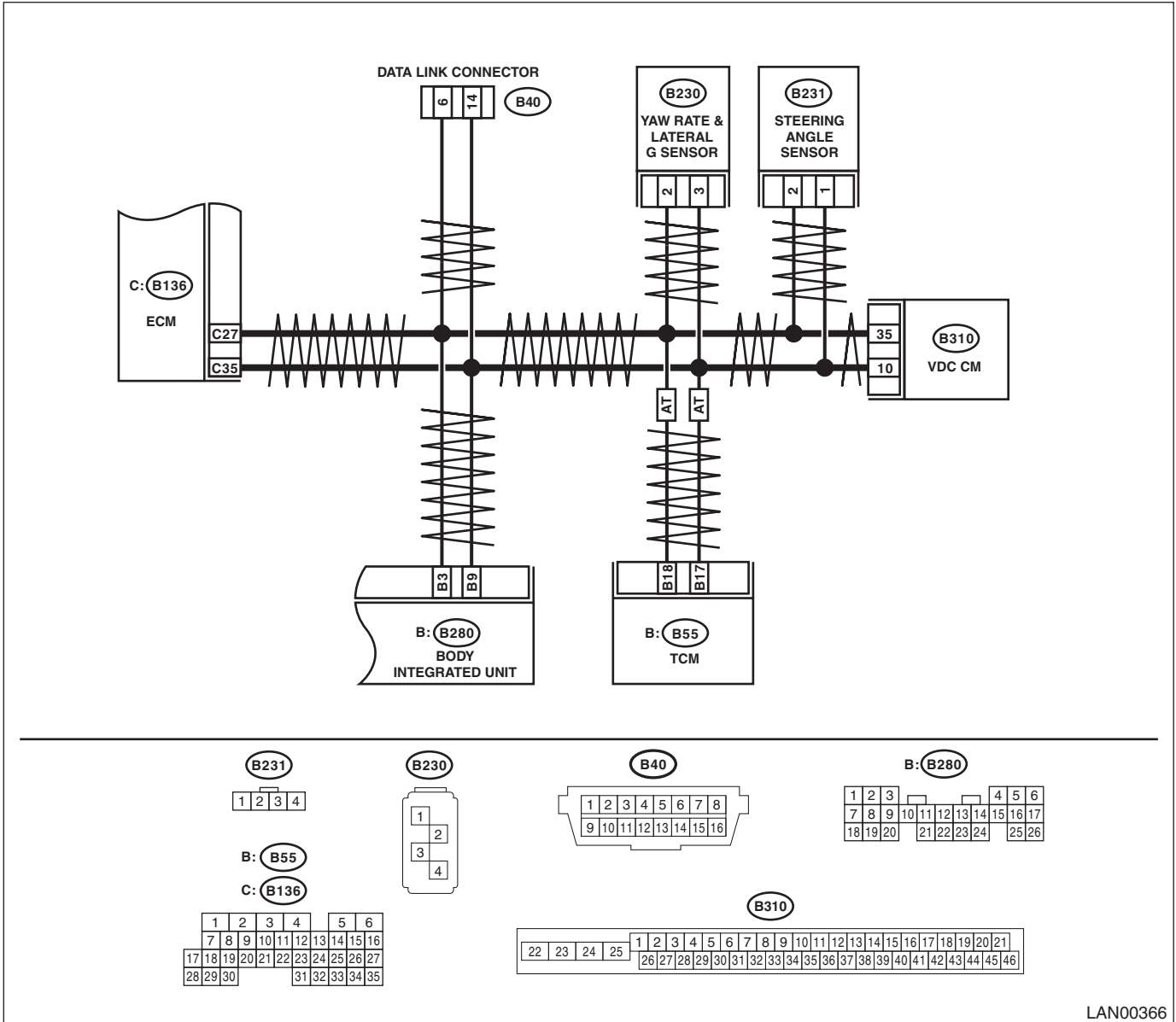

LAN00366

Diagnostic Procedure with Diagnostic Trouble Code (DTC)

LAN SYSTEM (DIAGNOSTICS)

Step	Check	Yes	No	
1	CHECK DTC. Using the Subaru Select Monitor, read all DTCs.	Are there any U1201, U1202, DTCs other than for the body integrated unit?	Perform the diagnosis according to DTC.	Go to step 2.
2	CHECK DTC. Read the DTC of body integrated unit using Subaru Select Monitor.	Is U1223 a current malfunction?	Go to step 3.	Go to step 7.
3	CHECK DTC. 1) Turn the ignition switch to OFF. 2) Disconnect all connectors (B280, B310, B55, B136, B230, B231) that are connected to high speed CAN communication line. 3) Connect the disconnected connectors. 4) Read the DTC of body integrated unit using Subaru Select Monitor.	Is U1223 a current malfunction?	Go to step 4.	Go to step 7.
4	CHECK HARNESS. 1) Disconnect all connectors (B280, B310, B55, B136, B230, B231) that are connected to high speed CAN communication line. 2) Using the tester, measure the resistance between terminals of harness. Connector & terminal (B40) No. 6 — (B310) No. 35: (B40) No. 14 — (B310) No. 10:	Is the resistance less than 10 Ω?	Go to step 5.	Repair or replace the harness.
5	CHECK DTC. 1) Connect the disconnected connectors. 2) Start the engine. 3) Read the DTC of body integrated unit using Subaru Select Monitor.	Is U1223 a current malfunction?	Go to step 6.	Go to step 7.
6	CHECK DTC. Using the Subaru Select Monitor, read all DTCs.	Is P1718 or P0600 displayed?	Replace the VDC/ABS CM. <Ref. to VDC-7, VDC Control Module and Hydraulic Control Unit (VDCCM&H/U).>	Replace the body integrated unit. <Ref. to SL-42, REMOVAL, Body Integrated Unit.>
7	CHECK HARNESS. 1) Shake the harness used for CAN communication circuit. 2) Read the DTC of body integrated unit using Subaru Select Monitor.	Is U1223 a current malfunction?	Repair or replace the harness.	Go to step 8.
8	CHECK CONNECTOR. 1) Turn the ignition switch to OFF. 2) Disconnect all connectors (B280, B310, B55, B136, B230, B231) that are connected to high speed CAN communication line.	Is there connector terminal where poor contact exists?	Repair the connector terminal where poor contact exists, or replace harness.	Temporary poor contact occurs.

Diagnostic Procedure with Diagnostic Trouble Code (DTC)

LAN SYSTEM (DIAGNOSTICS)

Q: DTC U1300 CAN-LS MALFUNCTION

DTC DETECTING CONDITION:

Either end of low-speed CAN communication line is open or shorted, the connector is not connected properly, or the terminal has poor crimping.

TROUBLE SYMPTOM:

No influence.

WIRING DIAGRAM:

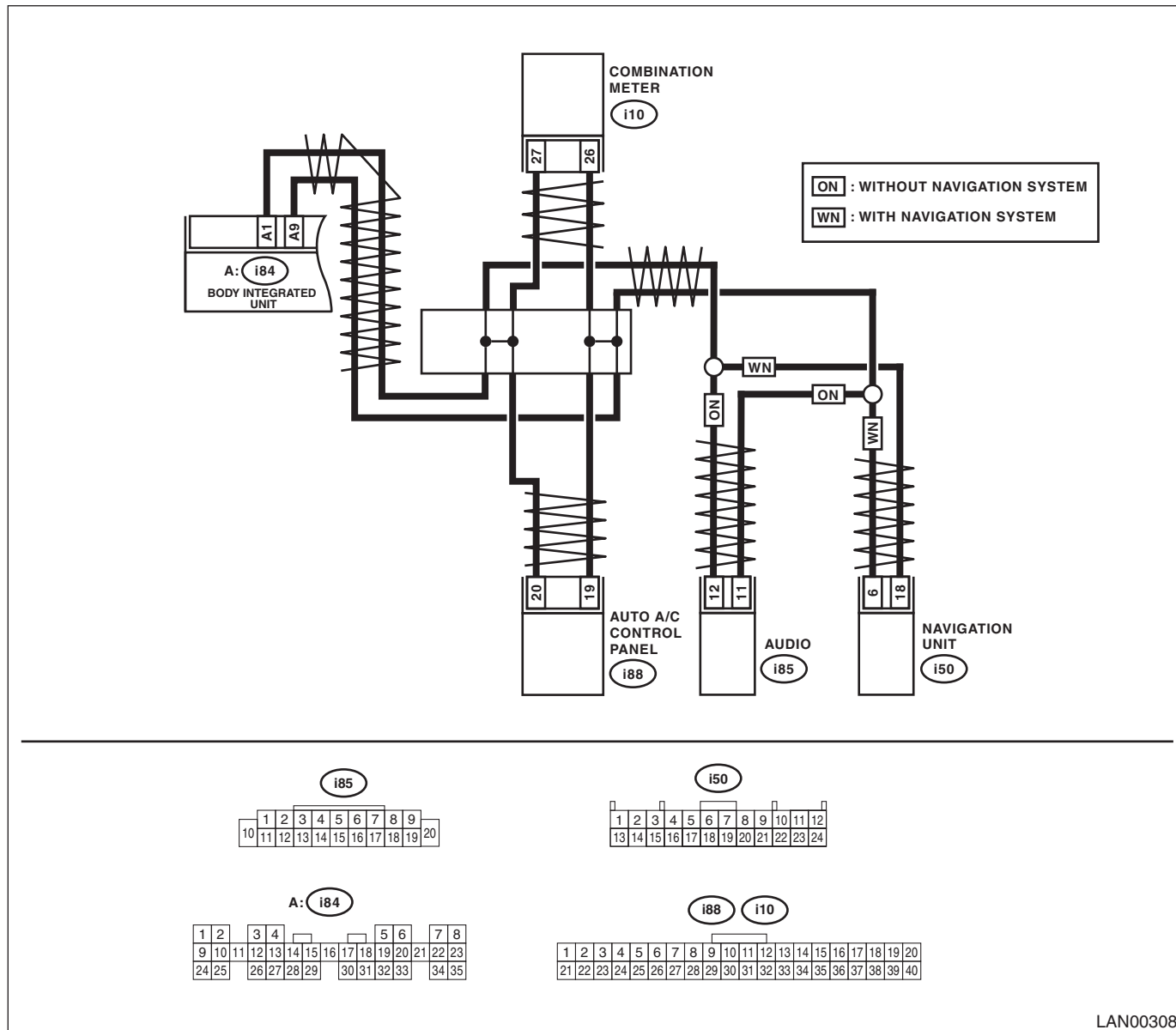

LAN00308

Diagnostic Procedure with Diagnostic Trouble Code (DTC)

LAN SYSTEM (DIAGNOSTICS)

Step	Check	Yes	No
1 CHECK DTC. Read the DTC of body integrated unit using Subaru Select Monitor.	Is U1300 a current malfunction?	Go to step 2.	Go to step 7.
2 CHECK DTC. Check the DTC displayed in the body integrated unit. 1) Disconnect all connectors (i84, i10, i88, i85 or i50) that are connected to low speed CAN communication line. 2) Connect the disconnected connectors. 3) Read the DTC of body integrated unit using Subaru Select Monitor.	Is U1300 a current malfunction?	Go to step 3.	Go to step 7.
3 CHECK DTC. Turn the ignition switch to OFF, and read the DTC again. 1) Turn the ignition switch to OFF. 2) Disconnect all connectors (i84, i10, i88, i85 or i50) that are connected to low speed CAN communication line. 3) Using the tester, measure the resistance between terminals of harness. Connector & terminal <i>(i84) No. 1 — (i10) No. 27 (combination meter):</i> <i>(i84) No. 9 — (i10) No. 26 (combination meter):</i> <i>(i84) No. 1 — (i88) No. 20 (auto A/C):</i> <i>(i84) No. 9 — (i88) No. 19 (auto A/C):</i> <i>(i84) No. 1 — (i85) No. 12 (audio):</i> <i>(i84) No. 9 — (i85) No. 11 (audio):</i> <i>(i84) No. 1 — (i50) No. 18 (navigation):</i> <i>(i84) No. 9 — (i50) No. 6 (navigation):</i>	Is the resistance less than 10 Ω?	Go to step 4.	Repair or replace the harness.
4 CHECK AUDIO OR NAVIGATION. 1) Turn the ignition switch to OFF. 2) Connect the disconnected connectors. 3) Disconnect the connector of navigation (i85) or audio (i50). 4) Read the DTC of body integrated unit using Subaru Select Monitor.	Is U1300 a current malfunction?	Go to step 5.	Repair the navigation or audio.
5 CHECK AUTO A/C ECM. 1) Turn the ignition switch to OFF. 2) Connect the audio or navigation connectors. 3) Disconnect the auto A/C ECM connector (i88). 4) Read the DTC of body integrated unit using Subaru Select Monitor.	Is U1300 a current malfunction?	Go to step 6.	Replace the auto A/C control module.
6 CHECK BODY INTEGRATED UNIT. 1) Turn the ignition switch to OFF. 2) Connect the auto A/C control module. 3) Replace the body integrated unit of your vehicle with the body integrated unit from other vehicle, which is working normally. 4) Read the DTC of body integrated unit using Subaru Select Monitor.	Is U1300 a current malfunction?	Replace the combination meter. <Ref. to IDI-16, REMOVAL, Combination Meter.>	Replace the body integrated unit.

Diagnostic Procedure with Diagnostic Trouble Code (DTC)

LAN SYSTEM (DIAGNOSTICS)

Step	Check	Yes	No
7 CHECK HARNESS. 1) Turn the ignition switch to OFF. 2) Shake the harness used for CAN communication circuit. 3) Read the DTC of body integrated unit using Subaru Select Monitor.	Is U1300 a current malfunction?	Repair or replace the harness.	Go to step 8 .
8 CHECK CONNECTOR. 1) Turn the ignition switch to OFF. 2) Disconnect the connector that is connected to low speed CAN circuit.	Is there poor contact at disconnected connector?	Repair the connector terminal, or replace harness.	Temporary poor contact occurs.

Diagnostic Procedure with Diagnostic Trouble Code (DTC)

LAN SYSTEM (DIAGNOSTICS)

R: DTC U1301 CAN-LS COUNTER ABNORMAL

DTC DETECTING CONDITION:

Communication becomes unstable because of low speed CAN communication error.

TROUBLE SYMPTOM:

Display error may occur in fuel gauge because the CAN communication is not transmitted (sending/receiving) normally.

WIRING DIAGRAM:

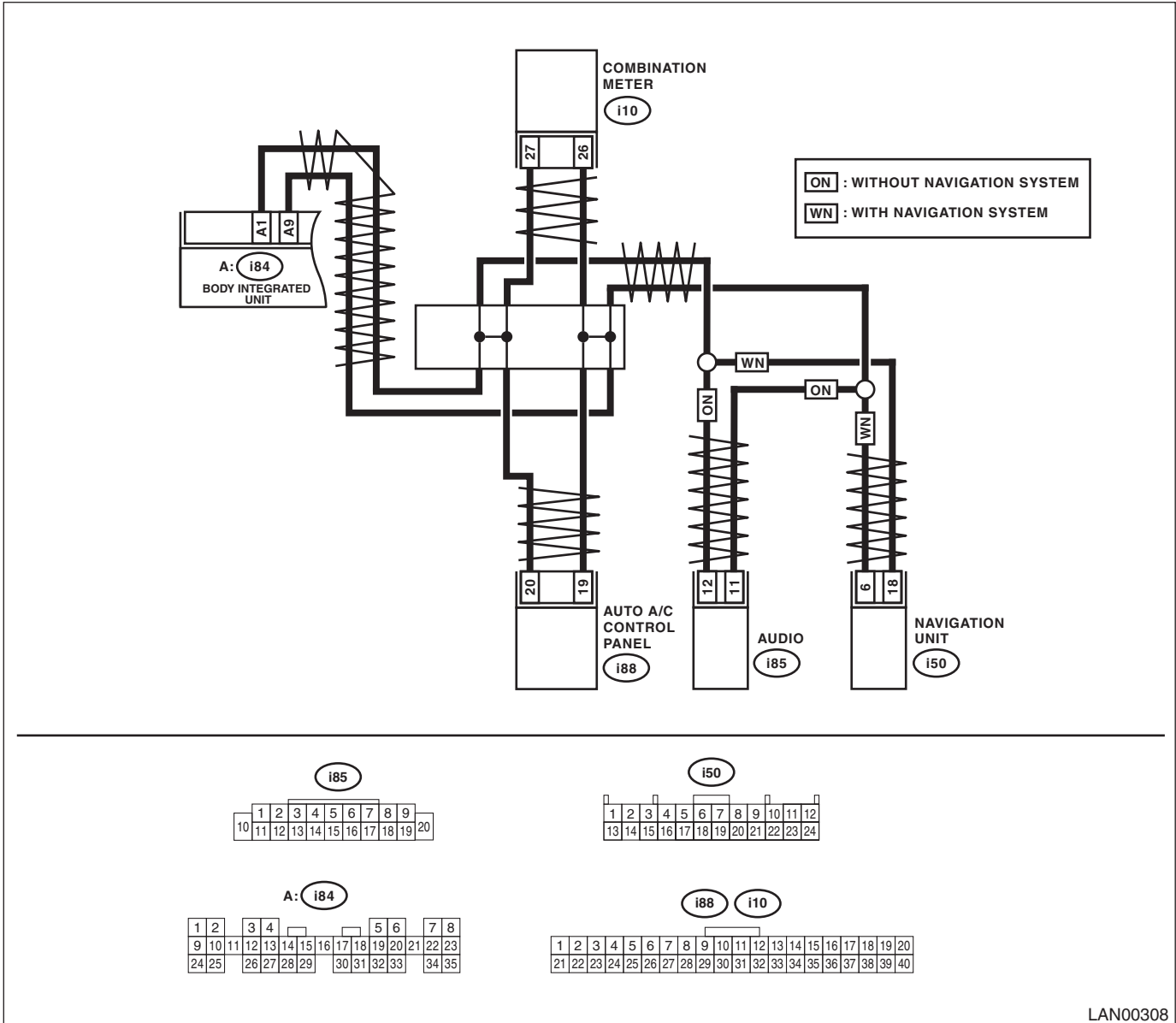

LAN00308

Diagnostic Procedure with Diagnostic Trouble Code (DTC)

LAN SYSTEM (DIAGNOSTICS)

Step	Check	Yes	No
1 CHECK DTC. Read the DTC of body integrated unit using Subaru Select Monitor.	Are there DTC U1300 or U1301?	Perform the diagnosis according to DTC.	Go to step 2.
2 CHECK DTC. Read the DTC of body integrated unit using Subaru Select Monitor.	Is U1301 a current malfunction?	Go to step 3.	Go to step 9.
3 CHECK DTC. Turn the ignition switch to OFF, and read the DTC again. 1) Turn the ignition switch to OFF. 2) Disconnect all connectors (i84, i10, i88, i85 or i50) that are connected to low speed CAN communication line. 3) Connect the disconnected connectors. 4) Read the DTC of body integrated unit using Subaru Select Monitor.	Is U1301 a current malfunction?	Go to step 4.	Go to step 9.
4 CHECK HARNESS. 1) Turn the ignition switch to OFF. 2) Disconnect all connectors (i84, i10, i88, i85 or i50) that are connected to low speed CAN communication line. 3) Using the tester, measure the resistance between terminals of harness. Connector & terminal (i84) No. 1 — (i10) No. 27 (combination meter): (i84) No. 9 — (i10) No. 26 (combination meter): (i84) No. 1 — (i88) No. 20 (auto A/C): (i84) No. 9 — (i88) No. 19 (auto A/C): (i84) No. 1 — (i85) No. 12 (audio): (i84) No. 9 — (i85) No. 11 (audio): (i84) No. 1 — (i50) No. 18 (navigation): (i84) No. 9 — (i50) No. 6 (navigation):	Is the resistance less than 10 Ω?	Go to step 5.	Repair or replace the harness.
5 CHECK AUDIO OR NAVIGATION. 1) Connect the disconnected connectors. 2) Disconnect the connector of navigation (i85) or audio (i50). 3) Read the DTC of body integrated unit using Subaru Select Monitor.	Is U1301 a current malfunction?	Go to step 6.	Go to step 9.
6 CHECK AUTO A/C CONTROL MODULE. 1) Turn the ignition switch to OFF. 2) Connect the audio or navigation module. 3) Disconnect the auto A/C control module connector (i88). 4) Read the DTC of body integrated unit using Subaru Select Monitor.	Is U1301 a current malfunction?	Go to step 7.	Replace the auto A/C control module. <Ref. to AC-29, REMOVAL, Control Unit (Auto A/C Model).>
7 CHECK COMBINATION METER. 1) Turn the ignition switch to OFF. 2) Connect the disconnected connectors. 3) Perform the self-diagnosis of combination meter.	Is the self-diagnosis of combination meter OK?	Go to step 8.	Replace the combination meter.
8 CHECK BODY INTEGRATED UNIT. 1) Turn the ignition switch to OFF. 2) Disconnect all connectors (i84, i10, i88, i85 or i50) that are connected to low speed CAN communication line. 3) Connect the disconnected connectors. 4) Read the DTC of body integrated unit using Subaru Select Monitor.	Is DTC U1301 a current malfunction?	Replace the body integrated unit.	Go to step 9.

Diagnostic Procedure with Diagnostic Trouble Code (DTC)

LAN SYSTEM (DIAGNOSTICS)

Step	Check	Yes	No
9 CHECK HARNESS. 1) Turn the ignition switch to OFF. 2) Shake the harness used for low speed CAN communication circuit. 3) Read the DTC of body integrated unit using Subaru Select Monitor.	Is U1301 a current malfunction?	Repair or replace the harness.	Go to step 10.
10 CHECK CONNECTOR. Check current data (meter failure) of the body integrated unit. 1) Turn the ignition switch to OFF. 2) Disconnect all connectors (i84, i10, i88, i85 or i50) that are connected to low speed CAN communication line.	Is there poor contact in connector terminal?	Repair the connector terminal, or replace harness.	Temporary poor contact occurs.

Diagnostic Procedure with Diagnostic Trouble Code (DTC)

LAN SYSTEM (DIAGNOSTICS)

S: DTC U1302 CAN-LS BUS OFF

DTC DETECTING CONDITION:

- Open or power supply-output short, GND-output short occurs in both CAN line.
- Internal error in each control module

TROUBLE SYMPTOM:

Display error may occur in fuel gauge because the CAN communication is not transmitted (sending/receiving) normally.

WIRING DIAGRAM:

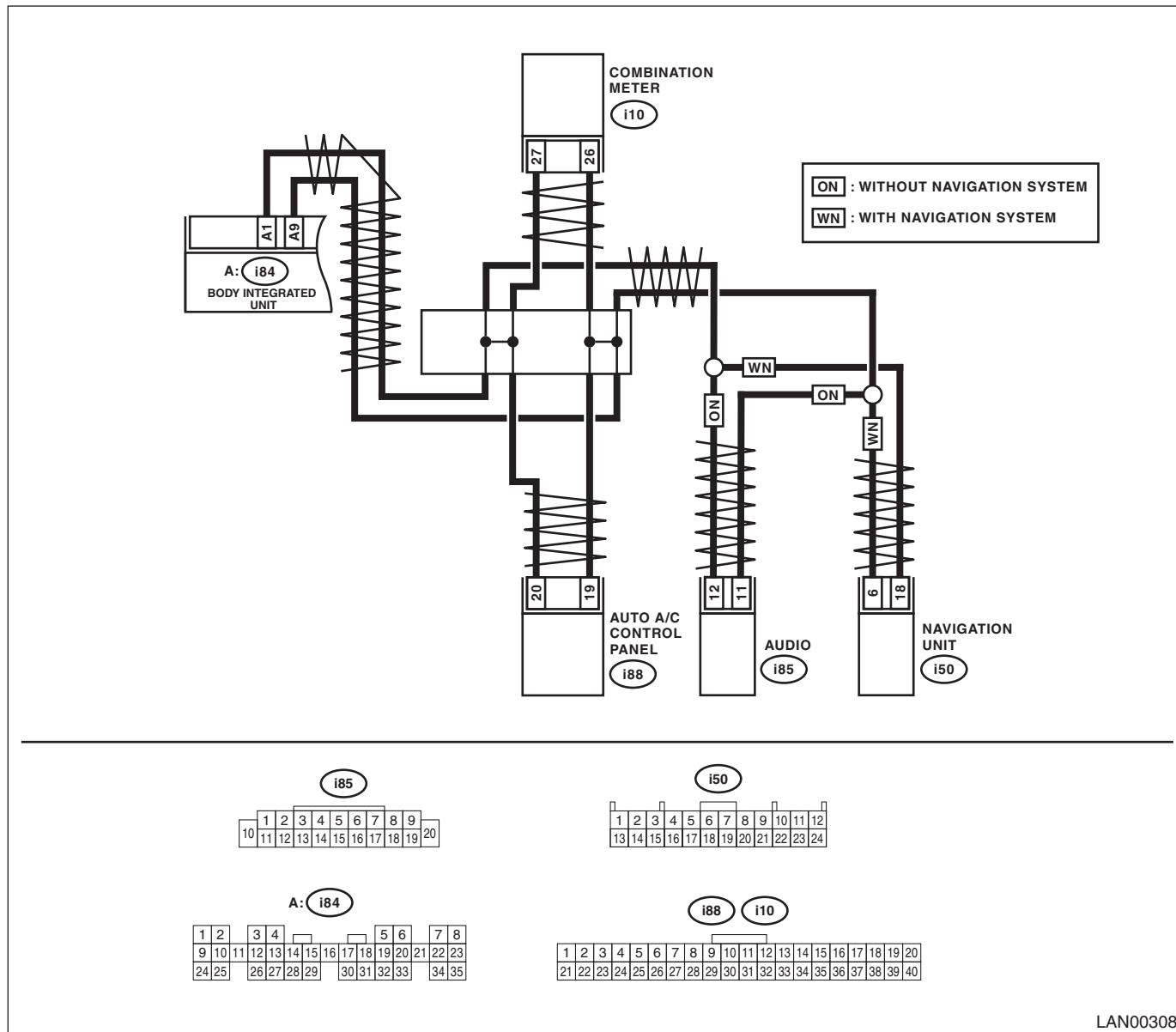

LAN00308

Diagnostic Procedure with Diagnostic Trouble Code (DTC)

LAN SYSTEM (DIAGNOSTICS)

Step	Check	Yes	No
1 CHECK DTC. Read the DTC of body integrated unit using Subaru Select Monitor.	Is U1302 a current malfunction?	Go to step 2.	Go to step 8.
2 CHECK DTC. Turn the ignition switch to OFF, and read the DTC again. 1) Turn the ignition switch to OFF. 2) Disconnect all connectors (i84, i10, i88, i85 or i50) that are connected to low speed CAN communication line. 3) Connect the disconnected connectors. 4) Read the DTC of body integrated unit using Subaru Select Monitor.	Is U1302 a current malfunction?	Go to step 3.	Go to step 8.
3 CHECK HARNESS. 1) Disconnect all connectors (i84, i10, i88, i85 or i50) that are connected to low speed CAN communication line. 2) Using the tester, measure the resistance between terminals of harness. Connector & terminal <i>(i84) No. 1 — (i10) No. 27</i> (combination meter): <i>(i84) No. 9 — (i10) No. 26</i> (combination meter): <i>(i84) No. 1 — (i88) No. 20 (auto A/C):</i> <i>(i84) No. 9 — (i88) No. 19 (auto A/C):</i> <i>(i84) No. 1 — (i85) No. 12 (audio):</i> <i>(i84) No. 9 — (i85) No. 11 (audio):</i> <i>(i84) No. 1 — (i50) No. 18 (navigation):</i> <i>(i84) No. 9 — (i50) No. 6 (navigation):</i>	Is the resistance less than 10 Ω?	Go to step 4.	Repair or replace the harness.
4 CHECK HARNESS. 1) Turn the ignition switch to OFF. 2) Connect the disconnected connectors. 3) Using the tester, measure the resistance between harness connector and chassis ground. Connector & terminal <i>(i84) No. 1 — Chassis ground:</i> <i>(i84) No. 9 — Chassis ground:</i>	Is the resistance 1 MΩ or more?	Go to step 5.	Go to step 7.
5 CHECK HARNESS. 1) Turn the ignition switch to ON. 2) Using the tester, measure the voltage between harness connector and chassis ground. Connector & terminal <i>(i84) No. 1 — Chassis ground:</i> <i>(i84) No. 9 — Chassis ground:</i>	Is the voltage less than 6 V?	Replace the body integrated unit.	Go to step 6.
6 CHECK HARNESS. With the tester connected, disconnect control module.	Is there any control module that the voltage becomes 6 V or less.	Replace the control module whose voltage has changed.	Repair or replace the short circuit of the harness.
7 CHECK HARNESS. With the tester connected, disconnect control module.	Is there any control module whose resistance has changed?	Replace the control module whose resistance has changed.	Repair or replace the short circuit of the harness.
8 CHECK HARNESS. 1) Shake the harness used for low speed CAN communication circuit. 2) Read the DTC of body integrated unit using Subaru Select Monitor.	Is U1302 a current malfunction?	Repair or replace the open, short circuit of the harness.	Go to step 9.

Diagnostic Procedure with Diagnostic Trouble Code (DTC)

LAN SYSTEM (DIAGNOSTICS)

	Step	Check	Yes	No
9	CHECK CONNECTOR. 1) Turn the ignition switch to OFF. 2) Disconnect all connectors (i84, i10, i88, i85 or i50) that are connected to low speed CAN communication line.	Is there poor contact in connector terminal?	Repair the connector terminal, or replace harness.	Temporary poor contact occurs.

Diagnostic Procedure with Diagnostic Trouble Code (DTC)

LAN SYSTEM (DIAGNOSTICS)

T: DTC U1311 CAN-LS METER UNIT DATA ABNORMAL

DTC DETECTING CONDITION:

Error data is received from combination meter.

TROUBLE SYMPTOM:

Defective data from combination meter occurs.

WIRING DIAGRAM:

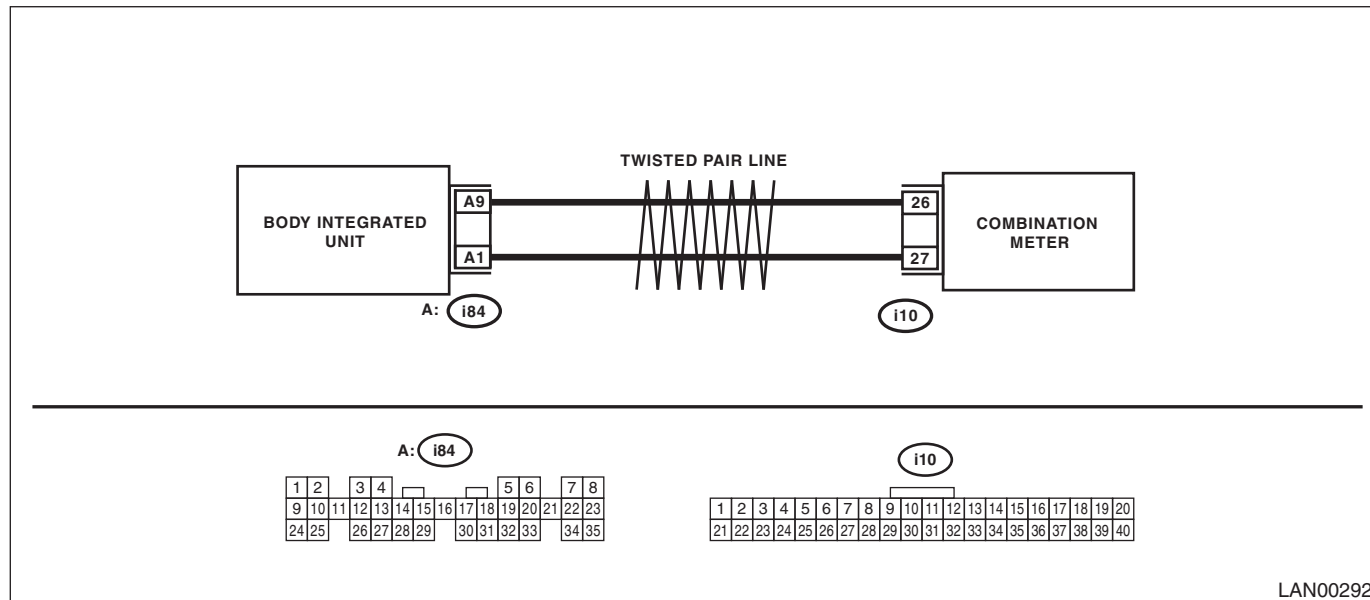

LAN00292

Step	Check	Yes	No
1	CHECK DTC. Read the DTC of body integrated unit using Subaru Select Monitor.	Is DTC U1301 or U1302 displayed?	Perform the diagnosis according to DTC. Go to step 2.
2	CHECK DTC. Read the DTC of body integrated unit using Subaru Select Monitor.	Is U1311 a current malfunction?	Go to step 3. Go to step 4.
3	CHECK DTC. 1) Turn the ignition switch to OFF. 2) Disconnect the combination meter connector (i10). 3) Read the DTC of body integrated unit using Subaru Select Monitor.	Is U1311 a current malfunction?	Replace the combination meter. <Ref. to IDI-16, REMOVAL, Combination Meter.> Go to step 4.
4	CHECK HARNESS. 1) Shake the harness used for low speed CAN communication circuit. 2) Read the DTC of body integrated unit using Subaru Select Monitor.	Is U1311 a current malfunction?	Repair or replace the harness. Go to step 5.
5	CHECK CONNECTOR. 1) Turn the ignition switch to OFF. 2) Disconnect all connectors (i84, i10, i88, i85 or i50) that are connected to low speed CAN communication line.	Is there poor contact in connector terminal?	Repair the connector terminal, or replace harness. Temporary poor contact occurs.

Diagnostic Procedure with Diagnostic Trouble Code (DTC)

LAN SYSTEM (DIAGNOSTICS)

U: DTC U1321 CAN-LS METER NO-RECEIVE DATA

DTC DETECTING CONDITION:

Not received error data from combination meter.

TROUBLE SYMPTOM:

Engine may not be started.

WIRING DIAGRAM:

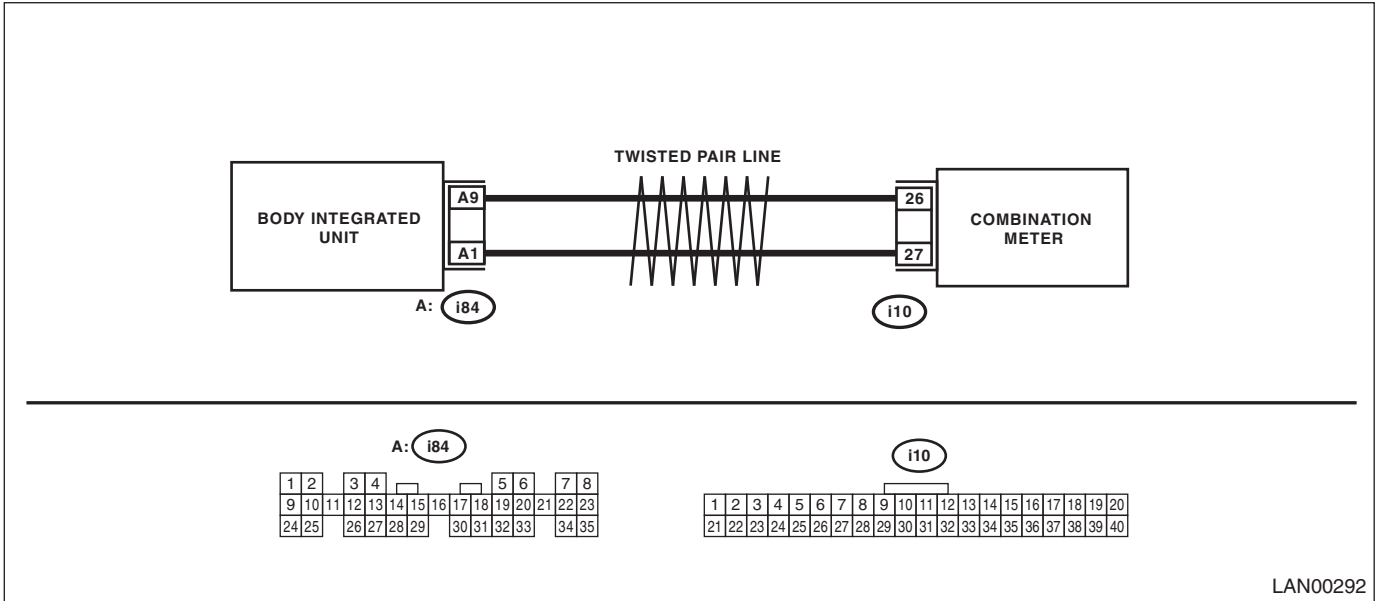

LAN00292

Diagnostic Procedure with Diagnostic Trouble Code (DTC)

LAN SYSTEM (DIAGNOSTICS)

Step	Check	Yes	No
1 CHECK ALL DTCS. Using the Subaru Select Monitor, read all DTCs.	Is DTC U1301 or U1302 displayed?	Perform the diagnosis according to DTC.	Go to step 2.
2 CHECK DTC. Read the DTC of body integrated unit using Subaru Select Monitor.	Is U1321 a current malfunction?	Go to step 3.	Go to step 7.
3 CHECK DTC. 1) Turn the ignition switch to OFF. 2) Disconnect all connectors (i84, i10, i88, i85 or i50) that are connected to low speed CAN communication line. 3) Connect the disconnected connectors. 4) Read the DTC of body integrated unit using Subaru Select Monitor.	Is U1321 a current malfunction?	Go to step 4.	Replace the combination meter. <Ref. to IDI-16, REMOVAL, Combination Meter.>
4 CHECK HARNESS. 1) Turn the ignition switch to OFF. 2) Disconnect all connectors (i84, i10, i88, i85 or i50) that are connected to low speed CAN communication line. 3) Using the tester, measure the resistance between terminals of harness. Connector & terminal (i84) No. 1 — (i10) No. 27 (combination meter): (i84) No. 9 — (i10) No. 26 (combination meter): (i84) No. 1 — (i88) No. 20 (auto A/C): (i84) No. 9 — (i88) No. 19 (auto A/C): (i84) No. 1 — (i85) No. 12 (audio): (i84) No. 9 — (i85) No. 11 (audio): (i84) No. 1 — (i50) No. 18 (navigation): (i84) No. 9 — (i50) No. 6 (navigation):	Is the resistance less than 10 Ω?	Go to step 5.	Repair or replace the harness.
5 CHECK COMBINATION METER. 1) Connect the disconnected connectors. 2) Perform the self-diagnosis of combination meter.	Is the self-diagnosis OK?	Go to step 6.	Replace the combination meter.
6 CHECK DTC. 1) Turn the ignition switch to OFF. 2) Disconnect all connectors (i84, i10, i88, i85 or i50) that are connected to low speed CAN communication line. 3) Connect the disconnected connectors. 4) Read the DTC of body integrated unit using Subaru Select Monitor.	Is U1321 a current malfunction?	Replace the body integrated unit. <Ref. to SL-42, Body Integrated Unit.>	Go to step 7.
7 CHECK DTC. 1) Shake the harness used for low speed CAN communication circuit. 2) Read the DTC of body integrated unit using Subaru Select Monitor.	Is U1321 a current malfunction?	Repair the poor contact, open circuit of harness or replace harness.	Go to step 8.
8 CHECK CONNECTOR. 1) Turn the ignition switch to OFF. 2) Disconnect all connectors (i84, i10, i88, i85 or i50) that are connected to low speed CAN communication line.	Is there poor contact in connector terminal?	Repair the connector terminal, or replace harness.	It is possible that temporary poor contact occurs.

Diagnostic Procedure with Diagnostic Trouble Code (DTC)

LAN SYSTEM (DIAGNOSTICS)

V: DTC B1500 KEYLESS UART COM. MALFUNCTION

DTC DETECTING CONDITION:

UART between keyless entry control module and body integrated unit is open or shorted, the connector is not connected properly, or the terminal is crimped improperly, keyless entry control module internal error.

TROUBLE SYMPTOM:

Door lock does not operate with keyless.

WIRING DIAGRAM:

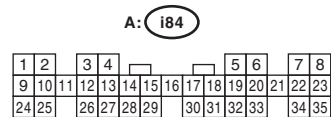
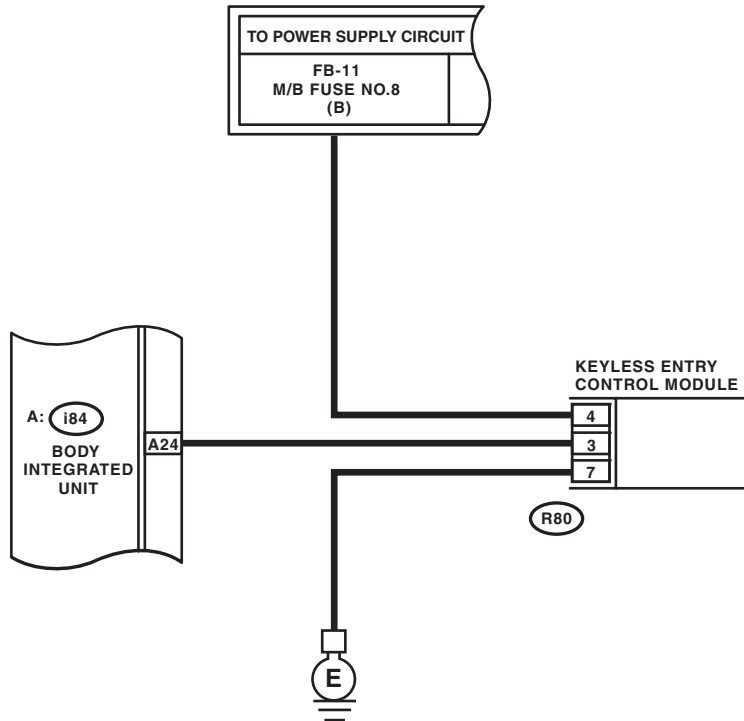

LAN00294

Diagnostic Procedure with Diagnostic Trouble Code (DTC)

LAN SYSTEM (DIAGNOSTICS)

Step	Check	Yes	No
1 CHECK DTC. Read the DTC of body integrated unit using Subaru Select Monitor.	Is B1500 current malfunction?	Go to step 2.	Go to step 6.
2 CHECK DTC. 1) Turn the ignition switch to OFF. 2) Disconnect the connectors from body integrated unit and keyless entry control module. 3) Connect the disconnected connectors. 4) Read the DTC of body integrated unit using Subaru Select Monitor.	Is B1500 current malfunction?	Go to step 3.	Go to step 6.
3 CHECK HARNESS. 1) Turn the ignition switch to OFF. 2) Disconnect the connectors from body integrated unit and keyless entry control module. 3) Using the tester, measure the resistance between terminals of harness. Connector & terminal (i84) No. 24 — (R80) No. 3:	Is the resistance less than 10 Ω?	Go to step 4.	Repair the open circuit of harness or replace harness.
4 CHECK HARNESS. Using the tester, measure the voltage between keyless entry control module and chassis ground. Connector & terminal (R80) No. 4 — Chassis ground:	Is the voltage battery voltage?	Go to step 5.	Check the power supply circuit for keyless entry control module.
5 CHECK OPERATION. 1) Install the keyless entry control module from other vehicle, which is working normally. 2) Register the keyless key which is working normally. 3) Operate the keyless key.	Is the door locking operate?	Replace the keyless entry control module. <Ref. to SL-40, REMOVAL, Keyless Entry Control Module.>	Replace the body integrated unit. <Ref. to SL-42, Body Integrated Unit.>
6 CHECK CONNECTOR. Disconnect the connectors from body integrated unit and keyless entry control module.	Is there poor contact in connector?	Repair the connector, or replace harness.	Temporary poor contact occurs.

General Diagnostic Table

LAN SYSTEM (DIAGNOSTICS)

15. General Diagnostic Table

A: INSPECTION

Read the DTC or inspect and diagnose the following data in the current data display using Subaru Select Monitor.

1. LAN SYSTEM

Item	Operation	Specifications		Note
		YES	NO	
DTC	DTC is not displayed when inspecting all DTCs.	DTC is not displayed.	Perform the diagnosis according to DTC.	—
Coolant Temp.	Check the current data display of ECM, TCM and body integrated unit. Three data value are the same.	Same values	Inspect LAN system.	If engine coolant temperature sensor is not OK, inspect the sensor circuit.
Rr Defogger SW	It turns to ON when pressing switch. (Low-speed CAN is OK)	Turns to ON.	Inspect rear defogger switch.	Rear defogger switch is connected with Low-speed CAN.
Rr defogger output	When switch input, it is output.	Output	Replace the body integrated unit.	If not operating with output, check the rear defogger relay.
Door lock SW (Open)	When locked with door lock switch, it turns to ON.	Turns to ON.	Inspect door lock switch.	The door lock switch is connected to the Low-speed CAN.
Door lock actuator	When locked with door lock switch, it is output.	Output	Replace the body integrated unit.	—

General Diagnostic Table

LAN SYSTEM (DIAGNOSTICS)

2. BODY INTEGRATED UNIT

Item	Operation	Specifications		Note
		YES	NO	
Illumination VR power supply	Operate the illumination volume, illumination light is controlled according to the change of voltage on data display.	Illumination light is controlled with changing of data.	Inspect the illumination volume.	—
Fuel level resistance	Check the fuel level resistance and fuel level resistance 2. Both resistances are same.	Same values	Inspect the body integrated unit.	Compare the input and output values of body integrated unit.
R wiper ON/INT SW input	When rear wiper SW to ON, data display turns to ON.	Turns to ON.	Inspect the rear wiper switch.	—
R wiper output	When rear wiper switch to ON, output signal turns to ON.	Turns to ON.	Replace the body integrated unit.	If not operate with output turned to ON, check the rear wiper motor.
Keyless Entry	Keyless entry LOCK/UNLOCK the doors.	Operate	Inspect the keyless antenna.	If the antenna is OK, replace the body integrated unit.
Brake Switch	When brake pedal is depressed, it turns to ON.	Turns to ON.	Inspect the brake switch.	—
Shift Lock Solenoid	The shift lock releases when depressing the brake pedal.	Released	Inspect the shift lock.	—
Registration function setting of body integrated unit	Does Vehicle equipment correspond to setting values?	Correspondence	Reconfigure the values according to vehicle equipment.	—
Customizing	When changing customize setting, the registration completes correctly.	Registered	Inspect the body integrated unit.	—
Manual Mode	Switch the shift (UP/DOWN) on Manual mode. Indicator is changed in 1 — 2.	Change	Inspect the shift lever.	—
Function check	Each checking item operate correctly. (Except for not equipped)	Operate	Inspect for nonfunctional actuator.	—
Security	After locking with keyless entry system and open the door, the security system operates and the horn sounds.	Horn sounds. (Security system operates.)	Inspect the security system.	—

General Diagnostic Table

LAN SYSTEM (DIAGNOSTICS)

WIRING SYSTEM SECTION

WIRING SYSTEM

WI

This service manual has been prepared to provide SUBARU service personnel with the necessary information and data for the correct maintenance and repair of SUBARU vehicles.

This manual includes the procedures for maintenance, disassembling, reassembling, inspection and adjustment of components and diagnostics for guidance of experienced mechanics.

Please peruse and utilize this manual fully to ensure complete repair work for satisfying our customers by keeping their vehicle in optimum condition. When replacement of parts during repair work is needed, be sure to use SUBARU genuine parts.

All information, illustration and specifications contained in this manual are based on the latest product information available at the time of publication approval.

WIRING SYSTEM



	Page
1. Basic Diagnostic Procedure	3
2. Working Precautions	14
3. Power Supply Circuit	15
4. Ground Circuit	22
5. Engine Electrical System	32
6. Radiator Fan System	60
7. Charging System	61
8. Starter System	62
9. Remote Engine Start System	64
10. AT Control System	68
11. AT Shift Lock Control System	75
12. Vehicle Dynamics Control System	76
13. Tire Pressure Monitoring System	80
14. Air Conditioning System	81
15. Power Seat System	89
16. Airbag System	90
17. Seat Belt Warning System	94
18. Occupant Detection System	95
19. Seat Heater System	96
20. Headlight System	97
21. Headlight Beam Leveler System	100
22. Front Fog Light System	102
23. Back-up Light System	104
24. Stop Light System	105
25. Clearance Light and Illumination Light System	106
26. Turn Signal Light and Hazard Light System	111
27. Interior Light System	114
28. Front Wiper and Washer System	118
29. Rear Wiper and Washer System	119
30. Wiper Deicer System	121
31. Audio System	122
32. Front Accessory Power Supply Socket System	124
33. Rear Accessory Power Supply Socket System	125
34. Navigation System	126
35. Horn System	130
36. Power Window System	131
37. Remote Control Mirror System	135
38. Rear Defogger System	136
39. Combination Meter System	137
40. Speedometer System	142
41. Clock System	143
42. Fuel Gauge System	144
43. Coolant Temperature System	145

44.	Oil Pressure Warning Light System	147
45.	Parking Brake / Brake Fluid Level Warning Light System	148
46.	Sunroof Control System	149
47.	Security System	150
48.	Immobilizer System	153
49.	Keyless Entry System	154
50.	Cruise Control System	158
51.	CAN Communication System	166
52.	Compass Mirror System	168
53.	Harness Components Location	169
54.	Front Wiring Harness	170
55.	Bulkhead Wiring Harness (In Engine Compartment)	172
56.	Bulkhead Wiring Harness (In Compartment)	176
57.	Engine Wiring Harness and Transmission Cord	179
58.	Instrument Panel Wiring Harness	183
59.	Rear Wiring Harness	185
60.	Door Cord	188
61.	Rear Wiring Harness and Rear Gate Cord	190

1. Basic Diagnostic Procedure

A: BASIC PROCEDURES

1. GENERAL DESCRIPTION

The most important purpose of diagnostics is to quickly determine which part is malfunctioning, to save time and labor.

2. IDENTIFICATION OF TROUBLE SYMPTOM

Determine what the problem is based on the symptom.

3. PROBABLE CAUSE OF TROUBLE

Look at the wiring diagram and check the system's circuit. Then check the switch, relay, fuse, ground, etc.

4. LOCATION AND REPAIR OF TROUBLE

- 1) Using the diagnostics, narrow down the causes.
- 2) If necessary, use a voltmeter, ohmmeter, etc.
- 3) Before replacing certain component parts (switch, relay, etc.), check the power supply, ground, for open wiring harness, poor connectors, etc. If no problem is encountered, check the component parts.

5. SYSTEM OPERATION CHECK

After repairing, ensure that the system operates properly.

B: BASIC INSPECTION

1. VOLTAGE MEASUREMENT

- 1) Using a voltmeter, connect the negative lead to a good ground point or negative battery terminal and the positive lead to the connector or component terminal.
- 2) Touch connector (A) with the positive probe of the volt meter. The voltmeter will indicate a voltage.
- 3) Touch connector (B) with the positive probe. The voltmeter will indicate no voltage.

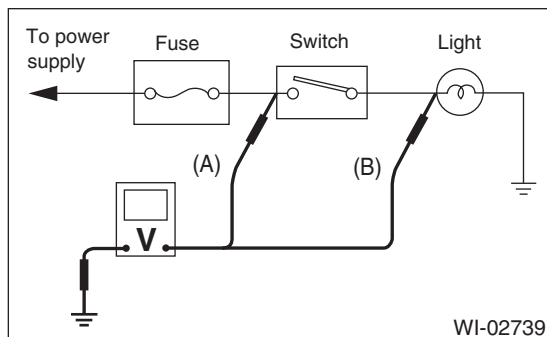

- 4) With the test set-up held as it is, turn the switch to ON. The voltmeter will indicate a voltage and, at the same time, the light will illuminate.

- 5) The circuit is in good order. If a problem such as a light failing to illuminate occurs, use the procedures outlined above to track down the malfunction.

2. CIRCUIT CONTINUITY CHECKS

- 1) Disconnect the battery terminal or connector so there is no voltage between the check points. Contact the two leads of an ohmmeter to each of the check points.

If the circuit has diodes, reverse the two leads and check again.

- 2) Use an ohmmeter to check for diode continuity. When contacting the negative lead to the diode positive side and the positive lead to the negative side, there should be continuity.

When contacting the two leads in reverse, there should be no continuity.

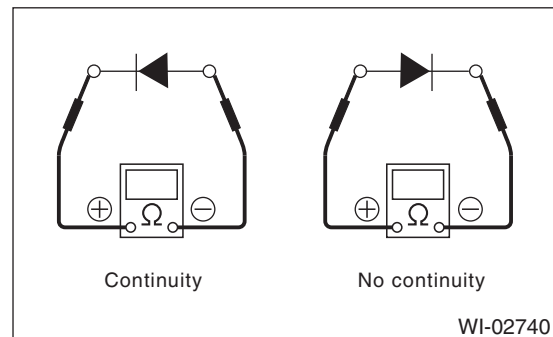

- 3) The symbol "○ — ○" indicates that continuity exists between two points or terminals. For example, when a switch position is at "3", continuity exists among terminals 1, 3 and 6, as shown in the table below.

Terminal	Switch Position					
Switch Position	1	2	3	4	5	6
OFF						
1	○ — ○				○ — ○	
2	○ — ○			○ — ○		
3	○ — ○		○ — ○			○ — ○
4	○ — ○	○ — ○				○ — ○

WI-02741

Basic Diagnostic Procedure

WIRING SYSTEM

3. HOW TO DETERMINE AN OPEN CIRCUIT

1) WITH VOLTMETER:

An open circuit is determined by measuring the voltage between respective connectors and ground using a voltmeter, starting with the connector closest to the power supply. The power supply must be turned ON so that current flows in the circuit. If voltage is not present between a particular connector and ground, the circuit between that connector and the previous connector is open.

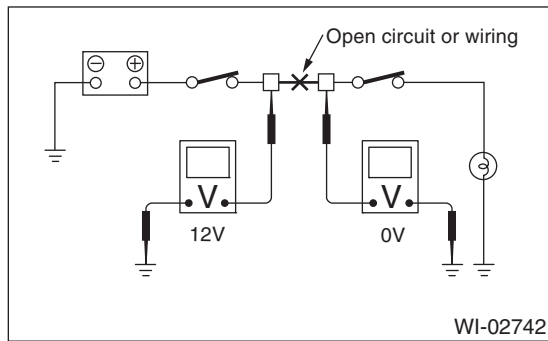

2) WITH OHMMETER:

Disconnect all connectors affected, and check continuity in the wiring between adjacent connectors. When the ohmmeter indicates "infinite", the wiring is open.

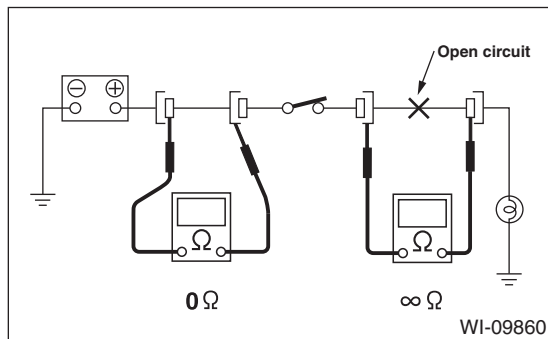

4. HOW TO DETERMINE A SHORT CIRCUIT

1) WITH TEST LIGHT:

Connect a test light (rated at approx. 3 watts) in place of the blown fuse and allow current to flow through the circuit. Disconnect one connector at a time from the circuit. Starting with the one located farthest from the power supply. If the test light goes out when a connector is disconnected, the wiring between that connector and the next connector (farther from the power supply) is shorted.

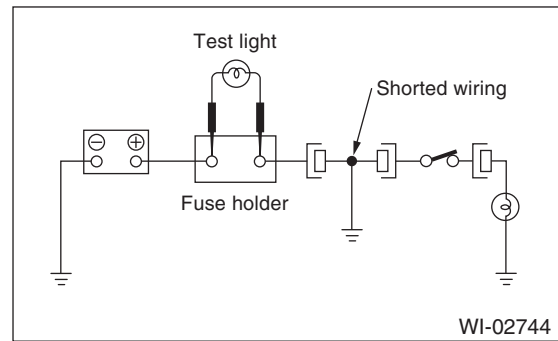

2) WITH OHMMETER:

Disconnect all affected connectors, and check continuity between each connector and ground. When the ohmmeter indicates continuity between a particular connector and a ground, that connector is shorted.

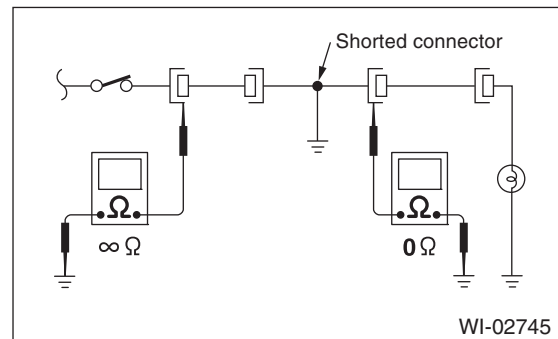

C: HOW TO READ WIRING DIAGRAMS

1. WIRING DIAGRAM:

The wiring diagram of each system is illustrated so that you can understand the path through which the electric current flows from the battery.

Sketches and codes are used in the diagrams. They should read as follows:

- Each connector and its terminal position are indicated by a sketch of the connector in a disconnected state which is viewed from the front.

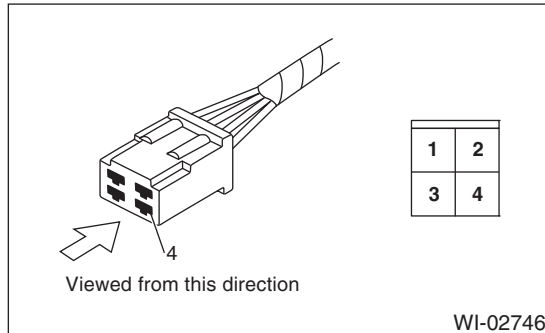

- The number of poles or pins, presence of a lock are indicated in the sketch of each connector. In the sketch, the highest pole number refers to the number of poles which the connector has. For example, the sketch of the connector shown in figure indicates the connector has 9 poles.

Connector used in vehicle	Connector shown in wiring diagram											
	Sketch	Symbol	Number of poles									
	<p>Double frames</p> <p>Indicates a lock is included.</p> <table border="1" style="margin: auto; text-align: center;"> <tr><td>4</td><td>3</td><td>2</td><td>1</td></tr> <tr><td>9</td><td>8</td><td>7</td><td>6</td><td>5</td></tr> </table> <p>Indicates the number of poles.</p>	4	3	2	1	9	8	7	6	5		<p>Numbered in order from upper right to lower left</p>
4	3	2	1									
9	8	7	6	5								
	<p>Indicates a lock is included.</p> <table border="1" style="margin: auto; text-align: center;"> <tr><td>1</td><td>2</td><td>3</td><td>4</td></tr> <tr><td>5</td><td>6</td><td>7</td><td>8</td><td>9</td></tr> </table> <p>Single frame</p>	1	2	3	4	5	6	7	8	9		<p>Numbered in order from upper left to lower right</p>
1	2	3	4									
5	6	7	8	9								

WI-02747

Basic Diagnostic Procedure

WIRING SYSTEM

- When one set of connectors is viewed from the front side, the pole numbers of one connector are symmetrical to those of the other. When these two connectors are connected as a unit, the poles which have the same number are joined.

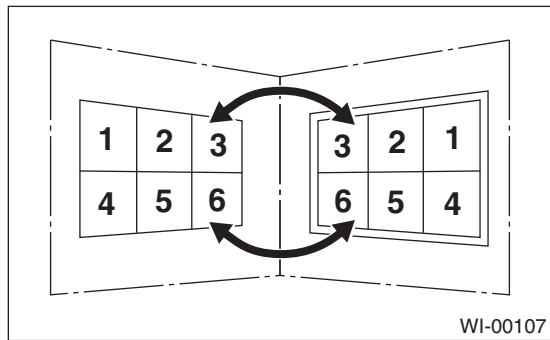

• WIRING DIAGRAM:

The connectors are numbered along with the number of poles, external colors, and mating connections in the accompanying list.

- The sketch of each connector in the wiring diagram usually shows the (A) side of the connector. The relationship between the wire color, terminal number and connector is described in the figure.

NOTE:

A wire which runs in one direction from a connector terminal sometimes may have a different color from that which runs in the other direction from that terminal.

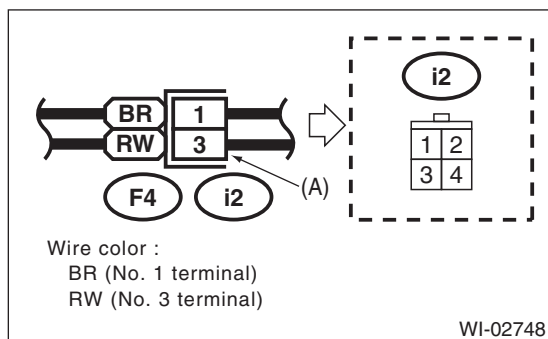

- In the wiring diagram, connectors which have no terminal number refer to one-pole types. Sketches of these connectors are omitted intentionally.

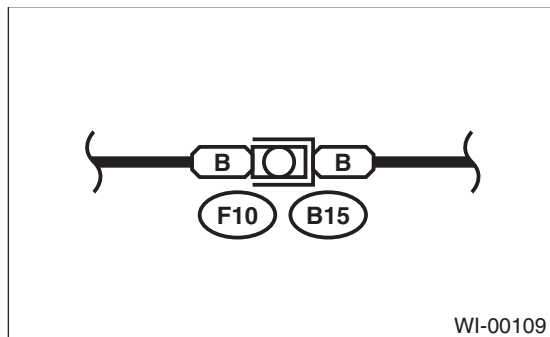

- The following color codes are used to indicate the colors of the wires.

Color code	Color
L	Blue
B	Black
Y	Yellow
G	Green
R	Red
W	White
Br	Brown
Lg	Light green
Gr	Gray
P	Pink
Or	Orange
Sb	Light blue
V	Violet
SA	Sealed (Inner)
SB	Sealed (Outer)

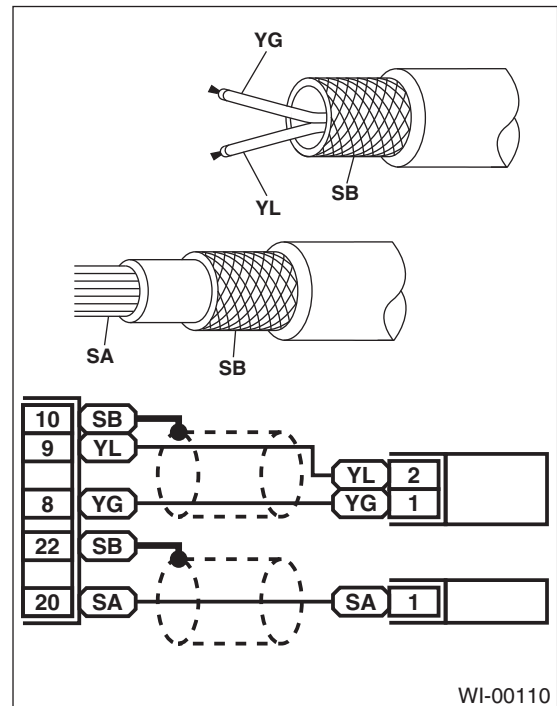

- The wire color code, which consists of two letters (or three letters including Br or Lg), indicates the standard color (base color of the wire covering) by its first letter and the stripe marking by its second letter.

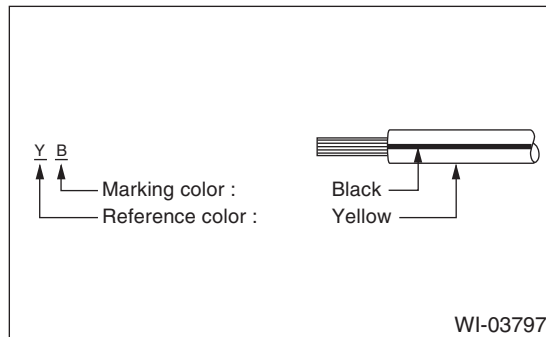

- The table lists the nominal sectional areas and allowable currents of the wires.

CAUTION:

When replacing or repairing a wire, be sure to use the same size and type of the wire which was originally used.

NOTE:

- The allowable current in the table indicates the tolerable amperage of each wire at an ambient temperature of 40°C (104°F).
- The allowable current changes with ambient temperature. Also, it changes if a bundle of more than two wires is used.

Nominal sectional area mm ²	No. of strands/ strand diameter	Outside diameter of wiring mm	Allowable current Amps/ 40°C (104°F)
0.3	7/0.26	1.8	7
0.5	7/0.32	2.2 (or 2.0)	12
0.75	30/0.18	2.6 (or 2.4)	16
0.85	11/0.32	2.4 (or 2.2)	16
1.25	16/0.32	2.7 (or 2.5)	21
2	26/0.32	3.1 (or 2.9)	28
3	41/0.32	3.8 (or 3.6)	38
5	65/0.32	4.6 (or 4.4)	51
8	50/0.45	5.5	67

- Each unit is either directly grounded to the body or indirectly grounds through a harness ground terminal. Different symbols are used in the wiring diagram to identify the two grounding systems.

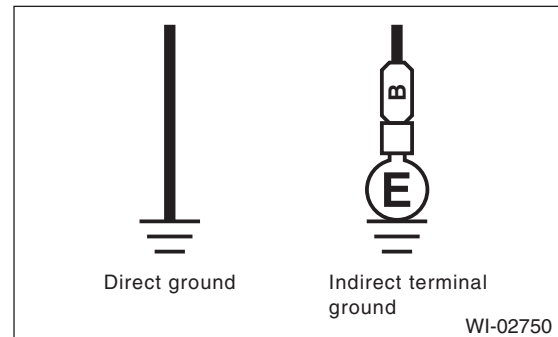

- The ground points shown in the wiring diagram refer to the following:

NOTE:

All wiring harnesses are provided with a ground point which must be securely connected.

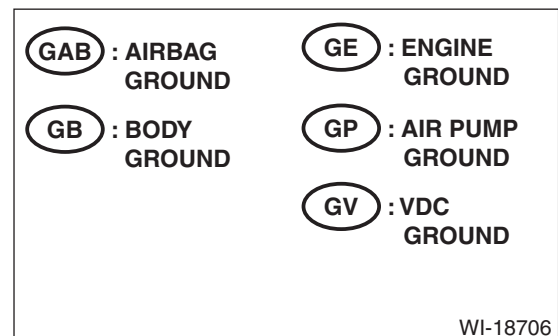

Basic Diagnostic Procedure

WIRING SYSTEM

- Relays are classified as normally-open or normally-closed.
- The normally-closed relay has one or more contacts. The wiring diagram shows the relay mode when the energizing circuit is OFF.

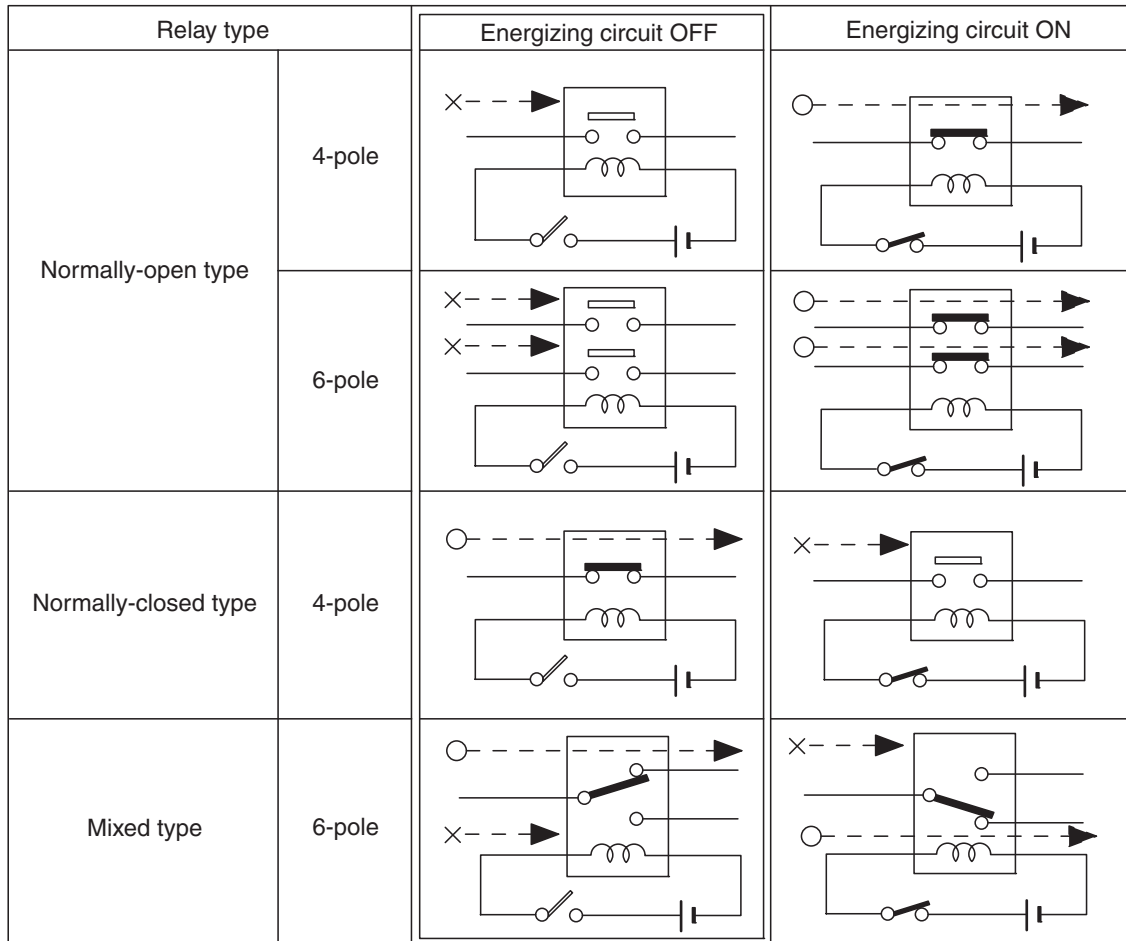

Key to symbols:

○ —▶ : Current flows.

× —▶ : Current does not flow.

WI-16724

- Each connector number shown in the wiring diagram corresponds to that in the wiring harness. The location of each connector in the actual vehicle is determined by reading the first character of the connector (for example, a "F" for F8, "i" for i16, etc.) and the type of wiring harness. The first character of each connector number corresponds to the area or system of the vehicle.

Symbol	Wiring harness and cord
F	Front wiring harness, Generator cord
B	Bulkhead wiring harness
E	Engine wiring harness
T	Transmission cord, Rear oxygen sensor cord
D	Front door cord LH & RH, Rear gate cord Rear door cord LH & RH, Rear defogger cord
i	Instrument panel wiring harness
R	Rear wiring harness LH&RH, Fuel tank cord, Roof cord, Rear gate cord
AB	Airbag wiring harness

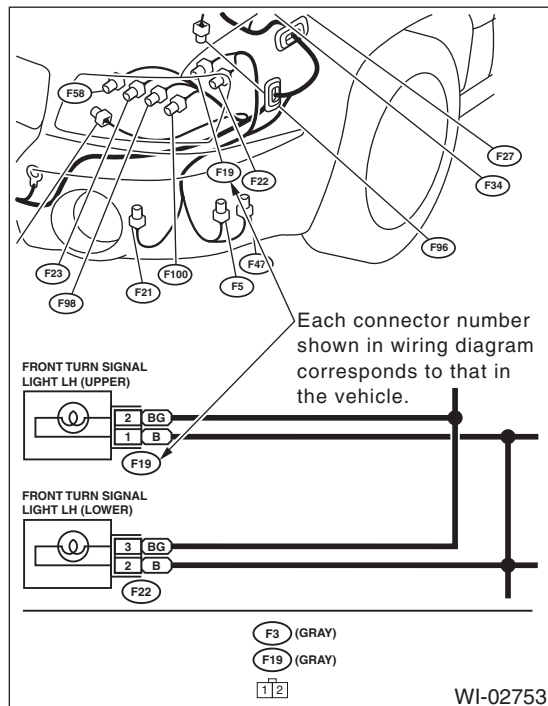

Basic Diagnostic Procedure

WIRING SYSTEM

D: SYMBOLS IN WIRING DIAGRAMS

A number of symbols are used in each wiring diagram to easily identify parts or circuits.

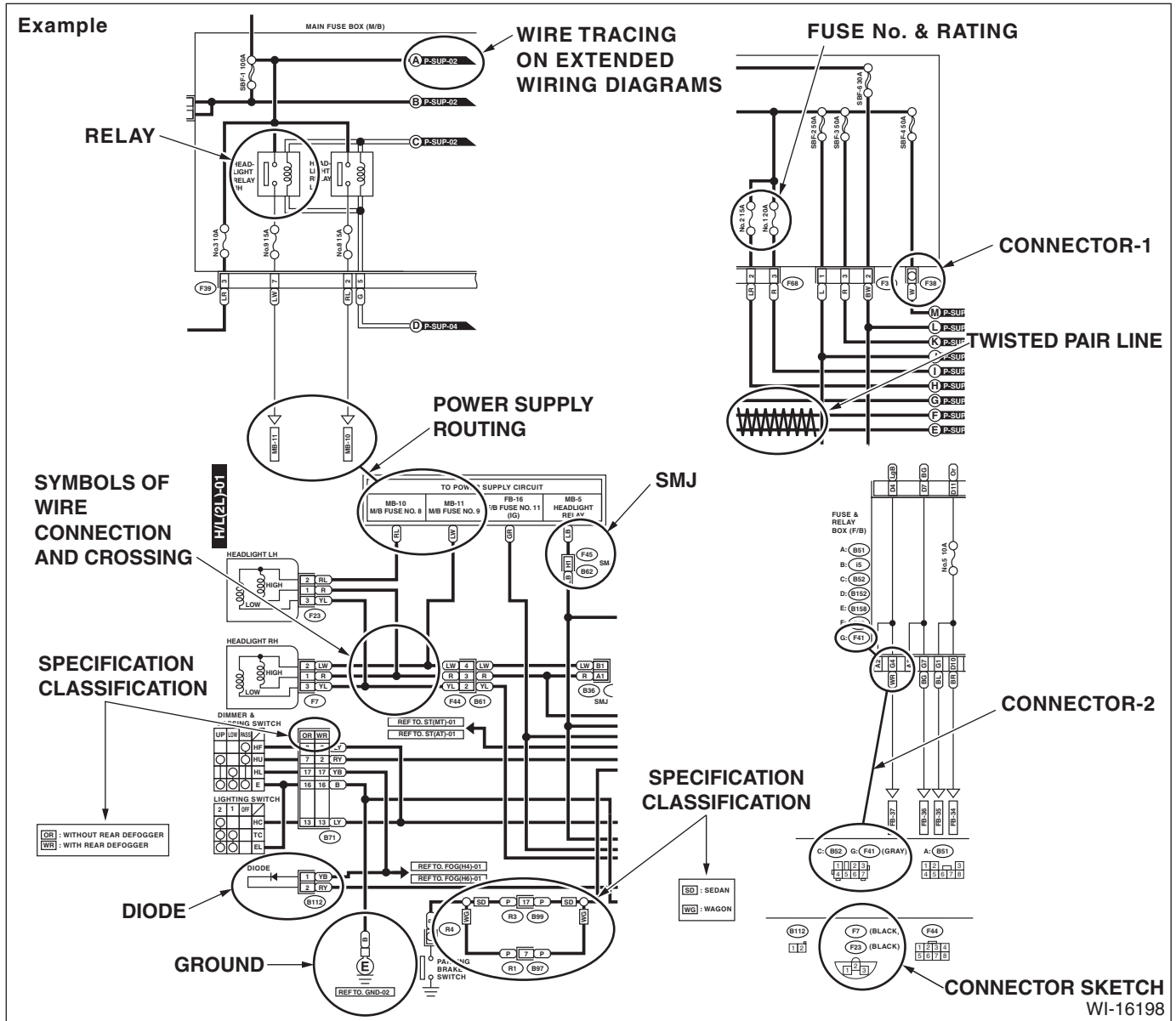

1. RELAY

A symbol used to indicate a relay.

2. CONNECTOR 1

The sketch of the connector indicates the one-pole types.

3. WIRING CONNECTION

Some wiring diagrams are indicated in foldouts for convenience. Wiring destinations are indicated where necessary by corresponding symbols. (When two pages are needed for clear indication)

4. FUSE NO. & RATING

The "FUSE No. & RATING" corresponds with that used in the fuse box (main fuse box, fuse and joint box).

5. CONNECTOR 2

- Each connector is indicated by a symbol.
- Each terminal number is indicated in the corresponding wiring diagram in an abbreviated form.
- For example, terminal number "G4" refers to No. 4 terminal of connector (G: F41) shown in the connector sketch.

6. CONNECTOR SKETCH

- Each connector sketch clearly identifies the shape and color of a connector as well as terminal locations. Non-colored connectors are indicated in natural color.
- When more than two types of connector number are indicated in a connector sketch, it means that the same type connectors are used.

7. GROUND

Each grounding point can be located easily by referring to the corresponding wiring harness.

8. DIODE

A symbol is used to indicate a diode.

9. WIRE TRACING ON EXTENDED WIRING DIAGRAMS

For a wiring diagram extending over at least two pages, a symbol (consisting of the same characters with arrows), facilitates wire tracing from one page to the next.

A ↔ A, B ↔ B

10. SYMBOLS OF WIRE CONNECTION AND CROSSING

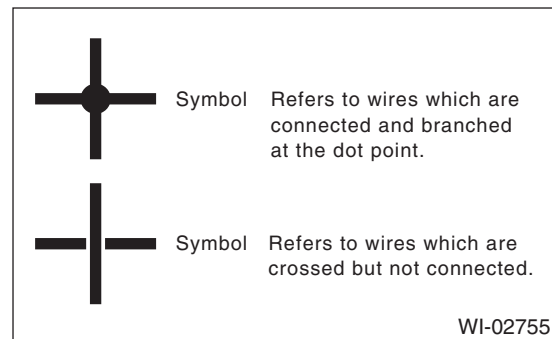

11. POWER SUPPLY CIRCUIT

A symbol is used to indicate the power supply in each wiring diagram.

"MB – 5", "MB – 6", etc., which are used as power-supply symbols throughout the text, correspond with those shown in the "DC POWER SUPPLY CIRCUIT" in the wiring diagram.

Accordingly, using the "DC POWER SUPPLY CIRCUIT" and wiring diagrams permits service personnel to understand the entire electrical arrangement of a system.

12. CLASSIFICATION BY SPECIFICATION

When the wiring diagram differ according to vehicle specifications, the specification difference is described by using abbreviations.

13. TWISTED PAIR LINE

The twisted pair line is indicated by a symbol in the wiring diagrams.

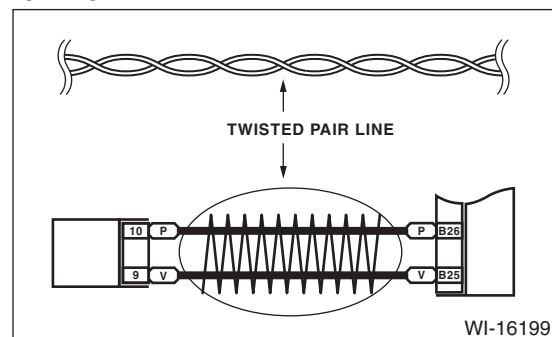











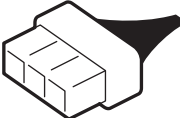



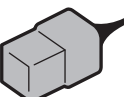

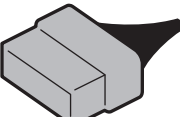





Basic Diagnostic Procedure

WIRING SYSTEM

E: CONNECTOR SYMBOL IN WIRING HARNESS

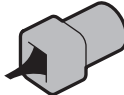
A number of connector symbols are used in each wiring diagram to easily identify the wiring harness connectors.

Standard type: Female		
Pole: From 1 to 8	Pole: From 9 to 20	Pole: More than 21
		
		
Standard type: Male		
		
		
Water proof type: Female		
Pole: From 1 to 8	Pole: From 9 to 20	Pole: More than 21
		
		
Water proof type: Male		
		
		

WI-02756

F: ABBREVIATION IN WIRING DIAGRAMS

Abbr.	Full name
ABS	Anti-lock Brake System
ACC	Accessory
A/C	Air Conditioner
ASSY	Assembly
AT	Automatic Transmission
A/F	Air/Fuel (Air fuel ratio sensor)
ATF	Automatic Transmission Fluid
AUX	Audio external input terminal
AWD	All Wheel Drive
B	Battery
CAN	Controller Area Network
CM	Control module
D	Drive range
DN	Down
E	Ground
ECM	Engine Control Module
EEPROM	Electric Erasable Programmable Read Only Memory
EGR	Exhaust Gas Recirculation
F/B	Fuse & Relay Box
FL	Front Left Hand
FR	Front Right Hand
FWD	Front Wheel Drive
G	Gravity (G sensor)
H/L	Headlight
HI	High
I/F	Interface
IG	Ignition
ILL	Illumination
INT	Intermittent
LCD	Liquid Crystal Display
LH	Left Hand
LO	Low
M	Motor
M/B	Main Fuse Box
MT	Manual Transmission
N	Neutral Range
NA	Natural Aspiration
OP	Open
P	Parking Range
PASS	Passing
PCV	Positive crankcase ventilation valve
R	Reverse range or rear
RH	Right Hand
RL	Rear Left
RR	Rear Right
SBF	Slow Blow Fuse
ST	Starter

Abbr.	Full name
TCM	Transmission Control Module
TPM	Tire Pressure Monitor
U	Up
VDC	Vehicle Dynamics Control
VFD	Vacuum Fluorescent Display
WASH	Washer

Working Precautions

WIRING SYSTEM

2. Working Precautions

A: PRECAUTIONS WHEN WORKING WITH THE PARTS MOUNTED ON THE VEHICLE

- 1) When working under a vehicle which is jacked-up, always be sure to use rigid rack.
- 2) The parking brake must always be applied during working. Also, in automatic transmission vehicles, keep the select lever set to the P (Parking) range.
- 3) Be sure the workshop is properly ventilated when running the engine. Further, be careful not to touch the belt or fan while the engine is operating.
- 4) Be careful not to touch hot metal parts, especially the radiator and exhaust system immediately after the engine has been turned off.

B: PRECAUTIONS IN TROUBLE DIAGNOSIS AND REPAIR OF ELECTRIC PARTS

- 1) The battery cable must be disconnected from the battery's (-) terminal, and the ignition switch must be set to the OFF position, unless otherwise required by the diagnostics.
- 2) Securely fasten the wiring harness with clamps and clips so that the harness does not interfere with the body end parts, edges, bolts or screws.
- 3) When installing parts, be careful not to catch them on the wiring harness.
- 4) When disconnecting a connector, do not pull the wires, but pull while holding the connector body.

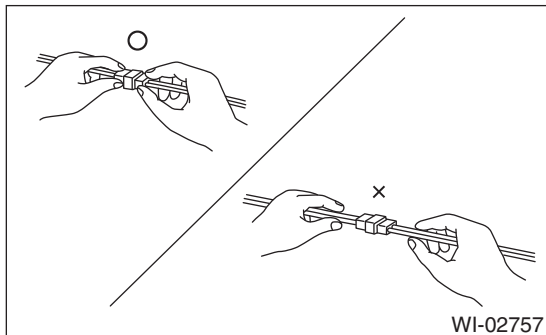

- 5) Some connectors are provided with a lock. One type of such a connector is disconnected by pushing the lock, and the other, by moving the lock up. In either type the lock shape must be identified before attempting to disconnect the connector. To connect, insert the connector until it snaps and confirm that it is connected securely.

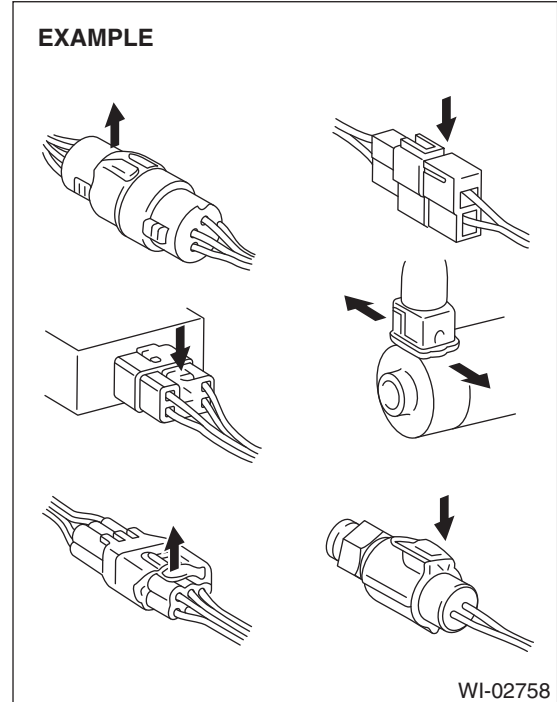

- 6) When checking continuity between connector terminals, or measuring voltage across the terminal and ground, always touch tester probe(s) to terminals from the wiring connection side. If the probe is too thick to gain access to the terminal, use "mini" test leads.

To check water-proof connectors (which are not measurable from the wiring side), touch test probes on the terminal side and be careful not to bend or damage the terminals.

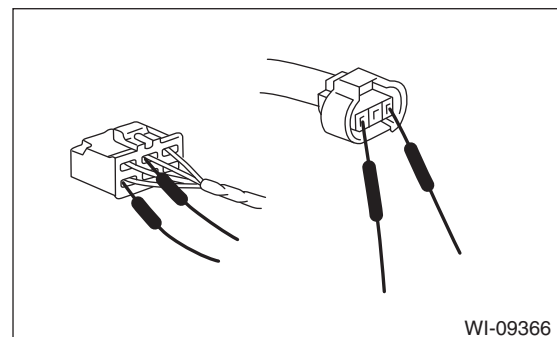

- 7) Sensors, relays, electrical unit, etc., are sensitive to strong impacts. Handle them with care so that they are not dropped or mishandled.

3. Power Supply Circuit

A: WIRING DIAGRAM

P-SUP-01

P-SUP-01

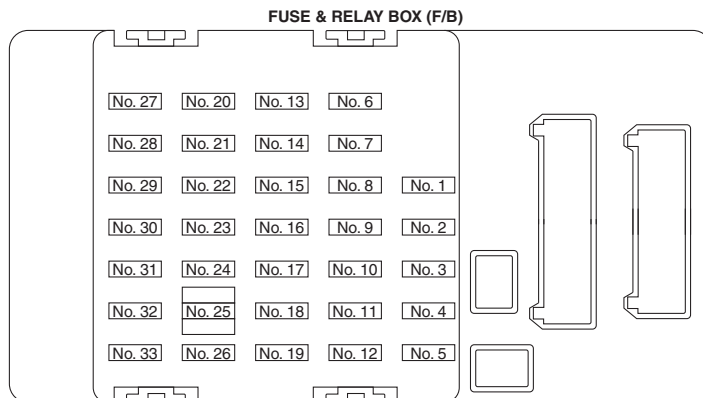
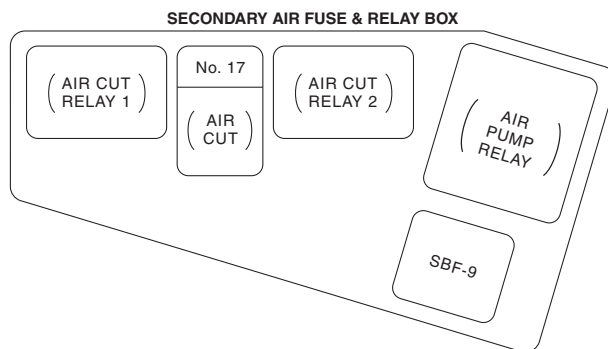
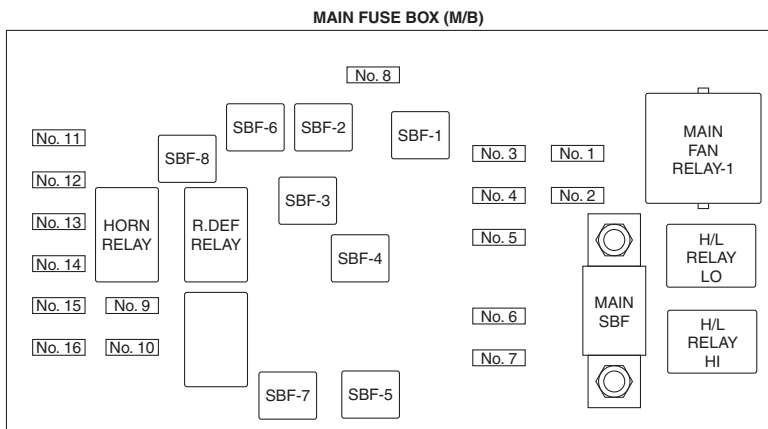

Power Supply Circuit

WIRING SYSTEM

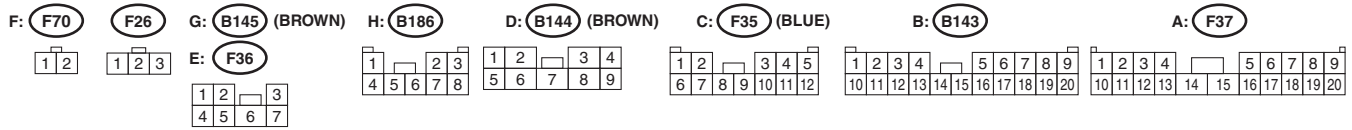
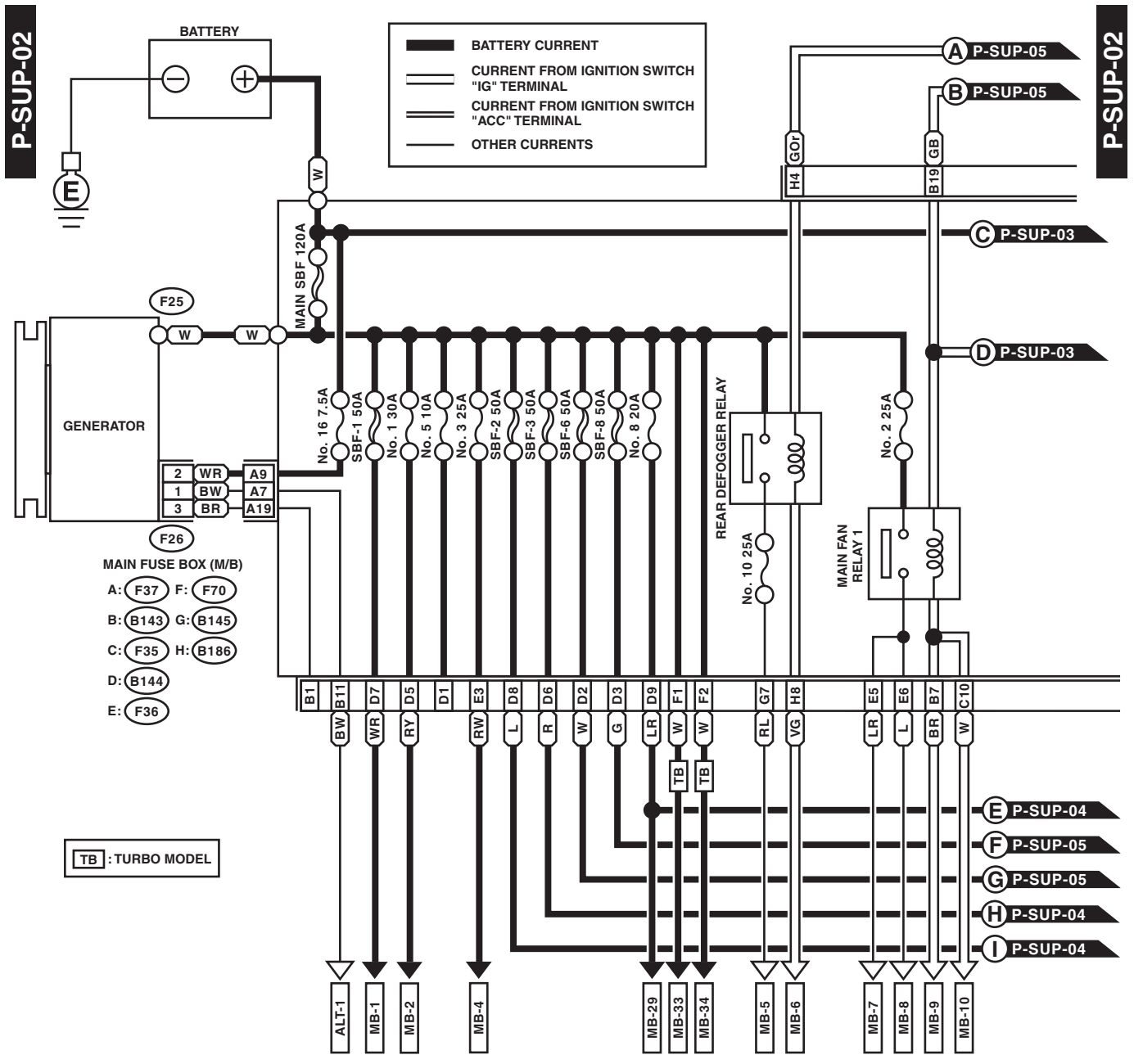

WI-19488

Power Supply Circuit

WIRING SYSTEM

P-SUP-03

P-SUP-03

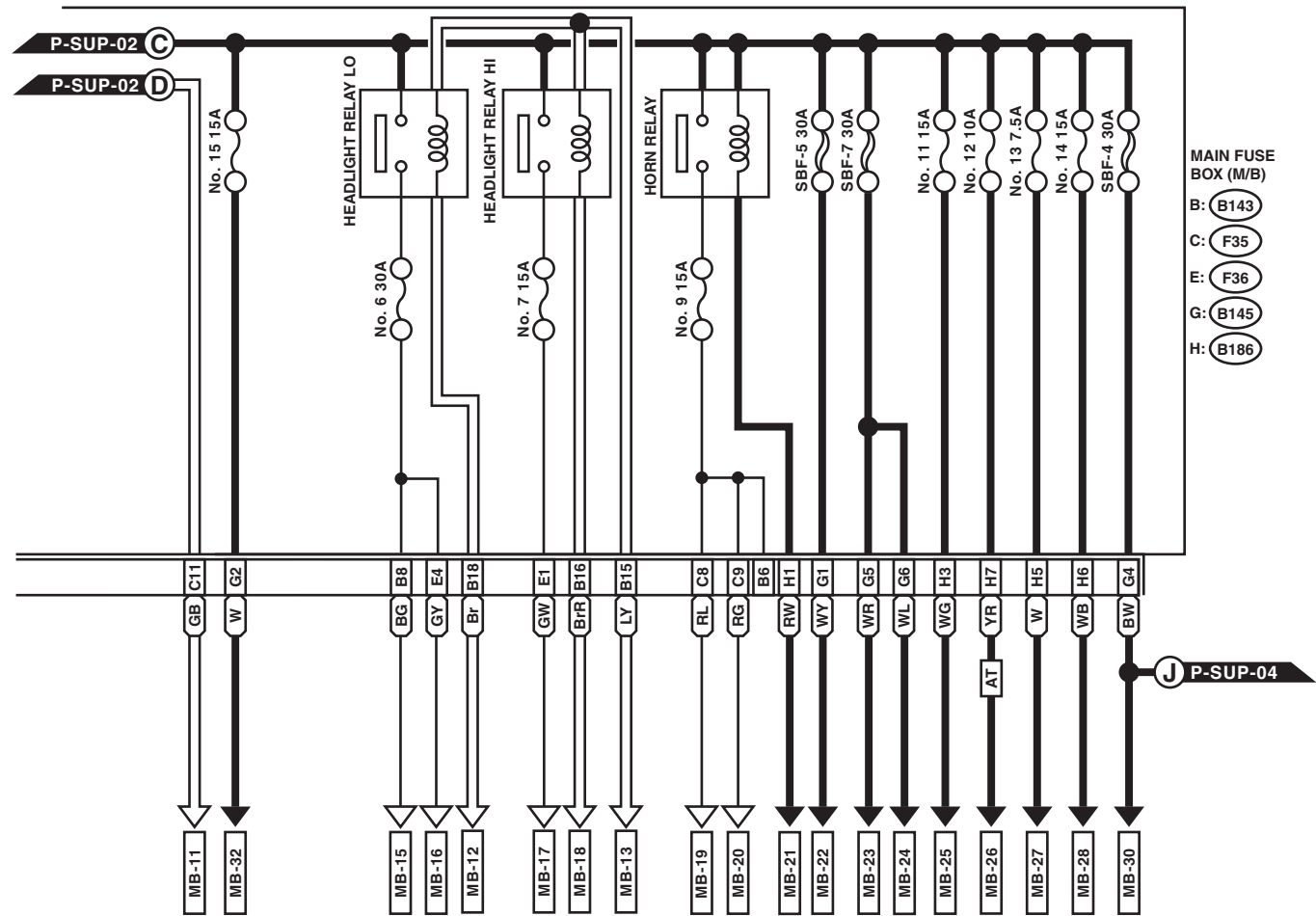

G: (B145) (BROWN)

H: (B186)

C: (F35) (BLUE)

B: (B143)

E: (F36)

1	2	3
4	5	6
7		

1		2	3
4	5	6	7
8			

1	2		3	4	5
6	7	8	9	10	11
12					

1	2	3	4		5	6	7	8	9
10	11	12	13	14	15	16	17	18	19
20									

WI-19657

Power Supply Circuit

WIRING SYSTEM

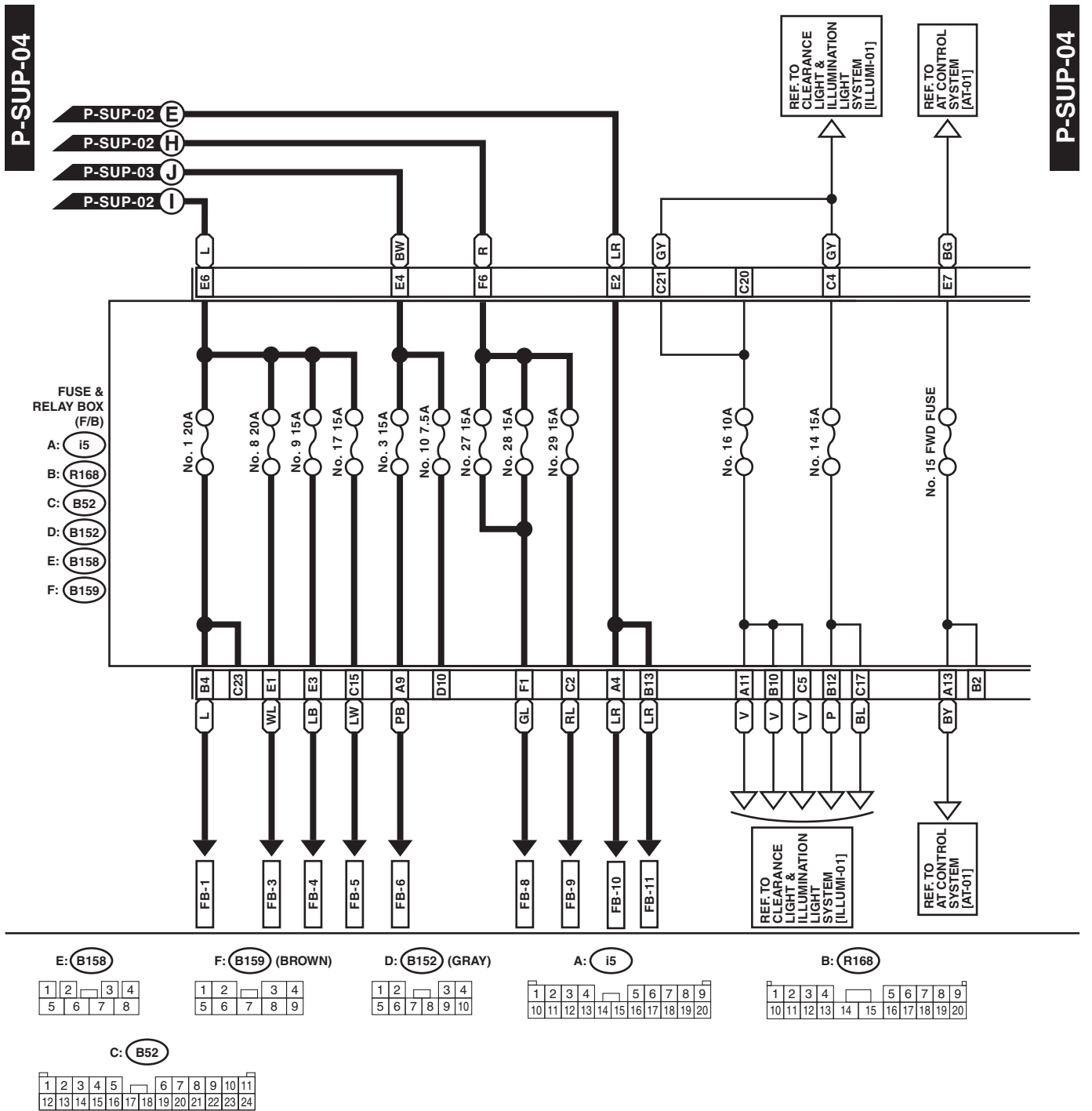

WI-19489

Power Supply Circuit

WIRING SYSTEM

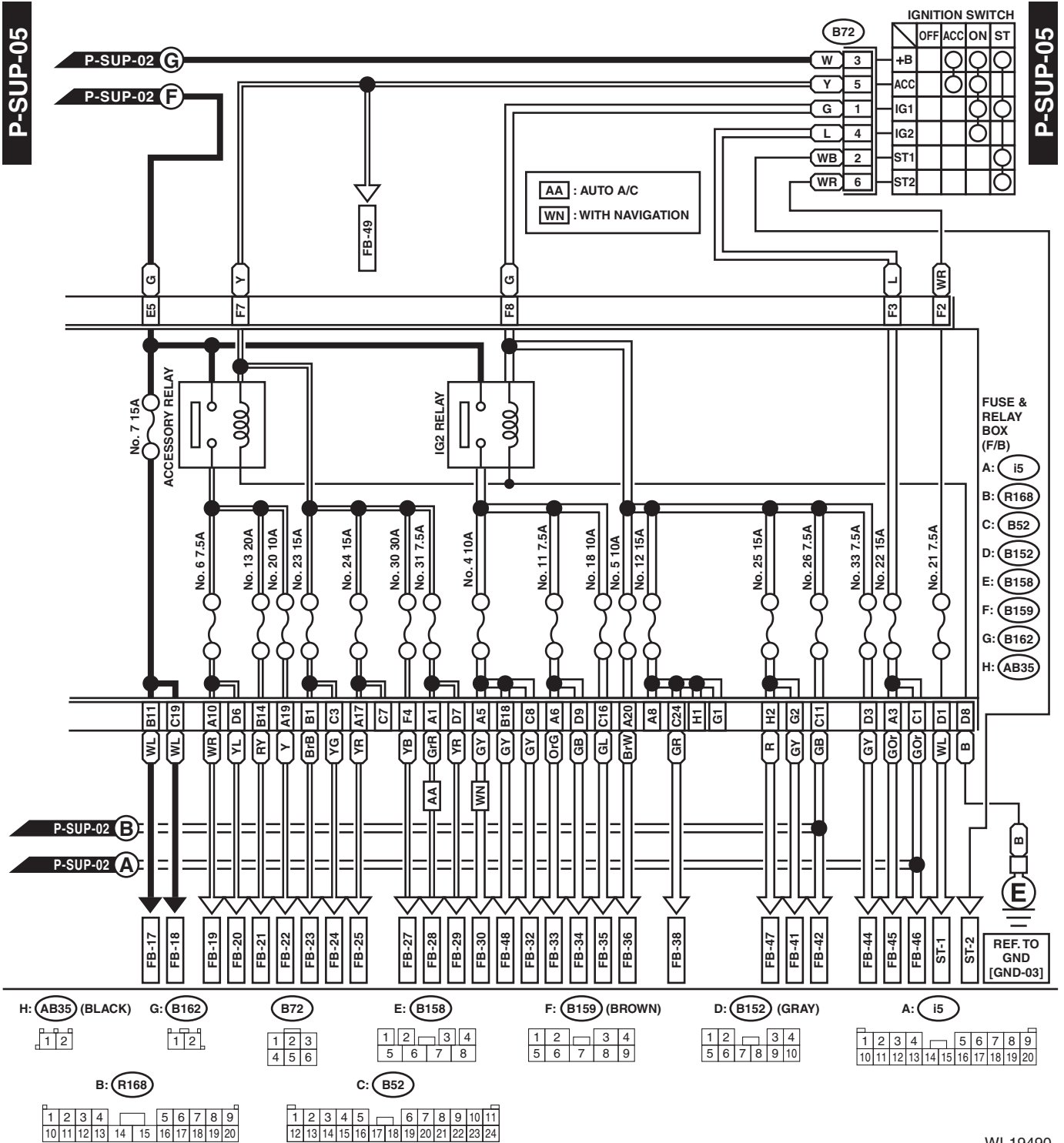

WI-19490

Power Supply Circuit

WIRING SYSTEM

No.	Load
MB-1	VDC CM
MB-2	VDC CM
MB-4	Sub fan relay
MB-5	Mirror heater LH
	Mirror heater RH
	Rear defogger
	A/C control panel
MB-6	Body integrated unit
MB-7	Main fan relay 2
MB-8	Main fan motor
MB-9	ECM
MB-10	Main fan relay 2
MB-11	Main fan relay 2
MB-12	Body integrated unit
MB-13	Body integrated unit
MB-15	Front fog light relay
MB-16	Head light LH
	Head light RH
MB-17	Daytime running light relay
MB-18	Body integrated unit
MB-19	Horn
MB-20	Horn
MB-21	Horn switch
	Body integrated unit
	Remote engine start CM
MB-22	A/F Oxygen sensor relay
MB-23	Main relay
	IG relay
	A/F Oxygen sensor relay
MB-24	Electronic throttle control relay
MB-25	Fuel pump relay
MB-26	TCM
MB-27	ECM
	Data link connector
MB-28	Key illumination
	Key warning switch
	Turn signal and hazard unit
	Body integrated unit
MB-29	Spot map light
	Room light
	Puddle light
	Body integrated unit
MB-30	Power window circuit breaker
MB-32	Tail and illumination relay
	Daytime running light relay
MB-33	Secondary air pump relay
MB-34	Secondary air combination valve relay 1
	Secondary air combination valve relay 2
ALT-1	Combination meter
ST-1	Starter relay

No.	Load
ST-2	Clutch start switch
	ECM
	Starter relay
FB-1	Trailer connector
FB-3	Stop light & brake switch
FB-4	Wiper deicer relay
FB-5	Seat heater relay
FB-6	Body integrated unit
FB-8	Blower motor relay
FB-9	Front fog light relay
FB-10	Audio
	Step light
	Clock
FB-11	Keyless entry CM
	Luggage room light
FB-17	A/C control pane (Auto A/C)
	Combination meter
	TPMS CM
FB-18	Body integrated unit
	Impact sensor
	Mode door actuator (Auto A/C)
	Air mix door actuator (Auto A/C)
FB-19	Remote control mirror switch
FB-20	Seat heater relay
	Compass mirror
FB-21	Rear accessory power supply socket
FB-22	Front accessory power supply socket
FB-23	Rear wiper motor
FB-24	Body integrated unit
	Rear washer motor
FB-25	Audio
	Clock
FB-27	Combination switch
	Front wiper motor
FB-28	A/C control pane (Auto A/C)
FB-29	Body integrated unit
FB-30	Navigation unit
FB-32	ECM
	Clutch switch (model with cruise control)
	Impact sensor
	Data link connector
	Stop light & brake switch
	Wiper deicer relay
FB-33	Clock
FB-34	Turn signal and hazard unit
FB-35	Inhibitor switch
	Auto headlight beam leveler CM
	Back-up light switch
FB-36	Combination meter

Power Supply Circuit

WIRING SYSTEM

No.	Load
FB-38	ECM
	TCM
	Body integrated unit
	Fuel pump relay
	Ignition coil No. 1 (turbo model)
	Ignition coil No. 2 (turbo model)
	Ignition coil No. 3 (turbo model)
	Ignition coil No. 4 (turbo model)
FB-41	Airbag CM
FB-42	Power window relay
FB-44	VDC CM
	Steering angle sensor
	Yaw rate & lateral G sensor
FB-45	A/C control panel
FB-46	A/C relay
	Intake door actuator
	Sub fan relay
	Pressure switch
	Blower motor relay
FB-47	Occupant detection control module
FB-48	TPMS CM
FB-49	Front washer motor

Ground Circuit

WIRING SYSTEM

4. Ground Circuit

A: WIRING DIAGRAM

1. BODY GROUND

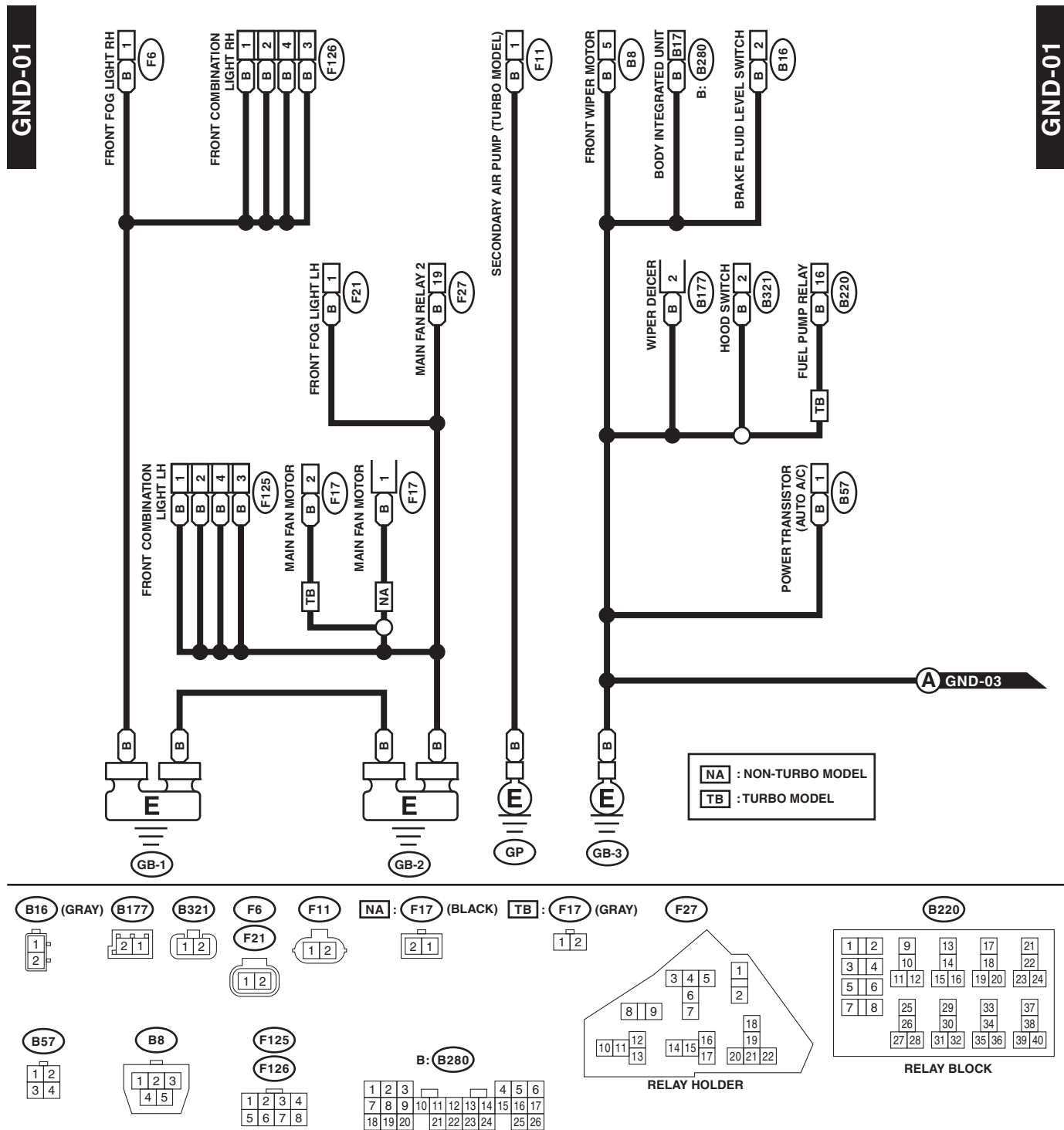

WI-19491

Ground Circuit

WIRING SYSTEM

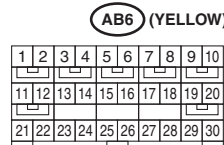
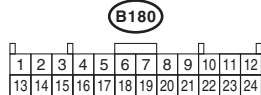
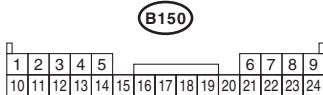
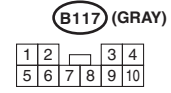
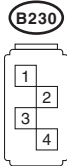
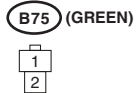
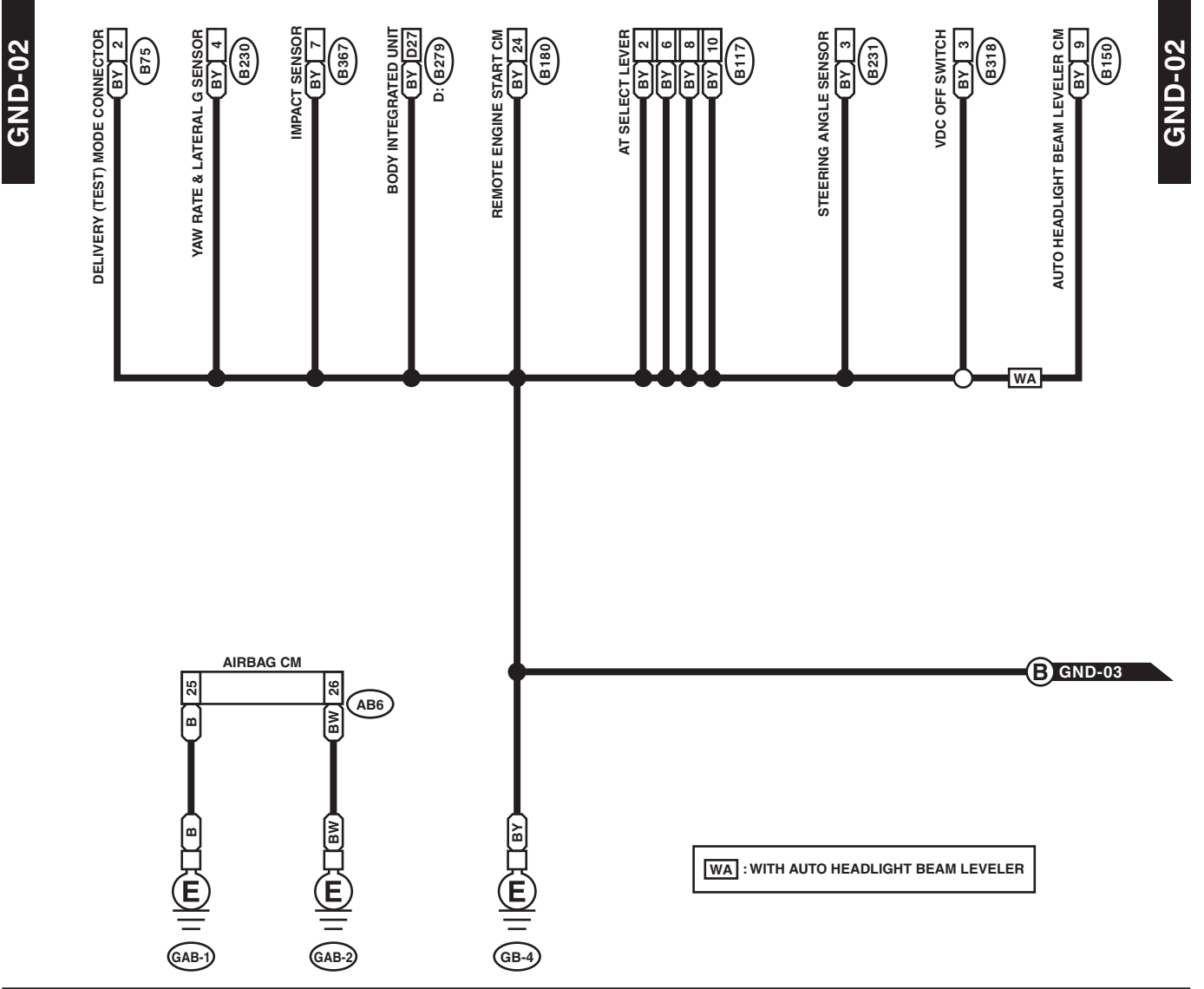

WI-19492

Ground Circuit

WIRING SYSTEM

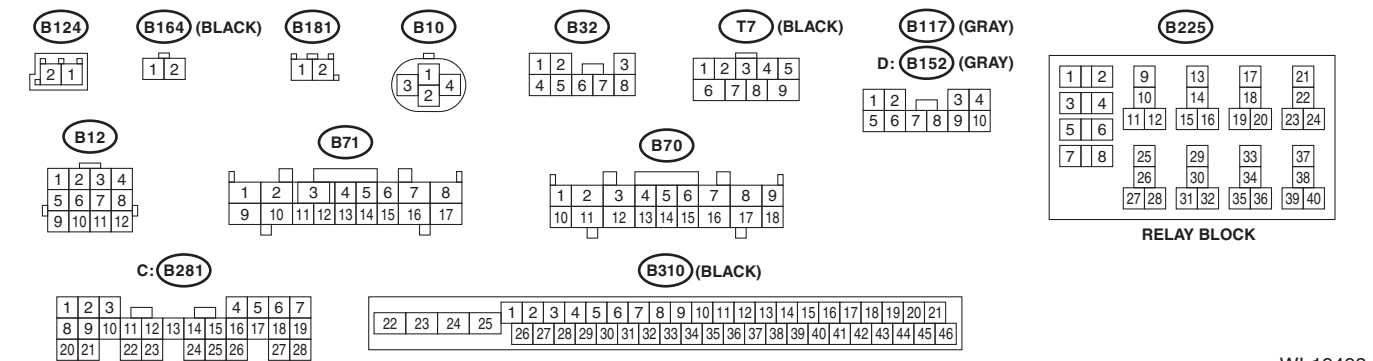
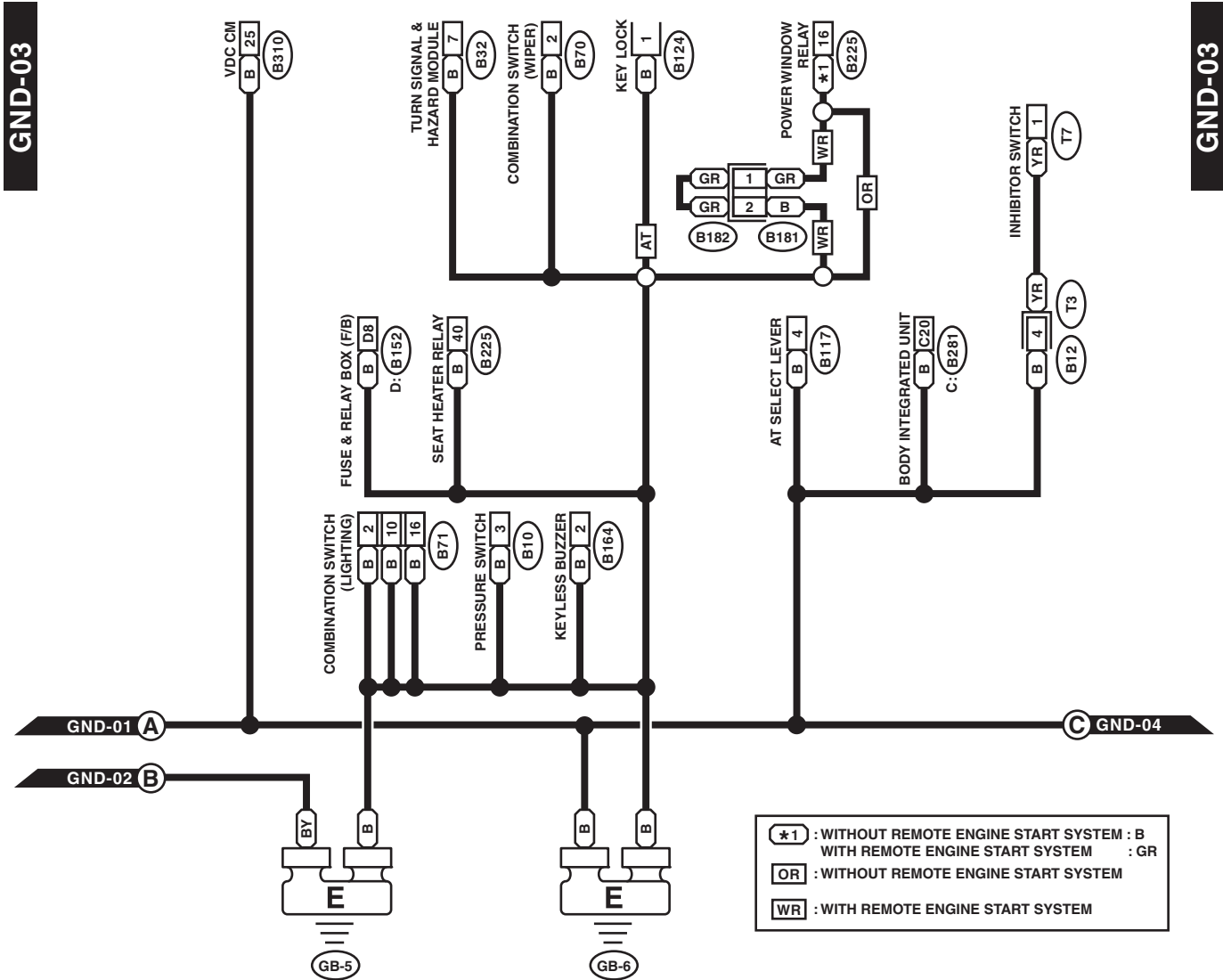

WI-19493

Ground Circuit

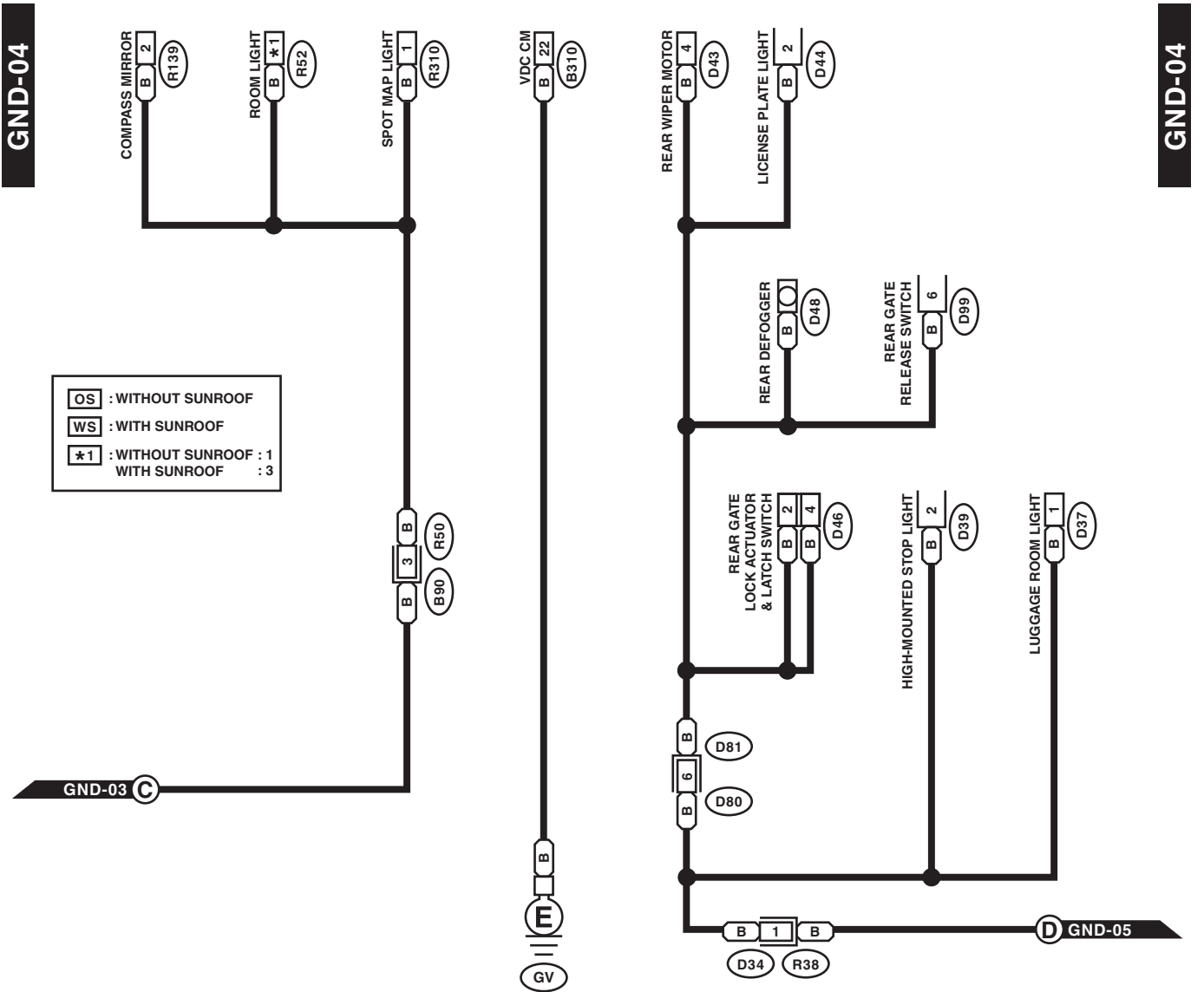

OS : WITHOUT SUNROOF
 WS : WITH SUNROOF
 *1 : WITHOUT SUNROOF : 1
 WITH SUNROOF : 3

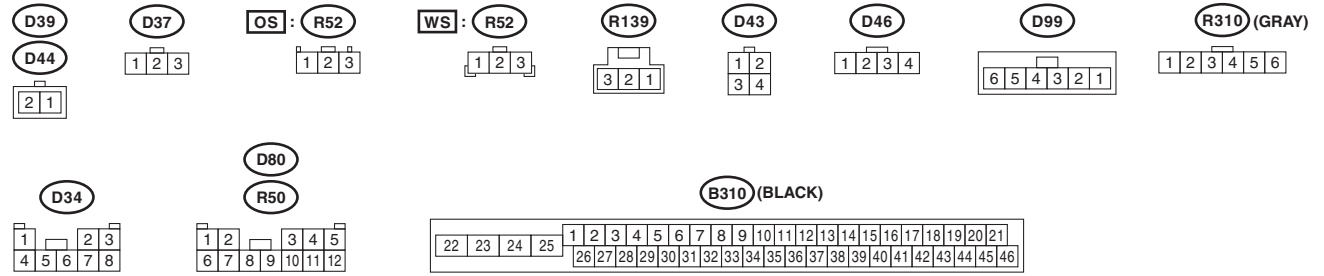

WI-19494

Ground Circuit

WIRING SYSTEM

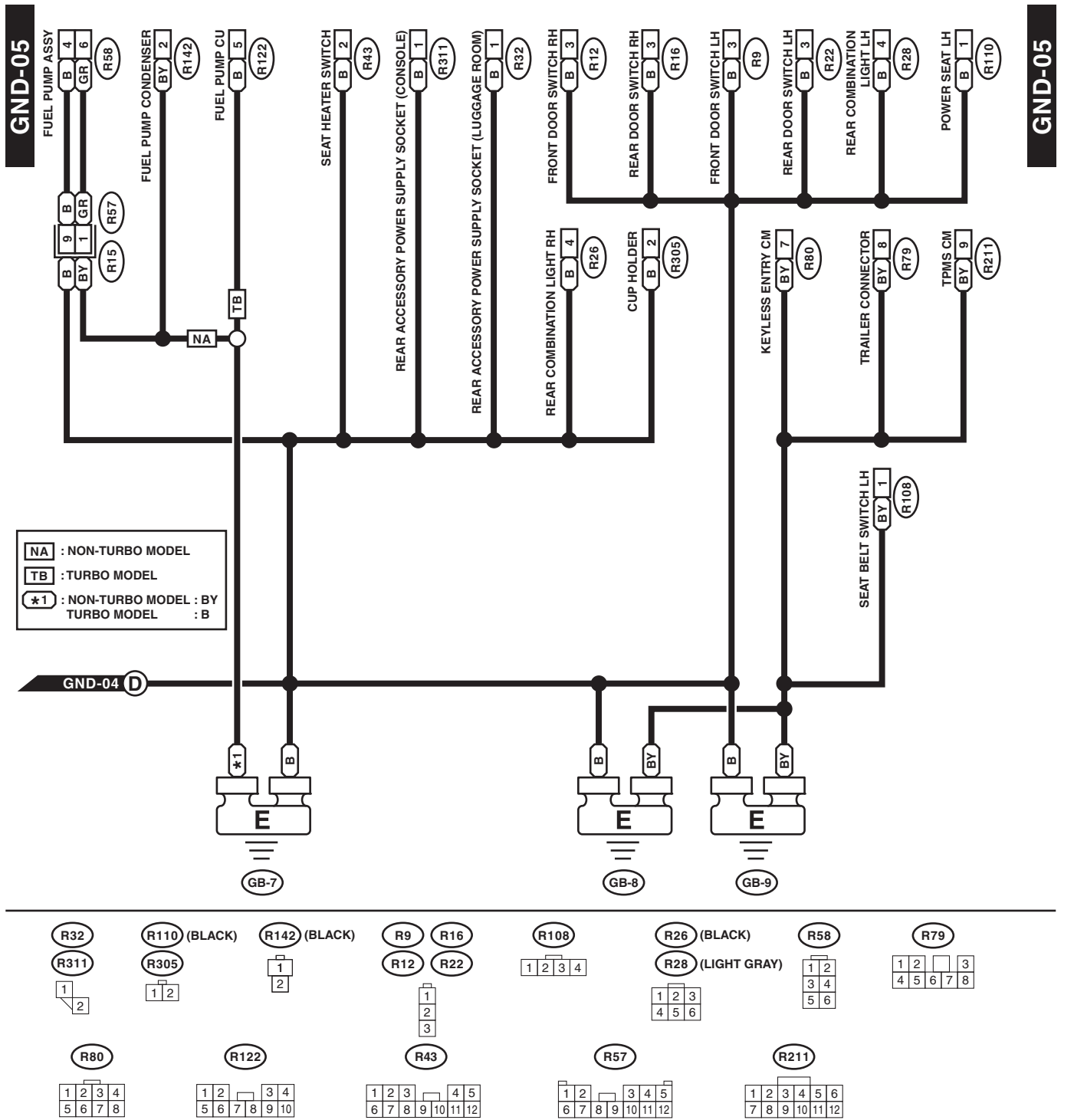

WI-19495

Ground Circuit

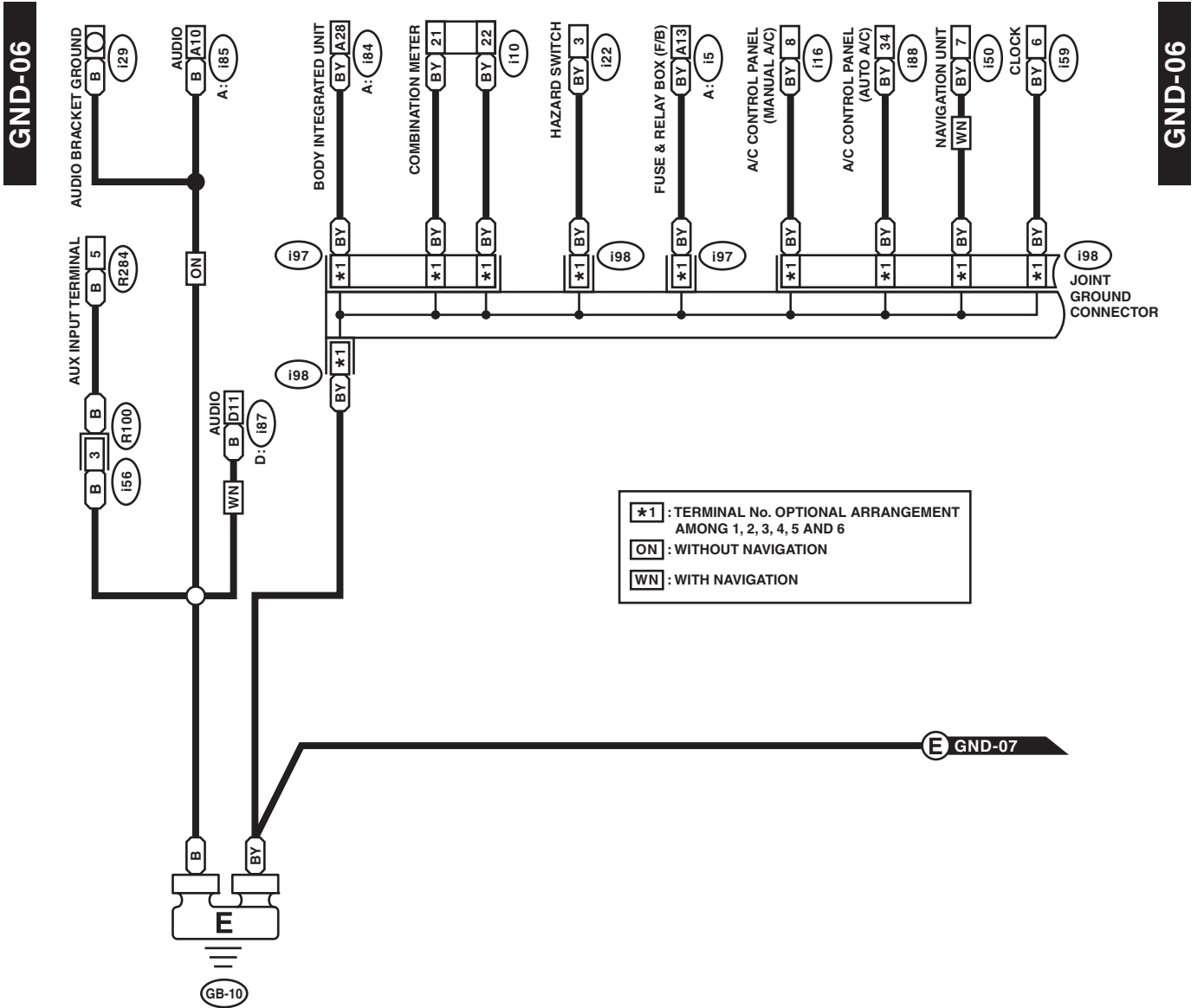

*1 : TERMINAL No. OPTIONAL ARRANGEMENT AMONG 1, 2, 3, 4, 5 AND 6
 ON : WITHOUT NAVIGATION
 WN : WITH NAVIGATION

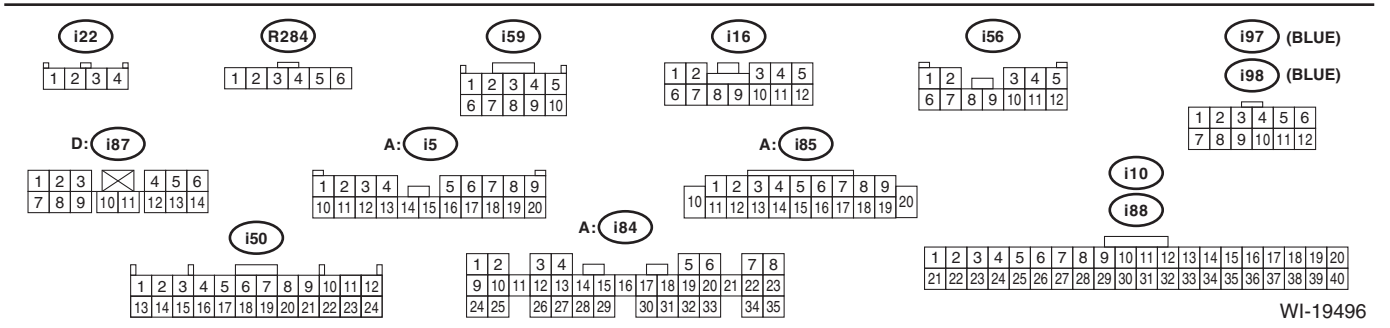

WI-19496

Ground Circuit

WIRING SYSTEM

GND-07

GND-07

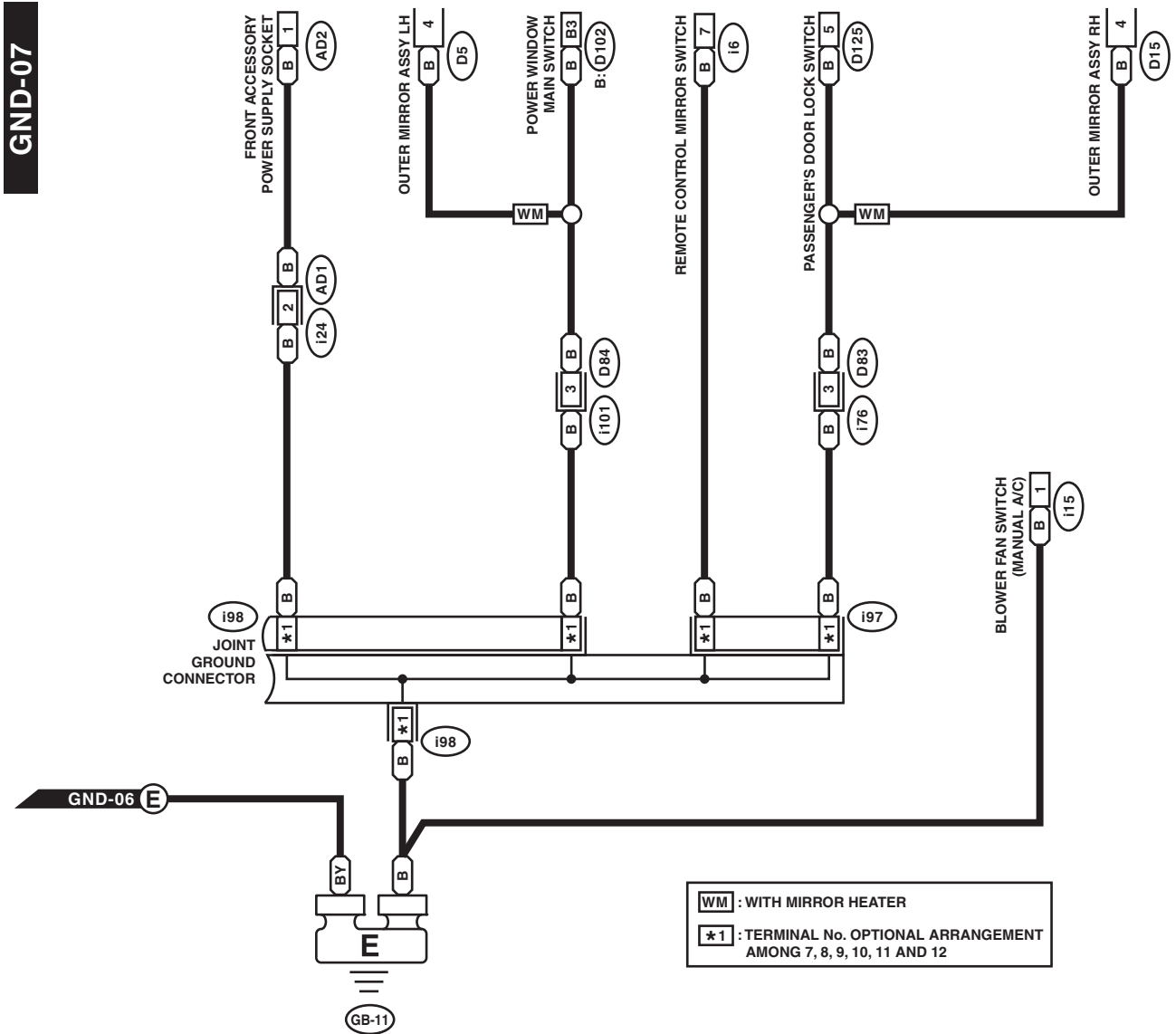

WM : WITH MIRROR HEATER
***1** : TERMINAL No. OPTIONAL ARRANGEMENT AMONG 7, 8, 9, 10, 11 AND 12

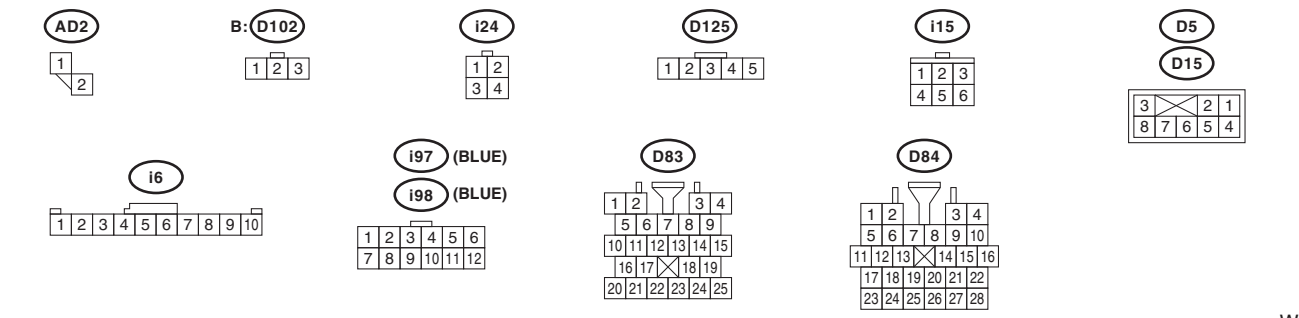

WI-19497

2. ENGINE GROUND (NON-TURBO MODEL)

GND-08

GND-08

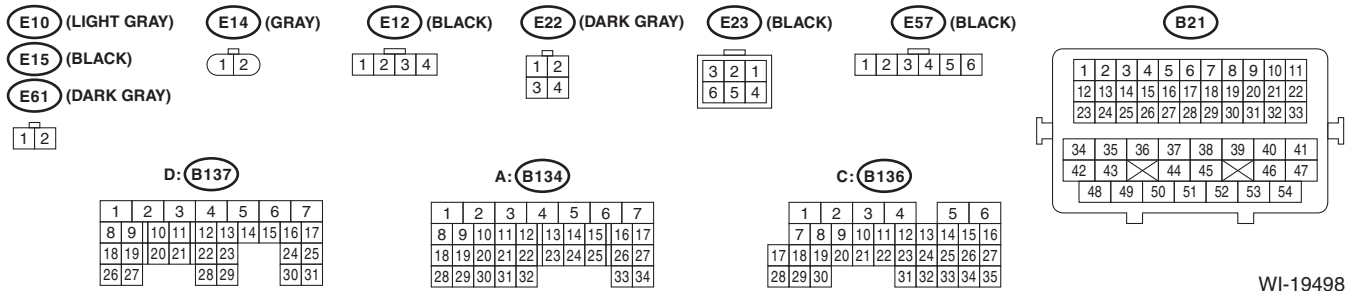
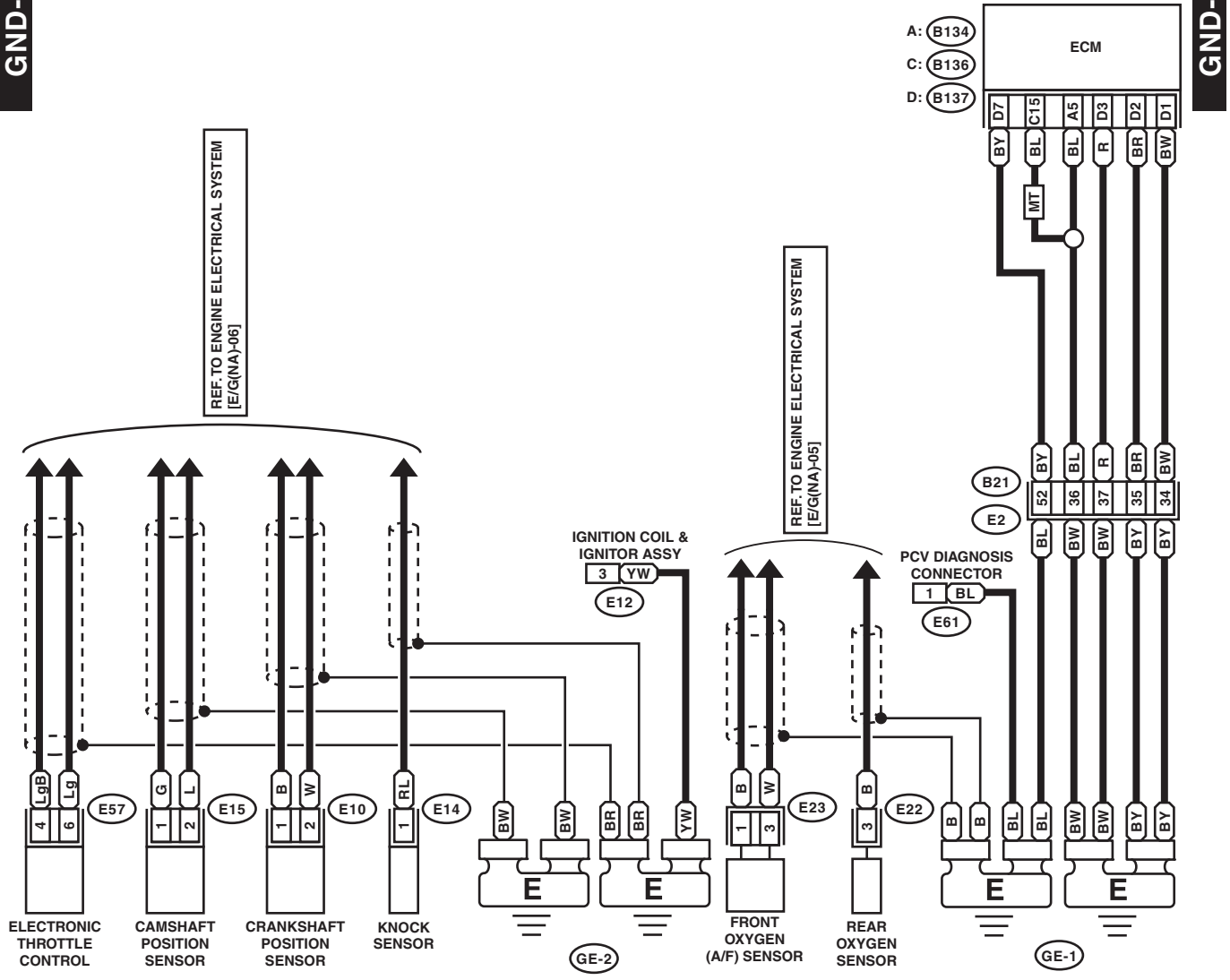

WI-19498

Ground Circuit

WIRING SYSTEM

3. ENGINE GROUND (TURBO MODEL)

GND-09

GND-09

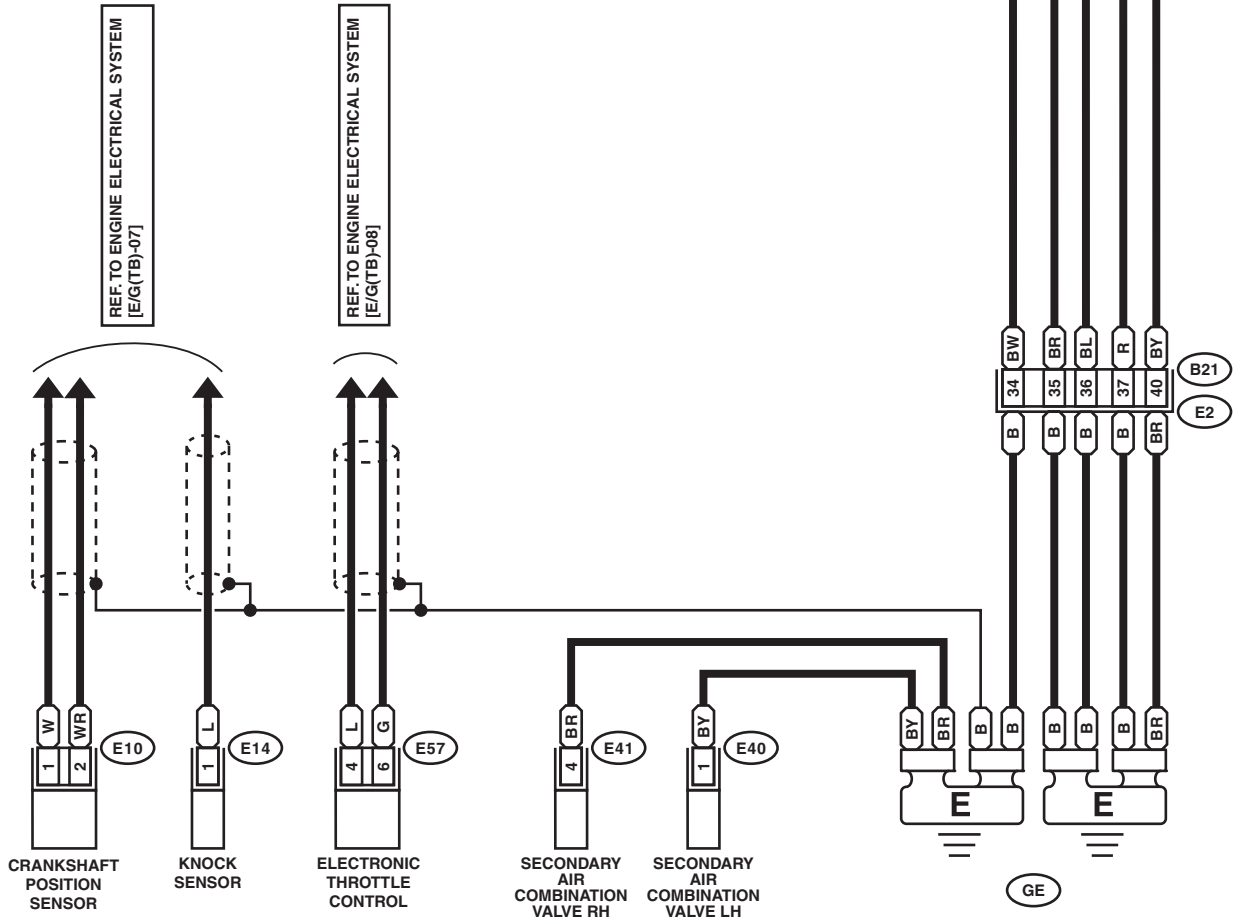

E10 (LIGHT GRAY)

E41 (BLACK)

E57 (BLACK)

D: B137

B21

E14 (LIGHT GRAY)

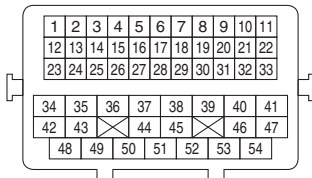
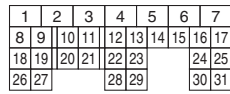
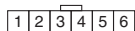

A: B134

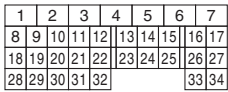

WI-19499

4. AT TRANSMISSION GROUND

GND-10

GND-10

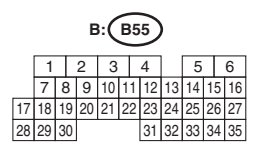
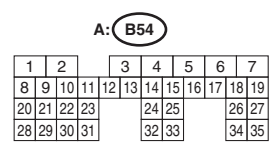
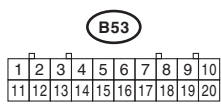
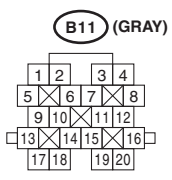
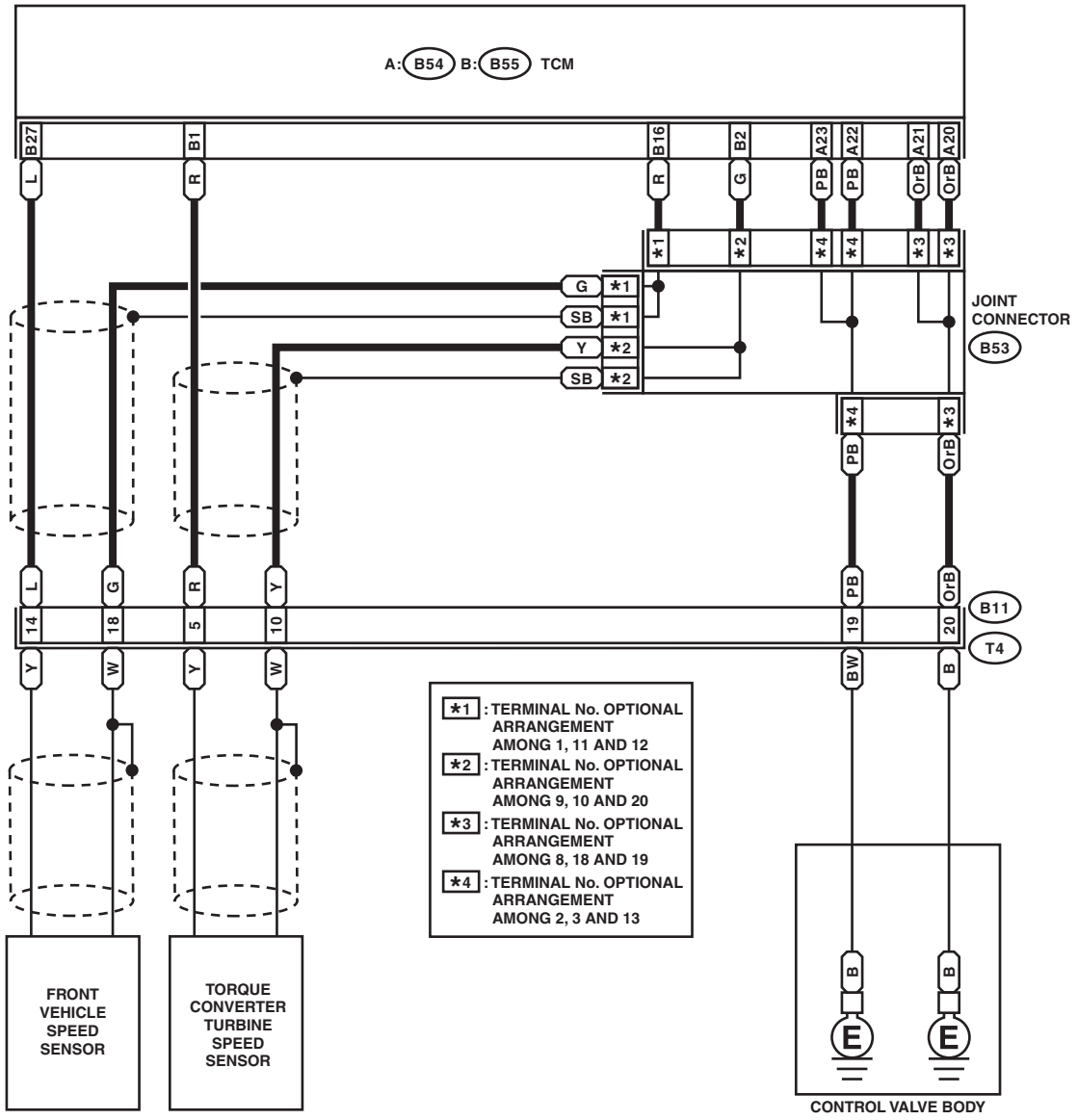

Engine Electrical System

WIRING SYSTEM

5. Engine Electrical System

A: WIRING DIAGRAM

1. NON-TURBO MODEL

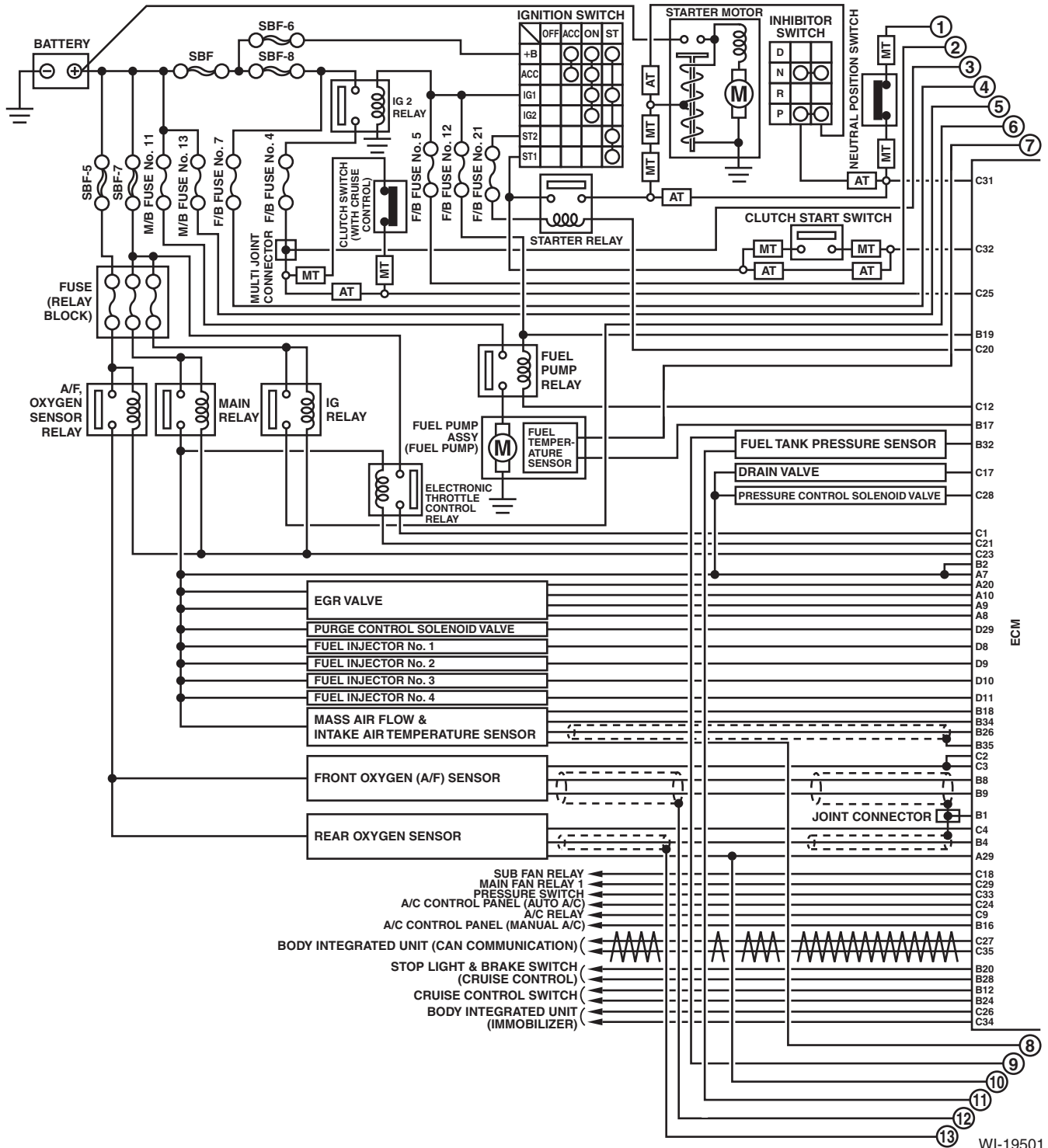

Engine Electrical System

WIRING SYSTEM

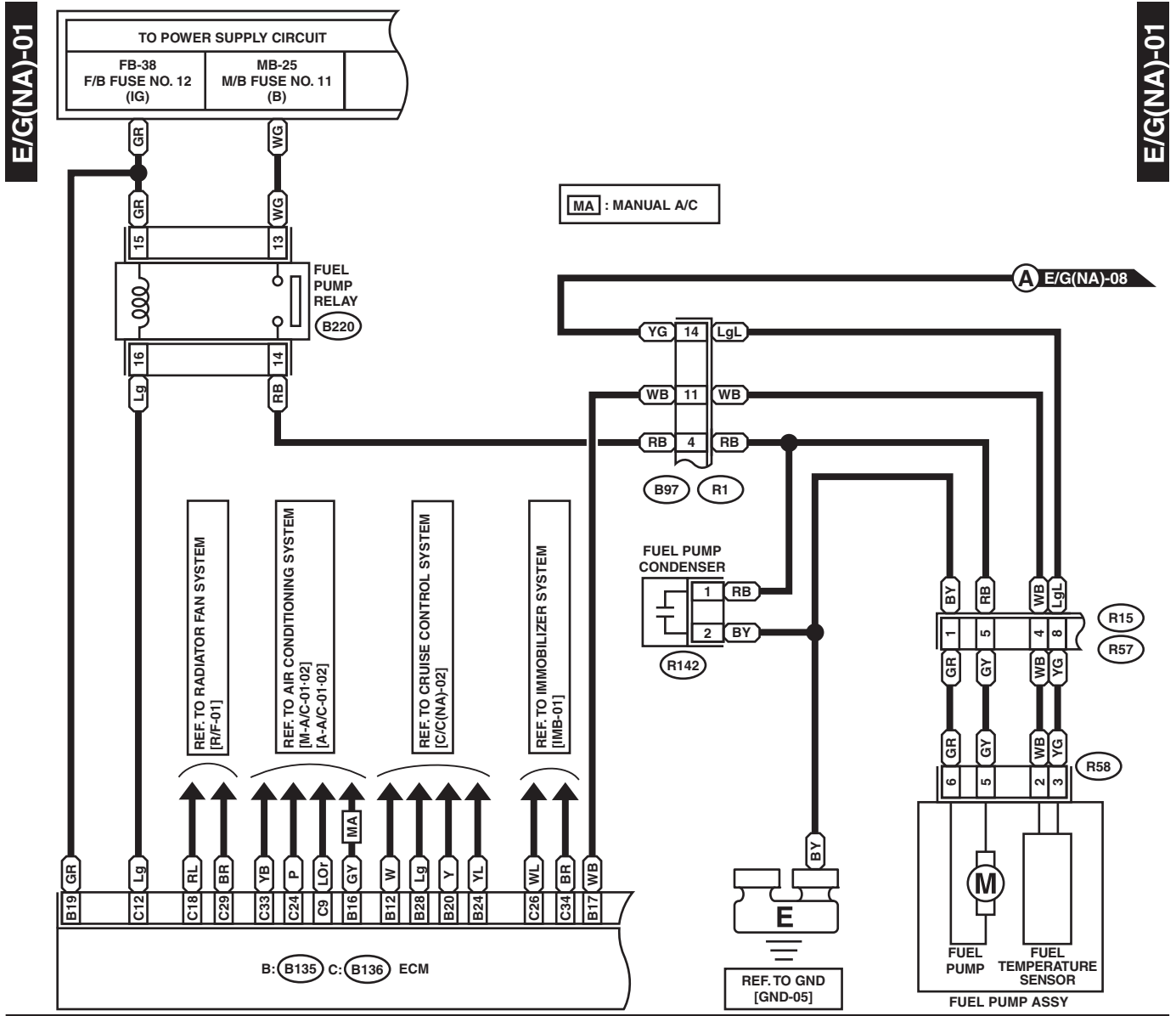

R142 (BLACK)



R58



R57

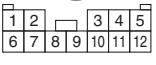

B97

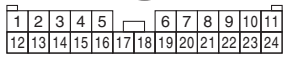

B: B135

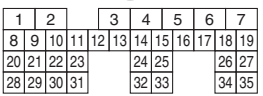

C: B136

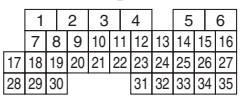

B220

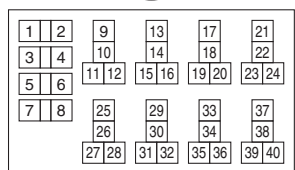

RELAY BLOCK

WI-19503

Engine Electrical System

WIRING SYSTEM

E/G(NA)-02

E/G(NA)-02

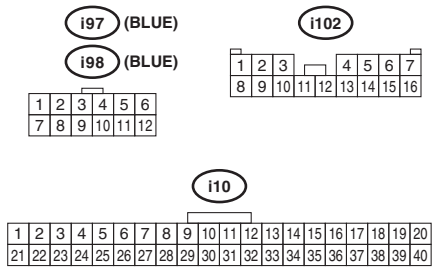
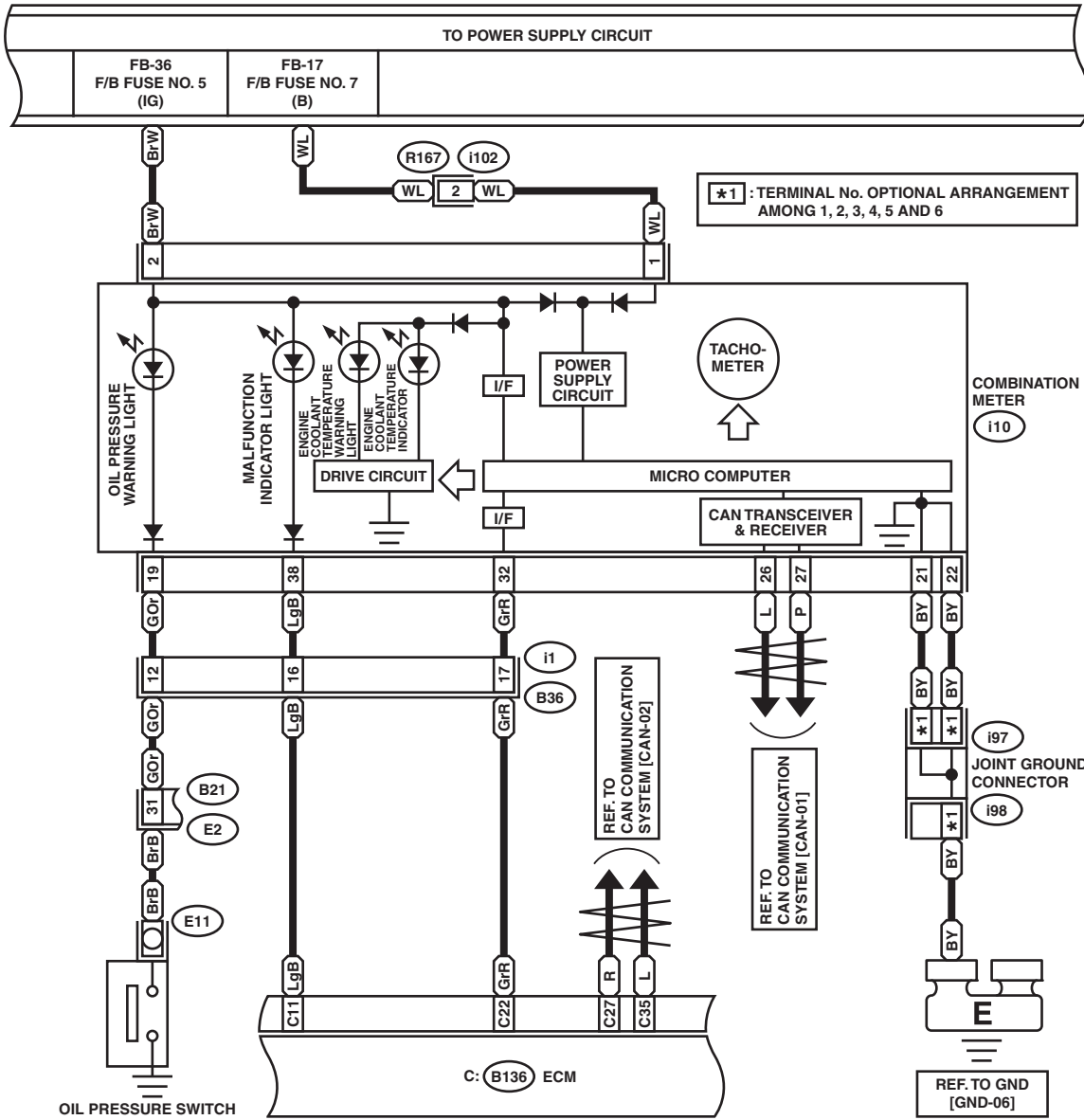

WI-19504

Engine Electrical System

WIRING SYSTEM

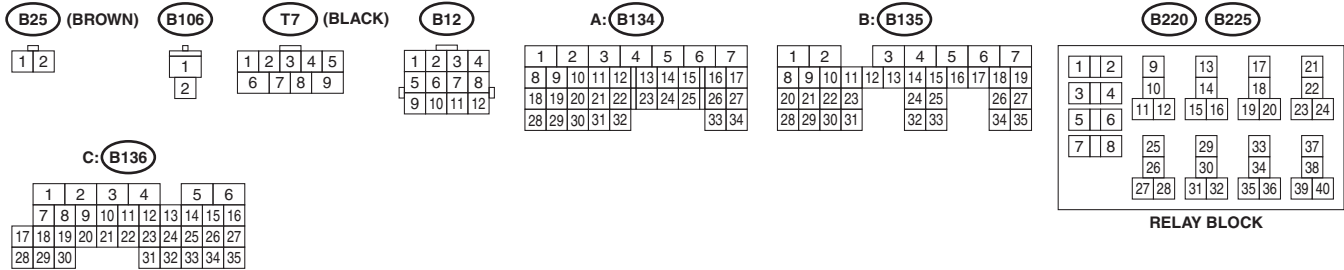
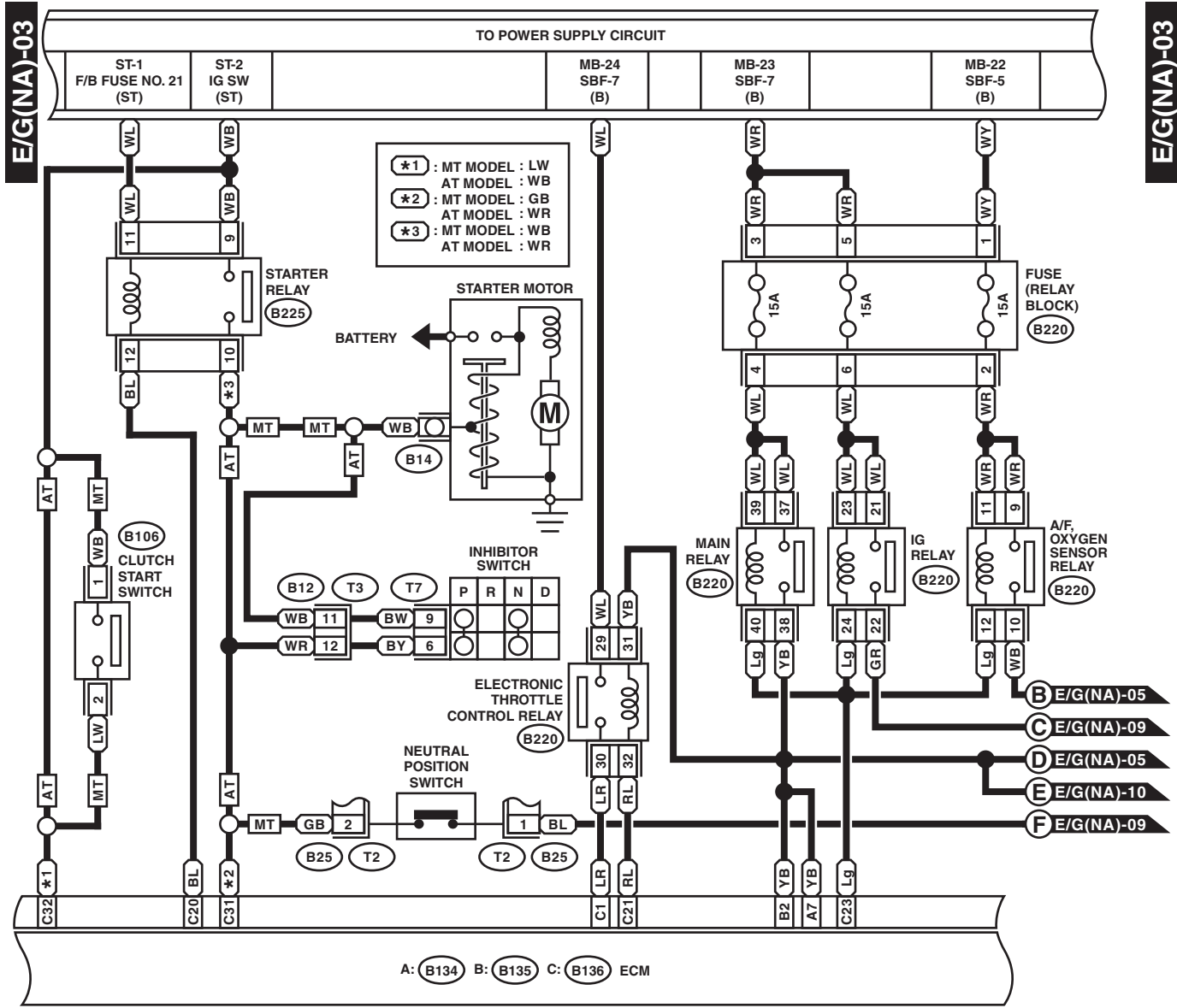

WI-19505

Engine Electrical System

WIRING SYSTEM

E/G(NA)-04

E/G(NA)-04

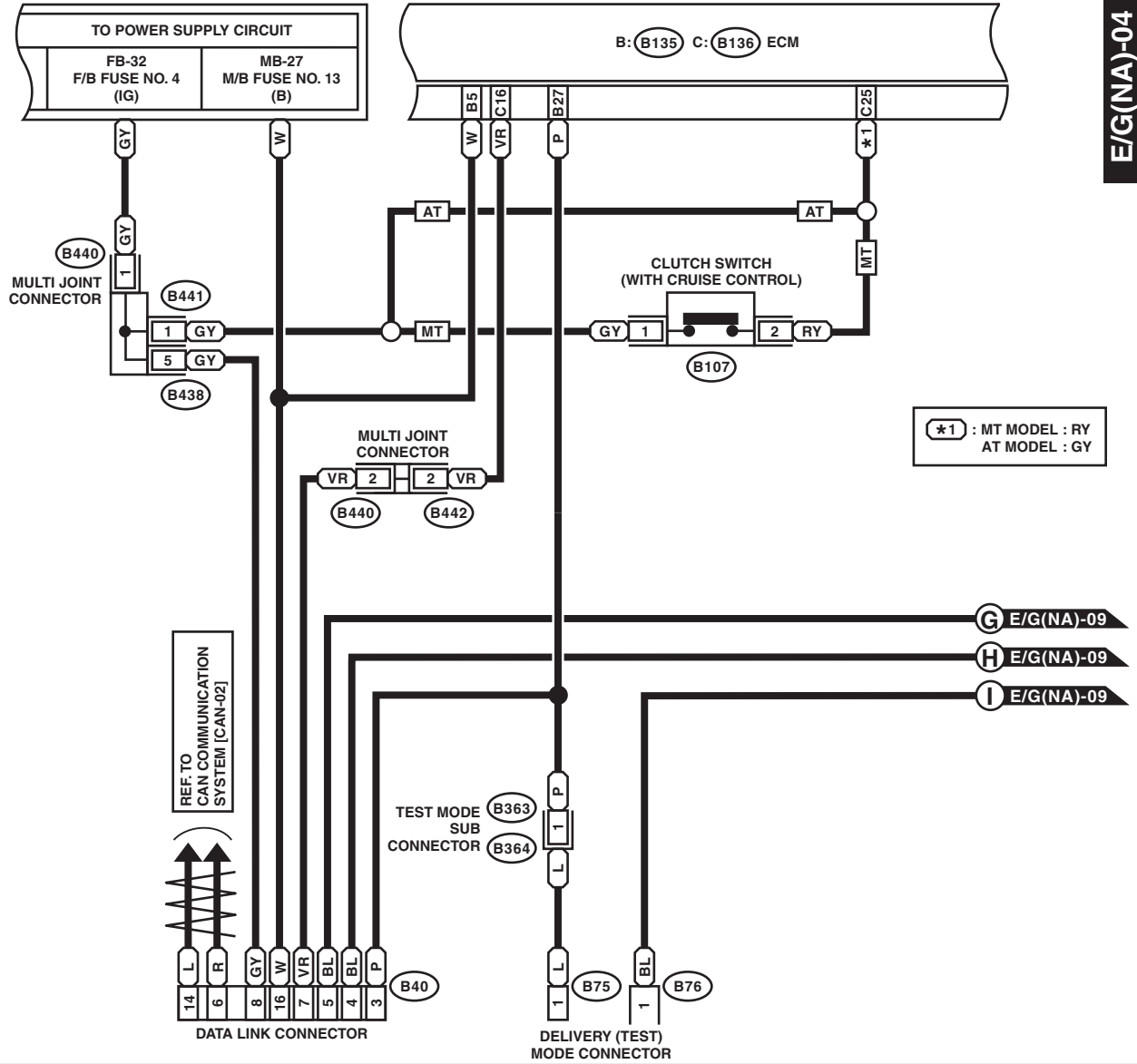

*1 : MT MODEL : RY
AT MODEL : GY

G E/G(NA)-09
H E/G(NA)-09
I E/G(NA)-09

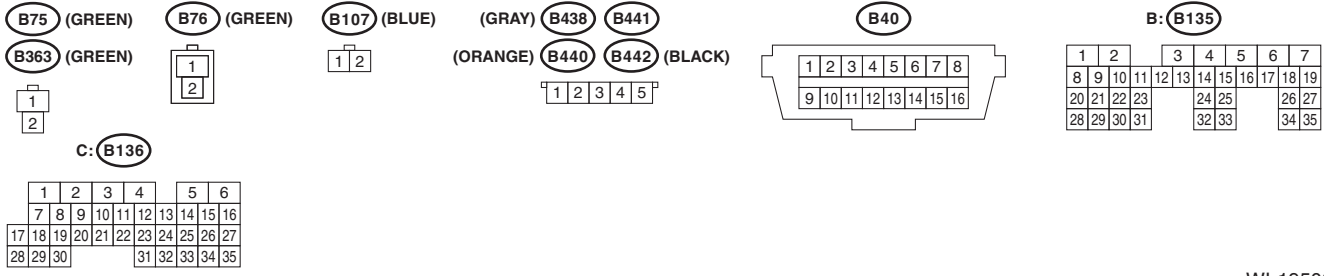

WI-19506

Engine Electrical System

WIRING SYSTEM

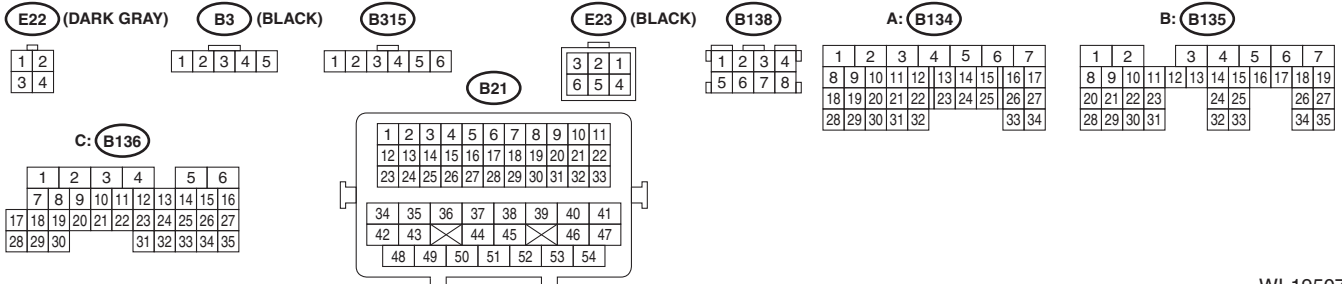
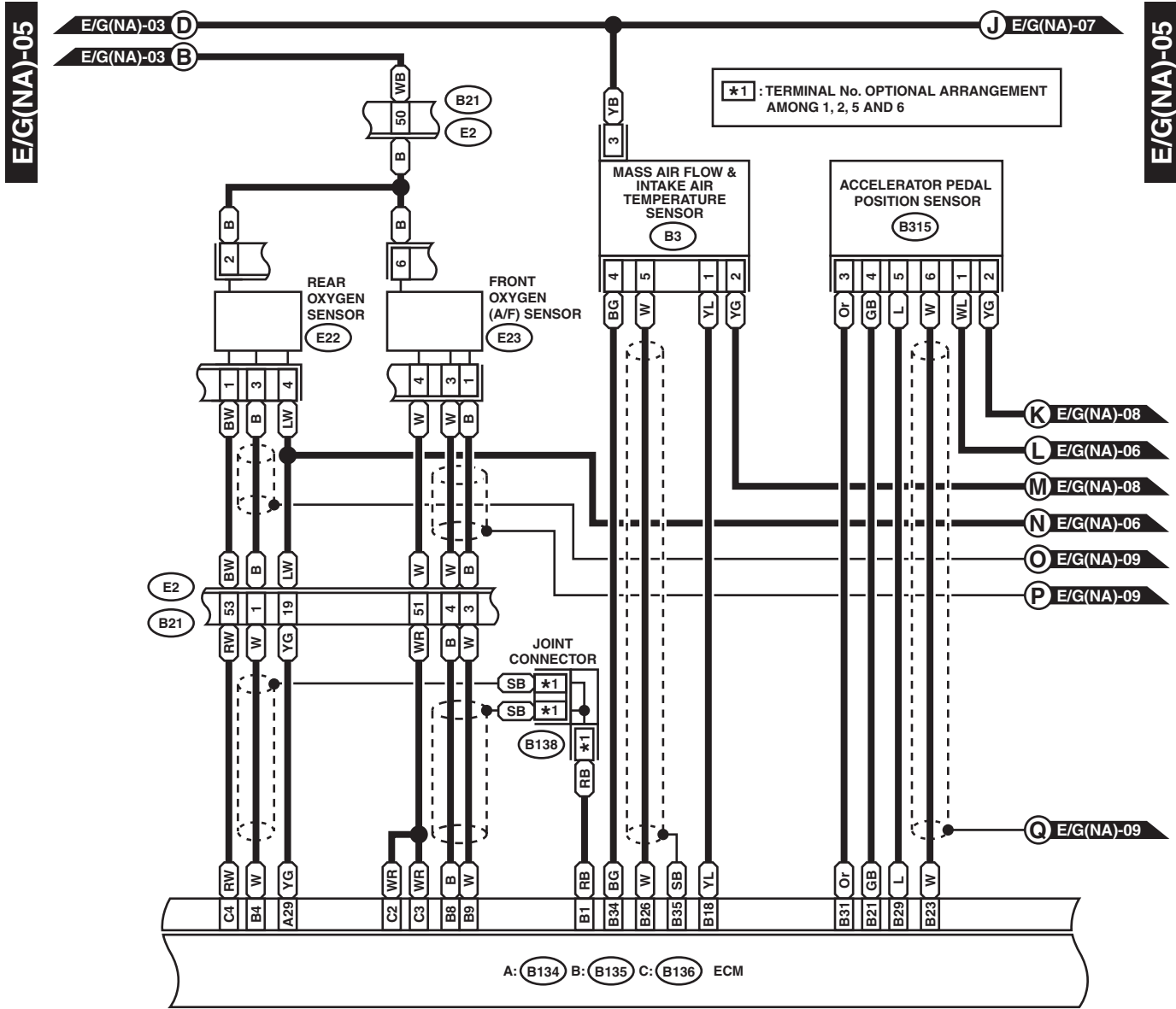

WI-19507

Engine Electrical System

WIRING SYSTEM

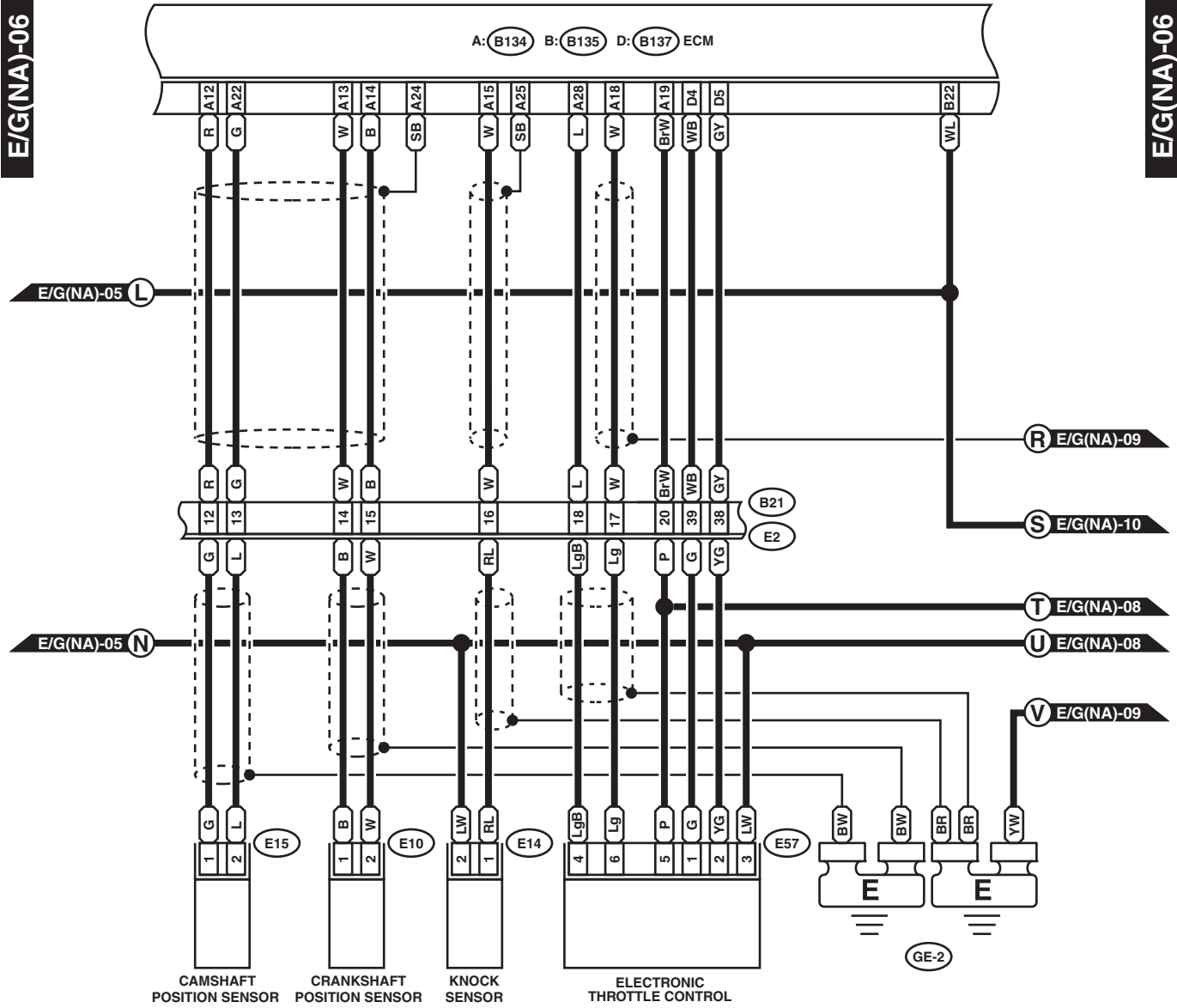

E10 (LIGHT GRAY)

E14 (GRAY)

E57 (BLACK)

D: B137

B21

E15 (BLACK)

1 2

1 2 3 4 5 6

1	2	3	4	5	6	7
8	9	10	11	12	13	14
15	16	17	18	19	20	21
22	23	24	25	26	27	28
29	30	31	32	33	34	35

1	2	3	4	5	6	7	8	9	10	11
12	13	14	15	16	17	18	19	20	21	22
23	24	25	26	27	28	29	30	31	32	33
34	35	36	37	38	39	40	41	42	43	44
45	46	47	48	49	50	51	52	53	54	

A: B134

B: B135

1	2	3	4	5	6	7
8	9	10	11	12	13	14
15	16	17	18	19	20	21
22	23	24	25	26	27	28
29	30	31	32	33	34	35

1	2	3	4	5	6	7
8	9	10	11	12	13	14
15	16	17	18	19	20	21
22	23	24	25	26	27	28
29	30	31	32	33	34	35

WI-19508

Engine Electrical System

WIRING SYSTEM

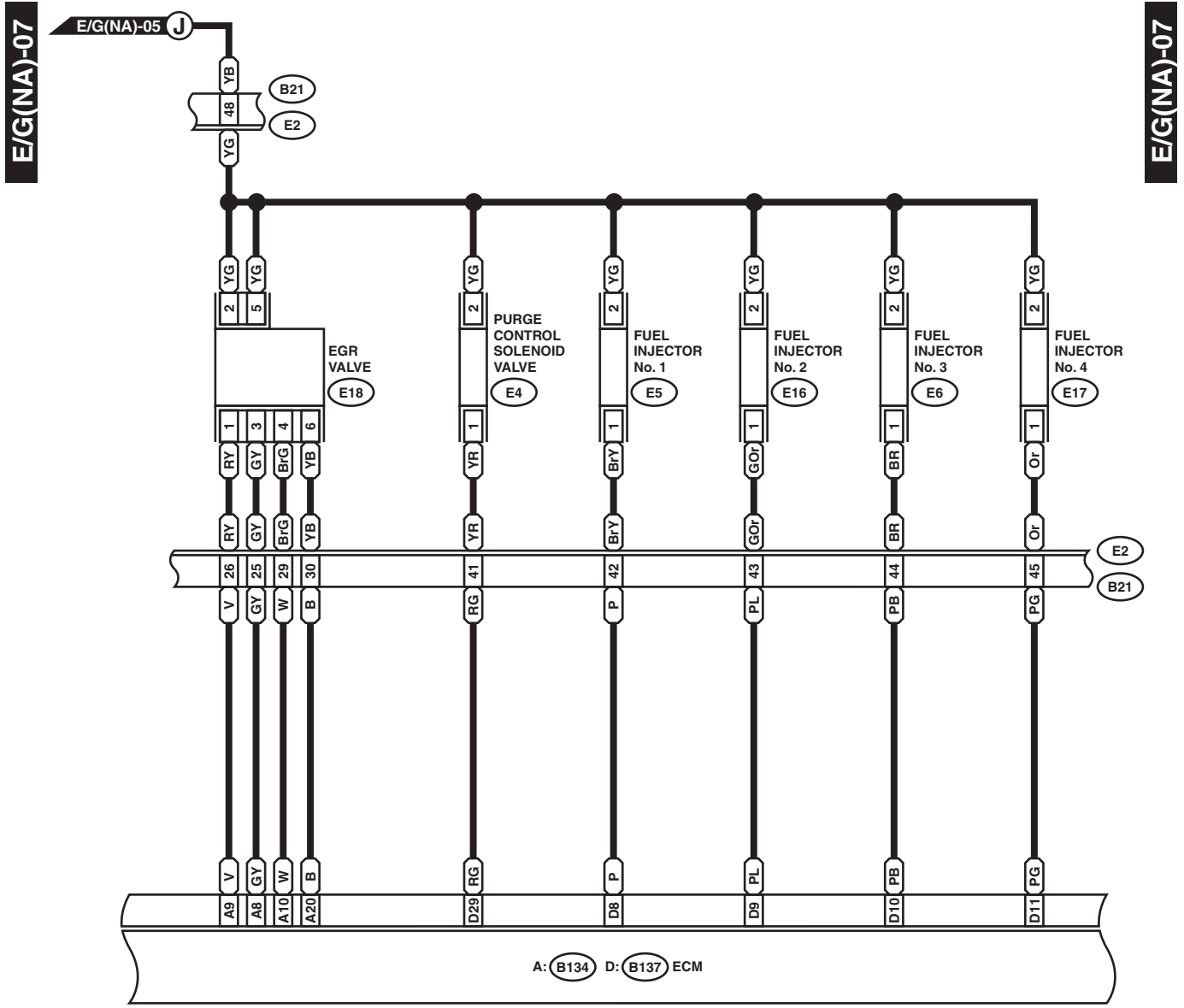

E4 (BLACK)

1 2 (DARK GRAY)

E5 (DARK GRAY) **E16** (DARK GRAY)
E6 (DARK GRAY) **E17** (DARK GRAY)

1 2

E18 (DARK GRAY)

1 2 3
4 5 6

D: B137

1	2	3	4	5	6	7
8	9	10	11	12	13	14
15	16	17	18	19	20	21
22	23	24	25	26	27	28
29	30	31	32	33	34	

A: B134

1	2	3	4	5	6	7
8	9	10	11	12	13	14
15	16	17	18	19	20	21
22	23	24	25	26	27	28
29	30	31	32	33	34	

B21

1	2	3	4	5	6	7	8	9	10	11
12	13	14	15	16	17	18	19	20	21	22
23	24	25	26	27	28	29	30	31	32	33
34	35	36	37	38	39	40	41			
42	43	44	45	46	47					
48	49	50	51	52	53	54				

WI-19658

Engine Electrical System

WIRING SYSTEM

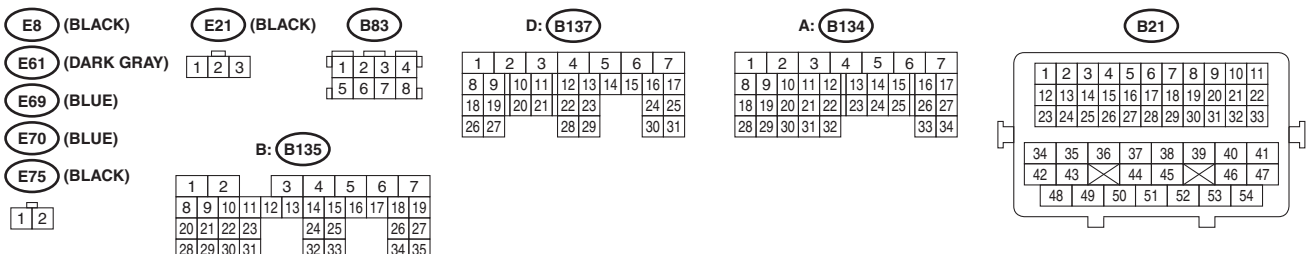
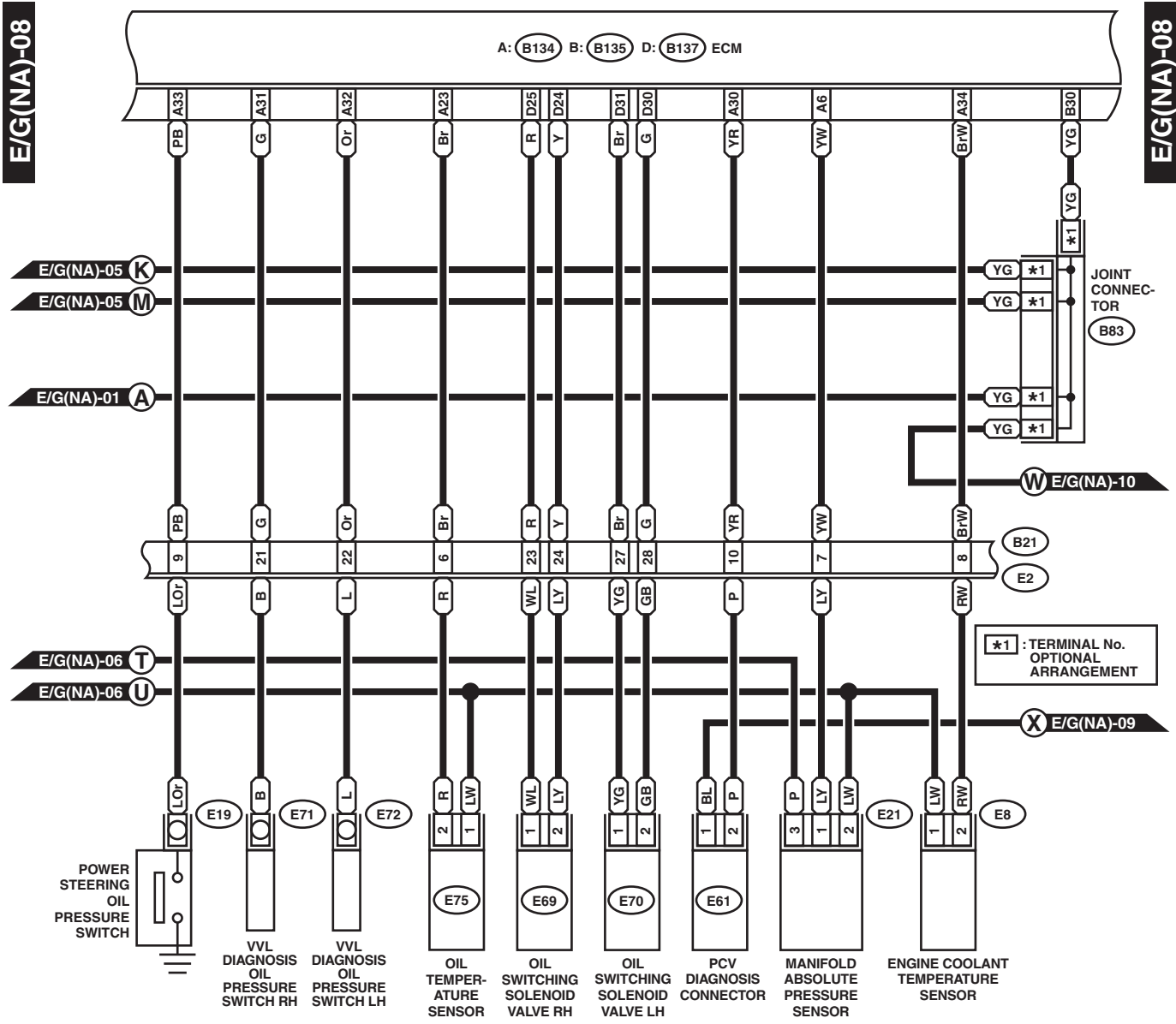

WI-19509

Engine Electrical System

WIRING SYSTEM

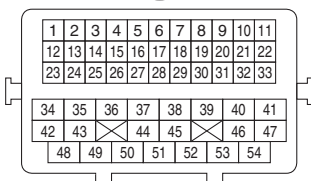
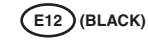
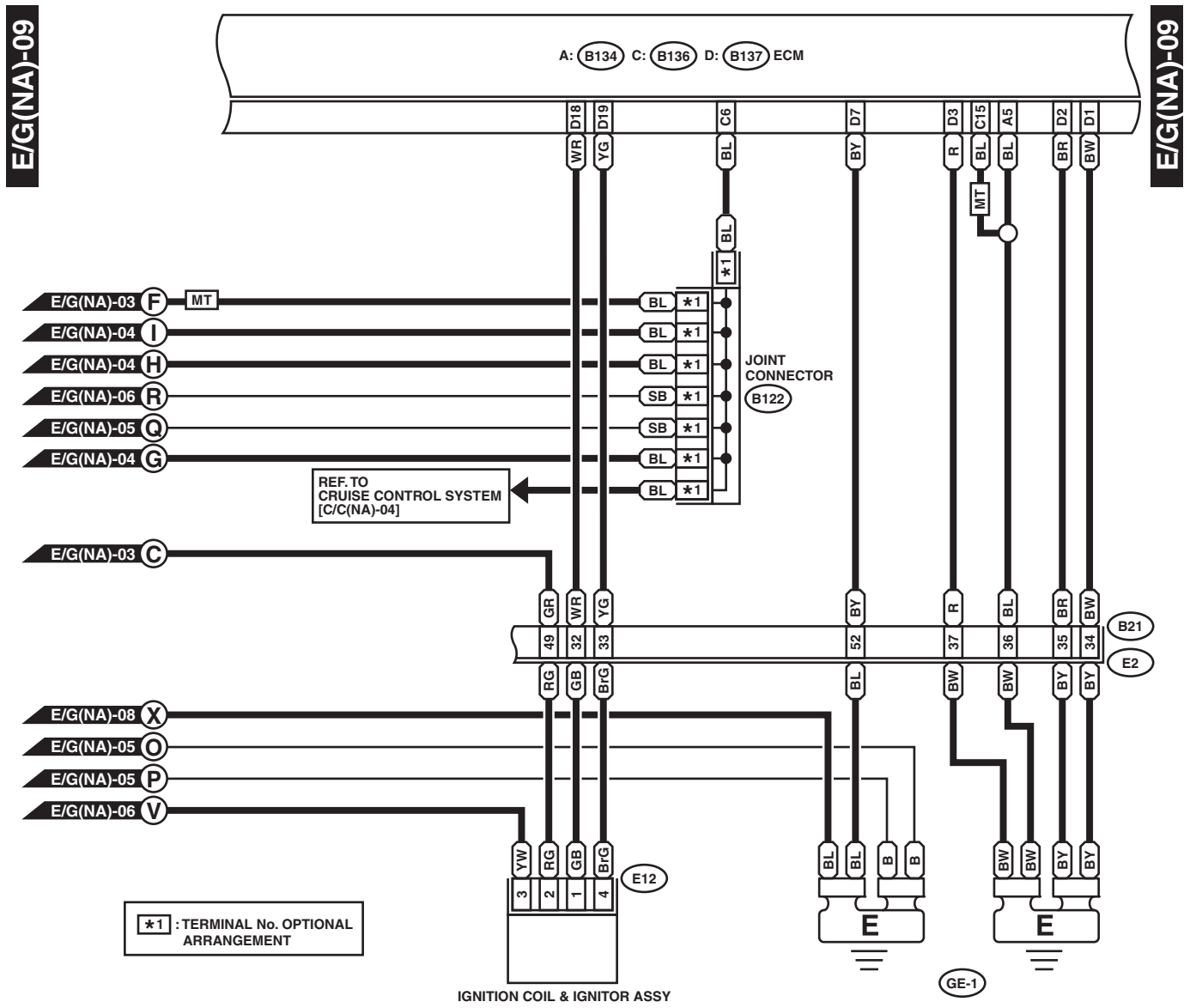

WI-19510

Engine Electrical System

WIRING SYSTEM

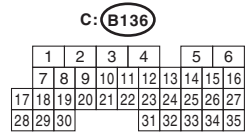
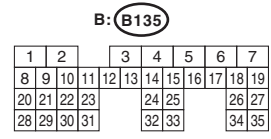
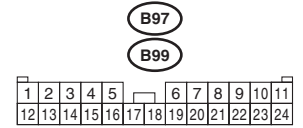
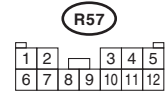
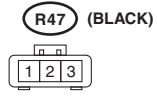
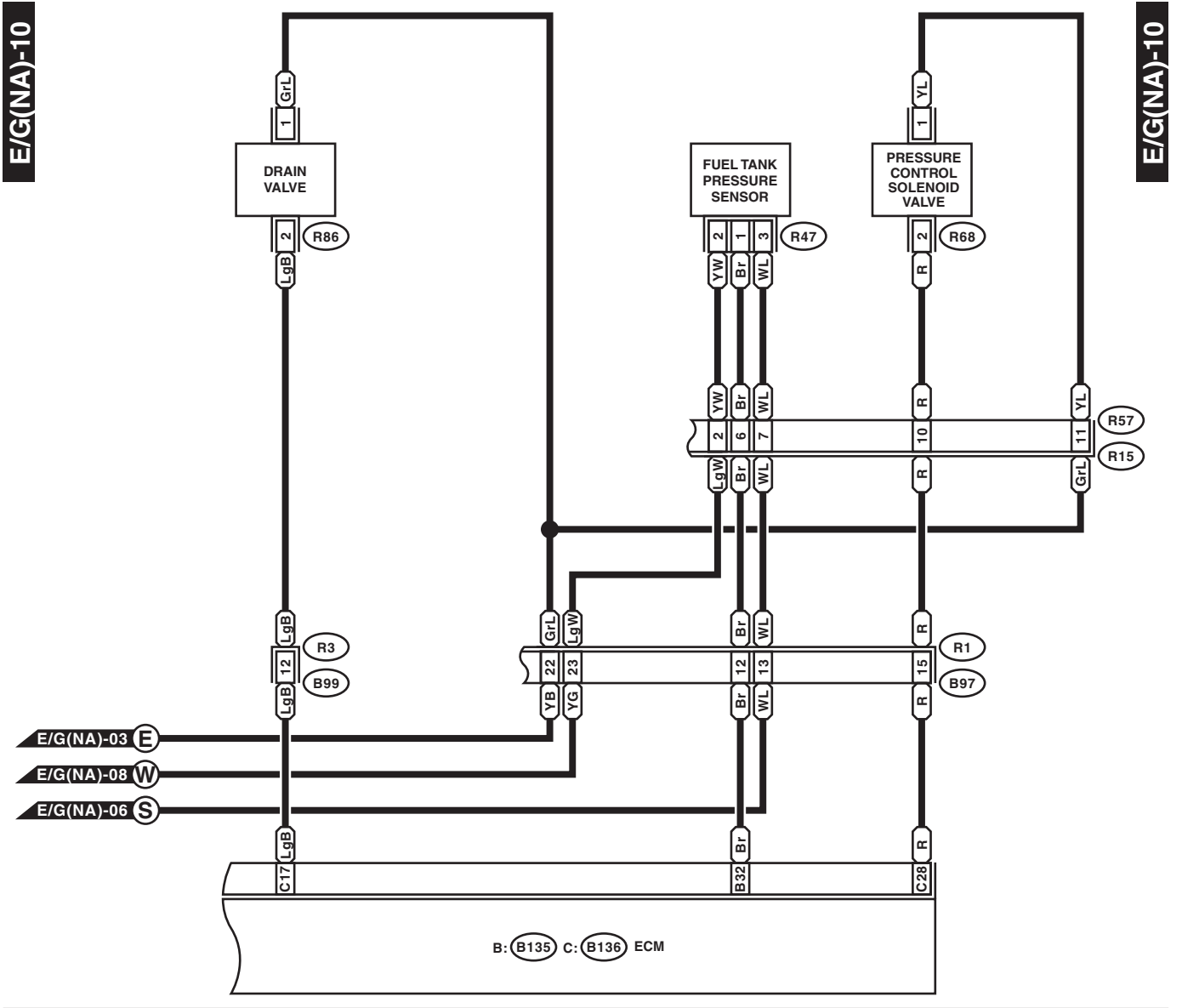

WI-19511

Engine Electrical System

WIRING SYSTEM

2. TURBO MODEL

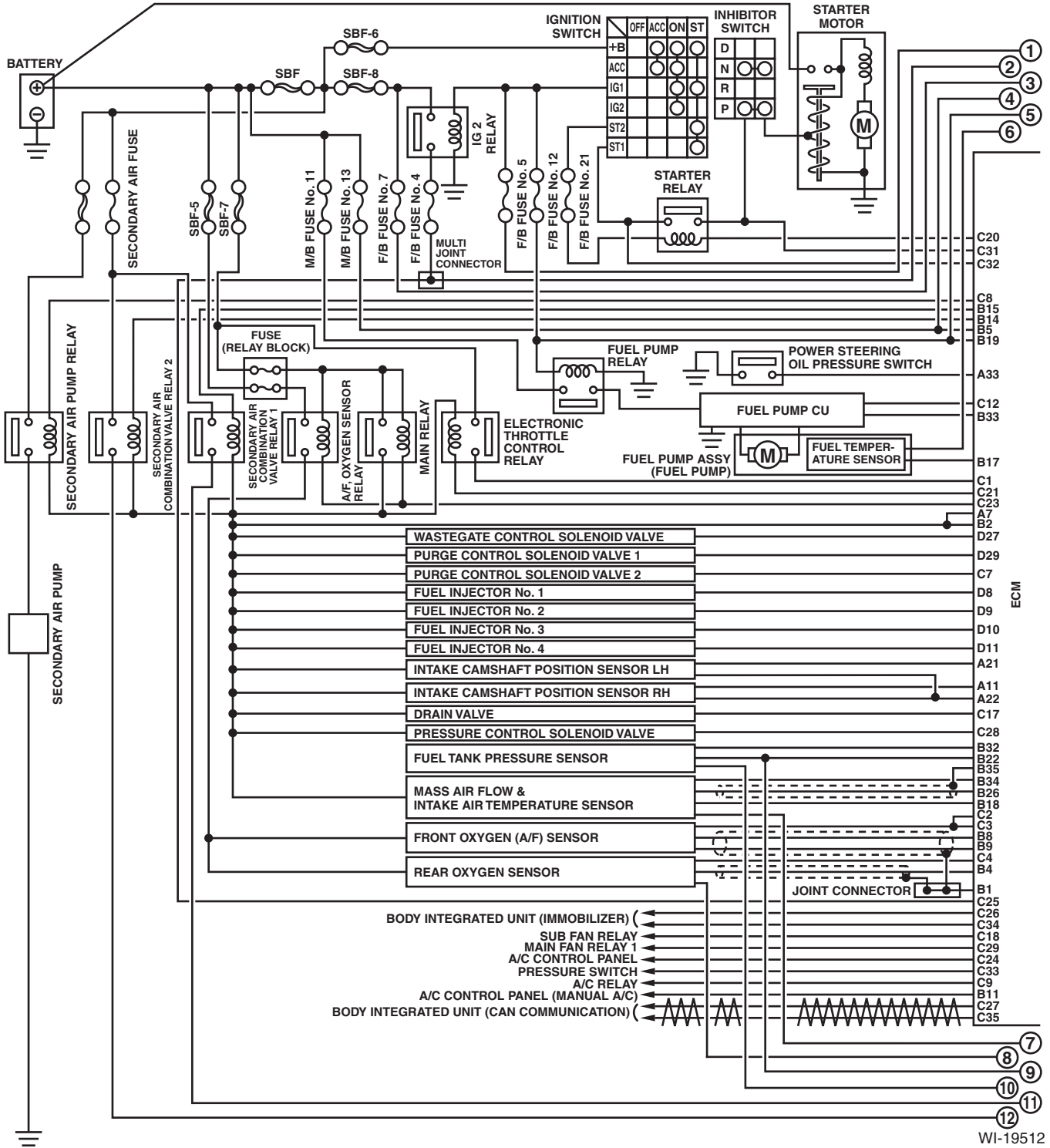

WI-19512

Engine Electrical System

WIRING SYSTEM

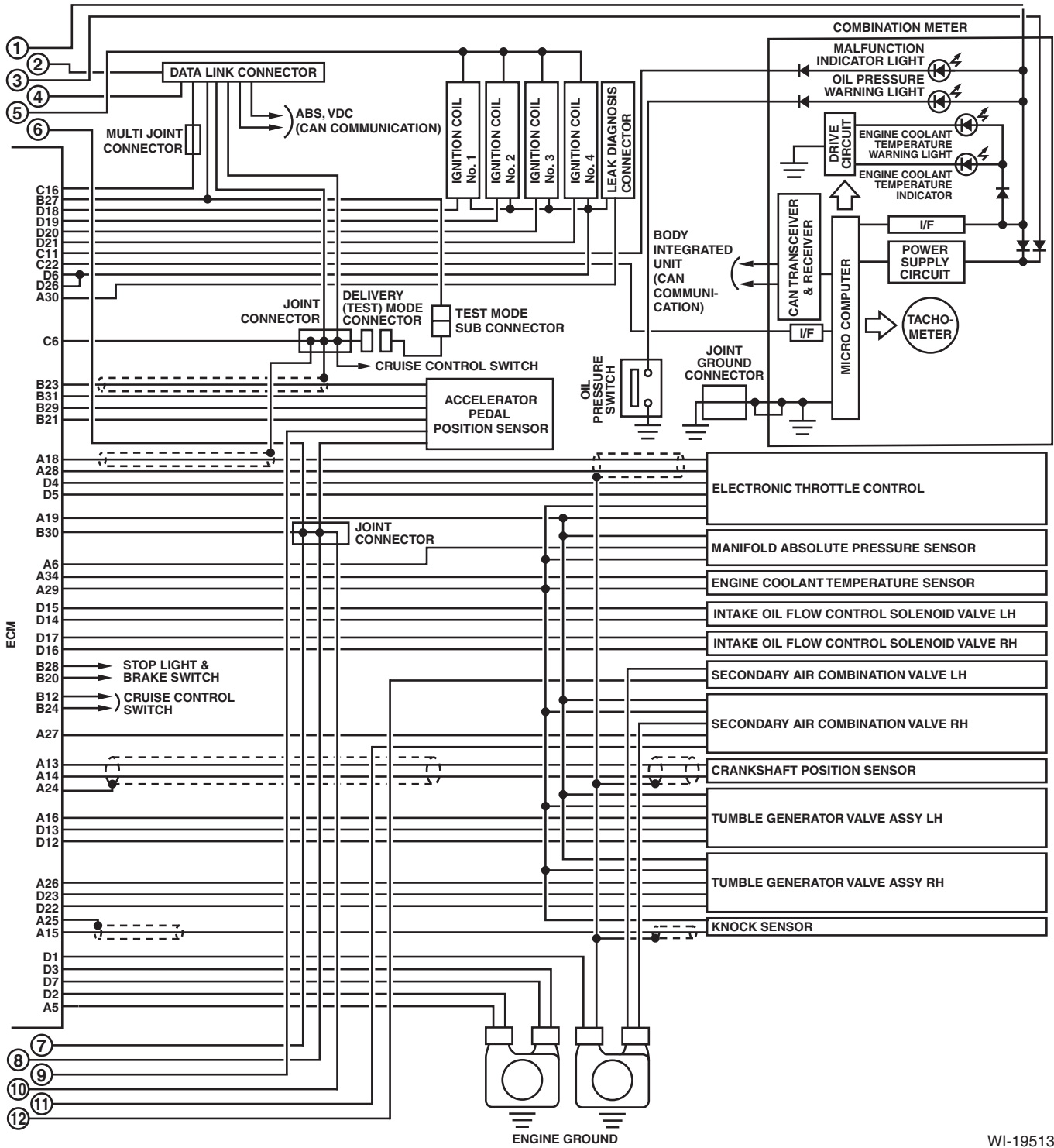

WI-19513

Engine Electrical System

WIRING SYSTEM

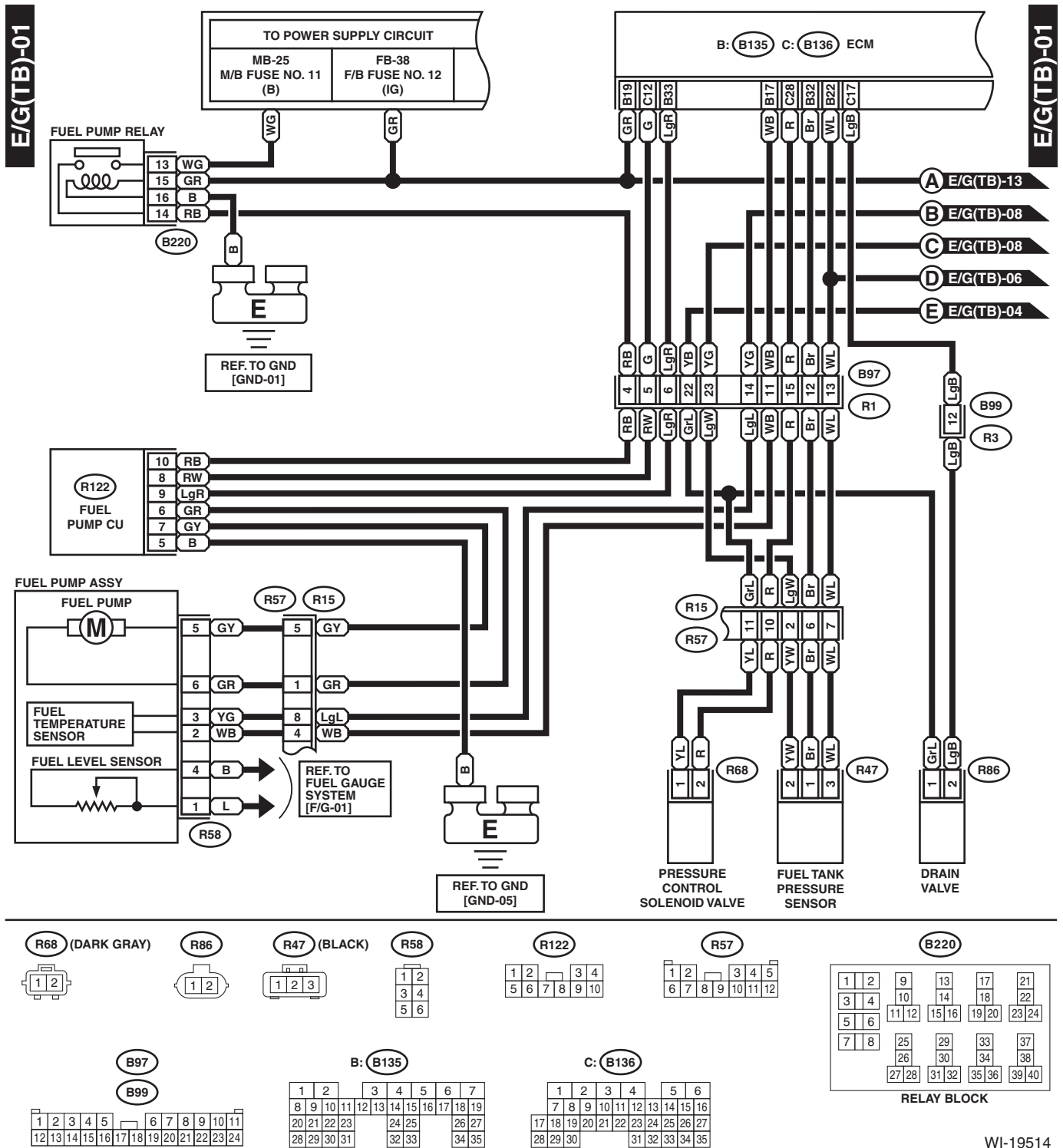

WI-19514

E/G(TB)-02

E/G(TB)-02

MA : MANUAL A/C

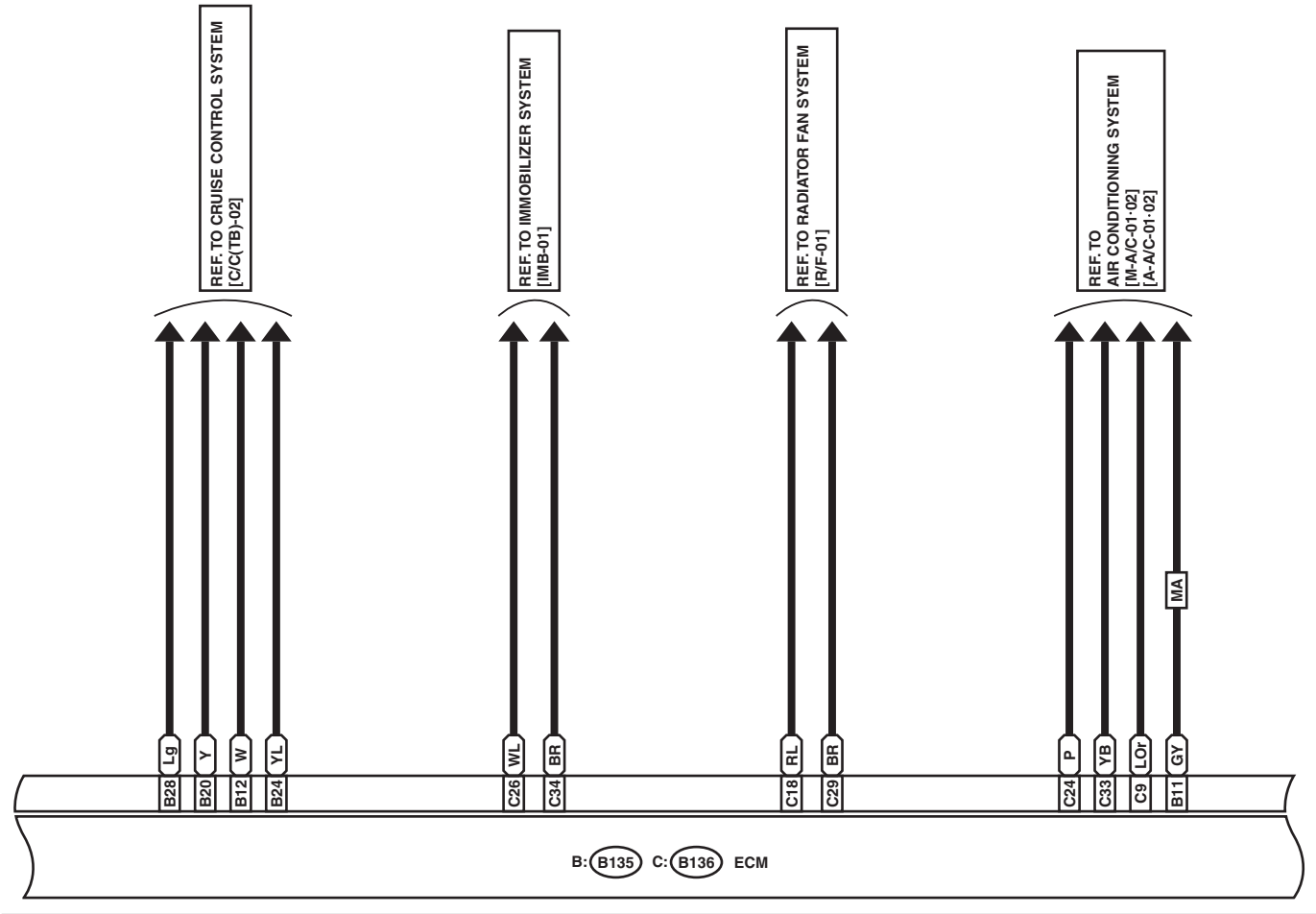

B: B135

1	2		3	4	5	6	7				
8	9	10	11	12	13	14	15	16	17	18	19
20	21	22	23		24	25		26	27		
28	29	30	31		32	33		34	35		

C: B136

			1	2	3	4		5	6			
			7	8	9	10	11	12	13	14	15	16
17	18	19	20	21	22	23	24	25	26	27		
28	29	30				31	32	33	34	35		

WI-19515

Engine Electrical System

WIRING SYSTEM

E/G(TB)-03

E/G(TB)-03

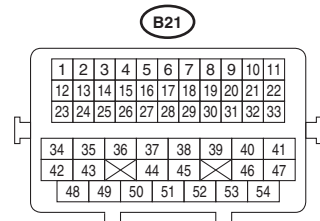
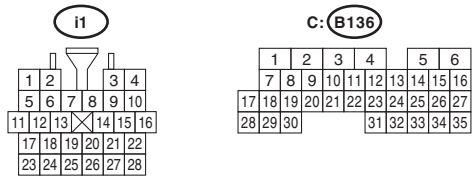
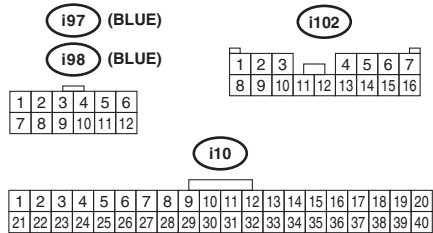
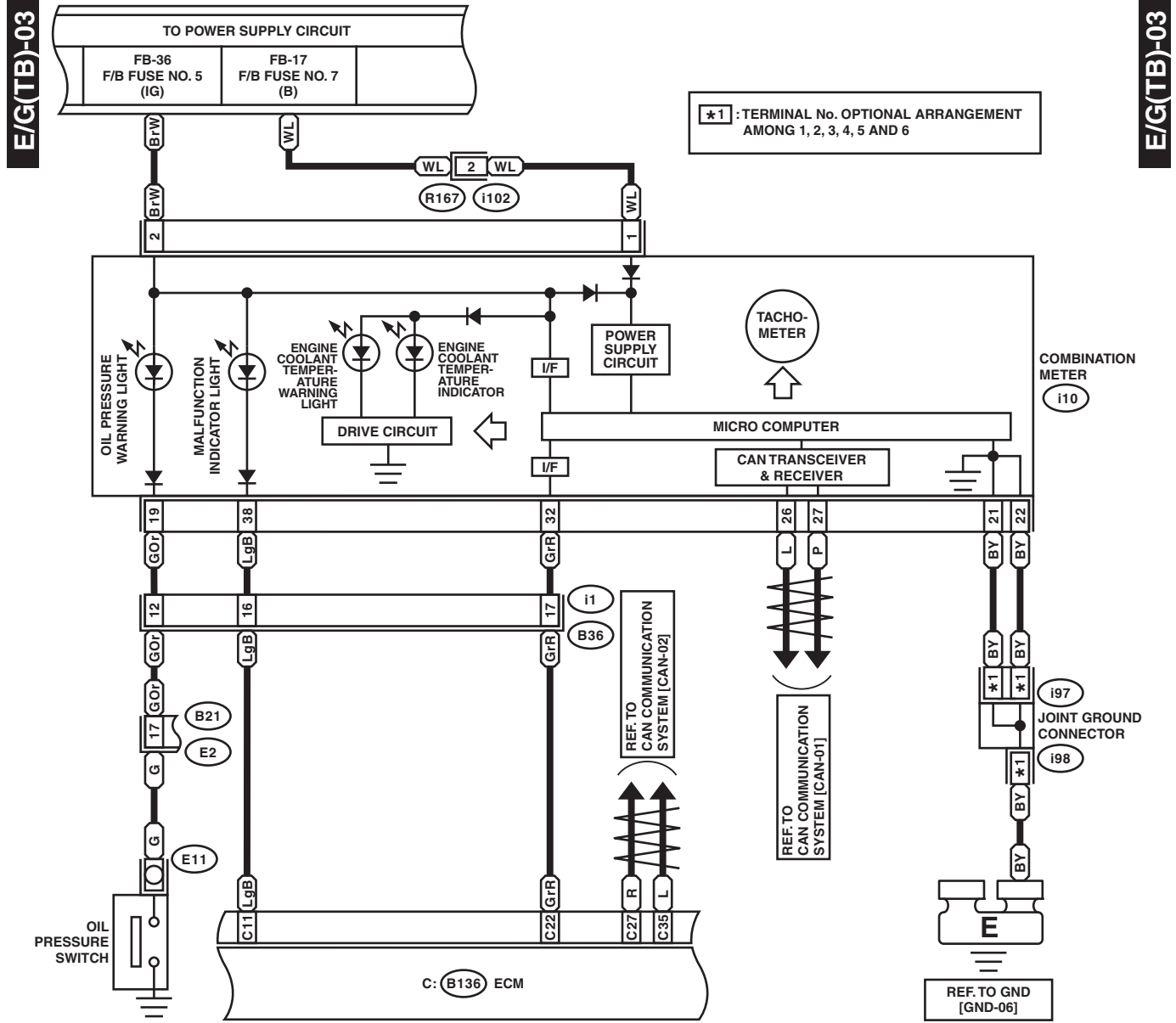

WI-19516

Engine Electrical System

WIRING SYSTEM

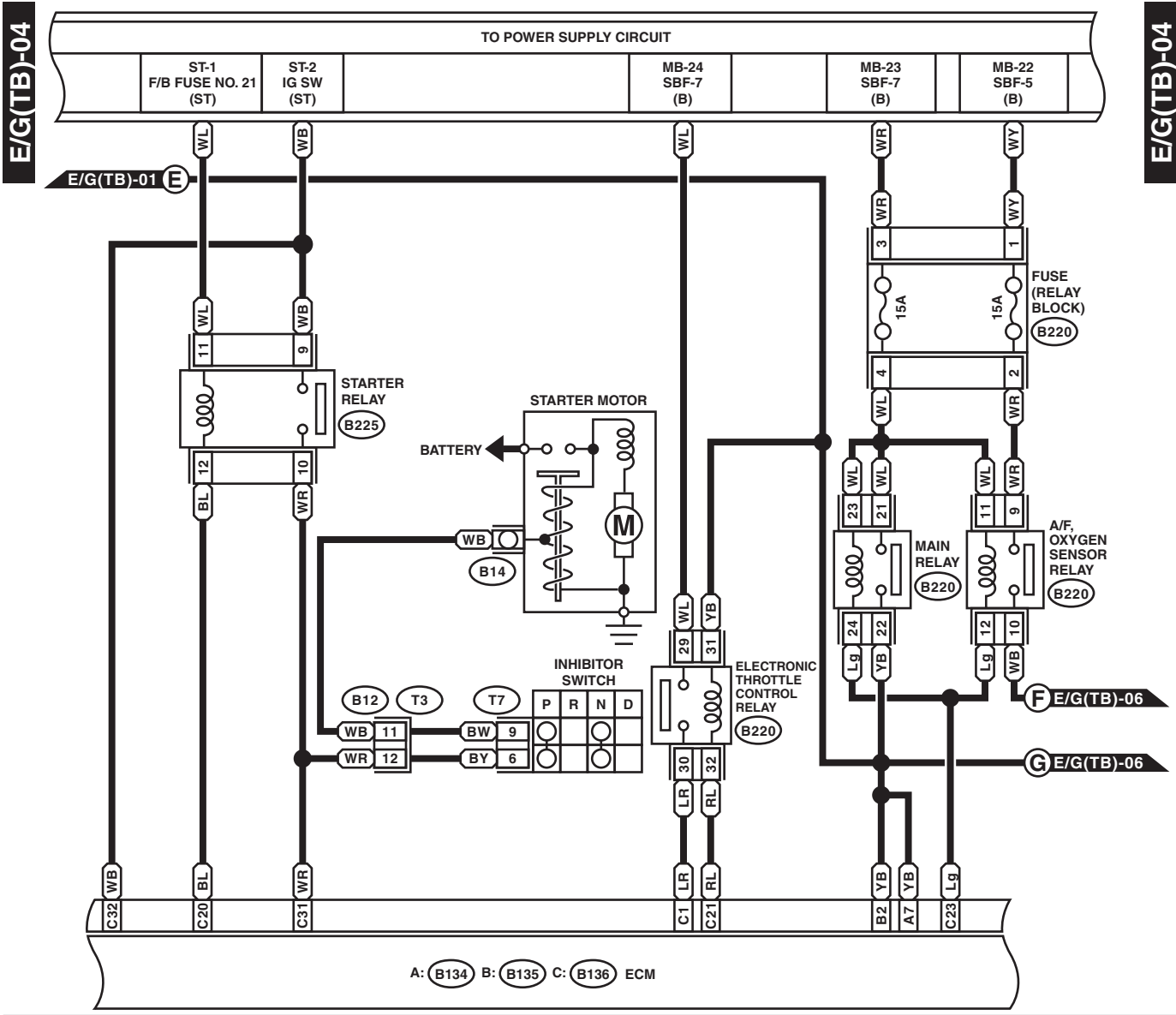

A: B134 B: B135 C: B136 ECM

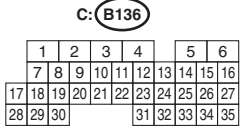
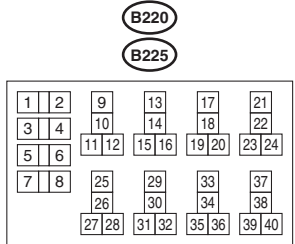
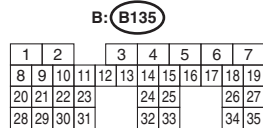
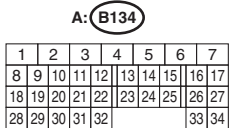
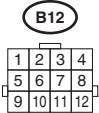
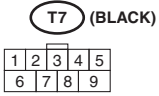

RELAY BLOCK

WI-19517

Engine Electrical System

WIRING SYSTEM

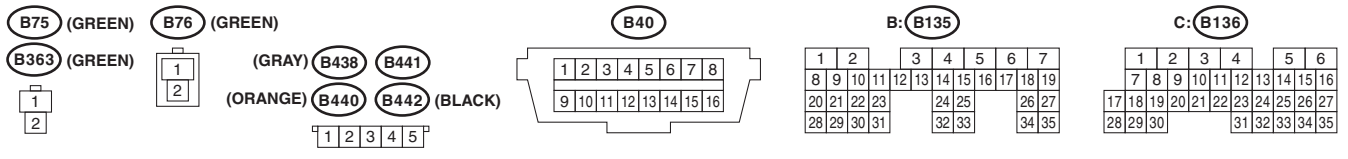
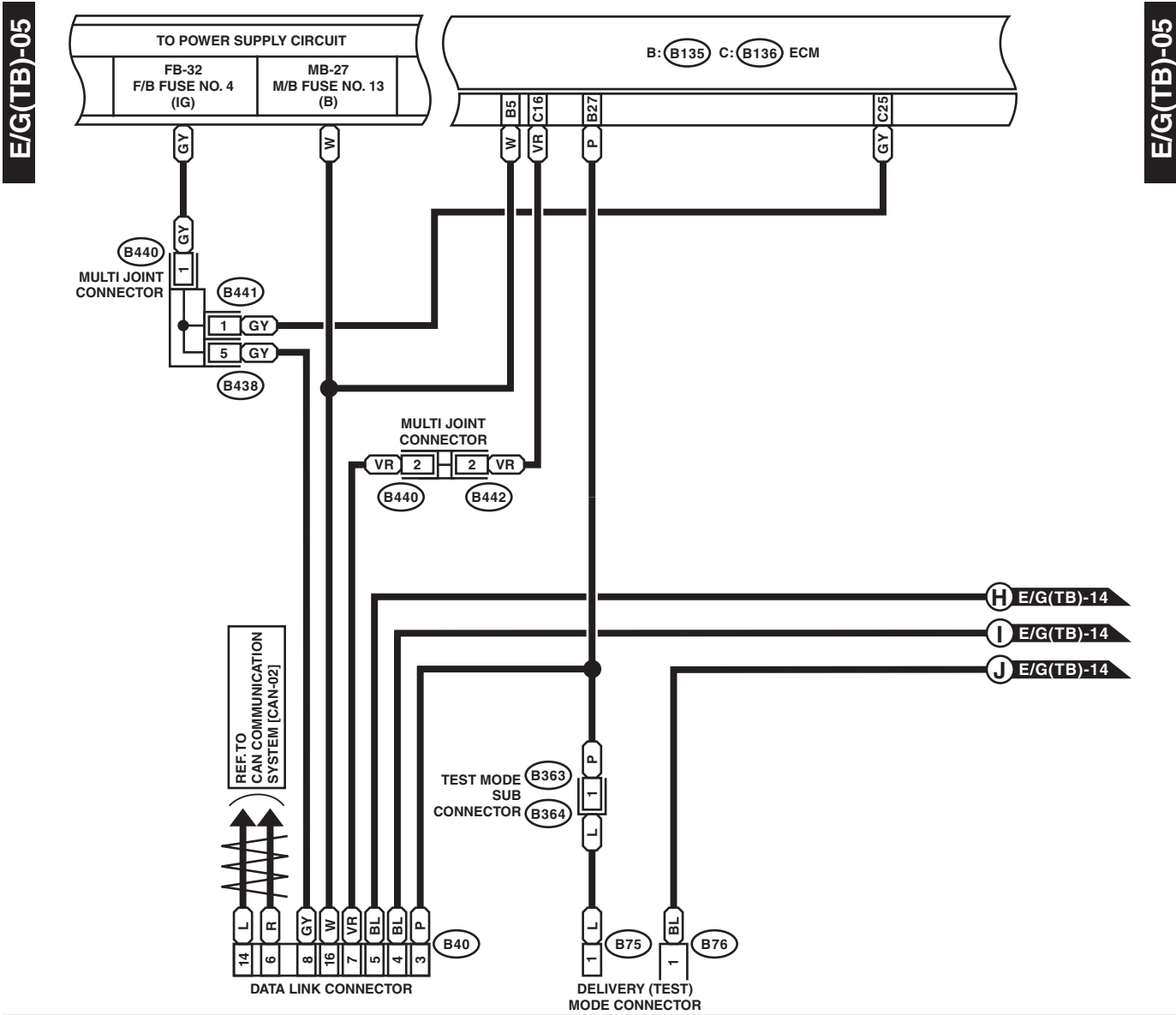

WI-19518

Engine Electrical System

WIRING SYSTEM

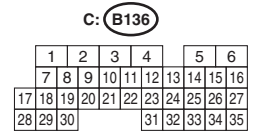
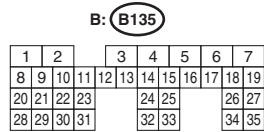
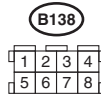
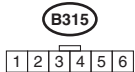
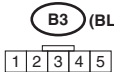
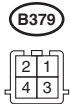
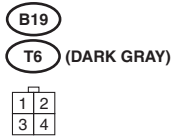
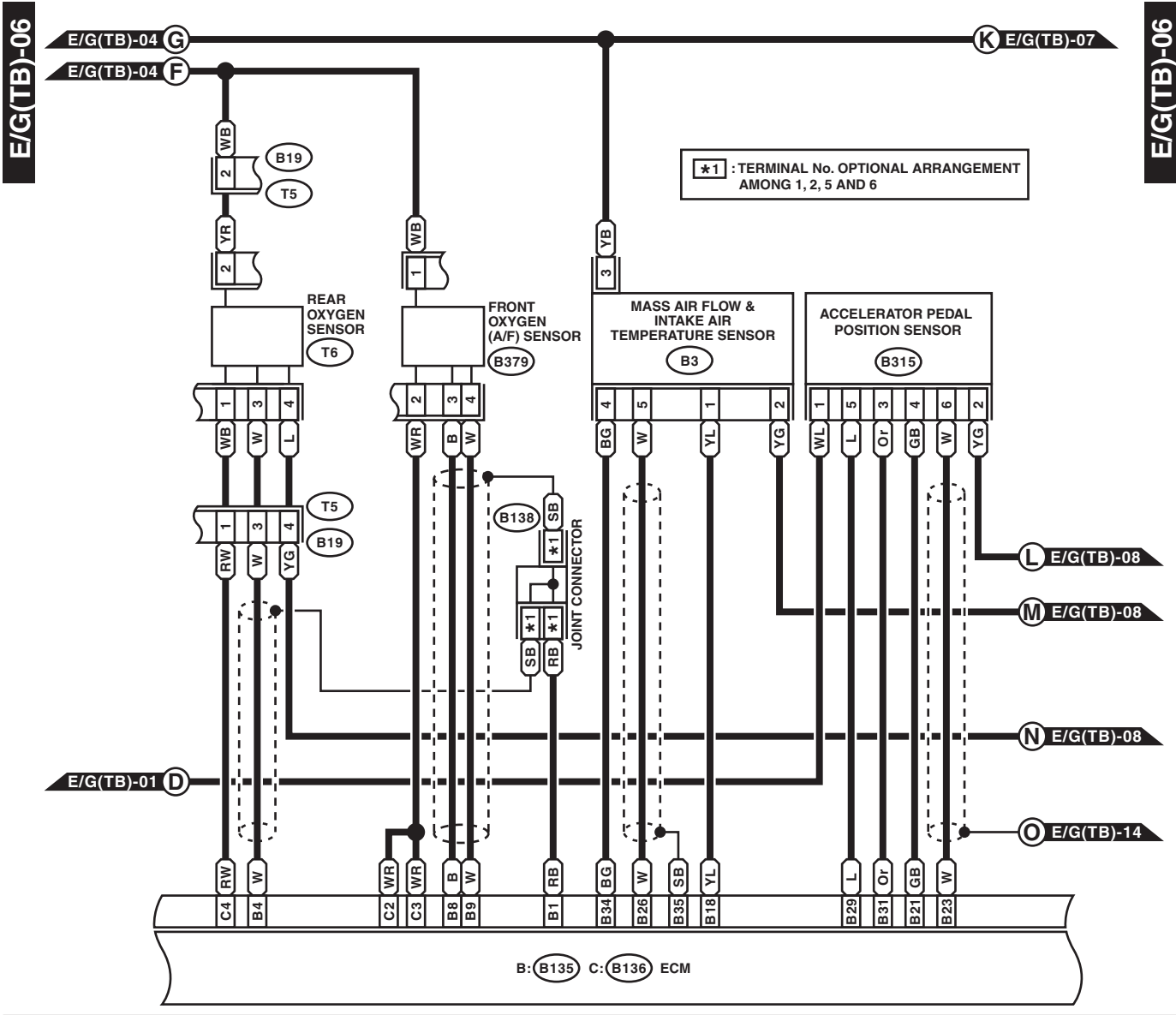

WI-19519

Engine Electrical System

WIRING SYSTEM

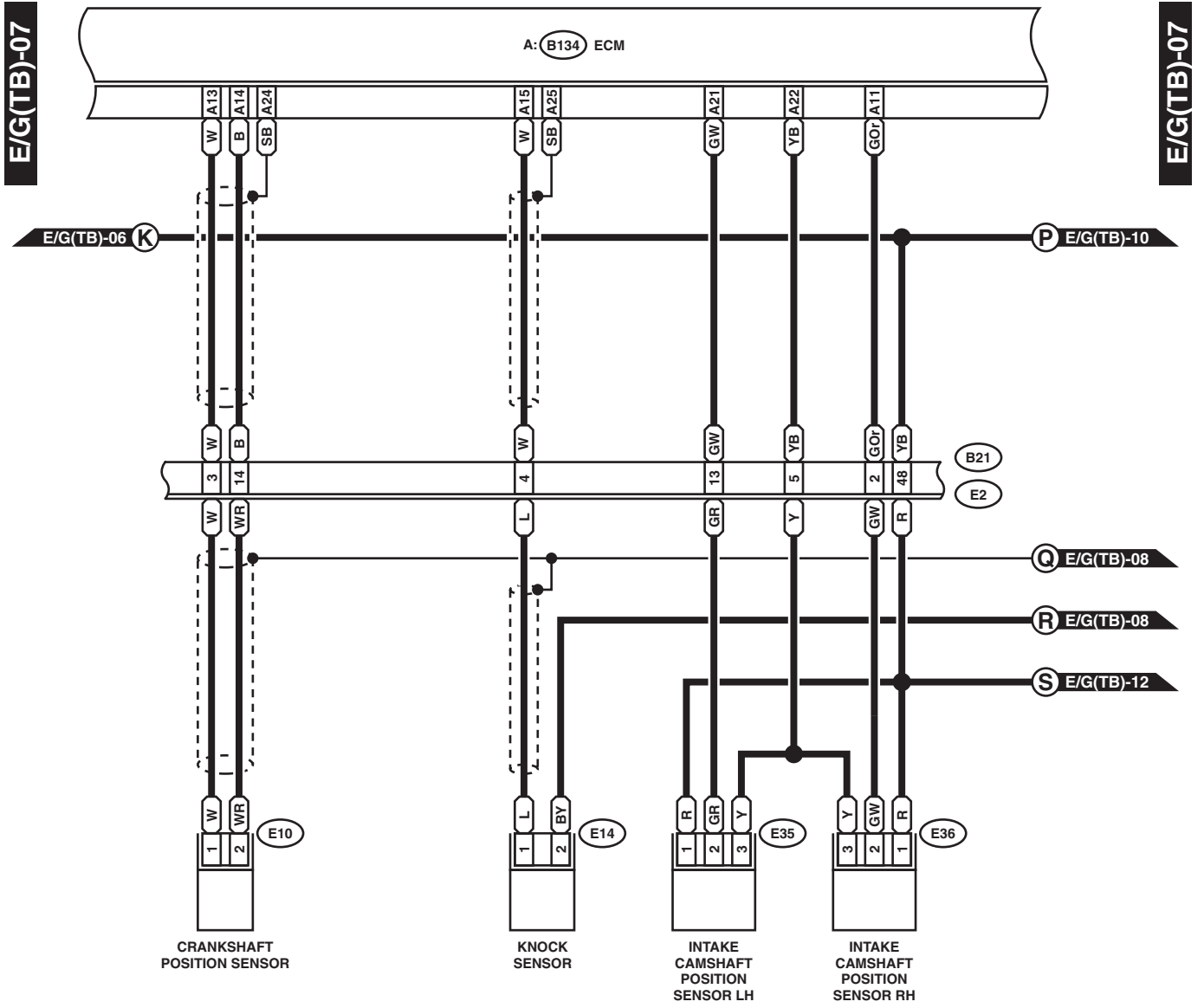

- E10 (LIGHT GRAY)
- E14 (LIGHT GRAY)
- E35 (LIGHT GRAY)
- E36 (LIGHT GRAY)

A: B134

1	2	3	4	5	6	7
8	9	10	11	12	13	14
15	16	17	18	19	20	21
22	23	24	25	26	27	28
29	30	31	32	33	34	

B21

1	2	3	4	5	6	7	8	9	10	11
12	13	14	15	16	17	18	19	20	21	22
23	24	25	26	27	28	29	30	31	32	33
34	35	36	37	38	39	40	41			
42	43	44	45	46	47					
48	49	50	51	52	53	54				

WI-19520

Engine Electrical System

WIRING SYSTEM

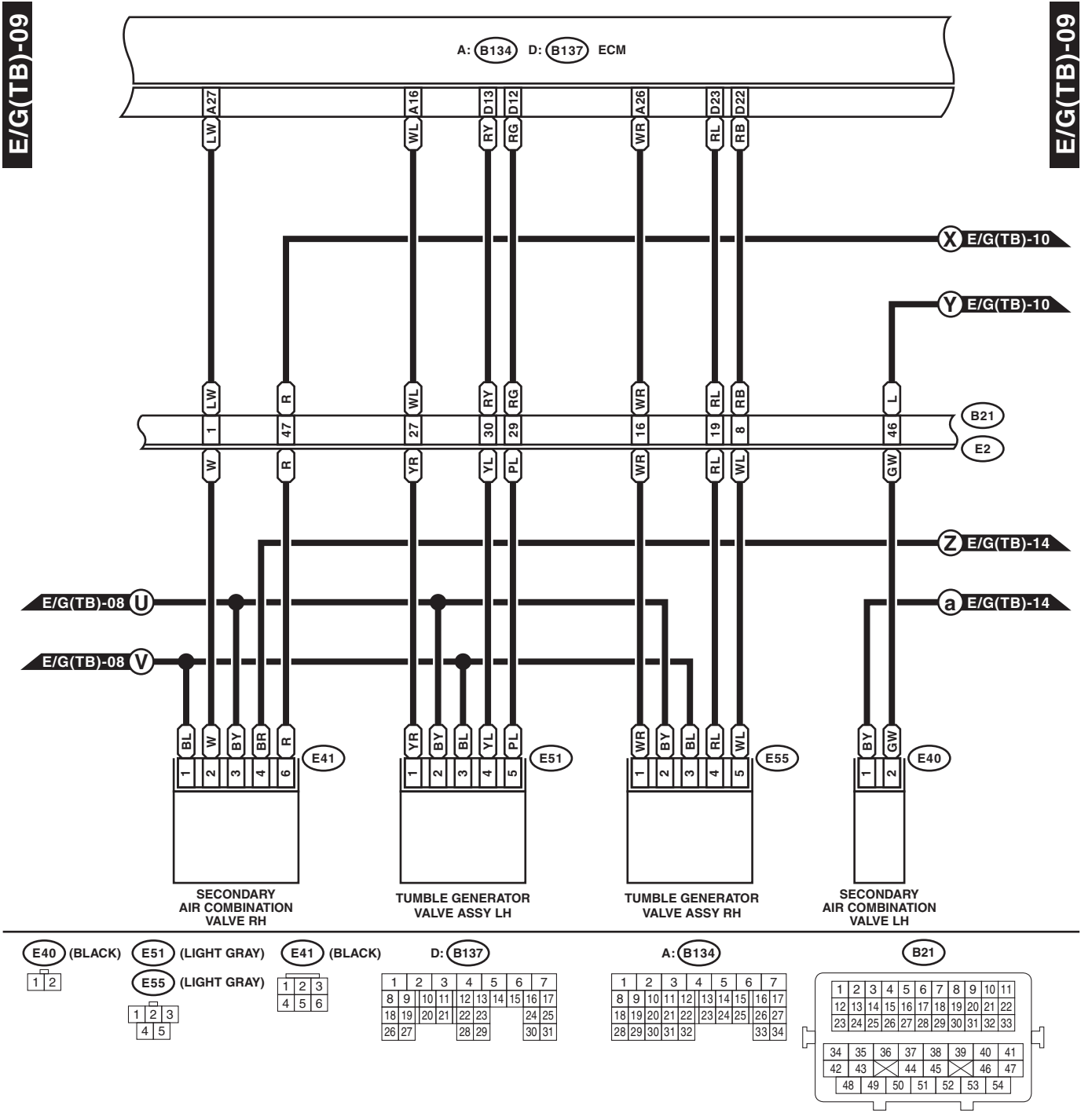

WI-19522

Engine Electrical System

WIRING SYSTEM

E/G(TB)-10

E/G(TB)-10

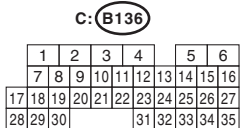
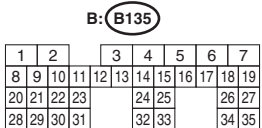
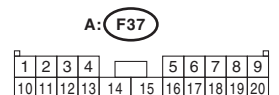
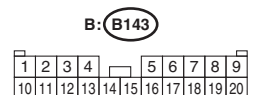
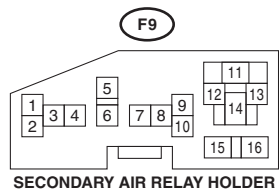
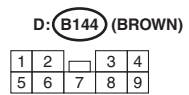
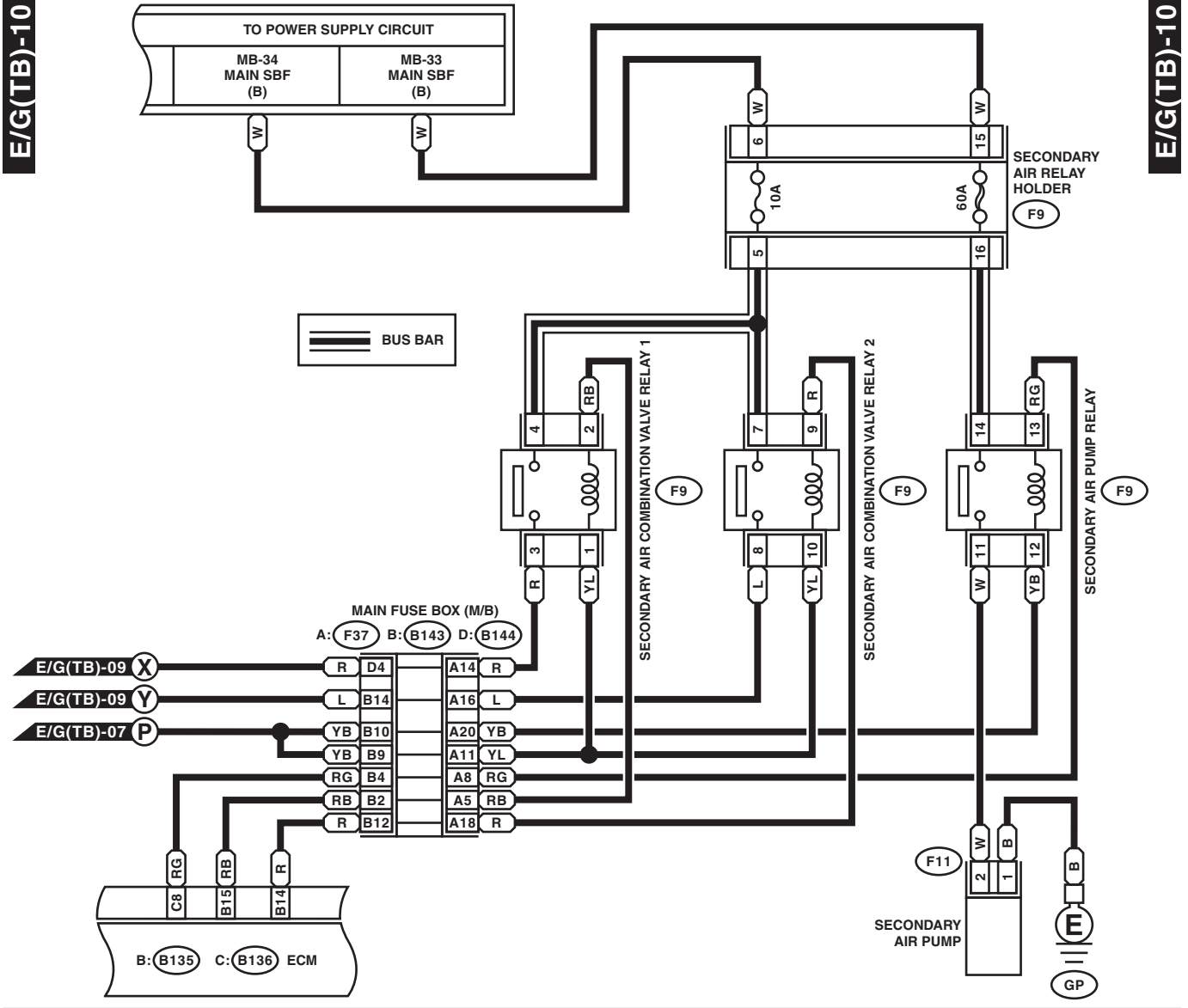

WI-19523

Engine Electrical System

WIRING SYSTEM

E/G(TB)-11

E/G(TB)-11

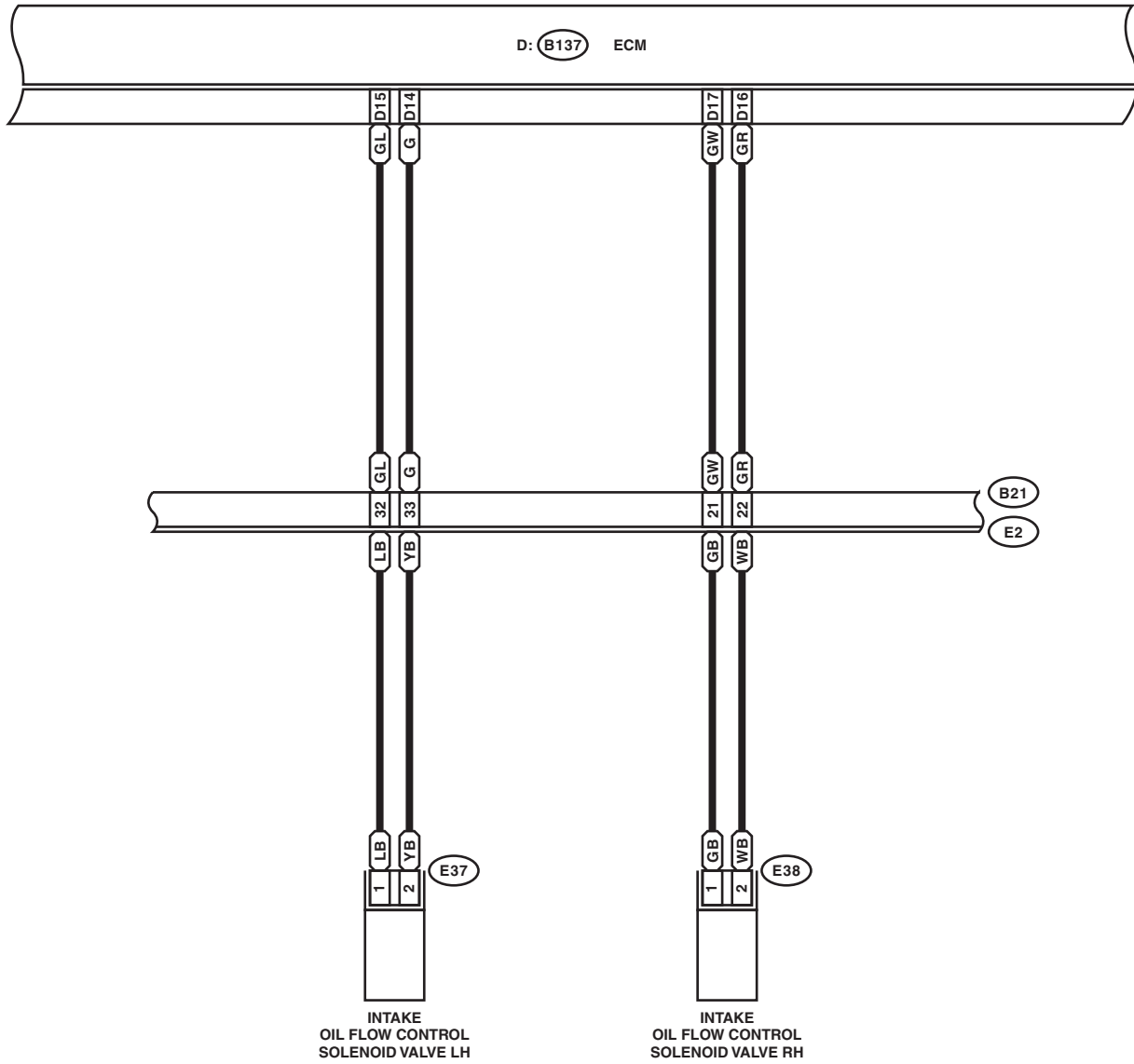

E37 (BLUE)

E38 (BLUE)



D: B137

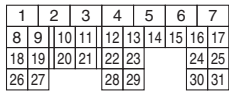

B21

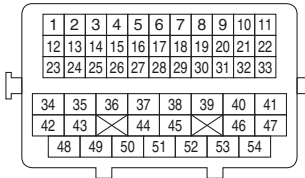

WI-19659

Engine Electrical System

WIRING SYSTEM

E/G(TB)-12

E/G(TB)-12

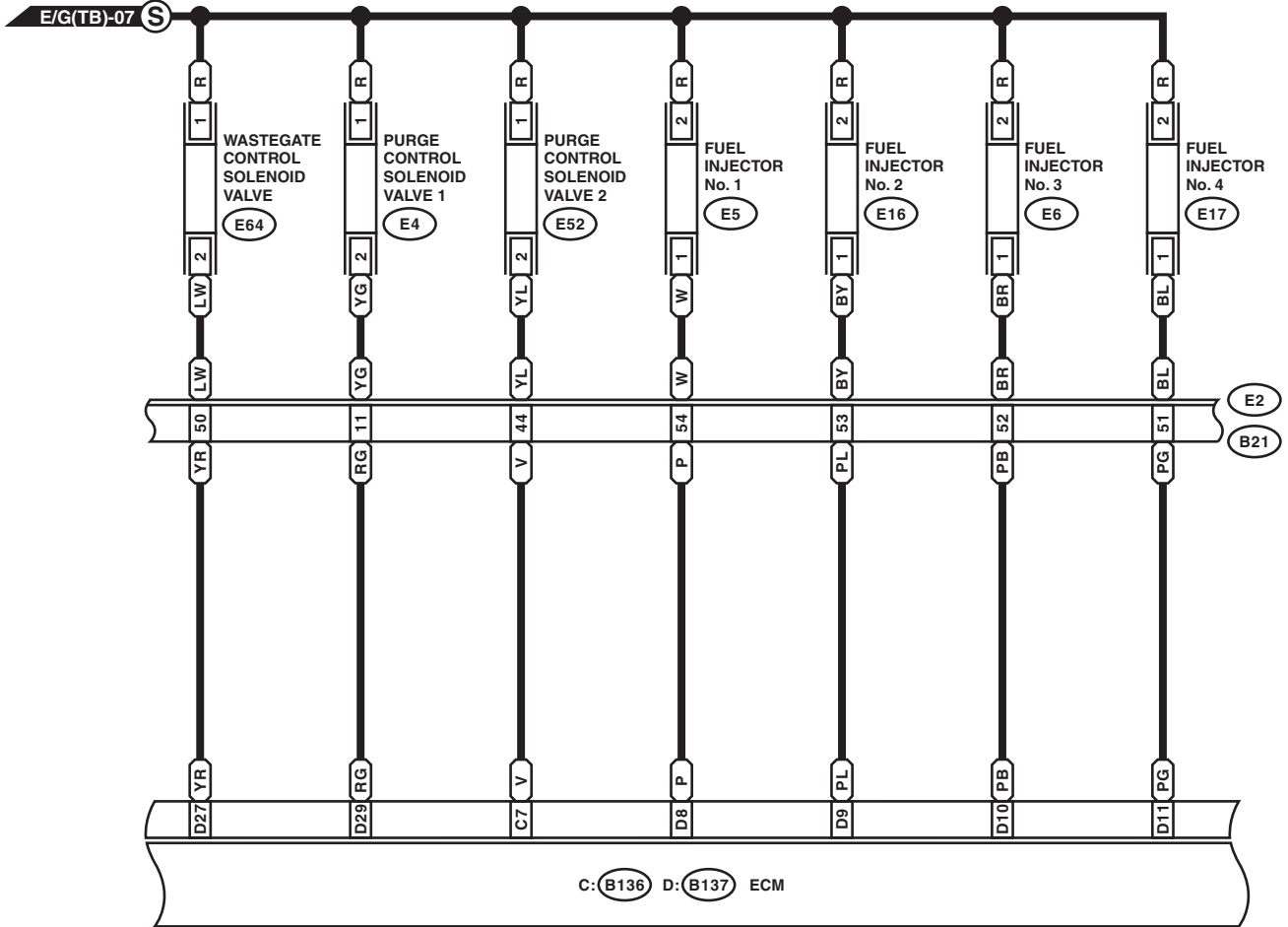

E4 (BLACK)

E5 (DARK GRAY)

D: B137

C: B136

B21

E52 (BLACK)

E6 (DARK GRAY)

1	2	3	4	5	6	7
8	9	10	11	12	13	14
15	16	17	18	19	20	21
22	23	24	25	26	27	28
29	30	31	32	33	34	35

1	2	3	4	5	6
7	8	9	10	11	12
13	14	15	16	17	18
19	20	21	22	23	24
25	26	27	28	29	30
31	32	33	34	35	

1	2	3	4	5	6	7	8	9	10	11
12	13	14	15	16	17	18	19	20	21	22
23	24	25	26	27	28	29	30	31	32	33
34	35	36	37	38	39	40	41			
42	43	44	45	46	47					
48	49	50	51	52	53	54				

E64 (BLUE)

E16 (DARK GRAY)

E17 (DARK GRAY)



WI-19524

Engine Electrical System

WIRING SYSTEM

E/G(TB)-13

E/G(TB)-13

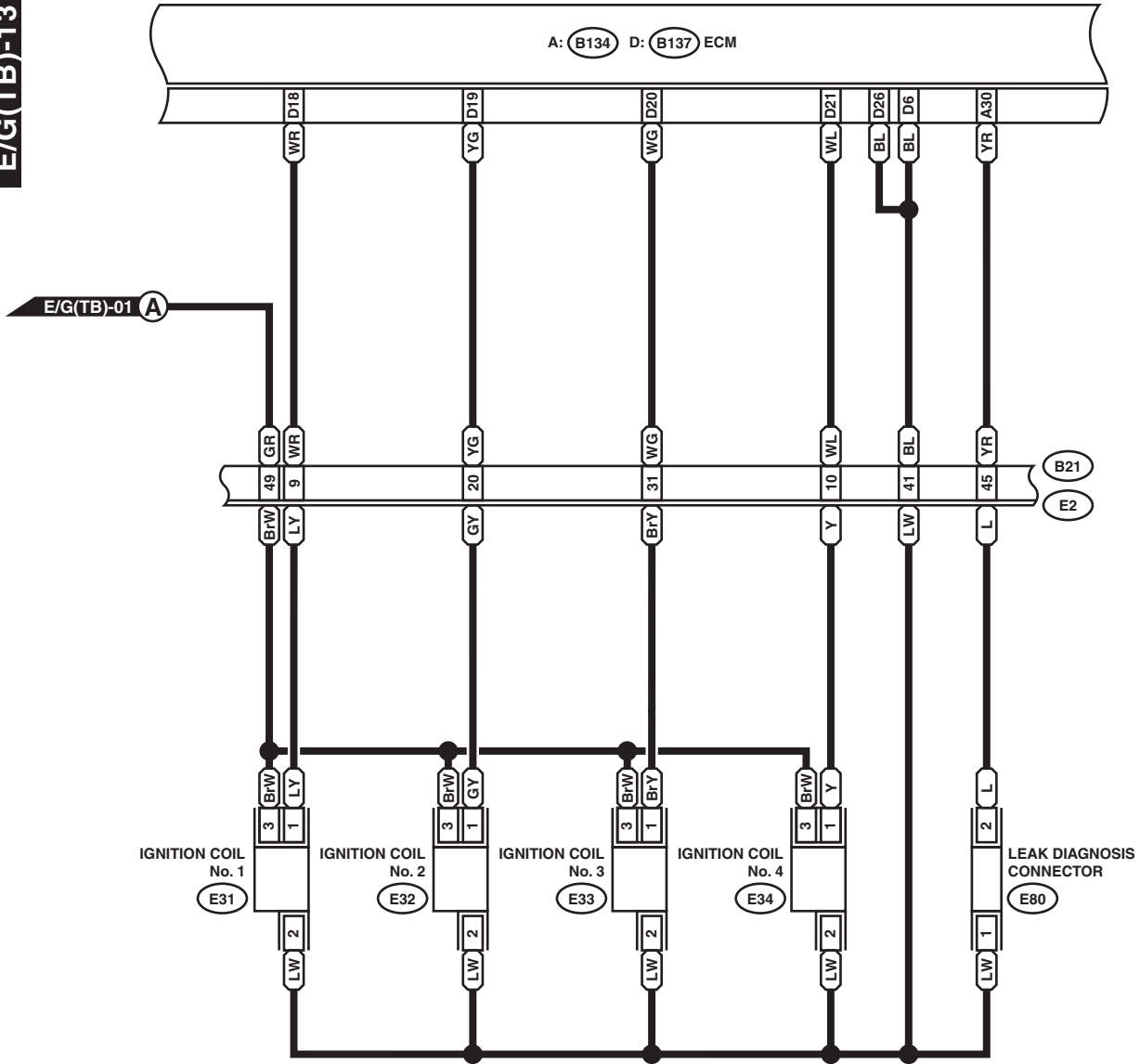

E80 (DARK GRAY)



E31 E33 (BLACK)

E32 E34 (BLACK)



D: B137

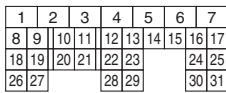

A: B134

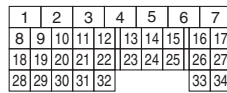

B21

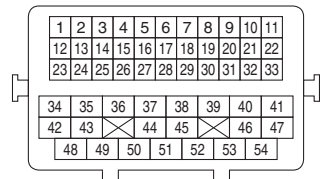

WI-19525

Engine Electrical System

WIRING SYSTEM

E/G(TB)-14

E/G(TB)-14

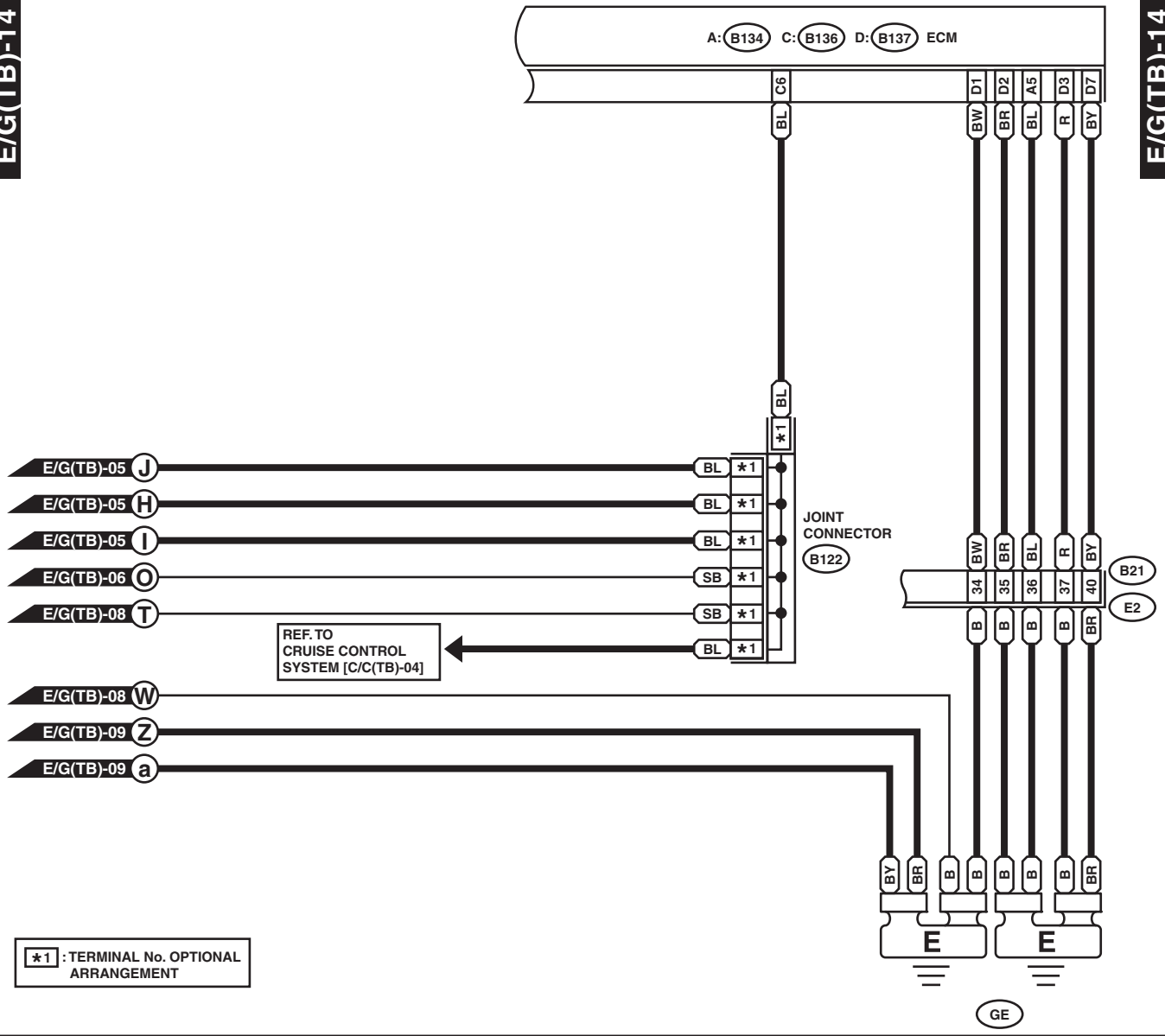

REF. TO CRUISE CONTROL SYSTEM [C/C(TB)-04]

*1 : TERMINAL No. OPTIONAL ARRANGEMENT

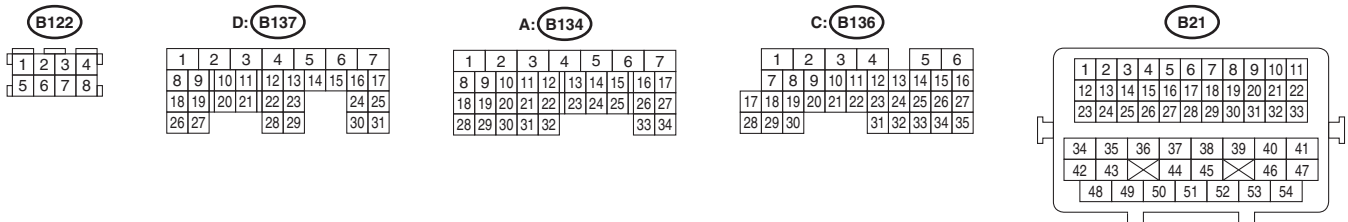

WI-19526

Radiator Fan System

WIRING SYSTEM

6. Radiator Fan System

A: WIRING DIAGRAM

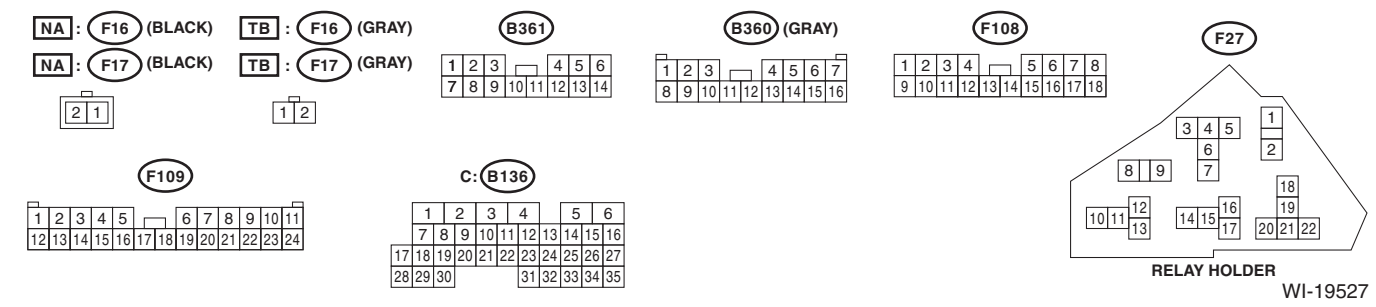
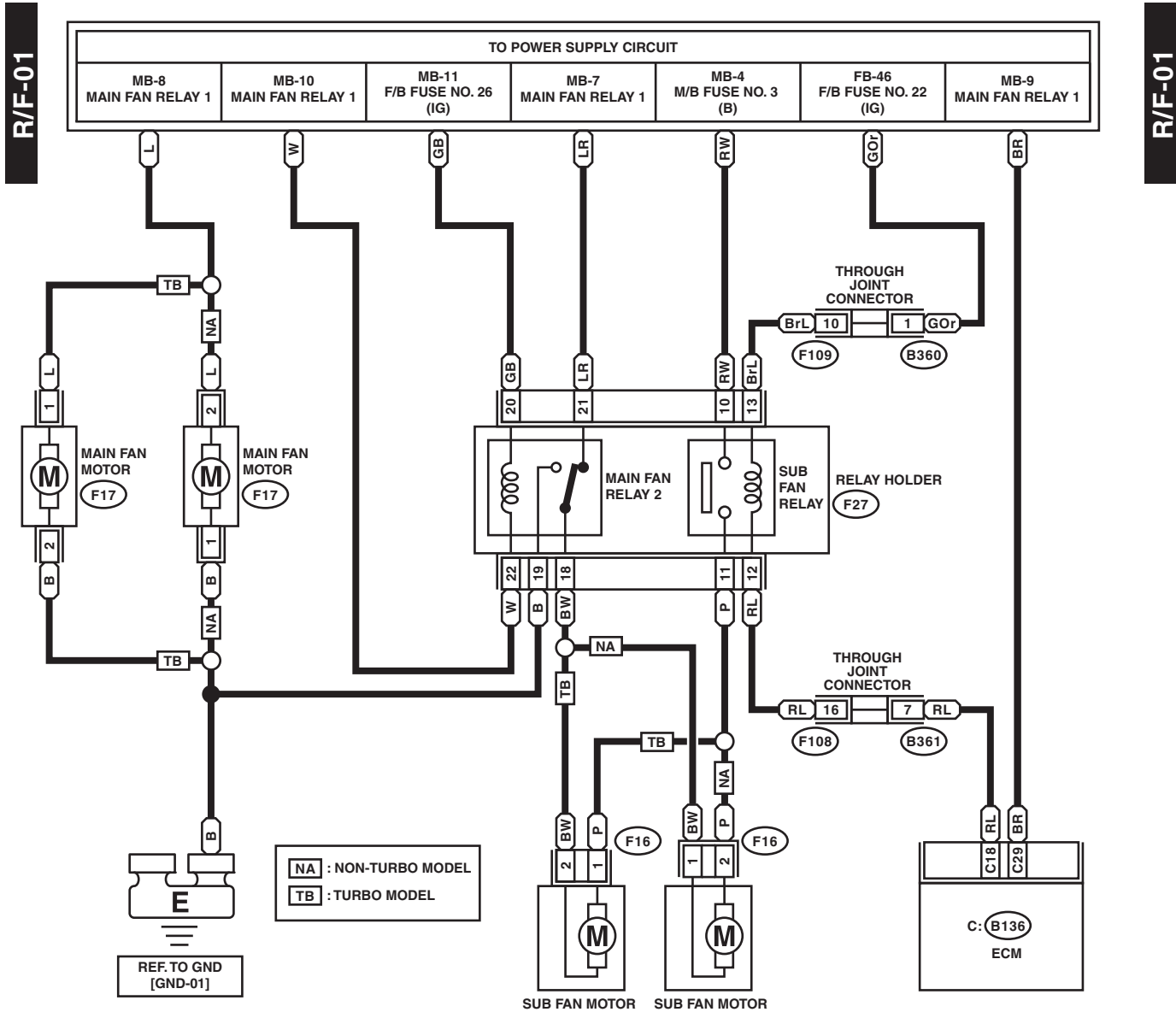

WI-19527

7. Charging System

A: WIRING DIAGRAM

CHG-01

CHG-01

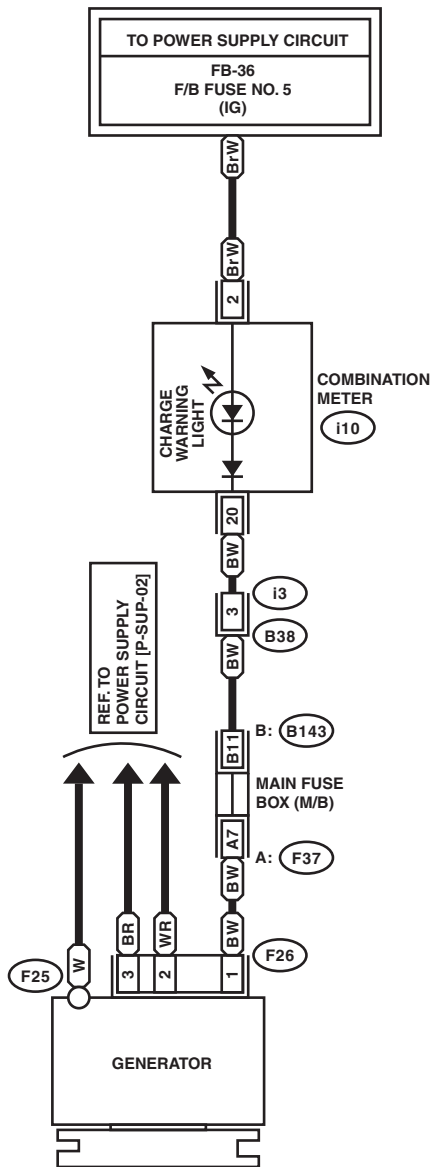

F26

1	2	3
---	---	---

B: B143

1	2	3	4	5	6	7	8	9		
10	11	12	13	14	15	16	17	18	19	20

A: F37

1	2	3	4	5	6	7	8	9		
10	11	12	13	14	15	16	17	18	19	20

i3

1	2	3	4		
5	6	7	8	9	10
11	12	13	14	15	16
17	18	19	20	21	22
23	24	25	26	27	28

i10

1	2	3	4	5	6	7	8	9	10	11	12	13	14	15	16	17	18	19	20
21	22	23	24	25	26	27	28	29	30	31	32	33	34	35	36	37	38	39	40

Starter System

WIRING SYSTEM

8. Starter System

A: WIRING DIAGRAM

1. NON-TURBO MODEL

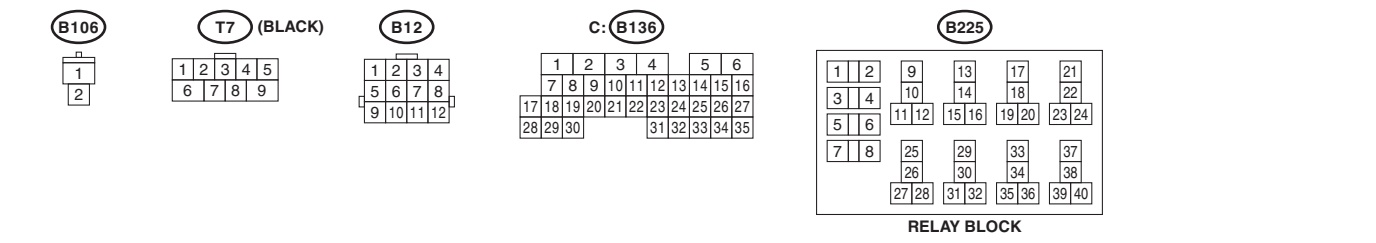
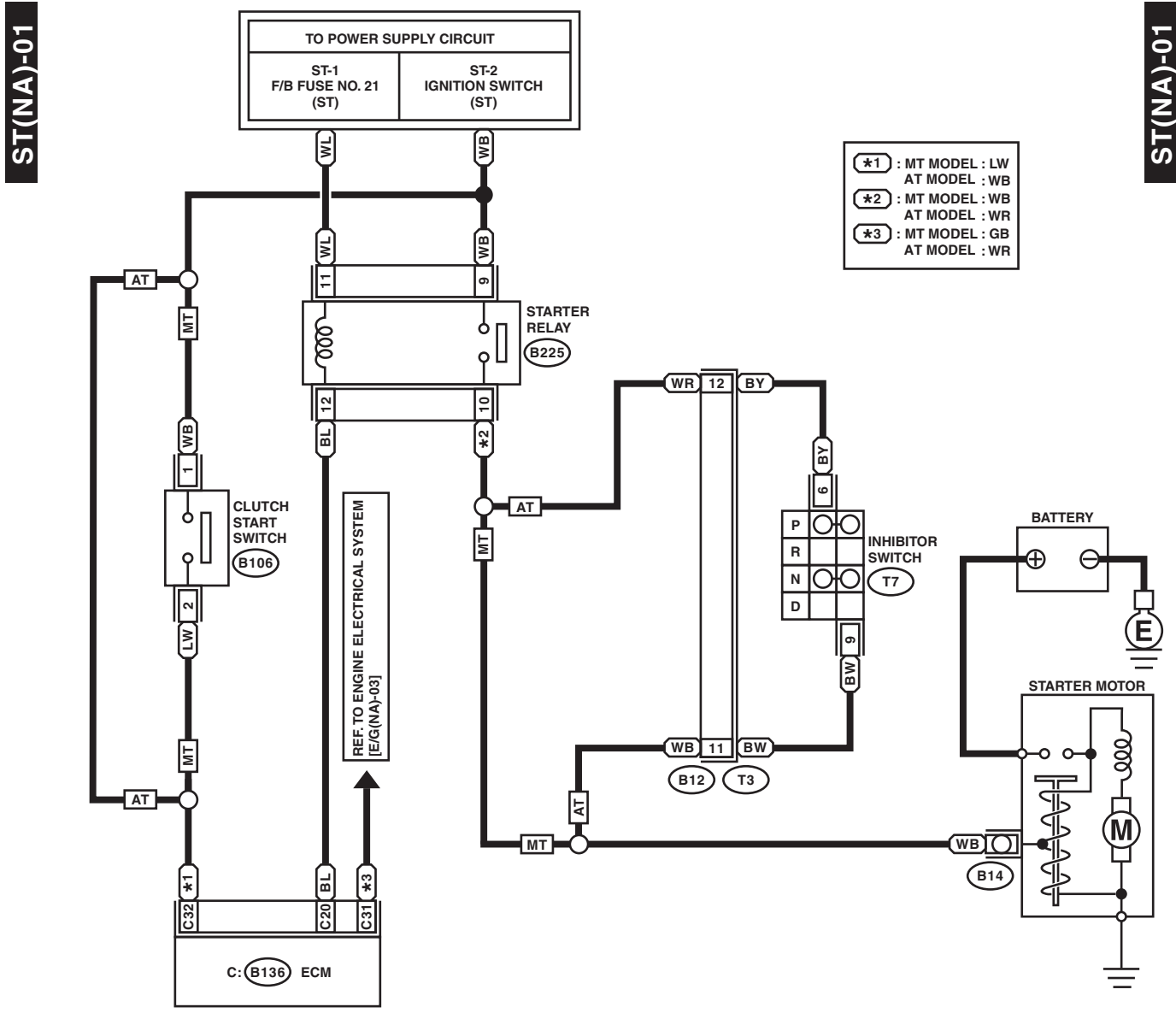

WI-19529

Starter System

2. TURBO MODEL

ST(TB)-01

ST(TB)-01

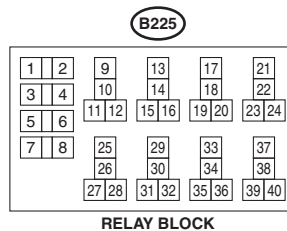
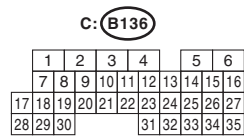
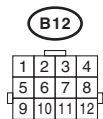
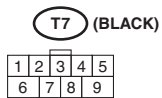
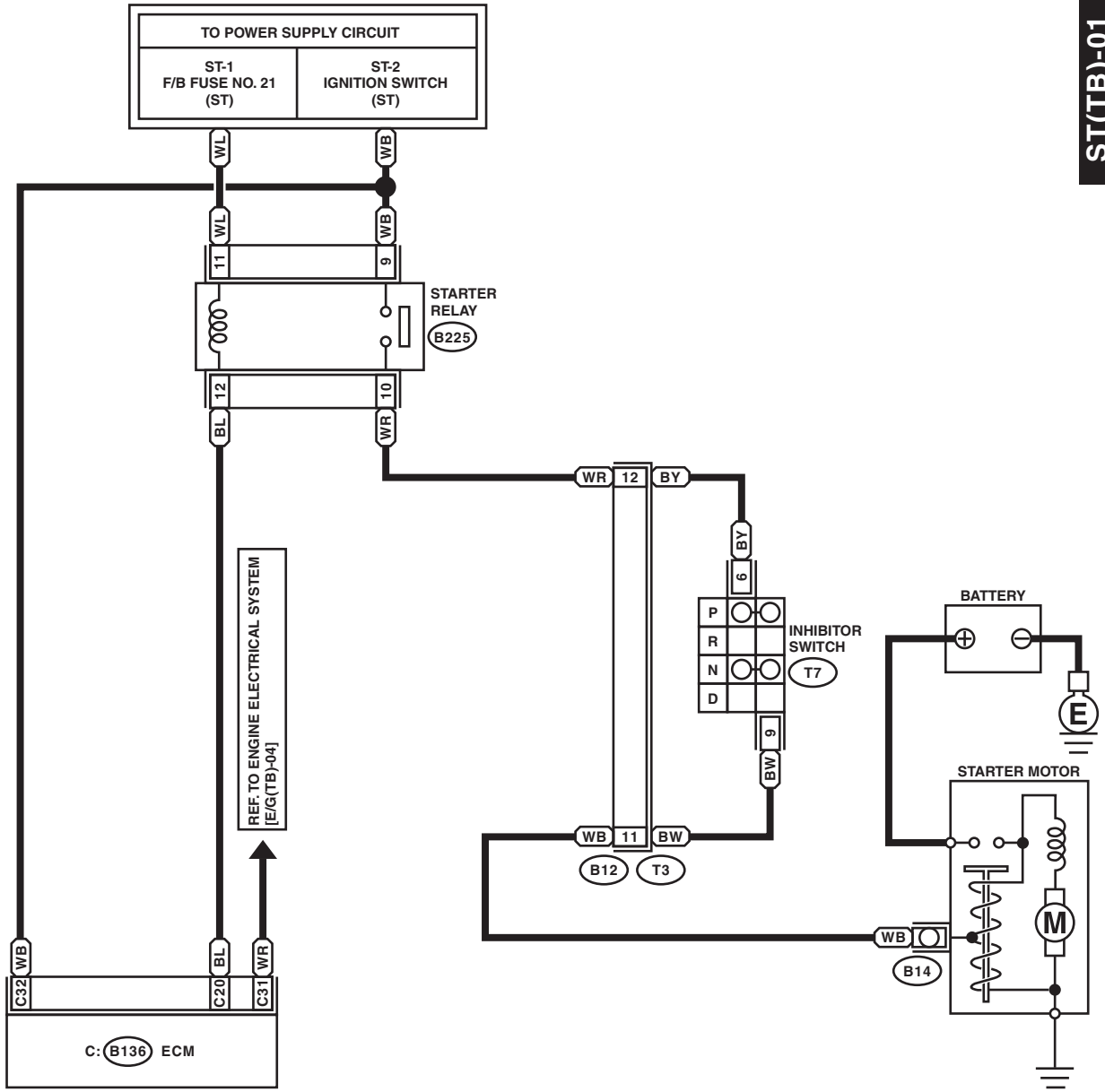

WI-19530

Remote Engine Start System

WIRING SYSTEM

9. Remote Engine Start System

A: WIRING DIAGRAM

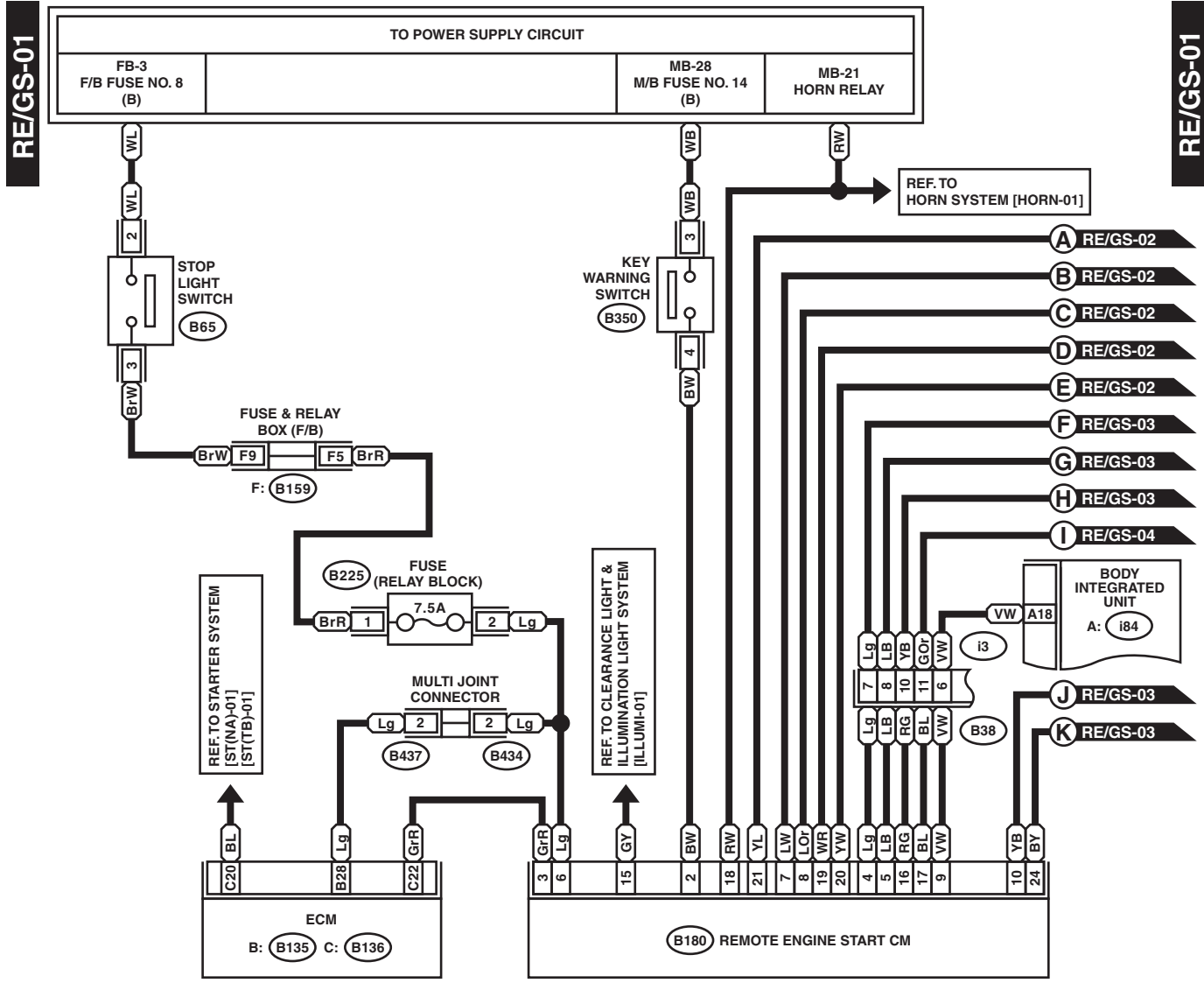

B65 (BLACK)



B350



B434 (PINK)



B437 (BLUE)

F: B159 (BROWN)

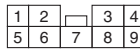

B180

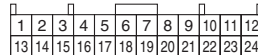

B225

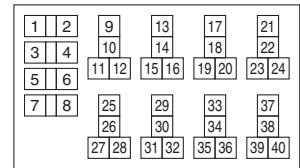

RELAY BLOCK

WI-19531

Remote Engine Start System

WIRING SYSTEM

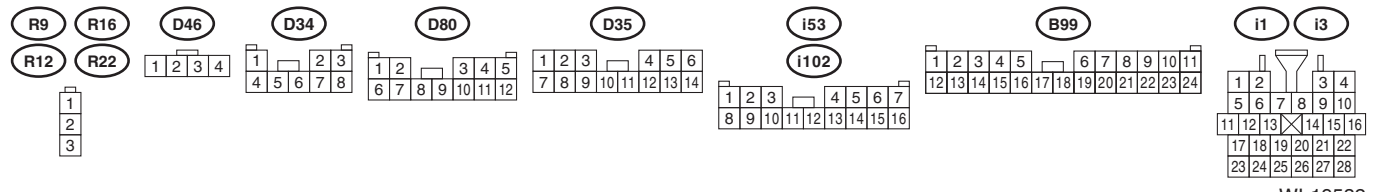
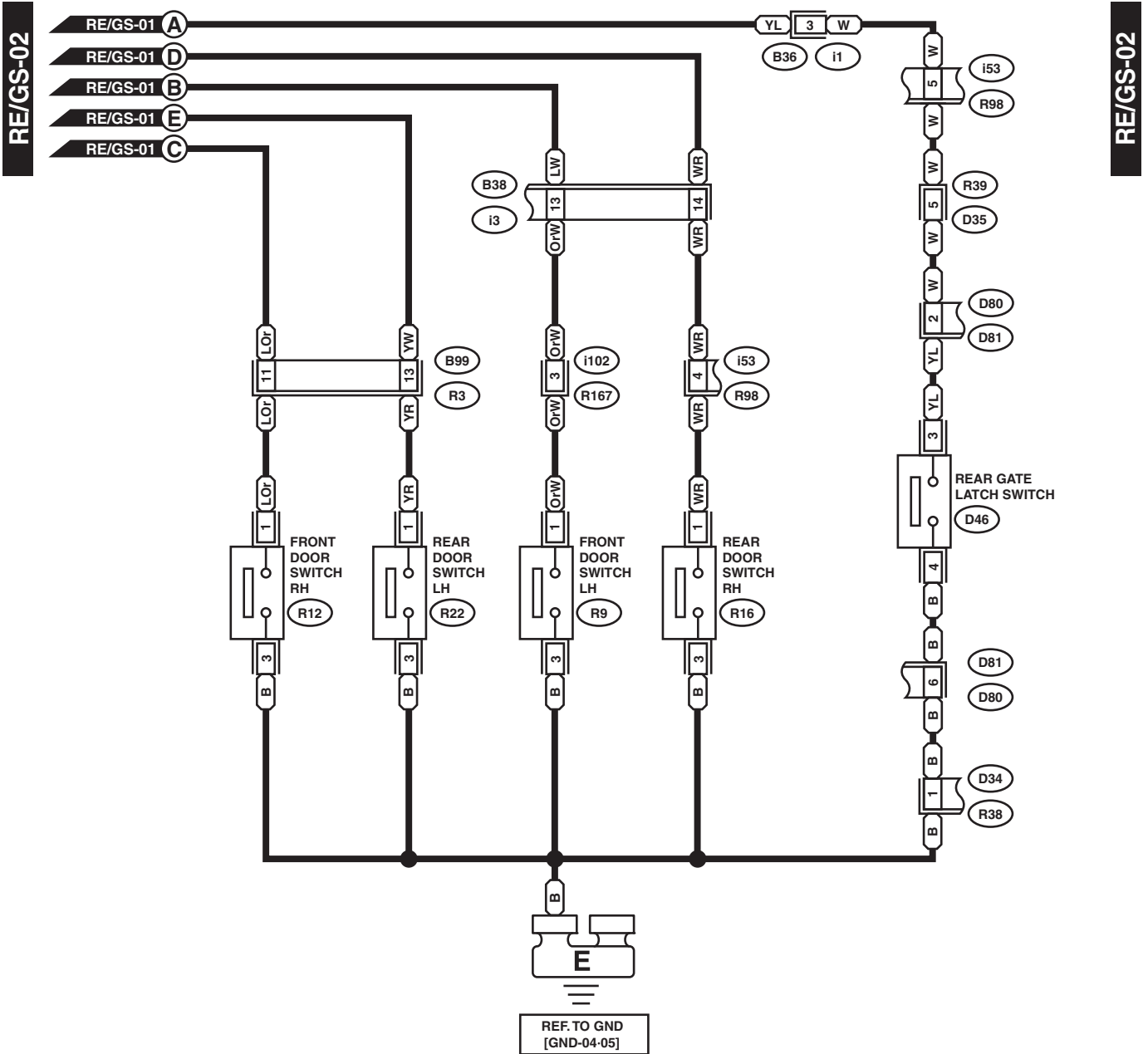

WI-19532

Remote Engine Start System

WIRING SYSTEM

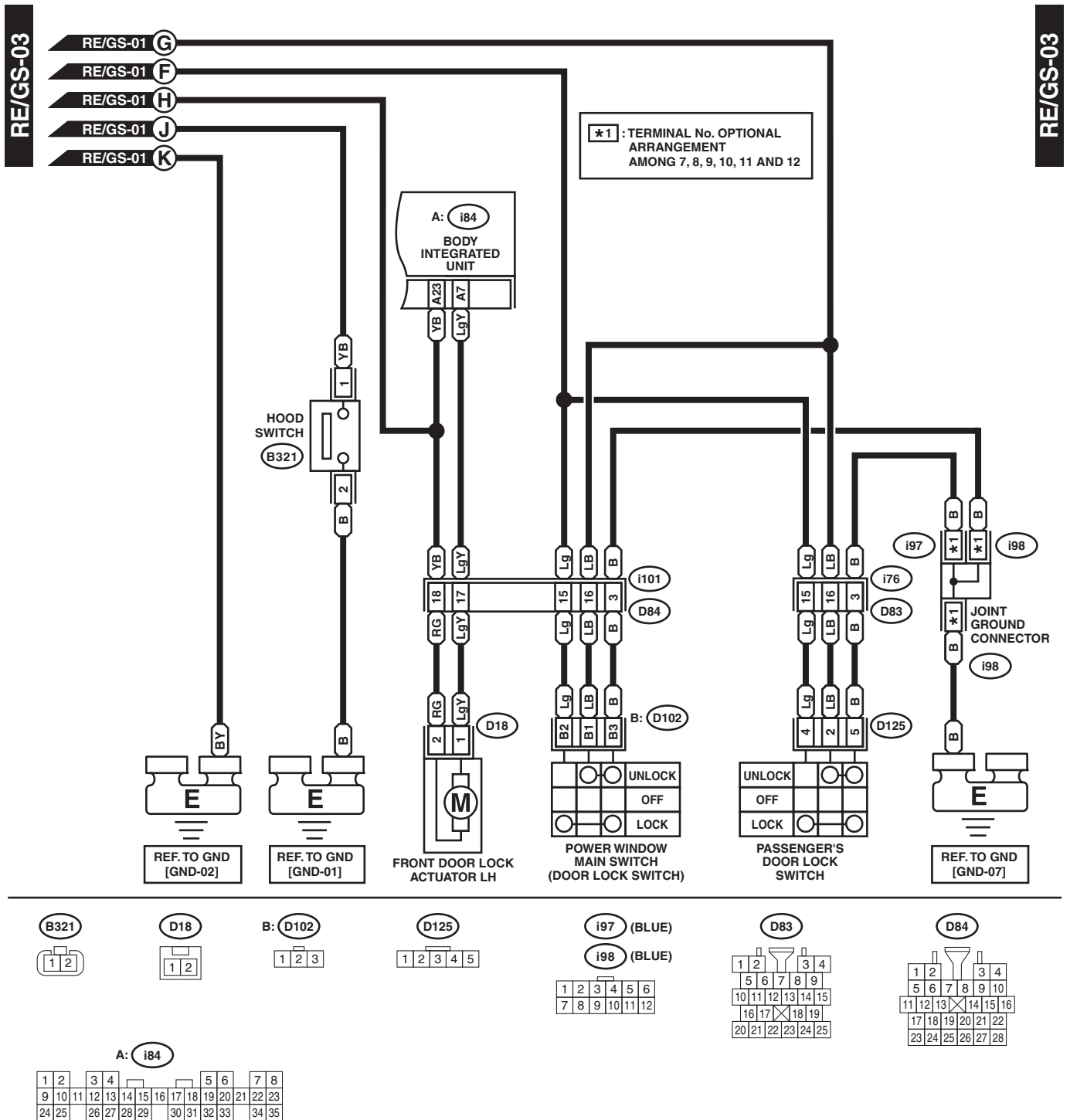

WI-19533

Remote Engine Start System

WIRING SYSTEM

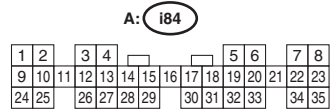
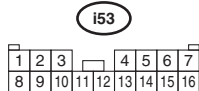
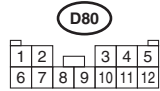
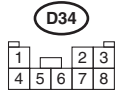
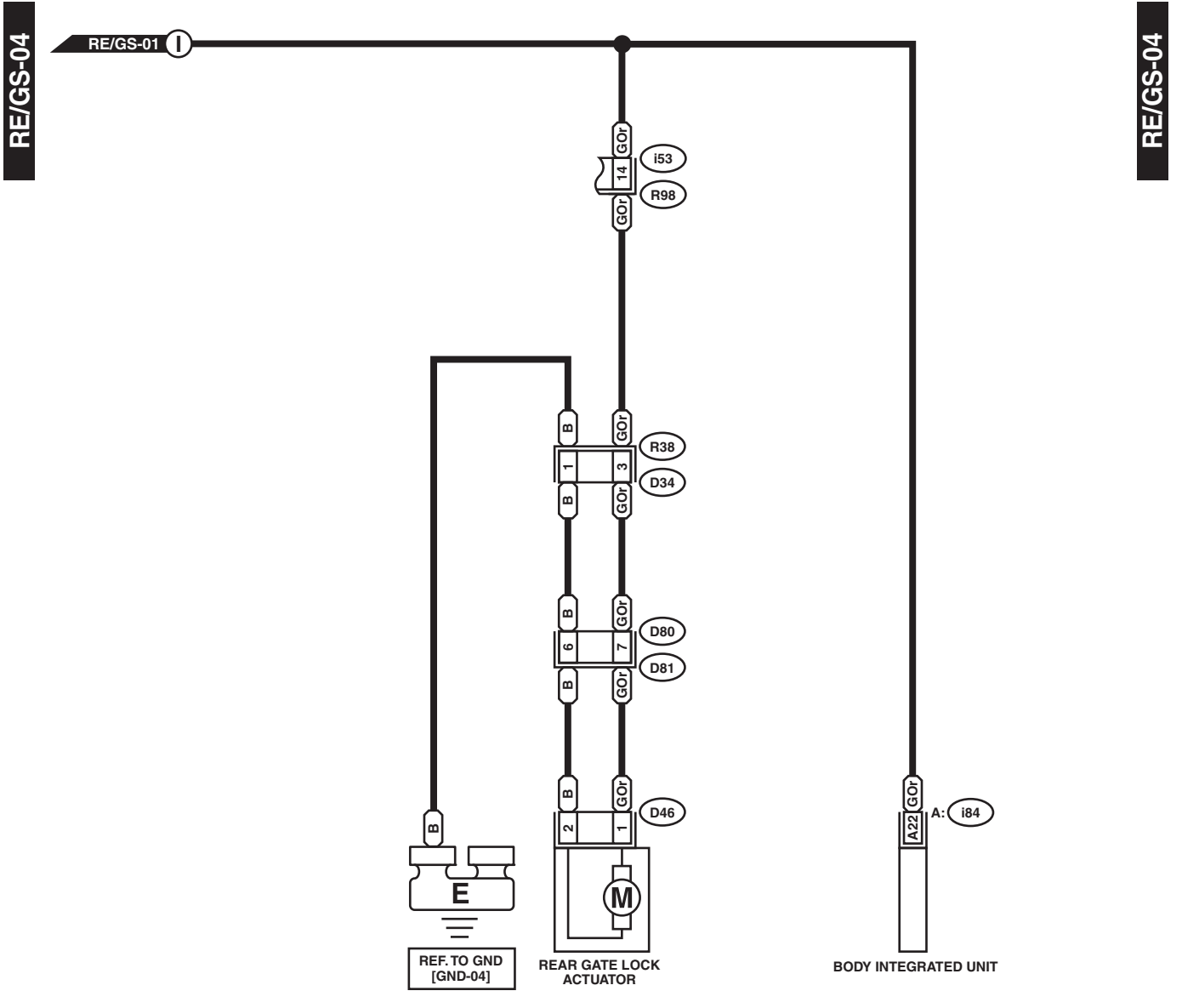

WI-19534

AT Control System

WIRING SYSTEM

10. AT Control System

A: WIRING DIAGRAM

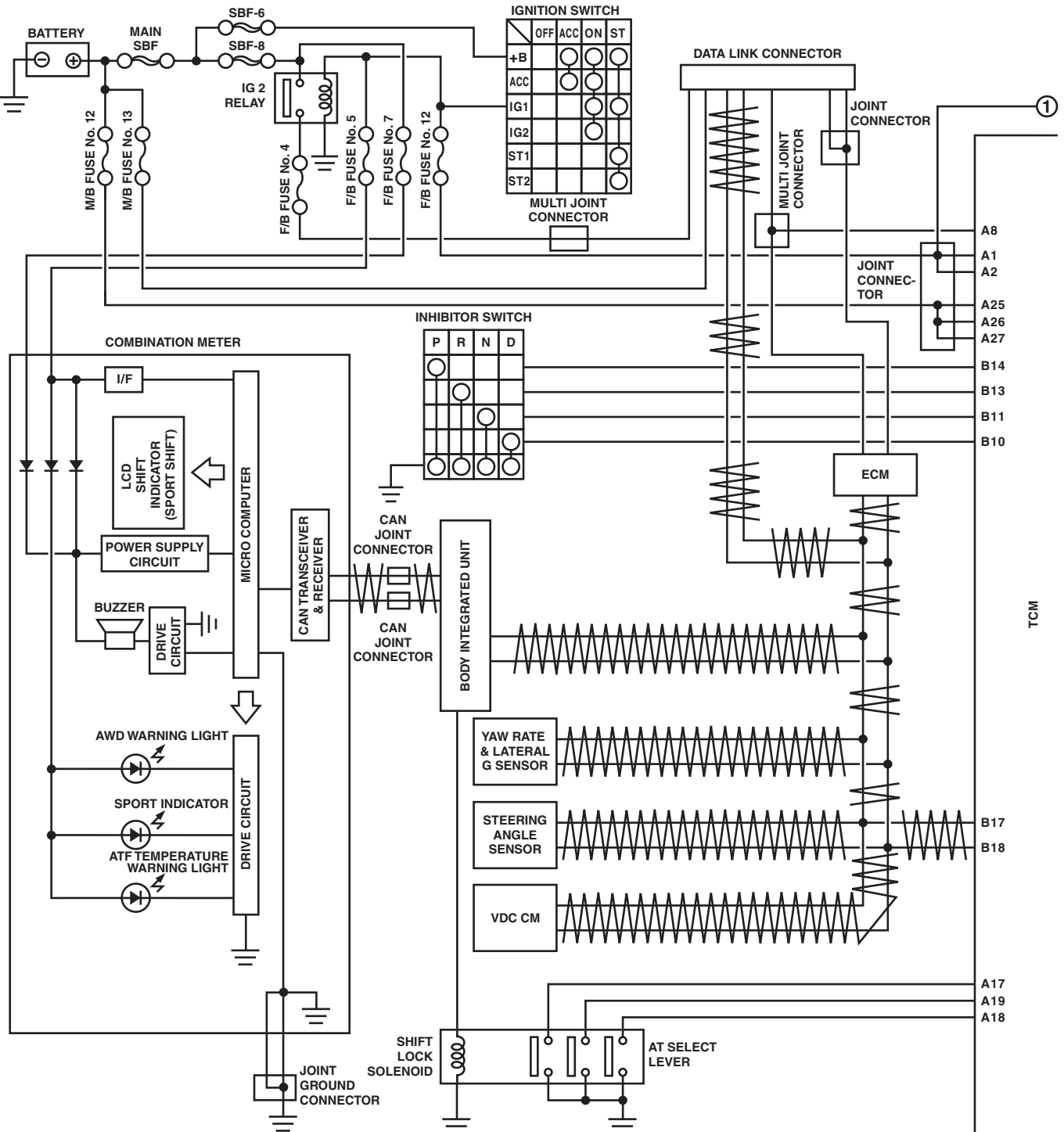

WI-19535

AT Control System

WIRING SYSTEM

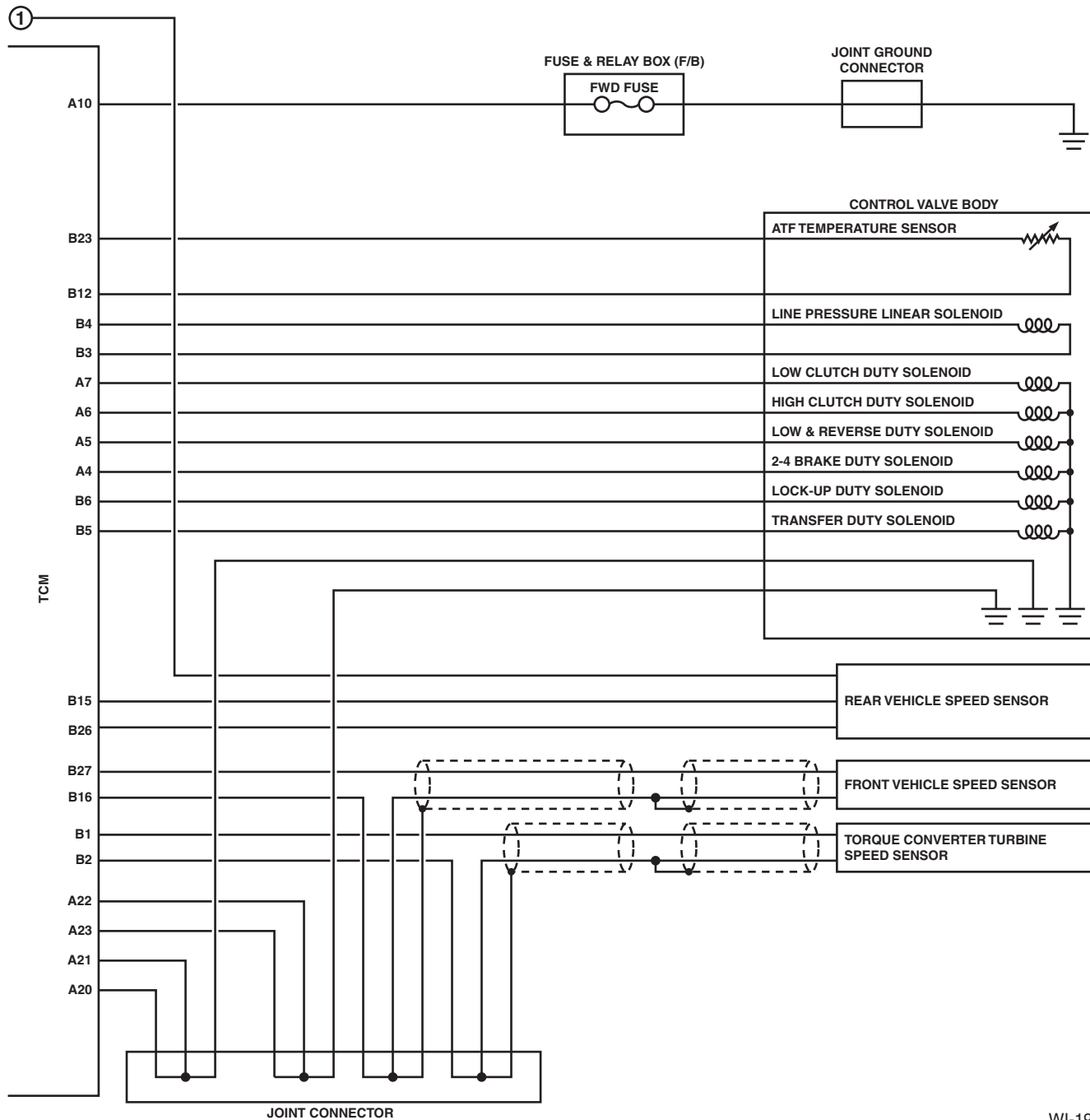

WI-19660

AT Control System

WIRING SYSTEM

AT-01

AT-01

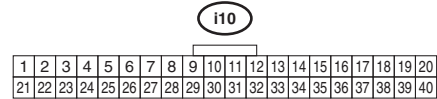
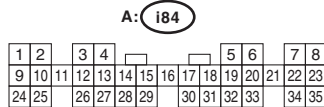
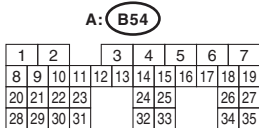
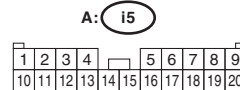
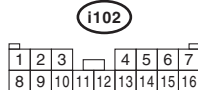
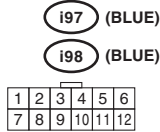
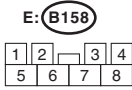
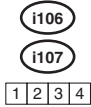
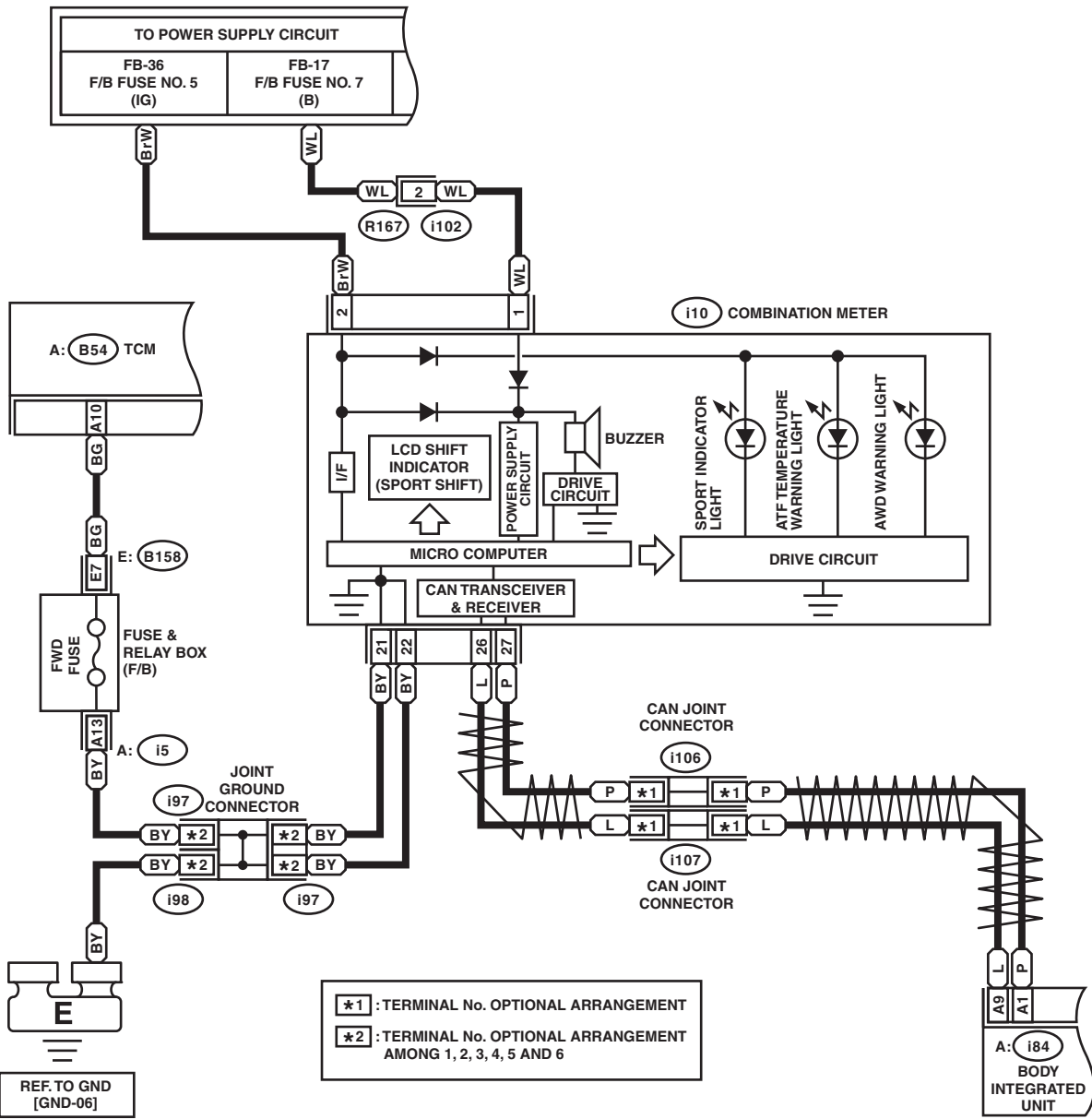

WI-19536

AT Control System

WIRING SYSTEM

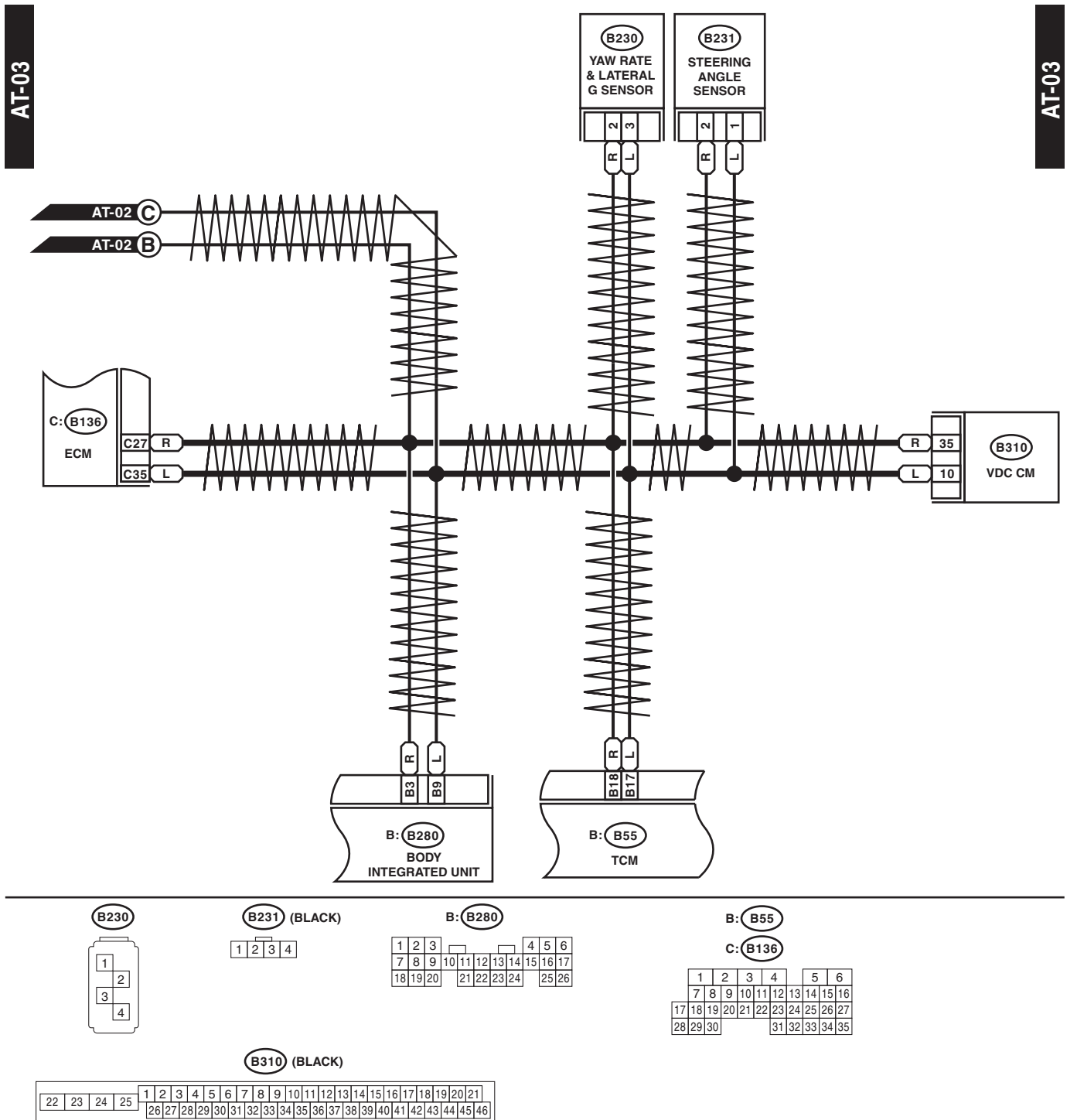

WI-19537

AT Control System

WIRING SYSTEM

AT-04

AT-04

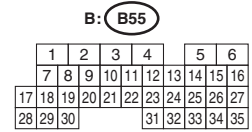
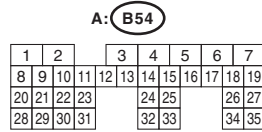
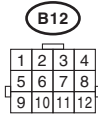
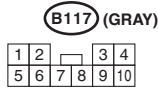
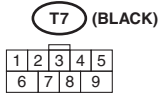
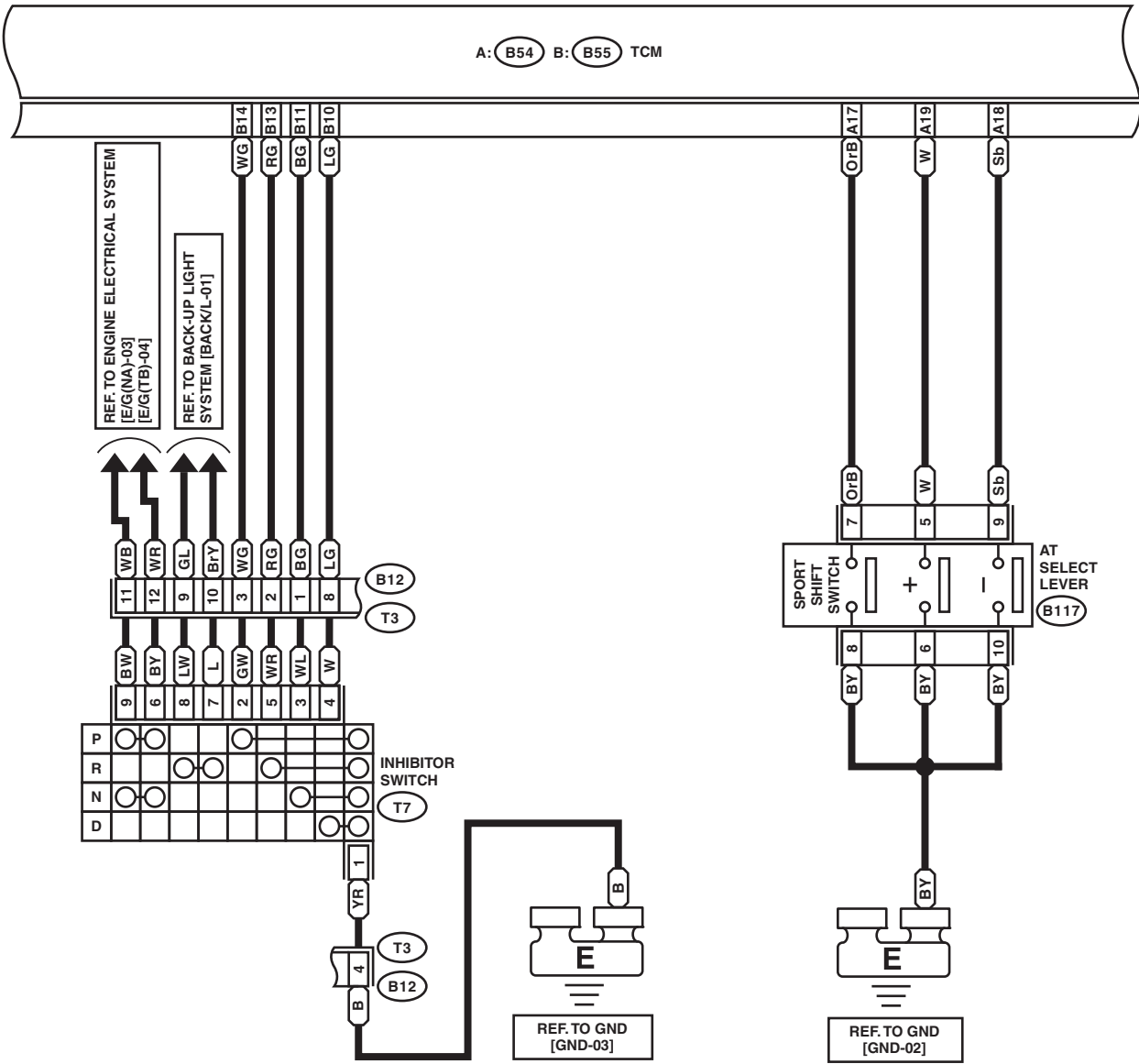

WI-19538

11. AT Shift Lock Control System

A: WIRING DIAGRAM

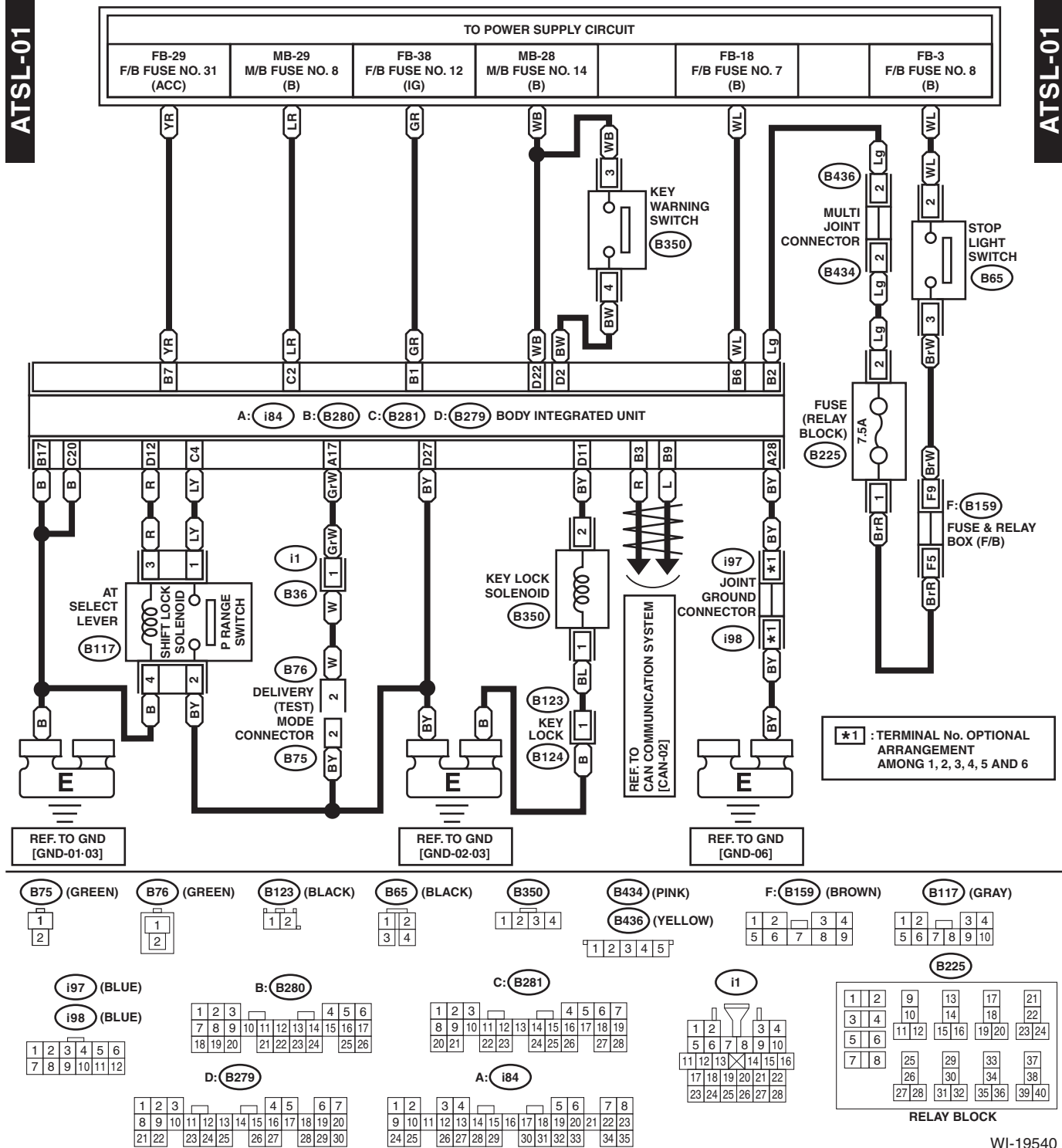

Vehicle Dynamics Control System

WIRING SYSTEM

12. Vehicle Dynamics Control System

A: WIRING DIAGRAM

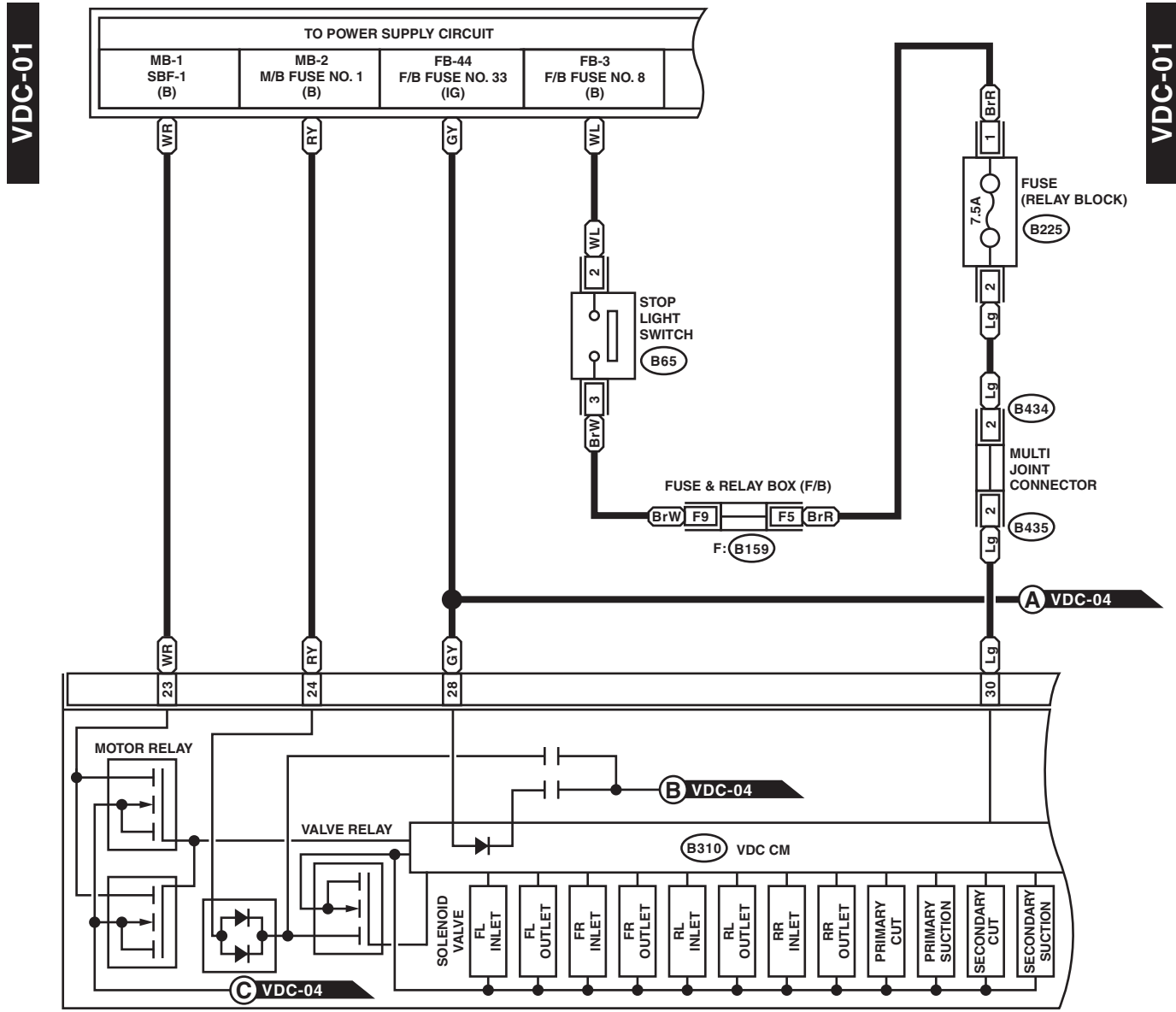

B65 (BLACK)



B434 (PINK)



B435 (BROWN)

F: B159 (BROWN)



B225

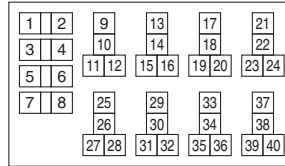

RELAY BLOCK

B310 (BLACK)

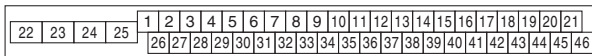

WI-19541

Vehicle Dynamics Control System

WIRING SYSTEM

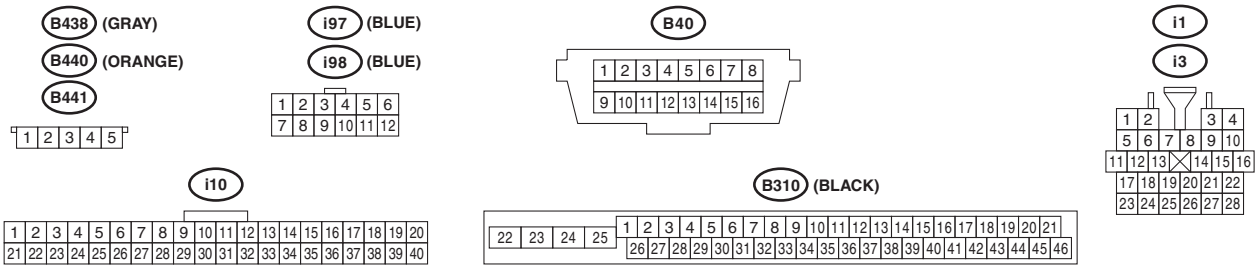
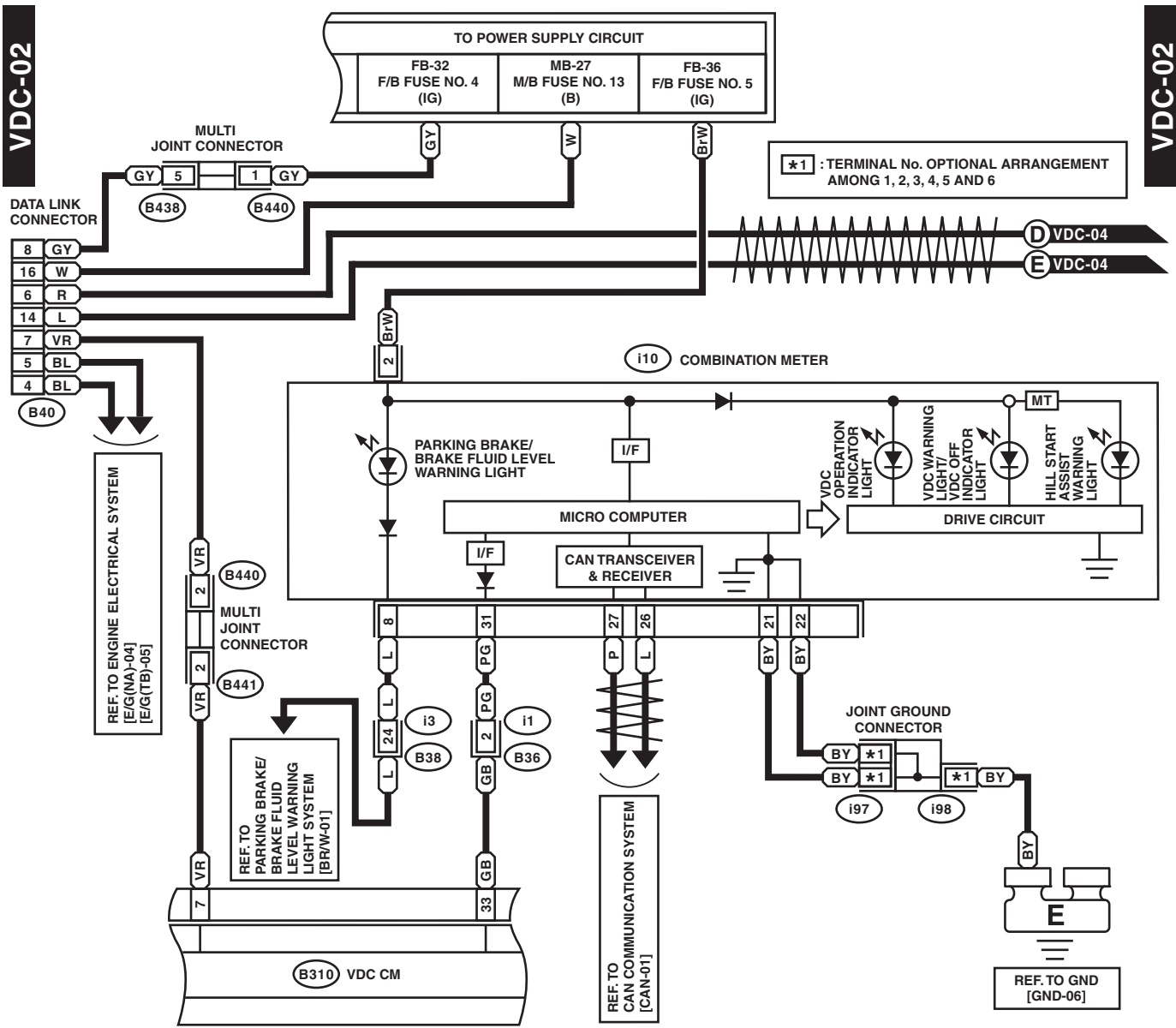

WI-19542

Vehicle Dynamics Control System

WIRING SYSTEM

VDC-03

VDC-03

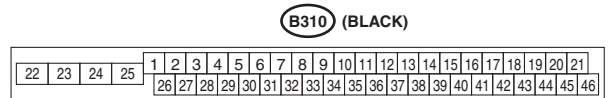
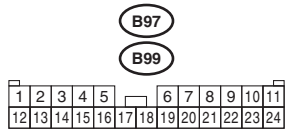
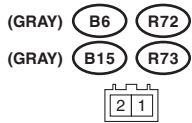
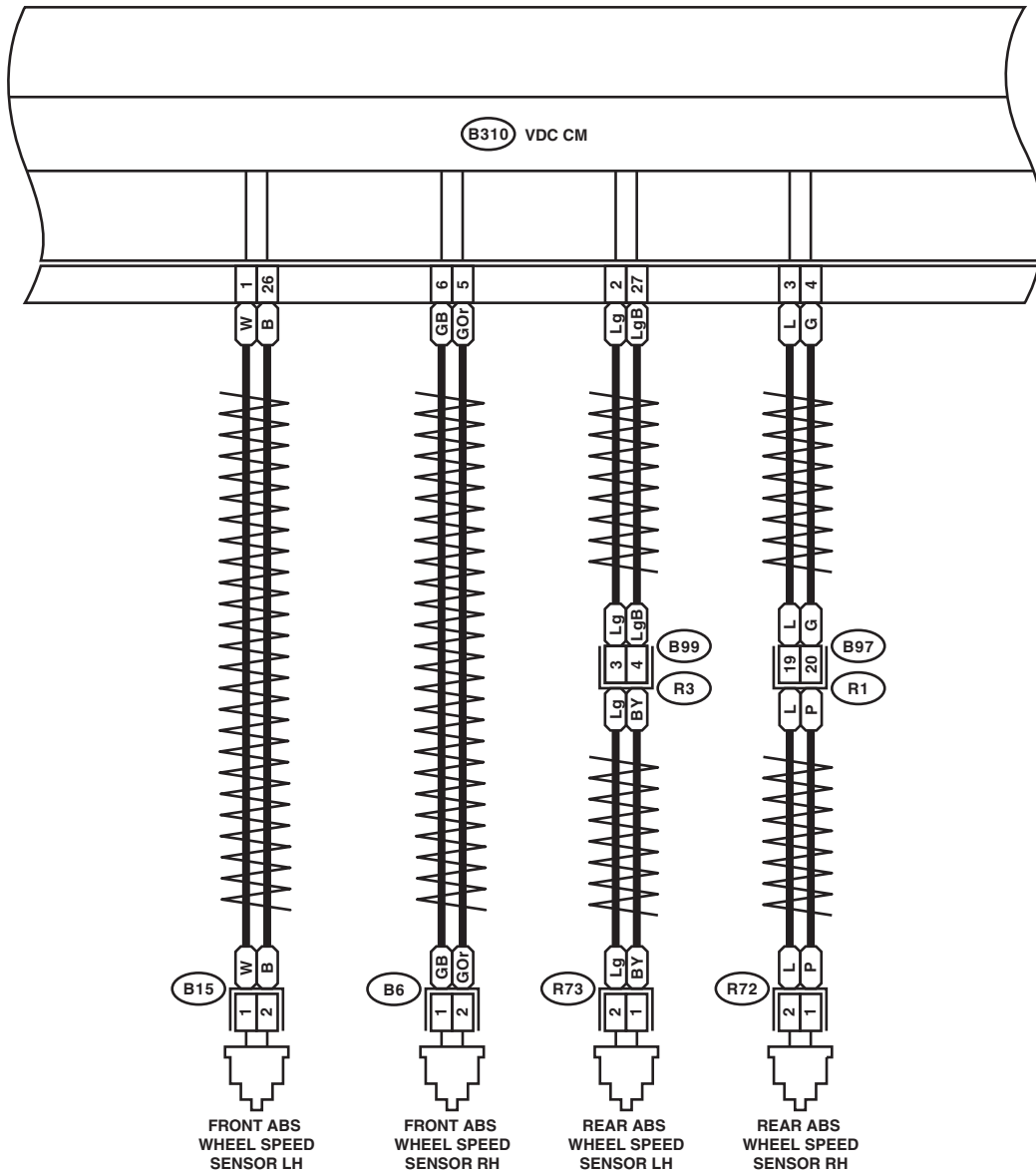

WI-19543

Vehicle Dynamics Control System

WIRING SYSTEM

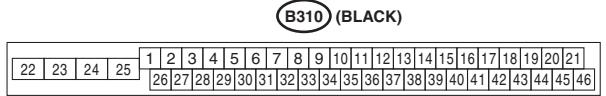
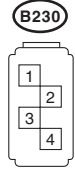
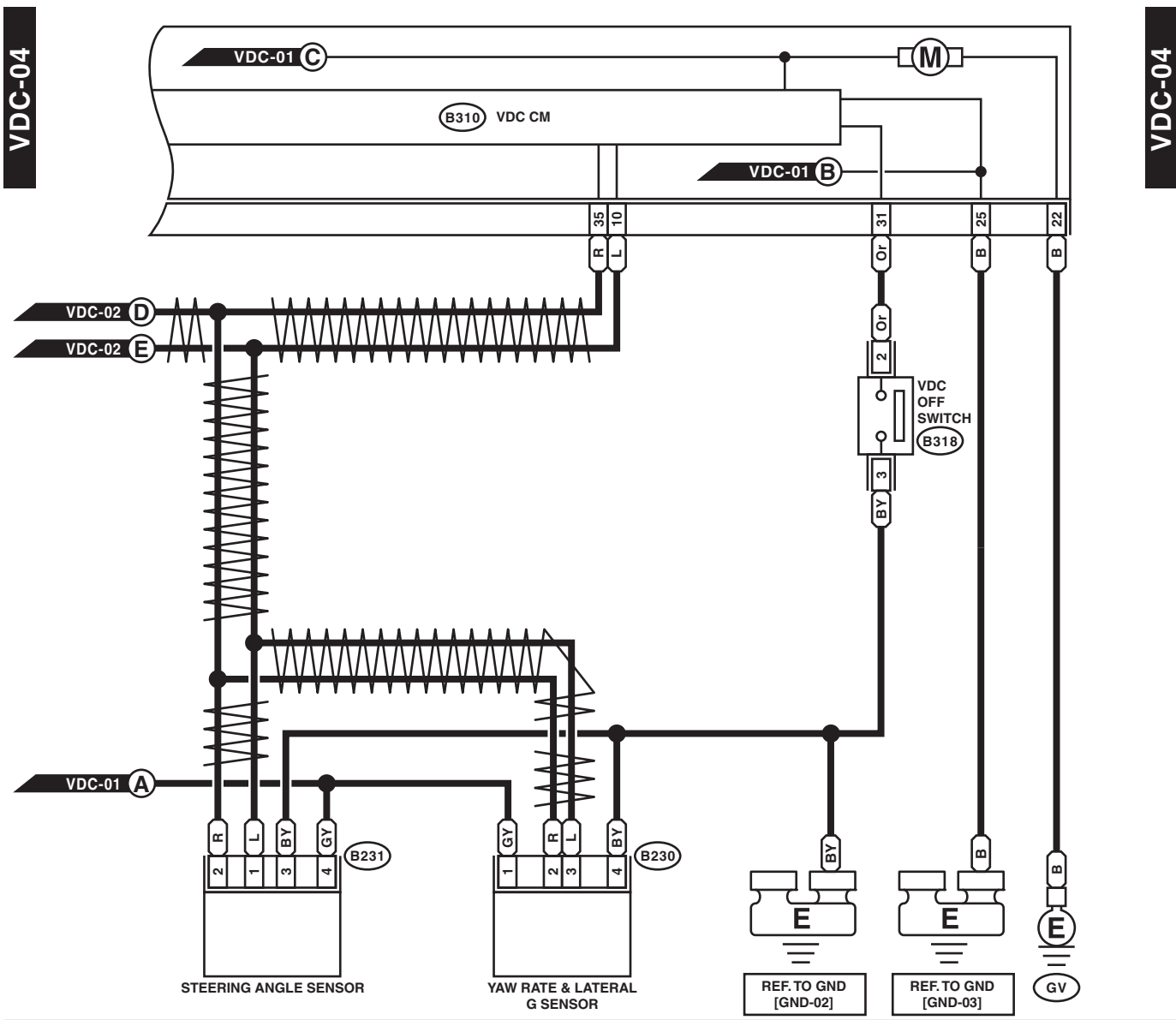

WI-19544

Tire Pressure Monitoring System

WIRING SYSTEM

13. Tire Pressure Monitoring System

A: WIRING DIAGRAM

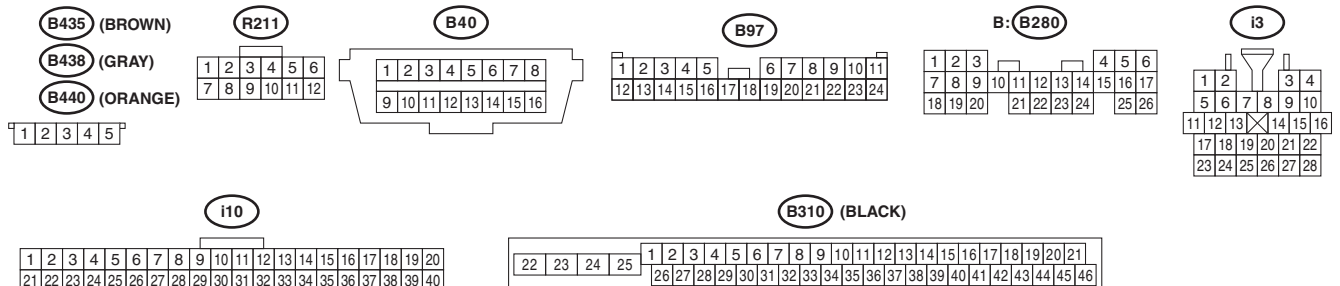
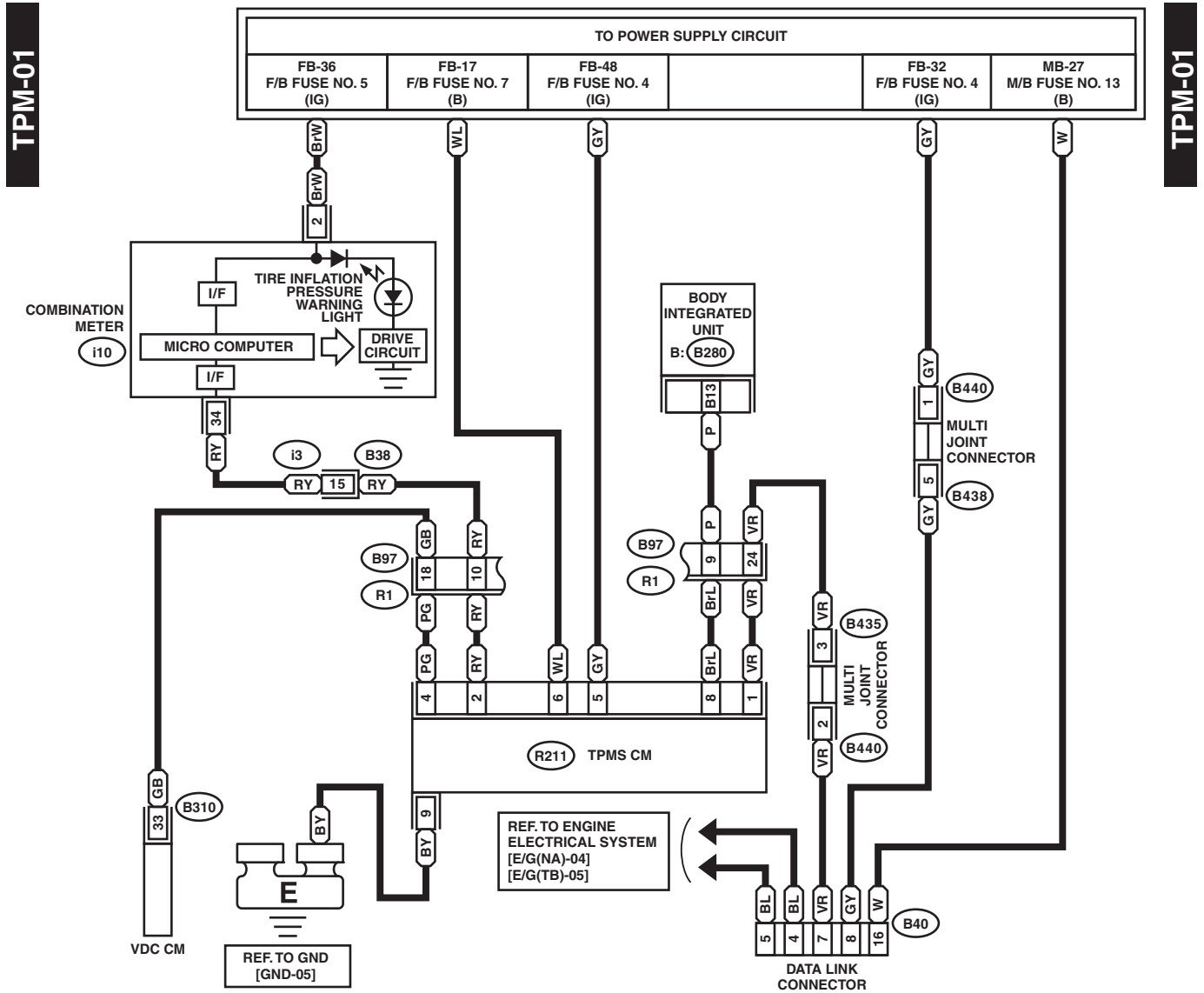

WI-19545

14. Air Conditioning System

A: WIRING DIAGRAM

1. MANUAL A/C MODEL

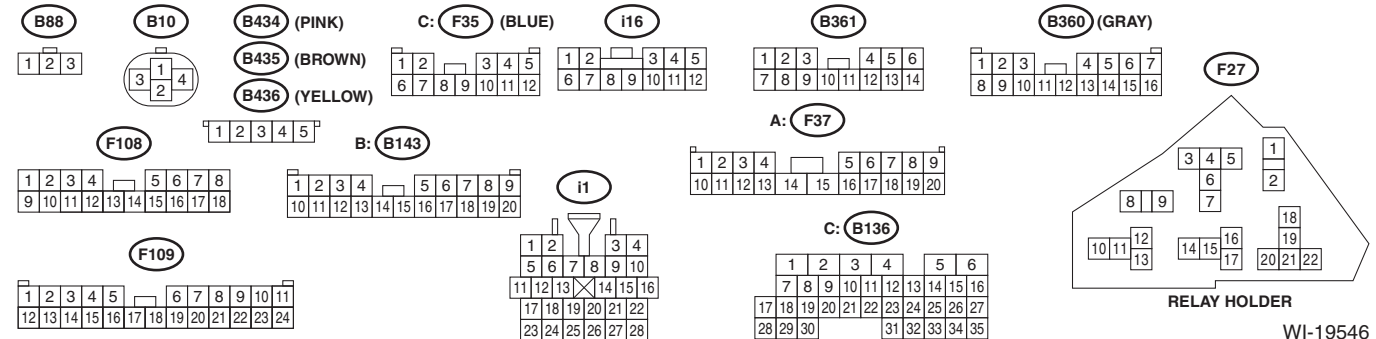
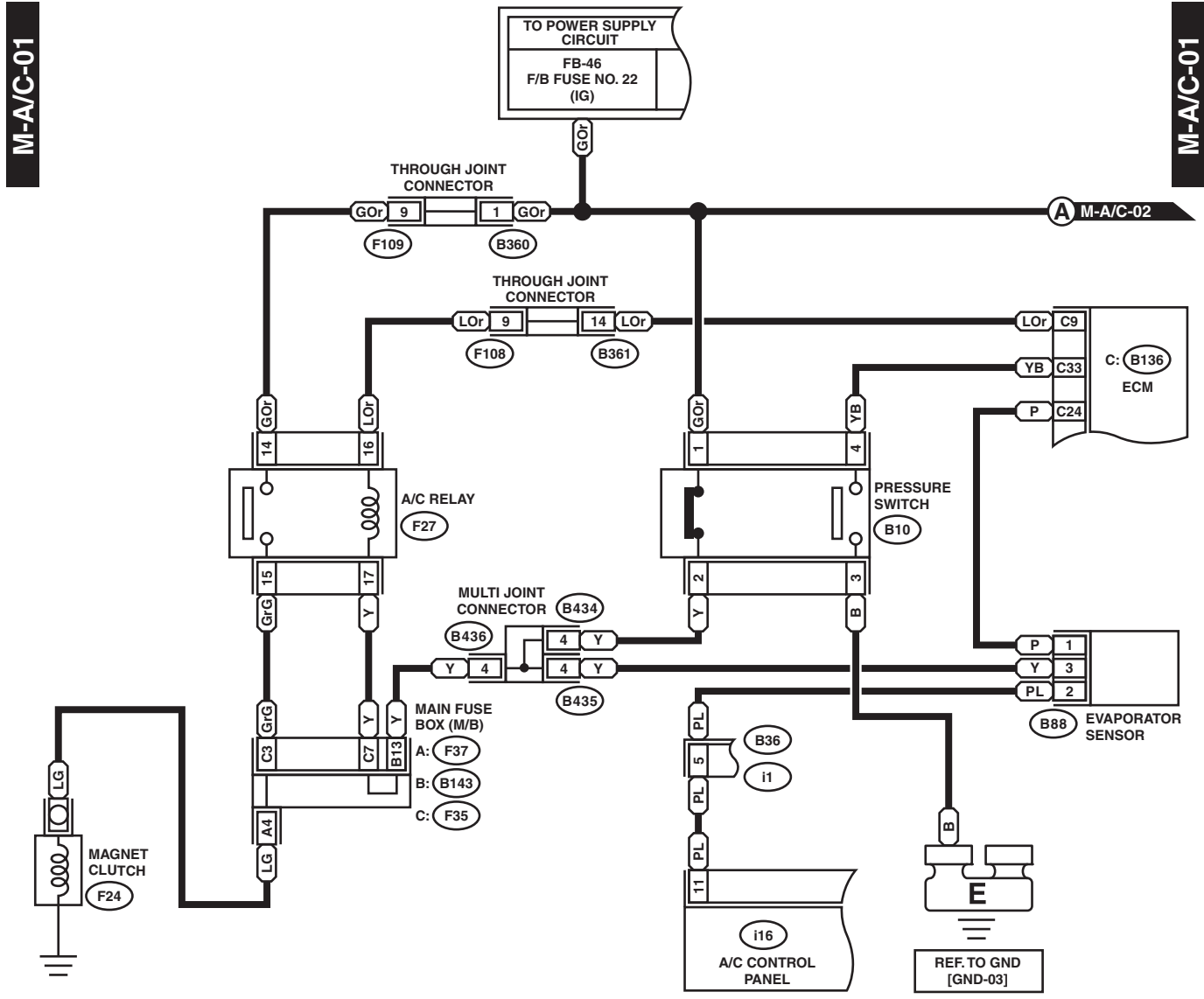

WI-19546

Air Conditioning System

WIRING SYSTEM

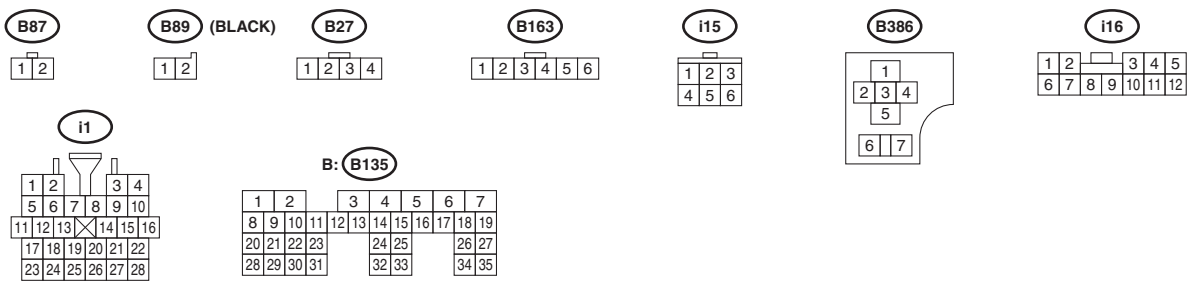
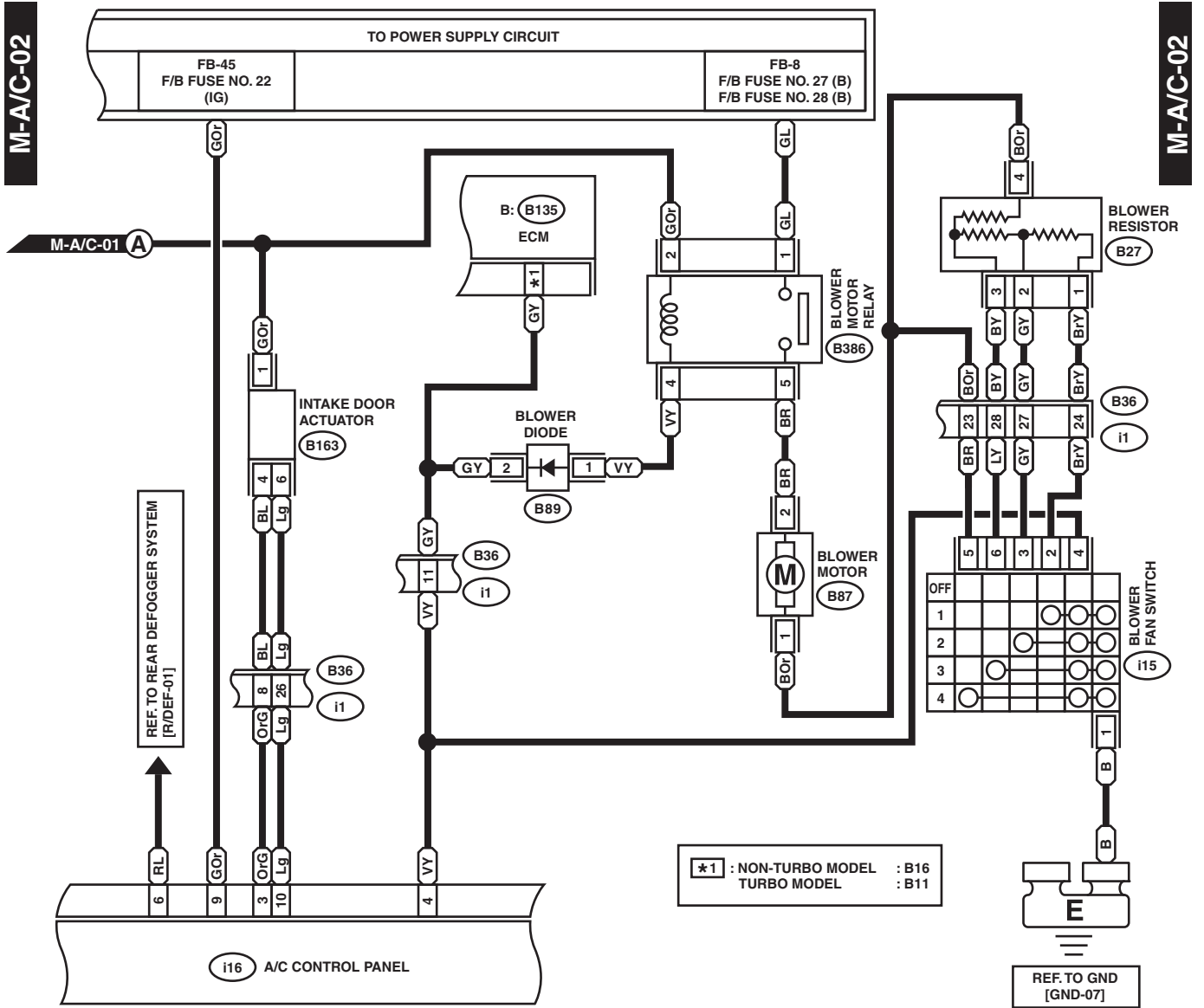

WI-19547

Air Conditioning System

WIRING SYSTEM

M-A/C-03

M-A/C-03

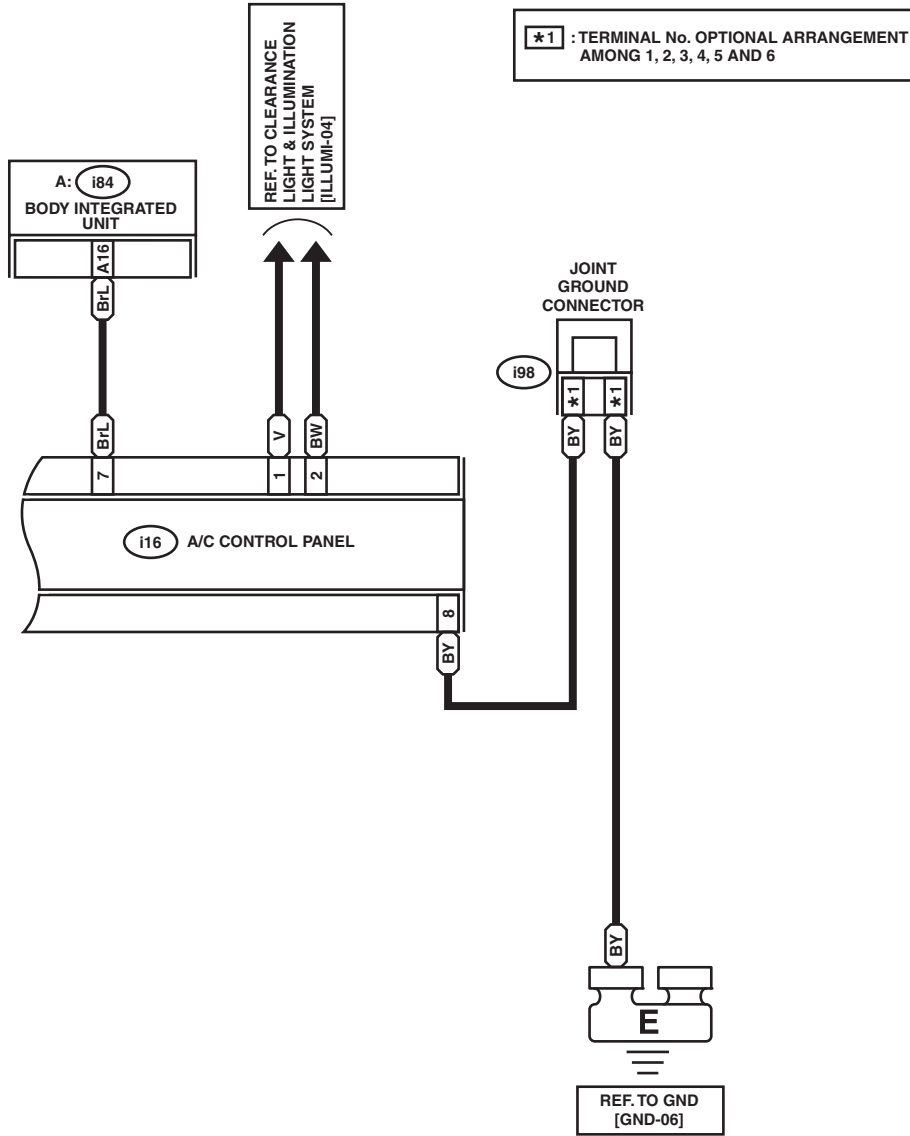

i16

1	2	3	4	5
6	7	8	9	10
11	12			

i98 (BLUE)

1	2	3	4	5	6
7	8	9	10	11	12

A: i84

1	2	3	4	5	6	7	8
9	10	11	12	13	14	15	16
17	18	19	20	21	22	23	
24	25	26	27	28	29	30	31
32	33	34	35				

WI-19548

Air Conditioning System

WIRING SYSTEM

2. AUTO A/C MODEL

A-A/C-01

A-A/C-01

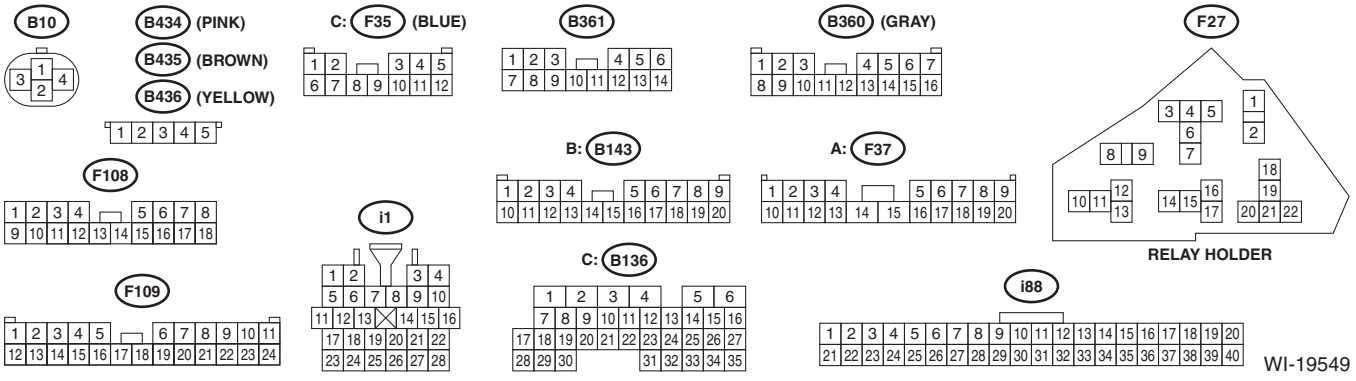
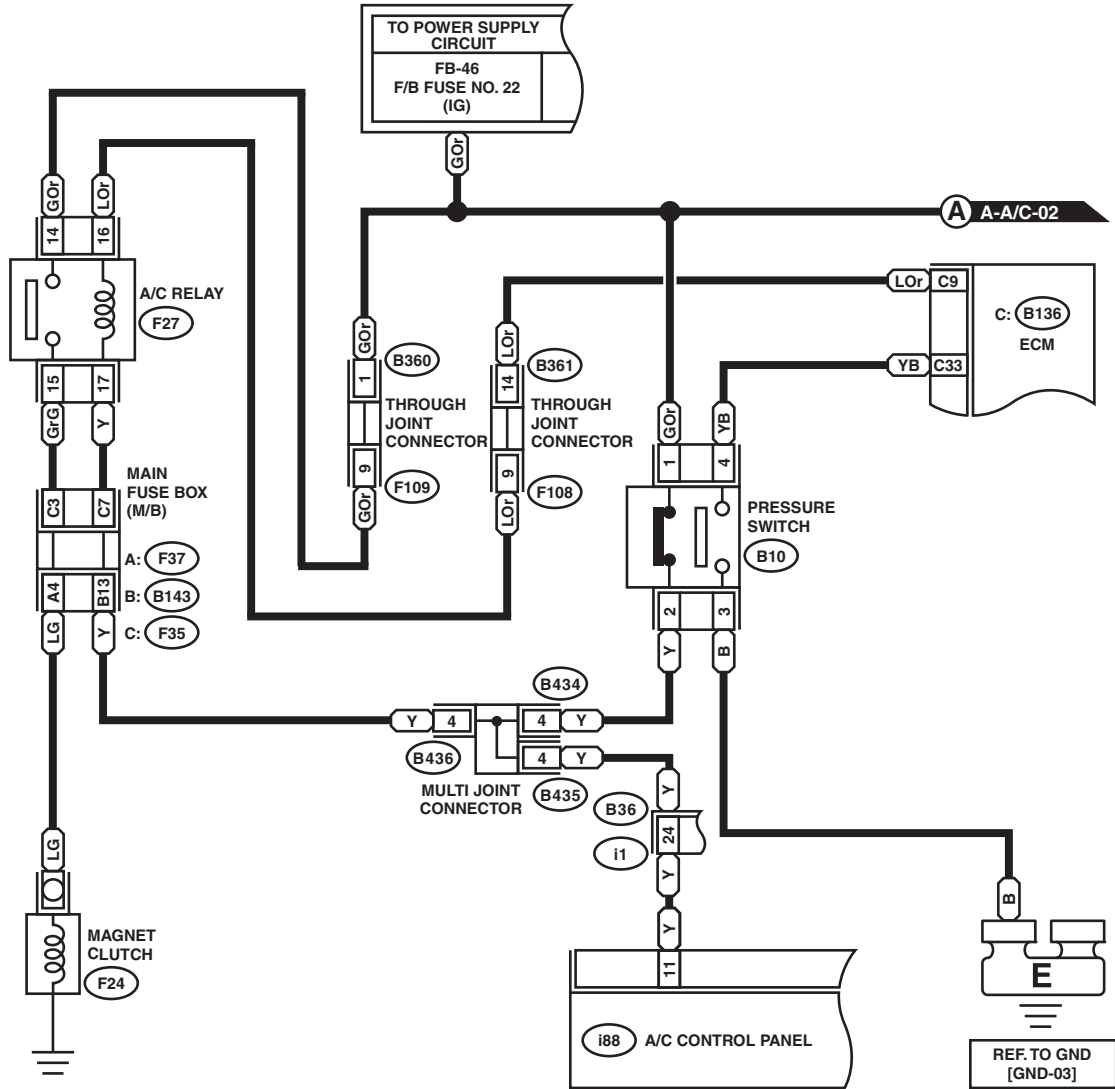

WI-19549

Air Conditioning System

WIRING SYSTEM

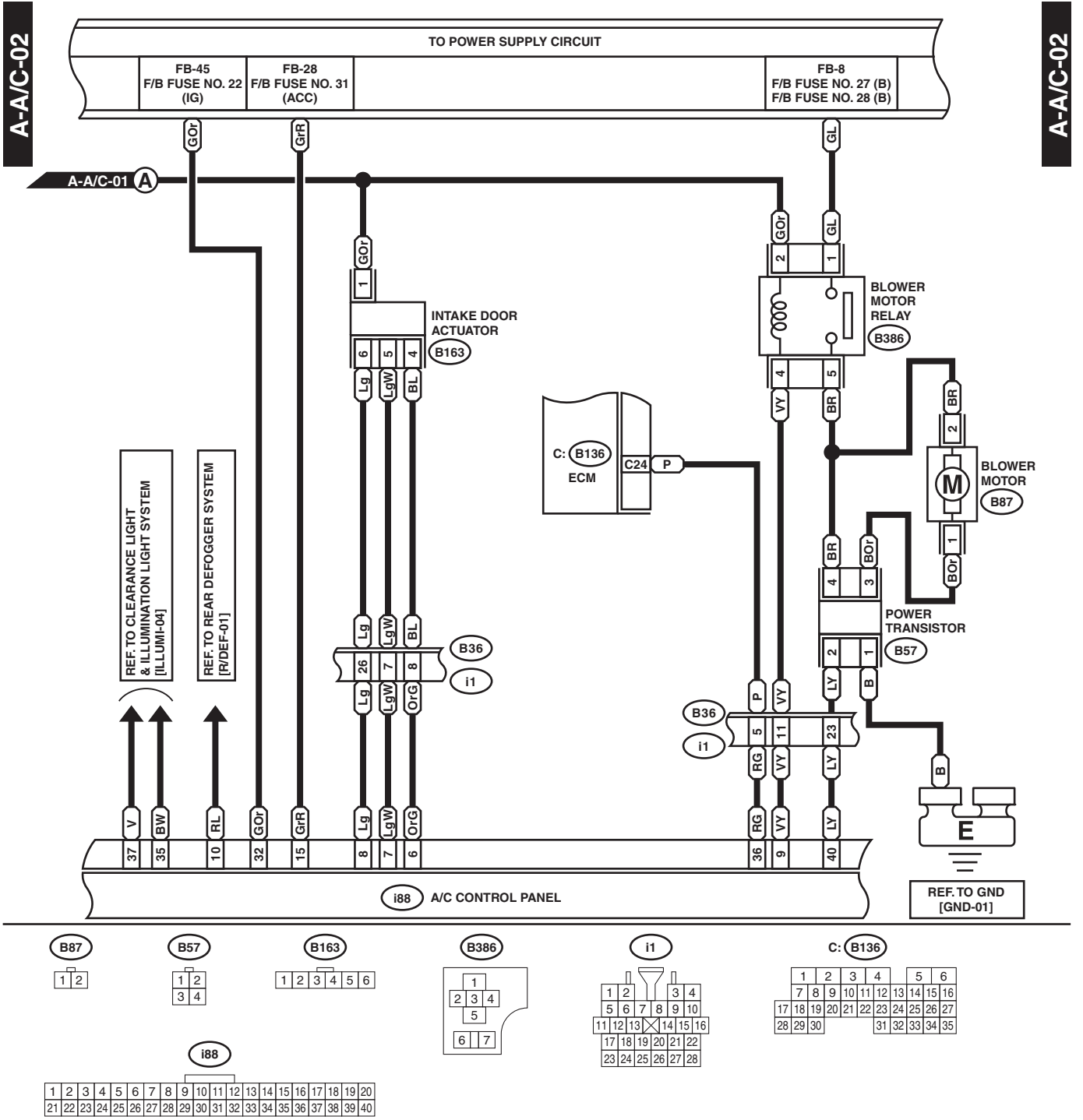

A-A/C-02

A-A/C-02

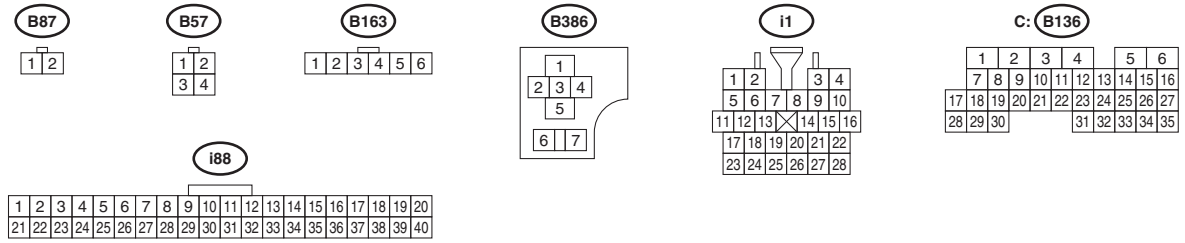

WI-19550

Air Conditioning System

WIRING SYSTEM

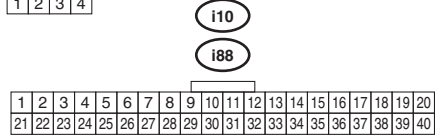
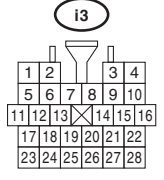
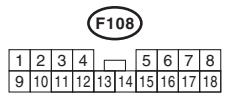
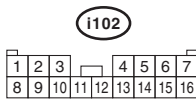
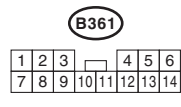
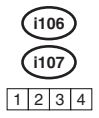
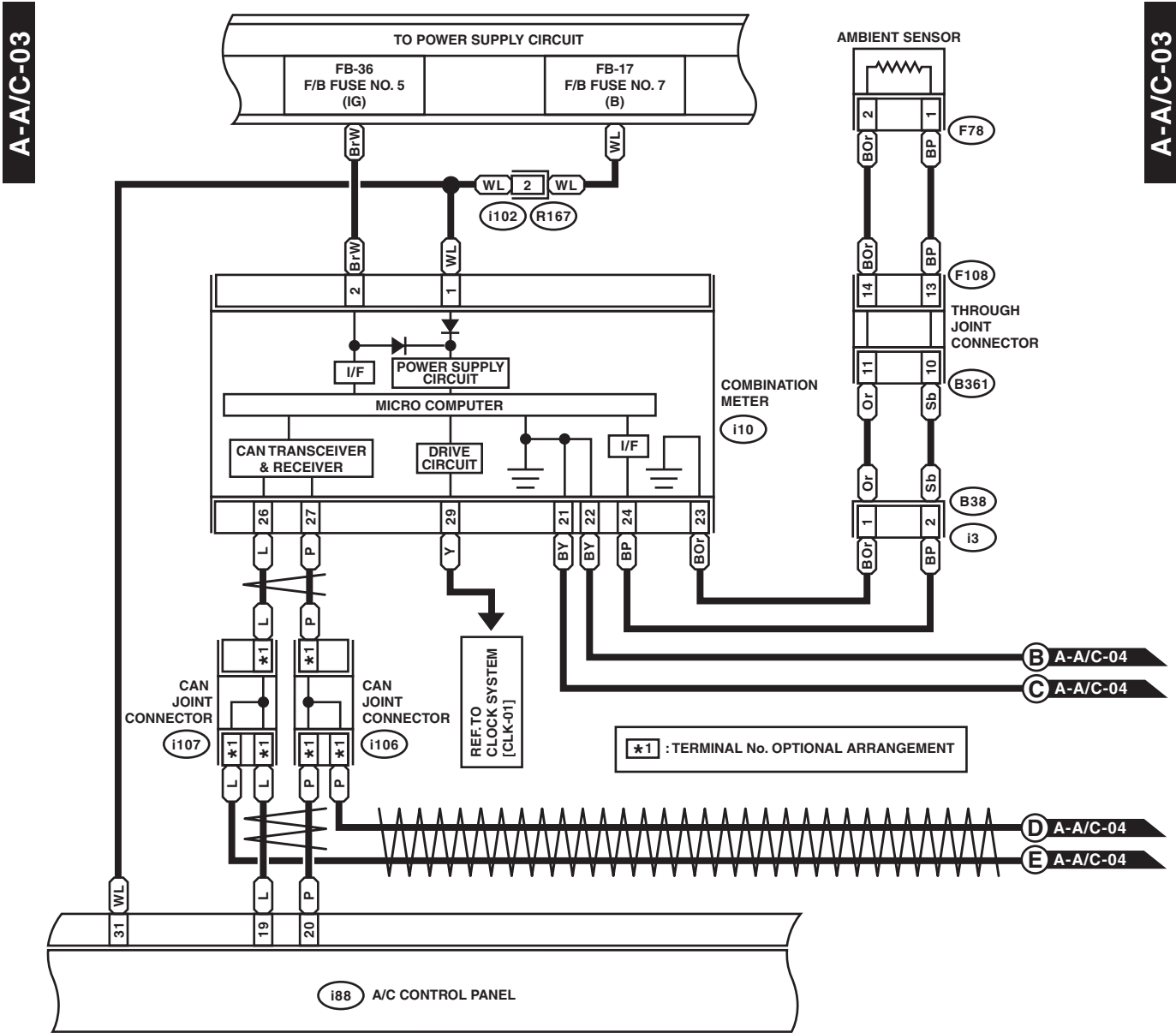

*1 : TERMINAL No. OPTIONAL ARRANGEMENT

- B** A-A/C-04
- C** A-A/C-04
- D** A-A/C-04
- E** A-A/C-04

Air Conditioning System

WIRING SYSTEM

A-A/C-04

A-A/C-04

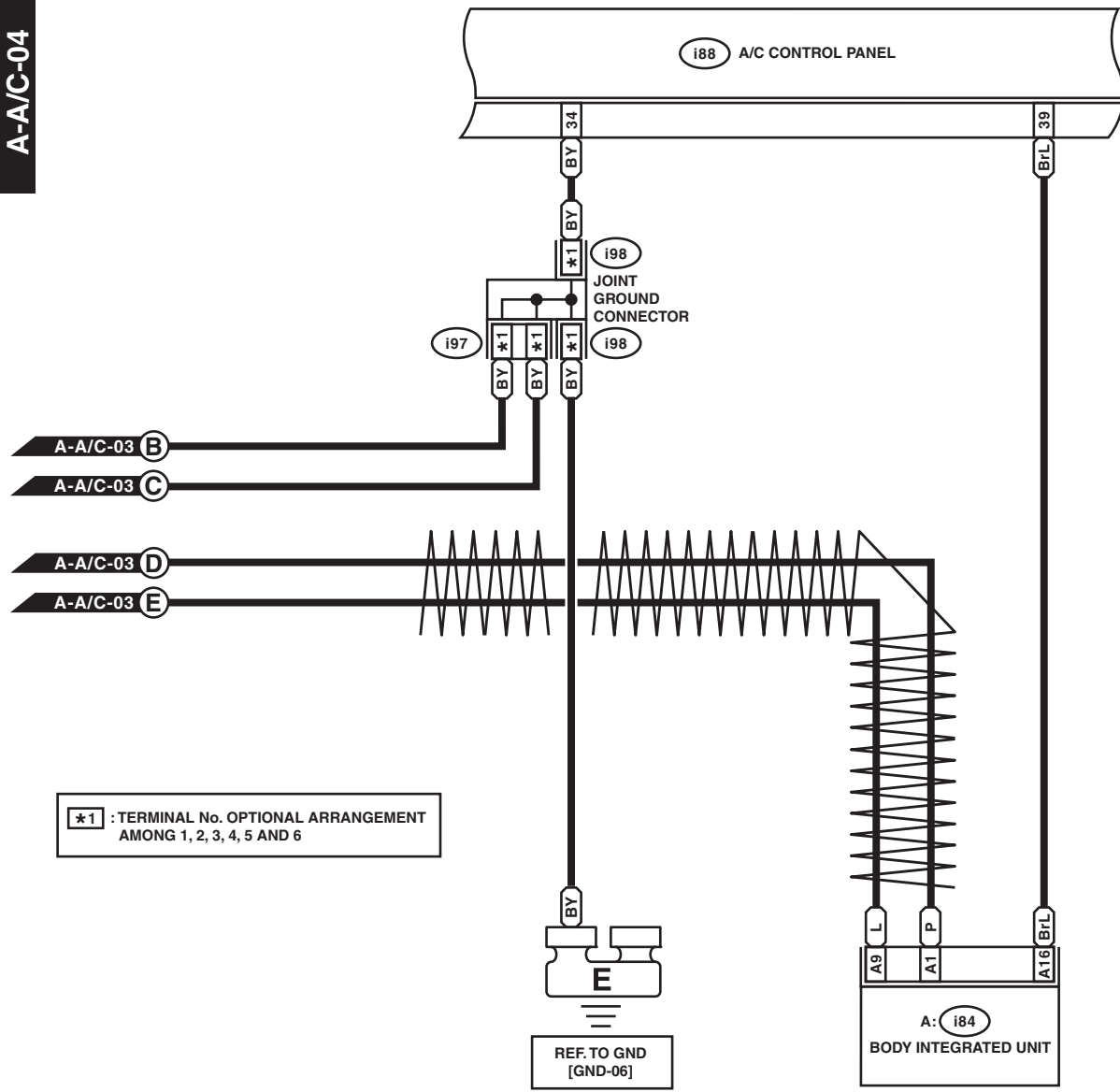

i97 (BLUE)						A: i84								i88																										
i98 (BLUE)																																								
1	2	3	4	5	6	1	2	3	4	5	6	7	8	1	2	3	4	5	6	7	8	9	10	11	12	13	14	15	16	17	18	19	20							
7	8	9	10	11	12	9	10	11	12	13	14	15	16	17	18	19	20	21	22	23	21	22	23	24	25	26	27	28	29	30	31	32	33	34	35	36	37	38	39	40

WI-19552

Air Conditioning System

WIRING SYSTEM

A-A/C-05

A-A/C-05

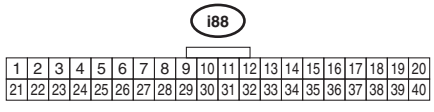
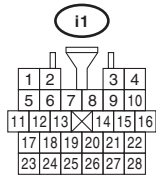
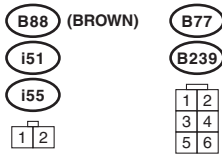
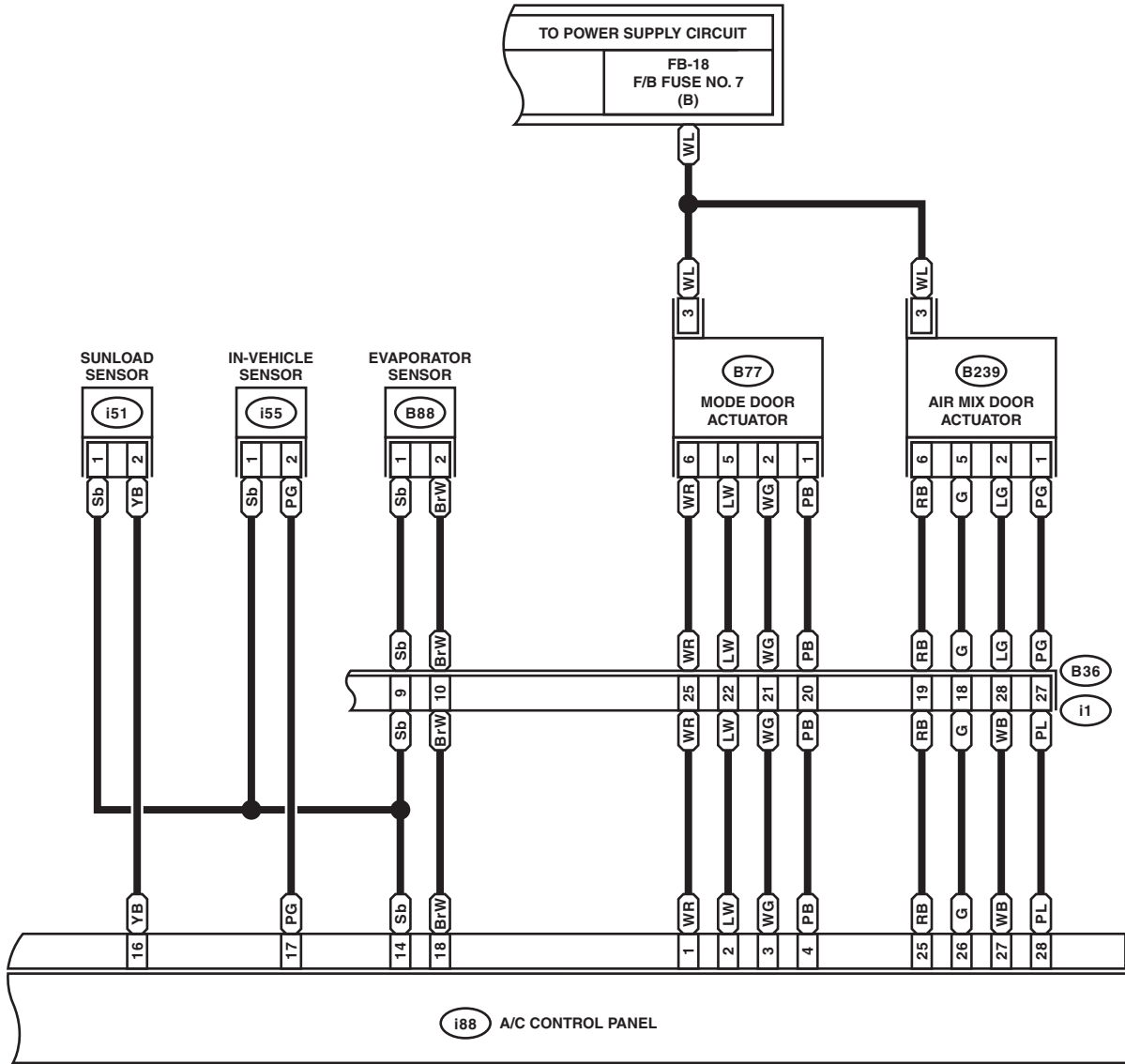

WI-19553

15. Power Seat System

A: WIRING DIAGRAM

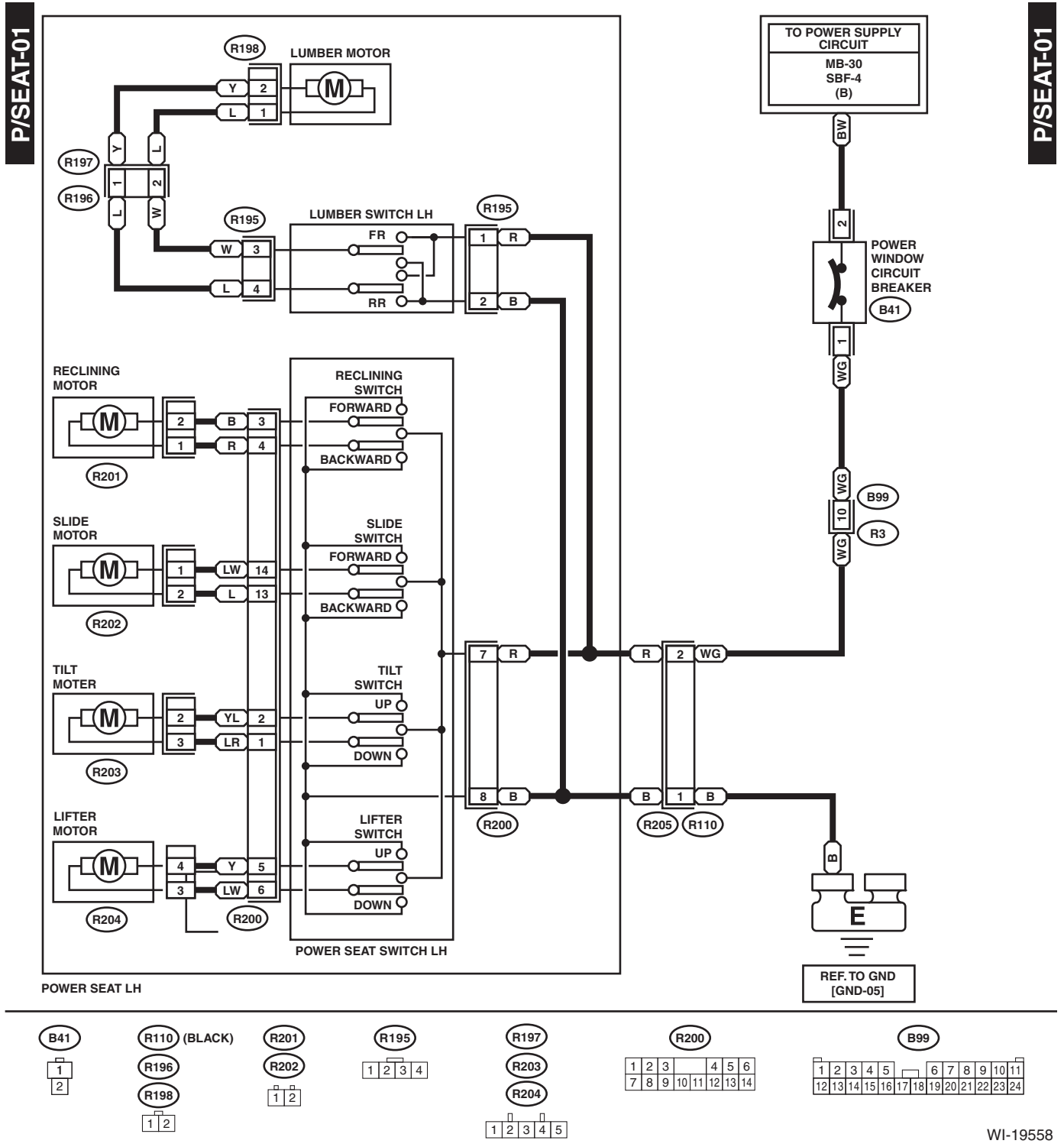

Airbag System

WIRING SYSTEM

16. Airbag System

A: WIRING DIAGRAM

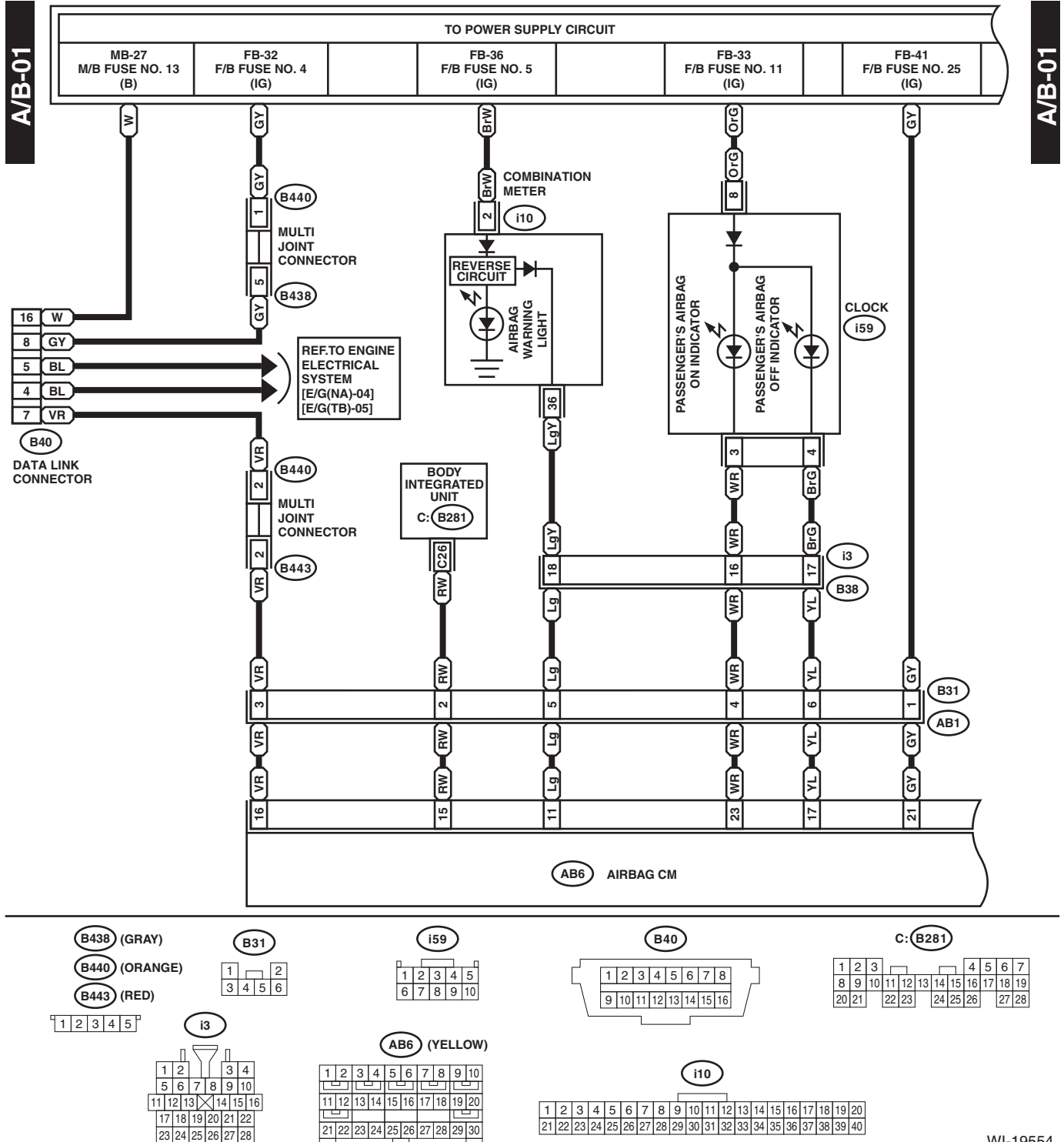

WI-19554

Airbag System

WIRING SYSTEM

A/B-02

A/B-02

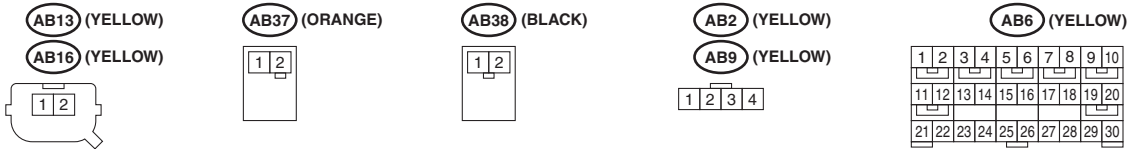
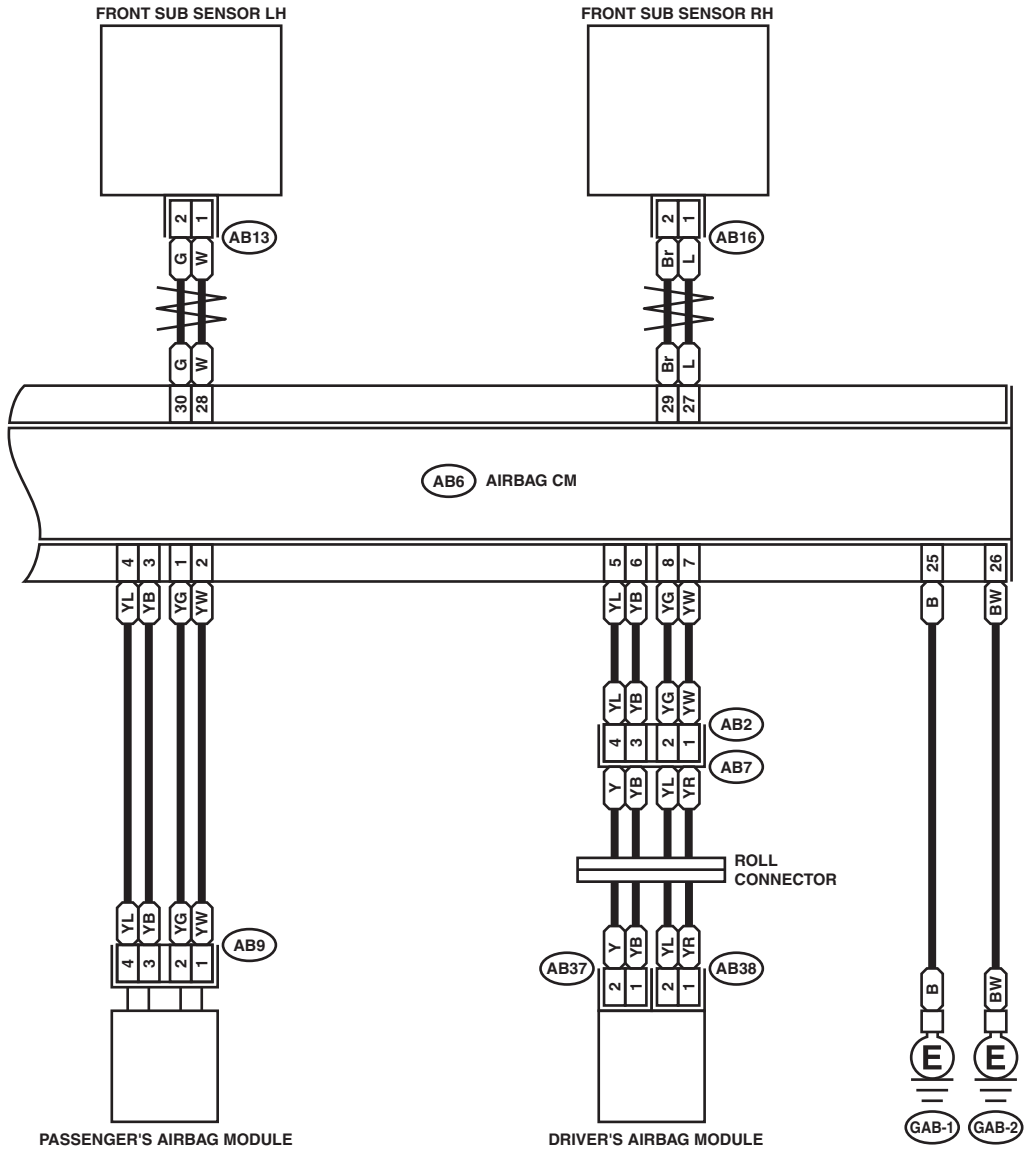

WI-19555

Airbag System

WIRING SYSTEM

A/B-03

A/B-03

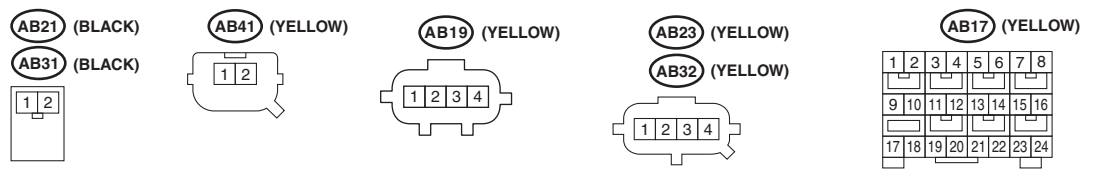
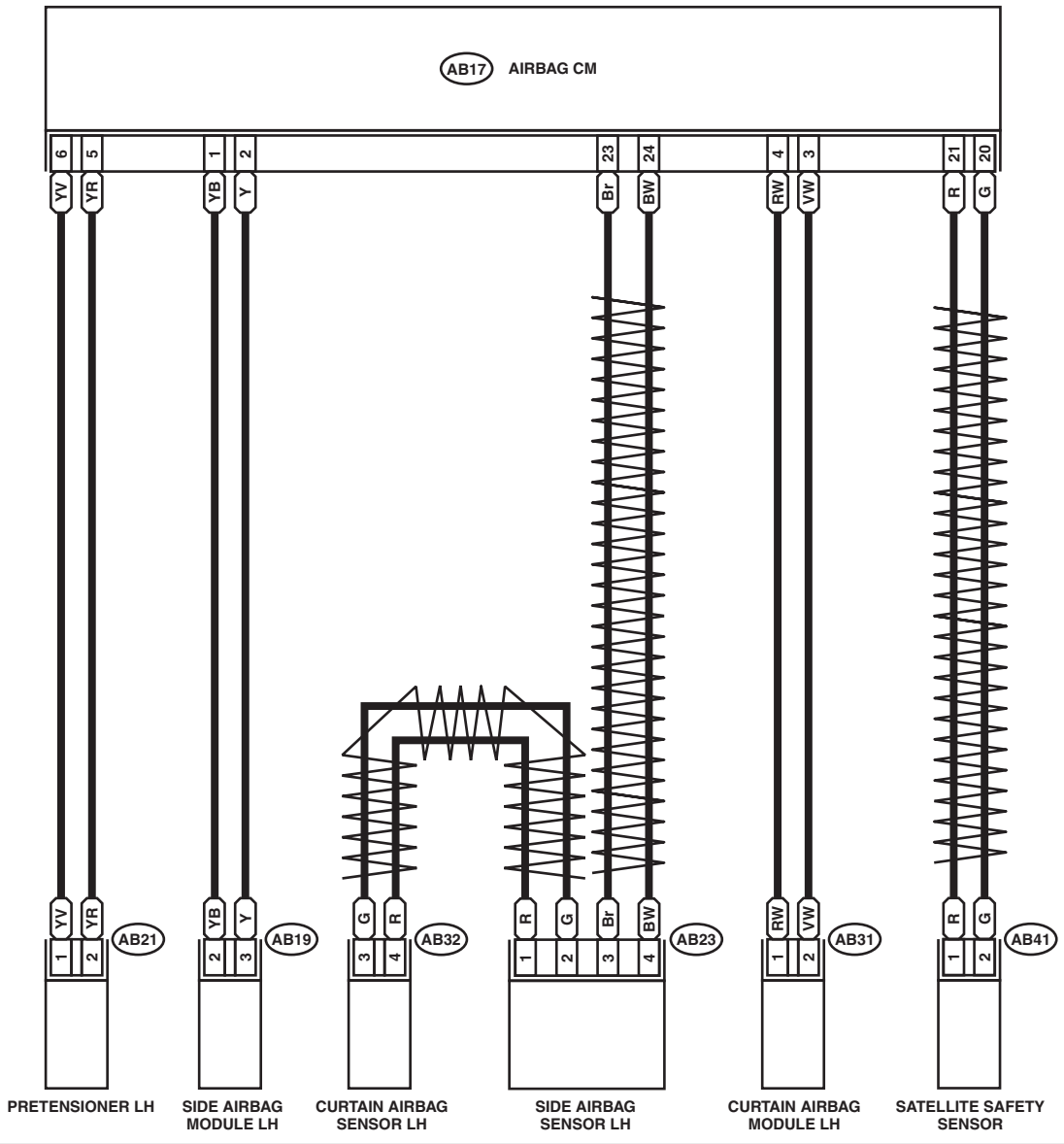

WI-19556

Airbag System

WIRING SYSTEM

A/B-04

A/B-04

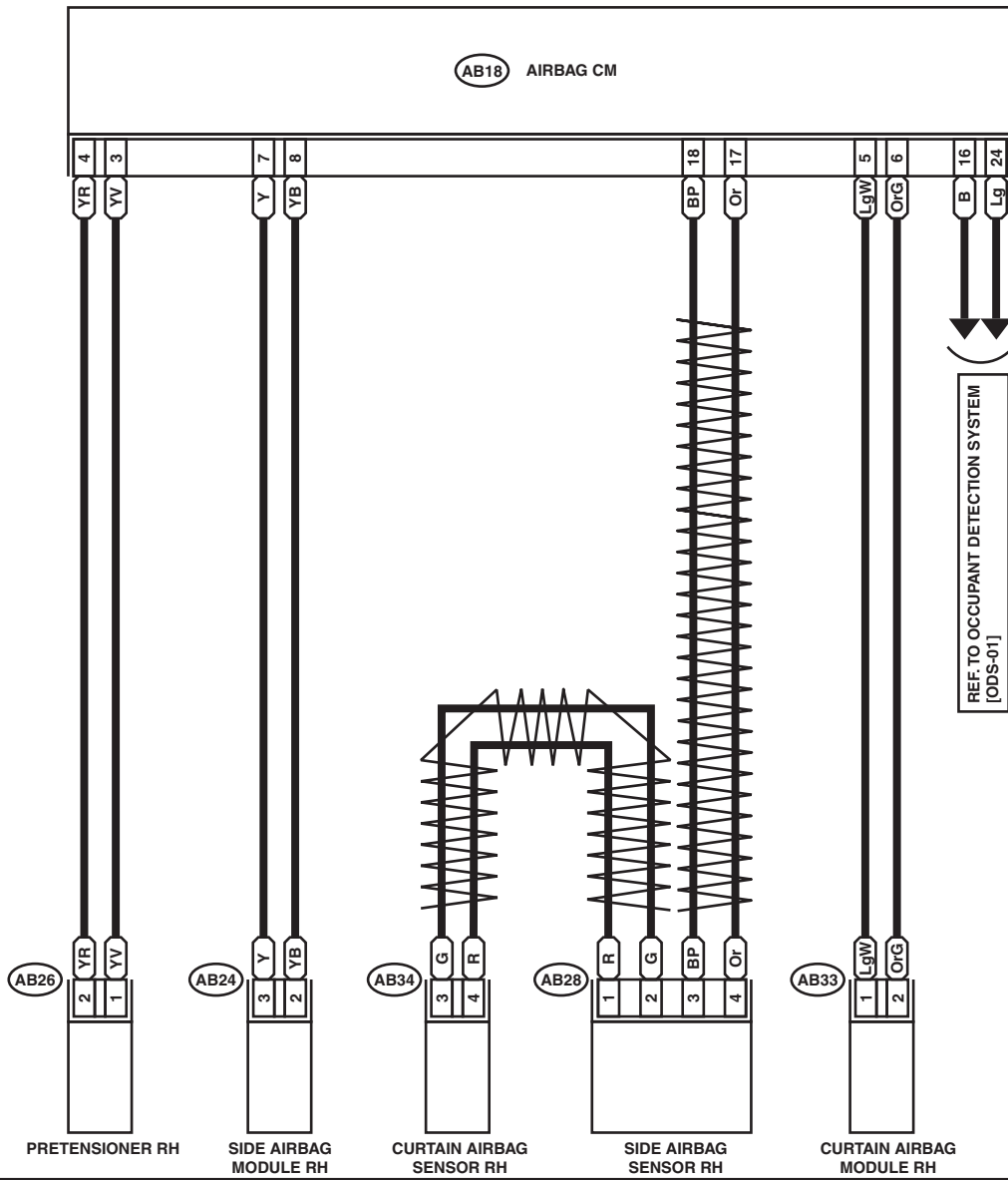

AB26 (BLACK)

AB24 (YELLOW)

AB28 (YELLOW)

AB18 (YELLOW)

AB33 (BLACK)

AB34 (YELLOW)

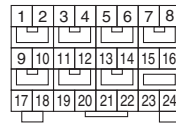
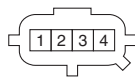
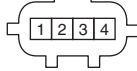

WI-19557

Seat Belt Warning System

WIRING SYSTEM

17. Seat Belt Warning System

A: WIRING DIAGRAM

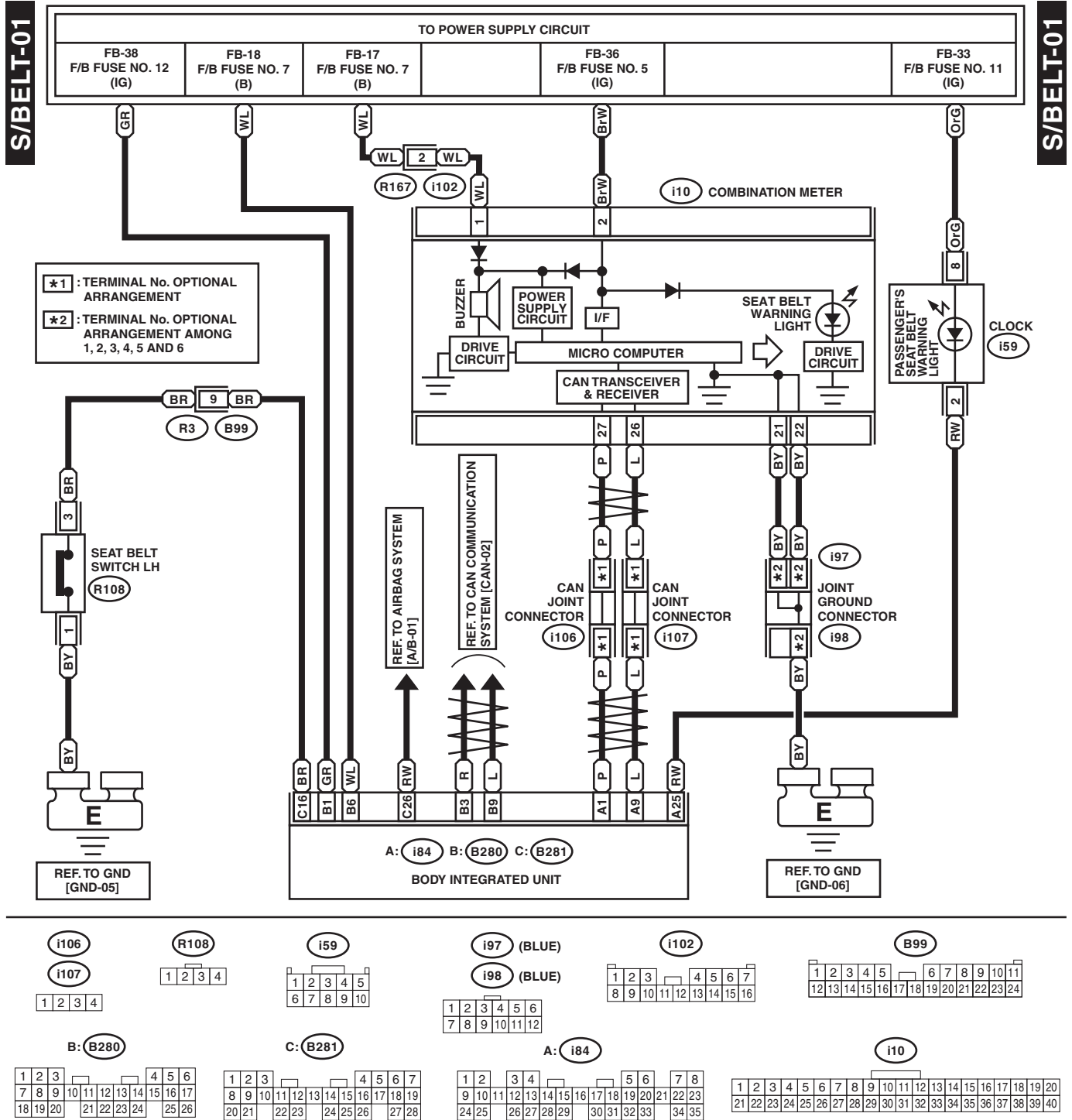

WI-19559

18. Occupant Detection System

A: WIRING DIAGRAM

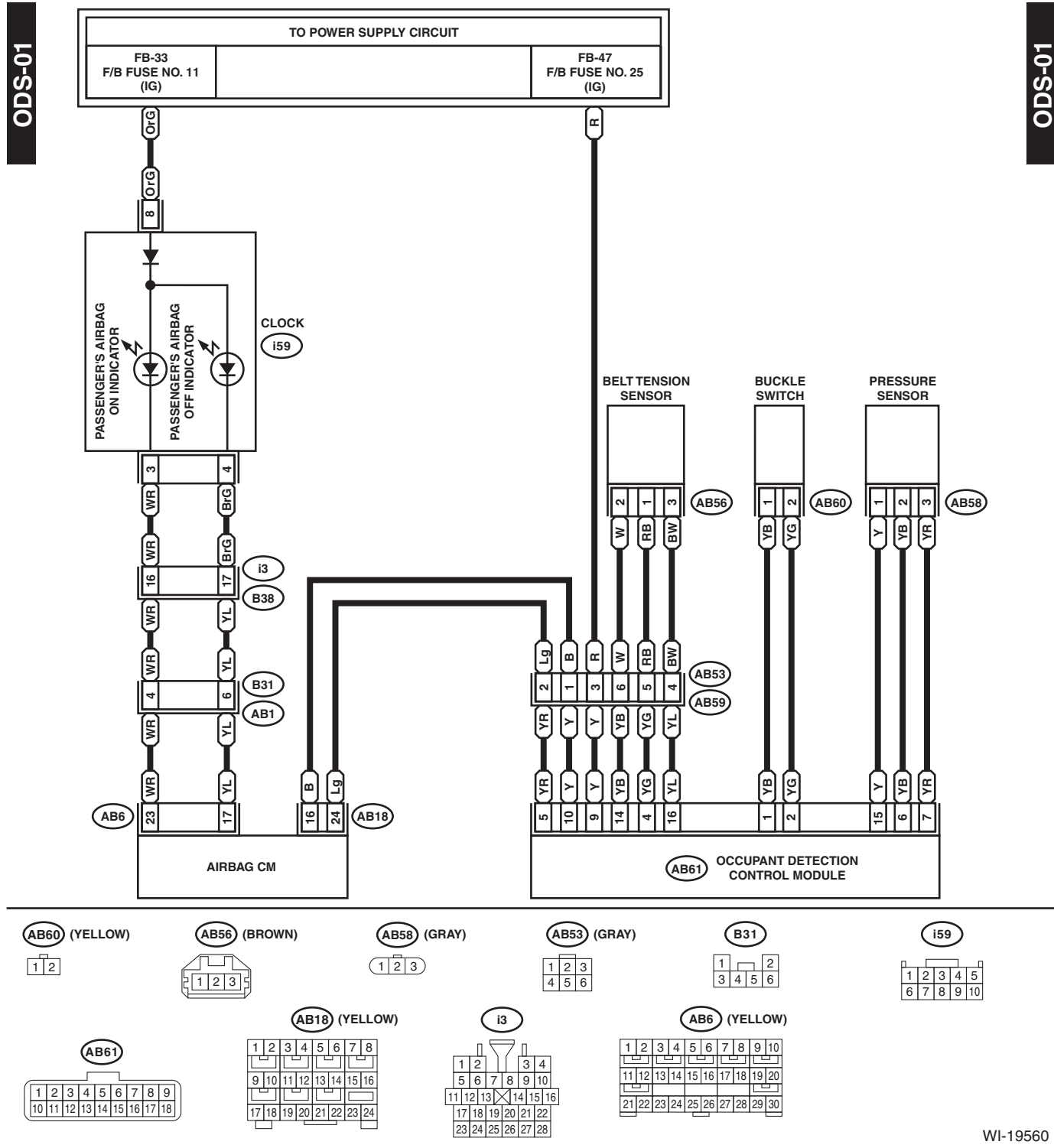

WI-19560

Seat Heater System

WIRING SYSTEM

19. Seat Heater System

A: WIRING DIAGRAM

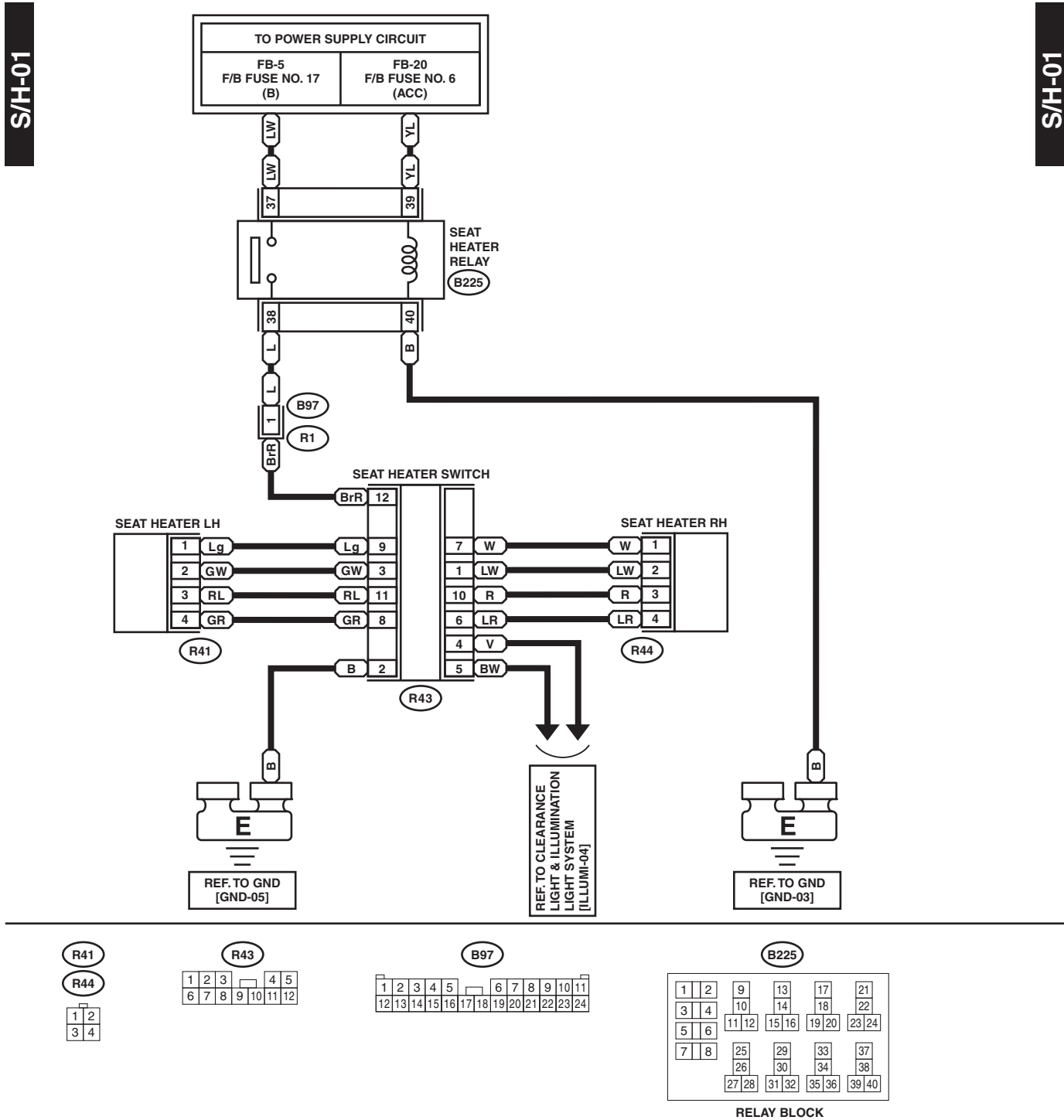

S/H-01

S/H-01

WI-19561

20.Headlight System

A: WIRING DIAGRAM

H/L-01

H/L-01

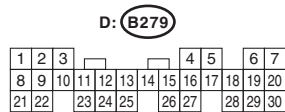
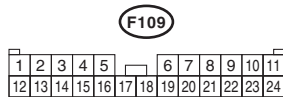
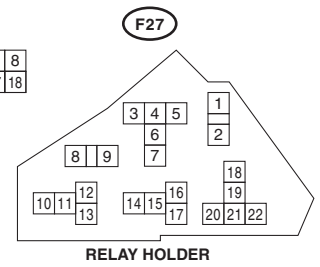
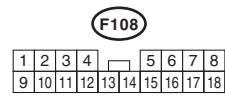
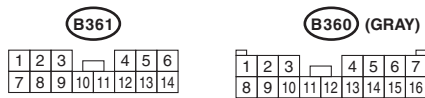
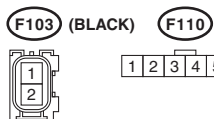
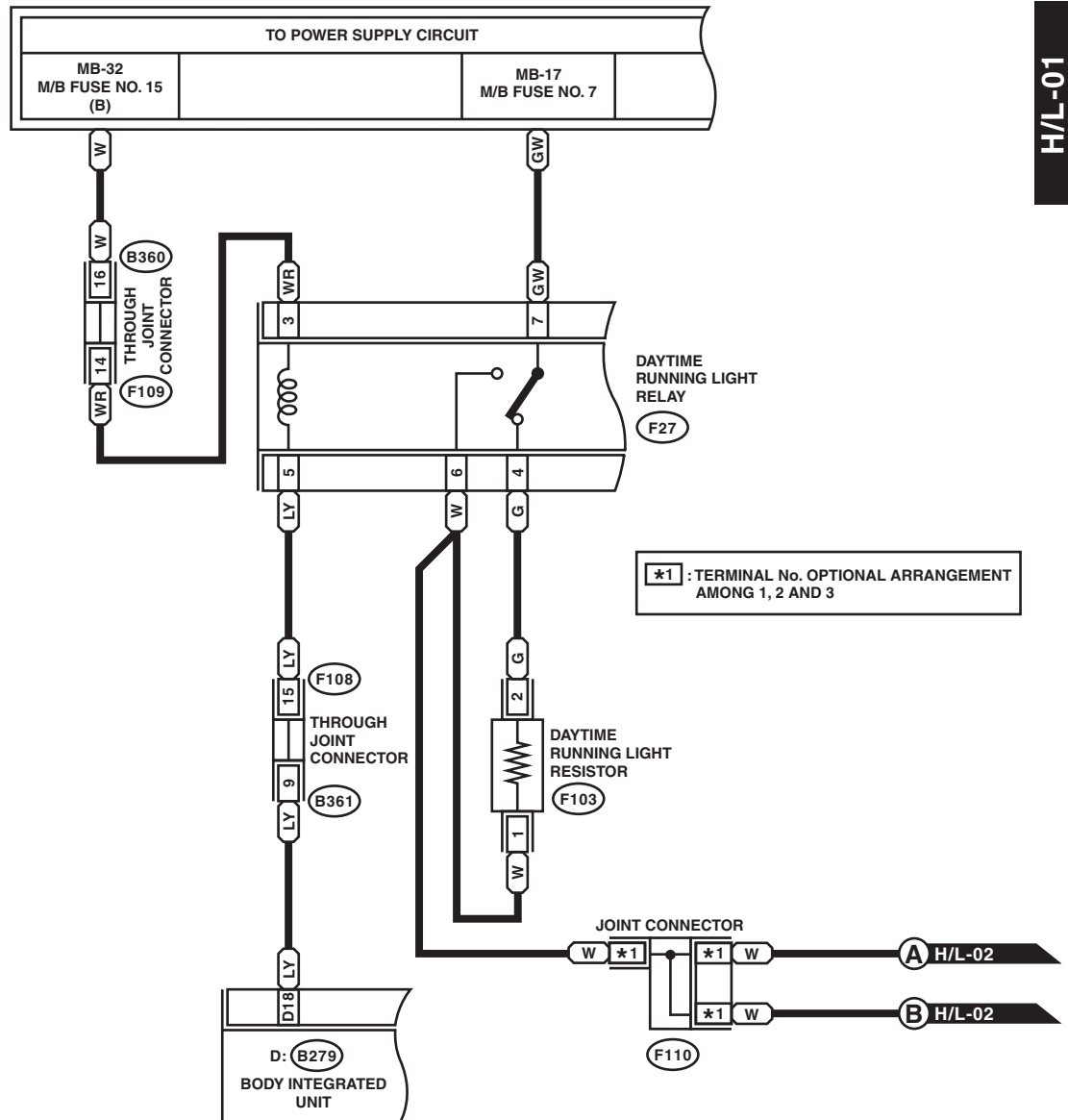

WI-19562

Headlight System

WIRING SYSTEM

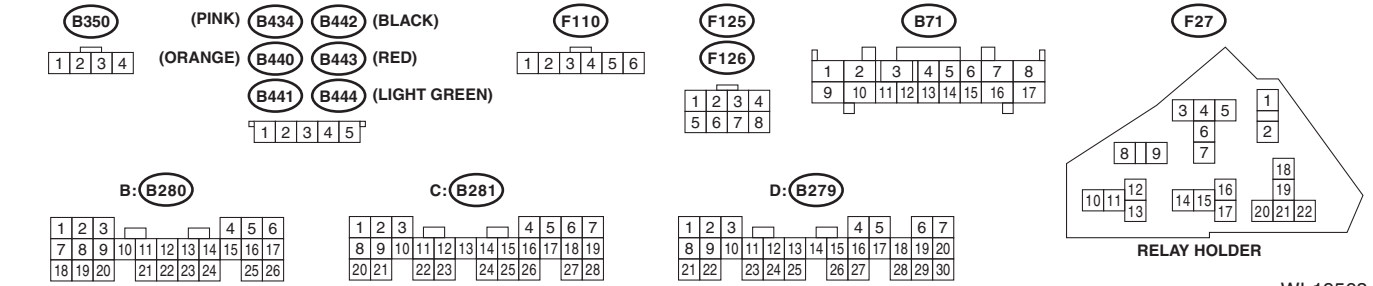
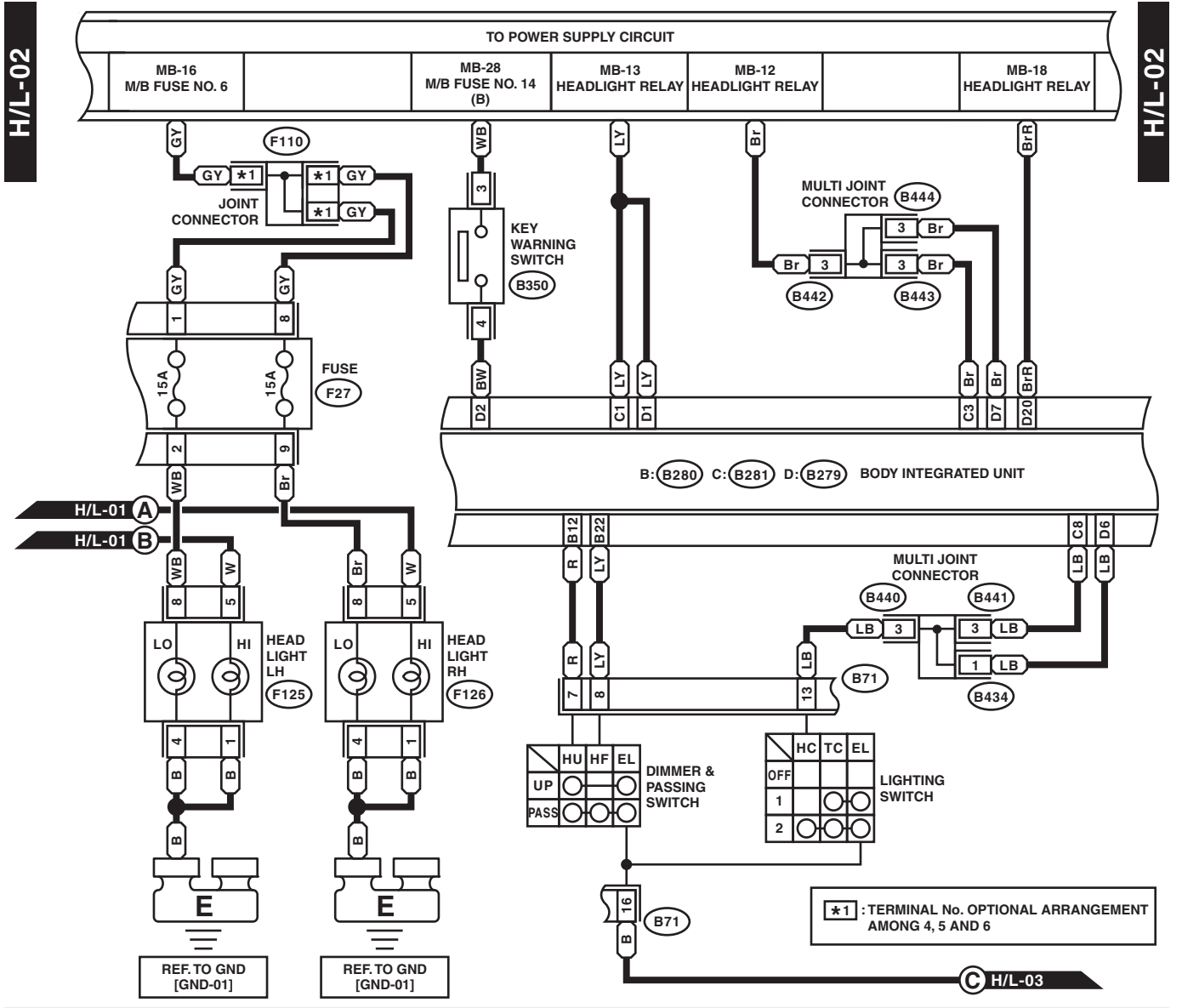

WI-19563

Headlight System

WIRING SYSTEM

H/L-03

H/L-03

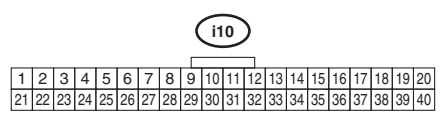
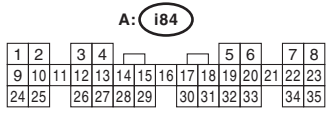
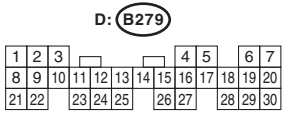
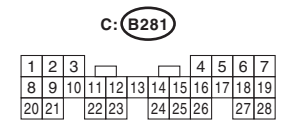
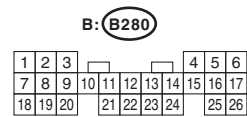
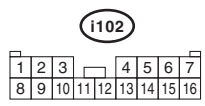
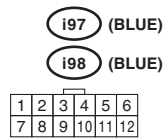
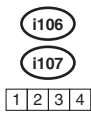
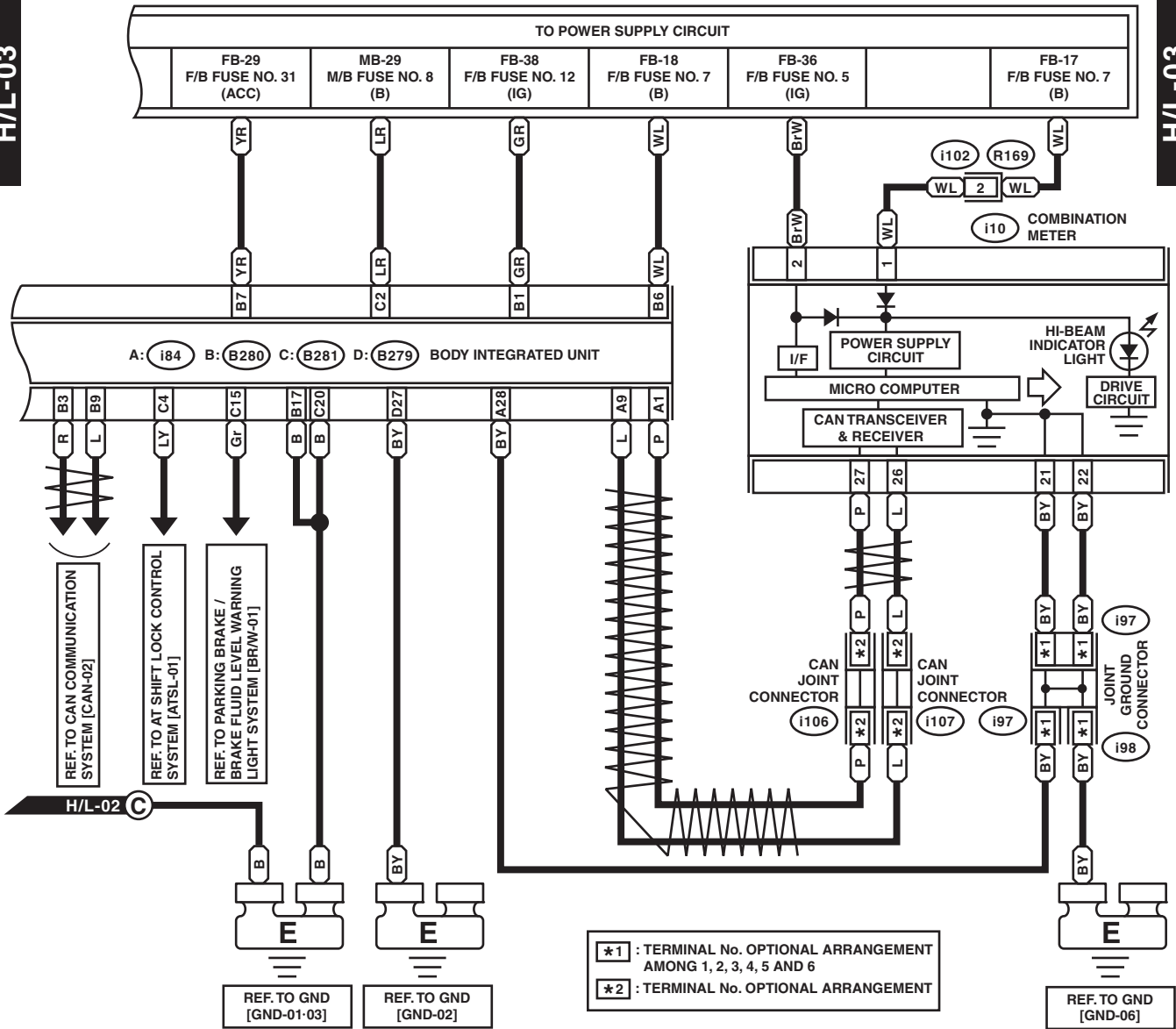

WI-19564

Headlight Beam Leveler System

WIRING SYSTEM

21. Headlight Beam Leveler System

A: WIRING DIAGRAM

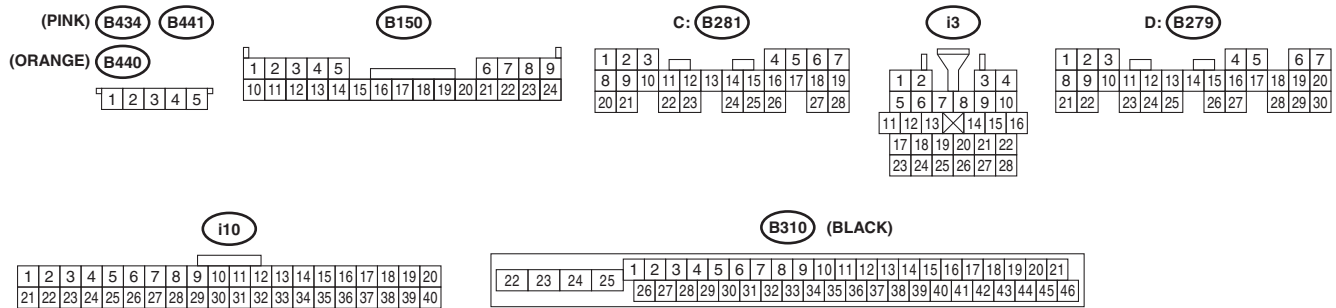
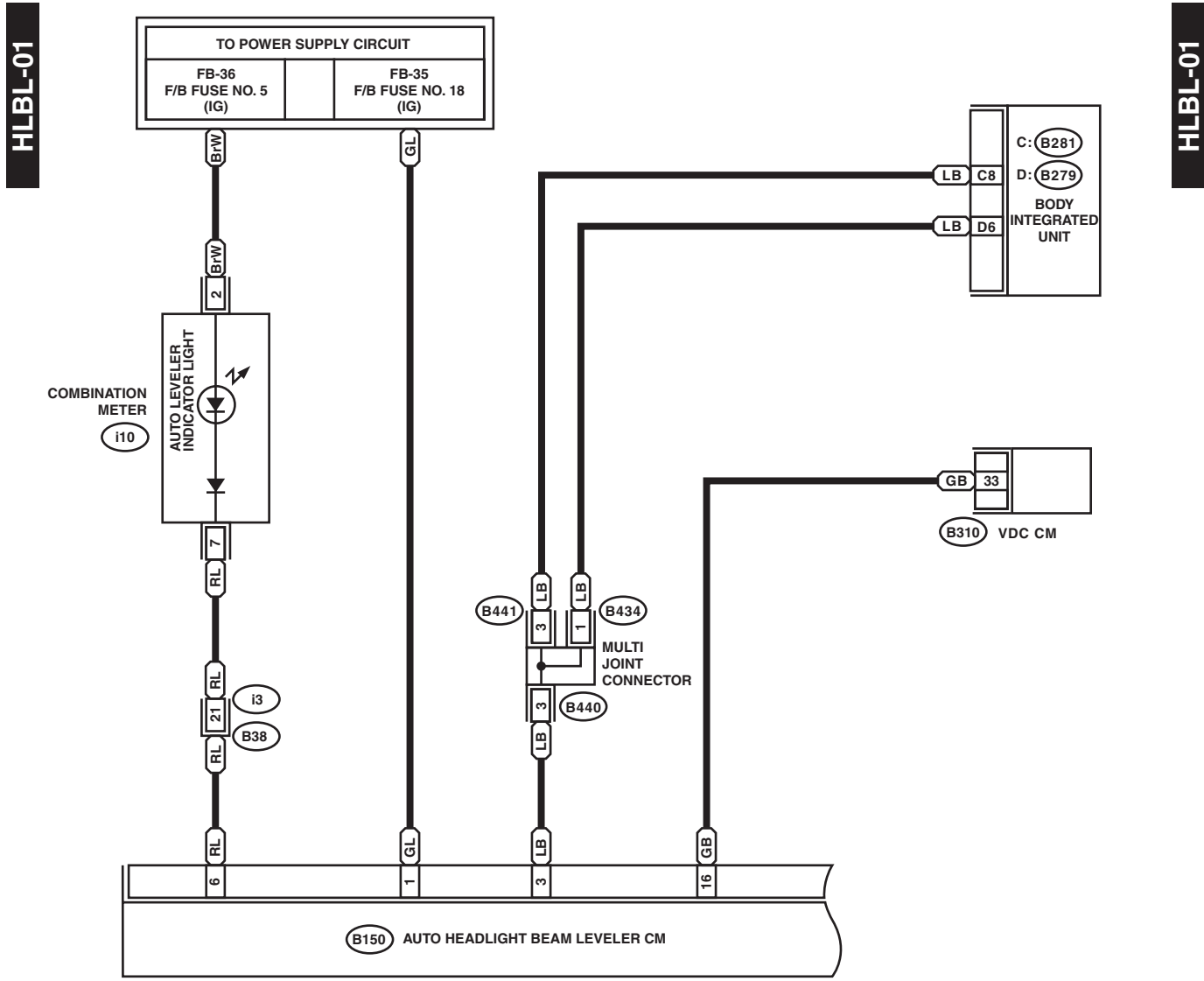

WI-19565

Headlight Beam Leveler System

WIRING SYSTEM

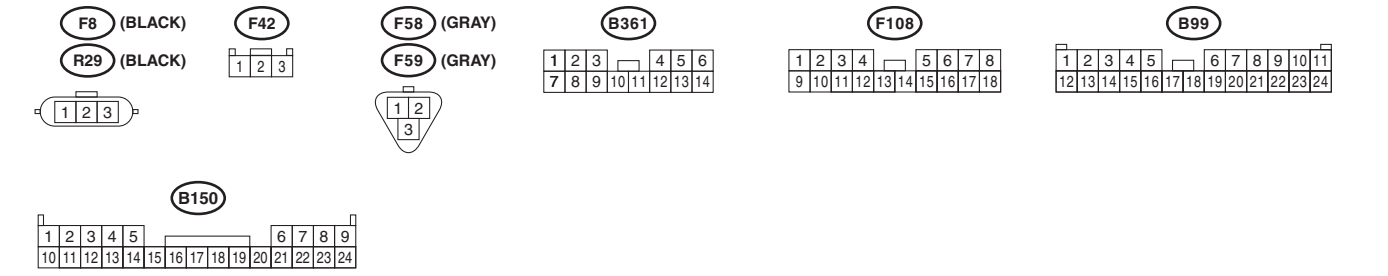
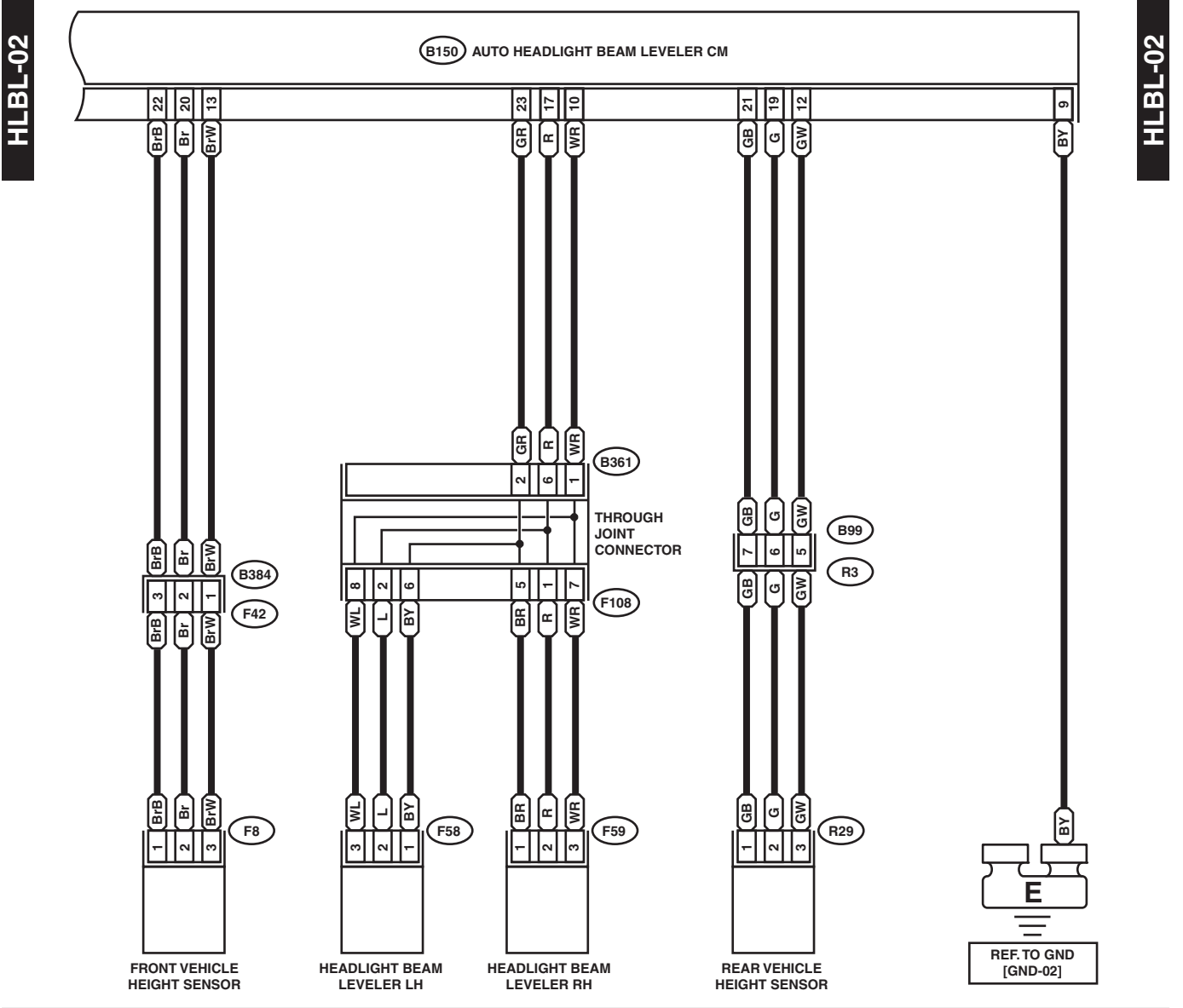

WI-19566

Front Fog Light System

WIRING SYSTEM

22. Front Fog Light System

A: WIRING DIAGRAM

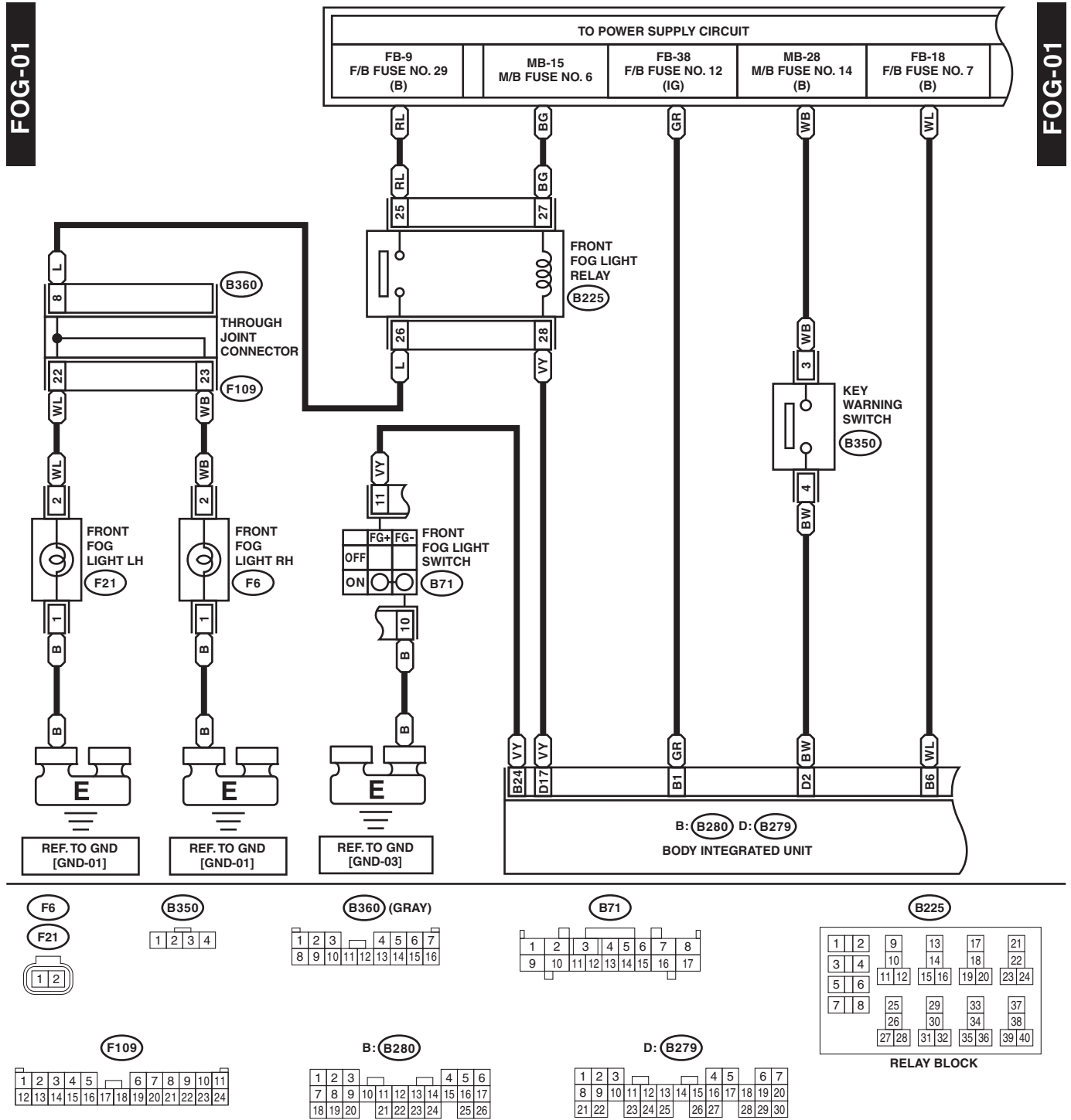

WI-19567

Front Fog Light System

WIRING SYSTEM

FOG-02

FOG-02

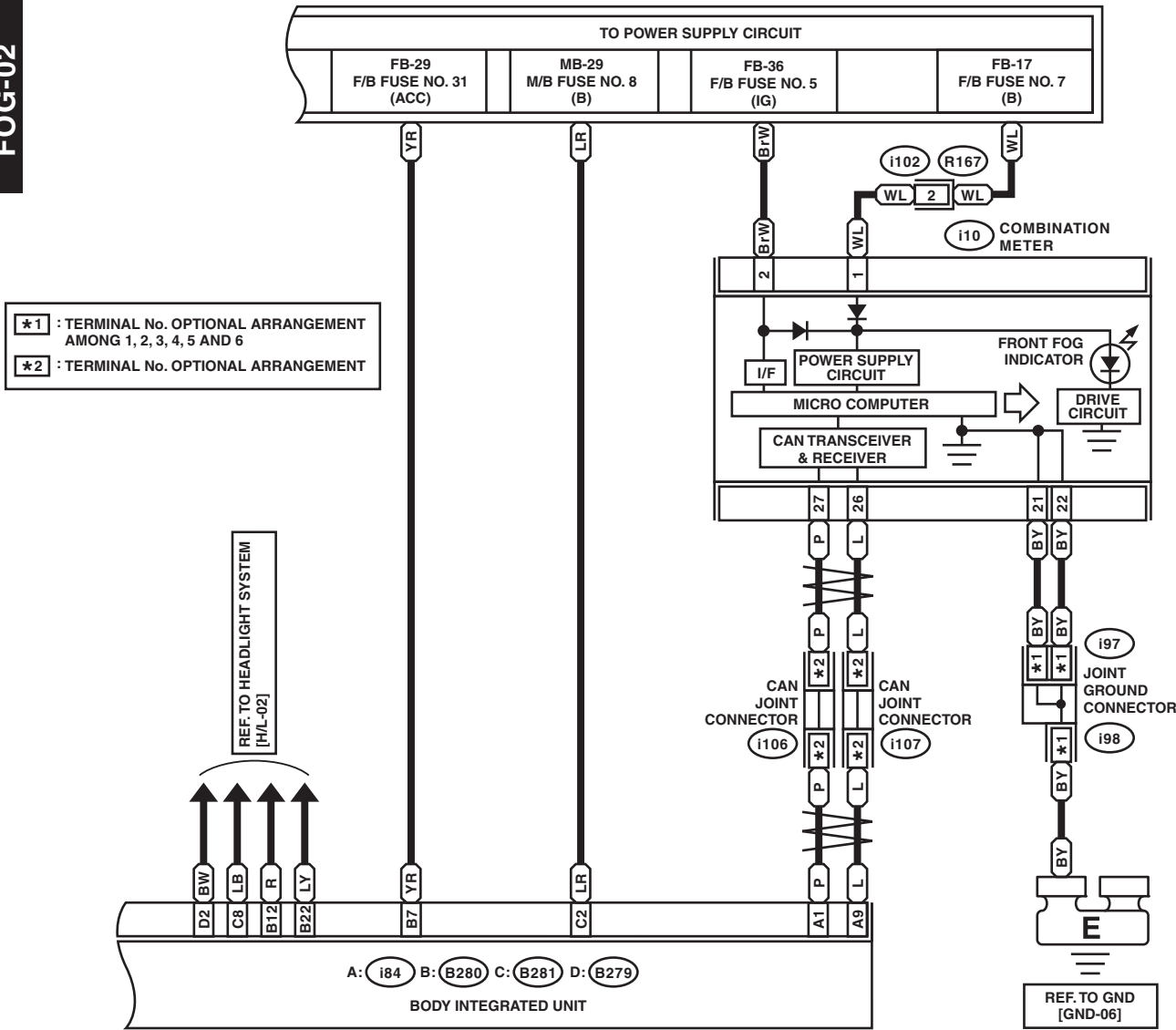

*1 : TERMINAL No. OPTIONAL ARRANGEMENT AMONG 1, 2, 3, 4, 5 AND 6
 *2 : TERMINAL No. OPTIONAL ARRANGEMENT

REF. TO HEADLIGHT SYSTEM [H/L-02]

A: (i84) B: (B280) C: (B281) D: (B279)
 BODY INTEGRATED UNIT

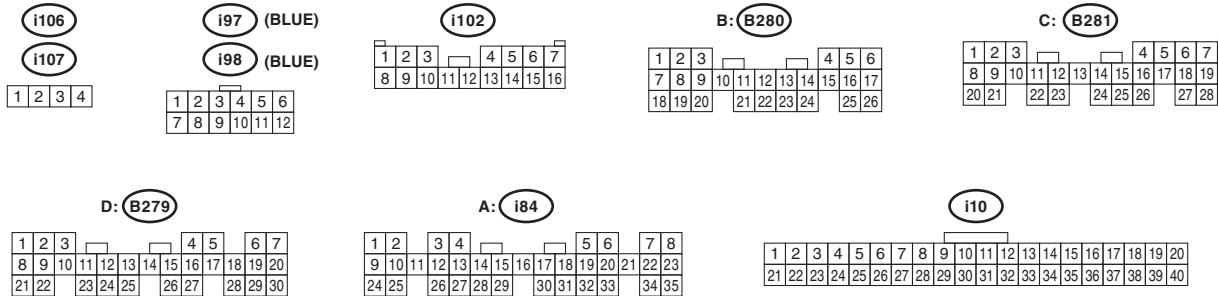

WI-20309

Back-up Light System

WIRING SYSTEM

23. Back-up Light System

A: WIRING DIAGRAM

BACK/L-01

BACK/L-01

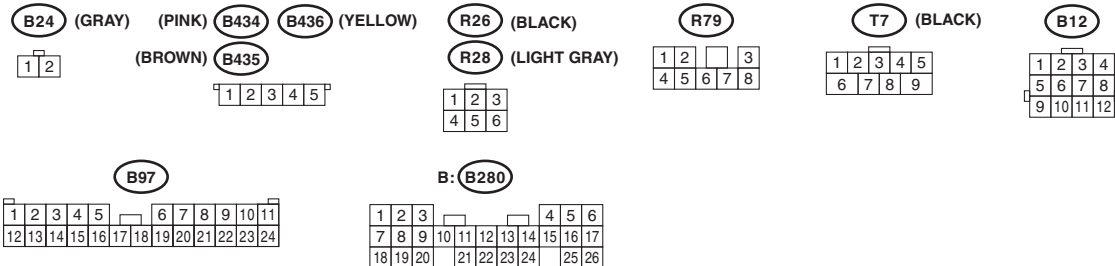
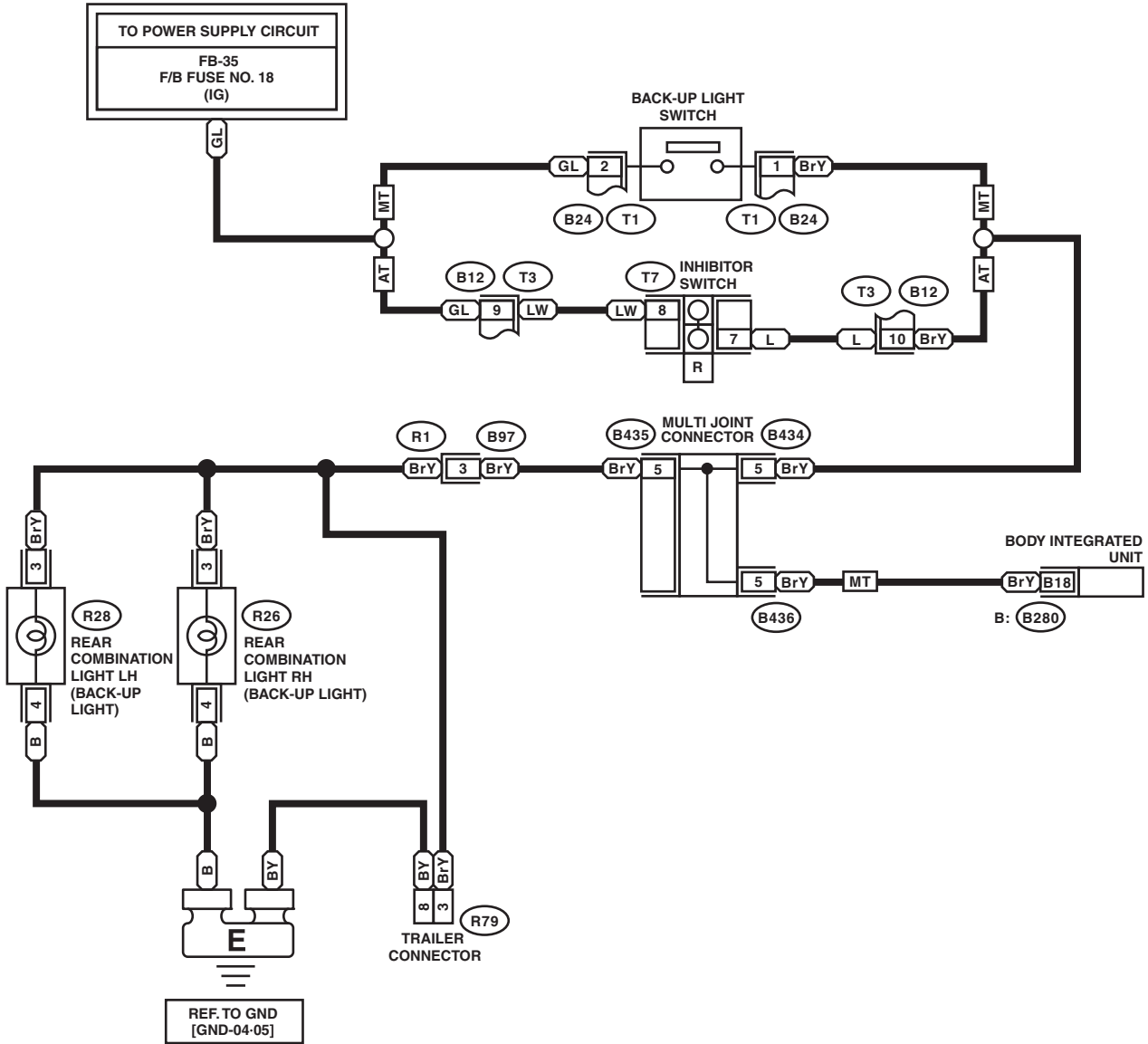

WI-19568

Stop Light System

24. Stop Light System

A: WIRING DIAGRAM

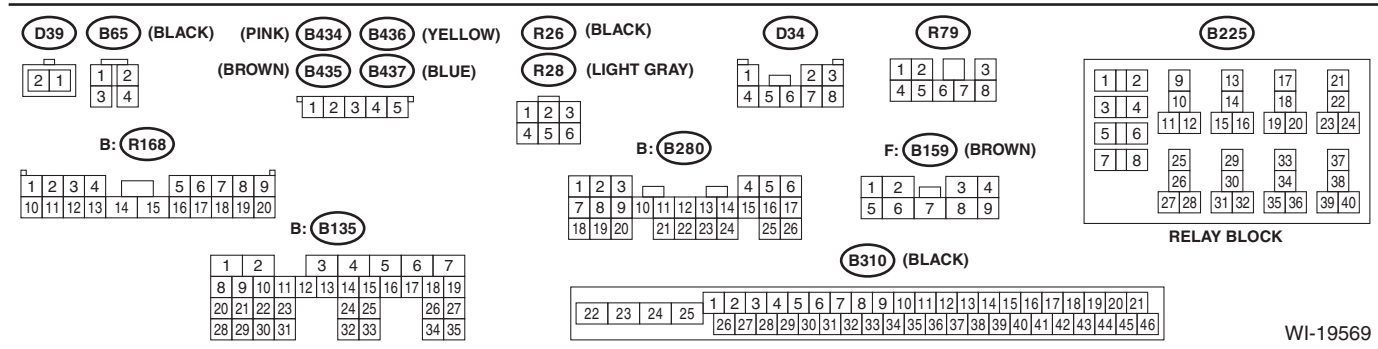
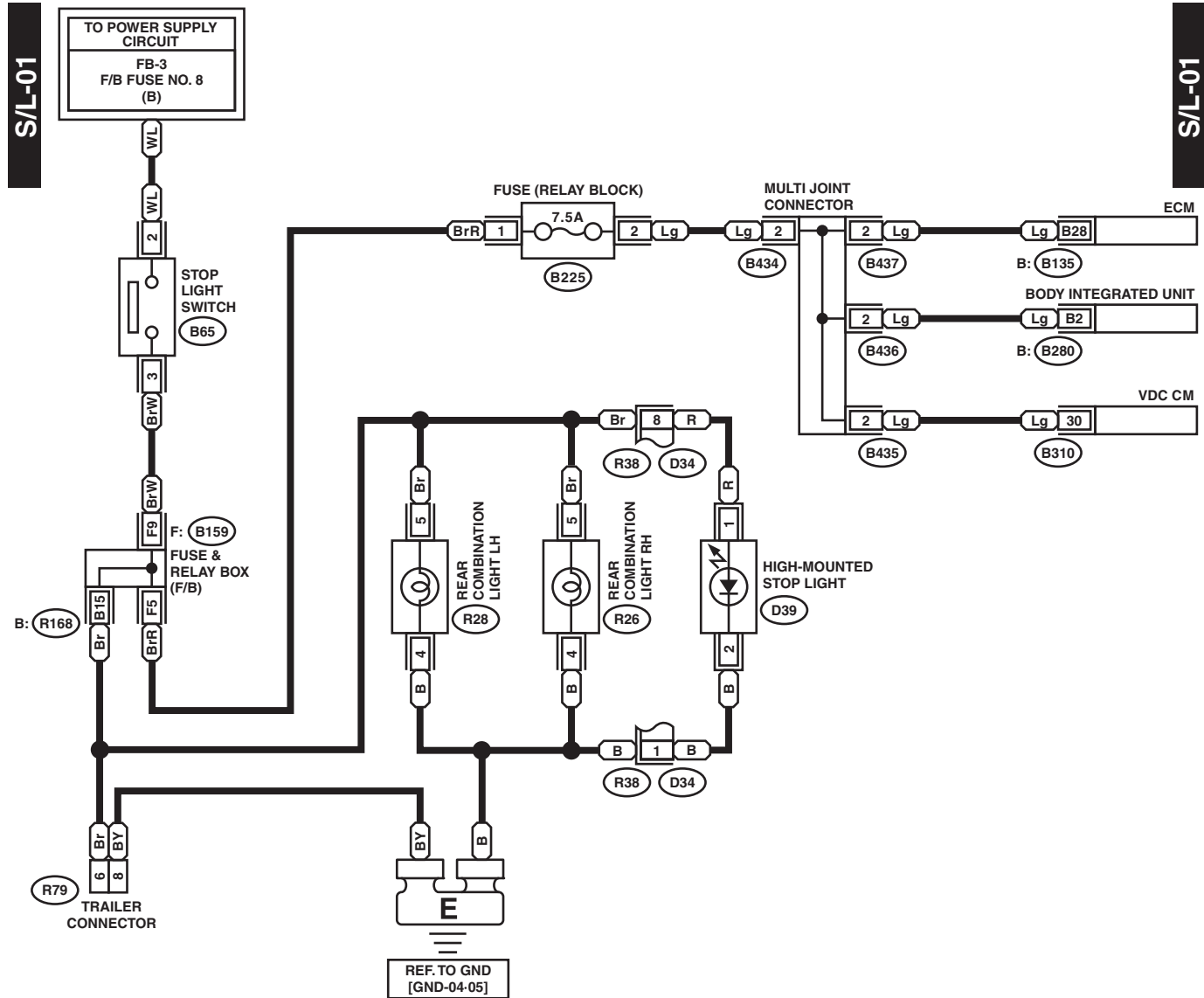

WI-19569

Clearance Light and Illumination Light System

WIRING SYSTEM

25. Clearance Light and Illumination Light System

A: WIRING DIAGRAM

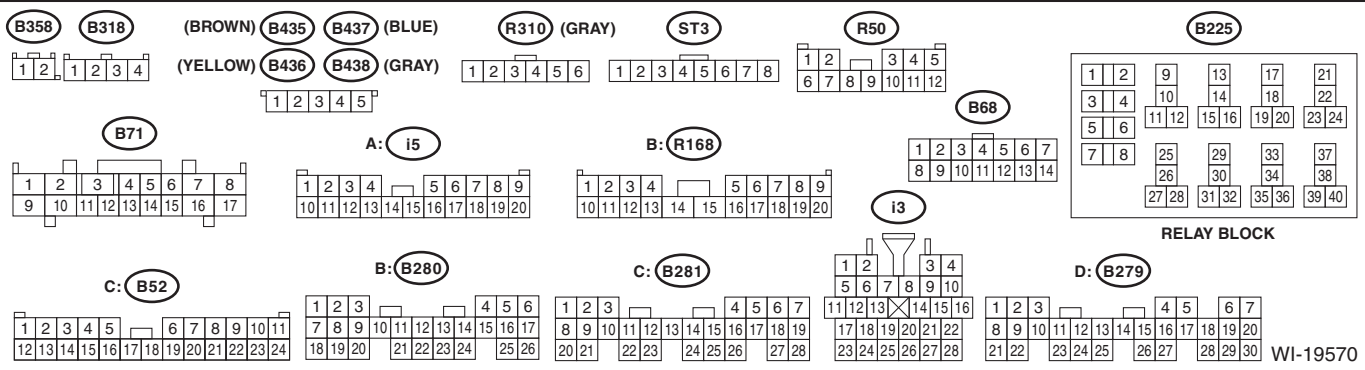
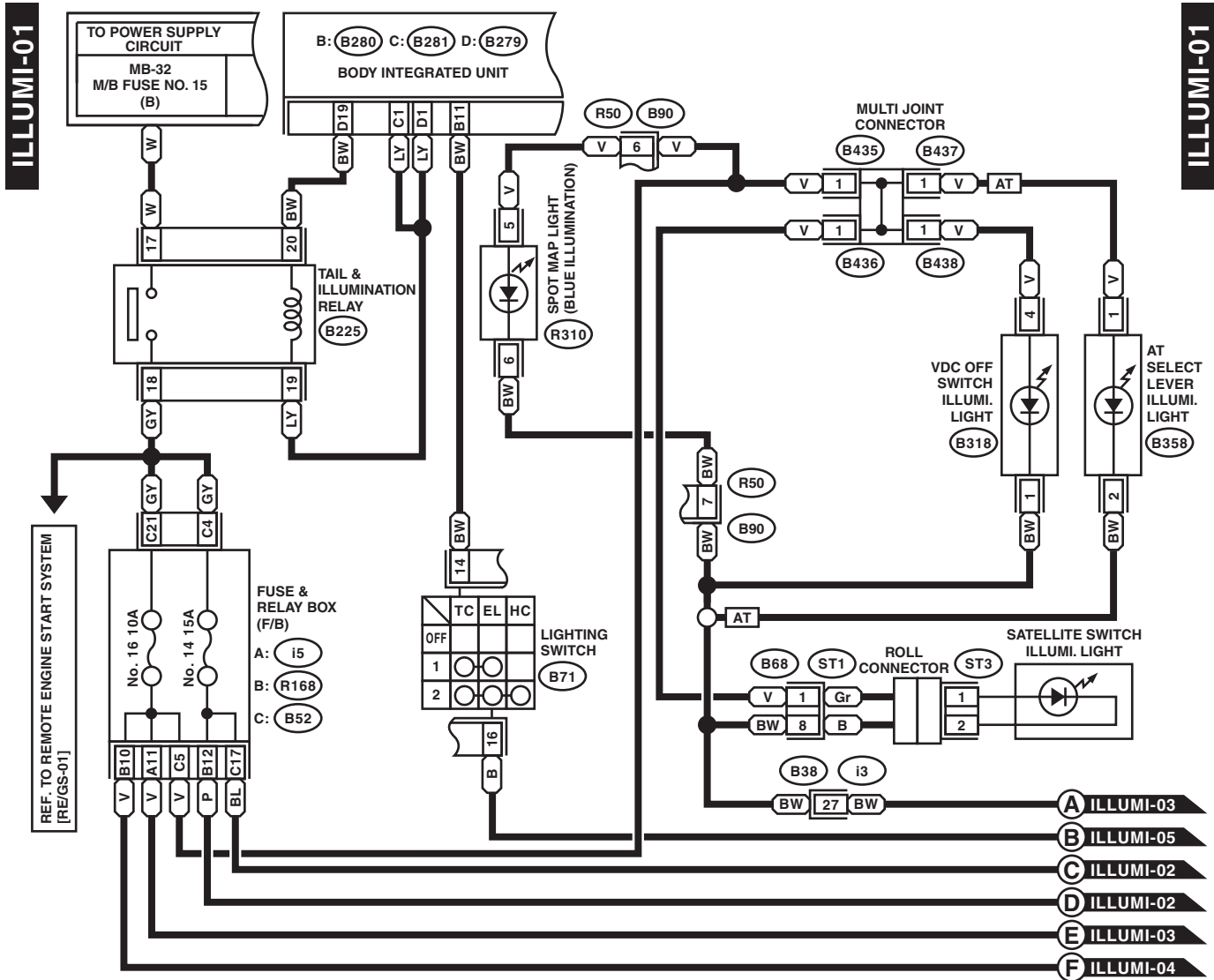

Clearance Light and Illumination Light System

WIRING SYSTEM

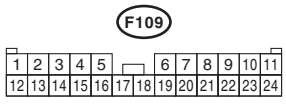
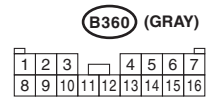
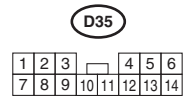
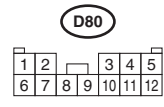
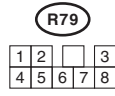
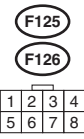
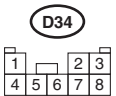
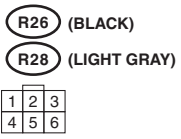
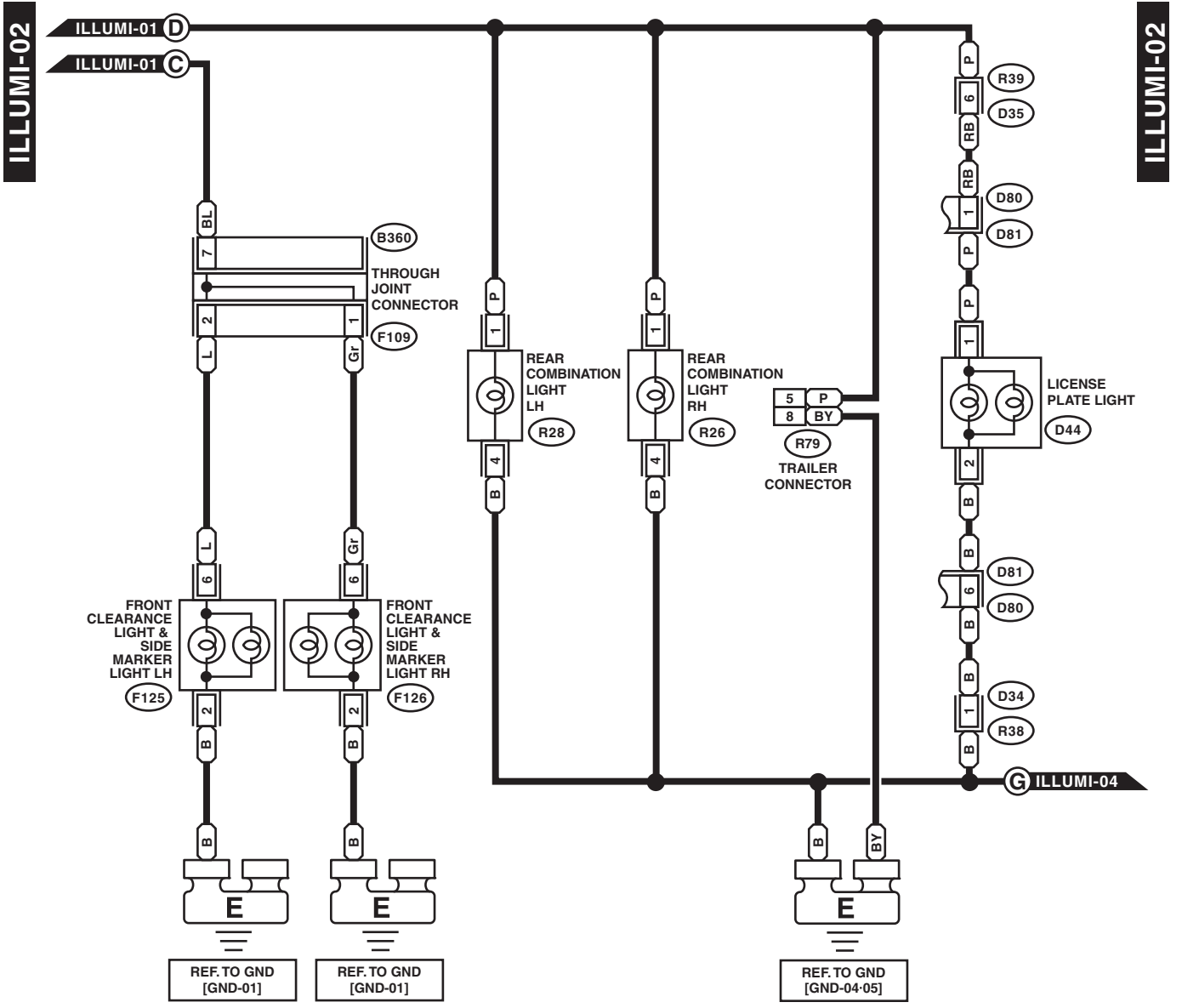

WI-19571

Clearance Light and Illumination Light System

WIRING SYSTEM

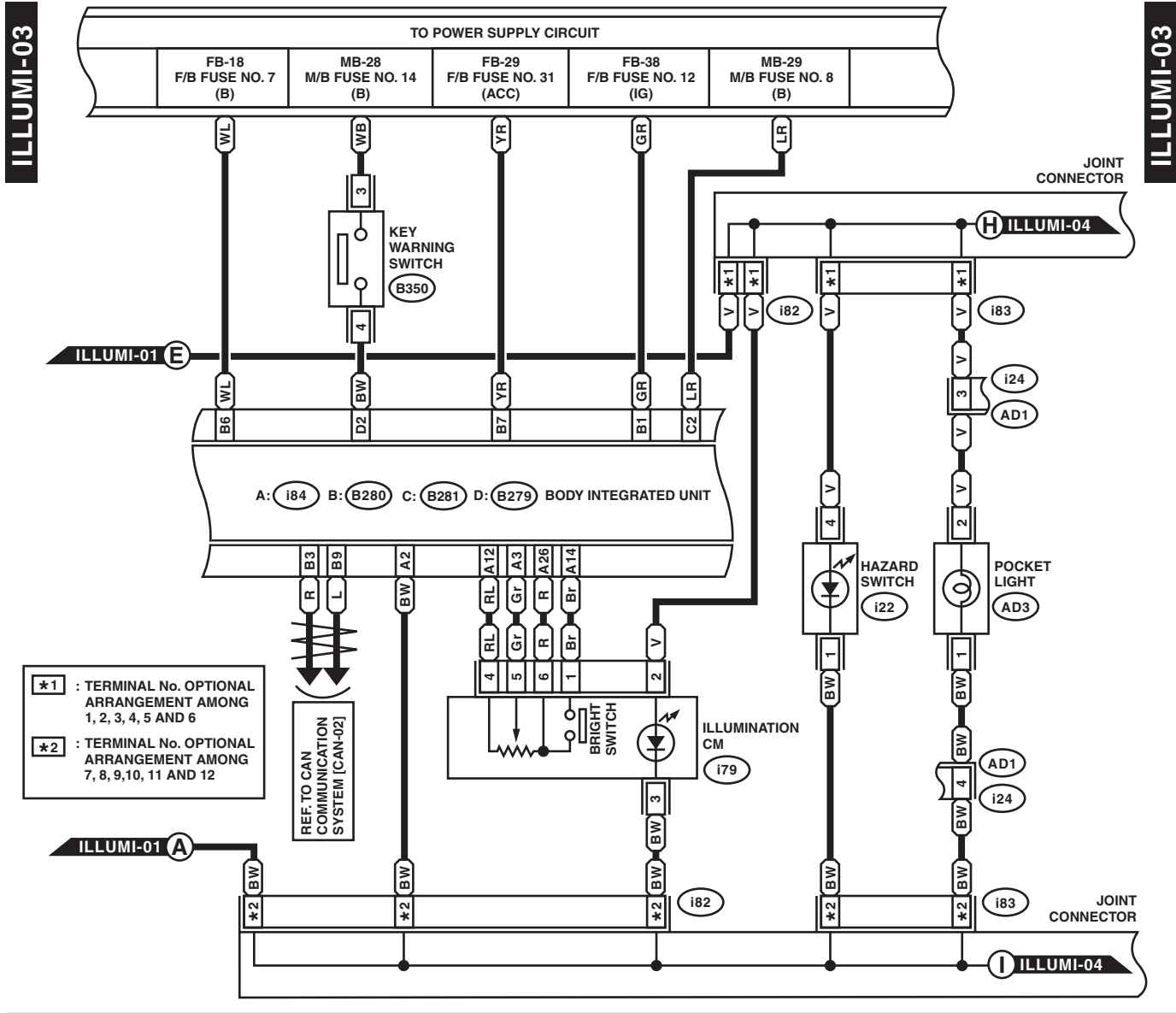

★1 : TERMINAL No. OPTIONAL ARRANGEMENT AMONG 1, 2, 3, 4, 5 AND 6
 ★2 : TERMINAL No. OPTIONAL ARRANGEMENT AMONG 7, 8, 9, 10, 11 AND 12

REF TO CAN COMMUNICATION SYSTEM [CAN-02]

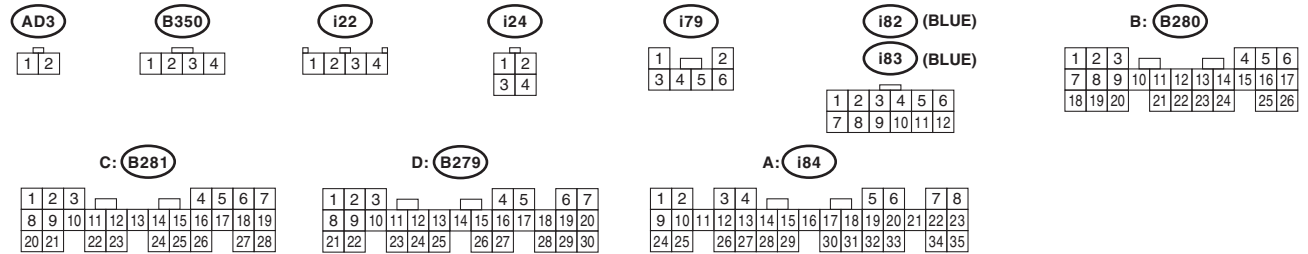

WI-19572

Clearance Light and Illumination Light System

WIRING SYSTEM

ILLUMI-04

ILLUMI-04

- MA** : MANUAL A/C
- AA** : AUTO A/C
- ON** : WITHOUT NAVIGATION
- WN** : WITH NAVIGATION
- *1** : TERMINAL No. OPTIONAL ARRANGEMENT AMONG 1, 2, 3, 4, 5 AND 6
- *2** : TERMINAL No. OPTIONAL ARRANGEMENT AMONG 7, 8, 9, 10, 11 AND 12

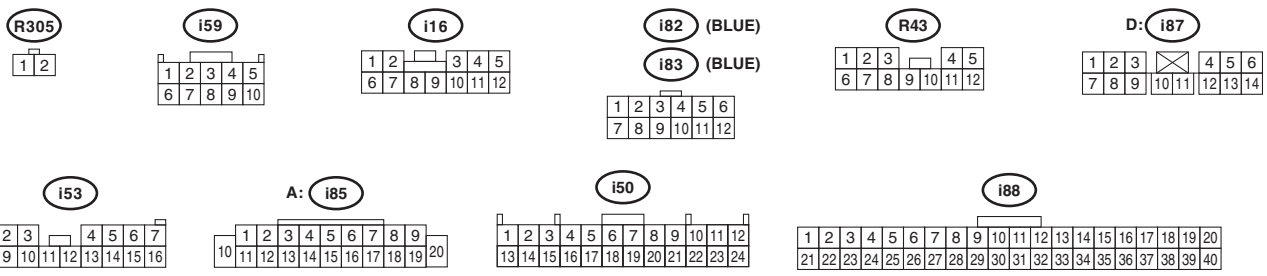
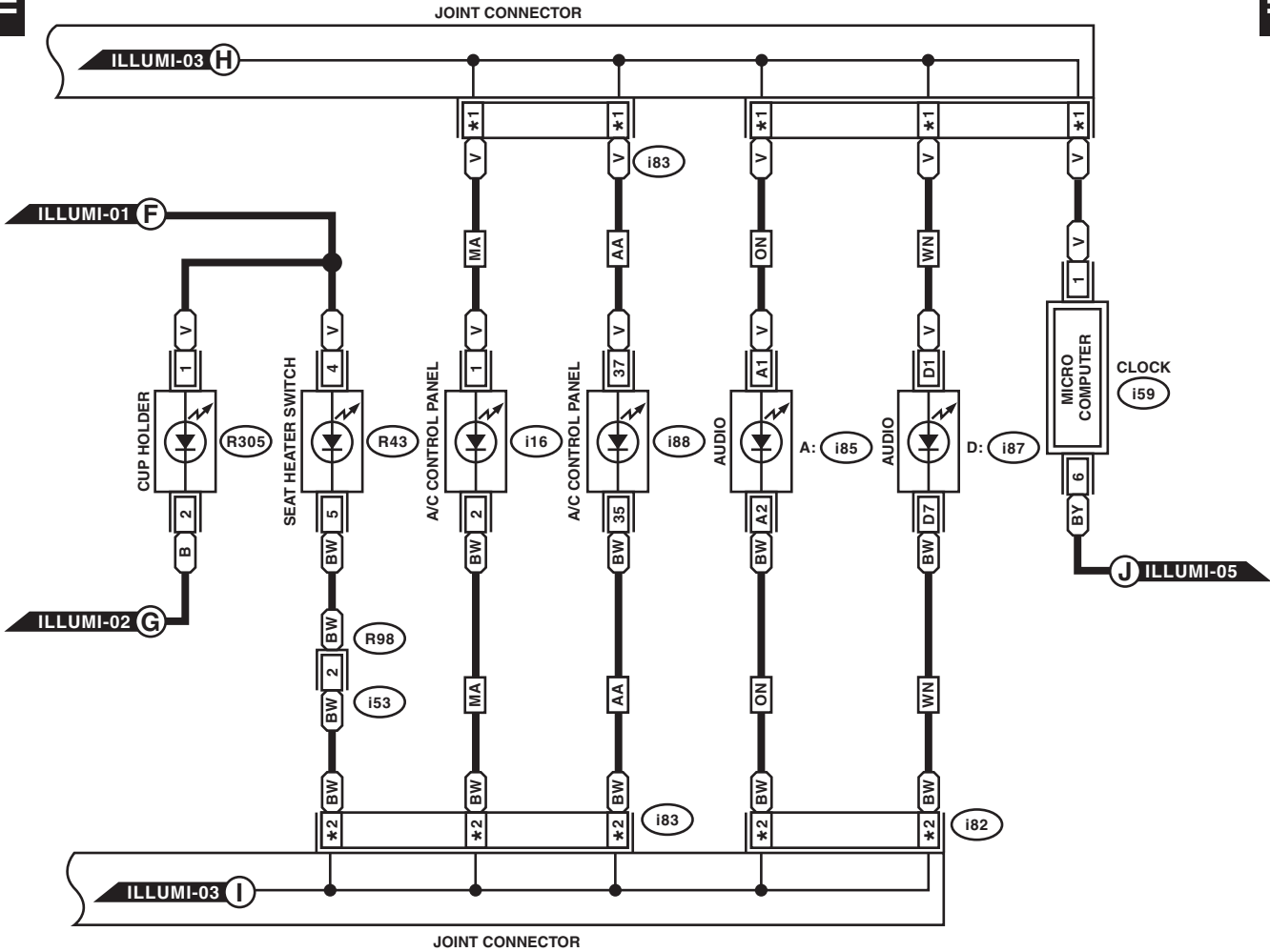

WI-25083

Clearance Light and Illumination Light System

WIRING SYSTEM

ILLUMI-05

ILLUMI-05

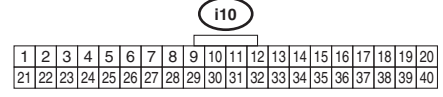
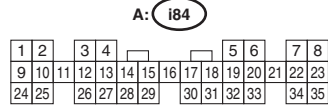
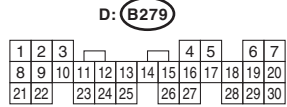
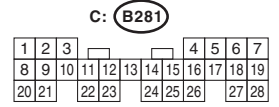
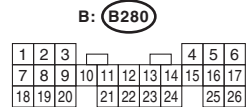
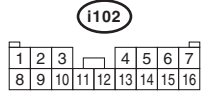
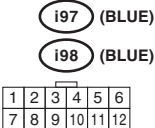
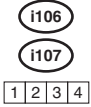
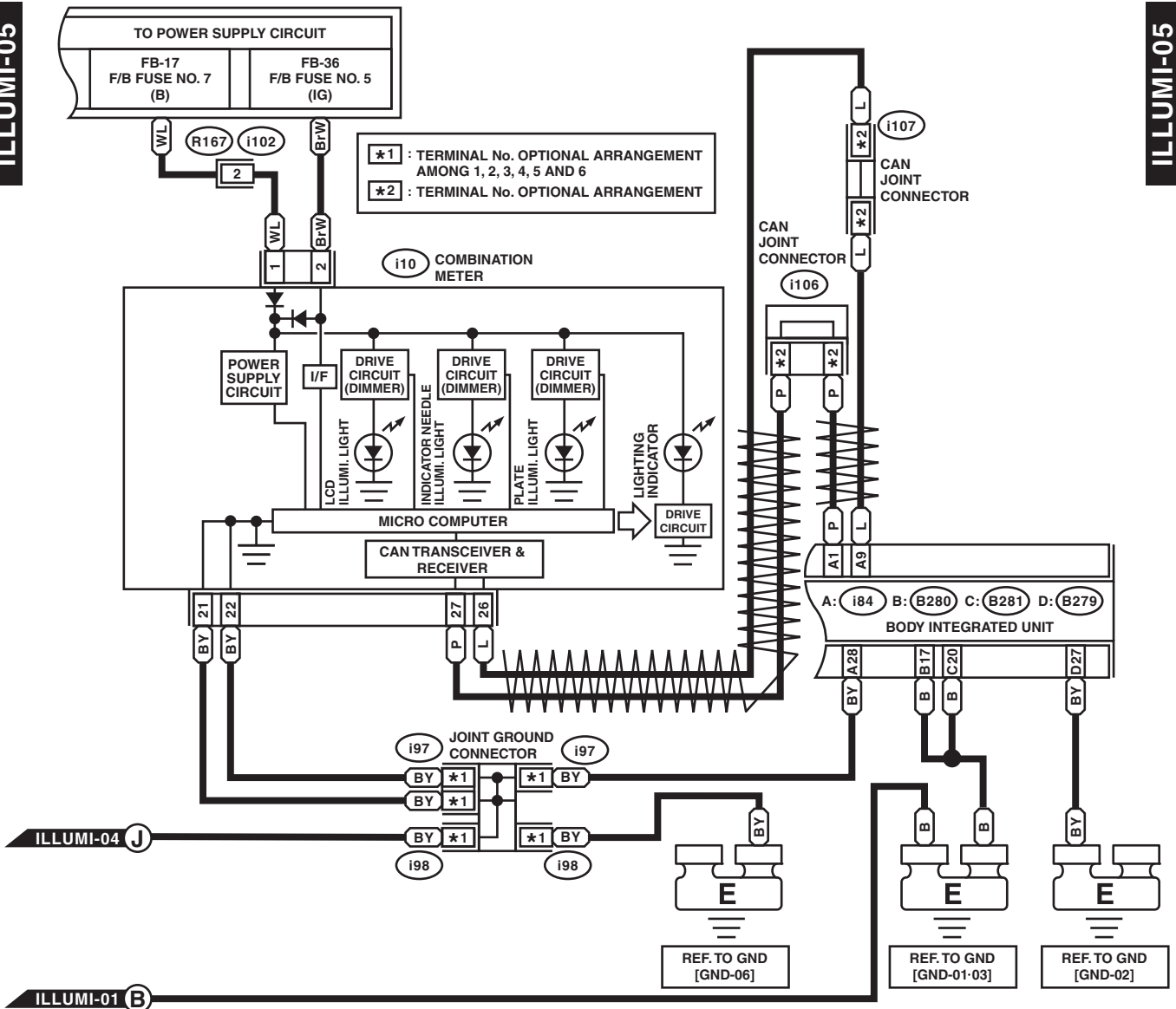

WI-25084

Turn Signal Light and Hazard Light System

26. Turn Signal Light and Hazard Light System

A: WIRING DIAGRAM

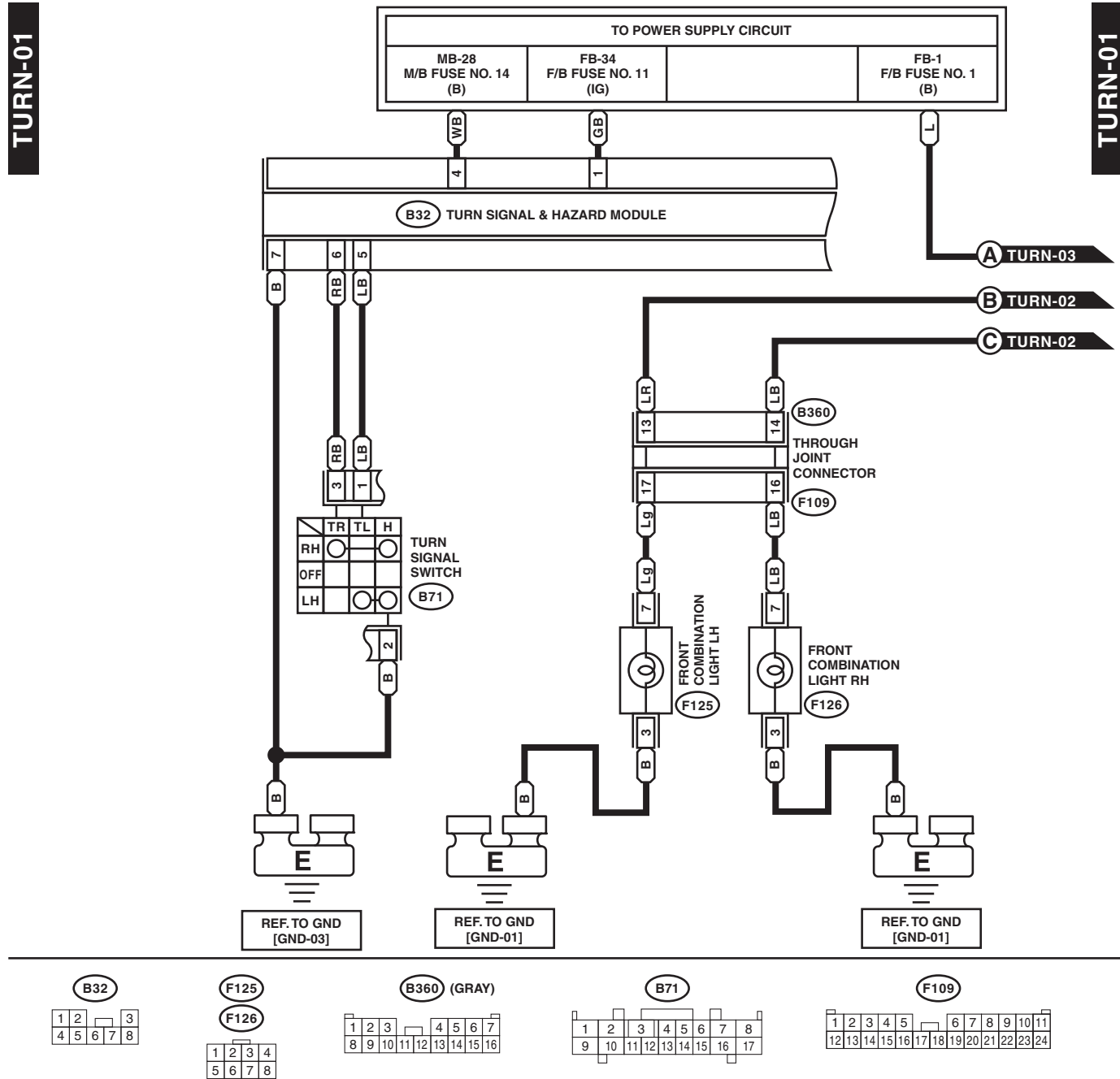

Turn Signal Light and Hazard Light System

WIRING SYSTEM

TURN-02

TURN-02

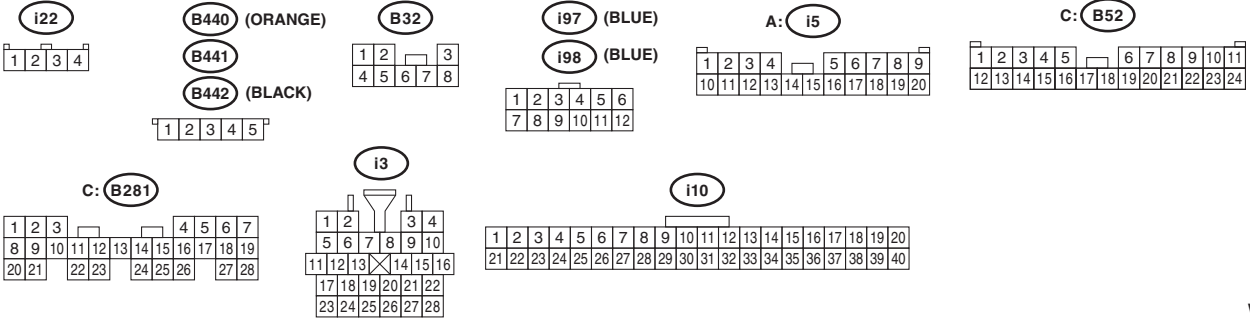
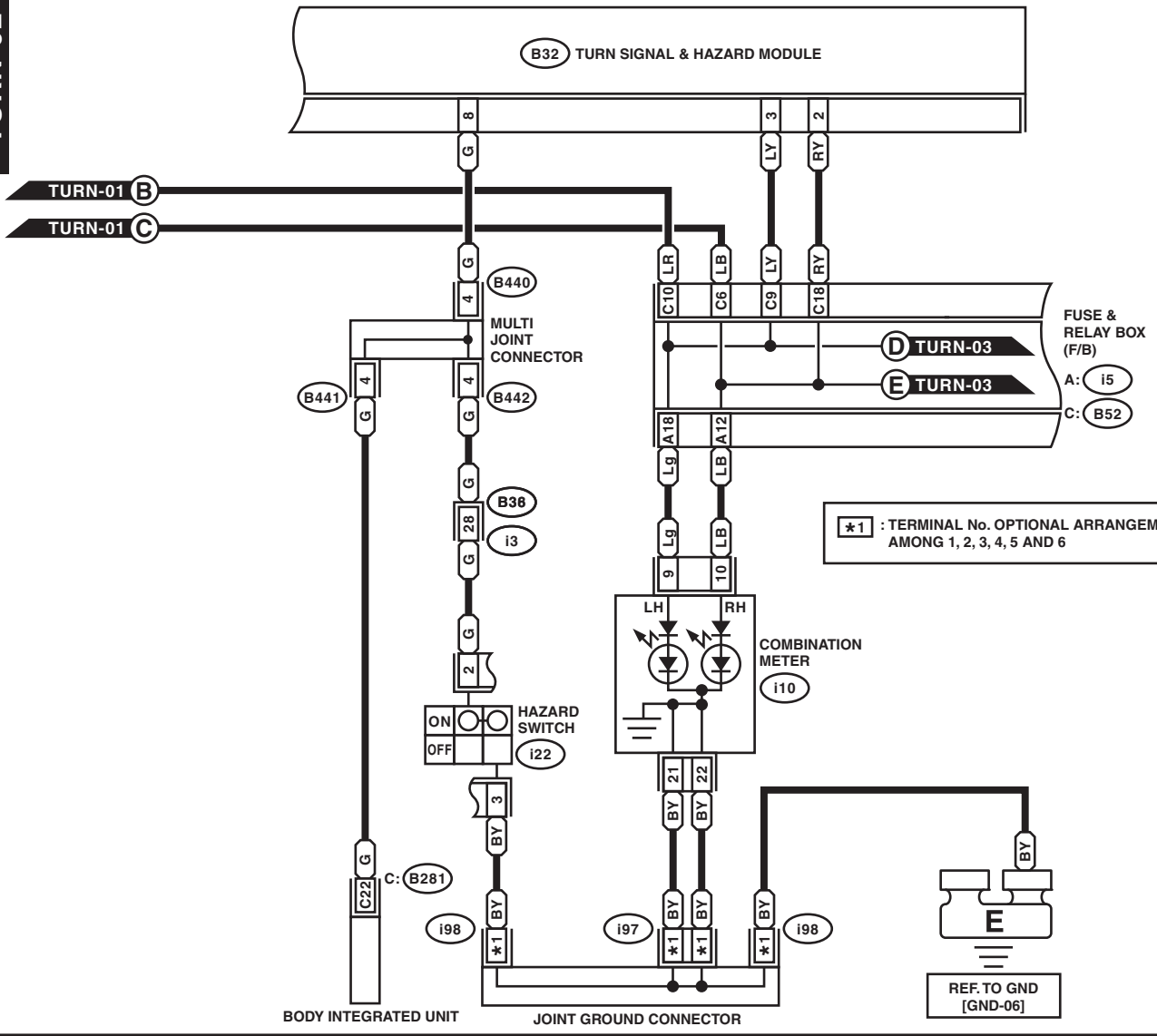

WI-19576

Turn Signal Light and Hazard Light System

WIRING SYSTEM

TURN-03

TURN-03

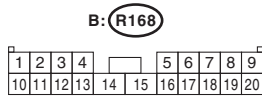
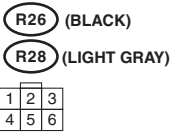
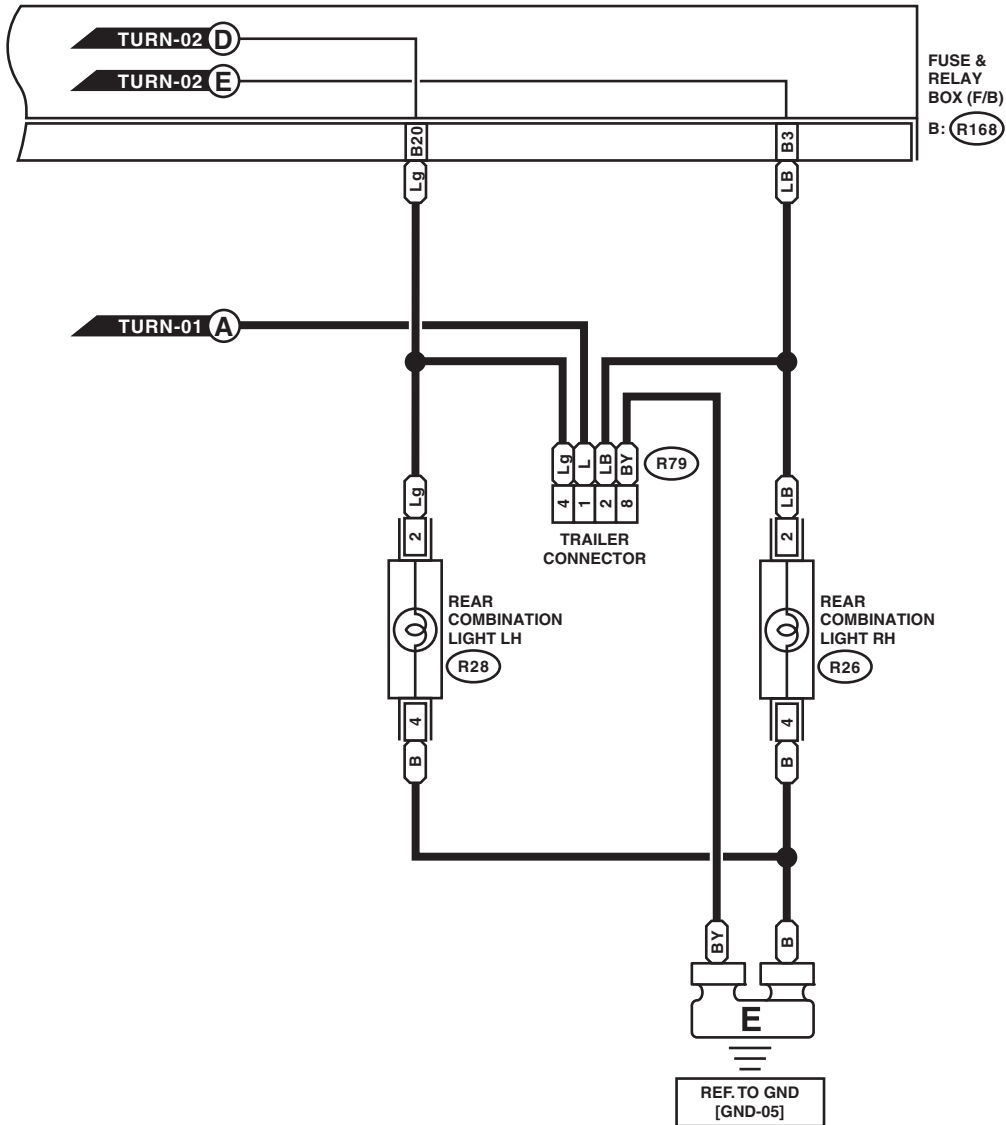

WI-19577

Interior Light System

WIRING SYSTEM

27. Interior Light System

A: WIRING DIAGRAM

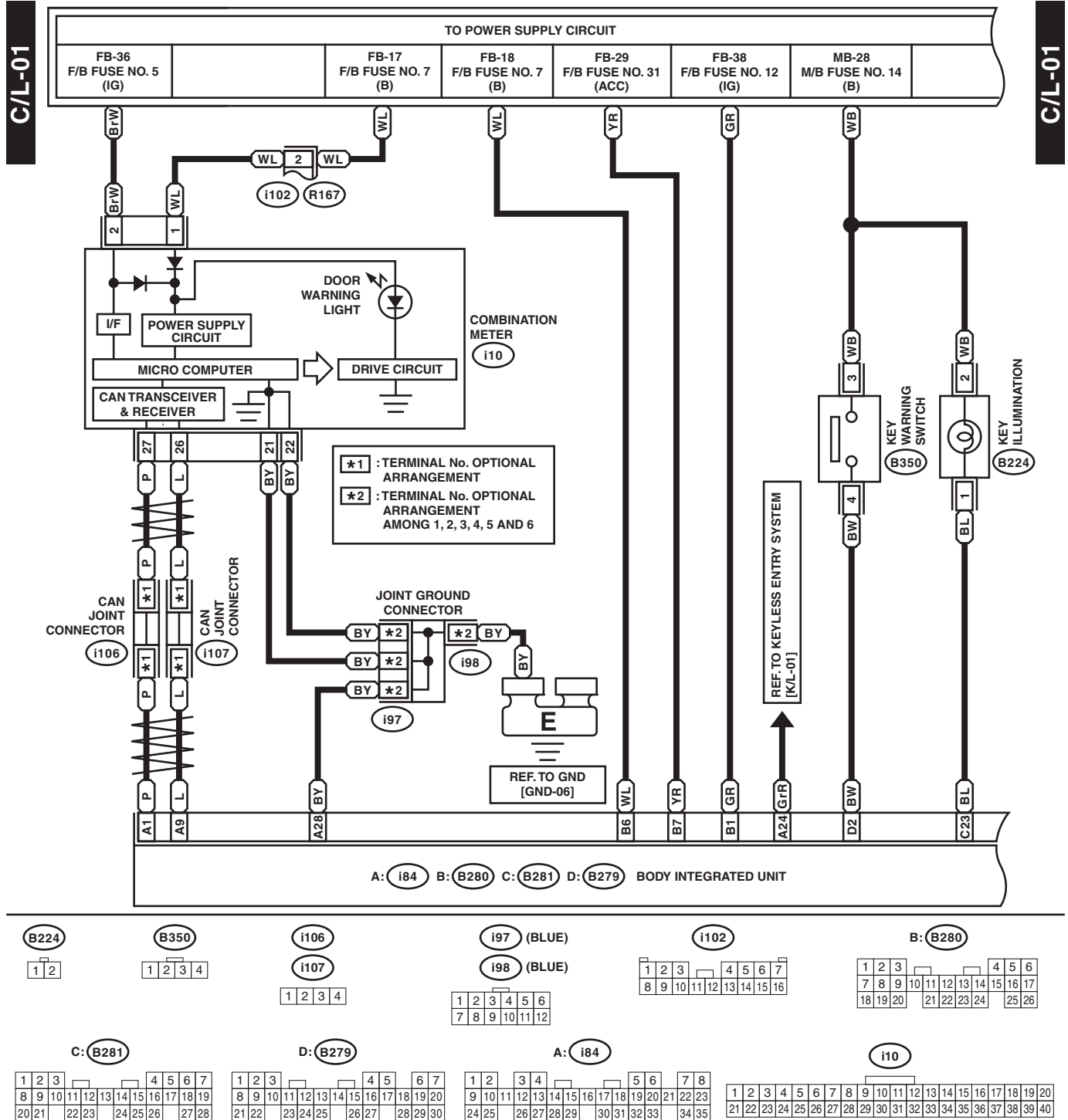

WI-19578

Interior Light System

WIRING SYSTEM

C/L-02

C/L-02

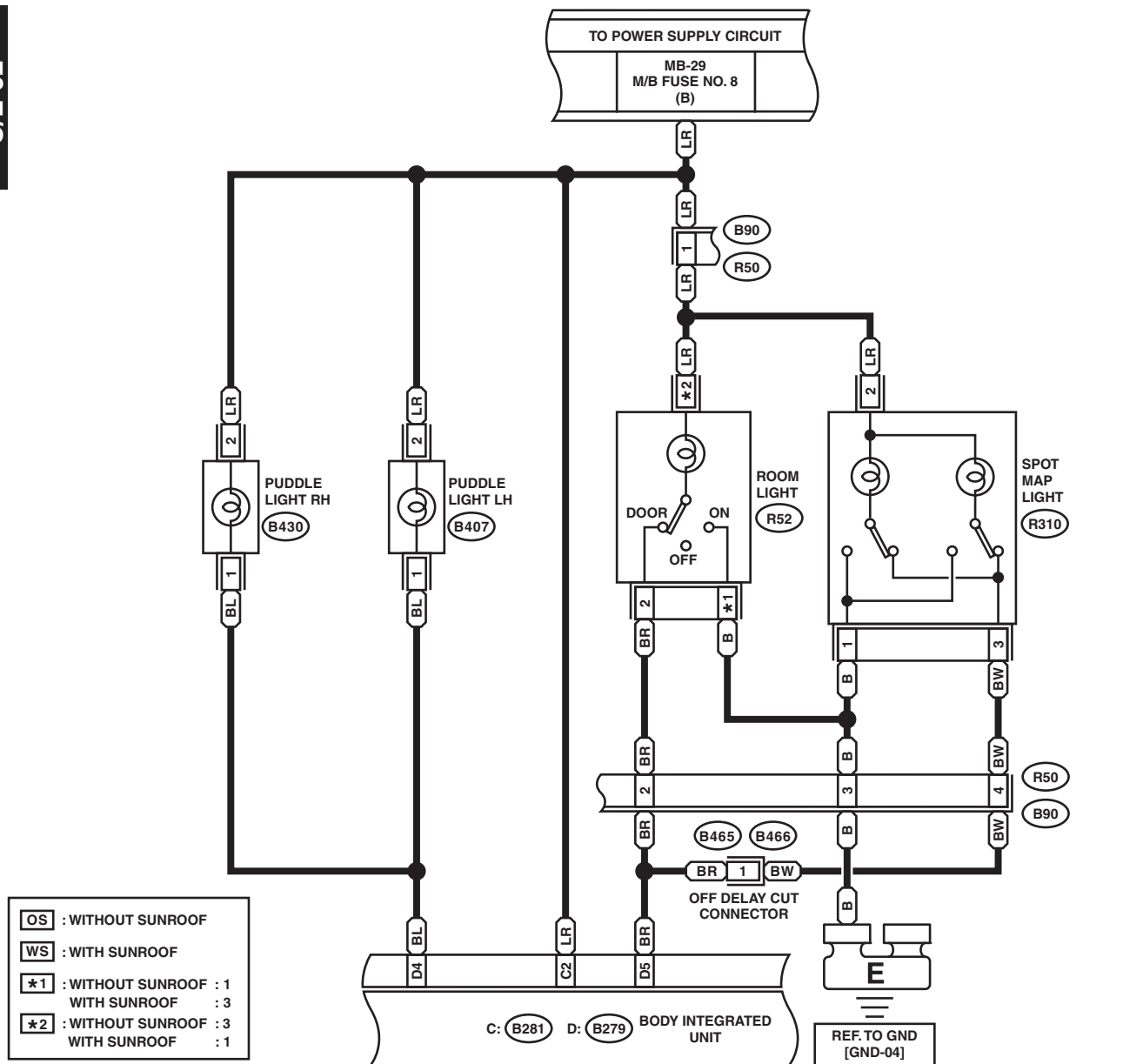

- OS : WITHOUT SUNROOF
- WS : WITH SUNROOF
- *1 : WITHOUT SUNROOF : 1
WITH SUNROOF : 3
- *2 : WITHOUT SUNROOF : 3
WITH SUNROOF : 1

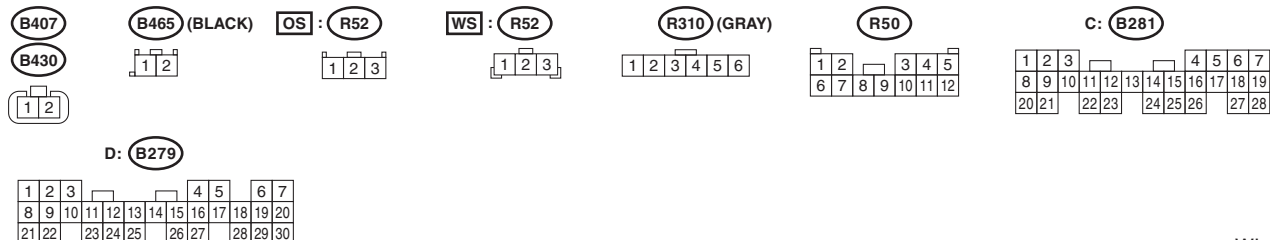

WI-19579

Interior Light System

WIRING SYSTEM

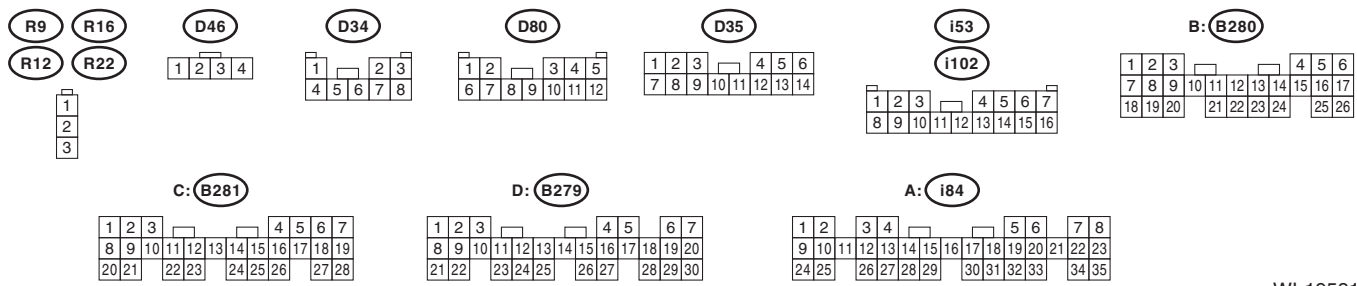
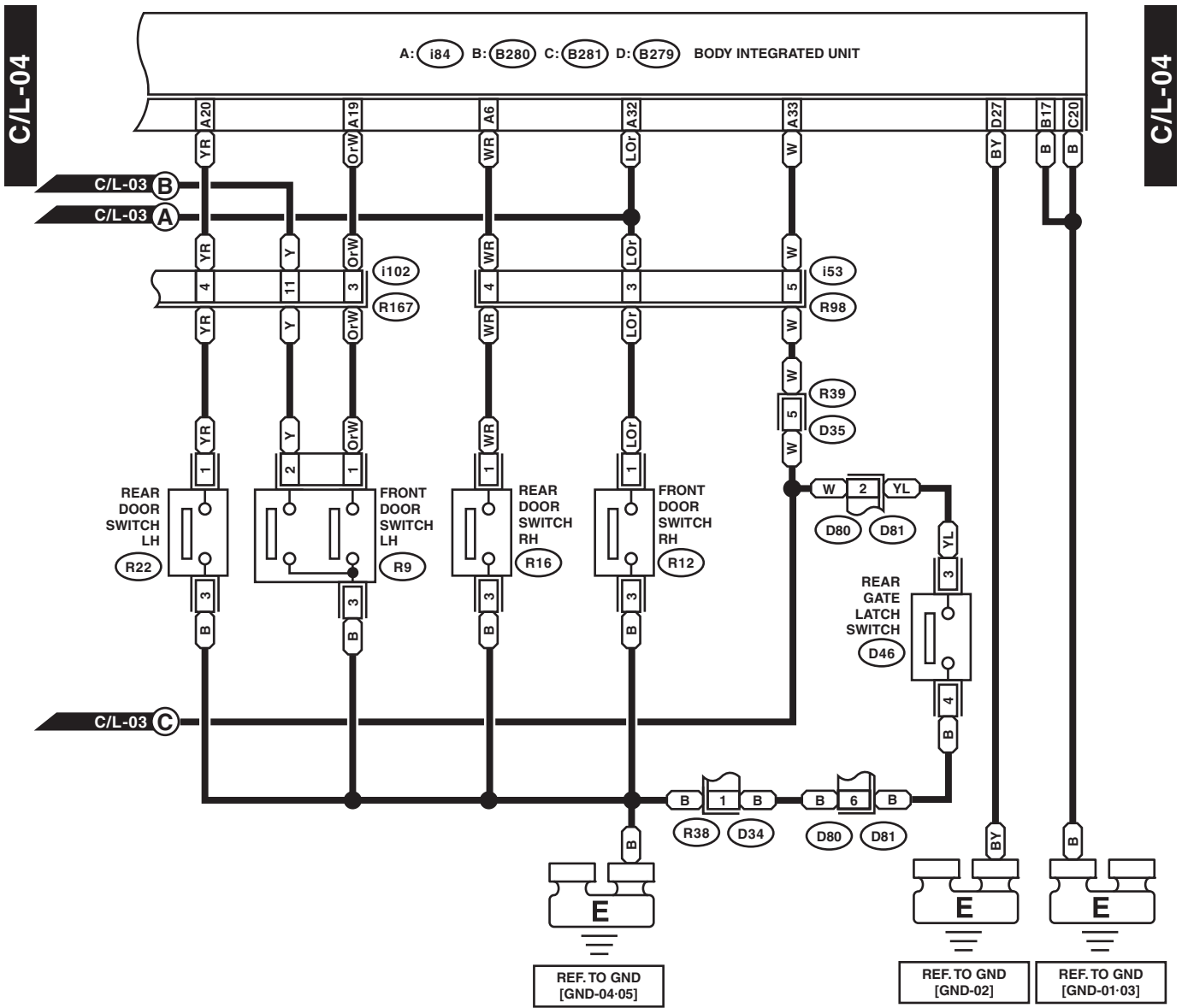

WI-19581

Front Wiper and Washer System

WIRING SYSTEM

28. Front Wiper and Washer System

A: WIRING DIAGRAM

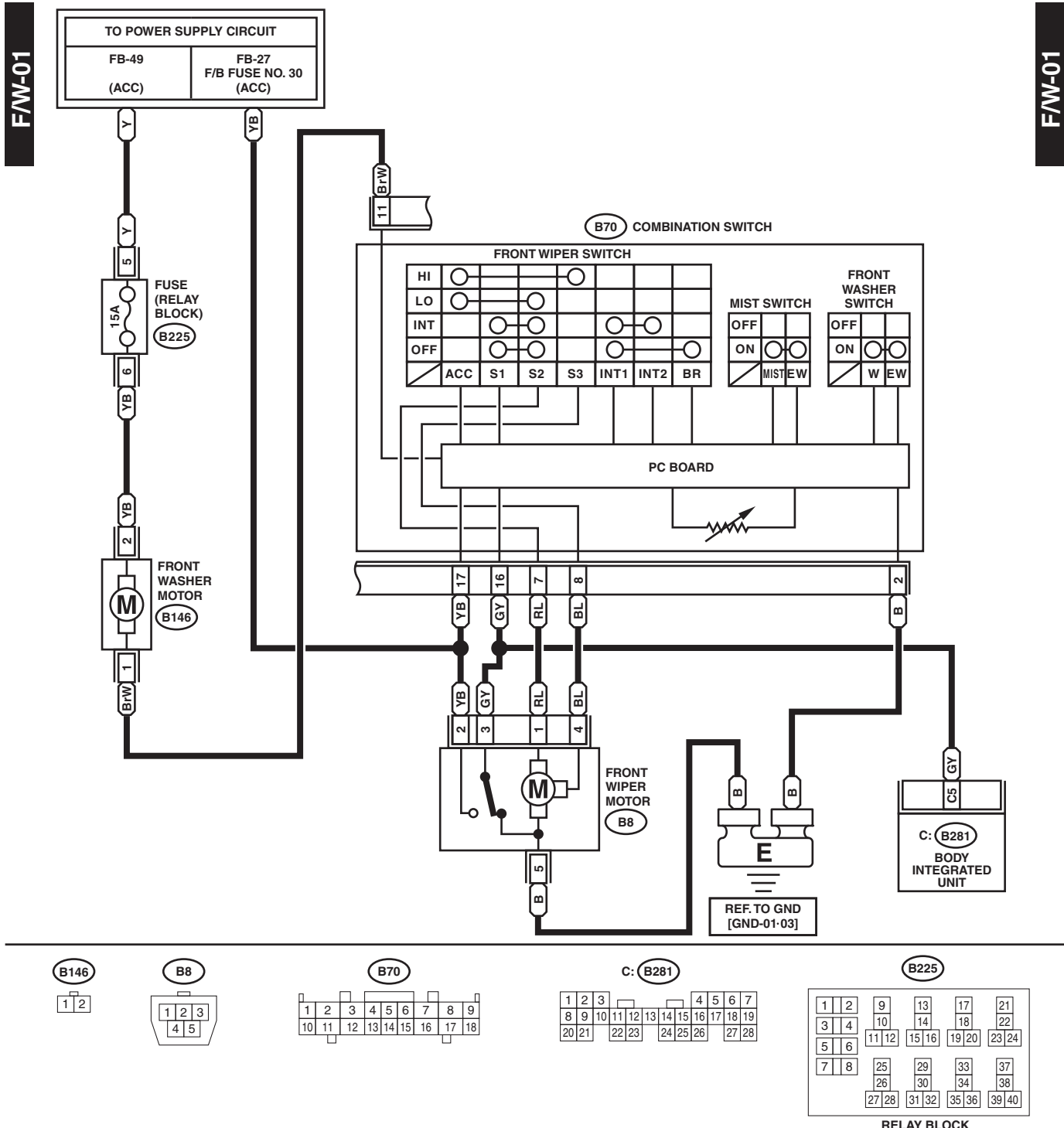

WI-19582

29. Rear Wiper and Washer System

A: WIRING DIAGRAM

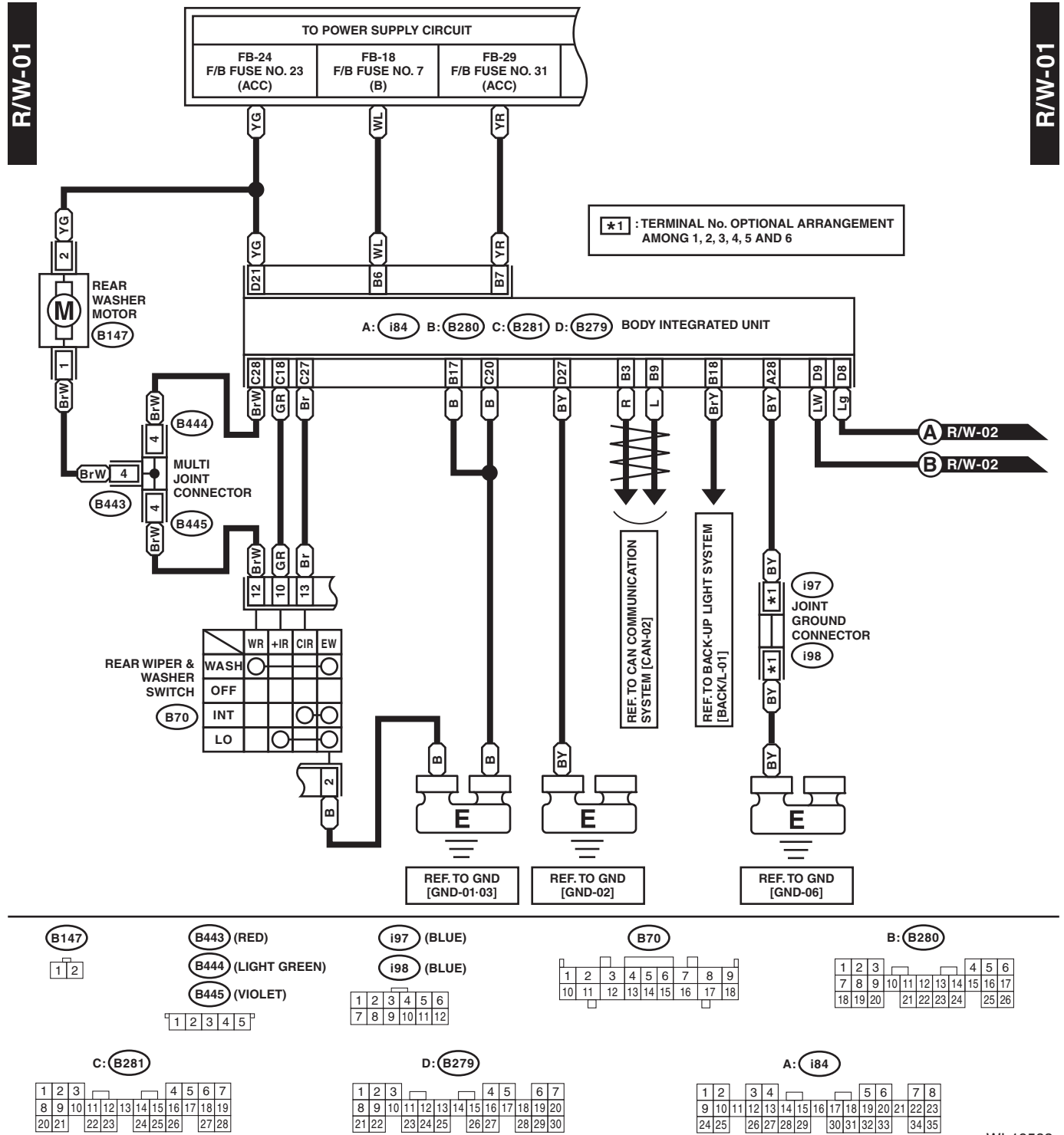

WI-19583

30. Wiper Deicer System

A: WIRING DIAGRAM

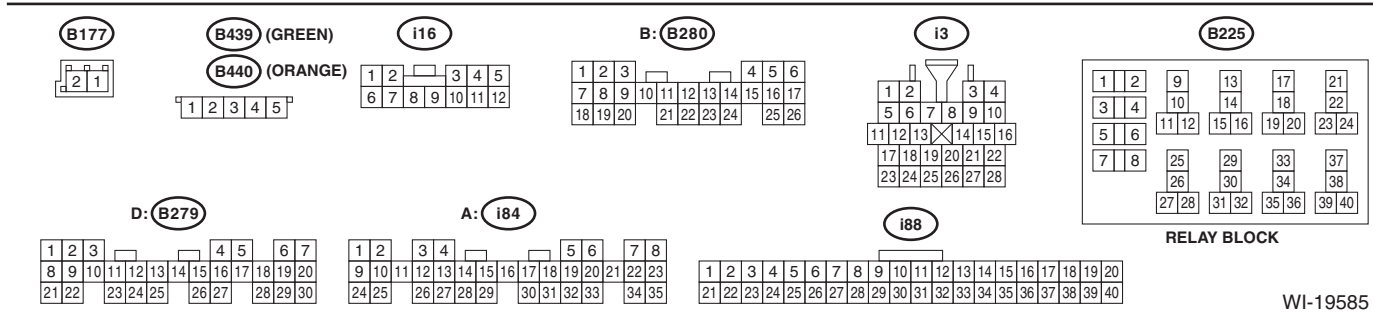
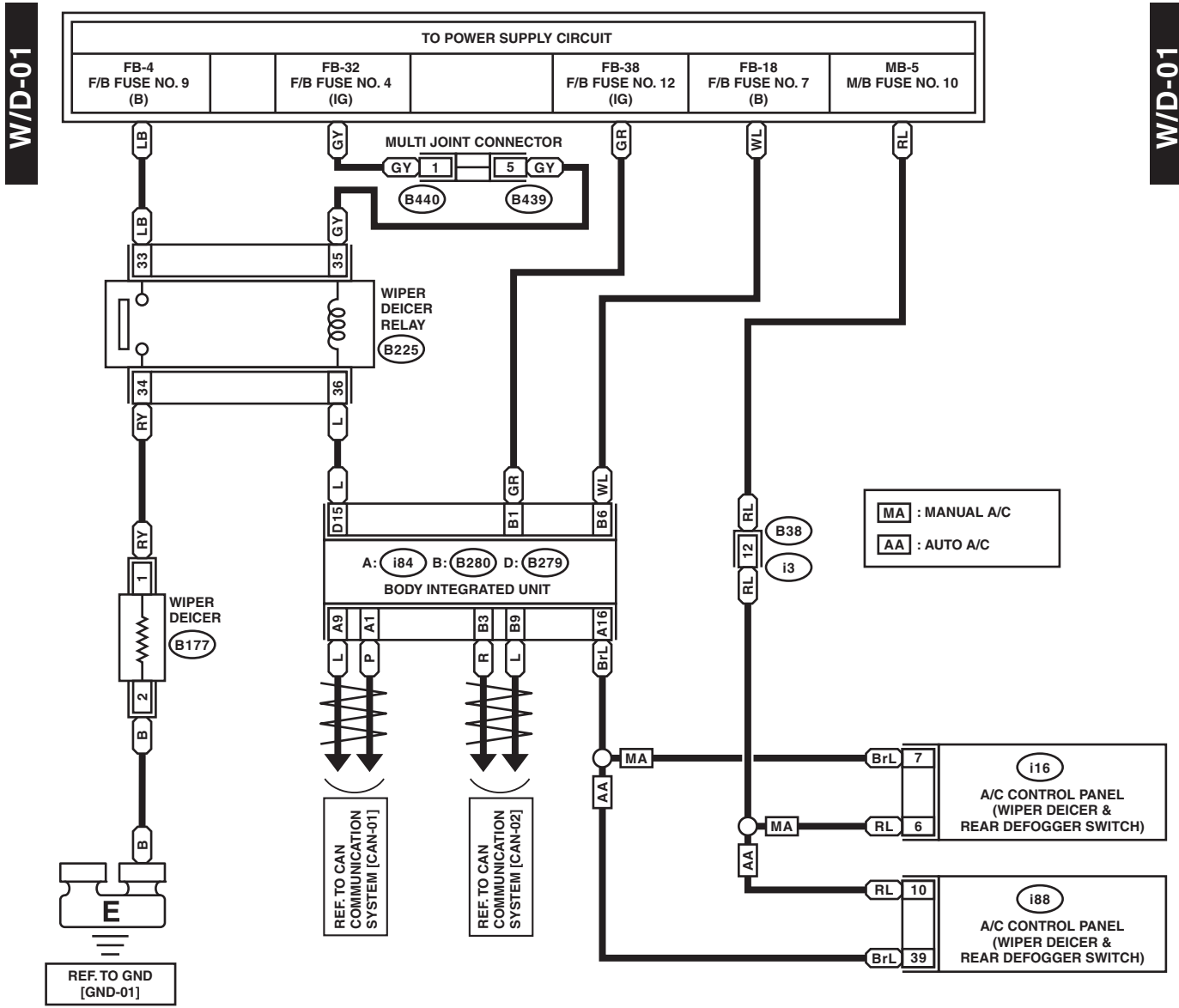

WI-19585

Audio System

WIRING SYSTEM

31. Audio System

A: WIRING DIAGRAM

1. MODELS WITHOUT NAVIGATION SYSTEM

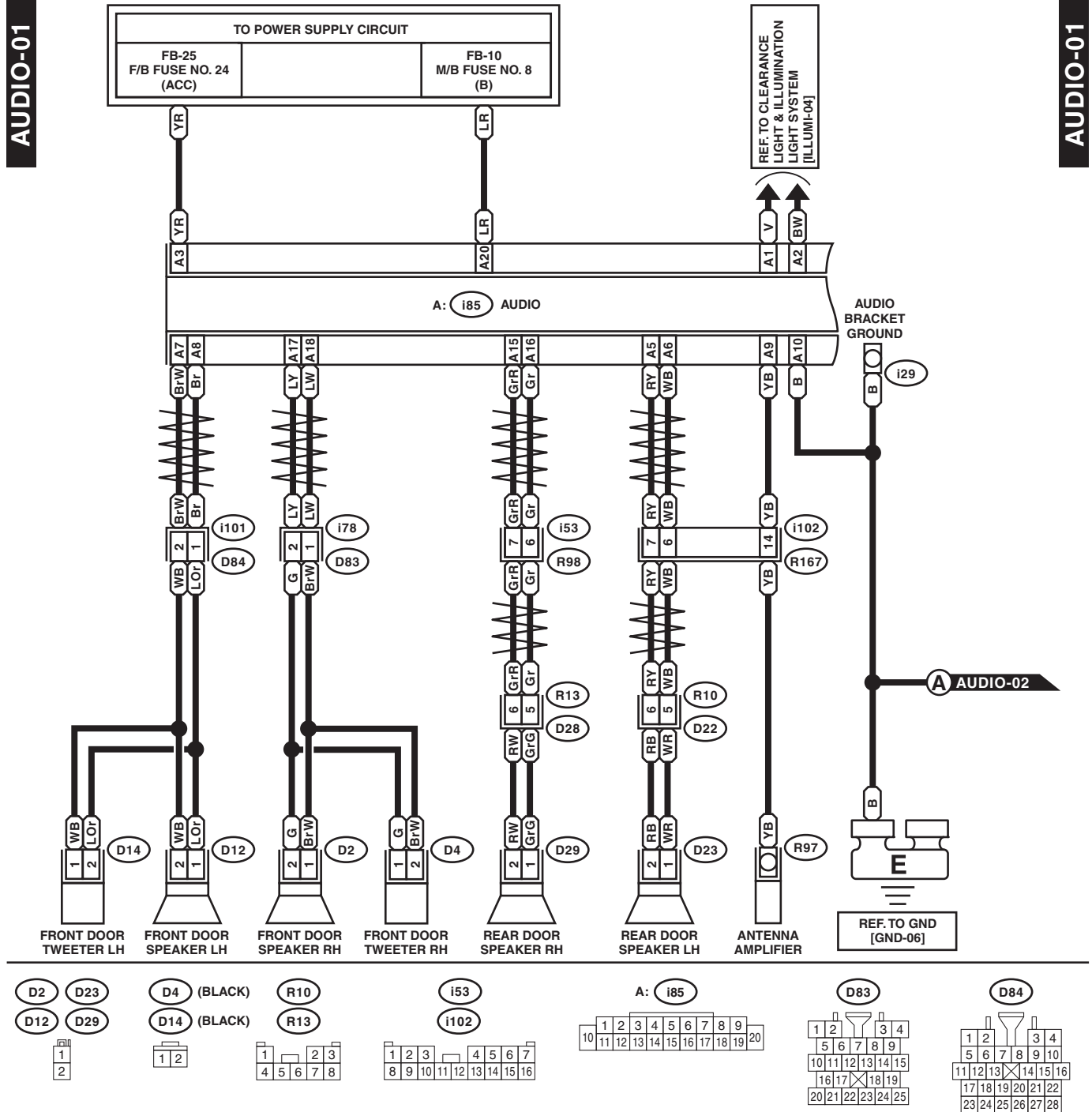

WI-19586

Audio System

WIRING SYSTEM

AUDIO-02

AUDIO-02

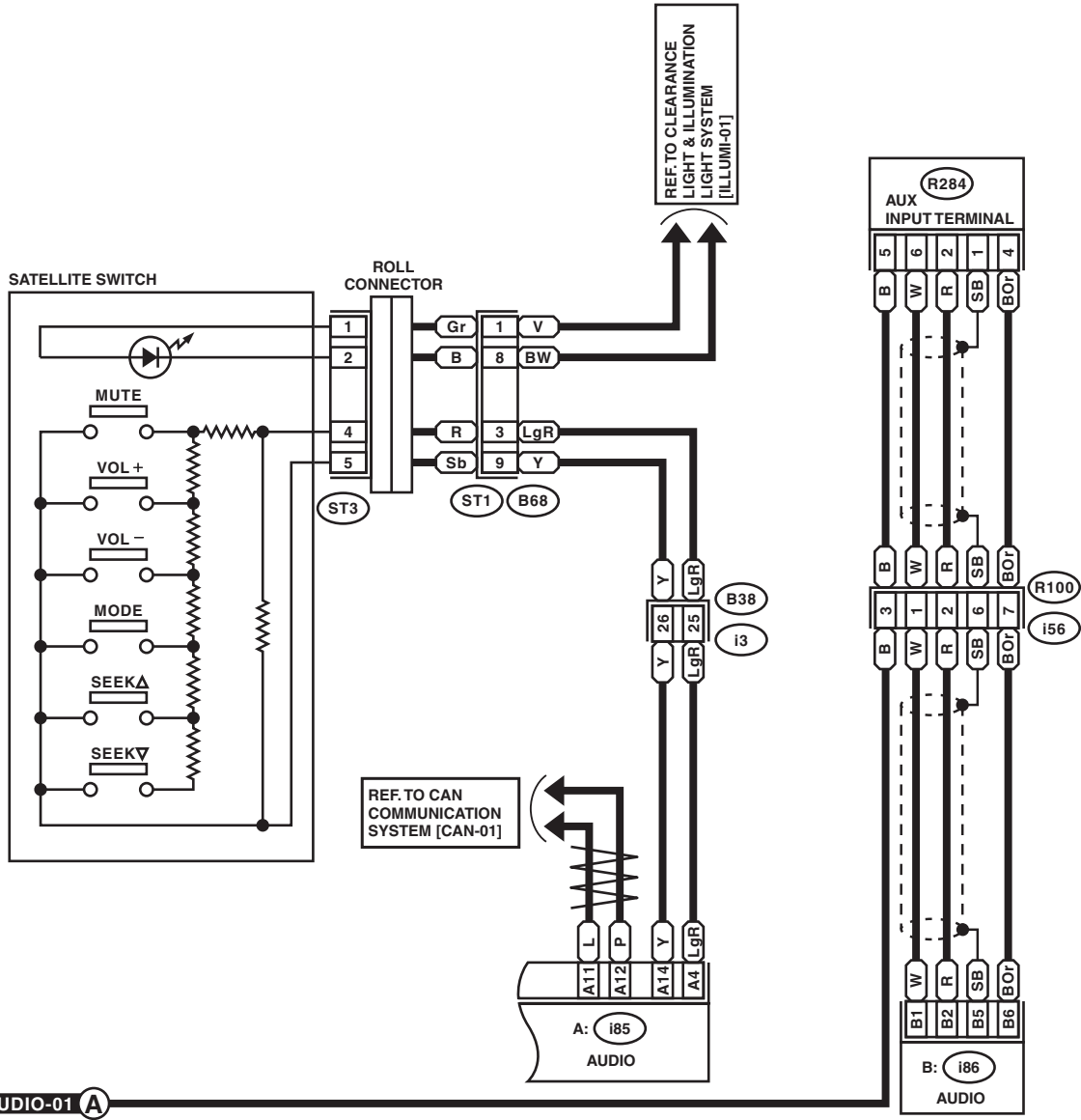

AUDIO-01 A

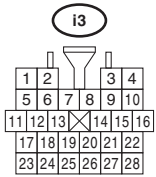
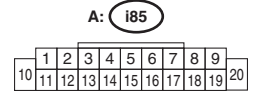
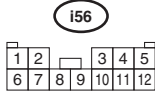
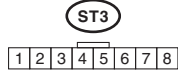
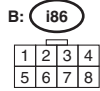
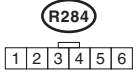

WI-19587

Front Accessory Power Supply Socket System

WIRING SYSTEM

32.Front Accessory Power Supply Socket System

A: WIRING DIAGRAM

FAPS-01

FAPS-01

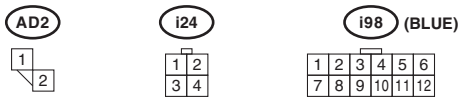
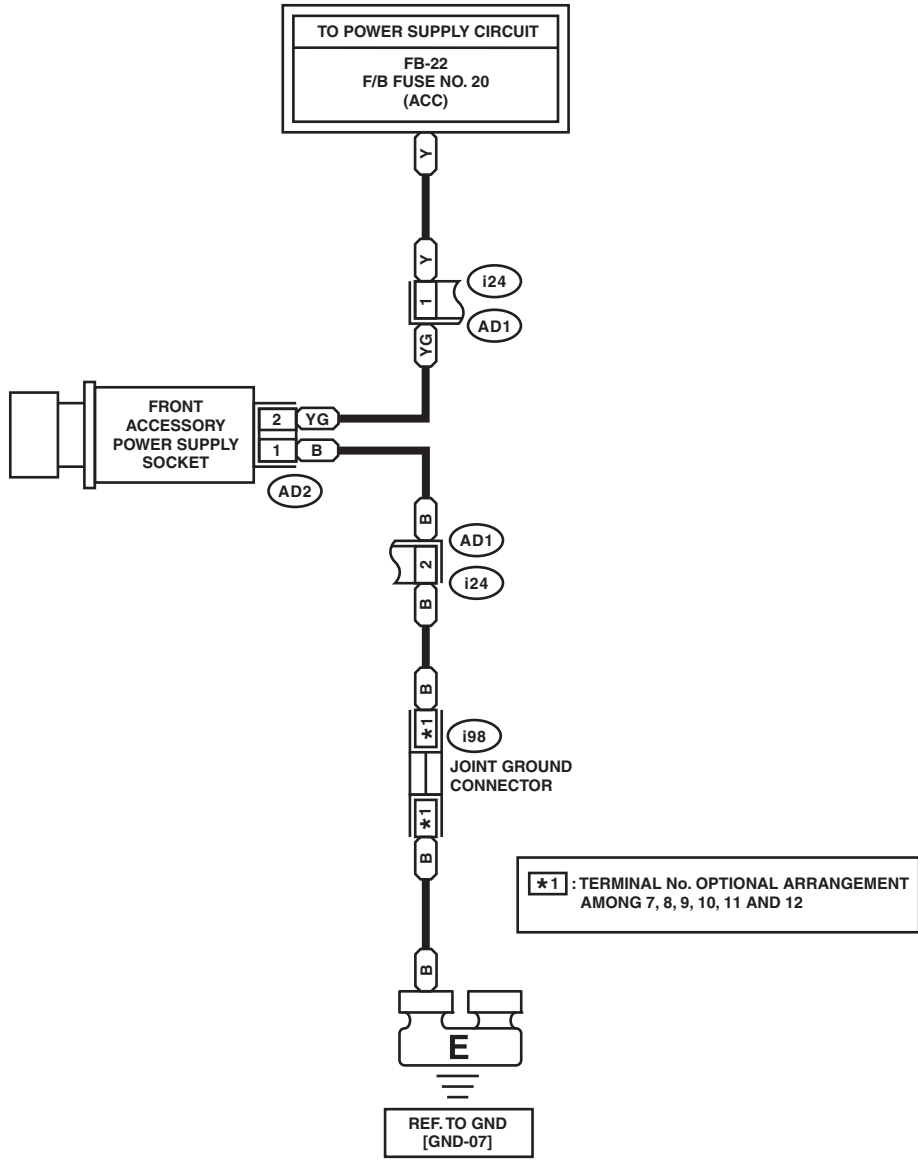

WI-19588

33.Rear Accessory Power Supply Socket System

A: WIRING DIAGRAM

RAPS-01

RAPS-01

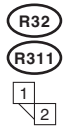
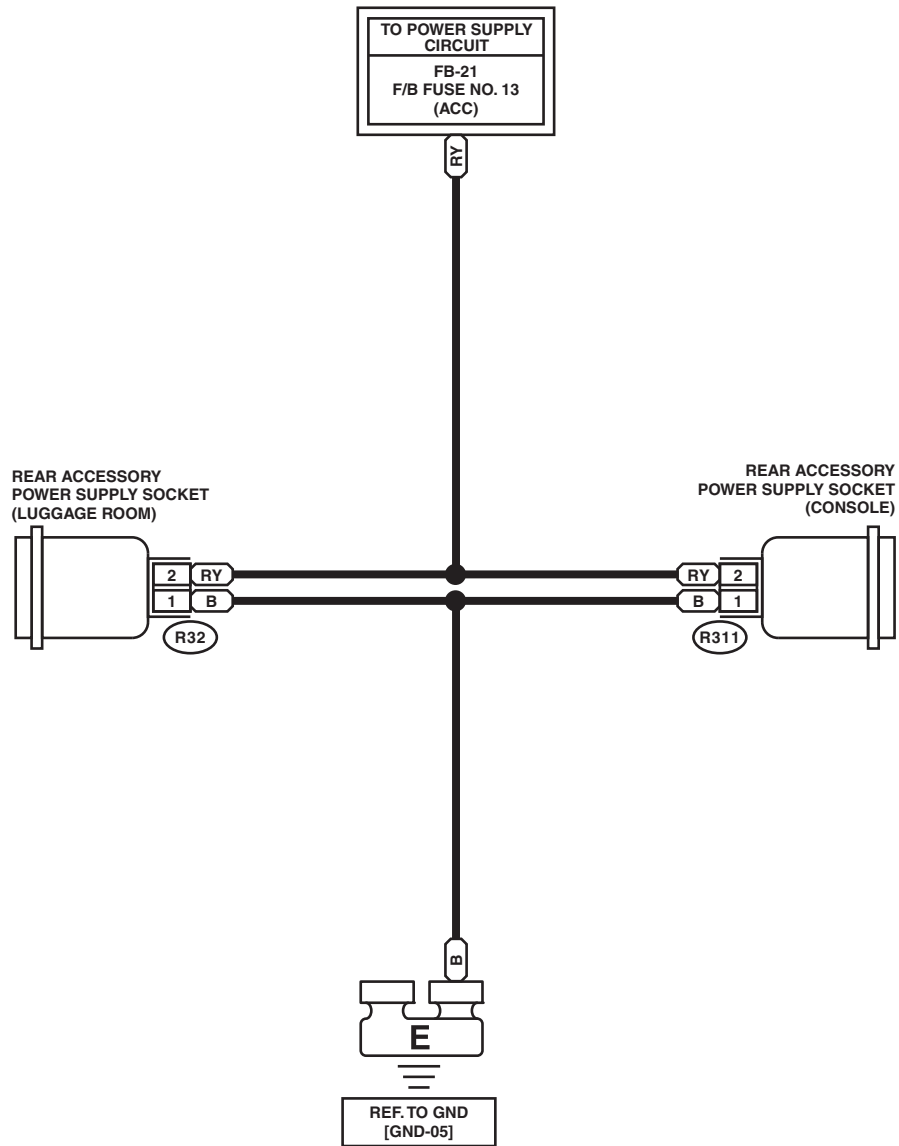

Navigation System

WIRING SYSTEM

34. Navigation System

A: WIRING DIAGRAM

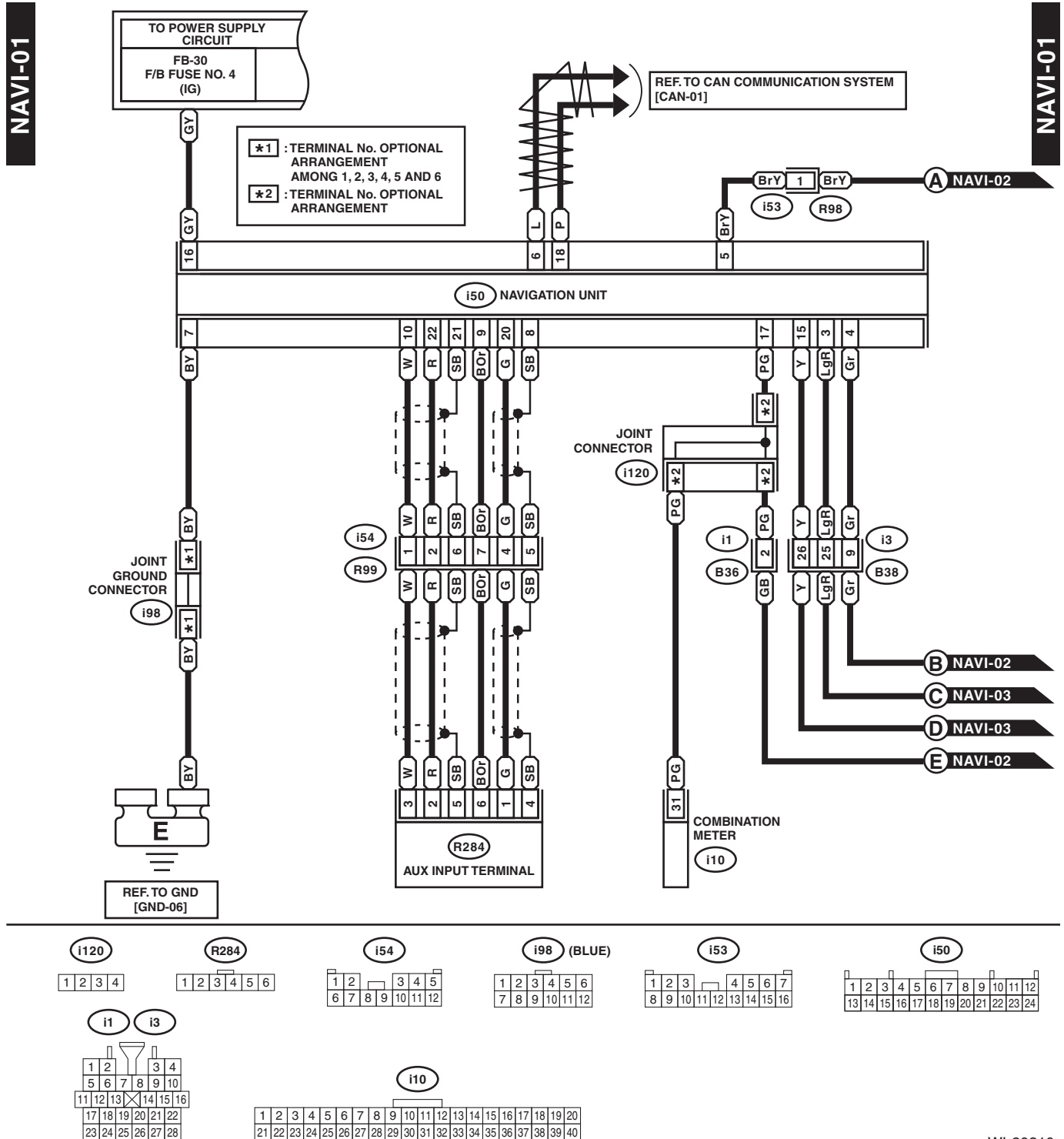

WI-20310

Navigation System

WIRING SYSTEM

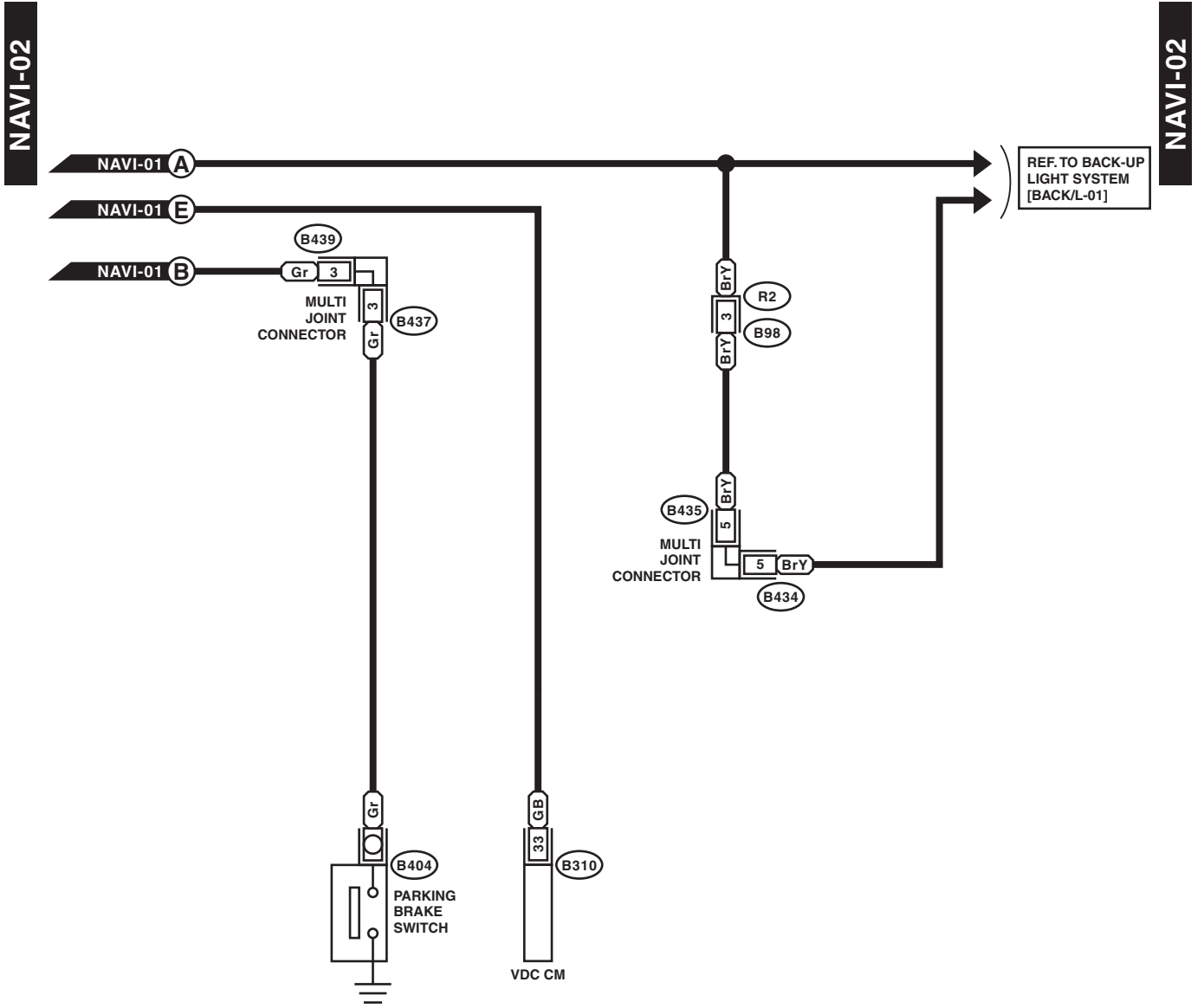

- (PINK) B434 (BLUE) B437
 - (BROWN) B435 (GREEN) B439
- 1 2 3 4 5

(B98)

1	2	3	4	5	6	7	8	9	10	11		
12	13	14	15	16	17	18	19	20	21	22	23	24

(B310) (BLACK)

22	23	24	25	1	2	3	4	5	6	7	8	9	10	11	12	13	14	15	16	17	18	19	20	21
26	27	28	29	30	31	32	33	34	35	36	37	38	39	40	41	42	43	44	45	46				

WI-20311

Navigation System

WIRING SYSTEM

NAVI-03

NAVI-03

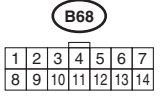
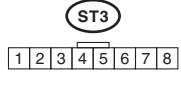
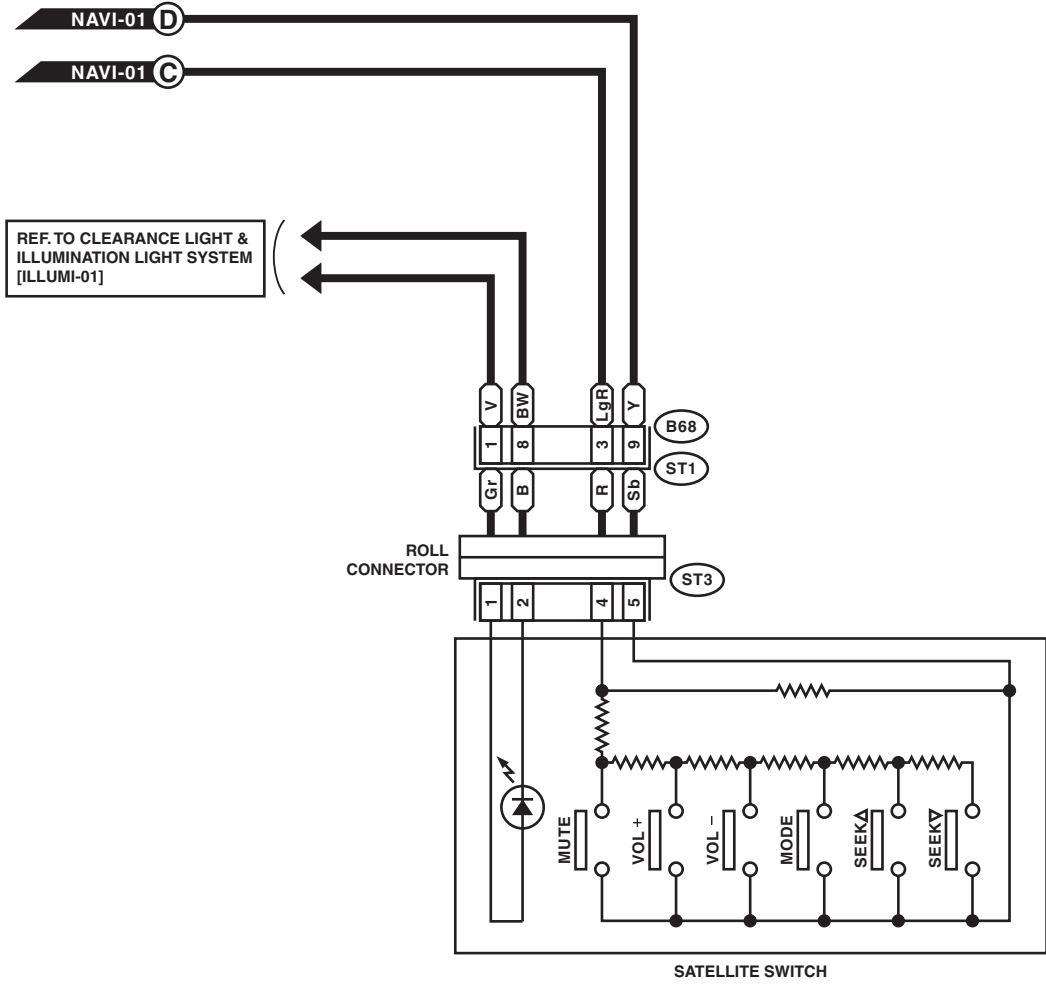

WI-20312

Navigation System

WIRING SYSTEM

NAVI-04

NAVI-04

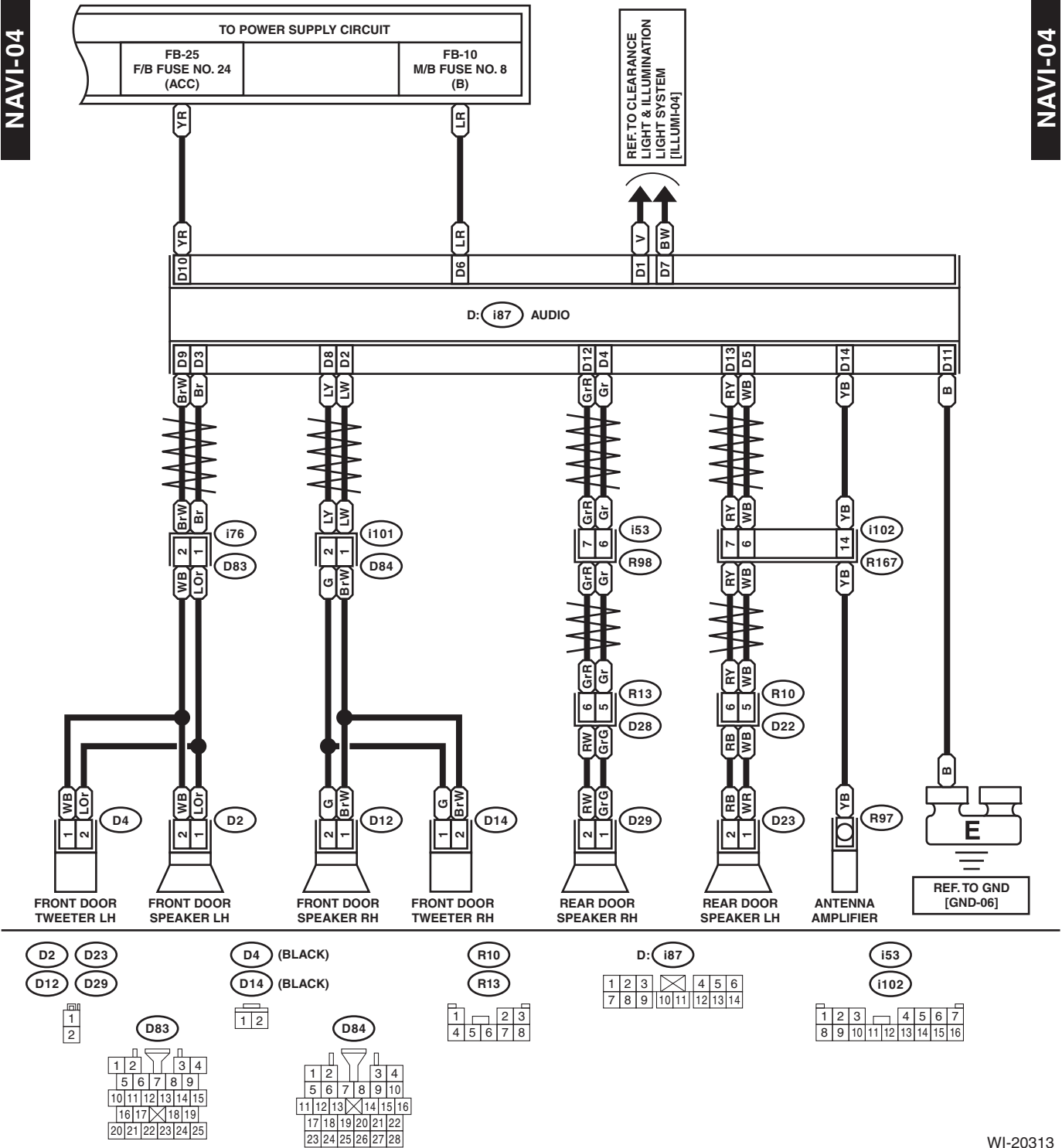

WI-20313

Horn System

WIRING SYSTEM

35.Horn System

A: WIRING DIAGRAM

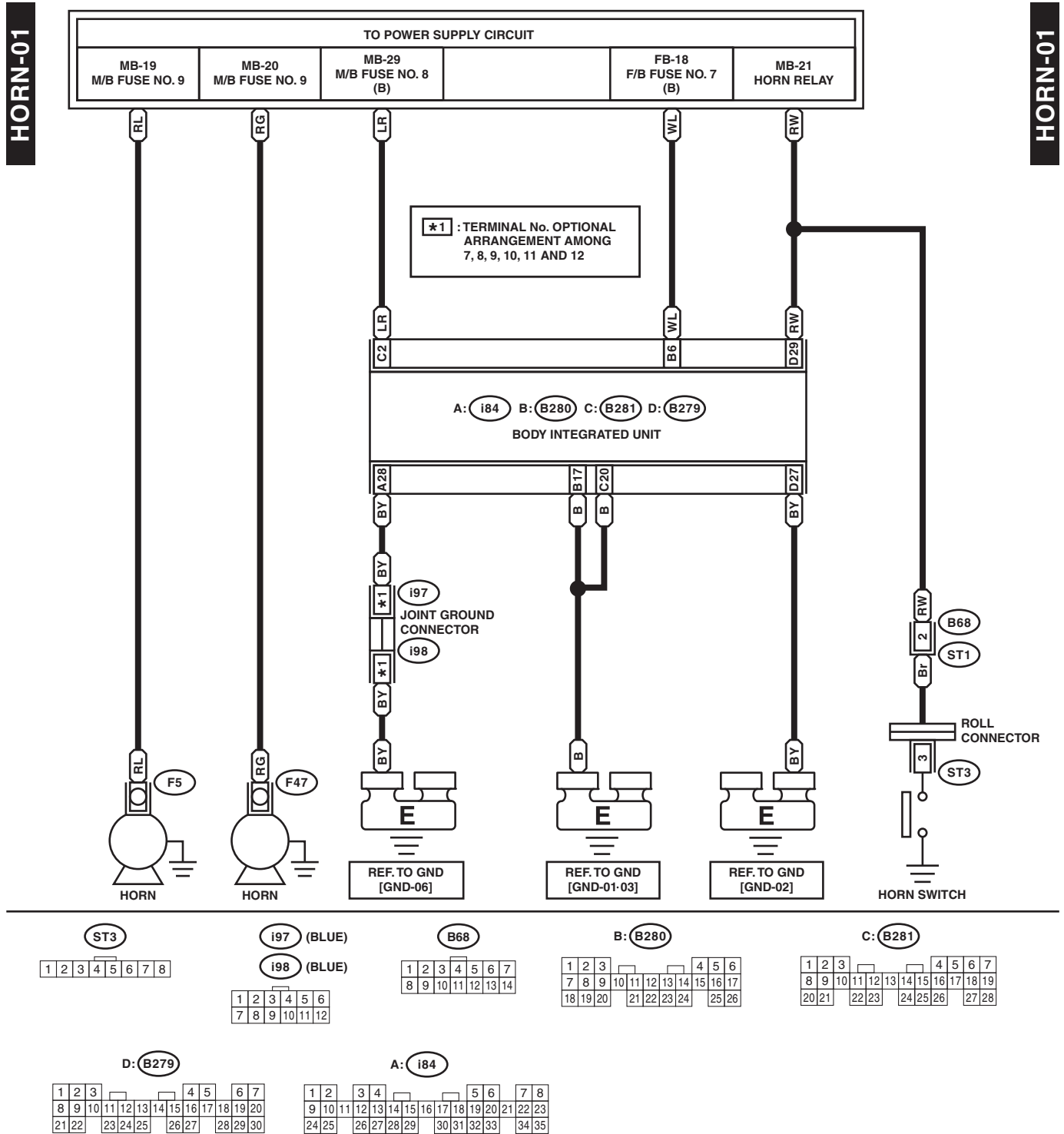

WI-19590

36. Power Window System

A: WIRING DIAGRAM

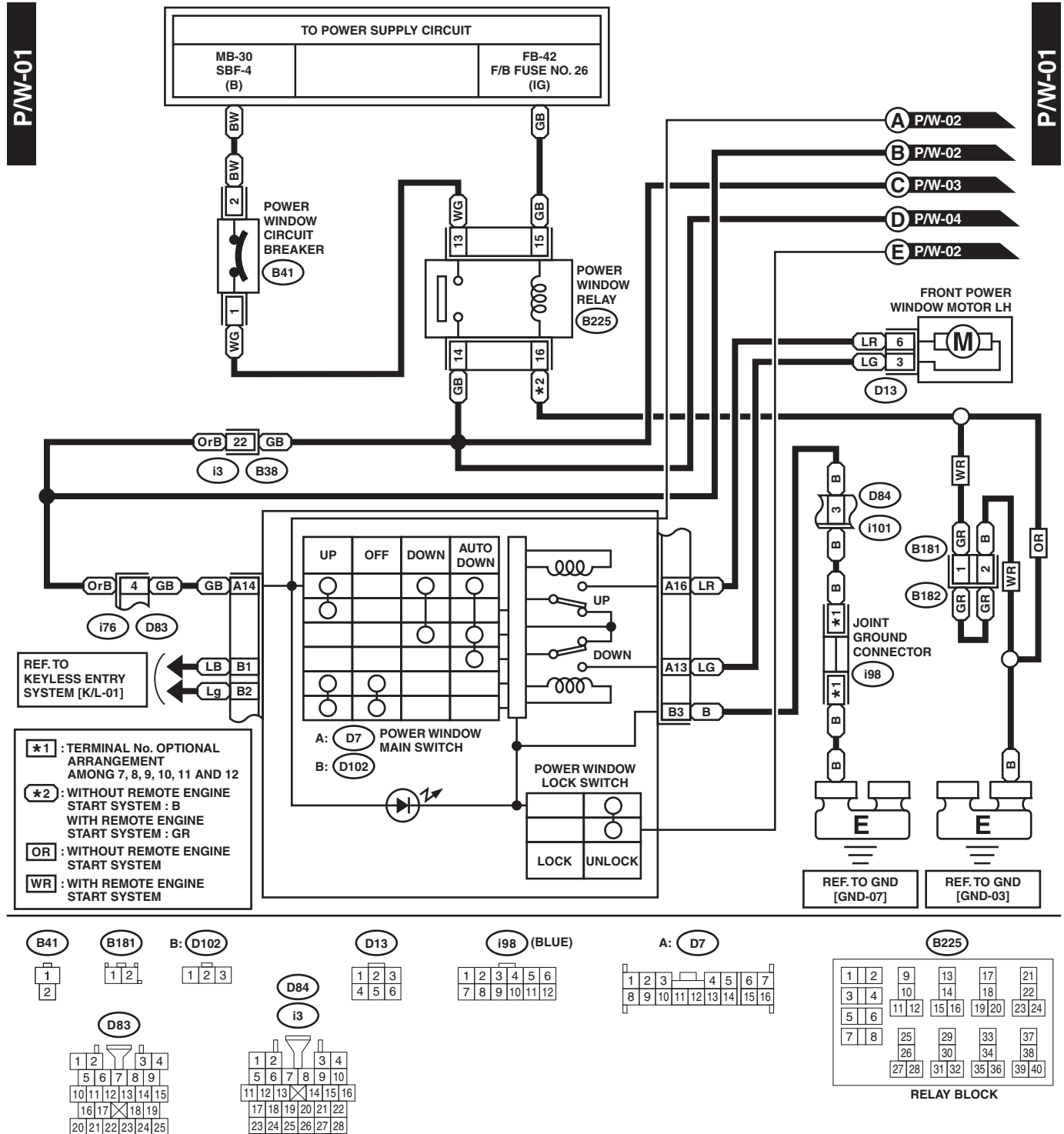

WI-19591

Power Window System

WIRING SYSTEM

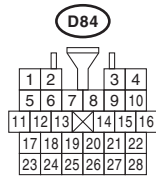
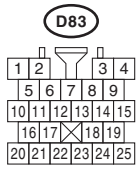
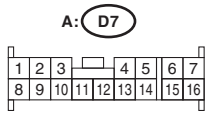
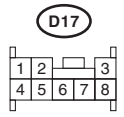
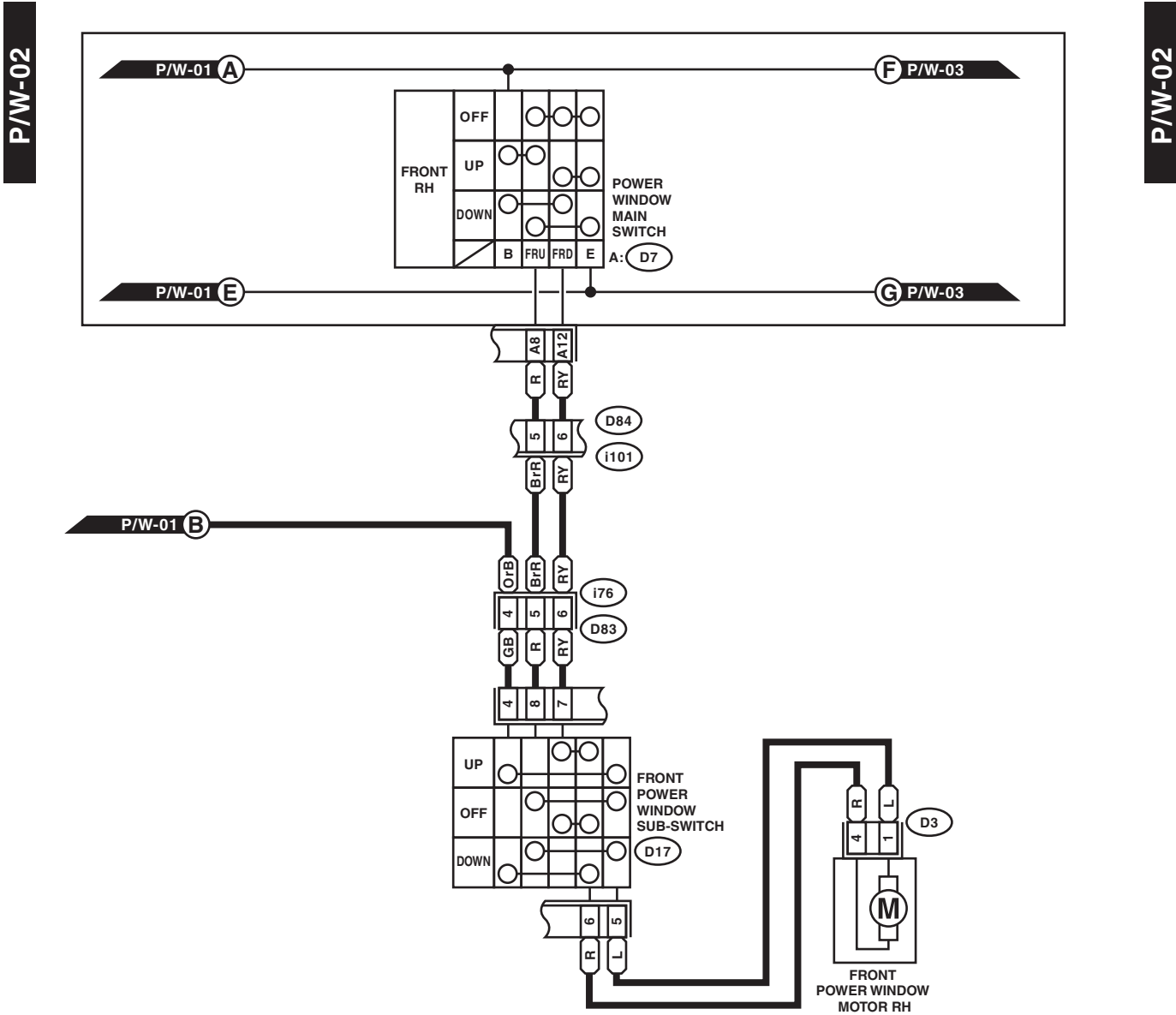

WI-19662

Power Window System

WIRING SYSTEM

P/W-03

P/W-03

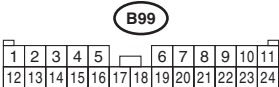
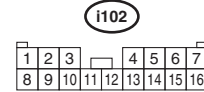
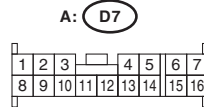
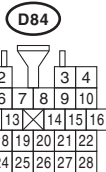
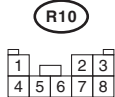
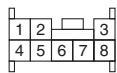
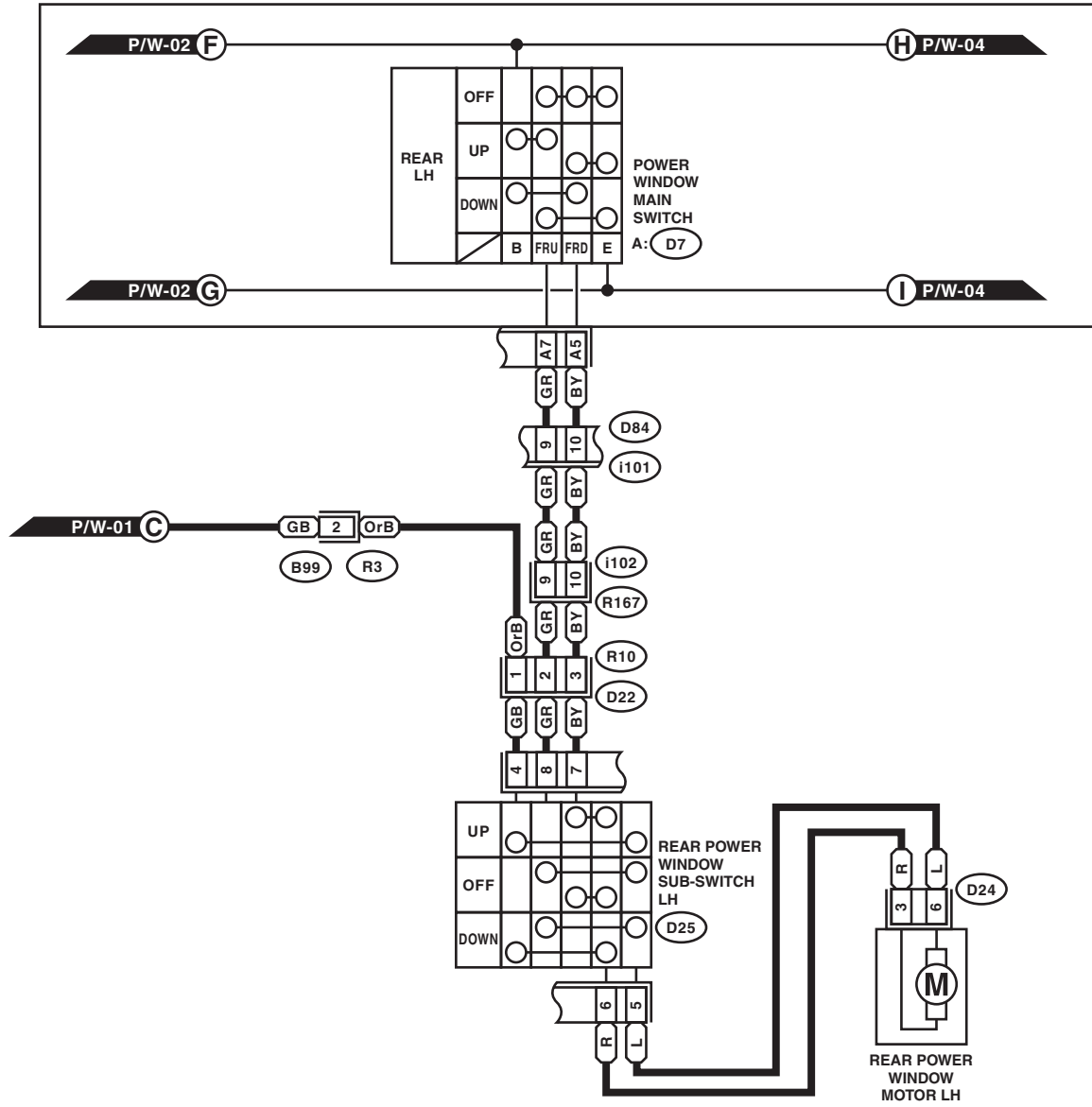

WI-19592

Power Window System

WIRING SYSTEM

P/W-04

P/W-04

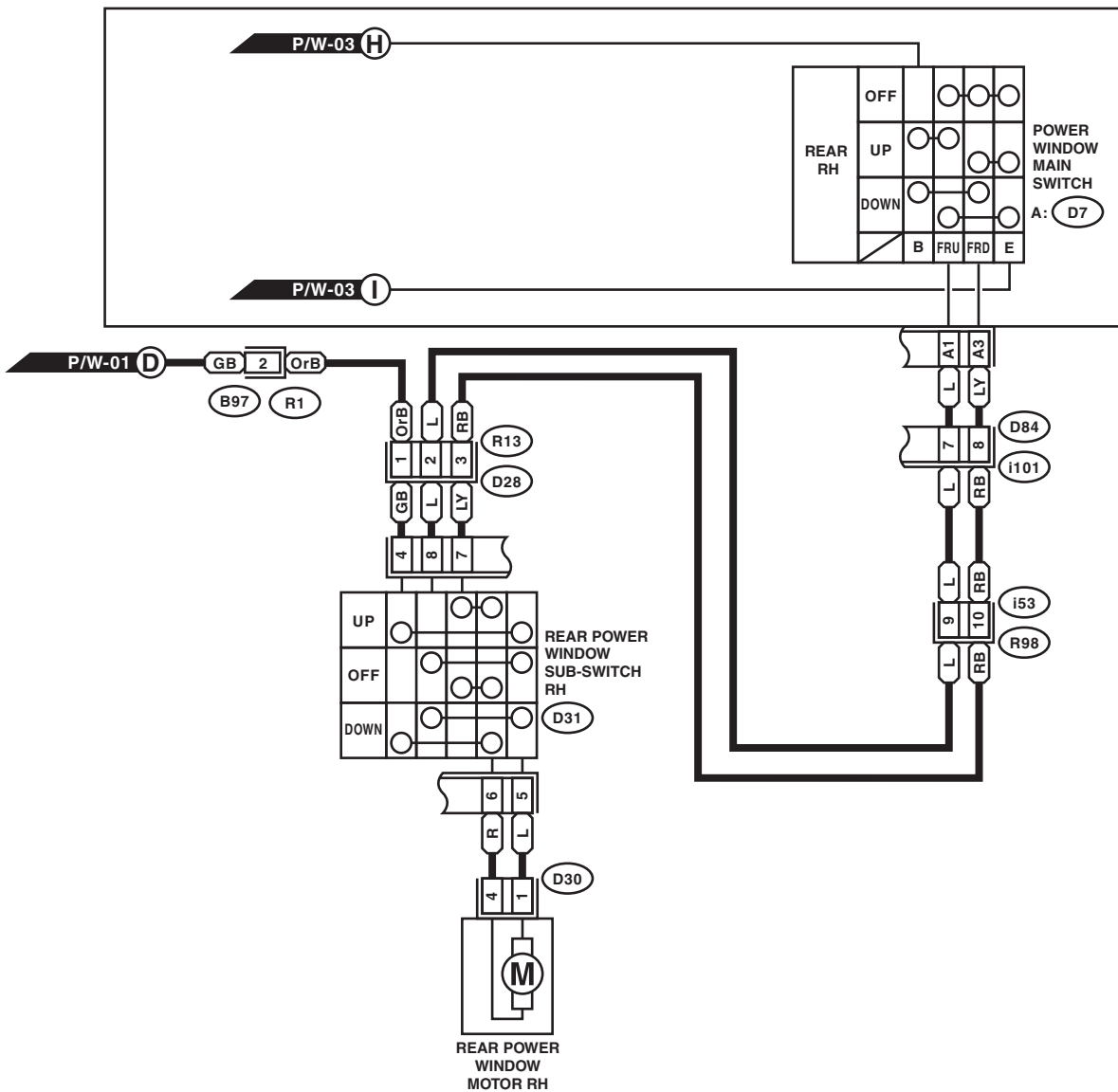

D30



D31

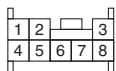

R13

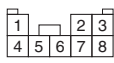

A: D7

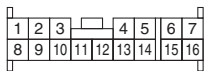

i53

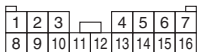

B97

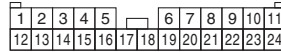

D84

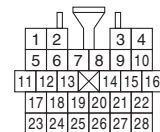

WI-19593

37. Remote Control Mirror System

A: WIRING DIAGRAM

R/M-01

R/M-01

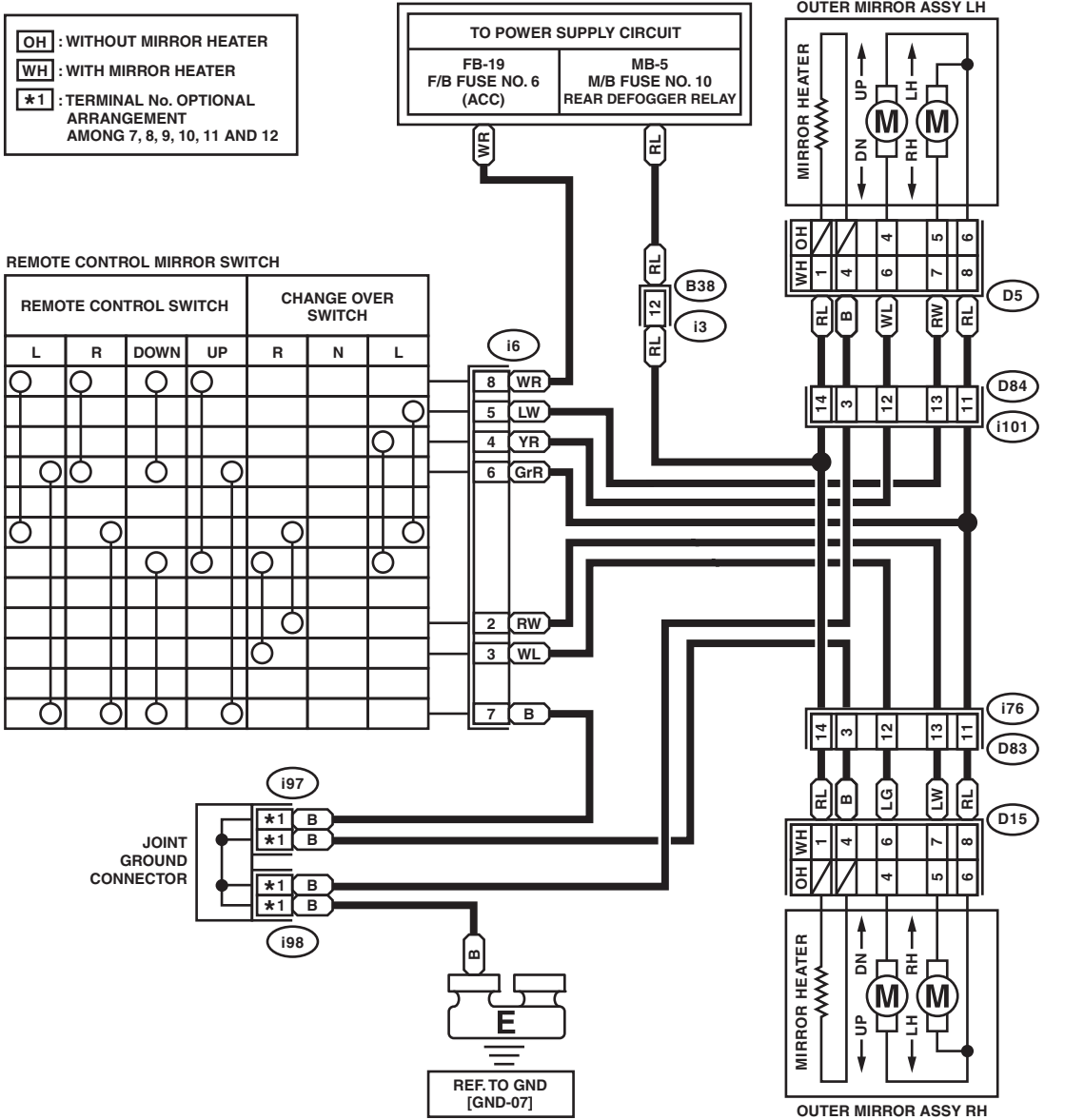

Rear Defogger System

WIRING SYSTEM

38.Rear Defogger System

A: WIRING DIAGRAM

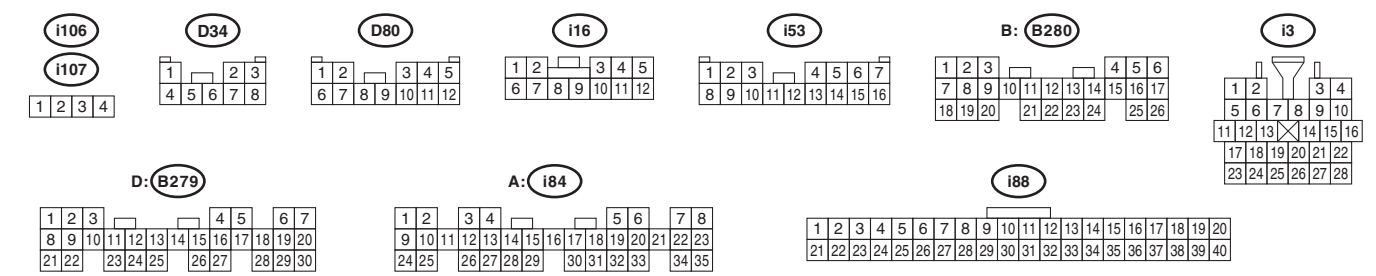
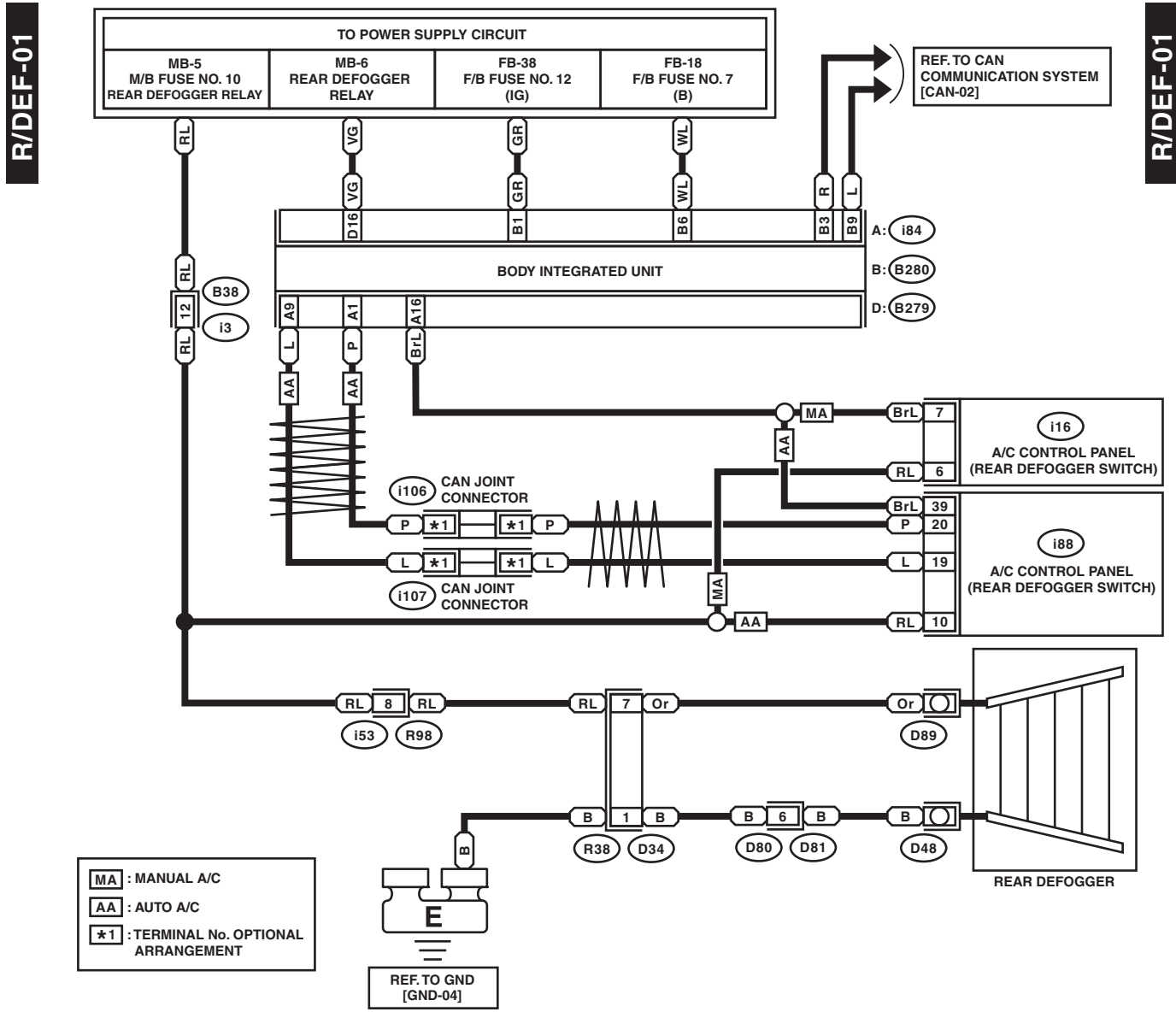

WI-19595

39. Combination Meter System

A: WIRING DIAGRAM

C/M-01

C/M-01

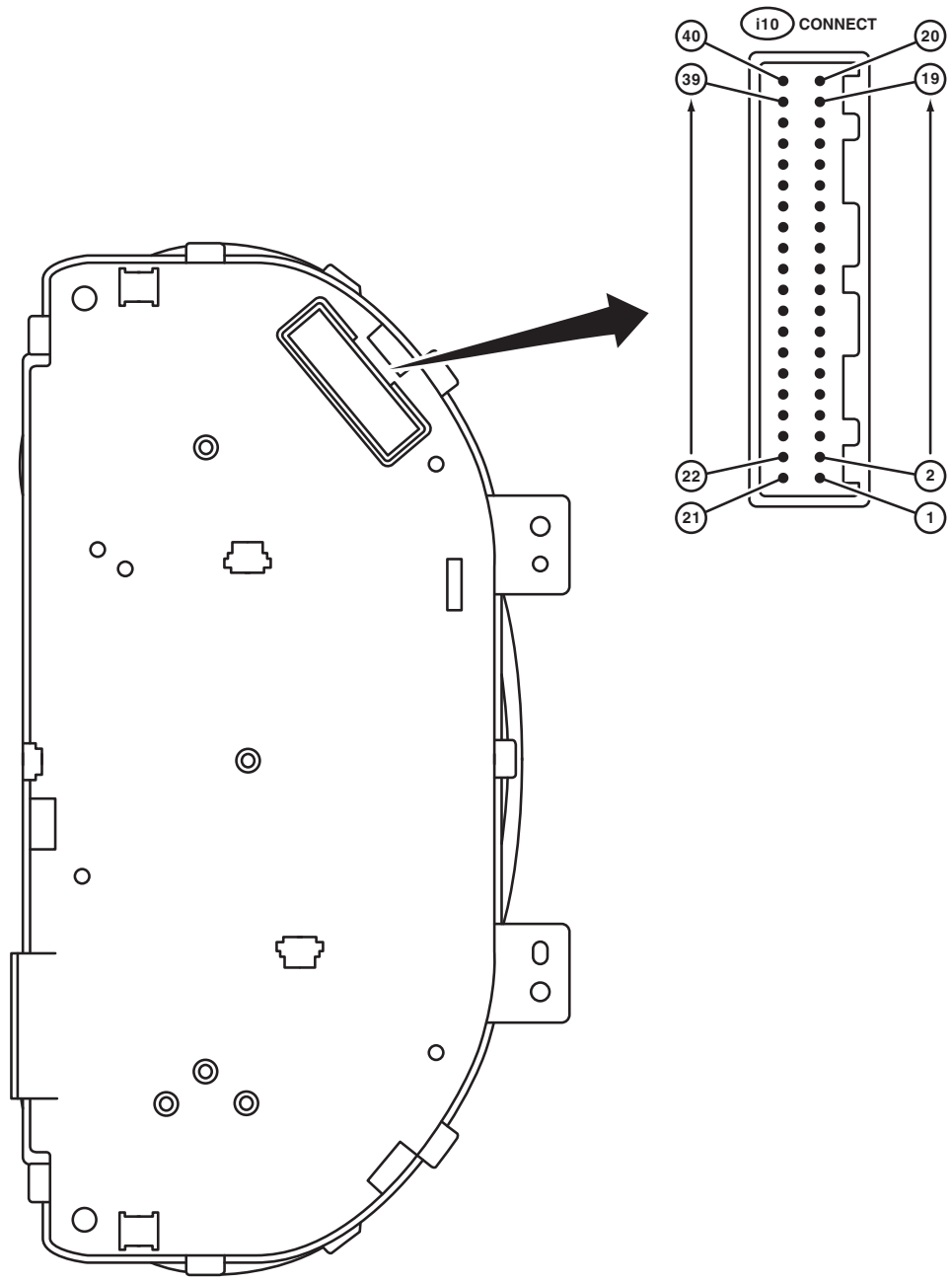

Combination Meter System

WIRING SYSTEM

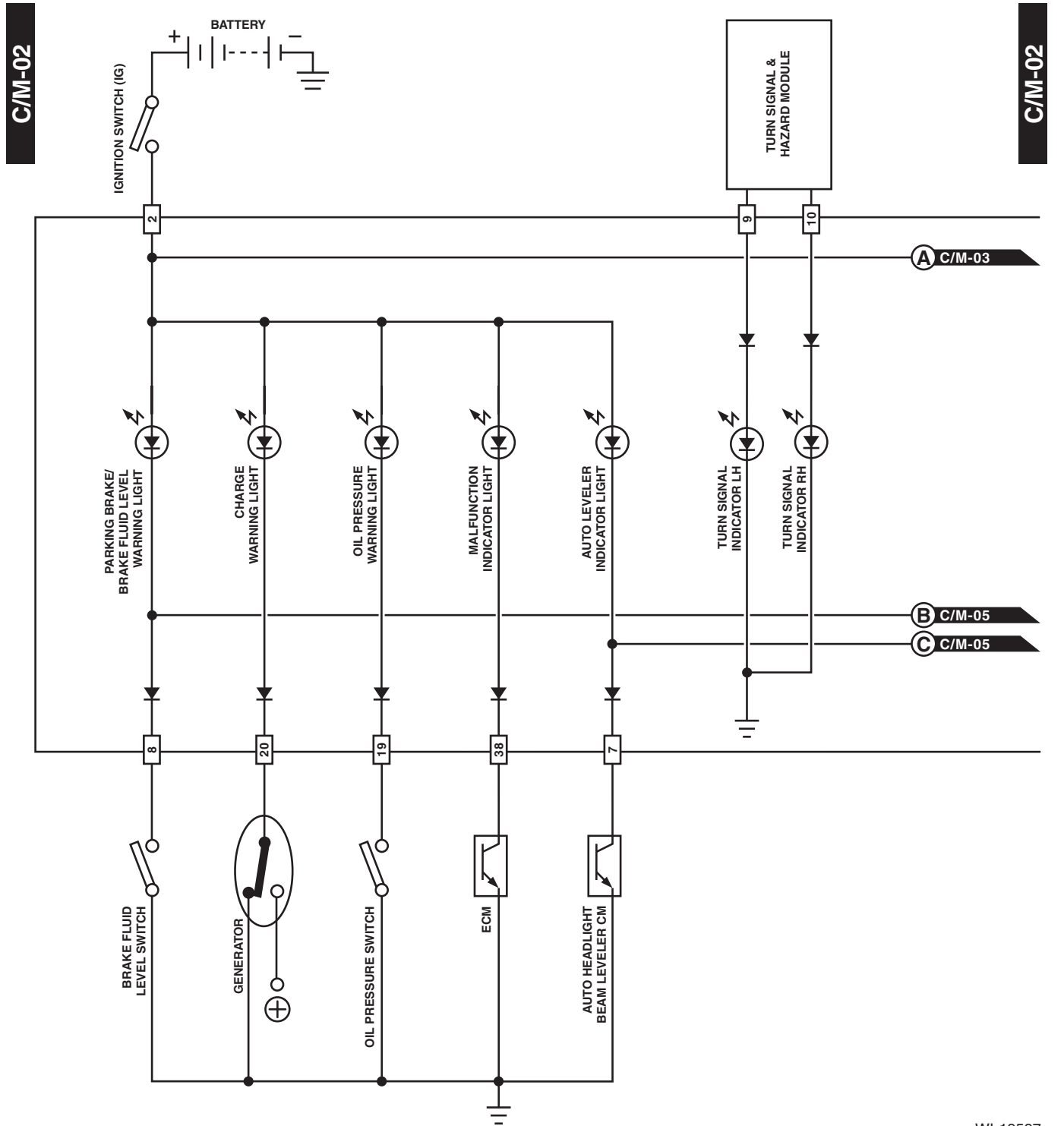

WI-19597

Combination Meter System

WIRING SYSTEM

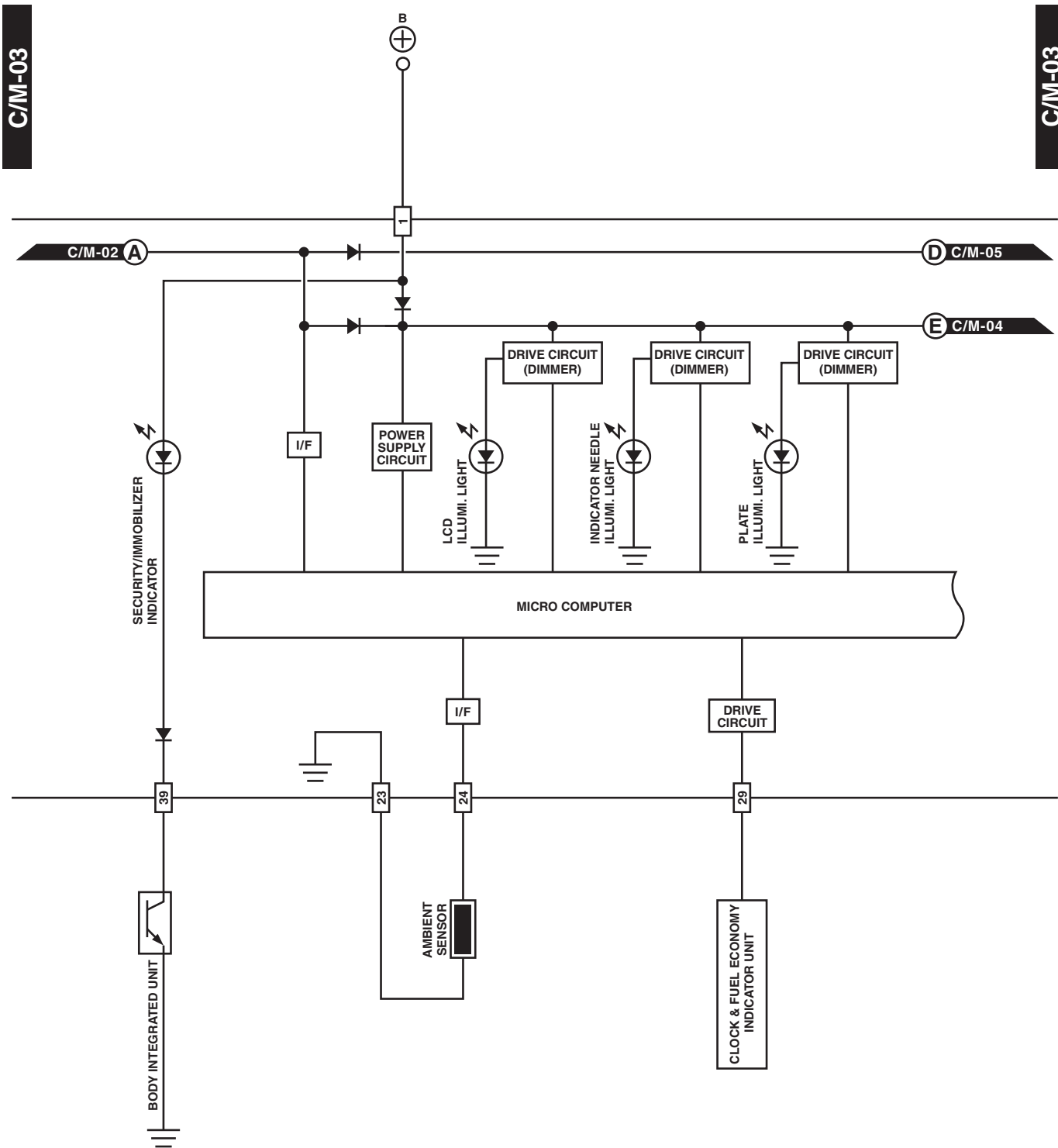

WI-25085

Combination Meter System

WIRING SYSTEM

C/M-04

C/M-04

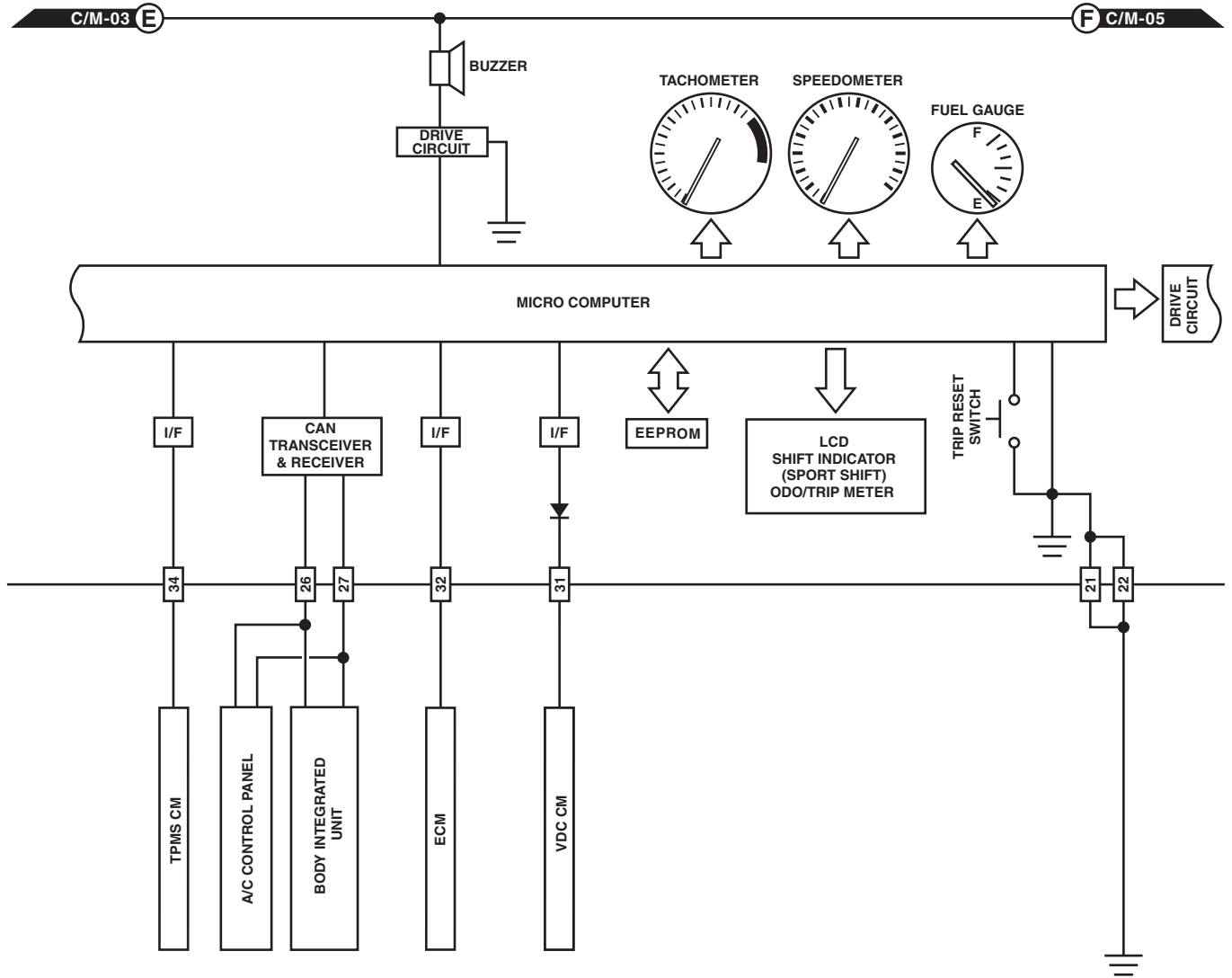

WI-19599

Combination Meter System

WIRING SYSTEM

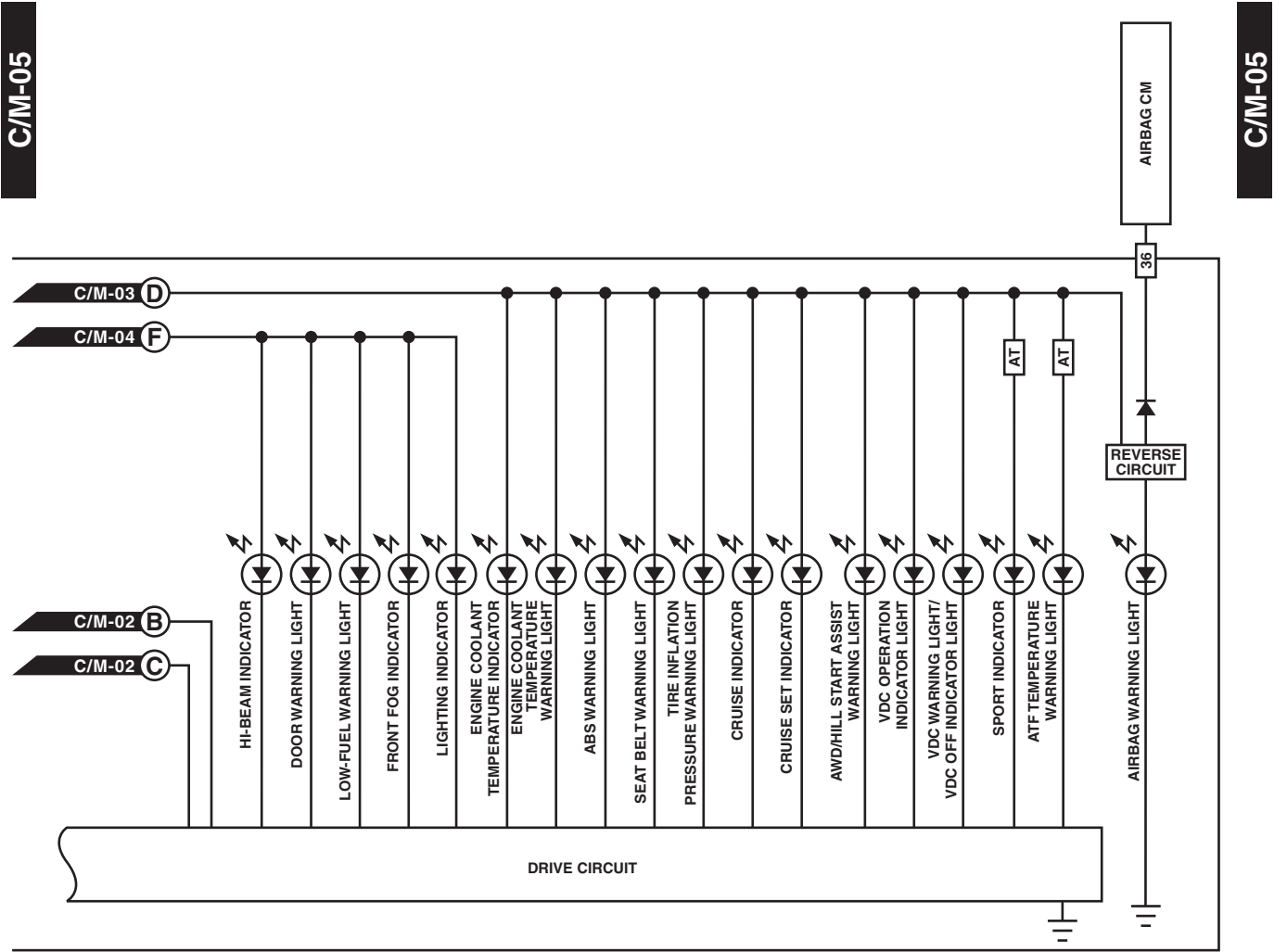

C/M-05

C/M-05

WI-19600

Speedometer System

WIRING SYSTEM

40.Speedometer System

A: WIRING DIAGRAM

SP-01

SP-01

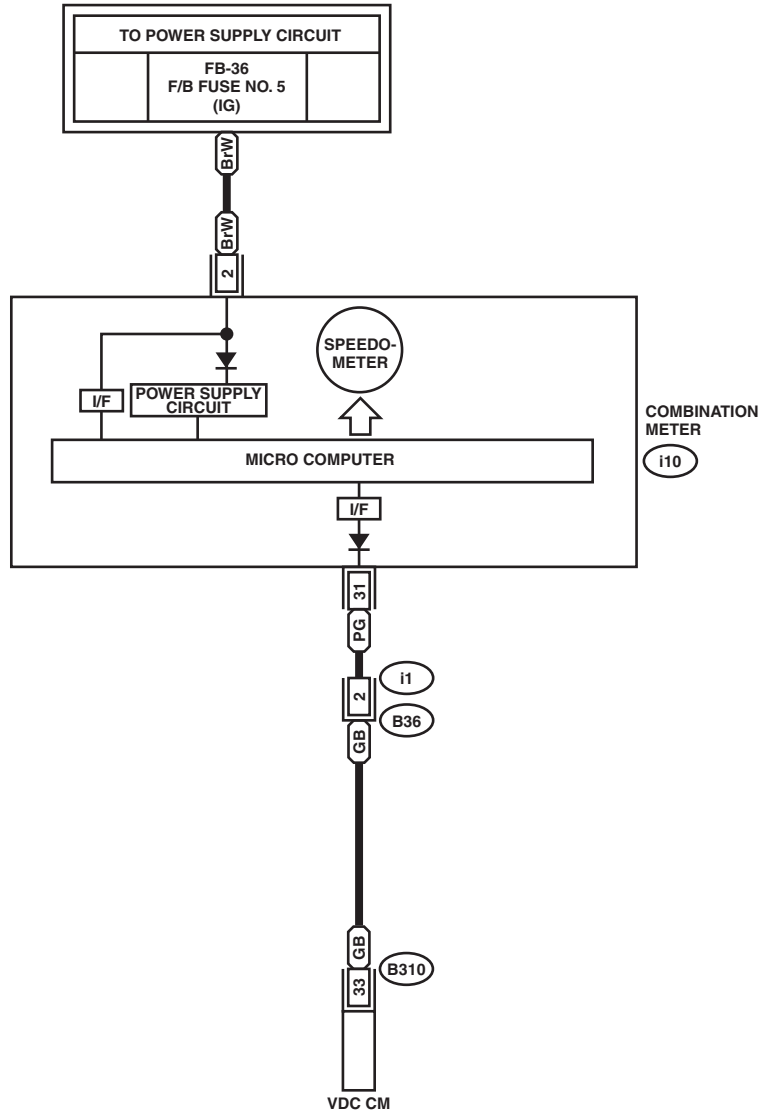

i1

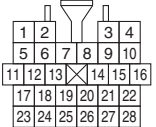

i10

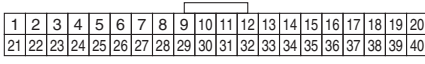

B310 (BLACK)

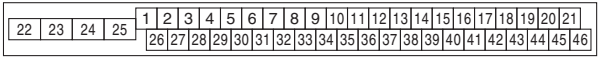

WI-19601

41.Clock System

A: WIRING DIAGRAM

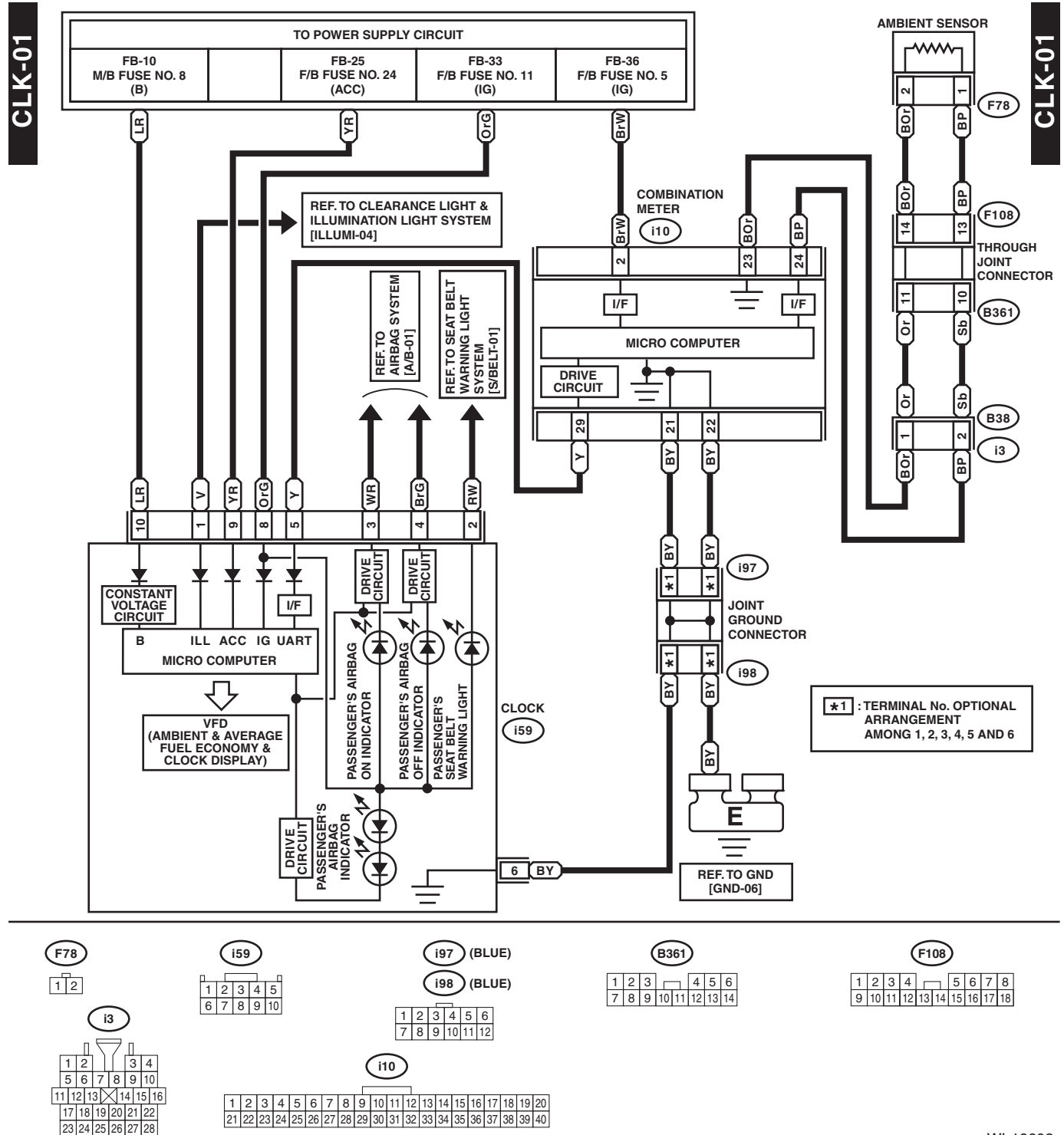

43. Coolant Temperature System

A: WIRING DIAGRAM

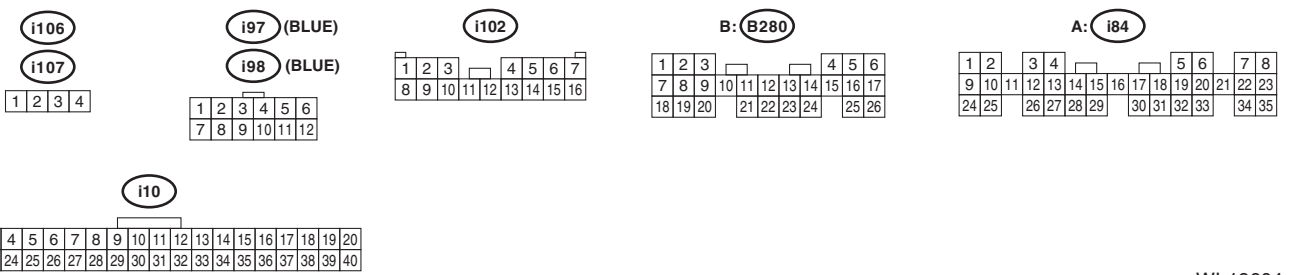
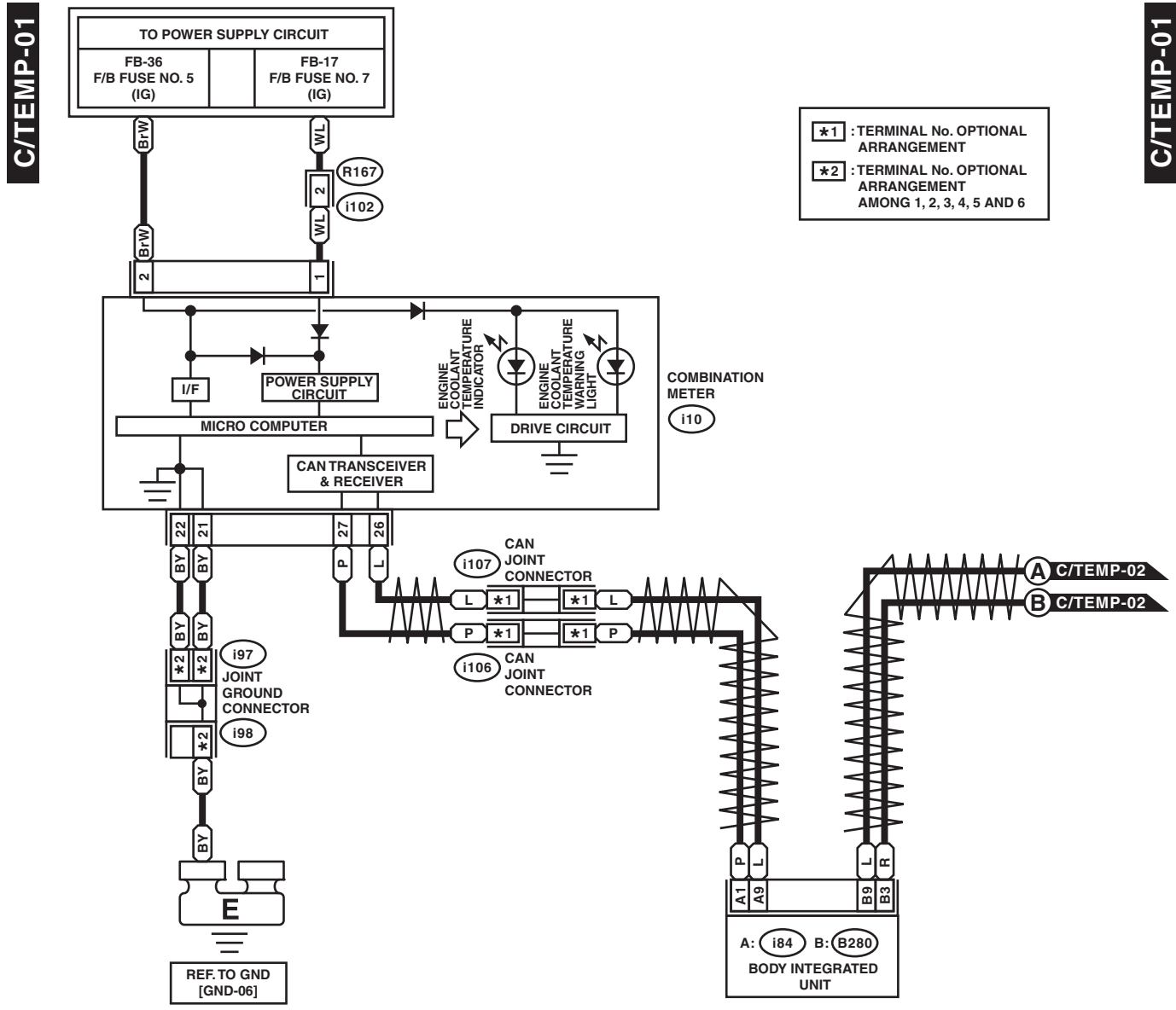

Coolant Temperature System

WIRING SYSTEM

C/TEMP-02

C/TEMP-02

NA : NON-TURBO MODEL
TB : TURBO MODEL

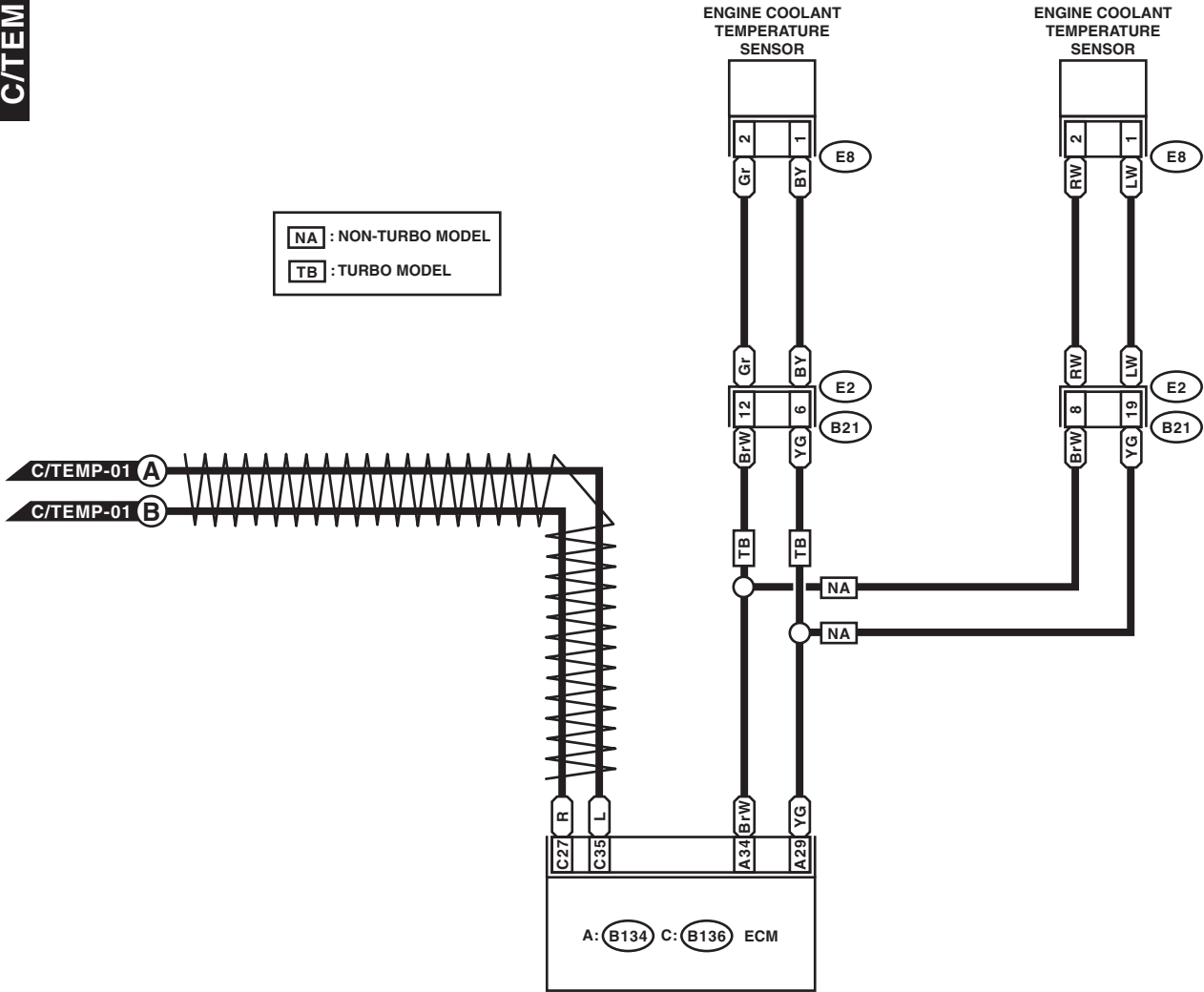

E8 (BLACK)

1	2
---	---

A: B134

1	2	3	4	5	6	7			
8	9	10	11	12	13	14	15	16	17
18	19	20	21	22	23	24	25	26	27
28	29	30	31	32	33	34			

C: B136

1	2	3	4	5	6					
7	8	9	10	11	12	13	14	15	16	
17	18	19	20	21	22	23	24	25	26	27
28	29	30	31	32	33	34	35			

B21

1	2	3	4	5	6	7	8	9	10	11
12	13	14	15	16	17	18	19	20	21	22
23	24	25	26	27	28	29	30	31	32	33
34	35	36	37	38	39	40	41			
42	43	44	45	46	47					
48	49	50	51	52	53	54				

WI-19605

44.Oil Pressure Warning Light System

A: WIRING DIAGRAM

OIL/P-01

OIL/P-01

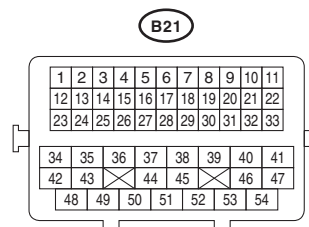
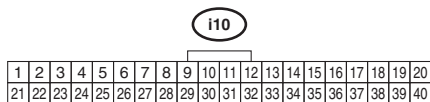
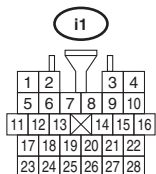
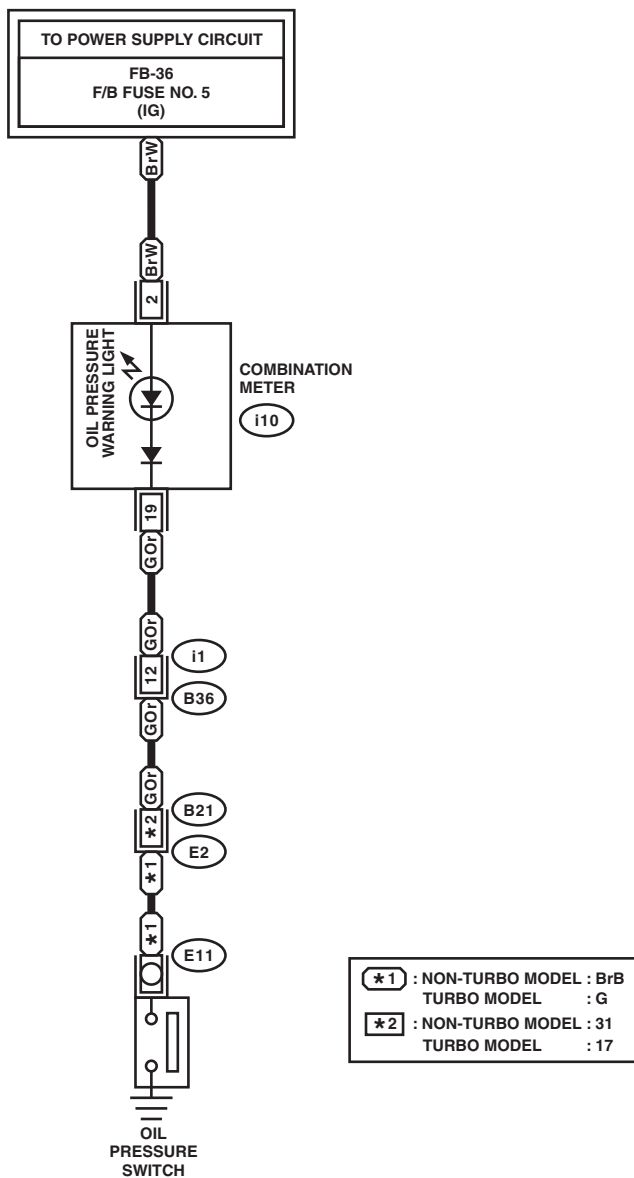

Parking Brake / Brake Fluid Level Warning Light System

WIRING SYSTEM

45. Parking Brake / Brake Fluid Level Warning Light System

A: WIRING DIAGRAM

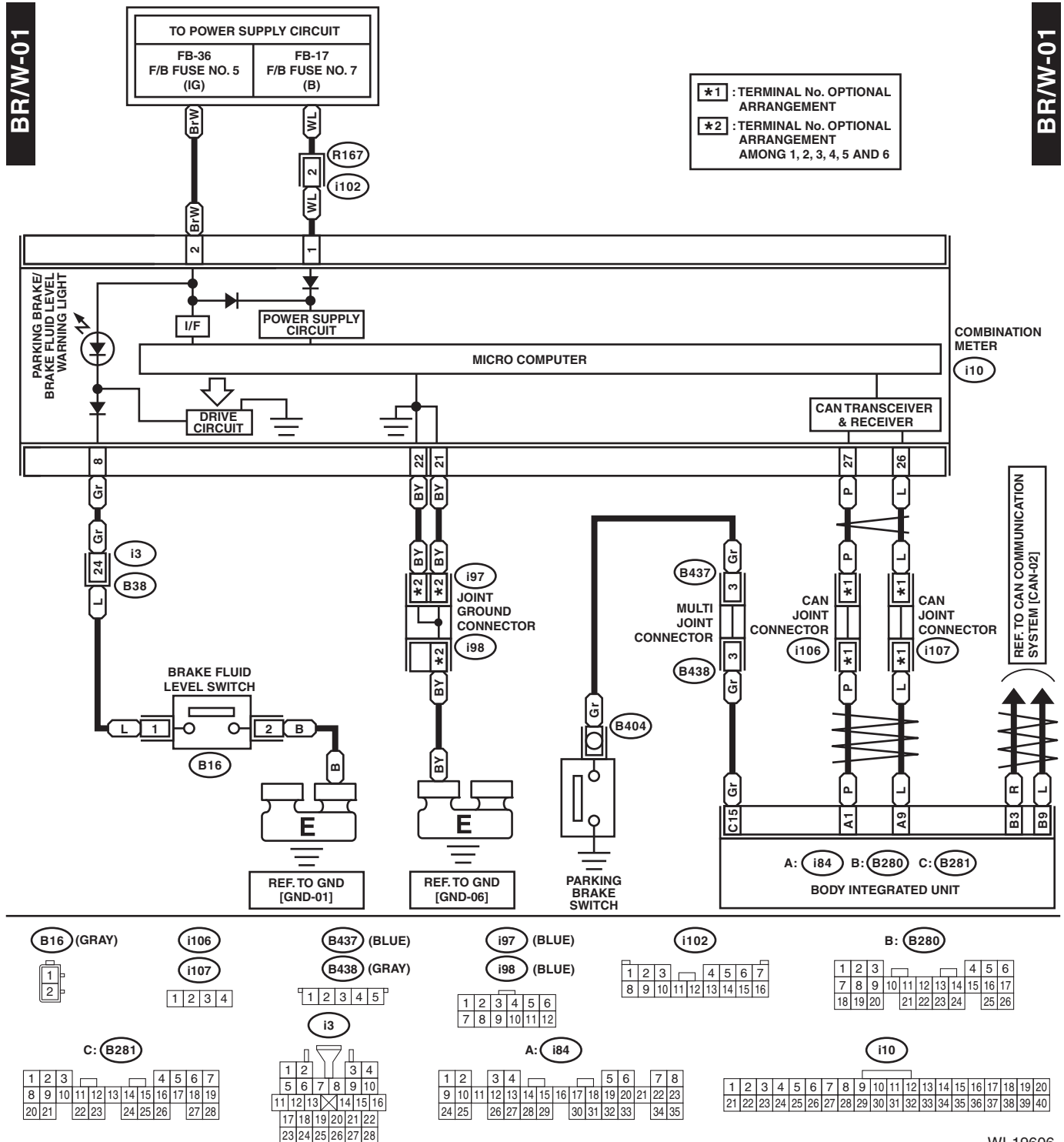

WI-19606

46.Sunroof Control System

A: WIRING DIAGRAM

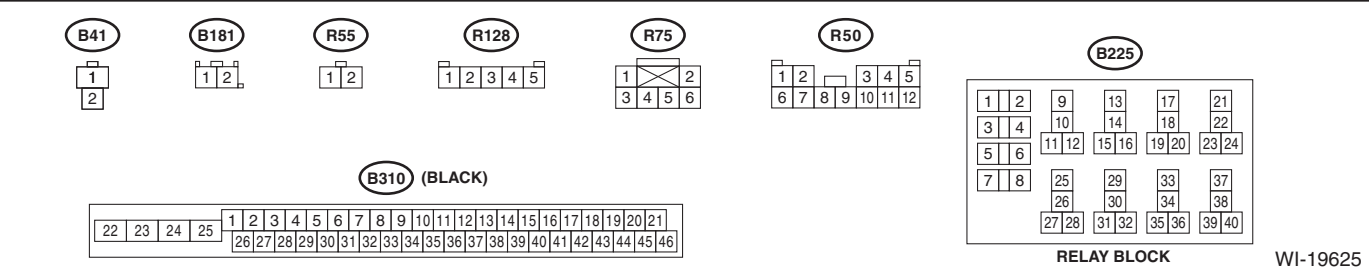
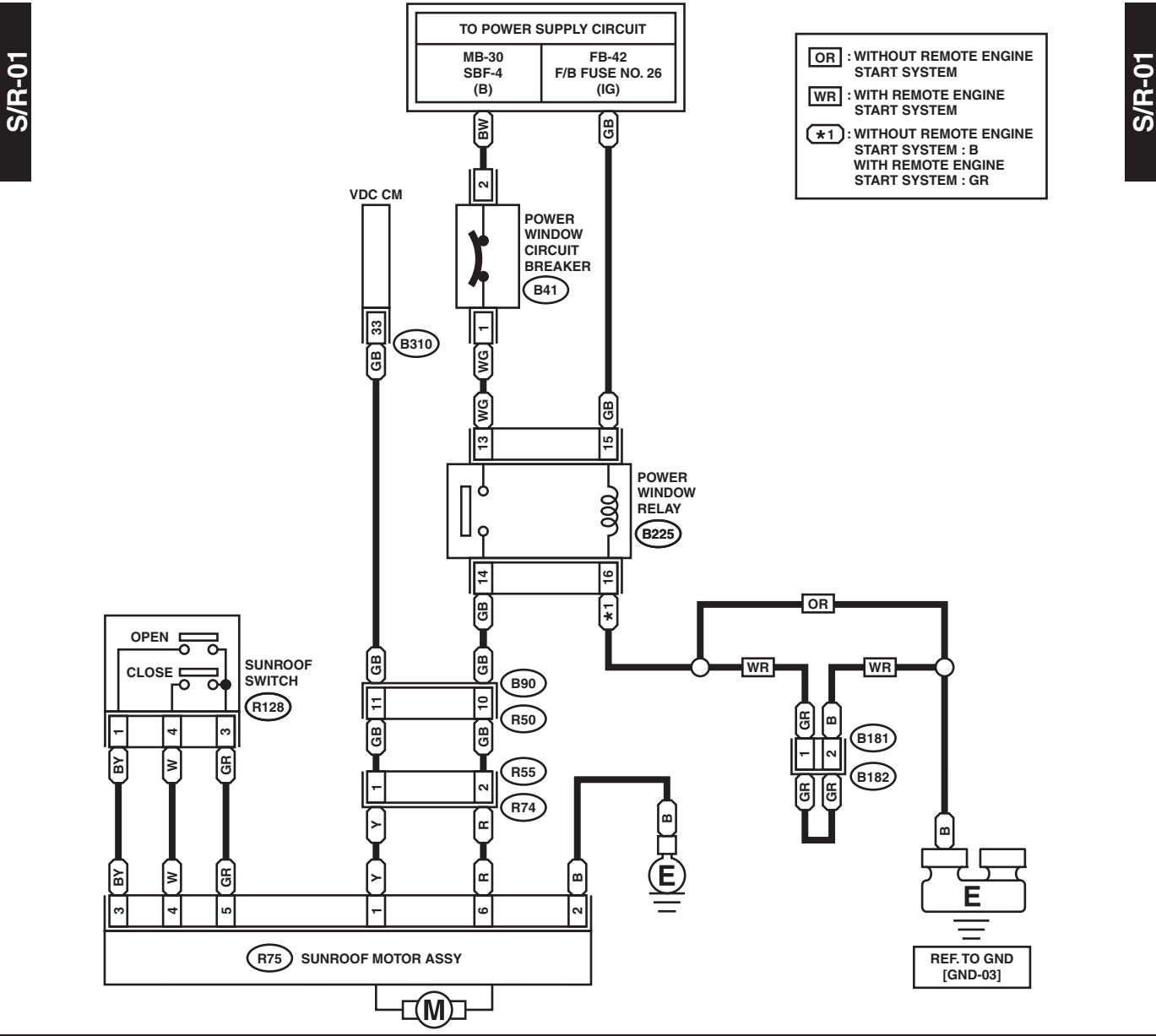

WI-19625

Security System

WIRING SYSTEM

47. Security System

A: WIRING DIAGRAM

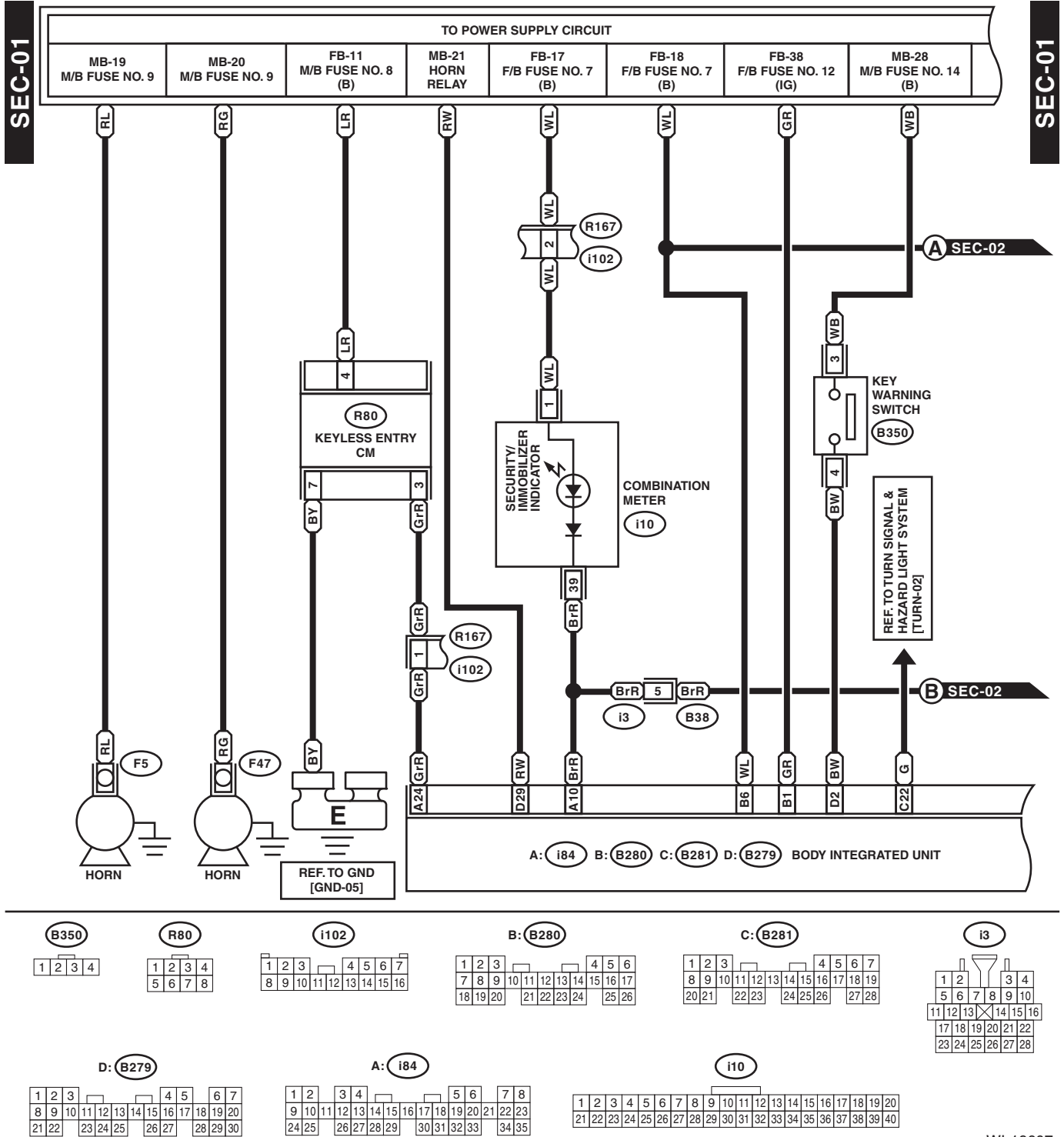

WI-19607

Security System

WIRING SYSTEM

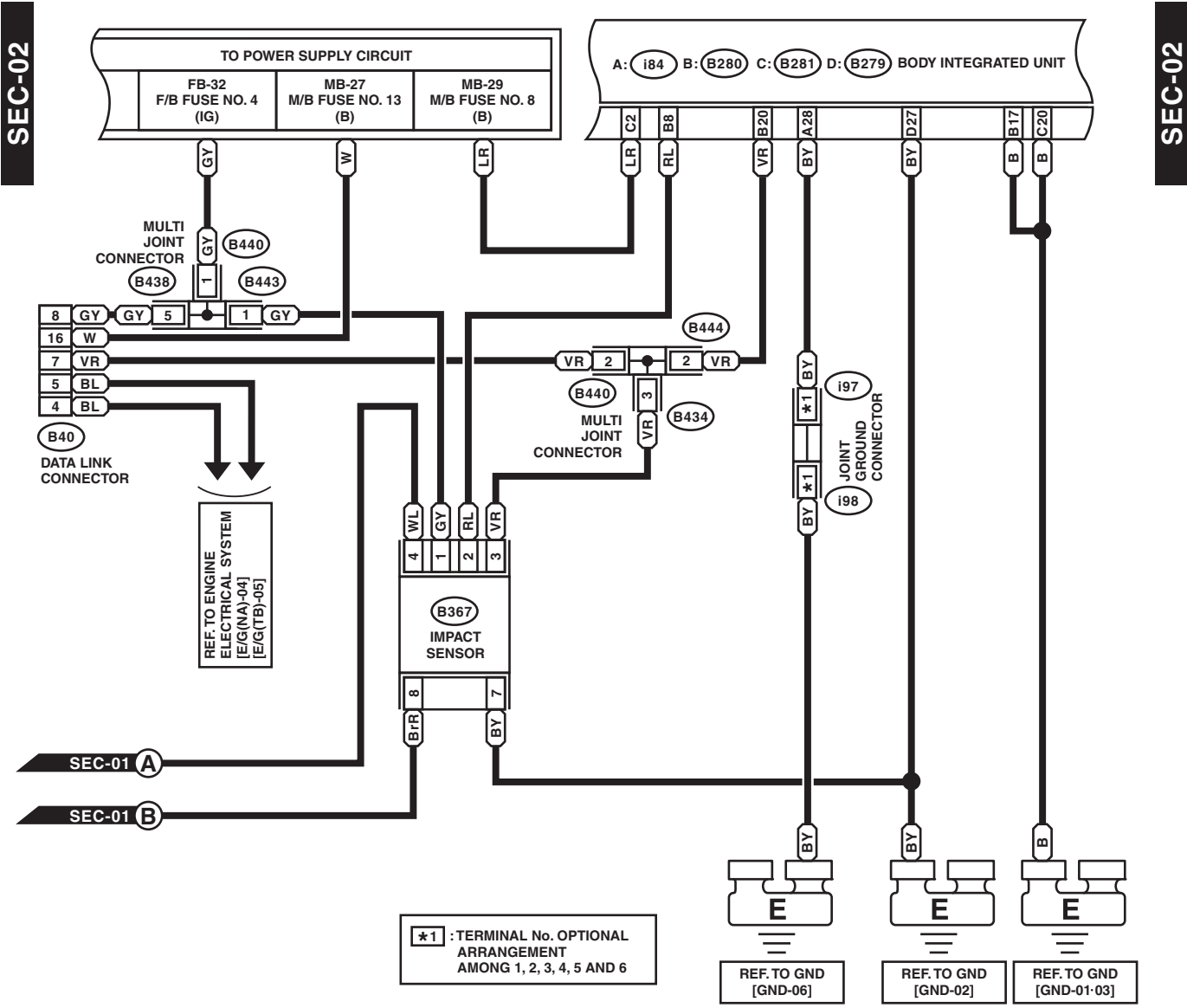

*1 : TERMINAL No. OPTIONAL ARRANGEMENT AMONG 1, 2, 3, 4, 5 AND 6

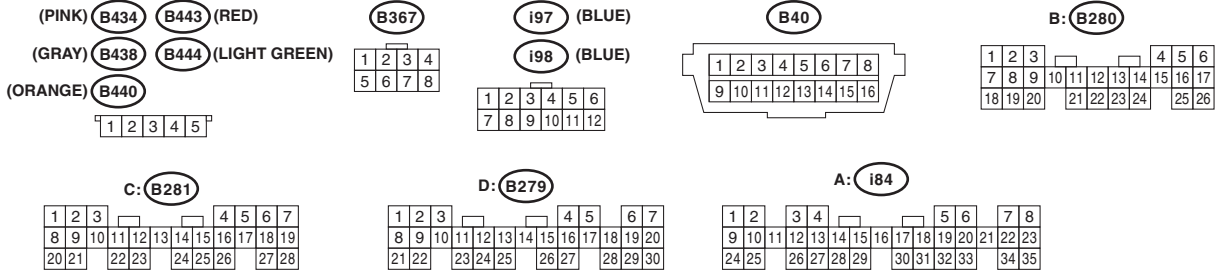

WI-19608

Security System

WIRING SYSTEM

SEC-03

SEC-03

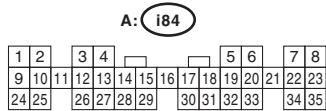
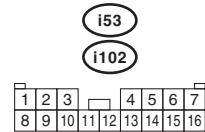
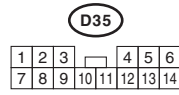
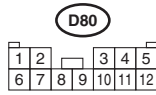
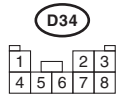
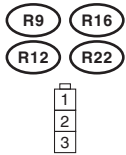
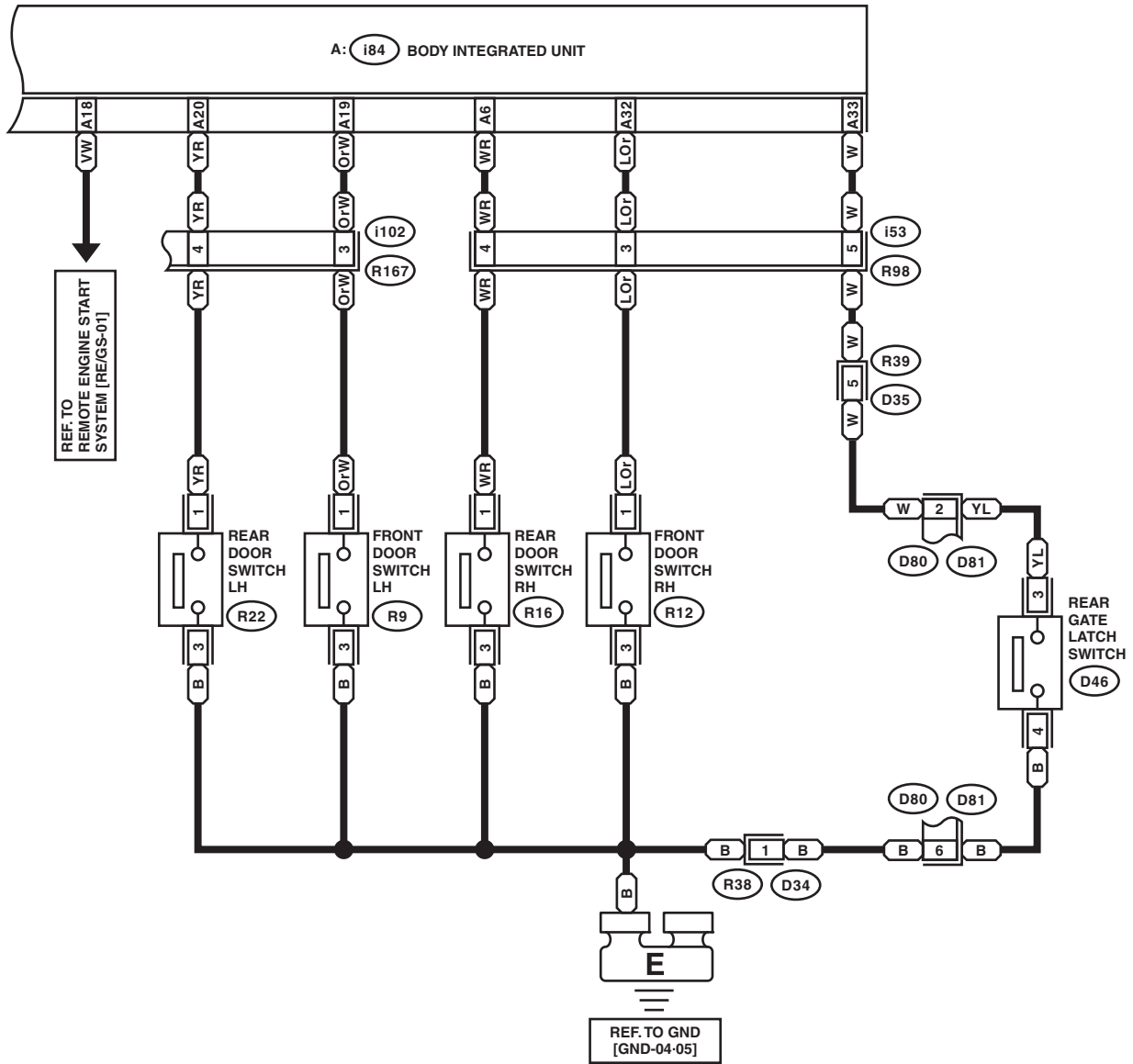

WI-19609

Keyless Entry System

WIRING SYSTEM

K/L-02

K/L-02

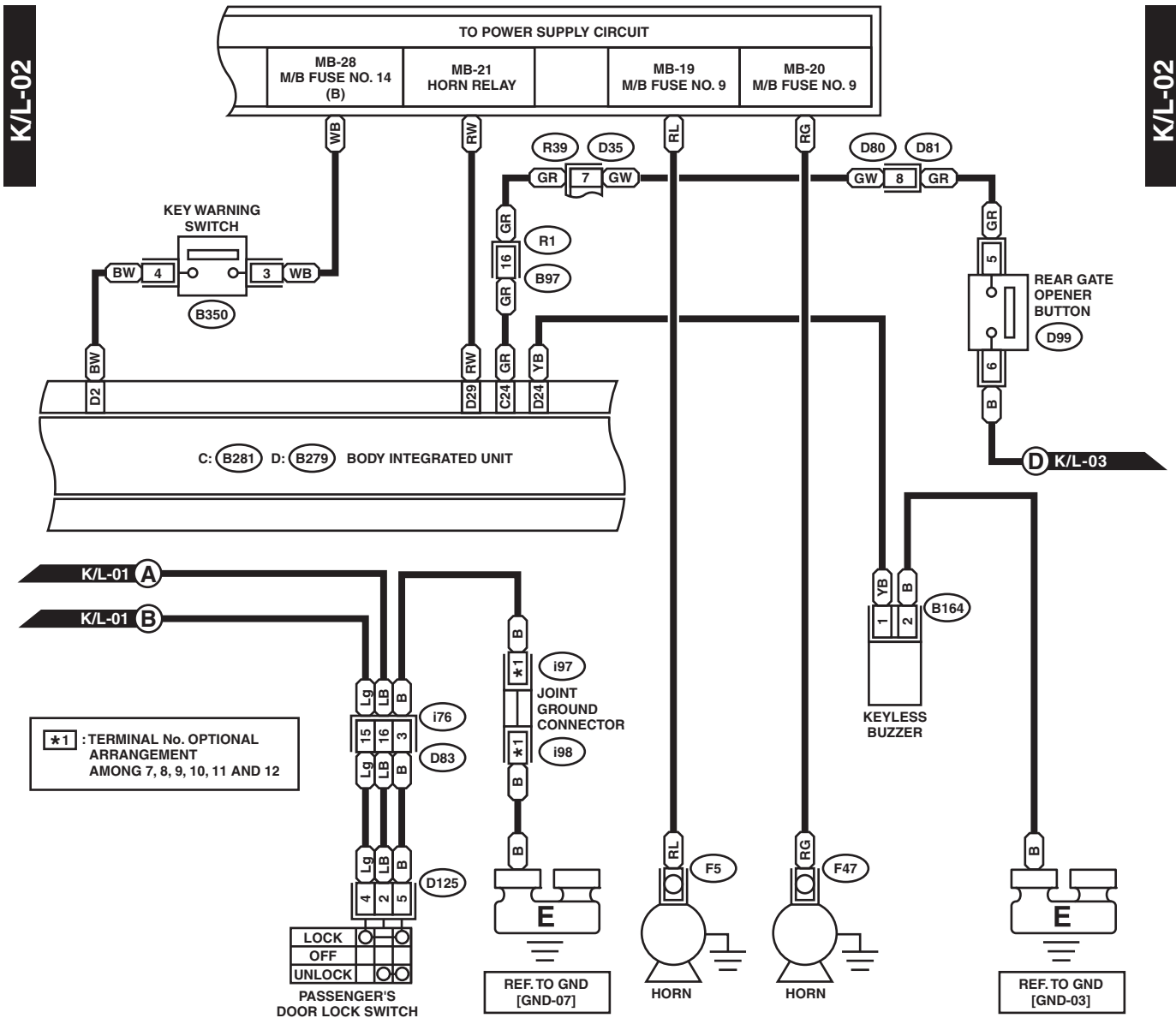

*1 : TERMINAL No. OPTIONAL ARRANGEMENT AMONG 7, 8, 9, 10, 11 AND 12

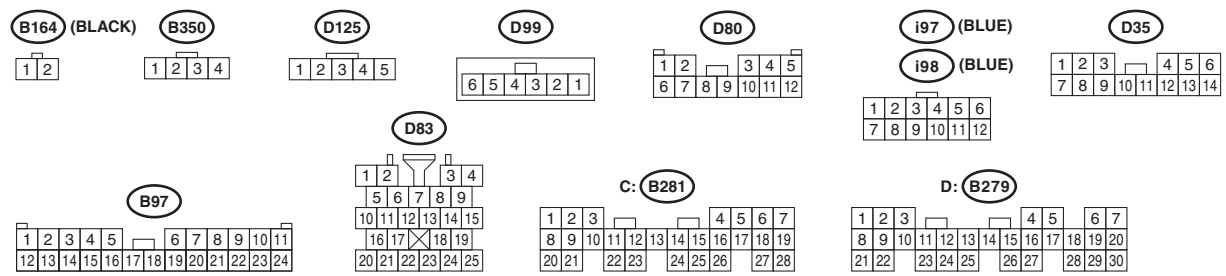

WI-19612

Keyless Entry System

WIRING SYSTEM

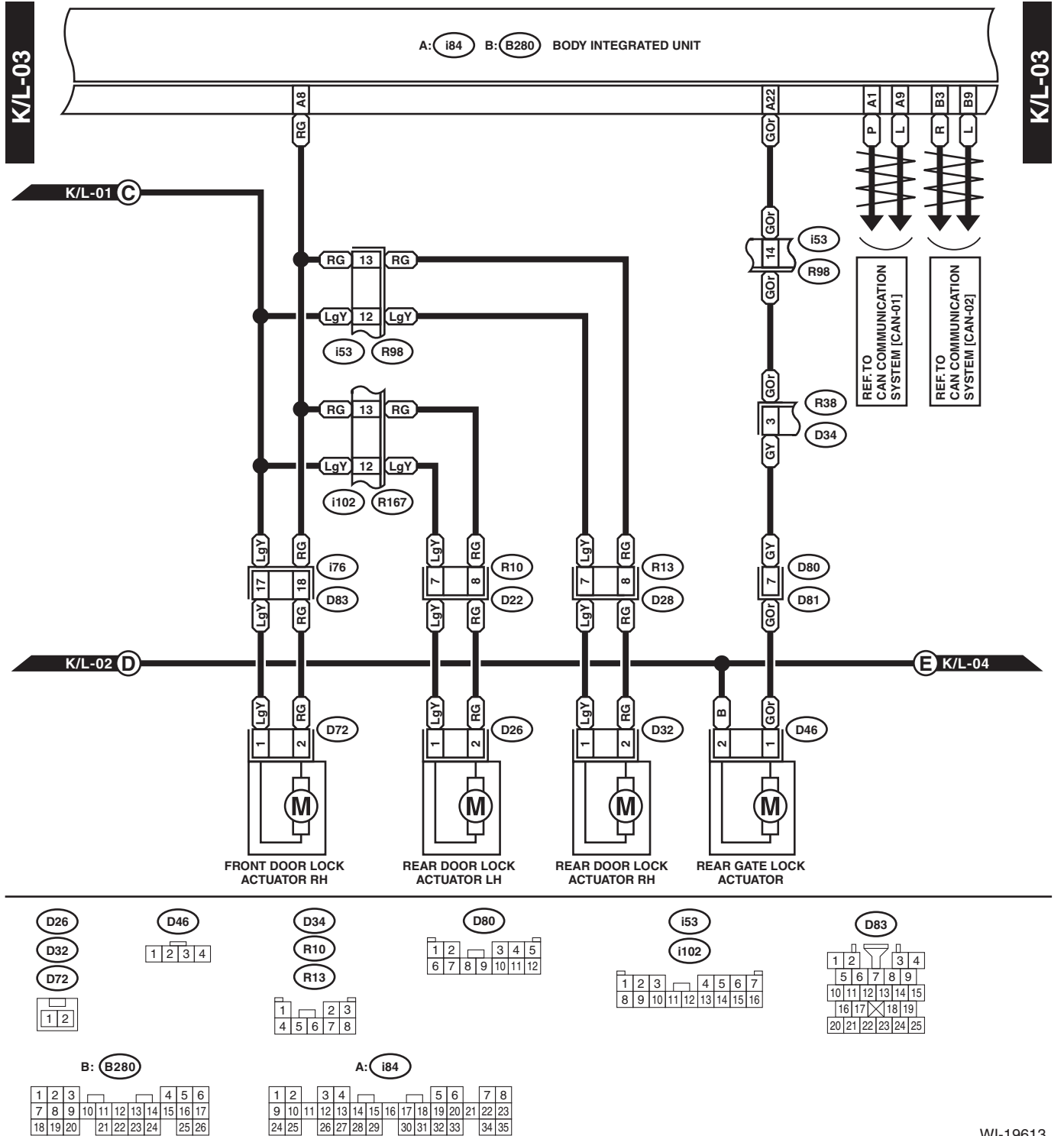

WI-19613

Keyless Entry System

WIRING SYSTEM

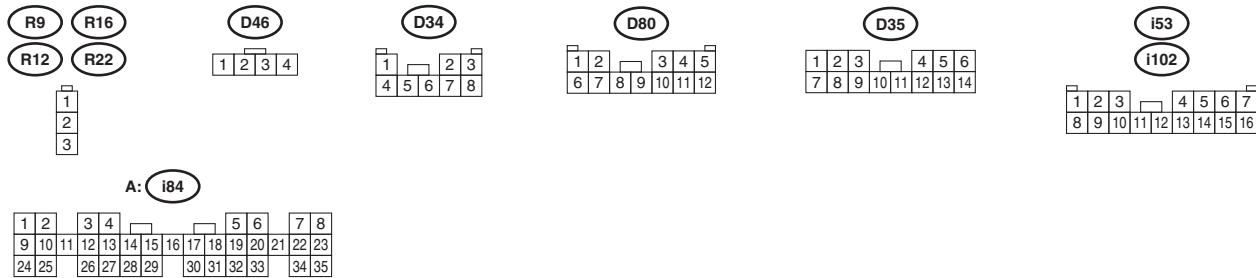
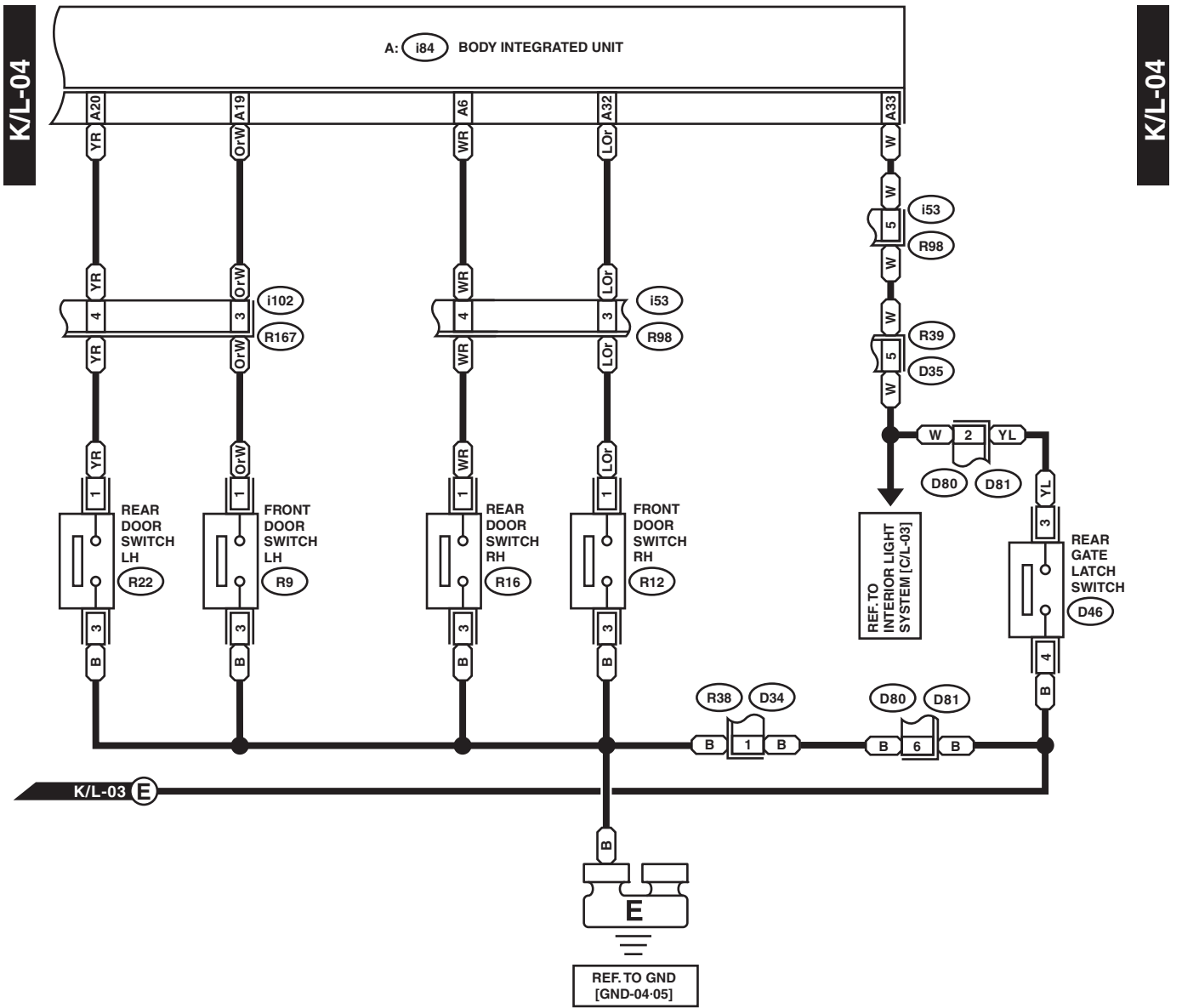

WI-19614

Cruise Control System

WIRING SYSTEM

50. Cruise Control System

A: WIRING DIAGRAM

1. NON-TURBO MODEL

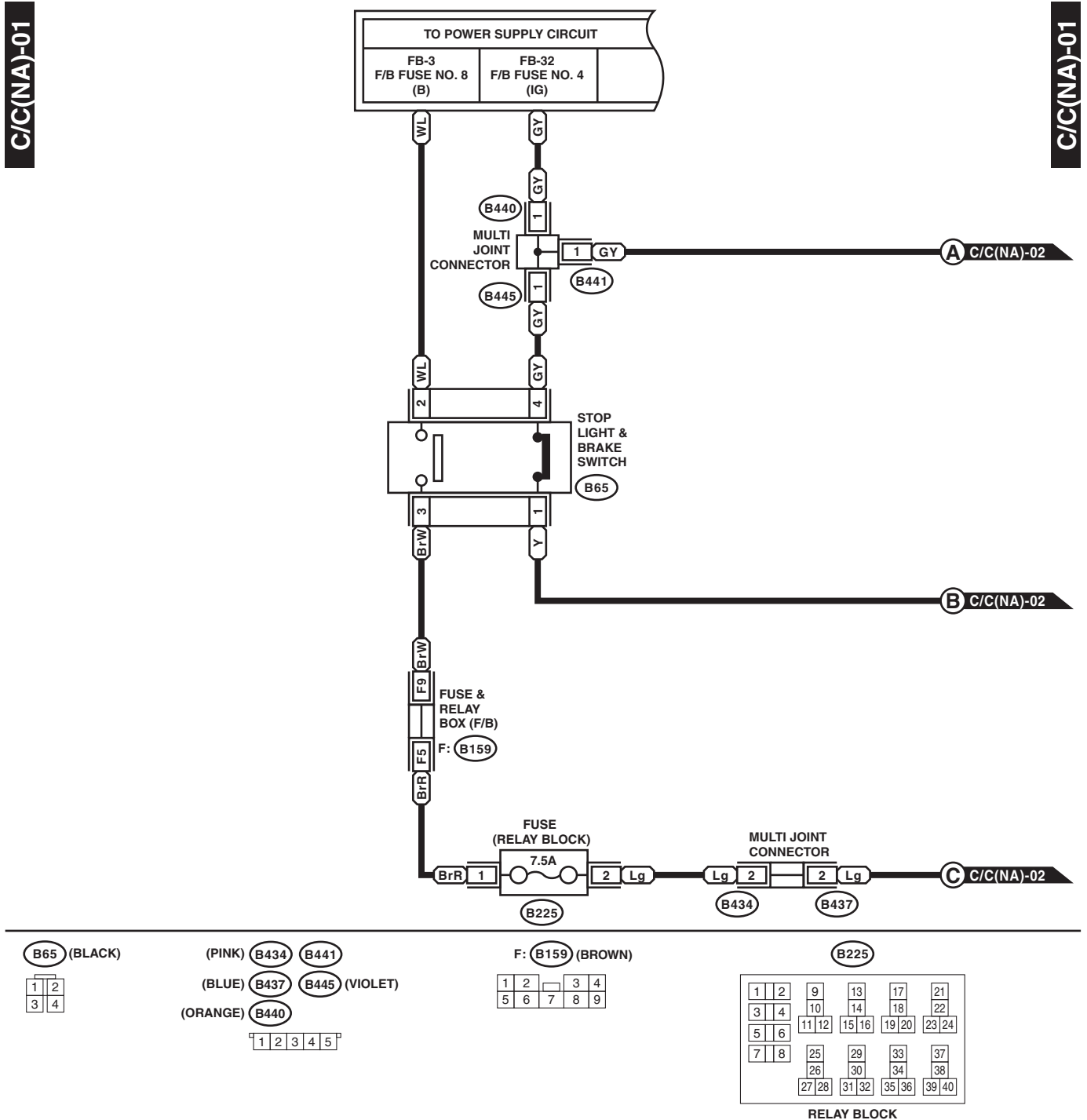

WI-19615

Cruise Control System

WIRING SYSTEM

C/C(NA)-02

C/C(NA)-02

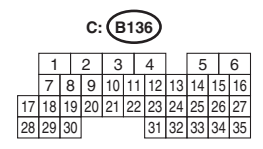
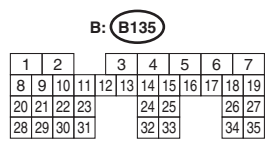
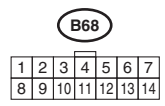
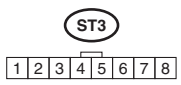
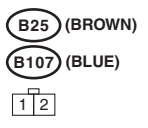
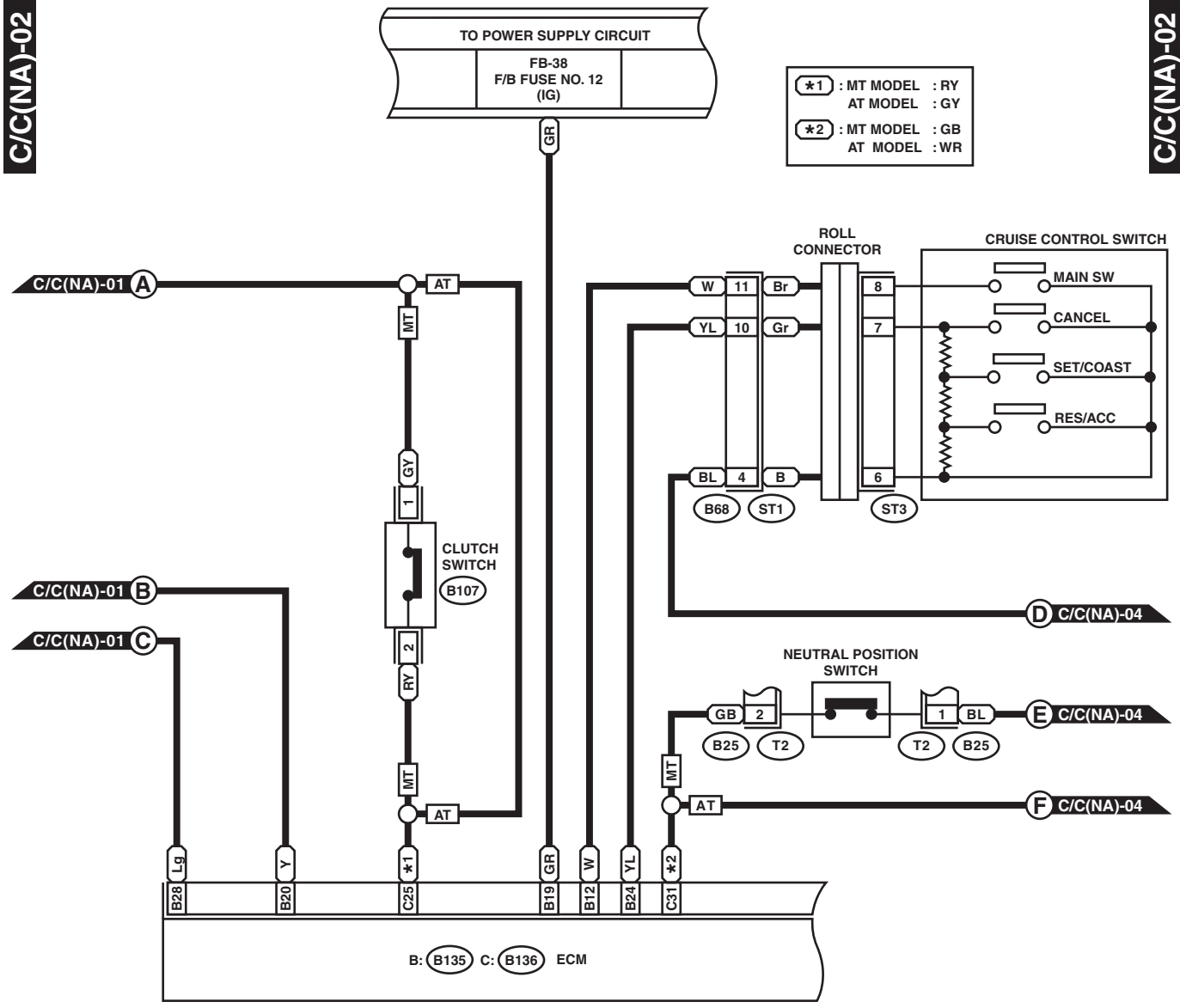

WI-19664

Cruise Control System

WIRING SYSTEM

C/C(NA)-03

C/C(NA)-03

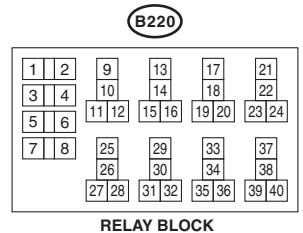
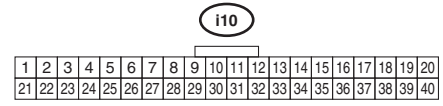
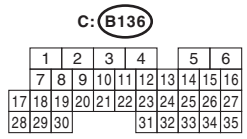
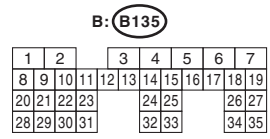
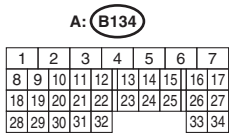
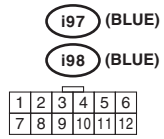
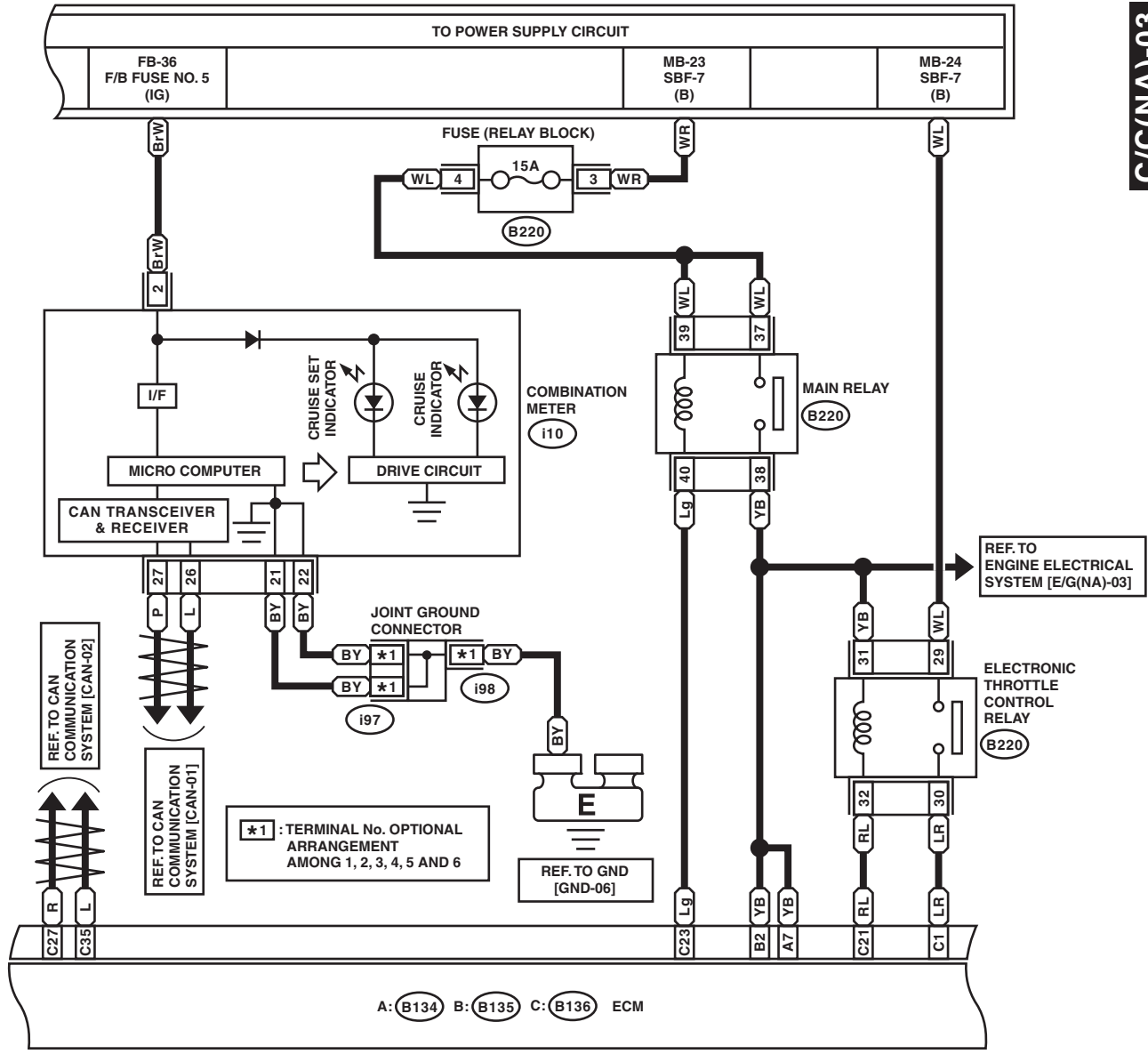

WI-19616

Cruise Control System

WIRING SYSTEM

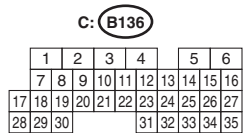
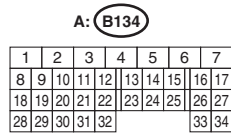
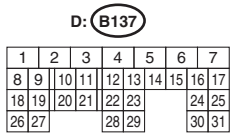
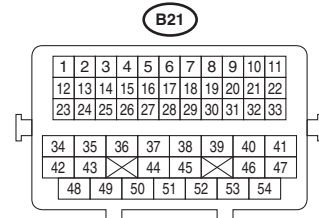
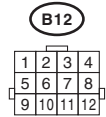
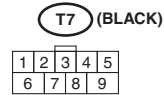
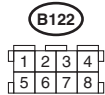
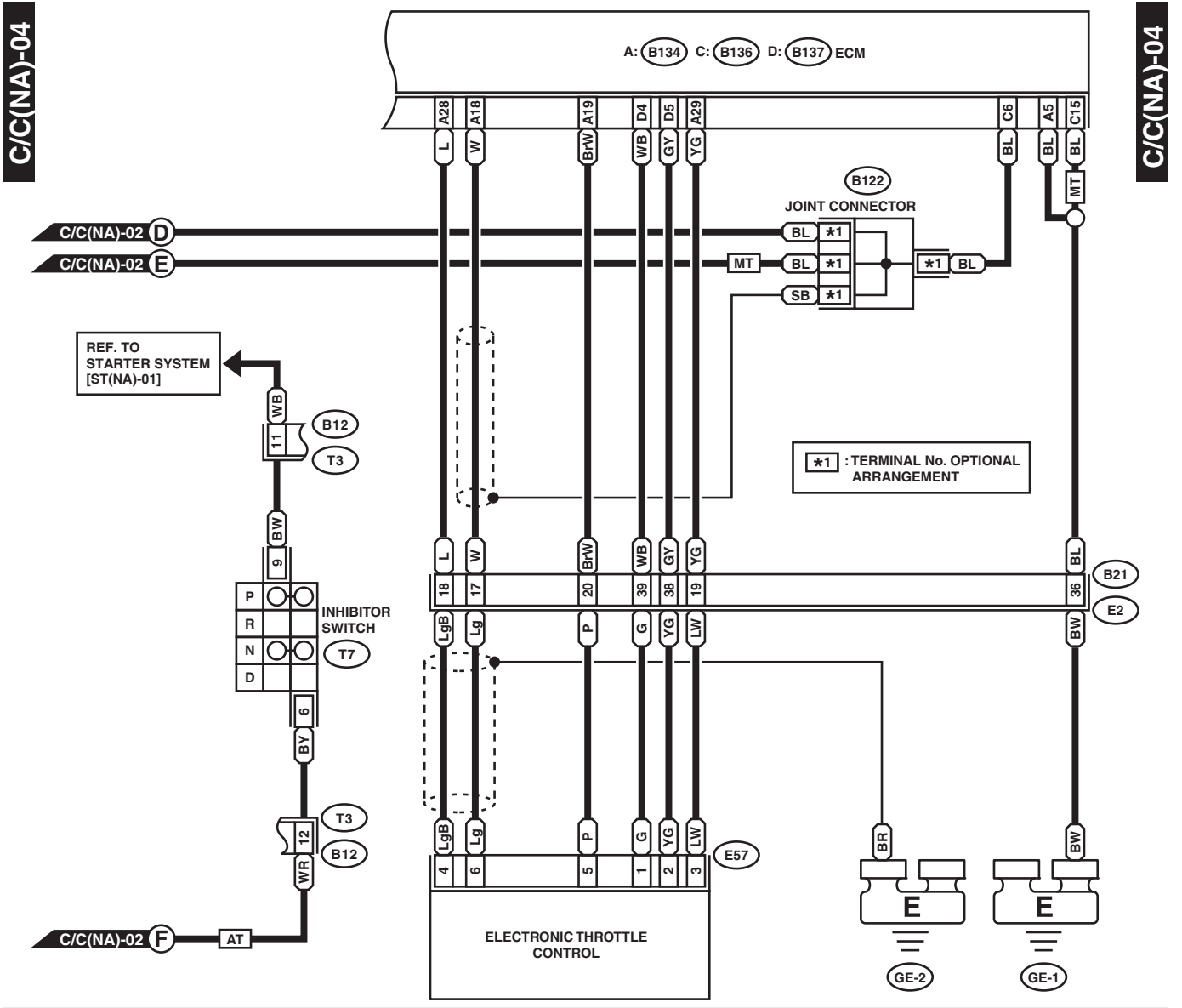

WI-19617

Cruise Control System

WIRING SYSTEM

2. TURBO MODEL

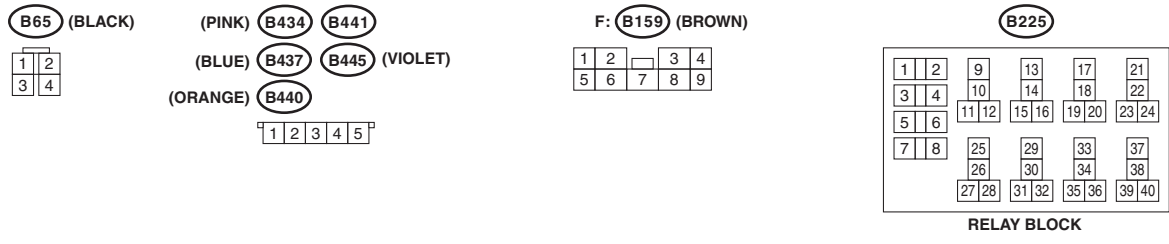
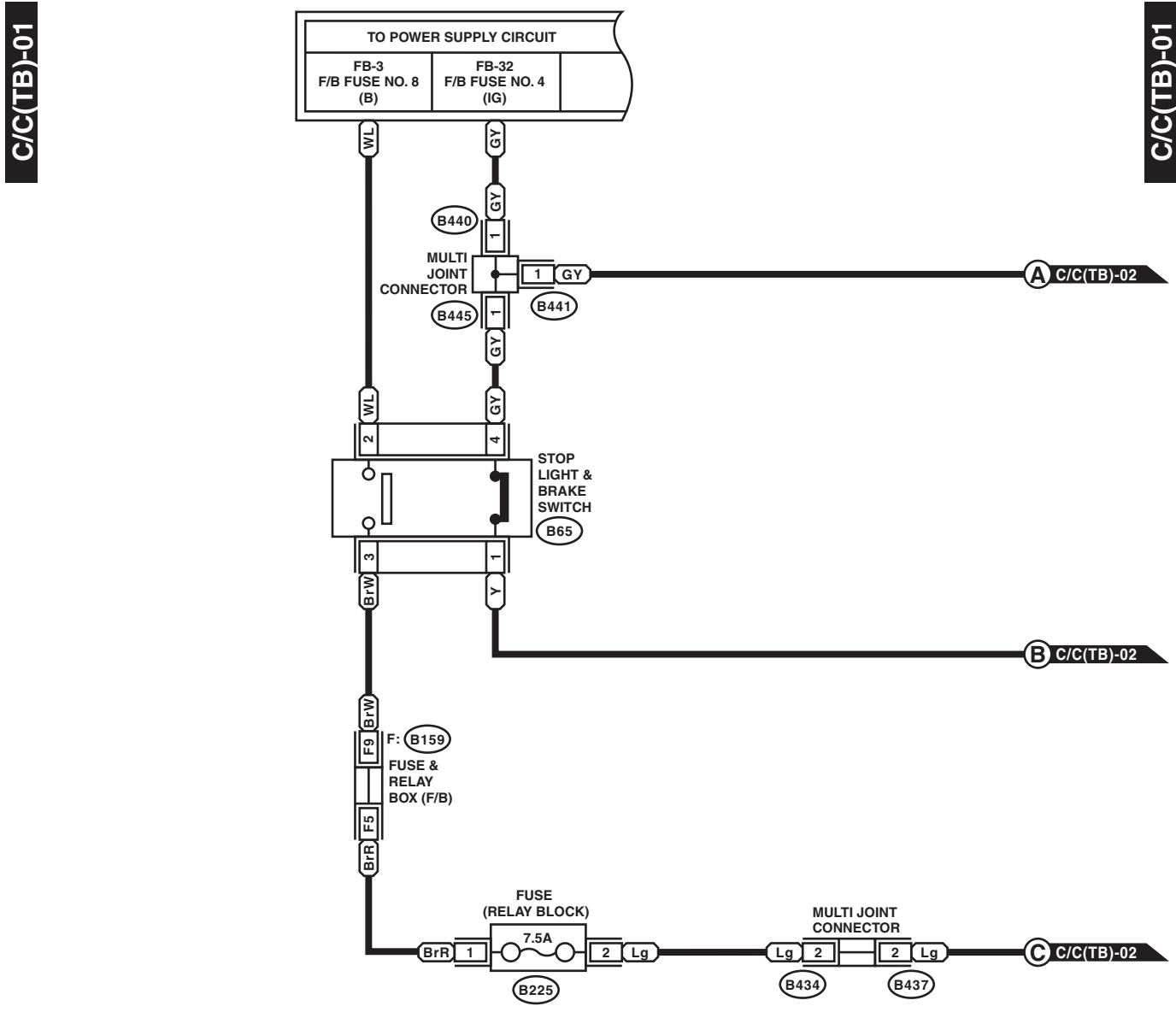

WI-19618

Cruise Control System

WIRING SYSTEM

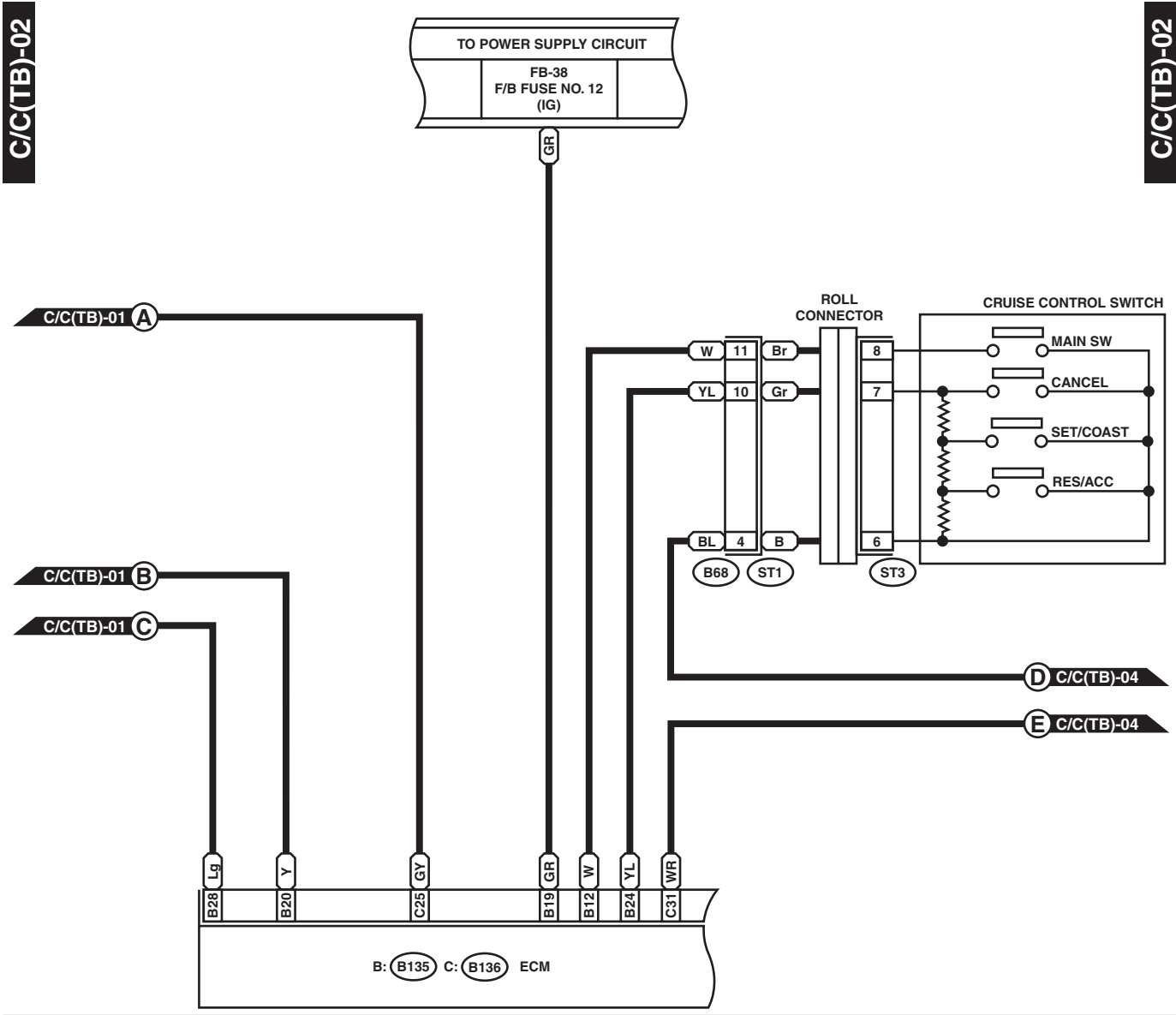

ST3

1	2	3	4	5	6	7	8
---	---	---	---	---	---	---	---

B68

1	2	3	4	5	6	7
8	9	10	11	12	13	14

B: B135

1	2	3	4	5	6	7
8	9	10	11	12	13	14
15	16	17	18	19	20	21
22	23	24	25	26	27	28
29	30	31	32	33	34	35

C: B136

1	2	3	4	5	6
7	8	9	10	11	12
13	14	15	16	17	18
19	20	21	22	23	24
25	26	27	28	29	30
31	32	33	34	35	

WI-19619

Cruise Control System

WIRING SYSTEM

C/C(TB)-03

C/C(TB)-03

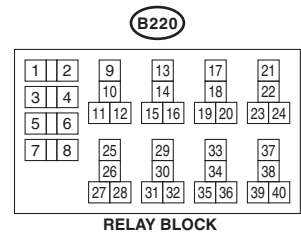
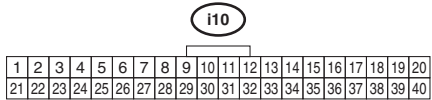
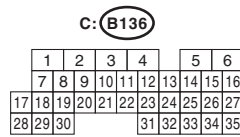
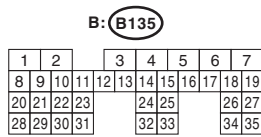
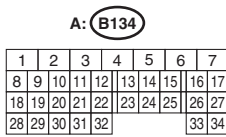
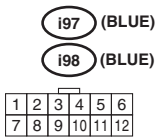
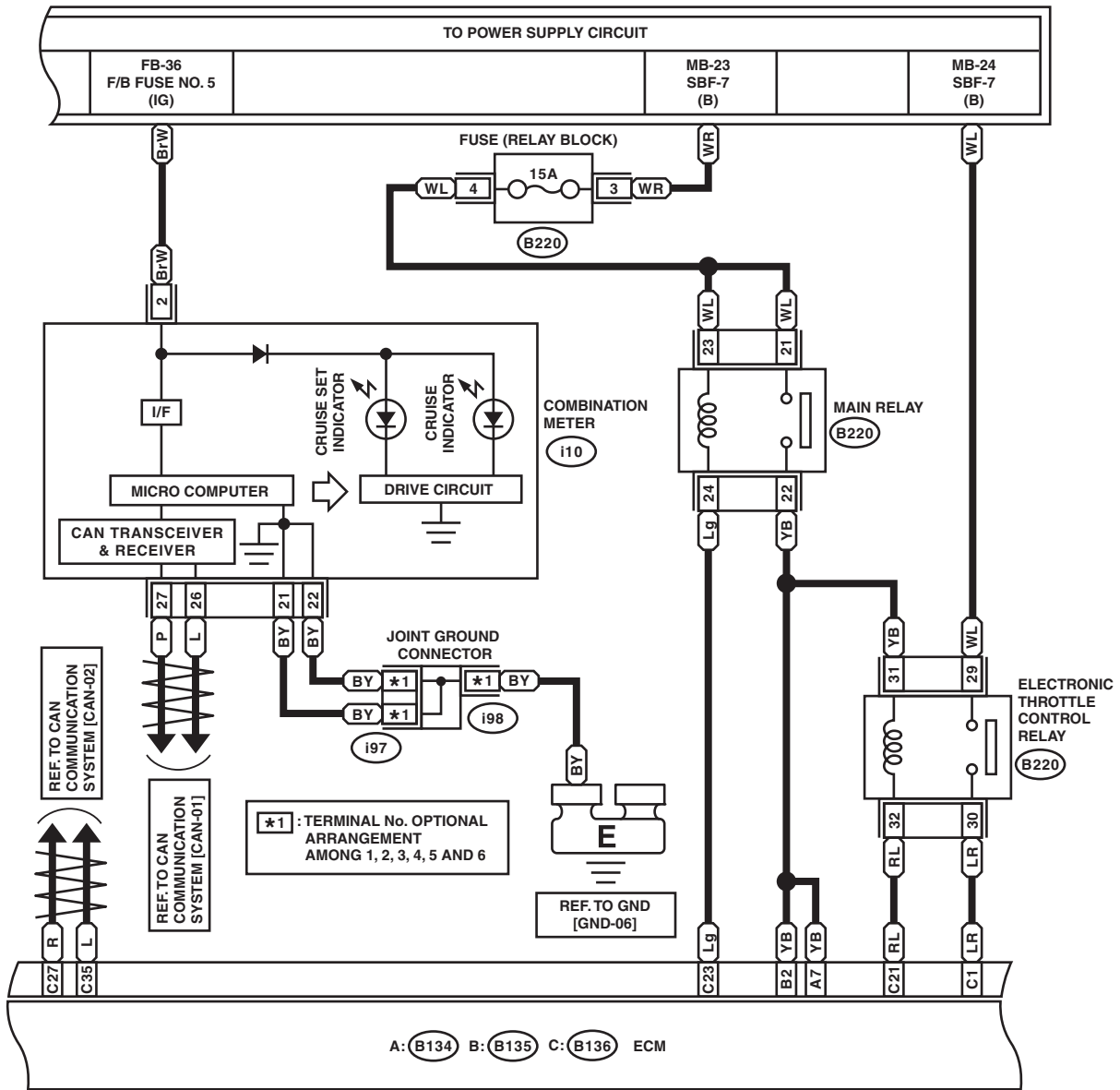

WI-19620

Cruise Control System

WIRING SYSTEM

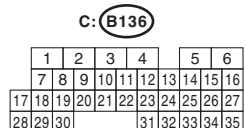
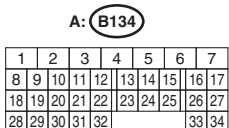
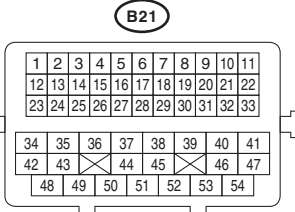
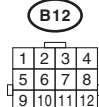
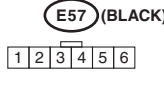
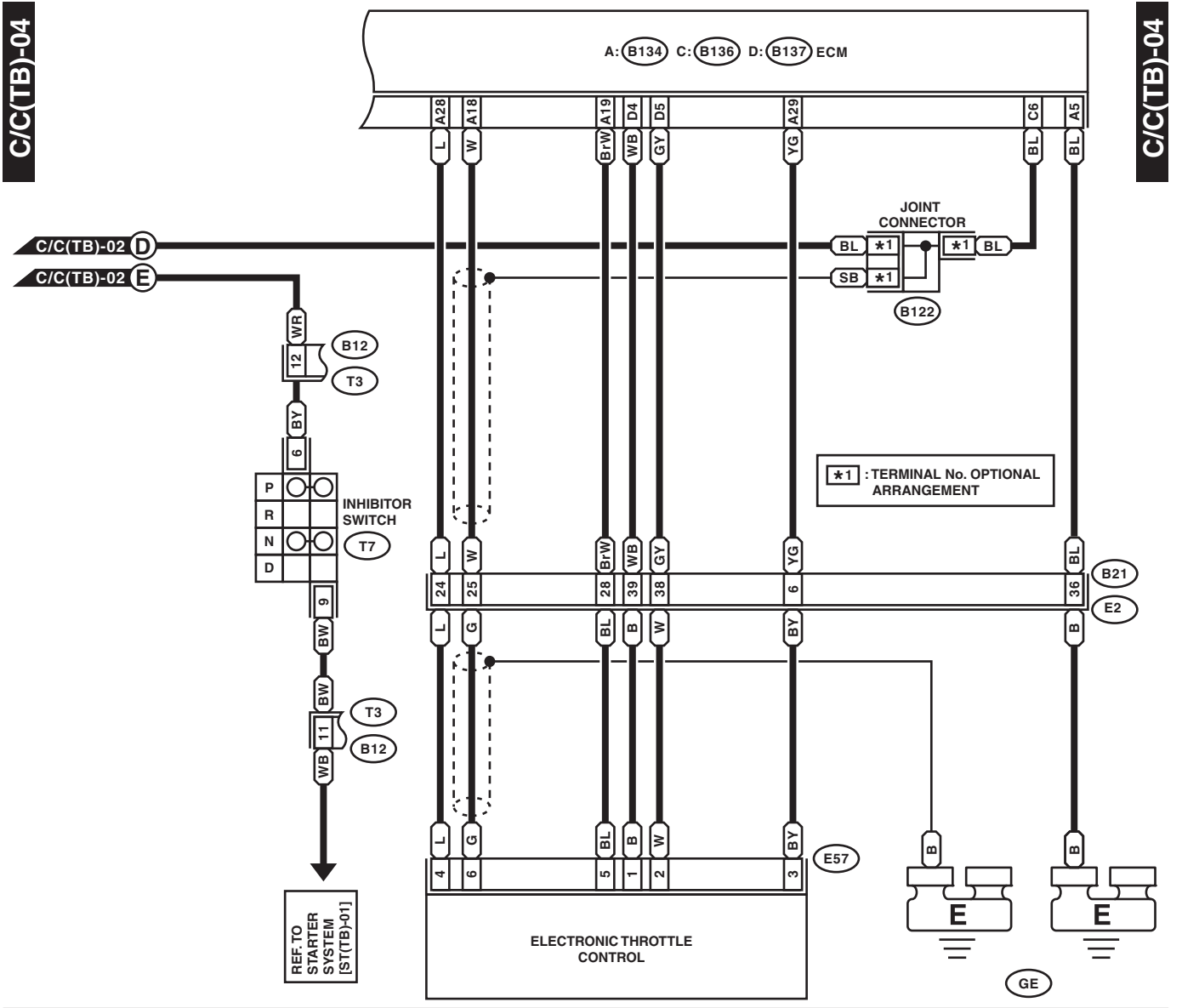

WI-19621

CAN Communication System

WIRING SYSTEM

51. CAN Communication System

A: WIRING DIAGRAM

1. LOW-SPEED CAN

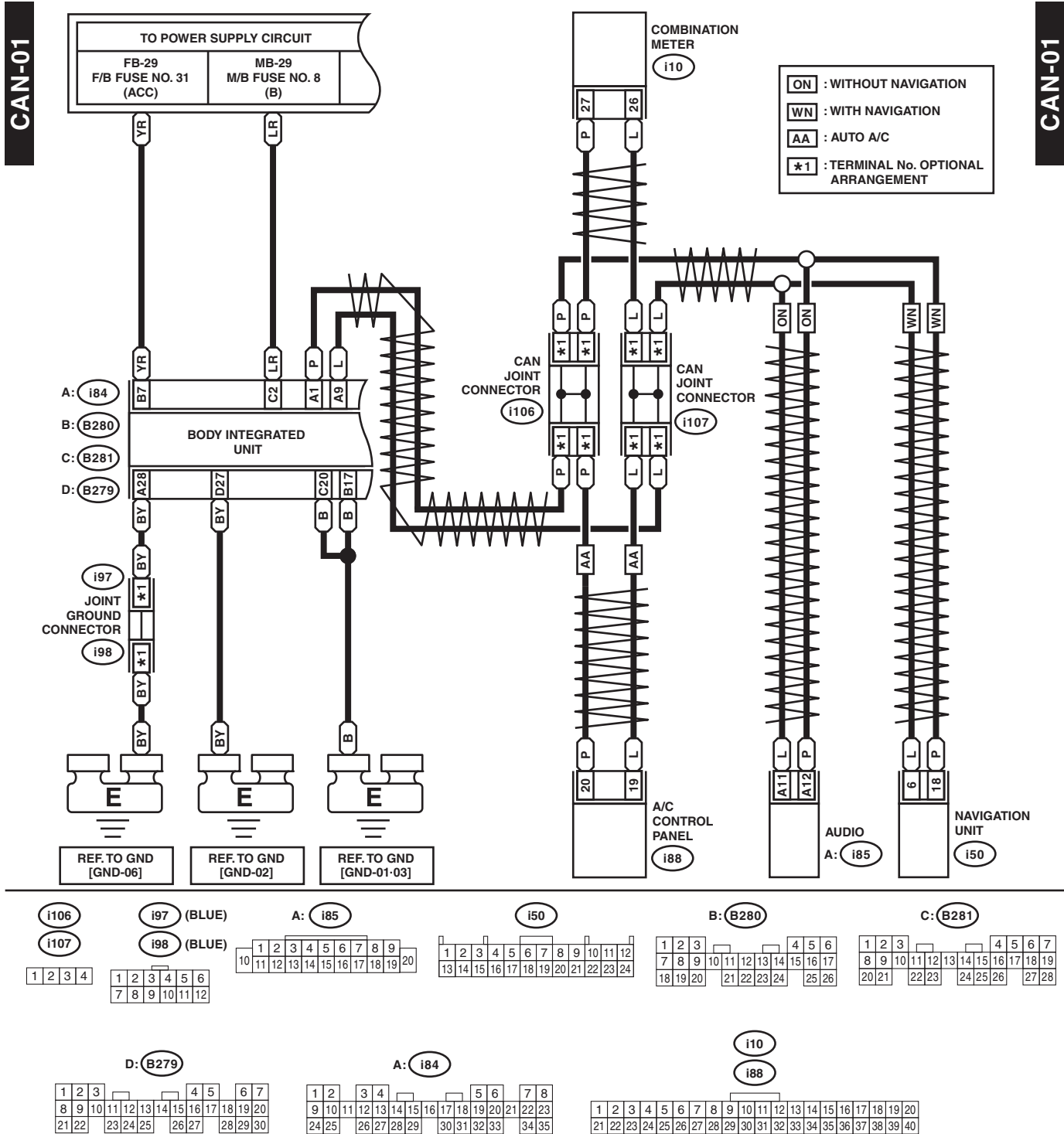

WI-19622

2. HIGH-SPEED CAN

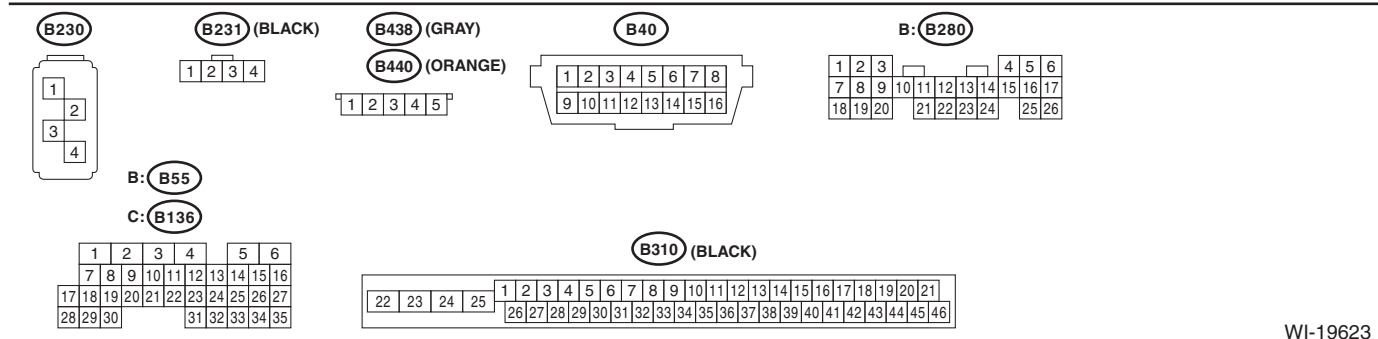
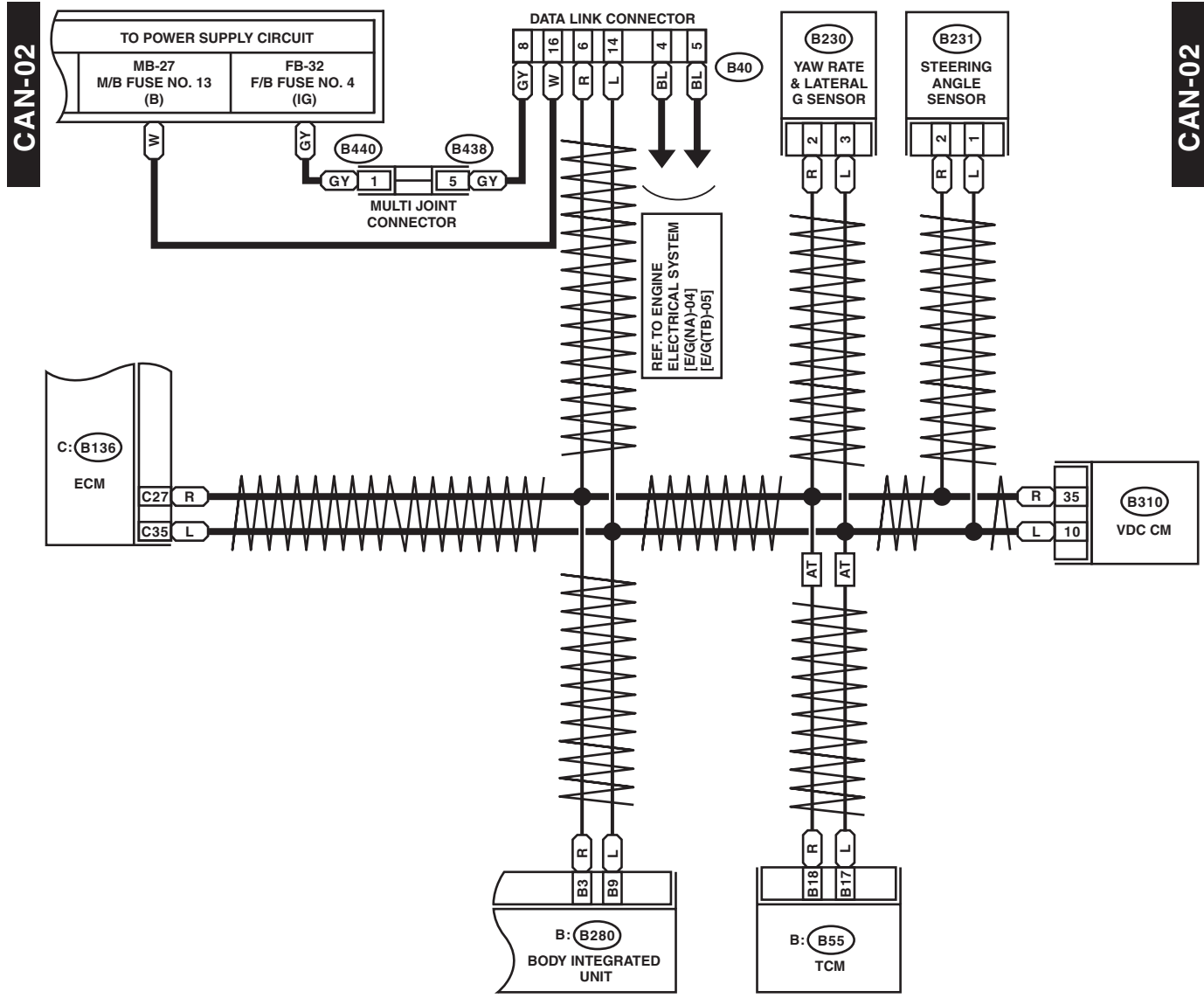

WI-19623

Compass Mirror System

WIRING SYSTEM

52. Compass Mirror System

A: WIRING DIAGRAM

COMPASS-01

COMPASS-01

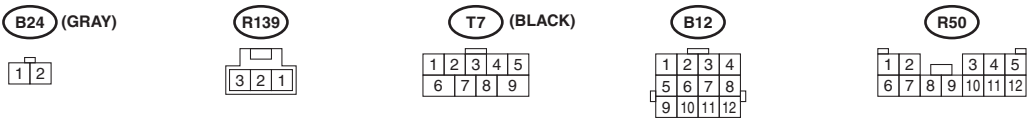
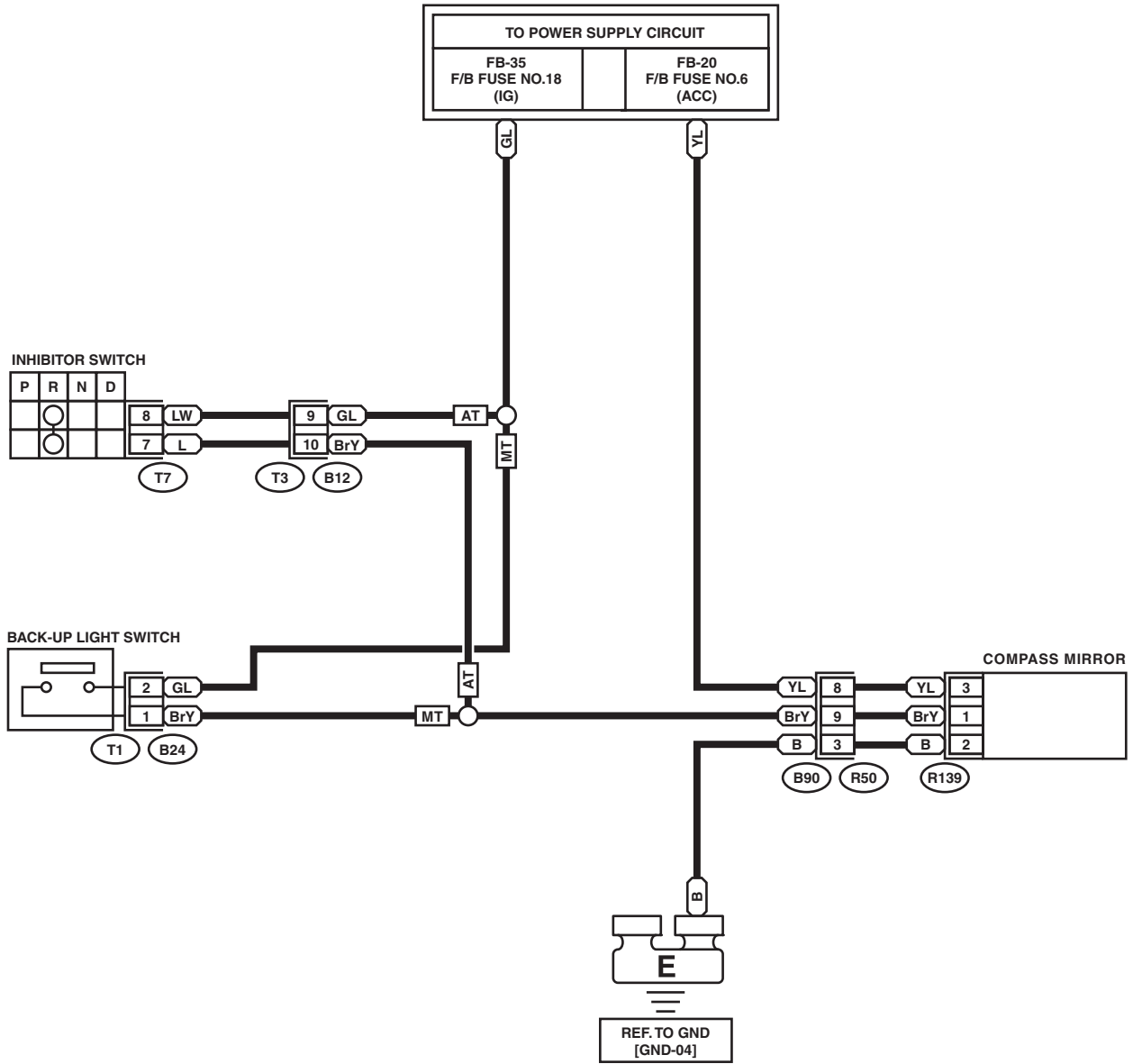

WI-19624

53. Harness Components Location

A: LOCATION

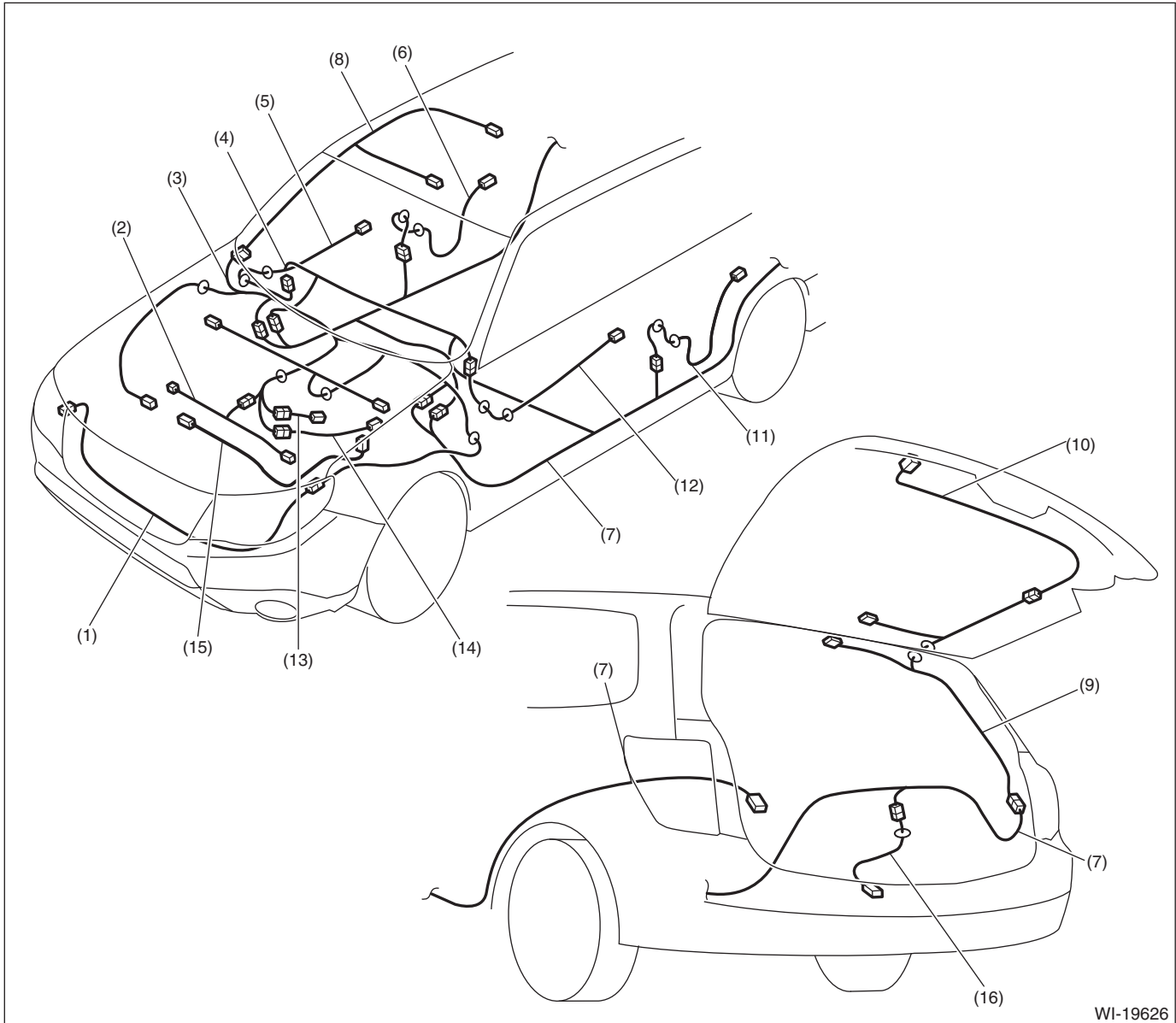

WI-19626

- | | | |
|-------------------------------------|---------------------------|------------------------------|
| (1) Front wiring harness | (7) Rear wiring harness | (12) Front door cord LH |
| (2) Engine wiring harness | (8) Roof cord | (13) Transmission cord |
| (3) Bulkhead wiring harness | (9) Rear gate cord No. 1 | (14) Rear oxygen sensor cord |
| (4) Instrument panel wiring harness | (10) Rear gate cord No. 2 | (15) Generator cord |
| (5) Front door cord RH | (11) Rear door cord LH | (16) Fuel cord |
| (6) Rear door cord RH | | |

Front Wiring Harness

WIRING SYSTEM

54. Front Wiring Harness

A: LOCATION

Connector				Connecting to	
No.	Pole	Color	Area	No.	Description
F5	1	Black	C-2		Horn
F6	2	★	C-1		Front fog light RH
F8	3	Black	C-4		Front vehicle height sensor
F9	16	★	B-5		Secondary air relay holder (turbo model)
F11	2	★	C-3		Secondary air pump (turbo model)
F16	2	Black	C-1		Sub fan motor (non-turbo model)
		Gray			Sub fan motor (turbo model)
F17	2	Black	C-2		Main fan motor (non-turbo model)
		Gray			Main fan motor (turbo model)
F21	2	★	D-3		Front fog light LH
F24	1	★	C-2		Magnet clutch
F25	1	★	C-2		Generator terminal B
F26	3	★	C-2		Generator
F27	22	★	B-4		Relay holder
F35	12	Blue	B-4		Main fuse box (M/B)
F36	7	★	B-4		
F37	20	★	C-4		
F42	3	★	C-4	B384	Bulkhead wiring harness
F47	1	Black	C-2		Horn
F58	3	Gray	C-3		Headlight beam leveler LH
F59	3	Gray	C-1		Headlight beam leveler RH
F70	2	★	B-4		Main fuse box (M/B)
F78	2	★	C-2		Ambient sensor
F103	2	Black	B-1		Daytime running light resistor
F108	18	★	B-4	B361	Through joint connector
F109	24	★	B-3	B360	
F110	6	★	C-4		Joint connector
F125	8	★	C-3		Front combination light LH
F126	8	★	C-1		Front combination light RH

★ : White or natural color

Front Wiring Harness

WIRING SYSTEM

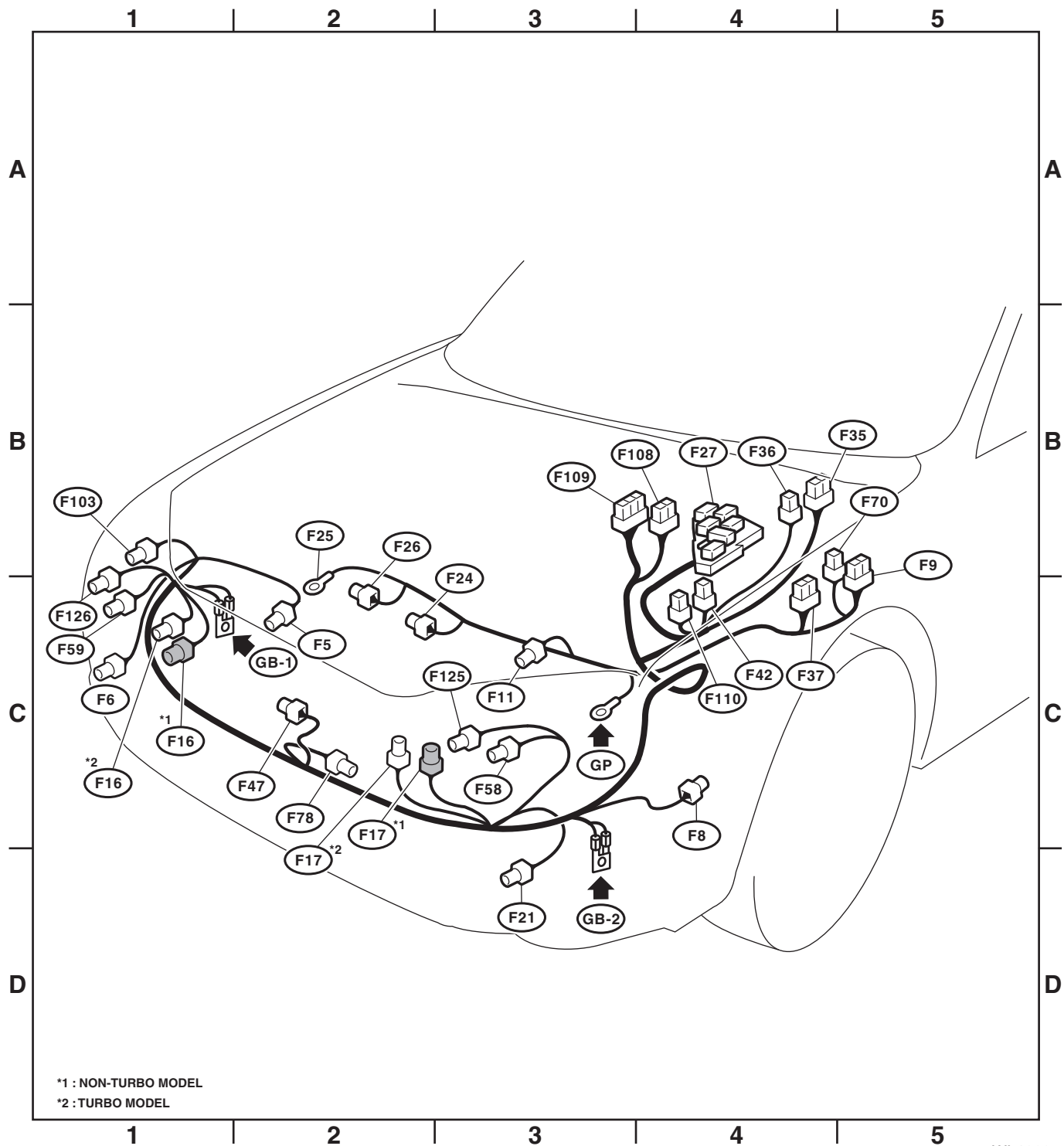

WI-19627

Bulkhead Wiring Harness (In Engine Compartment)

WIRING SYSTEM

55. Bulkhead Wiring Harness (In Engine Compartment)

A: LOCATION

1. NON-TURBO MODEL

Connector				Connecting to	
No.	Pole	Color	Area	No.	Description
B3	5	Black	B-2		Mass air flow and intake air temperature sensor
B6	2	Gray	B-2		Front ABS wheel speed sensor RH
B8	5	★	B-3		Front wiper motor
B10	4	★	B-4		Pressure switch
B11	20	Gray	B-3	T4	Transmission cord
B12	12	★	B-3	T3	
B14	1	Black	B-4		Starter motor
B15	2	Gray	B-4		Front ABS wheel speed sensor LH
B16	2	Gray	B-3		Brake fluid level switch
B21	54	★	B-3	E2	Engine wiring harness
B24	2	Gray	B-3	T1	Back-up light switch (MT model)
B25	2	Brown	B-4	T2	Neutral position switch
B143	20	★	B-4		Main fuse box (M/B)
B144	9	Brown	B-4		
B145	7	Brown	B-4		
B146	2	★	C-4		Front washer motor
B147	2	★	C-4		Rear washer motor
B164	2	Black	C-3		Keyless buzzer
B186	8	★	B-4		Main fuse box (M/B)
B310	46	Black	B-2		VDC CM
B321	2	★	B-1		Hood switch
B360	16	Gray	B-4	F109	Through joint connector
B361	14	★	B-4	F108	
B407	2	★	B-5		Puddle light LH
B430	2	★	B-3		Puddle light RH

★ : White or natural color

Connector				Connecting to	
No.	Pole	Color	Area	No.	Description
AB13	2	Yellow	C-3		Front sub sensor LH
AB16	2	Yellow	B-1		Front sub sensor RH

Bulkhead Wiring Harness (In Engine Compartment)

WIRING SYSTEM

2. TURBO MODEL

Connector				Connecting to	
No.	Pole	Color	Area	No.	Description
B3	5	Black	B-2		Mass air flow and intake air temperature sensor
B6	2	Gray	B-2		Front ABS wheel speed sensor RH
B8	5	★	B-3		Front wiper motor
B10	4	★	B-4		Pressure switch
B11	20	Gray	B-3	T4	Transmission cord
B12	12	★	B-3	T3	
B14	1	Black	B-3		Starter motor
B15	2	Gray	B-4		Front ABS wheel speed sensor LH
B16	2	Gray	B-3		Brake fluid level switch
B19	4	★	B-3	T5	Rear oxygen sensor cord
B21	54	★	B-3	E2	Engine wiring harness
B143	20	★	B-4		Main fuse box (M/B)
B144	9	Brown	B-4		
B145	7	Brown	B-4		
B146	2	★	C-4		Front washer motor
B147	2	★	C-4		Rear washer motor
B164	2	Black	C-3		Keyless buzzer
B186	8	★	B-4		Main fuse box (M/B)
B310	46	Black	B-2		VDC CM
B321	2	★	B-1		Hood switch
B360	16	Gray	B-4	F109	Through joint connector
B361	14	★	B-4	F108	
B379	4	★	B-3		Front oxygen (A/F) sensor
B384	3	★	B-4	F42	Front wiring harness
B407	2	★	B-5		Puddle light LH
B430	2	★	B-3		Puddle light RH

★ : White or natural color

Connector				Connecting to	
No.	Pole	Color	Area	No.	Description
AB13	2	Yellow	C-3		Front sub sensor LH
AB16	2	Yellow	B-1		Front sub sensor RH

Bulkhead Wiring Harness (In Engine Compartment)

WIRING SYSTEM

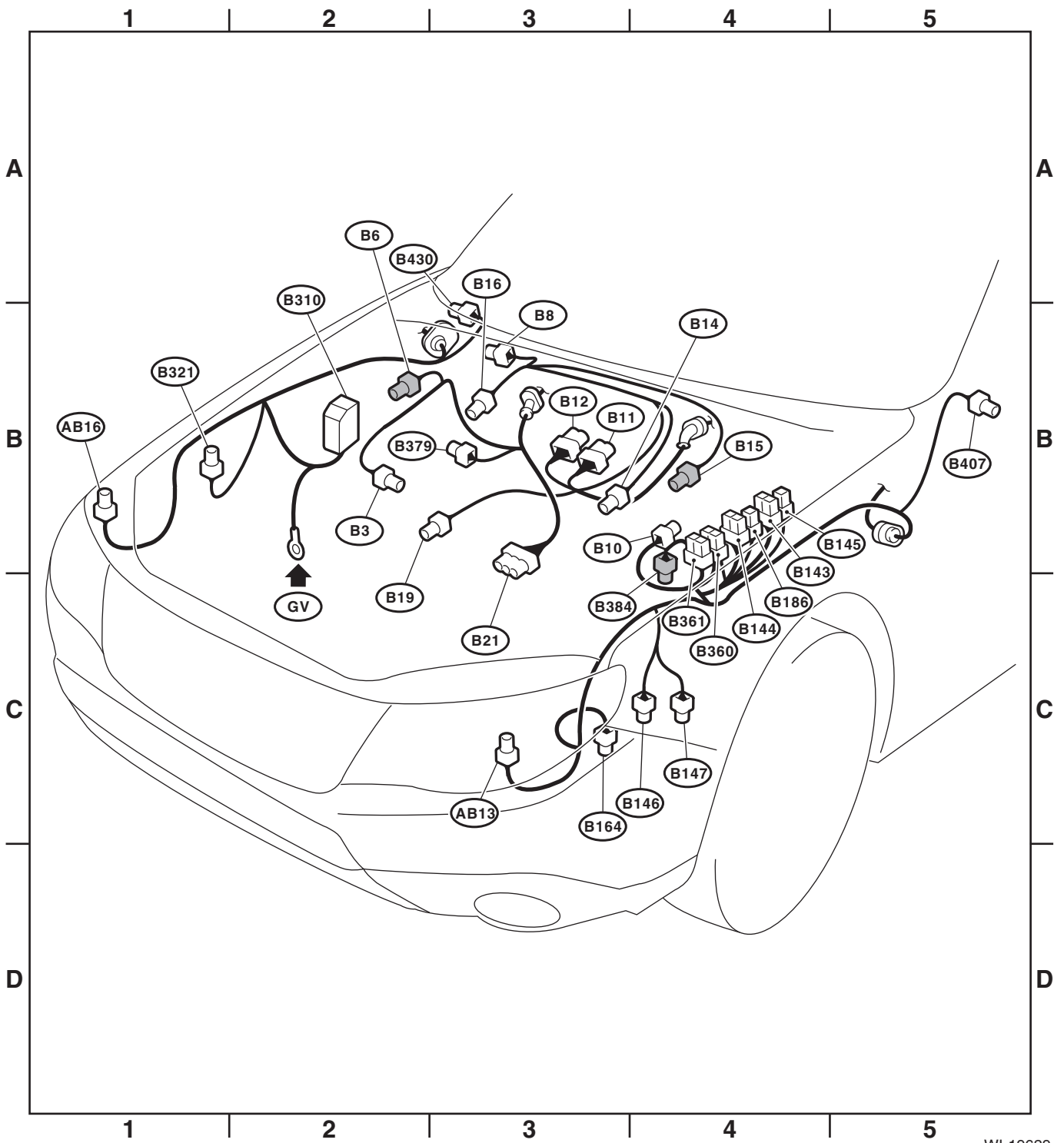

WI-19629

Bulkhead Wiring Harness (In Compartment)

WIRING SYSTEM

56. Bulkhead Wiring Harness (In Compartment)

A: LOCATION

Connector				Connecting to	
No.	Pole	Color	Area	No.	Description
B27	4	★	B-3		Blower resistor (Manual A/C)
B31	6	★	B-1	AB1	Airbag wiring harness
B32	8	★	C-2		Turn signal and hazard unit
B36	28	★	B-4	i1	Instrument panel wiring harness
B38	28	★	B-2	i3	
B40	16	★	C-3		Data link connector
B41	2	★	B-2		Power window circuit breaker
B52	24	★	B-2		Fuse & relay box (F/B)
B53	20	★	C-3		Joint connector
B54	35	★	C-3		TCM
B55	35	★	C-3		
B57	4	★	B-3		Power transistor (Auto A/C)
B65	4	Black	C-2		Stop light & brake switch
B68	14	★	C-2		Roll connector
B70	18	★	C-2		Combination switch
B71	17	★	C-2		
B72	6	★	C-2		Ignition switch
B75	2	Green	B-4	B76	Delivery (test) mode connector
B76	2	Green	B-4	B75	
B77	6	★	C-3		Mode door actuator (Auto A/C)
B83	8	★	C-4		Joint connector
B87	2	★	B-4		Blower motor
B88	2	Brown	B-3		Evaporator sensor (Auto A/C)
	3	★	B-3		Evaporator sensor (Manual A/C)
B89	2	Black	B-5		Blower diode
B90	12	★	B-5	R50	Roof cord
B97	24	★	C-5	R2	Rear wiring harness
B99	24	★	C-1	R3	
B106	2	★	C-2		Clutch start switch
B107	2	Blue	C-2		Clutch switch (model with cruise control)
B117	10	Gray	C-4		AT select lever
B122	8	★	C-4		Joint connector
B123	2	Black	C-1	B124	Key lock
B124	2	Black	C-1	B123	
B134	34	★	C-4		ECM
B135	35	★	C-4		
B136	35	★	C-4		
B137	31	★	C-4		
B138	8	★	C-4		Joint connector
B150	24	★	C-2		Auto headlight beam leveler CM
B152	10	Gray	B-2		Fuse & relay box (F/B)
B158	8	★	B-2		
B159	9	Brown	B-2		
B162	2	★	B-2		
B163	6	★	C-4		Intake door actuator
B177	2	★	B-5		Wiper deicer

Bulkhead Wiring Harness (In Compartment)

WIRING SYSTEM

Connector				Connecting to	
No.	Pole	Color	Area	No.	Description
B180	24	★	B-2		Remote engine start CM
B181	2	★	B-2	B182	Short connector
B182	2	★	C-2	B181	
B220	40	★	B-4		Fuse (Relay block)
					A/F Oxygen sensor relay
					Fuel pump relay
					IG relay (non-turbo model)
					Main relay
					Electronic throttle control relay
B224	2	★	C-2		Key illumination
B225	40	★	C-2		Fuse (Relay block)
					Starter relay
					Front fog light relay
					Power window relay
					Wiper deicer relay
					Tail and illumination relay
					Seat heater relay
B230	4	★	D-4		Yaw rate & lateral G sensor
B231	4	Black	C-2		Steering angle sensor
B239	6	★	B-3		Air mix door actuator (Auto A/C)
B279	30	★	B-3		Body integrated unit
B280	26	★	B-3		
B281	28	★	B-3		
B315	6	★	C-3		
B318	4	★	B-1		VDC OFF switch
B350	4	★	C-2		Key warning switch & key lock solenoid
B358	2	★	C-4		AT select lever illumination
B363	2	Green	B-1	B364	Test mode sub connector
B364	2	Green	B-1	B363	
B367	8	★	C-2		Impact sensor
B386	7	★	B-4		Blower motor relay
B404	1	Black	D-4		Parking brake switch
B415	2	Black	B-2		Immobilizer antenna
B434	5	Pink	D-1		Multi joint connector
B435	5	Brown	D-1		
B436	5	Yellow	D-1		
B437	5	Blue	D-1		
B438	5	Gray	D-1		
B439	5	Green	D-1		
B440	5	Orange	D-1		
B441	5	★	D-1		
B442	5	Black	D-2		
B443	5	Red	D-2		
B444	5	Light green	D-2		
B445	5	Violet	D-2		
B465	2	Black	C-5	B466	Off delay cut connector
B466	2	Black	C-5	B465	

★ : White or natural color

Bulkhead Wiring Harness (In Compartment)

WIRING SYSTEM

Connector				Connecting to	
No.	Pole	Color	Area	No.	Description
AB1	6	Yellow	B-1	B31	Bulkhead wiring harness
AB2	4	Yellow	C-2	AB7	Driver's airbag module
AB6	30	Yellow	C-4		Airbag CM
AB9	4	Yellow	C-4		Passenger's airbag module

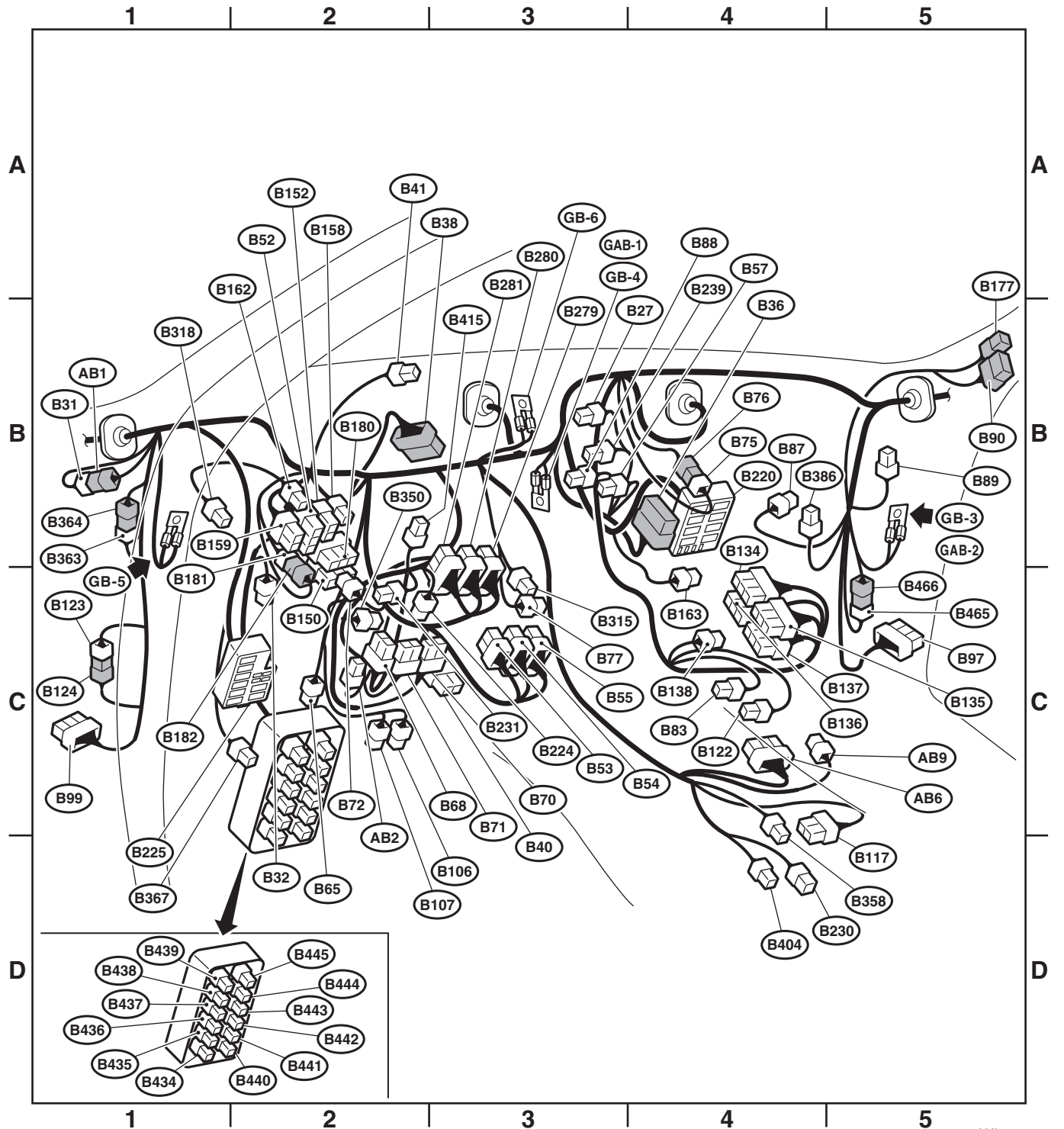

WI-19630

57.Engine Wiring Harness and Transmission Cord

A: LOCATION

1. NON-TURBO MODEL

Connector				Connecting to	
No.	Pole	Color	Area	No.	Description
E2	54	Black	A-3	B21	Bulkhead wiring harness
E4	2	Black	B-3		Purge control solenoid valve
E5	2	Dark gray	B-1		Fuel injector No. 1
E6	2	Dark gray	A-2		Fuel injector No. 3
E8	2	Black	B-2		Engine coolant temperature sensor
E10	2	Light gray	B-3		Crankshaft position sensor
E11	1	—	B-2		Oil pressure switch
E12	4	Black	A-2		Ignition coil & ignitor assembly
E14	2	Gray	B-4		Knock sensor
E15	2	Black	B-4		Camshaft position sensor
E16	2	Dark gray	B-4		Fuel injector No. 2
E17	2	Dark gray	B-4		Fuel injector No. 4
E18	6	Dark gray	A-4		EGR valve
E19	1	★	B-2		Power steering oil pressure switch
E21	3	Black	A-4		Manifold absolute pressure sensor
E22	4	Dark gray	A-1		Rear oxygen sensor
E23	6	Black	A-1		Front oxygen (A/F) sensor
E57	6	Black	A-3		Electronic throttle control
E61	2	Dark gray	A-3		PCV diagnosis connector
E69	2	Blue	A-2		Oil switching solenoid valve RH
E70	2	Blue	B-4		Oil switching solenoid valve LH
E71	1	★	A-2		Variable valve lift diagnosis oil pressure switch RH
E72	1	★	B-4		Variable valve lift diagnosis oil pressure switch LH
E75	2	Black	B-2		Oil temperature sensor

★ : White or natural color

• MT model

Connector				Connecting to	
No.	Pole	Color	Area	No.	Description
T1	2	Gray	D-2	B24	Bulkhead wiring harness
T2	2	Brown	D-2	B25	

• AT model

Connector				Connecting to	
No.	Pole	Color	Area	No.	Description
T3	12	Black	D-4	B12	Bulkhead wiring harness
T4	20	Gray	D-4	B11	
T7	9	Black	D-5		Inhibitor switch

Engine Wiring Harness and Transmission Cord

WIRING SYSTEM

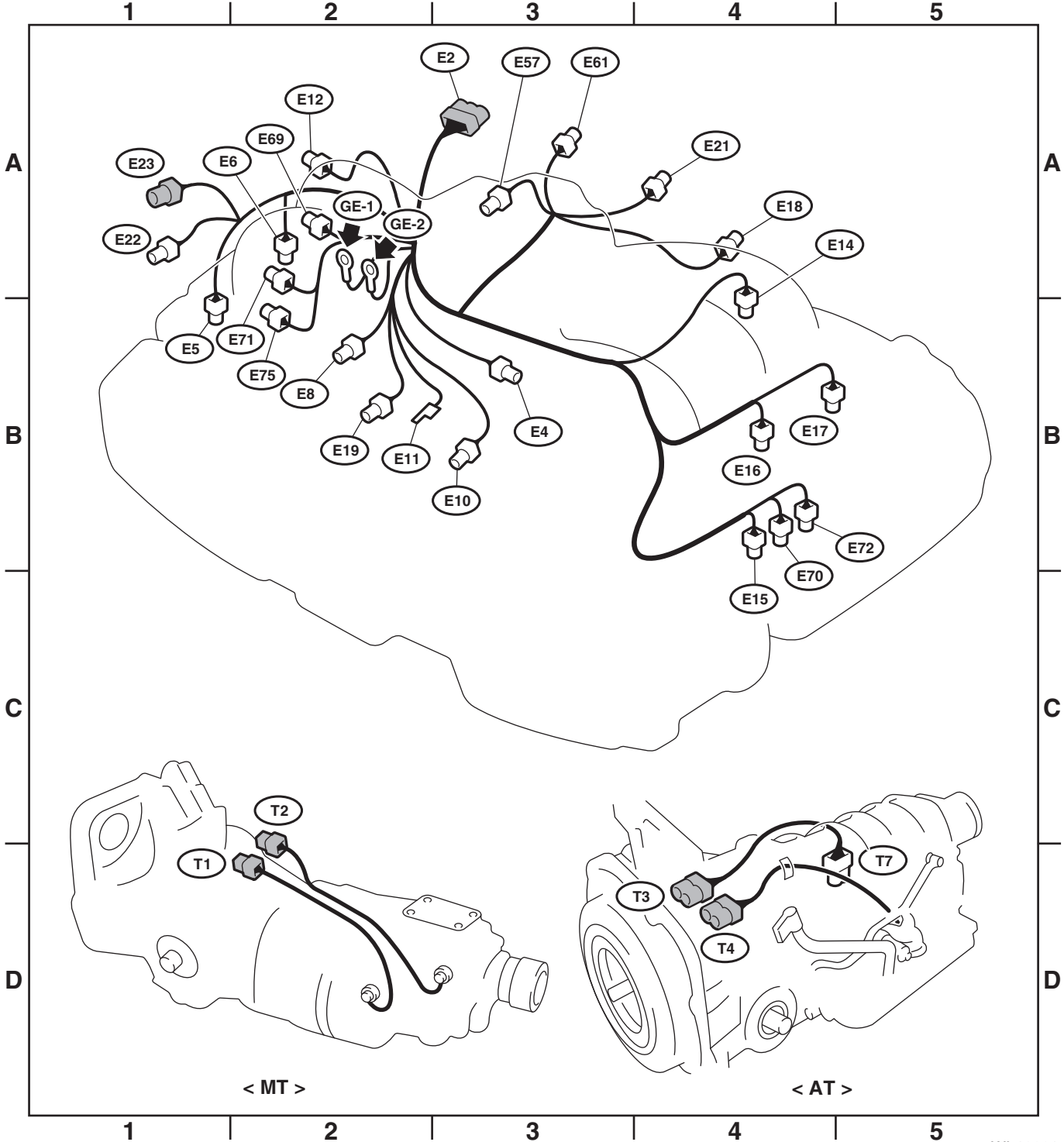

WI-19631

Engine Wiring Harness and Transmission Cord

WIRING SYSTEM

2. TURBO MODEL

Connector				Connecting to	
No.	Pole	Color	Area	No.	Description
E2	54	Black	A-2	B21	Bulkhead wiring harness
E4	2	Black	B-2		Purge control solenoid valve 1
E5	2	Dark gray	A-1		Fuel injector No. 1
E6	2	Dark gray	A-2		Fuel injector No. 3
E8	2	Black	B-2		Engine coolant temperature sensor
E10	2	Light gray	B-3		Crankshaft position sensor
E11	1	—	B-2		Oil pressure switch
E14	2	Light gray	A-3		Knock sensor
E16	2	Dark gray	B-4		Fuel injector No. 2
E17	2	Dark gray	B-4		Fuel injector No. 4
E19	1	★	B-2		Power steering oil pressure switch
E21	3	Black	A-3		Manifold absolute pressure sensor
E31	3	★	B-2		Ignition coil No. 1
E32	3	★	B-4		Ignition coil No. 2
E33	3	Black	A-2		Ignition coil No. 3
E34	3	Black	B-4		Ignition coil No. 4
E35	3	Light gray	A-4		Intake camshaft position sensor LH
E36	3	Light gray	A-2		Intake camshaft position sensor RH
E37	2	Blue	B-4		Intake oil flow control solenoid valve LH
E38	2	Blue	B-1		Intake oil flow control solenoid valve RH
E40	2	Black	B-4		Secondary air combination valve LH
E41	6	Black	B-2		Secondary air combination valve RH
E51	5	Light gray	B-4		Tumble generator valve assembly LH
E52	2	Black	A-3		Purge control solenoid valve 2
E55	5	Light gray	A-1		Tumble generator valve assembly RH
E57	6	Black	A-3		Electronic throttle control
E64	2	Blue	A-3		Wastegate control solenoid valve
E80	2	Dark gray	B-2		Leak diagnosis connector

★ : White or natural color

• AT model

Connector				Connecting to	
No.	Pole	Color	Area	No.	Description
T3	12	Black	D-4	B12	Bulkhead wiring harness
T4	20	Gray	D-4	B11	
T5	4	Dark gray	C-3	B19	
T6	4	Dark gray	D-5		Rear oxygen sensor
T7	9	Black	C-5		Inhibitor switch

Engine Wiring Harness and Transmission Cord

WIRING SYSTEM

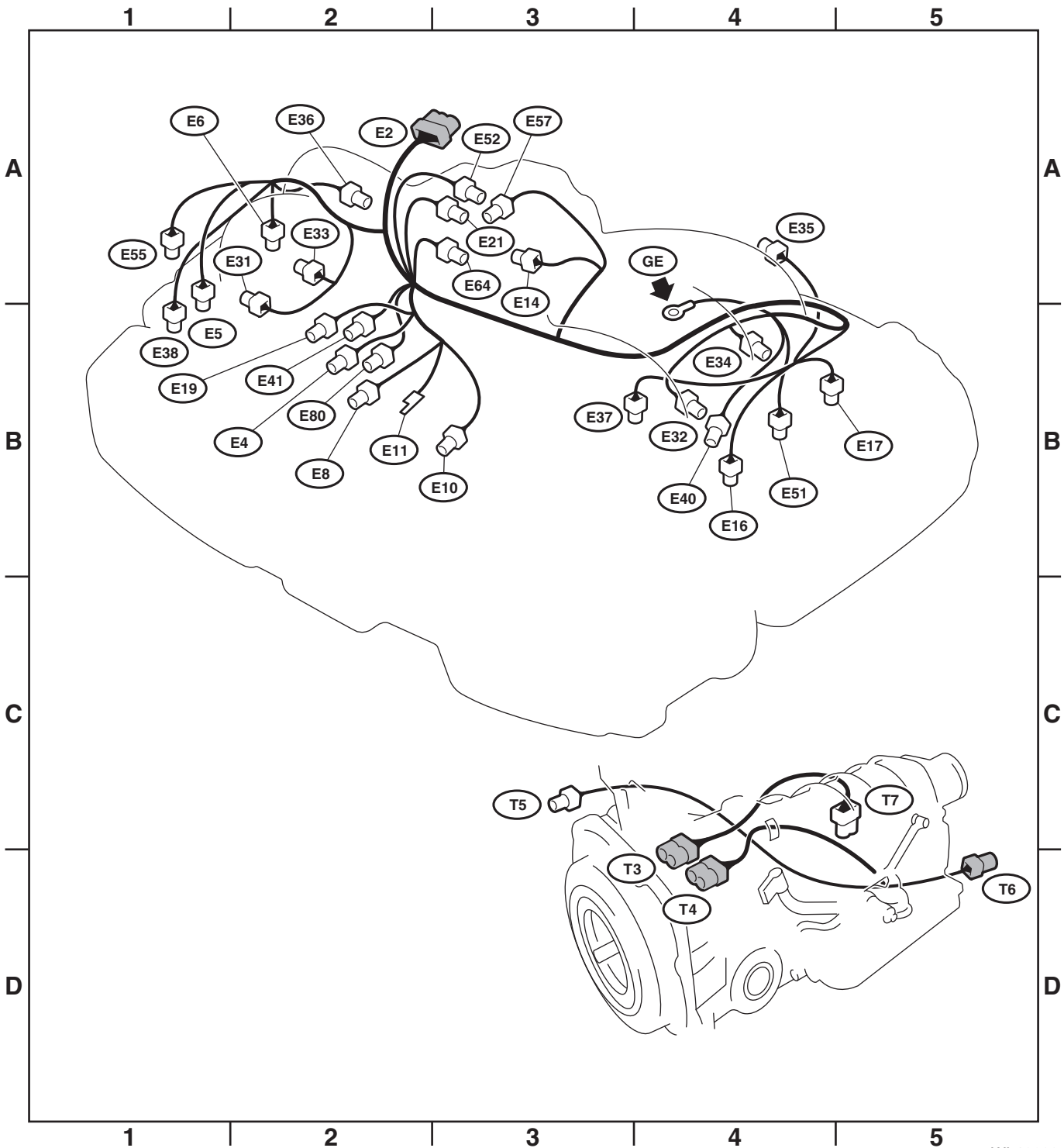

WI-19632

58. Instrument Panel Wiring Harness

A: LOCATION

Connector				Connecting to	
No.	Pole	Color	Area	No.	Description
i1	28	★	B-5	B36	Bulkhead wiring harness
i3	28	★	C-1	B38	
i5	20	★	C-2		Fuse & relay box (F/B)
i6	10	★	C-2		Remote control mirror switch
i10	40	★	B-2		Combination meter
i15	6	★	C-4		Blower fan switch (Manual A/C)
i16	12	★	C-4		A/C control panel (Manual A/C)
i22	4	★	B-3		Hazard switch
i24	4	★	C-4	AD1	Front accessory power supply socket & pocket light
i29	1	★	C-4		Audio bracket ground (without navigation system)
i50	24	★	C-4		Navigation unit
i51	2	★	B-4		Sunload sensor
i53	16	★	C-5	R98	Rear wiring harness RH
i55	2	★	C-3		In-vehicle sensor
i56	12	★	C-5	R100	Rear wiring harness RH
i59	10	★	C-3		Clock
i76	25	★	C-1	D83	Front door cord RH
i79	6	★	C-2		Illumination CM
i82	12	Blue	B-1		Joint connector
i83	12	Blue	B-1		
i84	35	★	B-1		Body integrated unit
i85	20	★	C-4		Audio (without navigation system)
i86	8	★	C-4		
i87	14	★	C-4		Audio (with navigation system)
i88	40	★	B-4		A/C control pane (Auto A/C)
i97	12	Blue	B-5		Joint ground connector
i98	12	Blue	B-5		
i101	28	★	C-1	D84	Front door cord LH
i102	16	★	C-1	R167	Rear wiring harness LH
i106	4	★	B-1		CAN joint connector
i107	4	★	B-1		
i120	4	★	B-2		Joint connector (with navigation system)

★ White or natural color

59.Rear Wiring Harness

A: LOCATION

Connector				Connecting to	
No.	Pole	Color	Area	No.	Description
R2	24	★	B-1	B97	Bulkhead wiring harness
R3	24	★	C-3	B99	
R9	3	★	C-4		
R10	8	★	C-4	D22	Rear door cord LH
R12	3	★	B-2		Front door switch RH
R13	8	★	B-2	D28	Rear door cord RH
R15	12	★	B-4	R57	Fuel cord
R16	3	★	A-3		Rear door switch RH
R41	4	★	C-3		Seat heater LH
R43	12	★	B-3		Seat heater switch
R44	4	★	B-3		Seat heater RH
R47	3	Black	B-4		Fuel tank pressure sensor
R50	12	★	B-1	B90	Bulkhead wiring harness
R52	3	★	A-3		Room light
R55	2	★	A-3	R74	Sunroof cord
R57	12	★	B-4	R15	Rear wiring harness
R58	6	★	B-4		Fuel pump assembly
R59	2	★	B-5		Fuel sub level sensor
R68	2	Dark gray	B-4		Pressure control solenoid valve
R72	2	★	B-4		Rear ABS wheel speed sensor RH
R73	2	★	B-4		Rear ABS wheel speed sensor LH
R74	2	★	A-3	R55	Roof cord
R75	6	★	A-4		Sunroof motor assembly
R98	16	★	B-1	i53	Instrument panel wiring harness
R100	12	★	B-1	i56	
R108	4	★	C-3		Seat belt switch LH
R110	2	Black	C-3		Power seat LH
R128	5	★	A-3		Sunroof switch
R139	3	★	B-3		Compass mirror
R142	2	Black	B-3		Fuel pump condenser
R167	16	★	C-3	i102	Instrument panel wiring harness
R168	20	★	C-3		Fuse & relay box (F/B)
R211	12	★	B-4		TPMS CM
R284	6	★	B-3		AUX input terminal
R305	2	★	C-4		Cup holder
R310	6	Gray	B-2		Spot map light
R311	2	★	B-3		Rear accessory power supply socket (console)

★ : White or natural color

Rear Wiring Harness

WIRING SYSTEM

Connector				Connecting to	
No.	Pole	Color	Area	No.	Description
AB17	24	Yellow	C-2		Airbag CM
AB18	24	Yellow	C-2		
AB19	4	Yellow	C-3		Side airbag module LH
AB21	2	Black	C-4		Pretensioner LH
AB23	4	Yellow	C-4		Side airbag sensor LH
AB24	4	Yellow	B-2		Side airbag module RH
AB26	2	Black	B-2		Pretensioner RH
AB28	4	Yellow	B-2		Side airbag sensor RH
AB34	4	Yellow	A-3		Curtain airbag sensor RH
AB35	2	Black	C-3		Fuse & relay box (F/B)
AB41	2	Yellow	B-4		Satellite safing sensor
AB53	18	Gray	B-2		Occupant detection control module
AB56	3	Brown	B-3		Belt tension sensor

Rear Wiring Harness

WIRING SYSTEM

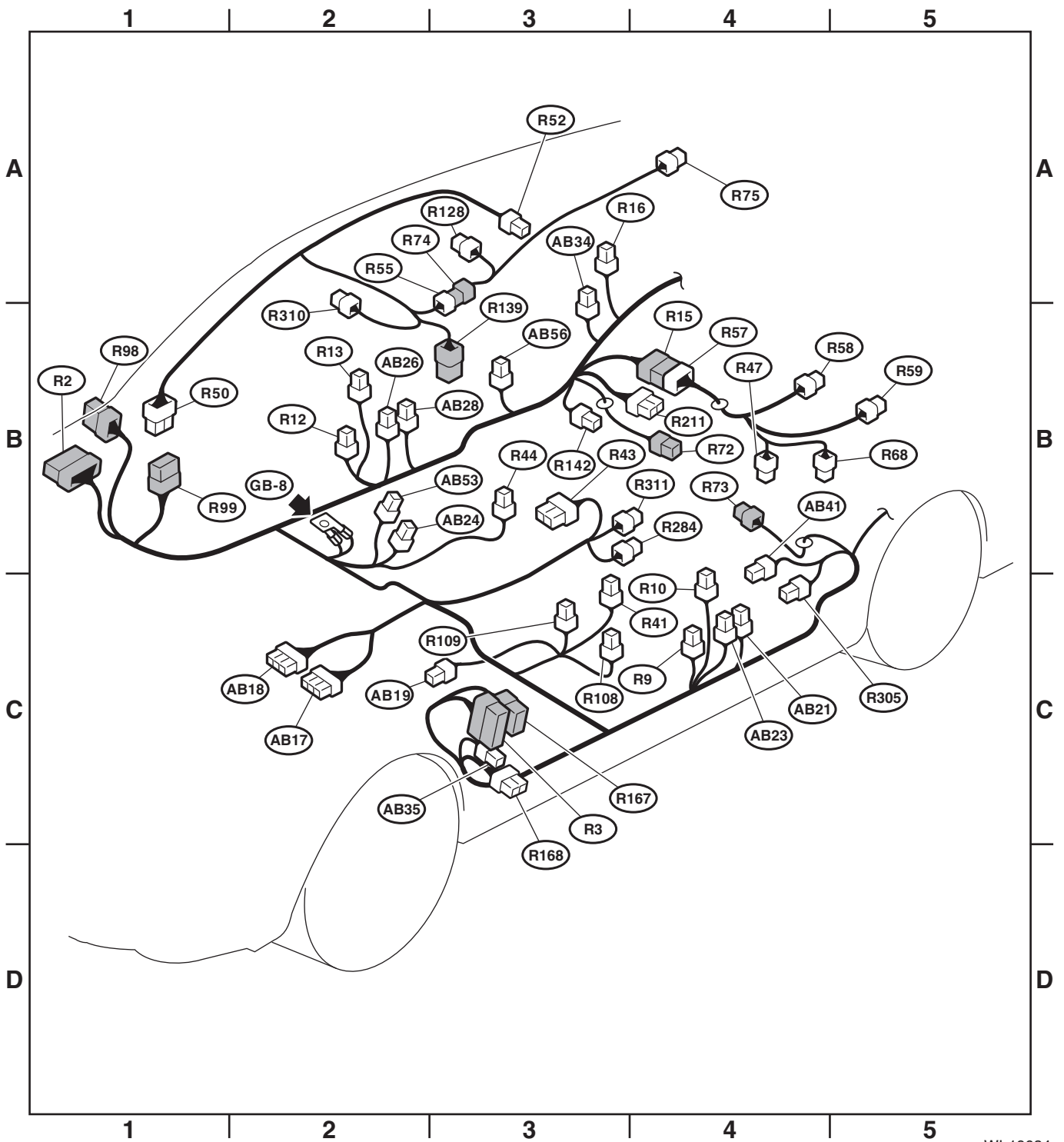

WI-19634

Door Cord

WIRING SYSTEM

60. Door Cord

A: LOCATION

Connector				Connecting to	
No.	Pole	Color	Area	No.	Description
D2	2	★	C-4		Front door speaker LH
D3	6	★	B-2		Front power window motor RH
D4	2	Black	C-3		Front door tweeter LH
D5	6	★	C-3		Outer mirror assembly LH (without mirror heater)
	8	★	C-3		Outer mirror assembly LH (with mirror heater)
D7	16	★	B-4		Power window main switch
D10	2	★	C-4		Step light LH
D12	2	★	B-2		Front door speaker RH
D13	6	★	C-4		Front power window motor LH
D14	2	Black	B-2		Front door tweeter RH
D15	6	★	B-2		Outer mirror assembly RH (without mirror heater)
	8	★	B-2		Outer mirror assembly RH (with mirror heater)
D17	8	★	B-2		Front power window sub-switch
D18	2	★	C-4		Front door lock actuator LH
D20	2	★	B-3		Step light RH
D22	8	★	C-4	R10	Rear wiring harness
D23	2	★	C-4		Rear door speaker LH
D24	6	★	B-4		Rear power window motor LH
D25	8	★	B-4		Rear power window sub-switch LH
D26	2	★	B-5		Rear door lock actuator LH
D28	8	★	B-3	R13	Rear wiring harness
D29	2	★	B-3		Rear door speaker RH
D30	6	★	B-3		Rear power window motor RH
D31	8	★	B-3		Rear power window sub-switch RH
D32	2	★	B-3		Rear door lock actuator RH
D72	2	★	B-3		Front door lock actuator RH
D83	28	★	B-2	i101	Instrument panel wiring harness
D84	25	★	C-3	i76	
D102	3	★	C-4		Power window main switch
D125	5	★	B-2		Passenger's seat door lock switch

★ : White or natural color

Door Cord

WIRING SYSTEM

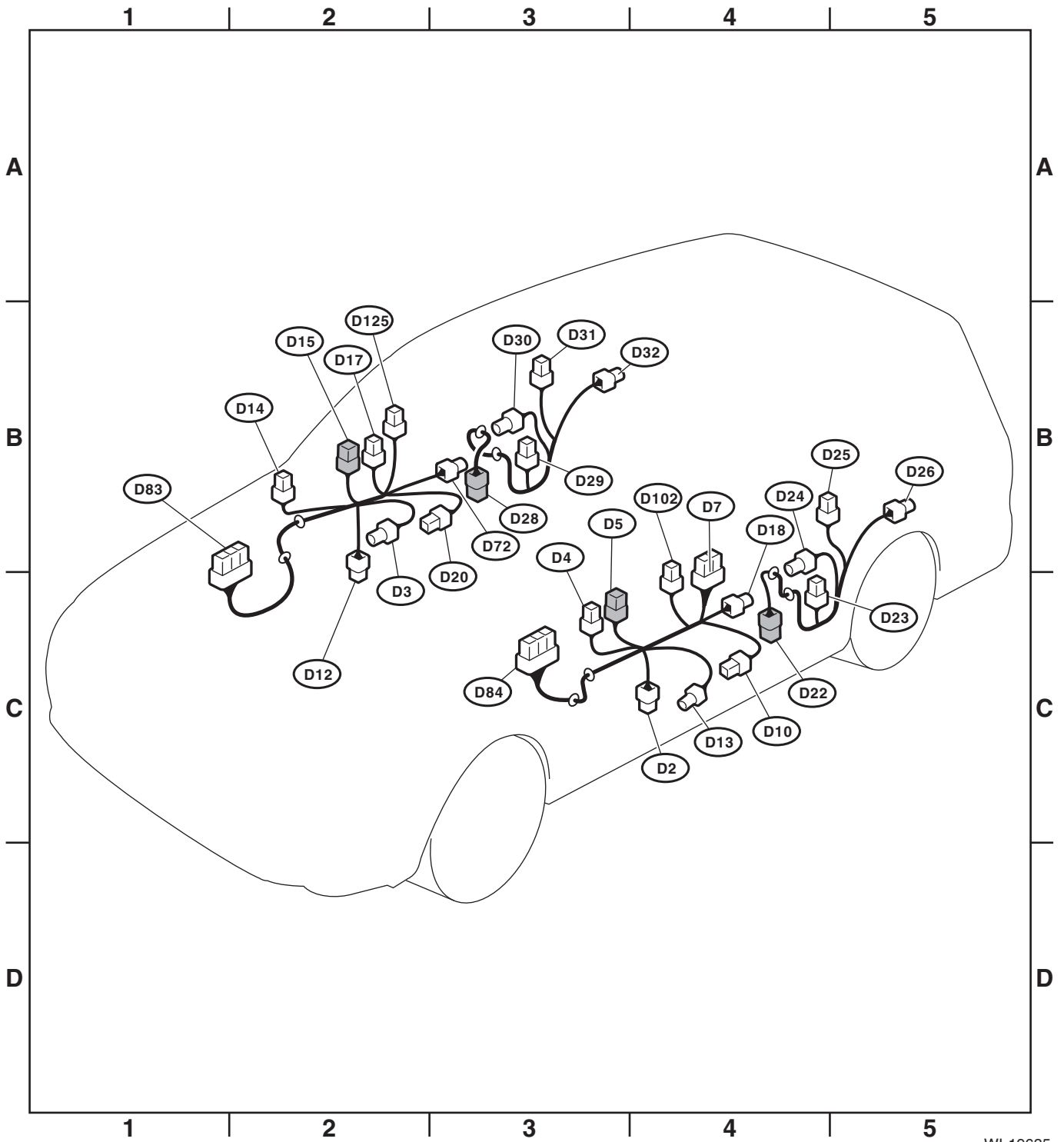

WI-19635

Rear Wiring Harness and Rear Gate Cord

WIRING SYSTEM

61.Rear Wiring Harness and Rear Gate Cord

A: LOCATION

Connector				Connecting to	
No.	Pole	Color	Area	No.	Description
R22	3	★	C-1		Rear door switch LH
R26	6	Black	C-5		Rear combination light RH
R28	6	Light gray	C-2		Rear combination light LH
R29	3	Black	C-3		Rear vehicle height sensor
R32	2	★	C-2		Rear accessory power supply socket (luggage room)
R38	8	★	C-4	D34	Rear gate cord No. 1
R39	14	★	B-4	D35	
R79	8	★	C-2		Trailer connector
R80	8	★	C-1		Keyless entry CM
R86	2	★	C-3		Drain valve
R97	1	★	C-2		Antenna amplifier
R122	10	★	C-4		Fuel pump CM

★ : White or natural color

Connector				Connecting to	
No.	Pole	Color	Area	No.	Description
D34	8	★	B-4	R38	Rear wiring harness
D35	14	★	B-4	R39	
D37	3	★	C-4		Luggage room light
D39	2	★	B-3		High-mounted stop light
D43	4	★	B-4		Rear wiper motor
D44	2	★	B-4		License plate light
D46	4	★	A-4		Rear gate lock actuator & latch switch
D48	1	★	B-3		Rear defogger (-)
D80	12	★	B-4	D81	Rear gate cord No. 2
D81	12	★	B-5	D80	Rear gate cord No. 1
D89	1	★	B-4		Rear defogger (+)
D99	6	★	B-4		rear gate opener button

★ : White or natural color

Connector				Connecting to	
No.	Pole	Color	Area	No.	Description
AB31	2	Black	C-2		Curtain airbag module LH
AB32	4	Yellow	C-1		Curtain airbag sensor LH
AB33	2	Black	C-4		Curtain airbag module RH

Rear Wiring Harness and Rear Gate Cord

WIRING SYSTEM

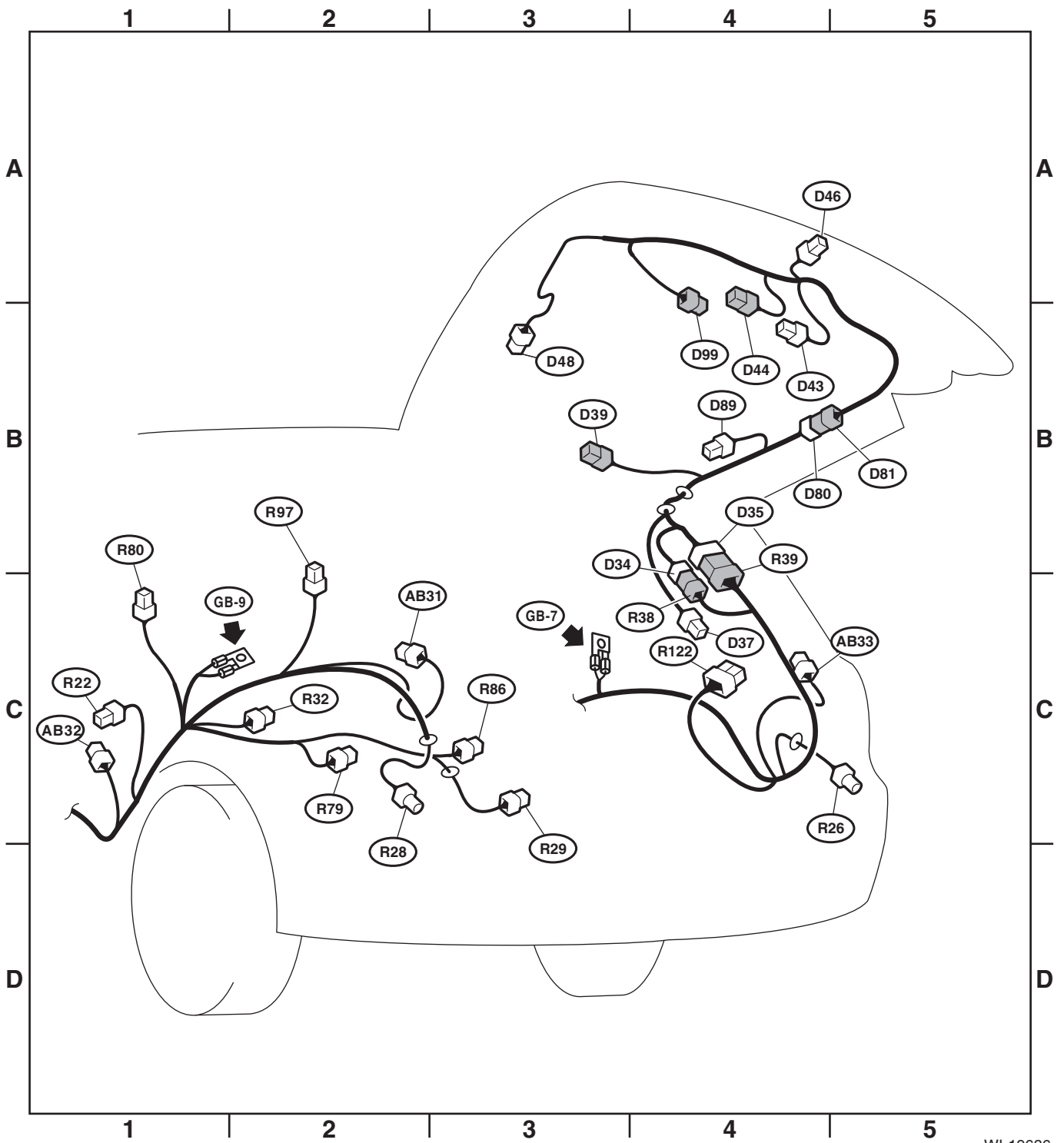

WI-19636

Rear Wiring Harness and Rear Gate Cord

WIRING SYSTEM
