

Brought to you by Eris Studios
NOT FOR RESALE

IGNITION

General Description

IGNITION

1. General Description

A: SPECIFICATIONS

Item		Designation
Ignition coil & ignitor ASSY	Model	FH0137
	Manufacturer	DIAMOND
	Secondary coil resistance	12.8 kΩ±15%
Spark plug	Type and manufacturer	CHAMPION: RC10YC4
	Equivalent	NGK: BKR5E-11
		NGK: BKR6E-11
	Thread size	mm
Spark gap	mm (in)	1.0 — 1.1 (0.039 — 0.043)

B: COMPONENT

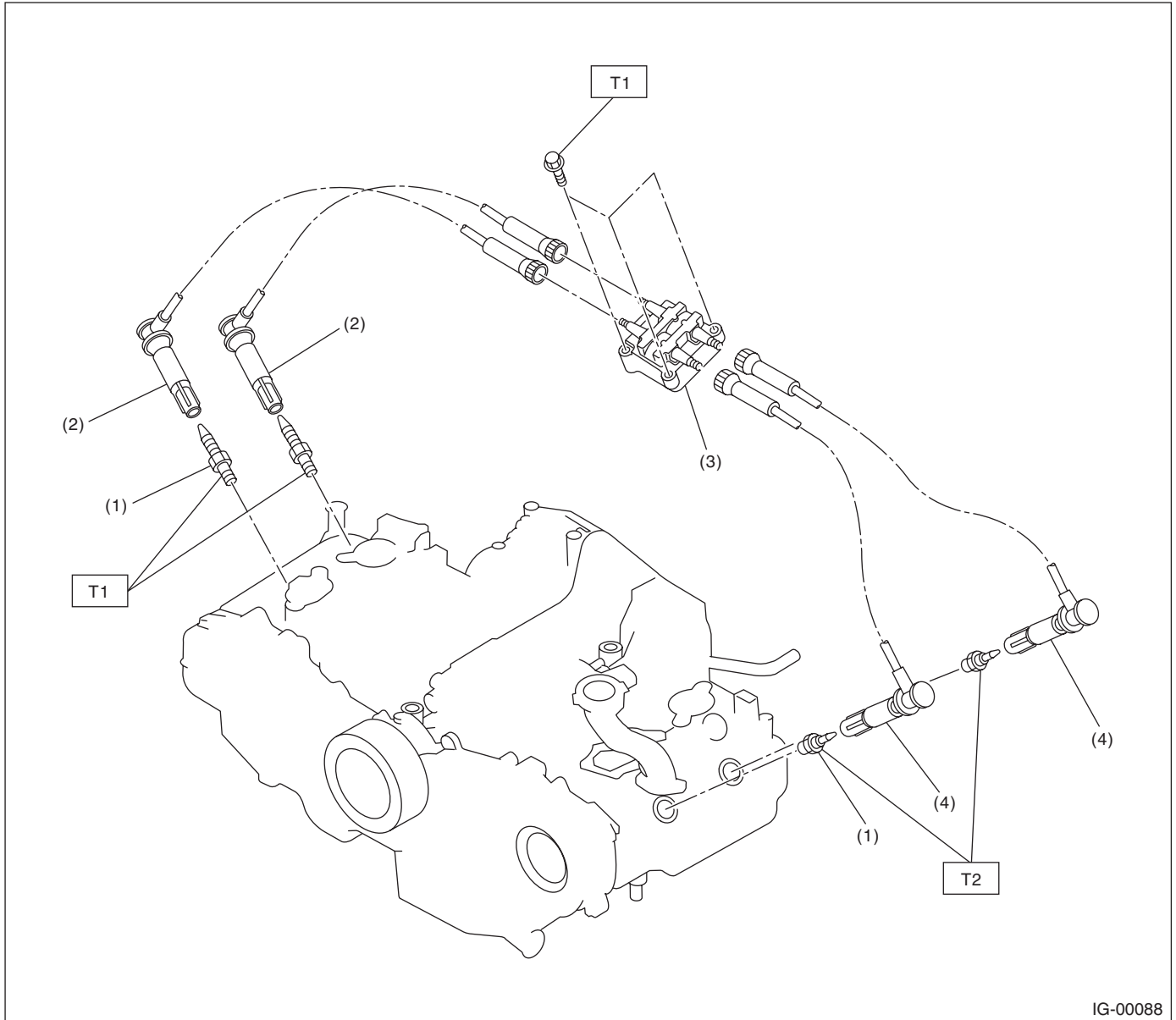

IG-00088

- (1) Spark plug
- (2) Spark plug cord (#1, #3)
- (3) Ignition coil & ignitor ASSY
- (4) Spark plug cord (#2, #4)

Tightening torque: N·m (kgf·m, ft·lb)

T1: 6.4 (0.65, 4.7)

T2: 21 (2.1, 15.5)

C: CAUTION

- Wear working clothing, including a cap, protective goggles, and protective shoes during operation.
- Remove contamination including dirt and corrosion before removal, installation or disassembly.
- Keep the disassembled parts in order and protect them from dust or dirt.
- Before removal, installation or disassembly, be sure to clarify the failure. Avoid unnecessary removal, installation, disassembly, and replacement.
- Be careful not to burn your hands, because each part on the vehicle is hot after running.
- Be sure to tighten fasteners including bolts and nuts to the specified torque.
- Place shop jacks or safety stands at the specified points.
- Before disconnecting electrical connectors of sensors or units, be sure to disconnect the ground cable from battery.

Spark Plug

IGNITION

2. Spark Plug

A: REMOVAL

CAUTION:

All spark plugs installed on an engine, must be of the same heat range.

Spark plug	
CHAMPION: RC10YC4	
Equivalent	NGK: BKR5E-11
	NGK: BKR6E-11

1. RH SIDE

- 1) Disconnect the ground cable from battery.

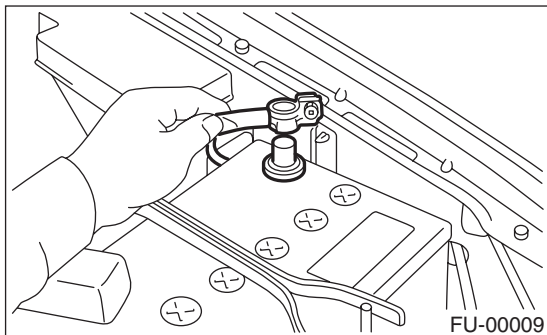

- 2) Remove the resonator chamber. <Ref. to IN(H4SO)-7, REMOVAL, Resonator Chamber.>
- 3) Remove the spark plug cords by pulling the boot, not the cord itself.

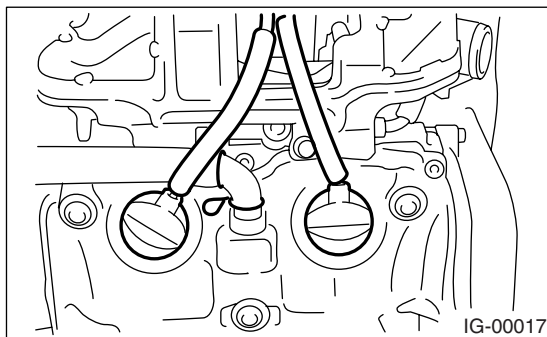

- 4) Remove the spark plugs using spark plug sockets.

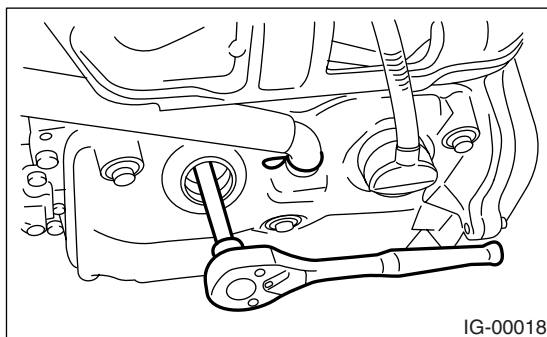

2. LH SIDE

- 1) Disconnect the ground cable from battery.

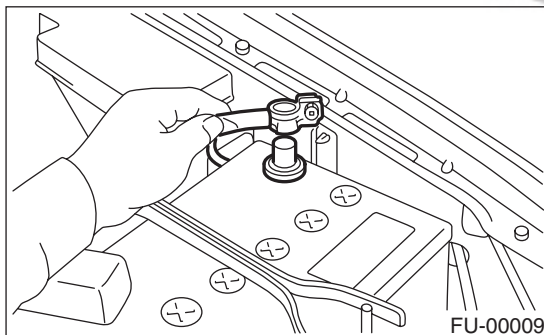

- 2) Disconnect the washer motor connector.

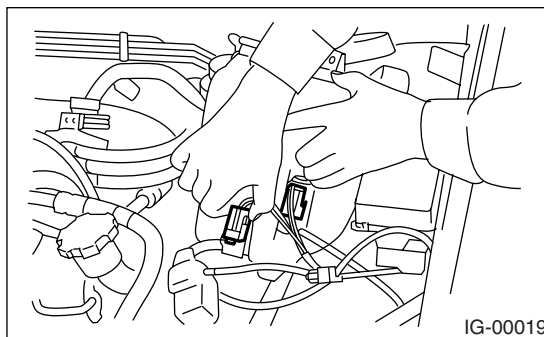

- 3) Disconnect the rear window glass washer hose from washer motor, then plug the connection with a suitable cap.
- 4) Remove the two bolts which hold the washer tank, then take the tank away from working area.

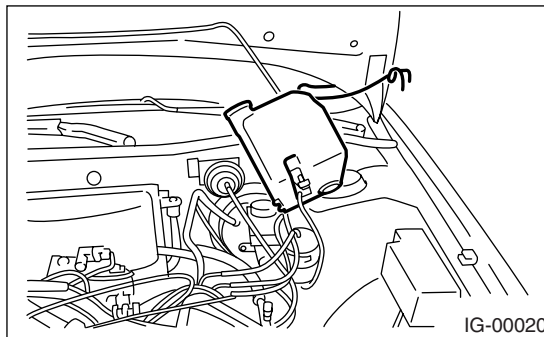

- 5) Remove the spark plug cords by pulling the boot, not the cord itself.

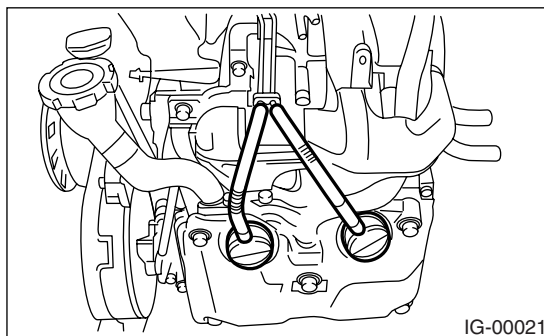

6) Remove the spark plugs with spark plug sockets.

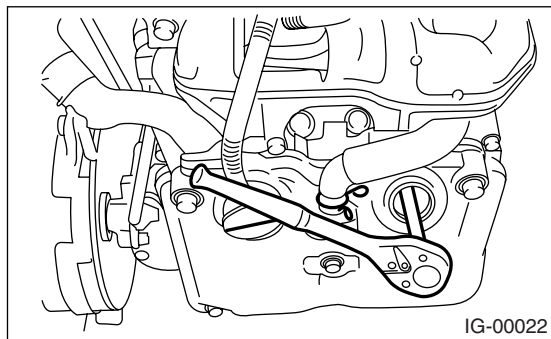

B: INSTALLATION

1. RH SIDE

Install in the reverse order of removal.

NOTE:

- For tightening torque, refer to "COMPONENT". <Ref. to IG(H4SO)-2, COMPONENT, General Description.>
- The above torque should be only applied to new spark plugs without oil on their threads. In case their threads are lubricated, the torque should be reduced by approx. 1/3 of the specified torque in order to avoid over-stressing.

2. LH SIDE

Install in the reverse order of removal.

NOTE:

- For tightening torque, refer to "COMPONENT". <Ref. to IG(H4SO)-2, COMPONENT, General Description.>
- The above torque should be only applied to new spark plugs without oil on their threads. In case their threads are lubricated, the torque should be reduced by approx. 1/3 of the specified torque in order to avoid over-stressing.

C: INSPECTION

Check the electrodes and inner and outer ceramic insulator of plugs, noting the type of deposits and the degree of electrode erosion.

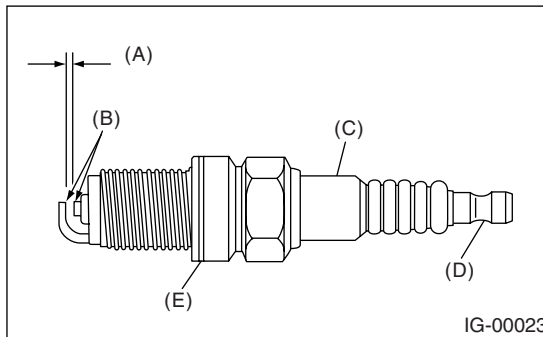

- (A) Electrode gap
- (B) Carbon accumulation or wear
- (C) Cracks
- (D) Damage
- (E) Damaged gasket

1) Normal:

Brown to grayish-tan deposits and slight electrode wear indicates correct spark plug heat range.

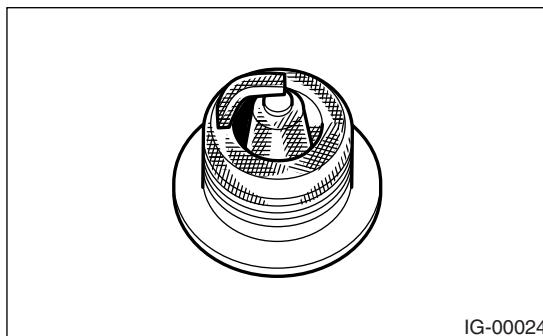

2) Carbon fouled:

Dry fluffy carbon deposits on insulator and electrode are mostly caused by slow speed driving in city, weak ignition, too rich fuel mixture, dirty air cleaner, etc.

It is advisable to replace with plugs having hotter heat range.

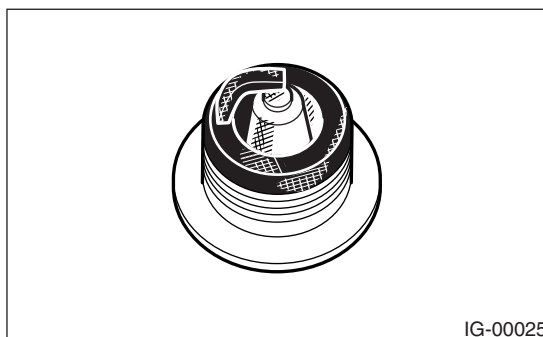

Spark Plug

IGNITION

3) Oil fouled:

Wet black deposits show excessive oil entrance into combustion chamber through worn rings and pistons or excessive clearance between valve guides and stems. If the same condition remains after repair, use a hotter plug.

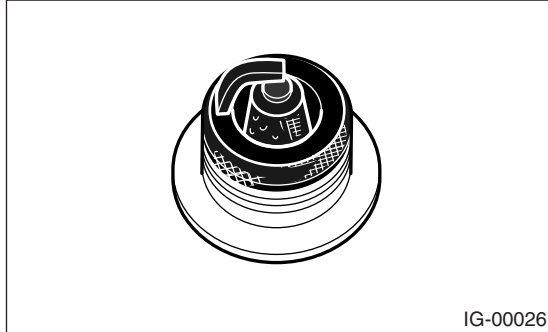

4) Overheating:

White or light gray insulator with black or gray brown spots and bluish burnt electrodes indicates engine overheating. Moreover, the appearance results from incorrect ignition timing, loose spark plugs, wrong selection of fuel, hotter range plug, etc. It is advisable to replace with plugs having colder heat range.

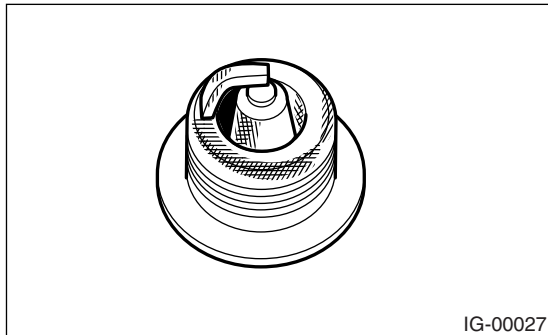

D: CLEANING

Clean the spark plugs in a sand blast type cleaner. Avoid excessive blasting. Clean and remove the carbon or oxide deposits, but do not wear away ceramic insulator.

If deposits are too stubborn, replace the plugs.

E: ADJUSTMENT

Correct it if the spark plug gap is measured with a gap gauge, and it is necessary.

Spark plug gap: L

1.0 — 1.1 mm (0.039 — 0.043 in)

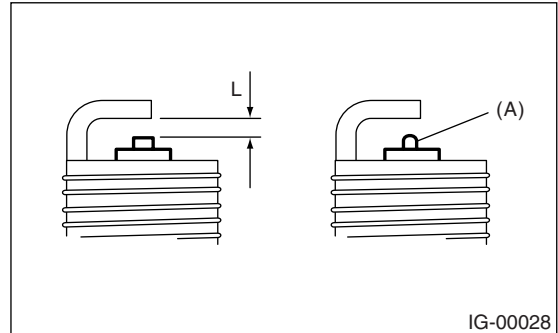

NOTE:

Replace with a new spark plug if this area (A) is worn to "ball" shape.

3. Ignition Coil & Ignitor ASSY

A: REMOVAL

1) Disconnect the ground cable from battery.

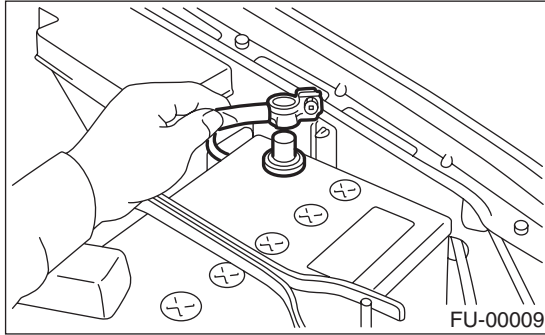

2) Disconnect the spark plug cords from ignition coil and ignitor ASSY.

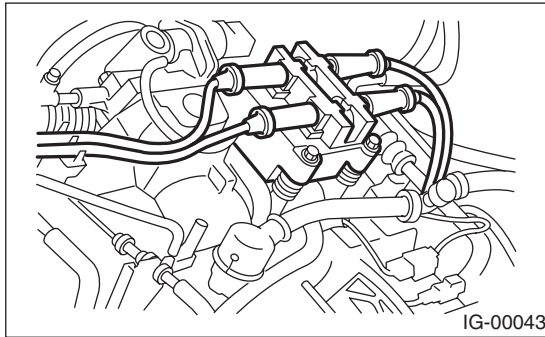

3) Disconnect the connector from ignition coil and ignitor ASSY.

4) Remove the ignition coil and ignitor ASSY.

NOTE:

Both the coil ground and ignition coil and ignitor ASSY are tightened by the bolt (A).

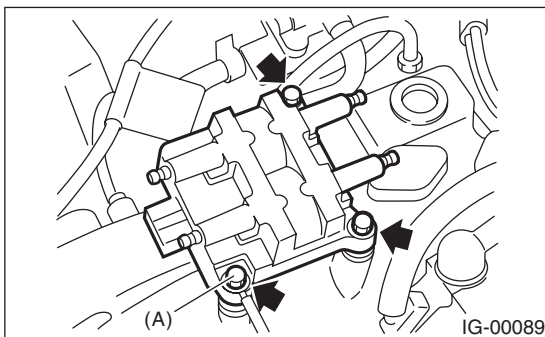

B: INSTALLATION

Install in the reverse order of removal.

NOTE:

• For tightening torque, refer to "COMPONENT".
<Ref. to IG(H4SO)-2, COMPONENT, General Description.>

• Install the coil ground to the place shown in the following figure.

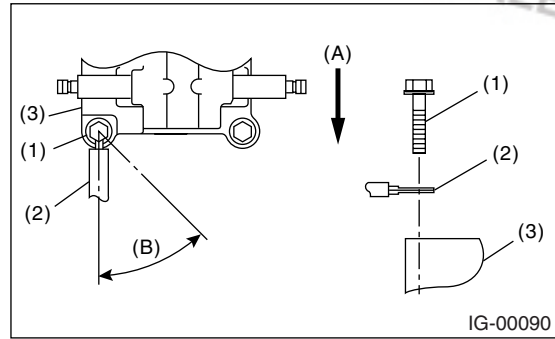

- (1) Bolt
- (2) Coil ground
- (3) Ignition coil & ignitor ASSY
- (A) Front side of engine
- (B) 45°

CAUTION:

Connect the spark plugs to correct position. Misconnection may damage the unit.

C: INSPECTION

Using the accurate tester, inspect the following items, and replace if defective.

- Secondary coil resistance

CAUTION:

- Ignitor is integrated in coil. Therefore, primary coil resistance can not be measured.
- If the resistance is extremely low, this indicates the presence of a short-circuit.

Specified resistance:

[Secondary side]

Between (A) and (B)

12.8 kΩ±15%

Between (C) and (D)

12.8 kΩ±15%

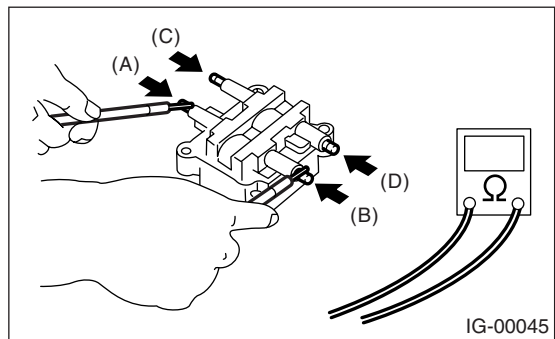

4. Spark Plug Cord

A: INSPECTION

Check for:

- 1) Damage to cords, deformation, burning or rust formation of terminals
- 2) Resistance values of cords

Resistance value:

#1 cord: 5.6 — 10.6 k Ω

#2 cord: 7.3 — 13.7 k Ω

#3 cord: 5.9 — 11.1 k Ω

#4 cord: 7.3 — 13.7 k Ω

