

Brought to you by Eris Studios
NOT FOR RESALE

STARTING/CHARGING SYSTEMS

General Description

STARTING/CHARGING SYSTEMS

1. General Description

A: SPECIFICATIONS

1. NON-TURBO MODEL

Item		Designation		
Starter	Type	Reduction type		
	Vehicle type	MT	AT	
	Model	M000T30471	M000T20171	
	Manufacturer	Mitsubishi Electric		
	Voltage and output	12 V — 1.0 kW	12 V — 1.4 kW	
	Direction of rotation	Counterclockwise (when observed from pinion)		
	Number of pinion teeth	8	9	
	No-load characteristics	Voltage	11 V	
		Current	95 A or less	90 A or less
		Rotating speed	2,500 rpm or more	2,000 rpm or more
	Load characteristics	Voltage	7.5 V	7.7 V
		Current	300 A	400 A
		Torque	8.84 N·m (0.90 kgf-m, 6.5 ft-lb) or more	16.7 N·m (1.70 kgf-m, 12.3 ft-lb) or more
		Rotating speed	870 rpm or more	710 rpm or more
	Lock characteristics	Voltage	4 V	3.5 V
		Current	680 A or less	960 A or less
Torque		17 N·m (1.73 kgf-m, 12.5 ft-lb) or more	31 N·m (3.16 kgf-m, 22.9 ft-lb) or more	
Generator	Type	Rotating-field three-phase, voltage regulator built-in type, with load response control system		
	Model	A2TB6291		
	Manufacturer	Mitsubishi Electric		
	Voltage and output	12 V — 75 A		
	Polarity on ground side	Negative		
	Direction of rotation	Clockwise (when observed from pulley side)		
	Armature connection	Three-phase Y-type		
	Output current	1,500 rpm — 30 A or more 2,500 rpm — 64 A or more 5,000 rpm — 76 A or more		
	Regulated voltage	14.1 — 14.8 V [20°C (68°F)]		
Battery	Type and capacity	12 V — 48 AH (55D 23L)	12 V — 52 AH (75D 23L)	

General Description

STARTING/CHARGING SYSTEMS

2. TURBO MODEL

Item		Designation		
Starter	Type	Reduction type		
	Vehicle type	MT	AT	
	Model	228000 — 9270	M001T20171	
	Manufacturer	DENSO	Mitsubishi Electric	
	Voltage and output	12 V — 1.0 kW	12 V — 1.4 kW	
	Direction of rotation	Counterclockwise (when observed from pinion)		
	Number of pinion teeth	9		
	No-load characteristics	Voltage	11 V	
		Current	90 A or less	
		Rotating speed	2,860 rpm or more	2,000 rpm or more
	Load characteristics	Voltage	8 V	7.7 V
		Current	280 A	400 A
		Torque	9.3 N·m (0.95 kgf·m, 6.9 ft·lb) or more	16.7 N·m (1.70 kgf·m, 12.3 ft·lb) or more
		Rotating speed	860 rpm or more	710 rpm or more
	Lock characteristics	Voltage	5 V	3.5 V
Current		515 A or less	960 A or less	
Torque		16 N·m (1.63 kgf·m, 11.8 ft·lb) or more	31 N·m (3.16 kgf·m, 22.9 ft·lb) or more	
Generator	Type	Rotating-field three-phase, voltage regulator built-in type, with load response control system		
	Model	A2TB6291		
	Manufacturer	Mitsubishi Electric		
	Voltage and output	12 V — 75 A		
	Polarity on ground side	Negative		
	Direction of rotation	Clockwise (when observed from pulley side)		
	Armature connection	Three-phase Y-type		
	Output current	1,500 rpm — 30 A or more		
		2,500 rpm — 64 A or more		
5,000 rpm — 76 A or more				
Regulated voltage	14.1 — 14.8 V [20°C (68°F)]			
Battery	Type and capacity	12 V — 48 AH (55D 23L)	12 V — 52 AH (65D 23L)	

General Description

STARTING/CHARGING SYSTEMS

B: COMPONENT

1. STARTER

• EXCEPT DOHC TURBO MT MODEL

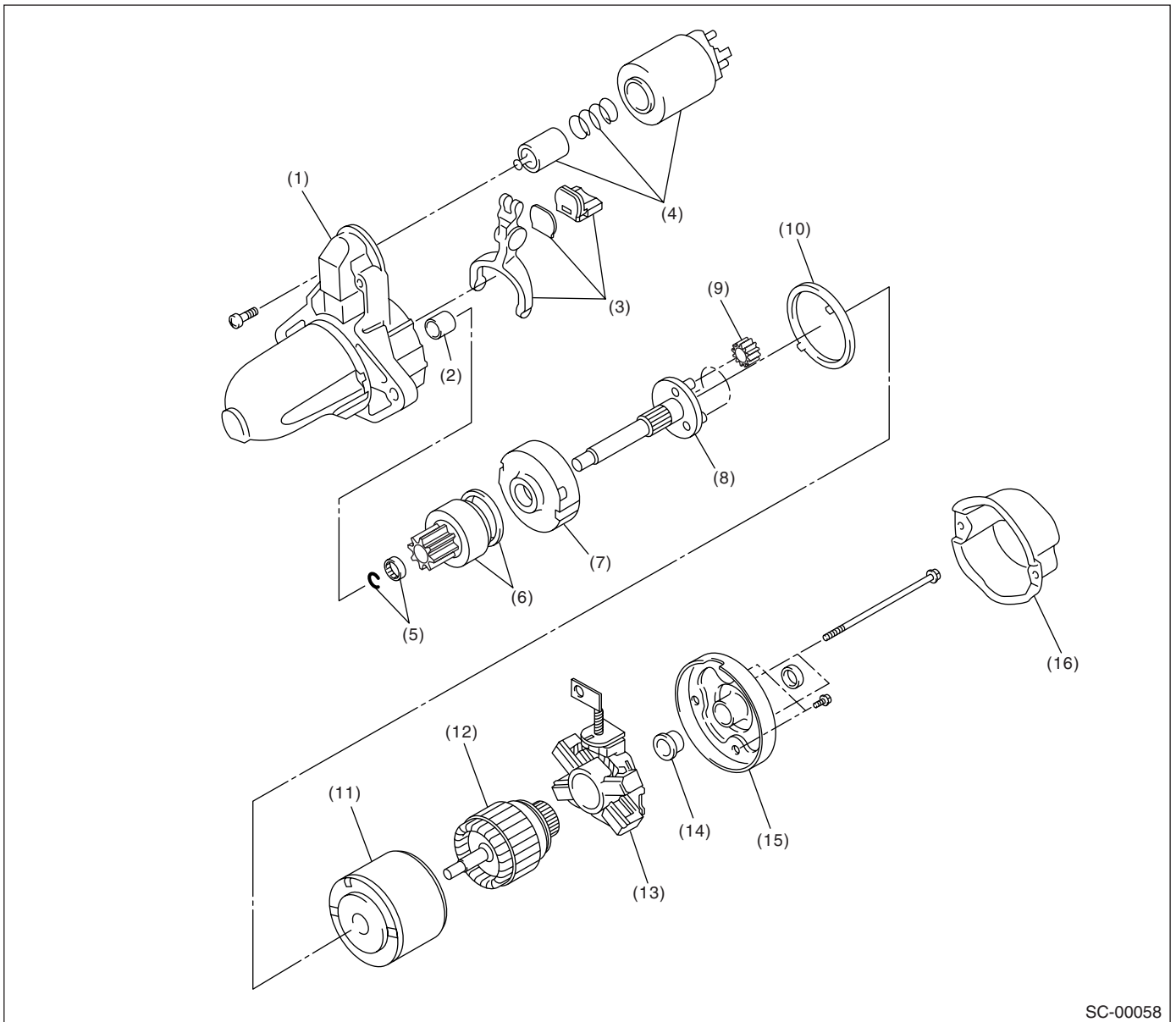

SC-00058

- | | | |
|------------------------|------------------------|------------------------|
| (1) Front bracket | (7) Internal gear ASSY | (13) Brush holder ASSY |
| (2) Sleeve bearing | (8) Shaft ASSY | (14) Sleeve bearing |
| (3) Lever set | (9) Gear ASSY | (15) Rear cover |
| (4) Magnet switch ASSY | (10) Packing | (16) Rear cover set |
| (5) Stopper set | (11) Yoke ASSY | |
| (6) Overrunning clutch | (12) Armature | |

General Description

STARTING/CHARGING SYSTEMS

• DOHC TURBO MT MODEL

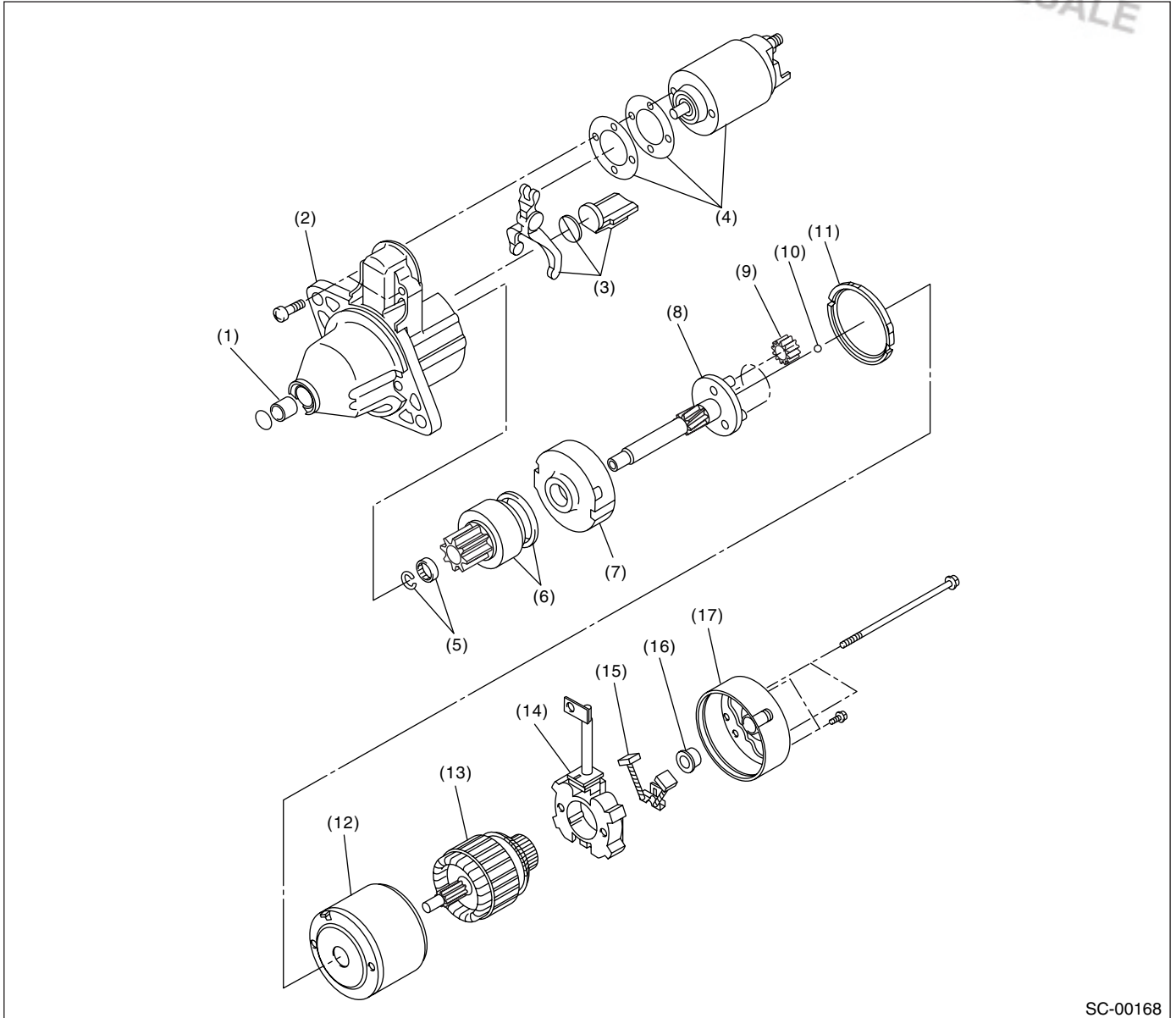

SC-00168

- | | | |
|----------------------------|----------------------------|----------------------------|
| (1) Sleeve bearing | (7) Internal gear assembly | (13) Armature |
| (2) Front bracket | (8) Shaft assembly | (14) Brush holder assembly |
| (3) Lever set | (9) Gear assembly | (15) Brush |
| (4) Magnet switch assembly | (10) Ball | (16) Sleeve bearing |
| (5) Stopper set | (11) Packing | (17) Rear bracket |
| (6) Overrunning clutch | (12) Yoke assembly | |

SC(H4SO)-5

2. GENERATOR

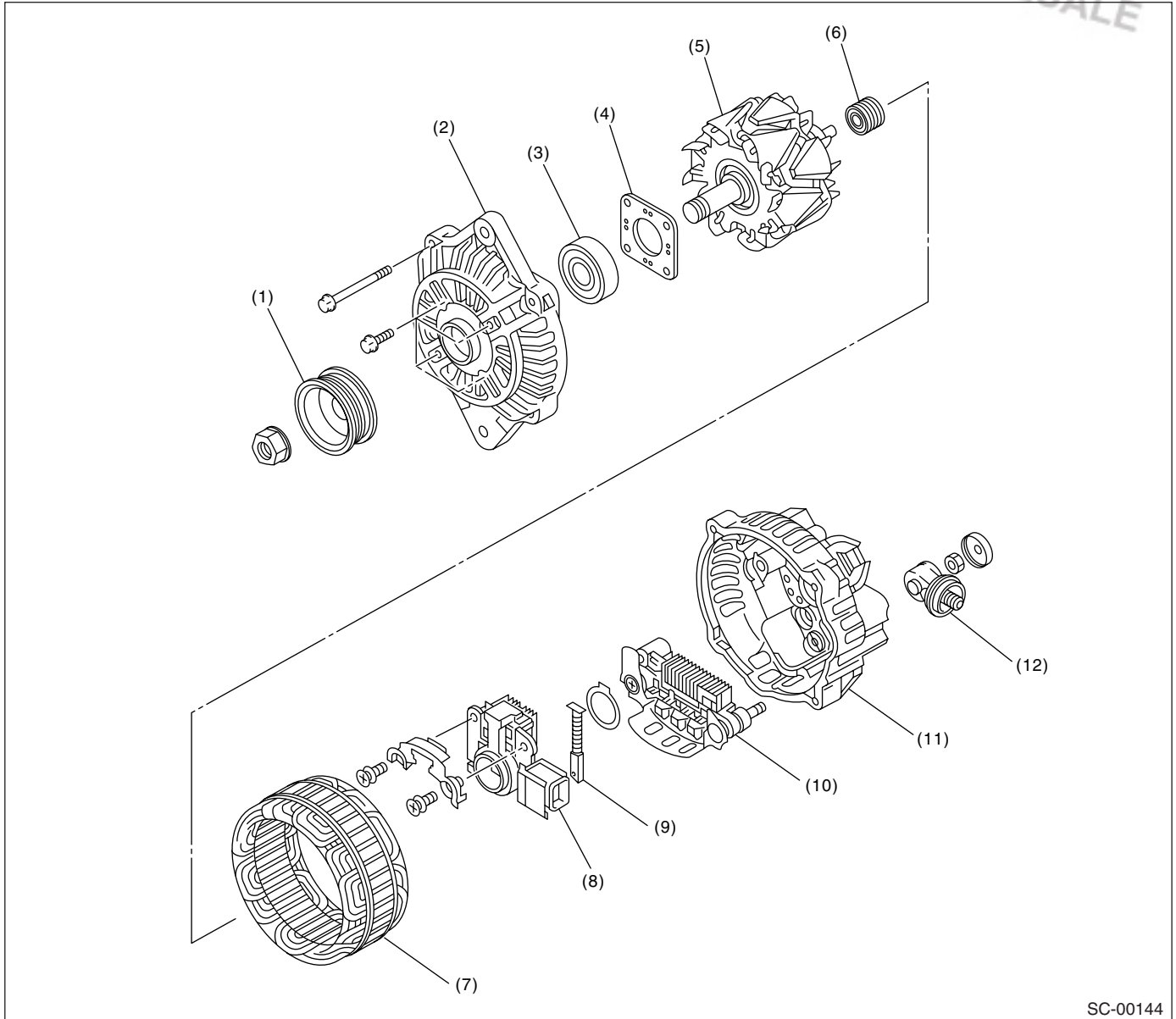

SC-00144

- | | | |
|----------------------|-----------------------------|-----------------|
| (1) Pulley | (5) Rotor | (9) Brush |
| (2) Front cover | (6) Bearing | (10) Rectifier |
| (3) Ball bearing | (7) Stator coil | (11) Rear cover |
| (4) Bearing retainer | (8) IC regulator with brush | (12) Terminal |

C: CAUTION

- Wear working clothing, including a cap, protective goggles, and protective shoes during operation.
- Remove contamination including dirt and corrosion before removal, installation or disassembly.
- Keep the disassembled parts in order and protect them from dust or dirt.
- Before removal, installation or disassembly, be sure to clarify the failure. Avoid unnecessary removal, installation, disassembly, and replacement.

- Be careful not to burn your hands, because each part on the vehicle is hot after running.
- Be sure to tighten fasteners including bolts and nuts to the specified torque.
- Place shop jacks or safety stands at the specified points.
- Before disconnecting electrical connectors of sensors or units, be sure to disconnect the ground cable from battery.

2. Starter

A: REMOVAL

1) Disconnect the ground cable from battery.

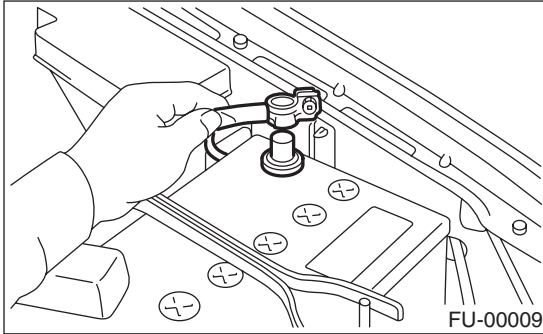

2) Remove the air cleaner case. (Non-turbo model)
<Ref. to IN(H4SO)-5, REMOVAL, Air Cleaner Case.>

3) Remove the intercooler. (Turbo model)
<Ref. to IN(H4DOTC)-10, REMOVAL, Intercooler.>

4) Remove the air cleaner case stay. (Non-turbo model)

- MT MODEL

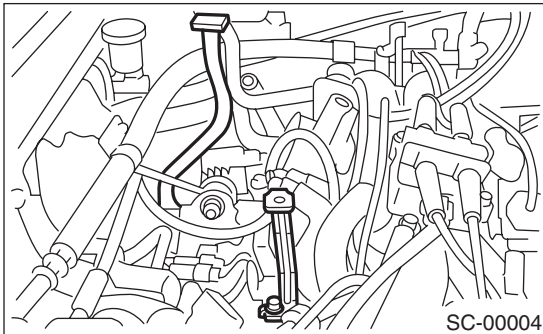

- AT MODEL

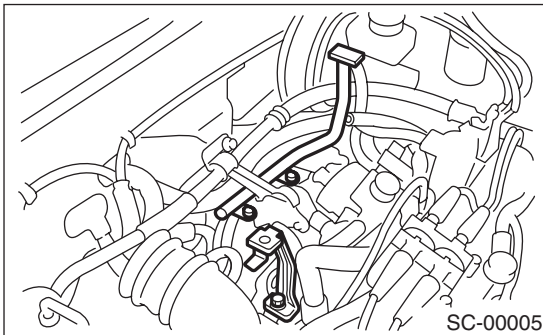

5) Disconnect the connector and terminal from starter.

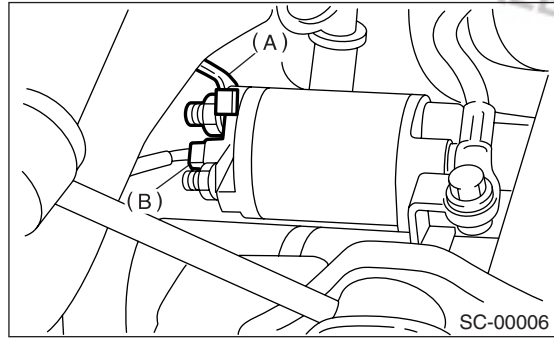

(A) Terminal
(B) Connector

6) Remove the starter from transmission.

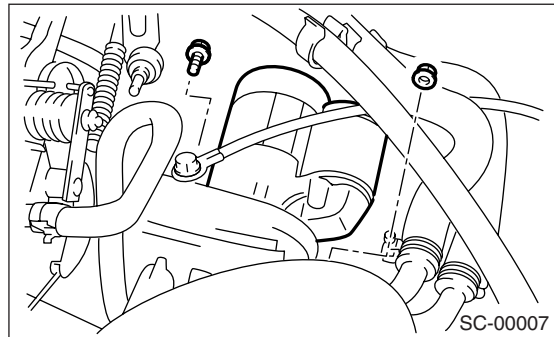

B: INSTALLATION

Install in the reverse order of removal.

Tightening torque:

50 N·m (5.1 kgf-m, 37 ft-lb)

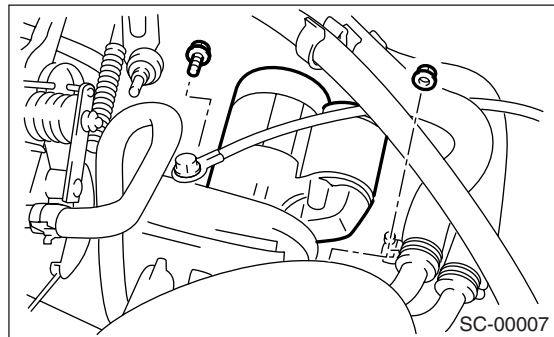

C: DISASSEMBLY

1. STARTER ASSEMBLY

1) Loosen the nut which holds the terminal M of switch assembly, and then disconnect the connector.

2) Remove the bolts which hold the switch assembly, and then remove switch assembly, plunger and plunger spring from starter as a unit.

Starter

STARTING/CHARGING SYSTEMS

NOTE:

Be careful because the pinion gap adjustment washer may sometimes be used on the mounting surface of switch assembly.

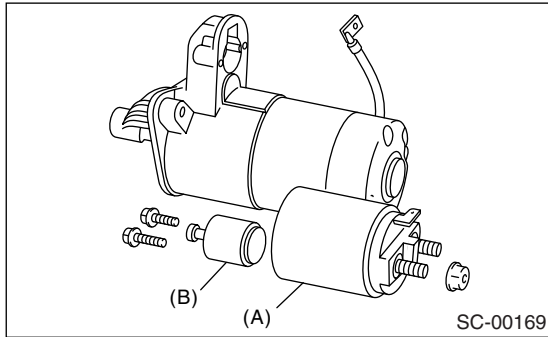

- (A) Switch assembly
- (B) Plunger

3) Remove both through-bolts and brush holder screws, and then detach the rear cover and brush holder.

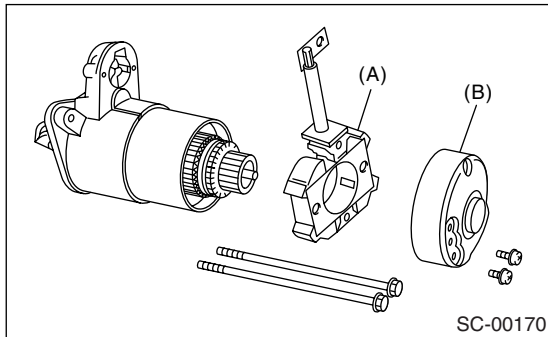

- (A) Brush holder
- (B) Rear cover

4) Remove the armature and yoke from front bracket. The ball used as a bearing will come off from the armature end.

NOTE:

Before removal of the yoke, put alignment marks on the yoke and front bracket.

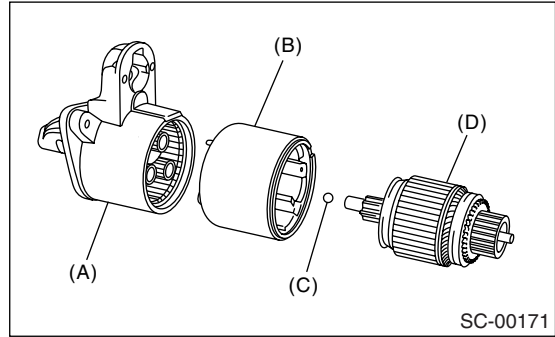

- (A) Front bracket
- (B) Yoke
- (C) Ball
- (D) Armature

5) Remove packing A, planetary gears, packing B and plate.

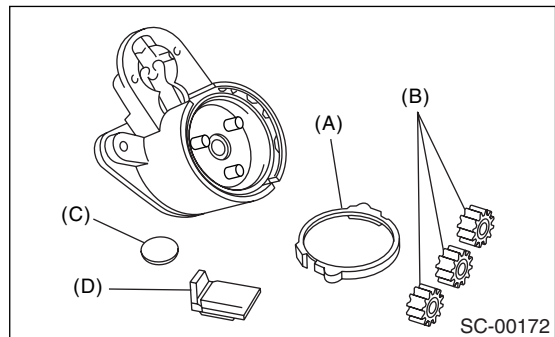

- (A) Packing A
- (B) Planetary gear
- (C) Plate
- (D) Packing B

6) Remove the shaft assembly and overrunning clutch as a unit.

NOTE:

Note the direction of the lever before removing.

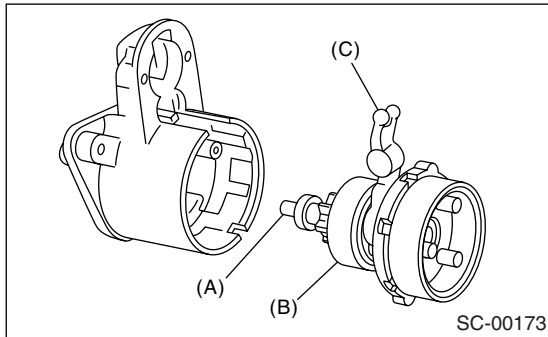

- (A) Shaft assembly
- (B) Overrunning clutch
- (C) Lever

7) Remove the overrunning clutch from shaft assembly as follows:

- (1) Remove the stopper from ring by lightly tapping the stopper with an appropriate tool (such as a fit socket wrench).
- (2) Remove the ring, stopper and clutch from shaft.

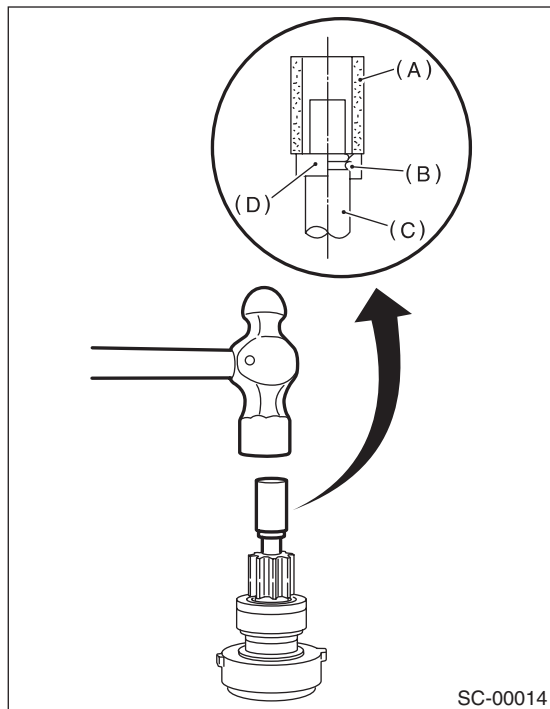

- (A) Socket wrench
- (B) Ring
- (C) Shaft
- (D) Stopper

2. BRUSH HOLDER

NOTE:

Only the brush holder of turbo MT model starter can be disassembled.

Slightly open the metal fitting while holding the insulating plate against the brush holder. Remove the insulating plate.

The brush and spring can be easily removed from the brush holder at this time.

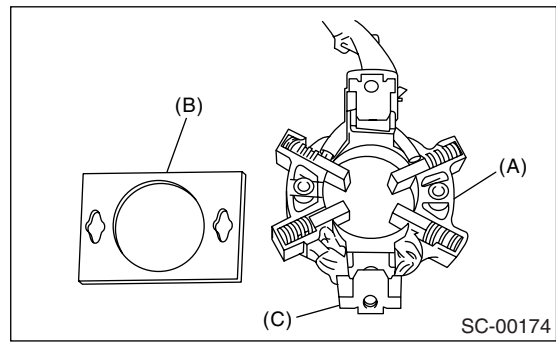

- (A) Brush holder
- (B) Insulating plate
- (C) Metal fitting

D: ASSEMBLY

- 1) Assemble in the reverse order of disassembly.
- 2) Apply grease to the following parts before assembly.

- Front and rear bracket sleeve bearings
- Armature shaft gear
- Outer periphery of plunger
- Mating surfaces of plunger and lever
- Gear shaft splines
- Mating surfaces of lever and clutch
- Ball at armature shaft end
- Planetary gear

E: INSPECTION

1. ARMATURE

- 1) Check the commutator for any sign of burns of rough surfaces or stepped wear. If wear is of a minor nature, correct it by using sand paper.
- 2) Run-out test

Check the commutator run-out, and then replace if it exceeds the limit.

Commutator run-out:

Standard

0.05 mm (0.0020 in)

Service limit

Less than 0.10 mm (0.0039 in)

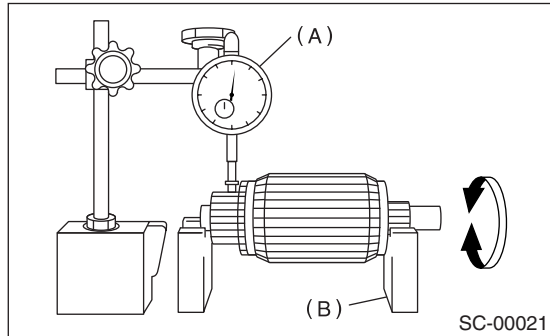

(A) Dial gauge
(B) V-block

3) Depth of segment mold

Check the depth of segment mold.

Depth of segment mold:

0.5 mm (0.020 in)

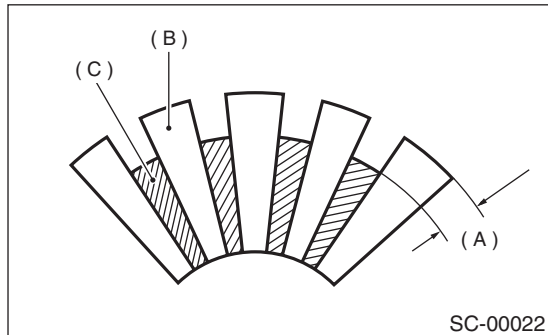

(A) Depth of mold
(B) Segment
(C) Mold

4) Armature short-circuit test

Check the armature for short-circuit by placing it on a growler tester. Hold an iron sheet against the armature core while slowly rotating armature. A short-circuited armature will cause the iron sheet to vibrate and to be attracted to core. If the iron sheet is attracted or vibrates, the armature, which is short-circuited, must be replaced or repaired.

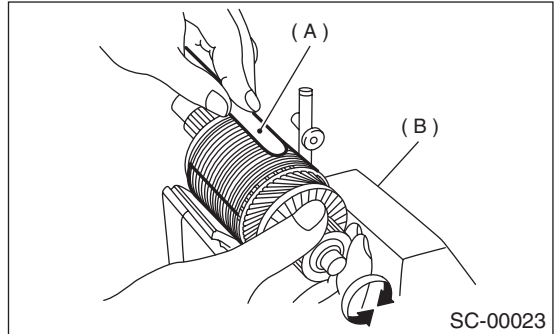

(A) Iron sheet
(B) Growler tester

5) Armature ground test

Using a circuit tester, touch one probe to the commutator segment and the other to shaft. There should be no continuity. If there is continuity, the armature is grounded.

Replace the armature if it is grounded.

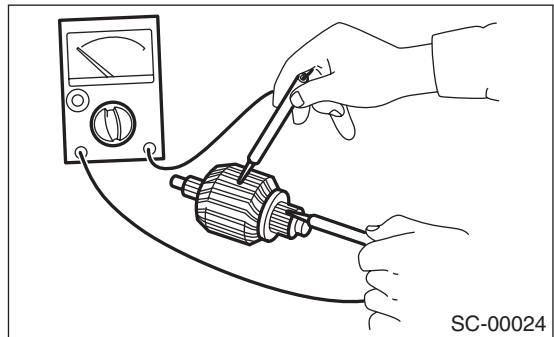

2. YOKE

Make sure the pole is set in position.

3. OVERRUNNING CLUTCH

Inspect the teeth of pinion for wear and damage. Replace if it is damaged. It is normal if the pinion rotates smoothly in direction of rotation (counterclockwise) and does not rotate in the opposite direction.

CAUTION:

Do not clean the overrunning clutch with oil to prevent grease from flowing out.

4. BRUSH AND BRUSH HOLDER

1) Brush length

Measure the brush length, and then replace if it is worn down to under the service limit.

Replace if abnormal wear or cracks are noticed.

Brush length:

Standard

12.3 mm (0.484 in)

Service limit

7.0 mm (0.276 in)

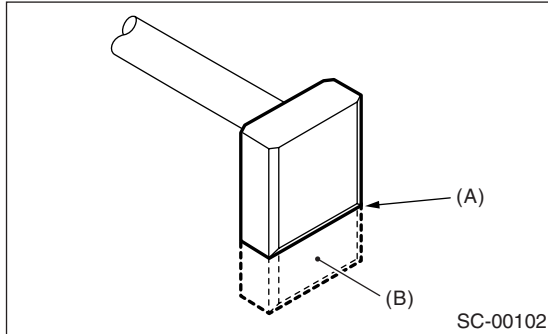

(A) Service limit line
(B) Brush

2) Brush movement

Be sure the brush moves smoothly inside brush holder.

3) Brush spring force

Measure the brush spring force with a spring scale. If it is less than the service limit, replace the brush holder.

Brush spring force:

Standard

Except DOHC turbo MT model

15.9 — 19.5 N (1.62 — 1.99 kgf, 3.57 — 4.38 lb) (when new)

DOHC turbo MT model

21.6 N (2.2 kgf, 4.9 lb) (when new)

Service limit

Except DOHC turbo MT model

2.5 N (0.25 kgf, 0.56 lb)

DOHC turbo MT model

5.9 N (0.6 kgf, 1.3 lb)

5. SWITCH ASSEMBLY

Using a circuit tester (set in “ohm”), check that there is continuity between terminals S and M, and between terminal S and ground.

Also check to be sure there is no continuity between terminals M and B.

Terminal/Specified resistance:

S — M/Less than 1 Ω

S — Ground/Less than 1 Ω

M — B/More than 1 MΩ

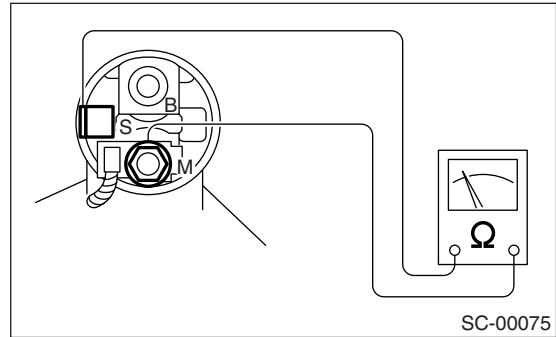

6. SWITCH ASSEMBLY OPERATION

1) Connect the terminal S of switch assembly to positive terminal of battery with a lead wire, and starter body to ground terminal of battery. The pinion should be forced endwise on shaft.

CAUTION:

With the pinion forced endwise on shaft, the starter motor may rotate because current flows through the pull-in coil to motor, however, this is not a problem.

2) Disconnect the connector from terminal M, and then connect the positive terminal of battery and terminal M using a lead wire and ground terminal to starter body.

In this test set up, the pinion should return to its original position even when it is pulled out with a screwdriver.

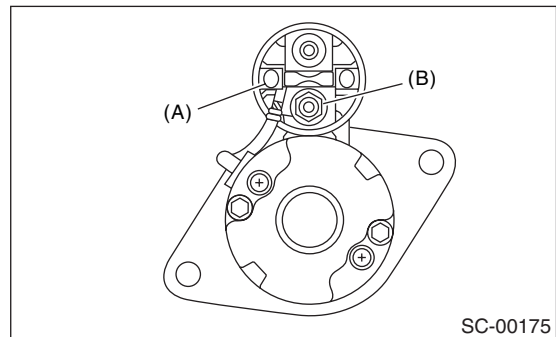

(A) Terminal S
(B) Terminal M

7. PINION GAP

1) Measure the pinion gap while the pinion is pulled out as shown in the figure.

Pinion gap:

0.5 — 2.0 mm (0.020 — 0.079 in)

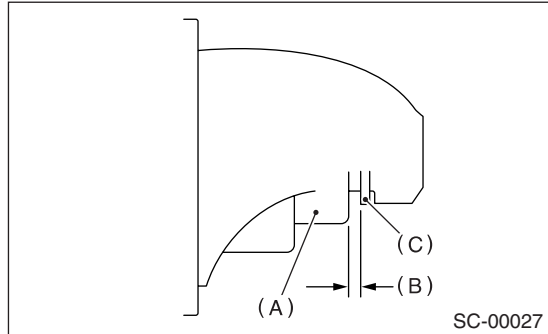

- (A) Pinion
- (B) Gap
- (C) Stopper

If the motor is running with the pinion forced end-wise on shaft, disconnect the connector from terminal M of switch assembly, and then connect terminal M to ground terminal (-) of battery with a lead wire. Next, gently push the pinion back with your fingertips, and then measure the pinion gap.

2) If the pinion gap is outside specified range, remove or add number of adjustment washers used on the mounting surface of switch assembly until correct pinion gap is obtained.

8. PERFORMANCE TEST

The starter should be submitted to performance tests whenever it has been overhauled, to assure its satisfactory performance when installed on the engine.

Three performance tests, no-load test, load test, and lock test, are presented here; however, if the load test and lock test cannot be performed, carry out at least the no-load test.

For these performance tests, use the circuit shown in figure.

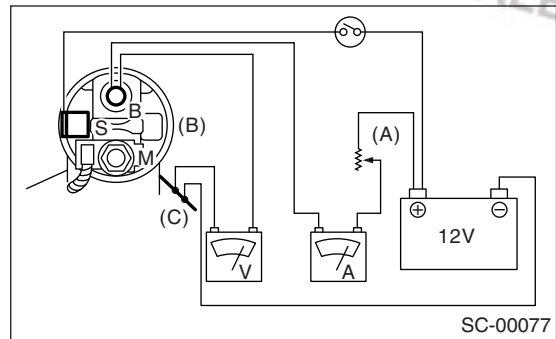

- (A) Variable resistor
- (B) Magnetic switch
- (C) Starter body

1) No-load test

With switch on, adjust the variable resistor to obtain 11 V, take the ammeter reading, and then measure the starter speed. Compare these values with the specifications.

No-load test (standards):

Voltage/Current

Non-turbo MT

MAX. 11 V/95 A

Turbo MT

MAX. 11 V/90 A

AT

MAX. 11 V/90 A

Rotating speed

Non-turbo MT

More than 2,500 rpm

Turbo MT

More than 2,860 rpm

AT

More than 2,000 rpm

2) Load test

Apply the specified braking torque to starter. The condition is satisfactory if the current draw and starter speed are within the specifications.

Load test (standards):

Voltage/Load

Non-turbo MT

7.5 V/8.84 N·m (0.90 kgf-m, 6.5 ft-lb)

Turbo MT

8 V/9.3 N·m (0.95 kgf-m, 6.9 ft-lb)

AT

7.7 V/16.7 N·m (1.70 kgf-m, 12.3 ft-lb)

Current/Speed

Non-turbo MT

More than 300 A/870 rpm

Turbo MT

More than 280 A/860 rpm

AT

More than 400 A/710 rpm

3) Lock test

With the starter stalled, or not rotating, measure the torque developed and current draw when the voltage is adjusted to the specified voltage.

Lock test (standards):

Voltage/Current

Non-turbo MT

Less than 4 V/680 A

Turbo MT

Less than 5 V/515 A

AT

Less than 3.5 V/960 A

Torque

Non-turbo MT

17 N·m (1.73 kgf-m, 12.5 ft-lb)

Turbo MT

16 N·m (1.63 kgf-m, 11.8 ft-lb)

AT

31 N·m (3.16 kgf-m, 22.9 ft-lb)

3. Generator

A: REMOVAL

1) Disconnect the ground cable from battery.

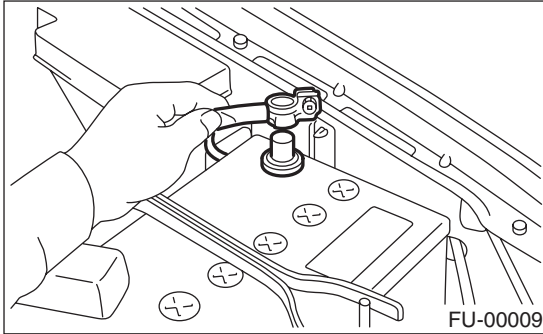

2) Disconnect the connector and terminal from generator.

- NON-TURBO MODEL

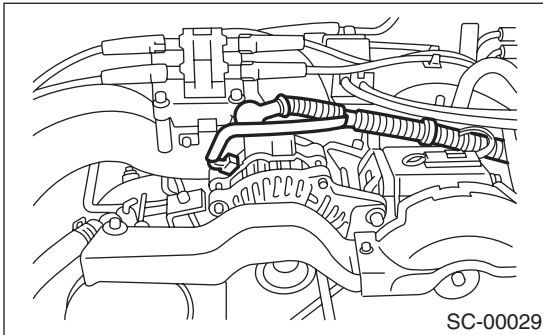

- TURBO MODEL

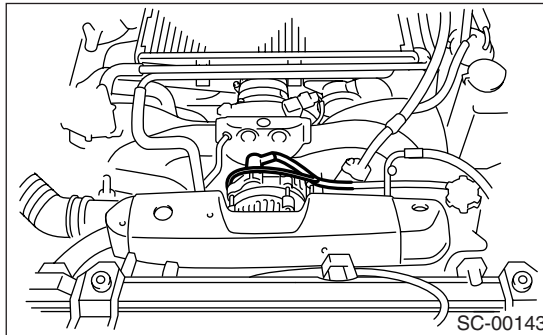

3) Remove the V-belt cover.

4) Remove the front side V-belt.

<Ref. to ME(H4SO)-39, FRONT SIDE BELT, REMOVAL, V-belt.> or <Ref. to ME(H4DOTC)-42, FRONT SIDE BELT, REMOVAL, V-belt.>

5) Remove the bolts which install generator onto bracket.

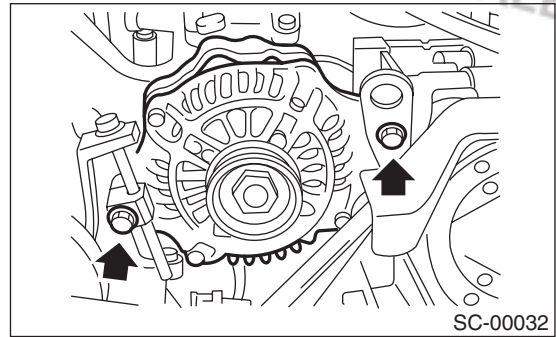

B: INSTALLATION

Install in the reverse order of removal.

Tightening torque:

25 N·m (2.5 kgf-m, 18.1 ft-lb)

CAUTION:

Check and adjust the V-belt tension. <Ref. to ME(H4SO)-40, INSPECTION, V-belt.> or <Ref. to ME(H4DOTC)-43, INSPECTION, V-belt.>

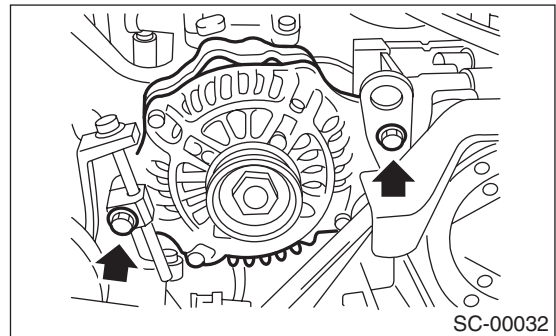

C: DISASSEMBLY

1) Remove the four through-bolts.

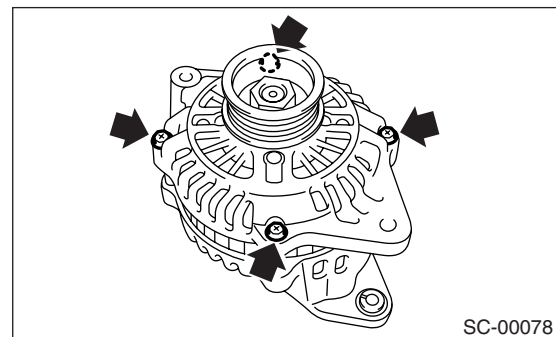

Generator

STARTING/CHARGING SYSTEMS

2) Heat portion (A) of rear cover to 50°C (122°F) with a heater drier.

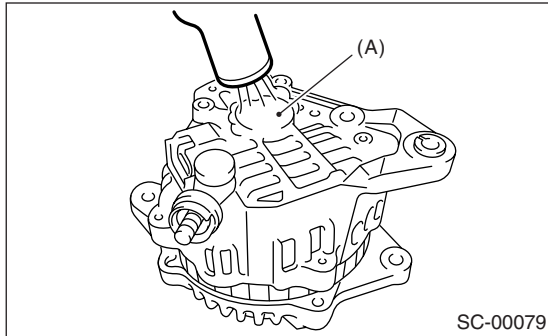

3) Then insert the tip of a flat tip screwdriver into the gap between stator core and front cover. Pry them apart to disassemble.

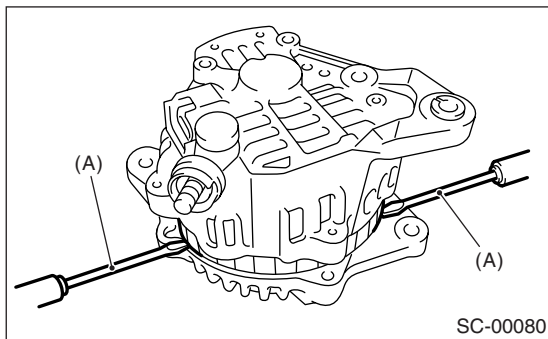

(A) Screwdriver

4) Hold the rotor with a vise and remove pulley nut.

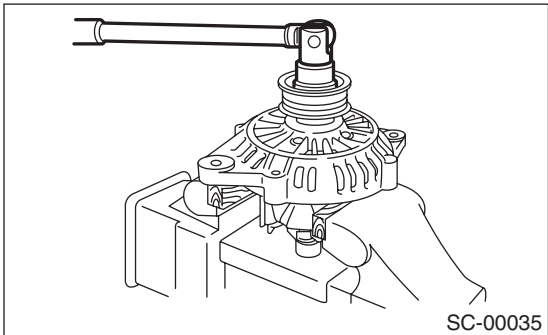

CAUTION:

When holding the rotor with a vise, place aluminum plates or wooden pieces on the vise jaws to prevent rotor from damage.

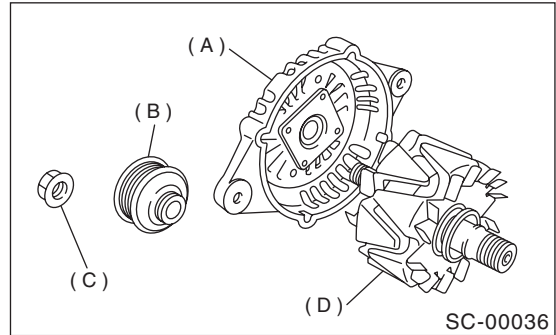

- (A) Front cover
- (B) Pulley
- (C) Nut
- (D) Rotor

5) Remove the ball bearing as follows.

(1) Remove the bolt, and then remove the bearing retainer.

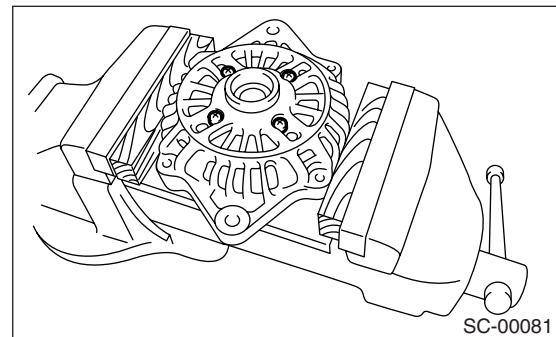

(2) Firmly install an appropriate tool (such as a fit socket wrench) to bearing inner race.

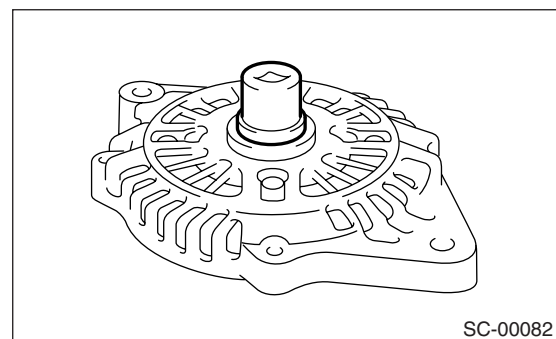

(3) Push the ball bearing off the front cover using a press.

Generator

STARTING/CHARGING SYSTEMS

6) Remove the bearing from rotor using a bearing puller.

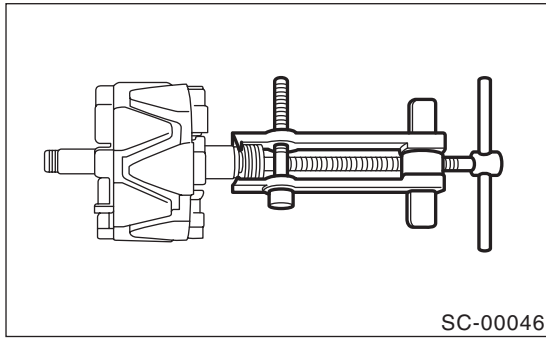

7) Unsolder connection between rectifier and stator coil to remove the stator coil.

CAUTION:

Do not allow a 180 — 270 W soldering iron to contact the terminals for more than 5 seconds at once because the rectifier cannot withstand so much heat.

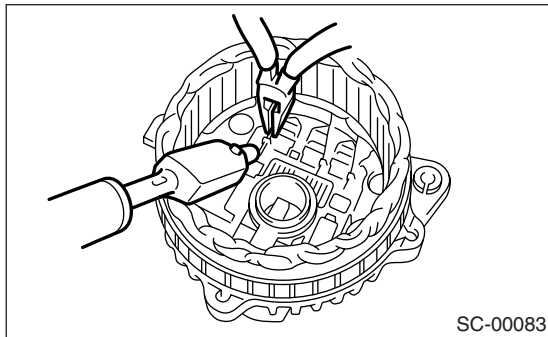

8) Remove the IC regulator as follows.
(1) Remove the screws which secure IC regulator to rear cover.

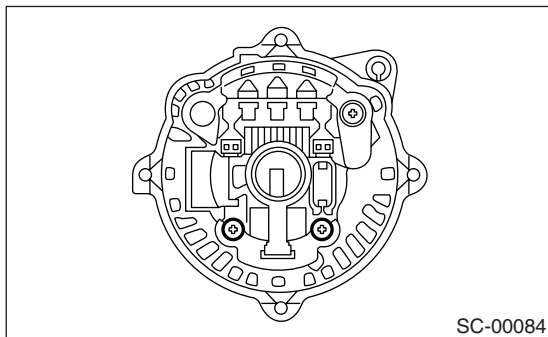

(2) Unsolder the connection between IC regulator and rectifier to remove the IC regulator.

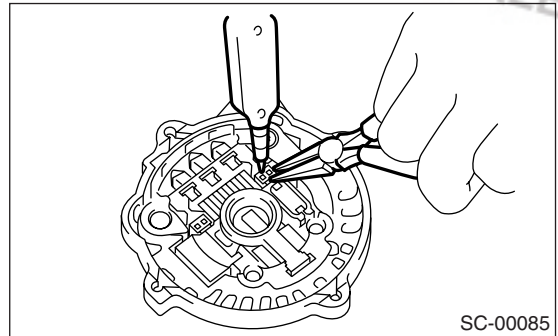

9) Remove the brush as follows.

(1) Remove cover A.

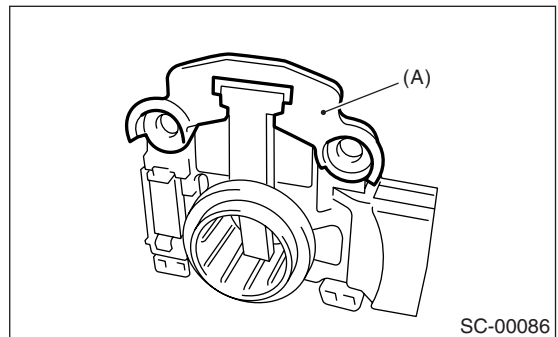

(2) Remove cover B.

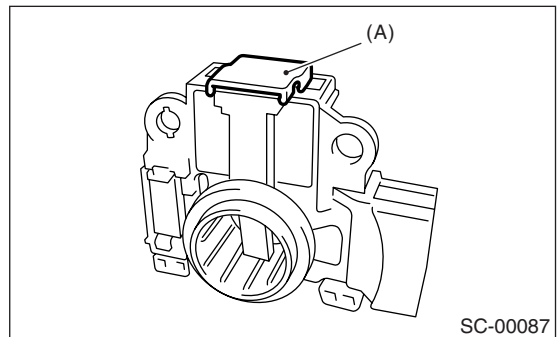

(3) Separate the brush from connection to remove.

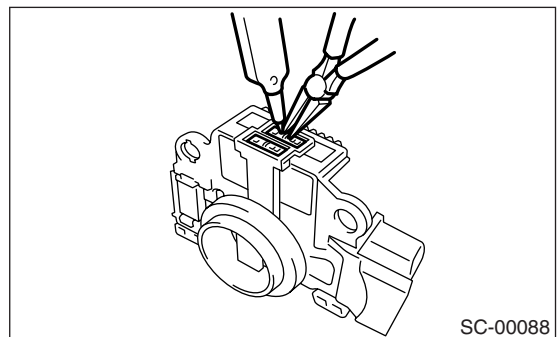

Generator

STARTING/CHARGING SYSTEMS

10) Remove the rectifier as follows.

(1) Remove the bolts which secure the rectifier.

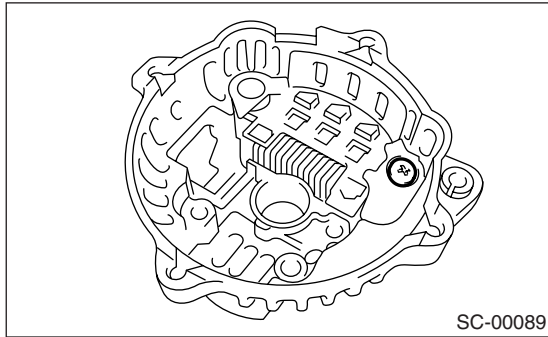

(2) Remove the cover of terminal B.

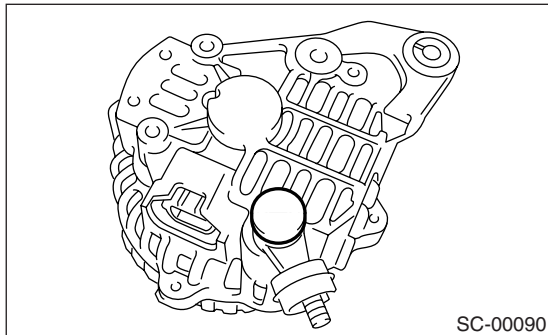

(3) Remove the nut of terminal B, and then remove the rectifier.



D: ASSEMBLY

Assemble in the reverse order of disassembly.

1) Pulling up brush

Before assembling, press the brush down into brush holder, and then fix them in that position by passing a [1 mm (0.08 in) dia. 40 to 50 mm (1.6 to 2.0 in) long] wire through the hole as shown in the figure.

CAUTION:

Be sure to remove the wire after reassembly.

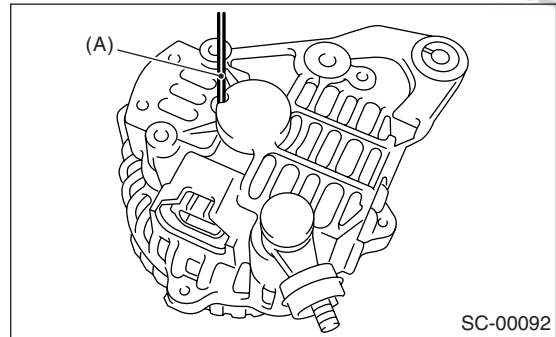

(A) Wire

2) Install the ball bearing.

(1) Set the ball bearing on the front cover, and then securely install an appropriate tool (such as a fit socket wrench) to the bearing outer race.

(2) Press the ball bearing into the specified position using a press.

(3) Install the bearing retainer.

3) Press the bearing (rear side) into the rotor shaft using a press to install.

4) Heat the bearing box in rear cover [50 to 60°C (122 to 140°F)], and then press the rear bearing into rear cover.

CAUTION:

Grease should not be applied to rear bearing. Remove the oil completely if it is found on bearing box.

5) After reassembly, turn the pulley by hand to check that rotor turns smoothly.

E: INSPECTION

1. DIODE

CAUTION:

Never use a mega tester (designed for reading high voltage) or any other similar instrument for this test; otherwise, the diodes may be damaged.

Generator

STARTING/CHARGING SYSTEMS

1) Checking positive diode

Check for continuity between the diode lead and positive side heat sink. The positive diode is in good condition if resistance is $1\ \Omega$ or less only in the direction from the diode lead to heat sink.

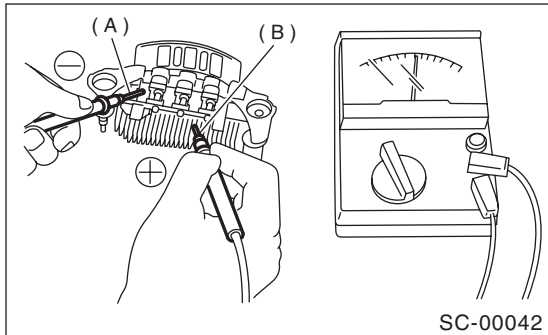

- (A) Diode lead
- (B) Heat sink (positive side)

2) Checking negative diode

Check for continuity between the negative side heat sink and diode lead. The negative diode is in good condition if resistance is $1\ \Omega$ or less only in the direction from the heat sink to diode lead.

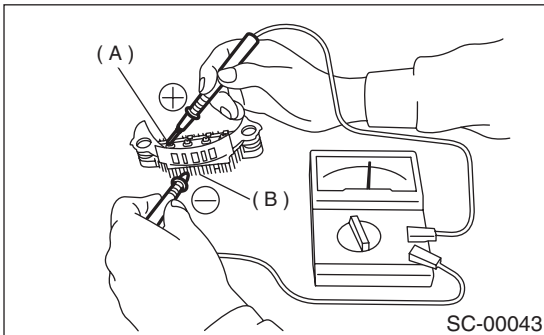

- (A) Diode lead
- (B) Heat sink (negative side)

3) Continuity test

Check the resistance between slip rings using circuit tester.

If the resistance is not within the specified range, replace the rotor assembly.

Specified resistance:

Approx. $1.8 - 2.2\ \Omega$

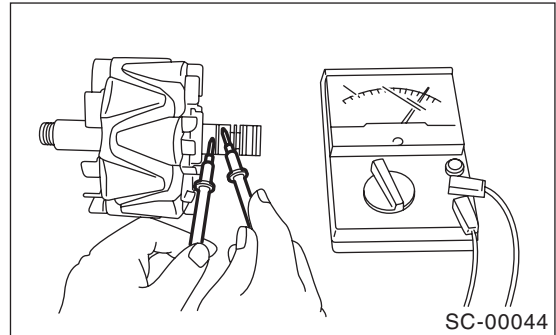

4) Insulation test

Check the continuity between slip ring and rotor core or shaft. If resistance is $1\ \Omega$ or less, the rotor coil is grounded, and so replace the rotor assembly.

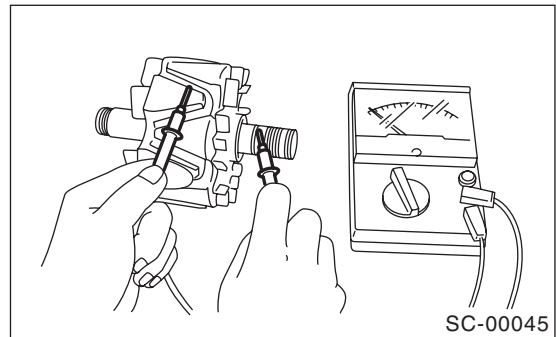

5) Ball bearing (rear side)

Check the rear ball bearing. Replace if it is noisy or if the rotor does not turn smoothly.

2. ROTOR

1) Slip ring surface

Inspect the slip rings for contamination or any roughness on the sliding surface. Repair the slip ring surface using a lathe or sand paper.

2) Slip ring outer diameter

Measure the slip ring outer diameter. If the slip ring is worn, replace the rotor assembly.

Slip ring outer diameter:

Standard

22.7 mm (0.894 in)

Limit

22.1 mm (0.870 in)

3. STATOR

1) Continuity test

Inspect the stator coil for continuity between each end of the lead wires. If resistance is $1\text{ M}\Omega$ or more, the lead wire is broken, and so replace the stator assembly.

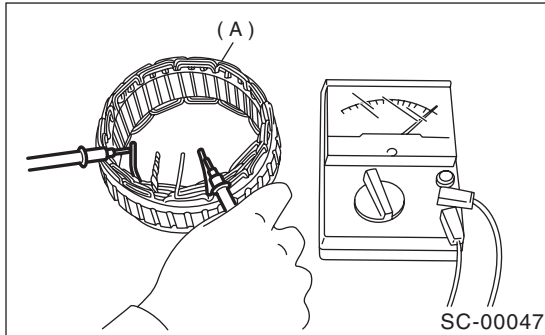

(A) Stator

2) Insulation test

Inspect the stator coil for continuity between stator core and each end of lead wire. If resistance is $1\ \Omega$ or less, the stator coil is grounded, and so replace the stator assembly.

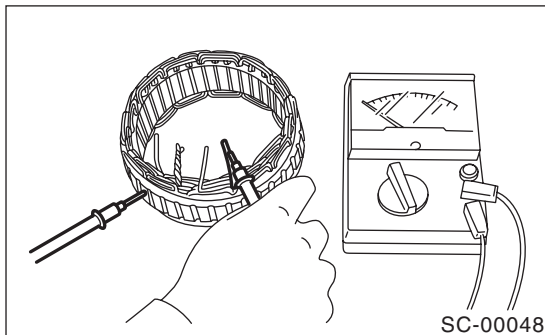

4. BRUSH

1) Measure the length of each brush. If wear exceeds the service limit, replace the brush. Each brush has the service limit mark (A) on it.

Brush length:

Standard

18.5 mm (0.728 in)

Service limit

5.0 mm (0.197 in)

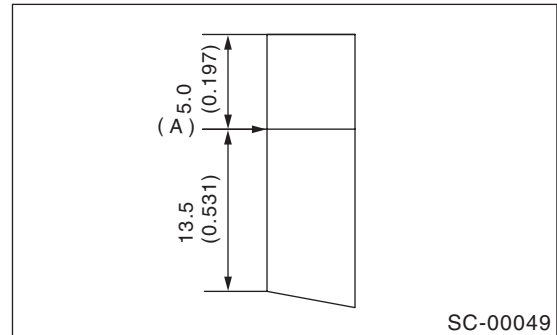

2) Checking brush spring for proper pressure

Using a spring pressure indicator, push the brush into the brush holder until its tip protrudes 2 mm (0.08 in). Then measure the pressure of brush spring. If the pressure is less than 2.648 N (270 g, 9.52 oz), replace the brush spring with a new one. The new spring must have a pressure of 4.609 to 5.786 N (470 to 590 g, 16.58 to 20.810 oz).

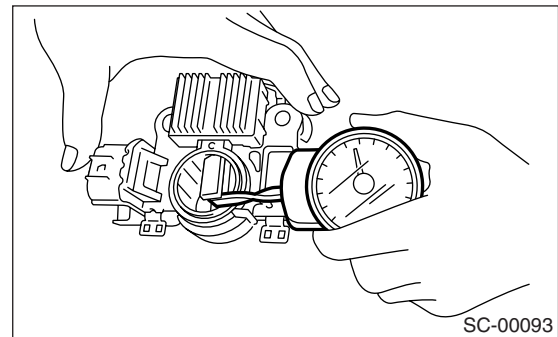

5. BEARING (FRONT SIDE)

Check the front ball bearing. If the resistance is felt while rotating, or if abnormal noise is heard, replace the ball bearing.

4. Battery

A: REMOVAL

- 1) Disconnect the positive (+) cable after disconnecting the ground (-) cable of battery.
- 2) Remove the flange nuts from battery rods, and then take off the battery holder.

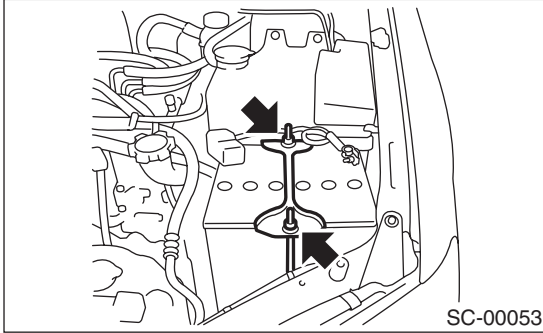

- 3) Remove the battery.

B: INSTALLATION

Install in the reverse order of removal.

Tightening torque:

3.4 N·m (0.35 kgf·m, 2.5 ft·lb)

NOTE:

- Clean the battery cable terminals, and then apply grease to retard formation of corrosion.
- Connect the positive (+) cable of battery and then the ground (-) cable of battery.

C: INSPECTION

WARNING:

- Electrolyte has toxicity; be careful handling the fluid.
- Avoid contact with skin, eyes or clothing. Especially at contact with eyes, flush with running water for 15 minutes and get prompt medical attention.
- Batteries produce explosive gasses. Keep sparks, flame, cigarettes away.
- Ventilate when charging or using in enclosed space.
- For safety, in case an explosion does occur, wear eye protection or shield your eyes when working near any battery. Never lean over a battery.
- Do not let the battery fluid contact eyes, skin, fabrics, or paint-work because battery fluid is corrosive acid.
- To lessen the risk of sparks, remove rings, metal watch-bands, and other metal jewelry. Never allow metal tools to contact the positive battery terminal and anything connected to it while you are at the same time in contact with any other metallic portion of the vehicle. This may cause a short circuit.

1. EXTERNAL PARTS:

Check for the existence of dirt or cracks on battery case, top cover, vent plugs, and terminal posts. If necessary, clean with water and wipe with a dry cloth.

Apply a thin coat of grease on the terminal posts to prevent corrosion.

2. ELECTROLYTE LEVEL:

Check the electrolyte level in each cell. If the level is below MIN LEVEL, bring the level to MAX LEVEL by pouring distilled water into the battery cell. Do not fill beyond MAX LEVEL.

3. SPECIFIC GRAVITY OF ELECTROLYTE:

- 1) Measure the specific gravity of electrolyte using a hydrometer and a thermometer.

Specific gravity varies with temperature of electrolyte so that it must be corrected at 20°C (68°F) using the following equation:

$$S_{20} = S_t + 0.0007 \times (t - 20)$$

S_{20} : Specific gravity corrected at electrolyte temperature of 20°C

S_t : Measured specific gravity

t : Measured temperature (°C)

Determine whether or not battery must be charged, according to corrected specific gravity.

Standard specific gravity: 1.220 — 1.290 [at 20°C (68°F)]

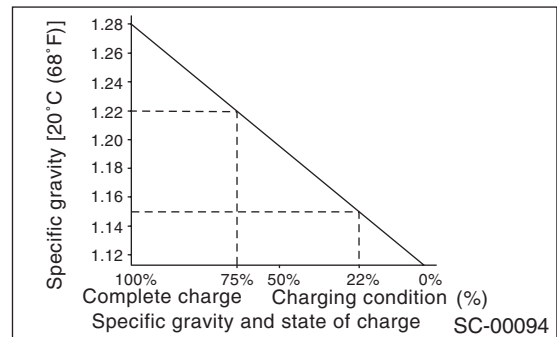

- 2) Measuring the specific gravity of the electrolyte in battery will disclose the state of charge of battery. The relation between specific gravity and state of charge is as shown in the figure.

D: MEASUREMENT

WARNING:

Do not bring an open flame close to the battery at this time.

CAUTION:

- Prior to charging, corroded terminals should be cleaned with a brush and common caustic soda solution.

- Be careful since the battery electrolyte overflows while charging the battery.
- Observe the instructions when handling battery charger.
- Before charging the battery on vehicle, disconnect battery ground terminal to prevent damage of generator diodes or other electrical units.

1. JUDGMENT OF BATTERY IN CHARGED CONDITION

1) Specific gravity of electrolyte is held within the specified range from 1.250 to 1.290 for more than one hour.

2) Voltage per battery cell is held at the specified range from 2.5 to 2.8 volts for more than one hour.

2. STATE OF CHARGE CHECK USING A HYDROMETER

Hydrometer indicator	State of charge	Corrective action
Green dot	Above 65%	Load test
Dark dot	Below 65%	Charge battery
Clear dot	Low electrolyte	Replace battery* (If cranking is difficult)

*: Check electrical system before replacement.

3. NORMAL CHARGING

Charge the battery at current value specified by manufacturer or at approx. 1/10 of the battery's ampere-hour rating.

4. QUICK CHARGING

Quick charging is a method in which the battery is charged in a short period of time with a relatively large current by using a quick charger.

Since a large current flow raises electrolyte temperature, the battery is subject to damage if large current is used for prolonged time. For this reason, the quick charging must be carried out within a current range that will not increase the electrolyte temperature above 40°C (104°F).

It should be also remembered that the quick charging is a temporary means to bring battery voltage up to a fair value and, as a rule, a battery should be charged slowly with a low current.

CAUTION:

- Observe the items in 3. NORMAL CHARGING.
- Never use more than 10 amperes when charging the battery because that will shorten battery life.

Brought to you by Eris Studios
NOT FOR RESALE