

Brought to you by Eris Studios
NOT FOR RESALE

MANUAL TRANSMISSION AND DIFFERENTIAL 5-SPEED (5MT)

GENERAL DESCRIPTION

MANUAL TRANSMISSION AND DIFFERENTIAL

1. General Description

A: SPECIFICATIONS

1. MANUAL TRANSMISSION AND DIFFERENTIAL

Model		2.5 L		2.0 L Turbo
		Sedan	Wagon	
Type		5-forward speeds with synchromesh and 1-reverse		
Transmission gear ratio		1st	3.454	3.454
		2nd	2.062	1.947
		3rd	1.448	1.366
		4th	1.088	0.972
		5th	0.780	0.738
		Reverse	3.333	
Front reduction gear	Final	Type of gear	Hypoid	
		Gear ratio	4.111	3.900
Rear reduction gear	Transfer	Type of gear	Helical	
		Gear ratio	1.000	1.100
	Final	Type of gear	Hypoid	
		Gear ratio	4.111	3.900
Front differential	Type and number of gear		Straight bevel gear (Bevel pinion: 2, Bevel gear: 2)	
Center differential	Type and number of gear		Straight bevel gear (Bevel pinion: 2, Bevel gear: 2 and viscous coupling)	
Transmission gear oil		GL-5		
Transmission oil capacity		3.5 ℓ (3.7 US qt, 3.1 Imp qt)		

2. TRANSMISSION GEAR OIL

Recommended oil

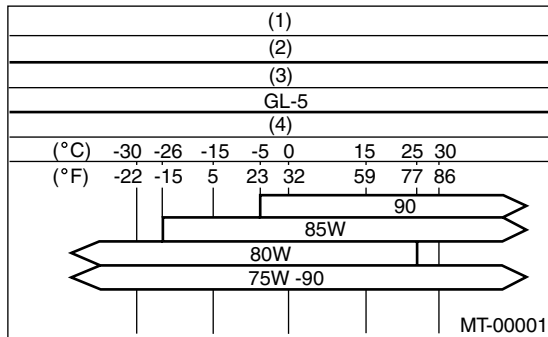

- (1) Item
- (2) Transmission gear oil
- (3) API classification
- (4) SAE viscosity No. and applicable temperature

GENERAL DESCRIPTION

MANUAL TRANSMISSION AND DIFFERENTIAL

3. TRANSMISSION CASE ASSEMBLY

Drive pinion shim adjustment

Hypoid gear backlash

0.13 — 0.18 mm (0.0051 — 0.0071 in)

Drive pinion shim			
Part No.	Thickness mm (in)	Part No.	Thickness mm (in)
32295AA031	0.150 (0.0059)	32295AA071	0.250 (0.0098)
32295AA041	0.175 (0.0069)	32295AA081	0.275 (0.0108)
32295AA051	0.200 (0.0079)	32295AA091	0.300 (0.0118)
32295AA061	0.225 (0.0089)	32295AA101	0.500 (0.0197)

Selection of main shaft rear plate

Main shaft rear plate		
Dimension "A" mm (in)	Part No.	Mark
4.00 — 4.13 (0.1575 — 0.1626)	32294AA041	1
3.87 — 3.99 (0.1524 — 0.1571)	32294AA051	2

4. DRIVE PINION ASSEMBLY

Preload adjustment of thrust bearing

Starting torque

0.3 — 0.8 N·m (0.03 — 0.08 kgf·m, 0.2 — 0.6 ft·lb)

Adjusting washer No. 1	
Part No.	Thickness mm (in)
803025051	3.925 (0.1545)
803025052	3.950 (0.1555)
803025053	3.975 (0.1565)
803025054	4.000 (0.1575)
803025055	4.025 (0.1585)
803025056	4.050 (0.1594)
803025057	4.075 (0.1604)

Adjusting washer No. 2	
Part No.	Thickness mm (in)
803025059	3.850 (0.1516)
803025054	4.000 (0.1575)
803025058	4.150 (0.1634)

5. MAIN SHAFT

Snap ring (Outer-25) to synchronizer hub clearance

0.060 — 0.100 mm (0.0024 — 0.0039 in)

Snap ring (Outer-25)			
Part No.	Thickness mm (in)	Part No.	Thickness mm (in)
805025051	2.42 (0.0953)	805025055	2.62 (0.1031)
805025052	2.47 (0.0972)	805025056	2.67 (0.1051)
805025053	2.52 (0.0992)	805025057	2.72 (0.1071)
805025054	2.57 (0.1012)	805025058	2.37 (0.0933)

6. REVERSE IDLER GEAR

Adjustment of reverse idler gear position

Reverse idler gear to transmission case (LH) wall clearance

6.0 — 7.5 mm (0.236 — 0.295 in)

Reverse shifter lever		
Part No.	Mark	Remarks
32820AA070	7	Further from case wall
32820AA080	8	Standard
32820AA090	9	Closer to the case wall

After installing a suitable reverse shifter lever, adjust the reverse idler gear to transmission case wall clearance to within 0 to 0.5 mm (0 to 0.020 in) using washers.

Washer (20.5 × 26 × t)			
Part No.	Thickness mm (in)	Part No.	Thickness mm (in)
803020151	0.4 (0.016)	803020154	1.9 (0.075)
803020152	1.1 (0.043)	803020155	2.3 (0.091)
803020153	1.5 (0.059)	—	—

GENERAL DESCRIPTION

MANUAL TRANSMISSION AND DIFFERENTIAL

7. SHIFTER FORK AND ROD

Select the suitable shifter forks so that both coupling sleeve and reverse driven gear are positioned in the center of their synchromesh mechanisms.

Rod end clearance

A: 1st-2nd — 3rd-4th

0.4 — 1.4 mm (0.016 — 0.055 in)

B: 3rd-4th — 5th

0.5 — 1.3 mm (0.020 — 0.051 in)

1st-2nd shifter fork		
Part No.	Mark	Remarks
32804AA060	1	Approach to 1st gear by 0.2 mm (0.008 in)
32804AA070	No mark	Standard
32804AA080	3	Approach to 2nd gear by 0.2 mm (0.008 in)

3rd-4th shifter fork		
Part No.	Mark	Remarks
32810AA061	1	Approach to 4th gear by 0.2 mm (0.008 in)
32810AA071	No mark	Standard
32810AA101	3	Approach to 3rd gear by 0.2 mm (0.008 in)

5th shifter fork (Non-turbo model)		
Part No.	Mark	Remarks
32812AA201	4	Approach to 5th gear by 0.2 mm (0.008 in)
32812AA211	5	Standard
32812AA221	6	Become distant from 5th gear by 0.2 mm (0.008 in)

5th shifter fork (Turbo model)		
Part No.	Mark	Remarks
32812AA231	7	Approach to 5th gear by 0.2 mm (0.008 in)
32812AA241	No mark	Standard
32812AA251	9	Become distant from 5th gear by 0.2 mm (0.008 in)

8. TRANSFER CASE OR REAR CASE

Neutral position adjustment

Adjustment shim	
Part No.	Thickness mm (in)
32190AA000	0.15 (0.0059)
32190AA010	0.30 (0.0118)

Reverse accent shaft		
Part No.	Mark	Remarks
32188AA090	3	Neutral position is closer to 1st.
32188AA100	0	Standard
32188AA110	1	Neutral position is closer to reverse gear.

Reverse check plate adjustment

Reverse check plate			
Part No.	Mark	Angle θ	Remarks
32189AA000	0	28°	Arm stops closer to 5th gear.
32189AA010	1	31°	Arm stops closer to 5th gear.
33189AA020	2	34°	Arm stops in the center.
32189AA030	3	37°	Arm stops closer to reverse gear.
32189AA040	4	40°	Arm stops closer to reverse gear.

GENERAL DESCRIPTION

MANUAL TRANSMISSION AND DIFFERENTIAL

9. EXTENSION ASSEMBLY

Thrust washer (50 × 61 × t) to taper roller bearing table outer race side clearance

0.2 — 0.3 mm (0.0008 — 0.012 in)

NOTE:

Be sure to keep the clearance within specifications.

Thrust washer (50 × 61 × t)	
Part No.	Thickness mm (in)
803050060	0.50 (0.0197)
803050061	0.55 (0.0217)
803050062	0.60 (0.0236)
803050063	0.65 (0.0256)
803050064	0.70 (0.0276)
803050065	0.75 (0.0295)
803050066	0.80 (0.0315)
803050067	0.85 (0.0335)
803050068	0.90 (0.0354)
803050069	0.95 (0.0374)
803050070	1.00 (0.0394)
803050071	1.05 (0.0413)
803050072	1.10 (0.0433)
803050073	1.15 (0.0453)
803050074	1.20 (0.0472)
803050075	1.25 (0.0492)
803050076	1.30 (0.0512)
803050077	1.35 (0.0531)
803050078	1.40 (0.0551)
803050079	1.45 (0.0571)

Thrust washer to center differential side clearance

0.15 — 0.35 mm (0.0059 — 0.0138 in)

Thrust washer	
Part No.	Thickness mm (in)
803036050	0.9 (0.035)
803036054	1.0 (0.039)
803036051	1.1 (0.043)
803036055	1.2 (0.047)
803036052	1.3 (0.051)
803036056	1.4 (0.055)
803036053	1.5 (0.059)
803036057	1.6 (0.063)
803036058	1.7 (0.067)

10. FRONT DIFFERENTIAL

Bevel gear to pinion backlash

0.13 — 0.18 mm (0.0051 — 0.0071 in)

Washer (38.1 × 50 × t)			
Part No.	Thickness mm (in)	Part No.	Thickness mm (in)
803038021	0.925 — 0.950 (0.0364 — 0.0374)	803038023	1.025 — 1.050 (0.0404 — 0.0413)
803038022	0.975 — 1.000 (0.0384 — 0.0394)	—	—

Pinion shaft to axle drive shaft clearance

0 — 0.2 mm (0 — 0.008 in)

Snap ring (Outer-28)			
Part No.	Thickness mm (in)	Part No.	Thickness mm (in)
805028011	1.05 (0.0413)	805028012	1.20 (0.0472)

11. TRANSFER DRIVE GEAR

Snap ring (Outer-30) to ball bearing clearance

0.01 — 0.15 mm (0.0004 — 0.0059 in)

Snap ring (Outer-30)	
Part No.	Thickness mm (in)
805030041	1.53 (0.0602)
805030042	1.65 (0.0650)
805030043	1.77 (0.0697)

GENERAL DESCRIPTION

MANUAL TRANSMISSION AND DIFFERENTIAL

B: COMPONENT

1. TRANSMISSION CASE

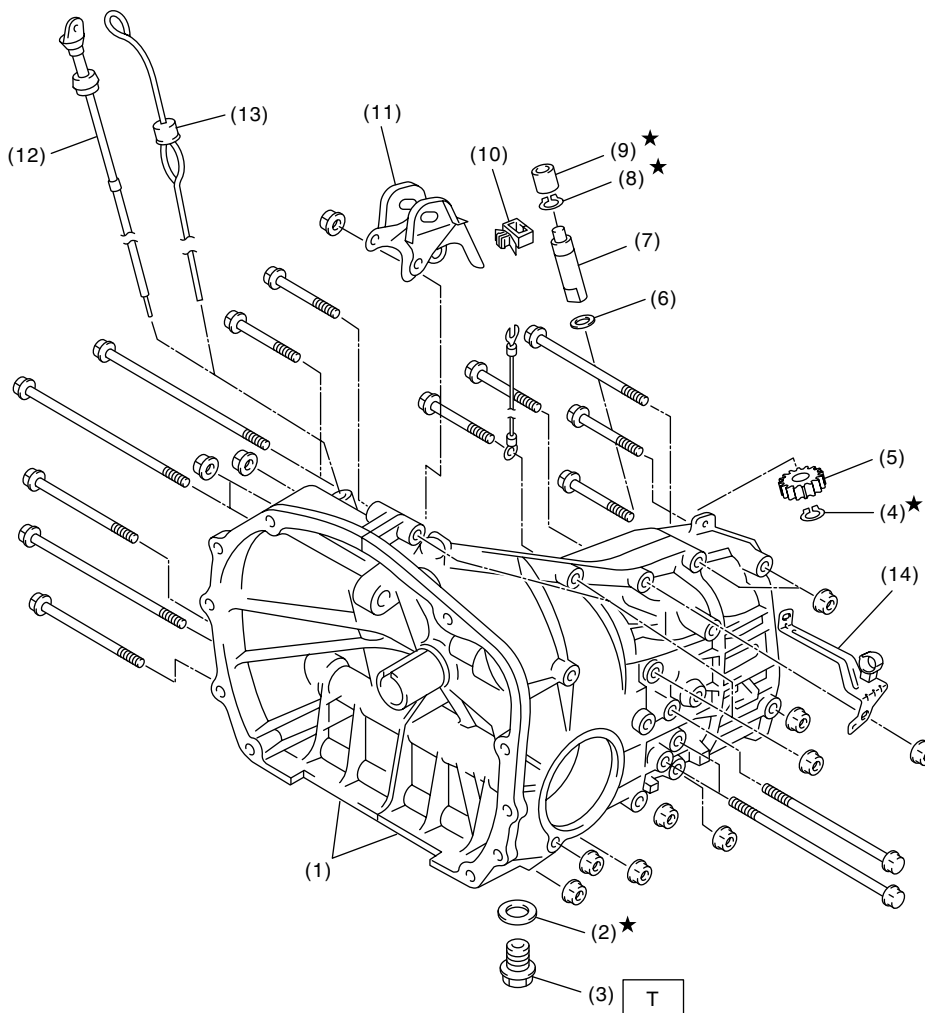

MT-00974

GENERAL DESCRIPTION

MANUAL TRANSMISSION AND DIFFERENTIAL

- | | | |
|-----------------------------|--|--|
| (1) Transmission case ASSY | (7) Speedometer shaft | (13) Oil level gauge (Turbo model) |
| (2) Gasket | (8) Snap ring (Outer) | (14) Harness bracket (Non-turbo model) |
| (3) Drain plug | (9) Oil seal | |
| (4) Snap ring (Outer) | (10) Clamp | |
| (5) Speedometer driven gear | (11) Pitching stopper bracket | |
| (6) Washer | (12) Oil level gauge (Non-turbo model) | |

Tightening torque: N-m (kgf-m, ft-lb)

T: 69 (7.0, 50.6)

• Transmission case tightening torque

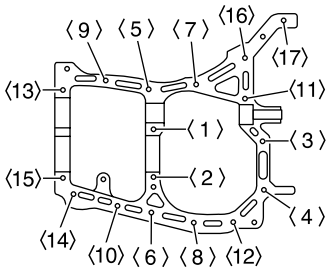
 <p>MT-00003</p>	Bolt No.	Bolt size	Tightening torque: N-m (kgf-m, ft-lb)
	<5> to <15>	8 mm	24.5 (2.5, 18.1)
	<1> to <4> <16>, <17>	10 mm	39 (4.0, 28.9)

GENERAL DESCRIPTION

MANUAL TRANSMISSION AND DIFFERENTIAL

2. DRIVE PINION ASSEMBLY

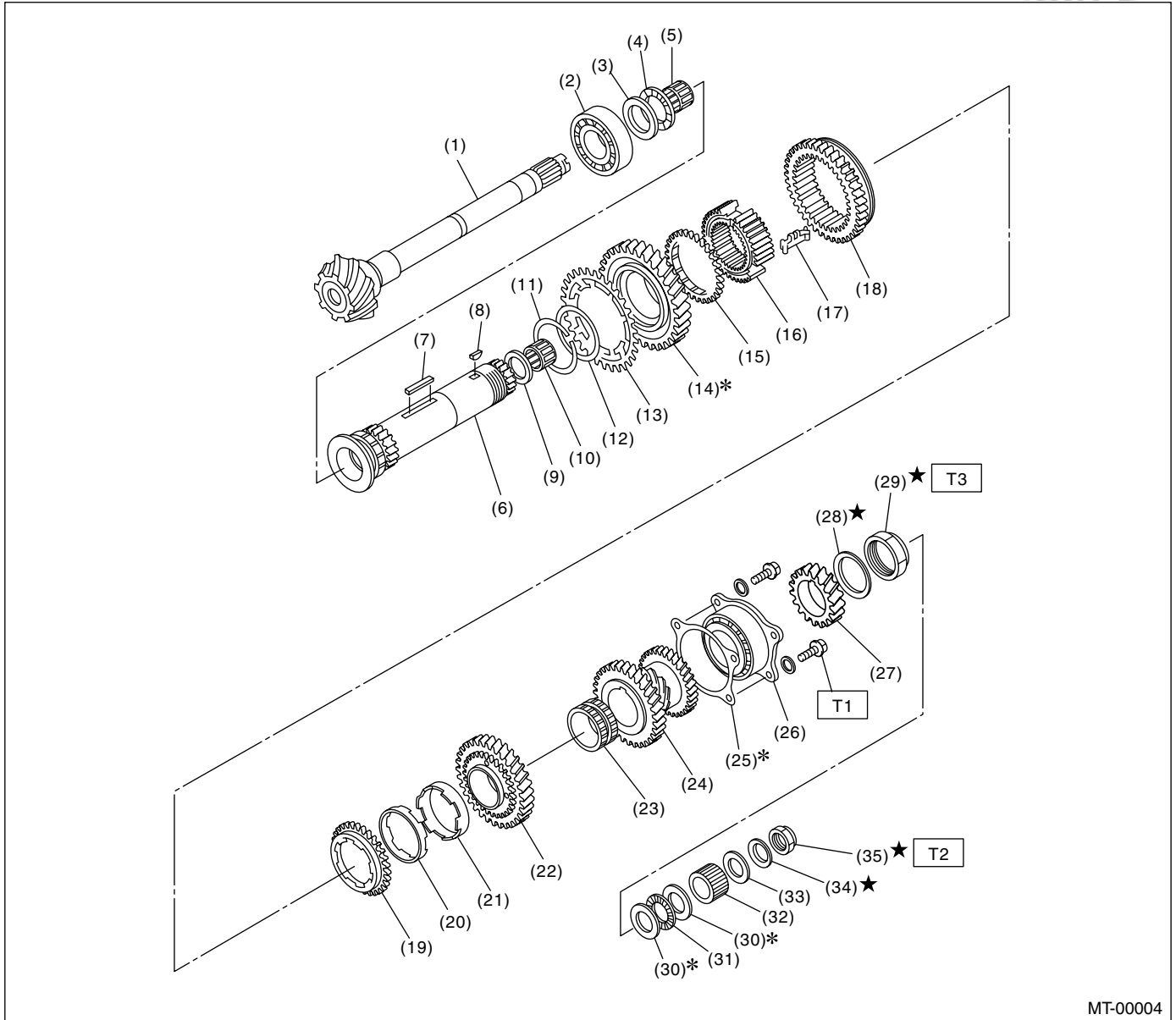

MT-00004

(1) Drive pinion shaft	(15) Baulk ring	(28) Lock washer
(2) Roller bearing	(16) 1st-2nd synchronizer hub	(29) Lock nut
(3) Washer	(17) Insert key	(30) Washer
(4) Thrust bearing	(18) Reverse driven gear	(31) Thrust bearing
(5) Needle bearing	(19) Outer baulk ring	(32) Differential bevel gear sleeve
(6) Driven shaft	(20) Synchro cone	(33) Washer
(7) Key	(21) Inner baulk ring	(34) Lock washer
(8) Woodruff key	(22) 2nd driven gear	(35) Lock nut
(9) Drive pinion collar	(23) 2nd driven gear bush	
(10) Needle bearing	(24) 3rd-4th driven gear	
(11) Snap ring (Outer)	(25) Driven pinion shim	
(12) Washer	(26) Roller bearing	
(13) Sub gear	(27) 5th driven gear	
(14) 1st driven gear		

Tightening torque: N·m (kgf·m, ft·lb)

T1: 30.5 (3.1, 22.5)

T2: 120 (12.2, 88.5)

T3: 260 (26.5, 191.7)

GENERAL DESCRIPTION

MANUAL TRANSMISSION AND DIFFERENTIAL

3. MAIN SHAFT ASSEMBLY

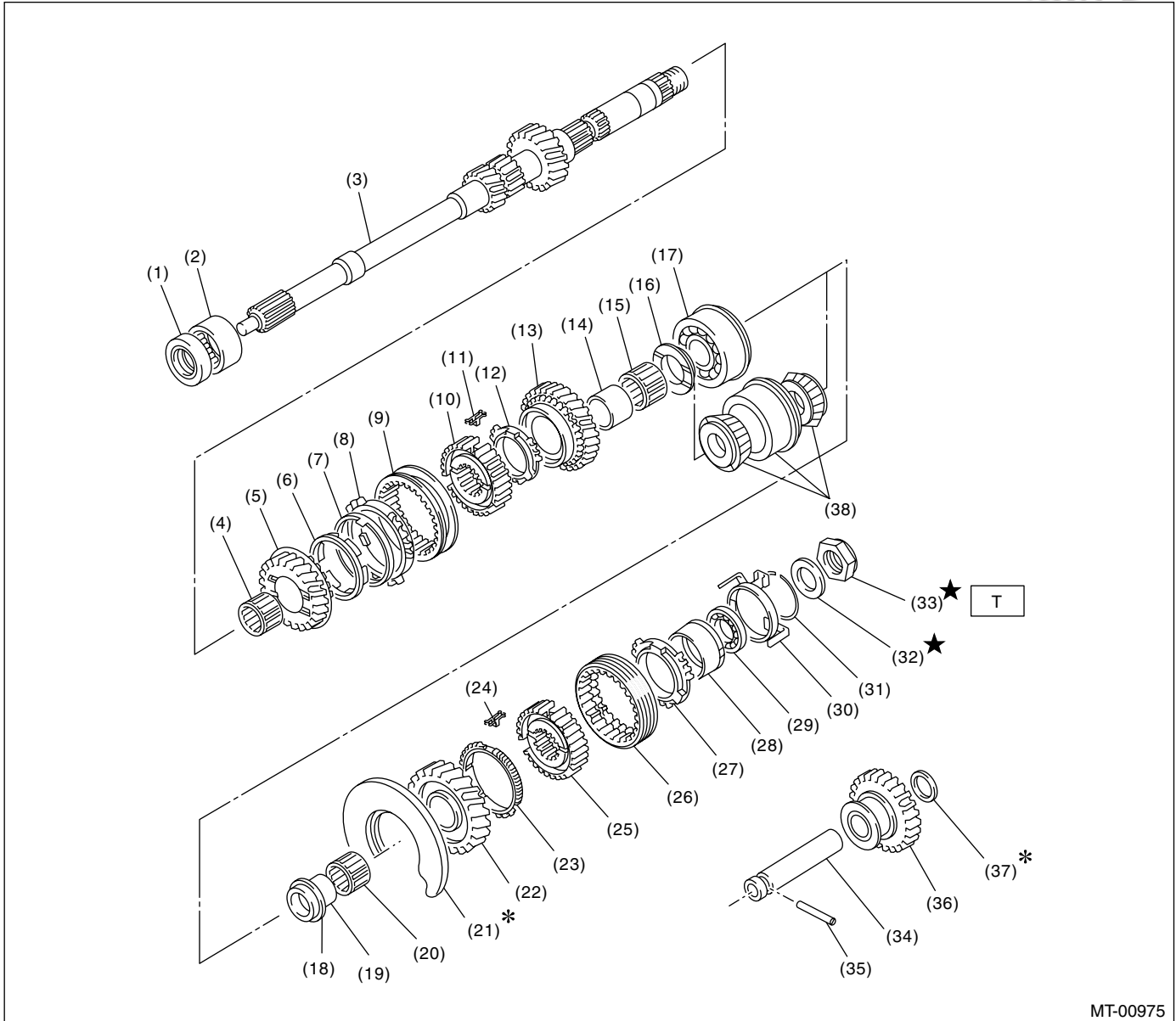

MT-00975

- | | | |
|----------------------------------|-------------------------------------|---|
| (1) Oil seal | (15) Needle bearing | (29) Ball bearing |
| (2) Needle bearing | (16) 4th gear thrust washer | (30) Synchro cone stopper |
| (3) Transmission main shaft | (17) Ball bearing (Non-turbo model) | (31) Snap ring |
| (4) Needle bearing | (18) 5th gear thrust washer | (32) Lock washer |
| (5) 3rd drive gear | (19) 5th needle bearing race | (33) Lock nut |
| (6) Inner baulk ring | (20) Needle bearing | (34) Reverse idler gear shaft |
| (7) 3rd synchro cone | (21) Main shaft rear plate | (35) Straight pin |
| (8) Outer baulk ring | (22) 5th drive gear | (36) Reverse idler gear |
| (9) 3rd-4th coupling sleeve | (23) 5th baulk ring | (37) Washer |
| (10) 3rd-4th synchronizer hub | (24) 5th-Rev shifting insert key | (38) Taper roller bearing (Turbo model) |
| (11) 3rd-4th shifting insert key | (25) 5th-Rev synchronizer hub | |
| (12) 4th baulk ring | (26) 5th-Rev coupling sleeve | |
| (13) 4th drive gear | (27) Rev baulk ring | |
| (14) 4th needle bearing race | (28) Rev synchro cone | |

Tightening torque: N-m (kgf-m, ft-lb)

T: 120 (12.2, 88.5)

GENERAL DESCRIPTION

MANUAL TRANSMISSION AND DIFFERENTIAL

4. SHIFTER FORK AND SHIFTER ROD

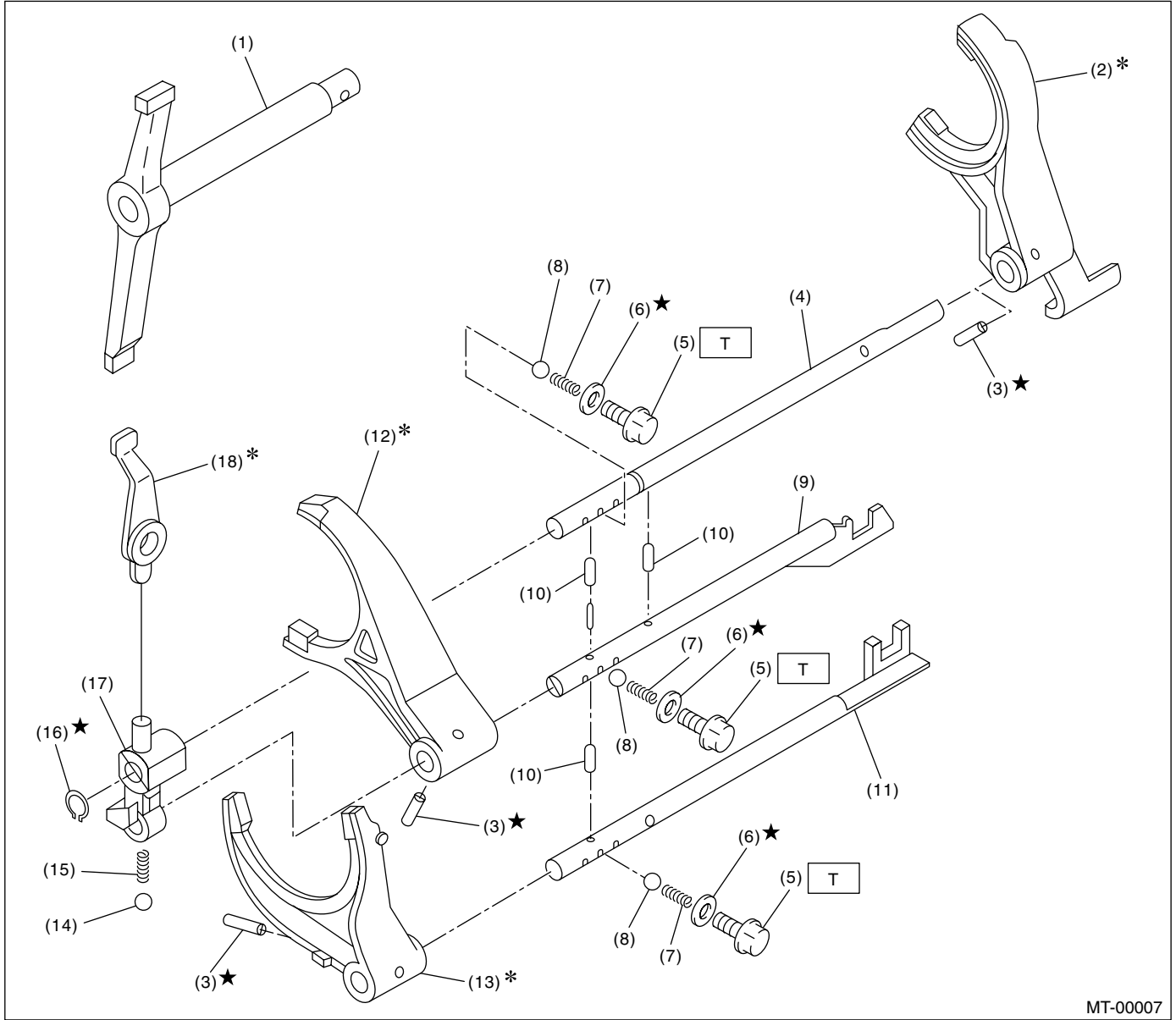

MT-00007

- | | | |
|--------------------------|---------------------------|----------------------------|
| (1) Shifter arm | (9) 3rd-4th fork rod | (17) Reverse fork rod arm |
| (2) 5th shifter fork | (10) Interlock plunger | (18) Reverse shifter lever |
| (3) Straight pin | (11) 1st-2nd fork rod | |
| (4) Reverse fork rod | (12) 3rd-4th shifter fork | |
| (5) Checking ball plug | (13) 1st-2nd shifter fork | |
| (6) Gasket | (14) Ball | |
| (7) Checking ball spring | (15) Spring | |
| (8) Ball | (16) Snap ring (Outer) | |

Tightening torque: N·m (kgf·m, ft·lb)
T: 19.5 (2.0, 14.4)

GENERAL DESCRIPTION

MANUAL TRANSMISSION AND DIFFERENTIAL

5. TRANSFER CASE AND EXTENSION

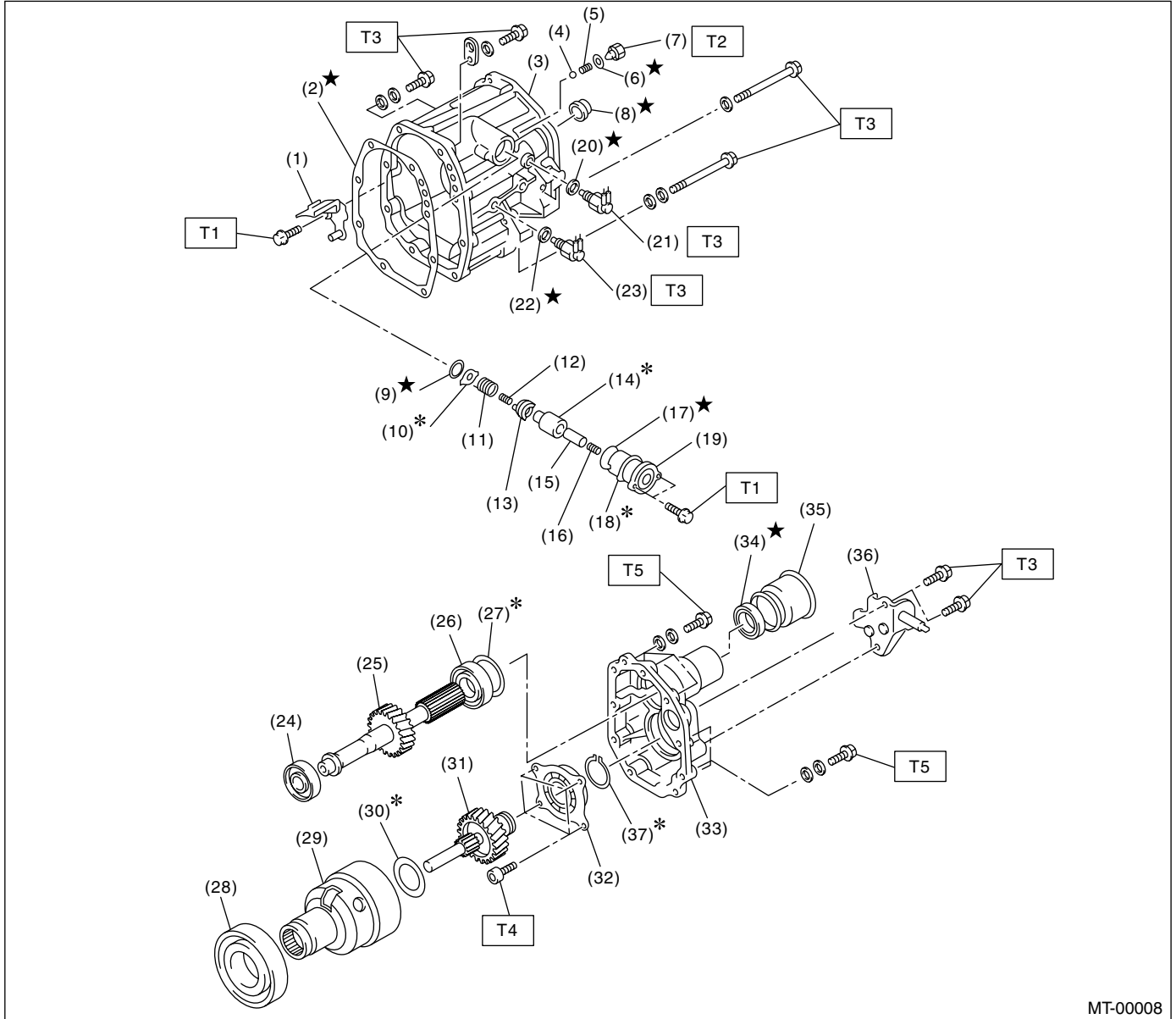

MT-00008

- | | | |
|----------------------------|----------------------------|--------------------------|
| (1) Oil guide | (16) Return spring | (31) Transfer drive gear |
| (2) Gasket | (17) O-ring | (32) Ball bearing |
| (3) Transfer case | (18) Adjusting select shim | (33) Extension case |
| (4) Ball | (19) Reverse check sleeve | (34) Oil seal |
| (5) Reverse accent spring | (20) Gasket | (35) Dust cover |
| (6) Gasket | (21) Neutral switch | (36) Shift bracket |
| (7) Plug | (22) Gasket | (37) Snap ring |
| (8) Oil seal | (23) Back-up light switch | |
| (9) Snap ring (Inner) | (24) Roller bearing | |
| (10) Reverse check plate | (25) Transfer driven gear | |
| (11) Reverse check spring | (26) Roller bearing | |
| (12) Reverse return spring | (27) Adjusting washer | |
| (13) Reverse check cam | (28) Ball bearing | |
| (14) Reverse accent shaft | (29) Center differential | |
| (15) Return spring cap | (30) Adjusting washer | |

Tightening torque: N·m (kgf·m, ft·lb)

T1: 6.4 (0.65, 4.7)

T2: 9.75 (1.0, 7.2)

T3: 25 (2.5, 18.1)

T4: 26 (2.7, 20)

T5: 40 (4.1, 29.7)

GENERAL DESCRIPTION

MANUAL TRANSMISSION AND DIFFERENTIAL

6. FRONT DIFFERENTIAL

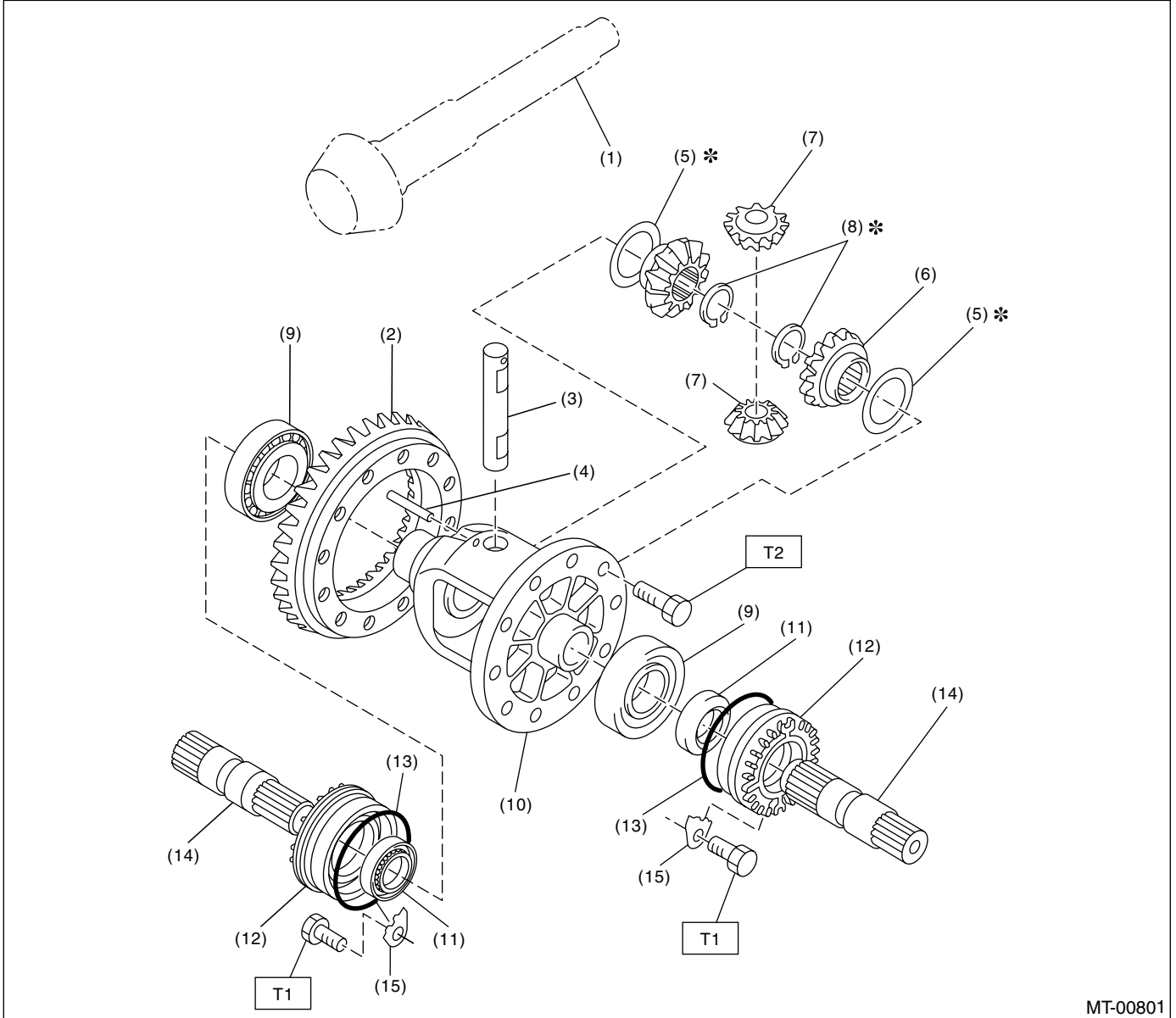

MT-00801

- | | | |
|-------------------------------|---------------------------------|--------------------------|
| (1) Drive pinion shaft | (8) Snap ring (Outer) | (15) Retainer lock plate |
| (2) Hypoid driven gear | (9) Roller bearing | |
| (3) Pinion shaft | (10) Differential case | |
| (4) Straight pin | (11) Oil seal | |
| (5) Washer | (12) Differential side retainer | |
| (6) Differential bevel gear | (13) O-ring | |
| (7) Differential bevel pinion | (14) Axle drive shaft | |

Tightening torque: N-m (kgf-m, ft-lb)

T1: 24.5 (2.5, 18.1)

T2: 62 (6.3, 45.6)

GENERAL DESCRIPTION

MANUAL TRANSMISSION AND DIFFERENTIAL

7. TRANSMISSION MOUNTING

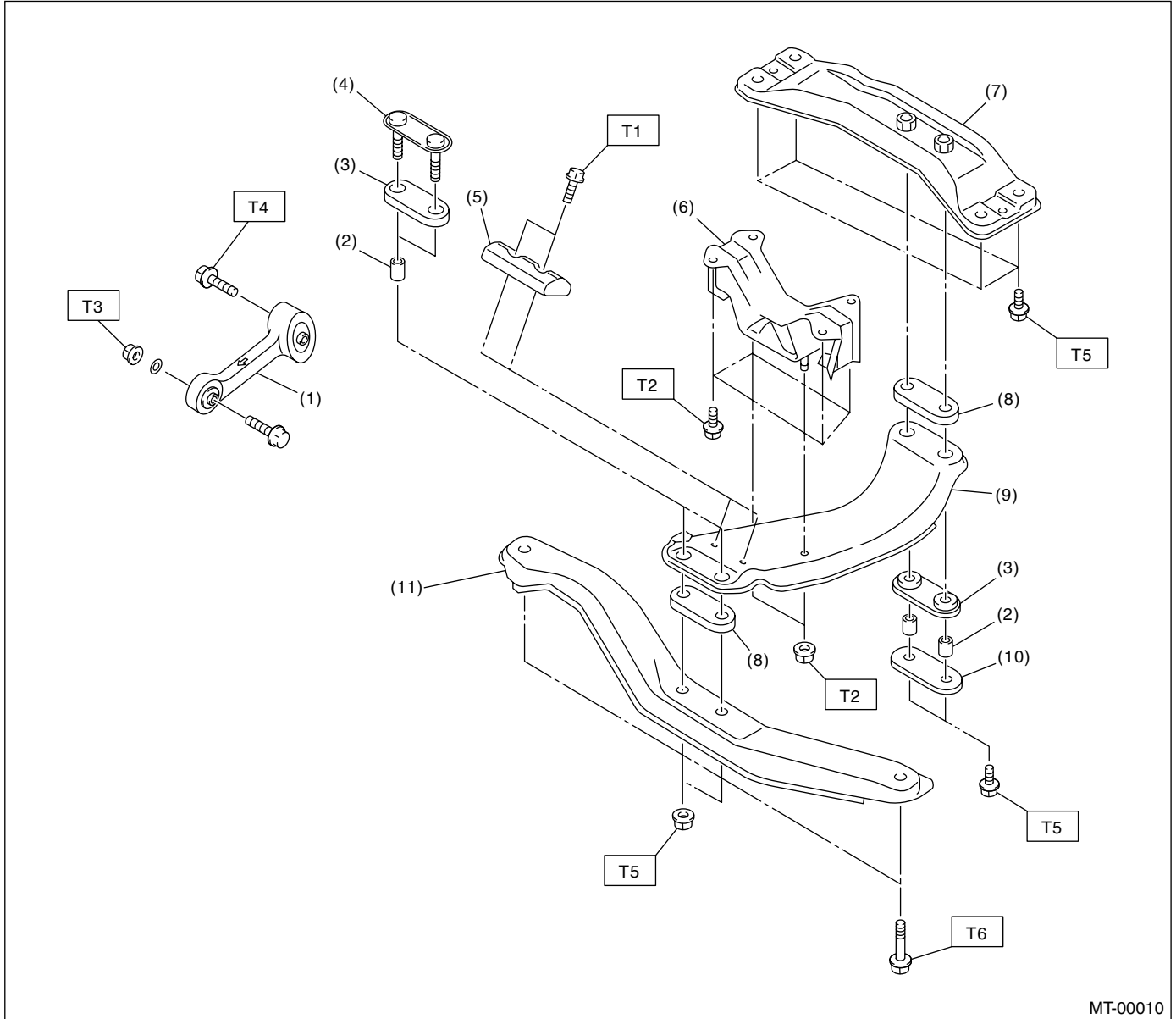

MT-00010

- | | |
|-------------------------|------------------------|
| (1) Pitching stopper | (8) Cushion D |
| (2) Spacer | (9) Center crossmember |
| (3) Cushion C | (10) Rear plate |
| (4) Front plate | (11) Front crossmember |
| (5) Dynamic damper | |
| (6) Rear cushion rubber | |
| (7) Rear crossmember | |

Tightening torque: N-m (kgf-m, ft-lb)

T1: 7.5 (0.76, 5.5)

T2: 35 (3.6, 26)

T3: 50 (5.1, 37)

T4: 58 (5.9, 43)

T5: 70 (7.1, 51)

T6: 140 (14.3, 103)

GENERAL DESCRIPTION

MANUAL TRANSMISSION AND DIFFERENTIAL

C: CAUTION

- Wear working clothing, including a cap, protective goggles, and protective shoes during operation.
- Remove contamination including dirt and corrosion before removal, installation, and disassembly.
- Keep the disassembled parts in order and protect them from dust or dirt.
- Before removal, installation or disassembly, be sure to clarify the failure. Avoid unnecessary removal, installation, disassembly and replacement.
- When disassembling the case and other light alloy parts, use a plastic hammer to force it apart. Do not pry it apart with a screwdriver or other tool.
- Be careful not to burn your hands, because each part on the vehicle is hot after running.
- Use SUBARU genuine gear oil, grease etc. or the equivalent. Do not mix gear oil, grease etc. with that of another grade or from other manufacturers.

- Be sure to tighten fasteners including bolts and nuts to the specified torque.
- Place shop jacks or safety stands at the specified points.
- Apply gear oil onto sliding or revolution surfaces before installation.
- Replace deformed or otherwise damaged snap rings with new ones.
- Before installing O-rings or oil seals, apply sufficient amount of gear oil to avoid damage and deformation.
- Be careful not to incorrectly install or fail to install O-rings, snap rings and other such parts.
- Before securing a part on a vise, place cushioning material such as wood blocks, aluminum plate, or shop cloth between the part and the vise.
- Avoid damaging the mating surface of the case.
- Before applying sealant, completely remove the old seal.

D: PREPARATION TOOL

1. SPECIAL TOOLS

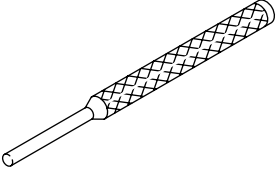
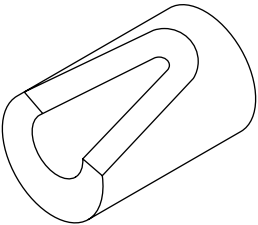
ILLUSTRATION	TOOL NUMBER	DESCRIPTION	REMARKS
 ST-398791700	398791700	REMOVER	Used for removing and installing spring pin (6 mm).
 ST-399411700	399411700	ACCENT BALL INSTALLER	Used for installing reverse shifter rail arm.

GENERAL DESCRIPTION

MANUAL TRANSMISSION AND DIFFERENTIAL

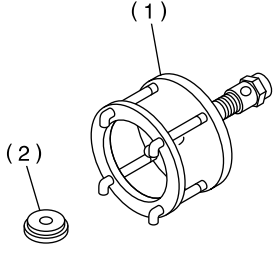
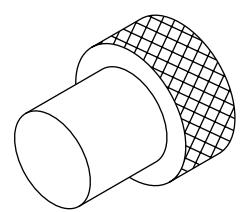
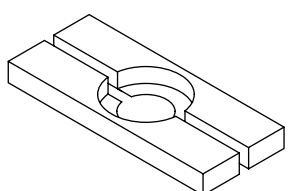
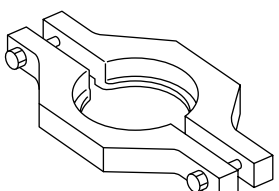
ILLUSTRATION	TOOL NUMBER	DESCRIPTION	REMARKS
 <p style="text-align: center;">ST-899524100</p>	899524100	PULLER SET	Used for removing and installing roller bearing (Differential). (1) PULLER (2) CAP
 <p style="text-align: center;">ST-399780104</p>	399780104	WEIGHT	Used for measuring preload on roller bearing.
 <p style="text-align: center;">ST-498077000</p>	498077000	REMOVER	Used for removing roller bearing of drive pinion shaft.
 <p style="text-align: center;">ST-498077300</p>	498077300	CENTER DIFFERENTIAL BEARING REMOVER	Used for removing the center differential cover ball bearing.

GENERAL DESCRIPTION

MANUAL TRANSMISSION AND DIFFERENTIAL

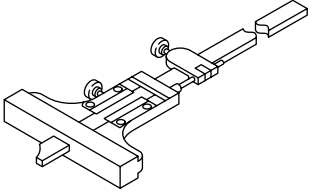
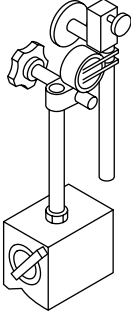
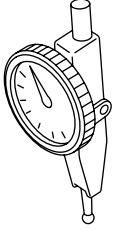
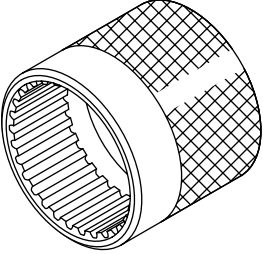
ILLUSTRATION	TOOL NUMBER	DESCRIPTION	REMARKS
 <p style="text-align: center;">ST-498147000</p>	498147000	DEPTH GAUGE	Used for adjusting main shaft axial end play.
 <p style="text-align: center;">ST-498247001</p>	498247001	MAGNET BASE	<ul style="list-style-type: none"> • Used for measuring backlash between side gear and pinion, and hypoid gear. • Used with DIAL GAUGE (498247100).
 <p style="text-align: center;">ST-498247100</p>	498247100	DIAL GAUGE	<ul style="list-style-type: none"> • Used for measuring backlash between side gear and pinion, and hypoid gear. • Used with MAGNET BASE (498247001).
 <p style="text-align: center;">ST-498427100</p>	498427100	STOPPER	Used for securing the drive pinion shaft assembly and driven gear assembly when removing the drive pinion shaft assembly lock nut.

GENERAL DESCRIPTION

MANUAL TRANSMISSION AND DIFFERENTIAL

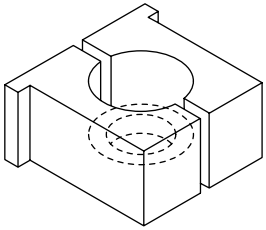
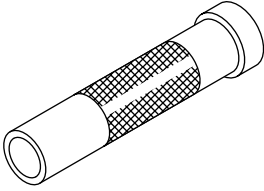
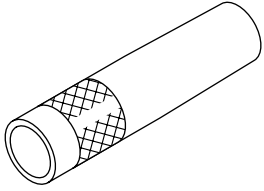
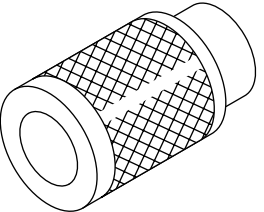
ILLUSTRATION	TOOL NUMBER	DESCRIPTION	REMARKS
 <p data-bbox="339 562 472 588">ST-498937000</p>	498937000	TRANSMISSION HOLDER	Used for removing and installing transmission main shaft lock nut.
 <p data-bbox="339 961 472 987">ST-499277100</p>	499277100	BUSH 1-2 INSTALLER	<ul style="list-style-type: none"> • Used for installing 1st driven gear thrust plate and 1st-2nd driven gear bush. • Used for installing roller bearing outer races to differential case.
 <p data-bbox="339 1365 472 1390">ST-499277200</p>	499277200	INSTALLER	Used for press-fitting the 2nd driven gear, roller bearings and 5th driven gear onto the driven shaft.
 <p data-bbox="339 1766 472 1791">ST-499757002</p>	499757002	INSTALLER	<ul style="list-style-type: none"> • Used for installing snap ring (OUT 25) and ball bearing (25 × 26 × 17). • Used for installing bearing cone of transfer driven gear (extension core side).

GENERAL DESCRIPTION

MANUAL TRANSMISSION AND DIFFERENTIAL

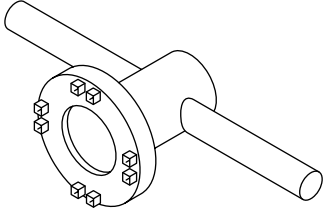
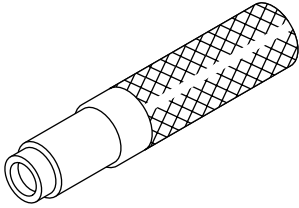
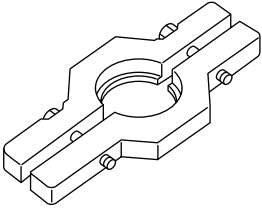
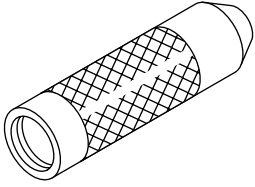
ILLUSTRATION	TOOL NUMBER	DESCRIPTION	REMARKS
 <p style="text-align: center;">ST-499787000</p>	499787000	WRENCH ASSY	Used for removing and installing differential side retainer.
 <p style="text-align: center;">ST-499827000</p>	499827000	PRESS	Used for installing speedometer oil seal when installing speedometer cable to transmission.
 <p style="text-align: center;">ST-499857000</p>	499857000	5TH DRIVEN GEAR REMOVER	Used for removing 5th driven gear.
 <p style="text-align: center;">ST-499877000</p>	499877000	RACE 4-5 INSTALLER	<ul style="list-style-type: none"> • Used for installing 4th needle bearing race and ball bearing onto transmission main shaft. • Used with REMOVER (899714110).

GENERAL DESCRIPTION

MANUAL TRANSMISSION AND DIFFERENTIAL

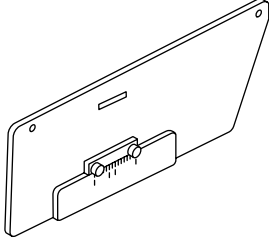
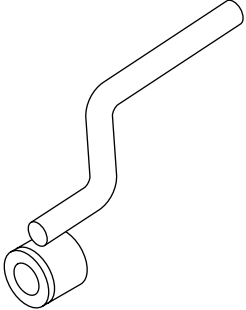
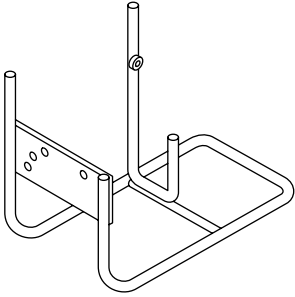
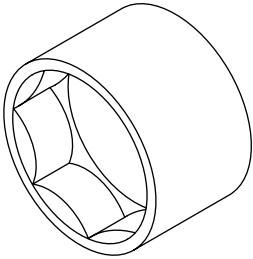
ILLUSTRATION	TOOL NUMBER	DESCRIPTION	REMARKS
 <p style="text-align: center;">ST-499917500</p>	499917500	DRIVE PINION GAUGE ASSY	Used for adjusting drive pinion shim.
 <p style="text-align: center;">ST-499927100</p>	499927100	HANDLE	Used for fitting transmission main shaft.
 <p style="text-align: center;">ST-499937100</p>	499937100	TRANSMISSION STAND SET	Stand used for transmission disassembly and assembly.
 <p style="text-align: center;">ST-499987003</p>	499987003	SOCKET WRENCH (35)	Used for removing and installing driven pinion lock nut and main shaft lock nut.

GENERAL DESCRIPTION

MANUAL TRANSMISSION AND DIFFERENTIAL

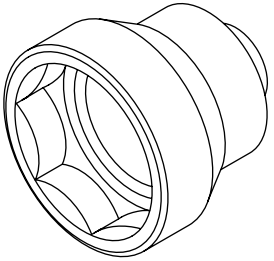
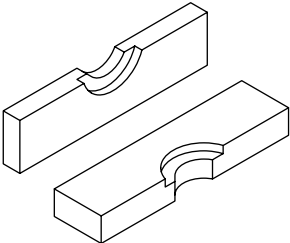
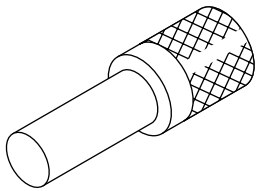
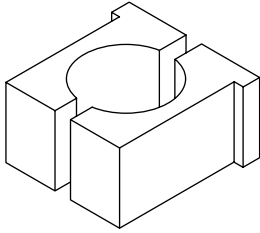
ILLUSTRATION	TOOL NUMBER	DESCRIPTION	REMARKS
 <p style="text-align: center;">ST-499987300</p>	499987300	SOCKET WRENCH (50)	Used for removing and installing driven gear assembly lock nut.
 <p style="text-align: center;">ST-899714110</p>	899714110	REMOVER	Used for fixing transmission main shaft, drive pinion and rear drive shaft.
 <p style="text-align: center;">ST-899864100</p>	899864100	REMOVER	Used for removing parts on transmission main shaft and drive pinion.
 <p style="text-align: center;">ST-899884100</p>	899884100	HOLDER	Used for tightening lock nut on sleeve.

GENERAL DESCRIPTION

MANUAL TRANSMISSION AND DIFFERENTIAL

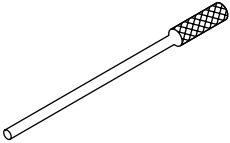
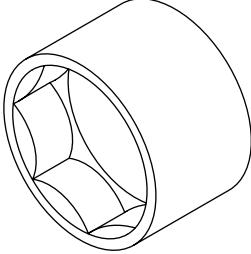
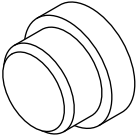
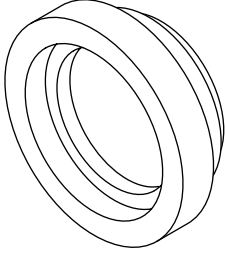
ILLUSTRATION	TOOL NUMBER	DESCRIPTION	REMARKS
 <p data-bbox="339 564 472 585">ST-899904100</p>	899904100	REMOVER	Used for removing and installing straight pin.
 <p data-bbox="339 968 472 989">ST-899988608</p>	899988608	SOCKET WRENCH (27)	Used for removing and installing drive pinion lock nut.
 <p data-bbox="339 1371 472 1392">ST-398497701</p>	398497701	ADAPTER	<ul style="list-style-type: none"> • Used for installing roller bearing onto differential case. • Used with INSTALLER (499277100).
 <p data-bbox="339 1768 472 1789">ST-499587000</p>	499587000	INSTALLER	Used for installing driven gears to driven shaft.

GENERAL DESCRIPTION

MANUAL TRANSMISSION AND DIFFERENTIAL

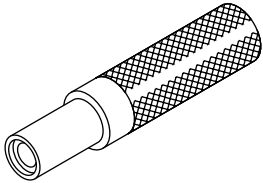
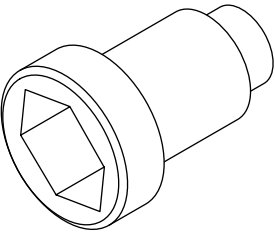
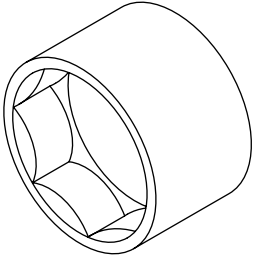
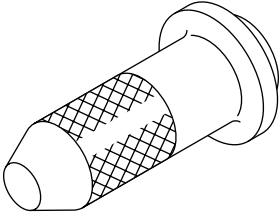
ILLUSTRATION	TOOL NUMBER	DESCRIPTION	REMARKS
 <p style="text-align: center;">ST-899824100</p>	899824100	PRESS	Used for installing speedometer shaft oil seal.
 <p style="text-align: center;">ST-499987100</p>	499987100	SOCKET WRENCH (35)	Used for removing and installing drive pinion lock nut.
 <p style="text-align: center;">ST-899984103</p>	899984103	SOCKET WRENCH (35)	Used for removing and installing drive pinion lock nut.
 <p style="text-align: center;">ST-498057300</p>	498057300	INSTALLER	Used for installing extension oil seal.

GENERAL DESCRIPTION

MANUAL TRANSMISSION AND DIFFERENTIAL

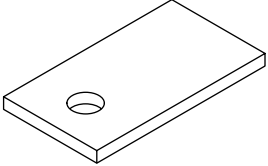
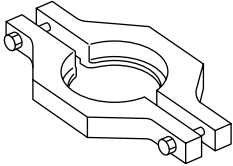
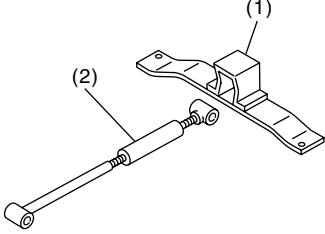
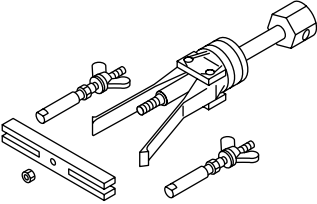
ILLUSTRATION	TOOL NUMBER	DESCRIPTION	REMARKS
 <p>ST-498255400</p>	498255400	PLATE	Used for measuring backlash.
 <p>ST-498077400</p>	498077400	SYNCHRONIZER CONE REMOVER	<ul style="list-style-type: none"> • Used for removing synchronizer cone of main shaft. • Used for removing 5th driven gear of drive pinion shaft.
 <p>ST41099AA000</p>	41099AA000	ENGINE SUPPORT BRACKET	Used for supporting engine. (1) Engine support bracket (41099AA010) (2) Engine support (41099AA020)
 <p>ST-398527700</p>	398527700	PULLER ASSY	Used for removing extension case roller bearing.

GENERAL DESCRIPTION

MANUAL TRANSMISSION AND DIFFERENTIAL

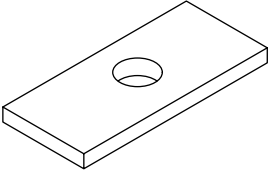
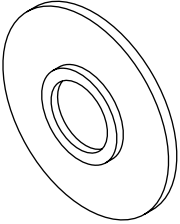
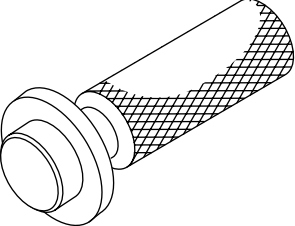
ILLUSTRATION	TOOL NUMBER	DESCRIPTION	REMARKS
 <p style="text-align: center;">ST-398643600</p>	398643600	GAUGE	Used for measuring total end play, extension end play and drive pinion height.
 <p style="text-align: center;">ST-398177700</p>	38177700	INSTALLER	<ul style="list-style-type: none"> • Used for installing bearing cone of transfer driven gear (transfer case side). • Used for installing ball bearing of transfer drive gear.
 <p style="text-align: center;">ST-499797000</p>	499797000	INSTALLER	Used for installing differential side retainer oil seal.

2. GENERAL PURPOSE TOOLS

TOOL NAME	REMARKS
Circuit Tester	Used for measuring resistance, voltage and ampere.

2. Transmission Gear Oil

A: INSPECTION

- 1) Park the vehicle on a level surface.
- 2) Turn the ignition switch to OFF, and then wait until the engine cools.
- 3) Remove the oil level gauge and wipe it clean.
- 4) Reinsert the level gauge all the way. Be sure the level gauge is correctly inserted and in the proper direction.
- 5) Pull out the oil level gauge again and check the oil level on it. If it is below the lower level, add oil through the oil level gauge hole to bring the level up to the upper level.

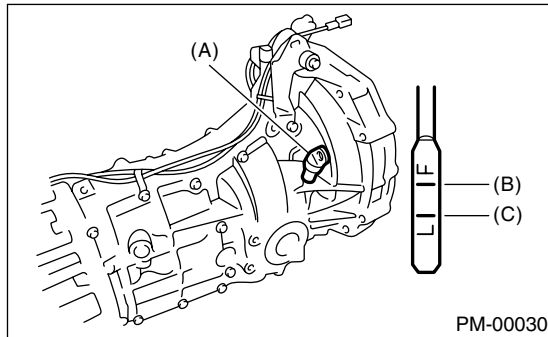

- (A) Oil level gauge
- (B) Upper level
- (C) Lower level

B: REPLACEMENT

- 1) Pull out the oil level gauge.
- 2) Lift-up the vehicle.
- 3) Drain the transmission gear oil completely.

CAUTION:

Directly after the engine has been running, the transmission gear oil is hot. Be careful not to burn yourself.

NOTE:

Tighten the transmission gear oil drain plug after draining the transmission gear oil.

Tightening torque:

69 N·m (7.0 kgf-m, 50.6 ft-lb)

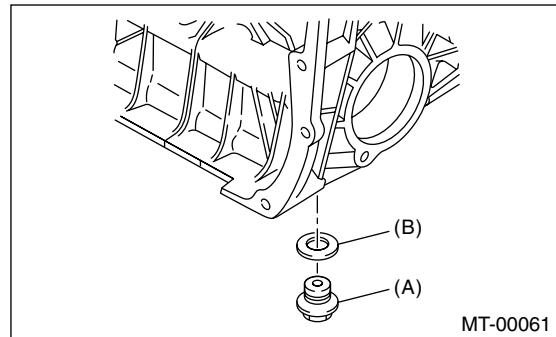

- (A) Drain plug
- (B) Gasket

- 4) Lower the vehicle.
- 5) Pour gear oil into the gauge hole.

Recommended gear oil:

Use GL-5 (75W-90) or equivalent.

Gear oil capacity:

3.5 l (3.7 US qt, 3.1 Imp qt)

- 6) Check the level of the transmission gear oil.

CAUTION:

When inserting the level gauge into transmission gear, align the protrusion on the side of the top part of level gauge with the notch in the gauge hole.

NOTE:

The level should be within the specified range marked on the gauge.

MANUAL TRANSMISSION ASSEMBLY

MANUAL TRANSMISSION AND DIFFERENTIAL

3. Manual Transmission Assembly

A: REMOVAL

- 1) Open the front hood fully, and support with stay.
- 2) Disconnect the ground cable from battery.
- 3) Remove the air intake duct and cleaner case. (Non-turbo model) <Ref. to IN(H4SO)-6, REMOVAL, Air Intake Duct.> and <Ref. to IN(H4SO)-5, REMOVAL, Air Cleaner Case.>
- 4) Remove the air cleaner case stay. (Non-turbo model)

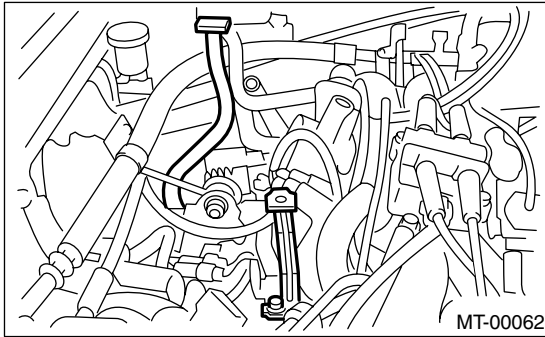

- 5) Remove the intercooler. (Turbo model) <Ref. to IN(H4DOTC)-10, REMOVAL, Intercooler.>

- 6) Disconnect the following connectors:

- (1) Neutral position switch connector
- (2) Back-up light switch connector
- (3) Vehicle speed sensor

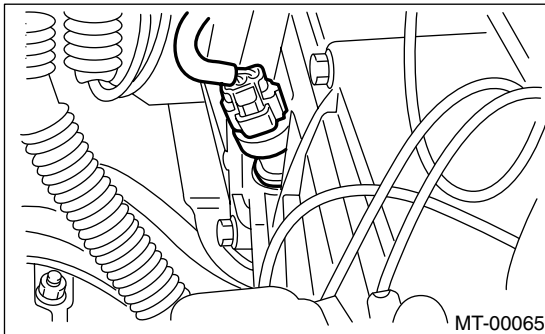

- 7) Remove the starter. <Ref. to SC(H4SO)-7, REMOVAL, Starter.>

- 8) Remove the operating cylinder from transmission.

- NON-TURBO MODEL

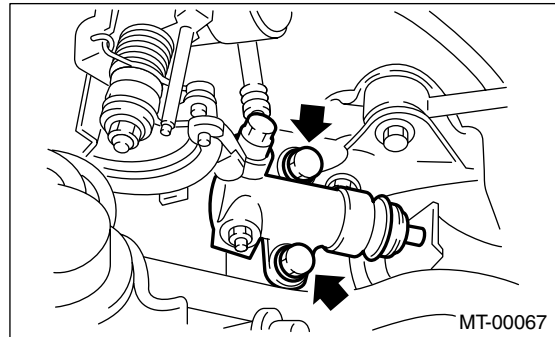

- TURBO MODEL

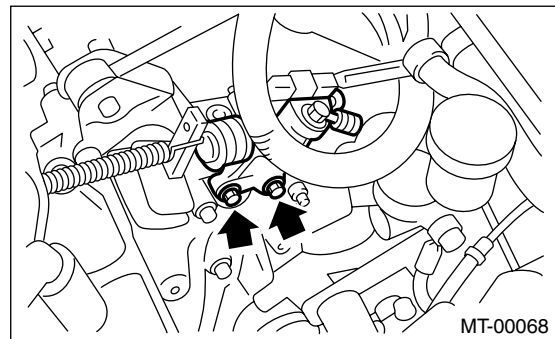

- 9) Remove the pitching stopper.

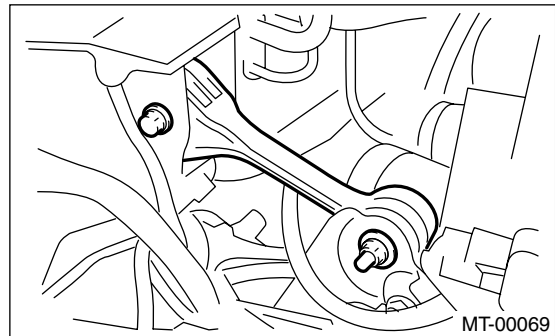

MANUAL TRANSMISSION ASSEMBLY

MANUAL TRANSMISSION AND DIFFERENTIAL

- 10) Set the ST.
ST 41099AA000 ENGINE SUPPORT ASSY

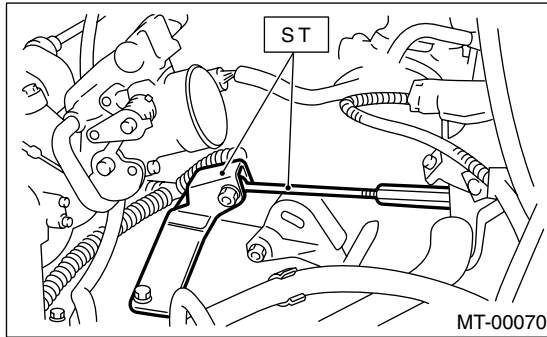

- 11) Separate the clutch release fork from release bearing. (Turbo model)

- (1) Remove the clutch operating cylinder from transmission.
- (2) Remove the plug using 10 mm hexagon wrench.

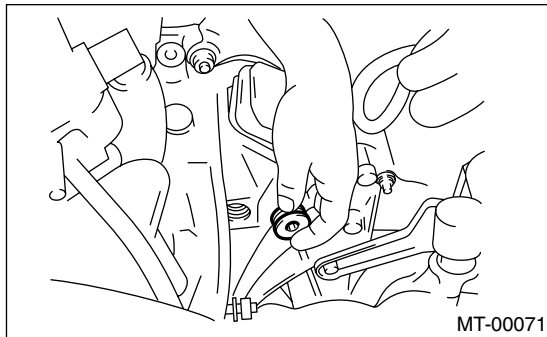

- (3) Screw the 6 mm dia. bolt into release fork shaft, and then remove it.

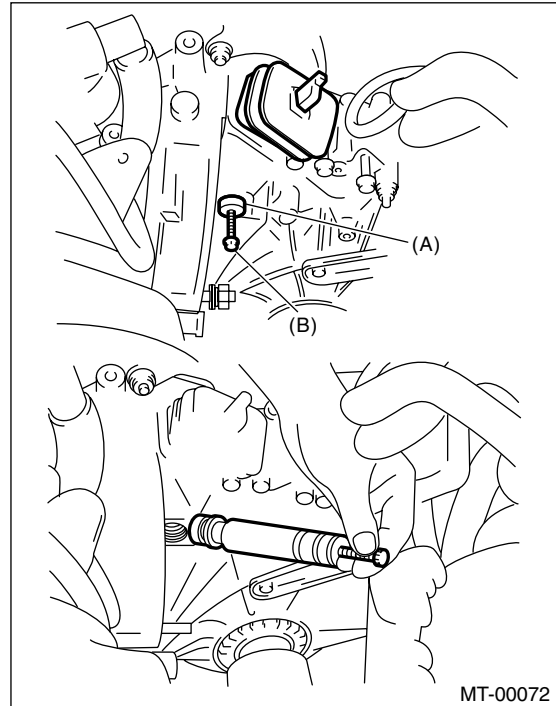

- (A) Shaft
(B) Bolt

- (4) Raise the release fork and unfasten the release bearing tabs to free release fork.

NOTE:

Step (4) is required to prevent interference with engine when removing the engine from transmission.

- 12) Remove the bolt which holds the right upper side of transmission to engine.

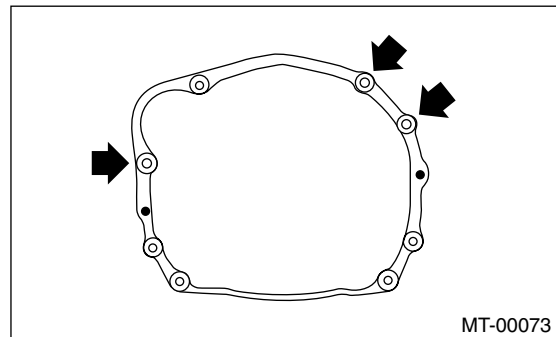

- 13) Remove the front and center exhaust pipes. (Non-turbo model) <Ref. to EX(H4SO)-4, REMOVAL, Front Exhaust Pipe.>

- 14) Remove the center exhaust pipe. (Turbo model). <Ref. to EX(H4DOTC)-8, REMOVAL, Center Exhaust Pipe.>

MANUAL TRANSMISSION ASSEMBLY

MANUAL TRANSMISSION AND DIFFERENTIAL

15) Remove the rear exhaust pipe and muffler.

CAUTION:

When removing the exhaust pipes, be careful each exhaust pipe does not drop out.

16) Remove the heat shield cover. (If equipped)

17) Remove the hanger bracket from right side of transmission.

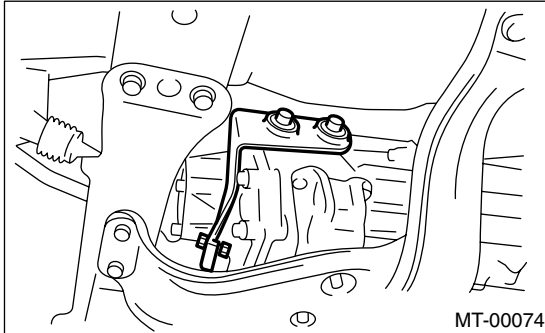

18) Remove the propeller shaft. <Ref. to DS-14, REMOVAL, Propeller Shaft.>

19) Remove the gear shift rod and stay from transmission.

- (1) Disconnect the stay from transmission.
- (2) Disconnect the rod from transmission.

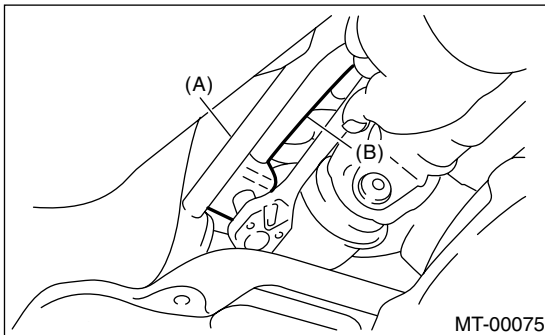

- (A) Stay
(B) Rod

20) Disconnect the stabilizer link from transverse link.

21) Remove the bolt securing ball joint of transverse link to housing.

• WAGON MODEL

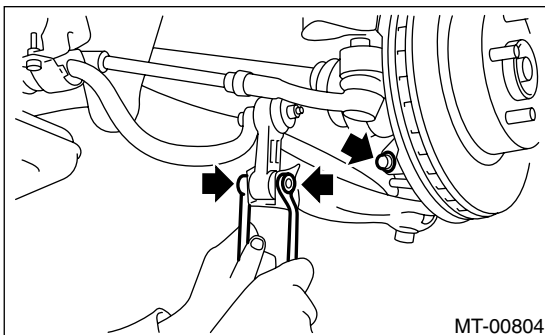

• SEDAN MODEL

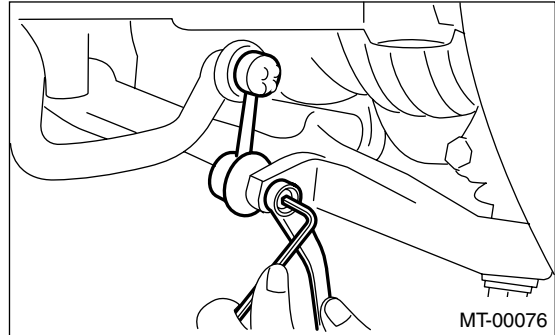

22) Remove the spring pins and separate the front drive shafts from each side of transmission.

NOTE:

Discard the removing spring pin. Replace with a new one.

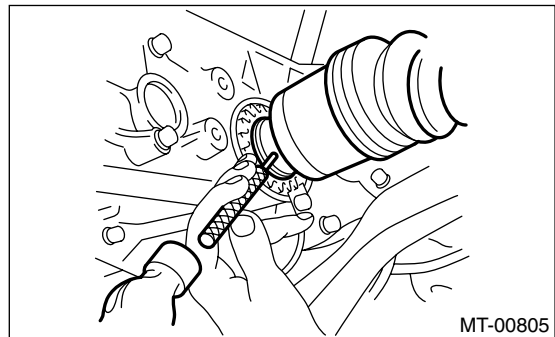

23) Remove the nuts which hold the lower side of transmission to engine.

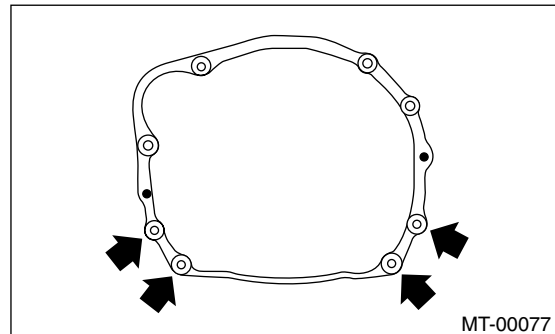

MANUAL TRANSMISSION ASSEMBLY

MANUAL TRANSMISSION AND DIFFERENTIAL

24) Place the transmission jack under transmission.

CAUTION:

Always support the transmission case with a transmission jack.

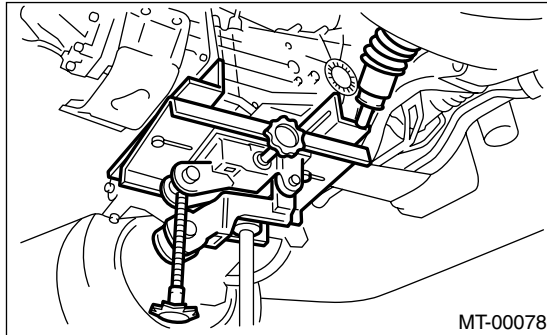

25) Remove the transmission rear crossmember from vehicle.

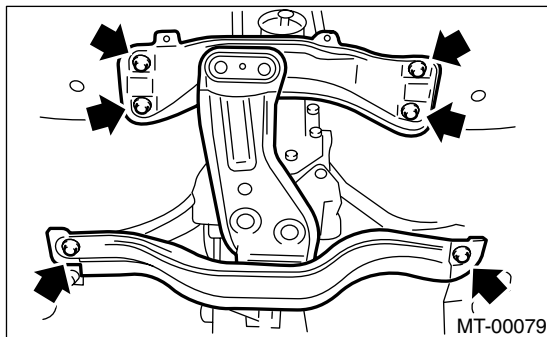

26) Remove the transmission.

NOTE:

Move the transmission jack toward rear until main shaft is withdrawn from clutch cover.

27) Separate the transmission assembly and rear cushion rubber.

28) Remove the clutch release bearing from engine side. (Turbo model) <Ref. to CL-15, REMOVAL, Release Bearing and Lever.>

B: INSTALLATION

1) Install the rear cushion rubber to transmission assembly.

Tightening torque:

35 N·m (3.57 kgf-m, 25.8 ft-lb)

2) Install the clutch release lever and bearing onto transmission. (Turbo model) <Ref. to CL-16, INSTALLATION, Release Bearing and Lever.>

3) Install the transmission onto engine.

(1) Gradually raise the transmission with transmission jack.

(2) Engage them at splines.

NOTE:

Be careful not to strike the main shaft against clutch cover.

4) Install the transmission rear crossmember.

Tightening torque:

T1: 70 N·m (7.1 kgf-m, 51 ft-lb)

T2: 140 N·m (14.3 kgf-m, 103 ft-lb)

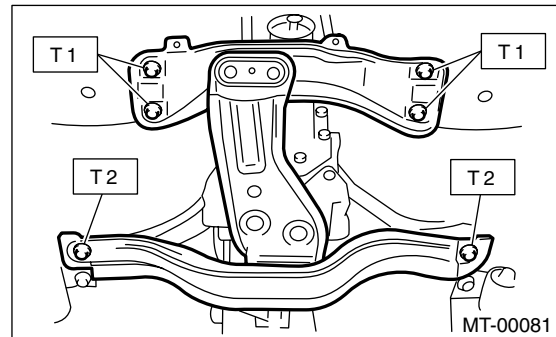

5) Take off the transmission jack.

6) Tighten the nuts which hold the lower side of transmission to engine.

Tightening torque:

50 N·m (5.1 kgf-m, 36.9 ft-lb)

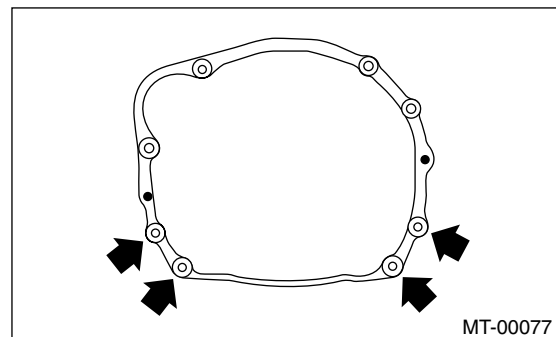

7) Connect the engine and transmission.

(1) Install the starter.

<Ref. to SC(H4SO)-7, INSTALLATION, Starter.>

(2) Tighten the bolt which holds right upper side of transmission to engine.

Tightening torque:

50 N·m (5.1 kgf-m, 36.9 ft-lb)

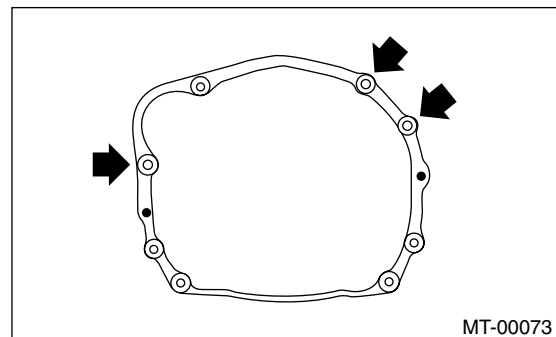

MANUAL TRANSMISSION ASSEMBLY

MANUAL TRANSMISSION AND DIFFERENTIAL

8) Remove the ST.

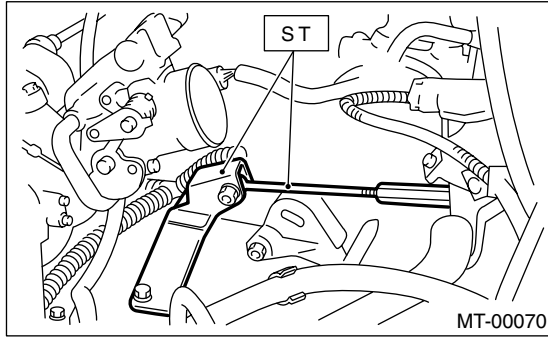

9) Install the pitching stopper.

Tightening torque:

T1: 50 N·m (5.1 kgf-m, 37 ft-lb)

T2: 58 N·m (5.9 kgf-m, 43 ft-lb)

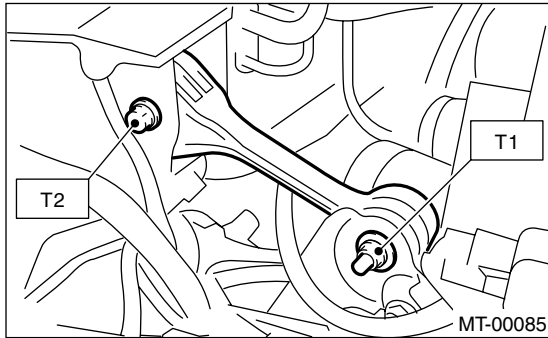

10) Lift-up the vehicle.

11) Install the front drive shaft into transmission.

12) Drive the spring pin into chamfered hole of drive shaft.

NOTE:

Always use a new spring pin.

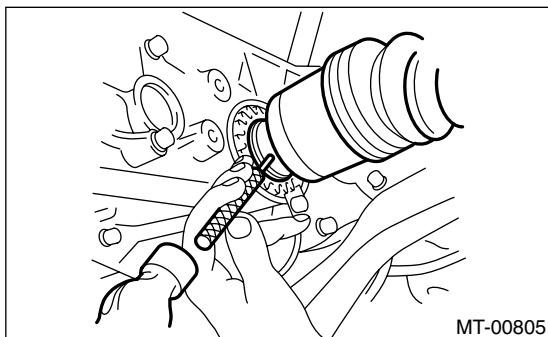

13) Install the ball joints of lower arm into knuckle arm of housing, and tighten the installing bolts.

Tightening torque:

49 N·m (5.0 kgf-m, 36 ft-lb)

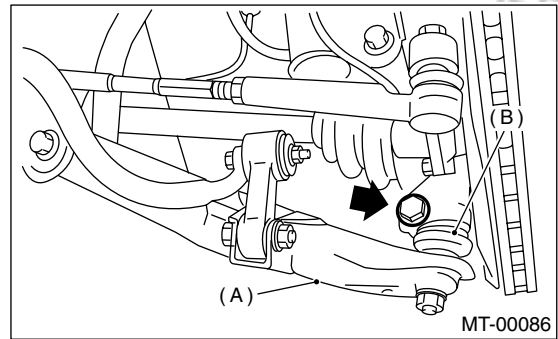

(A) Transverse link

(B) Ball joint

14) Install the stabilizer link from transverse link.

• WAGON MODEL

Tightening torque:

30 N·m (3.1 kgf-m, 22.1 ft-lb)

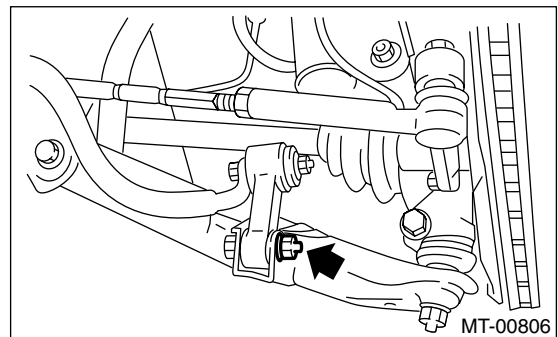

• SEDAN MODEL

Tightening torque:

45 N·m (4.6 kgf-m, 33.2 ft-lb)

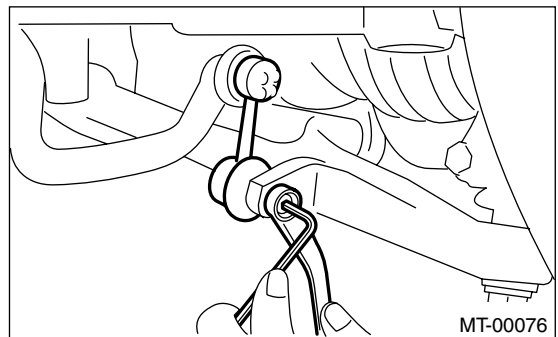

MANUAL TRANSMISSION ASSEMBLY

MANUAL TRANSMISSION AND DIFFERENTIAL

15) Install the gear shift rod and stay.

(1) Install the gear shift rod onto transmission.

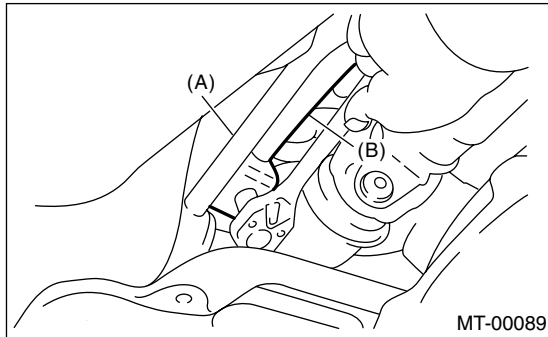

(A) Stay

(B) Rod

(2) Install the stay onto transmission.

16) Install the propeller shaft. <Ref. to DS-15, INSTALLATION, Propeller Shaft.>

17) Install the heat shield cover. (If equipped)

18) Install the hanger bracket on right side of transmission.

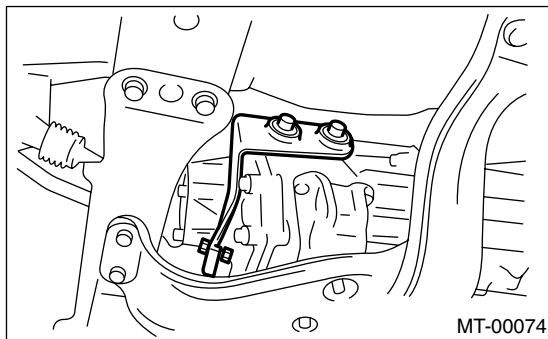

19) Install the rear exhaust pipe and muffler.

20) Install the front exhaust pipe and center exhaust pipe. (Non-turbo model)

<Ref. to EX(H4SO)-5, INSTALLATION, Front Exhaust Pipe.>

21) Install the center exhaust pipe. (Turbo model)

<Ref. to EX(H4DOTC)-9, INSTALLATION, Center Exhaust Pipe.>

22) Install the under cover.

23) Push the clutch release lever to fit the bearing into clutch cover. (Turbo model)

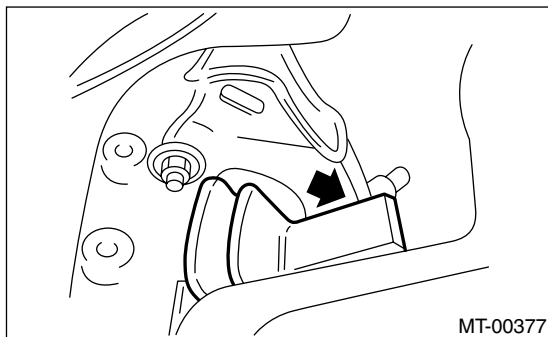

24) Install the operating cylinder.

Tightening torque:

37 N·m (3.8 kgf-m, 27.5 ft-lb)

• NON-TURBO MODEL

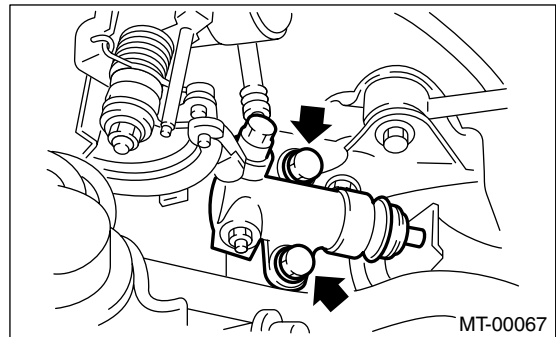

• TURBO MODEL

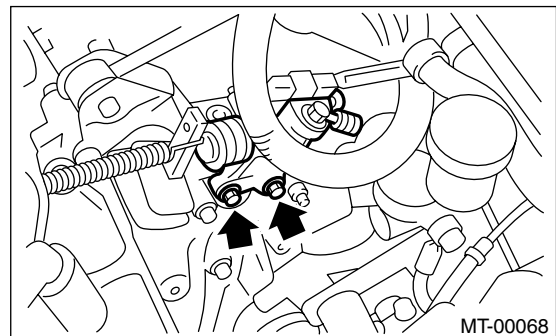

25) Connect the following connectors:

(1) Transmission ground cable

Tightening torque:

13 N·m (1.3 kgf-m, 9.4 ft-lb)

(2) Vehicle speed sensor connector

(3) Neutral position switch connector

(4) Back-up light switch connector

26) Install the air cleaner case stay.

Tightening torque:

16 N·m (1.6 kgf-m, 11.6 ft-lb)

27) Install the air cleaner case and duct.

28) Connect the battery ground cable to battery.

29) Take off the vehicle from lift arms.

TRANSMISSION MOUNTING SYSTEM

MANUAL TRANSMISSION AND DIFFERENTIAL

4. Transmission Mounting System

A: REMOVAL

1. PITCHING STOPPER

- 1) Disconnect the ground cable from battery.
- 2) Remove the air intake duct. (Non-turbo model)
<Ref. to IN(H4SO)-6, REMOVAL, Air Intake Duct.>
- 3) Remove the air cleaner case. (Non-turbo model)
<Ref. to IN(H4SO)-5, REMOVAL, Air Cleaner Case.>
- 4) Remove the intercooler. (Turbo model) <Ref. to IN(H4DOTC)-10, REMOVAL, Intercooler.>
- 5) Remove the pitching stopper.

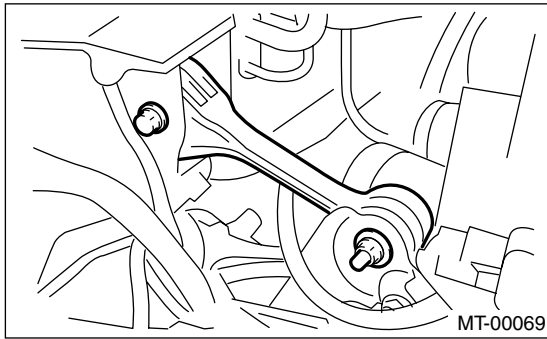

2. CROSSMEMBER AND CUSHION RUBBER

- 1) Disconnect the ground cable from battery.
- 2) Jack-up the vehicle and support it with sturdy racks.
- 3) Remove the front and center exhaust pipes. (Non-turbo model)
<Ref. to EX(H4SO)-4, REMOVAL, Front Exhaust Pipe.>
- 4) Remove the center exhaust pipe. (Turbo model)
<Ref. to EX(H4DOTC)-8, REMOVAL, Center Exhaust Pipe.>
- 5) Remove the rear exhaust pipe and muffler.
- 6) Remove the heat shield cover. (If equipped)
- 7) Set the transmission jack under the transmission body.

CAUTION:

Always support the transmission case with a transmission jack.

- 8) Remove the rear crossmember.

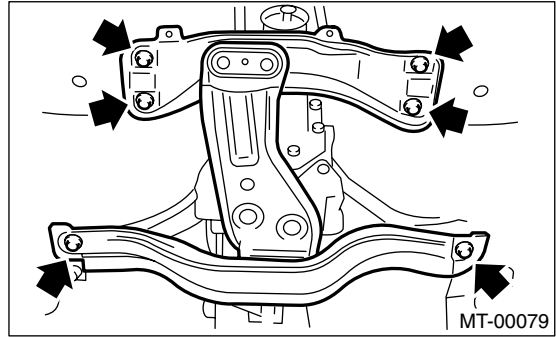

- 9) Remove the rear cushion rubber.

B: INSTALLATION

1. PITCHING STOPPER

- 1) Install the pitching stopper.

Tightening torque:

T1: 50 N·m (5.1 kgf-m, 37 ft-lb)

T2: 58 N·m (5.9 kgf-m, 43 ft-lb)

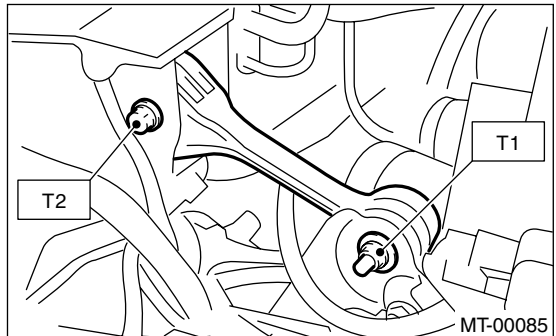

- 2) Install the air intake duct and cleaner case. (Non-turbo model)
<Ref. to IN(H4SO)-5, INSTALLATION, Air Cleaner Case.> and <Ref. to IN(H4SO)-6, INSTALLATION, Air Intake Duct.>
- 3) Install the intercooler. (Turbo model)
<Ref. to IN(H4DOTC)-10, INSTALLATION, Intercooler.>
- 4) Connect the battery ground cable to battery.

TRANSMISSION MOUNTING SYSTEM

MANUAL TRANSMISSION AND DIFFERENTIAL

2. CROSSMEMBER AND CUSHION RUBBER

1) Install the rear cushion rubber.

Tightening torque:

35 N·m (3.6 kgf-m, 26 ft-lb)

2) Install the rear crossmember.

Tightening torque:

T1: 70 N·m (7.1 kgf-m, 51 ft-lb)

T2: 140 N·m (14.3 kgf-m, 103 ft-lb)

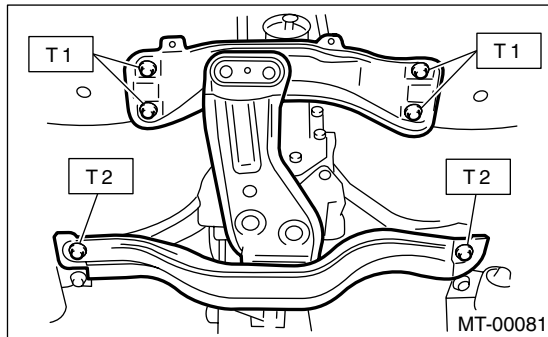

3) Remove the transmission jack.

4) Install the heat shield cover. (If equipped)

5) Install the front and center exhaust pipes. (Non-turbo model)

<Ref. to EX(H4SO)-5, INSTALLATION, Front Exhaust Pipe.>

6) Install the center exhaust pipe. (Turbo model)
<Ref. to EX(H4DOTC)-9, INSTALLATION, Center Exhaust Pipe.>

7) Install the rear exhaust pipe and muffler.

C: INSPECTION

Repair or replace parts if the results of the inspection below are not satisfactory.

1. PITCHING STOPPER

Make sure the pitching stopper is not bent or damaged. Make sure the rubber is not stiff, cracked, or otherwise damaged.

2. CROSSMEMBER AND CUSHION RUBBER

Make sure the crossmember is not bent or damaged. Make sure the cushion rubber is not stiff, cracked, or otherwise damaged.

OIL SEAL

MANUAL TRANSMISSION AND DIFFERENTIAL

5. Oil Seal

A: INSPECTION

Check the oil seal portion for leakage. If leakage is found, replace the oil seal with a new one.

B: REPLACEMENT

- 1) Clean the transmission exterior.
- 2) Drain the gear oil completely.

NOTE:

Tighten the drain plug after draining gear oil.

Tightening torque:

69 N·m (7.0 kgf·m, 50.6 ft·lb)

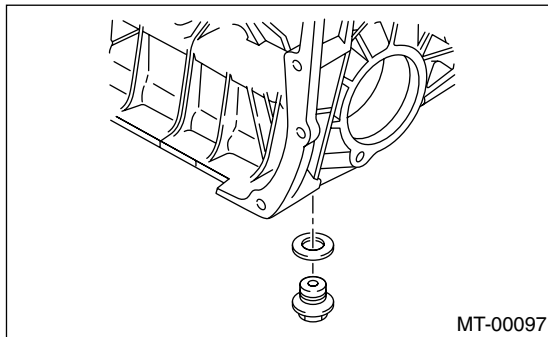

- 3) Remove the rear exhaust pipe and muffler.
 - 4) Remove the heat shield cover. (If equipped)
 - 5) Remove the propeller shaft. <Ref. to DS-14, REMOVAL, Propeller Shaft.>
 - 6) Using the ST, remove the oil seal.
- ST 398527700 PULLER ASSY

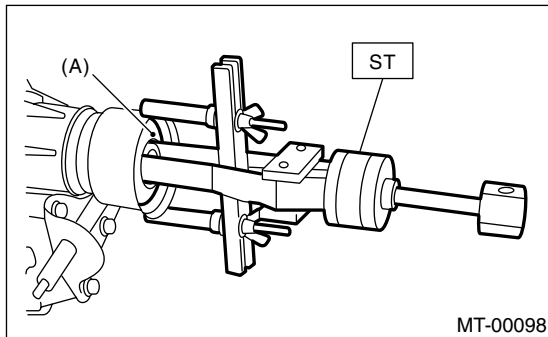

(A) Oil seal

- 7) Using the ST, install the oil seal.
- ST 498057300 INSTALLER

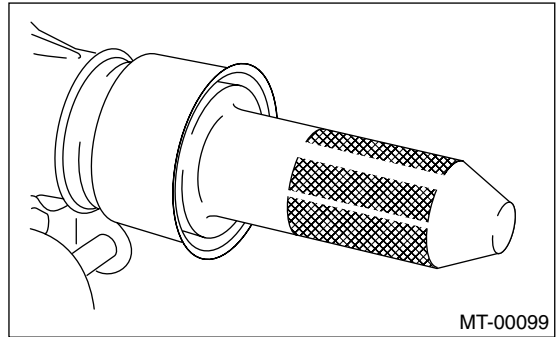

- 8) Install the propeller shaft. <Ref. to DS-15, INSTALLATION, Propeller Shaft.>
- 9) Install the heat shield cover. (If equipped)
- 10) Install the rear exhaust pipe and muffler.
- 11) Pour gear oil and check the oil level. <Ref. to 5MT-25, REPLACEMENT, Transmission Gear Oil.>

6. Switches and Harness

A: REMOVAL

1. BACK-UP LIGHT AND NEUTRAL POSITION SWITCH

- 1) Disconnect the ground cable from battery.
- 2) Remove the air intake duct and cleaner case. (Non-turbo model) <Ref. to IN(H4SO)-5, REMOVAL, Air Cleaner Case.> and <Ref. to IN(H4SO)-6, REMOVAL, Air Intake Duct.>
- 3) Remove the intercooler. (Turbo model) <Ref. to IN(H4DOTC)-10, REMOVAL, Intercooler.>
- 4) Disconnect the connector of back-up light switch and neutral position switch.

• NON-TURBO MODEL

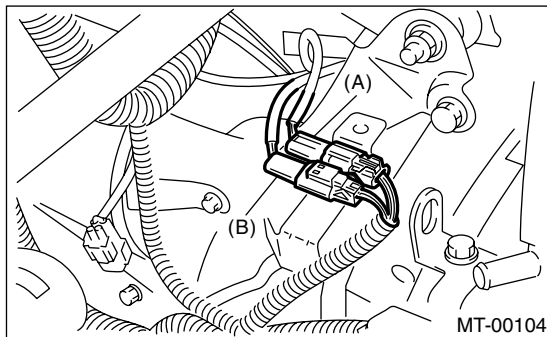

- (A) Neutral switch (Brown)
(B) Back-up light switch (Gray)

• TURBO MODEL

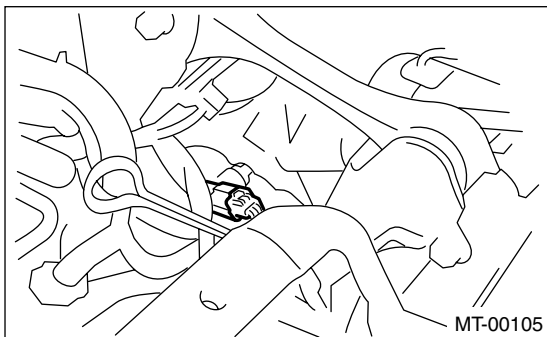

- 5) Lift-up the vehicle.

- 6) Remove the back-up light switch and neutral position switch with harness.

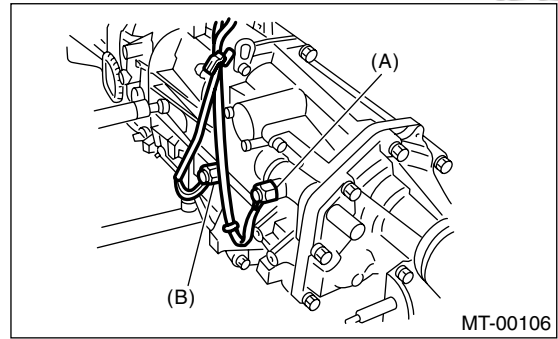

- (A) Neutral switch (Brown)
(B) Back-up light switch (Gray)

B: INSTALLATION

1. BACK-UP LIGHT SWITCH AND NEUTRAL POSITION SWITCH

- 1) Install the back-up light switch and neutral position switch with harness.

Tightening torque:

24.5 N·m (2.5 kgf·m, 18.1 ft·lb)

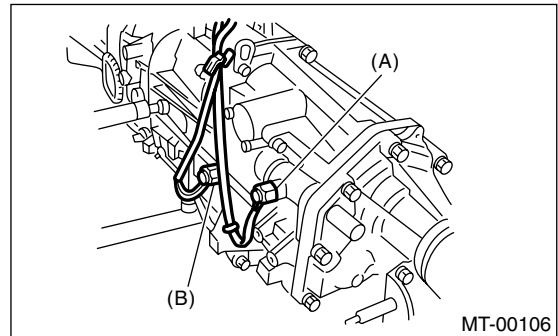

- (A) Neutral switch
(B) Back-up light switch

- 2) Connect the connector of back-up light switch and neutral position switch.
- 3) Install the air intake duct and cleaner case. (Non-turbo model) <Ref. to IN(H4SO)-5, INSTALLATION, Air Cleaner Case.> and <Ref. to IN(H4SO)-6, INSTALLATION, Air Intake Duct.>
- 4) Install the intercooler. (Turbo model) <Ref. to IN(H4DOTC)-10, INSTALLATION, Intercooler.>
- 5) Connect the battery ground cable to battery.

SWITCHES AND HARNESS

MANUAL TRANSMISSION AND DIFFERENTIAL

C: INSPECTION

1. BACK-UP LIGHT SWITCH

Inspect the back-up light switch. <Ref. to LI-6, INSPECTION, Back-up Light System.>

2. NEUTRAL POSITION SWITCH

- 1) Turn the ignition switch to OFF.
- 2) Disconnect the connector of neutral position switch.
- 3) Measure the resistance between neutral position switch terminals.

Non-turbo model:

Gear shift position	Terminal No.	Specified resistance
Neutral position	1 and 2	Less than 1 Ω
Other positions		More than 1 M Ω

Turbo model:

Gear shift position	Terminal No.	Specified resistance
Neutral position	1 and 3	Less than 1 Ω
Other positions		More than 1 M Ω

• NON-TURBO MODEL

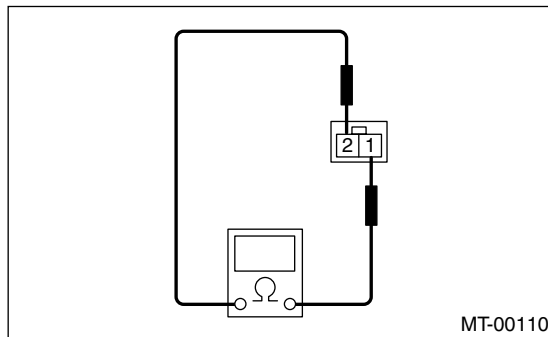

• TURBO MODEL

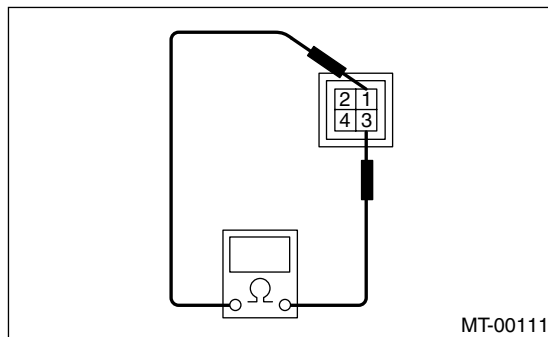

- 4) Replace defective parts.

7. Vehicle Speed Sensor

A: REMOVAL

- 1) Disconnect the ground cable from battery.
- 2) Lift-up the vehicle.
- 3) Remove the front, center rear exhaust pipes and muffler.
- 4) Disconnect the connector from vehicle speed sensor.
- 5) Turn and remove the vehicle speed sensor.

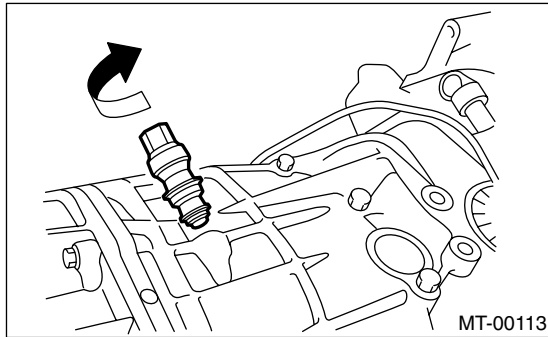

B: INSTALLATION

NOTE:

- Discard the vehicle speed sensor and after removal, replace with a new one.
- Ensure the sensor mounting hole is clean and free of foreign matter.
- Align the tip end of key with key groove on end of speedometer shaft during installation.

- 1) Hand tighten the vehicle speed sensor.
- 2) Tighten the vehicle speed sensor using suitable tool.

Tightening torque:

5.9 N·m (0.6 kgf-m, 4.3 ft-lb)

- 3) Connect the connector to vehicle speed sensor.
- 4) Install the front, center exhaust pipes and muffler.
- 5) Lower the vehicle.
- 6) Connect the battery ground cable to battery.

C: INSPECTION

The vehicle speed sensor can not be inspected as a single unit. Check if speedometer operates normally. If it does not operate normally, inspect the combination meter system. <Ref. to IDI-3, INSPECTION, Combination Meter System.>

PREPARATION FOR OVERHAUL

MANUAL TRANSMISSION AND DIFFERENTIAL

8. Preparation for Overhaul

A: PROCEDURE

- 1) Clean oil, grease, dirt and dust from transmission.
- 2) Remove the drain plug to drain oil. After draining, retighten it as before.

NOTE:

Replace the gasket with a new one.

Tightening torque:

69 N·m (7.0 kgf·m, 50.6 ft·lb)

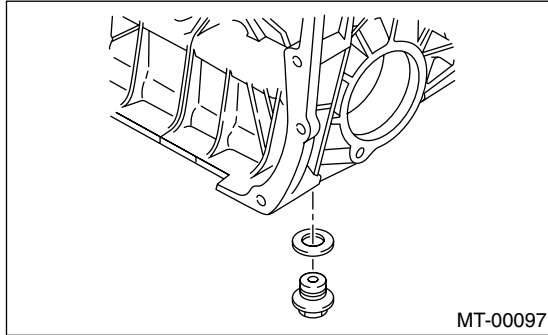

- 3) Attach the transmission to ST.
ST 499937100 TRANSMISSION STAND

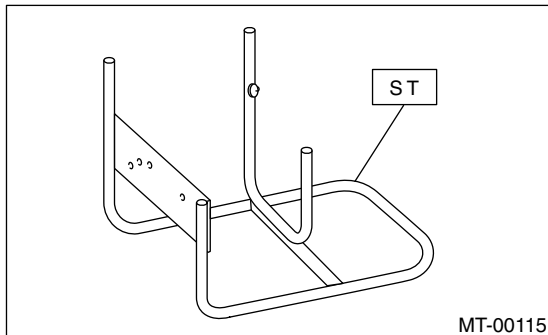

- 4) Rotating parts should be coated with oil prior to assembly.
- 5) All disassembled parts, if to be reused, should be reinstalled in the original positions and directions.
- 6) Gaskets, lock washers and lock nut must be replaced with new ones.
- 7) Liquid gasket should be used where specified to prevent leakage.

TRANSFER CASE AND EXTENSION CASE ASSEMBLY

MANUAL TRANSMISSION AND DIFFERENTIAL

9. Transfer Case and Extension Case Assembly

A: REMOVAL

- 1) Remove the manual transmission assembly from vehicle. <Ref. to 5MT-26, REMOVAL, Manual Transmission Assembly.>
- 2) Remove the back-up light switch and neutral position switch. <Ref. to 5MT-35, REMOVAL, Switches and Harness.>
- 3) Remove the transfer case with extension case assembly.

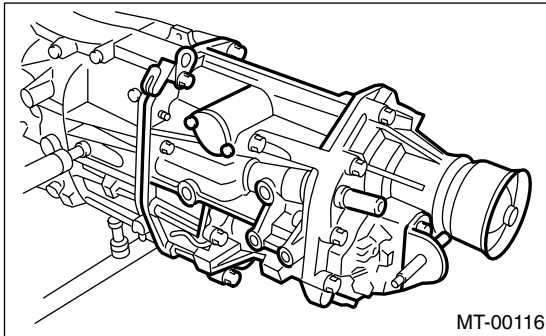

- 4) Remove the shifter arm.
- 5) Remove the extension case assembly.

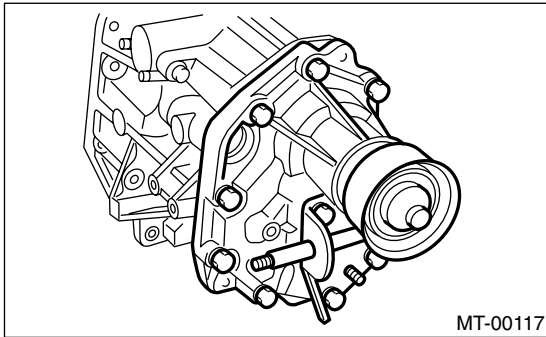

B: INSTALLATION

- 1) Install the center differential and transfer driven gear into transfer case.

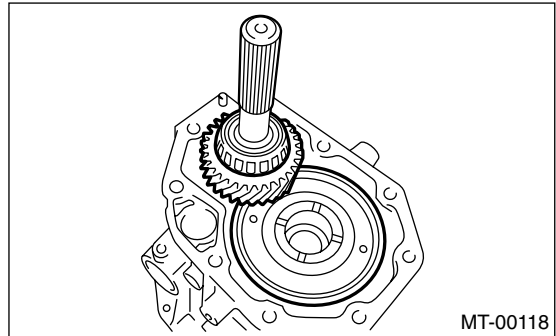

- 2) Remove the bearing outer race from the extension case.

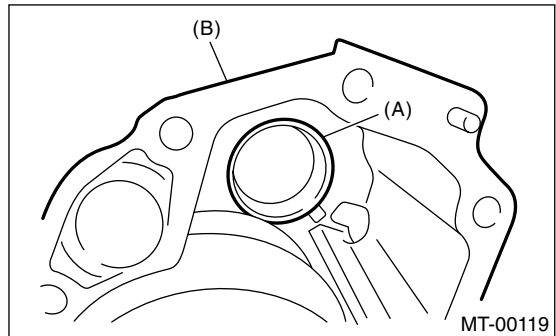

- (A) Bearing outer race
(B) Extension case

- 3) While pressing the bearing outer race horizontally, turn the driven shaft ten rotations.
- 4) Measure the height "W" between transfer case and taper roller bearing on the transfer driven gear.

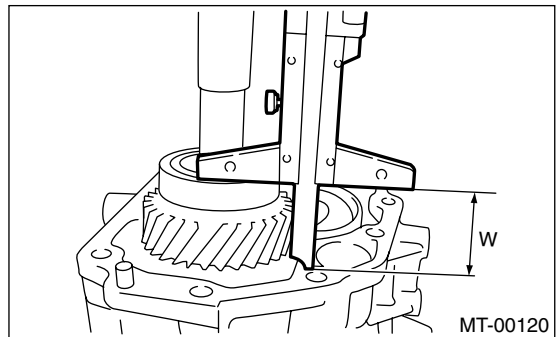

TRANSFER CASE AND EXTENSION CASE ASSEMBLY

MANUAL TRANSMISSION AND DIFFERENTIAL

5) Measure the depth "X".

NOTE:

Measure with bearing cone and thrust washer removed.

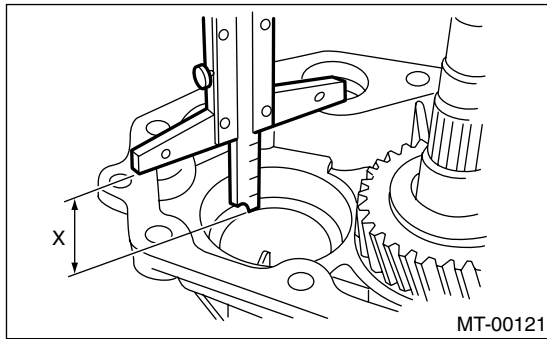

6) Calculate the space "t" using the following equation: $t = X - W + 0.2$ to 0.3 mm (0.008 to 0.012 in)

7) Select the nearest washer in the following table:

Standard clearance between thrust washer and taper roller bearing:

0.2 — 0.3 mm (0.008 — 0.012 in)

NOTE:

Be sure to keep the clearance within specifications.

Thrust washer (50 × 61 × t)	
Part No.	Thickness mm (in)
803050060	0.50 (0.0197)
803050061	0.55 (0.0217)
803050062	0.60 (0.0236)
803050063	0.65 (0.0256)
803050064	0.70 (0.0276)
803050065	0.75 (0.0295)
803050066	0.80 (0.0315)
803050067	0.85 (0.0335)
803050068	0.90 (0.0354)
803050069	0.95 (0.0374)
803050070	1.00 (0.0394)
803050071	1.05 (0.0413)
803050072	1.10 (0.0433)
803050073	1.15 (0.0453)
803050074	1.20 (0.0472)
803050075	1.25 (0.0492)
803050076	1.30 (0.0512)
803050077	1.35 (0.0531)
803050078	1.40 (0.0551)
803050079	1.45 (0.0571)

8) Fit the thrust washers on transfer drive shaft.

9) Install the bearing cone into extension case.

10) Measure the depth "S" between transfer case and center differential.

ST 398643600 GAUGE

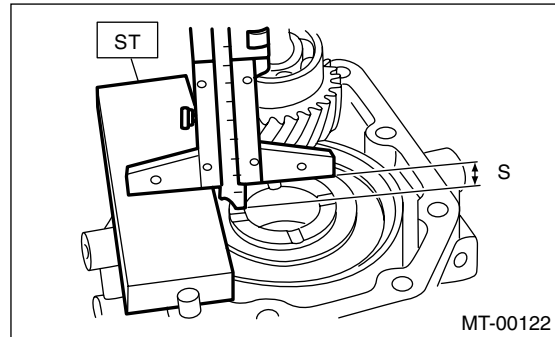

11) Measure the depth "T" between extension case and transfer drive gear.

ST 398643600 GAUGE

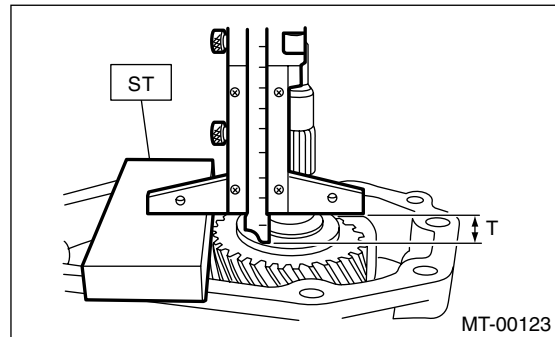

12) Calculate the space "U" using the following equation: $U = S + T - 30$ mm (1.18 in) [Thickness of ST]

13) Select the suitable washer in the following table:

Standard clearance:

0.15 — 0.35 mm (0.0059 — 0.0138 in)

Thrust washer	
Part No.	Thickness mm (in)
803036050	0.9 (0.035)
803036054	1.0 (0.039)
803036051	1.1 (0.043)
803036055	1.2 (0.047)
803036052	1.3 (0.051)
803036056	1.4 (0.055)
803036053	1.5 (0.059)
803036057	1.6 (0.063)
803036058	1.7 (0.067)

14) Fit the thrust washer on center differential.

TRANSFER CASE AND EXTENSION CASE ASSEMBLY

MANUAL TRANSMISSION AND DIFFERENTIAL

15) Apply proper amount of liquid gasket to the transfer case mating surface.

Liquid gasket:

THREE BOND 1215 (Part No. 004403007) or equivalent

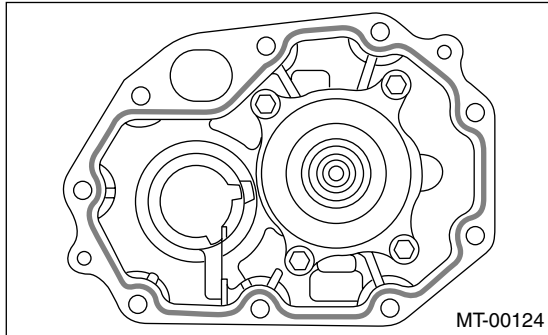

16) Install the extension assembly into transfer case.

Tightening torque:

40 N·m (4.1 kgf·m, 29.7 ft·lb)

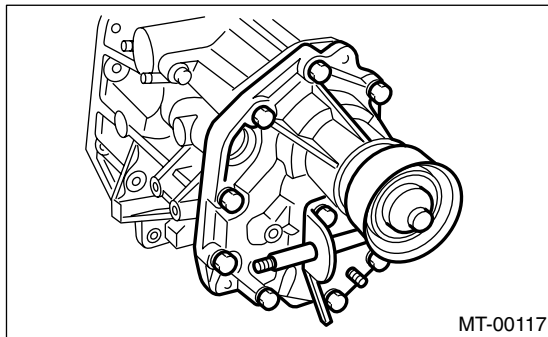

17) Install the shifter arm to transfer case.

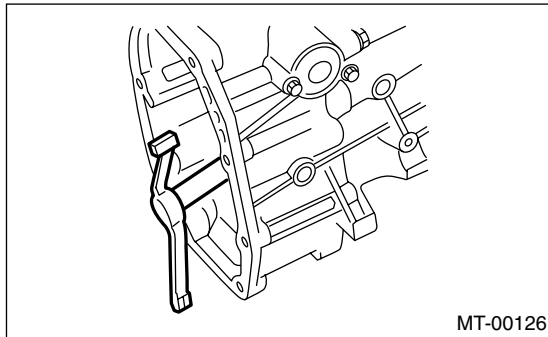

18) Hang the shifter arm on 3rd-4th fork rod.

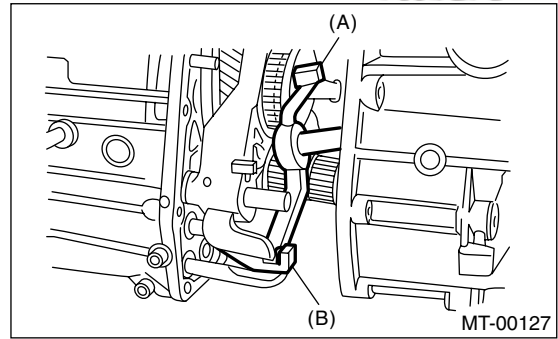

(A) Shifter arm

(B) 3rd-4th fork rod

19) Install the transfer case with extension case assembly to transmission case.

Tightening torque:

24.5 N·m (2.5 kgf·m, 18.1 ft·lb)

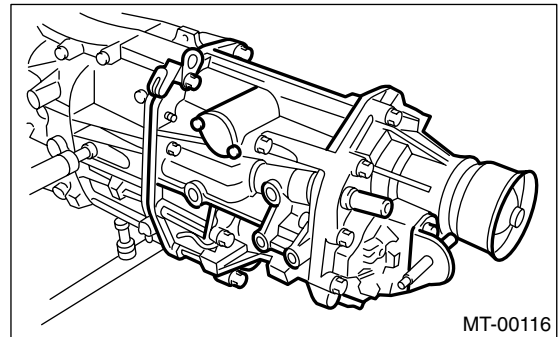

TRANSFER CASE AND EXTENSION CASE ASSEMBLY

MANUAL TRANSMISSION AND DIFFERENTIAL

C: DISASSEMBLY

1. TRANSFER CASE

- 1) Remove the reverse check assembly. <Ref. to 5MT-48, REMOVAL, Reverse Check Sleeve.>
- 2) Remove the oil guide.

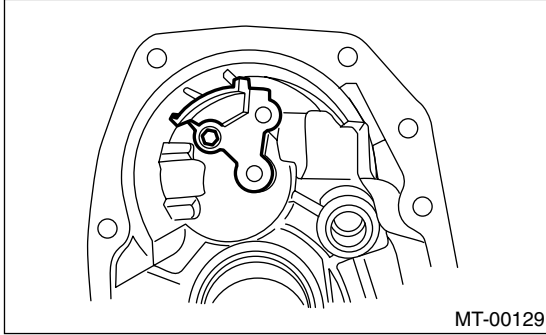

2. EXTENSION CASE

- 1) Remove the transfer drive gear assembly. <Ref. to 5MT-43, REMOVAL, Transfer Drive Gear.>
- 2) Remove the shift bracket.

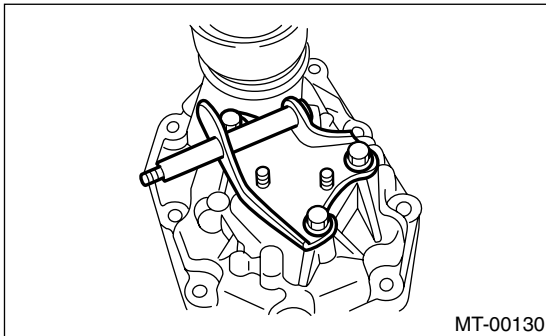

- 3) Remove the oil seal from extension case. <Ref. to 5MT-34, Oil Seal.>

D: ASSEMBLY

1. EXTENSION CASE

- 1) Using the ST, install the oil seal to extension case. <Ref. to 5MT-34, Oil Seal.>

NOTE:

Use a new oil seal.

- 2) Install the shift bracket to extension case.

Tightening torque:

24.5 N·m (2.5 kgf-m, 18.1 ft-lb)

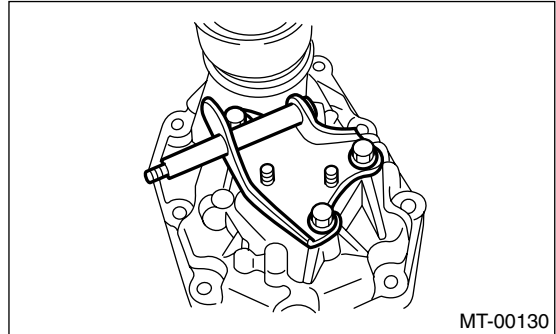

- 3) Install the transfer drive gear to extension case. <Ref. to 5MT-43, INSTALLATION, Transfer Drive Gear.>

2. TRANSFER CASE

- 1) Install the oil guide to transfer case.

Tightening torque:

6.4 N·m (0.65 kgf-m, 4.7 ft-lb)

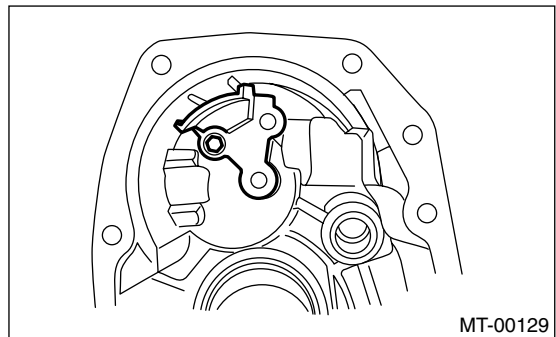

- 2) Install the reverse check sleeve assembly to transfer case. <Ref. to 5MT-48, INSTALLATION, Reverse Check Sleeve.>

10. Transfer Drive Gear

A: REMOVAL

- 1) Remove the manual transmission assembly from vehicle. <Ref. to 5MT-26, REMOVAL, Manual Transmission Assembly.>
- 2) Remove the back-up light switch and neutral position switch. <Ref. to 5MT-35, REMOVAL, Switches and Harness.>
- 3) Remove the transfer case with extension case assembly. <Ref. to 5MT-39, REMOVAL, Transfer Case and Extension Case Assembly.>
- 4) Remove the extension case assembly.
- 5) Remove the transfer driven gear.
- 6) Remove the transfer drive gear.

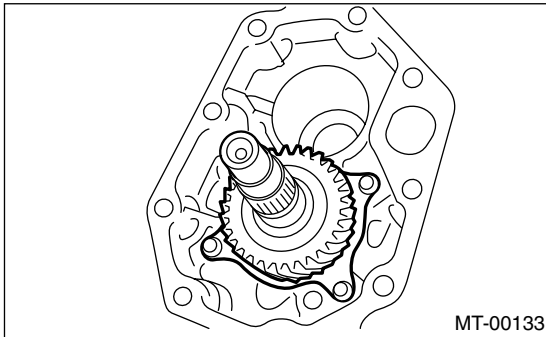

B: INSTALLATION

- 1) Install the transfer drive gear.

Tightening torque:

26 N·m (2.7 kgf·m, 20 ft·lb)

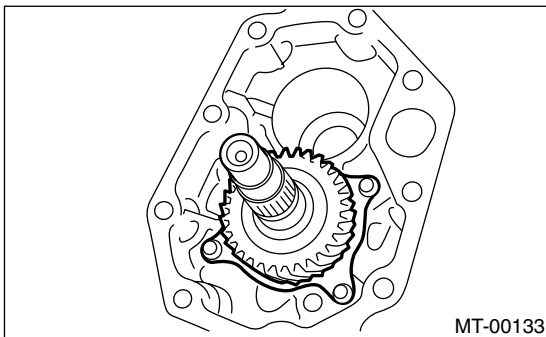

- 2) Install the transfer driven gear.
- 3) Install the extension case assembly.
- 4) Install the transfer case and extension case assembly. <Ref. to 5MT-39, INSTALLATION, Transfer Case and Extension Case Assembly.>
- 5) Install the back-up light switch and neutral position switch. <Ref. to 5MT-35, INSTALLATION, Switches and Harness.>
- 6) Install the manual transmission assembly from vehicle. <Ref. to 5MT-29, INSTALLATION, Manual Transmission Assembly.>

C: DISASSEMBLY

- 1) Remove the snap ring.

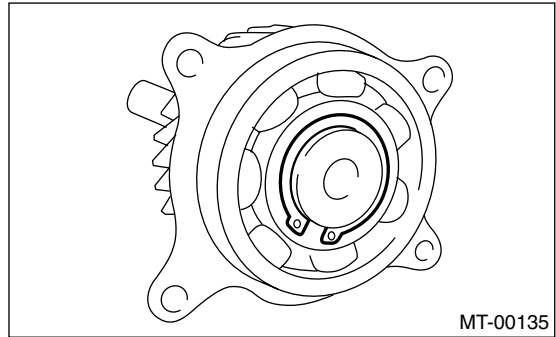

- 2) Remove the ball bearing.

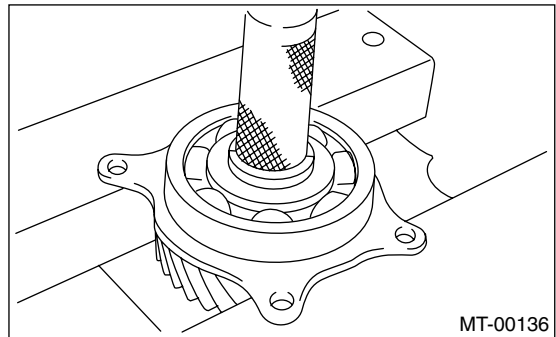

D: ASSEMBLY

- 1) Set the ST applying to inner race of bearing and install to drive shaft.

ST 398177700 INSTALLER

NOTE:

Do not apply pressure in excess of 10 kN (1 ton, 1.1 US ton, 1.0 Imp ton)

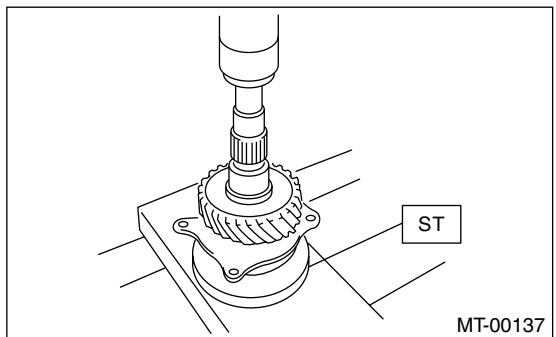

- 2) Install the snap ring on transfer drive shaft.
- 3) Check the clearance between snap ring and ball bearing. <Ref. to 5MT-44, INSPECTION, Transfer Drive Gear.>

TRANSFER DRIVE GEAR

MANUAL TRANSMISSION AND DIFFERENTIAL

E: INSPECTION

1) Bearings

Replace the bearings in the following cases:

- Broken or rusty bearings
- Worn or damaged
- Bearings that fail to turn smoothly or make abnormal noise when turned after gear oil lubrication.

2) Drive gear

Replace the drive gear in the following cases:

- If their tooth surfaces and shaft are excessively broken or damaged.

3) Measure the clearance between snap ring and inner race of ball bearing with a thickness gauge.

Clearance:

0.01 — 0.15 mm (0.0004 — 0.0059 in)

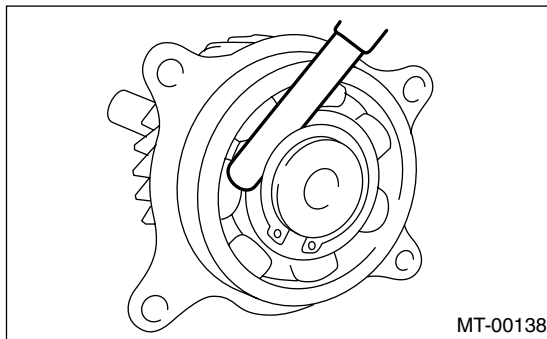

If the measurement is not within specification, select a suitable snap ring.

Snap ring (Outer-30)	
Part No.	Thickness mm (in)
805030041	1.53 (0.0602)
805030042	1.65 (0.0650)
805030043	1.77 (0.0697)

11. Transfer Driven Gear

A: REMOVAL

- 1) Remove the manual transmission assembly from vehicle. <Ref. to 5MT-26, REMOVAL, Manual Transmission Assembly.>
- 2) Remove the back-up light switch and neutral position switch. <Ref. to 5MT-35, REMOVAL, Switches and Harness.>
- 3) Remove the transfer case with extension case assembly. <Ref. to 5MT-39, REMOVAL, Transfer Case and Extension Case Assembly.>
- 4) Remove the extension case assembly.
- 5) Remove the transfer driven gear.

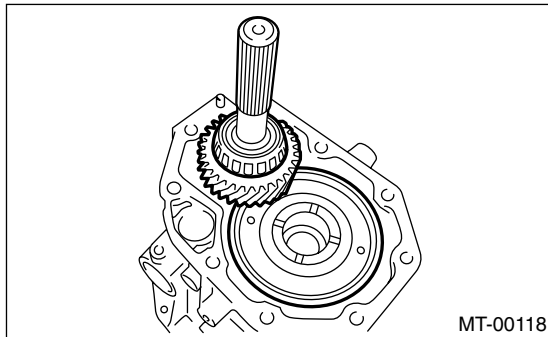

- 6) Remove the bearing outer race from extension case and transfer case.

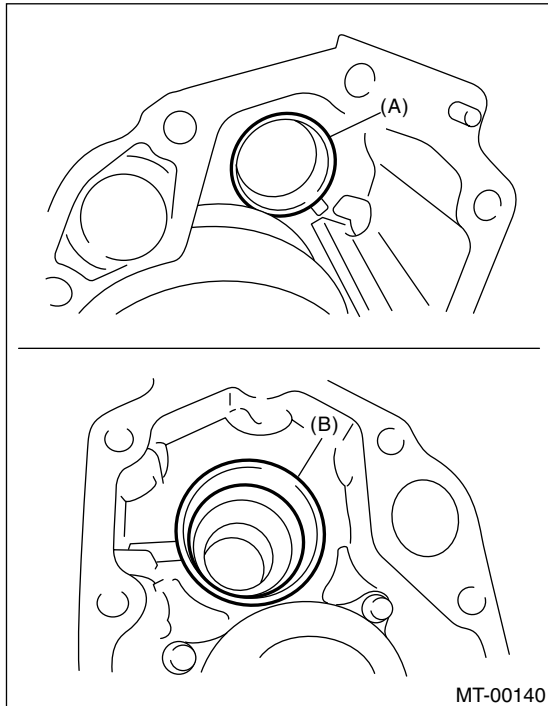

- (A) Bearing outer race (transfer case)
- (B) Bearing outer race (extension case)

B: INSTALLATION

- 1) Install the bearing outer race to extension case and transfer case.

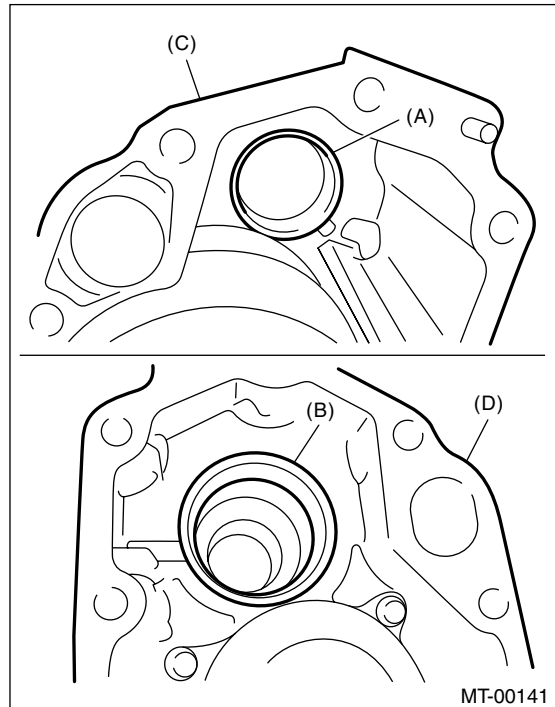

- (A) Bearing outer race
- (B) Bearing outer race
- (C) Transfer case
- (D) Extension case

- 2) Install the transfer driven gear.

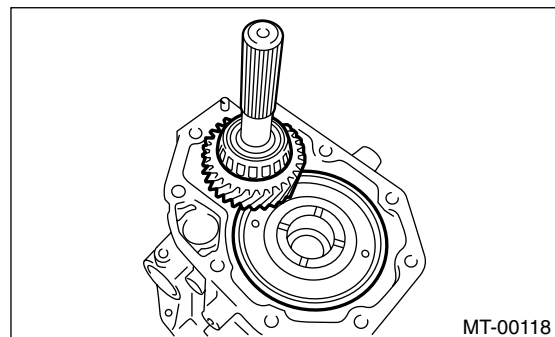

- 3) Install the transfer case and extension case assembly. <Ref. to 5MT-39, INSTALLATION, Transfer Case and Extension Case Assembly.>
- 4) Install the back-up light switch and neutral position switch. <Ref. to 5MT-35, INSTALLATION, Switches and Harness.>
- 5) Install the manual transmission assembly to vehicle. <Ref. to 5MT-29, INSTALLATION, Manual Transmission Assembly.>

TRANSFER DRIVEN GEAR

MANUAL TRANSMISSION AND DIFFERENTIAL

C: DISASSEMBLY

1) Using the ST, remove the roller bearing (extension case side).

ST 498077000 REMOVER

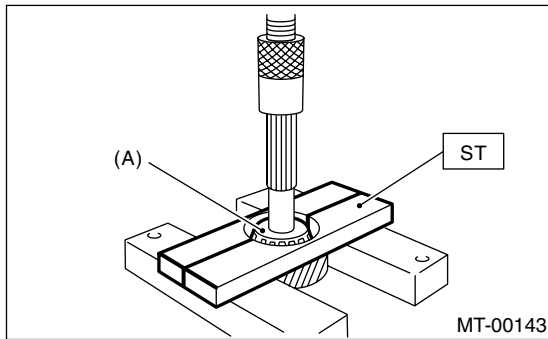

(A) Roller bearing

2) Using the ST1 and ST2, remove the roller bearing (transfer case side).

ST1 498077000 REMOVER

ST2 899864100 REMOVER

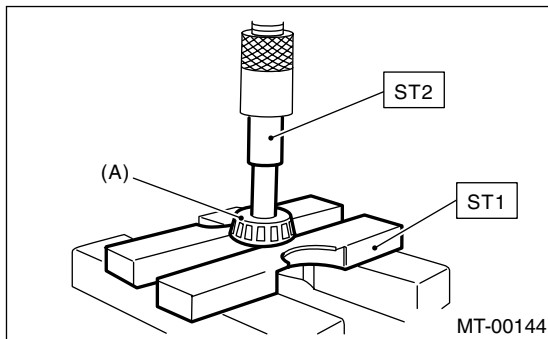

(A) Roller bearing

D: ASSEMBLY

1) Using the ST, install the roller bearing (extension case side).

ST1 398177700 INSTALLER

ST2 899864100 REMOVER

NOTE:

Do not apply pressure in excess of 10 kN (1 ton, 1.1 US ton, 1.0 Imp ton)

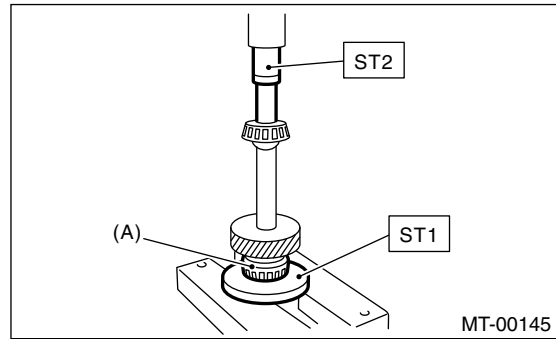

(A) Roller bearing

2) Using the ST, install the roller bearing (transfer case side).

ST 499757002 INSTALLER

NOTE:

Do not apply pressure in excess of 10 kN (1 ton, 1.1 US ton, 1.0 Imp ton)

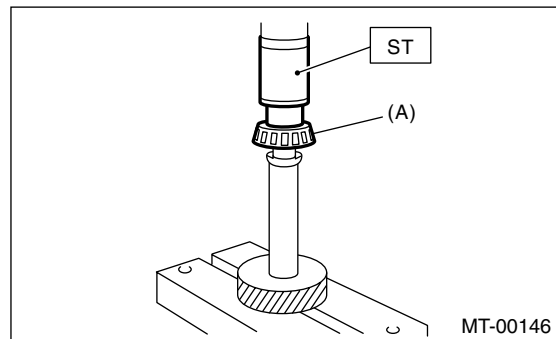

(A) Roller bearing

E: INSPECTION

1) Bearings

Replace the bearings in the following cases:

- Broken or rusty bearings
- Worn or damaged
- Bearings that fail to turn smoothly or make abnormal noise when turned after gear oil lubrication.

2) Driven gear

Replace the drive gear in the following cases:

- If their tooth surfaces and shaft are excessively broken or damaged.

12.Center Differential

A: REMOVAL

- 1) Remove the manual transmission assembly from vehicle. <Ref. to 5MT-26, REMOVAL, Manual Transmission Assembly.>
- 2) Remove the transfer case with extension case assembly. <Ref. to 5MT-39, REMOVAL, Transfer Case and Extension Case Assembly.>
- 3) Remove the extension case assembly. <Ref. to 5MT-39, REMOVAL, Transfer Case and Extension Case Assembly.>
- 4) Remove the transfer driven gear. <Ref. to 5MT-45, REMOVAL, Transfer Driven Gear.>
- 5) Remove the center differential.

B: INSTALLATION

- 1) Install the center differential into transfer case.
- 2) Install the transfer driven gear. <Ref. to 5MT-45, INSTALLATION, Transfer Driven Gear.>
- 3) Install the extension case assembly. <Ref. to 5MT-39, INSTALLATION, Transfer Case and Extension Case Assembly.>
- 4) Install the transfer case with extension case assembly. <Ref. to 5MT-39, REMOVAL, Transfer Case and Extension Case Assembly.>
- 5) Install the back-up light switch and neutral position switch. <Ref. to 5MT-35, REMOVAL, Switches and Harness.>
- 6) Install the manual transmission assembly to vehicle. <Ref. to 5MT-29, INSTALLATION, Manual Transmission Assembly.>

C: DISASSEMBLY

NOTE:

Do not disassemble the center differential because it is a non-disassemble part.

Remove the ball bearing using ST.

NOTE:

Do not reuse the ball bearing.

ST 498077300 CENTER DIFFERENTIAL BEARING REMOVER

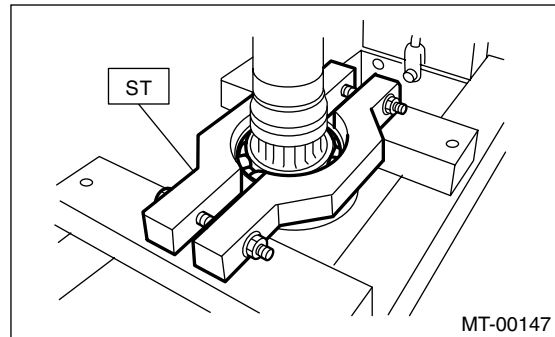

D: ASSEMBLY

Install the ball bearing to center differential assembly.

NOTE:

Do not apply pressure in excess of 10 kN (1 ton, 1.1 US ton, 1.0 Imp ton).

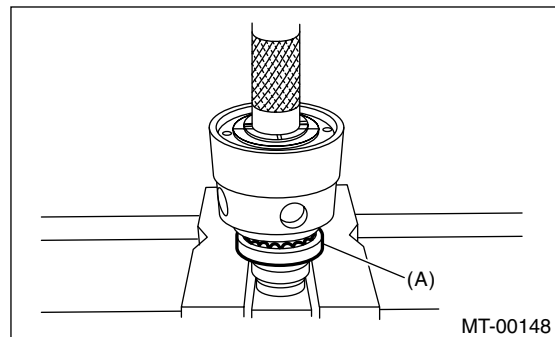

(A) Ball bearing

E: INSPECTION

1) Bearings

Replace the bearings in the following cases:

- Broken or rusty bearings
- Worn or damaged
- Bearings that fail to turn smoothly or make abnormal noise when turned after gear oil lubrication.
- Bearings having other defects

2) Center differential

Replace the center differential assembly in the following case:

- Worn or damaged

REVERSE CHECK SLEEVE

MANUAL TRANSMISSION AND DIFFERENTIAL

13. Reverse Check Sleeve

A: REMOVAL

- 1) Remove the manual transmission assembly from vehicle. <Ref. to 5MT-26, REMOVAL, Manual Transmission Assembly.>
- 2) Remove the transfer case with extension case assembly. <Ref. to 5MT-39, REMOVAL, Transfer Case and Extension Case Assembly.>
- 3) Remove the shifter arm.
- 4) Remove the plug, spring, washer and reverse check ball.

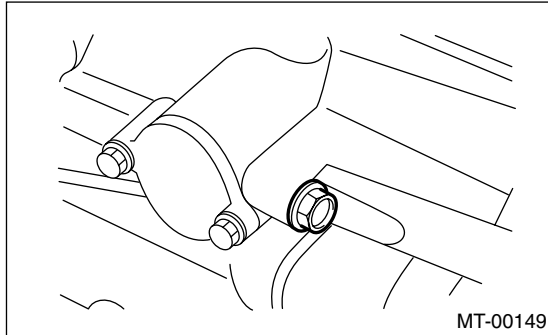

- 5) Remove the reverse check sleeve.

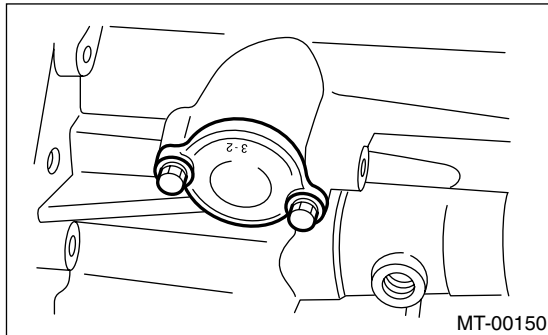

B: INSTALLATION

- 1) Install the reverse check sleeve.

Tightening torque:

6.4 N·m (0.65 kgf·m, 4.7 ft·lb)

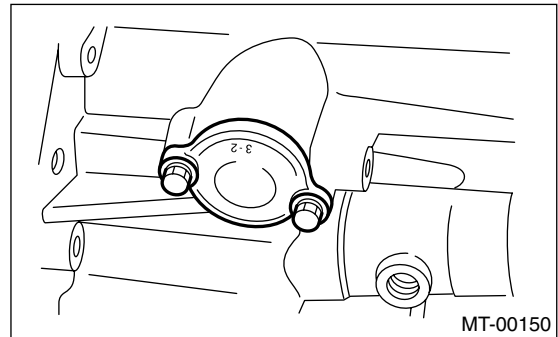

- 2) Install the ball, spring, washer and plug to transfer case.

Tightening torque:

9.75 N·m (1.0 kgf·m, 7.2 ft·lb)

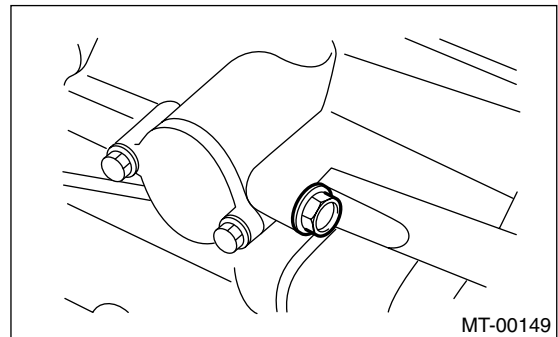

- 3) Install the shifter arm to transfer case assembly.
- 4) Install the transfer case with extension case assembly. <Ref. to 5MT-39, INSTALLATION, Transfer Case and Extension Case Assembly.>
- 5) Install the manual transmission assembly to vehicle. <Ref. to 5MT-29, INSTALLATION, Manual Transmission Assembly.>

REVERSE CHECK SLEEVE

MANUAL TRANSMISSION AND DIFFERENTIAL

C: DISASSEMBLY

1) Cover the reverse check sleeve with a rag, and remove the snap ring using a screwdriver.

NOTE:

Replace the snap ring with a new one if deformed or weakened.

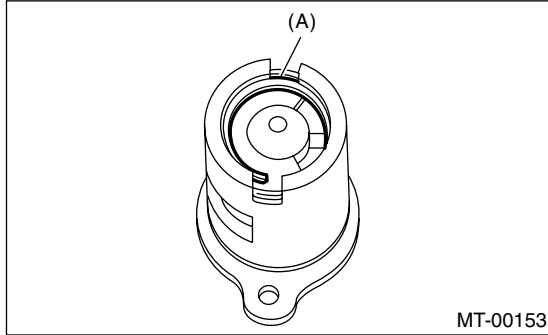

(A) Snap ring

2) Remove the reverse check plate, reverse check spring, reverse check cam, return spring (5th-Rev), reverse accent shaft, return spring cap and return spring (1st-2nd).

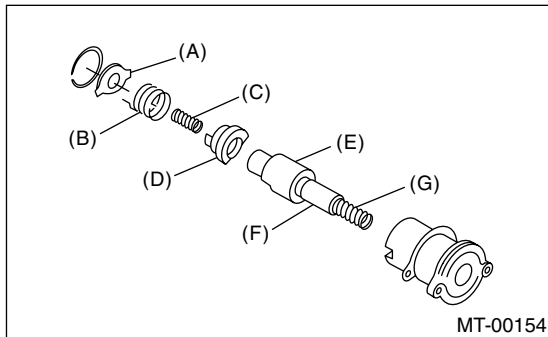

- (A) Reverse check plate
- (B) Reverse check spring
- (C) Return spring (5th-Rev)
- (D) Reverse check cam
- (E) Reverse accent shaft
- (F) Return spring cap
- (G) Return spring (1st-2nd)

3) Remove the O-ring.

NOTE:

- Reverse check sleeve assembly uses an O-ring which should not be scratched.
- Be careful not to break the adjustment shim placed between reverse check sleeve assembly and case.

D: ASSEMBLY

1) Install the return spring (1st-2nd), return spring cap, reverse accent shaft, check cam, return spring and check spring onto reverse check sleeve.

NOTE:

Be sure the bent section of reverse check spring is positioned in the groove in check cam.

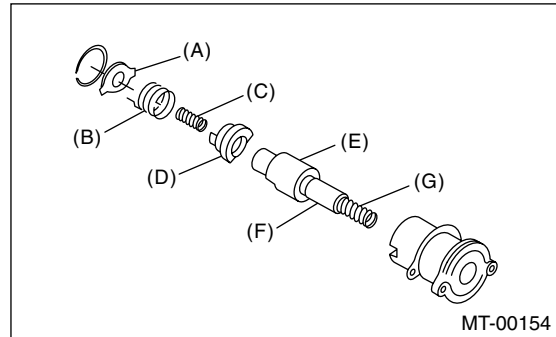

- (A) Reverse check plate
- (B) Reverse check spring
- (C) Return spring (5th-Rev)
- (D) Reverse check cam
- (E) Reverse accent shaft
- (F) Return spring cap
- (G) Return spring (1st-2nd)

2) Hook the bent section of reverse check spring over reverse check plate.

3) Rotate the cam so that the protrusion of reverse check cam is at the opening in plate.

4) With the cam held in that position, install the plate onto reverse check sleeve and hold with snap ring.

5) Position the O-ring in groove in sleeve.

REVERSE CHECK SLEEVE

MANUAL TRANSMISSION AND DIFFERENTIAL

E: INSPECTION

- Make sure the cutout section of reverse accent shaft is aligned with the opening in reverse check sleeve.
- Spin the cam by hand for smooth rotation.
- Move the cam and shaft all the way toward plate and release.

If the cam does not return properly, replace the reverse check spring; if shaft does not, check for scratches on the inner surface of sleeve. If sleeve is in good order, replace the spring.

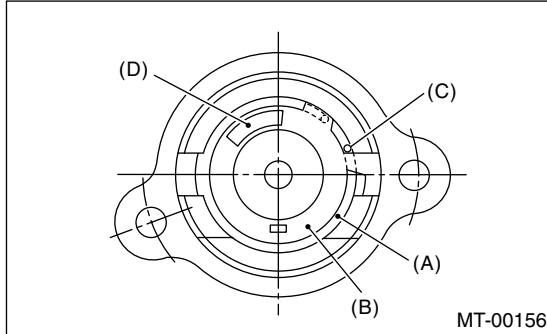

- (A) Snap ring
- (B) Reverse check plate
- (C) Check spring
- (D) Check cam

- Select a suitable reverse accent shaft and reverse check plate. <Ref. to 5MT-50, ADJUSTMENT, Reverse Check Sleeve.>

F: ADJUSTMENT

1. NEUTRAL POSITION ADJUSTMENT

- 1) Shift the gear into 3rd gear position.
- 2) Shifter arm turns lightly toward the 1st/2nd gear side but heavily toward the reverse gear side because of the function of return spring, until arm contacts the stopper.
- 3) Make adjustment so that the heavy stroke (reverse side) is a little more than the light stroke (1st/2nd side).
- 4) To adjust, remove the bolts holding reverse check sleeve assembly to the case, move the sleeve assembly outward, and place adjustment shim (0 to 1 ea.) between sleeve assembly and case to adjust the clearance.

CAUTION:

Be careful not to break the O-ring when placing shim(s).

NOTE:

- When the shim is removed, the neutral position will move closer to reverse; when shim is added, the neutral position will move closer to 1st gear.
- If the shims alone cannot adjust clearance, replace the reverse accent shaft and re-adjust.

Adjustment shim	
Part No.	Thickness mm (in)
32190AA000	0.15 (0.0059)
32190AA010	0.30 (0.0118)

Reverse accent shaft		
Part No.	Mark	Remarks
32188AA090	3	Neutral position is closer to 1st gear.
32188AA100	0	Standard
32188AA110	1	Neutral position is closer to reverse gear.

2. REVERSE CHECK PLATE ADJUSTMENT

- 1) Shift the shifter arm to "5th" and then to reverse to see if reverse check mechanism operates properly.
- 2) Also check to see if the arm returns to neutral when released from reverse position. If the arm does not return properly, replace the reverse check plate.

Reverse check plate			
Part No.	(A): No.	Angle θ	Remarks
32189AA000	0	28°	Arm stops closer to 5th gear.
32189AA010	1	31°	Arm stops closer to 5th gear.
32189AA020	2	34°	Arm stops in the center.
32189AA030	3	37°	Arm stops closer to reverse gear.
32189AA040	4	40°	Arm stops closer to reverse gear.

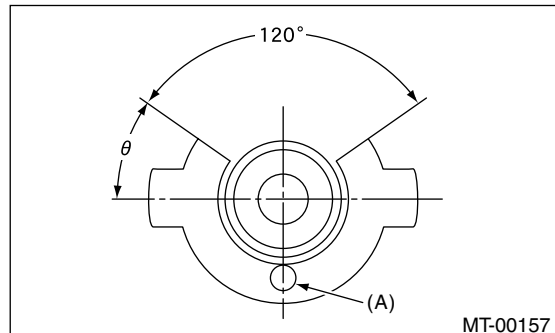

14. Transmission Case

A: REMOVAL

- 1) Remove the manual transmission assembly from vehicle. <Ref. to 5MT-26, REMOVAL, Manual Transmission Assembly.>
- 2) Remove the clutch release lever. <Ref. to CL-15, REMOVAL, Release Bearing and Lever.>
- 3) Remove the transfer case with extension case assembly. <Ref. to 5MT-39, REMOVAL, Transfer Case and Extension Case Assembly.>
- 4) Remove the bearing mounting bolts.

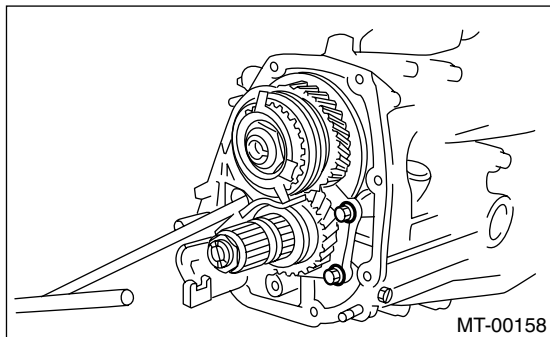

- 5) Remove the main shaft rear plate.

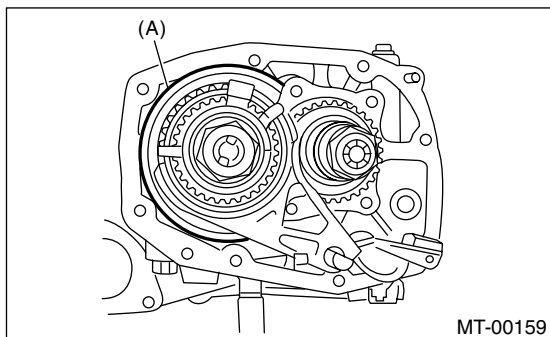

(A) Main shaft rear plate

- 6) Put vinyl tape around the splines of right and left axle drive shafts to prevent damage to oil seal.

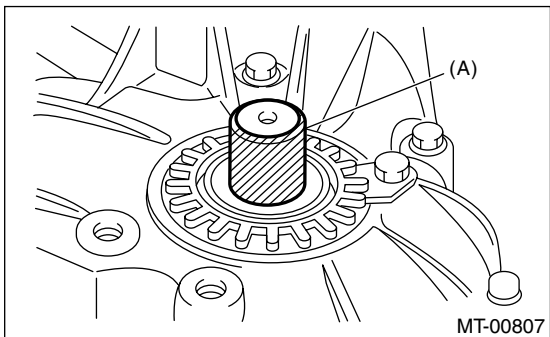

(A) Vinyl tape

- 7) Separate the transmission case into right and left cases by loosening the coupling bolts and nuts.

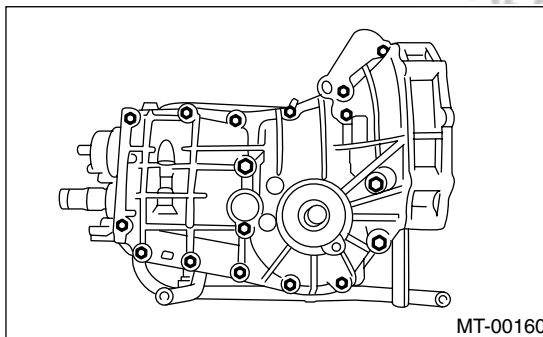

- 8) Remove the drive pinion shaft assembly from left side transmission case.

NOTE:

Use a hammer handle, etc. to remove if too tight.

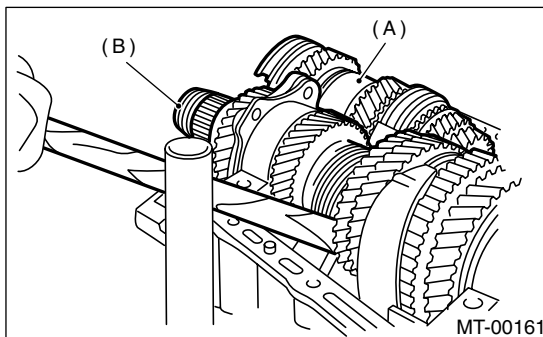

(A) Main shaft assembly

(B) Drive pinion shaft assembly

- 9) Remove the main shaft assembly.
- 10) Remove the differential assembly.

NOTE:

- Be careful not to confuse the right and left roller bearing outer races.
- Be careful not to damage the retainer oil seal.

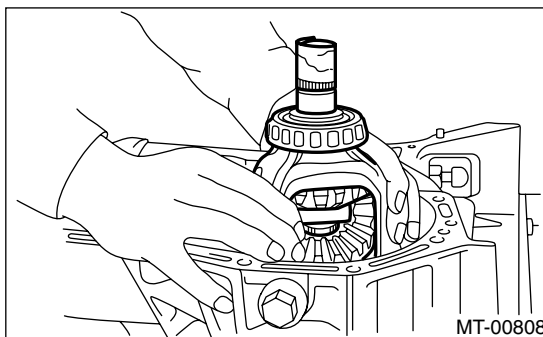

TRANSMISSION CASE

MANUAL TRANSMISSION AND DIFFERENTIAL

B: INSTALLATION

- 1) Wipe off grease, oil and dust on the mating surfaces of transmission cases with white gasoline.
- 2) Install the front differential assembly.
- 3) Install the main shaft assembly.
Install the transmission case knock pin into needle bearing knock pin hole.
- 4) Install the drive pinion shaft assembly.
Install the transmission case knock pin into roller bearing knock pin hole.
- 5) Apply liquid gasket, and then put the case right side and left side together.

Liquid gasket:

THREE BOND 1215 (Part No. 004403007) or equivalent

- 6) Tighten the seventeen bolts with bracket, clip, etc. as shown in the figure.

NOTE:

- Insert the bolts from bottom and tighten the nuts at top.
- Put the cases together so that drive pinion shim and input shaft holder shim are not caught up in between.
- Confirm that the speedometer gear is meshed.

Tightening torque:

8 mm bolt

25 N·m (2.5 kgf·m, 18.1 ft·lb)

★ 10 mm bolt

39 N·m (4.0 kgf·m, 28.9 ft·lb)

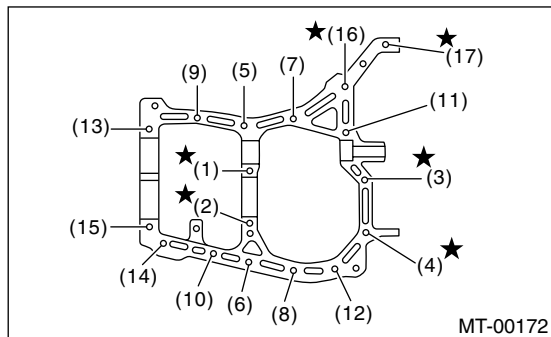

- 7) Tighten the ball bearing attachment bolts.

Tightening torque:

29 N·m (3.0 kgf·m, 21.7 ft·lb)

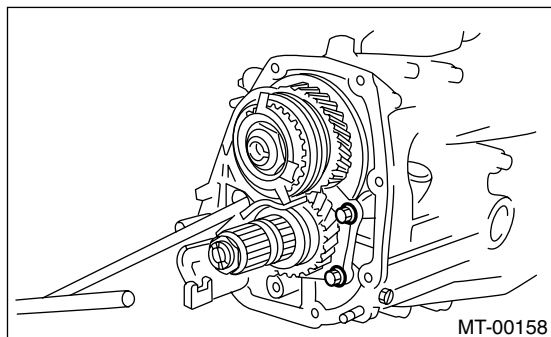

- 8) Backlash adjustment of hypoid gear and preload adjustment of roller bearing:

NOTE:

Support the drive pinion assembly with ST.
ST 498427100 STOPPER

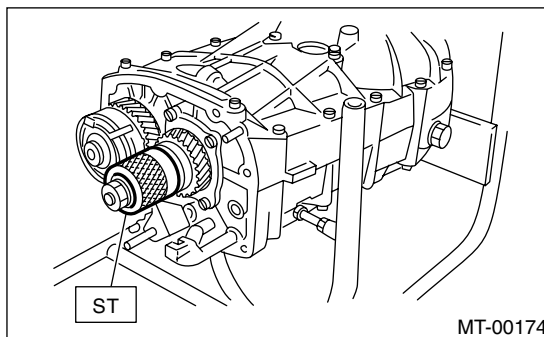

- 9) Place the transmission with case left side facing downward and put ST1 on bearing cup.

- 10) Screw the retainer assembly into left case from the bottom using ST2. Fit the ST3 on transmission main shaft. Shift the gear into 4th or 5th and turn the shaft several times. Screw in the retainer while turning ST3 until a slight resistance is felt on ST2. This is the contact point of hypoid gear and drive pinion shaft. Repeat the above sequence several times to ensure the contact point.

ST1 399780104 WEIGHT

ST2 499787000 WRENCH ASSY

ST3 499927100 HANDLE

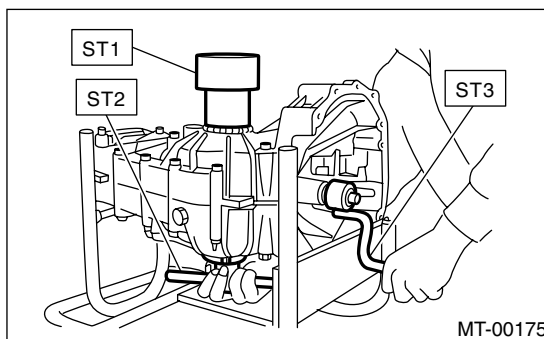

TRANSMISSION CASE

MANUAL TRANSMISSION AND DIFFERENTIAL

11) Remove the weight and screw in the retainer without O-ring on upper side and stop at the point where slight resistance is felt.

NOTE:

At this point, the backlash between hypoid gear and drive pinion shaft is zero.

ST 499787000 WRENCH ASSY

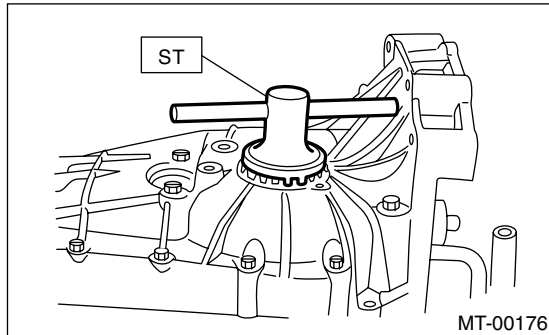

12) Fit the lock plate. Loosen the retainer on the lower side by 1-1/2 notches of lock plate and turn in the retainer on upper side by the same amount in order to obtain the backlash.

NOTE:

The notch on the lock plate moves by 1/2 notch if the plate is turned upside down.

13) Turn in the retainer on the upper side additionally by 1 notch in order to apply preload on taper roller bearing.

14) Tighten temporarily both the upper and lower lock plates and mark both holder and lock plate for later readjustment.

15) Turn the transmission main shaft several times while tapping around the retainer lightly with plastic hammer.

16) Inspect and adjust the backlash and tooth contact of hypoid gear. <Ref. to 5MT-72, INSPECTION, Front Differential Assembly.>

17) After checking the tooth contact of hypoid gears, remove the lock plate. Then loosen the retainer until the O-ring groove appears. Fit the O-ring into groove and tighten the retainer into the position where retainer has been tightened in. Tighten the lock plate.

NOTE:

Carry out this job on both upper and lower retainers.

Tightening torque:

T: 24.5 N·m (2.5 kgf·m, 18.1 ft·lb)

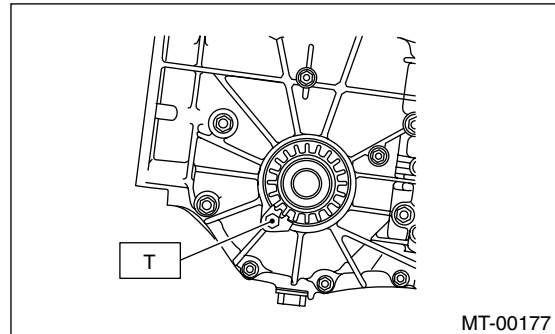

18) Selecting of main shaft rear plate. <Ref. to 5MT-59, ADJUSTMENT, Main Shaft Assembly.>

19) Install the clutch release lever and bearing. <Ref. to CL-16, INSTALLATION, Release Bearing and Lever.>

20) Install the transfer case with extension case assembly. <Ref. to 5MT-39, INSTALLATION, Transfer Case and Extension Case Assembly.>

21) Install the manual transmission assembly into the vehicle. <Ref. to 5MT-29, INSTALLATION, Manual Transmission Assembly.>

C: INSPECTION

Check the transmission case for cracks, damage, and oil leaks.

MAIN SHAFT ASSEMBLY

MANUAL TRANSMISSION AND DIFFERENTIAL

15. Main Shaft Assembly

A: REMOVAL

- 1) Remove the manual transmission assembly from vehicle. <Ref. to 5MT-26, REMOVAL, Manual Transmission Assembly.>
- 2) Remove the transfer case with extension case assembly. <Ref. to 5MT-39, REMOVAL, Transfer Case and Extension Case Assembly.>
- 3) Remove the transmission case. <Ref. to 5MT-39, REMOVAL, Transfer Case and Extension Case Assembly.>
- 4) Remove the drive pinion shaft assembly. <Ref. to 5MT-60, REMOVAL, Drive Pinion Shaft Assembly.>
- 5) Remove the main shaft assembly.

B: INSTALLATION

- 1) Install the needle bearing and oil seal onto the front of transmission main shaft assembly.

NOTE:

- Wrap the clutch splined section with vinyl tape to prevent damage to oil seal.
- Apply grease (Unilube #2 or equivalent) to the sealing lip of oil seal.
- Use a new one.

- 2) Install the needle bearing outer race knock pin hole into transmission case knock pin.

NOTE:

Align the end face of seal with surface (A) when installing oil seal.

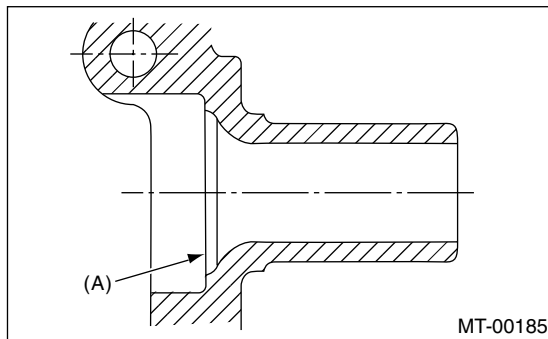

- 3) Install the drive pinion assembly. <Ref. to 5MT-60, INSTALLATION, Drive Pinion Shaft Assembly.>
- 4) Install the transmission case. <Ref. to 5MT-52, INSTALLATION, Transmission Case.>
- 5) Install the transfer case with extension case assembly. <Ref. to 5MT-39, INSTALLATION, Transfer Case and Extension Case Assembly.>

- 6) Install the manual transmission assembly to vehicle. <Ref. to 5MT-29, INSTALLATION, Manual Transmission Assembly.>

C: DISASSEMBLY

- 1) Put vinyl tape around the main shaft splines to protect oil seal from damage. Then pull out the oil seal and needle bearing by hand.
- 2) Remove the lock nut from transmission main shaft assembly.

NOTE:

Remove the caulking before removing lock nut.

- | | | |
|-----|-----------|---------------------|
| ST1 | 498937000 | TRANSMISSION HOLDER |
| ST2 | 499987003 | SOCKET WRENCH (35) |

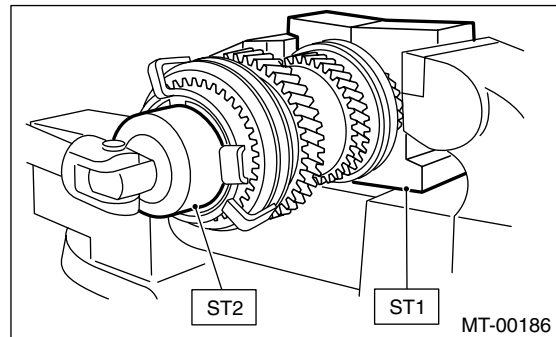

- 3) Remove the 5th-Rev sleeve and hub assembly, baulk ring, 5th drive gear and needle bearing.

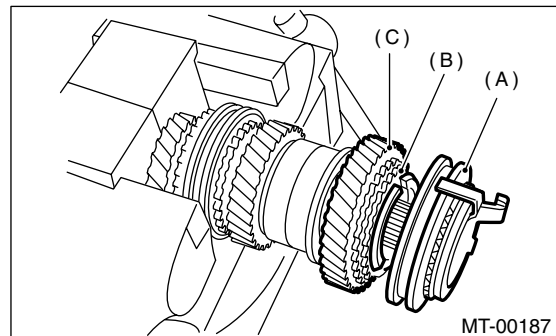

- | | |
|-----|-----------------------------|
| (A) | 5th-Rev sleeve and hub ASSY |
| (B) | Baulk ring |
| (C) | 5th drive gear |

MAIN SHAFT ASSEMBLY

MANUAL TRANSMISSION AND DIFFERENTIAL

4) Remove the snap ring and synchro cone stopper from 5th-Rev sleeve and hub assembly.

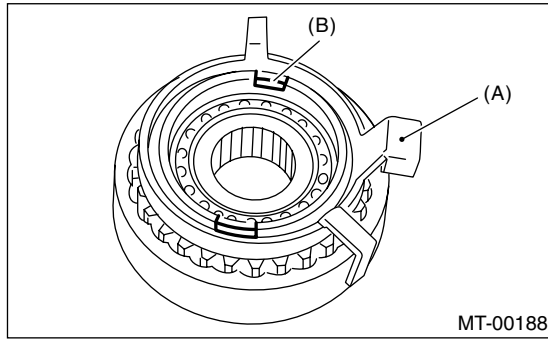

- (A) Synchro cone stopper
- (B) Snap ring

5) Using the ST1, ST2 and a press, remove the ball bearing, synchro cone and baulk ring (Rev).

NOTE:

- Replace the sleeve and hub with new ones. Do not attempt to disassemble because they must engage at a specified point. If they should be disassembled, mark engagement point on splines beforehand.

- Do not reuse the ball bearing.

ST1 499757002 INSTALLER

ST2 498077400 SYNCHRO CONE REMO-
VER

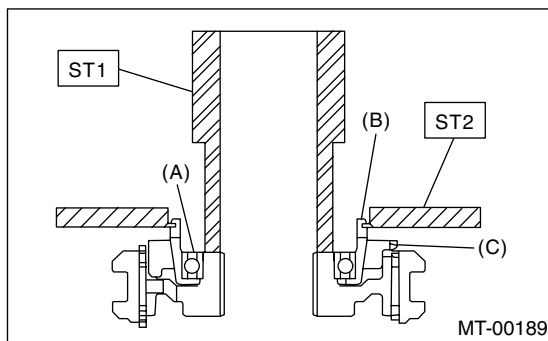

- (A) Ball bearing
- (B) Synchro cone
- (C) Baulk ring

6) Using the ST1 and ST2, remove rest of the parts.

NOTE:

Replace the sleeve and hub with new ones. Do not attempt to disassemble because they must engage at a specified point. If they should be disassembled, mark engagement point on splines beforehand.

ST1 899864100 REMOVER

ST2 899714110 REMOVER

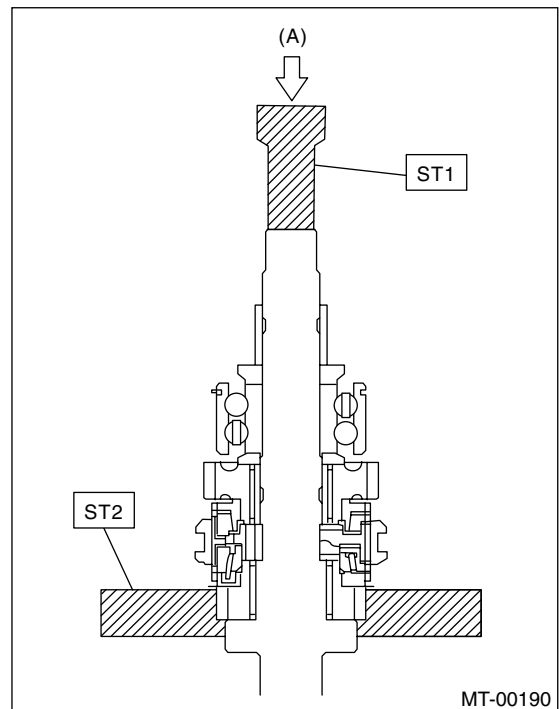

- (A) Press

MAIN SHAFT ASSEMBLY

MANUAL TRANSMISSION AND DIFFERENTIAL

D: ASSEMBLY

1) Assemble each sleeve and hub assembly.

NOTE:

Position the open ends of spring 120° apart.

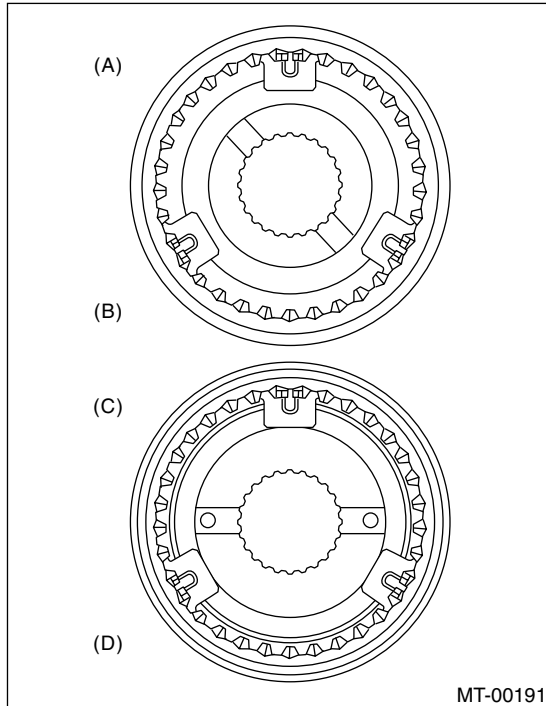

- (A) 3rd-4th hub ASSY
- (B) 3rd gear side
- (C) 5th-Rev hub ASSY
- (D) 5th gear side

2) Install the 3rd drive gear, outer baulk ring, synchro cone, inner baulk ring, sleeve and hub assembly for 3rd needle bearing on transmission main shaft.

NOTE:

Align the groove in baulk ring with shifting insert.

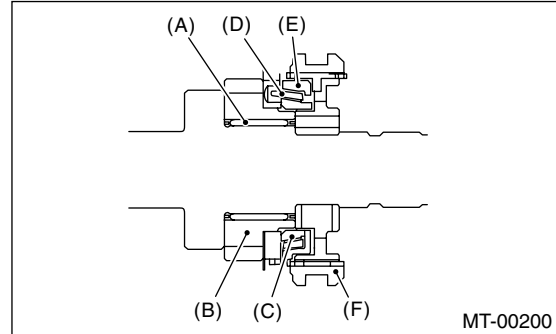

- (A) 3rd needle bearing
- (B) 3rd drive gear
- (C) Inner baulk ring
- (D) Synchro cone
- (E) Outer baulk ring
- (F) Sleeve and hub ASSY

3) Install the 4th needle bearing race onto transmission main shaft using ST1, ST2 and a press.

NOTE:

Do not apply pressure in excess of 10 kN (1 ton, 1.1 US ton, 1.0 Imp ton).

ST1 899714110 REMOVER

ST2 499877000 RACE 4-5 INSTALLER

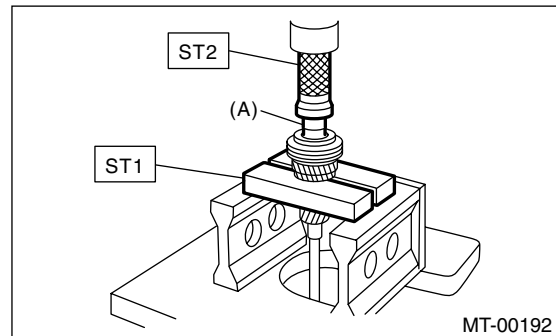

- (A) 4th needle bearing race

MAIN SHAFT ASSEMBLY

MANUAL TRANSMISSION AND DIFFERENTIAL

4) Install the baulk ring, needle bearing, 4th drive gear and 4th gear thrust washer to transmission main shaft.

NOTE:

Align the baulk ring and gear & hub assembly with key groove.

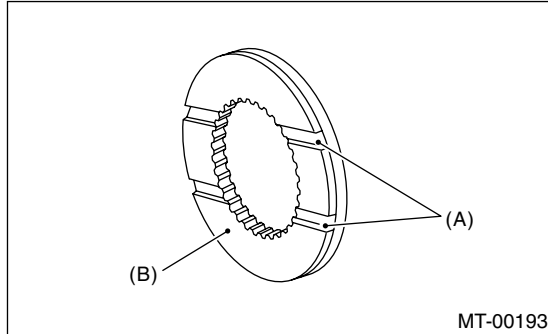

- (A) Groove
- (B) 4th gear side

5) Drive the ball bearing onto the rear section of transmission main shaft using ST1, ST2 and a press.

NOTE:

Do not apply pressure in excess of 10 kN (1 ton, 1.1 US ton, 1.0 Imp ton).

- ST1 899714110 REMOVER
- ST2 499877000 RACE 4-5 INSTALLER

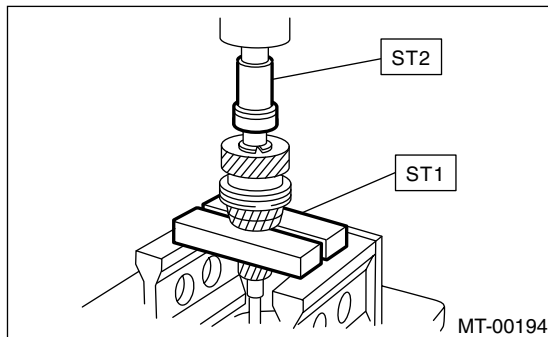

6) Using the ST1 and ST2, install the 5th gear thrust washer and 5th needle bearing race onto the rear section of transmission main shaft.

NOTE:

- Do not apply pressure in excess of 10 kN (1 ton, 1.1 US ton, 1.0 Imp ton).
- Face the thrust washer in correct direction.

- ST1 899714110 REMOVER
- ST2 499877000 RACE 4-5 INSTALLER

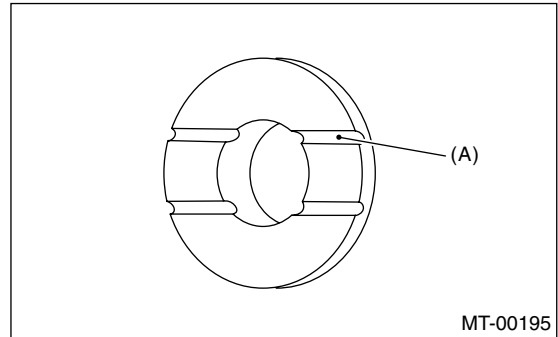

- (A) Face this surface to 5th gear side.

7) Install the bearing onto synchro cone.

8) Install the baulk ring and synchro cone onto 5th-Rev sleeve and hub assembly using ST and a press.

NOTE:

- Do not apply pressure in excess of 10 kN (1 ton, 1.1 US ton, 1.0 Imp ton).
- Use a new ball bearing.
- After press fitting, make sure the synchro cone rotates freely.

- ST 499757002 INSTALLER

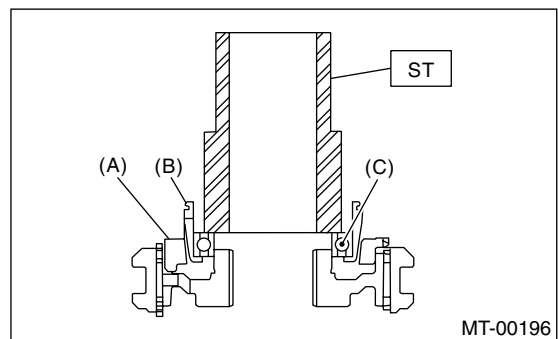

- (A) Baulk ring
- (B) Synchro cone
- (C) Ball bearing

MAIN SHAFT ASSEMBLY

MANUAL TRANSMISSION AND DIFFERENTIAL

9) Install the synchro cone stopper and snap ring to 5th-Rev sleeve and hub assembly.

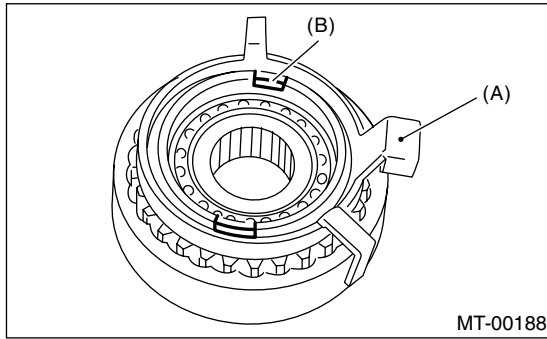

- (A) Synchro cone stopper
- (B) Snap ring

10) Install the rest parts to the rear section of transmission main shaft.

NOTE:

Align the groove in baulk ring with shifting insert.

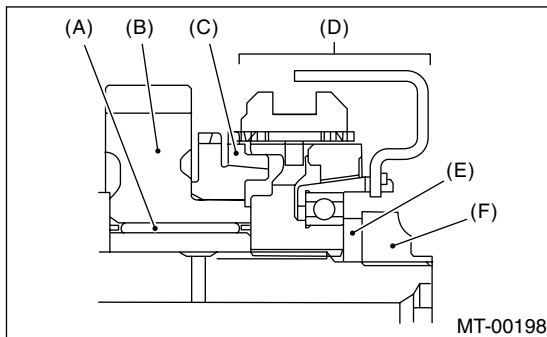

- (A) Needle bearing
- (B) 5th drive gear
- (C) Baulk ring
- (D) 5th-Rev sleeve and hub ASSY
- (E) Lock washer
- (F) Lock nuts

11) Tighten the lock nuts to the specified torque using ST1 and ST2.

NOTE:

Secure the lock nuts in two places after tightening.

ST1 499987003 SOCKET WRENCH
ST2 498937000 TRANSMISSION HOLDER

Tightening torque:

120 N·m (12.2 kgf·m, 88.5 ft·lb)

E: INSPECTION

Disassembled parts should be washed clean first and then inspected carefully.

1) Bearings

Replace the bearings in the following cases:

- Bearings whose balls, outer races and inner races are broken or rusty.
- Worn bearings
- Bearings that fail to turn smoothly or make abnormal noise when turned after gear oil lubrication.
- Bearings having other defects

2) Bushing (each gear)

Replace the bushing in the following cases:

- When the sliding surface is damaged or abnormally worn.
- When the inner wall is abnormally worn.

3) Gears

- Replace the gears with new ones if their tooth surfaces are broken, damaged, or excessively worn.
- Correct or replace if the cone that contacts the baulk ring is rough or damaged.
- Correct or replace if the inner surface or end face is damaged.

4) Baulk ring

Replace the ring in the following cases:

- When the inner surface and end face are damaged.
- When the ring inner surface is abnormally or partially worn down.
- When the contact surface of the synchronizer ring insert is scored or abnormally worn down.

5) Shifting insert key

Replace the insert if deformed, excessively worn, or defective in any way.

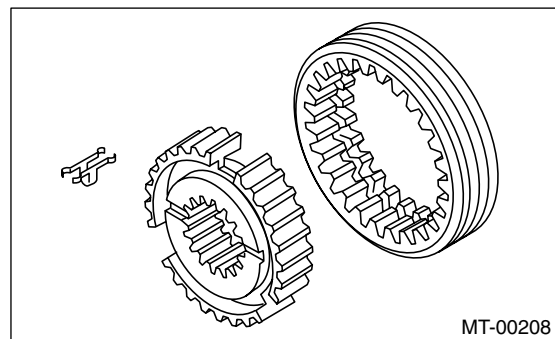

6) Oil seal

Replace the oil seal if the lip is deformed, hardened, damaged, worn, or defective in any way.

7) O-ring

Replace the O-ring if the sealing face is deformed, hardened, damaged, worn, or defective in any way.

8) Gearshift mechanism

Repair or replace the gearshift mechanism if excessively worn, bent, or defective in any way.

F: ADJUSTMENT

Selection of main shaft rear plate:

Using the ST, measure the amount (A) of ball bearing protrusion from transmission main case surface and select the proper plate in the following table:

NOTE:

Before measuring, tap the end of main shaft with a plastic hammer lightly in order to make the clearance zero between the main case surface and the moving flange of bearing.

ST 498147000 DEPTH GAUGE

Dimension (A) mm (in)	Part No.	Mark
4.00 — 4.13 (0.1575 — 0.1626)	32294AA041	1
3.87 — 3.99 (0.1524 — 0.1571)	32294AA051	2

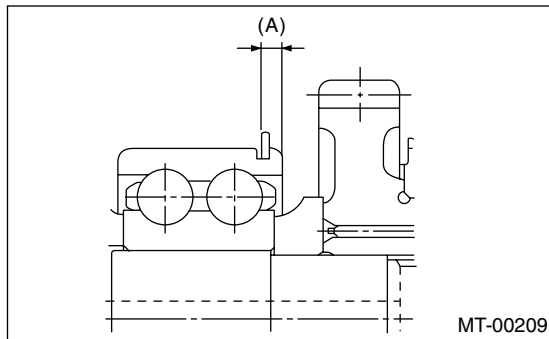

DRIVE PINION SHAFT ASSEMBLY

MANUAL TRANSMISSION AND DIFFERENTIAL

16. Drive Pinion Shaft Assembly

A: REMOVAL

- 1) Remove the manual transmission assembly from vehicle. <Ref. to 5MT-26, REMOVAL, Manual Transmission Assembly.>
- 2) Remove the transfer case with extension case assembly. <Ref. to 5MT-39, REMOVAL, Transfer Case and Extension Case Assembly.>
- 3) Remove the transmission case. <Ref. to 5MT-51, REMOVAL, Transmission Case.>
- 4) Remove the drive pinion shaft assembly.

NOTE:

Use a hammer handle, etc. to remove if too tight.

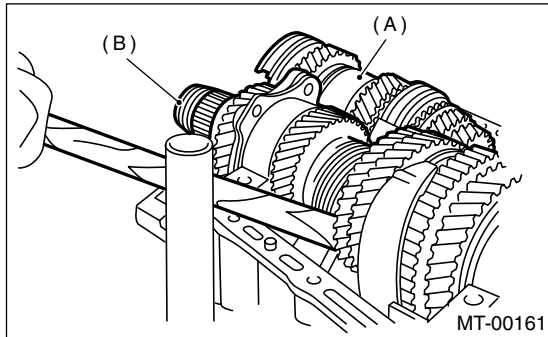

- (A) Main shaft assembly
- (B) Drive pinion shaft assembly

B: INSTALLATION

- 1) Remove the differential assembly.
- 2) Alignment marks/numbers on hypoid gear set:
The upper number on drive pinion is the match number for combining it with hypoid driven gear. The lower number is for shim adjustment. If no lower number is shown, the value is zero. The number on hypoid driven gear indicates a number for combination with drive pinion.

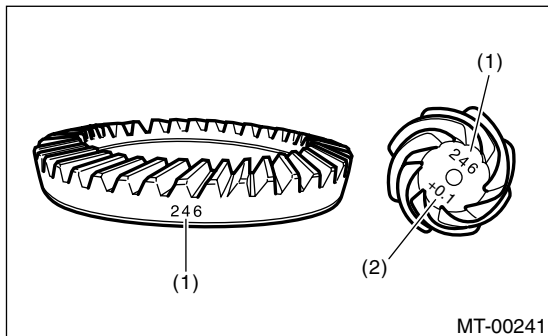

- (A) Match number
- (B) Shim adjust number

- 3) Place the drive pinion shaft assembly on right hand transmission main case without shim and tighten the bearing mounting bolts.
- 4) Inspection and adjustment of ST:

NOTE:

- Loosen the two bolts and adjust so that the scale indicates 0.5 correctly when the plate end and the scale end are on the same level.
- Tighten the two bolts.

ST 499917500 DRIVE PINION GAUGE ASSY

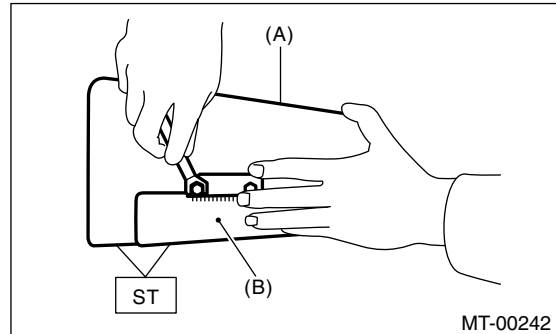

- (A) Plate
- (B) Scale

- 5) Position the ST by inserting the knock pin of ST into the knock hole in transmission case.

ST 499917500 DRIVE PINION GAUGE ASSY

- 6) Slide the drive pinion gauge scale with finger tip and read the value at the point where it matches with the end face of drive pinion.

ST 499917500 DRIVE PINION GAUGE ASSY

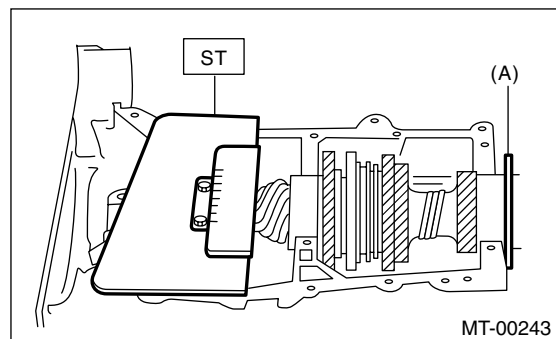

- (A) Adjust clearance to zero without shim.

- 7) The thickness of shim shall be determined by adding the value indicated on drive pinion to the value indicated on ST. (Add if the number on drive pinion is prefixed by + and subtract if the number is prefixed by -.)

ST 499917500 DRIVE PINION GAUGE ASSY

DRIVE PINION SHAFT ASSEMBLY

MANUAL TRANSMISSION AND DIFFERENTIAL

8) Select one to three shims from the next table for the value determined as described above and take a shim thickness which is closest to the indicated value.

Drive pinion shim	
Part No.	Thickness mm (in)
32295AA031	0.150 (0.0059)
32295AA041	0.175 (0.0069)
32295AA051	0.200 (0.0079)
32295AA061	0.225 (0.0089)
32295AA071	0.250 (0.0098)
32295AA081	0.275 (0.0108)
32295AA091	0.300 (0.0118)
32295AA101	0.500 (0.0197)

9) Install the differential assembly. <Ref. to 5MT-68, INSTALLATION, Front Differential Assembly.>

10) Set the transmission main shaft assembly and drive pinion assembly in position. (So there is no clearance between the two when moved all the way to the front). Inspect the suitable 1st-2nd, 3rd-4th and 5th shifter fork so that coupling sleeve and reverse driven gear are positioned in the center of their synchronizing mechanisms. <Ref. to 5MT-65, INSPECTION, Drive Pinion Shaft Assembly.>

11) Install the transmission case. <Ref. to 5MT-52, INSTALLATION, Transmission Case.>

12) Install the transfer case with extension case assembly. <Ref. to 5MT-39, INSTALLATION, Transfer Case and Extension Case Assembly.>

13) Install the manual transmission assembly to vehicle. <Ref. to 5MT-26, Manual Transmission Assembly.>

C: DISASSEMBLY

NOTE:

Attach a cloth to the end of driven shaft (on the frictional side of thrust needle bearing) to prevent damage during disassembly or reassembly.

1) Straighten the lock nut at staked portion. Remove the lock nut using ST1, ST2 and ST3.

ST1 899884100 HOLDER

ST2 498427100 STOPPER

ST3 899988608 SOCKET WRENCH (27)

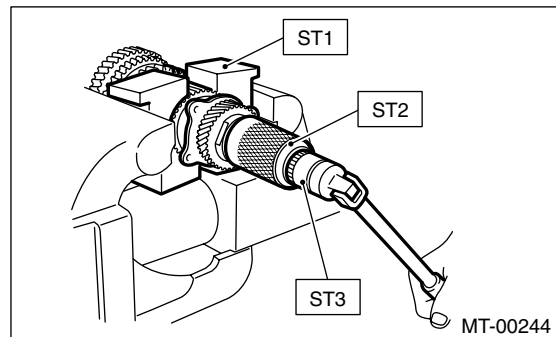

2) Withdraw the drive pinion from driven shaft. Remove the differential bevel gear sleeve, adjusting washer No. 1, adjusting washer No. 2, thrust bearing, needle bearing, drive pinion collar, needle bearing and thrust bearing.

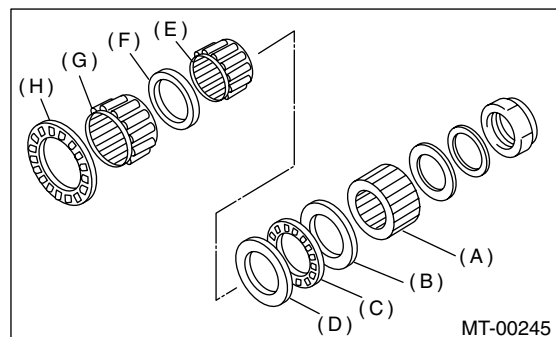

- (A) Differential bevel gear sleeve
- (B) Washer No. 1 (25 × 37.5 × t)
- (C) Thrust bearing (25 × 37.5 × 3)
- (D) Washer No. 2 (25 × 37.5 × 4)
- (E) Needle bearing (25 × 30 × 20)
- (F) Drive pinion collar
- (G) Needle bearing (30 × 37 × 23)
- (H) Thrust bearing (33 × 50 × 3)

DRIVE PINION SHAFT ASSEMBLY

MANUAL TRANSMISSION AND DIFFERENTIAL

3) Remove the roller bearing and washer using ST and press.

NOTE:

Do not reuse the roller bearing.

ST 498077000 REMOVER

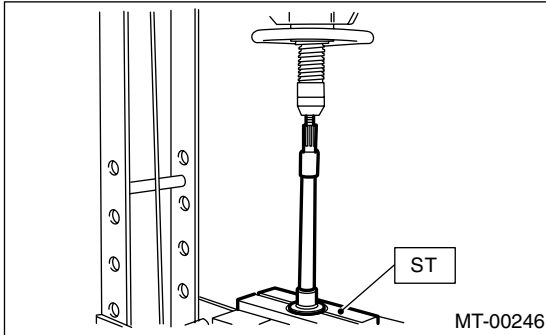

4) Straighten the lock nut at staked portion. Remove the lock nut using ST1 and ST2.

ST1 499987300 SOCKET WRENCH (50)

ST2 899884100 HOLDER

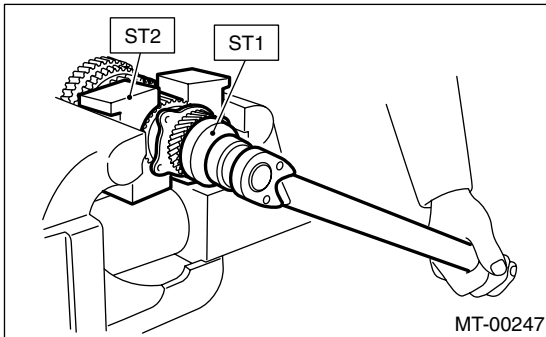

5) Remove the 5th driven gear using ST.

ST 499857000 5TH DRIVEN GEAR REMOVER

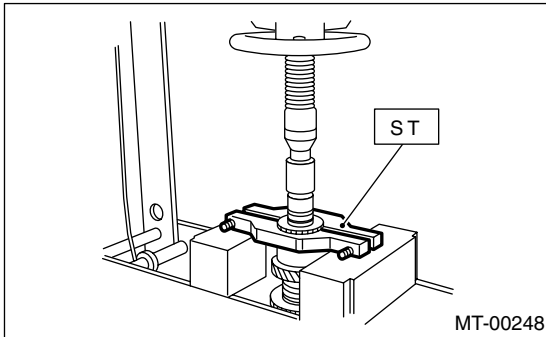

6) Remove the woodruff key.

7) Remove the roller bearing, 3rd-4th driven gear using ST1 and ST2.

ST1 499757002 INSTALLER

ST2 899714110 REMOVER

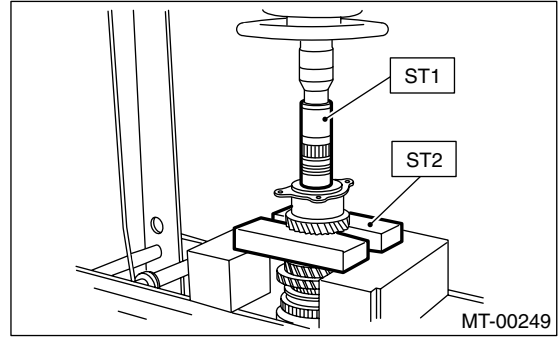

8) Remove the key.

9) Remove the 2nd driven gear, inner baulk ring, synchro cone and outer baulk ring.

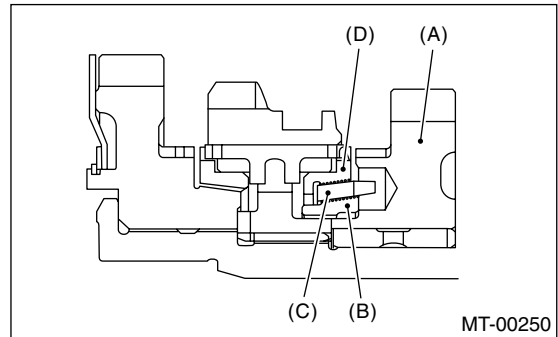

(A) 2nd driven gear

(B) Inner baulk ring

(C) Synchro cone

(D) Outer baulk ring

10) Remove the 1st driven gear, 2nd gear bushing, gear and hub using ST1 and ST2.

NOTE:

Replace the gear and hub if necessary. Do not attempt to disassemble if at all possible because they must engage at a specified point. If they should be disassembled, mark engagement point beforehand.

DRIVE PINION SHAFT ASSEMBLY

MANUAL TRANSMISSION AND DIFFERENTIAL

ST1 499757002 INSTALLER
ST2 899714110 REMOVER

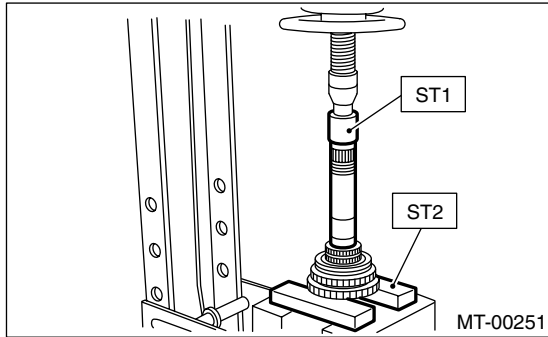

11) Remove the sub gear for 1st driven gear.

D: ASSEMBLY

1) Install the sleeve and hub assembly by matching alignment marks.

NOTE:

Use a new gear and hub assembly, if gear or hub have been replaced.

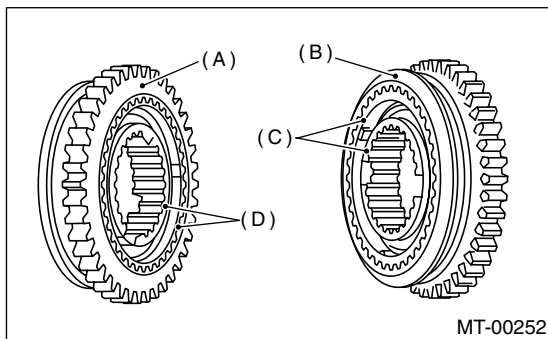

- (A) 1st gear side
- (B) 2nd gear side
- (C) Flush surface
- (D) Stepped surface

2) Install the washer, snap ring and sub gear to 1st driven gear.

3) Install the 1st driven gear, 1st baulk ring, gear and hub assembly onto driven shaft.

NOTE:

- Take care to install the gear and hub assembly in proper direction.
- Align the baulk ring and gear & hub assembly with key groove.

4) Install the 2nd driven gear bushing onto driven shaft using ST1, ST2 and press.

NOTE:

- Do not apply pressure in excess of 10 kN (1 ton, 1.1 US ton, 1.0 Imp ton).
- Attach a cloth to the end of driven shaft to prevent damage.

- When press fitting, align the oil holes of shaft and bush.

ST1 499277200 INSTALLER
ST2 499587000 INSTALLER

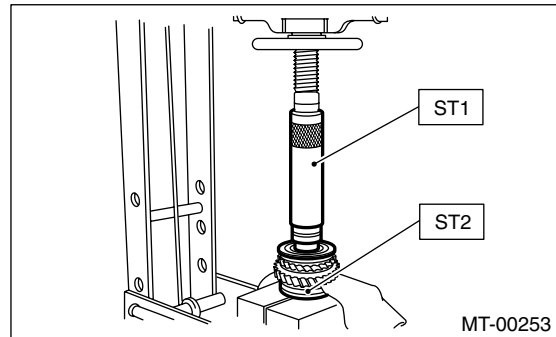

5) Install the 2nd driven gear, inner baulk ring, synchro cone, outer baulk ring and insert onto driven shaft.

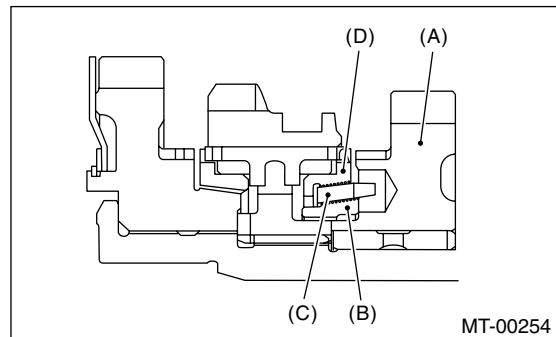

- (A) 2nd driven gear
- (B) Inner baulk ring
- (C) Synchro cone
- (D) Outer baulk ring

6) After installing the key on driven shaft, install the 3rd-4th driven gear using ST and press.

NOTE:

- Do not apply pressure in excess of 10 kN (1 ton, 1.1 US ton, 1.0 Imp ton).
- Align the groove in baulk ring with insert.

ST 499277200 INSTALLER

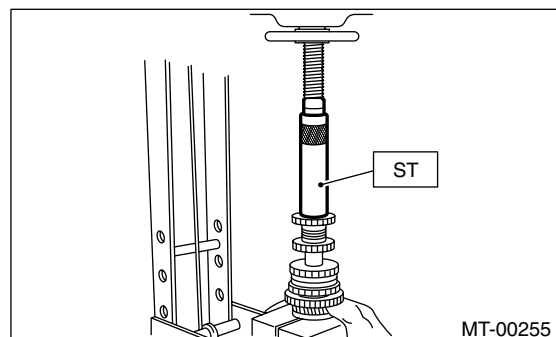

DRIVE PINION SHAFT ASSEMBLY

MANUAL TRANSMISSION AND DIFFERENTIAL

7) Install a set of roller bearings onto the driven shaft using ST and press.

NOTE:

Do not apply pressure in excess of 10 kN (1 ton, 1.1 US ton, 1.0 Imp ton).

ST 499277200 INSTALLER

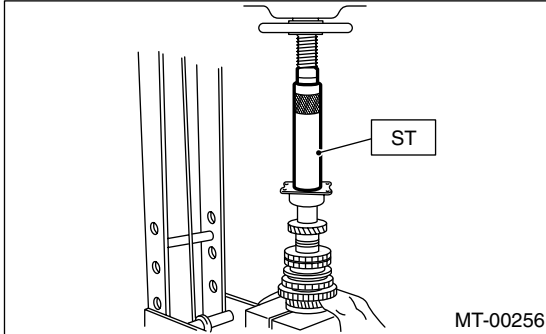

8) Position the woodruff key in groove on the rear of driven shaft. Install the 5th driven gear onto driven shaft using ST and press.

NOTE:

Do not apply pressure in excess of 10 kN (1 ton, 1.1 US ton, 1.0 Imp ton).

ST 499277200 INSTALLER

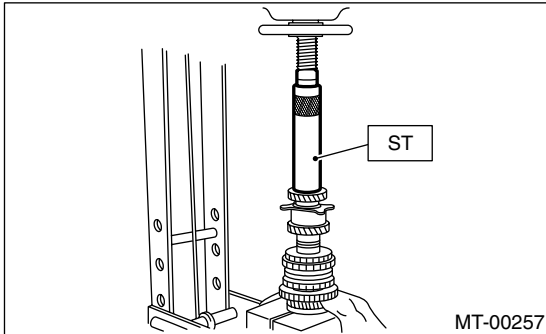

9) Install the lock washer. Install the lock nut and tighten to the specified torque using ST.

ST 499987300 SOCKET WRENCH (50)

Tightening torque:

260 N·m (26.5 kgf·m, 191.7 ft·lb)

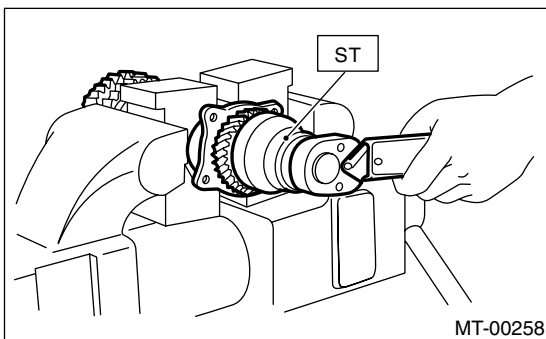

NOTE:

- Stake the lock nut at two points.

- Using the spring balancer, check that starting torque of roller bearing is 0.1 to 1.5 N (0.01 to 0.15 kgf, 0.02 to 0.33 ft).

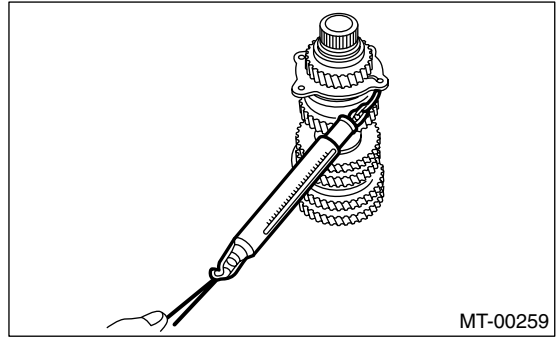

10) Install the roller bearing onto drive pinion.

NOTE:

When installing the roller bearing, note its directions (front and rear) because the knock pin hole in outer race is offset.

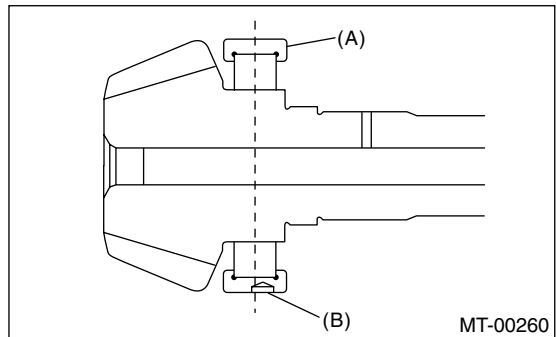

- (A) Roller bearing
- (B) Knock pin hole

11) Install the washer using ST1, ST2 and press.

ST1 499277100 BUSH 1-2 INSTALLER

ST2 499277200 INSTALLER

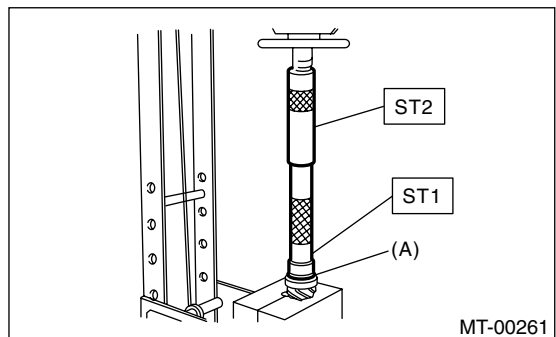

- (A) Washer

DRIVE PINION SHAFT ASSEMBLY

MANUAL TRANSMISSION AND DIFFERENTIAL

12) Install the thrust bearing and needle bearing.
Install the driven shaft assembly.

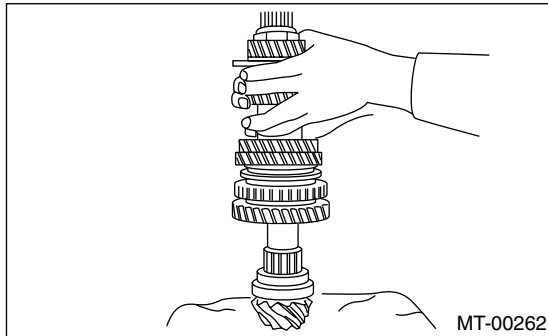

13) Install the drive pinion collar, needle bearing, adjusting washer No. 2, thrust bearing, adjusting washer No. 1 and differential bevel gear sleeve in that order.

NOTE:

Be careful because the spacer must be installed in proper direction.

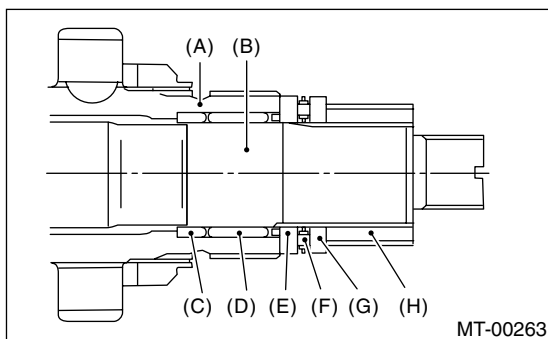

- (A) Driven shaft
- (B) Drive shaft
- (C) Drive pinion collar
- (D) Needle bearing (25 × 30 × 20)
- (E) Washer No. 2 (25 × 36 × 4)
- (F) Thrust bearing (25 × 37.5 × 3)
- (G) Washer No. 1 (25 × 36 × t)
- (H) Differential bevel gear sleeve

14) Adjust the thrust bearing preload. <Ref. to 5MT-66, ADJUSTMENT, Drive Pinion Shaft Assembly.>

E: INSPECTION

Disassembled parts should be washed clean first and then inspected carefully.

1) Bearings

Replace the bearings in the following cases:

- Bearings whose balls, outer races and inner races are broken or rusty.
- Worn bearings
- Bearings that fail to turn smoothly or make abnormal noise when turned after gear oil lubrication.
- The ball bearing on the rear side of the drive pinion shaft should be checked for smooth rotation before the drive pinion assembly is disassembled. In this case, because a preload is working on the bearing, its rotation feels like it is slightly dragging unlike the other bearings.

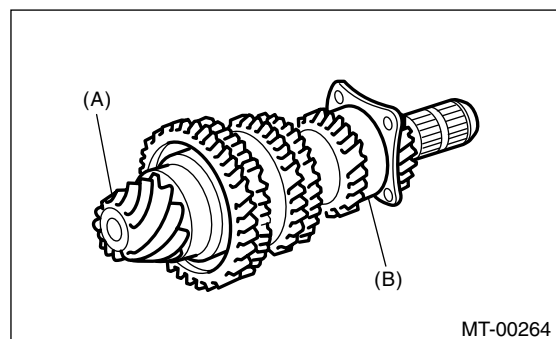

- (A) Drive pinion shaft
- (B) Ball bearing

- Bearings having other defects

2) Bushing (each gear)

Replace the bushing in the following cases:

- When the sliding surface is damaged or abnormally worn.
- When the inner wall is abnormally worn.

3) Gears

- Replace the gears with new ones if their tooth surfaces are broken, damaged, or excessively worn.

• Correct or replace if the cone that contacts the baulk ring is rough or damaged.

• Correct or replace if the inner surface or end face is damaged.

4) Baulk ring

Replace the ring in the following cases:

• When the inner surface and end face are damaged.

• When the ring inner surface is abnormally or partially worn down.

• If the gap between the end faces of the ring and the gear splined part is excessively small when the ring is pressed against the cone.

DRIVE PINION SHAFT ASSEMBLY

MANUAL TRANSMISSION AND DIFFERENTIAL

Clearance (A):

0.5 — 1.0 mm (0.020 — 0.040 in)

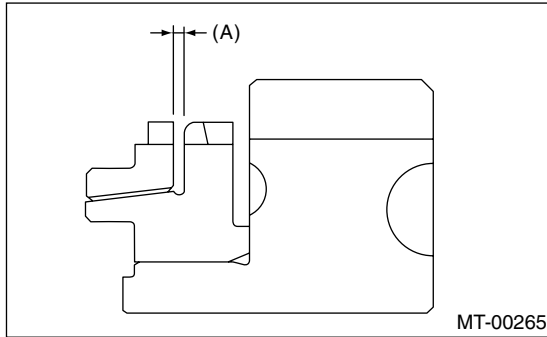

- When the contact surface of the synchronizer ring insert is scored or abnormally worn down.
- 5) Shifting insert key
Replace the insert if deformed, excessively worn, or defective in any way.

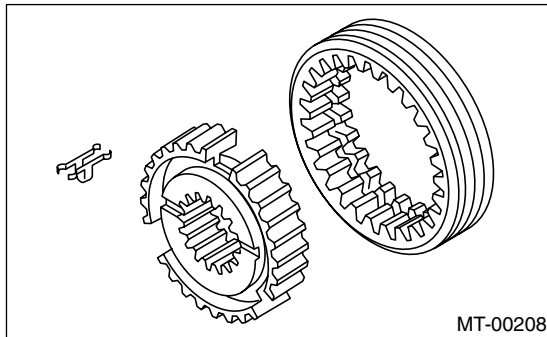

6) Oil seal

Replace the oil seal if the lip is deformed, hardened, damaged, worn, or defective in any way.

7) O-ring

Replace the O-ring if the sealing face is deformed, hardened, damaged, worn, or defective in any way.

F: ADJUSTMENT

1. THRUST BEARING PRELOAD

1) Select the adjusting washer No. 1 so that dimension (H) is zero through visual check. Position the washer (18.3 × 30 × 4) and lock washer (18 × 30 × 2) and install the lock nut (18 × 13.5).

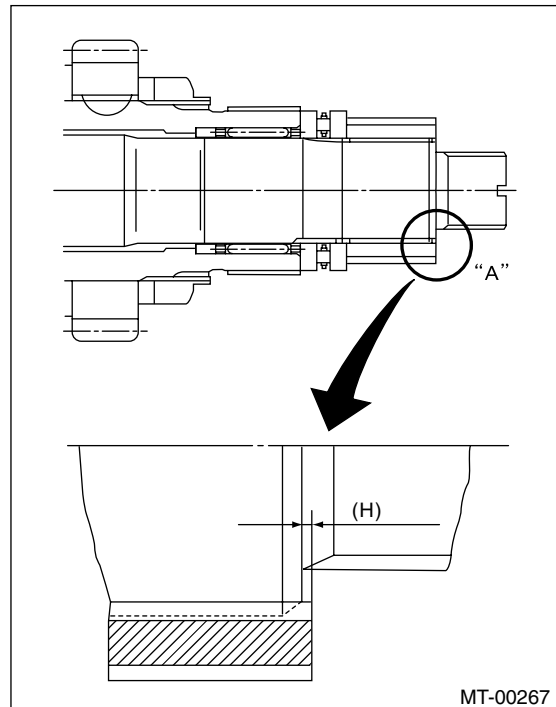

2) Using the ST1, ST2 and ST3, tighten the new lock nut to specified torque.

ST1 899884100 HOLDER

ST2 498427100 STOPPER

ST3 899988608 SOCKET WRENCH (27)

Tightening torque:

120 N·m (12.2 kgf·m, 88.5 ft·lb)

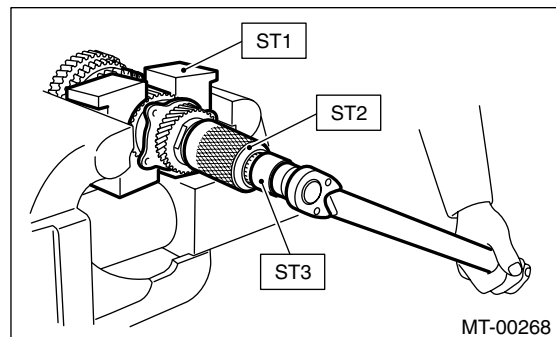

DRIVE PINION SHAFT ASSEMBLY

MANUAL TRANSMISSION AND DIFFERENTIAL

3) After removing the ST2, measure the starting torque using torque driver.

ST1 899884100 HOLDER

ST3 899988608 SOCKET WRENCH (27)

Starting torque:

0.3 — 0.8 N·m

(0.03 — 0.08 kgf-m, 0.2 — 0.6 ft-lb)

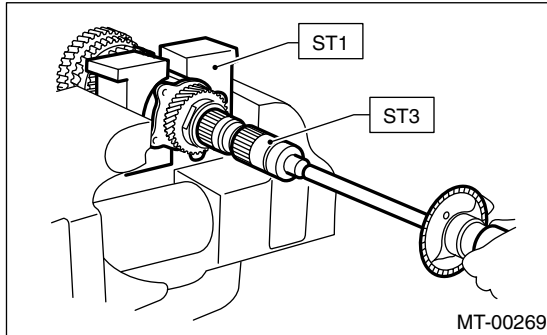

4) If the starting torque is not within specified limit, select a new adjusting washer No. 1 and recheck starting torque.

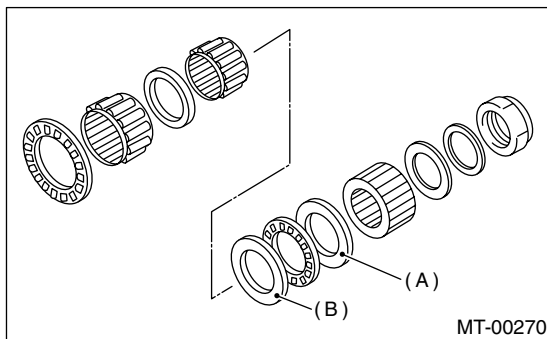

(A) Adjusting washer No. 1

(B) Adjusting washer No. 2

5) If the specified starting torque range cannot be obtained when a No. 1 adjusting washer is used, then select a suitable No. 2 adjusting washer from those listed in the following table. Repeat steps 1) through 4) to adjust starting torque.

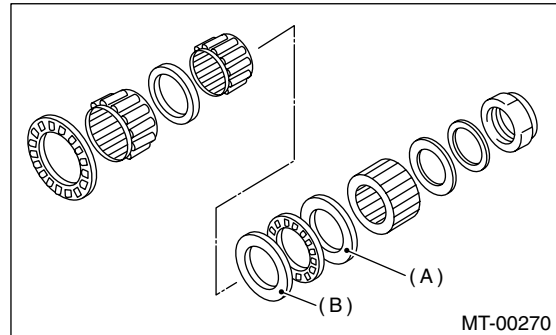

(A) Adjusting washer No. 1

(B) Adjusting washer No. 2

Starting torque	Dimension H	Washer No. 2
Low	Small	Select thicker one.
High	Large	Select thinner one.

Adjusting washer No. 2	
Part No.	Thickness mm (in)
803025059	3.850 (0.1516)
803025054	4.000 (0.1575)
803025058	4.150 (0.1634)

6) Recheck that the starting torque is within specified range, then clinch the lock nut at four positions.

Adjusting washer No. 1	
Part No.	Thickness mm (in)
803025051	3.925 (0.1545)
803025052	3.950 (0.1555)
803025053	3.975 (0.1565)
803025054	4.000 (0.1575)
803025055	4.025 (0.1585)
803025056	4.050 (0.1594)
803025057	4.075 (0.1604)

FRONT DIFFERENTIAL ASSEMBLY

MANUAL TRANSMISSION AND DIFFERENTIAL

17. Front Differential Assembly

A: REMOVAL

- 1) Remove the manual transmission assembly from vehicle. <Ref. to 5MT-26, REMOVAL, Manual Transmission Assembly.>
- 2) Remove the transfer case with extension case assembly. <Ref. to 5MT-39, REMOVAL, Transfer Case and Extension Case Assembly.>
- 3) Remove the transmission case. <Ref. to 5MT-51, REMOVAL, Transmission Case.>
- 4) Remove the drive pinion shaft assembly. <Ref. to 5MT-60, REMOVAL, Drive Pinion Shaft Assembly.>
- 5) Remove the main shaft assembly. <Ref. to 5MT-54, REMOVAL, Main Shaft Assembly.>
- 6) Remove the differential assembly.

NOTE:

- Be careful not to confuse the right and left roller bearing outer races.
- Be careful not to damage the retainer oil seal.

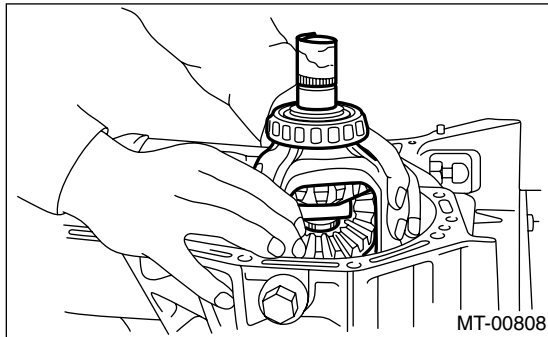

- 7) Remove the differential side retainers using ST. ST 499787000 WRENCH ASSY

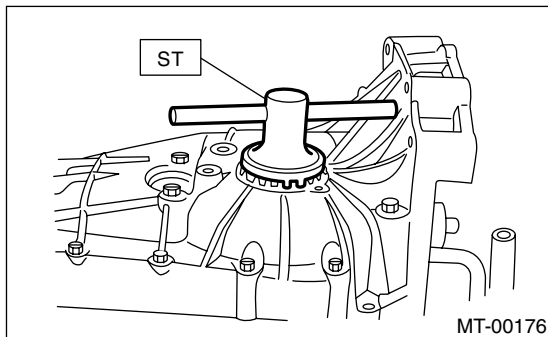

B: INSTALLATION

- 1) Install the differential side retainers using ST. ST 499787000 WRENCH ASSY
- 2) Install the bearing outer race to transmission case.
- 3) Install the differential assembly.

NOTE:

- Be careful not to fold the sealing lip of oil seal.
- Wrap the right and left spline sections of axle shaft with vinyl tape to prevent scratches.

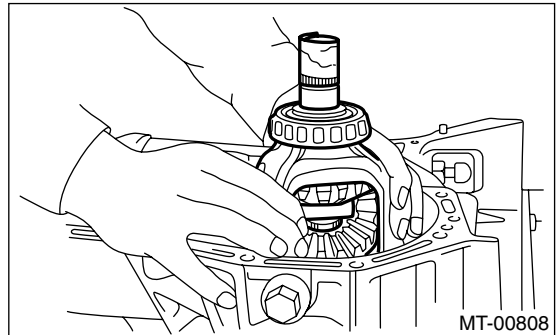

- 4) Install the main shaft assembly. <Ref. to 5MT-54, INSTALLATION, Main Shaft Assembly.>
- 5) Install the drive pinion assembly. <Ref. to 5MT-60, INSTALLATION, Drive Pinion Shaft Assembly.>
- 6) Install the transmission case. <Ref. to 5MT-52, INSTALLATION, Transmission Case.>
- 7) Install the transfer case with extension case assembly. <Ref. to 5MT-39, INSTALLATION, Transfer Case and Extension Case Assembly.>
- 8) Install the manual transmission assembly to vehicle. <Ref. to 5MT-29, INSTALLATION, Manual Transmission Assembly.>

FRONT DIFFERENTIAL ASSEMBLY

MANUAL TRANSMISSION AND DIFFERENTIAL

C: DISASSEMBLY

1. DIFFERENTIAL CASE ASSEMBLY

1) Remove the right and left snap rings from differential, and then remove the two axle drive shafts.

NOTE:

During reassembly, reinstall each axle drive shaft in the same place from which it was removed.

2) Loosen the twelve bolts and remove the hypoid driven gear.

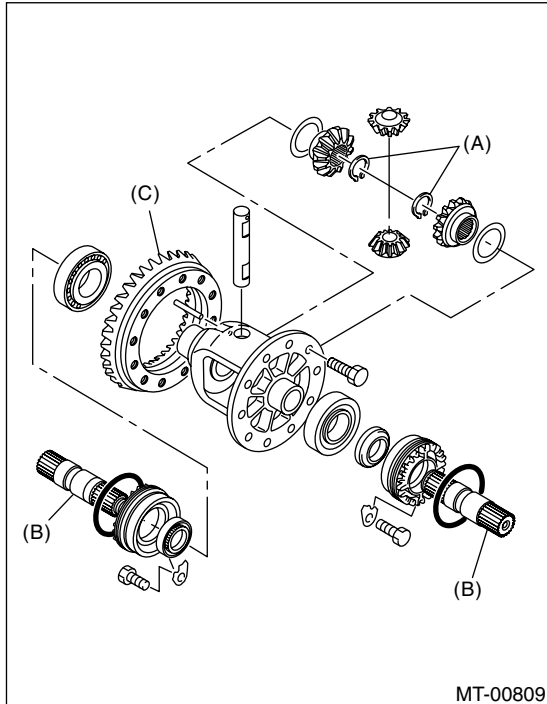

- (A) Snap ring
- (B) Axle drive shaft
- (C) Hypoid driven gear

4) Pull out the pinion shaft, and remove the differential bevel pinion and gear and washer.

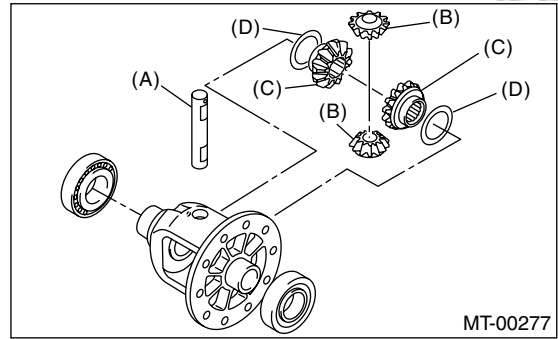

- (A) Pinion shaft
- (B) Bevel pinion
- (C) Bevel gear
- (D) Washer

5) Remove the roller bearing using ST. 899524100 PULLER SET

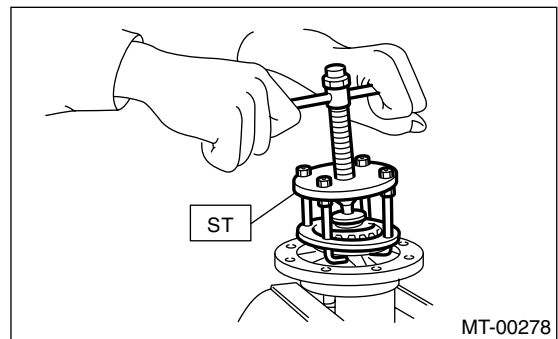

3) Drive out the straight pin from differential assembly toward hypoid driven gear.

ST 899904100 REMOVER

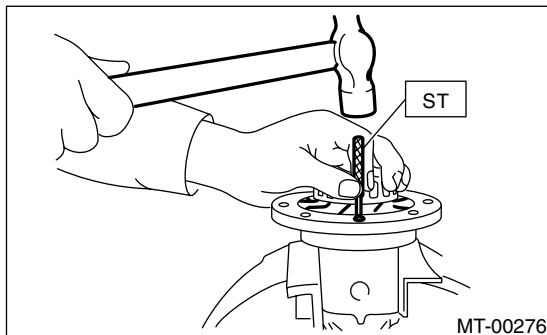

FRONT DIFFERENTIAL ASSEMBLY

MANUAL TRANSMISSION AND DIFFERENTIAL

2. SIDE RETAINER

1) Remove the O-ring.

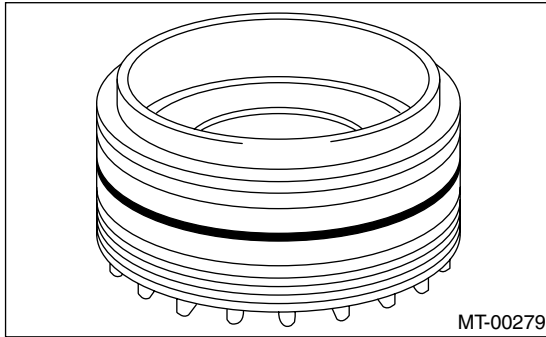

2) Remove the oil seal.

NOTE:

Do not reuse the oil seal. Prepare a new oil seal.

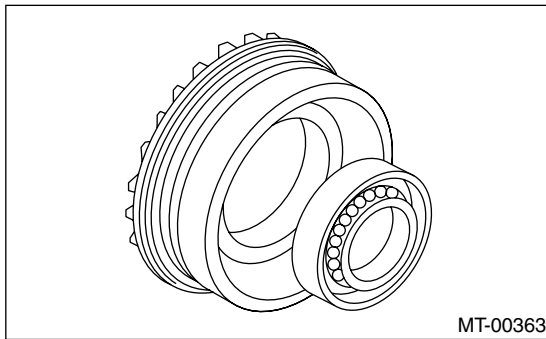

D: ASSEMBLY

1. DIFFERENTIAL CASE ASSEMBLY

1) Install the bevel gear and bevel pinion together with washers, and insert pinion shaft.

NOTE:

Face the chamfered side of washer toward gear.

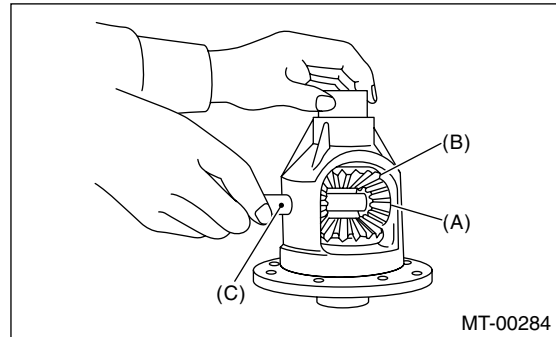

- (A) Bevel pinion
- (B) Bevel gear
- (C) Pinion shaft

2) Measure the backlash between bevel gear and pinion. If it is not within specifications, install a suitable washer to adjust it. <Ref. to 5MT-74, ADJUSTMENT, Front Differential Assembly.>

NOTE:

Be sure the pinion gear tooth contacts adjacent gear teeth during measurement.

ST1 498247001 MAGNET BASE

ST2 498247100 DIAL GAUGE

Standard backlash:

0.13 — 0.18 mm (0.0051 — 0.0071 in)

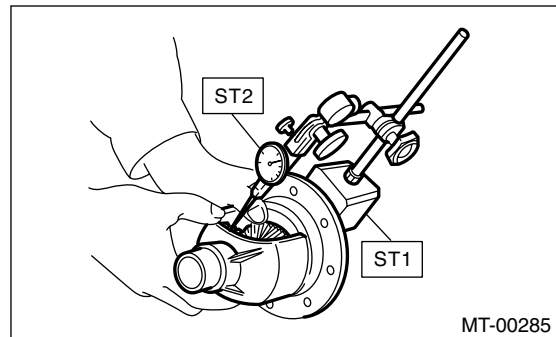

FRONT DIFFERENTIAL ASSEMBLY

MANUAL TRANSMISSION AND DIFFERENTIAL

3) Align the pinion shaft and differential case at their holes, and drive the straight pin into holes from the hypoid driven gear side, using ST.

NOTE:

Lock the straight pin after installing.

ST 899904100 REMOVER

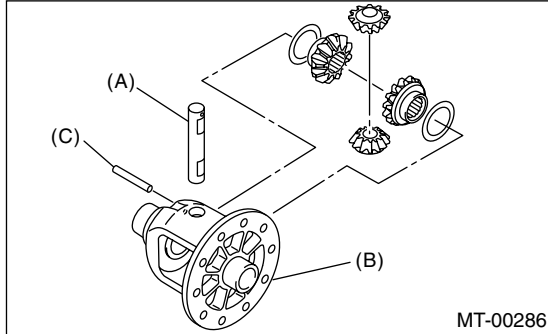

- (A) Pinion shaft
- (B) Differential case
- (C) Straight pin

4) Install the roller bearing to differential case.

NOTE:

- Do not apply pressure in excess of 10 kN (1 ton, 1.1 US ton, 1.0 Imp ton).
- Be careful because the roller bearing outer races are used as a set.

ST1 499277100 BUSH 1-2 INSTALLER

ST2 398497701 ADAPTER

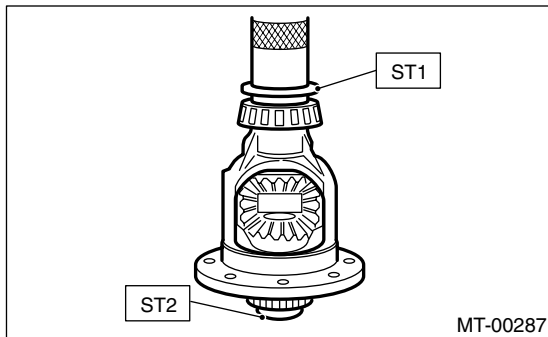

5) Install the hypoid driven gear to differential case using twelve bolts.

Tightening torque:

T: 62 N·m (6.3 kgf-m, 45.6 ft-lb)

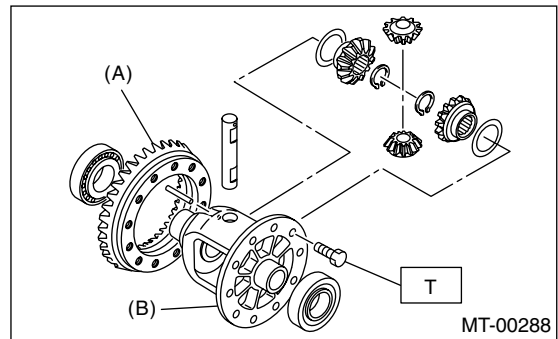

- (A) Hypoid driven gear
- (B) Differential case

6) Set the drive axle shaft into differential case and hold it using outer spring. Measure the shaft to case clearance to check if it is within specifications using thickness gauge.

NOTE:

Replace the snap ring with suitable one, if the measurement is not within specifications.

Snap ring (Outer)	
Part No.	Thickness mm (in)
805028011	1.05 (0.0413)
805028012	1.20 (0.0472)

Clearance

0 — 0.2 mm (0 — 0.008 in)

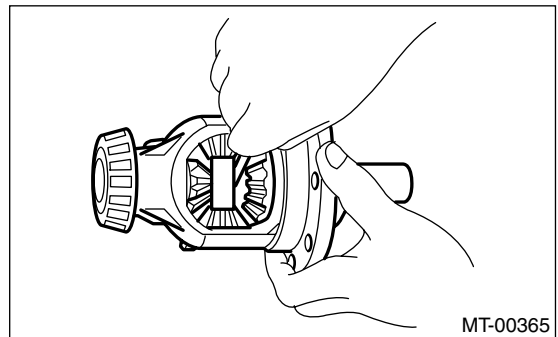

FRONT DIFFERENTIAL ASSEMBLY

MANUAL TRANSMISSION AND DIFFERENTIAL

2. SIDE RETAINER

1) Install a new oil seal.

ST 49979700 INSTALLER

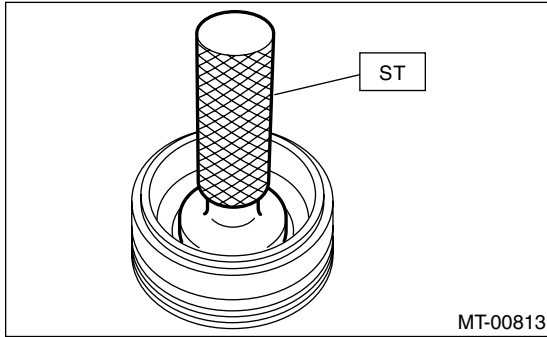

2) Install a new O-ring.

NOTE:

Do not stretch or damage the O-ring.

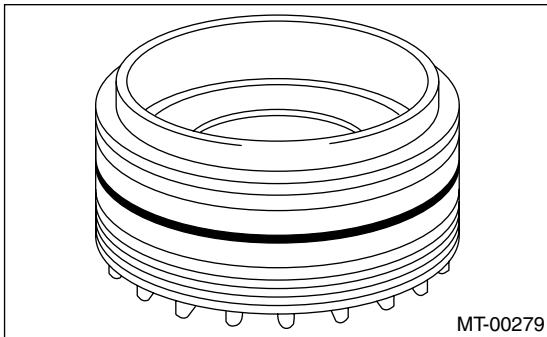

E: INSPECTION

Repair or replace the differential gear in the following cases:

- The hypoid drive gear and drive pinion shaft tooth surface are damaged, excessively worn, or seized.
- The roller bearing on the drive pinion shaft has a worn or damaged roller path.
- There is damage, wear, or seizure of the differential bevel pinion, differential bevel gear, washer, pinion shaft, and straight pin.
- The differential case has worn or damaged sliding surfaces.

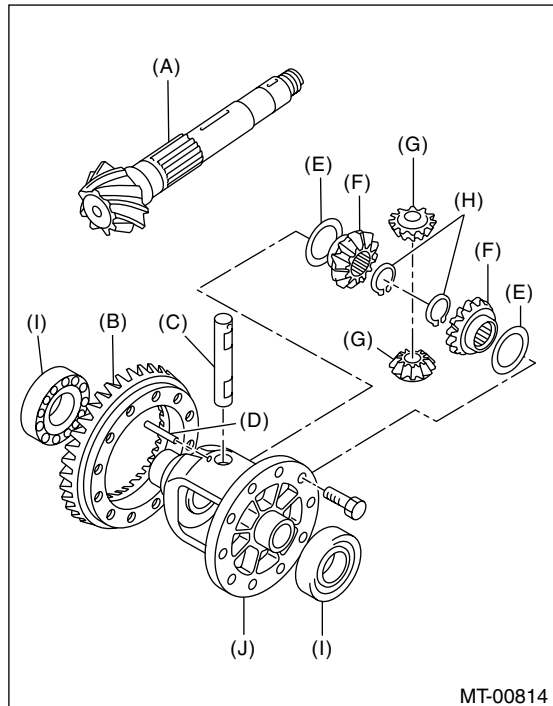

- (A) Drive pinion shaft
- (B) Hypoid driven gear
- (C) Pinion shaft
- (D) Straight pin
- (E) Washer
- (F) Differential bevel gear
- (G) Differential bevel pinion
- (H) Snap ring
- (I) Roller bearing
- (J) Differential case

FRONT DIFFERENTIAL ASSEMBLY

MANUAL TRANSMISSION AND DIFFERENTIAL

1. BEVEL PINION GEAR BACKLASH

Measure the backlash between bevel gear and pinion. If it is not within specifications, install a suitable washer to adjust it.

NOTE:

Be sure the pinion gear tooth contacts adjacent gear teeth during measurement.

ST1 498247001 MAGNET BASE

ST2 498247100 DIAL GAUGE

Standard backlash:

0.13 — 0.18 mm (0.0051 — 0.0071 in)

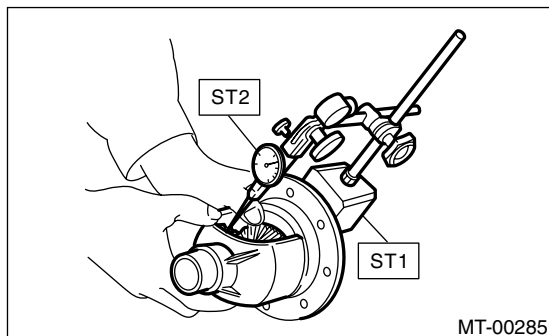

2. HYPOID GEAR BACKLASH

Set the ST1, ST2 and ST3. Insert the needle through transmission oil drain plug hole so that the needle comes in contact with the tooth surface at a right angle and check the backlash.

ST1 498247001 MAGNET BASE

ST2 498247100 DIAL GAUGE

ST3 498255400 PLATE

Backlash:

0.13 — 0.18 mm (0.0051 — 0.0071 in)

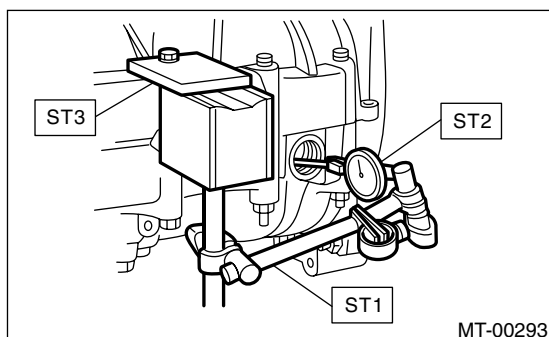

NOTE:

If the backlash is outside specified range, adjust it by turning the holder in right side case.

3. TOOTH CONTACT OF HYPOID GEAR

Check the tooth contact of hypoid gear as follows: Apply a uniform thin coat of red lead on both tooth surfaces of 3 or 4 teeth of the hypoid gear. Move the hypoid gear back and forth by turning the transmission main shaft until a definite contact pattern is developed on hypoid gear, and judge whether face contact is correct. If it is inaccurate, make adjustment. <Ref. to 5MT-74, ADJUSTMENT, Front Differential Assembly.>

- Tooth contact is correct.

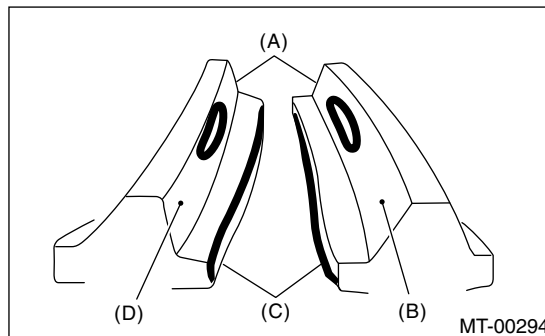

- (A) Toe
- (B) Coast side
- (C) Heel
- (D) Drive side

FRONT DIFFERENTIAL ASSEMBLY

MANUAL TRANSMISSION AND DIFFERENTIAL

F: ADJUSTMENT

1. BEVEL PINION GEAR BACKLASH

- 1) Disassemble the front differential. <Ref. to 5MT-68, REMOVAL, Front Differential Assembly.>
- 2) Select a differential washer from the table and install.

Washer	
Part No.	Thickness mm (in)
803038021	0.925 — 0.950 (0.0364 — 0.0374)
803038022	0.975 — 1.000 (0.0384 — 0.0394)
803038023	1.025 — 1.050 (0.0404 — 0.0413)

- 3) Adjust until the specified value is obtained.

Standard backlash:

0.13 — 0.18 mm (0.0051 — 0.0071 in)

2. HYPOID GEAR BACKLASH

Adjust backlash by turning the holder in right side case.

ST 499787000 WRENCH ASSY

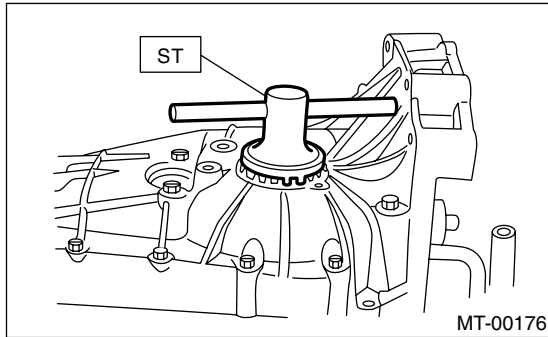

NOTE:

Each time holder rotates one tooth, backlash changes by 0.05 mm (0.020 in).

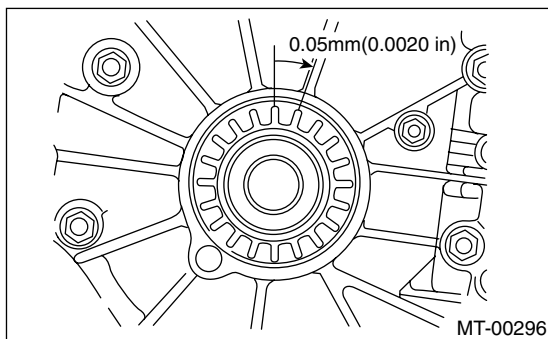

3. TOOTH CONTACT OF HYPOID GEAR

- 1) Adjust until the tooth contact is correct.
- 2) Check and adjust the tooth contact with following.

- Tooth contact

Checking item: Tooth contact pattern is slightly shifted toward to toe side under no-load rotation. [When loaded, contact pattern moves toward heel.]

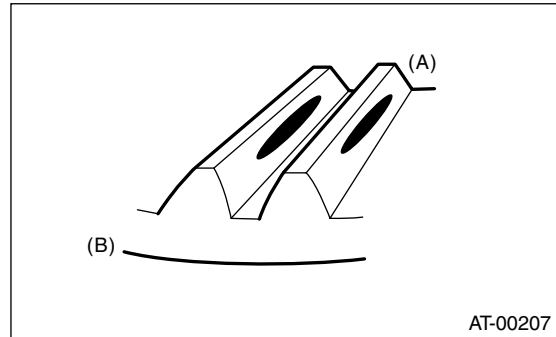

- (A) Toe side
- (B) Heel side

- Face contact

Checking item: Backlash is too large.

Contact pattern

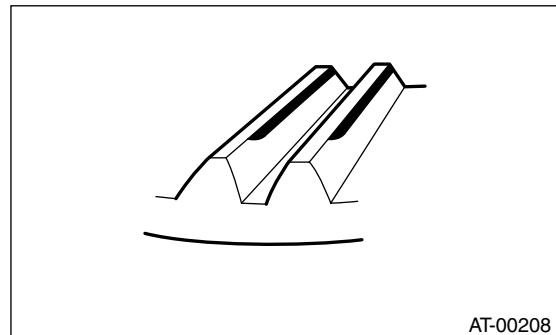

Corrective action: Reduce thickness of drive pinion shim in order to bring drive pinion close to driven gear.

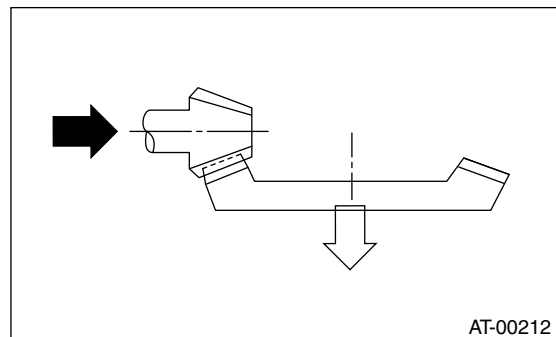

FRONT DIFFERENTIAL ASSEMBLY

MANUAL TRANSMISSION AND DIFFERENTIAL

- Flank contact

Checking item: Backlash is too small.

Contact pattern

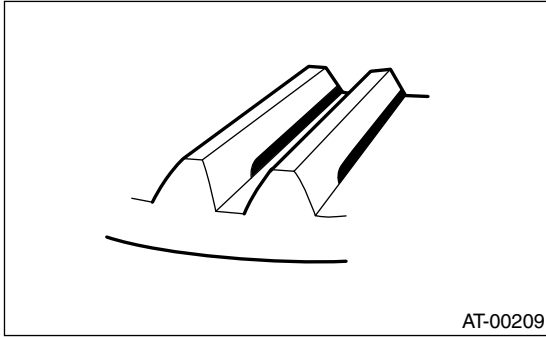

Corrective action: Increase thickness of drive pinion shim in order to move drive pinion away from driven gear.

Corrective action: Increase thickness of drive pinion shim in order to bring drive pinion close to driven gear.

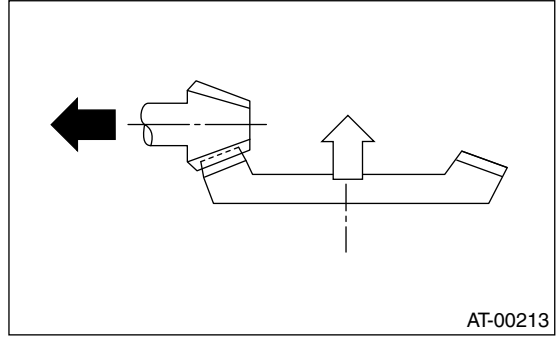

- Heel contact (Outside end contact)

Checking item: Contact area is small.

Contact pattern

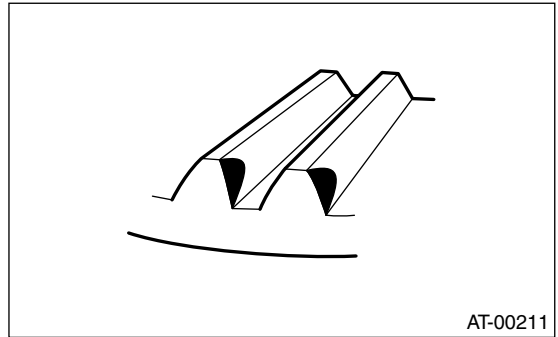
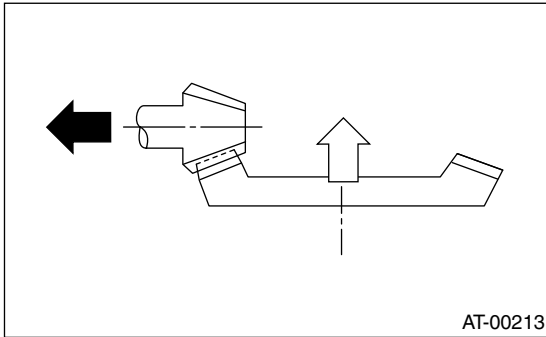

- Toe contact (Inside end contact)

Checking item: Contact area is small.

Contact pattern

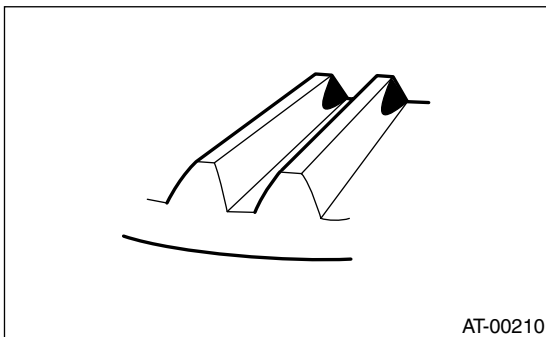

Corrective action: Reduce thickness of drive pinion shim in order to move drive pinion away from driven gear.

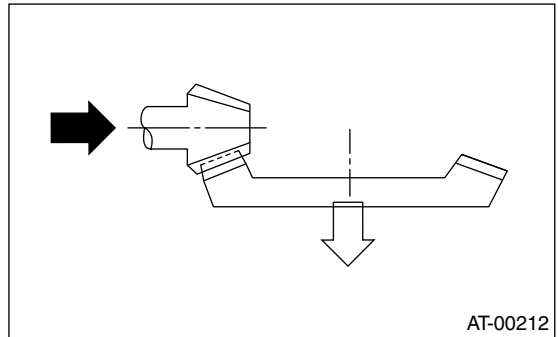

SPEEDOMETER GEAR

MANUAL TRANSMISSION AND DIFFERENTIAL

18.Speedometer Gear

A: REMOVAL

- 1) Remove the manual transmission assembly from vehicle. <Ref. to 5MT-26, REMOVAL, Manual Transmission Assembly.>
- 2) Remove the back-up light switch and neutral position switch. <Ref. to 5MT-35, REMOVAL, Switches and Harness.>
- 3) Remove the transfer case with extension case assembly. <Ref. to 5MT-39, REMOVAL, Transfer Case and Extension Case Assembly.>
- 4) Remove the transmission case. <Ref. to 5MT-51, REMOVAL, Transmission Case.>
- 5) Remove the vehicle speed sensor. <Ref. to 5MT-37, REMOVAL, Vehicle Speed Sensor.>
- 6) Remove the outer snap ring and pull out speedometer driven gear. Next, remove the oil seal, speedometer shaft and washer.

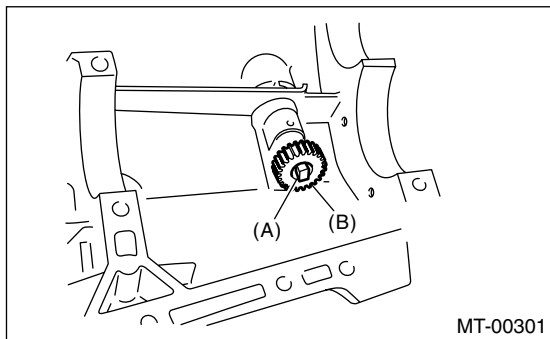

- (A) Outer snap ring
- (B) Speedometer driven gear

B: INSTALLATION

- 1) Install the washer and speedometer shaft, and press fit the oil seal with ST.

NOTE:

Use a new oil seal, if it has been removed.

ST 899824100 or 499827000 PRESS

- 2) Install the vehicle speed sensor. <Ref. to 5MT-37, INSTALLATION, Vehicle Speed Sensor.>

- 3) Install the speedometer driven gear and snap ring.

NOTE:

Use a new snap ring, if it has been removed.

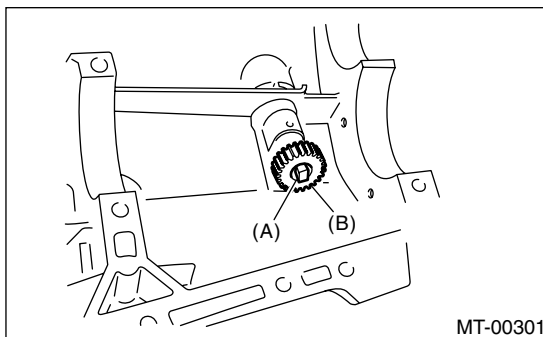

- (A) Outer snap ring
- (B) Speedometer driven gear

- 4) Install the transmission case. <Ref. to 5MT-52, INSTALLATION, Transmission Case.>

- 5) Install the transfer case with extension case assembly. <Ref. to 5MT-39, INSTALLATION, Transfer Case and Extension Case Assembly.>

- 6) Install the back-up light switch and neutral position switch. <Ref. to 5MT-35, INSTALLATION, Switches and Harness.>

- 7) Install the manual transmission assembly to vehicle. <Ref. to 5MT-29, INSTALLATION, Manual Transmission Assembly.>

C: INSPECTION

Check the speedometer gear, oil seal and speedometer shaft for damage. Replace if damaged.

19. Reverse Idler Gear

A: REMOVAL

- 1) Remove the manual transmission assembly from vehicle. <Ref. to 5MT-26, REMOVAL, Manual Transmission Assembly.>
- 2) Remove the back-up light switch and neutral position switch. <Ref. to 5MT-35, REMOVAL, Switches and Harness.>
- 3) Remove the transfer case with extension case assembly. <Ref. to 5MT-39, REMOVAL, Transfer Case and Extension Case Assembly.>
- 4) Remove the transmission case. <Ref. to 5MT-60, REMOVAL, Drive Pinion Shaft Assembly.>
- 5) Remove the drive pinion shaft assembly. <Ref. to 5MT-60, REMOVAL, Drive Pinion Shaft Assembly.>
- 6) Remove the main shaft assembly. <Ref. to 5MT-54, REMOVAL, Main Shaft Assembly.>
- 7) Remove the differential assembly. <Ref. to 5MT-68, REMOVAL, Front Differential Assembly.>
- 8) Remove the shifter forks and rods. <Ref. to 5MT-79, REMOVAL, Shifter Fork and Rod.>
- 9) Pull out the straight pin, and remove the idler gear shaft, reverse idler gear and washer.

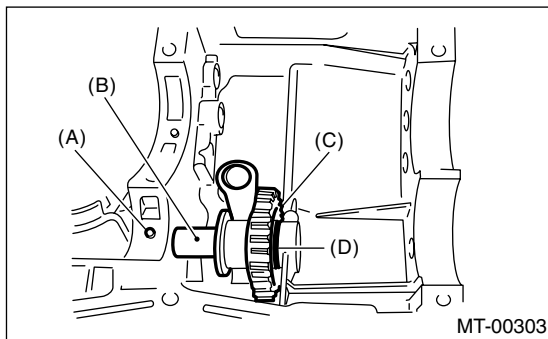

- (A) Straight pin
- (B) Idler gear shaft
- (C) Idler gear
- (D) Washer

- 10) Remove the reverse shifter lever.

B: INSTALLATION

- 1) Install the reverse shifter lever, reverse idler gear and reverse idler gear shaft, and secure with straight pin.

NOTE:

Be sure to install the reverse idler shaft from rear side.

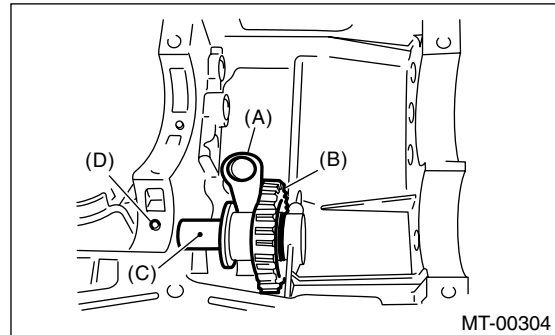

- (A) Reverse shifter lever
- (B) Reverse idler gear
- (C) Reverse idler gear shaft
- (D) Straight pin

- 2) Inspect and adjust the clearance between reverse idler gear and transmission case wall. <Ref. to 5MT-77, INSTALLATION, Reverse Idler Gear.> and <Ref. to 5MT-78, ADJUSTMENT, Reverse Idler Gear.>
- 3) Install the shifter forks and rods. <Ref. to 5MT-80, INSTALLATION, Shifter Fork and Rod.>
- 4) Install the differential assembly. <Ref. to 5MT-68, INSTALLATION, Front Differential Assembly.>
- 5) Install the main shaft assembly. <Ref. to 5MT-54, INSTALLATION, Main Shaft Assembly.>
- 6) Install the drive pinion shaft assembly. <Ref. to 5MT-60, INSTALLATION, Drive Pinion Shaft Assembly.>
- 7) Install the transmission case. <Ref. to 5MT-52, INSTALLATION, Transmission Case.>
- 8) Install the transfer case with extension case assembly. <Ref. to 5MT-39, INSTALLATION, Transfer Case and Extension Case Assembly.>
- 9) Install the back-up light switch and neutral position switch. <Ref. to 5MT-35, INSTALLATION, Switches and Harness.>
- 10) Install the manual transmission assembly to vehicle. <Ref. to 5MT-29, INSTALLATION, Manual Transmission Assembly.>

REVERSE IDLER GEAR

MANUAL TRANSMISSION AND DIFFERENTIAL

C: INSPECTION

1) Move the reverse shifter rod toward the reverse side. Inspect the clearance between reverse idler gear and transmission case wall. If out of specification, select the appropriate reverse shifter lever and adjust.

Clearance A:

6.0 — 7.5 mm (0.236 — 0.295 in)

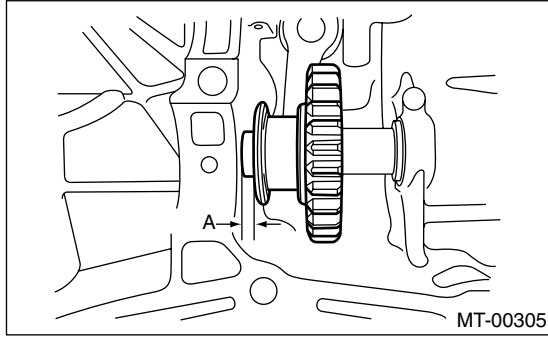

2) After installing a suitable reverse shifter lever, shift into neutral. Inspect the clearance between reverse idler gear and transmission case wall. If out of specification, select the appropriate washer and adjust.

Clearance:

0 — 0.5 mm (0 — 0.020 in)

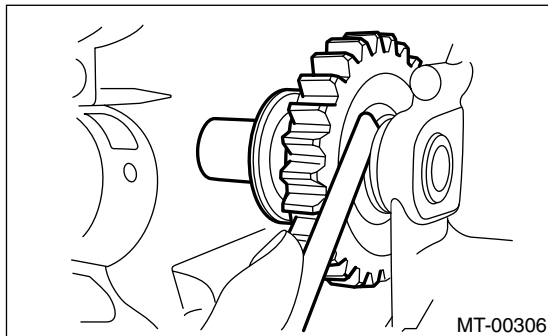

3) Check the reverse idler gear and shaft for damage. Replace if damaged.

D: ADJUSTMENT

1) Select the appropriate reverse shifter lever from the table below, and adjust until the gap between the reverse idler gear and transmission case wall is within specification.

Clearance A:

6.0 — 7.5 mm (0.236 — 0.295 in)

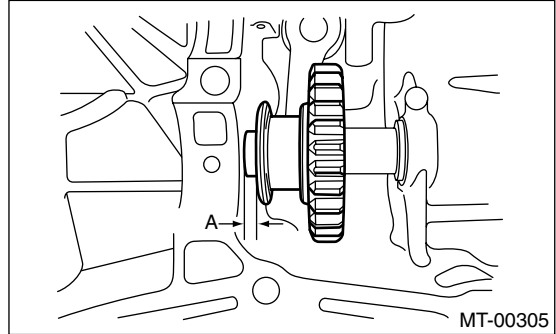

Reverse shifter lever		
Part No.	Mark	Remarks
32820AA070	7	Further from case wall
32820AA080	8	Standard
32820AA090	9	Closer to case wall

2) Select the appropriate washer from the table below, and adjust until the gap between the reverse idler gear and transmission case wall is within specification.

Clearance:

0 — 0.5 mm (0 — 0.020 in)

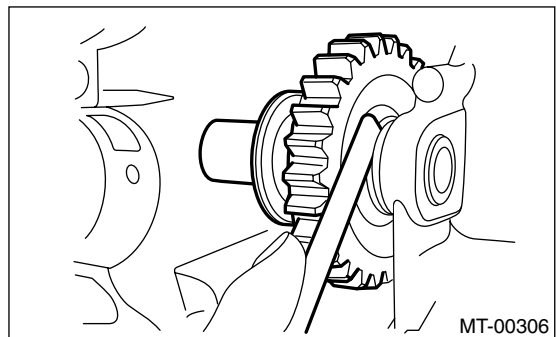

Washer	
Part No.	Thickness mm (in)
803020151	0.4 (0.016)
803020152	1.1 (0.043)
803020153	1.5 (0.059)
803020154	1.9 (0.075)
803020155	2.3 (0.091)

SHIFTER FORK AND ROD

MANUAL TRANSMISSION AND DIFFERENTIAL

20. Shifter Fork and Rod

A: REMOVAL

- 1) Remove the manual transmission assembly from vehicle. <Ref. to 5MT-26, REMOVAL, Manual Transmission Assembly.>
- 2) Remove the back-up light switch and neutral position switch. <Ref. to 5MT-35, REMOVAL, Switches and Harness.>
- 3) Remove the transfer case with extension case assembly. <Ref. to 5MT-39, REMOVAL, Transfer Case and Extension Case Assembly.>
- 4) Remove the transmission case. <Ref. to 5MT-51, REMOVAL, Transmission Case.>
- 5) Remove the drive pinion shaft assembly. <Ref. to 5MT-60, REMOVAL, Drive Pinion Shaft Assembly.>
- 6) Remove the main shaft assembly. <Ref. to 5MT-54, REMOVAL, Main Shaft Assembly.>
- 7) Remove the differential assembly. <Ref. to 5MT-68, REMOVAL, Front Differential Assembly.>
- 8) Drive out the straight pin with ST, and 5th shifter fork.

ST 398791700 STRAIGHT PIN REMOVER

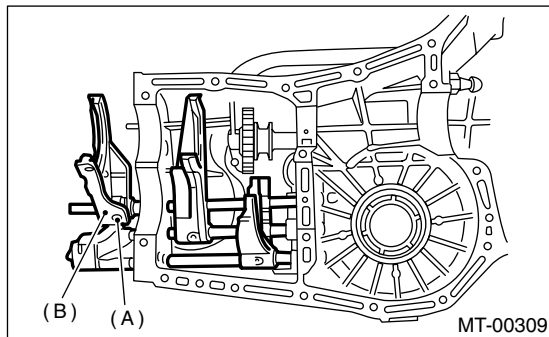

- (A) Straight pin
- (B) 5th shifter fork

- 9) Remove the plugs, springs and checking balls.

- 10) Drive out the straight pin, and pull out 3-4 fork rod and shifter fork.

NOTE:

When removing the rod, keep other rods in neutral. Also, when pulling out the straight pin, remove it toward the inside of case so that it does not hit against the case.

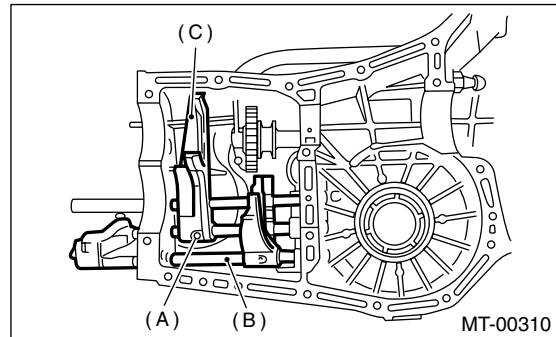

- (A) Straight pin
- (B) 3-4 fork rod
- (C) Shifter fork

- 11) Drive out the straight pin, and pull out 1-2 fork rod and shifter fork.

12) Remove the outer snap ring, and pull out the reverse shifter rod arm from reverse fork rod. Then take out the ball, spring and interlock plunger from rod.

And then remove the rod.

NOTE:

When pulling out the reverse shifter rod arm, be careful not to let the ball pop out of arm.

- 13) Remove the reverse shifter lever.

SHIFTER FORK AND ROD

MANUAL TRANSMISSION AND DIFFERENTIAL

B: INSTALLATION

1) Install the reverse arm fork spring, ball and interlock plunger to reverse fork rod arm. Insert the reverse fork rod into hole in reverse fork rod arm, and hold it with outer snap ring using ST.

NOTE:

Apply grease to plunger to prevent it from falling.

ST 399411700 ACCENT BALL INSTALLER

2) Position the ball, spring and new gasket in reverse shifter rod hole, on left side transmission case, and tighten the checking ball plug.

3) Install the 1-2 fork rod into 1-2 shifter fork via the hole on the rear of transmission case.

4) Align the holes in rod and fork, and new drive straight pin into these holes using ST.

NOTE:

- Set other rods to neutral.
- Make sure the interlock plunger is on the 3-4 fork rod side.

ST 398791700 STRAIGHT PIN REMOVER

5) Install the interlock plunger onto 3-4 fork rod.

NOTE:

Apply a coat of grease to plunger to prevent it from falling.

6) Install the 3-4 fork rod into 3-4 shifter fork via the hole on the rear of transmission case.

7) Align the holes in rod and fork, and new drive straight pin into these holes.

NOTE:

- Set the reverse fork rod to neutral.
- Make sure the interlock plunger (installing before) is on the reverse fork rod side.

ST 398791700 STRAIGHT PIN REMOVER

8) Install the 5th shifter fork onto the rear of reverse fork rod. Align holes in the two parts and new drive straight pin into place.

ST 398791700 STRAIGHT PIN REMOVER

9) Position the balls, checking ball springs and new gaskets into 3-4 and 1-2 rod holes, and install plugs.

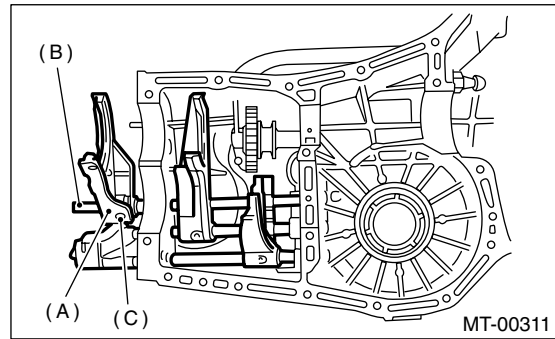

- (A) 5th shifter fork
- (B) Reverse fork rod
- (C) Straight pin

10) Install the differential assembly. <Ref. to 5MT-68, INSTALLATION, Front Differential Assembly.>

11) Install the main shaft assembly. <Ref. to 5MT-54, INSTALLATION, Main Shaft Assembly.>

12) Install the drive pinion shaft assembly. <Ref. to 5MT-60, INSTALLATION, Drive Pinion Shaft Assembly.>

13) Install the transmission case. <Ref. to 5MT-52, INSTALLATION, Transmission Case.>

14) Install the transfer case with extension case assembly. <Ref. to 5MT-39, INSTALLATION, Transfer Case and Extension Case Assembly.>

15) Install the back-up light switch and neutral position switch. <Ref. to 5MT-35, INSTALLATION, Switches and Harness.>

16) Install the manual transmission assembly to vehicle. <Ref. to 5MT-29, INSTALLATION, Manual Transmission Assembly.>

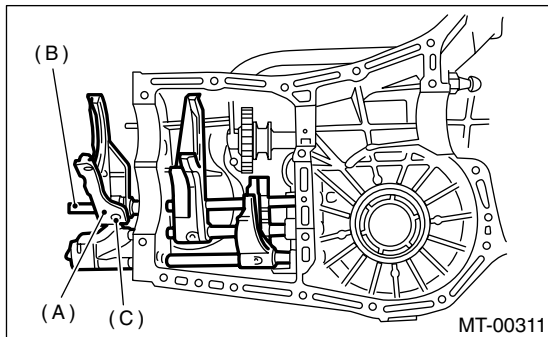

- (A) 5th shifter fork
- (B) Reverse fork rod
- (C) Straight pin

SHIFTER FORK AND ROD

MANUAL TRANSMISSION AND DIFFERENTIAL

C: INSPECTION

1) Check the shift shaft and shift rod for damage. Replace if damaged.

2) Gearshift mechanism:

Repair or replace the gearshift mechanism if excessively worn, bent, or defective in any way.

3) Inspect the clearance between 1st, 2nd driven gear and reverse driven gear. If any clearance is not within specifications, replace the shifter fork as required.

Clearance (a) and (b):

9.5 mm (0.374 in)

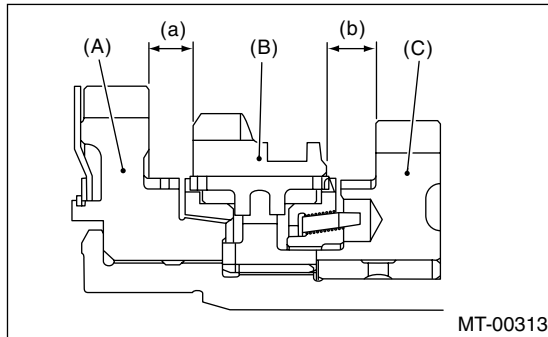

- (A) 1st driven gear
- (B) Reverse driven gear
- (C) 2nd driven gear

1st-2nd shifter fork		
Part No.	Mark	Remarks
32804AA060	1	Approach to 1st gear by 0.2 mm (0.008 in).
32804AA070	—	Standard
32804AA080	3	Become distant from 2nd gear by 0.2 mm (0.008 in).

4) Inspect the clearance between 3rd, 4th drive gear and coupling sleeve. If any clearance is not within specifications, replace the shifter fork as required.

Clearance (a) and (b):

7.3 mm (0.287 in)

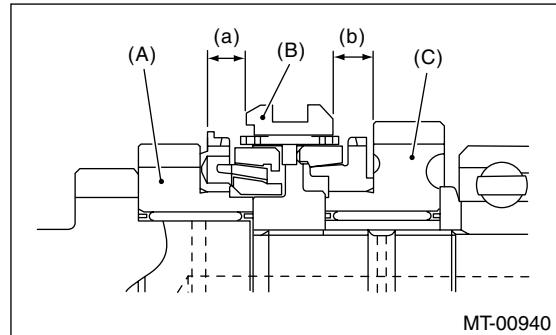

- (A) 3rd drive gear
- (B) Coupling sleeve
- (C) 4th drive gear

3rd-4th shifter fork		
Part No.	Mark	Remarks
32810AA061	1	Approach to 4th gear by 0.2 mm (0.008 in).
32810AA071	—	Standard
32810AA101	3	Become distant from 3rd gear by 0.2 mm (0.008 in).

5) Inspect the clearance between 5th drive gear and coupling sleeve. If any clearance is not within specifications, replace the shifter fork as required.

Clearance (a):

9.3 mm (0.366 in)

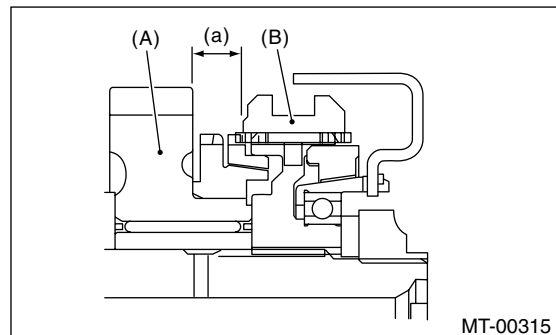

- (A) 5th drive gear
- (B) Coupling sleeve

SHIFTER FORK AND ROD

MANUAL TRANSMISSION AND DIFFERENTIAL

Brought to you by Eris Studios
NOT FOR RESALE

5th shifter fork (Non-turbo)		
Part No.	Mark	Remarks
32812AA201	4	Approach to 5th gear by 0.2 mm (0.008 in).
32812AA211	5	Standard
32812AA221	6	Become distant from 5th gear by 0.2 mm (0.008 in).

5th shifter fork (Turbo)		
Part No.	Mark	Remarks
32812AA231	7	Approach to 5th gear by 0.2 mm (0.008 in).
32812AA241	—	Standard
32812AA251	9	Become distant from 5th gear by 0.2 mm (0.008 in).

6) Inspect the rod end clearances (A) and (B). If any clearance is not within specifications, replace the rod or fork as required.

Clearance (A):

1st-2nd to 3rd-4th:

0.4 — 1.4 mm (0.016 — 0.055 in)

Clearance (B):

3rd-4th to 5th:

0.5 — 1.3 mm (0.020 — 0.051 in)

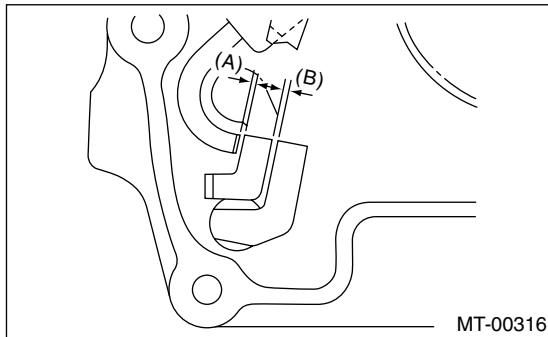

21. General Diagnostic

A: INSPECTION

1. MANUAL TRANSMISSION

Symptom	Possible cause	Remedy
1. Gears are difficult to intermesh. NOTE: The cause for difficulty in shifting gears can be classified into two kinds: one is malfunction of the gear shift system and the other is malfunction of the transmission. However, if the operation is heavy and engagement of the gears is difficult, defective clutch disengagement may also be responsible. Check whether the clutch is correctly functioning, before checking the gear shift system and transmission.	(a) Worn, damaged or burred chamfer of internal spline of sleeve and reverse driven gear	Replace.
	(b) Worn, damaged or burred chamfer of spline of gears	Replace.
	(c) Worn or scratched bushings	Replace.
	(d) Incorrect contact between synchronizer ring and gear cone or wear	Correct or replace.
2. Gear slips out. • Gear slips out when coasting on rough road. • Gear slips out during acceleration.	(a) Defective pitching stopper adjustment	Adjust.
	(b) Loose engine mounting bolts	Tighten or replace.
	(c) Worn fork shifter, broken shifter fork rail spring	Replace.
	(d) Worn or damaged ball bearing	Replace.
	(e) Excessive clearance between splines of synchronizer hub and synchronizer sleeve	Replace.
	(f) Worn tooth step of synchronizer hub (responsible for slip-out of 3rd gear)	Replace.
	(g) Worn 1st driven gear and driven shaft	Replace.
	(h) Worn 2nd driven gear and bushing	Replace.
	(i) Worn 3rd drive gear and needle bearing	Replace.
	(j) Worn 4th drive gear and needle bearing	Replace.
	(k) Worn reverse idler gear and bushing	Replace.
3. Unusual noise comes from transmission. NOTE: If an unusual noise is heard when the vehicle is parked with its engine idling and if the noise ceases when the clutch is disengaged, it may be considered that the noise comes from the transmission.	(a) Insufficient or improper lubrication	Lubricate or replace with specified oil.
	(b) Worn or damaged gears and bearings NOTE: If the trouble is only wear of the tooth surfaces, merely a high roaring noise will occur at high speeds, but if any part is broken, rhythmical knocking sound will be heard even at low speeds.	Replace.

GENERAL DIAGNOSTIC

MANUAL TRANSMISSION AND DIFFERENTIAL

2. DIFFERENTIAL

Symptom	Possible cause	Remedy
<p>1. Broken differential (case, gear, bearing, etc.)</p> <p>NOTE: Abnormal noise will develop and finally it will become impossible to continue to run due to broken pieces obstructing the gear revolution.</p>	(a) Insufficient or improper oil	Disassemble the differential and replace broken components and at the same time check other components for any trouble, and replace if necessary.
	(b) Use of vehicle under severe conditions such as excessive load and improper use of clutch	Readjust the bearing preload and backlash and face contact of gears.
	(c) Improper adjustment of taper roller bearing	Adjust.
	(d) Improper adjustment of drive pinion and hypoid driven gear	Adjust.
	(e) Excessive backlash due to worn differential side gear, washer or differential pinion vehicle under severe operating conditions.	Add recommended oil to specified level. Do not use the vehicle under severe operating conditions.
	(f) Loose hypoid driven gear clamping bolts	Tighten.
<p>2. Differential and hypoid gear noises</p> <p>Troubles of the differential and hypoid gear always appear as noise problems. Therefore noise is the first indication of the trouble. However noises from the engine, muffler, tire, exhaust gas, bearing, body, etc. are easily mistaken for the differential noise. Pay special attention to the hypoid gear noise because it is easily confused with other gear noises. There are the following four kinds of noises.</p> <ul style="list-style-type: none"> • Gear noise when driving: If noise increases as vehicle speed increases it may be due to insufficient gear oil, incorrect gear engagement, damaged gears, etc. • Gear noise when coasting: Damaged gears due to maladjusted bearings and incorrect shim adjustment • Bearing noise when driving or when coasting: Cracked, broken or damaged bearings • Noise which mainly occurs when turning: Unusual noise from differential side gear, differential pinion, differential pinion shaft, etc. 	(a) Insufficient oil	Lubricate.
	(b) Improper adjustment of hypoid driven gear and drive pinion	Check tooth contact.
	(c) Worn teeth of hypoid driven gear and drive pinion	Replace as a set. Readjust the bearing preload.
	(d) Loose roller bearing	Readjust the hypoid driven gear to drive pinion backlash and check tooth contact.
	(e) Distorted hypoid driven gear or differential case	Replace.
	(f) Worn washer and differential pinion shaft	Replace.