

FRONT SUSPENSION

5MT

	Page
1. General	2
2. Reverse Check Mechanism	4
3. Center Differential	9
4. Transmission Mounting	15

1. General

The Impreza's single-range manual transmission is of a full-time all-wheel-drive design integrating a transmission assembly, front differential, and transfer gear assembly with center differential into a single unit. The transmission creates five forward speeds and one reverse using the corresponding gears all provided with inertia lock-key type synchronizers.

The transmission and front differential are housed in an aluminum case which is split into right and left halves and constitutes also a clutch housing. Located at the rear and joined each other are the transfer case and extension case which house the transfer gears and center differential as well as part of the transmission assembly.

The major features of the transmission are as follows:

- The forward speed gears are helical gears featuring high tooth face strength, large tooth contact areas, and quiet operation.
- Reversing rotation is achieved by making a slidable reverse idler gear engage with both the reverse drive gear on the main shaft and the reverse driven gear integral with the 1st-2nd synchronizer hub on the drive pinion shaft.

The center differential compensates for the difference in front and rear axle speeds. It consists of a bevel gear set and a viscous coupling located at its rear end which are housed in a single case. The center differential, together with a pair of transfer gears, transmits the power from the transmission to the drive pinion shaft (front wheel drive shaft) and the propeller shaft. The viscous coupling functions as a differential-action-control element.

GENERAL

FRONT SUSPENSION

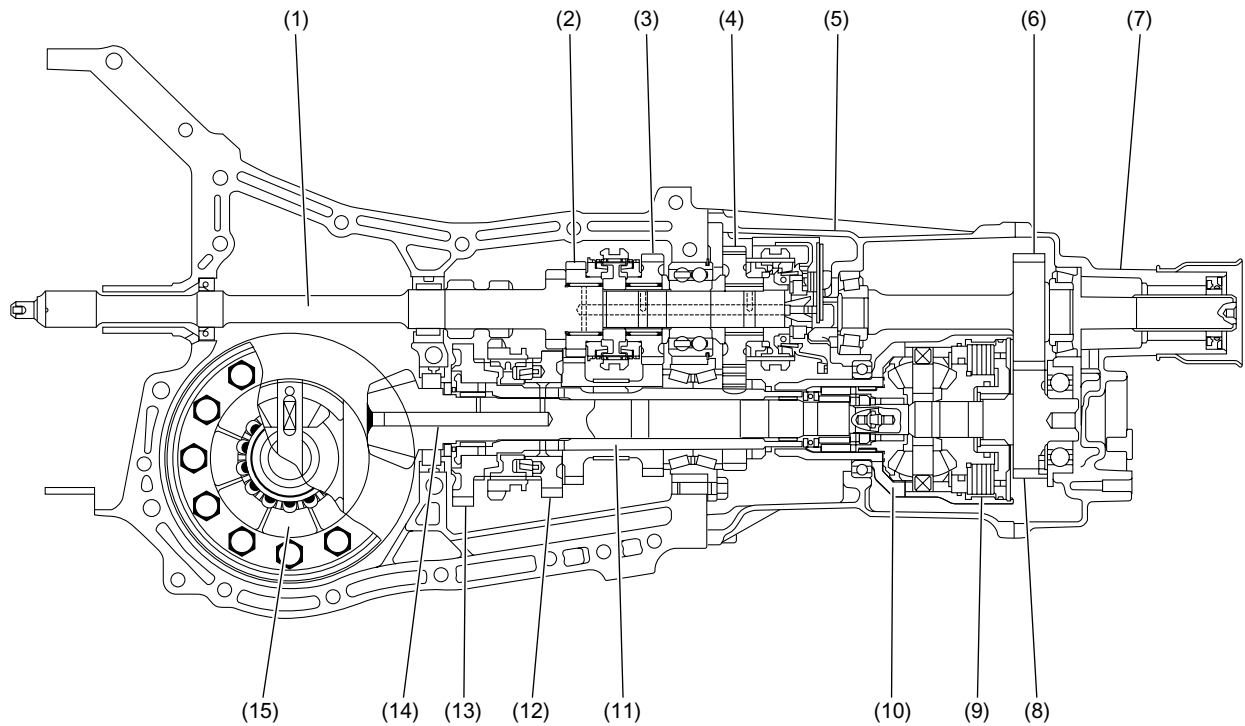

MT-00938

- | | | |
|--------------------------|-----------------------------------|----------------------------------|
| (1) Main shaft | (7) Extension case | (13) 1st driven gear |
| (2) 3rd drive gear | (8) Transfer drive gear | (14) Drive pinion shaft |
| (3) 4th drive gear | (9) Viscous coupling | (15) Front differential assembly |
| (4) 5th drive gear | (10) Center differential assembly | |
| (5) Transfer case | (11) Driven shaft (countershaft) | |
| (6) Transfer driven gear | (12) 2nd driven gear | |

REVERSE CHECK MECHANISM

FRONT SUSPENSION

2. Reverse Check Mechanism

Located in the transfer case, the reverse check mechanism prevents a direct 5th-to-reverse shift by using a selector arm and cam combination which allows the gear to be shifted into the reverse only after it has been returned once into the neutral.

A: CONSTRUCTION

The construction of the reverse check mechanism is as shown in the drawing on the opposing page. The reverse check sleeve is bolted to the transfer case and houses the mechanism's main components.

The reverse accent shaft is slidable inside the reverse check sleeve and its smaller-diameter end is fitted with the reverse check cam. The cam is rotatable and axially movable on the shaft but its leftward movement is restricted by a step formed on the sleeve's inner wall.

The reverse accent shaft has hollows in both ends. In the left end hollow are the 1st return spring and its cap and in the right end hollow is the reverse return spring which pushes the shaft leftward.

Around the check cam is the reverse check spring whose left end applies simultaneous leftward and rotational forces to the cam.

Both the reverse check spring and reverse return spring are retained at their right ends by the reverse check plate which is held in place by the snap ring.

The reverse accent shaft has a V-groove in which the detent ball is pressed by the reverse accent spring fitted through the hole in the reverse check sleeve.

The reverse check sleeve and reverse accent shaft have a slot and a notch at their bottoms, respectively, and the selector arm is inserted in the notch through the slot.

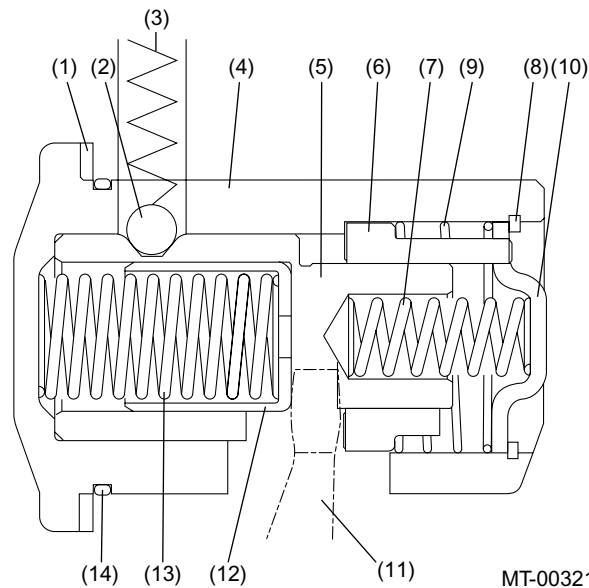

- | | | |
|---------------------------|---------------------------|------------------------|
| (1) Select adjust shim | (6) Reverse check cam | (11) Selector arm |
| (2) Detent ball | (7) Reverse return spring | (12) Spring cap |
| (3) Reverse accent spring | (8) Snap ring | (13) 1st return spring |
| (4) Reverse check sleeve | (9) Reverse check spring | (14) O-ring |
| (5) Reverse accent shaft | (10) Reverse check plate | |

B: OPERATION

The drawing below shows the state of the reverse check mechanism when the selector arm is in the neutral position. The 1st and 2nd gears will be selected if the selector arm is moved leftward from this point to a stop and then turned in either way. A rightward movement of the arm to a stop will enable selection of the 5th and reverse gears. In the neutral position, the selector arm receives a rightward force (force toward the 5th and reverse gear side) from the 1st return spring and a leftward force (force toward the 1st and 2nd gear side) from the reverse return spring to stay in that position.

The following explanation describes how the selector arm and reverse check mechanism operate when the driver selects the 5th gear and then selects the reverse gear.

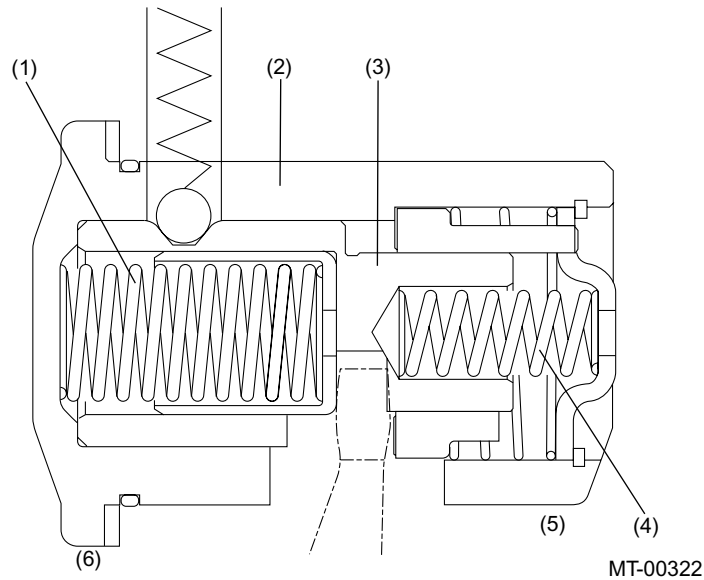

(1) 1st return spring

(3) Reverse accent shaft

(5) 5th and reverse gear side

(2) Reverse check sleeve

(4) Reverse return spring

(6) 1st and 2nd gear side

REVERSE CHECK MECHANISM

FRONT SUSPENSION

1. WHEN SELECTOR ARM IS MOVED TOWARD 5TH AND REVERSE GEAR SIDE

The selector arm moves rightward while pushing both the reverse accent shaft and reverse check cam simultaneously.

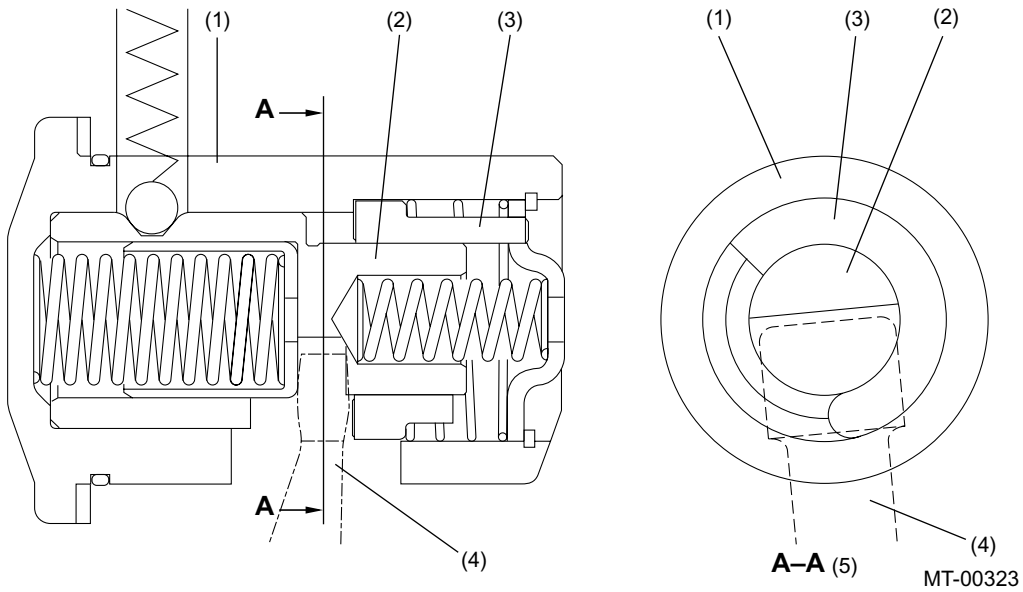

- (1) Reverse check sleeve
- (2) Reverse accent shaft
- (3) Reverse check cam
- (4) Selector arm
- (5) Neutral position

2. WHEN SHIFT IS MADE TO 5TH GEAR

The selector arm is turned toward the 5th gear selection direction. When the arm clears the edge of the reverse check cam as it turns, the cam becomes free of the selector arm's pressure and returns to its original position by the force of the reverse check spring.

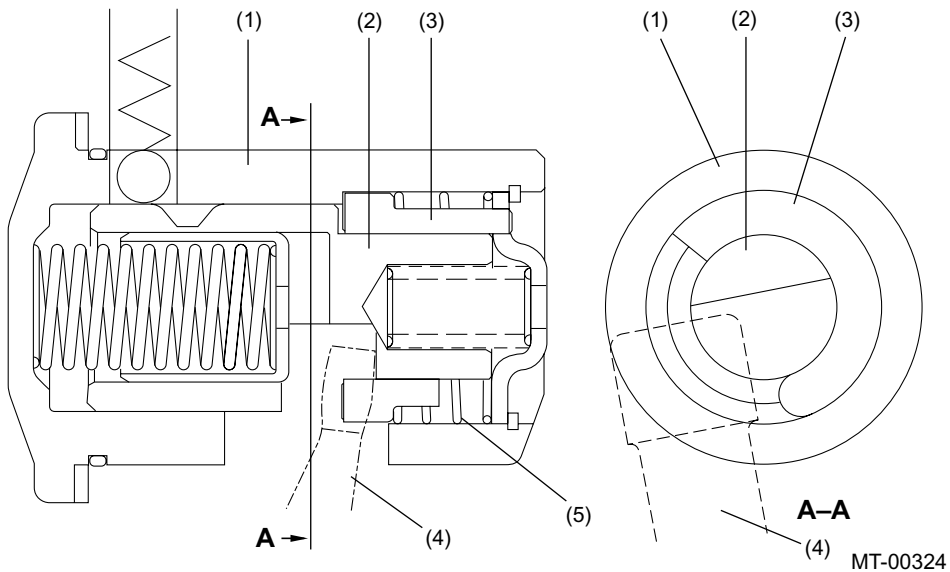

- (1) Reverse check sleeve
- (2) Reverse accent shaft
- (3) Reverse check cam
- (4) Selector arm
- (5) Reverse check spring

REVERSE CHECK MECHANISM

3. WHEN A SHIFT FROM 5TH TO REVERSE IS ATTEMPTED

The selector arm turns toward the reverse gear while pushing the reverse accent shaft rightward and the reverse check cam counterclockwise (as viewed in the direction of arrows A).

The reverse check cam, however, stops to rotate at a point where its stopper hits against the reverse check plate (this point corresponds to the neutral position in terms of the angle) and prevents the selector arm from moving toward the reverse gear selection direction. The selector arm is then axially pushed to the neutral position by the reverse accent shaft which is given a leftward force by the reverse return spring.

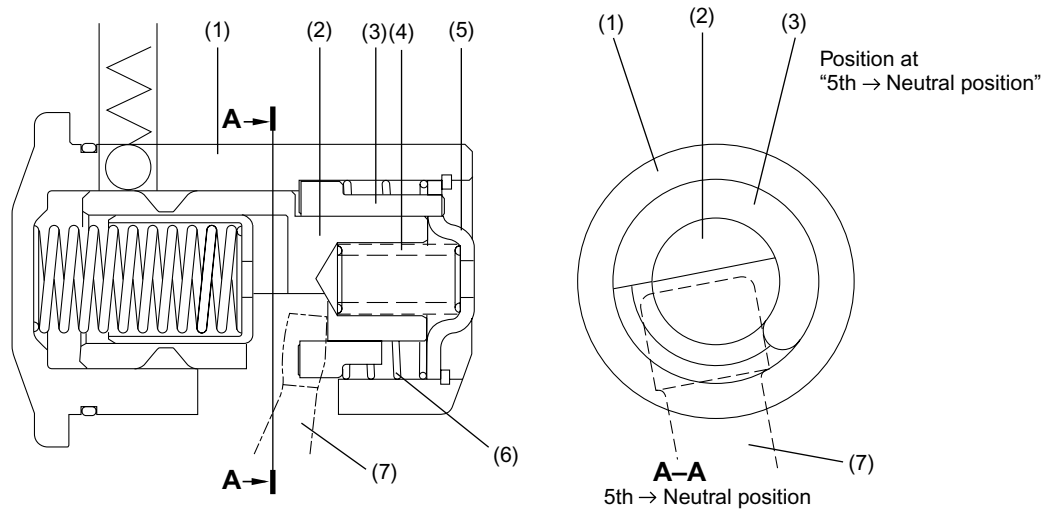

MT-00325

- (1) Reverse check sleeve
- (2) Reverse accent shaft
- (3) Reverse check cam
- (4) Reverse return spring

- (5) Reverse check plate
- (6) Reverse check spring
- (7) Selector arm

REVERSE CHECK MECHANISM

FRONT SUSPENSION

4. WHEN A SHIFT TO REVERSE IS MADE AFTER RETURN OF SELECTOR ARM TO NEUTRAL

As the ends of the reverse accent shaft and the reverse check cam are on the same plane, the selector arm now can turn toward the reverse gear selection direction after pushing leftward both the shaft and cam simultaneously.

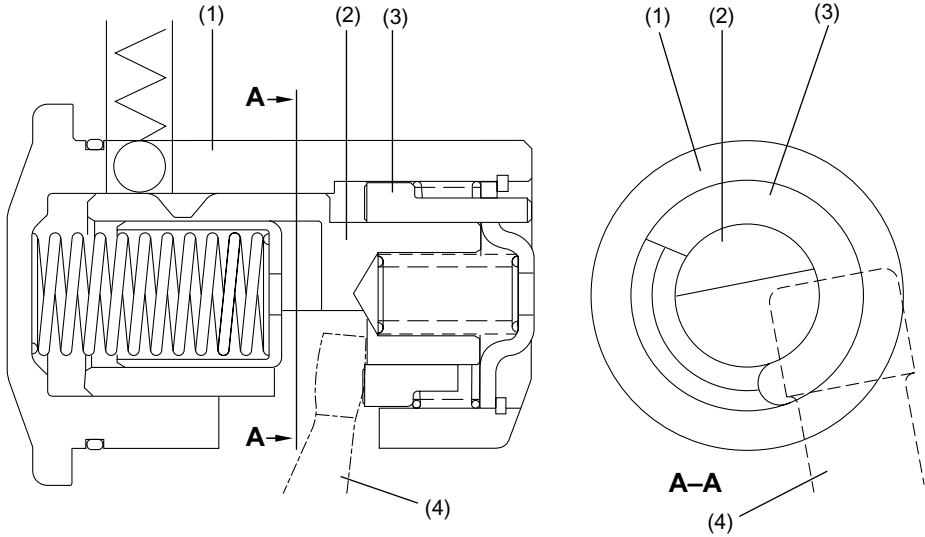

MT-00326

- (1) Reverse check sleeve
- (2) Reverse accent shaft

- (3) Reverse check cam
- (4) Selector arm

3. Center Differential

A: CONSTRUCTION

The center differential consists of a set of bevel gears and a viscous coupling.

The center differential has the following two functions: distributing the engine torque to the front and rear wheel drive shafts and absorbing the difference in rotating speed between the front and rear wheels.

The engine torque enters the center differential case from the transmission's driven shaft. The engine torque is then distributed through the bevel gear set directly to the drive pinion shaft and via the transfer drive and driven gears to the rear drive shaft.

The viscous coupling limits the bevel gear set's differential action when either front or rear wheels spin so that adequate torques are transmitted to the front and rear wheels and proper traction is obtained.

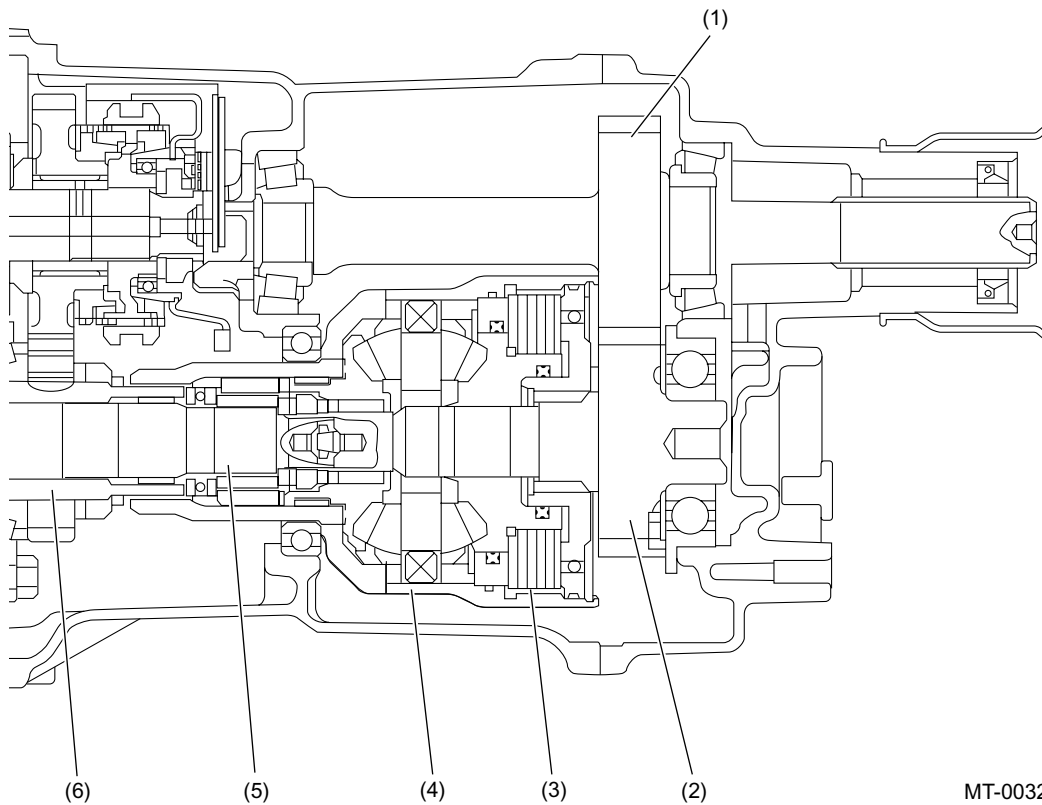

MT-00327

- | | |
|--------------------------|---|
| (1) Transfer driven gear | (4) Center differential (with viscous coupling) |
| (2) Transfer drive gear | (5) Drive pinion shaft |
| (3) Viscous coupling | (6) Driven shaft |

CENTER DIFFERENTIAL

FRONT SUSPENSION

B: MECHANISM OF VISCOUS COUPLING

The viscous coupling consists of a number of alternately arranged inner and outer plates and air-and-silicone oil mixture filled into a sealed space that is formed by the center differential case and the rear side gear of the differential gear set. The inner plates have their inner perimeters splined to the side gear and the outer plates have their outer perimeters splined to the center differential case. The outer plates are held apart by spacer rings. There are no spacer rings between the inner rings, so the inner rings are movable slightly in axial directions. X-section rings are used to prevent leakage of silicone oil which would otherwise occur if the oil is pressurized due to large difference in front and rear axle speeds.

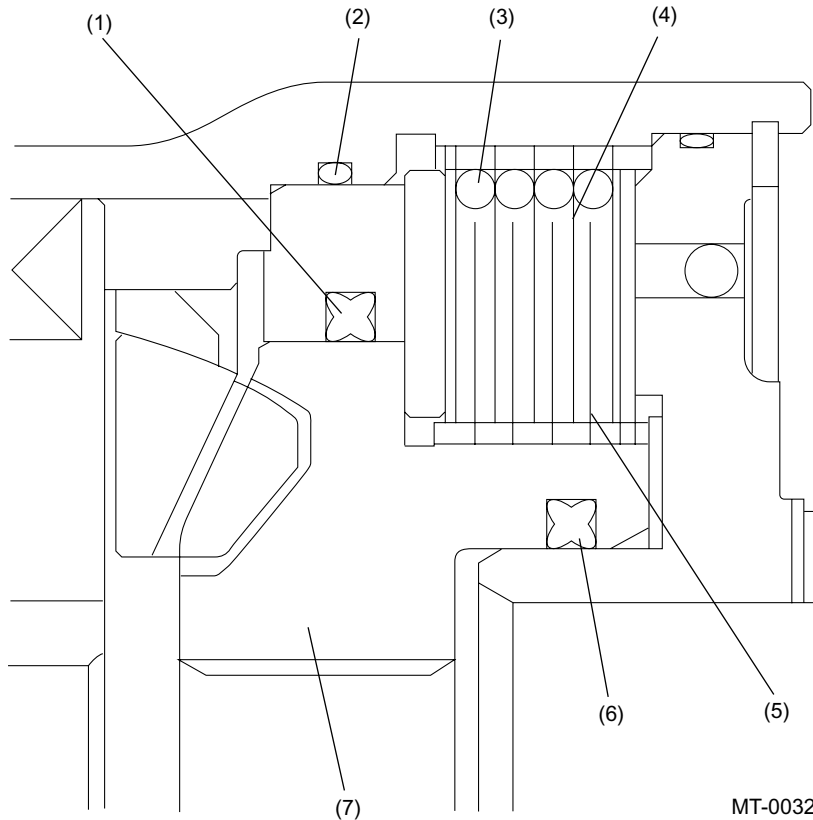

- (1) X-section ring
- (2) O-ring
- (3) Spacer ring
- (4) Outer plate

- (5) Inner plate
- (6) X-section ring
- (7) Side gear (rear)

1. TORQUE CHARACTERISTICS

When a speed difference occurs between the center differential case and the rear side gear, a shear force is generated in the silicone oil placed between the outer and inner plates. The torque is then transmitted by the silicone oil between the center differential case and the rear side gear.

The greater the speed difference, the greater the shear force generated in the silicone oil. The relationship between the torque transmission and the speed difference is shown in the figure below. As can be seen from the figure, the smaller the speed difference, the smaller the torque transmission and the differential action.

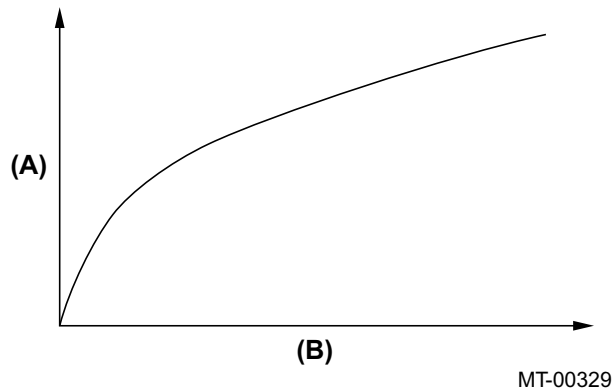

- (A) Driving torque
- (B) Speed difference

2. HUMP PHENOMENON

Silicone oil is heated and expanded as differential action continues. This causes the pressure of air inside the viscous coupling to increase and the pressure of oil between plates to decrease. As a result, the inner and outer plates are pushed together. This direct plate-to-plate contact causes a non-viscous operation to occur, and this phenomenon is called "hump".

The hump eliminates the rotating speed difference between the center differential case and the rear side gear (or locks the differential), so soon after it has occurred, the internal pressure and temperature drop. The viscous coupling then returns to the normal shear torque transmitting operation. (The hump phenomenon does not occur under normal operating conditions.)

CENTER DIFFERENTIAL

FRONT SUSPENSION

C: FUNCTION

When there is no speed difference between the front and rear wheels, the center differential delivers the engine torque to the front and rear wheels at a ratio of 50:50.

When a rotating speed difference occurs between the front and rear wheels, the center differential operates to absorb it in a controlled way by the function of the viscous coupling.

1. DURING NORMAL DRIVING

During straight-line driving on a flat road at a constant speed, all the four wheels rotate at the same speed. The center differential delivers engine torque evenly to the front and rear wheels. The viscous coupling does not generate shear torque because there is no relative movements between the inner and outer plates.

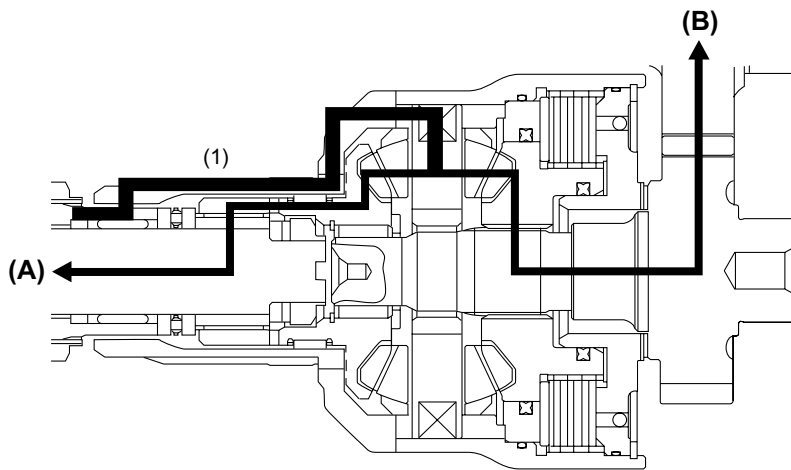

MT-00330

(1) Engine torque

(A) To front differential

(B) To rear differential

2. DURING TURNS AT LOW SPEEDS

During turns at low speeds, rotating speed difference occurs between the front and rear wheels, as well as between the left and right wheels. More particularly, the front wheels rotate faster than the rear wheels. The center differential then acts to absorb the speed difference to enable smooth driving.

Although the speed difference is small under this condition, operation of the viscous coupling causes more torque to be transmitted to the rear than to the front.

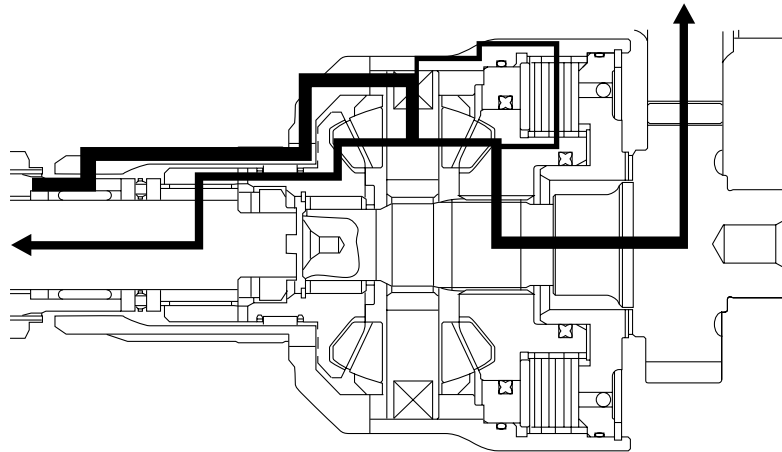

MT-00331

CENTER DIFFERENTIAL

FRONT SUSPENSION

3. DRIVING ON ROUGH OR SLIPPERY ROADS

- When front wheels are on a slippery surface

When the front wheels begin to spin, the resulting speed difference between the front and rear drive shafts causes the viscous coupling to generate significant amount of shear torque. As a result, the torque distributed to the rear wheels becomes much larger than that distributed to the spinning front wheels. The traction and driving stability are thus ensured on a rough or slippery road.

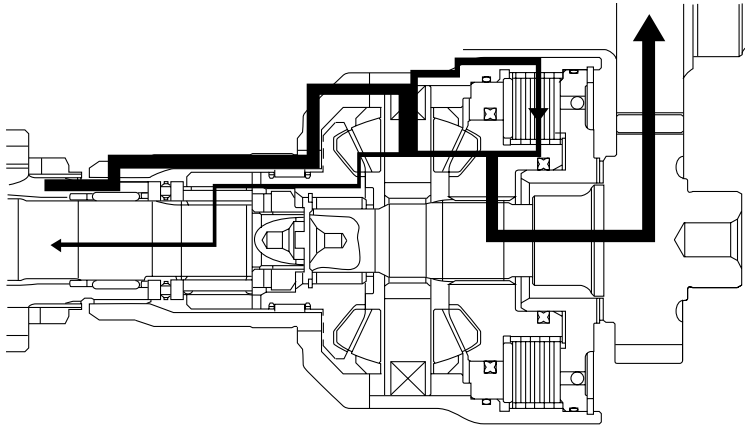

MT-00332

- When rear wheels are on a slippery surface

When the vehicle is accelerated quickly from a standing start with the rear wheels on a slippery surface, the distribution of the vehicle weight on the front and rear wheels changes and the rear wheels start spinning. Due to the resulting speed difference between the front and rear drive shafts, the viscous coupling generates a significant amount of shear torque, now in the direction opposite to that generated when the front wheels are on a slippery surface. As a result, the torque distributed to the front wheels becomes much larger than that distributed to the rear wheels.

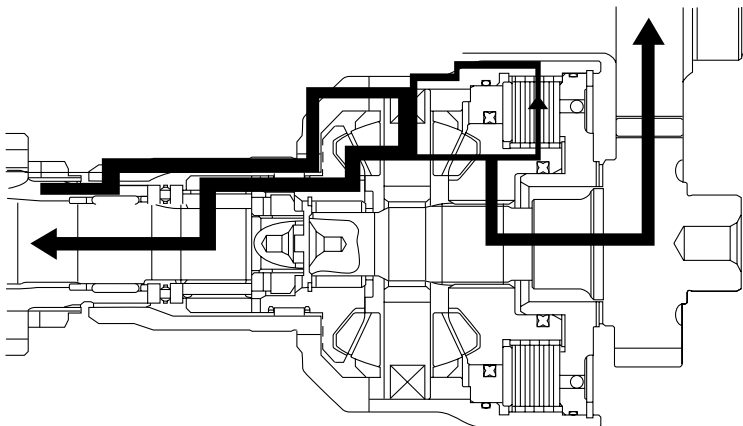

MT-00333

4. Transmission Mounting

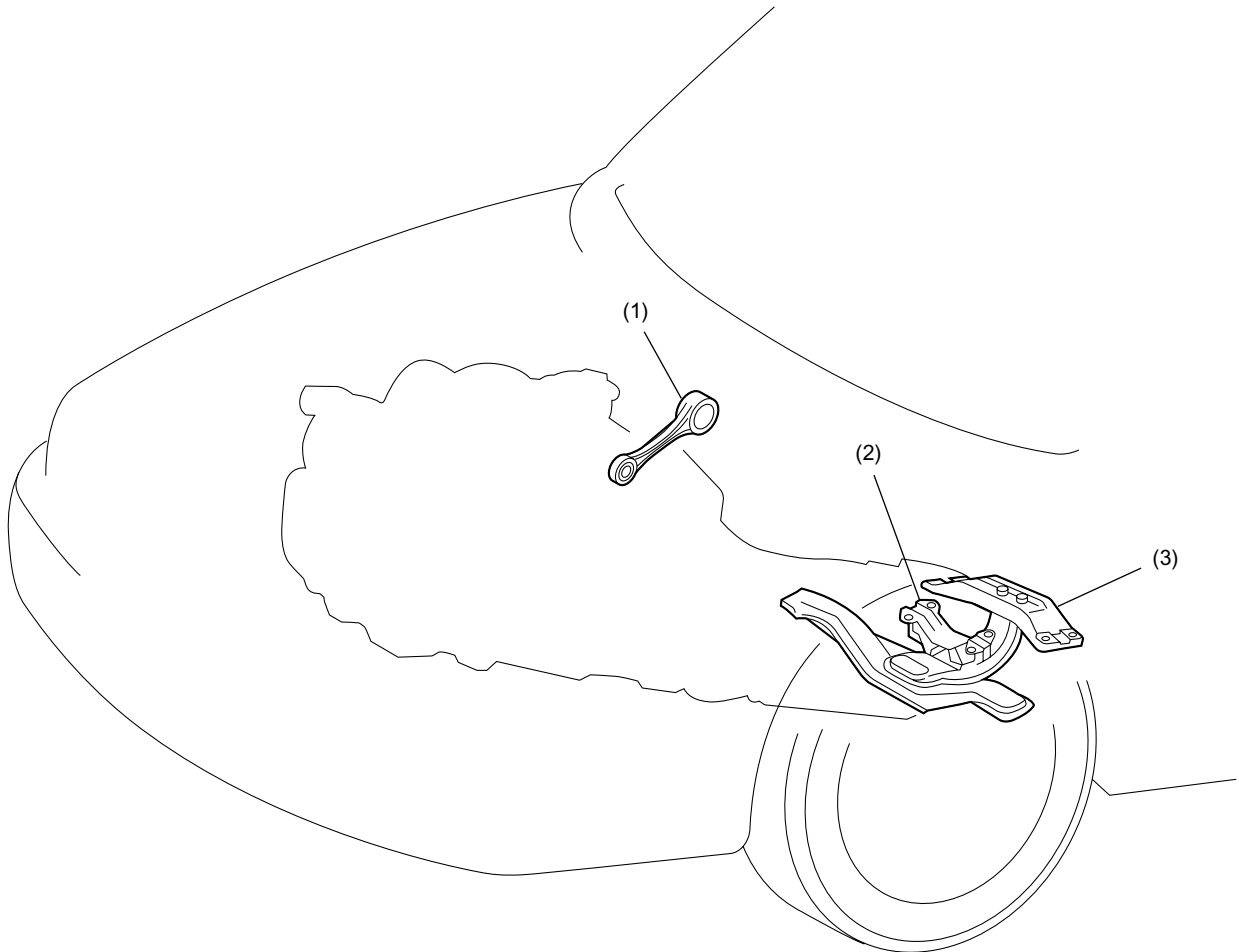

MT-00334

(1) Pitching stopper

(2) Cushion rubber

(3) Cross member

TRANSMISSION MOUNTING

FRONT SUSPENSION

MEMO