

AIRBAG SYSTEM (DIAGNOSTICS)

Basic Diagnostic Procedure

AIRBAG SYSTEM (DIAGNOSTICS)

1. Basic Diagnostic Procedure

A: PROCEDURE

	Step	Check	Yes	No
1	READ DTC. <Ref. to AB(diag)-23, Read Diagnostic Trouble Code (DTC).>	Is the normal code being detected?	Finish the diagnosis.	Go to step 2.
2	READ DTC. <Ref. to AB(diag)-23, Read Diagnostic Trouble Code (DTC).>	Is the DTC being detected?	Go to step 3.	Go to "Airbag Warning Light Failure". <Ref. to AB(diag)-26, Airbag Warning Light Failure.>
3	PERFORM THE DIAGNOSIS. 1) Judge the possible cause from "List of Diagnostic Trouble Code (DTC)". <Ref. to AB(diag)-31, List of Diagnostic Trouble Code (DTC).> 2) Inspect using "Diagnostic Chart with Diagnostic Trouble Code (DTC)". 3) Repair the cause of the trouble. 4) Perform the clear memory mode. <Ref. to AB(diag)-25, Clear Memory Mode.> 5) Perform the inspection mode. <Ref. to AB(diag)-24, Inspection Mode.> 6) Read any DTC again.	Is the DTC being detected?	Perform the procedure 1) to 5) in step 3.	Finish the diagnosis.

Check List for Interview

AIRBAG SYSTEM (DIAGNOSTICS)

2. Check List for Interview

A: CHECK

Customer's Name		Inspector's Name	
Date Vehicle Brought In	/ /	Registration No.	
Odometer Reading	km Miles	VIN	
Date Problem Occurred	/ /	Registration Year	/ /
Weather	<input type="checkbox"/> Fine <input type="checkbox"/> Cloudy <input type="checkbox"/> Rainy <input type="checkbox"/> Snowy <input type="checkbox"/> Other:		
Temperature	°C (°F)		
Road Condition	<input type="checkbox"/> Level road <input type="checkbox"/> Uphill <input type="checkbox"/> Downhill <input type="checkbox"/> Rough road <input type="checkbox"/> Others:		
Vehicle Operation	<input type="checkbox"/> Driving (<input type="checkbox"/> Constant Speed <input type="checkbox"/> Acceleration <input type="checkbox"/> Deceleration) <input type="checkbox"/> Starting <input type="checkbox"/> Idling <input type="checkbox"/> Steering wheel turn <input type="checkbox"/> Other:		
Details of Problem			
Check Airbag Warning Light	<input type="checkbox"/> Remains ON <input type="checkbox"/> Remains OFF		
Check DTC	<input type="checkbox"/> Normal Code <input type="checkbox"/> DTC: (Code:)		

General Description

AIRBAG SYSTEM (DIAGNOSTICS)

3. General Description

A: CAUTION

- When servicing a vehicle, be sure to turn the ignition switch to OFF, disconnect the ground cable from battery, and wait for more than 20 seconds before starting work.
- The airbag system is fitted with a backup power source. If the airbag system is serviced within 20 seconds after the ground cable is disconnected, it may inflate.

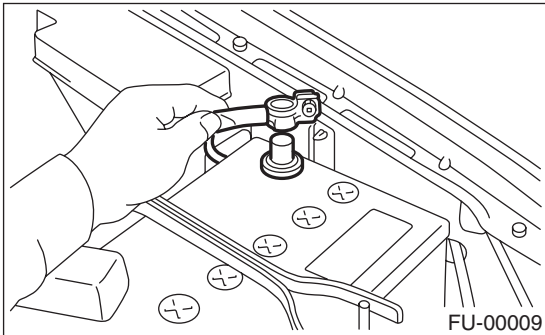

- If sensors, airbag module, airbag control module, pretensioner, and harness are deformed or damaged, replace them with new genuine parts.

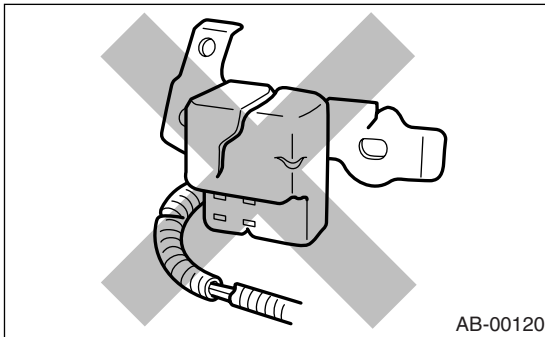

- Do not use the airbag system and pretensioners on other vehicles. When replacing parts, be sure to replace them with new parts.
- When checking the airbag system, be sure to use a digital circuit tester. Use of an analog circuit tester may cause the airbag to activate erroneously.

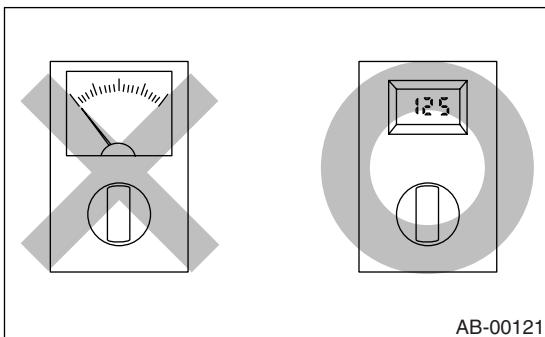

- When checking, use a test harness. Do not directly apply the tester probe to any connector terminal of the airbag.

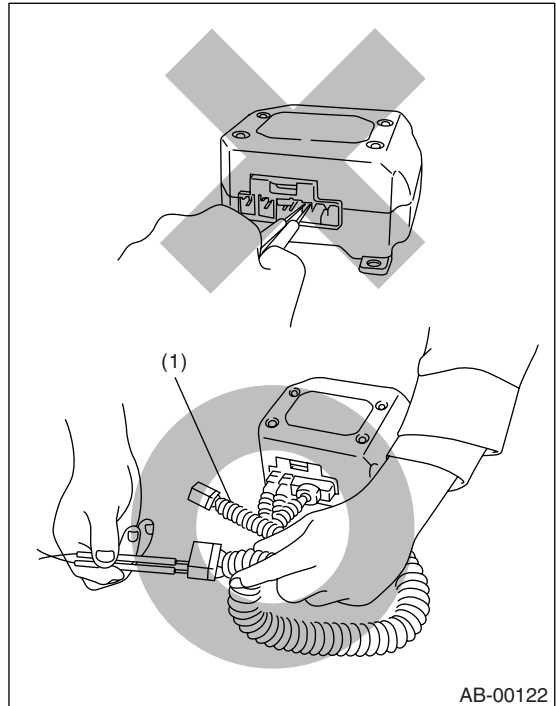

(1) Test harness

- Do not drop the airbag modulator parts, subject them to high temperature over 93°C (199°F), or let water, oil, or grease get on them; otherwise, the internal parts may be damaged and may be reliability greatly lowered.

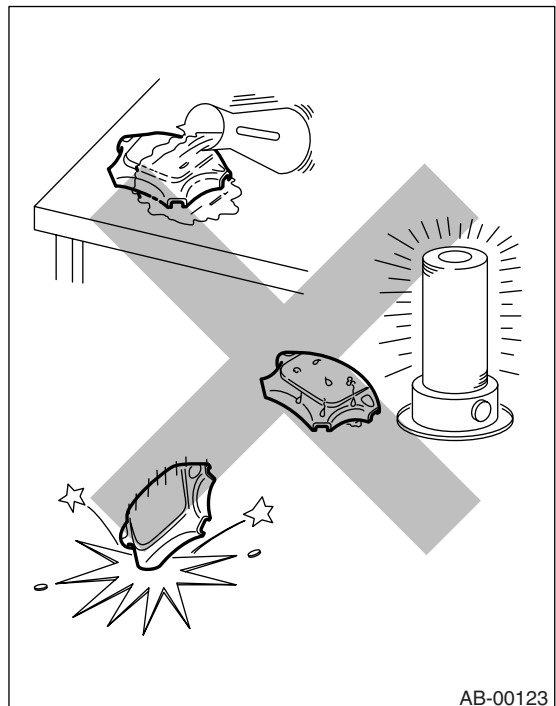

General Description

AIRBAG SYSTEM (DIAGNOSTICS)

- If any damage, opening, or rust is found on the airbag system wire harness, do not attempt to repair using soldering equipment. Be sure to replace the faulty harness with a new genuine part.

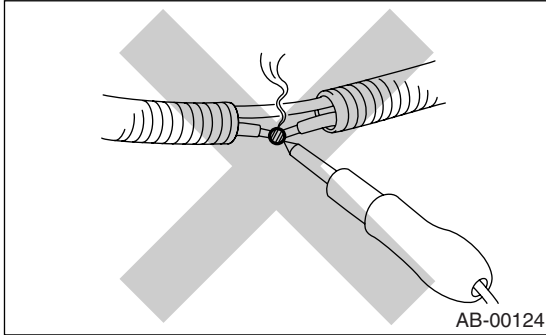

- Install the wire harness securely with the specified clips to avoid interference or tangled up with other parts.

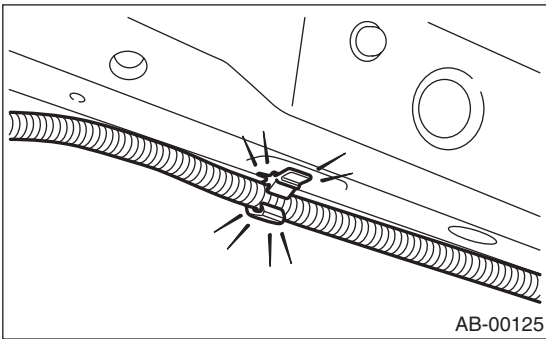

- Do not allow water or oil to come in contact with the connector terminals. Do not touch the connector terminals.

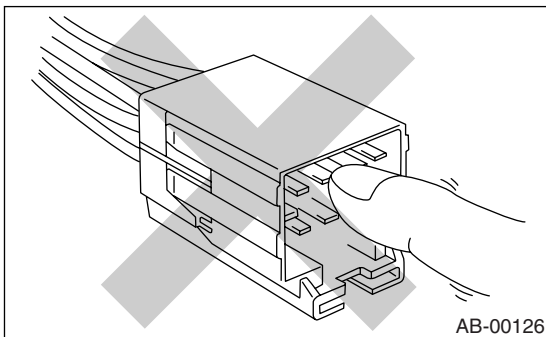

- Either of the airbag modules for driver, passenger or side, or pretensioner must not be disassembled.

- The airbag module cannot be used again if once inflated.

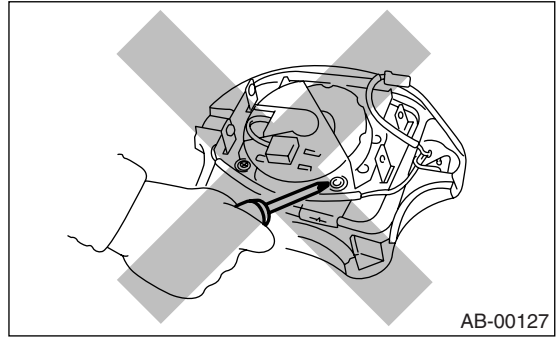

- After removal, keep the airbag module with the pad facing upward on a dry, clean, and flat surface away from heat and light sources, and moisture and dust.

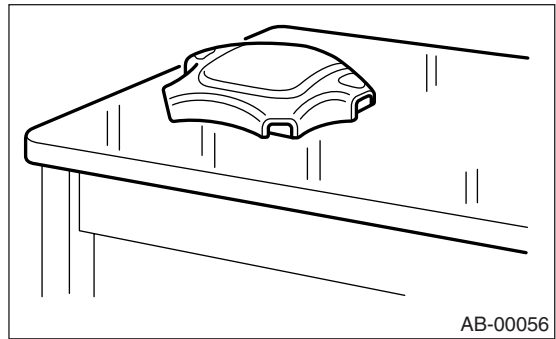

- Do not check continuity of either of the airbag modules for driver, passenger or side, or pretensioner.

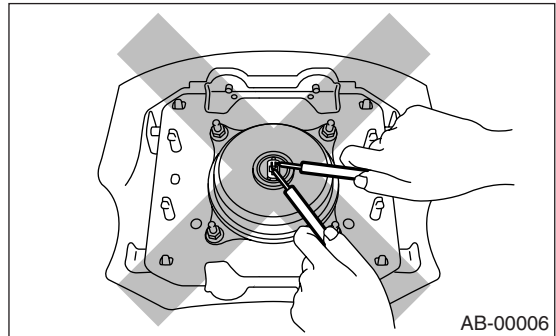

General Description

AIRBAG SYSTEM (DIAGNOSTICS)

- The removed front seat with the airbag module must be kept at least 200 mm (8 in) away from walls and other objects.

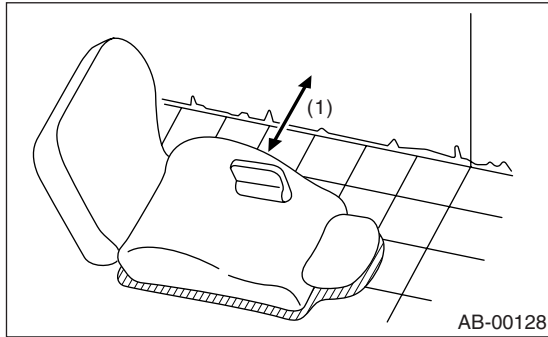

(1) More than 200 mm (8 in)

- When painting or performing sheet metal work on the front part of the vehicle, including the front wheel apron, front fender, and front side frame, remove the front sub sensors and wire harness of the airbag system.
- When painting or performing sheet metal work on the side of the vehicle, including the side sill, center pillar, and front and rear doors, remove the side airbag sensors and wire harness of the airbag system.

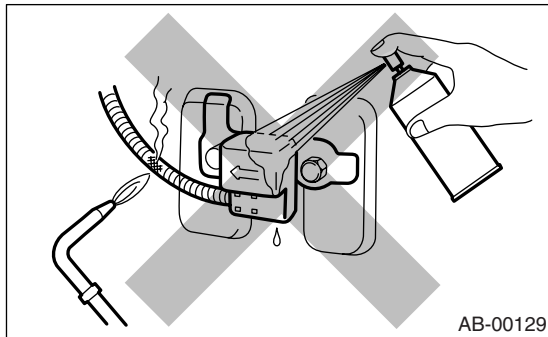

- Do not discard undeployed airbag modules. They could easily cause a serious accident if accidentally deployed.

General Description

AIRBAG SYSTEM (DIAGNOSTICS)

- When storing a removed airbag module, do not place any objects on it or pile airbag modules on top of each other. If the airbag inflates for some reason when it is placed with its pad side facing downward or under any object, a serious accident may result.

(1)

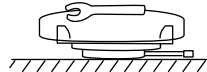
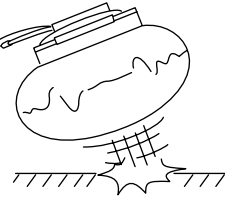
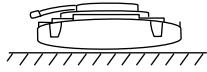
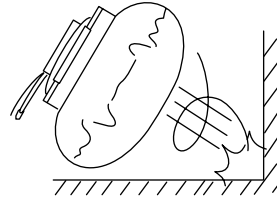
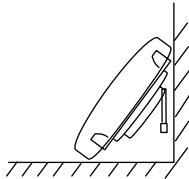
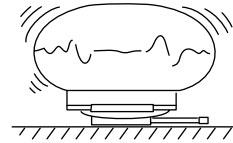
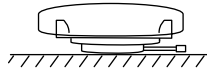

(2)

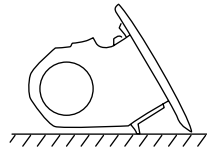
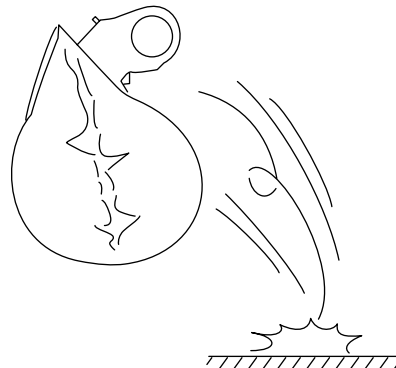
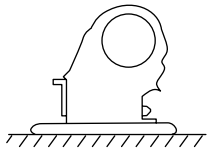
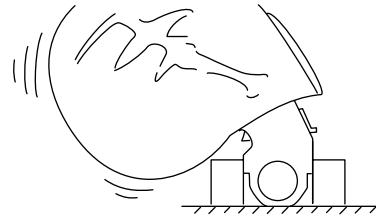
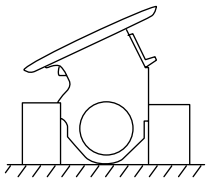

AB-00130

(1) Driver side airbag module

(2) Passenger side airbag module

General Description

AIRBAG SYSTEM (DIAGNOSTICS)

B: INSPECTION

Before diagnosing, check the following items that might be related to the engine problem:

1. BATTERY

Measure the battery voltage and specific gravity of electrolyte.

Standard voltage: 12 V

Specific gravity: Above 1.260

C: PREPARATION TOOL

1. SPECIAL TOOL

- TEST HARNESS F

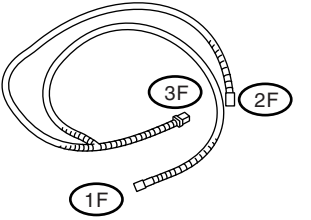
ILLUSTRATION	TOOL NUMBER	DESCRIPTION	REMARKS
 <p style="text-align: center;">ST98299FC010</p>	98299FC010	TEST HARNESS F	Used when measuring voltage, resistance of air-bag module harness.

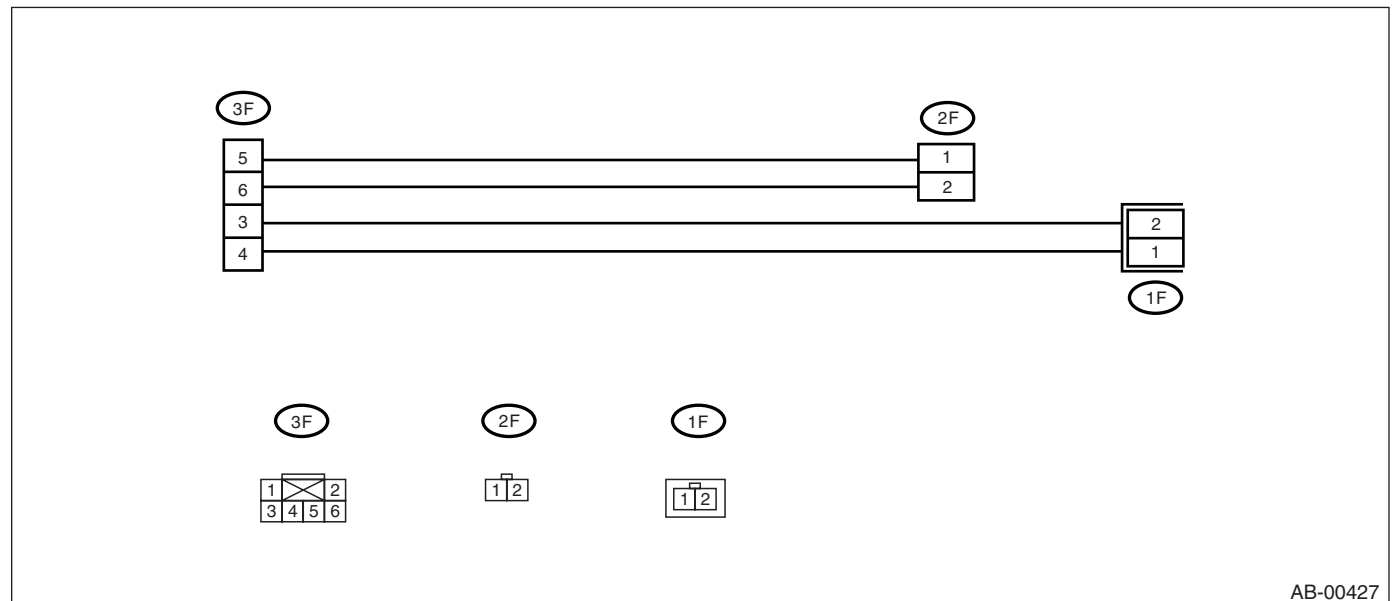

General Description

• TEST HARNESS H

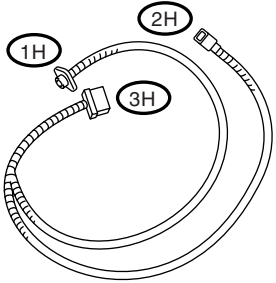
ILLUSTRATION	TOOL NUMBER	DESCRIPTION	REMARKS
 <p>ST98299FA030</p>	98299FA030	TEST HARNESS H	Used when measuring voltage, resistance of front sub sensor.

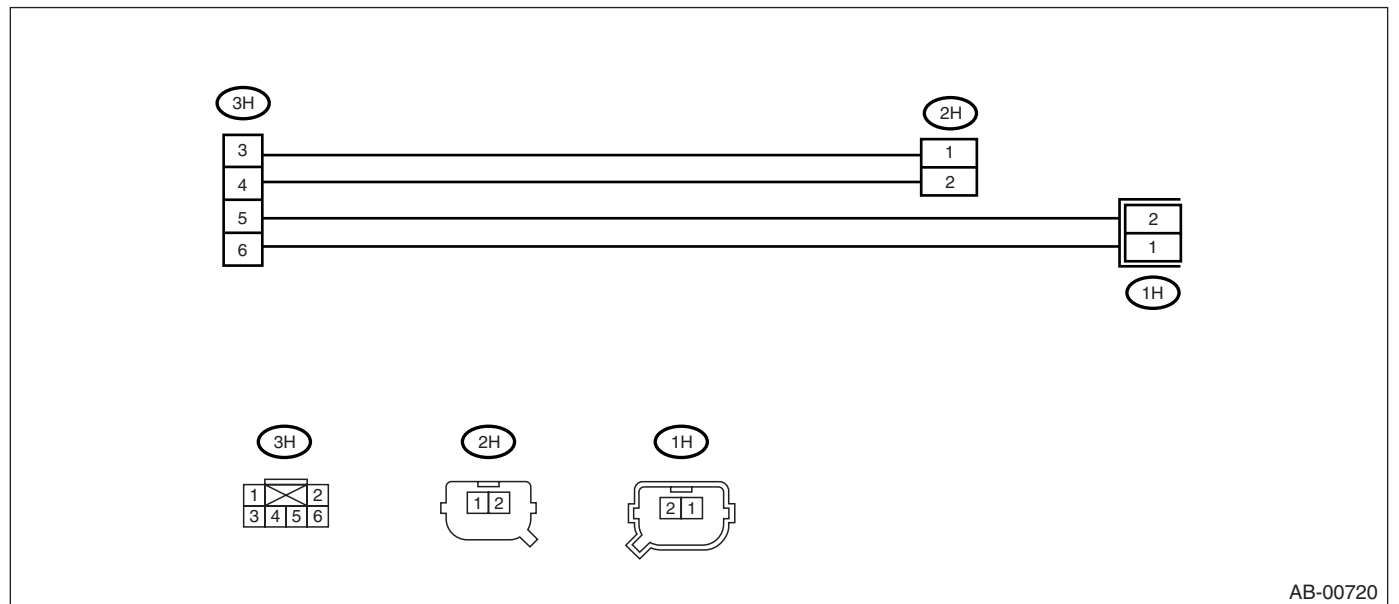

General Description

AIRBAG SYSTEM (DIAGNOSTICS)

• TEST HARNESS M

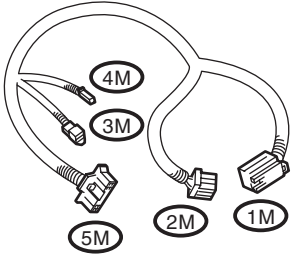
ILLUSTRATION	TOOL NUMBER	DESCRIPTION	REMARKS
 <p style="text-align: center;">ST98299FE020</p>	98299FE020	TEST HARNESS M	<ul style="list-style-type: none"> • Used when measuring voltage, resistance of airbag system. • Used with test harness T (98299SA060).

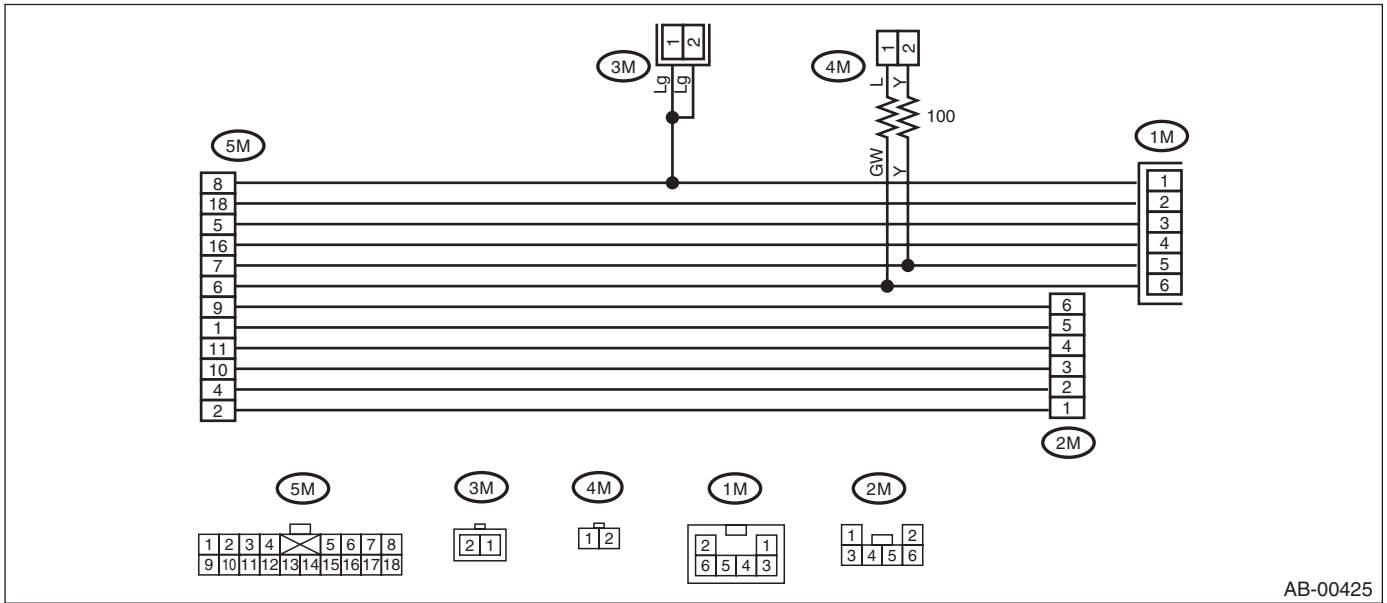

AB-00425

General Description

AIRBAG SYSTEM (DIAGNOSTICS)

• TEST HARNESS N

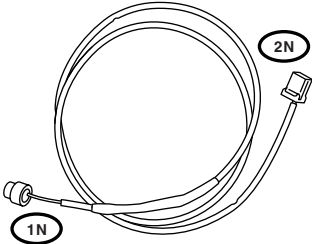
ILLUSTRATION	TOOL NUMBER	DESCRIPTION	REMARKS
 <p data-bbox="326 594 467 615">ST98299SA000</p>	98299SA000	TEST HARNESS N	Used when measuring voltage, resistance of driver's airbag module and seat belt pretensioner.

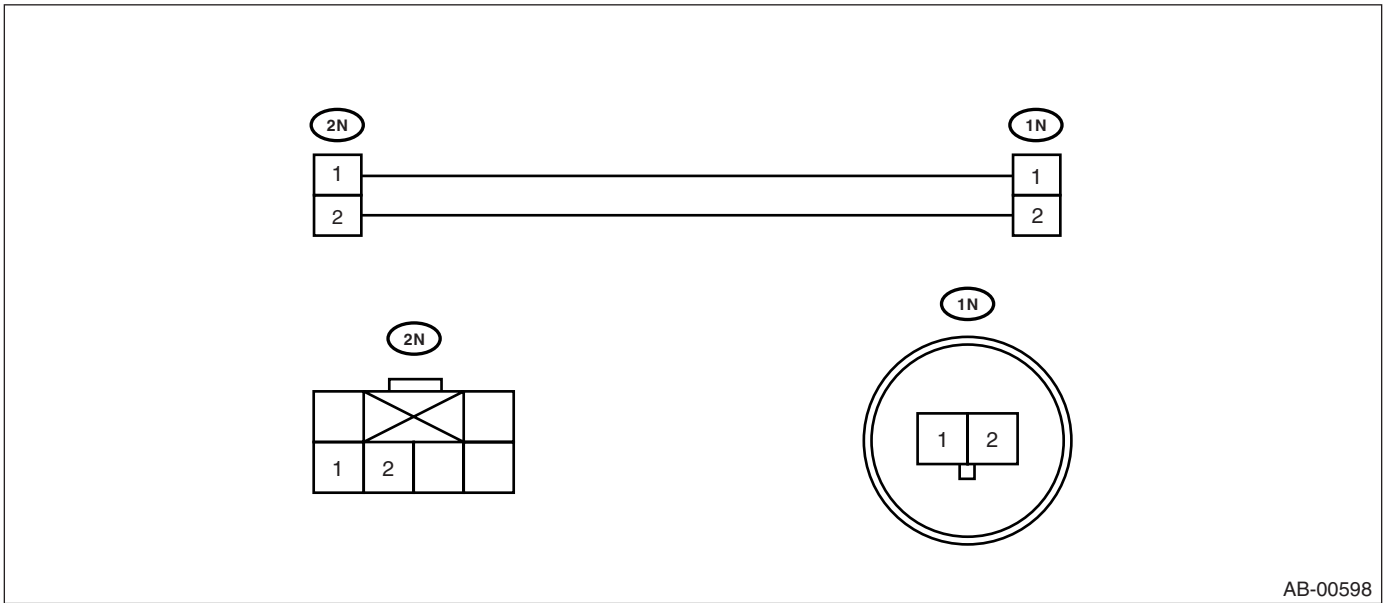

General Description

AIRBAG SYSTEM (DIAGNOSTICS)

• TEST HARNESS R

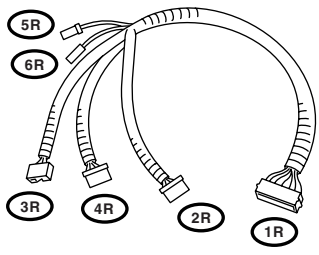
ILLUSTRATION	TOOL NUMBER	DESCRIPTION	REMARKS
 <p>ST98299FE030</p>	98299FE030	TEST HARNESS R	Used when measuring voltage, resistance of air-bag control module.

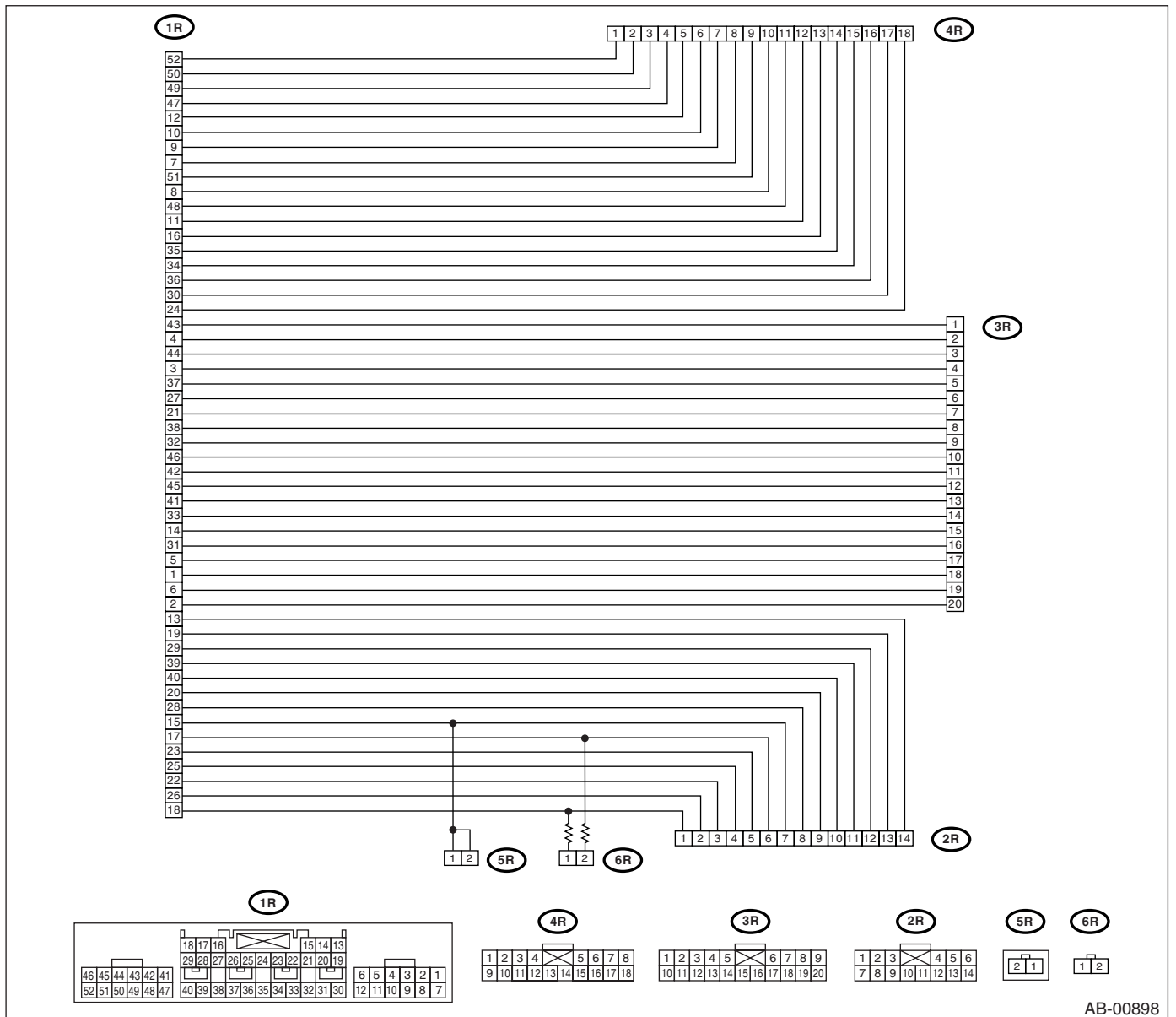

AB-00898

General Description

AIRBAG SYSTEM (DIAGNOSTICS)

• TEST HARNESS T

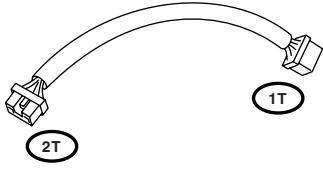
ILLUSTRATION	TOOL NUMBER	DESCRIPTION	REMARKS
 <p data-bbox="324 594 467 615">ST98299SA060</p>	98299SA060	TEST HARNESS T	<ul style="list-style-type: none"> • Used when measuring voltage, resistance of airbag system. • Used with test harness M (98299FE020).

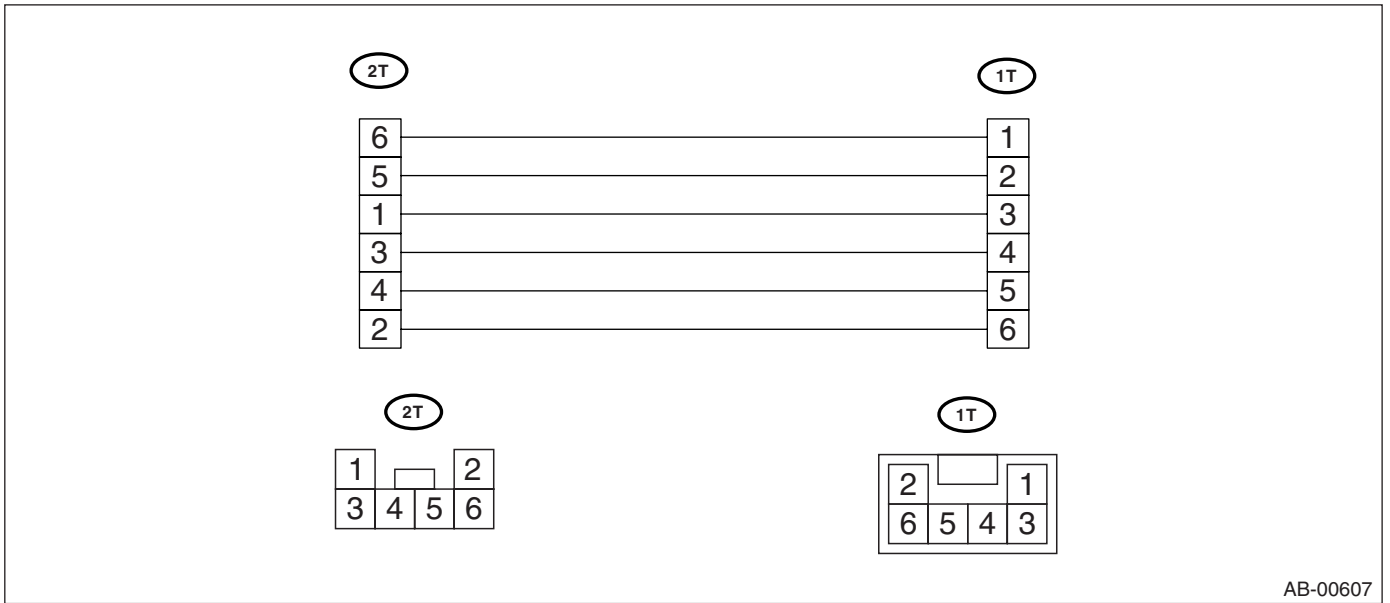

AB-00607

General Description

AIRBAG SYSTEM (DIAGNOSTICS)

• TEST HARNESS V

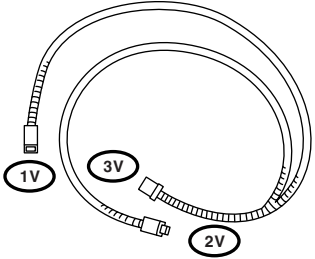
ILLUSTRATION	TOOL NUMBER	DESCRIPTION	REMARKS
 <p data-bbox="321 594 467 615">ST98299AG010</p>	98299AG010	TEST HARNESS V	Used when measuring voltage and resistance of side airbag sensor and curtain airbag sensor.

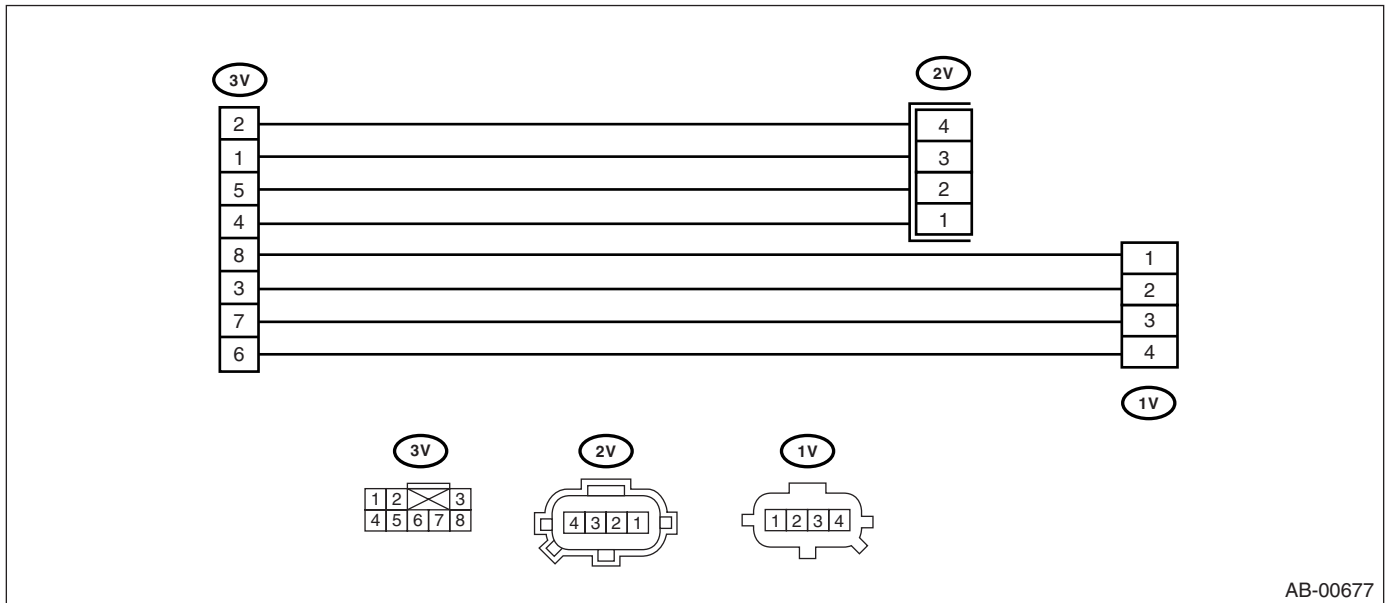

General Description

AIRBAG SYSTEM (DIAGNOSTICS)

• AIRBAG RESISTOR

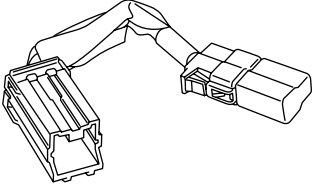
ILLUSTRATION	TOOL NUMBER	DESCRIPTION	REMARKS
 <p data-bbox="326 594 467 615">ST98299PA040</p>	98299PA040	AIRBAG RESISTOR	Used in replacement of airbag module which resistance value is same as airbag module.

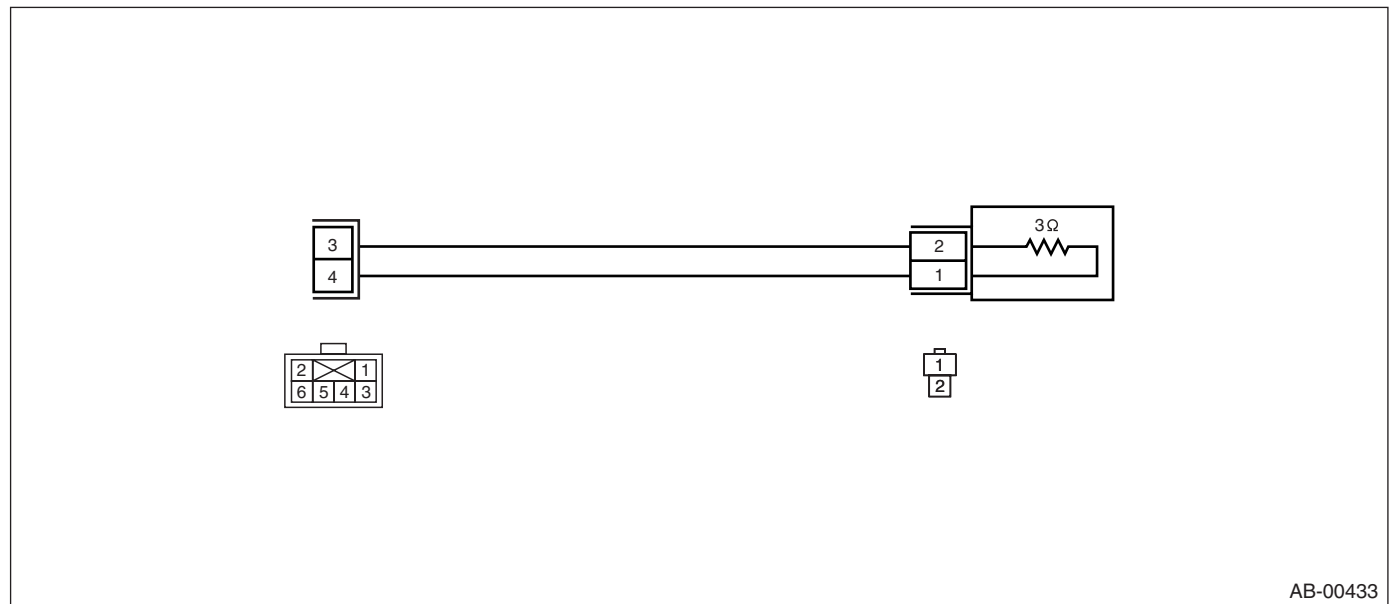

Electrical Component Location

AIRBAG SYSTEM (DIAGNOSTICS)

4. Electrical Component Location

A: LOCATION

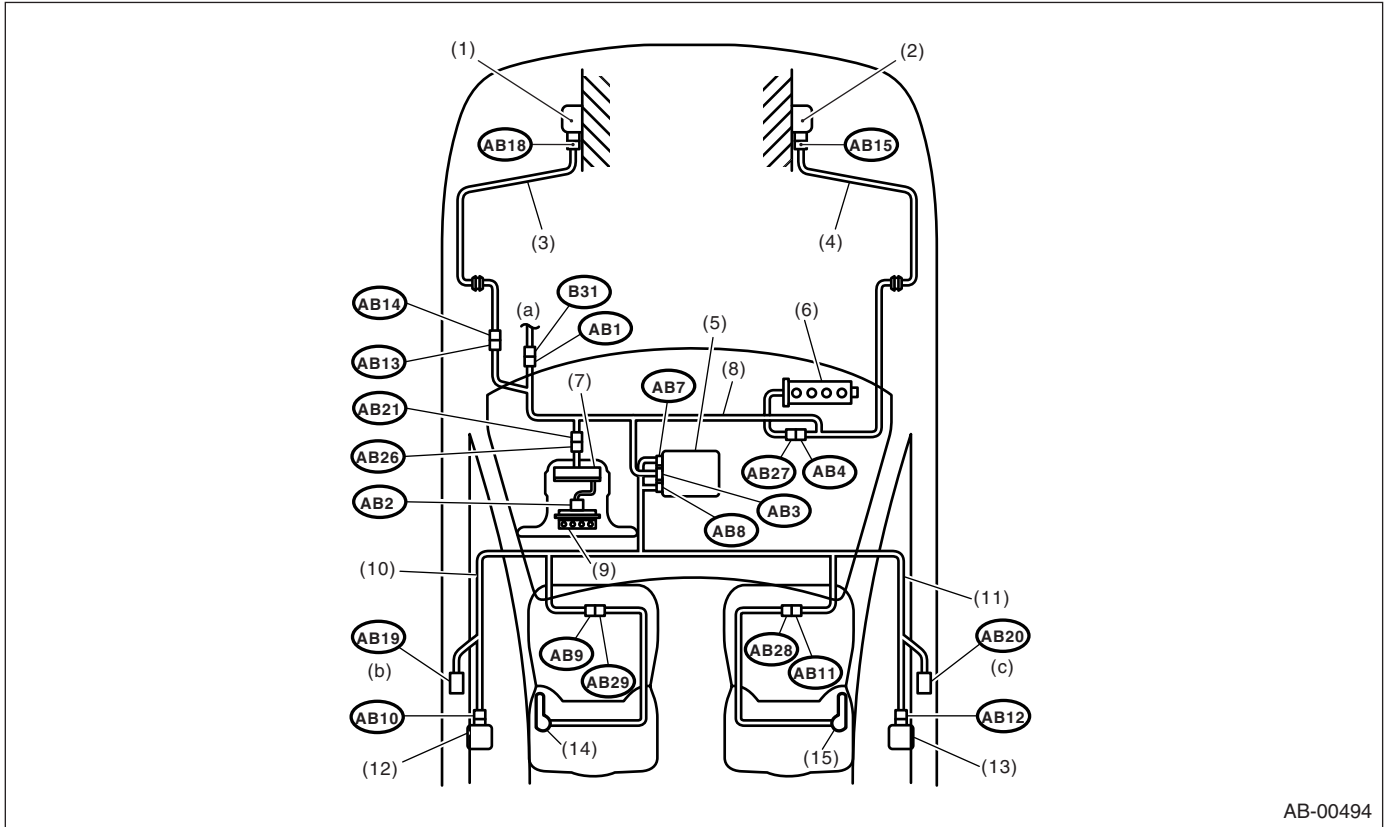

AB-00494

- | | | |
|--|-------------------------------|------------------------------------|
| (1) Front sub sensor (LH) | (7) Roll connector | (14) Side airbag module (LH) |
| (2) Front sub sensor (RH) | (8) Airbag main harness | (15) Side airbag module (RH) |
| (3) Front sub sensor harness (LH) | (9) Driver's airbag module | (a) To body harness |
| (4) Front sub sensor harness (RH) | (10) Side airbag harness (LH) | (b) To seat belt pretensioner (LH) |
| (5) Airbag control module with built-in safety and electric sensor | (11) Side airbag harness (RH) | (c) To seat belt pretensioner (RH) |
| (6) Passenger's airbag module | (12) Side airbag sensor (LH) | |
| | (13) Side airbag sensor (RH) | |

Connector No.	(AB1)	(AB2)	(AB3)	(AB4)	(AB7)	(AB8)	(AB9)	(AB10)	(AB11)	(AB12)	(AB13)	(AB14)
Pole	6	2	28	2	12	12	2	4	2	4	2	2
Color	Yellow	Black	Yellow	Yellow	Yellow	Yellow	Yellow	Yellow	Yellow	Yellow	Yellow	Yellow
Male/Female	Male	Female	Female	Female	Female	Female	Female	Female	Female	Female	Female	Male
Connector No.	(AB15)	(AB18)	(AB19)	(AB20)	(AB21)	(AB26)	(AB27)	(AB28)	(AB29)			
Pole	2	2	2	2	2	2	2	2	2			
Color	Yellow	Yellow	Black	Black	Yellow	Yellow	Yellow	Yellow	Yellow			
Male/Female	Female	Female	Female	Female	Female	Male	Male	Male	Male			

Airbag Control Module I/O Signal

AIRBAG SYSTEM (DIAGNOSTICS)

5. Airbag Control Module I/O Signal

A: WIRING DIAGRAM

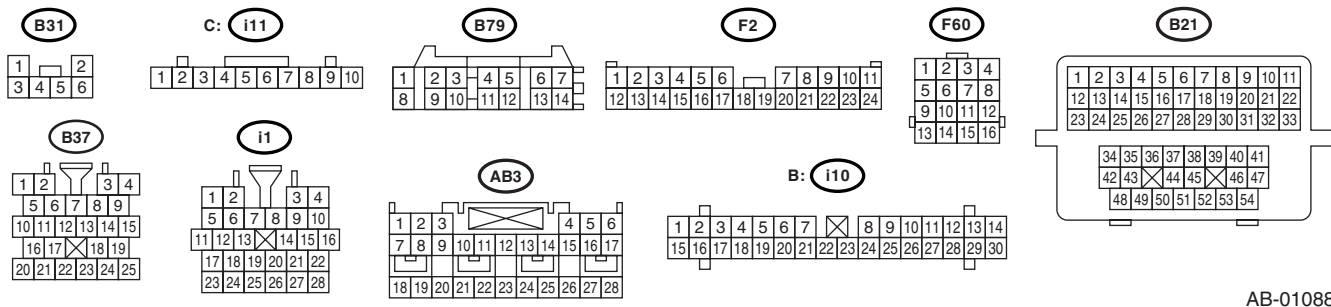
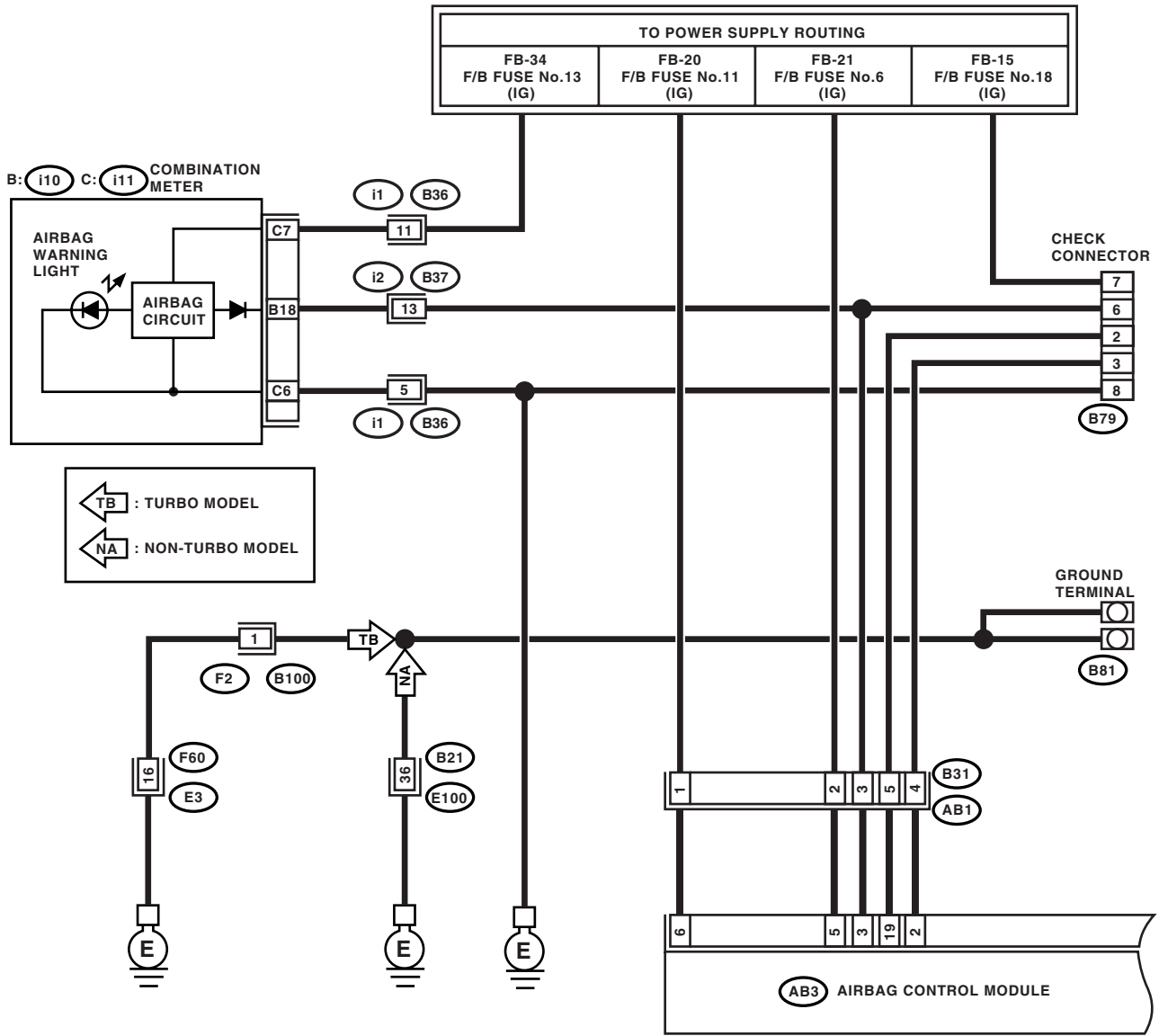

AB-01088

Airbag Control Module I/O Signal

AIRBAG SYSTEM (DIAGNOSTICS)

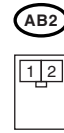
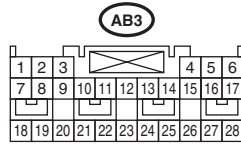
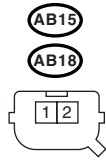
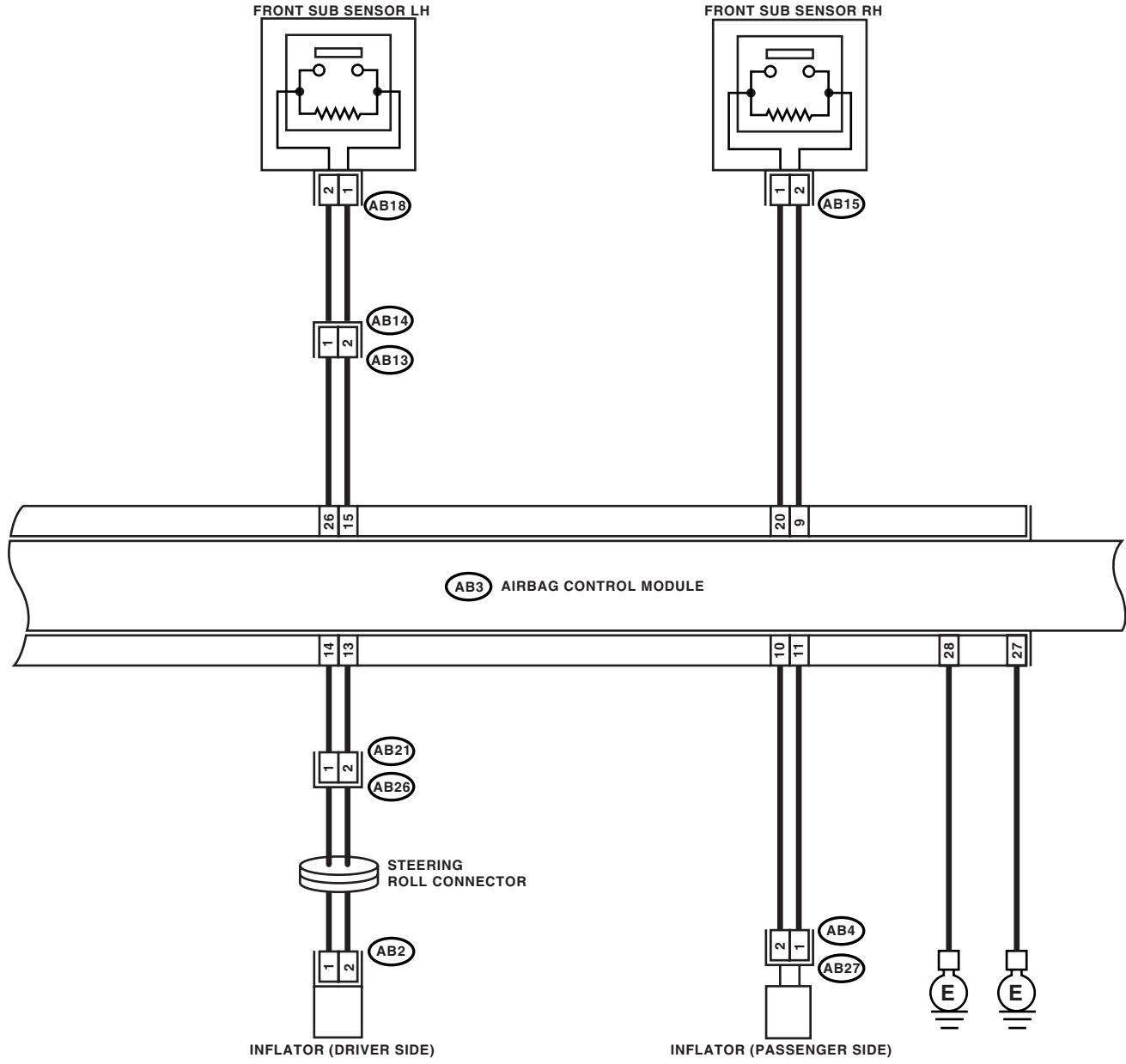

AB-01010

Airbag Control Module I/O Signal

AIRBAG SYSTEM (DIAGNOSTICS)

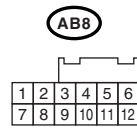
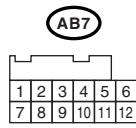
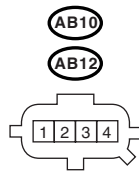
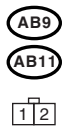
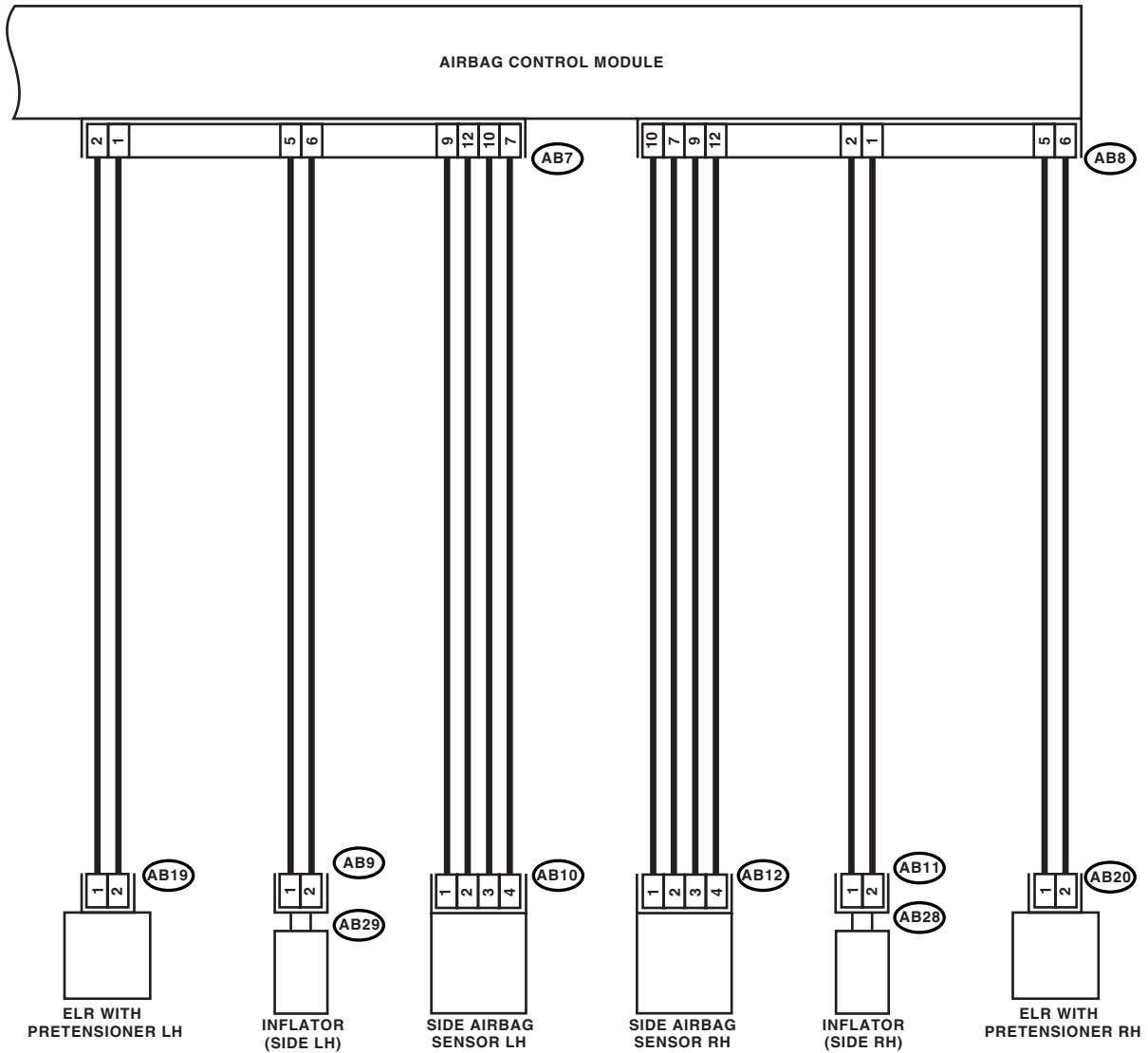

AB-00897

Airbag Connector

AIRBAG SYSTEM (DIAGNOSTICS)

6. Airbag Connector

A: PROCEDURE

1. POWER SUPPLY

1) How to disconnect:

- (1) Move the slide lock (A) in the direction of the arrow.
- (2) Disconnect the connector with the slide lock (A) moved.

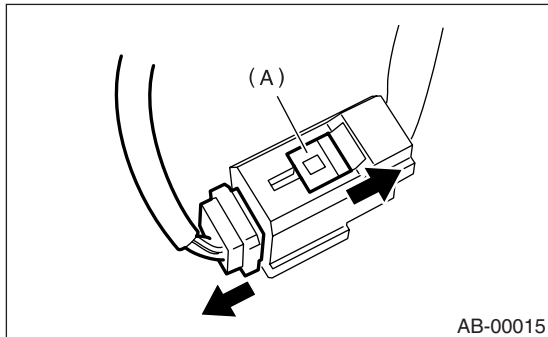

CAUTION:

When pulling, be sure to hold onto the connector and not the wire.

2) How to connect:

Holding the connector (A), and push it in carefully until a connecting sound is heard.

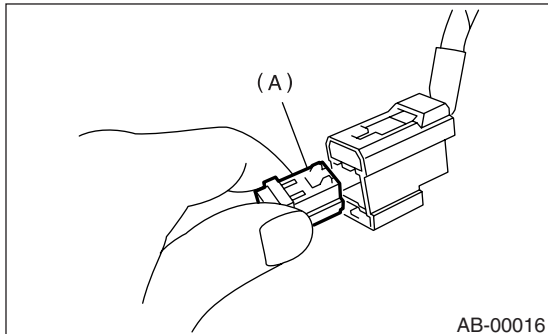

CAUTION:

Be sure to insert the connector in until it locks. Then pull on it gently to make sure that it is locked.

2. DRIVER'S AIRBAG (BETWEEN AIRBAG MAIN HARNESS AND ROLL CONNECTOR), PASSENGER'S AIRBAG AND SIDE AIRBAG

1) How to disconnect:

- (1) Push the lock arm (A).
- (2) With the lock arm (A) pushed in, move the slide lock (B) in the direction of the arrow.

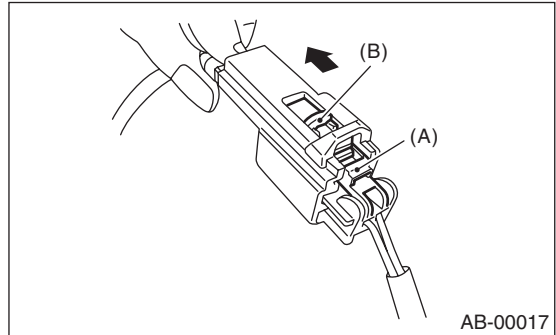

- (3) With the slide lock pulled, release the lock arm (to its original position) to separate the connector.

CAUTION:

When pulling, be sure to hold onto the connector and not the wire.

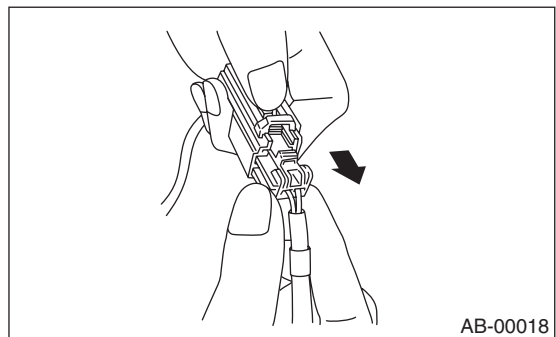

2) How to connect:

Holding the connector, push it in carefully until a connecting sound is heard.

CAUTION:

Be sure to insert the connector in until it locks. Then pull on it gently to make sure that it is locked.

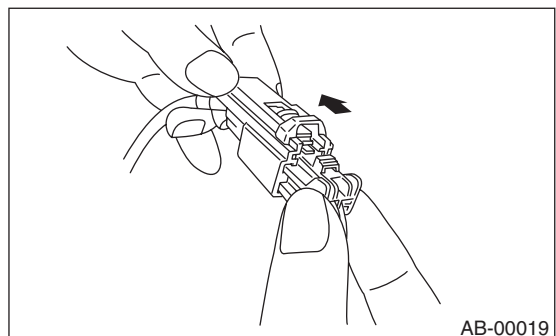

3. DRIVER'S AIRBAG MODULE AND PRE-TENSIONER

1) How to disconnect:

(1) Using a flat tip screwdriver, pry the push lock upward to unlock.

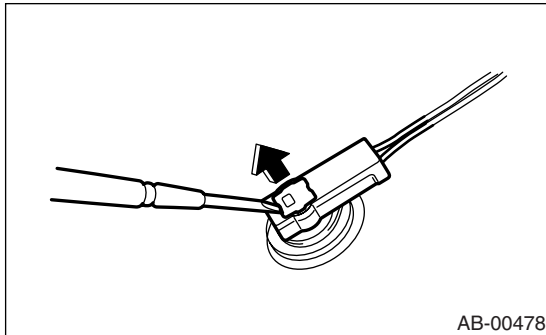

(2) Pull the connector to disconnect from driver's side airbag module assembly or retractor assembly.

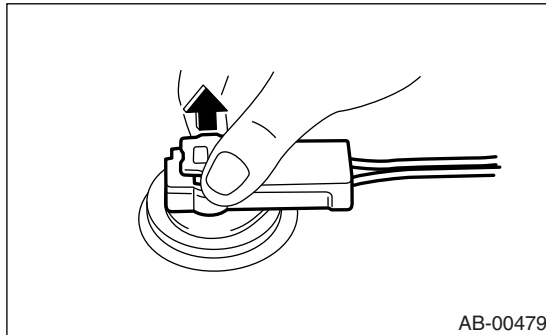

2) How to connect:

Connect the connector in reverse order of disconnecting. At this time, be sure to insert the push lock in until connecting sound is heard.

CAUTION:

- Be sure to insert the connector in until it locks. Then pull on it gently to make sure that it is locked.
- Be sure to push the push lock in securely.

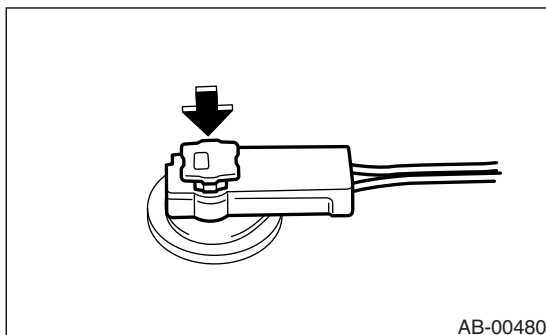

4. FRONT SUB SENSOR AND SIDE AIRBAG SENSOR

1) How to disconnect:

Holding outer part (A), pull it in the direction of the arrow.

CAUTION:

When pulling, be sure to hold onto the connector and not the wire.

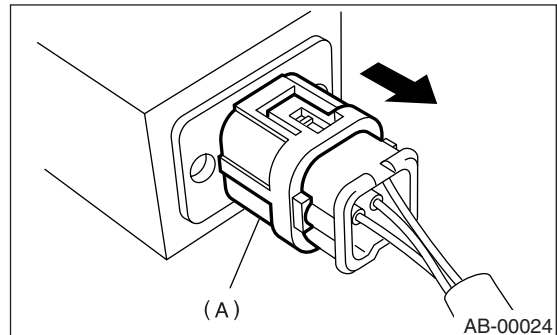

2) How to connect:

Holding the connector, push it in carefully until a connecting sound is heard.

CAUTION:

- Outer (A) moves back, and so do not put your hand on the outer part.
- Be sure to insert the connector in until it locks. Then pull on it gently to make sure that it is locked.

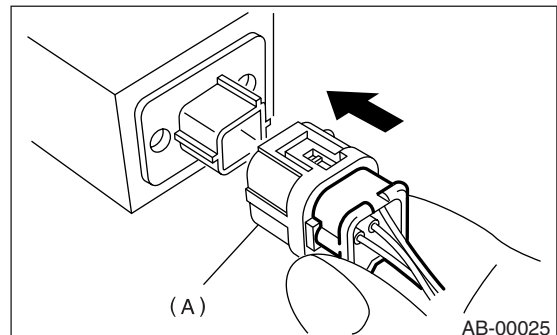

Airbag Warning Light Illumination Pattern

AIRBAG SYSTEM (DIAGNOSTICS)

7. Airbag Warning Light Illumination Pattern

A: INSPECTION

Keep the ignition switch to ON, and confirm that the airbag warning light remains off after being turned on for approx. 6 seconds.

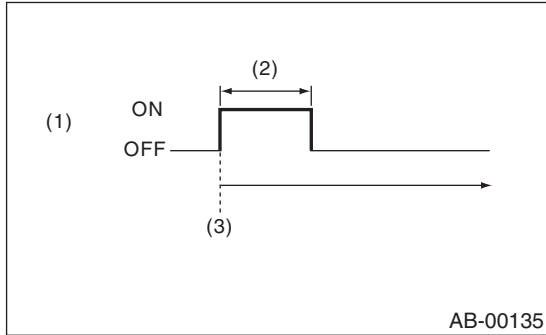

- (1) Airbag warning light
- (2) Approx. 6 seconds
- (3) Ignition switch ON

Read Diagnostic Trouble Code (DTC)

AIRBAG SYSTEM (DIAGNOSTICS)

8. Read Diagnostic Trouble Code (DTC)

A: OPERATION

- 1) Turn the ignition switch to ON.
- 2) Connect the ground terminal to check connector terminal No. 2 in the instrument panel lower cover area.

NOTE:

The harness of ground terminal is wrapped by tapes with the harness of check connector.

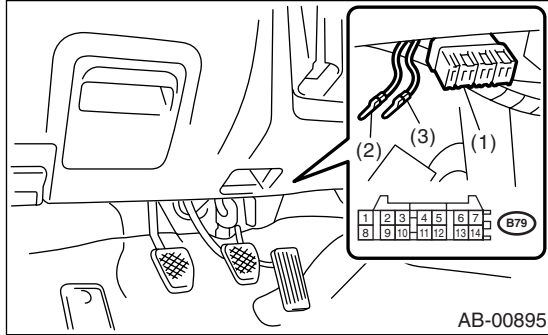

- (1) Check connector
- (2) Ground terminal
- (3) Ground terminal

3) Read the DTC by identifying the way airbag warning light flashes.

The airbag warning light flashes a code corresponding to the faulty parts.

The long segment (1.2 sec on) indicates a “ten”, and the short segment (0.3 sec on) indicates a “one”.

NOTE:

- “List of Diagnostic Trouble Code (DTC)” <Ref. to AB(diag)-31, List of Diagnostic Trouble Code (DTC).>
- “Airbag Warning Light Failure” <Ref. to AB(diag)-26, Airbag Warning Light Failure.>

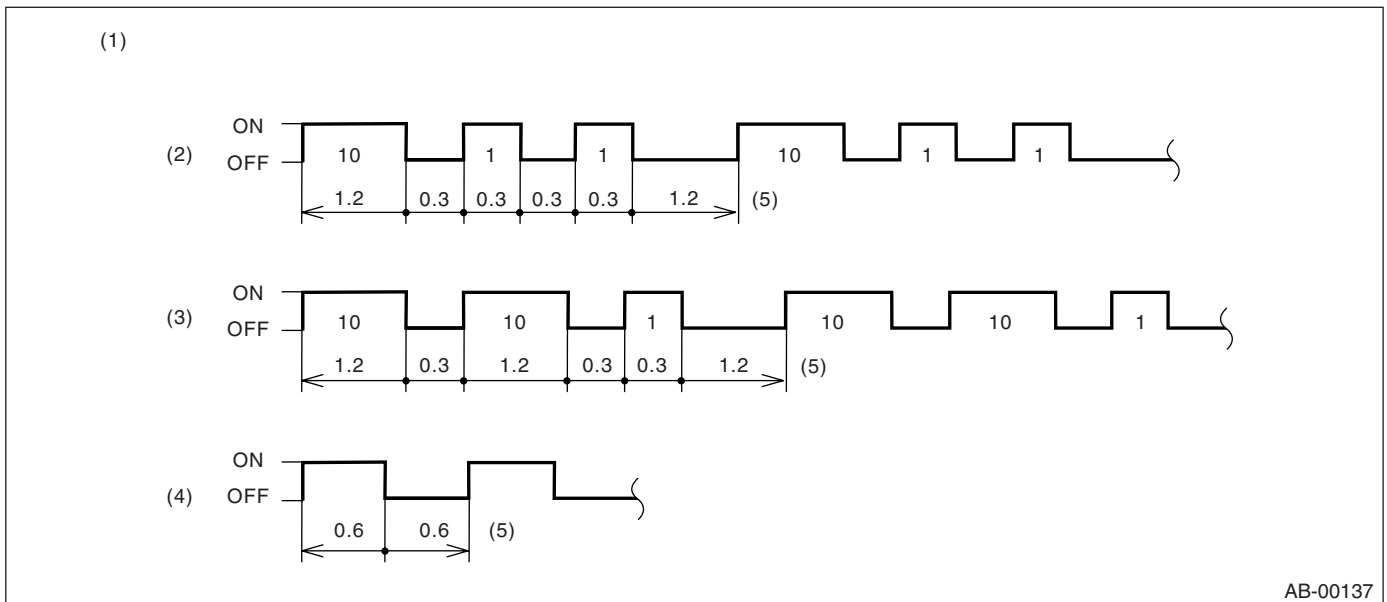

- (1) Example
- (2) Flashing code 12:
- (3) Flashing code 21:
- (4) Flashing normal code:
- (5) Sec.

4) Turn the ignition switch to OFF, and disconnect the ground terminal from the check connector terminal No. 2.

5) Wind tape around the ground terminal and return it to its original position.

9. Inspection Mode

A: PROCEDURE

Recreate the circumstance by referring to the conditions described in the checklist.

10. Clear Memory Mode

A: OPERATION

- 1) Turn the ignition switch to ON.
- 2) Connect the ground terminal (ground terminal "A") to check connector terminal No. 2 in the instrument panel lower cover area.

NOTE:

The harness of ground terminal is wrapped by tapes with the harness of check connector.

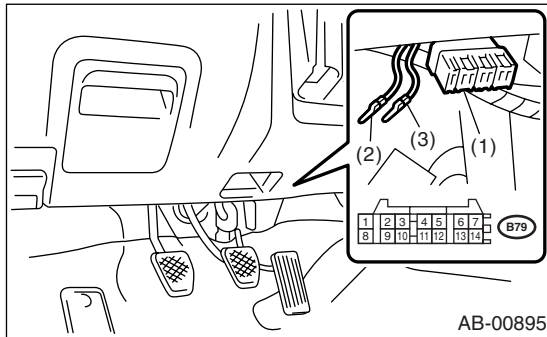

- (1) Check connector
- (2) Ground terminal "B"
- (3) Ground terminal "A"

- 3) While the warning light flashes, connect another diagnosis terminal (ground terminal "B") to the check connector terminal No. 3.
- 4) Once the memory is erased, the warning light returns to the normal flash rate (0.6 sec on). The failure to recover the normal flash rate indicates that trouble parts still remain. Having repaired such parts, erase the memory again and confirm that the normal flash rate has returned.
- 5) When the memory has been cleared, disconnect the ground terminal from check connector.
- 6) Wind tape around the ground terminal and return it to its original position.

Airbag Warning Light Failure

AIRBAG SYSTEM (DIAGNOSTICS)

11. Airbag Warning Light Failure

A: AIRBAG WARNING LIGHT REMAINS ON

DIAGNOSIS:

- Airbag warning light unit is faulty.
- Airbag control module to airbag warning light circuit is shorted or open.
- Grounding circuit is faulty.
- Airbag control module is faulty.
- (AB1) and (B31) are not connected properly.
- (AB3) is not connected properly to the airbag control module.

CAUTION:

- Before diagnosing the airbag system, be sure to turn the ignition switch to OFF, disconnect the ground cable from battery, and wait more than 20 seconds before starting to work.
- Before replacing the airbag module, seat belt pretensioner roll connector, control module, and sensor, reconnect each part and confirm that the warning light operates properly.
- When inspecting the airbag main harness, disconnect the airbag module connector of the driver and passenger seats for safety reasons.

WIRING DIAGRAM:

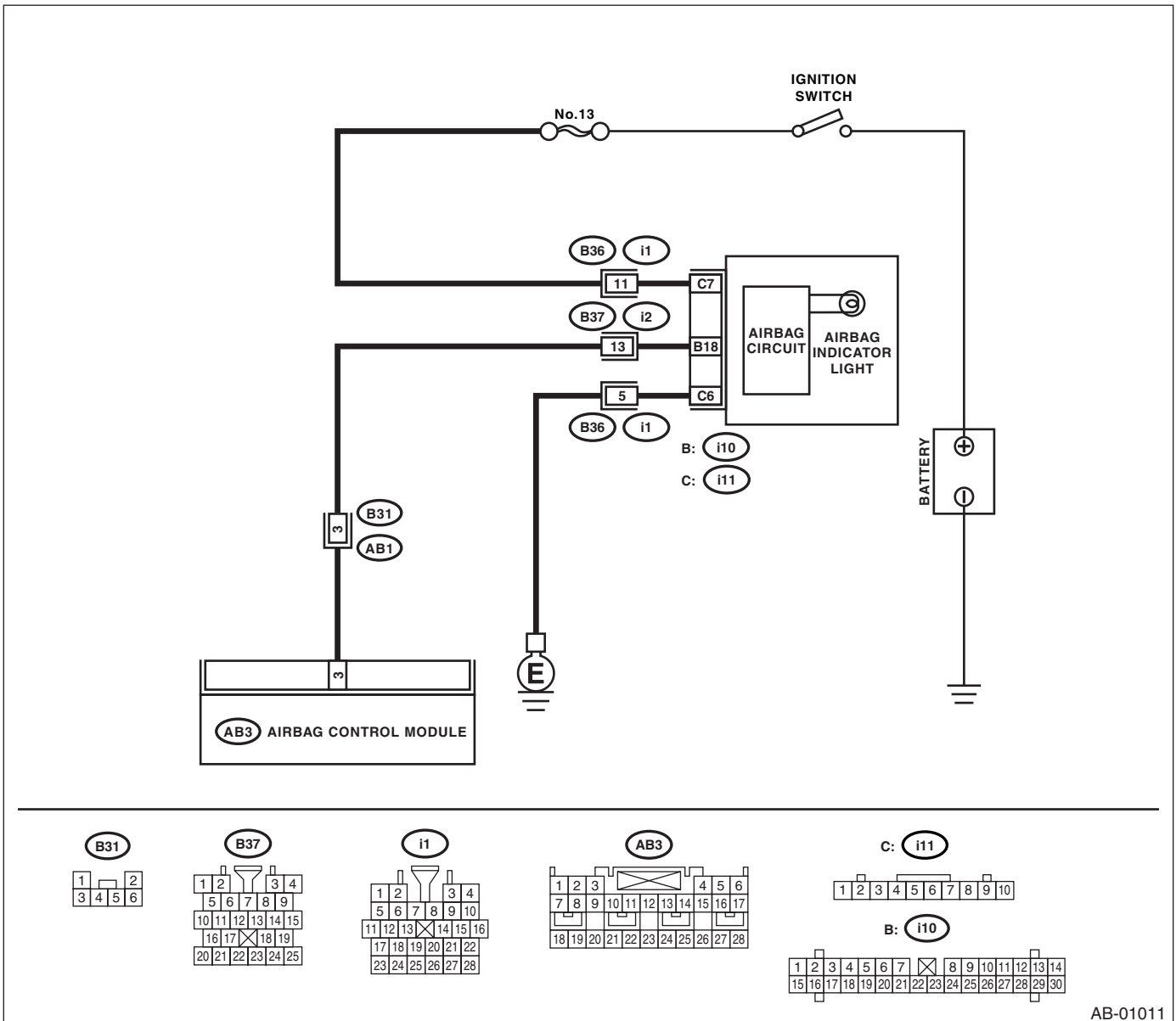

AB-01011

Airbag Warning Light Failure

AIRBAG SYSTEM (DIAGNOSTICS)

Step	Check	Yes	No
1 CHECK POOR CONTACT IN CONNECTORS (AB1) AND (B31). 1) Turn the ignition switch to OFF, disconnect the battery ground cable, and wait more than 20 seconds. 2) Remove the side sill cover. (Driver's side) 3) Confirm that firm contact is secured between connectors (AB1) and (B31).	Is the poor contact in connectors (AB1) and (B31)?	Repair the body harness or replace the body harness with airbag main harness.	Go to step 2.
2 CHECK AIRBAG WARNING LIGHT. 1) Turn the ignition switch to OFF, disconnect the battery ground cable, and wait more than 20 seconds. 2) Connect the connector (1T) in test harness T to the body harness connector (B31). 3) Connect the connector (1M) in test harness M to the connector (2T) in test harness T. 4) Connect the battery ground cable and turn the ignition switch to ON. 5) Connect two connectors, (3M) and (4M) in test harness M.	Is the airbag warning light turned off?	Go to step 4.	Go to step 3.
3 CHECK BODY HARNESS. Check the body harness. NOTE: After problem has been eliminated, disconnect the connectors (3M) and (4M).	Is the anything unusual to body harness?	Repair the body harness.	Replace the combination meter printed circuit. <Ref. to IDI-10, Combination Meter.>
4 CHECK POOR CONTACT. Confirm that firm contact is secured between the airbag control module and the connector (AB3). <Ref. to AB-16, Airbag Control Module.>	Is the poor contact in connector (AB3)?	Replace the body harness with airbag main harness or replace the airbag control module. <Ref. to AB-16, Airbag Control Module.>	Go to step 5.
5 CHECK AIRBAG MAIN HARNESS. 1) Turn the ignition switch to OFF, disconnect the battery ground cable, and wait more than 20 seconds. 2) Connect the connector (AB1) to (B31). 3) Disconnect the connectors (AB26) and (AB21). 4) Remove the glove box and disconnect the connectors (AB27) and (AB4). 5) Disconnect the connector (AB3) from the airbag control module, and connect the connector (1R) in test harness R. <Ref. to AB-16, Airbag Control Module.> 6) Connect the battery ground cable and turn the ignition switch to ON. 7) Connect the connectors (5R) and (6R) in test harness R. NOTE: After problem has been eliminated, disconnect the connectors (5R) and (6R).	Is the airbag warning light turned off?	Go to step 6.	Replace the body harness with airbag main harness.

Airbag Warning Light Failure

AIRBAG SYSTEM (DIAGNOSTICS)

Step	Check	Yes	No
6 CHECK GROUNDING CIRCUIT. 1) Turn the ignition switch to OFF, disconnect the battery ground cable, and wait more than 20 seconds. 2) Disconnect the connector (AB3) from the airbag control module. 3) Connect the connector (1R) in test harness R to body harness connector (AB3). 4) Measure the resistance between connector (2R) in test harness R and the chassis ground. Connector & terminal (2R) No. 10 — Chassis ground: (2R) No. 11 — Chassis ground:	Is the resistance less than 10 Ω ?	Replace the airbag control module. <Ref. to AB-16, Airbag Control Module.>	Repair the body-grounding circuit.

Airbag Warning Light Failure

B: AIRBAG WARNING LIGHT REMAINS OFF

DIAGNOSIS:

- Fuse No. 13 (in fuse box) is blown.
- Body harness circuit is open.
- Airbag warning light is faulty.
- Airbag main harness is faulty.
- Airbag control module is faulty.

CAUTION:

- Before diagnosing the airbag system, be sure to turn the ignition switch to OFF, disconnect the ground cable from battery, and wait more than 20 seconds before starting to work.
- Before replacing the airbag module, seat belt pretensioner roll connector, control module, and sensor, reconnect each part and confirm that the warning light operates properly.
- When inspecting the airbag main harness, disconnect the airbag module connector of the driver and passenger seats for safety reasons.

WIRING DIAGRAM:

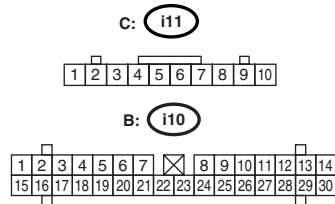
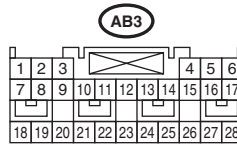
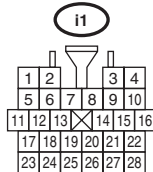
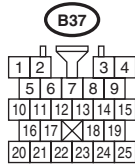
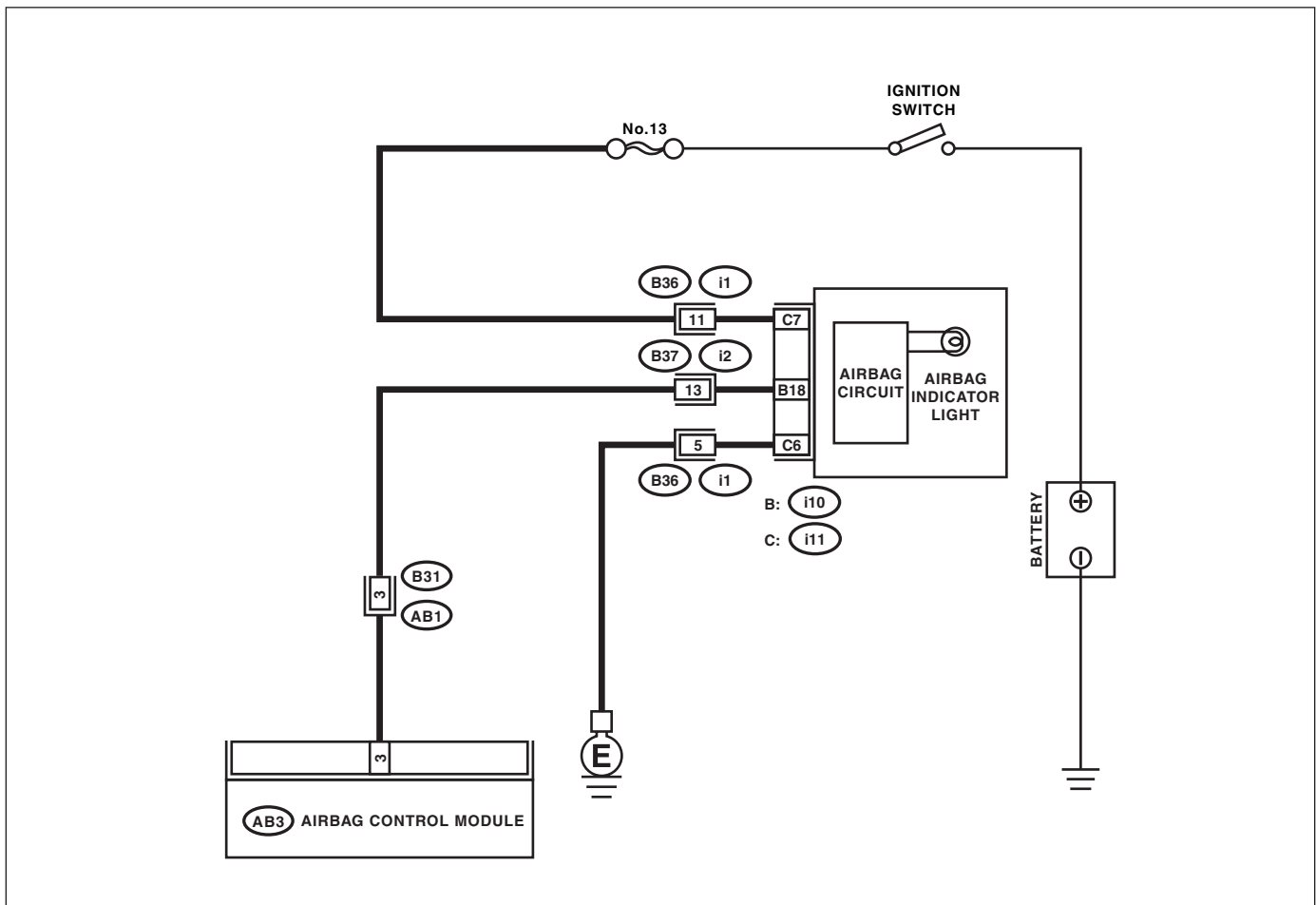

AB-01011

Airbag Warning Light Failure

AIRBAG SYSTEM (DIAGNOSTICS)

Step	Check	Yes	No
1 CHECK COMBINATION METER. Turn the ignition switch to ON, and confirm that warning lights equipped in the combination meter are turned on.	Do the warning lights not for airbag turn on?	Go to step 2.	Repair the combination meter power supply. <Ref. to IDI-3, Combination Meter System.>
2 CHECK FUSE No. 13 (IN MAIN FUSE BOX). Remove the fuse No. 13 and perform visual inspection.	Is the fuse No. 13 (in main fuse box) blown out?	Replace the fuse No. 13. If fuse No. 13 is blown out again, go to step 3.	Go to step 3.
3 CHECK AIRBAG WARNING LIGHT CIRCUIT (IN COMBINATION METER). 1) Turn the ignition switch to OFF, disconnect the battery ground cable, and wait more than 20 seconds. 2) Disconnect the connector (AB1) from (B31). 3) Connect the battery ground cable and turn the ignition switch to ON.	Is the airbag warning light turned on?	Go to step 4.	Replace the airbag warning light bulb or combination meter printed circuit. <Ref. to IDI-10, Combination Meter.>
4 CHECK AIRBAG MAIN HARNESS. 1) Turn the ignition switch to OFF, disconnect the battery ground cable, and wait more than 20 seconds. 2) Connect the connector (AB1) to (B31). 3) Disconnect the connector (AB3) from the airbag control module. <Ref. to AB-16, Airbag Control Module.> 4) Connect the battery ground cable and turn the ignition switch to ON.	Is the airbag warning light turned on?	Replace the airbag control module. <Ref. to AB-16, Airbag Control Module.>	Replace the body harness with airbag main harness.

List of Diagnostic Trouble Code (DTC)

AIRBAG SYSTEM (DIAGNOSTICS)

12. List of Diagnostic Trouble Code (DTC)

A: LIST

DTC	Memory function	Contents of diagnosis	Reference
11	Provided.	<ul style="list-style-type: none"> • Airbag main harness circuit is open, shorted or shorted to ground. • Airbag module harness (driver) circuit is open, shorted or shorted to ground. • Roll connector circuit is open, shorted or shorted to ground. • Airbag control module is faulty. • Driver's airbag module is faulty. 	<Ref. to AB(diag)-33, DTC 11, Diagnostic Chart with Trouble Code.>
12	Provided.	<ul style="list-style-type: none"> • Airbag main harness circuit is open, shorted or shorted to ground. • Airbag module harness (passenger) circuit is open, shorted or shorted to ground. • Airbag control module is faulty. • Passenger's airbag module is faulty. 	<Ref. to AB(diag)-35, DTC 12, Diagnostic Chart with Trouble Code.>
15	Provided.	<ul style="list-style-type: none"> • Airbag main harness circuit (driver) is shorted to power supply. • Airbag module harness (driver) is shorted to power supply. • Roll connector is shorted to power supply. • Airbag control module is faulty. • Driver's airbag module is faulty. 	<Ref. to AB(diag)-37, DTC 15, Diagnostic Chart with Trouble Code.>
16	Provided.	<ul style="list-style-type: none"> • Airbag main harness circuit (passenger) is shorted to power supply. • Airbag module harness (passenger) is shorted to power supply. • Airbag control module is faulty. • Passenger's airbag module is faulty. 	<Ref. to AB(diag)-39, DTC 16, Diagnostic Chart with Trouble Code.>
21	Provided.	Airbag control module is faulty.	<Ref. to AB(diag)-40, DTC 21, Diagnostic Chart with Trouble Code.>
22	Provided.	Front airbag module and seat belt pretensioner (LH/RH) are inflated.	<Ref. to AB(diag)-41, DTC 22, Diagnostic Chart with Trouble Code.>
23	Not provided.	(AB3), (AB7) and (AB8) are not connected properly to airbag control module.	<Ref. to AB(diag)-42, DTC 23, Diagnostic Chart with Trouble Code.>
24	Not provided.	<ul style="list-style-type: none"> • Airbag control module is faulty. • Airbag main harness circuit is open. • Fuse No. 11 (in joint box) is blown. • Body harness circuit is open. 	<Ref. to AB(diag)-43, DTC 24, Diagnostic Chart with Trouble Code.>
25	Provided.	<ul style="list-style-type: none"> • Airbag control module is faulty. • Airbag main harness circuit is open. • Fuse No. 6 (in joint box) is blown. • Body harness circuit is open. 	<Ref. to AB(diag)-45, DTC 25, Diagnostic Chart with Trouble Code.>
31	Provided.	<ul style="list-style-type: none"> • Front sub sensor harness (RH) circuit is shorted. • Front sub sensor harness (RH) circuit is open. • Front sub sensor (RH) is faulty. • Airbag control module is faulty. 	<Ref. to AB(diag)-47, DTC 31, Diagnostic Chart with Trouble Code.>
32	Provided.	<ul style="list-style-type: none"> • Front sub sensor harness (LH) circuit is shorted. • Front sub sensor harness (LH) circuit is open. • Front sub sensor (LH) is faulty. • Airbag control module is faulty. 	<Ref. to AB(diag)-49, DTC 32, Diagnostic Chart with Trouble Code.>
41	Provided.	<ul style="list-style-type: none"> • Side airbag harness (RH) is faulty. • Side airbag module (RH) is faulty. • Airbag control module is faulty. 	<Ref. to AB(diag)-52, DTC 41, Diagnostic Chart with Trouble Code.>

List of Diagnostic Trouble Code (DTC)

AIRBAG SYSTEM (DIAGNOSTICS)

DTC	Memory function	Contents of diagnosis	Reference
42	Provided.	<ul style="list-style-type: none"> • Side airbag harness (LH) is faulty. • Side airbag module (LH) is faulty. • Airbag control module is faulty. 	<Ref. to AB(diag)-54, DTC 42, Diagnostic Chart with Trouble Code.>
45	Provided.	<ul style="list-style-type: none"> • Side airbag harness (RH) is shorted to power supply. • Airbag control module is faulty. 	<Ref. to AB(diag)-56, DTC 45, Diagnostic Chart with Trouble Code.>
46	Provided.	<ul style="list-style-type: none"> • Side airbag harness (LH) is shorted to power supply. • Airbag control module is faulty. 	<Ref. to AB(diag)-58, DTC 46, Diagnostic Chart with Trouble Code.>
51	Provided.	<ul style="list-style-type: none"> • Side airbag sensor (RH) is faulty. • Side airbag harness (RH) is faulty. • Airbag control module is faulty. 	<Ref. to AB(diag)-60, DTC 51, Diagnostic Chart with Trouble Code.>
52	Provided.	<ul style="list-style-type: none"> • Side airbag sensor (LH) is faulty. • Side airbag harness (LH) is faulty. • Airbag control module is faulty. 	<Ref. to AB(diag)-62, DTC 52, Diagnostic Chart with Trouble Code.>
53	Provided.	Side airbag sensor (RH) is faulty.	<Ref. to AB(diag)-64, DTC 53, Diagnostic Chart with Trouble Code.>
54	Provided.	Side airbag sensor (LH) is faulty.	<Ref. to AB(diag)-64, DTC 54, Diagnostic Chart with Trouble Code.>
55	Provided.	Side airbag module is inflated.	<Ref. to AB(diag)-64, DTC 55, Diagnostic Chart with Trouble Code.>
61	Provided.	<ul style="list-style-type: none"> • Seat belt pretensioner (RH) circuit is open, shorted or shorted to ground. • Airbag control module is faulty. • Pretensioner is faulty. • Pretensioner harness is faulty. 	<Ref. to AB(diag)-65, DTC 61, Diagnostic Chart with Trouble Code.>
62	Provided.	<ul style="list-style-type: none"> • Seat belt pretensioner (LH) circuit is open, shorted or shorted to ground. • Airbag control module is faulty. • Pretensioner is faulty. • Pretensioner harness is faulty. 	<Ref. to AB(diag)-67, DTC 62, Diagnostic Chart with Trouble Code.>
65	Provided.	<ul style="list-style-type: none"> • Seat belt pretensioner (RH) circuit is shorted to power supply. • Pretensioner is faulty. • Pretensioner harness is faulty. • Airbag control module is faulty. 	<Ref. to AB(diag)-69, DTC 65, Diagnostic Chart with Trouble Code.>
66	Provided.	<ul style="list-style-type: none"> • Seat belt pretensioner (LH) circuit is shorted to power supply. • Pretensioner is faulty. • Pretensioner harness is faulty. • Airbag control module is faulty. 	<Ref. to AB(diag)-71, DTC 66, Diagnostic Chart with Trouble Code.>

Diagnostic Chart with Trouble Code

AIRBAG SYSTEM (DIAGNOSTICS)

13. Diagnostic Chart with Trouble Code

A: DTC 11

DTC DETECTING CONDITION:

- Airbag main harness circuit is open, shorted or shorted to ground.
- Airbag module harness (Driver) circuit is open, shorted or shorted to ground.
- Roll connector circuit is open, shorted or shorted to ground.
- Driver's airbag module is faulty.
- Airbag control module is faulty.

CAUTION:

- Before diagnosing the airbag system, be sure to turn the ignition switch to OFF, disconnect the ground cable from battery, and wait more than 20 seconds before starting to work.
- Before replacing the airbag module, seat belt pretensioner roll connector, control module, and sensor, reconnect each part and confirm that the warning light operates properly.
- When inspecting the airbag main harness, disconnect the driver's airbag module and passenger's airbag module connectors for safety reasons.

WIRING DIAGRAM:

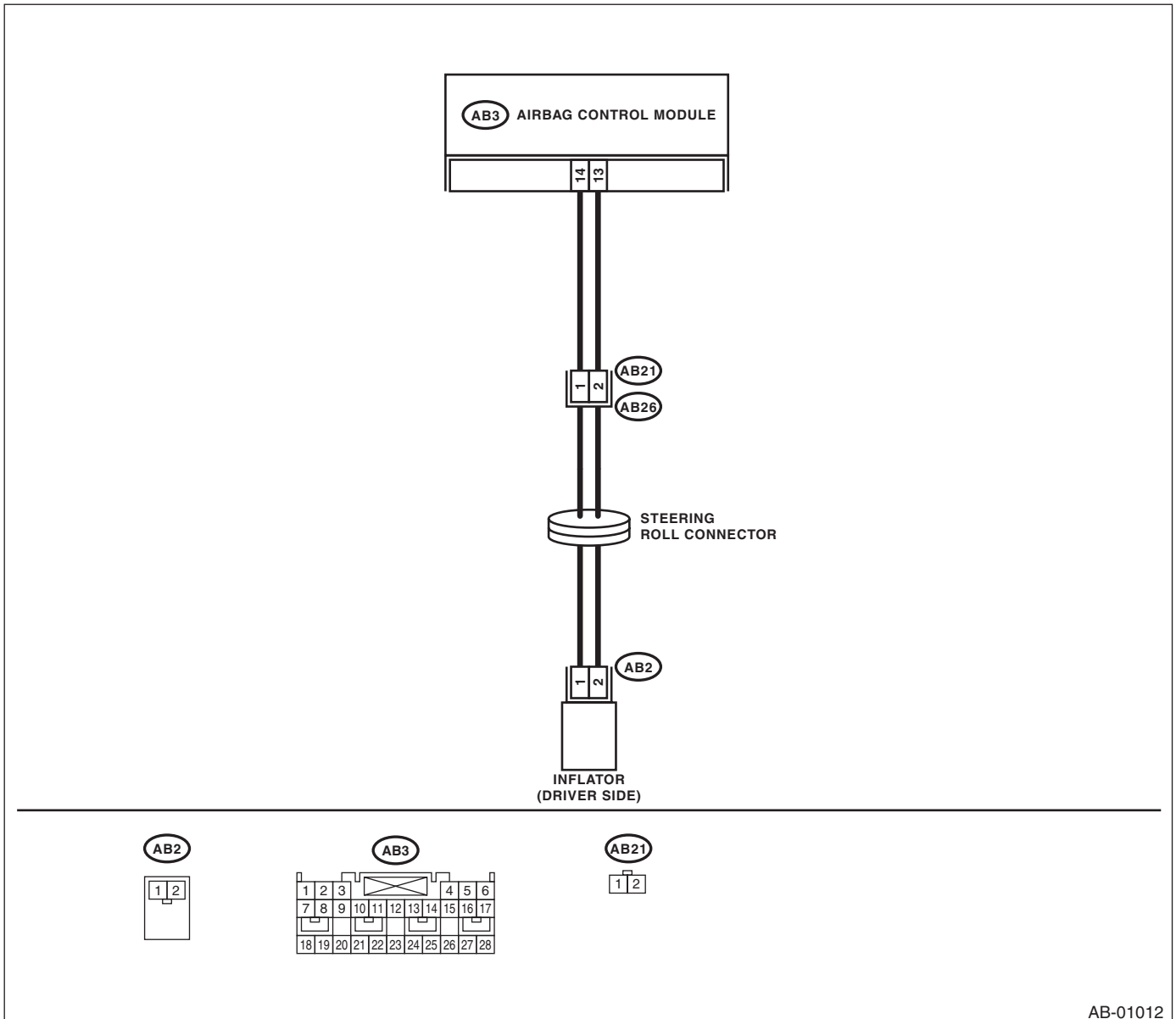

AB-01012

Diagnostic Chart with Trouble Code

AIRBAG SYSTEM (DIAGNOSTICS)

Step	Check	Yes	No
1 CHECK DRIVER'S AIRBAG MODULE. 1) Turn the ignition switch to OFF, disconnect the battery ground cable, and wait more than 20 seconds. 2) Remove the driver's airbag module. <Ref. to AB-12, Driver's Airbag Module.> 3) Connect the connector (1N) in test harness N to connector (AB2). 4) Connect the airbag resistor to connector (2N) in test harness N. 5) Connect the battery ground cable and turn the ignition switch to ON.	Does the airbag warning light operate properly?	Replace the driver's airbag module. <Ref. to AB-12, Driver's Airbag Module.>	Go to step 2.
2 CHECK ROLL CONNECTOR. 1) Turn the ignition switch to OFF, disconnect the battery ground cable, and wait more than 20 second. 2) Disconnect the test harness N from the connector (AB2). 3) Remove the instrument panel lower cover, disconnect the connector (AB26) from (AB21) and connect the connector (1F) in test harness F to connector (AB21). 4) Connect the airbag resistor to connector (3F) in test harness F. 5) Connect the battery ground cable and turn the ignition switch to ON.	Does the airbag warning light operate properly?	Replace the roll connector. <Ref. to AB-18, Roll Connector.>	Go to step 3.
3 CHECK AIRBAG MAIN HARNESS. 1) Turn the ignition switch to OFF, disconnect the ground cable, and wait more than 20 seconds. 2) Disconnect the airbag resistor from the connector (3F) in test harness F. 3) Remove the glove box, and disconnect connectors (AB27) and (AB4). <Ref. to AB-13, Passenger's Airbag Module.> 4) Disconnect the connector (AB3) from the airbag control module, and connect the connector (1R) in test harness R. <Ref. to AB-16, Airbag Control Module.> 5) Measure the resistance between connector (2R) in test harness R and the connector (3F) in test harness F. Connector & terminal (2R) No. 2 — (3F) No. 3: (2R) No. 4 — (3F) No. 4:	Is the resistance less than 10 Ω ?	Go to step 4.	Replace the body harness with airbag main harness.
4 CHECK AIRBAG MAIN HARNESS. Measure the resistance of the connector (2R) in test harness R. Connector & terminal (2R) No. 2 — (2R) No. 4: (2R) No. 4 — Chassis ground: (2R) No. 2 — Chassis ground:	Is the resistance more than 1 M Ω ?	Replace the airbag control module. <Ref. to AB-16, Airbag Control Module.>	Replace the body harness with airbag main harness.

Diagnostic Chart with Trouble Code

AIRBAG SYSTEM (DIAGNOSTICS)

B: DTC 12

DTC DETECTING CONDITION:

- Airbag main harness circuit is open, shorted or shorted to ground.
- Airbag module harness (Passenger) circuit is open, shorted or shorted to ground.
- Passenger's airbag module is faulty.
- Airbag control module is faulty.

CAUTION:

- Before diagnosing the airbag system, be sure to turn the ignition switch to OFF, disconnect the ground cable from battery, and wait more than 20 seconds before starting to work.
- Before replacing the airbag module, seat belt pretensioner roll connector, control module, and sensor, reconnect each part and confirm that the warning light operates properly.
- When inspecting the airbag main harness, disconnect the airbag module connector of the driver and passenger seats for safety reasons.

WIRING DIAGRAM:

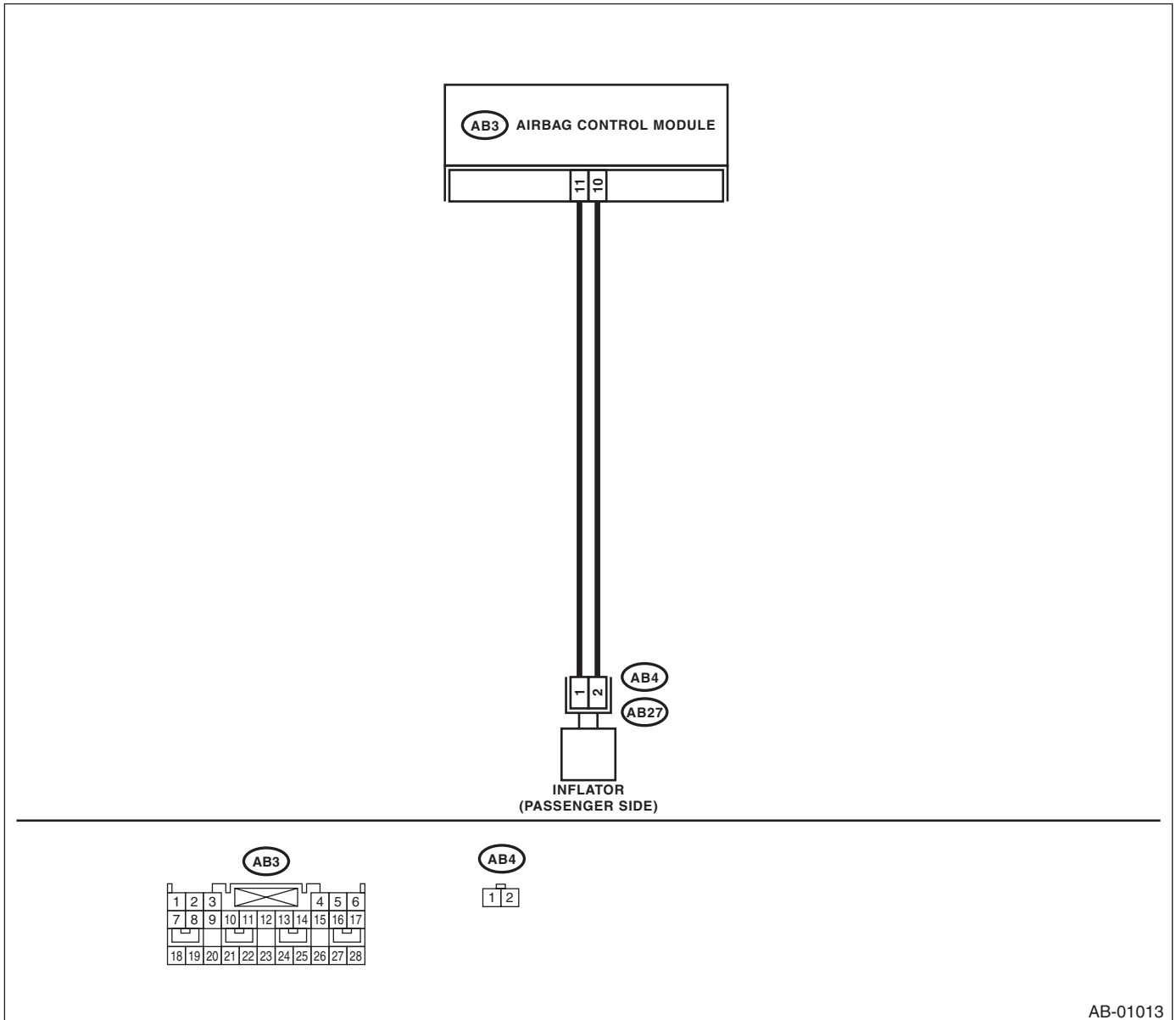

AB-01013

Diagnostic Chart with Trouble Code

AIRBAG SYSTEM (DIAGNOSTICS)

Step	Check	Yes	No
1 CHECK PASSENGER'S AIRBAG MODULE. 1) Turn the ignition switch to OFF, disconnect the battery ground cable, and wait more than 20 seconds. 2) Remove the glove box. 3) Disconnect the connector (AB27) from (AB4). 4) Connect the connector (1F) in test harness F to connector (AB4). 5) Connect the airbag resistor to connector (3F) in test harness F. 6) Connect the battery ground cable and turn the ignition switch to ON.	Does the airbag warning light operate properly?	Replace the passenger's airbag module. <Ref. to AB-13, Passenger's Airbag Module.>	Go to step 2.
2 CHECK AIRBAG MAIN HARNESS. 1) Turn the ignition switch to OFF, disconnect the battery ground cable, and wait more than 20 seconds. 2) Disconnect the airbag resistor from the connector (3F) in test harness F. 3) Remove the instrument panel lower cover and disconnect the connector (AB26) from (AB21). 4) Disconnect the connector (AB3) from the airbag control module, and connect the connector (1R) in test harness R. <Ref. to AB-16, Airbag Control Module.> 5) Measure the resistance between connector (2R) in test harness R and the connector (3F) in test harness F. <i>Connector & terminal</i> <i>(2R) No. 3 — (3F) No. 4:</i> <i>(2R) No. 5 — (3F) No. 3:</i>	Is the resistance less than 10 Ω?	Go to step 3.	Replace the body harness with airbag main harness.
3 CHECK AIRBAG MAIN HARNESS. Measure the resistance of the connector (2R) in test harness R. <i>Connector & terminal</i> <i>(2R) No. 3 — (2R) No. 5:</i> <i>(2R) No. 3 — Chassis ground:</i> <i>(2R) No. 5 — Chassis ground:</i>	Is the resistance more than 1 MΩ?	Replace the airbag control module. <Ref. to AB-16, Airbag Control Module.>	Replace the body harness with airbag main harness.

Diagnostic Chart with Trouble Code

AIRBAG SYSTEM (DIAGNOSTICS)

C: DTC 15

DTC DETECTING CONDITION:

- Airbag main harness circuit (Driver) is shorted to the power supply.
- Airbag module harness (Driver) is shorted to the power supply.
- Roll connector is shorted to the power supply.
- Driver's airbag module is faulty.
- Airbag control module is faulty.

CAUTION:

- Before diagnosing the airbag system, be sure to turn the ignition switch to OFF, disconnect the ground cable from battery, and wait more than 20 seconds before starting to work.
- Before replacing the airbag module, seat belt pretensioner roll connector, control module, and sensor, reconnect each part and confirm that the warning light operates properly.
- When inspecting the airbag main harness, disconnect the driver's airbag module and passenger's airbag module connectors for safety reasons.

WIRING DIAGRAM:

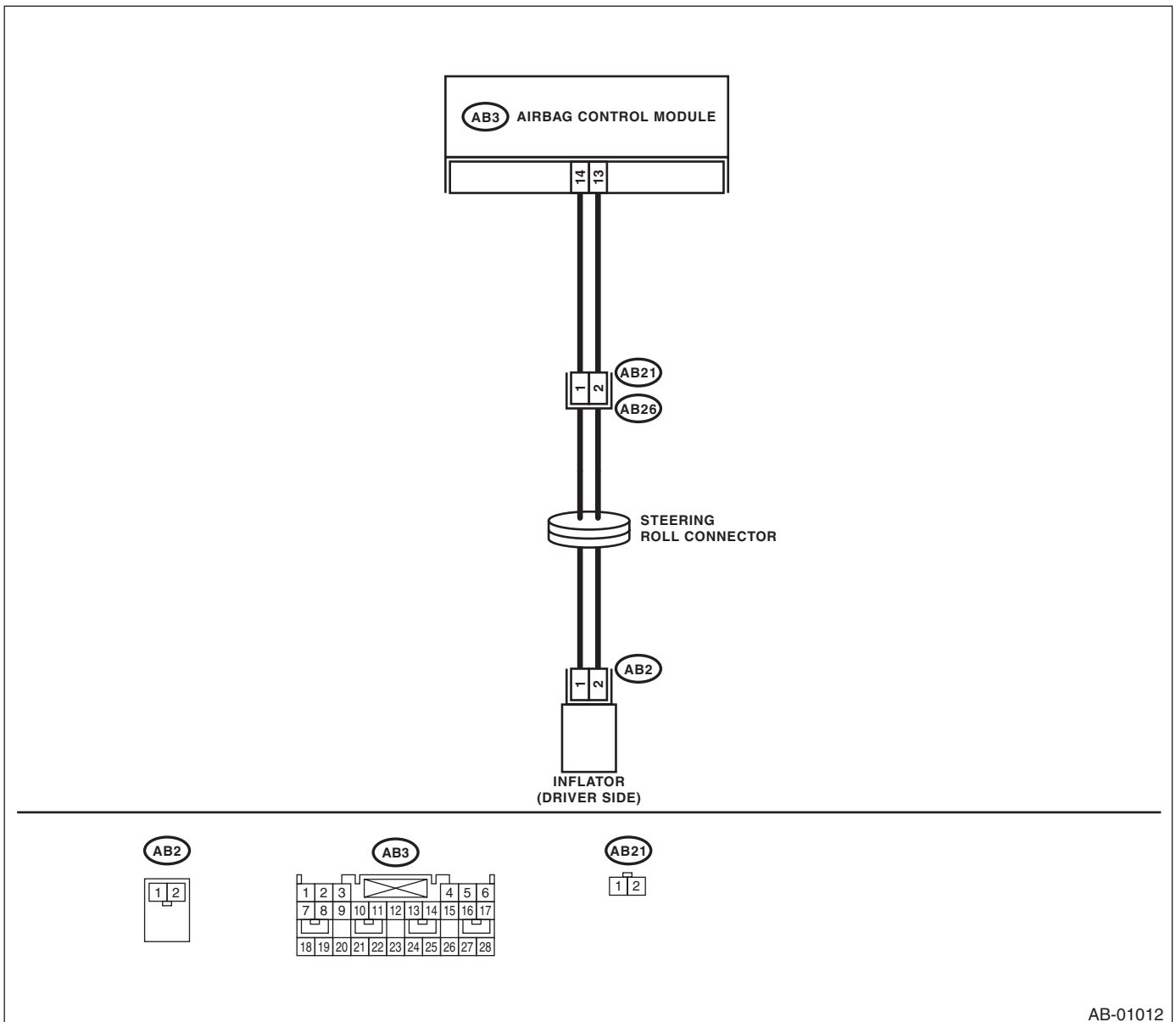

AB-01012

Diagnostic Chart with Trouble Code

AIRBAG SYSTEM (DIAGNOSTICS)

Step	Check	Yes	No
1 CHECK DRIVER'S AIRBAG MODULE. 1) Turn the ignition switch to OFF, disconnect the battery ground cable, and wait more than 20 seconds. 2) Remove the driver's airbag module. <Ref. to AB-12, Driver's Airbag Module.> 3) Connect the connector (AB2) to connector (1N) in test harness N. 4) Connect the airbag resistor to connector (2N) in test harness N. 5) Connect the battery ground cable and turn the ignition switch to ON.	Does the airbag warning light operate properly?	Replace the driver's airbag module. <Ref. to AB-12, Driver's Airbag Module.>	Go to step 2.
2 CHECK ROLL CONNECTOR. 1) Turn the ignition switch to OFF, disconnect the battery ground cable, and wait more than 20 seconds. 2) Disconnect the test harness N from the connector (AB2). 3) Remove the instrument panel lower cover panel and disconnect the connector (AB26) from (AB21). 4) Connect the connector (1F) in test harness F to connector (AB21). 5) Connect the airbag resistor to connector (3F) in test harness F. 6) Connect the battery ground cable and turn the ignition switch to ON.	Does the airbag warning light operate properly?	Replace the roll connector. <Ref. to AB-18, Roll Connector.>	Go to step 3.
3 CHECK AIRBAG MAIN HARNESS. 1) Turn the ignition switch to OFF, disconnect the battery ground cable, and wait more than 20 seconds. 2) Disconnect the airbag resistor from the connector (3F) in test harness F. 3) Remove the glove box, and disconnect the connectors (AB27) and (AB4). 4) Disconnect the connector (AB3) from the airbag control module, and connect the connector (1R) in test harness R. <Ref. to AB-16, Airbag Control Module.> 5) Connect the battery ground cable and turn the ignition switch to ON. (engine OFF) 6) Measure the voltage between connector (2R) in test harness R and the chassis ground. Connector & terminal (2R) No. 4 (+) — Chassis ground (-): (2R) No. 2 (+) — Chassis ground (-):	Is the voltage less than 1 V?	Replace the airbag control module. <Ref. to AB-16, Airbag Control Module.>	Replace the body harness with airbag main harness.

Diagnostic Chart with Trouble Code

AIRBAG SYSTEM (DIAGNOSTICS)

D: DTC 16

DTC DETECTING CONDITION:

- Airbag main harness circuit (Passenger) is shorted to the power supply.
- Airbag module harness (Passenger) is shorted to the power supply.
- Passenger's airbag module is faulty.
- Airbag control module is faulty.

CAUTION:

- Before diagnosing the airbag system, be sure to turn the ignition switch to OFF, disconnect the ground cable from battery, and wait more than 20 seconds before starting to work.
- Before replacing the airbag module, seat belt pretensioner roll connector, control module, and sensor, reconnect each part and confirm that the warning light operates properly.
- When inspecting the airbag main harness, disconnect the airbag module connector of the driver and passenger seats for safety reasons.

WIRING DIAGRAM:

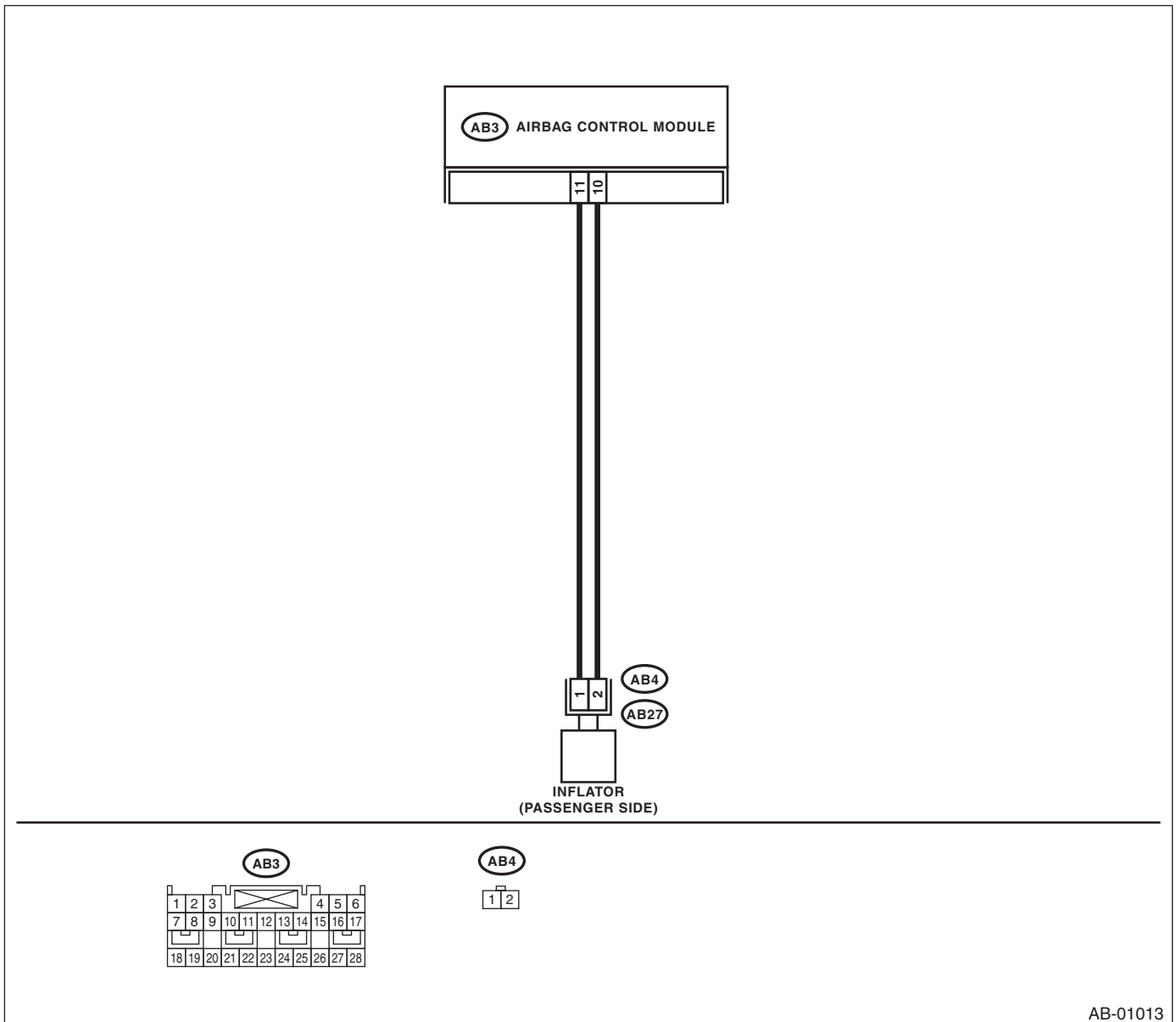

AB-01013

Diagnostic Chart with Trouble Code

AIRBAG SYSTEM (DIAGNOSTICS)

Step	Check	Yes	No
1 CHECK PASSENGER'S AIRBAG MODULE. 1) Turn the ignition switch to OFF, disconnect the battery ground cable, and wait more than 20 seconds. 2) Remove the glove box. 3) Disconnect the connector (AB27) from (AB4) 4) Connect the connector (1F) in test harness F to connector (AB4). 5) Connect the airbag resistor to connector (3F) in test harness F. 6) Connect the battery ground cable and turn the ignition switch to ON.	Does the airbag warning light operate properly?	Replace the passenger's airbag module. <Ref. to AB-13, Passenger's Airbag Module.>	Go to step 2.
2 CHECK AIRBAG MAIN HARNESS. 1) Turn the ignition switch to OFF, disconnect the battery ground cable, and wait more than 20 seconds. 2) Disconnect the airbag resistor from the connector (3F) in test harness F. 3) Remove the instrument panel lower cover and disconnect the connector (AB26) from (AB21). 4) Disconnect the connector (AB3) from the airbag control module, and connect the connector (1R) in test harness R. <Ref. to AB-16, Airbag Control Module.> 5) Measure the voltage between connector (2R) in test harness R and the chassis ground. Connector & terminal <i>(2R) No. 3 (+) — Chassis ground (-):</i> <i>(2R) No. 5 (+) — Chassis ground (-):</i>	Is the voltage less than 1 V?	Replace the airbag control module. <Ref. to AB-16, Airbag Control Module.>	Replace the body harness with airbag main harness.

E: DTC 21

DTC DETECTING CONDITION:

Airbag control module is faulty.

CAUTION:

- Before diagnosing the airbag system, be sure to turn the ignition switch to OFF, disconnect the ground cable from battery, and wait more than 20 seconds before starting to work.
- Before replacing the airbag module, seat belt pretensioner roll connector, control module, and sensor, reconnect each part and confirm that the warning light operates properly.

Step	Check	Yes	No
1 CHECK IF DTC 21 IS INDICATED. Read the DTC. <Ref. to AB(diag)-23, Read Diagnostic Trouble Code (DTC).>	Is the airbag warning light DTC 21 indicated?	Replace the airbag control module. <Ref. to AB-16, Airbag Control Module.>	Perform clear memory mode. <Ref. to AB(diag)-25, Clear Memory Mode.>

Diagnostic Chart with Trouble Code

AIRBAG SYSTEM (DIAGNOSTICS)

F: DTC 22

WIRING DIAGRAM:

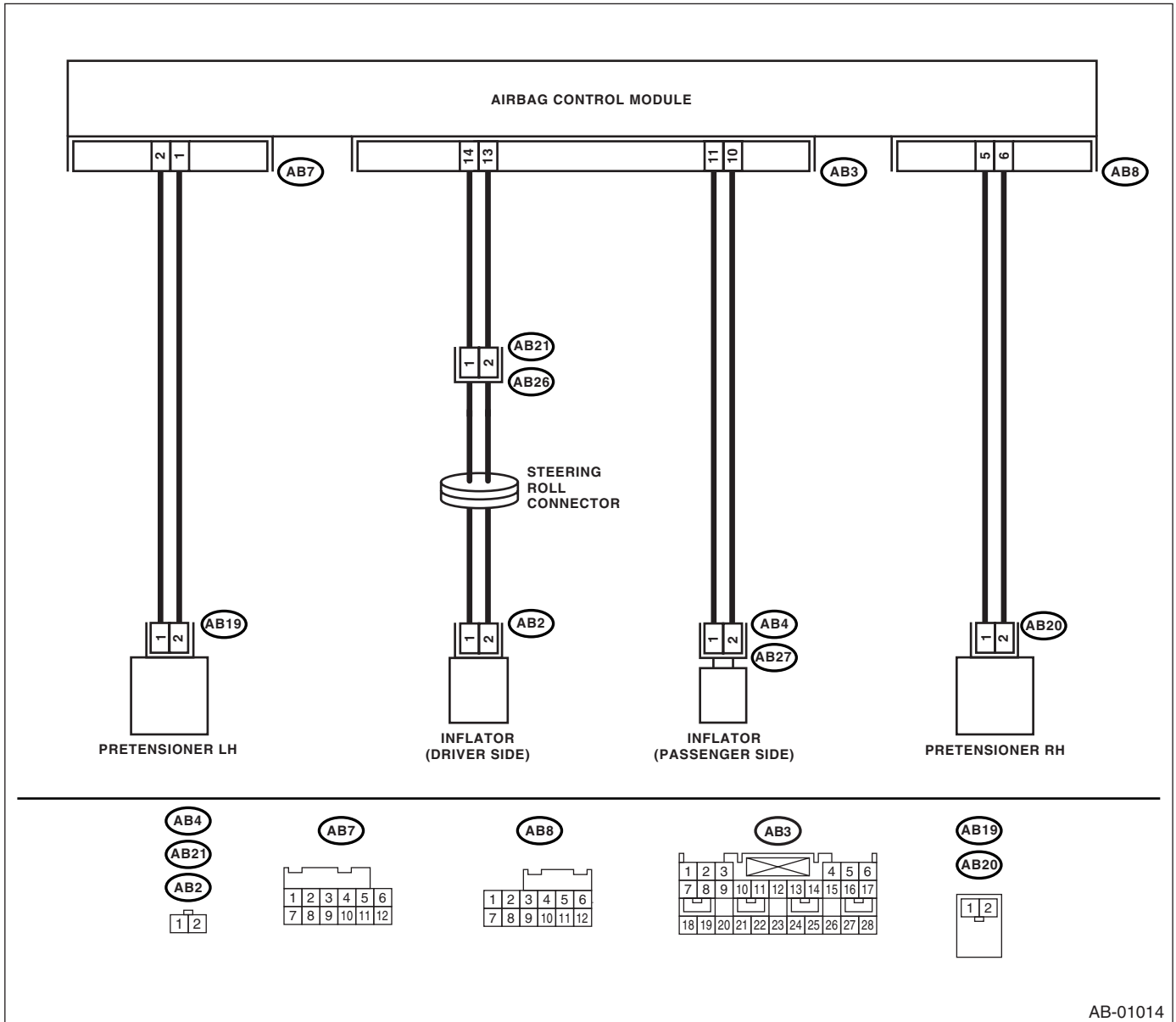

AB-01014

This DTC is indicated when the front airbag and the pretensioner are deployed.

Once this DTC is indicated, memory is not erasable; therefore replace the following parts.

- Airbag control module <Ref. to AB-16, Airbag Control Module.>
- Driver's airbag module <Ref. to AB-12, Driver's Airbag Module.>
- Passenger's airbag module <Ref. to AB-13, Passenger's Airbag Module.>
- Front sub sensor of both sides <Ref. to AB-19, Front Sub Sensor.>
- Front seat belt outer with pretensioner of both sides <Ref. to SB-8, Front Seat Belt.>

Diagnostic Chart with Trouble Code

AIRBAG SYSTEM (DIAGNOSTICS)

G: DTC 23

DTC DETECTING CONDITION:

(AB3), (AB7) and (AB8) are not connected properly to airbag control module.

CAUTION:

Before diagnosing the airbag system, be sure to turn the ignition switch to OFF, disconnect the ground cable from battery, and wait more than 20 seconds before starting to work.

Step	Check	Yes	No
1 CHECK POOR CONTACT IN CONNECTORS (AB3), (AB7) AND (AB8). 1) Turn the ignition switch to OFF, disconnect the battery ground cable, and wait more than 20 seconds. 2) Disconnect the connectors (AB3), (AB7) and (AB8) from the airbag control module. <Ref. to AB-16, Airbag Control Module.>	Check if rust or damage appear on the harness connector and the control module connector.	Replace the airbag control module. <Ref. to AB-16, Airbag Control Module.> Replace the body harness with airbag main harness. Replace the body harness with side airbag harness.	Go to step 2.
2 CHECK POOR CONTACT IN CONNECTORS (AB3), (AB7) AND (AB8). 1) Ensure that connectors are firmly reconnected. 2) Connect the battery ground cable and turn the ignition switch to ON.	Does the airbag warning light operate properly?	Finish the diagnosis.	Replace the airbag control module. <Ref. to AB-16, Airbag Control Module.>

Diagnostic Chart with Trouble Code

AIRBAG SYSTEM (DIAGNOSTICS)

H: DTC 24

DTC DETECTING CONDITION:

- Airbag control module is faulty.
- Airbag main harness circuit is open.
- Fuse No, 11 (in joint box) is blown.
- Body harness circuit is open.

CAUTION:

- Before diagnosing the airbag system, be sure to turn the ignition switch to OFF, disconnect the ground cable from battery, and wait more than 20 seconds before starting to work.
- Before replacing the airbag module, seat belt pretensioner roll connector, control module, and sensor, reconnect each part and confirm that the warning light operates properly.
- When inspecting the airbag main harness, disconnect the driver's airbag module and passenger's airbag module connectors for safety reasons.

WIRING DIAGRAM:

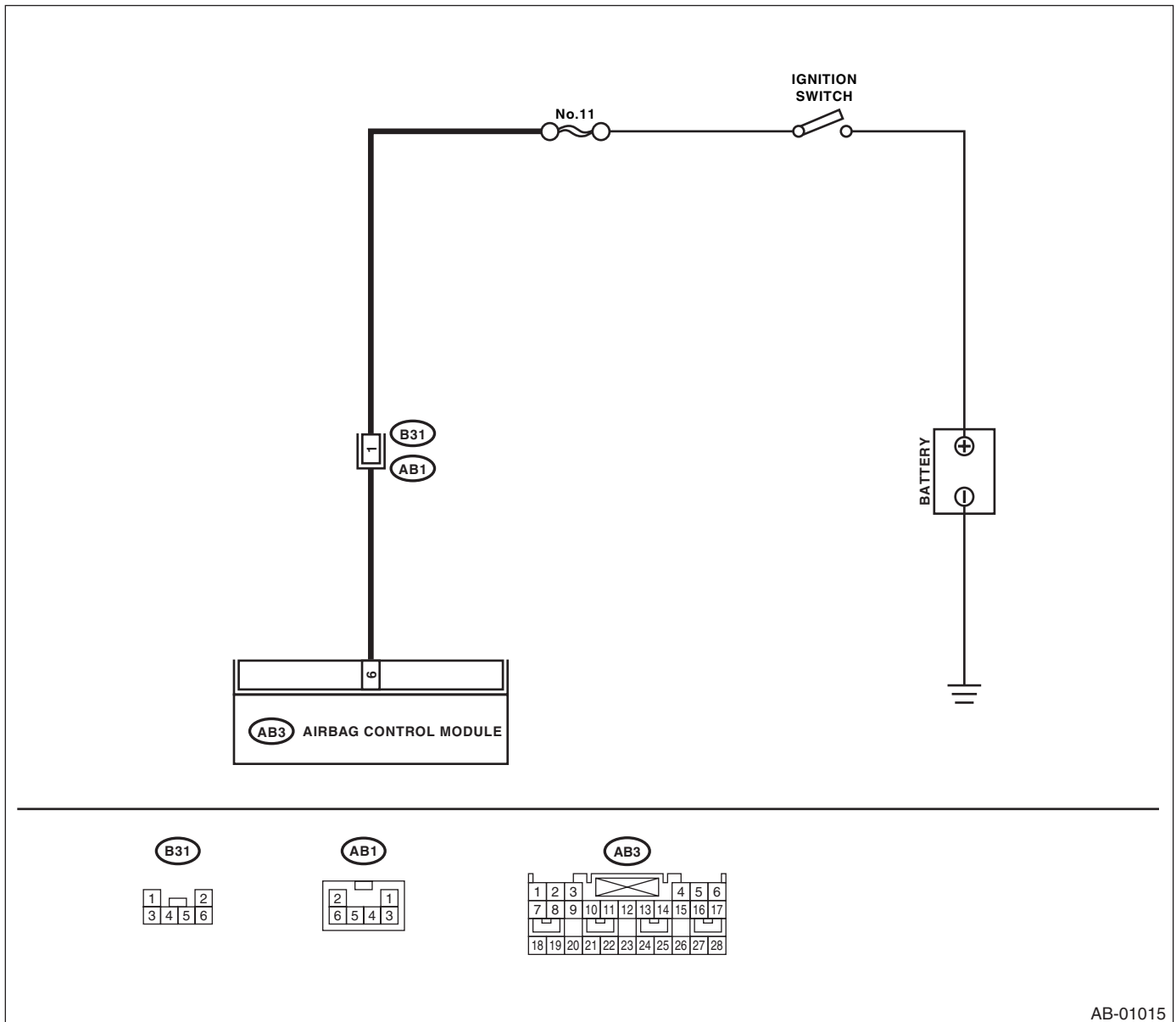

AB-01015

Diagnostic Chart with Trouble Code

AIRBAG SYSTEM (DIAGNOSTICS)

Step	Check	Yes	No
1 CHECK AIRBAG CONTROL MODULE. 1) Turn the ignition switch to OFF, disconnect the battery ground cable, and wait more than 20 seconds. 2) Disconnect the connector (AB3) from the airbag control module. <Ref. to AB-16, Airbag Control Module.> 3) Connect the connector (1R) in test harness R to connector (AB3). 4) Connect the battery ground cable and turn the ignition switch to ON. 5) Measure the voltage between connector (2R) in test harness R and chassis ground. Connector & terminal (2R) No. 1 (+) — Chassis ground (-):	Is the voltage more than 10 V?	Replace the airbag control module. <Ref. to AB-16, Airbag Control Module.>	Go to step 2.
2 CHECK AIRBAG MAIN HARNESS. 1) While checking control module, turn the ignition switch to OFF and disconnect the battery ground cable. Wait more than 20 seconds before operation. 2) Disconnect the airbag connector (AB1) from the body harness (B31). 3) Connect the connector (2M) in test harness M to connector (AB1). 4) Measure the resistance between connector (5M) in test harness M and the connector (2R) in test harness R. Connector & terminal (5M) No. 2 — (2R) No. 1:	Is the resistance less than 10 Ω?	Go to step 3.	Replace the body harness with air-bag main harness.
3 CHECK AIRBAG MAIN HARNESS. Measure the following resistance with the above-mentioned condition maintained. Connector & terminal (5M) No. 2 — Chassis ground: (2R) No. 1 — Chassis ground:	Is the resistance more than 1 MΩ?	Go to step 4.	Replace the body harness with air-bag main harness.
4 CHECK FUSE No. 11 (IN JOINT BOX). 1) Confirm that the ignition switch is turned OFF. 2) Remove the fuse No. 11 (in joint box) and perform visual inspection.	Is the fuse No. 11 blown out?	Replace the fuse No. 11. If fuse No. 11 is blown out again, repair the body harness.	Repair the body harness.

Diagnostic Chart with Trouble Code

AIRBAG SYSTEM (DIAGNOSTICS)

I: DTC 25

DTC DETECTING CONDITION:

- Airbag control module is faulty.
- Airbag main harness circuit is open.
- Fuse No. 6 (in joint box) is blown.
- Body harness circuit is open.

CAUTION:

- Before diagnosing the airbag system, be sure to turn the ignition switch to OFF, disconnect the ground cable from battery, and wait more than 20 seconds before starting to work.
- Before replacing the airbag module, seat belt pretensioner roll connector, control module, and sensor, reconnect each part and confirm that the warning light operates properly.
- When inspecting the airbag main harness, disconnect the driver's airbag module and passenger's airbag module connectors for safety reasons.

WIRING DIAGRAM:

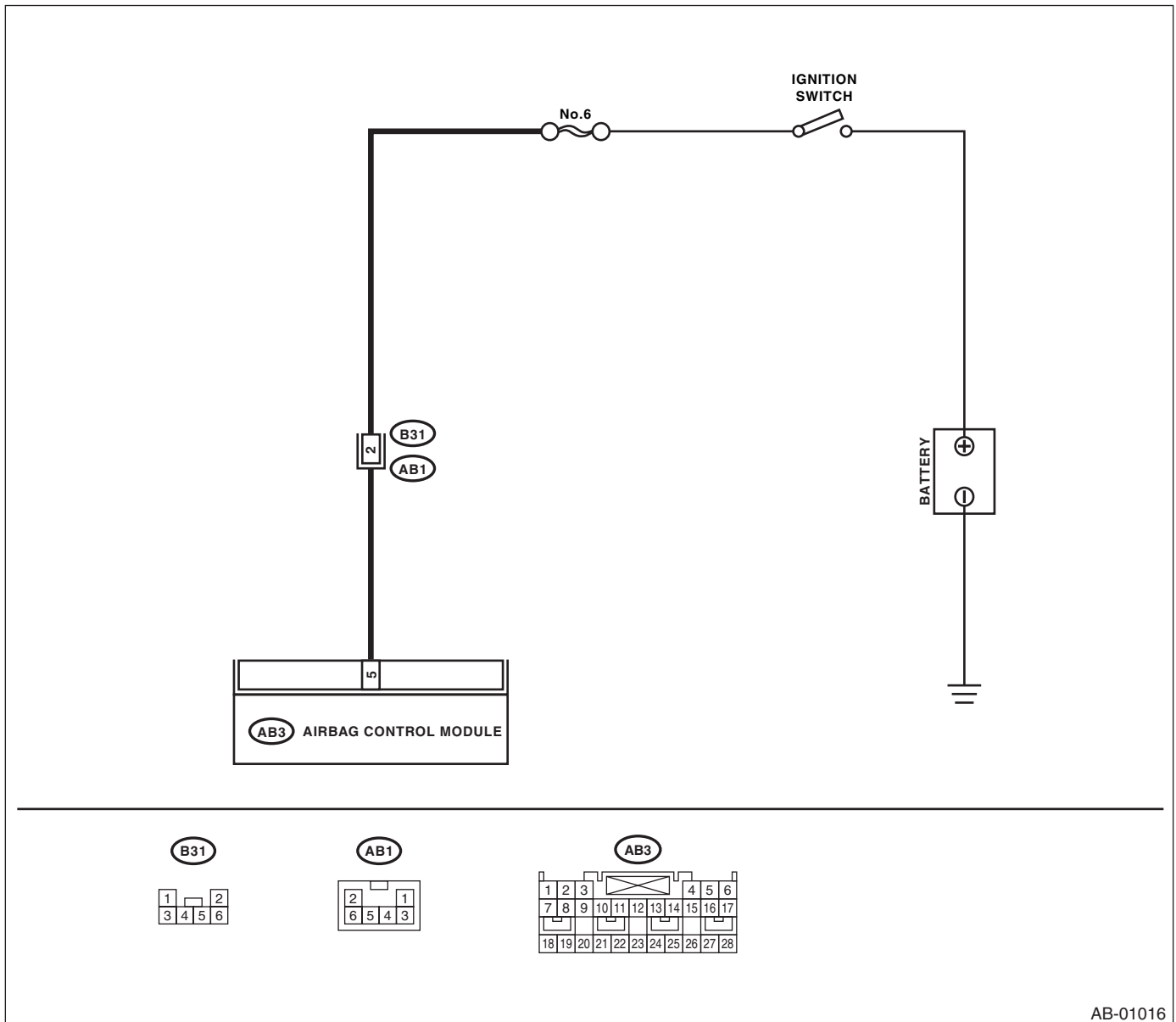

AB-01016

Diagnostic Chart with Trouble Code

AIRBAG SYSTEM (DIAGNOSTICS)

Step	Check	Yes	No
1 CHECK AIRBAG CONTROL MODULE. 1) Turn the ignition switch to OFF, disconnect the battery ground cable, and wait more than 20 seconds. 2) Disconnect the connector (AB3) from airbag control module. <Ref. to AB-16, Airbag Control Module.> 3) Connect the connector (1R) in test harness R to connector (AB3). 4) Connect the battery ground cable, and turn the ignition switch to ON. 5) Measure the voltage between the connector (2R) in test harness R and the chassis ground. Connector & terminal (2R) No. 6 (+) — Chassis ground (-):	Is the voltage more than 10 V?	Replace the airbag control module. <Ref. to AB-16, Airbag Control Module.>	Go to step 2.
2 CHECK AIRBAG MAIN HARNESS. 1) While checking control module, turn the ignition switch to OFF and disconnect the battery ground cable. Wait more than 20 seconds before operation. 2) Disconnect the airbag connector (AB1) from the body harness (B31). 3) Connect the connector (2M) in test harness M to the airbag connector (AB1). 4) Measure the resistance between the connector (5M) in test harness M and the connector (2R) in test harness R. Connector & terminal (5M) No. 4 — (2R) No. 6:	Is the resistance less than 10 Ω ?	Go to step 3.	Replace the body harness with airbag main harness.
3 CHECK AIRBAG MAIN HARNESS. Measure the following resistance with the above-mentioned condition maintained. Connector & terminal (5M) No. 4 — Chassis ground: (2R) No. 6 — Chassis ground:	Is the resistance more than 1 M Ω ?	Go to step 4.	Replace the body harness with airbag main harness.
4 CHECK FUSE No. 6 (IN JOINT BOX). 1) Confirm that the ignition switch is turned OFF. 2) Remove the No. 6 fuse (in joint box) and perform visual inspection.	Is the fuse No. 6 blown out?	Replace the fuse No. 6. If fuse No. 6 is blown out again, repair the body harness.	Repair the body harness.

Diagnostic Chart with Trouble Code

AIRBAG SYSTEM (DIAGNOSTICS)

J: DTC 31

DTC DETECTING CONDITION:

- Front sub sensor harness (RH) circuit is shorted.
- Front sub sensor harness (RH) circuit is open.
- Front sub sensor (RH) is faulty.
- Airbag control module is faulty.

CAUTION:

- Before diagnosing the airbag system, be sure to turn the ignition switch to OFF, disconnect the ground cable from battery, and wait more than 20 seconds before starting to work.
- Before replacing the airbag module, seat belt pretensioner roll connector, control module, and sensor, reconnect each part and confirm that the warning light operates properly.
- When inspecting the airbag main harness, disconnect the driver's airbag module and passenger's airbag module connectors for safety reasons.

WIRING DIAGRAM:

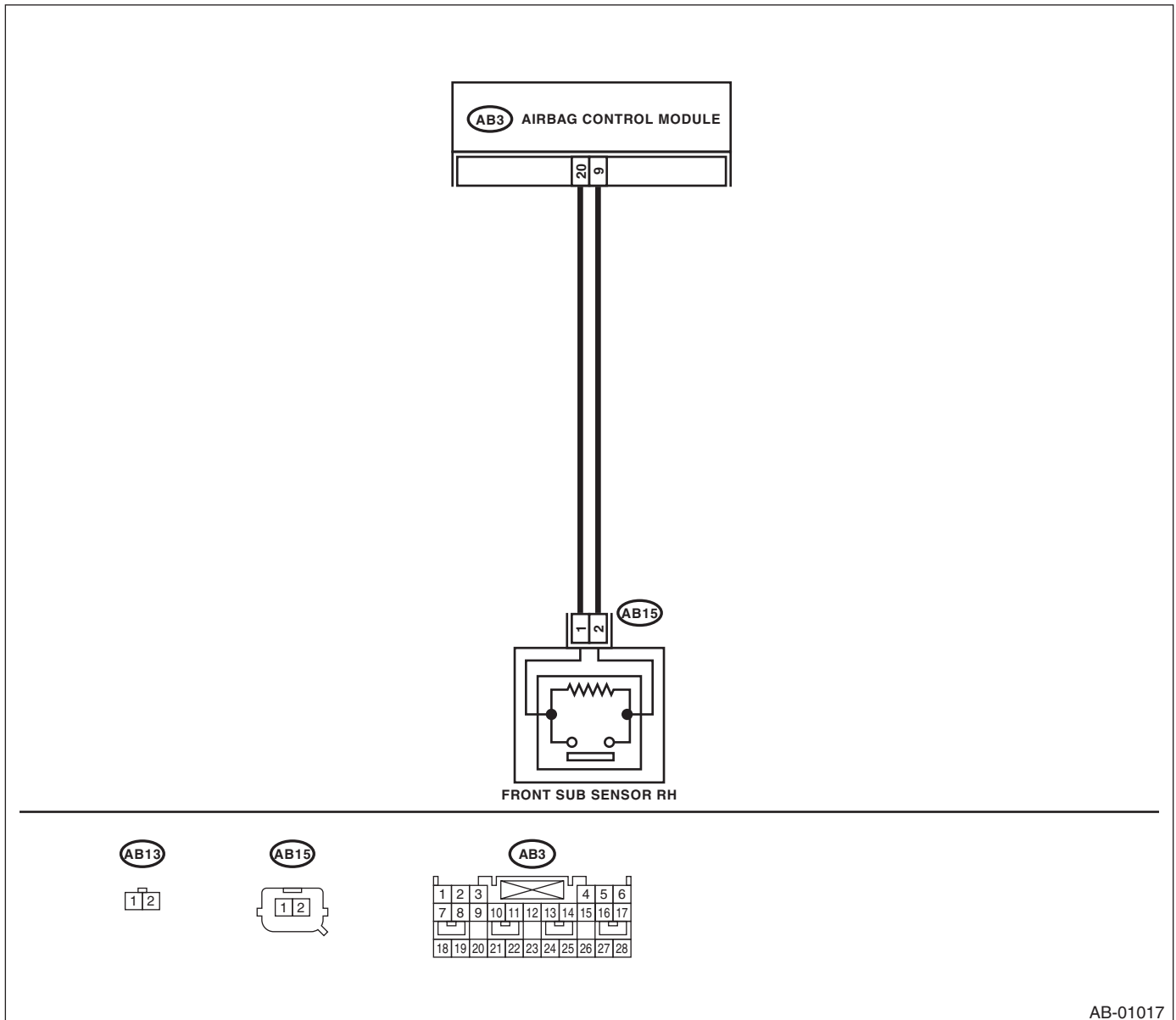

AB-01017

Diagnostic Chart with Trouble Code

AIRBAG SYSTEM (DIAGNOSTICS)

Step	Check	Yes	No
1 CHECK FRONT SUB SENSOR (RH) AND FRONT SUB SENSOR HARNESS (RH). 1) Turn the ignition switch to OFF, disconnect the battery ground cable, and wait more than 20 seconds. 2) Disconnect the connector (AB3) from the airbag control module, and connect the connector (1R) in test harness R. <Ref. to AB-16, Airbag Control Module.> 3) Measure the resistance of the connector (3R) in test harness R. Connector & terminal (3R) No. 7 — (3R) No. 9:	Is the resistance 750 Ω — 1 kΩ?	Replace the airbag control module. <Ref. to AB-16, Airbag Control Module.>	Go to step 2.
2 CHECK FRONT SUB SENSOR (RH) AND FRONT SUB SENSOR HARNESS (RH). Measure the resistance between connector (3R) in test harness R and the chassis ground. Connector & terminal (3R) No. 7 — Chassis ground: (3R) No. 9 — Chassis ground:	Is the resistance more than 1 MΩ?	Replace the airbag control module. <Ref. to AB-16, Airbag Control Module.>	Go to step 3.
3 CHECK AIRBAG MAIN HARNESS AND FRONT SUB SENSOR HARNESS (RH). 1) Disconnect the connector (AB15) from the front sub sensor. <Ref. to AB-19, Front Sub Sensor.> 2) Connect the connector (1H) in test harness H to connector (AB15). 3) Measure the resistance between connector (3R) in test harness R and connector (3H) in test harness H. Connector & terminal (3R) No. 7 — (3H) No. 6: (3R) No. 9 — (3H) No. 5:	Is the resistance less than 10 Ω?	Go to step 4.	Replace the body harness with airbag main harness.
4 CHECK AIRBAG MAIN HARNESS AND FRONT SUB SENSOR HARNESS (RH). Measure the resistance between connector (3R) in test harness R and the chassis ground. Connector & terminal (3R) No. 7 — Chassis ground: (3R) No. 9 — Chassis ground:	Is the resistance more than 1 MΩ?	Finish the diagnosis.	Replace the front sub sensor (RH). <Ref. to AB-19, Front Sub Sensor.>

Diagnostic Chart with Trouble Code

AIRBAG SYSTEM (DIAGNOSTICS)

K: DTC 32

DTC DETECTING CONDITION:

- Front sub sensor harness (LH) circuit is shorted.
- Front sub sensor harness (LH) circuit is open.
- Front sub sensor (LH) is faulty.
- Airbag control module is faulty.

CAUTION:

- Before diagnosing the airbag system, be sure to turn the ignition switch to OFF, disconnect the ground cable from battery, and wait more than 20 seconds before starting to work.
- Before replacing the airbag module, seat belt pretensioner roll connector, control module, and sensor, reconnect each part and confirm that the warning light operates properly.
- When inspecting the airbag main harness, disconnect the driver's airbag module and passenger's airbag module connectors for safety reasons.

WIRING DIAGRAM:

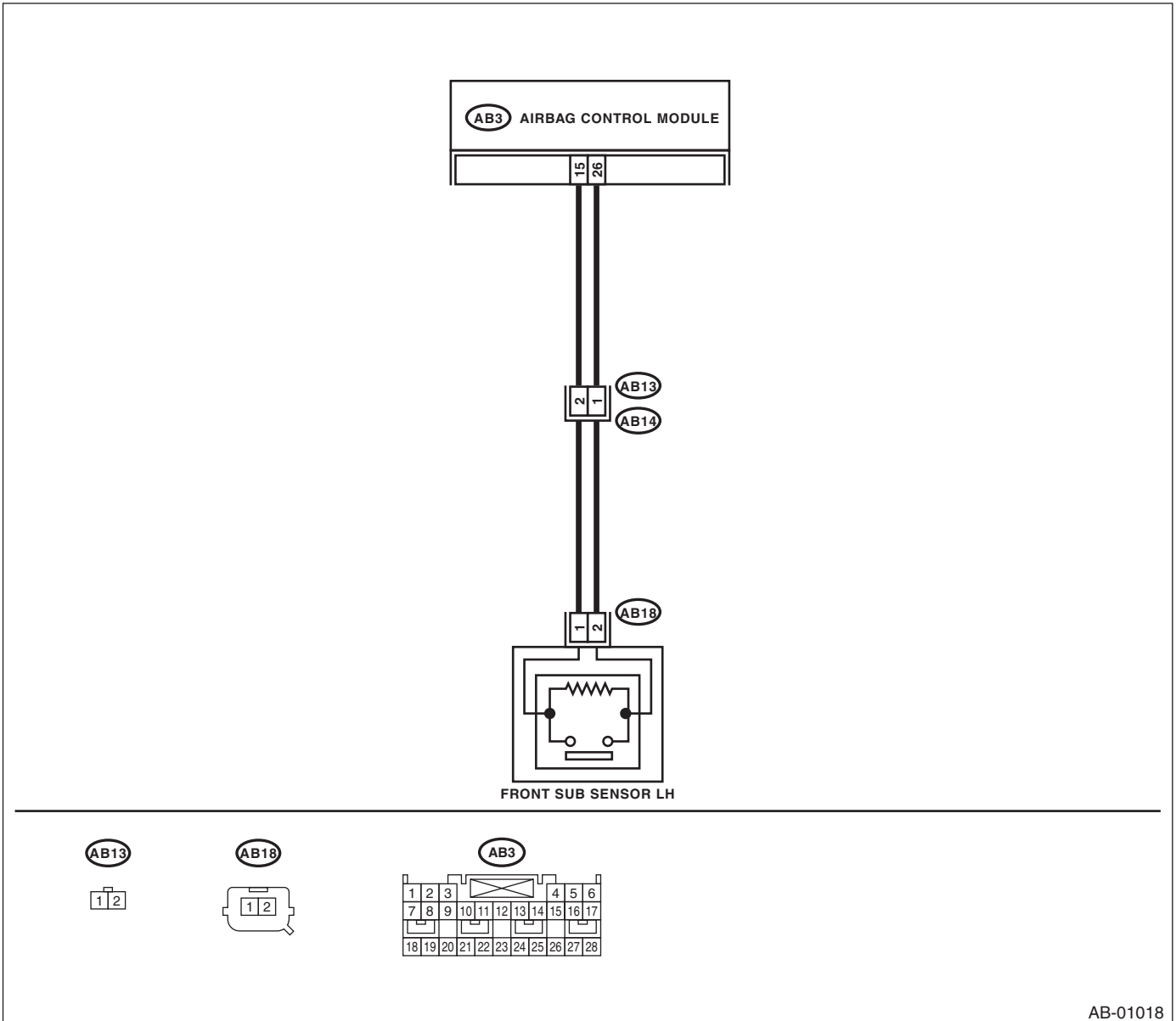

AB-01018

Diagnostic Chart with Trouble Code

AIRBAG SYSTEM (DIAGNOSTICS)

Step	Check	Yes	No
1 CHECK FRONT SUB SENSOR (LH) AND FRONT SUB SENSOR HARNESS (LH). 1) Turn the ignition switch to OFF, disconnect the battery ground cable, and wait more than 20 seconds. 2) Disconnect the connector (AB3) from the airbag control module, and connect connector (1R) in the test harness R to connector (AB3). <Ref. to AB-16, Airbag Control Module.> 3) Measure the resistance of the connector (3R) in the test harness R. Connector & terminal (3R) No. 8 — (3R) No. 6:	Is the resistance 750 Ω — 1 k Ω ?	Replace the airbag control module. <Ref. to AB-16, Airbag Control Module.>	Go to step 2.
2 CHECK FRONT SUB SENSOR (LH) AND FRONT SUB SENSOR HARNESS (LH). Measure the resistance between connector (3R) in test harness R and the chassis ground. Connector & terminal (3R) No. 8 — Chassis ground: (3R) No. 6 — Chassis ground:	Is the resistance more than 1 M Ω ?	Replace the airbag control module. <Ref. to AB-16, Airbag Control Module.>	Go to step 3.
3 CHECK AIRBAG MAIN HARNESS AND FRONT SUB SENSOR HARNESS (LH). 1) Disconnect the connector (AB18) from the front sub sensor. <Ref. to AB-19, Front Sub Sensor.> 2) Connect the connector (1H) in test harness H to connector (AB18). 3) Measure the resistance between connector (3R) in test harness R and connector (3H) in test harness H. Connector & terminal (3R) No. 6 — (3H) No. 5: (3R) No. 8 — (3H) No. 6:	Is the resistance less than 10 Ω ?	Go to step 4.	Go to step 5.
4 CHECK AIRBAG MAIN HARNESS AND FRONT SUB SENSOR HARNESS (LH). Measure the resistance between connector (3R) in test harness R and the chassis ground. Connector & terminal (3R) No. 6 — Chassis ground: (3R) No. 8 — Chassis ground:	Is the resistance more than 1 M Ω ?	Go to step 9.	Go to step 5.
5 CHECK AIRBAG MAIN HARNESS. 1) Disconnect the connector (AB13) from (AB14), and connect the connector (1F) in test harness F to (AB13). 2) Measure the resistance between connector (3R) in test harness R and connector (3F) in test harness F. Connector & terminal (3R) No. 6 — (3F) No. 3: (3R) No. 8 — (3F) No. 4:	Is the resistance less than 10 Ω ?	Go to step 6.	Replace the body harness with air-bag main harness.
6 CHECK AIRBAG MAIN HARNESS. Measure the resistance between connector (3R) in the test harness R and the chassis ground. Connector & terminal (3R) No. 6 — Chassis ground: (3R) No. 8 — Chassis ground:	Is the resistance more than 1 M Ω ?	Go to step 7.	Replace the body harness with air-bag main harness.

Diagnostic Chart with Trouble Code

AIRBAG SYSTEM (DIAGNOSTICS)

Step	Check	Yes	No
7 CHECK FRONT SUB SENSOR HARNESS (LH). 1) Connect the connector (2F) in test harness F to connector (AB14). 2) Measure the resistance between connector (3H) in test harness H and connector (3F) in test harness F. <i>Connector & terminal</i> <i>(3F) No. 5 — (3H) No. 5:</i> <i>(3F) No. 6 — (3H) No. 6:</i>	Is the resistance less than 10 Ω ?	Go to step 8 .	Replace the body harness with front sub sensor harness (LH).
8 CHECK FRONT SUB SENSOR HARNESS (LH). Measure the resistance between connector (3F) in test harness F and the chassis ground. <i>Connector & terminal</i> <i>(3F) No. 5 — Chassis ground:</i> <i>(3F) No. 6 — Chassis ground:</i>	Is the resistance more than 1 M Ω ?	Go to step 9 .	Replace the body harness with front sub sensor harness (LH).
9 CHECK FRONT SUB SENSOR (LH). 1) Connect the connector (2H) in test harness H to front sub sensor (LH). 2) Measure the resistance of the connector (3H) in test harness H. <i>Connector & terminal</i> <i>(3H) No. 3 — (3H) No. 4:</i>	Is the resistance 750 Ω — 1 k Ω ?	Go to step 10 .	Replace the front sub sensor (LH). <Ref. to AB-19, Front Sub Sensor.>
10 CHECK FRONT SUB SENSOR (LH). Measure the resistance between connector (3H) in test harness H and the chassis ground. <i>Connector & terminal</i> <i>(3H) No. 3 — Chassis ground:</i> <i>(3H) No. 4 — Chassis ground:</i>	Is the resistance more than 1 M Ω ?	Finish the diagnosis.	Replace the front sub sensor (LH). <Ref. to AB-19, Front Sub Sensor.>

Diagnostic Chart with Trouble Code

AIRBAG SYSTEM (DIAGNOSTICS)

L: DTC 41

DTC DETECTING CONDITION:

- Side airbag harness (RH) is faulty.
- Side airbag module (RH) is faulty.
- Airbag control module is faulty.

CAUTION:

- Before diagnosing the airbag system, be sure to turn the ignition switch to OFF, disconnect the ground cable from battery, and wait more than 20 seconds before starting to work.
- Before replacing the airbag module, seat belt pretensioner roll connector, control module, and sensor, reconnect each part and confirm that the warning light operates properly.
- When inspecting the airbag main harness, disconnect the driver's airbag module and passenger's airbag module connectors for safety reasons.
- When inspecting the side airbag harness, disconnect the side airbag module connector and seat belt pretensioner connector for the safety reasons.

WIRING DIAGRAM:

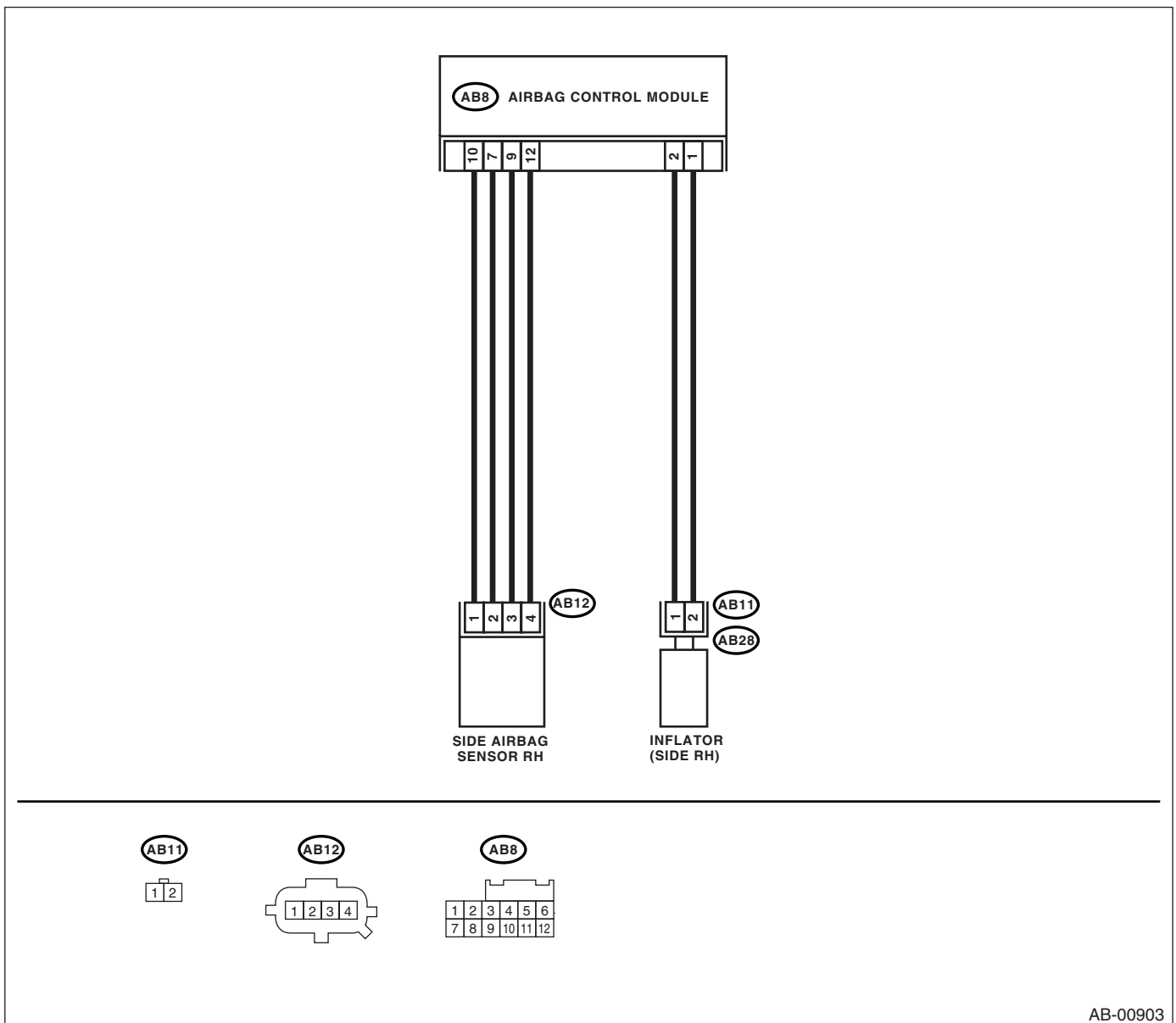

AB-00903

Diagnostic Chart with Trouble Code

AIRBAG SYSTEM (DIAGNOSTICS)

Step	Check	Yes	No
1 CHECK SIDE AIRBAG MODULE. 1) Turn the ignition switch to OFF, disconnect the battery ground cable, and wait more than 20 seconds. 2) Disconnect the connector (AB20) from the seat belt pretensioner (RH). <Ref. to SB-8, Front Seat Belt.> 3) Disconnect the connector (AB28) from (AB11), and connect the connector (1F) in test harness F to (AB11). 4) Connect the airbag resistor to connector (3F) in test harness F. 5) Connect the battery ground cable, and turn the ignition switch to ON.	Does the airbag warning light operate properly?	Replace the front seat with side airbag module (RH). <Ref. to SE-6, Front Seat.>	Go to step 2.
2 CHECK SIDE AIRBAG HARNESS (RH). 1) Turn the ignition switch to OFF, disconnect the battery ground cable, and wait more than 20 seconds. 2) Disconnect the airbag resistor from test harness F. 3) Disconnect the connector (AB8) from air bag control module. <Ref. to AB-16, Airbag Control Module.> 4) Connect the connector (1R) in test harness R to connector (AB8). 5) Measure the resistance between connector (3R) in test harness R and connector (3F) in test harness F. <i>Connector & terminal</i> <i>(3R) No. 20 — (3F) No. 4:</i> <i>(3R) No. 18 — (3F) No. 3:</i>	Is the resistance less than 10 Ω?	Go to step 3.	Replace the body harness with side airbag harness.
3 CHECK SIDE AIRBAG HARNESS (RH). Measure the resistance of the connector (3R) in test harness R. <i>Connector & terminal</i> <i>(3R) No. 20 — (3R) No. 18:</i>	Is the resistance more than 1 MΩ?	Go to step 4.	Replace the body harness with side airbag harness.
4 CHECK SIDE AIRBAG HARNESS (RH). Measure the resistance of the connector (3F) in test harness F. <i>Connector & terminal</i> <i>(3F) No. 3 — (3F) No. 4:</i>	Is the resistance more than 1 MΩ?	Go to step 5.	Replace the body harness with side airbag harness.
5 CHECK SIDE AIRBAG HARNESS (RH). Measure the resistance between connector (3F) in test harness F and the chassis ground. <i>Connector & terminal</i> <i>(3F) No. 3 — Chassis ground:</i> <i>(3F) No. 4 — Chassis ground:</i>	Is the resistance more than 1 MΩ?	Go to step 6.	Replace the body harness with side airbag harness.
6 CHECK SIDE AIRBAG HARNESS (RH). Measure the resistance between connector (3R) in test harness R and the chassis ground. <i>Connector & terminal</i> <i>(3R) No. 20 — Chassis ground:</i> <i>(3R) No. 18 — Chassis ground:</i>	Is the resistance more than 1 MΩ?	Replace the airbag control module. <Ref. to AB-16, Airbag Control Module.>	Replace the body harness with side airbag harness.

Diagnostic Chart with Trouble Code

AIRBAG SYSTEM (DIAGNOSTICS)

M: DTC 42

DTC DETECTING CONDITION:

- Side airbag harness (LH) is faulty.
- Side airbag module (LH) is faulty.
- Airbag control module is faulty.

CAUTION:

- Before diagnosing the airbag system, be sure to turn the ignition switch to OFF, disconnect the ground cable from battery, and wait more than 20 seconds before starting to work.
- Before replacing the airbag module, seat belt pretensioner roll connector, control module, and sensor, reconnect each part and confirm that the warning light operates properly.
- When inspecting the airbag main harness, disconnect the driver's airbag module and passenger's airbag module connectors for safety reasons.
- When inspecting the side airbag harness, disconnect the side airbag module connector and seat belt pretensioner connector for the safety reasons.

WIRING DIAGRAM:

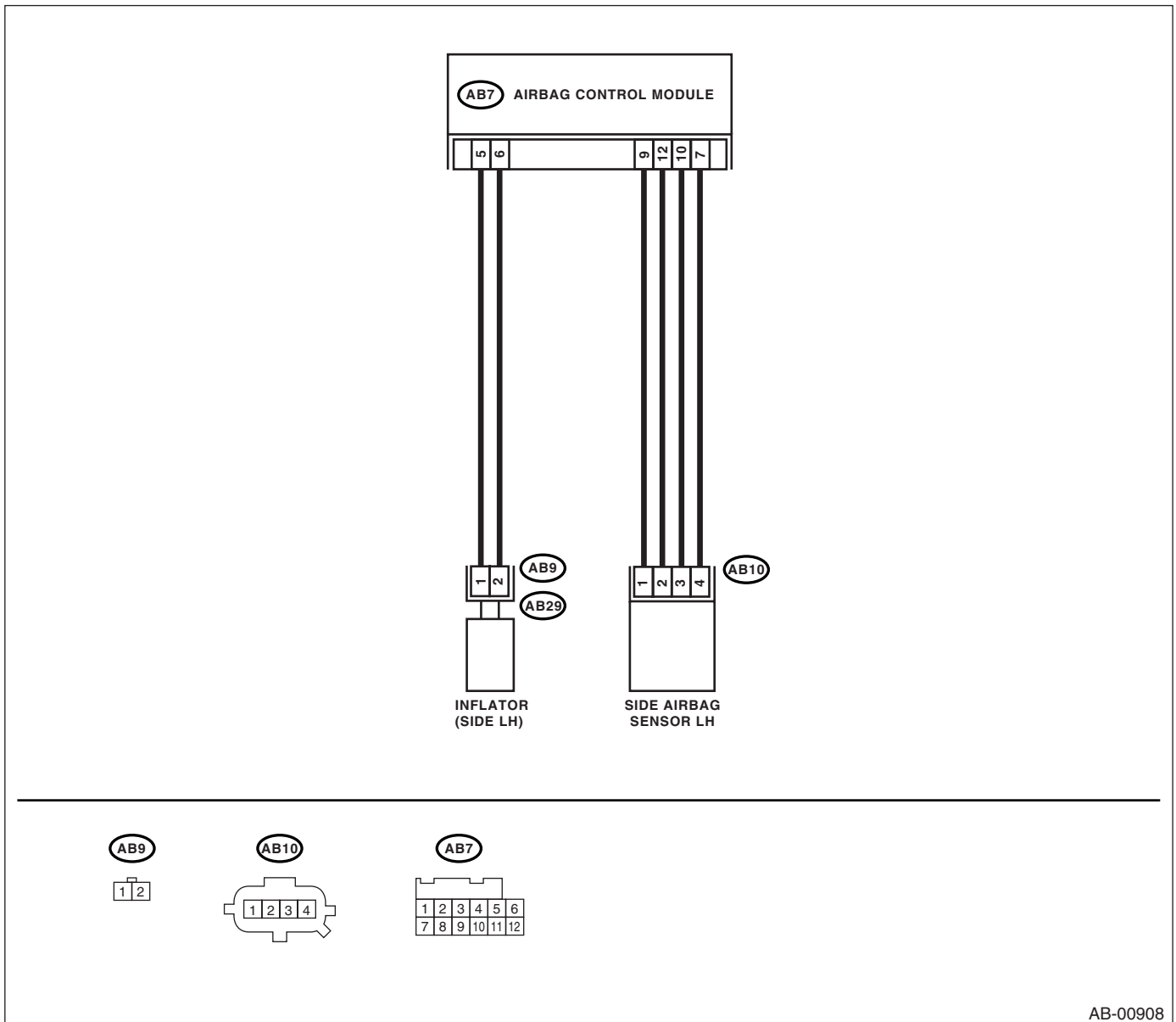

AB-00908

Diagnostic Chart with Trouble Code

AIRBAG SYSTEM (DIAGNOSTICS)

Step	Check	Yes	No
1 CHECK SIDE AIRBAG MODULE. 1) Turn the ignition switch to OFF, disconnect the battery ground cable, and wait more than 20 seconds. 2) Disconnect the connector (AB19) from the seat belt pretensioner (LH). <Ref. to SB-8, Front Seat Belt.> 3) Disconnect the connector (AB29) from (AB9), and connect the connector (1F) in test harness F to (AB9). 4) Connect the airbag resistor to connector (3F) in test harness F. 5) Connect the battery ground cable, and turn the ignition switch to ON.	Does the airbag warning light operate properly?	Replace the front seat with side airbag module (LH). <Ref. to SE-6, Front Seat.>	Go to step 2.
2 CHECK SIDE AIRBAG HARNESS (LH). 1) Turn ignition switch to OFF, disconnect the battery ground cable, and wait more than 20 seconds. 2) Disconnect the airbag resistor from the test harness. 3) Disconnect the connector (AB7) from the airbag control module. <Ref. to AB-16, Airbag Control Module.> 4) Connect the connector (1R) in test harness R to connector (AB7). 5) Measure the resistance between connector (3R) in test harness R and connector (3F) in test harness F. <i>Connector & terminal</i> <i>(3R) No. 12 — (3F) No. 3:</i> <i>(3R) No. 10 — (3F) No. 4:</i>	Is the resistance less than 10 Ω?	Go to step 3.	Replace the body harness with side airbag harness.
3 CHECK SIDE AIRBAG HARNESS (LH). Measure the resistance of the connector (3R) in test harness R. <i>Connector & terminal</i> <i>(3R) No. 12 — (3R) No. 10:</i>	Is the resistance more than 1 MΩ?	Go to step 4.	Replace the body harness with side airbag harness.
4 CHECK SIDE AIRBAG HARNESS (LH). Measure the resistance of the connector (3F) in test harness F. <i>Connector & terminal</i> <i>(3F) No. 3 — (3F) No. 4:</i>	Is the resistance more than 1 MΩ?	Go to step 5.	Replace the body harness with side airbag harness.
5 CHECK SIDE AIRBAG HARNESS (LH). Measure the resistance between connector (3F) in test harness F and the chassis ground. <i>Connector & terminal</i> <i>(3F) No. 3 — Chassis ground:</i> <i>(3F) No. 4 — Chassis ground:</i>	Is the resistance more than 1 MΩ?	Go to step 6.	Replace the body harness with side airbag harness.
6 CHECK SIDE AIRBAG HARNESS (LH). Measure the resistance between connector (3R) in test harness R and the chassis ground. <i>Connector & terminal</i> <i>(3R) No. 12 — Chassis ground:</i> <i>(3R) No. 10 — Chassis ground:</i>	Is the resistance more than 1 MΩ?	Replace the airbag control module. <Ref. to AB-16, Airbag Control Module.>	Replace the body harness with side airbag harness.

Diagnostic Chart with Trouble Code

AIRBAG SYSTEM (DIAGNOSTICS)

N: DTC 45

DTC DETECTING CONDITION:

- Side airbag harness (RH) is shorted to power supply.
- Airbag control module is faulty.

CAUTION:

- Before diagnosing the airbag system, be sure to turn the ignition switch to OFF, disconnect the ground cable from battery, and wait more than 20 seconds before starting to work.
- Before replacing the airbag module, seat belt pretensioner roll connector, control module, and sensor, reconnect each part and confirm that the warning light operates properly.
- When inspecting the airbag main harness, disconnect the driver's airbag module and passenger's airbag module connectors for safety reasons.
- When inspecting the side airbag harness, disconnect the side airbag module connector and seat belt pretensioner connector for the safety reasons.

WIRING DIAGRAM:

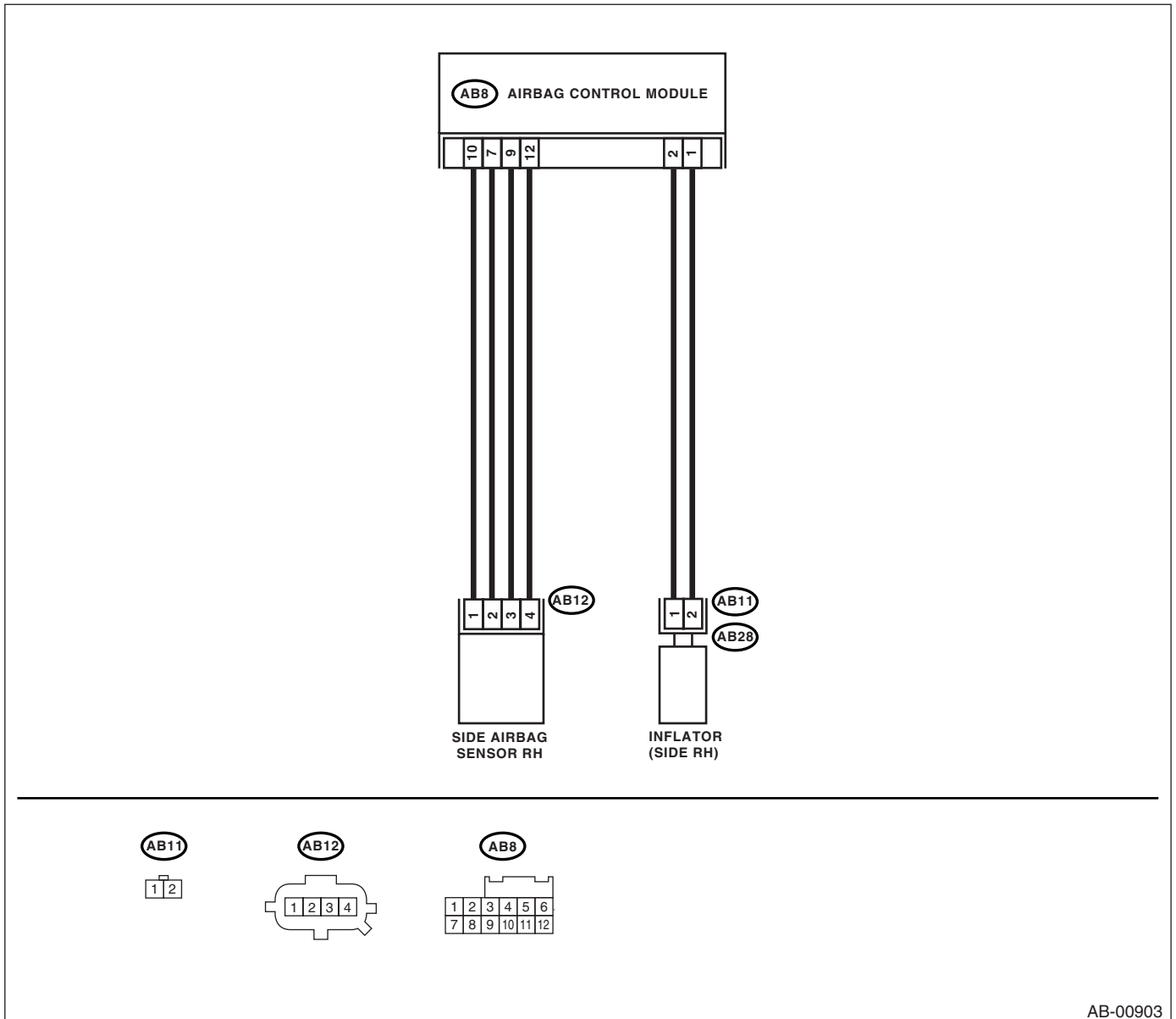

AB-00903

Diagnostic Chart with Trouble Code

AIRBAG SYSTEM (DIAGNOSTICS)

Step	Check	Yes	No
1 CHECK SIDE AIRBAG MODULE. 1) Turn the ignition switch to OFF, disconnect the battery ground cable, and wait more than 20 seconds. 2) Disconnect the connector (AB20) from the seat belt pretensioner (RH). <Ref. to SB-8, Front Seat Belt.> 3) Disconnect the connector (AB28) from (AB11), and connect the connector (1F) in test harness F to (AB11). 4) Connect the airbag resistor to connector (3F) in test harness F. 5) Connect the battery ground cable, and turn the ignition switch to ON.	Does the airbag warning light operate properly?	Replace the front seat with side airbag module (RH). <Ref. to SE-6, Front Seat.>	Go to step 2.
2 CHECK SIDE AIRBAG HARNESS (RH). 1) Turn the ignition switch to OFF, disconnect the battery ground cable, and wait more than 20 seconds. 2) Disconnect the airbag resistor from the test harness. 3) Disconnect the connector (AB8) from the airbag control module. <Ref. to AB-16, Airbag Control Module.> 4) Connect the connector (1R) in test harness R to connector (AB8). 5) Connect the battery ground cable, and turn the ignition switch to ON. 6) Measure the voltage between connector (3R) in test harness R and the chassis ground. Connector & terminal <i>(3R) No. 20 (+) — Chassis ground (-):</i> <i>(3R) No. 18 (+) — Chassis ground (-):</i>	Is the voltage less than 1 V?	Replace the airbag control module. <Ref. to AB-16, Airbag Control Module.>	Replace the body harness with side airbag harness.

Diagnostic Chart with Trouble Code

AIRBAG SYSTEM (DIAGNOSTICS)

O: DTC 46

DTC DETECTING CONDITION:

- Side airbag harness (LH) is shorted to power supply.
- Airbag control module is faulty.

CAUTION:

- Before diagnosing the airbag system, be sure to turn the ignition switch to OFF, disconnect the ground cable from battery, and wait more than 20 seconds before starting to work.
- Before replacing the airbag module, seat belt pretensioner roll connector, control module, and sensor, reconnect each part and confirm that the warning light operates properly.
- When inspecting the airbag main harness, disconnect the driver's airbag module and passenger's airbag module connectors for safety reasons.
- When inspecting the side airbag harness, disconnect the side airbag module connector and seat belt pretensioner connector for the safety reasons.

WIRING DIAGRAM:

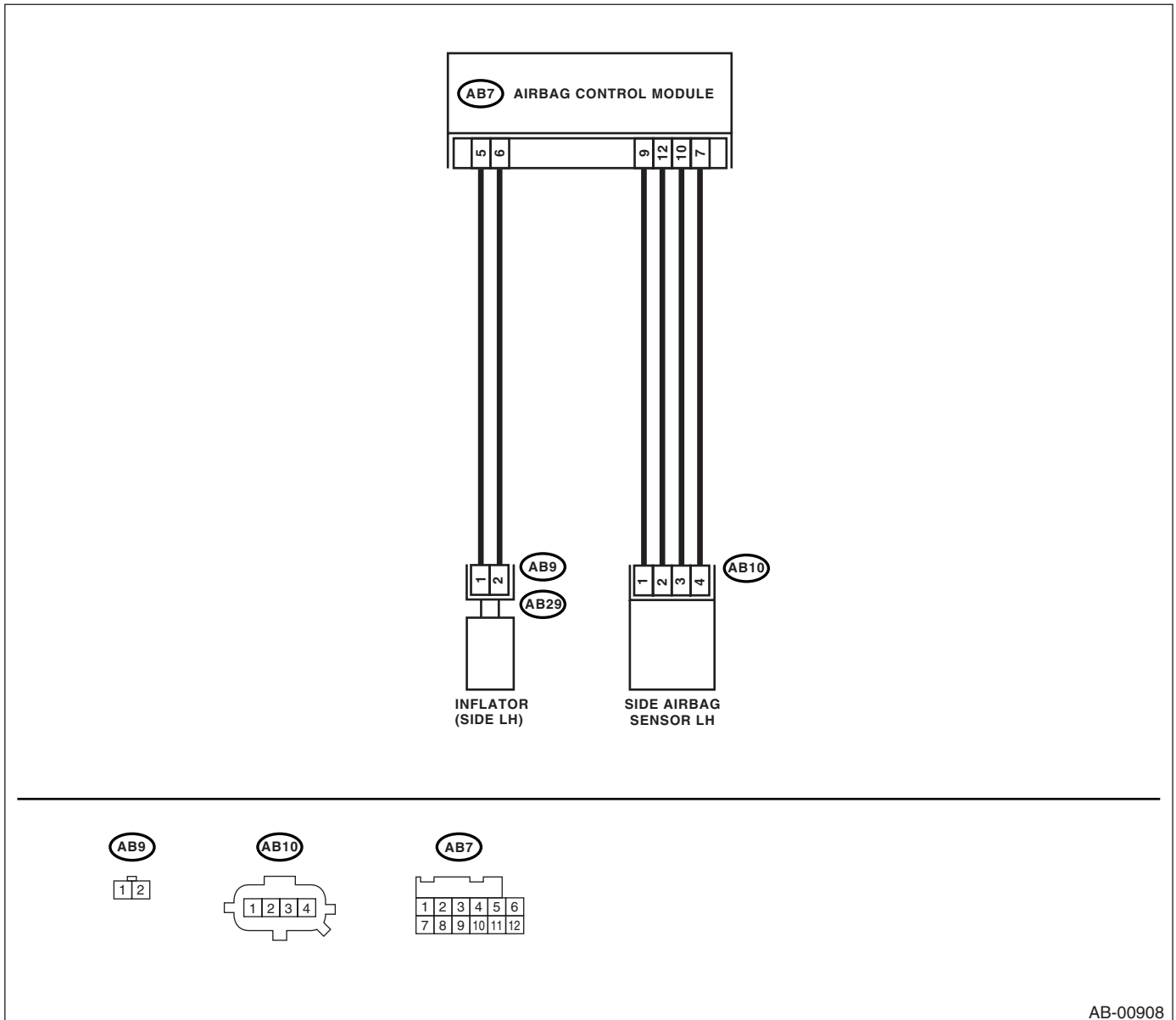

AB-00908

Diagnostic Chart with Trouble Code

AIRBAG SYSTEM (DIAGNOSTICS)

Step	Check	Yes	No
1 CHECK SIDE AIRBAG MODULE. 1) Turn the ignition switch to OFF, disconnect the battery ground cable, and wait more than 20 seconds. 2) Disconnect the connector (AB19) from the seat belt pretensioner (LH). <Ref. to SB-8, Front Seat Belt.> 3) Disconnect the connector (AB29) from (AB9), and connect the connector (1F) in test harness F to (AB9). 4) Connect the airbag resistor to connector (3F) in test harness F. 5) Connect the battery ground cable and turn the ignition switch to ON.	Does the airbag warning light operate properly?	Replace the front seat with side airbag module (LH). <Ref. to SE-6, Front Seat.>	Go to step 2.
2 CHECK SIDE AIRBAG HARNESS (LH). 1) Turn the ignition switch to OFF, disconnect the battery ground cable, and wait more than 20 seconds. 2) Disconnect the airbag resistor from the test harness. 3) Disconnect the connector (AB7) from the airbag control module. <Ref. to AB-16, Airbag Control Module.> 4) Connect the connector (1R) in test harness R to connector (AB7). 5) Connect the battery ground cable, and turn the ignition switch to ON. 6) Measure the voltage between connector (3R) in test harness R and the chassis ground. Connector & terminal <i>(3R) No. 12 (+) — Chassis ground (-):</i> <i>(3R) No. 10 (+) — Chassis ground (-):</i>	Is the voltage less than 1 V?	Replace the airbag control module. <Ref. to AB-16, Airbag Control Module.>	Replace the body harness with side airbag harness.

Diagnostic Chart with Trouble Code

AIRBAG SYSTEM (DIAGNOSTICS)

P: DTC 51

DTC DETECTING CONDITION:

- Side airbag sensor (RH) is faulty.
- Side airbag harness (RH) is faulty.
- Airbag control module is faulty.

CAUTION:

- Before diagnosing the airbag system, be sure to turn the ignition switch to OFF, disconnect the ground cable from battery, and wait more than 20 seconds before starting to work.
- Before replacing the airbag module, seat belt pretensioner roll connector, control module, and sensor, reconnect each part and confirm that the warning light operates properly.
- When inspecting the airbag main harness, disconnect the driver's airbag module and passenger's airbag module connectors for safety reasons.
- When inspecting the side airbag harness, disconnect the side airbag module connector and seat belt pretensioner connector for the safety reasons.

WIRING DIAGRAM:

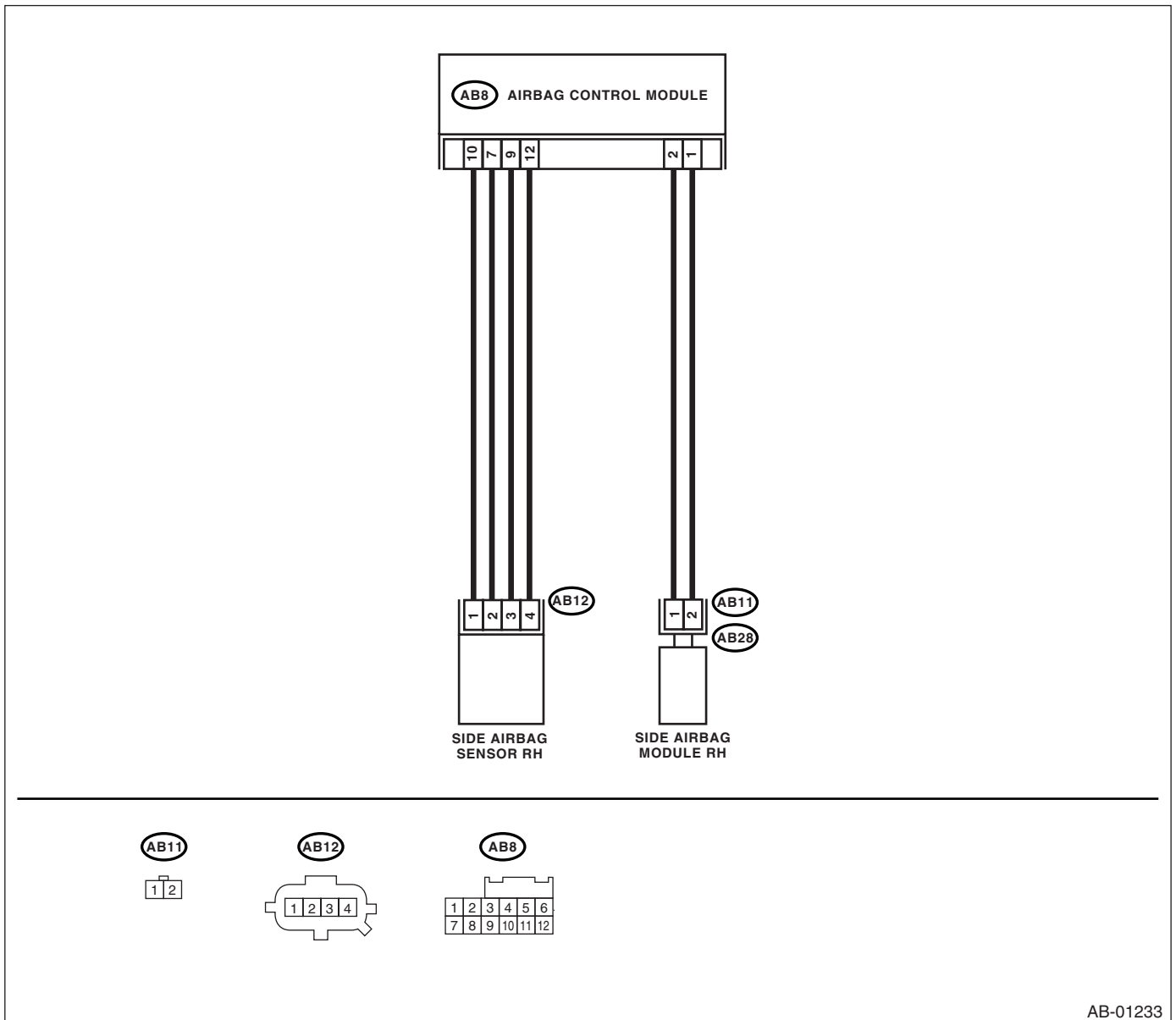

AB-01233

Diagnostic Chart with Trouble Code

AIRBAG SYSTEM (DIAGNOSTICS)

Step	Check	Yes	No
<p>1</p> <p>CHECK SIDE AIRBAG HARNESS (RH). 1) Turn the ignition switch to OFF, disconnect the battery ground cable, and wait more than 20 seconds. 2) Disconnect the connector (AB20) from the seat belt pretensioner (RH). <Ref. to SB-8, Front Seat Belt.> 3) Disconnect the connector (AB28) from (AB11). 4) Disconnect the connector (AB8) from the airbag control module. <Ref. to AB-16, Airbag Control Module.> 5) Connect the connector (1R) in test harness R to the connector (AB8). 6) Disconnect the connector (AB12) from the side airbag sensor (RH), and connect the connector (2V) in test harness V to connector (AB12). 7) Measure the resistance between connector (4R) in test harness R and connector (3V) in test harness V.</p> <p>Connector & terminal (4R) No. 5 — (3V) No. 2: (4R) No. 7 — (3V) No. 1: (4R) No. 8 — (3V) No. 5: (4R) No. 6 — (3V) No. 4:</p>	<p>Is the resistance less than 10 Ω?</p>	<p>Go to step 2.</p>	<p>Replace the body harness with side airbag harness.</p>
<p>2</p> <p>CHECK SIDE AIRBAG HARNESS (RH). Measure the resistance between connector (4R) in test harness R and the chassis ground.</p> <p>Connector & terminal (4R) No. 5 — Chassis ground: (4R) No. 7 — Chassis ground: (4R) No. 8 — Chassis ground: (4R) No. 6 — Chassis ground:</p>	<p>Is the resistance more than 1 MΩ?</p>	<p>Replace the side airbag sensor (RH). <Ref. to AB-17, Side Airbag Sensor.> When sensor replacement is not OK, replace the airbag control module. <Ref. to AB-16, Airbag Control Module.></p>	<p>Replace the body harness with side airbag harness.</p>

Diagnostic Chart with Trouble Code

AIRBAG SYSTEM (DIAGNOSTICS)

Q: DTC 52

DTC DETECTING CONDITION:

- Side airbag sensor (LH) is faulty.
- Side airbag harness (LH) is faulty.
- Airbag control module is faulty.

CAUTION:

- Before diagnosing the airbag system, be sure to turn the ignition switch to OFF, disconnect the ground cable from battery, and wait more than 20 seconds before starting to work.
- Before replacing the airbag module, seat belt pretensioner roll connector, control module, and sensor, reconnect each part and confirm that the warning light operates properly.
- When inspecting the airbag main harness, disconnect the driver's airbag module and passenger's airbag module connectors for safety reasons.
- When inspecting the side airbag harness, disconnect the side airbag module connector and seat belt pretensioner connector for the safety reasons.

WIRING DIAGRAM:

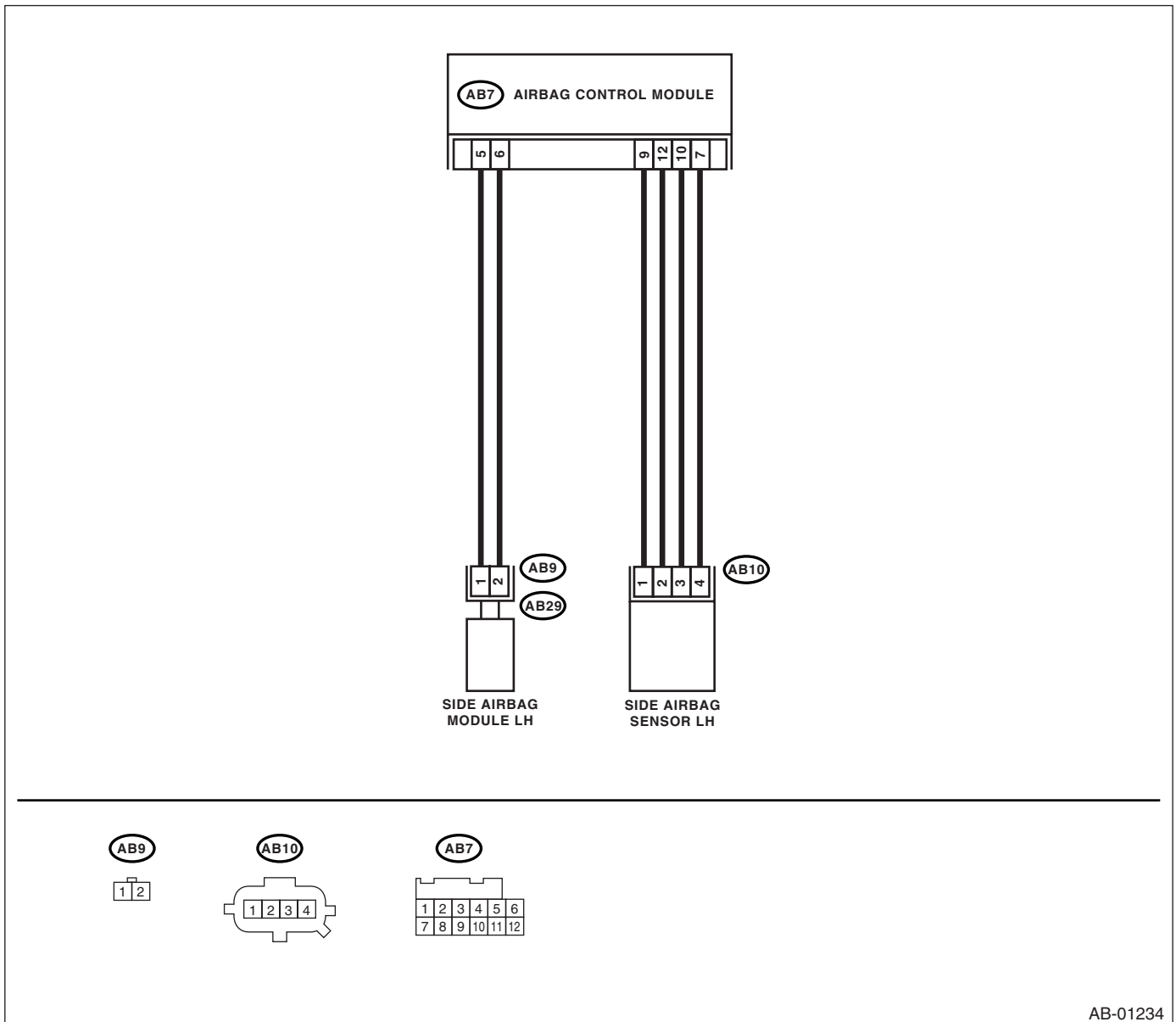

AB-01234

Diagnostic Chart with Trouble Code

AIRBAG SYSTEM (DIAGNOSTICS)

Step	Check	Yes	No
<p>1</p> <p>CHECK SIDE AIRBAG HARNESS (LH). 1) Turn the ignition switch to OFF, disconnect the battery ground cable, and wait more than 20 seconds. 2) Disconnect the connector (AB19) from the seat belt pretensioner (LH). <Ref. to SB-8, Front Seat Belt.> 3) Disconnect the connector (AB29) from (AB9). 4) Disconnect the connector (AB7) from the airbag control module. <Ref. to AB-16, Airbag Control Module.> 5) Connect the connector (1R) in test harness R to connector (AB7). 6) Disconnect the connector (AB10) from the side airbag sensor (LH), and connect the connector (2V) in test harness V to connector (AB10). 7) Measure the resistance between connector (4R) in test harness R and connector (3V) in test harness V.</p> <p>Connector & terminal <i>(4R) No. 3 — (3V) No. 4:</i> <i>(4R) No. 1 — (3V) No. 5:</i> <i>(4R) No. 2 — (3V) No. 1:</i> <i>(4R) No. 4 — (3V) No. 2:</i></p>	<p>Is the resistance less than 10 Ω?</p>	<p>Go to step 2.</p>	<p>Replace the body harness with side airbag harness.</p>
<p>2</p> <p>CHECK SIDE AIRBAG HARNESS (RH). Measure the resistance between connector (4R) in test harness R and the chassis ground.</p> <p>Connector & terminal <i>(4R) No. 3 — Chassis ground:</i> <i>(4R) No. 1 — Chassis ground:</i> <i>(4R) No. 2 — Chassis ground:</i> <i>(4R) No. 4 — Chassis ground:</i></p>	<p>Is the resistance more than 1 MΩ?</p>	<p>Replace the side airbag sensor (LH). <Ref. to AB-17, Side Airbag Sensor.> When sensor replacement is not OK, replace the airbag control module. <Ref. to AB-16, Airbag Control Module.></p>	<p>Replace the body harness with side airbag harness.</p>

Diagnostic Chart with Trouble Code

AIRBAG SYSTEM (DIAGNOSTICS)

R: DTC 53

DTC DETECTING CONDITION:

Side airbag sensor (RH) is faulty.

When Code 53 is displayed, the circuit within the side airbag sensor (RH) is faulty. Replace the side airbag sensor (RH).

<Ref. to AB-17, Side Airbag Sensor.>

S: DTC 54

DTC DETECTING CONDITION:

Side airbag sensor (LH) is faulty.

When Code 53 is displayed, the circuit within the side airbag sensor (LH) is faulty. Replace the side airbag sensor (LH).

<Ref. to AB-17, Side Airbag Sensor.>

T: DTC 55

This DTC is displayed when the side airbag is deployed.

When this DTC is displayed, the memory cannot be erased. Replace the following parts.

- Airbag control module <Ref. to AB-16, Airbag Control Module.>
- Front seat with side airbag module (Operating side) <Ref. to SE-6, Front Seat.>
- Side airbag sensor (Operating side) <Ref. to AB-17, Side Airbag Sensor.>

Diagnostic Chart with Trouble Code

AIRBAG SYSTEM (DIAGNOSTICS)

U: DTC 61

DTC DETECTING CONDITION:

- Seat belt pretensioner (RH) circuit is open, shorted or shorted to ground.
- Airbag control module is faulty.
- Pretensioner is faulty.
- Pretensioner harness is faulty.

CAUTION:

- Before diagnosing the airbag system, be sure to turn the ignition switch to OFF, disconnect the ground cable from battery, and wait more than 20 seconds before starting to work.
- Before replacing the airbag module, seat belt pretensioner roll connector, control module, and sensor, reconnect each part and confirm that the warning light operates properly.
- When inspecting the side airbag harness, disconnect the side airbag module connector and seat belt pretensioner connector for the safety reasons.

WIRING DIAGRAM:

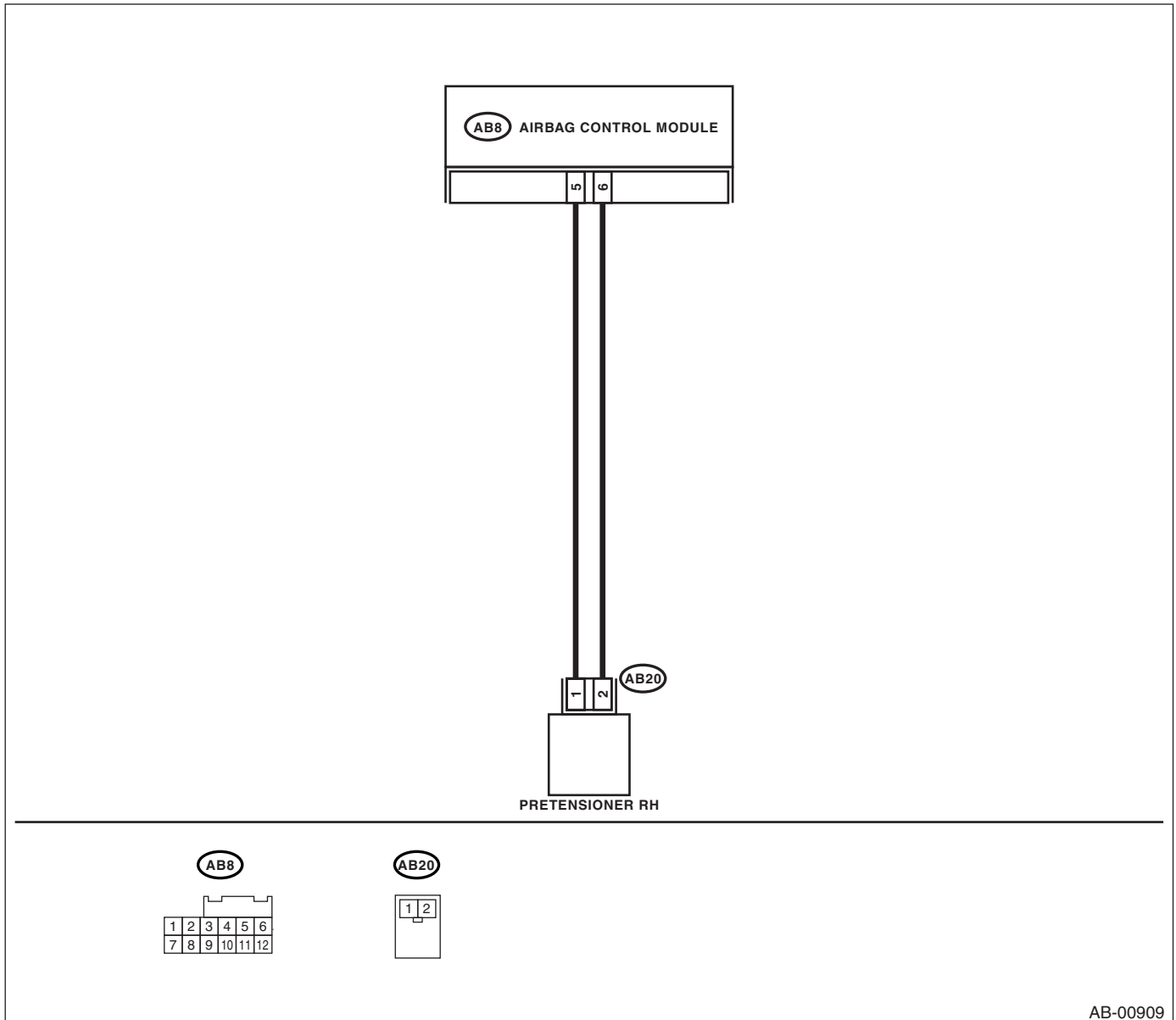

Diagnostic Chart with Trouble Code

AIRBAG SYSTEM (DIAGNOSTICS)

Step	Check	Yes	No
1 CHECK SEAT BELT PRETENSIONER. 1) Turn the ignition switch to OFF, disconnect the battery ground cable, and wait more than 20 seconds. 2) Disconnect the connector (AB20) from the seat belt pretensioner (RH). <Ref. to SB-8, Front Seat Belt.> 3) Connect the connector (1N) in test harness N to (AB20). 4) Connect the airbag resistor to connector (2N) in test harness N. 5) Connect the battery ground cable and turn the ignition switch to ON.	Does the airbag warning light operate properly?	Replace the seat belt pretensioner (RH). <Ref. to SB-8, Front Seat Belt.>	Go to step 2.
2 CHECK SIDE AIRBAG HARNESS (RH). 1) Turn the ignition switch to OFF, disconnect the battery ground cable, and wait more than 20 seconds. 2) Disconnect the airbag resistor from the test harness. 3) Disconnect the connector (AB28) from (AB11). 4) Disconnect the connectors (AB7) and (AB8) from the airbag control module. <Ref. to AB-16, Airbag Control Module.> 5) Connect the connector (1R) in test harness R to connector (AB8). 6) Measure the resistance between connector (3R) in test harness R and connector (2N) in test harness N. Connector & terminal <i>(3R) No. 19 — (2N) No. 1:</i> <i>(3R) No. 17 — (2N) No. 2:</i>	Is the resistance less than 10 Ω?	Go to step 3.	Replace the body harness with side airbag harness.
3 CHECK SIDE AIRBAG HARNESS (RH). Measure the resistance of the connector (3R) in test harness R. Connector & terminal <i>(3R) No. 17 — (3R) No. 19:</i>	Is the resistance more than 1 MΩ?	Go to step 4.	Replace the body harness with side airbag harness.
4 CHECK SIDE AIRBAG HARNESS (RH). Measure the resistance between connector (3R) in test harness R and the chassis ground. Connector & terminal <i>(3R) No. 17 — Chassis ground:</i> <i>(3R) No. 19 — Chassis ground:</i>	Is the resistance more than 1 MΩ?	Replace the airbag control module. <Ref. to AB-16, Airbag Control Module.>	Replace the body harness with side airbag harness.

Diagnostic Chart with Trouble Code

AIRBAG SYSTEM (DIAGNOSTICS)

V: DTC 62

DTC DETECTING CONDITION:

- Seat belt pretensioner (LH) circuit is open, shorted or shorted to ground.
- Airbag control module is faulty.
- Pretensioner is faulty.
- Pretensioner harness is faulty.

CAUTION:

- Before diagnosing the airbag system, be sure to turn the ignition switch to OFF, disconnect the ground cable from battery, and wait more than 20 seconds before starting to work.
- Before replacing the airbag module, seat belt pretensioner roll connector, control module, and sensor, reconnect each part and confirm that the warning light operates properly.
- When inspecting the side airbag harness, disconnect the side airbag module connector and seat belt pretensioner connector for the safety reasons.

WIRING DIAGRAM:

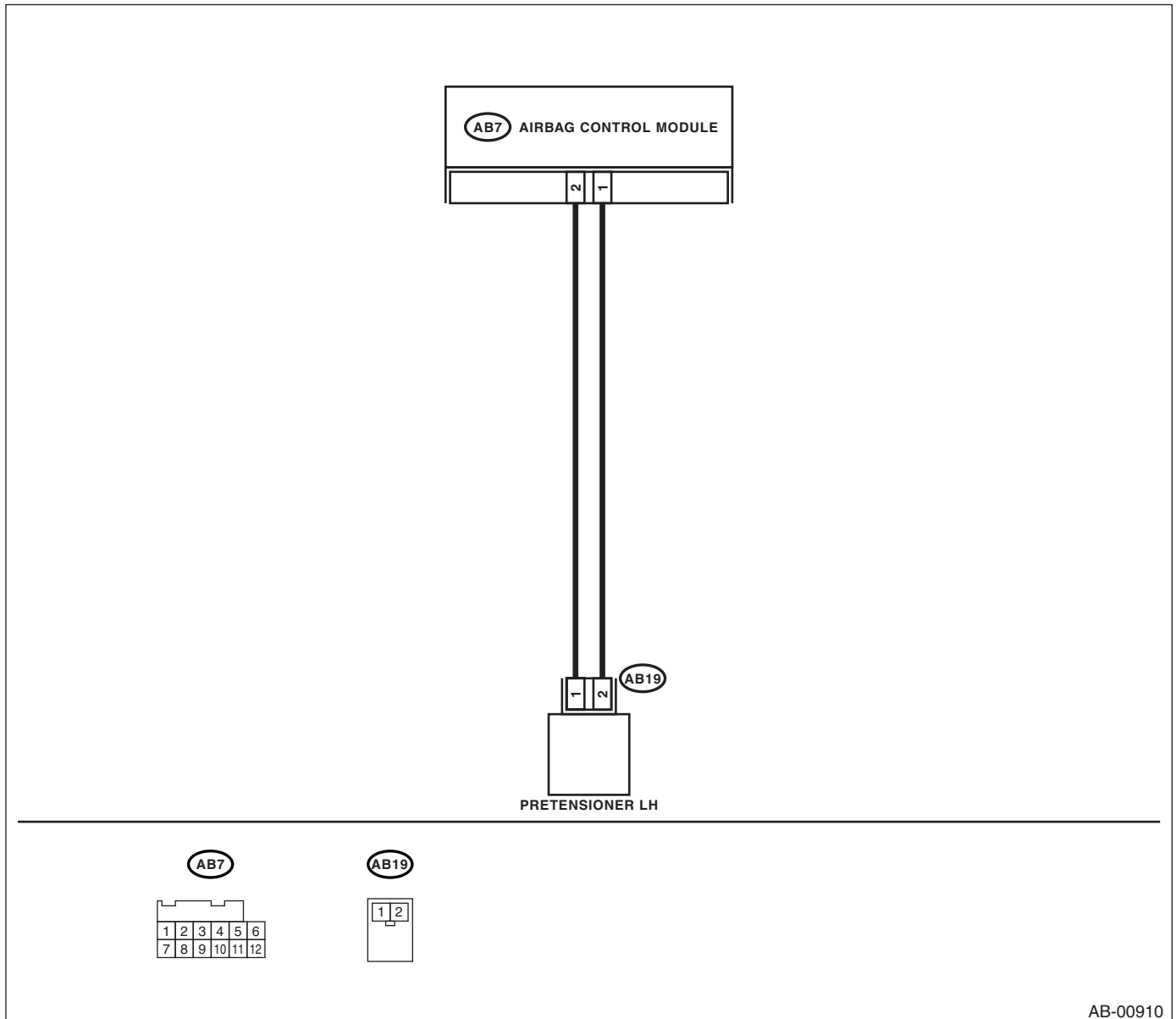

Diagnostic Chart with Trouble Code

AIRBAG SYSTEM (DIAGNOSTICS)

Step	Check	Yes	No
1 CHECK SEAT BELT PRETENSIONER. 1) Turn the ignition switch to OFF, disconnect the battery ground cable, and wait more than 20 seconds. 2) Disconnect the connector (AB19) from the seat belt pretensioner (LH). <Ref. to SB-8, Front Seat Belt.> 3) Connect the connector (1N) in test harness N to (AB19). 4) Connect the airbag resistor to the connector (2N) in test harness N. 5) Connect the battery ground cable and turn the ignition switch to ON.	Does the airbag warning light operate properly?	Replace the seat belt pretensioner (LH). <Ref. to SB-8, Front Seat Belt.>	Go to step 2.
2 CHECK SIDE AIRBAG HARNESS (LH). 1) Turn the ignition switch to OFF, disconnect the battery ground cable, and wait more than 20 seconds. 2) Disconnect the airbag resistor from the test harness. 3) Disconnect the connector (AB29) from (AB9). 4) Disconnect the connectors (AB7) and (AB8) from the airbag control module. <Ref. to AB-16, Airbag Control Module.> 5) Connect the connector (1R) in test harness R to the connector (AB7). 6) Measure the resistance between connector (3R) in test harness R and the connector (2N) in test harness N. <i>Connector & terminal</i> <i>(3R) No. 11 — (2N) No. 2:</i> <i>(3R) No. 13 — (2N) No. 1:</i>	Is the resistance less than 10 Ω?	Go to step 3.	Replace the body harness with side airbag harness.
3 CHECK SIDE AIRBAG HARNESS (LH). Measure the resistance of the connector (3R) in test harness R. <i>Connector & terminal</i> <i>(3R) No. 11 — (3R) No. 13:</i>	Is the resistance more than 1 MΩ?	Go to step 4.	Replace the body harness with side airbag harness.
4 CHECK SIDE AIRBAG HARNESS (LH). Measure the resistance between the connector (3R) in test harness R and the chassis ground. <i>Connector & terminal</i> <i>(3R) No. 11 — Chassis ground:</i> <i>(3R) No. 13 — Chassis ground:</i>	Is the resistance more than 1 MΩ?	Replace the airbag control module. <Ref. to AB-16, Airbag Control Module.>	Replace the body harness with side airbag harness.

Diagnostic Chart with Trouble Code

AIRBAG SYSTEM (DIAGNOSTICS)

W: DTC 65

DTC DETECTING CONDITION:

- Seat belt pretensioner (RH) circuit is shorted to the power supply.
- Pretensioner is faulty.
- Pretensioner harness is faulty.
- Airbag control module is faulty.

CAUTION:

- Before diagnosing the airbag system, be sure to turn the ignition switch to OFF, disconnect the ground cable from battery, and wait more than 20 seconds before starting to work.
- Before replacing the airbag module, seat belt pretensioner roll connector, control module, and sensor, reconnect each part and confirm that the warning light operates properly.
- When inspecting the side airbag harness, disconnect the side airbag module connector and seat belt pretensioner connector for the safety reasons.

WIRING DIAGRAM:

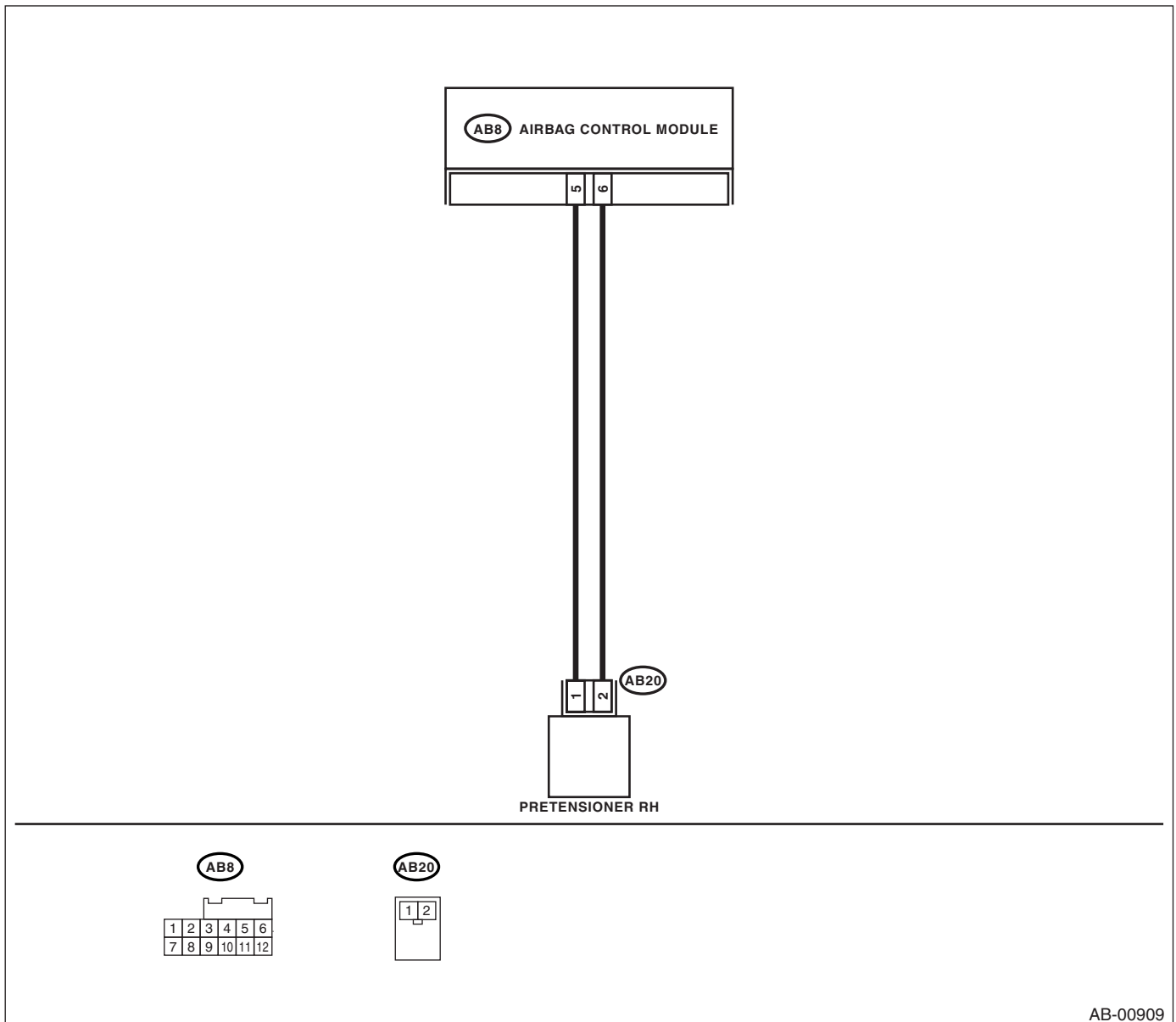

Diagnostic Chart with Trouble Code

AIRBAG SYSTEM (DIAGNOSTICS)

Step	Check	Yes	No
1 CHECK SEAT BELT PRETENSIONER. 1) Turn the ignition switch to OFF, disconnect the battery ground cable, and wait more than 20 seconds. 2) Disconnect the connector (AB20) from the seat belt pretensioner (RH). <Ref. to SB-8, Front Seat Belt.> 3) Connect the connector (1N) in test harness N to (AB20). 4) Connect the airbag resistor to connector (2N) in test harness N. 5) Connect the battery ground cable, and turn the ignition switch to ON.	Does the airbag warning light operate properly?	Replace the seat belt pretensioner (RH). <Ref. to SB-8, Front Seat Belt.>	Go to step 2.
2 CHECK SIDE AIRBAG HARNESS (RH). 1) Turn the ignition switch to OFF, disconnect the battery ground cable, and wait more than 20 seconds. 2) Disconnect the airbag resistor from the test harness. 3) Disconnect the connector (AB28) from (AB11). 4) Disconnect the connectors (AB7) and (AB8) from the airbag control module. <Ref. to AB-16, Airbag Control Module.> 5) Connect the connector (1R) in test harness R to the connector (AB8). 6) Connect the battery ground cable and turn the ignition switch to ON. 7) Measure the voltage between connector (3R) in test harness R and the chassis ground. Connector & terminal <i>(3R) No. 17 (+) — Chassis ground (-):</i> <i>(3R) No. 19 (+) — Chassis ground (-):</i>	Is the voltage less than 1 V?	Replace the airbag control module. <Ref. to AB-16, Airbag Control Module.>	Replace the body harness with side airbag harness.

Diagnostic Chart with Trouble Code

AIRBAG SYSTEM (DIAGNOSTICS)

X: DTC 66

DTC DETECTING CONDITION:

- Seat belt pretensioner (LH) circuit is shorted to the power supply.
- Pretensioner is faulty.
- Pretensioner harness is faulty.
- Airbag control module is faulty.

CAUTION:

- Before diagnosing the airbag system, be sure to turn the ignition switch to OFF, disconnect the ground cable from battery, and wait more than 20 seconds before starting to work.
- Before replacing the airbag module, seat belt pretensioner roll connector, control module and the sensor, reconnect each part and confirm that the warning light operates properly.
- When inspecting the side airbag harness, disconnect the side airbag module connector and seat belt pretensioner connector for the safety reasons.

WIRING DIAGRAM:

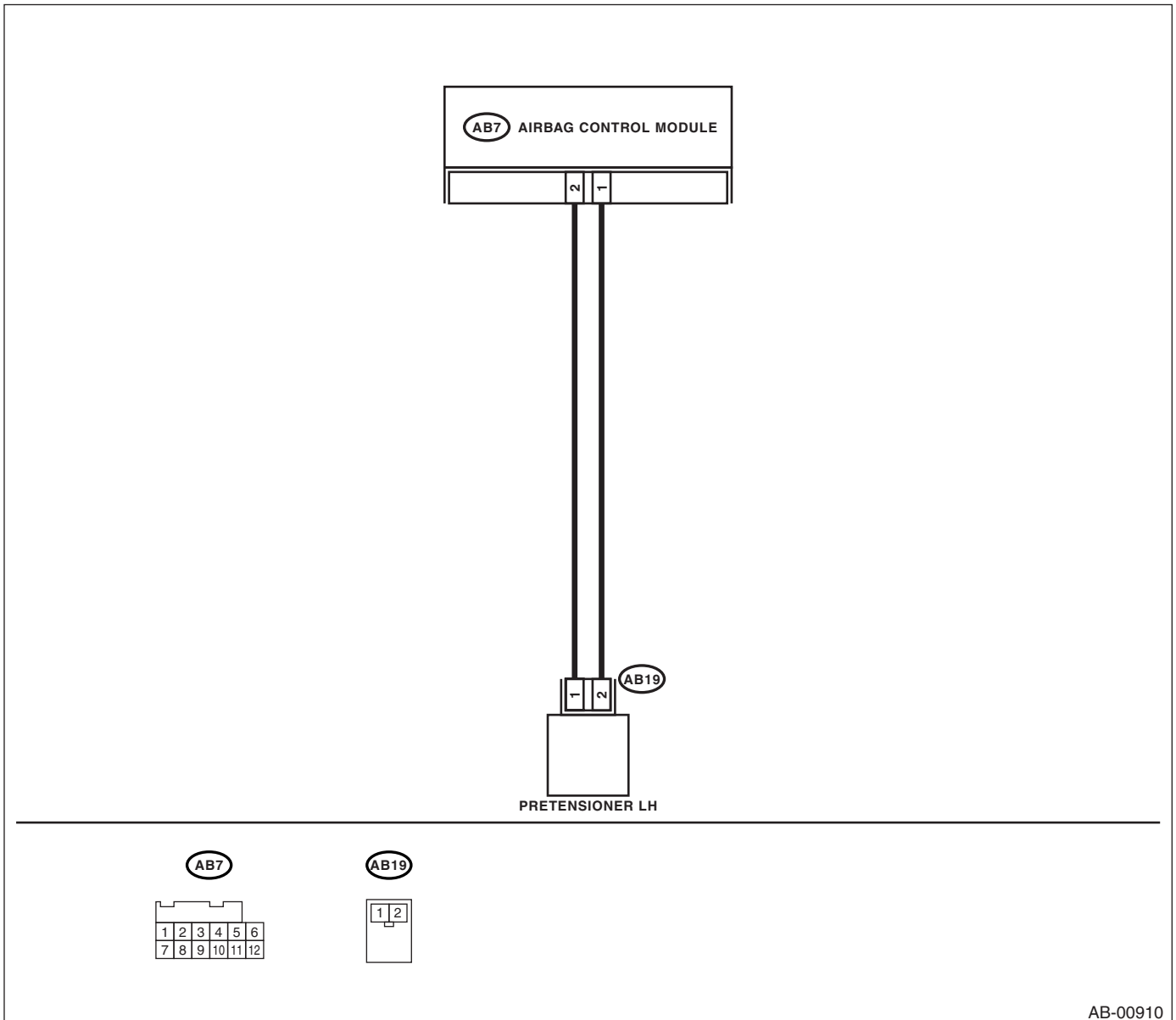

Diagnostic Chart with Trouble Code

AIRBAG SYSTEM (DIAGNOSTICS)

Step	Check	Yes	No
1 CHECK SEAT BELT PRETENSIONER. 1) Turn the ignition switch to OFF, disconnect the battery ground cable, and wait more than 20 seconds. 2) Disconnect the connector (AB19) from the seat belt pretensioner (LH). <Ref. to SB-8, Front Seat Belt.> 3) Connect the connector (1N) in test harness N to (AB19). 4) Connect the airbag resistor to the connector (2N) in test harness N. 5) Connect the battery ground cable and turn the ignition switch to ON.	Does the airbag warning light operate properly?	Replace the seat belt pretensioner (LH). <Ref. to SB-8, Front Seat Belt.>	Go to step 2.
2 CHECK SIDE AIRBAG HARNESS (LH). 1) Turn the ignition switch to OFF, disconnect the battery ground cable, and wait more than 20 seconds. 2) Disconnect the airbag resistor from the test harness. 3) Disconnect the connector (AB29) from (AB9). 4) Disconnect the connectors (AB7) and (AB8) from the airbag control module. <Ref. to AB-16, Airbag Control Module.> 5) Connect the connector (1R) in test harness R to the connector (AB7). 6) Connect the battery ground cable and turn the ignition switch to ON. 7) Measure the voltage between connector (3R) in test harness R and the chassis ground. Connector & terminal <i>(3R) No. 11 (+) — Chassis ground (-):</i> <i>(3R) No. 13 (+) — Chassis ground (-):</i>	Is the voltage less than 1 V?	Replace the airbag control module. <Ref. to AB-16, Airbag Control Module.>	Replace the body harness with side airbag harness.