

CRUISE CONTROL SYSTEM

General Description

CRUISE CONTROL SYSTEM

1. General Description

A: COMPONENT

1. TURBO MODEL

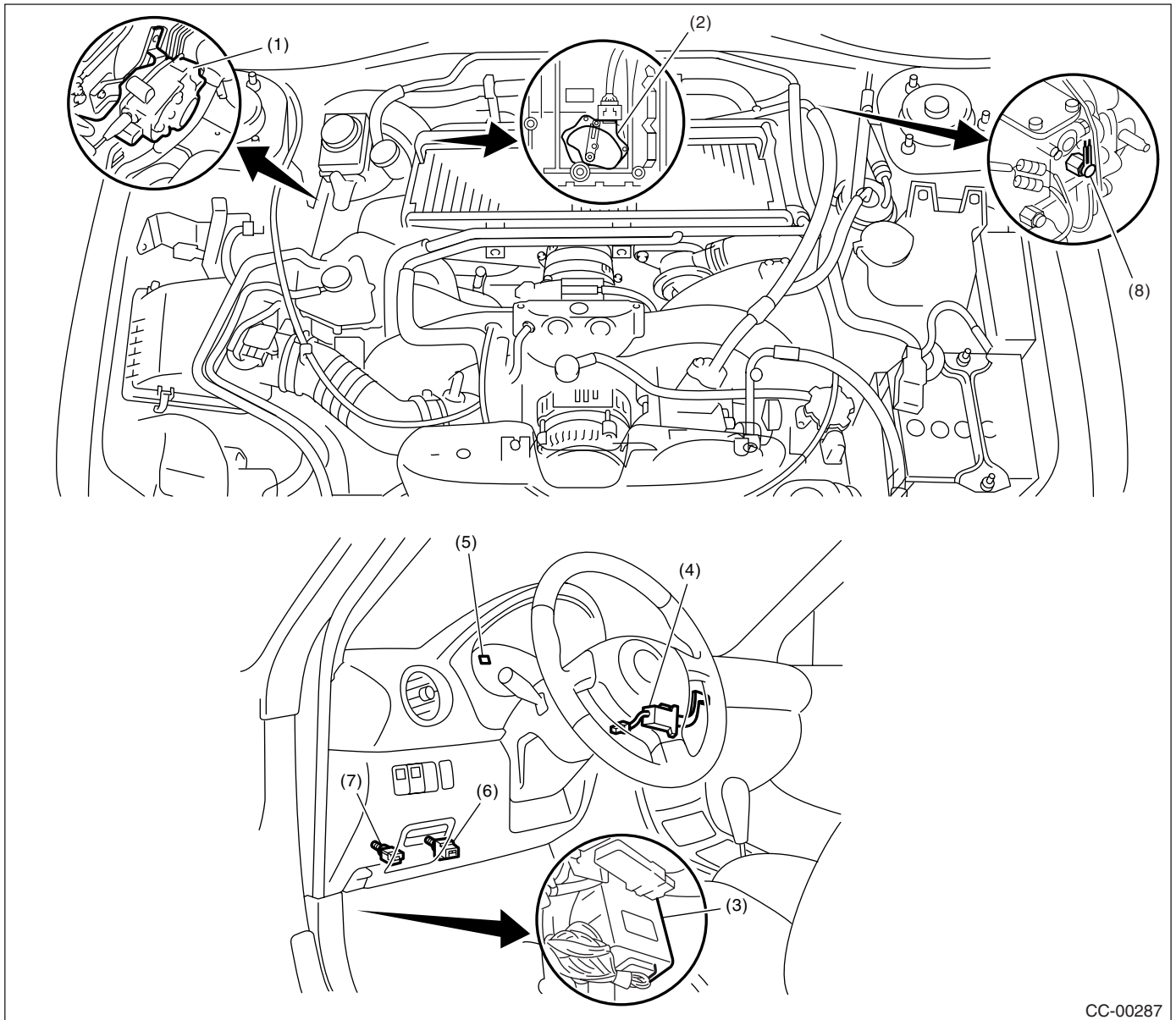

CC-00287

- | | | |
|---------------------------------|---|--|
| (1) Actuator | (4) Cruise control command switch (main switch built-in) | (6) Stop light and brake switch |
| (2) Inhibitor switch (AT model) | (5) Cruise indicator light and cruise set indicator light | (7) Clutch switch (MT model) |
| (3) Cruise control module | | (8) Neutral position switch (MT model) |

2. NON-TURBO MODEL

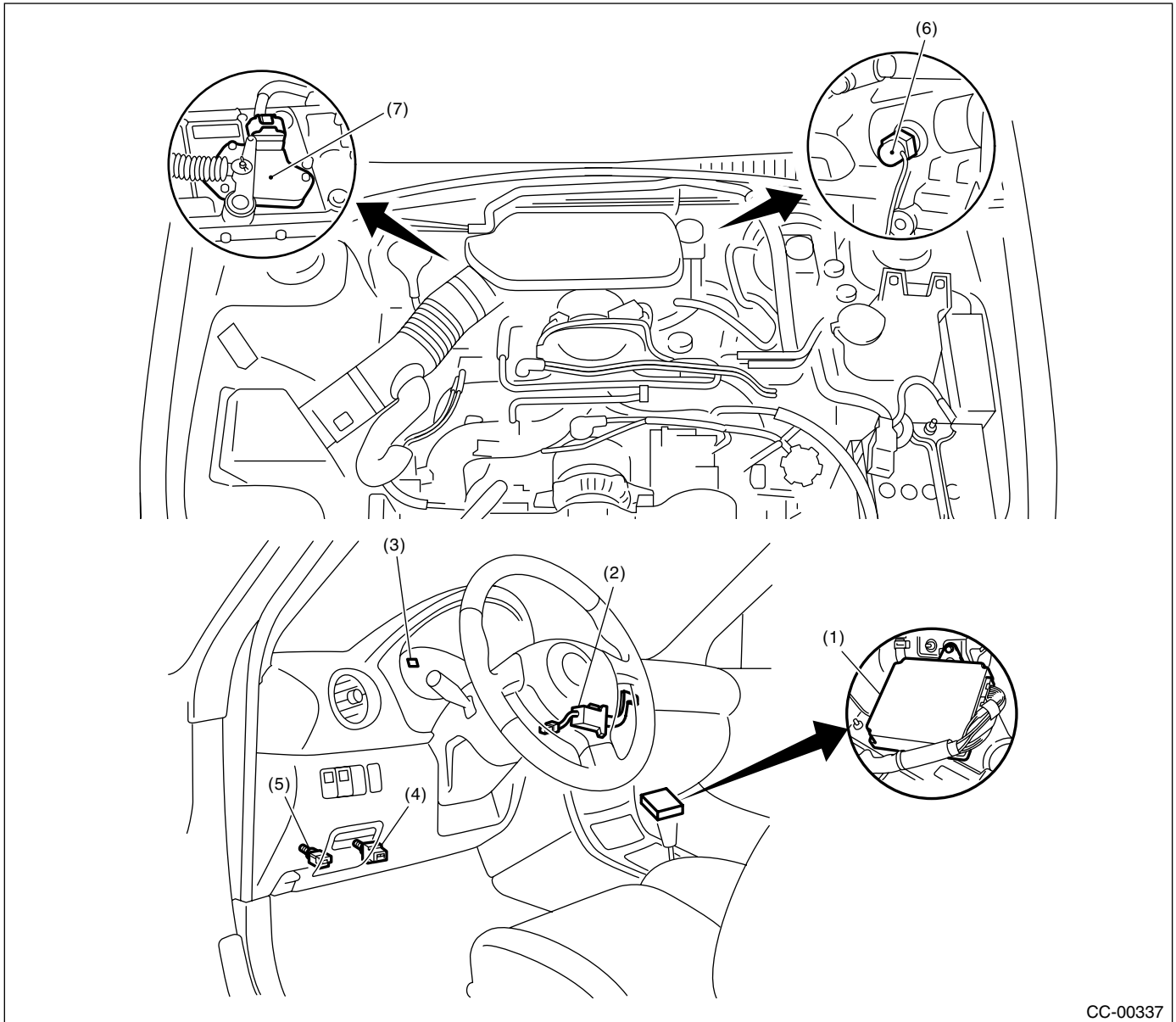

CC-00337

- | | | |
|---|---|---------------------------------|
| (1) Engine control module (ECM) | (3) Cruise indicator light & cruise set indicator light | (5) Clutch switch (MT model) |
| (2) Cruise control command switch (with built-in main switch) | (4) Stop light & brake switch | (6) Neutral position switch |
| | | (7) Inhibitor switch (AT model) |

General Description

CRUISE CONTROL SYSTEM

3. STi MODEL

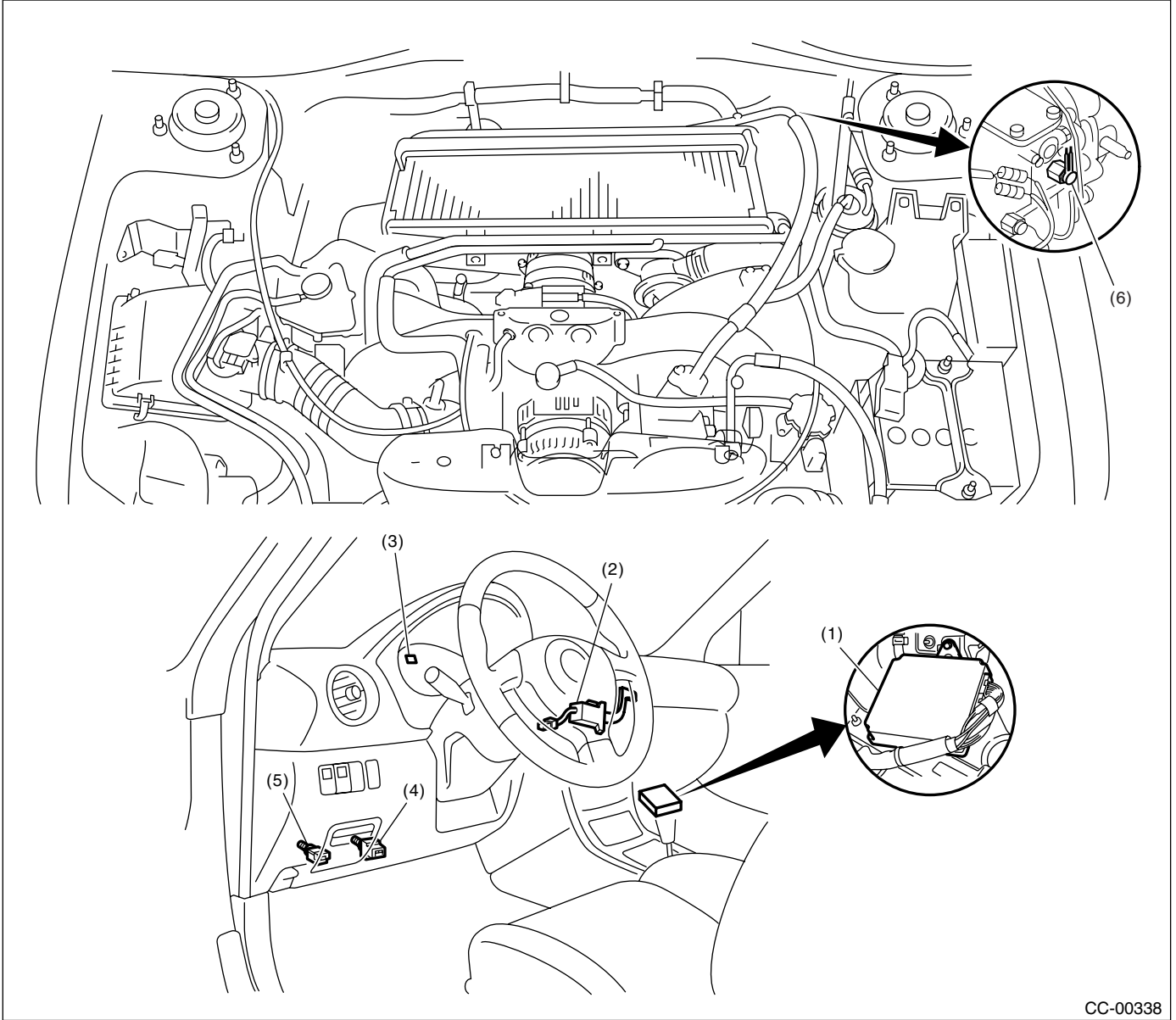

- | | | |
|---|---|------------------------------|
| (1) Engine control module (ECM) | (3) Cruise indicator light & cruise set indicator light | (5) Clutch switch (MT model) |
| (2) Cruise control command switch (with built-in main switch) | (4) Stop light & brake switch | (6) Neutral position switch |

B: CAUTION

- Before disassembling or reassembling parts, always disconnect the battery ground cable. When repairing the radio, control module and other parts with memory functions, make note of the memory before disconnecting the battery ground cable. All memory will be erased.
- Reassemble parts in the reverse order of disassembly unless otherwise indicated.
- Adjust parts to specifications specified in this manual.
- Connect the connectors and hoses securely during reassembly.
- After reassembly, ensure functional parts operate properly.

C: PREPARATION TOOL

TOOL NAME	REMARKS
Circuit Tester	Used for measuring resistance and voltage.

2. Actuator

A: REMOVAL

1. TURBO MODEL EXCEPT STi MODEL

CAUTION:

- Be careful not to apply excessive load to the wire cable when adjusting and/or installing; otherwise, the actuator may be deformed or damaged.
- Do not bend the cable sharply with a radius less than 100 mm (3.94 in); otherwise, cable may bend permanently, resulting in poor performance.
- When installing the cable, be careful not to sharply bend or pinch the inner cable; otherwise, the cable may break.

- 1) Disconnect the ground cable from battery.
- 2) Remove the clip bands from cruise control cable.
- 3) Loosen the nut which secures cruise control cable end to throttle cam, and then remove the cable from throttle cam.

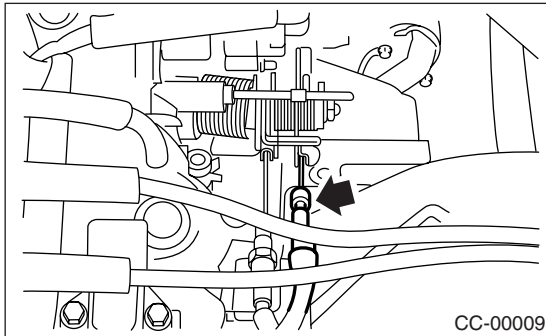

- 4) Remove the four actuator attaching bolts.
- 5) Remove the actuator while disconnecting the connector.

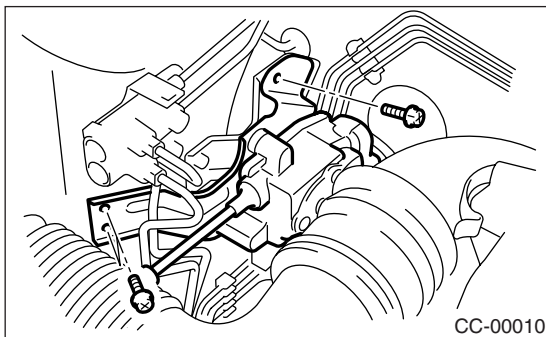

B: INSTALLATION

Install in the reverse order of removal.

Tightening torque:

ACTUATOR:

7.4 N·m (0.75 kgf·m, 5.4 ft·lb)

Cable end nut:

12 N·m (1.2 kgf·m, 8.7 ft·lb)

NOTE:

(A): Must be adjusted when the cable end outer is fixed in place, so that gap between throttle cam and lever is 0 — 1 mm (0 — 0.04 in), otherwise, inner cable deflection (D) is 1 — 8 mm (0.039 — 0.315 in) when the throttle cable is installed.

(Must be attached while the throttle cam is being pulled by wire cable.)

(B): Must be coated evenly on the cam end inner connection.

(C): Cover must be inserted securely, until tip of cable touches cover stopper.

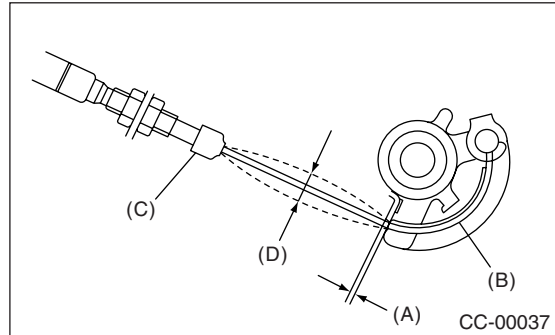

C: INSPECTION

Measure the cruise control actuator resistance.

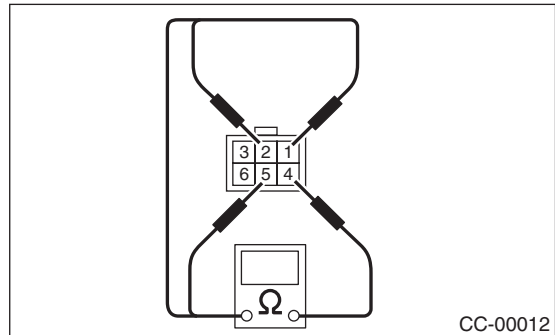

Terminal No.	Standard
4 and 1	Approx. 5 Ω
4 and 2	Approx. 5 Ω
4 and 5	Approx. 5 Ω
3 and 6	Approx. 39 Ω

If NG, replace the cruise control actuator.

3. Cruise Control Unit

A: REMOVAL

NOTE:

- The control of cruise control system for turbo model is performed at the cruise control module.
- The control of cruise control system for Non-turbo model and STi model are performed at Engine control module (ECM).

1. TURBO MODEL

- 1) Disconnect the ground cable from battery.
- 2) Remove the side sill front cover.

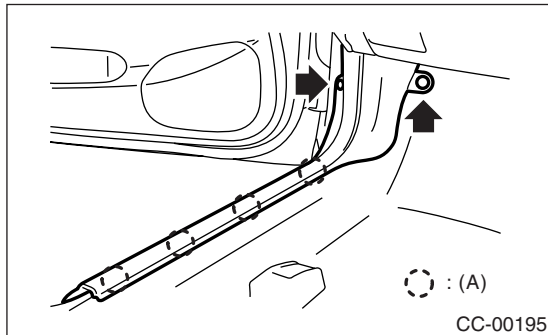

(A) Hook pawl

- 3) Disconnect the connector from cruise control module.
- 4) Remove the bolt, then detach the cruise control module (A).

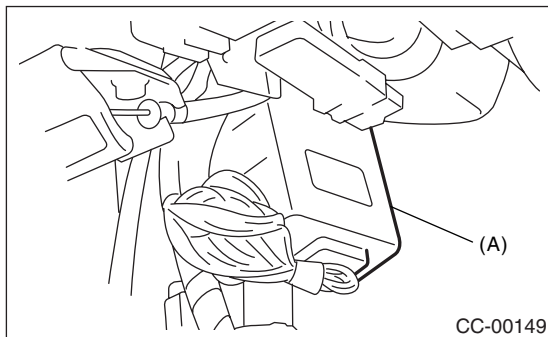

2. NON-TURBO MODEL

<Ref. to FU(H4SO)-37, REMOVAL, Engine Control Module (ECM).>

3. STi MODEL

<Ref. to FU(STi)-40, REMOVAL, Engine Control Module (ECM).>

B: INSTALLATION

1. TURBO MODEL

Install in the reverse order of removal.

2. NON-TURBO MODEL

<Ref. to FU(H4SO)-37, INSTALLATION, Engine Control Module (ECM).>

3. STi MODEL

<Ref. to FU(STi)-40, INSTALLATION, Engine Control Module (ECM).>

Cruise Control Command Switch

CRUISE CONTROL SYSTEM

4. Cruise Control Command Switch

A: REMOVAL

WARNING:

Before servicing, be sure to read the notes in the AB section for proper handling of the driver's airbag module. <Ref. to AB-3, CAUTION, General Description.>

- 1) Set the front wheels in straight ahead position.
- 2) Turn the ignition switch to OFF.
- 3) Disconnect the ground cable from battery and wait for at least 20 seconds before starting work.
- 4) Using the TORX® BIT T30 (Tamper resistant type), loosen the two TORX® bolts which secure driver's airbag module.

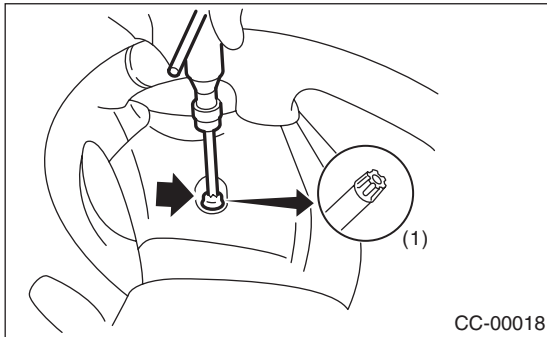

(1) TORX® BIT T30

- 5) Disconnect the airbag module connector on back of airbag module.
- 6) Remove the steering wheel. <Ref. to PS-21, REMOVAL, Steering Wheel.>
- 7) Remove four screws, and then remove the lower cover from steering wheel.

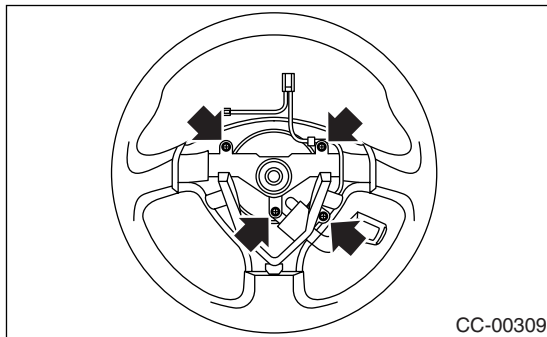

- 8) Remove the screw, and then remove the cruise control command switch from lower cover.

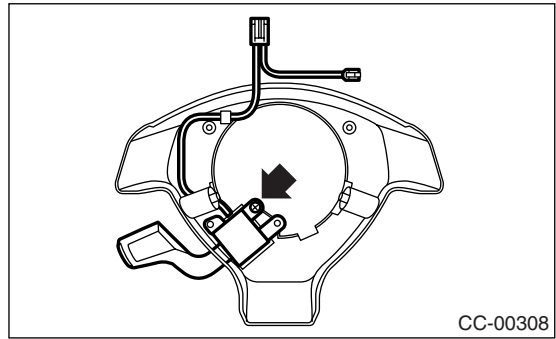

B: INSTALLATION

Install in the reverse order of removal.

C: INSPECTION

Measure the cruise control command switch resistance.

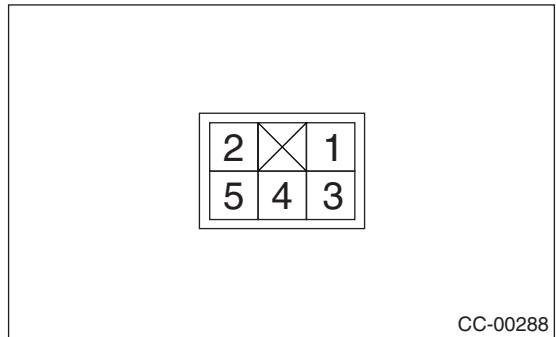

Switch	Position	Terminal No.	Standard value
CANCEL	ON	1 (+) and 2 (-)	Less than 1 Ω
	ON	1 (+) and 3 (-)	Less than 1 Ω
SET/COAST	OFF	1 and 2	More than 1 MΩ
	ON	1 and 2	Less than 1 Ω
RESUME/ ACCEL	OFF	1 and 3	More than 1 MΩ
	ON	1 and 3	Less than 1 Ω
MAIN SWITCH	OFF	5 and 4	More than 1 MΩ
	ON	5 and 4	Less than 1 MΩ

If NG, replace the cruise control command switch.

5. Stop Light and Brake Switch

A: REMOVAL

- 1) Disconnect the ground cable from battery.
- 2) Disconnect the connector from stop and brake switch, and then remove the switch. <Ref. to BR-48, REMOVAL, Stop Light Switch.>

B: INSTALLATION

Install in the reverse order of removal.

C: INSPECTION

Measure the brake switch (A) and stop light switch (B) resistance.

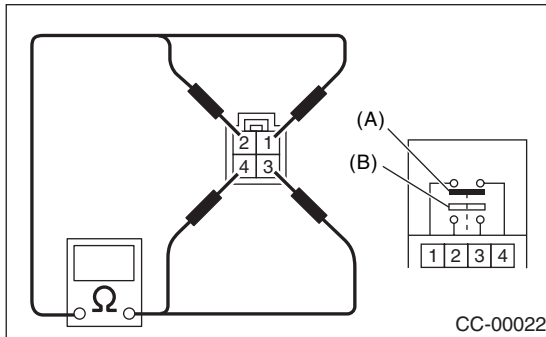

Switch	Pedal	Terminal No.	Standard
Brake	Released	1 and 4	Less than 1 Ω
	Depressed	1 and 4	More than 1 MΩ
Stop light	Released	2 and 3	More than 1 MΩ
	Depressed	2 and 3	Less than 1 Ω

If NG, replace the stop light and brake switch.

6. Clutch Switch

A: REMOVAL

- 1) Disconnect the ground cable from battery.
- 2) Disconnect the connector from clutch switch, and then remove the switch. <Ref. to CL-26, REMOVAL, Clutch Pedal.>

B: INSTALLATION

Install in the reverse order of removal.

C: INSPECTION

Measure the clutch switch resistance.

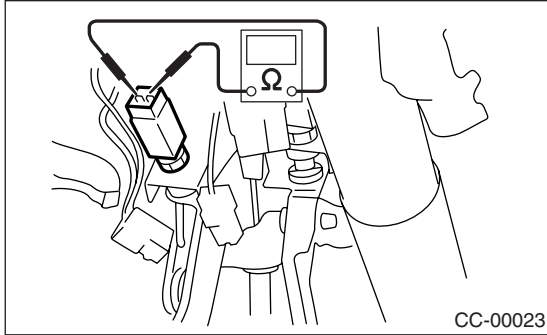

Switch	Pedal	Terminal No.	Standard
Clutch	Released	1 and 2	Less than 1 Ω
	Depressed	1 and 2	More than 1 M Ω

If NG, replace the clutch switch.

7. Inhibitor Switch

A: REMOVAL

- 1) Disconnect the ground cable from battery.
- 2) Disconnect the connector from inhibitor switch, and then remove the switch. <Ref. to 4AT-52, REMOVAL, Inhibitor Switch.>

B: INSTALLATION

Install in the reverse order of removal.

C: INSPECTION

Measure the inhibitor switch resistance.

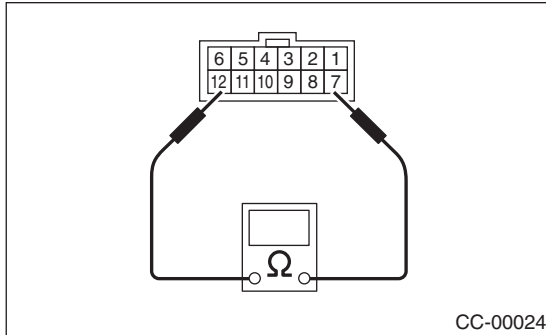

Selector lever position	Terminal No.	Standard
P	7 and 12	Less than 1 Ω
N		Less than 1 Ω
Except P and N		More than 1 MΩ

If NG, replace the inhibitor switch.

Neutral Position Switch

CRUISE CONTROL SYSTEM

8. Neutral Position Switch

A: REMOVAL

- 1) Disconnect the ground cable from battery.
- 2) Disconnect the connector from neutral position switch, and then remove the switch.

5MT model:

<Ref. to 5MT-36, BACK-UP LIGHT AND NEUTRAL POSITION SWITCH, REMOVAL, Switches and Harness.>

6MT model:

<Ref. to 6MT-44, REMOVAL, Neutral Position Switch.>

B: INSTALLATION

Install in the reverse order of removal.

C: INSPECTION

Measure the neutral position switch resistance.

- Turbo model

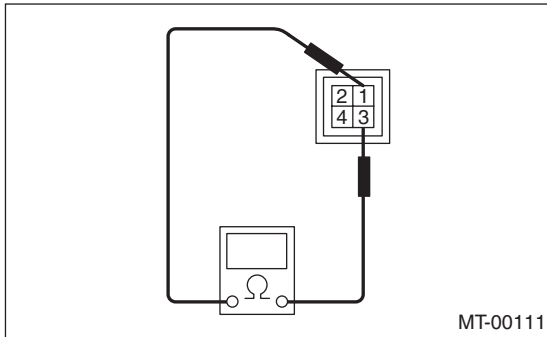

Gear shift position	Terminal No.	Specified resistance
Neutral position	1 and 3	Less than 1 Ω
Other positions		More than 1 M Ω

- Non-turbo model

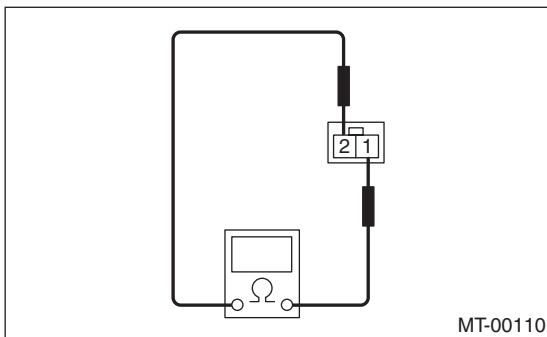

Gear shift position	Terminal No.	Specified resistance
Neutral position	1 and 2	Less than 1 Ω
Other positions		More than 1 M Ω

- STi model

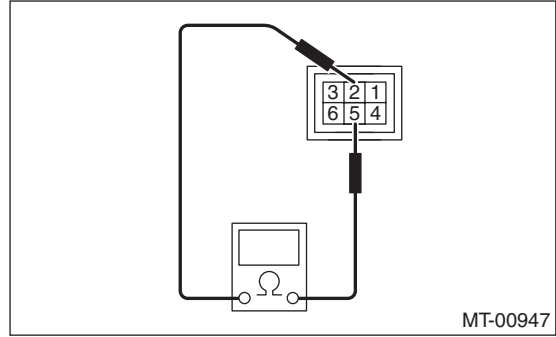

Gear shift position	Terminal No.	Specified resistance
Neutral position	2 and 5	Less than 1 Ω
Other positions		More than 1 M Ω

If NG, replace the neutral position switch.