

IMMOBILIZER (DIAGNOSTICS)

Basic Diagnostic Procedure

IMMOBILIZER (DIAGNOSTICS)

1. Basic Diagnostic Procedure

A: PROCEDURE

Step	Check	Yes	No
1 CHECK ILLUMINATION OF SECURITY INDICATOR LIGHT. 1) Turn the ignition switch to OFF or ACC position. 2) Wait at least 60 seconds.	Does the security indicator light blink?	Go to step 2.	Check the security indicator light circuit. <Ref. to IM(diag)-10, CHECK SECURITY INDICATOR LIGHT CIRCUIT, INSPECTION, Diagnostics Chart for Security Indicator Light.>
2 CHECK ILLUMINATION OF SECURITY INDICATOR LIGHT. Remove the key from ignition switch.	Does the security indicator light begin to blink within 1 second after the key is removed?	Go to step 3.	Check the key switch circuit. <Ref. to IM(diag)-12, CHECK KEY SWITCH CIRCUIT, INSPECTION, Diagnostics Chart for Security Indicator Light.>
3 CHECK ENGINE START. Turn the ignition switch to START position.	Does the engine start?	Go to step 4.	Go to step 5.
4 CHECK ILLUMINATION OF SECURITY INDICATOR LIGHT. Turn the ignition switch to ON.	Does the security indicator light illuminate?	Check the security indicator light circuit. <Ref. to IM(diag)-10, CHECK SECURITY INDICATOR LIGHT CIRCUIT, INSPECTION, Diagnostics Chart for Security Indicator Light.>	Immobilizer system is normal.
5 CHECK INDICATION OF DTC ON DISPLAY. 1) Turn the ignition switch to OFF. 2) Connect the Subaru Select Monitor to data link connector. <Ref. to IM(diag)-7, Subaru Select Monitor.> 3) Turn the ignition switch and Subaru Select Monitors switch to ON. 4) Read any DTC on the display.	Are DTCs indicated on display?	Go to step 6.	Repair the related parts.
6 PERFORM THE DIAGNOSIS. 1) Inspect using "Diagnostics Chart with Trouble Code". <Ref. to IM(diag)-15, Diagnostic Procedure with Diagnostic Trouble Code (DTC).> 2) Repair the trouble cause. 3) Perform the clear memory mode. 4) Read any DTC again.	Are DTCs indicated on display?	Inspect using "Diagnostic Procedure with Diagnostic Trouble Code (DTC)". <Ref. to IM(diag)-15, Diagnostic Procedure with Diagnostic Trouble Code (DTC).>	Finish the diagnostics.

2. General Description

A: CAUTION

CAUTION:

- The airbag system wiring harnesses routed near the immobilizer control module. All airbag system wiring harness and connectors are colored yellow. Do not use electrical test equipment on these circuits.
- Be careful not to damage the airbag system wiring harness when servicing the immobilizer control module.
- While diagnostic items are being checked, do not operate radios, portable telephones, etc. which emit electromagnetic waves near or inside the vehicle.

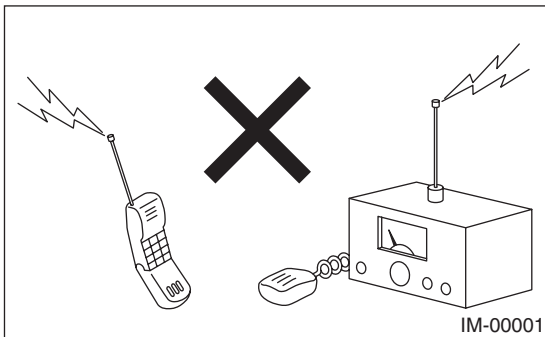

- When the ignition switch is being turned ON or OFF while diagnostic items are being checked, do not allow keys with different ID codes close to the ignition switch. If the ignition key is in a key holder, remove it from the holder before carrying out diagnoses.

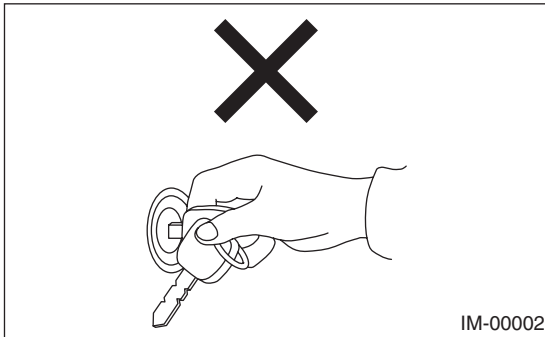

- When repeatedly turning the ignition switch to ON or OFF while diagnostic items are being checked, it should be switched in cycles of "ON" for at least 5 seconds → "OFF" for at least 8 seconds.

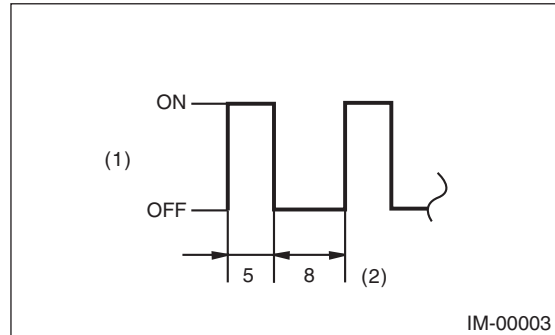

(1) Ignition switch position

(2) Sec.



- If the engine fails to start with a registered ignition key, detach the ignition key from ignition switch and wait for approx. 1 second until security indicator light begins to flash. And then start the engine again.
- Before checking the diagnostic items, obtain all keys and security ID for the vehicle to be checked possessed by owner.

General Description

IMMOBILIZER (DIAGNOSTICS)

B: PREPARATION TOOL

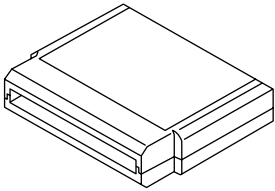
1. SPECIAL TOOL

ILLUSTRATION	TOOL NUMBER	DESCRIPTION	REMARKS
 <p style="text-align: center;">ST24082AA260</p>	24082AA260	CARTRIDGE	Troubleshooting for electrical system.
 <p style="text-align: center;">ST22771AA030</p>	22771AA030	SUBARU SELECT MONITOR KIT	Troubleshooting for electrical system.

2. GENERAL TOOL

TOOL NAME	REMARKS
Circuit tester	Used for measuring resistance, voltage and ampere.

3. Electrical Component Location

A: LOCATION

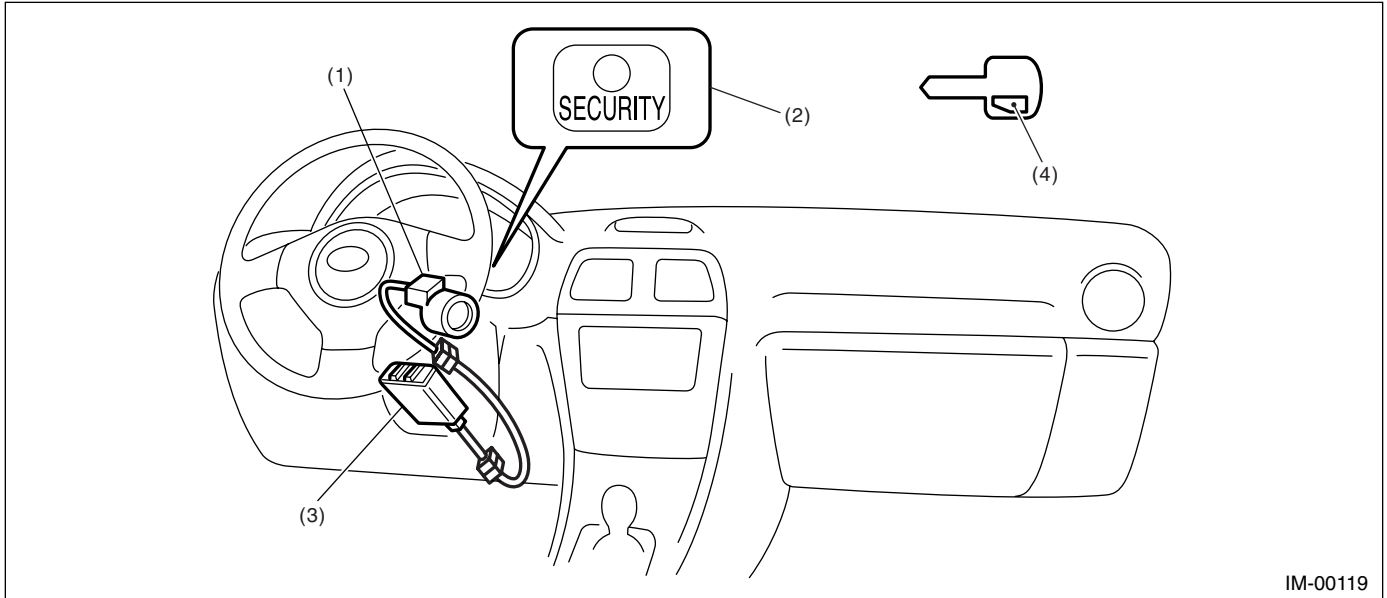

(1) Antenna

(2) Security indicator light (LED bulb)

(3) Immobilizer control module (IMM
ECM)

(4) Transponder

Immobilizer Control Module I/O Signal

IMMOBILIZER (DIAGNOSTICS)

4. Immobilizer Control Module I/O Signal

A: WIRING DIAGRAM

1. IMMOBILIZER

<Ref. to WI-99, WIRING DIAGRAM, Immobilizer
System.>

5. Subaru Select Monitor

A: OPERATION

1. HOW TO USE SUBARU SELECT MONITOR

1) Prepare the Subaru Select Monitor kit.

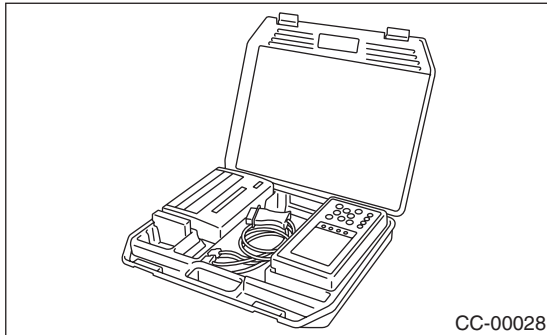

2) Connect the diagnosis cable to Subaru Select Monitor.

3) Insert the cartridge to Subaru Select Monitor.

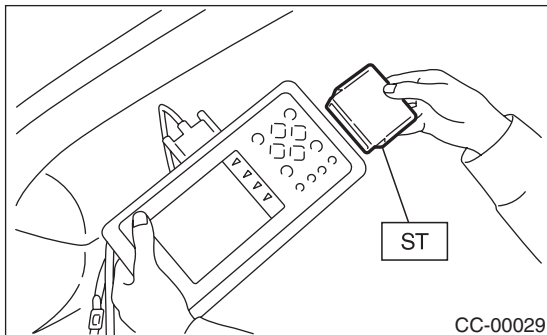

4) Connect the Subaru Select Monitor to data link connector.

(1) Data link connector is located in the lower portion of the instrument panel (on the driver's side).

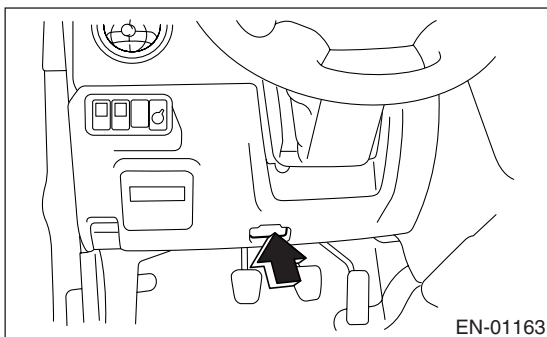

(2) Connect the diagnosis cable to data link connector.

CAUTION:

Do not connect the scan tools except for Subaru Select Monitor.

5) Turn the ignition switch to ON (engine OFF), and the Subaru Select Monitor switch to ON.

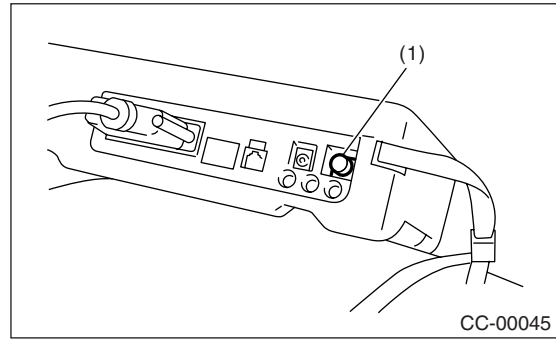

(1) Power switch

6) Using the Subaru Select Monitor, call up DTCs and various data, then record them.

2. READ DIAGNOSTIC TROUBLE CODE (DTC) FOR ENGINE

Refer to Read Diagnostic Trouble Code for information about how to indicate DTC. <Ref. to IM(diag)-8, Read Diagnostic Trouble Code (DTC).>

3. COMMUNICATION LINE CHECK

NOTE:

The communication line between ECM and body integrated module can be checked in "System Operation Check Mode". This is referred to as "Communication line check".

1) Connect the Subaru Select Monitor.

2) On the «Each system check» display, select the {Engine}.

3) Start the communication line check.

4) Is «Communication Line not Shorted» displayed on screen?

If displayed, go to step 5).

If "NO", go to step 6).

5) After diagnostic results, it is determined that the circuit is not shorted. Finish the communication line check.

6) If a problem is detected, repair the trouble cause. <Ref. to IM(diag)-16, DTC P1572 EGI — IMMOBILIZER COMMUNICATION (EXCEPT ANTENNA CIRCUIT), Diagnostic Procedure with Diagnostic Trouble Code (DTC).>

Read Diagnostic Trouble Code (DTC)

IMMOBILIZER (DIAGNOSTICS)

6. Read Diagnostic Trouble Code (DTC)

A: OPERATION

- 1) On the «Main Menu» display screen, select the {Each System Check} and press the [YES] key.
- 2) On the «System Selection Menu» display screen, select the {Engine Control System} and press the [YES] key.
- 3) Press the [YES] key after the information of engine type has been displayed.
- 4) On the «Engine Diagnosis» display screen, select the {Diagnostic Code(s) Display}, and then press the [YES] key.
- 5) On the «Diagnostic Code(s) Display» display screen, select the {Current Diagnostic Code(s)} or {History Diagnostic Code(s)}, and then press the [YES] key.

NOTE:

- For detailed operation procedure, refer to the SUBARU SELECT MONITOR OPERATION MANUAL.
- For detailed concerning DTC, refer to the List of DTC. <Ref. to IM(diag)-14, LIST, List of Diagnostic Trouble Code (DTC).>

7. Clear Memory Mode

A: OPERATION

- 1) On the «Main Menu» display screen, select the {Each System Check} and press the [YES] key.
- 2) On the «System Selection Menu» display screen, select the {Engine Control System} and press the [YES] key.
- 3) Press the [YES] key after the information of engine type has been displayed.
- 4) On the «Engine Diagnosis» display screen, select the {Clear Memory} and press the [YES] key.
- 5) When the 'Done' are shown on the display screen, turn the Subaru Select Monitor and ignition switch to OFF.

NOTE:

- After the memory has been cleared, the idle air control solenoid valve must be initialized. To execute this procedure, turn the ignition switch to ON. Wait 3 seconds before starting the engine.
- For detailed operation procedure, refer to the SUBARU SELECT MONITOR OPERATION MANUAL.

Diagnostics Chart for Security Indicator Light

IMMOBILIZER (DIAGNOSTICS)

8. Diagnostics Chart for Security Indicator Light

A: INSPECTION

1. CHECK SECURITY INDICATOR LIGHT CIRCUIT

WIRING DIAGRAM:

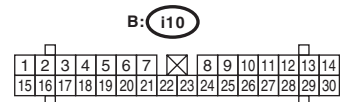
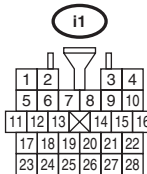
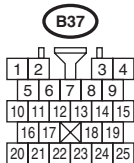
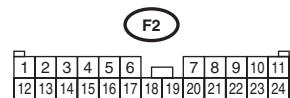
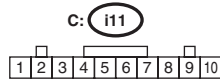
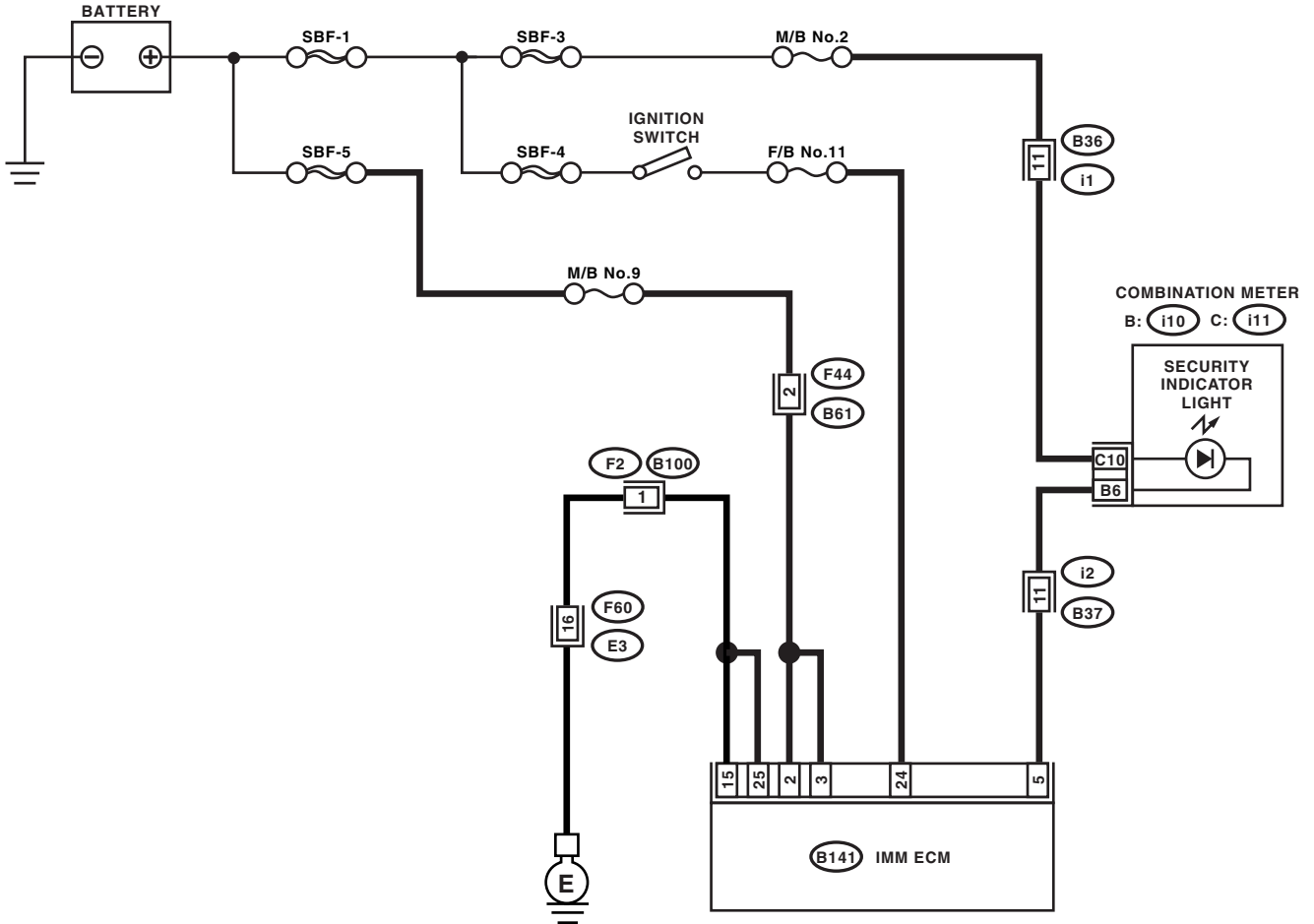

IM-00121

Diagnostics Chart for Security Indicator Light

IMMOBILIZER (DIAGNOSTICS)

Step	Check	Yes	No
1 CHECK SECURITY INDICATOR LIGHT. 1) Turn the ignition switch to OFF. 2) Disconnect the harness connector from IMM ECM. 3) Connect a resistor (750 Ω) between IMM ECM harness connector terminal No. 5 and chassis ground.	Does the security indicator light illuminate?	Go to step 2.	Go to step 5.
2 CHECK IMM ECM GROUND CIRCUIT. Measure the resistance between IMM ECM harness connector terminal and chassis ground. <i>Connector & terminal</i> <i>(B141) No. 15, No. 25 — Chassis ground:</i>	Is the resistance less than 10 Ω?	Go to step 3.	Repair the open circuit of IMMECM ground circuit.
3 CHECK IMM ECM IGNITION CIRCUIT. 1) Turn the ignition switch to ON. (engine OFF.) 2) Measure the voltage between IMM ECM harness connector terminal and chassis ground. <i>Connector & terminal</i> <i>(B141) No. 24 (+) — Chassis ground (-):</i>	Is the voltage more than 10 V?	Go to step 4.	Check the harness for open or short between IMM ECM and ignition switch.
4 CHECK IMM ECM POWER SUPPLY CIRCUIT. 1) Turn the ignition switch to OFF. 2) Measure the voltage between IMM ECM harness connector terminal and chassis ground. <i>Connector & terminal</i> <i>(B141) No. 2, No. 3 (+) — Chassis ground (-):</i>	Is the voltage more than 10 V?	Replace the IMM ECM <Ref. to SL-48, Immobilizer Control Unit.> and then replace all ignition keys (including the transponder). Then perform teaching operation. Refer to teaching operation manual (Pub. No. S0820GZ).	Check the harness for open or short between IMM ECM and fuse.
5 CHECK COMBINATION METER CIRCUIT. 1) Remove the combination meter. <Ref. to IDI-10, Combination Meter.> 2) Measure the voltage between combination meter harness connector terminal and chassis ground. <i>Connector & terminal</i> <i>(i11) No. 7 (+) — Chassis ground (-):</i>	Is the voltage more than 10 V?	Go to step 6.	Check the harness for open or short between combination meter and fuse.
6 CHECK COMBINATION METER CIRCUIT. Measure the resistance between IMM ECM harness connector terminal and combination meter harness connector terminal. <i>Connector & terminal</i> <i>(B141) No. 5 — (i11) No. 6:</i>	Is the resistance less than 10 Ω?	Faulty LED. Replace the combination meter printed circuit. <Ref. to IDI-11, DISASSEMBLY, Combination Meter.>	Repair the harness or connector.

Diagnostics Chart for Security Indicator Light

IMMOBILIZER (DIAGNOSTICS)

2. CHECK KEY SWITCH CIRCUIT

WIRING DIAGRAM:

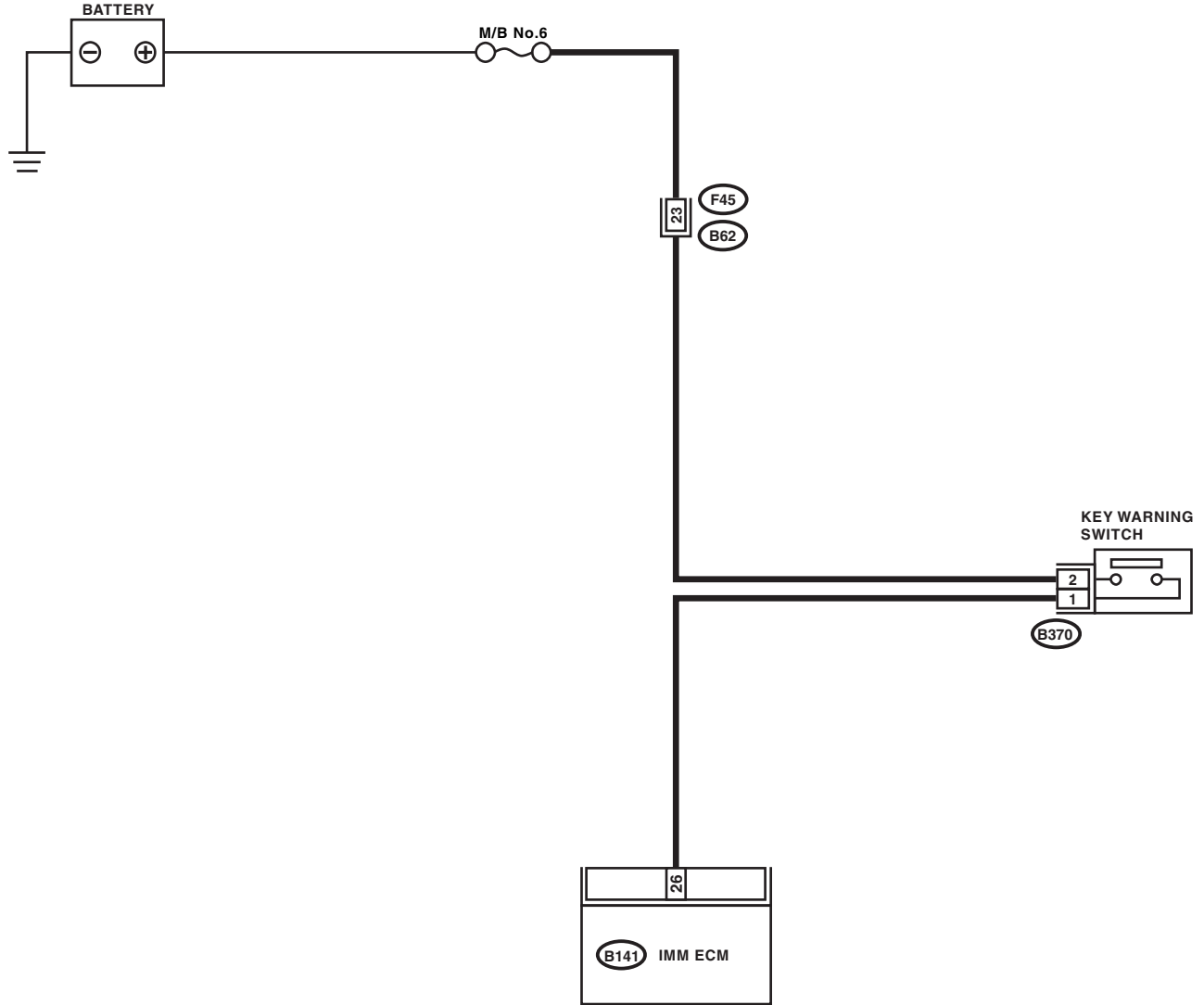

B141

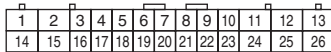

F45

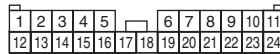

B370



IM-00123

Diagnostics Chart for Security Indicator Light

IMMOBILIZER (DIAGNOSTICS)

Step	Check	Yes	No
1 CHECK POWER SUPPLY CIRCUIT. 1) Disconnect the harness connector from key warning switch. 2) Measure the voltage between key warning switch harness connector terminal and chassis ground. <i>Connector & terminal</i> <i>(B370) No. 2 (+) — Chassis ground (-):</i>	Is the voltage more than 10 V?	Go to step 2.	Check the harness for open or short between key warning switch and fuse.
2 CHECK KEY WARNING SWITCH. 1) Insert the ignition key to the ignition switch. (OFF or ACC position) 2) Measure the resistance between key warning switch connector terminals. <i>Terminal</i> <i>No. 1 — No. 2:</i>	Is the resistance less than 1 Ω ?	Go to step 3.	Replace the key warning switch.
3 CHECK KEY WARNING SWITCH. 1) Remove the ignition key from the ignition switch. 2) Measure the resistance between key warning switch connector terminals. <i>Terminal</i> <i>No. 1 — No. 2:</i>	Is the resistance more than 1 M Ω ?	Go to step 4.	Replace the key warning switch.
4 CHECK HARNESS BETWEEN KEY WARNING SWITCH AND IMM ECM. 1) Disconnect the harness connector from key warning switch. 2) Disconnect the harness connector from IMM ECM. 3) Measure the resistance between key warning switch harness connector terminal and IMM ECM harness connector terminal. <i>Connector & terminal</i> <i>(B370) No. 1 — (B141) No. 26:</i>	Is the resistance less than 10 Ω ?	Replace the IMM ECM <Ref. to SL-48, Immobilizer Control Unit.> and then replace all ignition keys (including the transponder). Then perform teaching operation. Refer to teaching operation manual (Pub. No. S0820GZ).	Repair the harness between key warning switch and IMM ECM.

List of Diagnostic Trouble Code (DTC)

IMMOBILIZER (DIAGNOSTICS)

9. List of Diagnostic Trouble Code (DTC)

A: LIST

DTC	Item	Contents of diagnosis	Index No.
P1571	Reference Code Incompatibility	Reference code incompatibility between IMM ECM and ECM	<Ref. to IM(diag)-15, DTC P1571 REFERENCE CODE INCOMPATIBILITY, Diagnostic Procedure with Diagnostic Trouble Code (DTC).>
P1572	EGI — Immobilizer Communication (Except Antenna Circuit)	Communication failure between IMM ECM and ECM	<Ref. to IM(diag)-16, DTC P1572 EGI — IMMOBILIZER COMMUNICATION (EXCEPT ANTENNA CIRCUIT), Diagnostic Procedure with Diagnostic Trouble Code (DTC).>
P1574	Key — Immobilizer Communication	Failure of IMM ECM to verify key (transponder) ID code	<Ref. to IM(diag)-19, DTC P1574 KEY — IMMOBILIZER COMMUNICATION, Diagnostic Procedure with Diagnostic Trouble Code (DTC).>
P0513	Incorrect Immobilizer Key	Incorrect immobilizer key (Use of unregistered key in IMM ECM)	<Ref. to IM(diag)-20, DTC P0513 INCORRECT IMMOBILIZER KEY, Diagnostic Procedure with Diagnostic Trouble Code (DTC).>
P1576	EGI Control Module EEPROM	ECM malfunctioning	<Ref. to IM(diag)-20, DTC P1576 EGI CONTROL MODULE EEPROM, Diagnostic Procedure with Diagnostic Trouble Code (DTC).>
P1577	IMM Control Module EEPROM	IMM ECM malfunctioning	<Ref. to IM(diag)-20, DTC P1577 IMM CONTROL MODULE EEPROM, Diagnostic Procedure with Diagnostic Trouble Code (DTC).>
P1570	ANTENNA	Faulty antenna	<Ref. to IM(diag)-21, DTC P1570 ANTENNA, Diagnostic Procedure with Diagnostic Trouble Code (DTC).>

NOTE:

Perform the engine DTC when the DTC except immobilizer DTC is detected. <Ref. to EN(H4SO)(diag)-69, List of Diagnostic Trouble Code (DTC).> <Ref. to EN(H4DOTC)(diag)-73, List of Diagnostic Trouble Code (DTC).> <Ref. to EN(H4DOTC)(diag)-73, List of Diagnostic Trouble Code (DTC).>

10. Diagnostic Procedure with Diagnostic Trouble Code (DTC)

A: DTC P1571 REFERENCE CODE INCOMPATIBILITY

DTC DETECTING CONDITION:

Reference code incompatibility between IMM ECM and ECM

	Step	Check	Yes	No
1	PERFORM TEACHING OPERATION ON IGNITION KEY. Perform teaching operation on all keys of the vehicle. Refer to the teaching operation manual.	Is teaching operation for all keys completed?	END	Go to step 2.
2	CHECK DTC.	Is there any DTC related to immobilizer except DTC P1571?	Eliminate the cause of DTC except DTC P1571, and perform the teaching operation again.	Replace the ECM <Ref. to FU(STi)-40, Engine Control Module (ECM).>, IMM ECM <Ref. to SL-48, Immobilizer Control Unit.> and then replace all ignition keys (including the transponder). Then perform teaching operation. Refer to the teaching operation manual (Pub. No. S0820GZ).

Diagnostic Procedure with Diagnostic Trouble Code (DTC)

IMMOBILIZER (DIAGNOSTICS)

B: DTC P1572 EGI — IMMOBILIZER COMMUNICATION (EXCEPT ANTENNA CIRCUIT)

DTC DETECTING CONDITION:

Communication failure between IMM ECM and ECM

WIRING DIAGRAM:

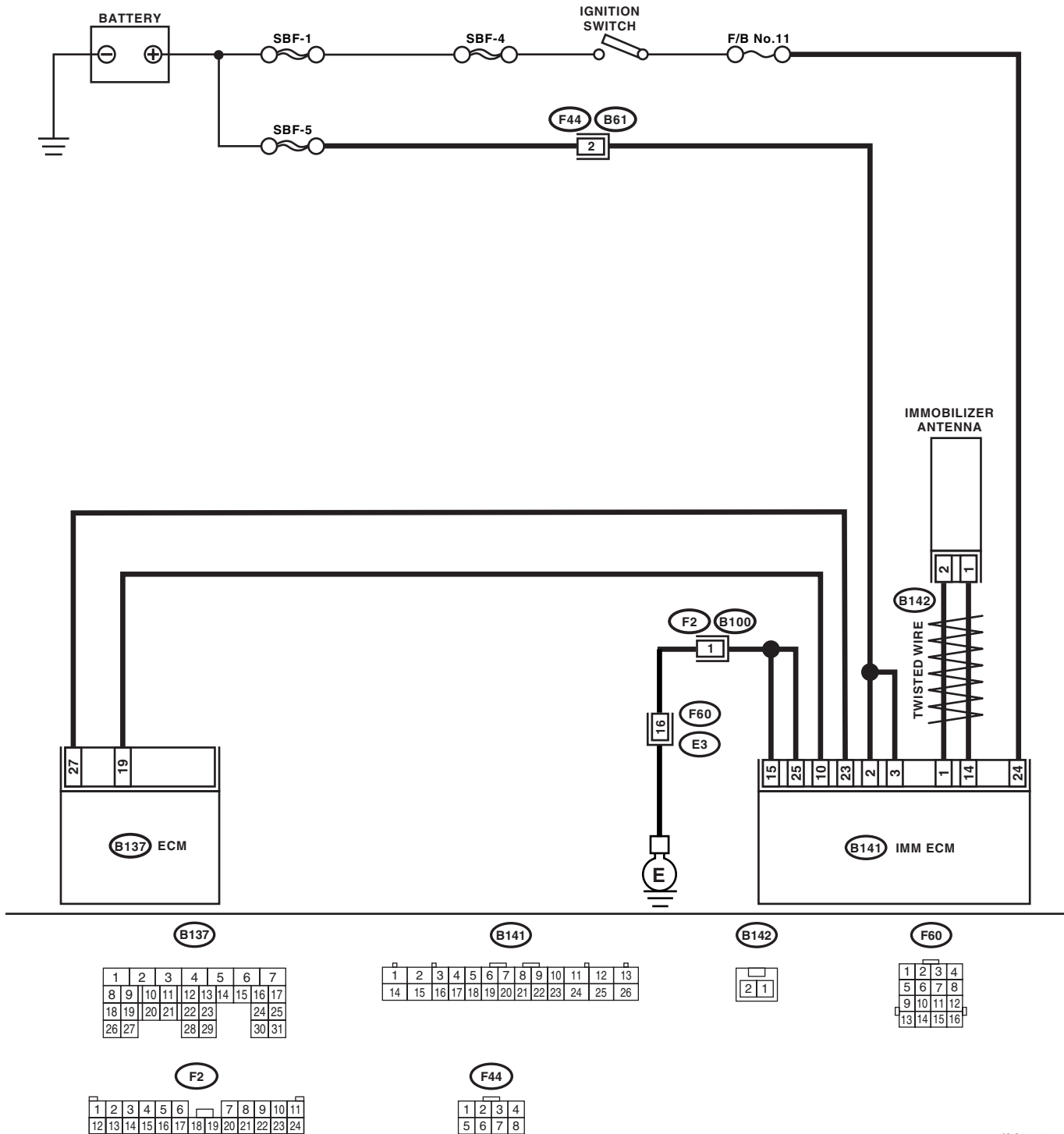

IM-00122

Diagnostic Procedure with Diagnostic Trouble Code (DTC)

IMMOBILIZER (DIAGNOSTICS)

Step	Check	Yes	No
<p>1 CHECK POWER SUPPLY CIRCUIT OF IMM ECM. 1) Turn the ignition switch to OFF. 2) Disconnect the harness connector from IMM ECM. 3) Measure the voltage between IMM ECM harness connector terminal and chassis ground. <i>Connector & terminal</i> (B141) No. 2, No. 3 (+) — Chassis ground (-):</p>	Is the voltage more than 10 V?	Go to step 2.	Check the harness for open or short between IMM ECM and fuse.
<p>2 CHECK IGNITION SWITCH CIRCUIT. 1) Turn the ignition switch to ON. (engine OFF.) 2) Measure the voltage between IMM ECM harness connector terminal and chassis ground. <i>Connector & terminal</i> (B141) No. 24 (+) — Chassis ground (-):</p>	Is the voltage more than 10 V?	Go to step 3.	Check the harness for open or short between IMM ECM and ignition switch.
<p>3 CHECK GROUND CIRCUIT OF IMM ECM. 1) Turn the ignition switch to OFF. 2) Measure the resistance between IMM ECM harness connector terminal and chassis ground. <i>Connector & terminal</i> (B141) No. 15, No. 25 — Chassis ground:</p>	Is the resistance less than 10 Ω ?	Go to step 4.	Repair the open circuit of IMMECM ground circuit.
<p>4 CHECK HARNESS BETWEEN IMM ECM AND ECM. 1) Disconnect the harness connector from ECM and IMM ECM. 2) Measure the resistance between IMM ECM harness connector terminal and ECM harness connector terminal. <i>Connector & terminal</i> (B141) No. 10 — (B137) No. 19:</p>	Is the resistance less than 10 Ω ?	Go to step 5.	Repair the open circuit of harness between IMM ECM and ECM.
<p>5 CHECK HARNESS BETWEEN IMM ECM AND ECM. Measure the resistance between IMM ECM harness connector terminal and ECM harness connector terminal. <i>Connector & terminal</i> (B141) No. 23 — (B137) No. 27:</p>	Is the resistance less than 10 Ω ?	Go to step 6.	Repair the open circuit of harness between IMM ECM and ECM.
<p>6 CHECK HARNESS OF COMMUNICATION LINE. 1) Turn the ignition switch to ON. (engine OFF.) 2) Measure the voltage between IMM ECM harness connector terminal and chassis ground. <i>Connector & terminal</i> (B141) No. 10, No. 23 (+) — Chassis ground (-):</p>	Is the voltage 0 V?	Go to step 7.	Repair the harness between IMM ECM and ECM, because there is short circuit with battery voltage line or ignition switch "ON" line.

Diagnostic Procedure with Diagnostic Trouble Code (DTC)

IMMOBILIZER (DIAGNOSTICS)

Step	Check	Yes	No
7 CHECK HARNESS OF COMMUNICATION LINE. Measure the voltage between ECM harness connector terminal and engine ground. Connector & terminal (B137) No. 19, No. 27 (+) — Engine ground (-):	Is the voltage 0 V?	Go to step 8 .	Repair the harness between IMM ECM and ECM, because there is short circuit with battery voltage line or ignition switch "ON" line.
8 CHECK ECM BY COMMUNICATION LINE CHECK. 1) Connect the harness connector to ECM. 2) Disconnect the harness connector from IMM ECM. 3) Perform communication line check. <Ref. to IM(diag)-7, COMMUNICATION LINE CHECK, OPERATION, Subaru Select Monitor.>	Does "Communication Line not Shorted" appear on the screen?	Replace the IMM ECM <Ref. to SL-48, Immobilizer Control Unit.> and then replace all ignition keys (including the transponder). Then perform teaching operation. Refer to the teaching operation manual (Pub. No. S0820GZ).	Replace the ECM. <Ref. to FU(STi)-40, Engine Control Module (ECM).> Then perform teaching operation. Refer to the teaching operation manual (Pub. No. S0820GZ).

Diagnostic Procedure with Diagnostic Trouble Code (DTC)

IMMOBILIZER (DIAGNOSTICS)

C: DTC P1574 KEY — IMMOBILIZER COMMUNICATION

DTC DETECTING CONDITION:

Failure of IMM ECM to verify key (transponder) ID code

Step	Check	Yes	No
1 CHECK IMM ECM FUNCTION. Insert the key to ignition switch (LOCK position), measure changes in voltage between Antenna connector. Connector & terminal (B142) No. 1 (+) — No. 2 (-):	Is the voltage -30 to 30 V? (Approx. 0.1 second after inserting the key) Is the voltage 0 V? (Approx. 1 second after inserting the key)	Go to step 2.	Replace the IMM ECM <Ref. to SL-48, Immobilizer Control Unit.> and then replace all ignition keys (including the transponder). Then perform teaching operation. Refer to the teaching operation manual (Pub. No. S0820GZ).
2 CHECK IGNITION KEY (TRANSPONDER). 1) Remove the key from ignition switch. 2) Start the engine using other keys that have undergone the teaching operation, furnished with vehicle.	Does the engine start?	Replace the ignition key (including the transponder). Then perform teaching operation. Refer to the teaching operation manual (Pub. No. S0820GZ).	Replace the IMM ECM <Ref. to SL-48, Immobilizer Control Unit.> and then replace all ignition keys (including the transponder). Then perform teaching operation. Refer to the teaching operation manual (Pub. No. S0820GZ).

Diagnostic Procedure with Diagnostic Trouble Code (DTC)

IMMOBILIZER (DIAGNOSTICS)

D: DTC P0513 INCORRECT IMMOBILIZER KEY

DTC DETECTING CONDITION:

Incorrect immobilizer key. (Use of unregistered key in IMM ECM)

	Step	Check	Yes	No
1	PERFORM TEACHING OPERATION ON IGNITION KEY. Perform teaching operation on all keys of the vehicle. Refer to the teaching operation manual (Pub. No. S0820GZ).	Is teaching operation for all keys completed?	END	Replace all ignition keys (including the transponder). Go to step 2.
2	PERFORM TEACHING OPERATION ON IGNITION KEY. Perform teaching operation on all keys with vehicle. Refer to the teaching operation manual (Pub. No. S0820GZ).	Is teaching operation for all keys completed?	END	Replace the IMM ECM <Ref. to SL-48, Immobilizer Control Unit.> and then replace all ignition keys (including the transponder). Then perform teaching operation. Refer to the teaching operation manual (Pub. No. S0820GZ).

E: DTC P1576 EGI CONTROL MODULE EEPROM

DTC DETECTING CONDITION:

ECM malfunctioning

1. REPLACE ECM.

Replace the ECM.

<Ref. to FU(H4SO)-37, Engine Control Module (ECM).> <Ref. to FU(H4DOTC)-48, Engine Control Module (ECM).> <Ref. to FU(H4DOTC)-48, Engine Control Module (ECM).>

Then perform teaching operation. Refer to the teaching operation manual (Pub. No. S0820GZ).

F: DTC P1577 IMM CONTROL MODULE EEPROM

DTC DETECTING CONDITION:

IMM ECM malfunctioning

1. REPLACE IMM ECM.

Replace the IMM ECM <Ref. to SL-48, Immobilizer Control Unit.>, and then replace all ignition keys (including the transponder). Then perform teaching operation. Refer to the teaching operation manual (Pub. No. S0820GZ).

G: DTC P1570 ANTENNA

DTC DETECTING CONDITION:

Faulty antenna

WIRING DIAGRAM:

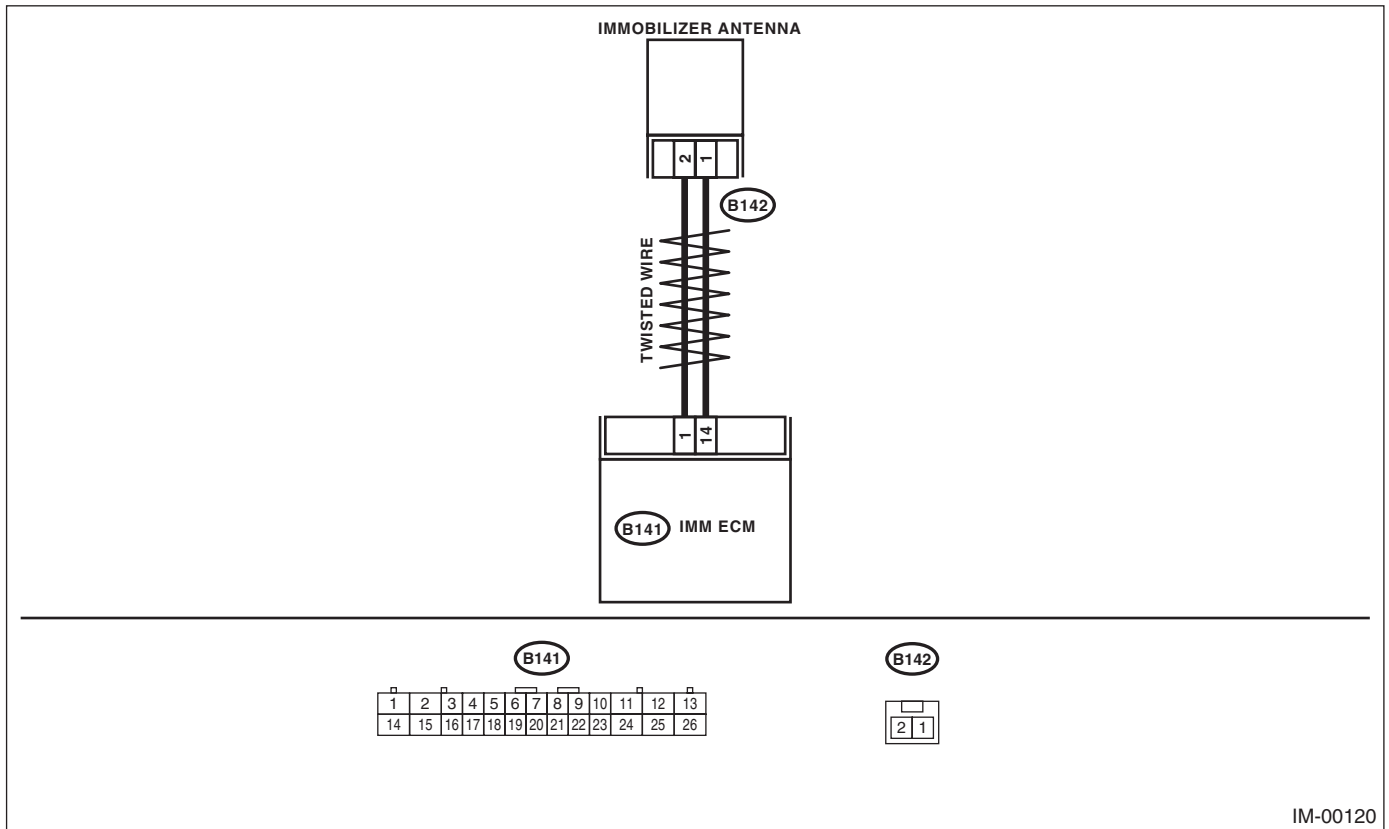

Diagnostic Procedure with Diagnostic Trouble Code (DTC)

IMMOBILIZER (DIAGNOSTICS)

Step	Check	Yes	No
1 CHECK ANTENNA CIRCUIT. 1) Turn the ignition switch to OFF. 2) Disconnect the harness antenna connector from IMM ECM. <Ref. to SL-49, Immobilizer Antenna.> 3) Measure the resistance of antenna circuit. Connector & terminal (B141) No. 1 — No. 14:	Is the resistance less than 10 Ω?	Go to step 2.	Replace the antenna. <Ref. to SL-49, Immobilizer Antenna.>
2 CHECK ANTENNA CIRCUIT. Measure the resistance between antenna harness connector and chassis ground. Connector & terminal (B141) No. 1 — Chassis ground:	Is the resistance less than 10 Ω?	Replace the antenna. <Ref. to SL-49, Immobilizer Antenna.>	Go to step 3.
3 CHECK ANTENNA CIRCUIT. Measure the resistance between antenna harness connector and chassis ground. Connector & terminal (B141) No. 14 — Chassis ground:	Is the resistance less than 10 Ω?	Replace the antenna. <Ref. to SL-49, Immobilizer Antenna.>	Go to step 4.
4 CHECK ANTENNA CIRCUIT. 1) Turn the ignition switch to ON. (engine OFF.) 2) Measure the voltage between antenna harness connector and chassis ground. Connector & terminal (B141) No. 1 (+) — Chassis ground (-):	Is the voltage 0 V?	Go to step 5.	Replace the antenna. <Ref. to SL-49, Immobilizer Antenna.>
5 CHECK ANTENNA CIRCUIT. Measure the voltage between antenna harness connector and chassis ground. Connector & terminal (B141) No. 14 (+) — Chassis ground (-):	Is the voltage 0 V?	Go to step 6.	Replace the antenna. <Ref. to SL-49, Immobilizer Antenna.>
6 CHECK IMM ECM FUNCTION. 1) Turn the ignition switch to OFF. 2) Connect the antenna harness connector to IMM ECM. 3) Insert the key to ignition switch, measure changes in voltage between antenna harness connector. Connector & terminal (B141) No. 1 (+) — No. 14 (-):	Is the voltage -30 to 30 V? (Approx. 0.1 second after inserting the key) Is the voltage 0 V? (Approx. 1 second after inserting the key)	Go to step 7.	Replace the IMM ECM <Ref. to SL-48, Immobilizer Control Unit.> and then replace all ignition keys (including the transponder). Then perform teaching operation. Refer to the teaching operation manual (Pub. No. S0820GZ).
7 CHECK IGNITION KEY (TRANSPONDER). 1) Remove the key from ignition switch. 2) Start the engine using other keys that have undergone the teaching operation, furnished with vehicle.	Does the engine start?	Replace the ignition key (including the transponder). Then perform teaching operation. Refer to the teaching operation manual (Pub. No. S0820GZ).	Replace the IMM ECM <Ref. to SL-48, Immobilizer Control Unit.> and then replace all ignition keys (including the transponder). Then perform teaching operation. Refer to the teaching operation manual (Pub. No. S0820GZ).