

SECURITY AND LOCKS

General Description

SECURITY AND LOCKS

1. General Description

A: COMPONENT

1. DOOR LOCK ASSEMBLY

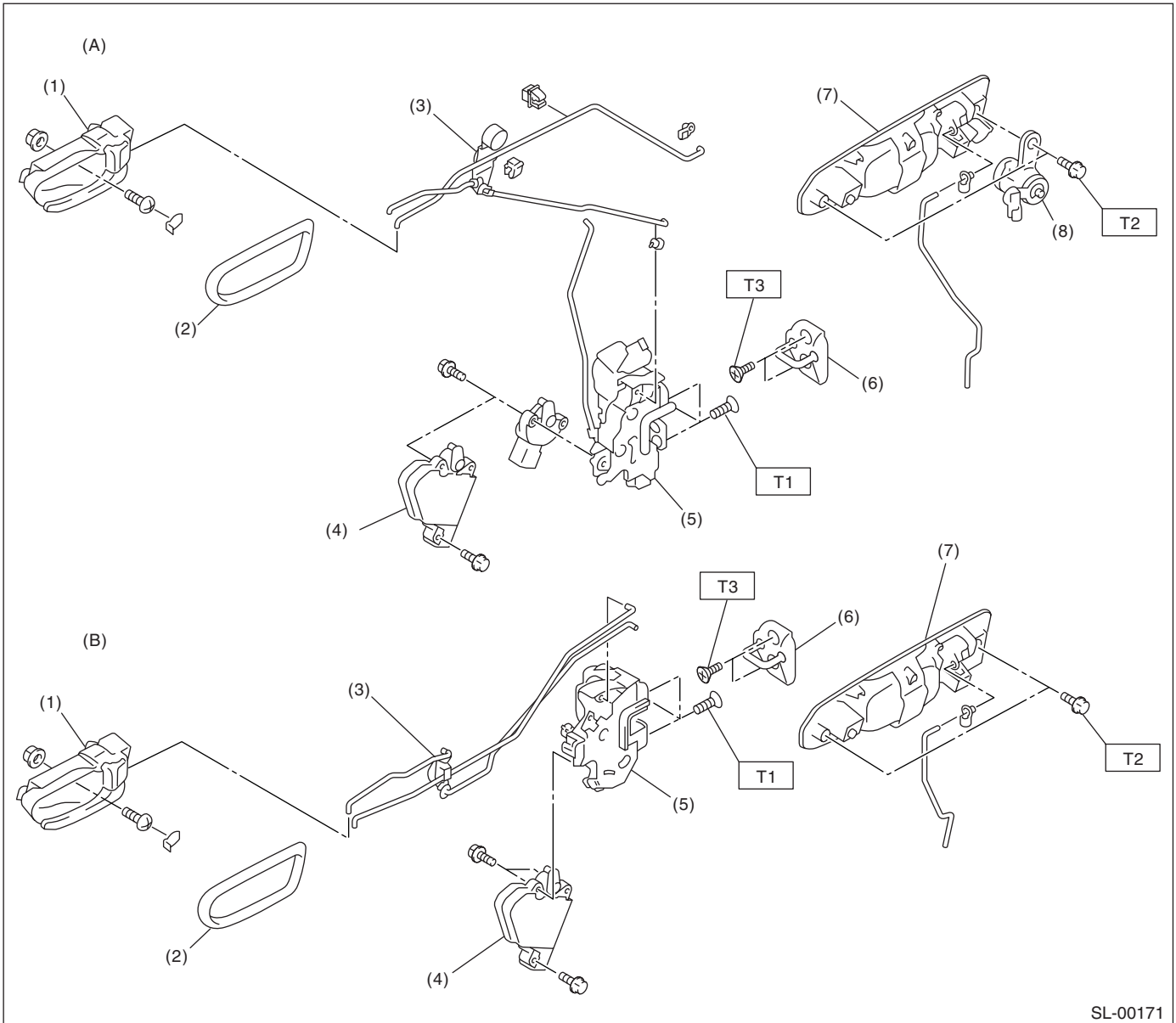

SL-00171

(A) Front

(B) Rear

- (1) Inner remote ASSY
- (2) Inner remote cover
- (3) Bell crank
- (4) Auto-door lock actuator

- (5) Door latch
- (6) Striker
- (7) Door outer handle
- (8) Key cylinder

Tightening torque: N-m (kgf-m, ft-lb)

T1: 6.4 (0.65, 4.7)

T2: 7.4 (0.75, 5.5)

T3: 17.6 (1.8, 13.0)

2. TRUNK LID AND REAR GATE LOCK

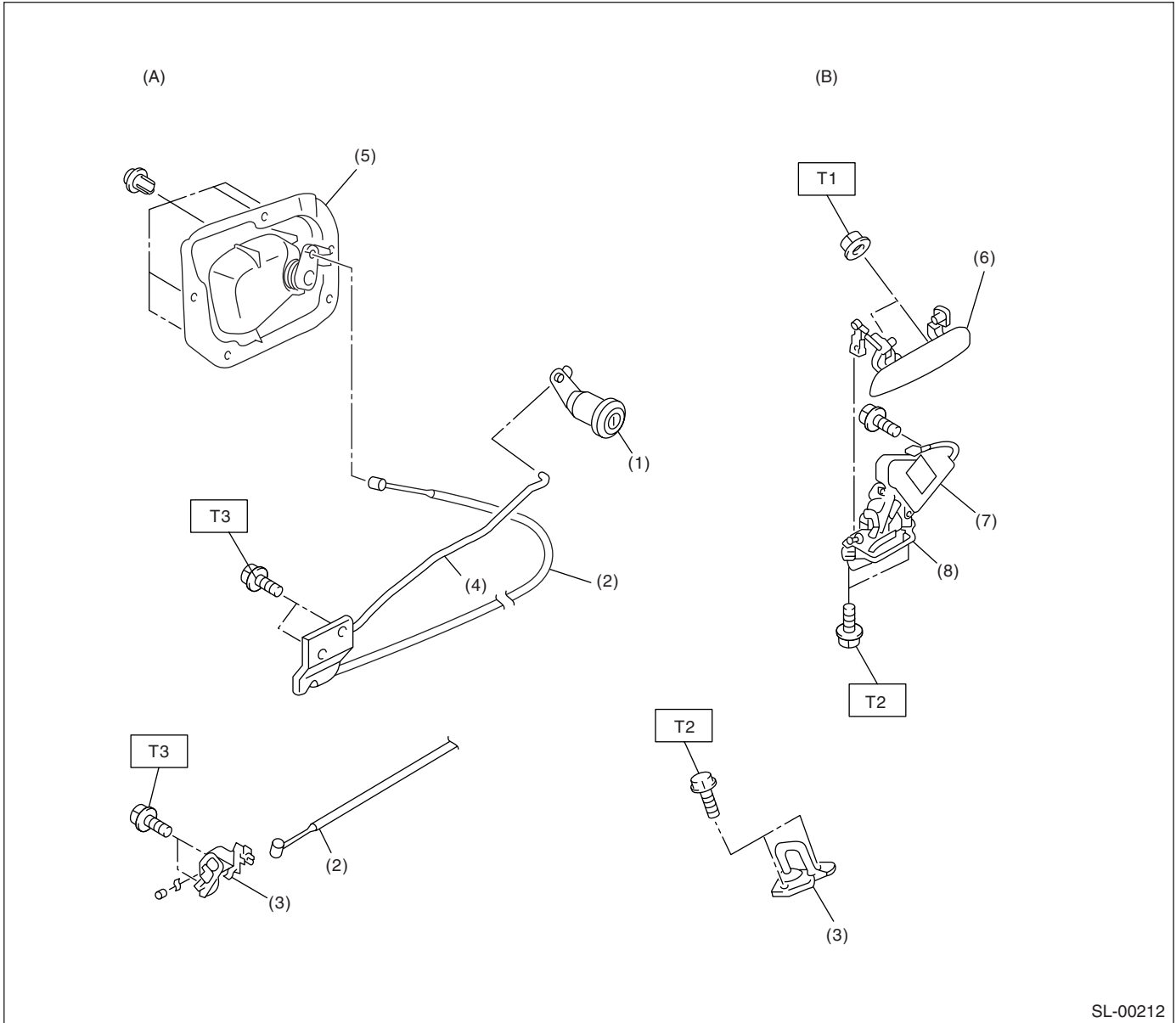

SL-00212

(A) Trunk

(B) Rear gate

- (1) Key cylinder
- (2) Cable
- (3) Striker
- (4) Trunk lid lock ASSY

- (5) Trunk lid release handle
- (6) Rear gate outer handle
- (7) Rear gate actuator
- (8) Rear gate latch

Tightening torque: N-m (kgf-m, ft-lb)

T1: 4.5 (0.45, 3.3)

T2: 25(2.5, 18.4)

T3: 18 (1.84, 13.3)

General Description

SECURITY AND LOCKS

3. HOOD LOCK AND REMOTE OPENERS

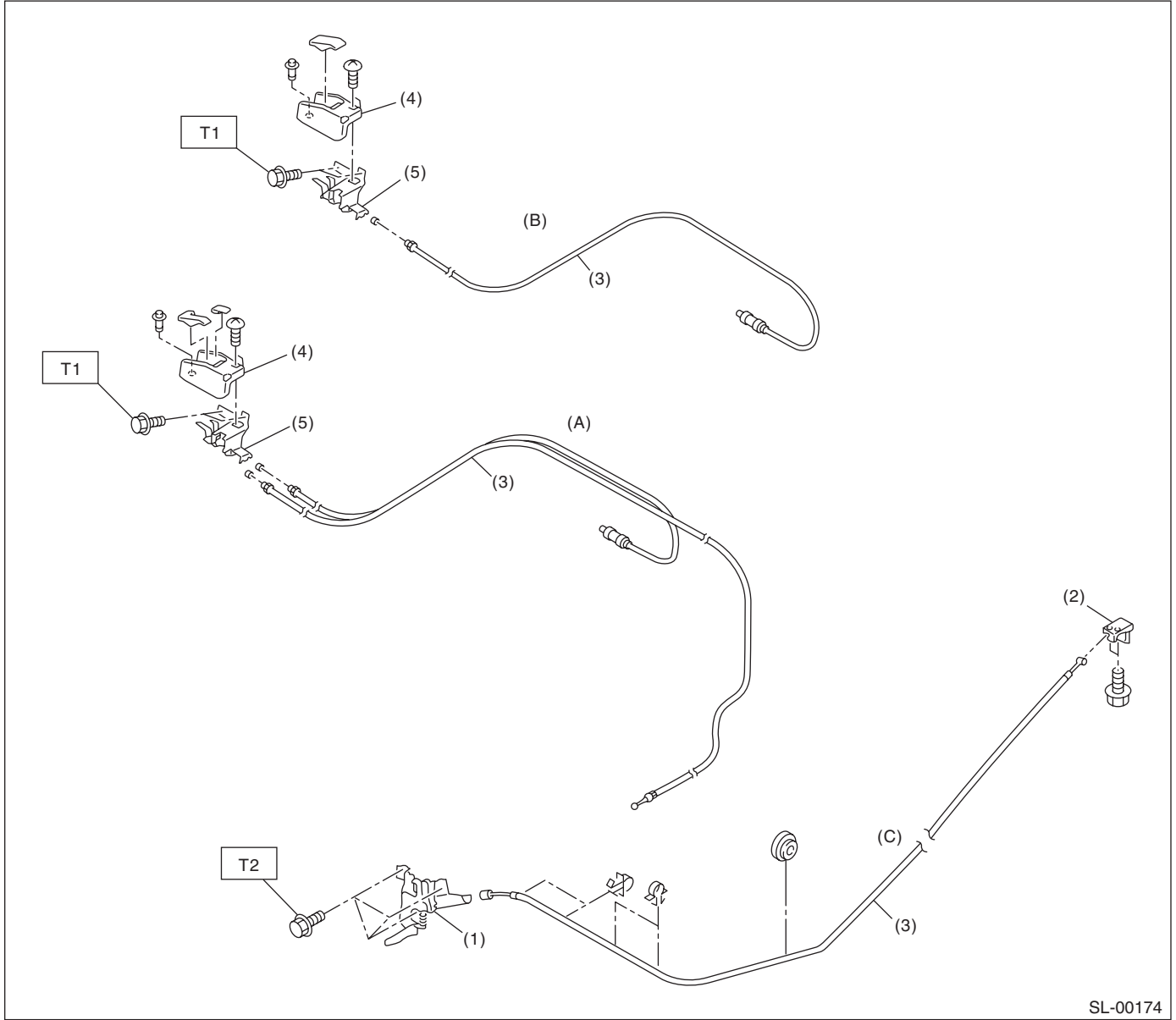

(A) Sedan

(B) Wagon

(C) Hood

(1) Hood lock ASSY

(4) Cover

Tightening torque: N·m (kgf·m, ft·lb)

(2) Lever ASSY

(5) Pull handle ASSY

T1: 6.5 (0.66, 4.7)

(3) Cable

T2: 32 (3.3, 23.9)

4. KEYLESS ENTRY SYSTEM

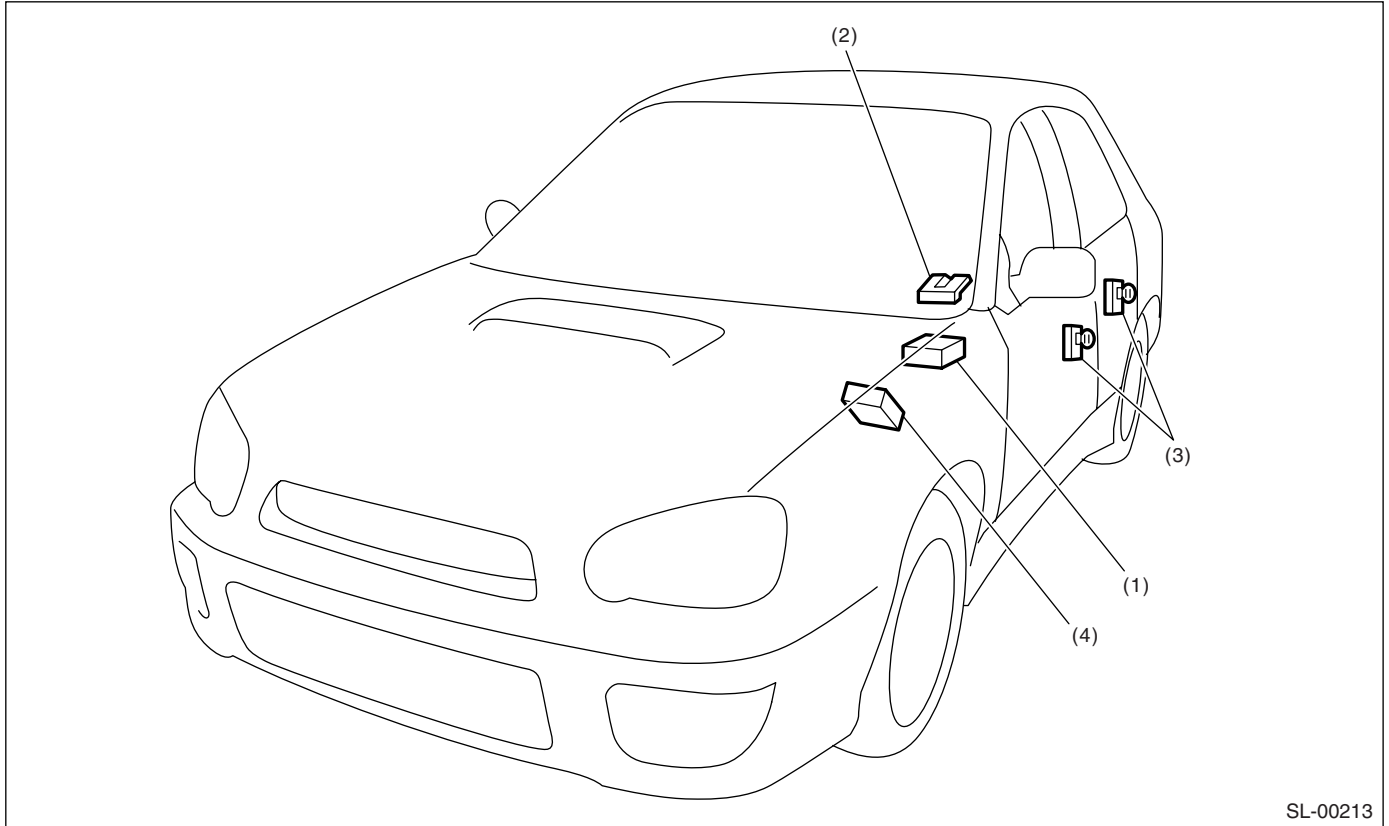

SL-00213

- (1) Keyless entry control unit
- (2) Rear gate latch (Wagon model)

- (3) Door switch

- (4) Body integrated unit

5. SECURITY SYSTEM

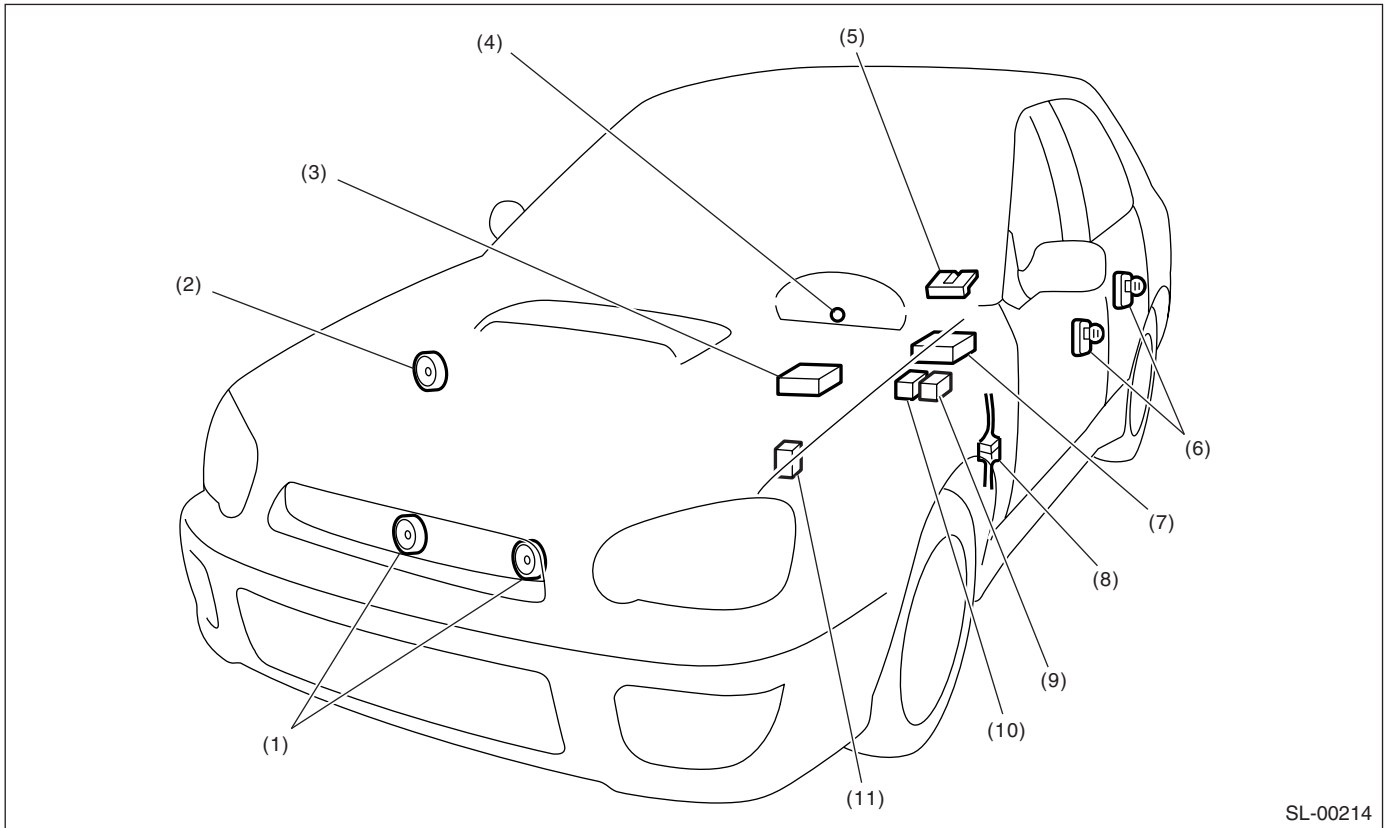

SL-00214

- | | | |
|---|---|------------------------------------|
| (1) Horn | (5) Trunk room light switch (Sedan model), rear gate latch switch (Wagon model) | (8) Passive arm connector |
| (2) Security horn | (6) Door switch | (9) Security horn relay |
| (3) Security control unit | (7) Keyless entry control unit | (10) Interrupt relay |
| (4) Security indicator light (in combination meter) | | (11) Horn relay (in main fuse box) |

B: CAUTION

- Before disassembling or reassembling parts, always disconnect the ground cable from battery. When repairing audio, control module, etc. which are provided with memory functions, record the memory contents before disconnecting the ground cable from battery. Otherwise, these contents are cancelled upon disconnection.
- Reassemble parts in the reverse order of disassembly procedure unless otherwise indicated.
- Adjust parts to the specifications contained in this manual if so designated.
- Connect the connectors securely during reassembly.
- After reassembly, ensure all functional parts operate smoothly.
- Airbag system wiring harness is routed near the electrical parts and switch.
- All airbag system wiring harness and connectors are colored yellow. Do not use electrical test equipment on these circuits.

- Be careful not to damage the airbag system wiring harness when servicing the ignition key cylinder.

C: PREPARATION TOOL

1. SPECIAL TOOL

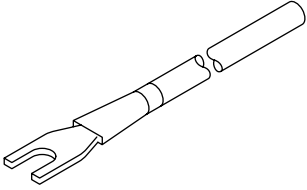
| ILLUSTRATION | TOOL NUMBER | DESCRIPTION | REMARKS |
|---|-------------|-------------|------------------------------|
|  <p style="text-align: center; font-size: small;">ST-925580000</p> | 925580000 | PULLER | Used for removing trim clip. |

2. GENERAL TOOL

| TOOL NAME | REMARKS |
|----------------|--|
| Circuit tester | Used for measuring resistance and voltage. |
| Drill | Used for replacing ignition key lock. |

Door Lock Control System

SECURITY AND LOCKS

2. Door Lock Control System

A: WIRING DIAGRAM

1. DOOR LOCK CONTROL

<Ref. to WI-165, WIRING DIAGRAM, Keyless Entry System.>

B: INSPECTION

1. SYMPTOM CHART

| Symptom | Repair order | Reference |
|---|--|--|
| The door lock control system does not operate. | 1. Check the fuse. | <Ref. to SL-8, CHECK FUSE, INSPECTION, Door Lock Control System.> |
| | 2. Check the power supply and ground circuit for the body integrated unit. | <Ref. to SL-8, CHECK POWER SUPPLY AND GROUND CIRCUIT, INSPECTION, Door Lock Control System.> |
| | 3. Check the door lock switch and the circuit. | <Ref. to SL-9, CHECK DOOR LOCK SWITCH AND CIRCUIT, INSPECTION, Door Lock Control System.> |
| | 4. Check the door lock actuator and the circuit. | <Ref. to SL-10, CHECK DOOR LOCK ACTUATOR AND CIRCUIT, INSPECTION, Door Lock Control System.> |
| The door lock switch does not operate. | Check the door lock switch and the circuit. | <Ref. to SL-9, CHECK DOOR LOCK SWITCH AND CIRCUIT, INSPECTION, Door Lock Control System.> |
| A specific door lock actuator does not operate. | Check the door lock actuator and the circuit. | <Ref. to SL-10, CHECK DOOR LOCK ACTUATOR AND CIRCUIT, INSPECTION, Door Lock Control System.> |

2. CHECK FUSE

| Step | Check | Yes | No |
|--|------------------------|----------------------------------|---|
| 1 CHECK FUSE. Remove and visually check the fuse No. 2 (in the main fuse box). | In the fuse blown out? | Replace the fuse with a new one. | Check the power supply and ground circuit. <Ref. to SL-8, CHECK POWER SUPPLY AND GROUND CIRCUIT, INSPECTION, Door Lock Control System.> |

3. CHECK POWER SUPPLY AND GROUND CIRCUIT

| Step | Check | Yes | No |
|---|--------------------------------|---------------|--|
| 1 CHECK POWER SUPPLY. 1) Disconnect the body integrated unit harness connector. 2) Measure the voltage between the harness connector terminal and chassis ground. Connector & terminal (B280) No. 1, 2 (+) — Chassis ground (-): | Is the voltage more than 10 V? | Go to step 2. | Check the harness for open circuits or shorts between the body integrated unit and the fuse. |

Door Lock Control System

| Step | Check | Yes | No |
|---|---|--|---------------------|
| 2 CHECK GROUND CIRCUIT. Measure the resistance between the harness connector terminal and chassis ground. <i>Connector & terminal</i> <i>(B280) No. 4, 13 — Chassis ground:</i> | Is the resistance less than 10 Ω ? | The power supply and ground circuit is OK. | Repair the harness. |

4. CHECK DOOR LOCK SWITCH AND CIRCUIT

| Step | Check | Yes | No |
|---|---|--|-------------------------------|
| 1 CHECK DOOR LOCK SWITCH CIRCUIT. 1) Disconnect the body integrated unit harness connector. 2) Measure the resistance between the harness connector terminal and chassis ground when moving the door lock switch to LOCK. <i>Connector & terminal</i> <i>(B281) No. 12 — Chassis ground:</i> | Is the resistance less than 10 Ω ? | Go to step 2. | Go to step 3. |
| 2 CHECK DOOR LOCK SWITCH CIRCUIT. Measure the resistance between the harness connector terminal and chassis ground when the door lock switch is moved to UNLOCK. <i>Connector & terminal</i> <i>(B281) No. 11 — Chassis ground:</i> | Is the resistance less than 10 Ω ? | The door lock switch is OK. | Go to step 3. |
| 3 CHECK DOOR LOCK SWITCH. 1) Disconnect the door lock switch harness connector. 2) Measure the resistance between the door lock switch terminals when moving the door lock switch to LOCK. <i>Connector & terminal</i> <i>Driver's side:</i> <i>(D7) No. 5 — No. 9</i> <i>Passenger's side:</i> <i>(D62) No. 4 — No. 5</i> | Is the resistance less than 10 Ω ? | Go to step 4. | Replace the door lock switch. |
| 4 CHECK DOOR LOCK SWITCH. Measure the resistance between the door lock switch terminals when moving the door lock switch to UNLOCK. <i>Connector & terminal</i> <i>Driver's side:</i> <i>(D7) No. 5 — No. 8</i> <i>Passenger's side:</i> <i>(D62) No. 2 — No. 5</i> | Is the resistance less than 1 Ω ? | Check the harness for open circuits or shorts between the body integrated unit and the door lock switch. | Replace the door lock switch. |

Door Lock Control System

SECURITY AND LOCKS

5. CHECK DOOR LOCK ACTUATOR AND CIRCUIT

| Step | Check | Yes | No |
|---|--------------------------------|--|-----------------------------------|
| 1 CHECK OUTPUT SIGNAL. Measure the voltage between the harness connector terminal of body integrated unit and chassis ground when moving the door lock switch to LOCK. <i>Connector & terminal</i> <i>(B280) No. 6 (+) — Chassis ground (-):</i> | Is the voltage more than 10 V? | Go to step 2. | Replace the body integrated unit. |
| 2 CHECK OUTPUT SIGNAL. Measure the voltage between the harness connector terminal of body integrated unit and chassis ground when moving the door lock switch to UNLOCK. <i>Connector & terminal</i> <i>(B280) No. 7 (+) — Chassis ground (-):</i> | Is the voltage more than 10 V? | Go to step 3. | Replace the body integrated unit. |
| 3 CHECK DOOR LOCK ACTUATOR. Check the door lock actuator. Front door lock actuator: <Ref. to SL-33, Front Door Lock Actuator.> Rear door lock actuator: <Ref. to SL-37, Rear Door Lock Actuator.> Rear gate latch lock actuator: <Ref. to SL-40, Rear Gate Latch Lock Actuator.> | Is the door lock actuator OK? | Check the harness for open circuits or shorts between the body integrated unit and the door lock actuator. | Replace the door lock actuator. |

3. Keyless Entry System

A: WIRING DIAGRAM

1. KEYLESS ENTRY

<Ref. to WI-165, WIRING DIAGRAM, Keyless Entry System.>

B: ELECTRICAL SPECIFICATION

1. KEYLESS ENTRY CONTROL UNIT

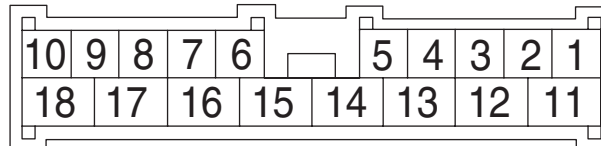

SL-00037

| Content | Terminal No. | Measuring condition |
|--------------------------|--------------|--|
| Body integrated unit | 1 (OUTPUT) | Battery voltage is present when pressing the keyless transmitter LOCK/ARM button. |
| Body integrated unit | 2 (OUTPUT) | Battery voltage is present when pressing the keyless transmitter UNLOCK/DISARM button. |
| Security control unit | 3 | — |
| Security control unit | 4 | — |
| Door lock switch | 5 (INPUT) | 0 V is present when operating the door lock switch. |
| Ignition switch (ON) | 6 (INPUT) | Battery voltage is present when ignition switch is turned to ON. |
| Key warning switch | 7 (INPUT) | Battery voltage is present when inserting the key into the ignition switch. |
| Door unlock switch | 8 (INPUT) | 0 V is present when operating the door lock switch. |
| Rear gate latch switch | 9 (INPUT) | 0 V is present when rear gate is open. |
| Door switch | 10 (INPUT) | 0 V is present when any door is open. |
| Ground | 11 | 0 V is constantly present. |
| Turn signal light (Left) | 12 (OUTPUT) | Battery voltage is present when pressing the keyless transmitter UNLOCK/DISARM or LOCK/ARM button. |
| Horn relay | 13 (OUTPUT) | 0 V is present when pressing the keyless transmitter LOCK/ARM button three times within 5 seconds. |
| Power supply (Backup) | 14 | Battery voltage is constantly present. |
| Power supply (Backup) | 15 | Battery voltage is constantly present. |
| Keyless buzzer | 16 (OUTPUT) | 0 V is present when pressing the keyless transmitter UNLOCK/DISARM or LOCK/ARM button. |
| Security control unit | 17 | — |
| Turn signal light (Left) | 18 (OUTPUT) | Battery voltage is present when pressing the keyless transmitter UNLOCK/DISARM or LOCK/ARM button. |

Keyless Entry System

SECURITY AND LOCKS

2. BODY INTEGRATED UNIT

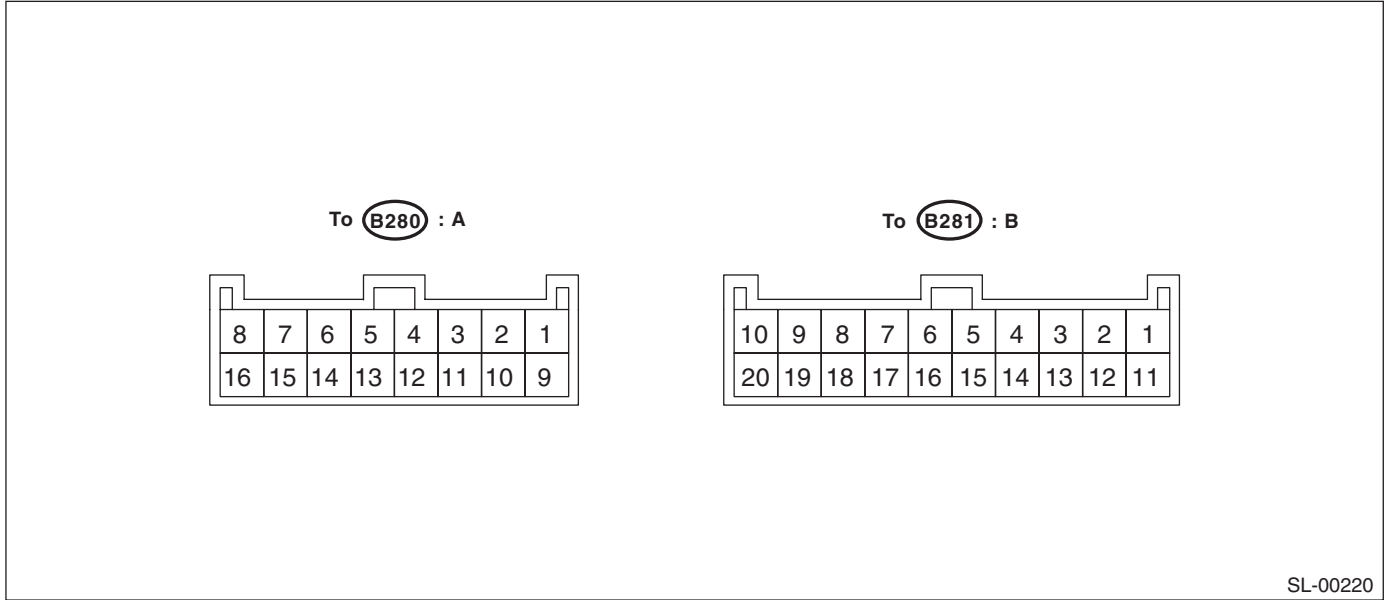

| Content | Terminal No. | Measuring condition |
|---|--------------|--|
| Door switch (Except driver's door) | B7 (INPUT) | 0 V is present when any door is open (Except driver's door). |
| Door switch (Driver's door) | B8 (INPUT) | 0 V is present when driver's door is open. |
| Door unlock switch | B11 (INPUT) | 0 V is present when operating the door unlock switch. |
| Door lock switch | B12 (INPUT) | 0 V is present when operating the door lock switch. |
| Keyless entry control unit | B13 (INPUT) | Battery voltage is present when pressing the keyless transmitter LOCK/ARM button. |
| Keyless entry control unit | B14 (INPUT) | Battery voltage is present when pressing the keyless transmitter UNLOCK/DISARM button. |
| Ignition switch (ON) | B19 (INPUT) | Battery voltage is present when ignition switch is turned to ON. |
| Key warning switch | B20 (INPUT) | Battery voltage is present when inserting the key into ignition switch. |
| Power supply | A1 | Battery voltage is constantly present. |
| Power supply | A2 | Battery voltage is constantly present. |
| Ground | A4 | 0 V is constantly present. |
| Room light | A5 (OUTPUT) | 0 V is present when pressing the keyless transmitter UNLOCK/DISARM button. |
| Door and rear gate lock actuator | A6 (OUTPUT) | Battery voltage is present when pressing the keyless transmitter LOCK/ARM button. |
| Door and rear gate lock actuator (Except driver side) | A7 (OUTPUT) | Battery voltage is present when pressing the keyless transmitter UNLOCK/DISARM button two times. |
| Door lock actuator (Driver side) | A8 (OUTPUT) | Battery voltage is present when pressing the keyless transmitter UNLOCK/DISARM button one time. |
| Ground | A13 | 0 V is constantly present. |

C: INSPECTION

1. SYMPTOM CHART

| Symptom | Repair order | Reference |
|---|--|--|
| None of the functions of the keyless entry system operate. | 1. Check the keyless transmitter battery and function. | <Ref. to SL-14, CHECK KEYLESS TRANSMITTER BATTERY AND FUNCTION, INSPECTION, Keyless Entry System.> |
| | 2. Check the fuse. | <Ref. to SL-15, CHECK FUSE, INSPECTION, Keyless Entry System.> |
| | 3. Check the keyless entry control unit power supply and ground circuit. | <Ref. to SL-15, CHECK POWER SUPPLY AND GROUND CIRCUIT, INSPECTION, Keyless Entry System.> |
| | 4. Replace the keyless entry control unit. | <Ref. to SL-55, Keyless Entry Control Unit.> |
| The keyless transmitter cannot be registered. | 1. Check the keyless transmitter battery and function. | <Ref. to SL-14, CHECK KEYLESS TRANSMITTER BATTERY AND FUNCTION, INSPECTION, Keyless Entry System.> |
| | 2. Check the ignition switch circuit. | <Ref. to SL-16, CHECK IGNITION SWITCH CIRCUIT, INSPECTION, Keyless Entry System.> |
| | 3. Check the door switch. | <Ref. to SL-16, CHECK DOOR SWITCH, INSPECTION, Keyless Entry System.> |
| | 4. Replace the keyless entry control unit. | <Ref. to SL-55, Keyless Entry Control Unit.> |
| The door lock or unlock does not operate. NOTE: If the door lock control system does not operate when using the door lock switch, check the door lock control system. <Ref. to SL-8, INSPECTION, Door Lock Control System.> | 1. Check the keyless transmitter battery and function. | <Ref. to SL-14, CHECK KEYLESS TRANSMITTER BATTERY AND FUNCTION, INSPECTION, Keyless Entry System.> |
| | 2. Check the key warning switch. | <Ref. to SL-17, CHECK KEY WARNING SWITCH, INSPECTION, Keyless Entry System.> |
| | 3. Check the door switch. | <Ref. to SL-16, CHECK DOOR SWITCH, INSPECTION, Keyless Entry System.> |
| | 4. Check the output signal to body integrated unit. | <Ref. to SL-18, CHECK OUTPUT SIGNAL TO BODY INTEGRATED UNIT, INSPECTION, Keyless Entry System.> |
| | 5. Replace the keyless entry control unit. | <Ref. to SL-55, Keyless Entry Control Unit.> |
| The panic alarm does not operate. | 1. Check the keyless transmitter battery and function. | <Ref. to SL-14, CHECK KEYLESS TRANSMITTER BATTERY AND FUNCTION, INSPECTION, Keyless Entry System.> |
| | 2. Check the horn operation. | <Ref. to SL-19, CHECK HORN OPERATION, INSPECTION, Keyless Entry System.> |
| | 3. Replace the keyless entry control unit. | <Ref. to SL-55, Keyless Entry Control Unit.> |

Keyless Entry System

SECURITY AND LOCKS

| Symptom | Repair order | Reference |
|---|---|--|
| The buzzer chirp and hazard light do not operate. | 1. Check the buzzer chirp function. | <Ref. to SL-15, CHECK BUZZER CHIRP SETTING, INSPECTION, Keyless Entry System.> |
| | 2. Check the buzzer and hazard light operation. | Buzzer <Ref. to SL-19, CHECK KEYLESS BUZZER, INSPECTION, Keyless Entry System.> |
| | | Hazard light <Ref. to SL-19, CHECK HAZARD LIGHT OPERATION, INSPECTION, Keyless Entry System.> |
| 3. Replace the keyless entry control unit. | <Ref. to SL-55, Keyless Entry Control Unit.> | |
| The room light operation do not activate. | 1. Check the room light operation. | <Ref. to SL-18, CHECK ROOM LIGHT OPERATION, INSPECTION, Keyless Entry System.> |
| | 2. Replace the keyless entry control unit. | <Ref. to SL-55, Keyless Entry Control Unit.> |
| The door warning does not operate. | 1. Check the door switch. | <Ref. to SL-16, CHECK DOOR SWITCH, INSPECTION, Keyless Entry System.> |
| | 2. Check the buzzer operation. | <Ref. to SL-19, CHECK KEYLESS BUZZER, INSPECTION, Keyless Entry System.> |
| | 3. Replace the keyless entry control unit. | <Ref. to SL-55, Keyless Entry Control Unit.> |

2. CHECK KEYLESS TRANSMITTER BATTERY AND FUNCTION

| Step | Check | Yes | No |
|--|--|---------------|---|
| 1 CHECK KEYLESS TRANSMITTER BATTERY. 1) Remove the battery from the keyless transmitter. <Ref. to SL-57, REMOVAL, Keyless Transmitter.> 2) Check the battery voltage. <Ref. to SL-57, INSPECTION, Keyless Transmitter.> | Is the voltage more than 2 V? | Go to step 2. | Replace the keyless transmitter battery. |
| 2 CHECK LED OF KEYLESS TRANSMITTER. 1) Press the LOCK/ARM or UNLOCK/DISARM button six times to synchronize with the keyless entry control unit. 2) Press the LOCK/ARM button. | Does the LED blink one time? | Go to step 3. | Replace the keyless transmitter. <Ref. to SL-57, REPLACEMENT, Keyless Transmitter.> |
| 3 CHECK LED OF KEYLESS TRANSMITTER. Keep the LOCK/ARM button pressed. | Does the LED blink one time, and then turn on? | Go to step 4. | Replace the keyless transmitter. <Ref. to SL-57, REPLACEMENT, Keyless Transmitter.> |
| 4 CHECK LED OF KEYLESS TRANSMITTER. Press the UNLOCK/DISARM button. | Does the LED blink one time? | Go to step 5. | Replace the keyless transmitter. <Ref. to SL-57, REPLACEMENT, Keyless Transmitter.> |

| Step | Check | Yes | No |
|--|-------------------------------|----------------------------|---|
| 5 CHECK LED OF KEYLESS TRANSMITTER. Keep the UNLOCK/DISARM button pressed. | Does the LED blink two times? | Keyless transmitter is OK. | Replace the keyless transmitter. <Ref. to SL-57, REPLACEMENT, Keyless Transmitter.> |

3. CHECK BUZZER CHIRP SETTING

| Step | Check | Yes | No |
|---|-------------------------------|------------------------------|--|
| 1 CHECK BUZZER CHIRP SETTING. 1) Check the current setting of the buzzer chirp. 2) Remove the key from the ignition switch. 3) Close all doors and the rear gate. 4) Press the LOCK/ARM or UNLOCK/DISARM button. | Does the buzzer signal chirp? | Buzzer chirp function is OK. | Go to step 2. |
| 2 CHECK BUZZER CHIRP SETTING. 1) Press the UNLOCK/DISARM button once. 2) Press both the LOCK/ARM and UNLOCK/DISARM buttons for more than 2 seconds. 3) Press the LOCK/ARM or UNLOCK/DISARM button. | Does the buzzer signal chirp? | Buzzer chirp function is OK. | Check the keyless transmitter function. <Ref. to SL-14, CHECK KEYLESS TRANSMITTER BATTERY AND FUNCTION, INSPECTION, Keyless Entry System.> |

4. CHECK FUSE

| Step | Check | Yes | No |
|--|------------------------|----------------------------------|--|
| 1 CHECK FUSE. Remove and visually check the fuse No. 6 (in the main fuse box) and No. 3 (in the fuse and relay box). | Is the fuse blown out? | Replace the fuse with a new one. | Check the power supply and ground circuit. <Ref. to SL-15, CHECK POWER SUPPLY AND GROUND CIRCUIT, INSPECTION, Keyless Entry System.> |

5. CHECK POWER SUPPLY AND GROUND CIRCUIT

| Step | Check | Yes | No |
|---|-----------------------------------|---|---|
| 1 CHECK POWER SUPPLY. 1) Disconnect the keyless entry control unit harness connector. 2) Measure the voltage between the harness connector terminal and chassis ground. <i>Connector & terminal</i> <i>(B176) No. 14, No. 15 (+) — Chassis ground (-):</i> | Is the voltage more than 10 V? | Go to step 2. | Check the harness for open circuits and shorts between the keyless entry control unit and fuse. |
| 2 CHECK GROUND CIRCUIT. Measure the resistance between the harness connector terminal and chassis ground. <i>Connector & terminal</i> <i>(B176) No. 11 — Chassis ground:</i> | Is the resistance less than 10 Ω? | The power supply and ground circuit are OK. | Repair the harness. |

Keyless Entry System

SECURITY AND LOCKS

6. CHECK IGNITION SWITCH CIRCUIT

| Step | Check | Yes | No |
|--|--------------------------------|--------------------------------|---|
| 1 CHECK IGNITION SWITCH SIGNAL. 1) Disconnect the keyless entry control unit harness connector. 2) Turn the ignition switch to ON. 3) Measure the voltage between harness connector terminal and chassis ground. Connector & terminal (B176) No. 6 (+) — Chassis ground (-): | Is the voltage more than 10 V? | Ignition switch circuit is OK. | Check the harness for open circuits and shorts between the keyless entry control unit and ignition relay. |

7. CHECK DOOR SWITCH

| Step | Check | Yes | No |
|---|---|--|--------------------------|
| 1 CHECK DOOR SWITCH CIRCUIT. Measure the voltage between the keyless entry control unit harness connector terminal and chassis ground. Connector & terminal Front and rear side door: (B176) No. 10 (+) — Chassis ground (-): Rear gate: (B176) No. 9 (+) — Chassis ground (-): | Is the voltage 0 V when each door or rear gate is opened? | Go to step 2. | Go to step 3. |
| 2 CHECK DOOR SWITCH CIRCUIT. Measure the voltage between the keyless entry control unit harness connector terminal and chassis ground. Connector & terminal Front and rear side door: (B176) No. 10 (+) — Chassis ground (-): Rear gate: (B176) No. 9 (+) — Chassis ground (-): | Is the voltage more than 10 V when each door or rear gate is closed? | The door switch is OK. | Go to step 3. |
| 3 CHECK DOOR SWITCH. 1) Disconnect the door switch harness connector. 2) Measure the resistance between the door switch terminals. Terminals Door switch No. 1 — No. 3: Rear gate latch switch No. 1 — No. 2: | Is the resistance more than 1 M Ω when the door switch is depressed? | Go to step 4. | Replace the door switch. |
| 4 CHECK DOOR SWITCH. Measure the resistance between the door switch terminals. Terminals Door switch No. 1 — No. 3: Rear gate latch switch No. 1 — No. 2: | Is the resistance less than 1 Ω when the door switch is released? | Check the harness for open circuits and shorts between the body integrated unit and door switch. | Replace the door switch. |

8. CHECK KEY WARNING SWITCH

| Step | Check | Yes | No |
|---|--|---|---------------------------------|
| 1 CHECK FUSE. Remove and visually check the fuse No. 6 (in the main fuse box). | Is the fuse blown out? | Replace the fuse with a new one. | Go to step 2. |
| 2 CHECK KEY WARNING SWITCH CIRCUIT. 1) Disconnect the keyless entry control unit harness connector. 2) Insert the key into the ignition switch. (LOCK position) 3) Measure the voltage between the harness connector terminal and chassis ground. Connector & terminal (B176) No. 7 (+) — Chassis ground (-): | Is the voltage more than 10 V? | Go to step 3. | Go to step 4. |
| 3 CHECK KEY WARNING SWITCH CIRCUIT. 1) Remove the key from the ignition switch. 2) Measure the voltage between the harness connector terminal and chassis ground. Connector & terminal (B176) No. 7 (+) — Chassis ground (-): | Is the voltage 0 V? | Key warning switch is OK. | Go to step 4. |
| 4 CHECK KEY WARNING SWITCH. 1) Disconnect the key warning switch harness connector. 2) Insert the key into the ignition switch. (LOCK position) 3) Measure the resistance between the key warning switch terminals. Terminals No. 1 — No. 2: | Is the resistance less than 1 Ω ? | Go to step 5. | Replace the key warning switch. |
| 5 CHECK KEY WARNING SWITCH. 1) Remove the key from the ignition switch. 2) Measure the resistance between the key warning switch terminals. Terminals No. 1 — No. 2: | Is the resistance more than 1 M Ω ? | Check the following: <ul style="list-style-type: none"> • Harness for open circuits and shorts between the key warning switch and fuse • Harness for open circuits and shorts between the keyless entry control unit and key warning switch | Replace the key warning switch. |

Keyless Entry System

SECURITY AND LOCKS

9. CHECK ROOM LIGHT OPERATION

| Step | Check | Yes | No |
|--|---|---|--|
| 1 CHECK ROOM LIGHT OPERATION. Make sure the room light illuminates when the room light switch is turned ON. | Does the room light illuminate? | Go to step 2. | Check the room light circuit. |
| 2 CHECK HARNESS BETWEEN ROOM LIGHT AND BODY INTEGRATED UNIT. 1) Disconnect the body integrated unit harness connector and room light harness connector. 2) Measure the resistance between the body integrated unit harness connector terminal and the room light harness connector terminal. <i>Connector & terminal</i> <i>(B280) No. 5 — (R52) No. 2:</i> | Is the resistance less than 10 Ω ? | The room light operation circuit is OK. | Check the harness for open circuits and/or shorts between the body integrated unit and room light. |

10. CHECK OUTPUT SIGNAL TO BODY INTEGRATED UNIT

| Step | Check | Yes | No |
|--|---|-----------------------------------|---|
| 1 CHECK OUTPUT SIGNAL. Measure the voltage between the keyless entry control unit harness connector terminal and chassis ground when UNLOCK/DISARM button of keyless transmitter is pressed. <i>Connector & terminal</i> <i>(B176) No. 2 (+) — Chassis ground (-):</i> | Is the voltage more than 10 V? | Go to step 2. | Replace the keyless entry control unit. |
| 2 CHECK OUTPUT SIGNAL. Measure the voltage between the keyless entry control unit harness connector terminal and chassis ground when LOCK/ARM button of keyless transmitter is pressed. <i>Connector & terminal</i> <i>(B176) No. 1 (+) — Chassis ground (-):</i> | Is the voltage more than 10 V? | Go to step 3. | Replace the keyless entry control unit. |
| 3 CHECK HARNESS BETWEEN KEYLESS ENTRY CONTROL UNIT AND BODY INTEGRATED UNIT. 1) Disconnect the keyless entry control unit harness connector and body integrated unit harness connector. 2) Measure the resistance between the keyless entry control unit harness connector terminal and body integrated unit harness connector terminal. <i>Connector & terminal</i> <i>(B176) No. 2 — (B281) No. 14:</i> <i>(B176) No. 1 — (B281) No. 13:</i> | Is the resistance less than 10 Ω ? | Replace the body integrated unit. | Check the harness for open circuit or shorts between the keyless entry control unit and body integrated unit. |

11. CHECK HORN OPERATION

| Step | Check | Yes | No |
|--|----------------------|---|--|
| 1 CHECK HORN OPERATION. Make sure the horn sounds when the horn switch is pushed. | Does the horn sound? | Go to step 2. | Check the horn circuit. |
| 2 CHECK HORN OPERATION. 1) Disconnect the keyless entry control unit harness connector. 2) Ground the harness connector terminal with a suitable wire. <i>Connector & terminal</i> <i>(B176) No. 13 — Chassis ground:</i> | Does the horn sound? | Replace the keyless entry control unit. | Check the harness for open circuits and/or shorts between the keyless entry control unit and horn relay. |

12. CHECK HAZARD LIGHT OPERATION

| Step | Check | Yes | No |
|---|--------------------------------|--|---|
| 1 CHECK HAZARD LIGHT OPERATION. Make sure the hazard light blinks when hazard switch is turned ON. | Does the hazard light blink? | Go to step 2. | Check the hazard light circuit. |
| 2 CHECK OUTPUT SIGNAL. 1) Remove the key from ignition switch. 2) Close all doors and rear gate. 3) Measure the voltage between keyless entry control unit harness connector terminal and chassis ground when LOCK/ARM button of keyless transmitter is pressed. <i>Connector & terminal</i> <i>(B176) No. 12, 18 (+) — Chassis ground (-):</i> | Is the voltage more than 10 V? | Check the harness for open or short between keyless entry control unit and turn signal lights. | Replace the keyless entry control unit. |

13. CHECK KEYLESS BUZZER

| Step | Check | Yes | No |
|--|---|---|---|
| 1 CHECK FUSE. Remove and check the fuse No. 2 (located in main fuse box). | Is the fuse blown out? | Replace the fuse with a new one. | Go to step 2. |
| 2 CHECK KEYLESS POWER SUPPLY. 1) Disconnect the connector from keyless buzzer. 2) Measure the voltage between keyless buzzer harness connector and chassis ground. <i>Connector & terminal</i> <i>(F102) No. 2 (+) — Chassis ground (-):</i> | Is the voltage more than 10 V? | Go to step 3. | Check the harness for open or short between fuse and keyless buzzer. |
| 3 CHECK HARNESS BETWEEN KEYLESS BUZZER AND KEYLESS ENTRY CONTROL UNIT. 1) Disconnect the connector from keyless entry control unit. 2) Measure the resistance between keyless buzzer and keyless entry control unit. <i>Connector & terminal</i> <i>(F102) No. 1 — (B176) No. 16:</i> | Is the resistance more than 10 Ω ? | Go to step 4. | Repair the harness between keyless buzzer and keyless entry control unit. |
| 4 CHECK KEYLESS BUZZER. Make sure that the buzzer sounds when connecting battery positive terminal to No. 2 terminal of keyless buzzer connector and battery ground terminal to No. 1 terminal of keyless buzzer connector. | Does the buzzer sound? | Replace the keyless entry control unit. | Replace the keyless buzzer. |

Security System

SECURITY AND LOCKS

4. Security System

A: WIRING DIAGRAM

<Ref. to WI-168, WIRING DIAGRAM, Security System.>

B: ELECTRICAL SPECIFICATION

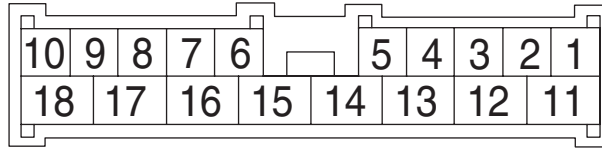

SL-00037

| Content | Terminal No. | Measuring condition |
|---------------------------------------|--------------|--|
| Empty | 1 | — |
| Ignition switch (ON) | 2 (INPUT) | Battery voltage is present when ignition switch is turned to ON. |
| Passive arm | 3 | — |
| Trunk room light switch (Sedan model) | 4 (INPUT) | 0 V is present when trunk lid or rear gate is open. |
| Rear gate latch switch (Wagon model) | | |
| Door switch | 5 (INPUT) | 0 V is present when any door is open. |
| Empty | 6 | — |
| Keyless entry control unit | 7 | — |
| Keyless entry control unit | 8 | — |
| Security indicator light | 9 (OUTPUT) | 0 V is present when activating the alarm operation. |
| Keyless entry control unit | 10 | — |
| Power supply (Backup) | 13 | Battery voltage is constantly present. |
| Ground | 14 | 0 V is constantly present. |
| Interrupt relay | 15 (OUTPUT) | Battery voltage is present when activating the alarm operation. |
| Security horn relay | 16 (INPUT) | Battery voltage is present when activating the alarm operation. |
| Security horn | 17 (OUTPUT) | Battery voltage is present when activating the alarm operation. |
| Security horn relay | 18 (INPUT) | Battery voltage is present when activating the alarm operation. |

C: INSPECTION

1. BASIC DIAGNOSTIC PROCEDURE

• With immobilizer model

| Step | Check | Yes | No |
|--|--|---------------|---|
| 1 CHECK VALET MODE SETTING. Check the valet mode is set. (Security indicator light blinks two times per a second when the valet mode is set.) | Does the security indicator light blink two times per a second? | Go to step 2. | Go to step 3. |
| 2 RELEASE VALET MODE SETTING. Release the valet mode setting. 1) Open the driver's door. 2) Push the UNLOCK/DISARM button on keyless transmitter for two seconds or more. 3) Check for the status of blinking for security indicator light. | Does the security indicator light blink one time per three seconds? | Go to step 3. | Go to symptom 1. <Ref. to SL-24, SYMPTOM CHART, INSPECTION, Security System.> |
| 3 CHECK SECURITY SYSTEM SET OPERATION. 1) Before starting this diagnosis, open all windows. 2) Remove the key from ignition key cylinder, and then close all doors and rear gate. 3) Press the LOCK/ARM button of keyless transmitter. | Can the security system be set? | Go to step 4. | Go to symptom 1. <Ref. to SL-24, SYMPTOM CHART, INSPECTION, Security System.> |
| 4 CHECK HAZARD LIGHT AND SECURITY INDICATOR LIGHT BLINKING. Check the status of blinking for both hazard light and security indicator light blinking. | Does the hazard light blink, and the security indicator light blink twice per two seconds? | Go to step 5. | Go to symptom 2. <Ref. to SL-24, SYMPTOM CHART, INSPECTION, Security System.> |
| 5 CHECK SECURITY ALARM OPERATION. 1) Unlock all doors using the door lock switch on front door. 2) Open any door, trunk lid or rear gate. | Does the security alarm operate when any door, trunk lid or rear gate is opened? | Go to step 6. | Go to symptom 3. <Ref. to SL-24, SYMPTOM CHART, INSPECTION, Security System.> |
| 6 CHECK SECURITY ALARM OPERATION. Check the security alarm operation. | Does all security alarm (horn, hazard light and security indicator light) operate? And is the starter motor deactivated? | Go to step 7. | Go to symptom 4. <Ref. to SL-24, SYMPTOM CHART, INSPECTION, Security System.> |
| 7 CHECK SECURITY ALARM CANCEL OPERATION. 1) Press the UNLOCK/DISARM button of keyless transmitter to stop all the security alarm. 2) Check for the status of blinking for security indicator light, and starter motor operation. | Does the security indicator light blink once per three seconds? And is the starter motor activated? | Go to step 8. | Go to symptom 5. <Ref. to SL-24, SYMPTOM CHART, INSPECTION, Security System.> |
| 8 CHECK BATTERY DISCONNECT PROTECTION. Check the battery disconnect protection. <Ref. to SL-24, CHECK BATTERY DISCONNECT PROTECTION, INSPECTION, Security System.> | Is the battery disconnect protection OK? | Go to step 9. | Replace the security control unit. |

Security System

SECURITY AND LOCKS

| Step | Check | Yes | No |
|---|---|--|--|
| 9 PERFORM IMPACT SENSITIVITY TEST. Perform the impact sensitivity test. <Ref. to SL-50, IMPACT SENSITIVITY TEST, INSPECTION, Security Control Unit.> | Is the impact sensitivity properly set? | Press the UNLOCK/DISARM button of keyless transmitter, and finish the diagnosis. | Adjust the impact sensitivity. <Ref. to SL-50, IMPACT SENSITIVITY, ADJUSTMENT, Security Control Unit.> |

• Without immobilizer model

| Step | Check | Yes | No |
|--|--|--|--|
| 1 CHECK VALET MODE SETTING. Check the valet mode is set. (Security indicator light blinks two times per a second when the valet mode is set.) | Does the security indicator light blink two times per a second? | Go to step 2. | Go to step 3. |
| 2 RELEASE VALET MODE SETTING. Release the valet mode setting. 1) Open the driver's door. 2) Push the UNLOCK/DISARM button on keyless transmitter for two seconds or more. 3) Check for the status of blinking for security indicator light. | Does the security indicator light go off? | Go to step 3. | Go to symptom 1. <Ref. to SL-24, SYMPTOM CHART, INSPECTION, Security System.> |
| 3 CHECK SECURITY SYSTEM SET OPERATION. 1) Before starting this diagnosis, open all windows. 2) Remove the key from ignition key cylinder, and then close all doors and rear gate. 3) Press the LOCK/ARM button of keyless transmitter. | Can the security system be set? | Go to step 4. | Go to symptom 1. <Ref. to SL-24, SYMPTOM CHART, INSPECTION, Security System.> |
| 4 CHECK HAZARD LIGHT AND SECURITY INDICATOR LIGHT BLINKING. Check the status of blinking for both hazard light and security indicator light blinking. | Does the hazard light blink, and the security indicator light blink once per two seconds? | Go to step 5. | Go to symptom 2. <Ref. to SL-24, SYMPTOM CHART, INSPECTION, Security System.> |
| 5 CHECK SECURITY ALARM OPERATION. 1) Unlock all doors using the door lock switch on front door. 2) Open any door, trunk lid or rear gate. | Does the security alarm operate when any door, trunk lid or rear gate is opened? | Go to step 6. | Go to symptom 3. <Ref. to SL-24, SYMPTOM CHART, INSPECTION, Security System.> |
| 6 CHECK SECURITY ALARM OPERATION. Check the security alarm operation. | Does all security alarm (horn, hazard light and security indicator light) operate? And is the starter motor deactivated? | Go to step 7. | Go to symptom 4. <Ref. to SL-24, SYMPTOM CHART, INSPECTION, Security System.> |
| 7 CHECK SECURITY ALARM CANCEL OPERATION. 1) Press the UNLOCK/DISARM button of keyless transmitter to stop all the security alarm. 2) Check for the status of blinking for security indicator light, and starter motor operation. | Does the security indicator light go off? And is the starter motor activated? | Go to step 8. | Go to symptom 5. <Ref. to SL-24, SYMPTOM CHART, INSPECTION, Security System.> |
| 8 CHECK BATTERY DISCONNECT PROTECTION. Check the battery disconnect protection. <Ref. to SL-24, CHECK BATTERY DISCONNECT PROTECTION, INSPECTION, Security System.> | Is the battery disconnect protection OK? | Go to step 9. | Replace the security control unit. |
| 9 PERFORM IMPACT SENSITIVITY TEST. Perform the impact sensitivity test. <Ref. to SL-50, IMPACT SENSITIVITY TEST, INSPECTION, Security Control Unit.> | Is the impact sensitivity properly set? | Press the UNLOCK/DISARM button of keyless transmitter, and finish the diagnosis. | Adjust the impact sensitivity. <Ref. to SL-50, IMPACT SENSITIVITY, ADJUSTMENT, Security Control Unit.> |

Security System

SECURITY AND LOCKS

2. CHECK BATTERY DISCONNECT PROTECTION

- 1) Remove the key from the ignition switch.
- 2) Close all the doors, trunk lid and rear gate.
- 3) Open the front hood.
- 4) Press the LOCK/ARM button of the keyless transmitter.
- 5) Disconnect the ground cable from the battery.
- 6) Reconnect the cable to the battery.
- 7) Check that the security indicator light blinks after reconnecting the battery cable.

If NG, replace the security control unit.

3. SYMPTOM CHART

| Symptom | | Repair order | Reference |
|---------|--|---|---|
| 1 | Security system cannot be set. | 1. Check the keyless transmitter function. | <Ref. to SL-14, CHECK KEYLESS TRANSMITTER BATTERY AND FUNCTION, INSPECTION, Keyless Entry System.> |
| | | 2. Check the fuse. | <Ref. to SL-25, CHECK FUSE, INSPECTION, Security System.> |
| | | 3. Check the security control unit power supply and ground circuit. | <Ref. to SL-25, CHECK POWER SUPPLY AND GROUND CIRCUIT, INSPECTION, Security System.> |
| | | 4. Check the door switch. | <Ref. to SL-25, CHECK DOOR SWITCH, INSPECTION, Security System.> |
| | | 5. Replace the security control unit. | <Ref. to SL-50, Security Control Unit.> |
| 2 | Security indicator light or hazard light does not blink. | Security indicator light | <Ref. to SL-26, CHECK SECURITY INDICATOR LIGHT CIRCUIT, INSPECTION, Security System.> |
| | | Hazard light | <Ref. to SL-28, CHECK HAZARD LIGHT OPERATION, INSPECTION, Security System.> |
| 3 | Security system does not alarm when one of the door, trunk lid or rear gate is opened. | Check the door switch. | <Ref. to SL-25, CHECK DOOR SWITCH, INSPECTION, Security System.> |
| 4 | Security alarm does not activate. | All functions | Check the door switch. <Ref. to SL-25, CHECK DOOR SWITCH, INSPECTION, Security System.> |
| | | Security indicator light | Check the security indicator light circuit. <Ref. to SL-26, CHECK SECURITY INDICATOR LIGHT CIRCUIT, INSPECTION, Security System.> |
| | | Security horn | Check the security horn. <Ref. to SL-27, CHECK SECURITY HORN, INSPECTION, Security System.> |
| | | Hazard light | Check the hazard light operation. <Ref. to SL-28, CHECK HAZARD LIGHT OPERATION, INSPECTION, Security System.> |
| | | Starter motor deactivation | Check the interrupt relay circuit. <Ref. to SL-28, CHECK INTERRUPT RELAY CIRCUIT, INSPECTION, Security System.> |
| 5 | Security system cannot be canceled. | Keyless transmitter | Check the keyless transmitter function. <Ref. to SL-14, CHECK KEYLESS TRANSMITTER BATTERY AND FUNCTION, INSPECTION, Keyless Entry System.> |
| | | Ignition switch | Check the ignition switch circuit. <Ref. to SL-29, CHECK IGNITION SWITCH CIRCUIT, INSPECTION, Security System.> |

4. CHECK FUSE

| Step | Check | Yes | No |
|--|------------------------|----------------------------------|---|
| 1 CHECK FUSE. Remove and visually check the fuse No. 2 (in main fuse box). | Is the fuse blown out? | Replace the fuse with a new one. | Check the power supply and ground circuit. <Ref. to SL-25, CHECK POWER SUPPLY AND GROUND CIRCUIT, INSPECTION, Security System.> |

5. CHECK POWER SUPPLY AND GROUND CIRCUIT

| Step | Check | Yes | No |
|---|---|---|--|
| 1 CHECK POWER SUPPLY. 1) Disconnect the security control unit harness connector. 2) Measure the voltage between the harness connector terminal and chassis ground. <i>Connector & terminal</i> <i>(B93) No. 13 (+) — Chassis ground (-):</i> | Is the voltage more than 10 V? | Go to step 2. | Check the harness for open circuits and shorts between the security control unit and fuse. |
| 2 CHECK GROUND CIRCUIT. Measure the resistance between the harness connector terminal and chassis ground. <i>Connector & terminal</i> <i>(B93) No. 14 — Chassis ground:</i> | Is the resistance less than 10 Ω ? | The power supply and ground circuit are OK. | Repair the harness. |

6. CHECK DOOR SWITCH

| Step | Check | Yes | No |
|---|--------------------------------|------------------------|---------------|
| 1 CHECK DOOR SWITCH CIRCUIT. Measure the voltage between the security control unit harness connector terminal and chassis ground when any door or rear gate is opened. <i>Connector & terminal</i> <i>Front and rear door:</i> <i>(B93) No. 5 (+) — Chassis ground (-):</i> <i>Trunk lid or rear gate:</i> <i>(B93) No. 4 (+) — Chassis ground (-):</i> | Is the voltage 0 V? | Go to step 2. | Go to step 3. |
| 2 CHECK DOOR SWITCH CIRCUIT. Measure the voltage between the security control unit harness connector terminal and chassis ground when all doors and rear gate are closed. <i>Connector & terminal</i> <i>Front and rear door:</i> <i>(B93) No. 5 (+) — Chassis ground (-):</i> <i>Trunk lid or rear gate:</i> <i>(B93) No. 4 (+) — Chassis ground (-):</i> | Is the voltage more than 10 V? | The door switch is OK. | Go to step 3. |

Security System

SECURITY AND LOCKS

| Step | Check | Yes | No |
|---|--|---|--------------------------|
| 3 CHECK DOOR SWITCH. 1) Disconnect the door switch harness connector. 2) Measure the resistance between the door switch terminals. <i>Terminals</i> <i>Door switch No. 1 — No. 3:</i> <i>Rear gate latch switch (Wagon model)</i> <i>No. 1 — No. 2:</i> <i>Trunk room light switch (Sedan model)</i> <i>No. 1 — No. 2:</i> | Is the resistance more than 1 M Ω when door switch is pushed? | Go to step 4. | Replace the door switch. |
| 4 CHECK DOOR SWITCH. Measure the resistance between the door switch terminals. <i>Terminals</i> <i>Door switch No. 1 — No. 3:</i> <i>Rear gate latch switch (Wagon model)</i> <i>No. 1 — No. 2:</i> <i>Trunk room light switch (Sedan model)</i> <i>No. 1 — No. 2:</i> | Is the resistance less than 1 Ω when door switch is released? | Check the harness for open circuits and shorts between the security control unit and door switch. | Replace the door switch. |

7. CHECK SECURITY INDICATOR LIGHT CIRCUIT

| Step | Check | Yes | No |
|--|---|--|---|
| 1 CHECK SECURITY INDICATOR LIGHT. 1) Disconnect the security control unit harness connector. 2) Ground the harness connector terminal with a suitable wire. <i>Connector & terminal</i> <i>(B93) No. 9 — Chassis ground:</i> | Does the security indicator light illuminate? | Replace the security control unit. | Go to step 2. |
| 2 CHECK POWER SUPPLY FOR SECURITY INDICATOR LIGHT. 1) Disconnect the connector from the combination meter. 2) Measure the voltage between the combination meter harness connector terminal and chassis ground. <i>Connector & terminal</i> <i>(i11) No. 3 (+) — Chassis ground (-):</i> | Is the voltage more than 10 V? | Go to step 3. | Check the harness for open circuits and shorts between the combination meter and the fuse. |
| 3 CHECK SECURITY INDICATOR LIGHT CIRCUIT. Measure the resistance between the combination meter harness connector terminal and security control unit harness connector terminal. <i>Connector & terminal</i> <i>(i10) No. 6 — (B93) No. 9:</i> | Is the resistance less than 10 Ω ? | Replace the combination meter printed circuit. | Check the harness for open circuits and shorts between the combination meter and security control unit. |

8. CHECK SECURITY HORN

| Step | Check | Yes | No |
|---|---|------------------------------------|---|
| 1 CHECK SECURITY HORN RELAY. Remove and check the security horn relay. <Ref. to SL-53, Security Horn Relay.> | Is the security horn relay OK? | Go to step 2 . | Replace the security horn relay. |
| 2 CHECK POWER SUPPLY FOR SECURITY HORN RELAY. Measure the voltage between the security horn relay harness connector terminal and chassis ground. <i>Connector & terminal</i> <i>(B243) No. 1 (+) — Chassis ground (-):</i> | Is the voltage more than 10 V? | Go to step 3 . | Check the harness for open circuits and shorts between the security horn relay and horn relay. |
| 3 CHECK POWER SUPPLY FOR SECURITY HORN RELAY. Measure the voltage between the security horn relay harness connector terminal and chassis ground. <i>Connector & terminal</i> <i>(B243) No. 2 (+) — Chassis ground (-):</i> | Is the voltage more than 10 V? | Go to step 4 . | Check the harness for open circuits and shorts between the security horn relay and the fuse. |
| 4 CHECK HARNESS BETWEEN SECURITY HORN RELAY AND SECURITY CONTROL UNIT. 1) Disconnect the security control unit harness connector. 2) Measure the resistance between the security horn relay harness connector terminal and security control unit harness connector terminal. <i>Connector & terminal</i> <i>(B243) No. 3 — (B93) No. 18:</i> | Is the resistance less than 10 Ω ? | Go to step 5 . | Check the harness for open circuits and shorts between the security horn relay and security control unit. |
| 5 CHECK HARNESS BETWEEN SECURITY HORN RELAY AND SECURITY CONTROL UNIT. Measure the resistance between the security horn relay harness connector terminal and security control unit harness connector terminal. <i>Connector & terminal</i> <i>(B243) No. 4 — (B93) No. 16:</i> | Is the resistance less than 10 Ω ? | Go to step 6 . | Check the harness for open circuits and shorts between the security horn relay and security control unit. |
| 6 CHECK HARNESS BETWEEN SECURITY CONTROL UNIT AND SECURITY HORN. 1) Disconnect the security horn harness connector. 2) Measure the resistance between the security control unit harness connector terminal and security horn harness connector terminal. <i>Connector & terminal</i> <i>(B93) No. 17 — (B204) No. 1:</i> | Is the resistance less than 10 Ω ? | Go to step 7 . | Check the harness for open circuits and shorts between the security control unit and security horn. |
| 7 CHECK SECURITY HORN. Remove and check the security horn. <Ref. to SL-52, Security Horn.> | Is the security horn OK? | Replace the security control unit. | Replace the security horn. |

Security System

SECURITY AND LOCKS

9. CHECK HAZARD LIGHT OPERATION

| Step | Check | Yes | No |
|---|---|---|---|
| 1 CHECK SECURITY CONTROL UNIT OUTPUT SIGNAL. 1) Remove the key from the ignition switch. 2) Open the driver's window, and then close all doors and rear gate. 3) Lock all doors with the keyless transmitter or door lock switch to arm the security system. 4) Unlock all doors with the door lock switch. 5) Measure the voltage between the security control unit harness connector terminal and chassis ground when any door is open. Connector & terminal (B93) No. 10 (+) — Chassis ground (-): | Is the voltage 1 — 4 V? | Go to step 2. | Replace the security control unit. |
| 2 CHECK HARNESS BETWEEN SECURITY CONTROL UNIT AND KEYLESS ENTRY CONTROL UNIT. 1) Disconnect the security control unit harness connector and keyless entry control unit harness connector. 2) Measure the resistance between the security control unit harness connector terminal and keyless entry control unit harness connector terminal. Connector & terminal (B93) No. 10 — (B176) No. 3: | Is the resistance less than 10 Ω ? | Check the hazard light output of keyless entry control unit. <Ref. to SL-19, CHECK HAZARD LIGHT OPERATION, INSPECTION, Keyless Entry System.> | Check the harness for open circuit and shorts between the security control unit and keyless entry control unit. |

10. CHECK INTERRUPT RELAY CIRCUIT

| Step | Check | Yes | No |
|---|--|------------------------------------|---|
| 1 CHECK INTERRUPT RELAY. Remove and check the interrupt relay. <Ref. to SL-54, Interrupt Relay.> | Is the interrupt relay OK? | Go to step 2. | Replace the interrupt relay. |
| 2 CHECK POWER SUPPLY FOR INTERRUPT RELAY. Measure the voltage between the interrupt relay harness connector terminal and chassis ground. Connector & terminal (B59) No. 1 (+) — Chassis ground (-): | Is the voltage more than 10 V when ignition switch is turned to START? | Go to step 3. | Check the harness for open circuits and shorts between the interrupt relay and ignition switch. |
| 3 CHECK HARNESS BETWEEN INTERRUPT RELAY AND SECURITY CONTROL UNIT. 1) Turn the ignition switch to OFF. 2) Disconnect the security control unit harness connector. 3) Measure the resistance between the interrupt relay harness connector terminal and security control unit harness connector terminal. Connector & terminal (B59) No. 4 — (B93) No. 15: | Is the resistance less than 10 Ω ? | Replace the security control unit. | Check the harness for open circuits and shorts between the interrupt relay and security control unit. |

11.CHECK IGNITION SWITCH CIRCUIT

| Step | Check | Yes | No |
|--|--------------------------------|--------------------------------|---|
| 1 CHECK IGNITION SWITCH SIGNAL. 1) Disconnect the security control unit harness connector. 2) Turn the ignition switch to ON. 3) Measure the voltage between the harness connector terminal and chassis ground. Connector & terminal (B93) No. 2 (+) — Chassis ground (-): | Is the voltage more than 10 V? | Ignition switch circuit is OK. | Check the harness for open circuits and shorts between the security control unit and ignition switch. |

5. Front Inner Remote

A: REMOVAL

- 1) Remove the door trim. <Ref. to EI-42, REMOVAL, Front Door Trim.>
- 2) Remove the sealing cover. <Ref. to EB-17, REMOVAL, Front Sealing Cover.>
- 3) Remove a screw and two rod joints.
- 4) Remove the front inner remote.

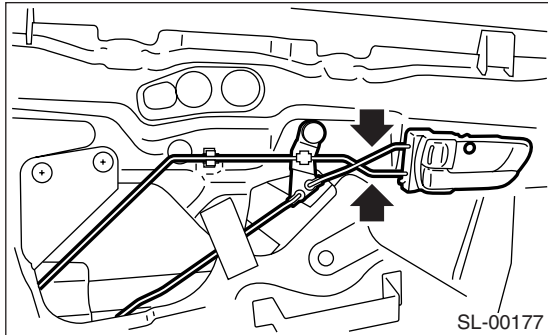

B: INSTALLATION

Install in the reverse order of removal.

NOTE:

Make sure the inner remote works properly after installation.

C: INSPECTION

- 1) Make sure the rod is not deformed.
- 2) Make sure the lever and rod work smoothly.

6. Front Outer Handle

A: REMOVAL

- 1) Remove the door trim. <Ref. to EI-42, REMOVAL, Front Door Trim.>
- 2) Remove the sealing cover. <Ref. to EB-17, REMOVAL, Front Sealing Cover.>
- 3) Remove the bolt (A).
- 4) Move the front door glass downward. Remove the bolt and rod clamp.
- 5) Remove the front outer handle.

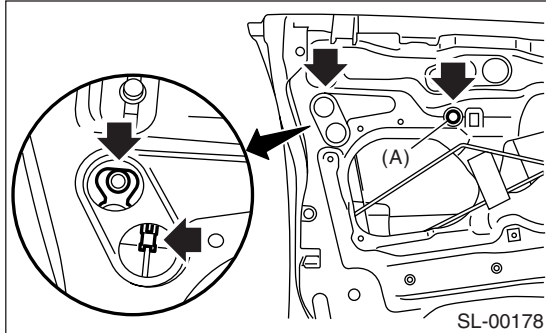

CAUTION:

Do not use excessive force to remove the handle from door panel. This will deform it.

B: INSTALLATION

Install in the reverse order of removal.

NOTE:

Make sure the outer handle works properly after installation.

C: INSPECTION

- 1) Make sure the rod is not deformed.
- 2) Make sure the lever and rod work smoothly.

Front Door Latch and Door Lock Actuator Assembly

SECURITY AND LOCKS

7. Front Door Latch and Door Lock Actuator Assembly

A: REMOVAL

- 1) Disconnect the ground cable from battery.
- 2) Remove the front door trim. <Ref. to EI-42, REMOVAL, Front Door Trim.>
- 3) Remove the sealing cover. <Ref. to EB-17, REMOVAL, Front Sealing Cover.>
- 4) Remove the front inner remote. <Ref. to SL-30, REMOVAL, Front Inner Remote.>
- 5) Remove three screws and a bolt.

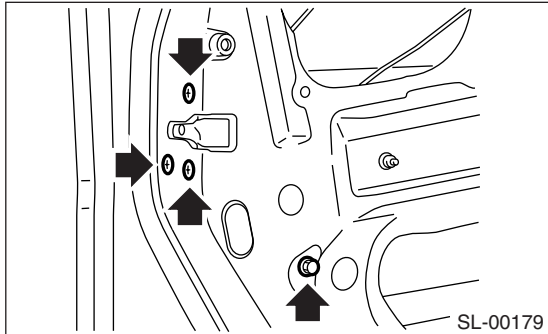

- 6) Remove the front door latch assembly, and then disconnect the connector.

B: INSTALLATION

Install in the reverse order of removal.

NOTE:

Make sure the lock works properly after installation.

C: INSPECTION

- 1) Make sure the rod is not deformed.
- 2) Make sure the lever and rod work smoothly.

8. Front Door Lock Actuator

A: REMOVAL

- 1) Remove the front door latch assembly. <Ref. to SL-32, REMOVAL, Front Door Latch and Door Lock Actuator Assembly.>
- 2) Remove the two screws to remove front door lock actuator.

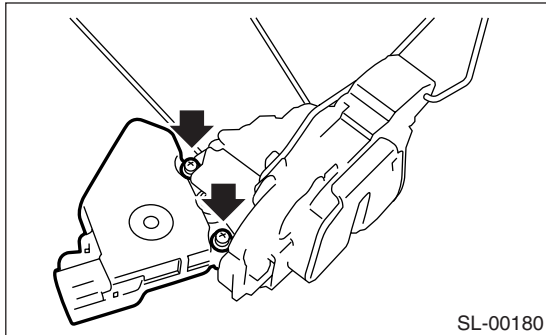

B: INSTALLATION

Install in the reverse order of removal.

NOTE:

Make sure the lock works properly after installation.

C: INSPECTION

- 1) Disconnect the door lock actuator harness connector.
- 2) Connect the battery to door lock actuator terminals.

If NG, replace the door lock actuator.

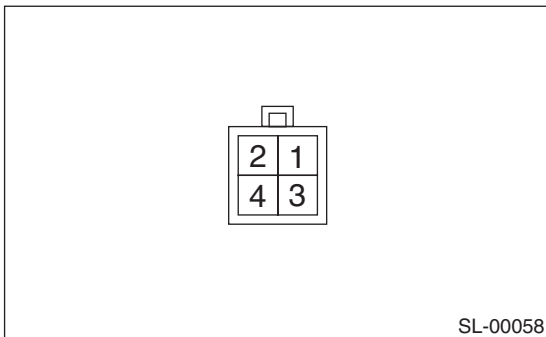

| Terminal No. | Actuator operation |
|-------------------------|--------------------|
| No. 3 (+) and No. 1 (-) | Unlocked → Locked |
| No. 1 (+) and No. 3 (-) | Locked → Unlocked |

9. Rear Inner Remote

A: REMOVAL

- 1) Remove the rear door trim. <Ref. to EI-43, REMOVAL, Rear Door Trim.>
- 2) Remove the sealing cover. <Ref. to EB-20, REMOVAL, Rear Sealing Cover.>
- 3) Remove a screw and two rod joints.
- 4) Remove the inner remote.

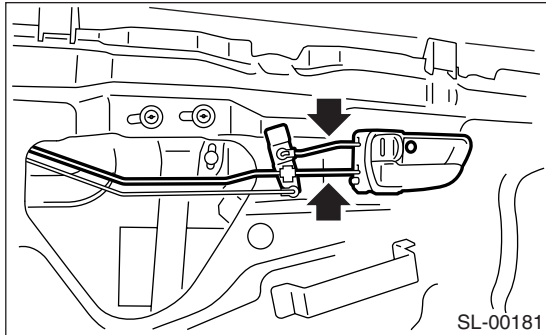

B: INSTALLATION

Install in the reverse order of removal.

NOTE:

Make sure the inner remote works properly after installation.

C: INSPECTION

- 1) Make sure the rod is not deformed.
- 2) Make sure the lever and rod work smoothly.
- 3) Make sure the child safety lock work properly.

10.Rear Outer Handle

A: REMOVAL

- 1) Remove the rear door trim. <Ref. to EI-43, REMOVAL, Rear Door Trim.>
- 2) Remove the sealing cover. <Ref. to EB-20, REMOVAL, Rear Sealing Cover.>
- 3) Remove the rear inner remote. <Ref. to SL-34, REMOVAL, Rear Inner Remote.>
- 4) Remove the rear door latch assembly. <Ref. to SL-36, REMOVAL, Rear Door Latch and Door Lock Actuator Assembly.>
- 5) Loosen two bolts and a nut to remove the rear outer handle.

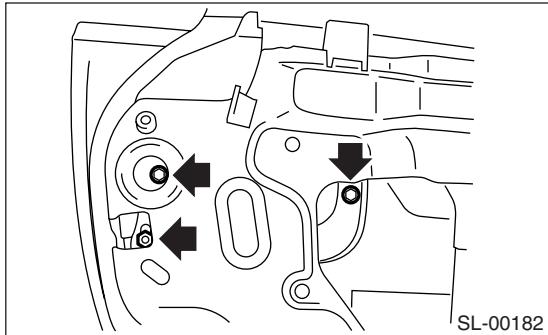

CAUTION:

Do not use excessive force to remove the handle from door panel. This will deform it.

B: INSTALLATION

Install in the reverse order of removal.

NOTE:

Make sure the outer handle works properly after installation.

C: INSPECTION

- 1) Make sure the rod is not deformed.
- 2) Make sure the lever and rod work smoothly.

Rear Door Latch and Door Lock Actuator Assembly

SECURITY AND LOCKS

11. Rear Door Latch and Door Lock Actuator Assembly

A: REMOVAL

- 1) Disconnect the ground cable from battery.
- 2) Remove the rear door trim. <Ref. to EI-43, REMOVAL, Rear Door Trim.>
- 3) Remove the sealing cover. <Ref. to EB-20, REMOVAL, Rear Sealing Cover.>
- 4) Remove the rear inner remote. <Ref. to SL-34, REMOVAL, Rear Inner Remote.>
- 5) Remove three screws and a bolt.

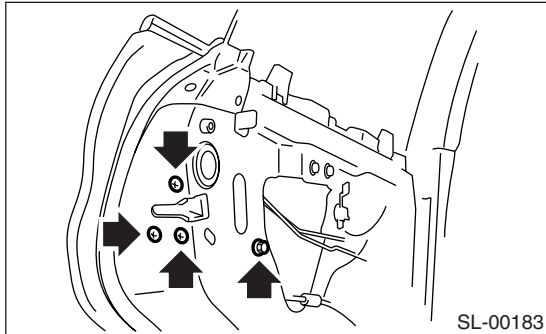

- 6) Disconnect the connector, and then remove the rear door latch assembly.

B: INSTALLATION

Install in the reverse order of removal.

NOTE:

Make sure the lock works properly after installation.

C: INSPECTION

- 1) Make sure the rod is not deformed.
- 2) Make sure the lever and rod work smoothly.

12.Rear Door Lock Actuator

A: REMOVAL

- 1) Remove the rear door latch assembly. <Ref. to SL-36, REMOVAL, Rear Door Latch and Door Lock Actuator Assembly.>
- 2) Loosen two screws to remove rear door lock actuator.

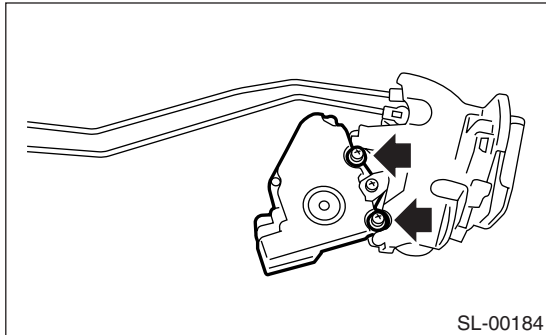

B: INSTALLATION

Install in the reverse order of removal.

NOTE:

Make sure the lock works properly after installation.

C: INSPECTION

- 1) Disconnect the door lock actuator harness connector.
- 2) Connect the battery to door lock actuator terminals.

If NG, replace the door lock actuator.

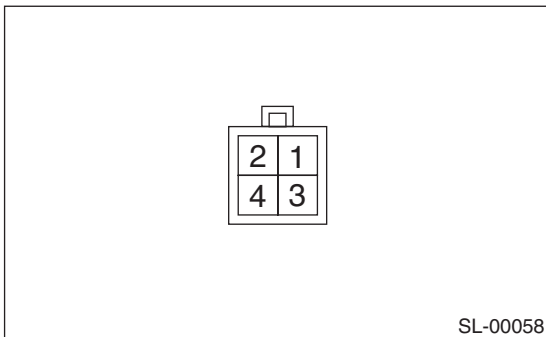

| Terminal No. | Actuator operation |
|-------------------------|--------------------|
| No. 3 (+) and No. 1 (-) | Unlocked → Locked |
| No. 1 (+) and No. 3 (-) | Locked → Unlocked |

13.Rear Gate Outer Handle

A: REMOVAL

- 1) Remove the rear gate trim. <Ref. to EI-57, REMOVAL, Rear Gate Trim.>
- 2) Remove the link and cable, and then loosen two nuts to remove the rear gate outer handle.

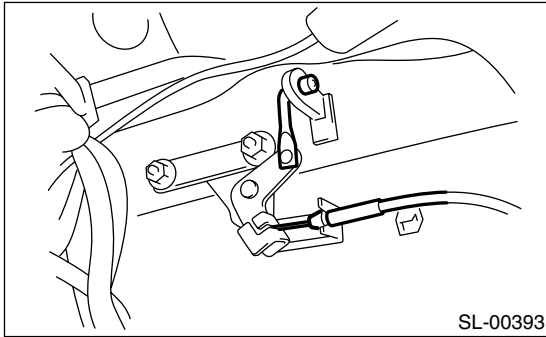

B: INSTALLATION

Install in the reverse order of removal.

NOTE:

Make sure the outer handle works properly after installation.

C: INSPECTION

- 1) Inspect the rod for deformation.
- 2) Make sure the lever and rod move smoothly.

14. Rear Gate Latch Assembly

A: REMOVAL

- 1) Disconnect the ground cable from battery.
- 2) Remove the rear gate trim. <Ref. to EI-57, REMOVAL, Rear Gate Trim.>
- 3) Remove three bolts.

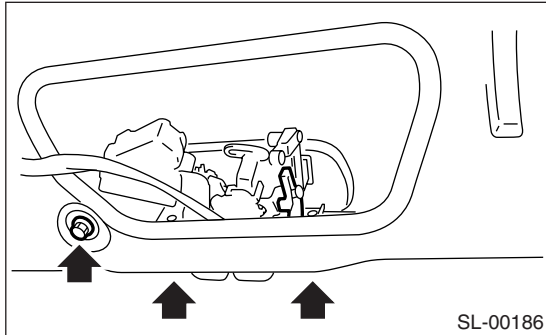

- 4) Disconnect the connectors, and then remove the rear gate latch assembly.

B: INSTALLATION

Install in the reverse order of removal.

NOTE:

Make sure the lock works properly after installation.

C: INSPECTION

- 1) Make sure the rod is not deformed.
- 2) Make sure the lever and rod work smoothly.

15. Rear Gate Latch Lock Actuator

A: REMOVAL

- 1) Remove the rear gate latch assembly. <Ref. to SL-39, REMOVAL, Rear Gate Latch Assembly.>
- 2) Loosen two screws to remove the rear gate lock actuator.

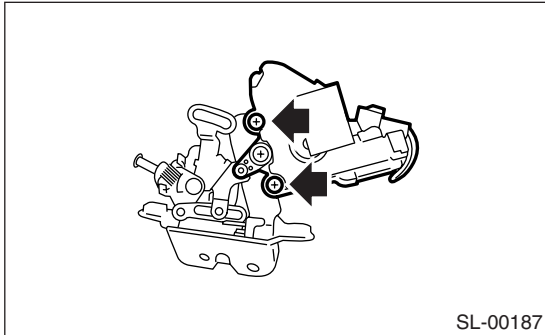

B: INSTALLATION

Install in the reverse order of removal.

NOTE:

Make sure the lock works properly after installation.

C: INSPECTION

- 1) Disconnect the door lock actuator harness connector.
- 2) Connect the battery to door lock actuator terminals.

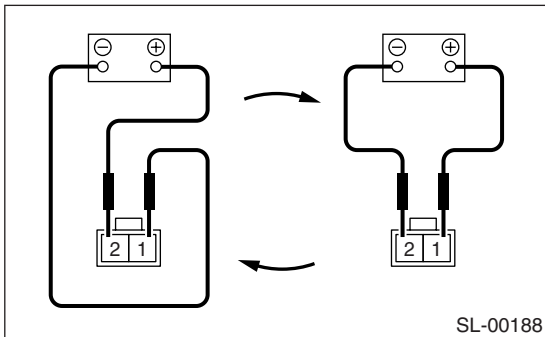

| Terminal No. | Actuator operation |
|-------------------------|--------------------|
| No. 1 (+) and No. 2 (-) | Unlocked → Locked |
| No. 2 (+) and No. 1 (-) | Locked → Unlocked |

If NG, replace the rear gate latch lock actuator.

16. Trunk Lid Lock Assembly

A: REMOVAL

- 1) Remove the trunk lid key cylinder rod clamp.
- 2) Loosen two bolts to remove the trunk lid lock assembly.

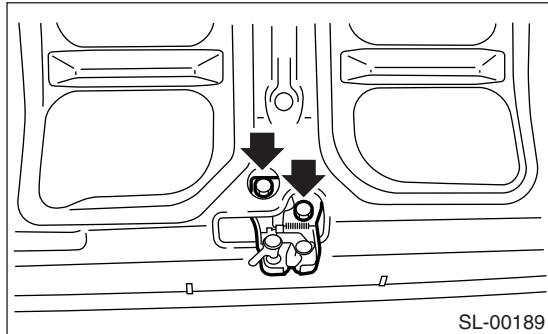

B: INSTALLATION

Install in the reverse order of removal.

NOTE:

- Apply grease to parts that rub.
- Make sure the lock works properly after installation.

C: INSPECTION

- 1) Check the striker for bending or abnormal wear.
- 2) Check the safety lever for improper movement.
- 3) Check other levers and the spring for rust formation and unsmooth movement.

17. Trunk Lid Release Handle

A: REMOVAL

1) Remove the five clips.

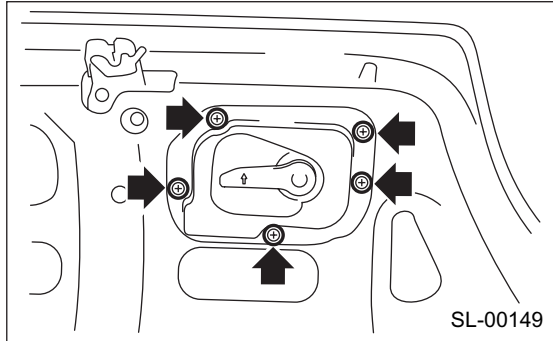

2) Remove the cable from trunk lid release handle.

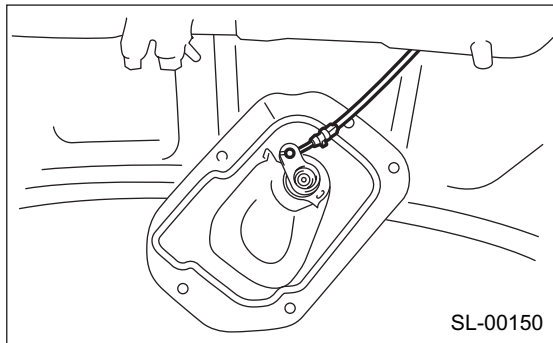

B: INSTALLATION

Install in the reverse order of removal.

C: INSPECTION

- 1) Make sure the cable is not deformed.
- 2) Make sure the lever works smoothly.

18. Front Hood Lock Assembly

A: REMOVAL

- 1) Open the front hood.
- 2) Remove the bolts. Remove the hood lock assembly.

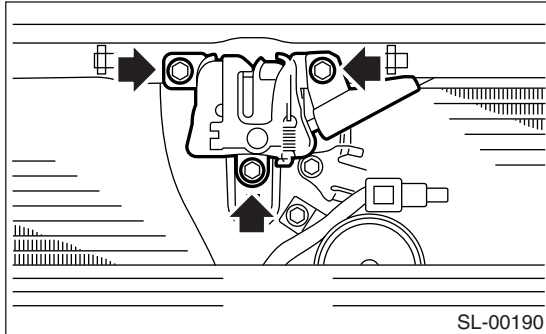

- 3) Remove the release cable from lock assembly.

B: INSTALLATION

Install in the reverse order of removal.

NOTE:

- Apply grease to parts that rub.
- Make sure the release cable works properly after installation.

C: ADJUSTMENT

Loosen the bolt. Adjust the lock assembly while moving it up and down.

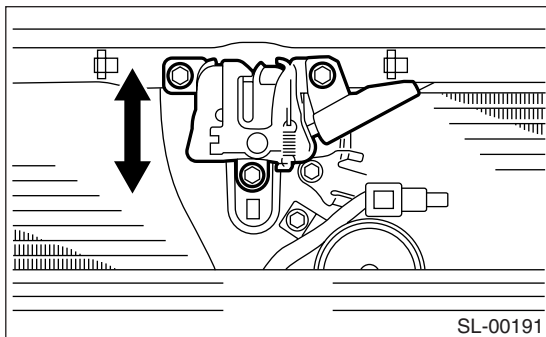

D: INSPECTION

- 1) Check the striker for bending or abnormal wear.
- 2) Check the safety lever for improper movement.
- 3) Check other levers and the spring for rust formation and unsmooth movement.

19. Remote Openers

A: REMOVAL

1. HOOD OPENER

- 1) Remove the release cable from hood lock.
- 2) Remove the bolt. Remove the opener lever.

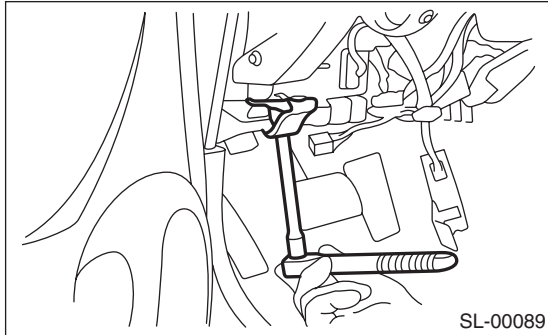

2. TRUNK LID OPENER

- 1) Remove the rear seat. <Ref. to SE-12, REMOVAL, Rear Seat.>
- 2) Remove the center pillar lower trim, and remove the side sill cover on passenger side. Remove the rear pillar lower trim. Pull back the floor mat. Remove the clip holding the cable.
- 3) Remove the bolt. Remove the opener pull handle.

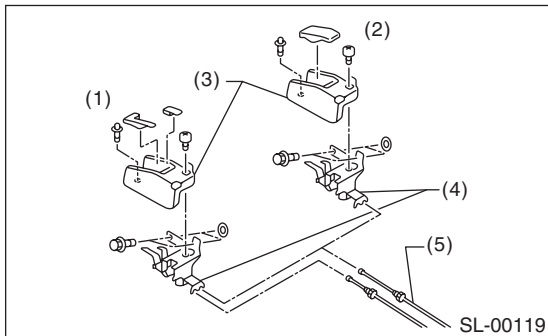

- (1) Sedan
- (2) Wagon
- (3) Cover
- (4) Pull handle ASSY
- (5) Cable

- 4) Remove the cable from opener pull handle.
- 5) Remove the striker from trunk lid.

- 6) Remove the cable from striker.

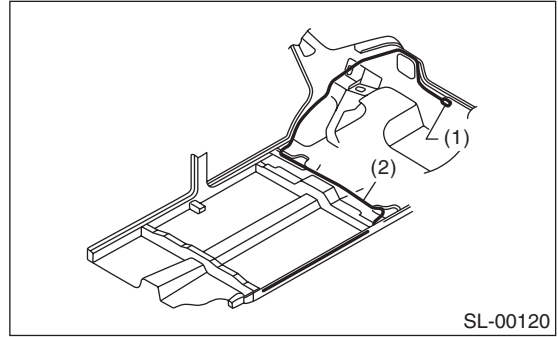

- (1) Striker
- (2) Cable

3. FUEL FLAP OPENER

- 1) Remove the rear seat. <Ref. to SE-12, REMOVAL, Rear Seat.>
- 2) Remove the center pillar lower trim, and remove the side sill cover on passenger side. Remove the rear pillar lower trim. Pull back the floor mat. Remove the clip holding the cable.
- 3) Remove the bolt. Remove the opener pull handle.

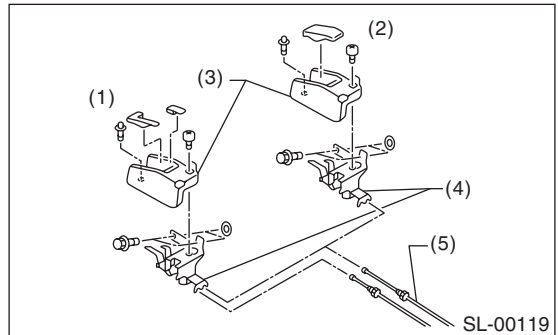

- (1) Sedan
- (2) Wagon
- (3) Cover
- (4) Pull handle ASSY
- (5) Cable

- 4) Remove the cable from opener pull handle.
- 5) Remove the right rear quarter trim. <Ref. to EI-53, REMOVAL, Rear Quarter Trim.>

6) Rotate the fuel lock inside the quarter panel to left and remove.

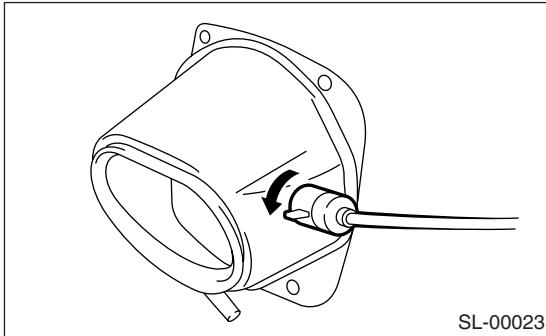

B: INSTALLATION

1. HOOD OPENER

Install in the reverse order of removal.

2. TRUNK LID OPENER

Install in the reverse order of removal.

3. FUEL FLAP OPENER

Install in the reverse order of removal.

C: INSPECTION

Make sure the fuel flap opens and closes smoothly.

20. Ignition Key Lock

A: REPLACEMENT

- 1) Remove the ground cable from battery.
- 2) Remove the steering column. <Ref. to PS-24, REMOVAL, Tilt Steering Column.>
- 3) Secure the steering column in a vise. Remove the bolt with a drill.

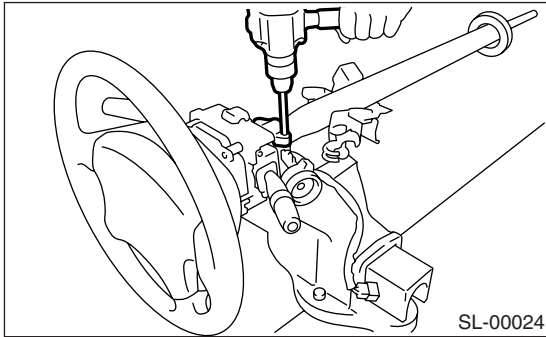

- 4) Remove the ignition key lock.
- 5) Use a new torn bolt. Tighten the torn bolt to end of thread.

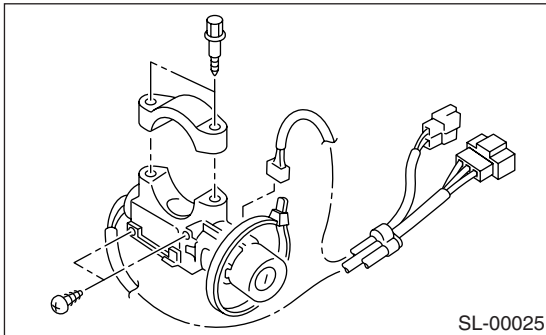

B: INSPECTION

- 1) Remove the instrument panel lower cover.
- 2) Remove the lower column cover.
- 3) Unfasten the hold-down clip which secures harness and disconnect the connector of ignition switch from body harness.
- 4) Turn the ignition key plate to each position and check the continuity between terminals of ignition connector.

| Switch position | Terminal No. | Standard |
|-----------------|---|---------------|
| LOCK | — | — |
| ACC | No. 1 and No. 2 | Less than 1 Ω |
| ON | No. 1 and No. 2 No. 1 and No. 4 No. 2 and No. 4 | Less than 1 Ω |
| ST | No. 1 and No. 3 No. 1 and No. 4 No. 3 and No. 4 | Less than 1 Ω |

If NG, replace the ignition switch.

21. Key Lock Cylinders

A: REPLACEMENT

1. FRONT DOOR

- 1) Remove the door trim. <Ref. to EI-42, REMOVAL, Front Door Trim.>
- 2) Pull back the sealing cover.
- 3) Move the front door glass downward.
- 4) Remove the rod clamp. Remove the bolt. Replace the key cylinder.

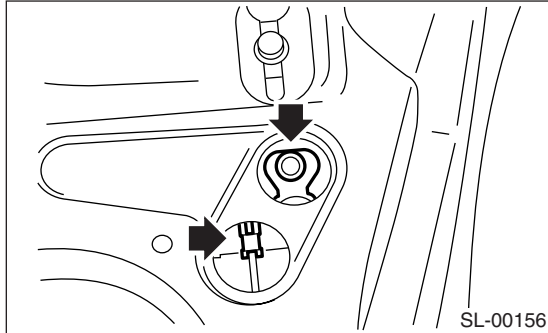

2. TRUNK LID

- 1) Remove the trunk lid release handle. <Ref. to SL-42, Trunk Lid Release Handle.>
- 2) Remove the rod clamp. Remove the lock plate. Replace the key cylinder.

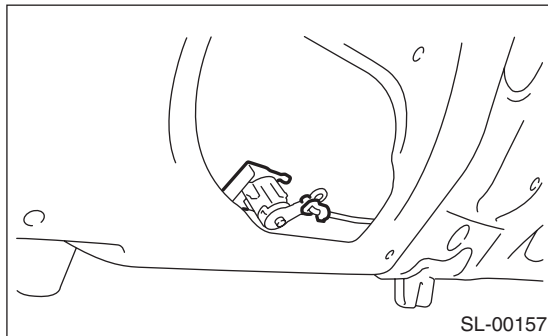

22. Immobilizer Control Unit

A: REMOVAL

NOTE:

- Prepare the security ID plate.
 - Prepare all registered immobilizer keys for the model with immobilizer.
 - Make a registration of immobilizer for the model with immobilizer. For detailed operation procedure, refer to "IMMOBILIZER REGISTRATION MANUAL".
 - If replacing the immobilizer control unit, check the current setting and note it. <Ref. to IM(diag)-7, OPERATION, Subaru Select Monitor.>
- 1) Disconnect the ground cable from battery.
 - 2) Remove the instrument panel lower cover. <Ref. to EI-48, REMOVAL, Instrument Panel Assembly.>
 - 3) Disconnect the connector from immobilizer control unit.
 - 4) Remove the immobilizer control unit.

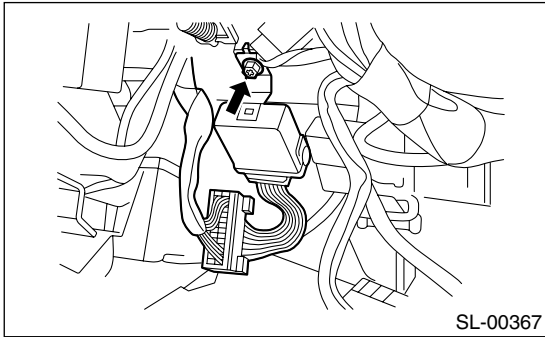

B: INSTALLATION

Install in the reverse order of removal.

NOTE:

Make sure it conforms to the current setting condition after installation. <Ref. to IM(diag)-7, OPERATION, Subaru Select Monitor.>

23. Immobilizer Antenna

A: REMOVAL

- 1) Disconnect the ground cable from battery.
- 2) Remove the instrument panel lower cover. <Ref. to EI-48, REMOVAL, Instrument Panel Assembly.>
- 3) Remove the screws, separate upper column cover and lower column cover.

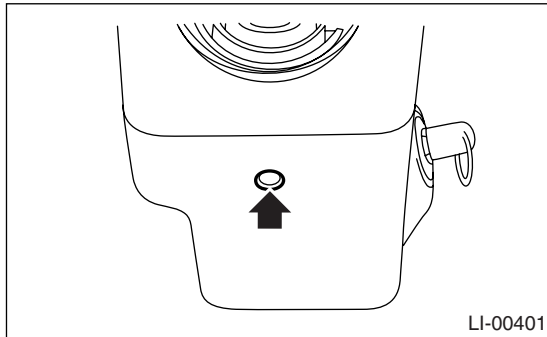

- 4) Disconnect the immobilizer antenna connector (A) from body harness.
- 5) Remove the screw, and detach the immobilizer antenna (B).

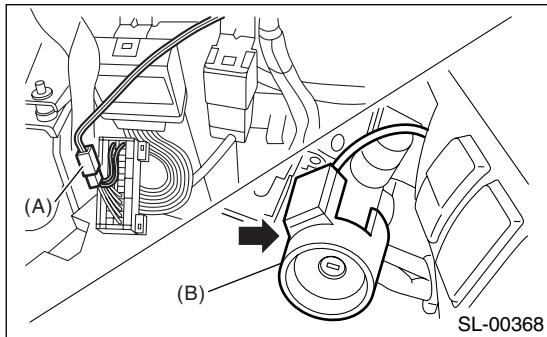

B: INSTALLATION

Install in the reverse order of removal.

Security Control Unit

SECURITY AND LOCKS

24. Security Control Unit

A: REMOVAL

- 1) Disconnect the ground cable from battery.
- 2) Remove the glove box. <Ref. to EI-44, REMOVAL, Glove Box.>
- 3) Disconnect the connector from the security control unit.
- 4) Remove the security control unit.

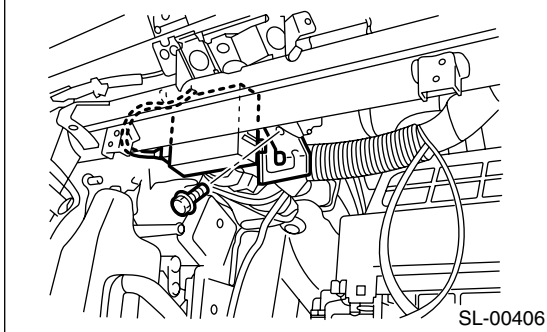

B: INSTALLATION

Install in the reverse order of removal.

Tightening torque (Security Control Unit Bracket):

$10 \pm 1.5 \text{ N}\cdot\text{m}$ ($1.0 \pm 0.15 \text{ kgf}\cdot\text{m}$, $7.5 \pm 1 \text{ ft}\cdot\text{lb}$)

C: INSPECTION

1. IMPACT SENSITIVITY TEST

- 1) Remove the key from the ignition switch.
- 2) Close all windows.
- 3) Close all doors and the rear gate.
- 4) Cover the hood with a blanket.
- 5) Press the LOCK/ARM button of the keyless transmitter.
- 6) Confirm that the security indicator light blinks every 2 seconds.
- 7) Hit the center of the windshield with your palm and make sure the alarm operates.

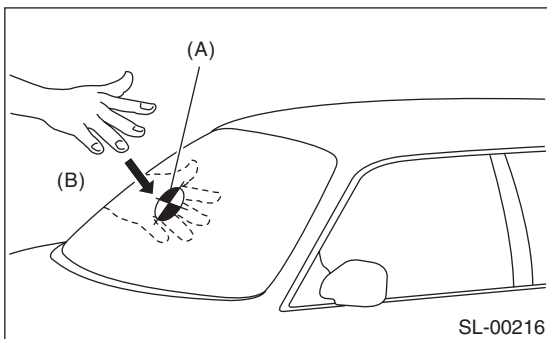

- (A) Center of windshield
(B) Hit with palm

If NG, adjust the impact sensitivity. <Ref. to SL-50, ADJUSTMENT, Security Control Unit.>

D: ADJUSTMENT

1. IMPACT SENSITIVITY

NOTE:

Before adjustment, make sure the security control unit has been securely installed on the bracket.

- 1) Remove the security control unit. <Ref. to SL-50, REMOVAL, Security Control Unit.>
- 2) Adjust the sensitivity adjust screw in the security control unit.

NOTE:

After adjusting, be sure to plug the adjust screw hole.

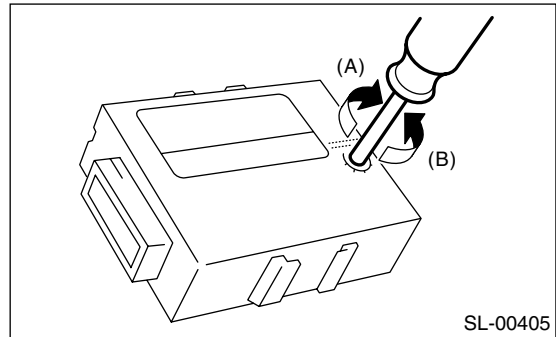

- (A) Max.
(B) Min.

- 3) Install the security control unit.
- 4) Perform the impact sensitivity test.

E: PROCEDURE

1. PASSIVE ARMING (ENTER THE PASSIVE MODE)

NOTE:

When passive arming mode has been programmed, arming of the system is automatically accomplished without using the remote transmitter. Note that in this mode, DOORS MUST BE LOCKED.

• To enter the passive mode

- 1) Open the driver's door.
- 2) Remove the two clips fastening the front portion of the side sill cover with a screwdriver.

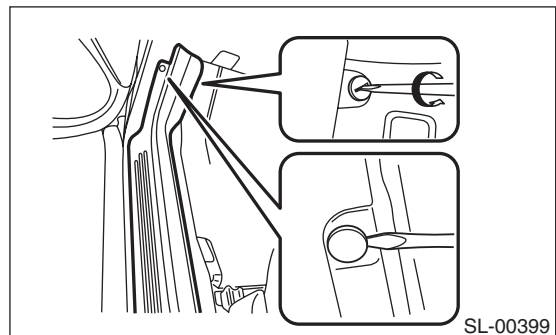

- 3) Remove the side sill cover by pulling it up.
- 4) Connect the connector (A).

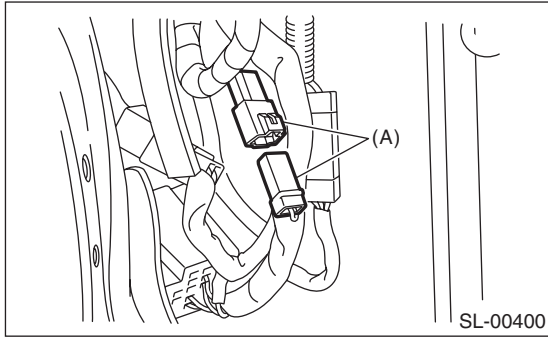

CAUTION:

Use extra care to the airbag system harnesses when setting the passive mode. Disconnection of connector could result in accidental inflation of airbag system.

NOTE:

To place the system in active arming mode, disconnect the connector (A).

- 5) Turn the ignition switch from LOCK to ON.
- 6) Install the side sill cover.

• Arming the system

- 1) Turn the ignition switch to ON.
- 2) Turn the ignition switch from ON to LOCK, and remove the key from ignition switch.

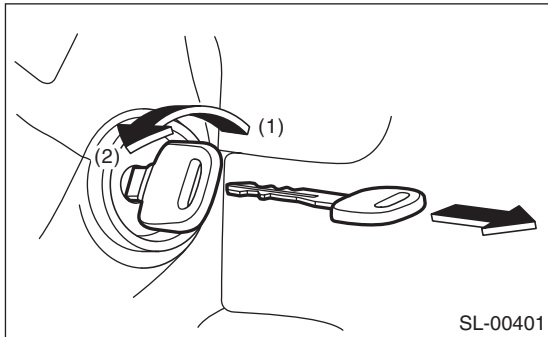

- (1) ON
- (2) LOCK

- 3) Open the door, and get out of the vehicle.
- 4) Before closing the doors, lock all doors with the inside door lock levers.

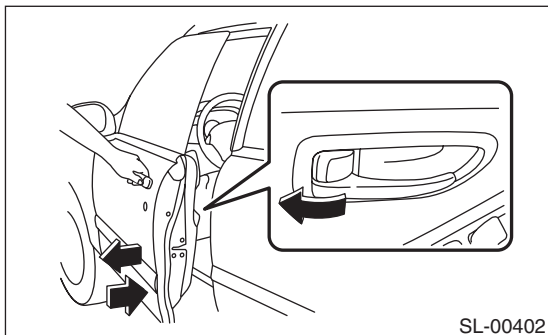

- 5) Close the doors. The system will automatically arm after one minute.

NOTE:

In the passive mode, the system can also be armed with the remote transmitter or with the power door locking switches. If the remote transmitter or power door lock switch is used to lock the vehicle, arming will take place immediately regardless of whether or not the passive mode has been selected.

CAUTION:

In passive mode, the system will automatically activate the alarm but **WILL NOT** automatically lock the doors. In order to lock the doors, you must either lock them as indicated in step 4) above or with the key once they have been closed. Failure to lock the doors manually will result in a higher security risk.

• Disarming the system

To disarm the system, briefly press the UNLOCK/DISARM button on keyless transmitter.

• Tripped sensor identification

If an electronic chirp sounds four times and the turn signal lights blink four times when you disarm the system, this indicates that the alarm was triggered. The number of times the indicator light blanks indicates what sensor caused the alarm condition.

2. ENTER IDENTIFICATION MODE

- 1) Open the driver's door and leave it open.

NOTE:

Check if the battery cable is connected.

- 2) Turn the ignition switch to ON two times. (LOCK → ON → LOCK → ON → LOCK)
- 3) The indicator light will start blinking.

| Number of times blinked | Vehicle state |
|-------------------------|--|
| 1 time | Any door, rear gate or trunk lid has been opened. |
| 3 times | The impact sensor in the system's unit has been activated. This may indicate that your vehicle has been shocked or tampered with by some outside force and/or unauthorized person. |
| 4 times | The ignition switch has been turned on, or the battery has been disconnected. |

- 4) Close the door and turn the ignition switch to ON.

25. Security Horn

A: REMOVAL

- 1) Disconnect the ground cable from battery.
- 2) Remove the nuts and then detach the security horn while disconnecting the connector.

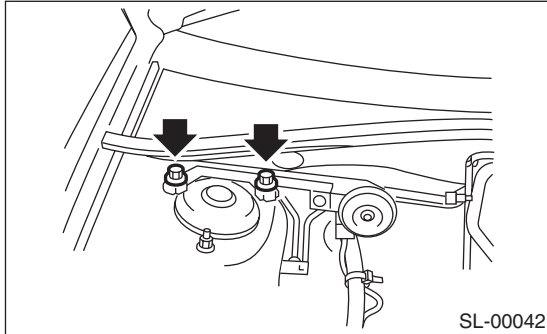

B: INSTALLATION

Install in the reverse order of removal.

C: INSPECTION

Connect the battery to the security horn terminal and case ground and make sure the horn sounds properly.

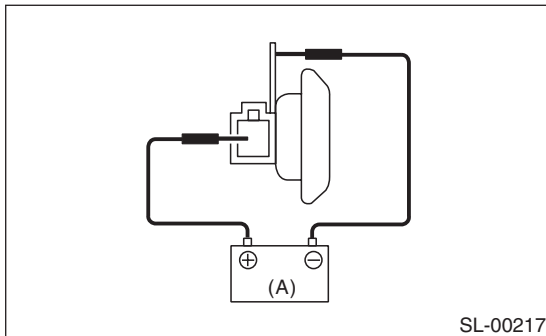

(A) Battery

If NG, replace the security horn.

26. Security Horn Relay

A: REMOVAL

- 1) Disconnect the ground cable from battery.
- 2) Remove the mounting bolt and detach the security horn relay (near the fuse box).

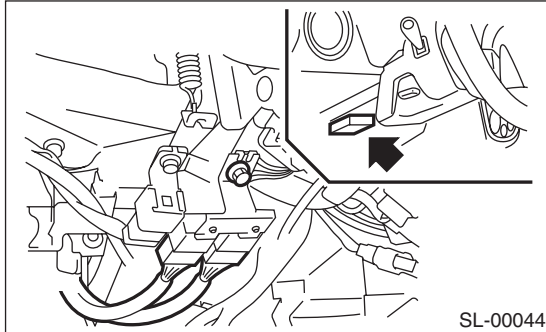

B: INSTALLATION

Install in the reverse order of removal.

C: INSPECTION

Measure the security horn relay resistance between terminals (indicated in the table below) when connecting terminal No. 4 to battery positive terminal and terminal No. 1 to battery ground terminal.

| Current | Terminal No. | Standard |
|---------|--------------|------------------------|
| Flow | 2 and 3 | Less than 1 Ω |
| No flow | | More than 1 M Ω |

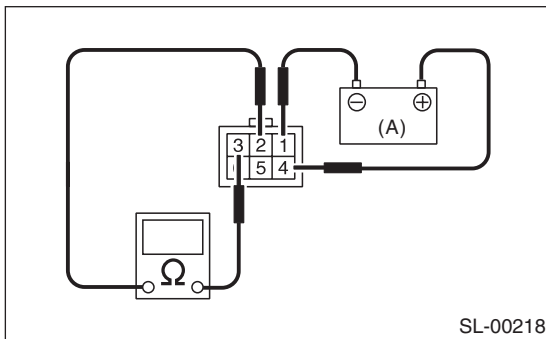

(A) Battery

If NG, replace the security horn relay.

27. Interrupt Relay

A: REMOVAL

- 1) Disconnect the ground cable from battery.
- 2) Remove the mounting nuts and detach the interrupt relay (near the fuse box).

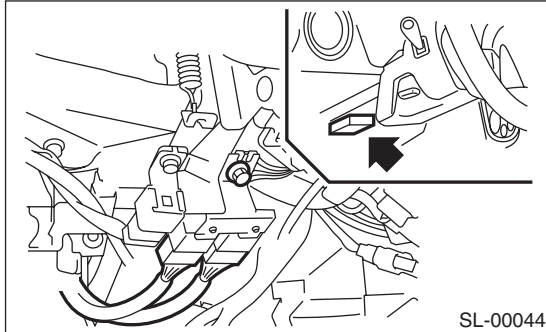

B: INSTALLATION

Install in the reverse order of removal.

C: INSPECTION

Measure the interrupt relay resistance between terminals (indicated in the table below) when connecting terminal No. 4 to battery positive terminal and terminal No. 1 to battery ground terminal.

| Current | Terminal No. | Standard |
|---------|--------------|------------------------|
| Flow | 2 and 6 | Less than 1 Ω |
| No flow | | More than 1 M Ω |

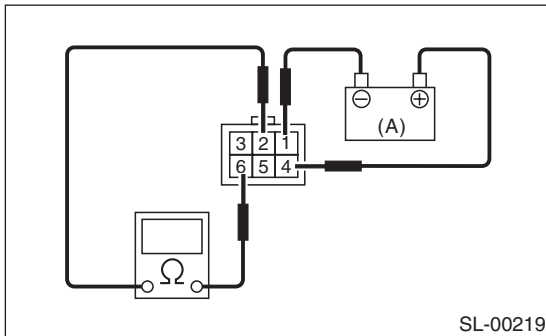

(A) Battery

If NG, replace the interrupt relay.

28. Keyless Entry Control Unit

A: REMOVAL

- 1) Disconnect the ground cable from battery.
- 2) Remove the instrument panel lower cover. <Ref. to EI-48, REMOVAL, Instrument Panel Assembly.>
- 3) Remove the nut, and then remove the keyless entry control unit while disconnecting connector.

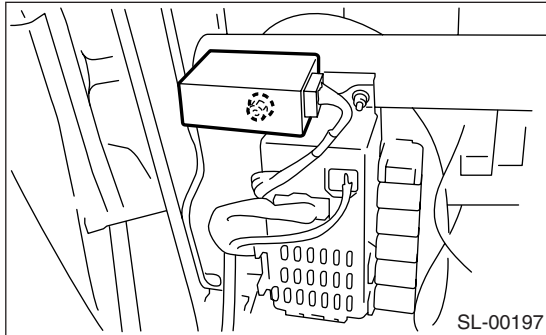

- 4) Disconnect the keyless entry control unit and other electrical control module.

B: INSTALLATION

Install in the reverse order of removal.

29. Body Integrated Unit

A: REMOVAL

- 1) Disconnect the ground cable from battery.
- 2) Remove the instrument panel lower cover. <Ref. to EI-48, REMOVAL, Instrument Panel Assembly.>
- 3) Remove the nut, then remove the body integrated unit while disconnecting the connector.

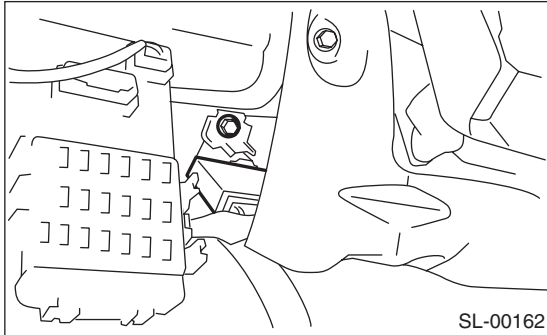

B: INSTALLATION

Install in the reverse order of removal.

30. Keyless Transmitter

A: REMOVAL

1. KEYLESS TRANSMITTER BATTERY

Remove the screw from keyless transmitter, and then remove the battery.

NOTE:

To prevent static electricity damage to keyless transmitter printed circuit board, touch the steel area of building with hand to discharge the static electricity carried on body or clothes before disassembling keyless transmitter.

B: INSTALLATION

1. KEYLESS TRANSMITTER BATTERY

Install in the reverse order of removal.

C: INSPECTION

1. KEYLESS TRANSMITTER BATTERY

Measure the voltage between battery (+) terminal and (-) terminal.

NOTE:

- Battery discharge occurs during measurement. Complete the measurement within 5 seconds.
- During battery voltage measurement, voltage falls more than 1.8 volts in 3 seconds period.

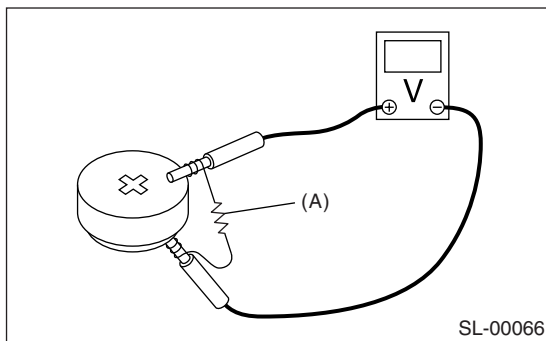

(A) Resistance 47 Ω

| Tester connection | | Standard |
|----------------------|----------------------|-------------|
| (+) | (-) | |
| Battery (+) terminal | Battery (-) terminal | 2.5 — 3.0 V |

If NG, replace the battery. (Use CR1620 or equivalent.)

D: REPLACEMENT

1. KEYLESS TRANSMITTER REGISTRATION

NOTE:

- A maximum of four transmitters can be registered for each individual vehicle.
- When replacing or adding the keyless transmitter (key), registration is also necessary.
- Finish the operation from step 1) through 4) within 45 seconds.

- 1) Sit on the driver's seat and close all doors and rear gate.
- 2) Open the driver's door.
- 3) Close the driver's door.
- 4) Turn the ignition switch from ON to LOCK ten times within 15 seconds.

NOTE:

Do not start the engine at this time.

- 5) The horn chirps one time to indicate that the system has entered in the programming mode.
- 6) Open the driver's door.
- 7) Close the driver's door.
- 8) Press any button on the keyless transmitter that you wish to program into the system.
- 9) Horn will chirp two times to indicate that the keyless transmitter has been programmed.

NOTE:

Repeat steps 6) through 9) for an additional keyless transmitter.

- 10) Remove the ignition key from the ignition switch.
- 11) The horn will chirp three times to indicate that the system has exited the programming mode.
- 12) Check the keyless entry system properly operates by operating each keyless transmitter.

