

WIPER AND WASHER SYSTEMS

General Description

WIPER AND WASHER SYSTEMS

1. General Description

A: SPECIFICATION

Front wiper motor	Input	12 V — 72 W or less
Rear wiper motor	Input	12 V — 42 W or less
Front washer motor	Pump type	Centrifugal
	Input	12 V — 36 W or less
Rear washer motor	Pump type	Centrifugal
	Input	12 V — 36 W or less

B: COMPONENT

1. FRONT WIPER

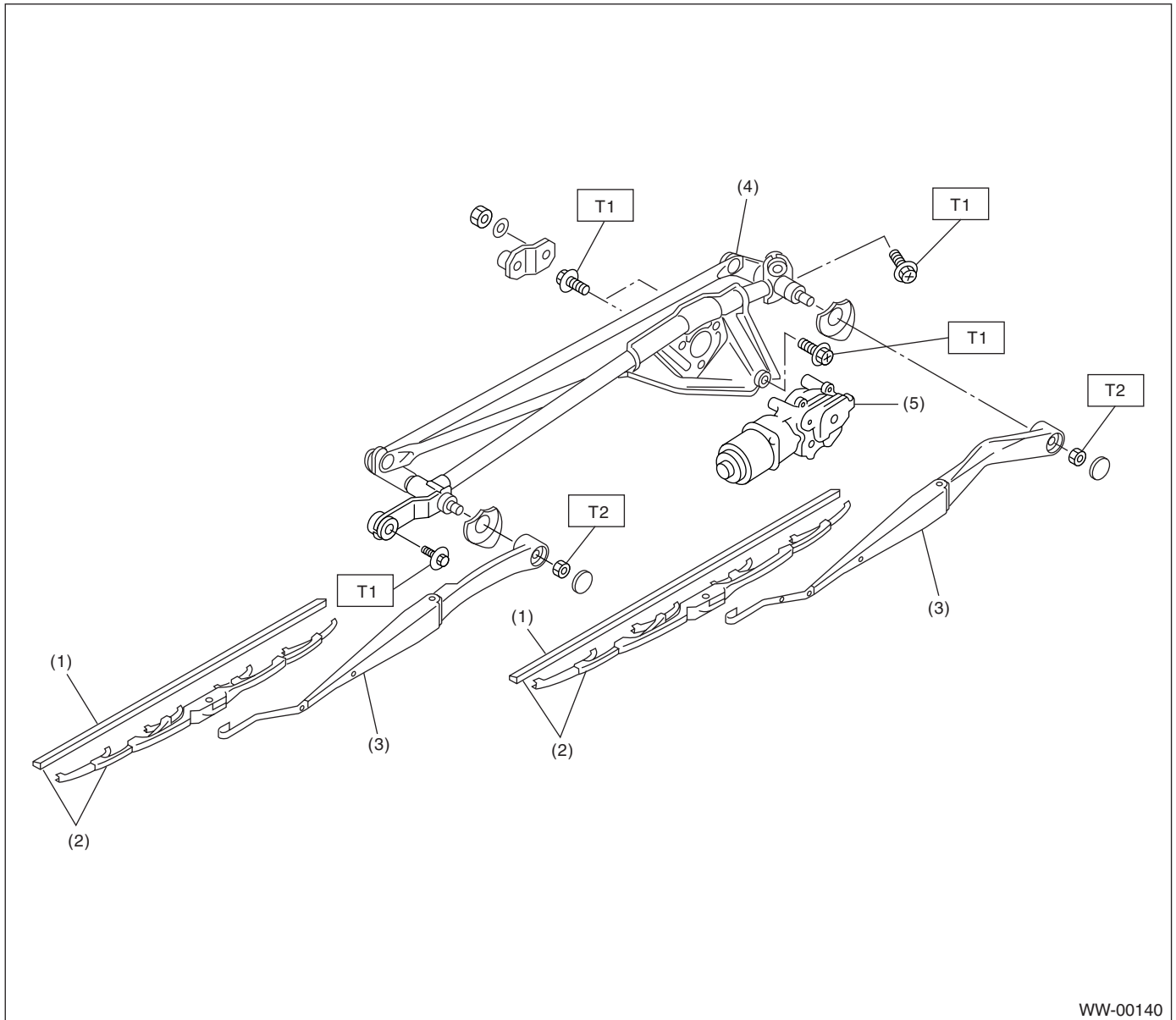

WW-00140

- (1) Wiper rubber
- (2) Wiper blade ASSY
- (3) Wiper arm

- (4) Wiper link
- (5) Wiper motor

Tightening torque: N·m (kgf·m, ft·lb)

T1: 6.0 (0.61, 4.4)

T2: 20 (2.0, 14.5)

2. REAR WIPER

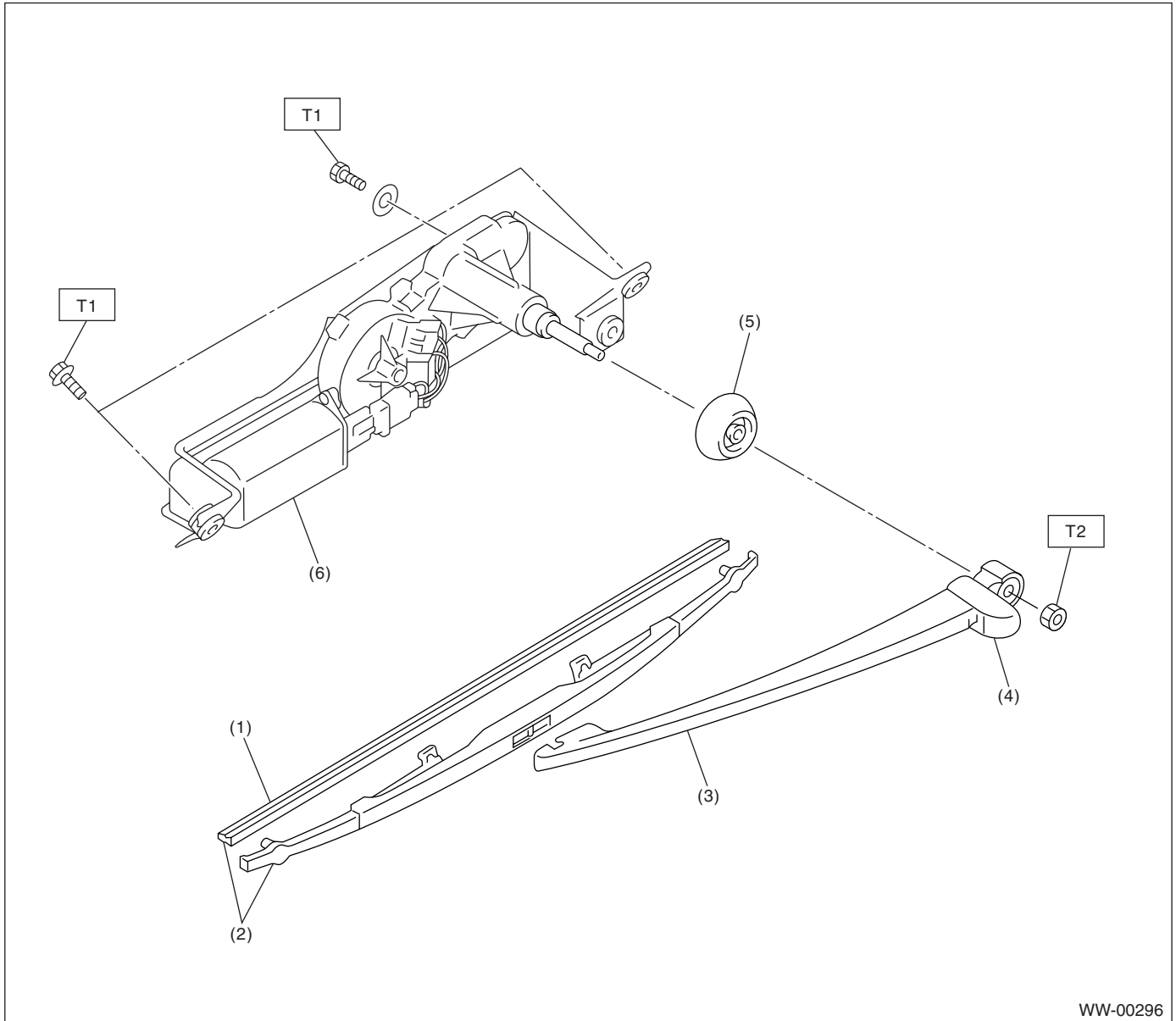

WW-00296

- | | |
|----------------------|---------------------|
| (1) Wiper rubber | (4) Wiper arm cover |
| (2) Wiper blade ASSY | (5) Cap |
| (3) Wiper arm | (6) Wiper motor |

Tightening torque: N·m (kgf·m, ft·lb)

T1: 6.0 (0.61, 4.4)

T2: 8.0 (0.82, 5.9)

General Description

WIPER AND WASHER SYSTEMS

3. WASHER TANK

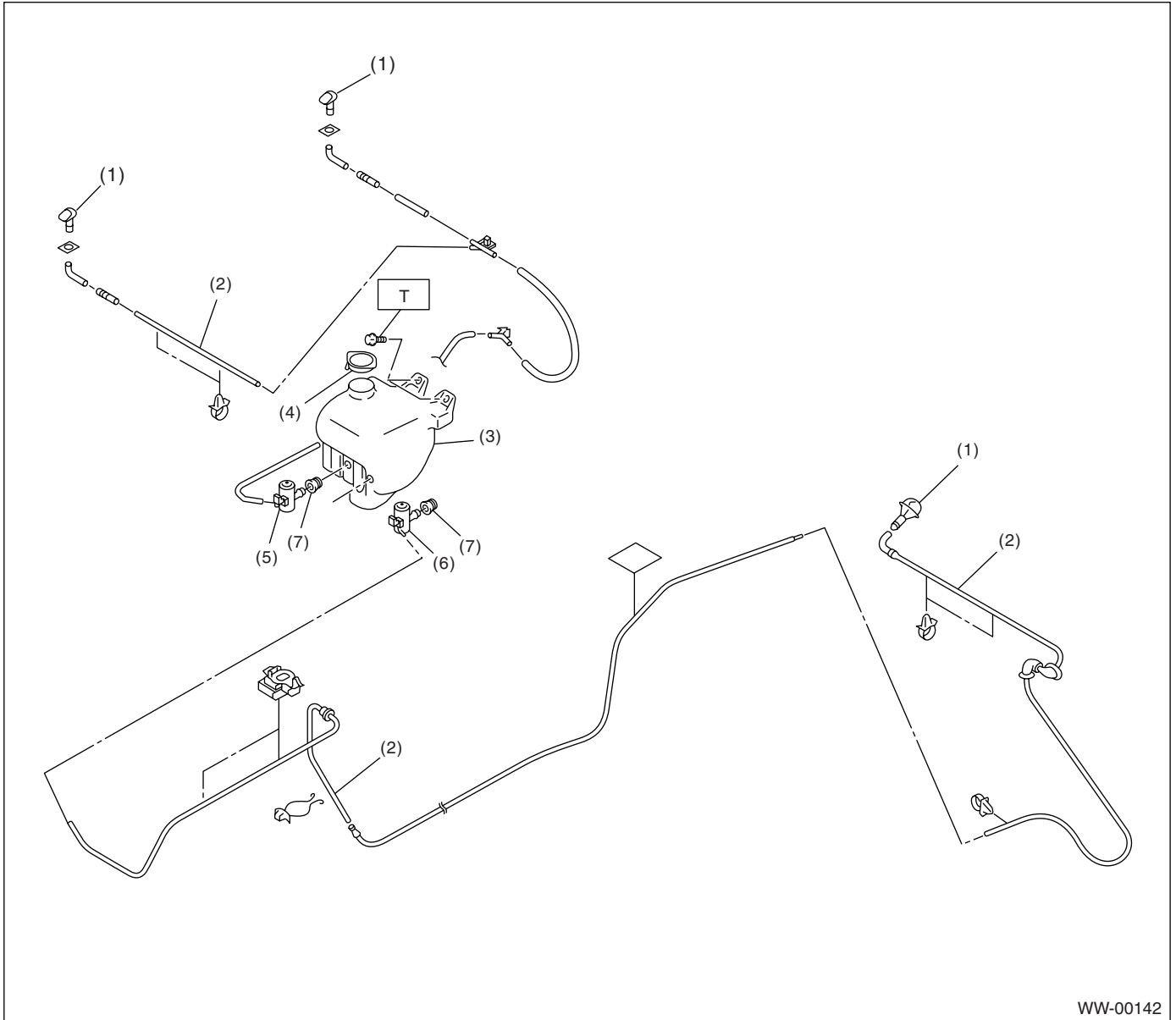

- (1) Washer nozzle
- (2) Washer hose
- (3) Washer tank
- (4) Washer tank cap

- (5) Front washer motor
- (6) Rear washer motor
- (7) Grommet

Tightening torque: N·m (kgf-m, ft-lb)
T: 6.0 (0.61, 4.4)

C: CAUTION

- Connect the connectors and hoses securely during reassembly.
- After reassembly, make sure functional parts operate smoothly.
- Be careful that wiring harnesses of airbag system pass near electrical parts and switches.
- Wiring harnesses and connectors of all airbag system are yellow color. Do not use a tester on these circuits.
- Care must be taken when connecting the piping hose so that no bending, jamming, etc. are caused.
- If even a little oil or grease such as silicon oil gets in the tank and washer passages, an oil film easily forms on the glass, causing the wiper to chatter and judder. Therefore, be careful not to let this happen.

Wiper and Washer System

WIPER AND WASHER SYSTEMS

2. Wiper and Washer System

A: WIRING DIAGRAM

1. WIPER AND WASHER (FRONT)

<Ref. to WI-136, WIRING DIAGRAM, Front Wiper and Washer System.>

2. WIPER AND WASHER (REAR)

<Ref. to WI-137, WIRING DIAGRAM, Rear Wiper and Washer System.>

B: INSPECTION

Symptom	Repair order
Wiper and washers do not operate.	(1) Wiper fuse (F/B No. 14, 15) (2) Combination switch (3) Wiper motor (4) Wiring harness
Wipers do not operate in LO or HI.	(1) Combination switch (2) Wiper motor (3) Wiring harness
Wipers do not operate in INT.	(1) Combination switch (2) Wiper motor (3) Wiring harness
Washer motor does not operate.	(1) Washer switch (2) Washer motor (3) Wiring harness
Wipers do not operate when washer switch is ON.	(1) Washer motor (2) Wiring harness
Washer fluid spray does not operate.	(1) Washer motor (2) Washer hose and nozzle

3. Combination Switch (Wiper)

A: REMOVAL

- 1) Disconnect the ground cable from battery.
- 2) Remove the instrument panel lower cover. <Ref. to EI-48, REMOVAL, Instrument Panel Assembly.>
- 3) Loosen the screw to remove steering column cover lower.

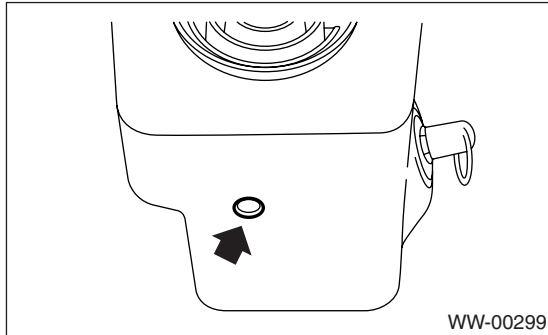

- 4) Remove the screw to steering column cover upper.

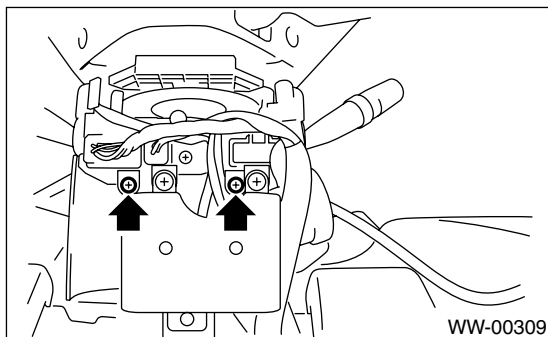

- 5) Disconnect the connectors from combination switches.
- 6) Loosen the screw to remove combination switch.

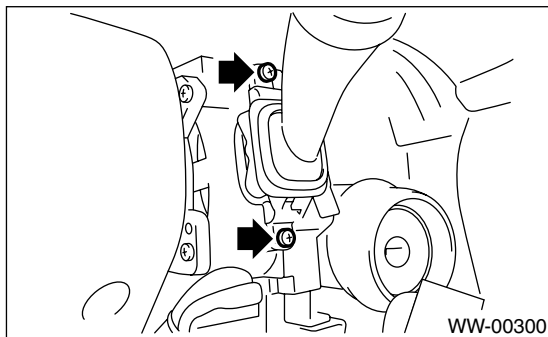

B: INSTALLATION

Install in the reverse order of removal.

C: INSPECTION

- Inspect the continuity between each connector terminal.

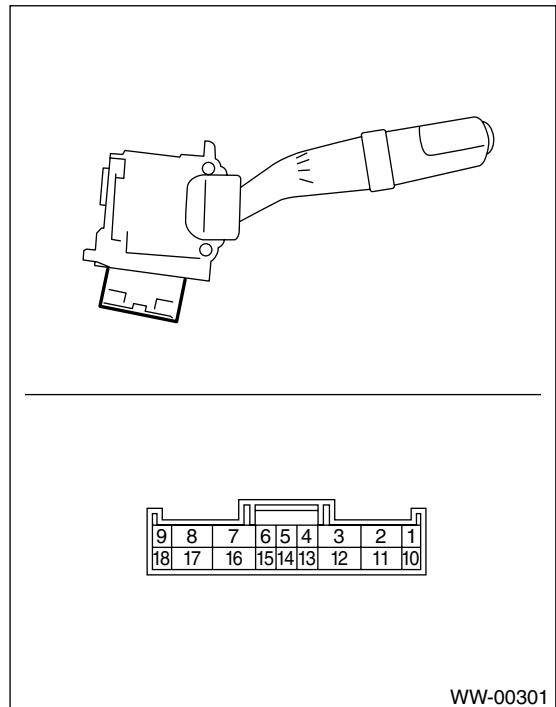

	Switch position	Terminal No.	Standard
FRONT	OFF	7 and 16	Less than 1 Ω
	INT	7 and 16	Less than 1 Ω
	LO	7 and 17	Less than 1 Ω
	HI	8 and 17	Less than 1 Ω
	Washer ON	2 and 11	Less than 1 Ω
REAR	Washer ON	2 and 10 10 and 12 2 and 12	Less than 1 Ω
	OFF	—	More than 1 MΩ
	ON	2 and 10	Less than 1 Ω
	Washer ON	2 and 10 10 and 12 2 and 12	Less than 1 Ω

If continuity is not as specified, replace the switch.

- Intermittent operation inspection
 - 1) Turn the wiper switch to INT.
 - 2) Adjust the intermittent control switch to MAX.
 - 3) Apply battery voltage to switch terminals 16 and 2.
 - 4) Inspect the voltage of combination switch terminals.

Terminals

No. 7 — No. 2:

Combination Switch (Wiper)

WIPER AND WASHER SYSTEMS

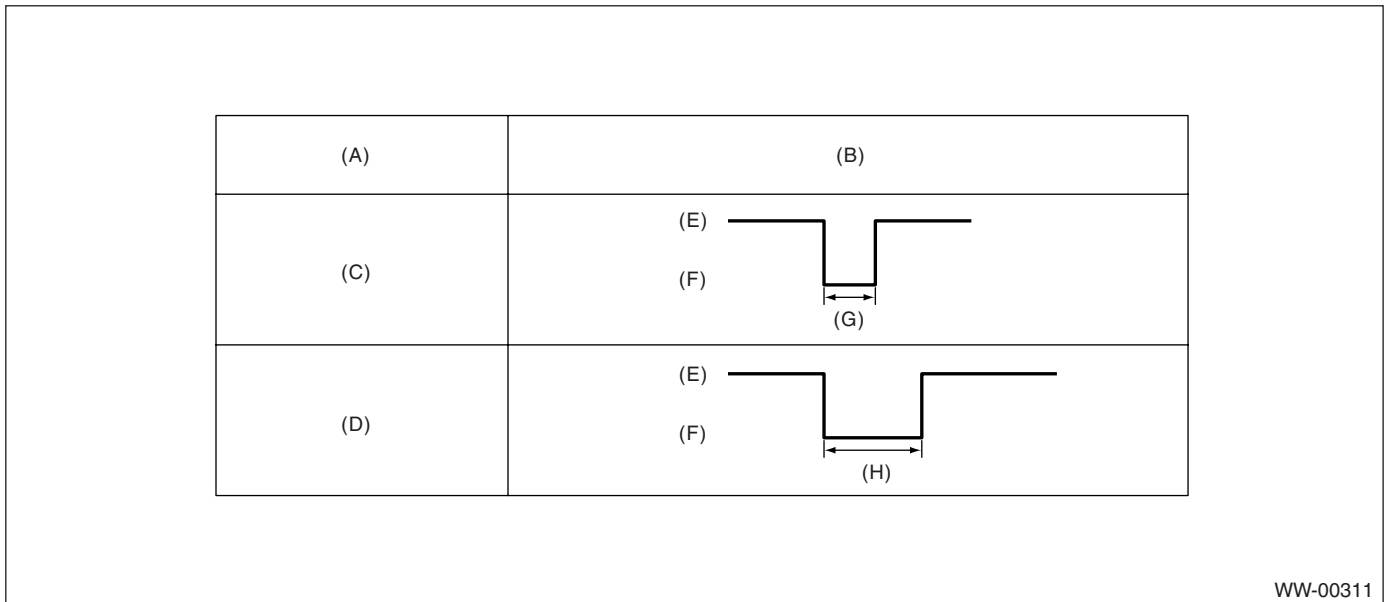

WW-00311

(A) Switch position
(B) Voltage
(C) MIN.

(D) MAX.
(E) 12 V
(F) 0 V

(G) 1.6 ± 1 sec.
(H) 16 ± 6 sec.

If operation is not as specified, replace the switch.

4. Wiper Blade

A: REMOVAL

While pushing the locking clip (A) up, pull out the blade from arm to arrow direction.

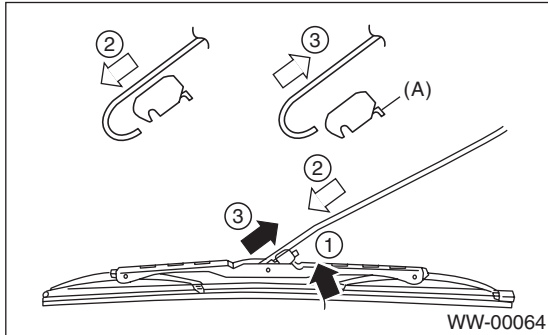

B: INSTALLATION

- 1) Install in the reverse order of removal.
- 2) Confirm that the clip is locked securely.

C: DISASSEMBLY

1. METAL TYPE

Pull on the side (A) of wiper rubber stopper, and then remove the rubber from blade assembly.

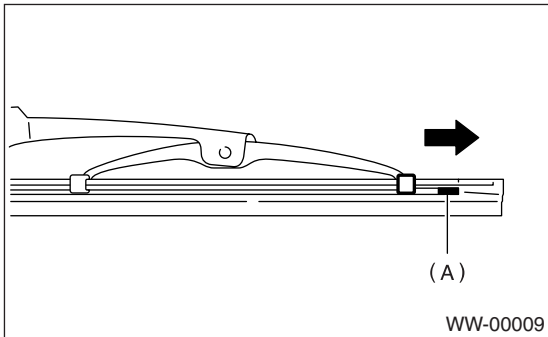

2. RESIN TYPE

Pull the wiper rubber top slightly from the stopper (A) and pull it out fully.

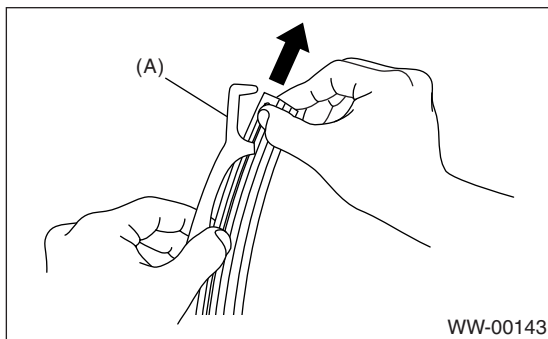

D: ASSEMBLY

1. METAL TYPE

- 1) Insert the wiper rubber onto blade so that the stopper is in the position shown.

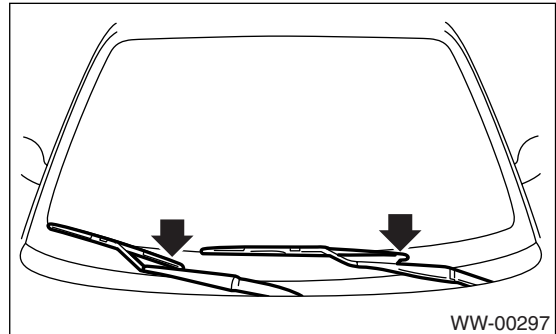

- 2) Make sure the wiper rubber is securely fastened to the pull stopper (A).

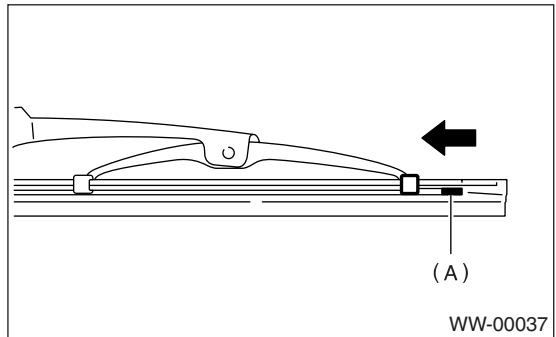

Wiper Blade

WIPER AND WASHER SYSTEMS

2. RESIN TYPE

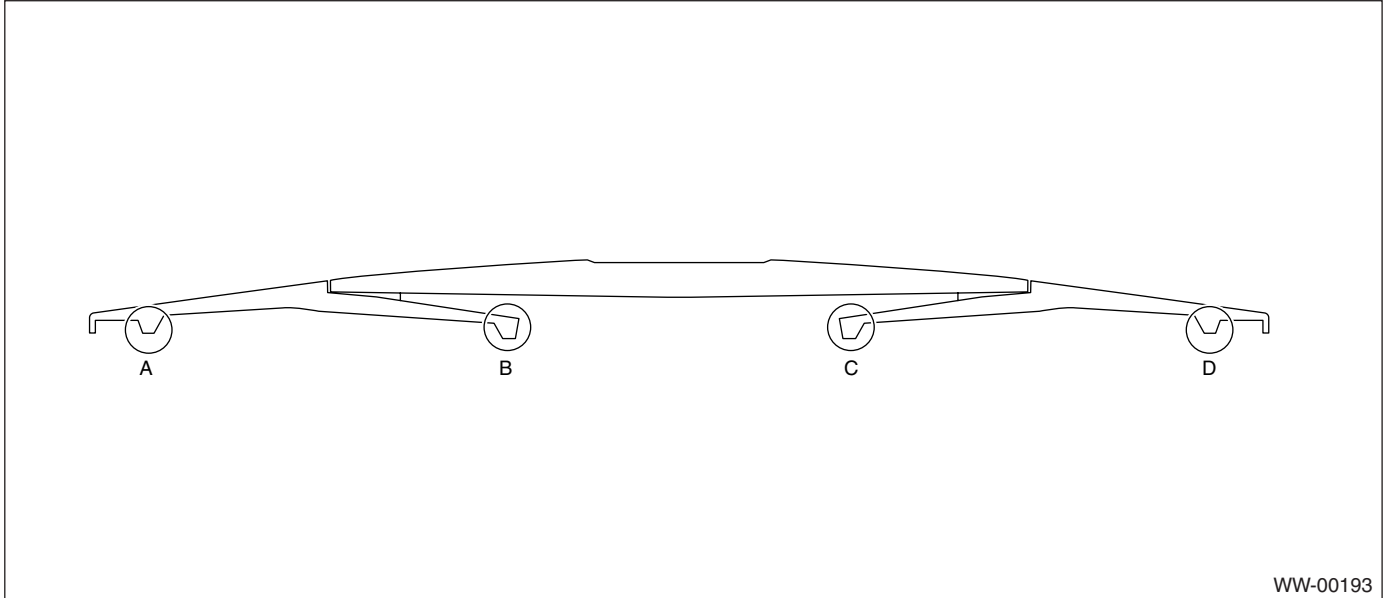

1) Insert the wiper rubber through the claw (B).

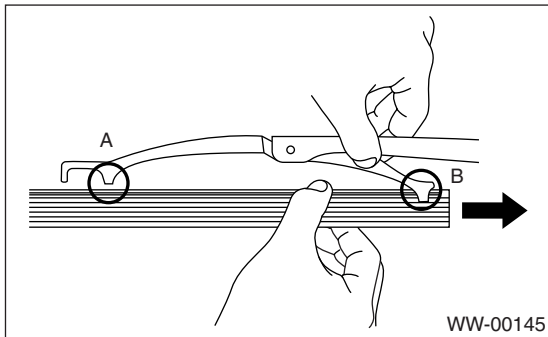

2) Insert the wiper rubber top until it protrudes about 20 mm (0.79 in) from the stopper (D).

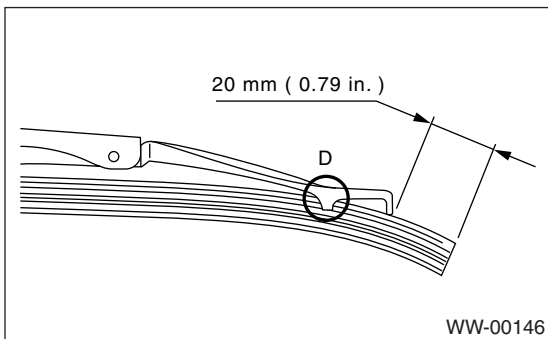

3) Insert the wiper rubber into the claw (A).

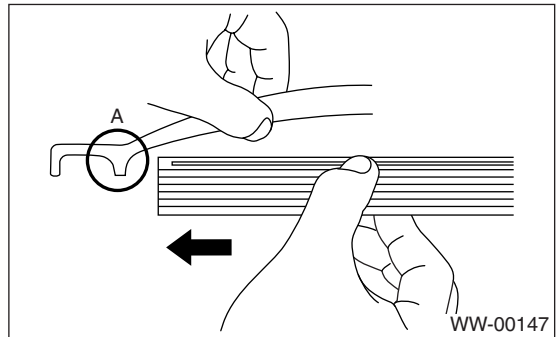

E: INSPECTION

1) When the wiper does not perform well, inspect the following:

- Make sure the movable part of the blade assembly moves smoothly.
- Make sure the wiper rubber is not deformed or damaged.

2) Replace them with new parts if damaged.

5. Washer Tank and Motor

A: REMOVAL

- 1) Open the hood.
- 2) Disconnect the ground cable from battery.
- 3) Remove the two bolts, hose and connector, and then remove the tank.

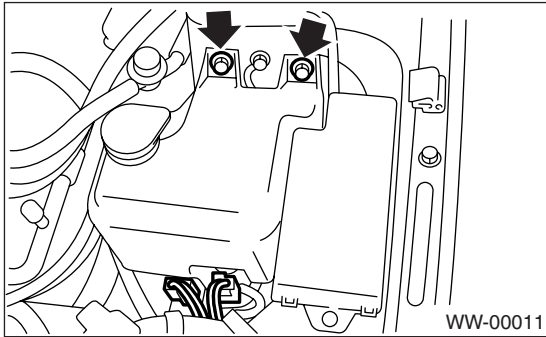

B: INSTALLATION

Install in the reverse order of removal.

Tightening torque:

6.0 N·m (0.61 kgf-m, 4.4 ft-lb)

C: DISASSEMBLY

Pull out the washer motor from tank.

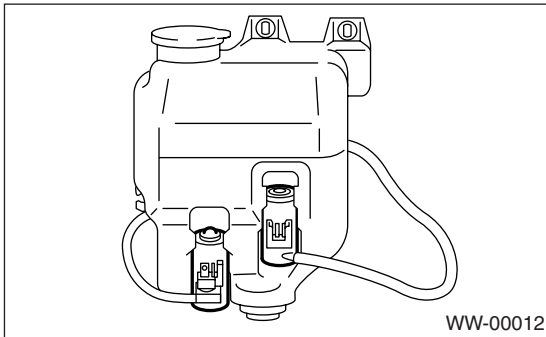

D: ASSEMBLY

- 1) Assemble in the reverse order of disassembly.
- 2) Confirm that water does not leak from installation area of motor.

E: INSPECTION

Apply battery voltage to the connector terminal of the washer motor and make sure the motor operates.

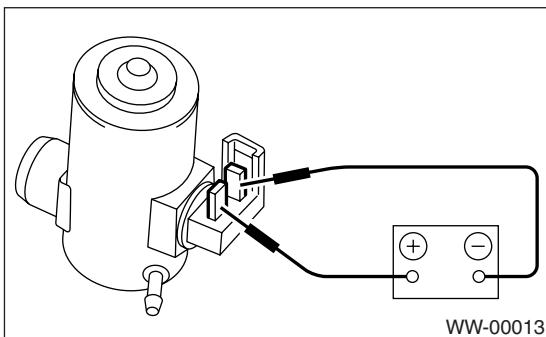

6. Front Wiper Arm

A: REMOVAL

- 1) Open the hood.
- 2) Remove the cap.
- 3) Remove the nut to remove arm.

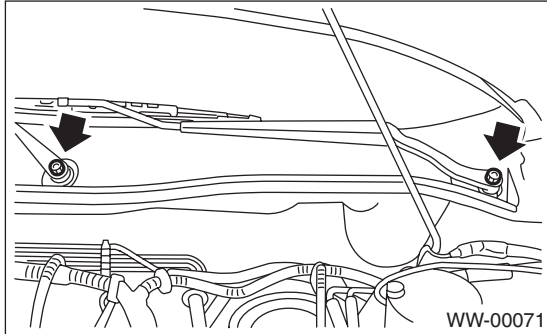

B: INSTALLATION

- 1) Install in the reverse order of removal.
- 2) Operate the wiper once.
- 3) Align the wiper blade to the ceramic print point mark (A) of front window panel.

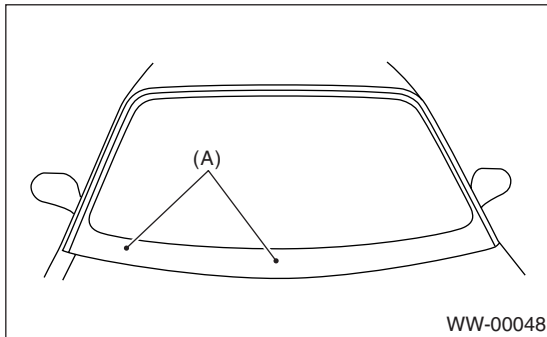

Tightening torque:

Refer to **COMPONENT** in **General Description**.

<Ref. to **WW-2, FRONT WIPER, COMPONENT, General Description.**>

C: ADJUSTMENT

Operate the wiper once. Align the wiper blade to the ceramic print point mark (A) of front window panel.

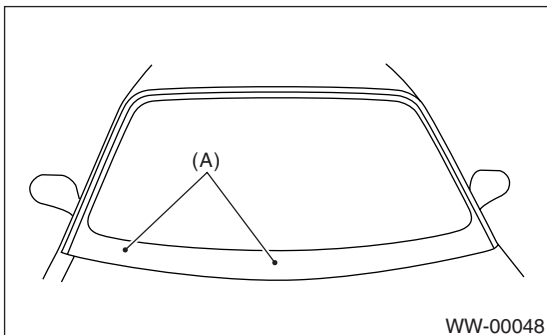

7. Front Wiper Motor and Link

A: REMOVAL

- 1) Disconnect the ground cable from battery.
- 2) Remove the cowl panel. <Ref. to EI-35, REMOVAL, Cowl Panel.>
- 3) Disconnect the connector of motor.
- 4) Remove the bolts to remove wiper link.

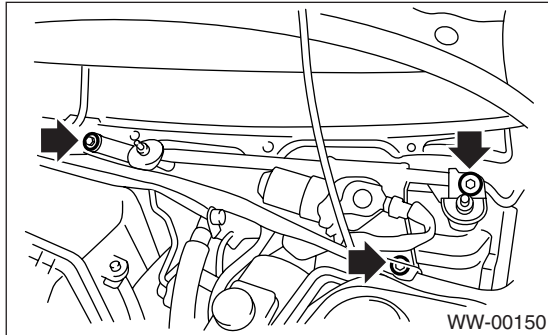

- 5) Remove the bolts and nuts to remove motor.

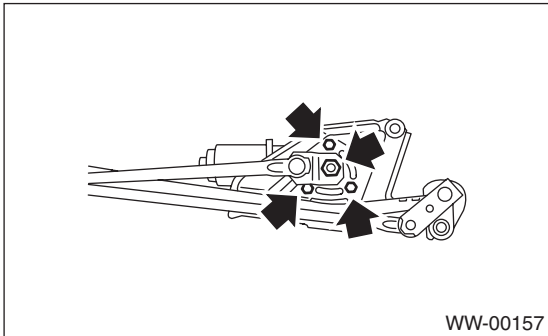

B: INSTALLATION

- 1) Connect the battery ground cable to battery.
- 2) To confirm that the motor is at auto stop position, connect the harness to motor and turn the wiper switch ON/OFF once.
- 3) Disconnect the ground cable from battery.
- 4) Tighten the nut where rod (A) and link plate (B) is aligned in a straight line.

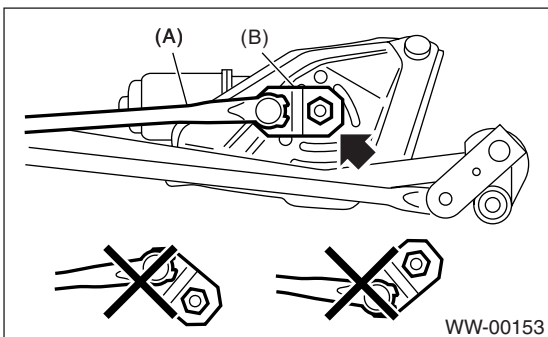

- 5) Install in the reverse order of removal.

Tightening torque:

Refer to **COMPONENT** in *General Description*.

<Ref. to **WW-2, FRONT WIPER, COMPONENT, General Description**.>

C: INSPECTION

- 1) When the battery is connected to the terminal of connectors, confirm that the motor operates at low speed.

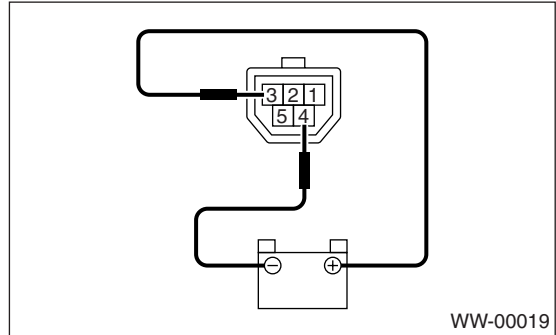

- 2) When the battery is connected to the terminal of connectors, confirm that the motor operates at high speed.

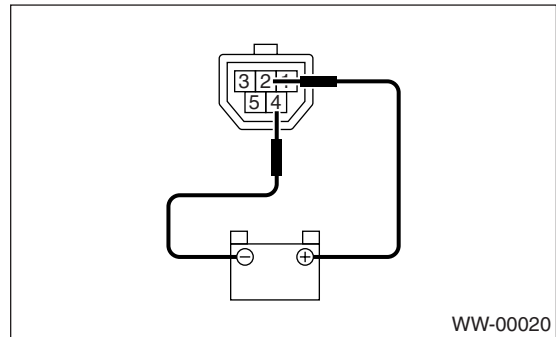

- 3) Connect the battery to terminals of connector, and then remove the terminal connection with motor rotated at low speed, and stop the wiper motor through operation.

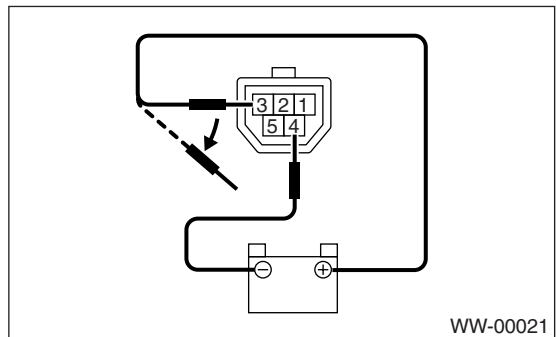

Front Wiper Motor and Link

WIPER AND WASHER SYSTEMS

4) Connect the battery and confirm that the motor stops at automatic stop position after the motor operates at low speed again.

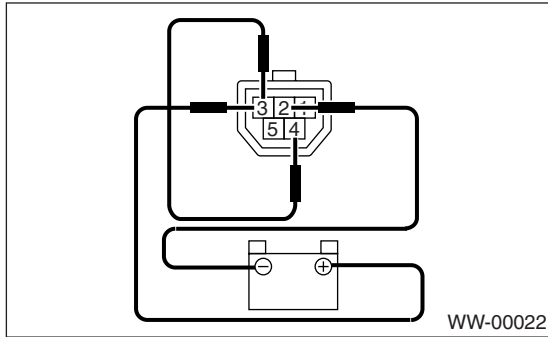

8. Front Washer Nozzle

A: REMOVAL

- 1) Remove the washer hose from the washer nozzle.
- 2) Open the clips on the underside of the hood with a thin screwdriver or other tool, and remove the washer nozzle.

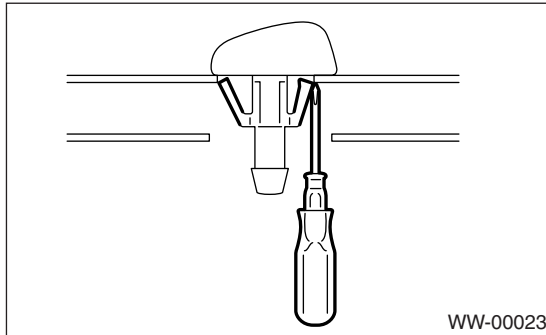

B: INSTALLATION

- 1) Install in the reverse order of removal.
- 2) Adjust the position of the washer liquid sprayer.
<Ref. to WW-15, ADJUSTMENT, Front Washer Nozzle.>

C: INSPECTION

- Make sure the nozzle and hose are not clogged.
- Make sure the hose is not bent.

D: ADJUSTMENT

- 1) Turn the wiper switch to OFF position.
- 2) When the vehicle stops, adjust the washer injection position as shown in the figure.

Injection position:

A: 257 mm (10.12 in)

B: 512 mm (20.16 in)

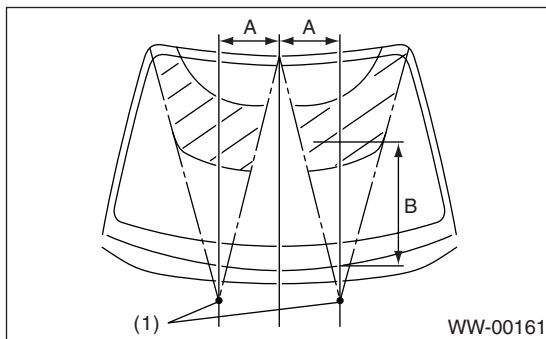

(1) Nozzle

9. Rear Wiper Arm

A: REMOVAL

- 1) Raise the wiper arm cover (A).
- 2) Remove the nut to remove wiper arm.

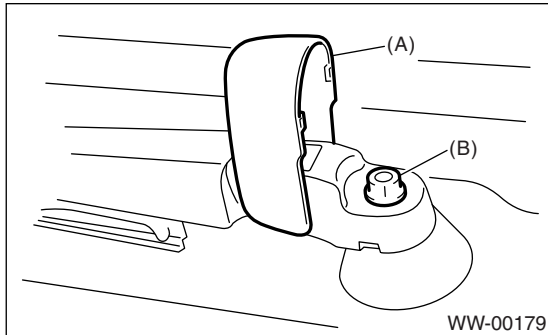

B: INSTALLATION

- 1) Install in the reverse order of removal.
- 2) Operate the rear wiper once.
- 3) Align the blade to rear defogger heat wire (A).

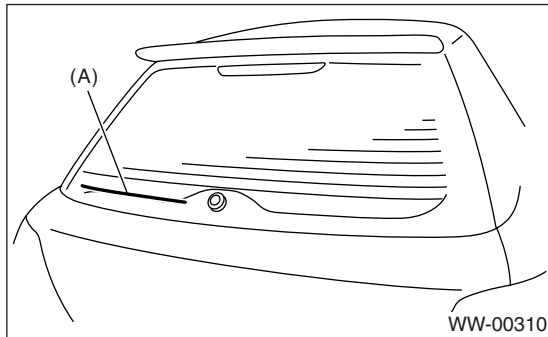

Tightening torque:

Refer to **COMPONENT** in *General Description*.

<Ref. to WW-3, REAR WIPER, COMPONENT, General Description.>

C: ADJUSTMENT

- 1) Operate the rear wiper once.
- 2) Align the blade to rear defogger heat wire (A).

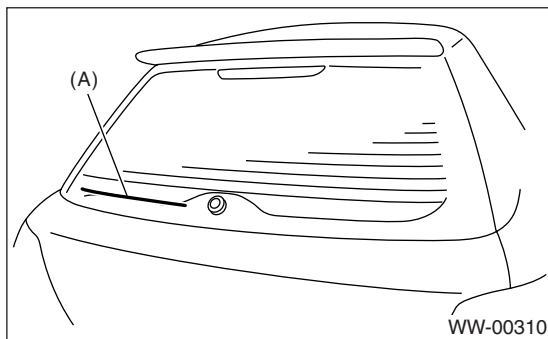

10.Rear Wiper Motor

A: REMOVAL

- 1) Disconnect the ground cable from battery.
- 2) Remove the rear wiper arm. <Ref. to WW-16, REMOVAL, Rear Wiper Arm.>
- 3) Remove the rear gate lower trim. <Ref. to EI-57, REMOVAL, Rear Gate Trim.>
- 4) Unclip the clip of harness, and then disconnect the connector of wiper motor.
- 5) Loosen the bolts to remove the wiper motor assembly (A).

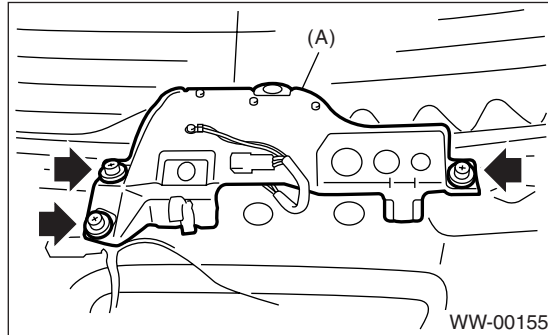

- 6) Remove rear wiper cushion.

B: INSTALLATION

- 1) Install in the reverse order of removal.
- 2) Install the rear wiper cushion with the arrow mark facing up, as shown in the figure.

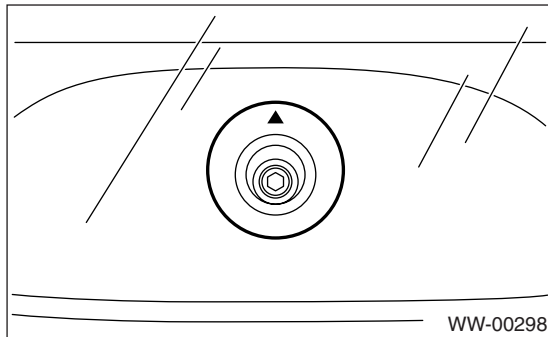

Tightening torque:

Refer to **COMPONENT** in **General Description**.

<Ref. to WW-3, **REAR WIPER, COMPONENT, General Description**.>

C: INSPECTION

- 1) Connect the battery to wiper motor connector and confirm that the wiper motor operates.

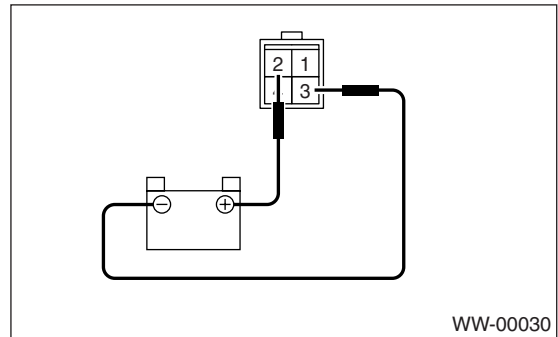

- 2) Connect the battery to terminal of connector, and then remove the terminal connections with motor rotated, and stop the wiper motor through operation.

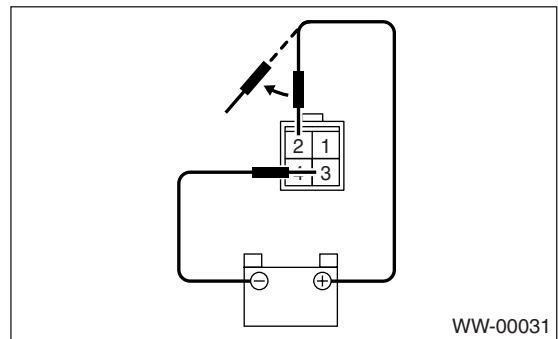

- 3) Connect the battery and confirm that the motor stops at automatic stop position after the motor operates at low speed again.

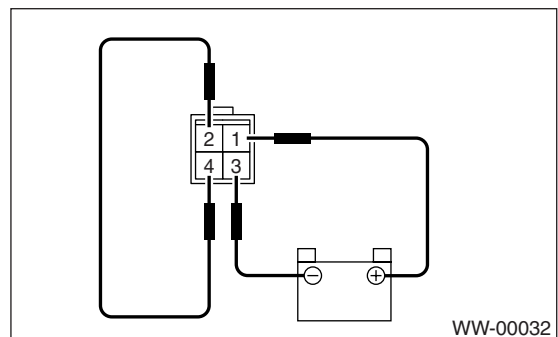

11.Rear Washer

A: REMOVAL

- 1) Remove the high-mount stop light. <Ref. to LI-25, REMOVAL, High-mounted Stop Light.>
- 2) Remove the washer hose from washer nozzle.
- 3) Open the clips on the underside of hood with a thin screwdriver or other tool, and then remove the washer nozzle.

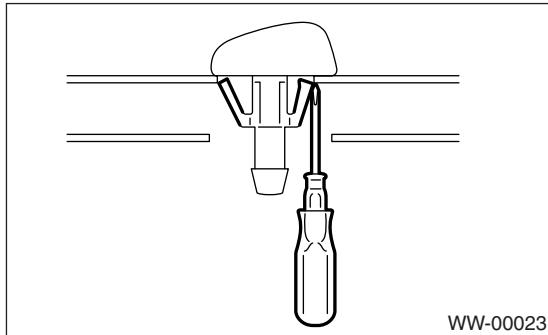

B: INSTALLATION

- 1) Install in the reverse order of removal.
- 2) Adjust the position of the washer liquid sprayer. <Ref. to WW-18, ADJUSTMENT, Rear Washer.>

C: INSPECTION

- Make sure the nozzle and hose are not clogged.
- Make sure the hose is not bent.

D: ADJUSTMENT

- 1) Turn the wiper switch to OFF position.
- 2) When the vehicle stops, adjust the washer injection position as shown in the figure.

Injection position:

A: 39 mm (1.54 in)

B: 72°

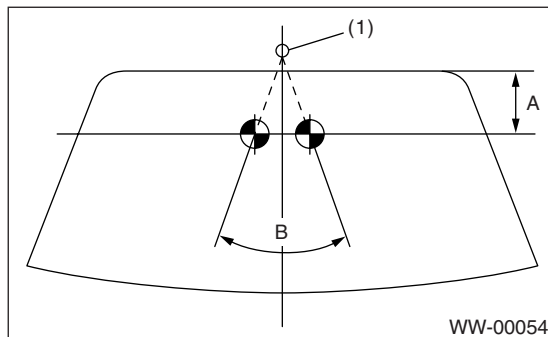

(1) Nozzle

12. Wiper Control Relay

If operation is not as specified, replace the switch.

A: REMOVAL

- 1) Disconnect the ground cable from battery.
- 2) Remove the right quarter lower trim. <Ref. to EI-53, REMOVAL, Rear Quarter Trim.>
- 3) Loosen the nut to remove control unit.

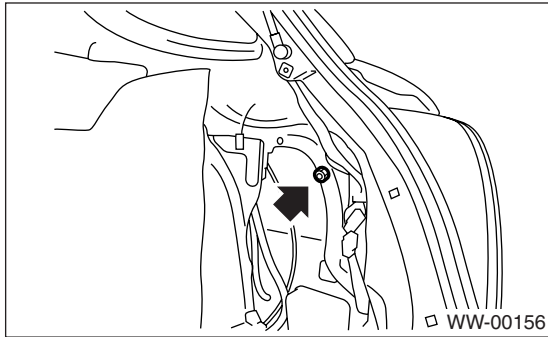

B: INSTALLATION

Install in the reverse order of removal.

C: INSPECTION

- 1) Disconnect the connector from wiper control relay.
- 2) Connect the positive (+) lead from the battery to terminal 8 and the negative (-) lead to terminal 6. Connect the positive (+) lead from the voltmeter to terminal 3 and the negative (-) lead to ground.

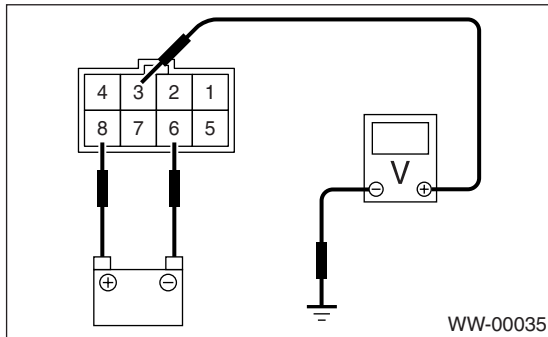

- 3) Measure the voltage when the wiper relay is operated.

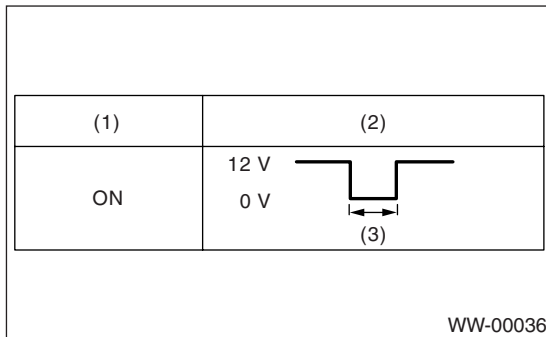

- (1) Switch position
- (2) Voltage
- (3) 9±2 sec.

