

**AUTOMATIC TRANSMISSION
(DIAGNOSTICS)
H4SO (non-turbo)**

Basic Diagnostic Procedure

AUTOMATIC TRANSMISSION (DIAGNOSTICS)

1. Basic Diagnostic Procedure

A: PROCEDURE

NOTE:

This section is specified for H4SO engine model.

Step	Check	Yes	No
1 CHECK PRE-INSPECTION. 1) Ask the customer when and how trouble occurred using interview checklist. <Ref. to 4AT(D)(diag)-4, Check List for Interview.> 2) Before performing the diagnosis, inspect following items which might influence the AT problems. <ul style="list-style-type: none"> • General inspection <Ref. to 4AT(D)(diag)-5, INSPECTION, General Description.> • Oil leak • Stall speed test <Ref. to 4AT-35, Stall Test.> • Line pressure test <Ref. to 4AT-38, Line Pressure Test.> • Transfer clutch pressure test <Ref. to 4AT-40, Transfer Clutch Pressure Test.> • Time lag test <Ref. to 4AT-37, Time Lag Test.> • Road test <Ref. to 4AT-34, Road Test.> • Inhibitor switch <Ref. to 4AT-52, Inhibitor Switch.> 	Is the item that might influence AT problem normal?	Go to step 2.	Repair or replace each item.
2 CHECK AT OIL TEMP WARNING LIGHT. Turn the ignition switch to ON.	Does the AT OIL TEMP warning light illuminate?	Go to step 4.	Go to step 3.
3 CHECK AT OIL TEMP WARNING LIGHT. 1) Turn the ignition switch to OFF. 2) Repair the AT OIL TEMP warning light circuit or power supply and ground line circuit. <Ref. to 4AT(D)(diag)-19, AT OIL TEMP Warning Light Display.> 3) Turn the ignition switch to ON.	Is the AT OIL TEMP warning light illuminate?	Go to step 4.	Go to step 5.
4 CHECK INDICATION OF DTC. Calling up the DTC. <Ref. to 4AT(D)(diag)-16, OPERATION, Read Diagnostic Trouble Code (DTC).> NOTE: If the communication function of select monitor cannot be executed normally, check the communication circuit. <Ref. to 4AT(D)(diag)-22, COMMUNICATION FOR INITIALIZING IMPOSSIBLE, Diagnostic Procedure for Select Monitor Communication.>	Is the DTC displayed?	Go to step 6. NOTE: Record all DTC.	Go to step 5.

Basic Diagnostic Procedure

AUTOMATIC TRANSMISSION (DIAGNOSTICS)

Step	Check	Yes	No
<p>5</p> <p>PERFORM THE GENERAL DIAGNOSTICS.</p> <p>1) Inspect using “Diagnostic Procedure without Diagnostic Trouble Code (DTC)”. <Ref. to 4AT(D)(diag)-89, Diagnostic Procedure without Diagnostic Trouble Code (DTC).></p> <p>2) Inspect using “General Diagnostic Table”. <Ref. to 4AT(D)(diag)-92, General Diagnostic Table.></p> <p>3) Perform the clear memory mode. <Ref. to 4AT(D)(diag)-18, WITH SUBARU SELECT MONITOR, OPERATION, Clear Memory Mode.></p> <p>4) Perform the inspection mode. <Ref. to 4AT(D)(diag)-17, Inspection Mode.></p> <p>5) Calling up the DTC. <Ref. to 4AT(D)(diag)-16, OPERATION, Read Diagnostic Trouble Code (DTC).></p>	<p>Is the DTC displayed?</p>	<p>Complete the diagnosis.</p>	<p>Go to step 6.</p>
<p>6</p> <p>PERFORM THE DIAGNOSIS.</p> <p>1) Inspect using “Diagnostic Procedure with Diagnostic Trouble Code (DTC)”. <Ref. to 4AT(D)(diag)-28, Diagnostic Procedure with Diagnostic Trouble Code (DTC).></p> <p>NOTE: For DTC table, refer to “List of Diagnostic Trouble Code (DTC)”. <Ref. to 4AT(D)(diag)-25, List of Diagnostic Trouble Code (DTC).></p> <p>2) Repair the trouble cause.</p> <p>3) Perform the clear memory mode. <Ref. to 4AT(D)(diag)-18, WITH SUBARU SELECT MONITOR, OPERATION, Clear Memory Mode.></p> <p>4) Perform the inspection mode. <Ref. to 4AT(D)(diag)-17, Inspection Mode.></p> <p>5) Calling up the DTC. <Ref. to 4AT(D)(diag)-16, OPERATION, Read Diagnostic Trouble Code (DTC).></p>	<p>Is the DTC displayed?</p>	<p>Inspect using “Diagnostics Procedure with Diagnostic Trouble Code (DTC)”. <Ref. to 4AT(D)(diag)-28, Diagnostic Procedure with Diagnostic Trouble Code (DTC).></p>	<p>Complete the diagnosis.</p>

Check List for Interview

AUTOMATIC TRANSMISSION (DIAGNOSTICS)

2. Check List for Interview

A: CHECK

Check the following items when problem has occurred.

NOTE:

Use copies of this page for interviewing customers.

Customer's name		
Date of purchase		
Date of repair		
Trans. model	TRANSMISSION	VIN
Odometer reading	km/h or miles	
Frequency	<input type="checkbox"/> Continuous <input type="checkbox"/> Intermittent (times a day)	
Weather	<input type="checkbox"/> Fine <input type="checkbox"/> Cloudy <input type="checkbox"/> Rainy <input type="checkbox"/> Snowy <input type="checkbox"/> Various/Others ()	
Place	<input type="checkbox"/> High <input type="checkbox"/> Suburbs <input type="checkbox"/> Inner city <input type="checkbox"/> Uphill <input type="checkbox"/> Rough road <input type="checkbox"/> Others ()	
Outdoor temperature	<input type="checkbox"/> Hot <input type="checkbox"/> Warm <input type="checkbox"/> Cool <input type="checkbox"/> Cold	
Vehicle speed	km/h (MPH)	
AT diagnostic indicator light (AT OIL TEMP warning light)	<input type="checkbox"/> Continuously blinking	<input type="checkbox"/> Not blinking
Select lever position	<input type="checkbox"/> P <input type="checkbox"/> R <input type="checkbox"/> N <input type="checkbox"/> D <input type="checkbox"/> 3 <input type="checkbox"/> 2 <input type="checkbox"/> 1	
Driving condition	<input type="checkbox"/> Not affected <input type="checkbox"/> At racing <input type="checkbox"/> While decelerating	<input type="checkbox"/> At starting <input type="checkbox"/> While accelerating <input type="checkbox"/> While turning (<input type="checkbox"/> RH / <input type="checkbox"/> LH)
POWER switch	<input type="checkbox"/> ON <input type="checkbox"/> OFF	
HOLD switch	<input type="checkbox"/> ON <input type="checkbox"/> OFF	
Symptoms	<input type="checkbox"/> No up-shift	
	<input type="checkbox"/> No down-shift	
	<input type="checkbox"/> No kick down	
	<input type="checkbox"/> Vehicle does not move (<input type="checkbox"/> Any position <input type="checkbox"/> Particular position)	
	<input type="checkbox"/> Lock-up malfunction	
	<input type="checkbox"/> Noise or vibration	
	<input type="checkbox"/> Shift shock or slip	
	<input type="checkbox"/> Select lever does not move	
	<input type="checkbox"/> Others ()	

General Description

AUTOMATIC TRANSMISSION (DIAGNOSTICS)

3. General Description

A: CAUTION

- **Supplemental Restraint System “Airbag”**

The airbag system wiring harness is routed near the TCM.

CAUTION:

- All airbag system wiring harness and connectors are colored yellow. Do not use an electrical test equipment on these circuit.
- Be careful not to damage the airbag system wiring harness when performing diagnostics and servicing the TCM.

- **Measurement**

When measuring the voltage and resistance of ECM, TCM or each sensor, use a tapered pin with diameter of less than 0.64 mm (0.025 in) in order to avoid poor contact. Do not insert the pin more than 0.65 mm (0.026 in).

B: INSPECTION

1. BATTERY

Measure the battery voltage and specific gravity of electrolyte.

Standard voltage: 12 V or more

Specific gravity: Above 1.260

2. TRANSMISSION GROUND

Make sure that the ground terminal bolt is tightened securely.

- **Chassis side**

Tightening torque:

13 N·m (1.3 kgf·m, 9.4 ft·lb)

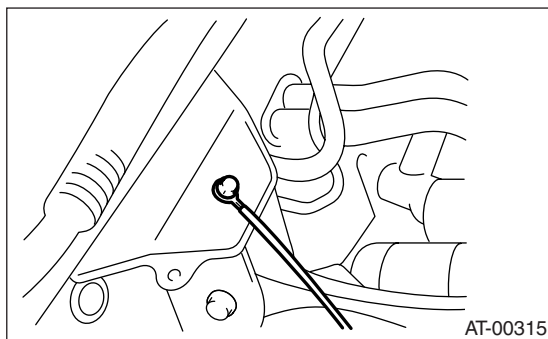

3. ATF LEVEL

Make sure that ATF level is within the specification. <Ref. to 4AT-31, INSPECTION, Automatic Transmission Fluid.>

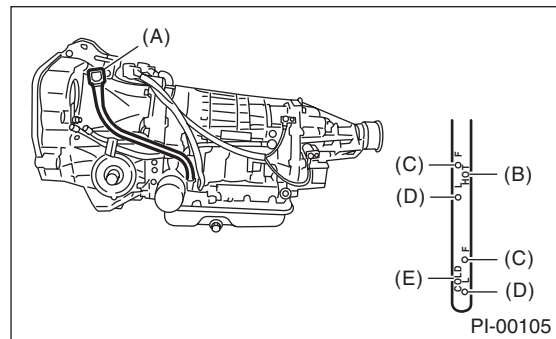

- (A) Level gauge
- (B) “HOT” side
- (C) Upper level
- (D) Lower level
- (E) “COLD” side

4. FRONT DIFFERENTIAL OIL LEVEL

Make sure that front differential oil level is within the specification. <Ref. to 4AT-33, INSPECTION, Differential Gear Oil.>

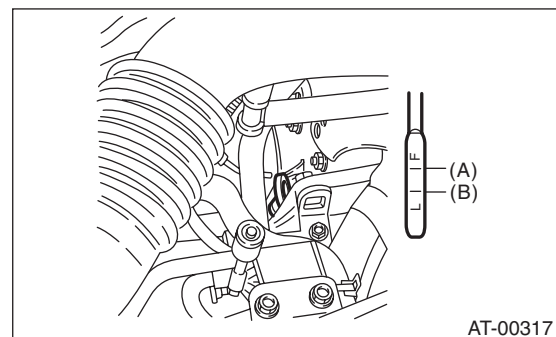

- (A) Upper level
- (B) Lower level

5. OPERATION OF SELECT LEVER

Make sure there is no abnormal noise, dragging or contact pattern in each select lever range.

General Description

AUTOMATIC TRANSMISSION (DIAGNOSTICS)

WARNING:

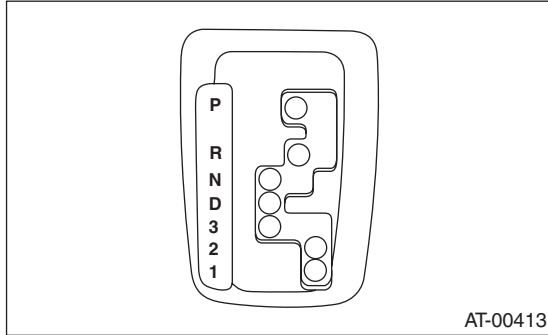

Stop the engine while checking operation of select lever.



AT-00413

C: PREPARATION TOOL

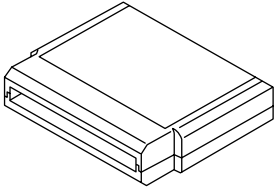
1. SPECIAL TOOL

ILLUSTRATION	TOOL NUMBER	DESCRIPTION	REMARKS
 <p>ST24082AA260</p>	24082AA260	CARTRIDGE	Troubleshooting for electrical systems.
 <p>ST22771AA010</p>	22771AA010	SUBARU SELECT MONITOR KIT	Troubleshooting for electrical systems.

2. GENERAL TOOL

TOOL NAME	REMARKS
Circuit tester	Used for measuring resistance, voltage and ampere.
Oscilloscope	Used for measuring sensor.

Electrical Component Location

AUTOMATIC TRANSMISSION (DIAGNOSTICS)

4. Electrical Component Location

A: LOCATION

1. CONTROL MODULE

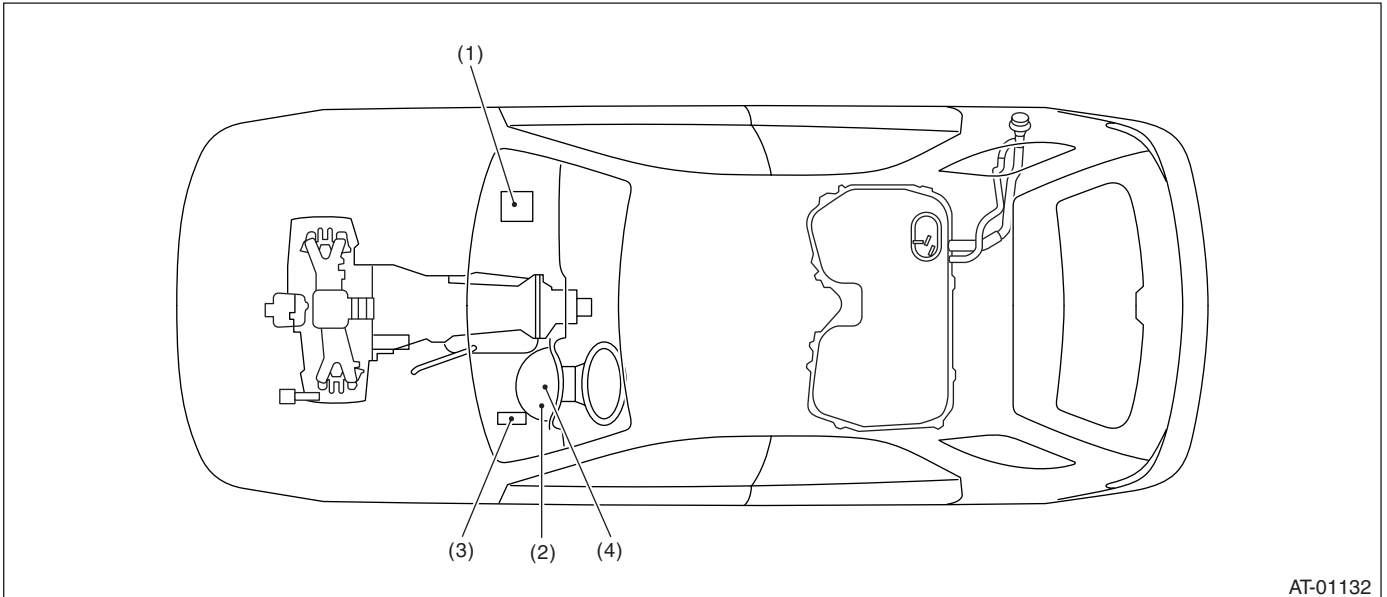

AT-01132

- | | | |
|--|---------------------------------------|-------------------------|
| (1) Engine control module (ECM) | (3) Transmission control module (TCM) | (4) Data link connector |
| (2) AT OIL TEMP warning light (AT warning light) | | |

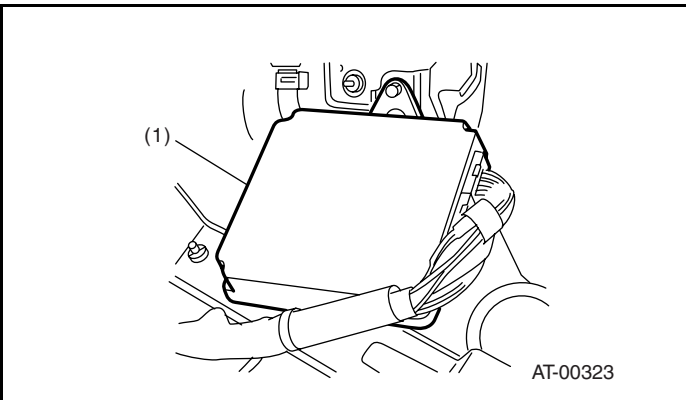

AT-00323

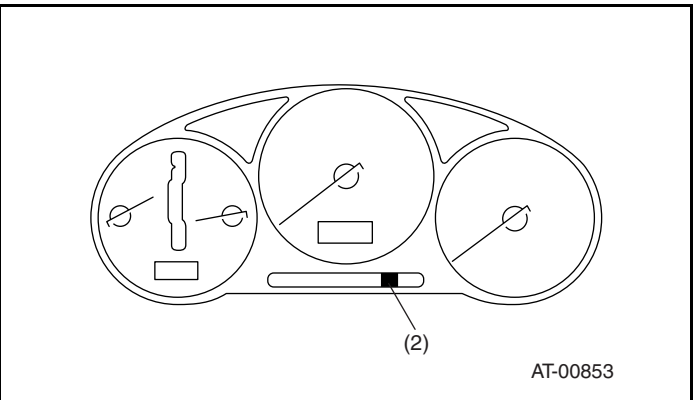

AT-00853

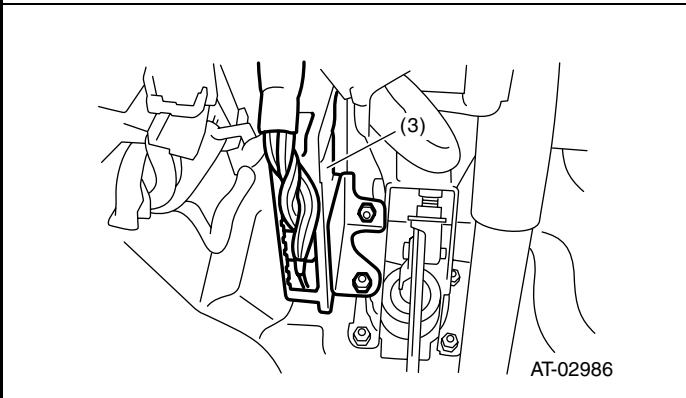

AT-02986

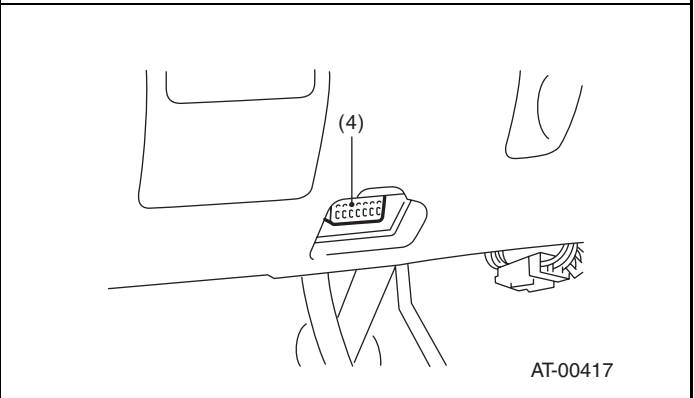

AT-00417

Electrical Component Location

AUTOMATIC TRANSMISSION (DIAGNOSTICS)

2. SENSOR

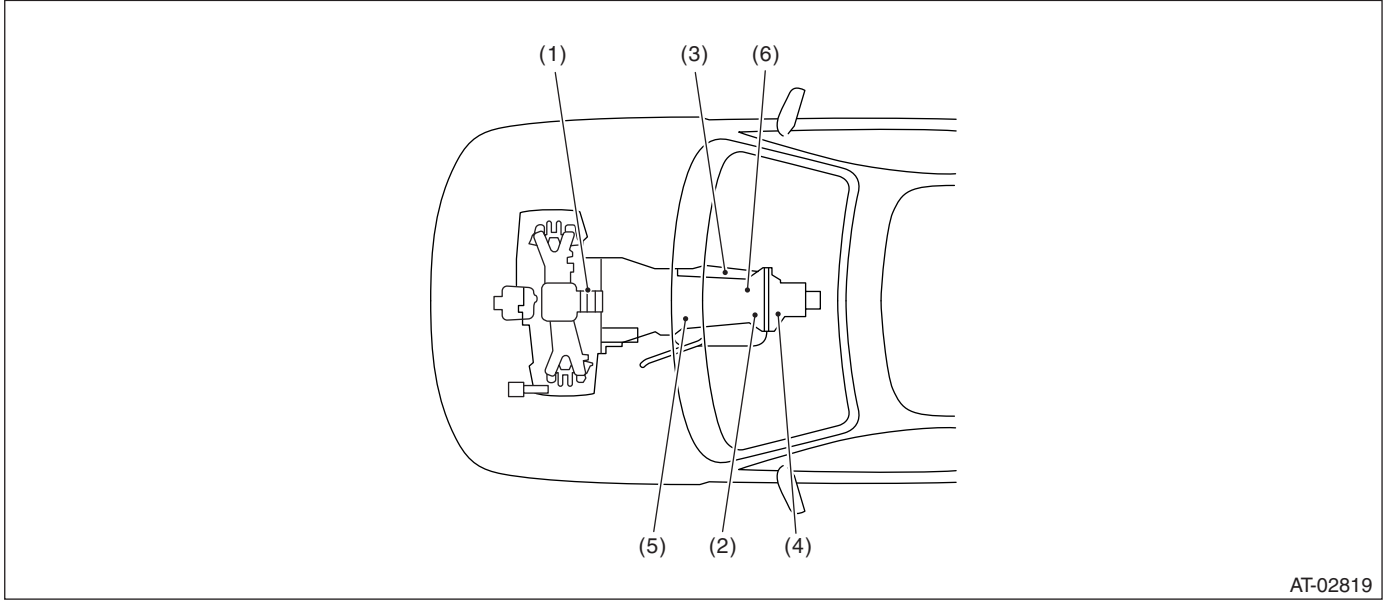

AT-02819

- | | | |
|--------------------------------|---|----------------------------|
| (1) Throttle position sensor | (4) Rear vehicle speed sensor | (6) ATF temperature sensor |
| (2) Front vehicle speed sensor | (5) Torque converter turbine speed sensor | |
| (3) Inhibitor switch | | |

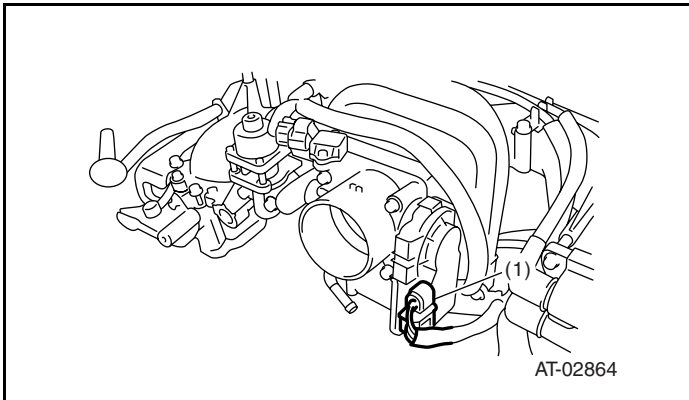

AT-02864

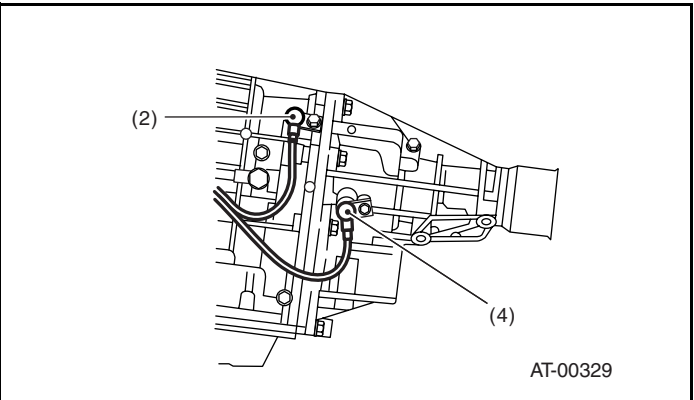

AT-00329

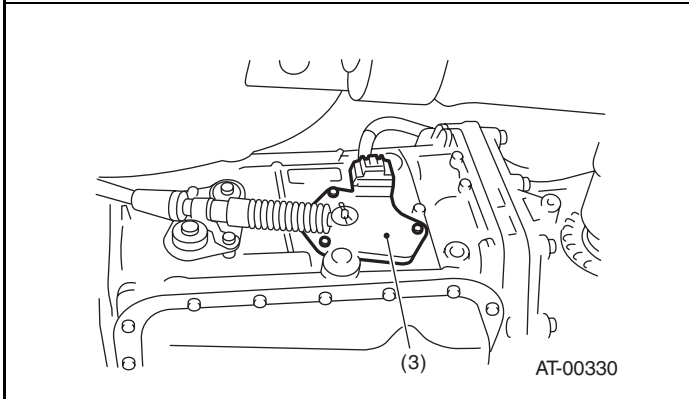

AT-00330

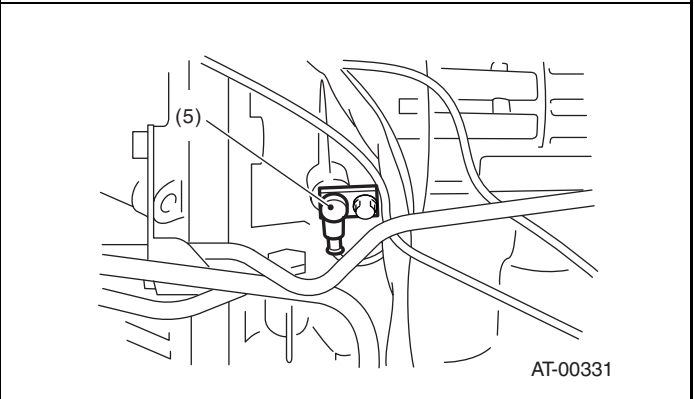

AT-00331

Electrical Component Location

AUTOMATIC TRANSMISSION (DIAGNOSTICS)

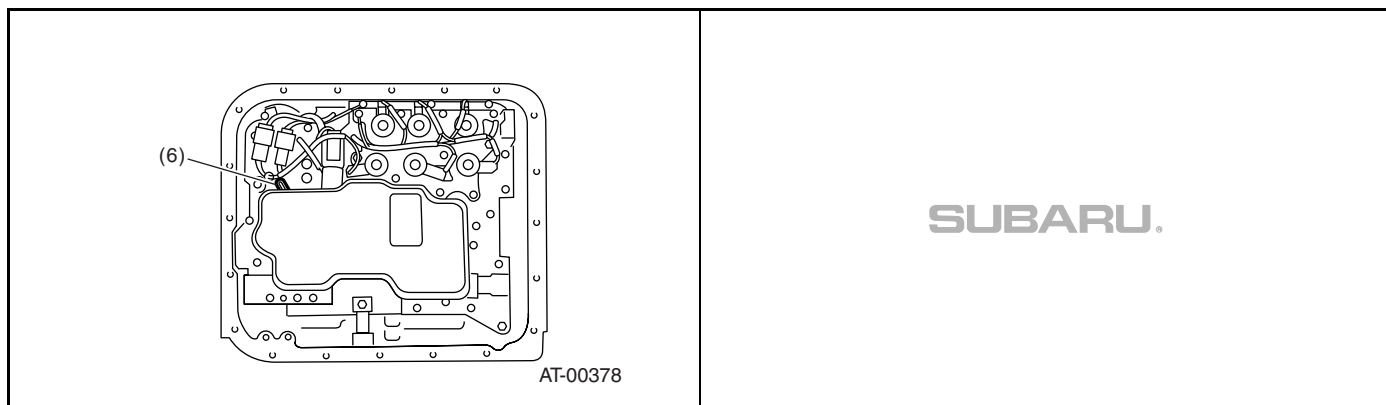

3. SOLENOID

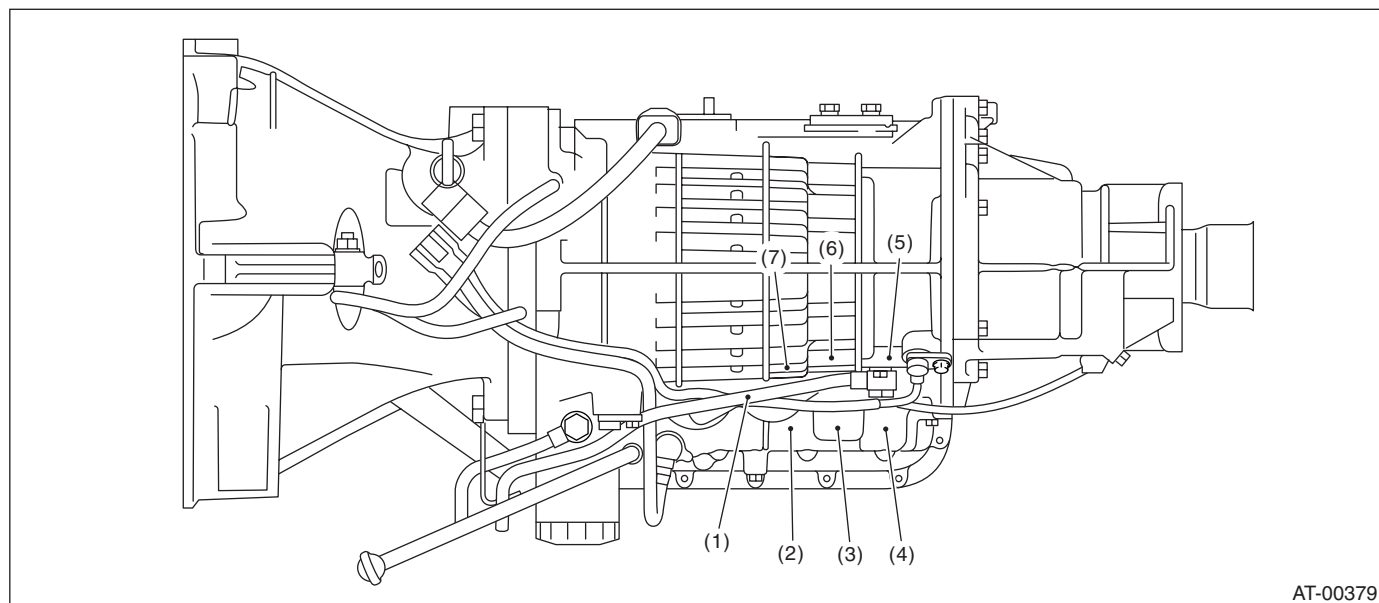

- | | | |
|-----------------------------------|---------------------------------|---------------------------|
| (1) Line pressure linear solenoid | (4) Low & reverse duty solenoid | (7) Lock-up duty solenoid |
| (2) High clutch duty solenoid | (5) Low clutch duty solenoid | |
| (3) 2-4 brake duty solenoid | (6) Transfer duty solenoid | |

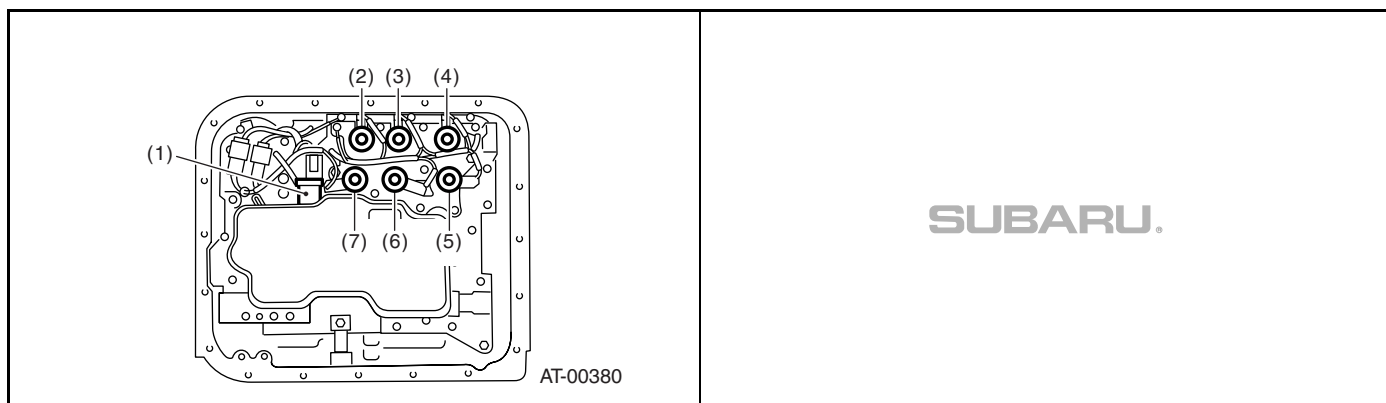

Transmission Control Module (TCM) I/O Signal

AUTOMATIC TRANSMISSION (DIAGNOSTICS)

5. Transmission Control Module (TCM) I/O Signal

A: ELECTRICAL SPECIFICATION

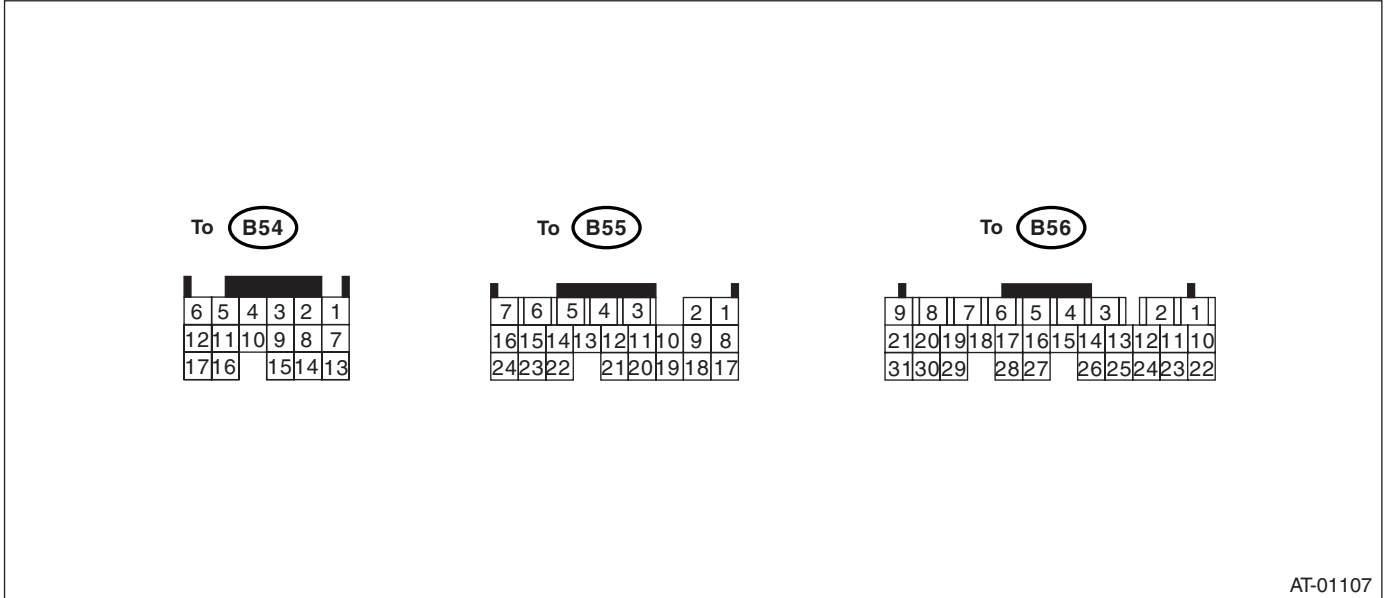

AT-01107

Check with ignition switch ON.						
Content		Connector No.	Terminal No.	Measuring conditions	Voltage (V)	Resistance to body (Ω)
Back-up power supply		B56	27	Ignition switch OFF	10 — 13	—
			29			
		B56	28			
ACC power supply		B56	16	Ignition switch ACC	10 — 13	—
Ignition power supply		B56	21	Ignition switch ON (with engine OFF)	10 — 13	—
		B56	31			
Inhibitor switch	“P” range switch	B55	5	Select lever in “P” range	Less than 1	—
				Select lever in any other than “P” range (except “N” range)	More than 8	
	“N” range switch	B55	22	Select lever in “N” range	Less than 1	—
				Select lever in any other than “N” range	More than 8	
	“R” range switch	B55	14	Select lever in “R” range	Less than 1	—
				Select lever in any other than “R” range	More than 8	
	“D” range switch	B55	4	Select lever in “D” range	Less than 1	—
				Select lever in any other than “D” range	More than 8	
	“3” range switch	B54	16	Select lever in “3” range	Less than 1	—
				Select lever in any other than “3” range	More than 8	
	“2” range switch	B54	4	Select lever in “2” range	Less than 1	—
				Select lever in any other than “2” range	More than 8	
	“1” range switch	B54	10	Select lever in “1” range	Less than 1	—
				Select lever in any other than “1” range	More than 8	
Brake switch		B55	20	Brake pedal depressed.	More than 10.5	—
				Brake pedal released.	Less than 1	

Transmission Control Module (TCM) I/O Signal

AUTOMATIC TRANSMISSION (DIAGNOSTICS)

Check with ignition switch ON.					
Content	Connector No.	Terminal No.	Measuring conditions	Voltage (V)	Resistance to body (Ω)
AT OIL TEMP warning light	B56	13	Light ON	Less than 1	—
			Light OFF	More than 9	
Accelerator pedal position sensor	B55	19	Throttle fully closed.	More than 0.2	—
			Throttle fully open.	Less than 4.6	
Accelerator pedal position sensor power supply	B55	10	Ignition switch ON (with engine OFF)	Approx. 4.6 — 5.4	—
ATF temperature sensor	B55	21	ATF temperature 20°C (68°F)	3.5 — 4.3	3.9 k — 4.7 k
			ATF temperature 80°C (176°F)	1.5 — 1.9	300 — 800
Rear vehicle speed sensor	B55	24	Vehicle speed at least 20 km/h (12 MPH)	More than 2 (AC range)	—
Front vehicle speed sensor	B55	6	Vehicle stopped.	0	450 — 650
			Vehicle speed at least 20 km/h (12 MPH)	More than 1 (AC range)	
Torque converter turbine speed sensor	B55	7	Engine idling after warm-up. ("D" range)	0	450 — 650
			Engine idling after warm-up. ("N" range)	More than 1 (AC range)	
Vehicle speed output signal	B56	1	Vehicle speed at least 10 km/h (6 MPH)	Less than 1 ← → More than 4	—
Engine speed signal	B55	13	Ignition switch ON (with engine OFF)	Less than 1	—
			Ignition switch ON (with engine ON)	More than 5 (AC range)	
Line pressure linear solenoid	B56	20	Ignition switch ON (with engine OFF) Throttle fully closed after warm-up. ("R" range)	3.7 — 7.5	4.0 — 8.0
			Ignition switch ON (with engine OFF) Throttle fully open after warm-up. ("R" range)	1.0 — 5.1	
Lock-up duty solenoid	B56	5	When lock up occurs.	More than 10.5	2.0 — 6.0
			When lock up is released.	Less than 1	
Transfer duty solenoid	B56	4	"P" or "N" range	Less than 1	2.0 — 6.0
			Select lever in 1st gear.	1.7 — 4.0	
2-4 brake duty solenoid	B56	6	"P" or "N" range	More than 10.5	2.0 — 6.0
			2nd or 4th gear	Less than 1	
High clutch duty solenoid	B56	8	3rd or 4th gear	Less than 1	2.0 — 6.0
			"P" or "N" range	More than 10.5	
Low clutch duty solenoid	B56	9	1st or 2nd gear	Less than 1	2.0 — 6.0
			"P" or "N" range	More than 10.5	
Low & reverse duty solenoid	B56	7	"P" or "N" range	More than 10.5	2.0 — 6.0
			"1" range	5 — 10	
Front vehicle speed sensor ground	B55	15	—	0	Less than 1
Rear vehicle speed sensor ground	B55	23	—	0	Less than 1

Transmission Control Module (TCM) I/O Signal

AUTOMATIC TRANSMISSION (DIAGNOSTICS)

Check with ignition switch ON.					
Content	Connector No.	Terminal No.	Measuring conditions	Voltage (V)	Resistance to body (Ω)
System ground line	B55	17	—	0	Less than 1
	B56	2			
	B56	3			
	B55	8			
Torque converter turbine speed sensor ground	B55	16	—	0	Less than 1
Sensor ground line 4	B55	9	—	0	Less than 1
Range lock signal	B56	18	"D" range 0 km/h (0 mile)	More than 10.5	20 — 40
			"D" range 20 km/h (12 mile/h)	Less than 1	
Data link signal (Subaru Select Monitor)	B54	2	—	—	—
FWD switch	B56	17	Fuse removed	9.5	—
			Fuse installed	Less than 1	
AWD indicator light	B56	14	FWD switch fuse installed	Less than 1	—
			FWD switch fuse removed	More than 9	
CAN communication signal (+)	B55	3	Ignition switch ON	Pulse signal	—
CAN communication signal (-)	B55	12	Ignition switch ON	Pulse signal	—

Subaru Select Monitor

AUTOMATIC TRANSMISSION (DIAGNOSTICS)

6. Subaru Select Monitor

A: OPERATION

1. READ DIAGNOSTIC TROUBLE CODE

1) Prepare the Subaru Select Monitor kit.

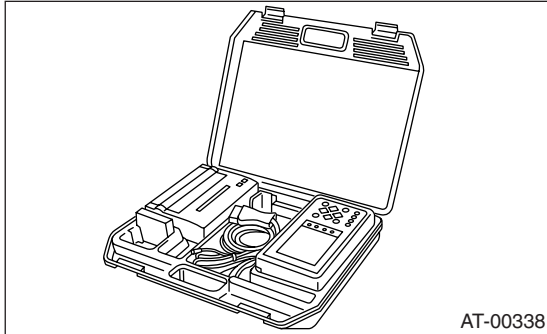

2) Connect the diagnosis cable to Subaru Select Monitor.

3) Insert the cartridge into Subaru Select Monitor.
<Ref. to 4AT(D)(diag)-6, PREPARATION TOOL, General Description.>

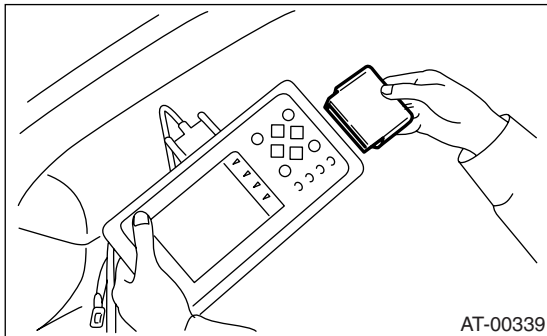

4) Connect the Subaru Select Monitor to data link connector.

(1) Data link connector located in the lower portion of instrument panel (on driver's side).

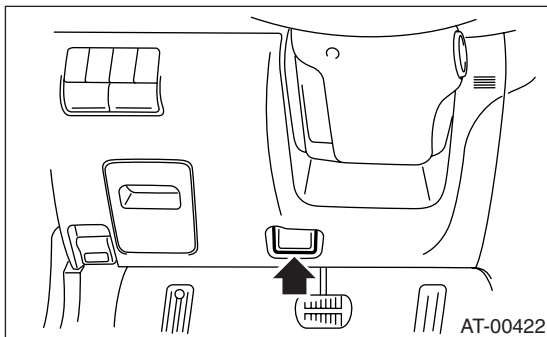

(2) Connect the diagnosis cable to data link connector.

NOTE:

Do not connect scan tools except for Subaru Select Monitor.

5) Turn the ignition switch to ON (engine OFF) and Subaru Select Monitor switch to ON.

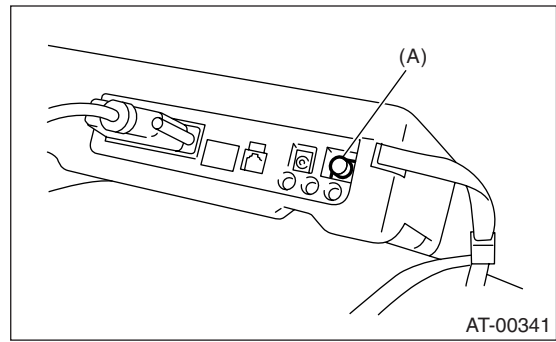

(A) POWER switch

6) On the «Main Menu» display screen, select the {Each System Check} and press the [YES] key.

7) On the «System Selection Menu» display screen, select the {Transmission Control System} and press the [YES] key.

8) Press the [YES] key after the information of transmission type is displayed.

9) On the «Transmission Diagnosis» display screen, select the {Diagnostic Code(s) Display} and press the [YES] key.

NOTE:

- For detailed operation procedure, refer to the SUBARU SELECT MONITOR OPERATION MANUAL.

- For details concerning the DTC, refer to the DTC LIST. <Ref. to 4AT(D)(diag)-25, List of Diagnostic Trouble Code (DTC).>

2. READ CURRENT DATA

1) On the «Main Menu» display screen, select the {Each System Check} and press the [YES] key.

2) On the «System Selection Menu» display screen, select the {Transmission Control System} and press the [YES] key.

3) Press the [YES] key after the information of transmission type is displayed.

4) On the «Transmission Diagnosis» display screen, select the {Current Data Display & Save} and press the [YES] key.

5) On the «Transmission Diagnosis» display screen, select the {Data Display} and press the [YES] key.

Subaru Select Monitor

AUTOMATIC TRANSMISSION (DIAGNOSTICS)

6) Using the scroll key, move the display screen up or down until desired data is shown.

- A list of the support data is shown in the following table.

Contents	Display	Unit of measure
Battery voltage	Battery Voltage	V
Rear vehicle speed sensor signal	Rear Wheel Speed	km/h or MPH
Front vehicle speed sensor signal	Front Wheel Speed	km/h or MPH
Engine speed signal	Engine Speed	rpm
ATF temperature signal	ATF Temp.	°C or °F
Throttle position sensor	Throttle Sensor Voltage	V
Throttle position	Throttle opening angle	%
Gear position	Gear Position	—
Line pressure control duty ratio	Line Pressure Duty Ratio	%
Lock up clutch control duty ratio	Lock Up Duty Ratio	%
Transfer clutch control duty ratio	Transfer Duty Ratio	%
Power supply for throttle position sensor	Throttle Power	V
Torque converter turbine speed signal	Turbine Revolution Speed	rpm
2-4 brake timing pressure control duty ratio	Brake Clutch Duty Ratio	%
Low clutch duty ratio	L/C Duty	%
High clutch duty ratio	H/C Duty	%
Low & reverse brake duty ratio	L&R/B Duty	%
Stop light switch signal	Stop Light Switch	ON or OFF
Parking range signal	P Range Signal	ON or OFF
Neutral range signal	N Range Signal	ON or OFF
Reverse range signal	R Range Signal	ON or OFF
Drive range signal	D Range Signal	ON or OFF
3rd range signal	3rd Range Signal	ON or OFF
2nd range signal	2nd Range Signal	ON or OFF
1st range signal	1st Range Signal	ON or OFF
AT diagnosis indicator lamp	Diagnosis Lamp	ON or OFF
Shift lock solenoid signal	Shift Lock solenoid	ON or OFF
FWD switch signal	FWD SW	ON or OFF
Cruise control On signal	Cruise Control Signal	ON or OFF
AT OIL TEMP warning light	AT OIL TEMP light	ON or OFF

NOTE:

For detailed operation procedure, refer to the SUBARU SELECT MONITOR OPERATION MANUAL.

3. CLEAR MEMORY MODE

- 1) On the «Main Menu» display screen, select the {2. Each System Check} and press the [YES] key.
- 2) On the «System Selection Menu» display screen, select the {Transmission Control System} and press the [YES] key.
- 3) Press the [YES] key after the information of transmission type is displayed.
- 4) On the «Transmission Diagnosis» display screen, select the {Clear Memory} and press the [YES] key.
- 5) When the “Done” is shown on display screen, turn the Subaru Select Monitor and ignition switch to OFF.

NOTE:

- For detailed operation procedure, refer to the SUBARU SELECT MONITOR OPERATION MANUAL.
- When {Clear Memory 2} is selected and executed, DTC and learned control memory is cleared. If Clear Memory 2 is performed, execute the learning control. <Ref. to 4AT(D)(diag)-15, FACILITATION OF LEARNING CONTROL, OPERATION, Subaru Select Monitor.>

4. FACILITATION OF LEARNING CONTROL

- 1) Shift the select lever to “P” range, and apply parking brake.
- 2) Lift-up the vehicle.
- 3) Connect the Subaru Select Monitor to data link connector, and then turn the ignition switch to ON.
- 4) Perform the {Clear Memory 2} using Subaru Select Monitor. <Ref. to 4AT(D)(diag)-14, CLEAR MEMORY MODE, OPERATION, Subaru Select Monitor.>
- 5) Using Subaru Select Monitor, check that the DTC is not output. <Ref. to 4AT(D)(diag)-13, READ DIAGNOSTIC TROUBLE CODE, OPERATION, Subaru Select Monitor.>
- 6) Warm-up the engine until the ATF temperature which is displayed on the Subaru Select Monitor is within 60 — 90°C (140 — 194°F). <Ref. to 4AT(D)(diag)-13, READ CURRENT DATA, OPERATION, Subaru Select Monitor.>
- 7) Shift the select lever to “R” range.
- 8) Turn all switches including headlight, air conditioner, seat heater, rear defogger and etc. to OFF.
- 9) Turn the ignition switch to OFF.
- 10) Depress the brake pedal fully until the facilitation of learning control is completed when the “Communication Failed!” is displayed on Subaru Select Monitor.
- 11) Turn the ignition switch to ON.
- 12) Read the current data to check that the Subaru Select Monitor is returned to normal operation. <Ref. to 4AT(D)(diag)-13, READ CURRENT DATA, OPERATION, Subaru Select Monitor.>
- 13) Shift the select lever to “P” range, and then wait for more than 3 seconds.
- 14) Shift the select lever to “R” range, and then wait for more than 3 seconds.
- 15) Shift the select lever to “N” range, and then wait for more than 3 seconds.
- 16) Shift the select lever to “D” range, and then wait for more than 3 seconds.
- 17) Shift the select lever to “N” range, and then wait for more than 3 seconds.
- 18) Slowly depress the accelerator pedal fully.
- 19) Slowly release the accelerator pedal fully.
- 20) Start the engine, and idle it.
- 21) Shift the select lever to “D” range.
- 22) Start the facilitation of learning control. At this time, the AT OIL TEMP warning light in combination meter blinks at 2 Hz. When the AT OIL TEMP warning light does not blink, turn the ignition switch to OFF and repeat the procedures from step 4). When the AT OIL TEMP warning light which blinking at 2 Hz changes to blink at 0.5 Hz, facilitation of learning control is completed.

NOTE:

When blinking of AT OIL TEMP warning light changes from 2 Hz to 4 Hz during facilitation of learning control, repeat the procedure from step 4).

23) Shift the select lever to “N” range, and then turn the ignition switch to OFF.

24) Shift the select lever to the “P” range, and then complete the facilitation of learning control.

Read Diagnostic Trouble Code (DTC)

AUTOMATIC TRANSMISSION (DIAGNOSTICS)

7. Read Diagnostic Trouble Code (DTC)

A: OPERATION

Refer to Subaru Select Monitor for information about how to obtain and understand DTC. <Ref. to 4AT(D)(diag)-13, OPERATION, Subaru Select Monitor.>

NOTE:

DTC can not be read through AT OIL TEMP warning light.

8. Inspection Mode

A: OPERATION

WARNING:

Observe the road traffic law.

Move the select lever to “D” range, and then drive the vehicle at 60 km/h (37 MPH) for at least 10 seconds.

Clear Memory Mode

AUTOMATIC TRANSMISSION (DIAGNOSTICS)

9. Clear Memory Mode

A: OPERATION

1. WITH SUBARU SELECT MONITOR

Refer to Subaru Select Monitor for information about how to clear DTC.

<Ref. to 4AT(D)(diag)-14, CLEAR MEMORY MODE, OPERATION, Subaru Select Monitor.>

10. AT OIL TEMP Warning Light Display

A: OPERATION

When any on-board diagnostics item is malfunctioning, the display on AT OIL TEMP warning light blinks from the time malfunction is detected after starting the engine until ignition switch is turned to OFF. The malfunctioning part or unit can be determined by a DTC during on-board diagnostics operation. Problems which occurred previously can also be identified through the memory function. If the POWER indicator does not show a problem (although a problem is occurring), the problem can be determined by checking the performance characteristics of each sensor using Subaru Select Monitor. The indicator signal is as shown in the figure.

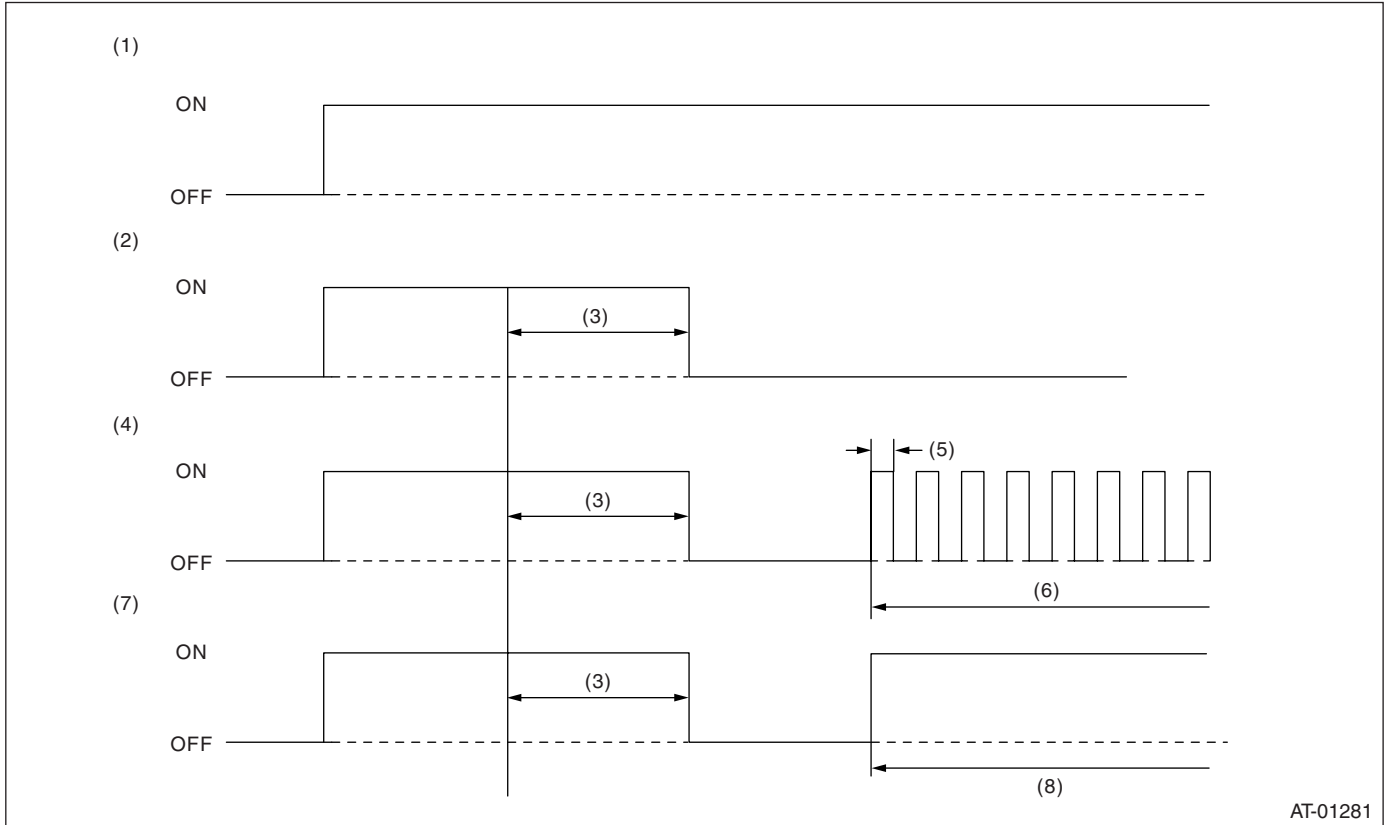

AT-01281

- | | | |
|----------------------------------|-------------------------------|--------------------------------------|
| (1) Ignition switch (engine OFF) | (4) Abnormal (Trouble occurs) | (7) Normal (ATF temperature is high) |
| (2) Normal | (5) 0.25 secs | (8) ATF temperature is high |
| (3) 2 secs | (6) Blink | |

Execute the inspection if AT OIL TEMP warning light does not operate normally. <Ref. to 4AT(D)(diag)-20, INSPECTION, AT OIL TEMP Warning Light Display.>

AT OIL TEMP Warning Light Display

AUTOMATIC TRANSMISSION (DIAGNOSTICS)

B: INSPECTION

DIAGNOSIS:

The AT OIL TEMP warning light circuit is open or shorted.

TROUBLE SYMPTOM:

- When the ignition switch is turned to ON (engine OFF), AT OIL TEMP warning light does not illuminate.

WIRING DIAGRAM:

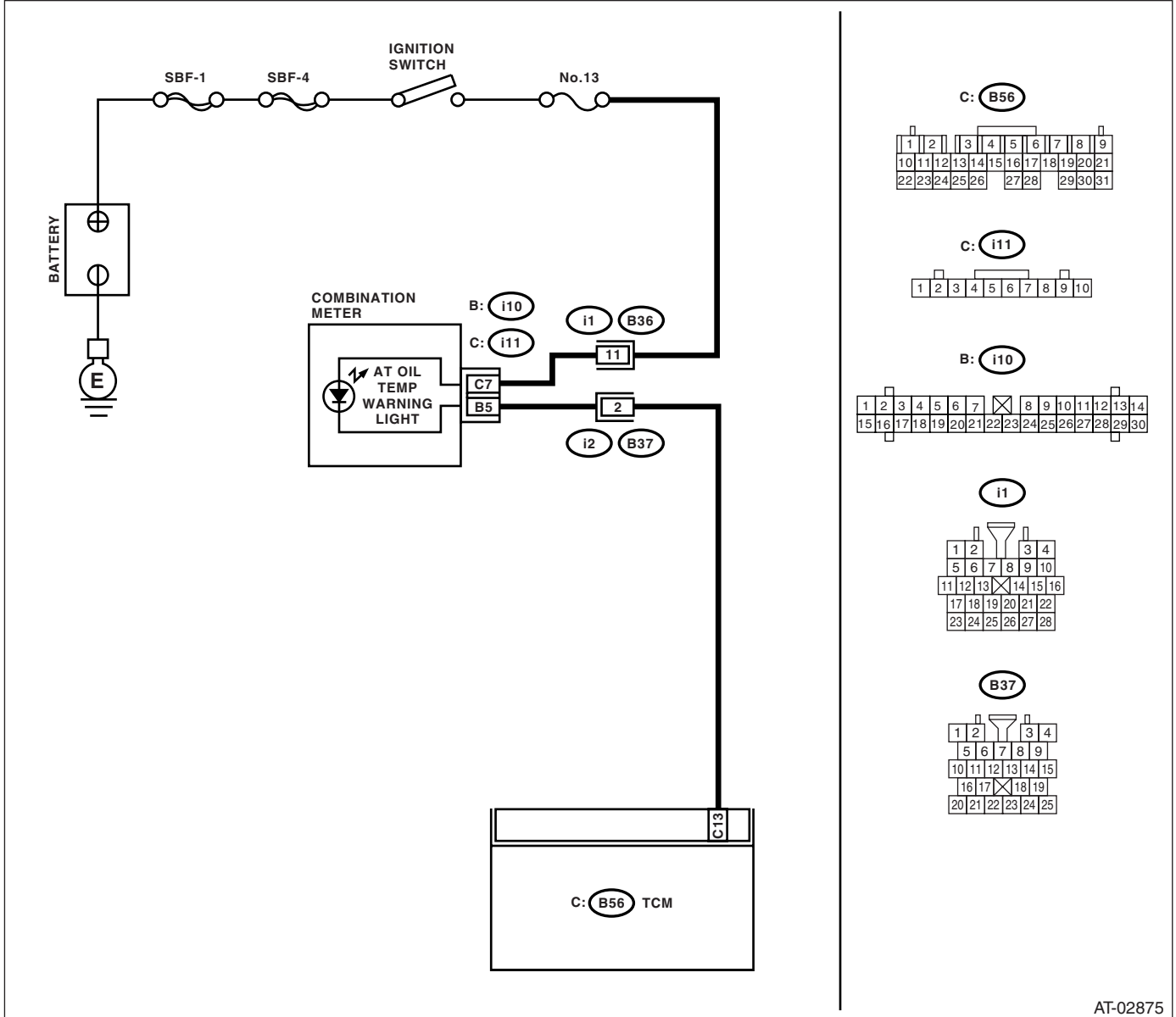

Step	Check	Yes	No	
1	CHECK AT OIL TEMP WARNING LIGHT. Turn the ignition switch to ON (engine OFF).	Does the AT OIL TEMP warning light illuminate?	Go to step 2.	Go to step 3.
2	CHECK FUSE (No. 13). Remove the fuse (No. 13).	Is the fuse (No. 13) blown out?	Replace the fuse (No. 13). If replaced fuse (No. 13) is blown out easily, repair short circuit in harness between fuse (No. 13) and combination meter.	Go to step 4.

AT OIL TEMP Warning Light Display

AUTOMATIC TRANSMISSION (DIAGNOSTICS)

Step	Check	Yes	No
3 CHECK AT OIL TEMP WARNING LIGHT. 1) Turn the ignition switch to OFF. 2) Remove the combination meter.	Is the AT OIL TEMP warning light OK?	Go to step 4.	Check the combination meter.
4 CHECK HARNESS CONNECTOR BETWEEN COMBINATION METER AND IGNITION SWITCH. 1) Turn the ignition switch to ON (engine OFF). 2) Measure the voltage between combination meter connector and chassis ground. <i>Connector & terminal</i> <i>(i11) No. 7 (+) — Chassis ground (-):</i>	Is the voltage more than 9 V?	Go to step 5.	Repair the open circuit in harness between combination meter and battery.
5 CHECK COMBINATION METER. Measure the voltage between combination meter connector and chassis ground. <i>Connector & terminal</i> <i>(i10) No. 5 (+) — Chassis ground (-):</i>	Is the voltage less than 9 V?	Repair the combination meter. <Ref. to IDI-10, Combination Meter.>	Go to step 6.
6 CHECK OPEN CIRCUIT OF HARNESS. 1) Turn the ignition switch to OFF. 2) Disconnect the connector from combination meter connector. 3) Measure the resistance of harness between combination meter. <i>Connector & terminal</i> <i>(B56) No. 13 — (i10) No. 5:</i>	Is the resistance less than 1 Ω ?	Go to step 7.	Repair the open circuit in harness between TCM and combination meter, and poor contact in coupling connector.
7 CHECK INPUT SIGNAL FOR TCM. 1) Connect the connector to TCM and combination meter. 2) Turn the ignition switch to ON (engine OFF). 3) Measure the voltage between TCM connector and chassis ground. <i>Connector & terminal</i> <i>(B56) No. 13 (+) — Chassis ground (-):</i>	Is the voltage less than 1 V?	Go to step 8.	Replace the TCM. <Ref. to 4AT-76, Transmission Control Module (TCM).>
8 INSPECT AT OIL TEMP WARNING LIGHT.	Does the AT OIL TEMP warning light illuminate?	Diagnose according to basic diagnostic procedure.	Inspect power supply and ground circuit.

Diagnostic Procedure for Select Monitor Communication

AUTOMATIC TRANSMISSION (DIAGNOSTICS)

11. Diagnostic Procedure for Select Monitor Communication

A: COMMUNICATION FOR INITIALIZING IMPOSSIBLE

DIAGNOSIS:

- Faulty harness connector

TROUBLE SYMPTOM:

- Subaru select monitor communication failure

WIRING DIAGRAM:

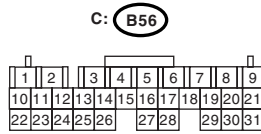
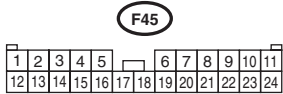
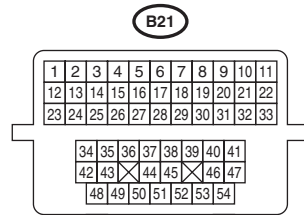
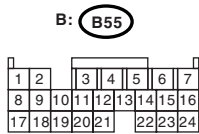
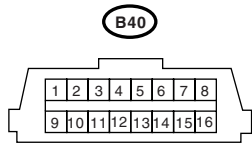
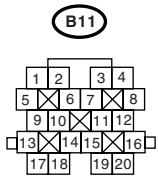
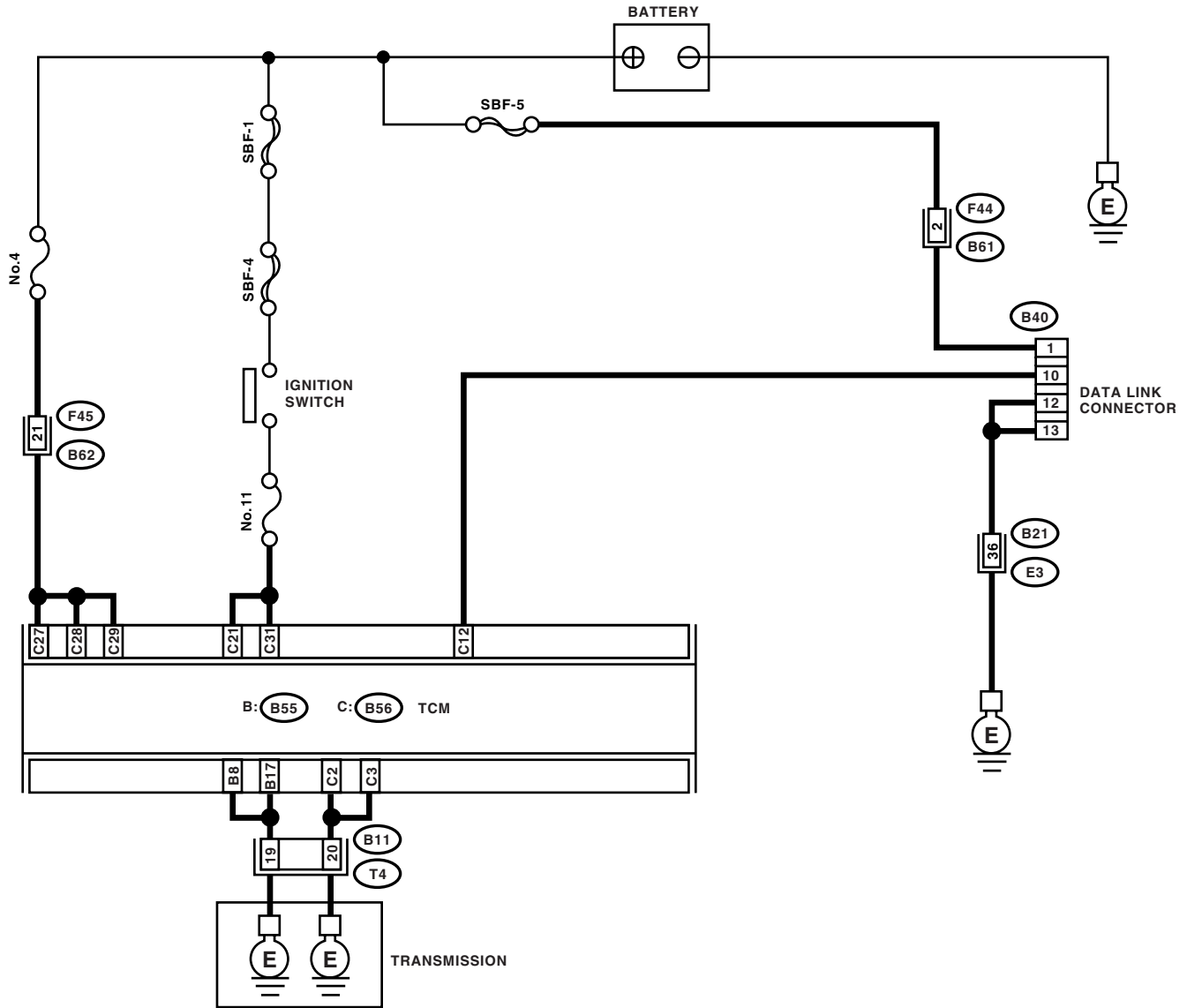

AT-02873

Diagnostic Procedure for Select Monitor Communication

AUTOMATIC TRANSMISSION (DIAGNOSTICS)

Step	Check	Yes	No
1 CHECK SUBARU SELECT MONITOR POWER SUPPLY CIRCUIT. Measure the voltage between data link connector and chassis ground. <i>Connector & terminal</i> <i>(B40) No. 1 (+) — Chassis ground (-):</i>	Is the voltage more than 10 V?	Go to step 2.	Repair the harness and connector between battery and data link connector, and poor contact in coupling connector.
2 CHECK SUBARU SELECT MONITOR GROUND CIRCUIT. Measure the resistance of harness between data link connector and chassis ground. <i>Connector & terminal</i> <i>(B40) No. 12 — Chassis ground:</i> <i>(B40) No. 13 — Chassis ground:</i>	Is the resistance less than 1 Ω ?	Go to step 3.	Repair the open circuit in harness between data link connector and ground terminal, and poor contact in coupling connector.
3 CHECK COMMUNICATION OF SUBARU SELECT MONITOR. 1) Turn the ignition switch to ON. 2) Using the Subaru Select Monitor, check whether communication to transmission systems can be executed normally.	Are the name of system displayed on Subaru Select Monitor?	Go to step 8.	Go to step 4.
4 CHECK COMMUNICATION OF SUBARU SELECT MONITOR. 1) Turn the ignition switch to OFF. 2) Disconnect the TCM connector. 3) Turn the ignition switch to ON and turn Subaru Select Monitor switch to ON. 4) Check whether communication to engine systems can be executed normally.	Are the name of system displayed on Subaru Select Monitor?	Go to step 6.	Go to step 5.
5 CHECK COMMUNICATION OF SUBARU SELECT MONITOR. 1) Turn the ignition switch to OFF. 2) Connect the TCM connector. 3) Disconnect the ECM connector. 4) Check whether communication to transmission systems can be executed normally.	Are the name of system displayed on Subaru Select Monitor?	Inspect the ECM.	Go to step 6.
6 CHECK HARNESS CONNECTOR BETWEEN EACH CONTROL MODULE AND DATA LINK CONNECTOR. 1) Turn the ignition switch to OFF. 2) Disconnect the TCM and ECM connectors. 3) Measure the resistance between TCM connector and chassis ground. <i>Connector & terminal</i> <i>(B40) No. 10 — Chassis ground:</i>	Is the resistance more than 1 M Ω ?	Go to step 7.	Check the harness and connector between each control module and data link connector.
7 CHECK OUTPUT SIGNAL FOR TCM. 1) Turn the ignition switch to ON. 2) Measure the voltage between TCM and chassis ground. <i>Connector & terminal</i> <i>(B40) No. 10 (+) — Chassis ground (-):</i>	Is the voltage more than 1 V?	Repair the harness and connector between each control module and data link connector.	Go to step 8.
8 CHECK HARNESS/CONNECTOR BETWEEN TCM AND DATA LINK CONNECTOR. Measure the resistance between TCM connector and data link connector. <i>Connector & terminal</i> <i>(B56) No. 12 — (B40) No. 10:</i>	Is the resistance less than 0.5 Ω ?	Go to step 9.	Check the harness and connector between TCM and data link connector.

Diagnostic Procedure for Select Monitor Communication

AUTOMATIC TRANSMISSION (DIAGNOSTICS)

Step	Check	Yes	No
9 CHECK INSTALLATION OF TCM CONNECTOR. Turn the ignition switch to OFF.	Is the TCM connector inserted into TCM?	Go to step 10 .	Insert the TCM connector into TCM.
10 INSPECTION OF TRANSMISSION HARNESS CONNECTOR.	Is the transmission harness connector inserted into bulk-head harness connector?	Go to step 11 .	Connect the bulk-head harness connector to transmission harness connector.
11 CHECK POOR CONTACT IN CONNECTORS.	Is there poor contact in control module and data link connector?	Repair the poor contact.	Go to step 12 .
12 CHECK IGNITION POWER SUPPLY CIRCUIT. 1) Turn the ignition switch to ON (engine OFF). 2) Measure the ignition power supply voltage between TCM connector and chassis ground. <i>Connector & terminal</i> <i>(B55) No. 27 (+) — Chassis ground (-):</i> <i>(B55) No. 28 (+) — Chassis ground (-):</i> <i>(B55) No. 29 (+) — Chassis ground (-):</i>	Is the voltage 10 — 13 V?	Go to step 14 .	Go to step 13 .
13 CHECK FUSE (No. 11). Remove the fuse (No. 11).	Is the fuse (No. 11) blown out?	Replace the fuse (No. 11). If replaced fuse (No. 11) has blown out easily, repair short circuit in harness between fuse (No. 11) and TCM.	Repair the open circuit in harness between fuse (No. 11) and TCM, or fuse (No. 11) and battery, and poor contact in coupling connector.
14 CHECK HARNESS CONNECTOR BETWEEN TCM AND TRANSMISSION. 1) Turn the ignition switch to OFF. 2) Disconnect the connector from TCM and transmission. 3) Measure the resistance of harness between TCM and transmission connector. <i>Connector & terminal</i> <i>(B55) No. 8 — (B11) No. 19:</i> <i>(B55) No. 17 — (B11) No. 19:</i> <i>(B56) No. 2 — (B11) No. 20:</i> <i>(B56) No. 3 — (B11) No. 20:</i>	Is the resistance less than 1 Ω ?	Go to step 15 .	Repair the open circuit in harness between TCM and transmission harness connector, and poor contact in connector.
15 CHECK HARNESS CONNECTOR BETWEEN TRANSMISSION AND TRANSMISSION GROUND. Measure the resistance of harness between transmission and transmission ground. <i>Connector & terminal</i> <i>(T4) No. 19 — Transmission ground:</i> <i>(T4) No. 20 — Transmission ground:</i>	Is the resistance less than 1 Ω ?	Go to step 16 .	Repair the open circuit in harness between transmission and transmission ground.
16 CHECK POOR CONTACT IN CONNECTORS.	Is there poor contact in TCM power supply, ground line and data link connector?	Repair the connector.	Replace the TCM. <Ref. to 4AT-76, Transmission Control Module (TCM).>

List of Diagnostic Trouble Code (DTC)

AUTOMATIC TRANSMISSION (DIAGNOSTICS)

12. List of Diagnostic Trouble Code (DTC)

A: LIST

DTC	Item	Diagnosis content	Reference
P0705	Transmission Range Sensor Circuit (PRNDL Input)	Inhibitor switch malfunction, open or short circuit	<Ref. to 4AT(D)(diag)-28, DTC P0705 TRANSMISSION RANGE SENSOR CIRCUIT (PRNDL INPUT), Diagnostic Procedure with Diagnostic Trouble Code (DTC).>
P0712	Transmission Fluid Temperature Sensor Circuit Low Input	ATF temperature sensor malfunction, open input signal circuit	<Ref. to 4AT(D)(diag)-37, DTC P0712 TRANSMISSION FLUID TEMPERATURE SENSOR CIRCUIT LOW INPUT, Diagnostic Procedure with Diagnostic Trouble Code (DTC).>
P0713	Transmission Fluid Temperature Sensor Circuit High Input	ATF temperature sensor malfunction, open input signal circuit	<Ref. to 4AT(D)(diag)-40, DTC P0713 TRANSMISSION FLUID TEMPERATURE SENSOR CIRCUIT HIGH INPUT, Diagnostic Procedure with Diagnostic Trouble Code (DTC).>
P0715	Input/Turbine Speed Sensor Circuit	Torque converter turbine speed sensor malfunction, open or short input signal circuit	<Ref. to 4AT(D)(diag)-43, DTC P0715 INPUT/TURBINE SPEED SENSOR CIRCUIT, Diagnostic Procedure with Diagnostic Trouble Code (DTC).>
P0719	Torque Converter/Brake Switch "B" Circuit Low	Brake switch malfunction, open input signal circuit	<Ref. to 4AT(D)(diag)-45, DTC P0719 TORQUE CONVERTER/BRAKE SWITCH "B" CIRCUIT LOW, Diagnostic Procedure with Diagnostic Trouble Code (DTC).>
P0720	AT Vehicle Speed Sensor Circuit	Front vehicle speed sensor malfunction, open or short input signal circuit	<Ref. to 4AT(D)(diag)-47, DTC P0720 OUTPUT SPEED SENSOR CIRCUIT, Diagnostic Procedure with Diagnostic Trouble Code (DTC).>
P0724	Torque Converter/Brake Switch "B" Circuit High	Brake switch malfunction, short input signal circuit	<Ref. to 4AT(D)(diag)-50, DTC P0724 TORQUE CONVERTER/BRAKE SWITCH "B" CIRCUIT HIGH, Diagnostic Procedure with Diagnostic Trouble Code (DTC).>
P0725	Engine Speed Input Circuit	Open or short engine speed output signal circuit	<Ref. to 4AT(D)(diag)-52, DTC P0725 ENGINE SPEED INPUT CIRCUIT, Diagnostic Procedure with Diagnostic Trouble Code (DTC).>
P0731	Gear 1 Incorrect Ratio	Vehicle speed sensor, torque converter turbine speed sensor, or control valve malfunction	<Ref. to 4AT(D)(diag)-53, DTC P0731 GEAR 1 INCORRECT RATIO, Diagnostic Procedure with Diagnostic Trouble Code (DTC).>
P0732	Gear 2 Incorrect Ratio	Vehicle speed sensor, torque converter turbine speed sensor, or control valve malfunction	<Ref. to 4AT(D)(diag)-53, DTC P0732 GEAR 2 INCORRECT RATIO, Diagnostic Procedure with Diagnostic Trouble Code (DTC).>
P0733	Gear 3 Incorrect Ratio	Vehicle speed sensor, torque converter turbine speed sensor, or control valve malfunction	<Ref. to 4AT(D)(diag)-53, DTC P0733 GEAR 3 INCORRECT RATIO, Diagnostic Procedure with Diagnostic Trouble Code (DTC).>
P0734	Gear 4 Incorrect Ratio	Vehicle speed sensor, torque converter turbine speed sensor, or control valve malfunction	<Ref. to 4AT(D)(diag)-53, DTC P0734 GEAR 4 INCORRECT RATIO, Diagnostic Procedure with Diagnostic Trouble Code (DTC).>

List of Diagnostic Trouble Code (DTC)

AUTOMATIC TRANSMISSION (DIAGNOSTICS)

DTC	Item	Diagnosis content	Reference
P0736	Reverse Incorrect Ratio	Vehicle speed sensor, torque converter turbine speed sensor, or control valve malfunction	<Ref. to 4AT(D)(diag)-54, DTC P0736 REVERSE INCORRECT RATIO, Diagnostic Procedure with Diagnostic Trouble Code (DTC).>
P0741	Torque Converter Clutch Circuit Performance or Stuck Off	Lock up clutch malfunction or locking of valve	<Ref. to 4AT(D)(diag)-55, DTC P0741 TORQUE CONVERTER CLUTCH CIRCUIT PERFORMANCE OR STUCK OFF, Diagnostic Procedure with Diagnostic Trouble Code (DTC).>
P0743	Torque Converter Clutch Circuit Electrical	Lock up solenoid malfunction, open or short output signal circuit	<Ref. to 4AT(D)(diag)-56, DTC P0743 TORQUE CONVERTER CLUTCH CIRCUIT ELECTRICAL, Diagnostic Procedure with Diagnostic Trouble Code (DTC).>
P0748	Pressure Control Solenoid "A" Electrical	Line pressure linear solenoid malfunction, open or short output signal circuit	<Ref. to 4AT(D)(diag)-58, DTC P0748 PRESSURE CONTROL SOLENOID "A" ELECTRICAL, Diagnostic Procedure with Diagnostic Trouble Code (DTC).>
P0753	Shift Solenoid "A" Electrical	Low clutch duty solenoid malfunction, open or short output signal circuit	<Ref. to 4AT(D)(diag)-60, DTC P0753 SHIFT SOLENOID "A" ELECTRICAL, Diagnostic Procedure with Diagnostic Trouble Code (DTC).>
P0758	Shift Solenoid "B" Electrical	2-4 brake duty solenoid malfunction, open or short output signal circuit	<Ref. to 4AT(D)(diag)-63, DTC P0758 SHIFT SOLENOID "B" ELECTRICAL, Diagnostic Procedure with Diagnostic Trouble Code (DTC).>
P0763	Shift Solenoid "C" Electrical	High clutch duty solenoid malfunction, open or short output signal circuit	<Ref. to 4AT(D)(diag)-66, DTC P0763 SHIFT SOLENOID "C" ELECTRICAL, Diagnostic Procedure with Diagnostic Trouble Code (DTC).>
P0768	Shift Solenoid "D" Electrical	Low & reverse duty solenoid malfunction, open or short output signal circuit	<Ref. to 4AT(D)(diag)-69, DTC P0768 SHIFT SOLENOID "D" ELECTRICAL, Diagnostic Procedure with Diagnostic Trouble Code (DTC).>
P0801	Reverse Inhibitor Control Circuit	Shift lock solenoid malfunction, open or short output signal circuit	<Ref. to 4AT(D)(diag)-72, DTC P0801 REVERSE INHIBIT CONTROL CIRCUIT, Diagnostic Procedure with Diagnostic Trouble Code (DTC).>
P1706	AT Vehicle Speed Sensor Circuit Malfunction (rear wheel)	Rear vehicle speed sensor malfunction, open or short input signal circuit	<Ref. to 4AT(D)(diag)-74, DTC P1706 AT VEHICLE SPEED SENSOR CIRCUIT MALFUNCTION (REAR WHEEL), Diagnostic Procedure with Diagnostic Trouble Code (DTC).>
P1707	AT AWD Solenoid Valve Circuit Malfunction	Transfer duty solenoid malfunction, open or short output signal circuit	<Ref. to 4AT(D)(diag)-77, DTC P1707 AT AWD SOLENOID VALVE CIRCUIT MALFUNCTION, Diagnostic Procedure with Diagnostic Trouble Code (DTC).>
P1708	Throttle Position Sensor Circuit Low Input	Throttle position sensor malfunction, open input signal circuit	<Ref. to 4AT(D)(diag)-79, DTC P1708 THROTTLE POSITION SENSOR CIRCUIT LOW INPUT, Diagnostic Procedure with Diagnostic Trouble Code (DTC).>
P1709	Throttle Position Sensor Circuit High Input	Throttle position sensor malfunction, open input signal circuit	<Ref. to 4AT(D)(diag)-82, DTC P1709 THROTTLE POSITION SENSOR CIRCUIT HIGH INPUT, Diagnostic Procedure with Diagnostic Trouble Code (DTC).>

List of Diagnostic Trouble Code (DTC)

AUTOMATIC TRANSMISSION (DIAGNOSTICS)

DTC	Item	Diagnosis content	Reference
P1714	Throttle Position Sensor Power Supply Circuit	Throttle position sensor malfunction, open or short input signal circuit	<Ref. to 4AT(D)(diag)-85, DTC P1714 THROTTLE POSITION SENSOR POWER SUPPLY CIRCUIT, Diagnostic Procedure with Diagnostic Trouble Code (DTC).>
P1718	CAN Communication Circuit	Open or short AT communication signal circuit	<Ref. to 4AT(D)(diag)-87, DTC P1718 CAN COMMUNICATION CIRCUIT, Diagnostic Procedure with Diagnostic Trouble Code (DTC).>

Diagnostic Procedure with Diagnostic Trouble Code (DTC)

AUTOMATIC TRANSMISSION (DIAGNOSTICS)

13. Diagnostic Procedure with Diagnostic Trouble Code (DTC)

A: DTC P0705 TRANSMISSION RANGE SENSOR CIRCUIT (PRNDL INPUT)

DIAGNOSIS:

- There is malfunction in inhibitor switch.
- The input signal circuit of inhibitor switch is open or shorted.

TROUBLE SYMPTOM:

- Shift characteristics are erroneous.
- Engine brake is not effected when select lever is in “3” range.
- Engine brake is not effected when select lever is in “2” range.
- Engine brake is not effected when select lever is in “1” range.

Diagnostic Procedure with Diagnostic Trouble Code (DTC)

AUTOMATIC TRANSMISSION (DIAGNOSTICS)

WIRING DIAGRAM:

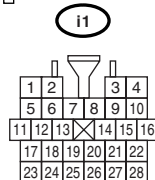
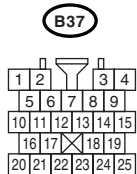
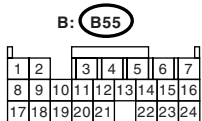
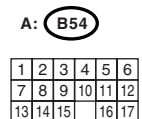
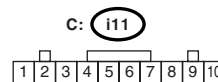
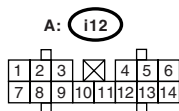
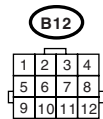
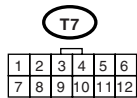
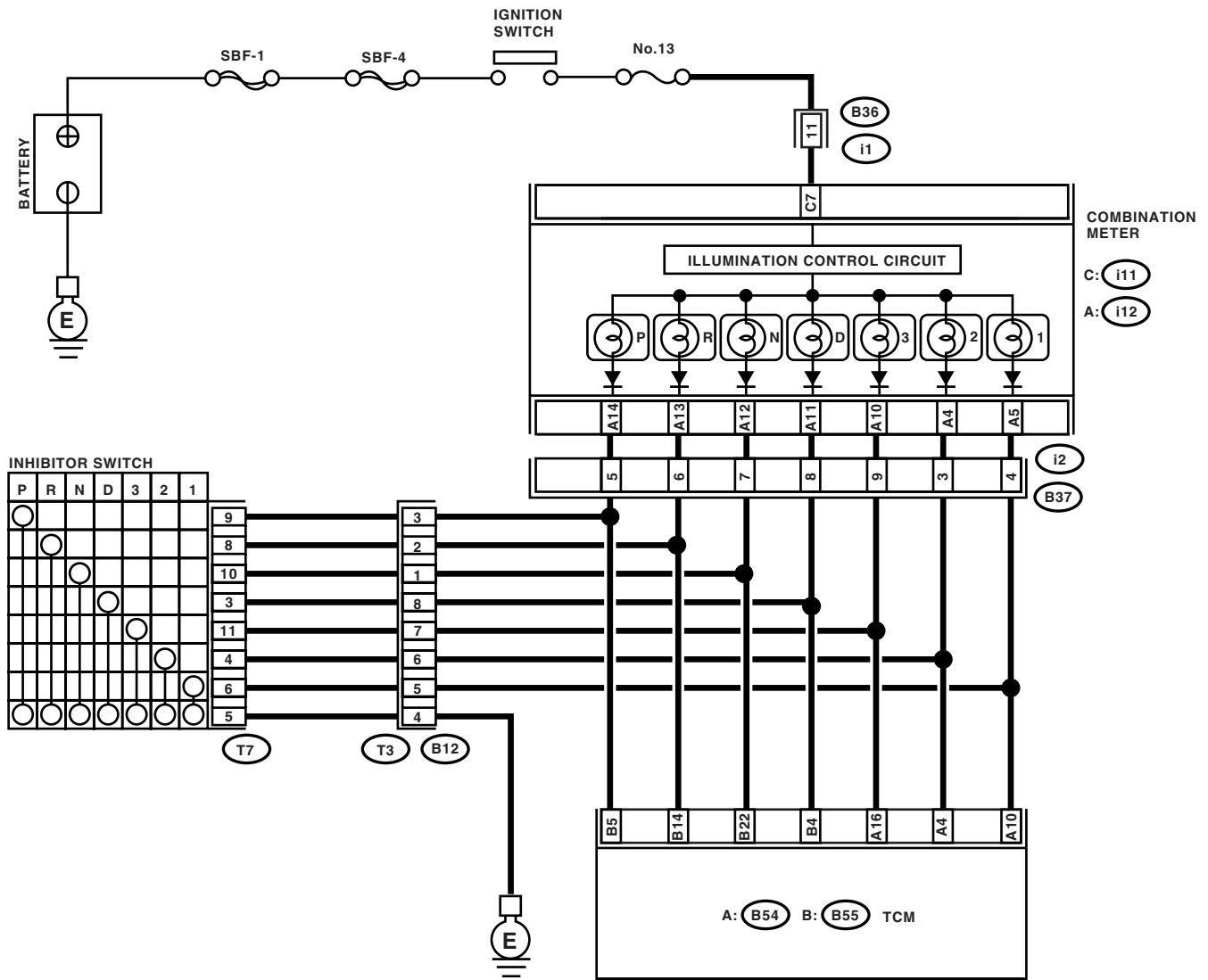

AT-02874

Step	Check	Yes	No
1	CHECK "P" RANGE SWITCH.		
	When the "P" range is selected, does LED light up?	Go to step 2.	Go to step 22.
2	CHECK INDICATOR LIGHT.		
	Does the combination meter "P" range indicator illuminate?	Go to step 3.	Go to step 26.

Diagnostic Procedure with Diagnostic Trouble Code (DTC)

AUTOMATIC TRANSMISSION (DIAGNOSTICS)

Step	Check	Yes	No	
3	CHECK "P" RANGE SWITCH.	When the "R" range is selected, does "P" range LED light up?	Go to step 28.	Go to step 4.
4	CHECK "R" RANGE SWITCH.	When the "R" range is selected, does LED light up?	Go to step 5.	Go to step 29.
5	CHECK INDICATOR LIGHT.	Does the combination meter "R" range indicator illuminate?	Go to step 6.	Go to step 32.
6	CHECK "R" RANGE SWITCH.	When the "N" range is selected, does "R" range LED light up?	Go to step 34.	Go to step 7.
7	CHECK "N" RANGE SWITCH.	When the "N" range is selected, does LED light up?	Go to step 8.	Go to step 35.
8	CHECK INDICATOR LIGHT.	Does the combination meter "N" range indicator illuminate?	Go to step 9.	Go to step 38.
9	CHECK "N" RANGE SWITCH.	When the "D" range is selected, does "N" range LED light up?	Go to step 40.	Go to step 10.
10	CHECK "D" RANGE SWITCH.	When the "D" range is selected, does LED light up?	Go to step 11.	Go to step 41.
11	CHECK INDICATOR LIGHT.	Does the combination meter "D" range indicator illuminate?	Go to step 12.	Go to step 44.
12	CHECK "D" RANGE SWITCH.	When the "3" range is selected, does "D" range LED light up?	Go to step 46.	Go to step 13.
13	CHECK "3" RANGE SWITCH.	When the "3" range is selected, does LED light up?	Go to step 14.	Go to step 47.
14	CHECK INDICATOR LIGHT.	Does the combination meter "3" range indicator illuminate?	Go to step 15.	Go to step 50.
15	CHECK "3" RANGE SWITCH.	When the "2" range is selected, does "3" range LED light up?	Go to step 52.	Go to step 16.
16	CHECK "2" RANGE SWITCH.	When the "2" range is selected, does LED light up?	Go to step 17.	Go to step 53.
17	CHECK INDICATOR LIGHT.	Does the combination meter "2" range indicator illuminate?	Go to step 18.	Go to step 56.
18	CHECK "2" RANGE SWITCH.	When the "1" range is selected, does "2" range LED light up?	Go to step 58.	Go to step 19.
19	CHECK "1" RANGE SWITCH.	When the "1" range is selected, does LED light up?	Go to step 20.	Go to step 59.
20	CHECK INDICATOR LIGHT.	Does the combination meter "1" range indicator illuminate?	Go to step 21.	Go to step 62.
21	CHECK "1" RANGE SWITCH.	When the "2" range is selected, does "1" range LED light up?	Go to step 64.	Replace the TCM. <Ref. to 4AT-76, Transmission Control Module (TCM).>
22	CHECK HARNESS CONNECTOR BETWEEN INHIBITOR SWITCH AND CHASSIS GROUND. 1) Turn the ignition switch to OFF. 2) Disconnect the connector from inhibitor switch. 3) Measure the resistance of harness between inhibitor switch and chassis ground. Connector & terminal (T7) No. 5 — Chassis ground:	Is the resistance less than 1 Ω?	Go to step 23.	Repair the open circuit in harness between inhibitor switch connector and chassis ground, and poor contact in coupling connector.

Diagnostic Procedure with Diagnostic Trouble Code (DTC)

AUTOMATIC TRANSMISSION (DIAGNOSTICS)

Step	Check	Yes	No
23 CHECK HARNESS CONNECTOR BETWEEN TCM AND INHIBITOR SWITCH. 1) Turn the ignition switch to OFF. 2) Disconnect the connectors from TCM and inhibitor switch. 3) Measure the resistance of harness between TCM and inhibitor switch connector. <i>Connector & terminal</i> <i>(B55) No. 5 — (T7) No. 9:</i>	Is the resistance less than 1 Ω ?	Go to step 24.	Repair the open circuit in harness between TCM and inhibitor switch connector, and poor contact in coupling connector.
24 CHECK INPUT SIGNAL FOR TCM. 1) Turn the ignition switch to OFF. 2) Connect the connector to TCM and inhibitor switch. 3) Turn the ignition switch to ON. 4) Move the select lever to "P" range. 5) Measure the voltage between TCM and chassis ground. <i>Connector & terminal</i> <i>(B55) No. 5 (+) — Chassis ground (-):</i>	Is the voltage less than 1 V?	Go to step 25.	Go to step 65.
25 CHECK INPUT SIGNAL FOR TCM. 1) Move the select lever except for "P" range. 2) Measure the voltage between TCM and chassis ground. <i>Connector & terminal</i> <i>(B55) No. 5 (+) — Chassis ground (-):</i>	Is the voltage more than 8 V?	Go to step 65.	Replace the TCM. <Ref. to 4AT-76, Transmission Control Module (TCM).>
26 CHECK "P" RANGE INDICATOR LIGHT BULB. 1) Turn the ignition switch to OFF. 2) Remove the combination meter.	Is the "P" range indicator light OK?	Go to step 27.	Replace the combination meter. <Ref. to IDI-10, Combination Meter.>
27 CHECK HARNESS CONNECTOR BETWEEN TCM AND COMBINATION METER. 1) Disconnect the connectors from TCM and combination meter. 2) Measure the resistance of harness between TCM and combination meter. <i>Connector & terminal</i> <i>(B55) No. 5 — (i12) No. 14:</i>	Is the resistance less than 1 Ω ?	Go to step 65.	Repair the open circuit in harness between TCM connector and combination meter, and poor contact in coupling connector.
28 CHECK HARNESS CONNECTOR BETWEEN TCM AND INHIBITOR SWITCH. 1) Turn the ignition switch to OFF. 2) Disconnect the connectors from TCM, inhibitor switch and combination meter. 3) Measure the resistance of harness between TCM connector and chassis ground. <i>Connector & terminal</i> <i>(B55) No. 5 — Chassis ground:</i>	Is the resistance more than 1 $M\Omega$?	Go to step 29.	Repair the ground short circuit in "P" range circuit.
29 CHECK HARNESS CONNECTOR BETWEEN TCM AND INHIBITOR SWITCH. 1) Turn the ignition switch to OFF. 2) Disconnect the connectors from TCM and inhibitor switch. 3) Measure the resistance of harness between TCM and inhibitor switch connector. <i>Connector & terminal</i> <i>(B55) No. 14 — (T7) No. 8:</i>	Is the resistance less than 1 Ω ?	Go to step 30.	Repair the open circuit in harness between TCM and inhibitor switch connector, and poor contact in coupling connector.

Diagnostic Procedure with Diagnostic Trouble Code (DTC)

AUTOMATIC TRANSMISSION (DIAGNOSTICS)

Step	Check	Yes	No
30 CHECK INPUT SIGNAL FOR TCM. 1) Turn the ignition switch to OFF. 2) Connect the connector to TCM and inhibitor switch. 3) Turn the ignition switch to ON. 4) Move the select lever to "R" range. 5) Measure the voltage between TCM and chassis ground. Connector & terminal (B55) No. 14 (+) — Chassis ground (-):	Is the voltage less than 1 V?	Go to step 31.	Go to step 65.
31 CHECK INPUT SIGNAL FOR TCM. 1) Move the select lever except for "R" range. 2) Measure the voltage between TCM and chassis ground. Connector & terminal (B55) No. 14 (+) — Chassis ground (-):	Is the voltage more than 8 V?	Go to step 65.	Replace the TCM. <Ref. to 4AT-76, Transmission Control Module (TCM).>
32 CHECK "R" RANGE INDICATOR LIGHT BULB. 1) Turn the ignition switch to OFF. 2) Remove the combination meter.	Is "R" range indicator light OK?	Go to step 33.	Replace the combination meter. <Ref. to IDI-10, Combination Meter.>
33 CHECK HARNESS CONNECTOR BETWEEN TCM AND COMBINATION METER. 1) Disconnect the connectors from TCM and combination meter. 2) Measure the resistance of harness between TCM and combination meter. Connector & terminal (B55) No. 14 — (i12) No. 13:	Is the resistance less than 1 Ω ?	Go to step 65.	Repair the open circuit in harness between TCM connector and combination meter, and poor contact in TCM connector.
34 CHECK HARNESS CONNECTOR BETWEEN TCM AND INHIBITOR SWITCH. 1) Turn the ignition switch to OFF. 2) Disconnect the connectors from TCM, inhibitor switch and combination meter. 3) Measure the resistance of harness between TCM connector and chassis ground. Connector & terminal (B55) No. 14 — Chassis ground:	Is the resistance more than 1 M Ω ?	Go to step 35.	Repair the ground short circuit in "R" range circuit.
35 CHECK HARNESS CONNECTOR BETWEEN TCM AND INHIBITOR SWITCH. 1) Turn the ignition switch to OFF. 2) Disconnect the connectors from TCM and inhibitor switch. 3) Measure the resistance of harness between TCM and inhibitor switch connector. Connector & terminal (B55) No. 22 — (T7) No. 10:	Is the resistance less than 1 Ω ?	Go to step 36.	Repair the open circuit in harness between TCM and inhibitor switch connector, and poor contact in coupling connector.
36 CHECK INPUT SIGNAL FOR TCM. 1) Turn the ignition switch to OFF. 2) Connect the connector to TCM and inhibitor switch. 3) Turn the ignition switch to ON. 4) Move the select lever to "N" range. 5) Measure the voltage between TCM and chassis ground. Connector & terminal (B55) No. 22 (+) — Chassis ground (-):	Is the voltage less than 1 V?	Go to step 37.	Go to step 65.

Diagnostic Procedure with Diagnostic Trouble Code (DTC)

AUTOMATIC TRANSMISSION (DIAGNOSTICS)

Step	Check	Yes	No
37 CHECK INPUT SIGNAL FOR TCM. 1) Move the select lever to except for "N" range. 2) Measure the voltage between TCM and chassis ground. <i>Connector & terminal</i> <i>(B55) No. 22 (+) — Chassis ground (-):</i>	Is the voltage more than 8 V?	Go to step 65.	Replace the TCM. <Ref. to 4AT-76, Transmission Control Module (TCM).>
38 CHECK "N" RANGE INDICATOR LIGHT BULB. 1) Turn the ignition switch to OFF. 2) Remove the combination meter.	Is the "N" range indicator light OK?	Go to step 39.	Replace the combination meter. <Ref. to IDI-10, Combination Meter.>
39 CHECK HARNESS CONNECTOR BETWEEN TCM AND COMBINATION METER. 1) Disconnect the connectors from TCM and combination meter. 2) Measure the resistance of harness between TCM and combination meter. <i>Connector & terminal</i> <i>(B55) No. 22 — (i12) No. 12:</i>	Is the resistance less than 1 Ω ?	Go to step 65.	Repair the open circuit in harness between TCM connector and combination meter, and poor contact in TCM connector.
40 CHECK HARNESS CONNECTOR BETWEEN TCM AND INHIBITOR SWITCH. 1) Turn the ignition switch to OFF. 2) Disconnect the connectors from TCM, inhibitor switch and combination meter. 3) Measure the resistance of harness between TCM connector and chassis ground. <i>Connector & terminal</i> <i>(B55) No. 22 — Chassis ground:</i>	Is the resistance more than 1 $M\Omega$?	Go to step 41.	Repair the ground short circuit in "N" range circuit.
41 CHECK HARNESS CONNECTOR BETWEEN TCM AND INHIBITOR SWITCH. 1) Turn the ignition switch to OFF. 2) Disconnect the connectors from TCM and inhibitor switch. 3) Measure the resistance of harness between TCM and inhibitor switch connector. <i>Connector & terminal</i> <i>(B55) No. 4 — (T7) No. 3:</i>	Is the resistance less than 1 Ω ?	Go to step 42.	Repair the open circuit in harness between TCM and inhibitor switch connector, and poor contact in coupling connector.
42 CHECK INPUT SIGNAL FOR TCM. 1) Turn the ignition switch to OFF. 2) Connect the connector to TCM and inhibitor switch. 3) Turn the ignition switch to ON. 4) Move the select lever to "D" range. 5) Measure the voltage between TCM and chassis ground. <i>Connector & terminal</i> <i>(B55) No. 4 (+) — Chassis ground (-):</i>	Is the voltage less than 1 V?	Go to step 43.	Go to step 65.
43 CHECK INPUT SIGNAL FOR TCM. 1) Move the select lever except for "D" range. 2) Measure the voltage between TCM and chassis ground. <i>Connector & terminal</i> <i>(B55) No. 4 (+) — Chassis ground (-):</i>	Is the voltage more than 8 V?	Go to step 65.	Replace the TCM. <Ref. to 4AT-76, Transmission Control Module (TCM).>
44 CHECK "D" RANGE INDICATOR LIGHT BULB. 1) Turn the ignition switch to OFF. 2) Remove the combination meter.	Is the "D" range indicator light OK?	Go to step 45.	Replace the combination meter. <Ref. to IDI-10, Combination Meter.>

Diagnostic Procedure with Diagnostic Trouble Code (DTC)

AUTOMATIC TRANSMISSION (DIAGNOSTICS)

Step	Check	Yes	No
45 CHECK HARNESS CONNECTOR BETWEEN TCM AND COMBINATION METER. 1) Disconnect the connectors from TCM and combination meter. 2) Measure the resistance of harness between TCM and combination meter. <i>Connector & terminal</i> <i>(B55) No. 4 — (i12) No. 11:</i>	Is the resistance less than 1 Ω ?	Go to step 65.	Repair the open circuit in harness between TCM connector and combination meter, and TCM connector.
46 CHECK HARNESS CONNECTOR BETWEEN TCM AND INHIBITOR SWITCH. 1) Turn the ignition switch to OFF. 2) Disconnect the connectors from TCM, inhibitor switch and combination meter. 3) Measure the resistance of harness between TCM connector and chassis ground. <i>Connector & terminal</i> <i>(B55) No. 4 — Chassis ground:</i>	Is the resistance more than 1 M Ω ?	Go to step 47.	Repair the ground short circuit in "D" range circuit.
47 CHECK HARNESS CONNECTOR BETWEEN TCM AND INHIBITOR SWITCH. 1) Turn the ignition switch to OFF. 2) Disconnect the connector from TCM and inhibitor switch. 3) Measure the resistance of harness between TCM and inhibitor switch connector. <i>Connector & terminal</i> <i>(B54) No. 16 — (T7) No. 11:</i>	Is the resistance less than 1 Ω ?	Go to step 48.	Repair the open circuit in harness between TCM and inhibitor switch connector, and poor contact in coupling connector.
48 CHECK INPUT SIGNAL FOR TCM. 1) Turn the ignition switch to OFF. 2) Connect the connector to TCM and inhibitor switch. 3) Turn the ignition switch to ON. 4) Move the select lever to "3" range. 5) Measure the voltage between TCM and chassis ground. <i>Connector & terminal</i> <i>(B54) No. 15 (+) — Chassis ground (-):</i>	Is the voltage less than 1 V?	Go to step 49.	Go to step 65.
49 CHECK INPUT SIGNAL FOR TCM. 1) Move the select lever except for "3" range. 2) Measure the voltage between TCM and chassis ground. <i>Connector & terminal</i> <i>(B54) No. 15 (+) — Chassis ground (-):</i>	Is the voltage more than 8 V?	Go to step 65.	Replace the TCM. <Ref. to 4AT-76, Transmission Control Module (TCM).>
50 CHECK "3" RANGE INDICATOR LIGHT BULB. 1) Turn the ignition switch to OFF. 2) Remove the combination meter.	Is the "3" range indicator light OK?	Go to step 51.	Replace the combination meter. <Ref. to IDI-10, Combination Meter.>
51 CHECK HARNESS CONNECTOR BETWEEN TCM AND COMBINATION METER. 1) Disconnect the connectors from TCM and combination meter. 2) Measure the resistance of harness between TCM and combination meter. <i>Connector & terminal</i> <i>(B51) No. 15 — (i12) No. 10:</i>	Is the resistance less than 1 Ω ?	Go to step 65.	Repair the open circuit in harness between TCM connector and combination meter, and poor contact in TCM connector.

Diagnostic Procedure with Diagnostic Trouble Code (DTC)

AUTOMATIC TRANSMISSION (DIAGNOSTICS)

Step	Check	Yes	No
52 CHECK HARNESS CONNECTOR BETWEEN TCM AND INHIBITOR SWITCH. 1) Turn the ignition switch to OFF. 2) Disconnect the connectors from TCM, inhibitor switch and combination meter. 3) Measure the resistance of harness between TCM connector and chassis ground. <i>Connector & terminal</i> <i>(B54) No. 15 — Chassis ground:</i>	Is the resistance more than 1 M Ω ?	Go to step 53.	Repair the ground short circuit in "3" range circuit.
53 CHECK HARNESS CONNECTOR BETWEEN TCM AND INHIBITOR SWITCH. 1) Turn the ignition switch to OFF. 2) Disconnect the connector from TCM and inhibitor switch. 3) Measure the resistance of harness between TCM and inhibitor switch connector. <i>Connector & terminal</i> <i>(B54) No. 4 — (T7) No. 4:</i>	Is the resistance less than 1 Ω ?	Go to step 54.	Repair the open circuit in harness between TCM and inhibitor switch connector, and poor contact in coupling connector.
54 CHECK INPUT SIGNAL FOR TCM. 1) Turn the ignition switch to OFF. 2) Connect the connector to TCM and inhibitor switch. 3) Turn the ignition switch to ON. 4) Move the select lever to "2" range. 5) Measure the voltage between TCM and chassis ground. <i>Connector & terminal</i> <i>(B54) No. 4 (+) — Chassis ground (-):</i>	Is the voltage less than 1 V?	Go to step 55.	Go to step 65.
55 CHECK INPUT SIGNAL FOR TCM. 1) Move the select lever except for "2" range. 2) Measure the voltage between TCM and chassis ground. <i>Connector & terminal</i> <i>(B54) No. 4 (+) — Chassis ground (-):</i>	Is the voltage more than 8 V?	Go to step 65.	Replace the TCM. <Ref. to 4AT-76, Transmission Control Module (TCM).>
56 CHECK "2" RANGE INDICATOR LIGHT BULB. 1) Turn the ignition switch to OFF. 2) Remove the combination meter.	Is the "2" range indicator light OK?	Go to step 57.	Replace the combination meter. <Ref. to IDI-10, Combination Meter.>
57 CHECK HARNESS CONNECTOR BETWEEN TCM AND COMBINATION METER. 1) Disconnect the connectors from TCM and combination meter. 2) Measure the resistance of harness between TCM and combination meter. <i>Connector & terminal</i> <i>(B54) No. 4 — (i12) No. 4:</i>	Is the resistance less than 1 Ω ?	Go to step 65.	Repair the open circuit in harness between TCM and combination meter, and poor contact in TCM connector.
58 CHECK HARNESS CONNECTOR BETWEEN TCM AND INHIBITOR SWITCH. 1) Turn the ignition switch to OFF. 2) Disconnect the connectors from TCM, inhibitor switch and combination meter. 3) Measure the resistance of harness between TCM and chassis ground. <i>Connector & terminal</i> <i>(B54) No. 4 — Chassis ground:</i>	Is the resistance more than 1 M Ω ?	Go to step 59.	Repair the ground short circuit in "2" range circuit.

Diagnostic Procedure with Diagnostic Trouble Code (DTC)

AUTOMATIC TRANSMISSION (DIAGNOSTICS)

Step	Check	Yes	No
59 CHECK HARNESS CONNECTOR BETWEEN TCM AND INHIBITOR SWITCH. 1) Turn the ignition switch to OFF. 2) Disconnect the connectors from TCM and inhibitor switch. 3) Measure the resistance of harness between TCM and inhibitor switch connector. <i>Connector & terminal</i> <i>(B54) No. 10 — (T7) No. 6:</i>	Is the resistance less than 1 Ω ?	Go to step 60 .	Repair the open circuit in harness between TCM and inhibitor switch connector, and poor contact in coupling connector.
60 CHECK INPUT SIGNAL FOR TCM. 1) Turn the ignition switch to OFF. 2) Connect the connector to TCM and inhibitor switch. 3) Turn the ignition switch to ON. 4) Move the select lever to "1" range. 5) Measure the voltage between TCM and chassis ground. <i>Connector & terminal</i> <i>(B54) No. 10 (+) — Chassis ground (-):</i>	Is the voltage less than 1 V?	Go to step 61 .	Go to step 65 .
61 CHECK INPUT SIGNAL FOR TCM. 1) Move the select lever except for "1" range. 2) Measure the voltage between TCM and chassis ground. <i>Connector & terminal</i> <i>(B54) No. 10 (+) — Chassis ground (-):</i>	Is the voltage more than 8 V?	Go to step 65 .	Replace the TCM. <Ref. to 4AT-76, Transmission Control Module (TCM).>
62 CHECK "1" RANGE INDICATOR LIGHT BULB. 1) Turn the ignition switch to OFF. 2) Remove the combination meter.	Is the "1" range indicator light OK?	Go to step 63 .	Replace the combination meter. <Ref. to IDI-10, Combination Meter.>
63 CHECK HARNESS CONNECTOR BETWEEN TCM AND COMBINATION METER. 1) Disconnect the connectors from TCM and combination meter. 2) Measure the resistance of harness between TCM and combination meter. <i>Connector & terminal</i> <i>(B54) No. 10 — (i12) No. 5:</i>	Is the resistance less than 1 Ω ?	Go to step 65 .	Repair the open circuit in harness between TCM and combination meter, poor contact in TCM connector.
64 CHECK HARNESS CONNECTOR BETWEEN TCM AND INHIBITOR SWITCH. 1) Turn the ignition switch to OFF. 2) Disconnect the connectors from TCM, inhibitor switch and combination meter. 3) Measure the resistance of harness between TCM connector and chassis ground. <i>Connector & terminal</i> <i>(B54) No. 10 — Chassis ground:</i>	Is the resistance more than 1 $M\Omega$?	Go to step 65 .	Repair the ground short circuit in "1" range circuit.
65 CHECK POOR CONTACT.	Is there poor contact in inhibitor switch circuit?	Repair the poor contact.	Go to step 66 .
66 CHECK INHIBITOR SWITCH.	Is the inhibitor switch in proper position?	Replace the TCM. <Ref. to 4AT-76, Transmission Control Module (TCM).>	Adjust the inhibitor switch and select cable. <Ref. to 4AT-52, Inhibitor Switch.> and <Ref. to CS-26, Select Cable.>

B: DTC P0712 TRANSMISSION FLUID TEMPERATURE SENSOR CIRCUIT LOW INPUT

DIAGNOSIS:

The input signal circuit of TCM to ATF temperature sensor is open or shorted.

TROUBLE SYMPTOM:

Excessive shift shock.

WIRING DIAGRAM:

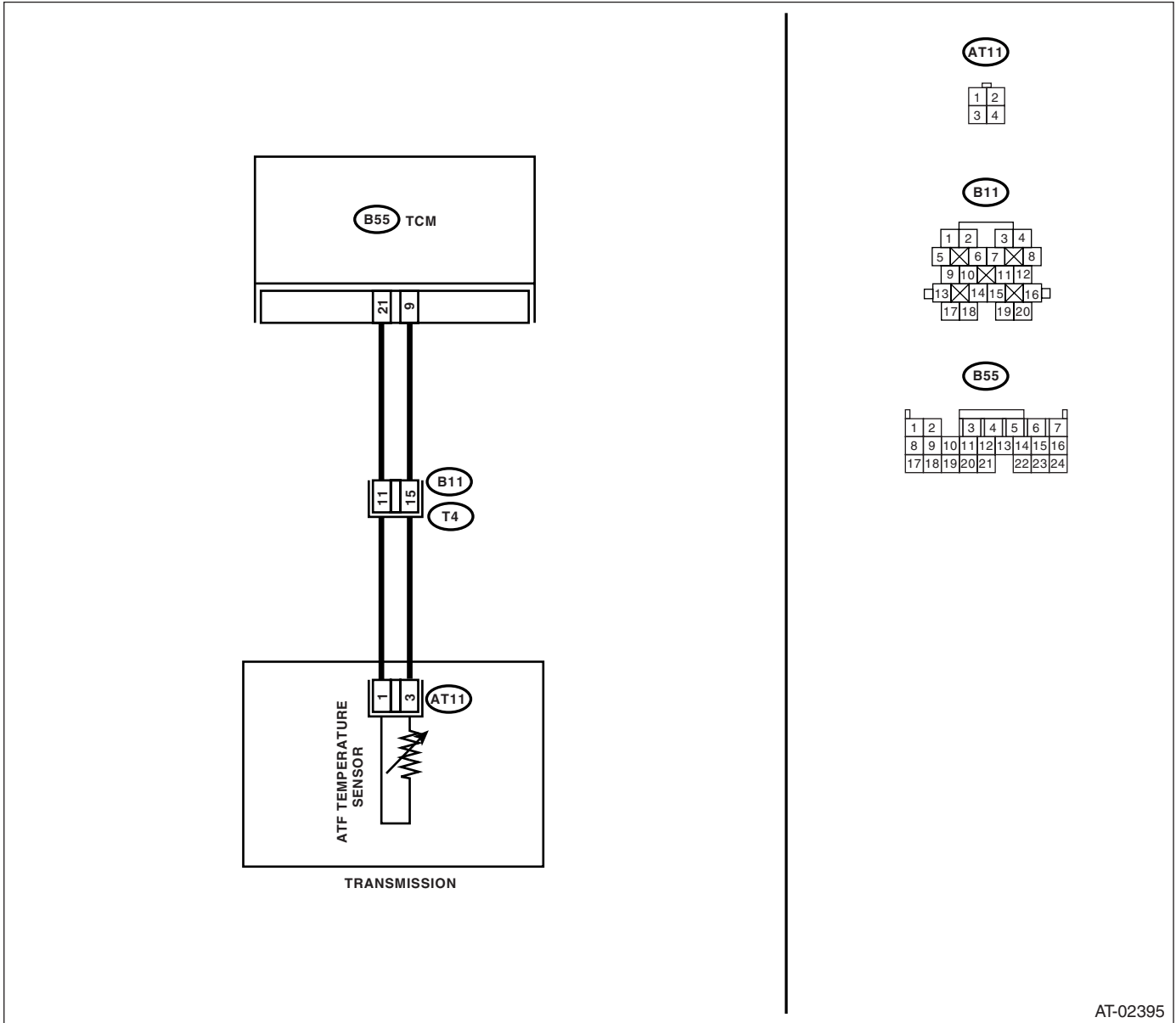

AT-02395

Diagnostic Procedure with Diagnostic Trouble Code (DTC)

AUTOMATIC TRANSMISSION (DIAGNOSTICS)

Step	Check	Yes	No
1 CHECK HARNESS CONNECTOR BETWEEN TCM AND ATF TEMPERATURE SENSOR. 1) Turn the ignition switch to OFF. 2) Disconnect the connector from transmission and TCM. 3) Measure the resistance of harness between TCM and transmission connector. <i>Connector & terminal</i> <i>(B55) No. 21 — (B11) No. 11:</i>	Is the resistance less than 1 Ω ?	Go to step 2.	Repair the open circuit in harness between TCM and transmission connector.
2 CHECK HARNESS CONNECTOR BETWEEN TCM AND ATF TEMPERATURE SENSOR. Measure the resistance of harness between TCM and transmission connector. <i>Connector & terminal</i> <i>(B55) No. 9 — (B11) No. 15:</i>	Is the resistance less than 1 Ω ?	Go to step 3.	Repair the open circuit in harness between TCM and transmission connector.
3 CHECK ATF TEMPERATURE SENSOR. 1) Turn the ignition switch to OFF. 2) Connect the connectors to transmission and TCM. 3) Turn the ignition switch to ON and start engine. 4) Warm-up the transmission until ATF temperature reaches to 80°C (176°F). NOTE: If ambient temperature is below 0°C (32°F), drive the vehicle until ATF reaches its operating temperature. 5) Disconnect the connector from transmission. 6) Measure the resistance between transmission connector terminals. <i>Connector & terminal</i> <i>(T4) No. 11 — No. 15:</i>	Is the resistance 300 — 800 Ω ?	Go to step 4.	Go to step 7.
4 CHECK ATF TEMPERATURE SENSOR. Measure the resistance between transmission connector terminals. <i>Connector & terminal</i> <i>(T4) No. 11 — No. 15:</i>	Does the resistance value increase when ATF temperature decreases?	Go to step 5.	Go to step 7.
5 CHECK INPUT SIGNAL FOR TCM USING SUBARU SELECT MONITOR. 1) Connect the connector to transmission. 2) Turn the ignition switch to ON (engine OFF).	Does the ATF temperature gradually decrease?	Even if the AT OIL TEMP warning light blinks, the circuit has returned to a normal condition at this time. Temporary poor contact of the connector or harness may be the cause. Repair the harness or contact in ATF temperature sensor and transmission connector.	Go to step 6.
6 CHECK POOR CONTACT.	Is there poor contact in ATF temperature sensor circuit?	Repair the poor contact.	Replace the TCM. <Ref. to 4AT-76, Transmission Control Module (TCM).>

Diagnostic Procedure with Diagnostic Trouble Code (DTC)

AUTOMATIC TRANSMISSION (DIAGNOSTICS)

Step	Check	Yes	No
<p>7</p> <p>CHECK HARNESS CONNECTOR BETWEEN TRANSMISSION AND ATF TEMPERATURE SENSOR.</p> <p>1) Turn the ignition switch to OFF. 2) Disconnect the connector from transmission. 3) Remove the transmission connector from bracket. 4) Lift-up the vehicle and place safety stand.</p> <p>NOTE: Raise all wheels off floor. 5) Drain the ATF.</p> <p>CAUTION: Do not drain the ATF until it cools down.</p> <p>6) Remove the oil pan, and disconnect the connector from ATF temperature sensor connector. 7) Measure the resistance of harness between ATF temperature sensor and transmission connector.</p> <p>Connector & terminal (T4) No. 11 — (AT11) No. 1:</p>	<p>Is the resistance less than 1 Ω?</p>	<p>Go to step 8.</p>	<p>Repair the open circuit in harness between ATF temperature sensor and transmission connector.</p>
<p>8</p> <p>CHECK HARNESS CONNECTOR BETWEEN TRANSMISSION AND ATF TEMPERATURE SENSOR.</p> <p>Measure the resistance of harness between ATF temperature sensor and transmission connector.</p> <p>Connector & terminal (T4) No. 15 — (AT11) No. 3:</p>	<p>Is the resistance less than 1 Ω?</p>	<p>Go to step 9.</p>	<p>Repair the open circuit in harness between ATF temperature sensor and transmission connector.</p>
<p>9</p> <p>CHECK HARNESS CONNECTOR BETWEEN TRANSMISSION AND ATF TEMPERATURE SENSOR.</p> <p>Measure the resistance of harness between transmission connector and transmission ground.</p> <p>Connector & terminal (T4) No. 11 — Transmission ground:</p>	<p>Is the resistance more than 1 $M\Omega$?</p>	<p>Go to step 10.</p>	<p>Repair the short circuit in harness between ATF temperature sensor and transmission connector.</p>
<p>10</p> <p>CHECK HARNESS CONNECTOR BETWEEN TRANSMISSION AND ATF TEMPERATURE SENSOR.</p> <p>Measure the resistance of harness between transmission connector and transmission ground.</p> <p>Connector & terminal (T4) No. 15 — Transmission ground:</p>	<p>Is the resistance more than 1 $M\Omega$?</p>	<p>Replace the ATF temperature sensor. <Ref. to 4AT-70, Shift Solenoids, Duty Solenoids and ATF Temperature Sensor.></p>	<p>Repair the short circuit in harness between ATF temperature sensor and transmission connector.</p>

Diagnostic Procedure with Diagnostic Trouble Code (DTC)

AUTOMATIC TRANSMISSION (DIAGNOSTICS)

C: DTC P0713 TRANSMISSION FLUID TEMPERATURE SENSOR CIRCUIT HIGH INPUT

DIAGNOSIS:

The input signal circuit of TCM to ATF temperature sensor is open or shorted.

TROUBLE SYMPTOM:

Excessive shift shock.

WIRING DIAGRAM:

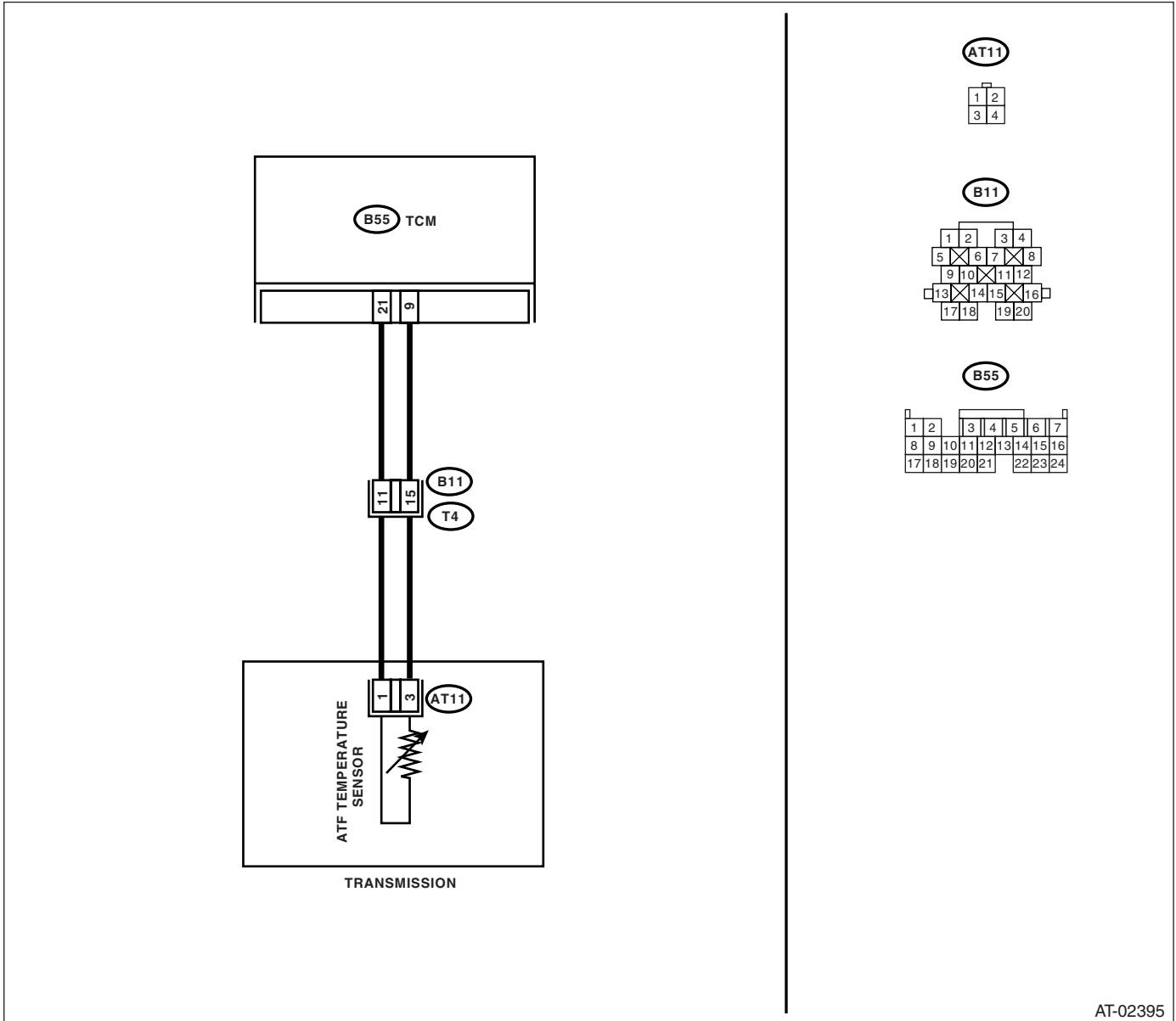

AT-02395

Diagnostic Procedure with Diagnostic Trouble Code (DTC)

AUTOMATIC TRANSMISSION (DIAGNOSTICS)

Step	Check	Yes	No
1 CHECK HARNESS CONNECTOR BETWEEN TCM AND ATF TEMPERATURE SENSOR. 1) Turn the ignition switch to OFF. 2) Disconnect the connector from TCM. 3) Measure the resistance between TCM connector terminals. <i>Connector & terminal</i> <i>(B55) No. 21 — No. 9:</i>	Is the resistance more than 500 Ω?	Go to step 2.	Go to step 4.
2 CHECK HARNESS CONNECTOR BETWEEN TCM AND ATF TEMPERATURE SENSOR. Measure the resistance of harness between TCM connector and chassis ground. <i>Connector & terminal</i> <i>(B55) No. 21 — Chassis ground:</i>	Is the resistance more than 1 MΩ?	Go to step 3.	Go to step 4.
3 CHECK HARNESS. Measure the resistance between TCM connector terminals while shaking the harness. <i>Connector & terminal</i> <i>(B55) No. 21 — No. 9:</i>	Does the resistance change?	Go to step 4.	Replace the TCM. <Ref. to 4AT-76, Transmission Control Module (TCM).>
4 CHECK HARNESS CONNECTOR BETWEEN TCM AND ATF TEMPERATURE SENSOR. 1) Turn the ignition switch to OFF. 2) Disconnect the connector from transmission. 3) Measure the resistance of harness between TCM connector and chassis ground. <i>Connector & terminal</i> <i>(B55) No. 21 — Chassis ground:</i>	Is the resistance more than 1 MΩ?	Go to step 5.	Repair the short circuit in harness between TCM and transmission harness.
5 CHECK HARNESS CONNECTOR BETWEEN TCM AND ATF TEMPERATURE SENSOR. Measure the resistance of harness between TCM connector and chassis ground. <i>Connector & terminal</i> <i>(B55) No. 9 — Chassis ground:</i>	Is the resistance more than 1 MΩ?	Go to step 6.	Repair the short circuit in harness between TCM and transmission harness.
6 CHECK ATF TEMPERATURE SENSOR. Measure the resistance between transmission connector terminals. <i>Connector & terminal</i> <i>(T4) No. 11 — No. 15:</i>	Is the resistance more than 500 Ω?	Even if the AT OIL TEMP warning light is blinking, the circuit has returned to normal condition at this time. A temporary short circuit of connector or harness may be the cause. Repair the harness or connector.	Go to step 7.

Diagnostic Procedure with Diagnostic Trouble Code (DTC)

AUTOMATIC TRANSMISSION (DIAGNOSTICS)

Step	Check	Yes	No
7 CHECK TRANSMISSION HARNESS. 1) Lift-up the vehicle and place it on rigid racks. 2) Drain the ATF. NOTE: Do not drain the ATF until it cools down. 3) Remove the oil pan. 4) Disconnect the harness connector from control valve. 5) Measure the resistance between ATF temperature sensor connector terminals 6) Measure the resistance between transmission connector and transmission ground. Connector & terminal (T4) No. 11 — Transmission ground:	Is the resistance more than 1 MΩ?	Go to step 8.	Replace the transmission harness.
8 CHECK TRANSMISSION HARNESS. Measure the resistance between transmission connector and transmission ground, Connector & terminal (T4) No. 15 — Transmission ground:	Is the resistance more than 1 MΩ?	Go to step 9.	Replace the transmission harness.
9 CHECK ATF TEMPERATURE SENSOR. Measure the resistance between control valve connector terminals Terminal No. 1 — No. 3:	Is the resistance more than 500 Ω?	Even if the AT OIL TEMP warning light is blinking, the circuit has returned to normal condition at this time. A temporary short circuit of connector or harness may be the cause. Repair the harness or connector.	Replace the control valve body. <Ref. to 4AT-61, Control Valve Body.>

D: DTC P0715 INPUT/TURBINE SPEED SENSOR CIRCUIT

DIAGNOSIS:

The input signal circuit of TCM is open or shorted.

TROUBLE SYMPTOM:

Excessive shift shock.

WIRING DIAGRAM:

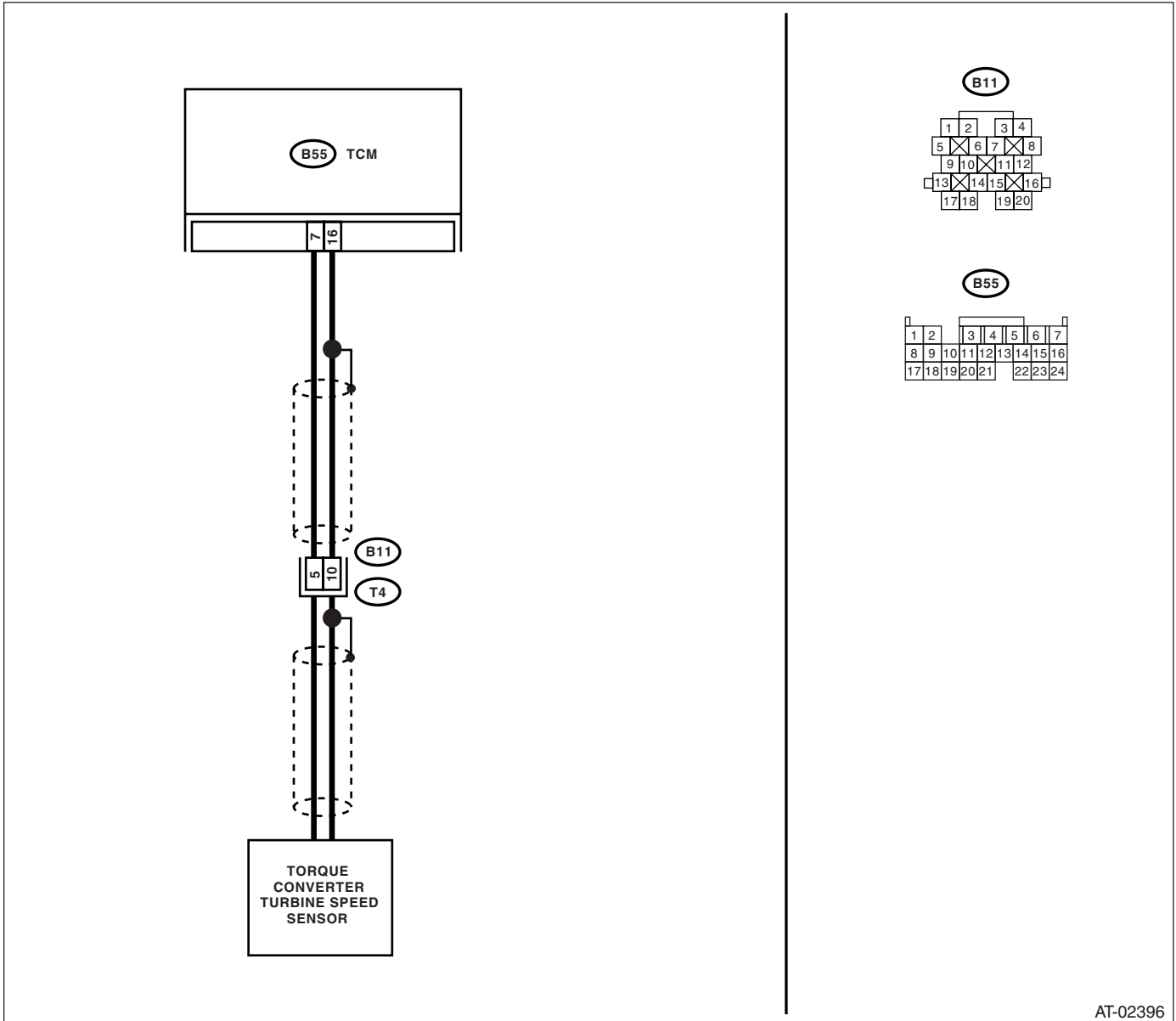

AT-02396

Diagnostic Procedure with Diagnostic Trouble Code (DTC)

AUTOMATIC TRANSMISSION (DIAGNOSTICS)

Step	Check	Yes	No
1 CHECK TORQUE CONVERTER TURBINE SPEED SENSOR. 1) Turn the ignition switch to OFF. 2) Disconnect the connector from transmission. 3) Measure the resistance between transmission connector receptacle's terminals. <i>Connector & terminal</i> <i>(T4) No. 5 — No. 10:</i>	Is the resistance 450 — 650 Ω ?	Go to step 2.	Replace the torque converter turbine speed sensor. <Ref. to 4AT-60, Torque Converter Turbine Speed Sensor.>
2 CHECK HARNESS CONNECTOR BETWEEN TCM AND TRANSMISSION. 1) Disconnect the connector from TCM. 2) Measure the resistance of harness between TCM connector and transmission connector. <i>Connector & terminal</i> <i>(B55) No. 7 — (B11) No. 5:</i>	Is the resistance less than 1 Ω ?	Go to step 3.	Repair the open circuit in harness between TCM and transmission connector.
3 CHECK HARNESS CONNECTOR BETWEEN TCM AND TRANSMISSION. Measure the resistance of harness between TCM connector and transmission connector. <i>Connector & terminal</i> <i>(B55) No. 16 — (B11) No. 10:</i>	Is the resistance less than 1 Ω ?	Go to step 4.	Repair the open circuit in harness between TCM and transmission connector, and poor contact in coupling connector.
4 CHECK HARNESS CONNECTOR BETWEEN TCM AND TRANSMISSION. Measure the resistance of harness between TCM connector and chassis ground. <i>Connector & terminal</i> <i>(B55) No. 16 — Chassis ground:</i>	Is the resistance more than 1 $M\Omega$?	Go to step 5.	Repair the short circuit in harness between TCM and transmission connector.
5 CHECK HARNESS CONNECTOR BETWEEN TCM AND TRANSMISSION. Measure the resistance of harness between TCM connector and chassis ground. <i>Connector & terminal</i> <i>(B55) No. 7 — Chassis ground:</i>	Is the resistance more than 1 $M\Omega$?	Go to step 6.	Repair the short circuit in harness between TCM and transmission connector, and poor contact in coupling connector.
6 CHECK INPUT SIGNAL FOR TCM USING SUBARU SELECT MONITOR. 1) Connect the connectors to TCM and transmission. 2) Connect the Subaru Select Monitor to data link connector. 3) Turn the ignition switch to ON and turn Subaru Select Monitor switch to ON. 4) Start the engine. 5) Move the select lever to "P" or "N" range. 6) Read the data of turbine speed using Subaru Select Monitor. • Compare the tachometer reading with Subaru Select Monitor indications.	Is the revolution value same as the tachometer reading shown on the combination meter?	Even if the AT OIL TEMP warning light blinks, the circuit has returned to a normal condition at this time. A temporary poor contact of the connector or harness may be the cause. Repair the harness or connector in TCM and transmission.	Go to step 7.
7 CHECK POOR CONTACT.	Is there poor contact in torque converter turbine speed sensor circuit?	Repair the poor contact.	Replace the TCM. <Ref. to 4AT-76, Transmission Control Module (TCM).>

Diagnostic Procedure with Diagnostic Trouble Code (DTC)

AUTOMATIC TRANSMISSION (DIAGNOSTICS)

E: DTC P0719 TORQUE CONVERTER/BRAKE SWITCH "B" CIRCUIT LOW

DIAGNOSIS:

Brake switch malfunction or input signal open circuit.

TROUBLE SYMPTOM:

Gear is not shifted down when climbing hill.

WIRING DIAGRAM:

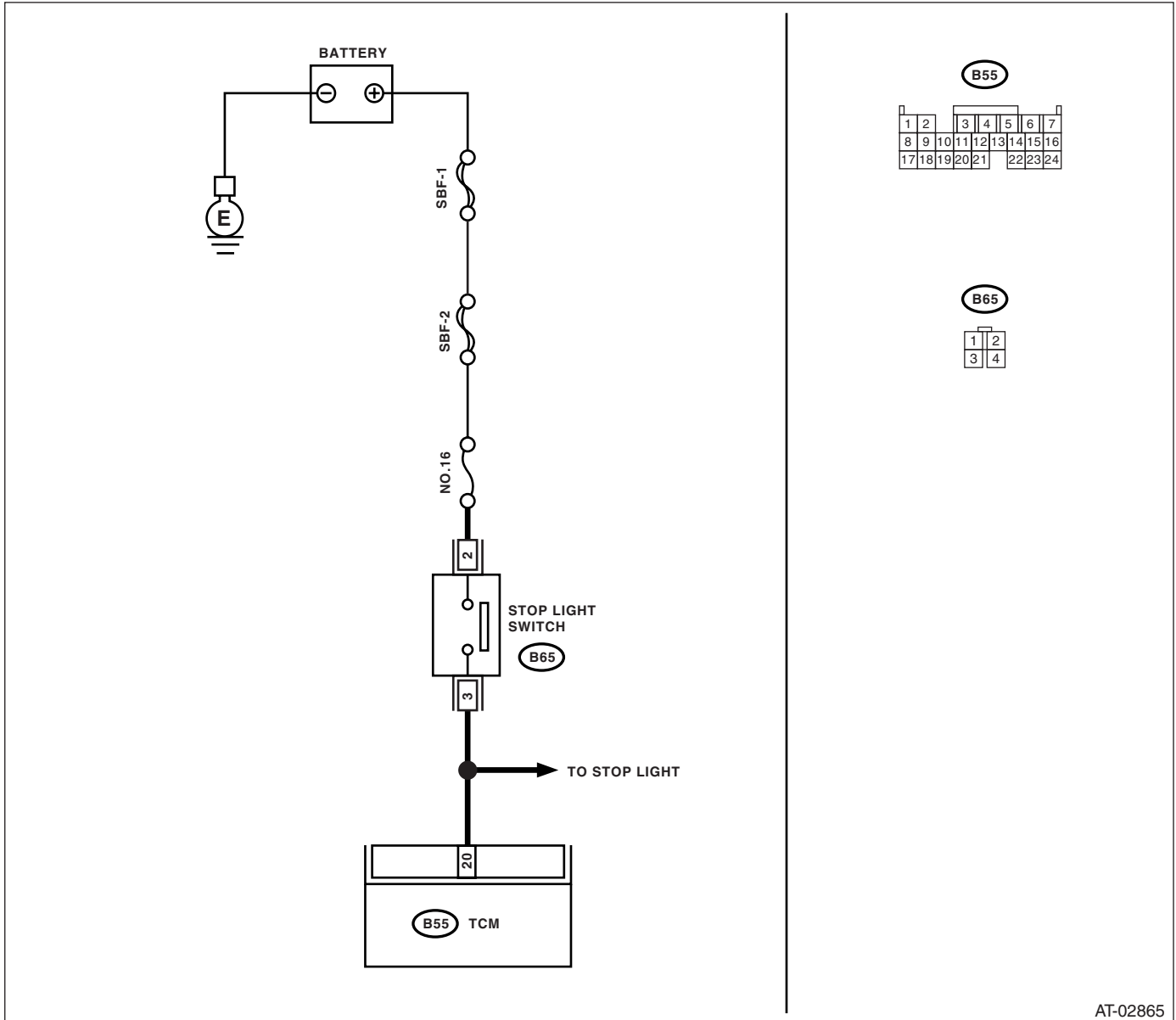

AT-02865

Step	Check	Yes	No
1 CHECK OPERATION OF BRAKE LIGHT. Depress the brake pedal.	Does the brake light illuminate?	Go to step 2.	Check the brake light circuit.
2 CHECK TCM INPUT SIGNAL. 1) Depress the brake pedal. 2) Measure the voltage of harness between TCM and stop light switch. Connector & terminal (B55) No. 20 (+) — Chassis ground (-):	Is the voltage more than 10 V?	Go to step 5.	Go to step 3.

Diagnostic Procedure with Diagnostic Trouble Code (DTC)

AUTOMATIC TRANSMISSION (DIAGNOSTICS)

Step	Check	Yes	No
3 CHECK HARNESS CONNECTOR BETWEEN TCM AND STOP LIGHT SWITCH. 1) Turn the ignition switch to OFF. 2) Disconnect the connector from TCM and stop light switch. 3) Measure the resistance between TCM and stop light switch. Connector & terminal (B55) No. 20 — (B65) No. 3:	Is the resistance less than 1 Ω ?	Go to step 4.	Repair the open harness between TCM and stop light switch.
4 CHECK HARNESS CONNECTOR BETWEEN TCM AND STOP LIGHT SWITCH. Measure the resistance between TCM and stop light switch. Connector & terminal (B55) No. 20 — (B65) No. 3:	Is the resistance more than 1 M Ω ?	Go to step 5.	Repair the short harness between TCM and stop light switch.
5 INSPECT POOR CONTACT.	Is there poor contact in the brake switch input signal circuit?	Repair poor contact.	Replace the TCM. <Ref. to 4AT-76, Transmission Control Module (TCM).>

Diagnostic Procedure with Diagnostic Trouble Code (DTC)

AUTOMATIC TRANSMISSION (DIAGNOSTICS)

F: DTC P0720 OUTPUT SPEED SENSOR CIRCUIT

DIAGNOSIS:

- The vehicle speed signal is abnormal.
- The circuit in combination meter is faulty.
- The harness connector between TCM and vehicle speed sensor is in short or open.

TROUBLE SYMPTOM:

- Erroneous idling.
- Engine stalls.
- Poor driving performance.

WIRING DIAGRAM:

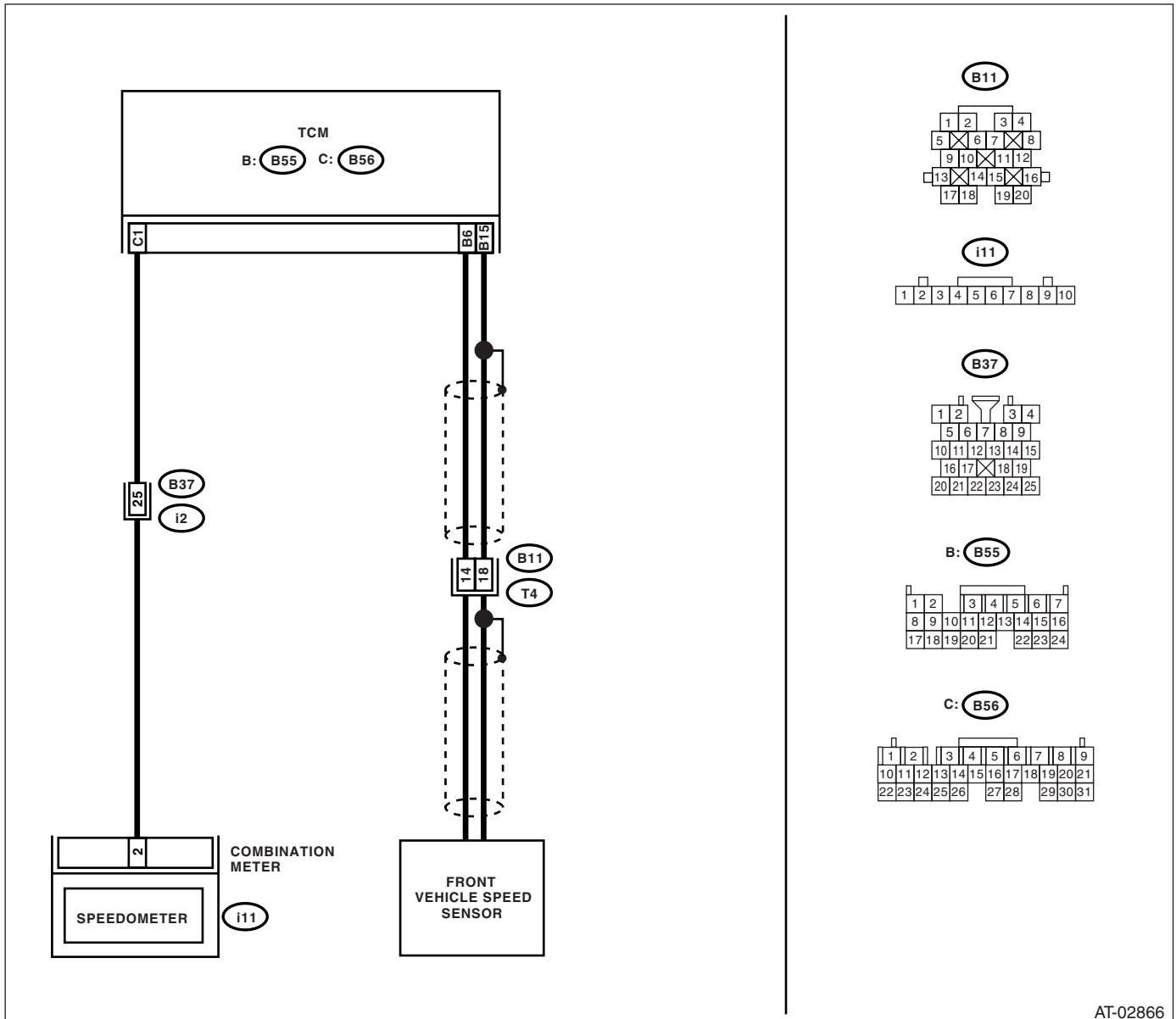

AT-02866

Diagnostic Procedure with Diagnostic Trouble Code (DTC)

AUTOMATIC TRANSMISSION (DIAGNOSTICS)

Step	Check	Yes	No
1 CHECK HARNESS CONNECTOR BETWEEN TCM AND TRANSMISSION. 1) Turn the ignition switch to OFF. 2) Disconnect the connector from TCM and transmission. 3) Measure the resistance of harness between TCM connector and transmission connector. <i>Connector & terminal</i> <i>(B55) No. 6 — (B11) No. 14:</i>	Is the resistance less than 1 Ω ?	Go to step 2.	Repair the open circuit in harness between TCM and transmission connector.
2 CHECK HARNESS CONNECTOR BETWEEN TCM AND TRANSMISSION. Measure the resistance of harness between TCM connector and transmission connector. <i>Connector & terminal</i> <i>(B55) No. 15 — (B11) No. 18:</i>	Is the resistance less than 1 Ω ?	Go to step 3.	Repair the open circuit in harness between TCM and transmission connector, and poor contact in coupling connector.
3 CHECK HARNESS CONNECTOR BETWEEN TCM AND TRANSMISSION. Measure the resistance of harness between TCM connector and transmission connector. <i>Connector & terminal</i> <i>(B55) No. 6 — Chassis ground:</i>	Is the resistance more than 1 $M\Omega$?	Go to step 4.	Repair the short circuit in harness between TCM and transmission connector.
4 CHECK HARNESS CONNECTOR BETWEEN TCM CONNECTOR AND TRANSMISSION. Measure the resistance of harness between TCM connector and transmission connector. <i>Connector & terminal</i> <i>(B55) No. 15 — Chassis ground:</i>	Is the resistance more than 1 $M\Omega$?	Go to step 5.	Repair the short circuit in harness between TCM and transmission connector, and poor contact in coupling connector.
5 CHECK FRONT VEHICLE SPEED SENSOR. Measure the resistance between transmission connector receptacle's terminals. <i>Connector & terminal</i> <i>(T4) No. 14 — No. 18:</i>	Is the resistance 450 — 650 Ω ?	Go to step 6.	Replace the front vehicle speed sensor. <Ref. to 4AT-55, Front Vehicle Speed Sensor.>

Diagnostic Procedure with Diagnostic Trouble Code (DTC)

AUTOMATIC TRANSMISSION (DIAGNOSTICS)

Step	Check	Yes	No
<p>6</p> <p>CHECK INPUT SIGNAL FOR TCM USING SUBARU SELECT MONITOR.</p> <p>1) Connect all connectors. 2) Connect the Subaru Select Monitor to data link connector. 3) Lift-up the vehicle and place safety stands.</p> <p>NOTE: Raise all wheels off floor.</p> <p>4) Turn the ignition switch to ON and turn Subaru Select Monitor switch to ON. 5) Start the engine. 6) Read the data of vehicle speed using Subaru Select Monitor.</p> <ul style="list-style-type: none"> • Compare the speedometer reading with Subaru Select Monitor indications. • Vehicle speed is indicated in "km/h" or "MPH". <p>7) Slowly increase the vehicle speed to 60 km/h or 37 MPH.</p> <p>NOTE: The speed difference between front and rear wheels may light the ABS warning light, but this indicates no malfunction. When AT control diagnosis is finished, perform the ABS memory clearance procedure of on-board diagnostics system. <Ref. to ABS(diag)-26, Clear Memory Mode.></p>	<p>Does the speedometer indication increase as Subaru Select Monitor front speed sensor data increases?</p>	<p>Even if the AT OIL TEMP warning light blinks, the circuit has returned to a normal condition at this time. A temporary poor connector or harness may be the cause. Repair the harness or connector in front vehicle speed sensor circuit.</p>	<p>Go to step 7.</p>
<p>7</p> <p>CHECK POOR CONTACT.</p>	<p>Is there poor contact in front vehicle speed sensor circuit?</p>	<p>Repair the poor contact.</p>	<p>Replace the TCM. <Ref. to 4AT-76, Transmission Control Module (TCM).></p>

Diagnostic Procedure with Diagnostic Trouble Code (DTC)

AUTOMATIC TRANSMISSION (DIAGNOSTICS)

G: DTC P0724 TORQUE CONVERTER/BRAKE SWITCH “B” CIRCUIT HIGH

DIAGNOSIS:
Brake switch malfunction or open brake switch input signal circuit.

TROUBLE SYMPTOM:

Gear is not shifted down when climbing hill.

WIRING DIAGRAM:

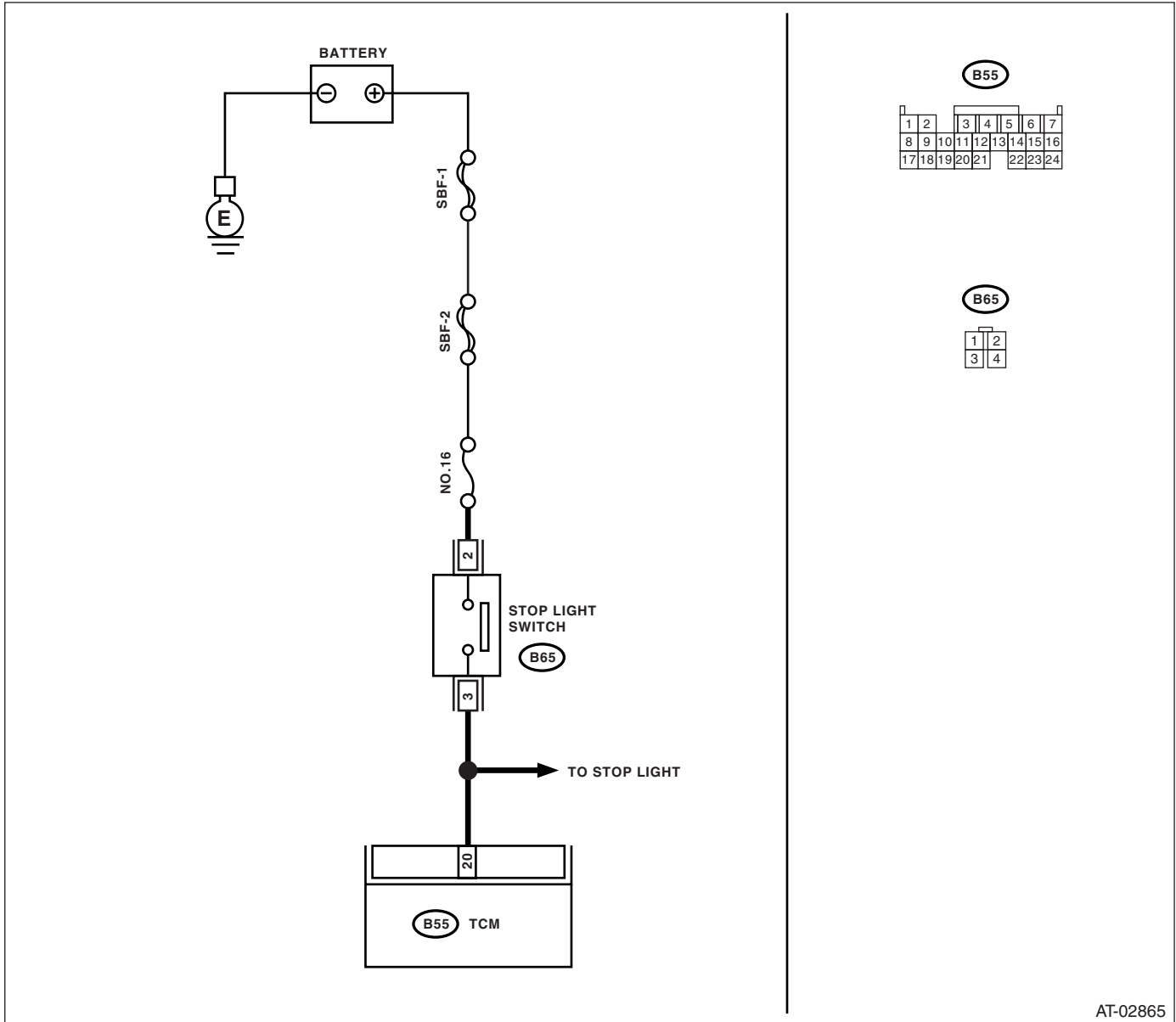

AT-02865

Step	Check	Yes	No
1 CHECK TCM INPUT SIGNAL. 1) Disconnect the harness connector from TCM. 2) Measure the voltage of harness between TCM and stop light switch. Connector & terminal (B55) No. 20 (+) — Chassis ground (-):	Is the voltage more than 10 V?	Go to step 2.	Go to step 4.

Diagnostic Procedure with Diagnostic Trouble Code (DTC)

AUTOMATIC TRANSMISSION (DIAGNOSTICS)

Step	Check	Yes	No
2 CHECK STOP LIGHT SWITCH. 1) Turn the ignition switch OFF. 2) Disconnect the connector from stop light switch. 3) Measure the resistance of harness between stop light switch connector. Connector & terminal (B65) No. 2 — No. 3:	Is the resistance more than 1 M Ω ?	Go to step 3.	Replace the stop light switch.
3 CHECK HARNESS CONNECTOR BETWEEN TCM AND STOP LIGHT SWITCH. 1) Turn the ignition switch ON. 2) Measure the voltage of harness between TCM and chassis ground. Connector & terminal (B55) No. 20 (+) — Chassis ground (-):	Is the voltage less than 1 V?	Go to step 4.	Repair the short in power supply circuit to harness between TCM and stop light switch.
4 INSPECT POOR CONTACT.	Is there poor contact in the brake switch input signal circuit?	Repair poor contact.	Replace the TCM. <Ref. to 4AT-76, Transmission Control Module (TCM).>

Diagnostic Procedure with Diagnostic Trouble Code (DTC)

AUTOMATIC TRANSMISSION (DIAGNOSTICS)

H: DTC P0725 ENGINE SPEED INPUT CIRCUIT

DIAGNOSIS:

The engine speed input signal circuit is open or shorted.

TROUBLE SYMPTOM:

- No lock-up (after engine warm-up).
- The AT OIL TEMP warning light remains on when vehicle speed is "0".

WIRING DIAGRAM:

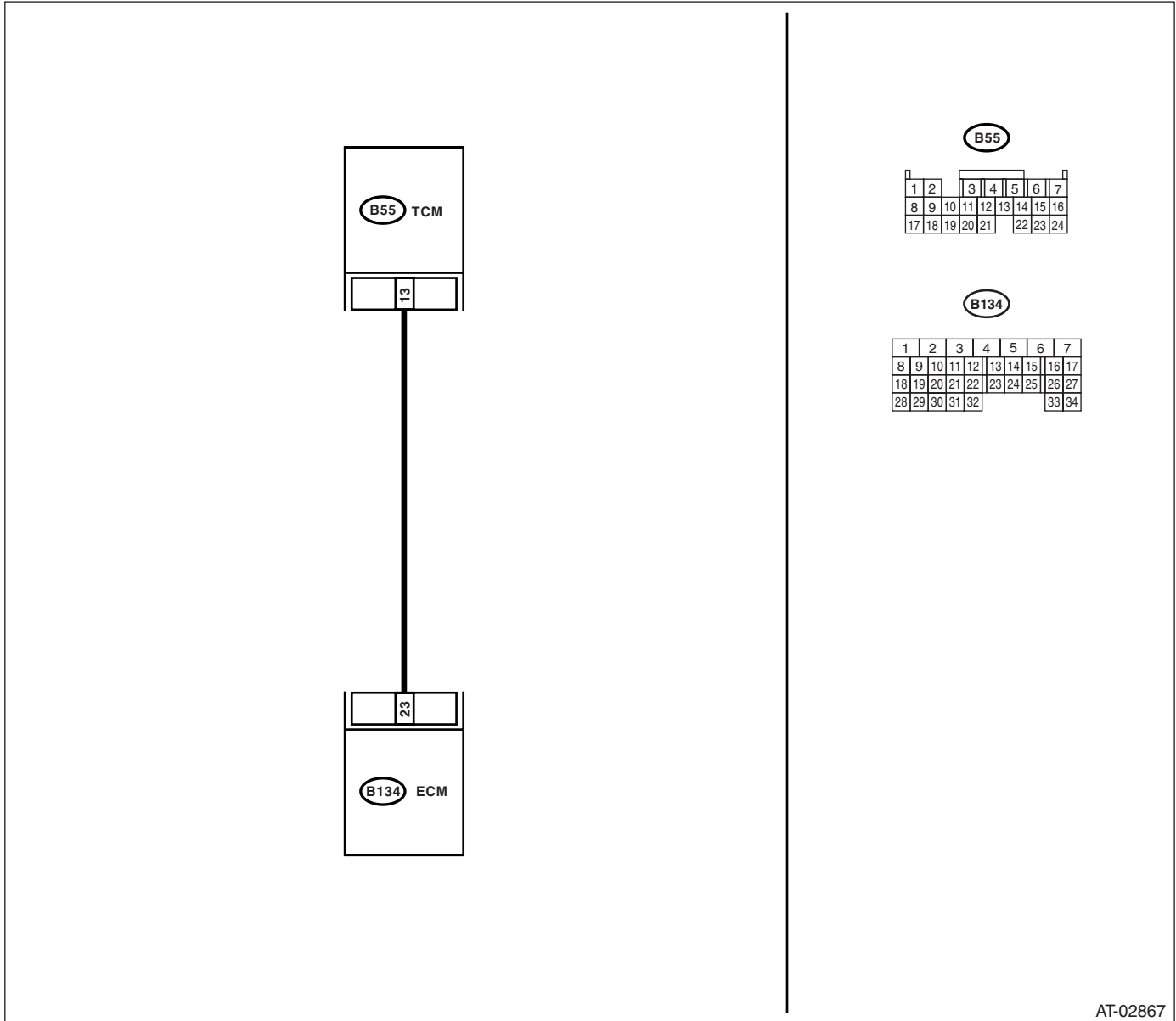

AT-02867

Step	Check	Yes	No
1 CHECK HARNESS CONNECTOR BETWEEN TCM AND ECM. 1) Turn the ignition switch to OFF. 2) Disconnect the connectors from TCM and ECM. 3) Measure the resistance of harness between TCM and ECM connector. Connector & terminal (B55) No. 13 — (B134) No. 23:	Is the resistance less than 1 Ω?	Go to step 2.	Repair the open circuit in harness between TCM and ECM connector.

Diagnostic Procedure with Diagnostic Trouble Code (DTC)

AUTOMATIC TRANSMISSION (DIAGNOSTICS)

Step	Check	Yes	No
2 CHECK HARNESS CONNECTOR BETWEEN TCM AND ECM. Measure the resistance of harness between TCM connector and chassis ground. <i>Connector & terminal (B55) No. 13 — Chassis ground:</i>	Is the resistance more than 1 MΩ?	Go to step 3.	Repair the short circuit in harness between TCM and ECM connector.
3 CHECK INPUT SIGNAL FOR TCM USING SUBARU SELECT MONITOR. 1) Connect the connectors to TCM and ECM. 2) Connect the Subaru Select Monitor to data link connector. 3) Start the engine and turn Subaru Select Monitor switch to ON. 4) Idle the engine. 5) Read the data of engine speed using Subaru Select Monitor. • Display shows the engine speed signal value sent from ECM.	Is the revolution value same as tachometer reading shown on combination meter?	Even if the AT OIL TEMP warning light blinks, the circuit has returned to a normal condition at this time. A temporary poor contact of the connector or harness may be the cause. Repair the harness or connector in TCM and ECM.	Go to step 4.
4 CHECK POOR CONTACT.	Is there poor contact in engine speed signal circuit?	Repair the poor contact.	Go to step 5.
5 CONFIRM DTC P0725. Replace the ECM with a new one.	Does the DTC appear again, after memory has been cleared?	Replace the TCM. <Ref. to 4AT-76, Transmission Control Module (TCM).>	Replace the ECM.

I: DTC P0731 GEAR 1 INCORRECT RATIO

NOTE:

Refer to DTC P0736 for diagnostic procedure. <Ref. to 4AT(D)(diag)-54, DTC P0736 REVERSE INCORRECT RATIO, Diagnostic Procedure with Diagnostic Trouble Code (DTC).>

J: DTC P0732 GEAR 2 INCORRECT RATIO

NOTE:

Refer to DTC P0736 for diagnostic procedure. <Ref. to 4AT(D)(diag)-54, DTC P0736 REVERSE INCORRECT RATIO, Diagnostic Procedure with Diagnostic Trouble Code (DTC).>

K: DTC P0733 GEAR 3 INCORRECT RATIO

NOTE:

Refer to DTC P0736 for diagnostic procedure. <Ref. to 4AT(D)(diag)-54, DTC P0736 REVERSE INCORRECT RATIO, Diagnostic Procedure with Diagnostic Trouble Code (DTC).>

L: DTC P0734 GEAR 4 INCORRECT RATIO

NOTE:

Refer to DTC P0736 for diagnostic procedure. <Ref. to 4AT(D)(diag)-54, DTC P0736 REVERSE INCORRECT RATIO, Diagnostic Procedure with Diagnostic Trouble Code (DTC).>

Diagnostic Procedure with Diagnostic Trouble Code (DTC)

AUTOMATIC TRANSMISSION (DIAGNOSTICS)

M: DTC P0736 REVERSE INCORRECT RATIO

DIAGNOSIS:

Vehicle speed sensor malfunction and torque converter turbine speed sensor malfunction, etc. or control valve malfunction.

TROUBLE SYMPTOM:

- Shift point is too high or too low.
- Excessive shift shock.
- Tight cornering condition is occurred.
- Gear is not shifted to reverse.
- Gear position is held by fail safe function.

Step	Check	Yes	No
1 CHECK THROTTLE POSITION SENSOR. 1) Connect the Subaru Select Monitor to data link connector. 2) Turn the ignition switch to ON. 3) Read the value of accelerator pedal position sensor using Subaru Select Monitor.	Does the value of accelerator pedal position sensor change from 0% to 100% smoothly when throttle position sensor was operated from fully closing to fully opening?	Go to step 2.	Check throttle position sensor circuit. <Ref. to 4AT(D)(diag)-79, DTC P1708 THROTTLE POSITION SENSOR CIRCUIT LOW INPUT, Diagnostic Procedure with Diagnostic Trouble Code (DTC).>
2 FRONT VEHICLE SPEED SENSOR. 1) Lift-up the vehicle and place safety stand. 2) Start the engine. 3) Move the select lever "D" range and slowly increase vehicle speed. NOTE: The speed difference between front and rear wheels may light ABS warning light, but this indicates no malfunction. When AT control diagnosis is finished, perform the ABS memory clearance procedure of on-board diagnostics system.	Does the vehicle speed displayed by Subaru Select Monitor almost correspond with vehicle speed indicated by combination meter?	Go to step 3.	Check the front vehicle speed sensor circuit.
3 CHECK TORQUE CONVERTER TURBINE SPEED SENSOR. 1) Move the select lever to "P" or "N" range. 2) Idle the engine.	Does the turbine speed sensor revolution displayed by Subaru Select Monitor almost correspond with engine revolution indicated by tachometer?	There are malfunctions in TCM, TCM connector poor contact, or transmission assembly mechanical malfunction.	Check the torque converter turbine speed sensor circuit.

Diagnostic Procedure with Diagnostic Trouble Code (DTC)

AUTOMATIC TRANSMISSION (DIAGNOSTICS)

N: DTC P0741 TORQUE CONVERTER CLUTCH CIRCUIT PERFORMANCE OR STUCK OFF

DIAGNOSIS:

- Lock up clutch malfunction
- Locking of valve

TROUBLE SYMPTOM:

Lock up is not operated.

WIRING DIAGRAM:

Step	Check	Yes	No
1	CHECK LOCK UP DUTY SOLENOID CIRCUIT. Check according as DTC P0743 procedure.	Is there malfunction?	Repair or replace the lock up duty solenoid circuit. Go to step 2.
2	CHECK INHIBITOR SWITCH CIRCUIT. Check according as DTC P0705 procedure.	Is there malfunction?	Repair or replace the inhibitor switch circuit. Go to step 3.
3	CHECK STOP LIGHT SWITCH CIRCUIT. Check according as DTC P0719 and DTC P0724 procedure.	Is there malfunction?	Repair or replace the stop light switch circuit. Go to step 4.
4	CHECK ATF TEMPERATURE SENSOR CIRCUIT. Check according to DTC P0712 and DTC P0713 procedure.	Is there malfunction?	Repair or replace the ATF temperature sensor circuit. Go to step 5.
5	CHECK THROTTLE POSITION SENSOR. 1) Connect the Subaru Select Monitor to data link connector. 2) Turn the ignition switch to ON. 3) Read the value of accelerator pedal position sensor using Subaru Select Monitor.	Does the value of accelerator pedal position sensor change from 0% to 100% smoothly when throttle position sensor was operated from fully closing to fully opening?	Go to step 6. Check the throttle position sensor circuit.
6	CHECK TORQUE CONVERTER TURBINE SPEED SENSOR. 1) Move the select lever to "P" or "N" range. 2) Idle the engine.	Does the engine revolution displayed by Subaru Select Monitor almost correspond with engine revolution indicated by tachometer?	Go to step 7. Check the torque converter turbine speed sensor circuit.
7	CHECK ENGINE SPEED SIGNAL. Idle the engine.	Does the engine revolution displayed by Subaru Select Monitor almost correspond with engine revolution indicated by tachometer?	There is malfunction in TCM, TCM connector poor contact, or transmission assembly mechanical malfunction. Check the engine speed signal circuit.

Diagnostic Procedure with Diagnostic Trouble Code (DTC)

AUTOMATIC TRANSMISSION (DIAGNOSTICS)

O: DTC P0743 TORQUE CONVERTER CLUTCH CIRCUIT ELECTRICAL

DIAGNOSIS:

The output signal circuit of lock-up duty solenoid is open or shorted.

TROUBLE SYMPTOM:

No "lock-up" (after engine warm-up).

WIRING DIAGRAM:

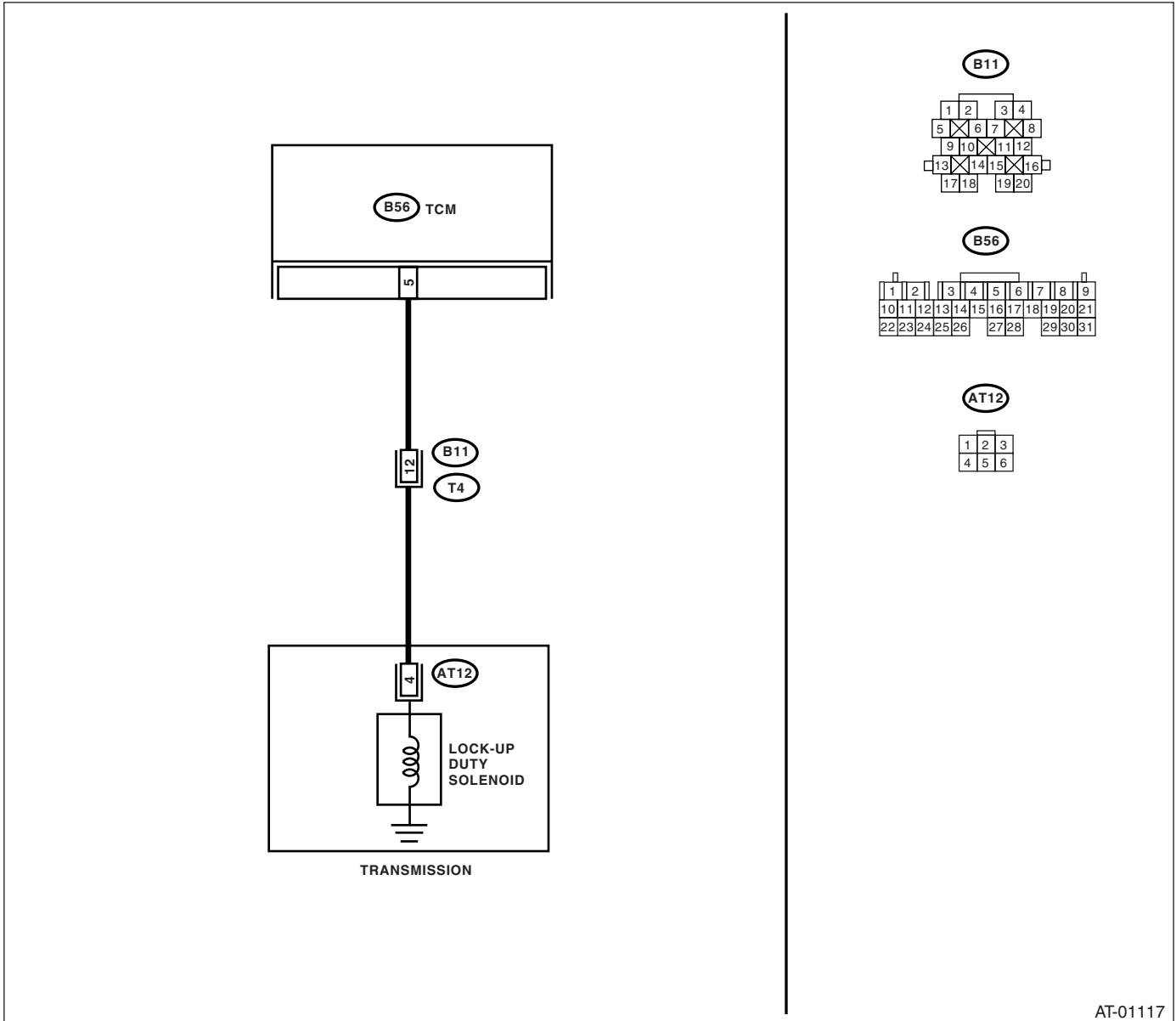

Step	Check	Yes	No	
1	CHECK DTC.	Do multiple DTCs appear in the on-board diagnostics test mode?	Go to another DTC.	Go to step 2.

Diagnostic Procedure with Diagnostic Trouble Code (DTC)

AUTOMATIC TRANSMISSION (DIAGNOSTICS)

Step	Check	Yes	No
2 CHECK HARNESS CONNECTOR BETWEEN TCM AND TRANSMISSION. 1) Turn the ignition switch to OFF. 2) Disconnect the connector from TCM and transmission. 3) Measure the resistance of harness between TCM and transmission connector. <i>Connector & terminal</i> <i>(B56) No. 5 — (B11) No. 12:</i>	Is the resistance less than 1 Ω ?	Go to step 3.	Repair the open circuit in harness between TCM and transmission connector.
3 CHECK HARNESS CONNECTOR BETWEEN TCM AND TRANSMISSION. Measure the resistance of harness connector between TCM connector and chassis ground. <i>Connector & terminal</i> <i>(B56) No. 5 — Chassis ground:</i>	Is the resistance more than 1 $M\Omega$?	Go to step 4.	Repair the short circuit in harness between TCM and transmission connector.
4 CHECK LOCK-UP DUTY SOLENOID. Measure the resistance between transmission connector receptacle's terminals. <i>Connector & terminal</i> <i>(T4) No. 12 — No. 20:</i>	Is the resistance 2.0 — 6.0 Ω ?	Go to step 6.	Go to step 5.
5 CHECK LOCK-UP DUTY SOLENOID (IN TRANSMISSION). 1) Disconnect the transmission connector. 2) Drain the ATF. CAUTION: Do not drain the ATF until it cools down. 3) Remove the oil pan and disconnect connector from lock-up duty solenoid. 4) Measure the resistance between lock-up duty solenoid and transmission ground. <i>Connector & terminal</i> <i>(AT12) No. 4 — Transmission ground:</i>	Is the resistance 2.0 — 6.0 Ω ?	Go to step 6.	Replace the control valve body. <Ref. to 4AT-61, Control Valve Body.>
6 CHECK HARNESS CONNECTOR BETWEEN LOCK-UP DUTY SOLENOID AND TRANSMISSION. Measure the resistance of harness between lock-up duty solenoid and transmission connector. <i>Connector & terminal</i> <i>(T4) No. 12 — (AT12) No. 4:</i>	Is the resistance less than 1 Ω ?	Go to step 7.	Repair the open circuit in harness between TCM and transmission connector.
7 CHECK HARNESS CONNECTOR BETWEEN LOCK-UP DUTY SOLENOID AND TRANSMISSION. Measure the resistance of harness between transmission connector and transmission ground. <i>Connector & terminal</i> <i>(T4) No. 12 — Transmission ground:</i>	Is the resistance more than 1 $M\Omega$?	Even if the AT OIL TEMP warning light blinks, the circuit has returned to a normal condition at this time. A temporary poor contact of the connector or harness may be the cause. Repair the harness or connector in lock-up duty solenoid and transmission.	Repair the short circuit in harness between lock-up duty solenoid and transmission connector.

Diagnostic Procedure with Diagnostic Trouble Code (DTC)

AUTOMATIC TRANSMISSION (DIAGNOSTICS)

P: DTC P0748 PRESSURE CONTROL SOLENOID "A" ELECTRICAL

DIAGNOSIS:

The output signal circuit of line pressure linear solenoid is open or shorted.

TROUBLE SYMPTOM:

Excessive shift shock.

WIRING DIAGRAM:

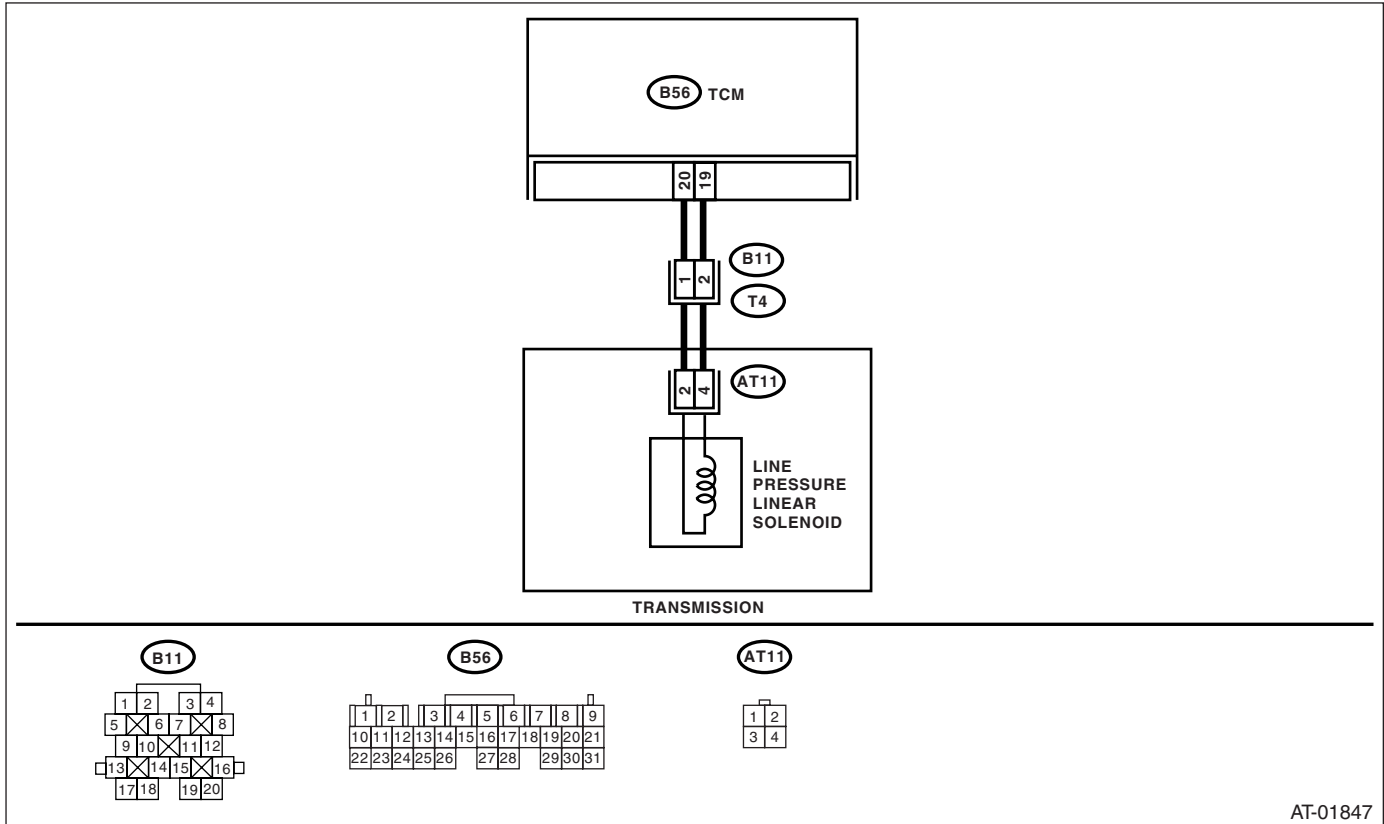

AT-01847

Step	Check	Yes	No
1 CHECK HARNESS CONNECTOR BETWEEN TCM AND TRANSMISSION. 1) Turn the ignition switch to OFF. 2) Disconnect the connector from transmission and TCM. 3) Measure the resistance of harness between TCM and transmission connector. <i>Connector & terminal</i> (B56) No. 19 — (B11) No. 2: (B56) No. 20 — (B11) No. 1:	Is the resistance less than 1 Ω ?	Go to step 2.	Repair the open circuit in harness between TCM and transmission connector.
2 CHECK HARNESS CONNECTOR BETWEEN TCM AND CHASSIS GROUND. Measure the resistance of harness between TCM connector and chassis ground. <i>Connector & terminal</i> (B56) No. 19 — Chassis ground: (B56) No. 20 — Chassis ground:	Is the resistance more than 1 M Ω ?	Go to step 3.	Repair the short circuit in harness between TCM and transmission connector.
3 CHECK LINE PRESSURE LINEAR SOLENOID. Measure the resistance between transmission connector receptacle's terminals. <i>Connector & terminal</i> (T4) No. 1 — No. 2:	Is the resistance 4 — 8 Ω ?	Go to step 5.	Go to step 4.

Diagnostic Procedure with Diagnostic Trouble Code (DTC)

AUTOMATIC TRANSMISSION (DIAGNOSTICS)

Step	Check	Yes	No
<p>4</p> <p>CHECK LINE PRESSURE LINEAR SOLENOID (IN TRANSMISSION).</p> <p>1) Remove the transmission connector from bracket. 2) Drain the ATF.</p> <p>CAUTION: Do not drain the ATF until it cools down.</p> <p>3) Remove the oil pan, and disconnect connector from line pressure linear solenoid. 4) Measure the resistance between line pressure linear solenoid connector and transmission ground.</p> <p>Connector & terminal (AT11) No. 2 — No. 4:</p>	<p>Is the resistance 4 — 8 Ω?</p>	<p>Go to step 5.</p>	<p>Replace the control valve body. <Ref. to 4AT-61, Control Valve Body.></p>
<p>5</p> <p>CHECK HARNESS CONNECTOR BETWEEN TRANSMISSION AND LINE PRESSURE LINEAR SOLENOID.</p> <p>Measure the resistance of harness between line pressure linear solenoid and transmission connector.</p> <p>Connector & terminal (T4) No. 2 — (AT11) No. 4: (T4) No. 1 — (AT11) No. 2:</p>	<p>Is the resistance less than 1 Ω?</p>	<p>Go to step 6.</p>	<p>Repair the open circuit in harness between line pressure linear solenoid and transmission connector.</p>
<p>6</p> <p>CHECK HARNESS CONNECTOR BETWEEN TRANSMISSION AND LINE PRESSURE LINEAR SOLENOID.</p> <p>Measure the resistance of harness between transmission connector and transmission ground.</p> <p>Connector & terminal (T4) No. 1 — Transmission ground: (T4) No. 2 — Transmission ground:</p>	<p>Is the resistance more than 1 MΩ?</p>	<p>Even if the AT OIL TEMP warning light blinks, the circuit has returned to a normal condition at this time. A temporary poor contact of the connector or harness may be the cause. Repair the harness or connector in line pressure linear solenoid and transmission.</p>	<p>Repair the short circuit in harness between line pressure linear solenoid and transmission connector.</p>

Diagnostic Procedure with Diagnostic Trouble Code (DTC)

AUTOMATIC TRANSMISSION (DIAGNOSTICS)

Q: DTC P0753 SHIFT SOLENOID "A" ELECTRICAL

DIAGNOSIS:

The output signal circuit of low clutch duty solenoid is open or shorted.

TROUBLE SYMPTOM:

Excessive shift shock.

WIRING DIAGRAM:

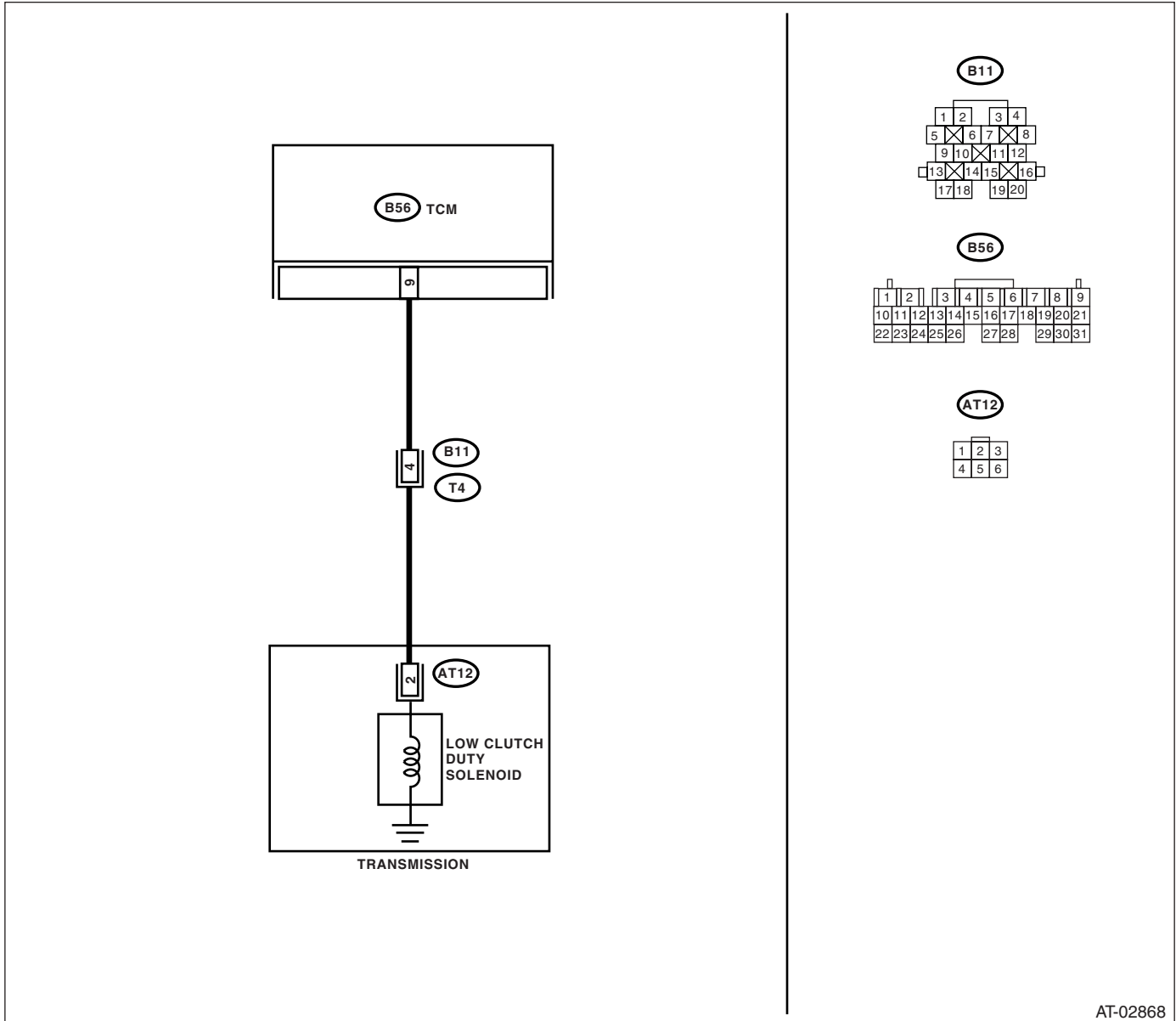

Step	Check	Yes	No
1 CHECK HARNESS CONNECTOR BETWEEN TCM AND TRANSMISSION. 1) Turn the ignition switch to OFF. 2) Disconnect the connector from TCM and transmission. 3) Measure the resistance of harness between TCM and transmission connector. Connector & terminal (B56) No. 9 — (B11) No. 2:	Is the resistance less than 1 Ω ?	Go to step 2.	Repair the open circuit in harness between TCM and transmission connector.

Diagnostic Procedure with Diagnostic Trouble Code (DTC)

AUTOMATIC TRANSMISSION (DIAGNOSTICS)

Step	Check	Yes	No
2 CHECK HARNESS CONNECTOR BETWEEN TCM AND TRANSMISSION. Measure the resistance of harness between TCM connector and chassis ground. <i>Connector & terminal</i> <i>(B56) No. 9 — Chassis ground:</i>	Is the resistance more than 1 M Ω ?	Go to step 3.	Repair the short circuit in harness between TCM and transmission connector.
3 CHECK LOW CLUTCH DUTY SOLENOID. Measure the resistance between transmission connector terminals. <i>Connector & terminal</i> <i>(T4) No. 4 — No. 20:</i>	Is the resistance 2.0 — 6.0 Ω ?	Go to step 4.	Go to step 7.
4 CHECK OUTPUT SIGNAL FROM TCM USING SUBARU SELECT MONITOR. 1) Connect the connectors to TCM and transmission. 2) Connect the Subaru Select Monitor to data link connector. 3) Start the engine and turn Subaru Select Monitor switch to ON. 4) Warm-up the transmission until ATF temperature is above 80°C (176°F). NOTE: If ambient temperature is below 0°C (32°F), drive the vehicle until ATF reaches its operating temperature. 5) Stop the engine and turn ignition switch to ON (engine OFF). 6) Shift the select lever to “P” or “N” range, and depress the accelerator pedal. 7) Read the data of low clutch duty solenoid using Subaru Select Monitor. • Low clutch duty solenoid is indicated in “%”.	Is the value 100%?	Go to step 5.	Go to step 6.
5 CHECK OUTPUT SIGNAL FROM TCM USING SUBARU SELECT MONITOR. 1) Turn the ignition switch to ON (engine OFF). 2) Move the select lever to “D” range. 3) Read the data of low clutch duty solenoid.	Is the value 0%?	Even if the AT OIL TEMP warning light blinks, the circuit has returned to a normal condition at this time. A temporary poor contact of the connector or harness may be the cause. Repair the harness or connector in transmission.	Go to step 6.
6 CHECK POOR CONTACT.	Is there poor contact in low clutch duty solenoid circuit?	Repair the poor contact.	Replace the TCM. <Ref. to 4AT-76, Transmission Control Module (TCM).>

Diagnostic Procedure with Diagnostic Trouble Code (DTC)

AUTOMATIC TRANSMISSION (DIAGNOSTICS)

Step	Check	Yes	No
<p>7 CHECK LOW CLUTCH DUTY SOLENOID (IN TRANSMISSION). 1) Remove the transmission connector from bracket. 2) Drain the ATF.</p> <p>CAUTION: Do not drain the ATF until it cools down.</p> <p>3) Remove the oil pan, and disconnect connector from low clutch duty solenoid. 4) Measure the resistance between low clutch duty solenoid connector and transmission ground.</p> <p>Connector & terminal (AT12) No. 2 — Transmission ground:</p>	Is the resistance 2.0 — 6.0 Ω ?	Go to step 8.	Replace the control valve body. <Ref. to 4AT-61, Control Valve Body.>
<p>8 CHECK HARNESS CONNECTOR BETWEEN TRANSMISSION AND LOW CLUTCH DUTY SOLENOID. Measure the resistance of harness between low clutch duty solenoid and transmission connector.</p> <p>Connector & terminal (T4) No. 4 — (AT12) No. 2:</p>	Is the resistance less than 1 Ω ?	Go to step 9.	Repair the open circuit in harness between low clutch duty solenoid and transmission connector.
<p>9 CHECK HARNESS CONNECTOR BETWEEN TRANSMISSION AND LOW CLUTCH DUTY SOLENOID. Measure the resistance of harness between transmission connector and transmission ground.</p> <p>Connector & terminal (T4) No. 4 — Transmission ground:</p>	Is the resistance more than 1 M Ω ?	Even if the AT OIL TEMP warning light blinks, the circuit has returned to a normal condition at this time. A temporary poor contact of the connector or harness may be the cause. Repair the harness or connector in low clutch duty solenoid and transmission.	Repair the short circuit in harness between low clutch duty solenoid and transmission connector.

Diagnostic Procedure with Diagnostic Trouble Code (DTC)

AUTOMATIC TRANSMISSION (DIAGNOSTICS)

R: DTC P0758 SHIFT SOLENOID “B” ELECTRICAL

DIAGNOSIS:

The output signal circuit of 2-4 brake duty solenoid is open or shorted.

TROUBLE SYMPTOM:

Excessive shift shock.

WIRING DIAGRAM:

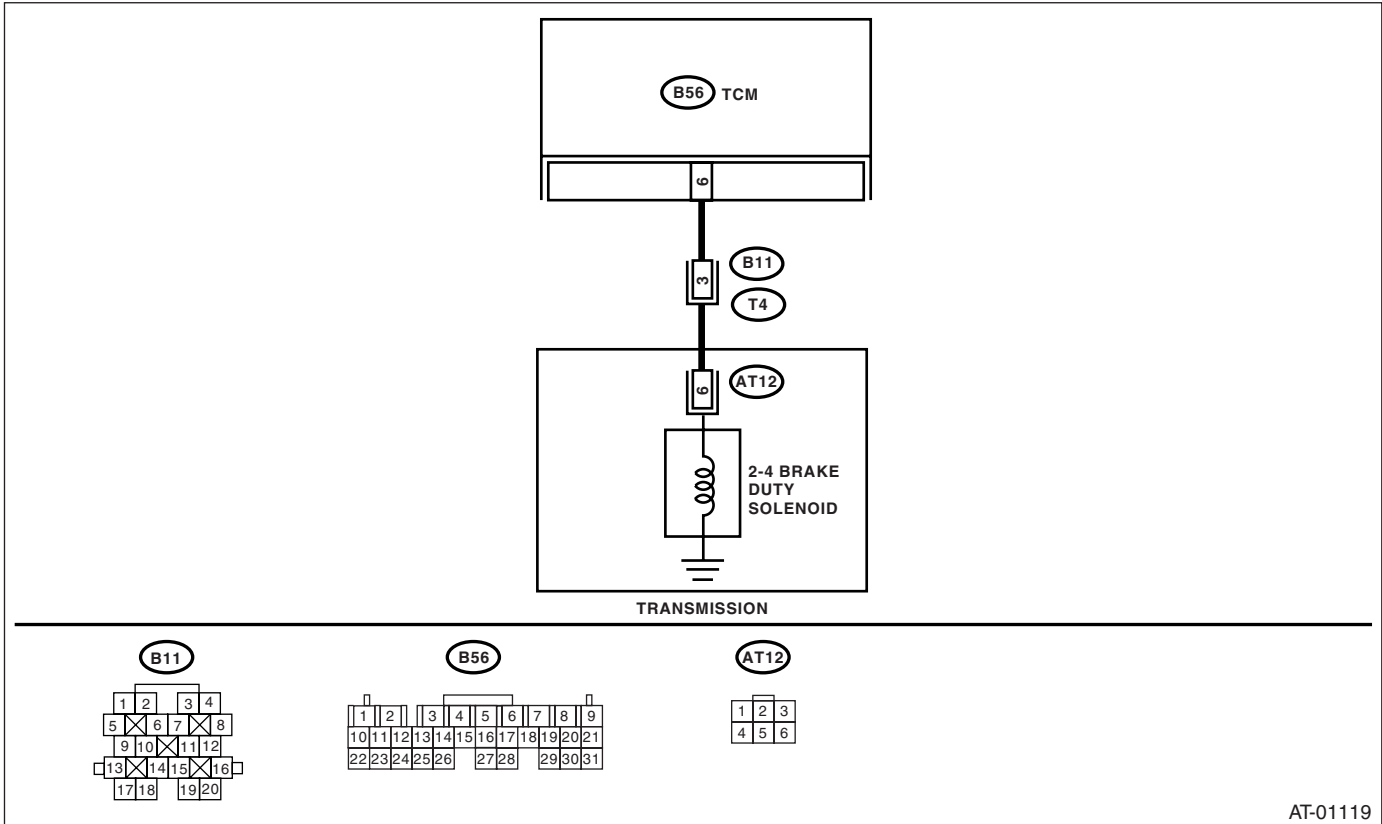

Step	Check	Yes	No
1 CHECK HARNESS CONNECTOR BETWEEN TCM AND TRANSMISSION. 1) Turn the ignition switch to OFF. 2) Disconnect the connector from TCM and transmission. 3) Measure the resistance of harness between TCM connector and shift transmission connector. <i>Connector & terminal</i> <i>(B56) No. 6 — (B11) No. 3:</i>	Is the resistance less than 1 Ω?	Go to step 2.	Repair the open circuit in harness between TCM and transmission connector.
2 CHECK HARNESS CONNECTOR BETWEEN TCM AND CHASSIS GROUND. Measure the resistance of harness between TCM connector and chassis ground. <i>Connector & terminal</i> <i>(B56) No. 6 — Chassis ground:</i>	Is the resistance more than 1 MΩ?	Go to step 3.	Repair the short circuit in harness between TCM and transmission connector.
3 CHECK 2-4 BRAKE DUTY SOLENOID. Measure the resistance between transmission connector terminals. <i>Connector & terminal</i> <i>(T4) No. 3 — No. 20:</i>	Is the resistance 2.0 — 6.0 Ω?	Go to step 4.	Go to step 7.

Diagnostic Procedure with Diagnostic Trouble Code (DTC)

AUTOMATIC TRANSMISSION (DIAGNOSTICS)

Step	Check	Yes	No
<p>4 CHECK OUTPUT SIGNAL FROM TCM USING SUBARU SELECT MONITOR.</p> <p>1) Connect all connectors. 2) Connect the Subaru Select Monitor to data link connector. 3) Start the engine and turn Subaru Select Monitor switch to ON. 4) Warm-up the transmission until ATF temperature is above 80°C (176°F).</p> <p>NOTE: If ambient temperature is below 0°C (32°F), drive the vehicle until ATF reaches its operating temperature.</p> <p>5) Stop the engine and turn ignition switch to ON (engine OFF). 6) Move the select lever to “N” range. 7) Read the data of 2-4 brake duty solenoid using Subaru Select Monitor.</p> <ul style="list-style-type: none"> • 2-4 brake duty solenoid is indicated in “%”. 	Is the value 100%?	Go to step 5.	Go to step 6.
<p>5 CHECK OUTPUT SIGNAL FROM TCM USING SUBARU SELECT MONITOR.</p> <p>1) Move the select lever to “2” range. 2) Turn the HOLD switch to ON.</p>	Is the value 0%?	Even if the AT OIL TEMP warning light blinks, the circuit has returned to a normal condition at this time. A temporary poor contact of the connector or harness may be the cause. Repair the harness or connector in TCM and transmission.	Go to step 6.
<p>6 CHECK POOR CONTACT.</p>	Is there poor contact in 2-4 brake duty solenoid circuit?	Repair the poor contact.	Replace the TCM. <Ref. to 4AT-76, Transmission Control Module (TCM).>
<p>7 CHECK 2-4 BRAKE DUTY SOLENOID (IN TRANSMISSION).</p> <p>1) Remove the transmission connector from bracket. 2) Drain the ATF.</p> <p>CAUTION: Do not drain the ATF until it cools down.</p> <p>3) Remove the oil pan, and disconnect connector from 2-4 brake duty solenoid. 4) Measure the resistance of harness between 2-4 brake duty solenoid connector and transmission ground.</p> <p>Connector & terminal (AT12) No. 6 — Transmission ground:</p>	Is the resistance 2.0 — 6.0 Ω?	Go to step 8.	Replace the control valve body. <Ref. to 4AT-61, Control Valve Body.>
<p>8 CHECK HARNESS CONNECTOR BETWEEN 2-4 BRAKE DUTY SOLENOID AND TRANSMISSION.</p> <p>Measure the resistance of harness between 2-4 brake duty solenoid and transmission connector.</p> <p>Connector & terminal (T4) No. 3 — (AT12) No. 6:</p>	Is the resistance less than 1 Ω?	Go to step 9.	Repair the open circuit in harness between 2-4 brake duty solenoid and transmission connector.

Diagnostic Procedure with Diagnostic Trouble Code (DTC)

AUTOMATIC TRANSMISSION (DIAGNOSTICS)

Step	Check	Yes	No
<p>9 CHECK HARNESS CONNECTOR BETWEEN 2-4 BRAKE DUTY SOLENOID AND TRANSMISSION. Measure the resistance of harness between transmission connector and transmission ground. Connector & terminal (T4) No. 3 — Transmission ground:</p>	<p>Is the resistance more than 1 MΩ?</p>	<p>Even if the AT OIL TEMP warning light blinks, the circuit has returned to a normal condition at this time. A temporary poor contact of the connector or harness may be the cause. Repair the harness or connector in high clutch duty solenoid and transmission.</p>	<p>Repair the short circuit harness between 2-4 brake duty solenoid and transmission connector.</p>

Diagnostic Procedure with Diagnostic Trouble Code (DTC)

AUTOMATIC TRANSMISSION (DIAGNOSTICS)

S: DTC P0763 SHIFT SOLENOID “C” ELECTRICAL

DIAGNOSIS:

The output signal circuit of high clutch duty solenoid is open or shorted.

TROUBLE SYMPTOM:

Excessive shift shock.

WIRING DIAGRAM:

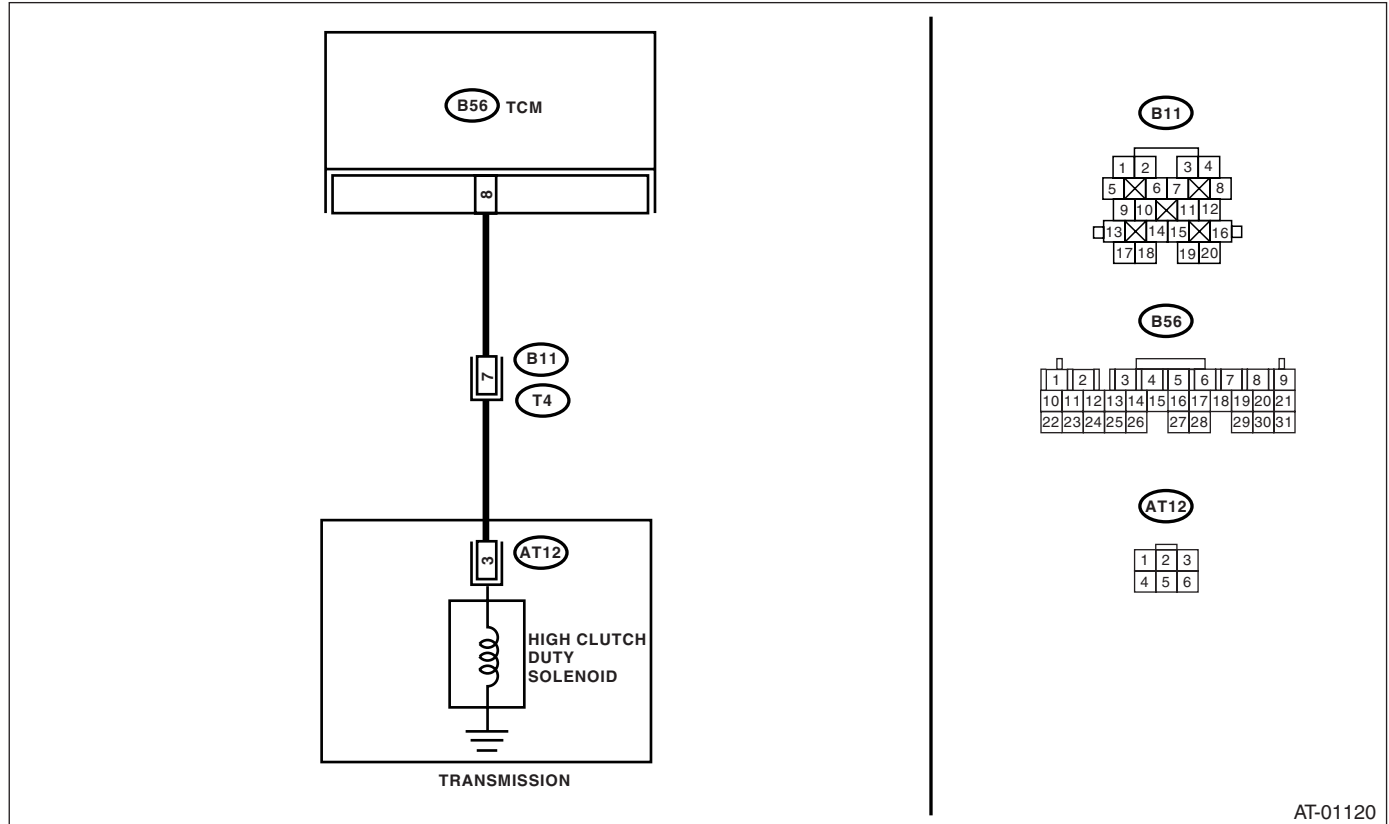

AT-01120

Step	Check	Yes	No
1 CHECK HARNESS CONNECTOR BETWEEN TCM AND TRANSMISSION. 1) Turn the ignition switch to OFF. 2) Disconnect the connector from TCM and transmission. 3) Measure the resistance of harness between TCM and transmission connector. <i>Connector & terminal (B56) No. 8 — (B11) No. 7:</i>	Is the resistance less than 1 Ω ?	Go to step 2.	Repair the open circuit in harness between TCM and transmission connector.
2 CHECK HARNESS CONNECTOR BETWEEN TCM AND TRANSMISSION. Measure the resistance of harness connector between TCM connector and chassis ground. <i>Connector & terminal (B56) No. 8 — Chassis ground:</i>	Is the resistance more than 1 $M\Omega$?	Go to step 3.	Repair the short circuit in harness between TCM and transmission connector.
3 CHECK HIGH CLUTCH DUTY SOLENOID. Measure the resistance between transmission connector receptacle's terminals. <i>Connector & terminal (T4) No. 7 — No. 20:</i>	Is the resistance 2.0 — 6.0 Ω ?	Go to step 4.	Go to step 7.

Diagnostic Procedure with Diagnostic Trouble Code (DTC)

AUTOMATIC TRANSMISSION (DIAGNOSTICS)

Step	Check	Yes	No
<p>4 CHECK OUTPUT SIGNAL FROM TCM USING SUBARU SELECT MONITOR. 1) Connect the connectors to TCM and transmission. 2) Lift-up the vehicle and place safety stand. NOTE: Raise all wheels off ground. 3) Connect the Subaru Select Monitor to data link connector. 4) Start the engine and turn Subaru Select Monitor switch to ON. 5) Start the engine and warm-up the transmission until ATF temperature is above 80°C (176°F). NOTE: If ambient temperature is below 0°C (32°F), drive the vehicle until ATF reaches its operating temperature. 6) Read the data of high clutch duty solenoid using Subaru Select Monitor. • High clutch duty solenoid is indicated in “%”. 7) Move the select lever to “D” range and slowly increase vehicle speed and measure at 3rd or 4th gear. NOTE: The speed difference between front and rear wheels may light the ABS warning light, but this indicates no malfunction. When AT control diagnosis is finished, perform the ABS memory clearance procedure of on-board diagnostics system. <Ref. to ABS(diag)-26, Clear Memory Mode.></p>	Is the value 100%?	Go to step 5.	Go to step 6.
<p>5 CHECK OUTPUT SIGNAL FROM TCM USING SUBARU SELECT MONITOR. Return the engine to idling speed and move select lever to “N” range. NOTE: The speed difference between front and rear wheels may light the ABS warning light, but this indicates no malfunction. When AT control diagnosis is finished, perform the ABS memory clearance procedure of on-board diagnostics system. <Ref. to ABS(diag)-26, Clear Memory Mode.></p>	Is the value 100%?	Even if the AT OIL TEMP warning light blinks, the circuit has returned to a normal condition at this time. A temporary poor contact of the connector or harness may be the cause. Repair the harness or connector in TCM and transmission.	Go to step 6.
<p>6 CHECK POOR CONTACT.</p>	Is there poor contact in high clutch duty circuit?	Repair poor contact.	Replace the TCM. <Ref. to 4AT-76, Transmission Control Module (TCM).>

Diagnostic Procedure with Diagnostic Trouble Code (DTC)

AUTOMATIC TRANSMISSION (DIAGNOSTICS)

Step	Check	Yes	No
<p>7 CHECK HIGH CLUTCH DUTY SOLENOID (IN TRANSMISSION). 1) Remove the transmission connector from bracket. 2) Drain the ATF.</p> <p>CAUTION: Do not drain the ATF until it cools down.</p> <p>3) Remove the oil pan and disconnect connector from high clutch duty solenoid. 4) Measure the resistance between high clutch duty solenoid connector and transmission ground.</p> <p>Connector & terminal (AT12) No. 3 — Transmission ground:</p>	Is the resistance 2.0 — 6.0 Ω?	Go to step 8.	Replace the control valve body. <Ref. to 4AT-61, Control Valve Body.>
<p>8 CHECK HARNESS CONNECTOR BETWEEN HIGH CLUTCH DUTY SOLENOID AND TRANSMISSION. Measure the resistance of harness between high clutch duty solenoid and transmission connector.</p> <p>Connector & terminal (T4) No. 7 — (AT12) No. 3:</p>	Is the resistance less than 1 Ω?	Go to step 9.	Repair the open circuit in harness between TCM and transmission connector.
<p>9 CHECK HARNESS CONNECTOR BETWEEN HIGH CLUTCH DUTY SOLENOID AND TRANSMISSION. Measure the resistance of harness between transmission connector and transmission ground.</p> <p>Connector & terminal (T4) No. 7 — Transmission ground:</p>	Is the resistance more than 1 MΩ?	Even if the AT OIL TEMP warning light blinks, the circuit has returned to a normal condition at this time. A temporary poor contact of the connector or harness may be the cause. Repair the harness or connector in high clutch duty solenoid and transmission.	Repair the short circuit in harness between high clutch duty solenoid and transmission connector.

Diagnostic Procedure with Diagnostic Trouble Code (DTC)

AUTOMATIC TRANSMISSION (DIAGNOSTICS)

T: DTC P0768 SHIFT SOLENOID “D” ELECTRICAL

DIAGNOSIS:

The output signal circuit of low & reverse duty solenoid is open or shorted.

TROUBLE SYMPTOM:

Gear is not changed.

WIRING DIAGRAM:

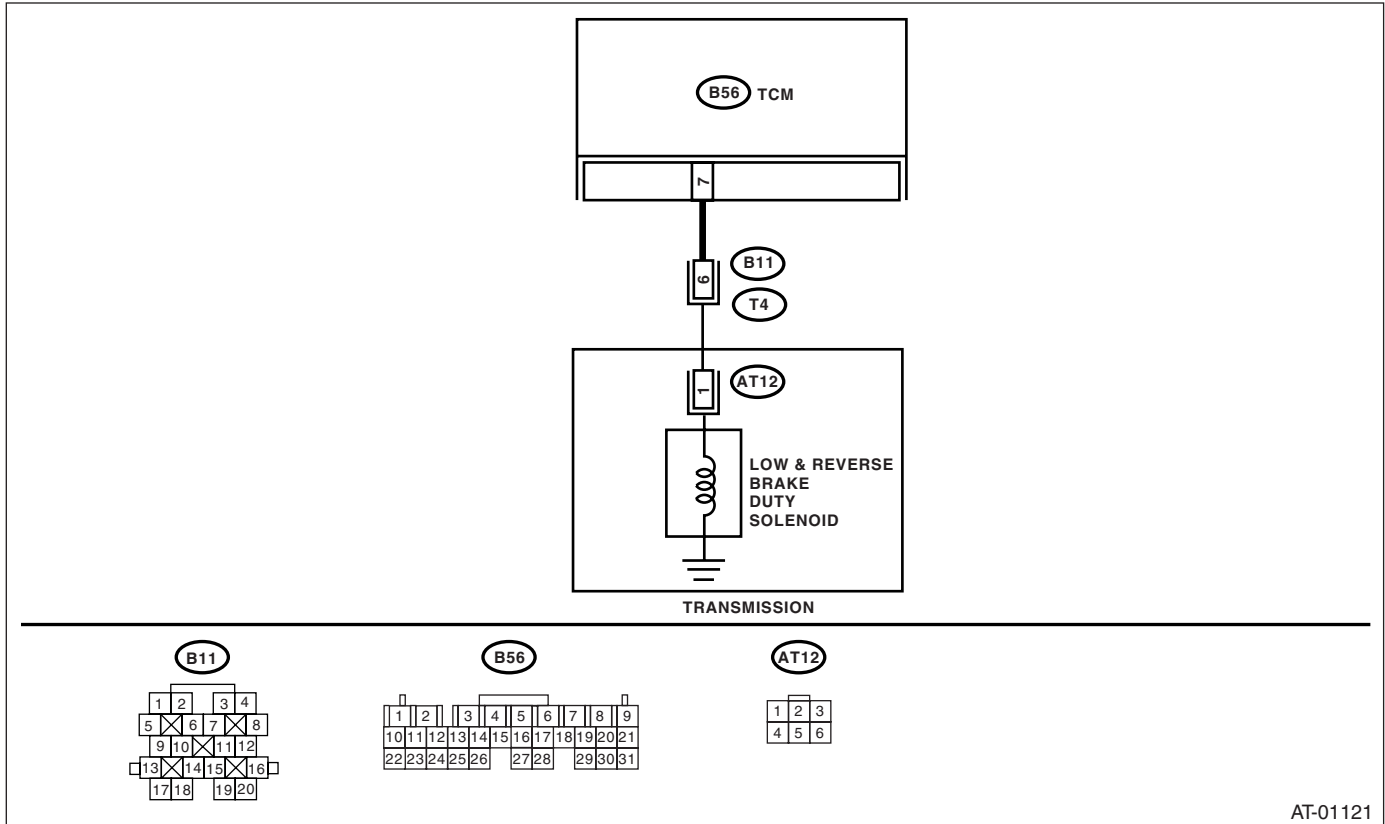

AT-01121

Step	Check	Yes	No
1 CHECK HARNESS CONNECTOR BETWEEN TCM AND TRANSMISSION. 1) Turn the ignition switch to OFF. 2) Disconnect the connector from transmission and TCM. 3) Measure the resistance of harness between TCM connector and transmission connector. <i>Connector & terminal (B56) No. 7 — (B11) No. 6:</i>	Is the resistance less than 1 Ω ?	Go to step 2.	Repair the open circuit in harness between TCM and transmission connector.
2 CHECK HARNESS CONNECTOR BETWEEN TCM AND CHASSIS GROUND. Measure the resistance of harness between TCM connector and chassis ground. <i>Connector & terminal (B56) No. 7 — Chassis ground:</i>	Is the resistance more than 1 $M\Omega$?	Go to step 3.	Repair the short circuit in harness between TCM and transmission connector.
3 CHECK LOW & REVERSE BRAKE DUTY SOLENOID. Measure the resistance between transmission connector receptacle's terminals. <i>Connector & terminal (T4) No. 6 — No. 20:</i>	Is the resistance 2.0 — 6.0 Ω ?	Go to step 4.	Go to step 7.

Diagnostic Procedure with Diagnostic Trouble Code (DTC)

AUTOMATIC TRANSMISSION (DIAGNOSTICS)

Step	Check	Yes	No
<p>4</p> <p>CHECK OUTPUT SIGNAL FROM TCM USING SUBARU SELECT MONITOR.</p> <p>1) Connect all connectors. 2) Connect the Subaru Select Monitor to data link connector. 3) Start the engine and turn Subaru Select Monitor switch to ON. 4) Warm-up the transmission until ATF temperature is above 80°C (176°F).</p> <p>NOTE: If ambient temperature is below 0°C (32°F), drive the vehicle until ATF reaches its operating temperature.</p> <p>5) Stop the engine and turn ignition switch to ON (engine OFF). 6) Shift the select lever to “P” or “N” range, and depress the accelerator pedal. 7) Read the data of low & reverse duty solenoid using Subaru Select Monitor.</p> <ul style="list-style-type: none"> • Low & reverse duty solenoid is indicated in “%”. 	Is the value 100%?	Go to step 5.	Go to step 6.
<p>5</p> <p>CHECK OUTPUT SIGNAL FROM TCM USING SUBARU SELECT MONITOR.</p> <p>1) Move the select lever to “1” range. 2) Read the data of low & reverse duty solenoid.</p>	Is the value 55%?	Even if the AT OIL TEMP warning light blinks, the circuit has returned to a normal condition at this time. A temporary poor contact of the connector or harness may be the cause. Repair the harness or connector in TCM and transmission.	Go to step 6.
<p>6</p> <p>CHECK POOR CONTACT.</p>	Is there poor contact in low & reverse duty solenoid circuit?	Repair the poor contact.	Replace the TCM. <Ref. to 4AT-76, Transmission Control Module (TCM).>
<p>7</p> <p>CHECK LOW & REVERSE BRAKE DUTY SOLENOID (IN TRANSMISSION).</p> <p>1) Remove the transmission connector from bracket. 2) Drain the ATF.</p> <p>CAUTION: Do not drain the ATF until it cools down.</p> <p>3) Remove the oil pan, and disconnect connector from low & reverse duty solenoid. 4) Measure the resistance between low & reverse duty solenoid connector and transmission ground.</p> <p>Connector & terminal (AT12) No. 1 — Transmission ground:</p>	Is the resistance 2.0 — 6.0 Ω?	Go to step 8.	Replace the low & reverse brake duty solenoid. <Ref. to 4AT-70, Shift Solenoids, Duty Solenoids and ATF Temperature Sensor.>

Diagnostic Procedure with Diagnostic Trouble Code (DTC)

AUTOMATIC TRANSMISSION (DIAGNOSTICS)

Step	Check	Yes	No
<p>8</p> <p>CHECK HARNESS CONNECTOR BETWEEN TRANSMISSION AND LOW & REVERSE DUTY SOLENOID.</p> <p>Measure the resistance of harness between low & reverse duty solenoid and transmission connector.</p> <p>Connector & terminal (T4) No. 6 — (AT12) No. 1:</p>	<p>Is the resistance less than 1 Ω?</p>	<p>Go to step 9.</p>	<p>Repair the open circuit in harness between low & reverse brake duty solenoid and transmission connector.</p>
<p>9</p> <p>CHECK HARNESS CONNECTOR BETWEEN TRANSMISSION AND LOW & REVERSE BRAKE DUTY SOLENOID.</p> <p>Measure the resistance of harness between transmission connector and transmission ground.</p> <p>Connector & terminal (T4) No. 6 — Transmission ground:</p>	<p>Is the resistance more than 1 $M\Omega$?</p>	<p>Even if the AT OIL TEMP warning light blinks, the circuit has returned to a normal condition at this time. A temporary poor contact of the connector or harness may be the cause. Repair the harness or connector in low & reverse brake duty solenoid and transmission.</p>	<p>Repair the short circuit in harness between low & reverse brake duty solenoid and transmission connector.</p>

Diagnostic Procedure with Diagnostic Trouble Code (DTC)

AUTOMATIC TRANSMISSION (DIAGNOSTICS)

U: DTC P0801 REVERSE INHIBIT CONTROL CIRCUIT

DIAGNOSIS:

Shift lock solenoid malfunction, open or short reverse inhibitor control circuit.

TROUBLE SYMPTOM:

- Gear is shifted from “N” range to “R” range during driving at 20 km/h (12 MPH) or more.
- Gear can not be shifted from “N” range to “R” range.

WIRING DIAGRAM:

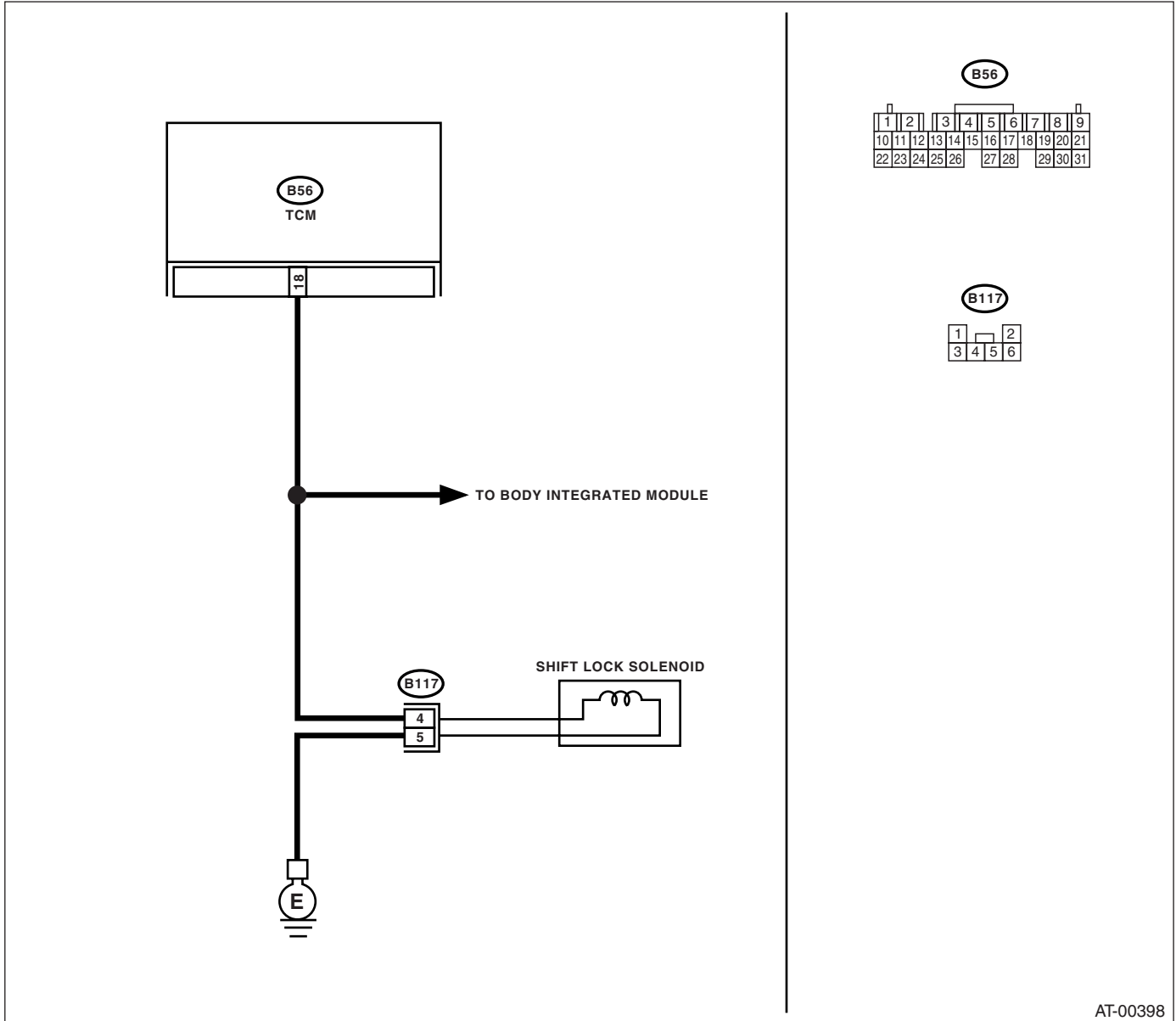

AT-00398

Step	Check	Yes	No
1 CHECK HARNESS CONNECTOR BETWEEN TCM AND SHIFT LOCK SOLENOID. 1) Turn the ignition switch to OFF. 2) Disconnect the connector from TCM and shift lock solenoid. 3) Measure the resistance of harness between TCM and shift lock solenoid connector. <i>Connector & terminal</i> <i>(B56) No. 18 — (B117) No. 4:</i>	Is the resistance less than 1 Ω ?	Go to step 2.	Repair the open circuit in harness between TCM and shift lock solenoid connector.

Diagnostic Procedure with Diagnostic Trouble Code (DTC)

AUTOMATIC TRANSMISSION (DIAGNOSTICS)

Step	Check	Yes	No
2 CHECK HARNESS CONNECTOR BETWEEN TCM AND SHIFT LOCK SOLENOID. Measure the resistance of harness between TCM and chassis ground. <i>Connector & terminal</i> <i>(B56) No. 18 — Chassis ground:</i>	Is the resistance more than 1 M Ω ?	Go to step 3.	Repair the short circuit in harness between TCM and shift lock solenoid connector.
3 CHECK HARNESS BETWEEN SHIFT LOCK SOLENOID AND CHASSIS GROUND. Measure the resistance of harness between shift lock solenoid and chassis ground. <i>Connector & terminal</i> <i>(B117) No. 5 — Chassis ground:</i>	Is the resistance less than 1 Ω ?	Go to step 4.	Repair the open circuit in harness between chassis ground terminal and shift lock solenoid connector.
4 CHECK SHIFT LOCK SOLENOID. Measure the resistance between shift lock solenoid. <i>Connector & terminal</i> <i>(B117) No. 5 — No. 4:</i>	Is the resistance 20 — 40 Ω ?	Go to step 5.	Replace the shift lock solenoid.
5 CHECK TCM OUTPUT SIGNAL. 1) Connect all connectors. 2) Turn the ignition switch to ON. 3) Move the select lever to "D" range. 4) Measure the voltage between TCM and chassis ground. <i>Connector & terminal</i> <i>(B56) No. 18 (+) — Chassis ground (-):</i>	Is the voltage more than 10.5 V?	Go to step 6.	Go to step 7.
6 CHECK OUTPUT SIGNAL FROM TCM. 1) Lift-up the vehicle and place safety stand. NOTE: Raise all wheels off ground. 2) Start the engine. 3) Move the select lever "D" range and slowly increase vehicle speed to 20 km/h (12 MPH). NOTE: The speed difference between front and rear wheels may light ABS warning light, but this indicates no malfunction. When AT control diagnosis is finished, perform the ABS memory clearance procedure of on-board diagnostics system. 4) Measure the voltage between TCM and chassis ground. <i>Connector & terminal</i> <i>(B56) No. 18 (+) — Chassis ground (-):</i>	Is the voltage less than 1 V?	Even if the AT OIL TEMP warning light blinks, the circuit has returned to a normal condition at this time. A temporary poor contact of the connector or harness may be cause. Repair the harness or connector in reverse inhibitor control circuit.	Go to step 7.
7 CHECK POOR CONTACT.	Is there poor contact in the reverse inhibitor control circuit?	Repair the poor contact.	Replace the TCM. <Ref. to 4AT-76, Transmission Control Module (TCM).>

Diagnostic Procedure with Diagnostic Trouble Code (DTC)

AUTOMATIC TRANSMISSION (DIAGNOSTICS)

V: DTC P1706 AT VEHICLE SPEED SENSOR CIRCUIT MALFUNCTION (REAR WHEEL)

DIAGNOSIS:

The input signal circuit of TCM is open or shorted.

TROUBLE SYMPTOM:

No lock-up or excessive tight corner "braking".

WIRING DIAGRAM:

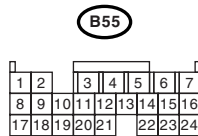
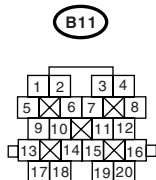
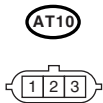
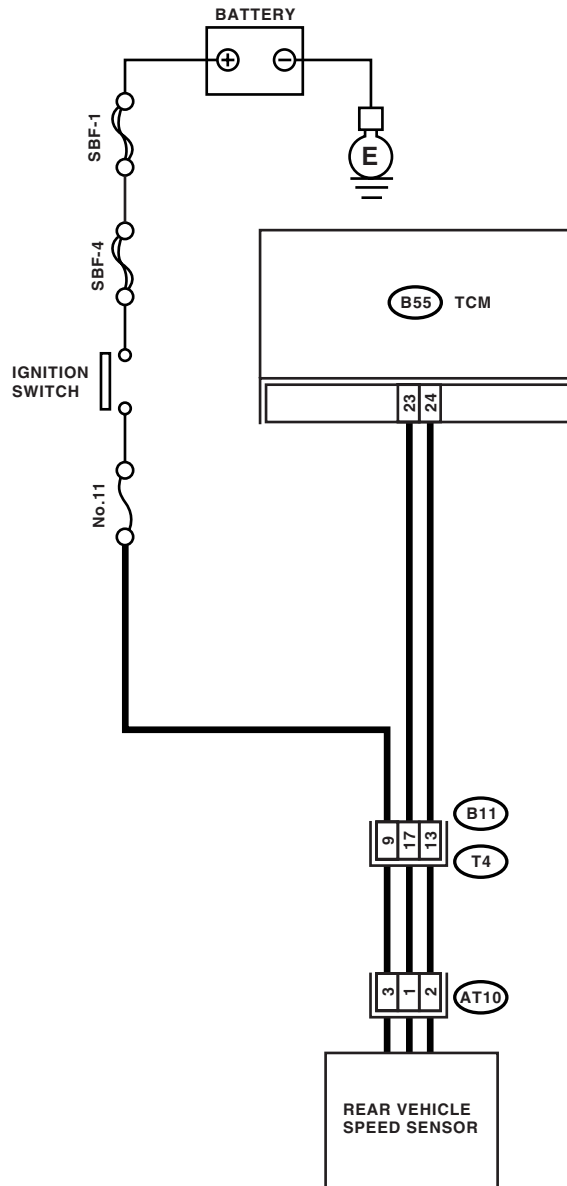

AT-02869

Diagnostic Procedure with Diagnostic Trouble Code (DTC)

AUTOMATIC TRANSMISSION (DIAGNOSTICS)

Step	Check	Yes	No
<p>1 CHECK IGNITION POWER SUPPLY CIRCUIT.</p> <p>1) Turn the ignition switch to OFF. 2) Disconnect the connector from rear vehicle speed sensor. 3) Turn the ignition switch to ON. 4) Measure the ignition power supply between rear vehicle speed sensor connector and transmission ground.</p> <p>Connector & terminal (AT10) No. 3 (+) — Transmission ground (-):</p>	Is the voltage more than 10 V?	Go to step 2.	Check harness between rear vehicle speed sensor and battery for open circuit, short or poor contact. Repair the harness if required.
<p>2 CHECK HARNESS CONNECTOR BETWEEN TCM AND TRANSMISSION.</p> <p>1) Turn the ignition switch to OFF. 2) Measure the resistance of harness between TCM and transmission connector.</p> <p>Connector & terminal (B55) No. 23 — (AT10) No. 1:</p>	Is the resistance less than 1 Ω ?	Go to step 3.	Repair the open circuit or poor contact of connector in harness between TCM and rear vehicle speed sensor connector.
<p>3 CHECK HARNESS CONNECTOR BETWEEN TCM AND TRANSMISSION.</p> <p>Measure the resistance of harness between TCM and transmission connector.</p> <p>Connector & terminal (B54) No. 24 — (AT10) No. 2:</p>	Is the resistance less than 1 Ω ?	Go to step 4.	Repair the open circuit or poor contact of connector in harness between TCM and rear vehicle speed sensor connector.
<p>4 CHECK HARNESS CONNECTOR BETWEEN TCM AND TRANSMISSION.</p> <p>Measure the resistance of harness between TCM connector and chassis ground.</p> <p>Connector & terminal (B55) No. 23 — Chassis ground:</p>	Is the resistance more than 1 M Ω ?	Go to step 5.	Repair the short circuit in harness between TCM and rear vehicle speed sensor connector.
<p>5 CHECK HARNESS CONNECTOR BETWEEN TCM AND TRANSMISSION.</p> <p>Measure the resistance of harness between TCM connector and chassis ground.</p> <p>Connector & terminal (B55) No. 24 — Chassis ground:</p>	Is the resistance more than 1 M Ω ?	Go to step 6.	Repair the short circuit in harness between TCM and rear vehicle speed sensor connector.
<p>6 PREPARE OSCILLOSCOPE.</p>	Do you have an oscilloscope?	Go to step 8.	Go to step 7.
<p>7 CHECK INPUT SIGNAL FOR TCM.</p> <p>1) Connect the connectors to TCM and transmission. 2) Lift-up the vehicle and place safety stands.</p> <p>NOTE: Raise all wheels off ground.</p> <p>3) Start the engine and set vehicle in 20 km/h (12 MPH) condition.</p> <p>NOTE: The speed difference between front and rear wheels may light the ABS warning light, but this indicates no malfunction. When AT control diagnosis is finished, perform the ABS memory clearance procedure of on-board diagnostics system. <Ref. to ABS(diag)-26, Clear Memory Mode.></p> <p>4) Measure the AC voltage between TCM connector terminals.</p> <p>Connector & terminal (B55) No. 24 (+) — No. 23 (-):</p>	Is the voltage more than 2 V?	Go to step 9.	Replace the rear vehicle speed sensor.

Diagnostic Procedure with Diagnostic Trouble Code (DTC)

AUTOMATIC TRANSMISSION (DIAGNOSTICS)

Step	Check	Yes	No
<p>8 CHECK INPUT SIGNAL FOR TCM USING OSCILLOSCOPE.</p> <p>1) Connect the connectors to TCM and transmission.</p> <p>2) Lift-up the vehicle and place safety stands.</p> <p>NOTE: Raise all wheels off ground.</p> <p>3) Set the oscilloscope to TCM connector terminals.</p> <p style="padding-left: 20px;">Connector & terminal</p> <p style="padding-left: 40px;">Positive lead; (B55) No. 24:</p> <p style="padding-left: 40px;">Earth lead; (B55) No. 23:</p> <p>4) Start the engine and set vehicle in 20 km/h (12 MPH) condition.</p> <p>NOTE: The speed difference between front and rear wheels may light the ABS warning light, but this indicates no malfunction. When AT control diagnosis is finished, perform the ABS memory clearance procedure of on-board diagnostics system. <Ref. to ABS(diag)-26, Clear Memory Mode.></p> <p>5) Measure the signal voltage indicated on oscilloscope.</p>	<p>Is the pulse voltage approx. 5 V?</p>	<p>Go to step 9.</p>	<p>Replace the rear vehicle speed sensor.</p>
<p>9 CHECK POOR CONTACT.</p>	<p>Is there poor contact in rear vehicle speed sensor circuit?</p>	<p>Repair the poor contact.</p>	<p>Replace the TCM. <Ref. to 4AT-76, Transmission Control Module (TCM).></p>

Diagnostic Procedure with Diagnostic Trouble Code (DTC)

AUTOMATIC TRANSMISSION (DIAGNOSTICS)

W: DTC P1707 AT AWD SOLENOID VALVE CIRCUIT MALFUNCTION

DIAGNOSIS:

The output signal circuit of transfer duty solenoid is open or shorted.

TROUBLE SYMPTOM:

- Excessive tight corner “braking”.
- Front wheel slips on the slippery road.

WIRING DIAGRAM:

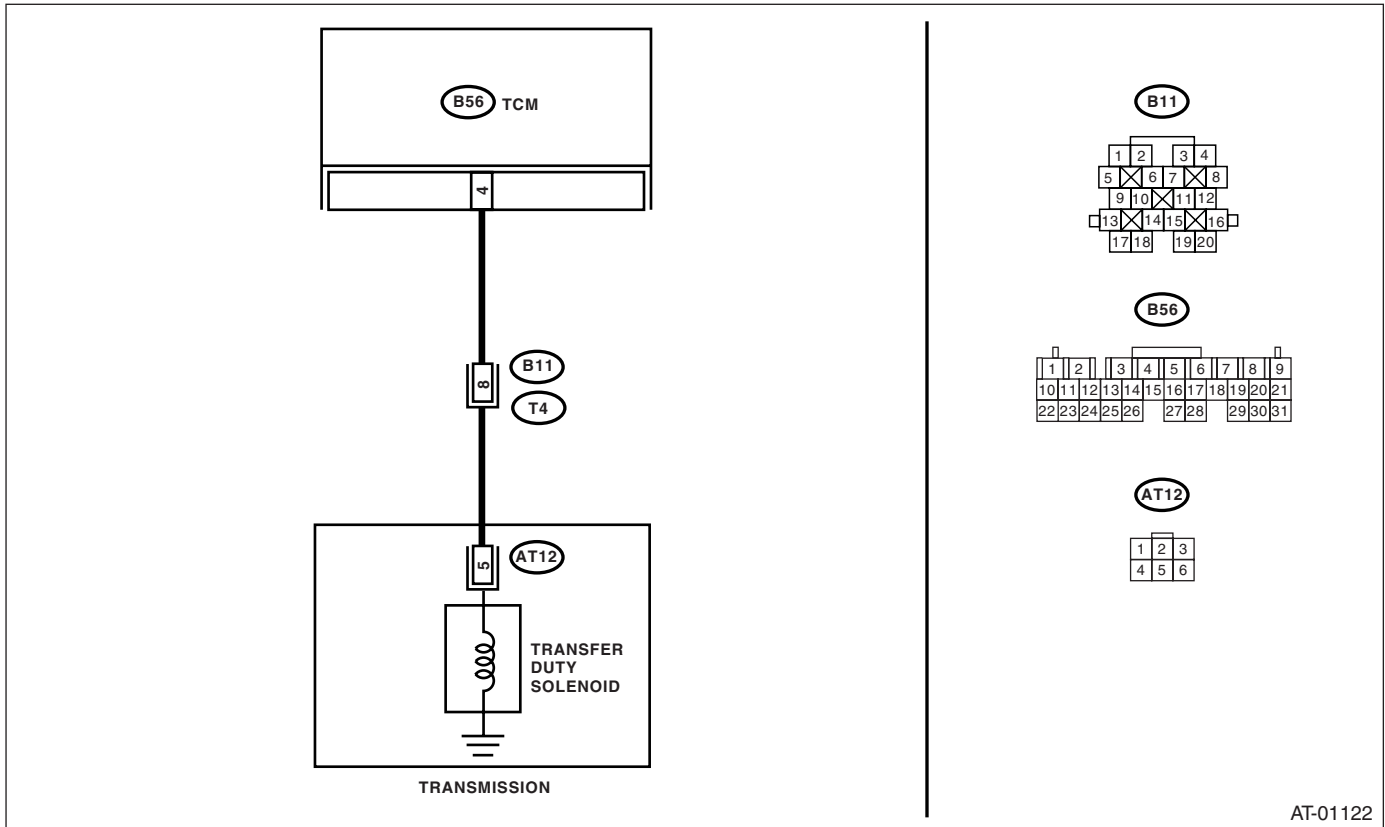

AT-01122

Step	Check	Yes	No
1 CHECK HARNESS CONNECTOR BETWEEN TCM AND TRANSMISSION. 1) Turn the ignition switch to OFF. 2) Disconnect the connector from TCM and transmission. 3) Measure the resistance of harness between TCM connector and transmission connector. <i>Connector & terminal</i> <i>(B56) No. 4 — (B11) No. 8:</i>	Is the resistance less than 1 Ω ?	Go to step 2.	Repair the open circuit in harness between TCM and transmission connector.
2 CHECK HARNESS CONNECTOR BETWEEN TCM AND TRANSMISSION. Measure the resistance harness connector between TCM and chassis ground. <i>Connector & terminal</i> <i>(B56) No. 4 — Chassis ground:</i>	Is the resistance more than 1 M Ω ?	Go to step 3.	Repair the short circuit in harness between TCM and transmission connector.
3 CHECK TRANSFER DUTY SOLENOID. Measure the resistance between transmission connector and transmission terminals. <i>Connector & terminal</i> <i>(T4) No. 8 — No. 20:</i>	Is the resistance 2.0 — 6.0 Ω ?	Go to step 5.	Go to step 4.

Diagnostic Procedure with Diagnostic Trouble Code (DTC)

AUTOMATIC TRANSMISSION (DIAGNOSTICS)

Step	Check	Yes	No
<p>4</p> <p>CHECK TRANSFER DUTY SOLENOID (IN TRANSMISSION).</p> <p>1) Lift-up the vehicle and place safety stand.</p> <p>NOTE: Raise all wheels off ground.</p> <p>2) Drain the ATF.</p> <p>CAUTION: Do not drain the ATF until it cools down.</p> <p>3) Remove the extension case and disconnect connector from transfer duty solenoid.</p> <p>4) Measure the resistance between transfer duty solenoid connector and transmission ground.</p> <p>Connector & terminal (AT12) No. 5 — Transmission ground:</p>	<p>Is the resistance 2.0 — 6.0 Ω?</p>	<p>Go to step 5.</p>	<p>Replace the control valve body. <Ref. to 4AT-61, Control Valve Body.></p>
<p>5</p> <p>CHECK HARNESS CONNECTOR BETWEEN TRANSFER DUTY SOLENOID AND TRANSMISSION.</p> <p>Measure the resistance of harness between transfer duty solenoid and transmission connector.</p> <p>Connector & terminal (T4) No. 8 — (AT12) No. 5:</p>	<p>Is the resistance less than 1 Ω?</p>	<p>Go to step 6.</p>	<p>Repair the open circuit in harness between transfer duty solenoid and transmission connector.</p>
<p>6</p> <p>CHECK HARNESS CONNECTOR BETWEEN TRANSFER DUTY SOLENOID AND TRANSMISSION.</p> <p>Measure the resistance of harness between transmission connector and transmission ground.</p> <p>Connector & terminal (T4) No. 8 — Transmission ground:</p>	<p>Is the resistance more than 1 MΩ?</p>	<p>Even if the AT OIL TEMP warning light blinks, the circuit has returned to a normal condition at this time. A temporary poor contact of the connector or harness may be the cause. Repair the harness or contact in transfer duty solenoid and transmission.</p>	<p>Repair the short circuit in harness between transfer duty solenoid and transmission connector.</p>

Diagnostic Procedure with Diagnostic Trouble Code (DTC)

AUTOMATIC TRANSMISSION (DIAGNOSTICS)

X: DTC P1708 THROTTLE POSITION SENSOR CIRCUIT LOW INPUT

DIAGNOSIS:

The input signal circuit of accelerator pedal position sensor is open or shorted.

TROUBLE SYMPTOM:

- Shift point too high or too low.
- Excessive shift shock.
- Excessive tight corner "braking".

WIRING DIAGRAM:

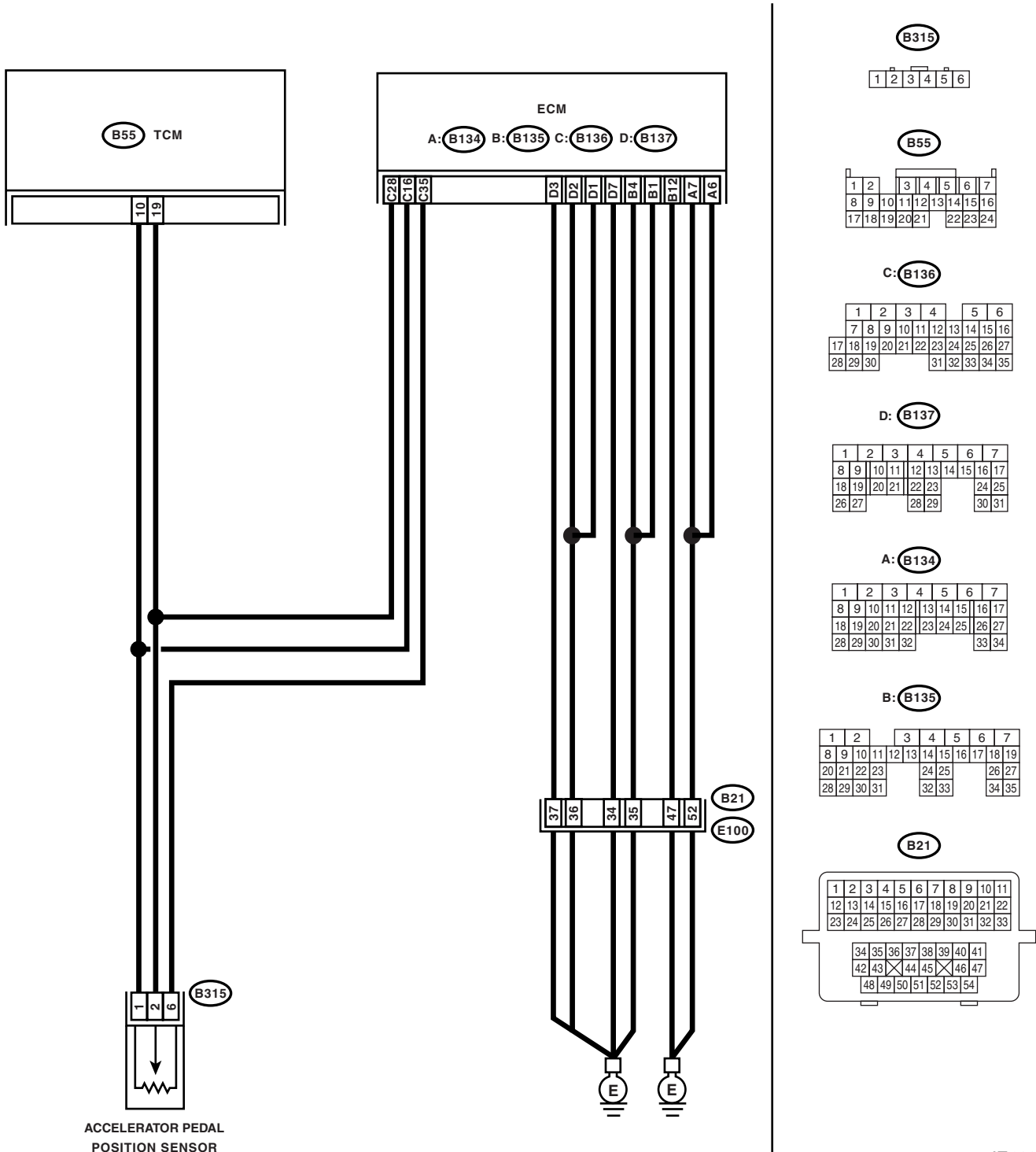

Diagnostic Procedure with Diagnostic Trouble Code (DTC)

AUTOMATIC TRANSMISSION (DIAGNOSTICS)

Step	Check	Yes	No
1	CHECK ENGINE GROUND TERMINALS.	Go to step 2 .	Tighten the engine ground terminals.
2	CHECK GROUND CIRCUIT OF ECM. 1) Turn the ignition switch to OFF. 2) Disconnect the connector from ECM. 3) Measure the resistance of harness between ECM and engine ground. Connector & terminal <i>(B134) No. 7 — Engine ground:</i> <i>(B134) No. 6 — Engine ground:</i> <i>(B135) No. 1 — Engine ground:</i> <i>(B135) No. 4 — Engine ground:</i> <i>(B135) No. 12 — Engine ground:</i> <i>(B137) No. 1 — Engine ground:</i> <i>(B137) No. 2 — Engine ground:</i> <i>(B137) No. 3 — Engine ground:</i> <i>(B137) No. 7 — Engine ground:</i>	Go to step 3 .	Repair the open circuit in harness between ECM connector and engine grounding terminal.
3	CHECK ACCELERATOR PEDAL POSITION SENSOR. 1) Disconnect the connector from accelerator pedal position sensor. 2) Measure the resistance between accelerator pedal position sensor connector receptacle's terminals. Connector & terminal <i>(B315) No. 1 — No. 6:</i>	Go to step 4 .	Replace the accelerator pedal position sensor.
4	CHECK ACCELERATOR PEDAL POSITION SENSOR. Measure the resistance between accelerator pedal position sensor connector receptacle's terminals. Connector & terminal <i>(B315) No. 2 — No. 6:</i>	Go to step 5 .	Replace the accelerator pedal position sensor.
5	CHECK HARNESS CONNECTOR BETWEEN TCM AND ACCELERATOR PEDAL POSITION SENSOR. 1) Disconnect the connector from TCM. 2) Measure the resistance of harness between TCM and accelerator pedal position sensor connector. Connector & terminal <i>(B55) No. 19 — (B315) No. 2:</i>	Go to step 6 .	Repair the open circuit in harness between TCM and accelerator pedal position sensor connector, and poor contact in coupling connector.
6	CHECK HARNESS CONNECTOR BETWEEN TCM AND ACCELERATOR PEDAL POSITION SENSOR. Measure the resistance of harness between TCM connector and chassis ground. Connector & terminal <i>(B55) No. 19 — Chassis ground:</i>	Go to step 8 .	Repair the short circuit in harness between TCM and accelerator pedal position sensor connector.
7	CHECK HARNESS CONNECTOR BETWEEN ECM AND ACCELERATOR PEDAL POSITION SENSOR. 1) Disconnect the connector from ECM. 2) Measure the resistance of harness between accelerator pedal position sensor and chassis ground. Connector & terminal <i>(B315) No. 6 — Chassis ground:</i>	Go to step 8 .	Repair the short circuit in harness between ECM and accelerator pedal position sensor.

Diagnostic Procedure with Diagnostic Trouble Code (DTC)

AUTOMATIC TRANSMISSION (DIAGNOSTICS)

Step	Check	Yes	No
8 CHECK INPUT SIGNAL FOR TCM USING SUBARU SELECT MONITOR. 1) Connect the connectors to TCM, accelerator pedal position sensor and ECM. 2) Connect the Subaru Select Monitor to data link connector. 3) Turn the ignition switch to ON (engine OFF). 4) Turn the Subaru Select Monitor switch to ON. 5) Throttle fully closed. 6) Read the data of accelerator pedal position sensor using Subaru Select Monitor. • Accelerator pedal position SENSOR input signal is indicated.	Is the voltage more than 0.2 V?	Even if the AT OIL TEMP warning light blinks, the circuit has returned to a normal condition at this time. A temporary poor contact of the connector or harness may be the cause. Repair the harness or connector in accelerator pedal position sensor circuit.	Go to step 9.
9 CHECK POOR CONTACT.	Is there poor contact in accelerator pedal position sensor circuit?	Repair the poor contact.	Replace the TCM. <Ref. to 4AT-76, Transmission Control Module (TCM).>

Diagnostic Procedure with Diagnostic Trouble Code (DTC)

AUTOMATIC TRANSMISSION (DIAGNOSTICS)

Y: DTC P1709 THROTTLE POSITION SENSOR CIRCUIT HIGH INPUT

DIAGNOSIS:

The input signal circuit of accelerator pedal position sensor is shorted.

TROUBLE SYMPTOM:

- Shift point too high or too low.
- Excessive shift shock.
- Excessive tight corner "braking".

WIRING DIAGRAM:

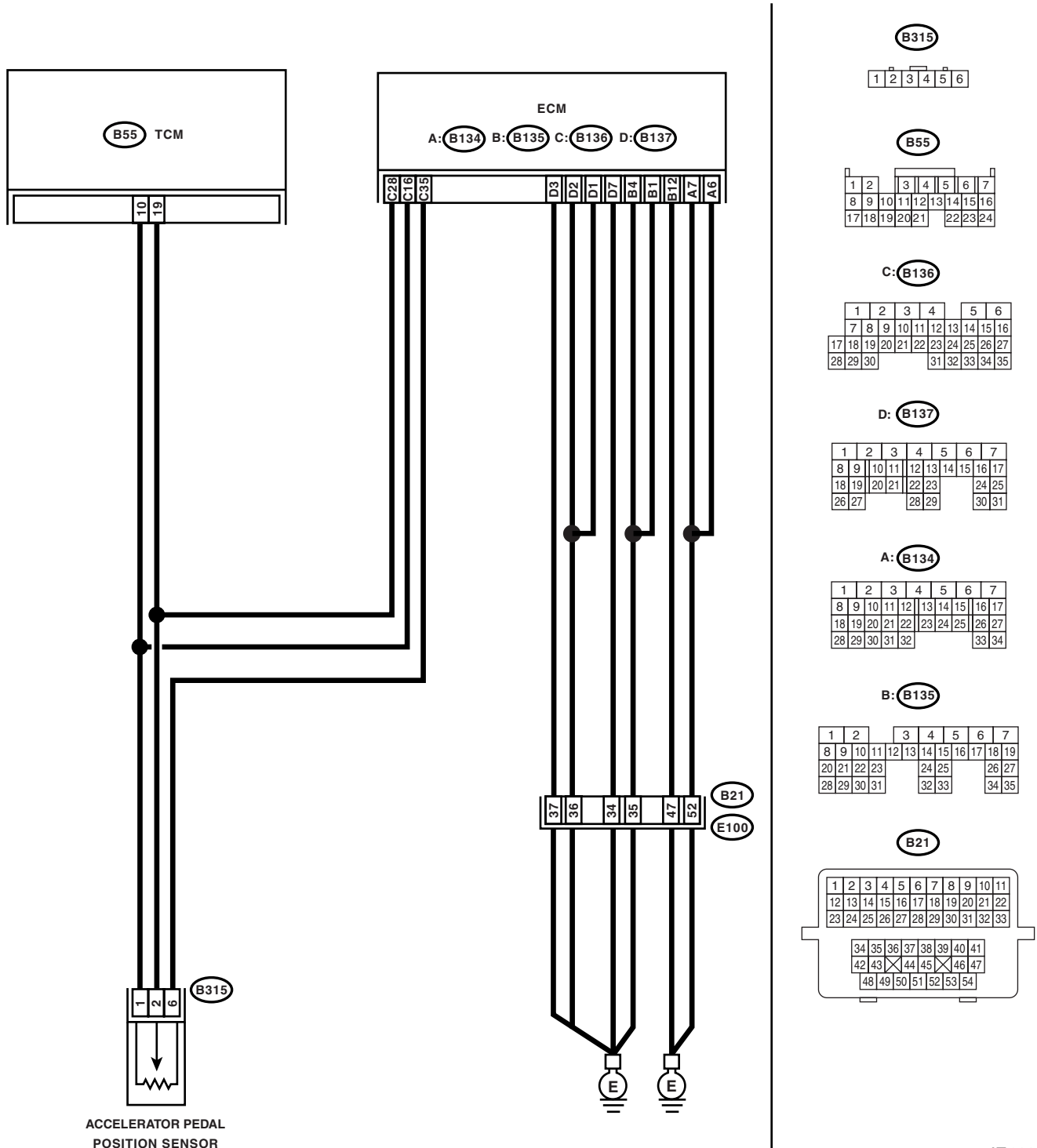

Diagnostic Procedure with Diagnostic Trouble Code (DTC)

AUTOMATIC TRANSMISSION (DIAGNOSTICS)

Step	Check	Yes	No
1	CHECK ENGINE GROUND TERMINALS.	Go to step 2.	Tighten the engine ground terminals.
2	CHECK GROUND CIRCUIT OF ECM. 1) Turn the ignition switch to OFF. 2) Disconnect the connector from ECM. 3) Measure the resistance of harness between ECM and engine ground. Connector & terminal (B134) No. 7 — Engine ground: (B134) No. 6 — Engine ground: (B135) No. 1 — Engine ground: (B135) No. 4 — Engine ground: (B135) No. 12 — Engine ground: (B137) No. 1 — Engine ground: (B137) No. 2 — Engine ground: (B137) No. 3 — Engine ground: (B137) No. 7 — Engine ground:	Go to step 3.	Repair the open circuit in harness between ECM connector and engine grounding terminal.
3	CHECK ACCELERATOR PEDAL POSITION SENSOR. 1) Disconnect the connector from accelerator pedal position sensor. 2) Measure the resistance between accelerator pedal position sensor connector receptacle's terminals. Connector & terminal (B315) No. 1 — No. 6:	Go to step 4.	Replace the accelerator pedal position sensor.
4	CHECK ACCELERATOR PEDAL POSITION SENSOR. Measure the resistance between accelerator pedal position sensor connector receptacle's terminals. Connector & terminal (B315) No. 6 — No. 2:	Go to step 5.	Replace the accelerator pedal position sensor.
5	CHECK HARNESS CONNECTOR BETWEEN TCM AND ACCELERATOR PEDAL POSITION SENSOR. 1) Disconnect the connector from TCM. 2) Measure the resistance of harness between TCM connector and chassis ground. Connector & terminal (B55) No. 19 — Chassis ground:	Go to step 6.	Repair the short circuit in harness between TCM and accelerator pedal position sensor connector.
6	CHECK HARNESS CONNECTOR BETWEEN ECM AND ACCELERATOR PEDAL POSITION SENSOR. 1) Disconnect the connector from ECM. 2) Measure the resistance of harness between ECM connector and accelerator pedal position sensor connector. Connector & terminal (B315) No. 6 — (B136) No. 35:	Go to step 7.	Repair the short circuit in harness between ECM and accelerator pedal position sensor connector.

Diagnostic Procedure with Diagnostic Trouble Code (DTC)

AUTOMATIC TRANSMISSION (DIAGNOSTICS)

Step	Check	Yes	No
7 CHECK INPUT SIGNAL FOR TCM USING SUBARU SELECT MONITOR. 1) Connect the connectors to TCM, accelerator pedal position sensor and ECM. 2) Connect the Subaru Select Monitor to data link connector. 3) Turn the ignition switch to ON (engine OFF). 4) Turn the Subaru Select Monitor switch to ON. 5) Throttle fully opened. 6) Read the data of accelerator pedal position sensor using Subaru Select Monitor. • Accelerator pedal position sensor input signal is indicated.	Is the voltage less than 4.6 V?	Go to step 8 .	Even if the AT OIL TEMP warning light blinks, the circuit has returned to a normal condition at this time. A temporary poor contact of the connector or harness may be the cause. Repair the harness or connector in accelerator pedal position sensor circuit.
8 CHECK POOR CONTACT.	Is there poor contact in accelerator pedal position sensor circuit?	Repair the poor contact.	Replace the TCM. <Ref. to 4AT-76, Transmission Control Module (TCM).>

Diagnostic Procedure with Diagnostic Trouble Code (DTC)

AUTOMATIC TRANSMISSION (DIAGNOSTICS)

Z: DTC P1714 THROTTLE POSITION SENSOR POWER SUPPLY CIRCUIT

DIAGNOSIS:

The power supply circuit of throttle position sensor is open or shorted.

TROUBLE SYMPTOM:

- Shift point too high or too low.
- Excessive shift shock.
- Excessive tight corner "braking".

WIRING DIAGRAM:

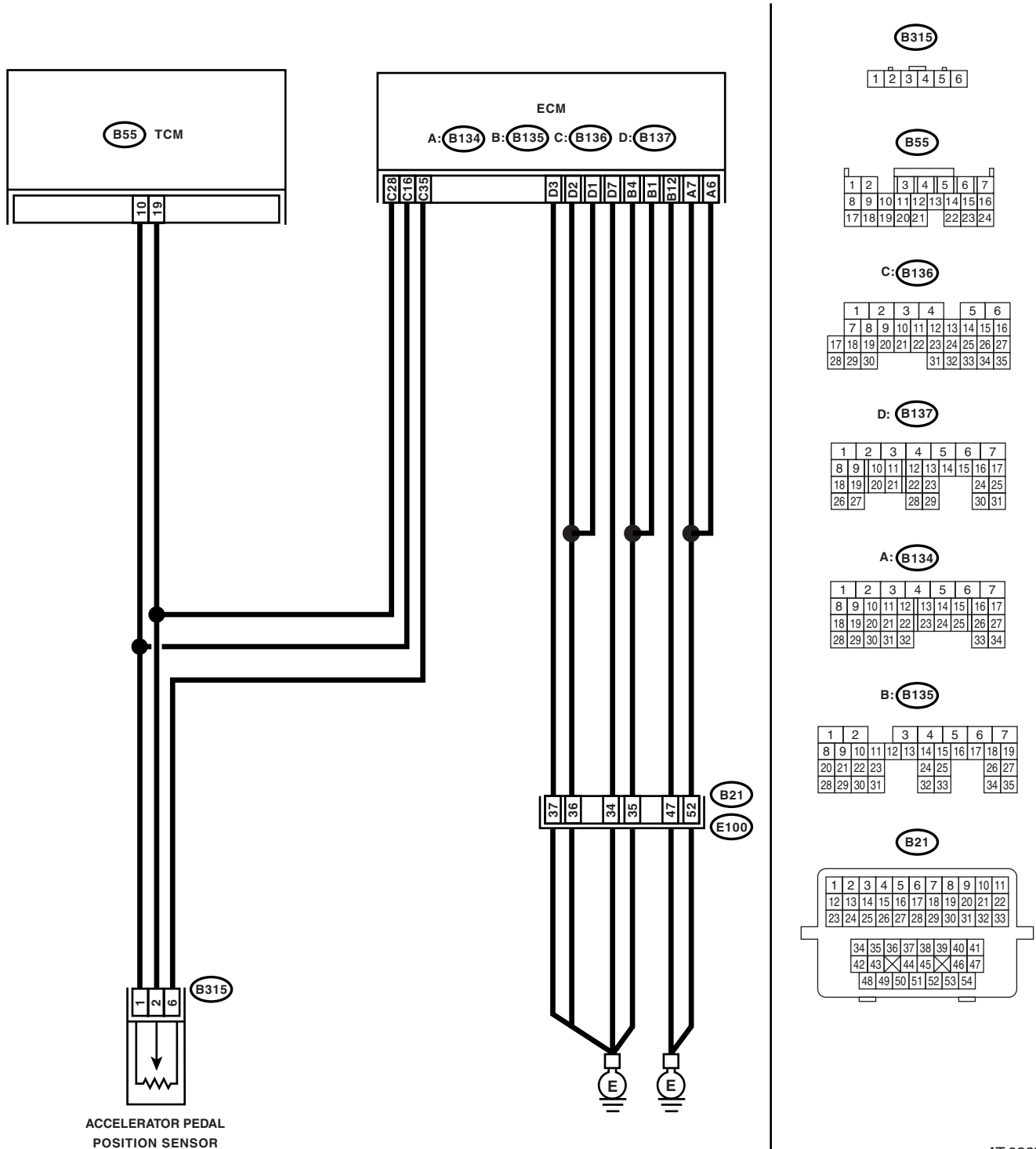

Diagnostic Procedure with Diagnostic Trouble Code (DTC)

AUTOMATIC TRANSMISSION (DIAGNOSTICS)

Step	Check	Yes	No
1 CHECK HARNESS CONNECTOR BETWEEN TCM AND THROTTLE POSITION SENSOR. 1) Disconnect the connector from TCM. 2) Measure the resistance of harness between TCM and throttle position sensor connector. <i>Connector & terminal</i> <i>(B55) No. 10 — (B315) No. 1:</i>	Is the resistance less than 1 Ω ?	Go to step 2.	Repair the open circuit in harness between TCM and throttle position sensor connector, and poor contact in coupling connector.
2 CHECK HARNESS CONNECTOR BETWEEN TCM AND THROTTLE POSITION SENSOR. Measure the resistance of harness between TCM connector and chassis ground. <i>Connector & terminal</i> <i>(B55) No. 10 — Chassis ground:</i>	Is the resistance more than 1 $M\Omega$?	Go to step 3.	Repair the short circuit in harness between TCM and throttle position sensor connector.
3 CHECK HARNESS CONNECTOR BETWEEN TCM AND ECM. 1) Connect all connectors. 2) Turn the ignition switch to ON. 3) Measure the voltage between TCM and chassis ground. <i>Connector & terminal</i> <i>(B55) No. 10 (+) — Chassis ground (-):</i>	Is the voltage 4.6 — 5.4 V?	Go to step 4.	Even if the AT OIL TEMP warning light blinks, the circuit has returned to a normal condition at this time. A temporary poor contact of the connector or harness may be the cause. Repair the harness or connector in throttle position sensor circuit.
4 CHECK POOR CONTACT.	Is there poor contact in throttle position sensor circuit?	Repair the poor contact.	Replace the TCM. <Ref. to 4AT-76, Transmission Control Module (TCM).>

Diagnostic Procedure with Diagnostic Trouble Code (DTC)

AUTOMATIC TRANSMISSION (DIAGNOSTICS)

AA:DTC P1718 CAN COMMUNICATION CIRCUIT

DIAGNOSIS:

Input signal circuit of TCM is open or shorted.

WIRING DIAGRAM:

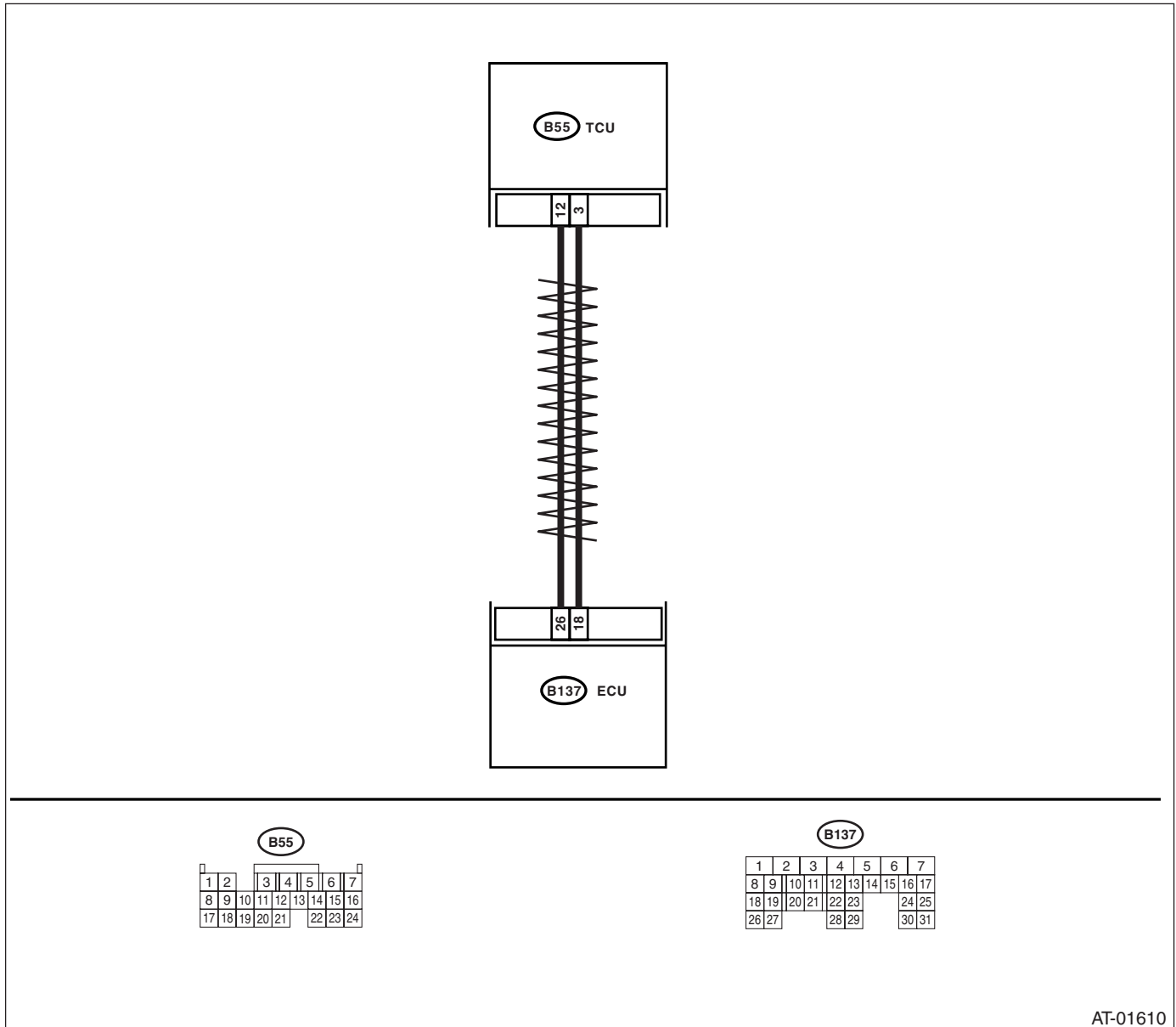

AT-01610

Step	Check	Yes	No	
1	CHECK DTC. Check if multiple trouble codes appear in the on-board diagnostics test mode.	Are multiple DTCs displayed?	Go to other DTC.	Go to step 2.
2	CHECK HARNESS CONNECTOR BETWEEN TCM AND ECM. 1) Turn the ignition switch to OFF. 2) Disconnect TCM and ECM connectors. 3) Measure resistance of harness between ECM and TCM connector. Connector & Terminal (B55) No. 3 — (B137) No. 18:	Is the measured value less than 1 Ω?	Go to step 3.	Repair open circuit in harness between TCM and ECM, or poor contact in coupling connector.

Diagnostic Procedure with Diagnostic Trouble Code (DTC)

AUTOMATIC TRANSMISSION (DIAGNOSTICS)

Step	Check	Yes	No
3 CHECK HARNESS CONNECTOR BETWEEN TCM AND ECM. Measure resistance of harness between ECM and TCM connector. Connector & Terminal (B55) No. 12 — (B137) No. 26:	Is the measured value less than 1 Ω ?	Go to step 4.	Repair open circuit in harness between TCM and ECM, or poor contact in coupling connector.
4 CHECK HARNESS CONNECTOR BETWEEN TCM AND ECM. Measure resistance of harness between TCM and chassis ground. Connector & Terminal (B55) No. 3 — Chassis ground: (B55) No. 12 — Chassis ground:	Is the measured value more than 1 M Ω ?	There is failure in the TCM or ECM. (Replace and check again)	Repair short circuit in harness between TCM and ECM.

14. Diagnostic Procedure without Diagnostic Trouble Code (DTC)

A: INSPECTION OF FWD SWITCH

DIAGNOSIS:

- The LED does not come on even if FWD switch is ON.
- The FWD switch circuit is open or short.

WIRING DIAGRAM:

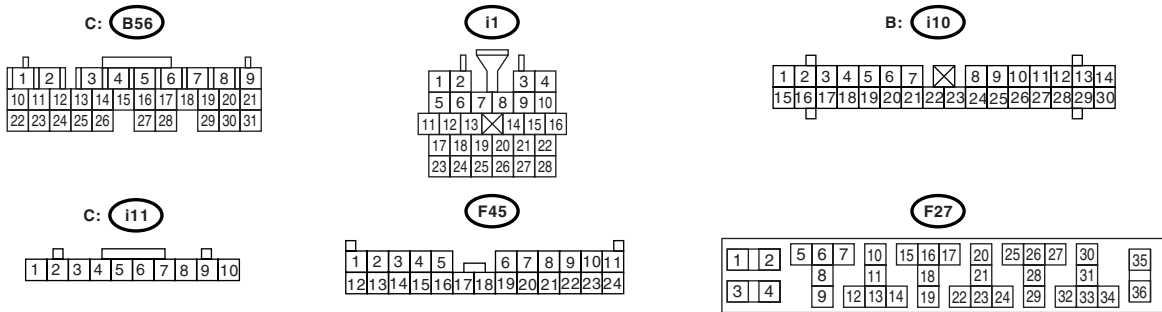
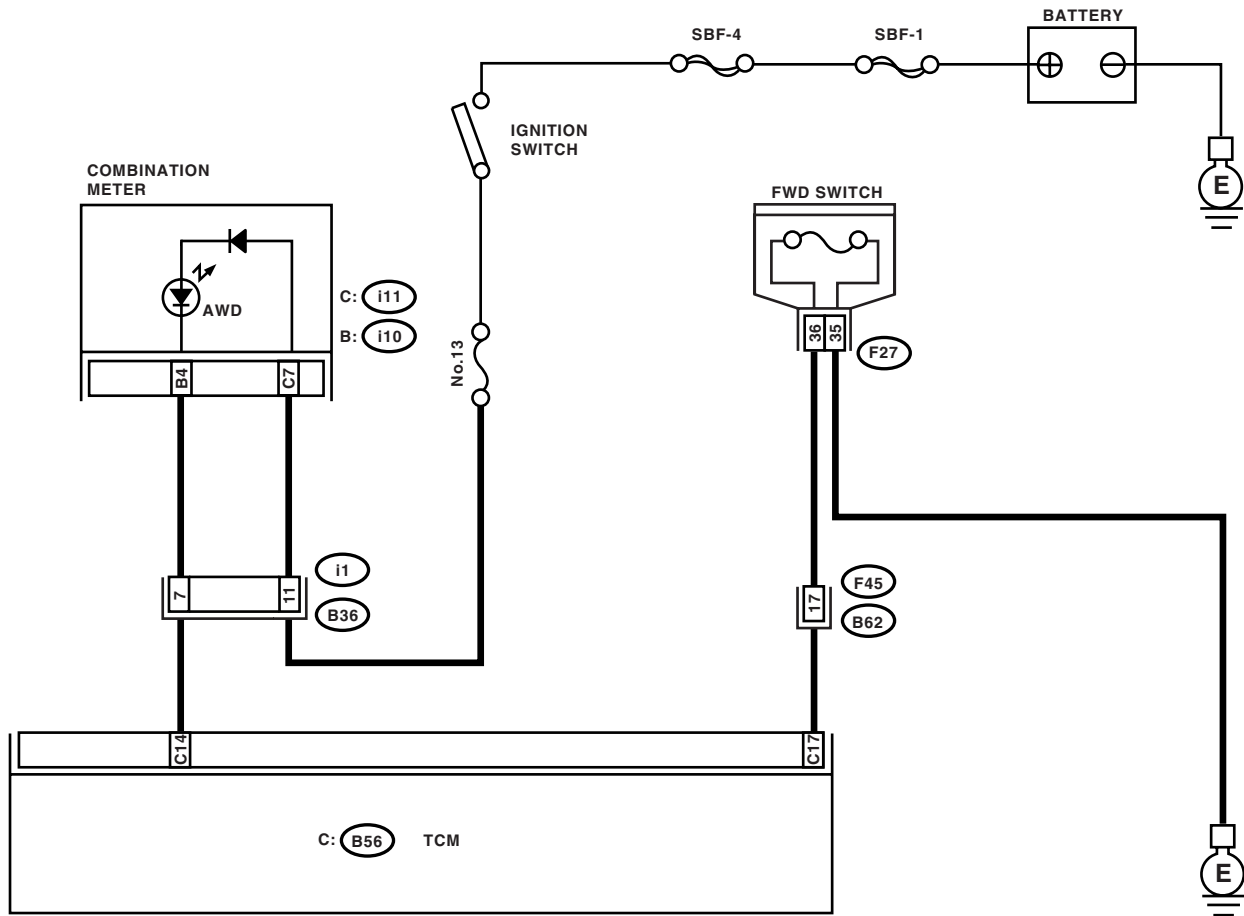

Diagnostic Procedure without Diagnostic Trouble Code (DTC)

AUTOMATIC TRANSMISSION (DIAGNOSTICS)

Step	Check	Yes	No
1	CHECK SPARE FUSE.	Go to step 2 .	Replace the fuse.
2	CHECK FWD SWITCH. Connect the Subaru Select Monitor to data link connector.	Go to step 3 .	Go to step 4 .
3	CHECK COMBINATION METER.	Go to INSPECTION FOR CRUISE CONTROL SWITCH. <Ref. to 4AT(D)(diag)-91, CHECK CRUISE CONTROL SWITCH, Diagnostic Procedure without Diagnostic Trouble Code (DTC).>	Go to step 9 .
4	CHECK HARNESS CONNECTOR BETWEEN TCM AND FWD SWITCH. 1) Turn the ignition switch to OFF. 2) Disconnect the connector from TCM. 3) Measure the resistance of harness between TCM and FWD switch connector. Connector & terminal (B56) No. 17 — (F27) No. 36:	Is the resistance less than 1 Ω ?	Go to step 5 .
5	CHECK HARNESS CONNECTOR BETWEEN FWD SWITCH AND CHASSIS GROUND. Measure the resistance of harness between FWD switch and chassis ground. Connector & terminal (F27) No. 35 — Chassis ground:	Is the resistance less than 1 Ω ?	Go to step 6 .
6	CHECK HARNESS CONNECTOR BETWEEN TCM AND FWD SWITCH. Measure the resistance of harness connector between TCM and body to make sure that circuit does not short. Connector & terminal (B56) No. 17 — Chassis ground:	Is the resistance more than 1 M Ω ?	Go to step 7 .
7	CHECK INPUT SIGNAL FOR TCM. 1) Turn the ignition switch to OFF. 2) Connect the connector to TCM. 3) Turn the ignition switch to ON. 4) Measure the signal voltage for TCM while installing the fuse to FWD switch connector. Connector & terminal (B56) No. 17 (+) — Chassis ground (-):	Is the voltage less than 1 V?	Go to step 8 .
8	CHECK INPUT SIGNAL FOR TCM. Measure the signal voltage for TCM while removing the fuse from FWD switch connector. Connector & terminal (B56) No. 17 (+) — Chassis ground (-):	Is the voltage 6 — 9.1 V?	Go to step 9 .
			Replace the TCM. <Ref. to 4AT-76, Transmission Control Module (TCM).>

Diagnostic Procedure without Diagnostic Trouble Code (DTC)

AUTOMATIC TRANSMISSION (DIAGNOSTICS)

Step	Check	Yes	No
9 CHECK HARNESS CONNECTOR BETWEEN TCM AND COMBINATION METER. 1) Turn the ignition switch to OFF. 2) Disconnect the connector from TCM and combination meter. 3) Measure the resistance of harness between TCM and check connector. <i>Connector & terminal (B56) No. 14 — (i10) No. 4:</i>	Is the resistance less than 1 Ω ?	Go to step 10.	Repair the open circuit in harness between TCM and combination meter and poor contact in coupling connector.
10 CHECK HARNESS CONNECTOR BETWEEN TCM AND COMBINATION METER. Measure the resistance of harness connector between TCM and chassis ground to make sure that circuit does not short. <i>Connector & terminal (B56) No. 14 — Chassis ground:</i>	Is the resistance more than 1 M Ω ?	Go to step 11.	Repair the short circuit in harness between TCM and combination meter connector.
11 CHECK OUTPUT SIGNAL EMITTED FROM TCM. 1) Turn the ignition switch to OFF. 2) Connect the connector to TCM and combination meter. 3) Turn the ignition switch to ON. 4) Measure the signal voltage for TCM while installing the fuse to FWD switch connector. <i>Connector & terminal (B56) No. 14 (+) — Chassis ground (-):</i>	Is the voltage less than 1 V?	Go to step 12.	Go to step 13.
12 CHECK OUTPUT SIGNAL EMITTED FROM TCM. Measure the signal voltage for TCM while removing the fuse from FWD switch connector. <i>Connector & terminal (B56) No. 14 (+) — Chassis ground (-):</i>	Is the voltage 6 — 9.1 V?	Go to step 13.	Replace the TCM. <Ref. to 4AT-76, Transmission Control Module (TCM).>
13 CHECK FUSE.	Is the fuse OK?	Go to step 14.	Replace the fuse.
14 CHECK POOR CONTACT.	Is there poor contact in FWD switch circuit?	Repair the poor contact.	Replace the TCM. <Ref. to 4AT-76, Transmission Control Module (TCM).>

B: CHECK CRUISE CONTROL SWITCH

Step	Check	Yes	No
1 CHECK CRUISE CONTROL SWITCH.	When the cruise control is set, does LED light up?	Go to step CHECK INHIBITOR SWITCH. <Ref. to 4AT(D)(diag)-28, DTC P0705 TRANSMISSION RANGE SENSOR CIRCUIT (PRNDL INPUT), Diagnostic Procedure with Diagnostic Trouble Code (DTC).>	Check the cruise control. <Ref. to CC(ETC)(diag)-18, Diagnostic Procedure with Diagnostic Trouble Code (DTC).>

General Diagnostic Table

AUTOMATIC TRANSMISSION (DIAGNOSTICS)

15. General Diagnostic Table

A: INSPECTION

Symptom	Problem parts
Starter does not rotate when select lever is in "P" or "N" range, starter rotates when select lever is in "R", "D", "3" or "2" range.	<ul style="list-style-type: none"> • Inhibitor switch • Select cable • Select lever • Starter motor and harness
Noise when select lever is in "P" or "N" range.	<ul style="list-style-type: none"> • Strainer • Transfer duty solenoid • Oil pump • Drive plate • ATF level too high or too low
Hissing noise occurs during standing start.	<ul style="list-style-type: none"> • Strainer • ATF level too high or too low
Noise occurs while driving in "D1".	<ul style="list-style-type: none"> • Final gear • Planetary gear • Reduction gear • Differential gear oil level too high or too low
Noise occurs while driving in "D2".	
Noise occurs while driving in "D3".	<ul style="list-style-type: none"> • Final gear • Low & reverse brake • Reduction gear • Differential gear oil level too high or too low
Noise occurs while driving in "D4".	<ul style="list-style-type: none"> • Final gear • Low & reverse brake • Planetary gear • Reduction gear • Differential gear oil level too high or too low
Engine stalls while shifting from "1" range to another.	<ul style="list-style-type: none"> • Control valve • Lock-up damper • Engine performance • Input shaft
Vehicle moves when select lever is in "N" range.	<ul style="list-style-type: none"> • Select cable • Inhibitor switch • TCM • Low clutch
Shock occurs when select lever is moved from "N" to "D" range.	<ul style="list-style-type: none"> • Accelerator pedal position sensor • ATF temperature sensor • Line pressure linear solenoid • Low clutch duty solenoid • Low clutch • TCM • Harness • Control valve • ATF deterioration
Excessive time lag occurs when select lever is moved from "N" to "D" range.	<ul style="list-style-type: none"> • Control valve • Low clutch • Line pressure linear solenoid • Seal ring • Front gasket of transmission case
Shock occurs when select lever is moved from "N" to "R" range.	<ul style="list-style-type: none"> • Accelerator pedal position sensor • ATF temperature sensor • Line pressure linear solenoid • TCM • Harness • Control valve • ATF deterioration

General Diagnostic Table

AUTOMATIC TRANSMISSION (DIAGNOSTICS)

Symptom	Problem parts
Excessive time lag occurs when select lever is moved from "N" to "R" range.	<ul style="list-style-type: none"> • Control valve • Low & reverse clutch • Reverse clutch • Line pressure linear solenoid • Seal ring • Front gasket of transmission case
Vehicle does not start in any shift range (engine stalls).	<ul style="list-style-type: none"> • Parking brake mechanism • Planetary gear
Vehicle does not start in any shift range (engine revving up).	<ul style="list-style-type: none"> • Strainer • Line pressure linear solenoid • Control valve • Drive pinion • Hypoid gear • Axle shaft • Differential gear • Oil pump • Input shaft • Output shaft • Planetary gear • Drive plate • ATF level too low • Front gasket of transmission case
Vehicle does not start in "R" range only (engine revving up).	<ul style="list-style-type: none"> • Select cable • Select lever • Line pressure linear solenoid • Control valve • Low & reverse clutch • Reverse clutch
Vehicle does not start in "R" range only (engine stalls).	<ul style="list-style-type: none"> • Low clutch • 2-4 brake • Planetary gear • Parking brake mechanism
Vehicle does not start in "D", "3" range only (engine revving up).	<ul style="list-style-type: none"> • Low clutch • One-way clutch
Vehicle does not start in "D", "3" or "2" range only (engine revving up).	<ul style="list-style-type: none"> • Low clutch
Vehicle does not start in "D", "3" or "2" range only (engine stalls).	<ul style="list-style-type: none"> • Reverse clutch
Vehicle starts in "R" range only (engine revving up).	<ul style="list-style-type: none"> • Control valve
Acceleration during standing starts is poor (high stall rpm).	<ul style="list-style-type: none"> • Control valve • Low clutch • Reverse clutch • ATF level too low • ATF deterioration • Front gasket of transmission case • Differential gear oil level too high or too low
Acceleration during standing starts is poor (low stall rpm).	<ul style="list-style-type: none"> • Oil pump • Torque converter one-way clutch • Engine performance
Acceleration is poor when select lever is in "D", "3" or "2" range (normal stall rpm).	<ul style="list-style-type: none"> • TCM • Control valve • High clutch • 2-4 brake • Planetary gear
Acceleration is poor when select lever is in "R" (normal stall rpm).	<ul style="list-style-type: none"> • Control valve • High clutch • 2-4 brake • Planetary gear

General Diagnostic Table

AUTOMATIC TRANSMISSION (DIAGNOSTICS)

Symptom	Problem parts
Does not shift from 1st to 2nd gear.	<ul style="list-style-type: none"> • TCM • Rear vehicle speed sensor • Front vehicle speed sensor • Accelerator pedal position sensor • Control valve • 2-4 brake
Does not shift from 2nd to 3rd gear.	<ul style="list-style-type: none"> • TCM • Control valve • High clutch
Does not shift from 3rd to 4th gear.	<ul style="list-style-type: none"> • TCM • ATF temperature sensor • Control valve • 2-4 brake
Engine brake is not effected when select lever is in "3" range.	<ul style="list-style-type: none"> • Inhibitor switch • TCM • Accelerator pedal position sensor • Control valve
Engine brake is not effected when select lever is in "3" or "2" range.	<ul style="list-style-type: none"> • Control valve
Engine brake is not effected when select lever is in "1" range.	<ul style="list-style-type: none"> • Control valve • Low & reverse brake
Shift characteristics are erroneous.	<ul style="list-style-type: none"> • Inhibitor switch • TCM • Front vehicle speed sensor • Rear vehicle speed sensor • Accelerator pedal position sensor • Control valve • Ground earth
No lock-up occurs.	<ul style="list-style-type: none"> • TCM • Accelerator pedal position sensor • ATF temperature sensor • Control valve • Lock-up facing • Engine speed signal
Parking brake is not effected.	<ul style="list-style-type: none"> • Select cable • Select lever • Parking mechanism
Shift lever cannot be moved or is hard to move from "P" range.	
ATF spurts out.	<ul style="list-style-type: none"> • ATF level too high
Differential oil spurts out.	<ul style="list-style-type: none"> • Differential gear oil too high
Differential oil level changes excessively.	<ul style="list-style-type: none"> • Seal pipe • Double oil seal
Odor is produced from ATF supply pipe.	<ul style="list-style-type: none"> • High clutch • 2-4 brake • Low & reverse clutch • Reverse clutch • Lock-up facing • ATF deterioration
Shock occurs from 1st to 2nd gear.	<ul style="list-style-type: none"> • TCM • Torque converter turbine speed sensor • Accelerator pedal position sensor • 2-4 brake duty solenoid • ATF temperature sensor • Line pressure linear solenoid • Control valve • 2-4 brake • ATF deterioration • Engine performance • Low & reverse duty solenoid

General Diagnostic Table

AUTOMATIC TRANSMISSION (DIAGNOSTICS)

Symptom	Problem parts
Slippage occurs from 1st to 2nd gear.	<ul style="list-style-type: none"> • TCM • Accelerator pedal position sensor • 2-4 brake duty solenoid • ATF temperature sensor • Line pressure linear solenoid • Control valve • 2-4 brake
Shock occurs from 2nd to 3rd gear.	<ul style="list-style-type: none"> • TCM • Torque converter turbine speed sensor • Accelerator pedal position sensor • 2-4 brake duty solenoid • ATF temperature sensor • Line pressure linear solenoid • Low & reverse duty solenoid • Control valve • High clutch • 2-4 brake • ATF deterioration • Engine performance • High clutch duty solenoid
Slippage occurs from 2nd to 3rd gear.	<ul style="list-style-type: none"> • TCM • Accelerator pedal position sensor • 2-4 brake duty solenoid • ATF temperature sensor • Line pressure linear solenoid • Control valve • High clutch • 2-4 brake • Low & reverse duty solenoid
Shock occurs from 3rd to 4th gear.	<ul style="list-style-type: none"> • TCM • Torque converter turbine speed sensor • Accelerator pedal position sensor • 2-4 brake duty solenoid • ATF temperature sensor • Line pressure linear solenoid • Control valve • Low clutch duty solenoid • 2-4 brake • ATF deterioration • Engine performance
Slippage occurs from 3rd to 4th gear.	<ul style="list-style-type: none"> • TCM • Accelerator pedal position sensor • 2-4 brake duty solenoid • ATF temperature sensor • Line pressure linear solenoid • Control valve • 2-4 brake
Shock occurs when select lever is moved from "3" to "2" range.	<ul style="list-style-type: none"> • TCM • Torque converter turbine speed sensor • Accelerator pedal position sensor • ATF temperature sensor • Line pressure linear solenoid • Control valve • 2-4 brake duty solenoid • 2-4 brake • ATF deterioration • High clutch duty solenoid

General Diagnostic Table

AUTOMATIC TRANSMISSION (DIAGNOSTICS)

Symptom	Problem parts
Shock occurs when select lever is moved from "D" to "1" range.	<ul style="list-style-type: none"> • TCM • Torque converter turbine speed sensor • Accelerator pedal position sensor • ATF temperature sensor • Line pressure linear solenoid • Control valve • ATF deterioration • Low & reverse brake duty solenoid • Low & reverse clutch solenoid
Shock occurs when select lever is moved from "2" to "1" range.	<ul style="list-style-type: none"> • TCM • Torque converter turbine speed sensor • Accelerator pedal position sensor • ATF temperature sensor • Line pressure linear solenoid • Control valve • Low & reverse clutch • ATF deterioration • 2-4 brake duty solenoid • Low & reverse brake duty solenoid
Shock occurs when accelerator pedal is released at medium speeds.	<ul style="list-style-type: none"> • TCM • Accelerator pedal position sensor • ATF temperature sensor • Line pressure linear solenoid • Control valve • Lock-up damper • Engine performance
Vibration occurs during straight-forward operation.	<ul style="list-style-type: none"> • TCM • Lock-up duty solenoid • Lock-up facing • Lock-up damper
Vibration occurs during turns (tight corner "braking" phenomenon).	<ul style="list-style-type: none"> • TCM • Front vehicle speed sensor • Rear vehicle speed sensor • Accelerator pedal position sensor • ATF temperature sensor • Transfer clutch • Transfer valve • Transfer duty solenoid • ATF deterioration • Harness
Front wheel slippage occurs during standing starts.	<ul style="list-style-type: none"> • TCM • Front vehicle speed sensor • Accelerator pedal position sensor • ATF temperature sensor • Transfer clutch • Control valve • Transfer pipe • Transfer duty solenoid
Vehicle is not set in FWD mode.	<ul style="list-style-type: none"> • TCM • Transfer clutch • Control valve • Transfer duty solenoid • FWD fuse
Select lever is hard to move.	<ul style="list-style-type: none"> • Select cable • Select lever • Detention spring • Manual plate
Select lever is excessively hard to move (unreasonable resistance).	<ul style="list-style-type: none"> • Detention spring • Manual plate

General Diagnostic Table

AUTOMATIC TRANSMISSION (DIAGNOSTICS)

Symptom	Problem parts
Select lever slips out of operation during acceleration or while driving on rough terrain.	<ul style="list-style-type: none">• Select cable• Select lever• Detention spring• Manual plate

General Diagnostic Table

AUTOMATIC TRANSMISSION (DIAGNOSTICS)
