

How to Use This Manuals

HOW TO USE THIS MANUALS

1. How to Use This Manuals

A: HOW TO USE THIS MANUALS

1. STRUCTURE

Each section consists of SCT that are broken down into SC that are divided into sections for each component. The specification, maintenance and other information for the components are included, and the diagnostic information has also been added where necessary.

2. CONTENTS

The first page has an index with tabs.

3. COMPONENT

Illustrations are provided for each component. The information necessary for repair work (tightening torque, grease up points, etc.) is described on these illustrations. Information is described using symbol.

To order parts, refer to parts catalogue.

Example:

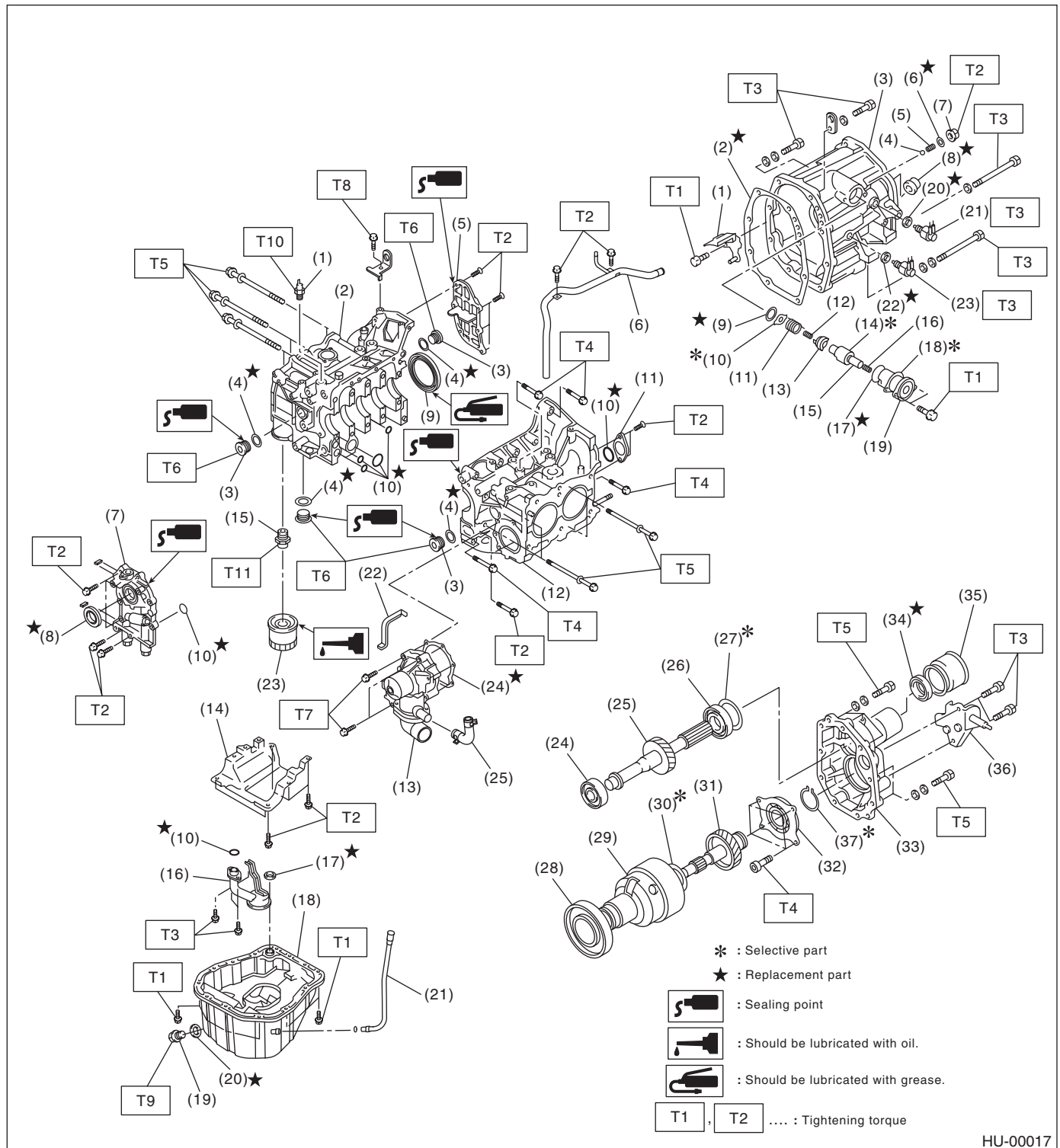

HU-00017

How to Use This Manuals

HOW TO USE THIS MANUALS

4. DEFINITIONS OF “NOTE”, “CAUTION”, AND “WARNING”

- **Note:**

The supplementary explanation to facilitate the work is described.

- **Caution:**

The matter that must not be performed because failure to follow the description causes damage to the vehicle or parts, and the one to which attention should be particularly paid during the work are described.

- **Warning:**

The matter that may seriously damage the worker or others and the one results in failures or accidents in case of failure to follow the description are described.

5. SPECIFICATIONS

If necessary, specifications are also included.

6. INSPECTION

Inspections to be carried out before and after maintenance are included.

7. MAINTENANCE

- Maintenance instructions for serviceable parts describe work area and detailed step with illustration. It also describes the use of special tool, tightening torque, caution for each procedure.
- If many serviceable parts are included in one service procedure, appropriate reference is provided for each parts.

Example:

15.Main Shaft ← (A)

A: REMOVAL ← (B)

1) Remove the manual transmission assembly from vehicle. <Ref. to MT-33, REMOVAL, Manual Transmission Assembly.> ← (C)

11) Tighten the lock nuts to the specified torque using ST1 and ST2.

NOTE: ← (D)

Secure the lock nuts in two places after tightening.

ST1 498937000 TRANSMISSION HOLDER

ST2 499987003 (E) SOCKET WRENCH (35) (F)

Tightening torque:

120 N·m (12.2 kgf-m, 88.5 ft-lb) ← (G)

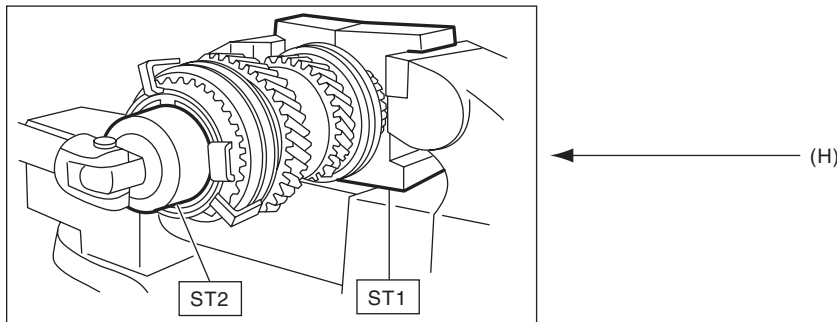

HU-00041

(A) Component

(B) Process

(C) Reference

(D) Cautions

(E) Tool number of special tool

(F) Name of special tool

(G) Tightening torque

(H) Illustration

8. DIAGNOSIS

Tables showing a step-by-step process make it easy to conduct diagnosis.

How to Use This Manuals

HOW TO USE THIS MANUALS

9. SI UNITS

Measurements in these manuals are according to the SI units. Metric and yard/pound measurements are also included.

Example:

Tightening torque:

45 N·m (4.6 kgf·m, 33.2 ft·lb)

SI unit list

Item	SI units	Conventional unit	Remarks
Force	N (Newton)	kgf	1 kgf = 9.80655 N
Mass (Weight)	kg, g	kg, g	
Capacity	ℓ, mℓ or cm ³	ℓ or cc	1 cc = 1 cm ³ = 1 mℓ
Torque	N·m	kgf·m, kgf·cm	1 kgf·m = 9.80655 N·m
Rotating speed	rpm	rpm	
Pressure	kPa (kilopascal)	kgf/cm ²	1 kgf/cm ² = 98.0655 kPa
		mmHg	1 mmHg = 0.133322 kPa
Power	W	PS	1 PS = 0.735499 kW
Calorie	W·h	cal	1 kcal = 1.16279 W·h
Fuel consumption rate	g/kW·h	g/PS·h	1 g/PS·h = 1.3596 g/kW·h

The figure used in these manuals are described in the SI units and conventional units are described in ().

10.EXPLANATION OF TERMINOLOGY

• List

AAI	: Air Assist Injection	HID	: High-Intensity Discharge
AAR	: Angular Adjusted Roller	H/U	: Hydraulic Unit
A/B	: Airbag	IG	: Ignition
ABS	: Anti-lock Brake System	IN	: Intake
A/C	: Air Conditioner	INT	: Intermittent
AC	: Angular Contact	I/O	: Input / Output
ACC	: Accessory	ISC	: Idle Speed Control
A/F	: Air Fuel Ratio	LAN	: Local Area Network
ALT	: Generator	LCD	: Liquid Crystal Display
ASSY	: Assembly	LED	: Light Emitting Diode
AT	: Automatic Transmission	LH	: LH (Left Hand)
ATF	: Automatic Transmission Fluid	LSD	: Limited Slip Differential
AVCS	: Active Valve Control System	M/B	: Main Fuse & Relay Box
AWD	: All Wheel Drive	MFI	: Multi-Point Fuel Injection
BATT	: Battery	MP-T	: Multi-Plate Transfer
BJ	: Bell Joint	MT	: Manual Transmission
CAN	: Controller Area Network	NA	: Natural Aspiration
CD	: Compact Disc	OP	: Option Parts
COMPL	: Complete	OBD	: On-Board Diagnosis
CPU	: Central Processing Unit	P/S	: Power Steering
DOHC	: Double Overhead Camshaft	P/W	: Power Window
DTC	: Diagnosis Trouble Code	PCV	: Positive Crankcase Ventilation
DOJ	: Double Offset Joint	PID	: Parameter Identification
DVD	: Digital Versatile Disc or Digital Video Disc	RAM	: Random Access Memory
EBD	: Electronic Brake Distribution	RH	: RH (Right Hand)
EBJ	: High-efficiency Compact Ball Fixed Joint	ROM	: Read Only Memory
EDJ	: High-efficiency Compact Double Offset Joint	rpm	: Revolution Per Minute
ECM	: Engine Control Module	SOHC	: Single Overhead Camshaft
EGI	: Electronic Gasoline Injection	SRS	: Supplemental Restraint System
E/G	: Engine	SSM	: Subaru Select Monitor
EGR	: Exhaust Gas Recirculation	ST	: Special Tool
EX	: Exhaust	SW	: Switch
ETC	: Electronic Throttle Control	TGV	: Tumble Generator Valve
F/B	: Fuse & Joint Box	VDC	: Vehicle Dynamics Control
FWD	: Front Wheel Drive	V.I.N.	: Vehicle Identification Number
GPS	: Global Positioning System	VTD	: Variable Torque Distribution

How to Use This Manuals

HOW TO USE THIS MANUALS

SPECIFICATIONS

SPC

	Page
1. Impreza	2

