

Disc Brake Pad and Disc

PERIODIC MAINTENANCE SERVICES

19. Disc Brake Pad and Disc

A: INSPECTION

1. DISC BRAKE PAD AND DISC

1) Jack-up the vehicle and support it with rigid racks. Remove the wheels.

2) Visually check the pad thickness through inspection hole of disc brake assembly. Replace the pad if necessary.

NOTE:

When replacing a pad, always replace the pads for both the left and right wheels at the same time. Also replace the pad clips if they are twisted or worn.

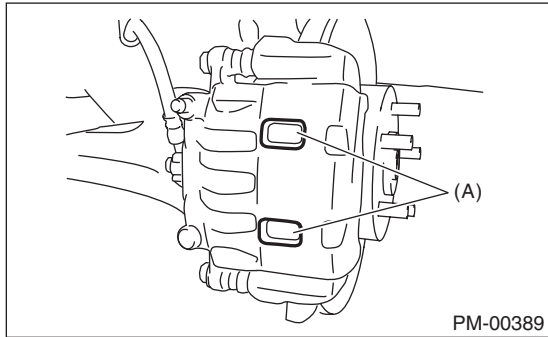

(A) Inspection hole

• Front (back metal not included)

Pad thickness	mm (in)
Standard	11 (0.43)
Wear limit	1.5 (0.059)

• Rear (back metal not included)

Pad thickness	mm (in)
Standard	9.0 (0.354)
Wear limit	1.5 (0.059)

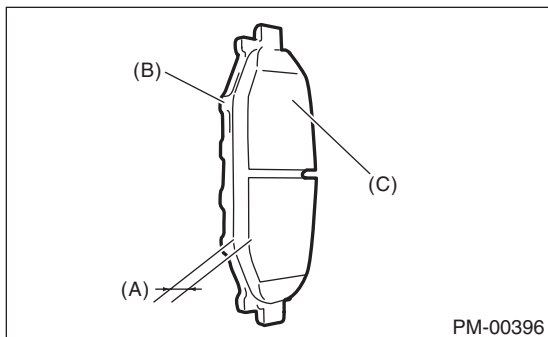

- (A) Pad thickness
- (B) Back metal
- (C) Lining

3) Check the disc rotor, and correct or replace if it is damaged or worn.

• Front

Disc rotor thickness	mm (in)
Standard	24 (0.94)
Wear limit	22 (0.87)

• Rear

Disc rotor thickness	mm (in)
Standard	10 (0.39)
Wear limit	8.5 (0.33)

4) Remove the caliper body. <Ref. to BR-16, Front Disc Brake Assembly.> <Ref. to BR-23, Rear Disc Brake Assembly.>

5) Tighten the wheel nuts to secure disc rotor.

6) Set a dial gauge at a point of 10 mm (0.39 in) or less from outer periphery of the rotor, and then measure the disc rotor runout.

Disc rotor runout limit:

Front: 0.050 mm (0.0020 in)

Rear: 0.050 mm (0.0020 in)

