

# Steering System (Power Steering)

## PERIODIC MAINTENANCE SERVICES

### 25. Steering System (Power Steering)

#### A: INSPECTION

##### 1. STEERING WHEEL

1) Set the steering wheel in a straight-ahead position, and check the wheel spokes to make sure they are correctly set in their specified positions.

2) Lightly turn the steering wheel to the left and right to determine the point where front wheels start to move.

Measure the distance of the movement of steering wheel at the outer periphery of wheel.

##### **Steering wheel free play:**

**0 — 17 mm (0 — 0.67 in)**

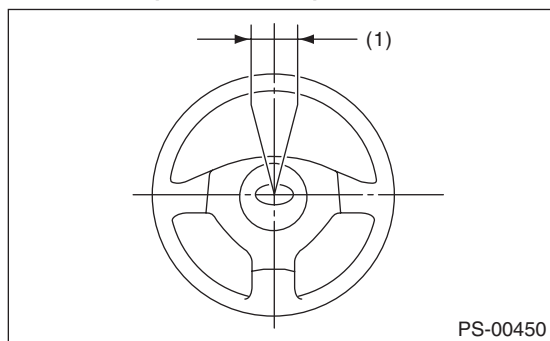

(1) Steering wheel free play

Move the steering wheel vertically toward the shaft to ascertain if there is play in the direction.

##### **Maximum permissible play:**

**0.5 mm (0.020 in)**

3) Drive the vehicle and check the following items during operation.

(1) Steering force:

The effort required for steering should be smooth and even at all points, and should not vary.

(2) Pulled to one side:

Steering wheel should not be pulled to either side while driving on a level surface.

(3) Wheel runout:

Steering wheel should not show any sign of runout.

(4) Return factor:

Steering wheel should return to its original position after it has been turned and then released.

##### 2. STEERING SHAFT JOINT

If steering wheel play is excessive, disconnect the universal joint of steering shaft and then check the play where the joints cross and yawing torque. Also, check the seal for damage or serrations for wear. If loose joints, tighten the mounting bolts to specified torque.

##### **Tightening torque:**

**24 N·m (2.4 kgf-m, 17.4 ft-lb)**

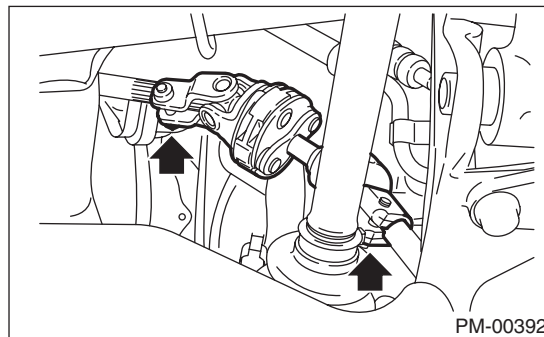

##### 3. GEARBOX

1) With the vehicle placed on a level surface, turn the steering wheel 90° in both the left and right directions.

While the wheel is being rotated, reach under the vehicle and check for looseness in gearbox.

##### **Tightening torque:**

**60 N·m (6.1 kgf-m, 44.3 ft-lb)**

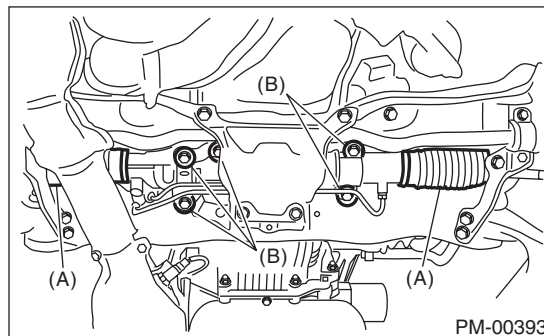

(A) Boot

(B) Gearbox mounting bolt

2) Check the boot for damage, cracks or deterioration.

3) With the vehicle placed on a level surface, quickly turn the steering wheel to the left and right. While steering wheel is being rotated, check the gear backlash. If any noise is noticed, adjust the gear backlash in the following manner.

- (1) Apply liquid gasket to at least 1/3 of entire perimeter of adjusting screw thread.

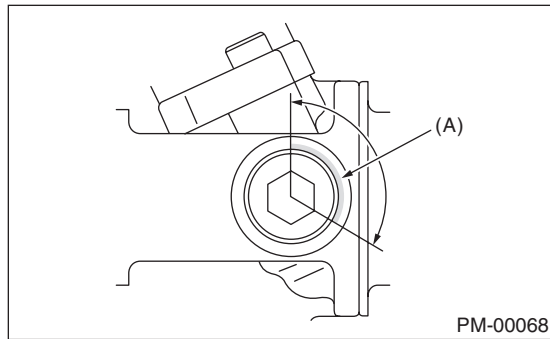

(A) Apply liquid gasket to at least 1/3 of entire perimeter.

- (2) Tighten the adjusting screw to 25 N-m (2.5 kgf-m, 18 ft-lb) and then loosen.
- (3) Tighten the adjusting screw to 3.9 N-m (0.4 kgf-m, 2.9 ft-lb) and then loosen it within 20°.
- (4) Install the lock nut. While holding the adjusting screw with a wrench, tighten the lock nut using ST.

ST 926230000 SPANNER

**Tightening torque (lock nut):**  
**25 N-m (2.5 kgf-m, 18.4 ft-lb)**

Hold the adjusting screw with wrench to prevent it from turning while tightening the lock nut.

## 4. TIE-ROD

- 1) Check the tie-rod and tie-rod end for bend, cracks or other damages.

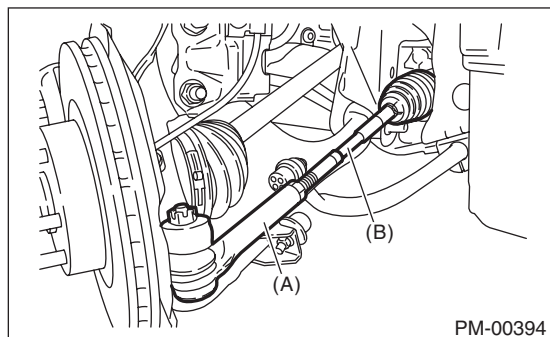

(A) Tie-rod end  
 (B) Tie-rod

- 2) Make sure there is free play at the connection of knuckle ball joint and check the dust seal for damage, and the ball stud for play. If loose castle nut, tighten it to the specified tightening torque, and tighten further within 60° until the cotter pin hole is aligned.

**Tightening torque:**  
**27 N-m (2.75 kgf-m, 19.9 ft-lb)**

- 3) Check the tightening of tie-rod end lock nut. If it is loose, tighten it to the specified torque.

**Tightening torque:**  
**85 N-m (8.7 kgf-m, 62.7 ft-lb)**

## 5. POWER STEERING FLUID LEVEL

NOTE:

- At power steering fluid temperature 20°C (68°F); read the fluid level on the "COLD" side.
  - At power steering fluid temperature 80°C (176°F); read the fluid level on the "HOT" side.
- 1) Place the vehicle with engine "OFF" on a level surface.
  - 2) Check the fluid level using the scale on the outside of the reservoir tank. If the level is below "MIN", fill fluid up to "MAX" level.

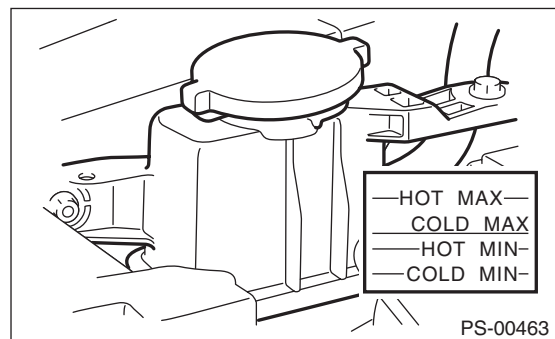

**CAUTION:**

If the power steering fluid is spilt over exhaust pipe, wipe it off with cloth to avoid emitting smoke or causing a fire.

NOTE:

If fluid level is at MAX level or above, drain fluid to keep the level in the specified range of indicator by using a syringe or the like.

**Recommended fluid:**  
**SUBARU PS fluid or DEXRON III**

**Fluid capacity:**  
**0.7 ℓ (0.7 US qt, 0.6 Imp qt)**

## 6. POWER STEERING FLUID FOR LEAKS

Inspect the underside of oil pump and gearbox of power steering system, hoses, pipes and their couplings for fluid leaks.

If leakage is found, tighten the mounting bolt (or nut) again or replace with a new part.

NOTE:

- Wipe the leaked fluid off after correcting fluid leaks.
- When inspecting the fluid leakage, be careful of the clearance between the hose (or piping) and other parts.

# Steering System (Power Steering)

## PERIODIC MAINTENANCE SERVICES

### 7. HOSES OF OIL PUMP FOR DAMAGES

Check the pressure hose and return hose of oil pump for crack, swell or damage. Replace the hose with a new part if necessary.

#### NOTE:

Prevent hoses from turning and/or bending when installing hoses.

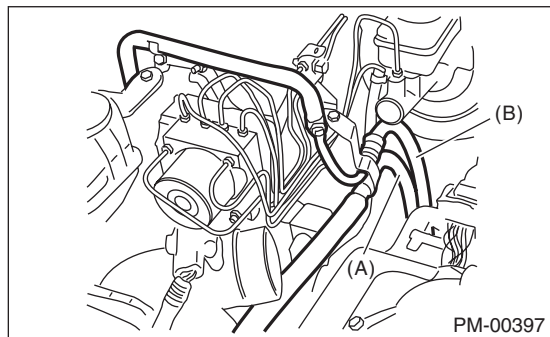

- (A) Pressure hose
- (B) Return hose

### 10. FITTING BOLTS AND NUTS

Inspect the fitting bolts and nuts of oil pump and bracket for looseness, and retighten them if necessary.

Inspect and/or retighten them when engine is cold.

### 8. POWER STEERING PIPES FOR DAMAGES

Check the power steering pipes for corrosion and damage.

Replace the pipe with a new part if necessary.

### 9. GEARBOX BOOTS

Inspect both sides of the gearbox boot as follows, and correct the defects if necessary.

- 1) Positions (A) and (B) of the gearbox boot are fitted correspondingly in grooves (A) and (B) of the gearbox and rod (C).
- 2) Clips are fitted outside of positions (A) and (B) of boot.
- 3) Boot does not have crack or hole.

#### NOTE:

Rotate (B) position of gearbox boot against the torsion produced by the adjustment of toe-in etc. Apply grease to the groove (C).

