

# Timing Belt

## PERIODIC MAINTENANCE SERVICES

### 7. Timing Belt

#### A: REPLACEMENT

- 1) Remove the radiator fan and air conditioner fan. <Ref. to CO(H4SO)-23, REMOVAL, Radiator Main Fan and Fan Motor.> <Ref. to CO(H4SO)-25, REMOVAL, Radiator Sub Fan and Fan Motor.>
- 2) Protect the radiator with cardboard and blanket.
- 3) Remove the V-belt covers.

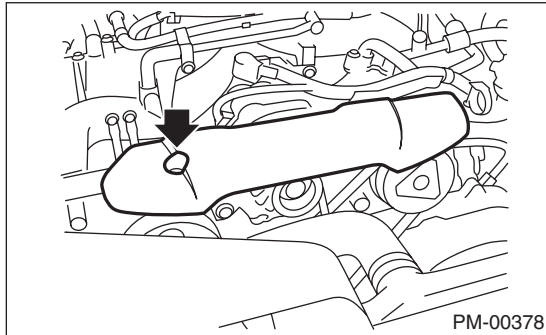

- 4) Remove the V-belts. <Ref. to ME(H4SO)-39, REMOVAL, V-belt.>
- 5) Remove the crank pulley. <Ref. to ME(H4SO)-46, REMOVAL, Crank Pulley.>
- 6) Remove the timing belt cover. <Ref. to ME(H4SO)-49, REMOVAL, Timing Belt Cover.>
- 7) Using ST, turn the crankshaft and align the alignment marks on crankshaft and left and right cam sprockets with alignment marks of belt cover and oil pump.

ST 499987500 CRANKSHAFT SOCKET

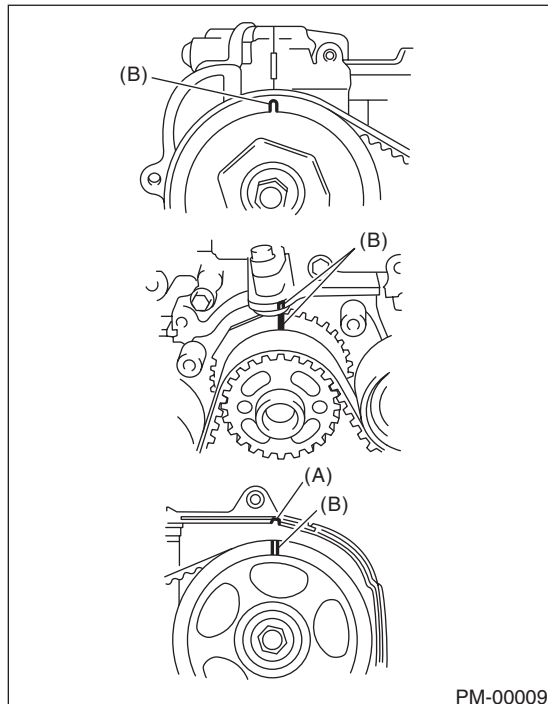

- (A) Notch
- (B) Alignment mark

- 8) Remove the belt idler (A).
- 9) Remove the belt idler No. 2 (B).

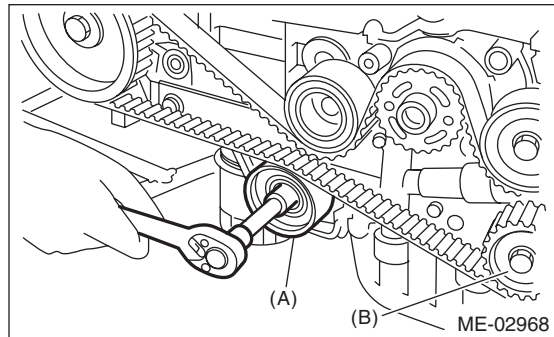

- 10) Remove the timing belt.
- 11) Remove the automatic belt tension adjuster assembly.

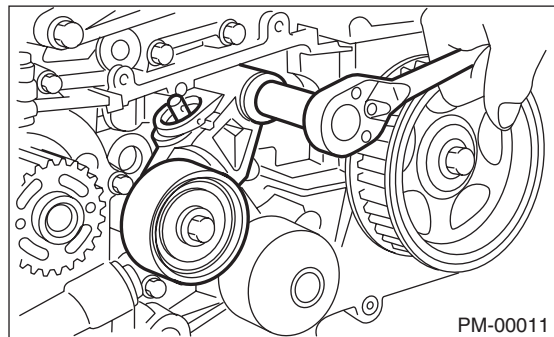

- 12) Install in the reverse order of removal. <Ref. to ME(H4SO)-51, INSTALLATION, Timing Belt.>

#### B: INSPECTION

##### 1. CHECK TIMING BELT POSITION

- 1) Remove the timing belt cover (LH).
- 2) Turn the crank pulley to set #1 cylinder piston to top dead center of compression stroke and check the followings.

- (1) Check that the arrow (A) of camshaft pulley LH points to the upright.

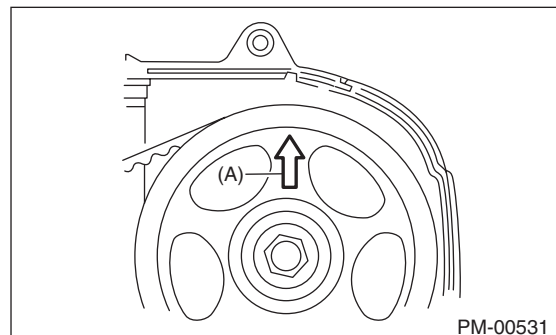

- (2) Remove the sealing rubber (B) of the timing belt cover RH.

(3) Check that the arrow (C) of camshaft pulley RH points to the upright.

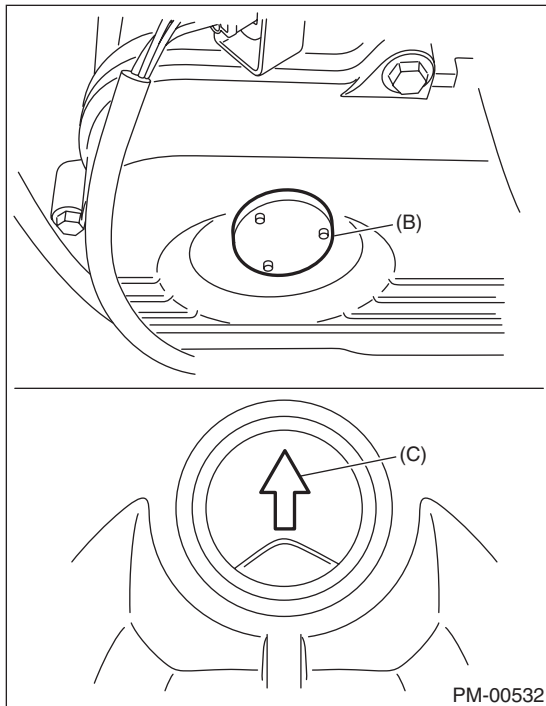

3) When camshaft pulley or timing belt position is offset, check for any defect and repair or replace as required.

## 2. OTHER INSPECTIONS

- 1) Remove the timing belt cover (LH).
- 2) While cranking engine at least four rotations, check the timing belt back surface for cracks or damage. Replace the faulty timing belt as needed.
- 3) When the side part of timing belt (arrow direction shown in the figure) is abnormally worn (fluff or jumping out of core) or damaged, check the idlers, tensioner, water pump pulley and cam sprocket to determine idler alignment (squareness). Replace the worn or damaged timing belt.
- 4) Install the timing belt cover (LH).